

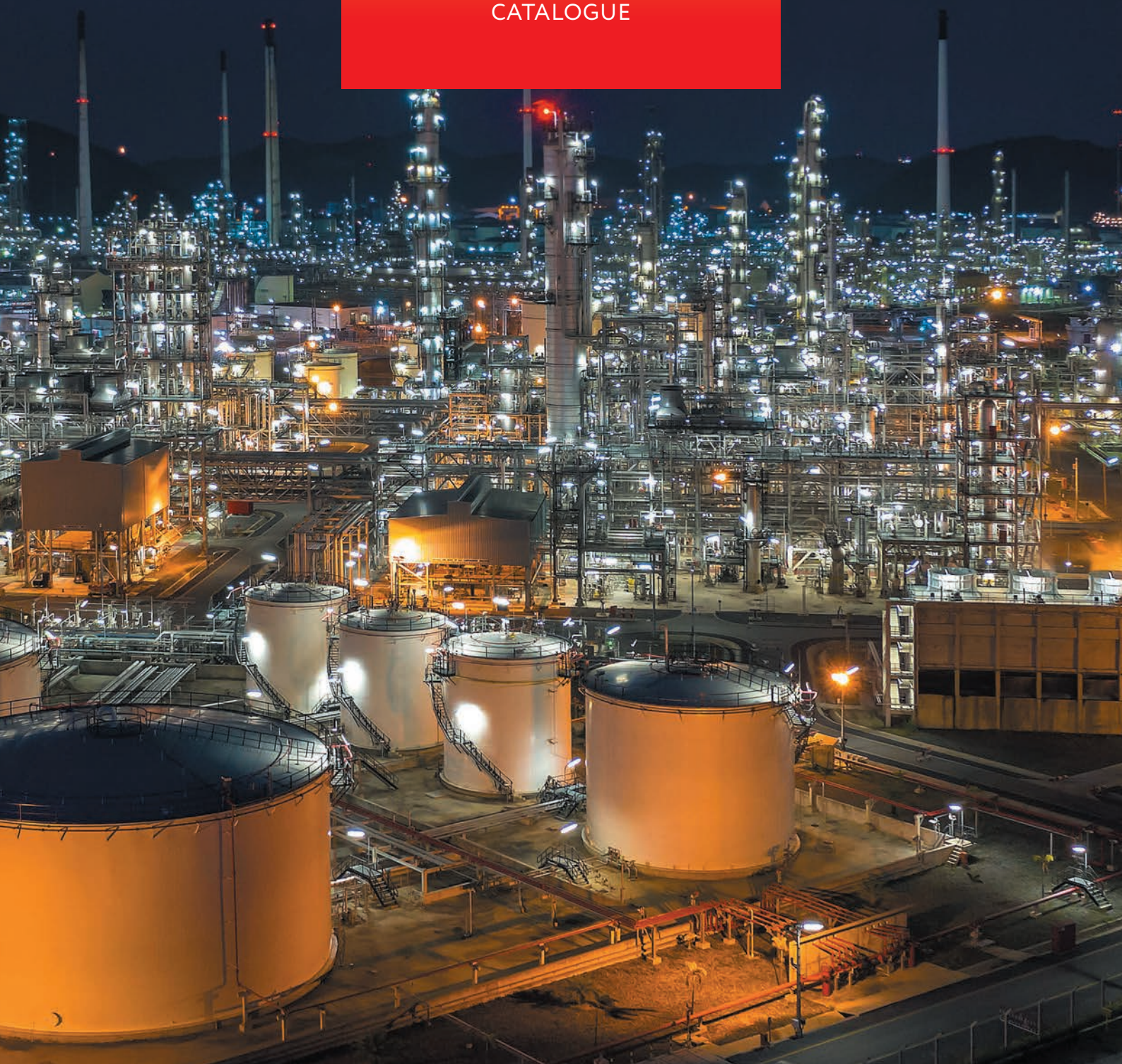

# HEAT TRACING COMPONENTS & SOLUTIONS

CATALOGUE







# HEAT TRACING COMPONENTS & SOLUTIONS

CATALOGUE

# Table of Contents

About SST Group .....	4
Our Products .....	5
Turnkey Heat Tracing Solutions .....	6
Our Capabilities .....	7
Quality Assurance .....	8

## 1. ECO Line

### Self-Regulating Heating Cables

Self-Regulating Heating Cable LTM .....	10
Self-Regulating Heating Cable LTL .....	12
Self-Regulating Heating Cable LTR .....	14

### Junction Boxes

Junction Box Eco CB .....	16
---------------------------	----

### Measuring and Control Equipment

Temperature Sensor TST04 .....	17
Capillary Thermostat heatTHERM-AT .....	18
Electronic Temperature Controller PT-300 .....	20

Accessories .....	22
-------------------	----

## 2. CLASSIC Line

### Self-Regulating Heating Cables

Self-Regulating Heating Cable VTM .....	24
Self-Regulating Heating Cable VTL .....	26
Self-Regulating Heating Cable VTR .....	28

### Junction Boxes

Junction Box for Self-Regulating Heating Cables to Power Connection with Pipe Installation Support ...	30
Junction Box for Self-Regulating Heating Cables to Power Connection .....	32
Junction Box for Light Indication .....	34
Junction Box for Series-Resistance Heating Cables .....	36
Junction Box for Connection of Mineral-Insulated Heating Cables .....	38

### Measuring and Control Equipment

Digital Thermostat eTRON-T .....	40
Electronic Temperature Controller PTM-2000 .....	42
Temperature Sensors & Power Supply Unit .....	44
Precipitation & Water Sensors .....	45

Connection Technology CLASSIC-CON .....	46
---	----

## 3. PREMIUM Line

### Self-Regulating Heating Cables

Self-Regulating Heating Cable HTM .....	48
Self-Regulating Heating Cable HTA .....	50
Self-Regulating Heating Cable HTP .....	52
Self-Regulating Heating Cable BTC .....	54
Self-Regulating Heating Cable BTX .....	56
Self-Regulating Heating Cable CTE .....	58

### Series-Resistance Heating Cables

Series-Resistance Heating Cable SNF .....	60
Series-Resistance Heating Cable SNF-L .....	62

<b>Extra-High Temperature Series-Resistance Cables</b>	
Metal Outer Jacket Fibreglass-Insulated Cable MOIC-F .....	64
Metal Outer Jacket Mineral-Insulated Cable MOIC-M .....	66
<b>Junction Boxes</b>	
Junction Boxes for Self-Regulating Heating Cables .....	68
Junction Boxes for Self-Regulating Heating Cables (3 and More Circuits) .....	70
Junction Boxes for Light Indication and Connection of Heating Cables to Power Supply .....	72
Junction Boxes for Connection of Data, Control and Signal Cables .....	76
Junction Boxes for Series-Resistance Heating Cables Connection .....	78
Junction Boxes for Connection of Mineral-Insulated Heating Cables .....	80
Junction Box for Power Cables Connection .....	82
Junction Boxes for Three-Phase Series-Resistance Heating Cables Connection .....	84
Premium Line Models Assortment & Ordering Information.....	86
<b>Enclosures</b>	
Explosion-Proof Polyester Enclosure .....	88
<b>Cable glands</b>	
Explosion-Proof Cable Gland KBB-R for Armored Cables .....	90
Flexible Sealed Gland FSG .....	92
<b>Pipe Installation Support</b>	
Pipe Support Stand UVK .....	94
<b>Measuring and Control Equipment</b>	
Capillary Thermostat exTHERM-AT .....	96
<b>Electric Heating Control System ConTrace</b> .....	98
Control and Monitoring Modules ConTrace MS .....	100
Power and Interface Switching Module ConTrace IPS .....	102
Remote Temperature Measurement Module ConTrace AS .....	104
Remote Temperature Measurement Unit ConTrace AS-xxx-Ex .....	106
<b>Accessories</b>	
Connection Kits for Self-Regulating Heating Cables .....	108
Connectors for SNF, SNF-L Cables .....	110
Cable Entry Unit LEK/U .....	111
Brackets .....	112
Tapes & Straps .....	116
<b>VeLL Heat Tracing System</b>	
VeLL Heat Tracing System: VLL-A .....	118
VeLL Heat Tracing System: VLL-C .....	120
<b>Heat Tracing System Based on Skin-Effect</b> .....	122
<b>Oil &amp; Gas Wells Electric Heating System Stream Tracer™</b> .....	124
<b>Longline Heat Tracing System</b> .....	126
<b>Questionnaires</b> .....	128

# About SST Group



SST Group is one of the top-3 global providers of industrial heat tracing as well as residential and commercial electric heating cable solutions.



Design & provision of all types of electric cable heating, de-icing and heat tracing systems of any complexity, including a full range of solutions for long & extra-long pipelines.



Extensive engineering and project management experience as an EPC contractor. SST Group is officially listed as a trusted supplier of heat tracing systems among the world's largest EPC contractors.



Worldwide presence: export to over 60 countries worldwide, offices in Germany, Switzerland, Russia, UAE, India, China.



International certification, including IECEx, ATEX, VDE. ISO 9001:2000 International quality management system since 2004.

For over a quarter century, SST Group has been successfully working with international industrial and top Russian corporations. The company has taken part in projects in Russia, Belarus, Kazakhstan, Uzbekistan, Turkmenistan, China, Korea, UAE and is continuously expanding the geography of its projects. Thousands of buildings and infrastructure objects are equipped with SST Group systems and solutions.



# Our Products

## We provide best-in-class heat tracing systems for all climatic conditions:

- VeLL systems for heating extra-long pipelines up to 150 km from one feeding point
- Downhole system Stream Tracer™ to prevent wax formation in oil wells
- Systems based on self-regulating heating cables to protect pipelines and tanks from freezing
- Skin-effect systems for heating pipelines up to 60 km from one feeding point
- Systems based on series-resistance heating cables for heating pipelines, tanks and process equipment in temperatures up to 600 °C
- Longline systems for heating pipelines of intermediate length up to 4 km
- Subsea heat tracing solutions

20 000 km

of pipelines heat traced

20 000+

heat tracing projects implemented

1000 km

total length of electric heating systems based on skin-effect

10 years

guarantee for SST Group electric heating systems

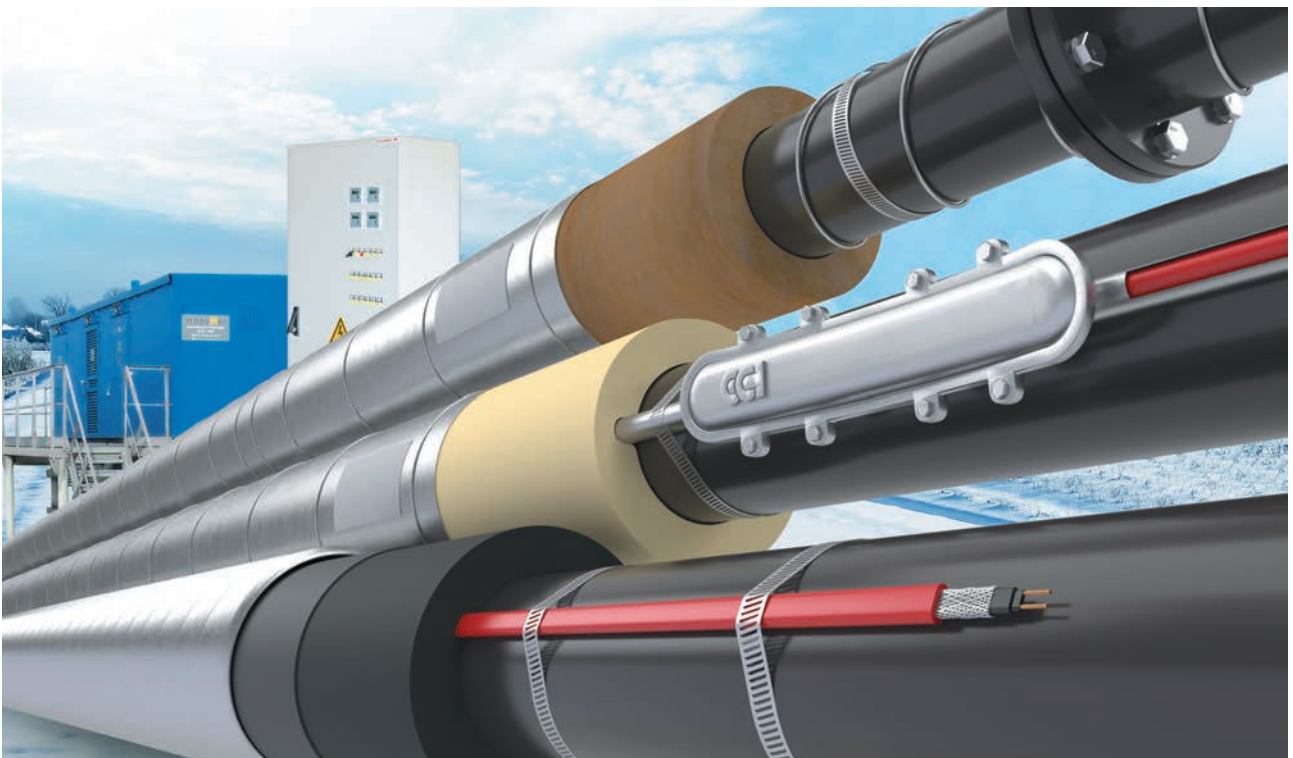

# Turnkey Heat Tracing Solutions

SST Group provides turnkey solutions in heat tracing, thermal insulation and design engineering, including a full range of all system components and services.

We provide basic and detailed engineering, procurement, delivery, implementation, documentation, service and training.

Thanks to our integrated approach and project implementation control at all phases, our customers can always expect high quality and efficiency of the installed systems.

We have the complete infrastructure required to develop and implement innovative solutions – from product development and manufacturing to installation, start-up & commissioning and post warranty service.





# Our Capabilities

## Research and Development

Every year SST Group presents new products and solutions to consumers, created in our own R&D-center. Our team carries out fundamental research, new product developments (including OEM-products and customized products) as well as application-specific tests. This enables us to make evolutionary and revolutionary changes to heat tracing systems and their components.

## Manufacturing

Extensive manufacturing experience, qualified staff and automated machinery allow to meet the demanding world standards and the highest quality levels.

SST Group is the one of the few global manufacturers of electrically conductive plastics and self-regulating heating cables. We produce a matrix for high, medium, and low temperature cables, which is compatible with heating systems of all global manufacturers.

Cutting-edge switchboard manufacturing

Specialized equipment: electron-beam machining (EBM), polymer compounders, testing equipment



60 000 km / year  
cable manufacturing capacity

45 000 m<sup>2</sup>  
of production facilities

## Design Engineering

An in-house R&D-center and engineering team of 100+ design engineers enable SST Group to prepare high-quality design and project documentation. We design heat tracing systems, thermal insulation, and power supply systems for various applications, including explosion hazard areas. Our services include field supervision to ensure that the structural and architectural parameters match the adopted design.

# Quality Assurance

We pay special attention to compliance with international standards in the area of quality management system, lean manufacturing, health, safety and environmental protection.

SST Group complies to ISO 9001 since 2004. Our company's unified quality management system is certified for compliance with **ISO 9001:2015**, which covers the design, implementation, installation, warranty and post warranty maintenance of heat tracing systems, as well as the production, implementation and installation of switchboard equipment and low-voltage complex equipment.

SST Group production facilities are certified by global EPC contractors, including Total, Petrofac, WorleyParsons, Linde, Technip.

Our company has passed certification by TÜV Rheinland for **ISO 14001:2015** environmental management system and complies to all requirements of health and safety standard **GOST R 54934-2012 / OHSAS 18001:2007**.

Our products have been certified in accordance with international standards by some of the largest European certification centers: **CSA Group, VDE, DEKRA and NANIO CCVE**. Industrial electric cable heating systems by SST Group comply with the International Electrotechnical Commission's Standards Relating to Equipment for Use in Explosive Atmospheres (**IECEx**). Self-regulating heating cables and heat tracing systems based on skin-effect (IRHS-15000) are **ATEX-certified**. In addition our company holds a number of certificates, such as:

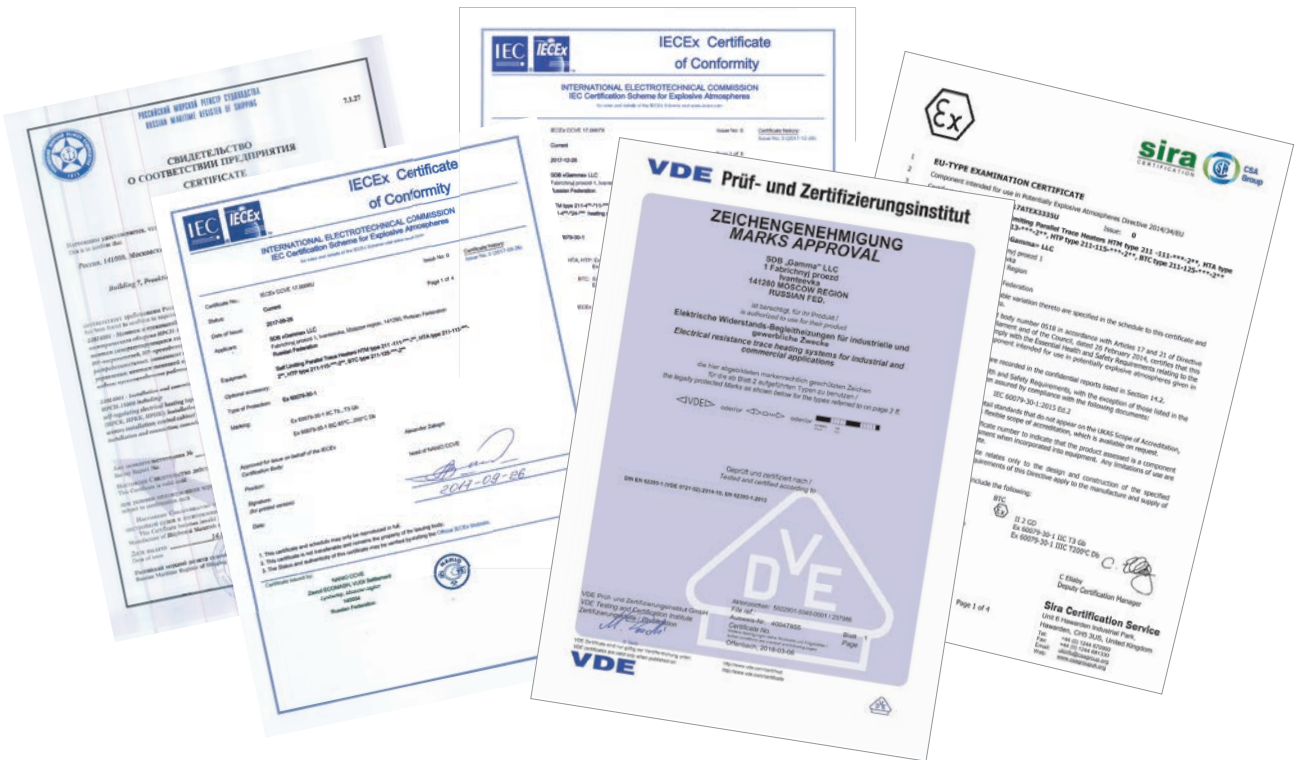



# Self-Regulating Heating Cable LTM

LTM is an industrial-grade self-regulating heating cable that can be used for freeze protection of pipelines and vessels in non-Ex areas.

The power output adjusts automatically in response to the ambient temperature.

Due to its self-regulating characteristics it will not overheat even when the cable is overlapped. This guarantees maximum safety and reliability.

Installation of LTM heating cable is quick and simple and requires no special skills or tools.

Thanks to its parallel construction the heating cable can be fitted on site to exact length without any complicated design calculations.

The LTM cable with fluoropolymer outer jacket is characterized by high resistance to high temperatures, chemicals and UV radiation.

Termination, splicing and power connection components are available in convenient kits.

## Features

- 10 or 15 W/m
- Self-regulating, automatically adjusts power output in response to ambient temperature
- Thermoplastic and fluoropolymer outer jacket
- Easy to install
- Can be cut to required length on site without any complicated design calculations
- Will not overheat even when overlapped
- Full range of accessories available
- UV and high chemical resistance (fluoropolymer)

## Application Areas

- Freeze protection of pipelines and vessels (non-Ex)



## Construction

1. 0.56 mm<sup>2</sup> nickel-plated copper conductors
2. Semi-conductive self-regulating matrix
3. Matrix insulation
4. Aluminum foil with drainage wires or tinned copper braid
5. Thermoplastic or fluoropolymer outer jacket

# Self-Regulating Heating Cables

## Technical Data

Rated voltage	230 VAC
Maximum continuous operating temperature (trace heater energized)	+65 °C
Maximum continuous exposure temperature (trace heater de-energized)	+85 °C
Ambient temperature range	-60 ... +55 °C
Minimum installation temperature:	
Thermoplastic outer jacket	-30 °C
Fluoropolymer outer jacket	-60 °C
Minimum bending radius	25 mm
Maximum screen resistance	18 Ohm/km
Maximum braiding resistance	10 Ohm/km
Conductor cross-section	0.56 mm <sup>2</sup>
Dimension:	
Thermoplastic elastomer outer jacket, aluminum foil	8.30×5.50 mm
Fluoropolymer outer jacket, braiding	8.60×5.40 mm
Weight:	
Thermoplastic elastomer outer jacket, aluminum foil	66 kg/km
Fluoropolymer outer jacket, braiding	98 kg/km

## Power Output Curve

Nominal power output at rated voltage 230 VAC

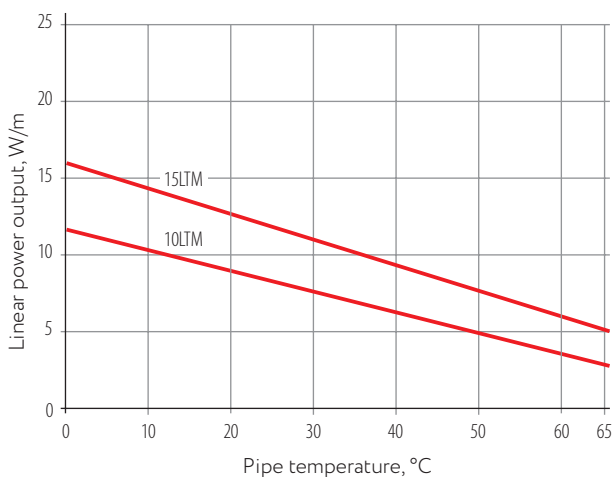

## Maximum Heating Circuit Length

For use with type C circuit breakers according to IEC 60898-1:2015

Type	Turn-on temperature, °C	Heating circuit length/m at 230 VAC 10 A
10LTM	10	88
	-20	68
	Inside pipe	60
15LTM	10	63
	-20	46

## Approvals



## Marking

Example: 15LTM-AT



1. Linear power output, W/m at +10 °C
2. Cable type
3. Screen type: B – tinned copper wire braiding, A – aluminum foil screen
4. Outer jacket material: T – Thermoplastic elastomer, P – Fluoropolymer

## Types

Outer jacket type	Order code	Outer jacket color	Name	Power output, W/m
Thermoplastic elastomer outer jacket, aluminum foil	1101000000	Black	10LTM-AT	10
	1101000001		15LTM-AT	15
Fluoropolymer outer jacket, braiding	1101000004	Blue	10LTM-BP	10
	1101000005		15LTM-BP	15

# Self-Regulating Heating Cable LTL

LTL is an industrial-grade self-regulating heating cable that can be used for freeze protection of pipelines and vessels and also for snow and ice prevention on roofs and gutters in non-hazardous areas.

The power output adjusts automatically in response to the ambient temperature.

Due to its self-regulating characteristics it will not overheat even when the cable is overlapped. This guarantees maximum safety and reliability.

Installation of LTL heating cable is quick and simple and requires no special skills or tools. Thanks to its parallel construction the heating cable can be fitted on site to exact length without any complicated design calculations.

Termination, splicing and power connection components are available in convenient kits.

## Features

- 15, 20, 25 or 30 W/m
- Self-regulating, automatically adjusts power output in response to ambient temperature
- Thermoplastic outer jacket
- Easy to install
- Can be cut to required length on site without any complicated design calculations
- Will not overheat even when overlapped
- Full range of accessories available
- UV-resistant

## Application Areas

- Freeze protection of pipelines and vessels (non-Ex)
- Snow and ice prevention on roofs and gutters (non-Ex)



## Construction

1. 1.00 mm<sup>2</sup> nickel-plated copper conductors
2. Semi-conductive self-regulating matrix
3. Matrix insulation
4. Aluminum foil with drainage wire or tinned copper braid
5. Thermoplastic outer jacket

# Self-Regulating Heating Cables

## Technical Data

Rated voltage	230 VAC
Maximum continuous operating temperature (trace heater energized)	+65 °C
Maximum continuous exposure temperature (trace heater de-energized)	+85 °C
Ambient temperature range	-60 ... +55 °C
Minimum installation temperature:	
Thermoplastic outer jacket	-30 °C
Minimum bending radius	25 mm
Maximum screen resistance	18 Ohm/km
Maximum braiding resistance	10 Ohm/km
Conductor cross-section	1.00 mm <sup>2</sup>
Dimension:	
Thermoplastic elastomer outer jacket, aluminum foil	10.20×5.70 mm
Thermoplastic elastomer outer jacket, braiding	10.90×6.00 mm
Weight:	
Thermoplastic elastomer outer jacket, aluminum foil	86 kg/km
Thermoplastic elastomer outer jacket, braiding	113 kg/km

## Power Output Curve

Nominal power output at rated voltage 230 VAC

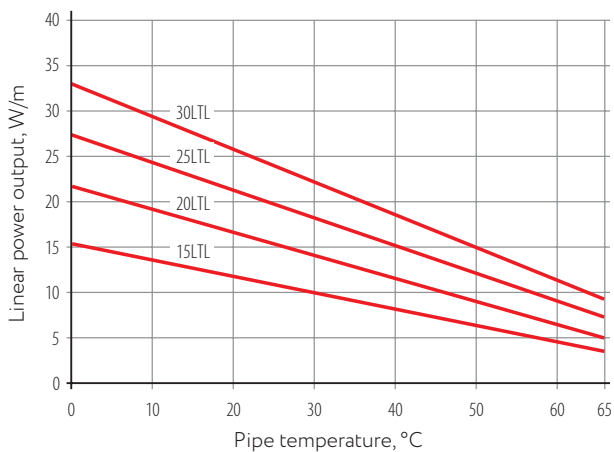

## Maximum Heating Circuit Length

For use with type C circuit breakers according to IEC 60898-1:2015

Type	Turn-on temperature, °C	Heating circuit length/m at 230 VAC	
		10 A	16 A
15LTL	10	92	120
	-20	51	69
20LTL	10	70	97
	-20	37	51
25LTL	In gutters	60	80
	10	53	73
30LTL	-20	28	41
	10	40	62
	-20	18	35

## Approvals



## Marking

Example: 15LTL-BT

① ② ③④

1. Linear power output, W/m at +10 °C
2. Cable type
3. Screen type: B – tinned copper wire braiding, A – aluminum foil screen
4. Outer jacket material: T – Thermoplastic elastomer

## Types

Outer jacket type	Order code	Outer jacket color	Name	Power output, W/m
Thermoplastic elastomer outer jacket, aluminum foil	1101001000	Black	15LTL-AT	15
	1101001001		20LTL-AT	20
	1101001002		25LTL-AT	25
	1101001003		30LTL-AT	30
Thermoplastic elastomer outer jacket, braiding	1101001004	Black	15LTL-BT	15
	1101001005		20LTL-BT	20
	1101001006		25LTL-BT	25
	1101001007		30LTL-BT	30

# Self-Regulating Heating Cable LTR

LTR is an industrial-grade self-regulating heating cable that can be used for freeze protection of pipelines and vessels and also for snow and ice prevention on roofs and gutters in non-hazardous areas.

The power output adjusts automatically in response to the ambient temperature.

Due to its self-regulating characteristics it will not overheat even when the cable is overlapped. This guarantees maximum safety and reliability.

Installation of LTR heating cable is quick and simple and requires no special skills or tools. Thanks to its parallel construction the heating cable can be fitted on site to exact length without any complicated design calculations.

Termination, splicing and power connection components are available in convenient kits.

## Features

- 10, 20, 30 or 40 W/m
- Self-regulating, automatically adjusts power output in response to ambient temperature
- Thermoplastic and fluoropolymer outer jacket
- Easy to install
- Can be cut to required length on site without any complicated design calculations
- Will not overheat even when overlapped
- Full range of accessories available
- UV and high chemical resistance (fluoropolymer)

## Application Areas

- Freeze protection of pipelines and vessels (non-Ex)
- Snow and ice prevention on roof and gutters (non-Ex)



## Construction

1. 1.25 mm<sup>2</sup> nickel-plated copper conductors
2. Semi-conductive self-regulating matrix
3. Matrix insulation
4. Aluminum foil with drainage wires or tinned copper braid
5. Thermoplastic or fluoropolymer outer jacket



# Self-Regulating Heating Cables

## Technical Data

Rated voltage	230 VAC
Maximum continuous operating temperature (trace heater energized)	+65 °C
Maximum continuous exposure temperature (trace heater de-energized)	+85 °C
Ambient temperature range	-60 ... +55 °C
Minimum installation temperature:	
Thermoplastic outer jacket	-30 °C
Fluoropolymer outer jacket	-60 °C
Minimum bending radius	25 mm
Maximum screen resistance	18 Ohm/km
Maximum braiding resistance	10 Ohm/km
Conductor cross-section	1.25 mm <sup>2</sup>
Dimension:	
Thermoplastic elastomer outer jacket, aluminum foil	12.50×5.80 mm
Thermoplastic elastomer outer jacket, braiding	13.20×6.10 mm
Fluoropolymer outer jacket, braiding	12.80×5.70 mm
Weight:	
Thermoplastic elastomer outer jacket, aluminum foil	106 kg/km
Thermoplastic elastomer outer jacket, braiding	141 kg/km
Fluoropolymer outer jacket, braiding	152 kg/km

## Power Output Curve

Nominal power output at rated voltage 230 VAC

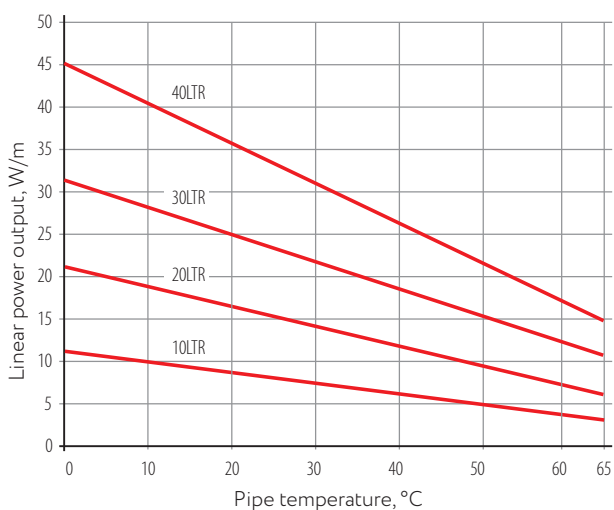

## Maximum Heating Circuit Length

For use with type C circuit breakers according to IEC 60898-1:2015

Type	Turn-on temperature, °C	Heating circuit length/m at 230 VAC 16 A
10LTR	10	180
	-20	108
20LTR	10	102
	-20	53
	In gutters	65
30LTR	10	62
	-20	40
40LTR	10	49
	-20	27

## Approvals



## Marking

Example: 15LTR-BT



1. Linear power output, W/m at +10 °C
2. Cable type
3. Screen type: B - tinned copper wire braiding, A - aluminum foil screen
4. Outer jacket material: T - Thermoplastic elastomer, P - Fluoropolymer

## Types

Outer jacket type	Order code	Outer jacket color	Name	Power output, W/m
Thermoplastic elastomer outer jacket, aluminum foil	1101002000	Black	10LTR-AT	10
	1101002002		20LTR-AT	20
	1101002004		30LTR-AT	30
	1101002005		40LTR-AT	40
Thermoplastic elastomer outer jacket, braiding	1101002006	Black	10LTR-BT	10
	1101002008		20LTR-BT	20
	1101002010		30LTR-BT	30
	1101002011		40LTR-BT	40
Fluoropolymer outer jacket, braiding	1101002012	Blue	10LTR-BP	10
	1101002014		20LTR-BP	20
	1101002016		30LTR-BP	30
	1101002017		40LTR-BP	40

# Junction Box ECO CB

Junction box ECO CB is suitable to connect 1 or 2 self-regulating heating cables to a mains power supply. It can be used for indoor as well as protected outdoor applications in non-hazardous areas.

## Features

- Wall-mounted
- Non-flammable
- Silicone- and halogene-free
- Quick and easy installation

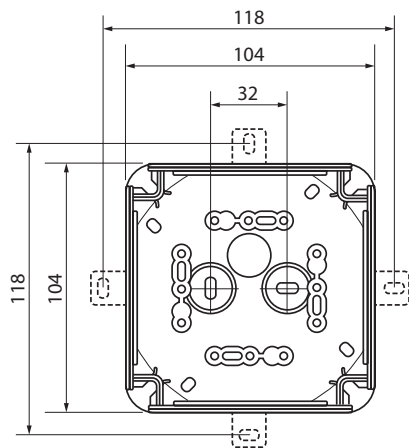

## Wiring Diagram

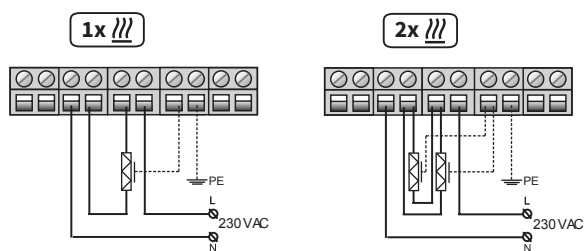

## Technical Data

Degree of protection	IP66
Ambient temperature range	-25 ... +40 °C
Rated current	32 A
Rated voltage	230 VAC
Dimensions	104×104×70 mm
Weight	0.158 kg
Material	polypropylene
Color	gray

Terminal Block	
Rated connecting capacity	1.5–6 mm <sup>2</sup> , Cu
Tightening torque	0.7 Nm

Rated connecting capacity mm <sup>2</sup> and types of conductors	Conductors to be connected per pole
6 sol/f*	1–2
4 sol/f	1–4
2.5 sol/f	1–6
1.5 sol/f	1–8

\* sol – solid conductor;  
f – flexible conductor with a finer wire diameter.

## Approvals



## Marking

Example: ECO CBX

① ②

1. Connection box type
2. X – box model (blank, 1 and 2)

## Types

Type	Order code	Connection kit	Cable glands	
			Size	Number
ECO CB	1110001001	-	M25x1,5	1
ECO CB1	1110001002	ECO SCK-S	M25x1,5	1
ECO CB2	1110001003	ECO SCK-D	M25x1,5	1

# Temperature Sensor TST04

Temperature sensor TST04 is designed to measure temperature and transmit a control signal to the controller. TST04 is programmed at the factory for a specified maintenance temperature. Hence,

reprogramming the temperature is not possible. Temperature sensor TST04 can be used only with PT-300 controller. It can be used to measure the temperature of hard surfaces and air.

## Features

- Control of the heated surface temperature
- Control of the ambient temperature

## Application Areas

- Freeze protection of pipelines and vessels (non-Ex)

## Construction



## Technical Data

Switching temperature values (on / off)	+2 ... +5 °C
Operating temperature range	-55 ... +60 °C
Sensing element type	digital
Number of cores in connection cable	3
Length of the installation wire	5 m
Maximum sensor distance from the controller	100 m
Compatible with thermostat type	PT-300

## Approvals



## Types

Name	Order code
Temperature sensor TST04	2121001000

# Capillary Thermostat heatTHERM-AT

heatTHERM-AT capillary thermostat can be used to control electric cable heating systems for freeze protection of pipelines and vessels. The thermostat controls the electric cable heating system according to the ambient temperature.

heatTHERM-AT is a temperature monitor (TW). When the temperature of the sensing element falls below

the setting point, a micro switch trips the transmission mechanism and the power circuit closes. At the same time, the signal circuit is opened. If the temperature of the sensing element exceeds the set value (switching differential), the micro switch trips, opening the power circuit. The signal circuit, in turn, closes.

## Features

- Stable switching point position due to ambient temperature compensation (standard)
- Maximum switching capacity 16 A, 230 V
- Tested according to DIN EN 14597
- Operating life at least 250,000 switching cycles
- Switching point deviation during the entire operating life of up to  $\pm 5\%$
- Protection type IP54

## Application Areas

- Freeze protection of pipelines and vessels (non-Ex)

## Construction

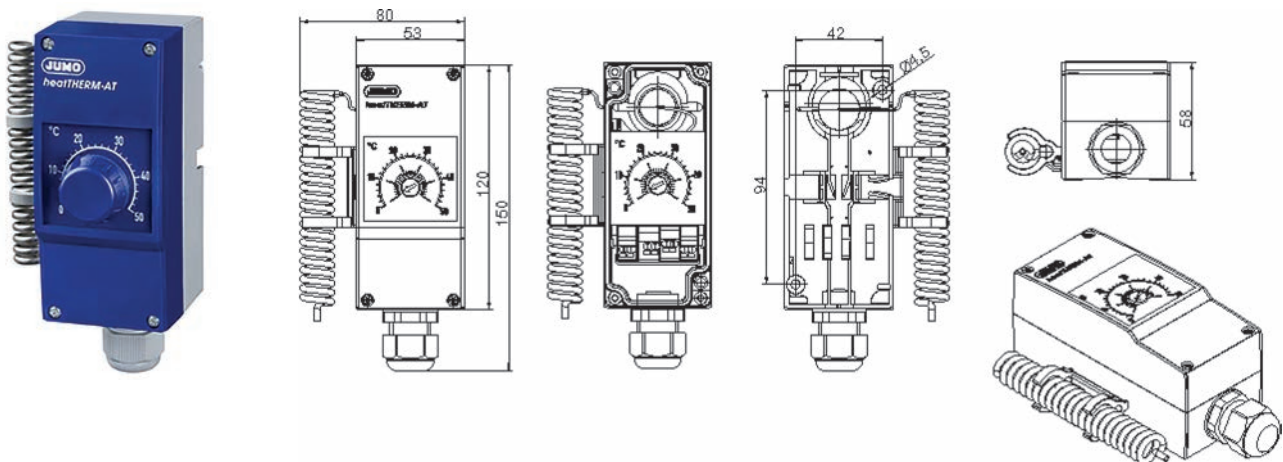

## Technical Data

Temperature setting range	-10 ... +40 °C
Maximum switching capacity	contact deck 1-2 AC 230 V +10%, 16 (2.5) A, cos φ = 1 (0.6) contact deck 1-4 AC 230 V +10 %, 2 (04) A, cos φ = 1 (0.6)
Hysteresis	Approx. 2.5 %
Protection type	IP54
Weight	Approx. 200 g
Cable inlet	Cable gland M20×1.5, for cable ø6-12 mm
Ambient temperature range	-30 ... +80 °C
Diameter of probe	17 mm coiled probe
Capillary material	Stainless steel (CrNi)
Dimension	Without cable glands and probe 120×53×58 mm Included cable glands and probe 160×80×58 mm
Installation type	Surface mounted

## Approvals



## Function Diagram

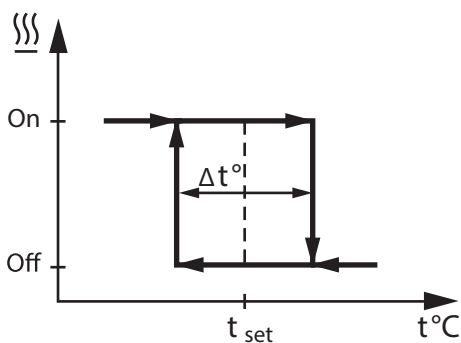

## Wiring Diagram

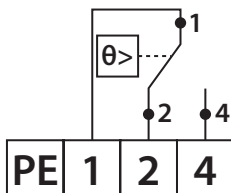

## Marking

Example: heatTHERM-AT(-10...+40)

①

②

1. Type of thermostat
2. Control temperature range

## Types

Name	Order code
Jumo heatTHERM-AT(-10...+40)	1120001001

# Electronic Temperature Controller PT-300

The electronic temperature controller is designed to maintain the temperature in the set range.

PT-300 is used in general-purpose industrial electric heating systems of pipelines and tanks, in de-icing systems, as well as for maintaining a positive temperature in control cabinets within the set temperature range. The required temperature range corresponds to the selected pre-programmed TST04

temperature sensor. The sensor is programmed at the factory and cannot be reprogrammed.

The regulator, in conjunction with the connected temperature sensor TST04, maintains the temperature according to the factory setting and does not require any settings for installation and operation.

The on/off button allows to switch off the heating system when it is not needed.

## Features

- Easy operation
- Small size
- Max. switching capacity 8 A
- Maintenance of set temperature without additional adjustments
- Indication of power and heating status
- Parameter storage in non-volatile memory
- Relay changeover contact

## Application Areas

- Freeze protection of pipelines and vessels

## Construction

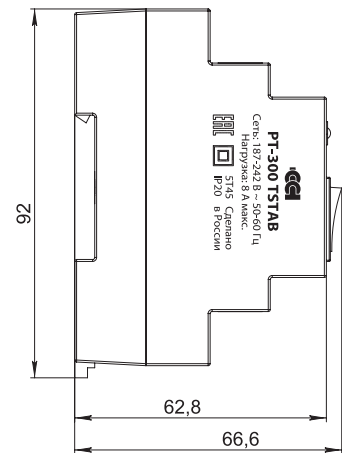
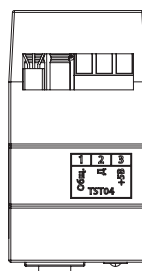
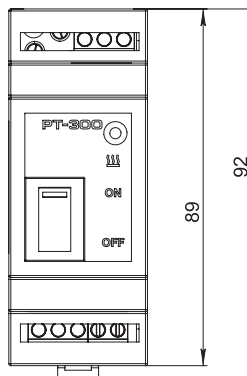
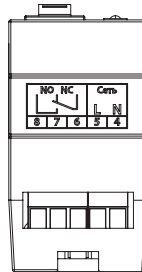
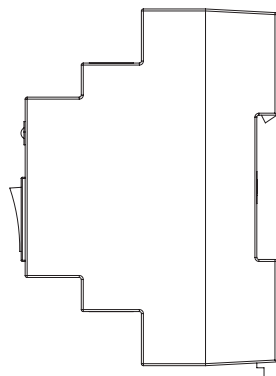

## Technical Data

Temperature setting range	set by sensor TST04
Supply voltage	~220 V, 50 Hz
Power consumption	0,5 W
Dimensions	35×90×68 mm
Weight	100 g
Operating temperature	+5 ... +45 °C
Relative humidity	80 %
Degree of protection	IP20
Mounting type	DIN-rail, 2 modules
Type of temperature sensor*	TST04
Maximum sensor distance from the controller	up to 100 m
Number of temperature measurement channels	1
Number of control channels	1
Switching capacity	8 A
Temperature measurement accuracy	±0.5 °C

\* The sensor is not included in the scope of supply and must be ordered separately

## Function Diagram

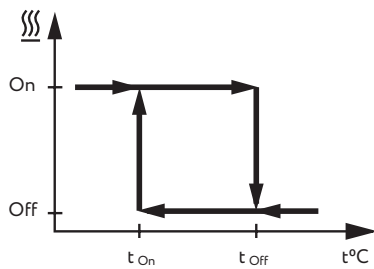

## Wiring Diagram

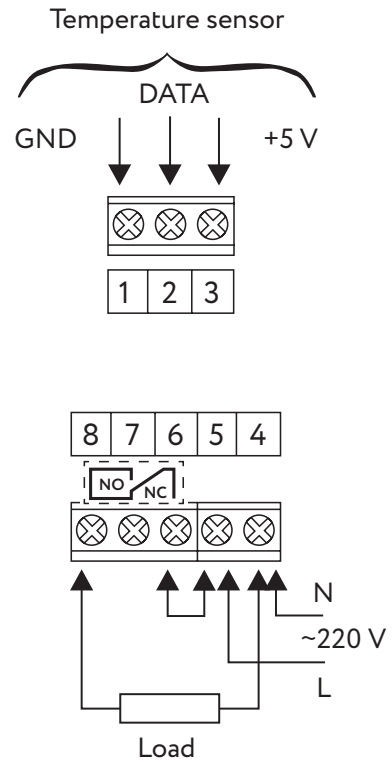

## Types

Name	Order code
Electronic temperature controller PT-300	1120004000

## Accessories

Name	Order code
Temperature sensor TST04 (in the required configuration)	1121001000

## Approvals



# Accessories

SST accessories are perfectly suited to use with the self-regulating heating cables LTM, LTL and LTR and are available in a wide range of different versions for every application. There are connection kits, end

termination kits, repair kits and junction boxes available. All components are combined in sets to ensure an easy and reliable installation on site.

## Features

- Easy and quick installation
- Wide range of kits available
- Suitable perfectly with ECO self-regulating heating cables
- “Ready to install” solutions
- UV-resistant

## Application Areas

- Freeze protection of pipelines and vessels (non-Ex)

## Variations

Connection of one or two self-regulating heating cables to a box, including end termination



ECO connection kit SCK-S (S=single)



ECO end termination kit Con-ET



ECO junction box CB





ECO connection kit SCK-D (D=double)

## Variations

Repair kit

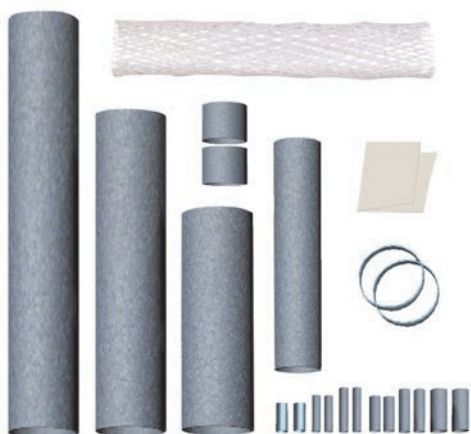

ECO repair kit HSRK

## Connection Kit vs. Heating Cable Type

Name	Maximum exposure temperature, °C	Ref. type of self-regulating heating tape
ECO SCK-S/D	85	LTM, LTL, LTR
ECO Con-ET	85	LTM, LTL, LTR
ECO HSRK	85	LTM, LTL, LTR

## Approvals



## Set Components

Set	amount	type	amount	type
ECO CB-1	1x	ECO CB	1x	ECO SCK-S
ECO CB-2	1x	ECO CB	1x	ECO SCK-D

## Types

Name	Order code
ECO CB	1110001001
ECO CB-1	1110001002
ECO CB-2	1110001003
ECO SCK-S	1101100000
ECO SCK-D	1101100001
ECO Con-ET	2101100200
ECO HSRK	1101100002

# Self-Regulating Heating Cable VTM

VTM is an industrial-grade self-regulating heating cable that can be used for freeze protection of pipelines and vessels.

The power output adjusts automatically in response to the ambient temperature.

Due to its self-regulating characteristics it will not overheat even when the cable is overlapped. This guarantees maximum safety and reliability.

Installation of VTM heating cable is quick and simple and requires no special skills or tools. Thanks to its parallel construction the heating cable can be fitted on site to exact length without any complicated design calculations.

Termination, splicing and power connection components are available in convenient kits.

## Features

- 15 W/m
- Self-regulating, automatically adjusts power output in response to ambient temperature
- Thermoplastic outer jacket
- Easy to install
- Can be cut to required length on site without any complicated design calculations
- Will not overheat even when overlapped
- UV-resistant
- VDE certified

## Application Areas

- Freeze protection of pipelines and vessels (non-Ex)



## Construction

1. 0.56 mm<sup>2</sup> nickel-plated copper conductors
2. Semi-conductive self-regulating matrix
3. Matrix insulation
4. Tinned copper braid
5. Thermoplastic outer jacket

# Self-Regulating Heating Cables

## Technical Data

Rated voltage	230 VAC
Maximum continuous operating temperature (trace heater energized)	+65 °C
Maximum continuous exposure temperature (trace heater de-energized)	+85 °C
Ambient temperature range	-60 ... +55 °C
Minimum installation temperature: Thermoplastic outer jacket	-30 °C
Minimum bending radius	25 mm
Maximum braiding resistance	10 Ohm/km
Conductor cross-section	0.56 mm <sup>2</sup>
Dimension: Thermoplastic elastomer outer jacket, braiding	9,00 × 5.80 mm
Weight: Thermoplastic elastomer outer jacket, braiding	91 kg/km

## Maximum Heating Circuit Length

For use with type C circuit breakers according to IEC 60898-1:2015

Type	Turn-on temperature, °C	Heating circuit length/m at 230 VAC 10A
15VTM	10	68
	-20	49

## Power Output Curve

Nominal power output at rated voltage 230 VAC

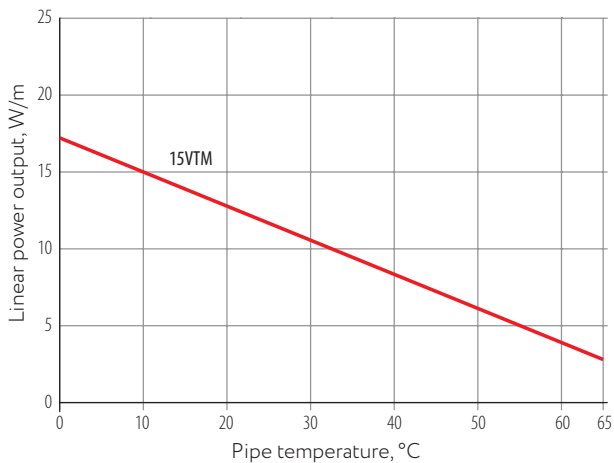

## Approvals



## Marking

Example: 15VTM-BT



1. Linear power output, W/m at +10 °C
2. Cable type
3. Screen type: B - Tinned copper wire braiding
4. Outer jacket material: T - Thermoplastic elastomer

## Types

Outer jacket type	Order code	Outer jacket color	Name	Power output, W/m
Thermoplastic elastomer outer jacket, braiding	2101000003	Black	15VTM-BT 15	

# Self-Regulating Heating Cable VTL

VTL is an industrial-grade self-regulating heating cable that can be used for freeze protection of pipelines and vessels and also for snow and ice prevention on roofs and gutters.

The power output adjusts automatically in response to the ambient temperature.

Due to its self-regulating characteristics it will not overheat even when the cable is overlapped. This guarantees maximum safety and reliability.

Installation of VTL heating cable is quick and simple and requires no special skills or tools. Thanks to its parallel construction the heating cable can be fitted on site to exact length without any complicated design calculations.

Termination, splicing and power connection components are available in convenient kits.

## Features

- 15, 20 or 30 W/m
- Self-regulating, automatically adjusts power output in response ambient temperature
- Thermoplastic outer jacket
- Easy to install
- Can be cut to required length on site without any complicated design calculations
- Will not overheat even when overlapped
- UV-resistant
- VDE certified

## Application Areas

- Freeze protection of pipelines and vessels (non-Ex)
- Snow and ice prevention on roof and gutters (non-Ex)



## Construction

1. 1.00 mm<sup>2</sup> nickel-plated copper conductors
2. Semi-conductive self-regulating matrix
3. Matrix insulation
4. Aluminum foil with drainage wire or tinned copper braid
5. Thermoplastic outer jacket

# Self-Regulating Heating Cables

## Technical Data

Rated voltage	230 VAC
Maximum continuous operating temperature (trace heater energized)	+65 °C
Maximum continuous exposure temperature (trace heater de-energized)	+85 °C
Ambient temperature range	-60 ... +55 °C
Minimum installation temperature:	
Thermoplastic outer jacket	-30 °C
Minimum bending radius	25 mm
Maximum screen resistance	18 Ohm/km
Maximum braiding resistance	10 Ohm/km
Conductor cross-section	1.00 mm <sup>2</sup>
Dimension:	
Thermoplastic elastomer outer jacket, aluminum foil	10.20 × 5.70 mm
Thermoplastic elastomer outer jacket, braiding	10.90 × 6.00 mm
Weight:	
Thermoplastic elastomer outer jacket, aluminum foil	86 kg/km
Thermoplastic elastomer outer jacket, braiding	113 kg/km

## Power Output Curve

Nominal power output at rated voltage 230 VAC

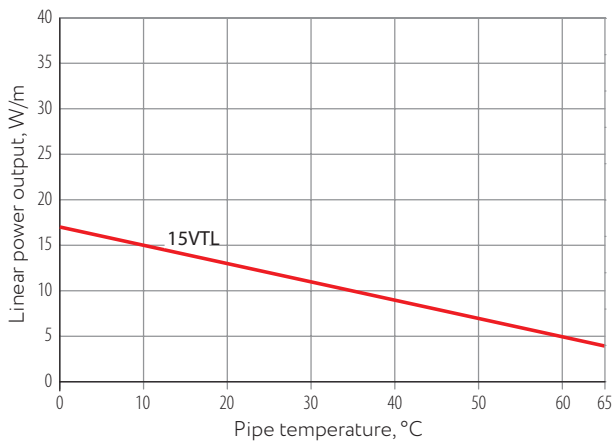

## Maximum Heating Circuit Length

For use with type C circuit breakers according to IEC 60898-1:2015

Type	Turn-on temperature, °C	Heating circuit length/m at 230 VAC	
		10A	16 A
15VTL	10	98	128
	-20	55	73
20VTL	10	74	103
	-20	39	55
30VTL	In gutters	60	80
	10	42	66
	-20	19	38

## Approvals



## Marking

Example: 15VTL-BT



1. Linear power output, W/m at +10 °C
2. Cable type
3. Screen type: B – Tinned copper wire braiding, A – Aluminum foil screen
4. Outer jacket material: T – Thermoplastic elastomer

## Types

Outer jacket type	Order code	Outer jacket color	Name	Power output, W/m
Thermoplastic elastomer outer jacket, aluminum foil	2101001000		15VTL-AT	15
	2101001001	Black	20VTL-AT	20
	2101001003		30VTL-AT	30
Thermoplastic elastomer outer jacket, braiding	2101001004		15VTL-BT	15
	2101001005	Black	20VTL-BT	20
	2101001007		30VTL-BT	30

# Self-Regulating Heating Cable VTR

VTR is an industrial-grade self-regulating heating cable that can be used for freeze protection of pipelines and vessels and also for snow and ice prevention on roofs and gutters.

The power output adjusts automatically in response to the ambient temperature.

Due to its self-regulating characteristics it will not overheat even when the cable is overlapped. This guarantees maximum safety and reliability.

Installation of VTR heating cable is quick and simple and requires no special skills or tools. Thanks to its parallel construction the heating cable can be fitted on site to exact length without any complicated design calculations.

Termination, splicing and power connection components are available in convenient kits.

## Features

- 10, 20, 30 or 40 W/m
- Self-regulating, automatically adjusts power output in response to ambient temperature
- Thermoplastic outer jacket
- Easy to install
- Can be cut to required length on site without any complicated design calculations
- Will not overheat even when overlapped
- UV-resistant
- VDE certified

## Application Areas

- Freeze protection of pipelines and vessels (non-Ex)
- Snow and ice prevention on roof and gutters (non-Ex)



## Construction

1. 1.25 mm<sup>2</sup> nickel-plated copper conductors
2. Semi-conductive self-regulating matrix
3. Matrix insulation
4. Tinned copper braid
5. Thermoplastic outer jacket

# Self-Regulating Heating Cables

## Technical Data

Rated voltage	230 VAC
Maximum continuous operating temperature (trace heater energized)	+65 °C
Maximum continuous exposure temperature (trace heater de-energized)	+85 °C
Ambient temperature range	-60 ... +55 °C
Minimum installation temperature: Thermoplastic outer jacket	-30 °C
Minimum bending radius	25 mm
Maximum braiding resistance	10 Ohm/km
Conductor cross-section	1.25 mm <sup>2</sup>
Dimension: Thermoplastic elastomer outer jacket, braiding	13.20 × 6.10 mm
Weight: Thermoplastic elastomer outer jacket, braiding	141 kg/km

## Maximum Heating Circuit Length

For use with type C circuit breakers according to IEC 60898-1:2015

Type	Turn-on temperature, °C	Heating circuit length/m at 230 VAC 16 A
10VTR	10	193
	-20	116
20VTR	10	109
	-20	56
	in gutters	65
30VTR	10	66
	-20	42
40VTR	10	53
	-20	29

## Power Output Curve

Nominal power output at rated voltage 230 VAC

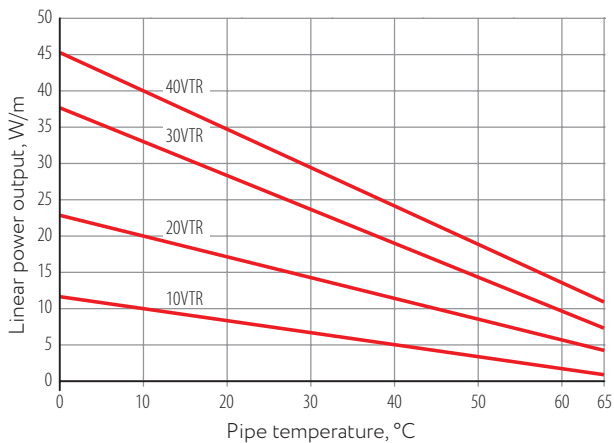

## Approvals



## Marking

Example: 10VTR-BT



1. Linear power output, W/m at +10 °C
2. Cable type
3. Screen type: B - Tinned copper wire braiding
4. Outer jacket material: T - Thermoplastic elastomer

## Types

Outer jacket type	Order code	Outer jacket color	Name	Power output, W/m
Thermoplastic elastomer outer jacket, braiding	2101002006	Black	10VTR-BT	10
	2101002008		20VTR-BT	20
	2101002010		30VTR-BT	30
	2101002011		40VTR-BT	40

# Junction Box for Self-Regulating Heating Cables to Power Connection with Pipe Installation Support

Junction box for self-regulating heating cables is designed for connection of self-regulating heating cables to power network. The junction box is equipped with a pipe installation support stand UVK which allows fixation of the junction box directly onto the pipeline. The junction box is used as part of cable heat trace systems for pipelines and vessels in non-hazardous areas. The junction box design ensures

moisture and dust ingress protection IP66 and high corrosion stability. The junction box is available with cable glands for connection of unarmored power cables. The installed terminal blocks ensure fast and safe connection of multi-core or single-core conductors. Our boxes are available with screw clamp terminals as well as with push-in terminals.

## Features

- Non-hazardous approved solution
- Perfect solution for installation of self-regulating heating cables through thermal insulation
- Excludes the risk of damage to heating cables
- All required component parts are included
- Quick and easy installation
- High thermal stability
- Non-corrosive

## Application Areas

- Temperature maintenance or freeze protection of pipelines and vessels in non-hazardous areas



JB2212-223-1xxxx

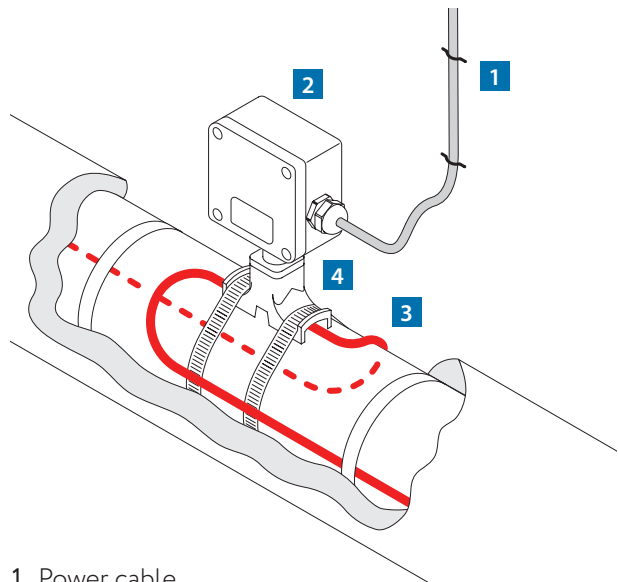

1. Power cable
2. JB2212-223-1xxxx junction box
3. Heating cable
4. Pipe support stand UVK



## Construction

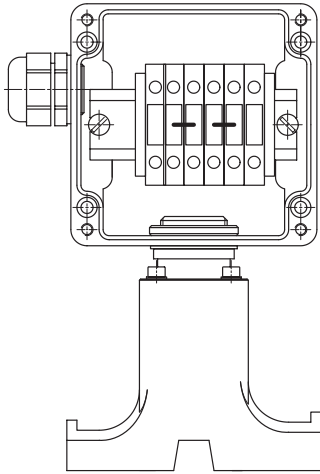

JB2212-223-1xxxx box with screw clamp terminal block

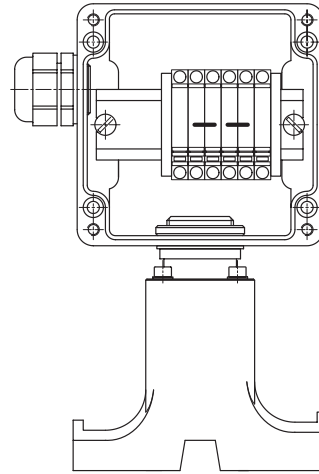

JB2212-223-1xxxx box with push-in terminals block

## Technical Data

Degree of protection	IP66
Ambient temperature range	-55...+55 °C
Operating voltage	max. 750 V
Operating current	max. 32 A
Enclosure dimensions	122×120×90 mm
Total weight (maximum)	1.35 kg
Material box	Glass fiber reinforced polyester
Color	Grey
Pipe installation support material	Glass fiber reinforced polyester
Color	Black

## Approvals



° Certification is underway

## Types

Name	Order code
JB2212-223-11310	2210001610
JB2212-223-12310	2210001611
JB2212-223-11300	2210001608
JB2212-223-12300	2210001609

## Application Types

Application	Terminals	Name
Heating cable branching*	screw, 2L, 2N, 2PE	JB2212-223-11310
	push-in, 2L, 2N, 2PE	JB2212-223-12310
Power connection*	screw, 2L, 2N, 2PE	JB2212-223-11300
	push-in, 2L, 2N, 2PE	JB2212-223-12300

\* All junction boxes for power connection are equipped with a cable gland M25×1,5 for the power cable and terminal jumpers L-L, N-N

## Accessories (to be ordered separately)

Metal pipe strap PFS/3 – for mounting the box onto the pipeline. For ordering information see “Accessories”, p. 117.

The heating cable termination kit is specified depending on the type of cable used. For ordering information see CLASSIC-CON units, pp. 46-47.

Flexible sealed gland FSG – for mechanical protection of cables in open space sets. For ordering information see pp. 92-93.

# Junction Box for Self-Regulating Heating Cables to Power Connection

Junction box for self-regulating heating cables is designed for connection of self-regulating heating cables to power network. The junction box is used as a part of heat tracing systems for pipelines and vessels in non-hazardous areas. The junction box design ensures moisture and dust ingress protection IP66 and high corrosion stability. The junction box is

available with cable glands for connection of unarmored power and heating cables. The installed terminal blocks ensure fast and safe connection of multi-core or single-core conductors. Our boxes are available with screw clamp terminals as well as with push-in terminals.

## Features

- Non-hazardous area solution
- All required component parts are included
- Quick and easy installation
- High thermal stability
- Non-corrosive

## Application Areas

- Temperature maintenance or freeze protection of pipelines and vessels in non-hazardous and ex-hazardous areas



JB2212-223-2xxxx

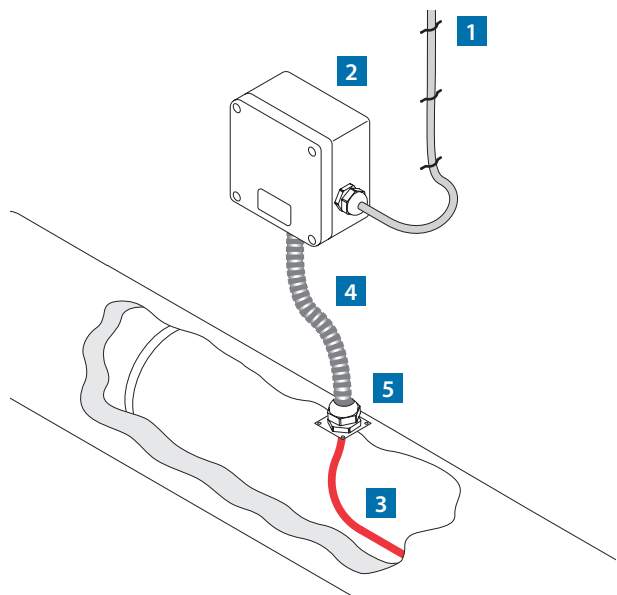

1. Power cable
2. JB2212-223-2xxxx junction box
3. Heating cable
4. Flexible sealed gland
5. Cable entry unit

## Construction

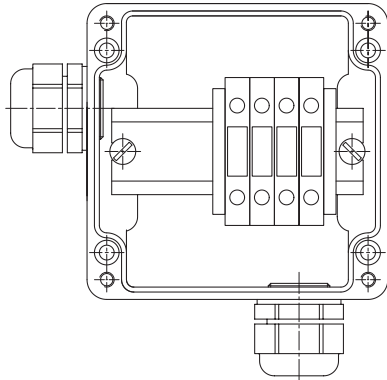

JB2212-223-2xxxx box with screw clamp terminal block

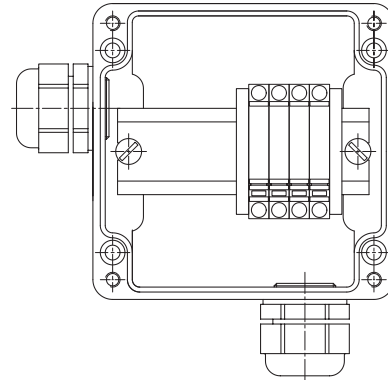

JB2212-223-2xxxx box with push-in terminal block

## Technical Data

Degree of protection	IP66
Ambient temperature range	-55...+55 °C
Operating voltage	max. 750 V
Operating current	max. 32 A
Enclosure dimensions	122×120×90 mm
Total weight (maximum)	1.1 kg
Box material	Glass fiber reinforced polyester
Color	Grey

## Application Types

Application	Terminals	Name
1 heating cable		
Power connection	screw, 1L, 1N, 2PE	JB2212-223-21340
2x M25 x 1,5	push-in, 1L, 1N, 2PE	JB2212-223-22340
Connection	screw, 1L, 1N, 2PE	JB2212-223-21350
1x M25 x 1,5	push-in, 1L, 1N, 2PE	JB2212-223-22350
1x M25x1,5 screw plug		
Application	Terminals	Name
3 heating cable		
Power connection*	screw, 3L, 3N, 3PE	JB2212-223-21360
4x M25 x 1,5	push-in, 3L, 3N, 3PE	JB2212-223-22360
Connection*	screw, 3L, 3N, 3PE	JB2212-223-21370
1x M25 x 1,5	push-in, 3L, 3N, 3PE	JB2212-223-22370
3x M25x1,5 screw plug		

\* With jumper L-L, N-N

## Approvals



\* Certification is underway

## Types

Name	Order code
JB2212-223-21340	2210001600
JB2212-223-22340	2210001601
JB2212-223-21350	2210001602
JB2212-223-22350	2210001603
JB2212-223-21360	2210001604
JB2212-223-22360	2210001605
JB2212-223-21370	2210001606
JB2212-223-22370	2210001607

## Accessories (to be ordered separately)

Brackets PB, KP, PL.JB0606 – for mounting the box onto the pipeline. For ordering information see “Accessories”, pp. 112-113.

Z-profile – for mounting the box onto a metal structure or onto a wall.

The heating cable termination kit is specified depending on the type of cable used. For ordering information see CLASSIC-CON units, pp. 46-47.

Flexible sealed gland FSG – for mechanical protection of cables in open space sets. For ordering information see pp. 92-93.

Cable entry unit LEK/U – for penetrating of thermal insulation. For ordering information see “Accessories”, p. 111.

# Junction Box for Light Indication

The junction box for light indication is designed for the purpose of light indication and connection of self-regulating heating cables to power network. The junction box is used as a part of heat tracing systems for pipelines and vessels in non-hazardous areas. The junction box is equipped with a pipe installation support stand UVK which allows fixation directly

onto the pipeline/vessel. The junction box design ensures moisture and dust ingress protection IP66 and high corrosion stability. The installed terminal blocks ensure fast and safe connection of multi-core or single-core conductors. Our boxes are available with screw clamp terminals as well as with push-in terminals.

## Features

- Non-hazardous area approved solution
- Excludes the risk of damage to heating cables
- All required component parts are included
- Quick and easy installation
- High thermal stability
- Non-corrosive

## Application Areas

- Temperature maintenance or freeze protection of pipelines and vessels in non-hazardous areas



JB2212-223-1xxxx

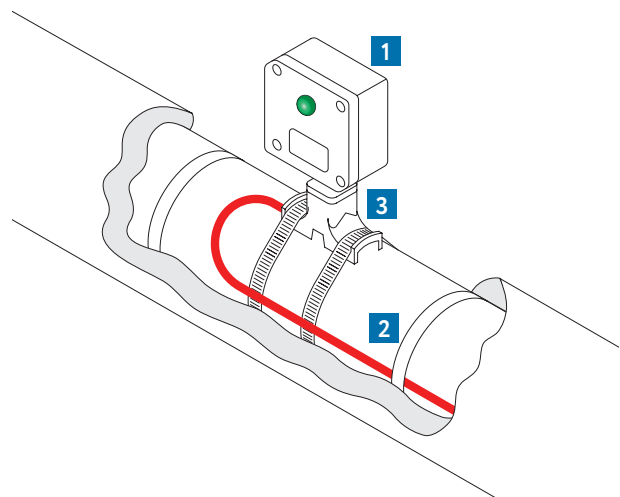

1. JB2212-223-1xxxx junction box
2. Heating cable
3. Pipe support stand UVK

## Construction

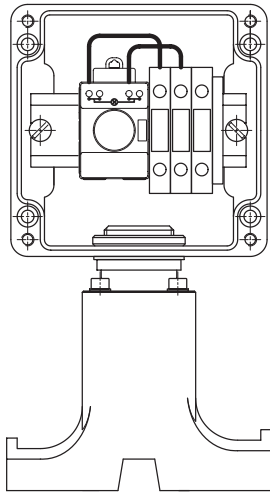

JB2212-223-1xxxx box with screw clamp terminal block

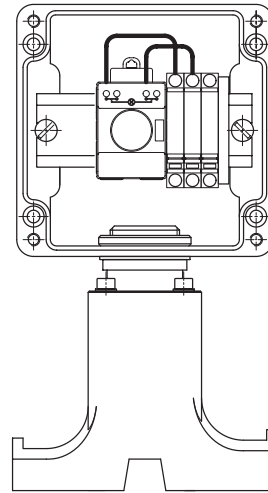

JB2212-223-1xxxx box with push-in terminal block

## Technical Data

Degree of protection	IP66
Ambient temperature range	-55...+55 °C
Operating voltage on terminals	max. 750 V
Maximum voltage on light module	250 V
Operating current	max. 32 A
Electric lamp lifetime	> 10 <sup>5</sup> h
Lamp consuming power	< 1 W
Light source	green LED
Light coverage	180°
Enclosure dimensions	122×120×90 mm
Total weight (maximum)	1.35 kg
Material box	Glass fiber reinforced polyester
Color	Grey
Pipe installation support material	Glass fiber reinforced polyester
Color	Black

## Application types

Application	Terminals	Name
Light ind. end box	screw, 1L, 1N, 1PE	JB2212-223-11320
	push-in, 1L, 1N, 1PE	JB2212-223-12320

## Approvals



\* Certification is underway

## Types

Name	Order code
JB2212-223-11320	2210001612
JB2212-223-12320	2210001613

## Accessories (to be ordered separately)

Metal pipe strap PFS/3 – for mounting the box onto the pipeline. For ordering information see “Accessories”, p. 117.

# Junction Box for Series-Resistance Heating Cables

The junction box for series-resistance heating cables SNF is designed for connection of heating cables to power network. The junction box could be mounted on a wall of a building or using a bracket directly on a pipe/vessel surface. The box enables connection of SNF cable heating sections to power cable. The junction box is used as a part of heat tracing systems for pipelines and vessels in non-hazardous areas.

The junction box design ensures moisture and dust ingress protection IP66 and high corrosion stability. The junction box is available with cable glands for connection of unarmored power and heating cables. The installed terminal blocks ensure fast and safe connection of multi-core or single-core conductors. The boxes are available with screw clamp terminals as well as with push-in terminals.

## Features

- Non-hazardous area approved solution
- Perfect solution for installation of series-resistance cables SNF through thermal insulation
- Excludes the risk of damage to heating cables
- All required component parts are included
- Quick and easy installation
- High thermal stability
- Non-corrosive

## Application Areas

- Temperature maintenance or freeze protection of pipelines and vessels in non-hazardous areas



JB2212-...-2xxxx

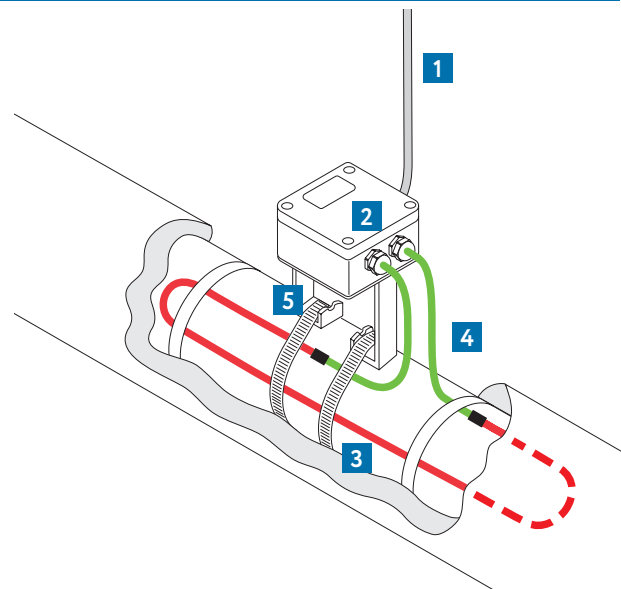

1. Power cable
2. JB2212-...-2xxxx junction box
3. Heating cable
4. Connection cable (cold lead)
5. Bracket

## Construction

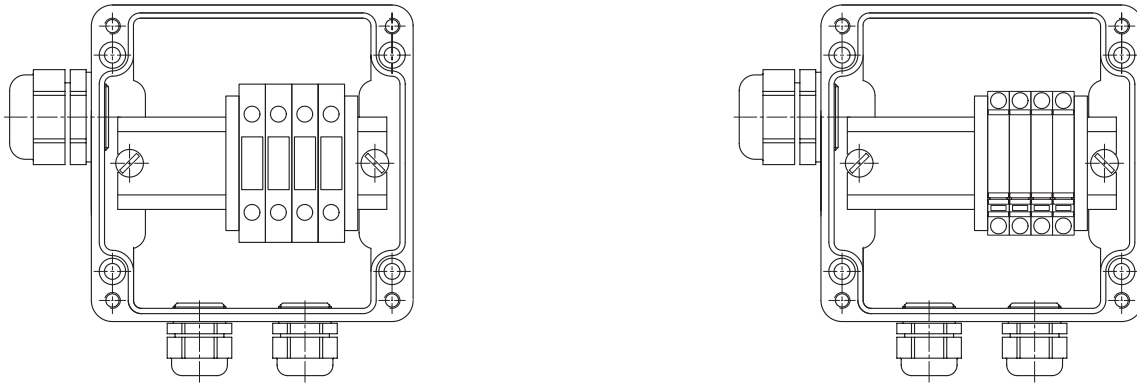

JB2212-223-2xxxx box with screw clamp (left) and push-in (right) terminal block. Number of terminals and cable glands could differ from drawings.

## Technical Data

Degree of protection	IP66	
Ambient temperature range	-55...+55 °C	
Operating voltage	max. 750 V	
Operating current	JB2212-223...	max. 32 A
	JB2212-333...	max. 50A
	JB2212-523...	max. 50A
Dimensions enclosure	JB2212-223...	122×120×90 mm
	JB2212-333...	160×160×90 mm
	JB2212-533...	260×160×90 mm
Weight	JB2212-223...	1.2 kg
	JB2212-333...	1.8 kg
	JB2212-533...	2.2 kg
Box material	Glass fiber reinforced polyester	
Color	Grey	

## Approvals



° Certification is underway

## Types

Name	Order code
JB2212-223-21380	2210001614
JB2212-223-22380	2210001615
JB2212-333-21380	2210001618
JB2212-333-22380	2210001619
JB2212-533-21130	2210001622
JB2212-533-22130	2210001623

## Application types

Application	Terminals	Name
Loop to Power JB2221-223-2xxxx		
1x M25x1.5	screw, 1L, 1N, 2PE	JB2212-223-21380
2x M20x1.5	push-in, 1L, 1N, 2PE	JB2212-223-22380
Star to Power JB2221-333-2xxxx		
1x M25x1.5	screw, 3L, 3N, 2PE	JB2212-333-21380
3x M20x1.5	push-in, 3L, 3N, 2PE	JB2212-333-22380
Delta to Power JB2221-533-2xxxx		
1x M25x1.5	screw, 7L, 6PE	JB2212-533-21130
6x M20x1.5	push-in, 7L, 6PE	JB2212-533-22130

° Terminal jumpers L-L-L and N-N-N

°° Terminal jumpers L-L and L-L-L

## Accessories (to be ordered separately)

Brackets PB, KP, PL.JB0606 – for mounting the box onto the pipeline. For ordering information see “Accessories”, pp. 112-113.

Z-profile – for mounting the box onto a metal structure or onto a wall.

Metal pipe strap PFS/3 – for mounting the bracket onto a pipeline. For ordering information see “Accessories”, p. 117.

Flexible sealed gland FSG – for mechanical protection of cables in open space sets. For ordering information see pp. 92-93.

Cable entry unit LEK/U – for penetrating of thermal insulation. For ordering information see “Accessories”, p. 111.

# Junction Box for Mineral-Insulated Heating Cables

The junction box for heating mineral-insulated cables is designed for connection of mineral-insulated (MI) heating cables to power network. The junction box could be mounted on a wall of a building or using a bracket directly on a pipe/vessel surface. The box enables connection of one mineral-insulated cable heating section to power cable. The junction box is used as a part of heat tracing systems for pipelines and vessels in non-hazardous areas. The junction box

design ensures moisture and dust ingress protection IP66 and high corrosion stability. The junction box is available with cable glands for connection of unarmored power cables. The installed terminal blocks ensure fast and safe connection of multi-core or single-core conductors. The boxes are available with screw clamp terminals as well as with push-in terminals.

## Features

- Non-hazardous area solution
- All required component parts are included
- Quick and easy installation
- High thermal stability
- Non-corrosive

## Application Areas

- Temperature maintenance or freeze protection of pipelines and vessels in non-hazardous areas



JB2212-...-2xxxx

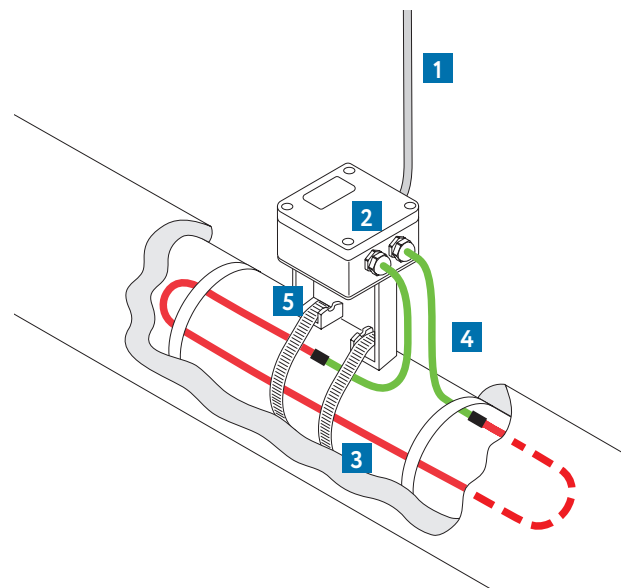

1. Power cable
2. JB2212-...-2xxxx junction box
3. Heating cable
4. Connection cable (cold lead)
5. Bracket



## Construction

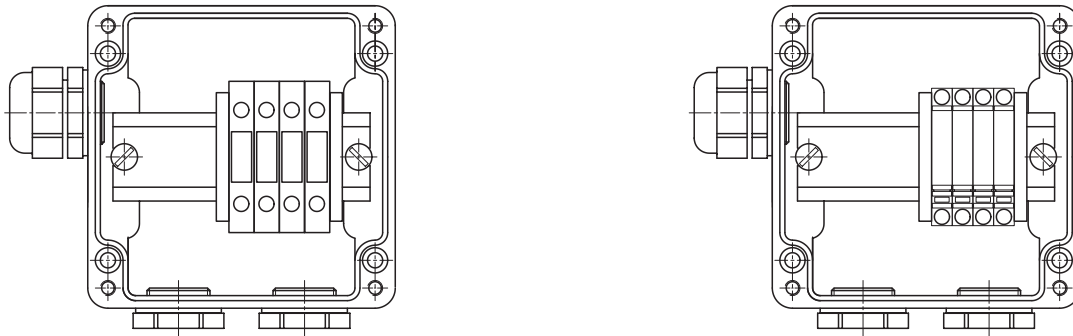

JB2212-223-2xxxx box with screw clamp (left) and push-in (right) terminal block. Number of terminals and cable glands may vary.

## Technical Data

Degree of protection	IP66	
Ambient temperature range	-55...+55 °C	
Operating voltage	max. 750 V	
Operating current	JB2212-223...	max. 32 A
	JB2212-333...	max. 50 A
	JB2212-533...	max. 50 A
Dimensions enclosure	JB2212-223...	122×120×90 mm
	JB2212-333...	160×160×90 mm
	JB2212-533...	260×160×90 mm
Weight	JB2212-223...	1.20 kg
	JB2212-333...	1.65 kg
	JB2212-533...	2.00 kg
Material box	Glass fiber reinforced polyester	
Color	Grey	
Pipe installation support material	Glass fiber reinforced polyester	
Color	Black	

## Application types

Application	Terminals	Name
Loop to Power JB2221-223-2xxxx		
1x M25x1.5	screw, 1L, 1N, 2PE	JB2212-223-21390
2x M20x1.5 screw plug	push-in, 1L, 1N, 2PE	JB2212-223-22390
Star to Power JB2221-333-2xxxx		
1x M25x1.5	screw, 3L, 3N, 2PE	JB2212-333-21390
3x M20x1.5 screw plug	push-in, 3L, 3N, 2PE	JB2212-333-22390
Delta to Power JB2221-533-2xxxx		
1x M25x1.5	screw, 7L, 6PE	JB2212-533-21140
6x M20x1.5 screw plug	push-in, 7L, 6PE	JB2212-533-22140

° Terminal jumpers L-L-L and N-N-N

°° Terminal jumpers L-L and L-L-L

## Approvals



° Certification is underway

## Types

Name	Order code
JB2212-223-21390	2210001616
JB2212-223-22390	2210001617
JB2212-333-21390	2210001620
JB2212-333-22390	2210001621
JB2212-533-21140	2210001624
JB2212-533-22140	2210001625

## Accessories (to be ordered separately)

Brackets PB, KP, PL.JB0606 – for mounting the box onto the pipeline. For ordering information see “Accessories”, pp. 112-113.

Z-profile – for mounting the box onto a metal structure or onto a wall.

Metal pipe strap PFS/3 – for mounting the bracket onto a pipeline. For ordering information see “Accessories”, p. 117.

Flexible sealed gland FSG – for mechanical protection of cables in open space sets. For ordering information see pp. 92-93.

Cable entry unit LEK/U – for penetrating of thermal insulation. For ordering information see “Accessories”, p. 111.

# Digital Thermostat eTRON-T

The eTRON-T is a compact single-channel digital thermostat for simple temperature control of electric heating systems. Measurement input permits the connection of PT-100 resistance thermometers. The measured value is shown on a 3-digit LC display.

The switching status of the relay K1 is indicated by a LED-indicator. The instrument is operated from 3 keys on the front panel. Electrical connection is made via screw terminals.

## Features

- Adjustable switching hysteresis
- Simple, space-saving installation
- Time-delayed switch "on" after power-on
- 3-digit LC display with special characters for °C and °F
- Parameter level protected by code
- Wide temperature setting range

## Application Areas

- Freeze protection of pipelines and vessels
- Monitoring and controlling of thermal processes

## Construction

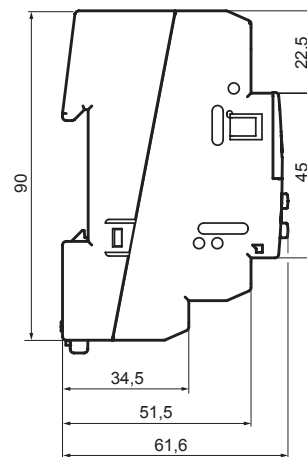
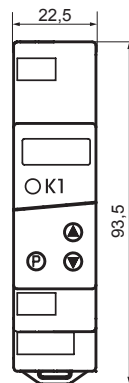

## Technical Data

Temperature setting range	-200...+600 °C
Type of sensors (not included in delivery kit)	PT100 (EN 60 751)
Supply voltage	195...253 VAC, 48...63 Hz
Power consumption	4 VA
Dimensions (W×H×D)	93.5×22.5×61.6 mm
Weight	110 g
Operating temperature range	0...+55 °C
Relative humidity (at 30 °C)	75 %
Degree of protection	IP20
Mounting type	DIN-rail, 1.25 modules
Number of temperature measurement / control channels	1 channel 10 A / 230 VAC, 50...60 Hz

## Approvals



## Wiring Diagram

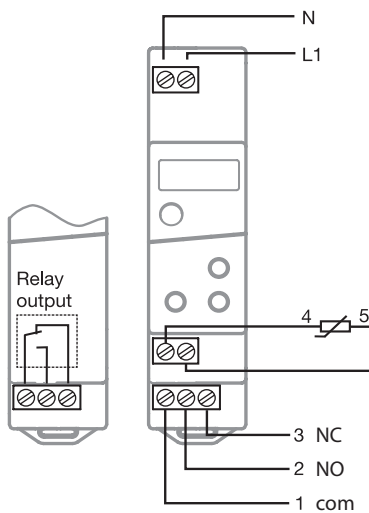

## Marking

Example: eTRON-T



1. Type of thermostat

## Types

Name	Order code
Digital thermostat eTRON-T	2120001100

## Accessories

Name	Order code
Surface RTD temperature sensor Pt100, stainless steel, 2 wires, class B, L=2500 mm	2121001100

# Electronic Temperature Controller PTM-2000

The electronic temperature controller PTM-2000 is an eight-channel temperature monitoring and four-channel control device. PTM-2000 controller is used as a part of various electric heating cable systems and ensures optimal temperature maintenance for each channel. The algorithms used for heating control, in combination with a wide range of different sensor types, ensure optimum control of the heat tracing system and save energy.

Temperature control will be realized by using processing signals received from temperature, precipitation and water sensors. PTM-2000 can be integrated into computerized process control systems via data transmission interface RS485 or Modbus RTU. Heating control is effected by means of output relay channels. All operating parameters and conditions of the connected heating systems are shown on a display. The PTM-2000 controller is designed to be mounted on a DIN-rail 35 mm in control cabinets.

## Features

- 8 temperature measuring channels
- 4 independent control channels
- Excellent accuracy
- High interference immunity of measurement channels
- Digital matrix display with white backlight
- Simultaneous display of temperatures and heating status for 4 channels
- Temperature setting range from -100 °C to +600 °C
- Easy adjustment of controlled temperatures
- DIN-rail mounting
- Communication interface RS485, Modbus RTU
- The preset parameters are saved in non-volatile device memory

## Application Areas

- Temperature maintenance or freeze protection of pipelines and vessels
- Snow and ice prevention on roof and gutters

## Operation Features

5 control algorithms are provided by the device:

1. **TUBE**: analog control based on ON/OFF temperature settings
2. **TUBE+**: proportional control based on ambient air temperature/surface temperature
3. **ROOF / ROAD**: control of de-icing systems for roofs by 4 channels or open areas by 2 channels
4. **TIMER**: control of power output percentage by setable time period
5. **MEASURER**: Measuring & indication of 8 temperature channels



- |                   |               |
|-------------------|---------------|
| ⏻ Power supply    | ⬆ Scroll up   |
| RS485 Modbus RTU  | ⬇ Scroll down |
| 🔌 Heating Circuit | ✓ Enter       |
| 🔔 Alarm           | ✕ Cancel      |

LED color indications

- ⏻ Red indicates the controller is energized
- RS485 Orange indicates data exchange
- 🔌 🟢 Green indicates switched on

## Construction

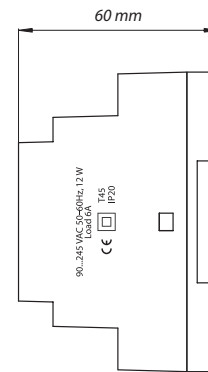
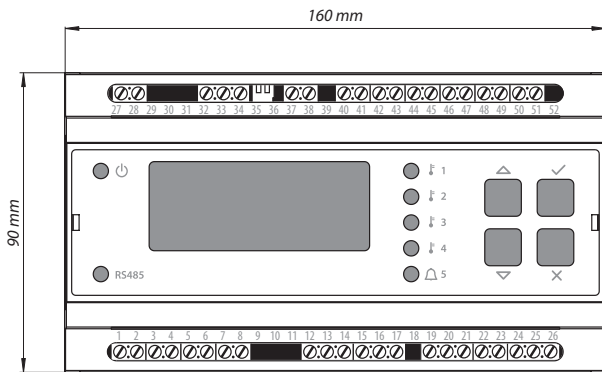

## Technical Data

System operation temperature	-100...+600 °C with 4...20 mA -100...+600 °C with PT100 -55...+60 °C with TST01 standard -55...+125 °C with TST01 silicone
Supply voltage	90...245 VAC, 50...60 Hz
Power consumption	12 W
Dimensions (WxHxD)	90×160×60 mm
Weight	450 g
Operating temperature range	+5...+40 °C
Relative humidity (at 30 °C)	90 %
Degree of protection	IP20
Mounting type	DIN-rail, 9 modules
Interface, communication protocol	RS485, Modbus RTU
Type of sensors (not included in delivery kit)	TST01, TSP02, TSP03-D, TSW01, up to 4 pcs. PT100 sensors when using 24V thermal 4...20 mA signal converter(s)
Maximum sensor distance from the controller	1000 m for normalized signal 4...20 mA 100 m for temperature sensor TST01
Number of temperature measurement channels	8 channels: - 4 sensors TST01 (DS18S20) - 4 signals 4...20 mA
Number of precipitation and water measurement channels	6 channels: - 2 precipitation sensors - 4 water sensors
Number of control channels	4 channels (K1...K4) for pipe or roof heating or 3 channels for roof plus one for open area or 2 channels for roof plus 2 channels for open area or 2 channels for area heating 6A / 230 VAC, 50...60 Hz
Number of emergency channels	1 channel (K5) 6A / 230 VAC, 50...60 Hz
Number of indication channels	1 channel (K0) 3A / 230 VAC, 50...60 Hz
Color	Light-grey face enclosure Black enclosure base.

## Terminal Block Layout

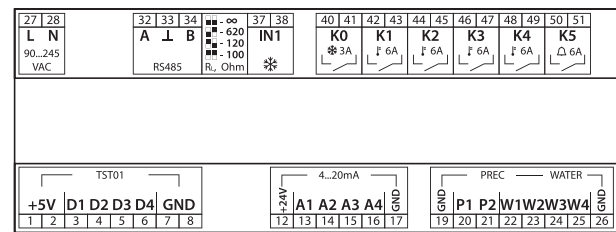

## Approvals



## Types

Name	Order code
Electronic temperature controller PTM-2000	2120001000

## Accessories

Name	Order code
Temperature sensor TST01	2121001000
Precipitation sensor for roof and gutter TSP02	2121002000
Precipitation sensor for open areas TSP03-D	2121002001
Water sensor TSW01	2121003000
Power supply unit for precipitation sensors BPDO (required for TSP02 or TSP03-D)	2122001000

# Temperature Sensors & Power Supply Unit

## Temperature Sensors TST01, PT100

Temperature sensors are designed for continuous temperature measurement and transmission of values. Temperature sensors are used with electronic temperature controllers for electric heating cable systems in industrial and commercial applications.

### Features

- Temperature control of the heated surface
- Ambient temperature control

### Application Areas

- Snow and ice prevention on roof and gutters and open areas

### Construction



TST01

PT100

### Technical Data

Type of sensor	TST01	PT100
Temperature measurement range	-55 ... +60 °C	-50 ... +260 °C
Sensing element type	Digital	Analog
Number of cores in connection cable	3	2
Length of the installation wire	5 m	2.5 m
Maximum sensor distance from the controller	100 m	100 m
Compatible with thermostat type	PTM-2000	eTRON-T

### Approvals



### Types

Name	Order code
Temperature sensor TST01	2121001000
Temperature sensor Pt100 2.5	2121001100

## Power Supply Unit BPDO

Power supply unit is designed to supply power to the integrated heating element in the precipitation sensors TSP02 and TSP03.

### Features

- Power supply of the heating element inside the precipitation sensor

### Application Areas

- Snow and ice prevention on open areas

### Construction



BPDO

### Technical Data

Type of device	BPDO
Input voltage	230 VAC, 50 Hz
Output voltage	36 VAC, 50 Hz
Rated output power	5 W
Operating temperature range	+5 ... +40 °C
Degree of protection	IP20
Dimensions (WxHxD)	89×70×65
Mounting type	DIN-rail, 6 modules

### Types

Name	Order code
Power supply unit BPDO	2122001000

# Precipitation & Water Sensors

## Precipitation Sensors TSP02, TSP03-D

Precipitation sensors are designed to determine the presence of precipitation on a heated surface. The sensors are designed for use with commercial heating systems. If the sensor detects water, contacts in the connected thermostat will be closed. In combination with a temperature sensor, energy-efficient use of the heating system is ensured.

### Features

- Installation on a vertical wall (TSP02)
- Installation in screed (TSP03-D)

### Application Areas

- Snow and ice prevention in open area heating systems and roof and gutters

### Construction



TSP02

TSP03-D

### Technical Data

Type of sensor	TSP02	TSP03-D
Dimensions (W×H×D)	110×210×160 (with bracket)	100×95×95
Supply voltage	36 VAC, 50 Hz	36 VAC, 50 Hz
Rated power	3,5 W	10 W
Operating temperature range	-40 ... +50 °C	-40 ... +50 °C
Length of the installation wire	3 m	3 m
Max. sensor distance from the controller	100 m	100 m
Compatible with thermostat type	PTM-2000	PTM-2000

### Approvals



### Types

Name	Order code
Precipitation sensor TSP02	2121002000
Precipitation sensor TSP03-D	2121002001

## Water Sensor TSW01

Our water sensor is designed to determine the presence of water in heated gutters. If the water sensor detects the presence of precipitation, contacts in the connected thermostat will be closed and the connected heating system will be switched on.

### Features

- Installation in gutters

### Construction



TSW01

### Technical Data

Type of sensor	TSW01
Dimensions (W×H×D)	160×40×15
Length of the installation wire	3 m
Max. sensor distance from the controller	100 m
Compatible with thermostat type	PTM-2000

### Types

Name	Order code
Water sensor TSW01	2121003000

# Connection Technology CLASSIC-CON

CLASSIC-CON is the ideal plug for connection to self-regulating heating cables VTR. 3-pole connectors CLASSIC-CON are available for switching applications up to 250 V. All connectors are mechanically coded.

Mechanical codings have the advantage that only associated pairs of male and female connectors can be connected, thus ensuring the correct polarity. This gives you the security of a clear distinction.

## Features

- 3 pole connector
- Application 250 V, 20 A
- For cable diameters 10–14 mm
- Spring clamp connection
- Correct polarity ensured
- Wide range of connectors
- Color of housing-light grey

## Application Areas

- Pluggable connection technology for self-regulating heating cables VTR (non-Ex)

## Types



Classic-CON m



Classic-CON f



Classic-CON JB-m



## Technical Data

Rated voltage	230 VAC
Rated current	20 A
Rated impulse voltage	4 kV
Max continuous temperature	+100 °C
Degree of protection (IP)	IP66/68
Contact material	CuZn
Mechanical coding	Code 0
Marking of poles	L, N, PE
Pollution degree	3
Connection type	Tension clamp
Surface finish	Silver plated
Housing material	Polyamide
Strain relief	Yes
Halogen free	Yes
Lockable	Yes
Color	Light grey
Length	80.4 mm
Length CLASSIC-CON JB m	48.1 mm
Width	34.6 mm
Width CLASSIC-CON JB m	35.0 mm
Height	34.6 mm
Height CLASSIC-CON JB m	35.0 mm

## Classification

ECLASS 8.1	27440605: Plug-in connector for building installation
ETIM 6.0	EC002560: Plug-in connector for building installation
ETIM 5.0	EC002560: Plug-in connector for building installation
ETIM 4.0	EC002560: Plug-in connector for building installation

## Connection Data

Cable diameter	14 mm
Cross-section, solid	2.5 mm <sup>2</sup>
Cross-section, stranded (max.)	1.5 mm <sup>2</sup>
Cross-section, stranded (min.)	0.75 mm <sup>2</sup>
Terminations per pole	2

Note:

Fine stranded conductors require no cable end sleeve!

## Approvals



## Types

Type	Description	Order code
CLASSIC-CON-f	Female plug	2101100100
CLASSIC-CON-m	Male plug	2101100101
CLASSIC-CON-set	Set	2101100103
CLASSIC-CON-JB m	Male junction box connection	2101100105
CLASSIC-CON-JB-Set	Junction box set	2101100106

# Self-Regulating Heating Cable HTM

HTM is an industrial-grade self-regulating heating cable that can be used for freeze protection of pipelines and vessels. It can be used in non-hazardous and ex-hazardous areas. The power output adjusts automatically in response to the ambient temperature. Due to its self-regulating characteristics it will not overheat even when the cable is overlapped. This guarantees maximum safety and reliability.

Installation of HTM heating cable is quick and simple and requires no special skills or tools. Thanks to its parallel construction the heating cable can be fitted on site to exact length without any complicated design calculations.

## Features

- 10 or 15 W/m
- Ex-approved solution
- Self-regulating, automatically adjusts power output in response to ambient temperature
- Thermoplastic outer jacket
- Easy to install
- Can be cut to required length on site without any complicated design calculations
- Will not overheat even when overlapped
- Can be used in explosive environments without temperature limiter
- Full range of accessories available
- UV-resistant

## Application Areas

- Freeze protection of pipelines and vessels in non-hazardous and ex-hazardous areas



## Construction

1. 0.56 mm<sup>2</sup> nickel-plated copper conductors
2. Semi-conductive self-regulating matrix
3. Matrix insulation
4. Tinned copper braid
5. Thermoplastic outer jacket

# Self-Regulating Heating Cables

## Technical Data

Rated voltage	230 VAC
Maximum continuous operating temperature (trace heater energized)	+65 °C
Maximum continuous exposure temperature (trace heater de-energized)	+85 °C
Ambient temperature range	-60 ... +55 °C
Minimum installation temperature: Thermoplastic elastomer outer jacket	-30 °C
Minimum bending radius	25 mm
Maximum braiding resistance	10 Ohm/km
Conductor cross-section	0.56 mm <sup>2</sup>
Dimension: Thermoplastic elastomer outer jacket	9.00×5.80 mm
Weight: Thermoplastic elastomer outer jacket	91 kg/km

## Power Output Curve

Nominal power output at rated voltage 230 VAC

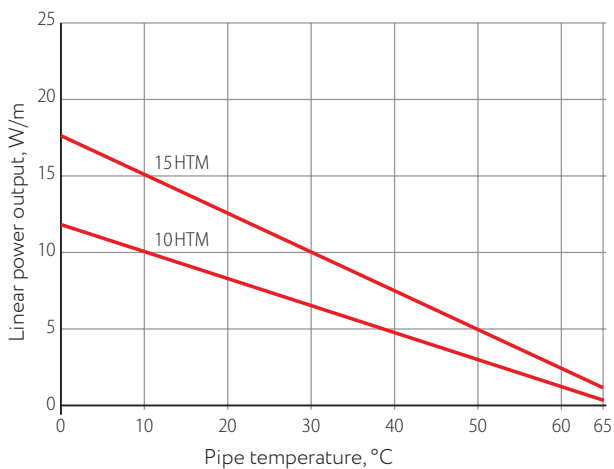

## Maximum Heating Circuit Length

For use with type C circuit breakers according to IEC 60898-1:2015

Type	Turn-on temperature, °C	Heating circuit length/m at 230 VAC 10 A
10HTM	10	100
	-20	77
15HTM	10	72
	-20	52

## Approvals



II 2 GD  
Ex 60079-30-1 IIC T6 Gb  
Ex 60079-30-1 IIIC T85°C Db

Sira 17ATEX3335U  
Sira 18ATEX3038X



IECEX CCVE 17.0006U  
IECEX CCVE 17.0007X



## Marking

Example: 15HTM2-BT

① ② ③ ④ ⑤

1. Linear power output, W/m at +10 °C
2. Cable type
3. Supply voltage: 2 – 230 VAC
4. Screen type: B – Tinned copper wire braiding
5. Outer jacket material: T – Thermoplastic elastomer

## Types

Outer jacket type	Order code	Outer jacket color	Name	Power output, W/m
Thermoplastic elastomer outer jacket, braiding	3201000002	Black	10HTM2-BT	10
	3201000003		15HTM2-BT	15

# Self-Regulating Heating Cable HTA

HTA is an industrial-grade self-regulating heating cable that can be used for temperature maintenance or freeze protection of pipelines and vessels. It can be used in non-hazardous and ex-hazardous areas.

The power output adjusts automatically in response to the ambient temperature.

Due to its self-regulating characteristics it will not overheat even when the cable is overlapped. This guarantees maximum safety and reliability.

Installation of HTA heating cable is quick and simple and requires no special skills or tools. Thanks to its parallel construction the heating cable can be fitted on site to exact length without any complicated design calculations.

## Features

- 15, 20 or 30 W/m
- Ex-approved solution
- Self-regulating, automatically adjusts power output in response to ambient temperature
- Thermoplastic or fluoropolymer outer jacket
- Easy to install
- Can be cut to required length on site without any complicated design calculations
- Will not overheat even when overlapped
- Can be used in explosive environments without temperature limiter
- Full range of accessories available
- UV- and chemical-resistant (fluoropolymer)

## Application Areas

- Temperature maintenance or freeze protection of pipelines and vessels in non-hazardous and ex-hazardous areas



## Construction

1. 1.00 mm<sup>2</sup> nickel-plated copper conductors
2. Semi-conductive self-regulating matrix
3. Matrix insulation
4. Tinned copper braid
5. Thermoplastic or fluoropolymer outer jacket

# Self-Regulating Heating Cables

## Technical Data

Rated voltage	230 VAC
Maximum continuous operating temperature (trace heater energized)	+65 °C
Maximum continuous exposure temperature (trace heater de-energized)	+85 °C
Ambient temperature range	-60 ... +55 °C
Minimum installation temperature:	
Thermoplastic elastomer outer jacket	-30 °C
Fluoropolymer outer jacket	-60 °C
Minimum bending radius	25 mm
Maximum braiding resistance	10 Ohm/km
Conductor cross-section	1.00 mm <sup>2</sup>
Dimension:	
Thermoplastic elastomer outer jacket	10.90 × 6.00 mm
Fluoropolymer outer jacket	10.50 × 5.60 mm
Weight:	
Thermoplastic elastomer outer jacket	113 kg/km
Fluoropolymer outer jacket	122 kg/km

## Power Output Curve

Nominal power output at rated voltage 230 VAC

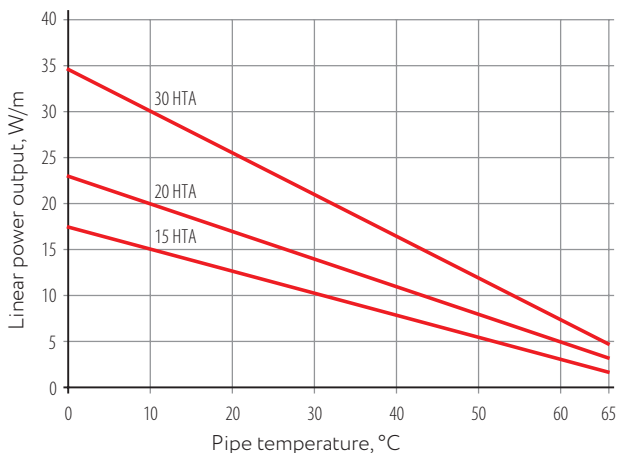

## Maximum Heating Circuit Length

For use with type C circuit breakers according to IEC 60898-1:2015

Type	Turn-on temperature, °C	Heating circuit length/m at 230 VAC	
		10A	16A
15HTA	10	104	136
	-20	58	78
20HTA	10	79	110
	-20	42	58
30HTA	10	45	70
	-20	20	40

## Approvals



II 2 GD  
Ex 60079-30-1 IIC T6 Gb  
Ex 60079-30-1 IIC T85°C Db

Sira 17ATEX3335U  
Sira 18ATEX3038X



IECEX CCVE 17.0006U  
IECEX CCVE 17.0007X



## Marking

Example: 15HTA2-BT

① ② ③ ④ ⑤

1. Linear power output, W/m at +10 °C
2. Cable type
3. Supply voltage: 230 VAC
4. Screen type: B - Tinned copper wire braiding
5. Outer jacket material: T - Thermoplastic elastomer, P - Fluoropolymer

## Types

Outer jacket type	Order code	Outer jacket color	Name	Power output, W/m
Thermoplastic elastomer outer jacket, braiding	3201001006	Black	15HTA2-BT	15
	3201001007		20HTA2-BT	20
	3201001009		30HTA2-BT	30
Fluoropolymer outer jacket, braiding	3201001012	Blue	15HTA2-BP	15
	3201001013		20HTA2-BP	20
	3201001015		30HTA2-BP	30

# Self-Regulating Heating Cable HTP

HTP is an industrial-grade self-regulating heating cable that can be used for temperature maintenance or freeze protection of pipelines and vessels. It can be used in non-hazardous and ex-hazardous areas. The power output adjusts automatically in response to the ambient temperature.

Due to its self-regulating characteristics it will not overheat even when the cable is overlapped. This guarantees maximum safety and reliability.

Installation of HTP heating cable is quick and simple and requires no special skills or tools. Thanks to its parallel construction the heating cable can be fitted on site to exact length without any complicated design calculations.

## Features

- 10, 20, 33 or 40 W/m
- Ex-approved solution
- Self-regulating, automatically adjusts power output in response to ambient temperature
- Thermoplastic or fluoropolymer outer jacket
- Easy to install
- Can be cut to required length on site without any complicated design calculations
- Will not overheat even when overlapped
- Can be used in explosive environments without temperature limiter
- Full range of accessories available
- UV- and chemical-resistant (fluoropolymer)

## Application Areas

- Temperature maintenance or freeze protection of pipelines and vessels in non-hazardous and ex-hazardous areas



## Construction

1. 1.25 mm<sup>2</sup> nickel-plated copper conductors
2. Semi-conductive self-regulating matrix
3. Matrix insulation
4. Tinned copper braid
5. Thermoplastic or fluoropolymer outer jacket

# Self-Regulating Heating Cables

## Technical Data

Rated voltage	230 VAC
Maximum continuous operating temperature (trace heater energized)	+65 °C
Maximum continuous exposure temperature (trace heater de-energized)	+85 °C
Ambient temperature range	-60 ... +55 °C
Minimum installation temperature:	
Thermoplastic elastomer outer jacket	-30 °C
Fluoropolymer outer jacket	-60 °C
Minimum bending radius	25 mm
Maximum braiding resistance	10 Ohm/km
Conductor cross-section	1.25 mm <sup>2</sup>
Dimension:	
Thermoplastic elastomer outer jacket	13.20 × 6.10 mm
Fluoropolymer outer jacket	12.80 × 5.70 mm
Weight:	
Thermoplastic elastomer outer jacket	141 kg/km
Fluoropolymer outer jacket	152 kg/km

## Power Output Curve

Nominal power output at rated voltage 230 VAC

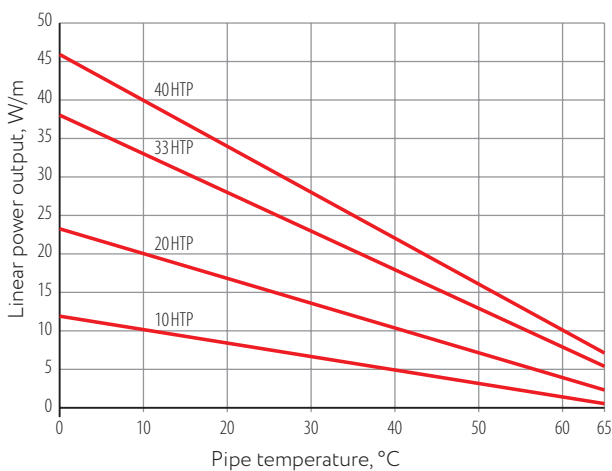

## Maximum Heating Circuit Length

For use with type C circuit breakers according to IEC 60898-1:2015

Type	Turn-on temperature, °C	Heating circuit length/m at 230 VAC		
		16A	20A	32A
10HTP	10	205	-	-
	-20	123	165	195
20HTP	10	116	140	-
	-20	60	80	115
33HTP	10	70	90	108
	-20	45	58	85
40HTP	10	56	73	91
	-20	31	47	72

## Approvals



II 2 GD  
Ex 60079-30-1 IIC T6 Gb  
Ex 60079-30-1 IIIC T85°C Db

Sira 17ATEX3335U  
Sira 18ATEX3038X



IECEX CCVE 17.0006U  
IECEX CCVE 17.0007X



## Marking

Example: 33HTP2-BT

① ② ③ ④ ⑤

1. Linear power output, W/m at +10 °C
2. Cable type
3. Supply voltage: 2 – 230 VAC
4. Screen type: B – Tinned copper wire braiding
5. Outer jacket material: T – Thermoplastic elastomer, P – Fluoropolymer

## Types

Outer jacket type	Order code	Outer jacket color	Name	Power output, W/m
Thermoplastic elastomer outer jacket, braiding	3201002006	Black	10HTP2-BT	10
	3201002008		20HTP2-BT	20
	3201002010		33HTP2-BT	33
	3201002011		40HTP2-BT	40
Fluoropolymer outer jacket, braiding	3201002012	Blue	10HTP2-BP	10
	3201002014		20HTP2-BP	20
	3201002016		33HTP2-BP	33
	3201002017		40HTP2-BP	40

# Self-Regulating Heating Cable BTC

BTC is an industrial-grade self-regulating heating cable that can be used for temperature maintenance or freeze protection of pipelines and vessels. It can be used in non-hazardous and ex-hazardous areas.

The power output adjusts automatically in response to the ambient temperature.

Due to its self-regulating characteristics it will not overheat even when the cable is overlapped. This guarantees maximum safety and reliability.

Installation of BTC heating cable is quick and simple and requires no special skills or tools. Thanks to its parallel construction the heating cable can be fitted on site to exact length without any complicated design calculations.

## Features

- 15, 30, 45 or 60 W/m
- Steam purging possible
- Ex-approved solution
- Self-regulating, automatically adjusts power output in response to ambient temperature
- Fluoropolymer outer jacket
- Easy to install
- Can be cut to required length on site without any complicated design calculations
- Will not overheat even when overlapped
- Can be used in explosive environments without temperature limiter
- Full range of accessories available
- UV- and chemical-resistant

## Application Areas

- Temperature maintenance or freeze protection of pipelines and vessels in non-hazardous and ex-hazardous areas



## Construction

1. 1.25 mm<sup>2</sup> nickel-plated copper conductors
2. Semi-conductive self-regulating matrix
3. Matrix insulation
4. Tinned copper braid
5. Outer jacket (fluoropolymer)



# Self-Regulating Heating Cables

## Technical Data

Rated voltage	230 VAC
Maximum continuous operating temperature (trace heater energized)	+120 °C
Maximum continuous exposure temperature (trace heater de-energized)	+200 °C
Ambient temperature range	-60 ... +55 °C
Minimum installation temperature:	
Fluoropolymer outer jacket	-60 °C
Minimum bending radius	25 mm
Maximum braiding resistance	10 Ohm/km
Conductor cross-section	1.25 mm <sup>2</sup>
Dimension:	
Fluoropolymer outer jacket	12.80 × 5.70 mm
Weight:	
Fluoropolymer outer jacket	152 kg/km

## Power Output Curve

Nominal power output at rated voltage 230 VAC

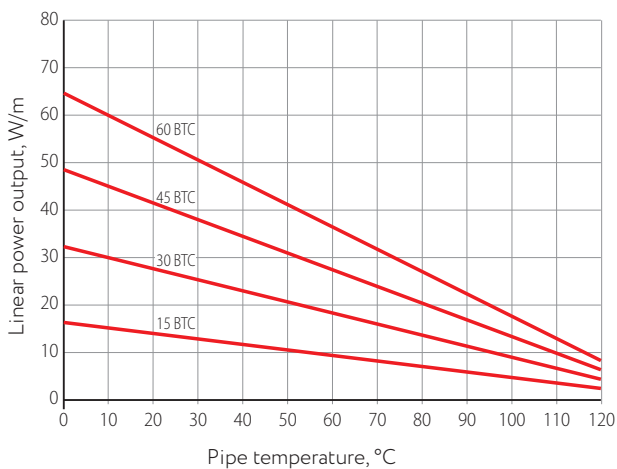

## Maximum Heating Circuit Length

For use with type C circuit breakers according to IEC 60898-1:2015

Type	Turn-on temperature, °C	Heating circuit length/m at 230 VAC		
		16A	20A	32A
15BTC	10	165	200	-
	-20	117	152	189
30BTC	10	90	120	-
	-20	73	97	120
45BTC	10	70	82	-
	-20	49	66	82
60BTC	10	51	66	-
	-20	39	53	66

## Approvals



II 2 GD  
Ex 60079-30-1 IIC T3 Gb  
Ex 60079-30-1 IIIC T200°C Db

Sira 17ATEX3335U  
Sira 18ATEX3038X



IECEX CCVE 17.0006U  
IECEX CCVE 17.0007X



## Marking

Example: 15BTC2-BP



1. Linear power output, W/m at +10 °C
2. Cable type
3. Supply voltage: 2 – 230 VAC
4. Screen type: B – Tinned copper wire braiding
5. Outer jacket material: P – Fluoropolymer

## Types

Outer jacket type	Order code	Outer jacket color	Name	Power output, W/m
Fluoropolymer outer jacket, braiding	3201003000	Red	15BTC2-BP	15
	3201003002		30BTC2-BP	30
	3201003004		45BTC2-BP	45
	3201003005		60BTC2-BP	60

# Self-Regulating Heating Cable BTX

BTX is an industrial-grade self-regulating heating cable that can be used for temperature maintenance or freeze protection of pipelines and vessels. It can be used in non-hazardous and ex-hazardous areas.

The power output adjusts automatically in response to the ambient temperature.

Due to its self-regulating characteristics it will not overheat even when the cable is overlapped. This guarantees maximum safety and reliability.

Installation of BTX heating cable is quick and simple and requires no special skills or tools. Thanks to its parallel construction the heating cable can be fitted on site to exact length without any complicated design calculations.

## Features

- 15, 30, 45, 60, 75 or 100 W/m
- For extra-high temperatures
- Steam purging possible
- Ex-approved solution
- Self-regulating, automatically adjusts power output in response to ambient temperature
- Fluoropolymer outer jacket
- Easy to install
- Can be cut to required length on site without any complicated design calculations
- Will not overheat even when overlapped
- Can be used in explosive environments without temperature limiter
- Full range of accessories available
- UV- and chemical-resistant

## Application Areas

- Temperature maintenance or freeze protection of pipelines and vessels in non-hazardous and ex-hazardous areas



## Construction

1. 1.25 mm<sup>2</sup> nickel-plated copper conductors
2. Semi-conductive self-regulating matrix
3. Matrix insulation
4. Tinned copper braid
5. Outer jacket (fluoropolymer)

# Self-Regulating Heating Cables

## Technical Data

Rated voltage	230 VAC
Maximum continuous operating temperature (trace heater energized)	+250 °C
Maximum continuous exposure temperature (trace heater de-energized)	+250 °C
Ambient temperature range	-65 ... +55 °C
Minimum installation temperature: Fluoropolymer outer jacket	-40 °C
Minimum bending radius	35 mm
Maximum braiding resistance	10 Ohm/km
Conductor cross-section	1.25 mm <sup>2</sup>
Dimension: 15BTX - 75BTX	12.10 × 5.40 mm
100BTX	14.40 × 5.60 mm
Weight: 15BTX - 75BTX	146 kg/km
100BTX	195 kg/km

## Power Output Curve

Nominal power output at rated voltage 230 VAC

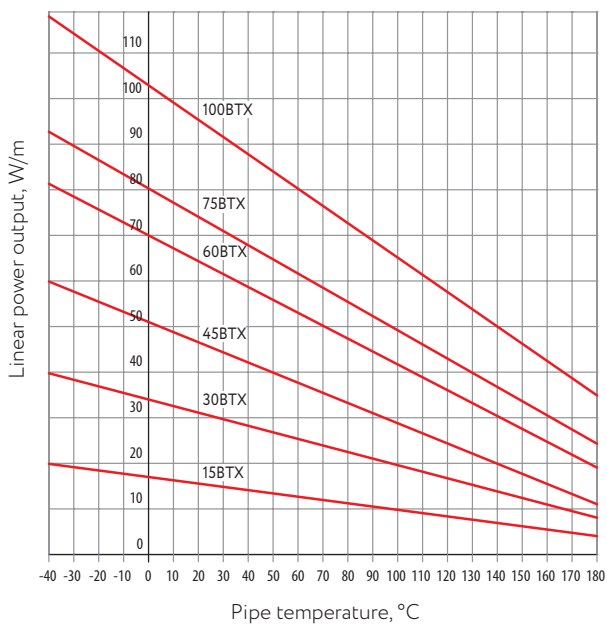

## Maximum Heating Circuit Length

For use with type C circuit breakers according to IEC 60898-1:2015

Type	Turn-on temperature, °C	Heating circuit length/m at 230 VAC			
		16A	20A	32A	50A
15BTX	10	122	154	172	172
	-20	98	122	172	172
30BTX	10	82	102	122	122
	-20	66	82	122	122
45BTX	10	62	76	100	100
	-20	50	62	98	100
60BTX	10	50	62	86	86
	-20	32	40	62	86
75BTX	10	34	44	70	76
	-20	18	24	38	60
100BTX	10	30	36	58	84
	-20	24	30	50	76

## Approvals



Ex e IIC T3 Gb  
Ex tb IIIC T200°C Db  
IECEx SIR 19.0009 (15BTX - 75BTX)



Ex e IIC T2 Gb  
Ex tb IIIC T300°C Db  
IECEx SIR 19.0010 (100BTX)

## Marking

Example: 15BTX2-BP

① ② ③ ④ ⑤

- Linear power output, W/m at +10 °C
- Cable type
- Supply voltage: 2 - 230 VAC
- Screen type: B - Tinned copper wire braiding
- Outer jacket material: P - Fluoropolymer

## Types

Outer jacket type	Order code	Outer jacket color	Name	Power output, W/m
Fluoropolymer outer jacket, braiding	3201004000	Black	15BTX2-BP	15
	3201004001		30BTX2-BP	30
	3201004002		45BTX2-BP	45
	3201004003		60BTX2-BP	60
	3201004004		75BTX2-BP	75
	3201004005		100BTX2-BP	100

# Self-Regulating Heating Cable CTE

CTE is an industrial-grade self-regulating heating cable used to prevent formation of ice and accumulation of snow on outdoor industrial sites (open pump sites, ramps, helipads).

Due to its self-regulating characteristics it will not overheat even when the cable is overlapped. This guarantees maximum safety and reliability.

Installation of CTE heating cable is quick and simple and requires no special skills or tools.

Thanks to its parallel construction the power output of the heating cable is everywhere the same.

Thus it can be fitted on site to exact piping length without any complicated design calculations.

CTE can be supplied as pre-fabricated connection-ready sections with cold leads.

## Features

- 80 W/m
- Self-regulating, automatically adjusts power output in response to ambient temperature
- Thermoplastic outer jacket
- Easy to install
- Can be cut to required length on site without any complicated design calculations
- Will not overheat even when overlapped
- Full range of accessories available

## Application Areas

- Temperature maintenance or freeze protection of pipelines and vessels in non-hazardous and ex-hazardous areas



1. Nickel-plated copper conductors, 2.00 mm<sup>2</sup>
2. Semi-conductive self-regulating matrix
3. Matrix insulation
4. Tinned copper braid
5. Thermoplastic outer jacket

## Versions

- CTE...BT Thermoplastic elastomer outer jacket with tinned copper braiding

# Self-Regulating Heating Cables

## Technical Data

Rated voltage	230 VAC
Maximum continuous operating temperature (energized)	+80 °C
Maximum continuous exposure temperature (de-energized)	+100 °C
Ambient temperature range	-60...+55 °C
Minimum installation temperature	-30 °C
Minimum bending radius	25 mm
Maximum braiding resistance	10 Ohm/km
Conductor cross-section	2.00 mm <sup>2</sup>
Dimension (CTE...BT)	16.8×7.2 mm
Weight (CTE...BT)	215 kg/km

## Power Output Curve

Nominal power output at rated voltage 230 VAC

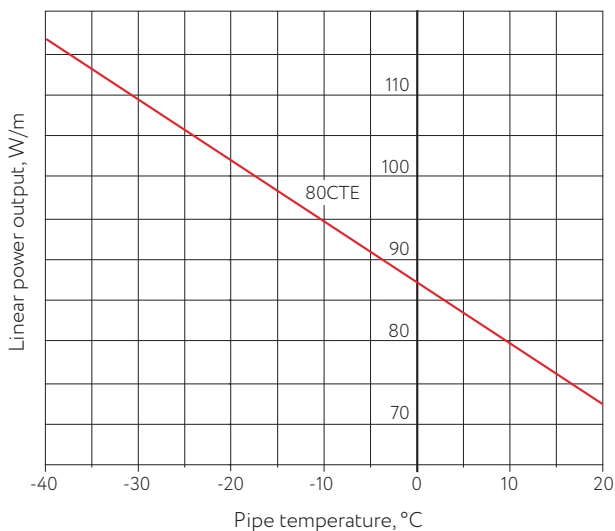

## Accessories

(to be ordered separately)

TKT/M kit for connection to the installation wire (without boxes) – see p. 109.

Zinc-plated fastening tape for securing the cable – see p. 117.

## Maximum Heating Circuit Length

For use with type C circuit breakers according to IEC 60898-1:2015

Type	Turn-on temperature, °C	Heating circuit length/m at 230 VAC	
		25 A	30 A
80CTE	10	78	83
	0	76	80
	-10	74	76
	-20	72	74
	-30	69	72
	-40	65	69

## Marking

Example: 80CTE2-BT

① ② ③ ④ ⑤ ⑥

1. Linear power 80 W/m (to IEC 60079-1-30)
2. Type of self-regulating heating cable: CT – mid-temperature
3. Cable version: E – for industrial applications
4. Rated voltage: 2 – 230 VAC (other voltages on request)
5. Braiding material: B – Copper tinned wire
6. Outer jacket material: T – Thermoplastic Elastomer

## Approvals



## Types

Outer jacket type	Order code	Outer jacket color	Name	Power output, W/m
Thermoplastic elastomer outer jacket, braiding	3201005100	Green	80CTE2-BT	80

# Series-Resistance Heating Cable SNF

SNF is a flexible heating cable with a fixed specific resistance and is specifically designed for use in areas where high operating temperatures and high output power is required. By using fluoropolymer for external insulation, the heating cable is particularly suitable for use in chemically aggressive and corrosive

environments. The special design of the SNF heating cable ensures high mechanical strength. Installation of SNF heating cables on site is quick and easy. Thanks to its small outside dimensions it can be easily attached to irregular objects such as pumps, valves and flanges.

## Features

- Temperature resistance up to 260 °C
- High mechanical resistance (7J impact resistance)
- Ex-approved solution
- Steam cleaning resistant, high chemical resistance

## Application Areas

- Temperature maintenance or freeze protection in non-hazardous and ex-hazardous areas

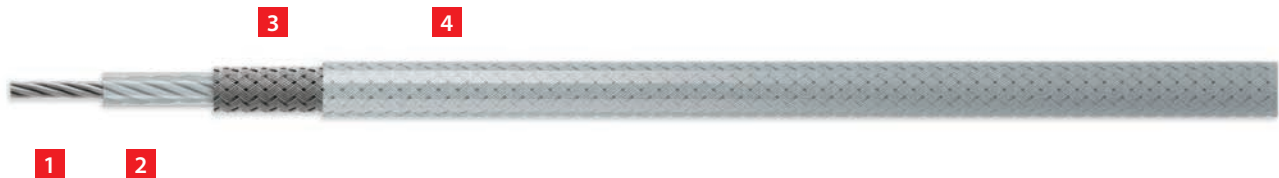

## Construction

1. Series-resistance heating conductor
2. Fluoropolymer insulation
3. Nickel-plated copper braid
4. Fluoropolymer outer jacket

# Series-Resistance Heating Cables

## Types

Name	Nominal resistance (Ohm/km) at +20 °C	Outer diameter, mm	Order code
SNF 01R8	1.8	7.80	3202001701
SNF 02R9	2.9	6.74	3202001702
SNF 04R4	4.4	5.88	3202001703
SNF 07R1	7.1	5.10	3202001704
SNF 09R7	9.7	5.25	3202001705
SNF 11R9	11.9	4.96	3202001706
SNF 17R4	17.4	4.69	3202001707
SNF 24R8	24.8	4.48	3202001708
SNF 32R7	32.7	4.73	3202001709
SNF 0050	50	4.55	3202001710
SNF 0062	62	4.52	3202001711
SNF 0080	80	4.40	3202001712
SNF 0100	100	4.70	3202001713
SNF 0142	142	4.61	3202001714
SNF 0178	178	4.52	3202001715
SNF 0200	200	4.55	3202001716
SNF 0250	250	4.55	3202001717
SNF 0340	340	4.45	3202001718
SNF 0410	410	4.28	3202001719
SNF 0490	490	4.45	3202001720
SNF 0590	590	4.55	3202001721
SNF 0665	665	4.70	3202001722
SNF 0765	765	4.52	3202001723
SNF 1000	1000	4.40	3202001724
SNF 1300	1300	4.34	3202001725
SNF 1480	1480	4.51	3202001726
SNF 1865	1865	4.76	3202001727
SNF 2825	2825	4.70	3202001728
SNF 3950	3950	4.61	3202001729
SNF 5900	5900	4.34	3202001730
SNF 7000	7000	4.30	3202001731
SNF 8000	8000	4.27	3202001732

## Technical Data

Maximum exposure temperature	+260 °C (intermittent +300 °C)	
Minimum installation temperature	-70 °C	
Rated voltage	up to 450/750 VAC (U <sub>0</sub> /U)	
Maximum power output	40 W/m	
Mechanical resistance	7J	
Minimal bending radius	for cable diameter up to 6 mm	2.5 × diameter
	for cable diameter above 6 mm	6 × diameter

## Approvals



Ex 60079-30-1 IIC Gb  
 Ex 60079-30-1 IIIC Db  
 Ex 60079-30-1 IIC T6...T2 Gb  
 Ex 60079-30-1 IIIC 85°C...260°C Db  
 CML 19ATEX3498U  
 CML 19ATEX3499X



IECEx CCVE 18.0005U  
 IECEx CCVE 18.0004X



## Marking

Example: SNF 32R7



1. Cable type (SNF)
2. Resistance code (32R7 – 32.7 Ohm/km)

# Series Resistance Heating Cable SNF-L

---

SNF-L is a flexible heating cable with a fixed specific resistance and is specifically designed for use in areas where high operating temperatures and high output power is required. By using fluoropolymer for external insulation, the heating cable is particularly suitable for use in chemically aggressive and corrosive

environments. The special design of SNF-L heating cable ensures high mechanical strength. Installation of the heating cables on site is quick and easy. Thanks to its small outside dimensions it can be easily attached to irregular objects such as pumps, valves and flanges.

## Features

- Temperature resistance up to +260 °C
- Mechanical resistance (4J impact resistance)
- Ex-approved solution
- Steam cleaning resistant, high chemical resistance

## Application Areas

- Temperature maintenance or freeze protection in non-hazardous and ex-hazardous areas



## Construction

1. Resistive heating wire
2. Fluoropolymer insulation
3. Nickel-plated copper braid
4. Fluoropolymer outer jacket



# Series-Resistance Heating Cables

## Types

Name	Nominal resistance (Ohm/km) at +20 °C	Outer diameter, mm	Order code
SNFL 17R4	17.4	4.29	3202001407
SNFL 24R8	24.8	4.08	3202001408
SNFL 32R7	32.7	3.93	3202001409
SNFL 0050	50	3.75	3202001410
SNFL 0062	62	3.72	3202001411
SNFL 0080	80	3.6	3202001412
SNFL 0100	100	3.9	3202001413
SNFL 0142	142	3.81	3202001414
SNFL 0178	178	3.72	3202001415
SNFL 0200	200	3.75	3202001416
SNFL 0250	250	3.75	3202001417
SNFL 0340	340	3.65	3202001418
SNFL 0410	410	3.48	3202001419
SNFL 0490	490	4.05	3202001420
SNFL 0590	590	3.75	3202001421
SNFL 0665	665	3.9	3202001422
SNFL 0765	765	3.72	3202001423
SNFL 1000	1000	3.6	3202001424
SNFL 1300	1300	3.54	3202001425
SNFL 1480	1480	3.71	3202001426
SNFL 1865	1865	3.96	3202001427
SNFL 2825	2825	3.9	3202001428
SNFL 3950	3950	3.81	3202001429
SNFL 5900	5900	3.54	3202001430
SNFL 7000	7000	3.5	3202001431
SNFL 8000	8000	3.47	3202001432

## Technical Data

Maximum exposure temperature	+260 °C (intermittent +300 °C)	
Minimum installation temperature	-70 °C	
Rated voltage	Up to 450/750 VAC (U <sub>0</sub> /U)	
Maximum power output	40 W/m	
Mechanical resistance	4J	
Minimal bending radius	for cable diameter up to 6 mm	2.5 × diameter
	for cable diameter above 6 mm	6 × diameter

## Approvals



Ex 60079-30-1 IIC Gb  
 Ex 60079-30-1 IIIC Db  
 Ex 60079-30-1 IIC T6...T2 Gb  
 Ex 60079-30-1 IIIC 85...260 °C Db  
 CML 19ATEX3498U  
 CML 19ATEX3499X



IECEx CCVE 18.0005U  
 IECEx CCVE 18.0004X



## Marking

Example: SNFL 32R7



1. Cable type (SNFL)
2. Resistance code (32R7 – 32.7 Ohm/km)

# Metal Outer Jacket Fibreglass-Insulated Cable MOIC-F

High temperature metal overjacket industrial cable for heating pipelines, vessels and process equipment.

Heating cable MOIC-F is specially designed to be an effective and reliable solution where high operating temperature has to be maintained when thermal conditions are high (for example, for heating of bitumen facilities and pipelines).

Due to high thermal stability of the fiberglass insulation, MOIC-F cable can be used where outer jacket temperature reaches up to +800 °C.

MOIC-F cable has an excellent mechanical strength and high corrosion stability, it is fire-resistant, safe in operation and can be used in corrosive environments and explosion hazardous areas.

Correct calculation of the electric heating cable system power output makes it possible to use MOIC-F in a wide temperature range.

The cable is supplied as ready-made sections that consist of the heating cable, connection couplings, installation wires, cable entries and flexible installation wires.

## Features

- Operating temperature up to +800 °C
- High mechanical resistance
- Ex-approved solution
- Can be used in chemically aggressive and corrosive environments
- Wide range of controls and accessories

## Application Areas

- Temperature maintenance in non-hazardous and ex-hazardous areas, extra-high thermal conditions, chemically aggressive environments



## Construction

1. Series-resistance heating wire
2. Fiberglass insulation
3. Stainless steel\*\* outer jacket (plain or corrugated)

\*\* Other jacket materials available on request (Cu, Incoloy etc)

## Approvals



\* Certification is underway

# Extra-High Temperature Series-Resistance Cables

## Technical Data

Maximum exposure temperature	for MOIC HT series	+800 °C
	for MOIC LT series	+650 °C
Minimum installation temperature		-70 °C
Rated voltage		Up to 670 VAC
Maximum power output		300 W/m
Minimal bending radius	for plain outer jacket cable	40 mm
	for corrugated outer jacket cable	30 mm

## Marking, Heating Cable

Example: MOIC-F-170-SA/2-HT

① ② ③ ④ ⑤

1. Cable name (Metal Outer jacket Industrial Cable, Fiberglass)
2. Resistance, Ohm/km
3. Outer jacket type (SA = steel annealed, SU = steel non-annealed)
4. Outer jacket shape (1 = plain surface, 2 = corrugated surface)
5. Thermal resistance (HT = +800 °C, LT = +650 °C)

## Marking, Heating Sections

Example: 30MOIC-F2-170-HSA/2-0510/020

① ② ③ ④ ⑤ ⑥ ⑦ ⑧

1. Linear power output, W/m
2. Cable name (Metal Outer jacket Industrial Cable, Fiberglass)
3. Rated voltage (2 = 230 VAC)
4. Resistance, Ohm/km
5. Temperature group and outer jacket type (H = high temperature, L = low temperature, SA = steel annealed, SU = steel non-annealed)
6. Outer jacket shape (1 = plain surface, 2 = corrugated surface)
7. Hot cable length, dm
8. Cold fragment length on every side, dm

## Types

Cable name	Nominal resistance (Ohm/km) at +20 °C	Order code
MOIC-F-170-SA/1-HT	170	3202003000
MOIC-F-230-SA/1-HT	230	3202003001
MOIC-F-440-SA/1-HT	440	3202003002
MOIC-F-620-SA/1-HT	620	3202003003
MOIC-F-890-SA/1-HT	890	3202003004
MOIC-F-1400-SA/1-HT	1400	3202003005
MOIC-F-2500-SA/1-HT	2500	3202003006
MOIC-F-3600-SA/1-HT	3600	3202003007
MOIC-F-170-SU/2-LT	170	3202003008
MOIC-F-230-SU/2-LT	230	3202003009
MOIC-F-440-SU/2-LT	440	3202003010
MOIC-F-620-SU/2-LT	620	3202003011
MOIC-F-890-SU/2-LT	890	3202003012
MOIC-F-1400-SU/2-LT	1400	3202003013
MOIC-F-2500-SU/2-LT	2500	3202003014
MOIC-F-3600-SU/2-LT	3600	3202003015
MOIC-F-170-SU/2-HT	170	3202003016
MOIC-F-230-SU/2-HT	230	3202003017
MOIC-F-440-SU/2-HT	440	3202003018
MOIC-F-620-SU/2-HT	620	3202003019
MOIC-F-890-SU/2-HT	890	3202003020
MOIC-F-1400-SU/2-HT	1400	3202003021
MOIC-F-2500-SU/2-HT	2500	3202003022
MOIC-F-3600-SU/2-HT	3600	3202003023
MOIC-F-170-SA/2-HT	170	3202003024
MOIC-F-230-SA/2-HT	230	3202003025
MOIC-F-440-SA/2-HT	440	3202003026
MOIC-F-620-SA/2-HT	620	3202003027
MOIC-F-890-SA/2-HT	890	3202003028
MOIC-F-1400-SA/2-HT	1400	3202003029
MOIC-F-2500-SA/2-HT	2500	3202003030
MOIC-F-3600-SA/2-HT	3600	3202003031

# Metal Outer Jacket Mineral-Insulated Cable MOIC-M

Heating cable MOIC-M is intended for heating pipelines, tanks and process equipment in the temperature range from -60 to +600 °C, including aggressive and explosive areas.

MOIC-M can be used in oil refining, chemical, pharmaceutical, food and other industries.

If the thermal output of the electric heating system is correctly calculated, the cable can be used in a broad temperature range.

Shipped as ready-made sections. A section consists of a heating cable, couplings, cold cable inserts, cable glands and flexible installation wires.

MOIC-M sections are purposefully designed for efficient and reliable operation where a high operating temperature has to be maintained, combined with high thermal output (for example, in the heating of bitumen plants and pipelines).

Due to the high thermal stability of the magnesium oxide insulation, the MOIC-M cable can be safely operated at ambient temperatures up to +600 °C.

MOIC-M cable has excellent mechanical strength and high corrosion resistance, can be operated in aggressive environments and hazardous areas, is fire-resistant and safe to operate.

- High mechanical strength
- High chemical resistance
- Easy installation
- Shipped as prefabricated sections

- Power supply voltage up to 660 V
- Temperature resistance up to +600 °C
- Explosion- and fire-safe

1. Heating conductor
2. MgO (magnesium oxide) core insulation
3. Outer metal jacket of the heating cable
4. Hard brazing
5. Current-carrying conductor
6. Coupling
7. Outer metal jacket of the cold cable insert
8. Cable connector M20
9. Grounding
10. Flexible installation wire

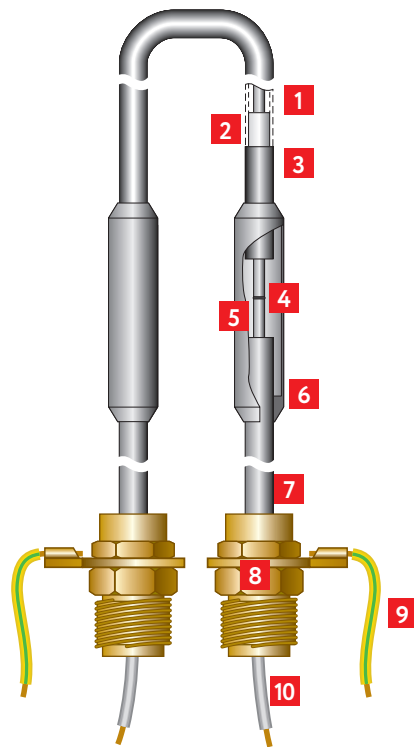

## Approvals



° Certification is underway

## Resistance to corrosive substances

Material, jacket	Sulfur compounds (H <sub>2</sub> S, SO <sub>2</sub> )		Sulfuric acid <sup>°</sup>	Hydrochloric acid	Fluoride acid	Alkalis	Phosphoric acid	Sea water	Nitric acid	Chlorine <sup>°°</sup>		Organic acids <sup>°°°</sup>
	dry	moist								dry	moist	
Copper	not recommended	not recommended	not recommended	not recommended	not recommended	allowable	allowable	allowable	allowable	not recommended	not recommended	to be confirmed
Copper-nickel alloy	allowable	not recommended	to be confirmed	not recommended	allowable	allowable	allowable	allowable	allowable	allowable	allowable	to be confirmed
Stainless steel	allowable	allowable	allowable	allowable	allowable	allowable	allowable	allowable	allowable	allowable	allowable	allowable
Inconel	allowable	allowable	allowable	allowable	allowable	allowable	allowable	allowable	allowable	allowable	allowable	allowable

- recommended
- to be confirmed
- allowable
- not recommended

° - Depending on concentration and temperature  
 °° - Resistance to chlorines depends on the chemical composition of the salt  
 °°° - Different resistance to different organic acids

# Extra-High Temperature Series-Resistance Cables

## Technical Data

Operating voltage	up to 660 V
Maximum linear power	up to 400 W/m
Insulation resistance, min	10 <sup>3</sup> MOhm·m
Maximum thermal resistance	up to +600 °C
Ambient temperature range	-60...+50 °C
Ex marking	1Ex e IIC T1...T3 Gb X
Degree of external protection GOST 14254-96	IP67
Earth leakage current	3 mA/100 m
Minimum installation temperature	-60 °C
Minimum bending radius	6 outer diameters

## Accessories (to be ordered separately)

Junction boxes for connection of heating cables with mineral insulation (see pp. 80-81).

## Cable Versions (used in section)

Cable	Material core	Resistance core at 20 °C, Ohm/km	Outer diameter of cable, mm	Cold ends		Order code
				Cross section, mm	Diameter, mm	
Heating cable with a copper jacket						
MOIC-M-4-C-LT	Copper	4	5,9	16	8,3	3202003100
MOIC-M-7-C-LT	Copper	7	5,3	10	7,3	3202003101
MOIC-M-11-C-LT	Copper	11	4,9	6,0	6,4	3202003102
MOIC-M-17-C-LT	Copper	17	4,6	6,0	6,4	3202003103
MOIC-M-25-C-LT	Copper	25	3,7	6,0	6,4	3202003104
MOIC-M-40-C-LT	Copper	40	3,4	2,5	5,3	3202003105
MOIC-M-63-C-LT	Copper	63	3,2	2,5	5,3	3202003106
Heating cable with a copper-nickel jacket						
MOIC-M-4-CN-MT	Copper	4	5,9	16	8,3	3202003107
MOIC-M-7-CN-MT	Copper	7	5,3	10	7,3	3202003108
MOIC-M-11-CN-MT	Copper	11	4,9	6,0	6,4	3202003109
MOIC-M-17-CN-MT	Copper	17	4,6	6,0	6,4	3202003110
MOIC-M-25-CN-MT	Copper	25	3,7	6,0	6,4	3202003111
MOIC-M-40-CN-MT	Copper	40	3,4	2,5	5,3	3202003112
MOIC-M-63-CN-MT	Copper	63	3,2	2,5	5,3	3202003113
MOIC-M-160-CN-MT	Constantan	160	4,9	6,0	6,4	3202003114
MOIC-M-250-CN-MT	Constantan	250	4,4	2,5	5,3	3202003115
MOIC-M-400-CN-MT	Constantan	400	4,0	2,5	5,3	3202003116
MOIC-M-630-CN-MT	Constantan	630	3,7	2,5	5,3	3202003117
MOIC-M-1000-CN-MT	Constantan	1000	3,4	2,5	5,3	3202003118
MOIC-M-1600-CN-MT	Constantan	1600	3,2	2,5	5,3	3202003119
Heating cable with an inconel jacket						
MOIC-M-160-I-MT	Nichrome	160	6,5	6,0	6,4	3202003120
MOIC-M-250-I-MT	Nichrome	250	5,3	6,0	6,4	3202003121
MOIC-M-400-I-MT	Nichrome	400	4,7	2,5	5,3	3202003122
MOIC-M-630-I-MT	Nichrome	630	4,3	2,5	5,3	3202003123
MOIC-M-1000-I-MT	Nichrome	1000	3,9	2,5	5,3	3202003124
MOIC-M-1600-I-MT	Nichrome	1600	3,6	2,5	5,3	3202003125
MOIC-M-2500-I-MT	Nichrome	2500	3,4	2,5	5,3	3202003126
MOIC-M-4000-I-MT	Nichrome	4000	3,2	2,5	5,3	3202003127
MOIC-M-6300-I-MT	Nichrome	6300	3,2	2,5	5,3	3202003128
MOIC-M-10000-I-MT	Nichrome	10000	3,2	2,5	5,3	3202003129
Heating cable with a stainless steel jacket						
MOIC-M-160-ST-HT	Nichrome	160	6,5	6,0	6,4	3202003130
MOIC-M-250-ST-HT	Nichrome	250	5,3	6,0	6,4	3202003131
MOIC-M-400-ST-HT	Nichrome	400	4,7	2,5	5,3	3202003132
MOIC-M-630-ST-HT	Nichrome	630	4,3	2,5	5,3	3202003133
MOIC-M-1000-ST-HT	Nichrome	1000	3,9	2,5	5,3	3202003134
MOIC-M-1600-ST-HT	Nichrome	1600	3,6	2,5	5,3	3202003135
MOIC-M-2500-ST-HT	Nichrome	2500	3,4	2,5	5,3	3202003136
MOIC-M-4000-ST-HT	Nichrome	4000	3,2	2,5	5,3	3202003137
MOIC-M-6300-ST-HT	Nichrome	6300	3,2	2,5	5,3	3202003138
MOIC-M-10000-ST-HT	Nichrome	10000	3,2	2,5	5,3	3202003139

## Ordering Information

**Example:** Heating section, cable MOIC-M  
35MOIC-M 2-250-CN-0250-040

① ② ③ ④ ⑤ ⑥ ⑦

- Linear power output, W/m
- Section name (metal outer jacket industrial cable, mineral insulated)
- Rated voltage: (2 – 230, 3 – 400, 5 – custom value, 6 – 660 V)
- Resistance, Ohm/km
- Outer jacket type (C – copper, CN – copper-nickel alloy, I – inconel, ST – stainless steel)
- Hot cable length, dm
- Cold fragment length on every side, dm

## Available Jacket Options

1. Copper	Maximum temperature resistance up to +200 °C
2. Copper-nickel alloy	Maximum temperature resistance up to +400 °C
3. Inconel or stainless steel	Maximum temperature resistance up to +600 °C

## Maximum Operating Temperatures

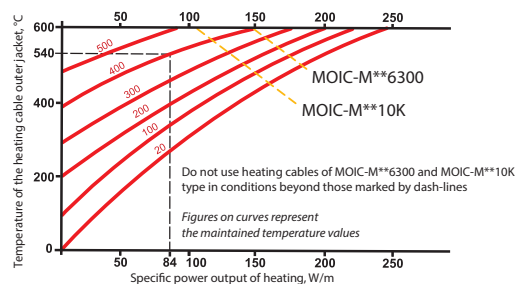
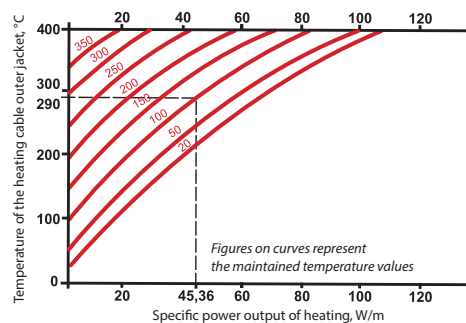
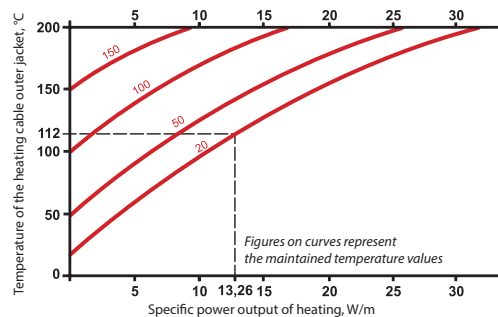

# Junction Boxes for Self-Regulating Heating Cables

Designed for connecting self-regulating electric heating cables to the power network and for branching of self-regulating heating cables\*.

Box models are supplied in 2 installation variants:

- complete with a pipe installation stand UVK for direct mounting onto the surface of a pipeline or tank;
- for installation onto a wall, onto a nearby metal structure or using a bracket directly onto the pipeline (brackets supplied separately).

## Features

- Efficient solution for power supply and input of self-regulating heating cables connection through thermal insulation in electric heating cable systems
- Compatible with all types of self-regulating electric heating cables
- Excludes the risk of damage to heating cables at connection points
- Approved for installation in explosion hazard areas

The enclosure design ensures moisture and dust ingress protection IP66 and high corrosion stability. Cable gland of the box is intended for connecting unarmoured power cables with a diameter of 7 to 18 mm or armored power cables with a diameter of 12 to 20 mm.

The installed terminal blocks allow the connection of multi-core or single-core wires with a cross-section of 1.5 to 10 mm<sup>2</sup>. Design options with screw or push-in terminals are available to order.

- Critical components are included in the scope of supply. Metal pipe strap PFS/3, cable entry unit and flexible sealed gland FSG to be ordered separately
- Wide application range
- Quick and easy installation
- High thermal stability
- Non-corrosive

## Application Areas

The box allows connection of up to three self-regulating electric heating cables to the power cable and connection of up to three cables for branching.

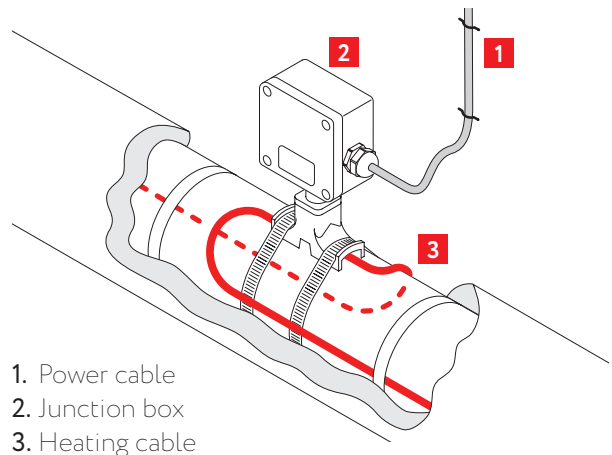

1. Power cable
2. Junction box
3. Heating cable

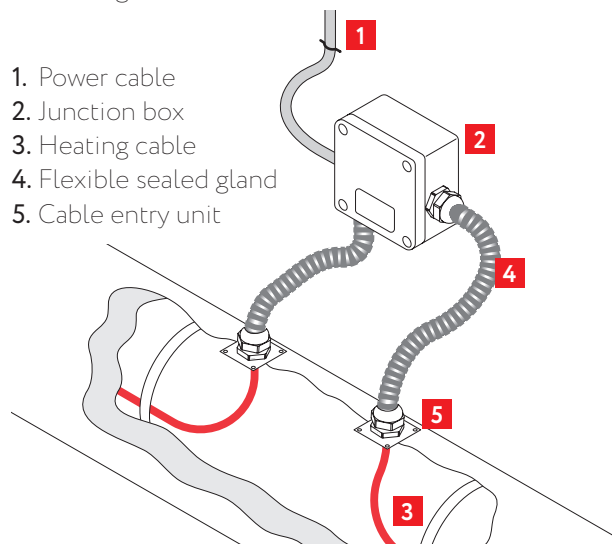

1. Power cable
2. Junction box
3. Heating cable
4. Flexible sealed gland
5. Cable entry unit

\* This junction box is compatible with self-regulating heating cables HTM, HTA, HTP, BTC, BTX, CTE. For ordering information, see pp. 48-59

# Power Supply of Self-Regulating Heating Cables

## Technical Data

Dust and moisture protection rating	IP66
Explosion protection marking	Ex eb IIC T6...T3 Gb Ex tb IIIC T85°C... T165°C Db
Temperature group of the explosion hazard area	T6
Operating ambient temperature range	-60...+55 °C
Operating voltage	max 550 V
Operating current	max 50 A
Enclosure dimensions JB 2221-223	122×120×91.5 mm
Total weight (maximum)	1.55 kg
Material Box / Color	Glass fiber reinforced polyester / Black
Material Pipe installation support / Color	polyester / Black

## Construction

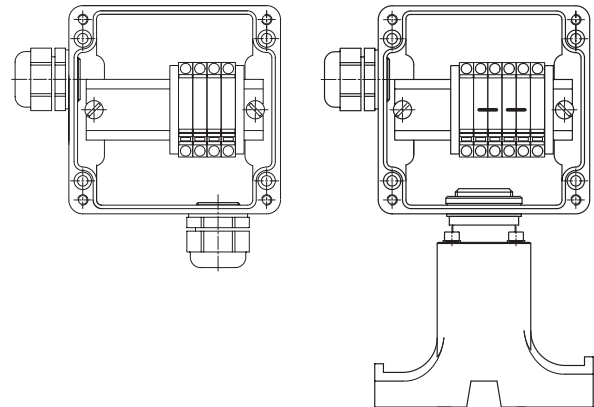

Quantity, type of terminals and placement of DIN-rail with terminal block could differ from drawings.

## Delivery Set

Model	Cable glands and plugs (P=plastic; B=brass)								Earthing tag	Terminated earthing wire	Pipe installation support	Terminal block	Type of terminals	Order code
	Side A		Side B		Side C		Side D							
	Cable gland	Screw plug	Cable gland	Screw plug	Cable gland	Screw plug	Cable gland	Screw plug						
JB2221-223-2X340°			1xM25 P		1xM25 P							1L, 1N, 2PE	screw/ push-in	3210001612
JB2221-223-2X350				1xM25 P	1xM25 P									3210001613
JB2221-223-2X360			3xM25 P		1xM25 P							3L, 3N, 3PE		3210001614
JB2221-223-2X370				3xM25 P	1xM25 P									3210001615
JB2221-223-1X300					1xM25 P					V		2L, 2N, 2PE		3210001603
JB2221-223-1X310						1xM25 P				V				3210001604
JB2221-223-1X11						1xM25 P		V	V	V				3210002006
JB2221-223-1X12					1xM25 B			V	V	V				3210002008
JB2221-223-1X13					1xM25 P			V	V	V				3210002010
JB2221-223-2X11			1xM25 P		1xM25 B		1xM25 P	V	V			2L, 1N, 2PE/ 3L, 2N, 2PE		3210002012
JB2221-223-2X12			1xM25 P		1xM25 B		1xM25 P	V	V					3210002013
JB2221-223-2X13			1xM25 P		1xM25 P		1xM25 P	V	V					3210002014
JB2221-223-2X14			1xM25 P		1xM25 P		1xM25 P	V	V					3210002015
JB2221-223-2X15			1xM25 P		1xM25 B		1xM25 B	V	V					3210002016

Order codes are valid for junction boxes with push-in terminal block.  
Additional configurations are available upon request.

° X = 1 for screw type terminal block; X=2 for push-in type terminal block

# Junction Boxes for Self-Regulating Heating Cables (3 and More Circuits)

## Application

Junction boxes for 3 and more self-regulating heating cables connection are designed for connecting of self-regulating electrical heating cables to the power

network\* and for the branching of self-regulating heating cables. The box also supports branching of the power cable in utility networks.

Boxes' models are supplied in 2 installation variants:

- complete with a pipe installation support stand UVK for direct mounting onto the surface of a pipeline or tank;
- for installation onto a wall, onto a nearby metal structure or using a bracket directly onto the pipeline (brackets supplied separately).



PREMIUM line

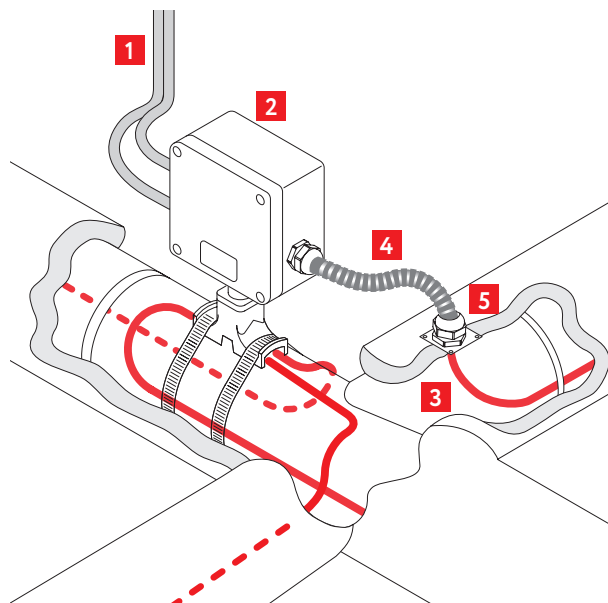

- 1. Power cable
- 2. Junction box
- 3. Heating cable
- 4. Flexible sealed gland
- 5. Cable entry unit

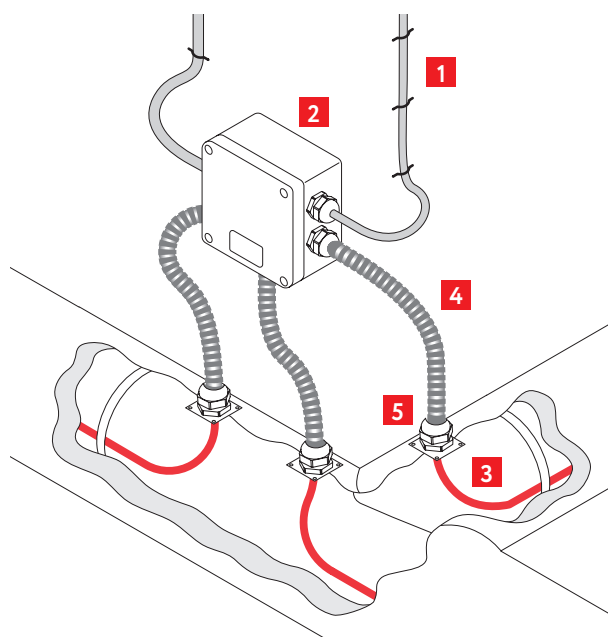

- 1. Power cable
- 2. Junction box
- 3. Heating cable
- 4. Flexible sealed gland
- 5. Cable entry unit

\* This junction box is compatible with self-regulating heating cables HTM, HTA, HTP, BTC, BTX, CTE. For ordering information, see pp. 48-59



# Power Supply of Self-Regulating Heating Cables

## Technical Data

Dust and moisture protection rating	IP66
Explosion protection marking	Ex eb IIC T6...T3 Gb Ex tb IIIC T85°C... T165°C Db
Temperature group of the explosion hazard area	T6
Operating ambient temperature range	-60...+55 °C
Operating voltage	max 550 V
Operating current	max 50 A
Enclosure dimensions	160×160×94.5 mm
Total weight (maximum)	2.76 kg
Material Box / Color	Glass fiber reinforced
Material Pipe installation support / Color	polyester / Black

## Construction

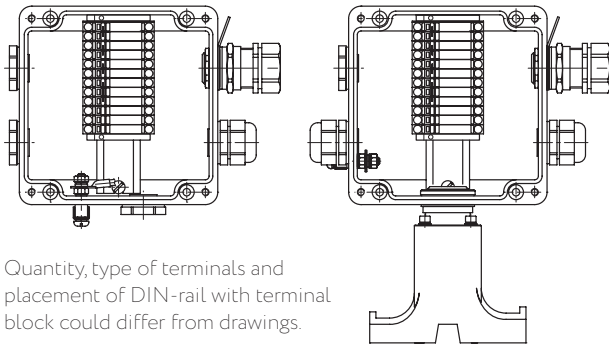

Quantity, type of terminals and placement of DIN-rail with terminal block could differ from drawings.

## Delivery Set

Model	Cable glands and plugs (P=plastic; B=brass)								Earthing tag	Terminated earthing wire	Pipe installation support	Terminal block	Type of terminals	Order code
	Side A		Side B		Side C		Side D							
	Cable gland	Screw plug	Cable gland	Screw plug	Cable gland	Screw plug	Cable gland	Screw plug						
JB2221-333-1X11					1xM25 B			3xM25 P	V	V	V			3210002100
JB2221-333-1X12					1xM25 B			1xM25 B 2xM25 P	V	V	V			3210002101
JB2221-333-1X13					1xM25 B			1xM25 P 2xM25 P	V	V	V			3210002102
JB2221-333-1X14					1xM25 B			2xM25 B 1xM25 P	V	V	V			3210002103
JB2221-333-1X15					1xM25 B			2xM25 P 1xM25 P	V	V	V			3210002104
JB2221-333-1X16					1xM25 P			3xM25 P	V	V	V			3210002105
JB2221-333-1X17					1xM25 P			1xM25 P 2xM25 P	V	V	V			3210002106
JB2221-333-1X18					1xM25 P			2xM25 P 1xM25 P	V	V	V			3210002107
JB2221-333-1X19					1xM25 B			1xM25 P 1xM25 B 1xM25 P	V	V	V			3210002108
JB2221-333-2X11				1xM25 P	1xM25 B	1xM25 P		1xM25 P 1xM25 P	V	V				3210002109
JB2221-333-2X12				1xM25 P	1xM25 B	1xM25 P		1xM25 B 1xM25 P	V	V				3210002110
JB2221-333-2X13				1xM25 P	1xM25 B	1xM25 P		2xM25 B	V	V		3L, 2N, 2PE/ 6L, 3N, 3PE	screw/ push-in	3210002111
JB2221-333-2X14				1xM25 P	1xM25 B	1xM25 P		2xM25 P	V	V				3210002112
JB2221-333-2X15				1xM25 P	2xM25 B			2xM25 B	V	V				3210002113
JB2221-333-2X16				1xM25 P	1xM25 B 1xM25 P			2xM25 B	V	V				3210002114
JB2221-333-2X17				1xM25 P	1xM25 P	1xM25 P		1xM25 P 1xM25 P	V	V				3210002115
JB2221-333-2X18				1xM25 P	1xM25 P	1xM25 P		2xM25 P	V	V				3210002116
JB2221-333-2X19				1xM25 P	2xM25 P			2xM25 P	V	V				3210002117
JB2221-333-2X20				1xM25 P	2xM25 B			1xM25 P 1xM25 P	V	V				3210002118
JB2221-333-2X21				1xM25 P	1xM25 B 1xM25 P			1xM25 B 1xM25 P	V	V				3210002119
JB2221-333-2X22				1xM25 P	1xM25 B 1xM25 P			1xM25 B 1xM25 P	V	V				3210002120
JB2221-333-2X23				1xM25 P	2xM25 P			2xM25 P	V	V				3210002121

Order codes are valid for junction boxes with push-in terminal block. Additional junction box configurations are available upon request.

\* X = 1 for screw type terminal block; X=2 for push-in type terminal block

## Accessories (to be ordered separately)

Connection kit for self-regulating heating cables is specified depending on the type of cable used. For ordering information see "Accessories", pp. 108-109.

Brackets PB, KP, PL.JB0606 – for mounting the box onto the pipeline. For ordering information see "Accessories", pp. 112-113.

Z-profile – for mounting the box onto a metal structure or onto a wall.

Metal pipe strap PFS/3 – for mounting the bracket onto the pipeline. For ordering information see "Accessories", p. 117.

Flexible sealed gland FSG – for mechanical protection of cables in open space sets. For ordering information see pp. 92-93.

Cable entry unit LEK/U – for penetrating of thermal insulation. For ordering information see "Accessories", p. 111.

## Approvals



Nº IECEx CCVE 18.0006X



\* Certification is underway

# Junction Boxes for Light Indication and Connection of Heating Cables to Power Supply

Junction boxes for light indication are designed to indicate the availability of power for heating sections based on self-regulating electric heating cables\* and is intended for connecting heating cables to power network.

Box models are supplied in 2 installation variants:

- complete with a pipe installation stand UVK for direct mounting onto the surface of a pipeline or tank;
- for installation onto a wall, onto a nearby metal structure or using a bracket directly onto the pipeline (brackets supplied separately).

Box model JB2221-223-1X320\* supports light indication only – end box.

Boxes JB2221-223 – allow connecting of one self-regulating heating cable to the power cable or two cables if the box is used for splicing.

Boxes JB2221-333 – allow connection to the power cable of up to three self-regulating heating cables with screw terminal straps and up to two – with push-in terminals.

The enclosure design ensures moisture and dust ingress protection IP66 and high corrosion stability. Cable glands of the box are intended for connecting unarmored power cables with a diameter of 7 to 18 mm or armored power cables with a diameter of 12 to 20 mm.

The installed terminal blocks allow the connection of multi-core or single-core wires with a cross-section of 1.5 to 10 mm<sup>2</sup>. Design options with screw or push-in terminals are available to order.

A light indicator with a super bright LED signals voltage at the heating section termination.

The green LED has a long service life and has a 180° angle view, including in direct sunlight.

## Features and Application Areas

- Provides light indication of power voltage presence at the end of heating cable section and connection of cables to power network
- Compatible with all types of self-regulating electric heating cables
- Approved for installation in explosion hazard areas
- High mechanical strength
- Critical component parts are included in the scope of supply. Metal pipe strap PFS/3, cable entry unit and flexible sealed gland FSG to be ordered separately
- Wide application range
- Quick and easy installation
- High thermal stability
- Non-corrosive



\* This junction box is compatible with self-regulating heating cables HTM, HTA, HTP, BTC, BTX, CTE. For ordering information, see pp. 48–59

# Light Indication of Voltage Presence and Power Supply of Self-Regulating Heating Cables

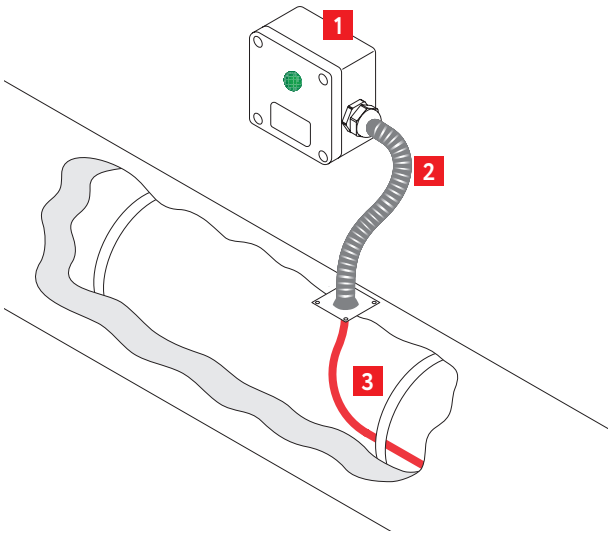

1. Junction box JB2221-223-2X(27-31)
2. Flexible sealed gland
3. Heating cable

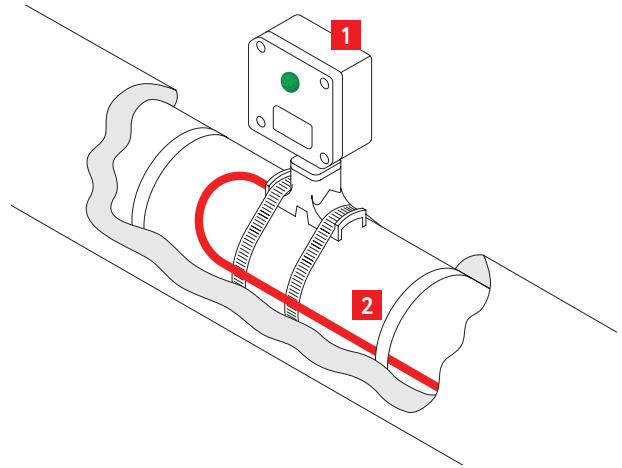

1. Junction box JB2221-223-1X(21-23)
2. Heating cable

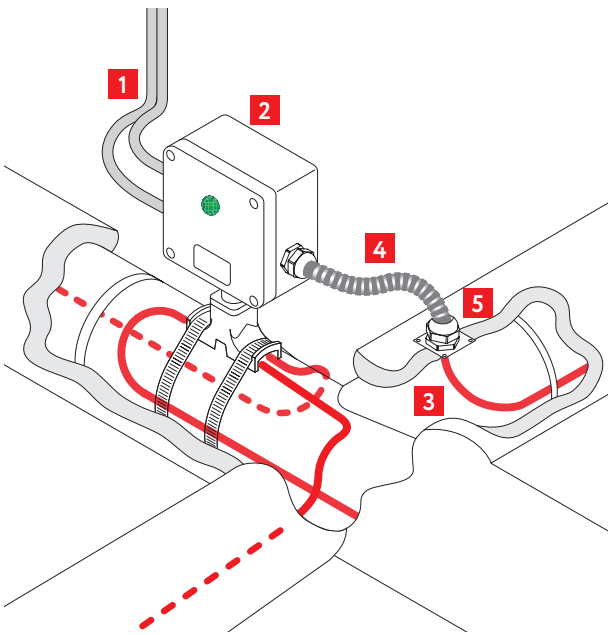

1. Power cable
2. Junction box JB2221-333-1X(23-30)
3. Heating cable
4. Flexible sealed gland
5. Cable entry unit

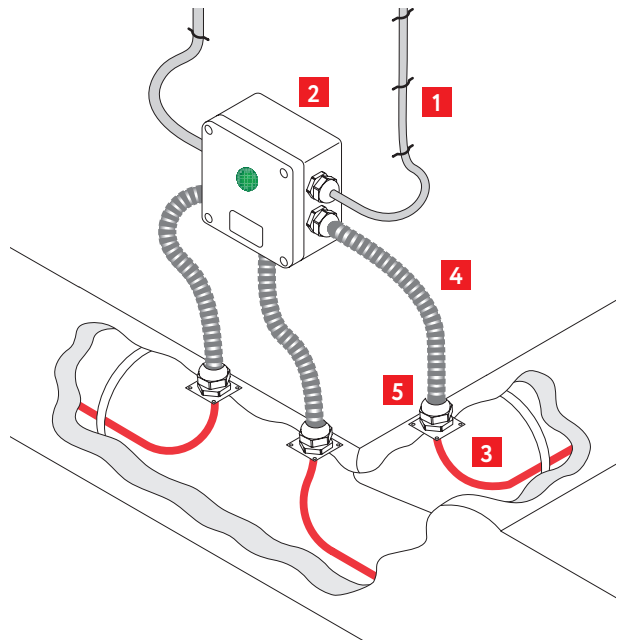

1. Power cable
2. Junction box JB2221-333-2X(27-33)
3. Heating cable
4. Flexible sealed gland
5. Cable entry unit

PREMIUM line

# Junction Boxes for Light Indication and Connection of Heating Cables to Power Supply

## Technical Data

Dust and moisture protection rating	IP66
Explosion protection marking	Ex db eb IIC T6...T3 Gb Ex tb IIIC T85°C...T165°C Db
Temperature group of the explosion hazard area	T6
Operating ambient temperature range	-60...+55 °C
Operating voltage	max 550 V
Operating current	max 50 A
Electric life of the LED	>10 <sup>5</sup> hours
LED power intake	<1 W
Light source	green LED
View angle	180°
Enclosure dimensions	JB2221-223 122×120×91.5 mm JB2221-333 160×160×94.5 mm
Total weight (maximum)	JB2221-223 1.55 kg JB2221-333 2.44 kg
Material Box / Color	
Material Pipe installation support / Color	Glass fiber reinforced polyester / Black

## Accessories (to be ordered separately)

Connection kit for self-regulating heating cables is specified depending on the type of cable used. For ordering information see "Accessories", pp. 108-109.

Brackets PB, KP, PL.JB0606 – for mounting the box onto the pipeline. For ordering information see "Accessories", pp. 112-113.

Z-profile – for mounting the box onto a metal structure or onto a wall.

Metal pipe strap PFS/3 – for mounting the bracket onto the pipeline. For ordering information see "Accessories", p. 117.

Flexible sealed gland FSG – for mechanical protection of cables in open space sets. For ordering information see pp. 92-93.

Cable entry unit LEK/U – for penetrating of thermal insulation. For ordering information see "Accessories", p. 111.

## Construction

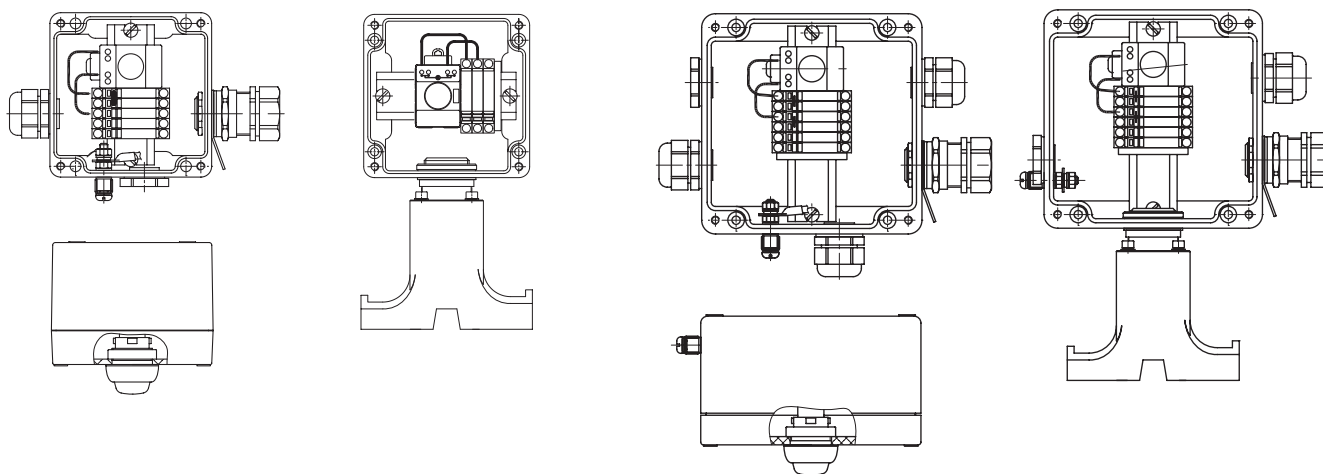

Boxes JB2221-223 (left) and JB2221-333 (right) with push-in terminals. Quantity, type of terminals and placement of DIN-rail with terminal block could differ from drawings.

# Light Indication of Voltage Presence and Power Supply of Self-Regulating Heating Cables

## Delivery Set

Model	Cable glands and plugs (P=plastic; B=brass)								Earthing tag	Terminated earthing wire	Pipe installation support	Terminal block	Type of terminals	Light Indicator	Order code	
	Side A		Side B		Side C		Side D									
	Cable gland	Screw plug	Cable gland	Screw plug	Cable gland	Screw plug	Cable gland	Screw plug								
JB2221-223-1X320*											V	1L,1N,1PE	screw/push-in	V	3210001605	
JB2221-223-1X21						1xM25 P			V	V	V			V	3210002201	
JB2221-223-1X22					1xM25 B				V	V	V	1L,1N,1PE / 2L,1N,2PE	screw/push-in	V	3210002202	
JB2221-223-1X23					1xM25 P				V	V	V			V	3210002203	
JB2221-223-2X27			1xM25 P						V	V				V	3210002204	
JB2221-223-2X28				1xM25 P	1xM25 P		1xM25 P		V	V		1L,1N,1PE / 2L,1N,2PE	screw/push-in	V	3210002205	
JB2221-223-2X29			1xM25 P		1xM25 P		1xM25 P		V	V				V	3210002206	
JB2221-223-2X30				1xM25 P	1xM25 B		1xM25 P		V	V				V	3210002207	
JB2221-223-2X31			1xM25 P		1xM25 B		1xM25 P		V	V				V	3210002208	
JB2221-333-1X23					1xM25 P			2xM25 P	V	V	V				V	3210002209
JB2221-333-1X24					1xM25 P		1xM25 P	1xM25 P	V	V	V				V	3210002210
JB2221-333-1X25					1xM25 P			2xM25 P	V	V	V				V	3210002211
JB2221-333-1X26					1xM25 B			2xM25 P	V	V	V		V	3210002212		
JB2221-333-1X27					1xM25 B		1xM25 B	1xM25 P	V	V	V		V	3210002213		
JB2221-333-1X28					1xM25 B		1xM25 P	1xM25 P	V	V	V		V	3210002214		
JB2221-333-1X29					1xM25 B			2xM25 P	V	V	V		V	3210002215		
JB2221-333-1X30					1xM25 B			1xM25 B 1xM25 P	V	V	V		V	3210002216		
JB2221-333-2X27				1xM25 P	2xM25 P		2xM25 P		V	V		2L,2N,2PE	screw/push-in	V	3210002217	
JB2221-333-2X28			1xM25 P		2xM25 P		2xM25 P		V	V				V	3210002218	
JB2221-333-2X29			1xM25 P		1xM25 B	1xM25 P	2xM25 P		V	V				V	3210002219	
JB2221-333-2X30			1xM25 P		1xM25 B 1xM25 P		1xM25 P		V	V				V	3210002220	
JB2221-333-2X31				1xM25 P	1xM25 B	1xM25 P	1xM25 B 1xM25 P		V	V				V	3210002221	
JB2221-333-2X32				1xM25 P	1xM25 B 1xM25 P		1xM25 B 1xM25 P		V	V				V	3210002222	
JB2221-333-2X33			1xM25 P		1xM25 B 1xM25 P		1xM25 B 1xM25 P		V	V				V	3210002223	

\* X = 1 for screw type terminal block; X=2 for push-in type terminal block

Order codes are valid for junction boxes with push-in terminal block.

Additional junction box configurations are available upon request.

## Approvals



Nº IECEx CCVE 18.0006X



\* Certification is underway

# Junction Boxes for Connection of Data, Control and Signal Cables

Junction boxes models range JB222(3)1-223-1X(14-17) and JB222(3)1-223-2X(16-24) is designed for connecting control cables to the electric heating systems.

The boxes' installation can have 2 mounting variants depending on the models chosen:

- JB222(3)1-223-1X(14-17) – with a pipe installation support UVK, to be mounted on the surface of the heated pipeline, tank, etc.
- JB222(3)1-223-2X(16-24) – installation on a wall or on a nearby metal structure or using a bracket directly on a pipeline. Brackets are supplied separately.

The box allows connection of one or two control cables, up to three temperature sensors and input

through thermal insulation of up to four temperature sensors (one reserved).

The enclosure design ensures moisture and dust ingress protection IP66 and high corrosion stability. Cable glands are intended for connecting unarmored power cables with a diameter of 7 to 18 mm or armored power cables with a diameter of 12 to 20 mm.

The installed terminal blocks allow the connection of multi-core or single-core wires with a cross-section of 0.5 to 2.5 mm<sup>2</sup>. Design options with screw or push-in terminal blocks and with various types of explosion protection: models JB2221 – type e (increased safety) and models JB2231 – type ia (intrinsic safety) – are available.



## Features and Application Areas

- Efficient solution for control cables connection and input through thermal insulation
- Approved for installation in explosion hazard areas
- Critical component parts included in the scope of supply. Metal pipe strap PFS/3, cable entry unit and flexible sealed gland FSG to be ordered separately
- Wide application range
- Quick and easy installation
- High thermal stability
- Non-corrosive

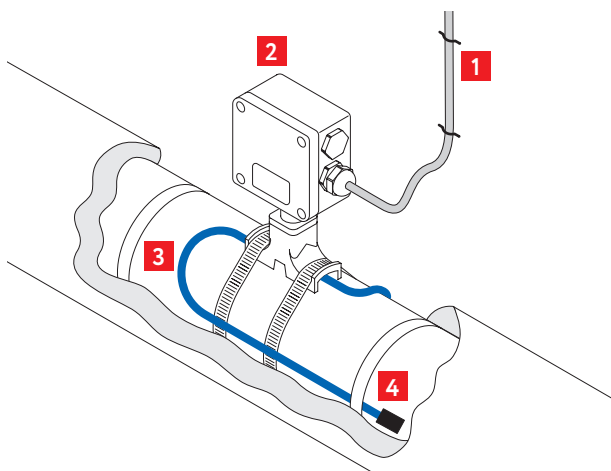

1. Control cable
2. Junction box JB222(3)1-223-1X(14-17)
3. Installation sensor cable
4. Temperature sensor

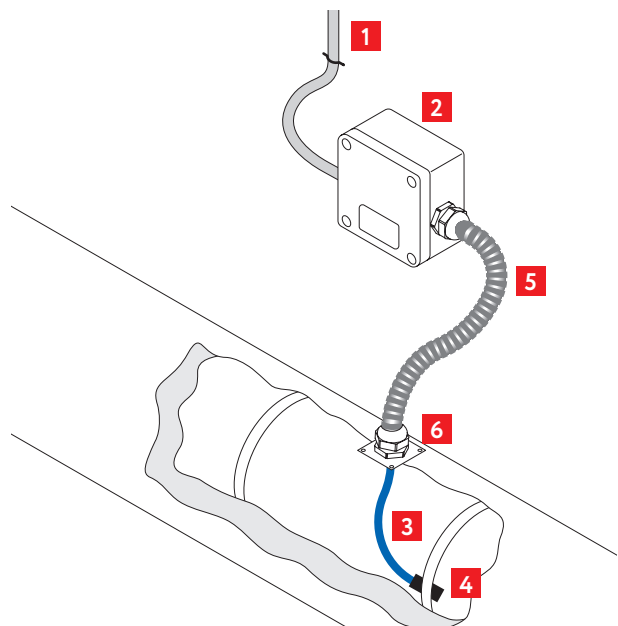

1. Control cable
2. Junction box JB222(3)1-223-2X(16-24)
3. Installation sensor cable
4. Temperature sensor
5. Flexible sealed gland
6. Cable entry unit

# Connection of Data, Control and Signal Cables

## Technical Data

Dust and moisture protection rating	IP66
Explosion protection marking	Ex eb IIC T6...T3 Gb Ex ia IIC T6 Gb Ex tb IIC T85°C... T165°C Db
Operating ambient temperature range	T6
Operating ambient temperature range	-60...+55 °C
Operating voltage	max 550 V
Operating current	max 21 A
Enclosure dimensions	122×120×91.5 mm
Total weight (maximum)	1.8 kg
Material Box / Color	Glass fiber reinforced polyester / Black
Material Pipe installation support / Color	polyester / Black

## Accessories (to be ordered separately)

Brackets PB, KP, PL.JB0606 – for mounting the box onto the pipeline. For ordering information see “Accessories”, pp. 112-113.

Z-profile – for mounting the box onto a metal structure or onto a wall.

Metal pipe strap PFS/3 – for mounting the pipe support stand or bracket onto the pipeline. For ordering information see “Accessories”, p. 117.

Flexible sealed gland FSG – for mechanical protection of cables in open space sets. For ordering information see pp. 92-93.

Cable entry unit LEK/U – for penetrating of thermal insulation. For ordering information see “Accessories”, p. 111.

## Construction

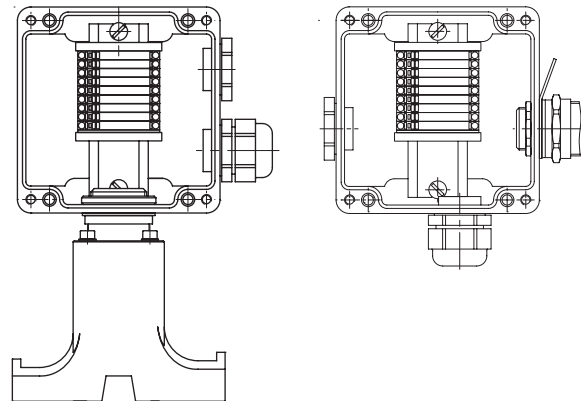

Boxes JB222(3)1-223-1XXX (left) and JB222(3)1-223-2XXX (right) with push-in terminal block. Quantity, type of terminals and placement of DIN-rail with terminal block could differ from drawings.

## Approvals



Nº IECEx CCVE 18.0006X



\* Certification is underway

PREMIUM line

## Delivery Set

Model	Cable glands and plugs (P=plastic; B=brass)								Pipe installation support	Terminal block	Type of terminals	Order code	
	Side A		Side B		Side C		Side D						
	Cable gland	Screw plug	Cable gland	Screw plug	Cable gland	Screw plug	Cable gland	Screw plug					
JB22Y1°-223-1X14**								1xM25 B	1xM25 P	V	9L	screw/ push-in	3210002300
JB22Y1-223-1X15								2xM25 B		V			3210002301
JB22Y1-223-1X16								1xM25 P	1xM25 P	V			3210002302
JB22Y1-223-1X17								2xM25 P		V			3210002303
JB22Y1-223-2X16			1xM25 B					1xM25 P	1xM25 P				3210002304
JB22Y1-223-2X17				1xM25 P	1xM25 B			1xM25 B					3210002305
JB22Y1-223-2X18			1xM25 B		1xM25 B			1xM25 B					3210002306
JB22Y1-223-2X19			1xM25 P		1xM25 B				1xM25 P				3210002307
JB22Y1-223-2X20			1xM25 P		1xM25 B			1xM25 P					3210002308
JB22Y1-223-2X21				1xM25 P	1xM25 P				1xM25 P				3210002309
JB22Y1-223-2X22			1xM25 P		1xM25 P				1xM25 P				3210002310
JB22Y1-223-2X23			1xM25 P		1xM25 P			1xM25 P					3210002311
JB22Y1-223-2X24			1xM25 P		1xM25 B			1xM25 B					3210002312

Order codes are valid for junction boxes with push-in terminal block and “e” explosion proof level. Additional junction box configurations are available upon request.

° Y = 2 for “e” explosion proof level; Y = 3 for “ia” explosion proof level  
 \*\* X = 1 for screw type terminal block; X=2 for push-in type terminal block

# Junction Boxes for Series-Resistance Heating Cables Connection

Junction boxes are designed for connecting of series-resistance heating cables, such as SNF\*, to power network.

Boxes' models are supplied in 2 installation variants:

- complete with a pipe installation support stand UVK for direct mounting onto the surface of a pipeline or tank;
- for installation onto a wall, onto a nearby metal structure or using a bracket directly onto the pipeline (brackets supplied separately).

The enclosure design ensures moisture and dust ingress protection IP66 and high corrosion stability. Cable glands of the box are intended for connecting unarmored power cables with a diameter of 7 to 18 mm or armored power cables with a diameter of 12 to 20 mm.

The installed terminal blocks allow the connection of multi-core or single-core wires with a cross-section of 1.5 to 10 mm<sup>2</sup> (JB2221-223 models) or up to 16 mm<sup>2</sup> (JB2221-333, JB2221-533 models). Design options with screw or push-in terminals are available to order.

## Features and Application Areas

- Efficient solution for power supply and input of SNF series-resistance heating cables
- Designed for loop, star and delta connection
- Excludes the risk of damage to heating cables at connection points
- Critical component parts are included in the scope of supply. Metal pipe strap PFS/3, cable entry unit and flexible sealed gland FSG to be ordered separately

- Approved for installation in explosion hazard areas
- Wide application range
- Quick and easy installation
- High thermal stability
- Non-corrosive

PREMIUM Line

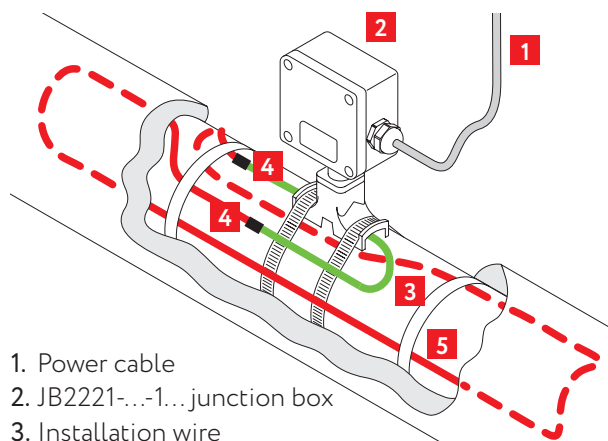
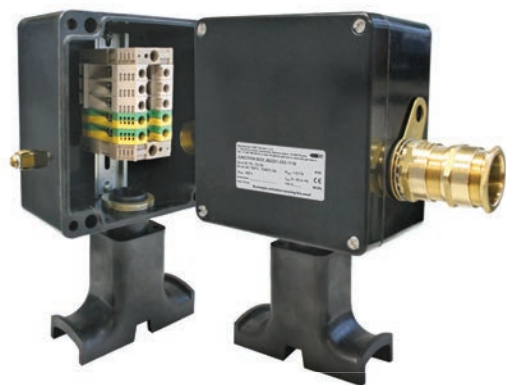

1. Power cable
2. JB2221-...-1... junction box
3. Installation wire
4. Connector SNF MF
5. Heating cable

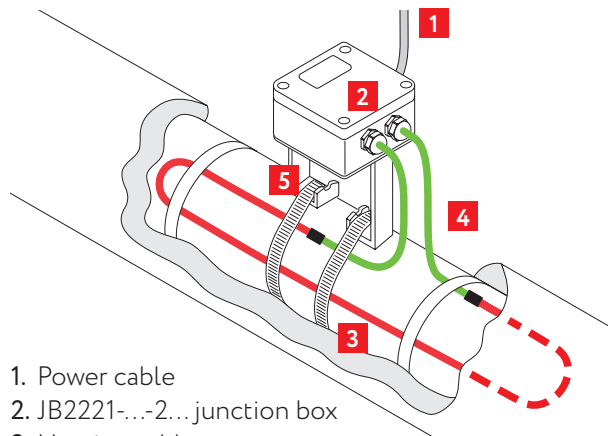

1. Power cable
2. JB2221-...-2... junction box
3. Heating cable
4. Connection cable (cold lead)
5. Bracket

## Application Types

JB2221-223 – Loop to power connection

JB2221-333 – Star to power connection

JB2221-533 – Delta to power connection

\* This junction box is compatible with series resistance heating cables SNF, SNF-L. For ordering information, see pp. 60–63



# Power Supply of Series-Resistance Heating Cables

## Technical Data

Dust and moisture protection rating	IP66	
Explosion protection marking	Ex eb IIC T6...T3 Gb Ex tb IIIC T85°C... T165°C Db	
Temperature group of the explosion hazard area	T6	
Operating ambient temperature range	-60...+55 °C	
Operating voltage	JB2221-223	max 550 V
	JB2221-333, JB2221-533	max 750 V
Operating current	JB2221-223	max 50 A
	JB2221-333, JB2221-533	max 66 A
Enclosure dimensions	JB2221-223	122×120×91.5 mm
	JB2221-333	160×160×94.5 mm
	JB2221-533	260×160×90 mm
Total weight (maximum)	JB2221-223	1.35 kg
	JB2221-333	2.26 kg
	JB2221-533	2.30 kg
Material Box / Color	Glass fiber reinforced	
Material Pipe installation support / Color	polyester / Black	

## Approvals



Nº IECEx CCVE 18.0006X



° Certification is underway

## Construction

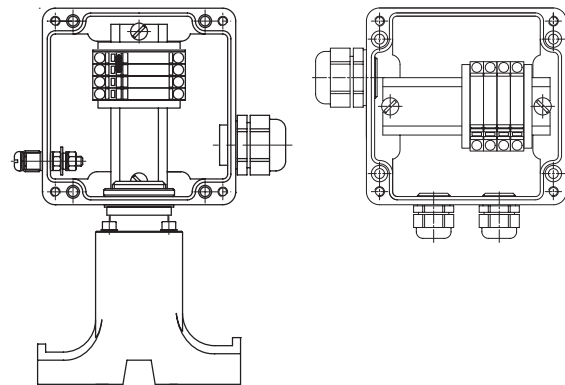

Quantity of terminals and placement of DIN-rail with terminal block could differ from drawings.

## Accessories (to be ordered separately)

Brackets PB, KP, PL.JB0606 – for mounting the box onto the pipeline. For ordering information see “Accessories”, pp. 112-113.

Z-profile – for mounting the box onto a metal structure or onto a wall.

Metal pipe strap PFS/3 – for mounting the pipe support stand or bracket onto the pipeline. For ordering information see “Accessories”, p. 117.

Flexible sealed gland FSG – for mechanical protection of cables in open space sets. For ordering information see pp. 92-93.

Cable entry unit LEK/U – for penetrating of thermal insulation. For ordering information see “Accessories”, p. 111.

## Delivery Set

Model	Cable glands and plugs (P=plastic; B=brass)								Earthing tag	Terminated earthing wire	Pipe installation support	Terminal block	Type of terminals	Order code
	Side A		Side B		Side C		Side D							
	Cable gland	Screw plug	Cable gland	Screw plug	Cable gland	Screw plug	Cable gland	Screw plug						
JB2221-223-1X18°							1xM25 P	V	V	V	2L,1N,2PE / 1L,1N,2PE	screw/ push-in	3210002400	
JB2221-223-1X19						1xM25 B	V	V	V	3210002401				
JB2221-223-1X20						1xM25 P	V	V	V	3210002402				
JB2221-333-1X20							1xM32 P	V	V	V	2L,1N,2PE / 3L,2N,3PE	screw/ push-in	3210002403	
JB2221-333-1X21						1xM32 B	V	V	V	3210002404				
JB2221-333-1X22						1xM32 P	V	V	V	3210002405				
JB2221-223-2X380			2xM20 P		1xM25 P						1L,1N,2PE		3210001616	
JB2221-333-2X380			3xM20 P		1xM25 P						3L,3N,2PE		3210001620	
JB2221-533-2X130			6xM20 P		1xM25 P						7L, 6PE		3210001624	

Order codes are valid for junction boxes with push-in terminal block. Additional junction box configurations are available upon request.

° X = 1 for screw type terminal block; X=2 for push-in type terminal block

# Junction Boxes for Connection of Mineral-Insulated Heating Cables

Junction boxes for connecting of heating cables with mineral insulation are designed in 3 enclosure dimensions and intended for loop, star and delta connection. The box can be mounted onto a wall, onto a nearby metal structure or using a bracket directly onto the pipeline. The choice of the mounting option also depends on the temperature of the heated system (pipeline). At a pipeline temperature of over 200 °C, it is recommended to mount the box on a wall or on an adjacent metal structure. The box allows to connect one section of the heating cable.

The enclosure design ensures moisture and dust ingress protection IP66 and high corrosion stability. Cable glands of the box are intended for connecting unarmored power cables with a diameter of 7 to 18 mm or armored power cables with a diameter of 12 to 20 mm.

Installed terminal blocks allow the connection of multi-core or single-core wires with a cross-section of 1.5 to 10 mm<sup>2</sup> (JB2221-223 models) or up to 16 mm<sup>2</sup> (JB2221-333, JB2221-533 models). Design options with screw or push-in terminals are available to order.

## Features and Application Areas

- Efficient solution for power supply to cables with mineral insulation
- Approved for installation in explosion hazard areas
- Necessary component parts included in the scope of supply
- Flexible sealed gland FSG to be ordered separately

- Designed for loop, star and delta connection
- Wide application range
- Quick and easy installation
- High thermal stability
- Non-corrosive

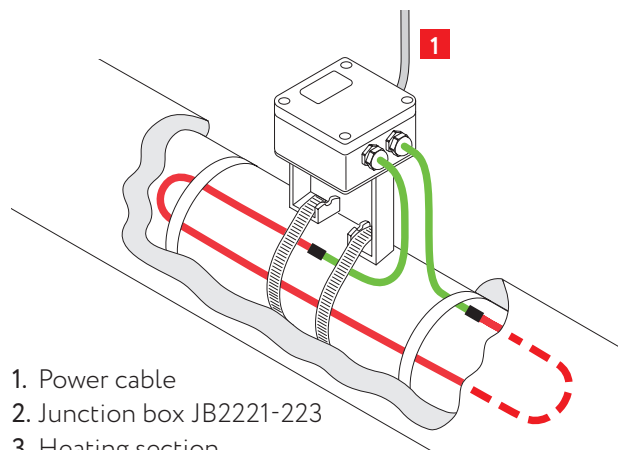

1. Power cable
2. Junction box JB2221-223
3. Heating section
4. Coupling
5. Bracket

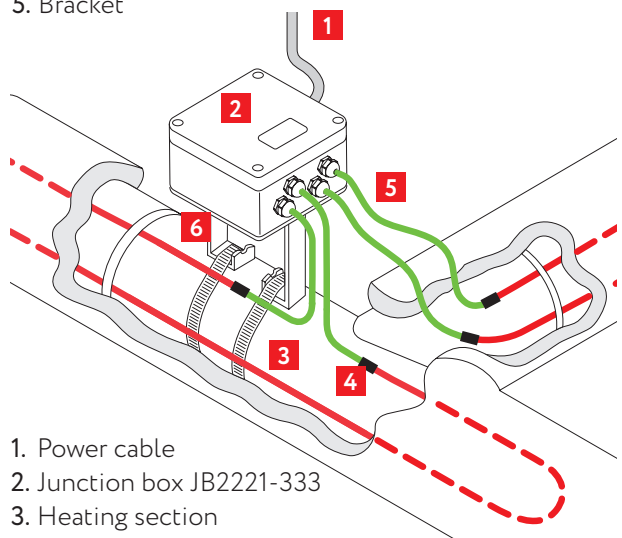

1. Power cable
2. Junction box JB2221-333
3. Heating section
4. Coupling
5. Installation wire
6. Bracket

° This junction box is compatible with heating cables MOIC-F, MOIC-M. For ordering information, see pp. 64–67

# Power Supply Heating Sections Based on Cables with Mineral Insulation

## Technical Data

Dust and moisture protection rating	IP66	
Explosion protection marking	Ex eb IIC T6...T3 Gb Ex tb IIIC T85°C... T165°C Db	
Temperature group of the explosion hazard area	T6	
Operating ambient temperature range	-60...+55 °C	
Operating voltage	JB2221-223	max 550 V
	JB2221-333, JB2221-533	max 750 V
Operating current	JB2221-223	max 50 A
	JB2221-333, JB2221-533	max 66 A
Enclosure dimensions	JB2221-223	122×120×91.5 mm
	JB2221-333	160×160×94.5 mm
	JB2221-533	260×160×90 mm
Total weight (maximum)	JB2221-223	1.26 kg
	JB2221-333	1.95 kg
	JB2221-533	2.10 kg
Material Box / Color	Glass fiber reinforced polyester / Black	
Material Pipe installation support / Color	polyester / Black	

## Accessories (to be ordered separately)

Brackets PB, KP, PL.JB0606 – for mounting the box onto the pipeline. For ordering information see “Accessories”, pp. 112-113.

Z-profile – for mounting the box onto a metal structure or onto a wall.

Metal pipe strap PFS/3 – for mounting the pipe support stand or bracket onto the pipeline. For ordering information see “Accessories”, p. 117.

Flexible sealed gland FSG – for mechanical protection of cables in open space sets. For ordering information see pp. 92-93.

Cable entry unit LEK/U – for penetrating of thermal insulation. For ordering information see “Accessories”, p. 111.

## Construction

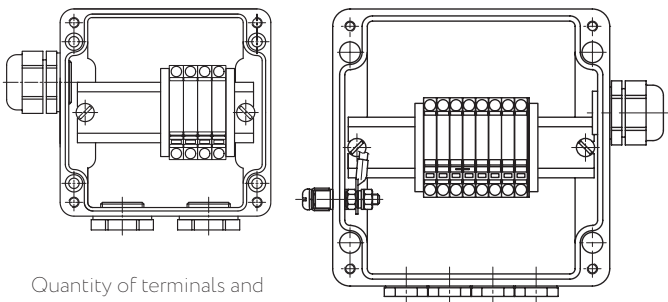

Quantity of terminals and placement of DIN-rail with terminal block could differ from drawings.

## Approvals



Nº IECEx CCVE 18.0006X



\* Certification is underway

PREMIUM line

## Delivery Set

Model	Cable glands and plugs (P=plastic; B=brass)								Earthing tag	Terminated earthing wire	Pipe installation support	Terminal block	Type of terminals	Order code
	Side A		Side B		Side C		Side D							
	Cable gland	Screw plug	Cable gland	Screw plug	Cable gland	Screw plug	Cable gland	Screw plug						
JB2221-223-2X25*			2xM20 P				1xM25 B		V	V		screw/ push-in	3210002450	
JB2221-223-2X26			2xM20 P				2xM25 P		V	V	1L,1N,2PE		3210002451	
JB2221-333-2X24			4xM20 P					1xM25 P	V	V			3210002452	
JB2221-333-2X25			4xM20 P				1xM25 B		V	V	2L,1N,2PE/ 3L,2N,3PE		3210002453	
JB2221-333-2X26			4xM20 P						V	V			3210002454	
JB2221-223-2X390			2xM20 P	1xM25 P							1L,1N,2PE		3210001617	
JB2221-333-2X390			3xM20 P	1xM25 P							3L,3N,2PE	3210001621		
JB2221-533-2X140			6xM20 P	1xM25 P							7L,6PE	3210001625		

Order codes are valid for junction boxes with push-in terminal block. Additional junction box configurations are available upon request.

\* X = 1 for screw type terminal block; X=2 for push-in type terminal block

# Junction Box for Power Cables Connection

Junction boxes JB2221-544-2X(11-59) are designed for power distribution during installation, repair and upgrade of power cables and utility networks in explosion hazard areas.

The box is mounted onto a nearby metal structure. The box allows connection of up to six power cables.

The enclosure design ensures moisture and dust ingress protection IP66 and high corrosion stability.

The box has following cable glands:

- up to two glands for unarmored cable with a diameter of 14 to 25 mm or armored cable with a diameter

of 17 to 26.3 mm (for models JB2221-544-21(11-38)) or armored cable with a diameter of 23.5 to 33.6 mm (for models JB2221-544-21(39-59)).

- up to four glands for unarmored cable with a diameter of 7 to 18 mm or armored cable with a diameter of 12 to 20 mm.

The installed terminal blocks allow the connection of multi-core or single-core wires with a cross-section of 2.5 to 35 mm<sup>2</sup>.

## Features and Application Areas

- Efficient solution for power supply cables connection in electric heating systems
- Approved for installation in explosion hazard areas
- Critical component parts are included in the scope of supply. Flexible sealed gland FSG to be ordered separately
- Wide application range
- Quick and easy installation
- High thermal stability
- Non-corrosive

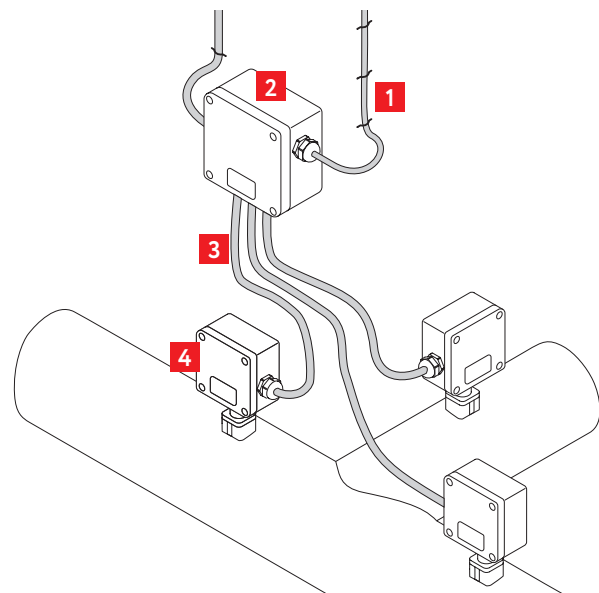

1. Power cable
2. Junction box JB2221-544-2X(11-59)
3. Power cable
4. Junction box

## Technical Data

Dust and moisture protection rating	IP66
Explosion protection marking	Ex eb IIC T6...T3 Gb Ex tb IIIC T85°C... T165°C Db
Temperature group of the explosion hazard area	T6
Operating ambient temperature range	-60...+55 °C
Operating voltage	max 750 V
Operating current	max 109 A
Enclosure dimensions	250×255×120 mm
Total weight (maximum)	5.80 kg
Material box	Glass fiber reinforced polyester
Color	Black

## Construction

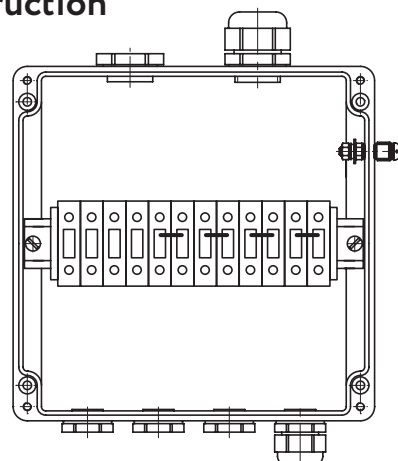

# Connection of Power Supply Cables

## Accessories (to be ordered separately)

Z-profile – for mounting the box onto a metal structure or onto a wall.

Flexible sealed gland FSG – for mechanical protection of cables in open space sets. For ordering information see pp. 92-93.

## Approvals



Nº IECEx CCVE 18.0006X

\* Certification is underway

## Delivery Set

Model	Cable glands and plugs (P=plastic; B=brass)								Earthing tag	Terminated earthing wire	Terminal block	Type of terminals	Order code
	Side A		Side B		Side C		Side D						
	Cable gland	Screw plug	Cable gland	Screw plug	Cable gland	Screw plug	Cable gland	Screw plug					
JB2221-544-2111		2xM25 P	4xM25 B						V	V			3210002500
JB2221-544-2112	1xM25 B	1xM25 P	4xM25 B						V	V			3210002501
JB2221-544-2113	2xM25 P		4xM25 B						V	V			3210002502
JB2221-544-2114		2xM25 P	3xM25 P	1xM25 P					V	V			3210002503
JB2221-544-2115		2xM25 P	4xM25 P						V	V			3210002504
JB2221-544-2116	1xM25 P	1xM25 P	4xM25 P						V	V			3210002505
JB2221-544-2117	2xM25 P		4xM25 P						V	V			3210002506
JB2221-544-2118	1xM32 B	1xM32 P	1xM25 B	3xM25 P					V	V			3210002507
JB2221-544-2119	1xM32 B	1xM32 P	2xM25 B	2xM25 P					V	V			3210002508
JB2221-544-2120	1xM32 B	1xM32 P	3xM25 B	1xM25 P					V	V			3210002509
JB2221-544-2121	1xM32 B	1xM32 P	4xM25 B						V	V			3210002510
JB2221-544-2122	1xM32 B	1xM32 P	2xM25 P	2xM25 P					V	V			3210002511
JB2221-544-2123	1xM32 B	1xM32 P	3xM25 P	1xM25 P					V	V			3210002512
JB2221-544-2124	1xM32 B	1xM32 P	4xM25 P						V	V			3210002513
JB2221-544-2125	2xM32 B			4xM25 P					V	V			3210002514
JB2221-544-2126	2xM32 B		1xM25 B	3xM25 P					V	V			3210002515
JB2221-544-2127	2xM32 B		2xM25 B	2xM25 P					V	V			3210002516
JB2221-544-2128	2xM32 B		3xM25 B	1xM25 P					V	V			3210002517
JB2221-544-2129	2xM32 B		4xM25 B						V	V			3210002518
JB2221-544-2130	1xM32 P	1xM32 P	1xM25 P	3xM25 P					V	V			3210002519
JB2221-544-2131	1xM32 P	1xM32 P	2xM25 P	2xM25 P					V	V			3210002520
JB2221-544-2132	1xM32 P	1xM32 P	3xM25 P	1xM25 P					V	V			3210002521
JB2221-544-2133	1xM32 P	1xM32 P	4xM25 P	0xM25 P					V	V			3210002522
JB2221-544-2134	2xM32 P			4xM25 P					V	V			3210002523
JB2221-544-2135	2xM32 P		1xM25 P	3xM25 P					V	V	6L, 2N,4PE	screw	3210002524
JB2221-544-2136	2xM32 P		2xM25 P	2xM25 P					V	V			3210002525
JB2221-544-2137	2xM32 P		3xM25 P	1xM25 P					V	V			3210002526
JB2221-544-2138	2xM32 P		4xM25 P						V	V			3210002527
JB2221-544-2139	1xM40 B	1xM40 P	1xM25 B	3xM25 P					V	V			3210002528
JB2221-544-2140	1xM40 B	1xM40 P	2xM25 B	2xM25 P					V	V			3210002529
JB2221-544-2141	1xM40 B	1xM40 P	3xM25 B	2xM25 P					V	V			3210002530
JB2221-544-2142	1xM40 B	1xM40 P	4xM25 B						V	V			3210002531
JB2221-544-2143	1xM40 B	1xM40 P	1xM25 P	3xM25 P					V	V			3210002532
JB2221-544-2144	1xM40 B	1xM40 P	2xM25 P	2xM25 P					V	V			3210002533
JB2221-544-2145	1xM40 B	1xM40 P	3xM25 P	1xM25 P					V	V			3210002534
JB2221-544-2146	2xM40 B			4xM25 P					V	V			3210002535
JB2221-544-2147	2xM40 B		1xM25 B	3xM25 P					V	V			3210002536
JB2221-544-2148	2xM40 B		2xM25 B	2xM25 P					V	V			3210002537
JB2221-544-2149	2xM40 B		3xM25 B	1xM25 P					V	V			3210002538
JB2221-544-2150	2xM40 B		4xM25 B						V	V			3210002539
JB2221-544-2151	1xM40 P	1xM40 P	1xM25 P	3xM25 P					V	V			3210002540
JB2221-544-2152	1xM40 P	1xM40 P	2xM25 P	2xM25 P					V	V			3210002541
JB2221-544-2153	1xM40 P	1xM40 P	3xM25 P	1xM25 P					V	V			3210002542
JB2221-544-2154	1xM40 P	1xM40 P	4xM25 P						V	V			3210002543
JB2221-544-2155	2xM40 P			4xM25 P					V	V			3210002544
JB2221-544-2156	2xM40 P		1xM25 P	3xM25 P					V	V			3210002545
JB2221-544-2157	2xM40 P		2xM25 P	2xM25 P					V	V			3210002546
JB2221-544-2158	2xM40 P		3xM25 P	1xM25 P					V	V			3210002547
JB2221-544-2159	2xM40 P		4xM25 P						V	V			3210002548

Additional junction box configurations are available upon request.

PREMIUM line

# Junction Boxes for Three-Phase Series-Resistance Heating Cables Connection

Boxes JB2221-544-21(60-64) and JB2221-544-2165 allow to connect heating sections based on a three-phase series-resistance heating cable with each other and with a power cable in explosion hazard areas.

The enclosure design ensures moisture and dust ingress protection IP66 and high corrosion stability.

The box can be mounted onto a nearby metal structure or using a bracket directly onto the pipeline. Depending on the purpose, the boxes are classified into power connecting boxes (for connecting the heating section to a source of power), maintenance boxes (for connecting two strings of the heating section) and terminal boxes (for connecting the heating section at the heating stretch termination).

The cable gland of the box JB2221-544-21(60-64) is intended for connecting armored cable with a diameter of 23.5 to 33.6 mm. The box allows the connection of one section using the star or loop configuration. For conveniently connecting heating sections and power cables and orienting the box at the connection point, the box has an opening on each side sealed by a plug. JB2221-544-2165 is intended for connecting armored cable with a diameter from 17 to 26.3 mm. The box allows connection of one section using the star configuration.

The installed terminal blocks allow the connection of multi-core or single-core wires with a cross-section of 2.5 to 35 mm<sup>2</sup>.

## Features and Application Areas

- Efficient solution for power supply to three-phase series-resistance heating cable LLS
- Approved for installation in explosion hazard areas
- Critical component parts are included in the scope of supply. Flexible sealed gland FSG to be ordered separately
- Wide application range
- Quick and easy installation
- High thermal stability
- Non-corrosive

## Construction

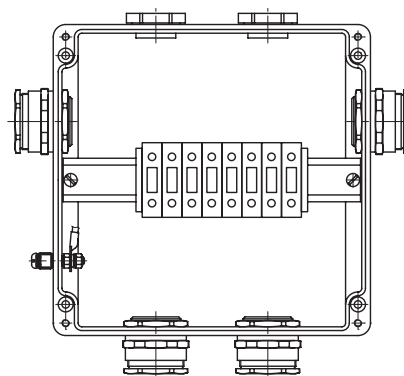

Junction box JB2221-544-21(63,64)

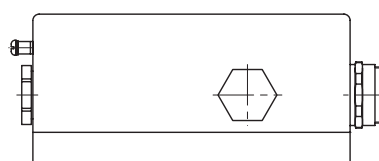
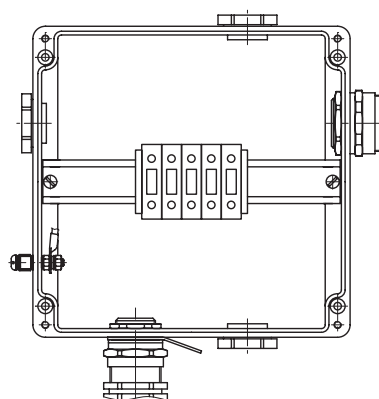

Junction box JB2221-544-21(60-62), JB2221-544-2165



# Power Supply of Three-Phase Series-Resistance Heating Cables

## Technical Data

Dust and moisture protection rating	IP66
Explosion protection marking	Ex eb IIC T6...T3 Gb Ex tb IIIC T85°C... T165°C Db
Temperature group of the explosion hazard area	T6
Operating ambient temperature range	-60...+55 °C
Operating voltage	max 750 V
Operating current	max 109 A
Enclosure dimensions	250×255×120 mm
Total weight (maximum)	
JB2221-544-21(60-64)	5.7 kg
JB2221-544-2165	4.8 kg
Material box	Glass fiber reinforced polyester
Color	Black

## Accessories (to be ordered separately)

Z-profile – for mounting the box onto a metal structure or onto a wall.

Plate PL.JB 1007 and bracket K.JB 10.YYY×ZZZ – for mounting the box onto the pipeline. For ordering information see “Accessories”, p. 115.

Flexible sealed gland FSG – for mechanical protection of cables in open space sets. For ordering information see pp. 92-93.

## Delivery Set

Model	Cable glands and plugs (P=plastic; B=brass)								Earthing tag	Terminated earthing wire	Terminal block	Type of terminals	Order code
	Side A		Side B		Side C		Side D						
	Cable gland	Screw plug	Cable gland	Screw plug	Cable gland	Screw plug	Cable gland	Screw plug					
JB2221-544-2160		1xM40 P	1xM40 B	1xM40 P		1xM40 P	1xM40 P		V	V	3L,2PE	screw	3210002700
JB2221-544-2161				1xM40 P	1xM40 P				V	V			3210002701
JB2221-544-2162				1xM40 P	1xM40 P		1xM40 P	1xM40 P	V	V	6L,6PE	screw	3210002702
JB2221-544-2163		1xM40 P		1xM40 P	2xM40 P				V	V			3210002703
JB2221-544-2164		2xM40 P		2xM40 P	1xM40 P		1xM40 P		V	V	3L,2PE	screw	3210002704
JB2221-544-2165		1xM40 P	1xM32 B	1xM40 P		1xM40 P	1xM40 P		V	V			3210002705

Additional junction box configurations are available upon request.

## Approvals



Nº IECEx CCVE 18.0006X



\* Certification is underway

# Premium Line Models Assortment

Junction box intended use	Dimensions	Box's model	Application		
For self-regulating heating cables (with pipe installation support)	122×120×91.5 mm	JB2221-223-1X11*	Junction box for T-connecting		
		JB2221-223-1X12	Junction box for connecting of up to 2 self-reg. heating circuits to power network		
		JB2221-223-1X13			
		JB2221-223-1X300			
		JB2221-223-1X310	Junction box for connecting of up to 3 self-reg. heating circuits to power network		
	160×160×94.5 mm	JB2221-333-1X11	Junction box for connecting of up to 2 self-reg. heating circuits to power network		
		JB2221-333-1X12	Junction box for connecting of up to 3 self-reg. heating circuits to power network		
		JB2221-333-1X13			
		JB2221-333-1X14			
		JB2221-333-1X15	Junction box for connecting of up to 3 self-reg. heating circuits to power network + it's branching		
		JB2221-333-1X16	Junction box for connecting of up to 2 self-reg. heating circuits to power network		
		JB2221-333-1X17	Junction box for connecting of up to 3 self-reg. heating circuits to power network		
		JB2221-333-1X18	Junction box for connecting of up to 3 self-reg. heating circuits to power network + it's branching		
		JB2221-333-1X19			
For self-regulating heating cables (wall mounted)	122×120×91.5 mm	JB2221-223-2X11	Junction box for connecting of 1 self-reg. heating circuit		
		JB2221-223-2X12	Junction box for connecting of 2 self-reg. heating circuits		
		JB2221-223-2X13	Junction box for connecting of 2 self-reg. heating circuits		
		JB2221-223-2X14	Junction box for connecting of 1 self-reg. heating circuit		
		JB2221-223-2X15	Junction box for connecting of 2 self-reg. heating circuits		
		JB2221-223-2X340	Junction box for connecting of 1 self-reg. heating circuit		
		JB2221-223-2X350			
		JB2221-223-2X360			
		JB2221-223-2X370	Junction box for connecting of up to 3 self-reg. heating circuits to power network		
		160×160×94.5 mm	JB2221-333-2X11	Junction box for connecting of 1 self-reg. heating circuit to power network	
	JB2221-333-2X12		Junction box for connecting of 2 self-reg. heating circuits to power network		
	JB2221-333-2X13				
	JB2221-333-2X14				
	JB2221-333-2X15		Junction box for connecting of 3 self-reg. heating circuits to power network		
	JB2221-333-2X16		Junction box for connecting of 1 self-reg. heating circuit to power network		
	JB2221-333-2X17				
	JB2221-333-2X18				
	JB2221-333-2X19				
	JB2221-333-2X20		Junction box for connecting of 1 self-reg. heating circuit to power network + it's branching		
	JB2221-333-2X21	Junction box for connecting of 2 self-reg. heating circuits to power network + it's branching			
JB2221-333-2X22	Junction box for connecting of 3 self-reg. heating circuits to power network + it's branching				
JB2221-333-2X23					
For light indication (with pipe installation support)	122×120×91.5 mm	JB2221-223-1X320	End junction box with light indication		
		JB2221-223-1X21	End junction box with light indication		
		JB2221-223-1X22	Junction box with light indication and for power connection		
		JB2221-223-1X23			
	160×160×94.5 mm	JB2221-333-1X23	Junction box with light indication and for connecting of up to 2 self-reg. heating circuits to power network		
		JB2221-333-1X24	Junction box with light indication and for connecting of up to 3 self-reg. heating circuits to power network		
		JB2221-333-1X25			
		JB2221-333-1X26			
		JB2221-333-1X27	Junction box with light indication and for connecting of up to 3 self-reg. heating circuits to power network		
		JB2221-333-1X28			
		JB2221-333-1X29			
		JB2221-333-1X30			
		For light indication (wall mounted)	122×120×91.5 mm	JB2221-223-2X27	Junction box with light indication
				JB2221-223-2X28	Junction box with light indication and for power connection of 1 self-reg. heating circuit
JB2221-223-2X29	Junction box with light indication and for power connection of 2 self-reg. heating circuit				
JB2221-223-2X30	Junction box with light indication and for power connection of 1 self-reg. heating circuit				
JB2221-223-2X31	Junction box with light indication and for power connection of 2 self-reg. heating circuit				
JB2221-333-2X27	Junction box with light indication and for connecting of up to 3 self-reg. heating circuits to power network				
JB2221-333-2X28					
JB2221-333-2X29					
JB2221-333-2X30					
160×160×94.5 mm	JB2221-333-2X31		Junction box with light indication and for connecting of up to 1 self-reg. heating circuit to power network + it's branching		
	JB2221-333-2X32		Junction box with light indication and for connecting of up to 2 self-reg. heating circuits to power network + it's branching		
	JB2221-333-2X33		Junction box with light indication and for connecting of up to 2 self-reg. heating circuits to power network + it's branching		
For data, control and signal cables connection (with pipe installation support)	122×120×91.5 mm		JB2221-223-1X14**	Junction box for connection of 1 control cable and up to 3 temperature sensors	
			JB2221-223-1X15**	Junction box for connection of 2 control cables and up to 3 temperature sensors	
		JB2221-223-1X16**	Junction box for connection of 1 control cable and up to 3 temperature sensors		
		JB2221-223-1X17**	Junction box for connection of 2 control cables and up to 3 temperature sensors		



# Ordering Information

Junction box intended use	Dimensions	Box's model	Application
For data, control and signal cables connection (wall mounted)	122×120×91.5 mm	JB2221-223-2X16**	Junction box for connection of 1 control cable and 1 air temperature sensor
		JB2221-223-2X17**	Junction box for connection of 1 control cable and 1 temperature sensor
		JB2221-223-2X18**	Junction box for connection of 1 control cable and 2 temperature sensors
		JB2221-223-2X19**	Junction box for connection of 1 control cable and 1 temperature sensor
		JB2221-223-2X20**	Junction box for connection of 1 control cable and 2 temperature sensors
		JB2221-223-2X21**	Junction box for connection of 1 control cable and 1 air temperature sensor
		JB2221-223-2X22**	Junction box for connection of 1 control cable and 1 temperature sensor
		JB2221-223-2X23**	Junction box for connection of 1 control cable and 2 temperature sensors
For series-resistance cables (with pipe installation support)	122×120×91.5 mm	JB2221-223-1X18	Junction box for connecting of series-resistance heating cables (end box)
		JB2221-223-1X19	Junction box for connecting of series-resistance heating cables (loop to power connection)
		JB2221-223-1X20	
	160×160×94.5 mm	JB2221-333-1X20	Junction box for connecting of series-resistance heating cable (end box)
JB2221-333-1X21		Junction box for connecting of series-resistance heating cable (star to power connection)	
122×120×91.5 mm	JB2221-223-2X380		Junction box for connecting of series-resistance heating cables (loop to power connection)
	160×160×94.5 mm	JB2221-333-2X380	Junction box for connecting of series-resistance heating cable (star to power connection)
	260×160×90 mm	JB2221-533-2X130	Junction box for connecting of series-resistance heating cable (delta to power connection)
For series-resistance cables (wall mounted)	122×120×91.5 mm	JB2221-223-2X25	Junction box for heating cables in mineral insulation
		JB2221-223-2X26	Junction box for heating cables in mineral insulation
	160×160×94.5 mm	JB2221-223-2X390	Junction box for heating cables in mineral insulation (loop to power connection)
		JB2221-333-2X24	Junction box for heating cables in mineral insulation
		JB2221-333-2X25	Junction box for heating cables in mineral insulation
		JB2221-333-2X26	Junction box for heating cables in mineral insulation
	260×160×90 mm	JB2221-333-2X390	Junction box for heating cable in mineral insulation (star to power connection)
		JB2221-533-2X140	Junction box for heating cable in mineral insulation (delta to power connection)
For power cables connection	250×255×120 mm	JB2221-544-21(11-38)	Distribution box for power cable connection and canalization, suitable for 2xM32 and 4xM25 cable glands
		JB2221-544-21(39-59)	Distribution box for power cable connection and canalization, suitable for 2xM40 and 4xM25 cable glands
For long line system connection		JB2221-544-21(60-65)	Junction box for 3-phase constant wattage heating cable LLS (long line system)

\* X=1 for junction box with screw type terminals; X=2 for junction box with push-in type terminals  
 \*\* The model has an equivalent with «ia» explosion proof level

## Ordering Information

Marking of JB models indicates class of boxes, dimensions, mounting type, terminals type. The last 2 digits indicate a box's model depending on application.

**Example:** Junction box JB2221-XXX-A-B-YY-Z

①
②
③
④
⑤
⑥

1. **Class of boxes:**  
2221 – Explosion-proof boxes
2. **Dimension code:**  
223 – 122×120×91.5 mm  
333 – 160×160×94.5 mm  
533 – 260×160×90 mm  
544 – 255×250×120 mm
3. **Mounting type:**  
1 – With pipe installation support  
2 – Wall mounted
4. **Terminals type:**  
1 – Screw  
2 – Push-in
5. **Model #:**  
11-99 – Application code
6. **Reserved number for accessories presence or absence:**  
0 – Earthing stud absence

## Non-Standard Versions

Please send us your request for non-standard junction boxes' models using Questionnaire form (see p. 133)

# Explosion-Proof Polyester Enclosure

Glass-reinforced polyester enclosures are used at chemical and petrochemical factories, on offshore platforms, oil processing plants and at other branches with potential availability of hazardous atmosphere (gas and combustible dust).

## Application Areas

- Control stations
- Automatic circuit breakers
- Control devices
- Electrical enclosures
- Switches and changeover switches
- Distribution boxes
- Alarm devices
- Instrument enclosures
- Battery containers

Enclosures consist of a case and a lid fixed with captive loosening resistant screws. Enclosures are made of polyester reinforced with fiberglass, providing maximum protection from highly corrosive agents.

Graphite black color gives the maximum protection from UV radiation. Chemical composition of enclosure material eliminates any risks from sources of ignition by the means of statically induced sparking resistance. Enclosure sealing system has the shape of labyrinth, where silicone sealing is protected from environmental factors impact. Due to this quality, enclosures have a high ingress protection performance – IP66.

A wide range of models is intended for installation of electrical components and automation equipment, could be mounted indoor or outdoor in explosion hazardous zones.

Inside enclosures the following electrical components could be installed: mounting panel, DIN-rails with terminals, earthing busbar and others. On the sides of boxes there could be installed explosion-proof cable glands for different cable types, couplings, plugs, valves, earthing tags, etc.

In SST Group these enclosure types are used for the production of explosion-proof equipment with “Equipment protection by increased safety” – “e” level; “Equipment dust ignition protection” – “t” level.

## Construction



# Enclosures

## Technical Data

Climatic version and location category according to GOST 15150-69	F1, NF1 (NF4, NF5, T1, T2, T3, T5, F5, MU1, MU2, MU3, MU4, W5 – upon requirement)
Ingress protection	IP66
Operating ambient temperature range	-60...+165 °C
Explosion proof marking	Ex eb IIC Gb, Ex tb IIIC Db
Impact resistance	IK08 /7J

## Types

Enclosure type	Length, mm	Width, mm	Height, mm	Order code
EE2221-011-0	80	75	55	3210001900
EE2221-111-0	110	75	55	3210001901
EE2221-223-0	122	120	90	3210001902
EE2221-333-0	160	160	90	3210001903
EE2221-423-0	220	120	90	3210001904
EE2221-533-0	260	160	90	3210001905
EE2221-544-0	255	250	120	3210001906
EE2221-633-0	360	160	90	3210001907
EE2221-655-0	360	360	160	3210001908
EE2221-764-0	400	405	121	3210001909

## Construction

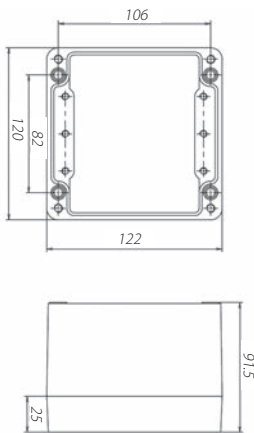

Enclosure EE2221-223-0

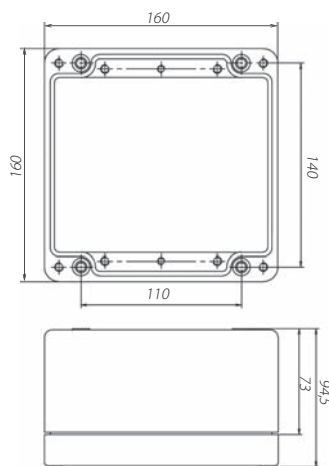

Enclosure EE2221-333-0

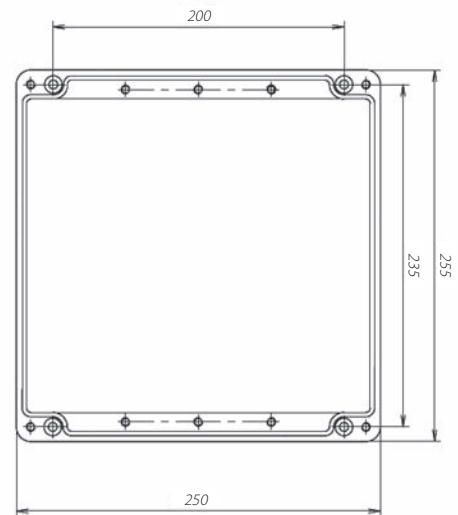

Enclosure EE2221-544-0



## Approvals



IECEx CCVE 19.0013U



⊙ Certification is underway

PREMIUM line

# Explosion-Proof Cable Gland KBB-R for Armored Cables

Explosion-proof cable gland KBB-R is used at chemical and petrochemical plants, sea platforms, oil refineries and other industrial units with hazardous atmospheres (gas and explosive dust).

KBB-R is designed for sealing and clamping of armored cables inside explosion-proof electrical enclosures, with indoor or outdoor installation, where explosive atmosphere occurrence is possible.

Cable gland KBB-R is supplied with a full installation set.

Cable gland material: brass, stainless steel.

Internal sealings material: elastomer, silicone.

Cable glands have explosion-proof marking with various types of explosion protection: "d" – flameproof enclosure, "e" – increased safety, "t" – protection by enclosures in dust atmospheres.

## Application Areas

■ Explosion hazard zones 0, 1, 2 according to IEC 60079-10-1:2006

■ Explosion hazard zones 20, 21, 22 according to IEC 60079-10-2:2009



## Technical Data

Dust and moisture protection rating	IP66
Explosion protection marking	1Ex d IIC Gb / 1Ex e IIC Gb / 2Ex nR IIC Gb Ex tb IIIC Db
Operating ambient temperature range	-60 ... + 130 °C
Minimum installation temperature	-60 °C
Impact resistance	IK08/7J

## Delivery Set

Main adapter sleeve
Elastomer sealing ring
Intermediate washer
Gasket
Clampint adapter sleeve
Earthing ring
Clamping nut screw

## Dimension Details

Cable gland type code	Thread standard	Diameter, mm	Height, mm	Thread length, mm
KBB-R20	M20×1.5	32	75	15
KBB-R20	M25×1.5	35	75	15
KBB-R25	M25×1.5	44	85	15
KBB-R32	M32×1.5	50	101	15
KBB-R40	M40×1.5	55	102	15

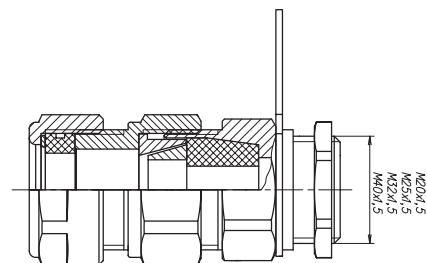

# Cable Glands

## Cable Glands' Specifications

Cable gland type code	Thread type (metric)	Thread type G (imperial) <sup>°</sup>	Minimum diameter of the outer jacket, mm	Maximum diameter of the outer jacket, mm
Cable gland complete with seals (letter "K" in the designation)				
KBB-R20	M20×1.5	1/2"	5,5-13	10-19
KBB-R20	M25×1.5	3/4"	5,5-13	10-20,5
KBB-R25	M25×1.5	3/4"	8-18	15-24
KBB-R32	M32×1.5	1"	13-24	20-31,5
KBB-R40	M40×1.5	1 1/4"	21-30	25-37,5
Cable gland with universal seals (letter "U" in the designation)				
KBB-R20	M25×1.5	3/4"	5-14	12-21

\* – G-thread cable glands produced on customer's request

## Ordering Information

**Example:** Cable gland **KBB-R20-PN-M25-K**

① ② ③ ④ ⑤ ⑥

1. Cable gland type;
2. Cable type (R – armored power cable);
3. Cable gland standard size (20, 25, 32, 40);
4. Cable gland material (PN – brass, SN – stainless steel);
5. Designation of type and size of connecting metric thread (tubular cylindrical (G) thread – to be ordered separately);
6. Gasket type (U – universal gaskets, K – gaskets set, Fn – for flat cable, small, Fw – for flat cable, big).

## Types

Name	Order code
KBB-R20	3299000000
KBB-R20	3299000001
KBB-R25	3299000002
KBB-R32	3299000003
KBB-R40	3299000004
KBB-R20	3299000005

## Approvals



<sup>°</sup> Certification is underway

# Flexible Sealed Gland FSG

Flexible sealed gland FSG is designed to provide mechanical protection of heating, power, control cables in aggressive environmental factors: physical, chemical, ecological. Certified for usage in explosion hazardous zones.

FSG is composed of corrugated steel pipe and 2 pipe fittings. Fittings types should be chosen by the customer according to the engineering design and product type structure.

Flexible sealed gland FSG applied for surface and concealed wiring, building necessary earth circuit of extraneous conductive parts.

Supplied with length range from 0 m to 100 m or longer – according to the customer's request.

A wide range of variants with a possibility of component selection allows to a customer to create an individual configuration depending on engineering design and working conditions.



## Features

- High mechanical strength and chemical resistance
- Possibility of equipping with pipe coupling for connection with junction boxes, utilities pipes and for penetration of thermal insulation
- Thermal resistant version (up to +200 °C)
- For all types of climates – on land, sea and offshore
- Certified for explosive hazardous zones

## Application

- Protection against aggressive environment influence (physical, chemical, ecological factors)

## Application Areas

- Hazardous and normal zones – indoor and outdoor
- Surface and concealed wiring
- Aggressive environments on land, on sea platforms

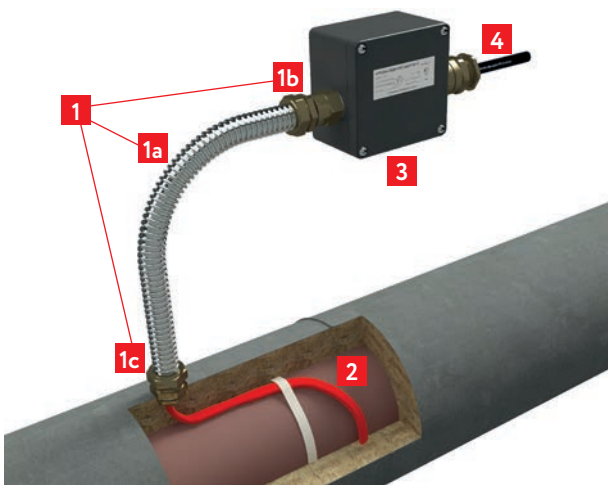

1. Mechanical protection unit FSG (Flexible sealed gland), as a set:
  - a) corrugated stainless steel pipe
  - b) coupling Y1
  - c) coupling Y2
2. Heating circuit (cable)
3. Junction box
4. Power cable

## Approvals



° Certification is underway

## Technical Data

Length of corrugated pipe as part of unit	from 0 to 100 m*
Dust and moisture protection rating	IP67
Explosion protection marking f or gas atmosphere	1Ex e IIC T6...T3 Gb 1Ex d IIC T6...T3 Gb
Explosion protection marking for dust atmosphere	Ex tb IIIC T85C... T200C Db
Temperature group of the explosion hazard area	T6
Operating ambient temperature range	-60...+80 °C
Minimum installation temperature	-60 °C
Climatic version	W

\* longer is possible according to a customer's request

## Accessories (to be ordered separately):

FSG installation set – for penetrating of thermal insulation with pipe fitting type “B”.

## Product Type Structure

Ordering code: X1\*X2-X3-Y1\*X4\*X5\*X6-X7-X8-X9-S10

Pos.	Numerical	Literal	Determination
X1		FSG	<b>Flexible sealed gland</b> Flexible sealed gland
X2	18 20 25 32	-	<b>Stainless steel corrugated pipe size</b> Stainless steel corrugated pipe 18A Stainless steel corrugated pipe 20A Stainless steel corrugated pipe 25A Stainless steel corrugated pipe 32A
X3	01 02	-	for non-armoured cable for armoured cable
Y1 Y2	-	A B C	Coupling A version – corrugated pipe and cable encapsulation Coupling B version – corrugated pipe encapsulation Coupling C version – pipe sealing
X4	-	H B	Thread type: external Thread type: internal
X5	-	M G Rp R Rc	Thread standard: metric Thread standard – G (tubular cylindrical) Thread standard – internal tubular cylindrical Thread standard – external taper pipe thread Thread standard – internal taper pipe thread
X6	20, 25, 32, 40	-	Thread size
X7	-	F R	Sealing type – for flat cable Sealing type – for round cable
X8	YY,Y	-	Corrugated pipe length, m
X9	200	T	Thermal resistant version, up to 200 °C
<b>Polymeric enclosure type</b>			
S10		T C H P N ng (...) - LS HF LSLTx HFLTxx	tracking resistant oversheath material high frost resistance high heat resistance oil-, petrol-resistant oversheath material, flame-retardant in single wiring oversheath material, flame-retardant in bunched wiring fire hazard rate (AF/R, A,B,C,D) for oversheath flame-retardant in bunched wiring dash with low fume and gas emission non-emitting corrosive gaseous products in burning and smoldering with low fume and gas emission and with low toxicity of combustion product non-emitting corrosive gaseous products in burning and smoldering and with low toxicity of combustion product

## Ordering Information

Example: FSG20-02-AHM25-ABG3/4"-K-5,0-T200

① ② ③ ④ ⑤ ⑥ ⑦ ⑧ ⑨ ⑩ ⑪ ⑫ ⑬ ⑭

1. Flexible sealed gland
2. Stainless steel corrugated pipe, type 20A
3. For armoured cable
4. Coupling Y1 version – corrugated pipe and cable encapsulation
5. Thread type – external
6. Thread standard – metric
7. Thread size
8. Coupling Y2 version – corrugated pipe and cable encapsulation
9. Thread type – internal
10. Thread standard – G (tubular cylindrical)
11. Thread size
12. Sealing type – for round cable
13. Corrugated pipe length, m
14. Thermal resistant version, up to 200 °C

# Pipe Support Stand UVK

UVK pipe support stand is designed for the purpose of fixing of junction boxes through thermal insulation. Depending on the junction box, up to three self-regulating heating cables could be connected. The pipe support stand is fixed by means of metal straps directly onto pipes or tanks. With the UVK pipe

support stand insulation thickness up to 100 mm is possible. The design of the stand provides mechanical strength and high corrosive stability of electric equipment being mounted. All the necessary fixing elements for electric equipment in inner part of the device is included in the delivery set.

## Features

- Efficient solution for installation of self-regulating heating cables through thermal insulation
- Excludes the risk of damage to self-regulating heating cables
- Quick and easy installation
- High thermal stability
- Non-corrosive

## Application Areas

- Installation of self-regulating heating cables in non-hazardous and ex-hazardous areas

## Construction

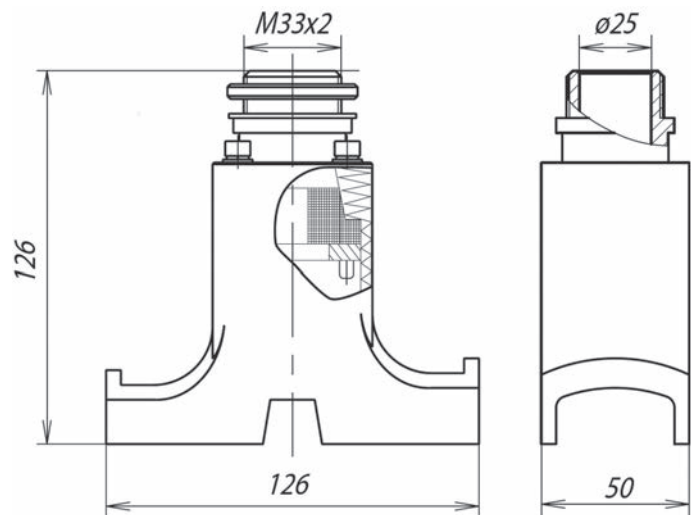



# Pipe Installation Support

## Technical Data

Degree of protection	IP66
Ambient temperature range	-60 ... +55 °C
Maximum exposure temperature	+240 °C (intermittent +260 °C)
Minimum installation temperature	-50 °C
Mechanical resistance	7J/7Nm
Dimensions	126×126×50 mm
Total weight	0.25 kg

## Material Specification

Support stand	Glass fiber reinforced polyester
Sealing grommet	Silicone rubber
Nuts	Carbon steel
Locknut	Carbon steel
Washers	Zinc-coated brass
Screws	Carbon steel
Plate	Carbon steel

## Accessories (to be ordered separately):

Metal strap PFS/3 – for fixing onto a pipe. For ordering information, see “Accessories”, pp. 117.

## Approvals



\* Certification is underway

## Types

Name	Order code
Support stand UVK	3210001500

# Capillary Thermostat exTHERM-AT

The explosion-proof surface-mounted thermostats of the exTHERM series are built to monitor and control temperatures in potentially ex-hazardous areas. The use in environments with gas and steam (zones 1 and 2); as well with conductive dust (zones 21 and 22) is permitted.

The exTHERM-AT is available as safety temperature monitor (STW). Thermostats work according to the liquid expansion or gas expansion principle. The electrical switching element is a pressure-resistant encapsulated thermostat with a snap-action switch. Stable switching points when ambient temperatures

fluctuate are made possible by the standard ambient temperature compensation. If the temperature on the temperature probe exceeds the setpoint value, the microswitch is activated by the transmission mechanics and the electrical circuit is opened or closed. If the temperature falls below the selected setpoint value (by the amount of the switching differential), the microswitch is reset to its initial position. If the measuring system is destroyed (i.e. if the expansion fluid escapes) the pressure in the membrane of the STW drops and permanently opens the electrical circuit. Unlocking is then no longer possible.

## Features

- Can be directly applied in ex-hazardous areas zones 1 (21) and 2 (22)
- Switching capacity 25A
- Maintenance-free terminal clamps
- Status signal contact
- Approvals according to ATEX, IECEx

## Application Areas

- Heat tracing systems
- Monitoring and controlling of thermal processes
- Freeze protection and temperature maintenance of pipelines and vessels in non-hazardous and ex-hazardous areas

## Construction

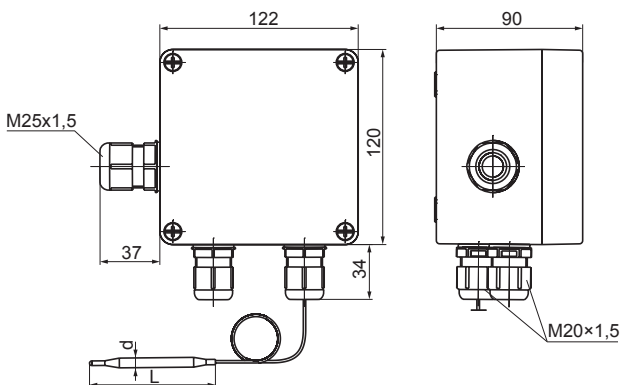
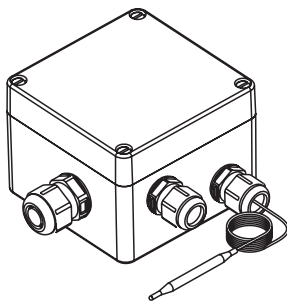

## Technical Data

Control temperature range	-20 ... +50 °C 0 ... +190 °C
Max. switching capacity	contact deck 1-2 AC 230 V +10 %, 25 (4) A, cos φ = 1 (0.6) contact deck 1-4 AC 230 V +10 %, 6.3 (2.5) A, cos φ = 1 (0.6)
Hysteresis	Approx. 7 %
Degree of protection	IP65
Weight	Approx. 1200 g
Cable entry	Ex cable gland M20×1.5, sealing area 6 to 13 mm Ex cable gland M25×1.5, sealing area 7 to 17 mm
Ambient temperature range	-40 ... +40 °C, T6 (+70 °C T4)
Capillary length	1000 mm
Capillary diameter	6 mm
Capillary material	Stainless steel (CrNi)
Dimension	Without cable glands 122×120×90 mm Incl. cable glands 159×154×90 mm
Installation type	Surface mounted

## Function Diagram

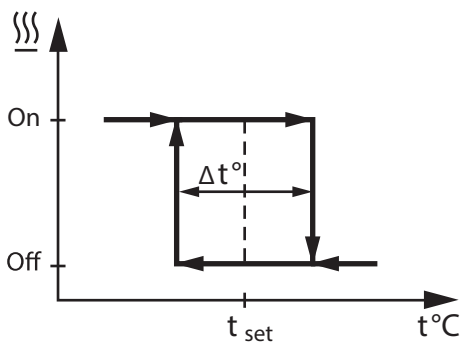

## Wiring Diagram

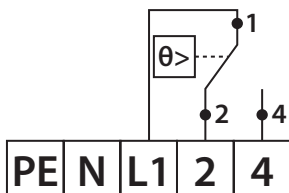

## Approvals



II 2G Ex db eb IIC T4/T5/T6 Gb  
II 2D Ex tb IIIC T85°C/T100 °C/  
T130 °C Db  
EPS 11 ATEX 1 354



IECEX EPS 13.0046



EPS 11 ATEX 1 354 (SIL 2)



## Marking

Example: exTHERM-AT(-20...+50)

①                      ②

1. Type of thermostat
2. Control temperature range

## Types

Name	Order code
exTHERM-AT(-20...+50)	3220001000
exTHERM-AT(0...+190)	3220001001

# Electric Heating Control System ConTrace

ConTrace is a specialized multi-level integrated control system for electric cable heating.

It is a complex of devices for analyzing, monitoring and controlling an electric heating system which

includes field and intrapanelboard devices, explosion-proof performance and intrinsically safe circuits.

Systems built on the components of ConTrace have a high level of functional reliability.

## Features

- High reliability
- Redundant control function
- Control modules are full all-in-one controllers
- Hot swap control modules
- Multilingual interface
- Easy and intuitive settings
- Individual total control of states of each heating line
- Broad system integration capabilities
- The possibility of using individual modules of the system as part of third-party control systems

PREMIUM line

## ConTrace Control Architecture

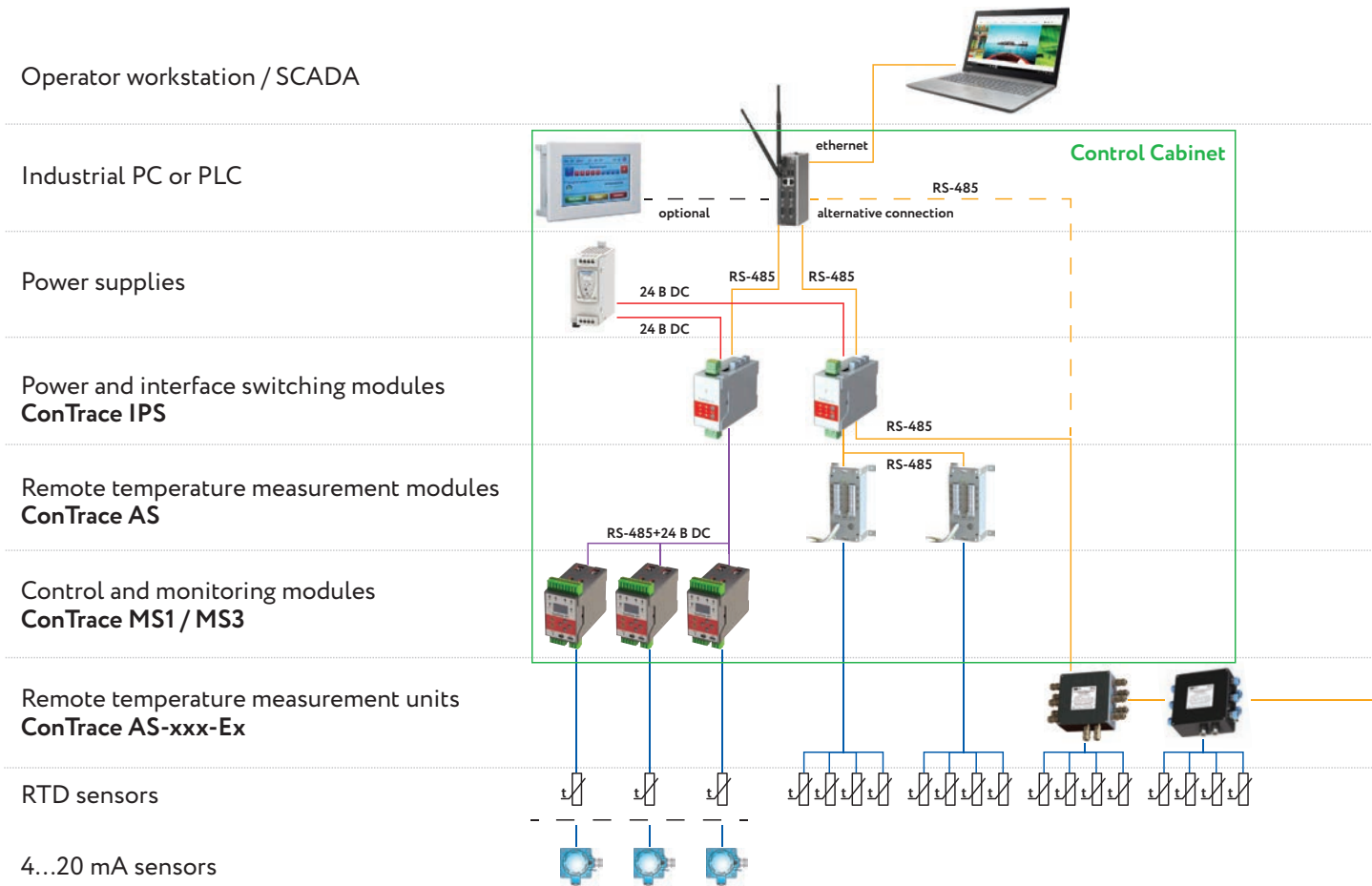

# Electric Heating Control System ConTrace

## The Scale of the Control System

Ability to build a unified control system up to 247 heating lines based on just one head controller.

Industrial PC communicates within the system and is responsible for interaction with the control room, and each individual MS module controls the system, i.e. each line is controlled by its own “controller”.

Length of the communication line between all control cabinets is up to 1 000 m.

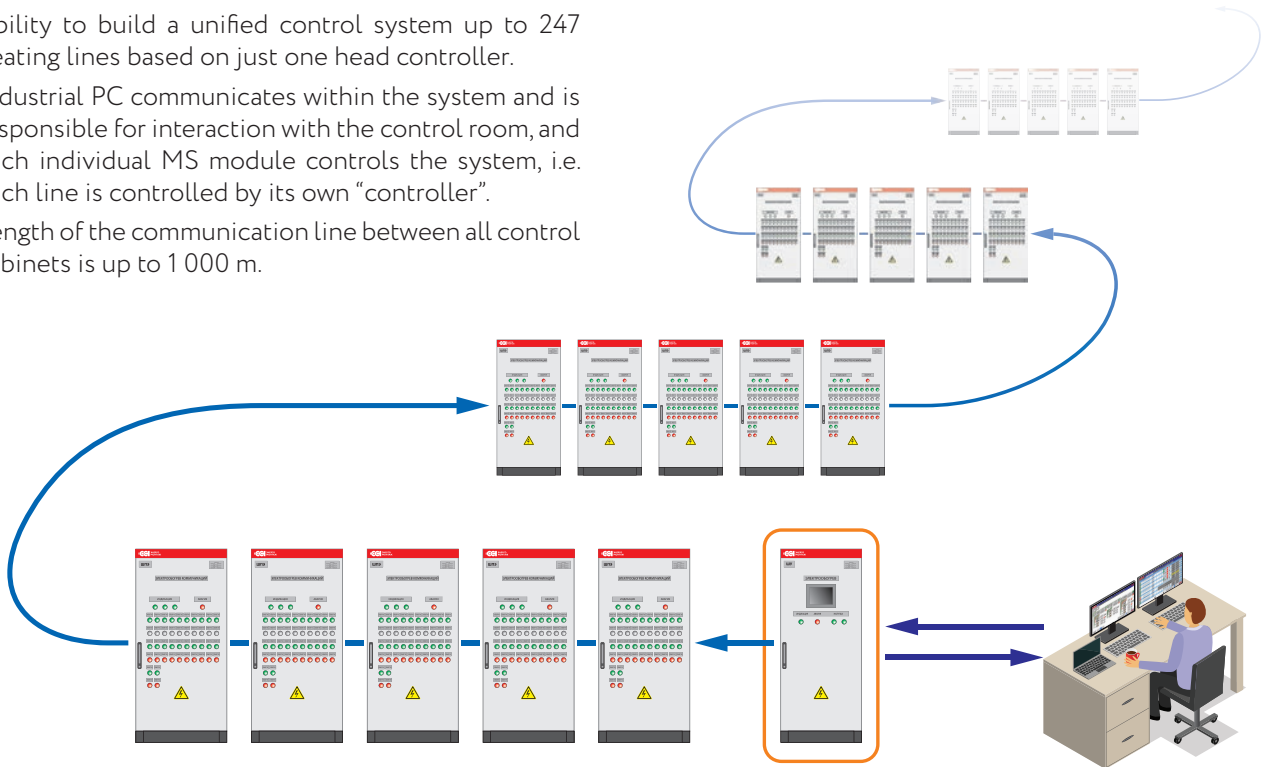

Remote monitoring and control system

Centralized control

Power supply of MS and IPS modules

Power and RS-485 network distribution

Converting RTD values to RS-485 signals

Monitoring and control of one single or three-phase heating line

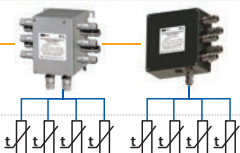

Field explosion-proof thermal converters

Temperature measurement of pipes, tanks, air, etc.

PREMIUM line

# Control and Monitoring Modules ConTrace MS

## Purpose

The main purpose of the ConTrace MS1 and MS3 modules is to control the electrical heating system. It is used for protection against freezing or maintaining the temperature of industrial pipelines and tanks.

## Description

Control and monitoring modules ConTrace MS1 and MS3 are full-fledged single-channel controllers capable of operating with maximum efficiency as a part of the multichannel specialized control system ConTrace. The control module is designed to control a three-phase or single-phase load using one of the options: an electromagnetic contactor, a solid-state relay or a continuously adjustable device controlled by a voltage of 0 ... 10 V.

## Setting and Control

Control and monitoring modules ConTrace MS have a two-color OLED-display and navigation buttons. Thanks to the intuitive interface and a sufficient number of indicators and controls on the device itself, each module can be configured from the front panel. The ConTrace MS module can also be configured by connecting a PC or laptop to the USB Type C connector on the front panel of the module. Remote configuration and management of the device is performed via the RS-485 interface.

## Monitoring of Electric Heating System

The control module continuously measures the operation current, as well as the leakage current in a non-contact manner. In the event that the leakage

current exceeds the value set by the operator or the load current exceeds the specified range, an alarm message is output and the load is disconnected. In this case, for the leakage current, a warning value can be set, after which the device will signal an event, but the heating will not be stopped.

Modules ConTrace MS are able to notify the expiration of the resource of individual nodes of the system, according to such parameters as the number of cycles of on-off contactor and the time of operating the heating cable. These values are available for user customization. In addition, the user is provided with information on the total running time of system and operating time of the ConTrace MS module after the last reboot.

The MS module has four digital inputs to monitor the operation of the actuators and receive remote control commands. The module also has a configurable discrete output, triggered by a user-defined scenario.

## Emergency Interception of Control

The function of emergency redundancy of MS modules is realized by the 1+1 principle, i.e. the same MS module is connected to the main MS module via a special connector. The backup module monitors the operation of the main control module and in the event of a failure of the main control module, the standby module intercepts control by itself. Also, a temperature sensor can be connected to the backup module, in which case it will act as a temperature limiter. This significantly increases the reliability of the control system and is applicable for particularly important loads.

## Features and Application Areas

- Each MS module is a full-fledged controller
- Ability to build a multi-channel control system
- System status monitoring during idle time
- Measurement of leakage currents
- Measurement of operation currents
- Ability to configure parameters from the module itself, via a connected PC or via RS-485
- Backup function with interception control
- Monitoring of external RCD
- Monitoring the status of the contactor
- Contactor life meter
- Running time counter
- Smooth or discrete load control
- Universal measuring channel for various types of temperature sensors
- Intrinsically safe circuits

## Construction

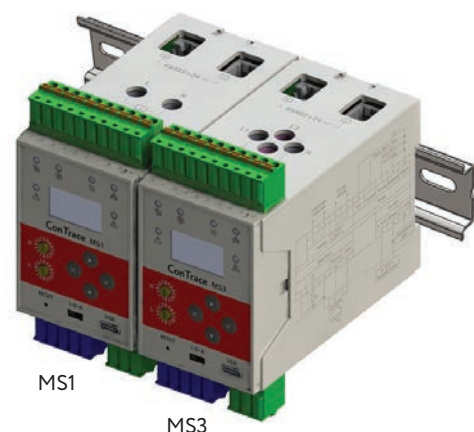

## Technical Data

Ex marking	Ex ia IIC
Supply voltage	24 V ===
Maximum measurable load current	60 A
Power consumption, max	2 W
Interface	RS-485
Communication protocol	Modbus / RTU
RS-485 interface connection	A, B, com
Connectors power supply / interface RS-485 and backup module	8P8C
Cable for power supply / RS-485 interface and a backup module	UTP/FTP cat.5
Type of terminal clamps	detachable
Clamping mechanism type of terminal clamps	spring
Cross-section / number of simultaneously connected wires to terminals	up to 2.5 mm <sup>2</sup> / 1
Diameter of through-holes for load conductors	8 mm
Discrete output of load control	250 V, 5 A
Analog output of load control	0...10 V
Impulse output for solid state load control relay	24 V
Discrete alarm output	250 V, 5 A
Number of discrete inputs	4
Number of measuring temperature channels	1
Type of sensors	see the table "Types of sensors"
Temperature measurement range	-100 ... +500 °C
Accuracy of measurements	0.5 °C
Operating temperature range	-40...+50 °C
Mounting type	DIN-rail 35 mm
Degree of protection	IP20
Dimensions (W×H×D), mm	55×109×110
Weight, g	500
Service life	not less than 10 years

## Sensors Types

Material	Type of RTD	Measuring range, °C	Order code
Platinum	PT50	-100 ... +500	3220900000
	PT100		3220900001
	Cu50		3220900010
Copper	Cu100	-100 ... +200	3220900011
	50M		3220900020
	100M		3220900021
Current loop 4...20 mA			

## Types

Name	Order code
Control and monitoring module ConTrace MS1	3220002000
Control and monitoring module ConTrace MS3	3220002001

## Installing MS modules in load circuits

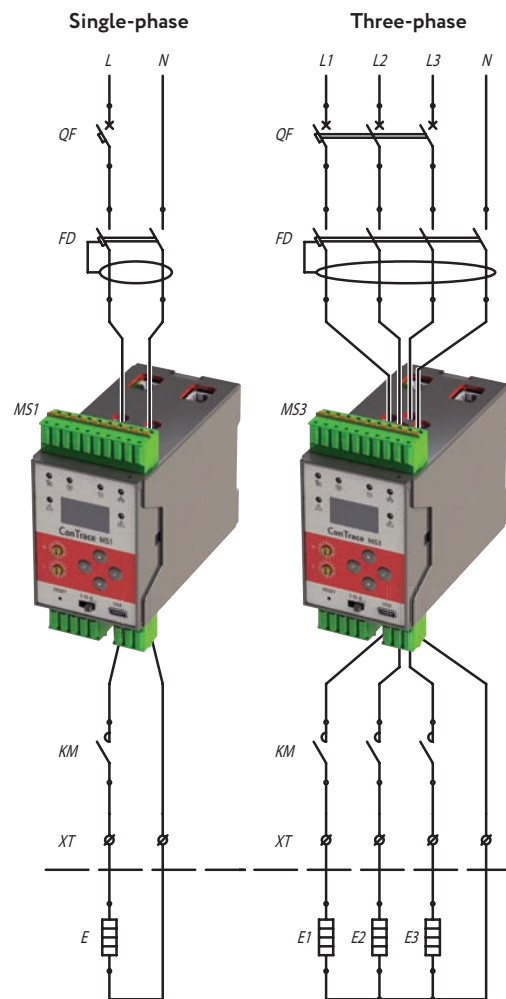

## Wiring Diagram

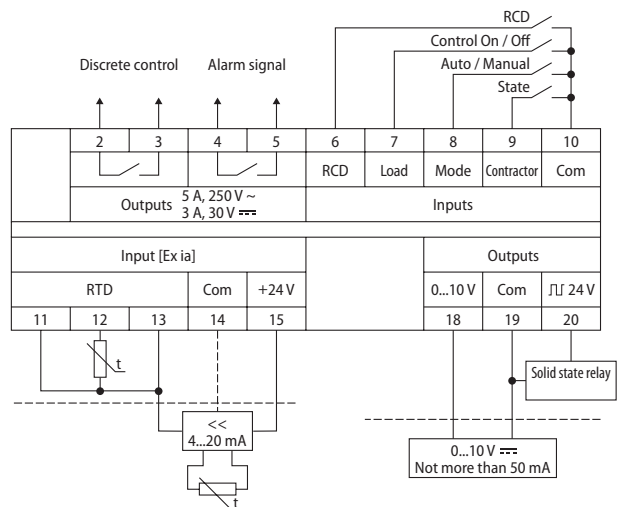

## Approvals



# Power and Interface Switching Module ConTrace IPS

## Purpose

The main purpose of the ConTrace IPS module is to provide the ConTrace MS modules with power and RS-485 communication interface. In addition to the MS modules, remote temperature measurement modules ConTrace AS and remote temperature measurement units ConTrace AS-xxx-Ex can also be connected to the ConTrace IPS module. In this way, all ConTrace devices form a single control system for electrical heating, ready for connection via the RS-485 Modbus RTU protocol to an industrial computer or PLC with the installed specialized software ConTrace.

Thanks to ConTrace IPS modules, the control system can be extended during operation by adding new ConTrace MS control modules and ConTrace AS remote temperature measurement devices.

## Description

The ConTrace IPS module, depending on the number of MS modules connected to it, is connected to the power units of the appropriate power, as well as to the RS-485 network, for communication with the industrial PC / PLC. Further, through the patch cord, it simultaneously transmits power and interface to the

ConTrace MS modules. Further, through the patch cord, it simultaneously transmits power and interface to the ConTrace MS modules. IPS has 2 outputs, combining power and interface buses. For each output, up to 20 MS modules can be connected in series. Thus, with the help of one IPS, it is possible to power up to 40 MS modules.

ConTrace IPS can work from either one or two power supplies. Operation from two power sources is assumed by the principle of primary / backup, with automatic switching to a working power supply and simultaneous signaling by closing the alarm relay contact. The IPS module is protected against excess supply voltage.

Each of the two output power and interface lines is equipped with its own protection against overcurrent, undervoltage and overvoltage. The operation of the protection is indicated by the LEDs on the front panel. Resetting the protection is done by pressing the "Reset" buttons on the device, separately for each outgoing line.

ConTrace IPS is supplied with three terminators of the ConTrace BT bus. This set is sufficient for implementing any connection scheme.

## Construction

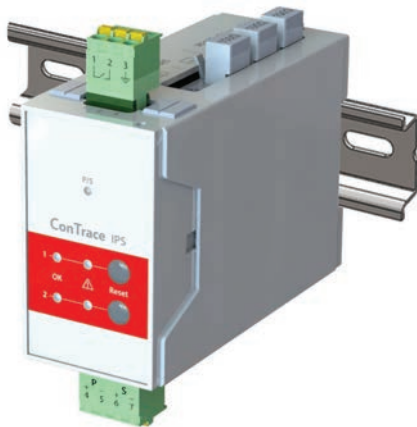

## Features and Application Areas

- Power and interface switching RS-485 for 40 MS modules
- Networking for 247 MS, AS, and AS-xxx-Ex Units
- Automatic switching from primary to redundant power supplies
- Indication and notification of alarms
- Protection of incoming and outgoing circuits

## Wiring Diagram

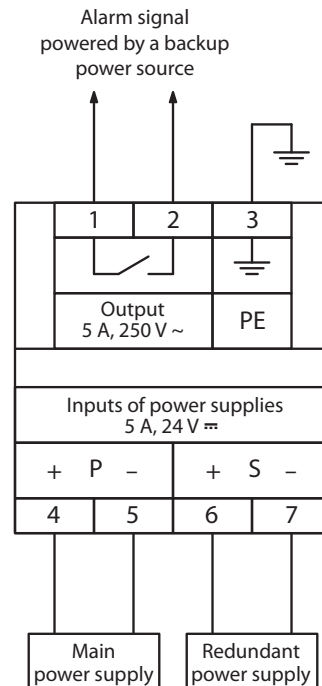



# Electric Heating Control System ConTrace

## Technical Data

Module supply voltage	20...30 V $\overline{=}$
Power consumption, max	3 W
Maximum number of MS modules	40 pcs <sup>°</sup>
Maximum number of MS modules in one RS-485 network segment	247 pcs
Maximum number of IPS modules in one RS-485 network segment without a repeater	32 pcs
Type of connectors RS-485+24 $\overline{=}$ и RS-485	8P8C
Type of connection cable RS-485+24 $\overline{=}$ и RS-485	UTP/FTP cat.5
Data transfer interface	RS-485
Built-in RS-485 signal repeater	Yes
The maximum current of each output line	3 A
Maximum allowable current for each output line	5 A

Maximum permissible long-term power	120 W
Discrete alarm output	250 V, 5 A
Type of terminal clamps	detachable
Clamping mechanism type of terminal clamps	spring
Cross-section / number of simultaneously connected wires to terminals	up to 2.5 mm <sup>2</sup> / 1
Operating temperature range	-40...+50 °C
Mounting type	DIN-rail 35 mm
Degree of protection	IP20
Dimensions (W×H×D), mm	45×75×109.7
Weight, g	145
Service life	not less than 10 years

<sup>°</sup> Taking into account the connected redundant modules in the "1 + 1" scheme

## Scheme of Connection IPS Modules in RS-485 Network

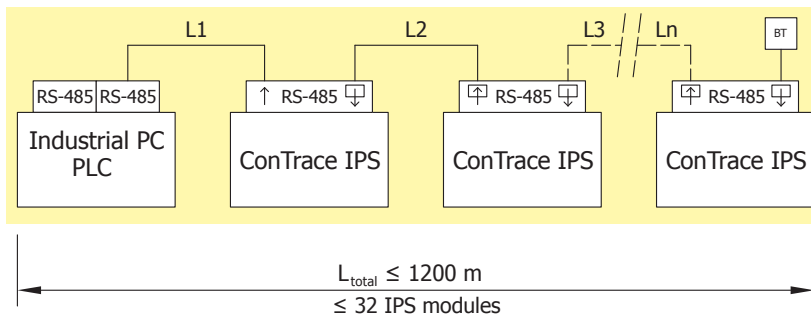

## Scheme of Connection MS1 / 3 Modules to the IPS Module

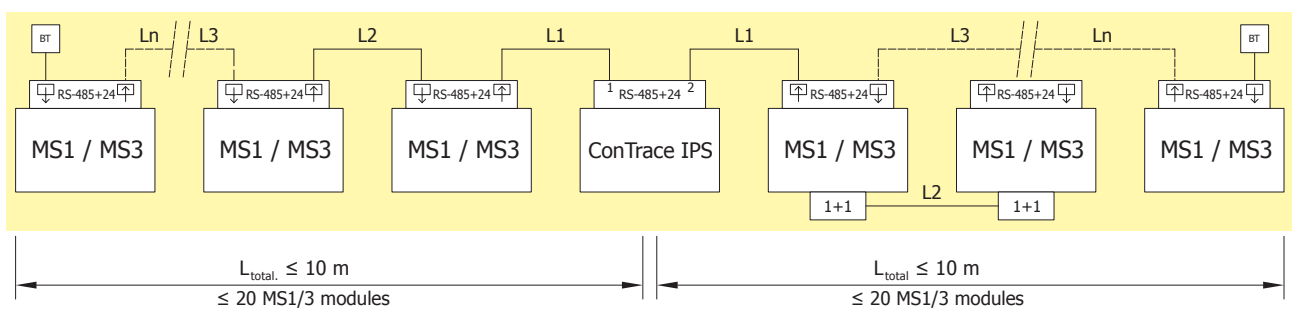

## Approvals



## Types

Name	Order code
Power and interface switching module ConTrace IPS	3220002010

# Remote Temperature Measurement Module ConTrace AS

## Purpose

The remote temperature measurement module ConTrace AS is used for temperature control of process pipelines and tanks of different industries. Designed for installation in control cabinets.

## Description

The remote temperature measurement module ConTrace AS is one of the components of the specialized control system for electrical heating ConTrace. Transmission of temperatures data is carried out via RS-485 (Modbus RTU). This makes possible to use the ConTrace AS modules as a part of third-party control systems that support this type of communication.

Using ConTrace AS modules allows for centralized control and transmission values of the temperatures of remote objects, which is particularly effective for a

large gathering of measurement points within a radius of 100 m. For each ConTrace AS module up to 8 RTD temperature sensors can be connected. Incoming data from sensors are transferred to the control device by means of only one cable according to the RS-485 standard. At a distance of 1,200 m, up to 16 ConTrace remote temperature measurement devices can be connected in series. This makes it possible to monitor changes in the temperature characteristics of the electrical heating system at 128 points simultaneously. ConTrace remote temperature measuring devices are fully compatible with each other, which allows the use of ConTrace AS modules installed in control cabinets simultaneously with ConTrace AS-xxx-Ex units located in an explosive area. The ConTrace AS modules can be connected in series with the field units of the remote temperature measurement ConTrace ASxxx-Ex in any order.

## Construction



## Connection and Indication

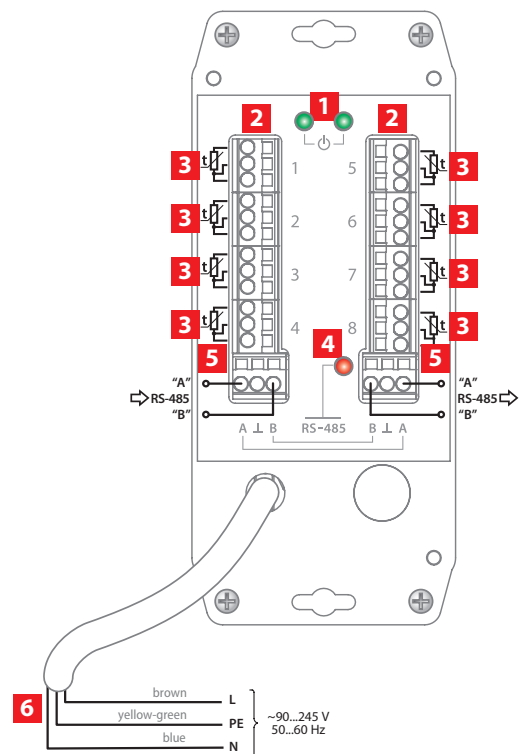

## Features and Application Areas

- Connection of 8 temperature sensors
- Up to 16 blocks can be daisy-chained together
- Up to 128 temperature sensors when scaling the system
- Maximum distance of the module from the control cabinet to 1,200 m
- Intrinsically safe circuit

1. Voltage presence LED
2. Terminal blocks for temperature sensors
3. Note for connecting temperature sensors
4. Data transfer LED on the RS-485 interface
5. Terminal blocks for the RS-485 interface
6. Power wires

# Electric Heating Control System ConTrace

## Technical Data

Ex marking	[Ex ia m] IIC
Supply voltage	90...245 VAC, 50...60 Hz
Power consumption, max	5 W
Interface	RS-485
Communication protocol	Modbus RTU
RS485 interface connection	A, B, com
RS485 communication speed	9 600 ...115 200 bps.
Max length of the RS485 network segment	1200 m <sup>o</sup>
Terminal blocks for connections	
1. Temperature Sensors	up do 2,5 mm <sup>2</sup>
2. Interface cable	
The length of the power supply wires	210 mm
The cross section of the supply wires	0.75 mm <sup>2</sup>
Ground wire length	230 mm
The cross-section of the ground wire	4.0 mm <sup>2</sup>
Number of temperature measurement channels	8
The resolution of the ADC of the measuring channel	23 bits
Type of sensors	see the table "Types of sensors"
Temperature measurement range	-100...+500 °C
Accuracy of measurements	0.5 °C
Maximum sensor distance from the unit	100 m
Sensor connection circuit	three-wire circuit
Operating temperature range	-55...+50 °C
Degree of protection	IP20
Dimensions (W×H×D), mm	81.4×189.4×64
Weight, g	1 000
Service life	not less than 10 years

<sup>o</sup> Depends on the selected data rate and the conditions for the protection of the control cable against electromagnetic interference

## Sensors Types

Material	Type of RTD	Measuring range, °C
Platinum	PT50	-100 ... +500
	PT100	
Copper	Cu50	-100 ... +200
	Cu100	
	50M	
	100M	

## Approvals



## Installation

Mounting to the mounting plate

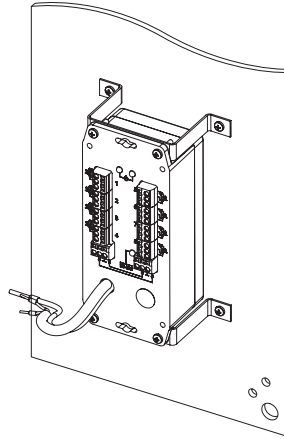

Mounting on profiles and traverses

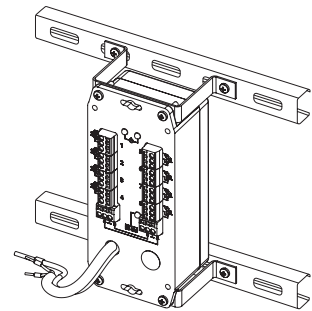

## Construction

The remote temperature measurement module AS is supplied with mounting brackets and mounting screws in the kit.

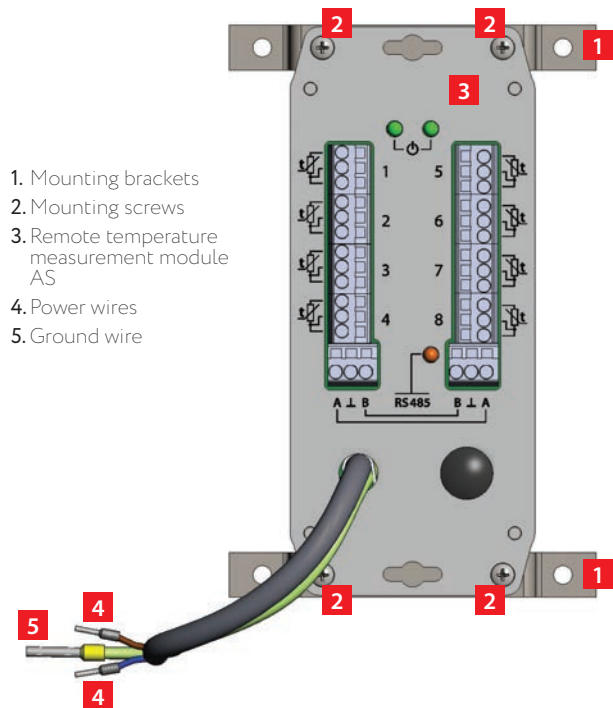

## Types

Name	Order code
Remote temperature measurement module ConTrace AS	3220002020

# Remote Temperature Measurement Unit ConTrace AS-xxx-Ex

## Purpose

The remote temperature measurement unit ConTrace AS-xxx-Ex is used for temperature control of process pipelines and tanks in different industries. Designed to be placed near desired monitoring locations, even in hazardous areas.

## Description

The remote temperature measurement unit ConTrace AS-xxx-Ex is one of the components of the specialized control system for electrical heating ConTrace. Transmission of temperature data is carried out via RS-485 (Modbus RTU). This makes possible to use ConTrace AS-xxx-EX units as a part of third-party control systems that support this type of communication.

Using ConTrace AS-xxx-Ex units allows for centralized control and transmission values of the temperatures of remote objects, which is particularly effective for a large gathering of measurement points within a radius of 100 m. For each ConTrace AS-xxx-Ex unit, depending on the modification, up to 8 RTD temperature sensors can be connected. Incoming data from sensors are transferred to the control cabinet by means of only one cable according to the RS-485 standard. At a distance of 1 200 m, up to 16 ConTrace AS-xxx-Ex units can be connected in series. This makes it possible to monitor changes in temperature characteristics of the electric heating system at 128 points simultaneously.

The intrinsically safe circuit and hazardous area enclosure allow the installation of the remote temperature measurement unit ConTrace AS-xxx-Ex in zones 1 and 2 (21, 22).





## Features and Application Areas

- Connection of 8 temperature sensors
- Up to 16 blocks can be daisy-chained together
- Up to 128 temperature sensors
- Maximum distance of the unit from control cabinet to 1,200 m
- Various modifications
- Operation in hazardous zones 1, 2 (21, 22)

## Construction



## Modifications

Design	Name	Number of measuring channels	Housing material	Material of cable glands*	Number / type of cable glands	Dimensions, mm HxWxD	Weight, kg	Type of construction**
	AS-8MM-Ex	8	Steel	Brass	Power supply: 2xM25 Sensors: 8xM20 Network: 2xM20	340×325×215	8,0	Transit/ Terminal
	AS-8PP-Ex	8	Polyester	Polyester	Power supply: 2xM25 Sensors: 8xM20 Network: 2xM20	315×290×125	4,5	Transit/ Terminal
	AS-8PM-Ex	8	Polyester	Brass	Power supply: 2xM25 Sensors: 8xM20 Network: 2xM20	380×325×125	6,0	Transit/ Terminal
	AS-4PM-Ex	4	Polyester	Brass	Power supply: 2xM25 Sensors: 8xM20 Network: 2xM20	325×325×125	4,5	Terminal

\* Brass cable glands are designed for use with armored cables, polyester - for non-armored cables

\*\* Units of transit / terminal type can be used for single installation as well as for serial connection

Units of the terminal type are not structurally designed for further transit of the power and information networks, so they can only be used for a single installation or be the last ones in the AS-xxx-Ex circuit

# Electric Heating Control System ConTrace

## Technical Data

Ex marking	1 Ex e ia m IIC T6	
Supply voltage	90...245 VAC, 50...60 Hz	
Power consumption, max	5 W	
Interface	RS-485	
Communication protocol	Modbus RTU	
RS485 interface connection	A, B, com	
RS485 communication speed	9 600 ... 115 200 bps.	
Max length of the RS-485 network segment	1200 m*	
Terminal blocks for connections	up to 2.5 mm <sup>2</sup>	
1. Temperature Sensors		
2. Interface cable		
Terminal blocks for mains power connections	up to 6 mm <sup>2</sup>	
Number of temperature measurement channels	8	
The resolution of the ADC of the measuring channel	23 bits	
Type of sensors	see the table "Types of sensors"	
Temperature measurement range	-100...+500 °C	
Accuracy of measurements	0.5 °C	
Maximum sensor distance from the unit	100 m	
Sensor connection circuit	three-wire circuit	
Operating temperature range	-55...+50 °C	
Degree of protection	IP66	
Dimensions (W×H×D), mm	AS-8MM-Ex	340×325×215
	AS-8PP-Ex	315×290×125
	AS-8PM-Ex	380×325×125
	AS-4PM-Ex	325×325×125
Weight, kg	AS-8MM-Ex	8.0
	AS-8PP-Ex	4.5
	AS-8PM-Ex	6.0
	AS-4PM-Ex	4.5
Service life	not less than 10 years	

\* Depends on the selected data rate and the conditions for the protection of the control cable against electromagnetic interference

## Sensors Types

Material	Type of RTD	Measuring range, °C
Platinum	PT50	-100 ... +500
	PT100	
Copper	Cu50	-100 ... +200
	Cu100	
	50M	
	100M	

## Accessories

1. Plate PL.JB 1007
2. Bracket K.JB10.YYYxZZZ

## Installation

Surface mount

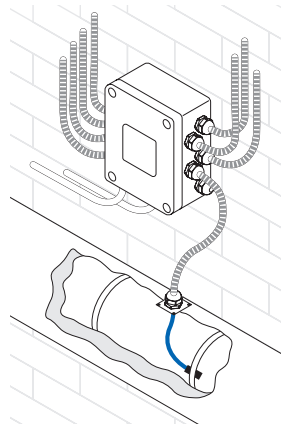

Mounting on a pipe

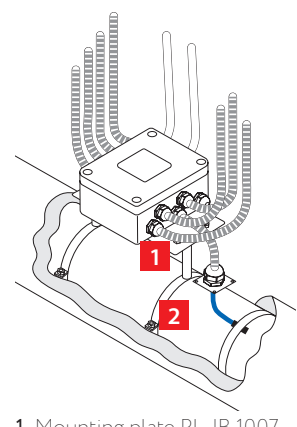

1. Mounting plate PL.JB 1007
2. Mounting bracket K.JB10.YYYxZZZ

## Construction

The design of the remote temperature measurement unit without a lid, example ConTrace AS-8PP-Ex.

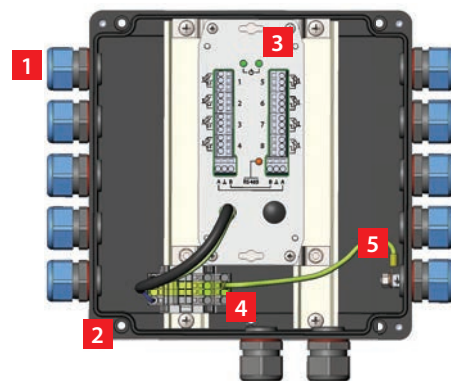

1. Cable glands
2. Explosion proof enclosure
3. Remote temperature measurement module
4. Terminal blocks for mains connection
5. Ground wire

## Approvals



## Types

Name	Order code
Remote temperature measurement unit ConTrace AS-8MM-Ex	3220002030
Remote temperature measurement unit ConTrace AS-8PP-Ex	3220002031
Remote temperature measurement unit ConTrace AS-8PM-Ex	3220002032
Remote temperature measurement unit ConTrace AS-4PM-Ex	3220002033

# Connection Kits for Self-Regulating Heating Cables

SST connection kits are available in a wide range of different types for various applications.

Our connection technology is the ideal solution when connecting self-regulating heating cables HTM, HTA, HTP and BTC to junction boxes as well as to cold cables.

Our connection kits and end termination kits are available in silicone form. The silicone adhesive enables an easily and quick installation. No “hot permit to work” is required for installation of these silicone kits in a potentially explosive atmosphere. All connection kits are Ex-approved in combination with SST self-regulating heating cables.

## Features

- Ex-approved solution
- Easy to install
- Full range of kits available
- Silicone connection kits can be installed in explosive environments without “hot permit to work”

## Application Areas

- Connection technology for all self-regulating heating cables

## Variations

To connect self-regulating heating cable into a junction box



TKL, TKR, TKW connection kit

Silicone-ET end termination kit



## Connection Kit vs. Heating Cable Type

Name	Ref. type of self-regulating heating cable
TKL	BTC
TKR	HTM, HTA, HTP
TKL/JB	BTC
TKR/JB	HTM, HTA, HTP
Silicone-ETL	BTC
Silicone-ETR	HTM HTA, HTP

## Variations

To connect self-regulating heating cable with a power supply cable as well as repair kit



TKT-M connection kits

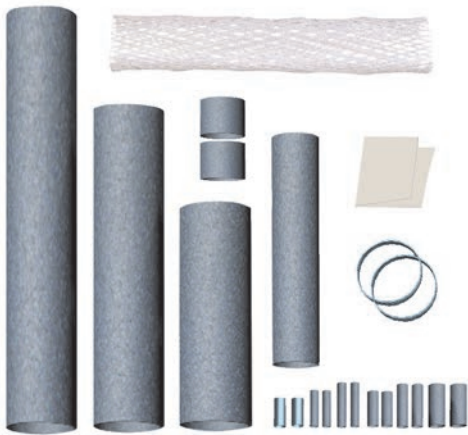

CP-6 connection kit



CP-7 connection kit

## Connection Kit vs. Heating Cable Type

Name	Ref. type of self-regulating heating cable
TKT-M	HTM, HTA, HTP, BTC
CP-6	HTM HTA, HTP (TPO)
CP-7	HTM, HTA, HTP, BTC (FEP)

## Approvals



II 2 GD  
Ex 60079-30-1 IIC T6 Gb  
Ex 60079-30-1 IIIC T85°C Db  
Sira 18ATEX3038X



IECEX CCVE 17.0007X



The system certificate is valid only for combination with SST self-regulating heating cables

## Types

Name	Order code
TKL	3290002101
TKR	3290002102
TKL/JB	3290002111
TKR/JB	3290002112
Silicone-ETL	3290002104
Silicone-ETR	3290002105
TKT-M	3290003101
CP-6	3290003102
CP-7	3290003103

# Connectors for SNF, SNF-L Cables

The SNF-MF connection technology for SNF series-resistance heating cables is available in different versions for all cable diameters. SNF MF connectors are the ideal solution for the fast and reliable connection of heating cables SNF, SNF-L with cold

cable and connection of two heating cables. The connector housing is made of a heat-resistant material that can withstand temperatures of up to +300 °C. All connectors are Ex-approved in combination with SNF and SNF-L series-resistance heating cables.

## Features

- Ex-approved solution
- Easy to install
- High mechanical strength and system structural reliability
- Can be installed in explosive environments without "hot permit to work"
- High chemical stability

## Application Areas

- Temperature maintenance or freeze protection of pipelines and vessels in non-hazardous and ex-hazardous areas



## Construction

1. Gland
2. Seal
3. Strain relief
4. Body case

## Approvals



Ex 60079-30-1 IIC T6...T2 Gb  
Ex 60079-30-1 IIIC 85°C...260°C Db  
CML 19ATEX3499X



IECEX CCVE 18.0004X



The system certificate is valid only for combination with SST SNF, SNF-L series-resistance heating cables.

## Connection Options

Name	Wire cross-section range, mm <sup>2</sup>	Application
SNF MF-03-01-1	up to 4	Hot-cold and hot-hot connection
SNF MF-05-00-1	4 – 10	Hot-cold connection
SNF MF-05-01-1	6 – 10	Hot-cold and hot-hot connection

## Types

Name	Order code
SNF MF-03-01-1	3290000001
SNF MF-05-00-1	3290000002
SNF MF-05-01-1	3290000003



# Cable Entry Unit LEK/U

## Construction

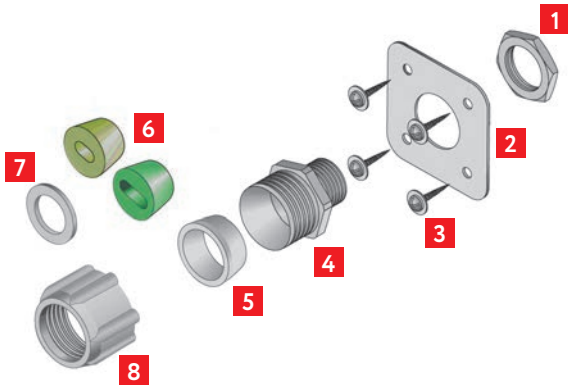

## Delivery Set

Part	Qty
1. Lock nut	1
2. Metal plate	1
3. Self-tapping screws	4
4. Connector body GW50416	1
5. Connector seal	1
6. Cable seal (2 types)	1
7. Washer	1
8. Connector head	1

## Types

Name	Order code
Cable entry unit LEK/U	7090100300

## Approvals

This product is exempt from mandatory certification

# Brackets

## Description

Support brackets are used in cases where it is not possible to reliably mount the junction box onto the surface of a nearby structure (supports, traverses, etc.) of the heated system.

When specifying the bracket, the dimensions of the heated system, its operating parameters and the

types of permissible installation work should be taken into account.

On pp. 112-115 product range of support brackets fully compatible with all types of SST junction boxes is shown.

If you have questions concerning compatibility with other equipment, please contact the nearest office of SST Group.

## Features

- Quick and easy installation, does not require special tools
- Increased structural strength and reliable fastening to the heated surface
- Resistance to vibration and alternating stresses
- High accuracy of surface interface
- Optimum size and weight
- Versatility and compatibility with all standard sizes of JB junction boxes

## Approvals

This product is exempt from mandatory certification

## Bracket PB

Intended for mounting onto small-diameter pipelines (up to 54 mm).

Compatible with JB2221-223-2XXX, JB2221-333-2XXX box models not supplied with UVK pipe installation support (MOIC cables boxes excluded).

Dimensions L×W×H, mm	Weight, kg/pc.	Mount
331×158×39	0,73	Two straps PFS*

Material – galvanized steel.

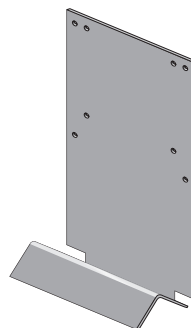

PB

## Types

Name	Order code
Bracket PB	7090101000

\* To be ordered separately

### Bracket PL.JB 0606-10

Intended for mounting onto pipelines with thermal insulation up to 100 mm thick.

Compatible with JB2221-223-2XXX, JB2221-333-2XXX box models not supplied with UVK pipe installation support, thermostat exTHERM-AT.

The equipment is mounted horizontally.

Dimensions L×W×H, mm	Weight, kg/pc.	Mount
158×158×103	0.54	Two straps PFS <sup>°</sup> . Fasteners included in the bracket kit.

Material – galvanized steel.

#### Types

Name	Order code
Bracket PL.JB 0606-10	7090101001

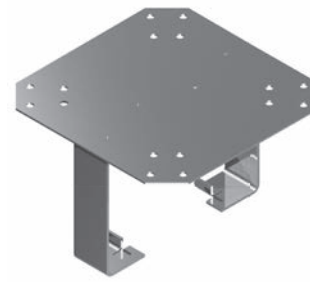

PL.JB 0606-10

### Bracket PL.JB 0606-20

Intended for mounting onto pipelines with thermal insulation up to 150 mm thick.

Compatible with JB2221-223-2XXX, JB2221-333-2XXX box models not supplied with UVK pipe installation support, thermostat exTHERM-AT.

The equipment is mounted vertically.

Dimensions L×W×H, mm	Weight, kg/pc.	Mount
299×160×40	1.09	Two straps PFS <sup>°</sup> . Fasteners included in the bracket kit.

Material: plate – galvanized steel, channel – steel.

#### Types

Name	Order code
Bracket PL.JB 0606-20	7090101002



PL.JB 0606-20

### Bracket KP1

Intended for mounting onto large diameter pipelines and tanks with thermal insulation up to 120 mm thick.

Compatible with JB2221-223-2XXX, JB2221-333-2XXX box models not supplied with UVK pipe installation support (JB2221-333-2(X)22 excluded).

Dimensions L×W×H, mm	Weight, kg/pc.	Mount
304×300×115	1.8	Weld

Material – steel.

#### Types

Name	Order code
Bracket KP1	7090101003

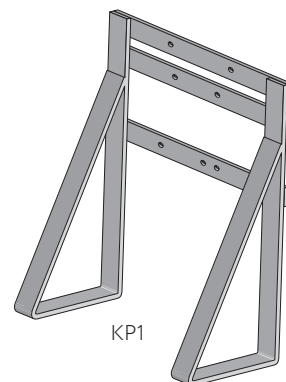

KP1

<sup>°</sup> To be ordered separately

# Brackets

## Bracket KP3

Intended for mounting onto adjacent metal structures, large diameter pipelines and tanks with thermal insulation up to 120 mm thick.

Compatible with JB2221-223-2XXX, JB2221-333-2XXX box models not supplied with UVK pipe installation support.

Dimensions L×W×H, mm	Weight, kg/pc.	Mount
152×158×128	0.6	Weld

Material – steel.

### Types

Name	Order code
Bracket KP3	7090101004

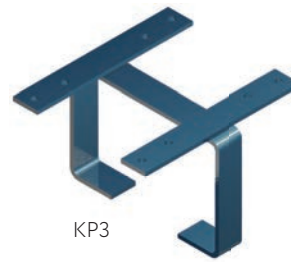

## Bracket KP101

Intended for fastening the fastening tape to the heated surface. Mounted by welding to the heated surface.

Material – steel.

### Types

Name	Order code
Bracket KP101	7090101005



## Adapter bracket KP 102

Intended for mounting the support stand UVK onto small diameter pipelines (less than 32 mm).

Mounted onto the lower part of the support. One support requires one bracket kit KP 102 and KP 102-01.

Designation	Dimensions L×W×H, mm	Weight, kg/pc.
KP 102	39×18×15	0.0338
KP 102-01	39×22×15	0.0386

Material – steel.

### Types

Name	Order code
Adapter bracket KP 102	7090101006
Adapter bracket KP 102-01	7090101007

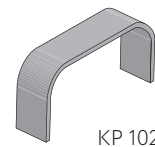

## Bracket K.JB10.YYY×ZZZ

Intended for mounting onto pipelines with longline electric heating system.

Compatible with JB2221-544-21(60-65) boxes. Boxes are bolted to the plate PL.JB 1007-01.

Dimensions L×W×H, mm	Weight, kg/pc.	Mount
299×160×40	1.09	Belt clamp, bolt tightening. Fasteners included in the bracket kit.

Material: channel – steel.

### Ordering Information

Bracket K.JB10.YYY×ZZZ  
(YYY – pipe diameter in mm, ZZZ – model).

### Product Range

YYY	ZZZ	Order code	YYY	ZZZ	Order code
057	050	7090101100	308	000	7090101124
057	064	7090101101	314	000	7090101125
057	090	7090101102	315	000	7090101126
057	100	7090101103	325	050	7090101127
089	070	7090101104	325	100	7090101128
089	100	7090101105	331	100	7090101129
108	050	7090101106	334	000	7090101130
108	060	7090101107	348	000	7090101131
108	100	7090101108	355	000	7090101132
114	060	7090101109	355	100	7090101133
114	070	7090101110	400	000	7090101134
134	000	7090101111	419	000	7090101135
159	050	7090101112	422	000	7090101136
159	100	7090101113	426	080	7090101137
168	090	7090101114	450	000	7090101138
219	050	7090101115	500	000	7090101139
219	100	7090101116	556	000	7090101140
219	120	7090101117	556	150	7090101141
234	000	7090101118	560	000	7090101142
273	000	7090101119	573	000	7090101143
273	075	7090101120	630	100	7090101144
273	100	7090101121	720	090	7090101145
280	000	7090101122	1020	110	7090101146
280	100	7090101123	1220	000	7090101147



K.JB10.YYY×ZZZ

## Plate PL.JB 1007

Intended for mounting onto pipelines with longline electric heating system.

Compatible with JB2221-544-21(60-65) boxes. Mod. 01 for securing JB junction boxes to the bracket K.JB10.YYY×ZZZ. Mod. 02 for securing JB boxes is mounted onto the heated pipeline with two PFS straps.

Designation	Dimensions L×W×H, mm	Weight, kg/pc.
PL.JB 1007-01	330×255×1.5	1.0
PL.JB 1007-02	300×255×1.5	0.76

Material – galvanized steel.

### Types

Name	Order code
Plate PL.JB 1007-01	7090101200
Plate PL.JB 1007-02	7090101201



PL.JB 1007-01



PL.JB 1007-02

# Tapes & Straps

## Self-Adhesive Fastening Tape

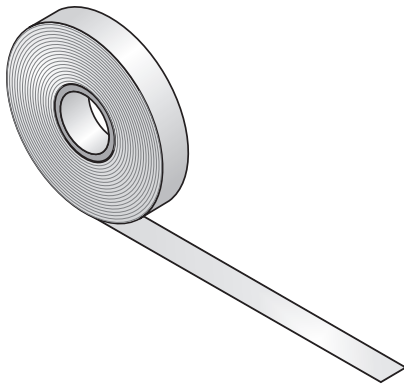

### Applications

Fastening of heating cable to high temperature pipes.  
Compatible with all heating cable types.

### Technical Data

Length	33 m
Width	11 mm
Permanent exposure temperature	200 °C
Recommended installation temperature	Not lower than -15 °C
Adhesive material	Modified silicone

### Types

Name	Order code
Fastening tape FT/HTM	7090100000

## Self-Adhesive Aluminum Fastening Tape

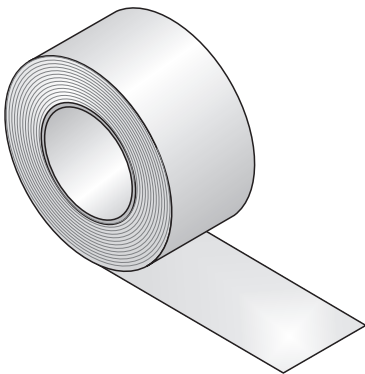

### Applications

Fastening of heating cable onto flat surfaces, e.g. tanks, or onto a valve / pump body, padding of heating cables laid onto plastic pipes.

### Technical Data

Length	50 m
Width	50 mm
Permanent exposure temperature	110 °C
Recommended installation temperature	Not lower than -5 °C
Adhesive material	Acryl

### Types

Name	Order code
Self-adhesive aluminum fastening tape	7090100001

## Fastening Tape

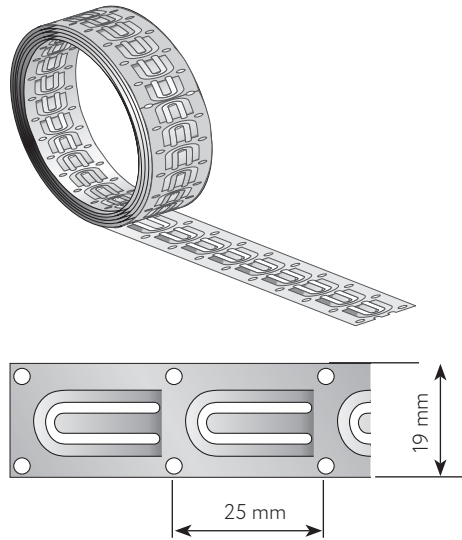

### Applications

Fastening of cable to a tank.

The fastening tape is fastened onto a tank using KP101 brackets or PFS straps.

Coil length upon request.

### Types

Name	Order code
Fastening tape 25, where 25 is the fastening spacing in mm.	7090100051

### Approvals

This product is exempt from mandatory certification.

## Straps for Mounting Junction Box Brackets Onto a Pipe

The strap is intended for mounting junction box brackets directly onto the surface of a heated system (pipe, tank) and also for mounting heating sections based on MOIC cables with mineral insulation. The kit contents make it possible to assemble worm drive

straps of the required diameter in a short time without the use of special tools. With the help of the strap, parts can be mounted onto structures and equipment of any shape and size.

Material – stainless steel.

### Features

- Quick-action lock allows to mount the strap without the use of special tools, simplifying and speeding up the installation process
- High strength and corrosion resistance
- Highly reliable installation
- Packaging convenient for storage and transportation

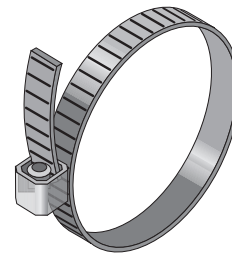

### Fasteners for PFS/30 Strap

Metal lock with a screw for tightening the strap. Intended for reliably connecting worm drive straps of the required diameter. The fasteners are universal and can be used both for creating small-diameter straps and for mounting large-sized parts. Allow to connect the strap's two loose ends. A small overlap is recommended when mounting the strap.

Material – stainless steel.

### Approvals

This product is exempt from mandatory certification.

### Types

Name	Order code
Fixing strap PFS/3 (3 m incl. 8 fixing elements)	7090100301
Fixing strap PFS/30 (30 m)	7090100302

Part name	Length, m	Width, mm	Type of band	Weight, kg	Type of packaging	Delivery kit, pcs.
PFS/3	3	12.7	Hose strap	0.3	Blister pack	Strap – 1 pc. Fastening element – 8 pcs.
PFS/30	30	9	Hose strap	1.447	Plastic reel	Strap – 1 pc. Fastening element – to be ordered separately / not included in the package.

# VeLL Heat Tracing System: VLL-A

VeLL heat tracing system is based on VLL-A and VLL-C special series-resistance heating cables. VLL-A is a series-resistant cable for extra long heating systems, approved for use in hazardous and non-hazardous areas when used as a part of SST designed VeLL Heat Tracing System. It has been designed for use in temperature maintenance or freeze protection applications of long and extra-long pipelines. VLL-A cable implements an aluminum heating wire, offering a cost-saving solution for a wide variety of heat-tracing applications.

Cables are installed in a linear way on the pipe surface. In case of pre-insulated pipeline fragments, the cable

is usually laid in conduits, which are on the pipe under thermal insulation.

At the end of a heating segment cables are connected together in star (Y). At start of the segment voltage is applied between cables. Its value depends on the pipeline length and necessary power output.

This is a specially designed conductor, resistant to high voltage up to 8 kV and thermal loads in operation up to +100 °C, also resistant to mechanical impact during installation or maintenance. The cable is supplied on drums with length, convenient for installation and connection on site.

## Features

- The only heat tracing system for heating extra-long pipelines up to 150 km without supply network
- High operating temperature up to +100 °C
- High mechanical reliability
- Electrical safety
- Connection technology and fasteners come in unified kits
- Easy and convenient installation

## Application Areas

- Temperature maintenance or freeze protection of extra-long pipelines in non-hazardous and ex-hazardous areas

## Construction

Type 1 – up to 10 kV

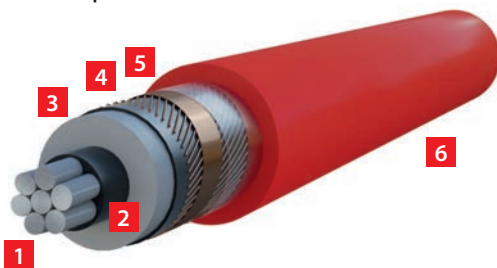

1. Aluminum conductor core
2. Conductor screen (semi-conductive layer)
3. Insulation XLPE
4. Insulation screen (semi-conductive layer)
5. Copper wire braid covered with copper foil
6. Special abrasion-resistant outer jacket

Type 2 – up to 3 kV

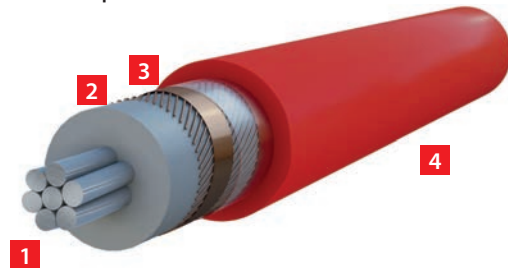

1. Aluminum conductor core
2. Insulation XLPE
3. Copper wire braid covered with copper foil
4. Special abrasion-resistant outer jacket



## Technical Data

Rated voltage	up to 8 000 VAC
Maximum continuous operating temperature (trace heater energized)	up to +100 °C
Maximum intermittent temperature (trace heater de-energized)	up to +120 °C
Ambient temperature range	-60 ... +55 °C
Minimum installation temperature	-40 °C
Conductive wire material	Aluminium
Linear power output per one segment, connected in star	up to 30 W/m (average value, depends on application)

## Product Characteristics

Type	Conductor size, mm <sup>2</sup>	Dimensions (max OD), mm	Weight, kg/km	Minimum bend radius	Order code
VLL-A 25	25	18.2-22.6	601-814	15 outer diameters	3202000100
VLL-A 35	35	19.5-25	674-900	15 outer diameters	3202000101
VLL-A 50	50	21.3-25.9	703-932	15 outer diameters	3202000102
VLL-A 70	70	22.4-27.3	721-986	15 outer diameters	3202000103

## Marking

Example: VLL-A-3.0-35-01



1. Cable type (VLL)
2. Type of conductor (A - aluminium)
3. Rated Voltage (3.0 kV)
4. Conductor cross-section (35 mm<sup>2</sup>)
5. Maximum continuous operating temperature (01 - 100 °C)

## Approvals



IECEx CCVE 19.0010X



\* Certification is underway

# VeLL Heat Tracing System: VLL-C

VLL-C is a series-resistance heating cable for extra-long oil & gas pipelines, approved for use in hazardous and non-hazardous areas. It has been designed for temperature maintenance or freeze protection of extra-long pipelines. VLL-C cable implements a copper heating wire, thus offers a perfect solution for a wide variety of heat tracing applications.

Cables are installed in a linear way on the pipe surface. In case of pre-insulated pipeline fragments, the cable is usually laid in conduits, which are on the pipe under thermal insulation.

At the end of a heating segment cables are connected together in star (Y). At start of the segment voltage is applied between cables. Its value depends on the pipeline length and necessary power output.

This is a specially designed conductor, resistant to high voltage up to 8 kV and thermal loads in operation up to +200 °C, also resistant to mechanical impact during installation or maintenance. The cable supplied on drums with length, convenient for installation and connection on site.

## Features

- The only heat tracing system for heating extra-long pipelines up to 150 km without supply network
- High operating temperature up to +200 °C
- High mechanical reliability
- Electrical safety
- Connection technology and fasteners come in unified kits
- Easy and convenient installation

## Application Areas

- Temperature maintenance or freeze protection of extra-long pipelines in non-hazardous and ex-hazardous areas

## Construction

Type 1 – up to 10 kV

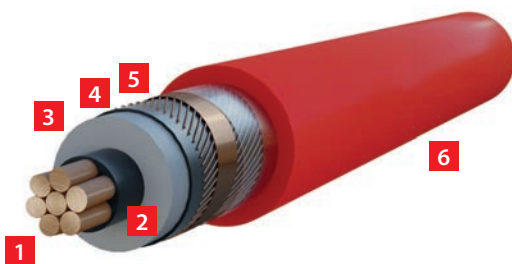

1. Copper conductor core
2. Conductor screen (semi-conductive layer)
3. Insulation XLPE
4. Insulation screen (semi-conductive layer)
5. Copper wire braid covered with copper foil
6. Special abrasion-resistant outer jacket

Type 2 – up to 3 kV

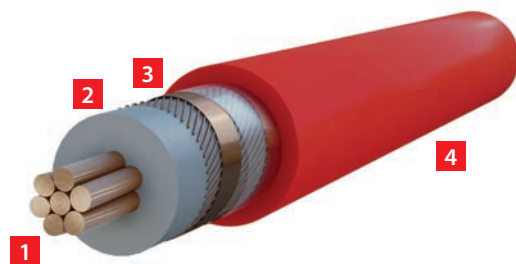

1. Copper conductor core
2. Insulation XLPE
3. Copper wire braid covered with copper foil
4. Special abrasion-resistant outer jacket

# VeLL Heat Tracing System

## Technical Data

Rated voltage	up to 8 000 VAC
Maximum continuous operating temperature (trace heater energized)	up to +200 °C
Maximum intermittent temperature (trace heater de-energized)	up to +250 °C
Ambient temperature range	-60 ... +55 °C
Minimum installation temperature	-40 °C
Conductive wire material	Copper
Linear power output per one segment, connected in star	up to 30 W/m (average value, depends on application)

## Product Characteristics

Type	Conductor size, mm <sup>2</sup>	Dimensions (max OD), mm	Weight, kg/km	Minimum bend radius	Order code
VLL-C 10	10	16.8-21.1	554-760	15 outer diameters	3202000150
VLL-C 15	15	18.2-22.6	601-814	15 outer diameters	3202000151
VLL-C 20	20	19.5-25	644-900	15 outer diameters	3202000152
VLL-C 30	30	22.4-26.6	739-958	15 outer diameters	3202000153
VLL-C 40	40	25.4-28.3	838-1019	15 outer diameters	3202000154

## Marking

Example: VLL-C-3.0-20-01



1. Cable type (VLL)
2. Type of conductor (C – copper)
3. Rated Voltage (3.0 kV)
4. Conductor cross-section (20 mm<sup>2</sup>)
5. Maximum continuous operating temperature (01 – 100 °C)

## Approvals



IECEx CCVE 19.0010X



\* Certification is underway

# Heat Tracing System Based on Skin-Effect

## Purpose

Heat tracing system IRHS-15000 based on skin-effect is intended for maintaining pipeline temperature, preventing freezing, and start-up heating of long pipelines. The system supports underground, overground, underwater installation, including explosive areas.

It is the only system capable of heating pipelines up to 60 km long (without an auxiliary network). This heating system can be used to heat pipelines of any length with an auxiliary power supply network.

## Structural design

IR-heater	Low-carbon steel pipe with a diameter of 15-60 mm, wall thickness 3-4 mm
IR-conductor	Special conductor is resistant to high voltage (up to 5 kV), thermal loads (up to +260 °C), and mechanical loads during installation
IRPK, IRSK, IRKK, IRS, KTP	Connection, power supply, terminal boxes, glands, control power station

## Operating principle

The heating element of IRHS-15000 is composed of an inductive-resistive heater (IR heater) with an external diameter of 15–60 mm and a wall thickness of at least 3.0 mm and a built-in insulated inductive-resistive copper conductor (IR conductor) with a cross section of 8–40 mm<sup>2</sup>.

At the terminal end of the heating segment, the IR-conductor is electrically connected to the IR-heater, and alternating voltage is supplied at the start end of the segment between the IR-heater and the IR-conductor. The voltage is determined based on the desired heat generation and the length of the heating section.

IR-conductor and IR-heater currents flow in opposite directions, resulting in a surface effect and proximity effect in the system. As a result, the current in the IR-heater flows along the inner layer near the inner surface of the IR-heater and there is no voltage on the IR-heater.

The IR-conductor is non-magnetic (copper), there is no noticeable surface effect in it, and the alternating current flows through the entire cross section of the IR-conductor.

The main heat generating element in the skin-effect system is the IR-heater, accounting for up to 80% of the system's output.

## Features and Application Areas

- Heating of pipelines up to 60 km without supply network
- High operating temperatures
- Electrical safety
- High mechanical strength of the heating system
- Approved for explosive areas

1. High-voltage line
2. Control power station (CPS)
3. IR-heater
4. IR-conductor
5. Thermal insulation
6. Heated pipeline

## Technical Data

Heated pipeline length	up to 30 km without an auxiliary network
Heating system output	up to 170 W/m
Maximum operating temperature	+240 °C
Maximum permissible temperature (without load)	+260 °C
Ambient temperature range	-60...+70 °C
Voltage on the heating element	up to 5 kV
Cross-section of the IR conductor	up to 40 mm <sup>2</sup>

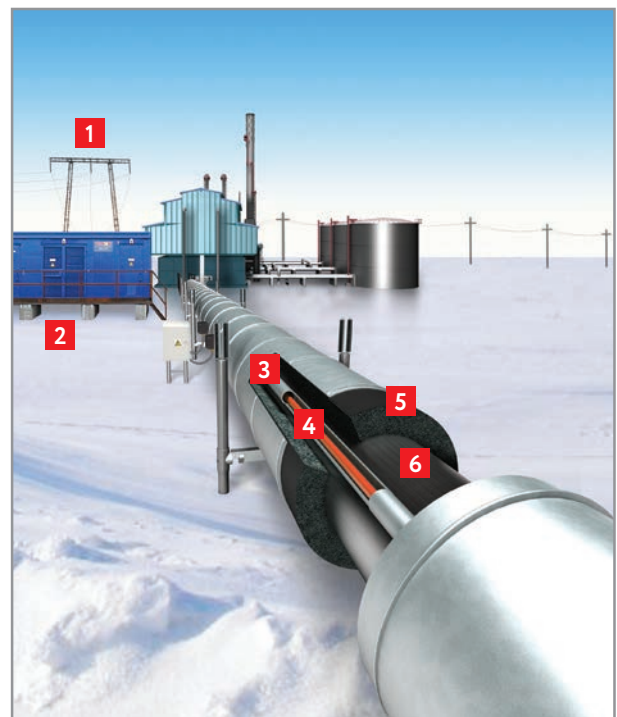

## Approvals

№ ОГН4.RU.1304.B00238  
IECEX CCVE 18.0002X  
DEKRA 18ATEX0033 X



# Heat Tracing System Based on Skin-Effect

## Control and Power Supply Diagram

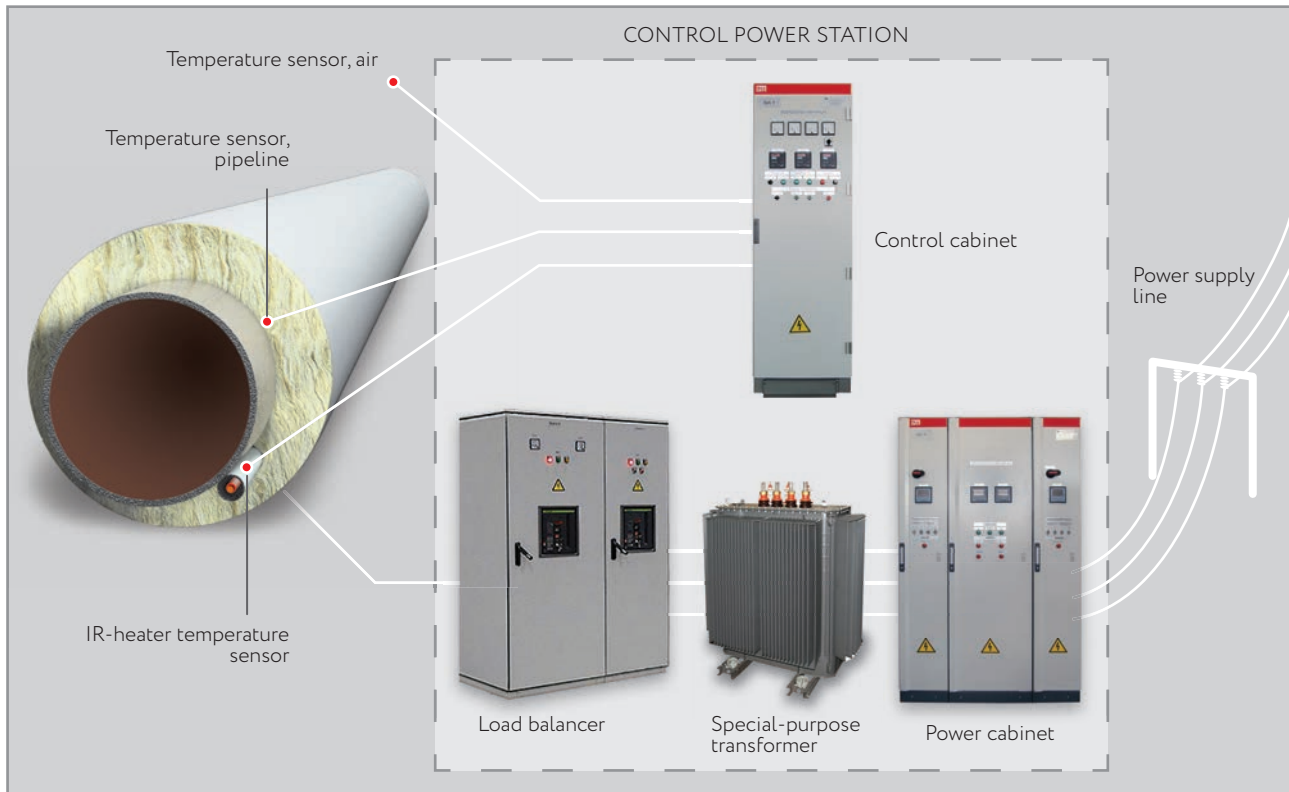

To power the load, transformer-capacitor converters are used, which consist of a load balancer and a special-purpose transformer. It allows to connect a high single-phase load (the skin system heater) to a three-phase supply, and there is no current misalignment on the power supply side.

The control system monitors ambient air temperature, IR-heater temperature, heated pipeline temperature, load current and load voltage. The control system allows to remotely control the heating and monitor all the vital parameters.

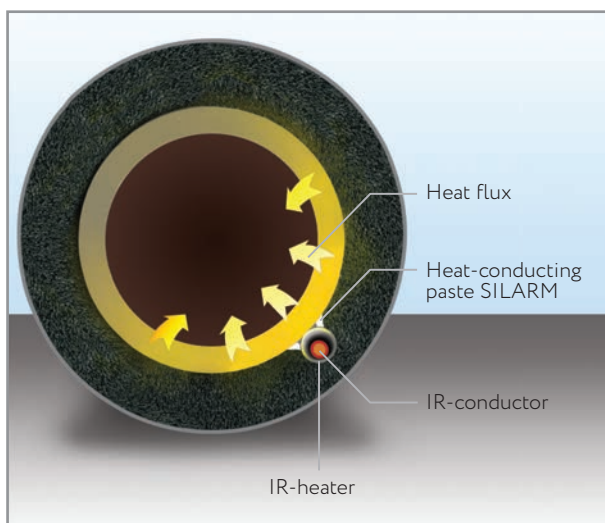

Safety of the system is provided by the surface effect causing the current to follow the internal surface of the IR-heater. The external surface potential is zero.

Heat transfer from the skin system to the pipeline is supported by the tight contact and the use of the heat-conducting paste SILARM.

## Heat Generation

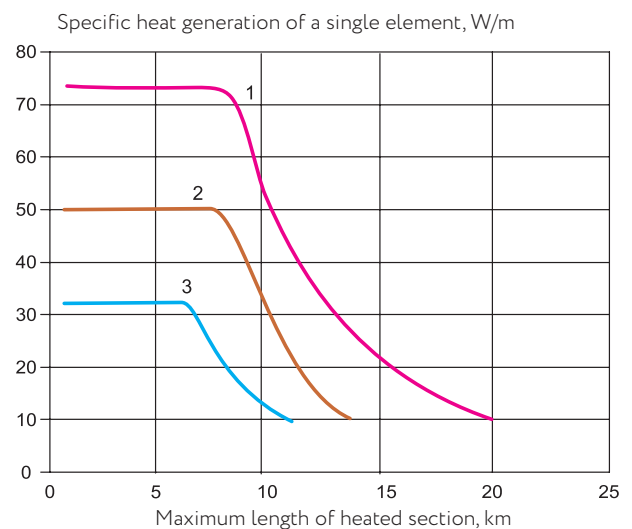

	Heater diameter	Cross-section of the current-carrying conductor
1	42×3	40 mm <sup>2</sup>
2	32×3	20 mm <sup>2</sup>
3	25×3	10 mm <sup>2</sup>

PREMIUM line

# Oil & Gas Wells Electric Heating System Stream Tracer™

The Stream Tracer™ system is an integrated solution for protecting oil wells from the formation of asphaltine-resin-paraffin deposits (ARPD) and preventing the formation of gas hydrates in natural gas wells. The main function of the system is to keep the fluid at a temperature above the paraffinization temperature in the tubing string.

Stream Tracer™ uses a special flexible self-supporting heater with increased and reduced power zones to significantly reduce the energy costs of the well heating system.

A special heating cable is placed inside the tubing using the mobile system. Power is supplied to the skin heater from the top end and a short-circuiting seal is installed at the bottom end. The fluid temperature is

maintained in the well at a level higher than the crystallization temperature of the paraffins, which prevents the formation of deposits.

The heater in the Stream Tracer™ system has a coaxial design, with heat generated both by current flow in the conductors and by currents induced in the complex external conductor. This approach makes it possible to improve the heat transfer efficiency from the heater to the oil fluid, compared with the series-resistance electric heating systems.

SST Group's proprietary heater with output power varying along the length reduces the energy costs of the wellbore heating system by up to 50% compared to systems based on conventional series-resistance cables.

## Features and Application Areas

- Well protection from ARPD formation
- Fault-free operation of equipment and longer service life
- Decreased emergency repairs
- Longer well workover intervals and reduced equipment downtime
- Better field performance due to a reduction of the heating energy costs by up to 50%\*
- Quick installation using a mobile system

## Construction

1. Power supply and control system
2. Special-purpose transformer
3. Terminal box
4. Flexible skin-heater placed in the tubing

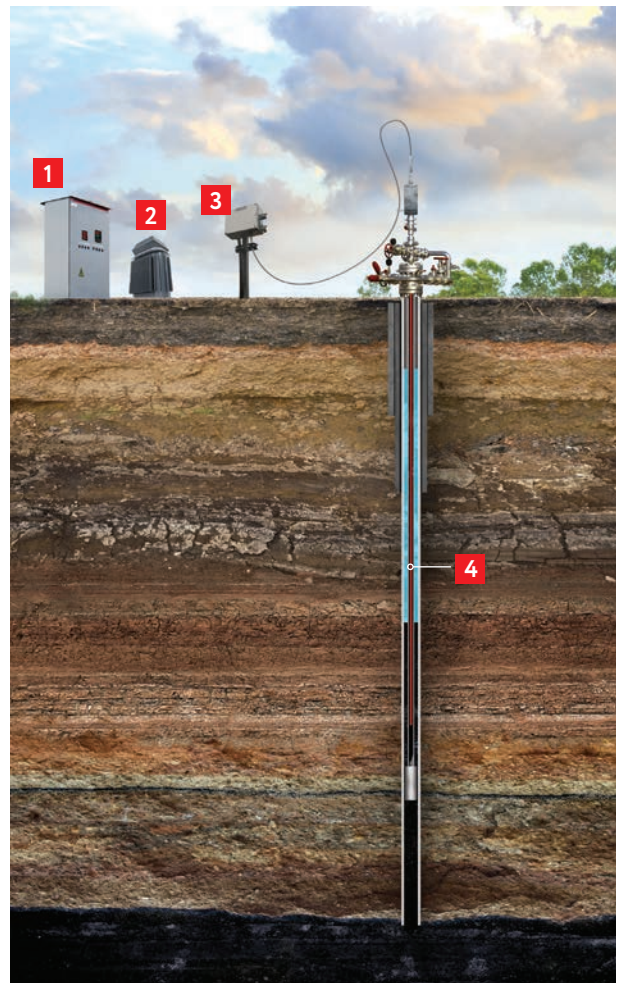

\* Compared with the well heating solution based on a resistive heating cable

# Oil & Gas Wells Electric Heating System Stream Tracer™



## Technical Data

Power supply voltage	up to 1 kV
Linear power	50 W/m
Heater length	1.5 km*
Minimum temperature of installation	-25 °C
Minimum bending radius	400 mm
Crushing force	up to 12 kN (at a running speed of 0.25 m/sec)
Tensile force	up to 28 kN
Chemical resistance to petroleum products	high

The heater remains operational at an external pressure of up to 150 atm and a temperature of up to +70 °C.

The heater remains operational after 100 bends at a radius of 400 mm (at temperatures above 0 °C).

## Energy Efficiency

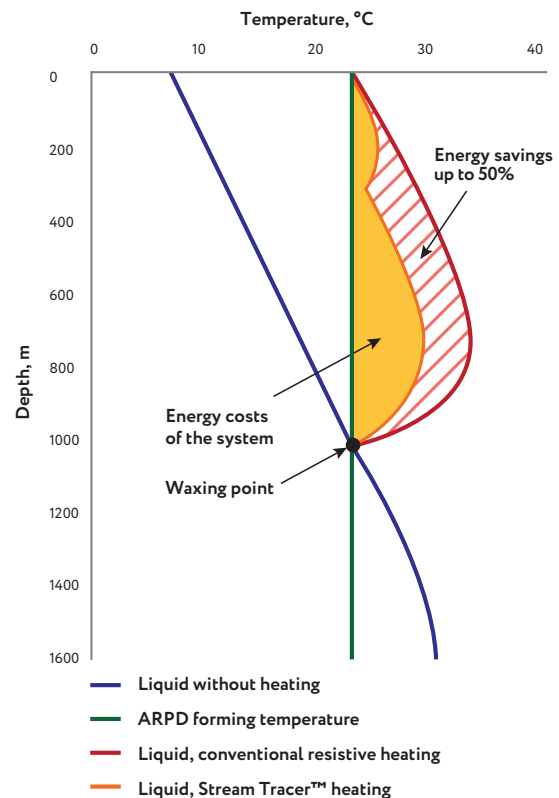

Energy efficiency of Stream Tracer™ compared to a series-resistance cable

The design and manufacturing technology offered by SST Group allows adjusting the linear power of heat generation in individual sections of the heater (the orange line in the figure), giving an advantage over the series-resistance heaters (the red line in the figure).

\* A heater 3 km long is under development

# Longline Heat Tracing System

SST longline heat tracing system is based on LLS heating cable which is composed of three parallel heating cores of copper wire insulated by silicone rubber, covered by a tinned copper wire armor and a silicone rubber jacket.

The heating cores are sized to support the desired heat generation by the required circuit length. Heating cables are connected directly to a three-phase power supply or, if required, to a step-up transformer.

The large heat transfer surface of the flat heating cable reduces operating temperature compared to similar heating cables with a cylindrical conductor design, thereby improving the efficiency, safety and service life of the

heating cable. Using as an insulator silicone rubber capable of retaining its electrical and mechanical properties over a broad temperature range makes it possible to achieve a heat generation level of up to 40 W/m.

LLS cables can be arranged in a straight line or spirally on a pipe. On pre-insulated pipelines the cables are usually routed via conduits mounted on the pipe under the thermal insulation.

The heating cable is delivered in convenient lengths for serial connection on site or as ready-made heating sections.

The system minimizes the number of power source connections and thus reduces the required investment into power supply networks.

## Features and Application Areas

- Heated section length up to 4 km
- High heat generation up to 40 W/m
- High efficiency, large heat transfer surface area and flexibility
- Full set of control tools and accessories
- Single connection to the power source to minimize the cost of the cable system
- Easy installation

## Construction



1. Heating cores of copper wire
2. Silicone rubber insulation
3. Tinned copper wire armor
4. Silicone rubber jacket

## IMPORTANT!

1. To avoid overheating, the cable should not overlap or be laid in insufficiently spaced stretches.
2. Installation instructions must be strictly followed.

## Applications

LLS is a three-phase series-resistance heating cable used to prevent freezing or maintain the temperature in pipelines of intermediate length (up to 4 km) in safe and explosive areas.

A typical application is maintaining the temperature in overground or underground oil and gas pipelines, protecting water lines from freezing.

## Power Supply System

The electric heating system is connected to either a source of power (a dedicated step-up transformer with a supply voltage higher than 380 V) or a three-phase grid via a power management system.

The power supply output should match to the power intake of the electric heating system. The included cold-start system helps to reduce starting currents.

## Longline Heat Tracing System

SST Energomontazh, part of SST Group, not only offers LLS heating cables forming a part of the electric heating system, but also designs, manufactures and carries out the installation of integrated systems adapted to the specific conditions on the customer's site. Scope of supply includes a source of power (if the voltage is other than 380 V), a power management and temperature control system, circuit integrity monitoring / control equipment, power connection boxes, maintenance boxes, connection fittings and other accessories designed for installation as part of your heat tracing system.



# Longline Heat Tracing System

## Technical Data

Maximum operating temperature	+130 °C
Maximum permissible temperature without load	+180 °C
Ambient temperature range	-60...+55 °C
Minimum installation temperature	-60 °C
Power supply	three-phase up to 900 V depending on version for specific application
Heat generation	up to 40 W/m depending on version for specific application
Ex marking	1Ex e IIC T3 Gb X
Degree of external protection GOST 14254-96	IP67
Heating core cross section	1.5 mm <sup>2</sup> , 3.0 mm <sup>2</sup> , 6.0 mm <sup>2</sup>

Please note that the manufacturer can change the dimensions of the cores to provide the required heat generation (W/m) at a given circuit length.

## Dimensions

Type	Nominal size, mm	Minimum bending radius, mm
LLS 3×1.5	14.9×7.8	40
LLS 3×3.0	16.9×8.5	45
LLS 3×6.0	19.6×9.4	50

## Maximum Pipe / System Temperature

Surface temperature of the heating cable must not exceed maximum temperature that its structural materials can withstand or the temperature class of the respective area (if installed in a potentially explosive area). This is achieved by limiting the heat generation of the heating cable depending on the temperature of the pipe or heated system to a safe level as part of the design or by means of a temperature control system.

For the most unfavorable heat exchange conditions, the pipeline temperature must be limited to the following threshold values:

Nominal heat generation, heating cable, W/m	Maximum temperature of the heated system, °C						
	Location						Safe
	Explosive						
	T <sub>6</sub>	T <sub>5</sub>	T <sub>4</sub>	T <sub>3</sub>	T <sub>2</sub>	T <sub>1</sub>	
5	55	70	100	100	100	100	100
10	50	65	95	95	95	95	95
20	30	45	75	75	75	75	75
25	20	35	70	70	70	70	70
30	10	25	55	55	55	55	55
35	-	15	45	45	45	45	45
40	-	-	30	30	30	30	30

## Model Installation Diagram

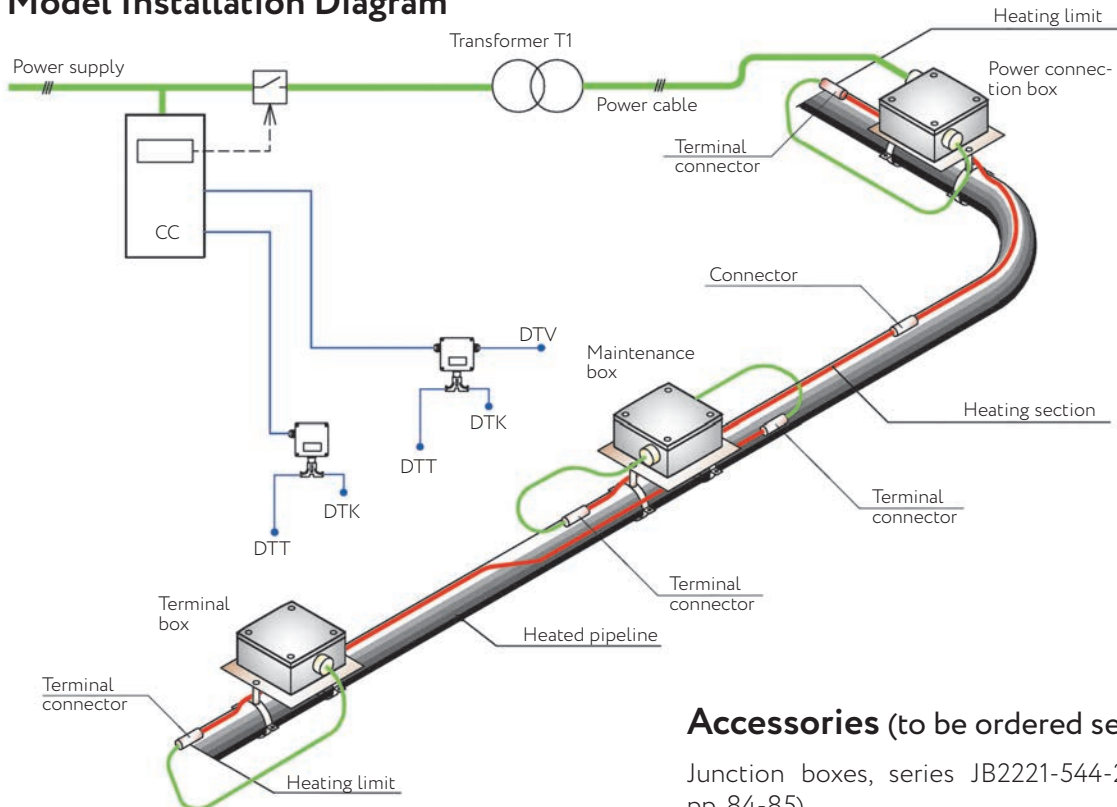

## Types

Name	Order code
LLS 3×1.5	3202000000
LLS 3×3.0	3202000001
LLS 3×6.0	3202000002
LLS-SK	3299004000
LLS-TK	3299004001

## Accessories (to be ordered separately)

Junction boxes, series JB2221-544-2X(60-64) (see pp. 84-85).

LLS-SK kit is a connection for splicing LLS heating cables on the site.

LLS-TK kit is a connection for the heating cable LLS 3×6.0, including installation wire connected to a power supply, maintenance or terminal box (factory-installed).

Please fill out and send us this questionnaire containing the parameters required to design the electric heating system. We will respond with a detailed quote.

## QUESTIONNAIRE

<b>1 Customer*</b>	Company	<input style="width: 100%;" type="text"/>				
	Name	<input style="width: 50%;" type="text"/>	Surname	<input style="width: 50%;" type="text"/>		
	Phone	<input style="width: 50%;" type="text"/>	E-mail	<input style="width: 50%;" type="text"/>		
<b>2 Site object*</b>	Name	<input style="width: 100%;" type="text"/>				
	Location*	<input style="width: 100%;" type="text"/>				
	Available design documentation for heated object	<input type="radio"/> Yes <input type="radio"/> No				
	Installer	<input style="width: 100%;" type="text"/>				
<b>3 Type of design works*</b>	<input type="checkbox"/> Thermotechnical stage (TTS) <small>(installation drawings and cabinets one-line diagrams)</small>	<input type="checkbox"/> Automation (ACS - automated control systems) <small>(a possibility of centralized control and data transfer to the higher level)</small>				
	<input type="checkbox"/> Electrotechnical stage (ETS) <small>(electric networks laying diagrams, cable record)</small>	<input type="checkbox"/> Thermal insulation (TI) <small>(equipment thermal insulation drawings, list of equipment to be installed)</small>				
	<input type="checkbox"/> Freeze protection	<input type="checkbox"/> Anti-condensate heating				
	<input type="checkbox"/> Temperature maintenance	<input type="checkbox"/> Heating-up		Time of heating	<input style="width: 50px;" type="text"/> hours	
<b>4 Purpose of the system</b>	Initial temperature	<input style="width: 50px;" type="text"/> °C				
	<input style="width: 50px;" type="text"/> °C, Required pipe temperature*					
	<input style="width: 50px;" type="text"/> °C, Minimum ambient temperature					
	<input style="width: 50px;" type="text"/> °C, Maximum ambient temperature					
	<input style="width: 50px;" type="text"/> °C, Standard process-oriented temperature* <small>(Product temperature under standard operational conditions)</small>					
	<input style="width: 50px;" type="text"/> °C, Maximum process-oriented temperature* <small>(The highest process-oriented temperature the product may occasionally attain)</small>					
	<input style="width: 50px;" type="text"/> °C, Maximum allowed product temperature* <small>(The product highest temperature having no adverse effect on the product properties)</small>					
<b>5 Temperature conditions</b>	<input style="width: 50px;" type="text"/> °C, Minimum activation temperature* <small>(The lowest temperature, which enables activation of the heating system)</small>					
	<input style="width: 50px;" type="text"/> °C, Maximum steam temperature in case an object steaming is stipulated					
<b>6 Steaming*</b>						
<b>7 Environment</b>	<input type="radio"/> Normal (water, household wastewater) <input type="radio"/> Corrosive (oil, lube oils, industrial wastes)					
<b>8 Pipeline location*</b>	<input type="checkbox"/> Open air	<input type="checkbox"/> Underground		Depth	<input style="width: 50px;" type="text"/> m	
	<input type="checkbox"/> Indoors			Soil	<input style="width: 100px;" type="text"/>	
<b>9 Cabling</b>	<input type="radio"/> External <input type="radio"/> Internal					
<b>10 Heat insulation type*</b>	<input type="checkbox"/> Mineral wool	<input type="checkbox"/> Preinsulated pipes				
	<input type="checkbox"/> Foamed rubber	<input type="checkbox"/> Other, heat conductivity coefficient <input style="width: 50px;" type="text"/> W/m·°C				
<b>11 Heat insulation installation</b>	<input type="checkbox"/> Onsite <input type="checkbox"/> Preinsulated pipes					
<b>12 Zone classification</b>	<input type="checkbox"/> Safe <input type="checkbox"/> Explosion hazardous					
<b>13 Pipe material*</b>	<input type="checkbox"/> Carbon steel	<input type="checkbox"/> Stainless steel				
	<input type="checkbox"/> Plastic	<input type="checkbox"/> Other, heat conductivity coefficient <input style="width: 50px;" type="text"/> W/m·°C				
<b>14 Parameters of pipeline*</b>	<b>Pipeline</b>					
	Pipeline name	<input style="width: 50px;" type="text"/>	<input style="width: 50px;" type="text"/>	<input style="width: 50px;" type="text"/>	<input style="width: 50px;" type="text"/>	<input style="width: 50px;" type="text"/>
	Pipeline diameter	<input style="width: 50px;" type="text"/>	<input style="width: 50px;" type="text"/>	<input style="width: 50px;" type="text"/>	<input style="width: 50px;" type="text"/>	<input style="width: 50px;" type="text"/>
	Heat insulation thickness, mm	<input style="width: 50px;" type="text"/>	<input style="width: 50px;" type="text"/>	<input style="width: 50px;" type="text"/>	<input style="width: 50px;" type="text"/>	<input style="width: 50px;" type="text"/>
	Pipe length, m	<input style="width: 50px;" type="text"/>	<input style="width: 50px;" type="text"/>	<input style="width: 50px;" type="text"/>	<input style="width: 50px;" type="text"/>	<input style="width: 50px;" type="text"/>
	Quantity of valves, pcs	<input style="width: 50px;" type="text"/>	<input style="width: 50px;" type="text"/>	<input style="width: 50px;" type="text"/>	<input style="width: 50px;" type="text"/>	<input style="width: 50px;" type="text"/>
	Quantity of flanges, pcs	<input style="width: 50px;" type="text"/>	<input style="width: 50px;" type="text"/>	<input style="width: 50px;" type="text"/>	<input style="width: 50px;" type="text"/>	<input style="width: 50px;" type="text"/>
	Quantity of pipe supports, pcs	<input style="width: 50px;" type="text"/>	<input style="width: 50px;" type="text"/>	<input style="width: 50px;" type="text"/>	<input style="width: 50px;" type="text"/>	<input style="width: 50px;" type="text"/>
	Pumped product	<input style="width: 50px;" type="text"/>	<input style="width: 50px;" type="text"/>	<input style="width: 50px;" type="text"/>	<input style="width: 50px;" type="text"/>	<input style="width: 50px;" type="text"/>
	Product density, kg/m <sup>3</sup>	<input style="width: 50px;" type="text"/>	<input style="width: 50px;" type="text"/>	<input style="width: 50px;" type="text"/>	<input style="width: 50px;" type="text"/>	<input style="width: 50px;" type="text"/>
Product heat capacity, J/(kg·°C)	<input style="width: 50px;" type="text"/>	<input style="width: 50px;" type="text"/>	<input style="width: 50px;" type="text"/>	<input style="width: 50px;" type="text"/>	<input style="width: 50px;" type="text"/>	
<b>15 Further information</b>	<input style="width: 100%;" type="text"/>				Date*	<input style="width: 100px;" type="text"/>

\* Required field (mandatory for completion)

Please fill out and send us this questionnaire containing the parameters required to design the electric heating system. We will respond with a detailed quote.

## QUESTIONNAIRE

<b>1 Customer*</b>	Company <input style="width: 600px;" type="text"/>
	Name <input style="width: 200px;" type="text"/> Surname <input style="width: 150px;" type="text"/>
	Phone <input style="width: 200px;" type="text"/> E-mail <input style="width: 150px;" type="text"/>
<b>2 Site object*</b>	Name <input style="width: 600px;" type="text"/>
	Location* <input style="width: 600px;" type="text"/>
	Available design documentation for heated object <input style="width: 400px;" type="text"/>
	Installer <input style="width: 600px;" type="text"/>
	Responsible representative <input style="width: 200px;" type="text"/> Phone <input style="width: 150px;" type="text"/>
<b>3 Type of design works*</b>	<input type="checkbox"/> Thermotechnical stage (TTS) (installation drawings and cabinets one-line diagrams) <input type="checkbox"/> Automation (ACS - automated control systems) (a possibility of centralized control and data transfer to the higher level)
	<input type="checkbox"/> Electrotechnical stage (ETS) (electric networks laying diagrams, cable record) <input type="checkbox"/> Thermal insulation (TI) (equipment thermal insulation drawings, list of equipment to be installed)
<b>4 Purpose of the system*</b>	<input type="checkbox"/> Freeze protection <input type="checkbox"/> Anti-condensate heating
	<input type="checkbox"/> Temperature maintenance <input type="checkbox"/> Heating-up Time of heating <input style="width: 50px;" type="text"/> hours Initial temperature <input style="width: 50px;" type="text"/> °C
<b>5 Temperature conditions</b>	<input style="width: 50px;" type="text"/> °C, Required vessel temperature*
	<input style="width: 50px;" type="text"/> °C, Minimum ambient temperature
	<input style="width: 50px;" type="text"/> °C, Maximum ambient temperature
	<input style="width: 50px;" type="text"/> °C, Standard process temperature* (Product temperature under standard operational conditions)
	<input style="width: 50px;" type="text"/> °C, Maximum process temperature* (The highest temperature the vessel may occasionally attain)
	<input style="width: 50px;" type="text"/> °C, Maximum allowed product temperature* (The product highest temperature having no adverse effect on the product properties)
	<input style="width: 50px;" type="text"/> °C, Minimum activation temperature* (The lowest temperature, which enables activation of the heating system)
<b>6 Steaming</b>	<input style="width: 50px;" type="text"/> °C, Maximum steam temperature in case an object steaming is provided
<b>7 Object location*</b>	<input type="checkbox"/> Open air <input type="checkbox"/> On the soil
	<input type="checkbox"/> Indoors <input type="checkbox"/> On supports, their design: <input style="width: 150px;" type="text"/>
<b>8 Cabling*</b>	<input type="checkbox"/> External Distance to heating control point <input style="width: 50px;" type="text"/> m
	<input type="checkbox"/> Internal Distance to power supply point <input style="width: 50px;" type="text"/> m
<b>9 Heat insulation type*</b>	<input type="checkbox"/> Mineral wool (mats) Thickness <input style="width: 50px;" type="text"/> mm
	<input type="checkbox"/> Others, heat-conductivity factor <input style="width: 50px;" type="text"/> W/m·°C
<b>10 Zone classification</b>	<input type="checkbox"/> Safe <input type="checkbox"/> Explosion hazardous (zone classification) <input style="width: 100px;" type="text"/>
<b>11 Vessel material*</b>	<input type="checkbox"/> Carbon steel <input type="checkbox"/> Stainless steel
	<input type="checkbox"/> Plastic <input type="checkbox"/> Other, heat conductivity coefficient <input style="width: 50px;" type="text"/> W/m·°C
<b>12 Parameters of the vessel*</b>	<input type="checkbox"/> Horizontal Diameter <input style="width: 50px;" type="text"/> mm <input type="checkbox"/> Vertical Height <input style="width: 50px;" type="text"/> mm Fullness coefficient <input style="width: 50px;" type="text"/>
	Walls thickness <input style="width: 50px;" type="text"/> mm
	Fittings and hatches: <input style="width: 400px;" type="text"/>
	Type of cover: <input type="checkbox"/> Flat Cover height <input style="width: 50px;" type="text"/> m
	<input type="checkbox"/> Spherical
	<input type="checkbox"/> Conic
<b>13 Parameters of the product</b>	Name* <input style="width: 300px;" type="text"/>
	Density <input style="width: 50px;" type="text"/> kg/m <sup>3</sup>
	Viscosity <input style="width: 50px;" type="text"/> kg/m·s at a temperature <input style="width: 50px;" type="text"/> °C
	Heat capacity <input style="width: 50px;" type="text"/> J/kg·°C
	Discharge <input style="width: 50px;" type="text"/> m <sup>3</sup> /h <input type="checkbox"/> Continuous <input type="checkbox"/> Cyclic
<b>14 Further information</b>	<input style="width: 300px;" type="text"/>
	<input style="width: 300px;" type="text"/>
	Date* <input style="width: 150px;" type="text"/>

\* Required field (mandatory for completion)

Please fill out and send us this questionnaire containing the parameters required to design the electric heating system. We will respond with a detailed quote.

## QUESTIONNAIRE (INCLUDES ATTACHMENT FOR PACKAGE TRANSFORMER SUBSTATION DESIGN)

<b>1 Customer*</b>	Company	<input style="width: 100%;" type="text"/>				
	Name	<input style="width: 20%;" type="text"/>	Surname	<input style="width: 60%;" type="text"/>		
	Phone	<input style="width: 20%;" type="text"/>	E-mail	<input style="width: 60%;" type="text"/>		
<b>2 Site object*</b>	Name	<input style="width: 100%;" type="text"/>				
	Location*	<input style="width: 100%;" type="text"/>				
	Available design documentation for heated object	<input type="radio"/> Yes <input type="radio"/> No				
	Installer	<input style="width: 100%;" type="text"/>				
<b>3 Type of design works*</b>	Responsible representative	<input style="width: 40%;" type="text"/>	Phone	<input style="width: 20%;" type="text"/>		
	<input type="checkbox"/> Thermotechnical stage (TTS) (installation drawings and package transformer substation (PTS) diagrams)	<input type="checkbox"/> Automation (ACS – automated control systems) (a possibility of centralized control and data transfer to the higher level)				
	<input type="checkbox"/> Electrotechnical stage (ETS) (electric networks laying diagrams, cable record)	<input type="checkbox"/> Thermal insulation (TI) (equipment thermal insulation drawings, list of equipment to be installed)				
<b>4 Purpose of system</b>	<input type="checkbox"/> Freeze protection	<input type="checkbox"/> Anti-condensate heating				
	<input type="checkbox"/> Temperature maintenance	<input type="checkbox"/> Heating-up	Time of heating	<input style="width: 20%;" type="text"/> hours	Initial temperature <input style="width: 20%;" type="text"/> °C	
<b>5 Temperature conditions</b>	<input style="width: 20%;" type="text"/> °C, Required pipeline temperature*					
	Minimum ambient temperature minus <input style="width: 20%;" type="text"/> °C, maximum ambient temperature <input style="width: 20%;" type="text"/> °C					
	<input style="width: 20%;" type="text"/> °C, Standard process temperature* (Product temperature under standard operational conditions)					
	<input style="width: 20%;" type="text"/> °C, Maximum process temperature* (The highest temperature the vessel may occasionally attain)					
	<input style="width: 20%;" type="text"/> °C, Maximum allowed product temperature* (The product highest temperature having no adverse effect on the product properties)					
<b>6 Pipeline location*</b>	<input type="checkbox"/> Open air					
	<input type="checkbox"/> Subsea					
	<input type="checkbox"/> Underground	Laying depth	<input style="width: 20%;" type="text"/> m	Soil	<input style="width: 20%;" type="text"/>	
	With pipeline laying depth of over 0.7m from the soil surface, specify the average temperature of the coldest month <input style="width: 20%;" type="text"/> °C					
<b>7 Heat insulation installation*</b>	<input type="checkbox"/> In plant conditions		<input type="checkbox"/> Onsite			
<b>8 Heat insulation type*</b>	<input type="checkbox"/> Mineral wool	<input type="checkbox"/> Foamed polyurethane				
	<input type="checkbox"/> Foamed rubber	<input type="checkbox"/> Other, heat conductivity coefficient		<input style="width: 20%;" type="text"/>	W/m·°C	
<b>9 Supply points location*</b>	<input type="checkbox"/> From one end of heated area		<input type="checkbox"/> Others <input style="width: 40%;" type="text"/>			
	<input type="checkbox"/> From both ends		Distance from power supply point to the beginning of heated area*		<input style="width: 20%;" type="text"/> m	
<b>10 Zone classification</b>	<input type="checkbox"/> Safe		<input type="checkbox"/> Explosion hazardous (area classification)			
<b>11 Pipe material*</b>	<input type="checkbox"/> Carbon steel		<input type="checkbox"/> Stainless steel			
	<input type="checkbox"/> Plastic		<input type="checkbox"/> Other, heat conductivity coefficient		<input style="width: 20%;" type="text"/> W/m·°C	
<b>12 Parameters of pipelines*</b>	<b>Pipeline</b>	1	2	3	4	5
	Pipeline name	<input style="width: 20%;" type="text"/>	<input style="width: 20%;" type="text"/>	<input style="width: 20%;" type="text"/>	<input style="width: 20%;" type="text"/>	<input style="width: 20%;" type="text"/>
	Pipe outer diameter, mm	<input style="width: 20%;" type="text"/>	<input style="width: 20%;" type="text"/>	<input style="width: 20%;" type="text"/>	<input style="width: 20%;" type="text"/>	<input style="width: 20%;" type="text"/>
	Pipe wall thickness, mm	<input style="width: 20%;" type="text"/>	<input style="width: 20%;" type="text"/>	<input style="width: 20%;" type="text"/>	<input style="width: 20%;" type="text"/>	<input style="width: 20%;" type="text"/>
	Heat insulation thickness, mm	<input style="width: 20%;" type="text"/>	<input style="width: 20%;" type="text"/>	<input style="width: 20%;" type="text"/>	<input style="width: 20%;" type="text"/>	<input style="width: 20%;" type="text"/>
	Pipe length, m	<input style="width: 20%;" type="text"/>	<input style="width: 20%;" type="text"/>	<input style="width: 20%;" type="text"/>	<input style="width: 20%;" type="text"/>	<input style="width: 20%;" type="text"/>
	Number of valves, pcs	<input style="width: 20%;" type="text"/>	<input style="width: 20%;" type="text"/>	<input style="width: 20%;" type="text"/>	<input style="width: 20%;" type="text"/>	<input style="width: 20%;" type="text"/>
	Number of flanges, pcs	<input style="width: 20%;" type="text"/>	<input style="width: 20%;" type="text"/>	<input style="width: 20%;" type="text"/>	<input style="width: 20%;" type="text"/>	<input style="width: 20%;" type="text"/>
Number of pipe supports, pcs	<input style="width: 20%;" type="text"/>	<input style="width: 20%;" type="text"/>	<input style="width: 20%;" type="text"/>	<input style="width: 20%;" type="text"/>	<input style="width: 20%;" type="text"/>	
<b>13 Further information</b>	More detailed further information can be entered in the Attachment					
	<input style="width: 100%;" type="text"/>				Date* <input style="width: 20%;" type="text"/>	

\* Required field (mandatory for completion)

Please make sure to fill in the Attachment!

Please fill out and send us this questionnaire containing the parameters required to design the electric heating system. We will respond with a detailed quote.

## ATTACHMENT TO THE QUESTIONNAIRE

<b>1 Customer*</b>	Company	<input type="text"/>		
	Name	<input type="text"/>	Surname	<input type="text"/>
	Phone	<input type="text"/>	E-mail	<input type="text"/>
<b>2 Site object*</b>	Name	<input type="text"/>		
	Location*	<input type="text"/>		
	Available design documentation for heated pipeline	<input type="radio"/> Yes <input type="radio"/> No		
	Installer	<input type="text"/>		
	Responsible representative	<input type="text"/>	Phone	<input type="text"/>
<b>3 PTS design</b>	<input type="checkbox"/>	Kiosk type without heat insulation and heating		
	<input type="checkbox"/>	Kiosk type with heat insulation and heating		
<b>4 Supply lead</b>	<input type="checkbox"/>	Cable	<input type="checkbox"/>	Others: <input type="text"/>
	<input type="checkbox"/>	Aerial		
<b>5 Installation</b>	<input type="checkbox"/>	On soil		
	<input type="checkbox"/>	On supports		
<b>6 Fire fighting system</b>	<input type="checkbox"/>	Indication	<input type="checkbox"/>	Automatic
	<input type="checkbox"/>	Fire extinguisher	<input type="checkbox"/>	Others: <input type="text"/>
<b>7 Ventilation system</b>	<input type="checkbox"/>	Natural draft	<input type="checkbox"/>	Air conditioner
	<input type="checkbox"/>	Forced draft	<input type="checkbox"/>	Others: <input type="text"/>
<b>8 Remote control</b>	<input type="checkbox"/>	Yes		
	<input type="checkbox"/>	No	<input type="checkbox"/>	Others: <input type="text"/>
<b>9 Telemetry</b>	<input type="checkbox"/>	Signaling	<input type="checkbox"/>	Monitoring
	<input type="checkbox"/>	Control	<input type="checkbox"/>	Others: <input type="text"/>
<b>10 Earthing</b>	<input type="checkbox"/>	Horizontal		
	<input type="checkbox"/>	Vertical	<input type="checkbox"/>	Others: <input type="text"/>
<b>11 Energy accounting</b>	<input type="checkbox"/>	Yes		
	<input type="checkbox"/>	No	<input type="checkbox"/>	Others: <input type="text"/>
<b>12 Transformer type</b>	<input type="checkbox"/>	Oil filled		
	<input type="checkbox"/>	Dry		
<b>13 Protection type</b>	<input type="checkbox"/>	Relay module		
	<input type="checkbox"/>	Electronic module		
<b>14 System's power supply parameters*</b>	<input type="checkbox"/>	Diesel generator	Supply voltage	<input type="text"/> V
	<input type="checkbox"/>	Power line	Frequency	<input type="text"/> Hz
	<input type="checkbox"/>	Others: <input type="text"/>	Number of phases	<input type="text"/>
<b>15 Further information</b>	<div style="border: 1px solid black; width: 100%; height: 100%;"></div>			
			Date*	<input type="text"/>

Questionnaires

\* Required field (mandatory for completion)

Please make sure to fill in the Questionnaire!

Please fill out and send us this questionnaire containing the parameters required to design the electric heating system. We will respond with a detailed quote.

## QUESTIONNAIRE

### 1 General information\*

Company	<input type="text"/>		
Oil field name	<input type="text"/>		
Well ID	<input type="text"/>		
Mode of operation	<input type="text"/>		
Well depth	<input type="text"/> m	The diameter of the production string	<input type="text"/> mm
Diameter of PSP (Pressure-compressor pipe)	<input type="text"/> mm	Depth of suspension of PSP	<input type="text"/> m

### 2 Temperatures distribution by the depth

Oil layer temperature	<input type="text"/> °C	Permafrost depth	<input type="text"/> m
Average temperature of the coldest month	<input type="text"/> °C	Maximum temperature of the warmest month	<input type="text"/> °C

### 3 Stratum fluid details

Water percentage	<input type="text"/> %	Paraffin percentage	<input type="text"/> %
The gas factor	<input type="text"/> m <sup>3</sup> /ton	Beginning temperature of paraffin's deposition	<input type="text"/> °C

### 4 Well operation mode

Static level	<input type="text"/> m	Fluid debit (with clean PSP)	<input type="text"/> m <sup>3</sup> /day
Oil debit	<input type="text"/>	Minimum fluid debit	<input type="text"/>
Dynamic level	<input type="text"/> m	Fluid temperature at wellhead	<input type="text"/> °C
The maximum depth of the heavy oil's deposits	<input type="text"/> m		

### 5 Well site's data

Type and size of wellhead flange for lubricator installation	<input type="text"/>
Explosive area borders during maintenance mode and normal operation mode	<input type="text"/>
Power supply available for heating system (voltage, power)	<input type="text"/>

### 6 Data for evaluation of the heating effectiveness

Well maintenance schedule	<input type="text"/> times per year
The period between cleaning of SPS from heavy oils	<input type="text"/> times per year
PSP cleaning method	<input type="text"/>

Data provided by (name, position)*	<input type="text"/>
Phone, e-mail*	<input type="text"/>

\* Required field (mandatory for completion).

Please fill out and send us this questionnaire containing the parameters required to design the electric heating system. We will respond with a detailed quote.

## QUESTIONNAIRE

For project documentation N \_\_\_\_\_

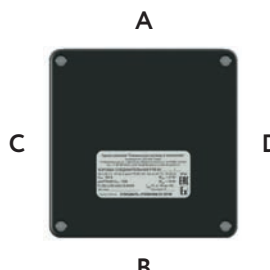
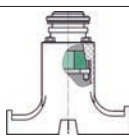
<b>1 Housing</b>	Dimensions	Length <input type="text"/> mm × Width <input type="text"/> mm × Depth <input type="text"/> mm									
	Enclosure material	<input type="radio"/> plastic	<input type="radio"/> aluminium	<input type="radio"/> stainless steel							
	Explosion protection level required	<input type="radio"/> "d"	<input type="radio"/> "ia"	<input type="radio"/> "e" <input type="radio"/> without explosion protection							
	IP	<input type="radio"/> IP 65	<input type="radio"/> IP 66	<input type="radio"/> IP 67 <input type="radio"/> IP 68							
	Temperature class	<input type="radio"/> T4	<input type="radio"/> T5	<input type="radio"/> T6							
	Operating temperature	T <sub>ambience</sub> from <input type="text"/> °C to <input type="text"/> °C									
<b>2 Terminal block</b>	Connection wire	<b>L</b>	<b>N</b>	<b>PE</b>							
	Nominal current	<input type="text"/> A	<input type="text"/> A	<input type="text"/> A							
	Wire section	<input type="text"/> mm <sup>2</sup>	<input type="text"/> mm <sup>2</sup>	<input type="text"/> mm <sup>2</sup>							
	Quantity	<input type="text"/> pcs	<input type="text"/> pcs	<input type="text"/> pcs							
	Type of terminals	<input type="radio"/> screw <input type="radio"/> spring									
<b>3 Cable glands</b>	Installation side	<b>A</b>	<b>B</b>	<b>C</b>	<b>D</b>						
	Cable gland type & size	<input type="text"/>	<input type="text"/>	<input type="text"/>	<input type="text"/>	<input type="text"/>	<input type="text"/>	<input type="text"/>	<input type="text"/>	<input type="text"/>	<input type="text"/>
	Cable type	<input type="text"/>	<input type="text"/>	<input type="text"/>	<input type="text"/>	<input type="text"/>	<input type="text"/>	<input type="text"/>	<input type="text"/>	<input type="text"/>	<input type="text"/>
	External Ø of cable, mm	<input type="text"/>	<input type="text"/>	<input type="text"/>	<input type="text"/>	<input type="text"/>	<input type="text"/>	<input type="text"/>	<input type="text"/>	<input type="text"/>	<input type="text"/>
	Internal Ø of cable, mm	<input type="text"/>	<input type="text"/>	<input type="text"/>	<input type="text"/>	<input type="text"/>	<input type="text"/>	<input type="text"/>	<input type="text"/>	<input type="text"/>	<input type="text"/>
	Quantity, pcs	<input type="text"/>	<input type="text"/>	<input type="text"/>	<input type="text"/>	<input type="text"/>	<input type="text"/>	<input type="text"/>	<input type="text"/>	<input type="text"/>	<input type="text"/>
	Cable gland material	<input type="text"/>	<input type="text"/>	<input type="text"/>	<input type="text"/>	<input type="text"/>	<input type="text"/>	<input type="text"/>	<input type="text"/>	<input type="text"/>	<input type="text"/>
	Mechanical cable protection	<input type="checkbox"/>	<input type="checkbox"/>	<input type="checkbox"/>	<input type="checkbox"/>	<input type="checkbox"/>	<input type="checkbox"/>	<input type="checkbox"/>	<input type="checkbox"/>	<input type="checkbox"/>	<input type="checkbox"/>
<b>4 Options and accessories</b>	<input type="checkbox"/> Anticondensation inner coating	<input type="checkbox"/> Protective hood			<input type="checkbox"/> External earthing lug						
	<input type="checkbox"/> Pipe installation support				<input type="checkbox"/> Drain unit			<input type="checkbox"/> LED-light indicator			
	<input type="checkbox"/> Terminals installation on 15 mm DIN-rail (i.a. at producer's option)				<input type="checkbox"/> Terminal bridges per customer specification						
	<input type="checkbox"/> Design based on model-analogue				Model: <input type="text"/>						
	<b>5 Quantity of junction boxes</b>		<input type="text"/> pcs								
<b>6 Additional information</b>		<input style="height: 30px;" type="text"/>									
<b>7 Contact information</b>	Company	<input type="text"/>			Contact person	<input type="text"/>					
	Phone	<input type="text"/>			E-mail	<input type="text"/>					

Date of completion

# Notes

---



# Notes

---

# Notes

---





part of



[www.gammaswiss.com](http://www.gammaswiss.com)

#### Europe

Switzerland  
+41 245345900  
[infoch@sst-international.com](mailto:infoch@sst-international.com)

Germany  
+49 9343 98091-00  
[info@sst-international.com](mailto:info@sst-international.com)

#### Middle East & India

United Arab Emirates  
+97 1544441205, +97 1569712266  
[sales-me@sst-international.com](mailto:sales-me@sst-international.com)

India  
+91 9810379128  
[sales@sstthermal.com](mailto:sales@sstthermal.com)

#### Russia & CIS

Russia  
+ 7 495 627-72-55  
[info@sst-em.ru](mailto:info@sst-em.ru)

Ukraine  
+38 044 499-11-22  
[market@teploluxe.ua](mailto:market@teploluxe.ua)