

## Cisco 1800 Series Integrated Services Routers Fixed Configuration Models

Cisco Systems® is redefining best-in-class enterprise and small- to midsize-business routing with a new line of integrated services routers that are optimized for the secure delivery of data services. Founded on 20 years of leadership and innovation, the Cisco® 1800 Series integrated services routers intelligently embed data, security, and wireless technology into a single, resilient system for fast, secure, scalable delivery of mission-critical business applications. The best-in-class Cisco 1800 Series architecture has been specifically designed to meet requirements of small to medium-sized businesses (SMBs), enterprise branch offices, and service provider-managed services applications for delivery of concurrent services at wire-speed performance. The integrated secure systems architecture of the Cisco 1800 Series delivers maximum business agility and investment protection.

**Figure 1.** Cisco 1800 Series Fixed-Configuration Routers



### Product Overview

Cisco 1800 Series integrated services routers are the next evolution of the award-winning Cisco 1700 Series modular and fixed-configuration routers. The Cisco 1801, 1802, 1803, 1811, and 1812 integrated services routers (Figure 1) are fixed-configuration, while the Cisco 1841 Integrated Services Router is modular. The routers are designed for secure broadband, Metro Ethernet, and wireless connectivity, and provide significant performance improvements, feature capability, versatility, and additional value compared to prior generations of Cisco 1700 Series. The Cisco 1800 Series fixed-configuration routers provide:

- Secure broadband access with concurrent services for branch and small offices
- Integrated ISDN Basic Rate Interface (BRI), analog modem, or Ethernet backup port for redundant WAN links and load balancing
- Secure wireless LAN for simultaneous 802.11a and 802.11b/g operation with use of multiple antennas
- Advanced security including:
  - Sophisticated Firewall features including Application Inspection, Transparent and Stateful Firewall
  - SSL and IP Security (IPSec) VPNs (Triple Data Encryption Standard [3DES] or Advanced Encryption Standard [AES])
  - Intrusion Prevention System (IPS)
  - Antivirus support through Network Admission Control (NAC) and enforcement of secure access policies

- 8-port 10/100 managed switch with VLAN support and optional Power over Ethernet (PoE)
- Easy deployment and remote-management capabilities through Web-based tools and Cisco IOS® Software

Cisco 1801, 1802, and 1803 routers provide high-speed DSL broadband access through asymmetric DSL (ADSL2/2+ Annex A and Annex M) over basic telephone service (Cisco 1801), ADSL2/2+ Annex B over ISDN (Cisco 1802), or Symmetrical High-Data-Rate DSL (G.SHDSL) (Cisco 1803) while helping to ensure reliable networking with integrated ISDN S/T BRI backup. The Cisco 1811 and 1812 provide high-speed broadband or Ethernet access through two 10/100BASE-T Fast Ethernet WAN ports and also provide integrated WAN backup through a V.92 analog modem (Cisco 1811) or ISDN S/T BRI interface (Cisco 1812).

The Cisco 1800 Series fixed-configuration routers help enable a network infrastructure for SMBs and enterprise small branch offices, providing access to the Internet, corporate headquarters, or other remote offices, while securing and protecting critical data with integrated Cisco IOS Software security features and capabilities. They also help businesses reduce costs by enabling deployment of a single device to provide multiple services (integrated router with redundant link, LAN switch, firewall, VPN, IPS, wireless technology, and quality of service [QoS]) typically performed by separate devices. Cisco IOS Software allows this flexibility, providing the industry's most robust, scalable, and feature-rich internetworking support, using the accepted standard networking software for the Internet and private WANs.

Table 1 summarizes the Cisco 1800 Series fixed-configuration router features.

**Table 1.** Product Summary

Feature	Cisco 1801	Cisco 1802	Cisco 1803	Cisco 1805	Cisco 1811	Cisco 1812
<b>DSL WAN Port</b>	ADSL over POTS	ADSL over ISDN	G.SHDSL (4-wire)	-	-	-
<b>10/100 FE WAN Ports</b>	1	1	1	2	2	2
<b>DOCSIS 2.0</b>	No	No	No	Yes	No	No
<b>Managed Switch Ports</b>	8	8	8	4	8	8
<b>ISDN BRI Dial Backup</b>	Yes	Yes	Yes	-	-	Yes
<b>V.92 Analog Modem Dial Backup</b>	-	-	-	Yes	Yes	-
<b>USB 2.0 Ports</b>	0	0	0	2	2	2
<b>802.11a/b/g Wireless Model</b>	Yes	Yes	Yes	Yes	Yes	Yes
<b>Auxiliary and Console Ports</b>	Yes	Yes	Yes	Yes	Yes	Yes

## Network Applications

### Secure Network Connectivity

Network security has become a fundamental building block of any network, and Cisco routers play an important role in embedding security at the customer's access edge. Recognizing this requirement, the Cisco 1800 Series fixed-configuration routers are equipped with the Cisco IOS Software Advanced IP Services feature set by default (except for the Cisco 1801). This Cisco IOS Software feature set facilitates hardware-based IPSec encryption on the motherboard and provides a robust array of security capabilities such as Cisco IOS Firewall, URL Filtering, IPS support, IPSec VPNs (DES, 3DES, and AES), Tunnel-less Group Encrypted VPN (GET VPN), Dynamic Multipoint VPN (DMVPN), Easy VPN server and client support, NAC for defense against worms and viruses, security policy enforcement, Secure Shell (SSH) Protocol Version 2.0, and Simple Network Management Protocol (SNMP) in one solution set. As Figure 2 demonstrates, the Cisco 1800 Series fixed-configuration routers help enable customers to deploy high-performance, concurrent, mission-critical data applications with integrated, end-to-end security.

**Figure 2.** Securing Small Branch Office with a Cisco 1800 Series Fixed-Configuration Router

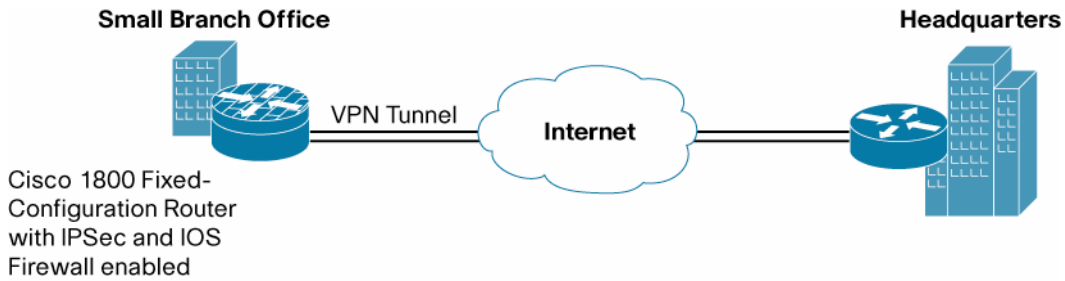

**Highly Available Internet Connection**

The Cisco IOS Software Advanced IP Services feature set offers basic and advanced routing capabilities to deliver failover protection and load balancing. These capabilities include Border Gateway Protocol (BGP), Open Shortest Path First (OSPF) Protocol, Enhanced Interior Gateway Routing Protocol (EIGRP), and Routing Information Protocol (RIP) routing protocols along with dial-on-demand routing (DDR) and reliable static routing using object tracking. Each of the Cisco 1800 Series fixed-configuration routers is equipped with either an ISDN BRI, V.92 analog modem, or Ethernet port for secondary WAN backup connection. If the primary DSL, cable, or Ethernet-access WAN is disconnected for some reason, the router will detect this failure and will fail over to the secondary backup WAN. As Figure 3 and 4 demonstrate, the Cisco 1800 Series fixed-configuration routers help enable customers to deliver high-performance and high-availability, mission-critical business applications.

**Figure 3.** High-Availability Small Branch Network with Cisco 1811 or 1812 Router

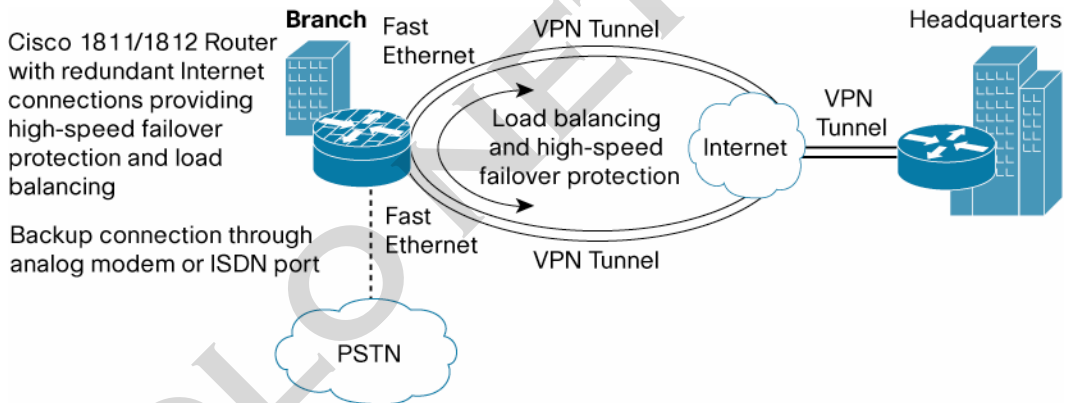

**Figure 4.** High-Availability Small Branch Network with Cisco 1801, 1802, or 1803 Router

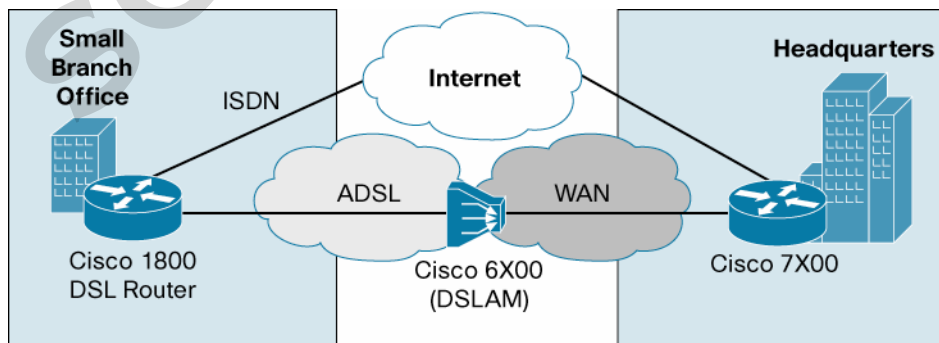

### Integrated Wireless LAN Capability

Cisco 1800 Series fixed-configuration routers offer models with an integrated wireless access point, providing secure router and secure wireless LAN services in one device, helping businesses reduce total cost of ownership with simplified WLAN deployment and management capabilities. The integrated wireless access point supports IEEE 802.11a/b/g simultaneously to provide high-speed wireless capability and flexibility to support 2.4 GHz and 5 GHz dual-band simultaneous operation, making them ideal choices for wireless hotspot deployments and wireless office solutions. Cisco Aironet®, Wi-Fi Certified and Cisco Compatible client devices are fully supported.

The Cisco 1800 Series routers with integrated wireless access points are Wi-Fi Certified and support Wi-Fi Protected Access (WPA and WPA2) providing secure mutual authentication and encryption via Cisco IOS Software features to meet the strict demands of today's businesses. These products also provide support for multiple wireless VLANs that can be configured to provide additional security, segmentation, and separation of user groups. When using the routers in conjunction with the Cisco Service Selection Gateway (SSG) and Subscriber Edge Services Manager (SESM), managed service providers can incorporate service-based authorization and accounting, and service and subscriber management for customizable, on-demand wireless services such as hotspots. Additional features such as local authentication allow users to maintain wireless connectivity to the router in the event that a remote authentication server goes down.

Figure 5 shows a Cisco 1800 Series fixed-configuration wireless router deployed in a small branch-office WLAN application.

**Figure 5.** Small Branch-Office WLAN

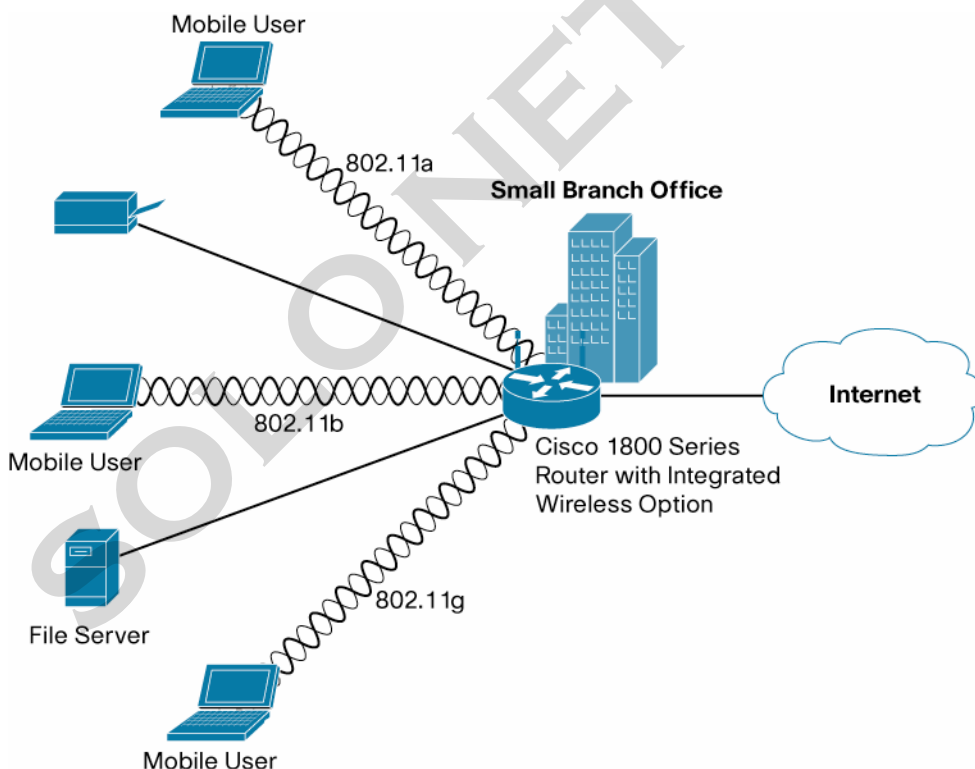

### Business-Class DSL and Ethernet Connectivity

The Cisco 1801, 1802, and 1803 routers combine the cost benefits of DSL service with the advanced routing capability required for business use of the Internet. These products are available as ADSL over POTS (Cisco 1801), ADSL over ISDN (Cisco 1802), or G.SHDSL (Cisco 1803). They deliver strong network security, QoS, and other Cisco IOS features at broadband speeds. Enhanced DSL QoS features, such as Weighted Random Early Detection

(WRED), committed access rate (CAR), and Class-Based Traffic Shaping, help ensure high performance for mission-critical applications. The Cisco 1803 supports G.SHDSL 2-wire and 4-wire capability providing longer reach and higher performance.

The Cisco 1811 and 1812 routers are focused on Ethernet access and are designed to be offered as customer premises equipment (CPE) in Metro Ethernet deployments. Because of their high-speed performance and dual Fast Ethernet WAN ports, they can support the high-bandwidth demands of Metro Ethernet and provide failover protection and load balancing if desired.

The eight-port switch on the Cisco 1800 Series fixed configuration routers is sufficient for connecting numerous devices and the optional PoE capability can supply power to IP telephones or other devices.

## Key Features and Benefits

### Architecture Features and Benefits

The Cisco 1800 Series fixed-configuration routers have been specifically architected to meet the requirements of SMBs and enterprise branch offices as well as service provider-managed applications for concurrent services for broadband access. The Cisco 1801, 1802, 1803, 1811, 1812, and 1841 routers together with other Cisco integrated services routers such as the Cisco 800, 2800, and 3800 Series provide the broadest range of secure connectivity options in the industry combined with high-availability features. In addition, Cisco IOS Software supports a complete suite of transport protocols, QoS, and network security. Table 2 lists the architecture features and benefits of the Cisco 1800 Series fixed-configuration routers.

**Table 2.** Architecture Features and Benefits

Feature	Benefit
<b>Hardware Architecture</b>	
High-Performance Processor	High-speed processor delivers exceptional processing power for applications and concurrent security and wireless services.
Integrated ADSL or G.SHDSL	Eliminates the need to deploy and manage a separate DSL modem.
Integrated 10/100BASE-T WAN Ports	Offers flexibility to connect to various types of DSL broadband or cable access or Ethernet access. Additional capability to deploy redundant WAN connections for failover protections and load balancing.
Integrated 8-Port 10/100BASE-T Managed Switch	Fully managed LAN switch ports connect multiple LAN devices and reduce the need for an additional LAN switch.
Integrated WAN Backup	ISDN S/T BRI or analog modem port provides high availability by establishing a backup WAN connection if the primary connection fails.
Onboard Hardware Encryption Acceleration	Delivers high-speed encryption and decryption rates for DES, 3DES, and AES to help ensure all available bandwidth to the Internet is utilized for maximum performance.
Expandable Memory Architecture	The default memory of 32 MB Flash and 128 MB DRAM is sufficient to support complex configurations and help ensure operation for an extended period. Memory is expandable to support maximum of 128 MB Flash and 384 MB DRAM, offering additional investment protection.
802.1Q VLAN	A total of eight VLANs can be configured to segment a network and offer additional security and separation of network traffic.
Real-Time Clock	Built-in, real-time clock maintains an accurate date and time for applications that require an accurate time stamp-such as logging and digital certificates.
Internal Power Supply	Eliminates the need for a cumbersome external power-adaptor module and provides easier cable management.
USB 2.0 Ports on Cisco 1811 and 1812	Integrated USB ports can be configured to work with optional USB token for off-platform storage of VPN credentials or for deployment of configuration stored on USB Flash devices.
Power over Ethernet (PoE)	802.3af Power over Ethernet support delivers power to IP phones or external wireless access points through the 10/100 switch ports to eliminate the need for power cords for these devices.
Rack- and Wall-Mountable	Delivers flexibility in mounting on a wall or in a standard 19-inch rack. Optional rack mount kit can be ordered for support in 19-inch rack.

Feature	Benefit
<b>Secure Networking</b>	
Cisco IOS Firewall, Including URL Filtering	Application Inspection, Transparent and Stateful firewall, and URL filtering protects the network from unauthorized user access. URL filtering prevents inappropriate Websites from being accessed and downloading of offensive content.
Intrusion Prevention System (IPS)	Detects harmful network activity and generates alarms to warn of threats and intrusion attempts. New IPS signatures can be dynamically loaded.
AutoSecure	Facilitates rapid implementation of firewall and security policies to optimize network security with a single Cisco IOS command.
Site-to-Site VPN	Connects remote access clients and branch offices to central sites more cost-effectively and flexibly than networks using leased lines, Frame Relay, or ATM.
Dynamic Multipoint VPN (DMVPN)	Allows for secure, direct spoke-to-spoke communication with the added benefit of configuration simplicity and zero-touch deployment. This feature allows users to better scale large and small IPSec VPNs by combining generic routing encapsulation (GRE) tunnels, IPSec encryption, and Next Hop Resolution Protocol (NHRP).
GET VPN	Group Encrypted Transport VPN (GET VPN) delivers highly scalable and manageable inter-site any-to-any VPN connectivity without the complexity typically encountered with meshed network designs and eliminates the need for traditional VPN tunnels. GET VPN supplements DMVPN by enabling high scale, always-on any-to-any site connectivity that is critical for ensuring transmission quality of latency-sensitive traffic such as voice, video and terminal services.
SSL VPN	SSL VPN delivers secure access to network resources by establishing an encrypted tunnel across the Internet using a broadband (cable, DSL) or ISP dial connection. Web-based clientless access and full network access is provided without pre-installed desktop software.
Cisco Easy VPN Remote and Server	Eases administration and management of point-to-point VPNs by actively pushing new security policies from a single headend to remote sites.
Network Admission Control (NAC)	Ensures client devices are using the most up-to-date antivirus application and signature files and protects the network from harmful threats by prohibiting network access if outdated versions are used.
<b>Wireless Networking</b>	
Integrated IEEE 802.11 a/b/g Access Point	Provides simultaneous operation at multiple Wi-Fi frequencies including 2.4 GHz and 5GHz. Supports Cisco Aironet, Wi-Fi Certified and Cisco Compatible client devices.
Wireless VLAN	Provides support for multiple wireless VLANs that can be configured to provide additional security, segmentation, and separation of user groups.
Multiple Antenna Options	Removable antennae provide flexibility to add multiband wall-mount and ceiling-mount antennas.
Certification	
Wi-Fi Protected Access (WPA and WPA2)	Wi-Fi Certified for WPA-Enterprise. Provides enterprise-class security for WLANs. Helps to ensure interoperable security with wireless LAN client devices from other manufacturers.
MEF 9/14 Certification	MEF compliant Ethernet over DOCSIS. Enables point to point VPN connectivity via Ethernet over DOCSIS. Secure connection between remote sites over multiple carrier network.
<b>Ease of Use and Management</b>	
Integrated Auxiliary Port	Allows remote configuration and management.
Cisco Router and Security Device Manager (SDM)	An intuitive, easy-to-use Web-based device management tool that helps resellers and customers to quickly and easily deploy, configure and monitor a Cisco access router without requiring knowledge of the Cisco IOS Software command-line interface (CLI).
Enhanced Setup	Optional setup wizard with context-sensitive questions guides the user through the router configuration process, allowing faster deployment.
CiscoWorks, CiscoWorks VPN/Security Management Solution (VMS), and Cisco IP Solution Center (ISC) Support	Enterprise advanced management and configuration capabilities are offered through a Web-based GUI.
Cisco Configuration Engine	Configures remote routers automatically across a WAN connection to save the cost of sending technical staff to remote sites.
Cisco AutoInstall	Configures remote routers automatically across a WAN connection to save the cost of sending technical staff to remote sites.

## Summary

As companies increase their security requirements and their need for integrated services, more intelligent branch-network solutions are required. The best-in-class Cisco 1800 Series architecture has been specifically designed to meet these requirements for secure concurrent services at wire-speed performance. The Cisco 1800 Series integrated services routers, consisting of the Cisco 1801, 1802, 1803, 1811, 1812, and 1841 routers, offer the opportunity to consolidate the functions of separate devices into a single, compact solution that can be remotely managed. By providing integrated services and high performance, the Cisco 1800 Series routers deliver security, versatility, scalability, and flexibility to deploy multiple applications in the small to medium-sized office and small enterprise branch office, and the service provider customer edge. The Cisco 1800 Series easily accommodates a wide variety of network applications, such as secure branch-office data access with broadband and Ethernet access including NAC for antivirus defense, VPN access and firewall protection, PoE support, inter-VLAN routing and support deployment of secure, enterprise-class WLANs. These routers give customers the industry's most flexible, secure, and adaptable infrastructure to meet both today's and tomorrow's business requirements for maximum investment protection.

## Product Specifications

Table 3 lists the product specifications for the Cisco 1801, 1802, 1803, 1805, 1811, and 1812 routers.

**Table 3.** Cisco 1800 Series Fixed-Configuration Routers

Product	Description
<b>Chassis</b>	
Form Factor	Desktop, 1-rack-unit (1-RU) high (4.75-cm high with rubber feet)
Chassis	Metal
Wall-Mountable	Yes
Rack-Mountable	Yes (optional 19-in. rack-mount kit required)
Dimensions (W x D)	<ul style="list-style-type: none"> <li>• 12.74 x 9.7 in. (32.36 x 24.64 cm)</li> <li>• Height without rubber feet: 1.75 in. (4.45 cm)</li> <li>• Height with rubber feet: 1.89 in. (4.80 cm)</li> </ul>
Weight	Maximum: 6.1 lb (2.8 kg)
<b>Architecture</b>	
Flash Memory	External removable Compact Flash
Flash Memory Capacity	<ul style="list-style-type: none"> <li>• Default: 64 MB</li> <li>• Maximum: 128 MB</li> </ul>
DRAM	Synchronous dual in-line memory module (DIMM) SDRAM (1 DIMM slot)
DRAM Capacity	<ul style="list-style-type: none"> <li>• Default: 256 MB</li> <li>• Maximum: 384 MB</li> </ul>
ADSL Port	One ADSL over POTS port on Cisco 1801. One ADSL over ISDN on Cisco 1802. The Cisco 1801 supports ADSL over POTS standards G.992.1 G.DMT and ANSI T1.413 DMT Issue 2. The Cisco 1802 supports ADSL over ISDN standards ETSI 101-388, U-R2, and G.992.1 G.DMT.

Product	Description
DSL Specifications	<ul style="list-style-type: none"> <li>• ST-Microelectronics 20190 chipset</li> <li>• Supports ADSL over basic telephone service with Annex A and Annex B ITU G. 992.1 (ADSL), G.992.3 (ADSL2), and G.992.5 (ADSL2+)</li> <li>• Supports ADSL over basic telephone service with Annex M (Except UK Mask); Enables extended upstream bandwidth, Optimized for PSD mask M9, EU-64) G.992.3 (ADSL2) and G.992.5 (ADSL2+) for Cisco 1801 only</li> <li>• G.992.1 ITU G.DMT support</li> <li>• G.994.1 ITU G.hs negotiation</li> <li>• Support for Reach-extended ADSL2 (G.922.3) Annex L</li> <li>• Complies with T1.413 ANSI ADSL DMT issue 2</li> <li>• DSL Forum TR-067</li> </ul> <p>The chipset does not provide interoperability with carrierless amplitude modulation/phase modulation (CAP)-based ADSL lines</p> <p>Annex A and Annex B are supported starting with Cisco IOS Software Release 12.4(4)T.</p> <p>Annex M (except UK Mask) is supported starting with the special Cisco IOS Software Release 12.4(11)XJ.</p> <p>The ADSL2 standard (ITU G.992.3) adds new features and functions targeted at improving ADSL performance and interoperability. In addition, the standard adds support for new applications, services, and deployment scenarios. Among the changes are improvements in data rate and reach performance, rate adaptation, improved diagnostics, and power enhancements. The conventional ADSL standard (ITU G.992.1) provides downstream data rates of up to 8 Mbps and upstream data rates of up to 0.8 Mbps, and ADSL2 provides higher downstream rates of up to 12 Mbps and upstream data rates of up to 1 Mbps.</p> <p>The ADSL2+ standard (ITU G.992.5) doubles the bandwidth used for downstream data transmission, effectively doubling the maximum downstream data rates, and achieving downstream data rates of up to 24 Mbps and upstream data rates of up to 1.5 Mbps.</p> <p>Cisco 1801-M supports ITU G.992.3 Annex M (except UK Mask) and adds capabilities for extended upstream bandwidth above 2.0 Mbps. This allows carriers and enterprises to cover applications traditionally served by T1, E1, G.SHDSL without overhauling the transport infrastructure. Exact data rates vary depending on the distance from the DSL access multiplexer (DSLAM), DSLAM type, line card and chipset, and firmware, noise profile, quality of copper, etc. The reach-extended ADSL2 standard (G.992.3) Annex L increases performance on loop lengths greater than 16,000 feet from the Central Office.</p>
ADSL Digital Subscriber Line Access Multiplexer (DSLAM) Interoperability	<p>The Cisco 1801 is interoperable with the following DSLAMs:</p> <ul style="list-style-type: none"> <li>• Cisco 6130 and Cisco 6260 IP DSL switches</li> <li>• Alcatel (ASAM 1000 and 7300)</li> <li>• Lucent Stinger (24- and 72-port line cards)</li> <li>• ECI HiFocus (16- and 32-port line cards)</li> </ul> <p>The Cisco 1802 is interoperable with the following DSLAMs:</p> <ul style="list-style-type: none"> <li>• Cisco 6260</li> <li>• Alcatel (ASAM 1000 and 7300)</li> <li>• Siemens (XpressLink 2.0 and XpressLink 2.1)</li> <li>• Lucent Stinger (48-port line cards)</li> <li>• ECI HiFocus (16- and 32-port line cards)</li> </ul>
G.SHDSL Port	One G.SHDSL port on Cisco 1803 supports either 2-wire mode or 4-wire mode. The Cisco 1803 supports the same standards as the Cisco G.SHDSL WIC and is based on ITU Recommendation G.991.2 (accepted worldwide).
G. SHDSL DSLAM Interoperability	<p>The Cisco 1803 in 2-wire mode is interoperable with the following DSLAMs:</p> <ul style="list-style-type: none"> <li>• Cisco 6000 Series IP DSL switches</li> <li>• Alcatel ASAM 7300 (12- and 24-port line cards)</li> <li>• ECI HiFocus SAM 2401 (16-port Metalink-based line cards)</li> <li>• Lucent Stinger FS (32- and 48-port line cards)</li> <li>• CopperEdge 200 DSLAM (24-port line cards)</li> </ul> <p>The Cisco 1803 in 4-wire mode is interoperable with the following DSLAMs:</p> <ul style="list-style-type: none"> <li>• Alcatel ASAM 7300 (12- and 24-port line cards)</li> <li>• CopperEdge 200 DSLAM (24-port line cards)</li> </ul>
DOCSIS	The Cisco 1805-D and Cisco 1805-D/K9 have an integrated CableLabs DOCSIS 2.0 certified cable modem.
10/100 WAN Ports	10/100BASE-T ports for WAN connection supporting DSL and cable modems and Ethernet access services. (One port is available on Cisco 1801, 1802, and 1803. Two ports are available on Cisco 1811 and 1812.)
10/100 LAN Switch	Eight 10/100BASE-T fully managed switch ports with 802.1Q VLAN and 802.3af PoE support
USB Ports	Two (USB 2.0) on Cisco 1811 and 1812 only. The Cisco 1801, 1802, and 1803 do not offer USB support.
ISDN S/T BRI Port	One ISDN S/T BRI port on Cisco 1801, 1802, 1803, and 1812
V.92 Analog Modem Port	One analog modem port on Cisco 1811
Console Port	One-up to 115.2 kbps
Auxiliary Port	One-up to 115.2 kbps
<b>IPSec and VPN</b>	
Integrated Hardware-Based Encryption	On motherboard
Encryption Support in Hardware	DES, 3DES, AES 128, AES 192, AES 256



Product	Description
IPSec Tunnels Supported	50
IPSec VPN Performance	40 Mbps 3DES @ 1400 byte packets
Cisco IOS Firewall Performance	100 Mbps @ 1400 byte packets
<b>Wireless</b>	
Wireless LAN Hardware	<ul style="list-style-type: none"> <li>• IEEE 802.11a/b/g</li> <li>• Automatic rate selection for 11a/11b/11g</li> <li>• Field-replaceable antennae</li> <li>• External antenna</li> <li>• Antenna diversity</li> <li>• Wi-Fi Certified for WPA-Personal and WPA-Enterprise</li> <li>• Default antenna gain-2.2 dBi</li> </ul>
Data Rates Supported	<ul style="list-style-type: none"> <li>• 802.11a: 6, 9, 12, 18, 24, 36, 48, and 54 Mbps</li> <li>• 802.11g: 1, 2, 5.5, 6, 9, 11, 12, 18, 24, 36, 48, and 54 Mbps</li> </ul>
Range	Range-Indoor 1 Mbps at 320 ft
Wireless LAN Software Features	<ul style="list-style-type: none"> <li>• Maximize throughput or maximize range option</li> <li>• Software-configurable transmit power</li> <li>• Quality of Service (QoS) for WLANs</li> <li>• Universal Client Mode (allows radio to connect router to external WLAN network)</li> <li>• Wireless Multi Media Certification (WMM)</li> </ul>
Wireless LAN Security Features	<ul style="list-style-type: none"> <li>• IEEE 802.1X per-user, per-session mutual authentication with a variety of extensible authentication protocol (EAP) types including Cisco LEAP, PEAP, EAP-TLS, EAP-EAP-FAST, EAP-SIM, EAP-MD5, EAP-TTLS</li> <li>• Preshared Key (PSK) Authentication</li> <li>• MAC authentication/filter encryption</li> <li>• WPA/WPA2 Temporal Key Integrity Protocol (TKIP) with support for per-packet key hashing, message integrity check (MIC), initialization vector (IV) changes, and broadcast key rotation</li> <li>• Static and dynamic wired equivalent privacy (WEP) keys of 40 bits and 128 bits</li> <li>• User database for survivable local authentication using LEAP &amp; EAP-FAST</li> <li>• Configurable limit to the number of wireless clients</li> <li>• Configurable RADIUS accounting for wireless clients</li> </ul>
Wireless LAN Management Features	<ul style="list-style-type: none"> <li>• Supported by CiscoWorks 2000, CiscoView and Router, and Security Device Management (SDM)</li> <li>• GUI-based network management for wireless interface is provided</li> </ul>
SSIDs	16
Wireless VLANs	16
MBSSIDs	8
Encrypted Wireless VLANs	8
<b>Software Support</b>	
Cisco IOS Software Release	12.4T
Cisco IOS Software Default Image	Advanced IP services (without voice services) except Cisco 1801 which comes with Cisco IOS IP Broadband feature set
<b>Number of Users</b>	
Recommended Number of Users	50 users recommended
<b>Routing</b>	
Routing Protocols	BGP, EIGRP, OSPF, RIPv1, RIPv2
Routed Protocols	IPv4, IPv6 unicast & multicast; (Internetwork Packet Exchange [IPX], IBM SNA, AppleTalk supported with optional Advanced Enterprise Services Feature Set)
<b>QoS</b>	
QoS Protocols	Weighted Fair Queuing (WFQ), Class-Based WFQ (CBWFQ), Weighted Random Early Detection (WRED), Committed Access Rate (CAR), Resource Reservation Protocol (RSVP), Network-Based Application Recognition (NBAR), Differentiated Services (DIFFSERV), link fragmentation and interleaving (LFI), Low-Latency Queuing (LLQ)
<b>VLAN</b>	
VLAN Support	802.1Q VLAN supported on all 10/100BASE-T ports
VLAN Configured	8 VLANs

Product	Description
<b>PoE</b>	
PoE Support	Supported on 10/100 Ethernet switch ports with optional PoE kit
PoE Standards	IEEE 802.3af, Cisco Prestandard PoE
External Power Supply	80W external power supply
<b>Power Supply Specifications</b>	
Internal Power Supply	Yes
Redundant Power Supply	No
DC Power Support	No
AC Input Voltage	100 to 240 VAC
Frequency	50 to 60 Hz
AC Input Current	1A maximum
Output Power	50W maximum
<b>Power Dissipation</b>	
System Power Dissipation	153 Btu per hour
<b>Environmental</b>	
Operating Temperature	32 to 104°F (0 to 40°C)
Operating Humidity	10 to 85 percent noncondensing operating; 5 to 95 percent noncondensing, nonoperating
Nonoperating Temperature	-4 to 149°F (-25 to 65°C)
Operating Altitude	10,000 ft (3000m) at 77°F (25°C)
Noise Level	Normal operating temperature: <ul style="list-style-type: none"> <li>• &lt;80°F (27°C): 34 dBA</li> <li>• &gt;80°F (27°C) through &lt;104°F (40°C): 36 dBA</li> <li>• &gt;104°F (40°C): 42 dBA</li> </ul>
<b>Regulatory Compliance</b>	
Safety	<ul style="list-style-type: none"> <li>• UL 60950</li> <li>• CAN/CSA C22.2 No. 60950</li> <li>• IEC 60950-1</li> <li>• EN 60950-1</li> <li>• AS/NZS 60950</li> </ul>
EMC Immunity	<ul style="list-style-type: none"> <li>• EN300386</li> <li>• EN55024(CISPR24)</li> <li>• EN61000-4-2</li> <li>• EN61000-4-3</li> <li>• EN41000-4-4</li> <li>• EN41000-4-5</li> <li>• EN41000-4-6</li> <li>• EN41000-4-8</li> <li>• EN41000-4-11</li> <li>• EN50082-1</li> <li>• EN61000-6-2</li> <li>• ITU-T K.21</li> </ul>
EMC Emissions	<ul style="list-style-type: none"> <li>• CFR 47 Part 15, Class A</li> <li>• ICES-003 Class A</li> <li>• EN55022 Class A</li> <li>• CISPR22 Class A</li> <li>• AS/NZS 3548 Class A</li> <li>• VCCI Class A</li> <li>• EN 300386</li> <li>• EN61000-3-2</li> <li>• EN61000-3-3</li> </ul>
Telecommunications	<ul style="list-style-type: none"> <li>• Telecom compliance standards depend upon country and interface type. Interfaces comply with FCC Part 68, CS-03, JATE Technical Conditions, European Directive 99/5/EC, and relevant Technical Basis for Regulation</li> </ul>

Product	Description
	<p>(TBRs). For specific information, refer to the data sheet for the specific interface card.</p> <ul style="list-style-type: none"> <li>Homologation requirements vary by country and interface type. For specific country information, refer to the online approvals database.</li> </ul> <p>Cisco 1801, 1802, 1803, and 1812 ISDN BRI S/T:</p> <ul style="list-style-type: none"> <li>TIA-968-A</li> <li>IC CS-03 Part VI</li> <li>JATE Technical Requirements</li> <li>TBR3</li> <li>S031</li> </ul>

## ADSL2+ Support

Table 4 lists the ADSL2+ (Asymmetric Digital Subscriber Line 2+) support provided through Cisco IOS Software Release 12.4(4)T.

**Table 4.** ADSL2/2+ Support (Annex A, Annex B and Annex M)

DSLAM	Line card	Line card Chipset	DSLAM Firmware
Alcatel 7300	ADSL2+ POTS	BRCM	L7D6AA47.020
Lucent Stinger	ADSL2+ POTS	GSPN	9.7.1e64
Alcatel 7300	ADSL2+ ISDN	BRCM	L7D6AA47.020
Lucent Stinger	ADSL2/2+ POTS (Annex A & Annex M)	stngr-72-gs-adsl-card/Conexant	9.9.1 (E.67.1.36)
ECI SAM480	ADSL2/2+ POTS (Annex A & Annex M)	ATUC-32/Infineon	A4_9.00.56
Ericsson EDA2.1	ADSL2/2+ POTS (Annex A & Annex M)	EDN312xp/Broadcom	CXC 132 7380 R2C09
Alcatel 7300	ADSL2+ ISDN (Annex B)	ADLT-F (24-port)/Broadcom	L7D6AA47.020

## Ordering Information

To place an order, visit the [Cisco Ordering Home Page](#).

For more information about the Cisco 1800 Series, including Cisco 1700 Series to Cisco 1800 Series migration guides, visit <http://www.cisco.com/go/1800>. Table 5 lists the ordering information for the Cisco 1801, 1802, and 1803 routers and other available options.

**Table 5.** Ordering Information

Product Part Number	Product Description
<b>Integrated Services Routers</b>	
CISCO1801	ADSL over POTS router with 8-port 10/100BASE-T switch, ISDN S/T backup, Cisco IOS IP broadband, 32 MB Flash, and 128 MB DRAM
CISCO1801-M	ADSL over POTS Annex M router with 8-port 10/100BASE-T switch, ISDN S/T backup, Cisco IOS IP broadband, 32 MB Flash, and 128 MB DRAM
CISCO1805-D	DOCSIS 2.0 with 4 Port FE switch, 64 MB Flash, 128 MB DRAM
CISCO 1805-D/K9	DOCSIS 2.0 with 4 Port FE switch, 64 MB Flash, 192 MB DRAM and Advanced IP Services IOS
CISCO1801/K9	ADSL over POTS router with 8-port 10/100BASE-T switch, ISDN S/T backup, Cisco IOS Advanced IP Services, 32 MB Flash, and 128 MB DRAM
CISCO1801-M/K9	ADSL over POTS Annex M router with 8-port 10/100BASE-T switch, ISDN S/T backup, Cisco IOS Advanced IP Services, 32 MB Flash, and 128 MB DRAM
CISCO1802	ADSL over POTS router with 8-port 10/100BASE-T switch, ISDN S/T backup, Cisco IOS IP broadband, 32 MB Flash, and 128 MB DRAM
CISCO1802/K9	ADSL over ISDN router with 8-port 10/100BASE-T switch, ISDN S/T backup, Cisco IOS Advanced IP Services, 32 MB Flash, and 128 MB DRAM
CISCO1803/K9	G.SHDSL router with 8-port 10/100BASE-T switch, ISDN S/T backup, Cisco IOS Advanced IP Services, 32 MB Flash, and 128 MB DRAM
CISCO1811/K9	Security router with dual 10/100 WAN ports, 8-port 10/100BASE-T switch, V.92 analog modem backup, Cisco IOS Advanced IP Services, 32 MB Flash, and 128 MB DRAM

Product Part Number	Product Description
CISCO1812/K9	Security router with dual 10/100 WAN ports, 8-port 10/100BASE-T switch, ISDN S/T backup, Cisco IOS Advanced IP Services, 32 MB Flash, and 128 MB DRAM
CISCO1801W-AG-B/K9	ADSL over POTS router with 8-port 10/100BASE-T switch, ISDN S/T backup, Cisco IOS Advanced IP Services, 32 MB Flash, and 128 MB DRAM, and integrated FCC-compliant 802.11a,b,g wireless capability
CISCO1801W-AG-C/K9	ADSL over POTS router with 8-port 10/100BASE-T switch, ISDN S/T backup, Cisco IOS Advanced IP Services, 32 MB Flash, and 128 MB DRAM, and integrated China-compliant 802.11a,b,g wireless capability
CISCO1801W-AG-N/K9	ADSL over POTS router with 8-port 10/100BASE-T switch, ISDN S/T backup, Cisco IOS Advanced IP Services, 32 MB Flash, and 128 MB DRAM, and integrated Australia/NZ compliant 802.11a,b,g wireless capability
CISCO1803W-AG-B/K9	G.SHDSL router with 8-port 10/100BASE-T switch, ISDN S/T backup, Cisco IOS Advanced IP Services, 32 MB Flash, 128 MB DRAM, and integrated FCC-compliant 802.11a,b,g wireless capability
CISCO1811W-AG-B/K9	Security router with dual 10/100 WAN ports, 8-port 10/100BASE-T switch, V.92 analog modem backup, Cisco IOS Advanced IP Services, 32 MB Flash, 128 MB DRAM, and integrated FCC-compliant 802.11a,b,g wireless capability
CISCO1811W-AG-C/K9	Security router with dual 10/100 WAN ports, 8-port 10/100BASE-T switch, V.92 analog modem backup, Cisco IOS Advanced IP Services, 32 MB Flash, 128 MB DRAM, and integrated China-compliant 802.11a,b,g wireless capability
CISCO1811W-AG-N/K9	Security router with dual 10/100 WAN ports, 8-port 10/100BASE-T switch, V.92 analog modem backup, Cisco IOS Advanced IP Services, 32 MB Flash, 128 MB DRAM, and integrated Australia/NZ-compliant 802.11a,b,g wireless capability
CISCO1812 W-AG-C/K9	Security router with dual 10/100 WAN ports, 8-port 10/100BASE-T switch, ISDN S/T backup, Cisco IOS Advanced IP Services, 32 MB Flash, 128 MB DRAM, and integrated China-compliant 802.11a,b,g wireless capability
<b>Memory Options</b>	
MEM180X-128U256D	128 to 256 MB small-outline dual-inline memory module (SODIMM) DRAM factory upgrade for the Cisco 180X routers
MEM180X-128U384D	128 to 384 MB SODIMM DRAM factory upgrade for the Cisco 180X routers
MEM180X-128D=	128 MB SODIMM DRAM for the Cisco 180X routers
MEM180X-256D=	256 MB SODIMM DRAM for the Cisco 180X routers
MEM181X-128U256D	128 to 256 MB SODIMM DRAM factory upgrade for the Cisco 181X routers
MEM181X-128U384D	128 to 384 MB SODIMM DRAM factory upgrade for the Cisco 181X routers
MEM181X-128D=	128 MB SODIMM DRAM for the Cisco 181X routers
MEM181X-256D=	256 MB SODIMM DRAM for the Cisco 181X routers
MEM1800-32U64CF	32 to 64 MB Cisco 1800 Series Compact Flash factory upgrade
MEM1800-32U128CF	32 to 128 MB Cisco 1800 Series Compact Flash factory upgrade
MEM1800-32CF=	32 MB Cisco 1800 Series Compact Flash Memory
MEM1800-64CF=	64 MB Cisco 1800 Series Compact Flash Memory
MEM1800-128CF=	128 MB Cisco 1800 Series Compact Flash Memory
<b>Wireless Antenna Options</b>	
AIR-ANTM2050D-R (=)	Cisco Dual-band swivel mount dipole antenna (2.2 dBi, 2.4 GHz and 5.0 dBi, 5 GHz)
AIR-ANTM5560P-R (=)	Cisco Dual-band diversity ceiling-mount omnidirectional antenna (4.0 dBi, 2.4 GHz and 5.0 dBi, 5 GHz)
AIR-ANTM4050V-R (=)	Cisco Dual-band wall-mount patch antenna (5.5 dBi, 2.4 GHz and 6.0 dBi, 5 GHz)
<b>Power over Ethernet Options</b>	
POE-180X	802.3af PoE module, 80W power supply, and cable factory upgrade for Cisco 180x and 181x routers
POE-180X=	802.3af PoE module, 80W power supply, and cable for Cisco 180x and 181x routers
<b>Other Options</b>	
ACS-1800-RM-19=	19 in. rack-mount kit for Cisco 180X and 181X routers
ACS-CF-GUARD=	Compact Flash Guard
ACS-180X=	Accessory kit for Cisco 180X routers
ACS-181X=	Accessory kit for Cisco 181X routers

For more information regarding Cisco 1800 Series routers and options, contact your Cisco representative or go to <http://www.cisco.com/go/1800>.

To upgrade the Cisco IOS Software for the Cisco 1800 Series, visit the [Cisco Software Center](#).

Table 6 gives the Cisco IOS Software images for the Cisco 1801, 1802, 1803, 1805, 1811, and 1812 routers.

**Table 6.** Cisco IOS Software Images for the Cisco 1801, 1802, 1803, 1805, 1811 and 1812 Routers

Cisco 1801, 1802, 1803, and 1805	Images	Platforms	First Cisco IOS Software Release
<b>Image Name</b>			
c180X-ipbroadband-mz	IP Broadband	CISCO 1801, 1801-M, 1802	12.3(8)YI, 12.4T
Default image: c180X-advipservicesk9-mz	Advanced IP Services	CISCO 1801, 1802, 1803	12.3(8)YI, 12.4T
c180X-adventerprisek9-mz	Advanced Enterprise Services	CISCO 1801, 1802, 1803	12.3(8)YI, 12.4T
Default image: c181x-advipservicesk9-mz	Advanced IP Services	CISCO 1811, 1812	12.3(8)YI, 12.4T
c181x-adventerprisek9-mz	Advanced Enterprise Services	CISCO 1811, 1812	12.3(8)YI, 12.4T

## Service and Support

Leading-edge technology deserves leading-edge support. Cisco offers a wide range of services programs to accelerate customer success. These innovative services programs are delivered through a unique combination of people, processes, tools, and partners, resulting in high levels of customer satisfaction. Cisco services help you protect your network investment, optimize network operations, and prepare your network for new applications to extend network intelligence and the power of your business.

Cisco SMARTnet<sup>®</sup> technical support for the Cisco 1800 Series is available on a one-time or annual contract basis. Support options range from help-desk assistance to proactive, onsite consultation.

All support contracts include:

- Major Cisco IOS Software updates in protocol, security, bandwidth, and feature improvements
- Full access rights to Cisco.com technical libraries for technical assistance, electronic commerce, and product information
- 24-hour-a-day access to the industry's largest dedicated technical support staff

For more information about Cisco services, refer to [Cisco Technical Support Services](#) or [Cisco Advanced Services](#).

## For More Information

For more information about the Cisco 1800 Series Integrated Services Router, visit <http://www.cisco.com/go/1800> or contact your local account representative.

For more information about Cisco products, contact:

- **United States and Canada:** 800 553-NETS (6387)
- **Europe:** +32 2 778 4242
- **Australia:** +61 2 9935 4107
- **Other:** 408 526-7209
- **Web:** <http://www.cisco.com>



**Americas Headquarters**  
Cisco Systems, Inc.  
San Jose, CA

**Asia Pacific Headquarters**  
Cisco Systems (USA) Pte. Ltd.  
Singapore

**Europe Headquarters**  
Cisco Systems International BV  
Amsterdam, The Netherlands

Cisco has more than 200 offices worldwide. Addresses, phone numbers, and fax numbers are listed on the Cisco Website at [www.cisco.com/go/offices](http://www.cisco.com/go/offices).

CCDE, CCSI, CCENT, Cisco Eos, Cisco HealthPresence, the Cisco logo, Cisco Lumin, Cisco Nexus, Cisco Nurse Connect, Cisco Stackpower, Cisco StadiumVision, Cisco TelePresence, Cisco WebEx, DCE, and Welcome to the Human Network are trademarks; Changing the Way We Work, Live, Play, and Learn and Cisco Store are service marks; and Access Registrar, Aironet, AsyncOS, Bringing the Meeting To You, Catalyst, CCDA, CCDP, CCIE, CCIP, CCNA, CCNP, CCSP, CCVP, Cisco, the Cisco Certified Internetwork Expert logo, Cisco IOS, Cisco Press, Cisco Systems, Cisco Systems Capital, the Cisco Systems logo, Cisco Unity, Collaboration Without Limitation, EtherFast, EtherSwitch, Event Center, Fast Step, Follow Me Browsing, FormShare, GigaDrive, HomeLink, Internet Quotient, IOS, iPhone, iQuick Study, IronPort, the IronPort logo, LightStream, Linksys, MediaTone, MeetingPlace, MeetingPlace Chime Sound, MGX, Networkers, Networking Academy, Network Registrar, PCNow, PIX, PowerPanels, ProConnect, ScriptShare, SenderBase, SMARTnet, Spectrum Expert, StackWise, The Fastest Way to Increase Your Internet Quotient, TransPath, WebEx, and the WebEx logo are registered trademarks of Cisco Systems, Inc. and/or its affiliates in the United States and certain other countries.

All other trademarks mentioned in this document or website are the property of their respective owners. The use of the word partner does not imply a partnership relationship between Cisco and any other company. (0903R)