

IBM Flex System X6 Compute Nodes Product Guide

IBM Redbooks Product Guide

The IBM® Flex System X6 Compute Node family, composed of the x880 X6, x480 X6, and x280 X6, are high-performance scalable compute nodes that are designed to take on the most demanding workloads. The performance, flexibility, and resiliency features enable the X6 to run mission-critical workloads, such as key business applications, database, analytics, and large virtual machine deployments.

Each compute node contains two Intel Xeon E7 processors. The x880 X6 uses E7-8800 v2 processors and supports joining two or four x880 compute nodes together to form a single 8-socket server with 192 DIMM slots. The x480 uses E7-4800 v2 processors and supports joining two x480 compute nodes together to form a single 4-socket server with 96 DIMM slots. The x280 has two E7-2800 v2 processors and 48 DIMM slots but does not offer scaling.

Suggested use: Mission-critical scalable databases, business analytics, virtualization, enterprise applications, and cloud applications.

Figure 1 shows the IBM Flex System X6 Compute Node.



Figure 1. The IBM Flex System X6 Compute Node

Did you know?

If you are using an application that requires significant computing power and you value the integration of components that IBM Flex System offers, then the X6 Compute Node family is an excellent choice. It offers the performance and reliability of the Intel Xeon E7 processor family, plus significant memory and I/O capacity, and lets you easily scale from two sockets all the way to eight sockets by simply adding more compute nodes and using the appropriate scalability connector on the front of the server.

Key features

The increasing demand for cloud-computing and analytics workloads by enterprises to meet social, mobile, and big data requirements drives innovation to find new ways to build informational systems. Clients are looking for cost-optimized and fit-for-purpose IT solutions that manage large amounts of data, easily scale performance, and provide enterprise class reliability.

Built on decades of innovation, IBM introduces its sixth generation of IBM Enterprise X-Architecture® technology into the IBM Flex System ecosystem with the announcement of the IBM Flex System X6 family of compute nodes. Like their rack-mount counterparts, the System x3850 X6 and x3950 X6, IBM Flex System X6 Compute Nodes are fast, agile, and resilient:

- *Fast* application performance means immediate access to information.
- *Agile* system design helps reduce acquisition costs and provides the ability to upgrade processor and memory technology at each refresh within the same chassis.
- *Resilient* platforms maximize application uptime and promote easy integration in virtual environments.

X6 servers continue to lead the way as the shift toward mission-critical scalable databases, business analytics, virtualization, enterprise applications, and cloud-computing applications accelerates.

Fast application performance

Each compute node offers numerous features to boost performance:

- Based on the Intel Xeon processor E7 v2 product family, which improves productivity by offering superior system performance:
 - Two processors in each compute node, which are scalable up to eight processors in four compute nodes.
 - Each processor has up to 15 cores and 37.5 MB of L3 cache, depending on the processor that is selected.
 - Processors operate at up to 3.4 GHz.
 - Memory bus speeds up to 1600 MHz.
 - QPI links between processors up to 8 GTps.
- Supports up to 48 DIMM sockets, with 24 DIMMs per processor.
- Intelligent and adaptive system performance with Intel Turbo Boost Technology 2.0 allows processor cores to run at maximum speeds during peak workloads by temporarily going beyond processor thermal design power (TDP).
- Intel Hyper-Threading Technology boosts performance for multi-threaded applications by enabling simultaneous multi-threading within each processor core, up to two threads per core.
- Intel Virtualization Technology integrates hardware-level virtualization hooks that allow operating system vendors to better use the hardware for virtualization workloads.
- Intel Advanced Vector Extensions (AVX) improve floating-point performance for compute-intensive technical and scientific applications.
- The usage of solid-state drives (SSDs) instead of traditional hard disk drives (HDDs) can improve I/O performance. An SSD can support up to 100 times more I/O operations per second (IOPS) than a typical HDD.

- PCI Express 3.0 I/O adapter slots that improve the theoretical maximum bandwidth by almost 100% (8 GTps per link using 128b/130b encoding) compared to the previous generation of PCI Express 2.0 (5 GTps per link using 8b/10b encoding).
- With Intel Integrated I/O Technology, the PCI Express 3.0 controller is integrated into the Intel Xeon processor E7 v2 product families. This integration helps reduce I/O latency and increase overall system performance.

Agile system design

The X6 Compute Nodes provides many scalability and flexibility features:

- Innovative front-access scalable design where a customer can start with one x880 X6 Compute Node with two sockets and simply add more processing power by inserting additional compute nodes into the chassis (up to a total of four, depending on the processor selection) and mounting a scalability connector to the front of all the compute nodes.
- The usage of front-access scalability connectors means that you can easily scale the X6 system by adding new compute nodes without removing existing compute nodes from the chassis.
- With the usage of E7-8800 v2 processors, upgrading from a 2-socket (one compute node) to 4-socket (two compute nodes) to 8-socket (four compute nodes) complex is as simple as inserting the extra compute nodes and attaching the appropriate scalability connector to the front of all the compute nodes. No tools are required. The usage of E7-4800 v2 processors allows an upgrade from a 2-socket (one compute node) to 4-socket (two compute nodes) complex in the same way.
- The usage of compute nodes as modular building blocks also allows clients to create the configuration that fits their application and environment needs, which reduces acquisition costs while giving them the flexibility to grow and modify their configuration later.
- Using 64 GB LRDIMMs, each compute node supports up to 3 TB of memory and up to 6 TB in a scaled complex.
- Offers 4 PCIe 3.0 I/O slots per compute node, and up to 16 slots in an 8-socket scaled complex.

Resilient platform

The server provides many features to simplify serviceability and increase system uptime:

- Advanced Processor Recovery allows the system to automatically switch access and control of networking, management, and storage in the event of a processor 1 failure, providing higher availability and productivity.
- Advanced Page Retire proactively protects applications from corrupted pages in memory, which is crucial for scaling memory to terabytes.
- Redundant bit steering, memory mirroring, and memory rank sparing for redundancy in the event of a non-correctable memory failure.
- The Intel Execute Disable Bit function can help prevent certain classes of malicious buffer overflow attacks when it is combined with a supported operating system.
- Intel Trusted Execution Technology provides enhanced security through hardware-based resistance to malicious software attacks, allowing an application to run in its own isolated space, which is protected from all other software running on a system.
- Redundant Intel Platform Controller Hub (PCH) connections to the processors allow the platform to maintain access to networking, storage, and server management during a processor failure.
- Hot-swap drives support RAID redundancy for data protection and greater system uptime.

- Flex System Enterprise Chassis-based hot-swap power supplies and hot-swap dual-motor redundant fans provide availability for mission-critical applications.
- A light path diagnostics panel and individual light path LEDs quickly lead the technician to failed (or failing) components. This panel simplifies servicing, speeds up problem resolution, and helps improve system availability.
- Predictive Failure Analysis (PFA) detects when system components (processors, memory, HDDs, SSDs, fans, and power supplies) operate outside of standard thresholds and generates proactive alerts in advance of a possible failure, therefore increasing uptime.
- Built-in Integrated Management Module Version II (IMM2) continuously monitors system parameters, triggers alerts, and performs recovery actions in case of failures to minimize downtime.
- Integrated industry-standard Unified Extensible Firmware Interface (UEFI) enables improved setup, configuration, and updates, and simplifies error handling.
- Integrated Trusted Platform Module (TPM) 1.2 support enables advanced cryptographic functions, such as digital signatures and remote attestation.
- Industry-standard Advanced Encryption Standard (AES) NI support for faster and stronger encryption.
- IBM Flex System Manager provides proactive systems management. It offers comprehensive systems management tools that help increase uptime, reduce costs, and improve productivity through advanced server management capabilities.
- Built-in diagnostic tests, using Dynamic Systems Analysis (DSA) Preboot, speed up troubleshooting tasks to reduce service time.
- Three-year customer-replaceable unit and onsite limited warranty, 9x5 next business day. Optional service upgrades are available.

Locations of key components and connectors

Figure 2 shows the front of the server and Figure 3 shows the inside of the server.

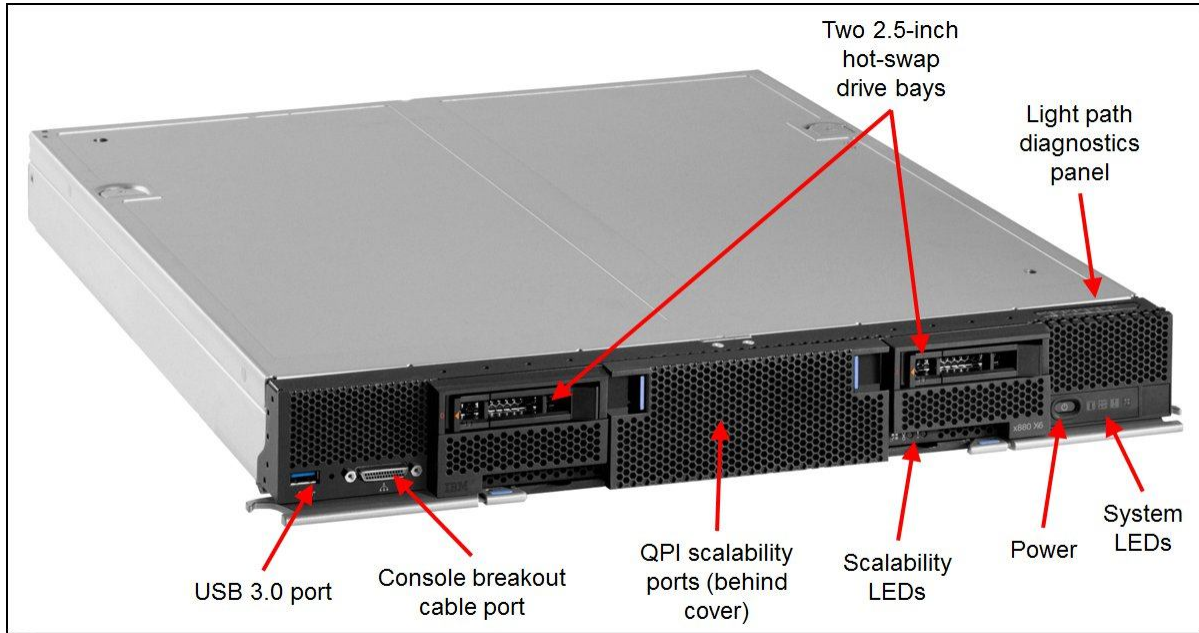

Figure 2. Front view of the IBM Flex System X6 Compute Node

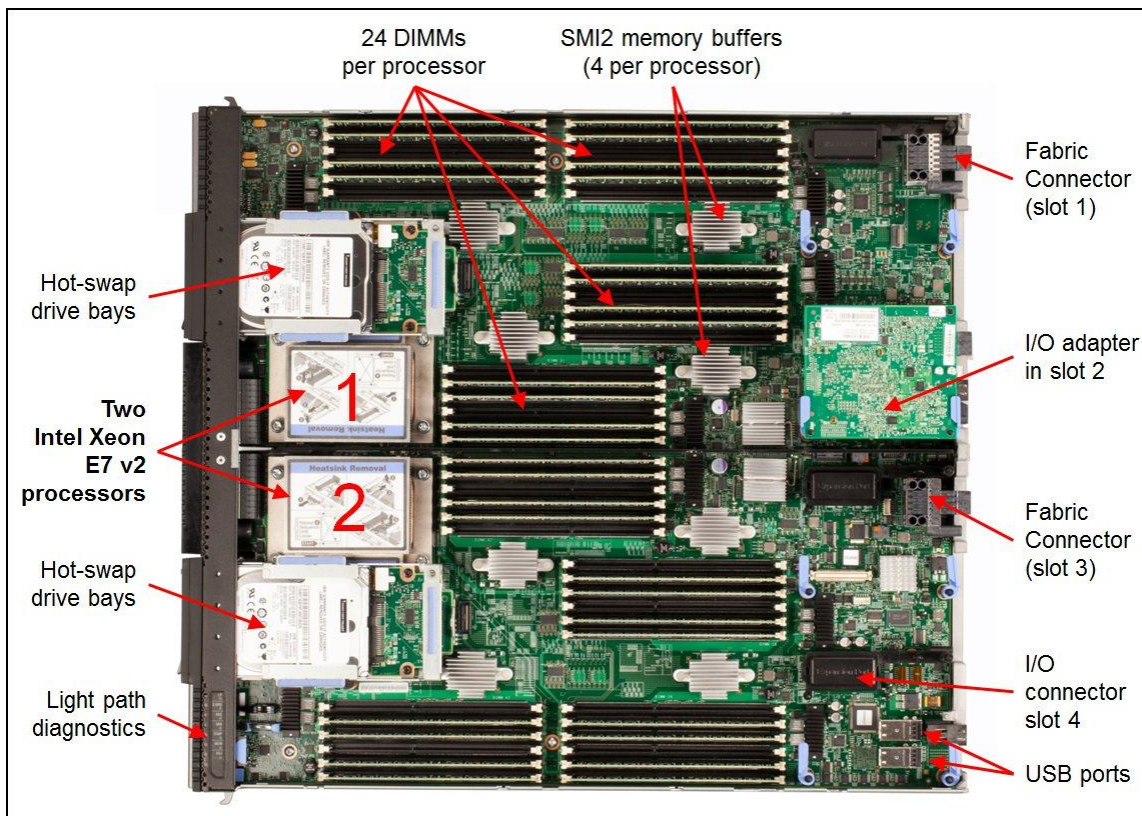

Figure 3. Inside view of the IBM Flex System X6 Compute Node

The following figure shows how four x880 Compute Nodes can be connected together to form a single 8-socket complex. Note this is for illustrative purposes only; in a production environment, you first install the compute nodes in the chassis and then attach the scalability connector to all four nodes.



Figure 4. Four x880 X6 Compute Nodes in an 8-socket complex

The following figure shows four x880 Compute Nodes that are connected to form an 8-socket complex that is installed in a Flex System Enterprise Chassis.



Figure 5. Four x880 X6 Compute Nodes as an 8-socket complex that is installed in a Flex System Enterprise Chassis

Standard specifications

The following table lists the standard specifications.

Table 1. Standard specifications (part 1 of 2)

Components	Specification (per node except where noted)
Form factor	Double-wide compute node.
Chassis support	IBM Flex System Enterprise Chassis.
Scalability	<p>x880 X6:</p> <ul style="list-style-type: none"> • Scales up to 4-socket by adding one x880 Compute Node + 4S scalability kit • Scales up to 8-socket by adding three x880 Compute Nodes + 8S scalability kit <p>x480 X6:</p> <ul style="list-style-type: none"> • Scales up to 4-socket by adding one x480 Compute Node + 4S scalability kit <p>x280 X6:</p> <ul style="list-style-type: none"> • Does not scale
Processor	<p>The processor selection determines whether the compute node is an x880 X6, x480 X6, or x280 X6:</p> <ul style="list-style-type: none"> • x880 X6: Two Intel Xeon processor E7-8800 v2 product family processors, each with 15 cores (up to 2.8 GHz), 12 cores (up to 3.0 GHz), 10 cores (up to 3.2 GHz), or 6 cores (up to 3.4 GHz). Three QPI links, up to 8.0 GTps each. Up to 1600 MHz memory speed. Up to 37.5 MB L3 cache per processor. • x480 X6: Two Intel Xeon processor E7-4800 v2 product family processors, each with 15 cores (up to 2.8 GHz), 12 cores (up to 2.6 GHz), 10 cores (up to 2.2 GHz), 8 cores (up to 2.0 GHz) or 6 cores (up to 1.9 GHz). Three QPI links, up to 8.0 GTps each. Up to 1600 MHz memory speed. Up to 37.5 MB L3 cache per processor. • x280 X6: Two Intel Xeon processor E7-2800 v2 product family processors, each with 15 cores (up to 2.8 GHz) or 12 cores (up to 2.3 GHz). Three QPI links, up to 8.0 GTps each. Up to 1600 MHz memory speed. Up to 37.5 MB L3 cache per processor.
Chipset	Intel C602J.
Memory	Up to 48 DIMM sockets (24 DIMMs per processor) using Low Profile (LP) DDR3 DIMMs. RDIMMs and LRDIMMs are supported. 1.5 V and low-voltage 1.35 V DIMMs are supported. Support for up to 1600 MHz memory speed, depending on the processor. Four SMI2 channels to memory buffer per processor. Two memory channels per memory buffer. Supports three DIMMs per channel.
Memory maximums	With LRDIMMs: Up to 3 TB with 48x 64 GB LRDIMMs and two processors. With RDIMMs: Up to 768 GB with 48x 16 GB RDIMMs and two processors.
Memory protection	ECC, Chipkill (for x4-based memory DIMMs), memory mirroring, and memory rank sparing.
Disk drive bays	Standard: Two 2.5-inch hot-swap SAS/SATA drive bays that support SAS, SATA, and SSD drives.

Table 1. Standard specifications (part 2 of 2)

Components	Specification
Maximum internal storage	With two 2.5-inch hot-swap drives: Up to 3.2 TB with 1.6 TB 2.5" NL SAS HDDs, or up to 2.4 TB with 1.2 TB 2.5" SAS HDDs, or up to 2 TB with 1 TB 2.5" NL SATA HDDs, or up to 3.2 TB with 1.6 TB 2.5" SAS SSDs. Intermix of SAS and SATA HDDs and SSDs is supported.
RAID support	RAID 0, 1, 1E, and 10 with integrated ServeRAID M1200e (based on LSI SAS3004), upgradeable to RAID 5 and 50. Two adjacent compute nodes each with two drives can form a 4-drive RAID 10 array.
Network interfaces	x2x models: None standard; optional Ethernet adapters.
PCI Expansion slots	Up to four I/O connectors for adapters. Two connectors have PCI Express 3.0 x24 (x16 + x8) interface with support for dual-ASIC adapters (slots 1 and 2), two other connectors have PCI Express 3.0 x8 interface (slots 3 & 4).
Ports	External: One USB 3.0. Console breakout cable port that provides local KVM and serial ports (cable comes standard with Flex System chassis; additional cables are optional). Internal: Two internal USB 2.0 for embedded hypervisor.
Systems management	UEFI, IBM Integrated Management Module 2 (IMM2) with Renesas SH7757 controller, Predictive Failure Analysis, light path diagnostics panel, automatic server restart, and remote presence. Support for IBM Flex System Manager™, IBM Systems Director, and IBM ServerGuide.
Security features	Power-on password, administrator's password, and Trusted Platform Module V1.2.
Video	Matrox G200eR2 video core with 16 MB video memory that is integrated into the IMM2. Maximum resolution is 1600x1200 at 75 Hz with 16 M colors.
Limited warranty	Three-year customer-replaceable unit and onsite limited warranty with 9x5/NBD.
Operating systems supported	Microsoft Windows Server, Red Hat Enterprise Linux, SUSE Linux Enterprise Server, VMware vSphere.
Service and support	Optional service upgrades are available through IBM ServicePac® offerings: Four-hour or 2-hour response time, 24-hour or 8-hour fix time, 1-year or 2-year warranty extension, and remote technical support for IBM hardware and selected IBM and OEM software.
Dimensions	Width: 435 mm (17.14 in.), height 55 mm (2.19 in.), depth 500 mm (19.7 in.)
Weight	Maximum weight: 12.25 kg (27 lbs).

The X6 Compute Nodes are shipped with the following items:

- Statement of Limited Warranty
- Important Notices
- Documentation CD that contains the *Installation and Service Guide*

Standard models

The following table lists the standard models. Currently, the x480 X6 is available as a standard model. The x280 X6 and x880 X6 are available configure-to-order only.

Table 2. Standard models

Model	Intel Processor** (2 maximum)	Memory	RAID	Disk bays (used/max)	10GbE Embedded	I/O slots (used/max)
x280 X6 (2-socket only)						
7903-A2x	2x E7-2850 v2 12C 2.3GHz 24MB 1600MHz 105W	2 x 16GB 1600 MHz	LSI 3004	2.5" HS (0 / 2) Open bay	No	0 / 4
7903-B2x	2x 7-2880 v2 15C 2.5GHz 37.5MB 1600MHz 130W	2 x 16GB 1600 MHz	LSI 3004	2.5" HS (0 / 2) Open bay	No	0 / 4
7903-C2x	2x E7-2890 v2 15C 2.8GHz 37.5MB 1600MHz 155W	2 x 16GB 1600 MHz	LSI 3004	2.5" HS (0 / 2) Open bay	No	0 / 4
x480 X6 (2-socket, can scale up to 4-socket)						
7903-D2x	2x E7-4809 v2 6C 1.9GHz 12MB 1333MHz 105W	2 x 16GB (1333 MHz)‡	LSI 3004	2.5" HS (0 / 2) Open bay	No	0 / 4
7903-F2x	2x E7-4820 v2 8C 2.0GHz 16MB 1600MHz 105W	2 x 16GB 1600 MHz	LSI 3004	2.5" HS (0 / 2) Open bay	No	0 / 4
7903-G2x	2x E7-4830 v2 10C 2.2GHz 20MB 1600MHz 105W	2 x 16GB 1600 MHz	LSI 3004	2.5" HS (0 / 2) Open bay	No	0 / 4
7903-H2x	2x E7-4850 v2 12C 2.3GHz 24MB 1600MHz 105W	2 x 16GB 1600 MHz	LSI 3004	2.5" HS (0 / 2) Open bay	No	0 / 4
7903-J2x	2x E7-4870 v2 15C 2.3GHz 30MB 1600MHz 130W	2 x 16GB 1600 MHz	LSI 3004	2.5" HS (0 / 2) Open bay	No	0 / 4
7903-L2x	2x E7-4880 v2 15C 2.5GHz 37.5MB 1600MHz 130W	2 x 16GB 1600 MHz	LSI 3004	2.5" HS (0 / 2) Open bay	No	0 / 4
7903-M2x	2x E7-4890 v2 15C 2.8GHz 37.5MB 1600MHz 155W	2 x 16GB 1600 MHz	LSI 3004	2.5" HS (0 / 2) Open bay	No	0 / 4
x880 X66 (2-socket, can scale up to 4-socket or 8-socket)						
7903-N2x	2x E7-8850 v2 12C 2.3GHz 24MB 1600MHz 105W	2 x 16GB 1600 MHz	LSI 3004	2.5" HS (0 / 2) Open bay	No	0 / 4
7903-Q2x	2x E7-8880 v2 15C 2.5GHz 37.5MB 1600MHz 130W	2 x 16GB 1600 MHz	LSI 3004	2.5" HS (0 / 2) Open bay	No	0 / 4
7903-R2x	2x E7-8890 v2 15C 2.8GHz 37.5MB 1600MHz 155W	2 x 16GB 1600 MHz	LSI 3004	2.5" HS (0 / 2) Open bay	No	0 / 4

** Processor detail: Processor quantity and model, cores, core speed, L3 cache, memory speed, and power consumption.

‡ For models D2x, the standard DIMM is rated at 1600 MHz, but operates at 1333 MHz to match the processor memory speed.

Chassis support

The X6 Compute Nodes are supported in the IBM Flex System Enterprise Chassis.

Up to seven X6 compute nodes can be installed in the chassis in 10U of rack space. The number of scaled systems that can be installed is as follows:

- Two-socket systems: Up to seven systems in an Enterprise Chassis
- Four-socket systems: Up to three systems in an Enterprise Chassis
- Eight-socket systems: One system in an Enterprise Chassis

It might also be possible to populate the remaining bays within the chassis with other standard or double-wide nodes. The actual number of servers that can be installed in a chassis also depends on these factors:

- The TDP power rating for the processors that are installed in the server
- The number of power supplies that are installed
- The capacity of the power supplies that are installed (2100 W or 2500 W)
- The power redundancy policy that is used (N+1 or N+N)

The following table provides guidelines about what number of X6 Compute Nodes can be installed. For more information, use the Power Configurator, found at the following website:

<http://ibm.com/systems/bladecenter/resources/powerconfig.html>

In the table:

- Green = No restriction to the number of X6 Compute Nodes that are installable.
- Yellow = Some bays must be left empty in the chassis.

Table 3. Maximum number of X6 Compute Nodes that are installable based on the power supplies that are installed and the power redundancy policy that is used

TDP rating	2100 W power supplies installed				2500 W power supplies installed			
	N+1, N=5 6 power supplies	N+1, N=4 5 power supplies	N+1, N=3 4 power supplies	N+N, N=3 6 power supplies	N+1, N=5 6 power supplies	N+1, N=4 5 power supplies	N+1, N=3 4 power supplies	N+N, N=3 6 power supplies
x280, x480, or x880 X6 with 2 sockets								
105 W	7	7	6	6	7	7	7	7
130 W	7	7	5	6	7	7	7	7
155 W	7	7	5	5	7	7	7	7
x480 or x880 X6 with 4 sockets								
105 W	3	3	3	3	3	3	3	3
130 W	3	3	3	3	3	3	3	3
155 W	3	3	2	3	3	3	3	3
x880 X6 with 8 sockets								
105 W	1	1	1	1	1	1	1	1
130 W	1	1	1	1	1	1	1	1
155 W	1	1	1	1	1	1	1	1

Scalability

The X6 compute nodes can scale to a 4-socket or 8-socket complex depending on the processor that is installed into the node:

- An x880 X6 node with Intel Xeon E7-8800 v2 family processors can scale up to an 8-socket configuration, and supports 2-socket, 4-socket, and 8-socket configurations. All the processors in these 2-socket, 4-socket, and 8-socket configurations must be identical.
- An x480 X6 node with Intel Xeon E7-4800 v2 family processors can scale up to a 4-socket configuration, and supports 2-socket and 4-socket configurations. All the processors in these 2-socket and 4-socket configurations must be identical.
- An x280 X6 node with Intel Xeon E7-2800 v2 family processors supports only 2-socket configurations. The processors in 2-socket configurations must be identical.

The scaled X6 compute nodes are connected together through a front interconnect system. The interconnection has a QPI bus plus the sideband signals that are needed for correct operation.

There are two scalability connector assemblies for X6 nodes, as shown in the following table.

Table 4. Scalability options for X6 compute nodes

Part number	Feature code	Description
00Y3871	A4D8	IBM Flex System x880 X6 4-Socket Scalability Connector (used to connect two x480 or x880 Compute Nodes together)
00Y3874	A4D9	IBM Flex System x880 X6 8-Socket Scalability Connector (used to connect four x880 Compute Nodes together)

The following figure shows the IBM Flex System x880 X6 4-Socket Scalability Connector and how it is used to connect two X6 servers together (x880 or x480).

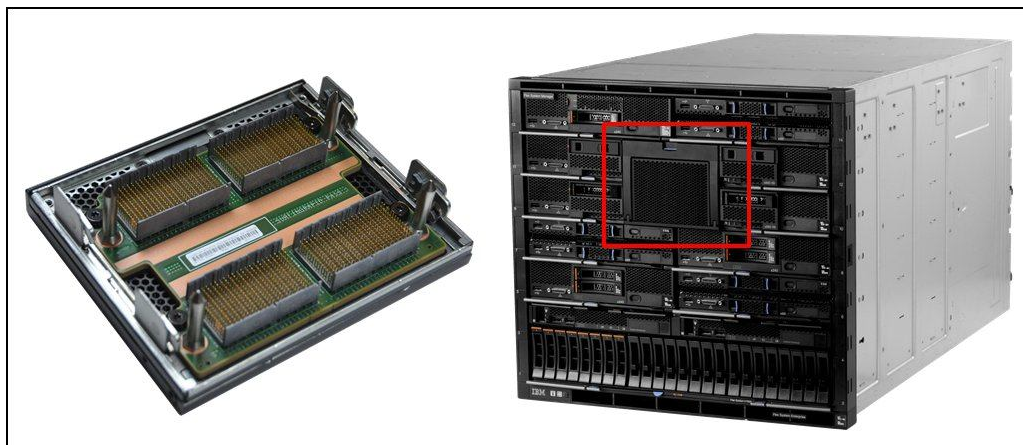

Figure 6. IBM Flex System x880 X6 4-Socket Scalability Connector

Processor options

The X6 compute nodes support the processor options that are listed in the following table. The server supports two Intel Xeon E7-2800 v2, E7-4800 v2, or E7-8800 v2 processors depending on model. The table also shows which server models have each processor standard. If no corresponding model for a particular processor is listed, the processor is available only through the configure-to-order (CTO) process.

No part numbers: All Flex System X6 Compute Nodes have two processors as a standard. There is no option part number for processors, only feature codes.

Table 5. Processor options

Feature code*	Intel Xeon processor description	Memory bus speed (RAS / Performance)†	Models where used
IBM Flex System x280 X6 Compute Node			
A4E0 / A4DF	Xeon E7-2850 v2 12C 2.3GHz 24MB 1600MHz 105W	1600 / 1066 MHz	A2x
A4E1 / A4DG	Xeon E7-2870 v2 15C 2.3GHz 30MB 1600MHz 130W	1600 / 1333 MHz	-
A4E2 / A4DE	Xeon E7-2880 v2 15C 2.5GHz 37.5MB 1600MHz 130W	1600 / 1333 MHz	B2x
A4E3 / A4DH	Xeon E7-2890 v2 15C 2.8GHz 37.5MB 1600MHz 155W	1600 / 1333 MHz	C2x
IBM Flex System x480 X6 Compute Node			
A4E4 / A4DJ	Xeon E7-4809 v2 6C 1.9GHz 12MB 1333MHz 105W	1333 / 1066 MHz	D2x
A4E5 / A4DK	Xeon E7-4820 v2 8C 2.0GHz 16MB 1600MHz 105W	1600 / 1066 MHz	F2x
A4E6 / A4DL	Xeon E7-4830 v2 10C 2.2GHz 20MB 1600MHz 105W	1600 / 1066 MHz	G2x
A4E7 / A4DM	XeonE7-4850 v2 12C 2.3GHz 24MB 1600MHz 105W	1600 / 1066 MHz	H2x
A4E8 / A4DN	Xeon E7-4860 v2 12C 2.6GHz 30MB 1600MHz 130W	1600 / 1333 MHz	
A4E9 / A4DP	Xeon E7-4870 v2 15C 2.3GHz 30MB 1600MHz 130W	1600 / 1333 MHz	J2x
A4EA / A4DQ	Xeon E7-4880 v2 15C 2.5GHz 37.5MB 1600MHz 130W	1600 / 1333 MHz	L2x
A4EB / A4DR	Xeon E7-4890 v2 15C 2.8GHz 37.5MB 1600MHz 155W	1600 / 1333 MHz	M2x
IBM Flex System x880 X6 Compute Node			
A4EC / A4DS	Xeon E7-8850 v2 12C 2.3GHz 24MB 1600MHz 105W	1600 / 1066 MHz	N2x
A4EE / A4DU	Xeon E7-8870 v2 15C 2.3GHz 30MB 1600MHz 130W	1600 / 1333 MHz	-
A4EG / A4DW	Xeon E7-8880 v2 15C 2.5GHz 37.5MB 1600MHz 130W	1600 / 1333 MHz	Q2x
A4EH / A4DX	Xeon E7-8890 v2 15C 2.8GHz 37.5MB 1600MHz 155W	1600 / 1333 MHz	R2x
A4EK / A4DZ	Xeon E7-8893 v2 6C 3.4GHz 37.5MB 1600MHz 155W	1600 / 1333 MHz	
A4EJ / A4DY	Xeon E7-8891 v2 10C 3.2GHz 37.5MB 1600MHz 155W	1600 / 1333 MHz	
A4ED / A4DT	Xeon E7-8857L v2 12C 3.0GHz 30MB 1600MHz 130W	1600 / 1333 MHz	
A4EF / A4DV	Xeon E7-8880L v2 15C 2.2GHz 37.5MB 1600MHz 105W	1600 / 1333 MHz	

* The first feature code is for CPU 1 and the second feature code is for CPU 2.

† The processors support two memory modes: RAS mode (also known as lockstep mode) and Performance mode (also known as independent mode). In Performance mode, the SMI2 link operates at twice the memory bus speed that is shown.

Memory options

IBM DDR3 memory is compatibility tested and tuned for optimal performance and throughput. IBM memory specifications are integrated into the light path diagnostic tests for immediate system performance feedback and optimum system uptime. From a service and support standpoint, IBM memory automatically assumes the IBM system warranty, and IBM provides service and support worldwide.

The X6 Compute Nodes support DDR3 memory operating at speeds up to 1600 MHz with 24 DIMMs per processor:

- A 2-socket configuration supports up to 48 DIMMs.
- A 4-socket scaled configuration supports up to 96 DIMMs.
- An 8-socket configuration supports up to 192 DIMMs.

The following table lists the memory options that are available for X6 Compute Nodes.

Table 6. Memory options

Part number	Feature code	Description	Maximum supported	Models where used
RDIMMs				
00D5024*	A3QE	4GB (1x4GB, 1Rx4, 1.35V) PC3L-12800 CL11 ECC DDR3 1600MHz LP RDIMM	48 (24 per CPU)	-
00D5036	A3QH	8GB (1x8GB, 1Rx4, 1.35V) PC3L-12800 CL11 ECC DDR3 1600MHz LP RDIMM	48 (24 per CPU)	-
46W0672	A3QM	16GB (1x16GB, 2Rx4, 1.35V) PC3L-12800 CL11 ECC DDR3 1600MHz LP RDIMM	48 (24 per CPU)	All models
LRDIMMs				
46W0676*	A3SR	32GB (1x32GB, 4Rx4, 1.35V) PC3L-12800 CL11 ECC DDR3 1600MHz LP LRDIMM	48 (24 per CPU)	-
46W0741*†	A451	64GB (1x64GB, 8Rx4, 1.35V) PC3-10600 DDR3 1333MHz LP LRDIMM	48 (24 per CPU)	-

* Not allowed if any eXFlash DIMMs are installed (when supported).

† 64 GB LRDIMMs are only supported in 2-socket or 4-socket configurations.

Each processor has four memory channels to memory buffers that are implemented using Scalable Memory Interface generation 2 (SMI2) chips. Each memory buffer has two memory channels and implements three DIMMs per channel.

The following rules apply when selecting the memory configuration:

- The X6 node supports RDIMMs and LRDIMMs.
- Mixing of RDIMM and LRDIMM is not supported.
- 4 GB RDIMMs and LRDRIMMs cannot be used with IBM eXFlash DIMMs (when supported)
- Mixing 1.5 V and 1.35 V DIMMs in the same server is supported. In such a case, all DIMMs operate at 1.5 V.
- The processors support two memory modes: Performance mode and RAS (or lockstep) mode. In RAS (lockstep) mode, DIMMs must be installed in a pair, and the SMI link operates at the speed of the memory bus.

- When RDIMMs are installed, the maximum number of ranks that are supported per channel is eight. With LRDIMMs, the rank count per channel can be 32 (LRDIMM ranks are only 25% of the electrical load of an RDIMM rank).
- All DIMMs in all processor memory channels operate at the same speed, which is determined as the lowest value of the following components:
 - o The memory mode used: Performance (independent) mode or RAS (lockstep) mode.
 - o Memory speed that is supported by a specific processor.
 - o Lowest of maximum operating speeds for selected memory configuration, depending on the rated speed, operating voltage, and quantity of DIMMs per channel, as shown under the “Maximum operating speed” section in the following table.

The following table shows the characteristics of the supported DIMMs. Tables cells that are highlighted with a gray background indicate that the server supports higher memory frequencies or larger memory capacity (or both) than the Intel processor specification defines.

Memory speed: In performance mode, memory channels operate independently, and the SMI2 link operates at twice the DDR3 speed. In RAS mode, two channels operate synchronously, and the SMI2 link operates at the DDR3 speed.

Table 7. Maximum memory speeds

DIMM specification	RDIMM				LRDIMM			
	Single rank		Dual rank		Quad rank		8-rank	
Rank	Single rank		Dual rank		Quad rank		8-rank	
Part numbers	00D5024 (4GB) 00D5036 (8GB)		46W0672 (16GB)		46W0676 (32GB)		46W0741 (64GB)	
Rated speed	1600 MHz		1600 MHz		1600 MHz		1333 MHz	
Rated voltage	1.35 V		1.35 V		1.35 V		1.35 V	
Operating voltage	1.35 V	1.5 V	1.35 V	1.5 V	1.35 V	1.5 V	1.35 V	1.5 V
Max qty supported*	96	96	96	96	96	96	96	96
Max DIMM capacity	8 GB	8 GB	16 GB	16 GB	32 GB	32 GB	64 GB	64 GB
Max memory capacity	0.75 TB	0.75 TB	1.5 TB	1.5 TB	3 TB	3 TB	6 TB	6 TB
Maximum operating speed - Performance mode (2:1 mode - SMI2 link operates at twice the DDR3 speed that is shown)								
1 DIMM per channel	1333 MHz	1333 MHz	1333 MHz	1333 MHz	1333 MHz	1333 MHz	1333 MHz	1333 MHz
2 DIMMs per channel	1333 MHz	1333 MHz	1333 MHz	1333 MHz	1333 MHz	1333 MHz	1333 MHz	1333 MHz
3 DIMMs per channel	1066 MHz	1333 MHz	1066 MHz	1333 MHz	1333 MHz	1333 MHz	1333 MHz	1333 MHz
Maximum operating speed - RAS mode (1:1 mode - SMI2 link operates at the DDR3 speed that is shown)								
1 DIMM per channel	1333 MHz	1600 MHz	1333 MHz	1600 MHz	1333 MHz	1600 MHz	1333 MHz	1333 MHz
2 DIMMs per channel	1333 MHz	1600 MHz	1333 MHz	1600 MHz	1333 MHz	1600 MHz	1333 MHz	1333 MHz
3 DIMMs per channel	1066 MHz	1333 MHz	1066 MHz	1333 MHz	1333 MHz	1333 MHz	1333 MHz	1333 MHz

* Maximum quantity that is supported is shown for all the processors that are installed.

The following memory protection technologies are supported:

- ECC
- Chipkill (for x4-based memory DIMMs)
- Redundant bit steering (Double Device Data Correction)
- Memory mirroring
- Memory rank sparing

Chipkill and Redundant Bit Steering are supported in RAS mode. Chipkill is supported in Performance mode.

If memory mirroring is used, DIMMs must be installed in pairs for Performance mode (minimum of one pair per each processor) and quads for RAS mode. DIMMs in the pair/quad must be identical in type and size.

If memory rank sparing is used, then a minimum of two single-rank or dual-rank DIMMs must be installed per populated channel (the DIMMs do not need being identical). In rank sparing mode, one rank of a DIMM in each populated channel is reserved as spare memory. The size of a rank varies depending on the DIMMs that are installed.

Internal storage

The X6 compute node has two 2.5-inch front-accessible hot-swap drive bays that are accessible from the front of the server. These bays are connected to the integrated ServeRAID M1210e controller.

The ServeRAID M1210e controller includes the following features:

- Based on the LSI SAS 3004 12 Gbps SAS/SATA RAID-on-Chip (ROC) controller
- Four-port controller with 12 Gbps throughput per port
- PCIe x4 Gen 2 host interface
- Supports RAID levels 0, 1, 10, and 1E; optionally supports RAID 5 and RAID 50.

RAID 5 and RAID 50 are supported through a Features on Demand upgrade, as shown in the following table. For 4-socket and 8-socket complexes, one FoD upgrade is required for each SAS controller on which you want to enable RAID 5.

Table 8. ServeRAID M1210e upgrades

Part number	Feature code	Name and description	Maximum supported
00AE930	A5H5	ServeRAID M1200 Zero Cache/RAID 5 Upgrade for IBM Systems (FOD)	1

Supported drives are listed in the "Internal drive options" section.

Internal drive options

The 2.5-inch drive bays support SAS or SATA HDDs or SATA SSDs. The following table lists the supported 2.5-inch drive options.

Table 9. 2.5-inch drive options for internal disk storage (Part 1 of 2)

Part number	Feature code	Description	Maximum supported
10K SAS hard disk drives			
00AJ146	A4TP	IBM 1.2TB 10K 6Gbps SAS 2.5" G3HS HDD	2
00AJ071	A4TN	IBM 900GB 10K 6Gbps SAS 2.5" SFF G3HS HDD	2
00AJ091	A4TM	IBM 600GB 10K 6Gbps SAS 2.5" SFF G3HS HDD	2
00AJ096	A4TL	IBM 300GB 10K 6Gbps SAS 2.5" SFF G3HS HDD	2
10K and 15K SAS self-encrypting drives (SEDs)			
00AJ151	A4U1	IBM 1.2TB 10K 6Gbps SAS 2.5" G3HS SED	2
00AJ076	A4U0	IBM 900GB 10K 6Gbps SAS 2.5" SFF G3HS SED	2
00AJ101	A4TZ	IBM 600GB 10K 6Gbps SAS 2.5" SFF G3HS SED	2
00AJ106	A4TY	IBM 300GB 10K 6Gbps SAS 2.5" SFF G3HS SED	2
00AJ116	A4U2	IBM 146GB 15K 6Gbps SAS 2.5" G3HS SED	2
15K SAS hard disk drives			
00AJ126	A4TS	IBM 600GB 15K 6Gbps SAS 2.5" G3HS HDD	2
00AJ081	A4TR	IBM 300GB 15K 6Gbps SAS 2.5" G3HS HDD	2
00AJ111	A4TQ	IBM 146GB 15K 6Gbps SAS 2.5" G3HS HDD	2
NL SATA drives			
00AJ141	A4TX	IBM 1TB 7.2K 6Gbps NL SATA 2.5" G3HS HDD	2
00AJ136	A4TW	IBM 500GB 7.2K 6Gbps NL SATA 2.5" G3HS HDD	2
00AJ131	A4TV	IBM 250GB 7.2K 6Gbps NL SATA 2.5" G3HS HDD	2

Table 9. 2.5-inch drive options for internal disk storage (Part 2 of 2)

Part number	Feature code	Description	Maximum supported
NL SAS drives			
00AJ086	A4TU	IBM 1TB 7.2K 6Gbps NL SAS 2.5" G3HS HDD	2
00AJ121	A4TT	IBM 500GB 7.2K 6Gbps NL SAS 2.5" G3HS HDD	2
Enterprise SSDs			
00AJ222	A4UD	IBM 1.6TB SAS 2.5" MLC G3HS Enterprise SSD	2
00AJ217	A4UC	IBM 800GB SAS 2.5" MLC G3HS Enterprise SSD	2
00AJ212	A4UB	IBM 400GB SAS 2.5" MLC G3HS Enterprise SSD	2
00AJ207	A4UA	IBM 200GB SAS 2.5" MLC G3HS Enterprise SSD	2
00AJ166	A4U5	S3700 800GB SATA 2.5" MLC G3HS Enterprise SSD	2
00AJ161	A4U4	S3700 400GB SATA 2.5" MLC G3HS Enterprise SSD	2
00AJ156	A4U3	S3700 200GB SATA 2.5" MLC G3HS Enterprise SSD	2
Enterprise Value SSDs			
00AJ395	A577	IBM 120GB SATA 2.5" MLC G3HS Enterprise Value SSD	2
00AJ400	A578	IBM 240GB SATA 2.5" MLC G3HS Enterprise Value SSD	2
00AJ405	A579	IBM 480GB SATA 2.5" MLC G3HS Enterprise Value SSD	2
00AJ410	A57A	IBM 800GB SATA 2.5" MLC G3HS Enterprise Value SSD	2

Internal tape drives

The server does not support an internal tape drive. However, it can be attached to external tape drives by using Fibre Channel connectivity.

Optical drives

The server does not support an internal optical drive option. However, you can connect an external USB optical drive, such as the IBM and Lenovo part number 73P4515 or 73P4516, or use the remote media feature of the IMMv2 and the Chassis Management Module.

Note: The USB port on the compute node supplies up to 0.5 A at 5 V. For devices that require more power, an additional power source is required.

I/O expansion options

The X6 compute node has four I/O expansion connectors for attaching I/O adapters, as shown in the following figure. Installing I/O adapters allows the server to connect to switch modules in the IBM Flex System Enterprise Chassis. The following figure shows the location of the four I/O expansion slots.

Note: Slots 3 and 4 support only a subset of the adapters that are supported in slots 1 and 2. Slots 3 and 4 do not support dual-ASIC adapters because of the PCIe lanes that are routed to slots 3 and 4. For specifics, see the "Network adapters" section.

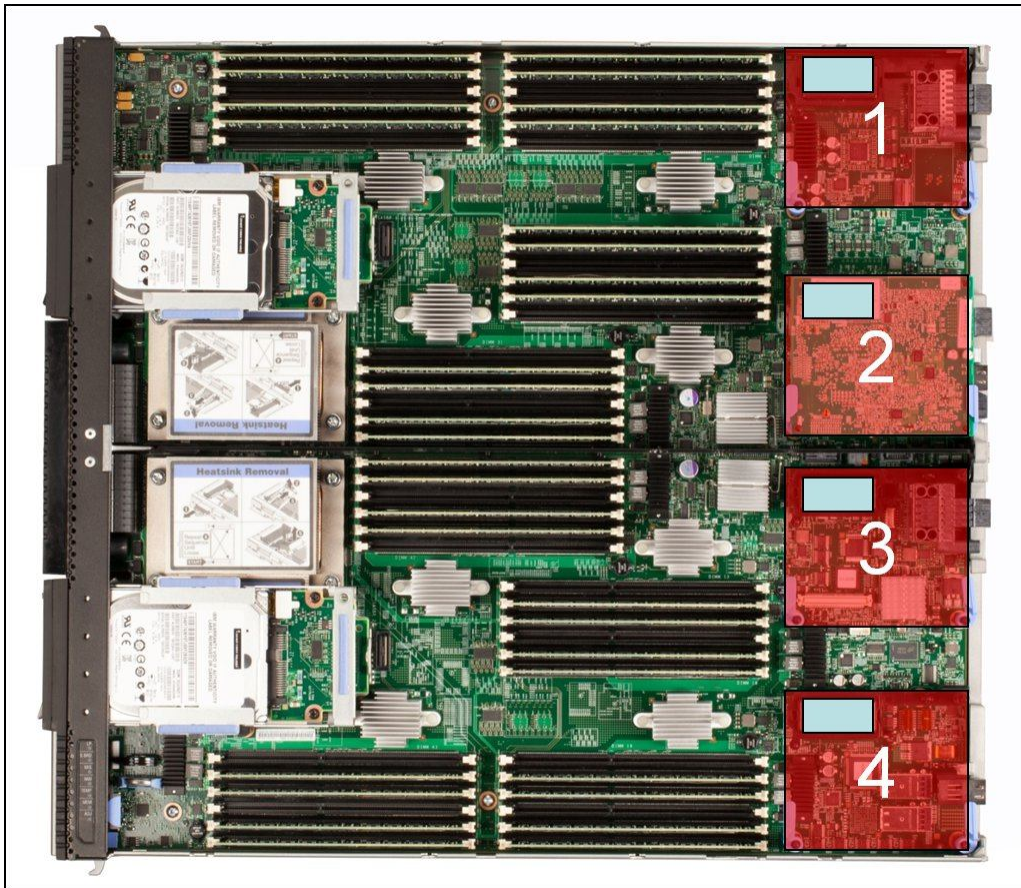

Figure 7. Location of the I/O adapter slots in the X6 Compute Node

A compatible switch or pass-through module must be installed in the corresponding I/O bays in the chassis, as indicated in the following table. Installing two switches means that all the ports of the adapter are enabled, which improves performance and network availability.

Table 10. Adapter to I/O bay correspondence

I/O adapter slot in the server	Port on the adapter	Corresponding I/O module bay in the chassis
Slot 1	Port 1	Module bay 1
	Port 2	Module bay 2
	Port 3 (for 4 & 8-port cards)	Module bay 1
	Port 4 (for 4 & 8-port cards)	Module bay 2
	Port 5 (for 8-port cards)	Module bay 1
	Port 6 (for 8-port cards)	Module bay 2
	Port 7 (for 8-port cards)	Module bay 1
	Port 8 (for 8-port cards)	Module bay 2
Slot 2	Port 1	Module bay 3
	Port 2	Module bay 4
	Port 3 (for 4 & 8-port cards)	Module bay 3
	Port 4 (for 4 & 8-port cards)	Module bay 4
	Port 5 (for 8-port cards)	Module bay 3
	Port 6 (for 8-port cards)	Module bay 4
	Port 7 (for 8-port cards)	Module bay 3
	Port 8 (for 8-port cards)	Module bay 4
Slot 3 (Dual-ASIC adapters are not supported.)	Port 1	Module bay 1
	Port 2	Module bay 2
Slot 4 (Dual-ASIC adapters are not supported.)	Port 1	Module bay 3
	Port 2	Module bay 4

For a list of supported switches, see the IBM Flex System Interoperability Guide, available at the following website:

<http://www.redbooks.ibm.com/fsig>

The following figure shows the location of the switch bays in the IBM Flex System Enterprise Chassis.

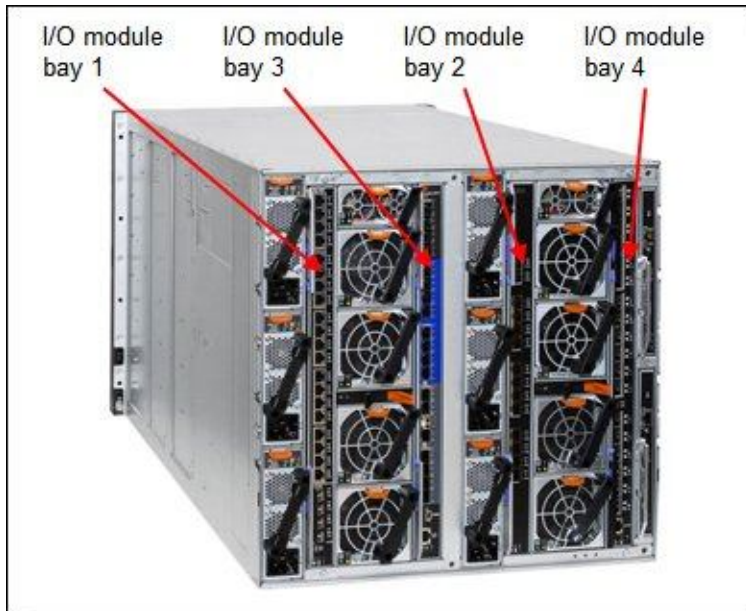

Figure 8. Location of the switch bays in the IBM Flex System Enterprise Chassis

The following figure shows how 2-port adapters are connected to switches that are installed in the chassis.

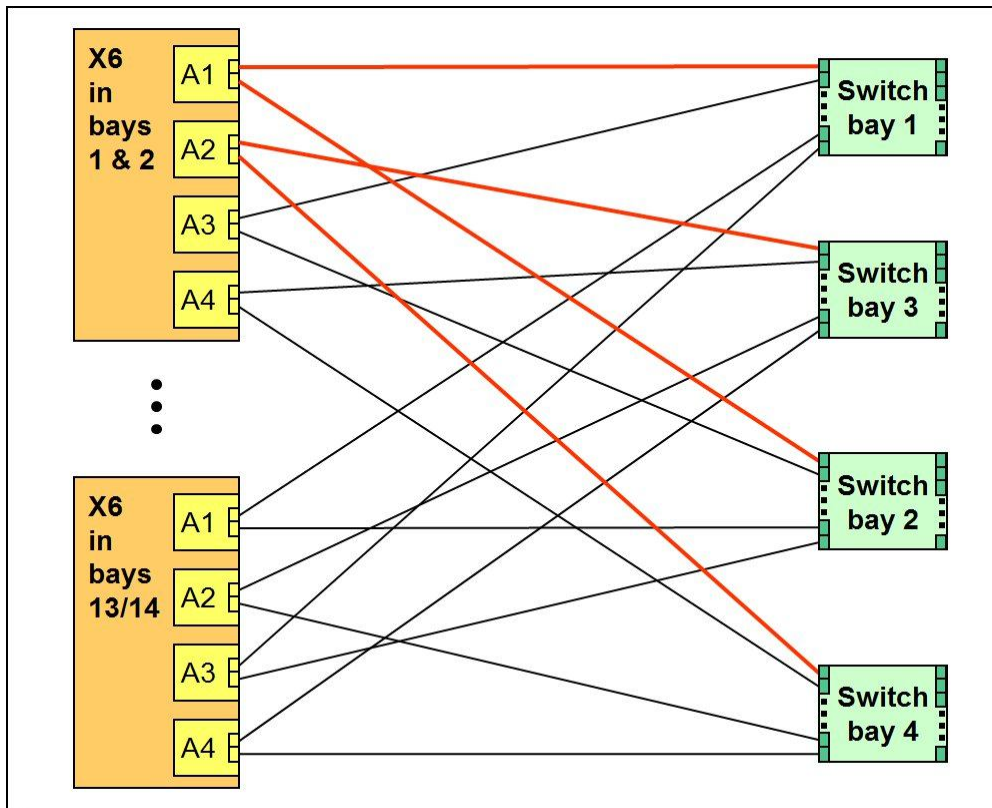

Figure 9. Logical layout of the interconnects between I/O adapters and I/O modules

Network adapters

An Ethernet adapter must be installed in slot 1 to provide network connectivity between the server and the chassis midplane and ultimately to the network switches.

The following table lists the supported network adapters and upgrades and the slots they are each supported in. Compatible switches must be installed in the corresponding bays of the chassis.

Note: The following adapters with two ASICs are not supported in slots 3 and 4:

- IBM Flex System CN4054R 10Gb Virtual Fabric Adapter
- IBM Flex System EN2024 4-port 1Gb Ethernet Adapter

Table 11. Network adapters

Part number	Feature code	IBM Flex System adapter	Number of ports	Maximum supported	Slots supported
40 Gb Ethernet					
90Y3482	A3HK	EN6132 2-port 40Gb Ethernet Adapter	2	4	1, 2, 3, 4
10 Gb Ethernet					
00Y3306	A4K2	CN4054R 10Gb Virtual Fabric Adapter	4	2	1, 2**
90Y3558	A1R0	CN4054 Virtual Fabric Adapter (SW Upgrade) (FCoE/iSCSI upgrade for 00Y3306; 1 per adapter)	License	2	Not applicable
88Y5920	A4K3	CN4022 2-port 10Gb Converged Adapter	2	4	1, 2, 3, 4
90Y3466	A1QY	EN4132 2-port 10Gb Ethernet Adapter	4	4	1, 2, 3, 4
1 Gb Ethernet					
49Y7900	A10Y	EN2024 4-port 1Gb Ethernet Adapter	4	2	1, 2**
InfiniBand					
90Y3454	A1QZ	IB6132 2-port FDR InfiniBand Adapter	2	2	2, 4

** Adapters with two ASICs are not supported in slots 3 and 4 because of the available PCIe lanes in those slots

For adapter-to-switch compatibility, see the IBM Flex System Interoperability Guide:
<http://www.redbooks.ibm.com/fsig>

For more information, see the list of IBM Redbooks® Product Guides in the Adapter cards category:
<http://www.redbooks.ibm.com/portals/puresystems?Open&page=pg&cat=adapters>

Storage host bus adapters

The following table lists the storage host bus adapters (HBAs) that are supported by the compute node.

Note: The following adapter with two ASICs is not supported in slots 3 and 4:

- IBM Flex System FC5054 4-port 16Gb FC adapter

Table 12. Storage adapters

Part number	Feature code	Description	Number of ports	Maximum supported	Slots supported
Fibre Channel					
88Y6370	A1BP	IBM Flex System FC5022 2-port 16Gb FC Adapter	2	2	2, 4
69Y1938	A1BM	IBM Flex System FC3172 2-port 8Gb FC Adapter	2	2	2, 4
95Y2375	A2N5	IBM Flex System FC3052 2-port 8Gb FC Adapter	2	2	2, 4
95Y2386	A45R	IBM Flex System FC5052 2-port 16Gb FC Adapter	2	2	2, 4
95Y2391	A45S	IBM Flex System FC5054 4-port 16Gb FC Adapter	4	1	2*
69Y1942	A1BQ	IBM Flex System FC5172 2-port 16Gb FC Adapter	2	2	2, 4

* Adapters with two ASICs are not supported in slots 3 and 4 because of the available PCIe lanes in those slots.

Power supplies

Server power is derived from the power supplies that are installed in the chassis. There are no server options regarding power supplies.

Integrated virtualization

The X6 compute node supports the ESXi hypervisor on a USB memory key through two internal USB ports (see Figure 3). The supported USB memory keys are listed in the following table.

There are two types of USB keys: preinstalled keys or blank keys. Blank keys allow you to download an IBM customized version of ESXi and load it onto the key. The compute node supports one or two keys installed, but only certain combinations:

Supported combinations:

- One preinstalled key
- One blank key
- One preinstalled key and one blank key
- Two blank keys

Unsupported combinations:

- Two preinstalled keys

Installing two preinstalled keys prevents ESXi from booting, as described at <http://kb.vmware.com/kb/1035107>. Having two keys that are installed provides a backup boot device. Both devices are listed in the boot menu, which allows you to boot from either device or to set one as a backup in case the first one becomes corrupted.

The supported USB memory keys are listed in the following table.

Table 13. Virtualization options

Part number	Feature code	Description	Maximum supported
41Y8298	A2G0	IBM Blank USB Memory Key for VMware ESXi Downloads	2
41Y8300	A2VC	IBM USB Memory Key for VMware ESXi 5.0	1
41Y8307	A383	IBM USB Memory Key for VMware ESXi 5.0 Update 1	1
41Y8311	A2R3	IBM USB Memory Key for VMware ESXi 5.1	1
41Y8382	A4WZ	IBM USB Memory Key for VMware ESXi 5.1 Update 1	1
41Y8385	A584	IBM USB Memory Key for VMware ESXi 5.5	1

Light path diagnostics panel

For quick problem determination when you are physically at the server, the compute node offers a 3-step guided path:

1. The Fault LED on the front panel
2. The light path diagnostics panel
3. LEDs next to key components on the system board

The light path diagnostics panel is visible when you remove the server from the chassis. The panel is at the upper right side of the compute node, as shown in the following figure.

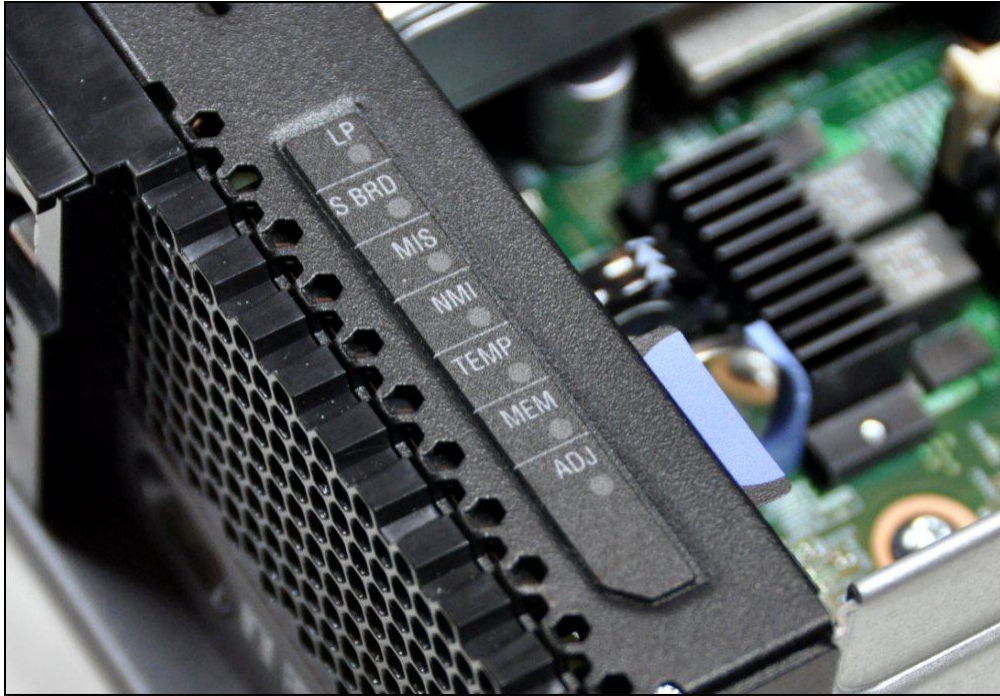

Figure 10. Location of X6 light path diagnostics panel

To illuminate the light path diagnostics LEDs, power off the compute node, slide it out of the chassis, and press the power button. The power button doubles as the light path diagnostics remind button when the server is removed from the chassis. The meanings of the LEDs are listed in the following table.

Table 14. Light path diagnostic panel LEDs

LED	Meaning
LP	The light path diagnostics panel is operational.
S BRD	A system board error is detected.
MIS	A mismatch has occurred between the processors, DIMMs, or HDDs.
NMI	A non-maskable interrupt (NMI) has occurred.
TEMP	An over-temperature condition occurred that was critical enough to shut down the server.
MEM	A memory fault has occurred. The corresponding DIMM error LEDs on the system board are also lit.
ADJ	A fault is detected in the adjacent expansion unit (if installed).

Remote management

The server contains an IBM Integrated Management Module II (IMM2), which interfaces with the advanced management module in the chassis. The combination of these two components provides advanced service-processor control, monitoring, and an alerting function. If an environmental condition exceeds a threshold or if a system component fails, LEDs on the system board are lit to help you diagnose the problem, the error is recorded in the event log, and you are alerted to the problem. A virtual presence capability comes standard for remote server management.

Remote server management is provided through industry-standard interfaces:

- Intelligent Platform Management Interface (IPMI) Version 2.0
- Simple Network Management Protocol (SNMP) Version 3
- Common Information Model (CIM)
- Web browser

The server also supports virtual media and remote control features, which provide the following functions:

- Remotely viewing video with graphics resolutions up to 1600x1200 at 75 Hz with up to 23 bits per pixel, regardless of the system state
- Remotely accessing the server using the keyboard and mouse from a remote client
- Mapping the CD or DVD drive, diskette drive, and USB flash drive on a remote client, and mapping ISO and diskette image files as virtual drives that are available for use by the server
- Uploading a diskette image to the IMM2 memory and mapping it to the server as a virtual drive
- Capturing blue-screen errors

Supported operating systems

The server supports the following operating systems:

- Microsoft Windows Server 2008 R2 Datacenter SP1
- Microsoft Windows Server 2008 R2 Enterprise SP1
- Microsoft Windows Server 2008 R2 Standard SP1
- Microsoft Windows Server 2012 Datacenter
- Microsoft Windows Server 2012 Enterprise
- Microsoft Windows Server 2012 Standard
- Microsoft Windows Storage Server 2012 Standard
- Microsoft Windows Server 2012 R2 Datacenter
- Microsoft Windows Server 2012 R2 Enterprise
- Microsoft Windows Server 2012 R2 Standard
- Microsoft Windows Storage Server 2012 R2 Standard
- Red Hat Enterprise Linux 6 Server x64 Edition U5
- Red Hat Enterprise Linux 7
- SUSE Linux Enterprise Server 11 for AMD64/EM64T SP3
- SUSE Linux Enterprise Server 11 with Xen for AMD64/EM64T SP3
- VMware vSphere 5.0
- VMware vSphere 5.0 Update 1
- VMware vSphere 5.1 U2
- VMware vSphere 5.1 Update 1 U2
- VMware vSphere 5.5

Note: Support by some of these operating system versions will be after the date of initial availability. For the latest information about the specific versions and service levels that are supported and any other prerequisites, see the IBM ServerProven® website at:

<http://www.ibm.com/systems/info/x86servers/serverproven/compat/us/nos/matrix.shtml>

Physical specifications

Dimensions and weight (approximate) for one X6 compute node:

- Width: 435 mm (17.1 in.)
- Height 56 mm (2.1 in.)
- Depth 500 mm (19.7 in.)
- Maximum weight: 12.25 kg (27 lbs)

Supported environment

The IBM Flex System X6 Compute Node complies with ASHRAE Class A3 specifications.

This is the supported operating environment:

Power on:

- Temperature: 5 to 40 °C (41 to 104 °F)
- Humidity, non-condensing: -12 °C dew point (10.4 °F) and 8 - 85% relative humidity
- Maximum dew point: 24 °C (75 °F)
- Maximum altitude: 3048 m (10,000 ft.)
- Maximum rate of temperature change: 5 °C/hr (41 °F/hr)

Power off:

- Temperature: 5 to 45 °C (41 to 113 °F)
- Relative humidity: 8 - 85%
- Maximum dew point: 27 °C (80.6 °F)

Storage (non-operating):

- Temperature: 1 to 60 °C (33.8 to 140 °F)
- Altitude: 3050 m (10,006 ft.)
- Relative humidity: 5 - 80%
- Maximum dew point: 29 °C (84.2°F)

Shipment (non-operating):

- Temperature: -40 to 60 °C (-40 to 140 °F)
- Altitude: 10,700 m (35,105 ft)
- Relative humidity: 5 - 100%
- Maximum dew point: 29 °C (84.2 °F)

Warranty options

The IBM Flex System X6 Compute Node has a 3-year onsite warranty with 9x5 next-business-day terms. IBM offers the warranty service upgrades through IBM ServicePac offerings, which are described in this section. The IBM ServicePac is a series of prepackaged warranty maintenance upgrades and post-warranty maintenance agreements with a well-defined scope of services, including service hours, response time, term of service, and service agreement terms and conditions.

IBM ServicePac offerings are country-specific. Each country might have its own service types, service levels, response times, and terms and conditions. Not all covered types of ServicePac might be available in a particular country. For more information about IBM ServicePac offerings that are available in your country, see the IBM ServicePac Product Selector at <https://www-304.ibm.com/sales/gss/download/spst/servicepac>.

The following table explains warranty service definitions in more detail.

Table 15. Warranty service definitions

Term	Description
IBM onsite repair (IOR)	A service technician comes to the server's location for equipment repair.
24x7x2 hour	A service technician is scheduled to arrive at your customer's location within two hours after remote problem determination is completed. We provide 24-hour service, every day, including IBM holidays.
24x7x4 hour	A service technician is scheduled to arrive at your customer's location within four hours after remote problem determination is completed. We provide 24-hour service, every day, including IBM holidays.
9x5x4 hour	A service technician is scheduled to arrive at your customer's location within four business hours after remote problem determination is completed. We provide service from 8:00 a.m. to 5:00 p.m. in the customer's local time zone, Monday through Friday, excluding IBM holidays. If it is after 1:00 p.m. and it is determined that onsite service is required, the customer can expect the service technician to arrive the morning of the following business day. For noncritical service requests, a service technician arrives by the end of the following business day.
9x5 next business day	A service technician is scheduled to arrive at your customer's location on the business day after we receive your call after remote problem determination is completed. We provide service from 8:00 a.m. to 5:00 p.m. in the customer's local time zone, Monday through Friday, excluding IBM holidays.

In general, here are the types of IBM ServicePac offerings:

- Warranty and maintenance service upgrades
 - One, two, three, four, or five years of 9x5 or 24x7 service coverage
 - Onsite repair from the next business day to four or two hours
 - One or two years of warranty extension
- Remote technical support services
 - One or three years with 24x7 coverage (severity 1) or 9-5 next business day for all severities
 - Installation and startup support for IBM System x® servers
 - Remote technical support for IBM System x® servers
 - Software support - Support Line
 - Microsoft or Linux software
 - VMware
 - IBM Systems Director

Regulatory compliance

The server conforms to the following standards:

- ASHRAE Class A3
- FCC - Verified to comply with Part 15 of the FCC Rules Class A
- Canada ICES-004, issue 3 Class A
- UL/IEC 60950-1
- CSA C22.2 No. 60950-1
- NOM-019
- Argentina IEC 60950-1
- Japan VCCI, Class A
- IEC 60950-1 (CB Certificate and CB Test Report)
- China CCC (GB4943); (GB9254, Class A); (GB17625.1)
- Taiwan BSMI CNS13438, Class A; CNS14336
- Australia/New Zealand AS/NZS CISPR 22, Class A
- Korea KN22, Class A, KN24
- Russia/GOST ME01, IEC 60950-1, GOST R 51318.22, GOST R 51318.249, GOST R 51317.3.2, and GOST R 51317.3.3
- IEC 60950-1 (CB Certificate and CB Test Report)
- CE Mark (EN55022 Class A, EN60950-1, EN55024, EN61000-3-2, and EN61000-3-3)
- CISPR 22, Class A
- TUV-GS (EN60950-1/IEC 60950-1 and EK1-ITB2000)

IBM Global Financing

IBM Global Financing can help you obtain the IT solution that you need while preserving funding for other strategic investments and optimizing cash flow. Our Fair Market Value (FMV) lease helps ensure that you have the latest IBM technology, and with our mid-lease upgrade capability, you can increase the capacity of the system with little to no change in monthly payments. At the end of the lease, take advantage of our flexible end-of-lease options to fit your changing business needs. IBM Global Financing has the breadth and depth of offerings, longevity, proven success, and global reach to help you develop a robust financing and asset management strategy that provides you with the opportunity to use new technologies and turn your ambitious vision into a tangible solution.

Here are some other reasons why working with us makes solid financial sense:

- Expand your purchasing power: Affordable monthly payments allow you to change the technology acquisition discussion from “what can I afford right now” to “what solution is really right for my business.” IBM Global Financing allows you to expand your purchase power to get you the right solution.
- Accelerate your project’s cash flow break-even point: Acquire your IBM technology today and begin to realize its benefits now. An FMV lease can help you get the solution that you need now, with low monthly payments that better align upfront costs with the anticipated return on investment from the technology.
- Easy to acquire with affordable rates: We offer a one-stop shopping for a total IT solution, so you can acquire IBM hardware, software, services, and the financing you need from one IT provider.

Plus, we provide simple, easy-to-understand contracts and quick approvals. As the world’s largest IT financing provider, with an asset base of US\$35.8 billion and over 125,000 customers, IBM Global Financing offers highly competitive rates that promote low total cost of ownership (TCO) and low monthly payments.

IBM Global Financing operates in more than 50 countries. Go to <http://ibm.com/financing> for financing options in your country and to contact a local financing specialist.

IBM Global Financing offerings are provided through IBM Credit LLC in the United States and other IBM subsidiaries and divisions worldwide to qualified commercial and government clients. Rates and availability subject to client’s credit rating, financing terms, offering type, equipment, and product type and options, and may vary by country. Non-hardware items must be one-time, non-recurring charges and are financed by means of loans. Other restrictions may apply. Rates and offerings are subject to change, extension or withdrawal without notice and may not be available in all countries. Contact your local IBM Global Financing representative for additional detail.

Related publications and links

For more information, see the following resources:

- IBM US Product Announcement:
<http://ibm.com/common/ssi/cgi-bin/ssialias?infotype=dd&subtype=ca&&htmlfid=897/ENUS114-051>
- IBM Flex System X6 Compute Node product page:
<http://ibm.com/systems/flex/compute-nodes/x86/bto/x280X6-x480X6-x880X6/>
- IBM Flex System Information Center:
<http://publib.boulder.ibm.com/infocenter/flexsys/information/index.jsp>
- *IBM Flex System X6 Compute Node Installation and Service Guide*:
http://publib.boulder.ibm.com/infocenter/flexsys/information/topic/com.ibm.acc.7903.doc/printable_doc.html
- ServerProven for IBM Flex System:
<http://ibm.com/systems/info/x86servers/serverproven/compat/us/flexsystems.html>
- ServerProven compatibility page for operating system support:
<http://ibm.com/systems/info/x86servers/serverproven/compat/us/nos/flexmatrix.shtml>
- IBM Redbooks Product Guides for IBM Flex System servers and options:
<http://www.redbooks.ibm.com/Redbooks.nsf/portals/puresystems?Open&page=pgbycat>
- *IBM Flex System Interoperability Guide*:
<http://www.redbooks.ibm.com/fsig>
- *Configuration and Option Guide*:
<http://www.ibm.com/systems/xbc/cog/>
- xREF - IBM x86 Server Reference:
<http://www.redbooks.ibm.com/xref>
- IBM System x Support Portal:
<http://ibm.com/support/entry/portal/>
- IBM System Storage® Interoperation Center (SSIC):
<http://www.ibm.com/systems/support/storage/ssic>

Notices

This information was developed for products and services offered in the U.S.A.

IBM may not offer the products, services, or features discussed in this document in other countries. Consult your local IBM representative for information on the products and services currently available in your area. Any reference to an IBM product, program, or service is not intended to state or imply that only that IBM product, program, or service may be used. Any functionally equivalent product, program, or service that does not infringe any IBM intellectual property right may be used instead. However, it is the user's responsibility to evaluate and verify the operation of any non-IBM product, program, or service. IBM may have patents or pending patent applications covering subject matter described in this document. The furnishing of this document does not give you any license to these patents. You can send license inquiries, in writing, to:

IBM Director of Licensing, IBM Corporation, North Castle Drive, Armonk, NY 10504-1785 U.S.A.

The following paragraph does not apply to the United Kingdom or any other country where such provisions are inconsistent with local law: INTERNATIONAL BUSINESS MACHINES CORPORATION PROVIDES THIS PUBLICATION "AS IS" WITHOUT WARRANTY OF ANY KIND, EITHER EXPRESS OR IMPLIED, INCLUDING, BUT NOT LIMITED TO, THE IMPLIED WARRANTIES OF NON-INFRINGEMENT, MERCHANTABILITY OR FITNESS FOR A PARTICULAR PURPOSE. Some states do not allow disclaimer of express or implied warranties in certain transactions, therefore, this statement may not apply to you. This information could include technical inaccuracies or typographical errors. Changes are periodically made to the information herein; these changes will be incorporated in new editions of the publication. IBM may make improvements and/or changes in the product(s) and/or the program(s) described in this publication at any time without notice.

Any references in this information to non-IBM Web sites are provided for convenience only and do not in any manner serve as an endorsement of those Web sites. The materials at those Web sites are not part of the materials for this IBM product and use of those Web sites is at your own risk. IBM may use or distribute any of the information you supply in any way it believes appropriate without incurring any obligation to you. Information concerning non-IBM products was obtained from the suppliers of those products, their published announcements or other publicly available sources. IBM has not tested those products and cannot confirm the accuracy of performance, compatibility or any other claims related to non-IBM products. Questions on the capabilities of non-IBM products should be addressed to the suppliers of those products. This information contains examples of data and reports used in daily business operations. To illustrate them as completely as possible, the examples include the names of individuals, companies, brands, and products. All of these names are fictitious and any similarity to the names and addresses used by an actual business enterprise is entirely coincidental.

Any performance data contained herein was determined in a controlled environment. Therefore, the results obtained in other operating environments may vary significantly. Some measurements may have been made on development-level systems and there is no guarantee that these measurements will be the same on generally available systems. Furthermore, some measurement may have been estimated through extrapolation. Actual results may vary. Users of this document should verify the applicable data for their specific environment.

COPYRIGHT LICENSE:

This information contains sample application programs in source language, which illustrate programming techniques on various operating platforms. You may copy, modify, and distribute these sample programs in any form without payment to IBM, for the purposes of developing, using, marketing or distributing application programs conforming to the application programming interface for the operating platform for which the sample programs are written. These examples have not been thoroughly tested under all conditions. IBM, therefore, cannot guarantee or imply reliability, serviceability, or function of these programs.

© Copyright International Business Machines Corporation 2014. All rights reserved.

Note to U.S. Government Users Restricted Rights -- Use, duplication or disclosure restricted by GSA ADP Schedule Contract with IBM Corp.

This document was created or updated on June 10, 2014.

Send us your comments in one of the following ways:

- Use the online **Contact us** review form found at:
ibm.com/redbooks
- Send your comments in an e-mail to:
redbook@us.ibm.com
- Mail your comments to:
IBM Corporation, International Technical Support Organization
Dept. HYTD Mail Station P099
2455 South Road
Poughkeepsie, NY 12601-5400 U.S.A.

This document is available online at <http://www.ibm.com/redbooks/abstracts/tips1160.html> .

Trademarks

IBM, the IBM logo, and ibm.com are trademarks or registered trademarks of International Business Machines Corporation in the United States, other countries, or both. These and other IBM trademarked terms are marked on their first occurrence in this information with the appropriate symbol (® or ™), indicating US registered or common law trademarks owned by IBM at the time this information was published. Such trademarks may also be registered or common law trademarks in other countries. A current list of IBM trademarks is available on the Web at <http://www.ibm.com/legal/copytrade.shtml>.

The following terms are trademarks of the International Business Machines Corporation in the United States, other countries, or both:

IBM Flex System Manager™
IBM Flex System®
IBM®
Redbooks®
Redbooks (logo)®
ServerProven®
ServicePac®
System Storage®
System x®
X-Architecture®

The following terms are trademarks of other companies:

Intel Xeon, Intel, Intel logo, Intel Inside logo, and Intel Centrino logo are trademarks or registered trademarks of Intel Corporation or its subsidiaries in the United States and other countries.

Linux is a trademark of Linus Torvalds in the United States, other countries, or both.

Microsoft, Windows, and the Windows logo are trademarks of Microsoft Corporation in the United States, other countries, or both.

Other company, product, or service names may be trademarks or service marks of others.