

TRACVISION[®]

BY KVH INDUSTRIES

TracVision M3 – DX Version

Circular Configuration



TracVision M3 Installation Guide

TracVision M3DX Installation Guide

Circular Configuration

These instructions explain how to install the TracVision M3DX satellite TV antenna system on a vessel. Complete instructions on how to use the system are provided in the *User's Guide*.

Installation Steps

1. Inspect Parts and Get Tools...3
2. Plan the Installation...4
3. Prepare the Mounting Site...5
4. Wire the Antenna...6
5. Remove the Shipping Restraint...7
6. Mount the Antenna...8
7. Wire the Interface Box...9
8. Connect Power...10
9. Mount the Interface Box...11
10. Turn On the System...12
11. Set Up the System...13
12. Run Check Switch Tests...16
13. Educate the Customer...18

Who Should Install the System?

To ensure a safe and effective installation, KVH recommends that a KVH-authorized marine technician install the TracVision M3DX antenna. KVH-authorized technicians have the tools and electronics expertise necessary to install the system. To find a technician near you, please visit www.kvh.com/wheretogetservice.

Related Documentation

The following additional documents are provided with the TracVision M3DX system:

<u>Document</u>	<u>Description</u>
User's Guide	Operation, setup, and troubleshooting information
Product Registration Form	Details on registering the product with KVH
Warranty Statement	Warranty terms and conditions
Contents List	List of every part supplied in the kit

Technical Support

If you need technical assistance, please contact KVH Technical Support:

Phone: +1 401 847-3327

E-mail: techs@kvh.com

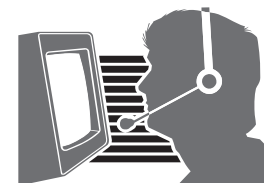

1 Inspect Parts and Get Tools

Before you begin, follow these steps to make sure you have everything you need to complete the installation.

- a. Unpack the box and ensure it contains everything shown on the *Contents List*. Save the packaging for future use.

IMPORTANT!

Always lift the antenna by the baseplate and never by the radome or any portion of the internal antenna assembly (see Figure 1).

- b. Carefully examine all of the supplied parts to ensure nothing was damaged in shipment.
- c. Gather all of the tools and materials listed below. You will need these items to complete the installation.
 - #2 Phillips screwdriver
 - 7/16" open-end wrench
 - 7/16" socket wrench
 - 1/2" socket or open-end wrench
 - Electric drill and 5/16" (8 mm) bit
 - Hole saw of desired diameter (for cable access hole, see [page 5](#))
 - Silicone sealant or equivalent
 - Adhesive tape
 - Light hammer
 - Center punch
 - Eight 1/4" fasteners (see "Mount the Interface Box" on page 11)
 - Satellite TV receiver(s) for your desired service (see [Figure 2](#) for a list of validated receivers; for information on connecting different receiver models, contact KVH Technical Support at 401-847-3327)

Figure 1: TracVision M3DX System Components

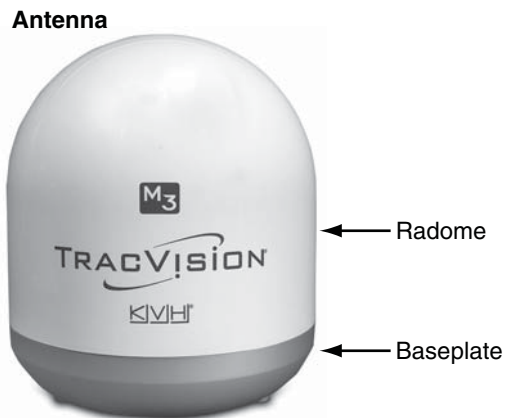

Figure 2: KVH-Validated Receivers

Standard-Definition Models		
DIRECTV	DISH Network	ExpressVu
D12 D11 D10	311	3100
High-Definition (HD) Models		
DIRECTV	DISH Network	ExpressVu
H21* H20*	211k 211	6100

* For compatibility with a Tri-Sat AutoSwitch, use model-manufacturer ID H21-200 or H20-600

2 Plan the Installation

Before you begin, consider the following installation guidelines:

- Minimize blockage. The antenna requires a clear view of the sky to receive satellite TV (see Figure 3). The fewer obstructions above decks, the better the system will perform.
- Make sure the mounting surface is wide enough to accommodate the antenna's base (see Figure 4). Also make sure it is flat, level (within $\pm 2^\circ$), strong enough to support the antenna's weight (18 lbs), and rigid enough to withstand vibration.
- Custom mounting solutions, including struts and masts, are available from several third-party manufacturers. Contact your local KVH dealer or distributor for details.
- KVH recommends that you do not mount the antenna on the same level as the radar, because the radar's energy might overload the antenna.
- Be sure to mount the antenna near enough to the supplied interface box belowdecks to allow you to connect the 50-ft. (15 m) coaxial cable between the antenna and the interface box, while still maintaining sufficient slack in the cable. **The antenna cable CANNOT be extended.**
- When choosing a location for the interface box and receiver(s), find a dry, well-ventilated area belowdecks away from any heat sources or salt spray. Also be sure the interface box front panel will be easily accessible to the user.

Figure 3: Blockage from Obstruction

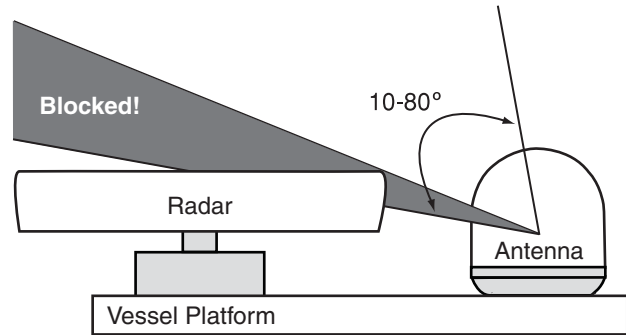
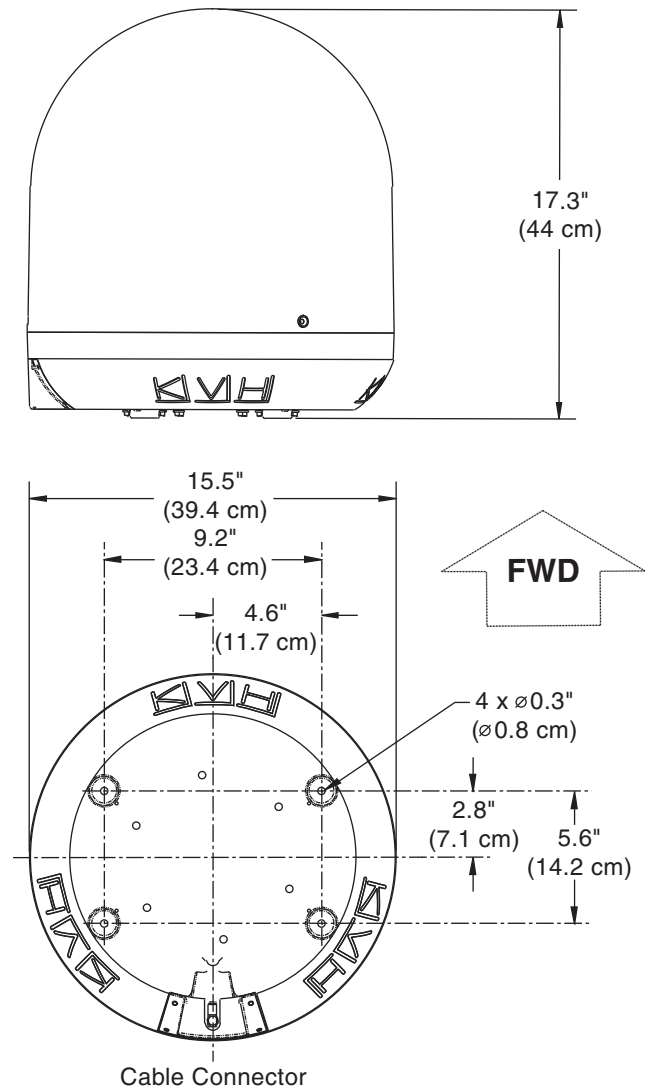

Figure 4: Antenna Dimensions



3 Prepare the Mounting Site

Once you have identified a suitable antenna mounting site, follow these steps to drill the mounting holes and cable access hole to prepare the site for installation.

- a. Unfold the supplied template and place it onto the mounting surface. Make sure the "FWD" (forward) arrow points toward the bow and is parallel to the vessel's centerline (see Figure 5).

NOTE: You do not need to mount the antenna exactly on the vessel's centerline, but the antenna's forward arrow must be parallel to it.

IMPORTANT!

Be sure the mounting surface is flat and level. Use a separate mounting plate, if necessary.

- b. Use the template to mark the locations for the four mounting holes.
- c. Drill a 5/16" (8 mm) hole at the four mounting hole locations you marked in Step b (see Figure 6). Later, you will insert four 1/4"-20 bolts through these holes to secure the antenna to the mounting surface.
- d. Mark a location for the cable access hole, either in the center of the antenna mounting hole pattern or in an area aft of the antenna. Later, you will route the antenna cable through this hole and into the vessel.
- e. Using a hole saw, drill the cable access hole in the location you marked in Step d. Be sure to size the hole appropriately to maintain a cable bend radius of at least 3" (75 mm). If the hole location is in the center of the antenna mounting hole pattern, the diameter of the cable access hole must not exceed 3.5" (88 mm). Smooth the edges of the hole to protect the cable.
- f. Clean and dry the antenna mounting surface.
- g. Peel off the paper backing from the supplied foam seal to expose the adhesive. Then press the foam seal down firmly onto the mounting surface, centered between the antenna mounting holes (see Figure 7).

Figure 5: Antenna Mounting Holes Layout

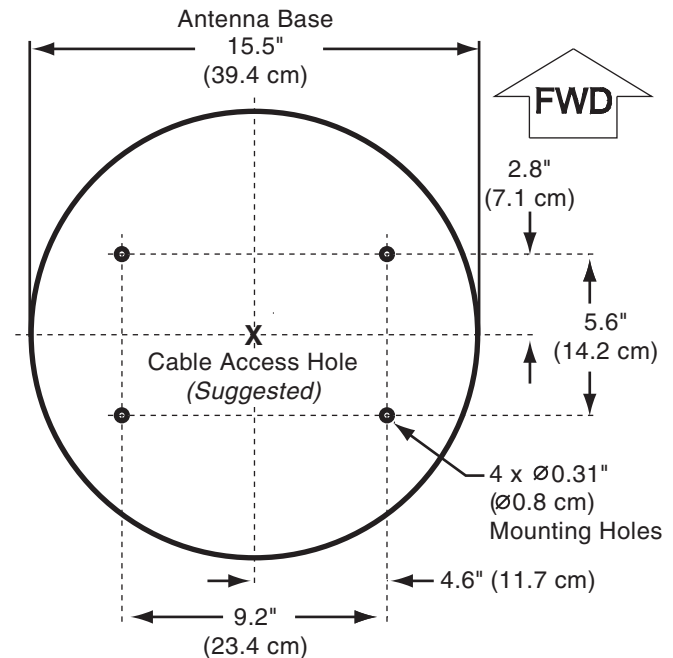

Figure 6: Drilling Antenna Mounting Holes

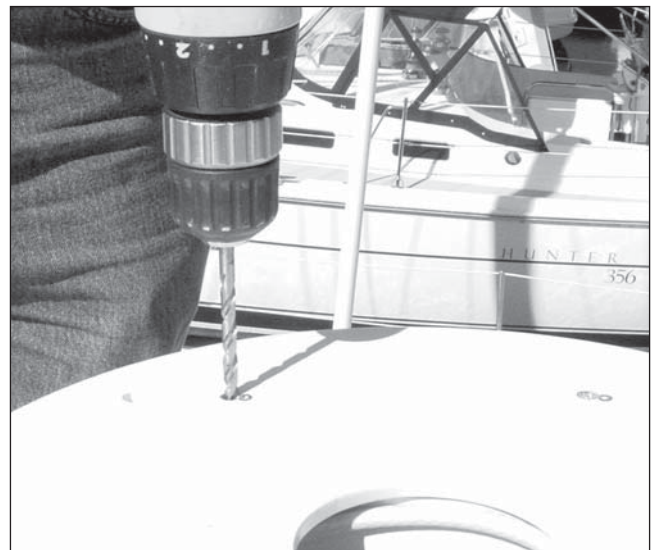
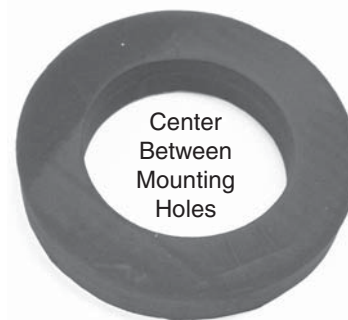

Figure 7: Foam Seal



4 Wire the Antenna

Follow these steps to connect the antenna cable to the antenna.

- a. Using the supplied 3 mm Allen hex key, remove the connector cover from the antenna's base (see Figure 8). Save the cover and the four M4 cap screws for later use.
- b. Route the antenna cable belowdecks through the cable access hole. Be sure to keep the end of the cable with the rubber sealing boot at the antenna site.
- c. If you are routing the cable underneath the antenna, attach the right-angle connector to the antenna end of the cable. Hand-tighten, then tighten with a 7/16" wrench for 1/4 turn to ensure an electrical and weather-proof connection. Then place the supplied right-angle rubber boot extension onto the end of the cable (see Figure 9).
- d. Connect the cable to the antenna. Hand-tighten, then tighten with a 7/16" wrench for 1/4 turn (see Figure 10).
- e. If you are using a right-angle connector, slide the right-angle rubber boot extension up the cable until it covers the right-angle connector.
- f. Slide the rubber boot up the cable until it covers the connector. If you are using a right-angle connector, be sure the boot mates with the extension (see Figure 11). This boot will help protect the connector from the elements.
- g. Reattach the cover over the connector, as shown in Figure 11. Secure in place with the M4 cap screws you removed in Step a. The cover must be attached before you mount the antenna.
- h. Leave an adequate service loop, approximately 8" (20 cm) of slack, in the antenna cable for easy serviceability.
- i. Weatherproof and seal the cable access hole as required.

Figure 8: Removing the Connector Cover

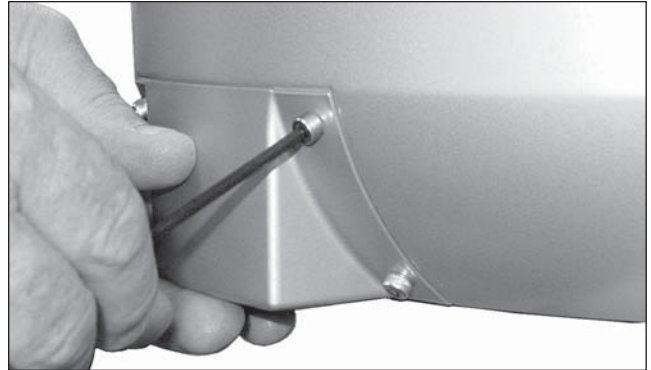

Figure 9: Rubber Boot Extension for Right-Angle Connector

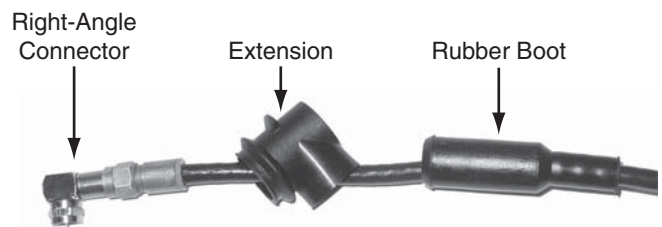
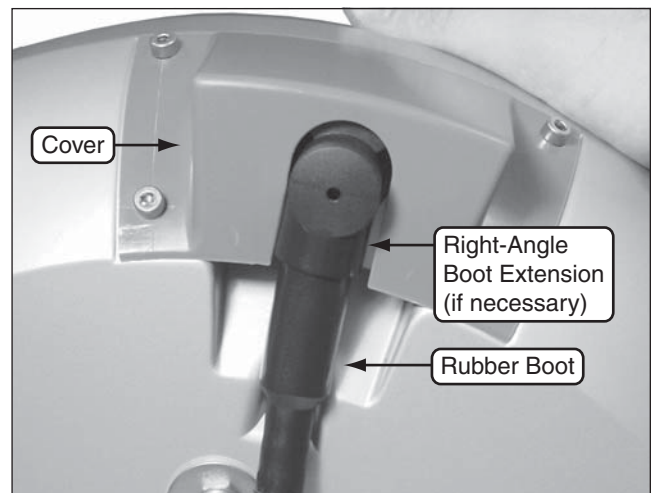

Figure 10: Connecting the Antenna Cable



Figure 11: Protecting the Cable Connection



5 Remove the Shipping Restraint

Follow these steps to remove the shipping restraint, which prevents the internal antenna assembly from moving during shipment. The antenna will not work with this restraint still in place.

- a. Remove the three #10-32 screws securing the radome to the antenna. Carefully remove the radome and set it aside in a safe place (see Figure 12).

NOTE: Due to the snug fit, some contact between the radome's sealing gasket and the antenna mechanism is normal.

- b. Using a 7/16" socket wrench, remove the shipping restraint bolt, washer, and spacer securing the antenna assembly to the base (see Figure 13 and Figure 14). Save the restraint for future use.

IMPORTANT!

Once you have removed the shipping restraint, handle the antenna unit carefully. Improper handling might damage the unit.

- c. Position the antenna onto the mounting surface. The antenna's base should rest squarely atop the foam seal.

Figure 12: Removing the Radome



Figure 13: Removing the Shipping Restraint



Figure 14: Shipping Restraint Hardware

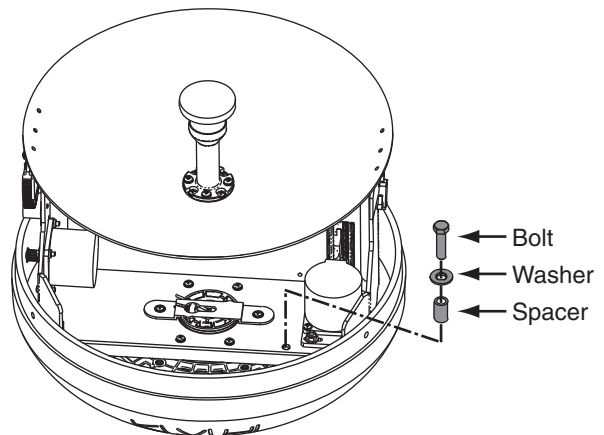

6 Mount the Antenna

Follow these steps to mount the antenna to the mounting surface.

- a. Align the four holes in the antenna's base with the four holes in the mounting surface. Be sure that the antenna's "Forward" arrow points toward the bow and is parallel to the vessel's centerline (see Figure 15).
- b. Secure the antenna's base to the mounting surface using four 1/4"-20 bolts, 5/8" washers, 1" washers, and lock nuts, as shown in Figure 16 and Figure 17.

IMPORTANT!

Be sure to insert the bolts from above and use the supplied hardware for a secure installation.

- c. Tighten the bolts until the foam seal is fully compressed and the antenna's four rubber feet are bottomed against the mounting surface.
- d. Reinstall the antenna radome. The radome's "TracVision" labels should face fore and aft. While pressing the radome down onto the base, secure the radome to the base using the three #10-32 screws you removed earlier.
- e. Install a protective plastic screw cap (supplied in the kit) over each radome screw.

Figure 15: "Forward" Arrow

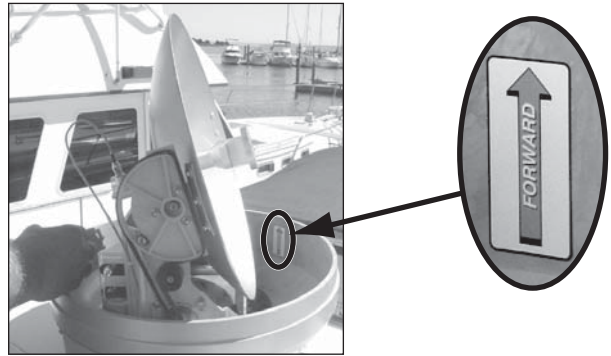

Figure 16: Tightening the Mounting Bolts from Above

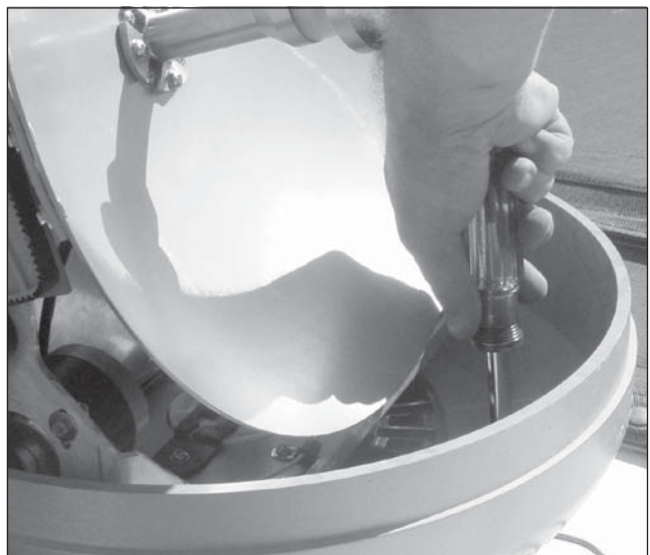
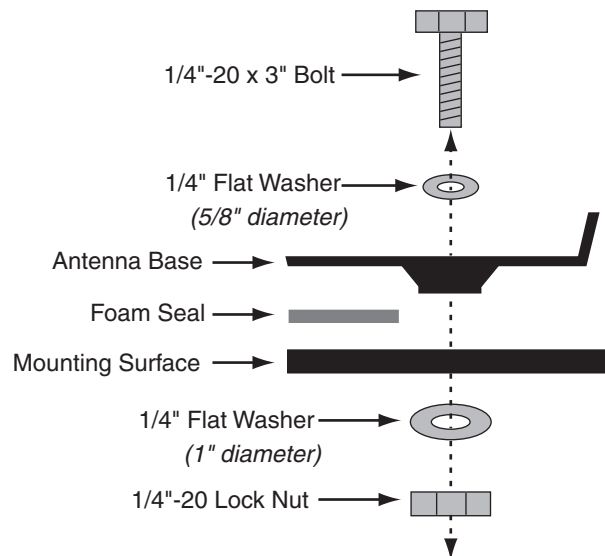

Figure 17: Mounting Hardware



7 Wire the Interface Box

Follow these steps to connect the antenna cable and receiver(s) to the interface box.

IMPORTANT!
Do not shorten or extend the antenna cable. Since the cable carries data, power, and communications, the integrity of this cable and its connections is very important.

IMPORTANT!
Be sure to route cables within the vessel appropriately to avoid damage. For example, do not route any cables through wet areas (bilges) or near hot exhaust pipes. Also be sure you do not kink the cable.

- a. Connect the antenna cable (A) to the "To KVH Antenna" jack on the interface box (see Figure 18).

TIP: If you have a Tri-Sat AutoSwitch for DIRECTV Ku-band Tri-Sat service, follow the receiver wiring instructions provided in the Tri-Sat AutoSwitch kit.

- b. Connect an RF coaxial cable (B) from the "Unstacked Output" jack on the interface box to the "Satellite In" jack on the receiver. This receiver will control satellite selection.

IMPORTANT!
Special Case - Conversion System
If you have a circular/linear conversion system (KVH part #01-0279-05), please refer to the special wiring instructions in the kit.

- c. Connect the receiver to the customer's television. Follow the instructions in the receiver's manual.
- d. If you need to connect an additional receiver, connect the receiver to the "Stacked Output" jack on the interface box through an in-line destacker (see Figure 19 and Figure 20).

The destacker converts the stacked signal from the interface box into an unstacked signal, which receivers are configured to decode.

Figure 18: Wiring the Interface box

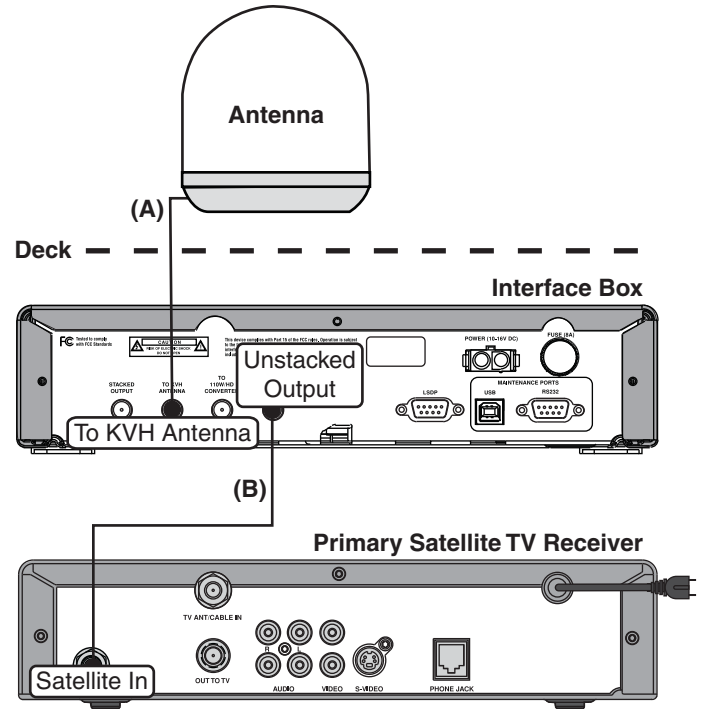
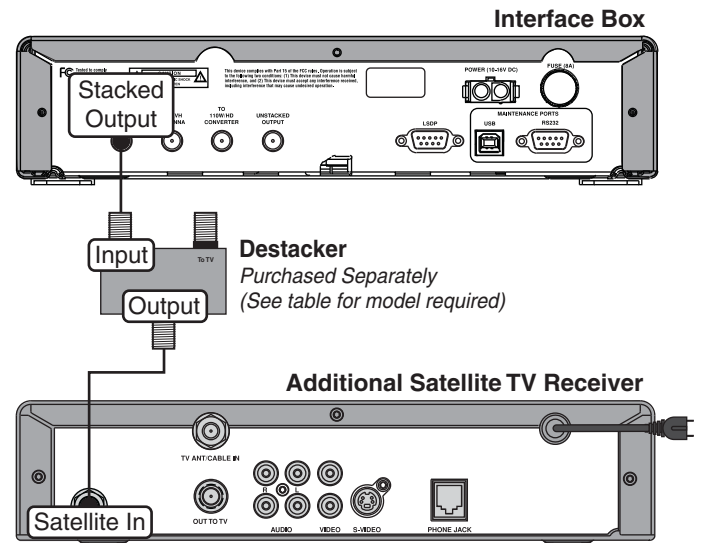

Figure 19: Destacker Models to Connect Additional Receiver(s)

# of Addl. Receivers	Destacker Model
1	Single-output (KVH part #19-0347)
2	Dual-output (KVH part #19-0410)

Figure 20: Connecting an Additional Receiver



8 Connect Power

The interface box requires 10-16 VDC power input supporting 50 watts (4.2 amps @ 12 VDC). Follow these steps to connect power to the interface box.

	CAUTION
For your own safety, shut down vessel power before you connect the wires.	

- a. Before you connect the power wires, turn off vessel power and test the circuit to ensure no power is present.
- b. Connect the individual power wires to a dedicated 10-amp or 15-amp circuit breaker. Connect the negative (black) wire to ground (power return), and connect the positive (red) wire to +12 VDC vessel power.
- c. Plug the other end of the wires into the “Power” jack on the rear panel of the interface box (see Figure 21).

NOTE: Do not remove the small ferrite coil that is clamped onto the power wires. This coil suppresses EMI (electromagnetic interference) from the interface box.

- d. Connect power to the receiver(s). Follow the instructions in the receiver’s manual.

Figure 21: Interface Box Power Wiring

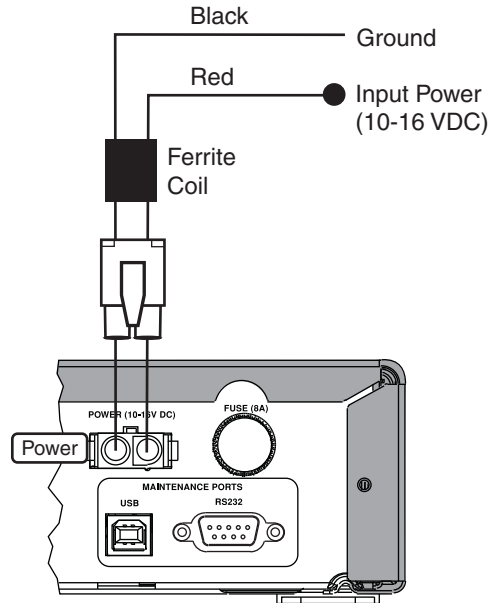

9 Mount the Interface Box

Once all cables are connected, follow these steps to install the interface box inside the vessel.

- a. Attach the two mounting brackets to the sides of the unit using three #2-56 screws. Simply screw these fasteners into the vent slots (see Figure 22).

IMPORTANT!

To avoid overheating, do not block the upper vents of the interface box.

- b. Secure the brackets to the mounting surface using appropriate 1/4" fasteners (not supplied).

NOTE: Be sure to leave enough slack in the connecting cables (service loop) for easy serviceability.

Figure 22: Interface Box Mounting

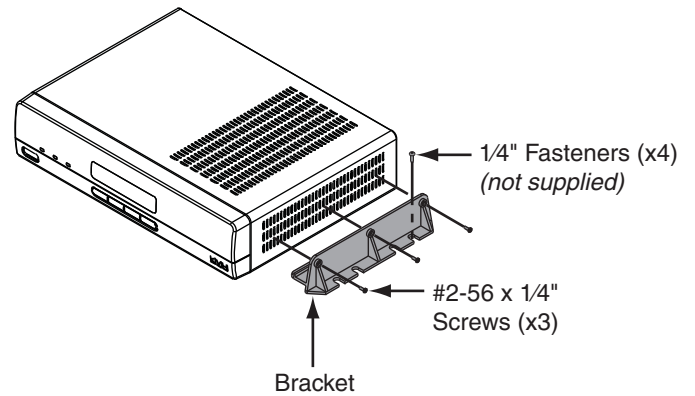

10 Turn On the System

Follow these steps to turn on the system for the first time.

- Ensure the antenna has a clear, unobstructed view of the sky.
- Apply power to the TV and receiver.
- Press the power switch on the front of the interface box to apply power to the TracVision system (see Figure 23).
- Wait while the antenna searches the sky for the satellite. Within a few minutes, all three status lights on the front of the interface box should be lit green (see Figure 23).

NOTE: If all three status lights are not lit green, refer to the User's Guide for troubleshooting information.

- Verify that the "System Needs Setup" screen is displayed on the interface box (see Figure 24).
- Using the buttons on the interface box front panel (see Figure 25), follow the steps in the next section to set up the TracVision system for the customer's service provider:

Option 1 - DIRECTV (see page 13)

Option 2 - DISH Network (see page 14)

Option 3 - ExpressVu (see page 15)

NOTE: If you do not see an operating mode on the following pages that tracks your desired set of satellites, you can select up to five satellites in Manual mode instead. Refer to the User's Guide for details.

Figure 23: Interface Box Power Switch and Status Lights

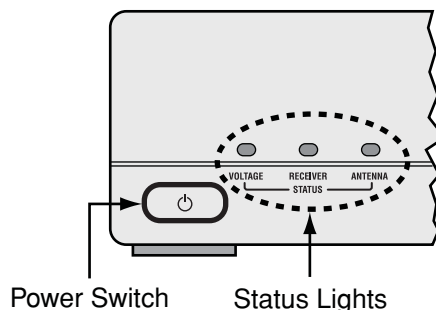

Figure 24: "System Needs Setup" Screen

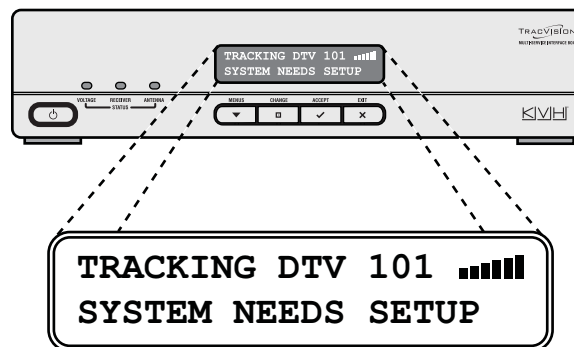
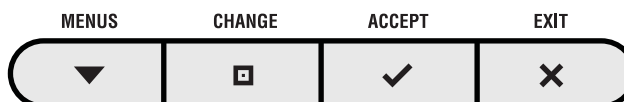

Figure 25: Interface Box Buttons



11 Set Up the System

Option 1 - DIRECTV

Follow these steps and refer to the flowchart in Figure 26 to set up the system for DIRECTV.

- Press any button on the interface box front panel.
- At "Service= DIRECTV?," press ACCEPT.
- At "Mode= Tri-Sat Auto," press CHANGE until the display shows the desired mode. Then press ACCEPT.

You may select any one of the following DIRECTV modes:

Mode	Satellites Tracked
Tri-Sat Auto	101, 110, and 119
Tri-Sat Pairs (<i>Not used</i>)	101, 110, and 119
Dual-Sat	101 and 119

Tri-Sat Auto

Select this mode if you have a Tri-Sat AutoSwitch installed for DIRECTV Tri-Sat service. Refer to the instructions that came with the kit for additional setup details.

Tri-Sat Pairs

Do not use for a new installation. This mode is only provided for compatibility with older DIRECTV HDTV configurations that required an HDTV converter instead of a Tri-Sat AutoSwitch.

Dual-Sat

Select this mode for DIRECTV service if you do not have a Tri-Sat AutoSwitch installed.

Figure 26: DIRECTV Setup

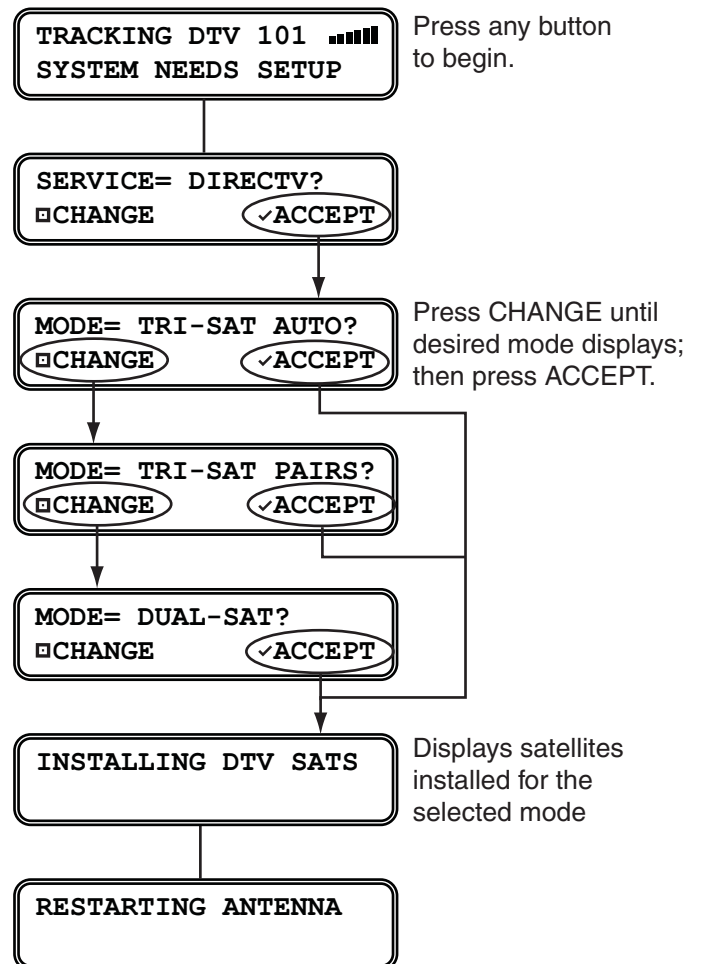

11 Set Up the System

Option 2 - DISH Network

Follow these steps and refer to the flowchart in Figure 27 to set up the system for DISH Network.

- Press any button on the interface box front panel.
- At "Service= DIRECTV?," press CHANGE until the display shows "Service= DISH." Then press ACCEPT.
- At "Mode= DISH 1000/129," press CHANGE until the display shows the desired mode. Then press ACCEPT.

You may select any one of the following DISH Network modes:

Mode	Satellites Tracked
DISH 1000/129	119, 110, and 129
DISH 1000/61	119, 110, and 61
DISH 500	119 and 110

DISH 1000/129 or DISH 1000/61

Select one of these modes for DISH Network's three-satellite service (DISH 1000). Use the map in Figure 28 to help determine the appropriate DISH 1000 mode for your geographic area.

DISH 500

Select this mode if you wish to receive programming from the 119 and 110 satellites for DISH 500 service.

- Follow the instructions in Step 12 on [page 16](#) to set up your receiver(s).

Figure 27: DISH Network Setup

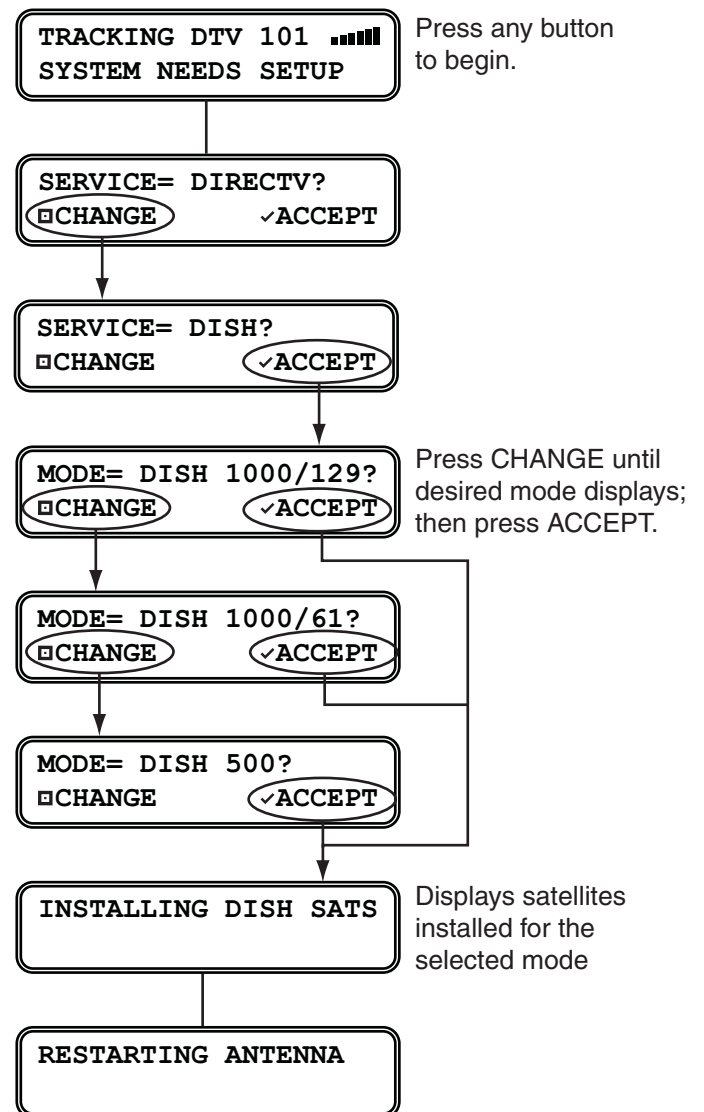

Figure 28: Recommended Areas for DISH 1000 Satellites



11 Set Up the System

Option 3 - ExpressVu

Follow these steps and refer to the flowchart in Figure 29 to set up the system for ExpressVu.

- Press any button on the interface box front panel.
- At "Service= DIRECTV?," press CHANGE until the display shows "Service= ExpressVu." Then press ACCEPT.
- At "Mode= Dual-Sat," press CHANGE until the display shows the desired mode. Then press ACCEPT.

You may select any one of the following ExpressVu modes:

Mode	Satellites Tracked
Dual-Sat	91 and 82
Single-Sat	91

Dual-Sat

Select this mode if you wish to receive ExpressVu programming from the 91 and 82 satellites.

Single-Sat

Select this mode if you wish to receive ExpressVu programming from just the 91 satellite.

- Follow the instructions in Step 12 on [page 16](#) to set up your receiver(s).

Figure 29: ExpressVu Setup

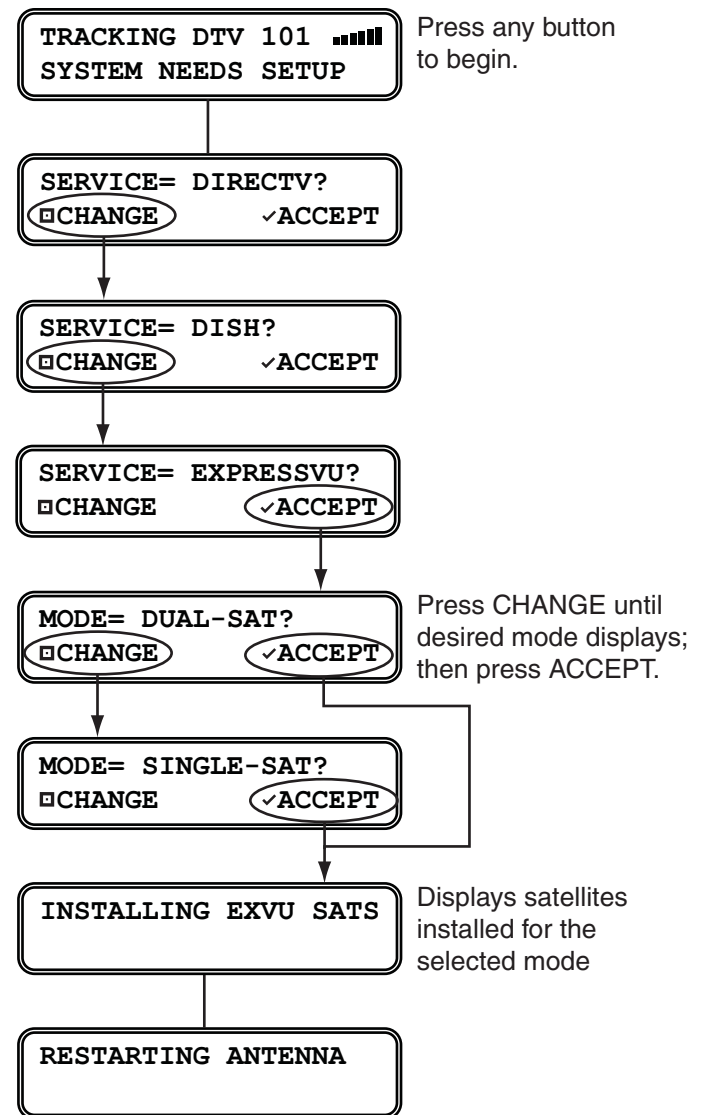

12 Run Check Switch Tests

If you set up the system for DISH Network or ExpressVu, follow these steps to run the receiver's Check Switch test as required.

Primary Receiver - 2 Check Switch Tests

Follow these steps to run two Check Switch tests on the primary receiver, which is connected to the "Unstacked Output" jack on the interface box. This receiver will control satellite selection.

NOTE: The first Check Switch test finds the satellites; the second Check Switch test configures the receiver for those satellites.

- a. Make sure the vessel is docked in calm water in a blockage-free area. Ensure the antenna has an unobstructed view of the sky.
- b. Apply power to the TV and receiver. (If the antenna is turned off, turn it back on and wait a few minutes for startup.)
- c. Using the receiver remote, go to the "Point Dish/Signal Strength" screen (press MENU, 6, 1, 1 on most models).
- d. Choose **Check Switch**, then press SELECT.
- e. Choose **Test**, then press SELECT.
- f. Wait at least 15 minutes before proceeding to allow the antenna to find all of the satellites. Disregard any messages on the TV; they do not correctly indicate when the antenna is ready for the next Check Switch test.
- g. After waiting 15 minutes, repeat Steps d-f to run a second Check Switch test.
- h. Refer to the tables in Figure 30 and verify the values displayed on your TV match those required for your selected satellite TV service.

If your values match, exit the menu and allow the receiver to download the program guide.

If your values do not match, follow the steps on the next page to reset the system before retrying this procedure.

DISH or ExpressVu Only

Figure 30: Expected Check Switch Results

DISH 1000/129 Results

Port	1	2	3
Satellite	119	110	129
Trans	OK	OK	OK
Status	Reception Verified		
Switch	SW64		

DISH 1000/61 Results

Port	1	2	3
Satellite	119	110	61
Trans	OK	OK	OK
Status	Reception Verified		
Switch	SW64		

DISH 500 Results

Input	1	1	2	2
Satellite	119	119	110	110
Polarity	Odd	Even	Odd	Even
Status	Reception Verified			
Switch	SW42			

ExpressVu Results*

Input	1	1	2	2
Satellite	91	91	82	82
Polarity	Odd	Even	Odd	Even
Status	Reception Verified			
Switch	SW21			

* If you selected ExpressVu Single-Sat mode, the TV will show an error message instead. This is normal for Single-Sat mode.

12 Continued Run Check Switch Tests

DISH or ExpressVu Only

Resetting the System Before Retrying the Primary Receiver Check Switch Procedure

If the receiver Check Switch results displayed on the TV do not match the expected values shown in [Figure 30 on page 16](#), follow these steps and refer to the flowchart in [Figure 31](#) to reset and reconfigure the system.

- On the interface box, press MENUS until the display shows "Diagnostics= No."
- Press CHANGE until the display shows "Diagnostics = Yes." Then press ACCEPT.
- At "System Reset= No," press CHANGE until the display shows "System Reset = Yes." Then press ACCEPT.
- At "Reset to Factory?," press ACCEPT.
- Wait a few minutes for the system to reset to its factory conditions.
- When the display shows "System Needs Setup," repeat the setup procedure on [page 14](#) (DISH) or [page 15](#) (ExpressVu) for the desired mode.
- Be sure the vessel is docked in calm water, and make certain the antenna has a clear, unobstructed view of the sky.
- Repeat the Check Switch steps on [page 16](#).

Additional Receiver(s) - 1 Check Switch Test

If you connected multiple receivers to the system, follow these steps to run a Check Switch test on each additional receiver (one at a time). *When you are done, reconnect the receivers as before.*

- Temporarily disconnect the primary receiver from the "Unstacked Output" jack.
- Connect the additional receiver to the "Unstacked Output" jack.
- Perform Steps a-e on [page 16](#) to run a single Check Switch test on the receiver.
- Wait 15 minutes, then verify the values on the TV match the values shown in [Figure 30 on page 16](#). If your values do not match, try running another Check Switch test.

Figure 31: Factory Reset

Press MENUS until
DIAGNOSTICS= No is displayed.

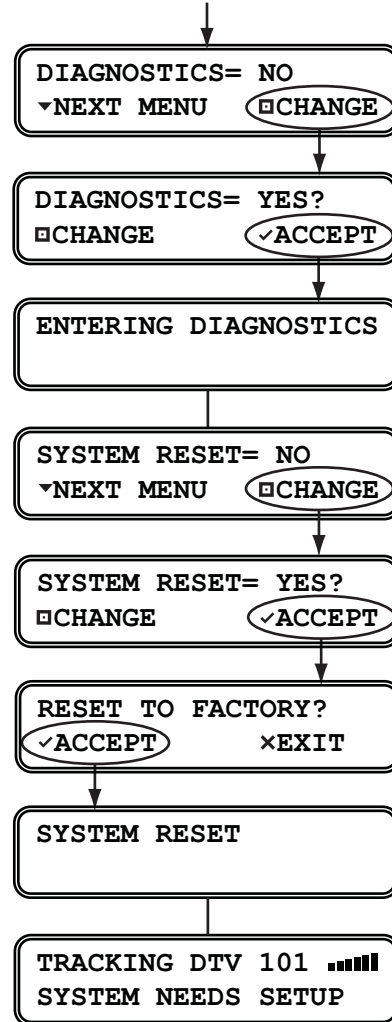

13 Educate the Customer

The installation process is complete! Before you leave the vessel, test the system to verify the antenna works properly. Then give the Customer Welcome Kit and all manuals to the customer and explain how to use the system. Also be sure the customer understands the following:

- Keep the radome installed on the antenna at all times. The radome protects the antenna's moving parts from wind, rain, and debris.

 CAUTION
<p>In the unlikely event that you need to remove the radome, remove power from the antenna first because the antenna's moving parts can cause injury.</p>

- The receiver must be activated before it can receive satellite programming. Refer to Figure 32 for activation details.
- The antenna must have a clear view of the sky to receive satellite TV. Common causes of blockage include trees, buildings, bridges, and equipment on the vessel itself (see Figure 33). Heavy rain or snow might also temporarily interrupt reception.
- Clean the antenna regularly. Dirt buildup can affect satellite TV reception.
- **(DISH 1000 only)** You may need to change the operating mode when traveling between regions (see page 14 for details).
- Please register the system with KVH. The registration process is quick, easy, online, and ensures the best possible service from KVH. Visit www.kvh.com/register or refer to the Product Registration Form for details.
- The vessel must be located within the selected satellite's coverage area. To view satellite coverage maps, visit: www.kvh.com/footprint.
- Refer to the *User's Guide* for complete operation and troubleshooting information.

Figure 32: Receiver Activation

Service:	Call to Activate:
DIRECTV	1-866-551-8004 (24 hours, 7 days a week)
DISH	1-866-399-8509 (Mon.-Fri., 8:30am - 5pm ET)
ExpressVu	1-888-SKY-DISH (24 hours, 7 days a week)

Figure 33: Blockage Example

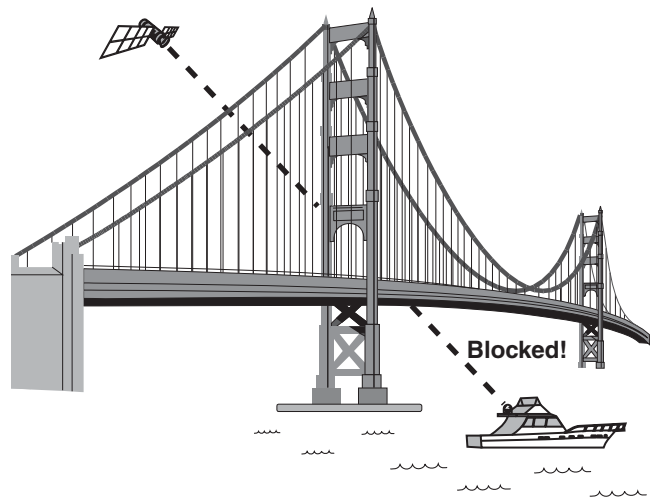



KVH Industries, Inc.

50 Enterprise Center Middletown, RI 02842-5279 U.S.A.
Phone: +1 401 847-3327 Fax: +1 401 849-0045
E-mail: info@kvh.com Internet: www.kvh.com

KVH Europe A/S

Kokkedal Industripark 2B 2980 Kokkedal Denmark
Phone: +45 45 160 180 Fax: +45 45 160 181
E-mail: info@kvh.dk Internet: www.kvh.com