

AMSTRAD COMPUTER

USER

THE OFFICIAL AMSTRAD CPC MAGAZINE

TIME SCANNERS

THEIR TIME HAS COME

COMPETITION

WIN THE ORIGINAL ART
WORK FOR TIME SCANNER

GAMEPLAN

TWELVE PAGES OF THE
LATEST GAMES INCLUDING
BATTY, BOMB JACK II, TANK
ATTACK, SKATE OR DIE,
AND MANY MORE.

THE REGULARS

THE TRIUMPHANT RETURN OF
THE HAIRY HACKER PLUS ALL
THE FAVOURITES

AUGUST 1989

£1.25



→ → PLAYFUL

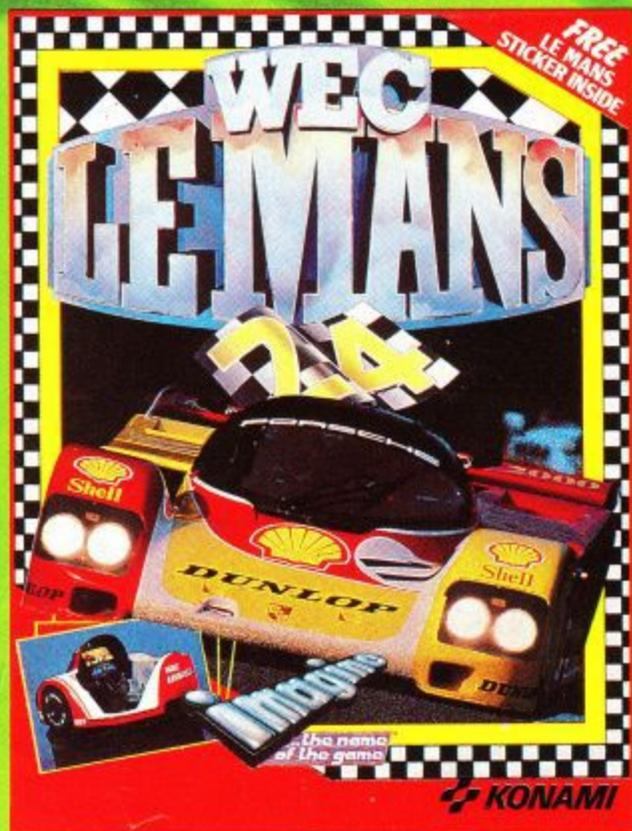

WEC LE MANS
 "Wec Le Mans has many things going for it... I reckon it will be the definitive racing conversion for 8-bit machines."
 Wec Le Mans is not a game – it is the ultimate driving experience.

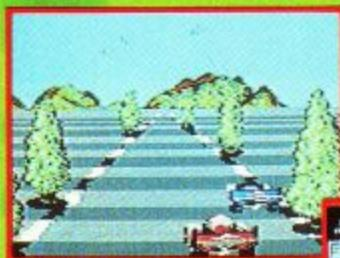

ROBOCOP
 "This is definitely the best tie-in to date... superb game and it doesn't miss a beat."
 C+VG GAME OF THE YEAR
 COMPUTER GAMES WEEK



BAD DUDES VS DRAGON NINJA
 "A sure winner with the official conversion to the home computer."
 COMPUTER GAMESWEEK
 "A very enjoyable and addictive game... The best conversion I have seen on the Amstrad."
 AMSTRAD ACTION
 "There is more than enough action in this one to keep you coming back for more."
 ACE

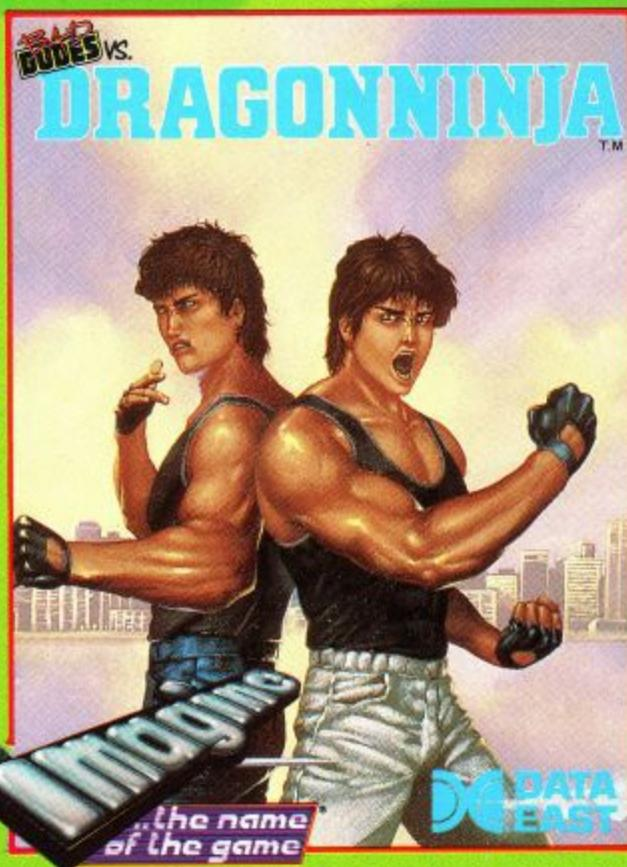

BATMAN
 OPERATION WOLF

ATARI ST AMIGA
19.95 24.95

ROBOCOP
 DRAGONNINJA

ATARI ST AMIGA
19.99 24.99

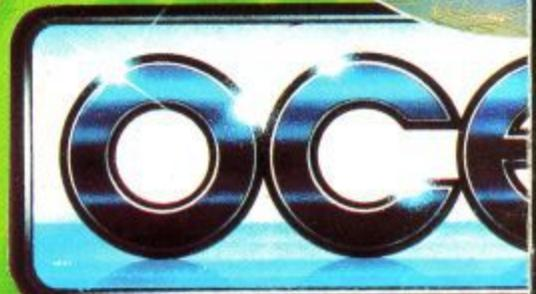

INTELLIGENCE

COP
 by the best film
 and is an utterly
 its own right-
 less it."
OF THE MONTH
VIDEO GAMES



BATMAN
 "Incredible presentation... Just the
 right way to capture the comic book
 feel."

ZZAP SIZZLER ZZAP 64

"Batman The Caped Crusader will
 suit riddlers of all ages."
 ACU STAR GAME AMSTRAD
 COMPUTER USER

"Ocean have made a fantastic job on
 Batman and being in two parts you
 get excellent value for money.
 Brilliant!"
 A CRASH SMASH CRASH

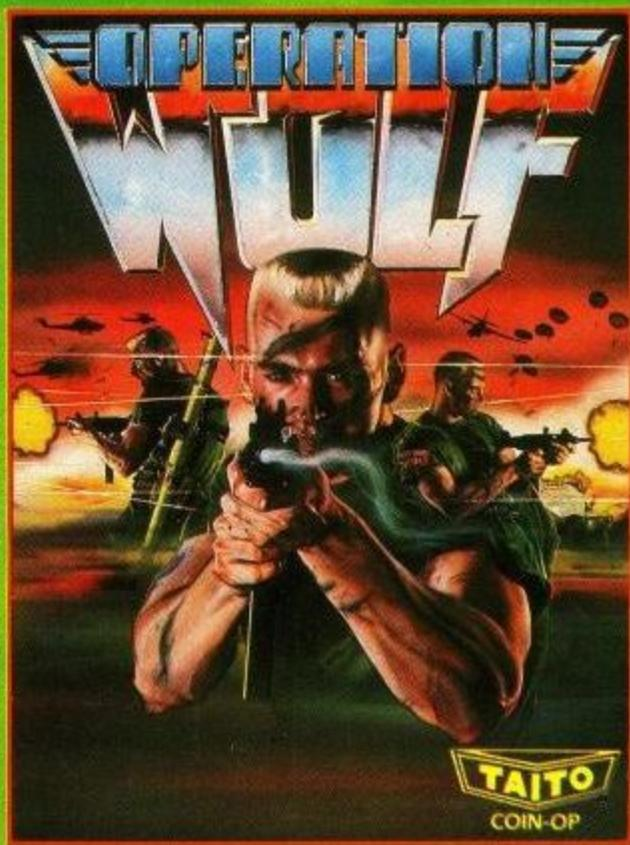
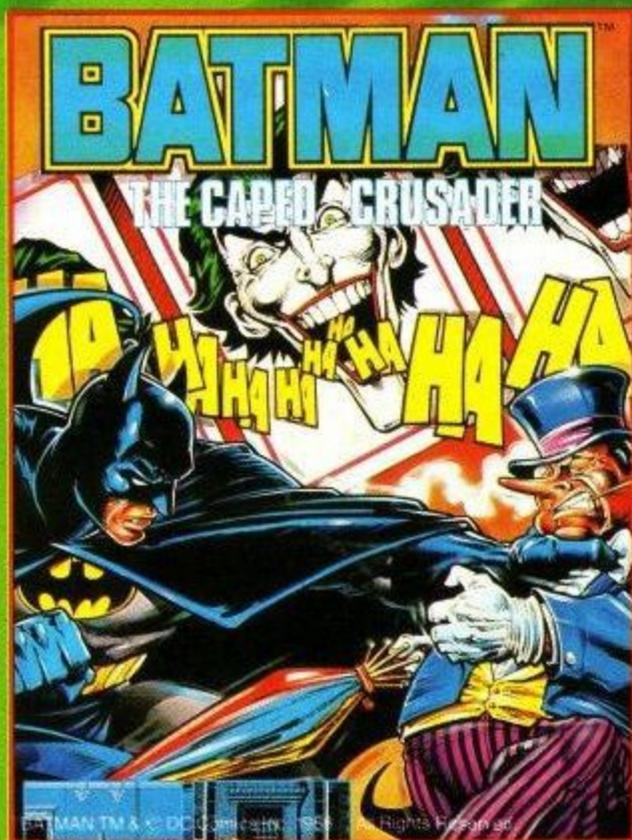

OPERATION WOLF
 Voted "Game of the year." The
 world's No. 1 arcade game.
 "Super-smooth scrolling and
 excellent graphics... Without
 doubt this is a first class
 shoot em up."

A CRASH SMASH CRASH

"Definitely the coin-op of the
 year.. Buy Operation Wolf
 it's a brilliant conversion."
 C+VG GAME OF THE MONTH
 COMPUTER + VIDEO GAMES



BATMAN
 ROBOCOP
 WEC LE MANS

SPEC/AMS
9.95
 COMM

OPERATION
 WOLF
 DRAGON NINJA

SPEC AMS
8.95 9.95
 COMM

The CRUCIAL COMPILATION



LAST NINJA REPLACES CRAZY CARS ON THE COMMODORE

THE ONE IN CROWD

ocean



GRYZOR Featuring all the game-play of the arcade original, Gryzor takes you into a thrilling alien world of force fields, fanatical guerillas and strange enemy defence systems – but you have the fire-power and maybe, with a 'little' skill, grit and split second timing, you can infiltrate the aliens' headquarters. Play Gryzor once and you'll be hooked!
© 1987 Konami



BARBARIAN THE STORY SO FAR... The evil sorcerer Drax has agreed that if a champion can be found who is able to defeat his demonic guardians, the Princess Mariana will be released. From the wastelands comes an unknown barbarian, a mighty warrior, wielding his broadsword with deadly skill. Can he vanquish the forces of Darkness? ONLY YOU CAN SAY...
© Palace Software Ltd



CRAZY CARS You are racing in the world's craziest race: "The American Cross Country Prestige Cars Race". If you are able to complete the race before the time runs out, you will get a faster car. You start with a Mercedes 560 SEC, and only the world's best drivers may drive a Ferrari GTO. PREPARE TO START, READY? GO!!!
© Titus Software Ltd.
LAST NINJA replaces CRAZY CARS ON C64

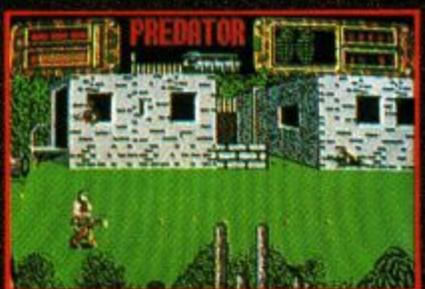

PREDATOR You've heard about Predator, the Schwarzenegger movie – now you can play the leading role. Take a crack commando unit into the South American jungle to rescue a bunch of trapped diplomats. Should be easy enough...and so it would be, if it weren't for the mysterious alien who keeps on taking-out your men.
© 1987 Twentieth Century Fox Film Corp. All rights reserved.



KARNOV Join Karnov, the fire-breathing Russian strongman, on his hazardous quest to defeat the evil dragon Ryu and find the Lost Treasure of Babylon. Karnov is a vast 4-way scrolling game that combines both strategy and fast action in nine challenging levels of gameplay. It is recognised by arcade addicts everywhere as one of the best games of its kind. Karnov also has something special in the way of characters – have you ever been killed by a skeleton on an Ostrich?
© Electronic Dreams Software Ltd

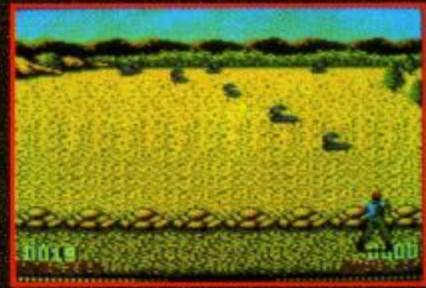

COMBAT SCHOOL Konami's arcade hit now for your home micro and already a No. 1 hit. Seven gruelling events featuring the Assault Course, Firing Range, Arm Wrestling and Combat with the instructor himself! Combat school throws down the challenge to the toughest of thoroughbred gamers.
© 1987 Konami



TARGET RENEGADE Every move you make, every step you take, they're watching you. Fight your way through the precinct – the back alleys, the car parks, fight your way through the villainous community, the skin-heads, the Beastie Boys, the bouncers. This is just the tip of the iceberg on your chilling quest to confront "MR. BIG".



PLATOON Lead your Platoon deep into enemy territory, you can almost feel the humidity, sense the threatening dangers as you encounter the enemy and his many booby traps. Having found the underground maze of tunnels, enter at your peril! Enemy soldiers lunge at you from the murky waters within, but this is the only way you can find vital information. If you come out of this alive, you'll be just one of the few!
© 1986 Hemdale Film Corporation. All rights Reserved.

SPECTRUM
AMSTRAD
COMMODORE



CASSETTE
£14.95

Avralite Publications Ltd
Greencoat House
Francis Street
London
SW1P 1DG
Tel: 01-834 1717
Fax: 01-828 0270

Editor

Carlo Jolly MA

Chief Sub Editor

Harold Mayes MBE

Staff Writers

Adrian Pumphrey

Reviewers

Andrew Banner

Mark Ulyatt

Adrian Wal-Hayes

Columnists

John Cook

David Foster

Vic Oliver

Phil Craven

John Kennedy

Art Director

Chris Winch

Designers

Paul Ellis

Adrian Hulf

Cartoonist

Julian Sharp

Advertising Manager

Clare Baxter

Advertising Sales

Sharon Green

Production Manager

Nick Fry

Production

Tanya Al-Rais

Publisher

Perry Trevers

Publishing and Commercial Director

Paul Coster BSc

Financial Director

Brendon McGrath

Chief Executive

Richard Hease

Subscriptions

Mike McKenzie

PO Box 74

Tunbridge

Kent

TN12 6DW

Distribution

SM Distribution

Streatham

London

SW16

Tel: 01-677 8111

Typesetters

Type Team

Sittingbourne

Kent

1989

Amstrad is a registered trade mark and, with the title Amstrad Computer User, is used with the permission of Amstrad plc. No part of this publication may be produced without permission. While every effort is made to ensure the accuracy of all features and listings we cannot accept any liability for any mistakes or misprints. The views and opinions expressed are not necessarily those of Amstrad or Amsoft but represent the views of our many readers, users, and contributors. Material for publication is accepted only on an all-rights basis. We regret that Amstrad Computer User cannot enter into personal correspondence.

REGULARS

LETTERS 6

More comments, questions and points of view from our readers.

NEWS 10

Three pages of hard news from the world of Amstrad.

COMPETITION 14

Win the original artwork for Time Scanner.

COMBAT ZONE 16

John Cook leads another mission into arcade hell.

MICRO-SCOPE 22

Trevor Cummings turns his curious eye towards more helpful tips.

10-LINERS 26

Material galore this month.

GAMEPLAN 33

Ten more games come under the scrutiny of the ACU reviewers.

HAIRY HACKER 52

The return of everybodies favorite biker. The Hacker is back with a column of his own.

AUNTIE JOHN 64

John Kennedy slips into something comfortable for the long hot summer's work ahead.



APPLICATIONS ADVICE 70

Another mailbag of problems is solved by our resident ace David Dorn.

FEATURES

COMPANY PROFILE 30

This month Adrian Pumphrey turns his keen eye on Electronic Arts.

FILM FEATURE 48

Richard Henderson looks at the lucrative world of film spin-offs.

RADIO DAYS 58

Andrew Banner reviews the rebirth of a craze in computer-to-computer communication.

This month's selection of games covers everything from the born-again craze of skateboarding with *Skate or Die* to the dark side of the future with the *Paranoia Complex*. For the trigger-happy there is WWII action *1942* and for the more genteel readers the aptly-named bat-and-ball game *Batty*.

TOP

- 1 (NS) *Fast Food* Code Masters
- 2 (I) *Rabooj* Amsoft
- 3 (I) *Trek Tunes V3* Code Masters
- 4 (NS) *Torment Island Entry* Code Masters
- 5 (NS) *Turbo Sprint* Amsoft
- 6 (NS) *Eye Hunter* Amsoft
- 7 (NS) *Dragon King* Amsoft
- 8 (NS) *Shanghai Warriors* Playlogic
- 9 (NS) *Fun School 2* Dataquest/Playlogic
- 10 (NS) *SOS Cowboy* Code Masters
- 11 (NS) *Jet Blade 2* Playlogic
- 12 (NS) *Run The Gauntlet* Ocean
- 13 (NS) *After Burner* Amsoft
- 14 (NS) *Snake Hunter* Code Masters
- 15 (NS) *Operation Wolf* Ocean
- 16 (NS) *TB* Amsoft
- 17 (NS) *EMS Simulator 2* Code Masters
- 18 (NS) *Great Cars 2* Code Masters
- 19 (NS) *WEG Le Mans* Amsoft
- 20 (NS) *Big Foot* Code Masters

GAMEPLAN

TIME SCANNER
All the world is a pinball machine and you are the guy who will tilt those features.

NAVY MOVES
Battle your way through hostile seas to encounter the enemy bases where the bad guys are dying to meet you.

SKATE OR DIE
Challenge Lester to a duel of a lifetime: as the boards clash you know it is do-or-die time.

PLUS
Blah Movie, Your Enemy Is, Tank Attack, Bomb Just It.

Amstrad User MAY 1989 Page 33

LETTERS

Printers

I have an Amstrad 664, 2160 printer and a Juki 6000 daisywheel printer; the latter I bought to get good letter quality print. Unfortunately I did not get a manual with the printer; as a result I am unable to utilise the printer capability fully without knowledge of the control codes used by the printer.

If any readers have a copy of the printer manual they could lend/sell/copy for me – I would pay any expenses incurred – I would be grateful.

I realise your magazine caters for the broad spectrum of Amstrad users, which I think it does rather well. As a dedicated hardware buff I have a few constructive comments.

You do not publish many hardware projects; those you print seem to be of very simple design. Is this because you consider your readership incapable of complex circuit construction, both with available tools and experience; software-orientated and therefore if they want to build print buffers, fax decoders and weather satellite receiver/decoders to add on to their CPCs they should look in electronics magazines.

Is the answer even simpler? No-one offers you projects like this to publish. If this is the case it might be useful if you suggest the types of project you would like people to provide.

The hardware you review tends to be printers, disc drives and so on. I am not complaining, as I tend to read them regularly but projects like the NOAA Satellite decoders offered by both Maplin Electronics and Circuit Electronics. I would like to read about the various PBC designers for the CPC.

Andy

Simmons,
Selston,
Notts.

ACU: Does anyone have a printer manual? So far as complex projects are concerned, if readers want to submit suggestions or projects we will try to accommodate the best.



Advice

I thought your readers would like to know of a problem I experienced with the game *Blasteroids*.

When a joystick splitter is used and the keys are defined with the joystick, you cannot enter the letter 'R' or key 50 because the game uses R as a Restart in the program. You have to play with the keys and a joystick unless anybody knows a way round it. The people at Mirrorsoft were not aware of this problem. Any ideas?

N. Jopling
Doncaster

Citizen 120-D

A few words about my rapturous affair with my marvellous Citizen 120-D printer. I paid £200 for it three years ago when it first came out and I still think it was terrific value even at that, although prices are lower now at £130 plus VAT.

A few points to add to your replies to Paul Easter and R. Jackson in the June issue. Surely boxes can be made with the letter I in caps in any W pro and then saved as a

text file and written into when reloaded, or all the information printed then boxes drawn around by hand? We use orange crayons as we are not allowed sharp instruments.

The 120-D makes the 7-bit CPC printer output into 8-bit; it has an in-built thingy to do this so your end bits are not chopped off. I has quadruple-density print also a 216th line feed and it supports NLQ in proportional and joined-up writing and double and too many well-explained niceties in the manual for me to mention. In short, a good bit of stuff for the wordsmith and art package user.

The enormously high-quality ribbon can be re-inked *ad infinitum* and as yet seems to go on and on. I am still re-inking my original – at least Alladdink is. The 120 also has a slide-out adjustable dip switch board, a paper aligner, a free tractor feed and the best manual I have seen for anything.

I would not use an Amstrad printer in a fit as its ribbons do not last five minutes and I use Tasword 6128 and Printmaster (Siren Soft) to produce this kind of stuff. Microdesign by Siren Soft is good for words and pictures à la my logo.

Phil Morley,
Whittlesey,
Peterborough.

**NOW IS THE
TIME TO
TAKE ...**

SPECIAL ACTION



DRILLER

SOLID 3 Dimensional Landscapes like you've never seen before. Thanks to Freescape - it feels like you're actually there. Interact with weird alien mechanisms, avoiding the Ketars Defences and gain access to the many sections of the Moon, Mitral. Experience Driller and Freescape in action ... "A NEW 3 DIMENSIONAL REALITY!" CRASH.



S.D.I.

"The graphics are great with fast flowing backgrounds and smooth, speedy sprites. I now know what I would do if the five minute warning went off ... I would play S.D.I." F.A.B. - COMPUTER GAMES WEEK.

S.D.I.
NOW THE ODDS ARE EVEN

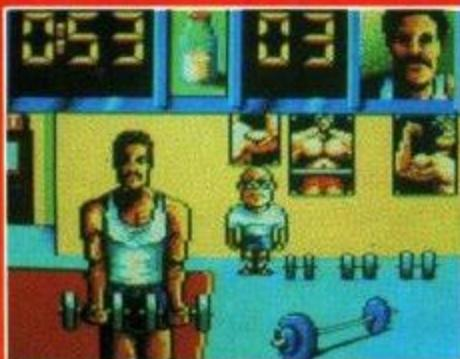

DALEY THOMPSON'S OLYMPIC CHALLENGE "Excellent animation with some great back-drops ... Daley Thompson's Olympic Challenge is first rate ... another gold medal winner from Ocean." A CRASH SMASH - CRASH.

THE VINDICATOR

"If you've spent hours developing your trigger finger here's a game to put it to the test. It's all action" CPC SILVER AWARD - CPC COMPUTING. "each level has a high standard of graphics ... The Vindicator is an excellent game." CRASH.



CAPTAIN BLOOD

"To sum up - Bloody excellent." "The graphics and sound are excellent ... an intelligent strategy game." YOUR SINCLAIR

5

**ALL-ACTION
CHART-BUSTERS
JAMMED INTO
ONE SPECIAL PACK**

SPECIAL ACTION from...



A M S T R A D
C O M M O D O R E
S P E C T R U M

£ 1 7 . 9 9
D I S K

Ocean Software Limited - 6 Central Street - Manchester - M2 5NS
Telephone: 061 832 6633 - Telex: 669977 OCEANS G - Fax: 061 834 0650

A M S T R A D
C O M M O D O R E
S P E C T R U M

£ 1 2 . 9 9
C A S S E T T E

Errors

I was very pleased to see that my seven 10-Liners has won a place in the June issue under the heading The Pattern Collection but not so pleased for young readers and tyro-typists to find that each of the 10-liners was compounded by errors.

I have every sympathy with letter-writer Bob Adams who writes: Why could you not print from the individual listings as you obviously did with Marion Clarke's *Solitaire* – the slashed 0 is a dead give-away.

The snide statement 'Just between you and me, squire, I can't see why it's called "Two into One"' – whoever wrote that fails to see that it is one program with 'f=f*-1' (DRAGON CURVE) left in and another (C CURVE) with it REM'd out!!

I have not TYPED it out but I do believe ***CURTAINS*** is correct and will work.
*Bill Hamley,
 Gainsborough.*

ACU: Sorry

Not Funny

Well done with your April food conspiracy which triggered endless anguish letters. There is no denying that you deliberately made the April issue into the worst magazine I have ever seen. When things became normal again in the May issue people would think how wonderful it is.

*Derek Wong,
 Thornton Heath,
 Surrey.*

ACU: All's well that ends well and stays well. Happy reading.

Weird Science

For about two-and-a-half years we have had a 6128 and we have hours of pleasure as we have explored different ways of using this wonderful machine. A few months ago we connected a cassette player so that we could take advantage of the exciting range of reasonably-priced software. The only disadvantage was that my dad kept complaining about the din when programs are loading, which meant that I could not always use tapes when I wanted to. I have just found a simple solution to the problem which may be helpful to other readers.

I have plugged some stereo headphones into the cassette player which means that I can locate programs at any time without

having to worry about the noise it creates. The headphones I have used are cheap – they were a give-away with a pack of cassette tapes we bought. They do not work very well as headphones but they do a fantastic job as a silencer for our equipment.

*Gareth Cool,
 Aylesbury,
 Bucks.*

Special effects

I was messing about on my computer one evening, as always, and I keyed-in the listing below. It was supposed to be the beginning of a machine code monitor. When I ran it I was amazed at the effect. I seem to have called &bb19 instead of &bb18. Please do not look at it if you are epileptic or you do not want your eyes to go weird.

```
10 FOR t=&2710 TO &2720
20 READ x$:POKE t,VAL("&" + x$)
30 NEXT
40 CALL &2710
50 DATA 21,0,0,7e,cd,5a,bb,cd,19,
bb,fe,20,c8,23,c3,13,27
```

*Willy Walters,
 High Wycombe,
 Bucks.*

ACU: A great discovery.

Action Man

I have just bought an Amstrad CPC6128 and am thoroughly fed up with it, mainly because, since purchasing it, I have heard that Amstrad is one of the worst companies with which to deal.

I am physically disabled, so cannot go to computer clubs or classes. Nor can I afford to pay for postal classes and I had assumed Amstrad was a big enough company to help if I had any teething problems. Not so. I wrote a query enclosing three tapes about a month ago – no reply and no return of tapes.

I decided to send a recorded delivery letter to the management. No reply.

So, the letter in the June magazine, Amstrad Shocker, was of interest and I felt I would write to ask of anyone has ever received a reply from Amstrad? While I still have the Amstrad could you ask if anyone could call to help me sort out games.

The keyboard is faulty – but luckily I deal with Currys/Dixons and Currys has always given me good service, so it is sorting it out for me – getting me another one. In view

of the Amstrad policy I am thinking of asking for it to be changed for another make.

*R. Conway,
 South Ruislip,
 Middlesex.*

DIY Help

I would like to build the DIY second disc drive. I have the second part but I cannot find the first. I know it is in the April, 1987 issue of *Computing with the Amstrad*. Is any-body willing to part with it?

*Colin Taylor,
 Enfield,
 Middlesex.*

To the rescue

I own a CPC 464. After typing-out the game *Solitaire* in the June issue. I cannot get it working. Is it possible to print a PROOF READER in your next magazine?

*S.G. Duffield
 Norwich*

ACU: Help is on the horizon. A proof reader will be provided with every type-in program in the next issue.

Pascal information

Can any readers help me? I have the Oxford Pascal from Systems Software (Oxford) Ltd, 168 Worcester Place, Oxford. Unfortunately this program, for obvious reasons, uses a protection against unauthorised use which consists of a colour control chart, without which it is impossible to use the program. Not having used it for a long time I find that I have lost the chart. I have tried to get in touch with the company but to no avail, so I wonder if anyone can help me? If anyone can please telephone 0924 377836 after 7pm reversing the charges.

*Sam Samuels,
 Wakefield.*

Proof at last

What happened to the proof reader prefix on all the type-in programs? Since the amalgamation of the two magazines, I have not found a type-in with the proof reader listed. Surely I am not the only reader of the magazine who has trouble in getting the programs to run.

*Ian Dempster,
 Birmingham.*

Adventures

I used to read *CPC Computing*, and I like your magazine very much. Can we have Gandalf's adventure pages back? I am a great fan of adventures and even if you cannot do that, at least do a page of hints, tips and solutions.

I do not think solutions would defeat the object of the game, because if you do not want to see the solution do not look.

I was flicking through the really old pages of *CPC Computing* when I saw they used to have a feature called Give your fingers a rest, which means that you could send for all the month's type-ins and listings on tape or disc. Could we have these back again?

Philip Calver,
Colchester, Essex.

ACU: Gandalf is on his wanderings at the moment but if sufficient interest is shown we will send one of the dwarfs to drag him back.

Accessories

About two-and-a-half years ago I bought Arnold. As a very active photo-journalist I needed his help to make light of a heavy workload. I equipped him with Rombo, Protext, Promerge Plus and Prospell. I fed him a diet of articles, newsletters and press releases. He digested and regurgitated it via a DMP 2000 and did a fine job.

I should explain that I am a hard taskmaster and like to see a beautifully printed page with good type, striking headlines, neat sub-heads and – if required – tidy graphics. To achieve this I bought a variety of superb software which included Stop Press, Qualitas Plus, Signwriter and Masterfile III. My choices were spot on and each program lived up to my expectations. Newsletters took a little time to produce but I think they were a joy to view and read. Anyway, I was proud of them but the trouble with people like me is that we are never satisfied and are always trying to find a way of improving things.

After much thought I decided that Arnold deserved a treat. I sold the ugly but dependable DMP 2000 and bought a Star LC24-10 printer. I could scarcely wait to set it working. Well, I would be getting a much faster printout and, as for the quality, £320 seemed like a bargain.

First impressions were very favourable. My letters looked terrific and I played with the fonts and decorative options until I was

able to drive that lovely little Star until it twinkled. Then the problems started. The first disappointment was the Qualitas does not support 24-pin printers and therefore I could not use my favourite fonts, Clarion and Yorkbold. Exit Qualitas. The next problem was the wonderful Signwriter program and equally good Stop Press, produced distorted screen dumps. Everything was elongated vertically and the printouts were very faint.

I can solve this problem partially on Stop Press by stretching the image by a factor of 1 to 1.25 but to get a reasonable density I must print using the NTQ option, which is about as fast as Eddie Edwards' take-off speed Signwriter allows you to select an aspect ratio prior to printing, but I cannot achieve acceptable print density. So exit Signwriter.

I tackled Star Micronics as well as the software producers and, as I understand from their explanations, an over-simplification is that 24-pin printers use only nine pins when in the graphics mode. Add to this the fact that a 24-pin printhead is taller than a 9-pin and you can see there is no solution as far as existing software is concerned. In time, of course, programs will be written to take into account the peculiarities of this new technology. Where does that leave me and does anyone really care?

It leaves me holding the baby. I now own a superb £320, 24-pin printer which has made £100 of software virtually useless. Nobody warned me about this when I bought it. I did not think to ask – why should I? After all, the advertisements said "fully Epson-compatible." Was this misrepresentation and is it in the spirit of the Fair Trading Act? Was ACU and the other Amstrad magazine aware of this problem? If so, why did they not warn us?

I would like your comments. Perhaps your experts can offer a simple solution. If not, it would be gratifying to think this letter might prompt other Arnold Users to think carefully before

Taking a second mortgage on one of these technological marvels. In the meantime, I will manage.

Vic Barnes
London.

Gratified

It was gratifying for me to see that my article Type It Yourself was found to be interesting – Letters ACU July. It is satisfying to have my question answered. It would please me to be able to thank the person who gave that answer.

Users of the Type-It-Yourself variables dump – ACU May – will no doubt be pleased also, to have all the six Basic tokens for variables, type-marked or default, at their disposal:-

type-marked integer (%) ...	2	0	0
default integer ...	11	0	0
type-marked string (\$) ...	3	0	0
default string ...	12	0	0
type-marked real (!) ...	4	0	0
default real ...	13	0	0

The CPS Basic uses default tokens when there has been a previous DEFINT, DEFSTR or DEFREAL command. No DEFine command is the equivalent of a DEFREAL one.

Thomas Betts,
West Wickham,
Kent.

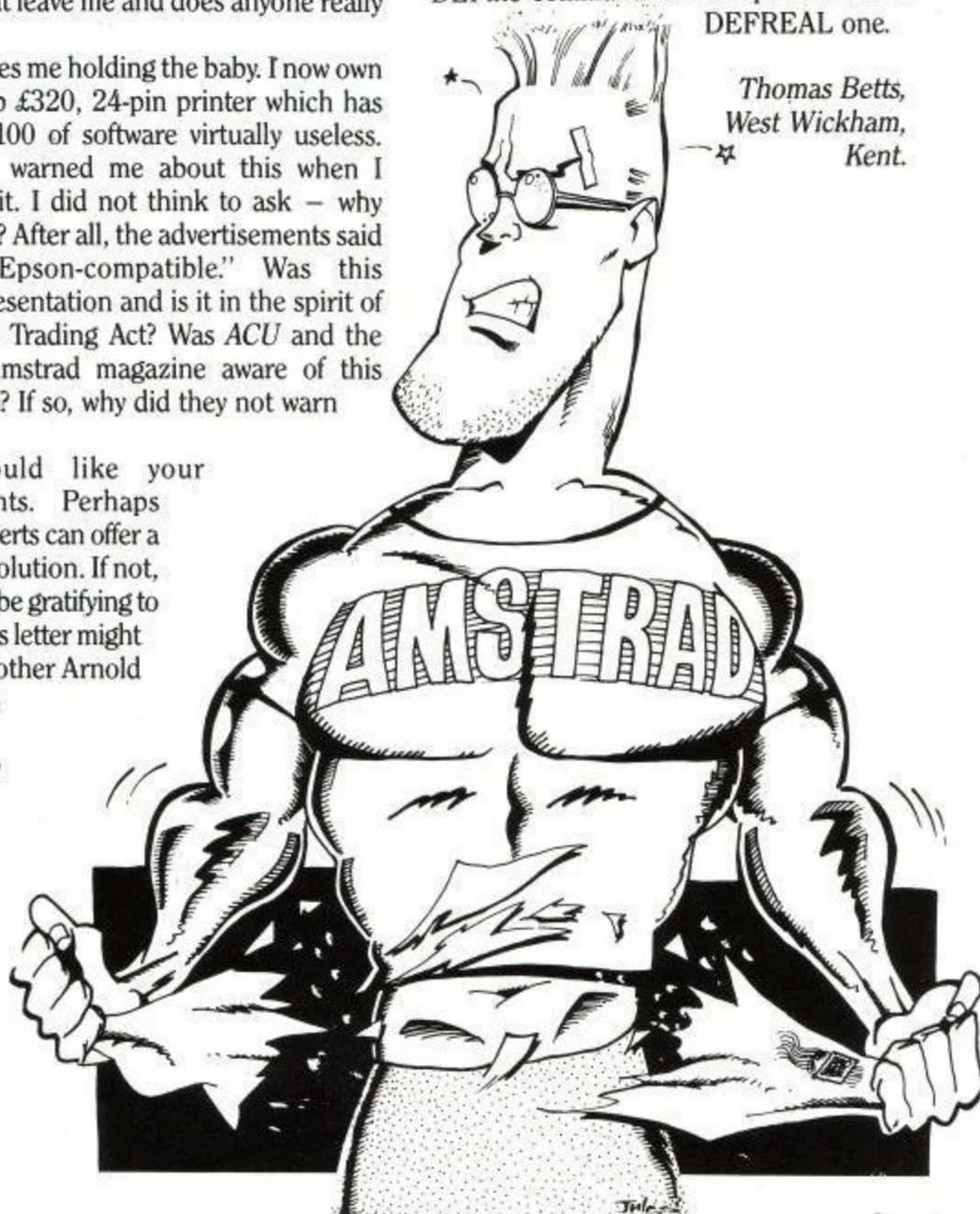



Audiogenic move into game world

AUDIOGENIC has announced its first computer game based on the immensely successful *Lone Wolf* gamebooks. Entitled *Lone Wolf - The Mirror of Death*, the game plunges you into the world created by Joe Dever in which you must use speed, skill and bravery to find the Lorestone, a gem of power which will restore the glory of your murdered peers.

There will be many encounters during your quest, including the Death Pits, the fire-spitting Daemonaks, the murderous Force Dischargers and a plethora of deadly demons. You have only a sword and four chosen Kai disciplines to aid you and only your wits will defeat the last creature, for spurned by the Mirror is an evil carbon copy of yourself, identical in every way.

All this makes for a highly action-packed combat game, or slash-'em-up, which is only to be the beginning of a *Lone Wolf* software saga. Many more games are likely to follow and, before you know it, there will be as many games as books. Prices will be

£14.95 for disc and £9.95 for the cassette version.

Another product designed round the *Lone Wolf* theme is a new telephone game similar to the incredibly popular *Fist*. *The Fortress Of Doom* can be played by telephoning 0898 300 341, where you will be greeted by mood music before setting out on a quest played in real-time.

The PhoneQuest telephone game system, which it uses, makes use of the latest voice-interactive technology. You have only to speak into the telephone and decisions and battles come your way. One warning, though, for those who may be easily hooked - the calls are charged at 38 pence per minute peak rate and 25 pence off-peak inclusive of VAT.

Also worthy of note are the two books to be released at the same time. Joe Dever's *Legend Of Lone Wolf* is a new series co-written by Joe Dever, of course, and John Grant who, within the pages, chronicle the history and adventures of the *Lone Wolf*.

Eclipse Of The Kai is the first of the books and tells of the destruction of the Kai warriors, an event leading to *Lone Wolf*'s creation. *The Dark Door Opens*, book 2, follows *Lone Wolf* in his quest to warn King Ulner of the impending doom.

Both books will cost £2.50 in paper-back format and are available from most good bookshops. They are published by Beaver, an imprint of Arrow Books.

Rick Dangerous

RICK DANGEROUS is a new game to come from Microprose, under the newly-acquired Firebird label. It is a vertically-scrolling climber game with more than a touch of humour. You control *Rick Dangerous* in a cartoon-like strategic game and must travel through four levels of comic fun which span the globe and offer varying tasks. The Amazon jungle, the Aztec temples, Egyptian tombs and dark fortresses of the west must all be negotiated for Rick to raise his popularity to Indiana Jones-like heights.

Rick Dangerous should be available how at £9.99 for cassette and £14.99 disc.

Also from Firebird is *Oriental Games*, with four beat-'em-ups featured in one package available in August. Kung Fu, Hollywood Rules, Sumo Wrestling and Kendo are all featured in a gargantuan contest of muscular mayhem.

You can participate in a six-round mini-tournament to find an exclusive 'master' of that particular fighting style, or alternatively you can play against the computer or a friend in a practice bout. Once you are a master of all four styles you can then, and only then, compete in the grand tournament to find a 'Grand Master' from 24 participants.

Another Firebird launch available in mid-August will be *Action Fighter*, a conversion of the successful Sega coin-op. It is a tough, vertically-scrolling shoot-'em-up set in the midst of heavy battle and is divided into four sections, each featuring a different kind of landscape.

You will start on a motorcycle which you must steer through the first level but it is not such an easy task as it sounds. Passing enemy vehicles and an enemy helicopter flying overhead all aim to thwart your progress but luckily you can avoid them and deal them their own kind of medicine, with weapons provided by the passing Sega van. Also by collecting floating letters you can transmute into more powerful methods of transport, thus allowing your task to become a little easier.

More modems from Dowty

THREE Hayes-compatible modems from Dowty, one of the leading U.K. manufacturers of datacomms equipment, are now available from Action Computer Supplies with stunning reduction. The Duo-Dual standard error-correcting modem, conforming to CCITT V21 and V23 standards, is offered at £269 compared to the RRP of £340. Its features include an automatic selection of tone or pulse dialling, XON/XOFF of CTS flow control and non-volatile memory.

The trio is offered at a more expensive £467 but is still £128 less than its recommended retail price. It is a multi-function, error-correcting modem conforming to V21, V22 and V23 standards and also features SPAR error detection and correction, asynchronous or synchronous operation at 1,200bps and automatic speed detection.

Also available is the Quattro multi-standard modem, conforming to V22bis, V22, V23 and V21, with Bell standard options. It is available at £546 but, compared to its retail price of £795, the reduction is staggering. Features include SPAR and MNP error-correction, automatic answering, speed detection, dialling and log on, and a constant speed serial interface.

For more information contact Action Computer Supplies, Abercorn Commercial Centre, Manor Farm Road, Wembley, Middlesex HA0 1WL, or telephone 0800 333 333.



Batman

OCEAN SOFTWARE, following previous movie successes such as *Robocop* and *Short Circuit*, has announced two new games to be released at the same time as their cinematic counterparts. *Batman, The Movie* is a film which could scarcely be avoided and has already

been heralded as the movie of 1989. The film, directed by Tim Burton and starring Michael Keaton and Jack Nicholson among other well-known stars, tries to delve more into the darker side of the man who dresses as a flying rodent and, as such, offers in any sombre views of heroism. The plot was written by Sam Hamm, whose credits include many Batman comic strips for DC comics and the game promises to follow this very closely.

Nightbreed, however, is a far more

wholesome cookie as it is the latest film from Clive 'Hellraiser' Barker. Based on his book *Cabal*, it leads the viewer through a tale of heroism and romance but not without Barker's brand of perverse horror twists. The monsters are still awesome, the special effects are still explicit, but perhaps the plot is a little more palatable than his directional debut. Again the Ocean game captures the subterranean world in which *Nightbreed* is set, and the plot is one and the same.

Easy living

FOR those who have problems with disc organisation, Greyhound Software markets a utility which could help immensely. Discbase CPC is a disc-file database which offers many features, including easy

entering of disc catalogues to make the database, and three comprehensive viewing formats for files and disc data by a list of files, of discs, and page-at-a-time CATs read instantly from memory.

Tony Carter, one of the two programmers of Discbase and Director of Greyhound Software with his son, explains why it was so essential to release Discbase. "We became involved in this because my Protext files and the odd Basic programs kept getting lost. We then

bought Fido from Pride Utilities, mainly to see what it did and whether it worked. It was so slow at searching that we felt it was still worth trying to do better. I have also tried one of the CP/M disc organisers but found it rather basic."

Discbase is available for £9.95 from Greyhound Software, Kennel Cottage, Hockley Lane, Wingerworth, Chesterfield, Derbyshire S42 6QQ. Telephone enquiries should be directed to 0246 235233, Mon-Sat 6-8pm.



Return of Postman Pat

HISTORY is in the making with the first original budget game to be licensed from a recognised figure. *Postman Pat* should now be available from Alternative Software at £1.99 for the cassette version.

Playing the prestigious delivery man, you must pick up parcels and letters in your home town of Greendale and deliver them to their destinations. Not only do you have to complete this mammoth task but there are other tasks which need completing, such as rounding up sheep and the delivery of prescriptions for Miss Hubbard.

Although the game is simple it is maddeningly addictive and there are two versions from which to choose, an easy one for younger players and a more difficult one for those who wish to stretch their playing skills.

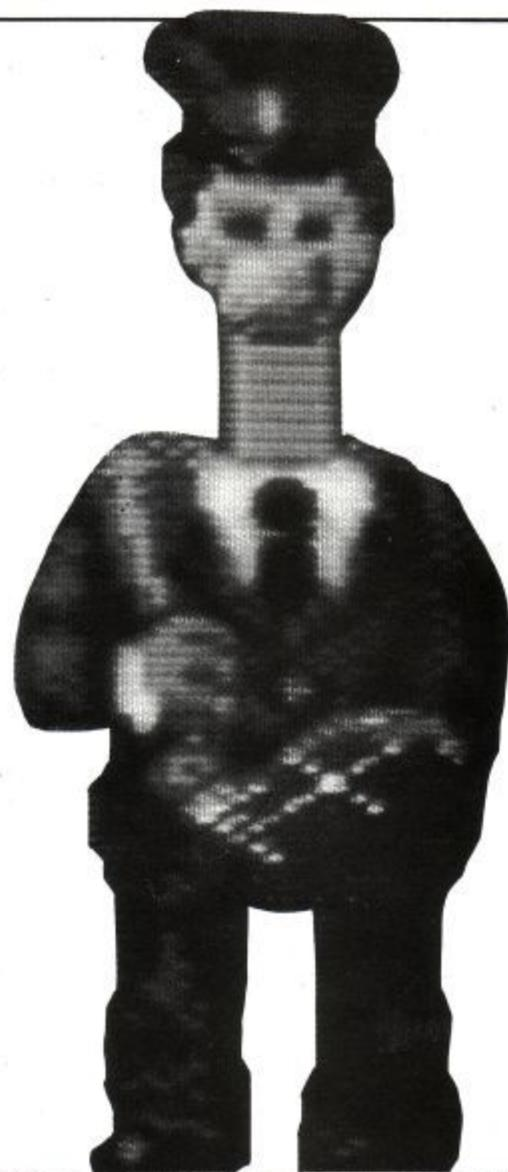

Emlyn Hughes

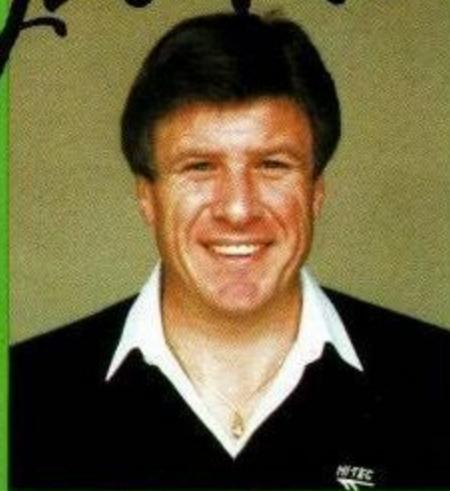

INTERNATIONAL

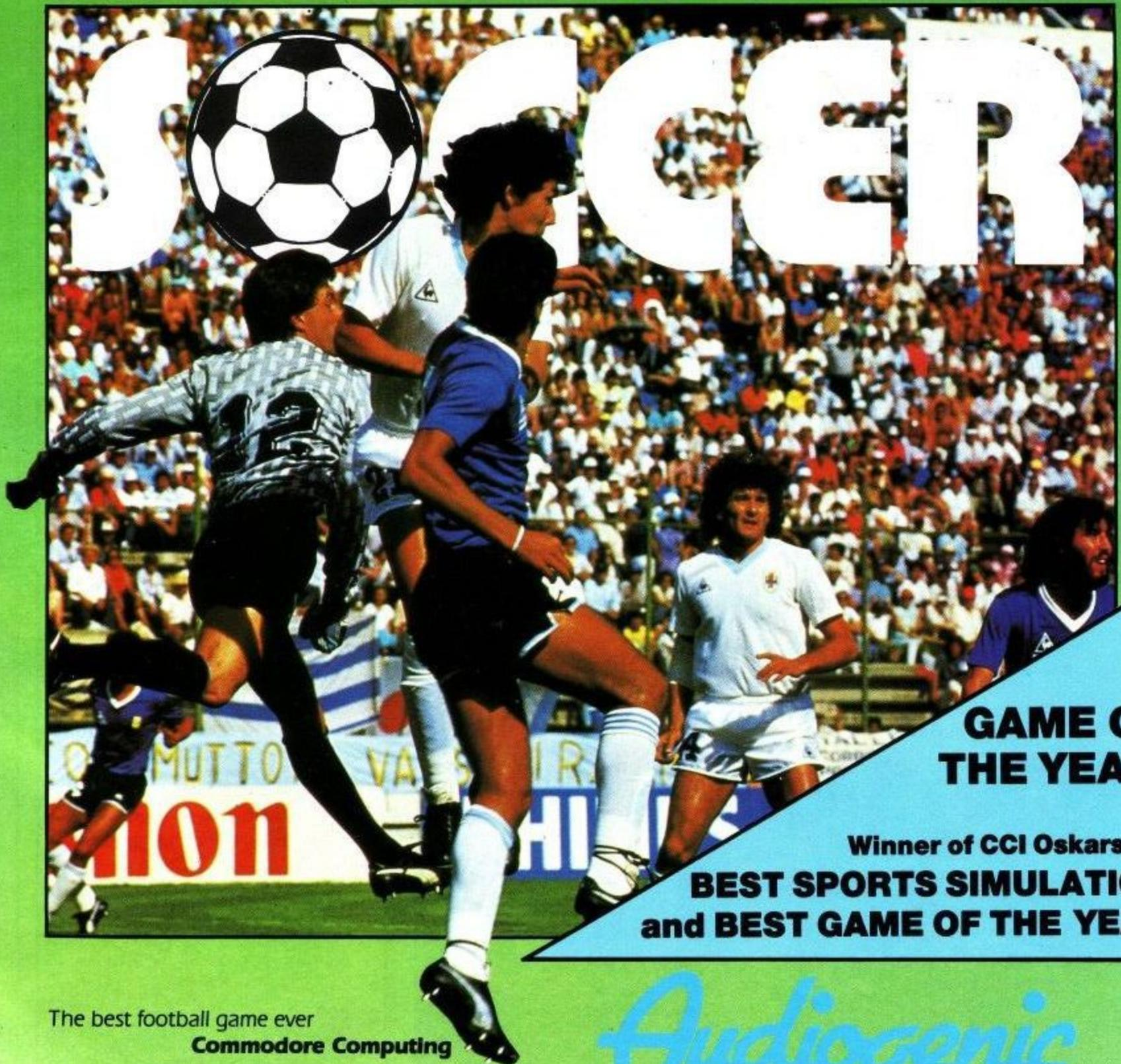

**GAME OF
THE YEAR!**

Winner of CCI Oskars for
**BEST SPORTS SIMULATION
and BEST GAME OF THE YEAR**

The best football game ever
Commodore Computing

Now available for your Amstrad CPC
Tape £9.95 Disc £14.95

*"Excellent graphics... highly enjoyable gameplay...
marvellous way to play football 91%" A.C.U.*

*"You ain't played footie on your CPC till you've mastered
Emlyn!" Amstrad Action Mastergame*

Audiogenic

Audiogenic Software Limited, Winchester House,
Canning Road, Harrow HA3 7SJ, England

Order by phone on 01 861 1166





Are you bored with the blank space on the wall? Well, thanks to those very helpful people at Activision you now have a chance to win the original artwork from the *Time Scanner* game, signed by the artist and framed. To win this coveted prize all you have to do is answer the three simple questions below and send us your answers.

1. What did pinball originate from?

- a) Bagatelle
- b) Chess
- c) Billiards

2. Which is the odd one out?

- a) Nudge
- b) Tilt
- c) Fast Forward

3. Who sang the song Pinball Wizard?

- a) Bros
- b) Roger Daltry
- c) Elton John

AT LEAST

25%

off all non-budget software RRP

1st choice for fast **FRIENDLY** service

CHOICE CHEATS

Complete those games that have defeated you so far!! Choice Cheats lets you play games much more easily by giving you options such as infinite lives and immunity.

TAPE £2.99
DISC £4.99

Choice Cheats 1

Choice Cheats 1 contains cheats for: By Fair Means or Foul, Cybernoid, Karnov, Operation Wolf, Flying Shark, Radius, Tanium, Advanced Pinball Simulator, Joe Blade 2, Star Trooper, Reflex and Shanghi Karate.

Choice Cheats 2

Choice Cheats 2 contains cheats for: BB vs Dragoninja, Hopper Copper, Arkonoid, Arkonoid 2, Dynamite Dan, Solomon's Key, Dizzy 2, ATV Simulator, Empire Strikes Back, Pro Ski Simulator, Batman and Head over Heals.

BUDGET

	Tape	Disc
Air Wolf	1.99	
Bary McGuigan's Boxing	1.99	
Bomb Jack	1.99	
Bubble Bobble	1.99	
Dun Darach	1.99	
Dynamite Dan	1.99	
European 5 a side	1.99	
Ghostbusters	1.99	
Gun Boat	1.99	
Joe Blade 2	1.99	
Shanghai Karate	1.99	
Star Trooper	1.99	
Steve Davis Snooker	1.99	
Thing	1.99	
Yabba Dabba Doo	1.99	
Yogi Bear	1.99	
Xeno	1.99	
Choice Cheats 1	2.99	4.99
Choice Cheats 2	2.99	4.99
ATV Simulator	2.99	
Big Foot	2.99	
Commando	2.99	
Football Manager	2.99	
Footballer of the Year	2.99	
Gauntlet	2.99	
Leader Board	2.99	
Moto Cross Simulator	2.99	
Pro Snooker	2.99	
SAS Combat	2.99	
Street Gang Football	2.99	
The Hit Squad	2.99	
Treasure Island Dizzy	2.99	
Twin Turbo V8	2.99	
Zorro	2.99	

CONTACT US

if you have written any **QUALITY** programs or have ideas we could develop. You may earn £££s

ADVENTURE

	Tape	Disc
Corruption (6128 only)	10.95	14.95
Gnome Ranger	10.95	10.95
Ingrid's Back	6.70	14.95
Lancelot	7.45	14.95
Mind Stone	7.45	9.70
Realm of the Trolls	10.95	9.70
S.D.I.	7.45	9.70
Time and Magic	10.95	10.95

LEISURE & SPORT

	Tape	Disc
By Fair Means or Foul	7.45	10.95
Emlyn Hughes Int. Socc.	7.45	10.95
Football Manager 2	7.45	10.95
Game Set and Match 2	9.70	13.45
Gary Lineker Hot Shots	7.45	10.95
Gold Silver Bronze	10.95	18.70
Question of Sport	10.95	14.95
Super Sports	7.45	10.95
Tour de Force	7.45	
WEC le Mans	7.45	10.95

EDUCATION

	Tape	Disc
Answer Back Quiz (6-11)	7.45	10.45
Factfiles (extra questions for above):		
Arithmetic (6-11)	3.70	6.70
English Words (12+)	3.70	6.70
Gen. Knowledge (6-11)	3.70	6.70
Gen. Knowledge (12+)	3.70	6.70
Natural History (10+)	3.70	6.70
Spelling (6-11)	3.70	6.70
Better Spelling (8+)	8.20	12.70
Better Maths (12-16)	8.20	12.70
Biology (12-16)	8.20	12.70
Chemistry (12-16)	8.20	12.70
Fun School (2-5)	4.45	6.70
Fun School (5-8)	4.45	6.70
Fun School (8-12)	4.45	6.70
Fun School 2 (under 6)	7.45	9.70
Fun School 2 (6-8)	7.45	9.70
Fun School 2 (over 8)	7.45	9.70
Giant Killer (over 10)		10.95
Magic Maths (4-8)	8.20	12.70
Mapwork Quiz (9+)	8.20	12.70
Maths Maria (8-12)	8.20	12.70
Maxi Maths (9-15)	8.20	12.70
Physics (12-16)	8.20	12.70
Playschool (3-7)	8.20	12.70

ARCADE

	Tape	Disc
4x4 Off Road Racing	7.45	10.95
Action Force	7.45	
After Burner	7.45	10.95
Arkanoid 2	6.70	10.95
Barbarian 2	7.45	10.95
Batman Caped crus.	7.45	10.95
Command Perf.	9.70	10.95
CrazyCars 2	7.45	10.95
Cybernoid	7.45	
Cybernoid 2	7.45	10.95
Dan Dare 2	5.95	
Dark Side	7.45	10.95
Driller	10.95	13.45
Echelon	9.70	10.95
Empire Strikes Back	7.45	10.95
Fire Trap	7.45	
Gothic		10.95
Giants	9.70	14.95
Karnov	7.45	10.95
Magnificent Seven	7.45	13.45
Marauder	7.45	
Netherworld	7.45	10.95
Operation Wolf	7.45	10.95
Pacland	7.45	10.95
Robocop	7.45	10.95
Rockstar	7.45	10.95
Running Man	7.45	10.95
Run The Gauntlet	7.45	10.95
Samurai Warrior	6.70	10.95
Thunderbirds	7.45	10.95
Thunder Blade	7.45	10.95
Venom Strikes Back	7.45	

BUSINESS

	Tape	Disc
Home Budget	1.75	
Mastercalc 128 (6128)		24.70
Masterfile 3		29.95
Matrix Spreadsheet		25.95
Maxam	14.95	19.95
Maxam 2 (6128)		37.45
Mini Office 2	10.95	14.95
Plan It		14.95
Promerge		18.70
Prospell		22.45
Protext	14.95	19.95
Tasspell		14.95
Tasword 464	18.70	22.45
Tasword 6128		22.45
Write Hand Man		22.45

DISCS & JOYSTICKS

Maxell Blank 3" discs each	2.60
Cruiser Joystick	8.95
Clear "Seal" n type" keyboard protectors, State 464 or 6128	7.95

THIS MONTH'S **SPECIAL OFFERS**

SCHOOL HOLIDAYS
Keep your children occupied with funschool and funschool 2

Buy any 2 of the funschool range and get a £1 voucher to use with your next order. Buy 3 and get 2 £1 vouchers

offer ends 15.8.89

SAVE OVER £1 WITH EVERY ORDER ON BUDGET SOFTWARE

Buy 3 priced at £1.99 for only £4.95 or 2 priced at £2.99 for only £4.95

2 for the price of 1

(while stocks last)

Any 2 for £1.99
Dun Darach
Euro 5 a Side
Thing
Xeno
Zorro

Any 2 for £7.45
Dark Side
Fire Trap
Marauder
Tour de Force
Venom Strikes Back

To avoid disappointment, feel free to quote a reserve title(s)

IF YOU DON'T SEE THE ITEM YOU REQUIRE, JUST PHONE (0706) 72728



All prices are inclusive of VAT, postage & packing in the UK. Overseas orders please write for details

Please send me the following:
Title _____ Price _____ Disc/cass _____
Total price _____



To order, fill in the coupon and send it with a cheque/postal order to

1st Choice Software Ltd
Dept ACU8
4 Paul Row, Temple Lane
Littleborough, Lancs, OL15 9QG

Name _____ Address _____ Post code _____

Life hots-up in the Combat Zone

Summers can be hell
in the depths of
arcade land. John
'Pinball Maniac' Cook
breaks into a sweat
over this months
new games.

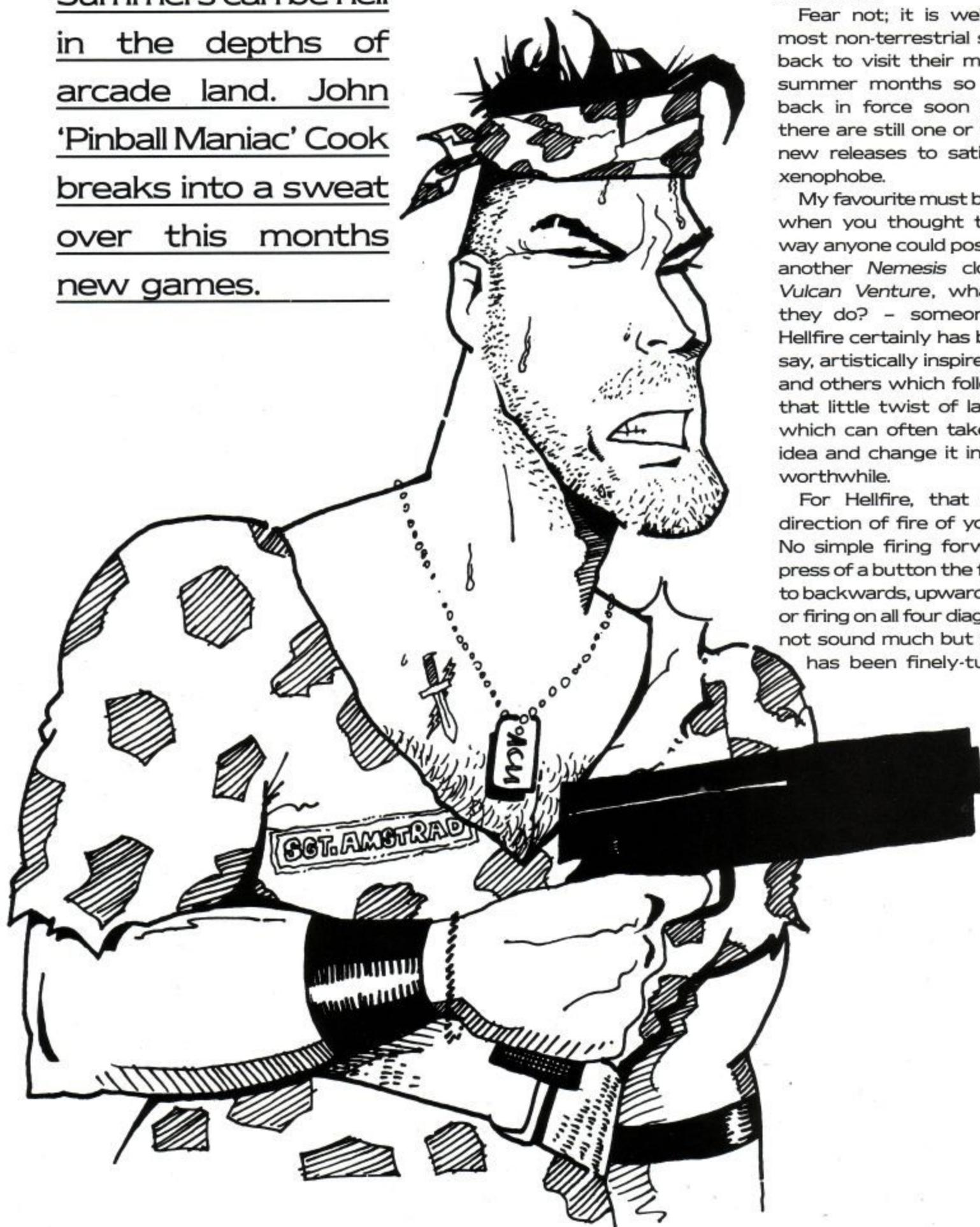

Singing, all together now - "Summertime... and the living is easy." Easy? Not here in the Combat Zone, where aliens are fought back from world domination, if not on the beaches, then certainly at the end of the pier. To look at the latest batch of games you might think that aliens had become an endangered species. We have wrestling games, shooting games, mind games, cutsie games; what about the straightforward alien bash?

Fear not; it is well-known that most non-terrestrial species travel back to visit their mothers in the summer months so they will be back in force soon and, besides, there are still one or two excellent new releases to satisfy the true xenophobe.

My favourite must be *Hellfire*. Just when you thought there was no way anyone could possibly produce another *Nemesis* clone - after *Vulcan Venture*, what else could they do? - someone does. Yes, *Hellfire* certainly has been, shall we say, artistically inspired by *Nemesis* and others which followed but has that little twist of lateral thinking which can often take an ordinary idea and change it into something worthwhile.

For *Hellfire*, that twist is the direction of fire of your spaceship. No simple firing forwards. At the press of a button the fire is changed to backwards, upwards/downwards or firing on all four diagonals. It might not sound much but the gameplay has been finely-tuned so that

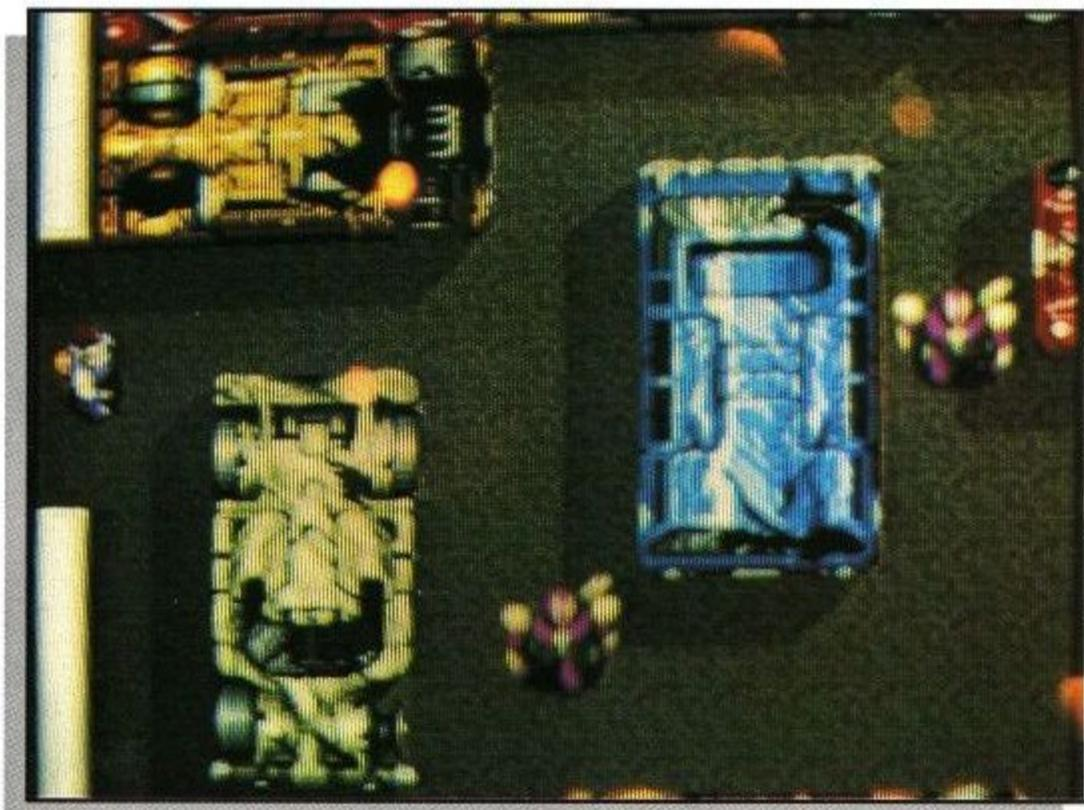

CRACK DOWN: Drive me to the river.

changing between directions of fire is not just desirable – it is essential. Fumbling for the correct combination under pressure in extremis piles on the adrenaline.

The gameplay is familiar if you have ever played games of this type; there are speed and weaponry power-ups and a constant right to left scroll but is very well-balanced in speed and variety of aliens. Definitely a PCB to look for in the next few months.

Regular readers will know I am keen about pinball. One thing about pins is that the makers of the things, the brand if you like, tend to have different feels to them. Stern tables of the early 1980s are my favourites but that is because I like plenty of targets at which to aim. Obviously not many other people did because Stern went out of business in the mid-1980s.

Another famous name in the pinball trade is Bally and one of its tables, *Truck Stop*, had me occupied for a few hours in the depths of a London arcade a few weeks ago. The theme of this is, as usual, heavily macho. You are supposed to be driving your big rig round the freeways of the U.S.A. and have to make sets of rollovers by making various ramp shots to 'visit' each city – Chicago, Denver, Dallas, New York, Los Angeles. Get all of them and the city lights lit and the

machine almost explodes.

With two sets of flippers on the playfield the upper set is placed to make a second set of ramps, *Truck Stop* is a fun table – not too difficult, not too complicated and one you can get into reasonably quickly. If you happen to pass one on your travels, I recommend you try it.

Do you remember I mentioned the Sega System 24 last month and the latest release for it, *Crack Down*? This month we bring you System 24, the circuit board.

I finally managed to obtain a reasonably full technical specification of the system, and, as you can imagine, it has a little more than 64K and a single Z-80. It has two CPUs, both full 16-bit variants of the 68000 family, the 68010. On top of that there is 1,360K of RAM available and a 256K ROM full of hardware routines available to the programmer.

There is hardware pixel scrolling, of course, and hardware windowing. Sprite handling – how about 2,048 16 by 16 pixel sprites? How about 4,325 colours displayable on-screen at once out of a palette of 32,768? The FM, eight-channel sound system scarcely needs mentioning, does it?

Although *Crack Down* is the best game on the system to date, *Gain Ground* was not bad but this looks like a system with a hardware specification which will stand up for two years at least and, as programmers get used to it, the games can only get better and better.

Capcom launched a new generic board about nine months ago in a blaze of publicity. Estimates of development time and costs ranged from \$5 million and two years through to \$2 million and five years. Who cares? It is producing games



BUCCANEERS: Nice ship, pity about the game.

like *Forgotten Worlds*, now a conversion from the U.S. Gold stable, and *Ghouls and Goblins*, a strangely unsuccessful follow-up to the original *Ghosts and Goblins*.

Now another game from it is *Dynasty Wars*. We are talking Chinese Dynasties here, the ones which do not just seem to last hundreds of years - they really do.

At the beginning of his bash you choose one of four characteristics. They are presented with the usual hilarious Japanese/English translations. Kuan Yu, for instance, is "Not only a great warrior who has defeated many famous, but also educated and well-mannered." Once you get into the game you have an interesting right/left, semi-perspective view of a battlefield through which you have to cream your way on horseback.

There are plenty of sprites, plenty of well-designed cannon fodder. You have magical ability as well which can summon fire, landslides and stuff. It is all done very well and competently but, even though it is a technically-impressive piece of work, somehow it failed to inspire so much as I hoped. It is certainly not a dud but treat this one warily.

Back to the vids. *Tetris*, the home computer game, made it to Tetris the arcade coin-op, did it not? It is the number one coin-op in the home of coin-ops, Japan. I suspected that, if successful, Tetris might spawn a new craze in vids, the puzzle game. Well, the first of them appears to have arrived.

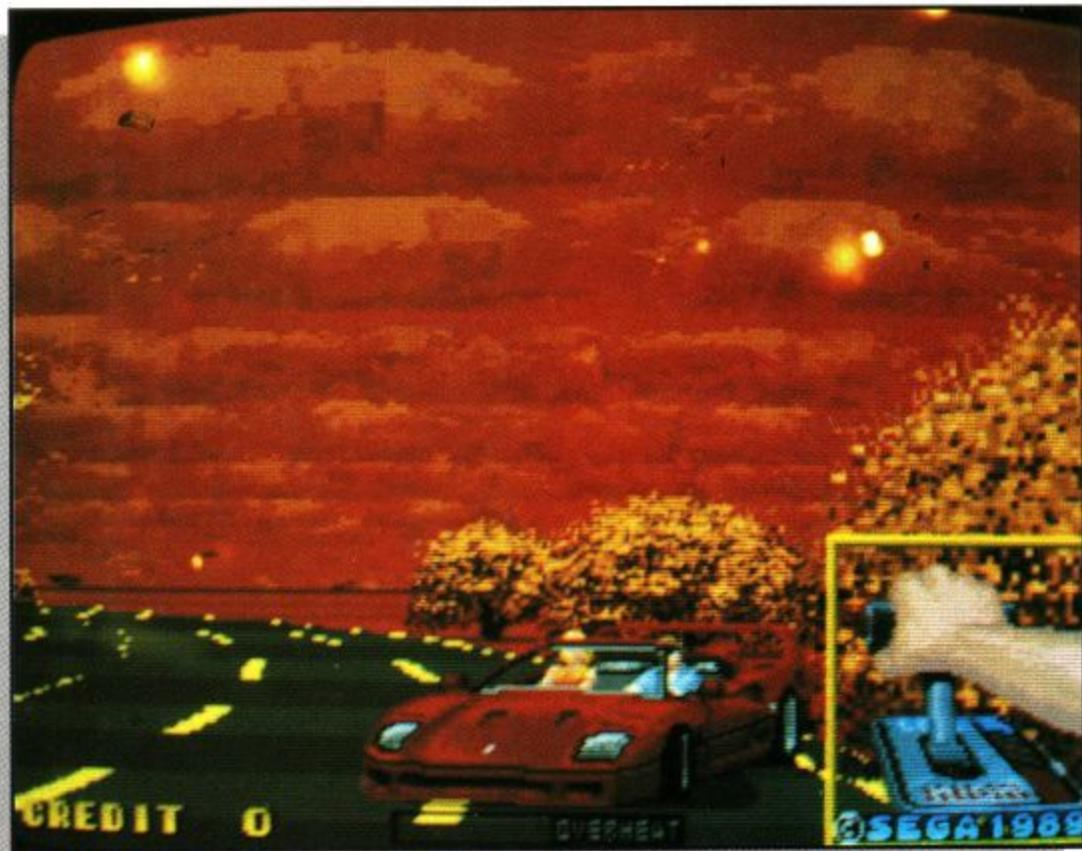

TURBO OUTRUN: Faster than ever.

"Never let it be
said we do not tell
you about the bad
as well as the
good. Here is one
to really avoid-
Buccaneers."

I do not know what it is called - the title screen is in characters rather than English - but it appears to be a version of that mega-hit from Activision, *Shanghai*.

It is a kind of patience, I guess. The game is played on a single screen full of Ma Yong titles and like the old card game *Pairs*, you have to designate pairs of titles and they are then removed from the screen. It is not particularly simple, though - the titles are aligned in rows and you can nominate titles only at the end of a row and you are doing it against a time limit. It will be interesting to see if it catches on.

Never let it be said we do not tell you about the bad as well as the good. Here is one really to avoid - *Buccaneers* from a rather obscure firm Duintronic. You control a pirate sprite and have to do the business in an extraordinarily lacklustre hack and slay job. Save your 10 pence pieces for better things and condemn this straight to Davey Jones locker.



Here is something silly for summer and a fun way to get your parents into the arcades. It is well-known that anyone over the age of 30 is allergic to vids so get them in with any one of the silly games doing the rounds.

Last year there was *Sweet Licks*. This was a unit with a padded hammer and around 12 holes. Up

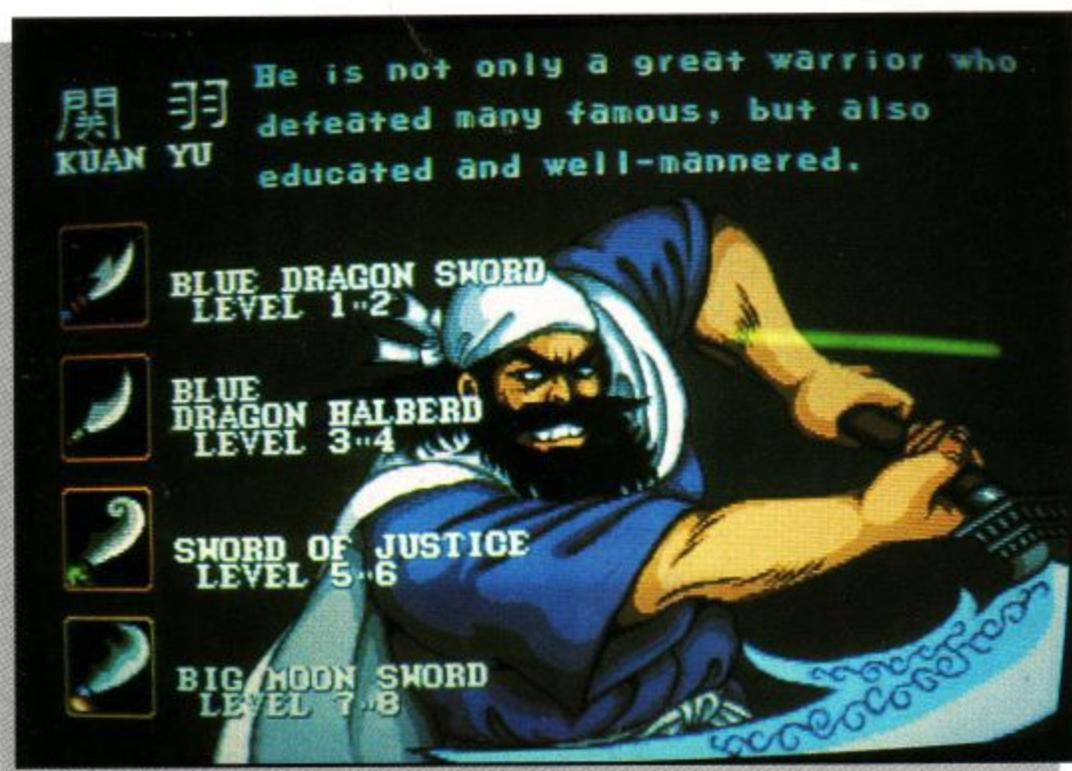

DYNASTY WARS: Hate over the ages.

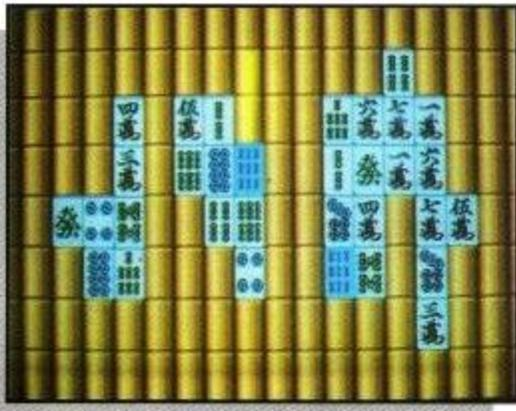

Crazy stuff.

from the holes pop gormless-looking moles and you had to bob them on the head before they ducked. At the start of the game they appeared only in ones and twos but fives had you flailing around all over the place. It also is the first coin-operated amusement game I ever got my mother to play.

Now there is another, very much

in the same mould, except it is crocodiles which are creeping out of caves to bite you on the hand. These kinds of games really are fun and leave the participant panting with effort and the audience – somehow there is always an audience – rolling on the floor with mirth.

First there was the hit game *Outrun*. Now, perhaps, even three years after the event, there is the

replay, *Turbo Outrun*. The graphics are better than before, by miles. The sound is terrific. Additional features include a turbo button on the gear lever which gives you an extra hit. Also, when completing a level, you have the option to add extra to the car. The gameplaying public wants more than this. Take my advice on this one; if you have to play a Sega driving game this summer, make it *Power Drift*.

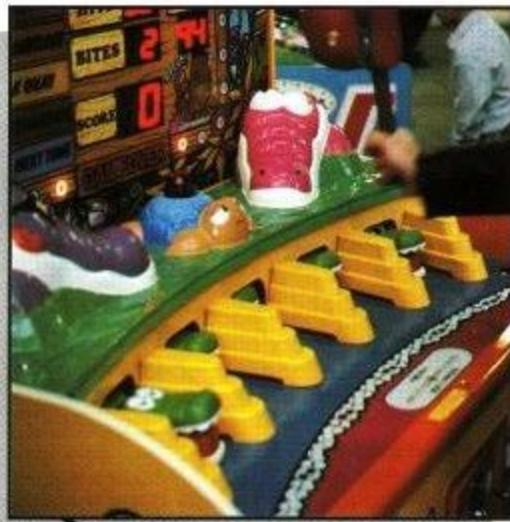

Silly.

“First there was the hit game *Outrun*. Now perhaps, even three years after the event, there is the replay, *Turbo Outrun*.”

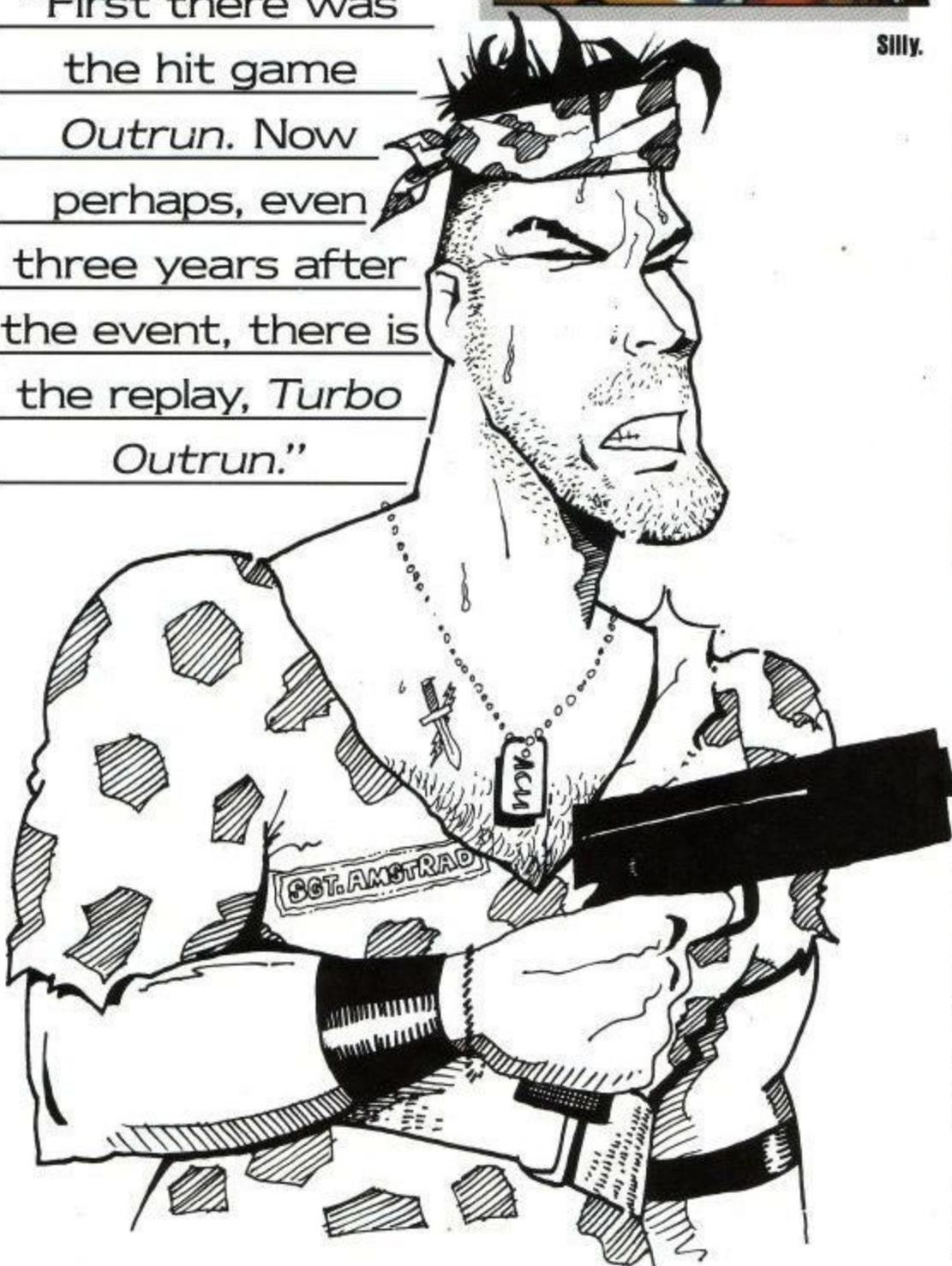

You might think that *Professional Wrestling* is silly in the U.K. and you would be correct but in the States, heavily-muscled nutters strut round rings in equally heavily-sequined posing pouches. They shout at each other and then proceed to add to the existing brain damage by flinging

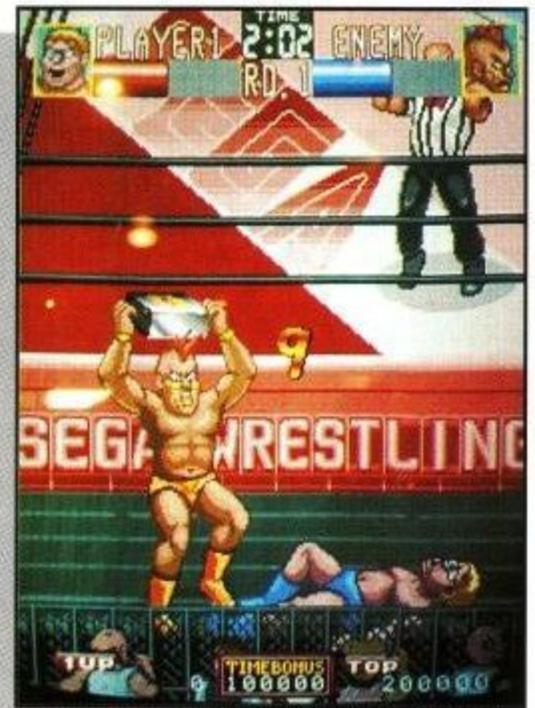

Take that, boy.

each other about the place – and it is big-time, prime-time TV to boot. This must explain the rash of wrestling games which has arrived on our shores.

Wrestling Superstars from Technos, *Champion Wrestler* from Taito, but I like best *Wrestle War* from Sega. It is a complicated game, as you can see from the controls; it has huge sprites but, more important, manages to capture the pure theatre and silliness of it all, while being a fun, playable game. It is not my cup of tea but combat fans will go for it.

Next time, an in-depth review of what is already being called the hottest PCB around, *Golden Axe* from Sega.

**WE'VE GOT
1,000!!**

**3" HEAD DRIVE
CLEANERS**

**SUITABLE FOR -
ALL AMSTRAD
3" DISK DRIVES**

**KIT COMPRISES:
3" CLEANING CASSETTE
TUBE HEAD CLEANING FLUID
INSTRUCTIONS**

~~£9.95~~

**OUR PRICE
ONLY £5.95**

PRINTER RIBBONS
(Nylon Fabric)

AMSTRAD	CITIZEN
DMP 2000/3000/3160 £3.80	120D £4.50
DMP 4000 £6.95	EPSON
PCW 8256/8512/LQ3500 £3.60	MX/FX/RX80/FX800 £3.20
PCW 9512 £3.70	LX80/86/GX80 £3.20
STAR	MX/FX/RX100/FX1000 .. £3.50
NL10 £4.85	MANNESMANTALLY
LC10 £4.95	MT80 £4.30

AMSTRAD

NEW JOYSTICK SPLITTER
Play with a friend! Splitter enables 2 joysticks to be used independently **ONLY £6.95**

PRINTER CABLE
664/464/6128 1m £8.95
2m £9.95
Extension Printer Cable
1m plus power. (PCW) £9.95
Monitor Extension Lead
664/6128 1m £8.50
PPC to Philips 8524/8533/8833/1081 £5.95
PC to Philips 8501 £5.95

**...FOR PEOPLE ON THE MOVE
COMPUTER
E-X-T-E-N-S-I-O-N
LEADS**

(Hard Disk type)
9512 £11.50
1512 £18.95
1640 £19.95
(Floppy Disk type)
1512 £17.75
1640 £18.75

DUST COVERS

PC1512/1640 £9.50
PCW8256/8512 sets 3 £9.50
PC9512 sets 3 £9.75
DMP 4000 £5.25 C120D £4.95
DMP 2000/3000/3160 £4.95
All covers clear with grey piping

RS232 GENDER CHANGERS
Avoid incompatible cables **ONLY £6.50**

**CABLES MADE FOR ALL RS232 AND
PARALLEL TYPES OF COMPUTER,
MODEMS & PRINTERS RING NOW
FOR QUOTE**

PPC to PC data transfer cable. Enables transfer of data simply

ONLY £10.50

**CENTRONICS
LINE BOOSTER**
In series, drives data twice as far with half the S to N ratio. Doubles your cable length! **ONLY £24.95**

DATA SWITCHBOXES

Enables you to quickly & easily switch between micros & printers
RS232 (Serial) Metal Cased
25-way 'D1' to 2-way £30.00
25-way 'D1' to 3-way £40.00
25-way 'D1' to 4-way £50.00
Centronics (Parallel) Metal Cased
36-way Centronics to 2-way Para £30.00
36-way Centronics to 3-way Para £40.00
36-way Centronics to 4-way Para £50.00
PARALLEL CROSSOVER 36-way Centronics
2 to 2 changeover Crossover £50.00

**UNIVERSAL PRINTER
STAND**

£12.95
The adjustable Printer Stand - 2 piece construction, fits all standard and wide carriage printers. Also provides convenient space for paper and storage. Rubber feet, vibration absorbing pads.

**TILT &
SWIVEL BASE**

Suitable for 12" & 14" TV or monitor **£14.75**

**JUST ARRIVED
Professional Mouse Pads . £4.75**

REMEMBER, our business is Cables for Computers, Printers, Monitors, Cassettes etc, etc. The above is a very small selection! Write or phone NOW for a quote. Trade EDUCATIONAL & EXPORT ENQUIRIES WELCOME

**AUTO SWITCHES
PARALLEL/SERIAL**

MP401 4-way Parallel .. £105
MP801 8-way Parallel .. £135
MS401 4-way Serial £105
MS801 8-way Serial £135



BUFFERS
PB 64K Ram £95
PB256K Ram .. £165

COPY HOLDERS

Clamps onto any table Angle & position your copy for easy typing on the computer. Sliding Rule also fitted **CH1. ONLY £16.95**
Exactly as above but self-standing for desk top use. Both for 9.5" x 11.5" copy. **ALSO ONLY £16.95**

DISKETTE STORAGE BOXES

Anti Static with removable lids Lock and 2 keys. Cream with see-through lid & custom dividers
To hold 40, 3.5" disks £8.95
To hold 80, 3.5" disks £10.50
To hold 50, 5.25" disks £8.95
To hold 100, 5.25" disks .. £9.95
To hold 120, 5.25" disks £10.95
PLUS COMBO BOX 40, 3.5" or 20 3" £8.25

**ANTI REFLECTION &
ANTI STATIC
SCREEN FILTERS**

COLOUR 12" £16.95
COLOUR 14" £17.95
MONO 12" £16.95
MONO 14" £17.95

£1 P&P IN UK, Access & Visa accepted. Please add 15% VAT to all orders. Cheques made payable to:

R.S.D. CONNECTIONS LTD Dept AU8, PO Box 1, Ware, Herts



Trade, Educational & Export enquiries welcome

Tel: 0920-5285/66284 Fax: 0920 66191



ROMANTIC ROBOT

regrets

Because of possible implications of the coming new Copyright Act we will NOT sell the MULTIFACE in the UK after 01/08/1989.

This is our LAST ADVERT and your LAST CHANCE to buy!

To help EVERYBODY to get THE ESSENTIAL CPC ADD-ON whilst still possible, we offer a massive **£10 OFF the MULTIFACE TWO.**

We also offer **£5 off INSIDER** and a **FREE Rodos Xtra** with each **Rodos.**

Please DO realize that this is more than an absolutely unique offer: this is the LAST CHANCE you have!

All sales will end on July 25

BUY NOW - or NEVER...

All offers apply only to MAIL ORDERS received with the coupon below 15.6.-25.7.1989

Is there life after Multiface? Maybe... But not without one!

I Order: MULTIFACE 2 £37.95 RODOS Plus RODOS EXTRA £29.95 Plus p&p UK £1, EUROPE £2
INSIDER £9.95 RODOS EXTRA £9.95 Overseas £3

I enclose a cheque PO for £..... or debit my No Card exp.....

Name & address

ROMANTIC ROBOT UK LTD 54 Deanscroft Ave, London NW9 8EN 24 hrs **01-200 8870** **ACU**

DISCOUNT SOFTWARE



from M.J.C. SUPPLIES

DISC GAMES

Chicago 30's	12.95
Chuck Yeager AFT	11.95
Colossus 4 Chess	11.95
Crazy Cars II	11.95
Dark Fusion	12.95
Dark Side	11.95
Driller	14.95
Emlyn Hughes Soccer	11.95
F15 Strike Eagle	11.95
Fists and Throttles	11.95
Forgotten Worlds	12.95
Game, Set and Match II	13.95
H.A.T.E.	12.95
Lancelot	14.95
Magnificent Seven	14.95
Microprose Soccer	15.95
Monopoly	11.95
Nightraider	11.95
Operation Wolf	11.95
Pacland	11.95
Pirates	14.95
Question of Sport	17.95
Real Ghostbusters	11.95
Renegade 3	11.95
Road Blasters	12.95
Robocop	11.95
Run The Gauntlet	12.95
Scrabble Deluxe	12.95
Six Pack III	11.95
Storm Lords	14.95
Superman	11.95
Supreme Challenge	12.95
Tank Attack	11.95
Thunderblade	11.95
Time and Magik	11.95
Times of Lore	11.95
Titan	11.95
Vindicators (by Domark)	12.95
Wanderer 3D	11.95
War In Middle Earth	11.95
WEC Le Mans	11.95

MJC SPECIAL

3D Pool
RRP £14.95 Ours £9.95
Offer Ends 31/7/89

EDUCATION

Animal Veg, Mineral	11.95
Answerback Junior Quiz	11.95
Factfile Arithmetic	7.95
Factfile Spelling	7.95
Factfile Sports	7.95
Fun School for 2-5 years	7.95
Fun School for 5-8 years	7.95
Fun School for 8-12	7.95
Fun School 2 for under 6 yrs	9.95
Fun School 2 for 6-8 yrs	9.95
Fun School 2 for over 8 yrs	9.95
World Wise	11.95

Note: Factfiles are question packs only and require the Answerback Junior Quiz.

DISC SERIOUS

Protect	18.95
Prospell	17.95
Promerge	17.95
Armor File	18.95
Armor Office Suite	26.95
Tasword 6128	19.50
Taspell	12.95
Tasprint	10.95
Tascopy	10.95
Tasdiary	10.95
Tassign 6128	23.95
Qualitas Plus	12.95
Qualitas Pica Font Pack	8.95
Qualitas Clarion Font Pack	8.95
Qualitas Newsroom Font Pack	8.95
Qualitas CPM + Utilities Disk	8.95
French Mistress	16.95
German Master	16.95
Spanish Tutor	16.95
Masterfile III Database	29.95
Mastercalc 128	25.95
Matrix Spreadsheet Plus	29.95
Stop Press Desktop Publishing	38.95
Extra Extra	19.95
Maxam (Assembler/Diss)	18.95
Poke Easy Plus	14.95
Mini Office II	15.95
Rodos Extra Disk	8.95
Advanced Art Studio	19.95

CPM BASED

At Last Plus	29.95
Supercalc 2	44.95
Armor C Compiler	39.95
Maxam II	39.95
Fortran	39.95
Nevada Cobol	39.95
Hisoft Devpac 80	39.95
Hisoft Pascal 80	39.95
Hisoft C Compiler	39.95
lankey 2 Finger Typing	19.95
lankey Crash Course	19.95

MJC SPECIAL

Protect CPM: including
Spellchecker & Mailmerge
RRP £59.95 OURS £41.95

CASSETTE BASED

Maxam 464	15.95
Protect 464	15.95
Tasword 464	15.95
German Master 464	14.95
French Mistress 464	14.95
Answerback JNR Quiz	8.95
Italian Tutor	14.95
Spanish Tutor	14.95

ALL ABOVE PRICES INCLUDE VAT, POSTAGE & PACKING IN THE U.K.
THE ABOVE SOFTWARE IS ONLY FOR THE AMSTRAD CPC RANGE

ACCESSORIES

DKT 64K Memory Exp	45.95
Multiface II Plus	42.95
Printer Lead 1M	8.95
Printer Lead 1.5M	9.95
Printer Lead 2.0M	10.95
3" Disc Cleaner	6.95
Amstrad RS232 Interface	55.95
Mono Screen filter	12.95
Colour Screen Filter	14.95
Comp Pro 5000 joystick	13.95
Quickshot Turbo Joystick	11.95
Cruiser Joystick	9.95
464 Monitor Ext Leads	6.95
6128 Monitor Ext Leads	7.95
1000 Fanfold Labels	5.95
Second Drive Lead	7.95
AMX Mouse + Art Software	59.95
AMX Mouse + Stop Press	69.95
464 Dust Cover (Mono/Col)	7.95
6128 Dust cover (Mono/Col)	7.95
KDS 5 1/4" 800k disc drive (state 464/6128)	149.95
KDS 8 bit Printer Port	18.95

BOOKS MANUALS

Adv Amstrad Graphics	7.95
Mastering Machine Code	8.95
The Amstrad CPM+ Book	12.95
Programming the Z80	19.95

RIBBONS

Printer	Quantity		
	1	2	5
DMP 2000/2160	3.50	6.00	14.00
Panasonic 1080/1081	3.95	7.00	16.00
Citizen 120D	3.95	7.00	15.00
Star LC10 (Black)	3.95	7.00	15.00
Micro-P165/200	4.95	8.00	18.00
Star LC10 Colour	5.95	11.00	-
Genuine Amsoft CF2 Disc		10	
PLEASE CALL FOR AVAILABILITY		for	£25.95

ROM BASED

Protect	28.95
Prospell	23.95
Promerge+	23.95
Maxam	28.95
Maxam 1.5	21.95
Utopia	21.95
BCPL	22.95
Rodos	28.95
Cage Rom (State which I/Face)	31.95
Rombo (if purchased with Rom)	28.95
KDS Rom Board (Holds 6)	24.95

Quali Pack

The Print Enhancement Package
Qualitas Plus KDS 8 Bit Port
Display Font Pack
R.R.P. £44.45 Package Price £34.95
Quali extra
As above, plus Carrion, Pica, and
Newsroom, font packs
R.R.P. £54.45 Our Price £44.50

CORNIX SOFTWARE

CARD INDEX: Easy to use filing system
CASS: 19.95
DISC: 24.95

SIMPLE ACCOUNTS: easy to use
accounts ideal for small business
includes VAT. CASS: 34.95
DISC: 39.95

JOB ESTIMATOR: useful tool for con-
tractors. DISC: 39.95

PRODUCT COSTING: DISC: 39.95 Full
specifications on all of the above programs
on request.

PRINTERS

All printers listed have a ten inch
(A4) carriage, are Epson compatible,
and feature friction and tractor feed
mechanisms for continuous or single
sheet paper. All prices include
the necessary cable

PANASONIC KXP - 1081

Offers all the draft mode text sizes of the
D.M.P. 2160, but is better built, more reliable,
and offers N.L.Q. in all sizes and effects, for
only £10.00 extra! Highly recommended.
£169.95

STAR LC-10

As well built and reliable as the Panasonic.
Has four N.L.Q. fonts (typefaces), in combina-
tion with all sizes and effects. New low prices
makes it well worth considering
£199.95

STAR LC-10 COLOUR

All the features of the LC-10, but with a seven
colour option for colourful text. If you want
colour graphics please call first for advice.
£249.95

STAR LC 24-10

24 pin version of the LC-10. Has 5 excellent
letter quality fonts available with all sizes and
effects. Two extra effect, outline and shadow
are also featured. Good value.
£339.95

Overseas Orders Welcome - Please write for details

WE ARE NOW IN OUR FIFTH YEAR OF SPECIALISING IN AMSTRAD MAIL ORDER, OUR POLICY IS TO PROVIDE THE WIDEST RANGE AT
DISCOUNT PRICES WITH A FAST TURN AROUND TIME - TRY OUR SERVICES WITH CONFIDENCE

CALLERS WELCOME: Mon-Fri 9 to 5 Sat 10 to 4

PLEASE SEND CHEQUES/POs TO:

M.J.C. SUPPLIES, (ACU)

40a Queen Street, Hitchin, Herts. SG4 9TS.

Tel: (0462) 32897/420847 or 421415 for enquiries/Credit Card orders

PROPRIETOR M.J. COOPER



MICRO-SCOPE

Researcher about
town Trevor
Cummings, turns
his attentions to
printers and the
CPC - from a
technical point of
view naturally.

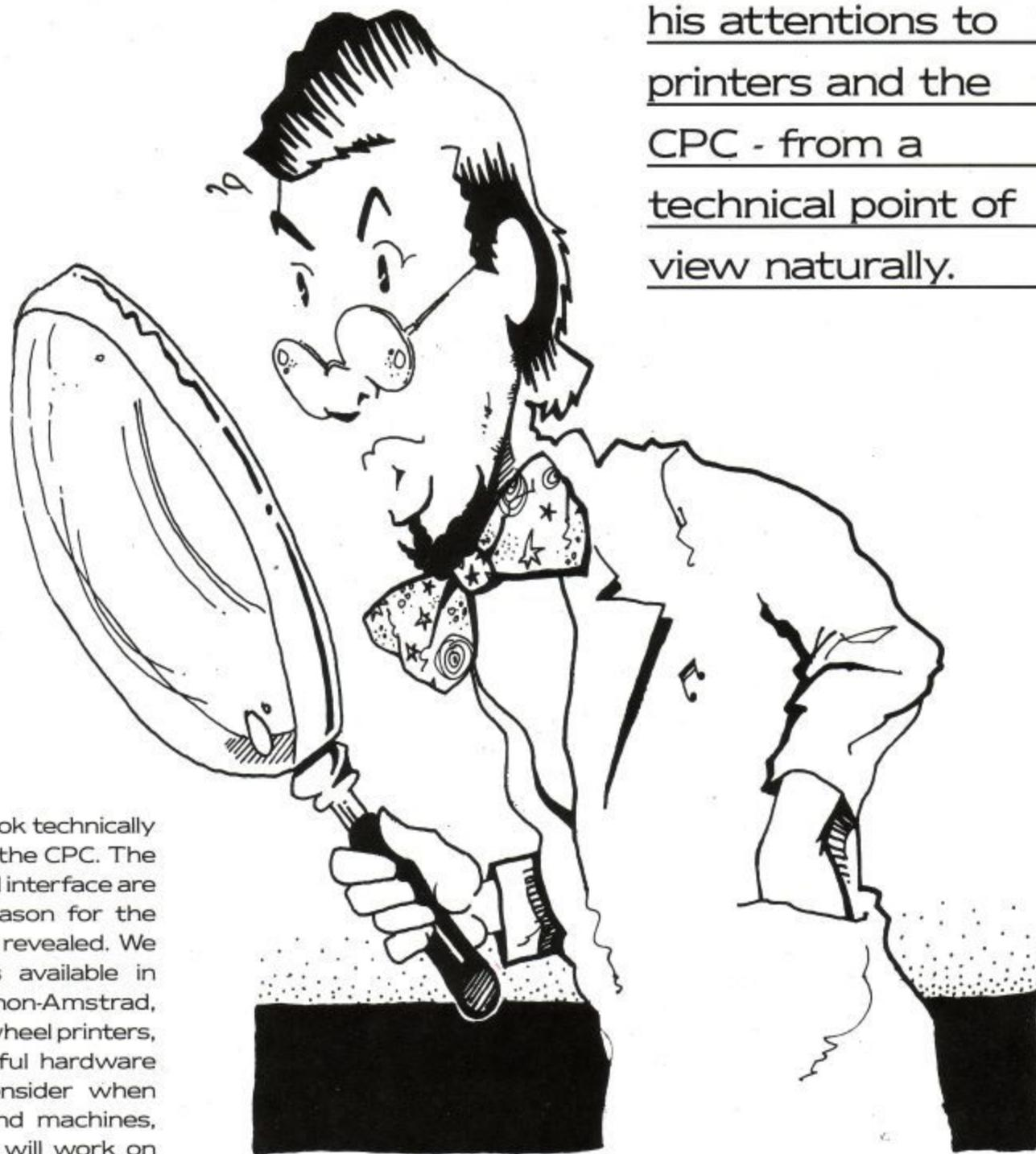

This month we look technically at printers and the CPC. The printer port and interface are examined and the reason for the missing eighth bit are revealed. We examine the options available in terms of Amstrad, non-Amstrad, dot matrix and daisywheel printers, along with other useful hardware and see what to consider when looking at second-hand machines, whether or not they will work on the CPC.

We cannot examine individual printers, though, as there are so many different ones but there is a

general overview of the options. In addition, as promised last month, we have an 8-bit printer port project which all D.I.Y. enthusiasts can build for less than £5. Budding machine code programmers for the project should look at the software as it is an example of intercepting and re-routing the CPC firmware routines.

Inside the computer each

character, such as the letter A, has an 8-bit binary code - A = 01000001. When it is moved, e.g., from memory to memory, screen, tape, disc drive and the printer, the eight wires of the computer data bus, D0 to D7, have this code on them. A 1 = high voltage and a 0 = low voltage. With D0 on the right and D7 on the left, the character A would have D0 as a high voltage, D1 as low, D2 as low, and so on. There are two ways to send such data to a printer, one bit at a time - D0 followed by D1, D2, and so on is serial

transmission and printers employing the method cannot be used on the CPC without the addition of a serial interface.

The other is the parallel method which sends all eight bits along eight wires simultaneously. As well as the data lines other control lines are either needed or are useful. The Centronics interface is a full set of parallel data and control lines. Most machines with this interface apply at least some of the signals to the same connector pin numbers, giving a good degree of standardisation.

Since the CPC uses this system, any printer with a Centronics interface should work whether it is an Amstrad one or not. The varieties include 80- and 135-column dot matrix machines, daisywheel printers and even colour plotters. So long as it has Centronics signals the printer should be satisfactory. I must point out that a number of printers, daisywheels in particular, have a few different characters for some of the codes. They can even have characters which are not on the keyboard. Good word processors provide the option to alter character codes to cure such problems. Modifying the CPC Translation Table is another way.

The standard Centronics connector has 36 pins but the CPC has only 34. There is a good reason for the difference but it does not really concern us. Pin 1 to pin 1 aligns the signal correctly so that the BUSY, STROBE and data lines are matched with the printer. This can be seen clearly in chapter seven of your computer manual. Note that pins 18 and 36 are missing from the diagram, since the computer does not have them, but the pin numbers match those of the printer.

Some Centronics printers and computers have fewer pins but still employ the same signals. A comparison of the printer and computer pinouts will show what to connect to where. Apart from the seven data bits the only two lines used by the CPC are the STROBE, pin 1, which the computer pulses low to tell the printer that valid data is available on the data lines, and BUSY,

pin 11, which the printer sends to say "I am not ready for any more yet." All handshaking is done with these two.

Unusually, the CPC outputs seven data bits instead of eight because the original DMP1 printer cannot make use of the eighth bit even if it were there. Most printers, however, have a second character set or graphics characters above code 127 and a 1 on the eighth bit (D7) is needed to get at them.

Unfortunately we cannot just open the machine and connect D7 of the data bus to D7 of the printer port because the data lines of the port are not connected to the internal bus. They come straight from an

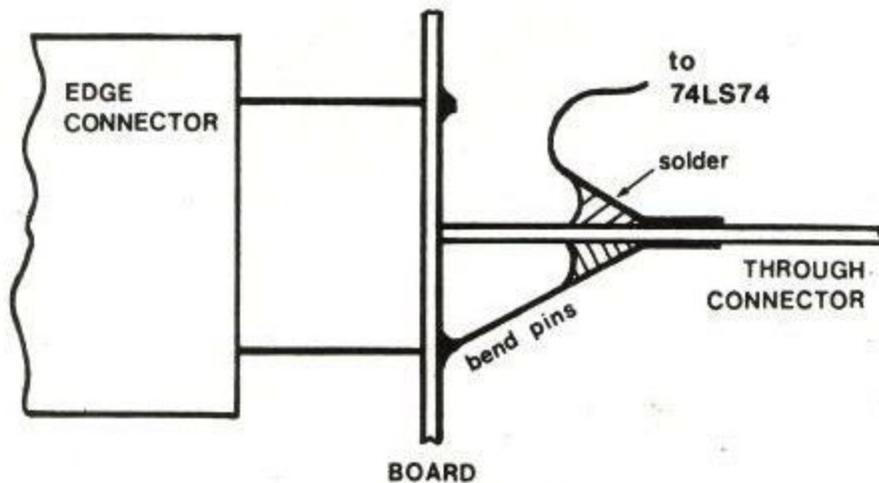

“The standard Centronics connector has 36 pins but the CPC has only 34.”

8-bit latch in the CPC and the eight bits consist of seven data bits and one STROBE line. We could change the software to turn the STROBE line into the eighth bit but where would we then find the necessary STROBE pulse? Alas, seven data bits and 1 STROBE are all we are given.

All is not lost. KDS Electronics produces an 8-bit printer port which plugs on to the 34-way printer outlet and, after running a small piece of software, is invisible to the user. If a high character is sent to the printer it gets there and, if the printer has a top set, it will be printed.

To check if your printer has such a set, find the self-test routine in its manual. It is usually activated by turning it on at the same time as depressing a switch. My machine needs the line feed pressed. This will print-out all the printer characters, top set included. The KDS 8-bit port sells for £18.95 and is available from mail order advertisers in this magazine.

We have already seen what this device can do so we will go straight into how it works. We need to create the eighth data bit (D7), set it to 0 or 1 depending on the character code and leave it set until the printer has received all the characters. We do it by intercepting the firmware routine MC WAIT PRINTER and running automatically our piece of eighth bit

setting software. Then we jump back to MC WAIT PRINTER, which will continue as normal and, among other things, change D7 into the STROBE signal.

The method is simple and uses one-half of a dual D-type flipflop chip which sends the output Q to the same logic level as input D when input C goes from low to high. It keeps Q at that level until the next time C goes high. If you look at the logic diagram you will see that data lines D5 and D6 are fed from the computer printer port to inputs C and D and the created D7 is output from Q and fed to the printer.

A 'shifty' bit of thinking will reveal that, if we shift the original D7 of the character to D6 and make D5 go low

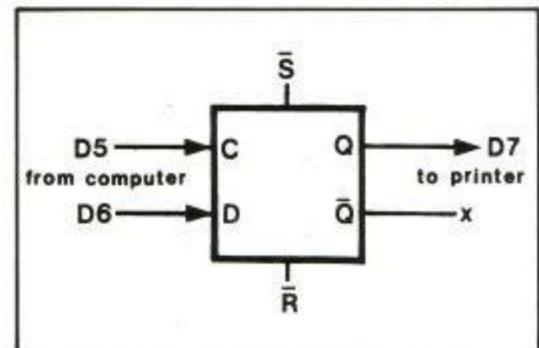

and then high, the original D7 will be latched at Q. Bar Q is always the logical opposite of Q and is not connected. Bar R and bar S are Reset and Set pins and are tied high to prevent them operating.

The listed program needs to be typed-in and saved. Run it whenever the printer is to be used. Lines 10 and 20 replace the start address of MC WAIT PRINTER in the computer jump table, with the start address of our machine code routine. The rest of the program pokes our machine code into a small unused area of memory starting at &BF10.

Do not type this is. It is the data of the Basic program:

When this program is reached the original character to be sent to the

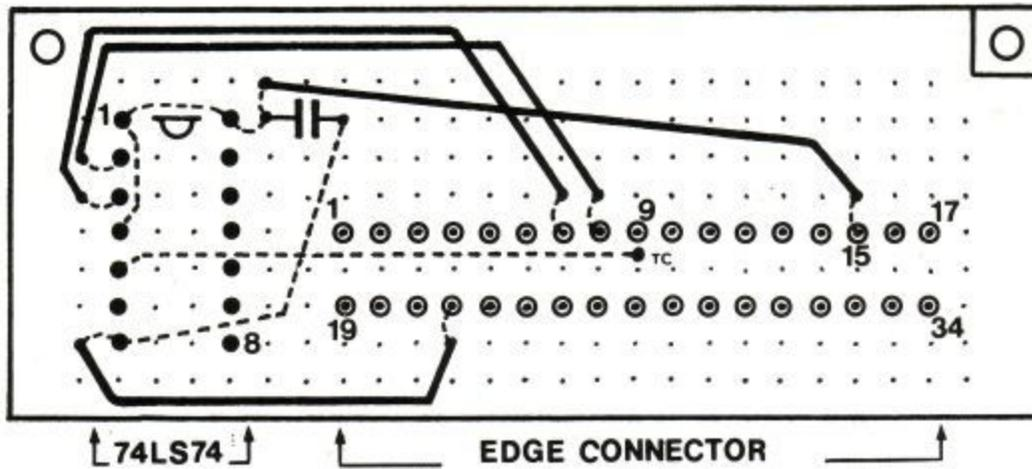

printer is in the accumulator with D7 intact.

Edge connector 34-way	MicroStyle EC34W	90 pence.
Through connector 34-way	MicroStyle TC34W	£2.
Capacitor	Maplin YR75S	8 pence.
Wire	Maplin BL92A	28 pence.

If there are problems obtaining any parts, MicroStyle will supply the full kit for £4.50 including postage.

Maplin Electronics, PO Box 3, Rayleigh, Essex SS6 2BR. Tel: 0702 554161.

MicroStyle, 212 Dudley Hill Road, Bradford, Yorkshire BD2 3DF. Tel: 0274 636652.

Tansy - see local Yellow Pages under Electrical Supplies Retailers.

The diagrams are straightforward with just a few points to mention. One is that no 5V power is available from the printer port, so we are powering the flipflop from inside the computer by connecting 5V to pin 15 of the computer printer connector.

This means opening the machine by turning it over, taking out the six screws, turning it back, taking out the two disc drive screws and lifting the top. A wire can then be soldered between pin 27 of the 50-way expansion connector and pin 15 of the 34-way edge connector and the machine closed again. Both pins are on top of the board and are easy to reach.

The data line D7, from Q, goes to the printer on pin 9 of the through connector - marked TC in the layout diagram - but pin 9 from the computer is grounded, so do not connect that pin to the through connector; cut it off after soldering

it to the board. In the same way we do not want the 5V going to the printer, so solder it to the board and cut off the rest of the pin. The board will need to be cut down to allow room for large peripherals on the expansion socket. Leave the through connector until last or soldering wires can be difficult.

In the layout diagram wires on top of the board are solid, those underneath are dotted. The chip and edge connector fit on the top. The half moon shape indicates the notch or dot on the chip. Both through and edge connectors are polarised, so be sure to fit them the correct way round. The capacitor - two short parallel lines - may be placed any way round.

- 1: saves the character and flags on the stack.
 - 2: rotates the accumulator right placing D7 (8th bit) in D6.
 - 3: printer port address into register B.
 - 4: re-set D7 and D5 to 0 leaving D6 intact. When D7 goes out the printer reads it as STROBE. As it is inverted along the way we send a 0 to keep it high.
 - 5: output the accumulator to the printer port. This makes sure that C on the flipflop (D5) is low. If it is not in a low state it certainly cannot go high. High followed by high will not trigger it.
 - 6: set D5 to 1 leaving D6 and D7 intact.
 - 7: output to printer port sending C high and latching D6 in Q. The eighth bit is now latched.
 - 8: bring back the original character and flags from the stack.
 - 9: jump to MC WAIT PRINTER. This is the usual address found in the jumpblock which we have replaced.
- When built, the 8-bit port slides on to the computer printer port and the printer cable attaches to its through connector. Both the 34-way through connector and the 34-way long pin-

edge connector are non-standard parts and cannot be found. We have a solution to the problem. MicroStyle will supply specially-made parts to all who want them.

The machine code is located at &BF10 to &BF1F which is an area of memory not generally used and which will survive a re-set. If strange things occur with the 8-bit port attached it may be that some software also wishes to use that area. If this problem occurs, lowering HIMEM by 16 bytes and locating the code above it would solve it. The Basic program would need to be changed to perform this task and the new start address would need to be poked into &BDF1/2, low byte first.

It will not be long before you wonder what happens if you connect your printer to the

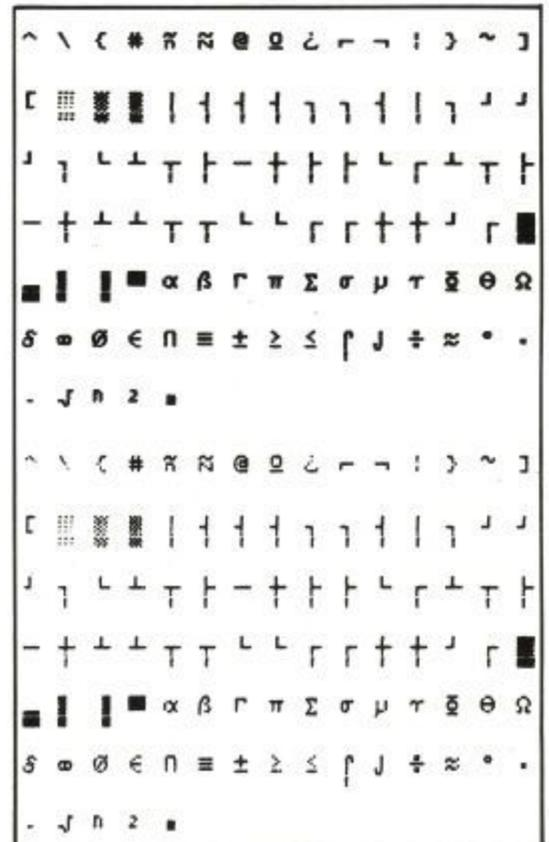

computer, without the port, and 5V is sent down the line. I have specified connecting the 5V to pin 15 and, on all the printers I have checked, including a Citizen, a Sharp and a Samleco, this pin is unused and unconnected. I cannot guarantee it but it seems to be standard, so check your printer pinouts to make sure.

All that is left now is for everybody to dust their soldering irons and to get stuck into the printer's extra characters. We would be interested to receive any clever programs which use the port for printing pictures or whatever. Problems with particular software and solutions would also be welcome.

10 LINERS

This month's
selection was
chosen to relax,
entertain and strain
the old brain box.

PUZZLE BY BJORNAR GRANDALEN

This little mind boggler will keep you occupied for weeks. A four by four grid is drawn on the screen with a shape drawn in it. After hitting a key the shape disappears, only to reappear a short time later jumbled. You must restore the shape to its former dimensions by moving the rows and columns of the grid, achieved by pressing the keys from A to H.

Eight shapes of varying complexity ensure that many hours of lateral thinking will be required before you can say you have conquered the program.

```

1 ok=1:L=1:FOR z=1 TO 8:READ w(z):NEXT:DIM P(143):FOR x=16 TO 143:READ P(x):PRIN
T:NEXT:MODE 1:CALL &BC02:PEN 3:PAPER 0:INK 1,0:INK 2,13:INK 3,26:g$=CHR$(10)+CHR
$(8):INPUT"Board(A-H):",a$:a$=UPPER$(a$):IF a$>"@AND a$<"I" THEN L=ASC(A$)-64:D
ATA 18,17,9,15 [F7]

2 CLS:WINDOW#1,12,28,4,20:PAPER#1,1:CLS#1:WINDOW#1,13,27,5,19:PAPER#1,2:CLS#1:FO
R x=8 TO 19 STEP 4:LOCATE 13,x:PAPER 1:PRINT SPACE$(15):NEXT:FOR x=16 TO 28 STEP
4:FOR y=4 TO 20:LOCATE x,y:PRINT" ":NEXT y,x:t=0:FOR y=1 TO 4:FOR x=1 TO 4:b(y,
x)=P(L*16+t) [74]

3 ENV 1,15,-1,6:t=t+1:NEXT x,y:INK 0,w(L):BORDER w(L):SYMBOL AFTER 32:SYMBOL 48,
0:SYMBOL 49,255,255,255,255,255,255,255:FOR x=13 TO 28 STEP 4:PEN 3:LOCATE x
,3:PRINT"11":NEXT:FOR x=5 TO 20 STEP 4:LOCATE 11,x:PRINT"1":g$;"1":NEXT:PEN#1,3:
DATA 11,6,3,4 [D7]

4 FOR y=1 TO 4:FOR x=1 TO 4:WINDOW#1,9+(4*x),11+(4*x),1+(4*y),3+(4*y):PAPER#1,2:
PRINT#1,BINS(b(y,x),9):NEXT x,y:FOR x=1 TO 4:PEN 2:PAPER 0:LOCATE 9+(x*4),2:PRI
NT CHR$(68+x):LOCATE 10,1+(x*4):PRINT CHR$(69-x):NEXT:DATA . . . .,484,457, . . .,295,79
. . . . [DA]

5 CALL &BB18:INK 3,13:FOR Z=1 TO 10:L*5:c=1+INT(RND*8):PEN 3:GOSUB 6:NEXT:ok=0:I
NK 3,26:SOUND 1,0,60,15,1, .,31:SOUND 2,0,70,12,1, .,9:PAPER 0:SPEED INK 6,6:DATA .8
4,273, .84, . .,273,273, . .,84, .,273,84, .,485,455,455,461,365 [32]

6 a$=UPPER$(INKEY$):IF a$>"@THEN IF ASC(a$)>64 AND ASC(a$)<73 THEN c=ASC(a$)-64:
PEN 3:IF c<5 THEN LOCATE 11,21-(c*4):PRINT CHR$(138):g$;CHR$(138):GOSUB 8:GOSUB
10 ELSE LOCATE 9+((c-4)*4),3:PRINT CHR$(140):CHR$(140):GOSUB 9:GOSUB 10:DATA .,3
65,365, . [F3]

7 IF a$=CHR$(127)THEN RUN ELSE IF ok THEN c=1+INT(RND*8):IF c<5 THEN GOSUB 8:RET
URN ELSE GOSUB 9:RETURN:ELSE IF ok=0 THEN 6:DATA 365,359,455,455,335,84,448,448,
273,292,84,273,73,292,273,84,73,273,7,7,84,273,484,457,84,484,256,64,457,295,4,1
,79 [46]

8 k=5-c:t=b(k,4):b(k,4)=b(k,3):b(k,3)=b(k,2):b(k,2)=b(k,1):b(k,1)=t:FOR h=1 TO 4
:WINDOW#1,9+4*h,11+4*h,1+4*k,3+4*k:PRINT#1,BINS(b(k,h),9):NEXT:LOCATE 11,1+4*k:
PRINT"1":g$;"1":o=RND:RETURN:DATA 84,295,79,273,484,457,26,50,295,79,152,176,9 [
9D]

9 k=c-4:t=b(4,k):b(4,k)=b(3,k):b(3,k)=b(2,k):b(2,k)=b(1,k):b(1,k)=t:FOR h=1 TO 4
:WINDOW#1,9+4*k,11+4*k,1+4*h,3+4*h:PRINT#1,BINS(b(h,k),9):NEXT:LOCATE 9+((c-4)*
4),3:PRINT"11":o=RND:RETURN:DATA 56,56,36,72,56,56,288,1,224,392,4,164,484,457,1
37,290 [51]

10 v=0:u=-1:FOR z=1 TO 4:FOR o=1 TO 4:u=u+1:IF b(z,o)=P((16*L)+u)THEN v=v+1:NEXT
o,z:IF v=16 THEN INK 2,26,13:INK 3,13,26:CALL &BB18:RUN:ELSE RETURN:ELSE RETURN
:DATA 295,79,74,64,35,14,256,485,407,215,461,377,176,152,380,125,50,26,317,359,4
70,467,335 [22]

```

EYE BY D. WOOD

Multi-coloured mania on your Amstrad as the program entertains with a series of colourful starbursts followed by an eye of many colours.

```

10 ON BREAK GOSUB 80 [E5]

20 MODE 0:g=0:i=1:r=0:INK 0,0:INK 1,15:INK 2,11:INK 3,6:INK 4,8:INK 5,18:INK 6,2
4:INK 7,5:INK 8,26:INK 9,19:INK 10,5:INK 11,17:INK 12,7:INK 13,22:INK 14,0:PAPER
0:GRAPHICS PEN i:BORDER 0:GOTO 80 [CC]

30 FOR q=1 TO 15:i=INT(14*RND)+1:x=INT(639*RND):y=INT(400*RND):s=INT(240*RND)+20
:p=INT(15*RND)+1:GRAPHICS PEN i:FOR a=1 TO 360 STEP p:N=INT(800*RND)+30:DEG:PLOT
x,y:DRAW x+s*COS(a),y+s*SIN(a):NEXT a:NEXT q [22]

40 i=0:x=320:y=200:d=190:s=300:FOR c=1 TO 14:t=INT(2*RND)+3:FOR a=1 TO 360 STEP
t:DEG:PLOT x,y:DRAW x+s*COS(a),y+d*SIN(a):NEXT a:d=d-14:s=s-16:i=i+1:GRAPHICS PE
N i:NEXT c [2D]

50 GRAPHICS PEN 0:x=320:y=200:FOR a=1 TO 360 STEP 3:DEG:PLOT x,y:DRAW x+13*COS(a
),y+13*SIN(a):NEXT a [E2]

60 GRAPHICS PEN 8:x=320:y=200:FOR a=1 TO 360 STEP 3:DEG:PLOT x,y:DRAW x+8*COS(a
),y+8*SIN(a):NEXT a [34]

70 FOR waste=1 TO 4000:NEXT:GOTO 30 [85]

80 CLS:GRAPHICS PEN 5:PLOT 1,1:DRAW 639,1:DRAW 639,399:DRAW 1,399:DRAW 1,1:PEN 1
:LOCATE 7,5:PRINT"E Y E":PEN 2:LOCATE 2,12:PRINT"1..run 2..list" [7B]

90 a$=INKEY$:IF a$="1" THEN CLS:RUN 30 [BE]

100 IF a$="2" THEN MODE 1:LIST ELSE 90 [B9]

```

HOT CITY LIGHTS

BY
DAVID HALL

Crank up the stereo to full volume and run this program. Kaleidoscopic patterns pulsate before your eyes at one of 50 speeds.

```
10 CLS:INK 1,14:INK 2,26:PEN 2:PRINT "+++ Welcome to the 'Hot City Lights' +++"
[6F]
20 PEN 1:INPUT "Speed (1-50)":s:IF s>50 OR s<1 THEN 10 [EB]
30 g$=CHR$(203):PEN 0:MODE 1:PAPER 0:INK 0,0:BORDER 0 [99]
40 a=(RND*12)+1:b=(RND*12)+1:m=m+1:c=a [A2]
50 IF m>s THEN m=1:FOR t=1 TO 3:INK t,RND*27:NEXT [C0]
60 PEN RND*4:IF RND*10>1.5 THEN PEN 0 [A6]
70 GOSUB 80:a=b:b=c:GOSUB 80:GOTO 40 [FD]
80 LOCATE 8+a,b:PRINT g$:LOCATE 33-a,b [FB]
90 PRINT g$:LOCATE 8+a,25-b:PRINT g$ [D8]
100 LOCATE 33-a,25-b:PRINT g$:RETURN [81]
```

KILL 'EM
ALL
BY
DAVID HALL

Shoot-'em-up time as you blast the marauding aliens out of the sky. Control moves your ship left, Copy moves your ship right, Space bar shoots, or use joystick. Reach 2,000 points and you have saved the Earth.

```
10 DATA 0000000C0C000000000000C0F0F0C000000040F0F0F00000058F00F0FA40000B53FA5
5A3F7A00047FFF2F1FFFBF28047FF BF280D75FF251AFFBA1E0D1A300F0F30251E0D0F0FCC
CC0F0F1E0D0F4E98CC8D0F1E0D0F4L.....0F1E0D0F4ECCCC8D0F1E0D0F4ECCCC8D0F1E0D0F4ECC
CC8D0F1E040F0F [68]
20 DATA CCCC0F0F28040F0F0F0F0F28000D0F0F0F1E00000D0F0F0F1E0000140F0F0F0F28
0000003C0F0F3C00000000003C3C00000000000458A00000000000CFCF00000000000458A0000
00000045658B8A0000000000458A00000000009ACFCF470000000000458A000000004565CFCF8B8A
00000000458A00 [6A]
30 DATA 0000009ACFCFCFCF4700000000458A0000004565CFCF8B8A000000458A0000009ACF
CFCFCFCFCF47000000458A0000009ACFCFCFCFCF47000000458A000000103030659A30302065CF
CFCFCFCFCF8B65CFCF8B65CFCF8B65CFCF8B65CFCF8B65CFCF8B65CFCF8B65CFCF8B65CFCF8B65CF
00000000000000 [EC]
40 DATA AF325E9C32729C32549C32589C1130752100C006787D127C131213CD26BC10F521A86106
C836002310FBCDEC272124E522409C3E2532429CCDD328CDD3280603C5CD5B28C13A589CFE00200D
10F2CD6E273A729CFE00C018DFCD282818DA3A5E9CFE00203AED5F0601FE403801047832619C3E01
325E9CED5FFE6c [AD]
50 DATA 30FA2130758716005F19EB1A6F131A673A619CFE02200411480019225F9C11204ECD2B29
3A5E9CFE49282E3C325E9C3A619CFE0228132A5F9CCD3E292A5F9C23225F9C11204EC32B292A5F9C
11070019CD3E292A5F9C2B18E732729CAF325E9CC9214A9C060736302310FB3E06CD90BB21160CCD
75BB214A9C0607 [C0]
60 DATA 7ECD5ABB2310F9C921509C06057E80FE3A28037718DA3E30772B7E3CFE3A28F618F1AF32
589C3E0A010000CD32BC3E07CD5ABB0E6406640010FD0D20F8CD0E283E0A010E0ECD32BCAF325E9C
2A5F9C11A861C32E293E4CCD1EBB200F3E2FCD1EBB20083A549CFE00201BC93A549CFE0020133C32
549CAF32579C2A [7F]
70 DATA 409C114D00ED5222559CCDB1282A559CCD29BCAFBE203523BE20312B22559C11804FCDB4
283A579CFE6E381BAF32549C11884F2A559C0604E51A7723131A7713E1CD26BC10F2C93C32579CC9
3C32589C18DA3E4ACD1EBB20323E17CD1EBB202B3E4BCD1EBB200C3E09CD1EBB2005CD252918312A
409C3A429C3CFE [48]
80 DATA 4A282632429C2322409C2BCD3E2918192A409C3A429C3DFE00280E32429C2B22409C1108
0019CD3E2911D04E2A409C0E16E506081A77231310FAE1CD26BC0D20F0C906163600CD26BC10F9C9
:SYMBOL AFTER 32:FOR t=40955 TO 42555:POKE t,PEEK(t) OR PEEK(t)/2:NEXT:PEN 2:INK
0,0:BORDER 0 [C0]
90 1=20000:FOR m=1 TO 3:READ a$:FOR t=1 TO LEN(a$) STEP 2:POKE 1,VAL("&"+MID$(a$,
t,2)):1=1+1:NEXT:NEXT:1=10000:FOR m=1 TO 5:READ a$:FOR t=1 TO LEN(a$) STEP 2:PO
KE 1,VAL("&"+MID$(a$,t,2)):1=1+1:NEXT:NEXT:INK 5,15:INK 15,15,2:INK 14,15,26:SPE
ED INK 9,40 [DF]
100 MODE 0:PEN 5:LOCATE 1,20:PEN 8:PRINT STRINGS(20,244):PEN 2:PRINT " SCORE:--"
:INK 3,3,6:PEN 12:PRINT:PRINT " KILL 'EM ALL":CALL 10000:WHILE INKEY$<>CHR$(1
3):LOCATE 6,10:PEN RND*15:SOUND 1,RND*20,2,15:PRINT "GAME OVER":WEND:GOTO 100 [
FA]
```

ITALICS
BY
DAVID HALL

An italic character set for your CPC.

```
10 SYMBOL AFTER 33 [3E]
20 FOR t=40964 TO 42740 STEP 8 [28]
30 FOR k=t TO t+1:POKE k,PEEK(k)/2:NEXT [15]
40 FOR k=t+5 TO t+7 [65]
50 a=PEEK(k):IF a>127 THEN a=a-128 [9F]
60 POKE k,a*2:NEXT:NEXT [47]
```

UPSIDEDOWN CHARACTERS

BY
DAVID HALL

Drive your friends crazy with this upside-down character set.

```
10 SYMBOL AFTER 33:CLS [86]
20 a$="I'll Turn you upside-down" [EE]
30 PRINT a$:FOR t=40964 TO 42740 STEP 8 [B8]
40 l=t+7:FOR k=t TO t+3 [B2]
50 a=PEEK(k):b=PEEK(l) [10]
60 POKE k,b:POKE l,a:l=l-1 [DA]
70 NEXT:NEXT:PRINT a$ [4A]
```

SNAKE
BY
R. MURPHY

I remember buying this game many years ago and it still manages to get me back to the keyboard. The aim is simple - just guide your snake round the arena eating the pills as you go but beware because colliding with either

the walls or your tail is fatal. There is, of course, a catch to this game and that is your tail. The offending appendage grows with each pill consumed, thus making it more difficult to avoid.

```
10 DI:MODE 1:BORDER 0:INK 0,1:INK 1,26:INK 2,24:INK 3,2:WINDOW#1,1,40,1,3:PAPER#1,3:PEN#1,2:CLS#1:LOCATE 14,14:PRINT"Keys:Z,X,+,:LOCATE 10,18:PRINT"SPACE or FIRE to start":PEN#1,2:PRINT#1,TAB(17);"SNAKX":IF s%>hi% THEN hi%=s% [52]

20 LOCATE#1,1,2:PEN#1,1:PRINT#1,"Score: ";s%;TAB(30);"Hi: ";hi%;WINDOW#0,1,40,4,26:x$="o000":y$=">vVv":dx%=0:dy%=-1:s%=0:fx%=0:fy%=0:ft%=0:k$="*":WHILE k$<>" " AND k$<>"Z" AND k$<>"X":k$=INKEY$:WEND:CLS#0:PEN 1:FRAME:EVERY 50 GOSUB 90:DI [26]

30 a%=LEN(x%):x%=ASC(MID$(x$,1)):y%=ASC(MID$(y$,1)):ox%=ASC(MID$(x$,a%)):oy%=ASC(MID$(y$,a%)):LOCATE ox%,oy%:PRINT " ";:x%=LEFT$(x$,a%-1):y%=LEFT$(y$,a%-1):x%=x%+dx%:y%=y%+dy% [0E]

40 PEN 1:IF x%=0 OR x%=41 OR y%=0 OR y%=23 THEN SOUND 1,999,25,15,,,31:GOTO 10 ELSE x%=CHR$(x%)+x%:y%=CHR$(y%)+y%:LOCATE x%,y%:IF COPYCHR$(#0)=CHR$(202) THEN SOUND 1,999,25,15,,,31:GOTO 10 [A6]

50 PEN 1:PRINT CHR$(202);:IF x%=fx% AND y%=fy% THEN ENT 1,3,5,1,6,-5,1,30,1,1:SO UND 2,100,39,12,,1:FOR f%=1 TO ROUND(ft%/2):x%=x%+RIGHT$(x$,1):y%=y%+RIGHT$(y$,1):NEXT:f%=0:LOCATE#1,15,3:PRINT#1,SPACE$(10);:s%=s%+10*ft% [6A]

60 EI:IF JOY(0)=1 THEN dx%=0:dy%=-1 ELSE IF JOY(0)=2 THEN dx%=0:dy%=1 ELSE IF JOY(0)=4 THEN dx%=-1:dy%=0 ELSE IF JOY(0)=8 THEN dx%=1:dy%=0 [CF]

70 IF INKEY(28)=0 THEN dx%=0:dy%=-1 ELSE IF INKEY(30)=0 THEN dx%=0:dy%=1 ELSE IF INKEY(71)=0 THEN dx%=-1:dy%=0 ELSE IF INKEY(63)=0 THEN dx%=1:dy%=0 [58]

80 DI:ak%=0:LOCATE#1,7,2:PRINT#1,s%,SPACE$(10);:LOCATE#1,15+ft%,3:PRINT#1," ";:IF s%<0 THEN PEN 1:SOUND 1,999,25,15,,,31:GOTO 10 ELSE GOTO 30 [3E]

90 DI:IF ak%=1 THEN RETURN ELSE h%=POS(#0):v%=VPOS(#0):SOUND 4,9,1,9,,,9:IF fx%<1 THEN fx%=2+INT(RND*38):fy%=2+INT(RND*20) ELSE ft%=ft%-1:IF ft%=0 THEN s%=s%-10:LOCATE fx%,fy%:PRINT " ";:LOCATE h%,v%:fx%=0:GOTO 90 ELSE ak%=1:RETURN [F9]

100 LOCATE fx%,fy%:IF COPYCHR$(#0)=CHR$(202) OR (fx%=ox% AND fy%=oy%) THEN fx%=0:GOTO 90 ELSE ft%=10:LOCATE#1,15,3:PRINT#1,STRING$(10,CHR$(143)):PEN 2:PRINT CHR$(231);:PEN 1:LOCATE h%,v%:ak%=1:RETURN [5B]
```

Kenny Dalglish

SOCCER MANAGER

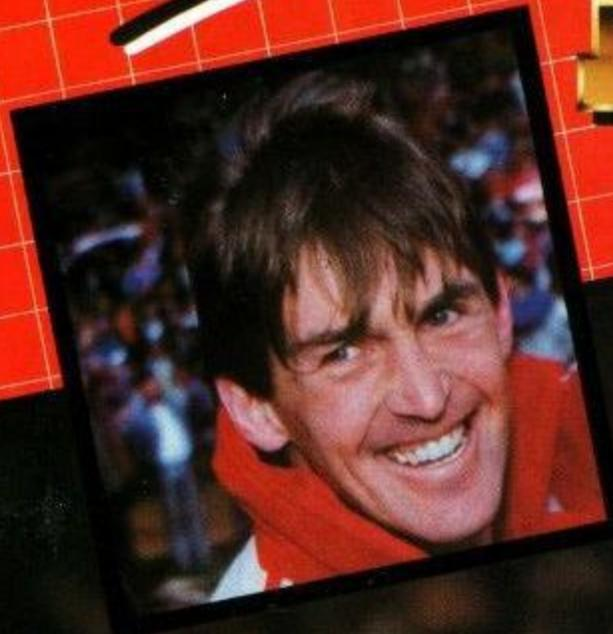

Cognito, the full-priced arm of award-winning outfit Zeppelin Games, brings you the ultimate football manager licence; the most respected chief in the game and the professional's choice - Kenny Dalglish. Kenny Dalglish has brought all the Liverpool discipline and flair of his playing days to the most demanding managerial post in soccer - Liverpool Football Club Manager. Now it is your turn to take on this most prestigious post

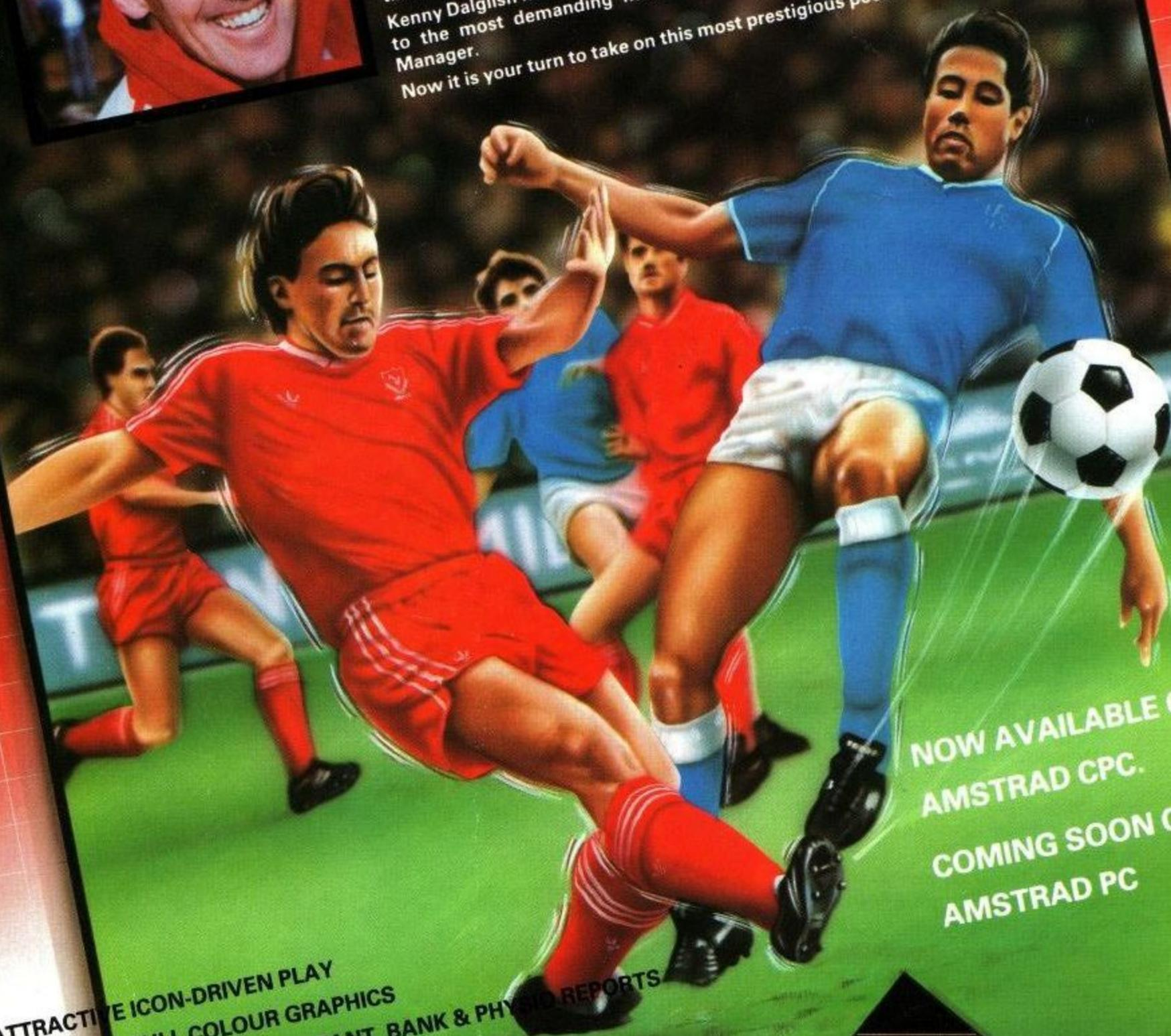

NOW AVAILABLE ON
AMSTRAD CPC.

COMING SOON ON
AMSTRAD PC

- ★ ATTRACTIVE ICON-DRIVEN PLAY
- ★ TOP-NOTCH FULL COLOUR GRAPHICS
- ★ CHAIRMAN, SCOUT, ACCOUNTANT, BANK & PHYSIO REPORTS
- ★ DETAILED GRAPHIC MATCH PLAY HIGHLIGHTS
- ★ FULL F.A. CUP AND LEAGUE CUP COMPETITION

Cognito

Californian dreaming in Langley

Adrian Pumphrey
talks to the guys
and dolls at E.A.
and writes nice
things under threat
of a drive in
Lesley's car.



Many a strange concept has crossed the Atlantic from the sunny shores of California. As a result of the many hours spent under a cruel sun whilst consuming many a variety of drink, who would not be slightly crazy faced with hour upon hour of glorious sunshine.

Despite its outwardly normal appearance the Electronic Arts building holds a few unusual concepts and more than a few unusual people. It is most unsettling to walk into a bustling office to see endless rows of smiling faces, not a stress line between them. That is until they step into the car of public relations person Lesley Mansford. Everything you ever heard about women drivers seems quite



probable when faced by the Bodacia style driving tactics of the ever helpful Lesley.

It all began way back in 1982 when William M. 'Trip' Hawkins convinced financier Don Valentine to part with his money. Hawkins left his job as director of marketing for Apple to set up E.A. because to quote a cliché, he believed in the industry. With a firm belief in the industry he set forth to produce his own brand of interactive fiction. Designed not only to entertain but suspend the belief of the user by transporting them to worlds of fantasy and impossible dreams. Co-founder Tim Mott brought his University management and research skills and was instrumental in developing the E.A. workstation. The third head honcho worked his way up through the ranks and now resides as head of



product development, Mark Lewis. To aid in the creation of these flights of fantasy the humble programmer, the life blood of the industry, is known as a software artist. With this title comes the freedom an artist needs to create

works of wonder. Each software artist uses a modified AT which is supplied by E.A. along with various programming and all important debugging tools. E.A. even has a Creativity division which produces software tools for the software artistes. One such inhouse development tools was Deluxe Paint which turned out to be the first best seller for the company.

In 1987 the company decided it was time to move abroad and it set

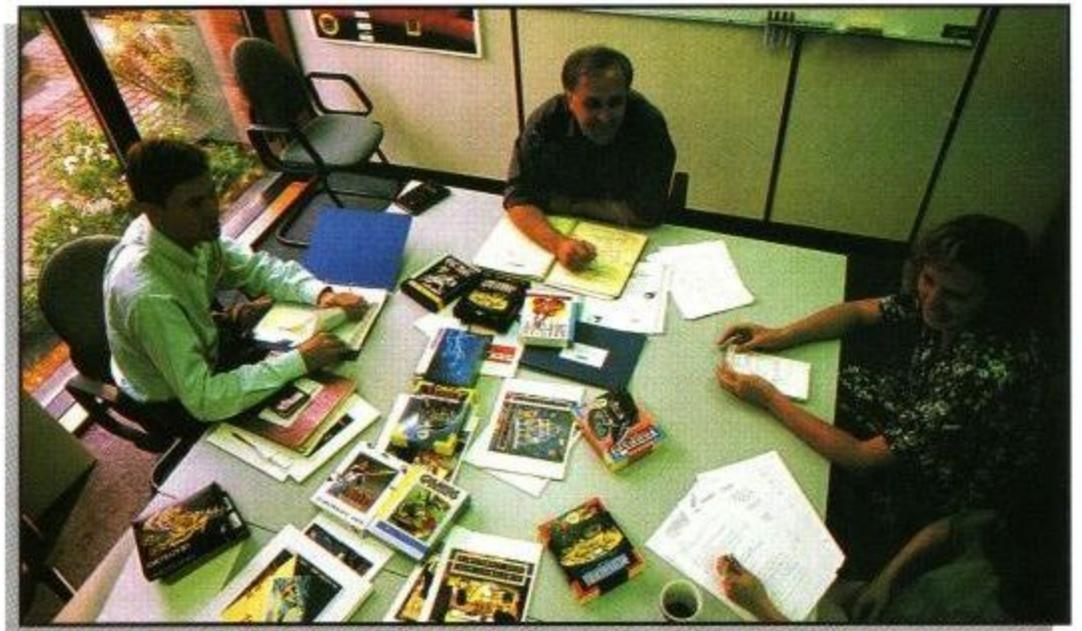

up bases in Australia, Japan and England. Continuing with the expansion plans the company is investing in the technology of tomorrow. CD-I is of great interest to E.A. and the company is developing a working system which will give the user television quality pictures coupled with compact disk quality sound. Past technological breakthroughs include hardware which allowed video and computer graphics to be mixed.

Electronic Arts was created not only to make money and produce great interactive entertainment but to provide an environment the founders wished to work in. To help them create this rarefied atmosphere they have a rather elaborate interviewing system. Eight hours of interviews with not only the employer but the people the prospective worker will be working with. This ensures that everybody gets along with each other and accounts for all those smiling faces which populate the E.A. offices. Employees are actively encouraged to take part in the working of the company and each week they all get together over a few drinks and discuss where they are going and how to get there.

E.A. drew many of its early

management ideas from the record industry. It drew comparisons between the varied tastes and fads of the record sales and applied them successfully to the world of computer games. Another idiosyncrasy of the industry the company had to face was the mercurial nature of the programmers - or as E.A. likes to say software artists. They surmounted many of the problems by creating teams comprised of

artists, programmers and musicians that not only got on well with each other but complemented each others skills. At the moment most of the software being published by the company comes from America but with the formation of the English and other bases new sources are starting to emerge. Due to the development times involved the first English E.A. products are only now hitting the streets.

Initially the company found the emerging technology crude and incapable of fulfilling the dream of true interactive entertainment. With the advent of the 16-bit machine the dream took a bold step forward.

The month the company was formed a report was published which named one hundred and thirty five software publishing companies. E.A. thinks of itself as the hundred and thirty sixth company. From this relatively late start the company now see itself as the world leader as far as sales and profitability is concerned.

I think Lesley was not too happy about my comments about her driving and as I race for the train I can see her standing there with the car door open saying, "would you like a lift to the station," like a Siren inviting sailors to a watery grave.

K & M COMPUTERS

THE LEADING AMSTRAD MAIL ORDER SPECIALISTS

★ NEW LOWER PRICES ★

ADVENTURES	Cass	Disc
Time and Magik	£11.25	£11.25
Gnome II: Ingrid's Back	£11.25	£14.75
Lancelot	£11.25	£11.25
Jinxter (6128)	£14.75	£14.75
Corruption (6128)	£14.75	
Return to Doom	£12.50	
Not a Penny More	£11.25	£14.75
Mindfighter	£11.25	£14.75

COMPILATIONS	Cass	Disc
The In Crowd	£11.25	
History In The Making	£15.95	£21.50
Taito Coin-op (Inc. Rastan)	£9.90	
Supreme Challenge (Inc. Elite)	£9.90	£13.10
Gold Silver & Bronze	£11.25	£21.50
Giants	£10.50	£15.95
Flight Ace	£11.25	£13.95
Arcade Muscle	£10.50	£Phone
Command Performance	£7.75	£15.95
Frank Bruno Big Box	£9.90	£13.10
We Are The Champions	£7.75	£13.10
Fists N Throttles	£9.90	£13.10
Supreme Challenge (Inc. Elite)	£9.90	£13.10
Computer Hits 5	£9.90	£13.10
Game Set & Match II	£9.90	£13.10
Space Age	£10.50	£11.25

STRATEGY/SIMULATION	Cass	Disc
Football Manager II	£7.75	£11.25
Football manager II Expansion Kit	£6.25	
Football Director II	£14.75	
Gunship	£11.25	£14.75
Ancient Battles	£11.25	
Microrpose Soccer	£11.25	£14.75
Times of Lore	£7.75	£11.25
Chuck Yeagers Ad. Trainer	£7.75	£11.25
3D Pool N	£7.75	£11.25
Bards Tale	£7.75	£11.25
Question of Sport	£11.25	£14.75
Football Director (464)	£7.75	
Roy of The Rovers	£7.75	£11.25
Risk N	£7.75	£11.25
War in Middle Earth	£7.75	£11.25
Heroes of The Lance	£7.75	£15.90
Airborne Ranger	£11.25	£14.75
Trivial Pursuit (New Edition)	£11.25	£14.75
P.H.M. Pegasus	£7.75	£11.25
Track-suit Manager N	£7.75	£11.25
Laser Squad N	£7.75	£11.25
4 Soccer Simulator	£7.75	£11.25
Archon Collection	£7.75	£11.25
Classic Games 4	£7.75	£11.25
Night Raider	£7.75	£11.25

EDUCATIONAL	Cass	Disc
Answer Back Jnr	£7.95	£11.95
Factfile 500s	£3.75	£6.75
Fun School (US 5-8, 8-12)	£5.0	£7.95
Maxi Maths (Geometry)	£8.50	£13.95
The Three Bears (6128)	£15.95	
Giant Killer (9-14)	£12.95	
Magic Maths (4-8)	£8.50	£12.95
Maths Mania (8-12)	£8.50	£12.95
Chemistry GCSE	£11.90	£14.95
Physics GCSE	£11.90	£14.95
Biology I (12-16)	£8.50	£12.95
Wordhang	£7.50	£11.95
Happy Writing	£7.50	£11.95
Physics I (12-16)	£8.50	£13.95
Mapwork Geography Quiz	£8.50	£13.95
Spanish Tutor	£12.95	£15.95
French Mistress	£12.95	£15.95
Italian Tutor	£12.95	£15.95
Iankey Crash Course (6128/PCW)	£19.90	
Iankey Two Finger (6128/PCW)	£19.90	
Fun School 2 (US 5, 6-8, 8+)	£7.99	£9.99

ARCADE	Cass	Disc
Operation Wolf	£7.75	£11.25
All New Ghostbusters	£8.99	£12.25
Run The Gauntlet	£7.75	£11.25
Double Dragon N	£7.75	£11.25
Pacland	£7.75	£11.25
H.K.M.	£7.75	£11.25
Robocop	£7.75	£11.25
Rambo 3	£7.75	£11.25
StormLord N	£7.75	£11.25
4x4 Off Road Racing	£7.75	£11.25
Dark Fusion	£7.75	£11.25
Road Blasters	£7.75	£11.25
Barbarian II	£7.75	£11.25
Game Over II	£7.75	£11.25
Total Eclipse	£7.75	£11.25
Crazy Cars II	£7.75	£11.25
1943 (Midway)	£7.75	£11.25
Afterburner	£7.75	£11.25
The Train	£7.75	£11.25
Munsters	£7.75	£11.25
WEC Le Mans	£7.75	£11.25
Led Storm	£7.75	£11.25
Vindicators	£7.75	
Wanderer 3D	£7.75	£11.25
Purple Satin Day	£7.75	£11.25
Operation Neptune N	£7.75	£11.25
Victory Road	£7.75	£11.25
Blasteroids	£7.75	£11.25
Batman (New)	£7.75	£11.25
Dragon Ninja	£7.75	£11.25
Superman	£7.75	£11.25
Captain Blood	£7.75	£11.25
Inc. Shrinking Sphere	£7.75	£11.25
Butcher Hill	£7.75	£11.25
Titan (Special Price)	£6.99	£10.25
Renegade III	£7.75	£11.25
Spitting Image	£7.75	£11.25
Dynamic Duo	£7.75	£11.25

BUDGET	Cass only
Spy Hunter	£2.75
Battleships	£1.80
Quest/Golden Eggcup	£1.80
Split Personalities	£1.80
Frank Bruno Boxing	£1.80
International Speedway	£1.80
Trantor	£2.75
Turbo Esprit	£1.80
BMX Simulator II	£2.75
Fairlight	£1.80
Video Classics	£1.80
Formula Grad Prix	£1.80
A.T.V. Simulator	£2.75
Peter Pack Rat	£1.80
Scuba Kidz	£1.80
Elevator Action	£1.80
Ace II	£2.75
Bombjack	£1.80
Twin Turbo VB	£2.75
Shockway Rider	£2.75
B.M.X. Freestyle	£2.75
Beach Buggy Sim	£1.80
Kickstart II	£1.80
Rocky Horror Show	£1.80
Turbo Boat Sim	£1.80
Jockey Wilson Darts	£2.75
Glider Rider	£1.80
Skateboard Kidz	£1.80
Treasure Island Dizzy	£2.75
FastFood	£2.75
Adv. Pinball Sim	£2.75
Graham Gooch Cricket	£1.80
Slug	£1.80
Blackbeard	£2.75

464 UPGRADE ROM
NOW AVAILABLE
ONLY £16.99 FROM US

SPECIAL PRICES ON A.M.S. SOFTWARE	
Stop Press	£39.95
Stop Press & Mouse	£72.95
Mouse & Art	£61.95
Mouse Mats	£4.95
Max	£16.95
Extra Extra	£21.95

KDS ELECTRONICS SPECIAL OFFERS	
Rombox	£24.95
5 1/2" Second Drive	£158.95
8 Bit Pr. Port	£18.75
Serial Int. + Rom	£44.95
Printer T Switch	£24.95
Screen Master	£14.95
Ramdos (disc)	£23.95
Romdos (Rom)	£27.95

MINI OFFICE II
STILL OUR No1 SELLER
Cass, £11.25 Disc \$14.75

AMSOFT/MAXELL 3" DISCS	
One	£2.50
Five	£12.50
Ten	£24.95
5 1/2" DISCS TEN	£3.90
3 1/2" DISCS TEN	£9.50

ROMANTIC ROBOT QUALITY PRODUCTS AT DISCONT PRICES	
Insider	£13.95
Multiface II +	£44.95
Rodos (on rom)	£25.95
Rodos extra	£8.75

ALL OUR PRICES
INCLUDE VAT + P&P
NOTHING EXTRA TO PAY
IN STOCK ITEMS SENT
BY RETURN OF POST
NO MINIMUM ORDER

SPECIAL OFFER
ORDER ANY FIVE
£1.80 BUDGET GAMES
AND PAY ONLY £8

ACCESSORIES	
Rombox Rombox	£34.95
464 Keyboard Ext. Leads	£6.99
6128 Keyboard Ext. Leads	£7.99
Cover Set 464 or 6128	£7.50
Cover Set DMP 2000/2160	£4.50
6128 Cassette Leads	£3.50
Lockable 3" Disc Boxes	£9.99
3" Disc Cabinet (Holds 10)	£5.95

JOYSTICKS	
Amstrad JY2	£13.95
Cheetah Starfighter	£13.95
Konix Navigator	£13.95
Gunshot	£5.75
Delta (Microswitch)	£9.50
Cheetah 125+	£7.95
Supercharger	£12.95
Cheetah Challenger	£4.75
Konix Autofire	£13.95
Konix Speedking	£9.99
Cruiser (Microswitch)	£9.50

BUSINESS/UTILITIES	Disc
Mastercalc 128	£27.95
Qualitas+	£12.99
Masterfile III	£32.95
Plan-it	£14.75
Professional Adv. Writer	£24.95
Tasspell	£13.95
Poke Easy Plus	£9.99 £14.99
Protext	£20.95
Prospell	£20.95
Promerge	£20.95
Protext Filer	£22.95
Protext CPM (Spell & Merge)	£50.95
Tasword 6128	£20.95
Personal Banking System	£23.95
Protext (on rom)	£32.50
Promerge + (on rom)	£29.95
Prospell (on rom)	£29.95

HARDWARE ETC	
2160 Printer	£159.95
DD1 Disc Drive	£159.95
MP2 Modulators (Phone)	£29.95
FD1 Second Drive	£99.95
64k Memory Expansion	£47.95
Screen Filter	£19.99
Surge Plugs	£12.50
Continuous Paper 2000	£16.50
Dk'T Colour TV Tuner	£72.95
464 Speech Synthesiser	£29.95
6128 Speech Synthesiser	£35.95
CIS Cassettes	45
Fanfold Labels (1000)	£5.90
CPM+ (Disc) Phone	£18.95
CPC6128 Manual	£14.95
Printer Cable	£8.99

NEW LINES AT LOWEST PRICES	
Atari St Super Pack	£360.00
Amiga A500 Inc. Mod.	£370.00
PCW8256 (Inc. VAT)	£389.00
PCW8512 (Inc. VAT)	£499.00
PCW9512 (Inc. VAT)	£510.00
PPC512 (Inc. VAT)	£449.00
PC1512 (Inc. VAT) from	£449.00
PC1640 (Inc. VAT) from	£550.00
PC2086 (Inc. VAT) from	£675.00
Utax Grp. 3 Fax (Inc. VAT)	£999.00
DMP4000 Printer	£375.00
DMP3520 Printer	£220.95
LQ3500 Printer	£375.00
Epson LX600 Printer	£299.00
Commodore PCI from	£349.00
80 C. Printer Muffler	£85.00

PLEASE NOTE OUR NEW ADDRESS
DUE TO THE GROWTH OF OUR BUSINESS WE HAVE HAD TO MOVE TO
MUCH LARGER PREMISES. SHOP OPEN 9 TILL 6 MON-SAT
WE CATER FOR MOST COMPUTERS, HUGE DISCOUNTS ON ALL PRODUCTS

DMP 2000/2160/3000 RIBBONS	
£3.99	EACH
£6.99	FOR TWO
£15.50	FOR FIVE

PCW OWNERS
WRITE OR PHONE FOR
NEW CATALOGUE
PC2000 SOFTWARE AVAILABLE
PRICES IN THIS ADVERT
ARE FOR AMSTRAD 464/6128

K & M COMPUTERS (CPC),
140, SANDY LANE CENTRE,
SKELMERSDALE,
LANCS, WN8 8LH
24 HRS PHONE 0695 29046

50p VOUCHER SENT WITH EVERY ORDER
WHEN ORDERING PLEASE STATE MAKE OF COMPUTER,
PLEASE MAKE CHEQUES & P.O. PAYABLE TO K & M COMPUTERS
OVERSEAS INC. EIRE ADD £1 PER ITEM OF SOFTWARE
WE SUPPLY GOVERNMENT & EDUCATIONAL ESTABLISHMENTS

ACCESS ORDERS BY PHONE OR MAIL
N = NEW RELEASE
PLEASE PHONE FOR AVAILABILITY
AND OTHER NEW RELEASES



This month's selection of games covers everything from the born-again craze of skateboarding with *Skate or Die* to the dark side of the future with the *Paranoia Complex*. For the trigger-happy there is WWII action *1942* and for the more genteel readers the aptly-named bat-and-ball game *Batty*.

GAMEPLAN



TIME SCANNER

All the world is a pinball machine and you are the guy who will tilt those features.



NAVY MOVES

Battle your way through hostile seas to encounter the enemy bases where the bad guys are dying to meet you.



SKATE OR DIE

Challenge Lester to a duel of a lifetime; as the boards clash you know it is do-or-die time.

PLUS

Blade Warrior, Total Eclipse II, Tank Attack, Bomb Jack II.

1	(NE)	Fast Food Code Masters
2	(1)	Robocop Ocean
3	(13)	Twin Turbo V8 Code Masters
4	(2)	Treasure Island Dizzy Code Masters
5	(RE)	Turbo Esprit Encore
6	(NE)	Spy Hunter Kixx
7	(7)	Dragon Ninja Ocean
8	(NE)	Shanghai Warriors Players
9	(5)	Fun School 2 Database/Mandarin
10	(3)	SAS Combat Code Masters
11	(10)	Joe Blade 2 Players
12	(NE)	Run The Gauntlet Ocean
13	(6)	After Burner Activision
14	(NE)	Arcade Muscle US Gold
15	(12)	Operation Wolf Ocean
16	(NE)	720 Kixx
17	(NE)	BMX Simulator 2 Code Masters
18	(NE)	Crazy Cars 2 Code Masters
19	(8)	WEC Le Mans Imagine
20	(4)	Big Foot Code Masters

Last week's position in brackets
Top 20 compiled by Gallup



anniversary of the death of Helyfre and the villagers know how to end the mindless havoc. You are the *Blade Warrior*, a ruthless fighter dedicated to freeing the people of Loxton.

It is predicted that at the stroke of 12 the demon will unleash a torrent of destruction on the land. The time is 23:50 and you have just 10 minutes to

find the skull which has become lost and re-unite it with the skeleton of the evil squire.

Blade Warrior is a typical budget release. It incorporates fair graphics, boring animation sequences, rough sound effects and bugs. A bug would seem to be an undocumented game feature these days. What with certain arcade conversions not working properly, some games slip through the rigorous testing of the Darling clan.

The game is of the platform type and is particularly boring to play. A simple plot – find a skull and stick it on the body when you find it.

There is little more one can say about a game which is so much like any other. The graphics are reasonable, the sound is satisfactory. It plays like a budget game – badly – and, for the money it is not a worthwhile investment. It is best to save your coppers and buy a full-price game for fuller enjoyment.

On a final note, Blade Warrior is so clever with a sword that he does not use it – he just avoids those dangerous objects.

Andrew Banner

The history books state that in the year 1479 a squire by the name of Helyfre dominated the small village of Loxton. His domination was evil and through the years he had performed numerous dark deeds, disrupting the villagers and causing horrid deaths.

The people had had enough of Helyfre and in the dead of

BLADE WARRIOR

Not so much cut and thrust, more leap and bound.

watched the crowd of jeering revolutionists. Finally they left the scene taking the head with them. He watched and waited until the charred remains of his master had cooled. He gathered them and stole back to a secret chamber where the body was laid to rest, still decapitated, but the servant was unable to find the head of his master. There

was much left to do. The body was lifeless but the spirit and soul lived on to cause havoc among the unsuspecting villagers.

Loxton was still very much under the watchful eye of Helyfre who, in death, had become the Death Demon. Evil

deeds were still being done 199 years later and the villagers were once more on the rampage, vowing to destroy the demon once and for all.

It is the eve of 200th



night they invaded his castle. There was to be no nonsense. They dragged him out of bed, cut off his head swiftly and proceeded to burn the headless body.

The once-peaceful Loxton people had turned savage and overthrew their dictator. During their glee at being free they forgot one small thing, Helyfre's faithful man servant but, after all, what could he do?

Plenty. This loyal subject

ROUND-UP	
NAME	Blade Warrior
SUPPLIER	Code Masters
PRICE	£2.99
GRAFFIX	
SONIX	
PLAYABILITY	
OVERALL	
<p>▀ A simple plot – find a skull and stick it on the body when you find it. ▀</p>	

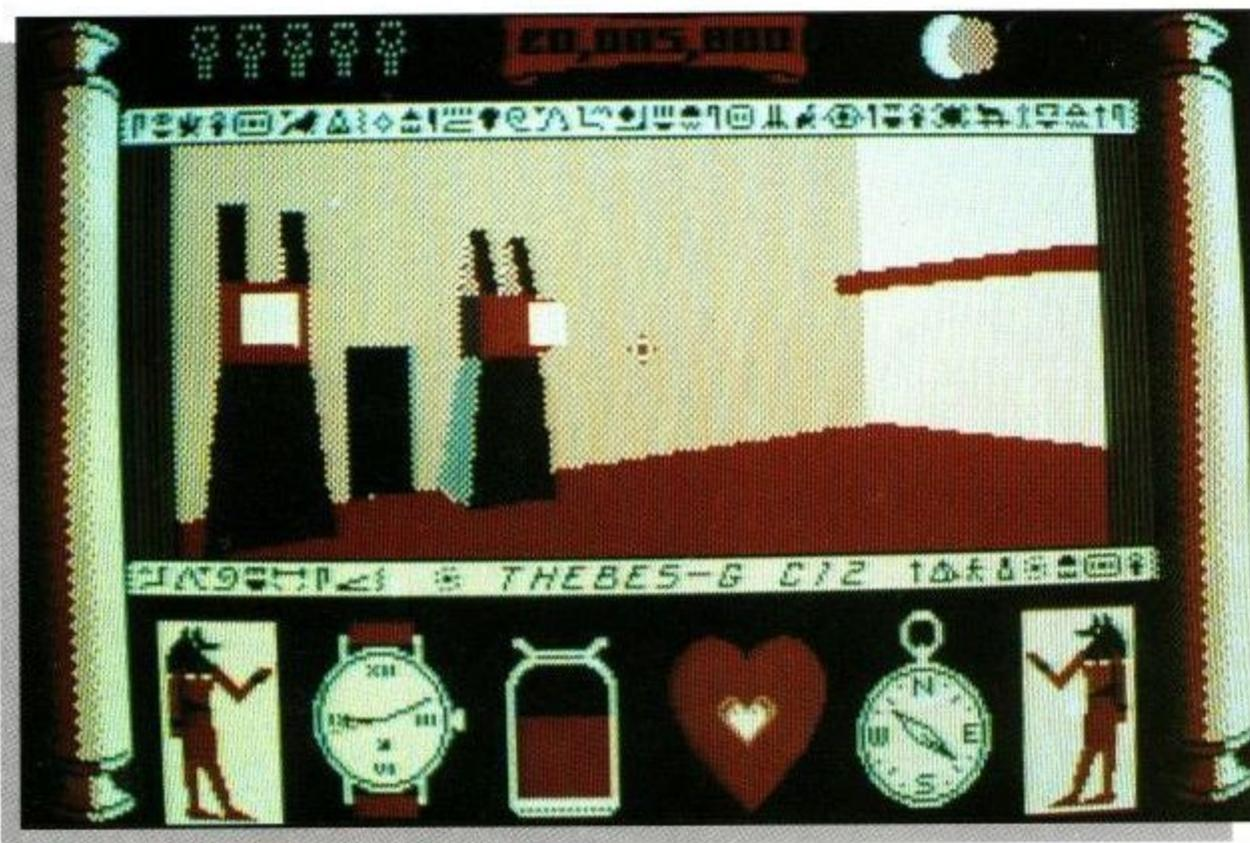

its former greatness before the next solar eclipse – in just one hour.

Playing Total Eclipse II is not exactly fun-packed. The graphics are jerky and somewhat slow but do not be deterred. The game may not be the fastest thing since Ben Johnson but it provides the adventurer with a hell of a challenge.

Once inside the maze of tunnels you will find yourself lost and in need of liquid refreshment. Water troughs can be found attached to some of the walls but they are few and far between. It is advisable to make a map of your route so far and to note where water can be found.

Inside there are many raised catwalks. Some are barred but most are open and falling off is simple. If you fall off you will black out for a short time. Some falls are fatal, so keep them to a minimum. As you wander

through the complex you will be informed if there is a piece of Sphinx in the room. Walk over to it and you will pick it up.

Many of the doors in the complex are blocked, some by bars, others by debris situated in front. Debris is removed easily – just blast it. Bared doors are not so easy to open and you will need to think about them.

Total Eclipse II is a great game for those with plenty of time on their hands. It is certainly one for adventure fanatics but if you like a mental challenge you should look seriously at this game.

Andrew Banner

Total Eclipse II

Go head-to-head with the curse of the ancients.

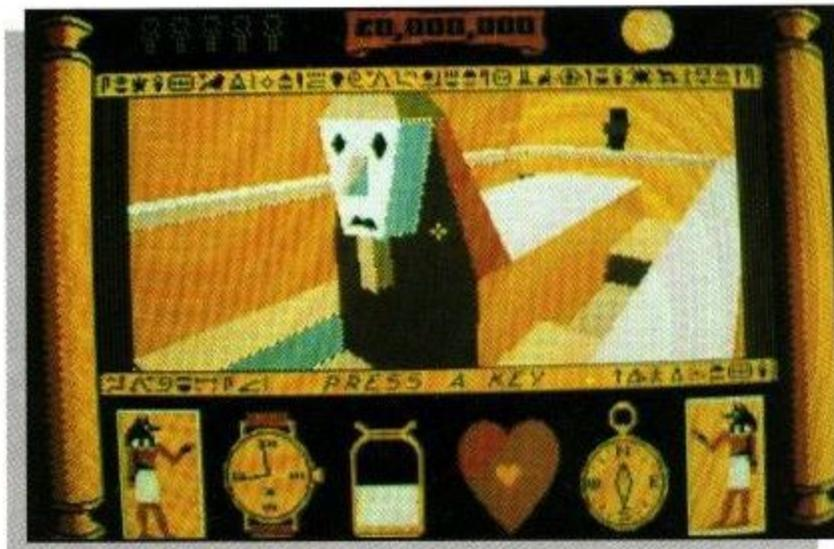

planets of which the earth is one.

You land your clapped-out Sopwith Camel biplane beside the huge structure. Your task is to infiltrate the pyramid and destroy the top chamber before the sun is blocked. Not an easy task but, nevertheless, one you may have done previously, *Total Eclipse II* asks you to return to Egypt and rebuild a mighty Sphinx which was destroyed in the revolution many hundreds of years ago.

Like its predecessor, Total Eclipse II used the award-winning Freescape 3D graphics technique and good it is, too.

The pieces of the Sphinx can be found littered in various subterranean caverns and rooms. You cannot just hang around as you must find and restore the sandstone statue to

Long ago in the mystical ages of ancient Egypt the people were revolting. The High Priest had become angry with his flock who were refusing to continue the sacrifices to the God of the Sun, Re. So great was his anger that he cracked and cast an evil spell over the people.

A shrine was erected in praise of the Sun God. The shrine was in the form of a huge pyramid, with a large chamber atop. The top chamber is cursed. If anything prevents the rays of the

sun reaching the chamber during daylight hours the offending object will be turned to dust.

Today is October 26, 1930 and in just two hours there will be a total solar eclipse. The

moon will cover the sun completely and blacken the earth. The moon will be but a memory, the explosion causing the destruction of not only the moon but the surrounding

ROUND-UP			
NAME	Total Eclipse II		
SUPPLIER	Incentive	PRICE	£11.20
GRAFFIX			
SONIX			
PLAYABILITY			
OVERALL			
Total Eclipse II uses the award winning Freescape 3D graphics technique and good it is too.			

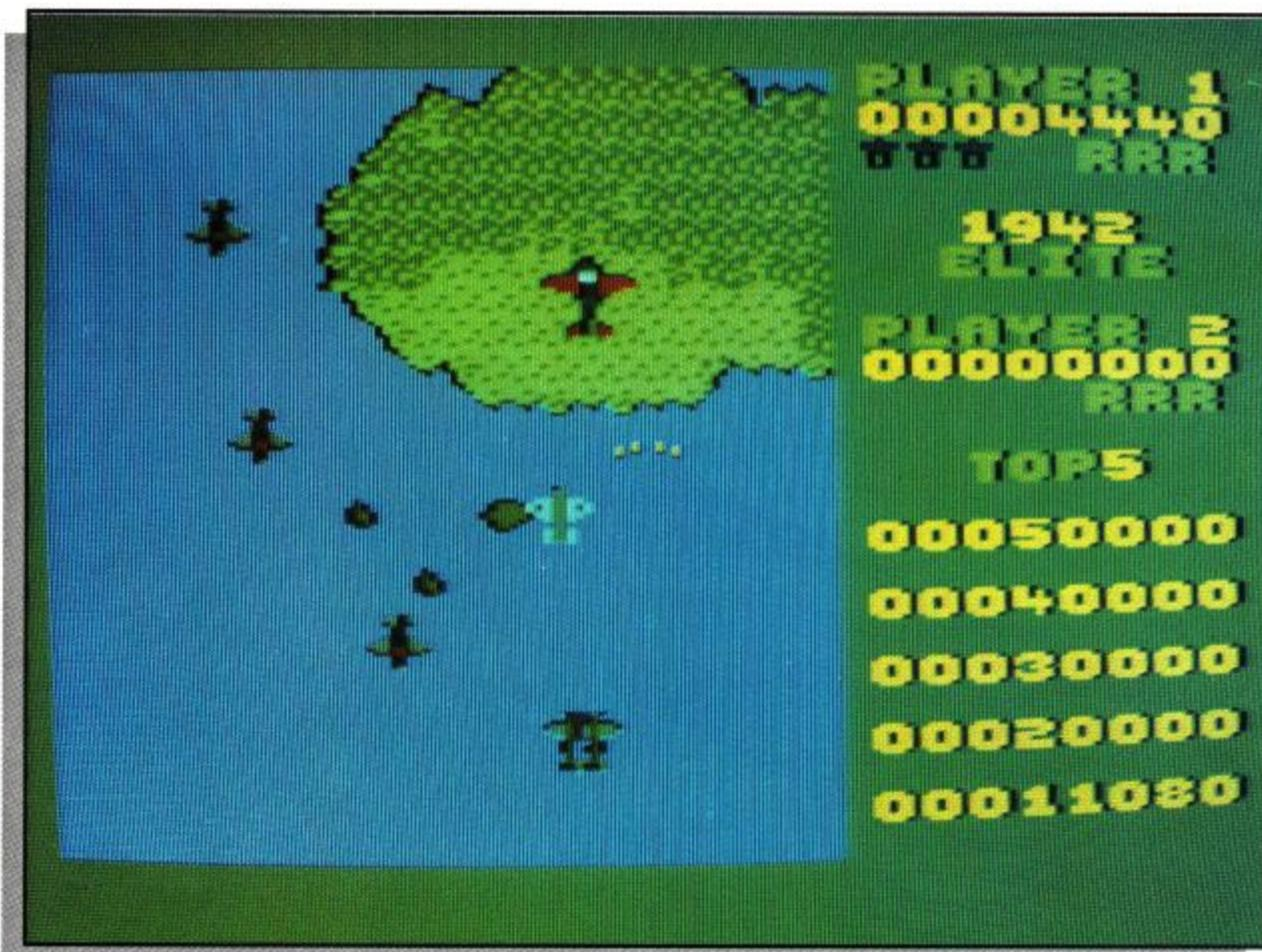

1942

A flight of fantasy as you soar through the skies twin cannons blazing.

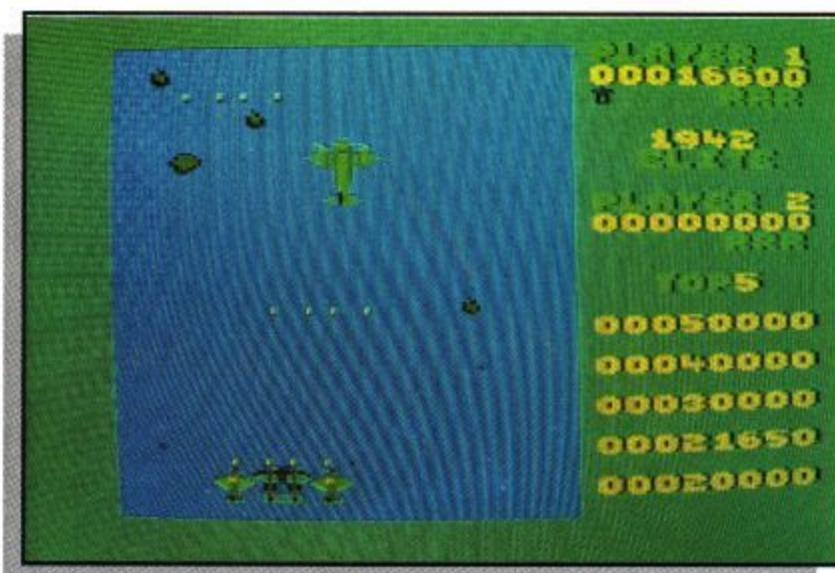

The war is drawing to a close and you are on the losing side. It looks as if it is suicide mission time again; as a one-man fighter just might be able to penetrate the enemy defences and strike a telling blow for freedom and righteousness.

This is not *Star Wars*, although with a plot like that it could be. This is World War II,

and based roughly on the Battle of Midway. Very roughly, I would say.

The objective is simple, which is why the Spectrum version sold

well. It consists of flying your fighter aircraft over land, sea and islands, in 32 stages of frantic action against enemy

fighters, bombers and superbombers. Obviously I am mistaken because I did not know there was a Japanese equivalent of the Flying Fortress.

What all this has to do with Midway is a matter of conjecture and inlay writers' hyperbole. What game is based on is the arcade game called *1942* from a few years ago.

The first point to note is that the screen scrolls vertically but

that it has been reduced in size and still is not particularly smooth. It is not so lumpy as you might get on a Spectrum, so there is at least that consolation and you have multi-colour graphics for a change.

That is the good side; now for

the bad news. The music on the title page is atrocious. It is supposed to be 767 Squadron but has been mangled virtually out of all recognition. The sound effects in the game are not much better either. Plinks and pings are the best description, though a needle falling on to a baking tray produces a similar result. I wonder if it was sampled?

Your fairly small fighter moves fairly sluggishly about the screen as the enemy fighters crawl

towards you. I pity them because someone obviously forgot to put some ammunition in their guns. You are not fired on until the big boys arrive. The sprite detection here is no great shakes, either.

If you shoot a particular enemy or collection of them a mysterious POW symbol appears. When you run into one of them an equally mysterious transformation occurs to your aircraft. Sometimes you can just fire faster; at other times you find extra aircraft stuck on to your wingtips, providing extra firepower that way. It makes you a good target, though, and when the Flying Fortresses arrive they can scarcely miss you.

What is wrong with *1942* is that the sprites are too small, the playing area is too small, the colours are poorly thought-out, the sound effects are probably the worst I have heard in any CPC game and, worst of all, it is boring to play.

Mark Ulyatt

ROUND-UP	
NAME	1942
SUPPLIER	Elite Systems
PRICE	£2.95
GRAFFIX	
SONIX	
PLAYABILITY	
OVERALL	
<p>▀ This is not <i>Star Wars</i>, although with a plot like that it could be. ▀</p>	

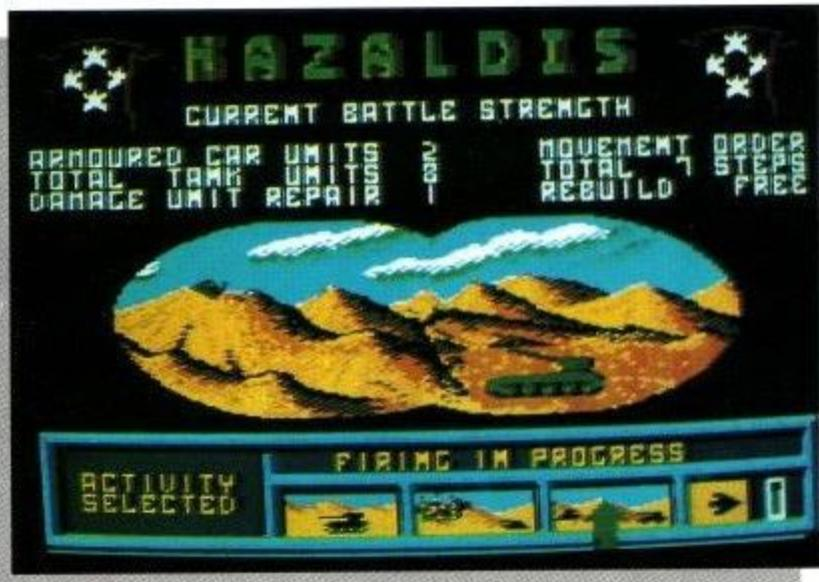

The heavy trundle of big league armour shook me to my boots; fear gnawed ceaselessly at my soul as the division drew closer still. I could see the eyes of the leading driver, see the smug look of satisfaction on the commander's face as he raised his arm and the force spread out. Where were our tanks? They had left the depot completely unguarded. I shouted to the radio operator to try them again – one last, desperate try.

Behind a hill 500 yards away the Armanian tank commander watched the Sarapan tanks spread out in front of the depot. Regret was plainly visible on his face as he watched the enemy open fire and the depot HQ disappeared in a shattering series of explosions. Fire, debris and smoke mingled as the tanks rolled forward and the people in the depot started to die.

He ran back to his own force – a smaller force – vaulted up to the scarred turret and signalled for the last desperate act of the war to begin. With the Sarapan forces enjoying the destruction of the helpless depot, he hoped to catch them unaware and make them pay for the lives they were taking so casually.

Anyone who has an appreciation of board games, wargaming, computer strategy games or great warfare films like the *Battle of the Bulge* should enjoy this lightweight combined computer/board wargame from CDS.

CDS also produced a previous uneasy marriage of formats in *Brian Clough's Football Fortunes*. Having seen the

TANK ATTACK

A computerised umpire who deals the deadly blows with sound and graphics.



cheap production standards in that package I was pleasantly surprised to see that this time you get a heavy laminated folding card board, 48 plastic playing pieces and a comprehensive rule book.

Tank Attack is a board game with computer moderation of conflict situations, for two to four players. It is a pity there is not a one-player version.

Taking the role of General of a tank corps, consisting of eight tanks and four armoured cars, the objective is to capture the

enemy headquarters or destroy all their forces. Everyone in the game need not be your enemy; alliances are possible and with the sharing of rebuilding and repair depots is possible.

Initially all pieces need to be deployed on the board in such a position that the other commanders cannot see the markings on their backs, as that is where their firepower strength is indicated.

Then it is movement time, with the computer issuing the number of movement points which depend on weather,

morale and a random factor for laughs.

Spotted an enemy unit? Good, then blast away. Each unit may fire only once and an enemy unit may not be subjected to fire from more than one unit. This seemed a little artificial and it is. Check the advanced rules section for elaboration on the basics and multiple firing.

There is some measure of data entry into the computer at that point but it does not take very long once you are familiar with the process and then you can watch the animated computer display of the conflict.

At the start of each day the newspaper, War News, is distributed free to all generals. It gives battle activities, strengths of the combatants, political news which affects morale and the weather forecast. Pay close attention to all this as it gives some clue to the day's movement point allowance and other battlefield information. As with all newspapers, though, there can be propaganda and bias, so take some things with a pinch of salt.

Tank Attack certainly works much better than the previous CDS offering and is an interesting marriage of two dissimilar formats. The computer presentation is first-class, with colourful graphics and animated sequences and combines well with the generally high-quality board game elements.

The game is not particularly difficult to play, yet offers all aficionados of the *Battle of the Bulge* a chance to take control of a tank corps, without all that noise.

Mark Ulyatt

ROUND-UP	
NAME	Tank Attack
SUPPLIER	CDS
PRICE	£12.99/£14.99
GRAFFIX	
SONIX	
PLAYABILITY	
OVERALL	
<p>Regret was plainly visible on his face as he watched the enemy open fire and the depot HQ disappear.</p>	

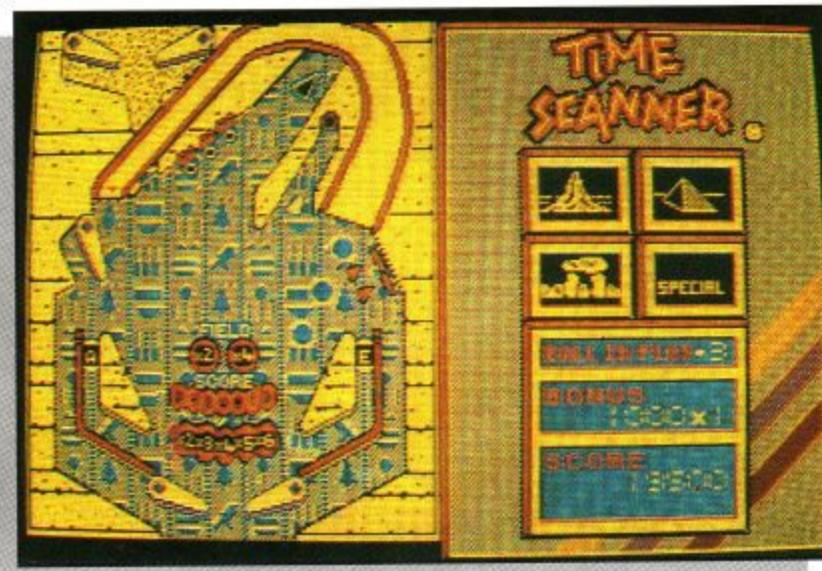
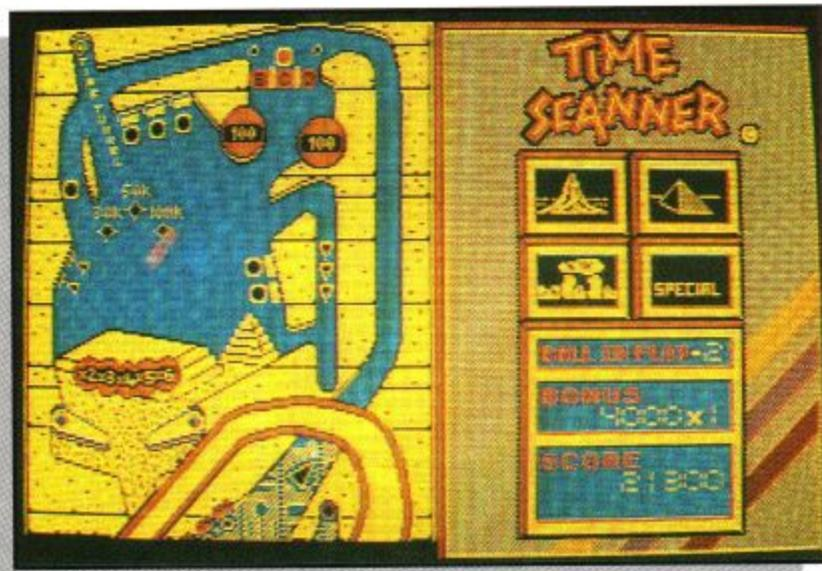

Time Scanner

The greatest challenge in the galaxy, an Earth size pinball machine.

From across the universe they came. Ancient Earth melodies shattered the calm as the fleet came even closer. The leader reached for the intergalactic communication device and screamed at the top of his lungs, "I'm a Pinball Wizard and I've come to play *Time Scanner*."

"The Who have a lot to answer for" mumbled a man on the street corner as the time

zones went crazy and the big silver ball started its epic journey across the biggest pinball table in the universe, the Earth. The journey begins near the site of an extinct volcano. This Hawaiian nightmare must be brought to life by lighting the letters which spell the word before you can move to the second of the four levels.

Like the other levels, the playing area is split into two

halves. You start on the top half, which is a table in its own right. Depending on the level, the top or bottom half of the table is used for collecting a few bonus points and the other for completing the task which will take you to the next level.

On level one the top half is used for bonus points. There are two ways for the ball to work its way to the lower level. One is through the ever-present gap between the centre flippers and the other down one of the two side shoots which are initially protected by knock-down shields.

When the ball passes from the domain of the top section to that of the lower there is a slight pause as the program page flips between the two halves and the

ball which was at the bottom of the top screen now appears at the top of the bottom screen. It is possible, by accurate shooting, to get the ball back on to the top level but when playing the volcano scene this is not necessary, as your task is in the lower section. To light the letters of the word "volcano" you must fire your ball up a central tube whose entrance is protected by knock-down tabs. Your five balls with which to complete this task can be lost, either through the flippers or down the two narrow tracks at the side of the screen. If you are fast enough you can use the three tilt directions – left, right and up – to deflect the ball from those hazardous areas.

Lighting the word results in a volcanic eruption, a dramatic darkening of the screen and the multi-ball option coming into play. Three balls blast round the screen for as long as you can keep them there, collecting those precious points. Three balls are slower than one but not so slow that you can relax your guard.

The time waves ripple and you find yourself in the ruins of a once great city. On this level the task is simple; all you have to do is drop three balls into a hole at the top of the upper screen. If it is as simple as it sounds, why did it take me so long to complete the level? It certainly was not my

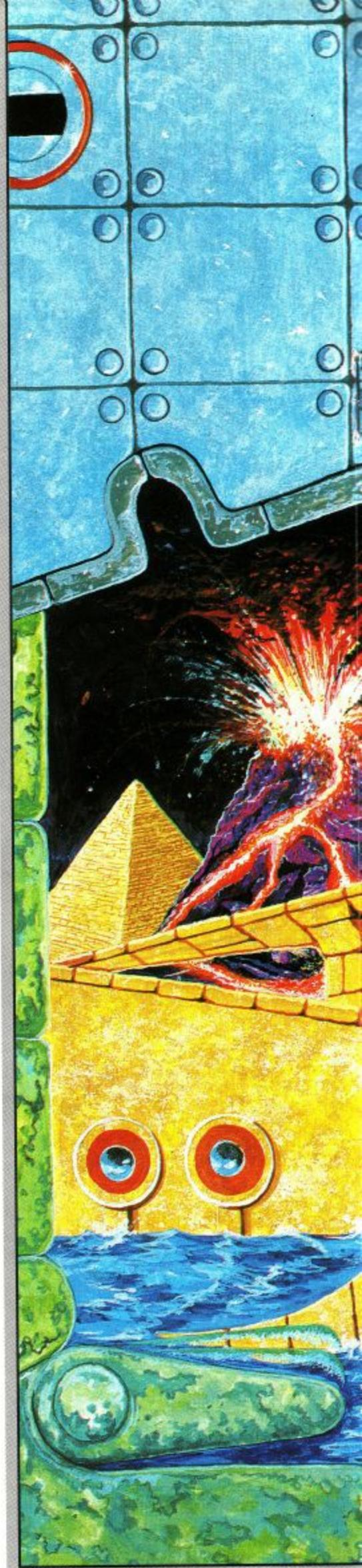

total lack of aim with the flippers or the fact that the ball insisted on falling through to the lower screen. On the lower screen there is a circular ramp which can be traversed by the ball for



three balls in the side pocket. As the balls are deposited a pyramid builds and at the final part of this level a mummified face breaks out from behind the wall.

top of the screen. Using your trusty silver ball you must blast away at the blocks which make up the letters. Be warned – this is no easy task and may well bring you back down to Earth with a bump.

It is surprising that the Amstrad plays better than the Amiga version. The feel of the table is there and as the sonics assault your ears and your eyeballs rattle in your head, remember that deaf, dumb and blind kid plays a mean pinball.

Adrian Pumphrey

The last level is called Final. To complete it and win the game you must indulge in a little brick blasting. At the top of the screen the letters spelling the word 'final' appear one at a time at the

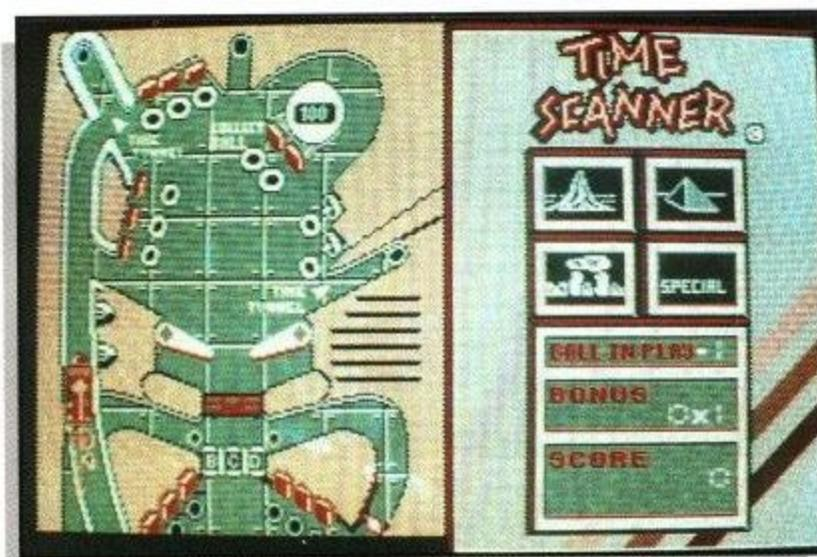

mega bonus points. Each ball deposited into the hole reappears in a box on the lower level. Once again, completing the level results in the manic three-ball session.

Ancient Egypt is the next port of call as you pay a visit to the pyramids. This level is a little trickier than the last as you have to light the letter spelling the word 'pyramid' and deposit

ROUND-UP

NAME	Time Scanner		
SUPPLIER	Activision	PRICE	£9.99/14.99
GRAFFIX			
SONIX			
PLAYABILITY			
OVERALL			
<p>It is surprising that the Amstrad version plays better than the Amiga version.</p>			

Most days I feel content. I work in the food vat department, you see. It is not that great; I get by but recently I have had the feeling that someone or something was out to get me. Friends are whispering behind my back, my work hours are changed all the time, my lunch time was reduced from eight minutes to five and the security guards all eye me suspiciously. I do not know why – I have done nothing wrong, I just like to look at trees. What is wrong with that? All this suspicion is getting to me; you could say I am becoming paranoid.

The *Paranoia Complex* seems like a computerised and poorer version of the role-playing game *Paranoia*, produced by West

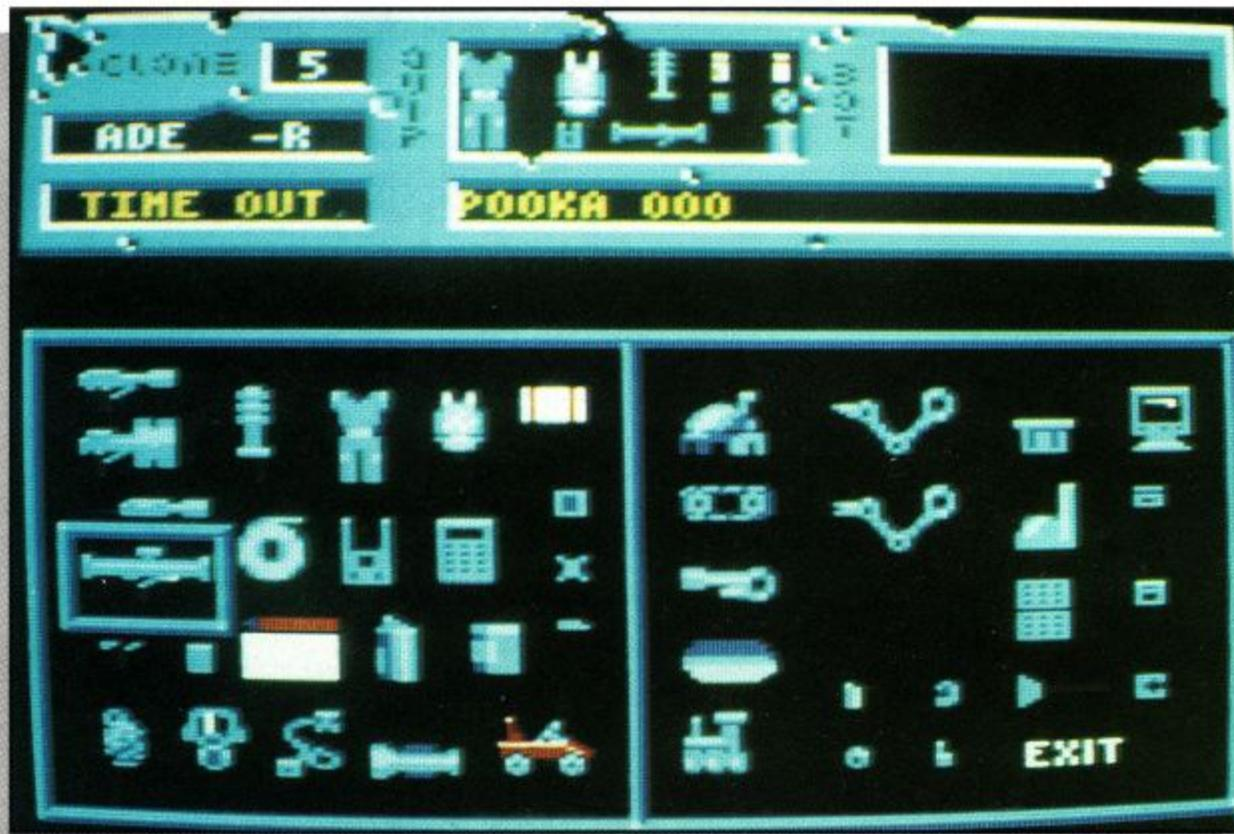

Paranoia Complex

Happy? Content? No grey clouds looming over the horizon? If so, this game is not for you. Or is it?

End Games. The game takes place in a sealed city underground, in the alpha sector – Paranoia called the city the Alpha Complex – in the not-too-distant future. Society is run by an all-powerful computer and social success is measured by security clearance, ranging from red to blue.

Your aim is to serve the computer which, of course, is deranged by eliminating traitors – real, suspected or just the gullible who you can frame. As you eliminate the traitorous scum you can rise in security level and ultimately be big enough to determine how to

escape from the complex completely.

The display is *Gauntlet*-esque, top-down, reduced screen, lumpy scrolling. On entering individual buildings the top is removed so that you can see in.

Equipment and food are two essentials in the game, so you will need to hunt traitors, serve the computer and earn plenty of credits. Scattered round the complex are computer terminals where you can buy foodcards and extra goodies like bots. Having a bot trog round after you with all your heavy kit is recommended.

Programming the foodcards is

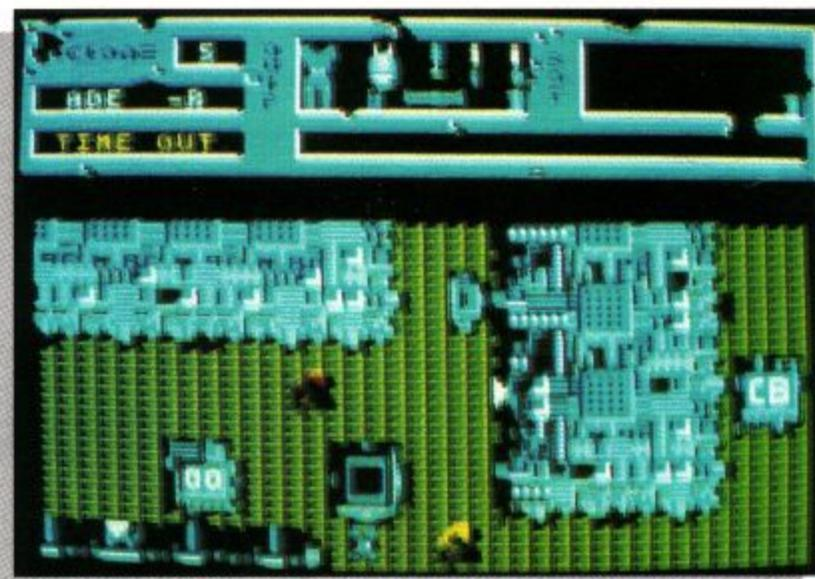

fun because you have to hold down 10 keys simultaneously, otherwise the programming goes wrong and you eat the equivalent of a very hot curry. Working out what to do to who, how to do it and with what to do it is where the enjoyment comes from this game, so do not play it as a maze game with shooting,

or you will be disappointed.

The graphics are nothing special, neither are the sonics, but the gameplay is well-balanced and when you get into it *Paranoia Complex* has much more depth than most action-orientated games.

Mark Ulyatt

ROUND-UP			
NAME	Paranoia Complex		
SUPPLIER	Gremlin	PRICE	£9.99/£14.99
GRAFFIX			
SONIX			
PLAYABILITY			
OVERALL			
⚠ Otherwise the programming goes wrong and you eat the equivalent of a very hot curry. ⚠			

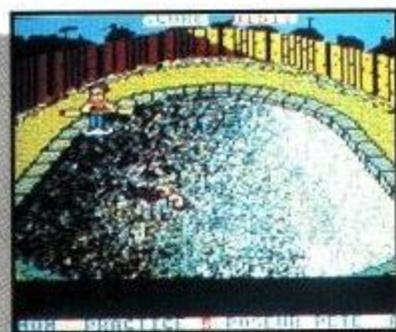

The guy who owns the skate shop is a bit of a grouch but that is no difficulty. The real problem is his son Lester. The obnoxious little brat is begging for a good thrashing, so you decide to play him at his own game – the skateboard. It is a pity Lester is so much better than you.

In the skate shop you can log in for the competition or view the current high scores. You can leave the shop either to practise the events individually or go for broke and challenge Lester to

white. The most unusual feature of the game is its complete lack of sound – an unusual move but it gives the program that extra touch of speed and playability.

There are two ramp events

which take place in an elongated half-pipe. One requires brute force as you waggle your joystick to gain a few feet in the high jump event. On the freestyle ramp you have 10 passes to

perform the most outlandish tricks before the unbelieving eyes of the judges. The tricks you perform depend on the angle of the joystick on take-off and the number of times you pumped the board while travelling the ramp.

You can start with the simple tricks, staying on your board and travelling a few feet into the air and, when you gain a little confidence, you can go for the rotates and handstands. Although you gain more points for the trickier manoeuvres you have a greater chance of bouncing your skater on his head a few times as he travels back down the ramp the difficult way.

The joust is an event in a class of its own and brings to mind the legendary times when knights fought on the fields of honour. Taking your boffing stick you attempt to unboard your rival as you pass each other in the pool. It is possible to delay for a short time at the rim of the pool or even slide your board along the top of the pool either to align

Skate or Die

Pit your skills against spoilt brat Lester, the boy begging for a good thrashing. But beware. Do not let your anger get the better of you on these testing tracks. Otherwise Lester will have the last laugh.



an all-out, four-wheeled war. Once outside the shop in practice mode you see a small street plan, each street branching to a different event.

The events range from the self expression of the freestyle ramp to the humbling experience of the pool joust. Most of the events take place on a static background and are very well-drawn but two of the events scroll and, to speed things a little, the colour has been kept to a minimum – black and

yourself for the attack or avoid the oncoming attack. After five passes the boffing stick is passed to the other player and the first person with three knockdowns wins the joust.

The final two events, downhill jam and race, both feature scrolling action. In the race you must traverse the building site, leaping over the barricades and hurtling down the pipe; avoid the obstacles at all costs as you cannot afford the time to pick yourself from the floor. In the jam you race against Lester through the back streets, creating a little mayhem as you go. Kicking over the trash cans can be fun but kicking Lester is even better. Skating into walls is not such a good idea but if you do nothing else, avoid the wire fence. Passing through this obstacle has a similar effect to an egg slicer. Each event is well put together and the desire to thrash Lester will have you returning for more, time and time again.

ROUND-UP	
NAME	Skate or Die
SUPPLIER	Electronic Arts
PRICE	£8.99/£14.99
GRAFFIX	
SONIX	
PLAYABILITY	
OVERALL	
<p>☛ The obnoxious little brat is begging for a good thrashing, so you decide to play him at his own game, the skateboard. ☛</p>	

Adrian Pumphrey

It is a man's world in today's Navy. So you can imagine my reaction when I saw the cover to *Navy Moves*. It portrays a macho nautical type in rubber clutching a weapon in both hands. The scenario is straightforward. You play a muscular Navy commando whose mission is to locate and destroy a nuclear submarine which is harboured in an enemy base.

The first part of the game consists of three zones which have to be negotiated successfully before moving to part two. Zone one has your commando driving a motorboat through mine-infested waters. Timing is crucial as you jump over mines and shoot kamikaze commandos bearing down on you with their aqua-bikes – a very frustrating stage.

Progressing to zone two and your commando has slipped into wetwear to find the undersea entrance to the enemy base. Watch for the sharks – I found a sharp blow with a handbag to the snout deterred them – and enemy scuba divers which guard the entrance. Once past them you have to capture a bathyscaphe, a miniature submarine with which you move into zone three. Things start to get very exciting now. Cruising in your bathyscaphe you are inspected closely by giant octopi and eventually come face to face with a giant, long thick sea monster, which can be killed by shooting it repeatedly in the mouth.

Part two of *Navy Moves* has your man emerging from the bathyscaphe inside your nuclear submarine. The objective is to make a deep penetration of the



NAVY MOVES

submarine and place a bomb at the base of its nuclear reactor, stop the submarine, make it emerge from the sea and then transmit a message from your base. Unfortunately, access to the main computer is needed for all the actions, plus the correct code words to activate each action in turn.



Codes can be gathered by killing and searching; the First Official will give you the code needed to stop the submarine and make it emerge. The First

and Second Machine Officials hold the codes to open the base of the reactor door and the First and Second Transmission Officials hold the code to allow you to transmit a message to your base.

Kill the Captain and you can have access to all the codes. The submarine is swarming with enemy marines armed with guns and flamethrowers, while you have only limited ammunition – although more can be gained by searching marines you have killed – so do not shoot too soon; rather avoid the enemy by lying prone on the deck, when

they will ignore you.

Navigating the submarine is tricky and the cutaway map provided will help enormously, as will the pause button. The game ends when your commando has completed all the tasks successfully and transmitted a message to his base; then you make your way to the top of the control tower to be rescued by your chums.

Navy Moves is a good follow-up to *Army Moves*. The graphics are of a very high quality, especially during the submarine sequences – much better than I would have expected from an Amstrad machine – and there were enough levels to satisfy even me. An added bonus was the inclusion of numerous illustrations and annotated diagrams of the equipment and the submarine.

Adrian Wall-Hayes



ROUND-UP			
NAME	Navy Moves		
SUPPLIER	Electronic Arts	PRICE	£9.99
GRAFFIX			
SONIX			
PLAYABILITY			
OVERALL			
<p>Kill the Captain and you can have access to all the codes.</p>			

Contrary to what you might think, *Bomb Jack II* is not a rare groove house mix but rather the sequel to one of the more memorable platform games of the early 1980s.

Elite Systems has decided to unleash the sequel on the unsuspecting public once more, thanks to its budget label, Encore, so you may even have this game in your collection already. If you cannot remember I would advise you not to buy it again just because it is cheaper – it has not improved.

The premise of *Bomb Jack II* is simple. Leap from platform to platform, stabbing enemies, collecting all the treasures. Still, if BJ2 was a good action game,



Bomb Jack II

Explosive action as small man is eaten alive by Lizard.

with plenty of excitement, snappy sonics and gripping graphics that would not matter; you could justifiably say that it was satisfactory.

Alas, is it not a good action game; the sonics are squeaks, the graphics just coloured blobs

and you could justifiably say only that it was as interesting as a puddle.

The puddle simulator starts in the great outdoors; note that the backdrops are completely irrelevant and serve only to distract the eye from following what passes for action. You can leap sideways to a platform on your level, straight up to a platform directly above, or you can run round on the platform you are on. The tricky part is when you have to leap up to a platform occupied by a monster before you can reach the platform where the last treasure awaits.

It is tricky because the monsters are difficult to deal with

in a random kind of way. Catch one from behind, stab, stab, and it is history. Alternatively, end up in front and you are pushed along, your energy level declining faster than the NHS. Once depleted, there is no hospital bed – just a life lost and wasted. What is really tricky is that some of the platforms which contain a monster and have to be traversed are very small, making it very difficult to get in a clean stab and finish the job early.

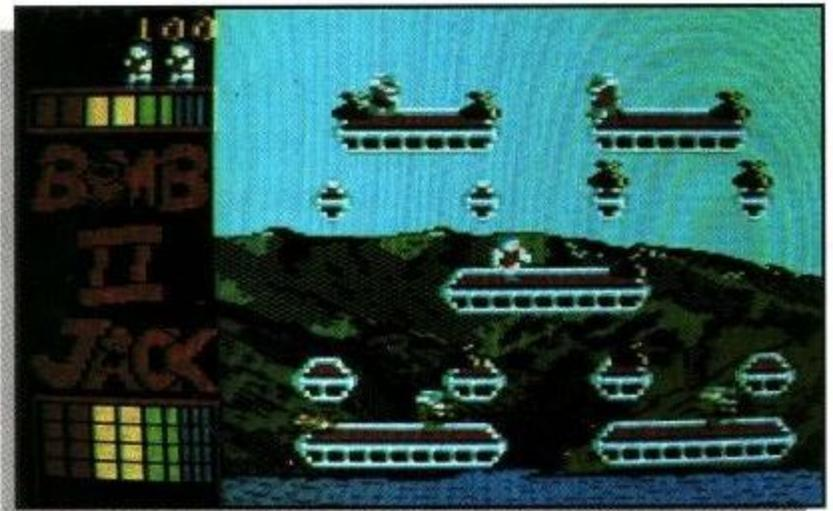

If you dilly-dally the monsters will mutate to a new form, sometimes a form more amenable to stabbing as well, so do not be afraid to wait if you cannot see a way out. One generation of uglies even leaps round the screen, which makes life more perilous in the short term, but easier in that all of them can be avoided.

There are bonus points for getting the treasures in the

ROUND-UP	
NAME	Bomb Jack II
SUPPLIER	Encore
PRICE	£2.99
GRAFFIX	
SONIX	
PLAYABILITY	
OVERALL	
Your energy level declining faster than the NHS.	

correct order but I did not really care. The graphics might be multi-coloured but they are multi-coloured blobs. There is little definition and they occasionally clash with the background, becoming difficult to see.

Bomb Jack II may have been a good idea in its day but that day has long since gone and this is one history lesson not worth paying to sit through.

Mark Ulyatt

How many times have you picked up a new game, only to find that it is not new but incredibly old and a clone at that? My guess is that is has happened to you often, as many games released today, especially budget games, are either clones or re-released games of yesteryear.

Breakout began in the mists of time – the late 1970s anyway. After some time the arcade operators noticed that there was

less and less interest being shown in the machines and they were taken out of service.

Breakout was forgotten about for many moons and then Taito resurrected it and re-launched it as *Arkanoid*. Since *Arkanoid* first appeared on a home computer we have been bombarded with similar clones of this ancient concept – bounce a ball round a court while knocking out coloured bricks.

The concept is simple and the game challenging and enjoyable, yet one can have just so much of a good thing. There must be 50 Breakout-type games available across the broad range of home computers, so will another one tip the balance?

I doubt it but it is worth thinking about. I have had enough of Breakout and *Arkanoid* and any other relatives to last me a lifetime.

It should be noted that any Breakout game should be played using either a paddle, mouse or any controller which is speed-sensitive. A joystick or keyboard will always give the same speed to the bat and so makes the game incredibly difficult.

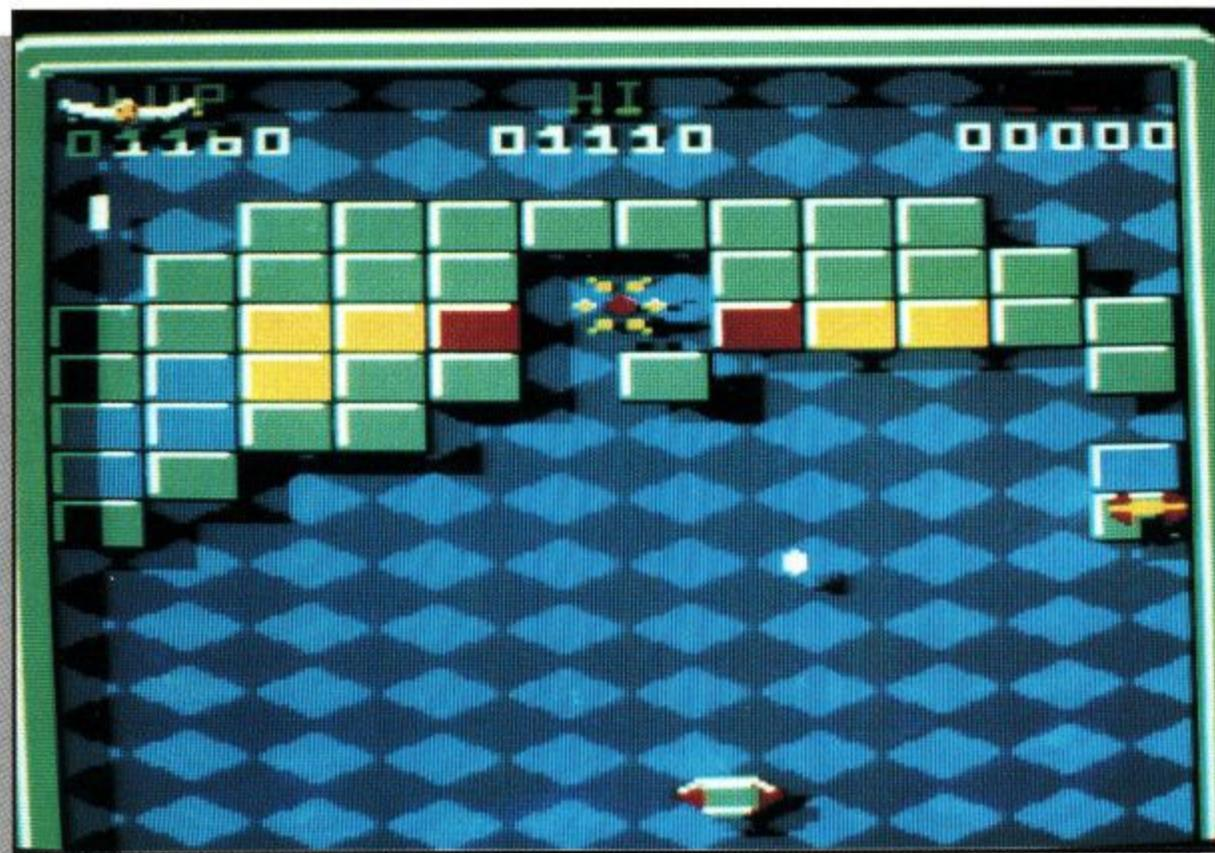

BATTY

They say the old games are the best, but what of a new game that plays like an old game?

Batty is the latest budget release from Encore. It is basically an *Arkanoid* clone with very few subtle differences. The main and most noticeable difference is a small space invader at the top of the screen firing lasers at you. They must be avoided. Other than that, the

game is virtually identical. The only differences are subtle to avoid infringement of copyright.

As usual, many blocks are tougher than others and require to be hit a number of times before they disintegrate. Some blocks release special pods which drop towards the bottom

of the screen. If caught they will change your bat into something special.

As you might expect, I am not exactly raving about this game. It is a copy of a copy of a copy. There is little which is new and it includes all the features from previous games.

I am not saying that the game is bad. In fact, it is reasonably good but it is becoming incredibly boring to keep seeing these kind of games. Does nobody have any new and original ideas?

Graphically, *Batty* is very colourful. The sound effects are reasonable but the gameplay is somewhat lacking because of the uncontrolability of the bat speed. If it were possible to play it with a mouse or paddle it would enter a whole new area of youngster fun.

Andrew Banner



		ROUND-UP		
NAME	Batty			
SUPPLIER	Encore	PRICE	£2.99	
GRAFFIX				
SONIX				
PLAYABILITY				
OVERALL				
The main and most noticeable difference is a small space invader at the top of the screen firing lasers at you.				

BrunWord & Printer

Pedals, mountains & sunshine but no CPC!

Peter Brunning's Idea of a Holiday
can be too much like hard work.

I laid in the shade just inside the Austrian border, map spread out, trying to decide if I was fit enough to cycle across the Alps by the highest pass which rises up to over 8000 feet. I was carrying a small tent which did allow me to stop anywhere if I ran out of energy. As it turned out I was right to wonder as it was really just beyond my capabilities. I have never worked so hard as the day I went over the Timmeljock pass and never felt so exhilarated as the experience of coming down the other side. It rained on the way up but I came over the top into brilliant sun shine, looking across the tops of many fantastic snow covered mountains. I stayed one night in Italy in a German speaking Gasthoff and then over an insignificant pass (in comparison) back into Austria. I came home by train, from just inside Germany, feeling the world was at my feet and with a promise that this was the start of many new travelling adventures.

It had been my ambition for countless years to cycle the Romantic Route which goes from Wurzburg in Germany to Austria, and then to continue over the Alps into Italy. Last year, for the first time, I felt fit enough and had the right gears on my cycle.

The Romantic Route certainly lived up to its name. The top section undulates gently and provides stimulation periodically with a series of fascinating ancient walled towns. The middle is best forgotten except for the campsite at Lech, where the owner insisted that I used a caravan as it was about to rain. Fifty miles on, the Alps were just discernable as a misty outline and gradually unfolded over a period of two days, into the majestic, snow covered scenery that dominates Austria.

That memory of only a year ago seems so distant now. I look into the office after a weekend off and wonder if I really want to wind up to that acute mental state needed to solve the next software problem. Then the phone rings or the post arrives and an excited letter or a praising telephone call provide the boost to mach 3 and the week takes

off. Writing software can be hard but there is no doubt that CPC users are very responsive to just a little above the ordinary.

The astute reader may have noticed a holiday spirit and an unusual light hearted patter to this advertisement. What is this all about? Quite simple, it's holiday time!

I was in the bath, taking a relaxed view of the heavy burden that programmers carry and reflecting on the problems of the world. Honesty is important to me, possibly almost to excess and yet it is so difficult to be completely honest. But imagine a world where everyone was totally dishonest. Where no one could be trusted. The world as we know it could not exist. This is light hearted so I won't labour where it relates.

It struck me as I lay in the closeted warmth of the bath, that there is a light hearted angle, which would suit the 'holiday period'. Ahha! I hear from the pages, as it dawns on the reader that this is a little more serious than the writer is letting on.

I cannot hold back any longer, so here it is. July is to be the 'holiday period', where a response from Brunning Software may be slow. But

hunger can still strike as it does not recognise such a distinction and you must still send in your orders! So here's a little carrot just for the month of July.

Send your order by post with a cheque or postal order and deduct £4.00 from our usual price, as listed below. You MUST also include a short letter which explains a reason why you deserve this discount and this MUST be an honest reason. Be kind and try not to be too serious. We will chose one letter that may be the most original or the funniest and include an extract in our advertisement. The writer of that letter will receive a full refund and a complimentary copy of BrunWord Elite.

The response to our Tasword upgrade, introduced last month, has been good. For the month of July we will extend this to include Protex and Mini Office II, as part of the honesty theme. For the month of July if you already own Tasword (disc), Protex (disc or ROM) or Mini Office II (disc), you can deduct £7.00 from any price listed below. Don't send the programme, just look into your conscience and remember that you rely on honesty just as we do. If you are a legitimate owner tell us and deduct your discount. You MUST also tell us why you deserve this discount, as explained above.

That's enough soft talk, it's time for a few serious comments. Our new booklet should be ready when this advertisement appears but won't be posted out until early August. Everyone on our list will eventually receive a copy and an attractive update offer. BrunWord Elite is also behind schedule and will not now be released until late summer. Let me leave you with a final thought. BrunWord Elite printed this entire page, heading, text, large box round the edge, all the lines and the invisible teddy. This was one printing operation, at the actual size that you see. (Standard CPC6128, 8 bit printer port and HQP45 printer).

For a serious overview of our programmes, please see our advertisement in last months ACU.

BrunWord 6128 with BrunSpell & DataFile. £30.00
BrunWord 464 with BrunSpell & DataFile. £25.00
BrunWord Junior. Not in special offer
Info-Script 6128 with BrunWord & BrunSpell. . . . £50.00
BrunWord Elite (available late summer). £90.00
BrunWord Elite and Info-Script include backup disc.
(All supplied on 3in disc - state which computer)

Brunning Software

34 Helston Road, Chelmsford,
Essex, CM1 5JF. Tel 0245 252854

Our software is only available directly from us.

DATTEL ELECTRONICS

**MIDI
COMPATIBLE**

music machine

THE RAM MUSIC MACHINE IS PROBABLY THE MOST EXCITING MUSIC ADD-ON AVAILABLE FOR ANY COMPUTER.

**FREE
MICROPHONE AND
HEADPHONES!**



- ▼ It's a full sound sampling system allowing any sound to be recorded digitally into computer RAM. Once stored the sound can be replayed at different pitches with many varying effects.
- ▼ It's an echo chamber & digital delay line. Create very interesting effects.
- ▼ Various sampled sounds are provided to get you going.
- ▼ The Music Machine can be used as a drum machine - eight drum sounds are provided, but you can easily produce more of your own.
- ▼ The powerful software allows you to compose tunes from individual bars of music. You can edit on screen & Save/Load sounds, instruments & rhythms.
- ▼ It's a two voice music/sound synth.

- ▼ Fully MIDI compatible. The Ram Music Machine supports full MIDI In, MIDI Out & MIDI Thru.
- ▼ Output through your Hi-Fi or Headphones. Comes complete with Microphone.
- ▼ Use a full size MIDI keyboard to play the Music Machine.
- ▼ Sounds produced by the Music Machine can be mixed with a MIDI Synthesiser's own sounds.
- ▼ On screen Sound Editor can produce MIDI data from your own compositions.
- ▼ No other product can offer so much in one unit - it's the total solution!!

ONLY £49.99 (Cassette)
ADD £5 IF DISK REQUIRED



LIGHTPEN/GRAPHICS SYSTEM

- ▼ Complete Lightpen and graphics system lets you create a whole range of effects on screen.
- ▼ It can magnify, shrink, colour fill and create circles, rectangles, lines and curves.
- ▼ Pictures can be edited at pixel level using a scratch pad which is magnified to full screen.
- ▼ Picture storage and retrieval, and a pen calibration feature.
- ▼ Printer dump utilities for Epson/Amstrad printers supplied (on cassette).

**ONLY £14.99
CASSETTE**

**OR £24.99
WITH SOFTWARE ON ROM -
NOTHING TO LOAD**
464 or 6128 (Please state which)

MEMORY EXPANSION

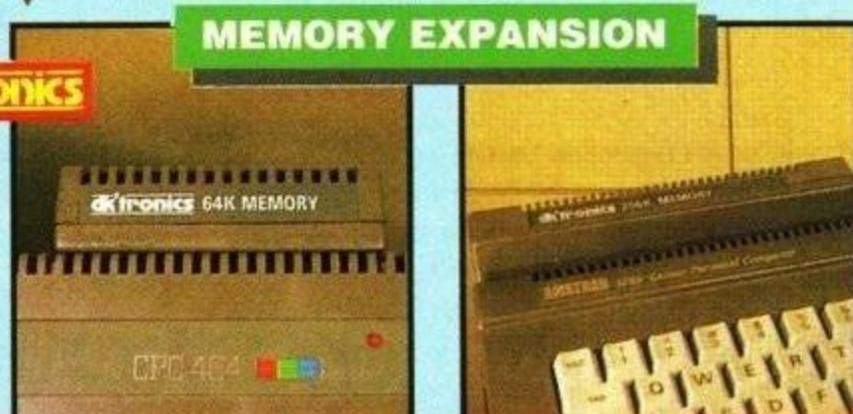

64K AND 256K MEMORY EXPANSION

- ▼ Simple plug in memory expansion gives instant extra memory.
- ▼ Features bank switching software for easy use by the programmer or for use as a data storage area.
- ▼ Ideal for use with the CPM 2.2 etc.
- ▼ The software also features some extra BASIC commands.
- ▼ 64K unit brings 464 up to CPC 6128 memory configuration making a much larger software base available. Will work straight off with many programs designed

- for this unit (including OCP Art Studio - see Ad.).
- 64K unit expands 464 to 128K.
- The 256K unit takes your 6128 to a massive 320K!!
- All bank switching done automatically by supplied software (cassette 464 - disk 6128).

ONLY £49.99

**64K for 464
ONLY £99.99
256K for 464 or 6128 (Please State)**



REALTIME CLOCK

- ▼ A simple but highly useful device.
- ▼ Easy to use realtime clock - battery backed to give the correct time and date always.
- ▼ Also features extra 8bit I/O port for external control applications - very useful.
- ▼ Comes complete with full instructions and set-up software.

ONLY £19.99
464 or 6128 (Please state which)

SPEECH SYNTHESISER & STEREO SOUND BOOSTER

- ▼ This easy to use Speech Synthesiser includes a powerful Stereo Amplifier and two Pod Speakers which is a great improvement on the sound of the internal mono speaker.
- ▼ Using the SPO/256 Speech Chip the unit has an almost infinite vocabulary.
- ▼ Text to speech software is provided in ROM to make speech output simplicity itself.
- ▼ Voicing is transparent to the user and the computer can carry on with other program tasks.
- ▼ Speech output is mono directed to both speakers. Booster gives stereo to internal sound output.



ONLY £29.99
464 or 6128 (Please state which)

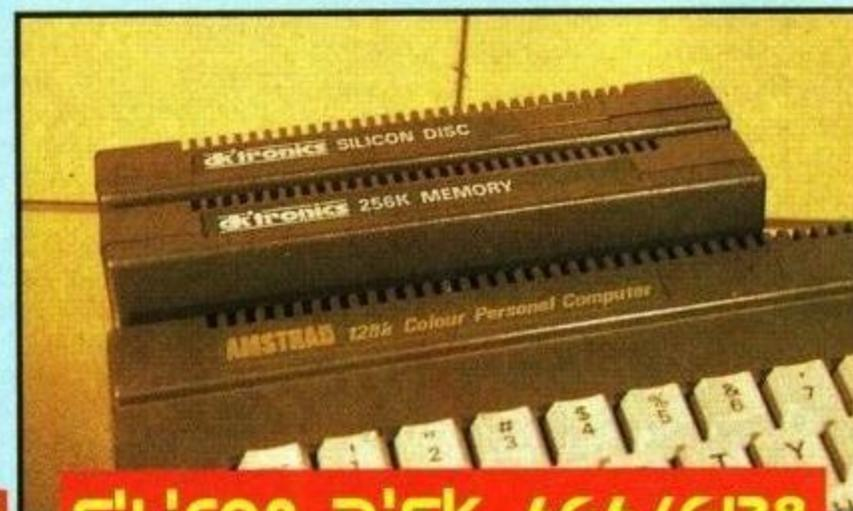

SILICON DISK 464/6128

- ▼ This is the fastest storage system available for the Amstrad CPC computers and is compatible with CPM 2.2, CPM+ and all DK'Tronics peripherals.
- ▼ The 2516K Silicon Disk is designed to be used in conjunction with at least one normal Disk Drive attached to the system.
- ▼ When the 2516K Silicon Disk is fitted only 2K is used for the Silicon Disk directory, leaving 254K for storage - that's 70K more than a normal Disk Drive.

- ▼ Data and programs can be exchanged between Silicon Disk and normal Disk, application programs can then work on their data at vastly increased speeds.
- ▼ Software is on ROM (nothing to load) and can be used in two modes - Basic under AMDOS with normal LOAD, SAVE CAT MERGE commands etc. and within CPM 2.2 CPM+ where commercial programs are designed to run on multi-drive systems.

ONLY £129.99
464 or 6128 (Please state which)

DATTEL ELECTRONICS

THE ULTIMATE GRAPHICS PACKAGE...

SPECIAL OFFER PACK!

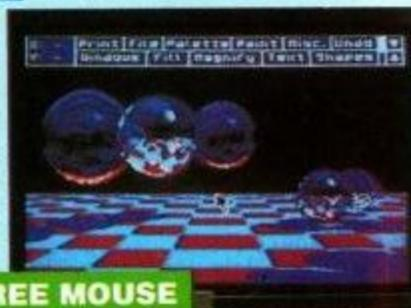
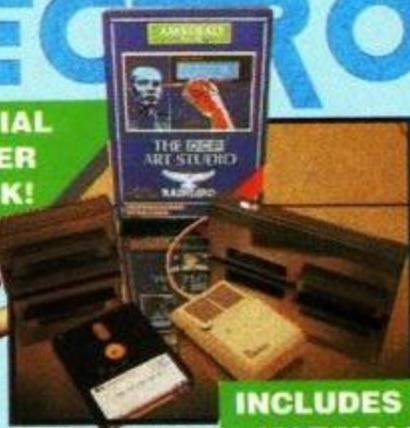
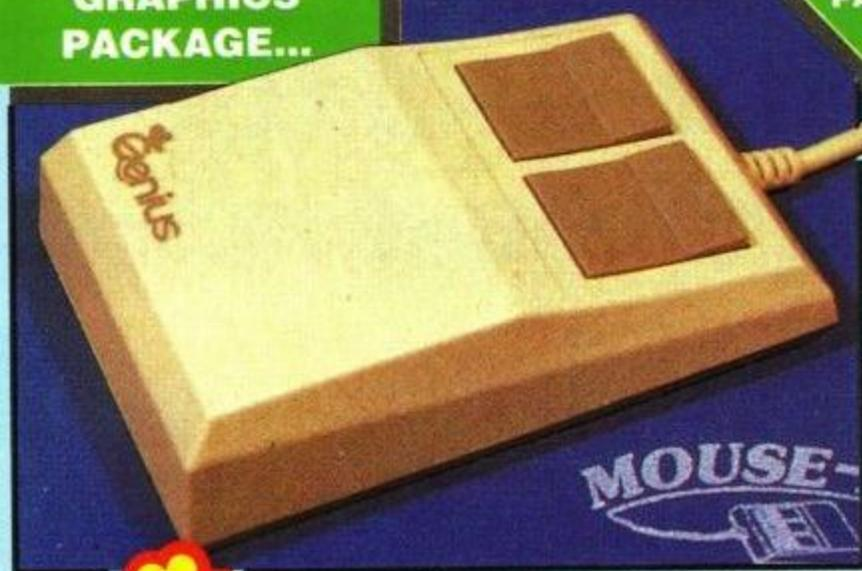

INCLUDES FREE MOUSE MAT/HOLDER WORTH £12.99



Genius Mouse

COMPLETE WITH

OCP ART STUDIO™

- ▼ Genius Mouse is a high resolution two button mouse featuring optical counting, teflon guides, microswitches, rubber coated ball and high quality interface.
- ▼ When combined with OCP Art Studio this graphics package is quite simply the best system available. The features are unmatched...
- ▼ Create an image - shrink it, expand it, move it, rotate it, copy it, colour it etc., etc.
- ▼ Spray patterns or shades, make elastic lines - stretch and manipulate shapes.
- ▼ Zoom in to add detail in fine mode.
- ▼ Pulldown/icon driven menus for ease of use.
- ▼ Mouse operation, plus joystick and keyboard control.
- ▼ 16 pens, 8 sprays, 16 brushes - so flexible anyone can create superb graphics easily.
- ▼ Full cut and paste facilities plus excellent printer support.
- ▼ Pixel edit, font editor, flip, invert, rotate, solid or textured fill and professional manual make Art Studio simply the best graphics package for the Amstrad CPC.

TAPE OR DISK FOR 464 OR 6128 (PLEASE STATE WHICH REQUIRED)
N.B. 464 NEEDS DK' 64K RAM PACK

ONLY £49.99
TOTAL PACKAGE INCLUDING GENIUS MOUSE/INTERFACE MOUSE MAT/HOLDER AND OCP ART STUDIO

NEW SLIMLINE DRIVE

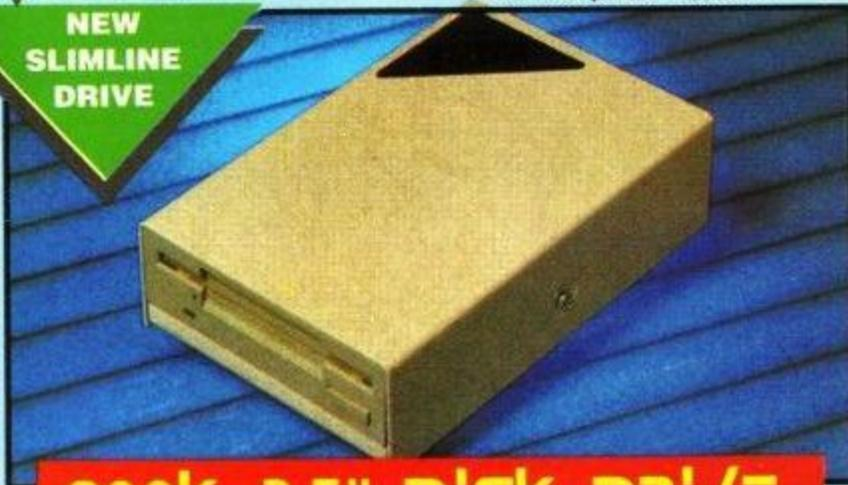

800k 3.5" Disk Drive

- ▼ Now you can add a superb top quality 3.5" drive to your CPC Amstrad.
- ▼ 800K of data storage on disks that cost less than £1.00.
- ▼ No need to flip disks.
- ▼ 3.5" disks are fast becoming industry standard.
- ▼ Comes complete with power supply and cables.
- ▼ We supply our drive with the RODOS operating system, giving
- ▼ not only this vast disk capacity but also over 50 new bar commands plus a printer buffer, etc.
- ▼ Easily fitted - full instructions.

464 owners must already have at least one Amstrad drive.

Only £119.99 for Drive and RODOS including PSU/Cables

- ▼ Turn your Amstrad Monitor into a full feature TV set with our TV Tuner System.
- ▼ Latest chip technology gives crystal clear reception on all channels.
- ▼ Built-in speaker.
- ▼ On/Off volume controls.
- ▼ Brightness and colour controls.
- ▼ Channel selector.
- ▼ Attractively styled to match your computer.
- ▼ Why not realise the full potential of your monitor?

ONLY £69.99

TV TUNER SYSTEM



PCW 8256/8512

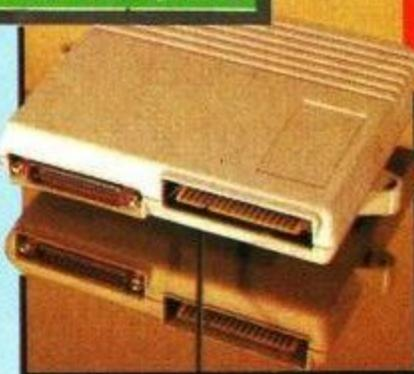

PCW 8256/8512 COMMUNICATOR

- ▼ Complete RS232 and Centronics/Parallel interface for the PCW Amstrad.
- ▼ Simply plugs into rear expansion slot.
- ▼ Attractively styled in computer colours.
- ▼ Full instructions supplied.

Only £49.99 complete

ALL ORDERS NORMALLY DESPATCHED WITHIN 48 HRS

HOW TO ORDER ...

BY PHONE



0782 744707

24hr Credit Card Line

BY POST



Send cheques/POs made payable to "Datel Electronics"

FAX

0782 744292

UK ORDERS POST FREE
EUROPE ADD £1
OVERSEAS ADD £3

PRICES AND SPECIFICATIONS CORRECT AT TIME OF PRESS AND SUBJECT TO CHANGE WITHOUT NOTICE

CALLERS WELCOME - Please reserve goods by telephone prior to visit.

DATTEL ELECTRONICS

DATTEL ELECTRONICS LTD., FENTON INDUSTRIAL ESTATE
GOVAN ROAD, FENTON, STOKE-ON-TRENT, ENGLAND.

SALES ONLY
0782 744707

TECHNICAL ONLY
0782 744324

King Of the hill

What makes more money, a film or the games and accessories which follow? Richard Henderson looks into the lucrative world of big film spin-offs.

By the time this magazine reaches the streets, the population of Britain will be in the final stretch of waiting for what most believe to be the biggest film since *Ben Hur*. On August 11 the bated breath will finally be expelled when *Batman - The Movie* arrives. Costing £25 million, it promises to be the most expensive super-hero venture yet undertaken. The set constructed at Pinewood studios, reported to be the largest outdoor set since *Cleopatra* cost £3 million to build and Jack Nicholson, who stars as arch-villain The Joker, demanded £1 million for his services.

Beyond the monetary stories, *Batman* has also been featured in many journals for its star-filled cast and the adamant behaviour of director Tim Burton, who even still refuses to allow journalists to talk to

actors or tour the set. The tabloids have certainly made the most of the press silence, with one Sunday newspaper sending a photographer to capture 'exclusive' pictures from skylights and windows in spiderman fashion.

In the U.S. children have been flocking to certain Warner Brothers films, most notably *The Dead Pool*, for a 90-second preview of Michael

Keaton and his rubber Batsuit. With all this marketing potential, there seems to be no other choice than to release a computer game based on the film, Ocean snapping up the rights as soon as the picture was announced.

Batman, of course, is not the only major motion picture to come our

THE FIRST WAS FOR HIMSELF
THE SECOND WAS FOR HIS COUNTRY
THIS TIME IS FOR HIS FRIENDS

STALLON RAMBO



way in the next few months which is based on a comic, *Watchmen*, too, has been recognised for what an excellent story it contains. The director of *Brazil*, *Jabberwocky*, *Time Bandits* and *The Adventures of Baron Munchausen* has been handed the task to bring Alan Moore's and Dave Gibbon's greatest strip to the cinema screen. Naturally a computer game based on the exploits of the character is to be released at the same time.

Another of the Ocean licence haul is Clive Barker's *Nightbreed*. This latest film promises many emotions and exotic locations and the plot is not only horror-orientated. David Cronenberg, director of *The Fly* stars in the movie, and special effects abound. Even Gary Bracey of Ocean is to star as a monster in the film.

LF.
NTRY.
ND

NE D III

18



"In the US children have been flocking to certain Warner Brothers films, most notably the *Dead Pool*, for a 90-second preview of Michael Keaton and his rubber Batsuit!"

Based on Barker's book *Cabal*, *Nightbreed* tells a tale of a murderer on the run who is forced to take refuge in the subterranean setting of Midian, a legendary city where all sins are supposedly forgotten; there he becomes one of the nightbreed, a band of living-dead shape changers.

James Bond makes another appearance this summer in Timothy Dalton's last film as 007, *Licence to Kill* which, as chronicled in the July issue, is to be released as a game by Domark, which is also responsible for the pixelisation of *A View to a Kill*, *Live and Let Die* and *The Living Daylights*. Though many rumours suggesting otherwise circulated freely, Dalton is to continue filming Bond movies way into the 1990s.

Jaws, the Spielberg terror spectacular of the 1970s, is also due

to be released on computer, more than 10 years after the release of the picture. *The Running Man*, the July cover game, has finally made an appearance and it is not the first, or

last, Arnie film to suffer computerisation. *The Predator* had great success when released and soon to come is the *Ocean Red Heat*, featuring incredibly large sprites and plenty of fighting action.

Other films being worked on which are certain to be converted to the home computer include *Robocop 2*. What is special about this picture, apart from being the sequel to *Robocop* is that the plot is being written by Frank Miller, the comic book genius whose credits include the much-acclaimed *The*



Dark Knight Returns and *Elektra Assassin*. His entire time is spent scribbling the next tin can adventure and we are bound to see a much larger budget forming than that used on the prequel.

Aliens II has also recently begun shooting, but unfortunately *Cyberpunk* fans may be

disappointed as William Gibson - *Neuromancer*, *Count Zero*, et al - has had his two preliminary scripts rejected and it looks as if the task has finally fallen on Eric Red to deliver the goods. If anybody is to grab the licence for the picture my money would be on Activision, which did a great job on the game of *Aliens*.

Those who have their ears constantly to the Hollywood grapevine will know that *Highlander 2 - Yellowknife* is now filming, as is *Ghostbusters 2*. The Last Ghostbuster, *Indiana Jones 3 - The Last Crusade* is, of course, soon to be released, as is its home computer counterpart, and Michael J Fox has signed to do not one *Back to the Future* sequel but two in succession,

"On the games front we have already seen many good film conversions including Star Wars, The Empire Strikes Back and Return of the Jedi. Others like the Rocky Horror Picture Show, Rambo II & III have all been great successes using the original ideas and gameplay."

which means we can have more games based on the short actor's exploits.

On the games front we have already seen many good film conversions, including *Star Wars*, *Empire Strikes Back* and *Return of the Jedi*, admittedly all from arcade machines. Others like *The Rocky Horror Picture Show*, *Rambo II & III*, *Ghostbusters* and *Aliens* have all been great successes using original ideas and gameplay.

Many poor films have also appeared as games. Take *Howard the Duck* as an example - or *Howard the Turkey* as the critics loved to call it. *Evil Dead* was another, as was *Friday the Thirteenth*.

All said, many film licensed games have been better than those converted from arcade machines

and, with many good, big budget films attracting more viewers than ever before - and surely more of a percentage of computer owners than an arcade game - it will be only a short time before most films in the cinema will be followed by home computer versions.



ALL OUR PRICES INCLUDE CARRIAGE & VAT

HSV COMPUTER SERVICES LIMITED. (ACU)

23, Hampstead House, Town Centre, Basingstoke, RG21 1LG

NEW!
Continuous Stationery
for your Personal Organiser
85GSM £7.95
for 250

Dust Covers

- * CPC 464 2pce set = £7.50
- * CPC 6128 2pce set = £7.50
- DMP 2000 Printer Cover = £4.50
- * State Mono or Colour

Strong water-resistant,
anti-static nylon
Grey with Royal Blue piping.

Stationery

- 9.5" X 11" 60GSM Micro-Perf all edges
- True A4 70GSM Micro-Perf all edges
- True A4 90GSM Micro-Perf all edges
- True A4 100GSM Micro-Perf all edges
(coloured-Cream, Blue, Grey or White)
- Labels 3.5" x 1.5" (1 across)
- Labels 3.5" x 1.5" (2 across)
- Labels 4.0" x 1.5" (1 across)
- Labels 4.0" x 1.5" (2 across)
- Labels 2.75" x 1.5" (3 across)

	500	1000	2000
9.5" X 11" 60GSM Micro-Perf all edges	£8.50	£9.50	£14.95
True A4 70GSM Micro-Perf all edges	£9.75	£12.95	£22.95
True A4 90GSM Micro-Perf all edges	£16.95	£14.95	£27.95
True A4 100GSM Micro-Perf all edges (coloured-Cream, Blue, Grey or White)		£31.95	
Labels 3.5" x 1.5" (1 across)		£5.25	£9.50
Labels 3.5" x 1.5" (2 across)		£5.75	£10.50
Labels 4.0" x 1.5" (1 across)		£5.75	£10.50
Labels 4.0" x 1.5" (2 across)		£6.75	£11.95
Labels 2.75" x 1.5" (3 across)		£4.75	£8.50

AMSOFT 3" discs 1= £2.50, 5=£11.95, 10= £22.95 (uncased)

MAXELL 3" discs (cased) 1=£2.65, 5=£12.50, 10=£23.95

NO EXTRAS TO PAY

DISK STORAGE BOXES
3" Lockable AMS-20 cased £9.95

Printer Ribbons

- DMP 2000/3000 Black £2.95
- DMP 2000/3000 Colours* £3.95

* Colours Available are:-
Red, Blue, Green, Brown.

Credit Card

Hotline (0256) 463507 Faxline (0256) 841018



Please help us to help you -
Minimum Order £8

ZEDASM ROM £19.95

The professional Z80 Text Editor/Assembler and System monitor. Superfast Z80 assembler (200 lines second). Supports page switching on 6128 machines, up to 80k of text source in memory at the same time.

DEMON DEVELOPMENT CARTRIDGE £19.95

The Ultimate machine code tool. Stop Any program Anytime by a press of a button, the memory remains intact and can be saved to Tape/Disc, debugged, traced, moved, disassembled etc.

EPROM PROGRAMMER KIT £27.50

Transfer your favourite programs (Basic/Machine code) onto Eprom. Programs 2764/27128 12.5 or 21 volt Eproms. Powerful but easy to use software, Rom to Rom copy, Editing, Verification, Single or block programming.

PCB DESIGNER CARTRIDGE £59.95

Design double sided printed circuit boards quickly and easily. Output to standard printer 1:1 or 2:1 scale. Predefined DILS & IDC connectors. Auto Routing. Zoom Editing etc. Too many functions to list here.

PASCAL COMPILER ROM £15

Our pascal compiler is easy to use, suitable for the absolute beginner and produces stand alone Machine code. Does NOT require CPM.

(Note cartridges have no through connector for 464 with Disk Drive)

JOHN MORRISON DEPT (ACU)

4 REIN GARDENS, TINGLEY,
WEST YORKSHIRE, WF3 1JR

TELEPHONE (0532) 537 507

S.A.E. for further information



PORTSMOUTH'S LEADING SOFTWARE/MAIL ORDER CLUB

SUPER SOFTWARE SALE

AMSTRAD BARGAINS

- | | | | |
|-----------------------|----------|------------------------|-------|
| Monopoly50p | } PACK 1 | 3D Chess.....50p | } 75p |
| Trivial Pursuit...50p | | 3D Boxing.....50p | |
| Scrabble.....50p | | Daley Thompson Day 1 | |
| Scalectrix50p | | Daley Thompson Day 2 | |
| Cluedo.....50p | | Plus Many Others @ 50p | |

JY2 JOYSTICKS £3.00

SPECIAL OFFER PACKS

PACK 1
£2

PACK 2
15 games
£5

PACK 3
SOLD OUT

Prices include VAT. Please add £1 Post & Packing. Cheques PO Cash to

PARKER ASSOCIATES

Dept M, 272 Grafton Street,
Buckland, Portsmouth.
Tel: 0705 831538

Hairy Hacker

The Hacker is back
and here to stay
with an all new
column of goodies.

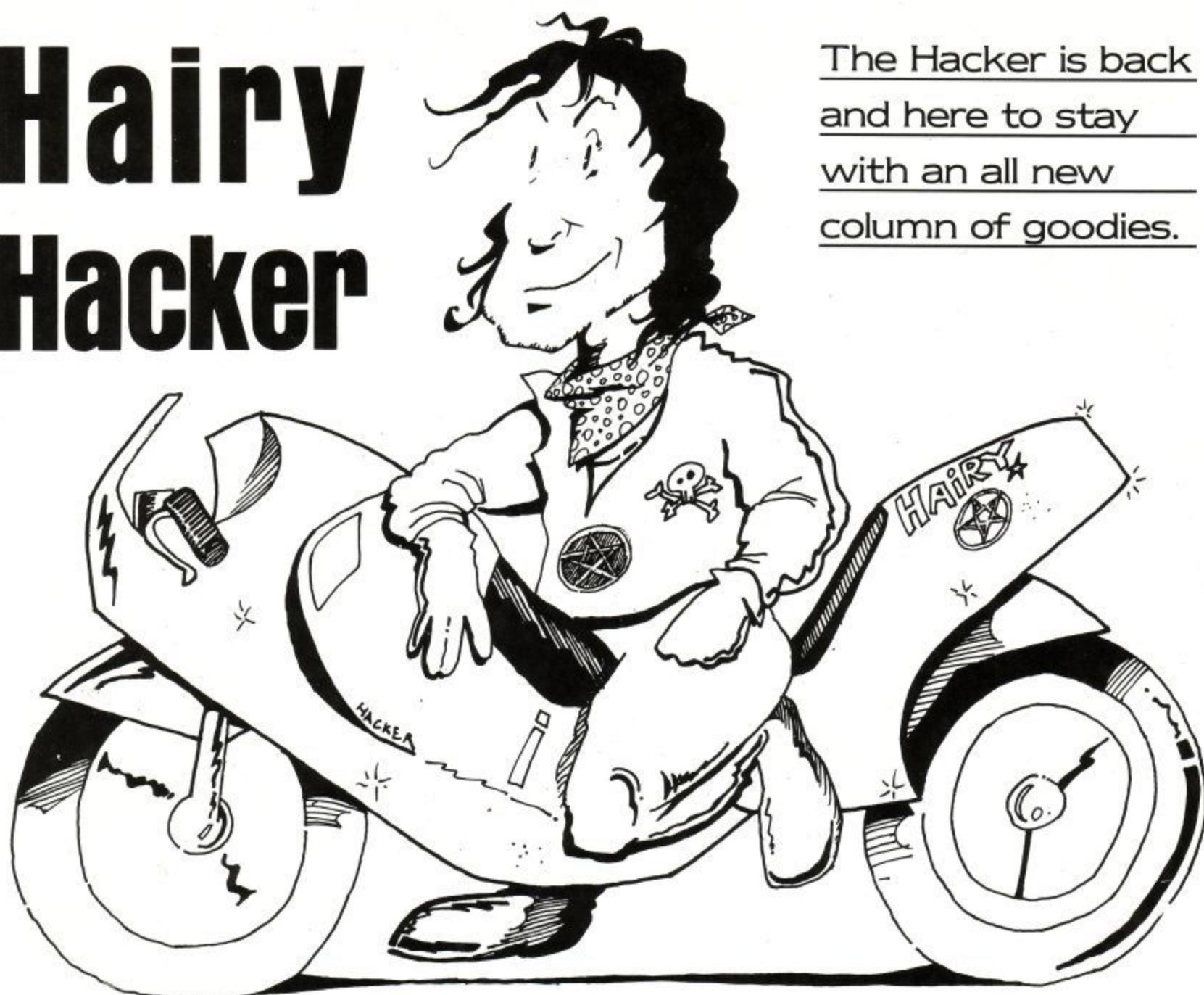

First off the starting-block is Richard Graham of Altrincham, who has found that typing the name "FREERIDE" into *Ikari Warriors* makes you almost invincible. In return, he would like to know how to get past the door near the transporter in the 'escape tunnel' in *Monty on the Run*.

The next letter has a one-liner poke for *Ghosts & Goblins*:
10 MEMORY &2000:load"!p":poke %509c,0:poke &5096,&c8:poke &828,0:call &5000. We might as well include it as Jan Cardon from Belgium went to plenty of trouble to get it to me.

There was a fourth communication this month. A map of Activator. Thanks to Peter Mardle and Neil Timpely for sending it.

So you want to hack? You are trying to back-up a game, or crack it to find infinite lives, and it loads a file all in one great block. Games do this to protect against copying without writing novel loaders like speedlock.

Where a normal, sane, binary file has a name, size and other useful

information on the front of it, these "headerless files" do not. Not only that, they sometimes use strange synchronisation bytes. I think that is out of order and will reveal a secret of hackery to you.

If you have some kind of debugger/monitor program you stick a breakpoint in CAS_READ

and peek at the registers. A glance at the firmware manual will soon tell you what those registers mean and it is only a short trip from there to saving the code. If you do not have a debugger, this sprinkling of machine code will help you:

```
10 'VAX's Headerless file loader
20 '
30 MEMORY &9EFF;OPENOUT"!D":MEMORY
&8000;CLOSEOUT;li=200
40 FOR i=&9F00 TO &A0E7
50 READ a$:a=VAL("&"+a$);POKE i,a
```

```
60 ck=ck+a:IF (i AND 7)<>7 THEN 100
70 t=t+ck:READ a$:a=VAL("&"+a$)
80 IF a=ck THEN ck=0;li=li+10;GOTO 100
90 PRINT"eRror in line ";li;END
100 NEXT
110 IF t<>51280 THEN PRINT"You missed a line";END
120 REM save "vaxcode",b,&9f00,485 will
130 REM save the code.
140 CALL &9F00
150 PRINT"Ready to go"+CHR$(13);
200 DATA 3A,A1,BC,32,F4,9F,2A,A2,428
210 DATA BC,22,F5,9F,3E,C3,32,A1,446
220 DATA BC,21,18,9F,22,A2,BC,C9,3DD
230 DATA 22,22,A0,EB,22,24,A0,32,2E7
240 DATA 26,A0,CD,FF,BB,CD,4E,BB,523
250 DATA 21,27,A0,CD,F7,9F,2A,22,397
260 DATA A0,CD,00,A0,21,34,A0,CD,3CF
270 DATA F7,9F,2A,24,A0,CD,00,A0,3F1
280 DATA 21,43,A0,CD,F7,9F,3A,26,3C7
290 DATA A0,CD,05,A0,21,52,A0,CD,3F2
300 DATA F7,9F,CD,18,BB,FE,20,CA,51E
310 DATA EA,9F,F6,20,FE,77,28,24,460
320 DATA FE,65,20,EE,CD,EA,9F,F5,5BC
```

```

330 DATA 21,C4,9F,22,31,00,3E,C3,208
340 DATA 32,30,00,2A,22,A0,ED,4B,286
350 DATA 24,A0,36,F7,23,0B,78,B1,348
360 DATA 20,F8,F1,C9,CD,EA,9F,F5,61D
370 DATA 05,E5,06,09,21,DB,A0,11,376
380 DATA 00,C0,CD,8C,BC,30,16,2A,345
390 DATA 24,A0,EB,2A,22,A0,01,00,29C
400 DATA 00,3E,02,CD,98,BC,30,05,296
410 DATA CD,8F,BC,38,0C,21,95,A0,3B2
420 DATA CD,F7,9F,CD,18,BB,CD,FF,5CF
430 DATA BB,3A,DB,A0,3C,32,DB,A0,459
440 DATA E1,D1,F1,C9,E5,D5,C5,F5,6E0
450 DATA CD,FF,BB,CD,4E,BB,21,B3,531
460 DATA A0,CD,F7,9F,06,04,E1,CD,4BB
470 DATA 00,A0,3E,20,CD,5A,BB,10,2F0
480 DATA F5,E1,2B,CD,00,A0,CD,18,453
490 DATA BB,C7,2A,24,A0,EB,2A,22,3A7
500 DATA A0,3A,26,A0,C3,00,00,7E,2E1
510 DATA B7,C8,CD,5A,BB,23,18,F7,493
520 DATA 7C,CD,05,A0,7D,F5,CB,3F,46A
530 DATA CB,3F,CB,3F,CB,3F,CD,12,3FD
540 DATA A0,F1,F5,E6,0F,FE,0A,38,48B
550 DATA 02,C6,07,C6,30,CD,5A,BB,3A7
560 DATA F1,C9,00,00,00,00,00,4C,206
570 DATA 6F,61,64,73,20,61,74,20,2BC
580 DATA 2E,2E,20,00,0D,0A,4C,65,144
590 DATA 6E,67,74,68,20,2E,2E,2E,25B
600 DATA 2E,20,00,0D,0A,53,79,6E,19F
610 DATA 63,20,62,79,74,65,20,2E,285
620 DATA 20,00,0D,0A,0A,50,72,65,168
630 DATA 73,73,20,73,70,61,63,65,312
640 DATA 20,74,6F,20,63,6F,6E,74,2D7
650 DATA 69,6E,75,65,2C,20,57,20,274
660 DATA 74,6F,20,77,72,69,74,65,32E
670 DATA 2C,0D,0A,45,20,74,6F,20,1AB
680 DATA 66,69,6E,64,20,65,6E,74,308
690 DATA 72,79,20,70,6F,69,6E,74,335
700 DATA 2E,0D,0A,0A,00,0D,0A,45,0AB
710 DATA 72,72,6F,72,20,77,68,69,32D
720 DATA 6C,65,20,77,72,69,74,69,320
730 DATA 6E,67,20,64,61,74,61,07,296
740 DATA 0D,0A,00,43,4F,44,45,20,152
750 DATA 45,4E,54,45,52,45,44,0A,211
760 DATA 0D,20,41,46,20,20,20,42,156
770 DATA 43,20,20,20,44,45,20,20,16C
780 DATA 20,48,4C,20,20,20,50,43,1A7
790 DATA 0D,0A,00,41,43,4F,44,45,173
800 DATA 2E,42,49,4E,00,00,00,00,107

```

Type that in, save it and run it. Errors in the typing will be revealed to you as it loads. You can then save the code, as in line 120, or use it there and then.

The progrette resides in the CAS_READ vector and tells you all the relevant information. Then you can hit space to continue as usual, press 'w' to write it out as a normal

file, or 'e' to find the entry address, though the program will not run afterwards.

All addresses, sync bytes and so on are displayed in hexadecimal, partly because this is the way most hackers think of such things but mostly because it is much easier to write hexadecimal print routines.

Here is the source code. Feel free to modify it and steal parts of it for nefarious purposes:

```

; The Hairy Hacker's headerless file reader.
; (C) 1989, hmwself.
nolist

ka_wait_key equ 88B18
txt_initialise equ 88B4E
txt_output equ 88B5A
scr_initialise equ 88BFF
cas_out_open equ 8BC8C
cas_out_close equ 8BC8F
cas_out_direct equ 8BC98
cas_read equ 8BCA1

org 89F00

;Store the original jump.
ld a,(cas_read)
ld (oldvec),a
ld hl,(cas_read+1)
ld (oldvec+1),hl

;Now put my vector in
ld a,&C3 ;Jump instruction
ld (cas_read),a
ld hl,vaxpat
ld (cas_read+1),hl
ret ;Back to the real

world...

vaxpat:
ld (old_hi),hl ;Save data address
ex de,hl
ld (old_de),hl ;Save length
ld (sync),a ;Save sync byte
call scr_initialise ;Helps if we can read the

screen...
call txt_initialise
ld hl,title
call strout ;Throw out data
ld hl,(old_hi)
call outword
ld hl,lele
call strout
ld hl,(old_de)
call outword
ld hl,syle
call strout
ld a,(sync)
call outbyte
ld hl,pele
call strout

k_get: ;What does the user do now ?
call ka_wait_key
cp " " ;Space just carries on
jp z,ld_n_go
or &20 ;Turn into lower case
cp "w" ;W writes the file
jr z,do_write
cp "e" ;E finds the entry point.
jr nz,k_get ;All else is invalid.

; User wants to find an entry point.
; So, first we read in the file to position the cassette

call ld_n_go
push af ;Save exit conditions

ld hl,entpat ;Patch breakpoint routine
ld (&31),hl ;into the restart vector.
ld a,&C3
ld (&30),a

;Now we fill the code area with restarts
ld hl,(old_hi)
ld bc,(old_de)

wiplp:
ld (hl),&F7 ;This is a restart
inc hl
dec bc
ld a,b
or c
jr nz,wiplp
pop af ;Restore exit conditions
ret ;Back to the user

;This is the bit that loads the code,
;and writes it out to disc

do_write:
call ld_n_go
push af ;Store result of load
push de
push hl

;Stuff to write file to disc

ld b,9 ;Open file for output
ld hl,namest
ld de,&C000
call cas_out_open
jr nc,filerr

ld hl,(old_de) ;Write out data as binary file
ex de,hl
ld hl,(old_hi)
ld bc,0
ld a,2
call cas_out_direct
jr nc,filerr

call cas_out_close
jr c,nofier

filerr:
ld hl,fiers ;File error routine.
call strout
call ka_wait_key
call scr_initialise

nofier:
ld a,(namest) ;Up the first char in name, so
inc a ;next write has different name.
ld (namest),a

pop hl
pop de
pop af ;Return the error status of the
ret ;read to user.

;This bit prints out the entry point.
entpat:
push hl ;Save all registers
push de
push bc
push af
call scr_initialise ;We'd like to see the
call txt_initialise ;screen please.
ld hl,rtn ;Tell user what's up
call strout

ld b,4

sndregs:
pop hl ;Now print out all those registers
call outword
ld a," "
call txt_output
djnz sndregs
pop hl ;PC points at next instruction, so
dec hl ;move it back one.
call outword
call ka_wait_key ;Wait for a key to be hit,
rst 0 ;and reboot time!

;This loads up the regs, & calls original cas routine
ld_n_go:
ld hl,(old_de)
ex de,hl
ld hl,(old_hi)
ld a,(sync)
oldvec: jp 0

```

```

strout:          ;Print an ASCIIIZ string from HL
ld a,(hl)
or a             ;Check for null
ret z
call txt_output ;Print next char
inc hl
jr strout

outword:        ;Output HL as 4 chars.
ld a,h
call outbyte
ld a,l          ;Fall into outbyte

outbyte:        ;Output byte in A as 2 chars.
push af
srl a
srl a
srl a
srl a
call outnib
pop af          ;Fall into outnib.

outnib:         ;Output lower half of A as char.
push af
and 15
cp 10
jr c,alfad
add 7

alfad:
add 48
call txt_output
pop af
ret

old_hl dw 0
old_de dw 0
sync db 0

title db "Loads at .. ",0
lele db 13,10,"Length .... ",0
syile db 13,10,"Sync byte , ",0
pele db 13,10,10
db "Press space to continue, "
db "W to write, ",13,10
db "E to find entry point.",13,10,10,0
fiers: db 13,10,"Error while writing data",7,13,10,0
rtm db "CODE ENTERED",10,13
db " AF BC DE HL "
db " PC",13,10,0
namst db "ACCODE.BIN"
    
```

The F7 is a re-start instruction. When the program you are cracking - sorry, backing-up - tries to run this, it calls the subroutine stored at 30H instantly. This is where my piece of code lives and that obligingly tells you what the victim program is using for an entry point.

Remember that doing a RUN" of a binary program causes all memory to be erased. So any binary code has to be loaded and then CALLED, or it will not do much good. Loading addresses can be found by de-protecting the loader - usually in Basic if there is one - or from Matt Cawley's "Excat" program, Utopia or similar.

"Them pokeys
ought to keep
most of you busy
for a month or so,
by which time I will
probably have
another bucket
load of goodies."

A welcome name just sprang into sight at the foot of the last letter - John "Hackman Girvin". He is in difficulty with his faithful tape deck going into reverse. This hack is for WEC Le Mans, and gives you three things you do not normally have - infinite time, no other competitors to force you off the road and invulnerability to hitting such things as lamp-posts, signs and tree-shaped objects. Also, your speed does not go down when you drive off the road.

Here is the poke; you run it, put it in the re-wound tape - or fast forwarded if your tape deck is doing John Girvin impressions.

Thank you for that pokette, and good luck with the hacking of Afterburner.

Them pokeys ought to keep most of you busy for a month or so, by which time I will probably have another bucket-load of goodies waiting for you. Now it is time to try for a snappy ending but only rubber bands have snappy endings, so have this one. If at first you don't succeed, try again at greater speed.

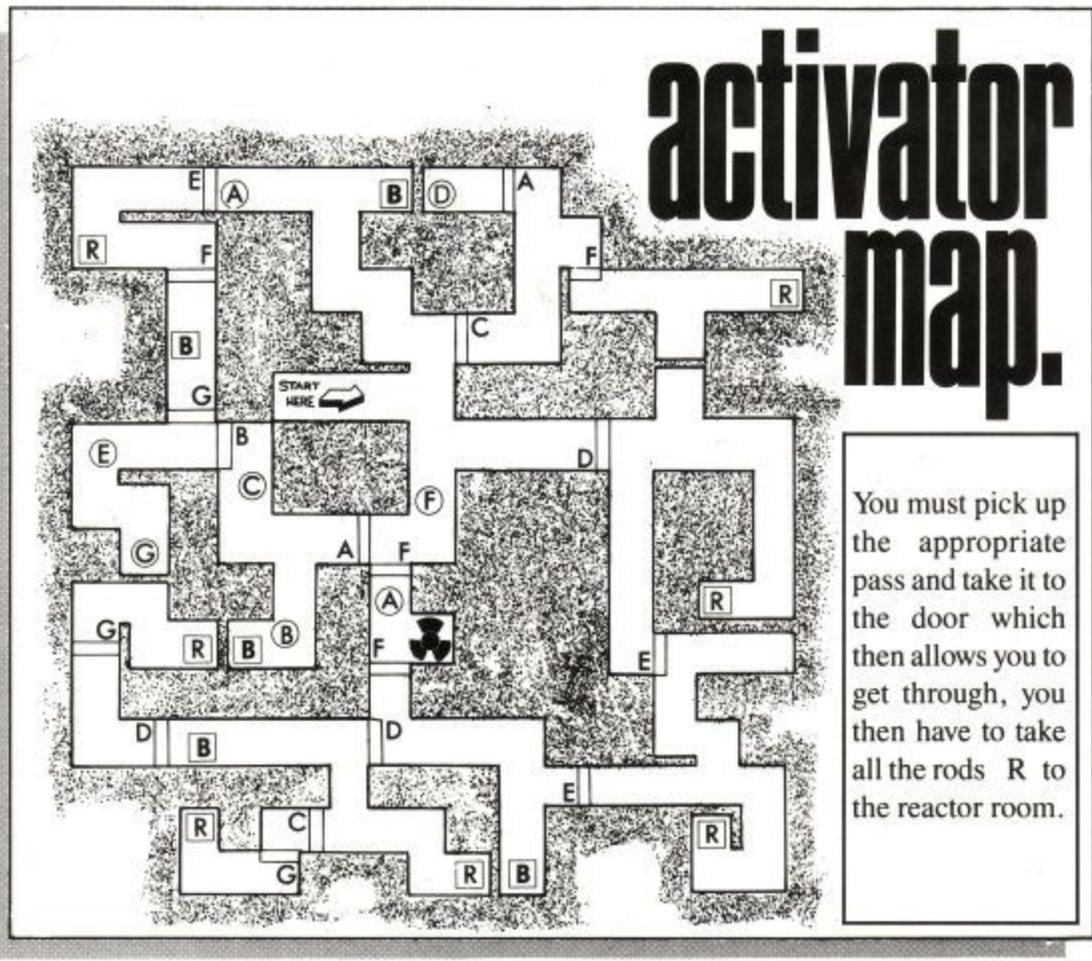

You must pick up the appropriate pass and take it to the door which then allows you to get through, you then have to take all the rods R to the reactor room.

You are here, I think.

```

1 'WEC LE MANS hacks
2 'By John Girvin
3 'April 1989
4 '
10 MODE 1:CALL &BC02
20 LOAD "wec",&99C5
30 RESTORE:addr=&BE80
40 HEAD bytes
50 IF byte$="LEMONS" THEN GOTO 90
60 POKE addr,VAL("&"+byte$)
70 addr=addr+1
80 GOTO 40
90 MODE 1:CALL &BE80
100 '*** LEAVE 110-170 IN ***
110 DATA 3e,c3,21,8e,bc,32,16,bd
120 DATA 22,17,bd,c3,c5,99,cd,37
130 DATA bd,21,00,00,22,4b,ab,21
140 DATA a0,be,22,4e,ab,c3,08,a6
150 DATA dd,21,b8,a8,11,ab,00,c0
160 DATA 47,a8,21,h3,be,22,61,a9
170 DATA c3,e2,a8,3e,c9
180 'Infinite time
190 DATA 32,42,13
200 'Remove other cars
210 DATA 32,t7,0e
220 'Invulnerability etc.
230 DATA 32,ab,0b
240 '*** LEAVE 250-260 IN ***
250 DATA a4,4b,4c,46,04,09,c3,72
260 DATA 80,LEMONS
    
```

DIXONS COMPUTER CENTRE

TITLE	Cass	Disc
Robocop	£7.45	£11.90
Run The Gauntlet	£8.45	£12.90
Dragon Ninja	£8.45	£12.90
Operation Wolf	£8.45	£11.90
Football Man. II	£8.45	£11.90
Afterburner	£8.45	£11.90
RType	£8.45	£11.90
Funschool II	£7.90	£7.90

BUSINESS	Disc
Mini Office II	£15.50
Stop Press	£36.90
Protext	£19.90
Masterfile III (6128)	£35.90
Fleet Street Editor (6128)	£35.90
Plan It	£17.90
Tasword (6128)	£19.40

ACCESSORIES	
Ram Delta Joystick	£8.95
Quickshot II Turbo Joystick	£11.95
Tac Two Joystick	£9.49
3" Drive Head Cleaner	£4.50
CPC Dust Covers (Statemodel)	£6.99
AMS Case (Holds 10 CF2)	£3.99
10 Blank Discs C15	£4.49
Printer Stand	£8.99

PRINTER RIBBONS	1+	2+
DMP 2000/2160	£3.49	£5.99
Citizen 120B	£3.90	£6.50
Star LC10	£3.90	£6.50
PCW 8256/512	£3.90	£65.0
PCW 9512	£3.30	£6.20
Ribbon Refresh	£8.95	£17.00

PRINTERS	
Star LC10	£195.00
Star LC10 Colour	£245.00
Star LC10	£319.00

DISCS	
10 CF2 (AMS/Maxell)	£25.90
10 5 1/4" Unbranded	£3.50
10 3 1/2" Unbranded	£8.50
25 5 1/4" In Disc Box	£13.00
25 3 1/2" Disc Box	£25.00

HARDWARE	
CPC464	£190.00
CPC464 Colour	£285.00
CPC6128 Mono	£285.00
CPC6128 Colour	£380.00

WE ALSO STOCK
AMSTRAD, COMMODORE, SCHNEIDER, AND STAR.

Write or phone for full CPC range price list. Also available - PCW and PC Price List.

Dixon Computer Centre,
Leazes Arcade,
Leazes Park Rad,
Newcastle-on-Tyne.

Tel: 091 261 4088 (24 hrs)



ONLY POOLS AND HORSES

PROGRAMS FOR PUNTERS FROM GENUINE EXPERTS

HANDICAP WINNER shows the **VALUE FOR MONEY** bets in handicaps. Over 380 winners in 1989 include 25/1, 16/1, 2 at 14/1, 4 at 12/1, 4 at 11/1, 5 at 10/1, 8 at 9/1, 11 at 8/1, 15/2, 10 at 7/1, 10 at 13/2 etc. **BOXFORM** weighs up a race by considering the many facets of form. Although several factors are built in, the user can easily add to, delete or modify them to produce a program tailor-made for the individual.

Two programs for the price of one. Easy to use and they never go out of date. All you need is a few minutes with a daily paper.

Tape £11.95. CMD 64/128, AMSTRAD CPC's, SPECTRUMS, B.B.C. B.
Disc £12.95 for CMD & BBC, £14.95 for CPC & SPEC +3

Other programs available covering all aspects of racing and football form. Write or phone for details.

Our programs save time not waste it. **BOXOFT CLEVER** and get the **BEST**

**BOXOFT, ACU 65 Allans Meadow,
Neston, South Wirral. L64 9SQ.**
Tel: 051-336-2668



POOLS AND HORSES

WIN WITH COURSEMASTER AND POOLSMATER

(formerly 'Pools Predictor' by Corwen Computer Systems)

The Computer Horseracing Programme

- ★ **RATES ANY RACE IN SECONDS** - ANY DAILY NEWSPAPER IS ALL YOU NEED
- ★ **NEVER** out of date - Both N. Hunt and Flat - Fast data entry.
- ★ **AMAZING ACCURACY!!** - Now you **CAN BEAT THE BOOKIE!**
- ★ Works on the simple principle that **FAST HORSES BEAT SLOW ONES!!!**
- ★ Clearly identifies best selection in every race plus these **AMAZING** Features: -
- ★ First, Second and Third choice shown for Forecasts and Tricasts, etc. Recommends most suitable type of bet.
- ★ Actually works out your **WINNINGS** on most popular bets including **SINGLES** and **DOUBLES**, win and each way. **PATENTS, YANKEES, CANADIANS, HEINZ** etc. Good **EACH WAY** and **LONG ODDS** bets clearly shown.
- ★ Will **PRINT** out your **BETTING SLIP** for you.
- ★ Maintains a **BANK ACCOUNT** - **BET** like **PROFESSIONALS** do! Records all your bets in any number of accounts. Keep a complete record of your betting or compare **COURSEMASTER** against your favourite tipster.
- ★ **PLUS!!!** - **THE AMAZING COURSEMASTER SYSTEM**. This superb betting system is included in the programme. A system which regularly produces huge wins from small stakes. Try it! Can pay for itself many times over on the first day!
- ★ Supplied with 20 page **BETTING GUIDE** and **MANUAL**.

FREE HOT TIP OF THE MONTH TO EVERY PURCHASER

Supplied on TAPE at £16.95 for: -
All Spectrums, Commodore 64/128, Amstrad
CPC's, BBC & Electron. Also available for
Sinclair QL on Microdrive at £16.95.

Supplied on DISC at £18.95 for: -
All Spectrums, Commodore 64/128, Amstrad
CPC's, Amstrad PCW's, BBC & Electron,
IBM/PC compatibles. All Amstrad PC's etc.

Please state machine and disc size

The Computer Football Pools Predictor

The amazing **POOLSMATER** programme is by far the best Pools predictor that we have ever seen. In just 10 weeks of trying this programme ourselves we won 12 dividends the largest being nearly £300. **POOLSMATER** is simple to use and requires only that you keep the league tables up to date using your usual newspaper.

- The result of many years research into the Football Pools by the programmer Martin Evans of C.C.S. the programme is a masterpiece of expertise and is simplicity itself to use.
- ★ Predicts Homes, Aways and Draws.
- ★ No fiddly typing in of teams etc. and no redundant databases.
- ★ Instant read out or Hardcopy if you have a Printer.
- ★ Uses scientific formula based on recent form home and away, league position, goals scored etc. It has long been realised that certain combinations of these factors return a much higher average of draws than the laws of average would expect. **POOLSMATER** looks for these factors and analyses their significance to give you the best possible chance of a win.
- ★ Also has a 'Sequence Predictor' option. Many people believe that certain numbers on the coupon come up more often than others and over a season patterns do seem to develop. The programme analyses these patterns and predicts the numbers most likely to come up next. Certainly more scientific than sticking a pin in or family birthdays etc!

If you do the **POOLS** then this is the programme for you.

SUPPLIED ON TAPE AT £16.95
FOR ALL SPECTRUMS, AMSTRAD CPC'S,
COMMODORE 64/128.

SUPPLIED ON DISK AT £18.95 FOR ALL
PCW'S, SPECTRUMS, COMMODORE
64/128, AMSTRAD CPC'S, AMSTRAD/IBM
COMPATIBLE PC'S.

British and Australian version available please state which. Please state disc size.

★ **SPECIAL COMPENDIUM DISK OR TAPE CONTAINING** ★

BOTH COURSEMASTER & POOLSMATER - TAPE £31.95 - DISK £34.95

INTRASET LTD, (DEPT ACU) FREEPOST NO. 10 Woodside Ave,
Clayton-Le-Woods, Chorley, Lancs, PR6 7QF.

PRE-SCHOOL, PRIMARY, JUNIOR

Education

Designed by
Experienced Teachers
For use in School and Home

Wide range of programs
For AMSTRAD CPC - PCW - PC1512
"ATARIST"

CASSETTE £9.50 - DISC £12.50
Send SAE for List. Stating Amstrad
model and child's age.



**ARC (ACU 8), 51 Coniston Crescent, HUMBERSTON,
SOUTH HUMBERSIDE DN36 4BA. (0472) 812226**

Another powerful new program from



SOFTWARE
KEYWORD

The dynamic word finder for home and business use

Now you need never be stuck for a word again because KeyWord contains dozens of synonyms for over 10,000 words.

With it you'll be able to quickly and effectively make use of the wealth of the English language, and once you've used it you'll wonder how you ever managed without it.

And it's so easy to use. Just type in a word and straight away you'll be offered a huge list of alternatives. Then using just the cursor keys, you can select the word that's nearest to your liking.

Or if it's not exactly the one you're looking for, just press Return to home in on another more closely related set of words - and so on.

And because KeyWord is installed as an RSX you can call it up from within other applications.



PLUS, as a special introductory offer, we'll send a wristwatch/calculator worth £4.95 to the sender of every order we receive before July 31st 1989.

- * Over 10,000 synonyms and antonyms.
- * Nearly 1,000 main subject headings.
- * Extra rapid word search.
- * Can select over 70 words at a time.
- * Simple operation.
- * Flexible 'roam' facility.
- * Can be used as a Thesaurus.

To order your copy please use the form on the right.

50 GOOD REASONS TO SHOP AT CRAZY JOE'S

10 Computer Hits 5	£6.99	Prodigy	£1.99
10 Great Games 3	£6.99	Real Ghostbusters	£6.99
1942	£2.99	Red Heat	£6.99
3D Pool	£6.99	Renegade 3	£6.99
720	£2.99	Return of the Jedi	£4.99
Army Moves	£2.99	Silicon Dreams	£4.99
Barbarian 2	£6.99	Skweek	£6.99
Blasteroids	£6.99	Split Personalities	£1.99
Bombjack 2	£1.99	Spy Hunter	£2.99
Chuck Yeager A.F.T.	£6.99	Storm Lord	£6.99
Dynamic Duo	£4.99	Superman	£5.99
Emlyn Hughes Int. Soccer	£6.99	Supreme Challenge	£6.99
Fernandez Must Die	£4.99	Tetris (disc)	£5.99
Firetrap	£1.99	Tiger Road	£4.99
Forgotten Worlds	£6.99	Time Scanner	£6.99
Game Over	£2.99	Typhoon	£4.99
Gauntlet 2	£2.99	Victory Road	£4.99
H.A.T.E.	£6.99	Vixen	£2.99
Heroes of the Lance	£5.99	Cheetah 125+ Joystick	£7.99
History in the Making	£12.99	Cheetah Mach One Joystick	£9.99
Human Killing Machine	£5.99	Konix Megablast	£6.99
Inc. Shrinking Sphere (disc)	£6.99	Konix Speedking	£9.99
Leaderboard	£2.99	Konix Navigator	£12.99
Marauder	£4.99	CF2 3" Discs	each £2.50
Pacmania (disc)	£7.99	CF2 3" Discs	for ten £22.50

CRAZY JOE'S

145 EFFINGHAM ST., ROTHERHAM, SOUTH YORKSHIRE S65 1BL
VISA AND ACCESS ORDERS TAKEN ON (0709) 829286
Please make cheque/P.O. payable to "Crazy Joe's"
P&P Free in U.K. on orders of £5 or over. Under £5 please add 50p.
Europe please add £1 per item. Rest of world add £1.50 per item.

3 1/2" DISC DRIVE £89.95 800k Storage Capacity

The quality 'TEAC' drive is just 1" high and*, when used with RODOS, ROMDOS, or RAMDOS, will give you a massive 800k of storage without flipping the disc. Is supplied cased, complete with power supply and cable, ready to plug in and go. (Please state 464/664/6128)

OPERATING SYSTEM	TOGETHER
RODOS (ROM) £29.95	£119.90
ROMDOS (ROM) £34.95	£124.90
RAMDOS (DISC) £24.95	£114.90

We buy and sell quality used computers and peripherals.
Ring us - we might have what you want.

Upgrade your 464

The amazing
ROMBOARD XTRA
including

6128 UPGRADE SOCKET

Features:	6 Standard ROM Sockets
plus -	Put a 6128 ROM in the 7th socket and you have a working 6128 operating system. Upgrading is as simple as that!
plus -	464/6128 selector
plus -	Cold start RESET BUTTON
plus -	Through connector for further expansions
ALL THIS FOR JUST £20	6128 ROM £19.50 64k RAM PACK £49.95

Third Drive Switching Cable

Connect to any combination of 5.25", 3.5" or 3" disc drives.
ONLY £8.50 (Please state makes of drives if known)

ROM Software	
Pretext	£29.95
Promerge+	£26.95
Prospell	£26.95
Utopia	£22.95
Maxam	£29.95
Maxam 1.5	£22.95
BCPL	£22.95

EPROM Programmer	
Put your own programs on ROM with the new 'FLEET' Programmer.	
* 8k, 16k, 32k EPROM	
* 12.5V + 21V SELECTABLE	
* ZIF SOCKET	
* MANY OTHER FEATURES	
£69.95	464 ADAPTOR £9.95

MICROSTYLE, 212 Dudley Hill Road, Bradford, BD2 3DF

Tel: 0274 636652

SWIFT SOFTWARE

TOP SOFTWARE AT ROCK-BOTTOM PRICES

NEW LOW PRICES

Buy with confidence with our 10-day money back guarantee — orders normally despatched the same day

THE ARNOR COLLECTION • THE ARNOR COLLECTION • THE ARNOR COLLECTION • THE ARNOR COLLECTION

Protext – Without doubt the most sophisticated word processor you'll find on any home micro. Its ease of use and advanced range of features are normally only found in business systems costing many times more. Protext is the number one wordprocessor for the CPC!

RRP	Disc £26.95	Rom £39.95
OUR PRICE	£18.50	£29.50
You Save	£8.45	£11.45

Promerge Plus – This rom offers all the features of the Promerge disc plus, among other features:

- * Two file editing
- * Background printing
- * Box/Column mode

RRP	Rom £34.95
OUR PRICE	£23.50
You Save	£11.45

ROMBO & PROTEXT

- * Protext instantly accessible
- * Seven free sockets
- * Select high or low bank (allowing addition of 2nd rom box)
- * On/off switch for each rom
- * In and out expansion port sockets

RRP	OUR PRICE	SAVE
£74.90	£49.50	£25.40

Prospell – With Prospell you can produce 100 per cent error-free documents, eliminating odd words and dubious spellings. You can also add words to create your own dictionary.

RRP	Disc £24.95	Rom £34.95
OUR PRICE	£17.50	£23.50
You Save	£7.45	£11.45

Maxam – The standard Assembler/Monitor/Editor for developing Z80 machine code. Used by many top software houses, this is an essential utility if you want to create machine code programs.

RRP	Disc £26.95	Rom £39.95
OUR PRICE	£18.50	£28.50
You Save	£8.45	£11.45

Utopia – Once you have installed Utopia you won't know how you managed without it! It gives you 50 new commands – all of which are available without having to write a single program.

RRP	Rom £29.95
OUR PRICE	£21.50
You Save	£8.45

Promerge – Promerge is more than just a simple mailmerger for standard letters. It includes powerful mathematical and text functions and, of course, integrates perfectly with Protext.

RRP	Disc £24.95
OUR PRICE	£19.50
You Save	£5.45

Maxam 1.5 – Enhanced version of the extremely successful assembler/monitor, designed to be used from Protext. The editor has therefore been removed, leaving room for many new features.

RRP	Rom £29.95
OUR PRICE	£21.50
You Save	£8.45

BCPL – One of the fastest, most flexible programming languages for the CPC. It is the precursor to C and has been used to write many operating systems and other major programs where speed is essential.

RRP	Disc £24.95	Rom £29.95
OUR PRICE	£18.50	£22.50
You Save	£6.45	£7.45

NEW • NEW • NEW • NEW • NEW • NEW • NEW • NEW • NEW • NEW • NEW • NEW • NEW • NEW • NEW • NEW

**SAVE £4.95
FREE**
with every copy of Pandora

OUT NOW! Pandora

As a special introductory offer, with every order for Pandora we'll send you a FREE calculator/wristwatch worth £4.95. But hurry, we can only guarantee this gift for orders received before July 31st 1989.



We reserve the right to replace the watch illustrated with another of similar or better quality.

- The program that takes the lid off your micro!
- Write arcade games – without knowing any assembler!
 - Multi-featured sprite designer
 - Animated sprites
 - Compile stand-alone programs
 - Can compile directly from Protext
 - Free games and examples supplied
 - Comprehensive manual



Dealer Enquiries Welcome

Please send me the following items (please tick)

	Disc	Rom
Protext & Rombo	—	£49.50 ()
Protext	£19.50 ()	£29.50 ()
Promerge	£19.50 ()	—
Promerge Plus	—	£24.50 ()
Prospell	£18.50 ()	£24.50 ()
Utopia	—	£22.50 ()
Maxam	£19.50 ()	£29.50 ()
Maxam 1.5	—	£22.50 ()
BCPL	£18.50 ()	£22.50 ()
Pandora	£29.95 ()	—

ORDER FORM

I enclose a cheque/Euro cheque/PO made payable to:
SWIFT SOFTWARE

Name _____

Address _____

Post Code _____ Tel. _____

SWIFT SOFTWARE ACU8, 347 LONDON ROAD, HAZEL GROVE, STOCKPORT, SK7 6AA. 061-456 0926

Packet Radio

As the lure of the
bulletin boards
increases so do the
phone bills. One
way round this
costly problem is
the age old
technique of
packet radio.



If you are an avid communications user you will know how expensive your hobby can be. For many, the thrill of being able to log on to a bulletin board leads only to debt with the telephone company.

Those in debt are disconnected for not being able to pay the extortionately high cost of owning and using a telephone. For those who face an expensive or have already had a high telephone bill, listen - there is an alternative at hand.

Rather than lining the pockets of British Telecom shareholders, losers can turn to another method of computer communication. Radio hams might have already guessed the alternative. Packet Radio could

change computer communication significantly.

Packet Radio is not a new concept. The Americans have been using radio to transmit and receive computer data for about 10 years. In the U.K. Packet has only recently gained ground as a widely-used medium for data transmission but already there are thousands of radio hams talking to each other in binary form.

Even though Packet Radio is a completely different medium from telephone transmissions, the way both are used is similar and many comms users will feel at home with it. Radio is normally used for one-to-one communication between two radio hams. Packet Radio is no exception to the rule, though there

“Using a bulletin board can be rewarding as you can do many things with them.”



addresses of establishments which have held such courses. Courses usually begin in September and prepare the candidate for the following May examination. Further, most courses are held as evening classes.

With certificate in hand you can buy your licence. With that you will be assigned a call sign, a number of digits and letters which are tagged on to the beginning of all transmissions which are addressed to you. Your radio will receive them and pass on only those which are for you. Likewise, the sender's call sign will also be tagged to the message so that the recipient will know its origin.

Like data telecommunication systems, you will require a modem to modulate the outgoing signal and to demodulate the incoming one. If you already own a modem for use over the telephone lines you are in for some bad news. Such a modem will be of no use to Packet Radio. Those modems produce data in long sequential streams, whereas Packet Radio requires data to be transmitted in packets.

Your new modem should be in the form of a Terminal Node Controller. They package the data automatically and are already set up for use with radio and incorporate the appropriate connectors at the rear.

Three typical TNC modems are sold by leading packet radio specialist Andrews Computer Services of Watford. They are the AEA PK88 modem, which allows use of both HF and VHF Packet Radio, and costs £129.95. If you are looking for something a little cheaper you might like to consider the Pac-Comm Tiny-2. It costs £109.95 and allows usage of VHF Packet only. If you have plenty of money and want the best you can turn to the all-singing, all-dancing AEA PK232 which will cost £279.95.

are hundreds of bulletin boards and they operate in the same kind of way as those available over the telephone lines.

Using a bulletin board can be rewarding, as you can do many things with them. One of the main purposes for which they are used is

to send electronic mail to pen friends and to up-load and down-load files. Many of the files available consist of utilities and demonstrations, most of which are of premium quality and are in the public domain.

To use Packet Radio, first, and most important, you need to be an amateur radio operator. This legally requires an operator's licence which

will cost £12. Before you can get your licence you need to pass an examination based on your knowledge of radio.

The examination is set by the City & Guilds Board and there are two a year. You have already missed the May examination and the next one is due for December. The paper is in two parts, both of which must be completed.

To learn for the examination you can choose any method you like. The easiest but not necessarily the cheapest would be to attend a course on the subject. Some adult institutes and education authorities run such courses and you should contact your local authority to find if there are any courses in your area. I have included some names and



All those modems are equipped with an RS232 interface. Unfortunately, Amstrad CPC computers do not have one of them built-in and so you will need to buy one if you do not already own such a device.

To use Packet Radio to its full potential you will require some specialised software. If you already have communications software you will be able to use it with Packet but you will be short of functions, file transfer especially. Dedicated Packet Radio software costs very little, as it is public domain. Once you have this you will have all the computing equipment you need to begin.

All you need then is the radio equipment. Radios can cost a small fortune but if you are prepared to pay the cost of a new radio you might be saving yourself a good deal of trouble in the long run.

If you attend any radio rallies you should be able to pick up a suitable unit for about 50 pence but it will be a very basic unit and is likely to be

just single-channel. Such a unit will need to be re-tuned and so, unless you are confident you could do it yourself, it will have to be done by a radio shop or obliging friend.

A typical new radio might be the Yaesu FT211R which has some special features which aid Packet Radio users. This costs about £250 and is fully-functional FM radio as well as being designed for Packet.

Packet Radio operates on a number of frequencies. The most popular is 144.650MHz VHF. This

“There are
hundreds of
bulletin boards in
the U.K. and
finding them all
will be an
education.”

channel is incredibly busy and is the rendezvous for many bulletin board systems and network nodes.

A network node is a radio substation. Calls are put through a network node if they are travelling a long way. The node receives the transmission and passes it on to the next node. The signal is passed on and on until it is close enough to the described recipient. It then sends the signal to the destination.

Another busy channel is 144.675MHz VHF. Here many one-to-one conversations take place. The next busiest frequency is 432.61MHz FM. Other channels include 70MHz VHF, 50MHz VHF and 1,296MHz VHF and 14.105MHz on HF.

Finally, you will need an aerial. The better the aerial the better your signal will be and you will be less likely to get interference. If you have run out of money at this point you could make an antenna. Just throw off your best overcoat or wedding suit from that old wire coat hanger and adjust the hanger slightly with two pairs of strong pliers and you

have a home-made aerial. Just attach some coaxial lead to it, place it in a prominent position close to a window and you can start.

All that work has finally paid off and you are now a fully-fledged Packet Radio user you might like to join a local amateur radio club and begin to become more and more involved. Amateur radio is a very broad field. There are millions of users all over the world, many of whom are now tuning to Packet Radio. There are hundreds of bulletin boards in the U.K. and finding them all will be an education. The fact is that Packet Radio is going places – places where no computer comms user has gone before.

Space, the final frontier? Well, possibly. At this moment there are hundreds of radio waves bouncing off a satellite hundreds of miles above the earth – a special packet radio satellite. Sounds fun? Well, it is not too expensive to get into and there is no harm in trying.

Contacts:
City & Guilds Examination
information.

Section 12
City & Guilds of London Institute,
46 Britannia Street,
London WC1X 9RG. Tel: 01-278 2468.

Courses:
International Correspondence
Schools,
312-314 High Street,
Sutton, Surrey. SM1 1PR.
Tel: 01-643 9568.

Radio & Telecomms Correspon-
dence School,
12 Moor View Drive,
Teignmouth, Devon. TQ14 9UN.
Tel: 06267 79398.

The Rapid Results College,
Tuition House, 27-37 St. George's
Road, London SW19 4DS.
Tel: 01-947 7272.

Specialist companies.
Andrews Computer Services,
Packet Radio suppliers,
Tel: 0923 229222.

Yaesu,
Tel: 0713 255 111.

IT'S A
funny thing



*"IT's a Funny Thing"
is a collection of stories,
anecdotes, witticisms, drawings
and cartoons with the common theme
of Information Technology.*

Contributions come from the rich, successful and famous - and not. They come from IT users and organisations for computer professionals as well as suppliers of hardware and software. They are company Chairmen, Managing Directors... Consultants, Programmers and Analysts. Some have chosen (possibly needed) to remain anonymous. They have given their best one-liners, favourite after dinner stories and illustrated humour. And they've given freely.

"IT's a Funny Thing" has been produced at cost all the way from the admin, to the artists, to the typesetters, to the printers. Nobody apart from The Wishing Well Appeal is making a penny. Even the space for this ad has been donated free by the publication.

Buy this book and you won't be the only one smiling. With all the Royalties going to Great Ormond Street you'll find quite a few children smiling as well.

Please send copies of "IT's a Funny Thing" at £10 per copy

Name _____

Address _____

Post Code _____

Cheques should be made payable to "The Wishing Well Appeal" and we ask you to allow 28 days for delivery.

Please complete this coupon and send with your cheque to:

IT's a Funny Thing, The Wishing Well Appeal,
C/O Digitus Ltd., 16-17 Clerkenwell Close, London EC1R 0AA



The Wishing Well Appeal
Great Ormond Street Children's Hospital

Help Great
Ormond Street
get better.

Take Your Pick

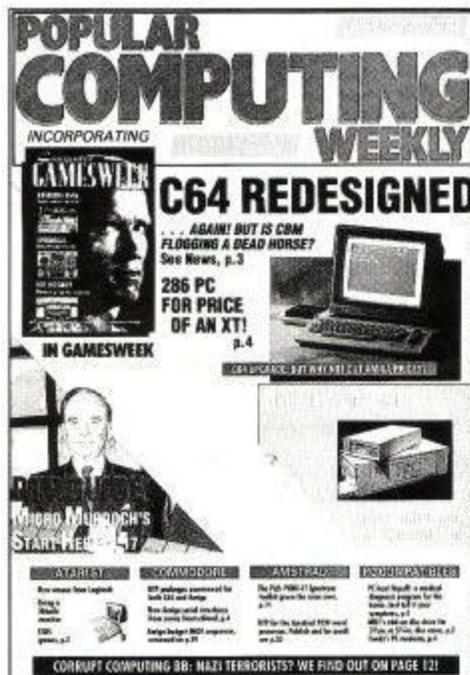

Popular Computing Weekly — the essential item on your shopping list. Up-to-the-minute news, views, advice, hardware and software reviews ... PLUS your FREE *Computer Gamesweek* supplement in every issue. Only 70p. On sale Thursday.

Which PC — the critical PC buyer and user guide. *Which PC* investigates the hardware/software market. Every issue our Buyers' Guides inform you of the options available ... makes buying easy. A large glossy magazine ... with bite! Only £1.45 Monthly.

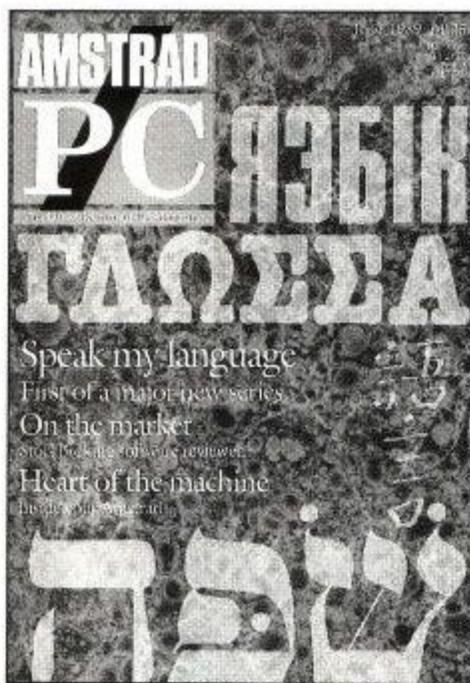

Amstrad Professional Computing — the official title for the professional user of Amstrad machines. Seriously researched features looking at the applications of Amstrads in business. Only £1.50 Monthly.

Amstrad PCW — the official monthly magazine dedicated to the 8,000 and 9,000 series Amstrads. Programming in Mallard Basic, software and book reviews and clear guides to word processing packages ... make sure you get the most from your word processor. Only £1.45 Monthly.

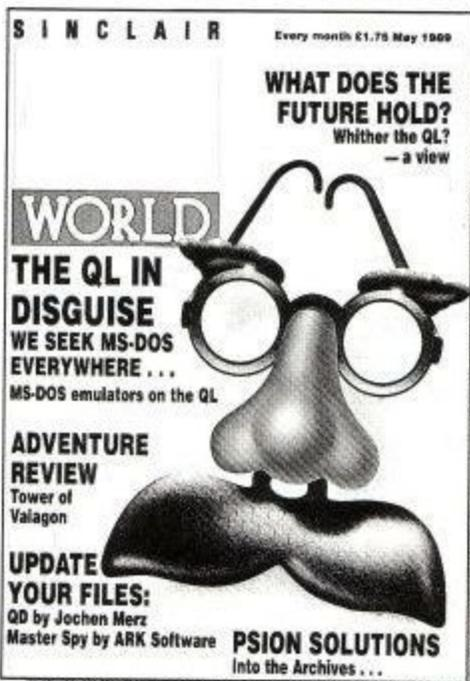
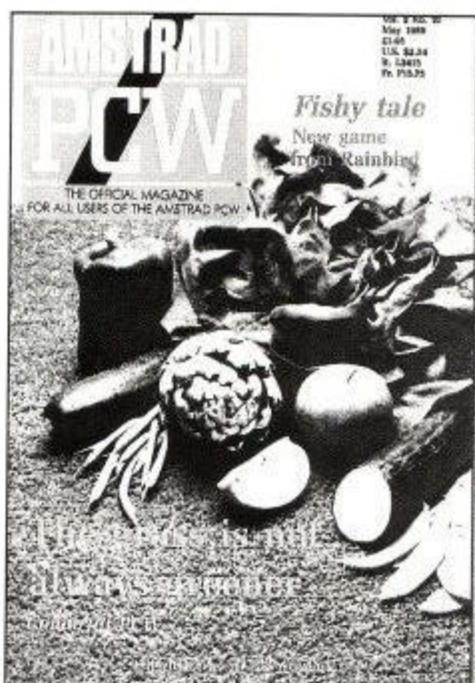

Sinclair QL World — the only magazine supporting the ever-popular Sinclair QL computer. QL Scene for news, details of the latest programs and add-ons available ... and more! Only £1.75 Monthly.

Amstrad Computer User — the official magazine for Amstrad CPC users. Packed with games, news, tips and ideas to unlock full value from these popular machines. We advise on what's available and how good it is even before it hits the streets! Only £1.25 Monthly.



Order your copy from your newsagent today. Subscriptions available.
Focus Magazines, Greencoat House, Francis Street, London SW1P 1DG. Tel: 01-834 1717.

Welcome to Auntie John's Summer Column



in the form of packets of data eight bits wide.

Remembering that a bit is an ON or OFF signal, you can imagine that eight separate wires are needed to carry information from one part of the computer to another. To store all that information a 16-bit address system is used. If you know binary arithmetic you will realise that 16 bits will give $16,384 * 16,384$ separate addresses and so the Z-80 can access 64K of memory directly, where 1K equals 1,024 bytes and one byte equals eight bits.

Experienced programmers will laugh at this point, since everybody knows about bits and bytes. They might, however, pause for a second

when they realise that the CPC6128 manages to break a few of the rules they hold so dear.

The Z-80 was designed to be able to use 64K

This month we look at the extra memory CPC6128 owners have. Most of the time the memory is unused by the Basic and machine code programmer and it rests on the sidelines doing nothing. That is a pity because computer memory is expensive and potentially very useful. Although it is many times cheaper than it was 10 or so years ago, world shortages recently have pushed up its price again. The moral is if you have it, use it.

Deep inside your beloved grey plastic box is a tiny chip of silicon encased in a little plastic packet and called a Zilog Z-80 microprocessor. The Z-80 is now getting rather old, though they have been saying that for years, and is what is referred to as an 8-bit microprocessor. The eight bits does not mean that inside it are eight pieces but that the information is moved round inside the computer

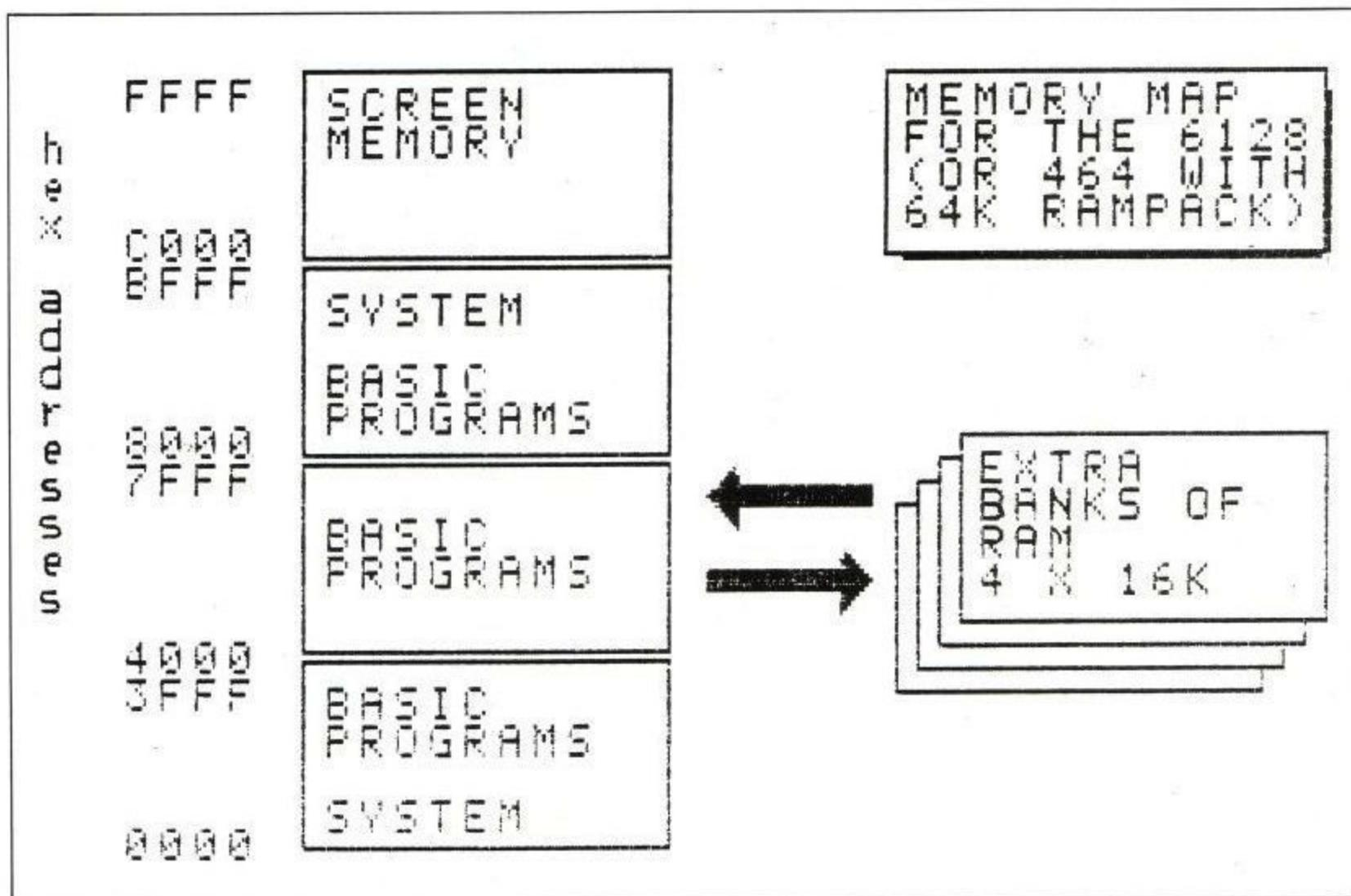

Summer is here at
last, school is almost
out and John
Kennedy has slipped
into something
casual to examine
the extra memory
on CPC6128s.

of memory and in a CPC6128 there is more than 170K of memory.

The CPC range was designed to make use of a technique called bank switching, by which the necessary portion of memory is switched on only when it is needed and so the 64K maximum rule is never violated. The 170K memory exists but the Z-80 is allowed to look only at certain parts of it at a time.

The design of the CPC allows yet more memory to be provided by ROMs and EPROMs. They overlap the bottom and top of the possible memory map and contain the operating system, Basic and, if disc

drives are present, the code needed to use them. Other programs such as word processors, assemblers and even other languages can also be stored in ROM and switched in when needed.

This sounds complicated but all this is completely transparent to the user, to whom it appears that the programs in ROM are like any other program, except that they take up no RAM and they load instantly. The switching of ROMs, EPROMs and RAMs is done from another of the chips in the CPC, called the gate array.

The firmware routine situated at address &BD05 will allow us to choose which 16K RAM bank goes where - figure 1. This machine code does not exist on a 464 or 664, so even if extra memory packs are plugged into those machines the CALL &BD05 routine will not work. Unless, of course, someone supplies

you with the necessary code. Some memory packs code with suitable code.

The extra 64K of memory on the 6128 is split into four banks, each 16K in size. There are several configurations all the memory banks can take but the ones on which we concentrate on are those which

switch the memory in and out of the addresses from &4000 to &7FFF. This block is in a good place to shift in and out and will form the basis for the subroutines which follow.

Moving round the banks of RAM can be a nasty business, especially if you are trying to execute a program

in one at the time. The computer would be running a program when the program vanishes and the computer becomes paranoid. The hardware also expects the screen display to occupy one of two places and will refuse to agree to any other locations, so take care when experimenting. You will not break anything but you can easily get into a situation where only a total power-down will save the day. It is interesting that the contents of the extra memory are not re-set whenever the ESC - SHIFT - CONTROL keys are pressed, so any picture or other data will not be affected by a minor crash - but do not take it for granted.

So what will we do with all this extra memory? The following machine code will allow you to store and retrieve screen images to and from the banked RAM. You will also be able to look at a miniature version of each stored screen so that you

can see what is happening. The machine code makes use of the RSX system, so you will not have to remember hex addresses. As an act of unheard generosity, I will even give you the hexcode in a Basic program.

Program 1 is the assembly language listing. The material at the start is all the machine code needed to set up the RSX table. Notice how each routine extracts some parameters - the numbers which follow the RSX - and uses them to

choose the bank of RAM in question. Each RSX must check that one, and only one, parameter is supplied and that the parameter is in the desired range. If this is not the case the routines return to Basic without doing anything; you might

Listing 1 - The assembly language listing.

```

;Assembly Language Program to Store and Fetch screens
;from the extra memory on a CPC6128.

log_rsx equ %bcd1
next_line equ %bc26
rambank equ %bd5b

    org %8000

    ld bc,commandtable
    ld hl,buffer
    call log_rsx
    ret

.buffer ds 4

.commandtable
    dw nametable
    jp storescreen
    jp fetchscreen
    jp miniscreen

.nametable
    db "STORESCREE", "N"+%80
    db "FETCHSCREE", "N"+%80
    db "MINISCREE", "N"+%80
    db 0

.storescreen
;Store screen display in extra memory.

    cp 1          ;Return to BASIC if there isn't exactly
    ret nz       ;one parameter.

    ld a,(IX)    ;Make sure the parameter is in the
    cp 5         ;range 1-4, and if not
    ret nc      ;return to BASIC.
    cp 0
    ret z

    add 3        ;Adjust the number, and call the
    call rambank ;firmware.

    ld hl,%c000 ;the start of the screen memory.
    ld de,%4000 ;the start of the Ram Bank.
    ld bc,%4000 ;the length of the screen.
    ldir        ;the magic machine code instruction LDIR!

    ld a,0
    call rambank ;Put back the original RAM bank.
    ret        ;and back to BASIC we go..

.fetchscreen
;Copy screen image from extra RAM to the screen.

    cp 1          ;Check for one parameter.
    ret nz

    ld a,(IX)
    cp 5
    ret nc
    cp 0
    ret z        ;Check for range 1 to 4.

    add 3        ;Adjust it and use the firmware
    call rambank ;to bank in the next memory.

    ld de,%c000 ;Move data FROM this address
    ld hl,%4000 ;TO this address
    ld bc,%4000 ;THIS amount,
    ldir        ;with this instruction.

    ld a,0
    call rambank ;Put original memory back.
    ret

.miniscreen
;Draw a miniture version of the image held
;in banked memory.

    cp 1
    ret nz      ;Check for a parameter.

    ld a,(IX)
    cp 5
    ret nc     ;Return if out of range.

    cp 0
    jr z,special ;The parameter value of ZERO
                ;is a special case.

.mini
    add 3

    push af
    call rambank ;Switch on the RAM bank.
    pop af

    ld hl,%c000 ;Set a different screen position
    cp 4        ;for each Banked RAM image to be
    jp z,shrink ;drawn at.

    ld hl,%c028
    cp 5
    jp z,shrink

    ld hl,%e3c0
    cp 6
    jp z,shrink

    ld hl,%e3e8

.shrink
    ld b,100    ;The height of the mini-image.
    ld de,%4000 ;The address stored image.
    .loop1
    push hl    ;Store the start addresses.
    push de
    ld c,40    ;The width of the mini-screen.
    .loop2
    ld a,(de)  ;Copy the data from the stored
    ld (hl),a  ;image to the actual screen..
    inc hl
    inc de:inc de ;Update the screen addresses.
    dec c
    ld a,c
    jr nz,loop2 ;End of 'width' loop

    pop hl    ;Cunningly read DE into HL
    call next_line ;and move it down a line
    call next_line ;or two and
    ex de,hl  ;then swap it back.

    pop hl
    call next_line ;Move HL to the next line.

    djnz loop1 ;End of 'height' loop

    ld a,0
    call rambank ;Put the original
    ret        ;block of RAM back in place.

.special
;Draw all the RAM banks, 1 to 4.

    ld a,1:call mini
    ld a,2:call mini
    ld a,3:call mini
    ld a,4:call mini

    ret

```

Listing 2 - The Basic HexCode loader program.

```

10 ' Machine Code Hex Loaded
20 ' SAVE program before running
30 '
40 MEMORY &7FFF
50 s=0
60 FOR a=&8000 TO &80E7
70 READ b$:b=VAL("&"+b$)
80 POKE a,b
90 s=s+b
100 NEXT a
110 IF s<>&6889 THEN PRINT "Error in data."

120 CALL &8000
130 PRINT "RSXs installed."
140 NEW
150 DATA 01,0E,80,21,0A,80,CD,D1,BC,C9,8C,9F,0E,80,19,80
160 DATA C3,3A,80,C3,5C,80,C3,7E,80,53,54,4F,52,45,53,43
170 DATA 52,45,45,CE,46,45,54,43,48,53,43,52,45,45,CE,4D
180 DATA 49,4E,49,53,43,52,45,45,CE,00,FE,01,C0,DD,7E,00
190 DATA FE,05,D0,FE,00,C8,C6,03,CD,5B,BD,21,00,C0,11,00
200 DATA 40,01,00,40,ED,B0,3E,00,CD,5B,BD,C9,FE,01,C0,DD
210 DATA 7E,00,FE,05,D0,FE,00,C8,C6,03,CD,5B,BD,11,00,C0
220 DATA 21,00,40,01,00,40,ED,B0,3E,00,CD,5B,BD,C9,FE,01
230 DATA C0,DD,7E,00,FE,05,D0,FE,00,2B,48,C6,03,F5,CD,5B
240 DATA BD,F1,21,00,C0,FE,04,CA,AD,80,21,28,C0,FE,05,CA
250 DATA AD,80,21,C0,E3,FE,06,CA,AD,80,21,EB,E3,06,64,11
260 DATA 00,40,E5,D5,0E,2B,1A,77,23,13,13,0D,79,20,F7,E1
270 DATA CD,26,BC,CD,26,BC,EB,E1,CD,26,BC,10,E5,3E,00,CD
280 DATA 5B,BD,C9,3E,01,CD,8B,80,3E,02,CD,8B,80,3E,03,CD
290 DATA 8B,80,3E,04,CD,8B,80,C9

```

like to add a routine to print an error message.

Program 2 in the Basic program will create the RSXs and then nuke itself so save it before running. When all is working you will have three RSXs logged on to your system - STORESCREEN, FETCHSCREEN and MINISCREEN. They all need the number of a RAM bank to use a number from 1 to 4. MINISCREEN is special because it also can take the number from 1 to 4. MINISCREEN is special because it also can take the number 0 after it. Try it and see what it does.

Program 3 is a short demonstration you can run after getting the RSXs to work. You must save a screen to disc or tape with which the program can load or, alternatively, you could write a short routine using DRAW and PLOT to put squiggles on the screen.

So the extra memory is put to good use. If you want a good exercise in programming, try using the RSXs to supply you with some pull-down menus. Pull-down menus are menus which appear on the screen, covering anything which was there previously. Whenever a choice is made from the menu they disappear and anything underneath is re-drawn. You can use STORESCREEN and FETCHSCREEN to protect the contents of the screen under the menus.

Listing 3 - A short Basic demonstration program.

```

10 ' Example Basic Program
20 'RSX's MUST already be defined!
30 MODE 1
40 LOAD "screen",&C000: 'A screen display of your own design.
41 REM Preceed name with ! if using a tape (spit) system
50 FOR a=1 TO 5
60 FOR b=1 TO 4
70 !STORESCREEN,b
80 NEXT b
90 !MINISCREEN,0
100 'try changing 0 to 1 above
110 NEXT a

```

ADVANTAGE

- Prices include VAT and First Class Postage
- Your Order will be processed within 24 hours
- We give a full refund if you are not satisfied

PUBLIC SOFTWARE

The following discs contain tried and tested software from the public domain, tailored and installed for CPC computers using CP/M Plus. Each disc has MENU selection and sorted directory utilities, plus documentation.

WORD-SPREAD-BASES ONLY £6.00 per disk

- VDE TEXT EDITOR** Easy to use full screen ASCII editor with automatic word-wrap, page breaks, printer control - ideal for compiler source code.
- SPREADSHEET** Ideal for home accounts and small business users. Easy to use. Good documentation.
- DBQ DATABASE** A relational database for storing simple date and producing reports and forms letters. Free format query language with macros and commands. Features on-line help. ALSO: Inventory Database.

HOME AND BUSINESS ONLY £6.00 per disk

- COMMUNICATIONS** Get communicating with UKModem7, MEX, Kermit. Includes Terminal Emulation.
 - FIXED ASSETS LOG** Record up to 350 items and their value. For home inventory, insurance, stocktaking control. Forms management and sort routine.
 - VIDEO CLERK** Track your video collection. This database system features 4 sort options and forms management plus extensive documentation.
- STD CODES in NUMERIC order with exchange names.

USEFUL UTILITIES ONLY £6.00 per disk

- COMPLEAT UTILITIES** The famous NSWEEP disc manager, Superzap sector/file editor, Unerase, DISCKITA for 178k CF2 format, 5 1/4" second drive., Screen dump etc.
- TEXT PROCESSING UTILITIES** Sideways prints text (eg spreadsheet) on its side, Alphabetic Sort, Word Count, WSclean convert WP file to ASCII, Simple Spelling Checker, Score Card Generator, Banner printers, Typewriter Emulator.
- DISC ORGANISATION** Catalogue your disc collection and produce a printed index, File Finder, Archive program, Squeeze and Unsqueeze - save disc space.
- THE CPM 2.2 COLLECTION** For 464 owners with just CPM 2.2 Includes NSWP, Sector Editor, Key Definer, Text Editor, Unerase, File Transfer, Grep, Easy Lister, Compare, Find.

ENTERTAINMENT ONLY £6.00 per disk

- GAMES COMPENDIUM** Pacman, Polish Pong, Chess, Othello, Mastermind, Spellit, Awari, Life, Golf, Maze, Biorhythms, Word Search Puzzle Maker, Tic-Tic-To - all written in machine code.
- ADVENTURES** The famous Colossal Cave Adventure plus Return To Arg.
- AMUSEMENTS & DIVERSIONS** 20 games for Mallard BASIC. Startrek, Whichword, Lander, 3D Tic-Tac-To, Merchant, Othello, Hangman, Baseball, Civil War, Maze, American Football, Nim, Horse Races, Blackjack Spies Crazy-B.

PROGRAMMING ONLY £6.00 per disk

- The Z80 PROGRAMMER** Z80 Assembler/Disassembler, Z80 Debugger, Z80 Library, Z80 - 8080 translators.
- THE SMALL C PROGRAMMER** Includes source code. Produces executable machine code programs.
- C TOOLBOX** See how other programmers do it with this useful set of C Source code programs. Disc includes the executable programs.
- PROLOG-80** New Artificial Language Interpreter with comprehensive manual.

BOURNES EDUCATIONAL SOFTWARE

Choose from World Wise, Word Hang, Timeman One, Timeman Two, Map Rally, Happy Writing, Happy Numbers, Happy Letters, Osprey and Animal Vegetable Minteral "Educational and FUN too!" ONLY £13.95 per disc.

SCHOOL SOFTWARE

Choose from Magic Maths, Playschool, Maths Mania, Maxi-Maths, Better Spelling, Better Maths, Physics Chemistry, Biology, Mapwork Quiz. "HIGHLY RECOMMENDED" ONLY £14.95 per disc.

NEMESIS

- Four Classic Adventure Games - The Trial of Arnold Blackwood, Aronold Goes to Somewhere Else, the Wise & Fool Of Arnold Blackwood and Brawn Free. "A good challenge, lots of hints and tips and a good range of responses" - 8000 PLUS £9.95
- BONZO SUPER MEDDLER & HACK PACK** Tape to disc £10.95
- BONZO'S DOO DAH** "I recommend it" - AA £10.95
- BONZO BLITZ** Speedlock straight to disc £10.95
- MINI OFFICE II** Integrated suite on disc £18.95
- KOSMOS FOREIGN LANGUAGE TUTORIALS** Each: £17.95
- HISOFT KNIFE PLUS** Disc Sector/File Editor £18.95

We stock a wide range of CPC products - please give us a call and discuss your requirements.

HIGH LEVEL LANGUAGES incl printed manuals

- MIX C COMPILER** £33.95
Hundreds of satisfied users agree this is the best floating point C compiler for the CPC (CPM+). The package includes a comprehensive manual and tutorial.
- MIX SPLIT SCREEN TEXT EDITOR** £19.95
Wordstar-similar functions for editing source code
- MIX ASM UTILITY** for integrating MASM80 £10.95
- MIX TUTORIAL EXAMPLES** Save your typing! £5.95
- MIX GRAPHICS LIBRARY & FULL SOURCE CODE** £10.95
- "THE WORKS" All the above items £59.95

NEVADA COBOL One step compile & run £33.95
Fast commercial business programming on your CPC

NEVADA PASCAL Sequential/indexed file I/O One step compile & run with trace style debugging and manual.
* SPECIAL OFFER - WHILE STOCKS LAST - £15.95 *

NEVADA FORTRAN ANSI X3.9-1966 Fortran IV Generates object code modules - just compile & run. With manual
* SPECIAL OFFER - WHILE STOCKS LAST - £15.95 *

- HISOFT C Compiler** with graphics library £44.95
- HISOFT PASCAL 80** Extensive implementation £44.95
- HISOFT FORTH** with GSX graphics £19.95
- FTL MODULA 2** A powerful new language £49.95
- FTL Advanced Programmers Toolkit** £34.95
- HISOFT DEVPAC V2** Assembly language tool £44.95
- HISOFT KNIFE PLUS** Disc Editor & File Recovery £19.95

ADVANTAGE

★ COMPUTERS ★ SOFTWARE ★
★ TRAINING ★ SUPPORT ★

We accept Sterling cheques, Eurocheques, Postal Orders, Access and Visa.
Non-EC countries please add £3 per order

ADVANTAGE - by post
56 BATH ROAD, CHELTENHAM GL53 7HJ
by telephone
0242 224340 or 0242 224848

Come and visit our new Showroom

SOFT EXCHANGE

Special Offers Discs £4.99

	TITLE	Disc	Cass	TITLE	Disc	Cass
Eye	Fun School 2-5	£6.99	£4.50	Run The Gauntlet		£6.99
	Fun School 5-8	£6.99	£4.50	Taito Coin Op Coll.	£10.95	£14.95
Movie	Fun School 8-12	£6.99	£4.50	Top 10 Collec.	£10.99	£6.99
	Fun School (2) 6-8	£9.25	£7.75	War In Middle Earth	£11.99	£6.99
Never Ending Story	Fun School (2) ov. 8	£9.25	£7.75	WEC Le Mans	£10.99	£6.99
	Fun School (2) un. 6	£9.25	£7.75	Blasteroids	£12.99	£7.99
Mind Fighter	Mini Office 2	£14.95	£12.49	In Crowd	N/A	£11.99
	Plan it	£14.95	£11.50	Last Dual	£10.99	£7.99
Baseball	Stop Press DTP	£36.99	N/A	The Deep	N/A	£7.49
	Extra Extra	£17.99	N/A	10 Great Games 2	N/A	£7.99
GFL Football	Stop Press Inc. Mouse	£62.99	N/A	Charbusters 20	N/A	£7.99
	Art Inc. Mouse	£60.99	N/A	Human K. Machine	£9.99	£6.99
Basketball	Time + Magik	£12.99	£11.99	Dragon Ninja	£9.99	£7.99
	Lancelot	£15.99	£11.99	Powerplays	N/A	£5.99
Championship Sprint	10 Great Games 5	£13.99	N/A	Wizballs	N/A	£4.99
	Arcade Force 4	£14.75	£10.50	Fantastic 4	N/A	£4.99
Galactic Games	Colossus Chess 4	£12.99	£8.95	Road Runner	N/A	£4.99
	Giants	£13.30	£11.99	Shadowy Skimmer	N/A	£6.50
Karnov	History in Making	£14.45	£18.49	Circus Games	N/A	£6.50
	Konami Collec.	£15.95	£8.95	Operation Wolf	N/A	£6.50
Rampage	Mega Games 1	£12.99	£10.99	Thunder Blade	N/A	£6.99
	Motor Massacre	£12.99	£8.99	Afterburner	£8.99	£6.99
Super Hang On	Netherworld	N/A	£6.50	Command Perform	£12.99	£10.99
	Pacland	£12.95	£6.50	Corruption	£14.99	N/A
Volleyball Sim	Pacmanis	£12.95	£6.50			
	Madballs					
Computer Hits 5						
Computer Hits 6						

To Order send Cheque/P.O. inc 50p p+p to:

SOFT EXCHANGE LTD,
101 CLIFTON ROAD
SOUTH NORWOOD SE25 6QA

POOLSWINNER II

THE ULTIMATE POOLS PREDICTION PROGRAM

- **MASSIVE DATABASE** Poolswinner is a sophisticated Pools prediction aid. It comes complete with the largest database available - 22000 matches over 10 years.
- **PREDICTS** Not just SCOREDRAWS, but ALWAYS, HOMES and NO SCORES.
- **SUCCESSFUL** SELEC guarantee that Poolswinner performs significantly better than chance.
- **ADAPTABLE** Probabilities are given on every fixture - choose as many selections as you need for your bet. The precise prediction formula can be set by the user - you can develop and test your own unique method.
- **SIMPLE DATA ENTRY** All team names are in the program. Simply type in the reference numbers from the screen. Or use FIXGEN to produce fixture list automatically (see below).
- **LEAGUE AND NON-LEAGUE** All English and Scottish League teams are supported, and also the non-league sides often used on pools coupons.
- **PRINTER SUPPORT** Full hard copy printout of data if you have a printer.

PRICE £18.00 (all inclusive)

NOW AVAILABLE

FIXGEN 88/9

AT LAST! No more struggling for hours to get the fixture list into the computer. FIXGEN has been programmed with all English and Scottish League fixtures for 1988/89. Simply type in the date, and the full fixture list is generated in seconds. Fully compatible with Poolswinner. Yearly updates available.

POOLSWINNER with FIXGEN £19.50 (for both)



COURSEWINNER v3

NOT JUST A TIPSTER PROGRAM, Coursewinner V3 can be used by experts and occasional punters alike.

THE PUNTERS COMPUTER PROGRAM You can develop and test your own unique winning system by adjusting the analysis formula, or use the program in simple mode. Coursewinner V3 uses statistical analysis of major factors including past form, speed ratings, course statistics, prize money, weight, going, trainer and jockey form etc. It outputs most likely winners, good long odds bets, forecasts, tricasts etc. The database includes vital course statistics for all British courses. You can update the database - never goes out of date. FULL PRINTER SUPPORT.

PRICE £18.00 (all inclusive) includes Flat AND National Hunt versions.

AVAILABLE FOR

All supplied on tape ...
(Automatic Conversion to disc)

AMSTRAD CPCs
BBCs
COMMODORE 64/128
SPECTRUM

DISCS ...
(Add £3.00)

AMSTRAD PCW
IBM Format
COMMODORE AMIGA
ATARI ST

Send Cheques/POs for return of post service to ...

selec
SOFTWARE

phone 24 hrs

62 ALTRINCHAM RD, GATLEY, CHEADLE, CHESHIRE SK8 4DP. ☎ 061-428 7425
(Send for full list of our software)

JACKSON COMPUTERS LIMITED

JOIN OUR DISCOUNT CLUB!

Life membership for £8.50

Software/Hardware Discounts of 5-20% off RRP
All AMSTRAD and other leading makes of software available
Complete computer system, Printers, modems, cables

Amstrad CPC464 with colour monitor £287.50
Amstrad CPC6128 with colour monitor £389.90
PCW8256/512 £388.70/£504.85
Amstrad PCW 9512 £552.00
Amstrad PC 1640 ECD Ring for details

PPC portable computers in stock and also PC2000 range. Ring for details.

All prices include VAT

Also free Life Membership when you purchase any AMSTRAD computer
TEL: Between 9am-5pm 01-655 1610

Send for full Price List & membership form to:

25 Spring Lane, Woodside, South Norwood
London SE25 4SP

COMPETITION

I E C H C W V Z A Z S S T D Y L N E T Q Q T N K P
T M Z T L E B C D D D E W M I I G W J Z Q U W S E B
S Z Y D Q B W K P R D S I G O B R F W S M S O C B
S D I A A C V O A C C R H T L U T E N O R K R W B
G O O I G D Q C P A J T E A I R S O P E A D D L P
O T M S G S S Q N F P O N S M L I E M A F Q P T G L
S M Y Y A M R N O E S K S J S S I A M A P P R Q Y M
R A W W E T E E N Z M E O T N L E T X A E F O Y M
E T W H E R F S T E O Y V A E R A M U R T V C Z A
V R Q E S G L K D N S C P I T E A B I C D S E A T
O I V E O F D I C T I X O S R C H P E K I C S Q H
C X W L V Q A M I D E R E M H D S U L J E S H S
T P S P T Q S C R Y I P P I P E D Q D D S Z O F C
S R E R W L K X R I A D N R R U M T R R A N V R L O
U I S I C S E O J T C E T A E L T Z A L E Q S B P
D N A N J L M V M M S A L B B S X E E H N R C G R
U T B T C E W H H B N S E D T Q A A R A S C P Y O
A E A E M U C R Q I D X O D K I L Y S P A G S C
Y R T R S E G A K C A P Y C N A T N U O C C A P E
B S A S Q X R O K T H E A D C L E A N E R S D A S
G V D R U M E A B X G J Z B X I P A A N O C L N S
S N O B B I R R E T N I R P M J Y W A S B X S K O
V M G N T E C L P C M O D E M S O D R A M S L Z R
J V T G D S K R O W T E N M P I Z L I Y R F D J S
Z Q N W D A I S Y W H E E L S Z F J Y N W V A B Z

ACCOUNTANCYPACKAGES - ADDRESSLABELS - BLANKMEDIA
COMPUTERS - DAISYWHEELPRINTERS - DAISYWHEELS - DATABASES
DOTMATRIXPRINTERS - DRAMS - DUSTCOVERS - EMSCARDS
FAXMACHINES - HARDDRIVES - HEADCLEANERS - JOYSTICKS
LASERPRINTERS - LIGHTPENS - MATHSCOPROCESSORS
MEMORYEXPANSIONS - MODEMS - MOUSEMATS - NETWORKS
PAPER - PERIPHERALS - PRINTERRIBBONS - SCANNERS
SPREADSHEETS - TAPESTREAMERS - UTILITIES - WORDPROCESSORS.

In the above grid you will find the names in-stock. These items are all supplied by COMSOFT. All entries to be returned by August 1st 1989. All prize winners will be notified direct and the list of winners will be printed in this magazine. The first five correct entries from the accumulated mail will receive a £50.00 Software Voucher which will be exchanged for computer software.

NAME

ADDRESS

All envelopes to be addressed to COMSOFT AUGUST COMPETITION

COMSOFT AMSTRAD ADVANCE SYSTEM CENTRE

48 Duke Street, Coldstream, Scotland TD12 4LF

Tel. no. 0890 3232 Fax no. 0809 2979 - SEND FOR CATALOGUE

LERM SOFTWARE - Z80c TOOLKIT.

THE UTILITY FOR ALL MACHINE CODE USERS - ONLY £9.99

"Excellent value for money", "Brilliant package",
that is what Your Sinclair said about the Spectrum
version of our Toolkit, now available for the Amstrad
464, 646, and 6128. 3 programs in 1. Copies to disc.
HAS OUR FULL MONEY BACK GUARANTEE - NOTHING TO LOSE!

* SUPERB ASSEMBLER - full screen editor - like a
word processor. Very fast - has its own monitor.

* TOOLKIT - shows what happens to registers when
running m/code, plus disassembler, debugger, etc.

* CIOS - reverse assembler - changes machine code
back into a source file - relocate your m/code!

IDEAL FOR BEGINNERS. MANY UNIQUE FEATURES. INCLUDES
HEX/DEC LOADER MODE SINGLE STEPPER. HALF THE PRICE OF
MANY RIVALS! SEE FOR DETAILS. ALL INCLUSIVE PRICE.

LERM, DEPT AC, 11 BEACONSFIELD CLOSE, WHITLEY BAY,
TYNE AND WEAR. NE25 0UH. TEL 031 2533015.

Only
£24.95

Including VAT and p&p.

Save £5 on RRP of £29.95 when you
order direct from Connect Software

MONEY MANAGER

Amstrad CPC 464, 664 and 6128
(disc only)

Over 25,000 sold in UK alone

Financial management software for personal and/or small business use

Money Manager provides individuals, businesses and professional people with a simple yet powerful way of managing their financial activities. All transactions can be entered easily and then presented in a wide variety of reports, ranging from a detailed listing of expenditure for tax purposes to summaries showing, for example, how much money has been spent over the past twelve months on petrol or electricity. Reports can also be presented in graphical form as pie and bar charts.

The Money Manager package has over 25,000 users in the UK alone. It is the ideal program for people who find that traditional accountancy programs are too complicated, unwieldy and time-consuming for their requirements.

- Any number of data files: Personal, Business, Accounts etc.
- 12 months per file, up to 100 entries (transactions) per month
- Move a file forward by a month at a time when required
- All options selected from the main menu
- Up to 9 user-defined accounts: Bank, Cash, Visa, Access etc.
- Up to 50 user-defined classes of income and expenditure
- A reference of up to 6 characters for each entry
- Your own descriptive text of 18 characters for each entry
- All the codes are displayed on screen whilst entering data
- Add, modify and delete existing entries at any time
- Quick insertion of standard entries and standing orders
- Entries can be sorted into date order automatically
- Single character 'mark' for even more selective reporting
- Reports showing each entry in a month or for whole year
- Reports may show classes merged into groups

- Spreadsheet type table showing class totals in each month
- Report showing class totals for each account
- Bar charts for up to 4 selected categories
- Pie charts of up to 10 selected 'slices'
- Report of monthly income, expenditure and cash-flow etc.
- Account statistics - monthly max, min, average, balance etc.
- Detailed Input and Output VAT reports
- Automatic calculation of VAT
- Simply ignore VAT features if they are not required
- Budget and cash-flow forecasts - may be updated
- Data search facility to find 'lost' items
- User-defined screen colours
- Comprehensive manual
- Two sets of sample data for practice and familiarisation
- Free telephone support for as long as you need it

To receive your copy of Money Manager by return post phone us now with your credit card number, or write to us at the address below enclosing your cheque for £24.95

**Connect
Software Ltd.**

01 743 9792 8am-10pm, 7 days a week

Connect Software Ltd., 3 Flanchford Rd., London W12 9ND



APPLICATION ADVICE

David Dorn tackles this month's problems and offers words of wisdom.



A quick one to start. A. James, who lives at the Beggar's Roost has written to tell me that he has a routine to do a fast fill in any mode, any colour, and all in machine code. It is a pattern fill rather than a solid fill and he has developed it under BBC Basic running under CP/M Plus. It strikes me as being the long way round. I reckon that this is really one for Liz Ting so get your machine to data statements utility out of the closet, and send it in.

Problems with MOII

Laszlo Cser, of Ashford, Middlesex bought a 6128 in February, along with all kinds of programs. Among them was *Mini Office II*, the Database Software integrated package. Cser says: "You will think this is funny but would you tell me

how to delete a file in Mini Office without re-formatting the entire disc? This problem has reached a critical stage, as now I have 39 unwanted pieces of text taking up space on the discs."

I do not think it is funny but it is one of the common problems beginners have. I can find no facility in the word processor module in MO II to delete files from disc. What you need to do is, first, never save anything on to the original disc but always use a 'text' disc; this should hold all your text files and nothing else.

Second, keep a second formatted disc handy, in case there is no room for the file you want to save on the 'text' disc. To delete any file, you will have to do the job from Basic, using the ':ERA' command. The syntax is ':ERA,"filename.ext"'.

It is probably a good idea to have separate discs for database files, spreadsheets, and so on, always remembering to keep a blank formatted disc handy for those awkward moments.

Phil and Protext/Rodos

Pete Ravenscroft of Knowle, Bristol tells me he has been playing with Rodos and Protext/spell/merge+ on his 664 with memory upgrade and 3.5in. 800K second drive. This is as a result of Phil Craven's comparative review of Rodos and Ram/Romdos in the June issue. Craven had had problems saving to big discs under Rodos, which Ravenscroft says he does not have. Funnily enough, neither do I. It is nothing to do with the version of Protext on ROM, or Rodos either.

What interests me most about Ravenscroft's letter is a little throwaway line "Rodos is a big improvement over Amsdos and opens the world of different disc drives. I shall soon be attempting to attach a 10MB hard disc." Did you notice it? I will be very interested to

hear if he manages to get a hard disc up and running, as I am sure hordes of other CPC users will be. There are a few of us who have been pestering various companies to produce a CPC hard drive, so I am sure there is plenty of interest.

HELP!

I received a letter from Jim Sedgwick in which he apologises for not enclosing some interesting material with his earlier letter, all to do with a printer dump problem. My problem is that we do not seem to have the first letter. Will he send it again?

Special Impediments

Nicholas De La Haye, aged 14, from Guernsey writes to say he has a problem with his speech synthesiser, which will talk to him only in a 'Robot' voice. He has tried using :FEED but cannot get a human-like sound and, judging by his letter, both he and his 6128 are fed up with it.

He asks if there is any way to make the voice tone more human in quality. In my part of the country - Washington, in the north-east - we all sound like SSIs. Seriously though, for the CPC you are stuck with Dalek-like voice sounds. I prefer the infinite variety of words you can produce with phoneme synthesis modules.

ROMing all over the world

Ben Clewett sent a word-processed but not spell-checked missive from Oxford seeking advice about ROM blowers. More specifically, he asks what programs you can transfer to ROM without breaking copyright laws. Is it just those you have written yourself, or can you transfer any title to which you have legal access?

I reckon that there are as many



answers to this question as there are people of whom to ask it. My stance is that if you have a program you use a good deal and want it on ROM, I can see no harm in doing the job, but with certain provisos. You must keep the original disc and not dispose of it in any way, either by sale or a swap. In other words, possession of the original, unaltered packages entitles you to use that package, so long as you required it legally.

Since I will not, on principle, buy any software which cannot be backed-up, I take the view that I am entitled to keep a working copy of a program, as well as the original. If I decide to keep that working copy on ROM, rather than on a 3in disc or tape, I cannot see it makes any difference.

If I sell the original package and keep the ROM for my use, I am in breach of copyright, since I no longer hold the licence to use the software. So, if the original is sold, the ROM must either be erased or go as part of the package.

Graduate Software, whose CP/M Plus ROMs I reviewed in *CPC Computing* before it and *ACU* were merged, had the same dilemma. It approached Digital Research and Amstrad with its idea and according to its managing director, got little in the way of reply. It has gone ahead and done the deed, successfully too, so the precedent is there. I hope that

is of some assistance to you.

You can contact me by Telecom Gold on 74:mik2050, or on Prestel on MBX 914177811 if you prefer to use your modem.

Lightpen answers

Katy Powell of Wisbech, Cambs asks what lightpen she needs to print pictures with her 464 and DMP 2160. The short answer is none but I sense that there is more to the question.

Before I go any further with it I have to tell you that, on the whole, a lightpen is my least favourite input device. They tend to be less than 100 percent accurate and make your wrist ache after a short time using them against an upright screen. I much prefer a mouse - the AMX mouse, now being sold by Database, or the Kempston mouse, which is also a good one, to a lightpen.

If a lightpen it must be, your best bet is the Trojan lightpen. It has some good software with it and is priced at around £20. There are screendumps included in the package, which should work well with your set-up.

Escroe plc

11 Mundells Court,
Welwyn Garden City,
Herts, AL7 1EN, England

Telephone UK: (0707) 334460 Intl: (44) 707 334460

DISKS, DISKS AND MORE DISKS AT TRADE PRICES
DIRECT TO THE PUBLIC AND COME COMPLETE
WITH USER SETS AND ENVELOPES. **LIFETIME
GUARANTEE.**

PRICES INCLUDE POSTAGE, PACKING AND V.A.T.

PAYMENT, CHEQUE OR ACCESS



ORDERS WELCOME FROM GOVERNMENT,
LOCAL AUTHORITY, EDUCATIONAL &
CORPORATES

BULK	2.80"	D/S CF2	D/S CF2DD	D/S 3.50	D/S880 3.50	HD 3.50	D/S96 5.25	HD 5.25	S/S 8.00	D/S 8.00	BULK	BULK
10	NOT	21.85	29.90	7.95	8.95	23.00	N/A	N/A	23.00	24.00	10	BULK
25	AVAILABLE	51.75	66.13	20.00	22.00	50.00	11.50	23.00	51.75	54.00	25	BULK
50	IN	97.75	130.00	FREE 100 LOCKABLE BOX WITH ANY OF THESE PURCHASES				97.75	102.75	50	BULK	
100		184.00	245.00	*35.00	*40.00	*90.00	*17.25	*44.00	184.00	194.00	100	BULK
250	BULK	430.00	600.00	140.00	165.00	375.00	68.00	170.00	430.00	455.00	250	BULK
500	FORM	850.00	1100.00	265.00	315.00	740.00	115.00	330.00	850.00	900.00	500	BULK
ALL MIMIC DISKS ARE PREFORMATTED TO ENSURE PERFECT PERFORMANCE												
2.80"		D/S CF2	D/SDD CF2DD	D/SDD 3.50	D/S880 3.50	HD 3.50	D/S96 5.25	OS HD 5.25	S/S 8.00	D/S 8.00		
IN PLASTIC CASES												
10	**24.15	**24.15	**32.20	8.95	11.50	25.00	5.75	11.50	25.00	27.00	10	MIMIC
20	**47.00	**47.00	**62.00	17.00	21.00	48.00	11.00	23.00	39.10	41.10	20	MIMIC
40	**92.00	**92.00	**120.00	33.00	40.00	94.00	21.00	44.00	73.60	81.80	40	MIMIC
80	**182.00	**182.00	**230.00	64.00	72.00	185.00	41.00	85.00	138.00	154.00	80	MIMIC
100	**220.00	**220.00	**275.00	77.00	85.00	225.00	50.00	100.00	165.00	185.00	100	MIMIC
2.80"		D/S CF2	D/SDD CF2DD	M200 3.50	M200 3.50	M240 3.50	M200 5.25	M240 5.25	8.00"	8.00"		
5.95		5.95	5.95	3.95	3.95	3.95	3.95	3.95	17.95	17.95		
10	24.15	24.15	46.00	16.50	16.50	39.00	9.50	18.50	25.00	26.00	10	
20	47.00	47.00	90.00	26.00	26.00	75.00	18.00	36.00	49.00	50.00	20	
40	92.00	92.00	175.00	50.00	50.00	148.00	35.00	70.00	94.00	95.00	40	
80	182.00	182.00	345.00	96.00	96.00	290.00	68.00	135.00	178.00	180.00	80	
100	220.00	220.00	425.00	105.00	105.00	350.00	84.00	160.00	215.00	220.00	100	
		MARLL	MAROPT	MARLL	SONY	SONY	SONY	MARLL	MARLL	VERBATIM	VERBATIM	

SIREN SOFTWARE

ADD A ONE MEGABYTE DISC DRIVE TO YOUR CPC FOR ONLY £124.99

Our 80 track double sided 3.5 inch disc drive will allow you to store up to 800K on a single 3.5 inch disc. 3.5 inch discs are fast becoming the industry standard and have been adopted by Amstrad for the PPC, Atari for the ST and Commodore for the Amiga.

The drive itself is a slimline 1 inch high NEC mechanism and comes cased and complete with power supply and cables. We have 3 different software packages that complete the system, RAMDOS and ROMDOS by KDS software (ROMDOS is a rom version of RAMDOS) or RODOS by Romantic Robot. When ordering please state 464/664/6128. 464 owners must already own a first drive and interface before they can use our disc drive.

All prices include VAT and postage and packing

- Disc Drive with RAMDOS..... only £124.99
- Disc Drive with ROMDOS..... only £134.99
- Disc Drive with RODOS..... only £134.99
- Six Socket romboard..... only £24.99
- Blank 3.5 inch Discs..... only £1.00



SIREN SOFTWARE TEL 061 228 1831
84-86 PRINCES STREET, MANCHESTER M1 6MG





GREAT STRATEGY GAMES

From E & J Software

TREBLE CHAMPIONS £9.95 Spec 48/128 : Ams CPC

A STUNNINGLY REALISTIC FOOTBALL STRATEGY GAME - Can you Win The League, The F.A. Cup & The League Cup - 4 Divisions of 20 Teams + 1 Div. 20 Non League Teams - Details of OVER 1500 Players - Results & Leagues ALL Divisions - League Cup with 1st, 2nd Rnds + S/Finals over 2 Legs - F.A. Cup includes Non League - Transfer Market buy ANY PLAYER ANY DIVISION - 3 Skill Levels - Start ANY Division - SAVE GAME - Time Management - Reserves - 2 In-Match Subs - Coaching + Fitness Training - PLUS MUCH MORE.

EUROPEAN CHAMPIONS £8.95 Spec 48/128 : Ams CPC

THE INTERNATIONAL CHALLENGE OF THE EUROPEAN NATIONS CUP - Genuine Nations Cup Format with full Random Draw of 32 Seeded Teams - Fixture List, Results and League Tables of ALL 8 Groups - Discipline & Medical Reports - Squad of 22 Players plus Other Players - 17 Month Itinerary of Qualifying Group, (Arrange Friendlies) and Finals - Plus many more Superb Features and Options. EUROPEAN CHAMPIONS includes E & J's MATCH PLAY SYSTEM which captures all the ACTION, DRAMA & TENSION of International Football.

WORLD CHAMPIONS £7.95 Spec 48/128 : Com 64/128 : Ams CPC

A COMPLETE WORLD CUP SIMULATION - Select Friendlies - 25 Players - Qualifying Group - 2 In-Match Subs - Discipline Table - Select Tour Opponents - Extra Time - final Rounds - Players Gain Experience - 7 Skill Levels - TEXT MATCH SIMULATION including: Bookings, Goal Times, Named & Recorded Goal Scorers, Injury Time, Corners, Free Kicks, Match Clock, Penalties - PLUS many more Features.

CRICKET MASTER £7.95 Spec 48/128 : Com 64/128 : Ams CPC

A SUPERB SIMULATION OF ONE DAY INTERNATIONAL/COUNTY CRICKET - Weather, Wicket & Outfield Conditions - Batting & Bowling Tactics - Team Selection - Fast, Medium & Spin Bowlers - 4 Types of Batsmen - Select Field Layout - 3 Skill Levels - Wides - Byes - No Ball - Run Out - Misfield - Dropped Catches - Scoreboard - Batting & Bowling Analysis - Run Rate - Single Option - 3 Game Speeds - STAR FEATURE a complete MATCH OVERVIEW showing Ball by Ball Action and Commentary and MUCH MORE!

TEST MASTER £8.95 Spec 48/128 : Ams CPC

A COMPREHENSIVE SIMULATION OF A 5 DAY TEST MATCH - Includes most of the Features of CRICKET MASTER and MATCH OVERVIEW plus Declarations - Nightwatchmen - Light Meter - Rain Stops Play - Varying Number of Overs per Day - Follow On - Save Game - New Ball - Bad Light Interruptions - TEST MASTER is a True representation of a Complete Test Match and offers the ULTIMATE CHALLENGE to All Cricket Enthusiasts.

Above games available on disc @ Plus £4.00 Spec & Ams or Plus £2.50 Com PER GAME

BUDGET SPECIALS ONLY £1.99 Spec/Com/Ams TAPE ONLY

PREMIER II An Exciting & Realistic Football Management game on 7 Skill levels. Can you succeed at the Highest Level in Football Management and win the Premier Super League.
EUROPEAN II A Superb Simulation of the European Cup on 7 Skill Levels. Can you guide your Team to Success and defeat the Top teams in Europe to become the European Cup Winners.

Please add 50p per order on Budget Specials for Postage and Packing
BUDGET GAMES ALSO AVAILABLE FROM MANY RETAIL OUTLETS

ALL GAMES are available by MAIL ORDER for IMMEDIATE despatch by 1st class post and include Full Instructions. State which Machine & Tape or Disc.

(Add 50p per Game outside UK or £1.50 per Game for AIRMAIL outside Europe.
Payment in Pounds Sterling Only)

Cheques or Postal Orders payable to E & J Software, SEND TO:
E & J SOFTWARE, Room A2, 37 Westmoor Road, ENFIELD, Middlesex, EN3 7LE

FANTASTIC DISCOUNTS

FULL PRICE GAMES ONLY
Buy 2 games deduct £3.00
Buy 3 games deduct £5.00
Buy 4 games deduct £7.00
Buy 5 games deduct £12.00

Amstrad
CPC

Amstrad
CPC

MODE - ONE

21 Orchard Drive
Burton-upon-Stather
Scunthorpe DN15 9EF
South Humberside.

0724 721204

*** LOOK! NEW LOW PRICES ***

TITLE	CASS	DISC
Airbourne Ranger	£10.80	£14.05
Arcade Muscle	£9.99	£12.99
Afterburner	£7.40	£10.65
Barbarian II	£7.40	£10.65
Batman (new)	£7.40	£10.65
Blasteroids	£7.40	£10.65
Bubble Ghost	£7.40	£10.65
Butcher Hill NR	£7.40	£10.65
Cyberoid II	£7.40	£10.65
Chuck Yeagers Aft	£6.90	£11.80
Crazy Cars II	£6.90	£10.65
Command Perf.	£9.99	Phone
Chicago 30's	£7.40	£10.65
Double Dragon NR	£7.40	£10.80
Dragon Ninja	£7.40	£10.65
Dark Fusion	£7.40	£10.65
Echelon	£10.60	£12.99
Eliminator NR	£7.90	£11.80
Fernandez Must Die	£6.90	£10.65
Fist N Throttles	£9.00	£12.99
Game Over II (+1)	£6.80	£10.65
Galactic Conquerer	£6.90	£10.65
Guerrilla War	£6.80	£10.65
Gunship	£9.80	£14.05
Giants	£10.40	£15.90
Game Set & Match II	£9.80	£12.99
H.K. Machine	£7.40	£10.65
I.S. Sphere	£7.40	£10.65
Jinks NR	£7.40	£10.65
Live and Let Die	£6.80	£10.65
Last Duel	£7.40	£10.65
Led Storm	£7.40	£10.65
Motor Massacre	£7.40	£10.65
Netherworld	£6.90	£11.80
Obliterator	£7.40	£10.65
Operation Wolf	£6.80	£10.65
Pacland	£6.90	£10.65
Pacmania	£6.90	£10.65
Purple Saturn Day	£7.40	£10.65
Question of Sport	£10.80	£14.30

TITLE	CASS	DISC
Roy of the Rovers	£6.80	£10.65
Return of the Jedi	£6.90	£10.65
Rambo III	£6.90	£10.65
R-Type	£6.90	£10.65
Robocop	£7.40	£10.65
Road Blasters	£7.40	£10.65
Real Ghostbusters	£7.40	£10.65
Renegade III	£6.90	£10.65
Red Heat NR	£7.40	£10.65
Rock Star	£7.40	£10.65
Skweek NR	£7.40	£10.65
Savage	£6.90	£10.65
Soldier of Light NR	£7.40	£10.65
Spitting Image	£6.80	£10.65
Supreme Challenge	£9.00	£12.99
S.D.I.	£7.40	£10.65
Taito Coin-Ops	£8.50	-----
Thunderblade	£7.40	£10.65
Titan	£7.40	£10.65
Timescanner NR	£7.40	£10.65
Total Eclipse	£6.90	£10.65
Typhoon	£6.80	£10.65
Victory Road	£6.80	£10.65
Vindicator	£7.40	£10.65
Wanderer (+3D Specs)	£7.40	£10.65
War in Middle Earth	£6.90	£10.65
WEC Le-Mans	£6.90	£10.65
1943-Midway	£7.40	£10.65
4 Soccer Simulators	£6.90	£10.65
4x4 Off Road Racing	£7.40	£10.65

BUDGETS-CASS ONLY	RRP	OUR
ATV Simulator	£2.99	£2.60
Batty	£2.99	£2.60
Bigfoot	£2.99	£2.60
Dan Dare II	£2.99	£2.60
Fast Food	£2.99	£2.60
Int Rugby Sim	£2.99	£2.60
Turbo Esprit	£1.99	£1.75
Who Dares Wins II	£1.99	£1.75

*** LOOK!! ALL £2.99 BUDGETS NOW £2.60 - ALL £1.99 BUDGETS NOW £1.75!! ***

This is only a small selection of titles we can supply (especially budgets!). Please write or phone for your choice if not shown.

All our prices include P&P within the U.K. Eire & Europe please add £1.20 per item. Elsewhere add £1.75. NR = new release, phone for availability.

Please make Cheques or Postal Orders payable to MODE ONE



"One single source" for all your Amstrad Computer needs at competitive prices!

THE COMPUTER CENTER

NEW SOFTWARE FOR THE AMSTRAD CPC RANGE

Happy Fractions :- £16.95 D - This program explains the fraction concept implementing excellent graphics display including equivalence, comparison, addition, subtraction. It offers an exciting flying saucer tutorial game.

Happy Breathing :- £16.95 D - An excellent educational program on the Respiratory System using graphics and text to explain each part and function of the system. There is an extensive tutorial and a very interesting game.

Arnold Plot :- £39.95 D/£24.95 T - General graph plotting package, contains a sophisticated "Data Editor" and a versatile plotting facility. It can support Epson compatible Dot Matrix Printers and Pin Plotters. Presentation: pie-charts, bar charts, graph, histograms, high/low charts. Tape version with reduced specification.

TMC The Micro Computer Ltd.,

9 St. James's Terrace, Nottingham NG1 6FW

Tel: (0602) 483440



STRATEGY SOFTWARE

Strategy games for the Amstrad CPC

THE FINAL CONFLICT - the game is a conflict between Nato and the Warsaw Pact in Europe. Options are either two player or solitaire against the computer. 25 different countries involved, over 160 units, infantry, corps, parachute, armoured, cities helicopters, different strengths, effects, supplies, fuel, casualties status, different seasons, city production levels, millions of troops involved, game lasts for weeks, save game, 18 page manual plus more.

SOCCER 6128 - football strategy game which lets you manage any team in the 4 divisions. Options are buy players, sell players, league programme, fixtures, opposition, play match, instructions, league table, accounts, playing staff, save game, 10 different positions, skill, form, goal scorers, injuries, up to 20 players in squad, sacking, over 2000 players, 80 English clubs, 60 European clubs, FA Cup, League Cup, European Cup, UEFA Cup, Cup Winners Cup plus much more. Reviewed in AMSTRAD ACTION July '88.

KURSK the clash of armour - was the biggest tank battle of WW2 in which the Germans had to beat the Soviet army to stand any chance of winning the war. The options are two player or solitaire against the computer. There are over 125 units which are infantry, armoured, corps, artillery, anti-tank plus cities which all have different effects in combat. There are also supplies like troops, provisions and fuel. The object of the game is to capture the key cities or destroy enemy units. Also save game plus much more.

SOFTWARE HIRE CLUB - we hire out top game titles of strategy and simulation games for the Amstrad CPC. Send a large S.A.E for details.

Title	disk	tape
THE FINAL CONFLICT	£8.00	£7.00
SOCCER 6128 For 6128 only	£8.00	£7.00
KURSK the clash of armour	£8.00	£7.00

Cheques or Postal orders Payable to STRATEGY SOFTWARE

Send to - STRATEGY SOFTWARE, 32 Albert Street, Seaham, Co Durham SR7 7LJ.

VSE

Technical Services

High Quality Repairs
Low Inclusive Prices
The Logical choice!

REPAIRS

Amstrad CPC 464.....£21.90
Amstrad CPC 6128.....£24.90

ACCESSORIES

CPC 6128 Rom.....£16.90
64K Ram Pack.....£43.90
Printer Cable.....£8.80

All repairs guaranteed 4 months, prices quoted apply to any single fault ★ and are inclusive of parts, labour and VAT.
Free return carriage for UK mail order customers. CPC 6128 Rom installation service available, only £8.00.
★ Excludes cabinet damage and replacement of complete keyboard or disk drive assemblies (free estimate given).

VSE Technical Services (Dept. 107), Unit 6,
8 Nursery Road, London SW9 8BP. Tel: 01-737 0234

DISCBASE

* Brilliant FILE DATABASE for your disk collection.
* Superbly easy to set up and use.

The first FAST Disc-File organiser for CPC machines -

* FAST Filename SEARCHES, with wildcards (under 1 second).
* AUTOMATIC UPDATE Insert disc, DISCBASE does the rest!
* Hard copy of lists of Files or Discs; or of Disc-CATS.
* Unique, super-fast file & disc viewing system.
* All vital routines in machine code.

'A first class utility' - 'Really does what it says' - User comments

Rrp £11.95, but send cheque/PO for only £9.95 direct to:

GREYHOUND SOFTWARE (C8)
Kennel Cott, Hockley Lane, Wingerworth,
CHESTERFIELD S42 6QQ.

Telephone enquiries: 0246 235233 Mon-Sat 6pm-8pm

CRAZY CARS II



AMIGA
ATARI ST
PC
AMSTRAD CPC
SPECTRUM
C 64/128

SCREENSHOTS FROM AMIGA VERSION



TITUS

UNIT 4 STANNETS
LAINDON NORTH TRADE CENTRE
BASILDON ESSEX SS156 DJ
PHONE: (0268) 541126

**FUN FROM DOWN UNDER
THAT WILL HAVE YOU STANDING
ON YOUR HEAD**

FOOLED YOU!

GNASTY GNOMES

THE

ocean

ATARI ST
19.99

AMIGA
24.99

SPECTRUM
8.99

CBM/AMSTRAD
9.99

FORTUN KIOSKEN
12 38.00

Ocean Software Limited · 6 Central Street · Manchester · M2 5NS
Telephone: 061 832 6633 · Telex: 669977 OCEANS G · Fax: 061 834 0650