

Description of Device Parameters

Tankside Monitor NRF81

Tank Gauging

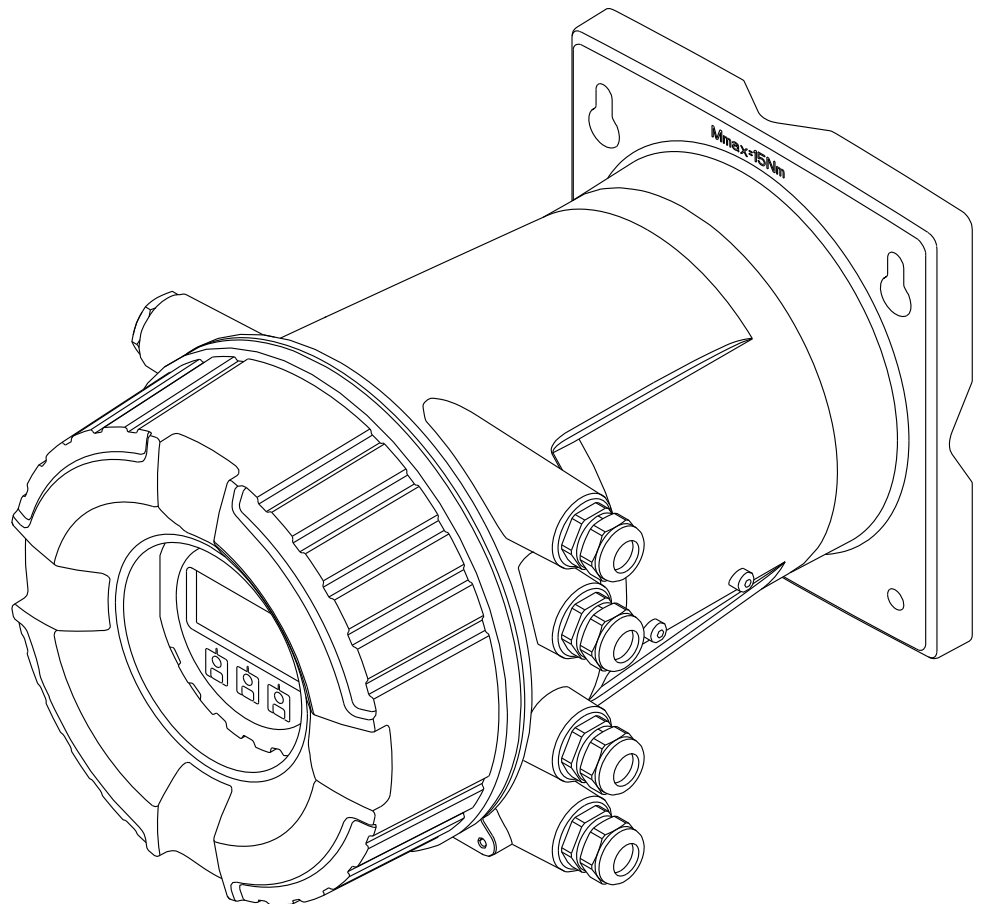

Table of contents

1	About this document	4
1.1	Document function	4
1.2	Symbols	4
2	Overview of the operating menu	6
3	The "Expert" menu	23
3.1	"System" submenu	26
3.2	"Input/output" submenu	50
3.3	"Communication" submenu	102
3.4	"Application" submenu	142
3.5	"Tank values" submenu	202
3.6	"Diagnostics" submenu	213
	Index	233





1 About this document

1.1 Document function







The document is part of the Operating Instructions and serves as a reference for parameters, providing a detailed explanation of each individual parameter of the operating menu.

1.2 Symbols



1.2.1 Safety symbols



Symbol	Meaning
	DANGER! This symbol alerts you to a dangerous situation. Failure to avoid this situation will result in serious or fatal injury.
	WARNING! This symbol alerts you to a dangerous situation. Failure to avoid this situation can result in serious or fatal injury.
	CAUTION! This symbol alerts you to a dangerous situation. Failure to avoid this situation can result in minor or medium injury.
	NOTE! This symbol contains information on procedures and other facts which do not result in personal injury.

1.2.2 Electrical symbols





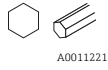

Symbol	Meaning
	Direct current
	Alternating current
	Direct current and alternating current
	Ground connection A grounded terminal which, as far as the operator is concerned, is grounded via a grounding system.
	Protective ground connection A terminal which must be connected to ground prior to establishing any other connections.
	Equipotential connection A connection that has to be connected to the plant grounding system: This may be a potential equalization line or a star grounding system depending on national or company codes of practice.

1.2.3 Tool symbols

Symbol	Meaning
 A0013442	Torx screwdriver
 A0011220	Flat blade screwdriver

Symbol	Meaning
 A0011219	Cross-head screwdriver
 A0011221	Allen key
 A0011222	Hexagon wrench



1.2.4 Symbols for certain types of information

Symbol	Meaning
	Tip Indicates additional information.
	Reference to documentation
	Reference to page
	Reference to graphic
	Operation via local display
	Operation via operating tool
	Write-protected parameter

1.2.5 Symbols in graphics

Symbol	Meaning
1, 2, 3 ...	Item numbers
A, B, C, ...	Views
A-A, B-B, C-C, ...	Sections

1.2.6 Symbols at the device

Symbol	Meaning
	Safety instructions Observe the safety instructions contained in the associated Operating Instructions.
	Temperature resistance of the connection cables Specifies the minimum value of the temperature resistance of the connection cables.

2 Overview of the operating menu

-  The following table lists all parameters the "Expert" menu may contain. The page number refers to where a description of the parameter can be found.
- Depending on the device version and parametrization some parameters will not be available in a given situation. For details on the conditions refer to the "Prerequisite" category in the description of the respective parameter.
- The representation essentially corresponds to the menu seen when using an operating tool (e.g. FieldCare). On the local display there may be minor differences in the menu structure. Details are mentioned in the description of the respective submenu.

Navigation

 Expert

Expert		
Direct access (0106)		→ 23
Locking status (0004)		→ 24
Access stat.disp (0091)		→ 24
Access stat.tool (0005)		→ 24
Ent. access code (0003)		→ 24
▶ System		→ 26
	▶ Display	→ 27
	Language (0104)	→ 27
	Format display (0098)	→ 28
	Value 1 to 4 display (0107-1 to 4)	→ 28
	Decimal places 1 to 4 (0095-1 to 4)	→ 29
	Separator (0101)	→ 30
	Number format (0099)	→ 30
	Header (0097)	→ 31
	Header text (0112)	→ 31
	Display interval (0096)	→ 31
	Display damping (0094)	→ 32

























Backlight (0111)	→ 32
Contrast display (0105)	→ 32
► System units	→ 34
Units preset (0605)	→ 34
Distance unit (0551)	→ 35
Pressure unit (0564)	→ 35
Temperature unit (0557)	→ 35
Density unit (0555)	→ 36
Decimal length (0573)	→ 36
Decimal pressure (0608)	→ 37
Decimal temp. (0614)	→ 37
Decimal density (0609)	→ 37
► Date / time	→ 41
Date/time (0790)	→ 42
Set date (0792)	→ 42
Year (0782)	→ 43
Month (0787)	→ 43
Day (0788)	→ 43
Hour (0789)	→ 44
Minute (0791)	→ 44
► Administration	→ 47
Def. access code (0093)	→ 48
Activate SW opt. (0029)	→ 48
Device reset (0000)	→ 48





















▶ Input/output	→ 50
▶ HART devices	→ 51
Number devices (13051)	→ 51
▶ HART Device(s)	→ 52
Device name (14722)	→ 53
Polling address (14712)	→ 53
Device tag (14713)	→ 53
Operating mode (14745)	→ 53
Comm. status (14710)	→ 54
#blank#(HART PV - description dependent on device) (14715)	→ 54
#blank#(HART SV - description dependent on device) (14705)	→ 54
#blank#(HART TV - description dependent on device) (14706)	→ 54
#blank#(HART QV - description dependent on device) (14716)	→ 55
HARTDEV PV mA (14708)	→ 55
HARTDEV PV % (14709)	→ 55
Output pressure (14719)	→ 56
Output density (14720)	→ 56
Output temp. (14721)	→ 56
Output vapor tmp (14726)	→ 57
Output level (14718)	→ 57
▶ HART device info	→ 59
▶ Element values	→ 65

























▶ Diagnostics	→ 66
▶ NMT dev. config	→ 68
▶ Forget device	→ 74
Forget device	→ 74
▶ Analog IP	→ 75
Operating mode (14014)	→ 76
RTD type (14021)	→ 76
Ohms offset (14026)	→ 77
RTD connect type (14022)	→ 77
Process value (14003)	→ 78
Process variable (14016)	→ 78
0 % value (14001)	→ 78
100 % value (14013)	→ 79
Input value [%] (14002)	→ 79
Input value (14015)	→ 79
Temp. offset (14025)	→ 80
Min. probe temp (14010)	→ 80
Max. probe temp (14011)	→ 80
Probe position (14009)	→ 81
Cal type AIP (14018)	→ 81
Act. calibration (14012)	→ 82
Damping factor (14004)	→ 82
Gauge current (14027)	→ 82
▶ Analog I/O	→ 83
Operating mode (13958)	→ 84

Current span (13987)	→ 85
Fixed current (13989)	→ 86
Analog source (13974)	→ 86
Failure mode (13988)	→ 87
Error value (13972)	→ 88
Output out range (13971)	→ 88
Error on event (13967)	→ 88
Input value (13979)	→ 89
0 % value (13954)	→ 89
100 % value (13968)	→ 89
Input value % (13955)	→ 90
Output value (13969)	→ 90
Readback value (13957)	→ 90
Feedback thresh. (13956)	→ 91
Process variable (13964)	→ 91
AI 0% value (13977)	→ 91
AI 100% value (13965)	→ 92
Error event type (13953)	→ 92
Process value (13963)	→ 92
Input val. in mA (13970)	→ 93
Input value [%] (13978)	→ 93
Damping factor (13951)	→ 93
Calibration (13966)	→ 93
Act. calibration (13981)	→ 94

























Used for SIL/WHG (13980)	→ 94
SIL/WHG chain (13952)	→ 95
► Digital Xx-x	→ 96
Operating mode (13911)	→ 97
Digital source (13907)	→ 97
Input value (13901)	→ 98
Contact type (13912)	→ 98
Output sim (13909)	→ 99
Output value (13902)	→ 100
Readback value (13903)	→ 100
Error on event (13916)	→ 100
Damping factor (13904)	→ 101
Used for SIL/WHG (13910)	→ 101
► Communication	→ 103
► "Modbus Xx-x" / "V1 Xx-x" submenu	
Commu I/F protoc (13201)	→ 103
Modbus value 1 to 4 (13206-1 to 4)	→ 104
Modbus discr. 1 to 4 (13240-1 to 4)	→ 104
► "Configuration" submenu (Modbus)	
Baudrate (13203)	→ 105
Parity (13204)	→ 106
Modbus address (13205)	→ 106
Float swap mode (13232)	→ 106
Invalid data (13243)	→ 107

Word type (13208)	→  107
CRC seed (13248)	→  107
Old TSM mode (13213)	→  108
Bus termination (13249)	→  108
► Integer convers	→  109
Level 0% (13214)	→  109
Level 100% (13250)	→  110
Temperature 0% (13215)	→  110
Temperature 100% (13216)	→  110
Pressure 0% (13217)	→  111
Pressure 100% (13251)	→  111
Density 0% (13252)	→  111
Density 100% (13218)	→  112
User 0% (13221)	→  112
User 100% (13222)	→  112
Percent 0% (13202)	→  113
Percent 100% (13234)	→  113
► UserVal source	→  114
UserVal 1 to 8 source (13209-1 to 8)	→  114
► GP values	→  115
GP 1 value 0% (13223)	→  115
GP 1 value 100% (13224)	→  115
GP 2 value 0% (13257)	→  116
GP 2 value 100% (13258)	→  116
GP 3 value 0% (13259)	→  116























GP 3 value 100% (13226)	→  117
GP 4 value 0% (13225)	→  117
GP 4 value 100% (13227)	→  117
► Discreteselect	→  118
Discrete 1 to 8select (13260-1 to 8)	→  118
► "Configuration" submenu (V1)	
Protocol variant (13269)	→  119
V1 address(V1 / MDP) (13235)	→  119
V1 address(BBB / MIC+232) (13236)	→  120
Level mapping (13268)	→  120
Line impedance (13266)	→  121
Comp. mode (13281)	→  121
► V1 input select.	→  122
UserVal 1 to 8 source (13209-1 to 8)	→  122
Alarm1 input src (13270)	→  123
Alarm2 input src (13271)	→  123
Alarm3 in-source (13283)	→  124
Alarm4 in-source (13284)	→  124
SP1 value select (13274)	→  125
SP2 value select (13275)	→  125
SP3 value select (13276)	→  126

	SP4 value select (13277)	→  126
	Value % select (13282)	→  126
	▶ HART output	→  128
	▶ Configuration	→  129
	Polling address (0219)	→  129
	No. of preambles (0217)	→  130
	PV source (11634)	→  130
	Assign PV (0234)	→  130
	0 % value (11632)	→  131
	100 % value (11633)	→  132
	PV mA selector (11631)	→  132
	Primary var (PV) (0201)	→  132
	Percent of range (0274)	→  133
	Assign SV (0235)	→  133
	Second.var(SV) (0226)	→  134
	Assign TV (0236)	→  134
	Tertiary var(TV) (0228)	→  135
	Assign QV (0237)	→  135
	Quaterna.var(QV) (0203)	→  136
	▶ Information	→  137
	HART short tag (0220)	→  137
	Device tag (0215)	→  138
	Device revision (0204)	→  138
	Device ID (0221)	→  138
	Device type (0209)	→  138

	Manufacturer ID (0259)	→ 139
	HART revision (0205)	→ 139
	HART descriptor (0212)	→ 139
	HART message (0216)	→ 140
	Hardware rev. (0206)	→ 140
	Software rev. (0224)	→ 140
	HART date code (0202)	→ 140
▶ Application		→ 142
▶ Tank config		→ 142
▶ Level		→ 143
Level source (14601)		→ 143
Operation mode (14656)		→ 144
Tank ref height (14603)		→ 144
Tank level (14655)		→ 144
Upper I/F level (15003)		→ 144
Lower I/F level (15004)		→ 145
Water level src (14971)		→ 145
Water level (14970)		→ 145
Man. water level (14959)		→ 146
▶ Temperature		→ 147
Liq temp source (14972)		→ 147
Man. liquid temp (15015)		→ 148
Liquid temp. (14978)		→ 148
Air temp. source (14993)		→ 148
Manual air temp. (14961)		→ 149

Air temp. (14986)	→  149
Vapor temp src (14973)	→  149
Man. vapor temp. (14960)	→  150
Vapor temp. (14985)	→  150
► Density	→  151
Density source (13454)	→  151
Observed density (13452)	→  152
Air density (14980)	→  152
Vapor density (14981)	→  152
UpDensity source (15006)	→  152
Manual density (14998)	→  153
Meas upper dens. (15001)	→  154
Meas middle dens (14997)	→  154
Meas lower dens. (15002)	→  154
Water density (13757)	→  154
► Pressure	→  155
P1 (bot) source (14994)	→  156
P1 (bottom) (14983)	→  156
P1 (bot) manual (14951)	→  156
P1 position (14952)	→  157
P1 offset (14953)	→  157
P1 absolut/gauge (14954)	→  157
P2 (mid) source (14995)	→  158
P2 (middle) (14987)	→  158
P2 (mid) manual (14955)	→  158























P2 offset (14975)	→ 📄 159
P1-2 distance (14974)	→ 📄 159
P2 absolut/gauge (14976)	→ 📄 159
P3 (top) source (14996)	→ 📄 160
P3 (top) (14988)	→ 📄 160
P3 (top) manual (14977)	→ 📄 160
P3 position (14956)	→ 📄 161
P3 offset (14957)	→ 📄 161
P3 absolut/gauge (14958)	→ 📄 161
Ambient pressure (14962)	→ 📄 162
▶ GP values	→ 📄 163
GP 1 to 4 source (14989-1 to 4)	→ 📄 163
GP 1 to 4 name (14963-1 to 4)	→ 📄 164
GP Value 1 (14966)	→ 📄 164
GP Value 2 (14967)	→ 📄 164
GP Value 3 (14968)	→ 📄 164
GP Value 4 (14969)	→ 📄 165
▶ Tank calculation	→ 📄 166
Local gravity (14979)	→ 📄 166
▶ HyTD	→ 📄 169
HyTD corr. value (13603)	→ 📄 169
HyTD mode (14652)	→ 📄 169
Starting level (13601)	→ 📄 169
Deform factor (13602)	→ 📄 170

▶ CTS _h	→  174
CTS _h corr value (13651)	→  174
CTS _h mode (14651)	→  175
Covered tank (13654)	→  175
Stilling well (13653)	→  175
Calibration temp (13652)	→  176
Linear exp coeff (13655)	→  176
▶ HTG	→  183
Density value (13706)	→  183
Tank level (13707)	→  184
HTG mode (13701)	→  184
Manual density (15009)	→  184
Min. level (13702)	→  185
Min. pressure (13703)	→  185
Safety distance (13705)	→  185
Hysteresis (13704)	→  186
▶ HTMS	→  189
HTMS mode (13751)	→  189
Manual density (15009)	→  190
Density value (13753)	→  190
Min. level (13752)	→  190
Min. pressure (13754)	→  191
Safety distance (13756)	→  191

	Hysteresis (13755)	→ 191
	Water density (13757)	→ 192
▶ Alarm		→ 193
▶ Alarm		→ 193
	Alarm mode (13864)	→ 194
	Error value (13851)	→ 195
	Alarm source (13866)	→ 196
	Alarm value (13863)	→ 197
	HH alarm value (13855)	→ 197
	H alarm value (13854)	→ 197
	L alarm value (13853)	→ 198
	LL alarm value (13852)	→ 198
	HH alarm (13857)	→ 198
	H alarm (13856)	→ 199
	HH+H alarm (13858)	→ 199
	L alarm (13859)	→ 199
	LL alarm (13868)	→ 199
	LL+L alarm (13869)	→ 200
	Any error (13867)	→ 200
	Clear alarm (13861)	→ 200
	Alarm hysteresis (13862)	→ 201
	Damping factor (13860)	→ 201
▶ Tank values		→ 202
▶ Level		→ 202
	Tank level (14655)	→ 202

Tank Level % (14654)	→ 📄 203
Tank ullage (14657)	→ 📄 203
Tank ullage % (14658)	→ 📄 203
Upper I/F level (15003)	→ 📄 203
Lower I/F level (15004)	→ 📄 204
Bottom level (15018)	→ 📄 204
Water level (14970)	→ 📄 204
Measured level (14653)	→ 📄 204
▶ Temperature	→ 📄 205
Liquid temp. (14978)	→ 📄 205
Vapor temp. (14985)	→ 📄 205
Air temp. (14986)	→ 📄 206
▶ NMT elem. values	→ 📄 206
▶ Element temp.	→ 📄 206
▶ Element position	→ 📄 206
▶ Density	→ 📄 208
Observed density (13451)	→ 📄 208
Vapor density (14981)	→ 📄 208
Air density (14980)	→ 📄 209
Meas upper dens. (15001)	→ 📄 209
Meas middle dens (14997)	→ 📄 209
Meas lower dens. (15002)	→ 📄 209
▶ Pressure	→ 📄 210
P1 (bottom) (14983)	→ 📄 210

P2 (middle) (14987)	→ 📄 210
P3 (top) (14988)	→ 📄 210
▶ GP values	→ 📄 211
GP 1 to 4 name (14963-1 to 4)	→ 📄 211
GP Value 1 (14966)	→ 📄 211
GP Value 2 (14967)	→ 📄 211
GP Value 3 (14968)	→ 📄 212
GP Value 4 (14969)	→ 📄 212
▶ Diagnostics	→ 📄 213
Actual diagnos. (0691)	→ 📄 214
Timestamp (0667)	→ 📄 215
Prev.diagnostics (0690)	→ 📄 215
Timestamp (0672)	→ 📄 215
Time fr. restart (0653)	→ 📄 216
Operating time (0652)	→ 📄 216
Date/time (0790)	→ 📄 216
▶ Diagnostic list	→ 📄 217
Diagnostics 1 to 5 (0692-1 to 5)	→ 📄 217
Timestamp 1 to 5 (0683-1 to 5)	→ 📄 217
▶ Event logbook	→ 📄 218
Filter options (0705)	→ 📄 218
▶ Simulation	→ 📄 220
Dev. alarm sim. (0654)	→ 📄 220
Diag. event sim. (0737)	→ 📄 220

Curr.out. 1 to 2 sim. (13985-1 to 2)	→  221
Simulation value (13976)	→  221
▶ Device info	→  222
Device tag (0011)	→  222
Serial number (0009)	→  223
Firmware version (0010)	→  223
Firmware CRC (8563)	→  223
W&M config CRC (8564)	→  223
Device name (0013)	→  224
Order code (0008)	→  224
Ext. order cd. 1 to 3 (0023-1 to 3)	→  224
ENP version (0012)	→  224
Device type (8561)	→  225
Module type (8526)	→  225
Comm. Slot (13285)	→  225
▶ Board info	→  226
Date/time (0790)	→  226
System temp. (8553)	→  226
W&M lock switch (8558)	→  226
▶ Data logging	→  228
Assign chan. 1 to 4 (0851-1 to 4)	→  229
Logging interval (0856)	→  230
Clear logging (0855)	→  231

3 The "Expert" menu

Navigation  Expert

Expert	
Direct access (0106)	→ 23
Locking status (0004)	→ 24
Access stat.disp (0091)	→ 24
Access stat.tool (0005)	→ 24
Ent. access code (0003)	→ 24
▶ System	→ 26
▶ Input/output	→ 50
▶ Communication	→ 102
▶ Application	→ 142
▶ Diagnostics	→ 213

Direct access

Navigation  Expert → Direct access (0106)

User entry 0 to 65 535

Factory setting 0

Additional information Enter the access code of a parameter in order to access this parameter directly (i.e. without navigation).

The direct access code consists of a five digit number and an optional channel code, e.g. 00353-2

- Leading zeros need not to be entered.
- If the channel code is not entered, channel 1 is automatically selected.
- In order to access a different channel: Enter the direct access code with the channel code.

 In this document, the direct access code is added in brackets after the parameter name in the *Navigation* category.

Locking status

Navigation   Expert → Locking status (0004)

Description Indicates curr. write protec. with highest prio.

Additional information

Read access	Operator
Write access	-

Access stat.disp



Navigation   Expert → Access stat.disp (0091)



Prerequisite The device has a local display.

Description Indicates access authorization to parameter.

Additional information

Read access	Operator
Write access	-

 The access authorization can be changed via the **Ent. access code** parameter (→  24).

 If an additional write protection is active, this restricts the current access authorization even further. The write protection status can be viewed via the **Locking status** parameter (→  24).

Access stat.tool

Navigation  Expert → Access stat.tool (0005)

Description Acc.authorization to parameters via operating tool.

Additional information

Read access	Operator
Write access	-

Ent. access code

Navigation   Expert → Ent. access code (0003)





Description Enter access code to disable write protec.

Additional information



Read access	Operator
Write access	Operator













3.1 "System" submenu

Navigation  Expert → System

▶ System	
▶ Display	→  27
▶ System units	→  34
▶ Date / time	→  41
▶ Administration	→  47

3.1.1 "Display" submenu

Navigation   Expert → System → Display

► Display	
Language	→  27
Format display	→  28
Value 1 to 4 display	→  28
Decimal places 1 to 4	→  29
Separator	→  30
Number format	→  30
Header	→  31
Header text	→  31
Display interval	→  31
Display damping	→  32
Backlight	→  32
Contrast display	→  32

Language

Navigation   Expert → System → Display → Language (0104)

Prerequisite The device has a local display.

Description Set display language.

- Selection**
- English
 - Deutsch *
 - Français *
 - Español *
 - Italiano *
 - Nederlands *
 - Portuguesa *
 - Polski *
 - русский язык(Ru) *

* Visibility depends on order options or device settings

- Svenska *
- Türkçe *
- 中文 (Chinese) *
- 日本語 (Japanese) *
- 한국어 (Korean) *
- العربية (Ara) *
- Bahasa Indonesia *
- ภาษาไทย (Thai) *
- tiếng Việt (Vit) *
- čeština (Czech) *

Factory setting

English

Additional information

Read access	Operator
Write access	Operator

Format display**Navigation**

Expert → System → Display → Format display (0098)

Prerequisite

The device has a local display.

Description

Select how measured val. are shown on the display.

Selection

- 1 value, max.
- Bargr. + 1 value
- 2 values
- Val. large+2val.
- 4 values

Factory setting

1 value, max.

Additional information

Read access	Operator
Write access	Operator

- The **Value 1 to 4 display** (→ 28) parameters specify which measured values are shown on the display and in which order.
- If more measured values are specified than the current display mode permits, the values alternate on the device display. The display time until the next change is configured in the **Display interval** parameter (→ 31).

Value 1 to 4 display**Navigation**

Expert → System → Display → Value 1 display (0107)

Prerequisite

The device has a local display.

* Visibility depends on order options or device settings

Description Select measured value that is shown on the display.

- Selection**
- None ¹⁾
 - Tank level
 - Measured level
 - Tank level %
 - Water level ¹⁾
 - Liquid temperature ¹⁾
 - Vapor temperature ¹⁾
 - Air temperature ¹⁾
 - Tank ullage
 - Tank ullage %
 - Observed density value ¹⁾
 - P1 (bottom) ¹⁾
 - P2 (middle) ¹⁾
 - P3 (top) ¹⁾
 - GP 1 value ¹⁾
 - GP 2 value ¹⁾
 - GP 3 value ¹⁾
 - GP 4 value ¹⁾
 - Gauge command ¹⁾
 - Gauge status ¹⁾
 - AIO B1-3 value ¹⁾
 - AIO B1-3 value mA ¹⁾
 - AIO B1-3 value % ¹⁾
 - AIO C1-3 value ¹⁾
 - AIO C1-3 value mA ¹⁾
 - AIO C1-3 value % ¹⁾
 - AIP B4-8 value ¹⁾
 - AIP B4-8 value mA ¹⁾
 - AIP B4-8 value % ¹⁾
 - AIP C4-8 value ¹⁾
 - AIP C4-8 value mA ¹⁾
 - AIP C4-8 value % ¹⁾

Factory setting Depending on device version

Additional information

Read access	Operator
Write access	Maintenance

Decimal places 1 to 4



Navigation Expert → System → Display → Decimal places 1 (0095)

Prerequisite The device has a local display.

Description This selection does not affect the measurement and calculation accuracy of the device.

1) not available for the **Value 1 display** parameter

- Selection**
- X
 - X.X
 - X.XX
 - X.XXX
 - X.XXXX

Factory setting x.x

Additional information

Read access	Operator
Write access	Maintenance

Separator



Navigation Expert → System → Display → Separator (0101)

Prerequisite The device has a local display.

Description Select separator for displaying numerical values.

- Selection**
- .
 - ,

Factory setting .

Additional information

Read access	Operator
Write access	Maintenance

Number format



Navigation Expert → System → Display → Number format (0099)

Prerequisite The device has a local display.

Description Choose number format for the display.

- Selection**
- Decimal
 - ft-in-1/16"

Factory setting Decimal

Additional information

Read access	Operator
Write access	Maintenance

The **ft-in-1/16"** option is only valid for distance values.

Header

Navigation Expert → System → Display → Header (0097)

Prerequisite The device has a local display.

Description Select display header contents.

Selection

- Device tag
- Free text

Factory setting Device tag

Additional information

Read access	Operator
Write access	Maintenance

Meaning of the options

- **Device tag**
The header contents is defined in the **Device tag** parameter (→ 138).
- **Free text**
The header contents is defined in the **Header text** parameter (→ 31).

Header text

Navigation Expert → System → Display → Header text (0112)

Prerequisite **Header** (→ 31) = **Free text**

Description Enter display header text.

Factory setting TG-Platform

Additional information

Read access	Operator
Write access	Maintenance

Display interval

Navigation Expert → System → Display → Display interval (0096)

Description Time meas. val. are shown if displ. alternates.

User entry 1 to 10 s

Factory setting 5 s

Additional information

Read access	Operator
Write access	Operator

Display damping**Navigation**

Expert → System → Display → Display damping (0094)

Prerequisite

The device has a local display.

Description

Display reaction time to fluctuations of meas.val.

User entry

0.0 to 999.9 s

Factory setting

0.0 s

Additional information

Read access	Operator
Write access	Maintenance

Backlight**Navigation**

Expert → System → Display → Backlight (0111)

Prerequisite

The device has a local display.

Description

Switch the local display backlight on and off.

Selection

- Disable
- Enable

Factory setting

Enable

Additional information

Read access	Operator
Write access	Operator

Contrast display**Navigation**

Expert → System → Display → Contrast display (0105)

Prerequisite

The device has a local display.

Description

Adjust display contrast setting to ambient cond.

User entry

20 to 80 %

Factory setting 30 %









Additional information

Read access	Operator
Write access	Operator

3.1.2 "System units" submenu

Navigation  Expert → System → System units

▶ System units

Units preset	→  34
Distance unit	→  35
Pressure unit	→  35
Temperature unit	→  35
Density unit	→  36
Decimal length	→  36
Decimal pressure	→  37
Decimal temp.	→  37
Decimal density	→  37

Units preset

Navigation

 Expert → System → System units → Units preset (0605)

Description

Units for length, pressure and temperature.

Selection

- mm, bar, °C
- m, bar, °C
- mm, PSI, °C
- ft, PSI, °F
- ft-in-16, PSI, °F
- ft-in-8, PSI, °F
- Customer value



Factory setting

mm, bar, °C

Additional information

Read access	Operator
Write access	Maintenance

If the **Customer value** option is selected, the units are defined in the following parameters. In any other case these are read-only parameters used to indicate the respective unit:

- Distance unit (→  35)
- Pressure unit (→  35)
- Temperature unit (→  35)

Distance unit



Navigation Expert → System → System units → Distance unit (0551)

Description Select distance unit.

Selection

<i>SI units</i>	<i>US units</i>
<ul style="list-style-type: none"> ■ m ■ mm ■ cm 	<ul style="list-style-type: none"> ■ ft ■ in ■ ft-in-16 ■ ft-in-8

Factory setting mm

Additional information

Read access	Operator
Write access	Maintenance (if Units preset (→ 34) = Customer value)

Pressure unit



Navigation Expert → System → System units → Pressure unit (0564)

Description Select process pressure unit.

Selection

<i>SI units</i>	<i>US units</i>	<i>Other units</i>
<ul style="list-style-type: none"> ■ bar ■ Pa ■ kPa ■ MPa ■ mbar a 	<ul style="list-style-type: none"> psi 	<ul style="list-style-type: none"> ■ inH2O ■ inH2O (68°F) ■ ftH2O (68°F) ■ mmH2O ■ mmHg

Factory setting bar

Additional information

Read access	Operator
Write access	Maintenance (if Units preset (→ 34) = Customer value)

Temperature unit



Navigation Expert → System → System units → Temperature unit (0557)

Description Select temperature unit.

Selection

<i>SI units</i>	<i>US units</i>
<ul style="list-style-type: none"> ■ °C ■ K 	<ul style="list-style-type: none"> ■ °F ■ °R

Factory setting °C

Additional information

Read access	Operator
Write access	Maintenance (if Units preset (→  34) = Customer value)

Density unit**Navigation**  Expert → System → System units → Density unit (0555)**Description**

Select density unit.

Selection*SI units*

- g/cm³
- g/ml
- g/l
- kg/l
- kg/dm³
- kg/m³

US units

- lb/ft³
- lb/gal (us)
- lb/in³
- STon/yd³

Other units

- °API
- SGU

Factory settingkg/m³**Additional information**

Read access	Operator
Write access	Maintenance

Decimal length**Navigation**  Expert → System → System units → Decimal length (0573)**Description**

Number of decimal places for length values.

Selection

- X
- X.X
- X.XX
- X.XXX
- X.XXXX

Factory setting

x.x

Additional information

Read access	Operator
Write access	Maintenance

 The setting does not affect the accuracy of the measurement or the calculations.

Decimal pressure



Navigation Expert → System → System units → Decimal pressure (0608)

Description Number of decimal places for pressure values.

- Selection**
- X
 - X.X
 - X.XX
 - X.XXX
 - X.XXXX

Factory setting x.xxx

Additional information

Read access	Operator
Write access	Maintenance

The setting does not affect the accuracy of the measurement or the calculations.

Decimal temp.



Navigation Expert → System → System units → Decimal temp. (0614)

Description Number of decimal places for temperature values.

- Selection**
- X
 - X.X
 - X.XX
 - X.XXX
 - X.XXXX

Factory setting x.x

Additional information

Read access	Operator
Write access	Maintenance

The setting does not affect the accuracy of the measurement or the calculations.

Decimal density



Navigation Expert → System → System units → Decimal density (0609)

Description Number of decimal places for density values.

Selection

- X
- X.X
- X.XX
- X.XXX
- X.XXXX

Factory setting

x.x

Additional information

Read access	Operator
Write access	Maintenance









The setting does not affect the accuracy of the measurement or the calculations.

3.1.3 "Date / time" submenu

The **Date / time** submenu is used to set the real-time clock of the device.

Setting the real-time clock via the display and operating module

1. Navigate to Expert → System → Date / time → Set date.
 - ↳ The current value of the real-time clock is displayed.
2. If the displayed value is correct: Press  to terminate the wizard.
3. If the displayed value is not correct: Press  to edit it.
 - ↳ The current value of the **Year** parameter is displayed.
4. If the displayed value is correct: Press  to go to the next value.
5. If the displayed value is incorrect: Press  and enter the correct value. Confirm the new value by pressing .
6. Repeat the last two steps for the following parameters: **Month, Day, Hour, Minute**.
 - ↳ The new value of the real-time clock is displayed.
7. Confirm the new value of the real-time clock by pressing .
8. Quit the wizard by pressing  again.

Setting the real-time clock via an operating tool (e.g. FieldCare)

1. Navigate to: Expert → System → Date / time

2.

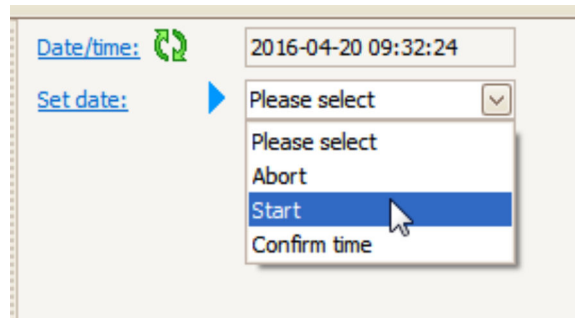

Go to the **Set date** parameter (→ ⓘ 42) and select the **Start** option.

3.

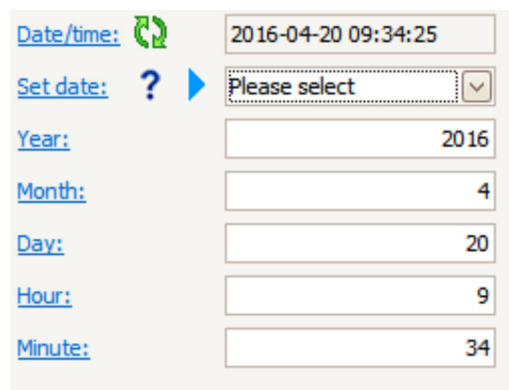

Use the following parameters to set the date and time: **Year, Month, Day, Hour, Minutes**.

4.

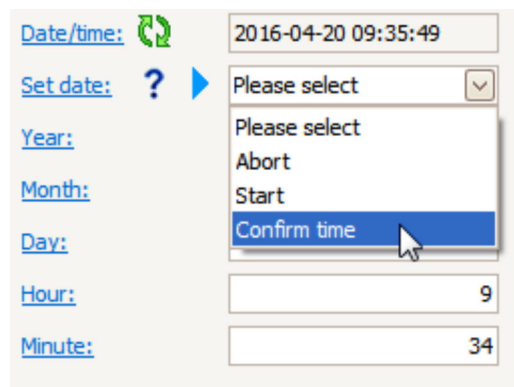

Go to the **Set date** parameter (→ ⓘ 42) and select the **Confirm time** option.

↳ The real-time clock is set to the current date and time.

Structure of the submenu on the display and operating module

Navigation  Expert → System → Date / time

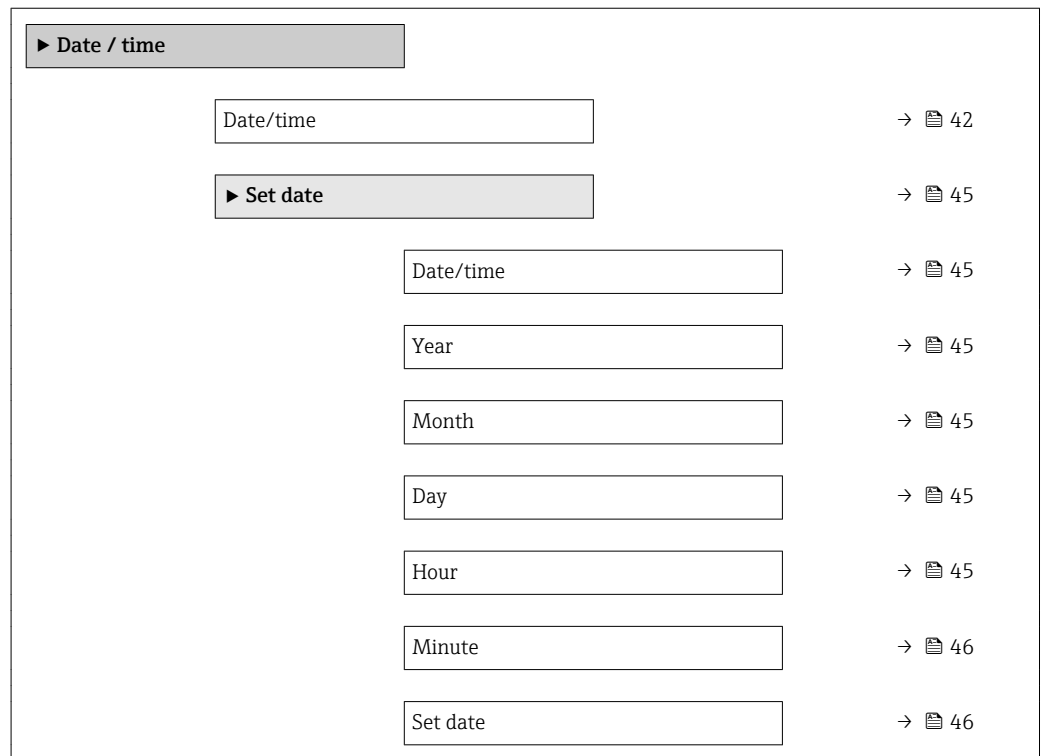

Structure of the submenu in an operating tool (e.g. FieldCare)

Navigation  Expert → System → Date / time

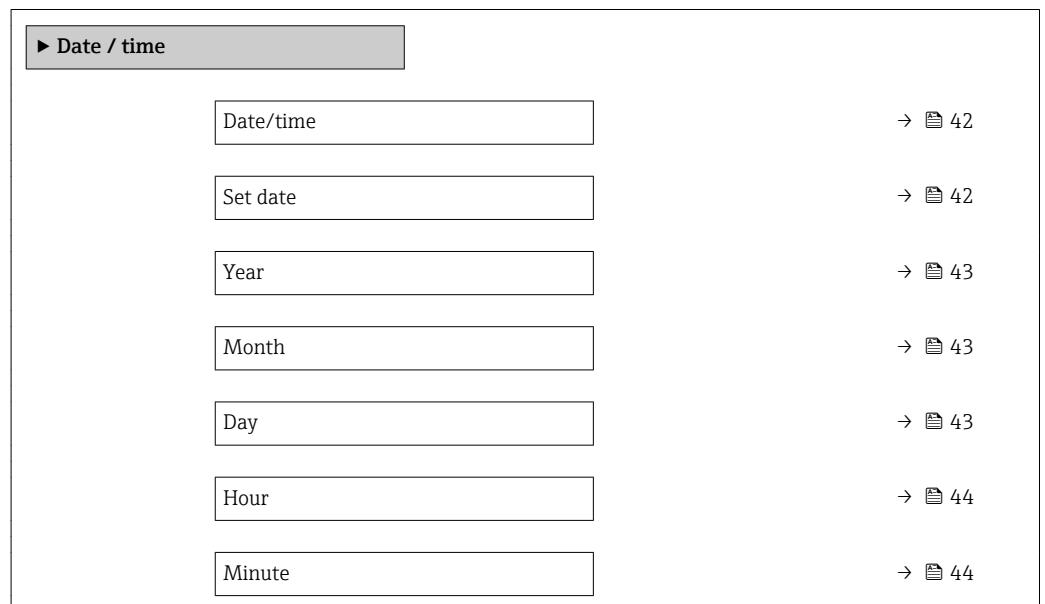

Description of parameters

Navigation  Expert → System → Date / time

Date/time

Navigation  Expert → System → Date / time → Date/time (0790)

Description Shows the current date and time from the real-time clock.

User interface Days (d), hours (h), minutes (m), seconds (s)

Factory setting

Additional information

Read access	Operator
Write access	-

Set date

Navigation  Expert → System → Date / time → Set date (0792)

Description Controls the setting of the real-time clock.

Selection

- Please select
- Abort
- Start
- Confirm time

Factory setting Please select

Additional information

Read access	Operator
Write access	Maintenance

Meaning of the options

- **Please select**
Prompts the user to select an action.
- **Abort**
Discards the entered date and time.
- **Start**
Starts the setting of the real time clock.
- **Confirm time**
Sets the real-time clock to the entered date and time.

Year



Navigation Expert → System → Date / time → Year (0782)

Prerequisite **Set date (→ 42) = Start**

Description Enter the current year.

User entry 2016 to 2079

Factory setting 2016

Additional information

Read access	Operator
Write access	Maintenance

Month



Navigation Expert → System → Date / time → Month (0787)

Prerequisite **Set date (→ 42) = Start**

Description Enter the current month.

User entry 1 to 12

Factory setting 1

Additional information

Read access	Operator
Write access	Maintenance

Day



Navigation Expert → System → Date / time → Day (0788)

Prerequisite **Set date (→ 42) = Start**

Description Enter the current day.

User entry 1 to 31

Factory setting 1

Additional information

Read access	Operator
Write access	Maintenance

Hour**Navigation** Expert → System → Date / time → Hour (0789)**Prerequisite** **Set date (→ 42) = Start****Description** Enter the current hour.**User entry** 0 to 23**Factory setting** 0**Additional information**

Read access	Operator
Write access	Maintenance

Minute**Navigation** Expert → System → Date / time → Minute (0791)**Prerequisite** **Set date (→ 42) = Start****Description** Enter the current minute.**User entry** 0 to 59**Factory setting** 0**Additional information**

Read access	Operator
Write access	Maintenance

"Set date" wizard

Navigation  Expert → System → Date / time → Set date

Date/time

Navigation  Expert → System → Date / time → Set date → Date/time (0790)

Description →  42

Year





Navigation  Expert → System → Date / time → Set date → Year (0782)

Description →  43

Month



Navigation  Expert → System → Date / time → Set date → Month (0787)

Description →  43

Day



Navigation  Expert → System → Date / time → Set date → Day (0788)

Description →  43

Hour



Navigation  Expert → System → Date / time → Set date → Hour (0789)

Description →  44

Minute

**Navigation**

Expert → System → Date / time → Set date → Minute (0791)

Description

→ 44

Set date

Navigation

Expert → System → Date / time → Set date → Set date

Description

Confirm the displayed new value of the real-time clock by pressing .

3.1.4 "Administration" submenu

Structure of the submenu on the display and operating module

Navigation  Expert → System → Administration

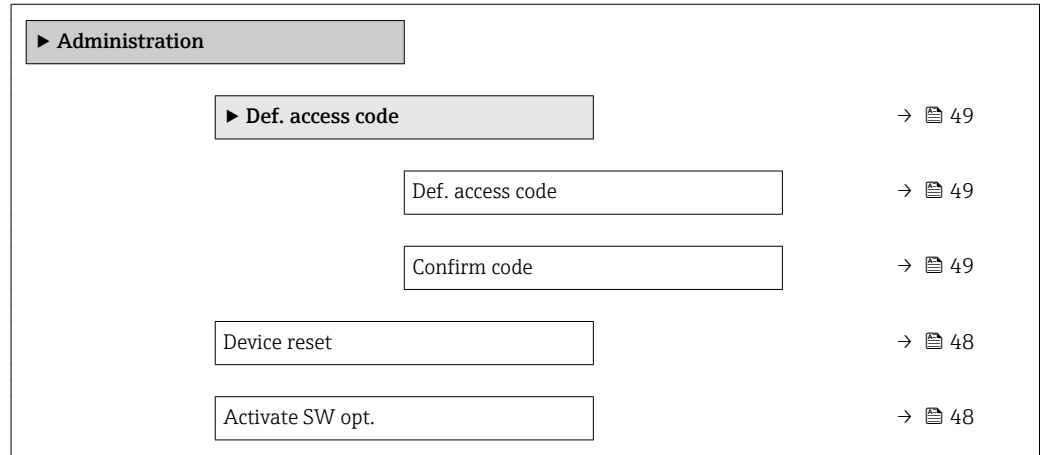

Structure of the submenu in an operating tool (e.g. FieldCare)

Navigation  Expert → System → Administration

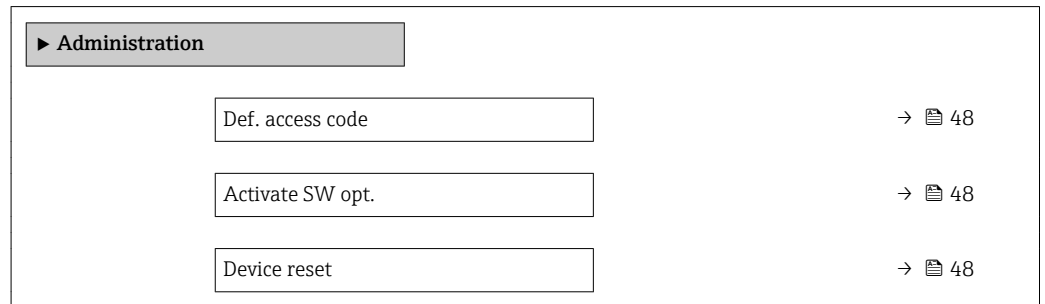

Description of parameters

Navigation  Expert → System → Administration

Def. access code

Navigation  Expert → System → Administration → Def. access code (0093)

Description Define release code for write access to parameters.

User entry 0 to 9 999



Factory setting 0

Additional information

Read access	Operator
Write access	Maintenance

 If the factory setting is not changed or 0 is defined as the access code, the parameters are not write-protected and the configuration data of the device can then always be modified. The user is logged on in the *Maintenance* role.

 The write protection affects all parameters marked with the  symbol in this document.

 Once the access code has been defined, write-protected parameters can only be modified if the access code is entered in the **Ent. access code** parameter (→  24).

Activate SW opt.

Navigation  Expert → System → Administration → Activate SW opt. (0029)

Description Enter code to unlock specific software options.

User entry Positive integer

Factory setting 0

Additional information

Read access	Operator
Write access	Maintenance

Device reset

Navigation  Expert → System → Administration → Device reset (0000)

Description Reset device configuration to a defined state.

- Selection**
- Cancel
 - To bus defaults **
 - To fact.defaults
 - Restart device

Factory setting Cancel

Additional information

Read access	Operator
Write access	Maintenance

"Define access code" wizard

Navigation  Expert → System → Administration → Def. access code

Def. access code 

Navigation  Expert → System → Administration → Def. access code → Def. access code

Description →  48

Confirm code 

Navigation  Expert → System → Administration → Def. access code → Confirm code

Description Confirm the entered access code.

User entry 0 to 9999

Factory setting 0





Additional information

Read access	Operator
Write access	Maintenance



** Visibility depends on communication



3.2 "Input/output" submenu

Navigation  Expert → Input/output



▶ Input/output	
▶ HART devices	→  51
▶ Analog IP	→  75
▶ Analog I/O	→  83
▶ Digital Xx-x	→  96

3.2.1 "HART devices" submenu

Navigation   Expert → Input/output → HART devices

▶ HART devices		
Number devices		→  51
▶ HART Device(s)		→  52
▶ Forget device		→  74

Number devices

Navigation   Expert → Input/output → HART devices → Number devices (13051)

Description Shows the number of devices on the HART bus.















Additional information

Read access	Operator
Write access	-

"HART Device(s)" submenu

 There is a **HART Device(s)** submenu for each HART slave device found on the HART loop.

Navigation  Expert → Input/output → HART devices → HART Device(s)

▶ HART Device(s)	
Device name	→  53
Polling address	→  53
Device tag	→  53
Operating mode	→  53
Comm. status	→  54
#blank# (PV - designation dependent on device)	→  54
#blank# (SV - designation dependent on device)	→  54
#blank# (TV - designation dependent on device)	→  54
#blank# (QV - designation dependent on device)	→  54
HARTDEV PV mA	→  55
HARTDEV PV %	→  55
Output pressure	→  56
Output density	→  56
Output temp.	→  56
Output vapor tmp	→  57
Output level	→  57
▶ HART device info	→  59
▶ Element values	→  65
▶ Diagnostics	→  66
▶ NMT dev. config	→  68

Device name

Navigation  Expert → Input/output → HART devices → HART Device(s) → Device name (14722)

Description Shows the name of the transmitter.

Additional information

Read access	Operator
Write access	-

Polling address

Navigation  Expert → Input/output → HART devices → HART Device(s) → Polling address (14712)

Description Shows the polling address of the transmitter.

Additional information

Read access	Operator
Write access	-

Device tag

Navigation  Expert → Input/output → HART devices → HART Device(s) → Device tag (14713)

Description Shows the device tag of the transmitter.

Additional information

Read access	Operator
Write access	-

Operating mode



Navigation  Expert → Input/output → HART devices → HART Device(s) → Operating mode (14745)

Prerequisite Not available if the HART device is a Prothermo NMT.

Description Selection of the operation mode.

Selection

- PV only
- PV,SV,TV & QV
- Level
- Measured level

Factory setting PV,SV,TV & QV

Additional information

Read access	Operator
Write access	Maintenance

Comm. status**Navigation**

 Expert → Input/output → HART devices → HART Device(s) → Comm. status (14710)

Description

Shows the operating status of the transmitter.

User interface

- Operating normal
- Device offline

Additional information

Read access	Operator
Write access	-

#blank# (HART PV - designation dependent on device)**Navigation**

 Expert → Input/output → HART devices → HART Device(s) → #blank# (14716)

Description

Shows the first HART variable (PV).

Additional information

Read access	Operator
Write access	-

#blank# (HART SV - designation dependent on device)**Navigation**

 Expert → Input/output → HART devices → HART Device(s) → #blank# (14705)

Prerequisite

For HART devices other than NMT: **Operating mode** (→  53) = PV,SV,TV & QV

Description

Shows the second HART variable (SV).

Additional information

Read access	Operator
Write access	-

#blank# (HART TV - designation dependent on device)**Navigation**

 Expert → Input/output → HART devices → HART Device(s) → #blank# (14706)

Prerequisite

For HART devices other than NMT: **Operating mode** (→  53) = PV,SV,TV & QV

Description Shows the third HART variable (TV).

Additional information

Read access	Operator
Write access	-

#blank# (HART QV - designation dependent on device)

Navigation   Expert → Input/output → HART devices → HART Device(s) → #blank# (14716)



Prerequisite For HART devices other than NMT: **Operating mode** (→  53) = PV,SV,TV & QV

Description Shows the fourth HART variable (QV).

Additional information

Read access	Operator
Write access	-

HARTDEV PV mA

Navigation   Expert → Input/output → HART devices → HART Device(s) → HARTDEV PV mA (14708)



Prerequisite Not available for Micropilot S FMR5xx and Prothermo 53x.

Description Shows the first HART variable (PV) in mA.

Additional information

Read access	Operator
Write access	-

HARTDEV PV %

Navigation   Expert → Input/output → HART devices → HART Device(s) → HARTDEV PV % (14709)

Prerequisite Not available for Micropilot S FMR5xx and Prothermo 53x.

Description Shows the first HART variable (PV) in percentage.

Additional information

Read access	Operator
Write access	-

Output pressure

Navigation	Expert → Input/output → HART devices → HART Device(s) → Output pressure (14719)				
Prerequisite	Not available for Micropilot S FMR5xx and Prothermo 53x. (In these cases the measured variables are allocated automatically).				
Description	Defines which HART variable is the pressure.				
Selection	<ul style="list-style-type: none"> ▪ No value ▪ Primary var (PV) ▪ Second.var(SV) ▪ Tertiary var(TV) ▪ Quaterna.var(QV) 				
Factory setting	No value				
Additional information	<table border="1"> <tr> <td>Read access</td> <td>Operator</td> </tr> <tr> <td>Write access</td> <td>Maintenance</td> </tr> </table>	Read access	Operator	Write access	Maintenance
Read access	Operator				
Write access	Maintenance				

Output density

Navigation	Expert → Input/output → HART devices → HART Device(s) → Output density (14720)				
Prerequisite	Not available for Micropilot S FMR5xx and Prothermo 53x. (In these cases the measured variables are allocated automatically).				
Description	Defines which HART variable is the density.				
Selection	<ul style="list-style-type: none"> ▪ No value ▪ Primary var (PV) ▪ Second.var(SV) ▪ Tertiary var(TV) ▪ Quaterna.var(QV) 				
Factory setting	No value				
Additional information	<table border="1"> <tr> <td>Read access</td> <td>Operator</td> </tr> <tr> <td>Write access</td> <td>Maintenance</td> </tr> </table>	Read access	Operator	Write access	Maintenance
Read access	Operator				
Write access	Maintenance				

Output temp.

Navigation	Expert → Input/output → HART devices → HART Device(s) → Output temp. (14721)
Prerequisite	Not available for Micropilot S FMR5xx and Prothermo 53x. (In these cases the measured variables are allocated automatically).

Description Defines which HART variable is the temperature.

Selection



- No value
- Primary var (PV)
- Second.var(SV)
- Tertiary var(TV)
- Quaterna.var(QV)

Factory setting No value

Additional information

Read access	Operator
Write access	Maintenance

Output vapor tmp

Navigation   Expert → Input/output → HART devices → HART Device(s) → Output vapor tmp (14726)

Prerequisite Not available for Micropilot S FMR5xx and Prothermo 53x. (In these cases the measured variables are allocated automatically).

Description Defines which HART variable is the vapor temp.

Selection



- No value
- Primary var (PV)
- Second.var(SV)
- Tertiary var(TV)
- Quaterna.var(QV)

Factory setting No value

Additional information

Read access	Operator
Write access	Maintenance

Output level

Navigation   Expert → Input/output → HART devices → HART Device(s) → Output level (14718)

Prerequisite Not available for Micropilot S FMR5xx and Prothermo 53x. (In these cases the measured variables are allocated automatically).

Description Defines which HART variable is the level.

Selection

- No value
- Primary var (PV)
- Second.var(SV)
- Tertiary var(TV)
- Quaterna.var(QV)



Factory setting

















No value

Additional information



Read access	Operator
Write access	Maintenance

"HART device information" submenu

Navigation   Expert → Input/output → HART devices → HART Device(s) → HART device info

▶ HART device info	
Pressure	→  59
Density	→  60
Temperature	→  60
Vapor temp.	→  60
Water level	→  61
Level source	→  61
Tank lvl to NMT	→  61
Manual value	→  62
HART bus	→  62
Device type	→  62
Device ID	→  62
Device date	→  63
Device descrip.	→  63
Device message	→  63
Software version	→  63
Custody transfer	→  64

Pressure

Navigation   Expert → Input/output → HART devices → HART Device(s) → HART device info → Pressure (14723)

Prerequisite Output pressure (→  56) ≠ No value

Description Shows the pressure value.

Additional information

Read access	Operator
Write access	-

Density**Navigation**

 Expert → Input/output → HART devices → HART Device(s) → HART device info → Density (14724)

Prerequisite

Output density (→  56) ≠ No value

Description

Shows the density value from HART device.

Additional information

Read access	Operator
Write access	-

Temperature**Navigation**

 Expert → Input/output → HART devices → HART Device(s) → HART device info → Temperature (14725)

Prerequisite

Output temp. (→  56) ≠ No value

Description

Shows the temperature measured by the connected HART device.

Additional information

Read access	Operator
Write access	-

Vapor temp.**Navigation**

 Expert → Input/output → HART devices → HART Device(s) → HART device info → Vapor temp. (14727)

Prerequisite

Output vapor tmp (→  57) ≠ No value



Description

Shows the temperature of the vapor phase.

Additional information

Read access	Operator
Write access	-

Water level

Navigation   Expert → Input/output → HART devices → HART Device(s) → HART device info → Water level (14717)

Prerequisite **Output level (→  57) ≠ No value**



Description Shows the water level value.

Additional information

Read access	Operator
Write access	-

Level source



Navigation   Expert → Input/output → HART devices → HART Device(s) → HART device info → Level source (14749)

Prerequisite Prothermo NMT53x

Description Source of level send to NMT.



- Selection**
- Manual value
 - Tank level

Factory setting Tank level

Additional information

Read access	Maintenance
Write access	Maintenance

Tank lvl to NMT

Navigation   Expert → Input/output → HART devices → HART Device(s) → HART device info → Tank lvl to NMT (14750)

Prerequisite Prothermo NMT53x with level measurement

Description Shows the level transferred to NMT.

Additional information

Read access	Maintenance
Write access	-

Manual value



Navigation Expert → Input/output → HART devices → HART Device(s) → HART device info → Manual value (14746)

Prerequisite Prothermo NMT53x with level measurement

Description Shows the manual set level.

User entry Signed floating-point number

Factory setting 0 mm

Additional information

Read access	Maintenance
Write access	Maintenance

HART bus

Navigation Expert → Input/output → HART devices → HART Device(s) → HART device info → HART bus (14711)

Description Information about the used IO-Slot.

Additional information

Read access	Operator
Write access	-

Device type

Navigation Expert → Input/output → HART devices → HART Device(s) → HART device info → Device type (14701)

Description For registration with HART Communic. Foundation.

Additional information

Read access	Operator
Write access	-

Device ID

Navigation Expert → Input/output → HART devices → HART Device(s) → HART device info → Device ID (14702)

Description Shows the device ID of the connected HART device.

Additional information

Read access	Operator
Write access	-

Device date

Navigation

  Expert → Input/output → HART devices → HART Device(s) → HART device info → Device date (14707)

Description



Date of the connected device.

Additional information

Read access	Operator
Write access	-

Device descrip.

Navigation

  Expert → Input/output → HART devices → HART Device(s) → HART device info → Device descrip. (14704)

Description



User def. HART descriptor of the connected device.

Additional information

Read access	Operator
Write access	-

Device message

Navigation

  Expert → Input/output → HART devices → HART Device(s) → HART device info → Device message (14703)

Description

User defined HART message of the connected device.

Additional information

Read access	Operator
Write access	-

Software version

Navigation

  Expert → Input/output → HART devices → HART Device(s) → HART device info → Software version (14747)

Prerequisite

Prothermo NMT53x

Description

Shows the software version of the NMT device.

Additional information

Read access	Maintenance
Write access	-

Custody transfer**Navigation**

 Expert → Input/output → HART devices → HART Device(s) → HART device info
→ Custody transfer (14748)

Prerequisite

Prothermo NMT53x with temperature measurement

Description

Hardware lock status of NMT.

Additional information

Read access	Maintenance
Write access	-

"Element values" submenu

 This submenu is only available for Prothermo NMT53x.

Navigation  Expert → Input/output → HART devices → HART Device(s) → Element values

"Element temperature" submenu

Navigation  Expert → Input/output → HART devices → HART Device(s) → Element values → Element temp.

Element temp 0 to 23

Navigation  Expert → Input/output → HART devices → HART Device(s) → Element values → Element temp. → Element temp 0 to 23 (14984)

Description Shows the temperature of an element in the NMT.

Additional information

Read access	Operator
Write access	-

"Element position" submenu

Navigation  Expert → Input/output → HART devices → HART Device(s) → Element values → Element position

Element pos. 0 to 23

Navigation  Expert → Input/output → HART devices → HART Device(s) → Element values → Element position → Element pos. 0 to 23 (15014)

Description Shows the position of selected element in the NMT.

Additional information





Read access	Operator
Write access	-

"Diagnostics" submenu

 This submenu is only available for Prothermo NMT53x.

Navigation  Expert → Input/output → HART devices → HART Device(s) → Diagnostics

► Diagnostics

Diag. code	→  66
Last Diagnostic	→  66
Reference 0	→  66
Reference 17	→  67

Diag. code

Navigation  Expert → Input/output → HART devices → HART Device(s) → Diagnostics → Diag. code (14739)

Description Shows the current diagnostic code of NMT.

Additional information

Read access	Operator
Write access	-

Last Diagnostic

Navigation  Expert → Input/output → HART devices → HART Device(s) → Diagnostics → Last Diagnostic (14742)

Description Shows the previous diagnostic code.

Additional information

Read access	Operator
Write access	-

Reference 0

Navigation  Expert → Input/output → HART devices → HART Device(s) → Diagnostics → Reference 0 (14740)

Prerequisite Prothermo NMT53x with temperature measurement.

Description Shows the temperature of reference element 0.

Additional information

Read access	Operator
Write access	-

Reference 17

Navigation

 Expert → Input/output → HART devices → HART Device(s) → Diagnostics
→ Reference 17 (14741)

Prerequisite

Prothermo NMT53x with temperature measurement.

Description

Shows the temperature of reference element 17.















Additional information

Read access	Operator
Write access	-

"NMT device config" submenu

 This submenu is only present if the connected HART device is a Prothermo NMT5xx.

Navigation  Expert → Input/output → HART devices → HART Device(s)
→ NMT dev. config

► NMT dev. config	
Config. device?	→  68
Access code	→  69
Total elements	→  69
Bottom point	→  69
Temp elem. short	→  70
Temp. elem. open	→  70
Output at error	→  70
Gain adjust	→  71
Kind of interval	→  71
Element interval	→  71
► Element setup	→  72
Select element	→  72
Zero adjust	→  72
Element temp.	→  73
Element position	→  73

Config. device?**Navigation**

 Expert → Input/output → HART devices → HART Device(s) → NMT dev. config
→ Config. device? (14728)

Description

Enable NMT device configuration.

Selection

- No
- Yes



Factory setting No

Additional information **Meaning of the options**

- **No**
Not configurable
- **Yes**
Configurable

Read access	Operator
Write access	Maintenance

Access code 

Navigation   Expert → Input/output → HART devices → HART Device(s) → NMT dev. config → Access code (14714)

Prerequisite **Config. device? (→  68) = Yes**

Description Shows the access code to configure the NMT device.



User entry 0 to 65 535

Factory setting 0

Additional information

Read access	Operator
Write access	Maintenance

Total elements



Navigation   Expert → Input/output → HART devices → HART Device(s) → NMT dev. config → Total elements (14730)

Description Shows the total no. of configurable temp. elements.

Additional information

Read access	Operator
Write access	-

Bottom point 

Navigation   Expert → Input/output → HART devices → HART Device(s) → NMT dev. config → Bottom point (14729)

Description Shows the bottom clearance from the end of probe.

User entry Signed floating-point number

Factory setting 0 mm

Additional information

Read access	Operator
Write access	Maintenance

Temp elem. short



Navigation

Expert → Input/output → HART devices → HART Device(s) → NMT dev. config → Temp elem. short (14731)

Description

Sets the temp. if element is broken (shorten).

User entry

Signed floating-point number

Factory setting

0 °C

Additional information

Read access	Operator
Write access	Maintenance

Temp. elem. open



Navigation

Expert → Input/output → HART devices → HART Device(s) → NMT dev. config → Temp. elem. open (14732)

Description

Sets the temp. if element is not connected.

User entry

Signed floating-point number

Factory setting

0 °C

Additional information

Read access	Operator
Write access	Maintenance

Output at error



Navigation

Expert → Input/output → HART devices → HART Device(s) → NMT dev. config → Output at error (14733)

Description

Defines if defective elements set output to max.

Selection

- Off
- On

Factory setting

Off

Additional information

Read access	Operator
Write access	Maintenance

Gain adjust



Navigation

Expert → Input/output → HART devices → HART Device(s) → NMT dev. config → Gain adjust (14736)

Description

Adjustm. of all temp. elements + reference 0 & 17.

User entry

Signed floating-point number

Factory setting

0

Additional information

Read access	Operator
Write access	Maintenance

Kind of interval



Navigation

Expert → Input/output → HART devices → HART Device(s) → NMT dev. config → Kind of interval (14744)

Description

Determines how the element positions are defined.

Selection

- Even
- Not even

Factory setting

Even

Additional information

Meaning of the options

- **Even**
First position bottom point + element interval for every next element.
- **Not even**
Position of elements can be set manually.

Read access	Operator
Write access	Maintenance

Element interval



Navigation

Expert → Input/output → HART devices → HART Device(s) → NMT dev. config → Element interval (14743)

Prerequisite

Kind of interval (→ 71) = Even

Description Shows the distance between the temp. elements.

User entry Signed floating-point number

Factory setting 0 mm

Additional information

Read access	Operator
Write access	Maintenance

"Element setup" submenu

Navigation  Expert → Input/output → HART devices → HART Device(s) → NMT dev. config → Element setup

Select element 

Navigation  Expert → Input/output → HART devices → HART Device(s) → NMT dev. config → Element setup → Select element (14734)

Description Chooses the temp. element configured manually.

User entry 1 to 16

Factory setting 1

Additional information

Read access	Operator
Write access	Maintenance

Zero adjust 

Navigation  Expert → Input/output → HART devices → HART Device(s) → NMT dev. config → Element setup → Zero adjust (14735)

Description Adjusts the offset of the selected temp. element.

User entry Signed floating-point number

Factory setting 0 None

Additional information

Read access	Operator
Write access	Maintenance

Element temp.

Navigation

 Expert → Input/output → HART devices → HART Device(s) → NMT dev. config → Element setup → Element temp. (14737)

Description

Shows the temperature of the element.

Additional information

Read access	Operator
Write access	-

Element position



Navigation

 Expert → Input/output → HART devices → HART Device(s) → NMT dev. config → Element setup → Element position (14738)

Description

Shows the position of the temperature element.

User entry

Signed floating-point number

Factory setting

0 mm

Additional information

Read access	Operator
Write access	Maintenance

"Forget device" wizard

 This submenu is only available if there is at least one unlocked device at the bus.

Navigation  Expert → Input/output → HART devices → Forget device

Forget device**Navigation**

 Expert → Input/output → HART devices → Forget device → Forget device

Description

Deletes an offline device from the device list.

Selection

- HART Device 1
- HART Device 2
- HART Device 3
- HART Device 4
- HART Device 5
- HART Device 6
- HART Device 7
- HART Device 8
- HART Device 9
- HART Device 10
- HART Device 11
- HART Device 12
- HART Device 13
- HART Device 14
- HART Device 15
- None

Factory setting

None

Additional information

Read access	Operator
Write access	Maintenance

3.2.2 "Analog IP" submenu

i There is an **Analog IP** submenu for each Analog I/O module of the device. This submenu refers to terminals 4 to 8 of this module (the analog input). They are primarily used to connect an RTD. For terminals 1 to 3 (analog input or output) refer to → 83.

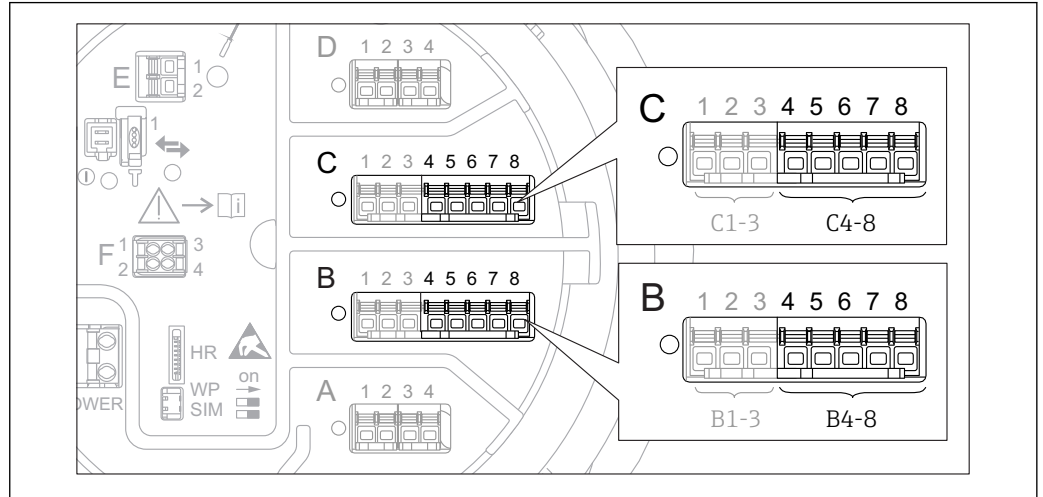

A0032465

1 Terminals for the "Analog IP" submenu ("B4-8" or "C4-8", respectively)

Navigation Expert → Input/output → Analog IP

▶ Analog IP

Operating mode	→ 83
RTD type	→ 83
Ohms offset	→ 84
RTD connect type	→ 84
Process value	→ 85
Process variable	→ 85
0 % value	→ 85
100 % value	→ 86
Input value [%]	→ 86
Input value	→ 86
Temp. offset	→ 87
Min. probe temp	→ 87

Max. probe temp	→ 80
Probe position	→ 81
Cal type AIP	→ 81
Act. calibration	→ 82
Damping factor	→ 82
Gauge current	→ 82

Operating mode

Navigation Expert → Input/output → Analog IP → Operating mode (14014)

Description Defines the operating mode of the analog input.

- Selection**
- Disabled
 - RTD temp input
 - Gauge supply

Factory setting Disabled

Additional information

Read access	Operator
Write access	Maintenance

RTD type

Navigation Expert → Input/output → Analog IP → RTD type (14021)

Prerequisite **Operating mode (→ 76) = RTD temp input**

Description Defines the type of the connected RTD.

- Selection**
- Cu50
 - Cu53
 - Cu90@0°C
 - Cu100@25°C
 - Cu100@0°C
 - Pt46 (w=1.391)
 - Pt50 (w=1.391)
 - Pt100(385)
 - Pt100(389)
 - Pt100(391)
 - Pt100
 - Pt500(385)

- Pt1000(385)
- Ni100(617)
- Ni120(672)
- Ni1000(617)

Factory setting Pt100(385)

Additional information

Read access	Operator
Write access	Maintenance

Ohms offset



Navigation Expert → Input/output → Analog IP → Ohms offset (14026)

Prerequisite **Operating mode (→ 76) = RTD temp input**

Description Defines a offset for the resistance. This value is added to the measured resistance before the calculation of the temperature.

User entry -10.0 to 10.0 Ohm

Factory setting 0 Ohm

Additional information The value entered in this parameter is added to the measured resistance before the calculation of the temperature.

Read access	Operator
Write access	Maintenance

RTD connect type



Navigation Expert → Input/output → Analog IP → RTD connect type (14022)

Prerequisite **Operating mode (→ 76) = RTD temp input**

Description Defines the connection type of the RTD.

- Selection**
- 4 wire RTD
 - 2 wire RTD
 - 3 wire RTD

Factory setting 4 wire RTD

Additional information

Read access	Operator
Write access	Maintenance

Process value

Navigation  Expert → Input/output → Analog IP → Process value (14003)

Prerequisite **Operating mode (→  76) ≠ Disabled**

Description Shows the value received via the analog input.

Additional information

Read access	Operator
Write access	-

Process variable



Navigation  Expert → Input/output → Analog IP → Process variable (14016)

Prerequisite **Operating mode (→  76) ≠ RTD temp input**

Description Determines type of measured value.

Selection

- Level linearized
- Temperature
- Pressure
- Density

Factory setting Level linearized

Additional information

Read access	Operator
Write access	Maintenance

0 % value



Navigation  Expert → Input/output → Analog IP → 0 % value (14001)

Prerequisite **Operating mode (→  76) = 4..20mA input**

Description The value represented by 4mA.

User entry Signed floating-point number

Factory setting 0 mm

Additional information

Read access	Operator
Write access	Maintenance

100 % value



Navigation Expert → Input/output → Analog IP → 100 % value (14013)

Prerequisite **Operating mode (→ 76) = 4..20mA input**

Description The value represented by 20mA.

User entry Signed floating-point number

Factory setting 0 mm

Additional information

Read access	Operator
Write access	Maintenance

Input value [%]

Navigation Expert → Input/output → Analog IP → Input value [%] (14002)

Prerequisite **Operating mode (→ 76) = 4..20mA input**

Description Shows the input value in percent. 0% corresponds to 4 mA. 100% corresponds to 20 mA.

- Additional information**
- 0% corresponds to 4 mA
 - 100% corresponds to 20 mA

Read access	Operator
Write access	-

Input value

Navigation Expert → Input/output → Analog IP → Input value (14015)

Prerequisite **Operating mode (→ 76) ≠ Disabled**

Description Shows the value received via the analog input.

Additional information

Read access	Operator
Write access	-

Temp. offset

Navigation	Expert → Input/output → Analog IP → Temp. offset (14025)
Prerequisite	Operating mode (→ 76) = RTD temp input
Description	Defines an offset for the measured temperature. The offset is applied after the resistance of the RTD has been converted to a temperature.
User entry	-20 to 20 °C
Factory setting	0 °C
Additional information	The offset defined in this parameter is applied after the resistance of the RTD has been converted to a temperature.

Read access	Operator
Write access	Maintenance

Min. probe temp

Navigation	Expert → Input/output → Analog IP → Min. probe temp (14010)
Prerequisite	Operating mode (→ 76) = RTD temp input
Description	Minimum approved temperature of the connected probe. If the temperature falls below this value, the W&M status will be 'invalid'.
User entry	-213 to 927 °C
Factory setting	-100 °C
Additional information	

Read access	Operator
Write access	Maintenance

Max. probe temp

Navigation	Expert → Input/output → Analog IP → Max. probe temp (14011)
Prerequisite	Operating mode (→ 76) = RTD temp input
Description	Maximum approved temperature of the connected probe. If the temperature rises above this value, the W&M status will be 'invalid'.
User entry	-213 to 927 °C
Factory setting	250 °C

Additional information

Read access	Operator
Write access	Maintenance

Probe position



Navigation

Expert → Input/output → Analog IP → Probe position (14009)

Prerequisite

Operating mode (→ 76) = RTD temp input

Description

Position of the temperature probe, measured from zero position (tank bottom or datum plate). This parameter, in conjunction with the measured level, determines whether the temperature probe is still covered by the product. If this is no longer the case, the status of the temperature value will be 'invalid'.

User entry

-5 000 to 30 000 mm

Factory setting

5 000 mm

Additional information

Read access	Operator
Write access	Maintenance

Cal type AIP



Navigation

Expert → Input/output → Analog IP → Cal type AIP (14018)

Prerequisite

Operating mode (→ 76) ≠ Disabled

Description

Calibration state of the analog input or output.

Selection

- Not calibrated
- User calibration
- Factory cal

Factory setting

Factory cal



Additional information

Meaning of the options

- Not calibrated
This is a display option only. It can not be selected. It is shown if the analog input is not in a calibrated state.
- User calibration
Activates a user calibration. The user calibration itself is defined in the **User calibration** wizard.
- Factory cal
Activates the factory calibration which is permanently stored in the device.



Read access	Operator
Write access	Maintenance

Act. calibration

Navigation  Expert → Input/output → Analog IP → Act. calibration (14012)**Prerequisite** **Operating mode (→  76) ≠ Disabled****Description** Shows calibration state of the analog input.**Additional information**

Read access	Operator
Write access	-

Damping factor

**Navigation**  Expert → Input/output → Analog IP → Damping factor (14004)**Prerequisite** **Operating mode (→  76) ≠ Disabled****Description** Defines the damping constant (in seconds).**User entry** 0 to 999.9 s**Factory setting** 0 s**Additional information**

Read access	Operator
Write access	Maintenance

Gauge current

Navigation  Expert → Input/output → Analog IP → Gauge current (14027)**Prerequisite** **Operating mode (→  76) = Gauge supply****Description** Current on the power supply for connected device.**Additional information**

Read access	Operator
Write access	-

3.2.3 "Analog I/O" submenu

i There is a **Analog I/O** submenu for each Analog I/O module of the device. This submenu refers to terminals 1 to 3 of this module (an analog input or output). For terminals 4 to 8 (always an analog input) refer to → 75.

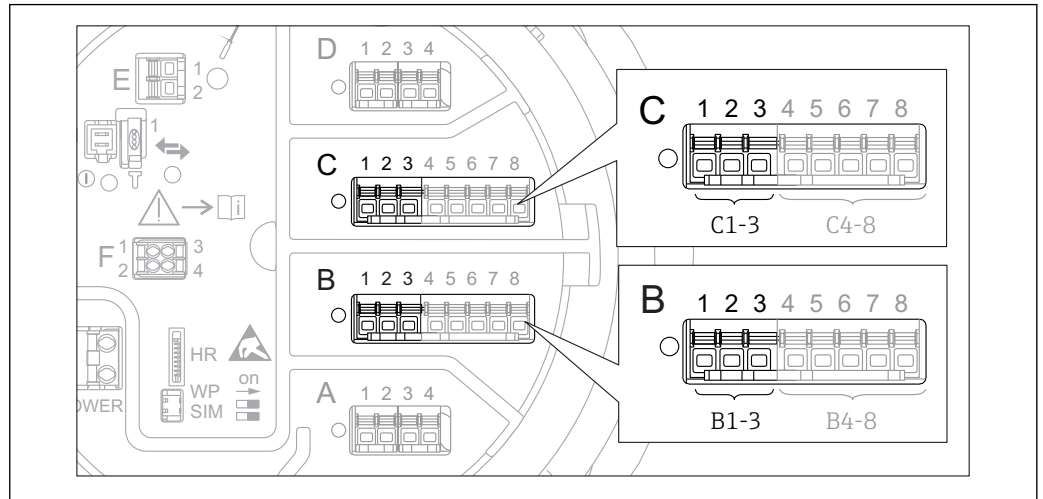

A0032464

2 Terminals for the "Analog I/O" submenu ("B1-3" or "C1-3", respectively)

Navigation Expert → Input/output → Analog I/O

▶ Analog I/O

Operating mode	→ 84
Current span	→ 85
Fixed current	→ 86
Analog source	→ 86
Failure mode	→ 87
Error value	→ 88
Output out range	→ 88
Error on event	→ 88
Input value	→ 89
0 % value	→ 89
100 % value	→ 89
Input value %	→ 90

Output value	→ 90
Readback value	→ 90
Feedback thresh.	→ 91
Process variable	→ 91
AI 0% value	→ 91
AI 100% value	→ 92
Error event type	→ 92
Process value	→ 92
Input val. in mA	→ 93
Input value [%]	→ 93
Damping factor	→ 93
Calibration	→ 93
Act. calibration	→ 94
Used for SIL/WHG	→ 94

Operating mode



Navigation

Expert → Input/output → Analog I/O → Operating mode (13958)

Description

Defines the operating mode of analog I/O module.

Selection

- Disabled
- 4..20mA input
- HART ma.+4..20mA
- HART master
- 4..20mA output
- HART slave

Factory setting

Disabled

Additional information

Read access	Operator
Write access	Maintenance

Meaning of the options



Operating mode (→  84)	Direction of signal	Type of signal
Disabled	-	-
4..20mA input	Input from 1 external device	Analog (4...20mA)
HART ma.+4..20mA	Input from 1 external device	<ul style="list-style-type: none"> ■ Analog (4...20mA) ■ HART
HART master	Input from up to 6 external devices	HART
4..20mA output	Output to higher-level unit	Analog (4...20mA)
HART slave	Output to higher-level unit	<ul style="list-style-type: none"> ■ Analog (4...20mA) ■ HART

Depending on the terminals used, the Analog I/O module is used in the passive or active mode.

Mode	Terminals of the I/O module		
	1	2	3
Passive (power supply from external source)	-	+	not used
Active (power supplied by the device itself)	not used	-	+

-  In the active mode the following conditions must be met:
- Maximum current consumption of the connected HART devices: 24 mA (i.e. 4 mA per device if 6 devices are connected).
 - Output voltage of the Ex-d module: 17.0 V@4 mA to 10.5 V@22 mA
 - Output voltage of the Ex-ia module: 18.5 V@4 mA to 12.5 V@22 mA

Current span 

- Navigation**   Expert → Input/output → Analog I/O → Current span (13987)
- Prerequisite** **Operating mode** parameter (→  84) ≠ **Disabled** option or **HART master** option
- Description** Current range for measured value transmission.
- Selection**
- 4...20 mA NAMUR
 - 4...20 mA US
 - 4...20 mA
 - Fixed current
- Factory setting** 4...20 mA NAMUR

Additional information

Read access	Operator
Write access	Maintenance

Meaning of the options

Option	Current range for process variable	Lower alarm signal level	Upper alarm signal level
4...20 mA	4 to 20.5 mA	< 3.6 mA	> 21.95 mA
4...20 mA NAMUR	3.8 to 20.5 mA	< 3.6 mA	> 21.95 mA
4...20 mA US	3.9 to 20.8 mA	< 3.6 mA	> 21.95 mA
Fixed current	Constant current, defined in the Fixed current parameter (→  86).		

 In the case of an error, the output current assumes the value defined in the **Failure mode** parameter (→  87).

Fixed current **Navigation**

  Expert → Input/output → Analog I/O → Fixed current (13989)

Prerequisite

Current span (→  85) = **Fixed current**

Description

Defines the fixed output current.

User entry

4 to 22.5 mA

Factory setting

4 mA



Additional information

Read access	Operator
Write access	Maintenance

Analog source **Navigation**

  Expert → Input/output → Analog I/O → Analog source (13974)

Prerequisite

- **Operating mode** (→  84) = **4..20mA output** or **HART slave**
- **Current span** (→  85) ≠ **Fixed current**

Description

Defines the variable transmitted via the AIO.

Selection

- None
- Tank level
- Tank level %
- Tank ullage
- Tank ullage %
- Measured level
- Distance
- Displacer position
- Water level
- Upper interface level
- Lower interface level
- Bottom level

- Tank reference height
- Liquid temperature
- Vapor temperature
- Air temperature
- Observed density value
- Average profile density ²⁾
- Upper density
- Middle density
- Lower density
- P1 (bottom)
- P2 (middle)
- P3 (top)
- GP 1 ... 4 value
- AIO B1-3 value ²⁾
- AIO B1-3 value mA ²⁾
- AIO C1-3 value ²⁾
- AIO C1-3 value mA ²⁾
- AIP B4-8 value ²⁾
- AIP C4-8 value ²⁾
- Element temperature 1 ... 24 ²⁾
- HART device 1...15 PV ²⁾
- HART device 1 ... 15 PV mA ²⁾
- HART device 1 ... 15 PV % ²⁾
- HART device 1 ... 15 SV ²⁾
- HART device 1 ... 15 TV ²⁾
- HART device 1 ... 15 QV ²⁾

Factory setting

Tank level

Additional information

Read access	Operator
Write access	Maintenance

Failure mode



Navigation

Expert → Input/output → Analog I/O → Failure mode (13988)

Prerequisite

Operating mode (→ 84) = 4..20mA output or HART slave

Description

Defines the output behavior in case of an error.

Selection

- Min.
- Max.
- Last valid value
- Actual value
- Defined value

Factory setting

Max.

Additional information

Read access	Operator
Write access	Maintenance

2) Visibility depends on order options or device settings

Error value

**Navigation** Expert → Input/output → Analog I/O → Error value (13972)**Prerequisite** **Failure mode (→ 87) = Defined value****Description** Defines the output value in case of an error.**User entry** 3.4 to 22.6 mA**Factory setting** 22 mA**Additional information**

Read access	Operator
Write access	Maintenance

Output out range

**Navigation** Expert → Input/output → Analog I/O → Output out range (13971)**Prerequisite** **Operating mode (→ 84) = 4..20mA output or HART slave****Description** Behavior of current output if value is out range.**Selection**

- Last valid value
- Alarm

Factory setting Alarm**Additional information**

Read access	Operator
Write access	Maintenance

Error on event

**Navigation** Expert → Input/output → Analog I/O → Error on event (13967)**Prerequisite** **Operating mode (→ 84) = 4..20mA output or HART slave****Description** Defines to which type of event (alarm or warning) the output responds.**Selection**

- Outp. rel. error
- Any error
- Error or warning

Factory setting Outp. rel. error



Additional information

Read access	Operator
Write access	Maintenance

Input value**Navigation**

  Expert → Input/output → Analog I/O → Input value (13979)

Prerequisite

- **Operating mode** (→  84) = 4..20mA output or HART slave
- **Current span** (→  85) ≠ Fixed current



Description

Shows the input value of the analog I/O module.



Additional information

Read access	Operator
Write access	-

0 % value**Navigation**

  Expert → Input/output → Analog I/O → 0 % value (13954)

Prerequisite

- **Operating mode** (→  84) = 4..20mA output or HART slave
- **Current span** (→  85) ≠ Fixed current

Description

Value corresponding to output current of 0% (4mA).

User entry

Signed floating-point number

Factory setting

0 Unitless



Additional information

Read access	Operator
Write access	Maintenance

100 % value**Navigation**

  Expert → Input/output → Analog I/O → 100 % value (13968)

Prerequisite

- **Operating mode** (→  84) = 4..20mA output or HART slave
- **Current span** (→  85) ≠ Fixed current

Description

Value corresp. to output current of 100% (20mA).

User entry

Signed floating-point number

Factory setting

0 Unitless



Additional information

Read access	Operator
Write access	Maintenance

Input value %**Navigation**

 Expert → Input/output → Analog I/O → Input value % (13955)

Prerequisite

- **Operating mode** (→  84) = 4..20mA output or HART slave
- **Current span** (→  85) ≠ Fixed current

Description

Shows the output value in percent.

Additional information

Read access	Operator
Write access	-

Output value**Navigation**

 Expert → Input/output → Analog I/O → Output value (13969)

Prerequisite

Operating mode (→  84) = 4..20mA output or HART slave

Description

Shows the output value in mA.

Additional information

Read access	Operator
Write access	-

Readback value**Navigation**

 Expert → Input/output → Analog I/O → Readback value (13957)

Prerequisite

Operating mode (→  84) = 4..20mA output or HART slave

Description

Shows measured (feedback) current at the output.

User interface

0 to 65 535 μ A

Factory setting

0 μ A

Additional information

Read access	Operator
Write access	-

Feedback thresh.

Navigation  Expert → Input/output → Analog I/O → Feedback thresh. (13956)

Prerequisite **Operating mode (→  84) = 4..20mA output or HART slave**

Description Shows the feedback threshold.

Additional information

Read access	Operator
Write access	-

Process variable



Navigation  Expert → Input/output → Analog I/O → Process variable (13964)

Prerequisite **Operating mode (→  84) = 4..20mA input or HART ma.+4..20mA**

Description Defines the type of measuring variable.

- Selection**
- Level linearized
 - Temperature
 - Pressure
 - Density

Factory setting Level linearized

Additional information

Read access	Operator
Write access	Maintenance

AI 0% value



Navigation  Expert → Input/output → Analog I/O → AI 0% value (13977)

Prerequisite **Operating mode (→  84) = 4..20mA input or HART ma.+4..20mA**

Description Defines value corresponding to 0% (4mA).



User entry Signed floating-point number

Factory setting 0 mm

Additional information

Read access	Operator
Write access	Maintenance



AI 100% value 

Navigation	  Expert → Input/output → Analog I/O → AI 100% value (13965)
Prerequisite	Operating mode (→  84) = 4..20mA input or HART ma.+4..20mA
Description	Value corresp. to output current of 100% (20mA).
User entry	Signed floating-point number
Factory setting	0 mm

Additional information

Read access	Operator
Write access	Maintenance



Error event type 

Navigation	  Expert → Input/output → Analog I/O → Error event type (13953)
Prerequisite	Operating mode (→  84) ≠ Disabled or HART master
Description	Type of event in case of an error in AIO module.
Selection	<ul style="list-style-type: none"> ▪ None ▪ Warning ▪ Alarm
Factory setting	Warning

Additional information

Read access	Operator
Write access	Maintenance

Process value

Navigation	  Expert → Input/output → Analog I/O → Process value (13963)
Prerequisite	Operating mode (→  84) = 4..20mA input or HART ma.+4..20mA
Description	Shows the input value scaled to customer units.

Additional information

Read access	Operator
Write access	-

Input val. in mA

Navigation  Expert → Input/output → Analog I/O → Input val. in mA (13970)

Prerequisite **Operating mode (→  84) = 4..20mA input or HART ma.+4..20mA**

Description Shows the input value in mA.

Additional information

Read access	Operator
Write access	-

Input value [%]

Navigation  Expert → Input/output → Analog I/O → Input value [%] (13978)

Prerequisite **Operating mode (→  84) = 4..20mA input or HART ma.+4..20mA**

Description Shows the input value as a percentage.

Additional information

Read access	Operator
Write access	-

Damping factor



Navigation  Expert → Input/output → Analog I/O → Damping factor (13951)

Prerequisite **Operating mode (→  84) ≠ Disabled or HART master**

Description Defines the damping constant (in seconds).

User entry 0 to 999.9 s

Factory setting 0 s

Additional information

Read access	Operator
Write access	Maintenance

Calibration



Navigation  Expert → Input/output → Analog I/O → Calibration (13966)

Prerequisite **Operating mode (→  84) ≠ Disabled or HART master**

Description Calibration state of the analog input or output.

Selection

- Not calibrated
- User calibration
- Factory cal

Factory setting Factory cal

Additional information

Read access	Operator
Write access	Maintenance

Act. calibration

Navigation  Expert → Input/output → Analog I/O → Act. calibration (13981)

Prerequisite **Operating mode (→  84) ≠ Disabled or HART master**

Description Indicates the calibration status of the Analog I/O module.

Additional information

Meaning of the options

- **User calibration**
The calibration entered by the user is active.
- **Factory cal**
The calibration stored permanently in the device is active.

Read access	Operator
Write access	-

Used for SIL/WHG

Navigation  Expert → Input/output → Analog I/O → Used for SIL/WHG (13980)

Prerequisite

- **Operating mode (→  84) = 4..20mA output or HART slave**
- The device has a SIL approval.

Description Determines whether the module is in SIL /WHG mode.

Selection

- Enabled
- Disabled

Factory setting Disabled

Additional information

Read access	Operator
Write access	Maintenance

SIL/WHG chain

Navigation Expert → Input/output → Analog I/O → SIL/WHG chain (13952)**Prerequisite**

- **Operating mode** (→  84) = **4..20mA output** or **HART slave**
- The device has a SIL approval.

Additional information

Read access	Operator
Write access	-

3.2.4 "Digital Xx-x" submenu

- i

 ■ In the operating menu, each digital input or output is designated by the respective slot of the terminal compartment and two terminals within this slot. **A1-2**, for example, denotes terminals 1 and 2 of slot **A**. The same is valid for slots **B**, **C** and **D** if they contain a Digital IO module.
- In this document, **Xx-x** designates any of these submenus. The structure of all these submenus is the same.

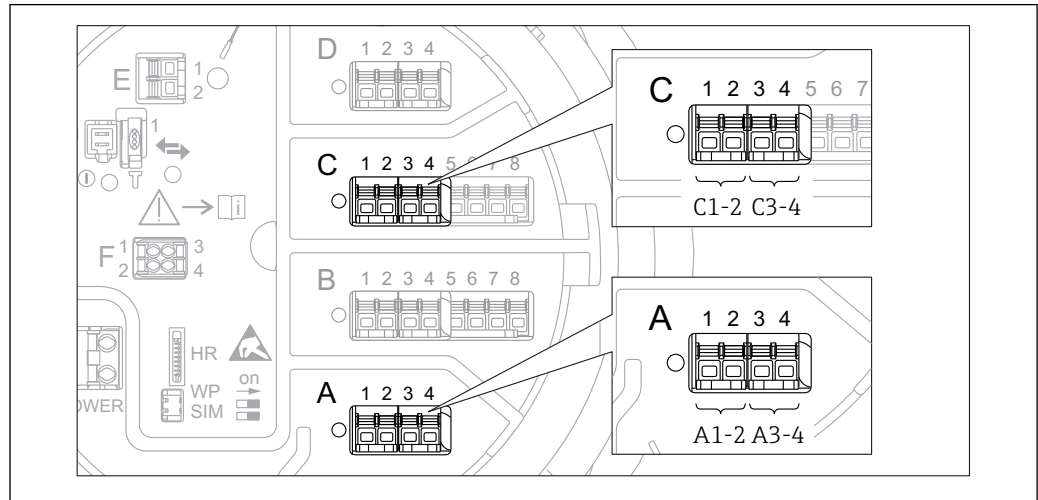

3 Designation of the digital inputs or outputs (examples)

Navigation 📁📁 Expert → Input/output → Digital Xx-x → Operating mode (13911)

▶ Digital Xx-x

Operating mode	→ 📖 97
Digital source	→ 📖 97
Input value	→ 📖 98
Contact type	→ 📖 98
Output sim	→ 📖 99
Output value	→ 📖 100
Readback value	→ 📖 100
Error on event	→ 📖 100
Damping factor	→ 📖 101
Used for SIL/WHG	→ 📖 101

Operating mode



Navigation Expert → Input/output → Digital Xx-x → Operating mode (13911)

Description Operating mode of the discrete I/O module.

- Selection**
- Disabled
 - Output passive
 - Input passive
 - Input active

Factory setting Disabled

Additional information

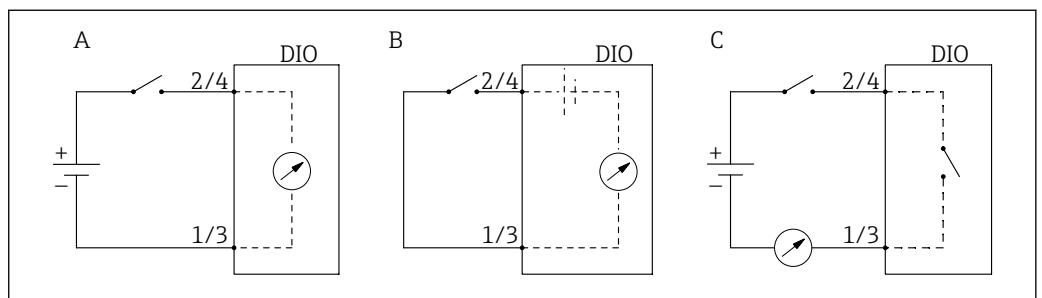

A0033028

4 Operating modes of the Digital I/O module

- A Input passive
- B Input active
- C Output passive

Read access	Operator
Write access	Maintenance

Digital source



Navigation Expert → Input/output → Digital Xx-x → Digital source (13907)

Prerequisite **Operating mode (→ 97) = Output passive**

Description Device state indicated by the digital output.

- Selection**
- None
 - Alarm x any
 - Alarm x High
 - Alarm x HighHigh
 - Alarm x High or HighHigh
 - Alarm x Low
 - Alarm x LowLow
 - Alarm x Low or LowLow
 - Digital Xx-x
 - Pri. Modbus x
 - Sec. Modbus x

Factory setting None

Additional information**Meaning of the options**

- **Alarm x any, Alarm x H, Alarm x HH, Alarm x H or HH, Alarm x L, Alarm x LL, Alarm x L or LL**

The digital output indicates if the selected alarm is currently active. The alarms themselves are defined in the **Alarm 1 to 4** submenus.

- **Digital Xx-x**³⁾

The digital signal present at the digital input **Xx-x** is passed through to the digital output.

- **Pri. Modbus x**
in preparation
- **Sec. Modbus x**
in preparation

Read access	Operator
Write access	Maintenance

Input value**Navigation**

 Expert → Input/output → Digital Xx-x → Input value (13901)

Prerequisite

Operating mode (→  97) = "Input passive" option or "Input active" option

Description

Shows the digital input value.

Additional information

Read access	Operator
Write access	-

Contact type**Navigation**

 Expert → Input/output → Digital X-x → Contact type (13912)

Prerequisite

Operating mode (→  97) ≠ Disabled

Description

Switching behavior of the input or output.

Selection

- NO
- NC

Factory setting

NO

Additional information

Read access	Operator
Write access	Maintenance

3) Only present if "Operating mode (→  97)" = "Input passive" or "Input active" for the respective Digital I/O module.

Output sim



Navigation Expert → Input/output → Digital X-x → Output sim (13909)

Prerequisite **Operating mode** (→ 97) = **Output passive**

Description Sets the output to a specific simulated value.

- Selection**
- Disable
 - Sim. active
 - Sim. inactive
 - Fault 1
 - Fault 2

Factory setting Disable

Additional information

Read access	Operator
Write access	Maintenance

The digital output consists of two relays connected in series:

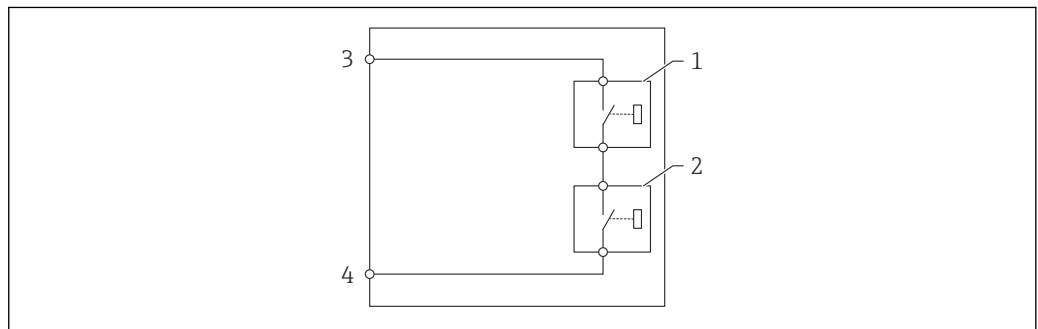

A0028602

5 The two relays of a digital output

1/2 The relays

3/4 The terminals of the digital output

The switching state of these relays is defined by the **Output sim** parameter as follows:

Output sim	State of relay 1	State of relay 2	Expected result on the terminals of the I/O module
Sim. active	Closed	Closed	Closed
Sim. inactive	Open	Open	Open
Fault 1	Closed	Open	Open
Fault 2	Open	Closed	Open

The **Fault 1** and **Fault 2** options can be used to check the correct switching behavior of the two relays.

Output value

Navigation  Expert → Input/output → Digital Xx-x → Output value (13902)

Prerequisite **Operating mode (→  97) = Output passive**

Description Shows the digital output value.

Additional information

Read access	Operator
Write access	-

Readback value

Navigation  Expert → Input/output → Digital Xx-x → Readback value (13903)

Prerequisite **Operating mode (→  97) = Output passive**

Description Shows the value read back from the output.

Additional information

Read access	Operator
Write access	-

Error on event



Navigation  Expert → Input/output → Digital Xx-x → Error on event (13916)

Prerequisite **Operating mode (→  97) = Output passive**

Description Type of events to which the output responds.

Selection

- Outp. rel. error
- Any error
- Error or warning

Factory setting Outp. rel. error

Additional information

Read access	Operator
Write access	Maintenance

Damping factor



Navigation Expert → Input/output → Digital Xx-x → Damping factor (13904)

Prerequisite **Operating mode (→ 97) ≠ Disabled**

Description Defines the damping constant.

User entry 1 to 10 s

Factory setting 5 s

Additional information

Read access	Operator
Write access	Maintenance

Used for SIL/WHG



Navigation Expert → Input/output → Digital Xx-x → Used for SIL/WHG (13910)

Prerequisite

- **Operating mode (→ 97) = Output passive**
- The device has a SIL certificate.

Description Determines whether the module is in SIL /WHG mode.

Selection

- Enabled
- Disabled

Factory setting Disabled

Additional information

Read access	Operator
Write access	Maintenance

3.3 "Communication" submenu

This menu contains a submenu for each digital communication interface of the device. The communication interfaces are designated by "X1-4" where "X" specifies the slot in the terminal compartment and "1-4" the terminals within this slot.

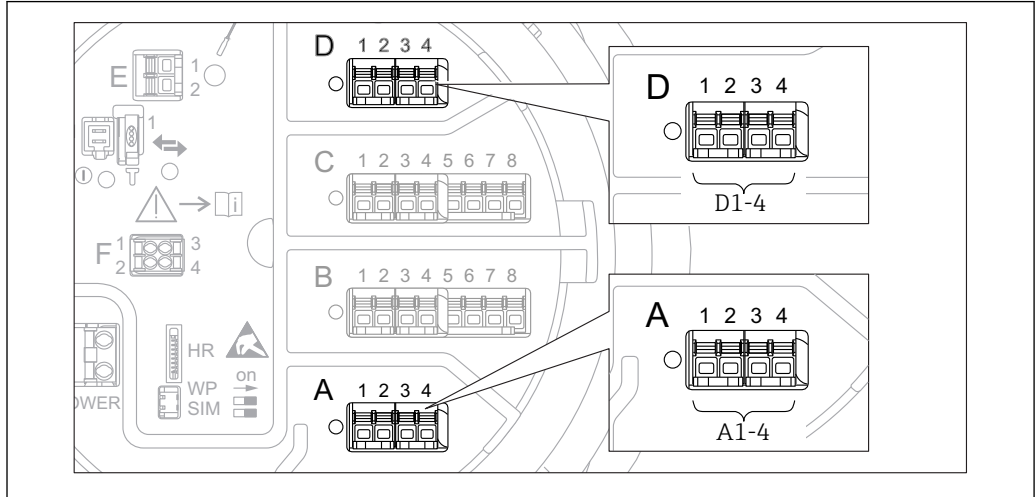

6 Designation of the "Modbus" or "V1" modules (examples); depending on the device version these modules may also be in slot B or C.









Navigation Expert → Communication

3.3.1 "Modbus Xx-x" or "V1 Xx-x" submenu



This submenu is only present for devices with **MODBUS** and/or **V1** communication interface. There is one submenu of this type for each communication interface.

Navigation   Expert → Communication → Modbus Xx-x / V1 Xx-x

▶ Modbus Xx-x

Commu I/F protoc	→  103
Modbus value 1 to 4	→  104
Modbus discr. 1 to 4	→  104
▶ Configuration	→  105
▶ Integer convers	→  109
▶ UserVal source	→  114
▶ GP values	→  115
▶ Discreteselect	→  118

▶ V1 Xx-x

Commu I/F protoc	→  103
▶ Configuration	→  119
▶ V1 input select.	→  122

Commu I/F protoc



Navigation   Expert → Communication → Modbus X1-4 / V1 X1-4 → Commu I/F protoc (13201)

Description Shows the type of communication protocol.

Additional information

Read access	Operator
Write access	-

Modbus value 1 to 4



Navigation	 Expert → Communication → Modbus Xx-x → Modbus value 1 to 4 (13206-1 to 4)
Prerequisite	Commu I/F protoc (→  103) = MODBUS
Description	Shows the respective floating point value.

Additional information

Read access	Operator
Write access	-

 The Modbus interface provides four floating point values which can be written to by the Host system. These values can be linked to specific functions (e.g. providing the air temperature value).

Modbus discr. 1 to 4

Navigation	 Expert → Communication → Modbus Xx-x → Modbus discr. 1 to 4 (13240-1 to 4)
Prerequisite	Commu I/F protoc (→  103) = MODBUS
Description	Shows integer value written by the host-system.

Additional information

Read access	Operator
Write access	-



 The Modbus interface provides four discrete (integer) registers which can be written to by the Host system. These values can be linked to specific functions (e.g. controlling a discrete output).

In the device these values are converted into the following discrete state values:









- Unknown (integer value 0)
- Inactive (integer value 1)
- Active (integer value 2)
- Invalid (integer value >= 3)

"Configuration" submenu (Modbus)

 Only visible for devices with a Modbus I/O module.

Navigation   Expert → Communication → Modbus Xx-x → Configuration → Baudrate (13203)

► Configuration

Baudrate	→  105
Parity	→  106
Modbus address	→  106
Float swap mode	→  106
Invalid data	→  107
Word type	→  107
CRC seed	→  107
Old TSM mode	→  108
Bus termination	→  108

Baudrate



Navigation   Expert → Communication → Modbus X1-4 → Configuration → Baudrate (13203)

Prerequisite **Commu I/F protoc (→  103) = MODBUS**

Description Defines the baud rate of the Modbus communication.

- Selection**
- 300 BAUD
 - 1200 BAUD
 - 2400 BAUD
 - 4800 BAUD
 - 9600 BAUD
 - 19200 BAUD

Factory setting 9600 BAUD

Additional information

Read access	Operator
Write access	Maintenance

Parity 

Navigation   Expert → Communication → Modbus X1-4 → Configuration → Parity (13204)

Prerequisite **Commu I/F protoc (→  103) = MODBUS**

Description Defines the parity of the Modbus communication.

Selection



- Odd
- Even
- None/1 stop bit
- None/2 stop bits

Factory setting None/1 stop bit

Additional information

Read access	Operator
Write access	Maintenance

Modbus address 

Navigation   Expert → Communication → Modbus X1-4 → Configuration → Modbus address (13205)

Prerequisite **Commu I/F protoc (→  103) = MODBUS**

Description Defines the Modbus address of the device.

User entry 1 to 247

Factory setting 1

Additional information

Read access	Operator
Write access	Maintenance

Float swap mode 

Navigation   Expert → Communication → Modbus X1-4 → Configuration → Float swap mode (13232)

Prerequisite **Commu I/F protoc (→  103) = MODBUS**

Description Format of the floating point value on modbus.

Selection



- Normal 3-2-1-0
- Swap 0-1-2-3
- WW Swap 1-0-3-2

Factory setting Swap 0-1-2-3

Additional information

Read access	Operator
Write access	Maintenance

Invalid data 

Navigation   Expert → Communication → Modbus Xx-x → Configuration → Invalid data (13243)

Prerequisite **Commu I/F protoc (→  103) = MODBUS**

Description Sets data value returned for invalid data.

- Selection**
- 0x00
 - 0xFF

Factory setting 0x00

Additional information

Read access	Operator
Write access	Maintenance

Word type 

Navigation   Expert → Communication → Modbus Xx-x → Configuration → Word type (13208)

Prerequisite **Commu I/F protoc (→  103) = MODBUS**

Description Selects integer range and type.



- Selection**
- Unsigned
 - Signed

Factory setting Unsigned

Additional information

Read access	Operator
Write access	Maintenance

CRC seed 

Navigation   Expert → Communication → Modbus Xx-x → Configuration → CRC seed (13248)

Prerequisite **Commu I/F protoc (→  103) = MODBUS**

Description CRC seed selection for communication CRC calc.

Selection

- 0x0000
- 0xFFFF

Factory setting 0xFFFF

Additional information

Read access	Operator
Write access	Maintenance

Old TSM mode

Navigation Expert → Communication → Modbus Xx-x → Configuration → Old TSM mode (13213)

Prerequisite **Commu I/F protoc (→ 103) = MODBUS**

Description Type of value avail. at NRF590 SW1 map. addresses.

Selection

- Float values
- Integer values

Factory setting Float values

Additional information

Read access	Operator
Write access	Maintenance

Bus termination

Navigation Expert → Communication → Modbus X1-4 → Configuration → Bus termination (13249)

Prerequisite **Commu I/F protoc (→ 103) = MODBUS**

Description Activates or deactivates the bus termination.

Selection

- Off
- On



Factory setting Off

Additional information













Read access	Operator
Write access	Maintenance

"Integer conversion" submenu

 Only visible for devices with a Modbus I/O module.

Navigation   Expert → Communication → Modbus Xx-x → Integer convers

▶ Integer convers

Level 0%	→  109
Level 100%	→  110
Temperature 0%	→  110
Temperature 100%	→  110
Pressure 0%	→  111
Pressure 100%	→  111
Density 0%	→  111
Density 100%	→  112
User 0%	→  112
User 100%	→  112
Percent 0%	→  113
Percent 100%	→  113

Level 0%



Navigation   Expert → Communication → Modbus Xx-x → Integer convers → Level 0% (13214)

Description Level representing 0% on the integer scale.

User entry Signed floating-point number

Factory setting 0.00 mm

Additional information	Read access	Operator
	Write access	Maintenance

Level 100%**Navigation** Expert → Communication → Modbus Xx-x → Integer convers → Level 100% (13250)**Description** Level representing 100% on the integer scale.**User entry** Signed floating-point number**Factory setting** 30.0 mm**Additional information**

Read access	Operator
Write access	Maintenance

Temperature 0%**Navigation** Expert → Communication → Modbus Xx-x → Integer convers → Temperature 0% (13215)**Description** Temperature representing 0% on the integer scale.**User entry** Signed floating-point number**Factory setting** 273.15 °C**Additional information**

Read access	Operator
Write access	Maintenance

Temperature 100%**Navigation** Expert → Communication → Modbus Xx-x → Integer convers → Temperature 100% (13216)**Description** Temperature representing 100% on integer scale.**User entry** Signed floating-point number**Factory setting** 273.15 °C**Additional information**

Read access	Operator
Write access	Maintenance

Pressure 0%



Navigation Expert → Communication → Modbus Xx-x → Integer convers → Pressure 0% (13217)

Description Pressure representing 0% on the integer scale.

User entry Signed floating-point number

Factory setting 0 bar

Additional information

Read access	Operator
Write access	Maintenance

Pressure 100%



Navigation Expert → Communication → Modbus Xx-x → Integer convers → Pressure 100% (13251)

Description Pressure representing 100% on the integer scale.

User entry Signed floating-point number

Factory setting 25 000 bar

Additional information

Read access	Operator
Write access	Maintenance

Density 0%



Navigation Expert → Communication → Modbus Xx-x → Integer convers → Density 0% (13252)

Description Density representing 0% on the integer scale.

User entry Signed floating-point number

Factory setting 0 kg/m³

Additional information

Read access	Operator
Write access	Maintenance

Density 100%

Navigation Expert → Communication → Modbus Xx-x → Integer convers → Density 100% (13218)

Description Density representing 100% on the integer scale.

User entry Signed floating-point number

Factory setting 1 000 kg/m³

Additional information

Read access	Operator
Write access	Maintenance

User 0%

Navigation Expert → Communication → Modbus Xx-x → Integer convers → User 0% (13221)

Description User spec. variable for 0% on the integer scale.

User entry Signed floating-point number

Factory setting 0

Additional information

Read access	Operator
Write access	Maintenance

User 100%

Navigation Expert → Communication → Modbus Xx-x → Integer convers → User 100% (13222)

Description User spec. variable for 100% on the integer scale.

User entry Signed floating-point number

Factory setting 0

Additional information

Read access	Operator
Write access	Maintenance

Percent 0%



Navigation Expert → Communication → Modbus Xx-x → Integer convers → Percent 0% (13202)

Description Percentage representing 0% on the integer scale.

User entry -200 to +400 %

Factory setting 0.00 %

Additional information

Read access	Operator
Write access	Maintenance

Percent 100%



Navigation Expert → Communication → Modbus Xx-x → Integer convers → Percent 100% (13234)

Description Percentage representing 100% on the integer scale.

User entry -200 to +400 %

Factory setting 100 %

Additional information

Read access	Operator
Write access	Maintenance

"User value source" submenu

 Only visible for devices with a Modbus I/O module.

Navigation  Expert → Communication → Modbus Xx-x → UserVal source
→ UserVal 1 source (13209)

UserVal 1 to 8 source**Navigation**

 Expert → Communication → Modbus Xx-x → UserVal source → UserVal 1 to 8 source
(13209-1 to 8)

Description

Selects parameter for User value x on the Modbus.

Selection

- None
- Tank ullage
- Distance
- Upper interface level
- Lower interface level
- Bottom level
- Average profile density ⁴⁾
- Vapor density
- Manual density
- P1 position
- P3 position
- GP 1...4 value
- AIO B1-3 value
- AIO C1-3 value
- AIP B4-8 value
- AIP C4-8 value
- HART device 1...15 PV
- HART device 1...15 PV mA
- HART device 1...15 PV %
- HART device 1...15 SV
- HART device 1...15 TV
- HART device 1...15 QV

Factory setting

None

Additional information









Read access	Operator
Write access	Maintenance

4) Visibility depends on order options or device settings

"GP values" submenu

Navigation  Expert → Communication → Modbus Xx-x → GP values → GP 1 value 0% (13223)

▶ GP values

GP 1 value 0%	→  115
GP 1 value 100%	→  115
GP 2 value 0%	→  116
GP 2 value 100%	→  116
GP 3 value 0%	→  116
GP 3 value 100%	→  117
GP 4 value 0%	→  117
GP 4 value 100%	→  117

GP 1 value 0% 

Navigation  Expert → Communication → Modbus Xx-x → GP values → GP 1 value 0% (13223)

Description GP1 value that represents 0% on integer scale.

User entry Signed floating-point number

Factory setting 0 Unitless

Additional information

Read access	Operator
Write access	Maintenance

GP 1 value 100% 

Navigation  Expert → Communication → Modbus Xx-x → GP values → GP 1 value 100% (13224)

Description GP1 value that represents 100% on integer scale.

User entry Signed floating-point number

Factory setting 0 Unitless

Additional information

Read access	Operator
Write access	Maintenance

GP 2 value 0%**Navigation**

Expert → Communication → Modbus Xx-x → GP values → GP 2 value 0% (13257)

Description

GP2 value that represents 0% on integer scale.

User entry

Signed floating-point number

Factory setting

0 None

Additional information

Read access	Operator
Write access	Maintenance

GP 2 value 100%**Navigation**

Expert → Communication → Modbus Xx-x → GP values → GP 2 value 100% (13258)

Description

GP2 value that represents 100% on integer scale.

User entry

Signed floating-point number

Factory setting

0 None

Additional information

Read access	Operator
Write access	Maintenance

GP 3 value 0%**Navigation**

Expert → Communication → Modbus Xx-x → GP values → GP 3 value 0% (13259)

Description

GP3 value that represents 0% on integer scale.

User entry

Signed floating-point number

Factory setting

0 Unitless

Additional information

Read access	Operator
Write access	Maintenance

GP 3 value 100%



Navigation Expert → Communication → Modbus Xx-x → GP values → GP 3 value 100% (13226)

Description GP3 value that represents 100% on integer scale.

User entry Signed floating-point number

Factory setting 0 Unitless

Additional information

Read access	Operator
Write access	Maintenance

GP 4 value 0%



Navigation Expert → Communication → Modbus Xx-x → GP values → GP 4 value 0% (13225)

Description GP4 value that represents 0% on integer scale.

User entry Signed floating-point number

Factory setting 0 Unitless

Additional information

Read access	Operator
Write access	Maintenance

GP 4 value 100%



Navigation Expert → Communication → Modbus Xx-x → GP values → GP 4 value 100% (13227)

Description GP4 value that represents 100% on integer scale.

User entry Signed floating-point number

Factory setting 0 Unitless

Additional information

Read access	Operator
Write access	Maintenance

"Discrete selector" submenu

Navigation  Expert → Communication → Modbus Xx-x → Discreteselect

Discrete 1 to 8select**Navigation**

 Expert → Communication → Modbus Xx-x → Discreteselect → Discrete 1 to 8select (13260-1 to 8)

Description

Discrete input for Discrete 1 Modbus value.

Selection

- None
- **Balance flag** option Visibility depends on order options or device settings
- Alarm 1...4 any
- Alarm 1...4 HighHigh
- Alarm 1...4 High or HighHigh
- Alarm 1...4 High
- Alarm 1...4 Low
- Alarm 1...4 Low or LowLow
- Alarm 1...4 LowLow
- Digital Xx-x
- Modbus A1-4 Discrete 1...4
- Modbus B1-4 Discrete 1...4
- Modbus C1-4 Discrete 1...4
- Modbus D1-4 Discrete 1...4

Factory setting



None

Additional information







Read access	Operator
Write access	Maintenance

"Configuration" submenu (V1)

 Only visible for devices with a V1 I/O module.



Navigation   Expert → Communication → V1 Xx-x → Configuration

► Configuration

- Protocol variant →  119
- V1 addressV1/MDP →  119
- V1 addressBBB/MIC+232 →  120
- Level mapping →  120
- Line impedance →  121
- Comp. mode →  121



Protocol variant



Navigation	  Expert → Communication → V1 Xx-x → Configuration → Protocol variant (13269)				
Description	Determines variant of the V1 protocol.				
Selection	<ul style="list-style-type: none"> ■ None ■ V1 				
Factory setting	None				
Additional information	<table border="1" style="width: 100%; border-collapse: collapse;"> <tr> <td style="padding: 2px;">Read access</td> <td style="padding: 2px;">Operator</td> </tr> <tr> <td style="padding: 2px;">Write access</td> <td style="padding: 2px;">Maintenance</td> </tr> </table>	Read access	Operator	Write access	Maintenance
Read access	Operator				
Write access	Maintenance				

V1 address



Navigation	  Expert → Communication → V1 Xx-x → Configuration → V1 address (13235)
Prerequisite	Protocol variant (→  119) = V1 or MDP
Description	Identifier of the device for the V1 communication.
User entry	0 to 99
Factory setting	1

Additional information

Read access	Operator
Write access	Maintenance

V1 address**Navigation**

Expert → Communication → V1 Xx-x → Configuration → V1 address (13236)

Prerequisite

Protocol variant (→ 119) = BBB or MIC+232

Description

Identifier of the previous device for V1.

User entry

0 to 255

Factory setting

1

Additional information

Read access	Operator
Write access	Maintenance

Level mapping**Navigation**

Expert → Communication → V1 Xx-x → Configuration → Level mapping (13268)

Prerequisite

Commu I/F protoc (→ 103) = V1

Description

Determines the transmittable range of levels.

Selection

- +ve
- +ve & -ve

Factory setting

+ve

Additional information

Read access	Operator
Write access	Maintenance

In V1, the level is always represented by a number in the range from 0 to 999 999. This number corresponds to a level as follows:

"Level mapping" = "+ve"

Number	Corresponding level
0	0.0 mm
999 999	99 999.9 mm

"Level mapping" = "+ve & -ve"

Number	Corresponding level
0	0.0 mm
500 000	50 000.0 mm
500 001	-0.1 mm
999 999	-49 999.9 mm

Line impedance



Navigation Expert → Communication → V1 Xx-x → Configuration → Line impedance (13266)

Prerequisite **Commu I/F protoc (→ 103) = V1**

Description Adjusts the impedance of the communication line.

User entry 0 to 15

Factory setting 15

Additional information

Read access	Operator
Write access	Maintenance

The line impedance affects the voltage difference between a logical 0 and a logical 1 on the message of the device to the bus. The default setting is suitable for most applications.

Comp. mode



Navigation Expert → Communication → Modbus Xx-x / V1 Xx-x → Configuration → Comp. mode (13281)

Description Defines the compatibility mode.

Selection

- NMS5x
- NMS8x

Factory setting NMS8x











Additional information

Read access	Operator
Write access	Maintenance

"V1 input select." submenu (V1)

 Only visible for devices with a V1 I/O module.

Navigation  Expert → Communication → V1 Xx-x → V1 input select.

▶ V1 input select.	
UserVal 1 to 8 source	→  122
Alarm1 input src	→  123
Alarm2 input src	→  123
Alarm3 in-source	→  124
Alarm4 in-source	→  124
SP1 value select	→  125
SP2 value select	→  125
SP3 value select	→  126
SP4 value select	→  126
Value % select	→  126

UserVal 1 to 8 source



Navigation  Expert → Communication → V1 Xx-x → V1 input select. → UserVal 1 to 8 source (13209-1 to 8)

Description Selects parameter for User value x on the Modbus.

- Selection**
- None
 - Tank ullage
 - Distance
 - Upper interface level
 - Lower interface level
 - Bottom level
 - Average profile density ⁵⁾
 - Vapor density
 - Manual density
 - P1 position
 - P3 position
 - GP 1...4 value

5) Visibility depends on order options or device settings



- AIO B1-3 value
- AIO C1-3 value
- AIP B4-8 value
- AIP C4-8 value
- HART device 1...15 PV
- HART device 1...15 PV mA
- HART device 1...15 PV %
- HART device 1...15 SV
- HART device 1...15 TV
- HART device 1...15 QV

Factory setting None

Additional information

Read access	Operator
Write access	Maintenance

Alarm1 input src 

Navigation   Expert → Communication → V1 Xx-x → V1 input select. → Alarm1 input src (13270)

Description Discrete value transmitted as V1 alarm 1 status.



- Selection**
- None
 - Alarm 1-4 any
 - Alarm 1-4 HighHigh
 - Alarm 1-4 High or HighHigh
 - Alarm 1-4 High
 - Alarm 1-4 Low
 - Alarm 1-4 Low or LowLow
 - Alarm 1-4 LowLow

Factory setting None

Additional information

Read access	Operator
Write access	Maintenance

Alarm2 input src 

Navigation   Expert → Communication → V1 Xx-x → V1 input select. → Alarm2 input src (13271)

Description Discrete value transmitted as V1 alarm 2 status.

- Selection**
- None
 - Alarm 1-4 any
 - Alarm 1-4 HighHigh
 - Alarm 1-4 High or HighHigh
 - Alarm 1-4 High

- Alarm 1-4 Low
- Alarm 1-4 Low or LowLow
- Alarm 1-4 LowLow

Factory setting

None

Additional information

Read access	Operator
Write access	Maintenance

Alarm3 in-source**Navigation**

Expert → Communication → V1 Xx-x → V1 input select. → Alarm3 in-source (13283)

Description

Discrete value transmitted as V1 alarm 3 status.

Selection

- None
- Alarm 1-4 any
- Alarm 1-4 HighHigh
- Alarm 1-4 High or HighHigh
- Alarm 1-4 High
- Alarm 1-4 Low
- Alarm 1-4 Low or LowLow
- Alarm 1-4 LowLow

Factory setting

None

Additional information

Read access	Operator
Write access	Maintenance

Alarm4 in-source**Navigation**

Expert → Communication → V1 Xx-x → V1 input select. → Alarm4 in-source (13284)

Description

Discrete value transmitted as V1 alarm 4 status.

Selection

- None
- Alarm 1-4 any
- Alarm 1-4 HighHigh
- Alarm 1-4 High or HighHigh
- Alarm 1-4 High
- Alarm 1-4 Low
- Alarm 1-4 Low or LowLow
- Alarm 1-4 LowLow

Factory setting

None

Additional information

Read access	Operator
Write access	Maintenance

SP1 value select**Navigation**

Expert → Communication → V1 → V1 input select. → SP1 value select (13274)

Description

Discrete value for V1 External Status bit 1.

Selection

- None
- Digital A1-2
- Digital A3-4
- Digital B1-2
- Digital B3-4
- Digital C1-2
- Digital C3-4
- Digital D1-2
- Digital D3-4

Factory setting

None

Additional information

Read access	Operator
Write access	Maintenance

SP2 value select**Navigation**

Expert → Communication → V1 → V1 input select. → SP2 value select (13275)

Description

Discrete value for V1 external status bit 2.

Selection

- None
- Digital A1-2
- Digital A3-4
- Digital B1-2
- Digital B3-4
- Digital C1-2
- Digital C3-4
- Digital D1-2
- Digital D3-4

Factory setting

None

Additional information

Read access	Operator
Write access	Maintenance

SP3 value select 

Navigation   Expert → Communication → V1 → V1 input select. → SP3 value select (13276)

Description Discrete value for V1 external status bit 3.

Selection

- None
- Digital A1-2
- Digital A3-4
- Digital B1-2
- Digital B3-4
- Digital C1-2
- Digital C3-4
- Digital D1-2
- Digital D3-4

Factory setting None

Additional information

Read access	Operator
Write access	Maintenance

SP4 value select 

Navigation   Expert → Communication → V1 → V1 input select. → SP4 value select (13277)

Description Discrete value for V1 external status bit 4.

Selection

- None
- Digital A1-2
- Digital A3-4
- Digital B1-2
- Digital B3-4
- Digital C1-2
- Digital C3-4
- Digital D1-2
- Digital D3-4

Factory setting None

Additional information

Read access	Operator
Write access	Maintenance

Value % select 

Navigation   Expert → Communication → V1 → V1 input select. → Value % select (13282)

Description Value transmitted as a 0..100% (V1 Z0/Z1 message).

Selection

- None
- Tank level %
- Tank ullage %
- AIO B1-3 value %
- AIO C1-3 value %

Factory setting

None

Additional information



Read access	Operator
Write access	Maintenance



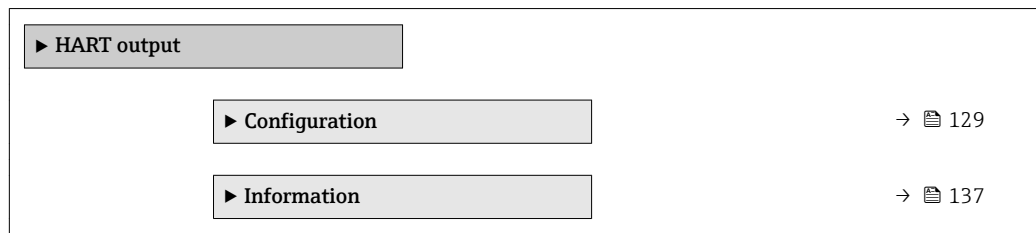











3.3.2 "HART output" submenu

Navigation  Expert → Communication → HART output



"Configuration" submenu

Navigation   Expert → Communication → HART output → Configuration

► Configuration	
Polling address	→  129
No. of preambles	→  130
PV source	→  130
Assign PV	→  130
0 % value	→  131
100 % value	→  132
PV mA selector	→  132
Primary var (PV)	→  132
Percent of range	→  133
Assign SV	→  133
Second.var(SV)	→  134
Assign TV	→  134
Tertiary var(TV)	→  135
Assign QV	→  135
Quaterna.var(QV)	→  136

Polling address



Navigation

  Expert → Communication → HART output → Configuration → Polling address (0219)

Description

Device address for HART communication.

User entry

0 to 63

Factory setting

15

Additional information

Read access	Operator
Write access	Maintenance

No. of preambles**Navigation**

Expert → Communication → HART output → Configuration → No. of preambles (0217)

Description

Number o preambles in the HART telegram.

User entry

5 to 20

Factory setting

5

Additional information

Read access	Operator
Write access	Maintenance

PV source**Navigation**

Expert → Communication → HART output → Configuration → PV source (11634)

Description

Sets PV config. acc. to analog HART slave/custom.

Selection

- AIO B1-3
- AIO C1-3
- Custom

Factory setting

Custom

Additional information

Read access	Maintenance
Write access	Maintenance

Assign PV**Navigation**

Expert → Communication → HART output → Configuration → Assign PV (0234)

Prerequisite

PV source (→ 130) = Custom

Description

Assigns a tank variable to the HART PV.

Selection

- None
- Tank level
- Tank ullage
- Measured level
- Distance

- Displacer pos
- Water level
- Upper I/F level
- Lower I/F level
- Bottom level
- Tank ref height
- Liquid temp.
- Vapor temp.
- Air temp.
- Observed density
- Profile density*
- Upper density
- Middle density
- Lower density
- P1 (bottom)
- P2 (middle)
- P3 (top)
- GP 1 value
- GP 2 value
- GP 3 value
- GP 4 value

Factory setting

Tank level

Additional information

Read access	Operator
Write access	Maintenance

 The **Measured level** option doesn't contain a unit. If a unit is needed, select the **Tank level** option.

0 % value



Navigation

 Expert → Communication → HART output → Configuration → 0 % value (11632)

Prerequisite

PV source = Custom

Description

0% value of the primary variable (PV).

User entry

Signed floating-point number

Factory setting

0 mm

Additional information

Read access	Operator
Write access	Maintenance

* Visibility depends on order options or device settings

100 % value 

Navigation   Expert → Communication → HART output → Configuration → 100 % value (11633)

Prerequisite **PV source = Custom**

Description 100% value of the primary variable (PV).

User entry Signed floating-point number

Factory setting 0 mm

Additional information

Read access	Operator
Write access	Maintenance

PV mA selector 

Navigation   Expert → Communication → HART output → Configuration → PV mA selector (11631)

Prerequisite **PV source = Custom**

Description Current for the primary HART variable (PV).

Selection

- None
- AIO B1-3 mA
- AIO C1-3 mA

Factory setting None

Additional information

Read access	Operator
Write access	Maintenance

Primary var (PV)

Navigation   Expert → Communication → HART output → Configuration → Primary var (PV) (0201)

Description Shows the primary HART variable (PV).

Additional information

Read access	Operator
Write access	-

Percent of range

Navigation  Expert → Communication → HART output → Configuration → Percent of range (0274)

Description Shows percentage of the primary variable (PV).

Additional information

Read access	Operator
Write access	-

Assign SV



Navigation  Expert → Communication → HART output → Configuration → Assign SV (0235)

Description Assigns a tank variable to the HART SV.

Selection

- None
- Tank level
- Tank ullage
- Measured level
- Distance
- Displacer pos
- Water level
- Upper I/F level
- Lower I/F level
- Bottom level
- Tank ref height
- Liquid temp.
- Vapor temp.
- Air temp.
- Observed density
- Profile density *
- Upper density
- Middle density
- Lower density
- P1 (bottom)
- P2 (middle)
- P3 (top)
- GP 1 value
- GP 2 value
- GP 3 value
- GP 4 value

Factory setting Liquid temp.

* Visibility depends on order options or device settings

Additional information

Read access	Operator
Write access	Maintenance

 The **Measured level** option doesn't contain a unit. If a unit is needed, select the **Tank level** option.

Second.var(SV)**Navigation**

 Expert → Communication → HART output → Configuration → Second.var(SV) (0226)

Prerequisite

Assign SV (→  133) ≠ None

Description

Shows the secondary HART variable (SV).

Additional information

Read access	Operator
Write access	-

Assign TV**Navigation**

 Expert → Communication → HART output → Configuration → Assign TV (0236)

Description

Assigns a tank variable to the HART TV.

Selection

- None
- Tank level
- Tank ullage
- Measured level
- Distance
- Displacer pos
- Water level
- Upper I/F level
- Lower I/F level
- Bottom level
- Tank ref height
- Liquid temp.
- Vapor temp.
- Air temp.
- Observed density
- Profile density^{*}
- Upper density
- Middle density
- Lower density
- P1 (bottom)
- P2 (middle)
- P3 (top)
- GP 1 value

* Visibility depends on order options or device settings

- GP 2 value
- GP 3 value
- GP 4 value

Factory setting

Water level

Additional information

Read access	Operator
Write access	Maintenance

 The **Measured level** option doesn't contain a unit. If a unit is needed, select the **Tank level** option.

Tertiary var(TV)

Navigation

 Expert → Communication → HART output → Configuration → Tertiary var(TV) (0228)

Prerequisite

Assign TV (→  134) ≠ None

Description

Shows the third HART variable (TV).

Additional information

Read access	Operator
Write access	-

Assign QV



Navigation

 Expert → Communication → HART output → Configuration → Assign QV (0237)

Description

Assigns a tank variable to the HART QV.

Selection

- None
- Tank level
- Tank ullage
- Measured level
- Distance
- Displacer pos
- Water level
- Upper I/F level
- Lower I/F level
- Bottom level
- Tank ref height
- Liquid temp.
- Vapor temp.
- Air temp.
- Observed density
- Profile density*

* Visibility depends on order options or device settings

- Upper density
- Middle density
- Lower density
- P1 (bottom)
- P2 (middle)
- P3 (top)
- GP 1 value
- GP 2 value
- GP 3 value
- GP 4 value

Factory setting

Observed density

Additional information

Read access	Operator
Write access	Maintenance

 The **Measured level** option doesn't contain a unit. If a unit is needed, select the **Tank level** option.

Quaterna.var(QV)**Navigation**

 Expert → Communication → HART output → Configuration → Quaterna.var(QV) (0203)

Prerequisite

Assign QV (→  135) ≠ None

Description

Shows the fourth HART variable (QV).













Additional information

Read access	Operator
Write access	-

"Information" submenu

Navigation  Expert → Communication → HART output → Information

▶ Information

HART short tag	→  137
Device tag	→  138
Device revision	→  138
Device ID	→  138
Device type	→  138
Manufacturer ID	→  139
HART revision	→  139
HART descriptor	→  139
HART message	→  140
Hardware rev.	→  140
Software rev.	→  140
HART date code	→  140

HART short tag



Navigation

 Expert → Communication → HART output → Information → HART short tag (0220)

Description

Defines the short tag for the measuring point. Maximum length: 8 characters Allowed characters: A-Z, 0-9, certain special characters.

Factory setting

NRF8x

Additional information

Read access	Operator
Write access	Maintenance

Device tag

**Navigation** Expert → Communication → HART output → Information → Device tag (0215)**Description** Enter a unique name for the measuring point to identify the device quickly within the plant.**Factory setting** NRF8x**Additional information**

Read access	Operator
Write access	Maintenance

Device revision

Navigation Expert → Communication → HART output → Information → Device revision (0204)**Description** For registration with HART Communic. Foundation.**User interface** 0 to 255**Factory setting** 2**Additional information**

Read access	Operator
Write access	-

Device ID

Navigation Expert → Communication → HART output → Information → Device ID (0221)**Description** For identifying the device in a HART network.**User interface** Positive integer**Factory setting** 123456**Additional information**

Read access	Operator
Write access	-

Device type

Navigation Expert → Communication → HART output → Information → Device type (0209)**Description** For registration with HART Communic. Foundation.

User interface 0 to 65 535

Factory setting 4 395

Additional information

Read access	Operator
Write access	-

Manufacturer ID

Navigation  Expert → Communication → HART output → Information → Manufacturer ID (0259)

Description For registration with HART Communic. Foundation.

User interface 0 to 65 535

Factory setting 17

Additional information

Read access	Operator
Write access	-

HART revision

Navigation  Expert → Communication → HART output → Information → HART revision (0205)

Description HART revision used by the device.

User interface 5 to 7

Factory setting 7

Additional information

Read access	Operator
Write access	-

HART descriptor



Navigation  Expert → Communication → HART output → Information → HART descriptor (0212)

Description User defined HART descriptor (16 characters).

Factory setting NRF8x

Additional information

Read access	Operator
Write access	Maintenance

HART message**Navigation** Expert → Communication → HART output → Information → HART message (0216)**Description** User defined HART message (32 characters).**Factory setting** NRF8x**Additional information**

Read access	Operator
Write access	Maintenance

Hardware rev.**Navigation** Expert → Communication → HART output → Information → Hardware rev. (0206)**Description** Hardware revision of the device.**User interface** 0 to 30**Factory setting** 1**Additional information**

Read access	Operator
Write access	-

Software rev.**Navigation** Expert → Communication → HART output → Information → Software rev. (0224)**Description** Software revision of the device.**User interface** 0 to 255**Factory setting** 2**Additional information**

Read access	Operator
Write access	-

HART date code**Navigation** Expert → Communication → HART output → Information → HART date code (0202)**Description** Enter date of the last configuration change. Use this format yyyy-mm-dd.

Factory setting



2009-07-20

Additional information

Read access	Operator
Write access	Maintenance





3.4 "Application" submenu

Navigation  Expert → Application



▶ Application	
▶ Tank config	→  142
▶ Tank calculation	→  166
▶ Alarm	→  193

3.4.1 "Tank configuration" submenu









Navigation  Expert → Application → Tank config

Tank config	
▶ Level	→  143
▶ Temperature	→  147
▶ Density	→  151
▶ Pressure	→  155
▶ GP values	→  163

"Level" submenu

Navigation   Expert → Application → Tank config → Level

▶ Level

Level source	→  143
Operation mode	→  144
Tank ref height	→  144
Tank level	→  144
Upper I/F level	→  144
Lower I/F level	→  145
Water level src	→  145
Water level	→  145
Man. water level	→  146

Level source 

Navigation   Expert → Application → Tank config → Level → Level source (14601)

Description Defines the source of the level value.

- Selection**
- No input value
 - HARTDEV 1 ... 15 level
 - Level SR *
 - Level *
 - Displacer pos *
 - AIO B1-3 value
 - AIO C1-3 value
 - AIP B4-8 value
 - AIP C4-8 value

Factory setting Dependent on the device version

Additional information

Read access	Operator
Write access	Maintenance

* Visibility depends on order options or device settings

Operation mode**Navigation** Expert → Application → Tank config → Level → Operation mode (14656)**Description** Selection of normal or HTG mode.**Selection**

- Normal
- HTG

Factory setting Normal**Additional information**

Read access	Operator
Write access	Maintenance

Tank ref height**Navigation** Expert → Application → Tank config → Level → Tank ref height (14603)**Description** Distance from dipping ref. point to datum plate.**User entry** 0 to 100 000 mm**Factory setting** Dependent on the device version**Additional information**

Read access	Operator
Write access	Maintenance

Tank level**Navigation** Expert → Application → Tank config → Level → Tank level (14655)**Description** Shows distance from zero to product surface.**Additional information**

Read access	Operator
Write access	-

Upper I/F level**Navigation** Expert → Application → Tank config → Level → Upper I/F level (15003)**Description** Up I/F Level measured from zero position.

Additional information

Read access	Maintenance
Write access	-

Lower I/F level**Navigation**

 Expert → Application → Tank config → Level → Lower I/F level (15004)

Description

Shows measured interface level from zero position.

Additional information

Read access	Maintenance
Write access	-

Water level src**Navigation**

 Expert → Application → Tank config → Level → Water level src (14971)

Description

Source of the bottom water level.

Selection

- Manual value
- Bottom level
- HART device 1 ... 15 level
- AIO B1-3 value
- AIO C1-3 value
- AIP B4-8 value
- AIP C4-8 value

Factory setting

Manual value

Additional information

Read access	Operator
Write access	Maintenance

Water level**Navigation**

 Expert → Application → Tank config → Level → Water level (14970)

Description

Shows the bottom water level.

Additional information

Read access	Operator
Write access	-

Man. water level

**Navigation**

Expert → Application → Tank config → Level → Man. water level (14959)

Prerequisite**Water level src (→ 145) = Manual value****Description**

Defines manual value of the bottom water level.

User entry

-2 000 to 5 000 mm

Factory setting









0 mm

Additional information



Read access	Operator
Write access	Maintenance

"Temperature" submenu

Navigation   Expert → Application → Tank config → Temperature

► Temperature	
Liq temp source	→  147
Man. liquid temp	→  148
Liquid temp.	→  148
Air temp. source	→  148
Manual air temp.	→  149
Air temp.	→  149
Vapor temp src	→  149
Man. vapor temp.	→  150
Vapor temp.	→  150

Liq temp source 

Navigation   Expert → Application → Tank config → Temperature → Liq temp source (14972)

Description Defines source for liquid temperature.

- Selection**
- Manual value
 - HART device 1 ... 15 temperature
 - AIO B1-3 value
 - AIO C1-3 value
 - AIP B4-8 value
 - AIP C4-8 value

Factory setting Manual value

Additional information

Read access	Operator
Write access	Maintenance

Man. liquid temp

Navigation Expert → Application → Tank config → Temperature → Man. liquid temp (15015)

Prerequisite **Liq temp source (→ 147) = Manual value**

Description Defines the manual value of the liquid temperature.

User entry -50 to 300 °C

Factory setting 25 °C

Additional information

Read access	Operator
Write access	Maintenance

Liquid temp.

Navigation Expert → Application → Tank config → Temperature → Liquid temp. (14978)

Description Shows temperature of the measured liquid.

Additional information

Read access	Operator
Write access	-

Air temp. source

Navigation Expert → Application → Tank config → Temperature → Air temp. source (14993)

Description Source for the air temperature.

Selection

- Manual value
- HART device 1 ... 15 temperature
- AIO B1-3 value
- AIO C1-3 value
- AIP B4-8 value
- AIP C4-8 value

Factory setting Manual value

Additional information

Read access	Operator
Write access	Maintenance

Manual air temp.



Navigation Expert → Application → Tank config → Temperature → Manual air temp. (14961)

Prerequisite **Air temp. source (→ 148) = Manual value**

Description Defines the manual value of the air temperature.

User entry -50 to 300 °C

Factory setting 25 °C

Additional information

Read access	Operator
Write access	Maintenance

Air temp.

Navigation Expert → Application → Tank config → Temperature → Air temp. (14986)

Description Shows the air temperature.

Additional information

Read access	Operator
Write access	-

Vapor temp src



Navigation Expert → Application → Tank config → Temperature → Vapor temp src (14973)

Description Source of the vapor temperature.

- Selection**
- Manual value
 - HART device 1 ... 15 vapor temp
 - AIO B1-3 value
 - AIO C1-3 value
 - AIP B4-8 value
 - AIP C4-8 value

Factory setting Manual value

Additional information

Read access	Operator
Write access	Maintenance

Man. vapor temp.**Navigation**

Expert → Application → Tank config → Temperature → Man. vapor temp. (14960)

Prerequisite**Vapor temp src** (→ 149) = **Manual value****Description**

Defines the manual value of the vapor temperature.

User entry

-50 to 300 °C

Factory setting

25 °C

Additional information

Read access	Operator
Write access	Maintenance

Vapor temp.**Navigation**

Expert → Application → Tank config → Temperature → Vapor temp. (14985)



Description

Shows the measured vapor temperature.











Additional information

Read access	Operator
Write access	-

"Density" submenu

Navigation   Expert → Application → Tank config → Density

► Density

Density source	→  151
Observed density	→  152
Air density	→  152
Vapor density	→  152
UpDensity source	→  152
Manual density	→  153
Meas upper dens.	→  154
Meas middle dens	→  154
Meas lower dens.	→  154
Water density	→  154

Density source



Navigation   Expert → Application → Tank config → Density → Density source (13454)

Description Determines how the density is obtained.

- Selection**
- HTG
 - HTMS
 - Profile density*
 - Upper density
 - Middle density
 - Lower density

Factory setting Dependent on the device version

Additional information

Read access	Operator
Write access	Maintenance

* Visibility depends on order options or device settings

Observed density

Navigation  Expert → Application → Tank config → Density → Observed density (13452)**Description** Shows the measured or calculated density.**Additional information**



Read access	Operator
Write access	-

Air density

**Navigation**  Expert → Application → Tank config → Density → Air density (14980)**Description** Density of the air surrounding the tank.**User entry** 0.0 to 500.0 kg/m³**Factory setting** 1.2 kg/m³**Additional information**

Read access	Operator
Write access	Maintenance

Vapor density

**Navigation**  Expert → Application → Tank config → Density → Vapor density (14981)**Description** Density of the gas phase in the tank.**User entry** 0.0 to 500.0 kg/m³**Factory setting** 1.2 kg/m³**Additional information**

Read access	Operator
Write access	Maintenance

UpDensity source

**Navigation**  Expert → Application → Tank config → Density → UpDensity source (15006)**Description** Defines upper density input source.

- Selection**
- Manual value
 - HART DEV 1 dens.
 - HART DEV 2 dens.
 - HART DEV 3 dens.
 - HART DEV 4 dens.
 - HART DEV 5 dens.
 - HART DEV 6 dens.
 - HART DEV 7 dens.
 - HART DEV 8 dens.
 - HART DEV 9 dens.
 - HART DEV 10 dens.
 - HART DEV 11 dens.
 - HART DEV 12 dens.
 - HART DEV 13 dens.
 - HART DEV 14 dens.
 - HART DEV 15 dens.
 - Upper density *
 - Middle density *
 - Lower density *
 - Profile density *
 - AIO B1-3 value
 - AIO C1-3 value
 - AIP B4-8 value
 - AIP C4-8 value

Factory setting Manual value

Additional information

Read access	Operator
Write access	Maintenance

Manual density



Navigation Expert → Application → Tank config → Density → Manual density (14998)

Prerequisite UpDensity source (→ 152) = Manual value

Description Defines the manual upper density of the medium.

User entry 0 to 3 000 kg/m³

Factory setting 800 kg/m³

Additional information

Read access	Operator
Write access	Maintenance

* Visibility depends on order options or device settings

Meas upper dens.

Navigation  Expert → Application → Tank config → Density → Meas upper dens. (15001)**Description** Shows the density of the upper phase.**Additional information**

Read access	Operator
Write access	-

Meas middle dens

Navigation  Expert → Application → Tank config → Density → Meas middle dens (14997)**Description** Density of the middle phase.**Additional information**

Read access	Operator
Write access	-

Meas lower dens.

Navigation  Expert → Application → Tank config → Density → Meas lower dens. (15002)**Description** Density of the lower phase.**Additional information**

Read access	Maintenance
Write access	-



















Water density

**Navigation**  Expert → Application → Tank config → Density → Water density (13757)**Description** Density of the water in the tank.**User entry** Signed floating-point number**Factory setting** 1 000 kg/m³**Additional information**

Read access	Operator
Write access	Maintenance

"Pressure" submenu

Navigation   Expert → Application → Tank config → Pressure

► Pressure	
P1 (bot) source	→  156
P1 (bottom)	→  156
P1 (bot) manual	→  156
P1 position	→  157
P1 offset	→  157
P1 absolut/gauge	→  157
P2 (mid) source	→  158
P2 (middle)	→  158
P2 (mid) manual	→  158
P2 offset	→  159
P1-2 distance	→  159
P2 absolut/gauge	→  159
P3 (top) source	→  160
P3 (top)	→  160
P3 (top) manual	→  160
P3 position	→  161
P3 offset	→  161
P3 absolut/gauge	→  161
Ambient pressure	→  162

P1 (bot) source

Navigation Expert → Application → Tank config → Pressure → P1 (bot) source (14994)

Description Source of the bottom pressure (P1).

Selection

- Manual value
- HART device 1 ... 15 pressure
- AIO B1-3 value
- AIO C1-3 value
- AIP B4-8 value
- AIP C4-8 value

Factory setting Manual value

Additional information

Read access	Operator
Write access	Maintenance

P1 (bottom)

Navigation Expert → Application → Tank config → Pressure → P1 (bottom) (14983)

Description Shows the pressure at the tank bottom.

Additional information

Read access	Operator
Write access	-

P1 (bot) manual

Navigation Expert → Application → Tank config → Pressure → P1 (bot) manual (14951)

Prerequisite **P1 (bot) source** (→ 156) = **Manual value**

Description Manual value of the bottom pressure (P1).

User entry -25 to 25 bar

Factory setting 0 bar

Additional information

Read access	Operator
Write access	Maintenance

P1 position

Navigation Expert → Application → Tank config → Pressure → P1 position (14952)

Description Position of the bottom pressure transmitter (P1).

User entry -10 000 to 100 000 mm

Factory setting 5 000 mm

Additional information

Read access	Operator
Write access	Maintenance

P1 offset

Navigation Expert → Application → Tank config → Pressure → P1 offset (14953)

Description Offset for the bottom pressure (P1). The offset is added to the measured pressure prior to any tank calculation.

User entry -25 to 25 bar

Factory setting 0 bar

Additional information

Read access	Operator
Write access	Maintenance

P1 absolut/gauge

Navigation Expert → Application → Tank config → Pressure → P1 absolut/gauge (14954)

Description Defines the type of pressure transmitter.

Selection

- Absolute
- Gauge

Factory setting Gauge

Additional information

Read access	Operator
Write access	Maintenance

P2 (mid) source**Navigation** Expert → Application → Tank config → Pressure → P2 (mid) source (14995)**Description** Source of the middle pressure (P2).**Selection**

- Manual value
- HART device 1 ... 15 pressure
- AIO B1-3 value
- AIO C1-3 value
- AIP B4-8 value
- AIP C4-8 value

Factory setting Manual value**Additional information**

Read access	Operator
Write access	Maintenance

P2 (middle)**Navigation** Expert → Application → Tank config → Pressure → P2 (middle) (14987)**Description** Pressure (P2) at the middle transmitter.**Additional information**

Read access	Operator
Write access	-

P2 (mid) manual**Navigation** Expert → Application → Tank config → Pressure → P2 (mid) manual (14955)**Prerequisite** **P2 (mid) source** (→ 158) = **Manual value****Description** Manual value of the middle pressure (P2).**User entry** -25 to 25 bar**Factory setting** 0 bar**Additional information**

Read access	Operator
Write access	Maintenance

P2 offset

Navigation	Expert → Application → Tank config → Pressure → P2 offset (14975)				
Description	Defines the offset for the middle pressure (P2). The offset is added to the measured pressure prior to any tank calculation.				
User entry	-25 to 2.5 bar				
Factory setting	0 bar				
Additional information	<table border="1"> <tr> <td>Read access</td> <td>Operator</td> </tr> <tr> <td>Write access</td> <td>Maintenance</td> </tr> </table>	Read access	Operator	Write access	Maintenance
Read access	Operator				
Write access	Maintenance				

P1-2 distance

Navigation	Expert → Application → Tank config → Pressure → P1-2 distance (14974)				
Description	Distance bottom to middle pressure transmitter.				
User entry	0 to 100 000 mm				
Factory setting	2 000 mm				
Additional information	<table border="1"> <tr> <td>Read access</td> <td>Operator</td> </tr> <tr> <td>Write access</td> <td>Maintenance</td> </tr> </table>	Read access	Operator	Write access	Maintenance
Read access	Operator				
Write access	Maintenance				

P2 absolut/gauge

Navigation	Expert → Application → Tank config → Pressure → P2 absolut/gauge (14976)				
Description	Defines the type of pressure transmitter.				
Selection	<ul style="list-style-type: none"> ■ Absolute ■ Gauge 				
Factory setting	Gauge				
Additional information	<table border="1"> <tr> <td>Read access</td> <td>Operator</td> </tr> <tr> <td>Write access</td> <td>Maintenance</td> </tr> </table>	Read access	Operator	Write access	Maintenance
Read access	Operator				
Write access	Maintenance				

P3 (top) source**Navigation** Expert → Application → Tank config → Pressure → P3 (top) source (14996)**Description** Source of the top pressure (P3).**Selection**

- Manual value
- HART device 1 ... 15 pressure
- AIO B1-3 value
- AIO C1-3 value
- AIP B4-8 value
- AIP C4-8 value

Factory setting Manual value**Additional information**

Read access	Operator
Write access	Maintenance

P3 (top)**Navigation** Expert → Application → Tank config → Pressure → P3 (top) (14988)**Description** Pressure (P3) at the top transmitter.**Additional information**

Read access	Operator
Write access	-

P3 (top) manual**Navigation** Expert → Application → Tank config → Pressure → P3 (top) manual (14977)**Prerequisite** **P3 (top) source** (→ 160) = **Manual value****Description** Manual value of the top pressure (P3).**User entry** -2.5 to 2.5 bar**Factory setting** 0 bar**Additional information**

Read access	Operator
Write access	Maintenance

P3 position

Navigation Expert → Application → Tank config → Pressure → P3 position (14956)

Description Position of the top pressure transmitter (P3).

User entry 0 to 100 000 mm

Factory setting 20 000 mm

Additional information

Read access	Operator
Write access	Maintenance

P3 offset

Navigation Expert → Application → Tank config → Pressure → P3 offset (14957)

Description Offset for the top pressure (P3). The offset is added to the measured pressure prior to any tank calculation.

User entry -2.5 to 2.5 bar

Factory setting 0 bar

Additional information

Read access	Operator
Write access	Maintenance

P3 absolut/gauge

Navigation Expert → Application → Tank config → Pressure → P3 absolut/gauge (14958)

Description Defines the type of pressure transmitter.

Selection

- Absolute
- Gauge

Factory setting Gauge

Additional information

Read access	Operator
Write access	Maintenance

Ambient pressure

**Navigation**

Expert → Application → Tank config → Pressure → Ambient pressure (14962)

Description

Manual value of the ambient pressure.

User entry

0 to 2.5 bar

Factory setting

1 bar







Additional information

Read access	Operator
Write access	Maintenance

"GP values" submenu

Navigation   Expert → Application → Tank config → GP values



▶ GP values

GP 1 to 4 source	→  163
GP 1 to 4 name	→  164
GP Value 1	→  164
GP Value 2	→  164
GP Value 3	→  164
GP Value 4	→  165

GP 1 to 4 source



Navigation

  Expert → Application → Tank config → GP values → GP 1 to 4 source (14989-1 to 4)

Description

Source of the general purpose value 1 GP1.

Selection

- No input value
- SM R distance
- Average profile density
- Net weight
- AIO B1-3 value
- AIO C1-3 value
- AIP B4-8 value
- AIP C4-8 value
- HART device 1...15 PV
- HART device 1...15 SV
- HART device 1...15 TV
- HART device 1...15 QV
- Modbus A1-4 Value 1...4
- Modbus B1-4 Value 1...4
- Modbus C1-4 Value 1...4
- Modbus D1-4 Value 1...4

Factory setting

No input value

Additional information

Read access	Operator
Write access	Maintenance

GP 1 to 4 name



Navigation Expert → Application → Tank config → GP values → GP 1 name (14963)

Description Defines the label for the respective GP value.

Factory setting GP Value 1

Additional information

Read access	Operator
Write access	Maintenance

GP Value 1

Navigation Expert → Application → Tank config → GP values → GP Value 1 (14966)

Description General purpose values.

Additional information

Read access	Operator
Write access	-

GP Value 2

Navigation Expert → Application → Tank config → GP values → GP Value 2 (14967)

Description General purpose values.

Additional information

Read access	Operator
Write access	-

GP Value 3

Navigation Expert → Application → Tank config → GP values → GP Value 3 (14968)

Description General purpose values.

Additional information

Read access	Operator
Write access	-

GP Value 4

Navigation Expert → Application → Tank config → GP values → GP Value 4 (14969)**Description**





General purpose values.

Additional information

Read access	Operator
Write access	-

3.4.2 "Tank calculation" submenu

Navigation  Expert → Application → Tank calculation

▶ Tank calculation	
Local gravity	→  166
▶ HyTD	→  169
▶ CTSh	→  174
▶ HTG	→  183
▶ HTMS	→  189

Local gravity

Navigation	 Expert → Application → Tank calculation → Local gravity (14979)
Description	Shows the manually entered local gravity value.
User entry	9.0 to 10.0 m/s ²
Factory setting	9.807 m/s ²

"HyTD" submenu*Overview*

Hydrostatic Tank Deformation can be used to compensate the vertical movement of the Gauge Reference Height (GRH) due to bulging of the tank shell caused by the hydrostatic pressure exerted by the liquid stored in the tank. The compensation is based on a linear approximation obtained from manual hand dips at several levels distributed over the full range of the tank.

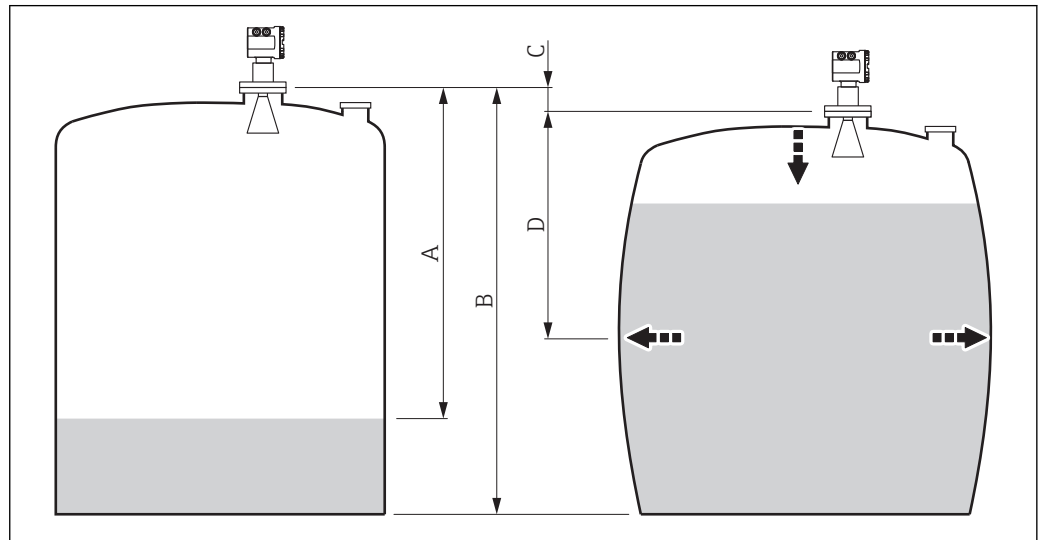

A0028721

 7 Correction of the hydrostatic tank deformation (HyTD)

- A "Distance" (level below $L_0 \rightarrow$ "HyTD corr. value" = 0)
- B Gauge Reference Height (GRH)
- C HyTD corr. value
- D "Distance" (level above $L_0 \rightarrow$ "HyTD corr. value" > 0)

 This mode should not be used in conjunction with HTG as with HTG the level is not measured relative to the gauge reference height.

Linear approximation of the HyTD correction

The real amount of deformation varies non-linearly with the level due to the construction of the tank. However, as the correction values are typically small compared to the measured level, a simple straight line method can be used with good results.

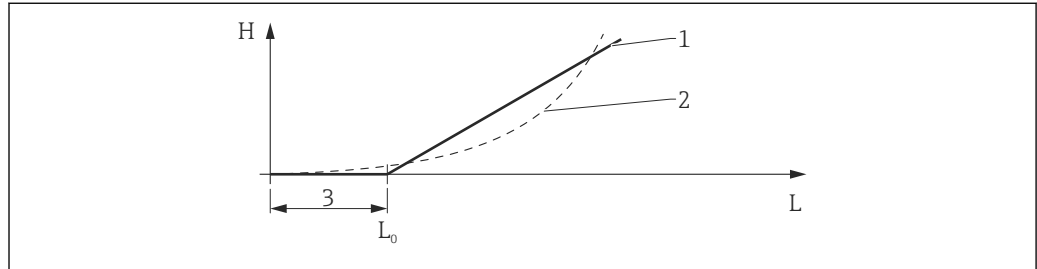

A0028724

8 Calculation of the HyTD correction

- 1 Linear correction according to "Deform factor (→ 170)"
- 2 Real correction
- 3 Starting level (→ 169)
- L Measured level
- H HyTD corr. value (→ 169)

Calculation of the HyTD correction

$$L \leq L_0 \Rightarrow C_{HyTD} = 0$$

$$L > L_0 \Rightarrow C_{HyTD} = - (L - L_0) \times D$$





A0028715

L	Measured level
L₀	Starting level
C_{HyTD}	HyTD corr. value
D	Deform factor

Description of parameters

Navigation  Expert → Application → Tank calculation → HyTD

▶ HyTD

HyTD corr. value	→  169
HyTD mode	→  169
Starting level	→  169
Deform factor	→  170

HyTD corr. value

Navigation  Expert → Application → Tank calculation → HyTD → HyTD corr. value (13603)

Description Shows the correction value from the HyTD.

Additional information

Read access	Operator
Write access	-

HyTD mode



Navigation  Expert → Application → Tank calculation → HyTD → HyTD mode (14652)

Description Activates the Hydrostatic Tank Deformation.

Selection

- No
- Yes

Factory setting No

Additional information

Read access	Operator
Write access	Maintenance

Starting level



Navigation  Expert → Application → Tank calculation → HyTD → Starting level (13601)

Description Starting level for the HyTD.

User entry 0 to 5 000 mm

Factory setting 500 mm

Additional information

Read access	Operator
Write access	Maintenance

Deform factor



Navigation

Expert → Application → Tank calculation → HyTD → Deform factor (13602)

Description

Deformation factor for the HyTD.

User entry

-1.0 to 1.0 %

Factory setting

0.2 %



Additional information

Read access	Operator
Write access	Maintenance

"CTSh" submenu

Overview

CTSh (correction of the thermal tank shell expansion) compensates for effects on the Gauge Reference Height (GRH) due to temperature effects on the tank shell or stilling well. The temperature effects are separated into two parts, respectively effecting the 'dry' and 'wetted' part of the tank shell or stilling well. The calculation is based on thermal expansion coefficients of steel and insulation factors for both the 'dry' and 'wet' shell. The assessed temperatures are based on manual or measured values and the temperature of the shell when the tank was calibrated (for details refer to API MPMS Chapter 12.1).

-  This correction is recommended for the following situations:
 - if the operating temperature deviates considerably from the temperature during calibration ($\Delta T > 10\text{ °C}$ (18 °F))
 - for extremely high tanks
 - for refrigerated, cryogenic or heated applications
-  As the use of this correction will influence the innage level reading, it is recommended to review the manual hand dip and level verification procedures prior to enabling this correction method.
-  This mode should not be used in conjunction with HTG as with HTG the level is not measured relative to the gauge reference height.

CTSh: Calculation of the wall temperature

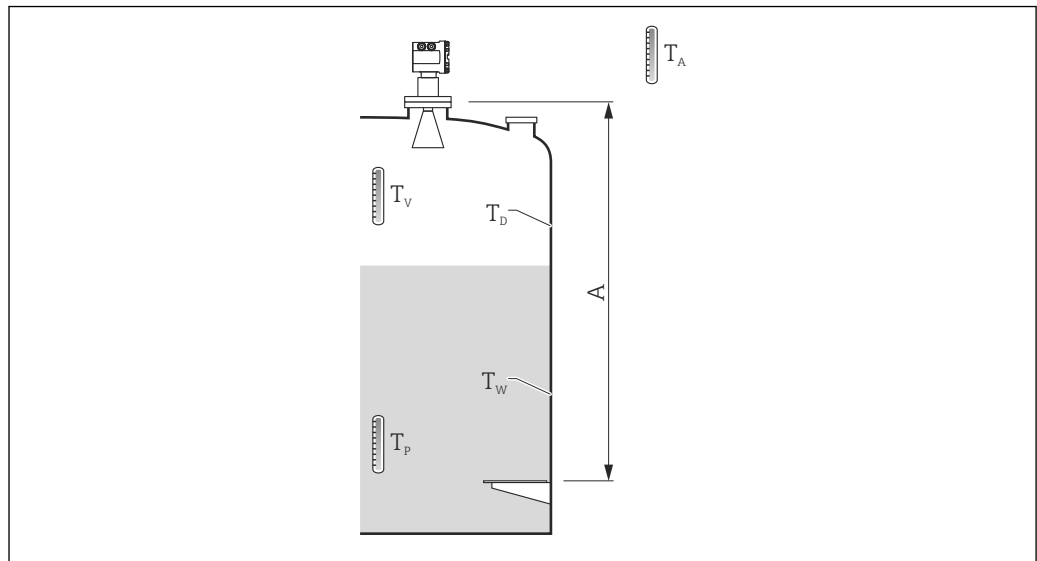

A0028714

9 Parameters for the CTSh calculation

A Gauge Reference Height (GRH)

T_W	Temperature of the wetted part of the tank shell
T_D	Temperature of the dry part of the tank shell
T_P	Product temperature
T_V	Vapor temperature (in the tank)
T_A	Ambient temperature (atmosphere surrounding the tank)

CTSh: Calculation of the wall temperature

Depending on the parameters **Covered tank** (→ 175) and **Stilling well** (→ 175), the temperatures T_W of the wetted and T_D of the dry part of the tank wall are calculated as follows:

Covered tank (→ 175)	Stilling well (→ 175)	T_W	T_D
Covered	Yes ¹⁾	T_P	T_V
	No	$(7/8) T_P + (1/8) T_A$	$(1/2) T_V + (1/2) T_A$
Open top	Yes	T_P	T_A
	No	$(7/8) T_P + (1/8) T_A$	T_A

1) This option is also valid for insulated tanks without a stilling well. This is due to the temperature inside and outside of the tank shell being the same due to the insulation of the tank.

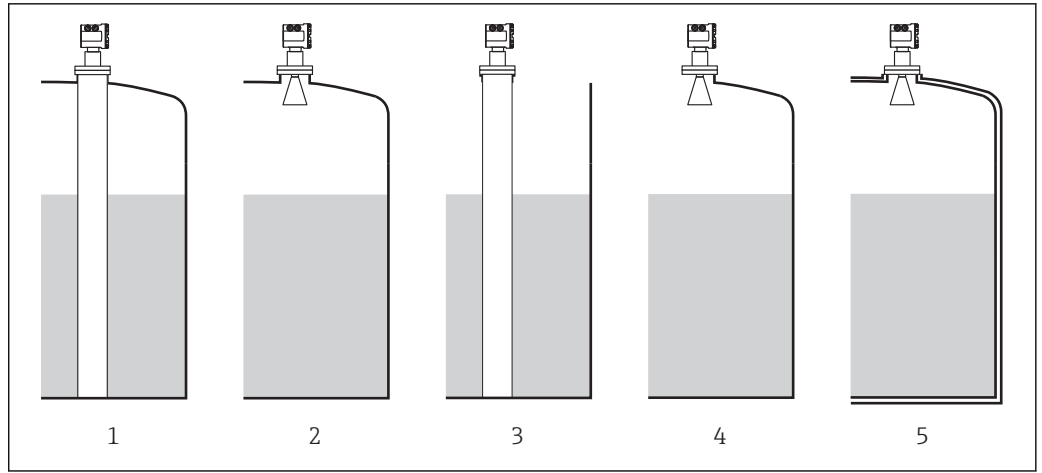

A0030381

- 1 Covered tank (→ 175) = Covered; Stilling well (→ 175) = Yes
- 2 Covered tank (→ 175) = Covered; Stilling well (→ 175) = No
- 3 Covered tank (→ 175) = Open top; Stilling well (→ 175) = Yes
- 4 Covered tank (→ 175) = Open top; Stilling well (→ 175) = No
- 5 Insulated tank: Covered tank (→ 175) = Open top; Stilling well (→ 175) = Yes

CTSh: Calculation of the correction

$$C_{CTSh} = \alpha (H - L)(T_D - T_{cal}) + \alpha L (T_W - T_{cal})$$







A0028716

H	Gauge Reference Height
L	Measured level
T_D	Temperature of the dry part of the tank shell (calculated from T _p , T _v and T _A)
T_W	Temperature of the wetted part of the tank shell (calculated from T _p , T _v and T _A)
T_{cal}	Temperature at which the measurement has been calibrated
α	Linear expansion coefficient
C_{CTSh}	CTSh correction value

Description of parameters

Navigation  Expert → Application → Tank calculation → CTSh

▶ CTSh

- CTSh corr value →  174
- CTSh mode →  175
- Covered tank →  175
- Stilling well →  175
- Calibration temp →  176
- Linear exp coeff →  176

CTSh corr value

Navigation  Expert → Application → Tank calculation → CTSh → CTSh corr value (13651)

Description Shows the CTSh correction value.

Additional information

Read access	Operator
Write access	-

CTSh mode 

Navigation   Expert → Application → Tank calculation → CTSh → CTSh mode (14651)

Description Activates or deactivates the CTSh.

Selection

- No
- Yes

Factory setting No

Additional information

Read access	Operator
Write access	Maintenance

Covered tank 

Navigation   Expert → Application → Tank calculation → CTSh → Covered tank (13654)

Description Determines whether the tank is covered.

Selection

- Open top
- Covered



Factory setting Open top

Additional information

Read access	Operator
Write access	Maintenance

 The **Covered** option is only valid for fixed tank roofs. For a floating roof select **Open top**.

Stilling well 

Navigation   Expert → Application → Tank calculation → CTSh → Stilling well (13653)

Description Determines if the device is on a stilling well.

Selection

- No
- Yes

Factory setting No

Additional information

Read access	Operator
Write access	Maintenance

Calibration temp

Navigation Expert → Application → Tank calculation → CTSh → Calibration temp (13652)

Description Temperature during calibration of the measurement.

User entry -50 to 250 °C

Factory setting 25 °C

Additional information

Read access	Operator
Write access	Maintenance

Linear exp coeff

Navigation Expert → Application → Tank calculation → CTSh → Linear exp coeff (13655)

Description Linear expansion coefficient of the tank shell.

User entry 0 to 100 ppm

Factory setting 15 ppm

Additional information

Read access	Operator
Write access	Maintenance

"HTG" submenu*Overview*

Hydrostatic Tank Gauging (HTG) is a method to calculate the level and the density of the product inside a tank using pressure measurements only. The pressure is measured at different heights of the tank using one, two or three pressure sensors. With these data either the density or the level of the product (or both) can be calculated.

HTG modes

Four HTG modes can be selected in the **HTG mode** parameter (\rightarrow  184). They determine which variables are measured and which are calculated. Depending on the selected mode a number of additional parameters are required for the calculation.

HTG mode (\rightarrow  184)	Measured variables	Required additional parameters	Calculated variables
P1 only	P1	<ul style="list-style-type: none"> ▪ ρ_P ▪ g ▪ H_{P1} 	L_{HTG}
P1 + P3	<ul style="list-style-type: none"> ▪ P1 ▪ P3 	<ul style="list-style-type: none"> ▪ ρ_P ▪ ρ_V ▪ ρ_A ▪ g ▪ H_{P1} ▪ H_{P3} 	L_{HTG} (more precise calculation for pressurized tanks)
P1 + P2	<ul style="list-style-type: none"> ▪ P1 ▪ P2 	<ul style="list-style-type: none"> ▪ ρ_A ▪ g ▪ H_{P1} ▪ H_{P1-P2} 	<ul style="list-style-type: none"> ▪ ρ_P ▪ L_{HTG}
P1 + P2 + P3	<ul style="list-style-type: none"> ▪ P1 ▪ P2 ▪ P3 	<ul style="list-style-type: none"> ▪ ρ_V ▪ ρ_A ▪ g ▪ H_{P1} ▪ H_{P1-P2} ▪ H_{P3} 	<ul style="list-style-type: none"> ▪ ρ_P ▪ L_{HTG} (more precise calculation for pressurized tanks)

HTG parameters

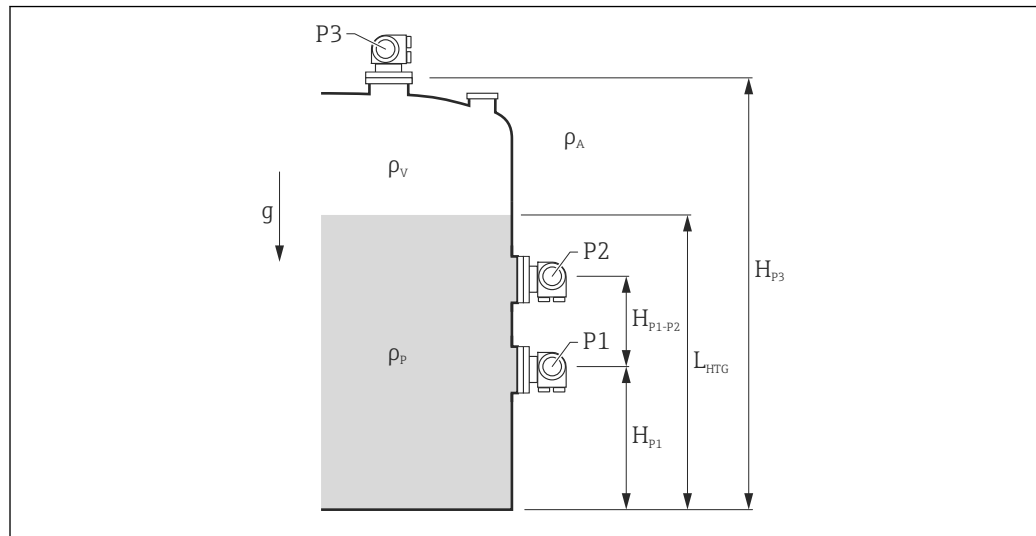

10 HTG parameters

Parameter	Navigation path
P1 (Bottom pressure)	Setup → Advanced setup → Tank config → Pressure → P1 (bottom)
H_{P1} (Position of P1 transmitter)	Setup → Advanced setup → Tank config → Pressure → P1 position
P2 (Middle pressure)	Setup → Advanced setup → Tank config → Pressure → P2 (middle)
H_{P1-P2} (Distance between P1 and P2 transmitters)	Setup → Advanced setup → Tank config → Pressure → P1-2 distance
P3 (Top pressure)	Setup → Advanced setup → Tank config → Pressure → P3 (top)
H_{P3} (Position of P3 transmitter)	Setup → Advanced setup → Tank config → Pressure → P3 position
ρ_P (Density of the product ¹⁾)	<ul style="list-style-type: none"> ■ Read-only: Setup → Advanced setup → Calculation → HTG → Density value ■ Writable: Setup → Advanced setup → Calculation → HTG → Manual density
ρ_V (Vapor density)	Expert → Application → Tank config → Density → Vapor density
ρ_A (Ambient air temperature)	Setup → Advanced setup → Tank config → Density → Air density
g (Local gravity)	Expert → Application → Tank Calculation → Local gravity
L_{HTG} (Calculated level)	Setup → Advanced setup → Calculation → HTG → Tank level

1) Depending on the **HTG mode** parameter (→ 184) this is a writable or a read-only parameter.

HTG evaluation: dependence on measured level

To calculate the level or density by HTG with the required accuracy, P1 and P2 have to be covered by a certain product level. To avoid a measurement with an insufficient accuracy, the calculation will stop before the level reaches the position of the pressure sensor.

Two parameters are defined for this purpose:

▪ **Min. level**

This parameter defines the position below which no level is accepted. If the calculation leads to **Tank level** < **Min. level**, the value of **Min. level** will be displayed instead of the calculated value.

▪ **Safety distance**

This parameter defines the minimum amount of product which must be present above the pressure sensor P1 or P2 for the level or density calculation to take place.



- The device always uses the bigger of these two values as the switch-over point for the level calculation.
- If **HTG mode** (→ 184) is set to **P1 only** or **P1 + P3**, the density is not calculated and the **Manual density** parameter (→ 153) is used instead.

Case 1: $H_{P1} < \text{Min. level} < H_{P2}$

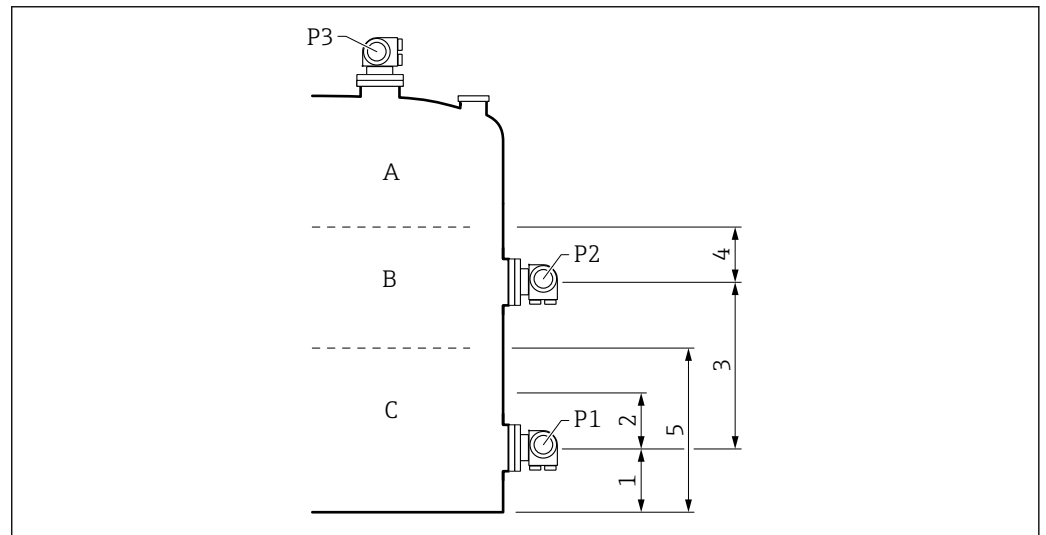

A0028718

- 1 P1 position (→ 157)
- 2 Safety distance (→ 185)
- 3 P1-2 distance (→ 159)
- 4 Safety distance (→ 185)
- 5 Min. level (→ 185)

Level L is in area	Calculation method for ρ_p	Calculation method for L
A	calculated from pressure	calculated from pressure
B	ρ_p held	calculated from pressure
C	ρ_p held	L = Min. level

Case 2: $Min. level < H_{P1}$

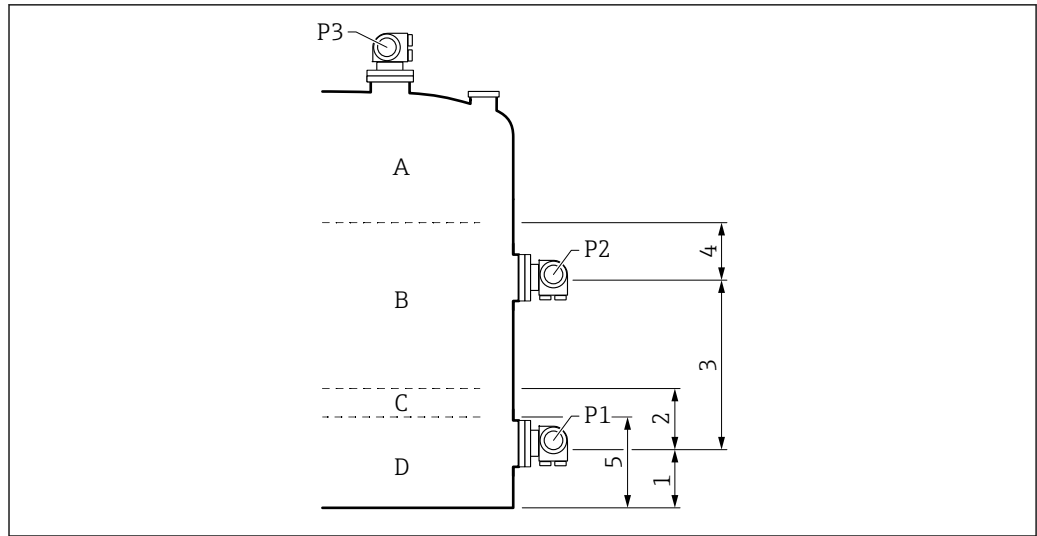

- 1 P1 position (→ 157)
- 2 Safety distance (→ 185)
- 3 P1-2 distance (→ 159)
- 4 Safety distance (→ 185)
- 5 Min. level (→ 185)

Level L is in area	Calculation method for ρ_p	Calculation method for L
A	calculated from pressure	calculated from pressure
B	ρ_p held	calculated from pressure
C/D	ρ_p held	L = Min. level

Case 3: $Min. level > H_{P2}$

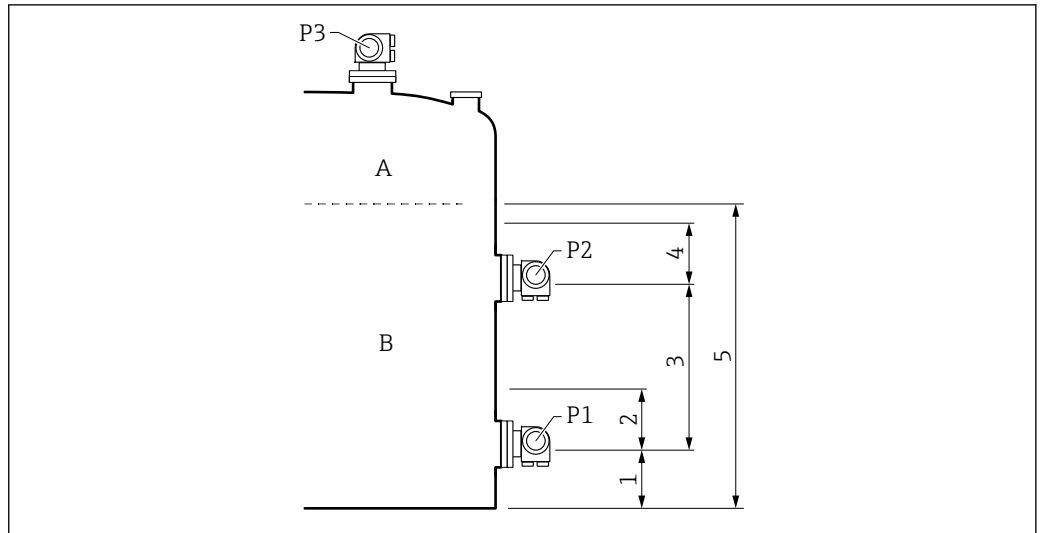



A0028717

- 1 P1 position (→ 157)
- 2 Safety distance (→ 185)
- 3 P1-2 distance (→ 159)
- 4 Safety distance (→ 185)
- 5 Min. level (→ 185)

Level L is in area	Calculation method for ρ_P	Calculation method for L
A	calculated from pressure	calculated from pressure
B	ρ_P held	L = Min. level

HTG evaluation: dependence on measured pressure

If the level of the product approaches the the P1 or P2 pressure sensor, the measured pressure becomes very small and the measurement might be too inaccurate for the Tank Gauging application. To solve this problem, a minimum pressure P_{\min} is defined in the **Min. pressure** parameter (→  185). If the pressure measured by the sensor P1 or P2, respectively, the software stops calculating the density and either holds the last calculated value (for the density) or returns the HTMinLevel (for HTGLevel).

- If P2 is smaller than P_{\min} , the software stops calculating the density and uses the last density value.
- If P1 is smaller than P_{\min} , the software stops calculating the level and uses the value of **Min. level** (→  185), instead.

Hysteresis

The level of the product in a tank is not constant but slightly varies, due for example to filling disturbances. If the level oscillates around the changeover level (**Min. level**), the algorithm will constantly switch between calculating the value and holding the previous result. To avoid this effect a positional hysteresis is defined around the changeover point.

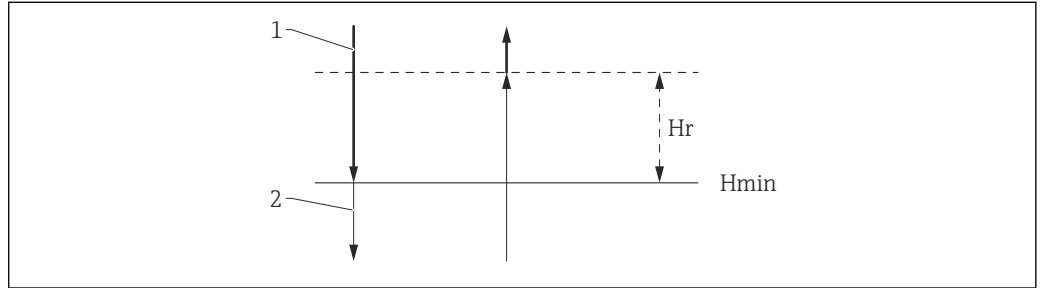

A0028720

11 HTG hysteresis

- 1 Value calculated
- 2 Value held/manual
- H_{min} Min. level
- H_r Hysteresis (→ 186)

Description of parameters

Navigation Expert → Application → Tank calculation → HTG

▶ HTG

Density value	→ 183
Tank level	→ 184
HTG mode	→ 184
Manual density	→ 184
Min. level	→ 185
Min. pressure	→ 185
Safety distance	→ 185
Hysteresis	→ 186

Density value

Navigation

Expert → Application → Tank calculation → HTG → Density value (13706)

Description

Shows the density calculated by HTG.

Additional information

Read access	Operator
Write access	-

Tank level**Navigation**
 Expert → Application → Tank calculation → HTG → Tank level (13707)
Description

Shows the level calculated by HTG.

User interface

Signed floating-point number

Factory setting

0 mm

Additional information

Read access	Operator
Write access	-

HTG mode**Navigation**
 Expert → Application → Tank calculation → HTG → HTG mode (13701)
Description

Defines the HTG mode.

Selection

- P1 only
- P1 + P3
- P1 + P2
- P1 + P2 + P3

Factory setting

P1 only

Additional information

Read access	Operator
Write access	Maintenance

Manual density**Navigation**
 Expert → Application → Tank calculation → HTG → Manual density (15009)
Description

Defines the manual density.

User entry0 to 3 000 kg/m³**Factory setting**800 kg/m³**Additional information**

Read access	Maintenance
Write access	Maintenance

Min. level 

Navigation   Expert → Application → Tank calculation → HTG → Min. level (13702)

Description Defines the minimum level for the HTG calculation.

User entry 0 to 20 000 mm

Factory setting 7 000 mm

Additional information

Read access	Operator
Write access	Maintenance

Min. pressure 

Navigation   Expert → Application → Tank calculation → HTG → Min. pressure (13703)

Description Minimum pressure for the HTG calculation.



User entry 0 to 100 bar

Factory setting 0.1 bar

Additional information

Read access	Operator
Write access	Maintenance

Safety distance 

Navigation   Expert → Application → Tank calculation → HTG → Safety distance (13705)

Description Minimum level above P1 and P2 pressure sensor.

User entry 0 to 10 000 mm

Factory setting 2 000 mm

Additional information

Read access	Operator
Write access	Maintenance

Hysteresis

**Navigation**

Expert → Application → Tank calculation → HTG → Hysteresis (13704)

Description

Hysteresis for the HTG calculation.

User entry

0 to 2 000 mm

Factory setting

50 mm

Additional information

Read access	Operator
Write access	Maintenance

"HTMS" submenu

Overview

The Hybrid Tank Measurement System (HTMS) is a method to calculate the density of a product in a tank based on both a (top mounted) level and at least one (bottom mounted) pressure measurement. An additional pressure sensor can be installed at the top of the tank to provide information about the vapor pressure and to make the density calculation more accurate. The calculation method also takes into account a possible level of water at the bottom of the tank to make density calculations as accurate as possible.

HTMS parameters

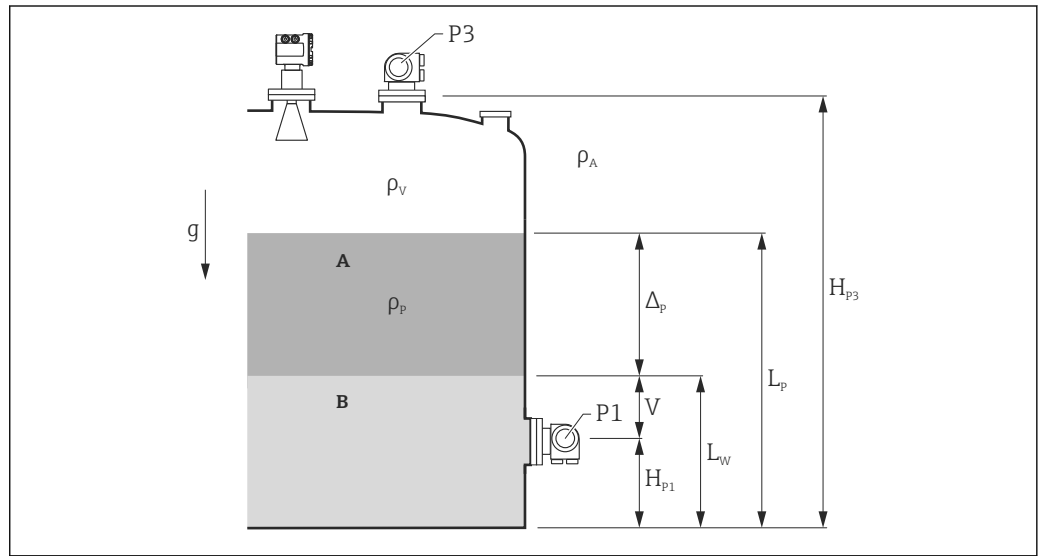

12 HTMS parameters

- A Product
- B Water

Parameter	Navigation path
P1 (Bottom pressure)	Setup → Advanced setup → Tank config → Pressure → P1 (bottom)
H _{P1} (Position of P1 transmitter)	Setup → Advanced setup → Tank config → Pressure → P1 position
P3 (Top pressure)	Setup → Advanced setup → Tank config → Pressure → P3 (top)
H _{P3} (Position of P3 transmitter)	Setup → Advanced setup → Tank config → Pressure → P3 position
ρ _p (Density of the product ¹⁾)	<ul style="list-style-type: none"> ■ Measured value: Setup → Advanced setup → Calculation → HTMS → Density value (13753) ■ User-defined value: Setup → Advanced setup → Calculation → HTMS → Manual density (14998)
ρ _v (Vapor density)	Expert → Application → Tank config → Density → Vapor density
ρ _A (Ambient air temperature)	Setup → Advanced setup → Tank config → Density → Air density
g (Local gravity)	Expert → Application → Tank Calculation → Local gravity
L _p (Level of the product)	Operation → Tank level (14655)
L _W (Bottom water level)	Operation → Water level (14970)
V = L _W - H _{P1}	
Δ _p = L _p - L _W = L _p - V - H _{P1}	

1) Depending on the situation this parameter is measured or a user-defined value is used.

HTMS modes

Two HTMS modes can be selected in the **HTMS mode** parameter (→  189). The mode determines whether one or two pressure values are used. Depending on the selected mode a number of additional parameters are required for the calculation of the product density.

 The **HTMS P1+P3** option must be used in pressurized tanks in order to compensate for the pressure of the vapor phase.

HTMS mode (→  189)	Measured variables	Required additional parameters	Calculated variables
HTMS P1	<ul style="list-style-type: none"> ▪ P₁ ▪ L_p 	<ul style="list-style-type: none"> ▪ g ▪ H_{P1} ▪ L_W (optional) 	ρ _p
HTMS P1+P3	<ul style="list-style-type: none"> ▪ P₁ ▪ P₃ ▪ L_p 	<ul style="list-style-type: none"> ▪ ρ_V ▪ ρ_A ▪ g ▪ H_{P1} ▪ H_{P3} ▪ L_W (optional) 	ρ _p (more precise calculation for pressurized tanks)

Minimum level

The density of the product can only be calculated if the product has a minimum thickness :

$$\Delta_p \geq \Delta_{p, \min}$$

A0028864

This is equivalent to the following condition for the product level:

$$L_p - V \geq \Delta_{p, \min} + H_{P1} = L_{\min}$$

A0028863

L_{min} is defined in the **Min. level** parameter (→  190). As can be seen from the formula it always must be bigger than H_{P1}.

If L_p - V falls below this limit, the density is calculated as follows:

- If a previous calculated value is available, this value will be kept as long as no new calculation is possible.
- If no value was previously calculated, the manual value (defined in the **Manual density** parameter (→  153)) will be used.

Hysteresis

The level of the product in a tank is not constant but slightly varies, due for example to filling disturbances. If the level oscillates around the changeover level (**Min. level** (→  190)), the algorithm will constantly switch between calculating the value and holding the previous result. To avoid this effect a positional hysteresis is defined around the changeover point.

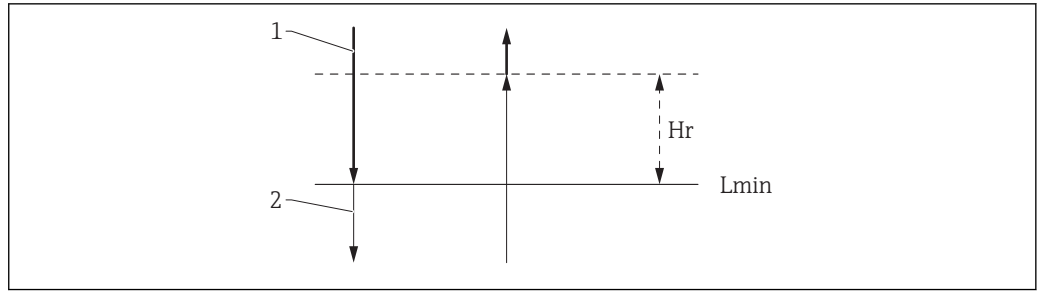

A0029148

13 HTMS hysteresis

- 1 Value calculated
- 2 Value held/manual
- L_{min} Min. level (→ 190)
- H_r Hysteresis (→ 191)

Description of parameters

Navigation Expert → Application → Tank calculation → HTMS

▶ HTMS

HTMS mode	→ 189
Manual density	→ 190
Density value	→ 190
Min. level	→ 190
Min. pressure	→ 191
Safety distance	→ 191
Hysteresis	→ 191
Water density	→ 192

HTMS mode

Navigation Expert → Application → Tank calculation → HTMS → HTMS mode (13751)

Description Defines the HTMS mode.

- Selection
- HTMS P1
 - HTMS P1+P3

Factory setting HTMS P1

Additional information

Read access	Operator
Write access	Maintenance

Meaning of the options

- HTMS P1
Only a bottom pressure transmitter (P1) is used.
- HTMS P1+P3
A bottom (P1) and top (P3) pressure transmitter are used. This option should be selected for pressurized tanks.

Manual density**Navigation**

Expert → Application → Tank calculation → HTMS → Manual density (15009)

Description

Defines the manual density.

User entry

0 to 3 000 kg/m³

Factory setting

800 kg/m³

Additional information

Read access	Maintenance
Write access	Maintenance

Density value**Navigation**

Expert → Application → Tank calculation → HTMS → Density value (13753)

Description

Shows the calculated product density.

Additional information

Read access	Operator
Write access	-

Min. level**Navigation**

Expert → Application → Tank calculation → HTMS → Min. level (13752)

Description

Defines the minimum product level for a HTMS calculation. If Lp - V falls below the limit defined in this parameter, the density retains its last value or the manual value is used instead.

User entry

0 to 20 000 mm

Factory setting

7 000 mm

Additional information

Read access	Operator
Write access	Maintenance

Min. pressure**Navigation**

Expert → Application → Tank calculation → HTMS → Min. pressure (13754)

Description

Defines the minimum pressure for a HTMS calculation. If the pressure P1 falls below the limit defined in this parameter, the density retains its last value or the manual value is used instead.

User entry

0 to 100 bar

Factory setting

0.1 bar

Additional information

Read access	Operator
Write access	Maintenance

Safety distance**Navigation**

Expert → Application → Tank calculation → HTMS → Safety distance (13756)

Description

Minimum level above P1 pressure sensor.

User entry

0 to 10 000 mm

Factory setting

2 000 mm

Additional information

Read access	Operator
Write access	Maintenance

Hysteresis**Navigation**

Expert → Application → Tank calculation → HTMS → Hysteresis (13755)

Description

Hysteresis for the HTMS calculation.

User entry

0 to 2 000 mm

Factory setting

50 mm

Additional information

Read access	Operator
Write access	Maintenance

Water density

**Navigation**

Expert → Application → Tank calculation → HTMS → Water density (13757)

Description

Density of the water in the tank.

User entry

Signed floating-point number

Factory setting1 000 kg/m³**Additional information**



















Read access	Operator
Write access	Maintenance

3.4.3 "Alarm" submenu

Navigation  Expert → Application → Alarm

"Alarm" submenu

Navigation  Expert → Application → Alarm → Alarm

▶ Alarm	
Alarm mode	→  194
Error value	→  195
Alarm source	→  196
Alarm value	→  197
HH alarm value	→  197
H alarm value	→  197
L alarm value	→  198
LL alarm value	→  198
HH alarm	→  198
H alarm	→  199
HH+H alarm	→  199
L alarm	→  199
LL alarm	→  199
LL+L alarm	→  200
Any error	→  200
Clear alarm	→  200
Alarm hysteresis	→  201
Damping factor	→  201

Alarm mode**Navigation**

Expert → Application → Alarm → Alarm → Alarm mode (13864)

Description

Defines the alarm mode of the selected alarm.

Selection

- Off
- On
- Latching

Factory setting

Off

Additional information

Read access	Operator
Write access	Maintenance

Meaning of the options

- **Off**
No alarms are generated.
- **On**
An alarm disappears if the alarm condition is no longer present (taking into consideration the hysteresis).
- **Latching**
All alarms remain active until the user selects **Clear alarm** (→ 200) = **Yes** or the power is switched off and on.

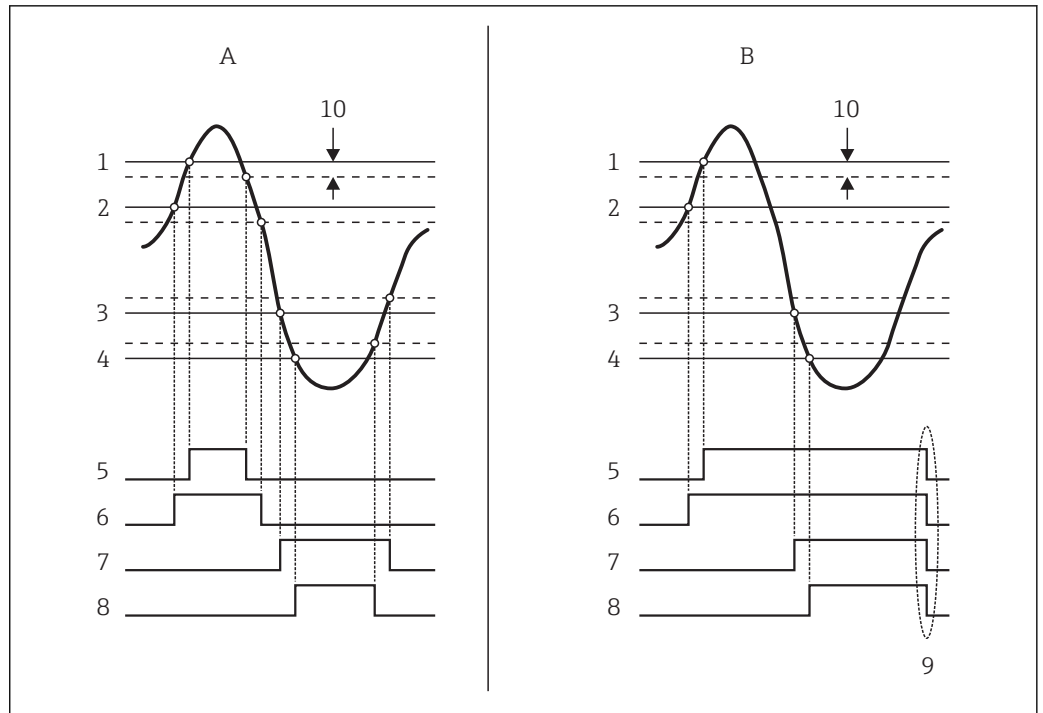

A0029539

14 Principle of the limit evaluation

- A Alarm mode (→ 194) = On
- B Alarm mode (→ 194) = Latching
- 1 HH alarm value (→ 197)
- 2 H alarm value (→ 197)
- 3 L alarm value (→ 198)
- 4 LL alarm value (→ 198)
- 5 HH alarm (→ 198)
- 6 H alarm (→ 199)
- 7 L alarm (→ 199)
- 8 LL alarm (→ 199)
- 9 "Clear alarm (→ 200)" = "Yes" or power off-on
- 10 Hysteresis (→ 201)

Error value



Navigation

Expert → Application → Alarm → Alarm → Error value (13851)

Prerequisite

Alarm mode (→ 194) ≠ Off

Description

Alarm to be issued if the input value is invalid.

Selection

- No alarm
- HH+H alarm
- H alarm
- L alarm
- LL+L alarm
- All alarms

Factory setting

All alarms

Additional information

Read access	Operator
Write access	Maintenance

Alarm source

Navigation Expert → Application → Alarm → Alarm → Alarm source (13866)

Prerequisite **Alarm mode (→ 194) ≠ Off**

Description Determines the process variable to be monitored.

- Selection**
- Tank level
 - Liquid temperature
 - Vapor temperature
 - Water level
 - P1 (bottom)
 - P2 (middle)
 - P3 (top)
 - Observed density value
 - Volume
 - Flow velocity
 - Volume flow
 - Vapor density
 - Middle density
 - Upper density
 - Correction
 - Tank level %
 - GP 1...4 value
 - Measured level
 - P3 position
 - Tank reference height
 - Local gravity
 - P1 position
 - Manual density
 - Tank ullage
 - Average profile density
 - Lower density
 - Upper interface level
 - Lower interface level
 - Bottom level
 - Displacer position
 - HART device 1...15 PV
 - HART device 1...15 SV
 - HART device 1...15 TV
 - HART device 1...15 QV
 - HART device 1...15 PV mA
 - HART device 1...15 PV %
 - Element temperature 1...24
 - AIO B1-3 value
 - AIO C1-3 value
 - AIP B4-8 value
 - AIP C4-8 value
 - None

Factory setting None

Additional information



Read access	Operator
Write access	Maintenance

Alarm value

Navigation  Expert → Application → Alarm → Alarm → Alarm value (13863)**Prerequisite** **Alarm mode (→  194) ≠ Off****Description** Current value of the variable being monitored.**User interface** Signed floating-point number**Factory setting** 0 None**Additional information**



Read access	Operator
Write access	-

HH alarm value

**Navigation**  Expert → Application → Alarm → Alarm → HH alarm value (13855)**Prerequisite** **Alarm mode (→  194) ≠ Off****Description** Defines the high-high(HH) limit value.**User entry** Signed floating-point number**Factory setting** 0 None**Additional information**

Read access	Operator
Write access	Maintenance

H alarm value

**Navigation**  Expert → Application → Alarm → Alarm → H alarm value (13854)**Prerequisite** **Alarm mode (→  194) ≠ Off****Description** Defines the high(H) limit value.**User entry** Signed floating-point number**Factory setting** 0 None**Additional information**

Read access	Operator
Write access	Maintenance

L alarm value**Navigation** Expert → Application → Alarm → Alarm → L alarm value (13853)**Prerequisite** **Alarm mode (→ 194) ≠ Off****Description** Defines the low limit value.**User entry** Signed floating-point number**Factory setting** 0 None**Additional information**

Read access	Operator
Write access	Maintenance

LL alarm value**Navigation** Expert → Application → Alarm → Alarm → LL alarm value (13852)**Prerequisite** **Alarm mode (→ 194) ≠ Off****Description** Defines the low-low(LL) limit value.**User entry** Signed floating-point number**Factory setting** 0 None**Additional information**

Read access	Operator
Write access	Maintenance

HH alarm**Navigation** Expert → Application → Alarm → Alarm → HH alarm (13857)**Prerequisite** **Alarm mode (→ 194) ≠ Off****Description** Shows whether an HH alarm is currently active.**Additional information**

Read access	Operator
Write access	-

H alarm

Navigation   Expert → Application → Alarm → Alarm → H alarm (13856)

Prerequisite **Alarm mode (→  194) ≠ Off**

Description Shows whether an H alarm is currently active.

Additional information

Read access	Operator
Write access	-

HH+H alarm

Navigation   Expert → Application → Alarm → Alarm → HH+H alarm (13858)

Prerequisite **Alarm mode (→  194) ≠ Off**

Description Shows if an HH or H alarm is currently active.

Additional information

Read access	Operator
Write access	-

L alarm

Navigation   Expert → Application → Alarm → Alarm → L alarm (13859)

Prerequisite **Alarm mode (→  194) ≠ Off**

Description Shows whether an L alarm is currently active.

Additional information

Read access	Operator
Write access	-

LL alarm



Navigation   Expert → Application → Alarm → Alarm → LL alarm (13868)

Prerequisite **Alarm mode (→  194) ≠ Off**

Description Shows whether an LL alarm is currently active.

Additional information

Read access	Operator
Write access	-

LL+L alarm**Navigation**
 Expert → Application → Alarm → Alarm → LL+L alarm (13869)
Prerequisite**Alarm mode (→  194) ≠ Off****Description**

Shows if an LL or L alarm is currently active.

Additional information

Read access	Operator
Write access	-

Any error**Navigation**
 Expert → Application → Alarm → Alarm → Any error (13867)
Prerequisite**Alarm mode (→  194) ≠ Off****Description**

Show whether any alarm is currently active.

User interface

- Unknown
- Inactive
- Active
- Error

Factory setting

Unknown

Additional information

Read access	Operator
Write access	-

Clear alarm**Navigation**
 Expert → Application → Alarm → Alarm → Clear alarm (13861)
Prerequisite**Alarm mode (→  194) = Latching****Description**

Deletes an alarm which is still active.

Selection

- No
- Yes

Factory setting

No

Additional information

Read access	Operator
Write access	Maintenance

Alarm hysteresis**Navigation**

Expert → Application → Alarm → Alarm → Alarm hysteresis (13862)

Prerequisite

Alarm mode (→ 194) ≠ Off

Description

Defines the hysteresis for the limit values.

User entry

Signed floating-point number

Factory setting

0.001

Additional information

Read access	Maintenance
Write access	Maintenance

Damping factor**Navigation**

Expert → Application → Alarm → Alarm → Damping factor (13860)

Description

Defines the damping constant (in seconds).

User entry

0 to 999.9 s

Factory setting





0 s

Additional information

Read access	Operator
Write access	Maintenance









3.5 "Tank values" submenu

Navigation  Expert → Tank values

▶ Tank values	
▶ Level	→  202
▶ Temperature	→  205
▶ Density	→  208
▶ Pressure	→  210
▶ GP values	→  211

3.5.1 "Level" submenu

Navigation  Expert → Tank values → Level

▶ Level	
Tank level	→  202
Tank Level %	→  203
Tank ullage	→  203
Tank ullage %	→  203
Upper I/F level	→  203
Lower I/F level	→  204
Bottom level	→  204
Water level	→  204
Measured level	→  204

Tank level

Navigation

 Expert → Tank values → Level → Tank level (14655)

Description

Shows distance from zero to product surface.

Additional information

Read access	Operator
Write access	-

Tank Level %**Navigation**
 Expert → Tank values → Level → Tank Level % (14654)
Description

Level measured in percent.

Additional information

Read access	Operator
Write access	-

Tank ullage**Navigation**
 Expert → Tank values → Level → Tank ullage (14657)
Description

Shows the remaining empty space in the tank.

Additional information

Read access	Operator
Write access	-

Tank ullage %**Navigation**
 Expert → Tank values → Level → Tank ullage % (14658)
Description

Shows the remaining empty space in percentage.

Additional information

Read access	Operator
Write access	-

Upper I/F level**Navigation**
 Expert → Tank values → Level → Upper I/F level (15003)
Description

Up I/F Level measured from zero position.

Additional information

Read access	Maintenance
Write access	-

Lower I/F level

Navigation  Expert → Tank values → Level → Lower I/F level (15004)

Description Shows measured interface level from zero position.

Additional information

Read access	Maintenance
Write access	-

Bottom level

Navigation  Expert → Tank values → Level → Bottom level (15018)

Description Shows the bottom level.

Additional information

Read access	Operator
Write access	-

Water level

Navigation  Expert → Tank values → Level → Water level (14970)

Description Shows the bottom water level.

Additional information

Read access	Operator
Write access	-

Measured level

Navigation  Expert → Tank values → Level → Measured level (14653)









Description Shows the measured level without any correction.

Additional information

Read access	Operator
Write access	-

3.5.2 "Temperature" submenu

Navigation   Expert → Tank values → Temperature

▶ Temperature	
Liquid temp.	→  205
Vapor temp.	→  205
Air temp.	→  206
▶ NMT elem. values	→  206
▶ Element temp.	→  206
Element temp 0 to 23	→  206
▶ Element position	→  206
Element pos. 0 to 23	→  206

Liquid temp.

Navigation   Expert → Tank values → Temperature → Liquid temp. (14978)

Description Shows temperature of the measured liquid.

Additional information	Read access	Operator
	Write access	-



Vapor temp.

Navigation   Expert → Tank values → Temperature → Vapor temp. (14985)

Description Shows the measured vapor temperature.

Additional information	Read access	Operator
	Write access	-

Air temp.

Navigation   Expert → Tank values → Temperature → Air temp. (14986)

Description Shows the air temperature.

Additional information

Read access	Operator
Write access	-

"NMT element values" submenu

Navigation  Expert → Tank values → Temperature → NMT elem. values

"Element temperature" submenu

Navigation  Expert → Tank values → Temperature → NMT elem. values
→ Element temp. → Element temp 0 to 23 (14984)

Element temp 1 to 24

Navigation  Expert → Tank values → Temperature → NMT elem. values → Element temp.
→ Element temp 1 to 24 (14984-1 to 24)

Description Shows the temperature of an element in the NMT.

Additional information

Read access	Operator
Write access	-

"Element position" submenu

Navigation  Expert → Tank values → Temperature → NMT elem. values
→ Element position

Element pos. 1 to 24

Navigation  Expert → Tank values → Temperature → NMT elem. values → Element position
→ Element pos. 1 to 24 (15014-1 to 24)

Description Shows the position of selected element in the NMT.







Additional information

Read access	Operator
Write access	-

3.5.3 "Density" submenu

Navigation  Expert → Tank values → Density

► Density

- Observed density →  208
- Vapor density →  208
- Air density →  209
- Meas upper dens. →  209
- Meas middle dens →  209
- Meas lower dens. →  209

Observed density

Navigation  Expert → Tank values → Density → Observed density (13451)

Description Calculated density of the product.

Additional information

Read access	Operator
Write access	-

 This value is calculated from different measured variables depending on the selected calculation method .

Vapor density

Navigation  Expert → Tank values → Density → Vapor density (14981)

Description Density of the gas phase in the tank.

User entry 0.0 to 500.0 kg/m³

Factory setting 1.2 kg/m³

Additional information

Read access	Operator
Write access	Maintenance

Air density

**Navigation** Expert → Tank values → Density → Air density (14980)**Description** Density of the air surrounding the tank.**User entry** 0.0 to 500.0 kg/m³**Factory setting** 1.2 kg/m³**Additional information**

Read access	Operator
Write access	Maintenance

Meas upper dens.

Navigation Expert → Tank values → Density → Meas upper dens. (15001)**Description** Shows the density of the upper phase.**Additional information**

Read access	Operator
Write access	-

Meas middle dens

Navigation Expert → Tank values → Density → Meas middle dens (14997)**Description** Density of the middle phase.**Additional information**

Read access	Operator
Write access	-



Meas lower dens.

Navigation Expert → Tank values → Density → Meas lower dens. (15002)**Description** Density of the lower phase.**Additional information**

Read access	Maintenance
Write access	-

3.5.4 "Pressure" submenu

Navigation  Expert → Tank values → Pressure

▶ Pressure	
P1 (bottom)	→  210
P2 (middle)	→  210
P3 (top)	→  210

P1 (bottom)

Navigation  Expert → Tank values → Pressure → P1 (bottom) (14983)

Description Shows the pressure at the tank bottom.

Additional information

Read access	Operator
Write access	-

P2 (middle)

Navigation  Expert → Tank values → Pressure → P2 (middle) (14987)

Description Pressure (P2) at the middle transmitter.

Additional information

Read access	Operator
Write access	-

P3 (top)

Navigation  Expert → Tank values → Pressure → P3 (top) (14988)

Description Pressure (P3) at the top transmitter.





Additional information

Read access	Operator
Write access	-



3.5.5 "GP values" submenu

Navigation   Expert → Tank values → GP values

▶ GP values

GP 1 to 4 name	→  211
GP Value 1	→  211
GP Value 2	→  211
GP Value 3	→  212
GP Value 4	→  212

GP 1 to 4 name

Navigation   Expert → Tank values → GP values → GP 1 name (14963)



Description Defines the label for the respective GP value.

Factory setting GP Value 1

Additional information

Read access	Operator
Write access	Maintenance

GP Value 1



Navigation   Expert → Tank values → GP values → GP Value 1 (14966)

Description General purpose values.

Additional information

Read access	Operator
Write access	-

GP Value 2

Navigation   Expert → Tank values → GP values → GP Value 2 (14967)

Description General purpose values.

Additional information

Read access	Operator
Write access	-

GP Value 3**Navigation**

  Expert → Tank values → GP values → GP Value 3 (14968)

Description

General purpose values.

Additional information

Read access	Operator
Write access	-

GP Value 4**Navigation**

  Expert → Tank values → GP values → GP Value 4 (14969)

Description























General purpose values.

Additional information

Read access	Operator
Write access	-

3.6 "Diagnostics" submenu

Navigation  Expert → Diagnostics

► Diagnostics		
Actual diagnos.		→  214
Timestamp		→  215
Prev.diagnostics		→  215
Timestamp		→  215
Time fr. restart		→  216
Operating time		→  216
Date/time		→  216
► Diagnostic list		→  217
Diagnostics 1 to 5		→  217
Timestamp 1 to 5		→  217
► Event logbook		→  218
Filter options		→  218
► Simulation		→  220
Dev. alarm sim.		→  220
Diag. event sim.		→  220
Curr.out. 1 to 2 sim.		→  221
Simulation value		→  221
► Device info		→  222
Device tag		→  222
Serial number		→  223
Firmware version		→  223
Firmware CRC		→  223

W&M config CRC	→ 223
Device name	→ 224
Order code	→ 224
Ext. order cd. 1 to 3	→ 224
ENP version	→ 224
Device type	→ 225
Module type	→ 225
Comm. Slot	→ 225
▶ Board info	→ 226
Date/time	→ 216
System temp.	→ 226
W&M lock switch	→ 226
▶ Data logging	→ 228
Assign chan. 1 to 4	→ 229
Logging interval	→ 230
Clear logging	→ 231

Actual diagnos.

Navigation

Expert → Diagnostics → Actual diagnos. (0691)

Description

Current occurred diag. event with its diag. info.

Additional information

Read access	Operator
Write access	-

The display consists of:

- Symbol for event behavior
- Code for diagnostic behavior
- Operating time of occurrence
- Event text

 If several messages are active at the same time, the messages with the highest priority is displayed.

 Information on what is causing the message, and remedy measures, can be viewed via the ⓘ symbol on the display.

Timestamp

Navigation  Expert → Diagnostics → Timestamp (0667)

Description Timestamp for the current diagnostic message.

Additional information

Read access	Operator
Write access	-

Prev.diagnostics

Navigation   Expert → Diagnostics → Prev.diagnostics (0690)

Description Event with diag.info occurred prior to current one.

Additional information

Read access	Operator
Write access	-

The display consists of:

- Symbol for event behavior
- Code for diagnostic behavior
- Operating time of occurrence
- Event text

 If several messages are active at the same time, the messages with the highest priority is displayed.

 Information on what is causing the message, and remedy measures, can be viewed via the ⓘ symbol on the display.

Timestamp

Navigation  Expert → Diagnostics → Timestamp (0672)

Description Timestamp of the previous diagnostic message.

Additional information

Read access	Operator
Write access	-

Time fr. restart**Navigation**

 Expert → Diagnostics → Time fr. restart (0653)

Description

Shows operating time since last device restart.

Additional information

Read access	Operator
Write access	-

Operating time**Navigation**

 Expert → Diagnostics → Operating time (0652)

Description

Indicates how long device has been in operation.

Additional information

Read access	Operator
Write access	-

Date/time**Navigation**

 Expert → Diagnostics → Date/time (0790)

Description

Displays the device internal real time clock.

Additional information



Read access	Operator
Write access	-

3.6.1 "Diagnostic list" submenu

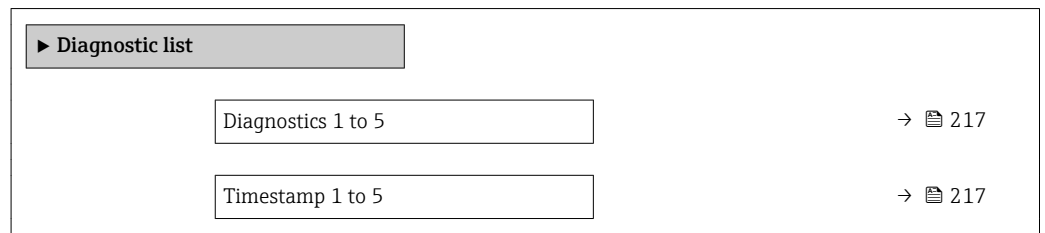
Navigation   Expert → Diagnostics → Diagnostic list



Diagnostics 1 to 5

Navigation   Expert → Diagnostics → Diagnostic list → Diagnostics 1 to 5 (0692-1 to 5)

Description Display the current diagnostics messages with the highest to fifth-highest priority.

Additional information The display consists of:

- Symbol for event behavior
- Code for diagnostic behavior
- Operating time of occurrence
- Event text

Timestamp 1 to 5

Navigation  Expert → Diagnostics → Diagnostic list → Timestamp (0683)

Description Timestamp of the diagnostic message.

Additional information

Read access	Operator
Write access	-



3.6.2 "Event logbook" submenu

Structure of the submenu on the local display

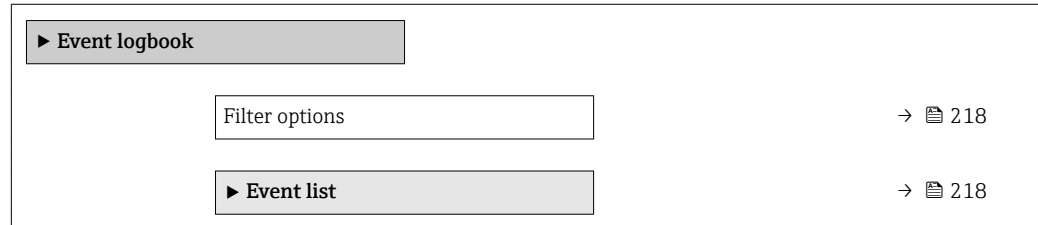
Navigation  Expert → Diagnostics → Event logbook



Description of parameters

Navigation   Expert → Diagnostics → Event logbook

Filter options

Navigation  Expert → Diagnostics → Event logbook → Filter options (0705)

Description Define category of messages shown in Events list.

Selection

- All
- Failure (F)
- Funct. check (C)
- Out of spec. (S)
- Mainten. req. (M)
- Information (I)



Factory setting All

Additional information 

- This parameter is only used for operation via the local display.
- The status signals are categorized according to NAMUR NE 107.



Read access	Operator
Write access	Maintenance



"Event list" submenu

 The **Event list** submenu (→  218) is only available when operating via the local display.

The **Event list** submenu doesn't contain any parameters but only the list of events of the category selected in the **Filter options** parameter. A maximum of 100 event messages is displayed in chronological order.

The following status symbols indicate, whether an event has appeared or disappeared at the time stated:





- : Event appeared
- : Event disappeared

 Remedy measures concerning the cause of the message can be called up via the  symbol on the display.

Navigation  Expert → Diagnostics → Event logbook → Event list

3.6.3 "Simulation" submenu

Navigation  Expert → Diagnostics → Simulation

▶ Simulation	
Dev. alarm sim.	→  220
Diag. event sim.	→  220
Curr.out. 1 to 2 sim.	→  221
Simulation value	→  221

Dev. alarm sim.

Navigation  Expert → Diagnostics → Simulation → Dev. alarm sim. (0654)

Description Switch the device alarm on and off.

Selection

- Off
- On

Factory setting Off

Additional information

Read access	Operator
Write access	Maintenance

Diag. event sim.

Navigation  Expert → Diagnostics → Simulation → Diag. event sim. (0737)

Description Select a diagnostic event to simulate this event.

Selection The diagnostic events of the device

Factory setting Off

Additional information

Read access	Operator
Write access	Maintenance

 To terminate the simulation, select **Off**.

Curr.out. # sim.



Navigation

- Expert → Diagnostics → Simulation → Curr.out. 1 sim. (13985-1)
- Expert → Diagnostics → Simulation → Curr.out. 2 sim. (13985-2)

Prerequisite

- The device has an Anlog I/O module.
- **Operating mode** (→ 84) = **4..20mA output** or **HART slave**

Description

Switches the simulation of the current on or off.

Selection

- Off
- On

Factory setting

Off

Additional information

Read access	Operator
Write access	Maintenance

Simulation value



Navigation

- Expert → Diagnostics → Simulation → Simulation value (13976)
- Expert → Diagnostics → Simulation → Simulation value (13976)

Prerequisite

Curr.out. sim. (→ 221) = **On**

Description

Defines the current to be simulated.

User entry

3.4 to 23 mA

Factory setting













The current at the time the simulation was started.

Additional information

Read access	Operator
Write access	Maintenance

3.6.4 "Device information" submenu

Navigation  Expert → Diagnostics → Device info

▶ Device info	
Device tag	→  222
Serial number	→  223
Firmware version	→  223
Firmware CRC	→  223
W&M config CRC	→  223
Device name	→  224
Order code	→  224
Ext. order cd. 1 to 3	→  224
ENP version	→  224
Device type	→  225
Module type	→  225
Comm. Slot	→  225
▶ Board info	→  226

Device tag

Navigation  Expert → Diagnostics → Device info → Device tag (0011)

Description Shows the device tag.

Factory setting NMS8x

Additional information

Read access	Operator
Write access	-

Serial number

Navigation  Expert → Diagnostics → Device info → Serial number (0009)

Description Shows the serial number of the measuring device.

Additional information

Read access	Operator
Write access	-

Firmware version

Navigation  Expert → Diagnostics → Device info → Firmware version (0010)

Description Shows the device firmware version installed.

Additional information

Read access	Operator
Write access	-

Firmware CRC

Navigation  Expert → Diagnostics → Device info → Firmware CRC (8563)

Description Result of the CRC of the firmware.

Additional information

Read access	Operator
Write access	-

W&M config CRC

Navigation  Expert → Diagnostics → Device info → W&M config CRC (8564)

Description Result of the CRC of the W&M parameters.

Additional information



Read access	Operator
Write access	-

Device name

Navigation  Expert → Diagnostics → Device info → Device name (0013)**Description** Shows the name of the transmitter.**Additional information**

Read access	Operator
Write access	-

Order code

**Navigation**  Expert → Diagnostics → Device info → Order code (0008)**Description** Shows the device order code.**Additional information**

Read access	Operator
Write access	Service

Ext. order cd. 1 to 3

**Navigation**  Expert → Diagnostics → Device info → Ext. order cd. 1 (0023)**Description** Display the three parts of the extended order code.**Additional information**

Read access	Operator
Write access	Service

The extended order code indicates the selected option of all ordering features and thus uniquely identifies the device.

ENP version

Navigation  Expert → Diagnostics → Device info → ENP version (0012)**Description** Shows the version of the electronic nameplate.**Additional information**

Read access	Operator
Write access	-

Device type

Navigation
 Expert → Diagnostics → Device info → Device type (8561)
Description

Displays the device type.

Additional information

Read access	Operator
Write access	-

Module type

Navigation
 Expert → Diagnostics → Device info → Module type (8526)
Description

Shows the type of installed IO module.

Additional information

Read access	Operator
Write access	-

Comm. Slot

Navigation
 Expert → Diagnostics → Device info → Comm. Slot (13285)
Description

IOM slot containing the protocol interface board.



Additional information

Read access	Operator
Write access	-

"Board info" submenu

Navigation  Expert → Diagnostics → Device info → Board info

▶ Board info

Date/time	→  226
System temp.	→  226
W&M lock switch	→  226

Date/time

Navigation  Expert → Diagnostics → Device info → Board info → Date/time (0790)

Description Shows the current date and time from the real-time clock.

User interface Days (d), hours (h), minutes (m), seconds (s)

Factory setting

Additional information

Read access	Operator
Write access	-

System temp.

Navigation  Expert → Diagnostics → Device info → Board info → System temp. (8553)

Description Shows the electronic temp. of the main board.

User interface Signed floating-point number

Factory setting 0 °C

Additional information

Read access	Operator
Write access	-

W&M lock switch

Navigation  Expert → Diagnostics → Device info → Board info → W&M lock switch (8558)

Description Shows the position of the W&M switch (WP).

User interface

- Enabled
- Disabled

Factory setting Enabled

Additional information

Read access	Operator
Write access	-

3.6.5 "Data logging" submenu

Structure of the submenu on the local display

Navigation  Expert → Diagnostics → Data logging

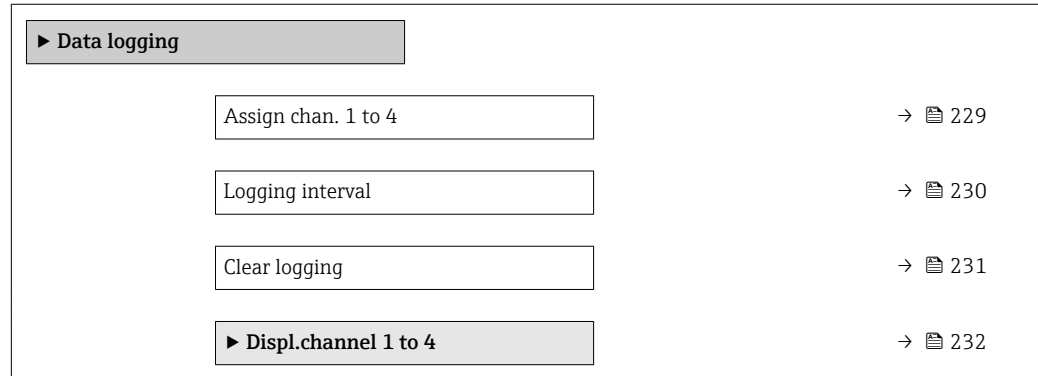

Structure of the submenu in an operating tool

Navigation  Expert → Diagnostics → Data logging

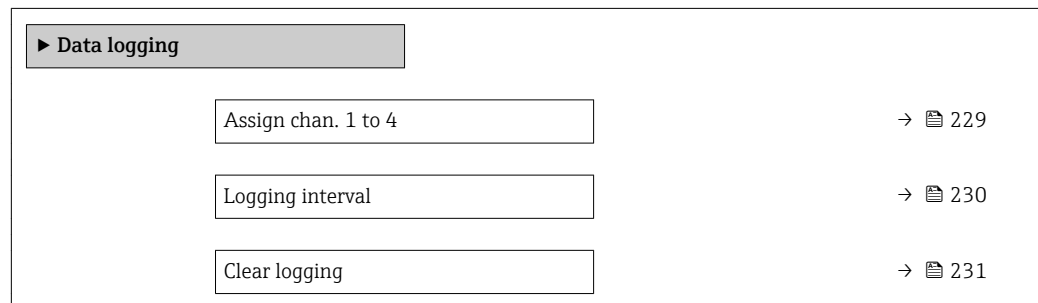

Description of parameters

Navigation  Expert → Diagnostics → Data logging

Assign chan. 1 to 4



Navigation  Expert → Diagnostics → Data logging → Assign chan. 1 (0851)

Description Assign a process variable to logging channel.

- Selection**
- Off
 - Tank level
 - Measured level
 - Tank level %
 - Distance
 - Water level
 - Upper I/F level
 - Lower I/F level
 - Displacer pos *
 - Upper density
 - Middle density
 - Lower density
 - Bottom level
 - Profile density *
 - Liquid temp.
 - Vapor temp.
 - Air temp.
 - Tank ullage
 - Tank ullage %
 - Observed density
 - P1 (bottom)
 - P2 (middle)
 - P3 (top)
 - GP 1 value
 - GP 2 value
 - GP 3 value
 - GP 4 value
 - AIO B1-3 value
 - AIO B1-3 mA
 - AIO B1-3 value %
 - AIO C1-3 value
 - AIO C1-3 mA
 - AIO C1-3 value %
 - AIP B4-8 value
 - AIP C4-8 value

Factory setting Off

* Visibility depends on order options or device settings

Additional information

A total of 1000 measured values can be logged. This means:

- 1000 data points if 1 logging channel is used
- 500 data points if 2 logging channels are used
- 333 data points if 3 logging channels are used
- 250 data points if 4 logging channels are used

If the maximum number of data points is reached, the oldest data points in the data log are cyclically overwritten in such a way that the last 1000, 500, 333 or 250 measured values are always in the log (ring memory principle).



 The logged data are deleted if a new option is selected in this parameter.

Read access	Operator
Write access	Maintenance

Logging interval



Navigation

-  Expert → Diagnostics → Data logging → Logging interval (0856)
-  Expert → Diagnostics → Data logging → Logging interval (0856)

Description

Defines the logging interval for data logging.

User entry

1.0 to 3 600.0 s

Factory setting

10.0 s

Additional information

This parameter defines the interval between the individual data points in the data log, and thus the maximum loggable process time T_{log} :

- If 1 logging channel is used: $T_{log} = 1000 \cdot t_{log}$
- If 2 logging channels are used: $T_{log} = 500 \cdot t_{log}$
- If 3 logging channels are used: $T_{log} = 333 \cdot t_{log}$
- If 4 logging channels are used: $T_{log} = 250 \cdot t_{log}$

Once this time elapses, the oldest data points in the data log are cyclically overwritten such that a time of T_{log} always remains in the memory (ring memory principle).

 The logged data are deleted if this parameter is changed.

Example

When using 1 logging channel

- $T_{log} = 1000 \cdot 1 \text{ s} = 1000 \text{ s} \approx 16.5 \text{ min}$
- $T_{log} = 1000 \cdot 10 \text{ s} = 10000 \text{ s} \approx 2.75 \text{ h}$
- $T_{log} = 1000 \cdot 80 \text{ s} = 80000 \text{ s} \approx 22 \text{ h}$
- $T_{log} = 1000 \cdot 3600 \text{ s} = 3600000 \text{ s} \approx 41 \text{ d}$

Read access	Operator
Write access	Maintenance

Clear logging



Navigation

- ☰ Expert → Diagnostics → Data logging → Clear logging (0855)
- ☰ Expert → Diagnostics → Data logging → Clear logging (0855)

Description

Clear the entire logging data.

Selection

- Cancel
- Clear data

Factory setting

Cancel

Additional information

Read access	Operator
Write access	Maintenance

"Displ.channel 1 to 4" submenu

i The **Displ.channel 1 to 4** submenu is only available when operating via the local display. When operating via FieldCare, the diagram can be displayed in the "Event List / HistoROM" function.

The **Displ.channel 1 to 4** submenu displays the measured value trend of the respective logging channel.

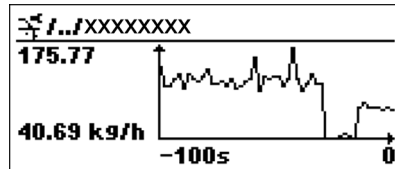

- x-axis: displays 125 to 500 measured values of a process variable (the number of values depending on the number of selected channels).
- y-axis: displays the approximate measured value span and constantly adapts this to the ongoing measurement.

i To quit the diagram and to return to the operating menu, press \oplus and \ominus simultaneously.

Navigation  Expert → Diagnostics → Data logging → Displ.channel 1 to 4

Index

Symbols

#blank# (Parameter) 54, 55

0 ... 9

0 % value (Parameter) 78, 89, 131

100 % value (Parameter) 79, 89, 132

A

Access code (Parameter) 69

Access status display (Parameter) 24

Access status tooling (Parameter) 24

Activate SW option (Parameter) 48

Active calibration (Parameter) 82, 94

Actual diagnostics (Parameter) 214

Administration (Submenu) 47, 48

Air density (Parameter) 152, 209

Air temperature (Parameter) 149, 206

Air temperature source (Parameter) 148

Alarm (Submenu) 193

Alarm 1 input source (Parameter) 123

Alarm 2 input source (Parameter) 123

Alarm 3 input source (Parameter) 124

Alarm 4 input source (Parameter) 124

Alarm hysteresis (Parameter) 201

Alarm mode (Parameter) 194

Alarm value (Parameter) 197

Alarm value source (Parameter) 196

Ambient pressure (Parameter) 162

Analog I/O (Submenu) 83

Analog input 0% value (Parameter) 91

Analog input 100% value (Parameter) 92

Analog input source (Parameter) 86

Analog IP (Submenu) 75

Any error (Parameter) 200

Application (Submenu) 142

Assign channel 1 (Parameter) 229

Assign PV (Parameter) 130

Assign QV (Parameter) 135

Assign SV (Parameter) 133

Assign TV (Parameter) 134

B

Backlight (Parameter) 32

Baudrate (Parameter) 105

Board info (Submenu) 226

Bottom level (Parameter) 204

Bottom point (Parameter) 69

Bus termination (Parameter) 108

C

Calibration (Parameter) 93

Calibration temperature (Parameter) 176

Calibration type AIP (Parameter) 81

Clear alarm (Parameter) 200

Clear logging data (Parameter) 231

Communication (Submenu) 102

Communication interface protocol (Parameter) 103

Communication interface protocol variant

(Parameter) 119

Communication Slot (Parameter) 225

Communication status (Parameter) 54

Compatibility mode (Parameter) 121

Configuration (Submenu) 105, 119, 129

Configure device? (Parameter) 68

Confirm access code (Parameter) 49

Contact type (Parameter) 98

Contrast display (Parameter) 32

Covered tank (Parameter) 175

CRC seed (Parameter) 107

CTSh (Submenu) 174

CTSh correction value (Parameter) 174

CTSh mode (Parameter) 175

Current output 1 simulation (Parameter) 221

Current output 2 simulation (Parameter) 221

Current span (Parameter) 85

Custody transfer (Parameter) 64

D

Damping factor (Parameter) 82, 93, 101, 201

Data logging (Submenu) 228, 229

Date / time (Submenu) 41, 42

Date/time (Parameter) 42, 45, 216, 226

Day (Parameter) 43, 45

Decimal places 1 (Parameter) 29

Decimal places density (Parameter) 37

Decimal places length (Parameter) 36

Decimal places pressure (Parameter) 37

Decimal places temperature (Parameter) 37

Define access code (Parameter) 48, 49

Define access code (Wizard) 49

Deformation factor (Parameter) 170

Density (Parameter) 60

Density (Submenu) 151, 208

Density 0% (Parameter) 111

Density 100% (Parameter) 112

Density unit (Parameter) 36

Density value (Parameter) 183, 190

Device alarm simulation (Parameter) 220

Device date (Parameter) 63

Device description (Parameter) 63

Device ID (Parameter) 62, 138

Device information (Submenu) 222

Device message (Parameter) 63

Device name (Parameter) 53, 224

Device reset (Parameter) 48

Device revision (Parameter) 138

Device tag (Parameter) 53, 138, 222

Device type (Parameter) 62, 138, 225

Diagnostic code (Parameter) 66

Diagnostic event simulation (Parameter) 220

Diagnostic list (Submenu) 217

Diagnostics (Submenu) 66, 213

Diagnostics 1 to 5 (Parameter) 217

- Digital input source (Parameter) 97
- Digital Xx-x (Submenu) 96
- Direct access
 - #blank# (14705) 54
 - #blank# (14706) 54
 - #blank# (14716) 54, 55
 - 0 % value (11632) 131
 - 0 % value (13954) 89
 - 0 % value (14001) 78
 - 100 % value (11633) 132
 - 100 % value (13968) 89
 - 100 % value (14013) 79
 - Access code (14714) 69
 - Access status display (0091) 24
 - Access status tooling (0005) 24
 - Activate SW option (0029) 48
 - Active calibration (13981) 94
 - Active calibration (14012) 82
 - Actual diagnostics (0691) 214
 - Air density (14980) 152, 209
 - Air temperature (14986) 149, 206
 - Air temperature source (14993) 148
 - Alarm 1 input source (13270) 123
 - Alarm 2 input source (13271) 123
 - Alarm 3 input source (13283) 124
 - Alarm 4 input source (13284) 124
 - Alarm hysteresis (13862) 201
 - Alarm mode (13864) 194
 - Alarm value (13863) 197
 - Alarm value source (13866) 196
 - Ambient pressure (14962) 162
 - Analog input 0% value (13977) 91
 - Analog input 100% value (13965) 92
 - Analog input source (13974) 86
 - Any error (13867) 200
 - Assign channel 1 (0851) 229
 - Assign PV (0234) 130
 - Assign QV (0237) 135
 - Assign SV (0235) 133
 - Assign TV (0236) 134
 - Backlight (0111) 32
 - Baudrate (13203) 105
 - Bottom level (15018) 204
 - Bottom point (14729) 69
 - Bus termination (13249) 108
 - Calibration (13966) 93
 - Calibration temperature (13652) 176
 - Calibration type AIP (14018) 81
 - Clear alarm (13861) 200
 - Clear logging data (0855) 231
 - Communication interface protocol (13201) 103
 - Communication interface protocol variant (13269) 119
 - Communication Slot (13285) 225
 - Communication status (14710) 54
 - Compatibility mode (13281) 121
 - Configure device? (14728) 68
 - Contact type
 - Digital X-x (13912) 98
 - Contrast display (0105) 32
 - Covered tank (13654) 175
 - CRC seed (13248) 107
 - CTSh correction value (13651) 174
 - CTSh mode (14651) 175
 - Current output 1 simulation (13985-1) 221
 - Current output 2 simulation (13985-2) 221
 - Current span (13987) 85
 - Custody transfer (14748) 64
 - Damping factor
 - Digital Xx-x (13904) 101
 - Damping factor (13860) 201
 - Damping factor (13951) 93
 - Damping factor (14004) 82
 - Date/time (0790) 42, 45, 216, 226
 - Day (0788) 43, 45
 - Decimal places 1 (0095) 29
 - Decimal places density (0609) 37
 - Decimal places length (0573) 36
 - Decimal places pressure (0608) 37
 - Decimal places temperature (0614) 37
 - Define access code (0093) 48
 - Deformation factor (13602) 170
 - Density (14724) 60
 - Density 0% (13252) 111
 - Density 100% (13218) 112
 - Density unit (0555) 36
 - Density value (13706) 183
 - Density value (13753) 190
 - Device alarm simulation (0654) 220
 - Device date (14707) 63
 - Device description (14704) 63
 - Device ID (0221) 138
 - Device ID (14702) 62
 - Device message (14703) 63
 - Device name (0013) 224
 - Device name (14722) 53
 - Device reset (0000) 48
 - Device revision (0204) 138
 - Device tag (0011) 222
 - Device tag (0215) 138
 - Device tag (14713) 53
 - Device type (0209) 138
 - Device type (8561) 225
 - Device type (14701) 62
 - Diagnostic code (14739) 66
 - Diagnostic event simulation (0737) 220
 - Diagnostics 1 to 5 (0692-1 to 5) 217
 - Digital input source
 - Digital Xx-x (13907) 97
 - Direct access (0106) 23
 - Discrete 1 to 8 selector (13260-1 to 8) 118
 - Display damping (0094) 32
 - Display interval (0096) 31
 - Distance unit (0551) 35
 - Element interval (14743) 71
 - Element position (14738) 73
 - Element position 0 to 23 (15014) 65
 - Element position 1 to 24 (15014-1 to 24) 206

Element temperature (14737)	73	HyTD mode (14652)	169
Element temperature 0 to 23 (14984)	65	Input value	
Element temperature 1 to 24 (14984-1 to 24)	206	Digital Xx-x (13901)	98
ENP version (0012)	224	Input value (13979)	89
Enter access code (0003)	24	Input value (14015)	79
Error event type (13953)	92	Input value % (13955)	90
Error on event		Input value in mA (13970)	93
Digital Xx-x (13916)	100	Input value percent (13978)	93
Error on event (13967)	88	Input value percent (14002)	79
Error value (13851)	195	Invalid data (13243)	107
Error value (13972)	88	Kind of interval (14744)	71
Expected SIL/WHG chain (13952)	95	L alarm (13859)	199
Extended order code 1 (0023)	224	L alarm value (13853)	198
Failure mode (13988)	87	Language (0104)	27
Feedback threshold (13956)	91	Last diagnostic (14742)	66
Filter options (0705)	218	Level 0% (13214)	109
Firmware CRC (8563)	223	Level 100% (13250)	110
Firmware version (0010)	223	Level mapping (13268)	120
Fixed current (13989)	86	Level source (14601)	143
Float swap mode (13232)	106	Level source (14749)	61
Format display (0098)	28	Line impedance (13266)	121
Gain adjust (14736)	71	Linear expansion coefficient (13655)	176
Gauge current (14027)	82	Liquid temp source (14972)	147
GP 1 name (14963)	164, 211	Liquid temperature (14978)	148, 205
GP 1 to 4 source (14989-1 to 4)	163	LL alarm (13868)	199
GP 1 value 0% (13223)	115	LL alarm value (13852)	198
GP 1 value 100% (13224)	115	LL+L alarm (13869)	200
GP 2 value 0% (13257)	116	Local gravity (14979)	166
GP 2 value 100% (13258)	116	Locking status (0004)	24
GP 3 value 0% (13259)	116	Logging interval (0856)	230
GP 3 value 100% (13226)	117	Lower interface level (15004)	145, 204
GP 4 value 0% (13225)	117	Manual air temperature (14961)	149
GP 4 value 100% (13227)	117	Manual density (15009)	184, 190
GP Value 1 (14966)	164, 211	Manual liquid temperature (15015)	148
GP Value 2 (14967)	164, 211	Manual upper density (14998)	153
GP Value 3 (14968)	164, 212	Manual value (14746)	62
GP Value 4 (14969)	165, 212	Manual vapor temperature (14960)	150
H alarm (13856)	199	Manual water level (14959)	146
H alarm value (13854)	197	Manufacturer ID (0259)	139
Hardware revision (0206)	140	Maximum probe temperature (14011)	80
HART bus (14711)	62	Measured level (14653)	204
HART date code (0202)	140	Measured lower density (15002)	154, 209
HART descriptor (0212)	139	Measured middle density (14997)	154, 209
HART device PV % (14709)	55	Measured upper density (15001)	154, 209
HART device PV mA (14708)	55	Minimum level (13702)	185
HART message (0216)	140	Minimum level (13752)	190
HART revision (0205)	139	Minimum pressure (13703)	185
HART short tag (0220)	137	Minimum pressure (13754)	191
Header (0097)	31	Minimum probe temperature (14010)	80
Header text (0112)	31	Minute (0791)	44, 46
HH alarm (13857)	198	Modbus address (13205)	106
HH alarm value (13855)	197	Modbus discrete 1 to 4 (13240-1 to 4)	104
HH+H alarm (13858)	199	Modbus value 1 to 4 (13206-1 to 4)	104
Hour (0789)	44, 45	Module type (8526)	225
HTG mode (13701)	184	Month (0787)	43, 45
HTMS mode (13751)	189	No. of preambles (0217)	130
Hysteresis (13704)	186	Number format (0099)	30
Hysteresis (13755)	191	Number of devices (13051)	51
HyTD correction value (13603)	169	Observed density (13451)	208

- Observed density (13452) 152
Observed density source (13454) 151
Ohms offset (14026) 77
Old TSM mode (13213) 108
Operating mode
 Digital Xx-x (13911) 97
Operating mode (13958) 84
Operating mode (14014) 76
Operating mode (14745) 53
Operating time (0652) 216
Operating time from restart (0653) 216
Operation mode (14656) 144
Order code (0008) 224
Output at error (14733) 70
Output density (14720) 56
Output level (14718) 57
Output out of range (13971) 88
Output pressure (14719) 56
Output simulation
 Digital X-x (13909) 99
Output temperature (14721) 56
Output value
 Digital Xx-x (13902) 100
Output value (13969) 90
Output vapor temperature (14726) 57
P1 (bottom) (14983) 156, 210
P1 (bottom) manual pressure (14951) 156
P1 (bottom) source (14994) 156
P1 absolute / gauge (14954) 157
P1 offset (14953) 157
P1 position (14952) 157
P1-2 distance (14974) 159
P2 (middle) (14987) 158, 210
P2 (middle) manual pressure (14955) 158
P2 (middle) source (14995) 158
P2 absolute / gauge (14976) 159
P2 offset (14975) 159
P3 (top) (14988) 160, 210
P3 (top) manual pressure (14977) 160
P3 (top) source (14996) 160
P3 absolute / gauge (14958) 161
P3 offset (14957) 161
P3 position (14956) 161
Parity (13204) 106
Percent 0% (13202) 113
Percent 100% (13234) 113
Percent of range (0274) 133
Polling address (14712) 53
Pressure (14723) 59
Pressure 0% (13217) 111
Pressure 100% (13251) 111
Pressure unit (0564) 35
Previous diagnostics (0690) 215
Primary variable (PV) (0201) 132
Probe position (14009) 81
Process value (13963) 92
Process value (14003) 78
Process variable (13964) 91
Process variable (14016) 78
PV mA selector (11631) 132
PV source (11634) 130
Quaternary variable (QV) (0203) 136
Readback value
 Digital Xx-x (13903) 100
Readback value (13957) 90
Reference 0 (14740) 66
Reference 17 (14741) 67
RTD connection type (14022) 77
RTD type (14021) 76
Safety distance (13705) 185
Safety distance (13756) 191
Secondary variable (SV) (0226) 134
Select element (14734) 72
Separator (0101) 30
Serial number (0009) 223
Set date (0792) 42
Simulation value (13976) 221
Software revision (0224) 140
Software version (14747) 63
SP 1 value selector (13274) 125
SP 2 value selector (13275) 125
SP 3 value selector (13276) 126
SP 4 value selector (13277) 126
Starting level (13601) 169
Stilling well (13653) 175
System polling address (0219) 129
System temperature (8553) 226
Tank level (13707) 184
Tank level (14655) 144, 202
Tank Level % (14654) 203
Tank level to NMT (14750) 61
Tank reference height (14603) 144
Tank ullage (14657) 203
Tank ullage % (14658) 203
Temperature (14725) 60
Temperature 0% (13215) 110
Temperature 100% (13216) 110
Temperature element open (14732) 70
Temperature element short (14731) 70
Temperature offset after conversion (14025) 80
Temperature unit (0557) 35
Tertiary variable (TV) (0228) 135
Timestamp (0667) 215
Timestamp (0672) 215
Timestamp (0683) 217
Total no. element (14730) 69
Units preset (0605) 34
Upper density input source (15006) 152
Upper interface level (15003) 144, 203
Used for SIL/WHG
 Digital Xx-x (13910) 101
Used for SIL/WHG (13980) 94
User 0% (13221) 112
User 100% (13222) 112
User value 1 to 8 source (13209-1 to 8) 114, 122
V1 address (13235) 119
V1 address (13236) 120
Value 1 display (0107) 28

Value percent selector (13282) 126
 Vapor density (14981) 152, 208
 Vapor temp source (14973) 149
 Vapor temperature (14727) 60
 Vapor temperature (14985) 150, 205
 W&M lock switch (8558) 226
 Water density (13757) 154, 192
 Water level (14717) 61
 Water level (14970) 145, 204
 Water level source (14971) 145
 Weight and measures configuration CRC (8564) 223
 Word type (13208) 107
 Year (0782) 43, 45
 Zero adjust (14735) 72
 Direct access (Parameter) 23
 Discrete 1 to 8 selector (Parameter) 118
 Discrete selector (Submenu) 118
 Display (Submenu) 27
 Display channel 1 to 4 (Submenu) 232
 Display damping (Parameter) 32
 Display interval (Parameter) 31
 Distance unit (Parameter) 35
 Document
 Function 4
 Document function 4

E

Element interval (Parameter) 71
 Element position (Parameter) 73
 Element position (Submenu) 65, 206
 Element position 0 to 23 (Parameter) 65
 Element position 1 to 24 (Parameter) 206
 Element setup (Submenu) 72
 Element temperature (Parameter) 73
 Element temperature (Submenu) 65, 206
 Element temperature 0 to 23 (Parameter) 65
 Element temperature 1 to 24 (Parameter) 206
 Element values (Submenu) 65
 ENP version (Parameter) 224
 Enter access code (Parameter) 24
 Error event type (Parameter) 92
 Error on event (Parameter) 88, 100
 Error value (Parameter) 88, 195
 Event list (Submenu) 218
 Event logbook (Submenu) 218
 Expected SIL/WHG chain (Parameter) 95
 Expert (Menu) 6, 23
 Extended order code 1 (Parameter) 224

F

Failure mode (Parameter) 87
 Feedback threshold (Parameter) 91
 Filter options (Parameter) 218
 Firmware CRC (Parameter) 223
 Firmware version (Parameter) 223
 Fixed current (Parameter) 86
 Float swap mode (Parameter) 106
 Forget device (Parameter) 74
 Forget device (Wizard) 74

Format display (Parameter) 28

G

Gain adjust (Parameter) 71
 Gauge current (Parameter) 82
 GP 1 name (Parameter) 164, 211
 GP 1 to 4 source (Parameter) 163
 GP 1 value 0% (Parameter) 115
 GP 1 value 100% (Parameter) 115
 GP 2 value 0% (Parameter) 116
 GP 2 value 100% (Parameter) 116
 GP 3 value 0% (Parameter) 116
 GP 3 value 100% (Parameter) 117
 GP 4 value 0% (Parameter) 117
 GP 4 value 100% (Parameter) 117
 GP Value 1 (Parameter) 164, 211
 GP Value 2 (Parameter) 164, 211
 GP Value 3 (Parameter) 164, 212
 GP Value 4 (Parameter) 165, 212
 GP values (Submenu) 115, 163, 211

H

H alarm (Parameter) 199
 H alarm value (Parameter) 197
 Hardware revision (Parameter) 140
 HART bus (Parameter) 62
 HART date code (Parameter) 140
 HART descriptor (Parameter) 139
 HART device information (Submenu) 59
 HART device PV % (Parameter) 55
 HART device PV mA (Parameter) 55
 HART Device(s) (Submenu) 52
 HART devices (Submenu) 51
 HART message (Parameter) 140
 HART output (Submenu) 128
 HART revision (Parameter) 139
 HART short tag (Parameter) 137
 Header (Parameter) 31
 Header text (Parameter) 31
 HH alarm (Parameter) 198
 HH alarm value (Parameter) 197
 HH+H alarm (Parameter) 199
 Hour (Parameter) 44, 45
 HTG (Submenu) 183
 HTG mode (Parameter) 184
 HTMS (Submenu) 189
 HTMS mode (Parameter) 189
 Hysteresis (Parameter) 186, 191
 HyTD (Submenu) 169
 HyTD correction value (Parameter) 169
 HyTD mode (Parameter) 169

I

Information (Submenu) 137
 Input value (Parameter) 79, 89, 98
 Input value % (Parameter) 90
 Input value in mA (Parameter) 93
 Input value percent (Parameter) 79, 93
 Input/output (Submenu) 50

Integer conversion (Submenu) 109
 Invalid data (Parameter) 107

K

Kind of interval (Parameter) 71

L

L alarm (Parameter) 199
 L alarm value (Parameter) 198
 Language (Parameter) 27
 Last diagnostic (Parameter) 66
 Level (Submenu) 143, 202
 Level 0% (Parameter) 109
 Level 100% (Parameter) 110
 Level mapping (Parameter) 120
 Level source (Parameter) 61, 143
 Line impedance (Parameter) 121
 Linear expansion coefficient (Parameter) 176
 Liquid temp source (Parameter) 147
 Liquid temperature (Parameter) 148, 205
 LL alarm (Parameter) 199
 LL alarm value (Parameter) 198
 LL+L alarm (Parameter) 200
 Local gravity (Parameter) 166
 Locking status (Parameter) 24
 Logging interval (Parameter) 230
 Lower interface level (Parameter) 145, 204

M

Manual air temperature (Parameter) 149
 Manual density (Parameter) 184, 190
 Manual liquid temperature (Parameter) 148
 Manual upper density (Parameter) 153
 Manual value (Parameter) 62
 Manual vapor temperature (Parameter) 150
 Manual water level (Parameter) 146
 Manufacturer ID (Parameter) 139
 Maximum probe temperature (Parameter) 80
 Measured level (Parameter) 204
 Measured lower density (Parameter) 154, 209
 Measured middle density (Parameter) 154, 209
 Measured upper density (Parameter) 154, 209
 Menu
 Expert 6, 23
 Minimum level (Parameter) 185, 190
 Minimum pressure (Parameter) 185, 191
 Minimum probe temperature (Parameter) 80
 Minute (Parameter) 44, 46
 Modbus address (Parameter) 106
 Modbus discrete 1 to 4 (Parameter) 104
 Modbus value 1 to 4 (Parameter) 104
 Module type (Parameter) 225
 Month (Parameter) 43, 45

N

NMT device config (Submenu) 68
 NMT element values (Submenu) 206
 No. of preambles (Parameter) 130
 Number format (Parameter) 30
 Number of devices (Parameter) 51

O

Observed density (Parameter) 152, 208
 Observed density source (Parameter) 151
 Ohms offset (Parameter) 77
 Old TSM mode (Parameter) 108
 Operating mode (Parameter) 53, 76, 84, 97
 Operating time (Parameter) 216
 Operating time from restart (Parameter) 216
 Operation mode (Parameter) 144
 Order code (Parameter) 224
 Output at error (Parameter) 70
 Output density (Parameter) 56
 Output level (Parameter) 57
 Output out of range (Parameter) 88
 Output pressure (Parameter) 56
 Output simulation (Parameter) 99
 Output temperature (Parameter) 56
 Output value (Parameter) 90, 100
 Output vapor temperature (Parameter) 57

P

P1 (bottom) (Parameter) 156, 210
 P1 (bottom) manual pressure (Parameter) 156
 P1 (bottom) source (Parameter) 156
 P1 absolute / gauge (Parameter) 157
 P1 offset (Parameter) 157
 P1 position (Parameter) 157
 P1-2 distance (Parameter) 159
 P2 (middle) (Parameter) 158, 210
 P2 (middle) manual pressure (Parameter) 158
 P2 (middle) source (Parameter) 158
 P2 absolute / gauge (Parameter) 159
 P2 offset (Parameter) 159
 P3 (top) (Parameter) 160, 210
 P3 (top) manual pressure (Parameter) 160
 P3 (top) source (Parameter) 160
 P3 absolute / gauge (Parameter) 161
 P3 offset (Parameter) 161
 P3 position (Parameter) 161
 Parity (Parameter) 106
 Percent 0% (Parameter) 113
 Percent 100% (Parameter) 113
 Percent of range (Parameter) 133
 Polling address (Parameter) 53
 Pressure (Parameter) 59
 Pressure (Submenu) 155, 210
 Pressure 0% (Parameter) 111
 Pressure 100% (Parameter) 111
 Pressure unit (Parameter) 35
 Previous diagnostics (Parameter) 215
 Primary variable (PV) (Parameter) 132
 Probe position (Parameter) 81
 Process value (Parameter) 78, 92
 Process variable (Parameter) 78, 91
 PV mA selector (Parameter) 132
 PV source (Parameter) 130

Q

Quaternary variable (QV) (Parameter) 136

R

Readback value (Parameter)	90, 100
Reference 0 (Parameter)	66
Reference 17 (Parameter)	67
RTD connection type (Parameter)	77
RTD type (Parameter)	76

S

Safety distance (Parameter)	185, 191
Secondary variable (SV) (Parameter)	134
Select element (Parameter)	72
Separator (Parameter)	30
Serial number (Parameter)	223
Set date (Parameter)	42, 46
Set date (Wizard)	45
Simulation (Submenu)	220
Simulation value (Parameter)	221
Software revision (Parameter)	140
Software version (Parameter)	63
SP 1 value selector (Parameter)	125
SP 2 value selector (Parameter)	125
SP 3 value selector (Parameter)	126
SP 4 value selector (Parameter)	126
Starting level (Parameter)	169
Stilling well (Parameter)	175

Submenu

Administration	47, 48
Alarm	193
Analog I/O	83
Analog IP	75
Application	142
Board info	226
Communication	102
Configuration	105, 119, 129
CTSh	174
Data logging	228, 229
Date / time	41, 42
Density	151, 208
Device information	222
Diagnostic list	217
Diagnostics	66, 213
Digital Xx-x	96
Discrete selector	118
Display	27
Display channel 1 to 4	232
Element position	65, 206
Element setup	72
Element temperature	65, 206
Element values	65
Event list	218
Event logbook	218
GP values	115, 163, 211
HART device information	59
HART Device(s)	52
HART devices	51
HART output	128
HTG	183
HTMS	189
HyTD	169

Information	137
Input/output	50
Integer conversion	109
Level	143, 202
NMT device config	68
NMT element values	206
Pressure	155, 210
Simulation	220
System	26
System units	34
Tank calculation	166
Tank configuration	142
Tank values	202
Temperature	147, 205
User value source	114
V1 input selector	122
System (Submenu)	26
System polling address (Parameter)	129
System temperature (Parameter)	226
System units (Submenu)	34

T

Tank calculation (Submenu)	166
Tank configuration (Submenu)	142
Tank level (Parameter)	144, 184, 202
Tank Level % (Parameter)	203
Tank level to NMT (Parameter)	61
Tank reference height (Parameter)	144
Tank ullage (Parameter)	203
Tank ullage % (Parameter)	203
Tank values (Submenu)	202
Temperature (Parameter)	60
Temperature (Submenu)	147, 205
Temperature 0% (Parameter)	110
Temperature 100% (Parameter)	110
Temperature element open (Parameter)	70
Temperature element short (Parameter)	70
Temperature offset after conversion (Parameter)	80
Temperature unit (Parameter)	35
Tertiary variable (TV) (Parameter)	135
Timestamp (Parameter)	215, 217
Total no. element (Parameter)	69

U

Units preset (Parameter)	34
Upper density input source (Parameter)	152
Upper interface level (Parameter)	144, 203
Used for SIL/WHG (Parameter)	94, 101
User 0% (Parameter)	112
User 100% (Parameter)	112
User value 1 to 8 source (Parameter)	114, 122
User value source (Submenu)	114

V

V1 address (Parameter)	119, 120
V1 input selector (Submenu)	122
Value 1 display (Parameter)	28
Value percent selector (Parameter)	126
Vapor density (Parameter)	152, 208

Vapor temp source (Parameter) 149
Vapor temperature (Parameter) 60, 150, 205

W

W&M lock switch (Parameter) 226
Water density (Parameter) 154, 192
Water level (Parameter) 61, 145, 204
Water level source (Parameter) 145
Weight and measures configuration CRC (Parameter)
. 223
Wizard
 Define access code 49
 Forget device 74
 Set date 45
Word type (Parameter) 107

Y

Year (Parameter) 43, 45

Z

Zero adjust (Parameter) 72



71320463

www.addresses.endress.com
