



Level



Pressure



Flow



Temperature



Liquid  
Analysis



Registration



Systems  
Components



Services



Solutions

## Operating Instructions

# Prosonic S FMU90

Level Measurement

Alternating Pump Control

Rake Control

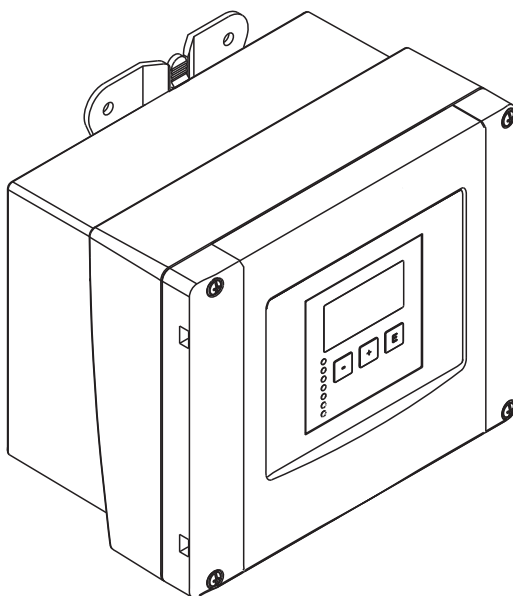
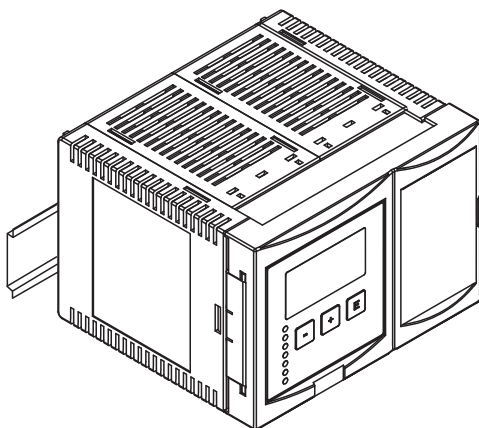

BA00288F/00/EN/13.12  
71164411

Valid as of software version  
02.01.00



## Table of Contents

<b>1</b>	<b>Safety Instructions</b>	<b>5</b>	6.5	Envelope curve display	69
1.1	Designated use	5	6.6	After the basic setup	70
1.2	Installation, commissioning, operation	5	<b>7</b>	<b>The "display" menu</b>	<b>71</b>
1.3	Operational safety and process safety	5	7.1	"display"	71
1.4	Notes on safety conventions and symbols	6	7.2	"display format"	72
<b>2</b>	<b>Identification</b>	<b>7</b>	7.3	"back to home"	73
2.1	Parts of the Prosonic S FMU90	7	<b>8</b>	<b>The "Relay/Controls" menu</b>	<b>74</b>
2.2	Nameplate (Example)	8	8.1	Configuration of a limit relay	74
2.3	Product structure	9	8.2	Configuration of an alarm or diagnostic relay	79
2.4	Scope of delivery	10	8.3	Configuration of a pump control – standard	81
2.5	Certificates and approvals	10	8.4	Configuration of a pump control – enhanced	96
2.6	Registered trademarks	10	8.5	Configuration of a rake control	121
<b>3</b>	<b>Installation</b>	<b>11</b>	<b>9</b>	<b>The "output/calculations" menu</b>	<b>127</b>
3.1	Incoming acceptance, transport, storage	11	9.1	The "allocation/calculations" submenu	128
3.2	Mounting the field housing	11	9.2	The "extended calibration" submenu	129
3.3	Mounting the DIN-rail housing	13	9.3	"HART settings" submenu (only for current output 1)	131
3.4	Mounting the remote display and operating module	16	9.4	"Simulation" submenu	133
3.5	Mounting of the sensors	17	<b>10</b>	<b>Troubleshooting</b>	<b>134</b>
3.6	Installation check	17	10.1	System error messages	134
<b>4</b>	<b>Wiring</b>	<b>18</b>	10.2	Possible calibration errors	138
4.1	Terminal compartment	18	10.3	Envelope curve display	139
4.2	Terminal assignment	20	10.4	Software history	142
4.3	Sensor connection	23	<b>11</b>	<b>Maintenance</b>	<b>143</b>
4.4	Connection of the sensor heater (for FDU90/FDU91)	25	11.1	Exterior cleaning	143
4.5	Connection of external switches (for FMU90-*****B***)	27	11.2	Repairs	143
4.6	Connection of a temperature sensor	27	11.3	Repairs to Ex-approved devices	143
4.7	Shortening the sensor cable	29	11.4	Replacement	143
4.8	Synchronization line	30	11.5	Replacing a sensor	143
4.9	Connection of the separate display and operating module	31	11.6	Spare Parts	144
4.10	Potential equalization	32	11.7	Return	145
4.11	Post-connection check	33	11.8	Disposal	145
<b>5</b>	<b>Operation</b>	<b>34</b>	11.9	Contact addresses of Endress+Hauser	145
5.1	Operating options	34	<b>12</b>	<b>Accessories</b>	<b>146</b>
5.2	Operation via the display and operating module	34	12.1	Commubox FXA195 HART	146
5.3	Operation via Endress+Hauser operating tool "FieldCare"	47	12.2	Commubox FXA291	146
5.4	Operation via Field Xpert SFX100	47	12.3	Protection cover for the field housing	146
5.5	Lock/unlock configuration	47	12.4	Mounting plate for the field housing	146
5.6	Reset to the default configuration	49	12.5	Mounting bracket	147
<b>6</b>	<b>Commissioning</b>	<b>50</b>	12.6	Adaption plate for remote display	148
6.1	Structure and Functions of the Prosonic S	50	12.7	Overvoltage protection (in IP66 housing)	148
6.2	First setup	52	12.8	Overvoltage protection HAW562	149
6.3	Preparing the basic setup	53	12.9	Extension cable for sensors	151
6.4	Basic setup	54	12.10	Temperature sensor FMT131	152

<b>13</b>	<b>Technical Data</b>	<b>153</b>
13.1	Technical data at a glance	153
<b>14</b>	<b>Operating menu</b>	<b>158</b>
14.1	"level"	158
14.2	"safety settings"	160
14.3	"relay/controls"	162
14.4	"output/calculations"	170
14.5	"device properties"	171
14.6	"system information"	172
14.7	"display"	174
14.8	"sensor management"	174
<b>15</b>	<b>Appendix</b>	<b>175</b>
15.1	Default block configuration	175
	<b>Index</b>	<b>178</b>

# 1 Safety Instructions

## 1.1 Designated use

The Prosonic S FMU90 is a transmitter for the ultrasonic sensors FDU90, FDU91, FDU91F, FDU92, FDU93, FDU95 and FDU96. The sensors of the class FDU8x can be connected as well.

The transmitter version for level measurements (→  9, "Product structure": FMU90 - \*1\*\*\*\*\*\*) can be applied for different measuring tasks, e.g.:

- level measurement in tanks and silos
- conveyor belt measurement
- level limit detection
- (alternating) pump control, screen and rake control

The version for level and flow measurements (→  9, "Product structure": FMU90 - \*2\*\*\*\*\*\*) is usable for further measuring tasks, e.g.:

- Flow measurement at open flumes and weirs
- (non-resettable) totalizers and (resettable) counters
- Control of samplers by time or counting pulses
- Backwater and dirt detection in flumes
- Simultaneous measurement of level and flow in a stormwater overflow basin with only one sensor

## 1.2 Installation, commissioning, operation

The Prosonic S FMU90 is fail-safe and constructed to the state-of-the-art. It meets the appropriate standards and EC directives. However, if you use it improperly or other than for its designated use, it may pose application-specific hazards, e.g. product overflow due to incorrect installation or configuration. Installation, electrical connection, start-up, operation and maintenance of the measuring device must therefore be carried out exclusively by trained specialists authorised by the system operator. Technical personnel must have read and understood these operating instructions and must adhere to them. You may only undertake modifications or repair work to the device when it is expressly permitted by the operating instructions.

## 1.3 Operational safety and process safety

Alternative monitoring measures must be taken to ensure operational safety and process safety during configuration, testing and maintenance work on the device.

### Hazardous areas

Measuring systems for use in hazardous environments are accompanied by separate "Ex documentation", which is an integral part of this Operating Manual. Strict compliance with the installation instructions and ratings as stated in this Additional documentation is mandatory.

- Ensure that all personnel are suitably qualified.
- Observe the specifications in the certificate as well as national and local regulations.

The transmitter may only be installed in suitable areas.

Sensors with a certificate for hazardous areas may be connected to a transmitter without a certificate.



Warning!

The sensors FDU83, FDU84, FDU85 and FDU86 with an ATEX, FM or CSA certificate are not certified for connection to the FMU90 transmitter.

For installations in the USA:













Installation should be in accordance with the National Electrical Code NFPA 70 (NEC)

For installations in Canada:

Installation should be in accordance with the Canadian Electrical Code (CEC)

## 1.4 Notes on safety conventions and symbols

In order to highlight safety-relevant or alternative operating procedures in the manual, the following conventions have been used, each indicated by a corresponding symbol in the margin.

Safety conventions	
	<p><b>Warning!</b> A warning highlights actions or procedures which, if not performed correctly, will lead to personal injury, a safety hazard or destruction of the instrument</p>
	<p><b>Caution!</b> Caution highlights actions or procedures which, if not performed correctly, may lead to personal injury or incorrect functioning of the instrument</p>
	<p><b>Note!</b> A note highlights actions or procedures which, if not performed correctly, may indirectly affect operation or may lead to an instrument response which is not planned</p>
Explosion protection	
	<p><b>Device certified for use in explosion hazardous area</b> If the device has this symbol embossed on its name plate it can be installed in an explosion hazardous area</p>
	<p><b>Explosion hazardous area</b> Symbol used in drawings to indicate explosion hazardous areas. Devices located in and wiring entering areas with the designation “explosion hazardous areas” must conform with the stated type of protection.</p>
	<p><b>Safe area (non-explosion hazardous area)</b> Symbol used in drawings to indicate, if necessary, non-explosion hazardous areas. Devices located in safe areas still require a certificate if their outputs run into explosion hazardous areas</p>
Electrical symbols	
	<p><b>Direct voltage</b> A terminal to which or from which a direct current or voltage may be applied or supplied</p>
	<p><b>Alternating voltage</b> A terminal to which or from which an alternating (sine-wave) current or voltage may be applied or supplied</p>
	<p><b>Grounded terminal</b> A grounded terminal, which as far as the operator is concerned, is already grounded by means of an earth grounding system</p>
	<p><b>Protective grounding (earth) terminal</b> A terminal which must be connected to earth ground prior to making any other connection to the equipment</p>
	<p><b>Equipotential connection (earth bonding)</b> A connection made to the plant grounding system which may be of type e.g. neutral star or equipotential line according to national or company practice</p>
	<p><b>Temperature resistance of the connection cables</b> States, that the connection cables must be resistant to a temperature of at least 85 °C (185 °F).</p>

## 2 Identification

### 2.1 Parts of the Prosonic S FMU90

#### 2.1.1 FMU90 in the field housing

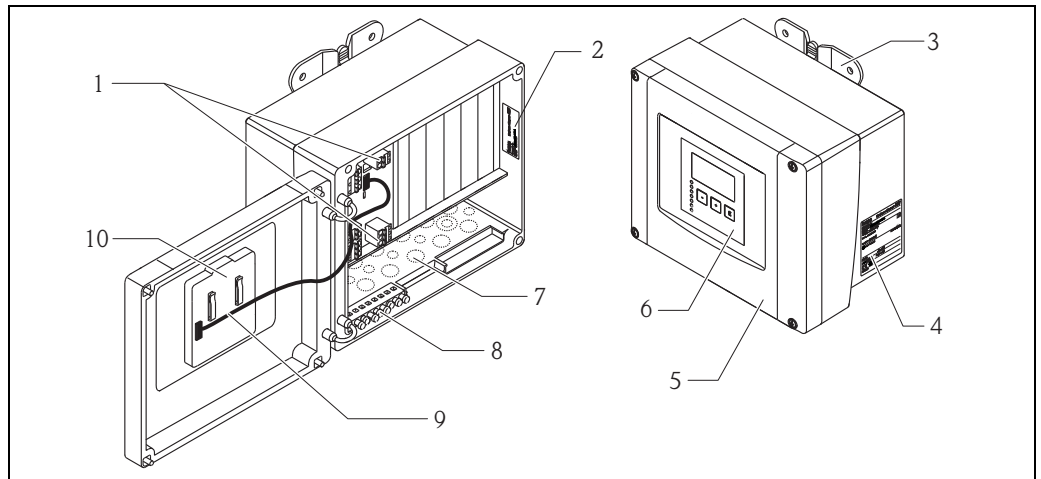

L00-FMU90xxx-03-00-00-xx-001

- |   |   |    |                                       |
|---|---|----|---------------------------------------|
| 1 | Terminals                                 | 6  | Display and operating module          |
| 2 | Instrument designation and identification | 7  | Prestamped openings for cable entries |
| 3 | Mounting help                             | 8  | Grounding terminals                   |
| 4 | Nameplate                                 | 9  | Display cable                         |
| 5 | Cover of the terminal compartment         | 10 | Short instructions                    |

#### 2.1.2 FMU90 in the DIN-rail housing

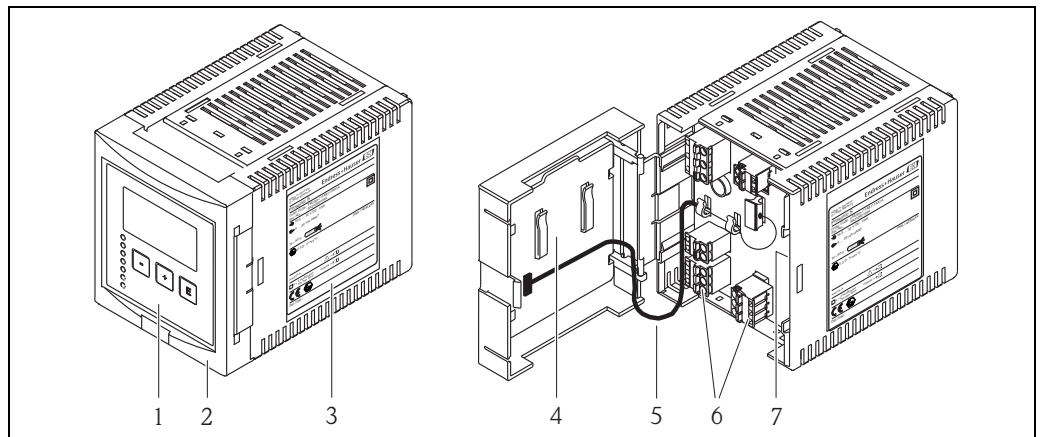

L00-FMU90xxx-03-00-00-xx-002

- |   |                                   |   |   |
|---|-----------------------------------|---|---|
| 1 | Display and operating module      | 5 | Display cable                             |
| 2 | Cover of the terminal compartment | 6 | Terminals                                 |
| 3 | Nameplate                         | 7 | Instrument designation and identification |
| 4 | Short instructions                |   |   |



**Note!**

The picture shows the smallest possible version of the DIN-rail housing. Depending on the version of the Prosonic S, the width of the housing may be larger.

### 2.1.3 FMU90 with remote display and operating module for cabinet door and switchboard mounting (96 x 96 mm (3.78 x 3.78 in))

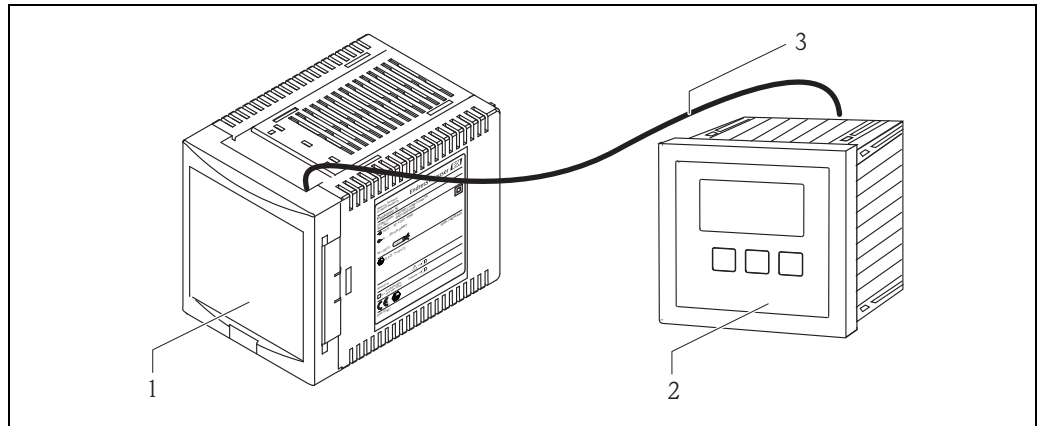

- 1 DIN-rail housing without display
- 2 Remote display and operating module for cabinet mounting
- 3 The cable (3 m (9.8 ft)) is supplied



Note!  
The picture shows the smallest possible version of the DIN-rail housing. Depending on the version of the Prosonic S, the width of the housing may be larger.

## 2.2 Nameplate (Example)

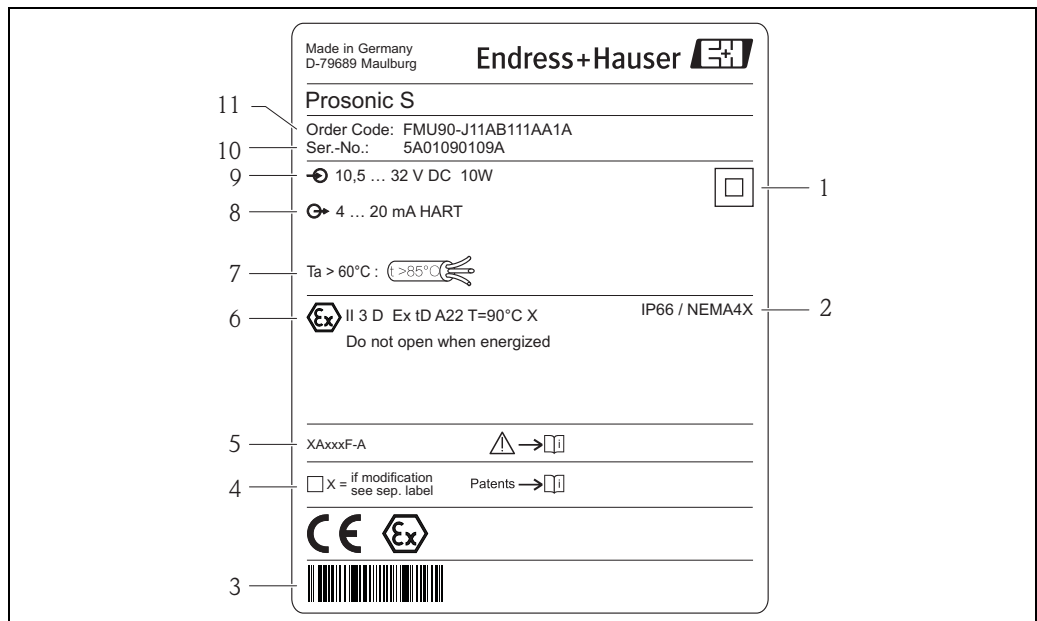

- 1 Specification of the electrical protection class (protective insulation)
- 2 Ingress protection
- 3 Barcode
- 4 Marked if a modification nameplate is present
- 5 Reference to additional safety-relevant documentation
- 6 Certificate-related data
- 7 Specification of required temperature resistance of the connection cables
- 8 Output signal
- 9 Power supply
- 10 Serial number
- 11 Order code (as defined by the product structure)



## 2.3 Product structure

<b>010</b>	<b>Approval</b>	
	R	Non-hazardous area
	J	ATEX II 3D
	N	CSA General Purpose
<b>020</b>	<b>Application</b>	
	1	Level + pump control, alternating
	2	Flow + totalizer + level + sample control + preprogrammed OCM flow curves
	3	Level + additional pump control
	4	Universal instrument (Level + Flow + Additional pump control)
<b>030</b>	<b>Housing, material</b>	
	1	Field mounting PC, IP66 NEMA 4x
	2	DIN rail mounting PBT, IP20
<b>040</b>	<b>Operation</b>	
	C	Illuminated display + keypad
	E	Illuminated display + keypad, 96x96, panel mounting, front IP65
	K	w/o display, via communication
<b>050</b>	<b>Power supply</b>	
	A	90-253 VAC
	B	10.5-32 VDC
<b>060</b>	<b>Level input</b>	
	1	1x sensor FDU9x/8x
	2	2x sensor FDU9x/8x
<b>070</b>	<b>Switch output</b>	
	1	1x relay, SPDT
	3	3x relay, SPDT
	6	6x relay, SPDT
<b>080</b>	<b>Output</b>	
	1	1x 0/4-20mA HART
	2	2x 0/4-20mA HART
	3	PROFIBUS DP
<b>090</b>	<b>Additional input</b>	
	A	w/o additional input
	B	4x limit switch + 1x temperature PT100/FMT131
<b>100</b>	<b>Datalog function</b>	
	A	Basic version
<b>110</b>	<b>Languages</b>	
	1	de, en, nl, fr, es, it, pt
	2	de, en, ru, pl, cs
	3	en, zh, ja, ko, th, id
<b>120</b>	<b>Additional option</b>	
	A	Basic version
	L	5-point linearity protocol only to order with FDU9x sensor + 5-point linearity protocol
<b>995</b>	<b>Marking</b>	
	1	Tagging (TAG)
	2	Bus address
FMU90 -		complete product designation

(\*): meaning of the language code:

cs: Czech; de: German; en: English; es: Spanish; fr: French; id: Bahasa (Indonesia, Malaysia); it: Italian; ja: Japanese; ko: Korean; nl: Dutch; pl: Polish; pt: Portuguese; ru: Russian; th: Thai; zh: Chinese

## 2.4 Scope of delivery

- Instrument according to the version ordered
- Endress+Hauser operating program on the enclosed CD-ROM
- For FMU90-\*\*\*E\*\*\*\*\*: remote display and operating module; retainers; connection cable (3 m (9.8 ft))
- For FMU90-\*21\*\*\*\*\* FMU and for FMU90-\*41\*\*\*\*\*: 2 slotted capstan screws (can be used to seal the housing)
- Accessories → 146
- Approval documentation: if this is not included in the operating manual (Refer to the nameplate for the names of the safety instructions that apply to your device version.)
- CD-ROM with further documentation, e.g.
  - Technical Information
  - Operating Instructions
  - Description of Instrument Functions
  - Slot/Index tables
- Brief operating instructions for quick commissioning, see the following table:

Brief operating instructions	Output	Application	Instrument version
KA01065F	HART	<ul style="list-style-type: none"> <li>■ Level measurement</li> <li>■ Alternating pump control</li> <li>■ Screen and rake control</li> </ul>	FMU90 - *****1**** FMU90 - *****2****
KA01066F		<ul style="list-style-type: none"> <li>■ Flow measurement</li> <li>■ Backwater and dirt detection</li> <li>■ Totalizers and counters</li> </ul>	FMU90 - *2*****1**** FMU90 - *4*****1**** FMU90 - *2*****2**** FMU90 - *4*****2****
KA01067F	PROFIBUS DP	<ul style="list-style-type: none"> <li>■ Level measurement</li> <li>■ Alternating pump control</li> <li>■ Screen and rake control</li> </ul>	FMU90 - *****3****
KA01068F		<ul style="list-style-type: none"> <li>■ Flow measurement</li> <li>■ Backwater and dirt detection</li> <li>■ Totalizers and counters</li> </ul>	FMU90 - *2*****3**** FMU90 - *4*****3****

## 2.5 Certificates and approvals

### CE mark, declaration of conformity

The device is designed to meet state-of-the-art safety requirements, has been tested and left the factory in a condition in which it is safe to operate. The device complies with the applicable standards and regulations as listed in the EC declaration of conformity and thus complies with the statutory requirements of the EC directives. Endress+Hauser confirms the successful testing of the device by affixing to it the CE mark.

## 2.6 Registered trademarks

HART®

Registered trademark of HART Communication Foundation, Austin, USA

ToF®

Registered trademark of the company Endress+Hauser GmbH+Co. KG, Maulburg, Germany

FieldCare®

Trademark of Endress+Hauser Process Solutions AG

## 3 Installation

### 3.1 Incoming acceptance, transport, storage

#### 3.1.1 Incoming acceptance

Check the packing and contents for any signs of damage.

Check the shipment, make sure nothing is missing and that the scope of supply matches your order.

#### 3.1.2 Transport, storage

Pack the measuring instrument so that it is protected against impacts for storage and transport. The original packing material provides the optimum protection for this.

Permissible storage temperature: -40 to +60 °C (-40 to +140 °F)

### 3.2 Mounting the field housing

#### 3.2.1 Dimensions of the field housing

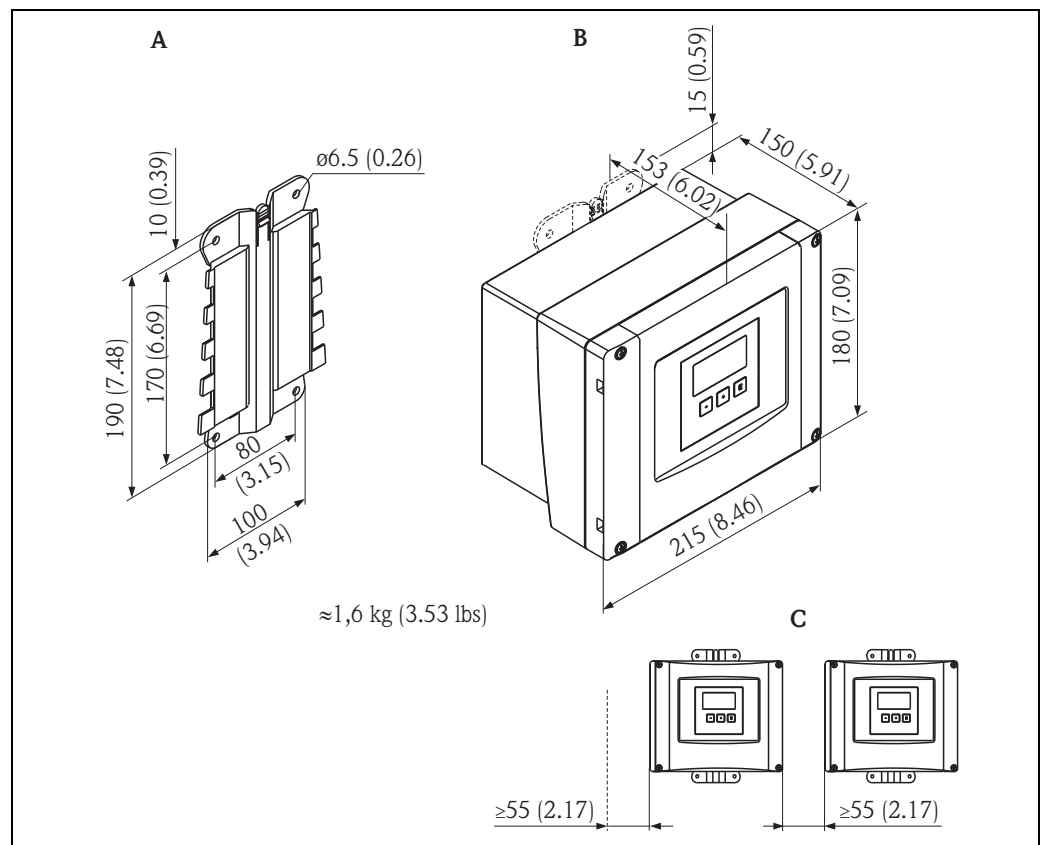

Dimensions in mm (in)

**A** Mounting help (supplied); can also be used as drilling template

**B** Field housing

**C** Minimum mounting distance

The dimensions of the field housing are the same for all instrument versions.

To open the housing, a minimum mounting distance of 55 mm (2.17 in) is required on the left.

### 3.2.2 Installation conditions

#### Weather protection

In order to avoid excessive sunlight exposure, the instrument should be mounted in a position which is protected against direct sunlight or a protection cover should be applied (→ 146, "Accessories").

#### Overvoltage protection

In order to protect the Prosonic against overvoltages (especially if mounted outdoors), connection of an overvoltage protection is recommended (→ 146, "Accessories").

#### Wall mounting

A mounting help for wall mounting is supplied. It also serves as drilling template. The mounting help should be mounted on a flat surface and may not become distorted.

#### Pipe mounting

A mounting plate is available for mounting of the field housing to 1" to 2" pipes (→ 146, "Accessories").

### 3.2.3 Installation

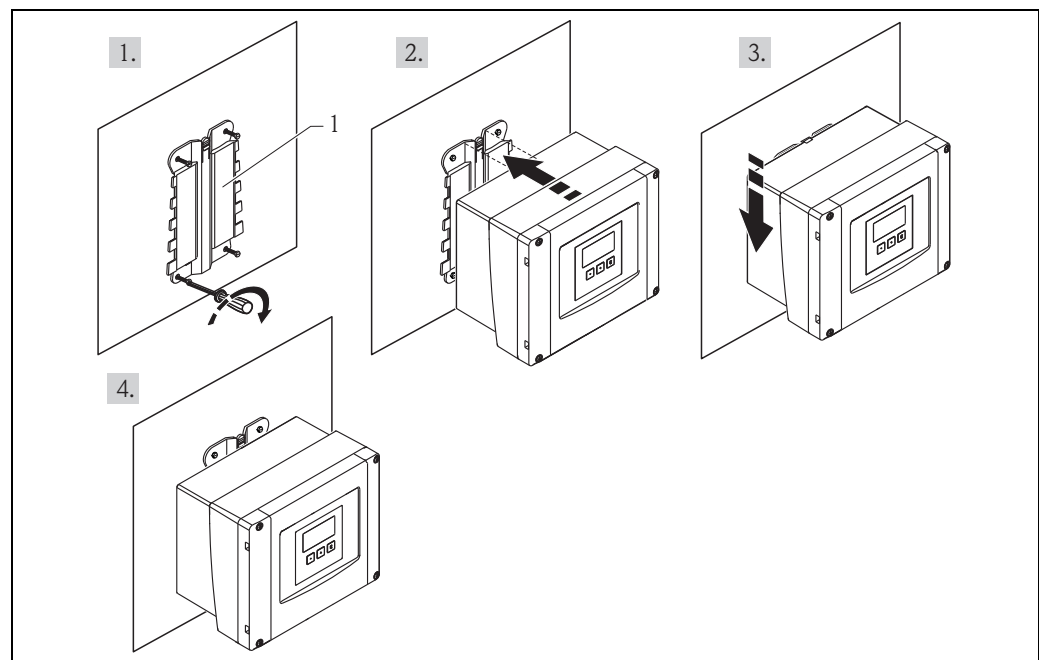

1 Wall mounting with mounting help

### 3.3 Mounting the DIN-rail housing

#### 3.3.1 Dimensions of the DIN-rail housing

The dimensions of the DIN-rail housing depend on the instrument version. The version determines, which terminal areas the Prosonic S contains. The dimensions are influenced by the following features of the product structure (→ 9, "Product structure"):

- 60: Level Input
- 70: Switch Output
- 80: Output

In order to determine the dimensions of a specific version, perform the following steps (see the example → 14):

1. Using the product structure, determine the options of the features 60, 70 and 80 of the instrument version in question.

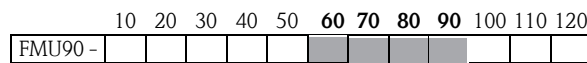

2. Using the following table, determine how many optional terminal areas this instrument version contains.

Feature and option of the product structure	corresponds to the following terminal area	present? yes = 1 no = 0
feature 60; option 2 and/or feature 80, option 2	2 sensor inputs and/or 2 analogue outputs	
feature 70, option 3 or 6	3 or 6 relays	
feature 80, option 3	PROFIBUS DP interface	
feature 90, option B	inputs for external switches and external temperature sensor	
Sum =		

3. The appropriate dimensions are given in the following diagram:

**Sum = 0**  
**(only basic terminal area)**

**Sum = 1, 2 or 3**  
**(1-3 optional terminal areas)**

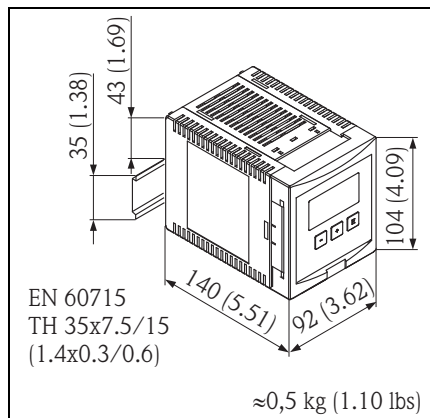

Dimensions in mm

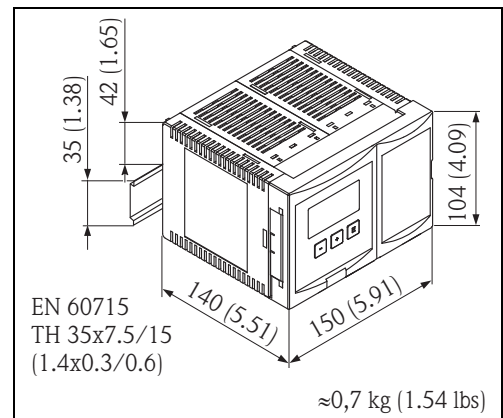

Dimensions in mm

**Sum = 4**  
**(4 optional terminal areas)**

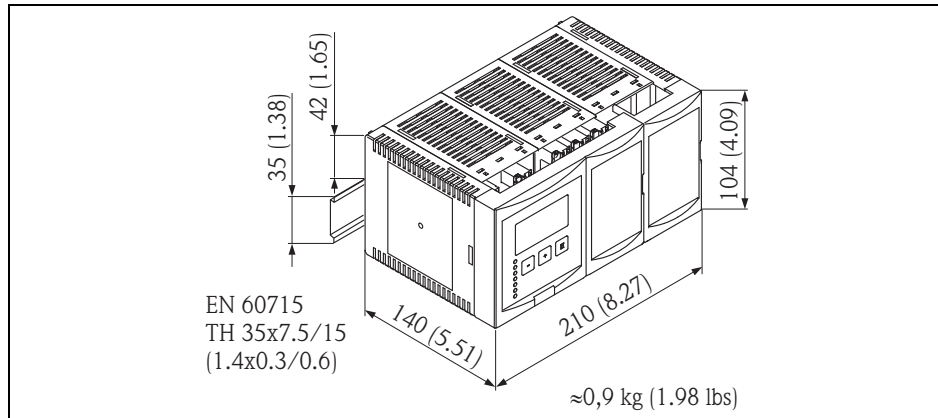

L00-FMU90xxx-06-00-00-xx-009

Dimensions in mm

**Example**

		10	20	30	40	50	60	70	80	90	100	110	120
FMU90 -	R	1	2	A	A	2	3	2	A	A	1	A	

feature and option of the product structure	corresponds to the following terminal area	present?
feature 60; option 2 and/or feature 80, option 2	2 sensor inputs and/or 2 analogue outputs	1 (yes)
feature 70, option 3 or 6	3 or 6 relays	1 (yes)
feature 80, option 3	PROFIBUS DP interface	0 (no)
feature 90, option B	inputs for external switches and external temperature sensor	0 (no)
Sum =		2

Sum = 2  
 => 104 x 150 x 140 mm (4.09 x 5.91 x 5.51 in)

### 3.3.2 Installation conditions

- The DIN-rail housing must be mounted outside hazardous areas in a cabinet.
- The housing is mounted on a DIN rail EN 60715 TH 35x7.5 or TH 37x15.
- Do not install the instrument in the vicinity of high-voltage lines, motor lines, contactors or frequency converters. The installation regulations for high-voltage lines, motor lines, contactors or frequency converters must be observed.
- To ensure easy mounting and opening of the housing, a distance of approx. 10 mm (0.39 in) should be kept between the instruments.
- In order to avoid interference signals, the sensor cables must not be laid parallel to high voltage or electric power lines.
- The cables may not be laid in the proximity to frequency converters.

### 3.3.3 Mounting

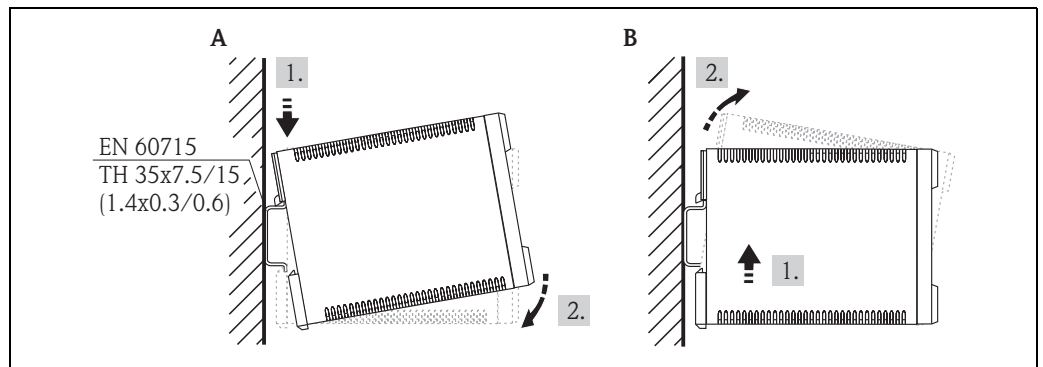

- A** Attaching the instrument to the rail  
**B** Detaching the instrument from the rail

L00-FMU90xxx-17-00-00-xx-001

### 3.4 Mounting the remote display and operating module

#### 3.4.1 Scope of delivery

If the Prosonic S is ordered with the display for cabinet door mounting, the following is contained in the scope of delivery:

- Display and operating module, 96 x 96 mm (3.78 x 3.78 in)
- 4 retainers (with nuts and screws)
- Connection cable (3 m (9.8 ft) ) for connection to the transmitter (preassembled with suitable plugs).

#### 3.4.2 Dimensions of the separate display and operating module

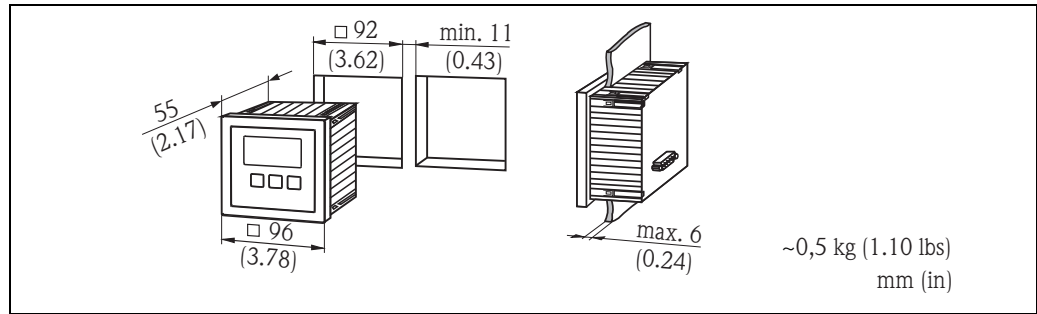

L00-FMU90xxx-06-00-00-xx-004

#### 3.4.3 Mounting

- Cut an opening of 92 x 92 mm (3.62 x 3.62 in) into the intended mounting position (e.g. cabinet door).
- Insert the remote display module into the opening and fix the retainers as shown in the following figure:

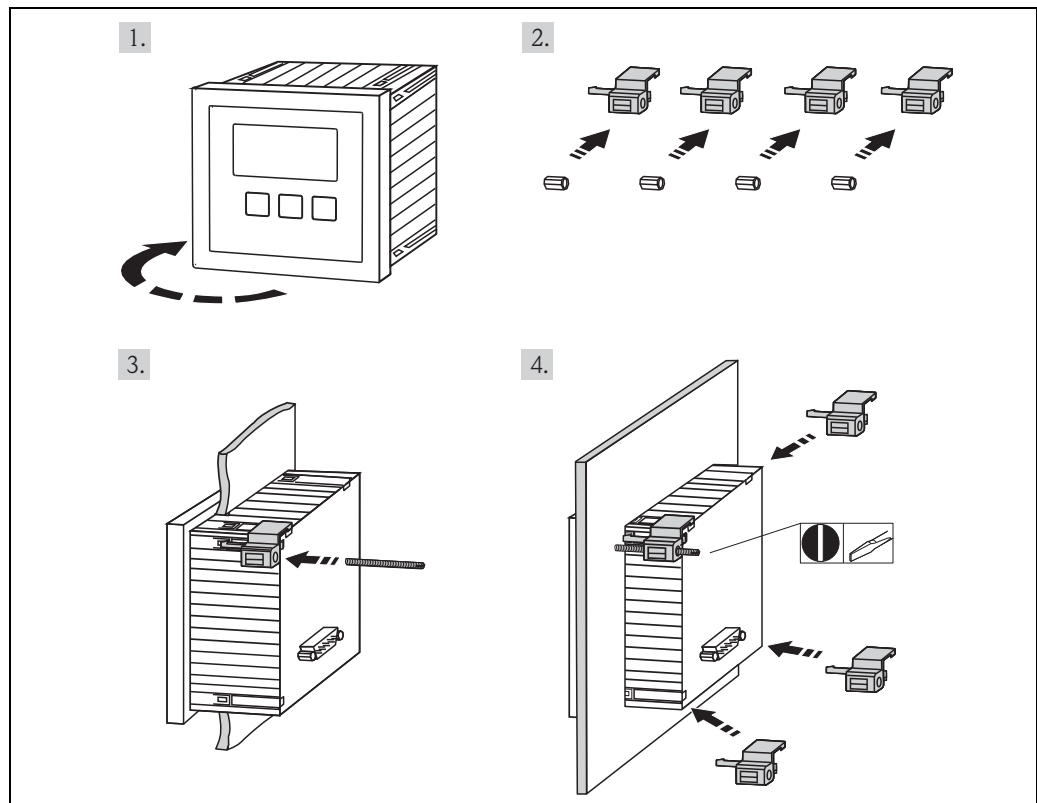

L00-FMU90xxx-17-00-00-xx-002



### 3.4.4 Adaption plate

If an opening of 138 x 138 mm (5.43 x 5.43 in) and the remote display of the Prosonic FMU860/861/862 are already present, you can use the adaption plate (Order Code: 52027441 → [146](#), "Accessories"). It is inserted into the remote display of the FMU860/861/862.



Note!

The adapter plate is mounted directly in the housing of the old remote display of the FMU86x series. The housing of the remote display of the FMU86x is the holder for the adapter plate and the new remote display of the FMU90/FMU95 in the format 96 x 96 mm (3.78 x 3.78 in).

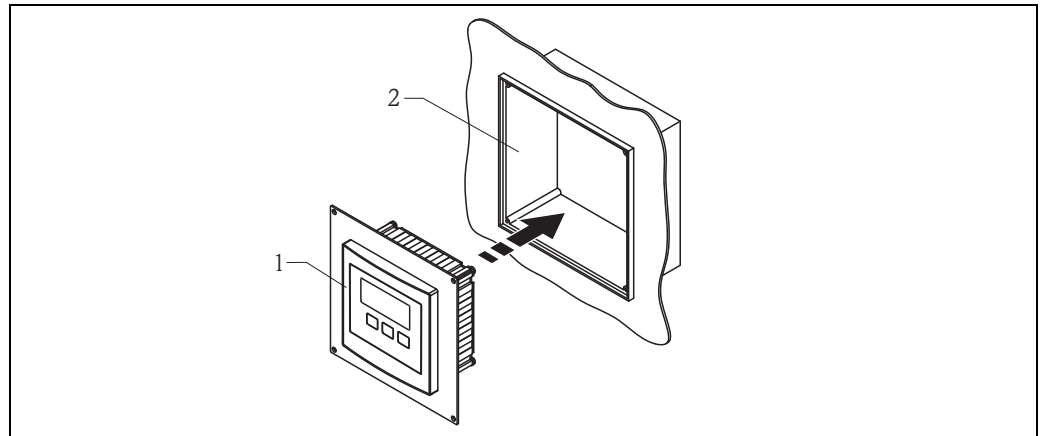

L00-FMU90xxx-06-00-00-xx-006

1 Remote display of the FMU90 with adaption plate

2 Opening of the remote display of the FMU860/861/862

### 3.5 Mounting of the sensors

Information on the mounting of the sensors can be found in the following documents:

- Technical Information TI00189F/00 (for FDU8x)
- Technical Information TI00396F/00 (for FDU9x)

These documents are supplied with the sensors.

### 3.6 Installation check

After installing the device, carry out the following checks:

- Is the device damaged (visual inspection)?
- Does the device correspond to the measuring point specifications such as process temperature, process pressure, ambient temperature, measuring range etc?
- If available: Are the measuring point number and labelling correct?
- Is the instrument sufficiently protected against rainfall and direct sunlight?
- For the field housing: Are the cable glands tightened correctly?
- Is the instrument securely mounted to the DIN rail or the mounting help (visual inspection)?
- For the field housing: Are the screws of the terminal compartment cover securely tightened (visual inspection)?

## 4 Wiring



Warning!

The instrument may only be installed if the supply voltage is switched off.

### 4.1 Terminal compartment

#### 4.1.1 Terminal compartment of the field housing

The field housing has a separate terminal compartment. It can be opened after loosening the four screws of the lid.

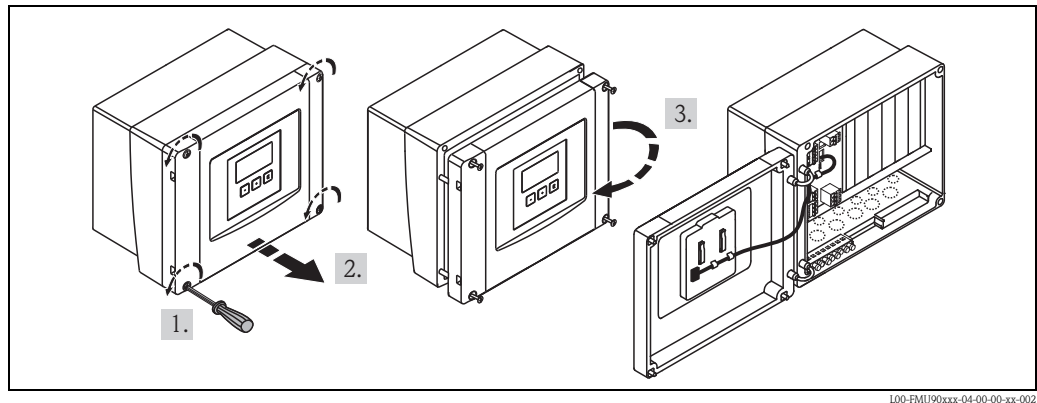

L00-FMU90xxx-04-00-00-xx-002

For easier wiring, the lid can be completely removed by unplugging the display plug and loosening the hinges:

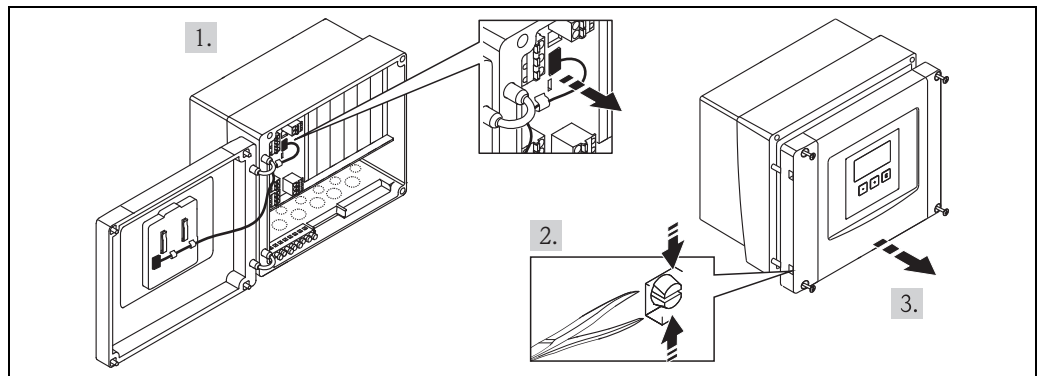

L00-FMU90KAx-04-00-00-xx-009

#### 4.1.2 Cable entries of the field housing

The following openings for cable entries are prestamped on the bottom of the housing :

- M20x1.5 (10 openings)
- M16x1.5 (5 openings)
- M25x1.5 (1 opening)

The required number and types of cable entries depend on the application at hand.

The prestamped openings can be removed by a suitable tool (e.g. knife or boring bit) or by punching them out cautiously.

### 4.1.3 Terminal compartment of the DIN-rail housing

#### Single instrument

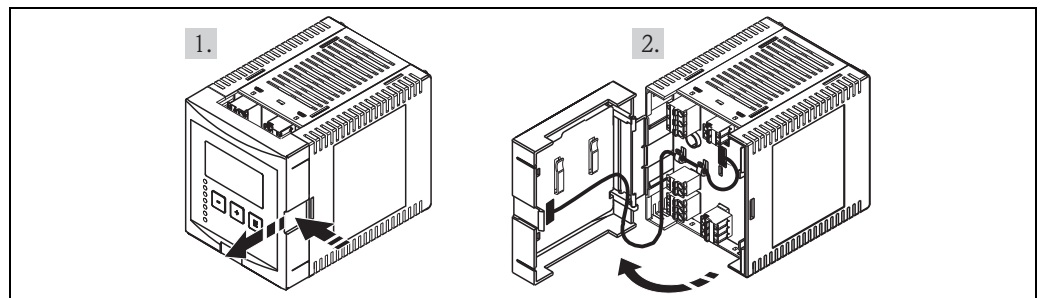

L00-FMU90xxx-04-00-00-xx-003

The catch can be unlocked by slightly pressing onto the clip. Then, the cover of the terminal compartment can be opened.

#### Several instruments mounted side by side

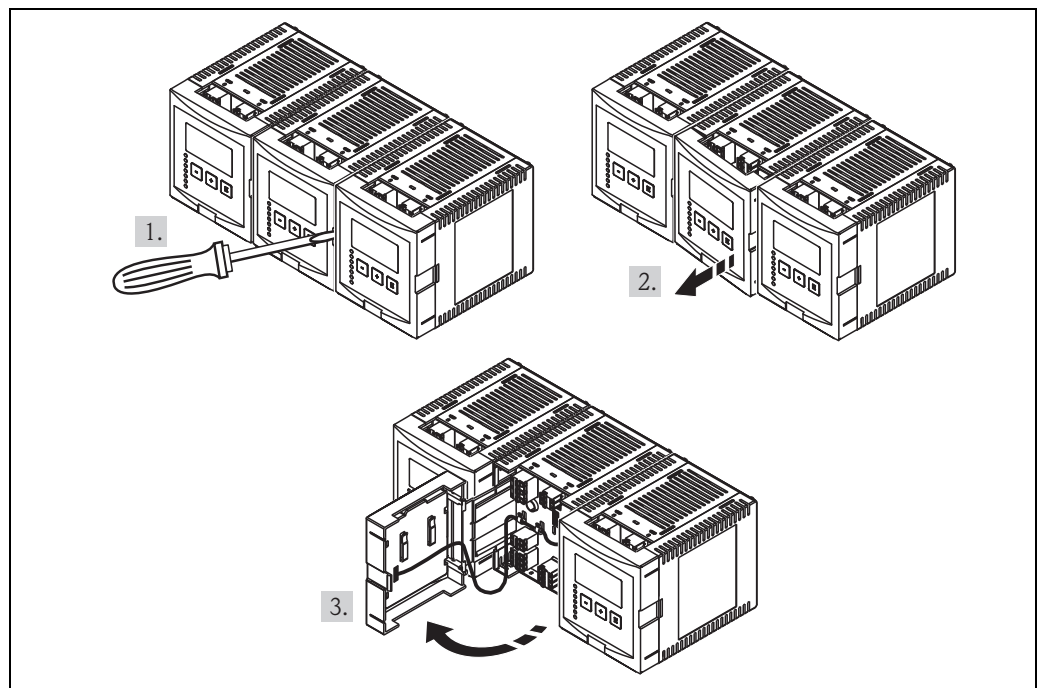

L00-FMU90xxx-04-00-00-xx-012

1. Open the catch of the cover (e.g. by a screwdriver).
2. Pull the cover out by approx. 20 mm (0.79 in) .
3. The cover can now be opened.



#### Note!

- The cables can be inserted into the housing from above or from below.
- The pictures show the smallest housing version but are valid for the larger versions as well.
- If the instruments are mounted next to each other and if the sensor cables run in parallel, the synchronization terminals (39 and 40) must be interconnected (→ 20, "Terminal assignment" and → 30, "Synchronization line").

## 4.2 Terminal assignment

Pluggable spring-force terminals for connection of the cables are supplied in the terminal compartment. Rigid conductors or flexible conductors with cable sleeve can directly be inserted and are contacted automatically.

Conductor cross section	0.2 mm <sup>2</sup> to 2.5 mm <sup>2</sup> (26 to 14 AWG)
Cable and sleeve cross section	0.25 mm <sup>2</sup> to 2.5 mm <sup>2</sup> (24 to 14 AWG)
min. stripping length	10 mm (0.39 in)

The terminal configuration depends on the instrument version ordered. There is a basic terminal area, which is present in every instrument version. Additional optional terminal areas are only present if the respective option has been selected in the product structure.

Terminal area	present for the following instrument versions	
Basic area	A	for all versions
	B	for instrument versions with 2 sensor inputs and/or 2 analogue outputs (FMU90 - *****2***** and/or FMU90 - *****2*****)
Optional areas	C	for instrument versions with 3 or 6 relays (FMU90 - *****3***** oder FMU90 - *****6*****)
	D	for instruments with external switch inputs and external temperature input (FMU90 - *****B****)
	E	for instrument versions with PROFIBUS DP interface (FMU90 - *****3*****)

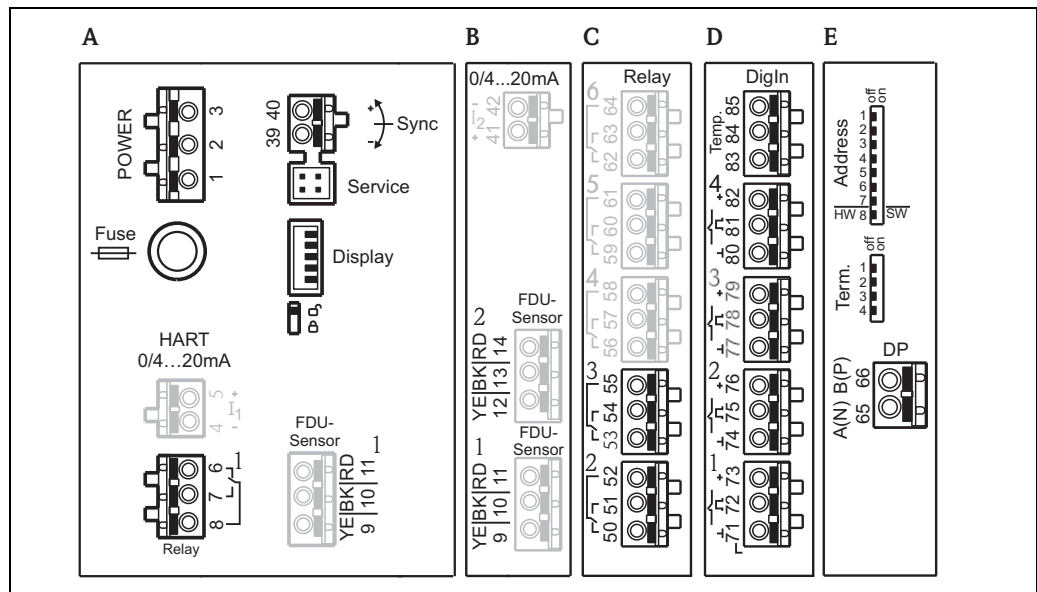

Terminals of the Prosonic S (the terminals depicted in grey are not present in every instrument version)

**A** Basic terminal area

**B-E** Optional terminal areas (present if the respective option has been selected in the product structure)



Note!

The depicted switching states of the relays refer to the de-energized state.

Terminals	Meaning	Terminal area	Remarks
<b>Auxiliary energy</b>			
1, 2	<ul style="list-style-type: none"> <li>■ L (für AC version)</li> <li>■ L+ (for DC version)</li> </ul>	A	depending on instrument version: <ul style="list-style-type: none"> <li>■ 90 to 253 V<sub>AC</sub></li> <li>■ 10,5 to 32 V<sub>DC</sub></li> </ul>
2	<ul style="list-style-type: none"> <li>■ N (for AC version)</li> <li>■ L- (for DC version)</li> </ul>	A	
3	Potential equalization	A	
Fuse		A	depending on instrument version: <ul style="list-style-type: none"> <li>■ 400 mA T (for AC)</li> <li>■ 2 A T (for DC)</li> </ul>
<b>Analog outputs (not available for Profibus DP instruments)</b>			
4, 5	Analog output 1; 4 to 20 mA with HART/ 0 to 20 mA w/o HART	A	<b>not</b> present for the PROFIBUS DP version
41, 42	Analog output 2 (optional); 4 to 20 mA/ 0 to 20 mA	B	only for the version with two analog outputs; no HART signal at this output
<b>Relay outputs</b>			
6, 7, 8	Relay 1	A	
50, 51, 52	Relay 2 (optional)	C	only for the versions with 3 or 6 relays
53, 54, 55	Relay 3 (optional)	C	only for the versions with 3 or 6 relays
56, 57, 58	Relay 4 (optional)	C	only for the version with 6 relays
59, 60, 61	Relay 5 (optional)	C	only for the version with 6 relays
62, 63, 64	Relay 6 (optional)	C	only for the version with 6 relays
<b>Bus communication (only available for Profibus DP instruments)</b>			
65	PROFIBUS A (RxT/TxD - N)	D	only for the PROFIBUS DP version
66	PROFIBUS B (RxT/TxD - P)	D	
<b>Synchronization</b>			
39, 40	Synchronization	A	→ 30, "Synchronization line"
<b>Level inputs</b>			
9 (YE), 10 (BK), 11 (RD)	Sensor 1 (FDU8x/9x) YE: yellow strand BK: black strand RD: red strand		<ul style="list-style-type: none"> <li>■ A: for versions with 1 sensor input</li> <li>■ B: for versions with 2 sensor inputs<sup>1)</sup></li> </ul>
12 (YE), 13 (BK), 14 (RD)	Sensor 2 (FDU8x/9x) (optional) YE: yellow strand BK: black strand RD: red strand	B	only for the version with 2 sensor inputs
<b>external switch inputs</b>			
71, 72, 73	external switch input 1	D	0: < 8 V or 72 and 73 interconnected 1: > 16 V or 72 and 73 not interconnected
74, 75, 76	external switch input 2	D	0: < 8 V or 75 and 76 interconnected 1: > 16 V or 75 and 76 not interconnected
77, 78, 79	external switch input 3	D	0: < 8 V or 78 and 79 interconnected 1: > 16 V or 78 and 79 not interconnected
80, 81, 82	external switch input 4	D	0: < 8 V or 81 and 82 interconnected 1: > 16 V or 81 and 82 not interconnected
<b>temperature input</b>			
83, 84, 85	temperature input: <ul style="list-style-type: none"> <li>■ PT100</li> <li>■ FMT131 (Endress+Hauser)</li> </ul>	D	→ 27, "Connection of a temperature sensor"

1) In this case, terminals 9/10/11 are not present on terminal area A.



**Warning!**

When using the public supply mains, an easily accessible power switch must be installed in the proximity of the device. The power switch must be marked as a disconnecter for the device (IEC/EN 61010)



**Note!**

- In order to avoid interference signals, the sensor cables should not be laid parallel to high voltage or electric power lines.
- The cables may not be laid in the proximity to frequency converters.

**Additional elements on the terminal areas**

Designation	Meaning/Remarks
Fuse	Fuse: 2 A T /DC or 400 mA T/AC
Display	Connection of the display or the remote display and operating module
Service	Service interface for connection of a PC/Notebook via Commubox FXA291
	Locking switch
Term.	Bus termination (only applicable for instruments with PROFIBUS interface)
Address	Bus address (only applicable for instruments with PROFIBUS interface)



**Warning!**

On wiring, the supply voltage must be switched off.

### 4.3 Sensor connection

#### 4.3.1 Connection diagram

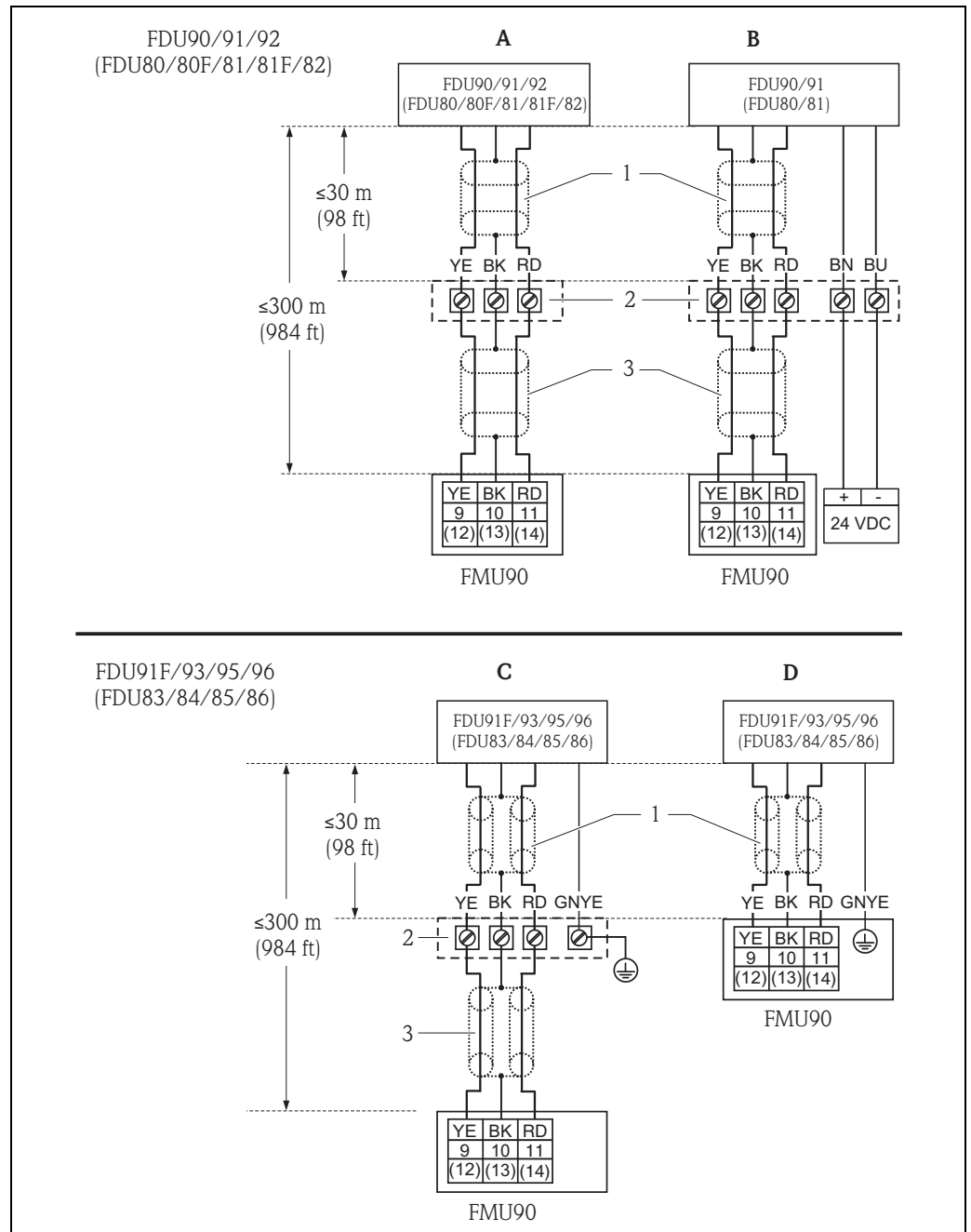

L00-FDU9xxxx-04-00-00-xx-002

- A** Without sensor heater
  - B** With sensor heater
  - C** Grounding at the terminal box
  - D** Grounding at the transmitter FMU90
  - 1 Screen of the sensor cable
  - 2 Terminal box
  - 3 Screen of the extension cable
- Colours of the strands: YE = yellow; BK = black; RD = red; BU = blue; BN = brown; GNYE = green-yellow

### 4.3.2 Connection hints



#### Caution!

- In order to avoid interference signals, the sensor cables should not be laid parallel to high voltage electric power lines. The cables may not be laid in the proximity to frequency converters.
- The cable screen serves as a return cable and must be connected to the transmitter without any electrical break. With the pre-assembled cables, the screen ends in a black strand (BK). With the extension cable, the screen must be twisted together and connected to the "BK" terminal.



#### Warning!

- The sensors FDU83, FDU84, FDU85 and FDU86 with an ATEX, FM or CSA certificate are not certified for connection to the FMU90 transmitter.
- For the sensors FDU91F/93/95/96 and FDU83/84/85/86:  
The ground lead (GNYE) must be connected to the local potential equalization **after a maximum distance of 30 m (98 ft)**. This can be done
  - either at the terminal box
  - or at the transmitter FMU90 or in the cabinet (if the distance to the sensor does not exceed 30 m (98 ft)).



#### Note!

For easier mounting it is advisable to use the sensors FDU90/91/92 and FDU80/80F/81/81F/82 with a maximum cable length of 30 m (98 ft) as well. For longer distances an extension cable with a terminal box should be used.

### 4.3.3 Extension cables for the sensors

For distances up to 30 m (98 ft) the sensor can be directly connected by the sensor cable. For longer distances, it is recommended to use an extension cable. The extension cable is connected via a terminal box. The total length (sensor cable + extension cable) may be up to 300 m (984 ft).



#### Caution!

If the terminal box is installed in explosion hazardous areas, all applicable national guidelines must be observed.

Suitable extension cables can be obtained from Endress+Hauser (→ [146](#), "Accessories")  
Alternatively, cables with the following properties can be used:

- Number of cores according to the connection diagram (see above)
- Braided wire screen for the yellow (YE) and red (RD) core (no foil screen)
- Length: up to 300 m (984 ft), (sensor cable + extension cable)
- Cross section: 0.75 mm<sup>2</sup> to 2.5 mm<sup>2</sup> (18 to 14 AWG)
- Up to 8 Ω per core
- Max. 60 nF (between core and screen)
- For FDU91F/93/95/96 and FDU 83/84/85/86:  
The earth lead must not be within the screening.



## 4.4 Connection of the sensor heater (for FDU90/FDU91)

The FDU90 and FDU91 sensors are available in a version with heater. The power for this heater must be provided by an external power supply unit. The supply voltage is connected to the brown (BN) and blue (BU) strands of the sensor cable.

### Technical Data

- 24 VDC  $\pm$  10%; residual ripple < 100 mV
- 250 mA per sensor

### 4.4.1 Connection in the field housing

For the sensor with heater, a special terminal module is supplied for the connection of the supply voltage. This terminal module can be inserted into the field housing:

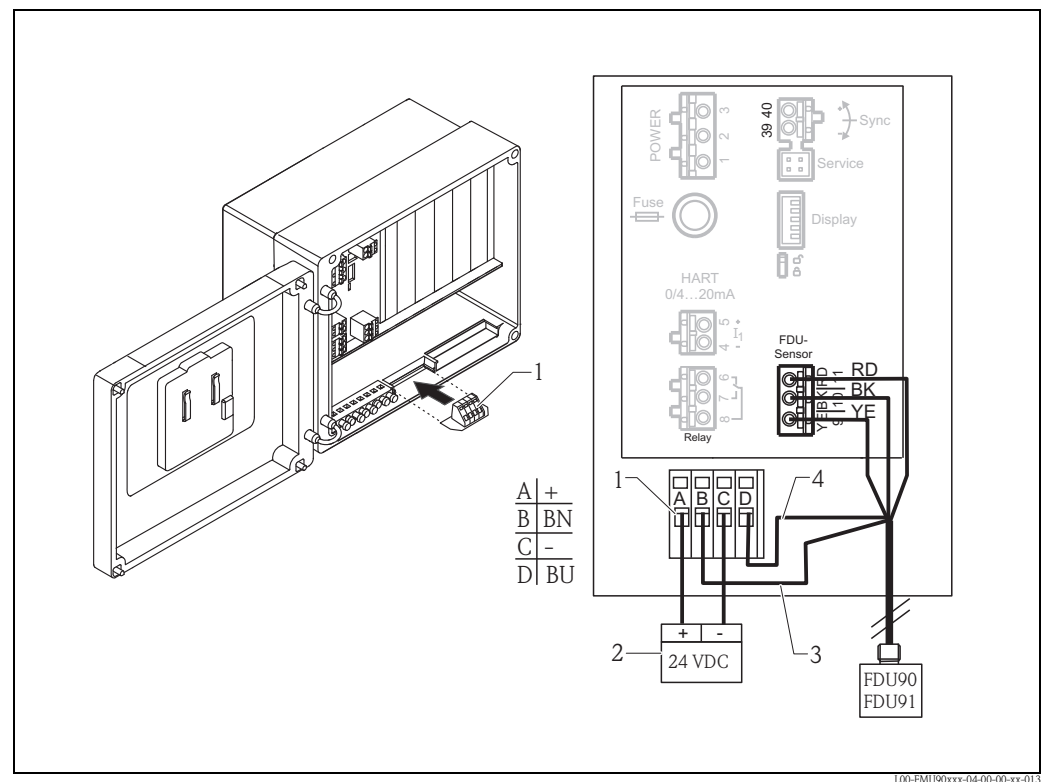

- 1 Terminal module for the sensor heater
- 2 External power supply unit
- 3 Brown strand (BN)
- 4 Blue strand (BU)

#### 4.4.2 Connection in the DIN-rail housing

The supply voltage must be provided in the cabinet, e.g. by a terminal on the DIN-rail:

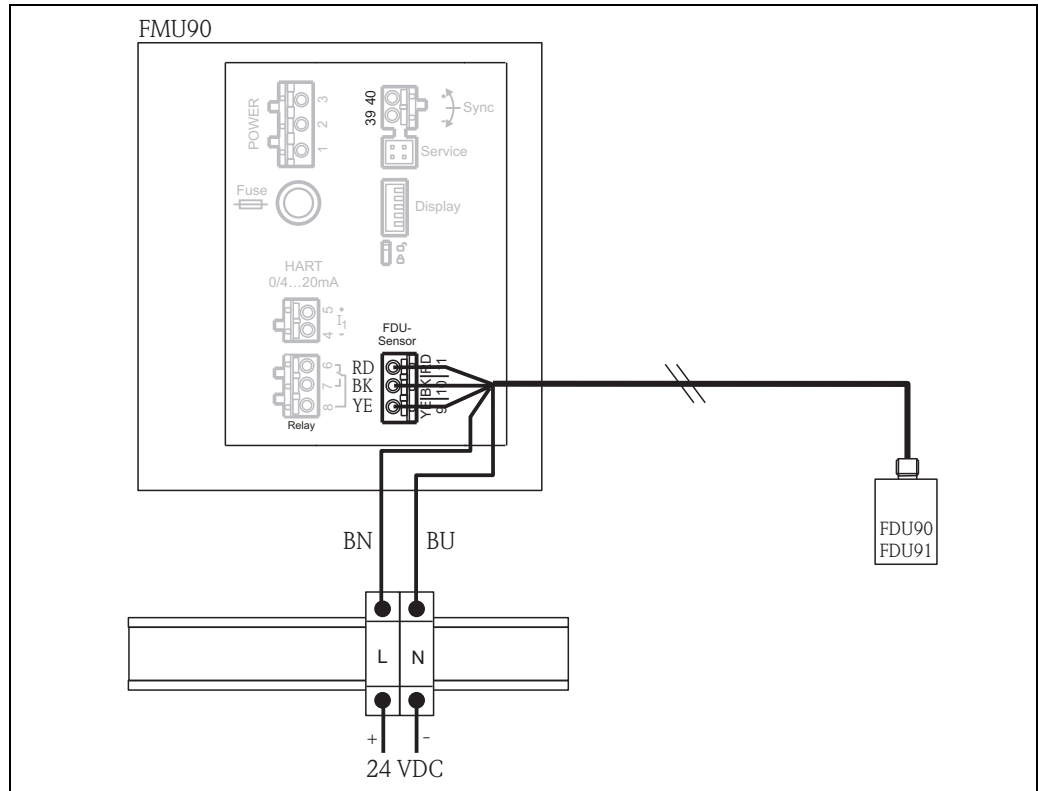

L00-FMU90xxx-04-00-00-xx-014



Note!

The terminal module supplied with the sensor can also be used for connection of the supply voltage. For the terminal assignment on this module → 25.

## 4.5 Connection of external switches (for FMU90-\*\*\*\*\*B\*\*\*)

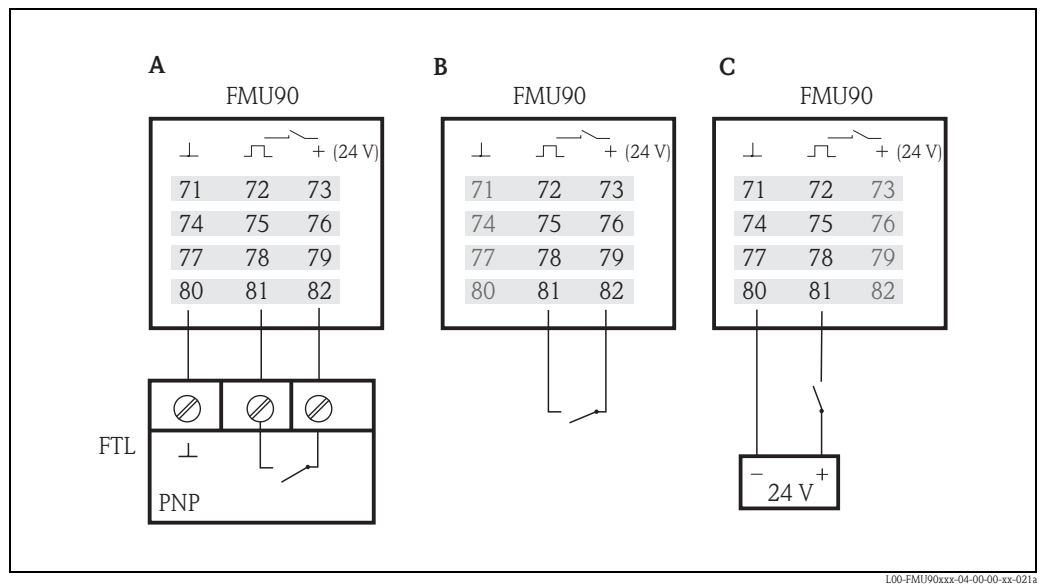

- A** *Liquiphant*  
**B** *External switch*  
**C** *External switch with external supply voltage*

The maximum short-circuit current at 24 V is 20 mA.

## 4.6 Connection of a temperature sensor

The Prosonic S FMU90 transmitter has an optional input for an external temperature probe (in the product structure: feature 90 "Additional input", option B). The following probes can be connected:

- a FMT131 temperature probe from Endress+Hauser
- a Pt100 temperature probe



Note!

- After connecting an external temperature sensor, the following is required:
  1. The type of the connected sensor (Pt100 or FMT131) must be selected in "sensor management/ext. temp. sensor" in the "sensor type" parameter.
  2. The external temperature sensor must be assigned to an ultrasonic sensor in "sensor management/FDU sensor/US sensor N" in the "temp. measurement" parameter.
- If the option "alarm" has been selected for the case of an error in external temperature sensor, this alarm is indicated by the alarm relay.

### 4.6.1 FMT131 (Endress+Hauser) (connectable to FMU90-\*\*\*\*\*B\*\*\*)

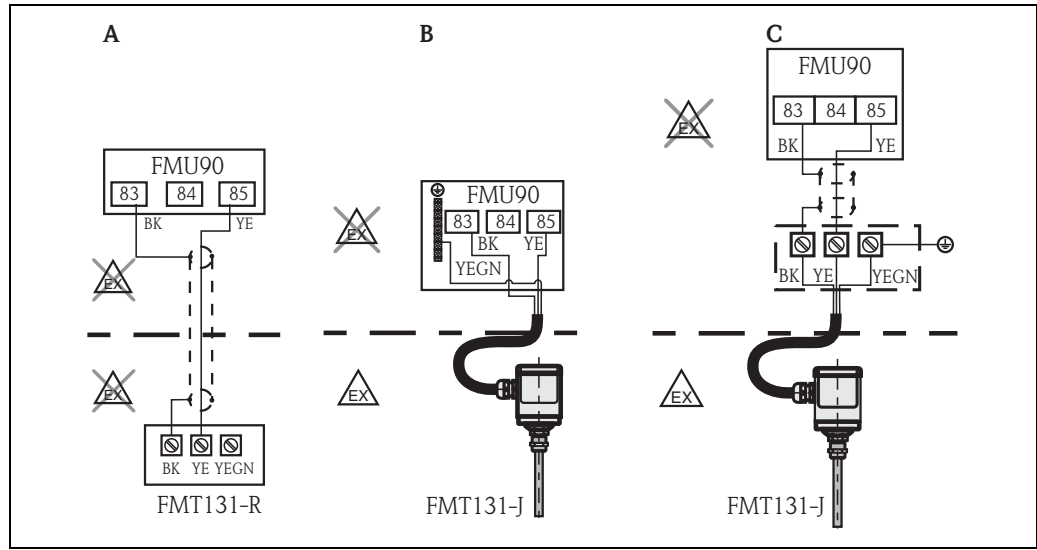

- A** Non-Ex area (FMT131-R)
- B** Ex area (FMT131-J) with grounding in the FMU90
- C** Ex area (FMT131-J) with grounding at a terminal box

- BK black
- YE yellow
- YEGN yellow-green



Note!  
For details refer to the Operating Instructions KA00019F/00.

### 4.6.2 Pt100 (connectable to FMU90-\*\*\*\*\*B\*\*\*)

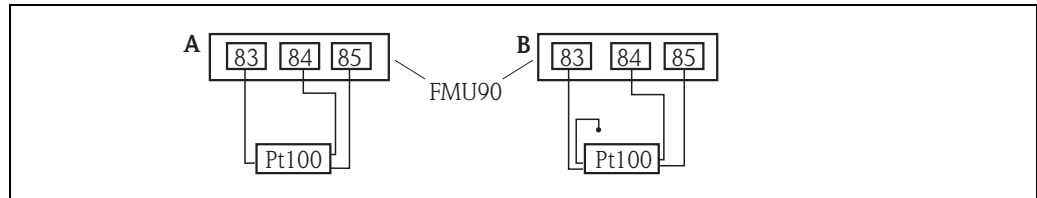

- A** Pt100 with 3-wire connection
- B** Pt100 with 4-wire connection (one connector remains unused)



Note!  
A Pt100 with 2-wire connection may not be used due to its insufficient measuring accuracy.



Warning!  
A Pt100 may not be connected in explosion hazardous areas. A FMT131 must be used instead.

### 4.7 Shortening the sensor cable

If required, the sensor cable can be shortened. Please note:

- Do not damage the cores when removing the insulation.
- The cable is shielded by a metallic braiding. This shielding serves as a return cable and corresponds to the black (BK) strand of the unshortened cable. After shortening the cable, loosen the metallic braiding, twist it together securely and connect it to the "BK" terminal.



Caution!

The protective earth conductor (GNYE), which is present in some of the sensor cables, may not be electrically connected to the cable shield.

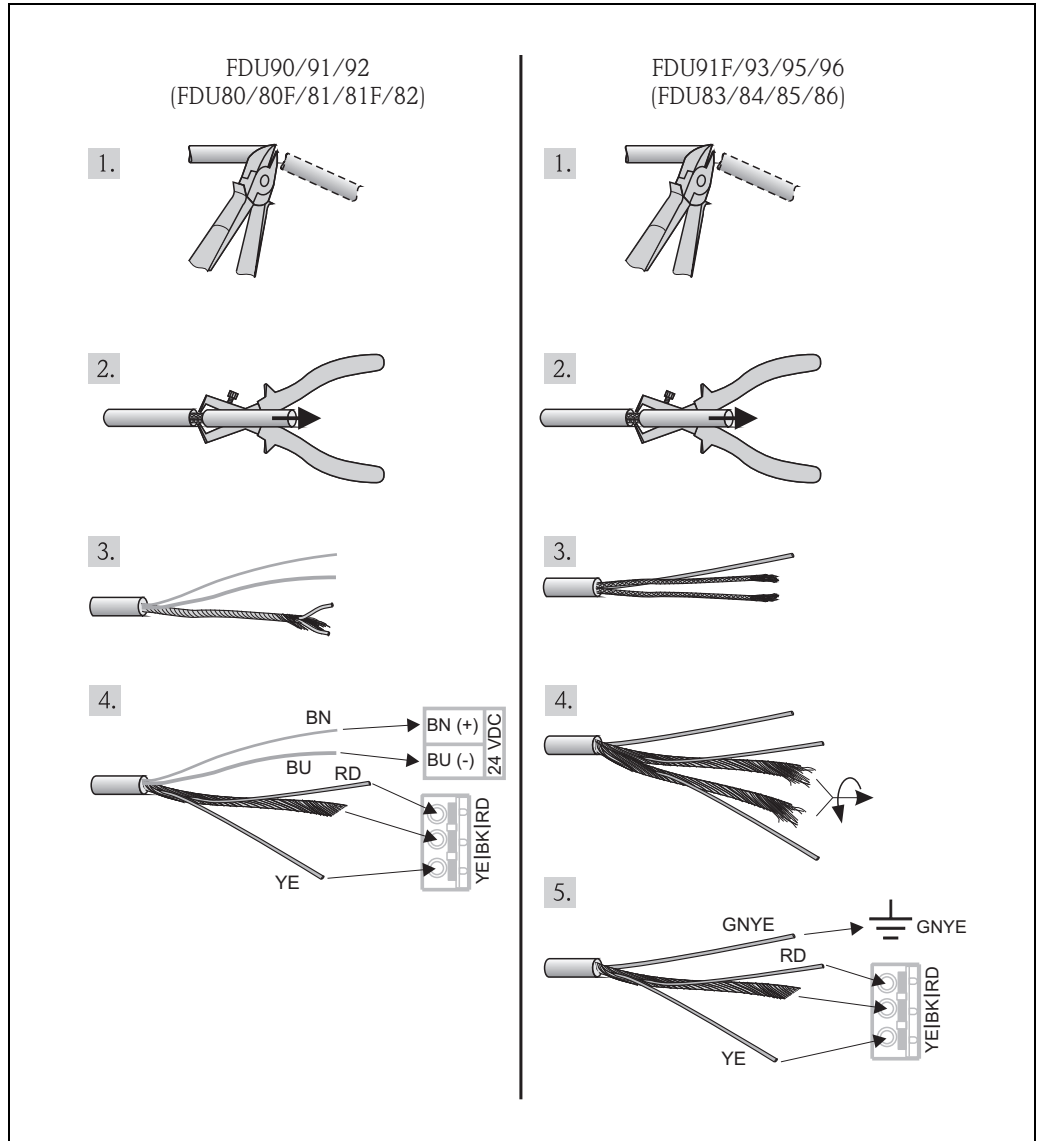

L00-FMU190xxx-04-00-00-xx-015

Colours of the strands: YE = yellow; BK = black; RD = red; BU = blue; BN = brown; GNYE = green-yellow



Note!

The blue (BU) and brown (BN) strands are only present for sensors with heater.

## 4.8 Synchronization line

- If wiring several Prosonic S (FMU90/FMU95) which are mounted in a common cabinet and if the sensor cables run in parallel, the synchronization terminals (39 and 40) must be interconnected.
- Up to 20 instruments can be synchronized in this way.
- The synchronization causes the evaluation units FMU9x to send the pulses simultaneously. Only after all sensors have received their signal, new simultaneous pulses are sent. This prevents pulses in the sensor cable of one sensor from influencing the received signal on the cable of a different sensor.
- If there are more than 20 instruments, groups must be formed, each containing a maximum of 20 instruments. For the instruments within each group, the sensor cables may run in parallel. The sensor cables of different groups must be separated from each other.
- Usual commercial screened cable can be used for synchronization:
  - Max. length: 10 m (33 ft) between the individual instruments
  - Cross section:  $2 \times (0.75 \text{ to } 2.5 \text{ mm}^2)$  (18 to 14 AWG)
  - For lengths up to 1 m (3.3 ft), an unscreened cable can be used; for lengths exceeding 1 m (3.3 ft), screening is required. The screen must be connected to ground
- Instruments of the Prosonic FMU86x family can be connected to the synchronization line as well. In this case a maximum of 10 instruments can be connected to each synchronisation line.

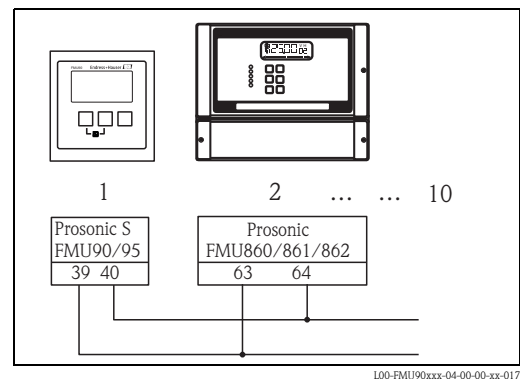
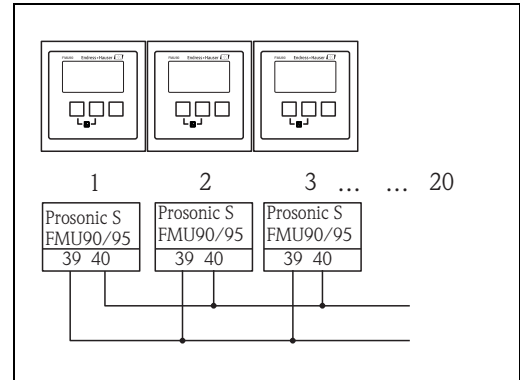

## 4.9 Connection of the separate display and operating module

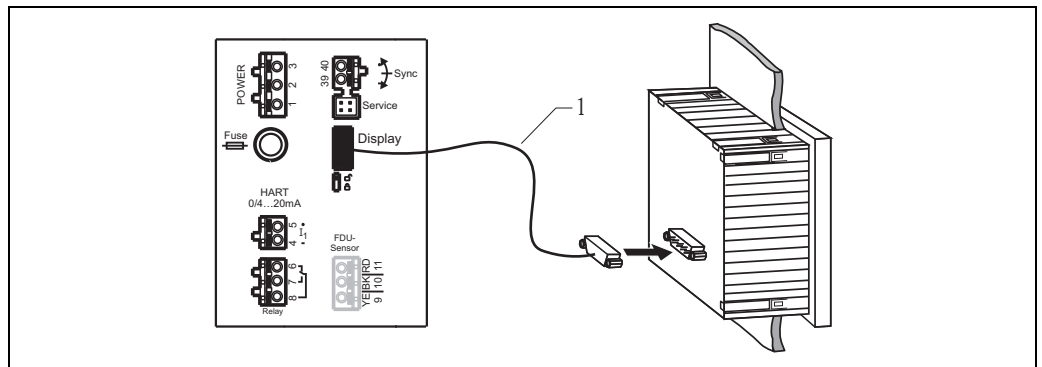

L00-FM190xxx-04-00-00-xx-005

1 Connection of the display plug with the cable (3 m (9.8 ft))

For the version of the Prosonic S with a separate display for panel mounting, a pre-assembled connecting cable (3 m (9.8 ft)) is supplied. The cable must be connected to the display plug of the Prosonic S.



Note!

Minimum diameter for cable bushing: 20 mm (0.79 in).

## 4.10 Potential equalization

### 4.10.1 Potential equalization in the field housing

 Warning!

The grounding line of the sensors FDU91F/93/95/96 and FDU83/84/85/86 must be connected to the local potential equalization system **after a maximum of 30 m (98 ft)**, →  23. The metallic terminal block (1) in the field housing can be used for this.

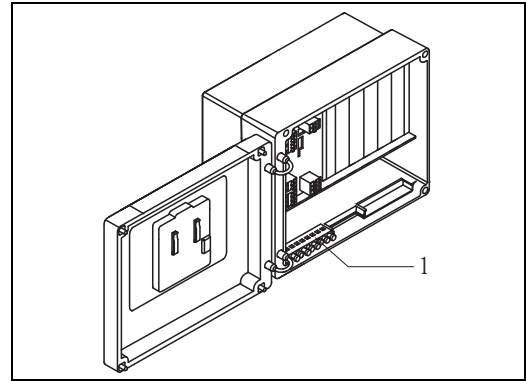

L00-FMU90xxx-04-00-00-xx-006

### Example

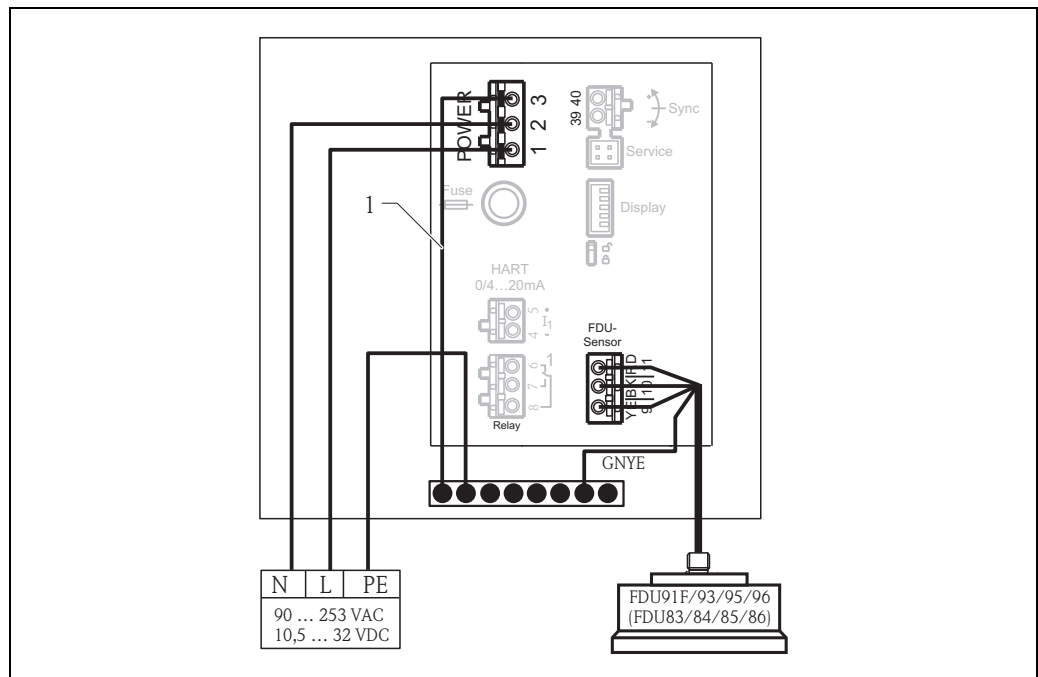

L00-FMU90xxx-04-00-00-xx-007

1 The wire is already connected on delivery



### 4.10.2 Potential equalization for the DIN-rail housing

If the DIN-rail housing is used, the potential equalization must be connected in the cabinet, e.g. at a metallic DIN rail:



Warning!

The grounding line of the sensors FDU91F/93/95/96 and FDU83/84/85/86 must be connected to the local potential equalization system **after a maximum of 30 (98 ft)** → 23.

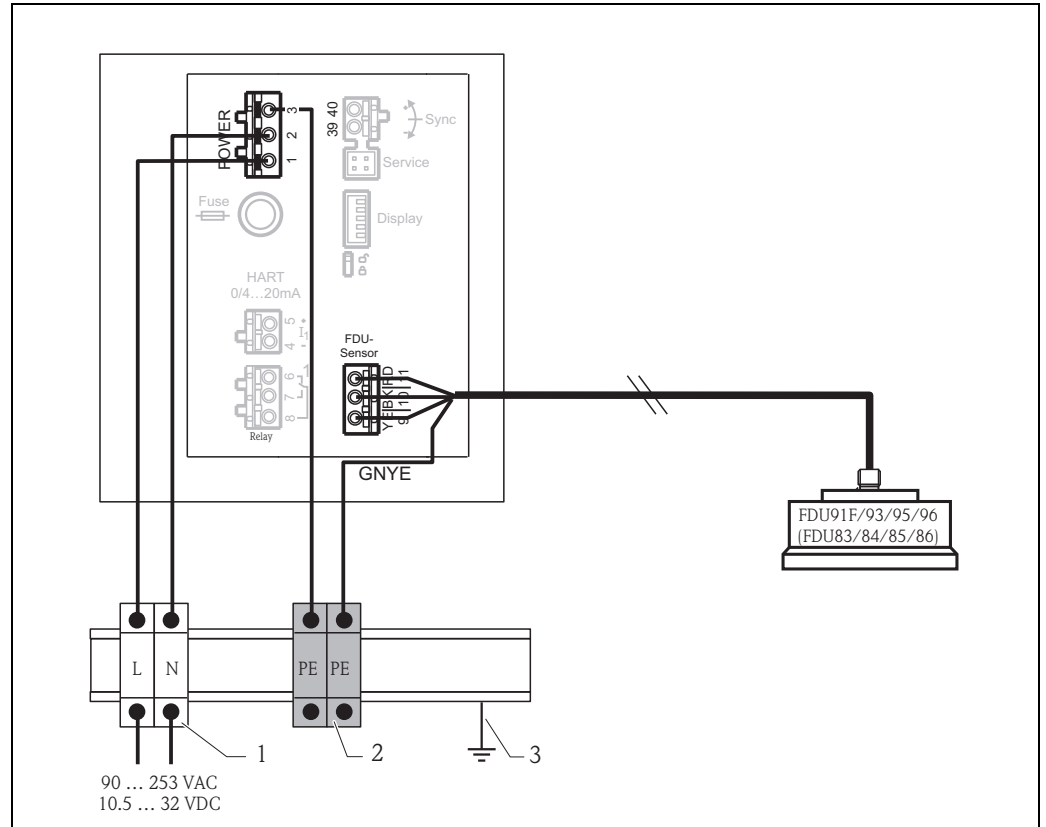

- 1 Terminal (isolated from the DIN rail)
- 2 Protective earth terminal (with contact to the DIN rail)
- 3 Protective ground via DIN rail



Caution!

The signal evaluation electronics and its direct connections (display interface, service interface etc.) are galvanically isolated from the supply voltage and the communication signals. Their electric potential is identical to the potential of the sensor electronics.

Pay attention to the potential difference if the sensors are connected to ground!



Note!

- The longest required distance has to be taken into account when removing the jacket of the sensor cable (GNYE in the above example).
- When shortening the sensor cable, comply to the notes → 29 "Shortening the sensor cable".

### 4.11 Post-connection check

After wiring the transmitter, carry out the following checks:

- Is the terminal assignment correct?
- For the field housing: Are the cable glands tight and is the cover of the terminal compartment securely closed?
- If auxiliary energy is switched on: Does a display appear on the display module (if available) and does the green LED light up?

## 5 Operation

### 5.1 Operating options

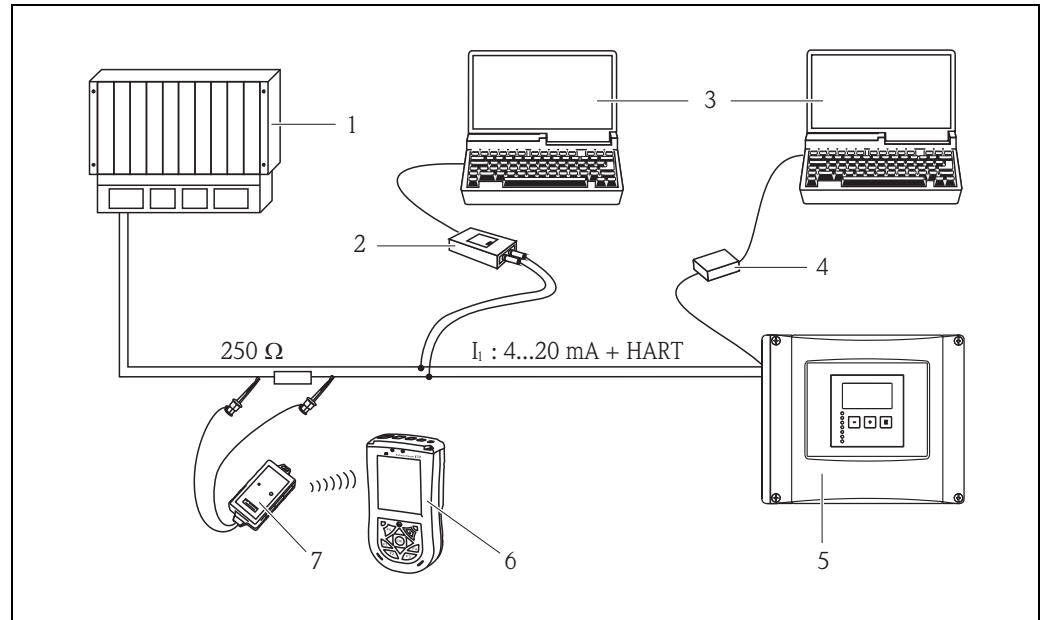

- 1 SPS, PLC, API  
 2 Commubox FXA195 (USB), HART-Protocol  
 3 FieldCare  
 4 Commubox FXA291 (service interface)  
 5 Operating and display module at the Prosonic S (if present)  
 6 Field Xpert SFX100  
 7 VIATOR Bluetooth-Modem with connection cable





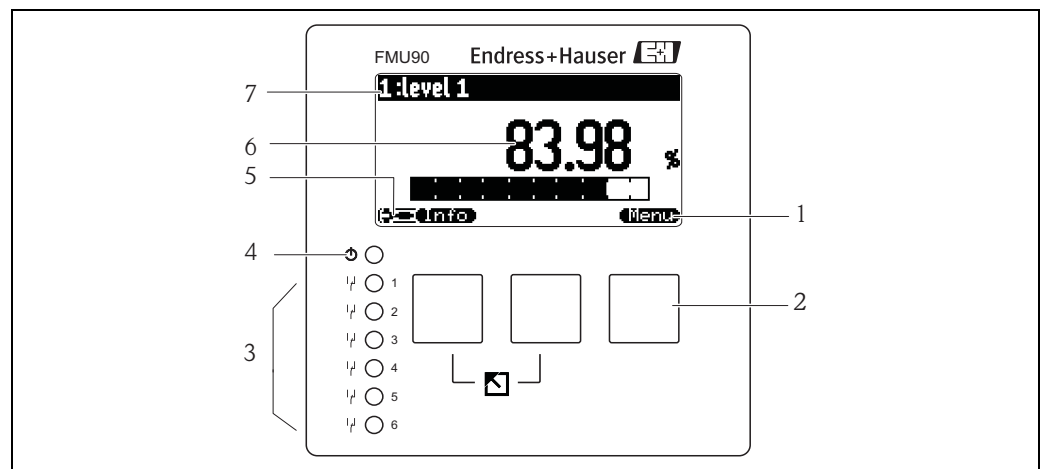







### 5.2 Operation via the display and operating module

#### 5.2.1 Display and operating elements



- 1 Softkey symbol  
 2 Key  
 3 LEDs indicating the switching states of the relays  
 4 LED indicating the operating state  
 5 Display symbols  
 6 Value of the parameter, including unit  
 7 Name of the parameter

## Display symbols

Symbol	Meaning
<b>Operating mode of the instrument</b>	
	<b>User</b> User parameters can be edited. Service parameters are locked.
	<b>Diagnosis</b> The service interface is connected.
	<b>Service</b> User and service parameters can be edited.
	<b>Locked</b> All parameters are locked.
<b>Locking state of the currently displayed parameter</b>	
	<b>Display parameter</b> The parameter can <b>not</b> be edited in the current operating mode of the instrument.
	<b>Editable parameter</b> The parameter can be edited.
<b>Scroll symbols</b>	
	<b>Scroll list available</b> Indicates that the list contains more parameters than can be represented on the display. By pressing  or  repeatedly, all parameters of the list can be accessed.
<b>Navigation in the envelope curve display</b>	
	<b>Move left</b>
	<b>Move right</b>
	<b>Zoom in</b>
	<b>Zoom out</b>













## LEDs

<b>LED indicating the operating state (pos. 4 in the figure)</b>	
green	normal measuring mode; no error detected
red (flashing)	Warning: An error is detected but the measurement continues. Reliability of the measured value is no longer ensured.
red	Alarm: An error is detected. The measurement is interrupted. The measured value assumes the value specified by the user (parameter "output on alarm").
off	supply voltage missing

<b>LEDs for the relays (pos. 3 in the figure)</b>	
yellow	The relay is activated.
off	The relay is de-activated (idle state).



**Keys (softkey operation)**

The function of the keys depends on the current position within the operating menu (softkey functionality). The key functions are indicated by softkey symbols in the bottom line of the display.

Symbol	Meaning
	<b>Move downwards</b> Moves the marking bar downwards within a selection list.
	<b>Move upwards</b> Moves the marking bar upwards within a selection list.
	<b>Enter</b> <ul style="list-style-type: none"> <li>Opens the marked submenu, the marked parameter set or the marked parameter</li> <li>Confirms the edited parameter value</li> </ul>
	<b>Previous parameter set</b> Reopens the previous parameter set within the submenu.
	<b>Next parameter set</b> Opens the next parameter set within the submenu.
	<b>Confirm selection</b> Selects the option of a selection list which is currently marked by the bar.
	<b>Increase value</b> Increases the active digit of an alphanumeric parameter.
	<b>Decrease value</b> Decreases the active digit of an alphanumeric parameter
	<b>Error list</b> Opens the list of all errors which are currently detected. If a warning is present, this symbol flashes. If an alarm is present, the symbol is displayed continuously.
	<b>Change Display</b> Change to the next page of measured values (only available if more than one pages of measured values have been defined; see "display" menu)
	<b>Info</b> Opens the Shortcut Menu, which contains the most important information about the current state of the instrument
	<b>Menu</b> Opens the Main Menu, which contains <b>all</b> parameters of the Prosonic S

**General key combinations**

The following key combinations do not depend on the menu position:

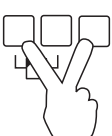
Key combination	Meaning
	<b>Escape</b> <ul style="list-style-type: none"> <li>While editing a parameter: Exit the editing mode without accepting the changes.</li> <li>Within the navigation: Move upwards to the previous layer of the menu.</li> </ul>
	<b>Increase contrast</b> Increases the contrast of the display module.
	<b>Decrease contrast</b> Decreases the contrast of the display module.

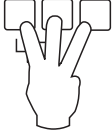
Key combination	Meaning
	<b>Locking</b> Locks the instrument against parameter changes. The instrument can only be unlocked again by the keys.

## 5.2.2 The operating menu

### Structure of the menu

The parameters of the Prosonic S are organized in an operating menu (consisting of a main menu and several submenus). Parameters which are related to each other are comprised in a common parameter set. To simplify the navigation within the menu, a five-digit position code is displayed with each parameter set.

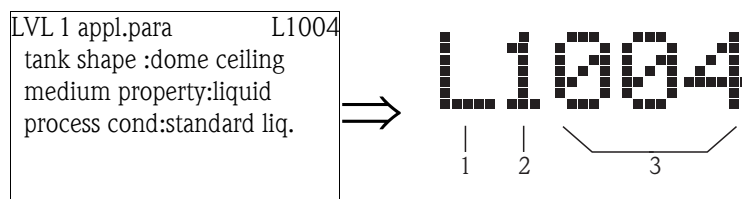

Identification of the parameter sets:

- 1 Submenu
- 2 Number of the associated input or output
- 3 Number of the parameter set within the submenus

■ The **first digit (1)** specifies the submenu<sup>1)</sup>:

- **L:** "level"
- **F:** "flow"
- **A:** "safety settings"
- **R:** "relay/controls"
- **O:** "output/calculations"
- **D:** "device properties", "calibr. display" and "sensor management"
- **I:** "system information"
- **S:** "service" (only available if the service password has been entered)

Diagrams of the submenus can be found in the chapter "Operating menu".

■ The **second digit (2)** is used if the parameter set occurs several times within the Prosonic S (e.g. for different inputs or outputs).

#### Example:

- O1201: "allocation current" for output 1
- O2201: "allocation current" for output 2

If the parameter set occurs only once within the Prosonic S, "X" is indicated at this position.

■ The **last three digits (3)** specify the individual parameter sets within the submenu.

1) Depending on the instrument version, the installation environment and the selected operating mode, some of the submenus may not be present.

## Parameter types

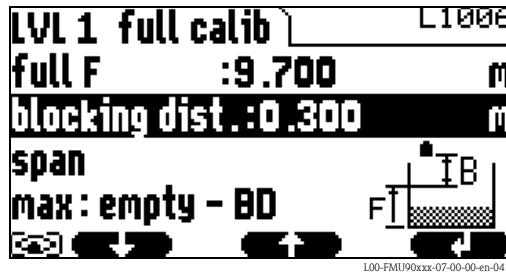

### Display parameters

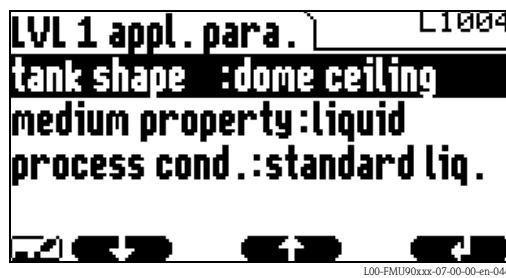

Parameters for which the  symbol is displayed in the left bottom corner of the display module, are either locked or display-only parameters.

### Editable parameters



Parameters, for which the  symbol is displayed in the left bottom corner of the display module, can be entered for editing by pressing .

The editing procedure depends on the type of parameter:

- when entering a **selection parameter**, the associated selection list appears (see below: "Editing a parameter with selection list").
- when entering a **numerical or alphanumeric parameter**, the text and number editor appears (see below: "Entering numbers and characters").

Navigation within the menu (Example)

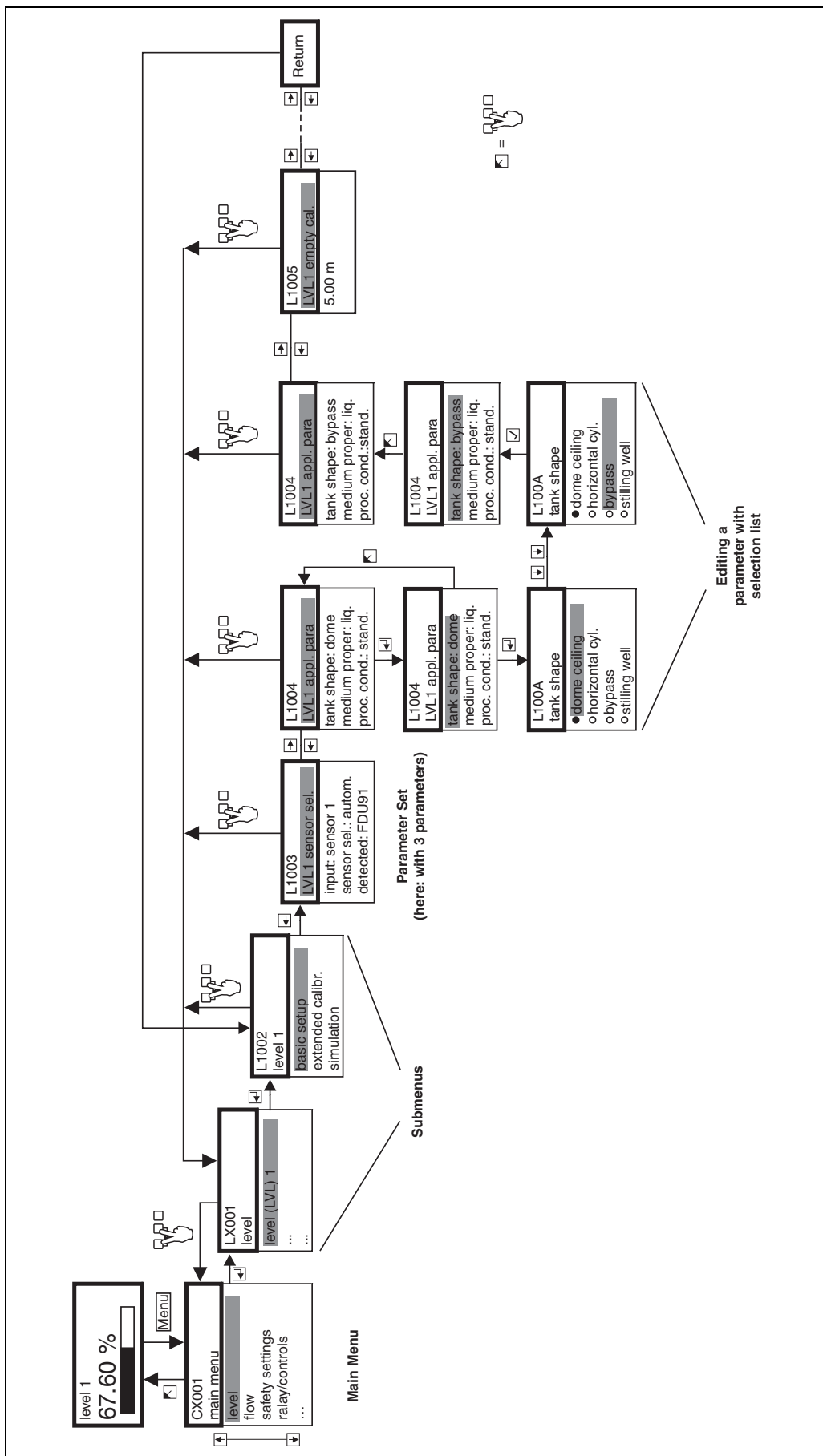

## Entering the menu

The navigation always starts from the main screen (measured value display<sup>2)</sup>). From there, the following menus can be opened by the keys:

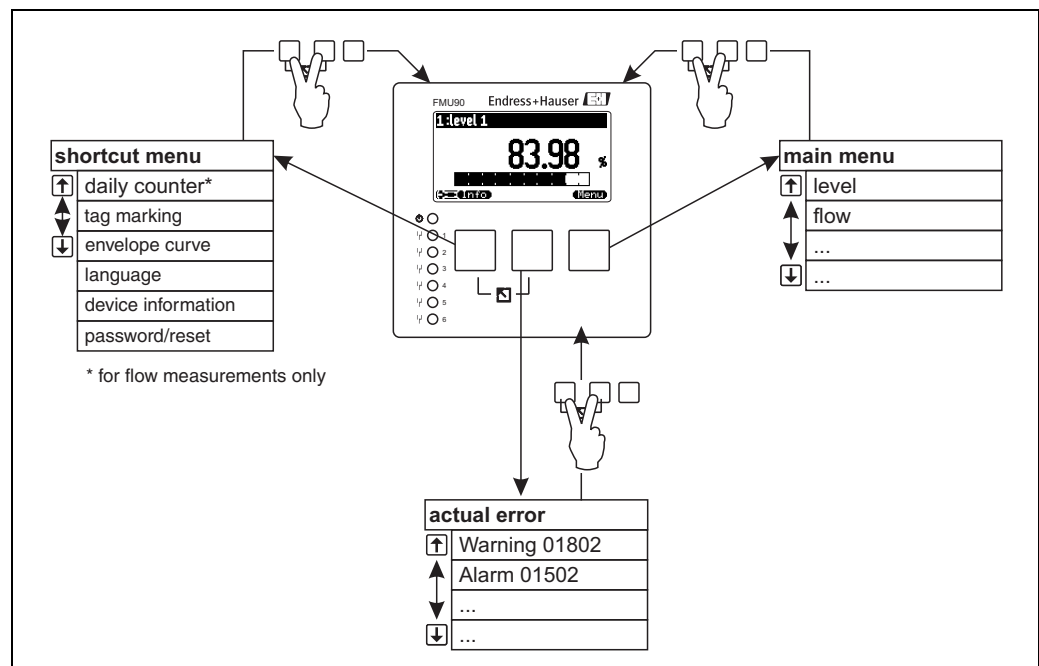

### ■ shortcut menu

The shortcut menu is accessed via the **"Info"** key. It allows quick access to device information:

- daily counter (for flow measurements)
- tag marking
- envelope curve: used to check the signal quality
- language: sets the display language
- device information: serial number, versions of software and hardware
- password/reset: used to enter the password or reset code

All parameters of the shortcut menu are contained in the main menu as well.

### ■ main menu

The main menu is accessed via the **"Menu"** key. It contains all parameters of the Prosonic S. It is divided into submenus. Some of the submenus consist of further submenus. Which submenus are actually present, depends on the instrument version and the installation environment.

An overview of all submenus and parameters is given in the chapter "Operating menu".

### ■ actual error

If the self-monitoring of the Prosonic S detects an error, the  softkey symbol appears above the middle key.

If the softkey symbol flashes, only "warnings"<sup>3)</sup> are present.

If the softkey symbol is displayed permanently, at least one "alarm"<sup>3)</sup> is present.

After pressing the key, a list of all currently present errors appears.

2) Note: Depending on the configuration, the appearance of the measured value display may be different from the example in the figure.

3) The difference between "Warning" and "Alarm" → Chap. 10.1



### Selecting a submenu

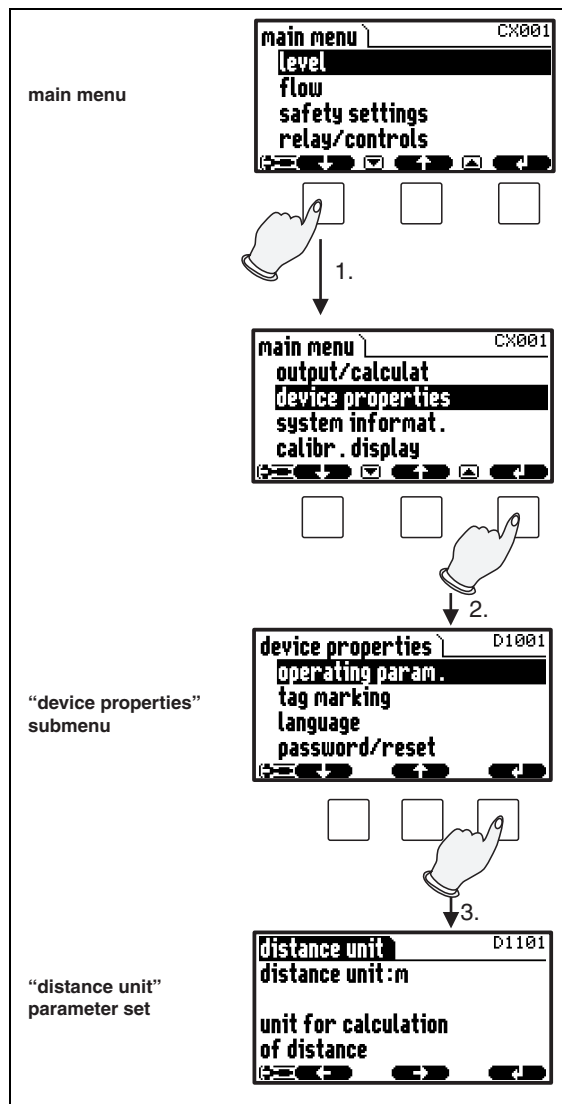

L00-FMU90xxx-19-00-00-yy-039

1. In the main menu, press or until the required submenu is marked by the bar.

**Note!**  
The symbols and indicate that the selection list contains more items than can be displayed on the module. Press or several times, to mark one of the hidden items.

2. Press , in order to enter the marked submenu.

3. If the submenu contains further submenus, continue until you reach the level of the parameter sets. This level is reached if the softkey symbols and appear.



**Note!**

If necessary, you can return to the previous level of the menu by pressing .

### Selecting a parameter

By pressing  $\leftarrow$  or  $\rightarrow$  you can switch between the parameter sets of the current submenu. For each parameter set the values of all its parameters are displayed. In order to change one of the values, proceed as follows:

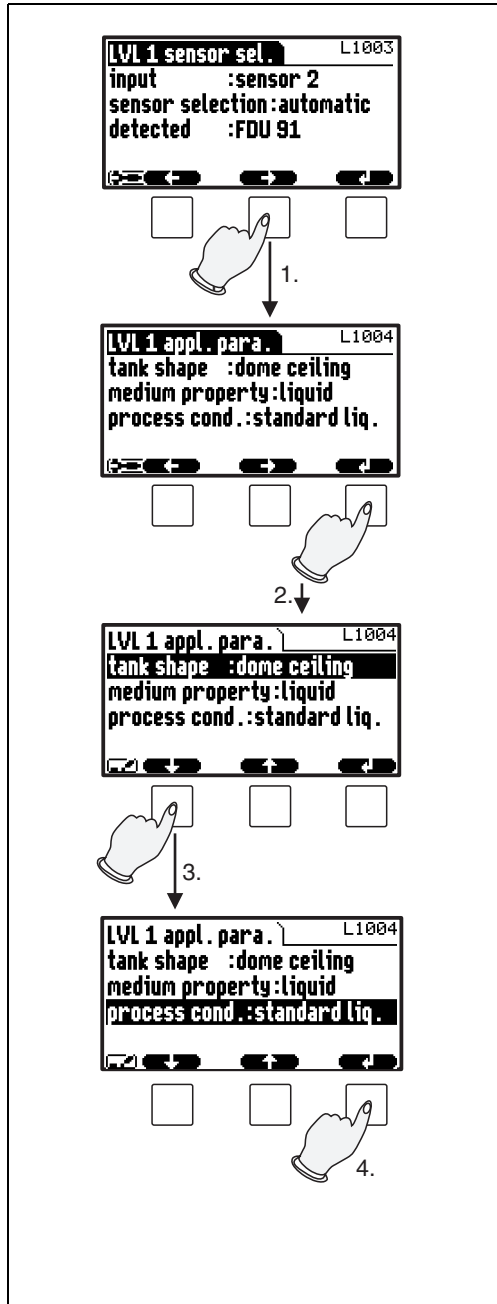

1. Press  $\leftarrow$  or  $\rightarrow$ , until you have reached the required parameter set.
2. Press  $\downarrow$ , in order to enter the parameter set.
3. Select the required parameter by pressing  $\leftarrow$  or  $\rightarrow$ .  
(This step is not required if the set contains only one parameter.)
4. Press  $\downarrow$ , in order to enter the editing mode of the parameter.  
The editing method depends on the type of parameter (selection list, numeric or alphanumeric parameter). For details refer to the following sections.

L00-FMU90xxx-19-00-00-en-040



Note!

If necessary, you can exit the parameter and parameter set by pressing  .

Editing a parameter with selection list

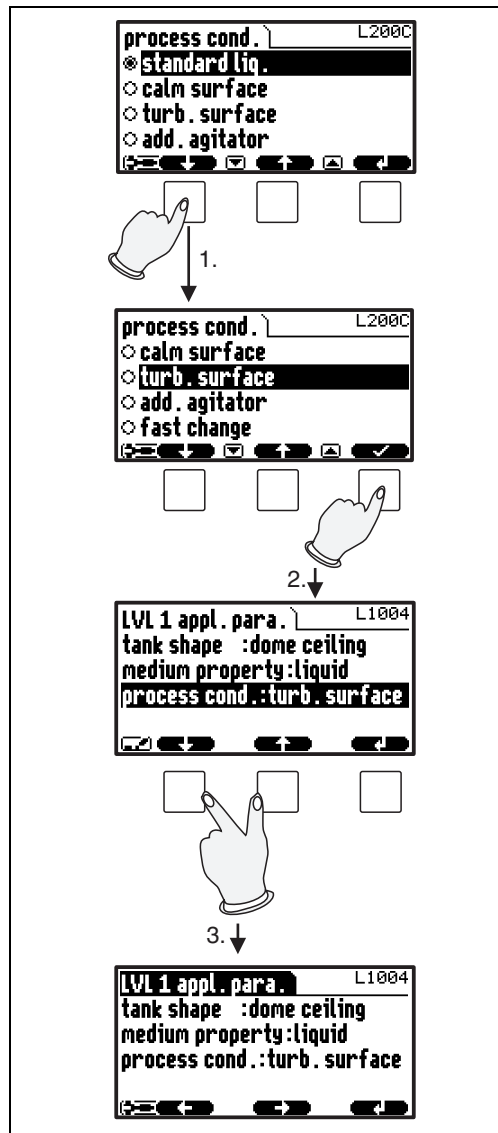

1. Press or , until the required option is marked by the bar (in the example: "turb. surface").

Note!

The symbols indicate that the selection list contains more items than can be displayed on the module. Press or several times, to mark one of the hidden items.

2. Press , in order to select the marked option. It is then stored in the instrument.

3. Press the left and middle keys simultaneously in order to quit the parameter.  
The software key symbols and reappear and you can switch to the next parameter set.



Note!

By pressing before you can quit the parameter without accepting your changes.

L00-FMI190xxx-19-00-00-en-041

Entering numbers and characters

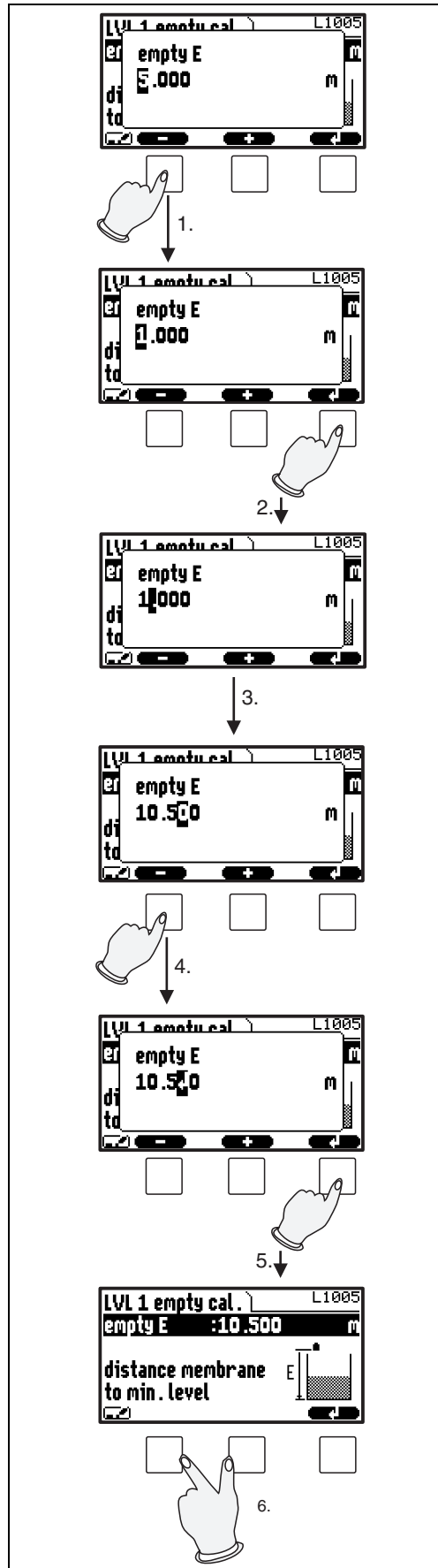

When you select a numeric parameter ("empty calibration", "full calibration" etc.) or an alpha-numeric parameter ("device marking" etc.), the editor for numbers and text strings appears. Enter the desired value in the following way:

1. The cursor is at the first digit. Press  $\square$  or  $\square$  until this digit has the required value.
2. Press  $\downarrow$  in order to confirm the value and to jump to the next digit.
3. Repeat the procedure for all relevant digits.
4. If all relevant digits have been entered: Press  $\square$  or  $\square$ , until  $\downarrow$  appears at the cursor.
5. Press  $\downarrow$  to store the complete value in the device.
6. Press the left and middle keys simultaneously in order to quit the parameter.

L00-FM190xxx-19-00-00-yy-042

### Special editing functions

Within the editor for alphanumeric characters, pressing  $\square$  or  $\square$  does not only lead to numbers and characters but also to the following symbols for special editing functions. They simplify the editing procedure.

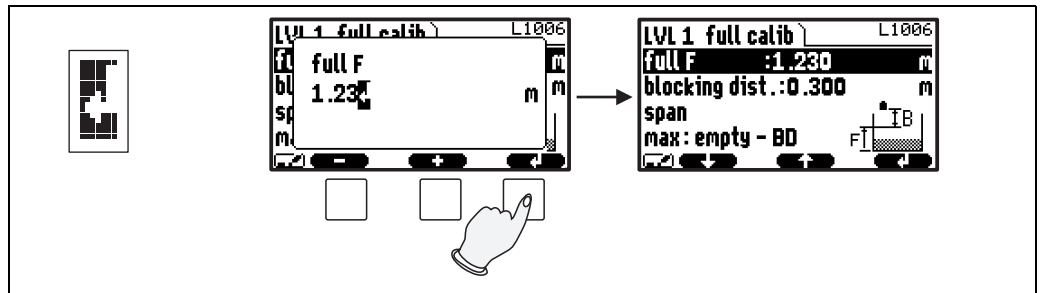

L00-FM190xxx-19-00-00-yy-043

**Enter:** The number left of the cursor is transferred to the instrument.

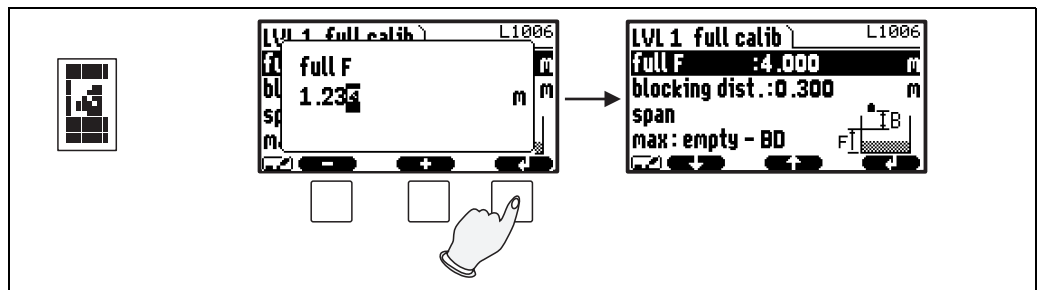

L00-FM190xxx-19-00-00-yy-044

**Escape:** The editor is closed. The parameter maintains its former value. The same behavior can be achieved by pressing the left and the middle key simultaneously ( $\square$ ).

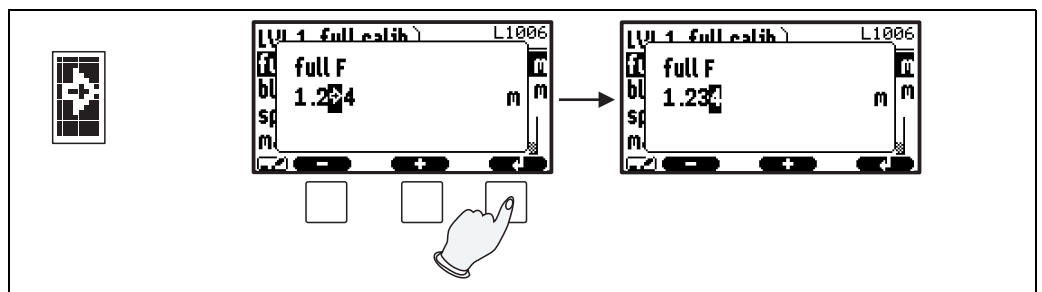

L00-FM190xxx-19-00-00-yy-045

**Next digit:** The cursor moves on to the next digit.

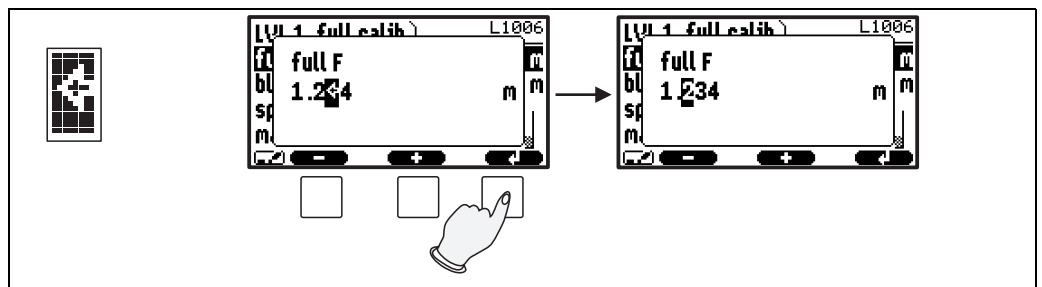

L00-FM190xxx-19-00-00-yy-046

**Previous digit:** The cursor moves back to the previous digit.

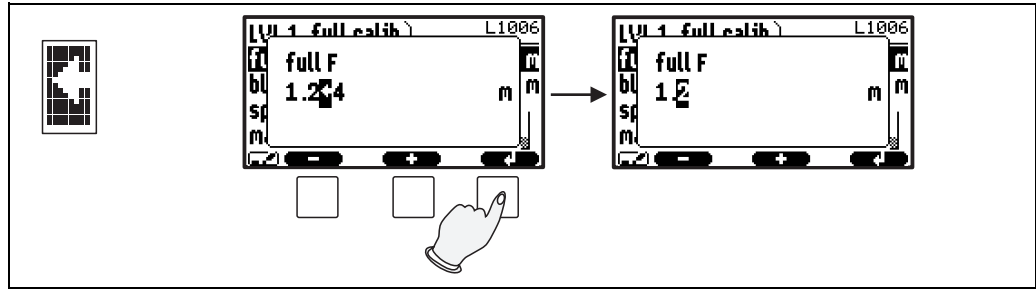

L00-FMU190xxx-19-00-00-yy-047

**Delete:** The current digit and all digits to its right are deleted.

### Return to the measured value display

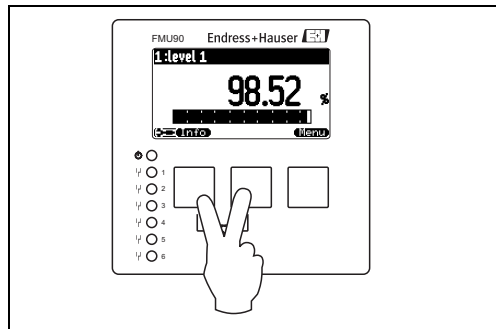

L00-FMU190xxx-19-00-00-en-048

By pressing the left and middle keys simultaneously you can return

- from a parameter to the parameter set
- from the parameter set to the submenu
- from the submenu to the main menu
- from the main menu to the measured value display

## 5.3 Operation via Endress+Hauser operating tool "FieldCare"

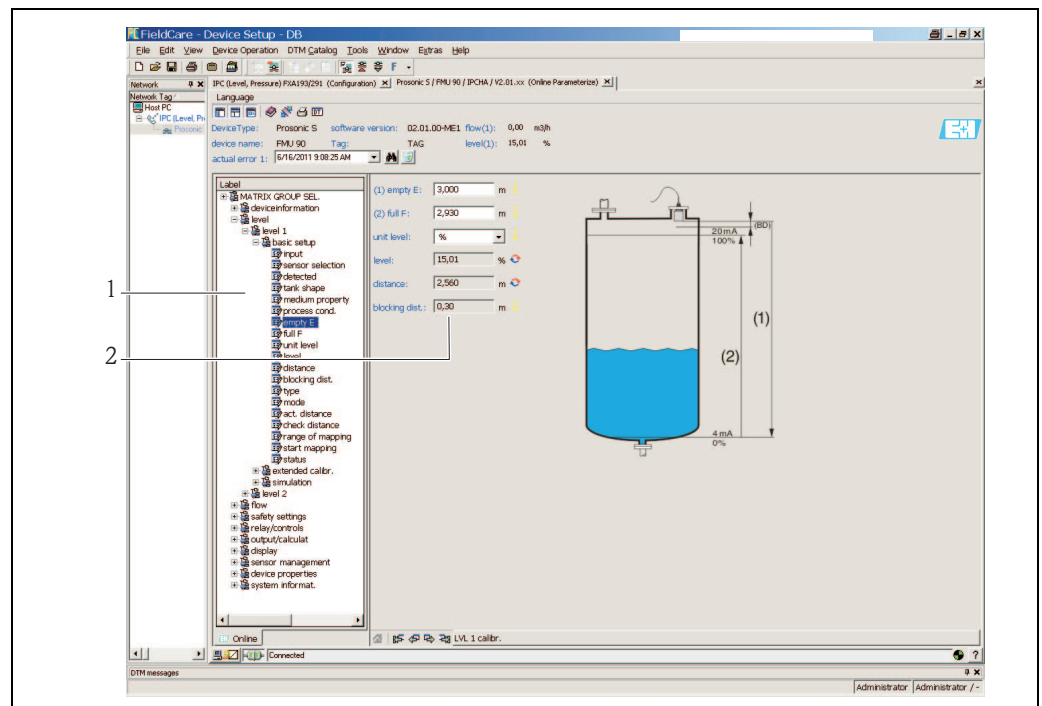

L00-FMU190ccc-19-00-00-en-087

Operation via FieldCare is similar to the operation via the display module.

- The operating menu can be found in the **navigation bar (1)**.
- Input fields for the parameters can be found in the **parameter editor (2)**.
- When you click on a parameter name, the **help pages** appear. They contain a detailed description of the respective parameter.

## 5.4 Operation via Field Xpert SFX100

Compact, flexible and robust industry handheld terminal for remote parametrization and measured value inspection via the HART current output or FOUNDATION Fieldbus. For details refer to Operating Instructions BA00060S/04/EN.

## 5.5 Lock/unlock configuration

### 5.5.1 Software locking

#### Locking

Go to the parameter "device properties/password-reset/code" and enter a value  $\neq 100$ . The instrument is locked against parameter changes. The  symbol appears on the display.

#### Unlocking

If you try to change a parameter, the "password-reset" parameter set appears. Select the "code" parameter and enter "100". Parameters can be changed again.

## 5.5.2 Locking by key combination

### Locking

Press all three keys simultaneously. The instrument is locked against parameter changes. The  symbol appears on the display.

### Unlocking

If you try to change a parameter, the "password/reset" parameter set appears. "key locked" is displayed in the "status" parameter. Press all three keys simultaneously. Parameters can be changed again.

## 5.5.3 Hardware locking

The instrument can be locked against parameter changes by the locking switch in the terminal compartment of the Prosonic S.

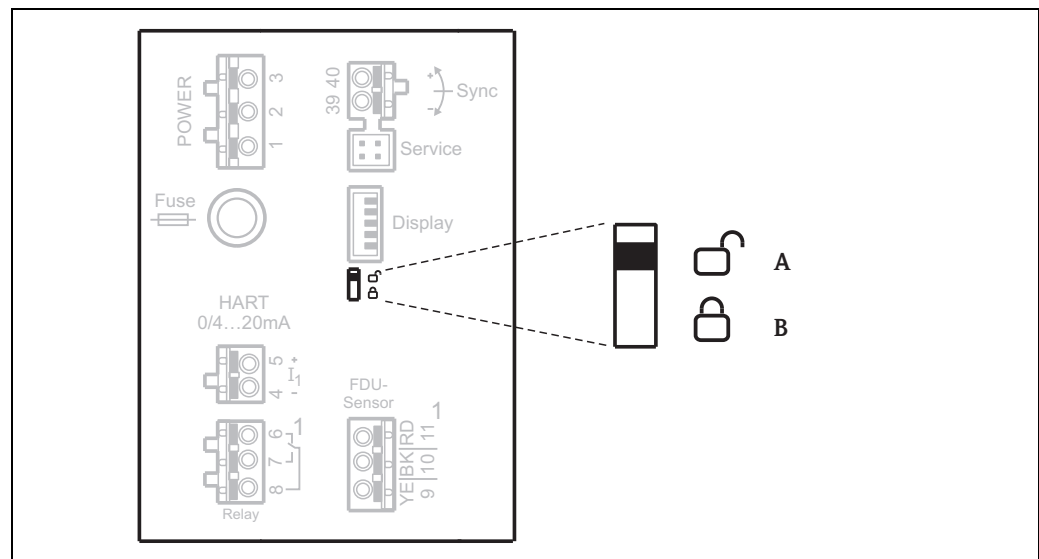

Switch position **A**: unlocked; parameters can be changed  
Switch position **B**: locked; parameters can not be changed.

If the switch is in position B,  appears on the display and parameters can not be changed. The instrument can only be unlocked by the switch.

## 5.5.4 Indication of the locking state

The current locking state of the instrument is displayed in the parameter "device properties/ password-reset/status". The following states may occur:

- **unlocked**  
All parameters (except of service parameters) can be changed.
- **code locked**  
The instrument has been locked via the operating menu. It can be unlocked by entering the unlocking code into the "code" parameter.
- **key locked**  
The key has been locked by a key combination. It can only be unlocked by pressing all three keys simultaneously.
- **switch locked**  
The instrument has been locked by the switch in the terminal compartment. It can only be unlocked by this switch.



## 5.6 Reset to the default configuration



### Caution!

A reset may lead to impairment of the measurement. As a rule, a basic calibration is required after a reset.

### Application of the Reset

It is advisable to reset the customer parameters if you want to use a device with an unknown history.

### Effects of the Reset

- All parameters are reset to their default values.
- The linearisation type is switched to "none". If a linearisation table is present, it is not deleted. If required, it can be reactivated at a later point of time.
- An interference echo curve is set "inactive". However, the curve is not deleted and can be reactivated at a later point of time.



### Note!

In the menu diagrams (→  158, "Operating menu") the default values of the parameters are printed in bold.

### Performing a Reset

In order to perform a reset, enter "333" into the parameter "device properties/password-reset/reset".

### 5-point linearity protocol



### Note!

The specified measuring accuracy is a typical value →  155, "Performance characteristics". With the production of the 5-point linearity protocol the measuring system (FDU9x sensor and FMU9x transmitter electronic) is adjusted exactly to one another and the measuring accuracy is optimized for the specified range.

To realize this, the parameter "zero distance" is fine adjusted. After a reset the value for the zero distance has to be re-parameterized in the service menu according to the data on the associated 5-point linearity protocol for the FDU9x sensor. Please contact the Endress+Hauser service.



### Note!

- To **delete a linearisation table**, use the parameter "basic setup/linearisation" → Chap. 6.4.7
- To **delete a interference echo mapping** selectively (without affecting other parameters), use the parameter "extended calibration/distance mapping/status" → Chap. 6.4.11

## 6 Commissioning



Warning!

For the version with field housing: The instrument may only be operated if the field housing is closed.

### 6.1 Structure and Functions of the Prosonic S

#### 6.1.1 Function blocks

The Prosonic S contains various function blocks. During the commissioning procedure the blocks are linked to each other in order to perform the desired measuring task. Depending on the instrument version and installation environment, the following function blocks may occur:

##### Signal inputs

- Sensor 1
- Sensor 2 (if selected in the product structure)

##### Signal evaluation (calculation of the measured value)

- Level 1
- Level 2 (for instruments with 2 current outputs)
- Flow 1 (for flow instruments)
- Flow 2 (for flow instruments)

##### Controls

- Pump control
- Rake control
- Backwater detection

##### Signal output

- Display
- Current output 1 with HART
- Current output 2 (if selected in the product structure)
- Relay 1
- Relay 2 (for instruments with 3 or 6 relays)
- Relay 3 (for instruments with 3 or 6 relays)
- Relay 4 (for instruments with 6 relays)
- Relay 5 (for instruments with 6 relays)
- Relay 6 (for instruments with 6 relays)

#### 6.1.2 Typical block configurations

##### 1-channel level measurement

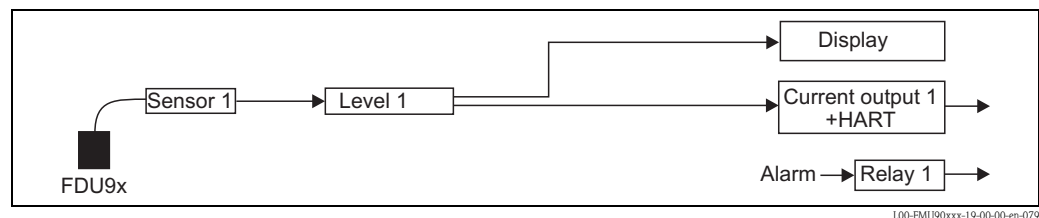

### 2-channel level measurement

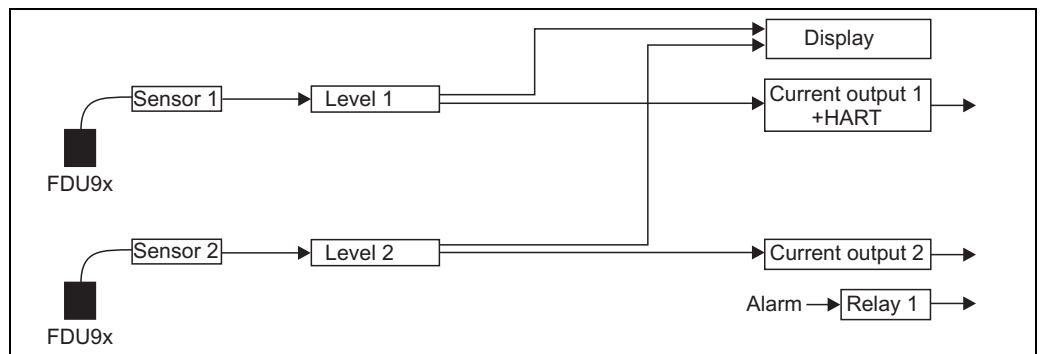

### Pump control

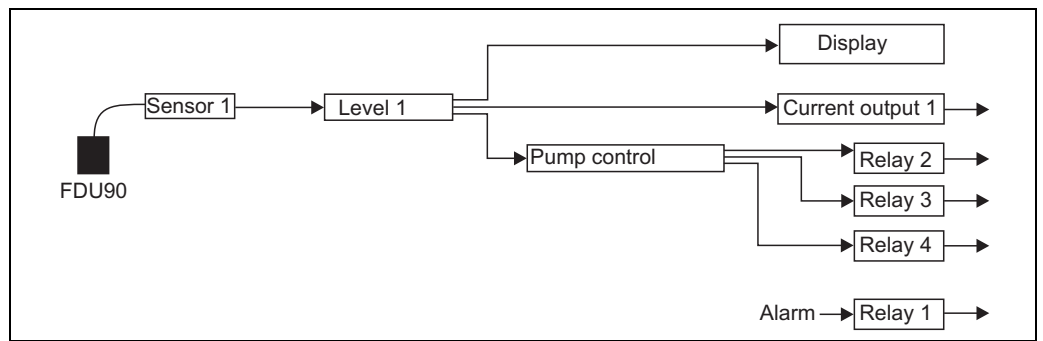

*The relays must be linked to the pump control by the user. By default, no relay is linked to the pump control.*

### Rake control

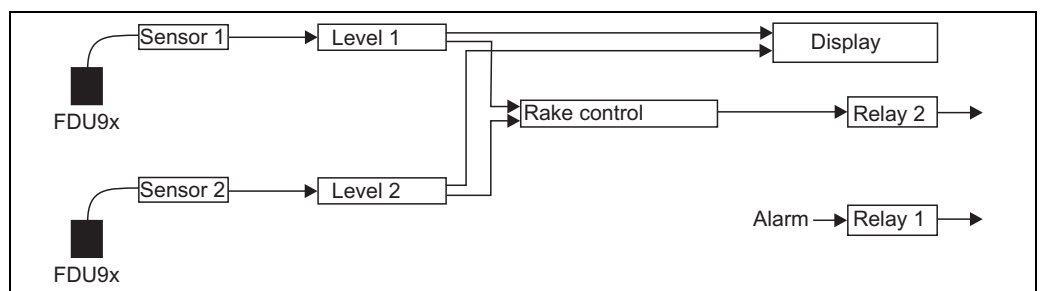

**Note!**

By default, relay 1 is always configured to be the alarm relay.

## 6.2 First setup



Note!

This chapter describes the commissioning of the Prosonic S via the display and operating module. Commissioning via FieldCare or the Field Xpert SFX100 is similar. For further instructions refer to the FieldCare Online Help or the Operating Instructions supplied with the Field Xpert SFX100.

After switching on the power supply for the first time, the instrument asks for a number of operating parameters:

1. Select the display language.
  - a. Press ↓ or ↑ to move the marking bar to the desired language.
  - b. Press ↵ to confirm your selection.



2. Select the unit for distance measurements.

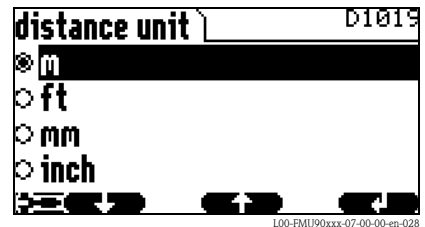

3. Select the temperature unit.

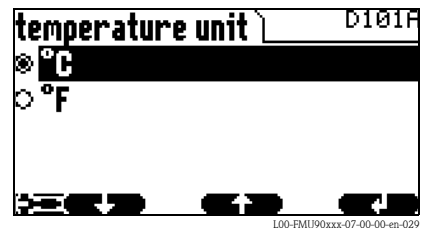

4. Select the operating mode.



Note!

The available options depend on the instrument version and the installation environment.

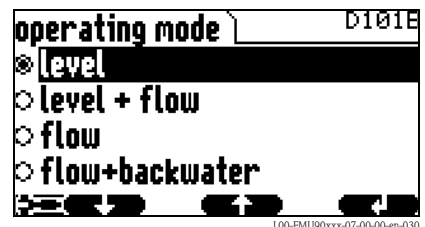

5. For level measurements:  
Select the control functions, which you are going to use.

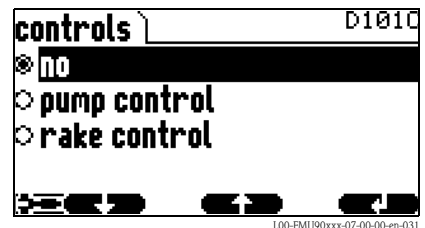

Note!



**By pressing** you can return to the previous parameter (e.g. in order to correct the value). All these parameters can also be changed at a later point of time in the "device properties/operating parameters" and "device properties/language" parameter sets.

### 6.3 Preparing the basic setup

1. After the first setup the main screen appears. However, the displayed value does not correspond to the real level before you have performed the basic setup. To do so, enter the main menu by pressing "Menu" (right key).

 Note!

In the "calibr. display" menu you can adjust the display to your requirements (displayed values, display format). The figure shows an example for a 2-channel instrument.

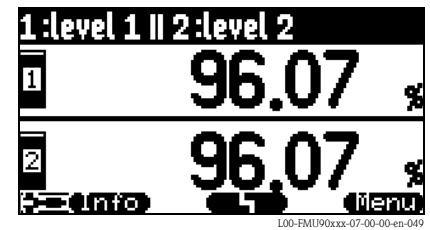

2. Select the "level" submenu.

- Select by ↓ and ↑
- Confirm by ↵

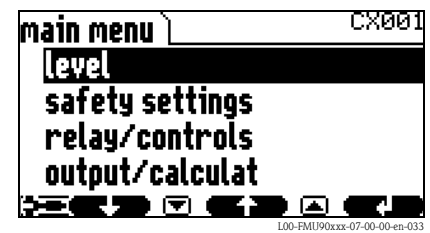

3. In the following submenu select the level channel you are going to calibrate.

 Note!

The selection "level (LVL) 2" is only available for instruments with 2 sensor inputs or 2 current outputs.

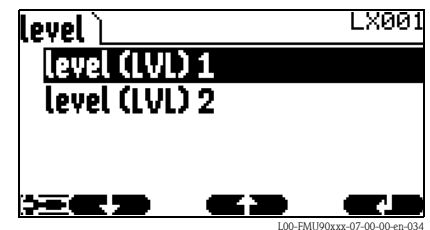

4. In the following submenu select "basic setup". This submenu contains all parameters needed for the basic setup.

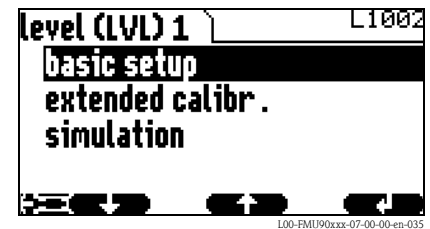

## 6.4 Basic setup

### 6.4.1 Overview

The following table gives an overview of the basic setup for level measurements. Detailed information on the parameters can be found in the sections 6.4.2. to 6.4.11.

Step	Parameter Set	Parameter	Remarks	Section
<b>Configuring the sensor</b>				
1	LVL N sensor selection (N = 1 or 2)	input	Allocate a sensor to the channel.	→ Chap. 6.4.2
		sensor selection	Specify the type of sensor ("automatic" for FDU9x)	
		detected	only available for "sensor selection" = "automatic"; indicates the detected type of sensor.	
2	application parameter	tank shape	Select the appropriate values for your application	→ Chap. 6.4.3
		medium property		
		process conditions		
3	empty calibration	empty E	Specify the distance between the reference point of the sensor and the minimum level (0%).	→ Chap. 6.4.4
4	full calibration	full F	Specify the distance between the minimum (0%) and maximum (100%) level.	→ Chap. 6.4.5
		blocking distance (BD)	Display parameter; the maximum value for the full calibration is: $F_{\max} = E - BD$	
5	unit level	unit level	Select the unit for the level measurement.	→ Chap. 6.4.6
		level	Displays the currently measured level.	
		distance	Displays the currently measured distance between the reference point of the sensor and the product level.	
<b>Linearisation (if no linearisation is required: continue by step 7: "distance correction")</b>				
6	linearisation	type	Select type of linearisation	→ Chap. 6.4.7
		mode	Specify, to which value the measurement refers: "level" or "ullage"	
		customer unit	Specify the unit for the linearized value; (not available for "type" = "none")	
		max. scale	Specify the maximum contents of the vessel (in customer units); (not available for "type" = "none")	
		diameter	Specify the diameter of the tank; (only available for "type" = "horizontal cylinder" or "sphere")	
		intermediate height	Specify the intermediate height of the tank or silo; (only available for "type" = "pyramid bottom", "conical bottom" oder "angled bottom")	
		edit	Used to enter, change or delete a linearisation table; (only available for "type" = "table")	
		status table	Enables or disables the linearisation table; (only available for "type" = "table")	

Step	Parameter Set	Parameter	Remarks	Section
<b>Interference echo suppression</b>				
7	distance correction	act. distance 1 act. distance 2	Indicates the currently measured distance between the reference point of the sensor and the product surface.	→ Chap. 6.4.8 → Chap. 6.4.9
		Check distance	Compare the indicated distance with the real value: <ul style="list-style-type: none"> <li>■ "distance = ok" → "distance mapping" (see below)</li> <li>■ "distance too small" → "distance mapping" (see below)</li> <li>■ "distance too big" → Basic setup completed</li> <li>■ "distance unknown" → Basic setup completed</li> <li>■ "manual" → "distance mapping" (see below)</li> </ul>	
8	distance mapping	act. distance 1 act. distance 2	Indicates the currently measured distance between the reference point of the sensor and the product surface.	→ Chap. 6.4.10
		range of mapping	Determines the range over which the mapping is recorded; confirm the predefined value or enter your own value.	
		start mapping	Select: <ul style="list-style-type: none"> <li>■ no: the mapping is not recorded</li> <li>■ yes: the mapping is recorded; after completion the "LVL 1(2) state" function appears (see below)</li> </ul>	
9	LVL 1(2) state	level 1(2)	Indicates the currently measured level.	→ Chap. 6.4.11
		act. distance	Indicates the currently measured distance between the reference point of the sensor and the product surface. Check the value: <ul style="list-style-type: none"> <li>■ Value correct: → Basic setup completed. Return to the measured value display by pressing  several times</li> <li>■ Value not incorrect: → go back to step 7 ("distance correction")</li> </ul>	
		status	Used to enable, disable or delete a mapping	
<b>When using FDU90 with flooding protection tube: Parametrization of the flooding detection</b>				
10	Menu: safety settings -> safety distance	safety dist. sensor 1 safety dist. sensor 2	In order to detect flooding reliably when using the FDU90 sensor with a flooding protection tube, a safety distance must be defined slightly below the lower edge of the flooding protection tube.	see BA00290F, Chapter 4
11	Menu: relay/controls -> relay allocation		Select the relay you want to use to indicate flooding	→ Chap. 8.2.2
12	relay N	function	1. Select "alarm diagnostics" 2. Select "diagnostics"	→ Chap. 8.2.3
		allocation	Select "safety distance channel 1/2". The relay is de-energized as soon as the level rises into the safety distance.	→ Chap. 8.2.4

## 6.4.2 "LVL N sensor selection" (N = 1 or 2)

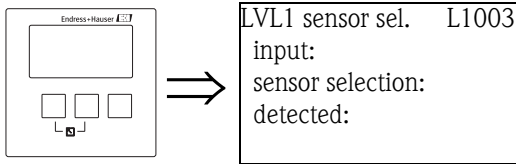

### "input"

Use this parameter to assign a sensor to the channel.

#### Selection:

- no sensor
- sensor 1
- sensor 2 (only for 2-channel instruments)

### "sensor selection"

Use this parameter to specify the type of the connected ultrasonic sensor.



Note!

- For the sensors **FDU9x** the option "automatic" is recommended (default setting). With this setting the Prosonic S recognizes the type of sensor automatically.
- For the sensors **FDU8x** the type has to be assigned explicitly. The automatic sensor recognition does not work for these sensors.



Caution!

After **exchanging a sensor**, observe the following:

The automatic sensor recognition is also active after a sensor has been exchanged<sup>4)</sup>. The Prosonic S recognizes the type of the new sensor automatically and changes the "detected" parameter if required. The measurement continues without a break.

Nevertheless, in order to ensure perfect measurement, the following checks are required:

- Check the **"empty calibration"** and **"full calibration"** parameters. Adjust these values if required. Take into account the blocking distance of the new sensor.
- Go to the **"distance correction"** parameter set and check the displayed distance. If required, perform a new interference echo suppression.

### "detected" (only available for "sensor selection" = "automatic")

Indicates the type of the automatically detected sensor.

4) if the new sensor is of the type FDU9x



### 6.4.3 "LVL N application parameters" (N = 1 or 2)

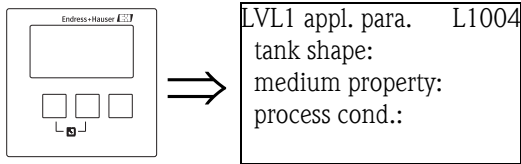

#### "tank shape"

Use this parameter to specify the tank shape of your application.

#### Selection:

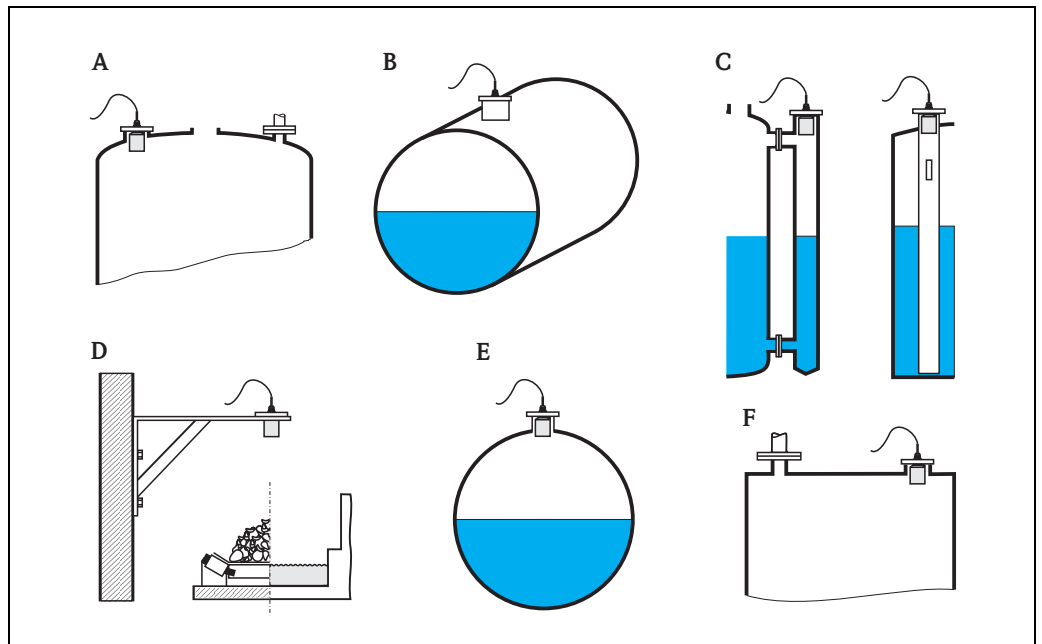

100-FM190xxx-14-00-00-xx-002

- A Dome ceiling
- B Horizontal cyl.
- C Bypass, stilling well/ultrasonic guide pipe
- D No ceiling, e.g. dumps, open levels, chanel, weirs
- E Sphere
- F Flat ceiling

#### "medium property"

Use this parameter to specify the type of medium.

#### Selection:

- liquid
- paste like
- solid < 4 mm
- solid > 4 mm
- unknown







Note!

If the medium does not fit into one of the groups, select "unknown".

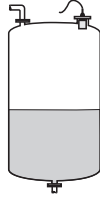
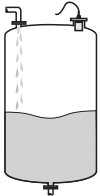
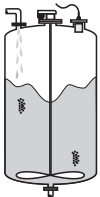
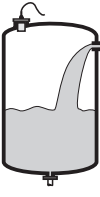
**"process conditions"**

Use this parameter to specify the process conditions of your application. The filters of the signal evaluation are automatically adjusted to the selected conditions.

"process conditions"	for the following situations	Example	filter settings
standard liquid	for all fluid applications which do not fit in any of the following groups		The filters and output damping are set to average values.
calm surface	Storage tanks with immersion tube or bottom filling		The averaging filters and output damping are set to large values. -> stable measured value -> accurate measurement -> slow reaction time
turbulent surface	Storage/accumulation tanks with uneven surface due to free filling, mixing nozzles or small bottom stirrers		Special filters for stabilizing the input signal are activated. -> stable measured value -> medium reaction time
additional agitator	Moving surfaces (possibly with vortex formation) due to agitators		Special filters for stabilizing the input signal are set to large values. -> stable measured value -> medium reaction time
fast change	Rapid level change, particularly in small tanks		The averaging filters are set to small values. -> rapid reaction time -> possibly unstable measured value
standard solid	For all bulk solid applications which do not fit in any of the following groups.		The filter and output damping are set to average values.
solid dusty	Dusty bulk solids		The averaging filters are set to detect even relatively weak signals.
conveyor belt	Bulk solids with rapid level change		The averaging filters are set to small values. -> rapid reaction time -> possibly unstable measured value
test: no filter	For service and diagnosis only		All filters are switched off.

### 6.4.4 "LVL N empty calibration" (N = 1 or 2)

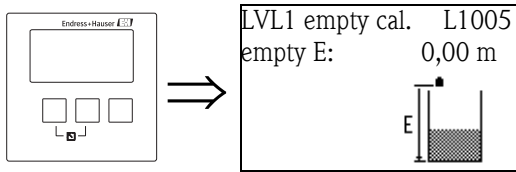

#### "empty E"

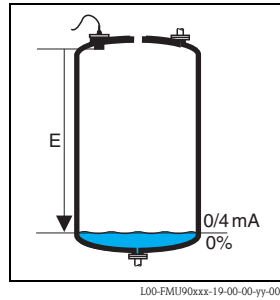

Use this parameter to specify the empty distance E, i.e. the distance between the reference point of the sensor and the minimum level (zero point).

- Default: max. measuring range of the respective sensor
- Range of values: depending on sensor type

 **Caution!**

The zero point should not be deeper than the point at which the ultrasonic wave impinges on the tank bottom

### 6.4.5 "LVL N full calibration" (N = 1 or 2)

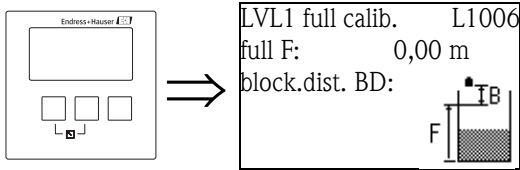

#### "full F"

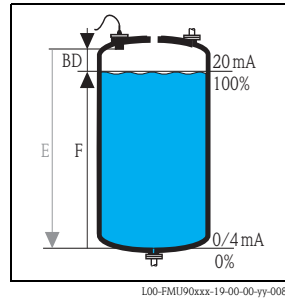

Use this parameter to specify the span F, i.e. the distance from the minimum level to the maximum level.

- Default setting: depending on sensor type
- Range of values: depending on sensor type
- blocking distance BD: depending on sensor type (see table)

Caution!

The maximum level may not project into the blocking distance:

$$F_{max} = E - BD$$

#### "blocking distance"

Indicates the blocking distance of the respective sensor. The blocking distance is measured from the reference point of the sensor.

Type of sensor	blocking distance (BD)	maximum measuring distance <sup>1)</sup>
FDU90	0,07 (0.2)	3,0 (9.8) (for liquids)
FDU91/FDU91F	0,3 (1.0)	10 (33) (for liquids)
FDU92	0,4 (1.3)	20 (66) (for liquids)
FDU93	0,6 (2.0)	25 (82) (for liquids)
FDU95 - *1*** (low temperature version)	0,7 (2.3)	45 (148) (for solids)
FDU95 - *2*** (high temperature version)	0,9 (3.0)	45 (148) (for solids)
FDU96	1,6 (5.2)	70 (230) (for solids)
FDU80/FDU80F	0,3 (1.0)	5 (16) (for liquids)
FDU81/81F	0,5 (1.6)	10 (33) (for liquids)
FDU82	0,8 (2.6)	20 (66) (for liquids)
FDU83	1,0 (3.3)	25 (82) (for liquids)
FDU84	0,8 (2.6)	25 (82) (for solids)
FDU85	0,8 (2,6)	45 (148) (for solids)
FDU86	1,6 (5.2)	70 (230) (for solids)

m (ft)

1) valid for optimum process conditions

### 6.4.6 "LVL N unit" (N = 1 or 2)

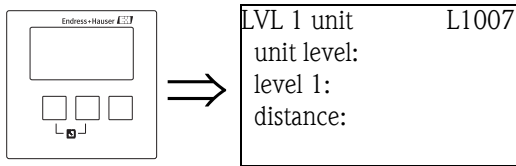

#### "unit level"

Use this parameter to select the level unit.  
If no linearization is performed, the level is displayed in this unit.

#### Selection:

- m
- ft
- inch
- mm
- % (Default)



#### Caution!

After a change of the level unit, the switching points of the limit and pump control relays have to be checked and to be adjusted if required.

#### "level N" (N = 1 or 2)

Displays the currently measured level F (from the zero point to the product surface) in the selected unit.

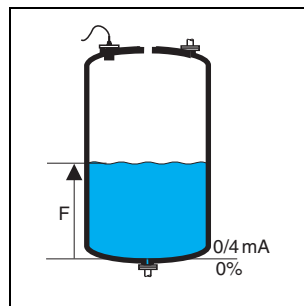

L00-FMU90xxxx-19-00-00-yy-021

#### "distance"

Displays the currently measured distance D from the reference point of the sensor to the product surface in the distance unit. If the display value does not match the real distance, an interference echo suppression must be performed prior to linearization.

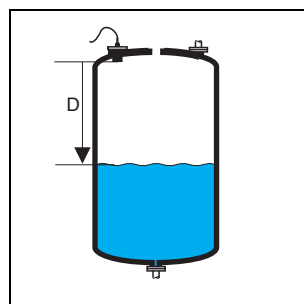

L00-FMU90xxxx-19-00-00-yy-022

**Note!**

The distance unit is defined during the first setup of the instrument. If required, it can be changed in the "device properties/operating params" menu.

### 6.4.7 "LVL N linearisation" (N = 1 or 2)

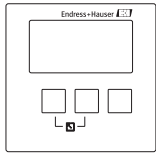

LVL 1 linearisat. L1008  
type:  
mode:

**Note!**

Number and type of the parameters in this set depend on the selected linearization type.

Only the parameters "type" and "mode" are always present.

The "linearization" is used to convert the level into other quantities. Especially, it can calculate the volume or mass within a vessel of arbitrary shape. The Prosonic S provides different linearization modes for the most common types of vessels. Additionally, a linearization table for arbitrarily shaped vessels can be entered.

**"type"**

Use this parameter to select the type of linearisation.

**Selection:**

- **none**

In this linearization type the measured level is not converted but displayed in the selected level unit (see above, "unit level").

- **linear**

In this linearization type the displayed value is proportional to the measured level.

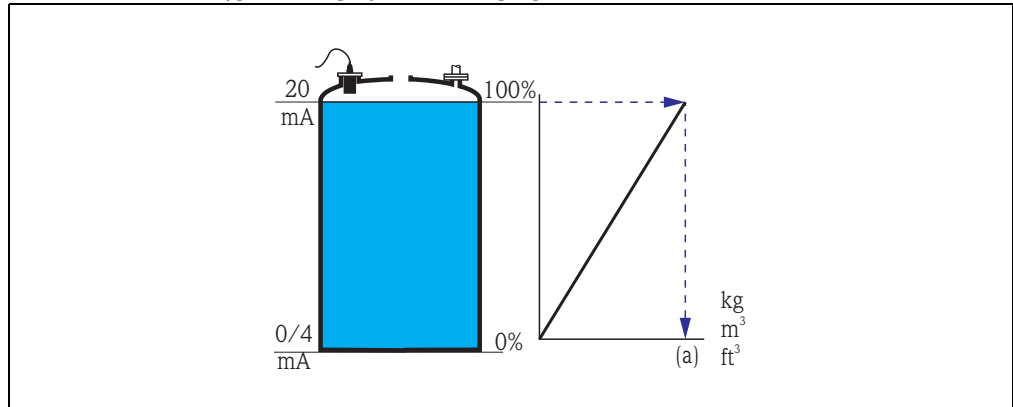

The following additional parameter have to be specified:

- the unit for the linearized value, e.g. kg, m<sup>3</sup>, ft<sup>3</sup>, ... ("**customer unit**")
- the maximum capacity (a) of the vessel, measured in the customer unit ("**maximum scale**").

- horizontal cylinder<sup>5)</sup>
- sphere

In these linearization types the measured level is converted to the volume in a horizontal cylinder or a spherical tank.

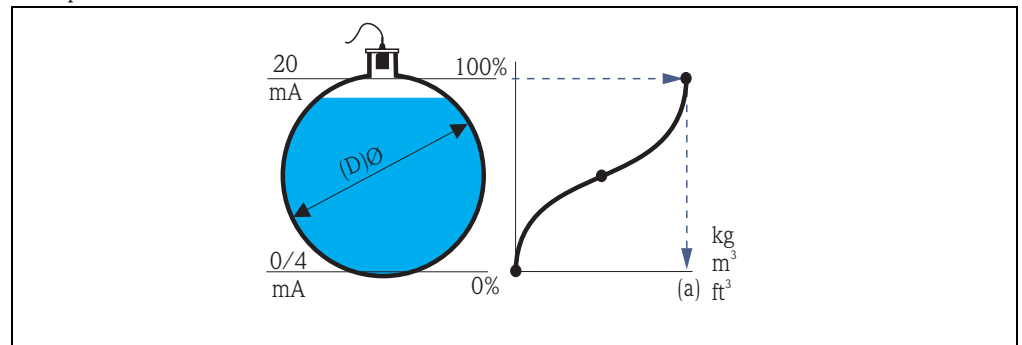

The following additional parameters have to be specified:

- the unit of the linearized value, e.g. kg, m<sup>3</sup>, ft<sup>3</sup>, ... ("**customer unit**")
- the diameter (D) of the tank ("**diameter**")
- the maximum capacity (a) of the tank, measured in the customer unit ("**maximum scale**").

- angled bottom (A)
- pyramid bottom (B)
- conical bottom (B)

In these linearisation modes the measured level is converted to the volume in the respective type of vessel.

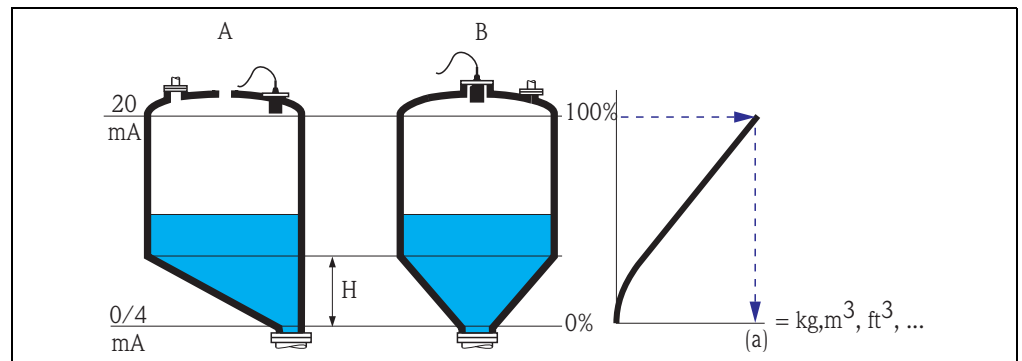

The following additional parameters have to be specified:

- the unit for the linearized value, e.g. kg, m<sup>3</sup>, ft<sup>3</sup>, ... ("**customer unit**")
- the intermediate height H according to the diagram ("**intermediate height**")
- the maximum capacity (a) of the tank, measured in the customer unit ("**maximum scale**").

5) This option is only valid for horizontal cylinders without dome ceiling. For tanks with dome ceiling FieldCare can be used to calculate a linearisation table and to upload it into the instrument.

■ **table**

In this linearization mode the measured value is calculated from a linearization table. The table may consist of up to 32 pairs of values (level - volume). The table must be monotonically increasing or decreasing.

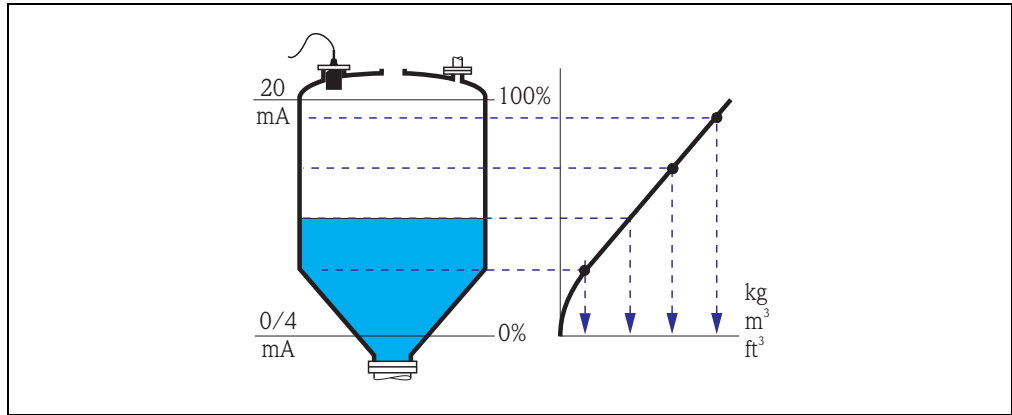

The following additional parameters have to be specified:

- the unit of the linearized value, e.g. kg, m<sup>3</sup>, ft<sup>3</sup>, ... ("**customer unit**")
- the linearization table ("**edit**")

**"customer unit"**

Use this parameter to select the desired unit for the linearized values (e.g. kg, m<sup>3</sup>, ft<sup>3</sup>, ...). This unit is only indicated on the display. It does not cause a conversion of the measured value.



Note!

After selecting the option "customer specific", the parameter "customized text" appears. An arbitrary string (consisting of up to 5 alphanumeric characters) can be entered into this parameter.

**"maximum scale"**

Use this parameter to specify the maximum content of the vessel in the customer unit.

**"diameter"**

Use this parameter to specify the diameter of the horizontal cylinder or the spherical tank respectively.

**"intermediate height"**

Use this parameter to specify the intermediate height of the vessel.

**"mode"**

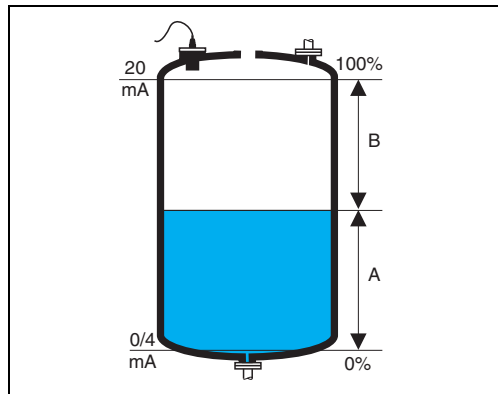

L00-FM190xxx-19-00-00-yy-015

Use this parameter to specify if the measurement refers to the "**level**" (A) or to the "**ullage**" (B).



**"edit"**

Use this parameter to enter, change or read a linearization table. There are the following options:

- **read:**  
The table editor is opened. The existing table can be read but not changed.
- **manual:**  
The table editor is opened. Table values can be entered and changed.
- **semi-automatic:**  
The table editor is opened. The level is automatically read by the Prosonic S. The measured value (volume, weight or flow) must be entered by the user.
- **delete:**  
The linearization table is deleted.

**The table editor**

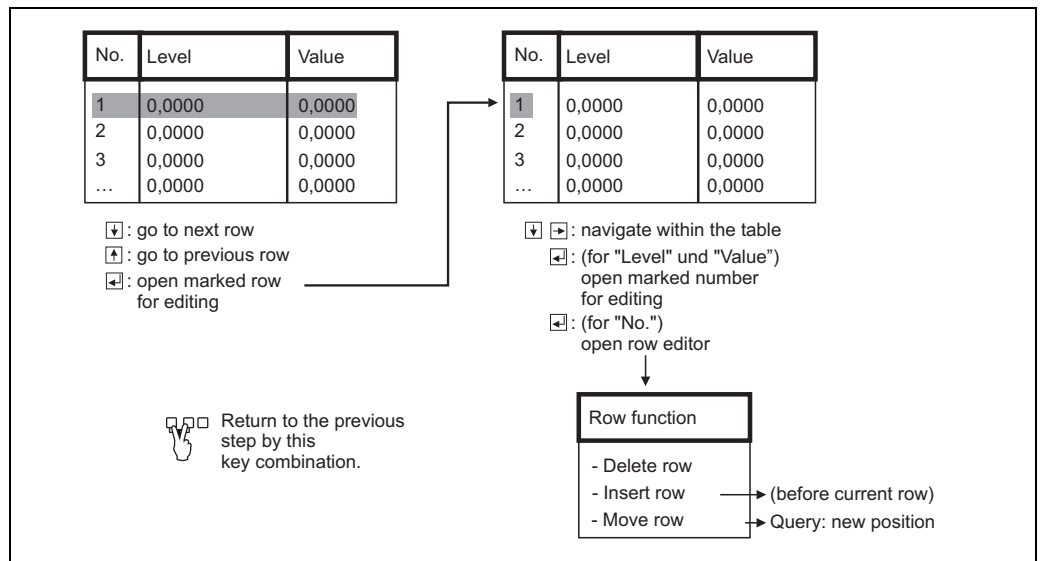

L00-FM190xxx-19-00-00-de-006

**"status table"**

Use this parameter to enable or disable the linearization table.

**Selection:**

- **enabled**  
The table is used.
- **disabled**  
The table is **not** used. The measured value is transferred to the output without linearization.

### 6.4.8 Interference echo suppression: Basic principles

The "**check value**" and "**distance mapping**" parameters are used to configure the interference echo suppression of the Prosonic S.

The following picture shows the operating principle of the interference echo suppression:

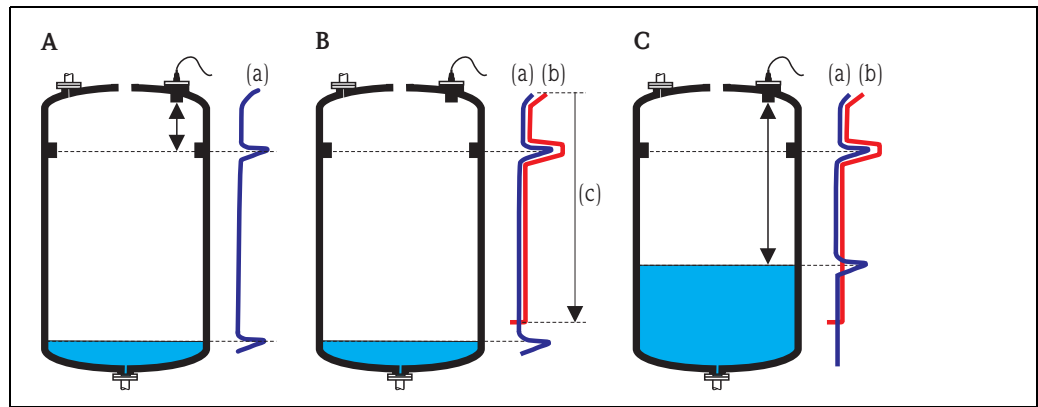

100-FM190xxx-19-00-00-yy-017

- A** The envelope curve **(a)** contains the level echo and an interference echo. Without interference echo suppression, the interference echo is evaluated.
- B** The interference echo suppression generates the mapping curve **(b)**. This curve suppresses all echos within the range of mapping **(c)**.
- C** From now on, only those echos are evaluated, which are higher than the mapping curve. The interference echo is below the mapping curve and is therefore ignored.



Note!

In order to include all interference echos, the interference echo suppression should be performed with the level as low as possible. If during commissioning the vessel can not be sufficiently emptied, it is advisable to repeat the interference echo suppression at a later point of time (as soon as the level reaches nearly 0%).

### 6.4.9 "LVL N check value" (N = 1 or 2)

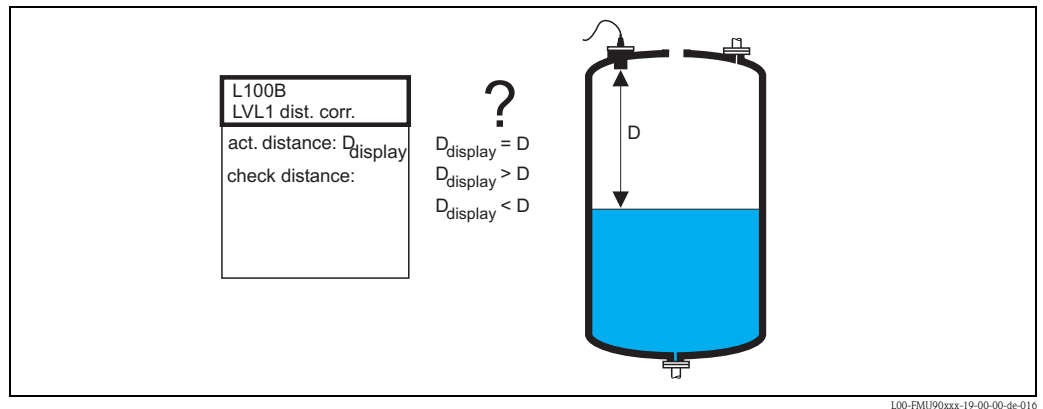
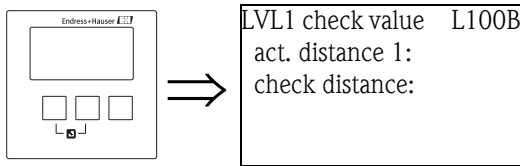

#### "actual distance N" (N = 1 or 2)

Displays the currently measured distance  $D_{\text{display}}$ .

#### "check distance"

Use this parameter to state if the displayed distance  $D_{\text{display}}$  matches the real distance  $D$  (measured by a rule for example). Based on your selection, the Prosonic S automatically proposes a suitable range of mapping.

You have got the following options:

##### ■ distance = ok

Choose this option if the displayed value  $D_{\text{display}}$  matches the real distance  $D$ .

After selecting this option, the Prosonic S changes to the "**LVL N distance mapping**" parameter set. The preset range of mapping is identical to  $D$ . That means: all interference echos above the current product surface will be suppressed by the mapping curve.

##### ■ distance too small

Choose this option if the displayed value  $D_{\text{display}}$  is smaller than the real distance  $D$ .

In this case the currently evaluated echo is an interference echo.

After selecting this option, the Prosonic S changes to the "**LVL N distance mapping**" parameter set. The preset range of mapping is slightly larger than  $D_{\text{display}}$ . Therefore, the currently evaluated interference echo is suppressed by the mapping curve.

If after the mapping  $D_{\text{display}}$  is still too small, repeat the mapping until  $D_{\text{display}}$  matches the real distance  $D$ .

##### ■ distance too big

Choose this option if the displayed value  $D_{\text{display}}$  exceeds the real distance  $D$ .

This error is not caused by interference echos. Therefore, no interference echo suppression is performed and the Prosonic S returns to the "level 1(2)" submenu. Check the calibration parameters, especially the "**empty calibration**" and the "**application parameters**".

##### ■ distance unknown

Choose this option if you do not know the real distance  $D$ .

In this case, an interference echo suppression can not be performed and the Prosonic S returns to the "level 1(2)" submenu.

##### ■ manual

Choose this option if you want to define the range of mapping manually.

The Prosonic S changes to the "**LVL N distance mapping**" function, where you can define the required range of mapping.

#### 6.4.10 "distance mapping"

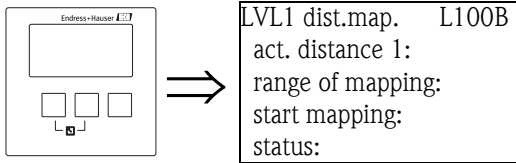

##### "actual distance N" (N = 1 or 2)

Displays the currently measured distance between the reference point of the sensor and the product surface. Compare this value to the real distance in order to find out if currently an interference echo is evaluated.

##### "range of mapping"

Use this parameter to specify the range of the mapping curve. Normally, a suitable value has already been entered automatically. Nevertheless, you can change this value if required.

##### "start mapping"

Select "**yes**" in this parameter in order to start the mapping. When the mapping is finished, the state is automatically changed to "**enable map**".

The "**LVL N state**" parameter set appears, in which the currently measured level and distance are displayed. Compare the displayed distance to the real distance in order to decide if a further mapping is necessary.

If yes: Press the left-arrow key (←) in order to return to the "**LVL N dist. map**" parameter set.

If no: Press the right-arrow key (→), in order to return to the "**level (LVL) N**" submenu.

### 6.4.11 "LVL N state" (N = 1 or 2)

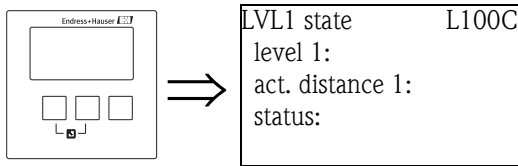

#### "level N" (N = 1 or 2)

Displays the currently measured level.

#### "act. distance N" (N = 1 or 2)

Displays the currently measured distance.

#### "status"

Use this parameter to define the status of the interference echo suppression.

##### ■ enable map

Choose this option in order to activate the interference echo suppression. The mapping is then used for signal evaluation.

##### ■ disable map

Choose this option in order to deactivate the interference echo suppression. The mapping is then no longer used for signal evaluation but it can be reactivated if required.

##### ■ delete map

Choose this option in order to delete the mapping. It can not be reactivated again and the instrument uses the preprogrammed default mapping.

## 6.5 Envelope curve display

After the basic setup an evaluation of the measurement with the aid of the envelope curve is recommended → Chap. 10.3.

## 6.6 After the basic setup

After the basic setup the Prosonic S transmits the measured value via

- the display module
- the current output  
(by default the complete measuring range (0% - 100%) is mapped to the current range [4 - 20mA])
- the HART signal



Note!

### Sensor management

For instruments with multiple sensor inputs it is possible to deactivate inputs (or sensors) which are not used. To do so, go to the function "sensor management/FDU sensor N/sensor operation" and select the desired option:

- **on**  
The sensor is switched on.
- **hold**  
The sensor is switched off. The last measured value is held.
- **off**  
The sensor is switched off. No measured value is transmitted.

Additional parameters are available for optimization of the measuring point. They can be parametrized as required. A detailed description of all instrument functions is given in the operating manual BA00290F/00, "Prosonic S FMU90 - Description of Instrument Functions". A PDF-file of this document is available from

- the supplied CD-ROM
- the internet at "[www.endress.com](http://www.endress.com)"

The following chapters describe the function groups "calibration display", "relay/controls" and "output/calculations".

## 7 The "display" menu

### 7.1 "display"

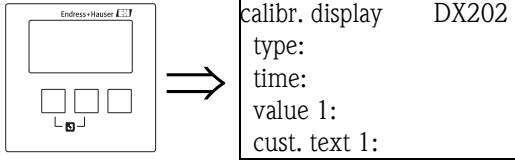

#### "type"

Use this parameter to select the format of the measured value display.

#### Selection:

- 1x value+bargraph (default for instruments with 1 current output)

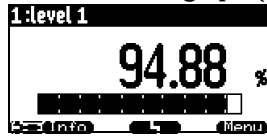

- 2x value+bargraph (default for instruments with 2 current outputs)



- value max. size

Up to two values are displayed alternately using the entire display:

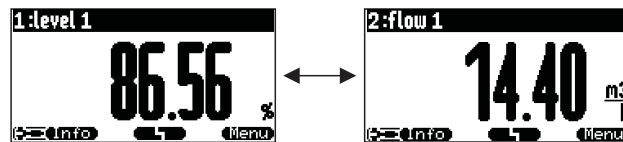

- alter 3x2 values

Up to 6 values can be displayed on three alternating pages. Each pages contains two values.

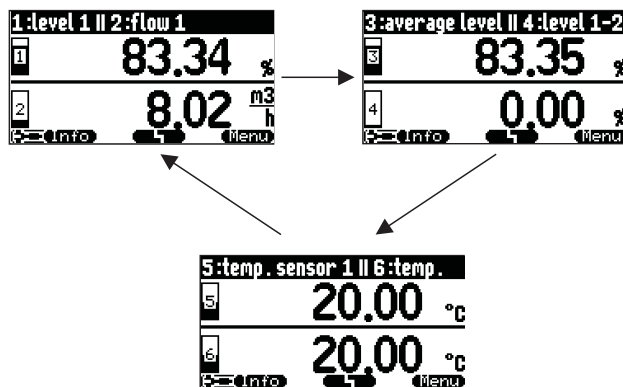

#### "time"

This parameter is used for the options "value max. size" and "alter 3x2 values". It specifies the time after which the next page appears.



Note!

To change to the next page immediately, press .

**"value 1" ... "value 6"**

Use these parameters to allocate a measured or calculated value to each of the display values. The selection depends on the instrument version and installation environment.



Note!

If "temp. sensor 1/2" is selected, depending on the setting in "sensor management/FDU sensor N" one of the following is displayed:

- the sensor temperature
- the average of the sensor temperature and the temperature of the external temperature probe
- the temperature of the external temperature probe

**"cust. text 1" ... "cust. text 6"**

These parameters can be used to allocate a text string to each of the display values. This text is displayed together with the value if "**customized text**" (in the "display format" parameter set) has been set to "**yes**".

## 7.2 "display format"

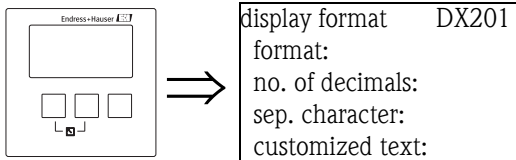
**"format"**

Use this parameter to select the display format for numbers.

**Selection:**

- decimal (Default)
- ft-in-1/16"

**"no. of decimals"**

Use this parameter to select the number of decimals for the representation of numbers.

**Selection:**

- x
- x.x
- x.xx (Default)
- x.xxx

**"sep. character"**

Use this parameter to select the separation character for the representation of decimal numbers.

**Selection:**

- point (.) (Default)
- comma (,)

**"customized text"**

Determines if "text 1" to "text 6" from the "calibration display" parameter set are displayed.

**Selection:**

- no (Default)
- yes



### 7.3 "back to home"

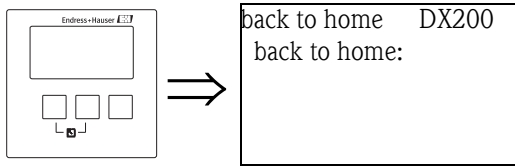

#### "back to home"

Use this parameter to specify the return time. If no entry is made during the specified time, the display returns to the measured value display.

- Range of values: 3 ... 9999 s
- Default: 900 s

## 8 The "Relay/Controls" menu

The "relay/controls" menu is used to configure the relays and control functions of the Prosonic S. The following relay functions are available for level measurements:

- Limit relay
- Alarm and diagnostics relay
- Pump control - standard
- Pump control - enhanced
- Rake control

The configuration of these functions is described in the following sections.

### 8.1 Configuration of a limit relay

#### 8.1.1 Overview

Step	Parameter set or submenu	Parameter	Remarks	Section
1	"relay/controls" menu		Select "relay configuration".	
2	relay allocation		Select a relay.	→ Chap. 8.1.2
3	relay N (N= 1 -6)	function	1. Select "limit" 2. Select the measured or calculated value to which the limit refers.	→ Chap. 8.1.3
4	relay N (N = 1 - 6)	limit type	Select a limit type.	→ Chap. 8.1.4
		switch on point	Define the switch on point. (only available for "limit type" = "standard" or "tendency/speed")	
		switch off point	Define the switch off point. (only available for "limit type" = "standard" or "tendency/speed")	
		upper switch point	Define the upper switch point. (only available for "limit type" = "inband" or "out of band")	
		lower switch point	Define the lower switch point. (only available for "limit type" = "inband" or "out of band")	
		hysteresis	Define the hysteresis. (only available for "limit type" = "inband" or "out of band")	
5	relay N (N = 1 - 6)	switch delay	Define the switch delay (Default: 0s).	→ Chap. 8.1.5
		invert	Select if the relay signal is to be inverted (default: no)	
		error handling	Define the reaction of the relay in the case of an error.	

### 8.1.2 "relay allocation"

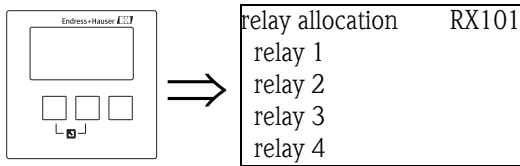

Use this parameter to select the relay you are going to configure.

#### Selection:

- All relays of the instrument version at hand



Note!

If a function has already been allocated to one of the relays, the name of this function is displayed next to the relay number.

### 8.1.3 "relay N" (N = 1 - 6) (Part 1: relay function)

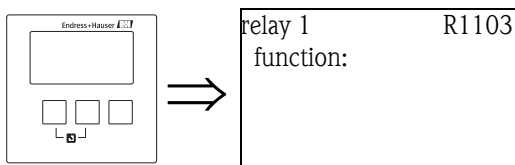

After selecting a relay, the parameter set "**relay N**" (N = 1 - 6) appears, which is used to configure the relay. Initially, it contains the "function" parameter only. To configure a limit relay, proceed according to the following steps:

1. Select the "**function**" parameter. The "**select function**" screen appears.
2. Select "**limit**". The "**function**" selection list appears.
3. Select the measured or calculated value to which the limit relay refers. The selection depends on the instrument version and the parametrization.



Note!

If temperature measurement of sensor N is selected as the function, it always refers to the temperature which has been assigned to the respective sensor in "sensor management/FDU sensor N". Possible temperatures are:

- sensor temperature
- average of sensor temperature and temperature of an external temperature sensor
- temperature of an external temperature sensor

### 8.1.4 "relay N" (N = 1 - 6) (Part 2: Limit type and switching points)

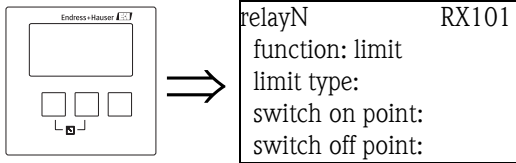

#### "Limit type"

Use this parameter to define the type of limit.

#### Selection:

##### ■ standard

For this limit type, a switch on point and a switch off point have to be defined. The switching behaviour depends on the relative position of these switching points.

##### a. switch on point > switch off point

The relay is energized if the measured value rises above the switch on point.  
The relay is de-energized if the measured value falls below the switch off point.

##### b. switch on point < switch off point

The relay is energized if the measured value falls below the switch on point.  
The relay is de-energized if the measured value rises above the switch off point.

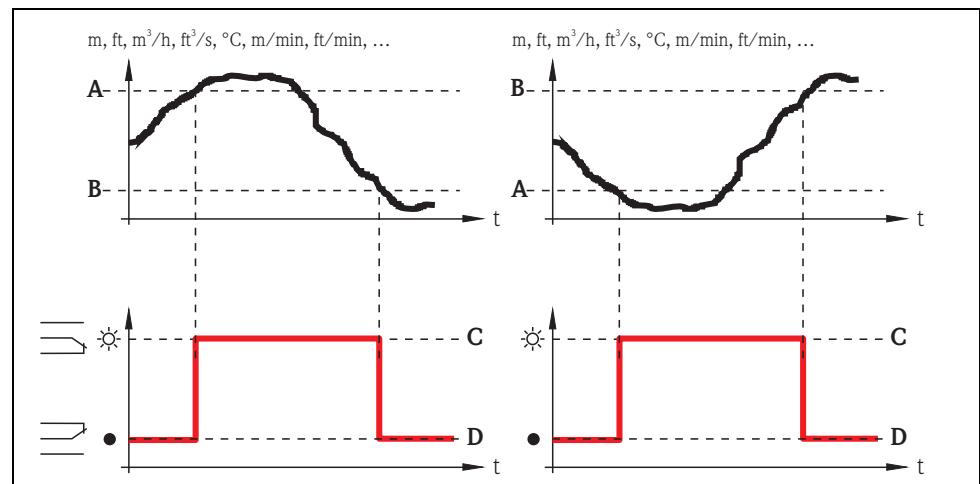

- A switch on point  
B switch off point  
C relay energized  
D relay de-energized

##### ■ tendency/speed

This limit type is similar to the "standard" type. The only difference is that variations with time of the measured value are examined instead of the measured value itself. Therefore, the unit for the switching points is "measuring value unit per minute".

##### ■ inband

For this limit type, an upper and a lower switching point have to be defined.

The relay is energized if the measured value is between the two switching points.

The relay is de-energized if the measured value is above the upper or below the lower switching point.

Additionally, a hysteresis can be defined, which affects both switching points.

■ **out of band**

For this limit type, an upper and a lower switching point have to be defined.

The relay is energized if the measured value is above the upper or below the lower switching point.

The relay is de-energized if the measured value is between the two switching points.

Additionally, a hysteresis can be defined, which affects both switching points.

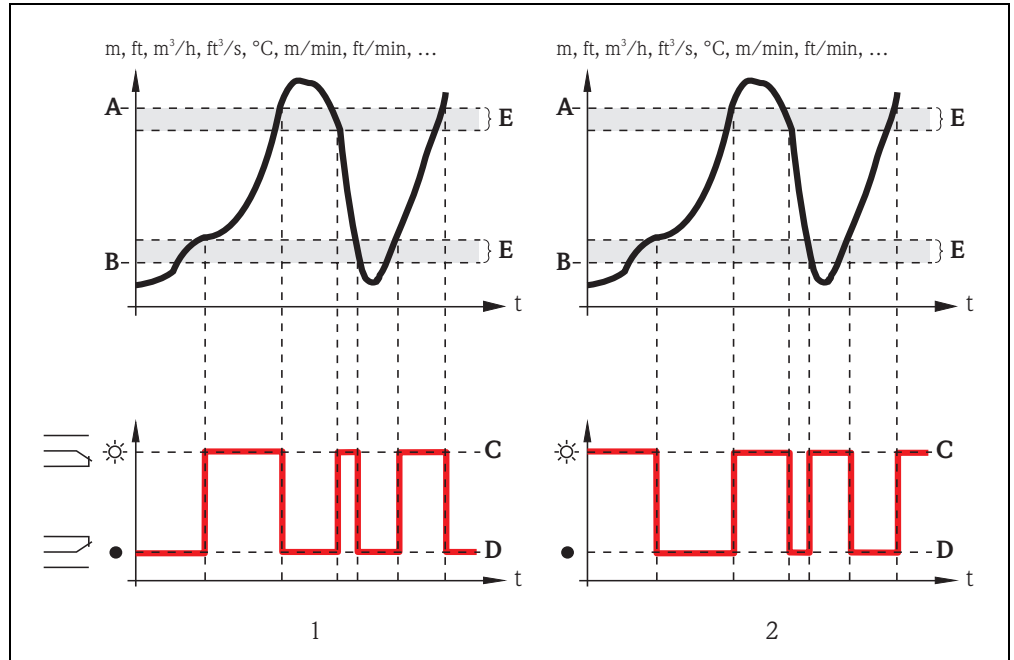

- 1 "inband" limit relay
- 2 "out of band" limit relay
- A Upper switching point
- B Lower switching point
- C Relay energized
- D Relay de-energized
- E Hysteresis

**"switch on point" and "switch off point"**  
(for the "standard" limit type)

Define the switching points in these parameters.  
They have the same unit as the measured value.



Caution!

After a change of the "unit level" or "flow unit" the switching points have to be checked and adjusted if required.

**"switch on /min" and "switch off /min"**  
(for the "tendency/speed" limit type)

Define the switching points in these parameters.  
Their unit is the measured value unit per minute.



Caution!

After a change of the "unit level" or "flow unit" the switching points have to be checked and adjusted if required.

**"upper switching point" and "lower switching point"**  
(for the "inband" and "out of band" limit types)

Define the switching points in these parameters.  
They have the same unit as the measured value.

**Caution!**

After a change of the "unit level" or "flow unit" the switching points have to be checked and adjusted if required.

**"hysteresis"**  
**(for the "inband" and "out of band" limit types)**

Define the hysteresis in this parameter. It has the same unit as the measured value. The hysteresis affects the upper and the lower switching point.

**8.1.5 "relay N (N = 1 - 6)"**  
**(Part 3: Relay behavior)**

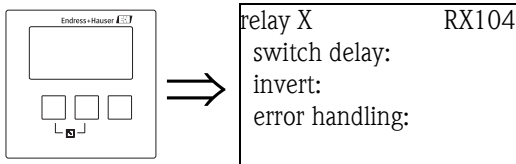
**"switch delay"**

Use this parameter to specify the switch delay (in seconds).

The relay does not switch immediately after the switch on point has been exceeded but only after the specified delay.

The measured value must exceed the switch-on point during the entire delay time.

**"invert"**

Use this parameter to specify if the switching direction of the relay is to be inverted.

**Selection:**

- **no (default)**

The switching direction of the relay is **not** inverted. The relay switches as described in the above sections.

- **yes**

The switching direction of the relay **is** inverted. The states "energized" and "de-energized" are interchanged as compared to the above description.

**"error handling"**

Use this parameter to specify the reaction of the relay in the case of an error.

**Selection:**

- **actual value**

The relay switches according to the currently measured value (although its reliability is not ensured).

- **hold (default)**

The current switching state of the relay is maintained.

- **switch on**

The relay is energized.

- **switch off**

The relay is de-energized.

## 8.2 Configuration of an alarm or diagnostic relay

### 8.2.1 Overview

Step	Parameter set or submenu	Parameter	Remark	Section
1	"relay controls" menu		Select "relay configuration"	
2	relay allocation		Select a relay	→ Chap. 8.2.2
3	relay N (N= 1 -6)	function	1. Select "alarm/diagnostics" 2. Select <ul style="list-style-type: none"> <li>- "alarm relay", if the relay is to indicate an alarm state of the Prosonic S.<sup>1)</sup></li> <li>- "diagnostics", if the relay is to indicate one or two user selectable states of the instrument.</li> </ul>	→ Chap. 8.2.3
4	relay N (N = 1 - 6)	allocation 1	Select the first instrument state which is to be indicated by the relay. (only available if "diagnostics" has been selected in the previous function)	→ Chap. 8.2.4
		allocation 2	Select the second instrument state which is to be indicated by the relay. (only available if "diagnostics" has been selected in the previous function)	
5	relay N (N = 1 - 6)	invert	Select if the relay signal is to be inverted (default: no)	→ Chap. 8.2.5

1) This is the default setting for relay 1.

### 8.2.2 "relay allocation"

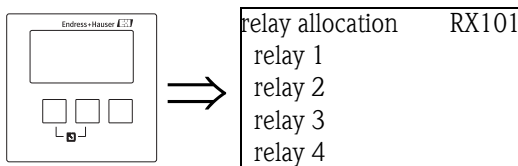

Use this parameter to select the relay you are going to configure.

**Selection:**

- All relays of the instrument version at hand



Note!

If a function has already been allocated to one of the relays, the name of this function is displayed next to the relay number.

### 8.2.3 "relay N" (N = 1 - 6) (Part 1: relay function)

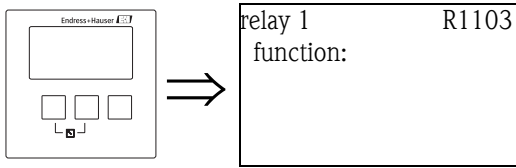

After selecting a relay, the parameter set "**relay N**" (N=1 - 6) appears, which is used to configure the relay. Initially, it contains only the "function" parameter. To configure an alarm relay or diagnostic relay, proceed according to the following steps:

1. Select the "**function**" parameter. The "**select function**" screen appears.
2. Select "**alarm/diagnostics**". The "**function**" selection list appears.
3. Select
  - "alarm relay", if the relay is to indicate an alarm state of the Prosonic S<sup>6)</sup>.
  - "diagnostics" if the relay is to indicate one or two user selectable states of the instrument.

### 8.2.4 "relay N" (N = 1 - 6) (Part 2: Allocation of the switching condition)

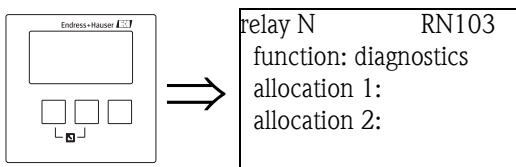

#### "allocation 1/2"

A specific instrument state or event can be allocated to each of these parameters. The relay is de-energized as soon as one of these states or events occurs.

#### Selection:

- echoloss sensor 1/2/1+2
- defective temperature sensor1/2
- defective external temperature sensor
- Accumulated alarm: defective temperature sensor
- overtemp. sensor 1/2
- Accumulated Alarm: overtemp.
- safety distance channel 1/2
- Accumulated Alarm: safety distance
- pump alarm
- pump operation

6) This is the default setting for relay 1.



### 8.2.5 "relay N" (N = 1 - 6) (Part 3: Relay behavior)

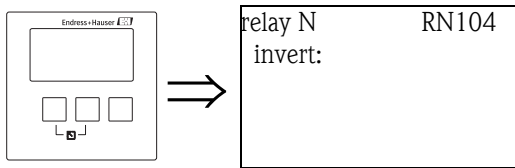

#### "invert" subfunction

Use this parameter to specify if the switching direction of the relay is to be inverted.

#### Selection:

##### ■ no (default)

The switching direction of the relay is **not** inverted. The relay switches as described in the above sections.

##### ■ yes

The switching direction of the relay **is** inverted. The states "energized" and "de-energized" are interchanged as compared to the above description.

## 8.3 Configuration of a pump control - standard



Note!

Depending on the order code of the instrument, different functionalities can be configured for the pump control. The order code of the instrument can be found on the nameplate and in the operating menu at "system information/device information".

This chapter is only valid for instruments with standard pump control (FMU90-\*1\*\*\*\*\* and FMU90-\*2\*\*\*\*\*).

For the enhanced pump control see chapter 5.3 (FMU90-\*3\*\*\*\*\* and FMU90-\*4\*\*\*\*\*).



Note!

The "pump control N" submenus are only present if "pump control" has been selected in "device properties/operating parameters/controls".

### 8.3.1 Basic principles

#### Switch points

The pump control is used to start or stop pumps depending on the measured level. To do this, a switch-on point and a switch-off point is defined for each pump. Additionally, a relay is assigned to the pump and the switching is performed by this relay.

Two cases can be distinguished for the switching behaviour of this relay:

a. **Switch-on point > Switch-off point**

The pump is switched on if the level rises above the switch-on point (A). It is switched off if the level drops below the switch-off point (B).

**Example:** Emptying of a flood control reservoir.

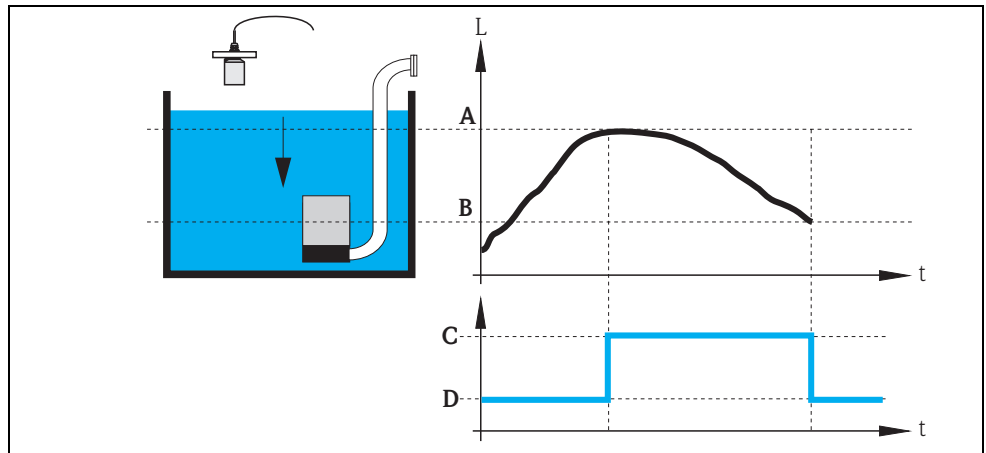

A: switch-on point; B: switch-off point; C: pump on; D: pump off

b. **Switch-on point < Switch-off point**

The pump is switched on if the level drops below the switch-on point (A). It is switched off if the level rises above the switch-off point (B).

**Example:** Filling of a storage vessel

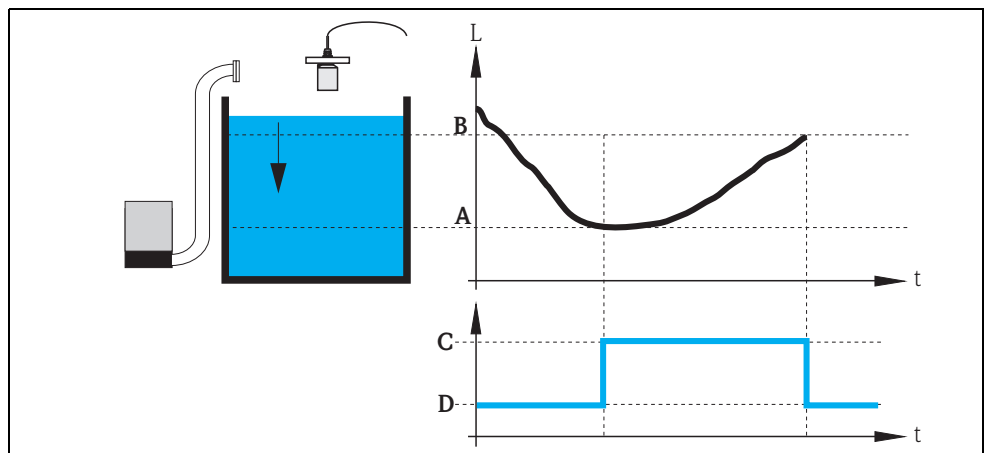

A: switch-on point; B: switch-off point; C: pump on; D: pump off

### Operating mode

The Prosonic S can control several pumps simultaneously – depending on the number of relays (s. feature 70 of the product structure). If two or more pumps are applied for one level channel, you can choose between two different operating modes:

a. **Non-alternating pump control**

In this mode, each pump is switched according to the switching points allocated to it.

b. **Alternating pump control**

In this mode, the switching points are not allocated to the individual pumps. Instead, the relays are switched in a way that ensures uniform usage of all pumps. This is achieved by the following rules:

1. If the level rises above one of the switch-on points, that relay switches on, which at that moment has been switched off the longest time. This is not necessarily the relay to which the switch-on point belongs.
2. If the level drops below one of the switch-off points, that relay switches off, which at that moment has been switched on the longest time. This is not necessarily the relay to which the switch-off point belongs.

However, there are two restrictions to these rules:

3. Rising of the level above a switch-on point effects switching on of a relay only if the corresponding switch-off point has been reached before.
4. Dropping of the level below a switch-off points effects switching-off of a relay only if the corresponding switch-on point has been reached before.

 **Note!**

If two pumps in the same range are to operate alternately, their switch-on and switch-off points are identical. This switching response can be achieved by assigning switch points to the second relay which can never be reached.

### Example

In the switching range between 60% and 40%, two pumps should be operated alternately, i.e. when pump 1 is running, pump 2 is switched off and vice versa. These relays are programmed as follows:

- Relay 1: switch-on point: 60%; switch-off point: 40%
- Relay 2: switch-on point: e.g. 160%; switch-off point: e.g. 120%.

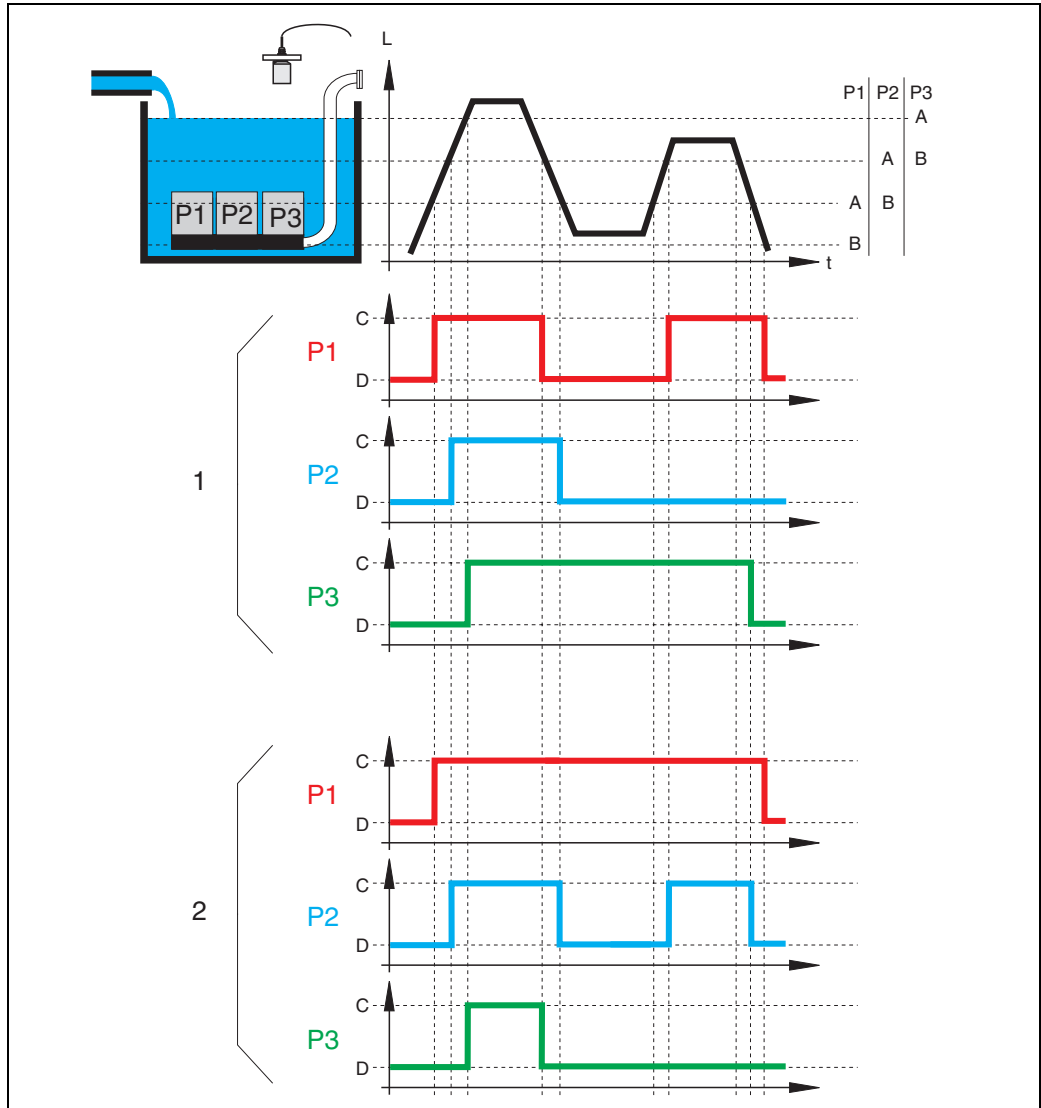

**1:** Alternating pump control; that pump is switched on (switched off), which has been switched off (switched on) the longest time.  
**2:** Non-alternating pump control; each switching point is allocated to a different pump.  
**A:** switch-on point of the pump; **B:** switch-off point of the pump; **C:** pump on; **D:** pump off;

### Limit control versus pump rate control

If several pumps are connected, you can choose between limit control (as described above) and pump rate control.

#### Limit control

If limit control has been selected, the relays are switched according to the switching points as described above.

#### Pump rate control

If pump rate control has been selected, there is only one switch-on point and one switch-off point, which are valid for all relays. Additionally, a desired **pump rate** has to be specified.

If the level rises above (or falls below) the switch-on point, initially only one pump is switched on. If the desired pump rate has not been achieved after the selected **hook-up interval**, an additional pump is switched on. Similarly, further pumps are switched on in intervals until the desired pump rate has been achieved.

However, if the level is already near to the switch-off point (distance < **switch-on barrier**), no further pumps are switched on, even if the pump rate has not yet been achieved.

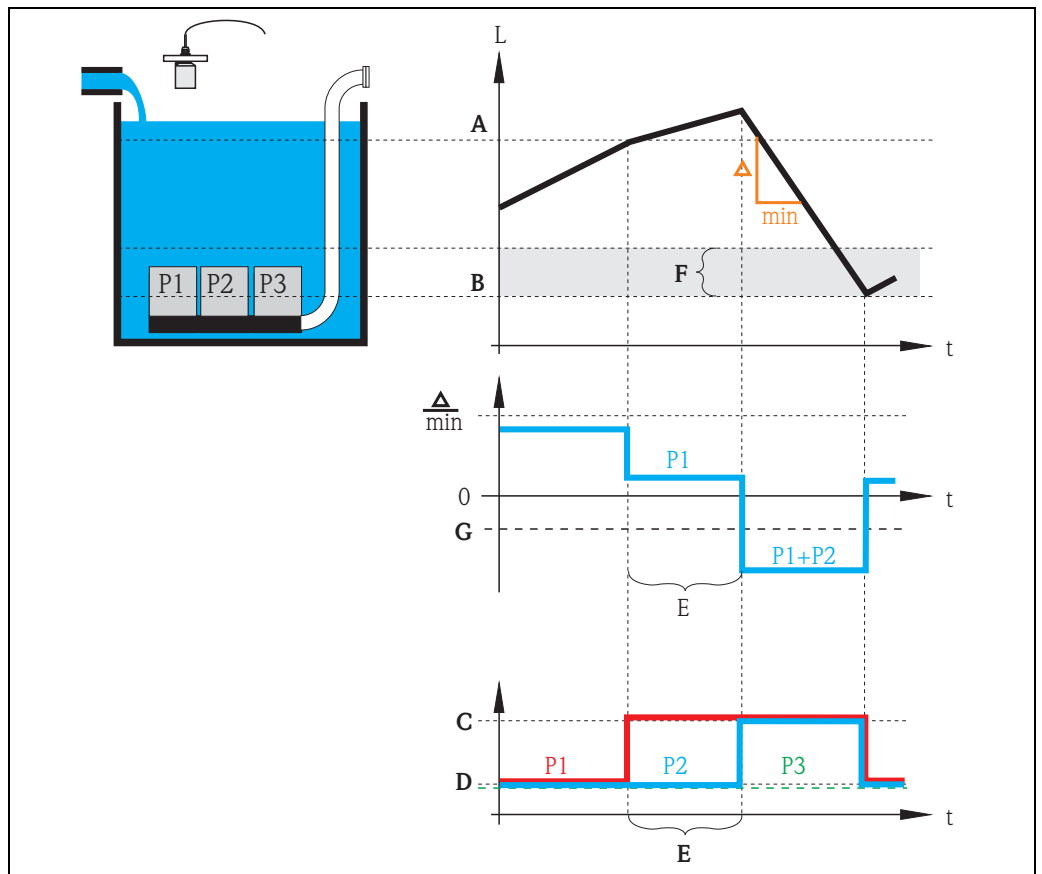

L00-FM190xxxx-19-00-00-yy-054

**A:** switch-on point; **B:** switch-off point; **C:** pump on; **D:** pump off; **E:** hook-up interval; **F:** switch-on barrier  
**G:** pump rate



**Note!**

If both the alternating pump control and the pump rate control are active, the pumps are alternately used as first pump.

## 8.3.2 Overview

### Parametrization of a pump control (type: limit control)

Step	Parameter set or submenu	Parameter	Remarks	section
1	"relay/controls" menu		Select "pump control1" or "pump control 2".	
2	pump control N (N = 1 or 2)	reference	Select the level according to which the pumps are controlled.	→ Chap. 8.3.3
		number of pumps	Select the number of pumps. Note: A relay must be available for each of the pumps.	
3	pump control N (N = 1 or 2)	function	Select "limit control".	→ Chap. 8.3.4
4	pump control N (N = 1 or 2)		Select a pump. (Each pump must be configured individually.)	→ Chap. 8.3.5
5	pump M control N (M = 1 - 6) (N = 1 or 2)	switch on point	Define the switch on point for this pump.	→ Chap. 8.3.5
		switch off point	Define the switch off point for this pump.	
		switch on delay	Define the switch on delay for this pump.	
		alternate	Select if the pump is to take part in the alternating pump control (Default: no).	
		crust reduction	Define the inaccuracy of the switching points (to reduce crust formation).	
6	pump M control N (M = 1 - 6) (N = 1 or 2)	backlash interval	Define the backlash interval	→ Chap. 8.3.7
		backlash time	Define the backlash time	
		error handling	Define the error handling	
7	relay allocation		Allocate a relay to the pump. Note: By default, relay 1 is configured as alarm relay.	→ Chap. 8.3.8
8	relay N (N = 1 - 6)	function	Select "pump M/control N"	→ Chap. 8.3.9
		invert	Select if the switching signal is inverted (default: no)	
9	pump control N		Select the next pump and continue with step 5 until all pumps have been configured. If all pumps are configured: Press  to return to the "relay/controls" menu.	

### Parametrization of a pump control (type: pump rate control)

Step	Parameter set or submenu	Parameter	Remarks	Section
1	"relay/controls" submenu		Select "pump control 1" or "pump control 2".	
2	pump control N (N = 1 or 2)	refernece	Select the level according to which the pumps are controlled.	→ Chap. 8.3.3
		number of pumps	Select the number of pumps. Note: A relay must be available for each of the pumps.	
3	pump control N (N = 1 or 2)	function	Select "rate control"	→ Chap. 8.3.4
4	pump control N (N = 1 or 2)	switch on point	Define the switch on point.	→ Chap. 8.3.10
		switch off point	Define the switch off point.	
		min. pumprate/min	Dfine the minimum pump rate.	
		crust reduction	Define the inaccuracy for the switching points (to reduce crust formation).	
		switch on border	Define the switch on border.	
		hook up interval	Define the hook-up interval.	
		alternate	Select if an alternating pump control is to be performed.	
5	pump control N (N = 1 or 2)		Select a pump. (The following parameters must be configured for each pump individually.)	→ Chap. 8.3.5
6	pumpe M control N (M = 1 - 6) (N = 1 or 2)	switch on delay	Define the switch on delay.	→ Chap. 8.3.11
		backlash interval	Define the backlash interval.	
		backlash time	Define the backlash time.	
		error handling	Define the error handling.	
7	relay allocation		Allocate a relay to the pump. Note: By default, relay 1 is configured as alarm relay.	→ Chap. 8.3.8
8	relay N (N = 1 - 6)	function	Select "pump M/control N".	→ Chap. 8.3.9
		invert	Select if the switching signal is inverted (default: no).	
9	pump control N		Select the next pump and continue with step 6 until all pumps have been configured. If all pumps are configured: Press  to return to the "relay/controls" menu.	

### 8.3.3 "pump control N" (N = 1 or 2)

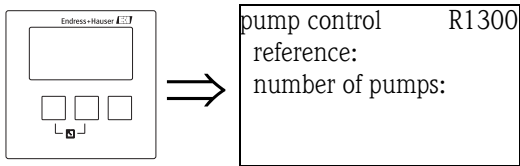

#### "reference"

Defines the level channel to which the pump control refers.

#### Selection:

- **none (default)**
- level 1
- level 2 (for instrument versions with 2 level inputs)

#### "number of pumps"

Defines the number of pumps participating in the pump control. At the end of the configuration procedure a relay must be allocated to each of the pumps ("relay allocation" parameter set).

- Range of values : 1 ... 6 (depending on the number of relays)
- Default: 1

### 8.3.4 "pump control N" (N = 1 or 2)

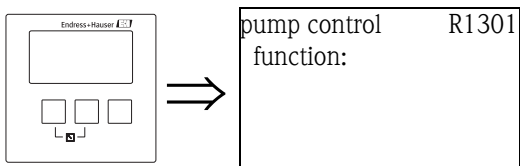

#### "function"

Determines the type of pump control.

#### Selection:

- **limit control (Default)**  
Each pump has its own switch-on point and switch-off point
- **rate control**  
There is only one switch-on point and one switch-off point for all pumps. If the switch-on point has been exceeded, several pumps are switched on in intervals until the defined pumprate is obtained. For details refer to the chapter "Limit control and rate control" → 84.



### 8.3.5 "pump control N" (N = 1 or 2)

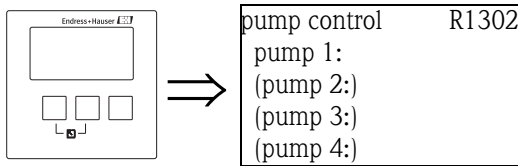

Determines, to which pump the following specifications refer.

**Selection**

- depending on the selected "number of pumps"

### 8.3.6 "pump M/control N" (M = 1 - 6; N = 1 or 2) (Part 1: Switching points for limit control)

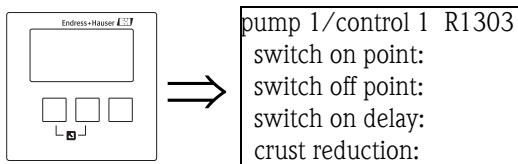

**"switch on point"**

Specifies the switch-on point of the respective pump. Use the selected level unit.



Caution!

After a change of the "unit level" the switch on point has to be checked and adjusted if required.

**"switch off point"**

Specifies the switch-off point of the respective pump. Use the selected level unit.



Caution!

After a change of the "unit level" the switch off point has to be checked and adjusted if required.

**"switch-on delay"**

Specifies the switch-on delay of the respective pump (in seconds).

When the level has risen above the switch-on point, the relay does not switch immediately but only after the specified switch-on delay. Assign different delays to the individual pumps in order to avoid simultaneous switching-on of several pumps (which could cause an overload of the power supply system).

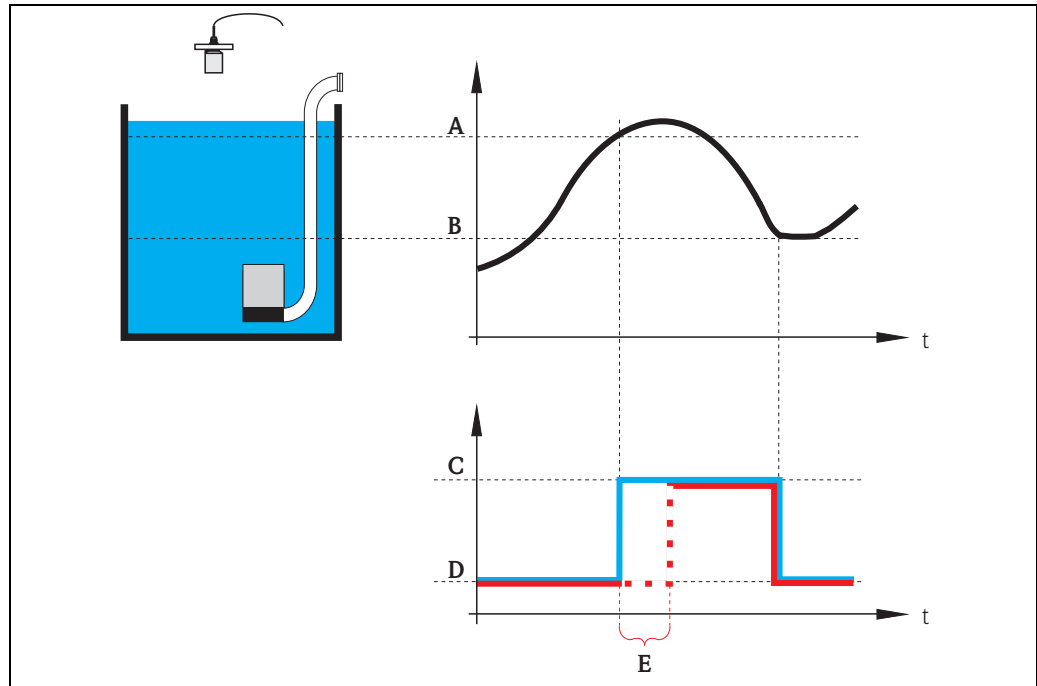

*A: switch-on point; B: switch-off point; C: pump on; D: pump off; E: switch-on delay*

L00-FMU90xxx-19-00-00-yy-055

**"alternate"**

Specifies if the pump should be included in the alternating pump control.

**Selection**

- **no (default)**

The pump is not included in the alternating pump control. Instead, it switches according to its own switch points.

- **yes**

The pump is included in the alternating pump control.

**"crust reduction"**

Specifies a range of inaccuracy (percentage of the measuring range) for the switching points of the pump. If this value is larger than "0", the switching points are not exactly constant. Instead, they vary within the specified range of inaccuracy.

This helps to avoid crust formation, which often occurs at fixed switching points.

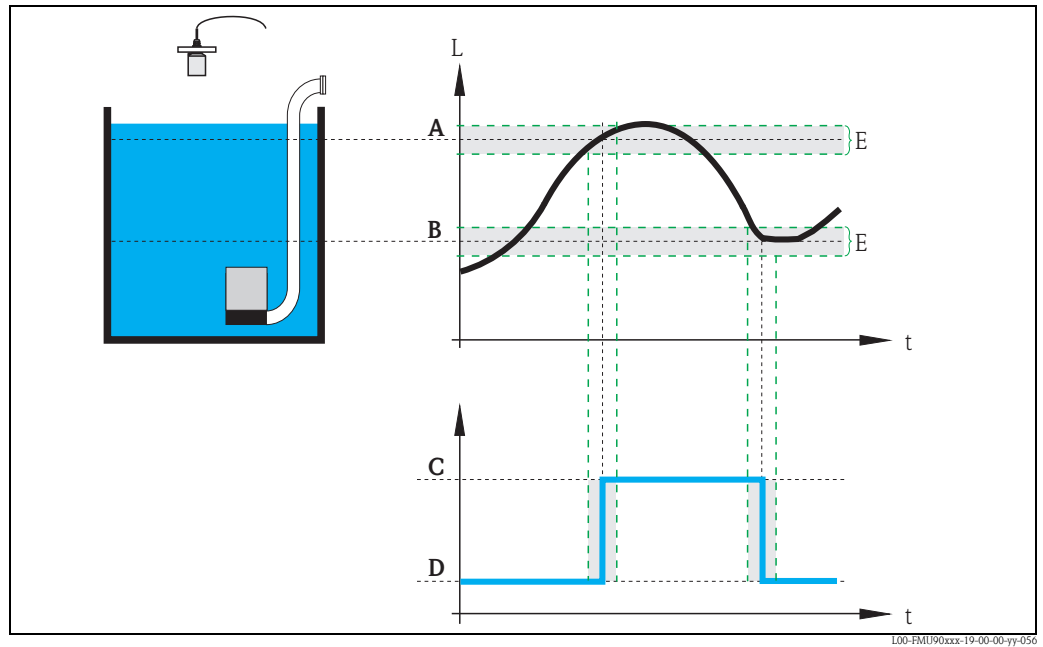

*A: switch-on point; B: switch-off point; C: pump on; D: pump off; E: inaccuracy ("crust reduction")*

100-FMU90xxx-19-00-00-yy-056

### 8.3.7 "pump M/control N" (M = 1 - 6, N = 1 or 2) (Part 2: Switching behavior for limit control)

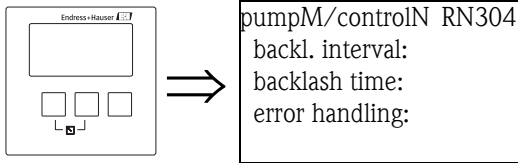

#### "backlash interval" and "backlash time"

Use these parameters if, you want to empty a vessel beyond the switch-off point in regular intervals. The "**backlash interval**" determines after which time this extended pumping will occur. The "**backlash time**" determines how long this additional pumping lasts.

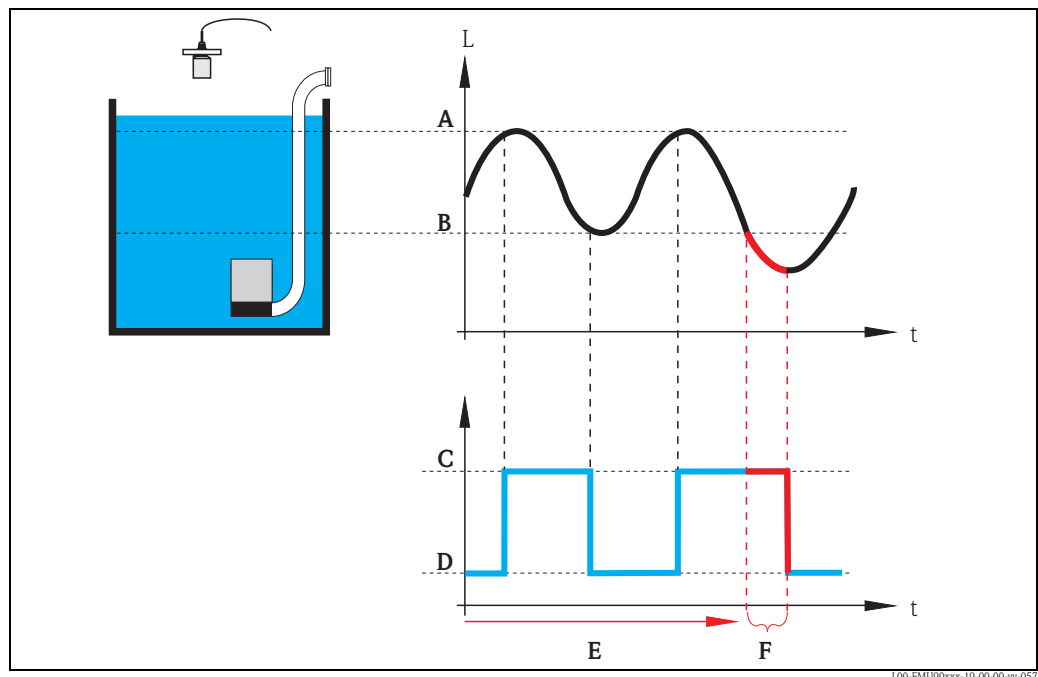

*A: switch-on point; B: switch-off point; C: pump on; D: pump off  
E: backlash interval; F: backlash time*

#### "error handling"

This parameter defines the reaction of the relay in the case of an error.

##### Selection:

##### ■ hold (default)

The current switching state of the relay is held.

##### ■ switch on

The relay is energized (i.e. the pump is switched on).

##### ■ switch off

The relay is de-energized (i.e. the pump is switched off).

##### ■ actual value

The relay switches according to the current measuring value (although its reliability is not ensured).

### 8.3.8 "relay allocation"

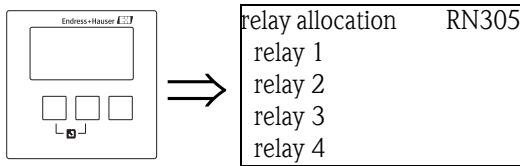

Allocates a relay to the pump.

**Selection:**

- All relays of the instrument version at hand

### 8.3.9 "relay N" (N = 1 - 6)

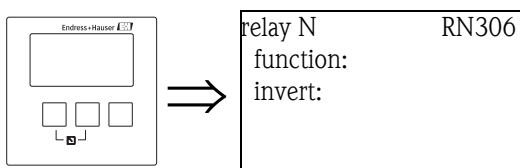

**"function"**

Allocates the desired function to the relay.

**Selection:**

- none (default)
- pump M/control N

**"invert"**

Determines if the switching behavior of the relay is inverted.

**Selection:**

- **no (default)**  
The switching behavior of the relay is **not** inverted. The relay is energized if the pump should be switched on.
- **yes**  
The switching behavior of the relay **is** inverted. The relay is energized if the pump should be switched off.

### 8.3.10 "pump control N" (N = 1 or 2) (Switching points for rate control)

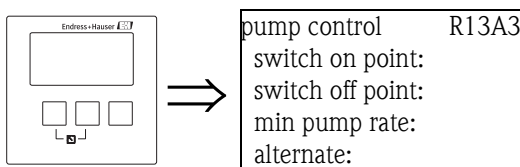

**"switch on point"**

Specifies the switch-on point. Use the selected level unit.



Caution!

After a change of the "unit level", the switch on point has to be checked and adjusted if required.

**"switch off point"**

Specifies the switch-off point. Use the selected level unit.



Caution!

After a change of the "unit level", the switch off point has to be checked and adjusted if required.

**"min pump rate"**

Specifies the desired minimum pump rate (for details see section "limit control and rate control").



Note!

If the vessel is to be emptied, a negative pump rate has to be specified.

**"crust reduction" subfunction**

Specifies a range of inaccuracy (percentage of the measuring range) for the switching points. If this value is larger than "0", the switching points are not exactly constant. Instead, they vary within the specified range of inaccuracy.

This helps to avoid crust formation, which often occurs at fixed switching points.

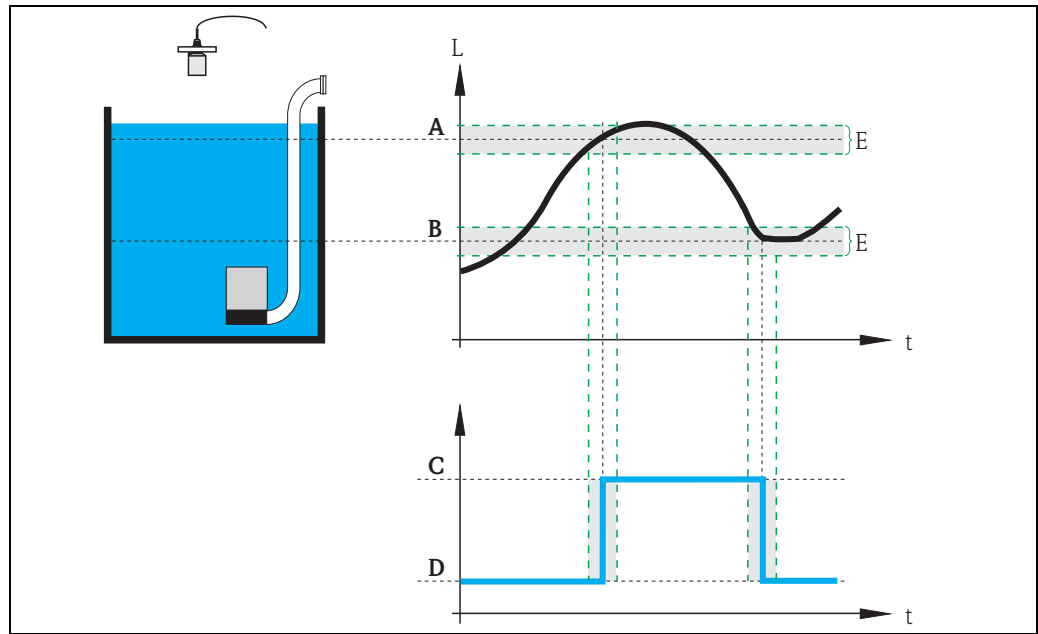

*A: switch-on point; B: switch-off point; C: pump on; D: pump off; E: inaccuracy ("crust reduction")*

**"switch on border"**

Specifies the switch-on border for the rate control (for details see → 84 "Limit control versus pump rate control").

**"hook up interval"**

Specifies the time interval between the switching-on of the different pumps (for details see → 84 "Limit control versus pump rate control").

**"alternate"**

Determines if an alternating pump control is to be performed.

### 8.3.11 "pump M/control N (M = 1 - 6, N = 1 or 2) (Switching behavior for rate control)

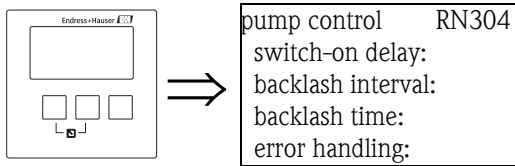

#### "switch-on delay"

→ 90

#### "backlash interval" and "backlash time"

→ 92

#### "error handling"

→ 92

## 8.4 Configuration of a pump control - enhanced



Note!

Depending on the order code of the instrument, different functionalities can be configured for the pump control. The order code of the instrument can be found on the nameplate and in the operating menu at "system information/device information".

This chapter is only valid for instruments with enhanced pump control (FMU90-\*31\*\*\*\*\* and FMU90-\*4\*\*\*\*\*).

For the standard pump control see chapter 5.2 (FMU90-\*1\*\*\*\*\* and FMU90-\*2\*\*\*\*\*).



Note!

The "pump control N" submenus are only present if "pump control" has been selected in "device properties/operating parameters/controls".

### 8.4.1 Basic principles

The pump control is used to start or stop pumps depending on the measured level. Up to two pump controls can be defined. One or more pumps can be allocated to each pump control. The pumps are switched on and off by the relays of the Prosonic S.

The switching behavior depends on:

- the selected "function"
- the selected type of "load control" (only relevant for alternating pump control)

#### Functions "limit simple" and "limit parallel"

For these functions, a switch-on point and a switch-off point is defined for each pump. The switching behaviour depends on the relative position of these two switching points:

- a. **Switch-on point > Switch-off point ("Emptying")**  
The pump is switched on if the level rises above the switch-on point (A). It is switched off if the level drops below the switch-off point (B).
- b. **Switch-on point < Switch-off point ("Filling")**  
The pump is switched on if the level drops below the switch-on point (A). It is switched off if the level rises above the switch-off point (B).

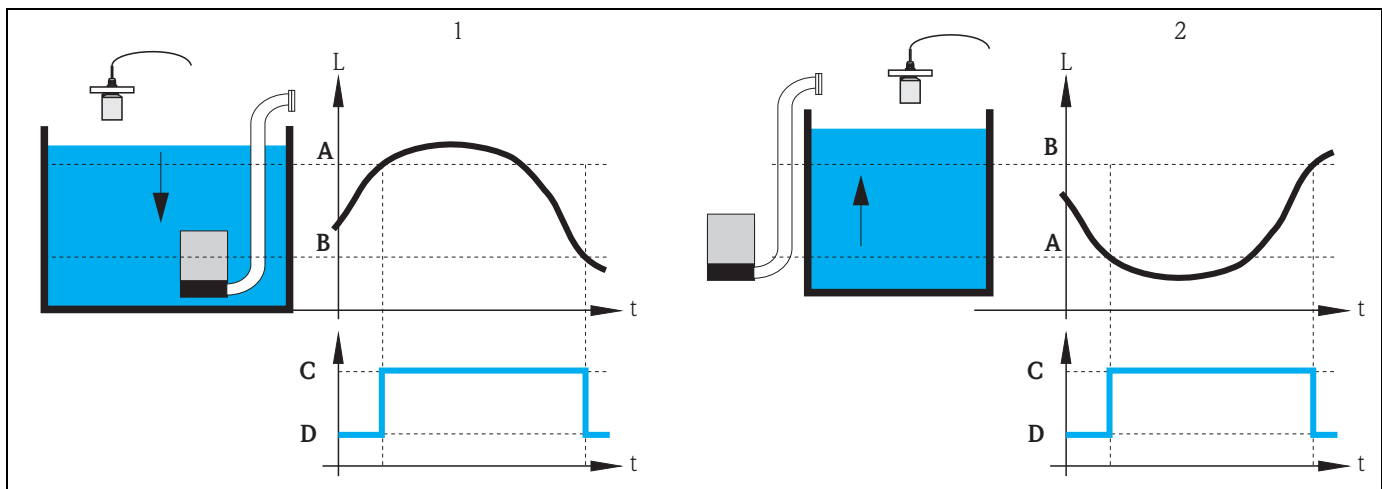

1: "Emptying" (switch-on point > switch-off point); 2: "Filling" (switch-on point < switch-off point)  
A: switch-on point; B: switch-off point; C: pump on; D: pump off





**Note!**

If several pumps are allocated to a pump control, the switching direction of all these pumps must be the same. Mixing of "filling" and "emptying" is not allowed.

The difference between "limit simple" and "limit parallel" relates to the control of more than one pump:

■ **limit simple (A)**

With this function, only one pump can be running at a time. Before a pump is switched on, the previously running pump is switched off automatically. Details depend on the relative position of the switching points, especially on the fact if the switching ranges of different pumps are overlapping. (Refer to the example in the diagram below).

■ **limit parallel (B)**

With this function, several pumps can be switched on at the same time.

**Example ("Emptying" with three pumps)**

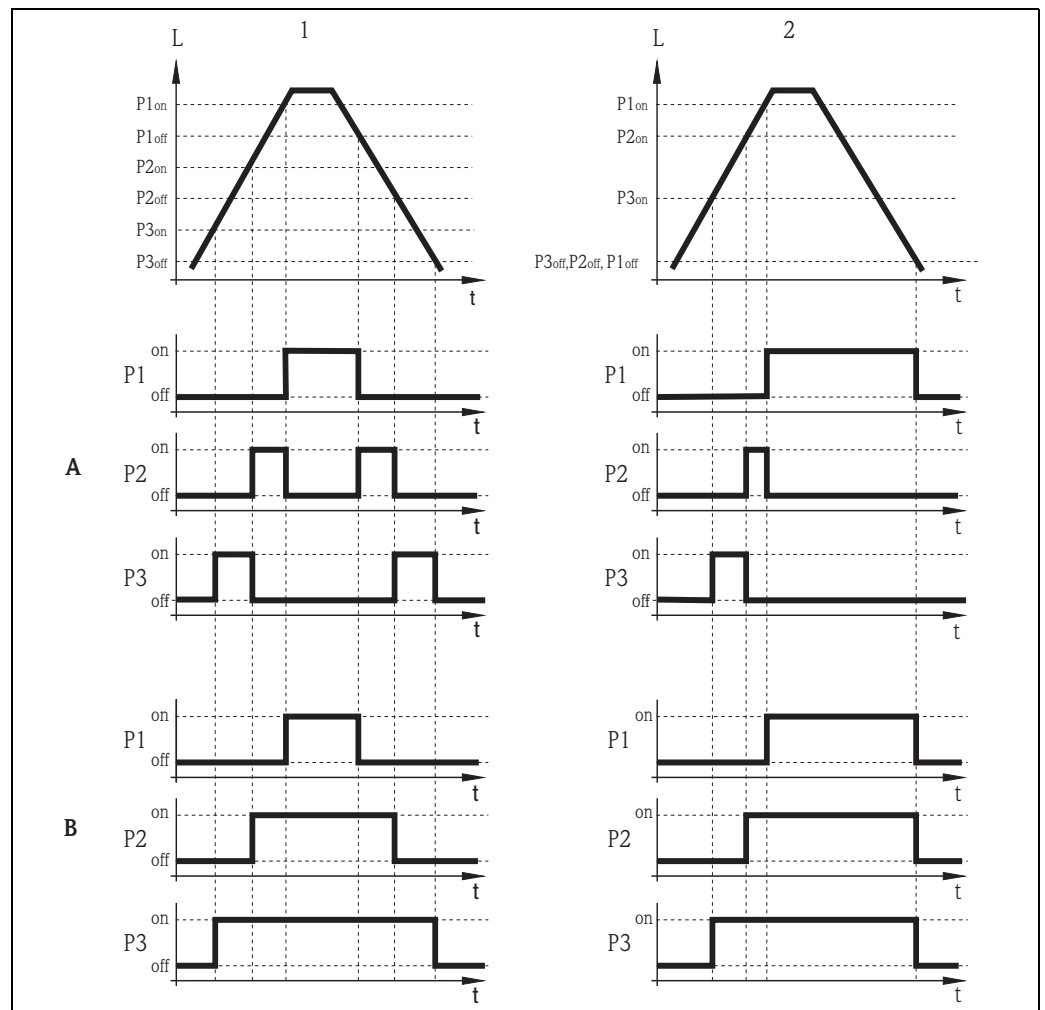

**A:** "limit simple"; **B:** "limit parallel"

**1:** Separated switching ranges; **2:** Overlapping switching ranges;

$P1_{on}$ ,  $P2_{on}$ ,  $P3_{on}$ : switch-off points for the pumps P1, P2 and P3

$P1_{off}$ ,  $P2_{off}$ ,  $P3_{off}$ : switch-off points for the pumps P1, P2 and P3

L00-FMU90xxx-19-00-00-yy-107

### Function "pump rate control"

If pump rate control has been selected, there is only one switch-on point and one switch-off point, which are valid for all relays. Additionally, a desired **pump rate** has to be specified.

If the level rises above (or falls below) the switch-on point, initially only one pump is switched on. If the desired pump rate has not been achieved after the selected **hook-up interval**, an additional pump is switched on. Similarly, further pumps are switched on in intervals until the desired pump rate has been achieved.

However, if the level is already near to the switch-off point (distance < **switch-on barrier**), no further pumps are switched on, even if the pump rate has not yet been achieved.

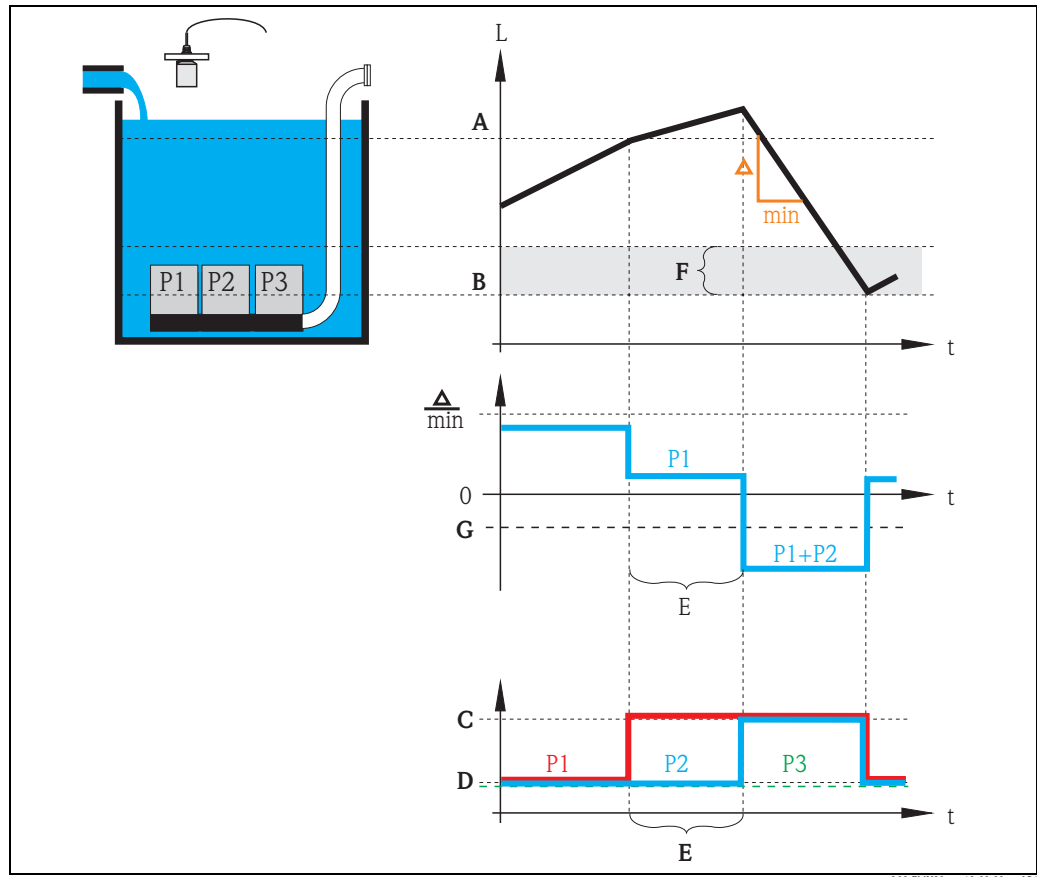

**A:** switch-on point; **B:** switch-off point; **C:** pump on; **D:** pump off; **E:** hook-up interval; **F:** switch-on barrier  
**G:** pump rate

### Alternating pump control

Optionally, a number of pumps can be allocated to the alternating pump control. In this mode, the switching points are no longer allocated to the individual pumps. Instead, a desired degree of use must be defined for each pump (e.g. equal usage of all pumps).

If the level rises above (or falls below) the switch-on point and a pump has to be switched on, the Prosonic S selects the pump according to an algorithm which ensures that in the course of time the desired degrees of use are obtained for all pumps.

The same is valid for the switching-off of pumps.



Note!

For the limit control (simple or parallel) it can be defined for each pump individually if it is to take part in the alternating pump control.

For pump rate control, it is only possible to allocate all pumps or no pump to the alternating pump control.

## 8.4.2 Basic setup

### Overview: Parametrization of a limit control (simple/parallel)

Step	Parameter set or submenu	Parameter	Remarks	see page
1	"relay/controls" menu		1. Select "pump control1" or "pump control 2". 2. Select "basic setup".	
2	pump control N (N = 1 or 2)	reference	Select the level according to which the pumps are controlled.	101
		number of pumps	Select the number of pumps. Note: A relay must be available for each pump.	101
		standby pump <sup>1)</sup>	Define, if one of the pumps is to be a standby pump.	101
		reset	Restarts an existing pump control; is not used during the parametrization.	101
3	pump control N (N = 1 or 2)	function	Select "rate control".	102
		load control	Select the type of load control (only relevant for alternating pump control)	102
4	pump control N (N = 1 or 2)		Select a pump. (Each pump must be configured individually.)	
5	pump M control N (M = 1 - 6) (N = 1 or 2)	switch on point	Define the switch on point for this pump.	103
		switch off point	Define the switch off point for this pump.	103
		switch on delay	Define the switch on delay for this pump.	104
		alternate	Select if the pump is to take part in the alternating pump control (Default: no).	104
		degree of use	Define the desired degree of use (percentage) for this pump; (only relevant for alternating pump control)	104
		max. use time	Define the maximum use time for this pump (only relevant for alternating pump control with "load control" = "starts+time")	105
		crust reduction	Define the inaccuracy of the switching points (to reduce crust formation).	105
6	pump M control N (M = 1 - 6) (N = 1 or 2)	backlash interval	Define the backlash interval.	106
		backlash time	Define the backlash time.	106
		error handling	Define the error handling.	106
7	pump M control N (M = 1 - 6) (N = 1 or 2)	pump feedback	Select the digital input used for pump feedback.	107
		feedback delay	Define the time interval in which a feedback is required.	107
		feedback meaning	Define the meaning of the pump feedback.	107
8	relay allocation		Allocate a relay to the pump. Note: By default, relay 1 is configured as alarm relay.	
9	relay N (N = 1 - 6)	function	Select "pump M/control N"	108
		invert	Select if the switching signal is inverted (default: no)	109
10	pump control N		Select the next pump and continue with step 5 until all pumps have been configured. If all pumps are configured: Press  to return to the "relay/controls" menu.	

1) only for instruments with external limit switches; the stand-by pump always is the last of the M pumps.

### Overview: Parametrization of a pump rate control

Step	Parameter set or submenu	Parameter	Remarks	Page
1	"relay/controls" submenu		Select "pump control 1" or "pump control 2".	
2	pump control N (N = 1 or 2)	reference	Select the level according to which the pumps are controlled.	101
		number of pumps	Select the number of pumps. Note: A relay must be available for each pump.	101
		standby pump <sup>1)</sup>	Define, if one of the pumps is to be a standby pump.	101
		reset	Restarts an existing pump control; is not used during the parametrization.	101
3	pump control N (N = 1 or 2)	function	Select "rate control".	102
		load control	Select the type of load control (only relevant for alternating pump control)	102
4	pump control N (N = 1 or 2)	switch on point	Define the switch on point.	109
		switch off point	Define the switch off point.	109
		min. pumprate/min	Define the minimum pump rate.	109
		crust reduction	Define the inaccuracy for the switching points (to reduce crust formation).	110
		switch on border	Define the switch on border.	110
		hook up interval	Define the hook-up interval.	110
		alternate	Select if an alternating pump control is to be performed.	110
5	pump control N (N = 1 or 2)		Select a pump. (The following parameters must be configured for each pump individually.)	
6	pumpe M control N (M = 1 - 6) (N = 1 or 2)	switch on delay	Define the switch on delay.	104
		degree of use	Define the desired degree of use (percentage) for this pump; (only relevant for alternating pump control)	104
		max. use time	Define the maximum use time for this pump (only relevant for alternating pump control with "load control" = "starts+time")	105
7	pump M control N (M = 1 - 6) (N = 1 or 2)	backlash interval	Define the backlash interval.	106
		backlash time	Define the backlash time.	106
		error handling	Define the error handling.	106
8	pump M control N (M = 1 - 6) (N = 1 or 2)	pump feedback	Select the digital input used for pump feedback.	107
		feedback delay	Define the time interval in which a feedback is required.	107
		feedback meaning	Define the meaning of the pump feedback.	107
9	relay allocation		Allocate a relay to the pump. Note: By default, relay 1 is configured as alarm relay.	
10	relay N (N = 1 - 6)	function	Select "pump M/control N".	108
		invert	Select if the switching signal is inverted (default: no).	109
11	pump control N		Select the next pump and continue with step 6 until all pumps have been configured. If all pumps are configured: Press  to return to the "relay/controls" menu.	

1) only for instruments with external limit switches; the stand-by pump always is the last of the M pumps.

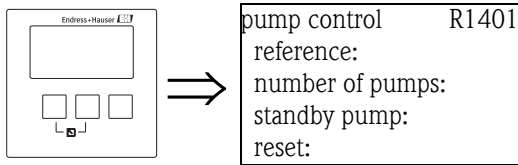
**"pump control N" (N = 1 or 2)****"reference"**

Defines the level channel to which the pump control refers.

**Selection:**

- **none (default)**
- level 1
- level 2 (for instrument versions with 2 level inputs)

**"number of pumps"**

Defines the number of pumps participating in the pump control. At the end of the configuration procedure a relay must be allocated to each of the pumps ("relay allocation" parameter set).

- Range of values : 1 ... 6 (depending on the number of relays)
- Default: 1

**"standby pump"**

*(only for instruments with external limit switches)*

Determines if one of the pumps is a standby pump.

**Selection:**

- **no (default)**  
There is no standby pump.
- **yes**  
The last of the pumps is a standby pump. It can not be configured individually. If a failure of one of the other pumps is reported to the Prosonic S, the standby pump substitutes for his pump.

Example:

number of pumps: 5

standby pump: yes

=> pump control for pumps 1 to 4; pump 5 is the standby pump

**"reset"**

This parameter is used to restart the pump control (e.g. after a failed pump has been repaired).



Note!

The reset has the same effect as a disconnection of the supply voltage. It does not influence the parametrization of the pump control.

**Selection:**

- **no (default)**  
The pump control is **not** reset.
- **yes**  
The pump control **is** reset.

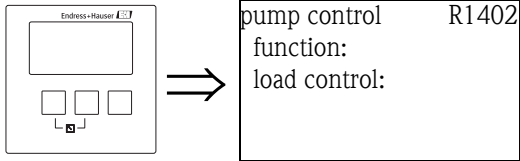
**"pump control N" (N = 1 or 2)***"function"*

Determines the type of pump control.

**Selection:**

- **limit parallel (Default)**

Each pump has its own switch-on point and switch-off point. Several pumps can be running at the same time.

- **limit simple**

Each pump has its own switch-on point and switch-off point. Only one pump can be running at a time.

- **rate control**

There is only one switch-on point and one switch-off point for all pumps. If the switch-on point has been exceeded, several pumps are switched on in intervals until the defined pump rate is obtained. For details refer to the chapter "Limit control and rate control".

*"load control"*

Determines, how the load of the pumps is measured for the alternating pump control.

**Selection:**

- **in order**

- If a pump is to be switched on, the Prosonic S selects the pump which currently has been idle longer than any other pump.
- If a pump is to be switched off, the Prosonic S selects the pump which currently has been running longer than any other pump.

- **time of use**

The total running time is considered for each pump.

- **starts (default)**

The number of starts is considered for each pump, irrespective of the time the pump has been running after each start.

- **starts+time**

Identical to the option "starts".

Additionally, a maximum use time is defined for each pump. After it has been running for this time, a pump is automatically replaced by another pump.

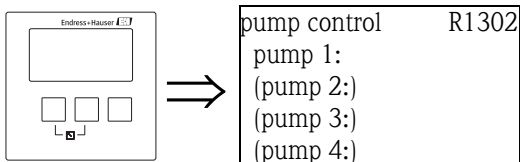
**"pump control N" (N = 1 or 2)**

Determines, to which pump the following specifications refer.

**Selection**

- depending on the selected "number of pumps"

**"pump M/control N" (M = 1 - 6; N = 1 or 2)**  
**(Part 1: Switching points for limit control)**

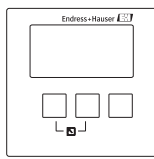

pump 1/control 1 R1303  
 switch on point:  
 switch off point:  
 switch on delay:  
 crust reduction:

*"switch on point"*

Specifies the switch-on point of the respective pump. Use the selected level unit.



**Caution!**

After a change of the "unit level" the switch-on point has to be checked and adjusted if required.

*"switch off point"*

Specifies the switch-off point of the respective pump. Use the selected level unit.



**Caution!**

After a change of the "unit level" the switch-off point has to be checked and adjusted if required.

*"switch-on delay"*

Specifies the switch-on delay of the respective pump (in seconds).

When the level has risen above the switch-on point, the relay does not switch immediately but only after the specified switch-on delay. Assign different delays to the individual pumps in order to avoid simultaneous switching-on of several pumps (which could cause an overload of the power supply system).

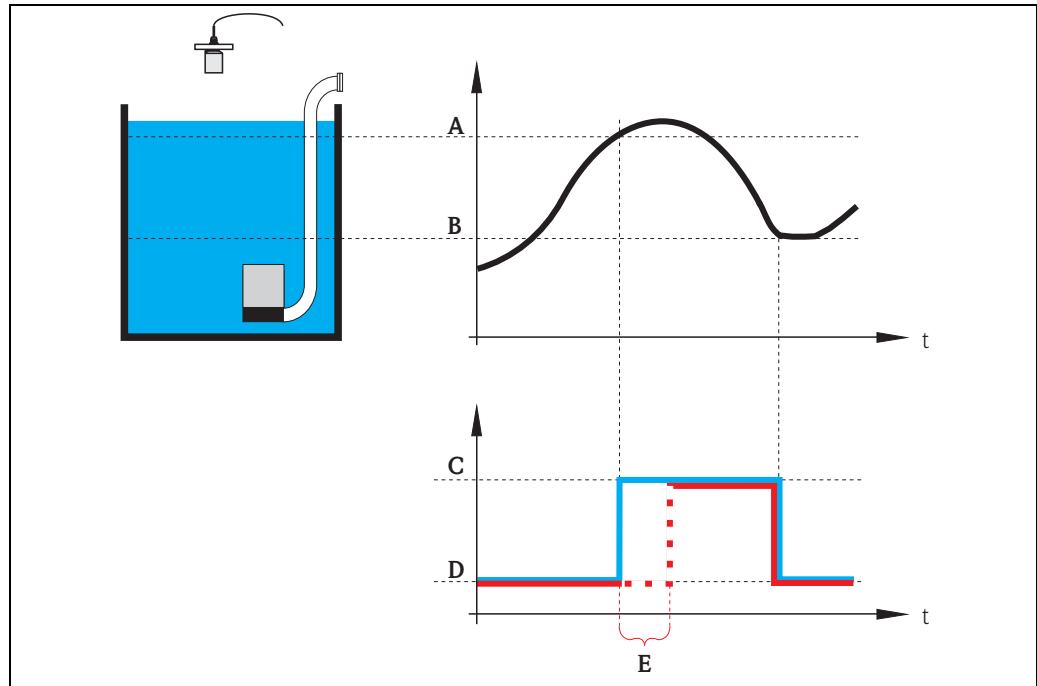

**A:** switch-on point; **B:** switch-off point; **C:** pump on; **D:** pump off; **E:** switch-on delay

L00-FMU90xxx-19-00-00-yy-055

*"alternate"*

Specifies if the pump should be included in the alternating pump control.

**Selection**

- **no (default)**

The pump is not included in the alternating pump control. Instead, it switches according to its own switch points.

- **yes**

The pump is included in the alternating pump control.

*"degree of use"*

(for "load control" = "time of use" or "starts")

Defines the desired degree of use (percentage) of this pump for an alternating pump control. The degree of use is only obtained, if the pump has been allocated to the alternating pump control.



Note!

The total degree of use of all pumps participating in the alternating pump control should be 100%.



"maximum use time"  
 (for "load control" = "starts+time")

Defines the maximum use time for this pump which is valid for the alternating pump control and for "load control" = "starts+time". After it has been running for this time, the pump is automatically replaced by another pump.

"crust reduction"

Specifies a range of inaccuracy (percentage of the measuring range) for the switching points of the pump. If this value is larger than "0", the switching points are not exactly constant. Instead, they vary within the specified range of inaccuracy. This helps to avoid crust formation, which often occurs at fixed switching points.

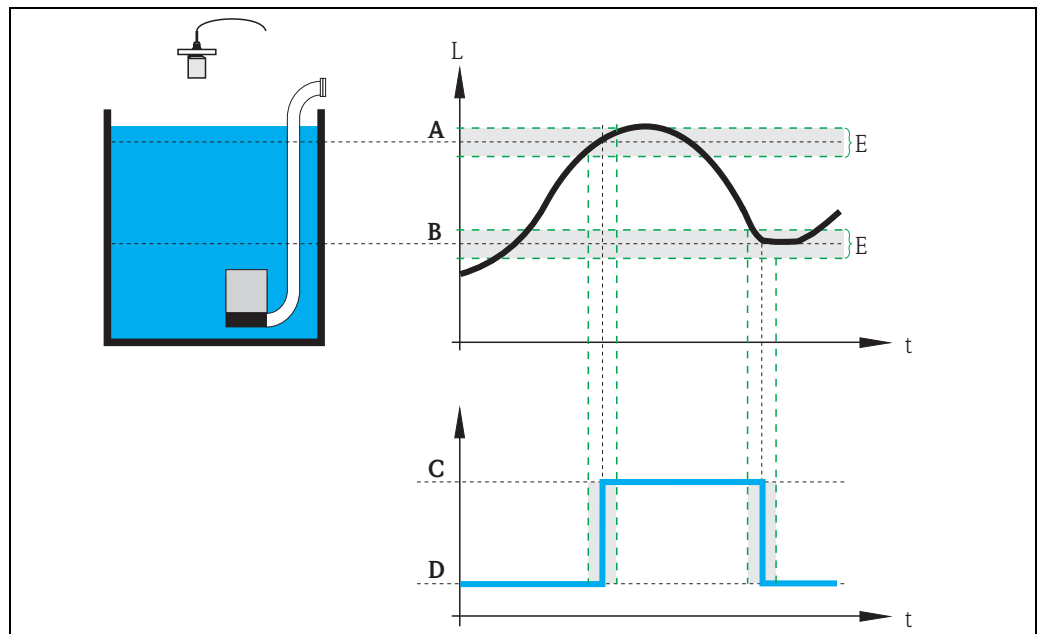

A: switch-on point; B: switch-off point; C: pump on; D: pump off; E: inaccuracy ("crust reduction")

"pump M/control N" (M = 1 - 6, N = 1 or 2)  
 (Part 2: Switching behavior for limit control)

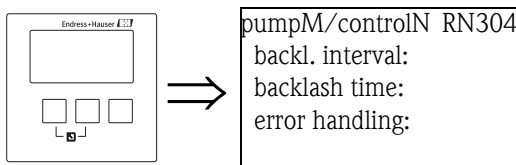

*"backlash interval" and "backlash time"*

Use these parameters if you want to empty a vessel beyond the switch-off point in regular intervals. The **"backlash interval"** determines after which time this extended pumping will occur. The **"backlash time"** determines how long this additional pumping lasts.

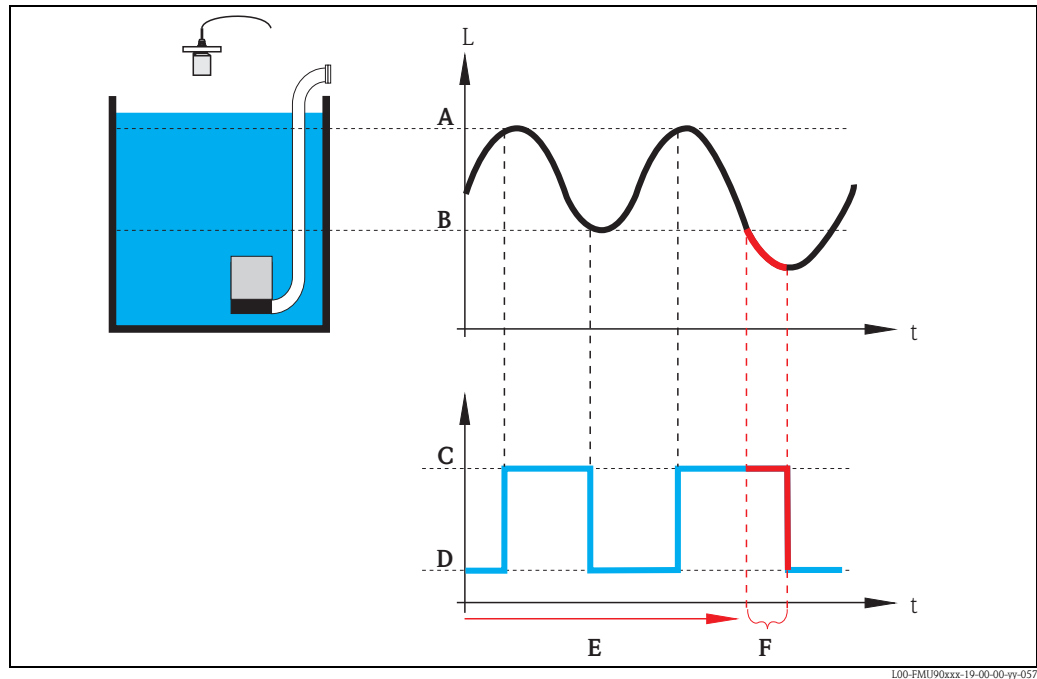

**A:** switch-on point; **B:** switch-off point; **C:** pump on; **D:** pump off; **E:** backlash interval; **F:** backlash time

*"error handling"*

This parameter defines the reaction of the relay in the case of an error.

**Selection:**

- **hold (default)**

The current switching state of the relay is held.

- **switch on**

The relay is energized (i.e. the pump is switched on).

- **switch off**

The relay is de-energized (i.e. the pump is switched off).

- **actual value**

The relay switches according to the current measuring value (although its reliability is not ensured).

**"pump M/control N" (M = 1 - 6, N = 1 or 2)**  
**(Part 3: Parametrization of the associated switch inputs)**



Note!

This parameter set is only available for instruments with external switch inputs (FMU90-\*\*\*\*\*B\*\*\*).

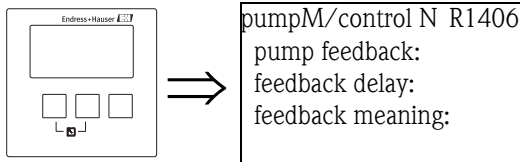

*"pump feedback"*

Defines which digital input is used for pump feedback.

**Selection:**

- **disabled (default)**  
no feedback
- **ext. digin 1**  
terminals 71, 72, 73
- **ext. digin 2**  
terminals 74, 75, 76
- **ext. digin 3**  
terminals 77, 78, 79
- **ext. digin 4**  
terminals 80, 81, 82

*"feedback delay"*

Defines in which time interval after a pump start a feedback is required.

Feedback messages after this time are ignored.

Default: 30 s



Note!

When setting the feedback delay, the startdelay of the relay (which is defined in the safety settings menu) has to be taken into account. Depending on the number of connected pumps the feedback delay must be at least "number of pumps x startdelay relay".

*"feedback meaning"*

Defines the meaning of the feedback signal.

**Selection:**

- **pump start (default)**  
The feedback signals the start of the pump.  
If no feedback is given within the feedback delay, the standby pump is started (if one has been defined).
- **pump failure**  
The feedback signals a failure of the pump. If a standby pump has been defined it is used to replace the failed pump.



Note!

- The standby pump can only be used for one failed pump.
- If additionally the failure is to be reported by a relay, a pump alarm relay has to be parametrized in the "relay configuration" submenu.

**Note!**

Behaviour of the Prosonic S if a pump failure is reported via the external switch inputs:

- If a pump failure is reported of a start report is missing during the operation of the pump, a pump failure is indicated on the display and via an error code.
- The relay of the respective pump remains energized in order to report the pump failure. A reset is only possible via "relay/controls/pump control N/basic setup/reset".

**Caution!**

If the connected pumps are shut down as a consequence of an error message, it is advisable for security reasons to switch off the control unit Prosonic S as well.

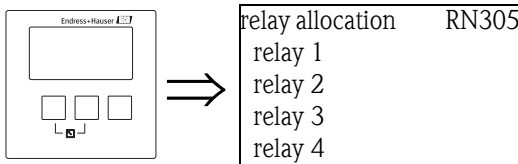
**"relay allocation"**

Allocates a relay to the pump.

**Selection:**

- All relays of the instrument version at hand

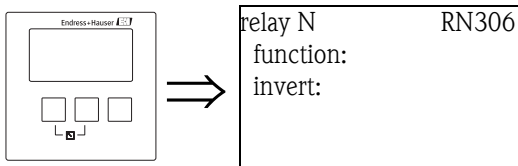
**"relay N" (N = 1 - 6)****"function"**

Allocates the desired function to the relay.

**Selection:**

- none (default)
- pump M/control N

**Note!**

If a standby pump has been parametrized: The standby pump is always the last of the pumps. Therefore, during the relay allocation the last pump must be selected in the "function" parameter.

**Example:**

number of pumps: 5

stand by pump: yes

=> for the standby pump: "function" = pump 5/control N

*"invert"*

Determines if the switching behavior of the relay is inverted.

**Selection:**■ **no (default)**

The switching behavior of the relay is **not** inverted. The relay is energized if the pump should be switched on.

■ **yes**

The switching behavior of the relay **is** inverted. The relay is energized if the pump should be switched off.

**"pump control N" (N = 1 or 2)**  
**(Switching points for rate control)**

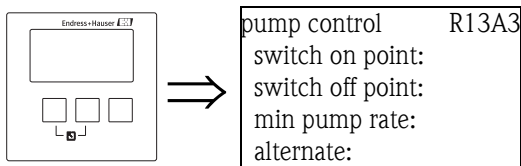
*"switch on point"*

Specifies the switch-on point. Use the selected level unit.

**Caution!**

After a change of the "unit level", the switch on point has to be checked and adjusted if required.

*"switch off point"*

Specifies the switch-off point. Use the selected level unit.

**Caution!**

After a change of the "unit level", the switch off point has to be checked and adjusted if required.

*"min pump rate"*

Specifies the desired minimum pump rate (for details see section "limit control and rate control").

**Note!**

If the vessel is to be emptied, a negative pump rate has to be specified.

*"crust reduction" subfunction*

Specifies a range of inaccuracy (percentage of the measuring range) for the switching points. If this value is larger than "0", the switching points are not exactly constant. Instead, they vary within the specified range of inaccuracy.

This helps to avoid crust formation, which often occurs at fixed switching points.

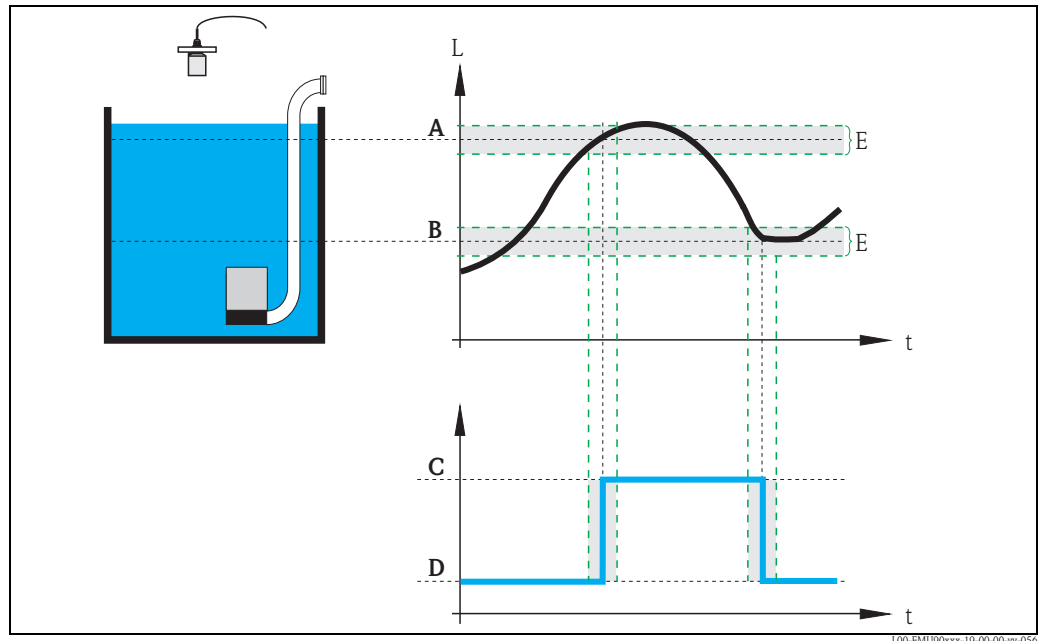

**A:** switch-on point; **B:** switch-off point; **C:** pump on **D:** pump off; **E:** inaccuracy ("crust reduction")

*"switch on border"*

Specifies the switch-on border for the rate control (for details see section "limit control and rate control").

*"hook up interval"*

Specifies the time interval between the switching-on of the different pumps (for details see section "limit control and rate control").

*"alternate"*

Determines if an alternating pump control is to be performed.

### 8.4.3 The "storm function" submenu

The storm function is used to avoid unnecessary running of the pump if the plant is flooded for a short time (e.g. in the case of strong rainfall).

#### "storm function N" ( N = 1 or 2)

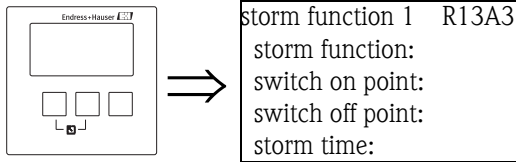

#### "storm function"

Use this parameter to switch the storm function on and off.

##### Selection:

- off (default)
- on

#### "switch on point"

Defines the switch on point for the storm function. If the level rises above this value, the storm function becomes active, i.e. all pumps are switched off.

Default: 95%



Note!

Storm detection is **not** indicated by an alarm.

#### "switch off point"

Defines the switch off point for the storm function. If the level falls below this value, the storm function is deactivated, i.e. the normal pump control becomes valid again.

Default: 90%



Note!

The switch off point must always be lower than the switch on point. It must be ensured that the switch off point is reached without the pumps (e.g. by an outlet).

#### "storm time"

Defines the maximum duration of a storm.

If the storm function has been active for this time, it is automatically deactivated, even if the level has not fallen below the switch off point or has risen above the switch on point a second time.

Default: 60 min

### 8.4.4 The "function test" submenu

The function test is used to avoid incrustations which may occur if pumps are switched off for a long time. If a pump has not been running for a defined time (max downtime), it is automatically switched on for a short time (max test time).



Note!

The function test affects all pumps, even the standby pump.

#### "function test N" ( N = 1 or 2)

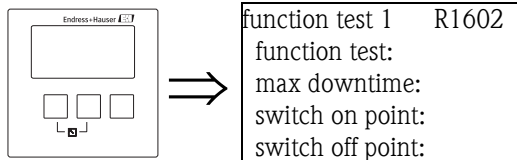

#### "function test"

Use this parameter to switch the automatic function test on and off.

#### Selection:

- off (default)
- on

#### "max. downtime" und "max. test time"

These parameters define when and how long a pump is switched on for the function test:

If a pump has not been running for the "**max. downtime**", it is switched on (even if momentarily other pumps are running).

It is automatically switched off after the "**max test time**".

#### max. downtime:

- Default: 0h
- Range of values: 0 to 9999 h

#### max. test time

- Default: 60 s
- Range of values: 0 to 2000 s

#### "switch on point" and "switch off point"

These parameters define a condition for the function test. A pump is only switched on for the function test, if these conditions are met. Details depend on the relative position of the switching points:

#### ■ switch on point > switch off point ("Emptying")

The function test is only performed if the level is above the switch on point.

If the level falls below the switch off point, the function test is terminated, even if the "maximum test time" has not yet elapsed.

#### ■ switch on point < switch off point ("Filling")

The function test is only performed if the level is below the switch on point.

If the level rises above the switch off point, the function test is terminated, even if the "maximum test time" has not yet elapsed.

#### Default:

- switch on point: 20%
- switch off point: 10%



### 8.4.5 The "flush control" submenu

The flush control is used to switch a pump on for a number of cycles (flush cycles) for a defined time (flush time). This switching-on takes place within the defined number of pump cycles. The figure below shows an example with 5 pump cycles and 2 flush cycles. The last two of the five pump cycles are used for flushing.

A pump cycle always starts with the first pump being switched on and ends if all pumps are switched off again.

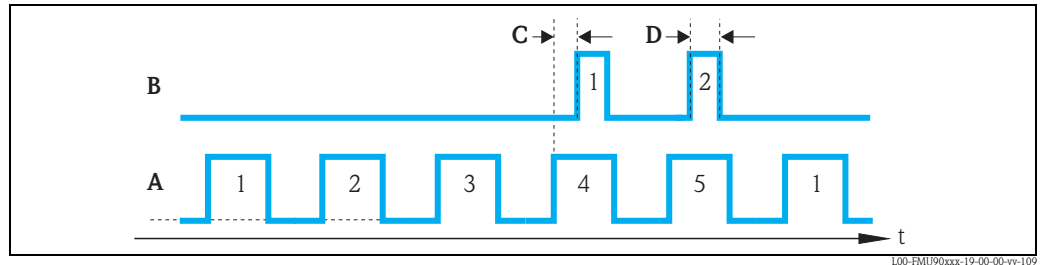

A: 5 pump cycles; B: 2 flush cycles; C: flush delay; D: flush time

#### "flush control N" ( N = 1 or 2)

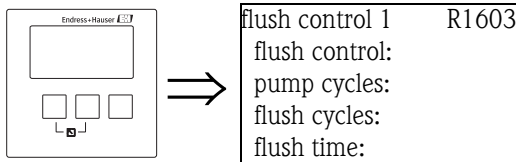

#### "flush control"

Use this parameter to switch the flush control on and off.

#### Selection:

- off (default)
- on

#### "pump cycles"

Defines the number of pump cycles after which the flush cycles are started.

Default: 0

#### "flush cycles"

Defines the number of flush cycles within the number of pump cycles.

Default: 0



Note!

The number of flush cycles must be equal or less than the number of pump cycles.

#### "flush time"

Defines, how long the flush relay is switched on.

Default: 0 s

Range of values: 0 to 255 s

#### "flush delay"

Defines the interval between the start of the pump cycle and the start of the flush relay.

Default: 0 s

Range of values: 0 to 255 s

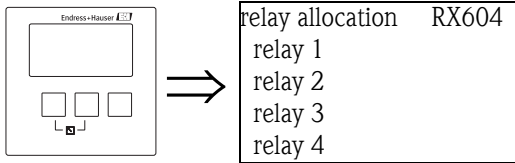
**"relay allocation"**

Defines which relay is the flush relay.

**Selection:**

- All relays of the instrument version at hand.

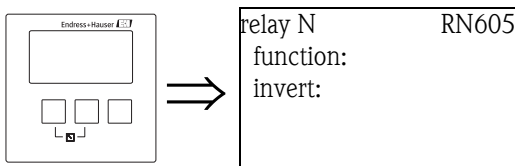
**"relay N" (N = 1 - 6)****"function"**

Allocates the desired function to the relay.

**Selection:**

- none (default)
- flush control N

**"invert"**

Determines if the switching behavior of the relay is inverted.

**Selection:**

- **no (default)**  
The switching behavior of the relay is **not** inverted. The relay is energized in the flush cycles.
- **yes**  
The switching behavior of the relay **is** inverted. The relay is de-energized in the flush cycles.

### 8.4.6 The "tariff control" submenu



Note!

The tariff control is only available for instruments with external limit switches (FMU90-\*\*\*\*\*B\*\*\*).

The tariff control allows to define two different switch-on and switch-off points for each pump. An external switch determines which of these switching points are currently valid. By connecting a time switch to the Prosonic S this allows to use low priced tariff times preferentially for pumping.

#### "tariff control N" (N = 1 or 2)

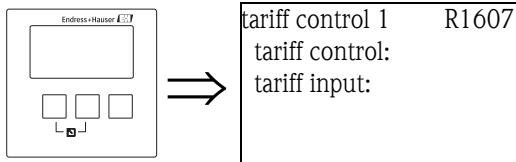

#### "tariff control"

Determines if a tariff control is to be performed.

**Selection:**

- no (default)
- yes

#### "tariff input"

Allocates one of the switch inputs to the tariff control.

**Selection:**

- disabled
- ext. digin 1 (terminals 71, 72, 73)
- ext. digin 2 (terminals 74, 75, 76)
- ext. digin 3 (terminals 77, 78, 79)
- ext. digin 4 (terminals 80, 81, 82)

#### "tariff control N" (N = 1 or 2) (pump selection)

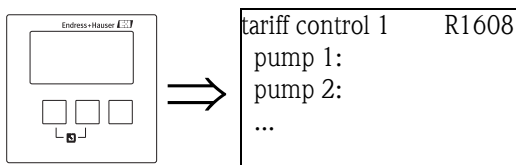

Select the pump for which you are going to configure the tariff control from this list.



Hinweis!

If a pump rate control is performed, this selection is omitted. Only one common switch-on point and switch-off point for tariff control must be defined.

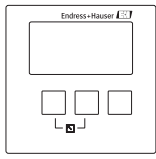
**"tariff ctrl N pump M" (N = 1 or 2, M = 1 - 6)**

```
tariff ctr. 1 p1    R1608
switch on point:
switch on point:
switch off point:
switch off point:
```

*"switch on point"*

Displays the switch on point which is valid as long as no signal is present at the tariff switch input. (Is equal to the switch-on point defined in the basic setup.)

*"switch on point tariff"*

Defines the switch of point which is valid if a signal is present at the tariff switch input.

*"switch off point"*

Displays the switch off point which is valid as long as no signal is present at the tariff switch input. (Is equal to the switch-off point defined in the basic setup.)

*"switch off point tariff"*

Defines the switch off point which is valid if a signal is present at the tariff switch input.

**Note!**

By selecting appropriate tariff switch points preferential pumping during the low-price tariff times can be achieved.

**Example for emptying:**

The switch points for tariff control are considerably below those of the basic setup. This results in a preferred pumping and emptying of the vessel during the low-price tariff time. During the high price tariff time on the other hand, as much water as possible is buffered in the vessel.

### 8.4.7 The "pump data" submenu

The most important operating data of the pumps can be displayed in this submenu.

#### "pump data N" (N = 1 or 2) (pump selection)

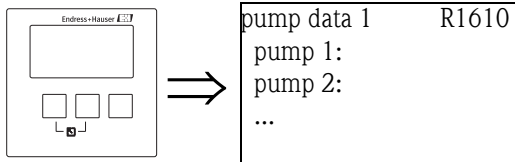

Select a pump from this list. The operating data of this pump will be displayed in the following parameter set.

#### "pump data N" (N = 1 or 2)

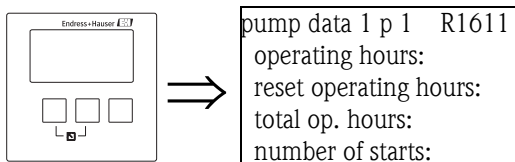

Note!

All pump data displayed in this parameter set are affected by a reset of the Prosonic S.

#### "operating hours"

Indicates how long the pump has been running since the last reset.

#### "reset operating hours"

Resets the "operating hours" to 0.

#### Selection:

##### ■ no

"operating hours" keeps its value.

##### ■ yes

"operating hours" is reset to 0.

#### "total operating hours"

Indicates the total time the pump has been running since commissioning. This value can not be reset.

#### "number of starts"

Indicates the number of times the pump has been started.

#### "starts per hour"

Indicates the average number of starts per hour.

#### "backlash starts"

Indicates the number of times the backlash time has been active for this pump.

*reset backlash starts*

Resets the number of backlash starts to 0.

**Selection:**

- **no**  
"backlash starts" keeps its value.
- **yes**  
"backlash starts" is reset to 0.

*last run time*

Indicates how long the pump has been running since the last switch-on.

**8.4.8 The "operating hours alarm" submenu**

A maximum run time can be defined for each pump. The operating hours alarm becomes active as soon as this run time is exceeded.

**"operating hours alarm N" (N = 1 or 2)**

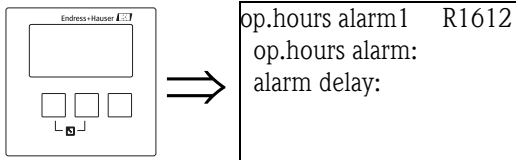

*"operating hours alarm"*

Use this parameter to switch the operating hours control on and off.

**Selection:**

- off (default)
- on

*"alarm delay"*

Defines the delay for the operating hours alarm. This delay is the same for all pumps.  
Default: 0s.

**"operating hours alarm N" (N = 1 or 2)  
(pump selection)**

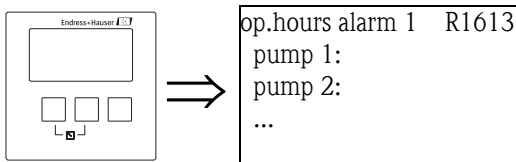

Select the pump for which you are going to configure the operating hours alarm.

**"operating hours N pump M" (N = 1 or 2, M = 1 - 6)**

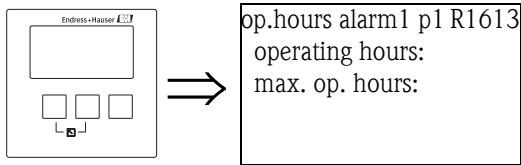

*"operating hours"*

Indicates how long the pump has been running since the last reset.

*"maximum operating hours"*

Defines the maximum running time of the pump. The operating hours alarm becomes active as soon as "operating hours" exceeds this value.

Default: 10000 h

Range of values 0 to 999999 h



**Note!**

The alarm is deactivated by a reset of the operating hours in the "pump data" submenu (e.g. after the maintenance of the pump has been completed).

**"relay allocation"**

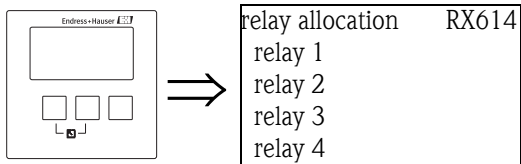

Defines a relay which is associated with the operating hours alarm.

**Selection:**

- All relays of the instrument version at hand.



**Note!**

The relay is not allocated to a specific pump. It only indicates that the operating hours alarm is active for one of the pumps. At the same time an error message is generated which states the number of the affected pump.

**"relay N" (N = 1 - 6)**

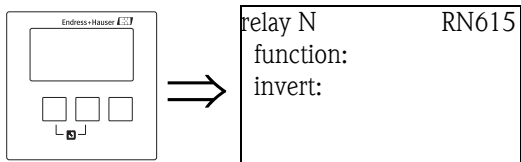

*"function"*

Allocates the desired function to the relay.

**Selection:**

- none (default)
- Operating hours alarm N (N = 1 or 2)

*"invert"*

Determines if the switching behavior of the relay is inverted.

**Selection:**■ **no (default)**

The switching behavior of the relay is **not** inverted. The relay is de-energized if an operating hours alarm is active.

■ **yes**

The switching behavior of the relay is **is** inverted. The relay is energized if an operating hours alarm is active.

**8.4.9 The "pump alarm" submenu**

Note!

This submenu is only available for instruments with external switches (FMU90-\*\*\*\*\*B\*\*\*).

The pump alarm is used to indicate a pump failure by one of the relays. This is only possible if a pump monitoring system is connected to one of the switch inputs and if "pump feedback" has been parametrized in the "basic setup" submenu.

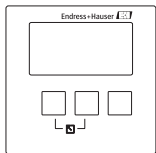
**"pump alarm N" (N = 1 or 2)**

```
pump alarm 1   R1617
pump alarm:
waiting time:
```

*"pump alarm"*

Use this parameter to switch the pump alarm function on and off.

**Selection:**■ **off (default)**■ **on***"waiting time"*

Defines the waiting time for the pump alarm. It is the same for all pumps.  
Default: 0s.

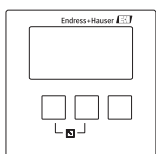
**"relay allocation"**

```
relay allocation  RX614
relay 1
relay 2
relay 3
relay 4
```

Defines which relay is used to indicate a pump alarm.

**Selection:**

## ■ All relays of the instrument version at hand.



Note!

The relay is not allocated to a specific pump. It only indicates that one of the pumps has generated an alarm. At the same time an error message is generated which states the number of the affected pump.



## 8.5 Configuration of a rake control

### 8.5.1 Basics

In order to detect clogging of a rake, the Prosonic S measures the upstream level L1 and the downstream level L2. Rake clogging causes L2 to become much lower than L1. Therefore, the rake control function evaluates either the difference  $L1 - L2$  or the ratio  $L2/L1$ .

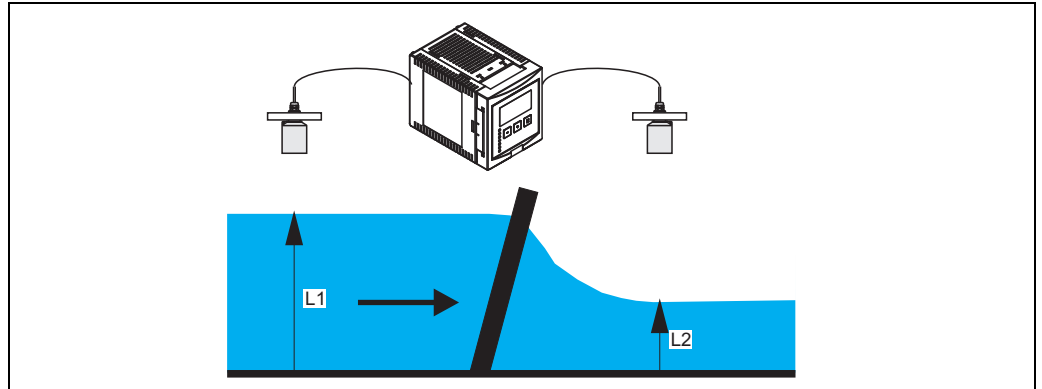

Rake clogging is indicated by a relay, which can be used, for example, to trigger a rake cleaning device.

### 8.5.2 Overview

Step	Parameter set or submenu	Parameter	Remarks	Section
1	"relay/controls" menu		Select "rake control"	
2	rake control	upstream water	Select the upstream water level signal (L1)	→ Chap. 8.4.3
		downstream water	Select the downstream water level signal (L2)	
		function	Select the criterion for rake clogging: <ul style="list-style-type: none"> <li>■ difference: <math>L1 - L2</math></li> <li>■ ratio: <math>L2/L1</math></li> </ul>	
3	rake control	switch on point	Define the switch on point	→ Chap. 8.4.4
		switch off point	Define the switch off point	
4	rake control	switch delay	Define the switch delay.	→ Chap. 8.4.5
		error handling	Define the error handling	
5	relay allocation		Select the relay for rake control	→ Chap. 8.4.6
6	relay N (N = 1 - 6)	function	Select "rake control"	→ Chap. 8.4.7
		invert	Select if the switching delay is to be inverted (default: no)	



Note!

In the "output/calculations" and "calibrate display" menus it is possible to define, that the difference  $L1-L2$  or the ratio  $L2/L1$  is displayed by the analog output and/or the display.

### 8.5.3 "rake control" (Part 1: Allocation)

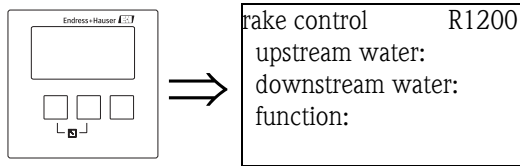

#### "upstream water"

Specifies, which signal refers to the upstream level.

##### Selection:

- level 1 (default)
- level 2

#### "downstream water"

Specifies, which signal refers to the downstream level.

##### Selection:

- level 1
- level 2 (default)

#### "function"

Used to select the criterion for the detection of rake clogging.

##### Selection:

- **difference (default)**  
Rake clogging is indicated if the difference  $L1 - L2$  exceeds a critical value.
- **ratio**  
Rake clogging is indicated if the ratio  $L2/L1$  falls below a critical value.

### 8.5.4 "rake control" (Part 2: Switching points)

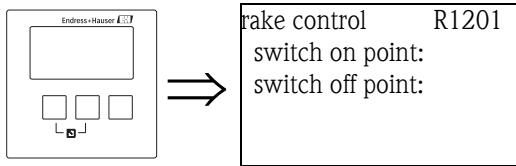

#### "switch on point" and "switch off point"

Used to specify the limit values for detection of rake clogging. The meaning of these limit values depends on the selected function.



Caution!

After a change of the "unit level" the switching points have to be checked and adjusted if required.

*function = "difference"*

In this case, the switch on and switch off points have to be specified in the level unit. The switch on point must be larger than the switch off point.

The rake control relay is energized if the difference  $L1 - L2$  rises above the switch on point. It is de-energized if the difference falls below the switch off point.

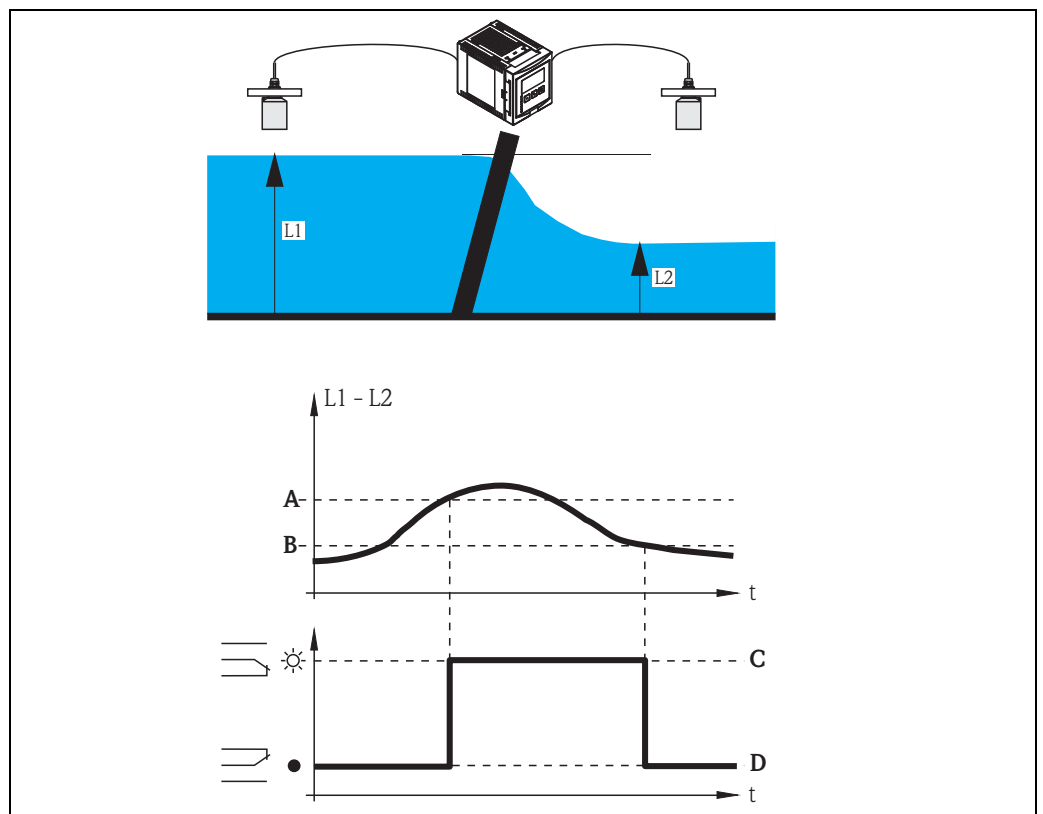

L00-FMU90xxxx-19-00-00-yy-059

**A:** switch on point; **B:** switch off point;

**C:** relay energized (i.e. rake cleaning on); **D:** relay de-energized (i.e. rake cleaning off)

*function = "ratio"*

In this case, the switch on and switch off points are numbers between 0 and 1. The switch on point must be smaller than the switch off point.

The rake control relay is energized if the ratio  $L2/L1$  falls below the switch on point. It is de-energized if the ratio rises above the switch off point.

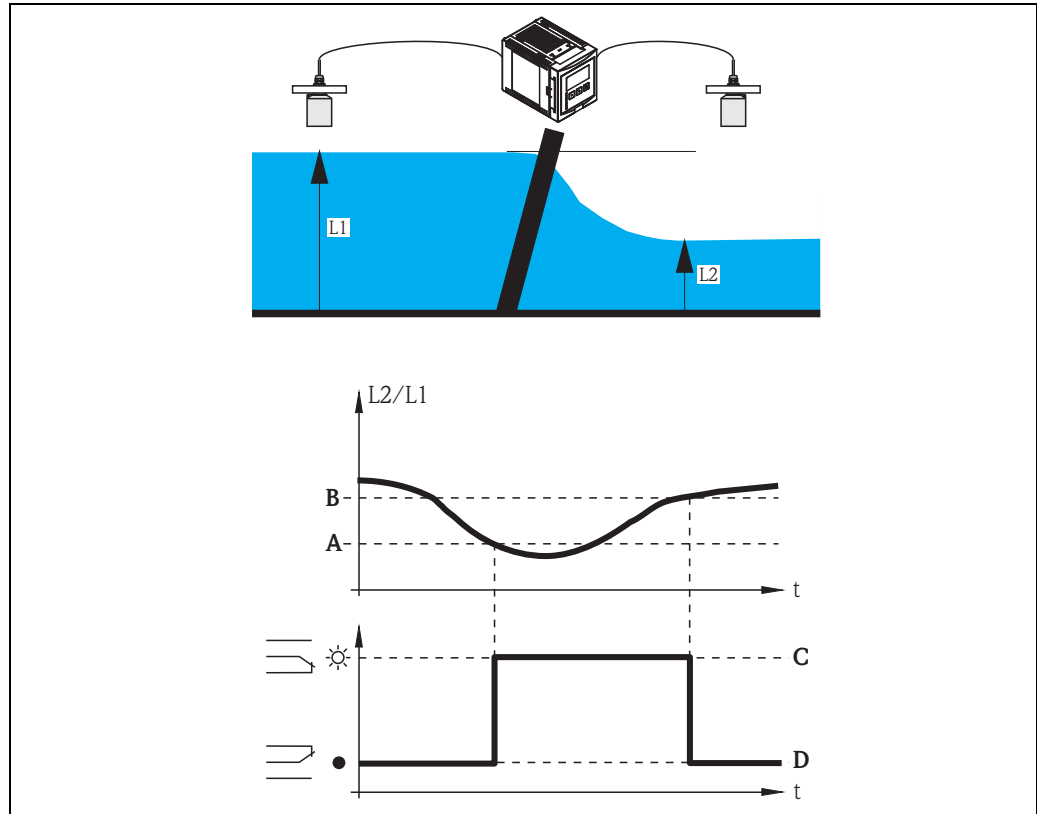

L00-FMU90xxx-19-00-00-yy-000

**A:** switch on point; **B:** switch off point;

**C:** relay energized (i.e. rake cleaning on); **D:** relay de-energized (i.e. rake cleaning off)

### 8.5.5 "rake control" (Part 3: Switching parameters)

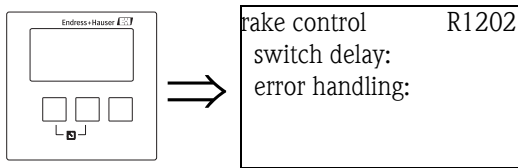

#### "switch delay"

Specifies the switch delay for the rake control.

The relay does not switch immediately after the switch on point has been exceeded but only after the specified switch delay. This is to prevent that random fluctuations of L1 or L2 activate the rake cleaning unnecessarily.

#### "error handling"

Specifies the behavior of the rake control relay in case of an error.

##### Selection:

##### ■ actual value (default)

The relay switches according to the current measuring value (although its reliability is not ensured).

##### ■ hold

The current switching state of the relay is held.

##### ■ switch on

The relay is energized.

##### ■ switch off

The relay is de-energized.

### 8.5.6 "relay allocation"

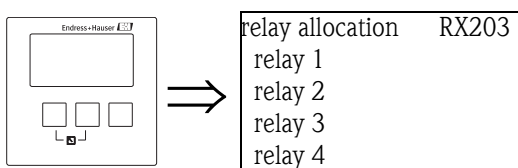

Allocates a relay to the rake control function.

##### Selection:

- All relays of the instrument version at hand.

### 8.5.7 "relay N" (N = 1 - 6)

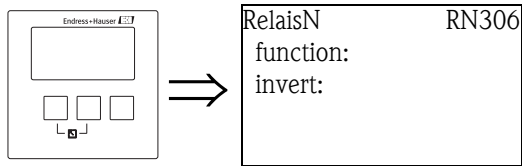

#### "function"

Allocates the desired function to the relay.

#### Selection:

- none (default)
- rake control

#### "invert"

Determines if the switching behavior of the relay is to be inverted.

#### Selection:

##### ■ no (default)

The switching behavior of the relay is **not** inverted. The relay is energized if the rake cleaner should be switched on.

##### ■ yes

The switching behavior of the relay **is** inverted. The relay is energized if the rake cleaner should be switched off.

## 9 The "output/calculations" menu

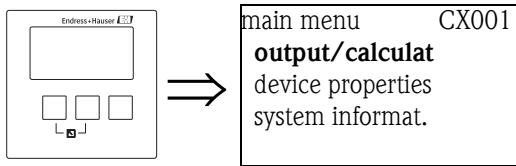

The "output/calculations" menu can be used to

- configure calculations such as averaging and subtraction
- configure the current outputs and the HART interface.

After entering the "output/calculations" menu, a selection screen appears in which you must choose the output you are going to configure.

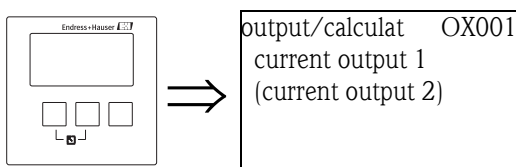

After this selection, additional submenus appear, which can be used to configure the output:

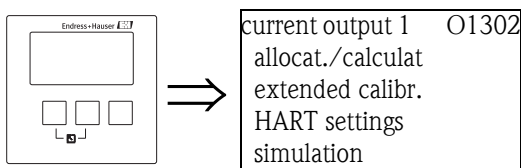

## 9.1 The "allocation/calculations" submenu

### 9.1.1 "allocation current N " (N = 1 or 2)

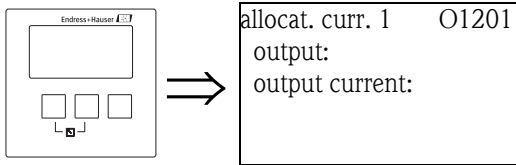

#### "output"

Allocates a measured or calculated value to the current output.

#### Selection:

The available options depend on the instrument version, the connected sensors and the instrument configuration. The following measured and calculated values may occur:

- level 1
- level 2
- flow 1
- flow 2
- average level:  $(\text{level1} + \text{level2})/2$
- level 1-2
- level 2-1
- level 1+2
- average flow
- flow 1-2
- flow 2-1
- flow 1+2
- backwater ratio  
downstream/upstream
- rake control ratio  
downstream/upstream

#### "output current"

Displays the output current (mA).



## 9.2 The "extended calibration" submenu

### 9.2.1 "mode current N" (N = 1 or 2)

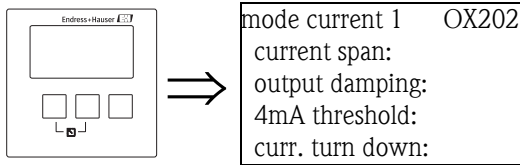

#### "current span"

Used to select the current span to which the measuring range is mapped.

##### Selection:

- **4-20 mA (default)**

The measuring range (0%-100%) is mapped to the current range 4-20 mA.

- **0-20 mA**

The measuring range (0%-100%) is mapped to the current range 0-20 mA.

- **fixed current HART**

A fixed current is output. The value can be defined in the "mA value" parameter. The measured value is transmitted by the HART signal.

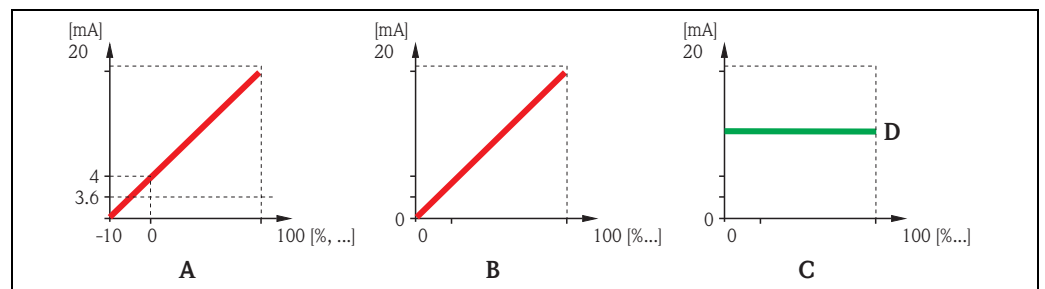

**A:** current span = 4-20 mA; **B:** current span = 0-20 mA; **C:** current span = fixed current HART;  
**D:** mA value

#### "mA value" (only available for "current span" = "fixed current HART")

Specifies the value of the fixed current.

- range of values: 3,6 - 22 mA
- default: 4 mA

**"output damping"**

Specifies the output damping  $\tau$  by which changes of the measured value are attenuated. After a surge in the level it takes  $5 \times \tau$  until the new measured value is reached.

- range of values: in preparation
- default: 1 s

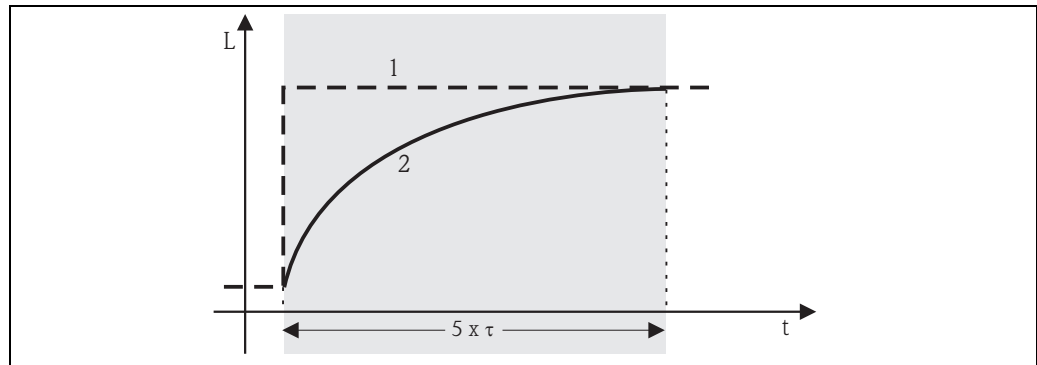

100-FMG60xxx-05-00-00-xx-012

**1:** measured value; **2:** output current

**"4 mA threshold" (only available for "current span" = "4-20mA")**

Used to switch on the 4mA threshold. The 4-mA threshold makes sure that the current never falls below 4 mA, even if the measured value is negative.

**Selection:**

- **off (default)**  
The threshold is switched off. Currents less than 4 mA may occur.
- **on**  
The threshold is switched on. The current never falls below 4 mA.

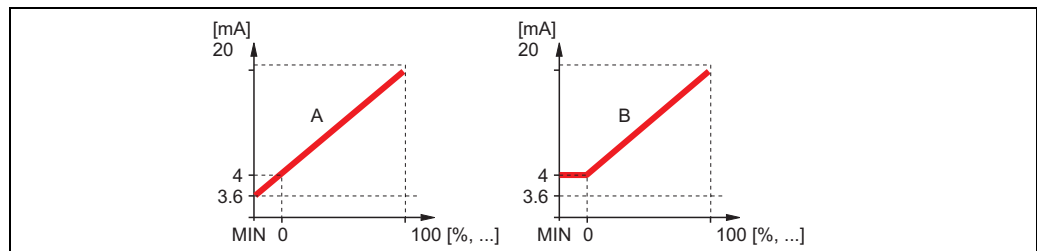

100-FMU90xxx-19-00-00-yy-067

**A:** 4mA threshold off; **B:** 4mA threshold on

**"current turn down" (not present for "current span" = "fixed current HART")**

Used to map only a part of the measuring range to the current output. The selected part is enlarged by this mapping.

**"turn down 0/4 mA" (only for "current turn down" = "on")**

Specifies the measured value for which the current is 0 or 4 mA (depending on the selected current span).

**"turn down 20 mA" (only for "current turn down" = "on")**

Specifies the measured value for which the current is 20 mA.

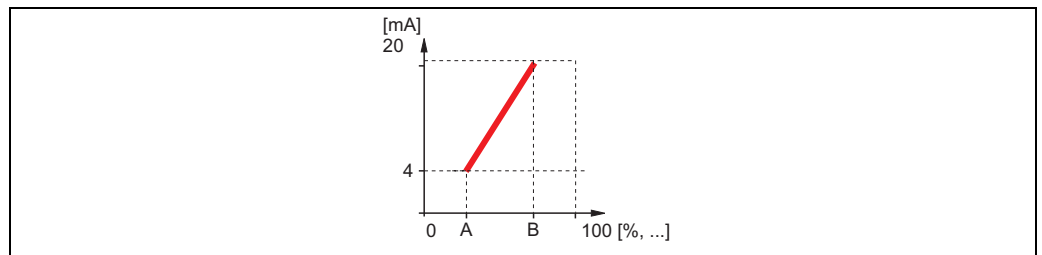

L00-FMU190xxx-19-00-00-yy-068

A: turn down 4mA ; B: turn down 20 mA

### 9.3 "HART settings" submenu (only for current output 1)

#### 9.3.1 "HART settings"

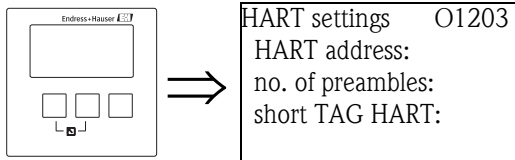

**"HART address"**

Defines the communication address for the instrument.

**Range of values:**

- for standard operation: **0 (default)**
- for multidrop operation: **1 - 15**



**Note!**

In multidrop operation, the output current is 4 mA by default. However, it can be adjusted in the "mA value" parameter of the "mode current" parameter set (see above).

**"no. of preambles"**

Specifies the number of preambles for the HART protocol. For lines with communication problems a slight increase of this value is recommended.

**"short TAG HART"**

in preparation

### 9.3.2 "additional HART value 2/3/4"

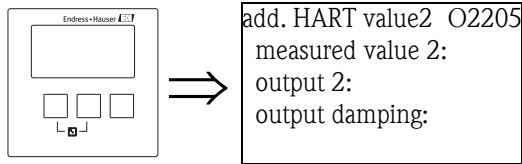

Use these parameter sets to configure the additional values transmitted by the HART protocol:

- measured value 2
- measured value 3
- measured value 4

The parameters are the same for all three measured values.



Note!

"measured value 1" is identical to the main value, which is linked to current output 1.

#### "measured value 2/3/4"

Specifies which measured value is transmitted.

##### Selection:

The selection depends on the instrument version, the connected sensors and the configuration. The following options may occur:

- none (default)
- level 1/2
- flow 1/2
- average level
- level 1-2 / 2-1 / 1+2
- rake control ratio
- backwater ratio
- temperature external sensor
- temperature sensor 1/2
- counter 1/2/3
- totalizer 1/2/3
- average flow
- flow 1-2 / 2-1 / 1+2
- distance sensor 1/2



Note!

If "temperature sensor 1/2" is selected, it always refers to the temperature which has been assigned to the respective sensor in "sensor management/FDU sensor N". Possible temperatures are:

- sensor temperature
- average of sensor temperature and temperature of an external temperature sensor
- temperature of an external temperature sensor

#### "output damping 2/3/4"

Specifies the output damping  $\tau$  by which a change of the measured value is attenuated.

After a surge of the measured value it takes  $5 \times \tau$  till the HART value has adopted the new value.

- range of values: in preparation
- default: 1 s

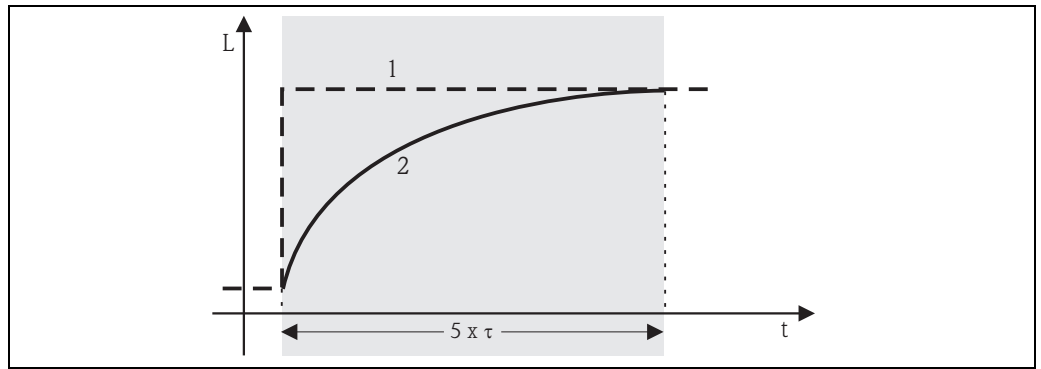

1: measured value; 2: HART output value

## 9.4 "Simulation" submenu

### 9.4.1 "simulation"

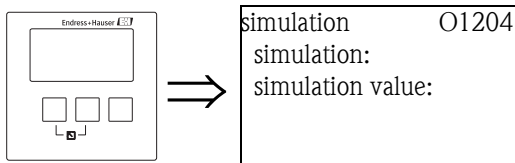

#### "simulation"

Used to switch on the simulation of the current.

##### Selection:

- **off (default)**

No simulation is performed. The instrument is in the measuring mode.

- **on**

The instrument is in the simulation mode. No measured value is transmitted to the output. Instead, the current output assumes the value specified in the "simulation value" subfunction.

#### "simulation value" (only for "simulation" = "on")

Specifies the value of the simulated output current (in mA).

## 10 Troubleshooting

### 10.1 System error messages

#### 10.1.1 Error signal



Errors occurring during commissioning or operation are signalled in the following way:

- Error symbol, error code and error description on the display and operating module
- Current output, configurable ("output on alarm" function).
  - MAX, 110%, 22mA
  - MIN, -10%, 3,6mA
  - HOLD (the last value is held)
  - user-specific value
- In the menu: "system information/error list/actual error"

#### 10.1.2 Last error

To access a list of the last errors which have been cleared, go to "system information/error list/last error".

#### 10.1.3 Types of errors

Type of error	Display symbol	Meaning
Alarm (A)	 continuous	The output signal assumes a value which can be defined by the "output on alarm" function: <ul style="list-style-type: none"> <li>■ MAX: 110%, 22 mA</li> <li>■ MIN: -10%, 3,6 mA</li> <li>■ Hold: last value is held</li> <li>■ user-specific value</li> </ul> Additionally, an error message appears on the display.
Warning (W)	 flashing	The instrument continues to measure. An error message is displayed.

### 10.1.4 Error codes

The error code consists of 6 digits with the following meaning:

- Digit 1: Type of error
  - A: alarm
  - W: warning
  - E: error (the user can define if the error behaves like an alarm or a warning.)
- Digits 2 and 3:
  - indicate the input channel, output channel or the relay to which the error refers. "00" means that the error does not refer to a specific channel or relay.
- Digits 4–6:
  - indicate the error according to the following table.

#### Example:

W 01 641	<ul style="list-style-type: none"> <li>■ W: Warning</li> <li>■ 01: sensor input 1</li> <li>■ 641: loss of echo</li> </ul>
----------	---

Code	Description of error	Remedy
A 00 100	software version does not fit to hardware version	
A 00 101	checksum error	full reset and recalibration required
A 00 102	checksum error	full reset and recalibration required
W 00 103	initializing - please wait	if the message does not disappear after a couple of seconds: replace electronics
A 00 106	downloading - please wait	wait for completion of the download
A 00 110	checksum error	full reset and recalibration required
A 00 111 A 00 112 A 00 114 A 00 115	electronics defective	switch instrument off/on; if the error persists: call Endress+Hauser service
A 00 116	download error	repeat download
A 00 117	hardware not recognised after exchange	
A 01 121 A 02 121	current output 01 or 02 not calibrated	call Endress+Hauser service
A 00 125	electronics defective	replace electronics
A 00 152	checksum error	full reset and recalibration required
W 00 153	initializing	if the message does not disappear after a couple of seconds: replace electronics
A 00 155	electronics defective	replace electronics
A 00 164	electronics defective	replace electronics
A 00 171	electronics defective	replace electronics
A 00 180	synchronization faulty	check synchronization wiring (s. chapter "Wiring")
A 00 183	hardware not supported	check if the installed board complies with the order code of the instrument; call Endress+Hauser service
A 01 231 A 02 231	sensor 01 or 02 defective - check connection	check for correct connection of the sensor (s. chapter "Wiring")
A 00 250	failure in external temperature sensor	check external temperature sensor and connection
A 01 281 A 02 281	temperature measurement 01 or 02 defective - check connection	check for correct connection of the sensor (s. chapter "Wiring")

Code	Description of error	Remedy
W 01 501 W 02 501	no sensor selected for channel 01 or 02	allocate sensor (s. "level" or "flow" menu)
A 01 502 A 02 502	Sensor 01 or 02 not recognized	Enter type of sensor manually ("level" or "flow" menu, submenu "basic calibration").
A 00 511	no factory calibration present	
A 01 512 A 02 512	mapping in process	wait for completion of mapping
W01 521 W02 521	new sensor 01 or 02 detected	
W01 601 W02 601	non-monotonic linearisation curve for level 01 or 02	re-enter linearisation (s. "level" menu)
W 01 602 W 02 602 W 01 603 W 02 603	non-monotonic linearisation for flow 01 or 02	re-enter linearisation (s. "flow" menu)
A 01 604 A 02 604	faulty calibration for level 01 or 02	adjust calibration (s. "level" menu)
A 01 605 A 02 605 A 01 606 A 02 606	faulty calibration flow 01 or 02	adjust calibration (s. "flow" menu)
W01 611 W02 611	linearisation points level 01 or 02: number < 2	enter further linearisation points (s. "level" menu)
W01 612 W02 612 W01 613 W02 613	linearisation points flow 01 or 02: number < 2	enter further linearisation points (s. "flow" menu)
W 01 620 ... W 06 620	pulse value too low for relay 01 - 06	check counting unit (see "flow" menu, "flow counter" submenu)
E 01 641 E 02 641	no usable echo sensor 01 or 02	check basic calibration for the respective sensor (s. "level" or "flow" menu)
A 01 651 A 02 651	Safety distance reached for sensor 01 or 02 - danger of overfilling	Error disappears if the level is out of the safety distance again. Possibly, the function "acknowledge alarm" must be used (s. "safety settings" menu)
E 01 661 E 02 661	temperature sensor 01 or 02 too high	
W 01 682 W 02 682	Current 01 or 02 out of measuring range	Perform basic calibration; check linearisation
W01 691 W02 691	filling noise detected sensor 01 or 02	
W00 692	backwater detected (if backwater detection is active)	
W00 693	dirt detected (if dirt detection is active)	
W 01 701	Operating hours alarm pump 1 ctrl 1	Reset operating hours
W 02 701	Operating hours alarm pump 1 ctrl 2	Reset operating hours
W 01 702	Operating hours alarm pump 2 ctrl 1	Reset operating hours
W 02 702	Operating hours alarm pump 2 ctrl 2	Reset operating hours
W 01 703	Operating hours alarm pump 3 ctrl 1	Reset operating hours
W 02 703	Operating hours alarm pump 3 ctrl 2	Reset operating hours
W 01 704	Operating hours alarm pump 4 ctrl 1	Reset operating hours
W 02 704	Operating hours alarm pump 4 ctrl 2	Reset operating hours



Code	Description of error	Remedy
W 01 705	Operating hours alarm pump 5 ctrl 1	Reset operating hours
W 02 705	Operating hours alarm pump 5 ctrl 2	Reset operating hours
W 01 706	Operating hours alarm pump 6 ctrl 1	Reset operating hours
W 02 706	Operating hours alarm pump 6 ctrl 2	Reset operating hours
W 01 711	Failure of pump 1 ctrl 1	check pump <sup>1)</sup>
W 02 711	Failure of pump 1 ctrl 2	check pump <sup>1)</sup>
W 01 712	Failure of pump 2 ctrl 1	check pump <sup>1)</sup>
W 02 712	Failure of pump 2 ctrl 2	check pump <sup>1)</sup>
W 01 713	Failure of pump 3 ctrl 1	check pump <sup>1)</sup>
W 02 713	Failure of pump 3 ctrl 2	check pump <sup>1)</sup>
W 01 714	Failure of pump 4 ctrl 1	check pump <sup>1)</sup>
W 02 714	Failure of pump 4 ctrl 2	check pump <sup>1)</sup>
W 01 715	Failure of pump 5 ctrl 1	check pump <sup>1)</sup>
W 02 715	Failure of pump 5 ctrl 2	check pump <sup>1)</sup>
W 01 716	Failure of pump 6 ctrl 1	check pump <sup>1)</sup>
W 02 716	Failure of pump 6 ctrl 2	check pump <sup>1)</sup>
W00 801	simulation level switched on	switch off level simulation (s. "level" menu)
W01 802 W02 802	simulation sensor 01 or 02 switched on	switch off simulation
W01 803 W02 803 W01 804 W02 804	simulation flow switched on	switch off simulation (see "flow" menu)
W01 805	simulation current 01 switched on	switch off simulation (s. "output/calculations" menu)
W02 806	simulation current 02 switched on	switch off simulation (see "output/calculations" menu)
W01 807 ... W06 807	simulation relay 01 - 06 switched on	switch off simulation
W01 808 W02 808	sensor 01 or 02 switched off	switch on sensor (see "device properties/sensor management" menu)
W01 809 W02 809	current calibration D/A active	
A 00 820 ... A 00 832	Different units for calculation of average value, sum, difference or rake control	Check the units of the respective basic calibrations (s. "level" or "flow" menu)

- 1) After a repair of the pump the pump control must be reset (→ Chap. 8.4.2) or the FMU90 must be switched off and on.

## 10.2 Possible calibration errors

Error	Remedy
<b>Incorrect measured value</b>	Check "actual distance" <ol style="list-style-type: none"> <li>a. <b>"Actual distance" is incorrect</b> <ul style="list-style-type: none"> <li>- For measurements in bypasses or ultrasound guide pipes: Select the appropriate option in the "application parameters" parameter set.</li> <li>- Perform tank map ("distance mapping")</li> </ul> </li> <li>b. <b>"Actual distance" is correct</b> <ul style="list-style-type: none"> <li>- Check "empty calibration" and "full calibration"</li> <li>- Check the linearization</li> </ul> </li> </ol>
<b>Measured value does not change when filling or emptying a vessel</b>	<ol style="list-style-type: none"> <li>a. Perform tank map (interference echo suppression)</li> <li>b. clean sensor if necessary</li> <li>c. choose better mounting position of the sensor (to avoid interference echos)</li> </ol>
<b>With an uneven surface the measured value jumps sporadically to higher levels</b>	<ol style="list-style-type: none"> <li>a. Perform tank map (interference echo suppression)</li> <li>b. Select "turbulent surface" or "additional agitator" in the "process conditions" parameter</li> <li>c. Increase "output damping"</li> <li>d. if possible: choose better mounting position and/or larger sensor</li> </ol>
<b>When filling the vessel, the measured value sporadically drops to lower levels</b>	<ol style="list-style-type: none"> <li>a. Change the "tank geometry" to "dome ceiling" or "horizontal cylinder" ("application parameters" parameter set)</li> <li>b. If possible: avoid central mounting position of the sensor.</li> <li>c. if possible: install sensor in bypass or ultrasound guide pipe.</li> </ol>
<b>Echo loss (Error E@@641)</b>	<ol style="list-style-type: none"> <li>a. Check all settings in the "application parameters" parameter set.</li> <li>b. if possible: choose better mounting position and/or larger sensor.</li> <li>c. Align the sensor membrane parallelly to the product surface (especially for solid applications).</li> </ol>

## 10.3 Envelope curve display

The measuring signal can be checked by the envelope curve display. From the envelope curve it is possible to see if there are interference echos and if they are completely suppressed by the interference echo suppression.

The envelope curve can be displayed on the display and operating module of the Prosonic S or in the FieldCare.

### 10.3.1 Envelope curve on the display module

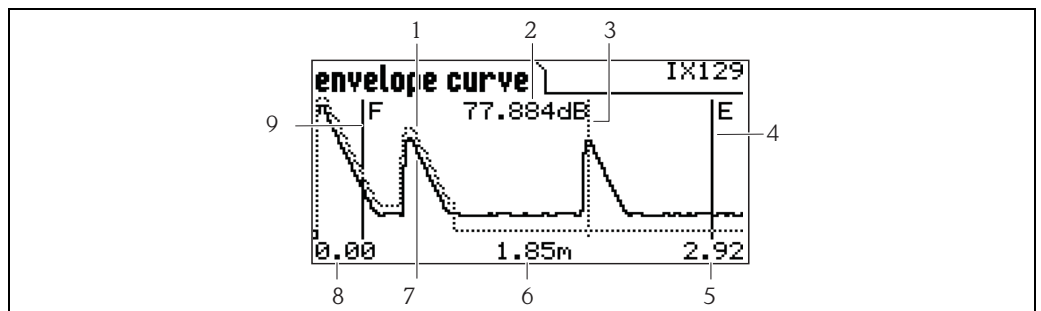

1. Go to the "system information" submenu.
2. Select the "envelope curve" submenu.
3. (only relevant for instruments with two sensor inputs): Select the sensor whose envelope curve you want to check.
4. Select the curves to be displayed:
  - **Envelope curve:** Only the envelope curve is displayed.
  - **Env. curve + FAC:** The envelope curve and the Floating Average Curve (FAC) are displayed.
  - **Env. curve + cust. map:** The envelope curve and the customer mapping curve (for interference echo suppression) are displayed.
5. Select the plot setting:
  - **single curve**
  - **cyclic**
6. Now, the envelope curve display appears:



L00-FMU90xxx-19-00-00-en-083

- 1 Customer mapping curve (dotted line<sup>7)</sup>)
- 2 Echo quality of the evaluated echo<sup>8)</sup>
- 3 Marking of the evaluated echo
- 4 Marking of the empty calibration E
- 5 Upper limit of the display range
- 6 Distance of the evaluated echo (measured from the reference point of the sensor)
- 7 Envelope curve (solid line)
- 8 Lower limit of the display range
- 9 Marking of the full calibration F

#### 7. Scaling of the envelope curve display

To display a part of the envelope curve in more detail, the curve can be scaled horizontally. To do so, press the left or middle key. The  or  symbol appears in the upper right corner of the display. You have got the following options:

- Press the **middle key** to **zoom in** the envelope curve.
- Press the **left key** to **zoom out** the envelope curve.

7) The Floating Average Curve (FAC) is represented by a dotted line as well.

8) The echo quality is the distance (in dB) between the peak of the echo and the Floating Average Curve (FAC).

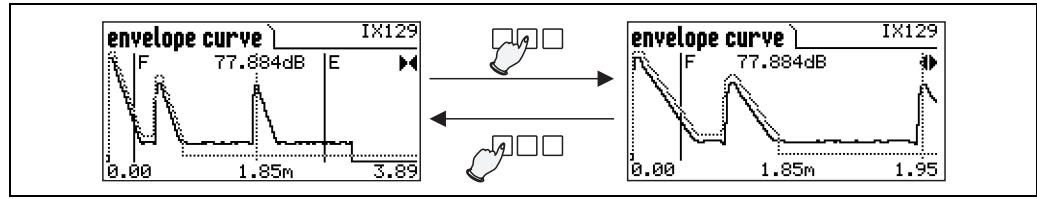

L00-FMU90xxx-19-00-00-en-084

8. **Moving the envelope curve display**

To move the envelope curve display, press the right key a second time. The ◀◀ or ▶▶ symbol appears in the upper right corner of the display. You have got the following options:

- Press the **middle key** to move the envelope curve **to the right**.
- Press the **left key** to move the envelope curve **to the left**.

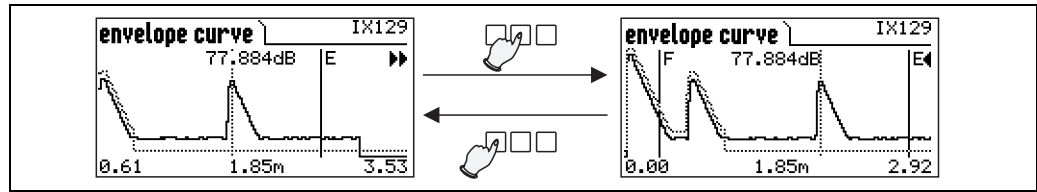

L00-FMU90xxx-19-00-00-en-085

9. **Quitting the envelope curve display**

Press  to quit the envelope curve display.

### 10.3.2 Envelope curve display in the FieldCare

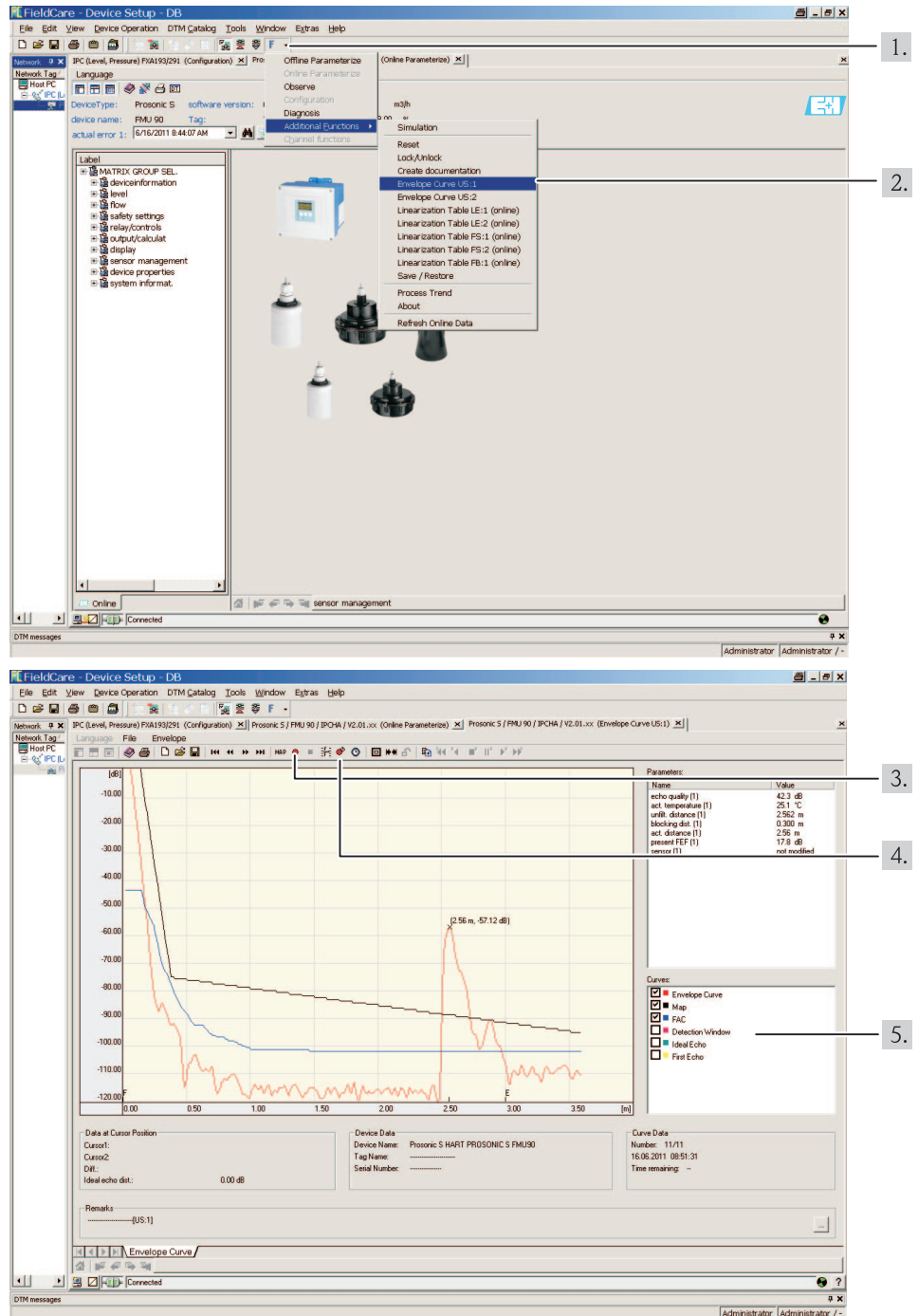

1. Click on "F" → "Additional Function" → "Envelope Curve".
2. Select the **sensor** whose envelope curve you want to check.
3. Click on "read curve" to display a **single curve**.
4. Click on "cyclic read" to display the curves **cyclically**.
5. Select the curves you want to check in the "Curves" window:
  - Envelope Curve
  - Map (= mapping of the interference echo suppression)
  - FAC (= Floating Average Curve)

## 10.4 Software history

Date	Software version	Changes to software	Documentation
12.2005	V 01.00.00	original software	<ul style="list-style-type: none"> <li>■ for level measurements: BA288F/00/en/12.05 52024316</li> <li>■ for flow measurements: BA289F/00/en/12.05 52024318</li> </ul>
06.2006	V 01.00.02	Relay functions for limit detection revised. No updates of "ToF Tool - Fieldtool Package" or "Fieldcare" required	
04.2007	V 02.00.00	Introduction of new options: binary inputs, e.g. for acquisition of limits or pump/motor switch positions	<ul style="list-style-type: none"> <li>■ for level measurements: BA288F/00/en/10.07 52024316</li> <li>■ for flow measurements: BA289F/00/en/10.07 52024318</li> </ul>
07.2009	V 02.01.00	Integration of the FDU90 sensor	<ul style="list-style-type: none"> <li>■ for level measurements: BA288F/00/en/07.09 71098292</li> <li>■ BA00288F/00/EN/13.12 71164411</li> <li>■ for flow measurements: BA289F/00/en/07.09 71098296</li> <li>■ BA00289F/00/EN/13.12 71164415</li> </ul>
02.2010	V02.01.01	Integration Temperaturplausibilisierung	
05.2011	V02.01.03	Improvement temperature plausibility; flow counter limitation; bugfix	

## 11 Maintenance

### 11.1 Exterior cleaning

When cleaning the exterior, always use cleaning agents that do not attack the surface of the housing and the seals.

### 11.2 Repairs

The Endress+Hauser repair concept assumes that the measuring devices have a modular design and that customers are able to undertake repairs themselves → 144, "Spare Parts". For more information on service and spare parts, please contact your Endress+Hauser sales representative.

### 11.3 Repairs to Ex-approved devices

When carrying out repairs to Ex-approved devices, please note the following:

- Repairs to Ex-approved devices may only be carried out by trained personnel or by the Endress+Hauser Service.
- Comply with the prevailing standards, national Ex-area regulations, safety instructions (XA) and certificates.
- Only use original spare parts from Endress+Hauser.
- When ordering a spare part, please note the device designation on the nameplate. Only replace parts with identical parts.
- Carry out repairs according to the instructions. On completion of repairs, carry out the specified routine test on the device.
- Only Endress+Hauser Service may convert a certified device into a different certified variant.
- Document all repair work and conversions.

### 11.4 Replacement

After a complete instrument or electronic module has been replaced, the parameters can be downloaded into the instrument again via the communication interface. Prerequisite to this is that the data were uploaded to the PC beforehand using FieldCare. Measurement can continue without having to carry out a new setup. Only a linearisation and a tank map (interference echo suppression) have to be recorded again.

### 11.5 Replacing a sensor

Sensors can be replaced if required.

After replacing a sensor, the following parameters of the "basic setup" submenu must be checked:

- for sensors FDU8x: sensor type  
(sensors of the type FDU9x are automatically detected by the Prosonic S)
- the empty calibration
- for level measurements: the full calibration
- the interference echo suppression

After that, the measurement can be continued without further restrictions.

## 11.6 Spare Parts

An overview of the spare parts for your device is available in the internet at [www.endress.com](http://www.endress.com). To obtain information on the spare parts, proceed as follows:

1. Go to "www.endress.com" and select your country.
2. Click "Instruments".

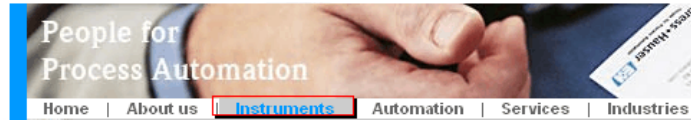

3. Enter the product name into the "product name" field.

### Endress+Hauser product search

**Via product name**  
Enter the product name



4. Select the device.
5. Click the "Accessories/Spare parts" tab.

General information	Technical information	Documents/ Software	Service	<b>Accessories/ Spare parts</b>
---------------------	-----------------------	---------------------	---------	---------------------------------

▶ Accessories  
 ▼ All Spare parts
 

- ▶ Housing/housing accessories
- ▶ Sealing
- ▶ Cover
- ▶ Terminal module
- ▶ HF module
- ▶ Electronic
- ▶ Power supply
- ▶ Antenna module



**Advice**  
Here you'll find a list of all available accessories and spare parts. To only view accessories and spare parts specific to your product(s), please contact us and ask about our Life Cycle Management Service.

◀ | 1 / 2 | ▶ | 🔍

6. Select the required spare parts (You may also use the overview drawing on the right side of the screen.)

When ordering spare parts, always quote the serial number indicated on the nameplate. As far as necessary, the spare parts also include replacement instructions.



## 11.7 Return

### Returning devices

The measuring device must be returned if repairs or a factory calibration are required, or if the wrong measuring device has been ordered or delivered. According to legal regulations, Endress+Hauser, as an ISO-certified company, is required to follow certain procedures when handling returned products that are in contact with medium.

To ensure swift, safe and professional device returns, please read the return procedures and conditions on the Endress+Hauser website at [www.services.endress.com/return-material](http://www.services.endress.com/return-material)

## 11.8 Disposal

In case of disposal please separate the different components according to their material consistence.

## 11.9 Contact addresses of Endress+Hauser

Contact addresses can be found on our homepage: [www.endress.com/worldwide](http://www.endress.com/worldwide). If you have any questions, please contact your Endress+Hauser sales representative.

## 12 Accessories

### 12.1 Commubox FXA195 HART

For intrinsically safe communication with FieldCare via the USB interface. For details refer to TI00404F/00/EN.

### 12.2 Commubox FXA291

For intrinsically safe communication with FieldCare via the service interface (IPC) of the instrument and the USB interface of a PC/Notebook.

Ordering Code: 51516983

### 12.3 Protection cover for the field housing

- Material: 316Ti (1.4571)
- is mounted by the mounting help of the Prosonic S
- Order-Code: 52024477

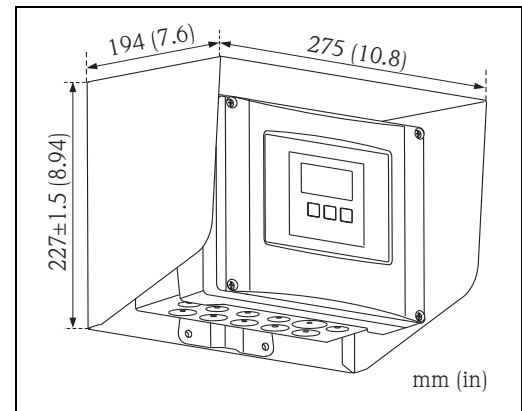

100-FMU190xxx-00-00-00-xx-003

### 12.4 Mounting plate for the field housing

- suited for the mounting help of the Prosonic S
- for 1" - 2" tubes
- Dimensions: 210 x 110 mm (8.27 x 4.33 in)
- Material: 316Ti (1.4571)
- fixing clips, screws and nuts are supplied
- Order code: 52024478

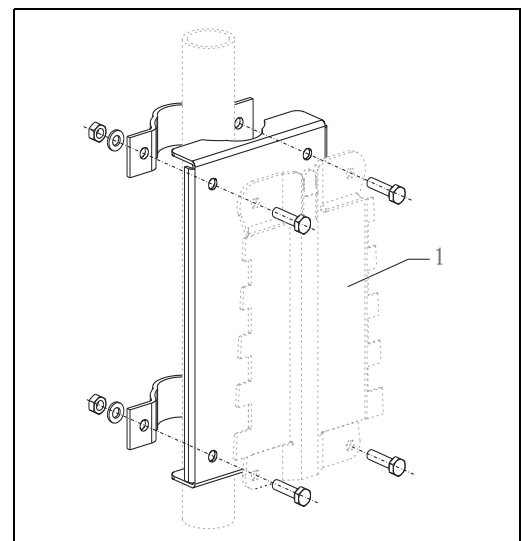

100-FMU190xxx-00-00-00-xx-001

1 Mounting help of the field housing

### 12.5 Mounting bracket

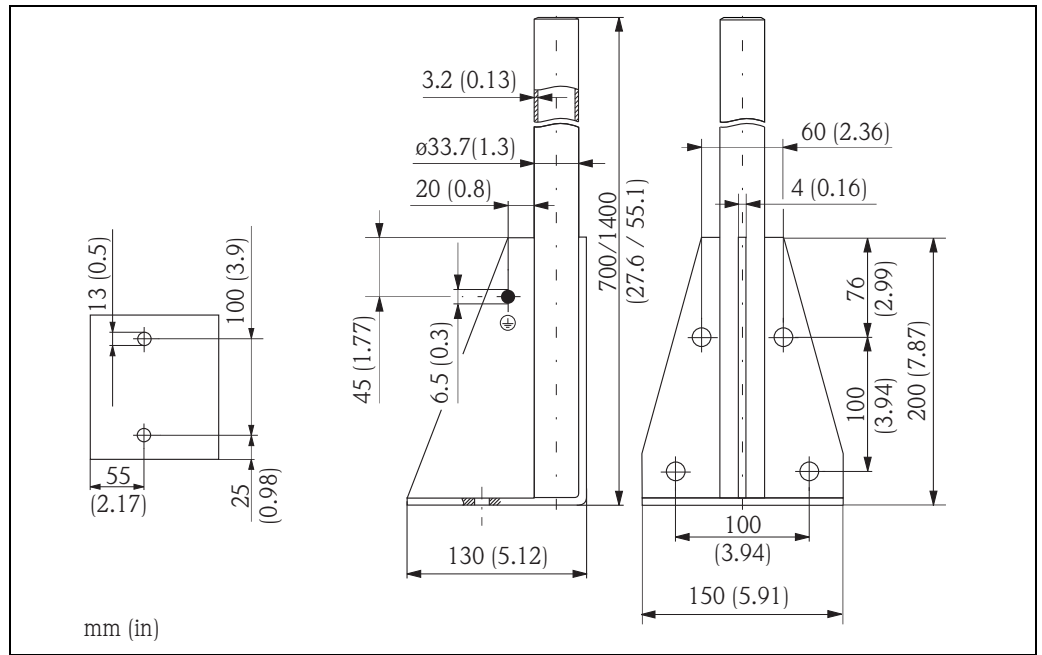

L00-FM1xx-00-00-00-xx-005

Height	Material	Order Code
700 (27.6)	galv. steel	919791-0000
700 (27.6)	316 Ti	919791-0001
1400 (55.16)	galv. steel	919791-0002
1400 (55.16)	316 Ti	919791-0003

mm (in)

## 12.6 Adaption plate for remote display

Used to mount the remote display into the opening (138 x 138 mm (5.43 x 5.43 in)) of the remote display module of the Prosonic FMU860/861/862 (Display size: 144 x 144 mm (5.67 x 5.67 in)).

Order-Code: 52027441



### Note!

The adapter plate will be mounted directly in the old remote display of the FMU86x series. The housing of the remote display of FMU860/861/862 is the holder for the adapter plate and the new remote display of the FMU90/95 in the format 96 x 96 mm (3.78 x 3.78 in).

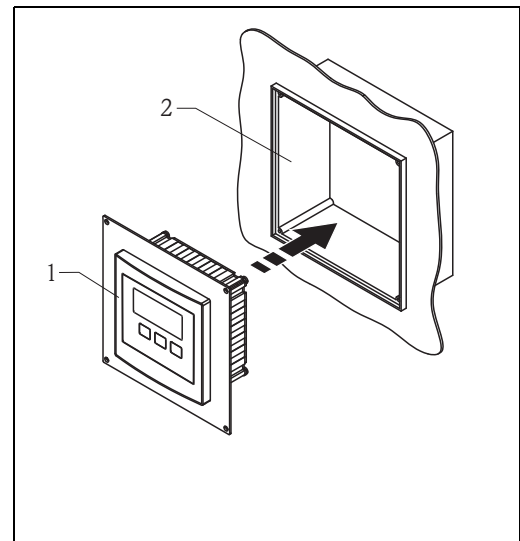

100-FMU90xxx-00-00-00-xx-001

- 1 Remote display of the Prosonic S with adaption plate
- 2 Opening of the remote display FMU860/861/862

Option:

Adaption plate 160 x 160 mm (6.3 x 6.3 in), thickness 3 mm (0.12 in), aluminum, opening 92 x 92 mm (3.62 x 3.62 in) for remote display of the FMU90 (size of the display: 96 x 96 mm (3.78 x 3.78 in)).

Can be used to replace the FMU86x remote display or DMU2160/2260.

Order Code: TSPFU 0390

Please contact your Endress+Hauser sales representative.

## 12.7 Overvoltage protection (in IP66 housing)

- Overvoltage protection for the mains voltage and up to 3 signal outputs
- Dimensions of housing: 292 x 253 x 106 mm (11.5 x 9.96 x 4.17 in)
- Order Code: 215095-0001

## 12.8 Overvoltage protection HAW562

### 12.8.1 System principle

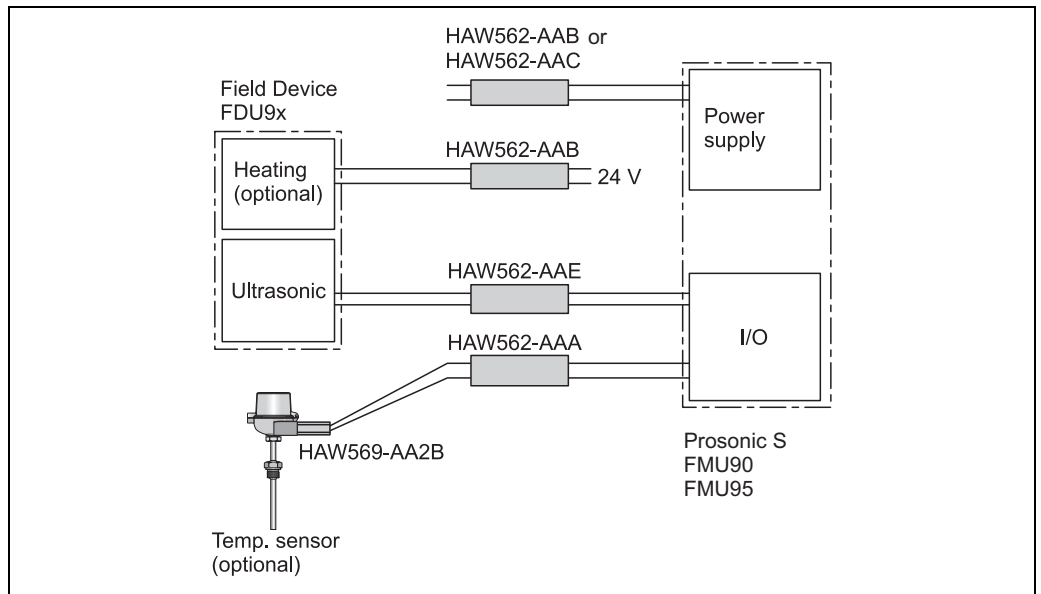

### 12.8.2 Application examples

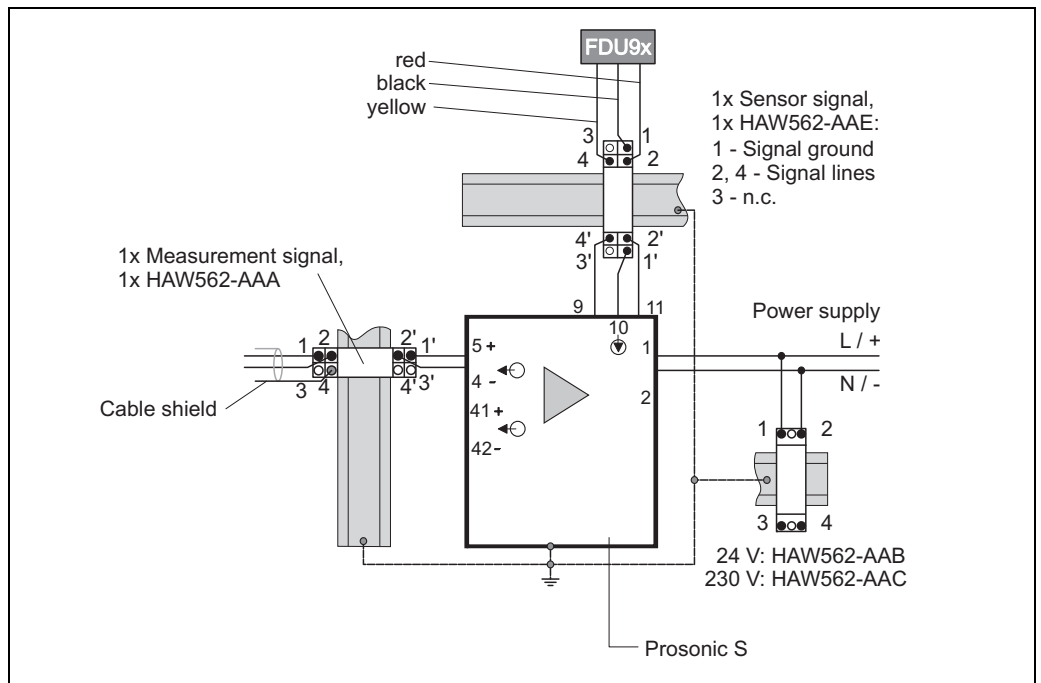

Level measurement with 1 Prosonic FDU9x level sensor, version 4 to 20 mA HART

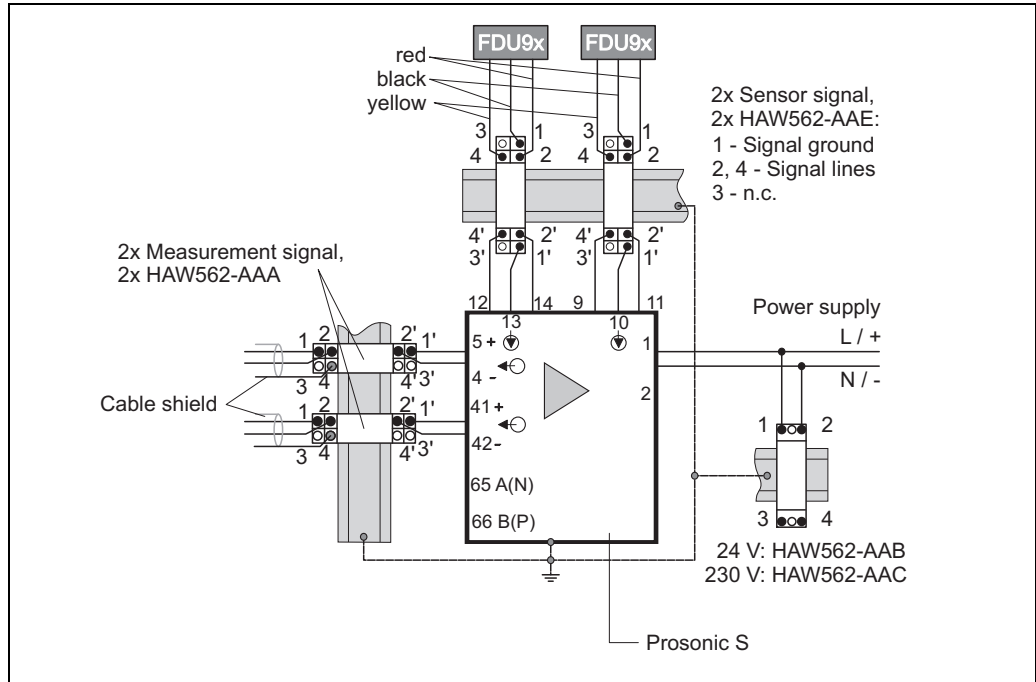

G09-HAW562zx-04-10-01-en-001

Level measurement with 2 Prosonic FDU9x level sensors, version 4 to 20 mA HART

### 12.8.3 Ordering information

Surge Arrester HAW562, compact device for DIN rail installation in signal and power supply lines and communication lines protecting field devices and systems against overvoltage and magnetic induction.

Approval				
AA				Non-hazardous area
8D				ATEX II 2 (1)G Ex ia IIC T6
Application				
A				Measuring signal 0/4-20 mA, PFM, PA, FF
B				Supply voltage 10-55 V (+/-20%)
C				Supply voltage 90-230 V (+/-10%)
D				Communication RS485/MOD-Bus/PROFIBUS DP
E				Protection module Prosonic FMU90
+ Additional selection (option)				
Additional approvals				
LA				SIL
Accessory enclosed				
PA				Screen grounding terminal
PB				Field housing
PC				Mounting bracket, wall/pipe
Marking				
Z1				Tagging (TAG), metal
Z3				Commissioning label, paper
Z6				Tagging (TAG), by customer
HAW562-			+	complete product designation

For details see Technical Informations TI01012K und TI01013K and the Operating Instruction BA00306K.

### 12.9 Extension cable for sensors

for Sensor	Material	Cable type	Order code
<ul style="list-style-type: none"> <li>■ FDU90</li> <li>■ FDU91</li> <li>■ FDU92</li> </ul>	PVC	LiYCY 2x(0.75)	71027742
<ul style="list-style-type: none"> <li>■ FDU91F</li> <li>■ FDU93</li> <li>■ FDU95</li> </ul>	PVC (-40 to +105 °C) (-40 to +221 °F)	LiYY 2x(0.75)D+1x0.75	71027743
<ul style="list-style-type: none"> <li>■ FDU95</li> <li>■ FDU96</li> </ul>	Silicone (-40 to +150 °C) (-40 to +302 °F)	Li2G2G 2x(0.75)D+1x0.75	71027745
<ul style="list-style-type: none"> <li>■ FDU90/FDU91 with heater</li> </ul>	PVC	LiYY 2x(0.75)D+2x0.75	71027746

Total length (sensor cable + extension cable): up to 300 m (984 ft)

## 12.10 Temperature sensor FMT131

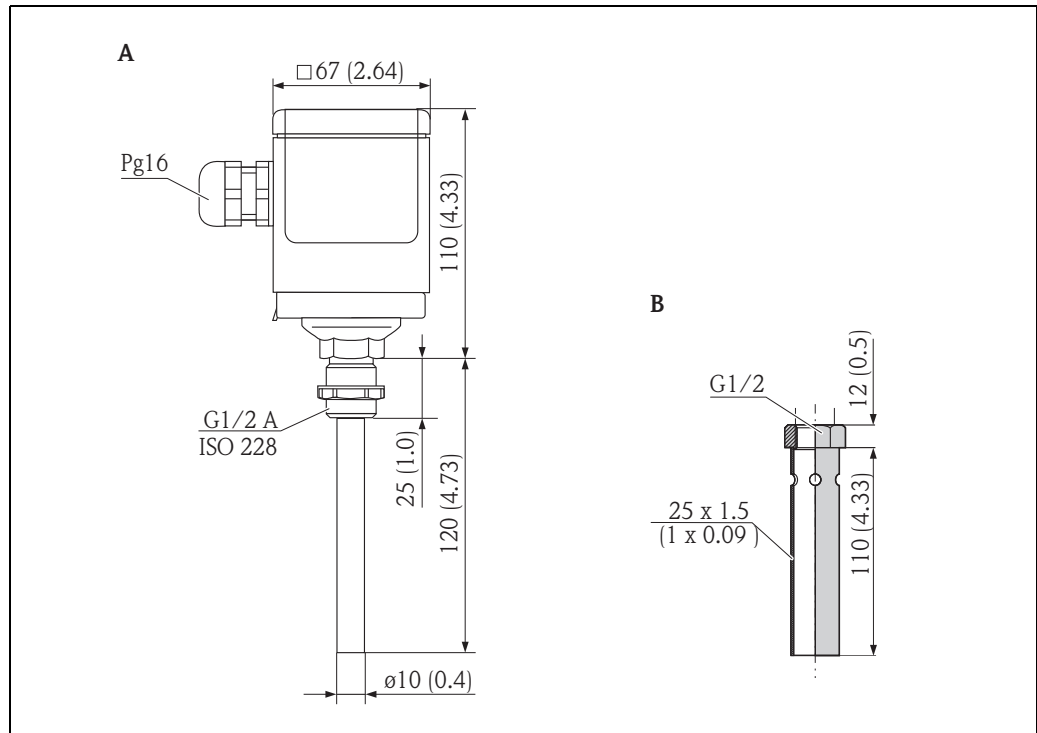

L00-FMU190xxxx-00-00-00-xx-002a

A Temperature sensor FMT131

B Weather protector

### Product structure

<b>010</b>	<b>Approval</b>
	<ul style="list-style-type: none"> <li>R Non-hazardous area</li> <li>J ATEX II 2G EEx m II T6/T5</li> <li>Q FM Cl.I Div. 1 Gr. A-D, zone 1, 2</li> <li>U CSA General Purpose (in preparation)</li> <li>S CSA Class I Div. 1</li> </ul>
<b>020</b>	<b>Cable length</b>
	<ul style="list-style-type: none"> <li>1 5 m/ 16 ft</li> <li>2 10 m/ 32 ft</li> <li>3 15 m/49 ft</li> <li>4 20 m/65 ft</li> <li>5 25 m/82 ft</li> <li>6 30 m/98 ft</li> <li>7 w/o cable, gland Pg16, IP66</li> <li>8 ... m</li> <li>A ... ft</li> </ul>
<b>995</b>	<b>Marking</b>
	<ul style="list-style-type: none"> <li>1 Tagging (TAG)</li> </ul>
FMT131 -	complete product designation

### Weather protection cover for FMT131

Order code: 942046-0000



## 13 Technical Data

### 13.1 Technical data at a glance

#### 13.1.1 Input

##### Sensor inputs

Depending on the instrument version, 1 or 2 of the sensors FDU90, FDU91, FDU91F, FDU92, FDU93, FDU95 and FDU96 can be connected. The Prosonic S identifies these sensors automatically.

Sensor	FDU90	FDU91 FDU91F	FDU92	FDU93	FDU95	FDU96
max. range <sup>1)</sup> in liquids	3 (9.8)	10 (33)	20 (66)	25 (82)	-	-
max. range <sup>1)</sup> in solids	1.2 (3.9)	5 (16)	10 (33)	15 (49)	45 (148)	70 (230)

m (ft)

- 1) This table gives the maximum range. The range depends on the measuring conditions. For an estimation see Technical Information TI00396F/00, chapter "Input".

In order to support existing installations, the sensors of the former series FDU8x can be connected as well. The type of sensor must be entered manually.

Sensor	FDU80 FDU80F	FDU81 FDU81F	FDU82	FDU83	FDU84	FDU85	FDU86
max. range <sup>1)</sup> in liquids	5 (16)	10 (33)	20 (66)	25 (82)	-	-	-
max. range <sup>1)</sup> in solids	2 (6.6)	5 (16)	10 (33)	15 (49)	25 (82)	45 (148)	70 (230)

m (ft)

- 1) This table gives the maximum range. The range depends on the measuring conditions. For an estimation see Technical Information TI00189F/00, chapter "Planning Recommendations".



#### Warning!

The sensors FDU83, FDU84, FDU85 and FDU86 with an ATEX, FM or CSA certificate are not certified for connection to the transmitter FMU90.

##### External limit switches (option)

Optionally, the Prosonic S FMU90 has four inputs for external limit switches (FMU90-\*\*\*\*\*B\*\*\*).

#### Switching options

- external passive limit switch (NC/NO switch)
- 0: < 8 V; 1: > 16 V

#### Usage (examples)

- pump feedback (for FMU90-\*3\*\*\*\*\*B\*\*\*) and FMU90-\*4\*\*\*\*\*B\*\*\*)
- pump tariff control (for FMU90-\*3\*\*\*\*\*B\*\*\*) and FMU90-\*4\*\*\*\*\*B\*\*\*)
- start/stop/reset of daily counters (for flow measurements) (for FMU90-\*2\*\*\*\*\*B\*\*\*) and FMU90-\*4\*\*\*\*\*B\*\*\*)
- min/max level detection, e.g. by Liquiphant

External temperature sensor      Optionally, the Prosonic S FMU90 has an input for an external temperature sensor (FMU90-\*\*\*\*\*B\*\*\*).

**Connectable sensors**

- Pt100 (3-wire or 4-wire connection)  
A Pt100 with 2-wire connection may not be used due to its insufficient accuracy.
- FMT131(from Endress+Hauser → 146, "Accessories")

**Usage (example)**

- Time-of-flight correction for a heated sensor (FDU90-\*\*\*B\*, FDU91-\*\*\*B\*).

**13.1.2 Output**

Analogue outputs

Number	1 or 2, depending on instrument version
Output signal	configurable at the instrument: <ul style="list-style-type: none"> <li>■ 4 to 20 mA with HART<sup>1)</sup></li> <li>■ 0 to 20 mA without HART</li> </ul>
Signal on alarm	<ul style="list-style-type: none"> <li>■ for setting 4 to 20 mA, selectable:                     <ul style="list-style-type: none"> <li>- -10% (3,6 mA)</li> <li>- 110% (22 mA)</li> <li>- HOLD (last current value is held)</li> <li>- user specific</li> </ul> </li> <li>■ for setting 0 to 20 mA:                     <ul style="list-style-type: none"> <li>- 110% (21,6 mA)</li> <li>- HOLD (last current value is held)</li> <li>- user specific</li> </ul> </li> </ul>
Output damping	freely selectable, 0 to 1000 s
Load	max. 600 Ω, influence negligible
max. ripple	$U_{SS} = 200 \text{ mV}$ at 47 to 125 Hz (measured at 500Ω)
max. noise	$U_{eff} = 2,2 \text{ mV}$ at 500 Hz to 10 kHz (measured at 500Ω)

1)      The HART signal is assigned to the first analogue output. The second analogue output does not carry a HART signal.

Relay outputs

Number	1, 3 or 6; depending on the instrument version
Type	potential-free relay, SPDT, can be inverted
Assignable functions	<ul style="list-style-type: none"> <li>■ limit (inband, out-of-band, trend, level limit)</li> <li>■ counting pulse<sup>1</sup> for flow counting (max. frequency 2 Hz; pulse width adjustable)</li> <li>■ time pulse<sup>1</sup> (max. frequency 2 Hz; pulse width adjustable)</li> <li>■ alarm/diagnosis (e.g. indication of backwater<sup>1</sup>, sludge<sup>1</sup>, echo loss etc.)</li> <li>■ pump control (alternating/fixed limit/pump rate)</li> <li>■ for FMU90-*3***** and FMU90-*4*****): additional pump control (standby pump, storm function to avoid unnecessary run times of the pumps, pump function test, flush control to clean pump shafts, operating hours alarm, pump alarm)</li> <li>■ rake control (difference or relative measurement)</li> <li>■ fieldbus relay (to be switched directly from the Profibus DP-bus)</li> </ul>
Switching power	<ul style="list-style-type: none"> <li>■ DC voltage: 35 V<sub>DC</sub>, 100 W</li> <li>■ AC voltage: 4 A, 250 V, 100 VA at cosφ = 0,7</li> </ul>
State on error	selectable: <ul style="list-style-type: none"> <li>■ HOLD (last value is held)</li> <li>■ energized</li> <li>■ de-energized</li> <li>■ present value is used</li> </ul>
Behaviour after power failure	switch-on delay selectable

LEDs <sup>2)</sup>	A yellow LED on the front panel is allocated to each relay, which lights if the relay is energized. The LED of an alarm relay lights during normal operation. The LED for a pulse relay briefly flashes at every pulse.
--------------------	---

- 1) for instrument versions with flow software (FMU90 – \*2\*\*\*\*\*)
- 2) for instrument versions with display and operating module

### 13.1.3 Power supply

Supply voltage/ Power consumption/ Current consumption	Instrument version	Supply voltage	Power consumption	Current consumption
	AC voltage (FMU90 – ****A****)	90 to 253 V <sub>AC</sub> (50/60 Hz)	max. 23 VA	max. 100 mA at 230 V <sub>AC</sub>
DC voltage (FMU90 – ****B****)	10,5 to 32 V <sub>DC</sub>	max. 14 W (typically 8 W)	max. 580 mA at 24 V <sub>DC</sub>	

Galvanic isolation

The following terminals are galvanically isolated from each other:

- auxiliary energy
- sensor inputs
- analogue output 1
- analogue output 2
- relay outputs
- bus connection (PROFIBUS DP)

Fuse

- 2 A T /DC
- 400 mA T /AC

accessible in the terminal compartment

### 13.1.4 Performance characteristics

Reference operating conditions

- Temperature = 24±5 °C (75±9 °F)
- Pressure = 960±100 mbar (14±1.45 psi)
- Relative humidity = 60±15 %
- Ideally reflecting surface, sensor vertically aligned (e.g. calm, plane liquid surface of 1 m<sup>2</sup> (10.76 ft<sup>2</sup>))
- No interference echoes within the signal beam
- Settings of the application parameters:
  - tank shape = flat ceiling
  - medium property = liquid
  - process condition = calm surface

Measuring uncertainty<sup>9)</sup>

±0,2 % of the maximum span of the sensor

Typical accuracy<sup>10)</sup>

±2 mm (0.08 in) + 0.17 % of the measured distance

Measured value resolution

1 mm (0.04 in) with FDU90/FDU91

9) according to NAMUR EN 61298-2

10) after calibration

---

Measuring frequency	<p>max. 3 Hz The exact value depends on the settings of the application parameters and the instrument version.</p>
	<p> Note! The maximum measuring frequency is obtained for "empty E" ≤ 2 m (≤6.6 ft) and "process condition" = "test: no filter".</p>

---

Influence of the vapor pressure	<p>The vapor pressure at 20 °C (68 °F) gives a hint on the accuracy of the ultrasonic level measurement. If the vapor pressure at 20 °C (68 °F) is below 50 mbar (1 psi), ultrasonic level measurement is possible with a very high accuracy. This is valid for water, aqueous solutions, water-solid-solutions, dilute acids (hydrochloric acid, sulfuric acid, ...), dilute bases (caustic soda, ...), oils, greases, slurries, pastes, ... High vapor pressures or outgassing media (ethanol, acetone, ammonia, ...) can influence the accuracy. If conditions like these are present, please contact your Endress+Hauser sales representative.</p>
---------------------------------	--

### 13.1.5 Environment

---

Ambient temperature	<p>-40 to 60 °C (-40 to 140 °F) The functionality of the LC display becomes restricted at <math>T_U &lt; -20\text{ °C}</math> (<math>T_U &lt; -4\text{ °F}</math>). If the device is operated outdoors in strong sunlight, a protective cover should be used (→  146, "Accessories").</p>
---------------------	--

---

Storage temperature	-40 to 60 °C (-40 to 140 °F)
---------------------	------------------------------

---

Climate class	<ul style="list-style-type: none"> <li>■ <b>Field housing:</b> according to DIN EN 60721-3 4K2/4K5/4K6/4Z2/4Z5/4C3/4S4/4M2 (DIN 60721-3 4K2 corresponds to DIN 60654-1 D1)</li> <li>■ <b>Housing for DIN rail mounting:</b> according to DIN EN 60721-3 3K3/3Z2/3Z5/3B1/3C2/3S3/3M1 (DIN 60721-3 3K3 corresponds to DIN 60654-1 B2)</li> </ul>
---------------	--

---

Vibration resistance	<ul style="list-style-type: none"> <li>■ Housing for DIN rail: DIN EN 60068-2-64 / IEC 68-2-64; 20 to 2000 Hz; 0,5 (m/s<sup>2</sup>)<sup>2</sup>/Hz</li> <li>■ Field housing: DIN EN 60068-2-64 / IEC 68-2-64; 20 to 2000 Hz; 1,0 (m/s<sup>2</sup>)<sup>2</sup>/Hz</li> </ul>
----------------------	---

---

Ingress protection	<ul style="list-style-type: none"> <li>■ Field housing: IP66 / NEMA 4x</li> <li>■ Housing for DIN rail: IP20</li> <li>■ separate display:             <ul style="list-style-type: none"> <li>– IP65 / NEMA 4 (front panel , if mounted in cabinet door)</li> <li>– IP20 (rear panel, if mounted in cabinet door)</li> </ul> </li> </ul>
--------------------	---

---

Electromagnetic compatibility (EMC)	<ul style="list-style-type: none"> <li>■ Electromagnetic compatibility according to all relevant requirements of the EN 61326- series and NAMUR recommendation EMC (NE21). For details see declaration of conformity.</li> <li>■ With respect to interference emission the devices meet the requirements of class A and are only provided for use in an "industrial environment"!</li> </ul>
-------------------------------------	--

### 13.1.6 Mechanical construction

Dimensions →  11 "Installation"

Weight

Housing version	Weight
Field housing	approx. 1.6 to 1.8 kg (3.53 to 3.97 lbs); depending on instrument version
Housing for DIN rail	approx. 0.5 to 0.7 kg (1.10 to 1.54 lbs); depending on instrument version (→  13 "Dimensions of the DIN-rail housing")
separate display and operating module	approx. 0.5 kg (1.10 lbs)

Materials

Part	Material
Housing bracket	PC-FR
Field housing	PC-FR
Housing for DIN rail	PBT-GF

For details see Technical Information TI00397F/00.

# 14 Operating menu

## 14.1 "level"

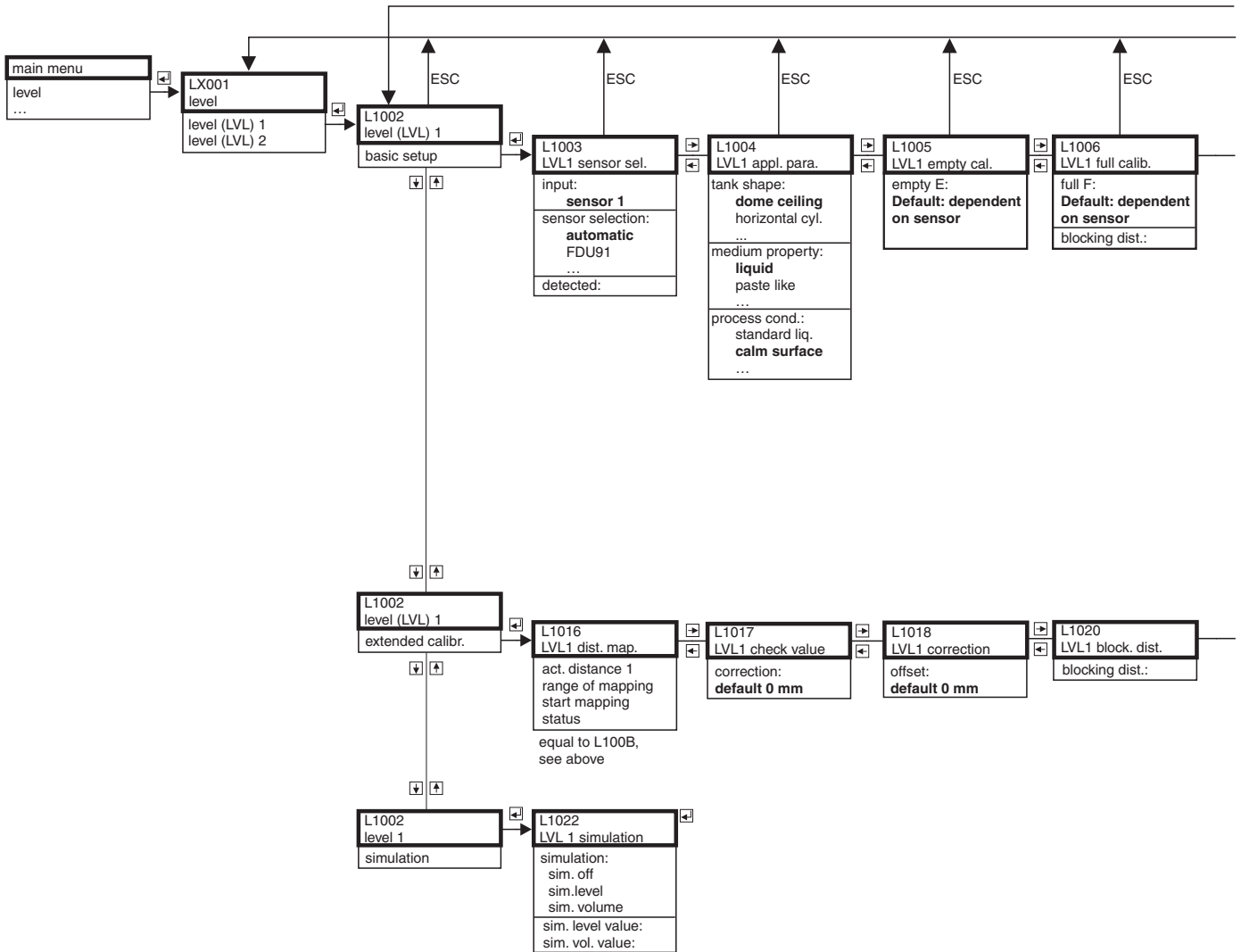

L00-FMU90xxx-19-01-01-en-106

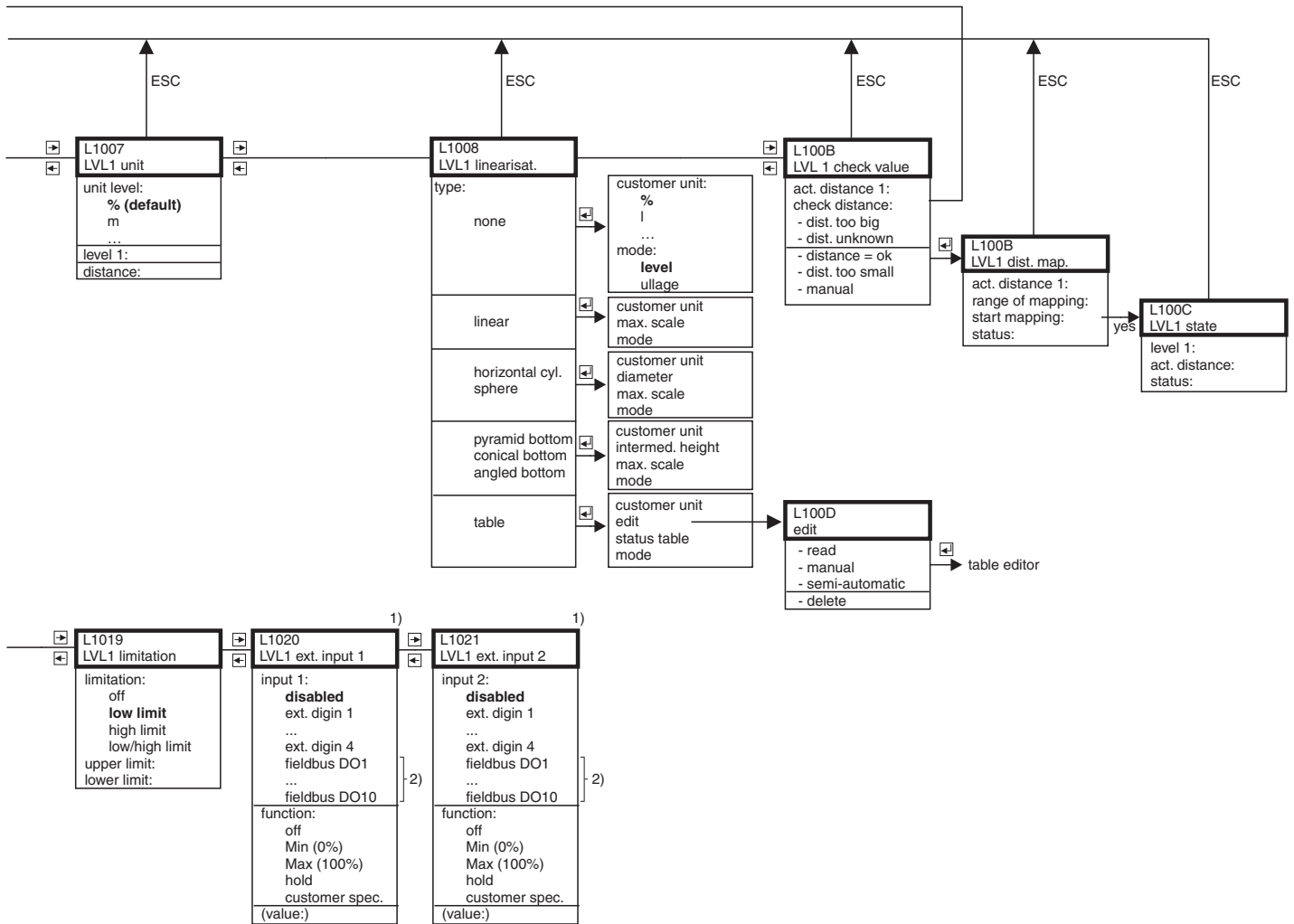

1) only for instrument version with additional switch inputs (FMU90-\*\*\*\*\*B\*\*\*)  
 2) only for PROFIBUS devices

## 14.2 "safety settings"

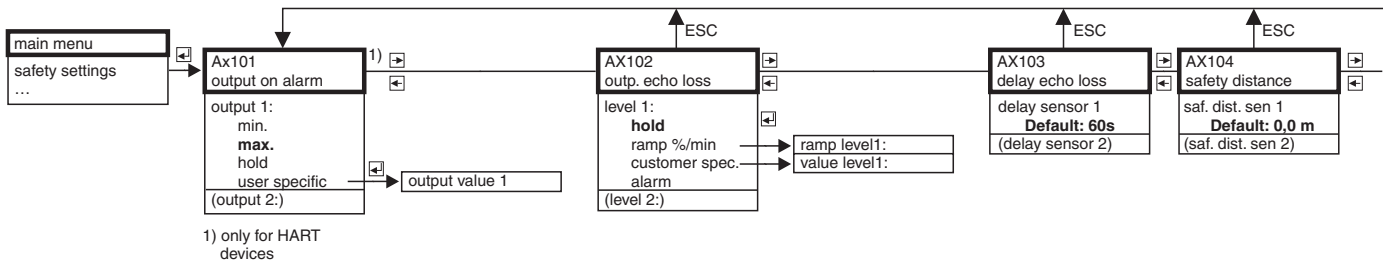



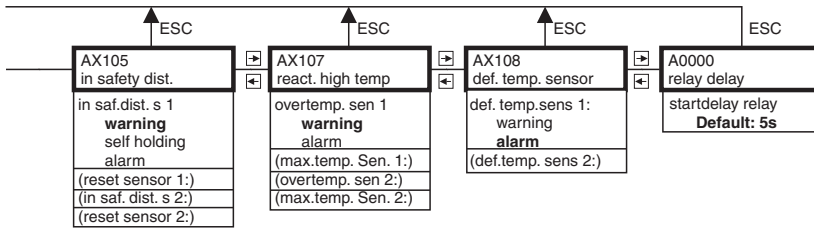

## 14.3 "relay/controls"

### 14.3.1 pump control - standard (FMU90 - \*1\*\*\*\*\* and FMU90 - \*2\*\*\*\*\*)

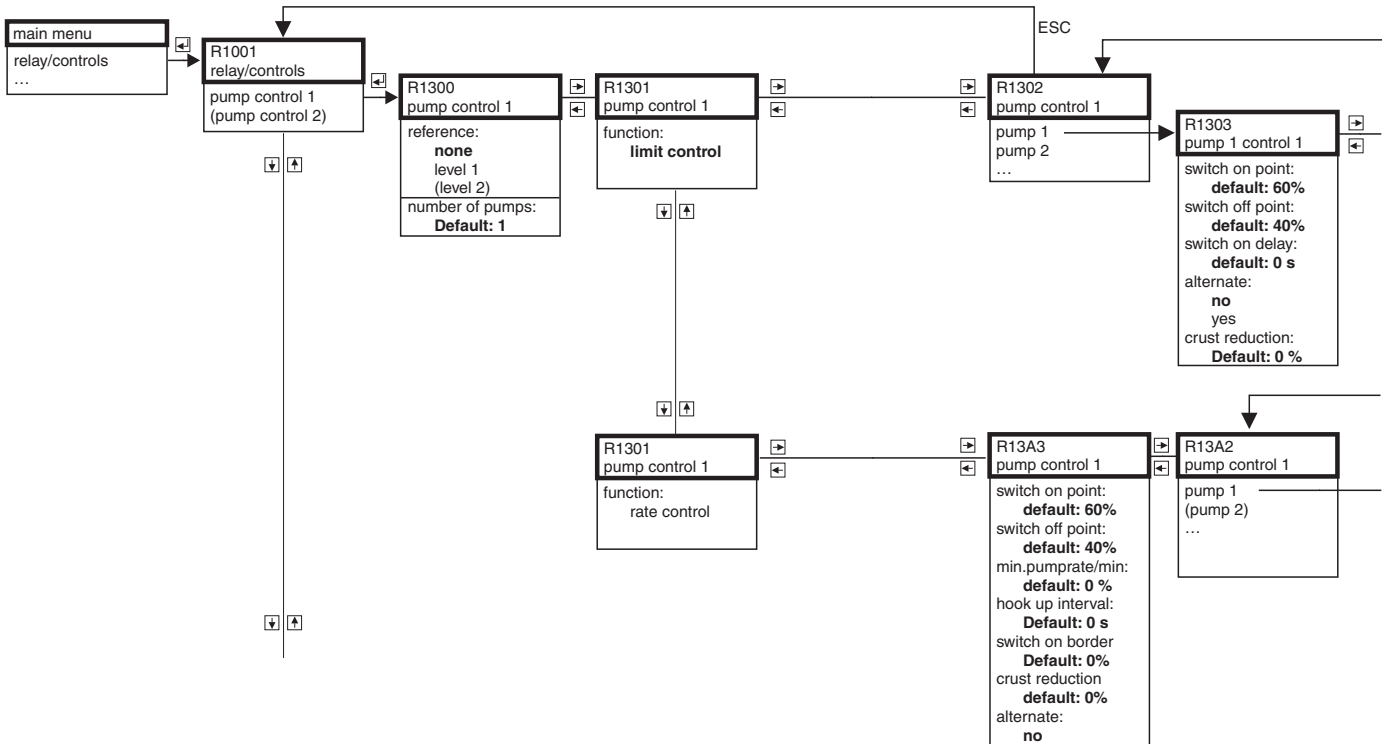

L00-FMU90xxx-19-04-01-en-106

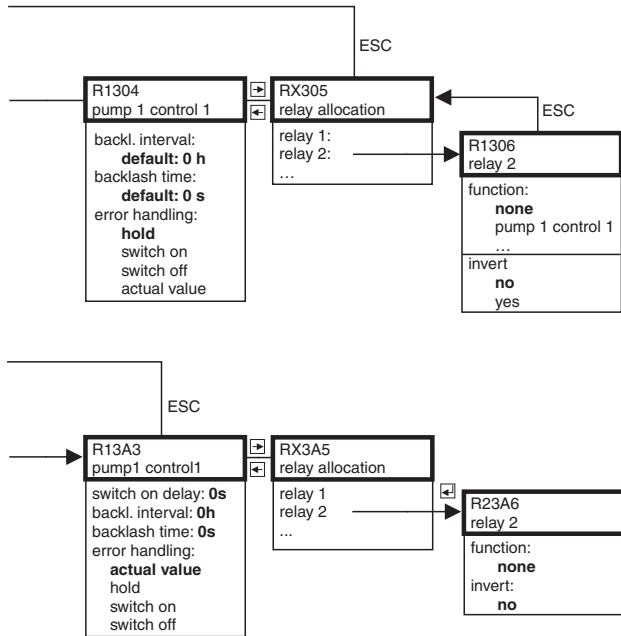

### 14.3.2 pump control - enhanced: basic setup (FMU90 - \*3\*\*\*\*\* and FMU90 - \*4\*\*\*\*\*)

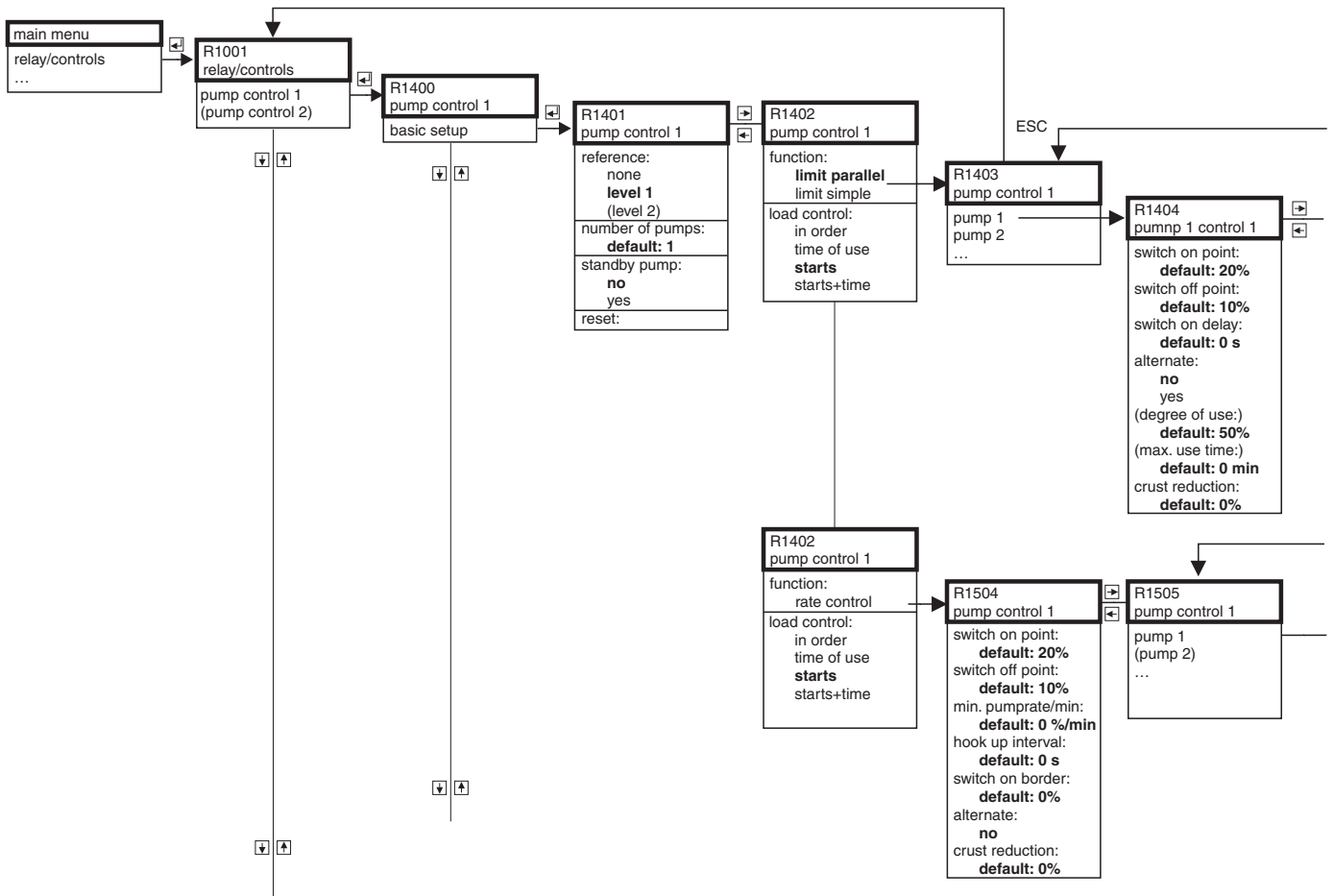

L00-FMU90xxx-19-16-01-es-106

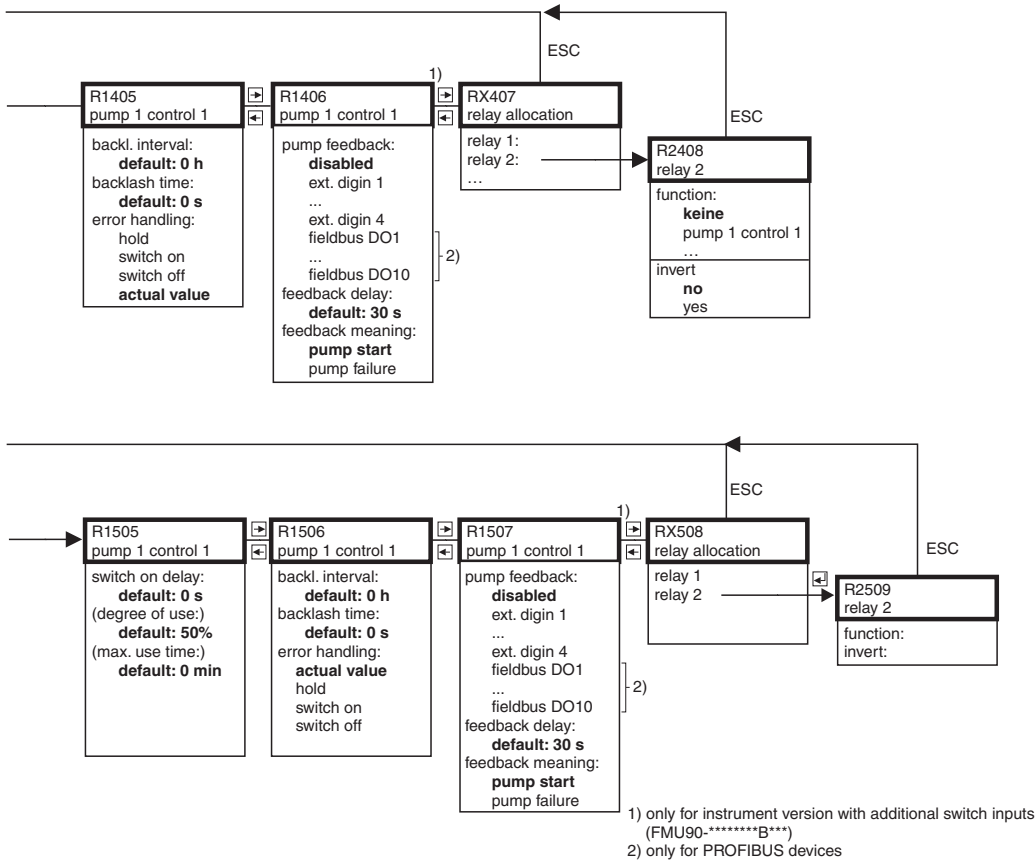

### 14.3.3 pump control - enhanced: additional settings (FMU90 - \*3\*\*\*\*\* and FMU90 - \*4\*\*\*\*\*)

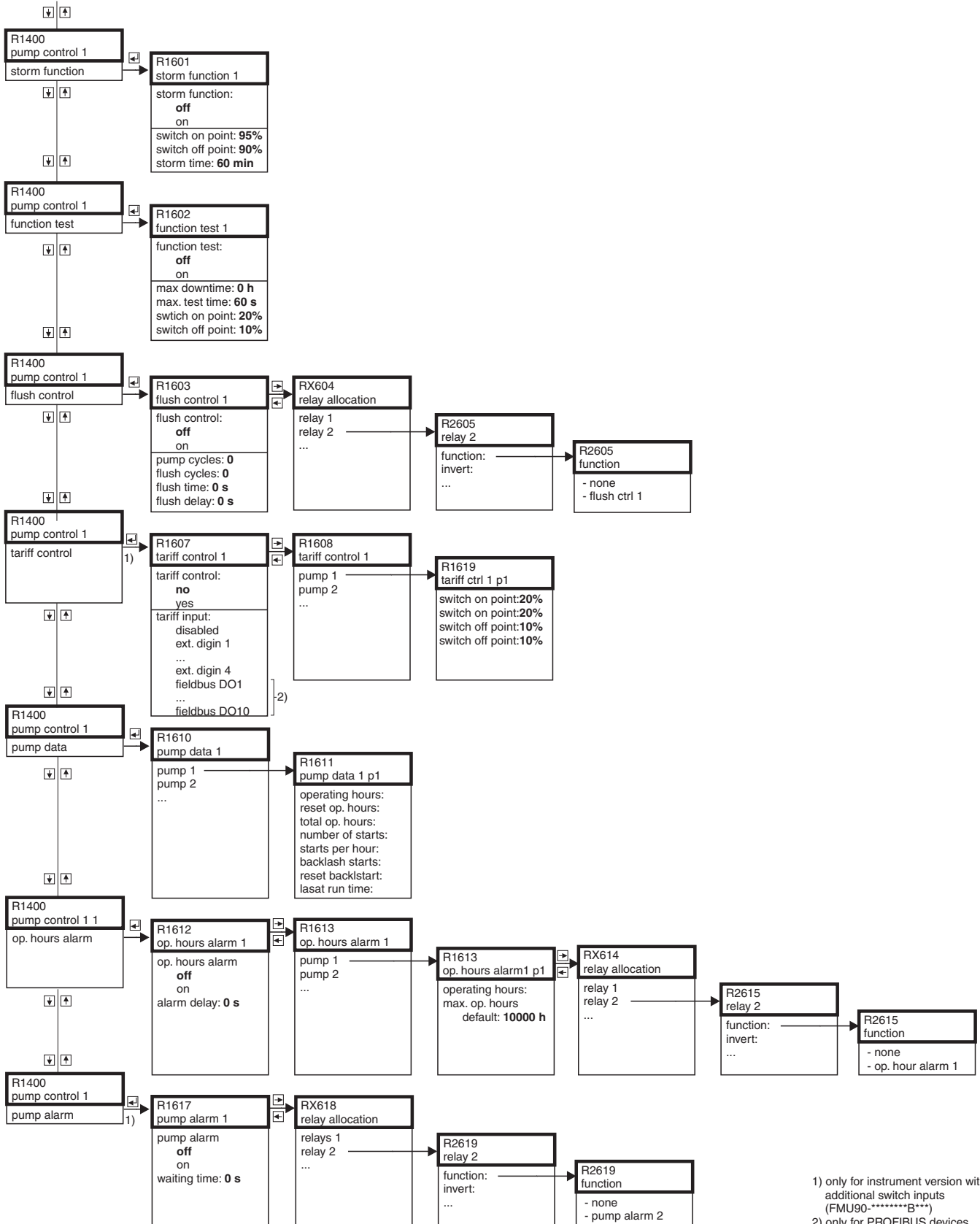

1) only for instrument version with additional switch inputs (FMU90-\*\*\*\*\*B\*\*\*\*)  
2) only for PROFIBUS devices



### 14.3.4 rake control/relay configuration/simulation

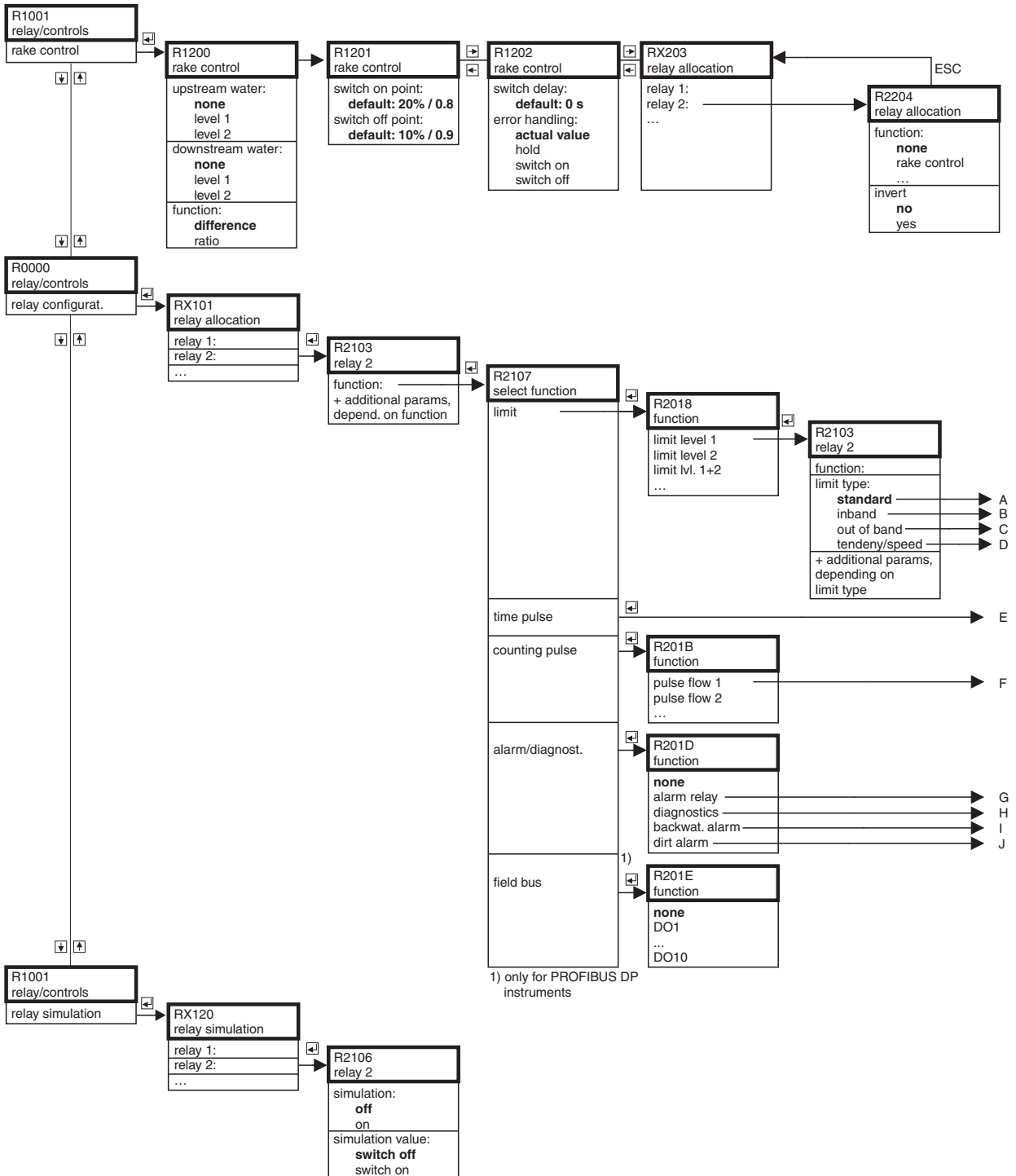



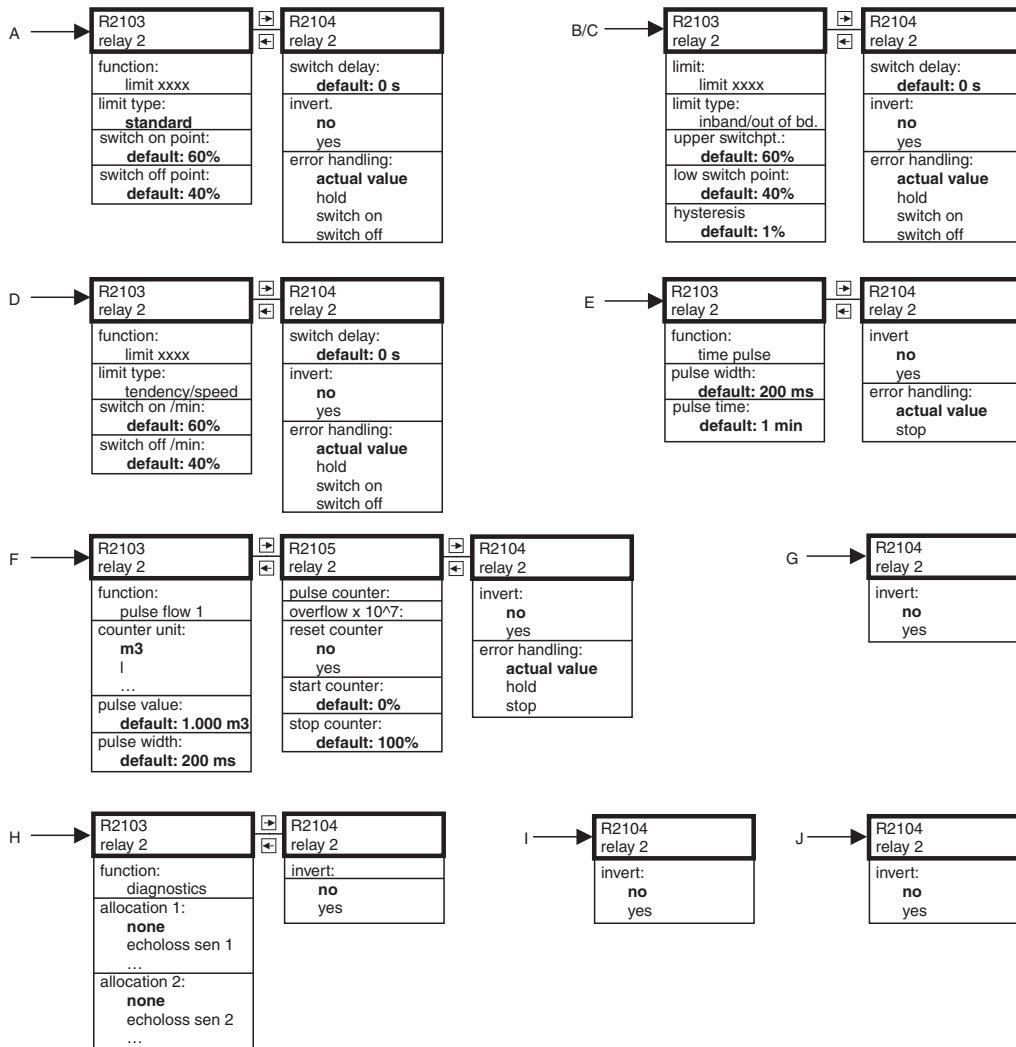

## 14.4 "output/calculations"

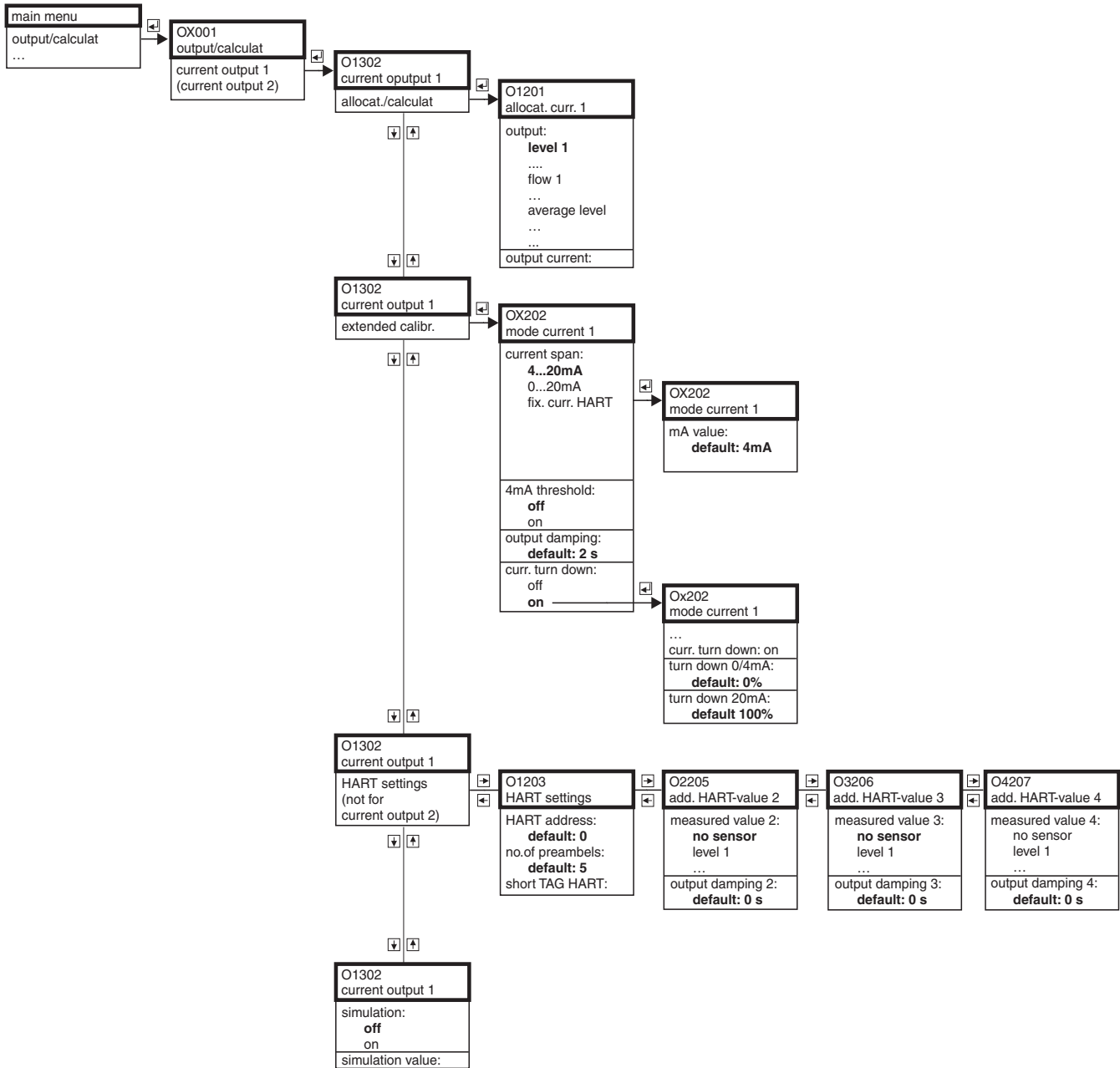

## 14.5 "device properties"

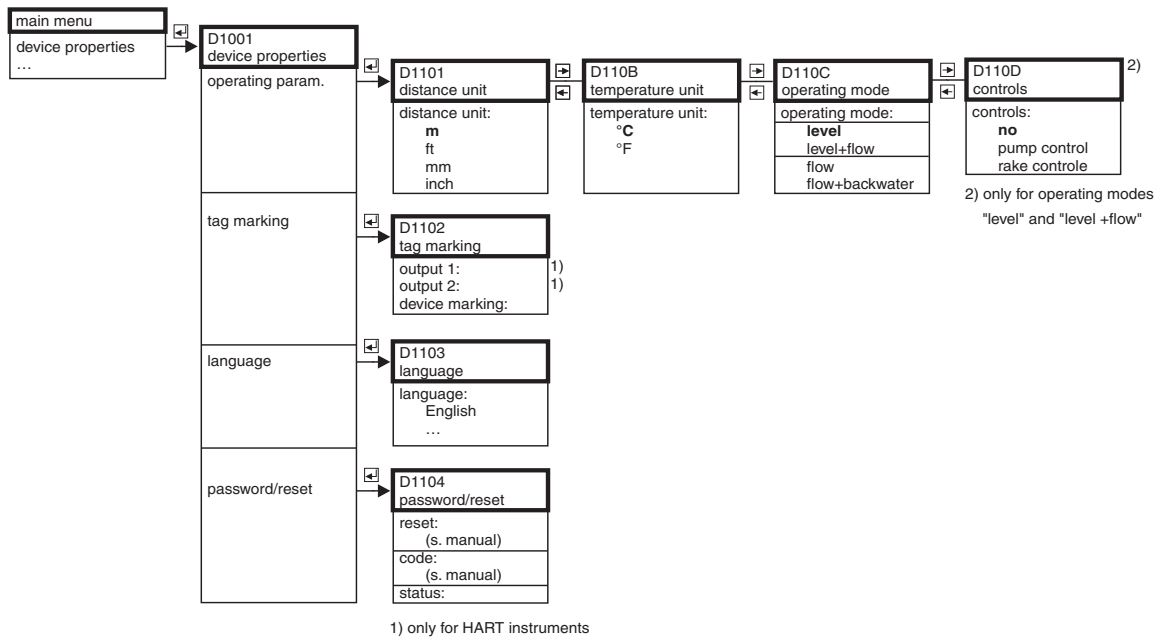

## 14.6 "system information"

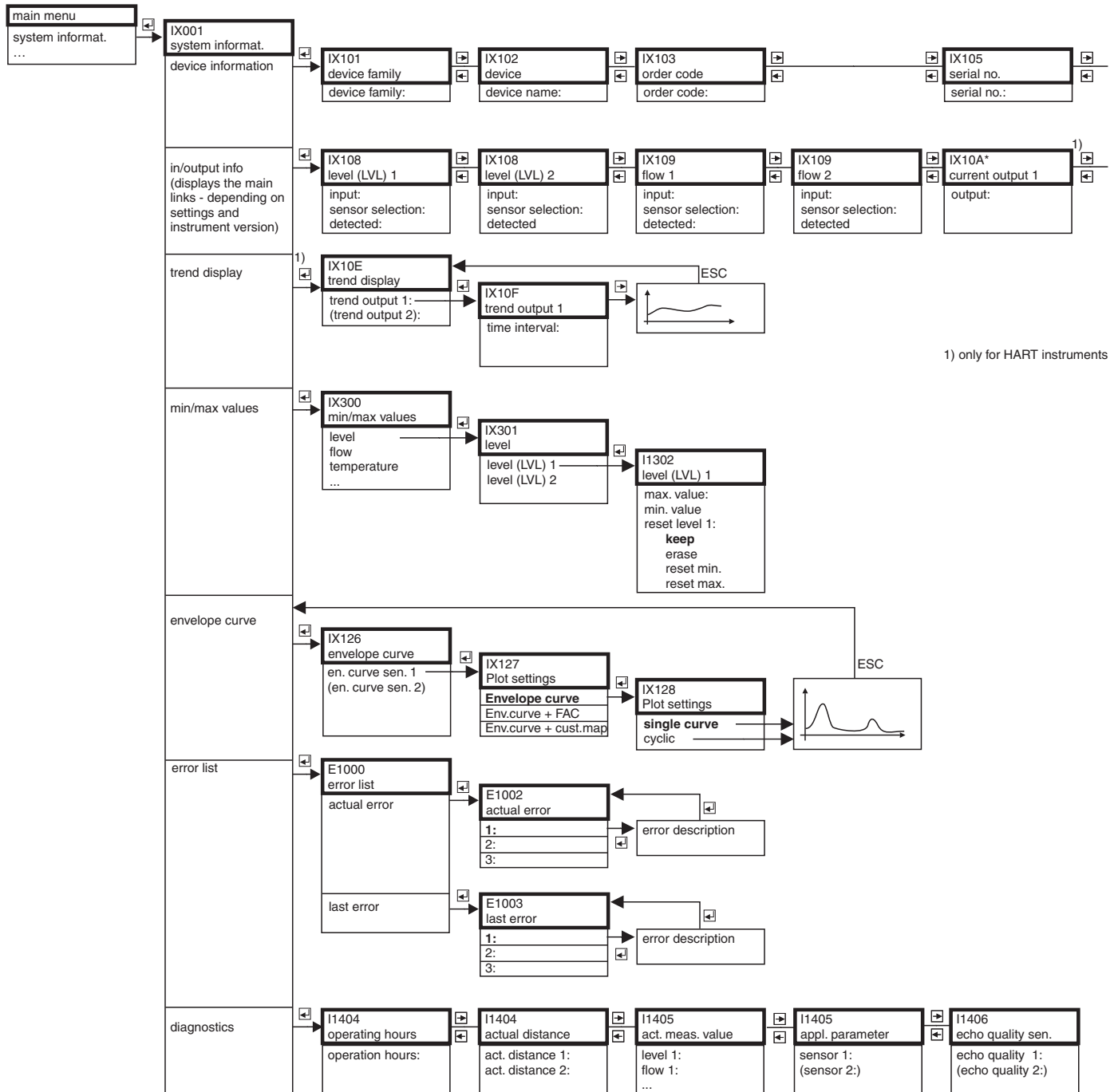

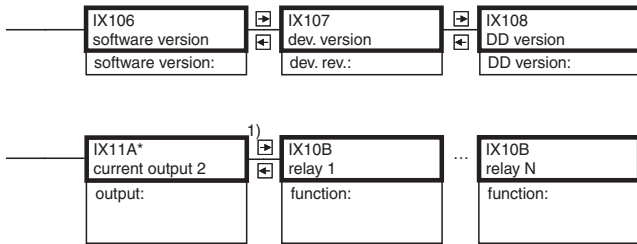

1) only for HART instruments

## 14.7 "display"

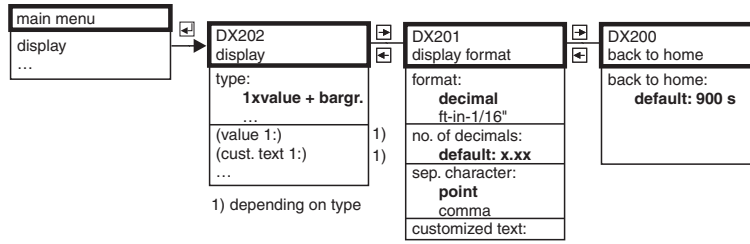

L00-FMU90xxx-19-09-01-es-106

## 14.8 "sensor management"

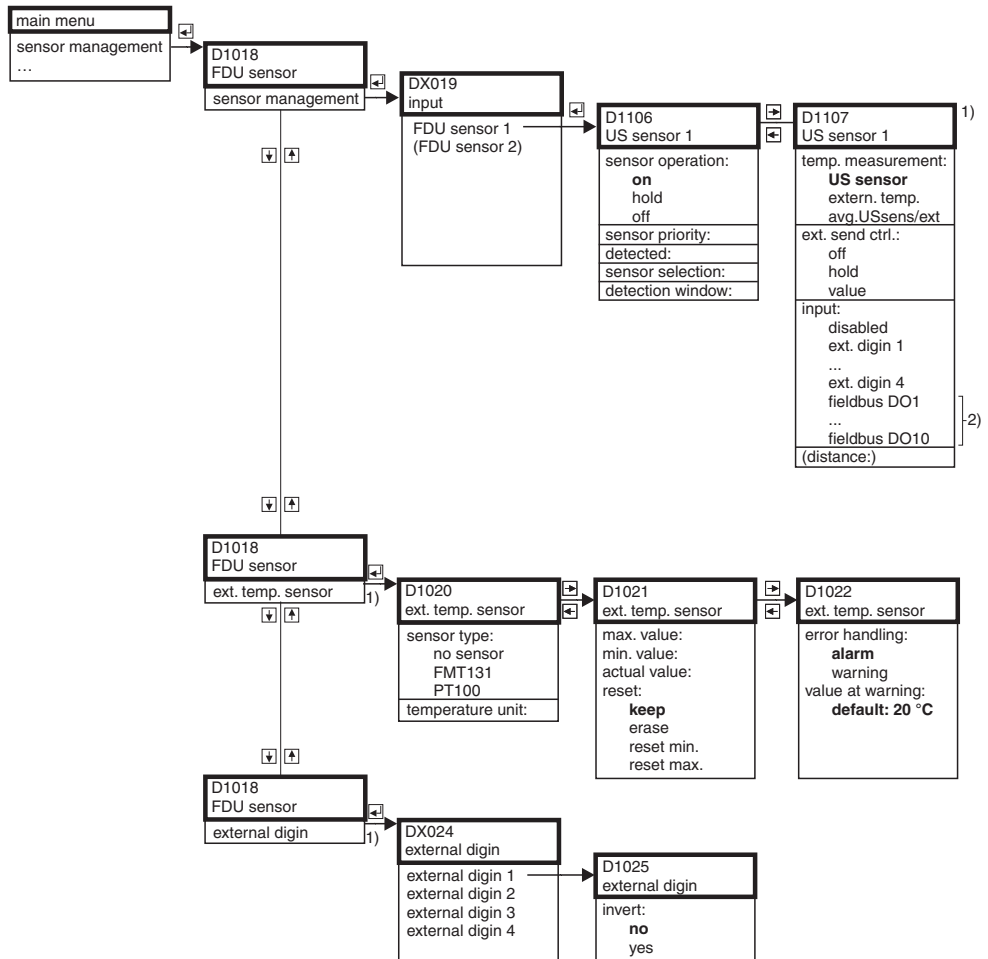

- 1) only for device version with additional switch inputs and connected external temperature sensor (FMU90-\*\*\*\*\*B\*\*\*)
- 2) only for PROFIBUS devices

L00-FMU90xxx-19-10-01-es-106

## 15 Appendix

### 15.1 Default block configuration

The block configuration on delivery depends on the instrument version:

#### 15.1.1 1 Sensor input / 1 current output (FMU90 - \*1\*\*\*1\*1\*\*\*\*)

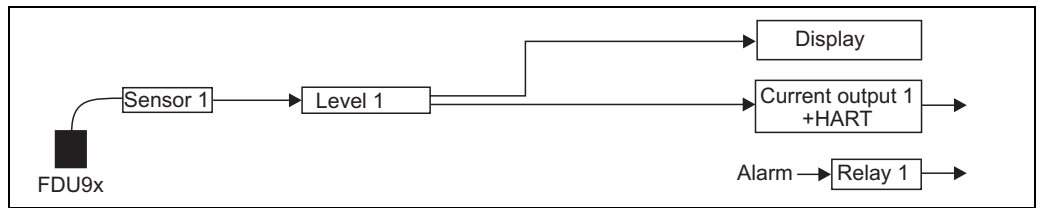

L00-FMU90xxx-19-00-00-en-079

#### 15.1.2 1 sensor input / 2 current outputs (FMU90 - \*1\*\*\*1\*2\*\*\*\*)

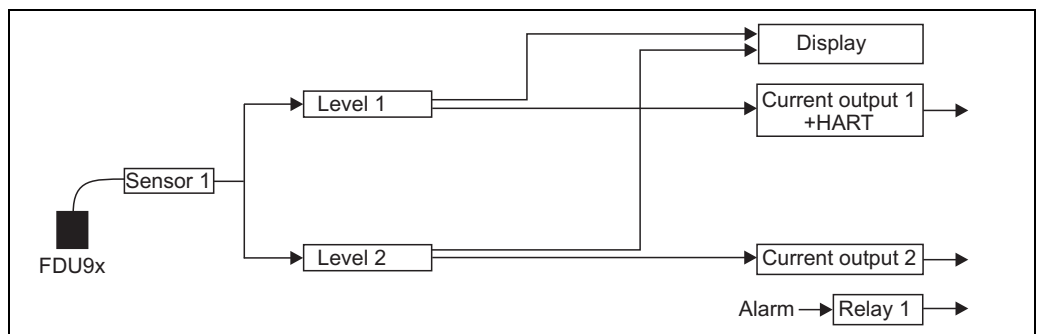

L00-FMU90xxx-19-00-00-en-088

#### 15.1.3 2 sensor inputs / 2 current outputs (FMU90 - \*1\*\*\*2\*2\*\*\*\*)

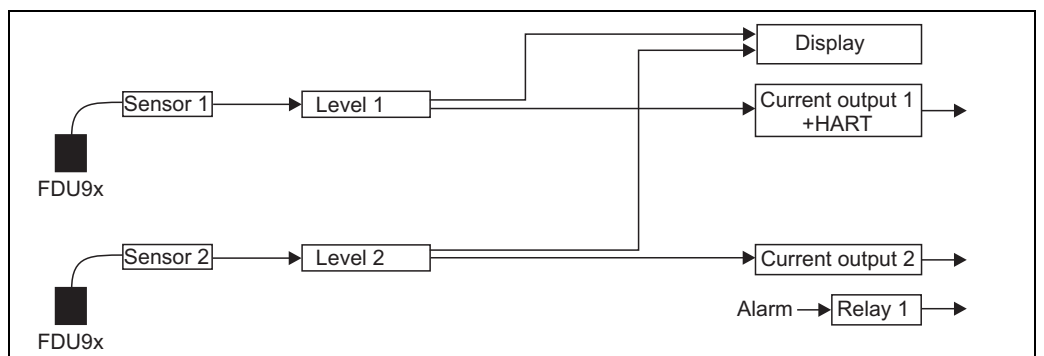

L00-FMU90xxx-19-00-00-en-080







# Index

## Symbols

"additional HART value 2/3/4" .....	132
"allocation current N" (N = 1 or 2) .....	128
"back to home" .....	73
"display format" .....	72
"display" .....	71
"HART settings" .....	131
"LVL N application parameters" (N = 1 or 2) .....	57
"LVL N check value" (N = 1 or 2) .....	67
"LVL N distance mapping" (N = 1 or 2) .....	68
"LVL N empty calibration" (N = 1 or 2) .....	59
"LVL N full calibration" (N = 1 or 2) .....	60
"LVL N linearisation" (N = 1 or 2) .....	62
"LVL N sensor selection" (N = 1 or 2) .....	56
"LVL N state" (N = 1 or 2) .....	69
"mode current M" (N = 1 or 2) .....	129
"pump control N" (N = 1 or 2) ... 88–89, 93, 101–102, 109	
"pump M/control N" (M = 1 - 6, N = 1 or 2) ... 89, 92, 103, 105, 107	
"Pumpensteuerung N" (N = 1 oder 2) ... 111–113, 115–120	
"rake control" .....	122–123, 125
"Relais N" (N = 1 - 6) (Pumpensteuerung) .....	114, 119
"Relaiszuordnung" (Pumpensteuerung) .....	114, 119–120
"relay allocation" .....	75, 79
"relay allocation" (rake control) .....	125
"relay N" (N = 1 - 6) (alarm/diagnostics) .....	80–81
"relay N" (N = 1 - 6) (limit) .....	75–76, 78
"relay N" (N = 1 - 6) (rake control) .....	126
"simulation" .....	133
"unit level" .....	61

## A

Adaption plate for remote display .....	148
Adaption plate for remote display module .....	17
Ambient conditions .....	156
Auxiliary energy .....	155

## B

Basic setup .....	54
Bedienmenü (Übersicht) .....	158
Block configuration (Default) .....	175

## C

Cable entries .....	18
Calibration errors .....	138
CE mark .....	10
cleaning .....	143
Commubox .....	146
Commubox FXA291 .....	146

## D

declaration of conformity .....	10
DIN-rail housing .....	7, 13
Display and operating module .....	34

## E

Envelope curve .....	139
----------------------	-----

Error codes .....	135
Error signal .....	134
Extension cable for sensors .....	151

## F

field housing .....	7, 11
Field Xpert SFX100 .....	47
FieldCare .....	47
First setup .....	52
Function blocks .....	50
FXA291 .....	146

## H

HART settings .....	131
---------------------	-----

## I

Incoming acceptance .....	11
Input .....	153
Interference echo suppression .....	66

## L

Linearisation .....	62
Locking .....	47

## M

Mechanical construction .....	157
Mounting bracket .....	147
Mounting plate for the field housing .....	146

## N

Nameplate .....	8
-----------------	---

## O

Operating menu (navigation) .....	39
Operational safety .....	5
Output .....	154
Overvoltage protection .....	148

## P

Performance characteristics .....	155
Potential equalization .....	32
process safety .....	5
Product structure .....	9
Produktstruktur .....	151
Protection cover for field housing .....	146

## R

Rake control .....	121
range of mapping (parameter) .....	68
Relay (alarm/diagnostic) .....	79
Relay (limit) .....	74
remote display and operating module .....	8, 16
repairs to Ex-approved devices .....	143
Reset to default configuration .....	49

## S

Safety conventions and symbols .....	6
Safety Instructions .....	5

Scope of delivery . . . . .	10
Sensor cable extension . . . . .	24
Sensor cable shortening . . . . .	29
Sensor connection . . . . .	23
Sensor heater . . . . .	25
Sensor mounting . . . . .	17
separate display and operating module . . . . .	31
Simulation . . . . .	133
Software history . . . . .	142
Spare Parts . . . . .	144
start mapping (parameter) . . . . .	68
Storage . . . . .	11
Synchronization line . . . . .	30
 <b>T</b>	
Terminal assignment . . . . .	20
Trademarks . . . . .	10
Transport . . . . .	11
 <b>W</b>	
Wiring . . . . .	18

[www.endress.com/worldwide](http://www.endress.com/worldwide)

---

**Endress+Hauser**   
People for Process Automation

---

