

# EPIC R/T 32/45-16

ROTARY TRANSFER MACHINE

## HYDROMAT OPERATING MANUAL



11600 ADIE ROAD  
ST. LOUIS, MISSOURI 63043  
PHONE: 314-432-4644  
TELECOPIER: 314-432-7552

REV. (12/05)

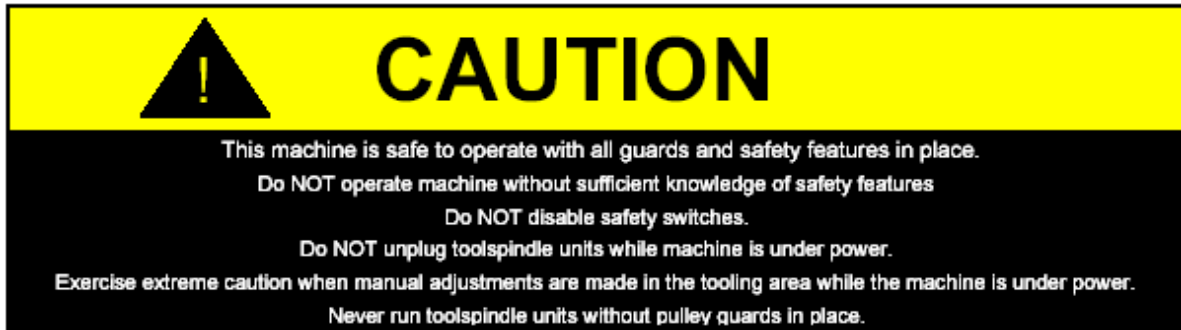

## **MACHINE SAFETY**

It is the users responsibility to provide proper safety devices and equipment to safeguard the operator from harm for any particular use, operation or set-up, and to adequately safeguard the machine, or machines, to conform to all Federal, State, and Local Government Safety Standards and all industry safety standards. It is suggested that only trained personnel operate the machine and equipment because improper use could damage the machine and cause personal injuries.

## **INDEMNIFICATION**

User agrees to indemnify and hold harmless HYDROMAT INC. from any and all claims or liabilities from accidents involving these machines caused by failure of user, his employees, or agents to follow instructions, warnings or recommendations furnished by HYDROMAT INC., or by failure of user to comply with Federal, State, and Local laws applicable to such equipment including the Occupational Safety and Health Act of 1970.



## TABLE OF CONTENTS

---

TABLE OF CONTENTS.....	iii
1. MACHINE TECHNICAL DETAILS.....	1-1
2. INSTALLATION OF MACHINE.....	2-1
3. SAFETY INSTRUCTIONS.....	3-1
4. HYDRAULIC AND CUTTING OIL RECOMMENDATIONS.....	4-1
5. COOLANT OIL FILTER SYSTEM.....	5-1
6. PENDANT CONTROL.....	6-1
7. CONTROL VALVES.....	7-1
8. UNITS AND ACCESSORIES.....	8-1
9. CUTOFF UNIT.....	9-1
10. BARFEEDER MAGAZINE.....	10-1
11. ROTARY INDEX TABLE.....	11-1
12. HYDRAULIC SYSTEMS.....	12-1
13. TROUBLESHOOTING.....	13-1
14. TECHNNA-CHECK <sup>®</sup> / BK MIKRO.....	14-1
15. MAINTENANCE REQUIREMENTS.....	15-1

## Table of Contents

### ENGLISH/METRIC SYSTEM CONVERSIONS

The following formulas were used in the conversion from Metric to English System equivalents in this manual. In all cases the English System equivalent as well as the Metric System equivalent has been calculated and noted where applicable in the text. If further conversions have to be made use the following list to assist in this conversion.

Hydraulic Pressure	Torque Conversion
1 PSI = 0.069 BARS 1 PSI = 0.070 kg/cm <sup>2</sup> 1 kg/cm <sup>2</sup> = 14.22 PSI 1 BAR = 14.5 PSI  PSI = pounds per square inch BAR = Barometric pressure	1 in-lb = 1.152 kg-cm 1 in-lb = 0.113 N-m 1 ft-lb = 1.356 N-m  in-lb = inch-pounds kg-cm = kilogram-centimeter N-m = Newton-meters
Motor Power	Force
1 hp = 0.746 kw 1 kw = 1.340 hp  hp = horsepower kw = kilowatts	1 lb = 4.448 N  N = Newtons lbs = pounds
Temperature Conversion	Fluid Measure
$^{\circ}C = 5/9 \times (^{\circ}F - 32)$ $^{\circ}F = (9/5 \times ^{\circ}C) + 32$  ° = degrees C = Celsius F = Fahrenheit	1 gal = 3.785 lit 1 p = 0.473 lit  gal = gallons lit = liters p = pint
Millimeters to Inch	Weight
1 in = 25.4 mm mm = millimeters	1 lb = 0.45 kg  lb = pound kg = kilogram
Volume	
1 ci = 16.387 cc  cc = cubic centimeters ci = cubic inches	

## HYDROMAT CUSTOMER SERVICE DEPARTMENT CONTACTS

As with any organization, the HYDROMAT INC. Customer Service Department has specialists for every function that we serve. Depending on your requirements, please call, fax, or email the appropriate person below.

**Phone: 314-432-0070**

**Fax: 314-993-2440**

**For the following services, please contact:**

### 1. *Machine Service/Technical Assistance:*

Max Bebie..... Vice President of Technical Services.....(ext. 4269) e-mail: mbebie@hydromat.com  
 Steve Palmer ..... Customer Service Manager.....(ext. 4333) e-mail: spalmer@hydromat.com  
 Kevin Miesner ..... HSL Technical Desk Manager .....(ext. 4363) e-mail: kmiesner@hydromat.com  
 Bobby Murray..... HSL Technical Coordinator/Trainer .....(ext. 4480) e-mail: bmurray@hydromat.com  
 George Atchison .... HSL Technical Coordinator .....(ext. 4932) e-mail: gatchison@hydromat.com  
 Tom Wilkes..... HSL Technical Coordinator .....(ext. 4724) e-mail: twilkes@hydromat.com

### 2. *Parts/Order Desk:*

When ordering parts or checking the status of a parts order, please dial extension 4200 to be connected with the first available parts technician. To reach a specific individual, please dial the extension listed below.

Raymond Johnson.. Customer Service Account Supervisor ..(ext. 4268) e-mail: rjohnson@hydromat.com  
 Jamie Garza ..... Customer Service Account Supervisor ..(ext. 4267) e-mail: jgarza@hydromat.com  
 Annette Engemann. Customer Service Account Assistant.....(ext. 4284) e-mail: aengemann@hydromat.com

### 3. *Training Classes:*

Judy Mitchell ..... Customer Service Office Manager/ .....(ext. 4331) e-mail: jmitchell@hydromat.com  
 ..... Training Coordinator

### 4. *Service Engineer/Trip Requests (Warranty/Non-Warranty):*

Max Bebie..... Vice President of Technical Services.....(ext. 4269) e-mail: mbebie@hydromat.com  
 Steve Palmer ..... Customer Service Manager.....(ext. 4333) e-mail: spalmer@hydromat.com  
 Kevin Miesner ..... HSL Technical Desk Manager .....(ext. 4363) e-mail: kmiesner@hydromat.com  
 Bobby Murray..... HSL Technical Coordinator/Trainer .....(ext. 4480) e-mail: bmurray@hydromat.com  
 George Atchison .... HSL Technical Coordinator .....(ext. 4932) e-mail: gatchison@hydromat.com  
 Tom Wilkes..... HSL Technical Coordinator .....(ext. 4724) e-mail: twilkes@hydromat.com

### 5. *Machine Rebuilding/Retools:*

Max Bebie..... Vice President of Technical Services.....(ext. 4269) e-mail: mbebie@hydromat.com  
 Steve Palmer ..... Customer Service Manager.....(ext. 4333) e-mail: spalmer@hydromat.com  
 Carlo Ilardi..... CS Engineering Manager.....(ext. 4390) e-mail: cilardi@hydromat.com  
 Tom Voges ..... Account Mgr. C.S. Retools & Rebuilds.(ext. 4647) e-mail: tvoges@hydromat.com  
 Shaun Ray..... Account Mgr. C.S. Retools & Rebuilds.(ext. 4666) e-mail: sray@hydromat.com

If none of the contacts are available, please leave a message with our **Customer Service Office Manager, Judy Mitchell, ext. 4331**. Hydromat's normal business hours are **(8:00 a.m. to 5:00 p.m. CST, Monday-Friday)**. If calling outside these hours, please leave a message on our voice mail system and your call will be returned as soon as possible. Your satisfaction is our primary goal. If, for any reason, you are dissatisfied with our performance, please call or fax our **Vice President of Technical Services, Max Bebie, ext. 4269**.

**1. MACHINE TECHNICAL DETAILS**

MACHINE FLOOR PLAN - EPIC R/T 32/45-16 .....	1-1
MACHINE TECHNICAL DETAILS - EPIC R/T 32/45-16 .....	1-2
HYDRAULIC POWERPACK .....	1-2
BARFEEDER MAGAZINE .....	1-3
CHIP CONVEYOR / COOLANT TANK .....	1-3

# MACHINE TECHNICAL DETAILS

## MACHINE FLOOR PLAN - EPIC R/T 32/45-16

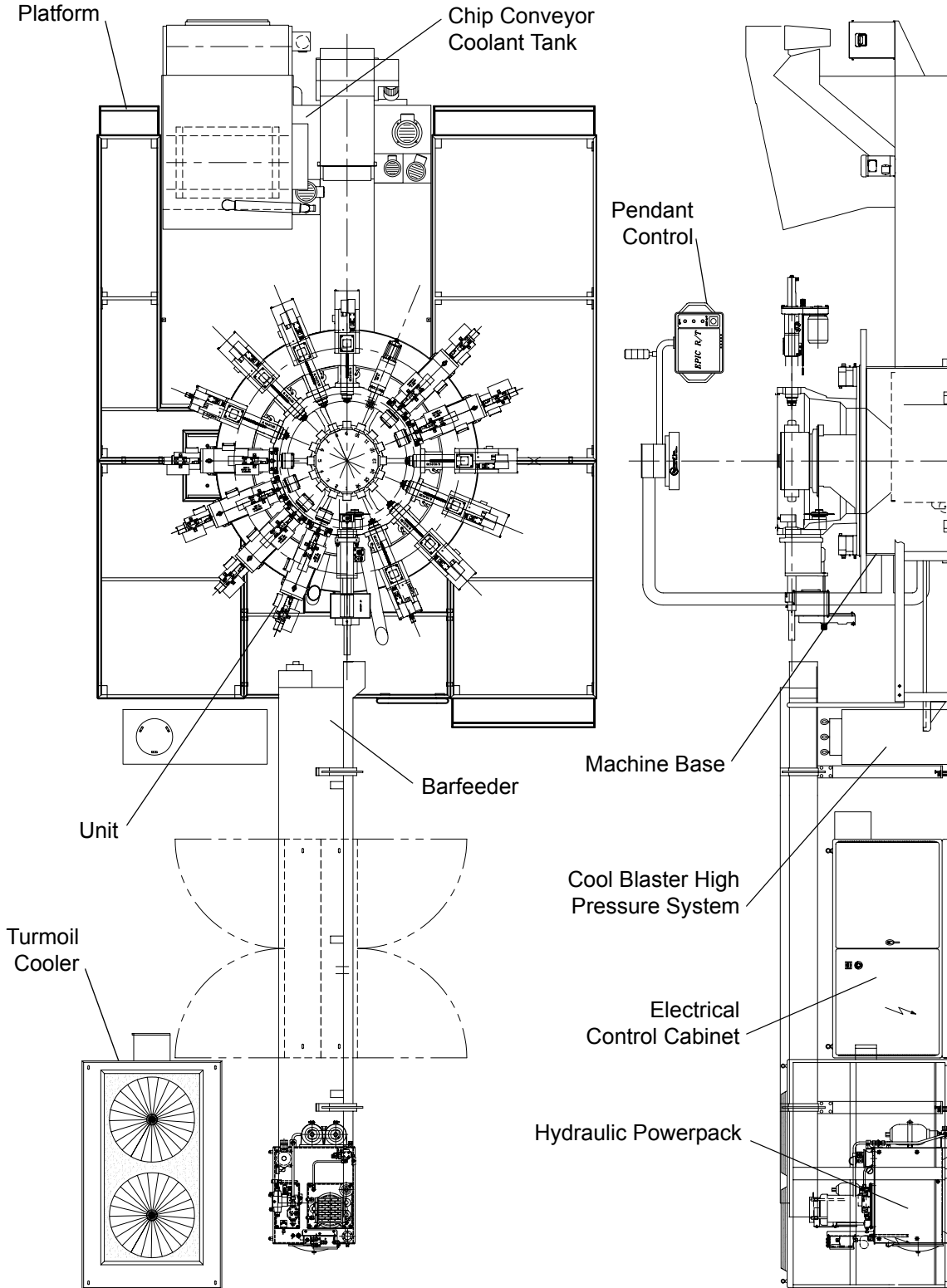

## 1. Machine Technical Details

### MACHINE TECHNICAL DETAILS - EPIC R/T 32/45-16

Diameter of cast iron spindle mounting ring		48.42"
Number of stations	Horizontal	16
Number of stations	Vertical	8
Maximum number of stations including Horizontal and Vertical		24
Collet/Chuck capacity	Bar Stock - Round	1 3/4"
Collet/Chuck capacity	Bar Stock - Hex.	1 1/2"
Collet /Chuck capacity	Bar Stock - Square	1 1/4"
Special Collets and Chucks available for extruded barstock, part blanks, and special applications		
Ejectors	(vary in size and shape according to workpiece) (see chapter 11 for ejector calculations)	
Ejectors are hydraulically actuated through the Control Pivot (see chapter 11)		
Workpiece length	Standard maximum	5.9"
Workpiece length (modification required)	Special maximum	6.3" / 7.0"
Maximum clamping depth in Collets	Up to dia .900"	3.0"
	Up to dia 1.50"	2.0"
	Up to dia 1.75"	.400"
Collet make	B32/45 Quick Change	
Table diameter over Collets		26.06"
Table indexing time		0.7 sec.
Cycle time		Refer to Machine Layout
180 degrees inverting of part possible at stations (separate Control Pivot is required for each inverting station change)		3 through 15
Electrical power requirements	3 phase 230V, 60 Hz. 200 amp or 3 phase 460V, 60Hz. 100 amp	
Total Machine Power: (varies with amount of Toolspindles)		94 KW = 126 HP
Total weight of Basic Machine with Toolspindles		15,000 lb
No lubrication needed on Basic Machine (see chapter 15 for maintenance)		

### HYDRAULIC POWERPACK

Measurements could vary depending on the model of Hydraulic Powerpack. Please refer to chapter 12 of the Operating Manual as well as the Powerpack chapter in your Unit Parts Manual.



## BARFEEDER MAGAZINE

Maximum Barstock length	Standard Barfeeder	12 ft
Maximum Barstock length	Special Barfeeder	16 ft
Maximum Barstock diameter		1 3/4"
Maximum capacity of 1" bars		8 pieces
Maximum capacity	Bundle Barfeeder	2,000 lb
Feed-in rate		1" in .2 sec.
Feed force		Infinitely adjustable
12 ft Tray Type Barfeeder Weight (depends on model)		525-1,000 lb
16 ft Tray Type Barfeeder Weight (depends on model)		1,000-1,200 lb
Bundle Barfeeder Weight (depends on model)		2,000-2,800 lb

## CHIP CONVEYOR / COOLANT TANK

Coolant Tank Capacity - VRF 500	580 gal
Flush Pump Capacity	55 GPM
Collet Flush Pump Capacity	13 GPM
High Pressure Pump Capacity	12 GPM
Standard Oil Cleaning System	Vacuum Filter Drum
Weight - Coolant Tank is mounted on rollers and easy to move	1,900 lb

**2. INSTALLATION OF MACHINE**

PRE-INSTALLATION OF MACHINE .....	2-1
WEIGHT OF MAJOR MACHINE COMPONENTS .....	2-2
EPIC R/T 32/45-16 .....	2-2
MACHINE INSTALLATION .....	2-3
LEVELING THE MACHINE BASE .....	2-4
CONNECTING THE HYDRAULIC POWERPACK .....	2-5
HYDRAULIC OIL RECOMMENDATIONS (POWERPACK) .....	2-6
OIL QUANTITY .....	2-6
ELECTRICAL POWER REQUIREMENTS .....	2-6
CONNECTING THE ELECTRICAL CONTROL CABINETS .....	2-7
HIGH VOLTAGE ELECTRICAL CONTROL CABINET .....	2-7
LOW VOLTAGE ELECTRICAL CONTROL CABINET .....	2-8
ALIGNING THE BARFEEDER .....	2-9
CONNECTING THE CHIP CONVEYOR AND PENDANT .....	2-10
FINAL PREPARATIONS FOR OPERATION .....	2-10

## INSTALLATION OF MACHINE

---

### PRE-INSTALLATION OF MACHINE

The Hydromat EPIC R/T Rotary Transfer Machine is completely controlled by Embedded Motion Control (EMC). This technology features special plug and play control architecture that is integrated or embedded into each toolspindle unit. This allows for fully independent and programmable functionality for each axis motion, thus eliminating the use of conventional Hydromat valves and more complex CNC control components.

The center of the Hydromat is a Rotary Indexing Table with ten to sixteen standard collets/chucks to hold the workpiece. The Toolspindle units are mounted around the perimeter of the Machine frame.

The Indexing Table moves the workpiece to each Toolspindle unit. The Toolspindle unit can perform most types of machining operations, such as drilling, cross drilling, boring, turning, milling, external and internal recessing, threading, tapping, etc.

Each Toolspindle unit is independent of the others, but working simultaneously, controlled by EMC Technology. The longest machining operation controls the cycle time. The advantage of the independent operation of each Toolspindle unit allows the ultimate of machining feeds and speeds for the best tool life and finishes. When a Toolspindle Unit is moved from one location on the machine to another, the only change needed is to program the unit's stroke. This makes changeover times fast.

Between the first and last station the completed workpiece is ejected from the machine, separate from any chips and oil.

Stock is automatically loaded into the Machine in the form of bars, coil, or blank parts. Where a Barfeeder is used, the bar end is ejected and the new bar is faced off before being seated into the Collet. This is controlled automatically and does not need assistance from the operator.

The Hydromat is a sophisticated Machine Tool and certain basic precautions should be taken during the installation, which may affect the warranty if not properly adhered to.

#### CAUTION

- **Be careful unpacking, lifting, and placing the Machine.**
- **Clean fittings and prevent dirt from getting into the hydraulic lines.**
- **Use the recommended hydraulic oil (see Ch. 2 and Ch. 4).**
- **After filtering the hydraulic oil, pour into the Filter Breather.**

#### DO NOT RUN THE HYDRAULIC POWERPACK WITHOUT OIL

- **Connect to the proper Power Supply (see Ch. 2).**
- **Wire the Electrical Cabinet according to the instructions in Ch. 2.**
- **Check for motor rotation as described in Ch. 2.**

When you are familiar with the machine manual and the installation instructions, the preparation of the Machine for production will be accomplished with ease.

## 2. Installation of Machine

### WEIGHT OF MAJOR MACHINE COMPONENTS

#### EPIC R/T 32/45-16

Machine Component	Weight
Average EPIC R/T 32/45-16 Machine With Toolspindles*	15,000 lb
Electrical Cabinet**	660 lb
Standard Chip Conveyor / Coolant Tank***	1,900 lb
Hydraulic Power Pack	550 lb
Tray Type Barfeeder 12 ft (Depending on Model)	525-1,000 lb
Tray Type Barfeeder 16 ft (Depending on Model)	1,000-1,200 lb
Bundle Barfeeder (Depending on Model)	2,000-2,800 lb
Pendant Arm Assembly	440 lb

\* Weight can be higher depending on setup

\*\* Depends on Cabinet configuration

\*\*\* Weight will be higher with options such as High Pressure Coolant and additional Side Tanks



#### **WARNING: RISK OF INJURY!**

**Use caution when lifting or moving Machine components to the installation site. Securely strap and support each part to prevent accidental dropping, which may result in component damage and injury to personnel.**

## MACHINE INSTALLATION

1. Place the machine at the approximate work site before removing the wooden pallet.
2. To remove the machine from the pallet, use a four way strap or cable and place the four hooks in the four special eye bolts provided on the Machine base frame. The lifting should be done with a direct vertical pull from over the center of the Machine. Be careful not to let the Machine swing or rotate when lifting, as one of the Toolspindle Units could be damaged.

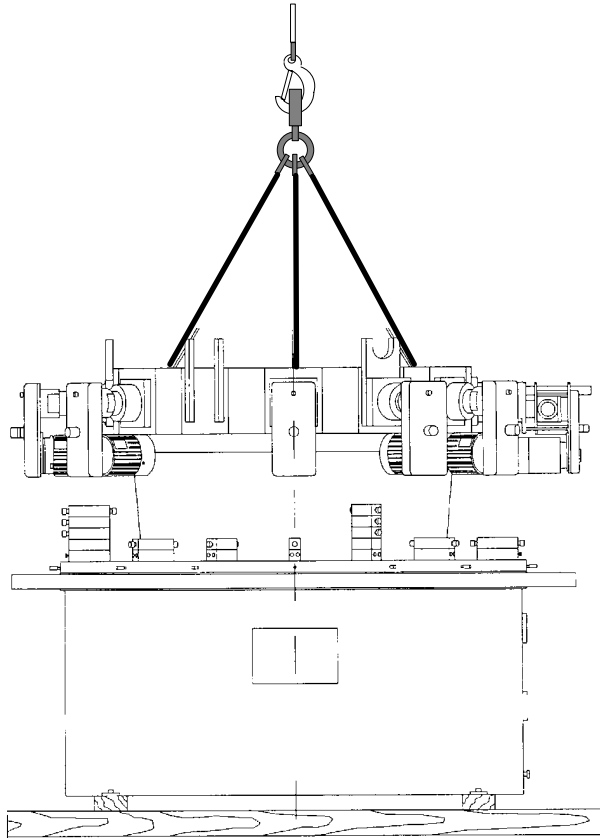

Removing the Machine From the Pallet



Lifting Eye Bolt in Place on the Machine Frame (4 Places)

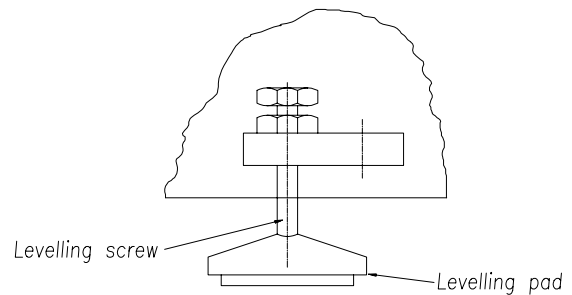

**WARNING: RISK OF INJURY!**

Use extreme caution when lifting the Machine. Use lifting straps or cables that are rated to handle the Machine weight. Never get under the suspended Machine.

**WEIGHT OF THE MACHINE IS APPROXIMATELY:**

**EPIC R/T 32/45-16 - 15,000 lb**

## 2. Installation of Machine

3. Before completely lowering the Machine to the floor put the four Leveling Pads in place and align them with the four Leveling Bolts, adjust the bolts to stabilize the Machine.

**NOTE:** Do not bolt the machine to the floor

4. Thoroughly remove all the rust preventative used during shipment, using paraffin as a cleaner. **WARNING: DO NOT USE SOLVENTS** (see Chapter 15) which would attack the painted areas. After cleaning, apply a light coat of oil to prevent rusting on the unpainted areas.
5. Place the Barfeeder, Electrical Control Panel, Hydraulic Powerpack, and any optional components in place in their approximate positions (see floor plan drawing). Use safe lifting procedures with properly rated lifting equipment.

### LEVELING THE MACHINE BASE

Use a machine bubble type level to check the Machine Base in two directions. If the machine shows an un-level condition, adjust the Leveling Bolts accordingly. The leveling may be done using either the top surface of the Index Table or the Machine Casting (see figure below).

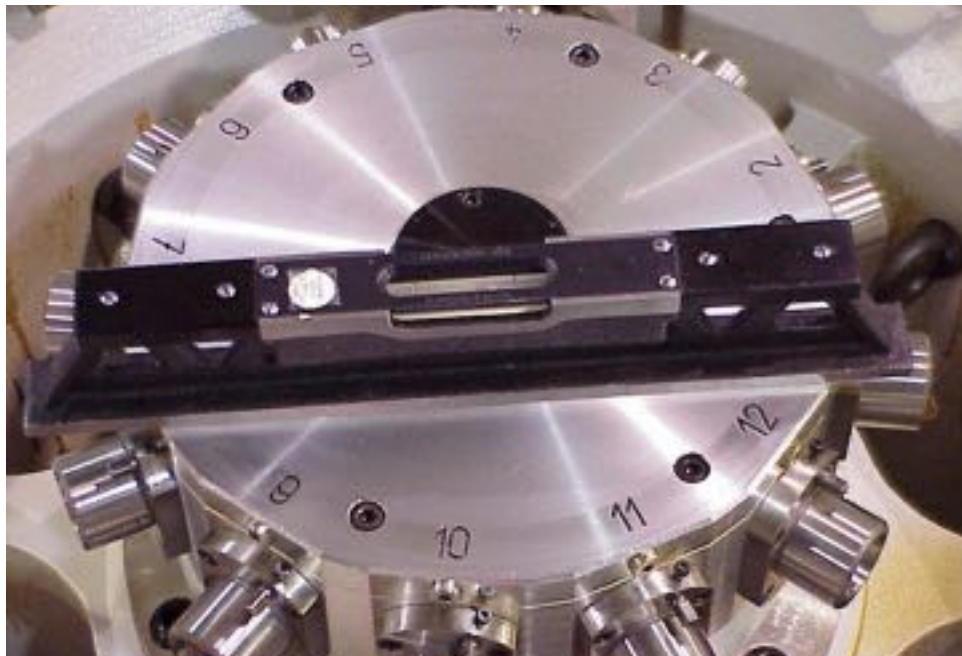

**Leveling The Machine**

## CONNECTING THE HYDRAULIC POWERPACK

1. Connect the Hydraulic lines between the Machine and the Powerpack, be careful to keep dirt from getting into the Hydraulic System. Inspect the lines for any contamination from shipping.
2. Fill the Hydraulic Powerpack with filtered Hydraulic Oil (see next page and Chapter 4) through the Filter Breather.
3. Place the Electrical Cabinet under the Barfeeder as shown (standard cabinets), and run the Electrical Power Connections through the fitting provided at the rear of the Electrical Control Cabinet.

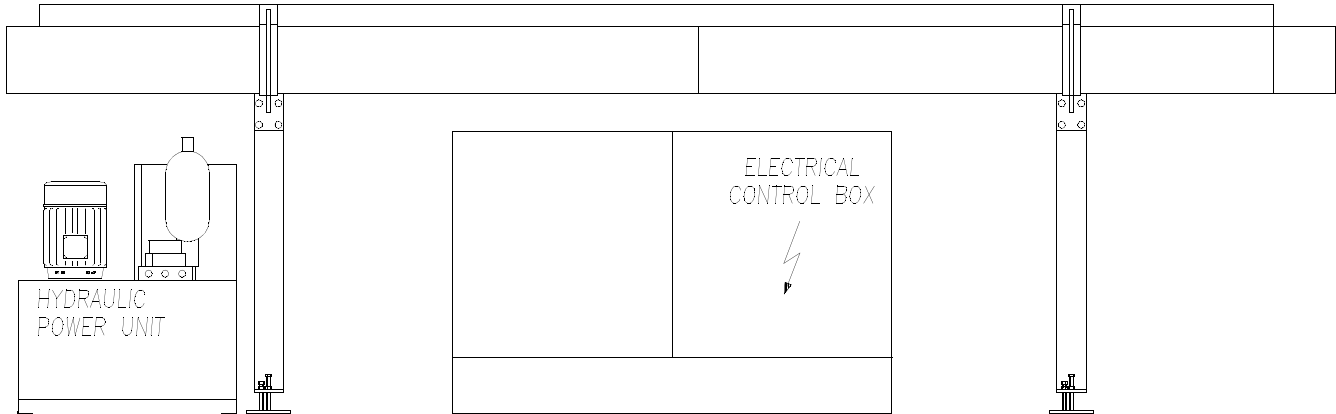

**Placement of Powerpack and Cabinet**



**Powerpack Connections**



**Machine Base Connections**

## 2. Installation of Machine

### HYDRAULIC OIL RECOMMENDATIONS (POWERPACK)

#### OIL QUANTITY

EPIC R/T 32/45-16 .....50 Gallons

We recommend the following list of lubricants for use in the HYDROMAT Hydraulic Powerpack:

AMOCO.....RYCON 21  
CHEVRON .....CHEVRON EP HYD. OIL AW46  
ENGINEERED LUBRICANTS .....ENLUBE 20-AW  
MOBIL.....DTE 25  
SHELL .....TELLUS 46  
TEXACO .....RANDON HD 46

See Chapter 4 for further hydraulic oil specifications.

### ELECTRICAL POWER REQUIREMENTS

Total Machine Power (may vary with number of Toolspindles) .....15-74 KW (20-100 HP)

Electrical Voltage Requirement (specified at Machine Order) .....3 phase 230V, 60 Hz  
.....or 3 phase 460V, 60 Hz

Recommended service for 3 phase 230V, 60 Hz .....200 amps

Recommended service for 3 phase 460V, 60 Hz .....100 amps

Fuse disconnect according to the Actual Machine Power



#### **WARNING: RISK OF INJURY!**

- In the interest of safety, observe local code, when sizing wire, fuses and electric service sizes.
- The Machine should be wired by a qualified electrician.
- The Machine must be connected to a protective earth ground. Incorrect connection can cause severe injury from electric shock.



## CONNECTING THE ELECTRICAL CONTROL CABINETS

1. With the Control Cabinets in place, install the Cable Channel between the Machine and the Electrical Control Cabinets. Put all the Electrical Cables into the channel between the Machine and the Control Cabinets.
2. Connect all the numbered wires to their corresponding terminals on the Terminal Strip provided (item 1).
3. Connect the correct Supply Power and Ground to the Electrical Control Panel at the main Disconnect Switches (items 3 and 4).
4. Consult the Machine Electrical Schematics for more detail.

### HIGH VOLTAGE ELECTRICAL CONTROL CABINET



**WARNING:**

**Make sure the incoming power supply matches the type specified on the Main disconnect cover. Failure to do so could result in severe Electrical Cabinet damage.**

**RISK OF INJURY!**

**Disconnect incoming power while wiring the Machine wires into the Electrical Control Cabinet. Failure to do so could result in severe electrical shock and death.**

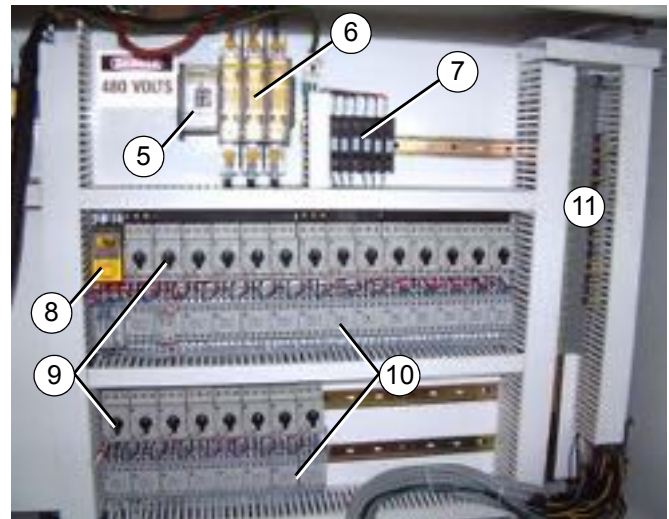
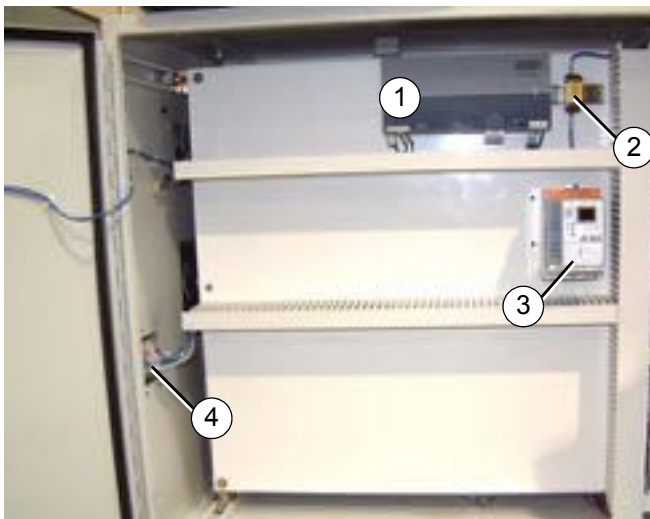

- 1 SOLA Power Supply
- 2 High Current DC Fuse
- 3 5 HP Variable Frequency Drive
- 4 Powerpack Plug
- 5 Disconnect
- 6 Main Fuses

- 7 High Voltage Fuses
- 8 Chip Conveyor Fuses
- 9 Manual Motor Starters/Overloads
- 10 Contactors
- 11 High Voltage Terminal Strip

### High Voltage Electrical Control Cabinet

## 2. Installation of Machine

### LOW VOLTAGE ELECTRICAL CONTROL CABINET

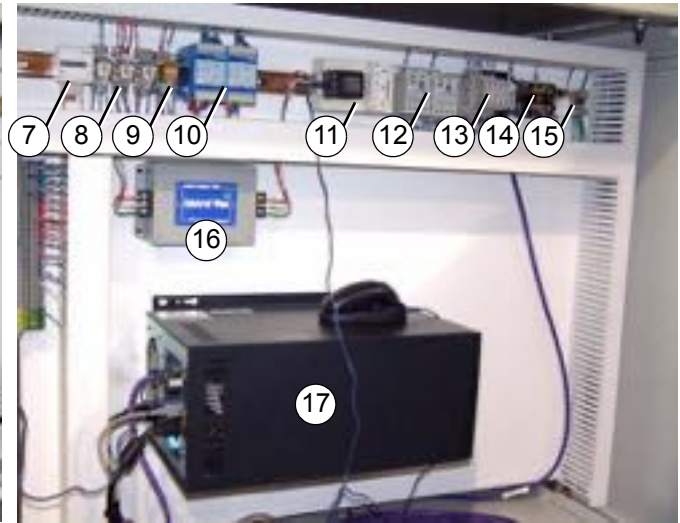
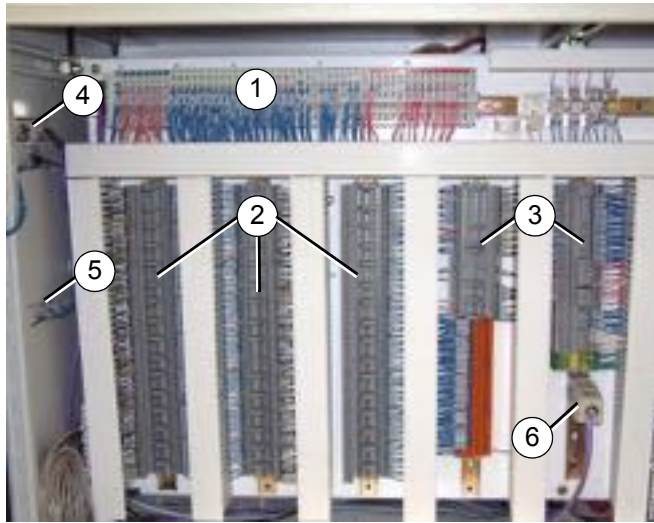

- |                    |                             |
|--------------------|-----------------------------|
| 1 WAGO I/O         | 10 BK MIKRO                 |
| 2 Unit Plugs       | 11 120 Volt AC Outlet       |
| 3 Misc. Fuses      | 12 Distribution Blocks      |
| 4 Loader Plug      | 13 CRM Master Control Relay |
| 5 Lube Plug        | 14 High Current DC Relay    |
| 6 Machine Profibus | 15 Ground Block             |
| 7 Hour Meter       | 16 Islatrol 120 VAC Filter  |
| 8 4 P DT Relay     | 17 Computer                 |
| 9 2 P DT Relay     |                             |

### Low Voltage Electrical Control Cabinet

## ALIGNING THE BARFEEDER

1. Connect the Attachment Rod between the Barfeeder and the Machine Base. The female end threads onto the upper right flange stud **without a Spring washer!** The threaded end fits through the bracket on the Barfeeder and is held with two nuts. Then connect the Adjusting rod as shown below. If assembled properly, the dimensions shown below will be correct.
2. Run the Electrical Cables through the rear of the Control Cabinet and connect the wires to their corresponding Terminals.
3. It is important that the Barfeeder is in exact alignment both vertically and horizontally with the Guide Bushing of the Cut-off Unit. Use the Locking Bolts and Leveling Bolts to align the Barfeeder to the Guide Bushing. When properly aligned, the appropriate size barstock should slide easily through the Guide Tube and Guide Bushing and into the center of the Index Table Collet.
4. Connect the Barfeeder Hydraulic lines between the Barfeeder and the Machine Base using the pre-marked fittings provided.

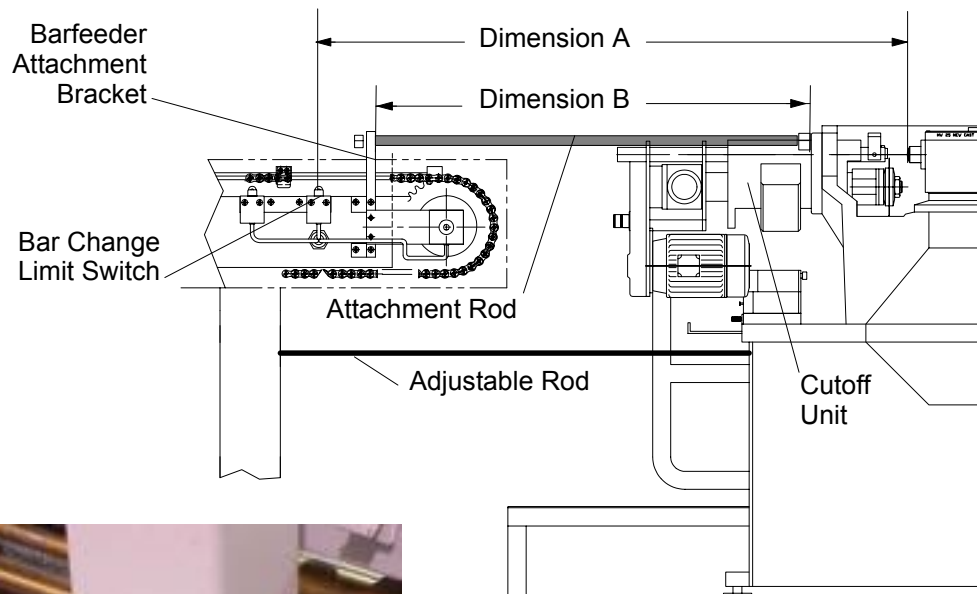
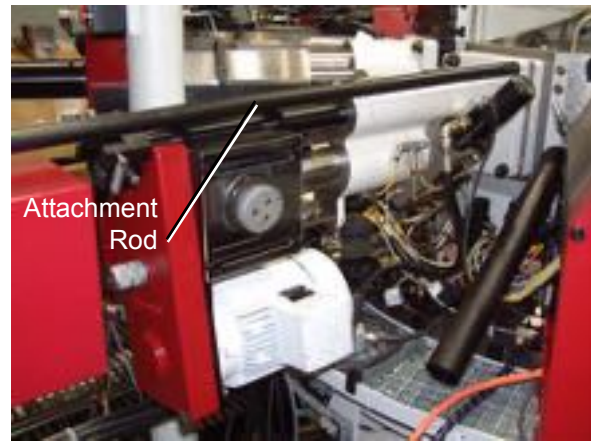

Dimension A - 1249.7mm or 49.2"  
 Dimension B - 873mm or 34.37"

**NOTE:** The attachment rod must be assembled exactly as shown or the Barchange will not be correct.



**Locking Bolt and Leveling Bolt**

## 2. Installation of Machine

### CONNECTING THE CHIP CONVEYOR AND PENDANT

1. Put the Chip Conveyor under the Machine and connect the Coolant Hoses to the Pump (see picture).
2. Connect the Electrical Connection Plug to the Machine Base.
3. Install the Pendant above the Machine as shown.
4. Locate the five taped wires in the Pendant arm and connect to the labeled terminal strip, located in the Emergency Stop and Auto Off Box.
5. Fill the Coolant Tank with coolant oil (see Chapter 4 for coolant recommendations).

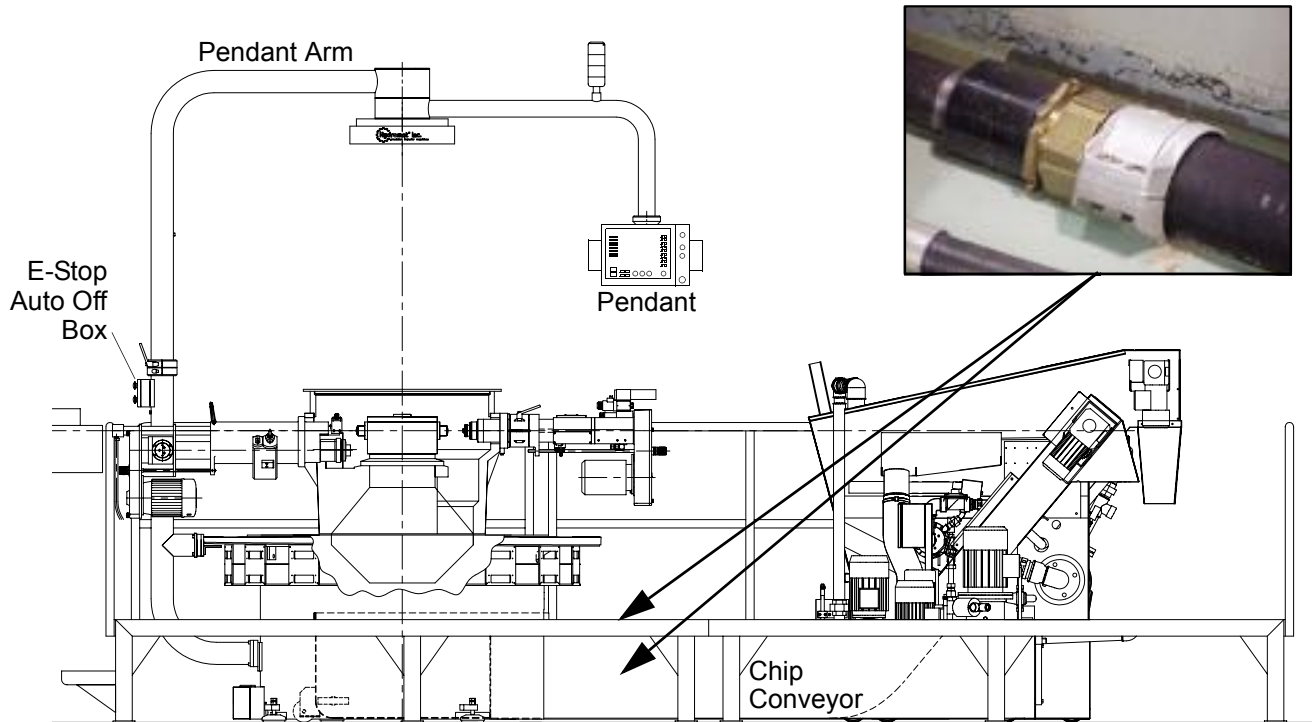

### FINAL PREPARATIONS FOR OPERATION

1. Arrange the two Platform Sections around the Machine Base and bolt them together
2. Switch on the Main Disconnect and press the “HYDRAULIC ON” button. **IMMEDIATELY** check the rotation of the Hydraulic Pump Motor, and confirm that it is turning in the correct direction as seen from the back of the motor.
3. Bleed the Hydraulic System as explained in Chapter 12.

**NOTE: Do not connect the High Pressure Pump (option) until proper rotation of the main system pump is confirmed. Disconnect the motor leads in the Electrical Cabinet (refer to the machine electrical schematics for wire numbers and location of the High Pressure Pump starter). Failure to do so will cause premature failure of the High Pressure Pump!**

**3. SAFETY INSTRUCTIONS**

GENERAL SAFETY INSTRUCTIONS .....	3-1
SAFETY FEATURES OF THE MACHINE.....	3-2
1. LID SAFETY SWITCHES.....	3-2
2. EMERGENCY STOP PUSH BUTTON SWITCHES .....	3-2
3. MAIN DISCONNECT WITH INTEGRAL DOOR LOCK.....	3-2
MACHINE SAFETY .....	3-3
INDEMNIFICATION .....	3-3
SAFE TOOL CHANGE PRACTICES.....	3-4
MACHINE SAFETY LABELS BILL OF MATERIAL .....	3-4
MACHINE SAFETY LABELS.....	3-5

## SAFETY INSTRUCTIONS

### GENERAL SAFETY INSTRUCTIONS

Do not operate the Machine before all safety procedures in this manual have been carefully reviewed.

- Be familiar with all of the safety features on the Hydromat Rotary Transfer Machine before you begin working on it.
- Make sure no one is working inside the machine before you turn on the power.
- Be sure that the Pendant Control and the Emergency Stop are always within reach while working on the machine.
- Protect your eyes by wearing safety glasses with side shields.
- Wear steel-toed safety shoes with oil resistant soles.
- If you have long hair, tie it back and cover it. Do not wear long sleeves, bulky clothing, neckties, jewelry, gloves, or any loose apparel.
- Make sure your work area is free of chips, hydraulic oil and coolant spills, air hoses, or anything that can cause you to trip and fall. Inspect the Platform for any unsafe or worn areas.
- Before turning on the machine, walk around it and check for loose, worn, or broken parts. If you suspect that something needs attention, do not operate the machine. Report anything unusual to your supervisor immediately.
- Make sure hydraulic pressure gauges show specified operating pressures. Refer to Chapter 12 for proper pressures and procedures.
- Make sure all cutting tools are securely clamped in their holders.
- Never operate the Machine without The Pulley Guards and Cover Lid in place and never override the Lid Safety switches, they are there for your protection.
- Never start Spindles with any Unit Belt cover removed.
- Never unplug a Unit Motor without first turning off the Spindles.
- Never reach into an operating Chip Conveyor, **always turn the conveyor Off first!**  
The Conveyor is turned on by the COOLANT ON push button and turned off with the SPINDLES AND COOLANT OFF push button.
- Before removing any hydraulic lines be sure to Turn Off Hydraulic Power Pack by E-Stop.
- **DO NOT** operate the machine with any exposed wires or broken Seal-Tite. These should be repaired immediately by a qualified electrician.



Keep Pendant Within Reach

Wear  
Safety  
Glasses

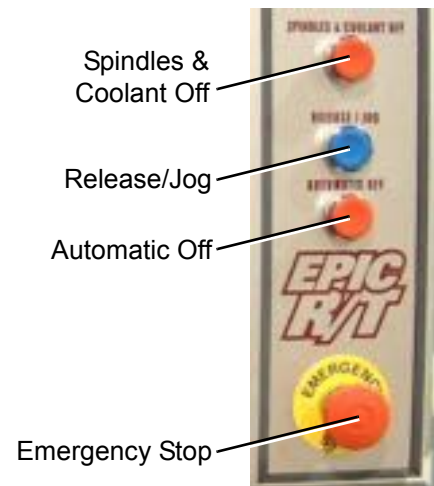

Pendant Buttons

### 3. Safety Instructions

## SAFETY FEATURES OF THE MACHINE

### 1. LID SAFETY SWITCHES

Location: Located on the Machine Base (three or more depending on set up).

Function: These Micro Switches are normally open and wired in a series, the Switches are held closed with the Lid Cover in place. If the Cover guard is opened while the Machine is in operation, the Toolspindle Units return to the home position and the Spindles stop (This is NOT an EMERGENCY STOP condition\*). The parts in the Table will not be finished and will require the operator to run a UNITS cycle before resuming AUTOMATIC operation, **turn off the inverting unit prior to unit cycle.**

\* The Hydraulic Powerpack remains on.



#### WARNING:

Inspect Machine for status of incomplete parts to avoid damaging the tooling.

### 2. EMERGENCY STOP PUSH BUTTON SWITCHES

Location: One on the Pendant Control (Red Mushroom Button).  
One on the stationary post for Pendant Control.  
One mounted on the Electrical Control Cabinet.

Function:

- Turns off the Spindle Motors.
- Returns the Toolspindles to the home position
- Shuts down the Hydraulic Powerpack.
- Turns off the Chip Conveyor
- Removes power to the MCR (Machine Control Relay) in the Electrical Cabinet, which de-energizes all PLC Outputs.

### 3. MAIN DISCONNECT WITH INTEGRAL DOOR LOCK

Location: The Main Disconnect Switch is mounted on the front door of the Electrical Cabinet.

Function: Switch has two positions: On and Off (Disconnects all Electrical Power to the Machine).

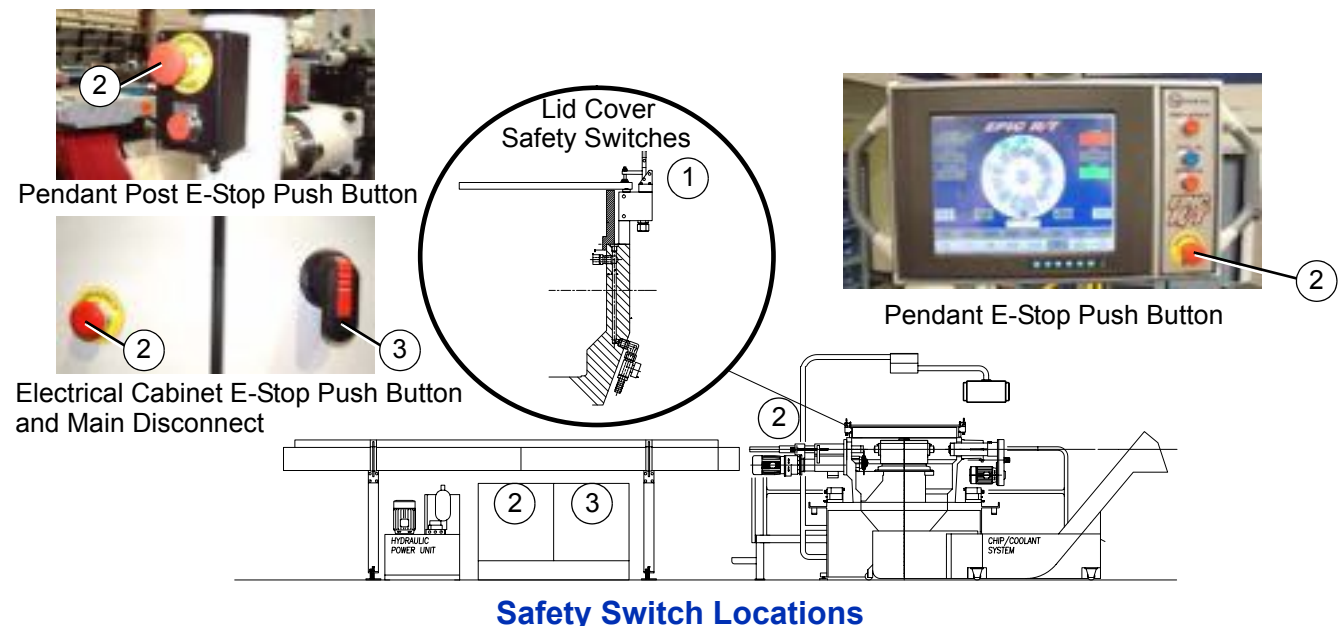

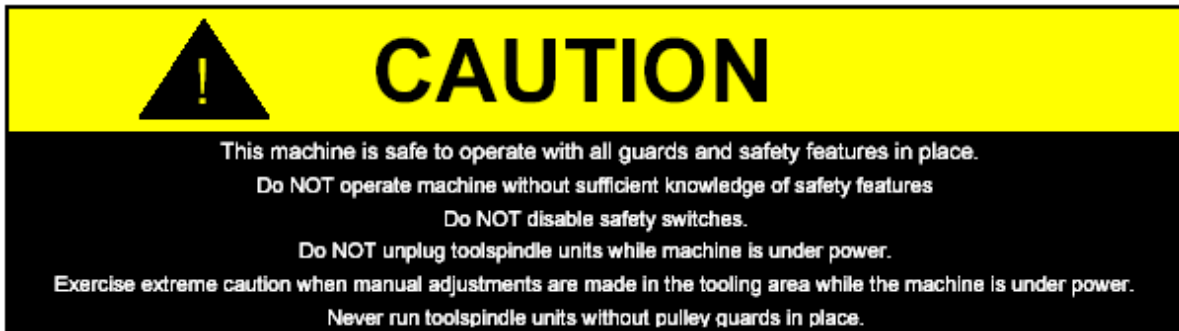

## **MACHINE SAFETY**

It is the users responsibility to provide proper safety devices and equipment to safeguard the operator from harm for any particular use, operation or set-up, and to adequately safeguard the machine, or machines, to conform to all Federal, State, and Local Government Safety Standards and all industry safety standards. It is suggested that only trained personnel operate the machine and equipment because improper use could damage the machine and cause personal injuries.

## **INDEMNIFICATION**

User agrees to indemnify and hold harmless HYDROMAT INC. from any and all claims or liabilities from accidents involving these machines caused by failure of user, his employees, or agents to follow instructions, warnings or recommendations furnished by HYDROMAT INC., or by failure of user to comply with Federal, State, and Local laws applicable to such equipment including the Occupational Safety and Health Act of 1970.



### 3. Safety Instructions

## SAFE TOOL CHANGE PRACTICES

- Move the Pendant Control close to where you're working for access to Machine controls.
- Always use the proper hand tools when removing and replacing Toolheads and perishable tooling. Incorrect wrenches can slip and cause hand injuries.
- Make sure that you can safely reach into the tooling area. If your access is restricted, remove the Lid Ring from the Machine frame.

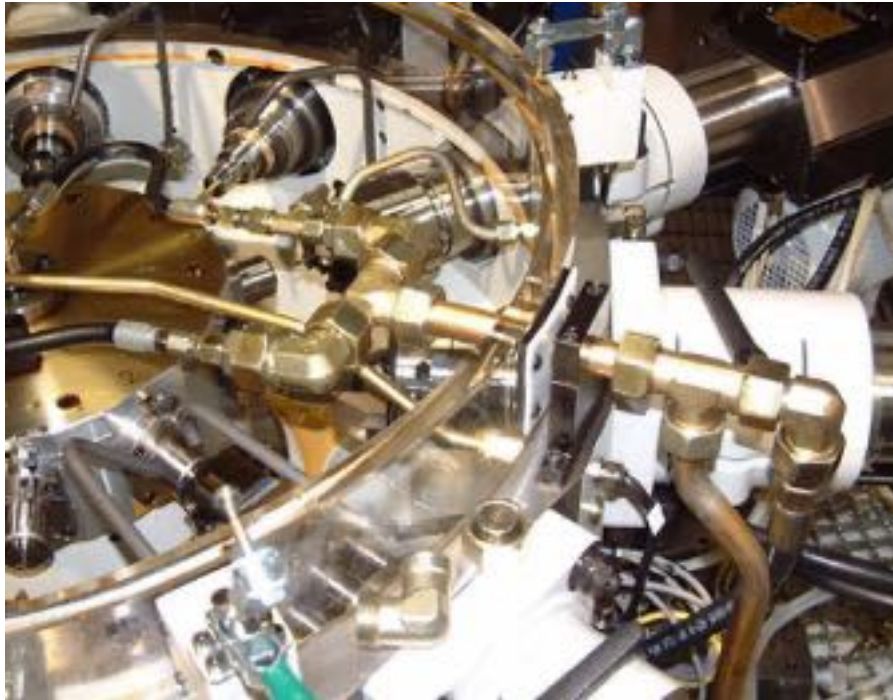

**Machine With Lids Removed for Greater Accessibility**

## MACHINE SAFETY LABELS BILL OF MATERIAL

<u>Item</u>	<u>Qty.</u>	<u>Description</u>	<u>Part Number</u>
1	4	Danger Electrical Hazard	O.000.0966
2	*	Caution Do Not Reach Into Machining Area - Lid Handle	O.000.0967
3	*	Caution Hydraulic Power Must Be Off - Unit Top Cover	O.000.0968
4	1	Caution Do Not Reach Into Conveyor - Chip Conveyor	O.000.0969
5	1	Caution This Machine is Safe to Operate - Pendant	O.000.0970
6	*	Caution Do Not Operate w/o Guards - Barfeeder & Unit Belt Cover	O.000.0971
7	1	Hydromat Inc.	O.000.0972
8	*	Bag Filter Warning	Knoll Supplied
9	1	Hydraulic Power Oil	O.000.1058
10	1	Recess Lube System	O.000.1059
11	1	Vogel Lube System	O.000.1060

\* Quantities Depend on Machine Configuration

**DANGER**

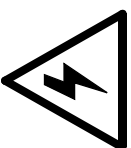

**Electrical hazard  
Authorized  
personnel only**

Riveted to Main Breaker Cover Inside Cabinet, Hydraulic Powerpack, Chip Conveyor Junction Box, and Machine Base Junction Box

**CAUTION**



**Do NOT reach into machining area until units have stopped rotating**

Riveted under every Lid Handle

**CAUTION**



**Do NOT operate without guards**

Riveted to Barfeeder Covers and each Toolspindle Unit Belt Cover

**CAUTION**



**Hydraulic power MUST be off before removing this cover**

Riveted to the top of each Toolspindle Unit

**WARNING**

**TO MINIMIZE THE RISK OF SERIOUS INJURY AND PROPERTY DAMAGE:**

- Do not use with gases-use only for liquid filtration
- Do not use with toxic liquids requiring ASME approved vessels
- Do not exceed operating pressure of 100 PSIG at 200°F
- Do not open or pressurize vessel until air has been vented
- Do not tighten clamp if vessel leaks or is under pressure
- Do not tighten clamp bolt above 10-1/2 ft. lb.
- Read and follow instructions and safety information in manual

Affixed to all Bag Filter Vessels (Not used on VRF500 Chip Conveyor)

**Hydromat Inc.**  
*precision transfer machines*

Riveted to Chip Conveyor Upper Panel

**CAUTION**



**Do NOT reach into conveyor or operate unless safety guards are in place and properly adjusted**

Riveted to Chip Conveyor Lower Panel

**CAUTION**

Riveted to Back of Pendant

RECESS LUBE SYSTEM ENWAY 132-MCGOWD OR EQUIVALENT  
+  
Riveted to Barfeeder Leg above Lube Tank

VOGEL LUBE SYSTEM EN LUBOL 98-SEP OR EQUIVALENT  
+  
Affixed to Vogel Unit

HYDRAULIC POWER CHEVRON AW46 HYD OIL OR EQUIVALENT  
+  
Affixed to side of Hydraulic Powerpack

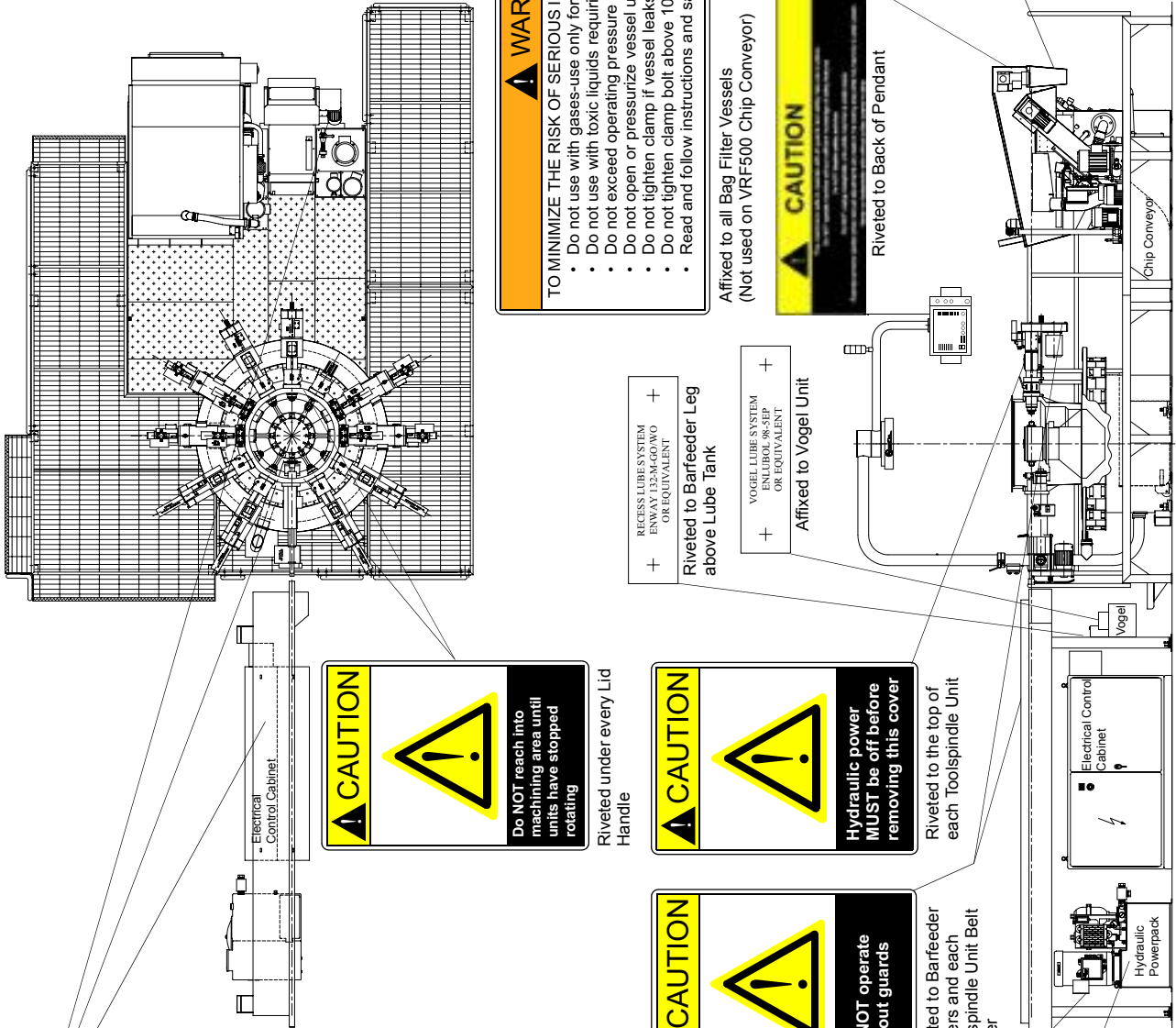

**Machine Safety Label Placement**

**4. HYDRAULIC AND CUTTING OIL RECOMMENDATIONS**

HYDRAULIC OIL RECOMMENDATIONS - POWERPACK.....	4-1
CUTTING OIL RECOMMENDATIONS - CHIP CONVEYOR.....	4-2
CUTTING FLUIDS COMPATIBILITY .....	4-2
BRASS AND ALUMINUM.....	4-2
COLD ROLLED LEDLOY STEEL, CARBON STEEL .....	4-2
ALLOY STEEL + STAINLESS STEEL.....	4-2
SUMMARY OF GREASE AND OIL RECOMMENDATIONS .....	4-3
HYDRAULIC POWERPACK .....	4-3
CUT OFF UNIT GEAR BOXES AND SAW HEAD .....	4-3
HYDRAULIC CNC 2-AXIS UNITS (WITH VOGEL LUBE UNIT).....	4-3
3-AXIS MILLING UNIT (WITH VOGEL LUBE UNIT).....	4-3
IBAG HIGH FREQUENCY UNIT .....	4-3
AIR/OIL LUBRICATOR ON LEAK OIL PRESSURIZATION SYSTEM.....	4-3
CROSS DRILL, MILLING HEADS, CUT OFF UNIT SWING TUBE AND THREADING UNITS	4-3
PERMANENTLY GREASED BEARINGS .....	4-3
RECESS UNITS WITH THRU THE DRAWBAR LUBRICATION .....	4-3
RECESS HEADS (OLDER STYLE).....	4-3

## HYDRAULIC AND CUTTING OIL RECOMMENDATIONS

### HYDRAULIC OIL RECOMMENDATIONS - POWERPACK

Oil quantity: EPIC R/T 20-10 - 20 gallons, all other models - 50 gallons.

This lubricant must have all of the general qualities and properties to insure its satisfactory performance as a Machine Tool Lubricant and a Hydraulic Medium.

It is recommended to change the Hydraulic Oil semi-annually or after 1,000 hours of operation, or according to the oil supplier's used oil testing program whichever occurs first. To be used under conditions consistent with good Machine Tool Practice.

The Hydraulic Oil must conform to the following specifications:

API gravity at 15.6 degrees (60 degrees fahrenheit) (ASTM D287).....	28 to 31.5
Viscosity system (ASTM D2422-75).....	ISO VG 46
Viscosity index (ASTM D 567) .....	90 minimum
Color (ASTM D1500).....	3 maximum
Flash (O.C.) min. (ASTM D92).....	385 degrees F
Fire (O.C.) min. (ASTM D92).....	425 degrees F
Neutralization no. (mg KOH per gm oil) (ASTM D 664).....	1.5 max.
Rust test (ASTM D 665 proc A).....	pass

**Should not contain any mineral acids**

We recommend the following list of lubricants for use in the Hydraulic Powerpack (in alphabetical order):

AMOCO.....	RYCON 21
CHEVRON .....	CHEVRON EP HYD. OIL AW46
ENGINEERED LUBRICANTS .....	ENLUBE 20-AW
MOBIL.....	DTE 25
SHELL .....	TELLUS 46
TEXACO .....	RANDON HD 46

## 4. Hydraulic and Cutting Oil Recommendations

### CUTTING OIL RECOMMENDATIONS - CHIP CONVEYOR

Cutting oils recommended for various materials being machined.

#### CUTTING FLUIDS COMPATIBILITY



**WARNING:**

**When machining various materials, cutting fluids must be compatible with the bar stock material. Your cutting fluid representative should be contacted during the planning of the part process. Incompatibility of fluids and chips can cause corrosion and chemical reaction which will void any warranties.**

#### BRASS AND ALUMINUM

This application calls for a light viscosity and possibly a fatted Cutting Oil. If a Cyclonic Oil Cleaning System is used, the viscosity must not exceed 60 SSU at 68 degrees Fahrenheit. A Soluble Oil can also be used, however, the Machine must be equipped with a Leak Oil Pressurizing System to prevent the water soluble coolant from being drawn into the Toolspindle Units and the Index Table. The Leak Oil System is available in a kit form through HYDROMAT Inc. and may be installed by the machine operator.

#### COLD ROLLED LEDLOY STEEL, CARBON STEEL

For metals with a machinability above 70\*, a medium viscosity Cutting Oil is recommended. This Cutting Oil should contain fatty additives and possibly a non-corrosive sulfur and phosphorus.

#### ALLOY STEEL + STAINLESS STEEL

For metals with a machinability below 70\*. a heavy-medium viscosity Cutting Oil containing non-corrosive sulfur, fat, and possibly phosphorous is recommended.

Each machining operation has it's own idiosyncrasy which may require special blends of Cutting Oil. The above descriptions are very general and are only intended as a guide line.

When additional information is required, please contact your local oil representative or one of the oil suppliers listed on the previous page.

\* % relative speed (1212 = 100)



**WARNING:**

**For safe operation of the Machine with Mineral Cutting Oil, please adhere to the following recommendations:**

- **Prohibit smoking around the Machine.**
- **Use only Cutting Fluids with a flash point higher than 260° F.**
- **Insure that no source of potential ignition exist inside or around the Machine such as faulty wiring, faulty solenoids, etc.**
- **Change dull cutting tools before excessive heat results from the machining operation. This condition could result in seizing of the tool and potential sparking.**

## SUMMARY OF GREASE AND OIL RECOMMENDATIONS

### HYDRAULIC POWERPACK

AMOCO.....	RYCON 21
CHEVRON .....	CHEVRON AW HYD. OIL AW46
ENGINEERED LUBRICANTS .....	ENLUBE 20-AW
MOBIL.....	DTE 25
SHELL .....	TELLUS 46
TEXACO .....	RANDON HD 46

### CUT OFF UNIT GEAR BOXES AND SAW HEAD

MOBIL.....	GEAR 629
SHELL .....	OMALA 150
CASTROL .....	HYPOID GEAR OIL 80W90

### HYDRAULIC CNC 2-AXIS UNITS (WITH VOGEL LUBE UNIT)

ENGINEERED LUBRICANTS .....	ENLUBOL 98-5EP
-----------------------------	----------------

### 3-AXIS MILLING UNIT (WITH VOGEL LUBE UNIT)

ENGINEERED LUBRICANTS .....	ENWAY 31-WO
-----------------------------	-------------

### IBAG HIGH FREQUENCY UNIT

MOBIL.....	DTE LIGHT OIL (NO ADDITIVES)
------------	------------------------------

### AIR/OIL LUBRICATOR ON LEAK OIL PRESSURIZATION SYSTEM

ENGINEERED LUBRICANTS .....	ENLUBE 20-AW
PARKER.....	F442P OIL

### CROSS DRILL, MILLING HEADS, CUT OFF UNIT SWING TUBE AND THREADING UNITS

MASTER LUBRICANTS .....	LUBRIKO GREASE M-6
MOBIL.....	MOBILLUX GREASE 2
SHELL .....	ALVANIA GREASE 2

### PERMANENTLY GREASED BEARINGS

KLUBER ISOFLEX .....	LDS 18 SPECIAL A
----------------------	------------------

### RECESS UNITS WITH THRU THE DRAWBAR LUBRICATION

ENGINEERED LUBRICANTS .....	ENWAY 132-M-GO/WO
-----------------------------	-------------------

### RECESS HEADS (OLDER STYLE)

AMOCO.....	RYCON 21
CHEVRON .....	CHEVRON AW HYD. OIL AW46
ENGINEERED LUBRICANTS .....	ENLUBOL 98-5EP
MOBIL.....	DTE 25
SHELL .....	TELLUS 46
TEXACO .....	RANDON HD 46

**5. COOLANT OIL FILTER SYSTEM**

COOLANT OIL SINGLE BAG FILTER .....	5-1
RECOMMENDED FILTER BAG: .....	5-1
TO SERVICE THE BAG FILTER DAILY: .....	5-1
DOUBLE BAG FILTER SYSTEM .....	5-2
HIGH PRESSURE COOLANT (OPTIONAL) .....	5-3
CENTRIFUGAL FILTER (OPTIONAL) .....	5-4
CLEANING PHASE DESCRIPTION .....	5-4
REVERSE-FLOW PHASE DESCRIPTION .....	5-4
MAGNETIC FILTER SYSTEM .....	5-5
INSTALLING THE CHIP CONVEYOR SCRAPER BELT .....	5-6
ASSEMBLING THE SCRAPER BELT .....	5-7
SETTING THE CONVEYOR BELT TENSION .....	5-8
ADJUSTING THE CONVEYOR DRIVE SHAFT .....	5-9
CHANGING THE BROACH BARS .....	5-9
KNOLL VACUUM ROTATION FILTER VRF500 (OPTIONAL) .....	5-10
FUNCTIONAL DESCRIPTION .....	5-10
VACUUM FILTER CYCLE TIMES AND SETTINGS .....	5-11
SYSTEM BACKFLUSH CONTROL FACTORS .....	5-11
VACUUM FILTER SEQUENCE DESCRIPTION .....	5-12
CLEANING THE SIEVE DRUM .....	5-12
REMOVAL / INSTALLATION OF THE VACUUM FILTER DRUM .....	5-13
VACUUM FILTER ADJUSTMENTS .....	5-14
VACUUM FILTER PREVENTIVE MAINTENANCE .....	5-15
VACUUM FILTER TROUBLE-SHOOTING .....	5-16
TURMOIL COOLER (OPTIONAL) .....	5-17
UNCRATING & INSPECTION .....	5-18
COOLER PLACEMENT .....	5-18
DESCRIPTION .....	5-18
PLUMBING HOOK-UP .....	5-18
ELECTRICAL HOOK-UP .....	5-18
FLOW SWITCH .....	5-21
TEMPERATURE CONTROLLER .....	5-21
START-UP .....	5-22
OPERATION .....	5-22
SAFETY INTERLOCKS .....	5-23
HIGH/LOW PRESSURE SWITCH (REFRIGERANT) .....	5-23
HIGH TEMPERATURE ALARM .....	5-23
FAN PRESSURE SWITCH .....	5-23
LOW FLOW .....	5-23
LOW TEMPERATURE THERMOSTAT .....	5-23
MAINTENANCE .....	5-24
AIR FILTERS .....	5-24
CONDENSER .....	5-24

## COOLANT OIL FILTER SYSTEM

### COOLANT OIL SINGLE BAG FILTER

Clean Cutting Oil is essential for trouble free operation of the Machine. The Coolant Oil flushing through the Index Table Collets keeps them clean and free of chips.

If aluminum or brass is being machined, a Bag Filter System is in use - Full Flo Filter Model #FCB II. The Bag must be changed regularly, as the Filter fills up with fine chips. If the Bag fills up with chips, the oil flow is reduced and chips will collect in the Table Collet / Ejector assemblies.

#### Recommended Filter Bag:

- Bag Polyester 100 micron CIPE 100 (for best finishes)
- Bag Polyester 200 micron CIPE 200 (standard)

#### To service the Bag Filter daily:

1. Turn off Spindles and Coolant.
2. Open the petcock on the top of the Filter vessel to the vessel of excess pressure.
3. Loosen the band clamp bolt and slide out the bag filter.
4. Dump chips into suitable container and clean the Bag thoroughly. Replace the Bag every week of operation.
5. Replace the Bag, reinstall the band clamp, and close the petcock.

**NOTE:** Coolant viscosity must not exceed 60 SSU at 100 degrees Fahrenheit.



#### **WARNING: RISK OF INJURY!**

**Do not attempt to service the bag filter unit without turning off the coolant pumps and releasing any residual pressure by opening the petcock.**



**Coolant Oil Single Bag Filter**



## 5. Coolant Oil Filter System

### DOUBLE BAG FILTER SYSTEM



**Double Bag Filter System**

The Double Bag Filter allows the operator to clean or replace one of the Bag Filters while the Machine remains in Automatic cycle.

One Bag Filter remains in service during the filter change. The Coolant flow is rerouted from one Filter to the other by a directional flow valve. The pressure gauge atop the canisters indicates which Bag Filter is active.

A pressure gauge is mounted on each Bag Filter to allow the operator to determine when the back pressure caused by a clogged Bag is high enough to justify cleaning.

Read the procedure on the previous page before servicing the Bag Filter.

**NOTE:** Always check that the gauge pressure on the Filter vessel, you are about to service, is “ZERO” before loosening the band clamp bolt. Open the petcock on the vessel to bleed the tank(s).

## HIGH PRESSURE COOLANT (OPTIONAL)

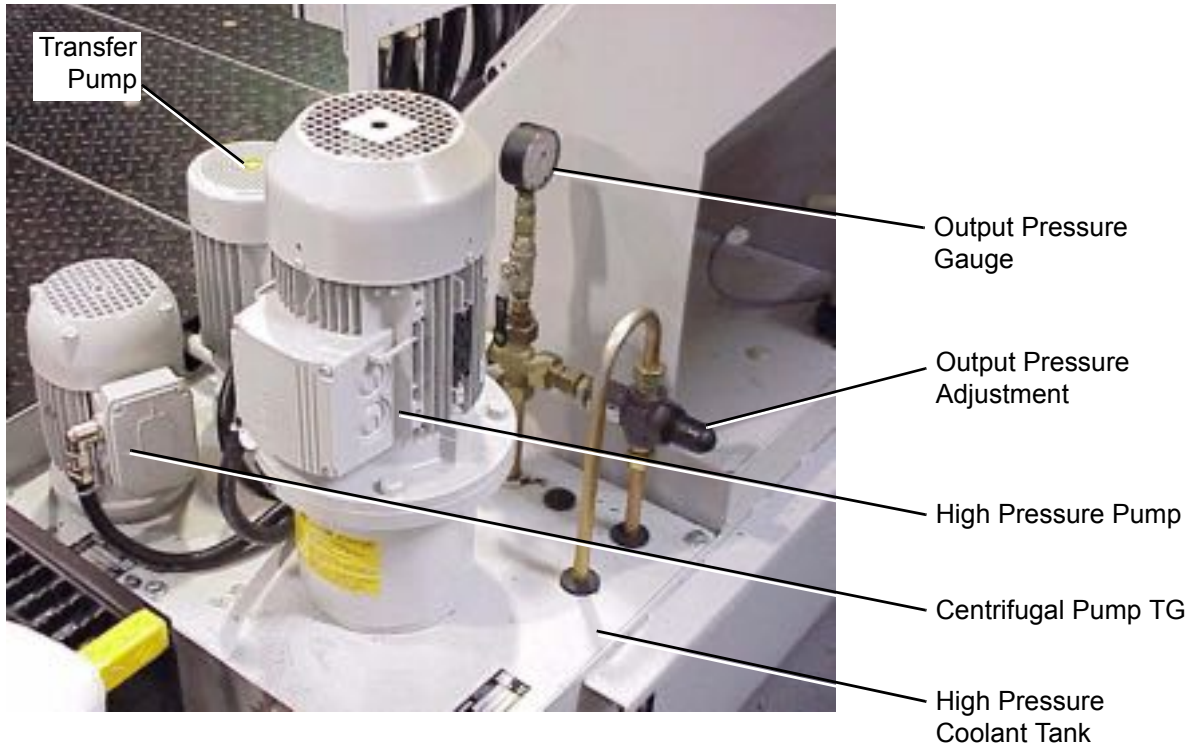

### Chip Conveyor High Pressure Description

The High Pressure Coolant system supplies filtered Coolant, typically 200 to 400 Psi. at 10 gal. per minute, to selected Coolant fed Toolspindle units.

The special tank is fed coolant by an auxiliary pump and is filtered through a Bag Filter. A float switch senses the tank level and is an input to the PLC, which cycles the auxiliary pump to maintain the tank level.

The High Pressure output is regulated by an adjustable pressure relief valve on the unit.

**NOTE:** Refer to “Service the Bag Filter daily” as described previously in this chapter.

## 5. Coolant Oil Filter System

### CENTRIFUGAL FILTER (OPTIONAL)

#### Cleaning Phase Description

- Dirty liquid enters the filter.
- Dirt particles settle on the filter fabric.
- Cleaned fluid runs into the supply tank.
- The inner pressure of the filter is within its set range.
- The valve at the discharge pipe (for reverse flow) is closed.
- Motor is switched off.

#### Reverse-Flow Phase Description

- Internal pressure of the filter exceeds the set value.
- Motor sets vane in rotation.
- The discharge valve opens.
- Dirt particles are rinsed with the help of the cleaned fluid, by the activated reverse flow, from the filter fabric.
- The motor runs for approximately 3 seconds.
- Discharge valve closes after an approx. 1 sec. delay after switching off the motor.
- The cleaning phase starts up.

Refer to the separate Knoll manual for detailed instructions on transport, installation, safety, maintenance, and system faults.



**Centrifugal Filter**

## MAGNETIC FILTER SYSTEM

The standard Chip Conveyor is equipped with a Magnetic Drum/Scraper System to eliminate the fine ferrous chips. The coolant flow is directed over the Magnetic Drum removing the fine suspended chips (see figure). This system is also used with a Bag Filter System to insure clean Cutting Oil to the Index Table Collets.

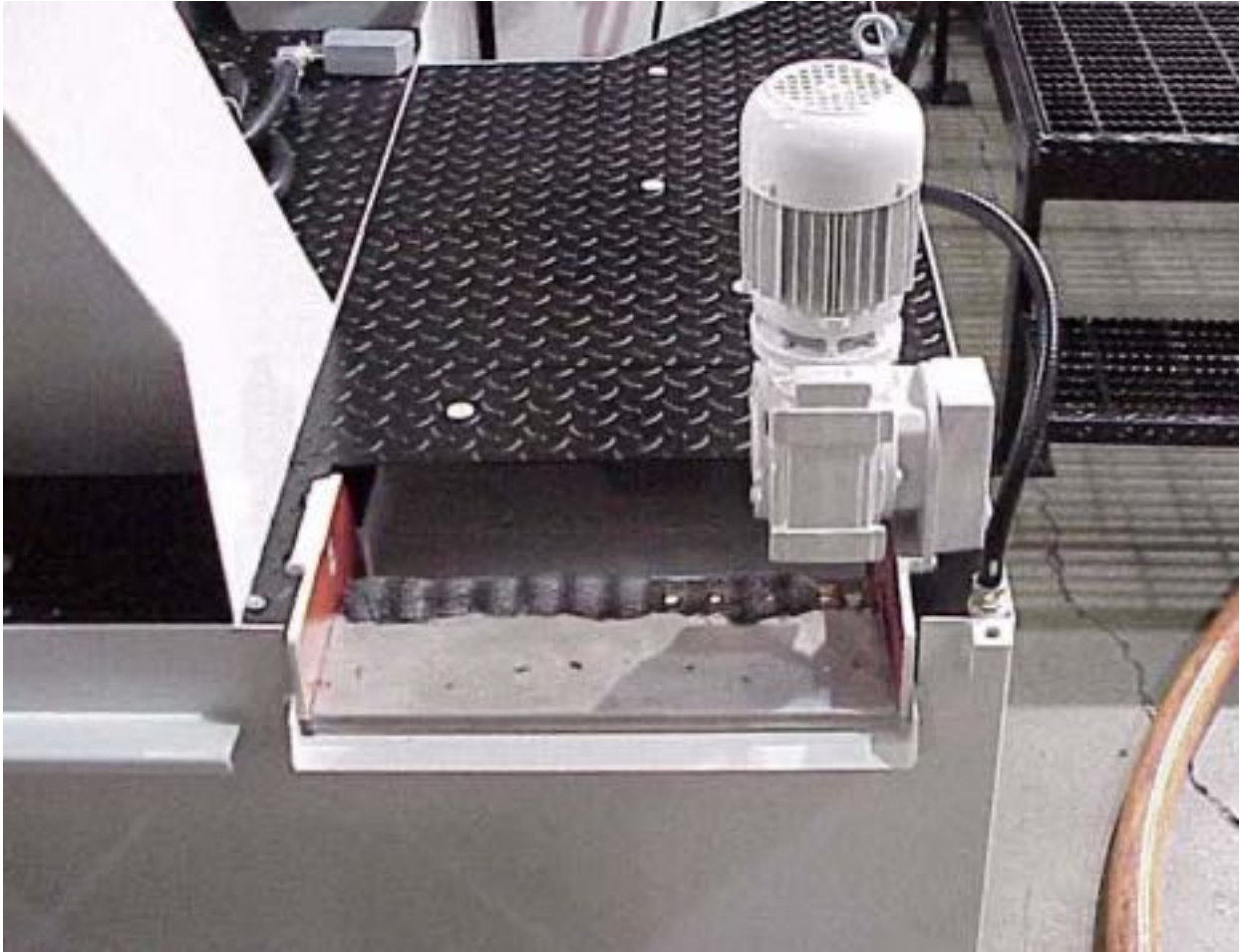

**Magnetic Filter System**

## INSTALLING THE CHIP CONVEYOR SCRAPER BELT

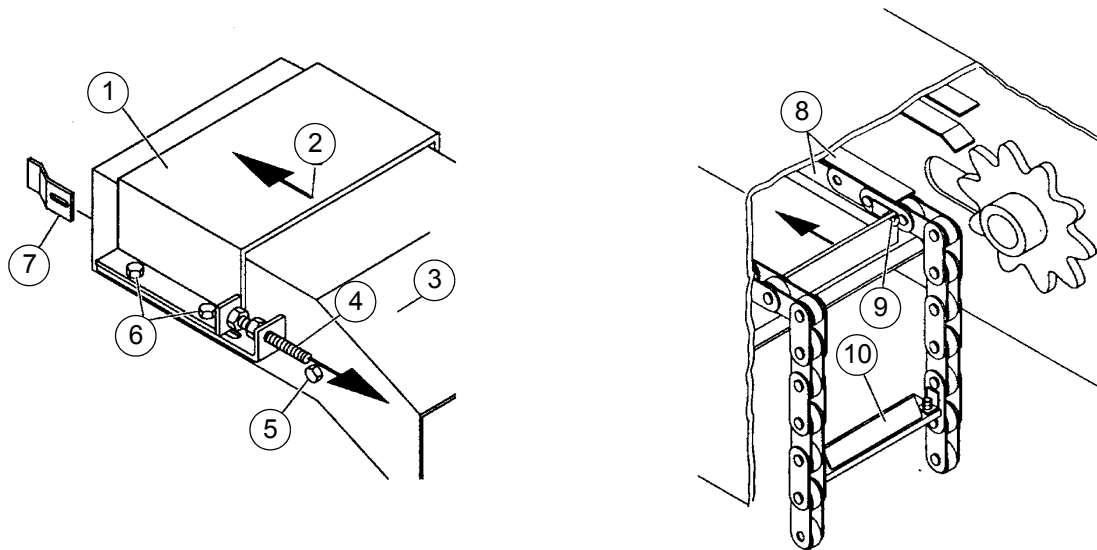

### CAUTION

- Recommended only for small or short scraper belts.
- Two or more persons are required to draw in the scraper belt depending on its size.

1. Remove covers (3) at the top of the container.
2. Loosen the fastening screws (6) on both sides of the gearing end frame, but do not remove completely.
3. Loosen the clamping bolts (4) on both sides of the gearing end frame and turn back completely in the direction of the arrow.
4. Loosen the fastening screw (5) on both sides of the chain wheel cover (7).
5. If installed: loosen drive shaft cover.
6. Push the gearing end frame (1) in the conveying direction to the stop (2).
7. Insert the scraper belt between the guide bars (8), approximately 1 meter (39") into the scraper conveyor.

- NOTE:**
- The fastening screws (9) of the broach bars must be at the top.
  - The reinforcing angles (10) of the broach bars point towards the guide sprocket wheel (opposite to the conveying direction)



### WARNING: DANGER OF INJURY DURING THE FEEDING PROCESS!

- Never touch movable parts of the scraper conveyor by hand.
- Do not pull or push the scraper belt without suitable devices.

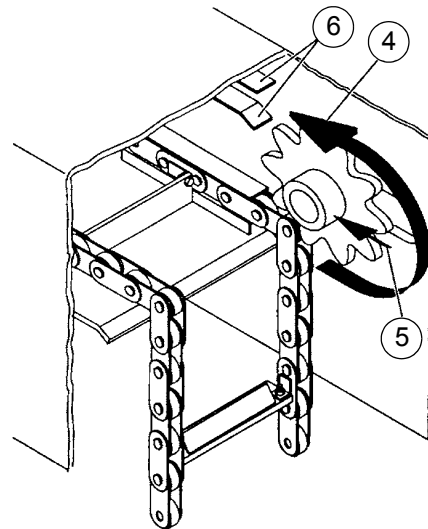
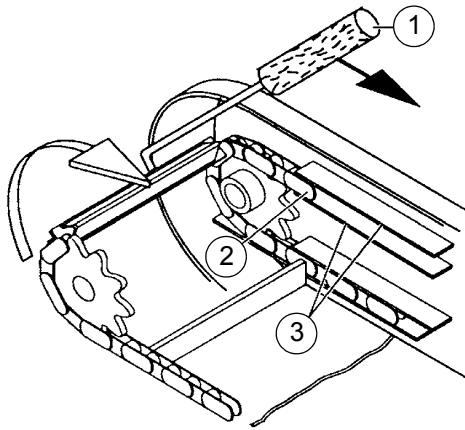

8. Insert scraper belt with hook (1) or suitable device up to the guide sprocket wheel.
9. Pull scraper belt around the guide sprocket wheel.
10. Insert scraper belt (2) between the upper guide bars (3) to approx. 1 m before the drive shaft.
11. Push the gearing end frame in the direction of the guide bars to the stop (5).
12. Insert conveyor chains in teeth of the driving chain wheel (4) and push the end of the scraper belt between the upper guide bars (6) into the container.

### ASSEMBLING THE SCRAPER BELT

1. Connect the ends of the bush conveyor chains with each other by means of the shackle type connectors (2).
2. Mount the cover plate (4) on the inserted shackle type connectors.
3. Insert the split-pin.

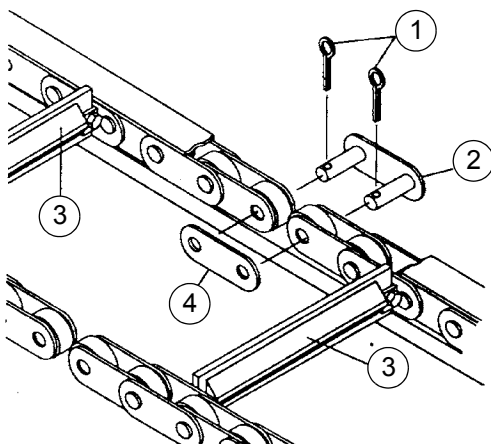

**NOTE:** The pins of the shackle type connectors (2) point to the inside. Remove the first broach bar respectively (3) to assemble the shackle type connectors.

## SETTING THE CONVEYOR BELT TENSION

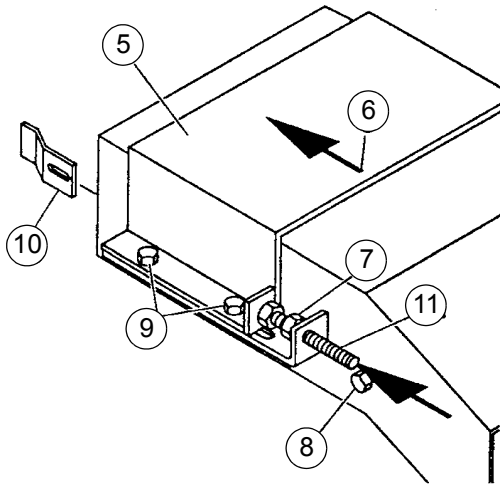

**NOTE:**

- Do not jam the gearing end frame.
- Apply tension gradually on both sides.

1. Loosen the fastening screws (9) on both sides of the gearing end frame, but do not remove completely.
2. Loosen the fastening screws (8) on both sides of the chain wheel cover (10), and, if necessary the fastening screws on the drive shaft cover.
3. Loosen the lock nuts (7) on both sides of the clamping bolts.
4. Screw in the clamping bolts (11) evenly in the direction of the arrow on both sides.
5. Tighten the lock nuts of the clamping bolts.
6. Tighten the fastening screws (9) on the gearing end frame.
7. Adjust the covers previously loosened at the same proportion as the gearing end frame and tighten.

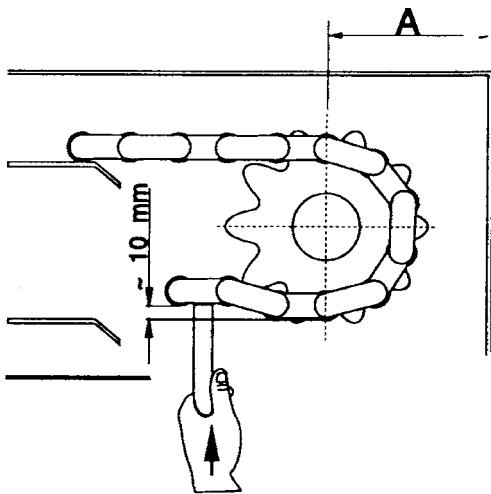

**NOTE:**

- The scraper belt must give approximately 10mm at moderate pressure from below.
- Distance "A" must be the same on both sides.

## ADJUSTING THE CONVEYOR DRIVE SHAFT

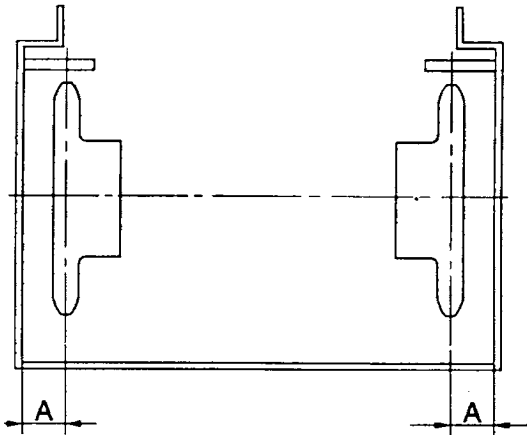

**NOTE:** Only necessary if distance “A” is not the same on both sides.

1. Loosen the axial shaft locks on both sides of the drive shaft bearings.
2. Move the chain wheels with the shaft in an axial direction until distance “A” is the same on both sides.
3. Fasten the axial shaft locks on both sides.

## CHANGING THE BROACH BARS

1. Loosen and remove the lock nuts (1) on both sides.
2. Remove the hexagon head screw (2) on both sides.
3. Remove the broach bar (4).
4. Insert the new broach bar. Note the direction for installation.
5. Screw in the hexagon head screw.
6. Loosen the hexagon head screw about half a turn and fasten in this position.
7. Install and tighten lock nut (1).

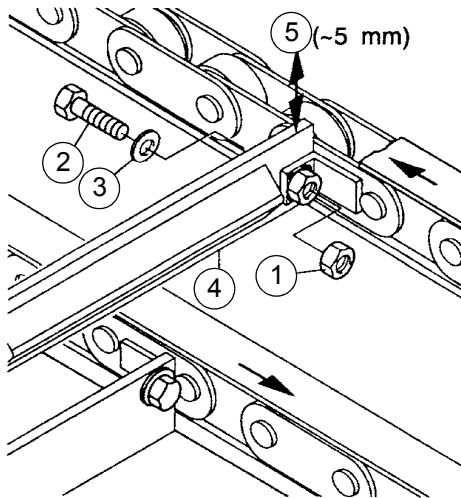

**NOTE:**

- Do not tighten the broach bar at the holding angle.
- The broach bar must be approximately 5mm movable in the oblong holes (5).



## 5. Coolant Oil Filter System

### KNOLL VACUUM ROTATION FILTER VRF500 (OPTIONAL)

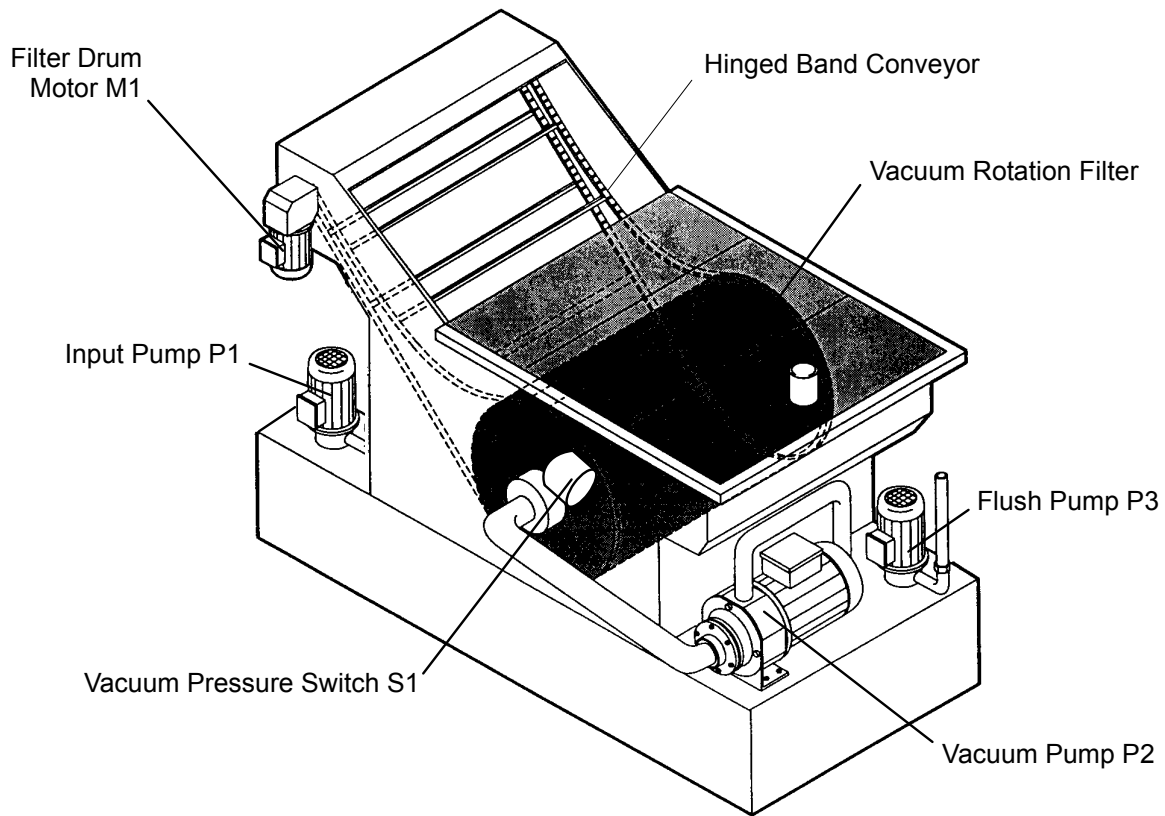

#### FUNCTIONAL DESCRIPTION

Dirty coolant is pumped into the entry tank of the vacuum rotation filter (Input Pump P1). The filter drum is completely submerged into the coolant and builds the vacuum chamber.

The vacuum pump (Pump P2) pumps the coolant from the inside of the filter drum to the clean media tank. The resulting vacuum condition draws the coolant inside the drum. The filter mesh screen holds the fines back and filters the coolant.

The vacuum inside the drum increases as the fines are deposited on the outside of the filter drum.

The filter drum motor (Motor M1) starts and rotates the filter drum as soon as the preset vacuum pressure of the vacuum pressure switch (Switch S1) is reached. The deposited fines on the filter drum outside are flushed off during the rotation of the filter drum. (Flush Pump P3). The hinge band scraper removes the flushed fines out of the tank.

## VACUUM FILTER CYCLE TIMES AND SETTINGS

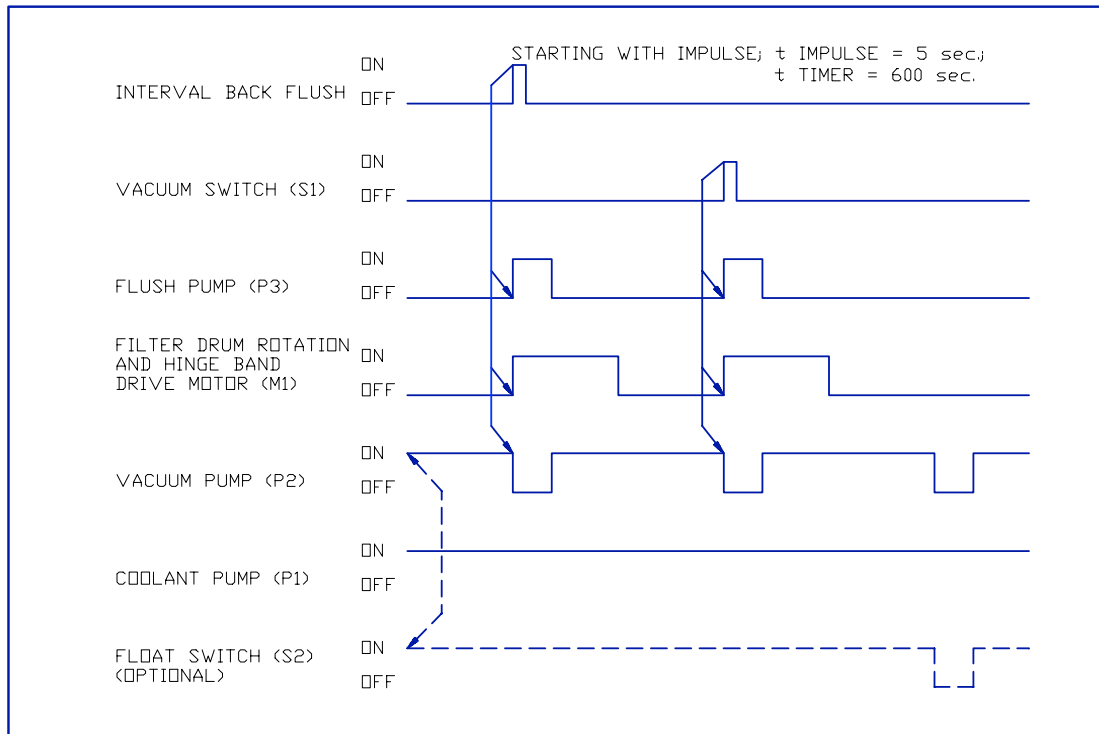

Setting	Cycle Time
Filter Drum Rotation and Hinge Band Scraper Motor (M1)	On Cycle 35 sec.
Vacuum Pressure Switch Setting (S1)	-0.15 bar
Coolant Pump (P1)	Stays ON All the Time
Vacuum Pump (P2)	Stays ON Except During Flush (OFF Cycle 5 sec.)
Flush Pump (P3)	ON cycle 5 sec.

## SYSTEM BACKFLUSH CONTROL FACTORS

Setting	Cycle Time
1. Interval Backflush	Every 600 sec. (10 min.) or When S1 Closes, Flush Cycle for 5 sec. Duration
2. Switching of Vacuum Pressure Switch (S1)	Flush Cycle for 5 sec. Duration

## 5. Coolant Oil Filter System

### VACUUM FILTER SEQUENCE DESCRIPTION

Receive back flush start impulse by:

A. Interval back flush (every 600 sec.)

or

B. Vacuum pressure switch (SI) contact

1. Stop vacuum pump (P2) for duration of 5 sec. - afterwards re-start the pump (P2).
2. Start back flush pump (P3) for duration of 5 sec. - afterwards stop the pump (P3).
3. Start filter drum rotation drive motor (MI) for duration of 35 sec. - afterwards stop the motor (MI).
4. The coolant pump (PI) is "ON" during the entire cycle.

**NOTE:** The above listed sequence, settings and timings might be altered to improve filtration process for special applications.

### CLEANING THE SIEVE DRUM

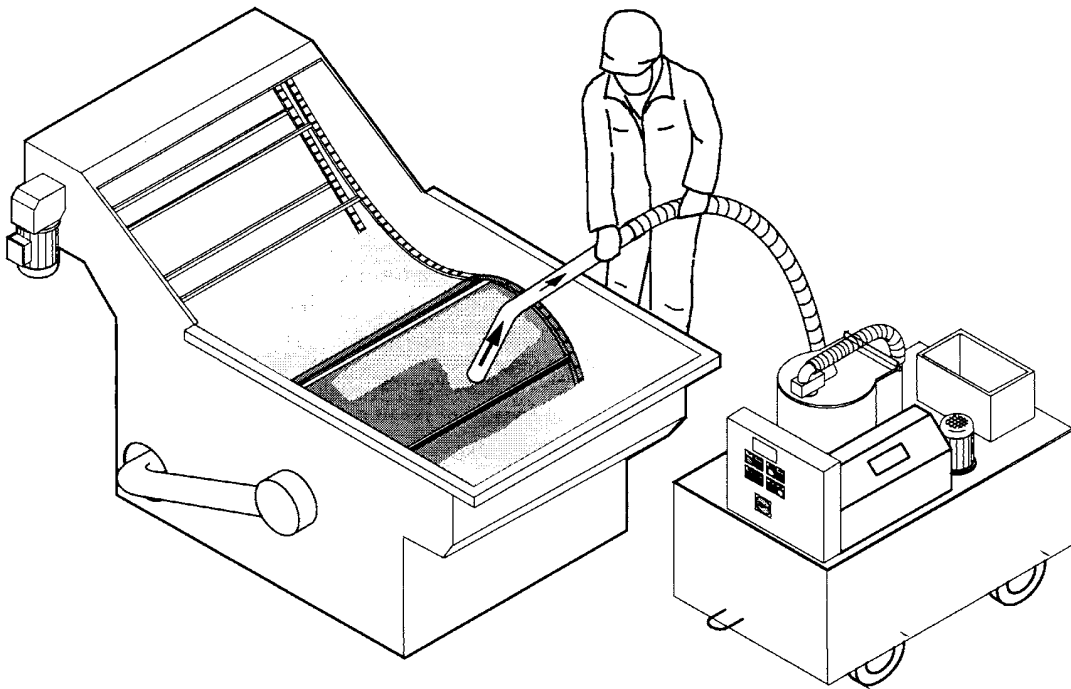

#### **WARNING!**

**During the cleaning process the machine power must be switched off.**

## REMOVAL / INSTALLATION OF THE VACUUM FILTER DRUM

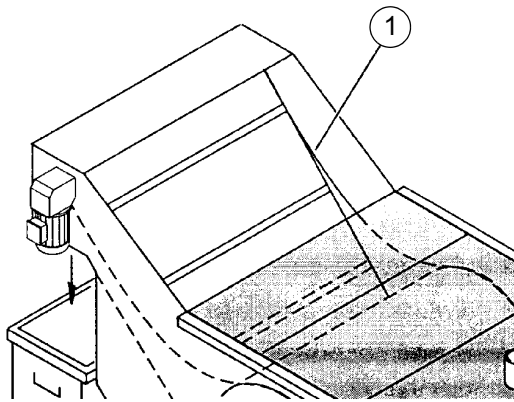

**NOTE:** The sieve drum is installed accordingly in the reverse sequence.

1. Switch equipment off and secure against accidental start-up (switch main switch off).
2. Remove tank lids.
3. Drain liquid from equipment.
4. Unscrew and remove the driving blades mounted at the drum circumference (index the drum in manual mode until all driver blades have been removed).

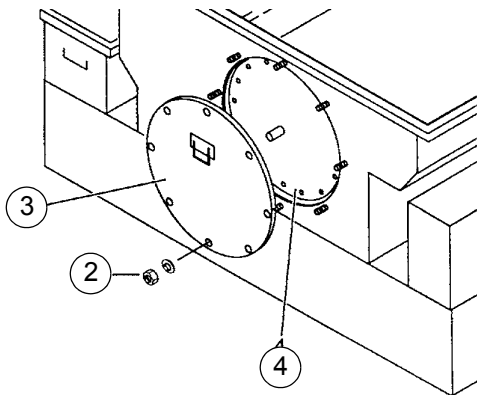

**WARNING: RISK OF INJURY!**

**Do not reach into the equipment when parts are moving or when the main switch is on.**

**NOTE:** Check bearing lid seal for damage, replace if required.

5. Switch equipment to manual operation; switch scraper belt drive on until the chain joints of the bush chain are visible and accessible at the top (1).
6. Switch equipment off and secure against accidental start-up (switch main switch off).
7. Fold stripper bar away from drum.
8. Open chain joints and remove scraper belt chain from the sieve drum (the chain need not be removed from the tank).
9. Remove the nuts (2) and pull the bearing lid straight from the drum.
10. Unscrew and remove the sieve drum lid (4).
11. Dismantle the rinsing pipe in the drum at the screwed connection and remove the pipe.
12. Check the holes of the rinsing pipe for soiling and clear, if required.
13. Remove the complete drum assembly from the housing.
14. Clean and check seals and bearings inside the drum, replace, if damaged.

### VACUUM FILTER ADJUSTMENTS

1. Set the vacuum pressure switch (3). This is accomplished by removing the black knob from the back side of the gauge and inserting it into the gauge front and adjusting for **-0.15 bar**. This is the pressure that the back flush cycle will be initiated by the PLC.

**NOTE:** The Vacuum Pressure Switch Gauge (3) will read zero when the drum is clean.

2. Turn on the vacuum filter (turn on coolant) and check the level of the dirty coolant in the drum reservoir. The dirty coolant should just spill into the overflow (1), completely submersing the vacuum drum.
3. To set the volume of dirty coolant from pump (2), adjust the flow control (8) until the dirty coolant level is high enough to flow into overflow (1). The flow through the flow control is increased by screwing its adjusting sleeve out (+) and decreased by adjusting the sleeve in (-).
4. Set the output volume from the vacuum pump (9), by adjusting the flow control (5) for **0.6 bar** on gauge (4), this will give an output of 500 liters/min. of water soluble coolant or 350 liters/min. of oil, see chart (7). The gauge reading can be increased (lowers output volume) by screwing its adjusting sleeve in (-) and decreased (increases output volume) by adjusting the sleeve out (+).

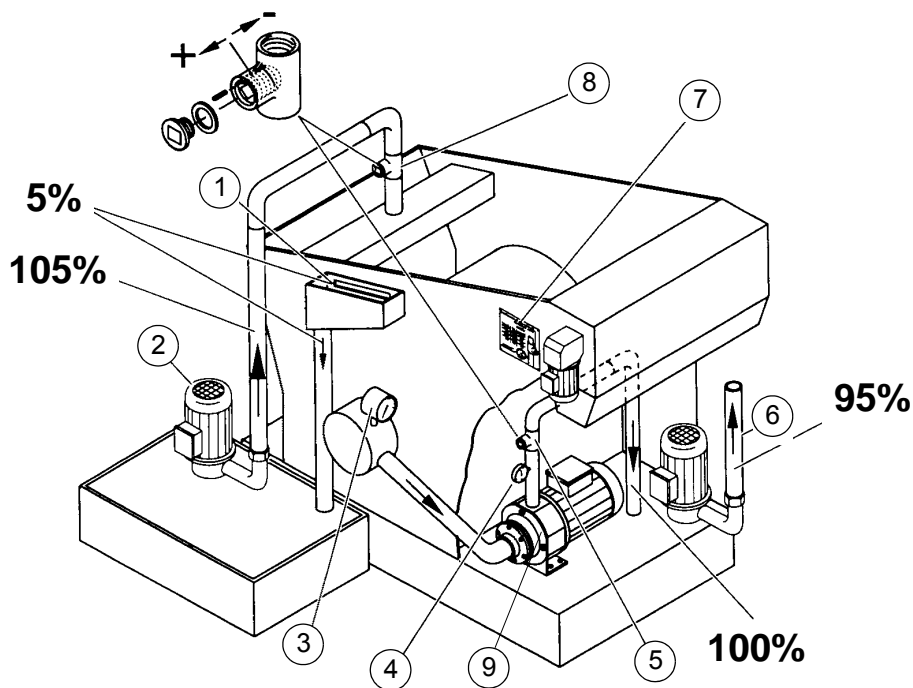

## VACUUM FILTER PREVENTIVE MAINTENANCE

Assembly/Component	Interval	Maintenance Work	Safety Instructions/Note
Sludge Container	1 Day	Drain Accumulated Liquid	
Pumps	-	See Manufacturers Operating Instructions	
Electrical Equipment • Motor(s)	-	See Manufactures Operating Instructions	
• Wiring	3 Months	Check For Breakage and Damage	Replace Defective Wiring.
• Filling Level Switch	3 Months	Check Function	Cross Both Switching Positions in Manual Operation.
• Safety Equipment	3 Months	Check Function	
Tanks and Piping	6 Months	Check For Leakage, Corrosion and Damage	Hazardous Materials Must Not Escape Under Any Circumstances.
Scraper Strips	6 Months	Check Plastic Insert For Wear	Replace Worn Inserts.
Sieve Drum	1 Month	Check For Wear and Damages, Then Clean.	Disassemble Drum in Case of Wear or Damages and Return it to the Manufacturer for Replacement.
	1 Year -	Change Sieve Drum if Necessary. Clean Tissue (Clean Tissue With Vacuum Cleaner or From the Inside Using a High Pressure Cleaner).	Cleaning Interval Depends on Type of Swarf/Chips and Coolant. Outside Influences May Damage the Filter Material.
Piping	1 Year	Disassemble, Clean, and Check (For Wear) the Return/Shut-Off Traps and Valves. Clean Sludge Filter of the Hose Assembly and Strainer Basket.	Switch Equipment Off, Relieve Piping From Pressure, Cooling Lubricant Off, Lower Piping, Operate Shut-Off Valve if Necessary, Replace Defective Parts.
Coolant Tanks/ Float Switch	500 hrs	Check for Contamination (Sludge Deposits) and Clean if Required.	Depending on the Tooling Method, the Interval May be Significantly Shortened. Coolant Tanks Are Extras and Thus not Installed in Every Equipment.
Manometer	-	Open Stop Valve Only for Measuring Process.	Useful Life of Manometer Increased.

## 5. Coolant Oil Filter System

### VACUUM FILTER TROUBLE-SHOOTING

Disturbance	Possible Causes	Remedy
No or Insufficient Reverse Flow Rinsing.	Contact-Making Vacuum Pressure Gauge Defective.	Replace Gauge
	Fill Level in Clean Water Tank Too Low.	Refill Liquid
	Holes in the Rinsing Nozzle of the Sieve Drum Obstructed.	Open and Clean Sieve Drum
	Fill Level in Rinsing Pump Tank Too Low.	Refill Liquid
Safety Clutch Slips (Loud Rattling Noise).	Coarse Parts Block the Equipment.	Remove Parts
	Safety Clutch Defective.	Replace Clutch
No Chip/Swarf Discharge.	Amount of Chips/Swarf Too High.	Reduce Discharge Cycle Time
Insufficient Cleaning Performance or Very Short Reverse Flow Rinsing Cycle. (<2 min)	Filter Tissue Clogged or Clotted.	Clean Tissue Surface With Vacuum Cleaning Device or From the Inside Using a High Pressure Cleaner. The Normal Reverse Flow Rinsing Cycle Ranges From 2-5 Minutes. Reverse Flow Rinsing Cycles <2 Minutes May Cause Damages at the Slush Pump.

## TURMOIL COOLER (OPTIONAL)

Model OC-1000 IL is a completely packaged In-Line type oil cooler with the total capacity to remove 125,000 BTU/HR while cooling oil flowing at 40 GPM (minimum) and 250 PSI (maximum) to 75°F. The cooler is supplied with a combination Set-Point/Ambient Tracking (CTC/ATC) type digital temperature controller, a stainless steel brazed plate type evaporator/heat exchanger, and a Low Flow switch. The cooler consists of a 10 HP, air cooled, condensing unit with full controls for automatic operation including a High/Low pressure switch, fan pressure switch, hot gas bypass valve and thermostatic expansion valve. The cooler is wired for 460/60/3 with a 115/60/1 control circuit and is supplied with a NEMA-12 electrical enclosure with a rotary disconnect switch. All is housed in a painted steel cabinet supplied with mounting skid, lifting pad eyes and aluminum air intake filters.



**Turmoil Cooler**



### **WARNING!**

**Do not attempt to start up this cooler until you have read through the instructions completely. Improper start-up will void the cooler warranty and damage the machine.**



## 5. Coolant Oil Filter System

### UNCRATING & INSPECTION

Rough handling during shipment may cause obvious and/or concealed damage. Upon arrival, the cooler should be inspected carefully and claims for damage must be filed immediately with the trucker.

When uncrating the cooler, inspect it thoroughly for signs of concealed damage. Coolers that have been dropped or shipped on their side may not show external damage. If damages are found, a claim must be filed with the carrier within 30 days of delivery.

The cooler is shipped fully charged with refrigerant and ready for operation. The cooler has been run for at least 4 hours under full load conditions before shipment. The Refrigerant DISCHARGE and SUCTION pressure gauges on the front panel should show a pressure reading of approximately 100 PSIG. If the pressure gauges show no pressure reading then the cooler most likely has **concealed damage** and has lost its charge of refrigerant. A qualified refrigeration mechanic should be called in to check for leaks.

### COOLER PLACEMENT

Place the cooler in a level location where it is accessible from the front and with enough room to make electrical and hose connections. Access for service is from the right side. The cooler will draw air in through the air filters on the left side and rear panels and will exhale air through the top. It is imperative that these vents remain open to permit the free movement of air (a minimum of two feet of open space on air intake and discharge sides).

### DESCRIPTION

Model OC-1000 IL is a completely packaged In-Line type oil cooler with the total capacity to remove 125,000 BTU/HR while cooling oil flowing at 40 GPM (minimum) and 250 PSI (maximum) to 75°F. The cooler is supplied with a combination Set-Point/Ambient Tracking (CTC/ATC) type digital temperature controller, a stainless steel brazed plate type evaporator/heat exchanger, and a Low Flow switch. The cooler consists of a 10 HP, air cooled, condensing unit with full controls for automatic operation including a High/Low pressure switch, fan pressure switch, hot gas bypass valve and thermostatic expansion valve. The cooler is wired for 460/60/3 with a 115/60/1 control circuit and is supplied with a NEMA-12 electrical enclosure with a rotary disconnect switch. All is housed in a painted steel cabinet supplied with mounting skid, lifting pad eyes and aluminum air intake filters.

### PLUMBING HOOK-UP

Make hose connections to the 1-1/2" MPT fittings located on the lower right side of the front panel tagged "INPUT" and "DISCHARGE". Flow will be out the DISCHARGE connection. The cooler is designed to cool a clean light oil flowing at 40 GPM (minimum).

### ELECTRICAL HOOK-UP

See the wiring diagram attached. Make power connections to the terminals provided on the disconnect switch in the NEMA-12 electrical enclosure. The supply voltage must be within  $\pm 10\%$  of the rated voltage on the Turmoil tag. Connect ground to the grounding terminals provided. Make electrical connections for High Temperature Interlock to terminals #20 & #21. Make electrical connections for Low Flow Interlock to terminals #22 and #23. The contacts across both interlocks will open on fault. Check for loose wires.

## 5. Coolant Oil Filter System

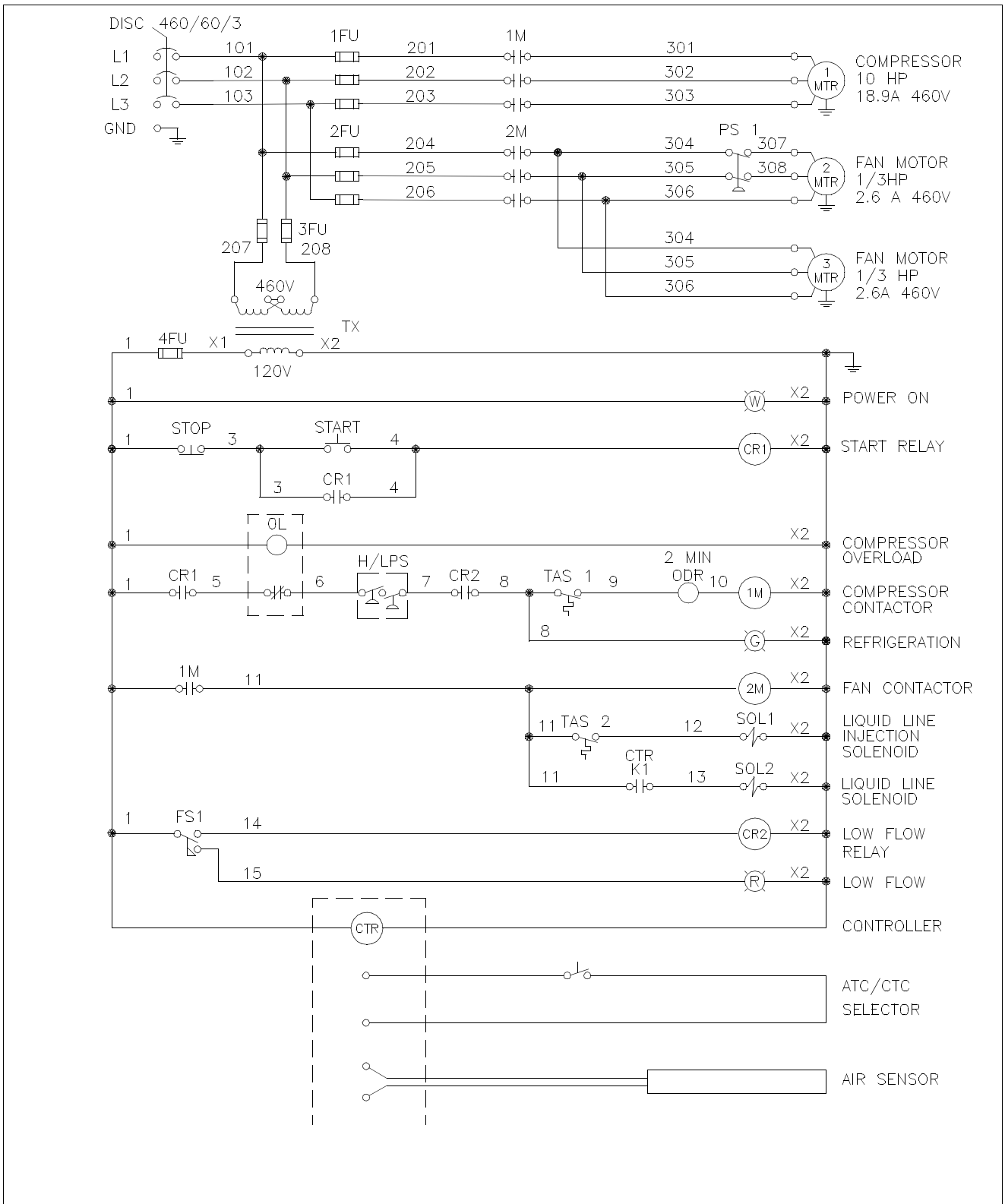

	<h3 style="margin: 0;">OC-1000 IL</h3> <h3 style="margin: 0;">WIRING DIAGRAM</h3> <p style="margin: 0;">SHEET 1 OF 2</p>	<p style="margin: 0; font-size: small;">735 West Swanzey Road West Swanzey, NH 03469</p>			
<table border="1" style="width: 100%; border-collapse: collapse;"> <tr> <td style="width: 33%;">BY: MAL</td> <td style="width: 33%;">DATE: 11/1/01</td> <td style="width: 33%;">REV C</td> </tr> </table>	BY: MAL	DATE: 11/1/01	REV C		
BY: MAL	DATE: 11/1/01	REV C			

HYDRAMAT OC-1000 IL ELEC REV C

## 5. Coolant Oil Filter System

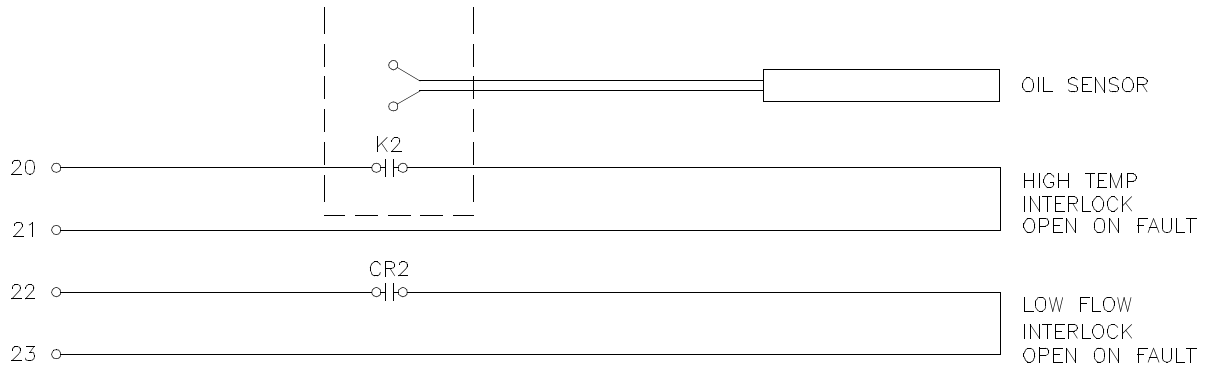

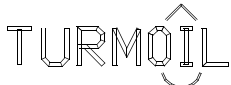
			OC-1000 IL WIRING DIAGRAM	 735 West Swanzezy Road West Swanzezy, NH 03469
BY: MAL	DATE: 11/1/01	REV C	SHEET 2 OF 2	

HYDROMAT OC-1000 IL ELEG REV C

### FLOW SWITCH

The OC-1000 IL is supplied with a flow switch to prevent damage if oil flow is substantially reduced. The switch contacts open if the oil flow drops below approximately 20 GPM, shutting off the compressor and condenser fans. The minimum suggested flow rate through the cooler is 40 GPM. Lower flow rates may significantly reduce the cooler capacity.

### TEMPERATURE CONTROLLER

The cooler is supplied with a digital temperature controller mounted on the door of the electrical enclosure. See the attached instruction sheet for operating this controller. A selector switch on the control panel tagged CTC/ATC sets the controller to respond as a Set Point controller (CTC) or as an Ambient tracking Controller (ATC).

The CTC setting works to maintain the oil temperature within  $\pm 0.5^\circ\text{F}$  of the adjustable set point. The controller will alternate flashing the set point temperature (S) and the actual temperature (F). The OIL sensor is installed in the INPUT line and is effectively sensing the oil sump temperature.

The ATC setting works to maintain the oil at an adjustable temperature differential relative to a fluctuating ambient temperature. The AIR sensor is mounted on the bottom of the electrical enclosure. The OIL sensor is in the INPUT line and is effectively sensing the sump oil temperature. The controller will alternate flashing the ambient temperature and the oil INPUT temperature.



**Turmoil Cooler Control Buttons**

## 5. Coolant Oil Filter System

### START-UP

Once the cooler has been installed and the proper plumbing and electrical connections have been made, it can be powered-up by turning the disconnect switch to the ON position. The white POWER ON light located on the front panel will energize as will the red LOW FLOW light if there is no or too little oil flow through the cooler. When there is at least 20 GPM oil flow through the cooler, the red LOW FLOW light will go out. The cooler will not start if the red LOW FLOW light is on.

If there is adequate oil flow through the cooler and the red LOW FLOW light is out, the cooler can be started by pressing the green START button. The green REFRIGERATION light will energize. The compressor is protected from short cycling by a three minute ON-DELAY RELAY. When the compressor and fan come on, check the fan rotation. The fan should be drawing air from inside the cabinet and blowing it upwards. If the fan is rotating in the wrong direction, exchange any two of the power leads to the cooler.

**Upon start-up check immediately that the compressor has the correct rotation.** (see page 5 of the attached Copeland Application Bulletin) Scroll compressors are directional dependent; i.e. they will compress in one direction only. Three phase scroll compressors will rotate in either direction depending on power phasing. Verification of proper phasing can be made by observing that the suction pressure drops and discharge pressure rises when the compressor is energized. Additionally, if operated in reverse, the compressor is noisier and its current draw is substantially reduced when compared to tabulated values. Although operating the Scroll compressor in the reverse direction for brief periods of time is not harmful, continued operation could result in failure.

The fan and compressor motors were synchronized at the factory. If the fans are blowing up, the compressor should be rotating correctly.

### OPERATION

If there is sufficient oil flow through the cooler and the red LOW FLOW light is out, start the cooler by pushing the green START button. The green REFRIGERATION light will come on and then the compressor and at least one fan will come on (after the 2 minute on-delay relay times out) and run continuously. The second condenser fan is pressure operated and will come on as the refrigerant head pressure increases. This fan will cycle to maintain a fairly constant head pressure.

Set the temperature controller to the desired oil temperature. When the controller is calling for cooling, the solenoid valve on the liquid line is open and refrigerant flows through the expansion valve to absorb heat and evaporate in the stainless steel plate type evaporator/heat exchanger. When the controller is calling for heating, the liquid line solenoid valve closes and the flow of refrigerant through the expansion valve stops. The compressor continues run, pumping refrigerant out of evaporator causing the suction pressure to drop. When the suction pressure drops to about 45 PSI the hot gas bypass regulating valve opens allowing hot refrigerant gas into the evaporator. This hot gas is cooled by the oil being pumped through the evaporator. When the controller calls for cooling again, the liquid line solenoid valve opens and liquid refrigerant again flows through the expansion valve into the evaporator where it evaporates as it absorbs heat, raising the suction pressure.

Adjust the controller to the desired setting. The cooler is now ready for continuous operation.

### SAFETY INTERLOCKS

#### High/Low Pressure Switch (Refrigerant)

The compressor is protected from excessively high discharge pressure or low suction pressure by a High/Low pressure switch (H/L PS) mounted inside the cabinet. High head pressure can be caused by a dirty condenser or by too little air flow through the condenser. Low suction pressure can be caused by loss of refrigerant charge, operating at too low an outlet temperature, a faulty solenoid valve, or too little flow of oil through the evaporator.

The High/Low Pressure Switch is factory set as follows:

Head Pressure - Cut Out	350 psi
Low Pressure - Cut In	55 psi
Differential	30 psi

If the cooler shuts down on the Low Pressure switch, it will come back on if the pressure builds back up to the Cut In setting. If the cooler continuously cycles on the Low Pressure switch, it most likely is operating at too low of an oil temperature or flow, or has a low refrigerant charge.

If the cooler shuts down on the High Pressure switch, it will stay off until the blue reset button on the High Low pressure switch is pushed in. If the cooler goes out on High Pressure, most likely the condenser or the condenser filter is clogged or blocked.

#### High Temperature Alarm

This cooler has a High Temperature interlock warning built into the temperature controller. See the ATC/CTC controller instructions attached. If the oil temperature entering the cooler is higher than the High Temperature setting, the cooler will continue to run but the contacts across terminals # 20 and #21 will open.

#### Fan Pressure Switch

The cooler is provided with a fan pressure switch. The switch will cycle the second fan motor to maintain a relatively constant head pressure. The fan will generally only cycle the fan off if the ambient temperature is low (around 65°F or lower).

The Fan Pressure Switch is factory set as follows:

Cut-In:	250 psi
Differential:	80 psi

#### Low Flow

The cooler is supplied with a Low Flow switch mounted in the DISCHARGE line. When the oil flow drops below 20 GPM, the compressor and fans shut down, the red LOW FLOW light comes on and the contacts across terminals #22 and #23 will open.

#### Low Temperature Thermostat

The cooler is supplied with a Low Temp thermostat mounted behind the lower front panel. This thermostat senses the temperature of the oil entering the cooler and shuts down the compressor if the incoming oil temperature is lower than the setting. This thermostat should be set at a temperature approximately 5°F lower than the controller setting.

## **5. Coolant Oil Filter System**

### **MAINTENANCE**

Each cooler is thoroughly tested and inspected before it leaves the factory. However, in order to obtain efficient service and long life from this cooler, it must be given proper care as with any other piece of mechanical equipment.

#### **Air Filters**

Keep Clean.

#### **Condenser**

Condenser fins should be cleaned of dust and dirt regularly.

**6. PENDANT CONTROL - EPIC R/T HYDROMAT**

PENDANT CONTROL FOR EPIC R/T HYDROMAT - GENERAL DESCRIPTION .....	6-1
HUMAN MACHINE INTERFACE (HMI) CONTROLLER .....	6-3
1. STATUS INDICATORS .....	6-3
2. CYCLE TIME .....	6-4
3. PART COUNT .....	6-4
4. INDICATOR LIGHTS .....	6-5
5. STATUS .....	6-5
ACTIVE UNITS .....	6-6
UNIT SETTINGS .....	6-7
PROGRAMMING SCREEN - PMAC .....	6-9
PMAC STATS SCREEN .....	6-11
PROGRAMMING SCREEN - BOSCH .....	6-13
ADVANCED MENU SCREEN .....	6-15
BOSCH AXIS PARAMETERS SCREEN .....	6-17
PMAC AXIS PARAMETERS SCREEN .....	6-18
JOG SINGLE AXIS BOSCH SCREEN .....	6-20
JOG MULTI-AXIS PMAC SCREEN .....	6-21
6. CHANGE PART .....	6-23
LOAD PROGRAM .....	6-24
7. DIAGNOSTICS .....	6-25
8. OPERATOR ACTIVE / CLEAR ACTIVE PASSWORD .....	6-25
9. CALCULATOR .....	6-25
10. MACHINE CONTROL KEYPAD .....	6-26
MAIN MENU .....	6-27
AIR, LUBE, AND HYDRAULICS CONTROL .....	6-28
CHIP CONVEYOR .....	6-29
CHIP CONVEYOR OPTIONAL EQUIPMENT .....	6-30
CYCLE TIMES .....	6-31
DIGITAL I/O .....	6-32
INVERTER .....	6-33
LOADING - BARFEEDER .....	6-34
LOADING SETUP .....	6-35
BUNDLE BARFEEDER .....	6-37
LOADING - PART LOADER (OPTIONAL) .....	6-38
PART TRACKING .....	6-39
PART AND BATCH COUNTERS .....	6-40
PASSWORDS .....	6-41
TABLE .....	6-43
UNIT INSTALLATION .....	6-44
PROGRAMMING A PART .....	6-48
SINGLE AXIS .....	6-48
TWO AXIS .....	6-52
MOTION PROGRAM COMMAND SUMMARY .....	6-58
G-CODE .....	6-58
M-CODE .....	6-59
MISCELLANEOUS COMMANDS .....	6-60
DEFAULTS .....	6-60
MOTION PROGRAM COMMAND DETAILS .....	6-61
G-CODE .....	6-61
M-CODE .....	6-67
CHANGING THE CONTROL MODE .....	6-69
RESTORING A BACKUP PLC PROJECT INTO AN EPIC MACHINE .....	6-70
HOW TO EMPTY THE FULL MACHINE OF PARTS FOR SHUTDOWN .....	6-72
LOADING THE MACHINE WITH PARTS .....	6-72
PENDANT LIGHT INDICATIONS .....	6-73



## PENDANT CONTROL FOR EPIC R/T HYDROMAT

### PENDANT CONTROL FOR EPIC R/T HYDROMAT - GENERAL DESCRIPTION

This Chapter is intended to provide the Hydromat Machine operator with a safe and productive operation of the Machine.

Before attempting to perform any Setup or Production the operator should familiarize them self with the purpose and function of all the pendant pushbuttons. Failure to do so could result in injury or damage to Tooling and Machine Units.

Immediately notify your company Maintenance Dept. of any malfunctioning touchscreen pushbuttons for repair before operating or resuming Production.

Chapter 13 contains a description of the troubleshooting procedures.

Call, Fax, or e-mail the Hydromat Service Dept. with any questions or comments regarding this procedure. See contact listing at the front of this manual.



**Pendant For EPIC R/T Hydromat**

## **6. Epic Pendant Control**

### **1. Human Machine Interface (HMI) Controller**

The touchscreen area of the pendant allows the operator to completely control the EPIC Hydromat.

### **2. Spindle / Coolant Off**

Turns off the Spindle Motors, Coolant Pumps, and Chip Conveyor Motor. If the Machine is in AUTOMATIC mode and the “SPINDLE/ COOLANT OFF” button is pressed, all the Toolspindles immediately return to their Home position without completing the machining cycle. At this point, before indexing the Table and/ or placing the Machine in the AUTOMATIC mode, the “UNITS” function must be activated to complete the machining cycle that was interrupted.

### **3. Release / Jog**

Pushbutton opens and closes all the collets in the Rotary index table for inserting and removing the workpieces. The Table must be in the 1/2 INDEX position. Refer to Setup Mode screen.

### **4. Automatic Off**

Turns off the AUTOMATIC cycle function. The current cycle is completed and the units return home before AUTOMATIC OFF becomes active.

### **5. Emergency Stop**

The Hydraulic Pump and the whole Machine shuts off. If this button is pressed during operation, the Toolspindles return immediately, without completing their current operation, and the table collets open.

### **6. LCD Display Adjustments**

- a. Auto - Resets the adjustments to the standard settings.
- b. Sel - Controls the settings for brightness, contrast, position, information, and all reset.
- c. Left Arrow - Press to scroll up through menu choices.
- d. Right Arrow - Press to scroll down through menu choices.
- e. Exit - Press to exit from the menu.
- f. On/Off - Press to turn the LCD Display On or Off.
- g. Power On/Off Indicator - Green indicates LCD power is On and Amber indicates LCD power is Off.

## HUMAN MACHINE INTERFACE (HMI) CONTROLLER



### HMI Description

#### 1. STATUS INDICATORS

Indicators change colors to display the status of a particular area of the machine.

##### a. Emergency Stop

Blue - Power on.

Red - Emergency Stop.

Yellow - Warning.

Green - In automatic.

##### b. Fault State

Blue - Status message present.

Red - Major or instant fault.

Yellow - Delayed fault.

Green - No faults.

## 6. Epic Pendant Control

### c. Hydraulics

Blue - Hydraulics off.

Red - Major fault.

Yellow - Minor fault.

Green - Hydraulics started.

### d. Safety Covers

Blue - Safety Covers closed but unlocked.

Red - Fault.

Yellow - Safety Covers open.

Green - Safety Covers closed.

### e. Spindles

Blue - Spindles not running.

Red - Faulted.

Yellow - Open.

Green - Spindles running.

### f. Coolant

Blue - Coolant off.

Red - Faulted.

Yellow - Chip Conveyor on, coolant off.

Green - Coolant on.

### g. Table

Blue - Table down, not active.

Red - Faulted.

Yellow - Table and Units not in sequence or Table in Half Table and Collets open.

Green - Table is active.

### h. Units Home

Blue - Solid, Units home. Flashing, in process of returning home.

Red - Faulted.

Yellow - Solid Yellow indicates a Warning; i.e., Tool Counter expired.

Green - Units active.

## 2. CYCLE TIME

Displays the cycle time. Press to enter the Cycle Time screen.

## 3. PART COUNT

Displays the count of how many parts have been completed. After a run, the counter is resettable to zero. Press to enter the Part and Batch Counter screen.

#### 4. INDICATOR LIGHTS

The colored lights will light up solid or blink to show the status of a particular area of the Machine. These Indicator Lights match the Stack Lights on top of the Pendant Pole. See Pendant Light Indicators later in this chapter.

#### 5. STATUS

Press STATUS to show the status of all the Units and Collets/Chucks. The outer ring shows the status of the horizontal Units, the middle ring shows the status of the vertical Units, and the inner ring shows the status of the Collets or Chucks.

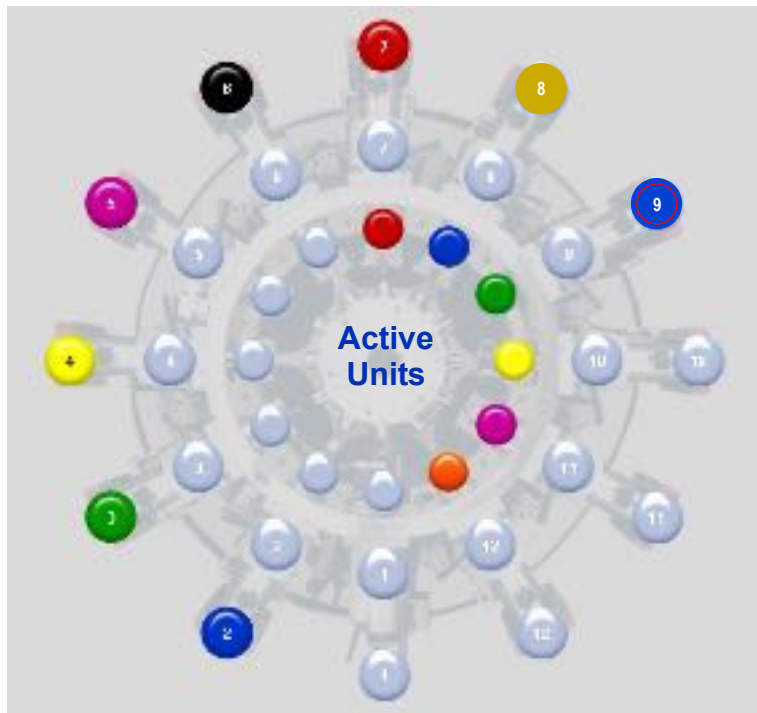

Status Screen

#### Units Color Key (Outer 2 Rings)

- Blue** - Unit is home and ready.
- Blue With Red Ring** - Unit is home and ready with part tracking turned off.
- Red** - Unit fault.
- Yellow** - Warning, remaining tool cycles are low.
- Green** - Unit is active.
- Violet** - Hold is active.
- Black** - Unit is off.
- Gold** - Homing/Send Programs.
- Gray** - No Unit attached.

#### Collet/Chuck Color Key (Inner Ring)

- Blue** - Collet/Chuck is open.
- Red** - Indexer or Chuck fault.
- Yellow** - Bad part present.
- Green** - Good part present.
- Violet** - Indexer is active.
- Orange** - Collet/Chuck is disabled.
- Gray** - Collet empty

## 6. Epic Pendant Control

### Active Units

Press Active Units in the center ring of the Status Screen to access the Active Units screen.

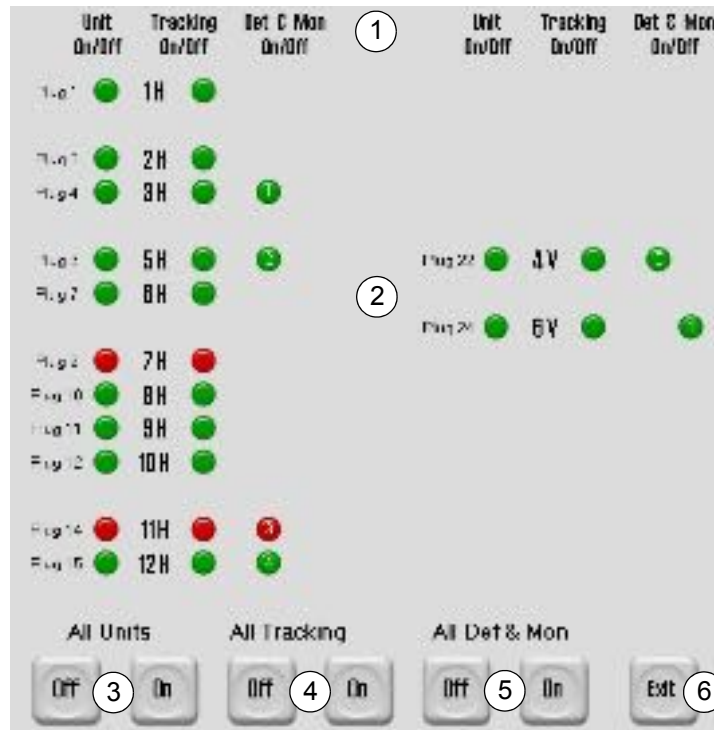

**Active Units Screen**

#### 1. Column Headings

Column Headings for the Active Units.

#### 2. Active Units Display

Displays which Units are active.

#### 3. All Units ON / OFF

Press the appropriate button to turn all Units On or Off.

#### 4. All Tracking ON / OFF

Press the appropriate button to turn all Tracking On or Off.

#### 5. All Det & Mon

Turns the Detectors and Monitors On or Off.

#### 6. Exit

Press to exit and return to the previous screen.

## Unit Settings

Click on a Unit colored circle in the middle (vertical) or outer (horizontal) ring of the Status screen to access the Unit Settings screen. Gray circle indicates no Unit present.

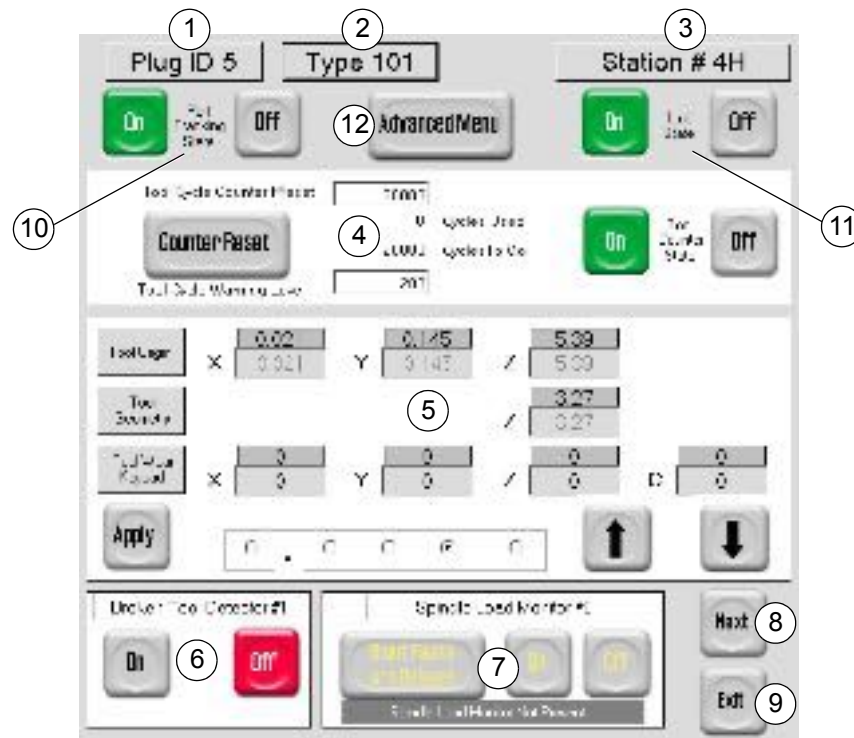

**Unit Settings Screen**

### 1. Plug ID #

Press to set Plug ID from 1-32 or to remove Unit. When pressing on a Unit circle at the Status screen, a message box will pop up if a Unit does not have a Plug ID defined.

### 2. Type #

Press to enter the Unit Type.

1-99 - Intelligent Bosch Control Valve, single axis.

100-199 - PMAC Controlled CNC Units, multi axis.

200-Above - Non Servo Units, ex., Inverter.

### 3. Station #

Press to display the Programming screen.

### 4. Tool Counter

This area is used to control the Tool Counter.

Tool Counter Preset - Enter total cycles required for the life of one tool

Cycles Used - Displays how many cycles used on one tool.

Cycles To Go - Displays cycles remaining.

## **6. Epic Pendant Control**

Tool Cycle Warning Level - Enter number for Tool Counter to show warning.

Counter Reset - Press to reset the Tool Counter to zero.

Tool Counter State - Press the appropriate ON/OFF button to turn the Tool Counter on or off.

## **5. Tool Origin, Geometry, and Wear Data**

Tool Origin - Press TOOL ORIGIN first, then you may change the data in the Origin Fields.

Tool Geometry - Press TOOL GEOMETRY first, then you may change the data in the Geometry Fields.

Tool Wear Keypad - Pressing TOOL WEAR KEYPAD brings up a keypad for entering values into the Tool Wear fields.

Apply - Applies the changes that have been made to the Tool Origin, Geometry, and Wear Data fields.

Quick Change Offset - Select appropriate decimal value to change.

Up Arrow - Increments current selected data field.

Down Arrow - Decrements current selected data field.

## **6. Broken Tool Detector**

Press the appropriate ON/OFF button to turn the Tool Detector on or off. Press on Broken Tool Detector # (text), a prompt will appear requesting which detector # is assigned to the Unit.

## **7. Spindle Load Monitor**

Press the appropriate ON/OFF button to turn the Spindle Load Monitor on or off.

Blunt Faults Are Instant - Press to toggle between Blunt Faults Are Instant and Blunt Faults Are Delayed.

## **8. Next**

Press to toggle between multiple Units on the same Station.

## **9. Exit**

Press to exit and return to the previous screen.

## **10. Part Tracking State**

Press the appropriate ON/OFF button to turn the Part Tracking on or off.

## **11. Unit State**

Press the appropriate ON/OFF button to turn the Unit on or off.

## **12. Advanced Menu**

Press to display the Advanced Menu screen that allows access to the Spindle Parameters, Axis Parameters, Jog, and IP Address screens. The appropriate screen will appear according to the Unit type.



**Programming Screen - PMAC**

Press STATION # on the Unit Settings screen to display the Programming screen.

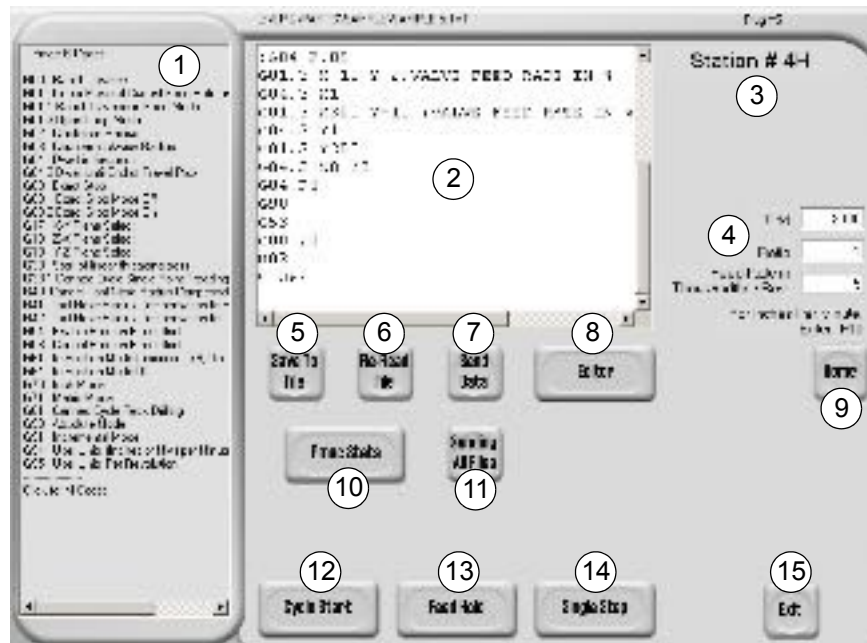

**Programming Screen - PMAC**

**1. PMAC G-Codes and M-Codes**

Displays a description of each available G-code and M-code. Only the codes listed may be used in this programming screen. See G-/M-code documentation later in this chapter.

**2. Programming Area**

Area for program writing and editing.

**3. Station # Display**

Displays the current Station #.

**4. Millimeters Per Minute Conversion Table**

Converts Spindle RPM and Feed rate in thousandths/Rev for programming code.

**5. Save To File**

Save to file.

**6. Re-Read File**

Displays last saved file.

**7. Send Data**

Download - Send last saved program to the controller.

**8. Editor**

Opens text file in a third party software editor.

## **6. Epic Pendant Control**

### **9. Home**

Homes the Unit.

### **10. PMAC Stats**

Go to PMAC diagnostic screen.

### **11. Sending All Files**

Sends current part programs to all motion controllers.

### **12. Cycle Start**

Cycles the Unit.

### **13. Feed Hold**

Stops the motion of this Unit.

### **14. Single Step**

Executes one line of motion program.

### **15. Exit**

Press to exit and return to the previous screen.

## PMAC Stats Screen

Press STATION # on the Unit Settings screen to display the Programming screen, then press PMAC Stats.

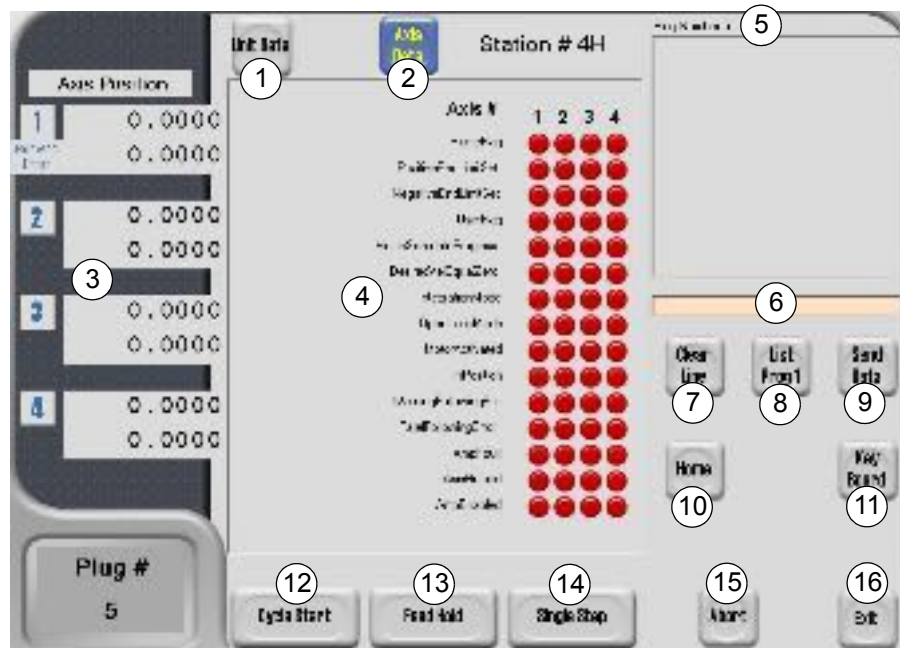

**PMAC Stats Screen**

### 1. Unit Data

Displays the Unit data.

### 2. Axis Data

Displays the Axis data.

### 3. Axis Position

The top row of the indicated Axis displays the actual position. The bottom row displays the following error.

### 4. Status Flags

Displays the status of either the Unit or Axis. Red - Off, Green - On.

### 5. Plug # Display

Displays the current Plug #.

### 6. Editor

Command line to the PMAC.

### 7. Clear Line

Deletes the data in the Command Line.

### 8. List Program 1

Will only list the first 256 bytes of the current program.

## **6. Epic Pendant Control**

### **9. Send Data**

Download - Send last saved program to the controller.

### **10. Home**

Homes the Unit.

### **11. Keyboard**

Displays a Keyboard for entering data.

### **12. Cycle Start**

Cycles the Unit.

### **13. Feed Hold**

Stops the motion of this Unit.

### **14. Single Step**

Executes one line of motion program.

### **15. Abort**

Immediately cancels the current program.

### **16. Exit**

Press to exit and return to the previous screen.

**Programming Screen - Bosch**

Press STATION # on the Unit Settings screen to display the Programming screen.

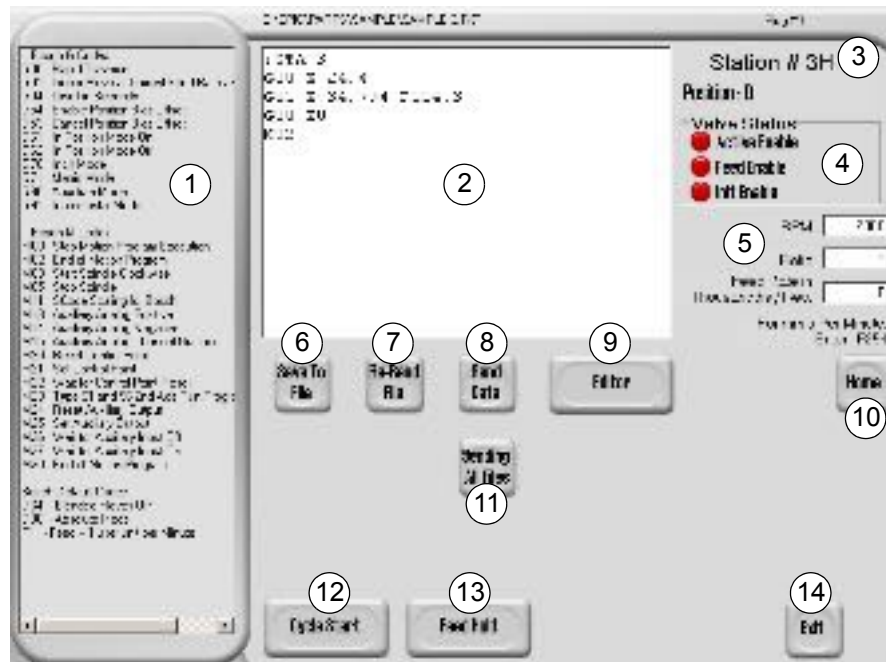

**Programming Screen - Bosch**

**1. Bosch G-Codes and M-Codes**

Displays a description of each available G-code and M-code. Only the codes listed may be used in this programming screen. See G-/M-code documentation later in this chapter.

**2. Programming Area**

Area for program writing and editing. Bosch Controllers require ALL CAPS programming for all motion programs.

**3. Station # Display**

Displays the current Station #.

**4. Valve Status**

Displays the status of the valves.

**5. Millimeters Per Minute Conversion Table**

Converts Spindle RPM and Feed rate in thousandths/Rev for programming code.

**6. Save To File**

Save to file.

**7. Re-Read File**

Displays last saved file.

**8. Send Data**

Send last saved program to the controller.

## **6. Epic Pendant Control**

### **9. Editor**

Opens text file in a third party software editor.

### **10. Home**

Homes the Unit.

### **11. Sending All Files**

Sends current part programs to all motion controllers.

### **12. Cycle Start**

Cycles the Unit.

### **13. Feed Hold**

Stops the motion of this Unit.

### **14. Exit**

Press to exit and return to the previous screen.

**Advanced Menu Screen**

Press ADVANCED MENU on the Unit Settings screen to display the Advanced Menu screen.

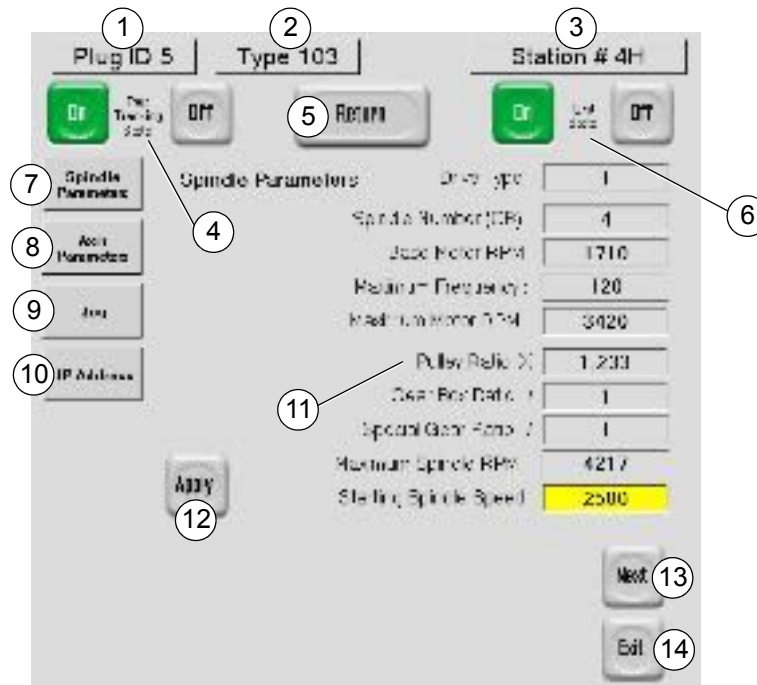

**Advanced Menu Screen**

**1. Plug ID #**

Press to set Plug ID from 1-32 or to remove Unit. When pressing on a Unit circle at the Status screen, a message box will pop up if a Unit does not have a Plug ID defined.

**2. Type #**

Press to enter the Unit Type.

1-99 - Intelligent Bosch Control Valve, single axis.

100-199 - PMAC Controlled CNC Units, multi axis.

200-Above - Non Servo Units, ex., Inverter.

**3. Station #**

Press to display the Programming screen.

**4. Part Tracking State**

Press the appropriate ON/OFF button to turn the Part Tracking on or off.

**5. Return**

Return to the Unit Settings screen.

**6. Unit State**

Press the appropriate ON/OFF button to turn the Unit on or off.

## 6. Epic Pendant Control

### 7. Spindle Parameters

Press to view the Spindle Parameter settings to the right.

### 8. Axis Parameters

Press to go to the appropriate Axis Parameters screen. The Bosch screen will display for single axis and the PMAC will display for multi-axis.

### 9. Jog

Press to go to the appropriate Jog screen. The Bosch screen will display for single axis and the PMAC will display for multi-axis.

### 10. IP or Node Address

Press to view the IP or Node Address to the right. Operator enters the IP or Node # from the Unit, then presses APPLY.

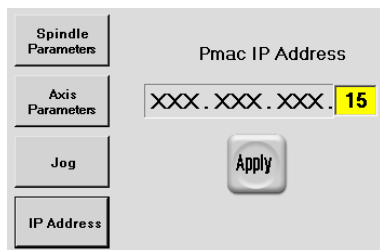

**IP Address Screen - PMAC**

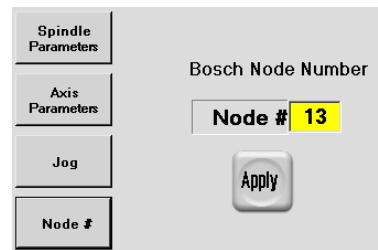

**Node Address Screen - Bosch**

### 11. Spindle Parameters Dialog

Press to display the Spindle Parameter settings. This area allows the operator to enter values and apply changes. The drive type is one of three types, #1 Frequency, #10 Geo Servo, or #20 High Frequency Spindle. The Spindle Number is the number of the Spindle Plug on the base of the Machine.

### 12. Apply

Press to apply changes.

### 13. Next

Press to toggle between multiple Units on the same Station.

### 14. Exit

Press to exit and return to the previous screen.



### Bosch axis parameters screen

At the Unit Settings screen press ADVANCED MENU/AXIS PARAMETERS to display the Bosch Axis Parameters screen.

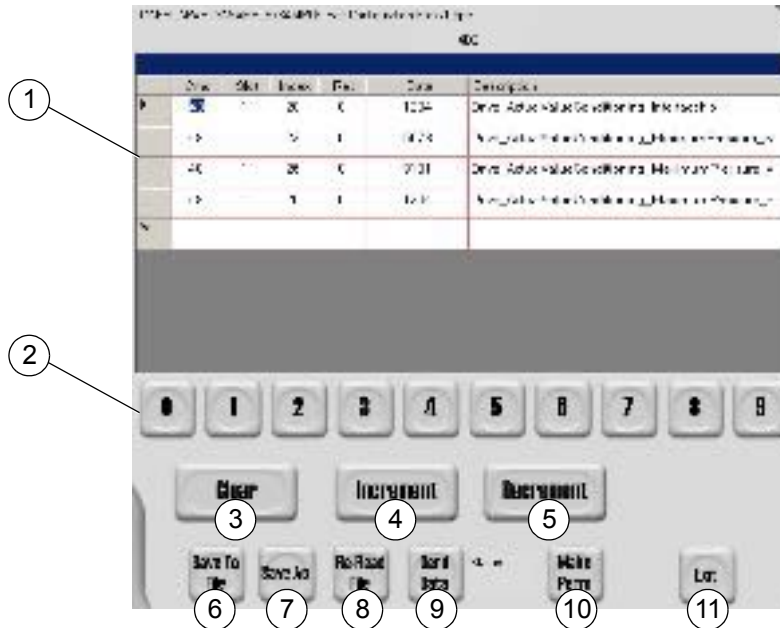

**Bosch Axis Parameters Screen**

#### 1. Parameter Entry Field

Fields where the Bosch Axis Parameters are set.

#### 2. Keyboard

Keyboard for entering data.

#### 3. Clear

Zeros out the entry fields.

#### 4. Increment

Press to Increment the value.

#### 5. Decrement

Press to Decrement the value.

#### 6. Save To File

Save to predetermined file for Unit.

#### 7. Save As

Save to another Unit.

#### 8. Re-Read File

Displays last saved parameter file.

#### 9. Send Data

Send data to Controller and Valve.

#### 10. Make Perm

Informs Valve after data transfer to retain perm data.

#### 11. Exit

Press to exit and return to the previous screen.

## 6. Epic Pendant Control

### PMAC axis parameters screen

At the Unit Settings screen press ADVANCED MENU/AXIS PARAMETERS to display the PMAC Axis Parameters screen.

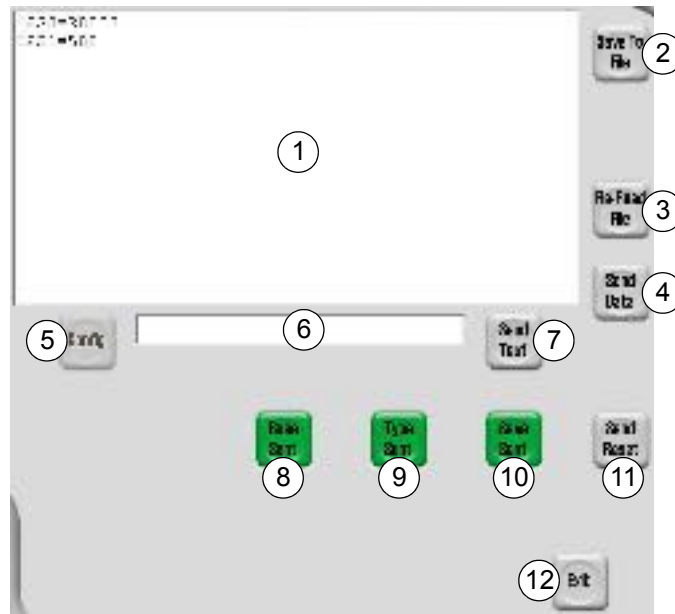

**PMAC Axis Parameters Screen**

#### 1. Parameter Entry Field

Fields where the Bosch Axis Parameters are set

#### 2. Save To File

Save to predetermined file for Unit.

#### 3. Re-Read File

Displays last saved parameter file.

#### 4. Send Data

Send data to Controller and Valve.

#### 5. Config

Provides access to re-install all PMAC PLC's and complete configuration.

#### 6. Single Command Line

Allows sending of single command to PMAC.

#### 7. Send Text

Sends single command line to PMAC.

**Note:** Buttons 8 through 11 do not appear until button 5 Config is pressed. After button 8 appears and is pressed, button 9 will appear, etc.

### CAUTION

**Do Not Continue with configuration unless you are trained and qualified.**

### 8. Send Base

Button appears after Config mode has been enabled. Press to confirm download of base configuration.

### 9. Send Type

After Send Base has been successful, Send Type appears, press to send type file.

### 10. Send Save

Press to send save.

### 11. Send Reset

Press to Send Reset

### 12. Exit

Press to exit and return to the previous screen.

## 6. Epic Pendant Control

### Jog Single Axis Bosch screen

At the Unit Settings screen press ADVANCED MENU/JOG to display the Bosch Jog screen. To jog the single axis Unit, press and hold the blue Release/Jog button on the pendant face.

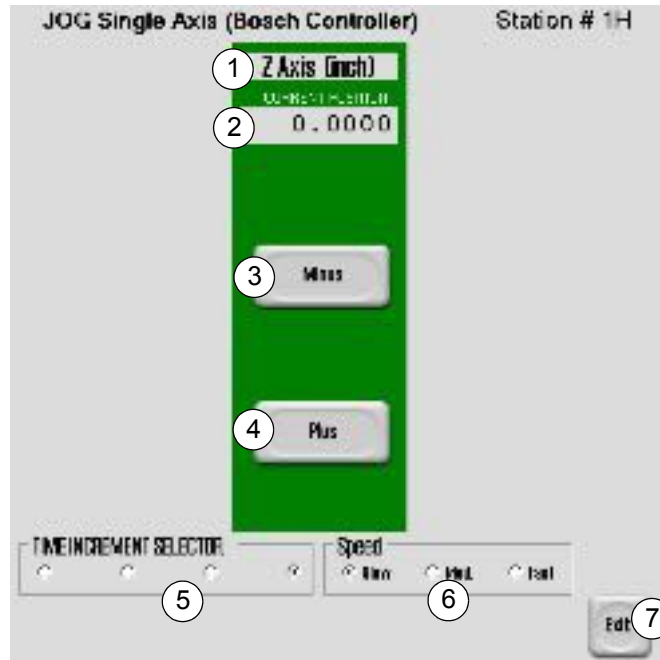

**Jog Single Axis Bosch Screen**

#### 1. Z Axis (mm)

The Z axis area controls the quill in and out movement.

#### 2. Current Position

Displays the actual current position.

#### 3. Minus

The operator must press and hold the Release/Jog button on the pendant face while Pressing the Z- button once to jog toward work piece.

#### 4. Plus

The operator must press and hold the Release/Jog button on the pendant face while Pressing the Z- button once to jog away from work piece.

#### 5. Time Increment Selector

Bosch only has time increments available. Inch mode - allows one inch increments. Metric mode - allows 10mm increments.

#### 6. Speed

Determine the jog speed by selecting slow, medium, or fast speed.

#### 7. Exit

Press to exit and return to the previous screen.

## Jog Multi-axis PMAC screen

At the Unit Settings screen press ADVANCED MENU/JOG to display the PMAC Jog screen. To jog the multi-axis Unit, press and hold the blue Release/Jog button on the pendant face.

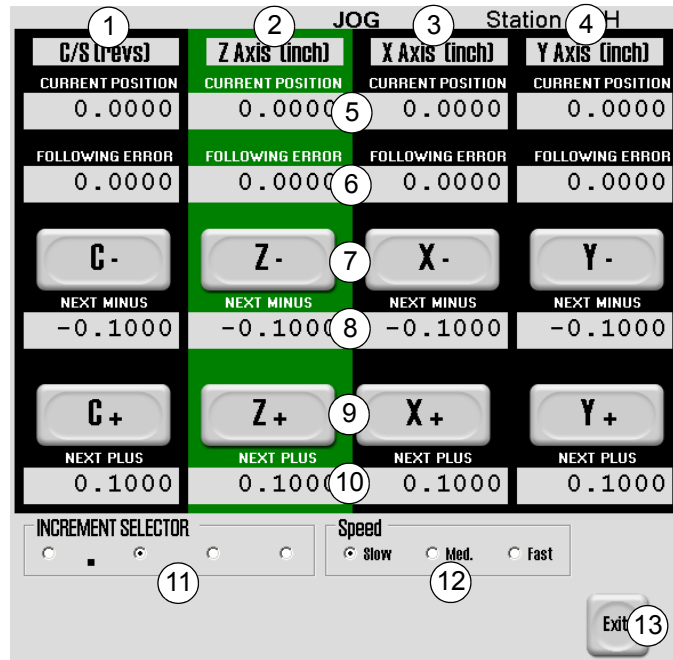

**Jog PMAC Multi-Axis Screen**

### 1. C/S (revs)

The C/S revs area of the jog screen controls the spindle revs.

### 2. Z Axis (mm)

The Z axis area of the jog screen controls the quills in and out movement of the quill.

### 3. X Axis (mm)

The X axis area of the jog screen controls the 50/100 head going in and out on a lathe type operation and the XY flange on a mill type operation.

### 4. Y Axis (mm)

The Y axis area of the jog screen controls the milling operation (up and down motion on horizontal units).

### 5. Current Position

Displays the actual current position for each of the 4 axis types.

### 6. Following Error

Displays distance the unit can't go for each of the 4 axis types.

### 7. C-, Z-, X-, and Y-

The operator must press and hold the Release/Jog button on the pendant face while Pressing the C-, Z-, X-, or Y- button once to jog backward.

## **6. Epic Pendant Control**

### **8. Next minus**

Displays the next actual position.

### **9. C+, Z+, X+, and Y+**

The operator must press and hold the Release/Jog button on the pendant face while Pressing the C+, Z+, X+, or Y+ button once to jog in desired direction.

### **10. Next plus**

Displays the next actual position.

### **11. Increment Selector**

Inch mode - allows one inch increments. Metric mode - allows 10mm increments.

### **12. Speed**

Determine the jog speed by selecting slow, medium, or fast speed.

### **13. Exit**

Press to exit and return to the previous screen.

## 6. CHANGE PART

Press CHANGE PART to display the Change Part screen. Select the program that you want to load, copy, or delete. Press to select DELETE, COPY, or CREATE NEW.

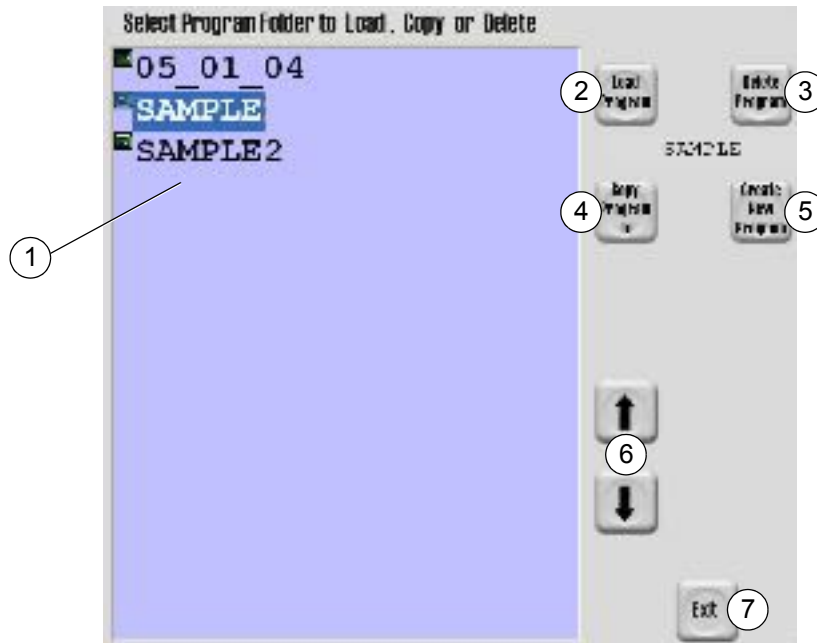

**Change Part Screen**

### 1. File Folder Display

Displays a particular file folder.

### 2. Load Program

Select the program that you want to run. Press Load Program. The Load Program screen appears.

### 3. Delete Program

Press to delete program.

### 4. Copy Program To

Press to copy from selected program to new name.

### 5. Create New Program

Makes a new program based on a saved configuration with a name of base (replaceable standard hardware configuration). Click on CREATE NEW PROGRAM, you will be prompted for a new file name, press enter. A new program is generated after the last saved profile in base program.

### 6. Up and Down Arrows

These arrows are used for scrolling up and down the menu screen.

### 7. Exit

Press to exit and return to the previous screen.

## 6. Epic Pendant Control

### Load Program

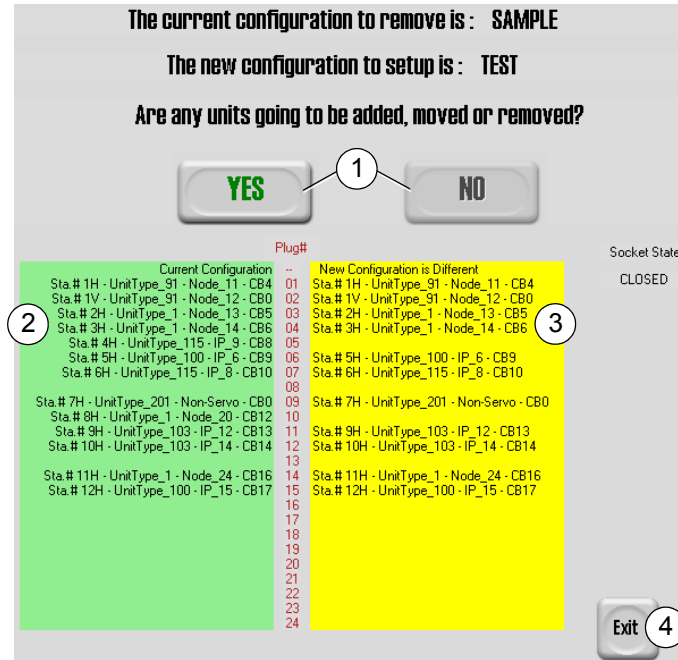

**Load Program Screen**

#### 1. Yes / No Buttons

Are any units going to be added, moved, or removed? Press Yes or No.

Yes or No:

- Sockets will be closed.
- Place Machine in E-Stop.
- Add, move, or remove Units.
- If Yes Only - Press re-connect button. (Button will appear at this step)



- Open sockets.
- Press Exit to save and exit screen.
- Press Home to re-home the machine.

#### 2. Current Configuration

Displays the current configuration.

#### 3. New Configuration

Displays the new configuration. The display remains green if the configuration is the same. If it is different the display turns to yellow.

#### 4. Exit

Press to save and return to the previous screen.



## 7. DIAGNOSTICS

Only authorized Hydromat service personnel have access to the Secured Area. Press DIAGNOSTICS/ SECURED AREA and enter the password.



**Diagnostics Screen**

## 8. OPERATOR ACTIVE / CLEAR ACTIVE PASSWORD

The Operator Active button is only visible when a Level 4 password is active. Press this button to release the currently stored password.

The Clear Active Password button is visible any time that a Level 3 or lower password is active. Press this button to release the currently stored password.



## 9. CALCULATOR

Press CALCULATOR to display a fully functioning calculator. Press Exit to close the calculator.



**Calculator Screen**

## 6. Epic Pendant Control

### 10. MACHINE CONTROL KEYPAD

Choose a button to control a particular area of the machine.

**a. Hydraulics**

Turns on the Hydraulic Powerpack. Covers must be closed!

**b. Home**

Returns Units to the home position.

**c. Spindles**

Starts the Toolspindle Motors. Covers must be closed and Table must be down.

**d. Coolant**

Turns on the coolant pumps and chip conveyor.

**e. Units**

Cycles the Toolspindle Units once without a Table index. SPINDLES must be on!

**f. Single Cycle**

Rotary Table Indexes one station and the Toolspindle Units complete machining cycle. Spindles must be on.

**g. Auto**

Starts the Machine in continuous Automatic cycle. Spindles and Coolant must be on.

**h. Barfeeder Reset / Loader Reset**

This pushbutton cancels the bar change sequence. The button must be held for 5 seconds. Loader option - Resets the Loader to the home position. The button must be held for 5 seconds.

**i. Barfeeder Reverse**

Runs the barfeeder pusher dog in the reverse direction.

**j. Barfeeder Forward / Loader Cycle**

Runs the barfeeder pusher dog in the forward direction. Spindles must be off. Loader option - If Loader is in Automatic Mode, a load cycle is started. If in Manual Mode, the load sequence is stepped through one step each time the button is pressed.

**k. Color Indicator**

Displays a screen that shows the meaning of the colors used on the Status screen.

**l. Alarms**

This pushbutton returns the display to the machine diagnostic menu screen. The screen shows currently active alarms and the history of alarms.

**m. 1/2 Index**

Moves the Rotary Table Index into Half Index Position for tool change. Table index must be activated to complete the index before resuming Machine operation. Spindles must be off and Covers must be closed!

**n. Table Index**

Indexes the Rotary Table one station. Covers must be closed!

**o. Tools**

This pushbutton is used for optional special tools.

**p. 1/2 Index Return**

If the Table is in 1/2 index this pushbutton will rotate the Table counterclockwise back to the machining position.

**q. Main Menu**

This pushbutton displays the Main Menu screen that allows access to machine functions and installed options; i.e., Table, Loader, Special Units, Inverter, etc.

**r. Chip Conveyor Override**

Pressing this button causes the chip conveyor to run for a predetermined time (1½ to 2 minutes) to recover dropped parts or tools from the machine.

**s. A.S.C.**

Stops the Machine at the end of an Automatic cycle then turns the Spindles and Coolant off.

**t. Fault Reset**

Resets the Machine Faults.

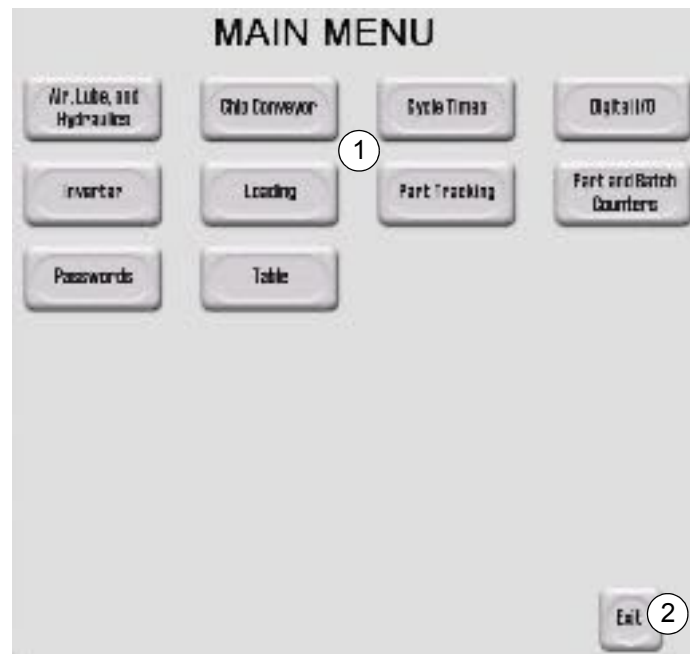
**Main Menu**

**Main Menu Screen**

**1. Main Menu Go To Buttons**

The Main Menu screen allows access to user functions and installed options (I.E. Barfeeder, Loader, Special units, Inverter, etc.). Simply press to select a button that will take you to the indicated screen allowing the operator to control a specific area of the Machine.

**2. Exit**

Press to exit and return to the previous screen.

## 6. Epic Pendant Control

### *Air, Lube, and Hydraulics Control*

The Air, Lube, and Hydraulics screen can be accessed by pressing “MAIN MENU/AIR, LUBE, AND HYDRAULICS”.

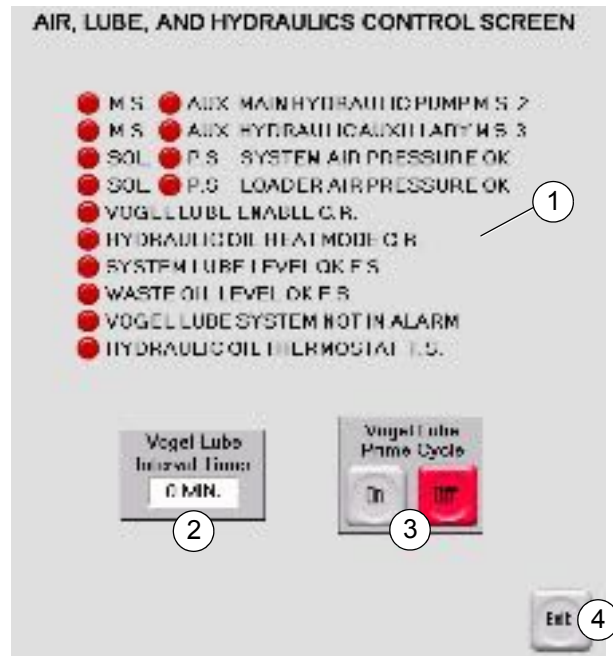

**Air, Lube, and Hydraulics Control Screen**

#### **1. Air, Lube, and Hydraulics Indicators**

Indicators display the status of air, lube, and hydraulics. Green indicates on and Red indicates off.

#### **2. Vogel Lube Interval Timer**

Allow operator to set the Vogel Lube Interval.

#### **3. Vogel Lube Prime Cycle On / Off**

Press to turn the Vogel Lube Prime Cycle On or Off. Continuous cycle Vogel every 30 seconds for 10 minutes.

#### **4. Exit**

Press to exit and return to the previous screen.

## Chip Conveyor

The Chip Conveyor screen can be accessed by pressing “MAIN MENU/CHIP CONVEYOR”.

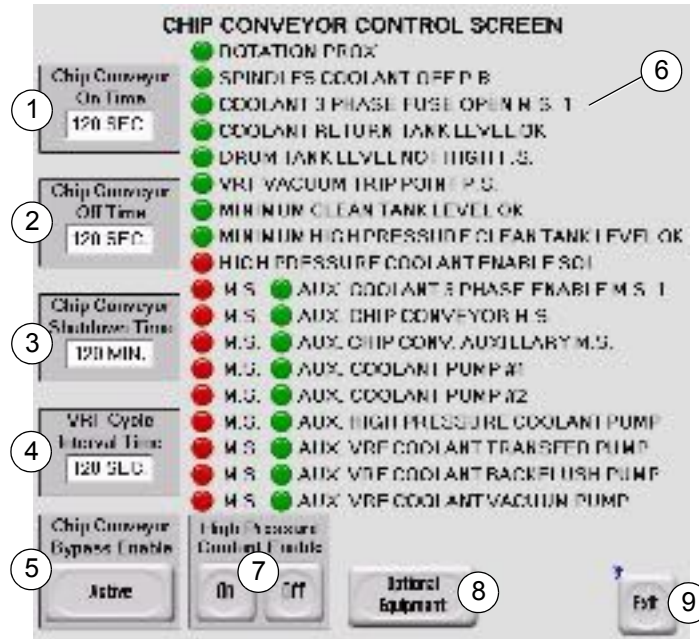

**Chip Conveyor Screen**

### 1. Chip conveyor On Time (Seconds)

Operator enters the duration of the Chip Conveyor ON cycle. Only applicable when coolant is on.

### 2. Chip Conveyor Off Time (Seconds)

Operator enters time Chip Conveyor is to remain OFF in seconds.

### 3. Chip Conveyor Shutdown Time (Seconds)

Operator enters the time Chip Conveyor is to run after coolant is off.

### 4. VRF Cycle Interval Time

Operator enters the VRF Cycle Interval Time.

### 5. Chip Conveyor Bypass Enable

Press to toggle between INACTIVE and ACTIVE to run Chip Conveyor continuously without coolant.

### 6. Chip Conveyor Indicators

Indicators display the status of different areas of the Chip Conveyor. Green indicates on and Red indicates off.

### 7. High Pressure Coolant Enable

On/Off Buttons for High Pressure Coolant.

### 8. Optional Equipment

Press to display the Chip Conveyor Options screen.

### 9. Exit

Press to exit and return to the previous screen.

## 6. Epic Pendant Control

### Chip Conveyor Optional Equipment

The Chip Conveyor Optional Equipment screen can be accessed by pressing “MAIN MENU/CHIP CONVEYOR/OPTIONAL EQUIPMENT”.

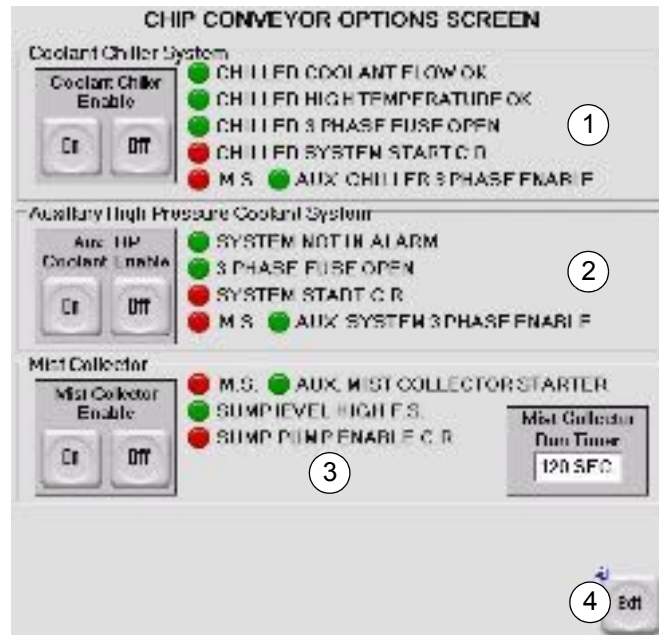

**Chip Conveyor Optional Equipment Screen**

#### 1. Coolant Chiller System

Press the appropriate On/Off Button to turn the Coolant Chiller On or Off. The indicators display the status of the Coolant Chiller System. Green indicates on and Red indicates off.

#### 2. Auxiliary High Pressure Coolant System

Press the appropriate On/Off Button to turn the Auxiliary High Pressure Coolant System On or Off. The indicators display the status of the Auxiliary High Pressure Coolant System. Green indicates on and Red indicates off.

#### 3. Mist Collector

Press the appropriate On/Off Button to turn the Coolant Chiller On or Off. The indicators display the status of the Coolant Chiller System. Green indicates on and Red indicates off.

Mist Collector Run Timer - Enter time in seconds for how long the Mist Collector runs after shutting the coolant off.

#### 4. Exit

Press to exit and return to the previous screen.

## Cycle Times

The Cycle Times screen can be accessed by pressing “MAIN MENU/CYCLE TIMES”.

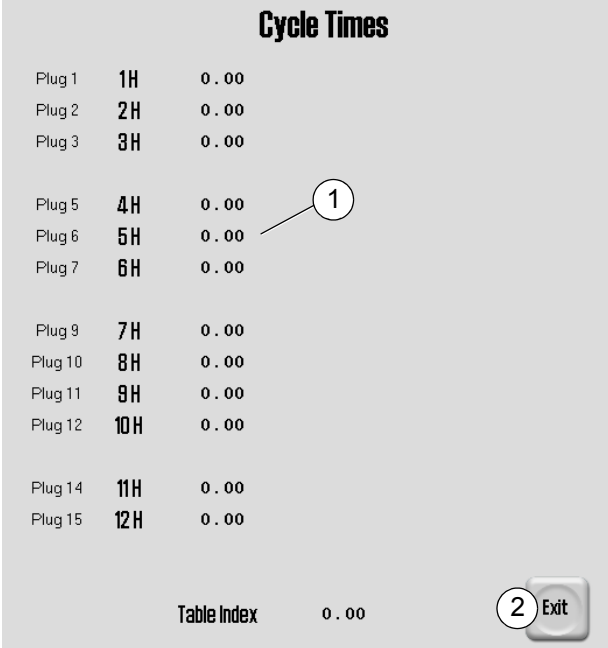

Cycle Times		
Plug 1	1H	0.00
Plug 2	2H	0.00
Plug 3	3H	0.00
Plug 5	4H	0.00
Plug 6	5H	0.00
Plug 7	6H	0.00
Plug 9	7H	0.00
Plug 10	8H	0.00
Plug 11	9H	0.00
Plug 12	10H	0.00
Plug 14	11H	0.00
Plug 15	12H	0.00
Table Index	0.00	2 Exit

**Cycle Times Screen**

### 1. Cycle Times

Displays the cycle time of indicated plug.

### 2. Exit

Press to exit and return to the previous screen.

## 6. Epic Pendant Control

### Digital I/O

The Digital I/O screen can be accessed by pressing “MAIN MENU/DIGITAL I/O”.

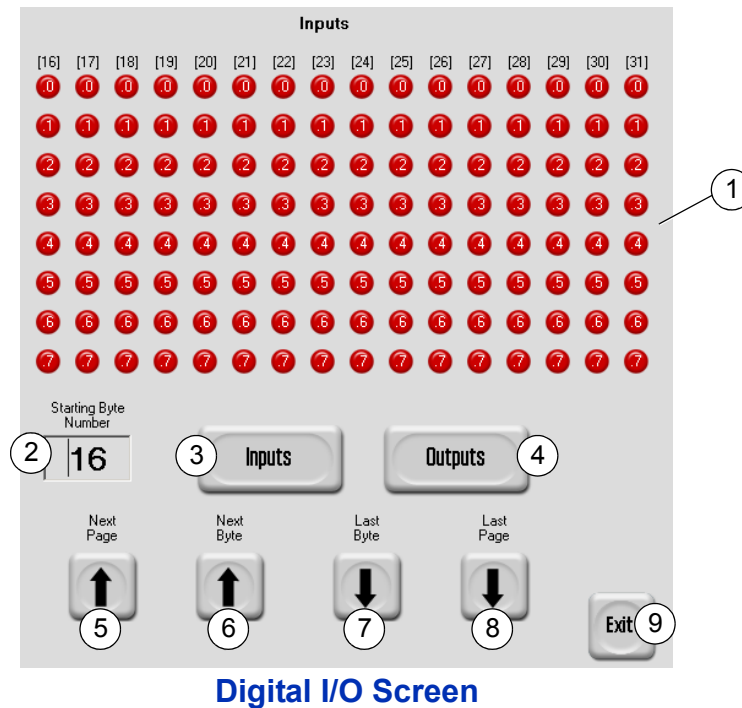

#### 1. Inputs / Outputs

Displays the Inputs / Outputs.

#### 2. Starting Byte Number

Enter value to view a starting byte number.

#### 3. Inputs

Press to view the Inputs.

#### 4. Outputs

Press to view the Outputs.

#### 5. Next Page

Press to view the next page.

#### 6. Next Byte

Press to view the next byte.

#### 7. Last Byte

Press to view the last byte.

#### 8. Last Page

Press to view the last page.

#### 9. Exit

Press to exit and return to the previous screen.



**Inverter**

The Inverter screen can be accessed by pressing “MAIN MENU/INVERTER”.

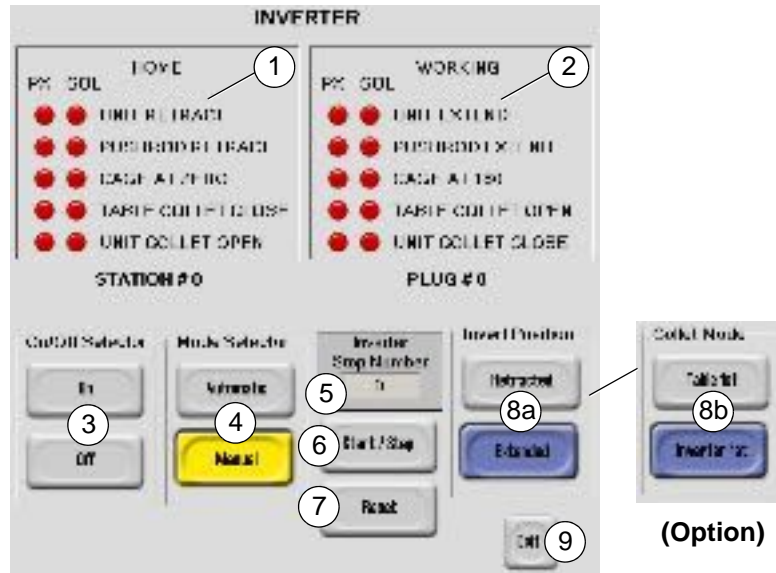

**Inverter Screen**

**1. Home Indicators**

Green indicates on and Red indicates off.

**2. Working Indicators**

Green indicates on and Red indicates off.

**3. On/Off Selector**

Select On or Off.

**4. Mode Selector**

Select Mode, AUTO or MANUAL.

**5. Inverter Step #**

Shows what step the Inverter is in.

**6. Start/Step**

If in AUTO Mode, press to start Inverter sequence. If in MANUAL Mode, press to step through one step at a time.

**7. Reset**

If Inverter is stopped, press RESET to bring the Inverter back to home position.

**8a. Invert Position**

Press to select EXTENDED or RETRACTED. This will be the position that the part is inverted at.

**8b. Collet Invert Mode**

Table 1st - In manual mode, moves the Inverter to part and clamps on part. Inverter 1st - In manual mode, opens the Collet and ejects the part into Inverter.

**9. Exit**

Press to exit and return to the previous screen.

## 6. Epic Pendant Control

### Loading - Barfeeder

The Barfeeder screen can be accessed by pressing “MAIN MENU/LOADING”.

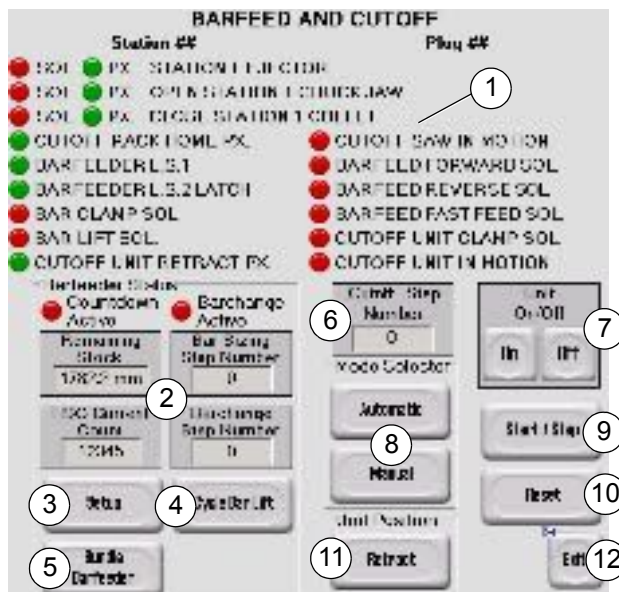

**Loading - Barfeeder Screen**

#### 1. Station and Plug # Indicators

Green indicates on and Red indicates off.

#### 2. Barfeeder Status

Displays the status of the Barfeeder's remaining stock, bar sizing step number, HSC current count, and the barchange step number.

#### 3. Setup

Press to access the setup options screen.

#### 4. Cycle Bar Lift

Press to cycle the bar lift.

#### 5. Bundle Barfeeder

Press to display the Bundle Barfeeder I/O screen.

#### 6. Cutoff Step Number

Displays the Cutoff Step Number

#### 7. Unit On / Off

Turns the Unit On or Off.

#### 8. Mode Selector

Press to select Automatic or Manual Mode.

#### 9. Start/Step

Steps through when MANUAL mode is selected. Press to start sequence when AUTO mode is selected.

#### 10. Reset

Press to reset loading device to its home position.

#### 11. Unit Position

Press to toggle the Cutoff Unit between Extended or Retracted.

#### 12. Exit

Press to exit and return to the previous screen.

## Loading Setup

The Loading Setup screen can be accessed by pressing “MAIN MENU/LOADING/SETUP”.

BAR LOADING SETUP AND DIAGNOSTICS SCREEN			
Station ##		Plug ##	
1 Saw To Collet Distance 1.2 in	2 Faceoff Length 0.5 in	3 Faceoff Position Offset 0.0 in	4 Maximum Remnant Space 2.0 in
5 Step Loading Tolerance 0.001 in	6 Minimum Stock Before Barchange 0.0 in	7 New Bar Drop Position 10.0 in	8 Ejector Back Delay Time 1.00 Sec
● BARCHANGE ACTIVE	● COUNTDOWN ACTIVE	● WRAP AROUND COMPLETE	● LED TO FACEOFF
● BARFEEDER L S 1	● BARFEEDER R S 2 LATCH	● MULTI CUT REQUIRED	
9			
10 Remaining Stock 882.7 mm	11 Cutoff Step Number 0	12 Bar Sizing Step Number 0	13 Barchange Step Number 0
14 HSC Current Count 12945	15 First Piece Length 0	16 Last Piece Length 0	17 Faceoff Position 60.0 in
18 Step Collet Required Count 12945	19 Step Collet Required Length 12945	20 Step Loading On Off	21 Time 1.00 Sec
			22 Exit

**Loading Setup Screen**

### 1. Saw to Collet Distance Data Entry Field

Distance between the face of the collet and the outside edge of the saw. This number is used to determine the homing location of a two axis saw. This setting is also used in calculating a proper barchange.

### 2. Faceoff Length Data Entry Field

This setting determines the minimum amount a new bar has removed from its leading edge. This number is typically set at 1/2 an inch but can be larger if needed. If this number is set to 0 the barfeeder will not face-off a new bar and load it directly into the collet.

### 3. Faceoff Position Offset Data Entry Field

This setting is used to adjust when a barchange occurs. Example: if the barchange begins 1 inch to early, then enter 1 inch to offset when the barchange starts.

### 4. Maximum Remnant Space Data Entry Field

This setting represents the amount of room in the machine to dispose of the trailing edge of a bar at barchange. This number should be set to amount of space minus Saw to Collet distance. Example: there is enough room to dispose of 4.5 inches of remnant in the machine, the Saw to Collet distance is 2 inches,  $4.5 - 2 = 2.5$ , enter 2.5 inches into this setting.

### 5. Step Loading Tolerance Data Entry Field

Used when Step Loading is enabled. This setting is for the amount of error allowed between the actual blank length and the measured length. Setting this to low may cause nuisance "Bar Not Feeding" faults.

## **6. Epic Pendant Control**

### **6. Minimum Stock Before Barchange Data Entry Field**

This is the minimum amount of bar stock that can remain before a barchange is initiated. This number is usually calculated by the machine controller as Saw To Collet Distance plus 1.5 inches or Blank Length plus .75 inches which ever is greater. By putting a value greater than .75 inches into this setting you can override the control and make the barchange start earlier.

### **7. New Bar Drop Position Data Entry Field**

This setting allows the operator to define how far past the barfeeder limit switches a new bar will be dropped onto the loading plane. This setting is only available when the machine is equipped with a Bar Lift or a Bundle Barfeeder.

### **8. Ejector Back Delay Time Data Entry Field**

This setting allows the operator to define how long the ejector proximity switch must be made before beginning the saw cutting cycle. This can be used to de-bounce the ejector prox. if the saw cycle starts to early do to feeding the bar stock to fast. When in Step Loading mode this setting is changed to "Encoder Settling Time". This is the amount of time the barfeeder must not see any movement before closing the collet in Step Loading mode.

### **9. Bar Loading Indicators**

Green indicates on and Red indicates off.

### **10. Remaining Stock Indicator**

Amount of stock left before barchange when machine is in Countdown mode.

### **11. Cutoff Step Number Indicator**

Loading sequence step number.

### **12. Bar Sizing Step Number Indicator**

Part Measuring sequence step number. Starts when Barfeeder reaches first limit switch.

### **13. Barchange Step Number Indicator**

Barchange sequence number during the barchange process.

### **14. HSC Current Count Indicator**

Encoder Count on barfeeder.

### **15. First Piece Length Indicator**

Partial Piece measured when Second Limit switch is actuated to when barfeeder stops moving forward.

### **16. Last Piece Length Indicator**

Barfeeder measured black length. (Only updates during countdown mode)

### **17. Face-off Position Indicator**

Distance between when the Second Limit switch on barfeeder is actuated and the face of the collet.

### **18. Step Collet Required Count Indicator**

Required Minimum HSC Count before collet is closed when in Step Loading mode.

**19. Step Collet Required Length Indicator**

Required minimum blank length in Step Load Mode.

**20. Step Loading On / Off**

Press to turn Step Loading On or Off.

**21. Home Saw**

Press to home the Saw.

**22. Exit**

Press to exit and return to the previous screen.

**Bundle Barfeeder**

The Bundle Barfeeder screen can be accessed by pressing “MAIN MENU/LOADING/BUNDLE BARFEEDER”.

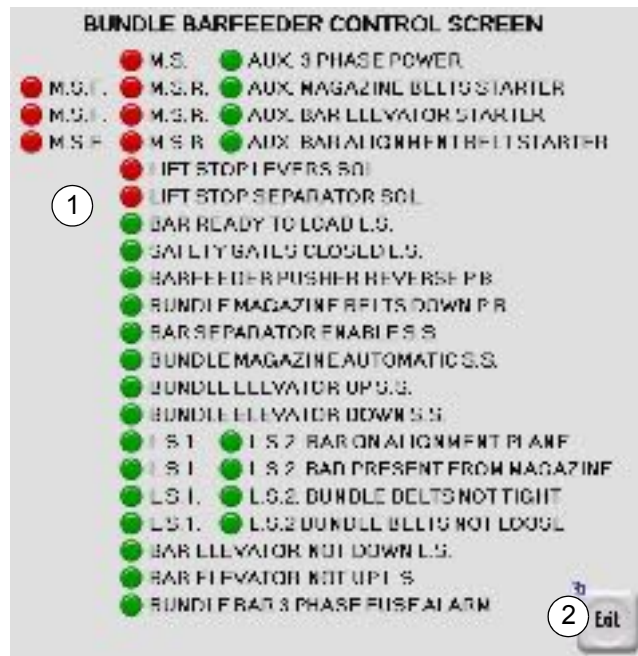

**Bundle Barfeeder Screen**

**1. Bundle Barfeeder Control Screen Indicators**

Displays the Bundle Barfeeder Indicators. Green indicates on and Red indicates off.

**2. Exit**

Press to exit and return to the previous screen.

## 6. Epic Pendant Control

### *Loading - Part Loader (Optional)*

The Loading Part Loader screen can be accessed by pressing “MAIN MENU/LOADING”.

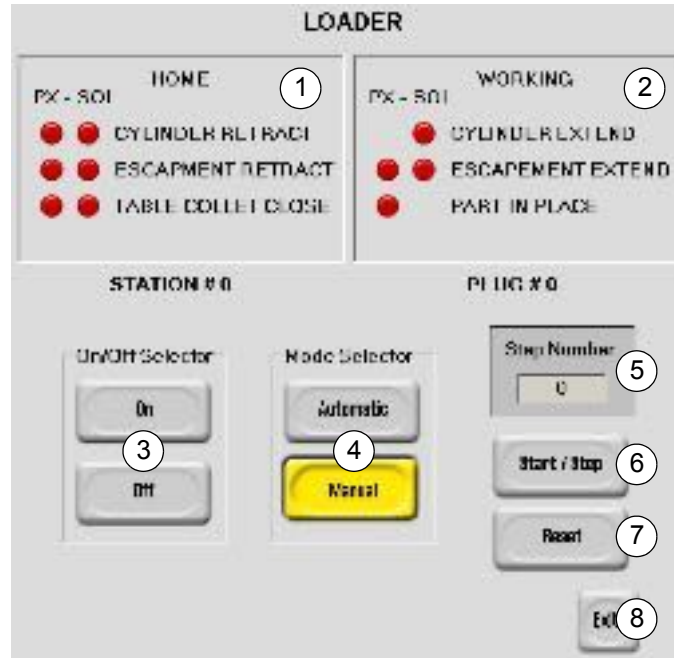

**Loading - Part Loader Screen**

#### 1. Home Indicators

Green indicates on and Red indicates off. These indicators may differ depending on Loader type.

#### 2. Working Indicators

Green indicates on and Red indicates off. These indicators may differ depending on Loader type.

#### 3. ON / OFF Selector

Press to turn the Loader On or Off.

#### 4. Mode Selector

Press to select Automatic or Manual Mode.

#### 5. Step Number

Displays the Step Number that the Loader is at.

#### 6. Start / Step

Steps through when MANUAL mode is selected. Press to start sequence when AUTO mode is selected.

#### 7. Reset

Press to reset loading device to it's home position.

#### 8. Exit

Press to exit and return to the previous screen.

## Part Tracking

The Part Tracking screen can be accessed by pressing “MAIN MENU/PART TRACKING” or by clicking on a Collet/Chuck at station 1 in the inner ring of the Status screen.

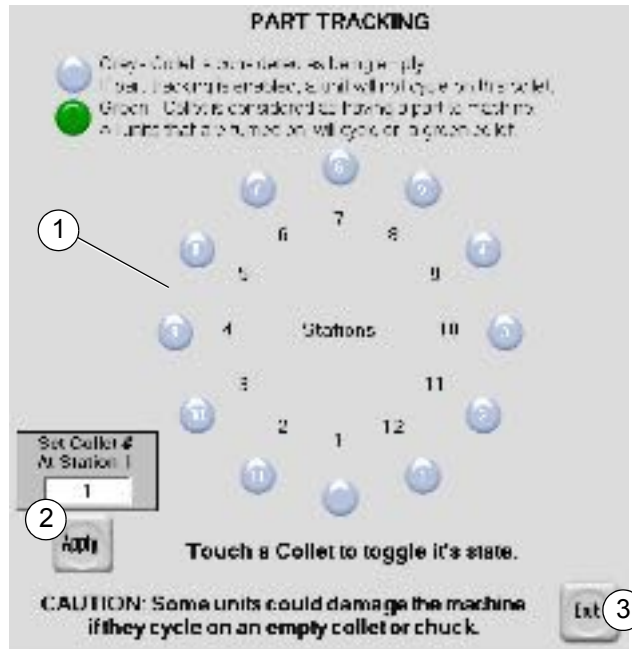

**Part Tracking Screen**

### 1. Part Tracking Display

Displays which stations the control system has detected parts in place.

### 2. Set Collet # at Station 1

Set Collet # at Station 1 by entering number then press apply.

### 3. Exit

Press to exit and return to the previous screen.

## 6. Epic Pendant Control

### Part and Batch Counters

The Part and Batch Counters screen can be accessed by pressing “MAIN MENU/PART AND BATCH COUNTERS”.

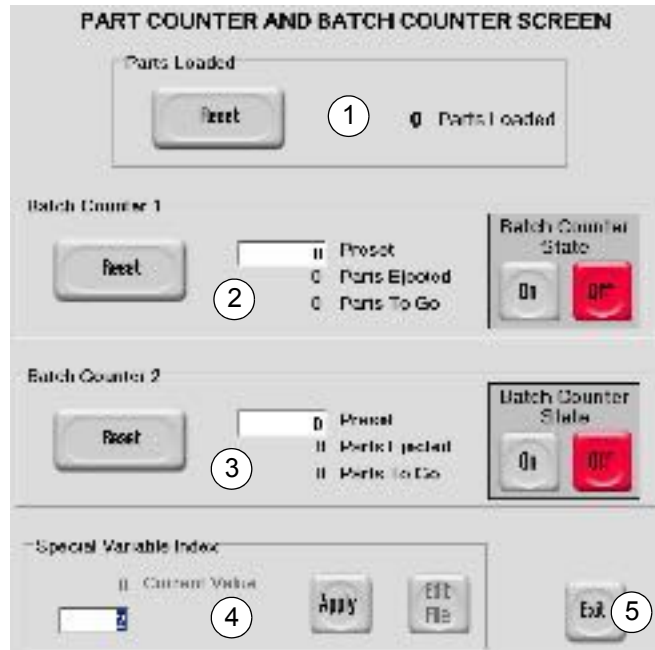

**Part and Batch Counters Screen**

#### 1. Parts Loaded

Counts the number of parts loaded. Press Reset to return the counter to zero.

#### 2. Batch Counter 1

Enter value to preset the counter. The parts ejected and parts to go are displayed. Press On or Off to turn the Batch Counter State On or Off. Press Reset to return the counters to zero.

#### 3. Batch Counter 2

Enter value to preset the counter. The parts ejected and parts to go are displayed. Press On or Off to turn the Batch Counter State On or Off. Press Reset to return the counters to zero.

#### 4. Special Variable Index

For setup of custom variables to be applied within the motion program. Applies to custom applications only.

#### 5. Exit

Press to exit and return to the previous screen.



## Passwords

The Passwords screen can be accessed by pressing “MAIN MENU/PASSWORDS”. A password prompt will pop up requiring a Level 1 password.

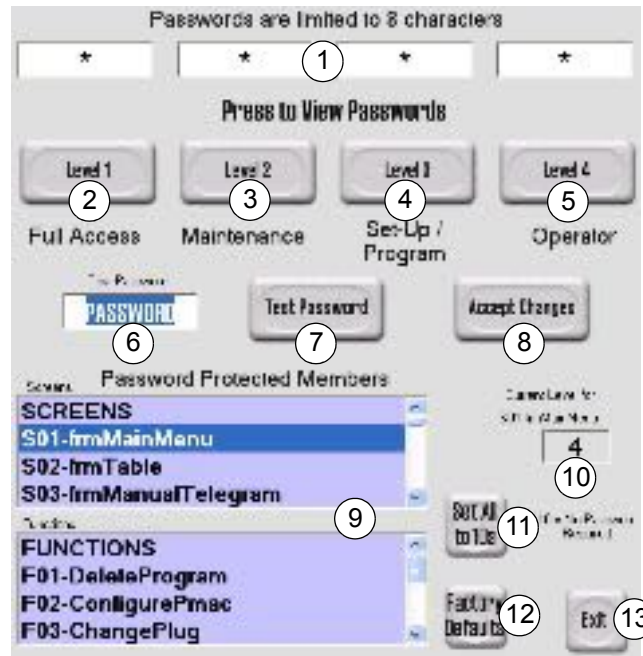

**Passwords Screen**

### 1. Password Fields

Field where the passwords can be viewed or changed by pressing the Level button below.

### 2. Level 1

Exits password screen.

### 3. Level 2

Allows operator to view the currently stored password.

### 4. Level 3

Allows operator to view the currently stored password.

### 5. Level 4

Allows operator to view the currently stored password.

### 6. Test Password Field

Enter password to check level.

### 7. Test Password

Reports back level for a stored password.

### 8. Accept Changes

Saves data.

## **6. Epic Pendant Control**

### **9. Password Protected Members**

Screens: Customer can set level of password for entering a particular screen.

Function: Customer can set level of password for entering a particular function.

### **10. Current Password Level**

Press to change current password level. Keypad will appear for entering number.

### **11. Set All to 10's**

Press to set all passwords to no password required.

### **12. Factory Defaults**

Press to restore the factory default settings.

### **13. Exit**

Press to exit and return to the previous screen.

**Table**

The Table screen can be accessed by pressing “MAIN MENU/TABLE”.

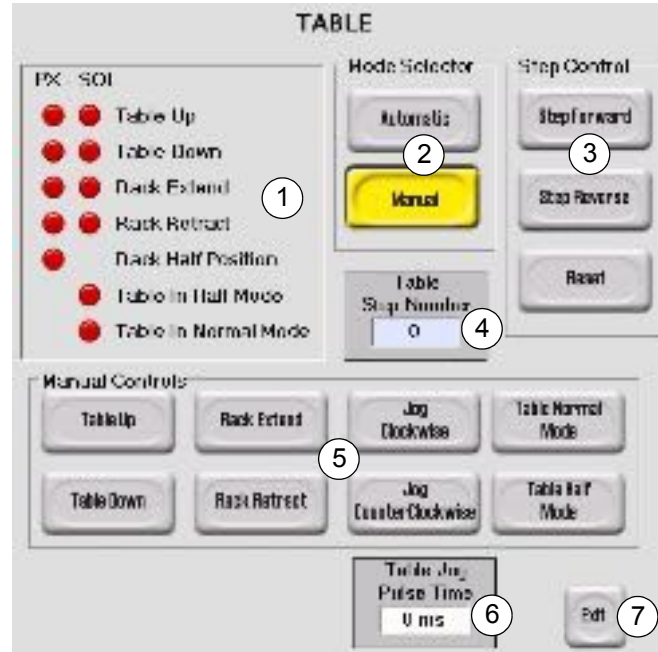

**Table Screen**

**1. Table Indicators**

Green indicates on and Red indicates off.

**2. Mode Selector**

Press the appropriate button to put Table in Auto or Manual mode.

**3. Step Control**

Press the appropriate button to step the Table forward or reverse. Press RESET after resetting the counter to zero and the table will attempt to set down.

**4. Table Step Number**

Displays which step the table is in.

**5. Manual Controls**

Press the appropriate button to manually control a specific area of the table.

**6. Table Jog Pulse Time**

Allows the operator to set pulse time of table forward or reverse in manual mode.

**7. Exit**

Press to exit and return to the previous screen.

## 6. Epic Pendant Control

### UNIT INSTALLATION

The following is a procedure for installing an Epic Unit.

1. Turn off the main Hydraulics.
2. Mount new Toolspindle Unit, plug Electrical Connector into Machine Base, and connect the Hydraulics and Lubrication Lines with provided Connection Blocks.
3. Open the Main Status Screen on the Pendant Control by pressing the STATUS button.



4. Press on the Station number where you would like to add a Unit. The outer ring represents the horizontal Units and the middle ring represents the vertical Units.
5. In the space next to the Replace button on Data Entry screen to the left, use the keypad to type in the plug number where you have plugged the unit into on the machine base. Then press the REPLACE button.



Status Screen

- The Unit Settings screen will now appear. Press the UNIT TYPE button at the top of the screen. Select the appropriate Unit Type from the drop down menu and use the keypad to type the number into the space next to the Replace button and press REPLACE. An incorrect Unit type will not work.



Unit Settings

- Press the ADVANCED MENU button for Unit Setup options.



## 6. Epic Pendant Control

8. The Advanced Menu type that corresponds to your selected Unit Type is displayed. Note: each Unit type will have different menu items. Press Spindle Parameters to make adjustments.

**Drive Type:** 0 = No frequency drive present  
1 = AC Tech frequency drive present  
2 = Danfoss frequency drive  
10 = Geo servo drive present with servomotor on spindle.

**Spindle Number:** CB (circuit breaker) plug around the base of machine the 3-phase 460VAC is plugged into. This is the top plug around the base of the machine.

**Base Motor RPM:** For frequency drive units this is the base frequency of the motor as written on the motor nameplate. (i.e. 1700, 3450).

**Max Frequency:** This displays the indicated Units maximum frequency.

**Max Motor RPM:** Drive type 1 Units (normally 2 x Base motor RPM).  
50/100 Units with 1710 RPM motors, the Max is 5,000.  
Single axis Units with 3410 RPM motors, the max is 5,000.  
Faster Units require special configuration (consult Hydromat).

**Pulley Ratio:** A handy chart to calculate pulley ratios for non 50/100 Units can be seen by clicking on the text of pulley ratio.

**Gear Box Ratio:** Defaults to 1 for no gear box present. If the Gear Box doubles the Spindle RPM enter 2.

**Special Gear Ratio:** Enter any special gear ratios. (Example for saw)

**Max Spindle RPM:** This displays the indicated Units maximum Spindle RPM.

**Start Spindle Speed:** Enter the desired spindle speed RPM for this Unit.

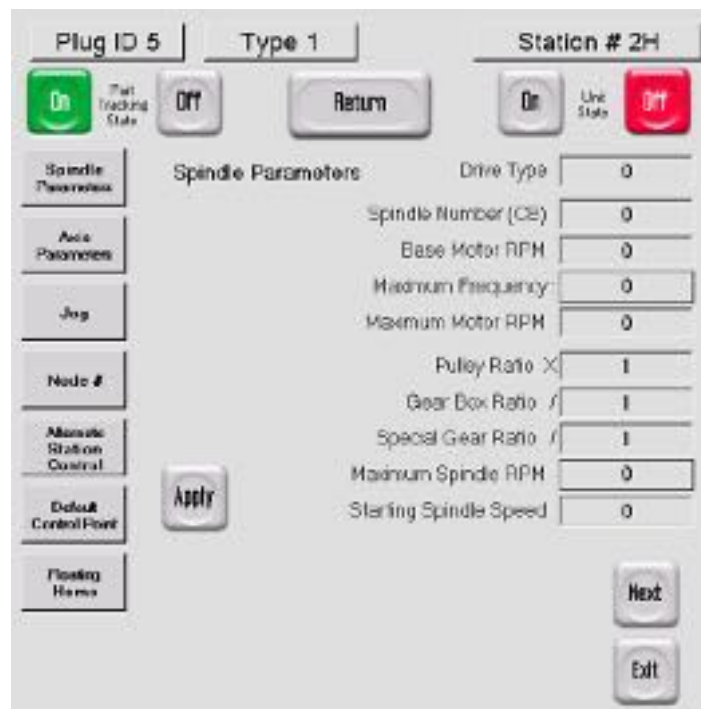

**Advanced Menu Screen**

- When installing a Single-axis Unit (26/80, 36/100, or 46/120), Press the NODE # button. Enter the Node number for the Profibus Bosch Valve on the single axis Units and press APPLY. This information can be found on the Unit identification tag on the Unit body. For Multi-axis Units and 3-axis Slide Flange Units, skip this step.

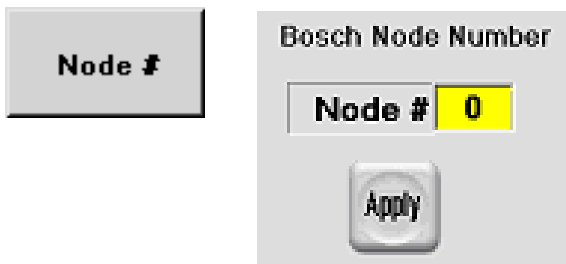

- When installing a Multi-axis Unit or 3-axis slide flange Unit, press the IP ADDRESS button as these Units communicate via Ethernet. Enter the IP address that can be found on the Unit identification tag attached to the Unit body and press APPLY.

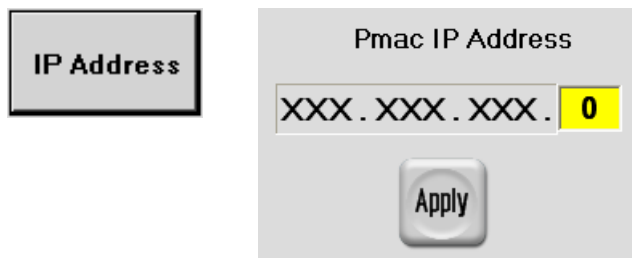

## 6. Epic Pendant Control

### PROGRAMMING A PART

#### SINGLE AXIS

This procedure explains how to create a part program for a Single Axis Unit on an Epic machine. All dimensions will be in mm.

1. Open the Main Status Screen on the Pendant Control by pressing the STATUS button.



2. At the Status screen, select the Unit that you want to make a new part program for by pressing the appropriate Unit number.

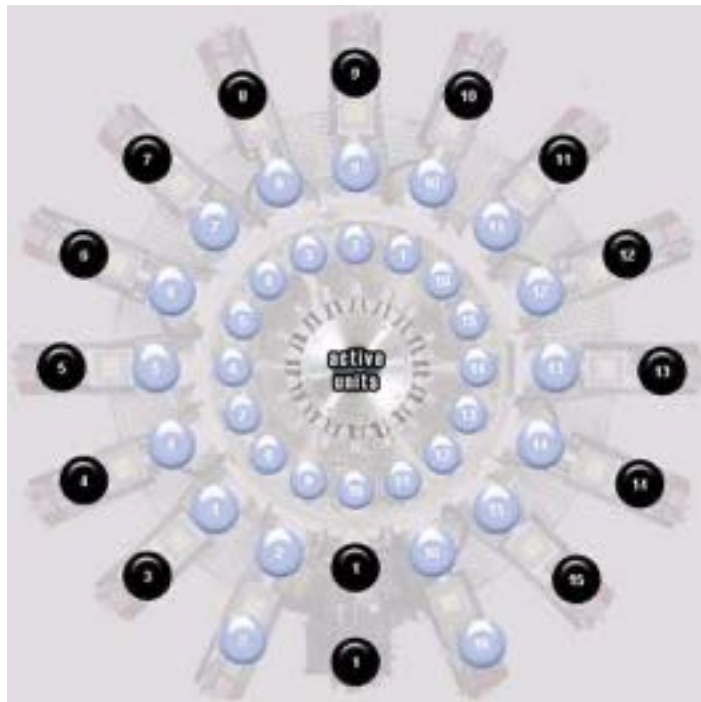

**Status Screen**

3. The Unit Settings screen will appear. Press on ADVANCED MENU then SPINDLE PARAMETERS.



Then





- Set the starting spindle RPM. If you change the spindle pulley ratios to get a different RPM range, update the ratio numbers. For a quick reference to pulley ratios, press on “PULLEY RATIO” and a little window will pop up with the standard pulley ratios.

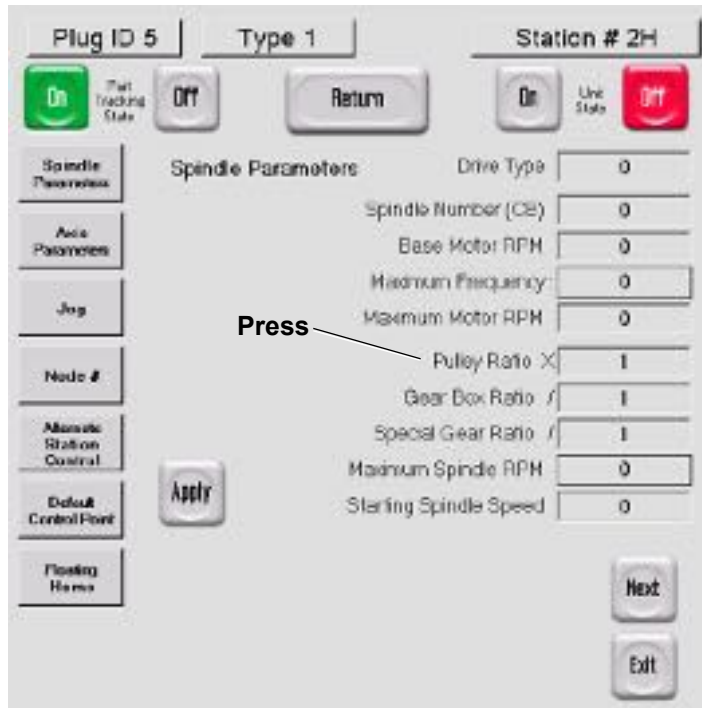

**Spindle Parameters**

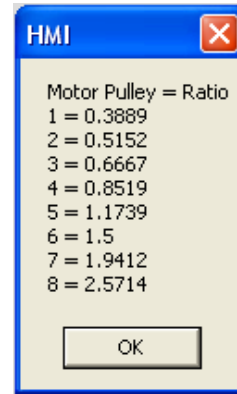

**Quick Reference**

- Press APPLY and then EXIT.

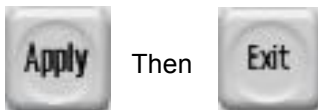

- Put the tool into the Machine. Once the Unit is homed the tool should be a minimum 16mm away from the part. This allows the Unit to home and extend closer to the part without damaging the tool.
- Press on the Unit you want to make a new part program for by pressing the appropriate Unit number.

## 6. Epic Pendant Control

8. Measure the tool geometry dimension of the tool you are putting into the machine. In “1.bmp”, the tool geometry is measured from the face of the HSK tool holder to the tip of the cutting tool. Enter this number into the epic application under Z Tool Geometry.

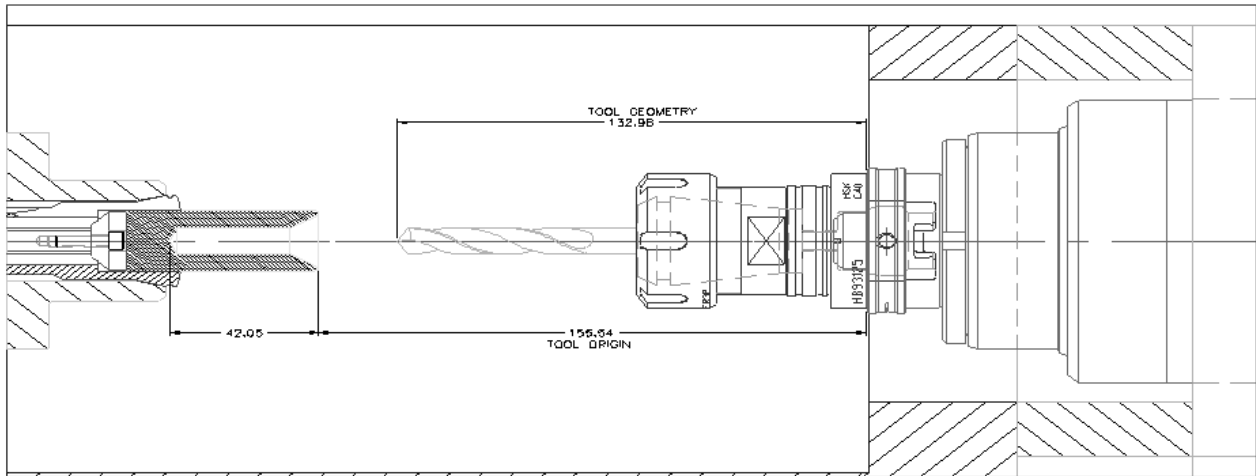

**1.bmp - Measuring Tool Geometry Dimension**

Tool Origin	Z	1.02
	Z	1.02
Tool Geometry	Z	0
	Z	0
Tool/Wear Keypad	Z	0
	Z	0

Apply

↑ ↓

**Tool Geometry**

9. Now measure the Tool origin. With a part loaded into the table and tabled in front of the Unit, measure from the face of the Spindle to the face of the part. A flexible metal scale is the easiest way to measure the dimension. This dimension is shown in “1.bmp” previously.
10. Enter this value into the Z tool Origin.
11. Enter 0 into the Z tool wear box.
12. Press on the “STATION #” button in the upper right corner.

Station # 2H

13. This is the part programming screen. Here you will type in the commands for your part program.

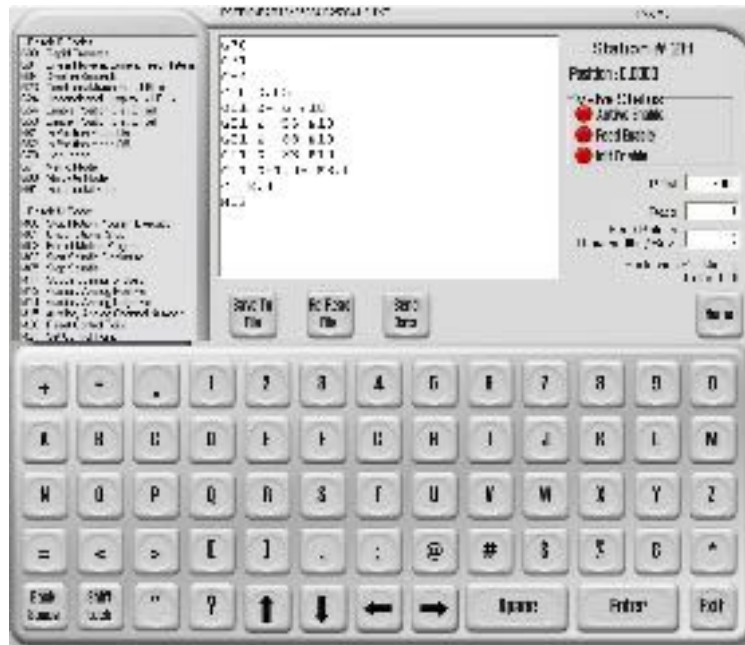

**Part Programming Screen**

14. Here is a sample part program for a drill.

- G71.....This places the unit in metric mode
- G54.....Enable position bias offset (enable origin, geometry, and tool wear)
- G00 Z3 .....Rapid move to 3mm away from the part. Positive values for Z are  
.....outside the part, negative values are into the part. Part lengths will vary  
.....slightly so don't rapid closer than 1mm to part.
- G01 Z-42.05 F50.....feed move at 50mm/min. to a depth of 42.05mm into the part. This  
.....42.05mm dimension should match the dimension on your part drawing.
- G04 F0.2 .....Pause at bottom of hole to ensure cleanup
- G53.....Cancel position bias offset to make sure unit comes all the way home
- G00 Z0 .....rapid home
- M02.....End of program

**Note:** The first cut from a part program should be very conservative with slow feeds and short or no rapid feeds. Once you verify that the program works correctly, more aggressive feeds and rapids can be used.

15. Press “SAVE TO FILE” and then “SEND DATA”.



16. If Unit is running for the first time, turn on spindles & verify spindle is rotating in the correct direction.

17. With Spindles and coolant on you can press “CYCLE START” to cut a part on that station.



## 6. Epic Pendant Control

### TWO AXIS

This procedure explains how to create a part program for a Two Axis 50/100 unit on an Epic Machine. All dimensions will be in mm.

1. Open the Main Status Screen on the Pendant Control by pressing the STATUS button.

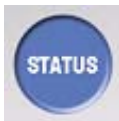

2. At the Status screen, select the Unit that you want to make a new part program for by pressing the appropriate Unit number.

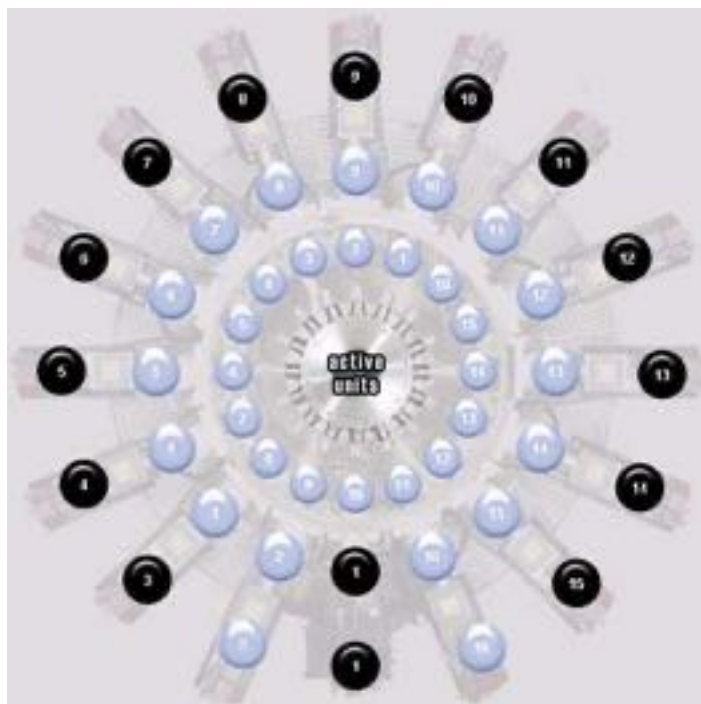

**Status Screen**

3. Press on ADVANCED MENU then SPINDLE PARAMETERS.

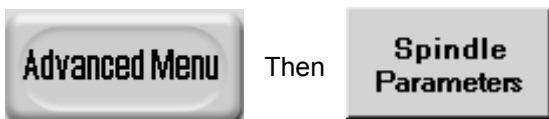

- Set the starting spindle RPM. If you change the spindle pulley ratios to get a different RPM range, update the ratio numbers. For a quick reference to pulley ratios, click on “PULLEY RATIO” and a little window will pop up with the standard pulley ratios.

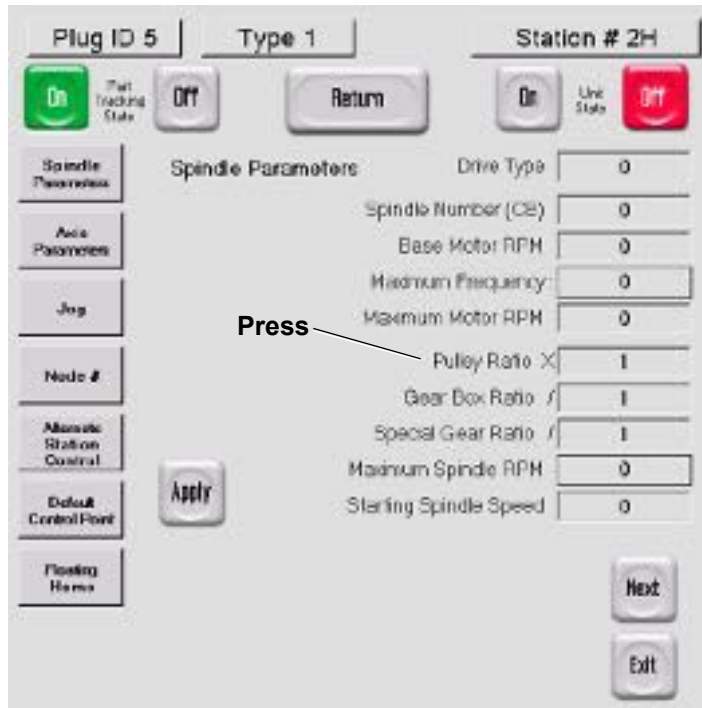

**Spindle Parameters**

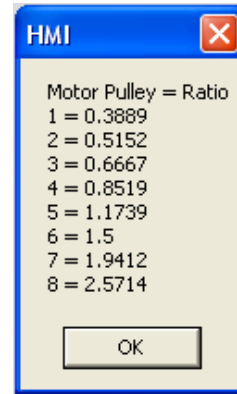

**Quick Reference**

- Press EXIT.



- Put your tool into the machine. Once the Unit is homed the tool should be a minimum 16mm away from the part. This allows the unit to home and extend closer to the part without damaging the tool if a part remains in the collet while homing. If your tool is too close you will need to add a spacer flange to the 50/100 unit to bring the tool away from the part.
- Press on the Unit you want to make a new part program for by pressing the appropriate Unit number.

## 6. Epic Pendant Control

8. Measure the Z tool geometry dimension of the tool you are putting into the machine. In “2axis1.bmp”, the tool geometry is measured from the face of the dovetail tool holder to the tip of the cutting tool. Enter this number into the epic application under Z Tool Geometry.

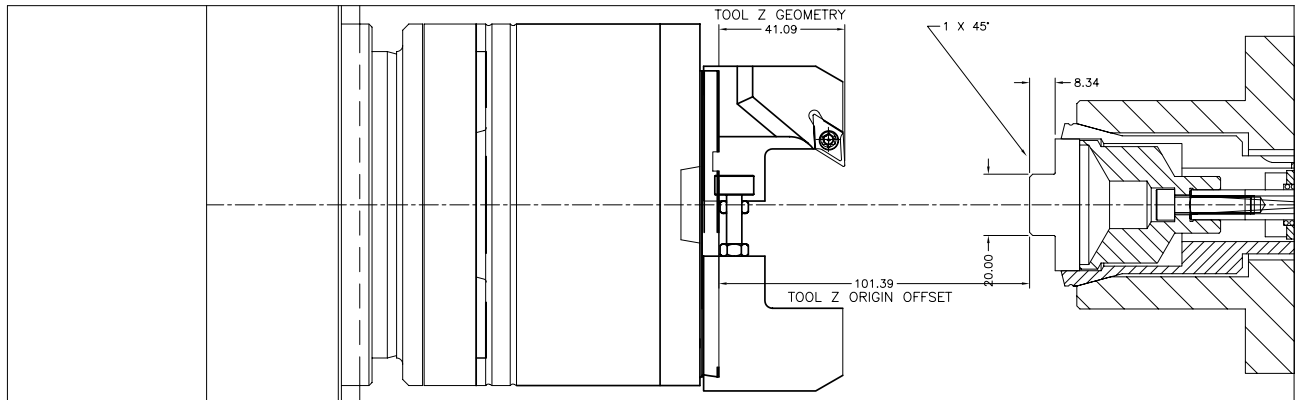

**2axis 1.bmp - Measuring The Z Tool Geometry Dimension**

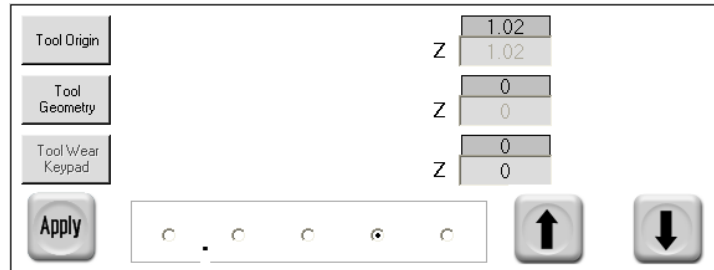

**Tool Geometry**

9. Now measure the Tool origin. With a part loaded into the table and tabled in front of the unit, measure from the face of the dovetail to the face of the part. A flexible metal scale is the easiest way to measure this dimension. This dimension is shown in “2axis 1.bmp” previously.
10. Enter this value into the Z tool Origin.
11. Enter 0 into the Z tool wear box.
12. Now calculate the X origin offset by jogging the tool out over the part.
13. Click on the advanced screen and then press jog.

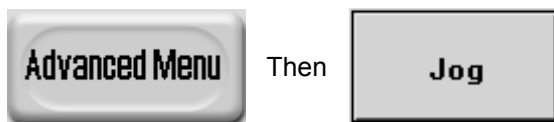

14. While holding the blue Release/Jog button on the pendant, press the Jog PLUS or MINUS button until the tool is over a turned diameter on the part.



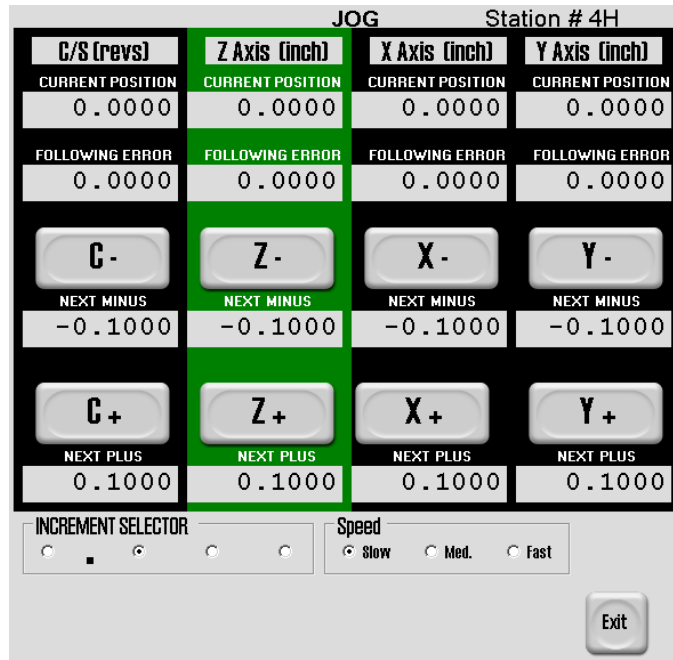

**Jog Screen**

15. Slow the jog speed to a slow speed. While holding the blue release button on the pendant, jog the X axis negative until the tool touches the part. See “2axis 2.bmp” and “2axis 3.bmp”

RELEASE / JOG

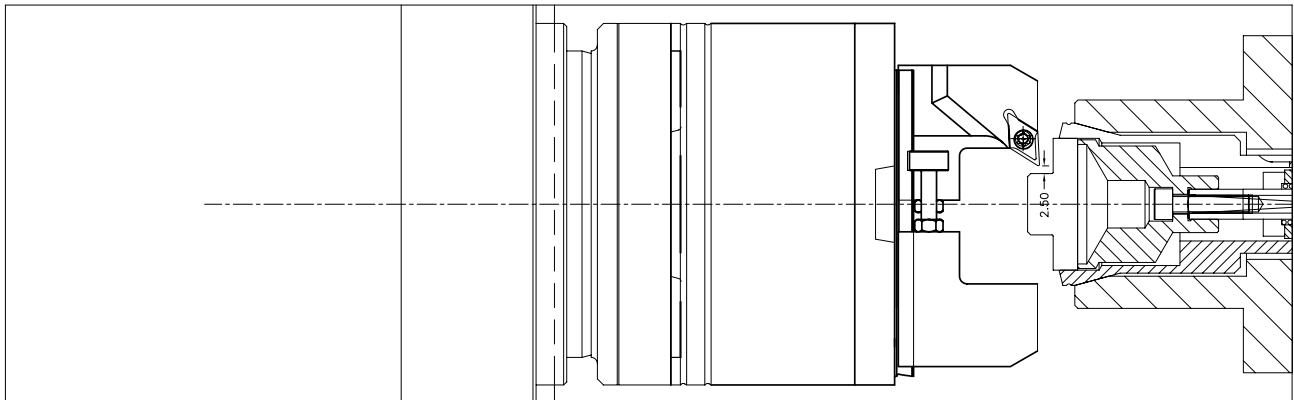

**2axis 2.bmp - Jog the X Axis Negative Until The Tool Touches The Part**

## 6. Epic Pendant Control

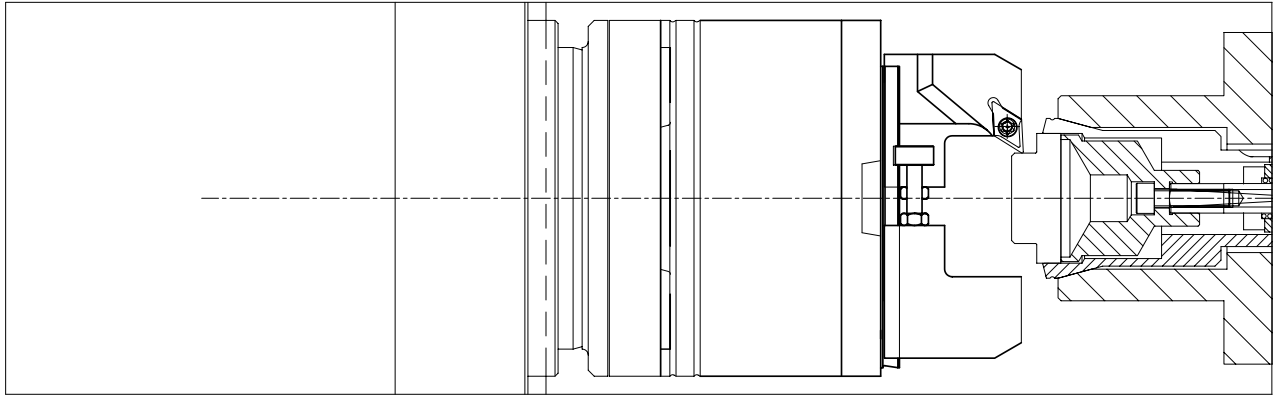

### 2axis 3.bmp - Jog the X Axis Negative Until The Tool Touches The Part

16. Now complete the following formula to calculate the X origin offset.
17.  $2 * (\text{positive value of the distance jogged in X}) + (\text{turned diameter in X})$
18. Example:  $2 * 2.5 + 20 = 25$
19. Press EXIT twice to get out of the Jog screen.

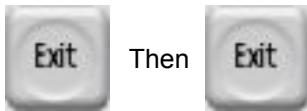

20. Press on the Unit again.
21. Enter the value you calculated for the X origin offset.
22. Press on the STATION # button in the upper right corner

Station # 2H

23. This is the part programming screen. Here you will type in the commands for your part program.
24. This is a sample part program for a chamfer and facing operation. See "2axis 4.bmp"

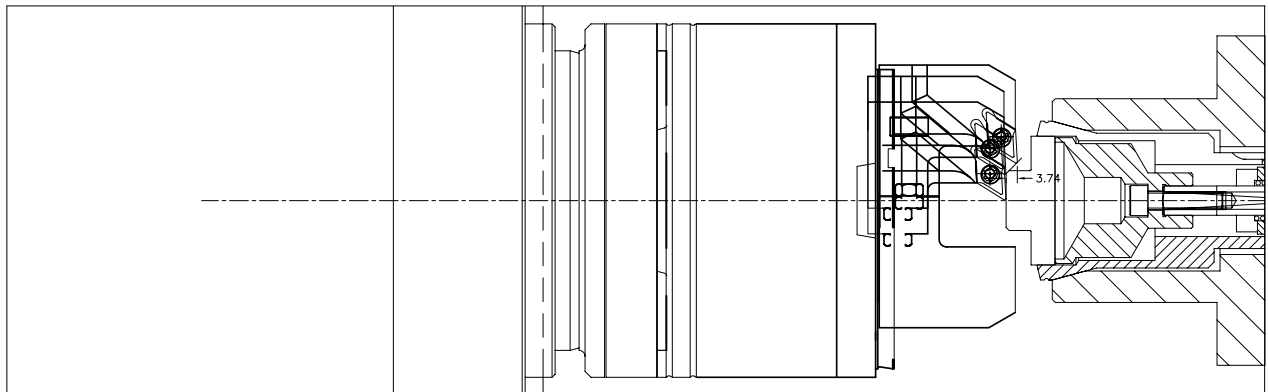

### 2axis 4.bmp - Chamfer and Facing Operation



OPEN PROG 1 CLEAR ..This is the start of all multi-axis programs  
M38.....Enable diameter entry mode for X-axis  
G18.....ZX Plane select for radius moves  
G54.....Enable origin & geometry offsets  
G00 X25 Z-3.74.....Rapid move past face of part3.74mm, with x-axis all the way open  
G04 F.2.....Dwell for a short time  
G01 X17.52 Z0 F50 .....Cut at a 45deg angle for the chamfer, 50mm/min. linear feed rate  
G01 X0 F50 .....Face part to 0 diameter, linear feed of 50mm/min.  
G00 Z5 .....Rapid away from part  
G53.....Cancel origin, geometry offsets  
G00 X0 Z0 .....Rapid home  
M02.....End of part program  
CLOSE.....End of part program

;Abort Routine

OPEN PROG 2 CLEAR ..Prog 2 is executed if spindles are turned off in the middle of the part program  
M38.....Enable diameter entry mode  
G01 Z5 X25 F100 .....Open Diameter, retract from part to z=5  
G53.....Cancel position bias offset  
G01 X0 Z0 F100 .....Feed to the home position  
M02.....End of part program  
CLOSE.....End of part program

**Note:** The first cut from a part program should be very conservative with slow feeds and short rapids or no rapid feeds. Once you verify that the program works correctly, then more aggressive feeds and rapids can be used.

25. Press “SAVE TO FILE” and then “SEND DATA”.



26. If this is the first time the unit has run, turn on spindles and verify that the spindle is rotating in the correct direction.

27. With Spindles and coolant on you can press “CYCLE START” to cut a part on that station.



## 6. Epic Pendant Control

# MOTION PROGRAM COMMAND SUMMARY

### G-CODE

Controller Type: P = PMAC, B=Bosch, A=Both

<u>Code</u>	<u>Controller</u>	<u>Description</u>
G00.....	A.....	Rapid Traverse
G01.....	A.....	Linear Move at Current Feed Rate and Mode
G01.1.....	P.....	Rapid Traverse in Feed Mode
G01.3.....	P.....	Open Loop Mode
G02.....	P.....	Clockwise Radius
G03.....	P.....	Counterclockwise Radius
G04.....	A.....	Dwell in Seconds
G04.3.....	P.....	Dwell until End of Travel Proximity
G09.....	P.....	Check for In Position before proceeding
G09.1.....	P.....	In Position Mode Off
G09.2.....	P.....	In Position Mode On
G17.....	P.....	X-Y Plane Select
G18.....	P.....	Z-X Plane Select
G19.....	P.....	Y-Z Plane Select
G22.....	B.....	Subroutine Call
G23.....	B.....	Conditional Jump
G24.....	B.....	Jump to Label
G33.....	P.....	Start of linear threading pass
G33.1.....	P.....	Canned Cycle Single Point Treading
G33.2.....	P.....	Canned Cycle Taper Threading
G33.3.....	P.....	Canned Cycle Threading with In Feed Angle
G33.4.....	P.....	Canned Cycle Threading with Zig Zag In Feed
G40.....	P.....	Cancel Tool Nose Radius Compensation
G41.....	P.....	Tool Nose Radius Compensation to Right of Tool Path
G42.....	P.....	Tool Nose Radius Compensation to Left of Tool Path
G41.1.....	P.....	Tool Nose Radius Compensation to Right of Tool Path
G42.1.....	P.....	Tool Nose Radius Compensation to Left of Tool Path
G52.....	B.....	Make the Current Position the Last Commanded Position
G53.....	A.....	Cancel Position Bias Offset
G54.....	A.....	Enable Position Bias Offset
G61.....	P.....	Exact Stop Mode Off (Blended Moves On)
G64.....	P.....	Exact Stop Mode On
G61.....	B.....	In Position Mode On
G62.....	B.....	In Position Mode Off
G70.....	B.....	Activate Inches Mode
G71.....	B.....	Activate MM Mode
G81.....	P.....	Canned Cycle Peck Drilling
G84.....	P.....	Canned Cycle Tapping
G90.....	A.....	Absolute Mode
G91.....	A.....	Incremental Mode
G94.....	P.....	User Units (Inches or MM) per Minute
G95.....	P.....	User Units Per Revolution

**M-CODE**

Controller Type: P = PMAC, B=Bosch, A=Both

M00	A	Unconditional Stop Motion Program Execution
M01	A	Conditional Stop Motion Program
M02	A	End of Motion Program
M03		Start Spindle Clockwise
M04		Start Spindle Counter Clockwise
M05		Stop Spindle
M11		S-Code Scaling for Bosch
M13		Axilliary Analog Positive (Bosch)
M14		Auxiliary Analog Negative (Bosch)
M15		Auxiliary Analog Channel Number (Bosch)
M16		Spindle in Spindle Mode Accel/Decel in Rate in Milti Seconds (F)
M16.1		Spindle in Tapping Mode Accel/Decel in Rate in Milti Seconds (F)
M17		Rapid Mode Accel/Decel in Rate in Milti Seconds for X,Y & Z Axis (F)
M17.1		Rapid Mode Accel/Decel in Rate in Milti Seconds for C Axis (F)
M17.2		Rapid Mode Accel/Decel in Rate in Milti Seconds for Z Axis (F)
M17.3		Rapid Mode Accel/Decel in Rate in Milti Seconds for X Axis (F)
M17.4		Rapid Mode Accel/Decel in Rate in Milti Seconds for Y Axis (F)
M18		Feed Mode Spindle Accel/Decel in Rate in Milti Seconds (F)
M20		Reset Control Point (Bosch)
M20.1 to M20.48		Reset Control Point (PMAC)
M21		Set Control Point (Bosch)
M21.1 to M21.48		Set Control Point (PMAC)
M22		Wait for Control Point Reset (Bosch)
M22.1 to M22.48		Wait for Control Point Reset (PMAC)
M23		Type 91 and 96 2nd Axis Run Program (Bosch)
M24		Reset Auxiliary Output (Bosch)
M25		Set Auxiliary Output (Bosch)
M26		Wait for Auxiliary Input Off (Bosch)
M27		Wait for Auxiliary Input On (Bosch)
M29		Reset all Axis In Position Zones to the default value
M29.01		Set all In position Zones to a Value (D or F Multiplier)
M29.10		Set Axis#1(C) to a Value (D or F Multiplier)
M29.11		Reset Axis#1 (C) back to the default value
M29.20		Set Axis#2(Z) to a Value (D or F Multiplier)
M29.21		Reset Axis#3 (Z) back to the default value
M29.30		Set Axis#3(X) to a Value (D or F Multiplier)
M29.31		Reset Axis#4 (X) back to the default value
M29.40		Set Axis#4(Y) to a Value (D or F Multiplier)
M29.41		Reset Axis#4 (Y) back to the default value
M30	A	End of Motion Program
M31		Abort Motion Program
M33.1		Cancel Pick Up Mode
M33.2		Enable Pick Up Mode
M33.3		Open the Spindle Collet
M33.4		Close the spindle collet
M33.5		Open the table collet

## 6. Epic Pendant Control

M33.6	.....	Close the table collet
M37	.....	Cancel diameter entry mode for X Axis
M38	.....	Enable diameter entry mode for X Axis
M40	.....	Cancel Spindle in Degrees Mode
M41	.....	Spindle in Degrees Mode
M42	.....	HS Index Drive Position Command (D)
M43	.....	Request Part Support
M44	.....	Cancel Part Support
M45	.....	Retract Cross Drill
M45.1	.....	Extend Cross Drill
M90	.....B.....	Valve Output On A1 or A2
M91	.....B.....	Valve Output Off A1 or A2

### MISCELLANEOUS COMMANDS

S	.....	Spindle R.P.M.
---	-------	----------------

### DEFAULTS

Modes active at the start of the program.

G61	.....	Blended Moves On
G64	.....	Blended Moves Off
G9.1	.....	In Position Mode Off
G90	.....	Absolute Mode
G94	.....	Inches per Minute
M37	.....	Radius Entry Mode
F1	.....	Feed = 1 user unit per Minute

## MOTION PROGRAM COMMAND DETAILS

### G-CODE

G00 - Rapid Traverse -> Usage G00 X-1.000 Z-1.000

The Axis moves at the default rapid traverse acceleration and velocity. The RPM of the of the spindle has no effect on this command.

G01 - Linear Move -> Usage: G01 X1.0000 Z1.0000 F.00800

The Axis move at the velocity commanded by the F word to the location specified by X and Z.

If the Unit is in absolute mode (G90) then the move is made relative to the X and Z Geometry. If the unit is in incremental mode (G91) the move is made relative to the current position of the Axis.

If the unit is in user units per revolution mode (G95) then the velocity of the Axis are determined by the feed rate and RPM.

G1.1 - Rapid Traverse

Similar to G00 except the axis are still coordinated.

The coordination may not be exact because of increased following error so the default feed rate may be over ridden with the F command to reduce following error. After the move is complete and in position command is issued and then the feed rate is returned to where it was prior to this command.

G01.3 - Open Loop Move -> Usage: G01.3 X3 Y3

Sends an open loop command of 3% (300 Mv) to the axis. See G04.3

G02 - CW Radius

Usage: G02 X1.0000 Y1.0000 Z1.0000 I1.0000 J1.0000 K0.0000 F.008

Or: G02 X1.0000 Y1.0000 Z1.0000 R1.0000 F.0008

The right hand rule is in effect. This means that if you point your right thumb in the Z minus direction your fingers will curl in the direction of a clockwise radius for a X Y circle.

There are five steps in programing a circle.

1. Define the work plane using G17, G18 or G19
2. Move to Axis to the start of the radius.
3. Define the end of the radius using X and Z Coordinates.
4. Define either the center of the radius using I, J, and K or define the size of the radius using R.
5. Define the feed rate (optional).

When using I, J, and K to define the center of the circle they correspond to X, Y, and Z respectively.

## 6. Epic Pendant Control

### G03 - CCW Radius

Usage: G03 X1.0000 Z1.0000 I1.0000 J1.0000 K1.0000 F.008

Or: G03 X1.0000 Z1.0000 R1.0000 F.0008

See G02 for details.

### G04 - Dwell Format: G04 F1.10

Dwell in seconds.

### G04.3 - Usage -> G04.3 X1 Y0

Causes the motion program to dwell until the axis conditions are met.

Dwells the motion program until X axis is all the way in. This is usually determined by a end of travel proximity switch. X0 would wait for a axis to travel all the way out Y0 and Y1 - Y Axis out and in respectively.

### G09 - In Position

Causes the previous move to stop momentarily before going on to the next move command. In other words the slide velocity does not slew to the next velocity, it stops and then restarts.

### G9.1 - Cancel In Position Mode

G9.2 - An In Position check will be done after every move until it is canceled

### G33 - Synchronize With The Spindle

The motion program waits until the marker pulse on the spindle encoder is high before the motion program is started., therefore any linear moves (not G00) made after this command and will be in sync. This command is usually used for manual threading cycles but it can synchronize any type of move.

Keep in mind that moves along both axis take more time which may cause a pitch lead error and that variations in load may cause variation in the time required to get in position.

### G33.1 - Canned Cycle Threading

Usage: G33.2 P11 D-.05 Q.0001 L-1.200 P11 A0 O1 T6 F2 V.002 S1 C.01

P = The pitch of the thread is simply the number of threads per inch or the pitch of the thread in MM.

Q = The amount to modify the pitch lead. (Optional)

D = The distance to the root of the thread. At the start of the thread we would normally be sitting on the "Major Diameter" of the thread. In this case it is towards the spindle and that is in the negative direction from the current position.

L or Z = The length of thread is -1.000 from the front of the part so we add the approach of .200 to the length of the thread making sure that (in this case) it is a negative number because the final position the tool is closer to the spindle than the start.

R = The number of roughing passes is divided by the depth of the thread, after the finish passes are totaled and subtracted from the thread depth.

F = It is usually desirable to slow up the penetration rate near the end of the threading cycle to improve the surface finish of the thread. This is simply the number of finish passes you require.  
(Optional)

G = This is the depth of each finish pass. The total ( $F * V$ ) is automatically subtracted from the depth of the primary passes so that the finish passes do not increase the total depth (D) of the thread.  
(Optional)

C = The clearance on the return stroke is the amount and direction to clear the part by during the return along the Z axis. Extra care is required when threading internally or cutting a tapered thread.

Before starting a canned threading cycle, move the tool to the start of the thread. On a 5/8 - 11 thread for example... if front of the part is the Z datum, you would move tool to X.625 (assuming you are in diameter mode) and Z.200. Then describe the thread with the canned cycle relative to the current position using .200 as the approach.

See G33.2

### G33.2 - Threading Canned Cycle

Same as G33.1 with the following additions:

L or Z = Length of Thread

X = End position in X (Optional)

### G33.3 - Threading Canned Cycle

Same as G33.2 with the following additions:

I = In Feed Angle

### G33.4 - Threading Canned Cycle

Same as G33.2 with the following additions:

I = Zig Zag Angle

The tool will zig zag from side to side as it feeds in. If the angle is too large the root of the thread will be too wide.

### G40 - Cancel Tool Nose Radius Comp -> Usage: G40

### G41 - Tool Nose Radius Comp Right -> Usage: G41

The tool nose radius or tool diameter is entered in the geometry screen on the operator interface panel.

### G42 - Tool Nose Radius Comp Left -> Usage: G42

The tool nose radius or tool diameter is entered in the geometry screen on the operator interface panel.

### G41.1 - Tool Nose Radius Comp Right -> Usage: G41 R.125

R = Radius of Tool or Tool Nose Radius

D = Diameter of Tool or Tool Nose Radius

### G42.1 - Tool Nose Radius Comp Left -> Usage: G42 R.03

R = Radius of Tool or Tool Nose Radius

D = Diameter of Tool or Tool Nose Radius

## 6. Epic Pendant Control

G53 - Cancel Position Bias Offset

G54 - Set the Position Bias Offset

It is entered from the operator interface. On the Z axis it is the distance from the Z axis programing datum to the home position so it is always a positive number. It is made up of the Origin which is the distance from part datum (often the front of the finished part) to the face of the spindle, minus the geometry which is the distance from the face of the spindle to the tip of the tool, which is typically the number acquired from the tool presetter. All the rest of the offsets such as the tool wear offset, chuck indexer offsets etc. are also added to this number so that just before the motion program is started the motion controller is passed one number that is the compilation of all the offsets.

On an X Y flange the Origin is the distance and direction from where you want the unit to be to the home position.

For example: If you have just finished centering an X Y flange on a collet you would enter the distance and direction from where each axis is currently, to the home position. If you are to the right of the home position by .010" then you would enter -.01" into the X Axis Tool Origin on the operator interface.

G61 - Exact Stop Mode Off (Blended Moves is turned on)

If the next move in the motion program requires a velocity change then the all axis will slew the new velocity without going to zero velocity first.

G64 - Exact Stop Mode On

All axis will come to zero velocity before proceeding to the next motion command. This will persist until a G61 cancels this mode.

G70 - Inch Mode

This command has not effect on a PMAC controlled unit. The control mode is set at startup of the operator interface.

G71 - Metric Mode

This command has not effect on a PMAC controlled unit. The control mode is set at startup of the operator interface.

G81 - Canned Drilling Cycles with Pullouts

A = First Pass  
B = Second Pass  
C = Third Pass  
D = Balance of Passes  
L = Depth of Hole  
R = Retract Clearance  
W = Dwell Time

A = First Pass

The depth to drill on the first drilling pass



B = Second Pass

The depth to drill on the second drilling pass

C = Third Pass

The depth to drill on the third drilling pass

D = Balance of Passes

The depth to drill on all remaining passes required to get to the depth of the hole.

L = First Pass

Position the drill to the start of the cut and leave the control in the feed style (G94 or G95) you intend to use. Enter the total depth of cut including the drill point (if necessary).

R = Retract Clearance

How far to pull out of the hole between each drilling pass

W = Dwell Time

The amount of time in seconds to dwell after the full depth of the hole is reached.

### G84 - Canned Tapping

Usage: G84 L-2 P20 R5 F10 H20

L or Z = Distance to move in Z

This would normally be the approach plus the depth of the hole. Note that unlike single point threading, tapping does not require an approach to allow the spindle time to sync with the Z axis. The spindle and the quill are in the same coordinate system when tapping and do not require time to synchronize as they are accelerated and decelerated together. They behave in exactly the same way the X and Z axis do on a 50-100 unit.

P = Pitch of Thread

The pitch may be a decimal number in order to make spacial threads or to specify a metric thread while in inch mode for example.

R = Threading Spindle Pulley Ratio

The pulley ratio is the number of turns of the motor that are required to turn the spindle exactly one revolution. The resolution of the spindle encoder can be up to 131072 counts per revolution so at least 4 decimal places are required in your calculation. If you are using a gear box remember to multiply the gear box ratio (5:1 is standard) by the pulley ratio to get the overall ratio.

F = Feed Rate in the Z Axis

The feed rate along the Z axis combined with the pulley ratio and the thread pitch determines the velocity of the spindle motor that is required to screw the tap in and out at exactly the right pitch. A fine pitch tap in combination with a high pulley ratio can easily demand a higher acceleration rate or peak velocity that the motor/amplifier can deliver. In this case you will get a following error or amplifier fault error when you cycle the unit. Your options at that point are to reduce the feed rate, change to pulley ratio or decrease the acceleration rate.

## 6. Epic Pendant Control

The Spindle RPM is the feed rate in inches per minute \* the threads per inch \* the pulley ratio.

For example, a ¼-20 tap at a feed rate of 10 inches per minute \* 20 pitches per inch would mean that in 1 minute the spindle would have to turn 200 revs. If you are using a 5:1 gear box then the motor would have to turn 1000 times in one minute. This is acceptable as the motor is capable of at least 3000 RPM.

If the motor is turning 1000 RPM and the spindle is turning 200 RPM then the surface feet per minute of the tap can be determined by the formula: Tap Diameter \* .262 \* Spindle RPM or  $.25 * .262 * 200 = 52.4$  Surface Feet per Minute.

H = Feed Rate of the Z Axis during “Tap Out”

### G90 - Absolute Mode

All moves are calculated relative to the X, Y and Z datums set using the geometry settings.

### G91 - Incremental Mode

All moves are calculated relative to current position of the tool. The first move of a program should not normally be an incremental move because the bias offset would not be used so the datums would not be used to position the tool relative to the part. Cancels Diameter Mode Programing (M07 & M08).

### G94 - User Units per Minute

All feed rates are interpreted as user units of travel per minute. When cutting an angle the feed rate is calculated along the hypotenuse of the triangle, so the move times may be slightly longer.

### G95 - Inches Per Revolution

All feed rates relative to one revolution of the spindle encoder. If the spindle slows down the axis will also slow down. If the spindle stops the unit will stop.

**M-CODE**

M00 - Stop Motion Program Execution

M01 - Optional Stop

The motion program is stopped at the end of the current move.

M02 - End of Motion Program

M03 - Start Spindle Clockwise

Usage: M3 S1000

Starts the spindle in a clockwise direction

M04 - Start Spindle Counter Clockwise

Usage: M3 S1000

Starts the spindle in a counter clockwise direction

M05 - Stop the Spindle

M16 - Spindle Accel/Decel

Usage: M16 F900

Sets the acceleration and deceleration of the spindle in mili-seconds.

M16.1 - Tapping Mode Accel/Decel

Usage: M16.1 F900

Sets the acceleration and deceleration of the spindle in mili-seconds.

M17 - Rapid Mode Accel/Decel

Usage: M17 F900

Sets the acceleration and deceleration of all axis except the spindle in mili-seconds.

M17.1 - Rapid Mode Accel/Decel for Axis 1

Usage: M17.1 F900

Sets the rapid mode acceleration and deceleration of Axis 1 mili-seconds.

M17.2 - Rapid Mode Accel/Decel for Axis 2

Usage: M17.1 F900

Sets the rapid mode acceleration and deceleration of Axis 2 mili-seconds.

M17.3 - Rapid Mode Accel/Decel for Axis 3

Usage: M17.1 F900

Sets the rapid mode acceleration and deceleration of Axis 3 mili-seconds.

M17.4 - Rapid Mode Accel/Decel for Axis 4

Usage: M17.1 F900

Sets the rapid mode acceleration and deceleration of Axis 4 mili-seconds.

## 6. Epic Pendant Control

M18 - Feed Mode Accel/Decel for Coordinate System 1

Usage: M18 F900

Sets the feed mode acceleration and deceleration of Coordinate System 1 milli-seconds.

M20.01 through M20.48 - Reset Control Bit

M21.01 through M21.48 - Set Control Bit

M22.01 through M22.48 - Set Control Bit

M29 - Reset In Position Zones to Default

M29.01 - Set All Axis In Position Zones

Usage: M29.01 D2.1

All axis in position zone will be set to 2.1 \* the default in position zone.

D3 would make it 3 times the normal size. This would usually speed up the cutting cycle but increases the risk of rounding corners etc.

M29.01 F2.1 also works.

M29.1 - Set Axis 1 In Position Zone

Usage: M29.1 D2

Or: M29.1 F2

M29.11 - Reset Axis 1 In Position Zones To The Default Value

M29.2 - Set Axis 2 In Position Zone

Usage: M29.2 D2

Or: M29.12F2

M29.21 - Reset Axis 2 In Position Zones To The Default Value

M29.3 - Set Axis 3 In Position Zone

Usage: M29.3 D2

Or: M29.13F2

M29.31 - Reset Axis 3 In Position Zones To The Default Value

M29.4 - Set Axis 4 In Position Zone

Usage: M29.4 D2

Or: M29.4 F2

M29.41 - Reset Axis 4 In Position Zones To The Default Value

M30 - End Motion Program

M33 - Pick Up Spindle Mode Controls

The Spindle Collet and the table Collet can be controlled from here.

The Spindle motor can be a frequency drive or a inverter drive depending on the application.

M33.1 - Cancel Pick Up Mode

M33.2 - Enable Pick Up Mode

M33.3 - Open the Spindle Collet

M33.4 - Close the Spindle Collet

M33.5 - Open the Table Collet

M33.6 - Close the Table Collet

M37 - Cancels X Axis Diameter mode programming. X Axis moves reverts back to normal operation. This is the default mode.

M38 - The control will handle X Axis moves as if X0.0 is the center of the spindle. This enables direct programming of part print diameters without the dividing it by 2 manually. The control forces absolute programming mode (G90) during this mode.

### CAUTION

**If your X Datum is not the center of the spindle and you are not in absolute mode, diameter mode programming may produce unexpected results.**

M40 - Cancel Spindle in Degrees Mode

M41 - Spindle in Degrees Mode

M42 - HS Index Drive Position Command

Usage: M42 D45

Commands the Index Drive currently in front of the unit to index to 45 Degrees.

M43 - Extend Part Support

S - The station number.

M44 - Retract Part Support

S - The station number.

### CHANGING THE CONTROL MODE

The following commands can be used after the motion program is closed to change the control mode.

M32=1 - Spindle Mode On

M32=2 - Tapping Mode On

### RESTORING A BACKUP PLC PROJECT INTO AN EPIC MACHINE

This procedure describes the proper way to restore a PLC project to an EPIC machine.

#### CAUTION

**This procedure should only be used as a last resort and only if there is no response from the PLC.**

1. Exit the EPIC application by pressing the “Calculator” button then the “Backspace” button on the calculator.
2. Open windows explorer. You should find this under the “Start” menu, “All Programs/Accessories/Windows Explorer”. You can also right click on the “Start” menu button and select “Explore”.
3. In Windows Explorer check to see if there is a folder “C:\Program Files\Rockwell Automation\SoftLogix5800\Data\Slot01”.
4. If there is not a folder this means that somehow the PLC was deleted from the chassis. If there is a folder skip to step 17.
5. Open the chassis monitor by going to the “Start” menu, “All Programs/Rockwell Automation/SoftLogix 5800/SoftLogix Chassis Monitor”.
6. If there is not a “SoftLogix” PLC in slot 1, add one by following the next steps. If there is one present, skip to step 17.
7. Click on Slot 1.
8. Click on the “Slot” menu in the menu bar.
9. Select “Create Module”.
10. Select “1789-Lxx” from the Module type menu (usually the first item on the menu). The “xx” number is different depending on which version of SoftLogix is installed.
11. Click “OK”
12. Select “Last Controller State” from Startup Mode drop box.
13. “Periodic Save Interval” should be 10, and check “Enable Periodic Save”.
14. Click “Next”
15. Click “Finish”
16. Skip to step 19
17. In Windows Explorer check to see if there is a folder “C:\Program Files\Rockwell Automation\SoftLogix5800\Data\Slot01”.
18. There are three files of interest in this folder: “ldslot01.acd, slot01.acd, and svslot01.acd”. All three files should be present and be at least 1,500 Kb in size. Usually if the PLC is not running, the file “svslot01.acd” is missing or is very small in size. Make note of these files and the Kb sizes for later reference.
19. In Windows Explorer check to see if there is a folder “C:\Program Files\Rockwell Automation\SoftLogix5800\Backup” and that there is a file called “svslot01.acd”. Make note of the Kb size and date of this file. If this file is present then there was a backup made and the date of the PLC will tell what revision the PLC program is.

20. In Windows Explorer go to “C:\Program Files\Rockwell Automation\SoftLogix5800\PLC Backup Function”. Double click on the “Restore PLC.bat” file. Be absolutely sure this is the file executing or the backup files may be erased.
21. Open the chassis monitor by going to the “Start” menu, “All Programs/Rockwell Automation/SoftLogix 5800/SoftLogix Chassis Monitor”.
22. Right Click on the PLC in slot 1.
23. Select “Run”
24. Click “Yes”
25. Reboot the Computer.
26. PLC is now restored.

## 6. Epic Pendant Control

### HOW TO EMPTY THE FULL MACHINE OF PARTS FOR SHUTDOWN

This procedure describes the proper way to finish out the remaining parts from the Collet Table before shutting down the Hydromat machine.



**WARNING:**

**Care must be taken not to machine into ejector pins in empty stations.**

1. At the Status screen, press on Station 1 horizontal (loading station) and the Unit Settings screen will appear.
2. At the Unit State area, press the OFF button.

Go to step 5 if Machine does not have Inverting.

3. Press SINGLE CYCLE until the first part is at the station before the Inverter.
4. Turn off the Inverting Station (if Machine has Inverting) by pressing the STATUS button on the Pendant. Then select the Inverting Station and turn OFF the Unit State at the Unit Settings screen.
5. Press AUTO and let the Machine cycle until the last part is ejected.
6. Press the COOLANT AND SPINDLES OFF button on the pendant.
7. Press the Emergency Stop pushbutton on the pendant.
8. Optional - The Electrical Cabinet Main Disconnect can now be turned off.

### LOADING THE MACHINE WITH PARTS

This procedure describes the proper way to load the Machine with parts.



**WARNING:**

**Care must be taken not to machine into Ejector Pins in empty stations.**

1. Pull out the Emergency Stop and turn on the Main Disconnect if it is off.
2. At the Machine Control Keypad, press HYDRAULICS to turn on Hydraulics.
3. Press Home to home the Units.
4. At the Machine Control Keypad, press COOLANT to turn on Coolant.
5. At the Machine Control Keypad, press SPINDLES to turn on Spindles.
6. At the Status screen, press on Station 1 horizontal and the Unit Settings screen will appear.
7. At the Unit State area, press the ON button.

Go to step 9 if Machine has Inverting.

8. Press AUTO to put the Machine into production. Skip Steps 9-11.
9. Press SINGLE CYCLE until the first part is at the station before the Inverter.
10. Turn on the Inverting Station (if Machine has Inverting) by pressing the STATUS button on the Pendant. Then select the Inverting Station and turn ON the Unit State at the Unit Settings screen.
11. Press AUTO to put the Machine into production.



## PENDANT LIGHT INDICATIONS

The following conditions are for the HYDROMAT ROTARY TRANSFER Machine and Barfeeder as indicated by the Green, Orange, Red, and Blue lights on top of the Pendant pole.

### RED SOLID

Indicates that the MCR relay is energized and Automatic Cycle is off.

### RED FLASHING

Indicates there is a Time Delay Fault.

### ORANGE SOLID

Indicates that the Barchange mode is active (countdown has been activated).

### RED AND ORANGE FLASHING

Indicates that there is a Bar Change Fault.

### RED, ORANGE AND GREEN FLASHING

Indicates that the Bar is not Feeding, the Saw did not finish its cycle.

### ORANGE FLASHING

Indicates that a Barchange is in progress.

### GREEN SOLID

Indicates that the Spindles are on without any Fault conditions.

### GREEN FLASHING

Indicates that the Machine has an Instantaneous Fault.

### BLUE SOLID

Indicates that all of the CNC units have returned to their Home positions.

### BLUE FLASHING

Indicates that all of the CNC units are in a Homing cycle.

**SEE CHAPTER 13 TROUBLESHOOTING FOR INFORMATION ON MACHINE FAULTS.**

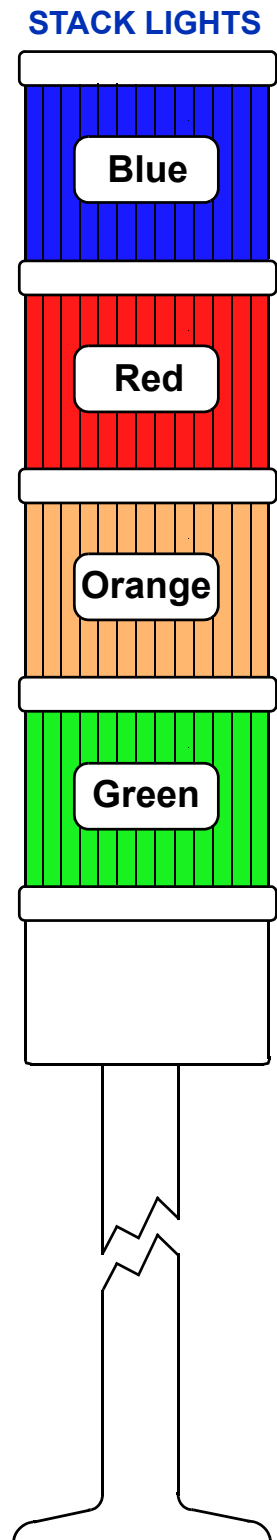

**7. CONTROL VALVES AND EMBEDDED CONTROLS**

BOSCH DIGITAL CONTROL VALVE IAC-R (OBE - ON-BOARD ELECTRONICS) ..... 7-1  
BOSCH ANALOG CONTROL VALVE (OBE - ON-BOARD ELECTRONICS)..... 7-1  
BOSCH VALVE TORQUE SPECIFICATIONS..... 7-2  
LOADING VALVES ..... 7-3  
INVERTING VALVE ..... 7-4  
SEQUENCE OF THE INVERTING VALVE ..... 7-4  
INVERTING VALVE ADJUSTMENTS..... 7-4  
PRESSURE SWITCH ..... 7-5  
BILL OF MATERIAL: PRESSURE SWITCH - 4.12.018-1/2..... 7-5  
DESCRIPTION OF THE TABLE INDEX VALVE..... 7-6  
DESCRIPTION OF THE FREQUENCY DRIVE ..... 7-7  
DESCRIPTION OF THE PMAC ASSEMBLY ..... 7-8

## CONTROL VALVES AND EMBEDDED CONTROLS

### BOSCH DIGITAL CONTROL VALVE IAC-R (OBE - ON-BOARD ELECTRONICS)

The Bosch Control Valve IAC-R is a self contained single axis motion controller. Programming and control is communicated through a profibus network. Feedback is received directly into the valve for position control. The Valve controls the velocity and positioning of the Unit.



**Bosch Digital Control Valve (IMC - Integrated Motion Control) For Single Axis**

### BOSCH ANALOG CONTROL VALVE (OBE - ON-BOARD ELECTRONICS)

The Bosch Control Valve OBE contains on-board electronics. The Valve is controlled by an External Motion Controller; i.e., PMAC (Amp only).

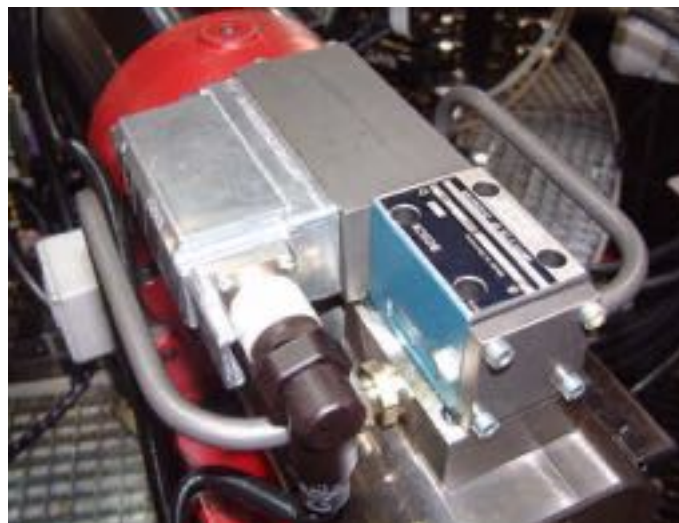

**Bosch Analog Control Valve (OBE - On-board Electronics) For Multi Axis**

## 7. Control Valves and Embedded Controls

### BOSCH VALVE TORQUE SPECIFICATIONS

All Bosch Valves require that the four Mounting Screws be tightened with a Torque Wrench. The Torque Wrench must have a 4 mm hex head set at 62 in.-lb (7 Nm) of torque. Using the specified Torque Wrench, install the four Mounting Screws in the Bosch Valve to the Unit as shown.

**Torque Wrench Specifications:**  
4 mm Hex Head  
Setting: 62 in.-lb (7 Nm)

4 Mounting Screws

Bosch Valve

Unit



**Mounting a Bosch Valve**

## LOADING VALVES

The Loading sequence is controlled by a series of valves like the example shown below.

- Loading Station 1 Collet Release - Controls the opening and closing of the station 1 collets.
- Collet Release - Opens and closes the remaining collets.
- Bar Clamp - Controls the material feed into the machine. It starts the Hydraulic Motor on the Barfeeder and moves the Bar forward into the open Collet on the Rotary Index Table.
- Saw Axis Control - Controls the saw axis.

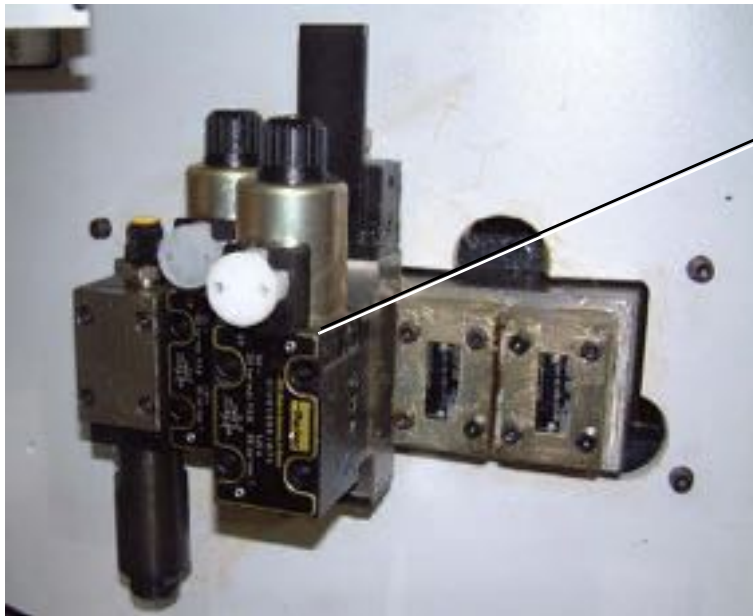

4/2 Way  
Solenoid  
Valve

**Loading Sequence Valves Below Station 1**

## 7. Control Valves and Embedded Controls

### INVERTING VALVE

The Inverting Valve can be placed at any of the Stations between 3 and 9 (on 10 station machines), 3 and 11 (on 12 station machines), and 3 and 15 (on 16 station machines). Its function is to turn the part 180 degrees around.

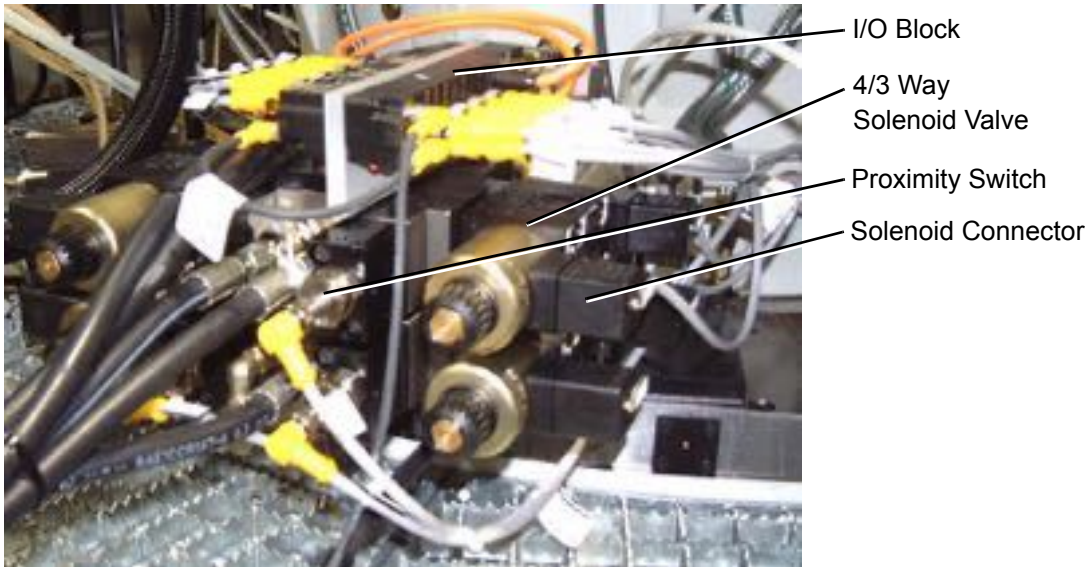

**Inverting Valve**

If the Inverting Unit is jammed, **DO NOT TRY TO FREE THE PART WITH YOUR HAND WHILE THE HYDRAULIC POWERPACK IS UNDER PRESSURE. PRESS THE “EMERGENCY STOP”**.

### SEQUENCE OF THE INVERTING VALVE

The sequence is as follows:

1. The Unit moves out and the Inverting Bushing goes over the part.
2. The Collet opens up over the Control Pivot, and the Ejector pushes the part into the Inverting Bushing.
3. The Inverting Bushing rotates 180 degrees.
4. The part is pushed back into the Collet by the Pushrod.
5. The Collet closes over the part.
6. The Inverting Unit moves back to the home position.
7. The Pushrod moves back to its home position.
8. The Inverting Bushing rotates back into the starting position.

### INVERTING VALVE ADJUSTMENTS

The following adjustments can be made to the Inverting Valve.

1. Pressures to all functions can be adjusted.
2. Sequence of motion can be altered or customized.
3. Collet clamping pressure can be lowered for thin sections.

**PRESSURE SWITCH**

The pressure switch indicates start and stop motion.

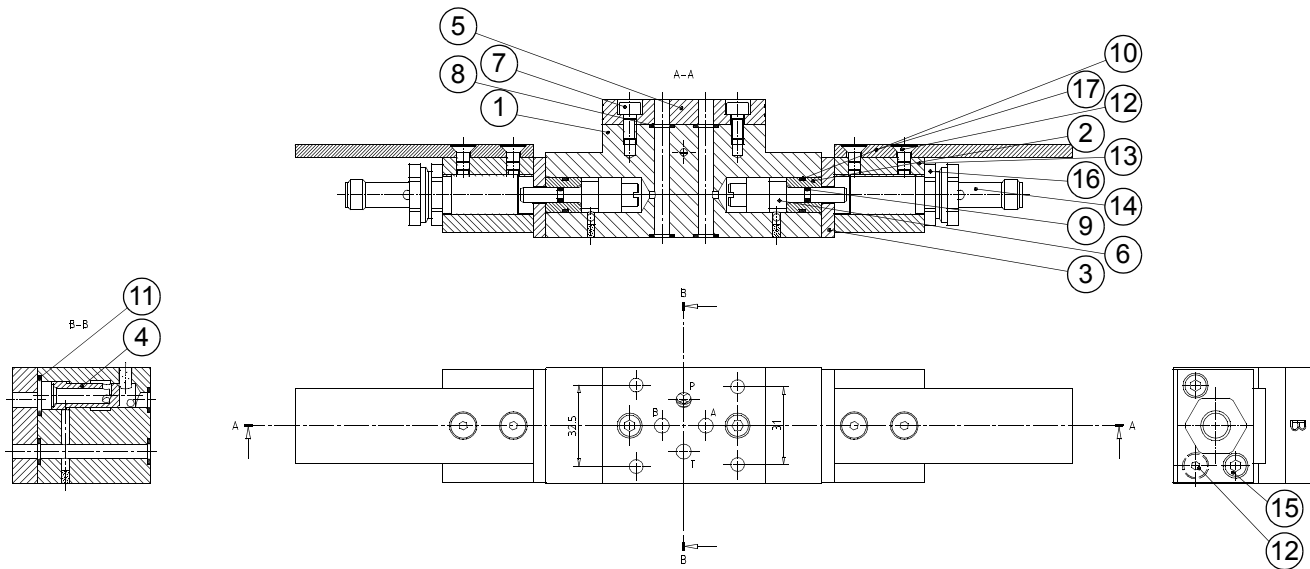

**Pressure Switch**

**BILL OF MATERIAL: PRESSURE SWITCH - 4.12.018-1/2**

<u>Item</u>	<u>Qty.</u>	<u>Description</u>	<u>Part Number</u>
1	1	Switch Block	4.12.118
2	2	Distance Plug	4.12.119
3	2	Plate	4.12.120
4	1	Proportioning Pressure Regulator	4.12.122
5	1	Connection Plate	4.12.123
6	2	Switch Piston	4.12.124
7	4	Cap Screw	M5 X 10
8	7	O-Ring	ORM 0071-16
9	2	O-Ring	OR 2012
10	2	O-Ring	OR 2043
11	1	O-Ring	OR 2050
12	8	Flat Head Screw	M5 X 12
13	2	Limit Switch Holder	4.12.153-1
14	2	Limit Switch	BES-516-207-S 27-E
15	4	Cap Screw	M5 X 40
16	2	Clamping Switch	BES 12.0-KH-2L
17	1	Guard	4.12.154

## 7. Control Valves and Embedded Controls

### DESCRIPTION OF THE TABLE INDEX VALVE

The Table Indexing Valve controls the functions for Table Lift, Turning, and Sitting Down. This Valve also controls the movement of the Table into a Half Index Position for the Barchange and tool changes. The Half Index Position is controlled by either the Pendant Control Push Button or the Barchange Sequencer during an Automatic Barchange.

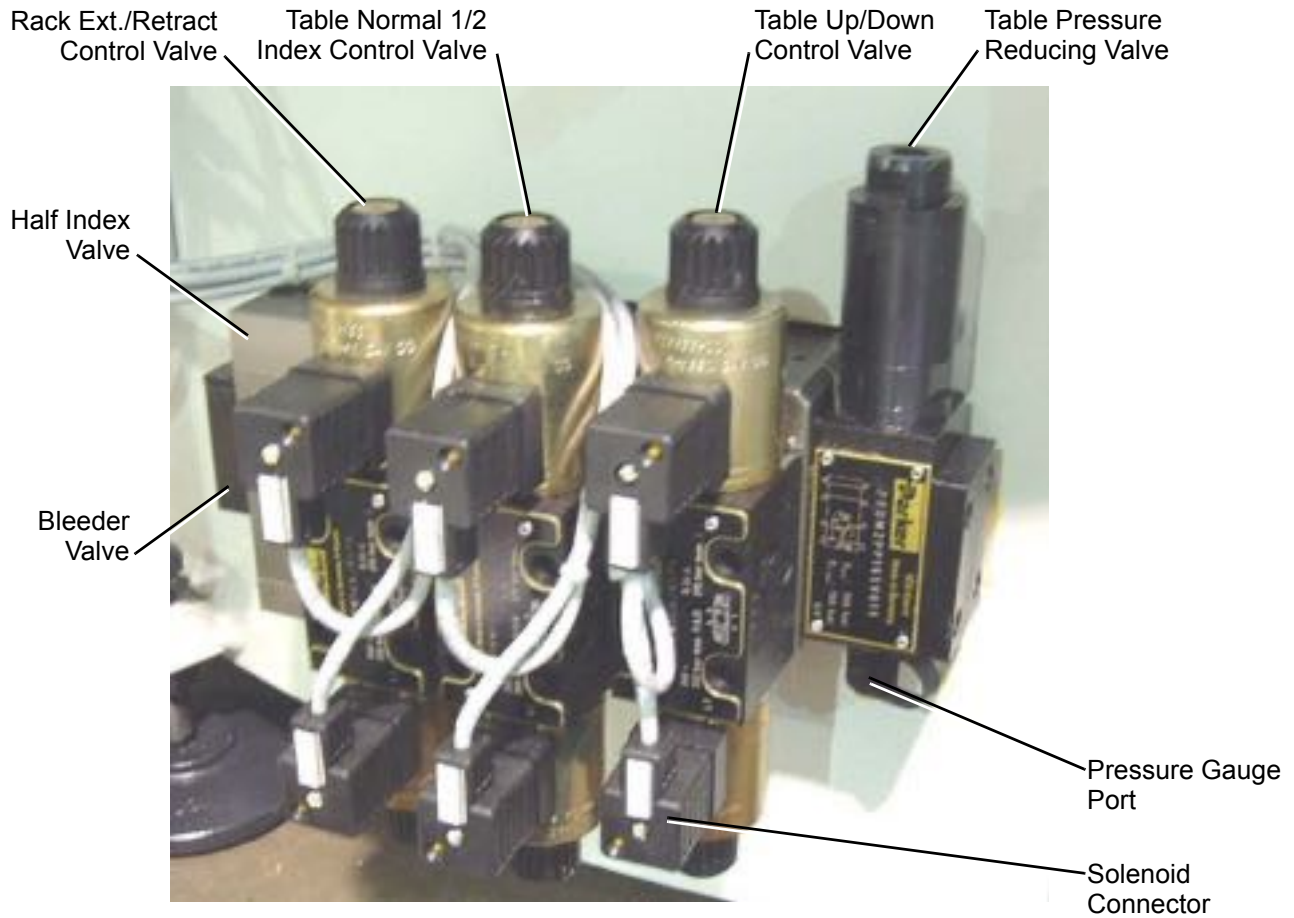
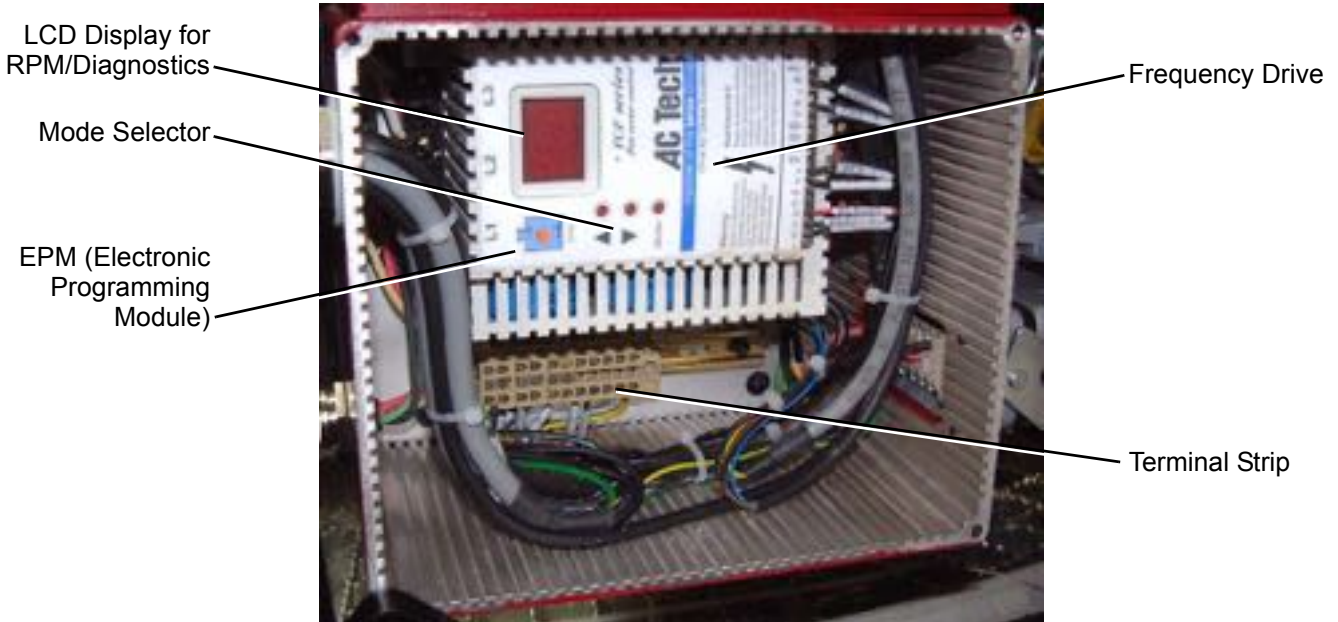

**Table Index Valve on Machine Base Below Platform at Last Station**



## DESCRIPTION OF THE FREQUENCY DRIVE - AC TECH

The Frequency Drive is located in the lower part of the Unit behind a cover. It controls the Unit Motor RPM and is used in conjunction with the Bosch IAC-R Valve on single axis Units or PMAC on multi-axis Units. When using different types of Motors you may replace the EPM to change parameters or use the Mode Selector to re-program.



Frequency Drive

## REMOVAL OF UNITS FROM THE MACHINE

1. Tag the unit with the following information if it exists:
  - Date removed from the machine
  - Machine Serial Number
  - Unit Type Number
  - Control Box Serial Number
  - Motor and Drive Data
2. Prepare cable end for storage. All cable ends and connectors need to be sealed in plastic bags.
3. Apply rust inhibitor.

**Note:** Read Reactivation of stored units below

## REACTIVATION OF STORED UNITS

If input power has not been applied to the drive for a period time exceeding two years (due to storage, etc.), the electrolytic DC bus capacitors within the drive can change internally, resulting in excessive leakage current. This can result in premature failure of the capacitors if the drive is operated after such a long period of inactivity or storage. In order to reform the capacitors and prepare the drive for operation after a long period of inactivity, apply input power to the drive for 8 hours prior to operating the motor.



### WARNING:

Severe damage to the drive can result if it is operated after a long period of storage or inactivity without reforming the DC bus capacitors!

## 7. Control Valves and Embedded Controls

### DESCRIPTION OF THE PMAC ASSEMBLY

The PMAC Assembly is located in the lower part of the Unit behind a cover. The PMAC Assembly is an embedded motion controller and is used to coordinate multiple axis for different machining task. It is used in conjunction with the Bosch OBE Valve and some Units with Servo Motors.

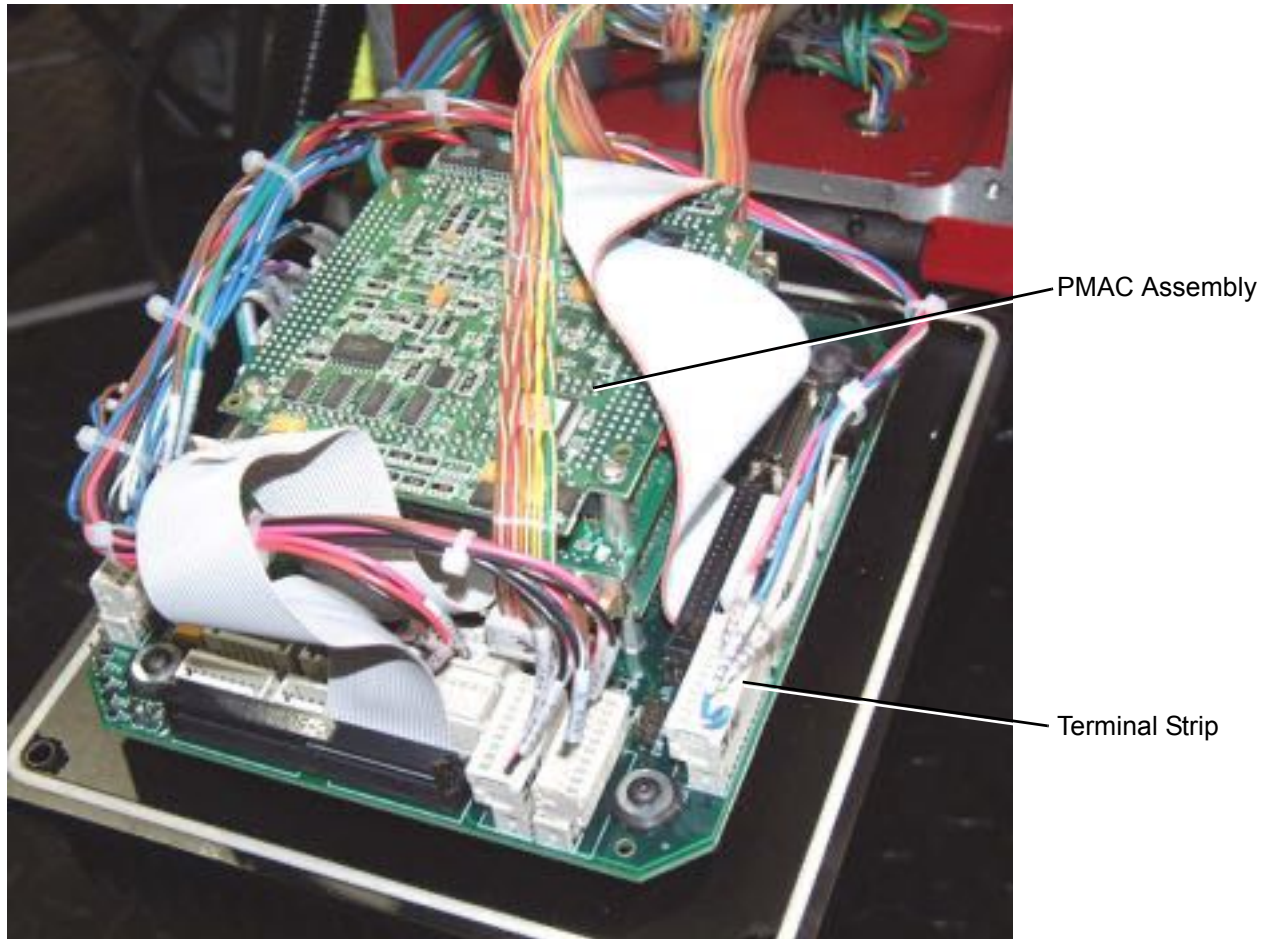

**PMAC Assembly**

**8. UNITS AND ACCESSORIES**

TOOLSPINDLE UNITS.....	8-1
TOOLSPINDLE NC-26/80 TECHNICAL DETAILS .....	8-1
TOOLSPINDLE NC-36/100 TECHNICAL DETAILS .....	8-2
TOOLSPINDLE NC-46/120 TECHNICAL DETAILS .....	8-3
CROSS SECTION OF A TOOLSPINDLE NC-26/80, 36/100, AND 46/120 .....	8-4
CROSS SECTION OF A COOLANT FED TOOLSPINDLE - NC-26/80, 36/100, AND 46/120.....	8-5
DESCRIPTION OF A TOOLSPINDLE NC-26/80, 36/100, & 46/120 .....	8-6
DESCRIPTION OF A COOLANT FED TOOLSPINDLE NC-26/80, 36/100, & 46/120 .	8-6
DESCRIPTION OF A NC TOOLSPINDLE UNIT .....	8-7
CHANGING THE PULLEYS ON NC-26/80, 36/100, & 46/120 TOOLSPINDLE UNITS	8-8
CHANGING THE PULLEYS.....	8-8
SETTING THE HARD STOPS ON TOOLSPINDLE & RECESS UNITS 26/80, 36/100, 46/120 .....	8-9
DESCRIPTION OF A CNC 50/100 2-AXIS SERVO UNIT .....	8-11
AXIS DIRECTION.....	8-11
CROSS SECTION OF A CNC 50/100 2-AXIS SERVO UNIT .....	8-12
CNC 50/100 2-AXIS UNIT Z AXIS STROKE LIMITER .....	8-13
SCALE MAINTENANCE .....	8-13
DESCRIPTION OF CNC 3-AXIS THREAD MILLING UNIT .....	8-14
CROSS SECTION OF A CNC 50/100 3-AXIS SERVO UNIT .....	8-16
CHANGING THE PULLEYS ON NC MULTI-AXIS SERVO UNITS .....	8-17
PCM QUICK CHANGE TOOLSPINDLES .....	8-18
HSK QUICK CHANGE TOOLSPINDLES.....	8-19
CENTERING THE TOOLSPINDLE UNIT ON A MOUNTING FLANGE .....	8-20
CENTERING ON A STANDARD X-Y FLANGE .....	8-21
STANDARD X-Y FLANGE.....	8-21
CENTERING ON AN EXTENDED RANGE MOVEMENT X-Y FLANGE & 50/100 CNC UNIT .....	8-22
SPECIAL EXTENDED RANGE MOVEMENT X-Y FLANGE .....	8-22
RPM CHARTS .....	8-23
RPM CHART FOR 26/80, 36/100, & 46/120 TOOLSPINDLE UNITS & GWE-20/50, GWE-30/60 THREADING UNITS .....	8-23
RPM CHART FOR 26/80, 36/100, & 46/120 TOOLSPINDLE UNITS WITH 1:7 GEAR BOX .....	8-23
RPM CHART FOR 26/80 & 36/100 TOOLSPINDLE UNITS WITH GEAR MOTOR....	8-24
RPM CHART FOR VE-46/120 TOOLSPINDLE UNITS WITH GEAR MOTOR .....	8-24
RPM CHART FOR GWE-20/50 & GWE-30/60 THREADING UNITS WITH GEAR MOTOR .....	8-25
RPM CHART FOR GWE-45/80 & GWE-45/120 THREADING UNITS WITH GEAR MOTOR.....	8-25
RPM CHART FOR QBE-20 CROSS DRILL HEADS.....	8-26
RPM CHART FOR QBE-30 CROSS DRILL HEADS.....	8-26
RPM CHART FK MILLING HEADS WITH 1:1.13 HEAD RATIO & STANDARD MOTOR .....	8-27
RPM CHART FK MILLING HEADS WITH 1:1.13 RATIO AND GEAR MOTOR .....	8-27
RPM CHART FK MILLING HEADS WITH 1:1.2 HEAD RATIO AND STANDARD MOTOR .....	8-28
RPM CHART FK MILLING HEADS WITH 1:1.2 RATIO AND GEAR MOTOR .....	8-28
RPM CHART FK MILLING HEADS WITH 1:1.3 HEAD RATIO & STANDARD MOTOR .....	8-29
RPM CHART FK MILLING HEADS WITH 1:1.3 HEAD RATIO & GEAR MOTOR... STANDARD MOTOR .....	8-29
RPM CHART FK MILLING HEADS WITH 1:1.5 HEAD RATIO AND STANDARD MOTOR .....	8-30
RPM CHART FK MILLING HEADS WITH 1:1.5 HEAD RATIO AND GEAR MOTOR .....	8-30

## 8. Table of Contents

RPM CHART FK MILLING HEADS WITH 1:2 HEAD RATIO AND STANDARD MOTOR .....	8-31
RPM CHART FK MILLING HEADS WITH 1:2 HEAD RATIO AND GEAR MOTOR .....	8-31
RECESS UNITS .....	8-32
RECESS UNIT WITH THRU THE DRAWBAR LUBRICATION NC-26/80, 36/100, & 46/120 .....	8-32
FUNCTION .....	8-32
THRU THE DRAWBAR LUBRICATION .....	8-32
SETTING THE HARD STOPS ON RECESS UNIT NC-26/80, 36/100, AND 46/120 .....	8-32
MAXIMUM RECESS DEPTH WITH NC-26/80, 36/100, AND 46/120 .....	8-32
REMOVING THE DRAWBAR AND UNIT SPRING - RECESS UNIT NC-26/80, 36/100, & 46/120 .....	8-32
CROSS SECTION OF A RECESS UNIT NC-26/80, 36/100, AND 46/120 .....	8-33
RECESS HEAD 26/80, 36/100, AND 46/120 .....	8-34
CHANGING THE PULLEYS ON RECESS UNITS NC-26/80, 36/100, AND 46/120 .....	8-35
RECESS TURNING .....	8-36
THREADING .....	8-36
SETTING THE HARD STOPS ON A THREADING UNIT .....	8-36
THREAD ROLLING UNIT 36/100 COOLANT FED WITH FETTE E HEAD .....	8-37
DESCRIPTION OF THREAD ROLLING 30/60 UNIT WITH FETTE TYPE E HEAD .....	8-38
THREAD ROLLING SEQUENCE .....	8-38
THREAD ROLLS ON FETTE TYPE-E HEAD .....	8-39
SETTING THE THREAD ROLLS AND ATTACHMENT MECHANISM .....	8-40
SETTING THE ROLLING ATTACHMENT MECHANISM .....	8-40
SPARE PARTS FOR RADIAL THREAD ROLLING HEADS - FETTE TYPE E .....	8-41
C. J. WINTER 234SA SERIES RADIAL THREAD ROLLING ATTACHMENT .....	8-42
PREPARATION AND INSTALLATION .....	8-42
RECESSING UNIT PREPARATION .....	8-42
PREPARING THE OUTER SUB-ASSEMBLY .....	8-42
PREPARING THE INNER SUB-ASSEMBLY .....	8-42
MAINTENANCE .....	8-44
REGULAR CLEANING .....	8-44
LUBRICATION .....	8-44
WEAR .....	8-44
SETUP PROCEDURE FOR 234 HEAD .....	8-45
C.J. WINTER ROTARY RADIAL ATTACHMENT PARTS DRAWING .....	8-46
INVERTING UNIT .....	8-47
TECHNICAL DETAILS OF INVERTING UNIT WDE-30 .....	8-47
INVERTING UNIT WDE-30 .....	8-48
INVERTING BUSHING WDE-30/60 .....	8-49
DESCRIPTION OF INVERTING UNIT WDE-40 .....	8-50
TECHNICAL DETAILS OF INVERTING UNIT WDE-40 .....	8-50
INVERTING UNIT WDE-40 .....	8-51
INVERTING UNIT WDE-40 LARGE DIA. .....	8-52
INVERTING BUSHING WDE-40/80 .....	8-53
SETUP OF THE INVERTING UNIT PUSHROD LENGTH .....	8-54
LUBRICATION ASSEMBLY WITH BASIC AIR SUPPLY .....	8-55
LUBRICATION AND LEAK OIL CONNECTIONS .....	8-56
LUBRICATION AND PRESSURIZED LEAK OIL ASSEMBLY .....	8-57
QUILL LUBRICATION OF NC UNITS .....	8-58
VOGEL LUBRICATION UNIT FOR CNC 50/100 2-AXIS, RECESS, RECESS TURN UNITS AND CROSS SLIDE FLANGES .....	8-59
RECOMMENDED OIL .....	8-59
VOGEL UNIT LUBRICATION .....	8-60
VOGEL CROSS SLIDE LUBRICATION .....	8-61

## UNITS AND ACCESSORIES

### TOOLSPINDLE UNITS

#### TOOLSPINDLE NC-26/80 TECHNICAL DETAILS

Drive: Standard AC Electric Motor size BG71  
 Special purpose AC Electric Motor size BG80

Transmission: Quick Change Pulleys and Timing Belt

Motor horsepower / RPM

BG71	0.75 / 3360 rpm	0.50 / 1680 rpm	0.34 / 1100 rpm	
BG80	1.50 / 3360 rpm	1.00 / 1680 rpm	0.75 / 1100 rpm	0.35 / 810 rpm

Motor RPM

3360	Spindle RPM range
1680	1290 - 6570
1100	640 - 4370
810	420 - 2860
	270 - 2100

Pulley No. 5.49.122- (1-8)

4 sets plus 2

Spindle stroke

80mm (3.15")

Spindle stroke limitation

by Adjusting Nut

Rapid approach range

see Chapter 7

Feed rate infinitely adjustable

0 to 4" / sec.

Feed force at 650 P.S.I.

660 pounds

Drilling capacity (stress proof 1144 steel)

3/8"

Movement of Toolspindle in Mounting Flange

70mm (2 3/4")

Micrometer adjustment for toolspindle

division .004"  
 revolution .100"

No lubrication needed (self lubricating with Hydraulic Oil)

## 8. Units and Accessories

### TOOLSPINDLE NC-36/100 TECHNICAL DETAILS

Drive: Standard AC Electric Motor size BG80  
Special purpose AC Electric Motor size BG90

Transmission: Quick Change Pulleys and Timing Belt

Motor horsepower / RPM

BG80	1.50 / 3360 rpm	1.00 / 1680 rpm	0.75 / 1100 rpm	0.35 / 810 rpm
BG 90	3.00 / 3360 rpm	2.00 / 1680 rpm	1.50 / 1100 rpm	0.75 / 810 rpm

Motor RPM

3360

1680

1100

810

Spindle RPM range

1290 - 6570

640 - 4370

420 - 2860

270 - 2100

Pulley No. 5.14.190- (1-8)

4 sets

Spindle stroke

maximum 100mm (3.93")

Spindle stroke limitation

by Adjusting Nut

Rapid approach range

see Chapter 7

Feed rate infinitely adjustable

0 to 3" / sec.

Feed force at 650 P.S.I.

835 pounds

Drilling capacity (stress proof 1144 steel)

3/4"

Movement of Toolspindle in Mounting Flange

90mm (3.54")

Micrometer adjustment for toolspindle

division .004"  
revolution .100"

No lubrication needed (self lubricating with Hydraulic Oil)

**TOOLSPINDLE NC-46/120 TECHNICAL DETAILS**

Drive: Standard AC Electric Motor size BG90  
 Special purpose AC Electric Motor size BG100

Transmission: Quick Change Pulleys and Timing Belt

Motor horsepower / RPM

BG 90	3.00 / 3360 rpm	2.00 / 1680 rpm	1.50 / 1100 rpm	0.75 / 810 rpm
BG100	4.00 / 3360 rpm	4.00 / 1680 rpm	2.00 / 1100 rpm	1.50 / 810 rpm

Motor RPM	Spindle RPM range
3360	1209 - 3830
1680	605 - 4620
1100	396 - 3025
810	290 - 2225

Pulley No. 6.14.130- (1-8) 4 sets

Spindle Pulley No. 6.14.221 (Only on Coolant Fed, 1-8) 4 sets

Spindle stroke 45/80	maximum 80mm (3.15")
Spindle stroke 46/120	maximum 120mm (4.72")

Spindle stroke limitation by Spacer Ring

Rapid approach range see Chapter 7

Feed rate infinitely adjustable 0 to 3" / sec.

Feed force at 650 P.S.I. 1260 pounds

Drilling capacity (ER40) 26mm"

Movement of Toolspindle in Flange 45/80 160mm (6.30")

Movement of Toolspindle in Flange 46/120 200mm (7 7/8")

Micrometer adjustment for toolspindle  
 division .004"  
 revolution .100"

No lubrication needed (self lubricating with Hydraulic Oil)

## 8. Units and Accessories

### CROSS SECTION OF A TOOLSPINDLE NC-26/80, 36/100, AND 46/120

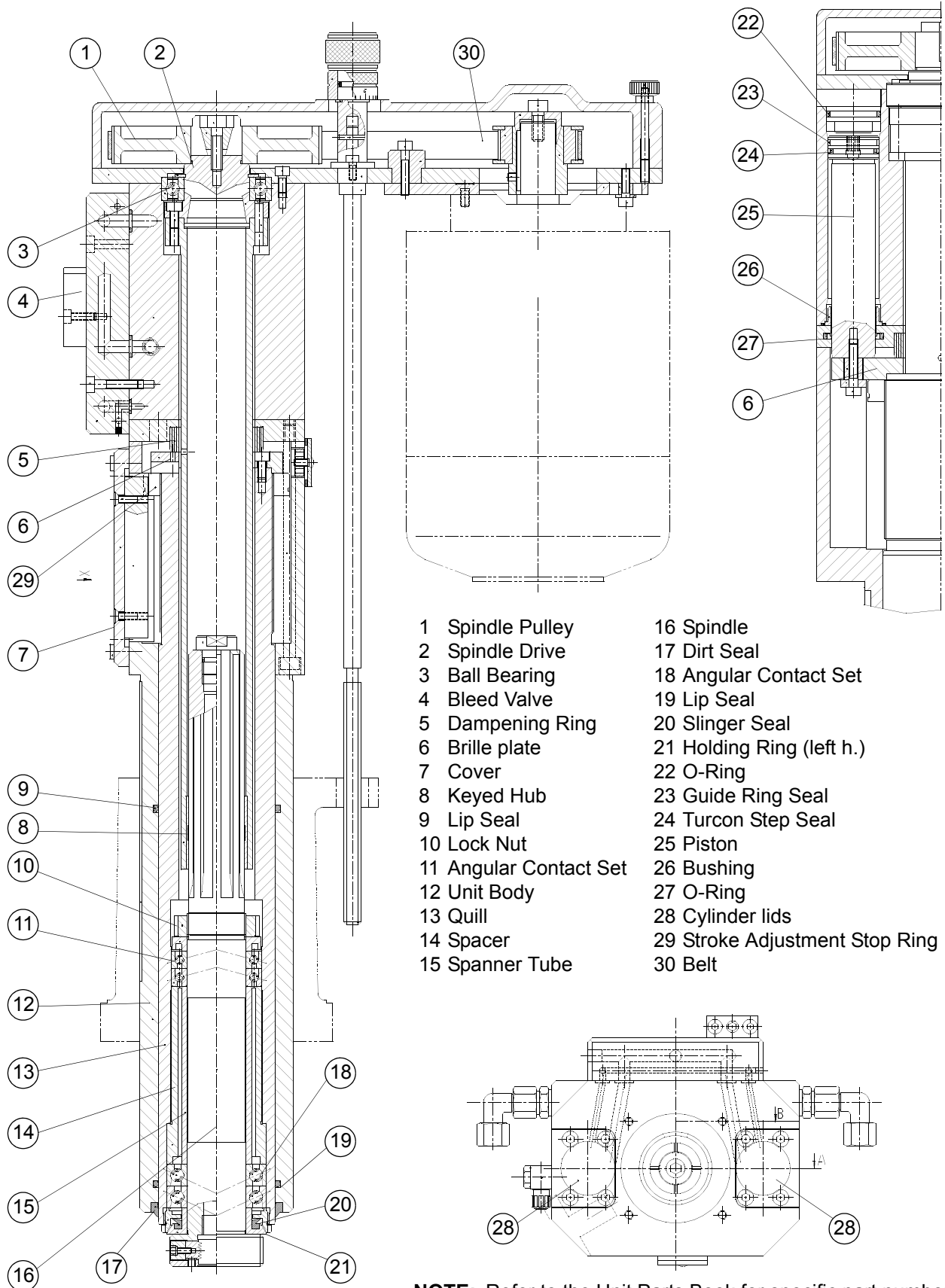

**NOTE:** Refer to the Unit Parts Book for specific part numbers.



CROSS SECTION OF A COOLANT FED TOOLSPINDLE - NC-26/80, 36/100, AND 46/120

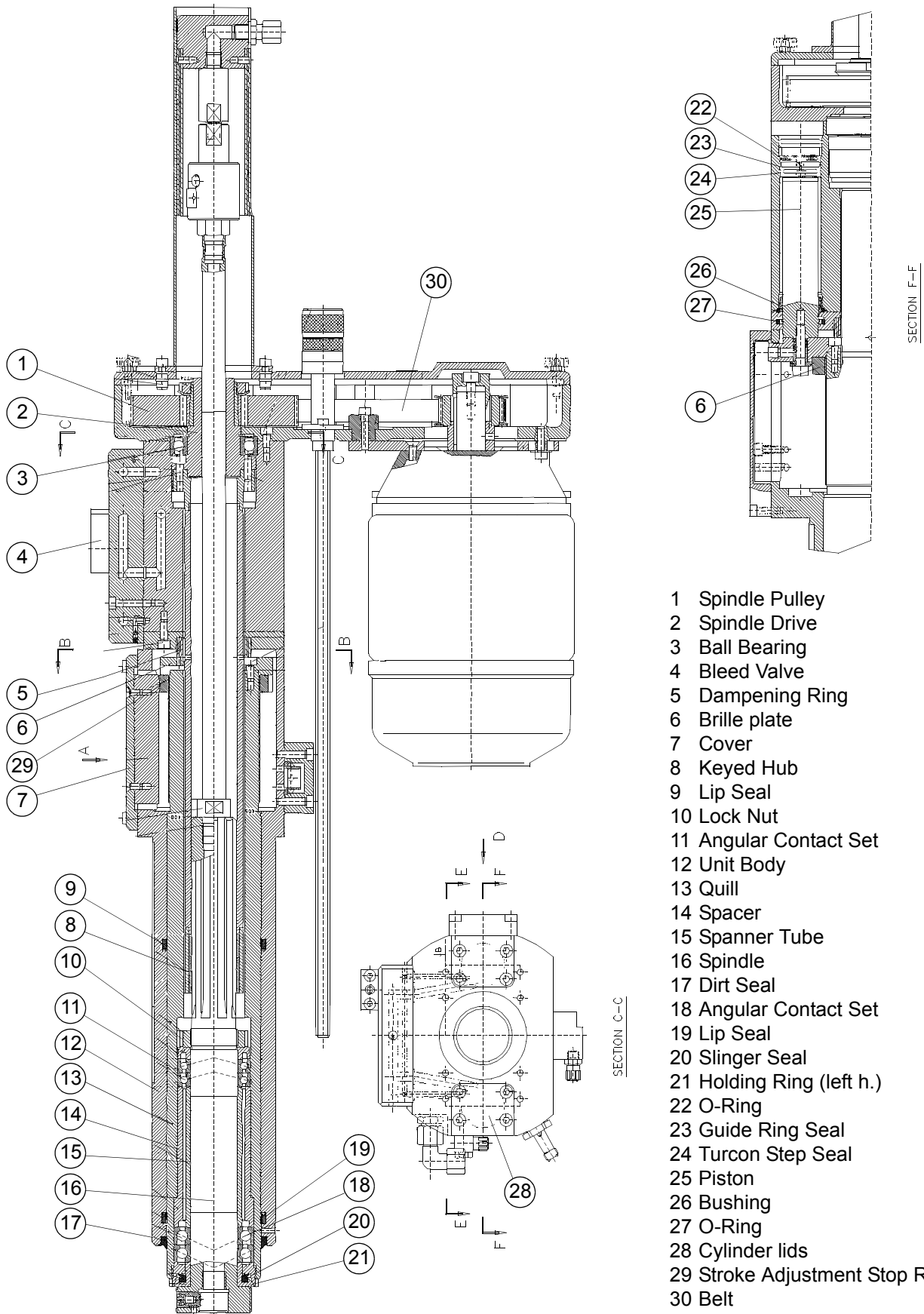

- 1 Spindle Pulley
- 2 Spindle Drive
- 3 Ball Bearing
- 4 Bleed Valve
- 5 Dampening Ring
- 6 Brille plate
- 7 Cover
- 8 Keyed Hub
- 9 Lip Seal
- 10 Lock Nut
- 11 Angular Contact Set
- 12 Unit Body
- 13 Quill
- 14 Spacer
- 15 Spanner Tube
- 16 Spindle
- 17 Dirt Seal
- 18 Angular Contact Set
- 19 Lip Seal
- 20 Slinger Seal
- 21 Holding Ring (left h.)
- 22 O-Ring
- 23 Guide Ring Seal
- 24 Turcon Step Seal
- 25 Piston
- 26 Bushing
- 27 O-Ring
- 28 Cylinder lids
- 29 Stroke Adjustment Stop Ring
- 30 Belt

## 8. Units and Accessories

### DESCRIPTION OF A TOOLSPINDLE NC-26/80, 36/100, & 46/120

The CNC controls the depth (Z-Axis) movement of the unit quill. The movement of the quill is Hydraulically controlled by a Bosch Servo Valve. The valve controls the flow of oil into the units piston cylinders. This valve is controlled by a Servo amplifier card that is commanded by the CNC control or the PMAC card.

Position feedback is provided by a scale. Integral scale reference marks give an accurate and repeatable Home position.

A Proximity switch is used to confirm to the machine PLC that the unit has reached its axis Home position before Table index is initiated. This input is "high true" (switch is on when the axis is in the home position).

Spindle rotation is provided by an conventional AC motor through a pulley belt drive assembly. Some versions of the unit have a Servo Motor. This gives the Unit the ability to be used as a threading station.

The position of the cutting tool from the part is adjusted with the Unit Depth Adjustment. This distance is normally set for at least .650". The CNC controller program rapid approach must be at least .040"-.050" less than this dimension to prevent any possible contact before feed motion begins. Normal production offsetting of the tool can be made from the CNC control.

The Units full stroke can be restricted for the purpose of protecting the Table Collets or Chuck Jaws. The full stroke should be first measured by jogging the Unit to its full forward position and the Stroke adjustment should be set at least .050" beyond this position.

### DESCRIPTION OF A COOLANT FED TOOLSPINDLE NC-26/80, 36/100, & 46/120

In addition to the features of Standard Toolspindle Units, Coolant Fed Units allow cutting fluid to be applied through the cutting tools.



#### **WARNING:**

**Do not run Coolant Fed Units under dry conditions (without coolant). If you must do this, please contact the Hydromat Customer Service Technical Help Desk.**



**NC-36/100 Standard**



**NC-36/100 Coolant Fed**

## DESCRIPTION OF A NC TOOLSPINDLE UNIT

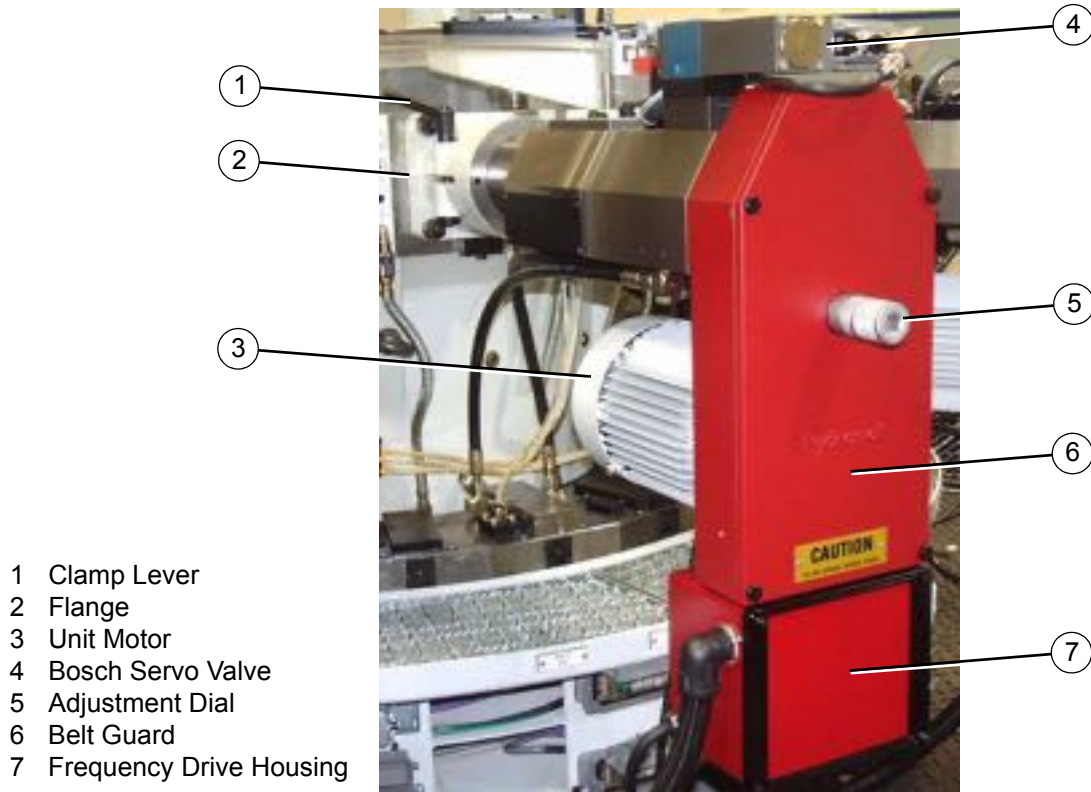

All Toolspindle Units are positioned in Mounting Flanges. With the Adjusting Dial, the Unit can be adjusted to the exact machining depth required. Check to insure that all the Clamping Levers are tightened before machining.

1 revolution on Adjusting Dial = .100" (3mm)

1 graduation on Adjusting Dial = .004" (0.1mm)

## 8. Units and Accessories

### CHANGING THE PULLEYS ON NC-26/80, 36/100, & 46/120 TOOLSPINDLE UNITS

The Toolspindle revolutions can be changed by installing a different Pulley Set. This provides the best R.P.M. for the material that is machined.

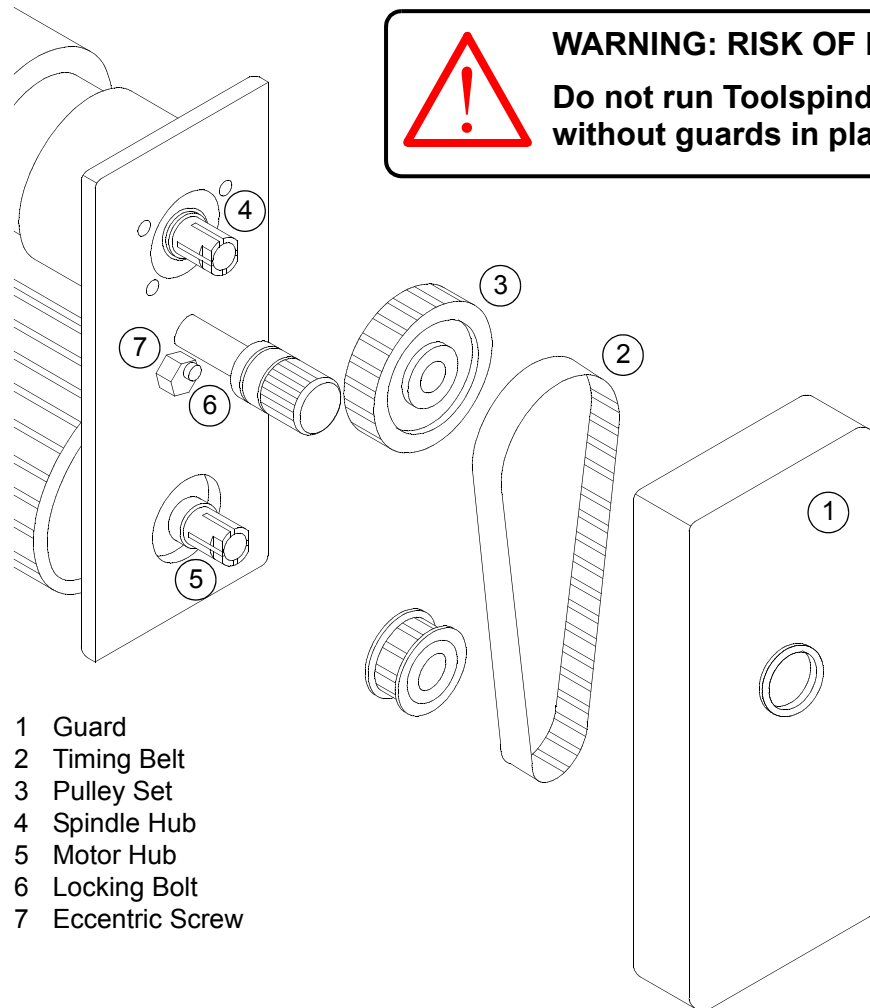

### Changing The Pulleys

1. Remove the Guard and the Rotating Union (**Machine Must Be Turned Off**).
2. Open the Locking Bolt and loosen the Eccentric Screw.
3. Remove the Timing Belt.
4. Loosen hex nut and remove pulley.
5. Mount the selected Pulleys.

### CAUTION

Do not over-tighten the Timing Belt, it should only be tight enough to eliminate play.

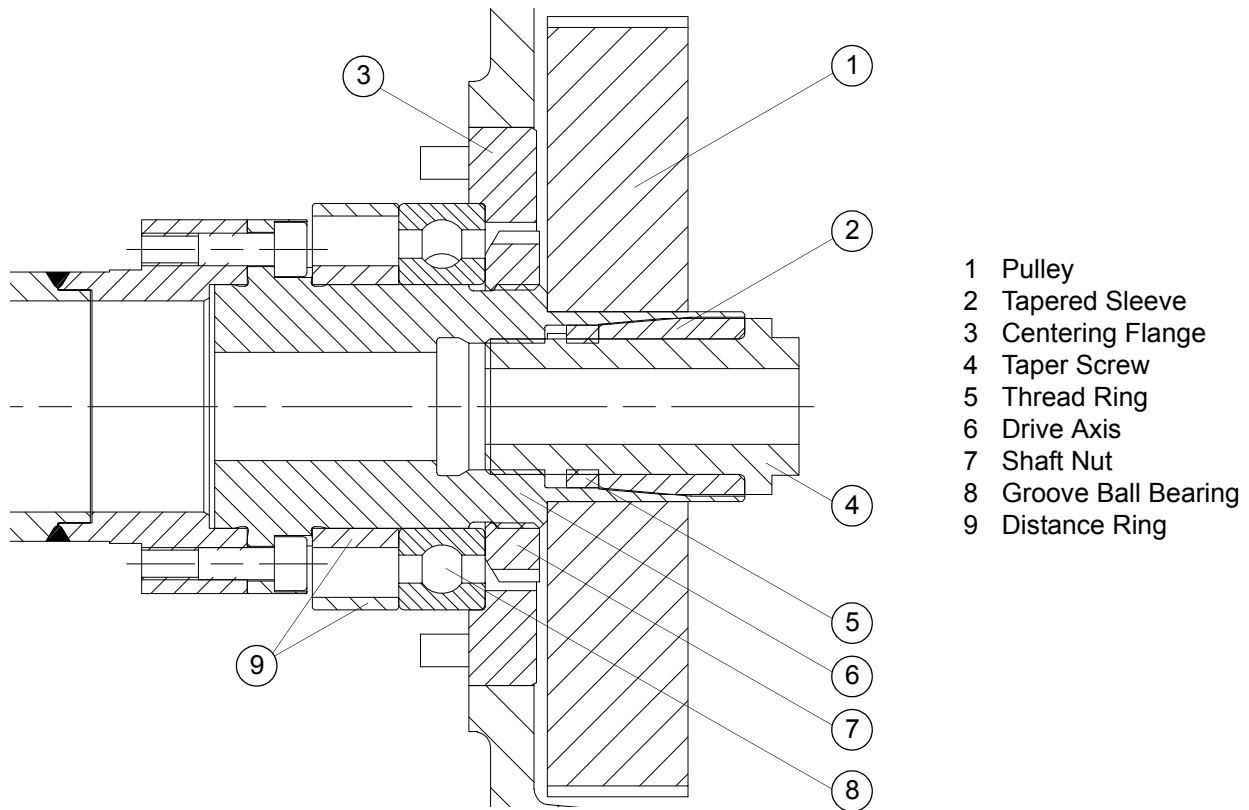

- 1 Pulley
- 2 Tapered Sleeve
- 3 Centering Flange
- 4 Taper Screw
- 5 Thread Ring
- 6 Drive Axis
- 7 Shaft Nut
- 8 Groove Ball Bearing
- 9 Distance Ring

### SETTING THE HARD STOPS ON TOOLSPINDLE & RECESS UNITS 26/80, 36/100, AND 46/120



#### **WARNING:**

**Do not remove the cover without first turning off the machine.**

1. Calculate the total stroke required. This length should equal 2 times the recess depth plus the recess position from the end of the part plus approximately 1/4".

#### **CAUTION**

**The Unit must use the full stroke of the Quill during machining operations. The Tool Head must never bottom out, this places extreme stress on the Drawbar and the Stop Knurl Nut.**

2. Set the center height of the Tools exactly on center using the Preset Block provided, then remove the Cutting Tools.
3. Mount the Toolholders on the Recess Head, back out the Recessing Unit with the Adjusting Spindle, back off the Stop Knurl Nut all the way, insert a blank part into the Index Table Collet, bleed the Unit Forward and move the Unit in to the approximate recessing position.
4. Remove the Unit Stroke Cover and adjust Unit Stroke Limiter Nut ensuring that Tool Holder does not hit Collet.

## 8. Units and Accessories

### CAUTION

The Spring Package on the Drawbar may be damaged if Unit Stroke is set too long.

26/80 Full stroke = 80 mm (3.150")  
36/100 Full stroke = 100 mm (3.937")  
46/120 Full stroke = 120 mm (4.724")

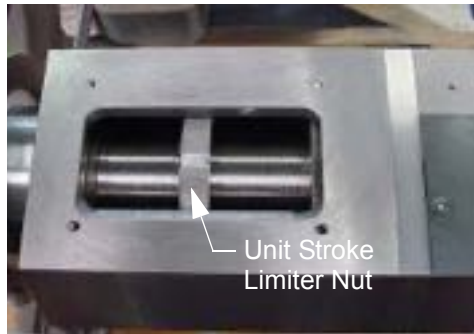

**Toolspindle and Recess Unit**

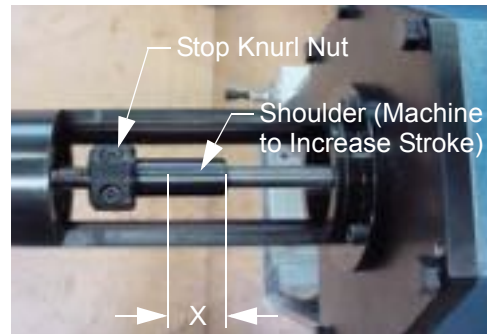

**Recess Unit**

### Stroke Control

5. Set the Recess Tools in the Toolholders and adjust them so that there is .020" clearance between the workpiece O.D. and the cutting point of the Tool.
6. With the Unit jogged forward, tighten the Stop Knurl Nut until the tip of the Cutting Tool touches the diameter of the part. Observe that the Quill does not move back during this procedure, then return the unit.
7. Tighten the Stop Knurl Nut to adjust the recess depth, 1 revolution = .040".
8. Close the Rapid Approach Adjusting Dial all the way, set the Feed Rate Adjusting Dial fully closed, then open one turn.
9. Insert a part blank into the Index Table Collet. Start Spindles and Manually cycle the Unit.
10. Check the recess depth and re-adjust as required with the Stop Knurl Nut.
11. Set the position of the recess feature using the Unit Adjusting Spindle.
12. Set the Rapid Approach and Feed Rate according to the Machine Layout.

**DESCRIPTION OF A CNC 50/100 2-AXIS SERVO UNIT**

The Hydraulic CNC 50/100 2-Axis Servo unit has the ability to single point a face, straight turn, taper turn, chamfer, or radius feature on either the O.D. or I.D. of the part.

A part program in the CNC controls memory, precisely controls the radial (X axis) and axial (Z axis) movements of the cutter that correspond to the diameter and length positions on the part.

The X axis motion is controlled by the position of the draw bar which moves the CNC Head sliders in or out. The Z axis is accomplished by moving the unit body in or out.

The X and Z axis movements of the cutter are Hydraulically controlled by Bosch Servo Valves which control the flow of oil into the X and Z axis cylinders. These Valves are controlled by a Servo amplifier card that is controlled by the CNC.

Position feedback is provided by X and Z axis scales. Integral scale reference marks give an accurate and repeatable Home position to both axes.

Two Proximity switches are used to confirm to the machine PLC that the unit has reached its X and Z axis Home positions before Table index is initiated. These inputs are “low true” (switch is off when axis is home).

Spindle rotation is provided by an conventional AC motor through a pulley belt drive assembly.

**Axis Direction**

X Axis tracks position of tools towards centerline of workpiece. Z Axis moves in/out toward centerline of machine.

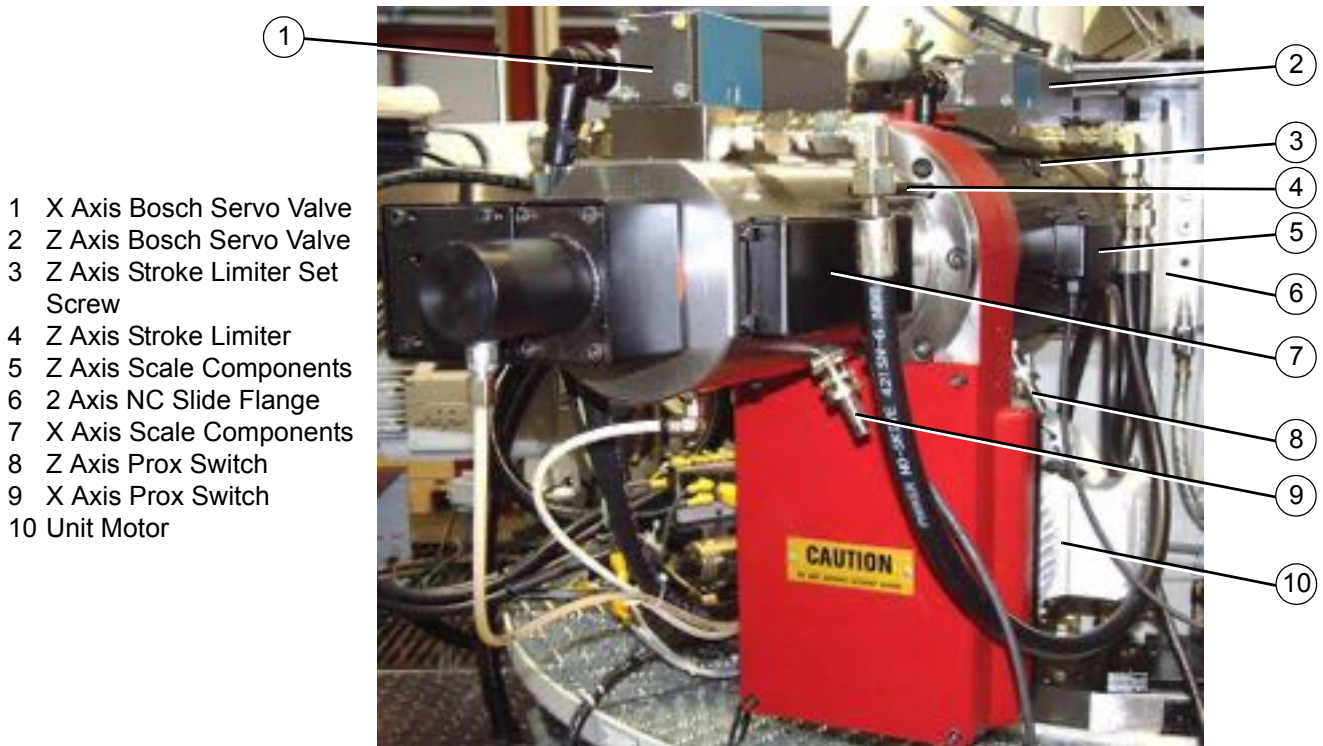

**CNC 50/100 2-Axis Servo Unit**

## 8. Units and Accessories

### CROSS SECTION OF A CNC 50/100 2-AXIS SERVO UNIT

**NOTE:** Refer to the Unit Parts Book for specific part numbers.

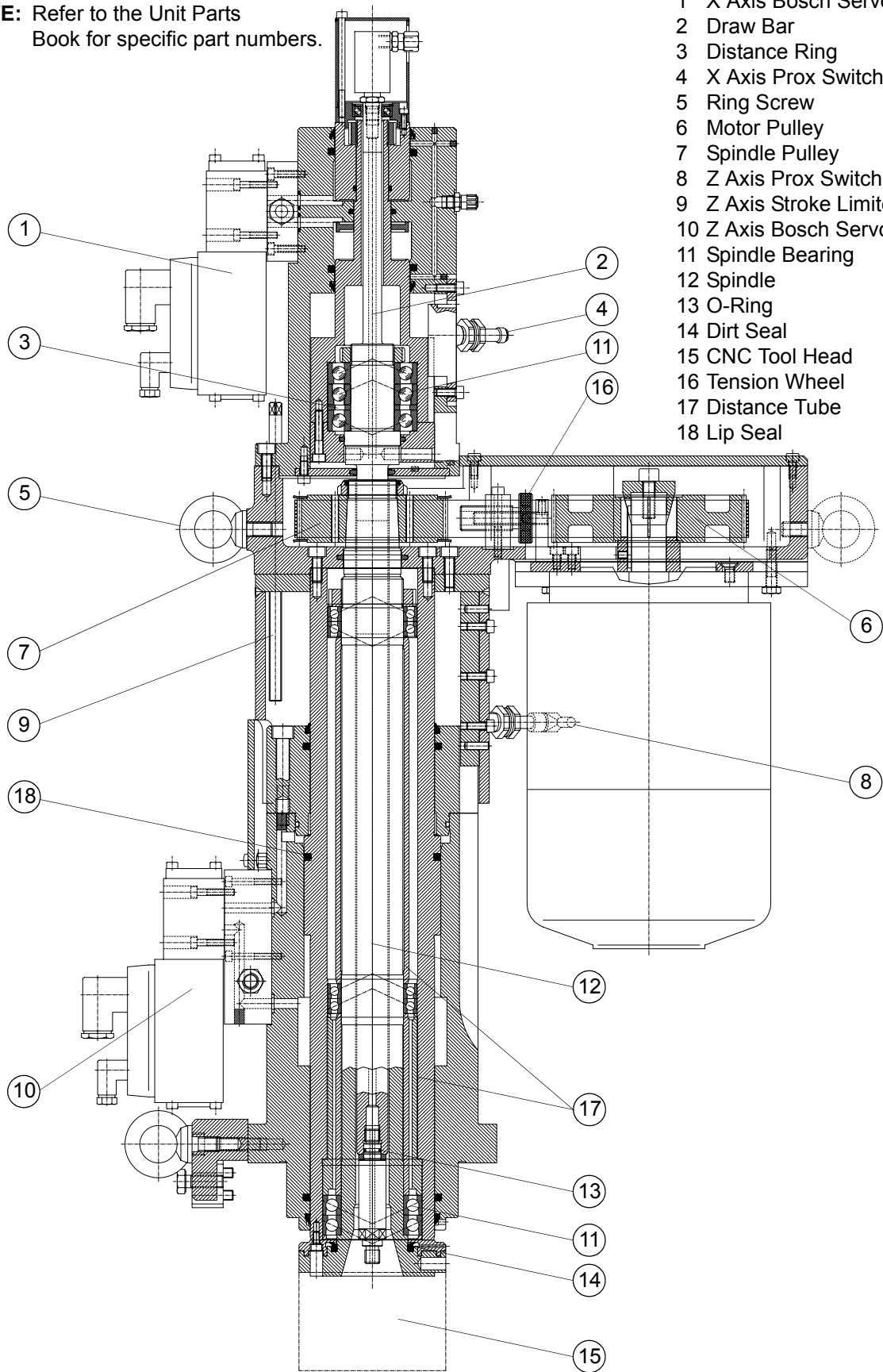

- 1 X Axis Bosch Servo Valve
- 2 Draw Bar
- 3 Distance Ring
- 4 X Axis Prox Switch
- 5 Ring Screw
- 6 Motor Pulley
- 7 Spindle Pulley
- 8 Z Axis Prox Switch
- 9 Z Axis Stroke Limiter
- 10 Z Axis Bosch Servo Valve
- 11 Spindle Bearing
- 12 Spindle
- 13 O-Ring
- 14 Dirt Seal
- 15 CNC Tool Head
- 16 Tension Wheel
- 17 Distance Tube
- 18 Lip Seal



### CNC 50/100 2-AXIS UNIT Z AXIS STROKE LIMITER

This feature allows the Z Axis stroke to be limited for the purpose of preventing the CNC Head from coming into contact with the Table Collet or Chuck Jaw in the case of an operator or programming error. This adjustment should be reset every time the Units program is changed during setup.

The stop should be set at least .050" from the full programmed stroke of the Z Axis. The limit should be verified by jogging the Units Z Axis to its full programmed position + .050" and then adjust the limiter until it makes contact. Loosen set screw and adjust the Z Axis Stroke Limiter (turning clockwise with wrench) until it bottoms out.

### SCALE MAINTENANCE

The scale must remain firmly attached to the unit at all times or the scale will not work properly. Check the tightness of the scale screws every 2000 hours. If the screws are loose, tighten them accordingly.

- 1 Z Axis Stroke Limiter
- 2 Scale Screws

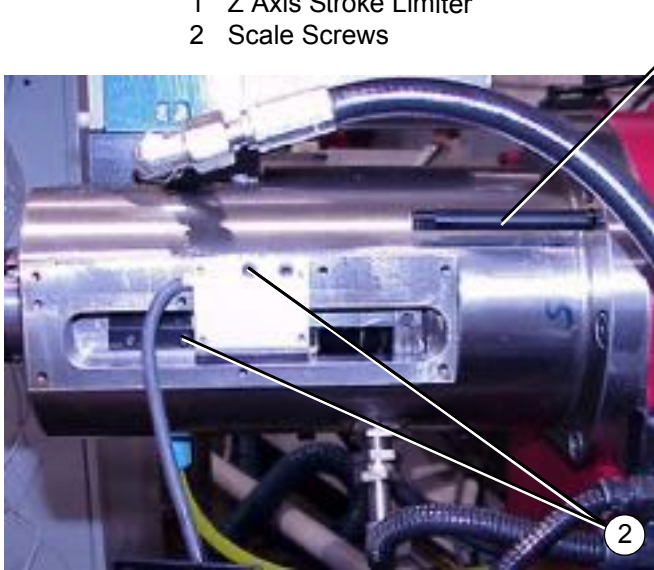

X Scale

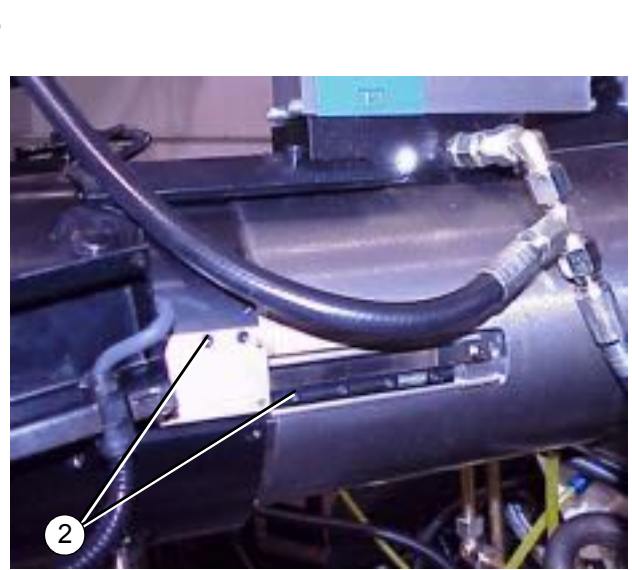

Z Scale

CNC 50/100 2-Axis Servo Unit X & Z Scale Locations With Covers Removed

## 8. Units and Accessories

### DESCRIPTION OF CNC 3-AXIS THREAD MILLING UNIT

The following is a description of the operator interface that controls the Hydromat thread milling unit. Hydromat Windows CNC controller is used with software application version 2.74. The configuration and tuning of this unit needs to be completed by a Hydromat engineer before starting this procedure.

From the Hydromat CNC applications main screen begin by clicking **System**, then **Edit Program**, and then **enter the password**, if required. This will bring you to the motion program generator. From here choose **Program**, then the thread milling station.

The first dialog box is the Origin Offset. This is the distance from the face of the toolspindle to the end of the workpiece in inches. (For our example, use 4 inches). When complete click **OK**. The next dialog box is the Geometry Offset. This is the total length in inches, of the cutting tool and toolholder when assembled. This is the length-preset value if you are using the Hydromat preset unit. (For our example, use 3 inches). The next dialog box is the Safe Zone. This is the distance from the end of the cutting tool to the face of the part. (For our example, use defaulted value of 1 inch). The next dialog box is the Spindle RPM. If there is a frequency drive at this station, then the RPM can be changed. (if not, the RPM value will be gray and can't be adjusted through software.) Click **OK**.

The next screen is the Motion Programming screen. The first move to make is a **Rapid Z**. The zero point for programming is now at the face of the workpiece. Positive programmed values are away from the workpiece. Negative values are toward the workpiece. (Set the Rapid Z value to 0.040 inch away from the face of the part for our example.) Then choose **In Position**. This will cause the unit to come to a stop for a short time at the programmed rapid position and not blend with the next move. The next move to make is a **Turn in Z** move. This Z value should bring the axis to the position on the workpiece where you want the thread to start. (For our example, set this to -.250.) The Feed Rate units for this move are in inches per revolution. (Set this value at .010 for our example). When you click **OK** the message, "You have exceeded the safe travel limits set in Z. Do you wish to continue?" will appear. Click **Yes**. This and the next message warn you that you are past the safe zone and the cutting tool is "in" part. Click **Yes**.

For our example we will produce an internal, right hand, conventionally milled 3/4-20 straight thread. To Begin click **Thread Features**. A dialog will appear with the choices **Straight Thread** or **Tapered Thread**. Choose and click **OK**. (For our example, choose **Straight**.) The next dialog that appears will give choices for the Type of Thread, the Sense of the Thread, and the Method to use. Make these selections and click **OK**.

In the next screen there are two main sections: Thread Properties and Milling Phases. First complete the Thread Properties section. **Fill in** the Thread Major Diameter (0.750 in. for our example). Next, **fill in** the Tool Major Diameter field (0.6250 for our 20 threads per inch example thread). Then **fill in** the Thread Pitch information (0.050 in. for our 20 threads per inch example thread). The allowable range for the pitch is 0.0125-5 in. Next click in the **Depth of Thread Field**. The value displayed is the correct depth of thread for Unified National (UN) threads. You have the option to change this value for other thread types, within the limits determined by the thread and tool major diameters.

The Milling Phase information now needs to be completed. The actual threading motion of the unit happens in four stages:

1. A Rapid Move, which brings the cutting tool close to the bore of the workpiece.
2. A Cam In Move, which brings the cutting tool to the full depth of cut.
3. A Thread Pass Move, which creates the thread.
4. A Cam Out Move, which truncates the thread & brings the cutting tool back to the center of the bore.

The program automatically calculates the correct amount of rapid approach based on the Thread Diameter, Tool Diameter, and Depth of Thread information. The Cam In Move is defaulted to 0.25 revolutions; the allowed range is from 0 to 1 revolution. The Feed Rate for this and the other milling phase moves are in inches per revolution. The Thread Pass Move is defaulted to 1.25 revolutions; the allowed range is from 1 to 10 revolutions. The Cam Out Move is defaulted to 0.25 revolutions; the allowed range is from 0 to 1 revolution. These default values in the milling phase are conservative, and are useful as first attempt values. To minimize machining time, both the Feed Rate and Move distances will probably need to be incrementally changed.

Below the milling phase dialog is a Text Field, which gives direction of movement and the ending Z position. This ending Z position is useful when the thread being produced is near the bottom of the bore of the workpiece and near the hard stop. Click **OK** to accept these values.

The next thing to do is home the unit by clicking **Home**. The defaulted Z home position is given in user coordinates. Click **OK** and then **Save**, which saves this program to the Part Folder. Then click **Download**, which sends this program to the Motion Controller.

**Set** the Z hard stop and bring a workpiece to the thread milling station. **Jog** the Z-axis forward until the end of the tool is at a point where the thread can be completed, but the tool won't bottom out against the workpiece. Now open the positions screen by clicking **Positions** from the main application. **Record** the Z-axis position for the thread mill unit. There are two M-12 stop screws situated just above the hydraulic cylinders on the unit. **Adjust** the stops to a point where the Z-axis can't move any farther forward.

**Compare** this hard stop position to the end of program position. The end of program position is in the text field just under the milling phase dialog. The hard stop position needs to be more negative than the end of program position. If it isn't the unit will stop at this point when running the motion program. **Jog** the thread mill unit home. This completes the operator interface description.

- 1 Z Scale Components (Beneath Cover)
- 2 Z Axis Prox Switch
- 3 B Axis Prox Switch
- 4 Unit Motor
- 5 Motor B (Scale Integrated)
- 6 Motor A (Scale Integrated)
- 7 A Axis Prox Switch
- 8 Belt Guard

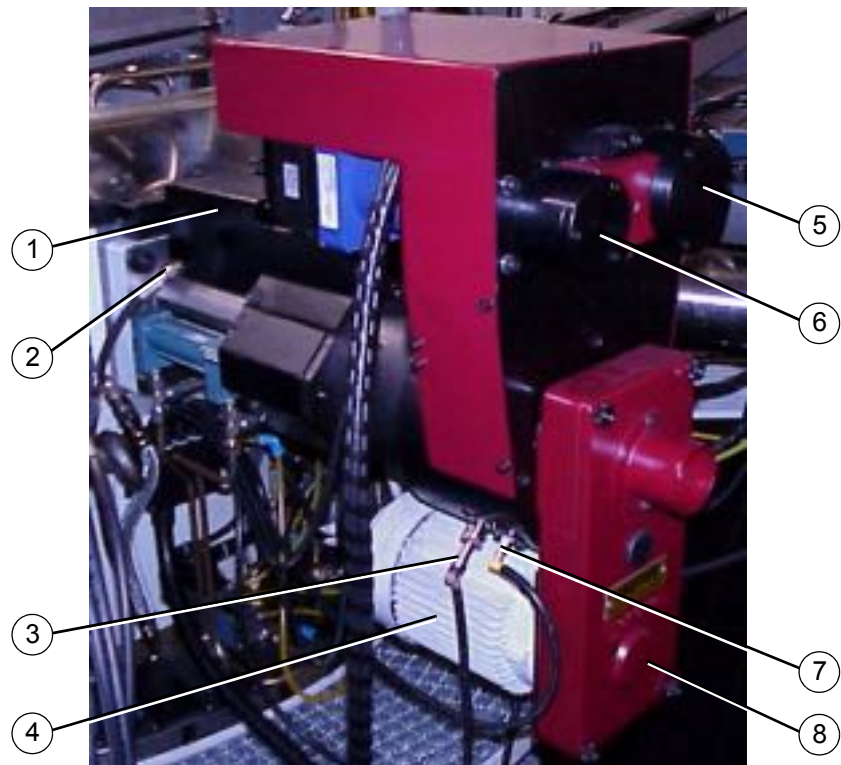

**CNC 3-Axis Thread Milling Unit**

## 8. Units and Accessories

### CROSS SECTION OF A CNC 50/100 3-AXIS SERVO UNIT

**NOTE:** Refer to the Unit Parts Book for specific part numbers.

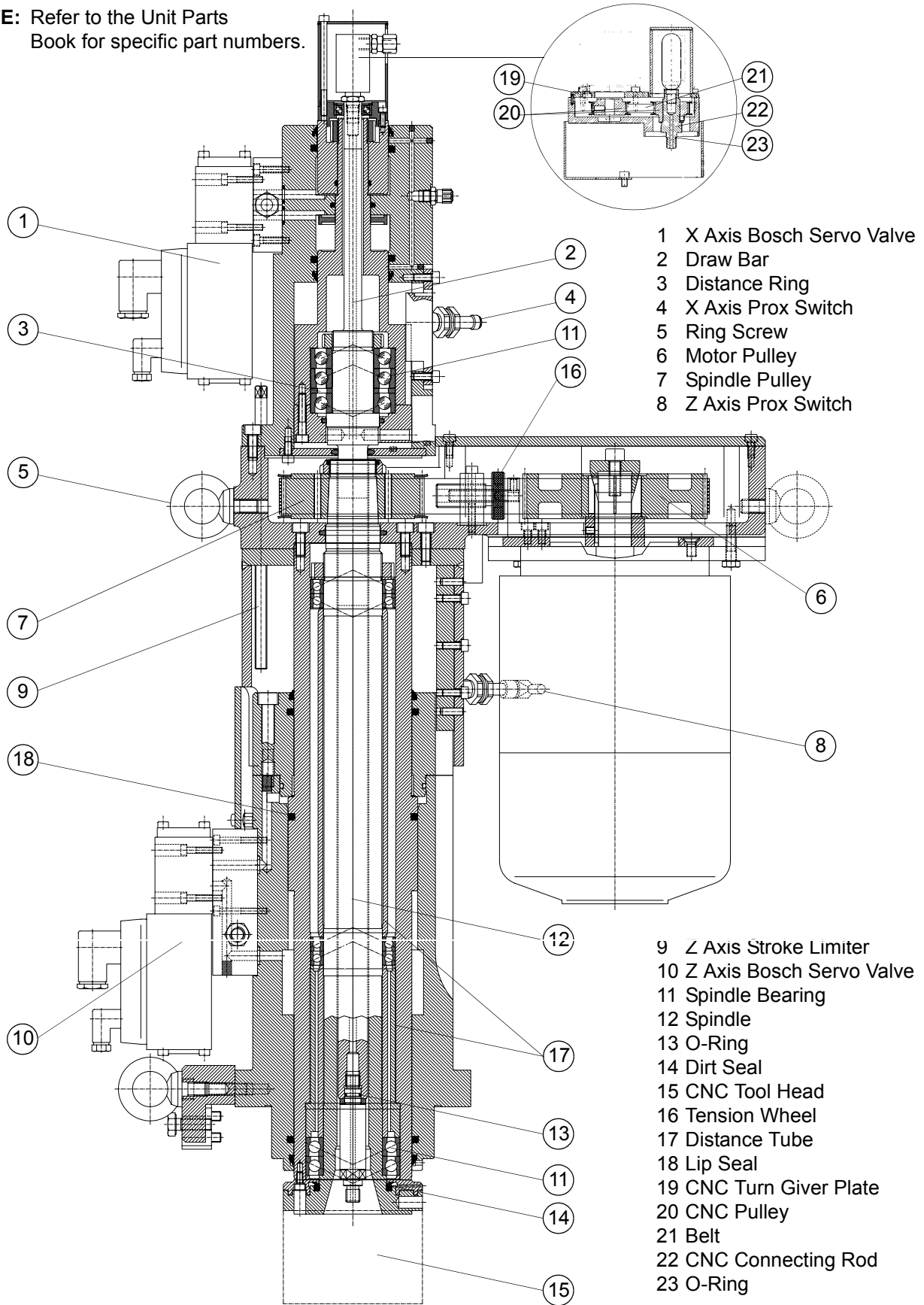

**CHANGING THE PULLEYS ON NC MULTI-AXIS SERVO UNITS**

1. Turn off Machine power.
2. Remove the Belt Cover.
3. Loosen eight 13mm Hex Head Cap Screws (3) on the Motor Plate Slide.
4. Turn the Tension Wheel (2) to loosen the Belt Tension.
5. Place a wrench on the Motor Hub (5) and loosen Cap Screw (6).
6. Remove the Motor Pulley (4) and replace.
7. Reassemble Motor Hub and set the Belt tension to allow about 1/2" deflection.
8. Retighten eight Cap Screws (3).

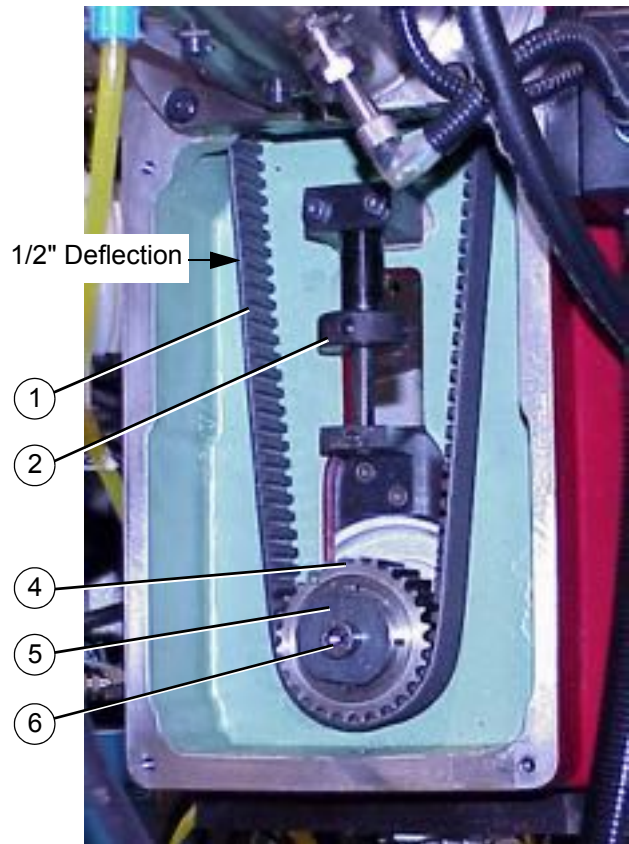
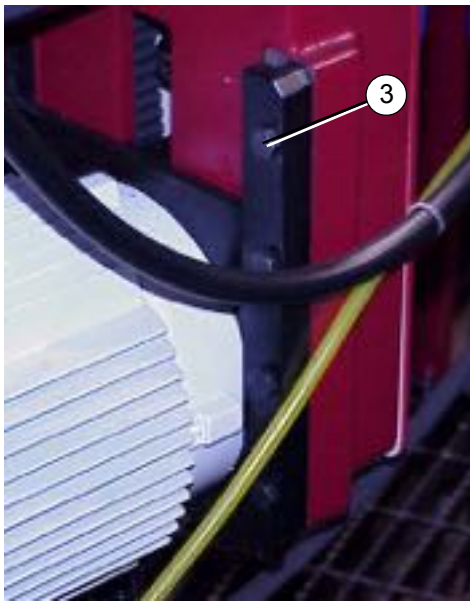

- 1 Belt
- 2 Tension Wheel
- 3 Cap Screw
- 4 Motor Pulley
- 5 Motor Hub
- 6 Cap Screw

**CNC 50/100 2-Axis Servo Unit  
(With Belt Cover Removed)**

Spindle Revolutions						
Pulley Set			Motor RPM			
Spindle	Motor	Ratio	840	1150	1740	3480
125	126-1	.579	480	660	1000	2000
125	126-2	.722	600	830	1250	2500
125	126-3	.968	810	1100	1680	3370
125	126-4	1.252	1050	1450	2180	4350

**NOTE:** The complete part number for the motor pulley is 6.42.126-1, 2, 3, or 4. The Spindle pulley 6.42.125 does not change.

**RPM Chart for CNC 50/100 Single and 2-Axis Servo Unit**

## 8. Units and Accessories

### PCM QUICK CHANGE TOOLSPINDLES

The PCM Quick Change Toolspindles incorporates a special locking system in the spindle nose that allows for quick removal of Tool Heads with a provided torque wrench. The torque wrench ensures that the proper torque is applied to the locking mechanism. The Quick Change system speeds set ups and tool changes, especially when incorporated with the Hydromat Optical Presetter.

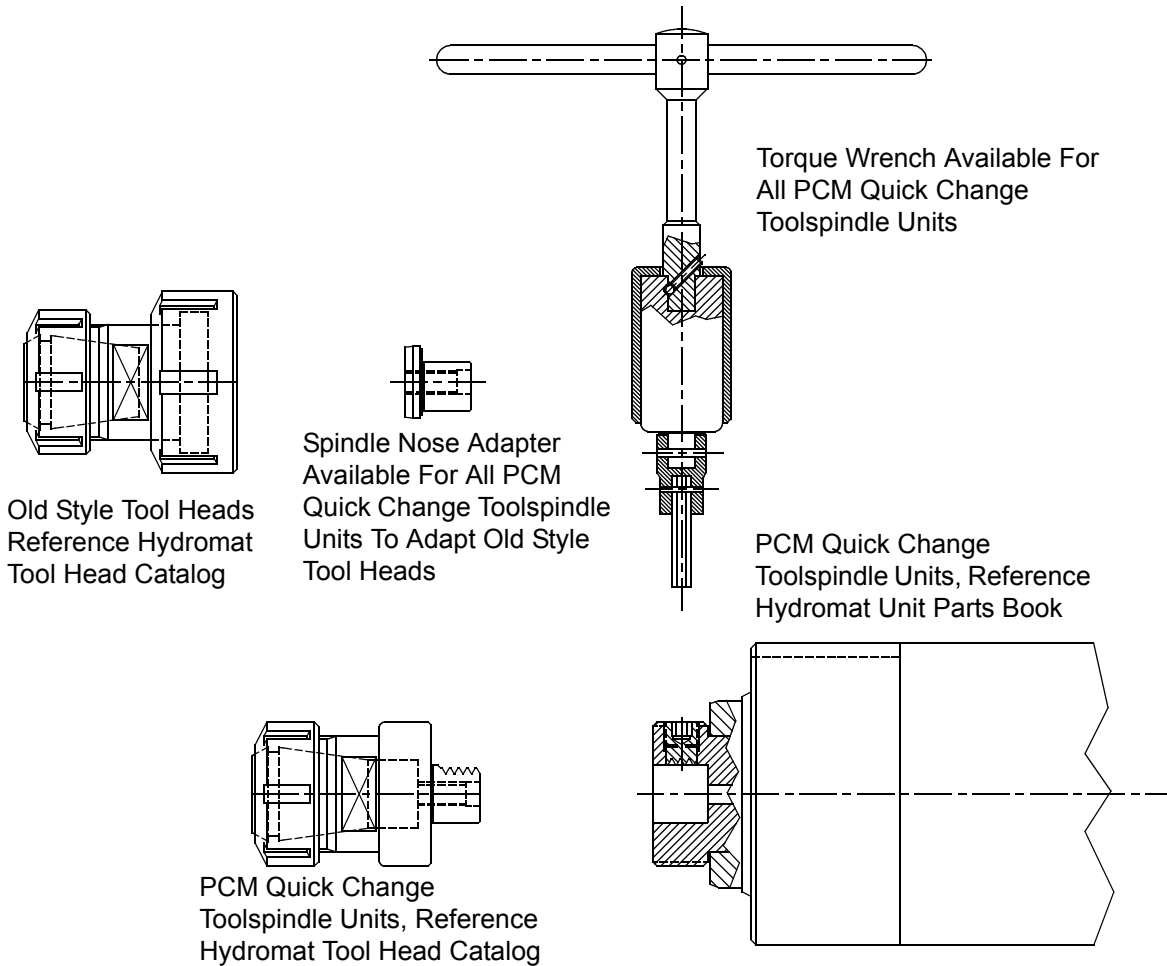

Hydromat PCM Quick Change Tool Head System			
Unit Size	Adapter	Torque Wrench	Tool Head Available
26/80	83812	S.O.060.048-02	Ref. Hydromat Tool Head Catalog
36/100	84812	S.O.060.048-03	Ref. Hydromat Tool Head Catalog
46/120	84812	S.O.060.048-03	Ref. Hydromat Tool Head Catalog

**HSK QUICK CHANGE TOOLSPINDLES**

The HSK Quick Change Toolspindles incorporates a special locking system in the spindle nose that allows for quick removal of Tool Heads with a provided torque wrench. The torque wrench ensures that the proper torque is applied to the locking mechanism. The Quick Change system speeds set ups and tool changes, especially when incorporated with the Hydromat Optical Presetter.

HSK Quick Change Tool Heads, Reference The Hydromat Tool Head Catalog

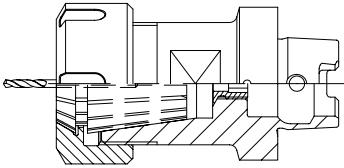

HSK Quick Change Toolspindle Units, Reference The Hydromat Unit Parts Book

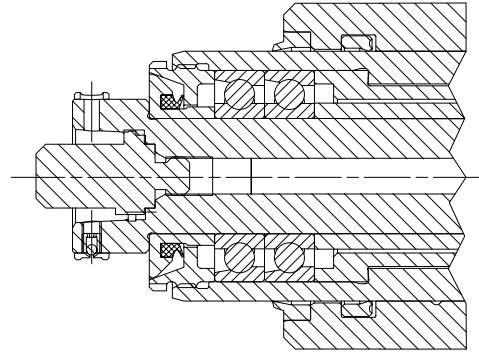

Torque Wrench Available For All HSK Quick Change Toolspindle Units



Hydromat HSK Quick Change Tool Head System			
Unit Size	Torque Wrench Model	Torque Wrench Part # - Description	Tool Head Available
26/80	HSK-C32	2850 3.0 NM 2.5 MM - w/2.5 MM Hex Bit	Ref. Hydromat Tool Head Catalog
36/100	HSK-C40	2850 6.0 NM 3.0 MM - w/3.0 MM Hex Bit	Ref. Hydromat Tool Head Catalog
46/120	HSK-C50	755-05 ASSY - 13.6 NM w/4.0 MM Hex Bit	Ref. Hydromat Tool Head Catalog

## 8. Units and Accessories

### CENTERING THE TOOLSPINDLE UNIT ON A MOUNTING FLANGE

Using the following sequence, a very accurate adjustment of the Mounting Flange is possible.

The following rules will help in obtaining an accurate adjustment:

- The Toolspindle Quill should be **extended** while using the setup procedure.
- The Toolspindle Unit must be clamped with the Clamp Handle for indicating.

If the Mounting Flange is out of alignment, it is readjusted using the following procedure:

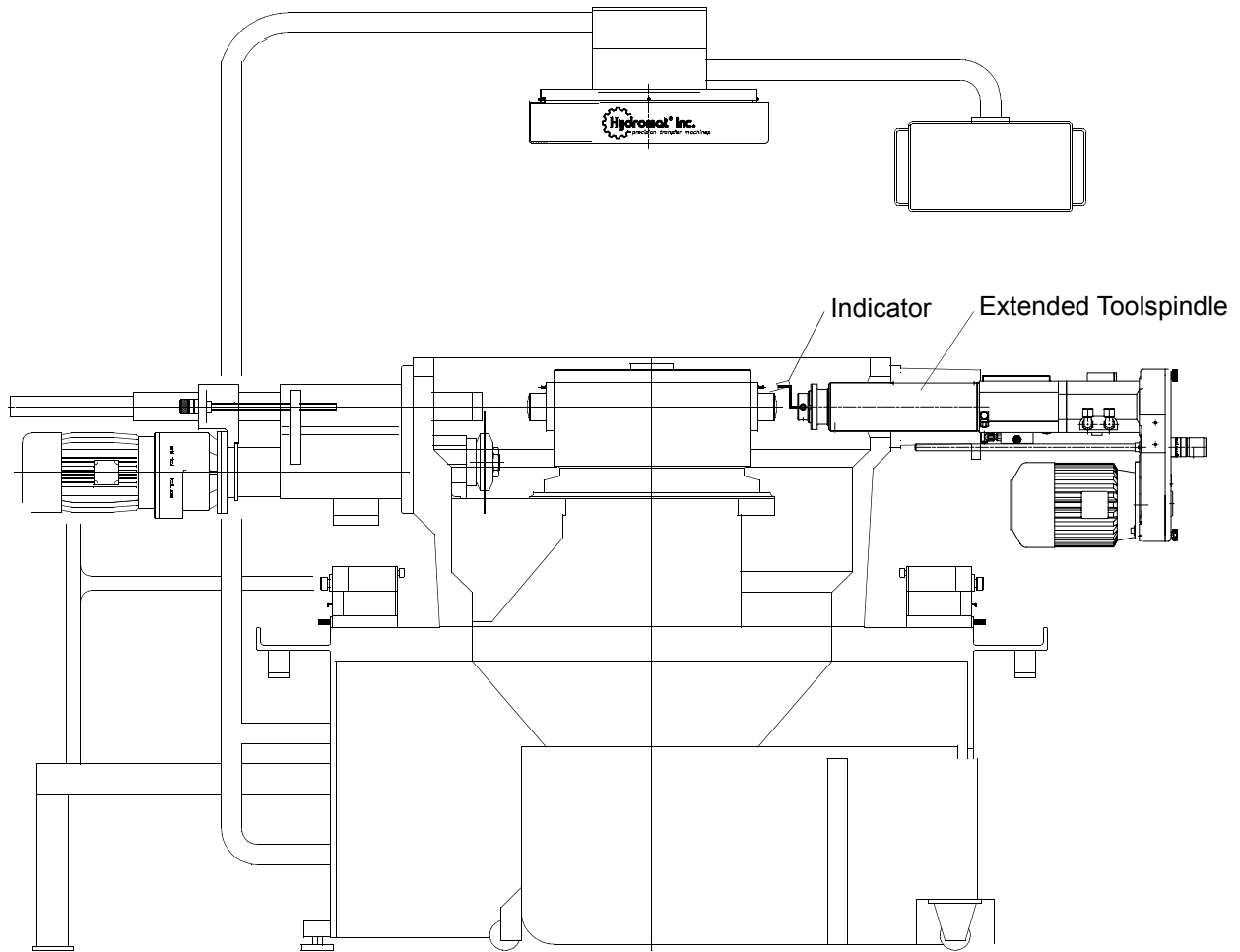



**CENTERING ON A STANDARD X-Y FLANGE**

1. Chuck a precision Master Piece in the Index Table Collet, mount a Dial Indicator onto the Spindle Nose of the Unit, remove the Pulley Guard (Machine must be turned off).
2. Loosen the Clamp Handle and using the Unit Adjusting Dial, move the Unit in until the Dial Indicator is over the Master Piece. Clamp the Unit in position with the Clamp Handle.
3. Loosen the Flange Clamp Nuts (3), re-tighten fully tight, then back them off 1/4 turn. (This will allow the Flange to be adjusted while it is kept flush with the Machine Casting by the pressure of the Disk Springs).
4. Touch-off the Dial Indicator to read zero on the top of the Master Piece, rotate the Spindle with the Drive Pulley to position the Dial Indicator at the bottom of the Master Piece. Using a Mirror check the variation on the Dial Indicator. Determine if the Flange must be raised or lowered.
5. To raise or lower the Flange, use a wrench to turn the top Micro Adjusting Screw. Continue adjusting until the Indicator has the same reading at the top and bottom.
6. Use the same procedure, turning the side Micro Adjusting Screw to adjust the horizontal alignment.
7. When the same Indicator reading is achieved in all four directions, tighten the Clamp Nuts in the following sequence: upper left - lower right - lower left - upper right.
8. Remove the Dial Indicator from the Spindle Nose and the Master Piece from the Index Table Collet. Install the Pulley Guard.

**NOTE:** When using hex. Collets, use the outside diameter of the Collet Flange in place of the Master Piece through this procedure.

**Standard X-Y Flange**

- 1 Toolspindle Mounting Flange
- 2 Mounting Stud
- 3 Clamp Nuts
- 4 Spring Washer Assembly
- 5 Micro Adjusting Screws

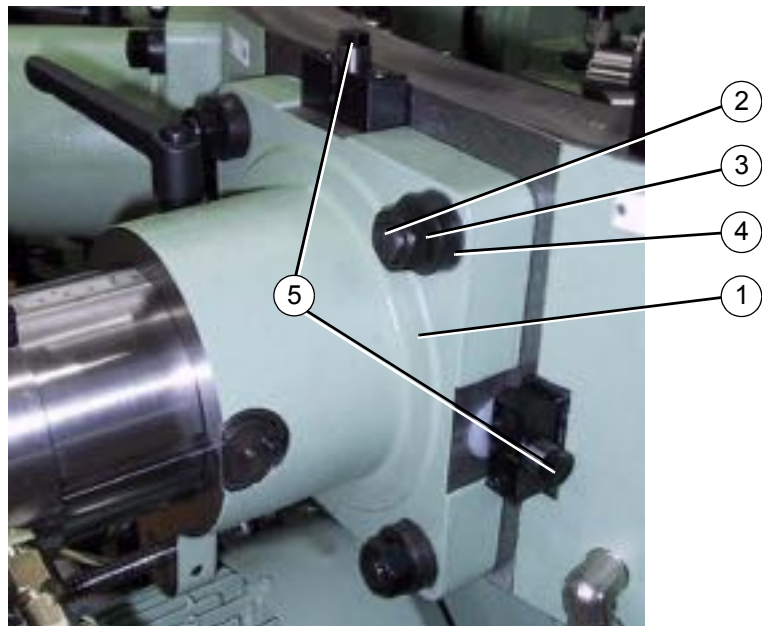

## 8. Units and Accessories

### CENTERING ON AN EXTENDED RANGE MOVEMENT X-Y FLANGE & 50/100 CNC UNIT

The same adjustments that are used on the Standard X-Y flange apply to the Special Extended Range Movement X-Y Flange and the 50/100 CNC Flange. See previous explanation.

#### Special Extended Range Movement X-Y Flange

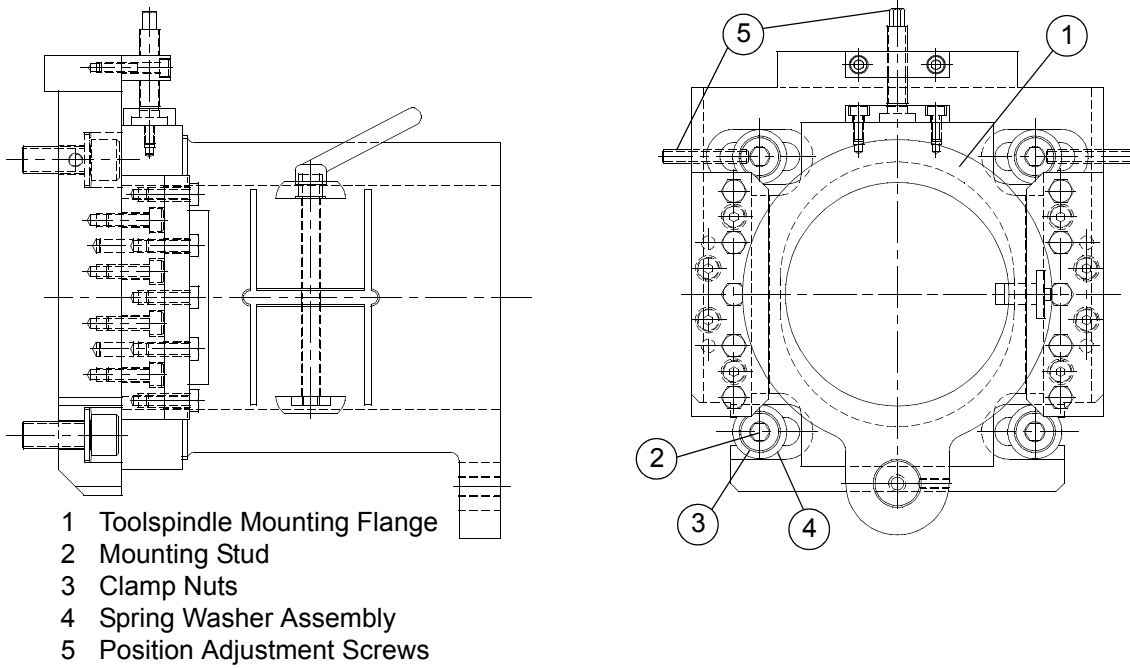

## RPM CHARTS

### RPM CHART FOR 26/80, 36/100, & 46/120 TOOLSPINDLE UNITS & GWE-20/50, GWE-30/60 THREADING UNITS

Pulley Set		26/80, 36/100, & GWE-20/50 & 30/60					46/120				
		Ratio	Motor RPM				Ratio	Motor RPM			
Spindle	Motor		840	1150	1740	3480		840	1150	1740	3480
1	8	2.57	2159	2956	4472		2.75	2310	3163	4785	9570
2	7	1.94	1630	2231	3376	6751	2	1680	2300	3480	6960
3	6	1.5	1260	1725	2610	5220	1.5	1260	1725	2610	5220
4	5	1.17	983	1346	2036	4072	1.14	958	1311	1984	3967
5	4	0.85	714	978	1479	2958	0.88	739	1012	1531	3062
6	3	0.67	563	771	1166	2332	0.67	563	771	1166	2332
7	2	0.52	437	598	905	1810	0.5	420	575	870	1740
8	1 (181-4)	0.39	328	449	679	1357	0.36	302	414	626	1253
8	178	0.33	277	380	574	1148					

 VE-20/80 and VE-26/80 Only

### RPM CHART FOR 26/80, 36/100, & 46/120 TOOLSPINDLE UNITS WITH 1:7 GEAR BOX

Pulley Set		26/80, 36/100, & GWE-20/50 & 30/60					46/120				
		I=1:7	Motor RPM				I=1:10	Motor RPM			
Spindle	Motor	Ratio	840	1150	1740	3480	Ratio	840	1150	1740	3480
1	8	2.57	308	422	639	1278	2.75	231	316	479	957
2	7	1.94	233	319	482	964	2	168	230	348	696
3	6	1.5	180	246	373	746	1.5	126	173	261	522
4	5	1.17	140	192	291	582	1.14	96	131	198	397
5	4	0.85	102	140	211	423	0.88	74	101	153	306
6	3	0.67	80	110	167	333	0.67	56	77	117	233
7	2	0.52	62	85	129	259	0.5	42	58	87	174
8	1 (181-4)	0.39	47	64	97	194	0.36	30	41	63	125

## 8. Units and Accessories

### RPM CHART FOR 26/80 & 36/100 TOOLSPINDLE UNITS WITH GEAR MOTOR

26/80 & 36/100					
Toolspindle Pulley Set			Gear Motor RPM		
Spindle	Motor	Ratio	175	315	483
1	8	2.6	455	819	1256
2	7	1.95	341	614	942
3	6	1.5	263	473	725
4	5	1.18	207	372	570
5	4	0.85	149	268	411
6	3	0.66	116	208	319
7	2	0.51	89	161	246
8	1 (181-4)	0.38	67	120	184
8	178	0.33	58	104	159

### RPM CHART FOR VE-46/120 TOOLSPINDLE UNITS WITH GEAR MOTOR

46/120					
Toolspindle Pulley Set			Gear Motor RPM		
Spindle	Motor	Ratio	173	306	454
1	8	2.75	476	842	1249
2	7	2	346	612	908
3	6	1.5	260	459	681
4	5	1.14	197	349	518
5	4	0.88	152	269	400
6	3	0.67	116	205	304
7	2	0.5	87	153	227
8	1 (181-4)	0.36	62	110	163
8	178				

**RPM CHART FOR GWE-20/50 & GWE-30/60 THREADING UNITS WITH GEAR MOTOR**

<b>GWE-20/50 and GWE-30/60 Threading Units</b>					
<b>Pulley Set</b>			<b>Gear Motor RPM</b>		
<b>Spindle</b>	<b>Motor</b>	<b>Ratio</b>	<b>175</b>	<b>315</b>	<b>483</b>
1	8	2.75	481	866	1328
2	7	2	350	630	966
3	6	1.5	263	473	725
4	5	1.14	200	359	551
5	4	0.88	154	277	425
6	3	0.67	117	211	324
7	2	0.5	88	158	242
8	1 (181-4)	0.36	63	113	174
8	178				

**RPM CHART FOR GWE-45/80 & GWE-45/120 THREADING UNITS WITH GEAR MOTOR**

<b>GWE-45/80 Threading Unit</b>					
<b>Pulley Set</b>			<b>Gear Motor RPM</b>		
<b>Spindle</b>	<b>Motor</b>	<b>Ratio</b>	<b>175</b>	<b>315</b>	<b>483</b>
1	8	2.6	455	819	1256
2	7	1.95	341	1597	942
3	6	1.5	263	473	725
4	5	1.18	207	372	570
5	4	0.85	149	268	411
6	3	0.66	116	208	319
7	2	0.51	89	161	246
8	1 (181-4)	0.38	67	120	184
8	178	0.33			

**8. Units and Accessories**

**RPM CHART FOR QBE-20 CROSS DRILL HEADS**

<b>QBE-20 CROSS DRILL HEAD</b>					
<b>Pulley Set</b>		<b>I=2:1</b>	<b>Motor RPM</b>		
<b>Spindle</b>	<b>Motor</b>	<b>Ratio</b>	<b>1150</b>	<b>1740</b>	<b>3480</b>
1	8	2.57	5911	8944	
2	7	1.94	4462	6751	
3	6	1.5	3450	5220	10440*
4	5	1.17	2691	4072	8143*
5	4	0.85	1955	2958	5916
6	3	0.67	1541	2332	4663
7	2	0.52	1196	1810	3619
8	1 (181-4)	0.39	897	1357	2714
8	178	0.33	759	1148	2297

 \* Settings Must Be Approved By Hydromat, Inc.

**RPM CHART FOR QBE-30 CROSS DRILL HEADS**

<b>QBE-30 CROSS DRILL HEAD</b>					
<b>Pulley Set</b>		<b>I=1.6:1</b>	<b>Motor RPM</b>		
<b>Spindle</b>	<b>Motor</b>	<b>Ratio</b>	<b>1150</b>	<b>1740</b>	<b>3480</b>
1	8	2.57	4729	7155	
2	7	1.94	3570	5401	
3	6	1.5	2760	4176	8352*
4	5	1.17	2153	3257	6515
5	4	0.85	1564	2366	4733
6	3	0.67	1233	1865	3731
7	2	0.52	957	1448	2895
8	1 (181-4)	0.39	718	1086	2172
8	178	0.33			

 \* Settings Must Be Approved By Hydromat, Inc.

**RPM CHART FK MILLING HEADS WITH 1:1.13 HEAD RATIO AND STANDARD MOTOR**

Milling Head Ratio = 1:1.13					
Pulley Set			Motor RPM		
Spindle	Motor	Ratio	840	1150	1740
1	8	2.57	1910	2615	3957
2	7	1.94	1442	1974	2987
3	6	1.5	1115	1527	2310
4	5	1.17	870	1191	1802
5	4	0.85	632	865	1309
6	3	0.67	498	682	1032
7	2	0.52	387	529	801
8	1 (181-4)	0.39	290	397	601
8	178	0.33	245	336	508

**RPM CHART FK MILLING HEADS WITH 1:1.13 RATIO AND GEAR MOTOR**

Milling Head Ratio = 1:1.13					
Pulley Set			Gear Motor RPM		
Spindle	Motor	Ratio	175	315	483
1	8	2.57	398	716	1099
2	7	1.94	300	541	829
3	6	1.5	232	418	641
4	5	1.17	181	326	500
5	4	0.85	132	237	363
6	3	0.67	104	187	286
7	2	0.52	81	145	222
8	1 (181-4)	0.39	60	109	167
8	178	0.33	51	92	141

## 8. Units and Accessories

### RPM CHART FK MILLING HEADS WITH 1:1.2 HEAD RATIO AND STANDARD MOTOR

Milling Head Ratio = 1:1.2					
Pulley Set			Motor RPM		
Spindle	Motor	Ratio	840	1150	1740
1	8	2.57	1800	2463	3727
2	7	1.94	1358	1859	2813
3	6	1.5	1050	1438	2175
4	5	1.17	819	1121	1697
5	4	0.85	595	815	1233
6	3	0.67	469	642	972
7	2	0.52	364	498	754
8	1 (181-4)	0.39	273	374	566
8	178	0.33	231	316	479

### RPM CHART FK MILLING HEADS WITH 1:1.2 RATIO AND GEAR MOTOR

Milling Head Ratio = 1:1.2					
Pulley Set			Gear Motor RPM		
Spindle	Motor	Ratio	175	315	483
1	8	2.57	375	674	1034
2	7	1.94	283	509	781
3	6	1.5	219	394	604
4	5	1.17	171	307	471
5	4	0.85	124	223	342
6	3	0.67	98	176	270
7	2	0.52	76	137	209
8	1 (181-4)	0.39	57	102	157
8	178	0.33	48	87	133



**RPM CHART FK MILLING HEADS WITH 1:1.3 HEAD RATIO AND STANDARD MOTOR**

Milling Head Ratio = 1:1.3					
Pulley Set			Motor RPM		
Spindle	Motor	Ratio	840	1150	1740
1	8	2.6	1696	2321	3512
2	7	1.95	1272	3515	2634
3	6	1.5	978	1339	2026
4	5	1.18	770	1054	1594
5	4	0.85	554	759	1148
6	3	0.66	430	589	892
7	2	0.51	333	455	689
8	1 (181-4)	0.38	248	339	513
8	178	0.33			

**RPM CHART FK MILLING HEADS WITH 1:1.3 HEAD RATIO AND GEAR MOTOR**

Milling Head Ratio = 1:1.3				
Pulley Set			Gear Motor RPM	
Spindle	Motor	Ratio	175	315
1	8	2.6	353	636
2	7	1.95	265	963
3	6	1.5	204	367
4	5	1.18	160	289
5	4	0.85	115	208
6	3	0.66	90	161
7	2	0.51	69	125
8	1 (181-4)	0.38	52	93
8	178	0.33		

## 8. Units and Accessories

### RPM CHART FK MILLING HEADS WITH 1:1.5 HEAD RATIO AND STANDARD MOTOR

Milling Head Ratio = 1:1.5					
Pulley Set			Motor RPM		
Spindle	Motor	Ratio	840	1150	1740
1	8	2.57	1479	2024	3063
2	7	1.94	1116	2690	2312
3	6	1.5	863	1182	1788
4	5	1.17	673	922	1394
5	4	0.85	489	670	1013
6	3	0.67	385	528	798
7	2	0.52	299	410	620
8	1 (181-4)	0.39	224	307	465
8	178	0.33			

### RPM CHART FK MILLING HEADS WITH 1:1.5 HEAD RATIO AND GEAR MOTOR

Milling Head Ratio = 1:1.5					
Pulley Set			Gear Motor RPM		
Spindle	Motor	Ratio	175	315	483
1	8	2.57	308	554	850
2	7	1.94	233	737	642
3	6	1.5	180	324	496
4	5	1.17	140	252	387
5	4	0.85	102	183	281
6	3	0.67	80	145	222
7	2	0.52	62	112	172
8	1 (181-4)	0.39	47	84	129
8	178	0.33			

**RPM CHART FK MILLING HEADS WITH 1:2 HEAD RATIO AND STANDARD MOTOR**

Milling Head Ratio = 1:2					
Pulley Set			Motor RPM		
Spindle	Motor	Ratio	840	1150	1740
1	8	2.6	1120	1533	2320
2	7	1.95	840	1150	1740
3	6	1.5	646	885	1338
4	5	1.18	508	696	1053
5	4	0.85	366	501	758
6	3	0.66	284	389	589
7	2	0.51	220	301	455
8	1 (181-4)	0.38	164	224	339
8	178	0.33			

**RPM CHART FK MILLING HEADS WITH 1:2 HEAD RATIO AND GEAR MOTOR**

Milling Head Ratio = 1:2					
Pulley Set			Gear Motor RPM		
Spindle	Motor	Ratio	175	315	483
1	8	2.6	233	420	644
2	7	1.95	175	315	483
3	6	1.5	135	242	372
4	5	1.18	106	191	292
5	4	0.85	76	137	211
6	3	0.66	59	107	163
7	2	0.51	46	82	126
8	1 (181-4)	0.38	34	61	94
8	178	0.33			

## RECESS UNITS

### RECESS UNIT WITH THRU THE DRAWBAR LUBRICATION NC-26/80, 36/100, AND 46/120

The Recess Toolspindle Unit is basically the same as the Standard Toolspindle Unit. The difference being the Recessing Head, Drawbar, and the Stop Knurl Nut. These items work together to perform the recess operation.



#### Function

The Recess Head is mounted onto the Spindle Nose and consists of two Angled Recess Sliders with Toolholders attached. The Recess Sliders are attached to the Drawbar which extends through the back of the Spindle. The end of the Drawbar is threaded where the Stop Knurl Nut is mounted.

In operation, the Toolspindle moves forward, with the Recess Head (15) and the Recess Sliders (14). When the Stop Knurl Nut (5) reaches the back of the Spindle Drive, it stops the forward motion of the Drawbar (2) and the Recessing Sliders (14). As the Toolspindle Quill (9) continues forward with the Recessing Head (15), it pulls the Recessing Sliders (14) together with the Toolholders, stretches the Spring (3) and performs the recessing operation.

As the Unit begins to retract, the Recess Sliders are forced open by a combination of centrifugal force and the retraction of the Spring (3) that is attached to the rear of the Spindle (11).

#### Thru The Drawbar Lubrication

Pressurized lubrication system that allows the lubricant to travel through the drawbar up to the sliding element of the toolhead. This method eliminates the need to grease the Recess Head.

The pressurized lubrication system regulator pressure should be set to 20 psi. Make sure the drip rate is set to 1 drop every 20 seconds. Check Auto Feed Tank fluid level (located on front leg of barfeeder) and fill if necessary by removing cap. See Chapter 4 for recommended oil.

### SETTING THE HARD STOPS ON RECESS UNIT NC-26/80, 36/100, AND 46/120

See set up as mentioned previously in this chapter.

#### Maximum Recess Depth With NC-26/80, 36/100, AND 46/120

26/80 Recess Head.....	3.0 mm (.118") stroke per side
36/100 Standard Recess Head.....	6.0 mm (.236") stroke per side
36/100 Large Recess Head .....	8.0 mm (.314") stroke per side
46/120 Standard Recess Head.....	8.0 mm (.314") stroke per side
46/120 Large Recess Head .....	12.0 mm (.472) stroke per side

### REMOVING THE DRAWBAR AND UNIT SPRING - RECESS UNIT NC-26/80, 36/100, & 46/120

1. Remove the Belt Cover (6) and the Knurled Nut (5).
2. Remove the 4 Socket Head Cap Screws and remove the Recess Head (15) from the Spindle with the Drawbar (2) still attached.
3. Remove the four Socket Head Cap Screws and separate the Unit Body (7) from the Bearing Housing (8) until the rear of the Quill is exposed (9).

4. Remove the six Socket Head Cap Screws from the rear of the Quill (9), separate the Bearing Housing (8) from the Unit Body (7), and then thread the Spring Holder (4) and Spring (3) from the Spindle (11).
5. Disassemble the Recess Head (1) and remove the Drawbar (2) from the front. ON 26/80 only, remove the Snap Ring (12).

**CROSS SECTION OF A RECESS UNIT NC-26/80, 36/100, AND 46/120**

**NOTE:** Refer to the Unit Parts Book for specific part numbers.

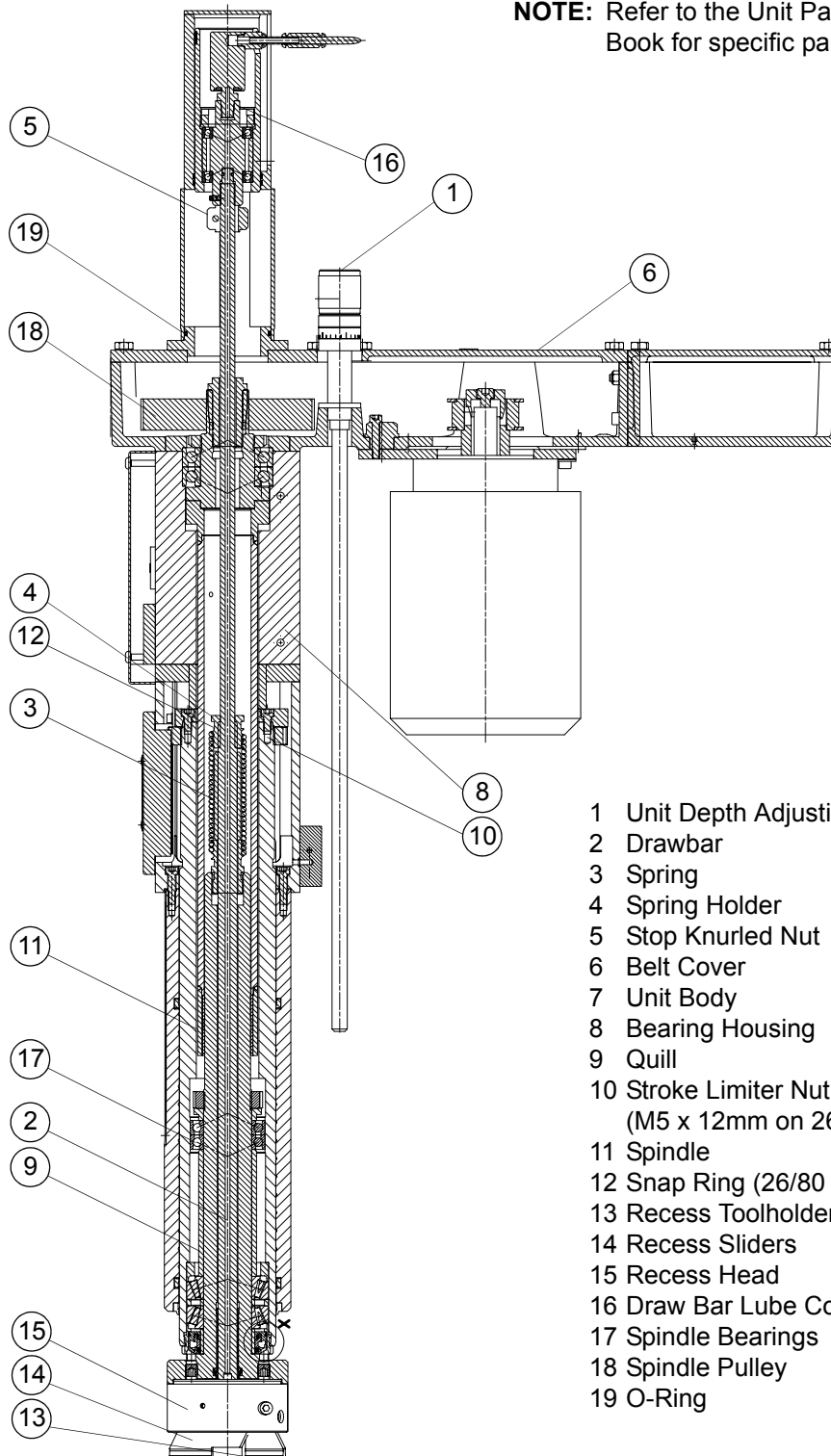

- 1 Unit Depth Adjusting Dial
- 2 Drawbar
- 3 Spring
- 4 Spring Holder
- 5 Stop Knurled Nut
- 6 Belt Cover
- 7 Unit Body
- 8 Bearing Housing
- 9 Quill
- 10 Stroke Limiter Nut M5 x 12mm  
(M5 x 12mm on 26/80)
- 11 Spindle
- 12 Snap Ring (26/80 only)
- 13 Recess Toolholder w/Tool
- 14 Recess Sliders
- 15 Recess Head
- 16 Draw Bar Lube Components
- 17 Spindle Bearings
- 18 Spindle Pulley
- 19 O-Ring

## 8. Units and Accessories

### Recess Head 26/80, 36/100, and 46/120

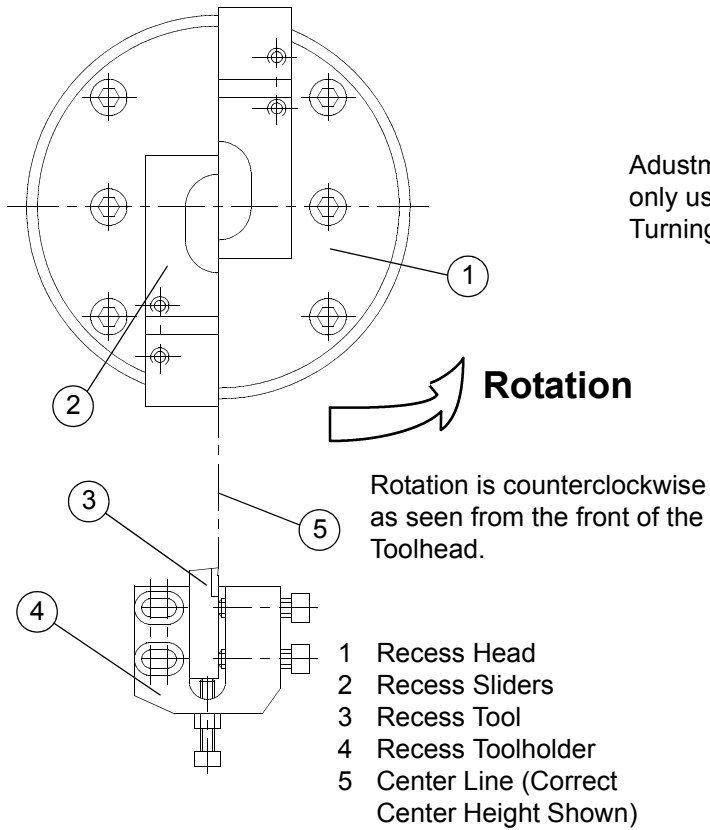

Adjustment Screw is only used on Recess Turning Operations.

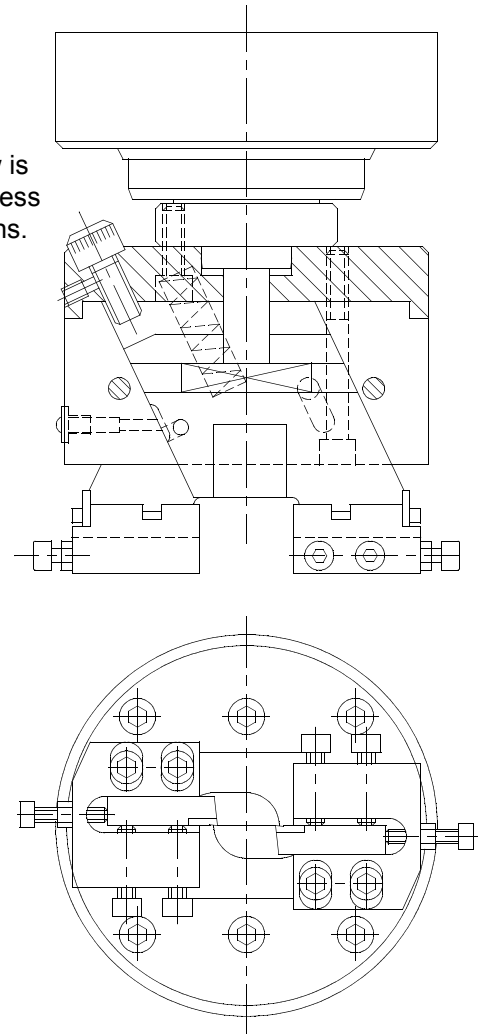

**CHANGING THE PULLEYS ON RECESS UNITS NC-26/80, 36/100, AND 46/120**

The Toolspindle revolutions can be changed by installing a different Pulley Set. This allows the best R.P.M. for the material that is machined.

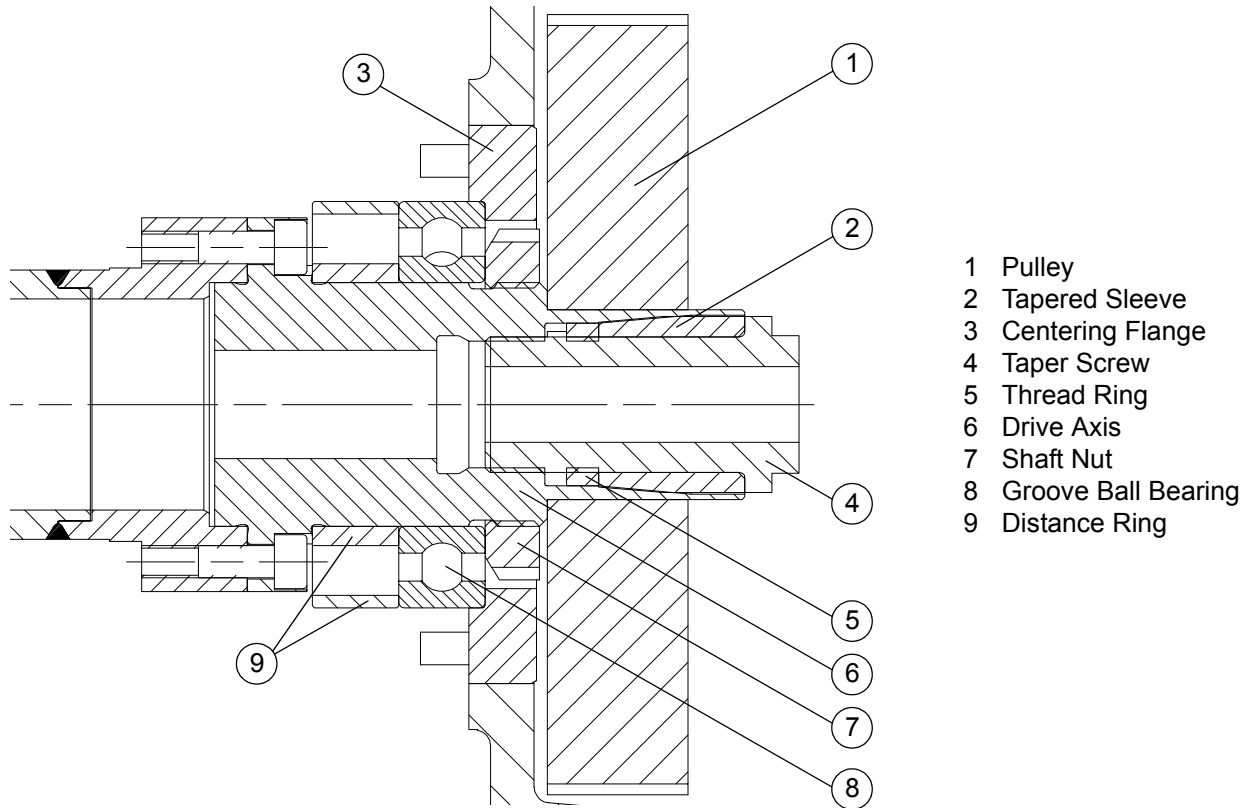

## 8. Units and Accessories

### RECESS TURNING

The Recess Turning operation is performed using a Recess Head mounted on a NC 2 Axis Unit. See the information provided earlier in this chapter on NC 2 Axis Servo Units.



### THREADING

The threading operation is performed using a NC Single Axis Unit with a Servo Motor. The Servo Motor allows the Unit to run at variable speeds as well as in reverse for threading purposes. See the documentation provided earlier in this chapter on NC Single Axis Units. Information on how to change the Pulleys and setting the hard stop is also provided in that section.



The CNC controls the depth (Z-Axis) movement of the Unit Quill as well as the feed rate of the Spindle. The movement of the quill is Hydraulically controlled by a Bosch Servo Valve.

Position feedback is provided by a scale. Integral scale reference marks give an accurate and repeatable Home position.

### SETTING THE HARD STOPS ON A THREADING UNIT

See set up as mentioned previously in this chapter for NC Toolspindle Units.



**THREAD ROLLING UNIT 36/100 COOLANT FED WITH FETTE E HEAD**

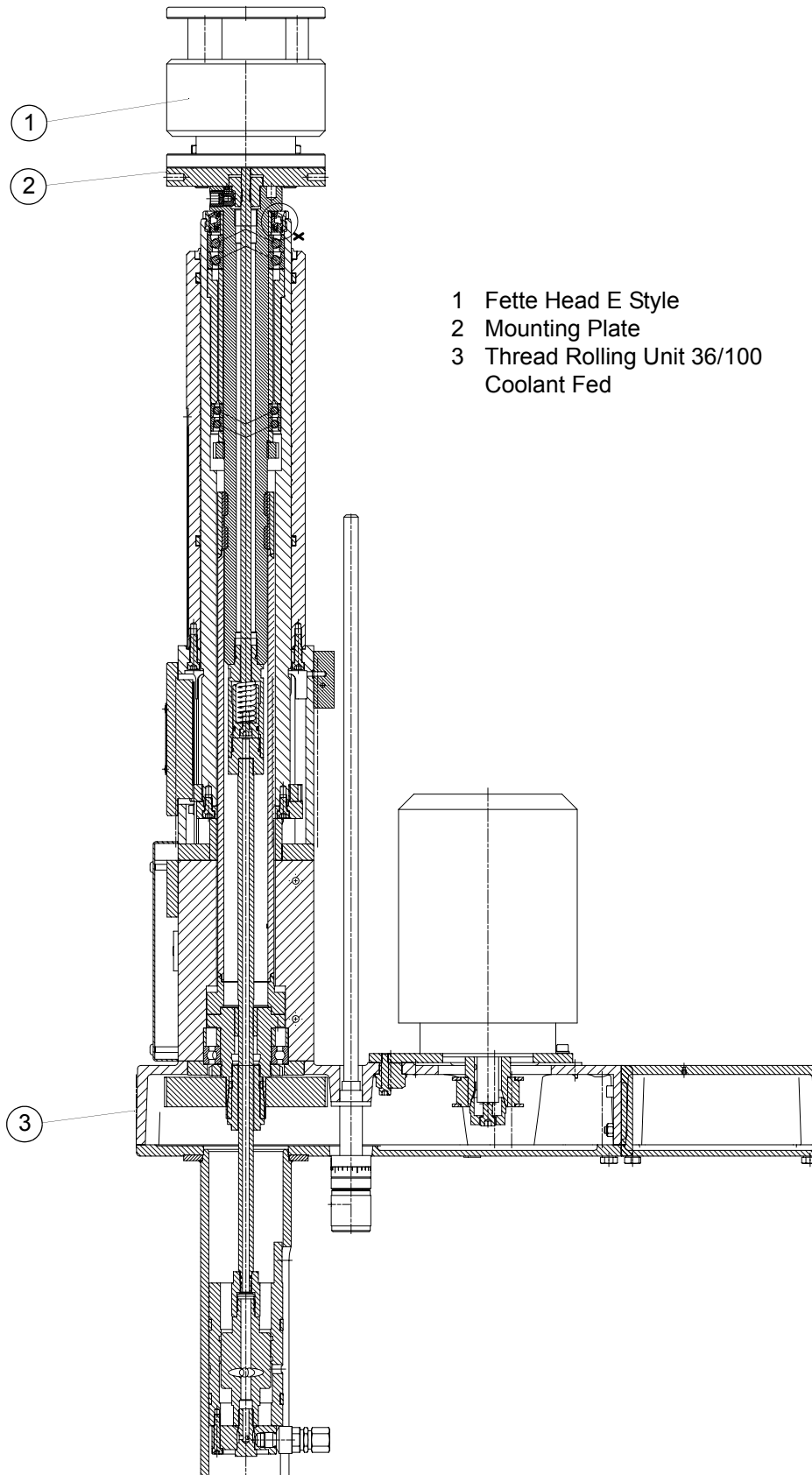

## 8. Units and Accessories

### DESCRIPTION OF THREAD ROLLING 30/60 UNIT WITH FETTE TYPE E HEAD

The Thread Rolling 30/60 Unit gives the machine the ability to roll O.D. threads quickly and allows rapid changeover and setup of threading operations. In the thread rolling process the part material is stressed beyond its yield point, being deformed permanently in the process. The grain structure of the material is, unlike cutting, displaced, not removed. As a result, the thread created, is harder than a comparable cut thread.

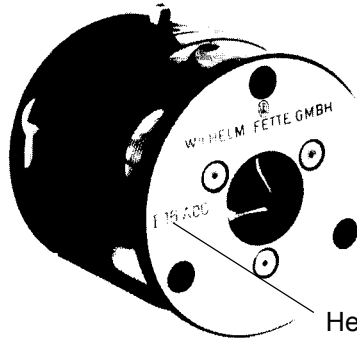

Head Model No.

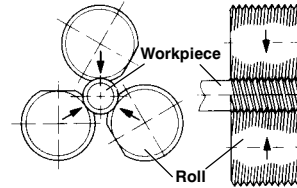

Radial Feed By Suitable Roll Geometry

Rolling Head Rotates, Component is Stationary

### Fette Type E Head

The Unit consists of a modified VE-30/60 CF Toolspindle with a Type E Fette Axial Thread Rolling Head. The Fette Type E Head generates a Thread by traversing axially over the part in the collet. The thread is produced in one single revolution of the rolls. The three rolls contact and penetrate into the part material. The maximum thread length is restricted by the width of the roll. The Unit is controlled by a Electric Control Box that controls every step in the Thread Rolling units cycle.

### Thread Rolling Sequence

1. The Control Box receives an electric impulse from the PLC to cycle. The Drill Detector checks for part presence and proper turned diameter. If either condition is not met, the Unit is not cycled and the Machine will go into Cycle Overtime with a Utility Units Fault.
2. The Extend Unit Solenoid is energized and the unit Quill moves forward, the Unit Retracted prox switch turns off and the Unit Extended prox turns on.
3. The Activate Drawbar Solenoid is energized for .7 seconds, the drawbar moves forward and closes the Fette Rolls. The rolls turn one revolution and stop in the flat area of the rolls.
4. The Extend Unit and Activate Drawbar Solenoids are de-energized and the unit Quill returns home. The Unit Retracted Prox turns back on and the Unit Extended prox turns off.
5. The Control Box signals the PLC that it is no longer active.

**THREAD ROLLS ON FETTE TYPE-E HEAD**

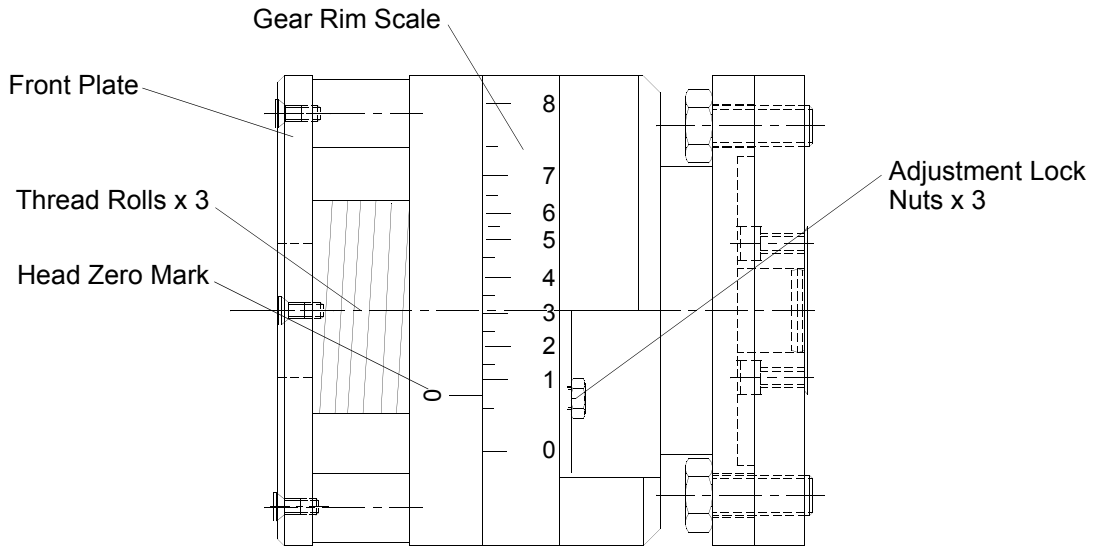

**Fette Type-E Head**

**NOTE:** Make sure the Zero Mark is aligned with the Zero on the Gear Rim Scale, and the blank is turned to the correct diameter, before attempting to engage the Fette Head. Loosen the 3 Lock Nuts and turn the Gear Rim to a higher number to increase the roll depth or to a lower number to decrease the roll depth.

Sequence of Assembly: 1-2-3 Clockwise,  
When Viewed From Front  
for Right-Hand and Left Hand Threads

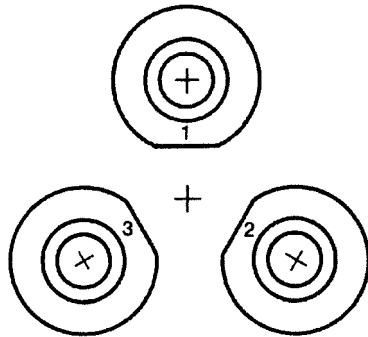

**Correct Orientation of Rolls**

View, When Assembling  
the Rolls

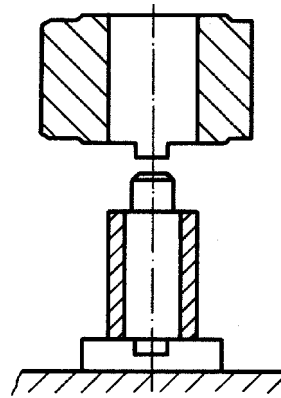

**Engaging Rolls Into Drive Plate**

## 8. Units and Accessories

### SETTING THE THREAD ROLLS AND ATTACHMENT MECHANISM

One set of three rolls (22) is required for each size of thread. They are marked 1, 2, and 3. The location of the rolls in the rolling attachment is specified. The rolls must be assembled in sequence 1-2-3 clockwise. It is important that a matching set be assembled.

The direction of rotation of the unit spindle determines whether rolling head “A” or “B” is to be used. This also determines the type of thread rolls (22) to be used. For example, thread rolls marked “A” can only be used in a “A” rolling head.

The identification marking of the thread rolls consists of the thread identification, the size of the rolling head, the type of rolling head and the roll number. To roll a M12 x 1.75 thread using rolling head type E16A, a set of thread rolls (22) is required, consisting of three rolls:

- M12 x 1.75 E 16 A 1
- M12 x 1.75 E 16 A 2
- M12 x 1.75 E 16 A 3

### Setting the Rolling Attachment Mechanism

**Loading:** The rolling head is ready for operation only when the spring is loaded and the clutch engaged. When this is the case, the engaging lugs of the synchronized gears (5) are radially positioned, and with driving plates (12) assembled, the slots of the plates which drive the thread-rolling dies (22) are positioned tangentially. They cannot be turned in the direction of rotation of the rolls. (Direction of rotation is different in versions “A” and “B”.) If the rolling head is not spring-loaded as described, then it must be loaded by turning the engaging lugs or a driving plate in the direction of rotation of the rolls. Alternatively, the hexagon socket-head screw (31) in the center of the rolling head must be turned with an Allen wrench, clockwise in the case of version “A”, (the opposite way for “B”), until the clutch engages. When the head is in use, this condition is re-established automatically by the action of thread rolls.

**Assembly of the thread rolls:** Thread rolls (22) should always be assembled with the rolling head in loaded condition. After loosening the three front plate screws (33), the front plate (4) can be taken off. The slots of the driving plates (12) must now be positioned tangentially. The set of thread rolls (22), consisting of numbers 1, 2 and 3 of the same version as the rolling head (e.g. rolls E 16 A for rolling head E 16 A), are assembled with the eccentric shafts (9) with bushes fitted (15) and turned clockwise until the flats of the rolls face the center. When the front plate (4) has been assembled and screwed down, the rolling head is ready for operation.

**Pitch diameter:** The distance between the thread rolls (22) can be changed by loosening the hex nuts (26) and turning the gear rim (8). Initially the 0-position should be selected. It may be necessary, because of variation in spring-action of the rolling head caused by the different tensile strengths of the material being rolled, to adjust the distance.

If the lower limit of the major diameter is not reached although the pitch diameter is within the given tolerance, then the blank diameter selected is too small. Since a blank diameter selected which is too large may cause damage to the thread rolls and rolling head, the correct blank diameter should be determined by staging several trial rolling operations.

**SPARE PARTS FOR RADIAL THREAD ROLLING HEADS - FETTE TYPE E**

E 8 A 02, E 8 B 02 (2-Roll System)  
 E 10 A 02, E 13 A 02, E 16 A 02, E 23 A 02, E 30 A 02 } 3-Roll System  
 E 10 B 02, E 13 B 02, E 16 B 02, E 23 B 02, E 30 B 02 }

Table 317

Part No.	Qty		Part Description
	E 8	E 10-E 30	
1	1	—	Spring housing
2	1	1	Drive gear plate
3	1	1	Cover plate
4	1	1	Front plate
5	2	3	Synchronized gear with DU-bush
6	1	1	Center gear
7	2	3	Adjusting gear
8	1	1	Gear rim
9	2	3	Eccentric spindle
10	1	1	Internal trip release lever
11	2	3	Spacer pin
12	2	3	Drive plate
13	2	2	Coupling pin
14	1	—	Shank MK . . .
15	2	3	Bush

Part No.	Qty		Part Description
	E 8	E 10-E 30	
16	4	4	Fitting key
17	2	3	Tension spring
18	1	1	Clutch stop
19	2	3	Pin
20	1	1	Pressure spring, heavy
21	1	1	Pressure spring, light
22	2	3	Thread roll
23	1	—	Internal trip release lever
24	1	—	Pin
25	1	1	DU-bush
26	2	2	Hexagon nut
27	2	—	Set screw
27	—	2	Washer
28	2	—	Guide piece with carbide blade
28	—	2	Stud bolt

Part No.	Qty		Part Description
	E 8	E 10-E 30	
29	4	4	Dowel pin
30	1	1	Straight pin
31	1	—	Pin
32	4	6	Cap screw
33	2	3	Cap screw
34	1	1	DU-bush
35	2	3	DU-bush, see Part No. 5
37	2	—	Straight pin
37	—	3*	Fitting key
38	2	3*	Straight pin
39	2	—	Set screw
41	2	2	Washer
42	—	1	Spring housing
45	—	1	Shank MK . . .

\* only for E 30 A 02 and E 30 B 02.

**Important:**  
 When ordering rolling head spare parts and thread-rolls **identical** to those already supplied, it is **essential** to give the type, size and serial number.

**Examples:**  
 Shank part 45 for rolling head  
 E 16 A 02—MK 4 Serial No. 109  
 Thread-rolls E 16 - 018 - A 29 for M 20 x 1.5

Fig. 313

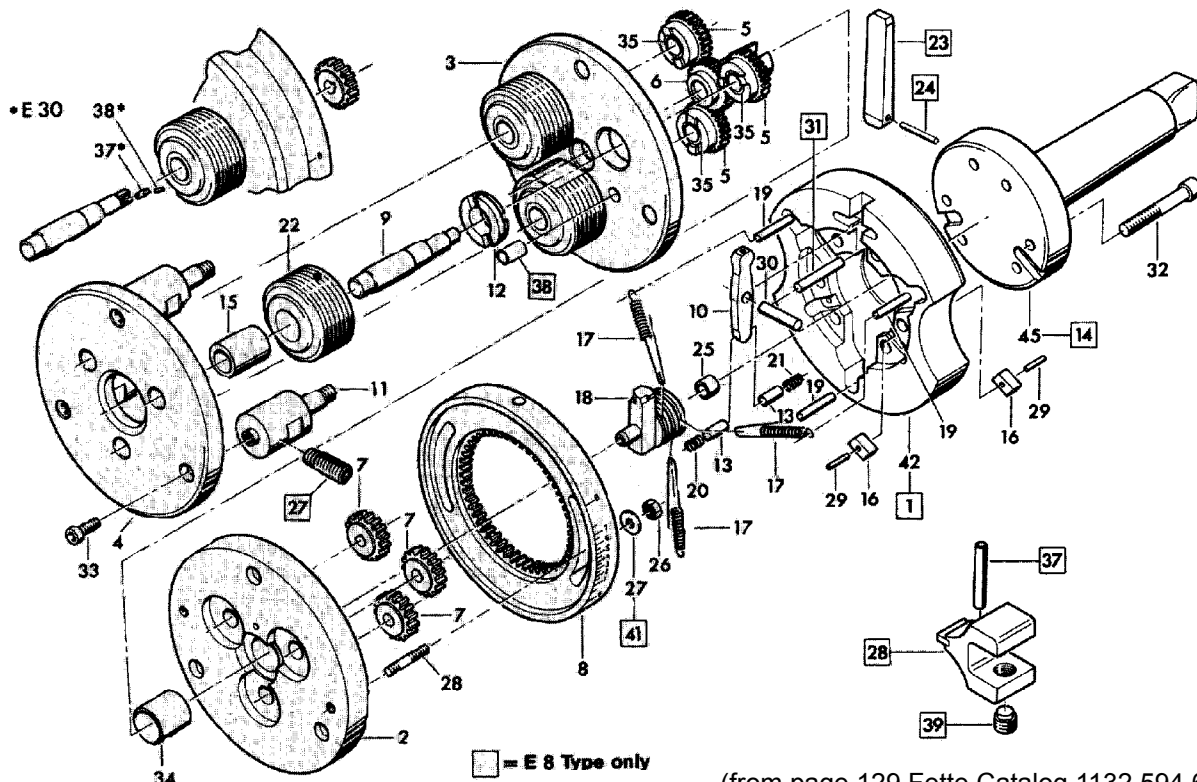

(from page 129 Fette Catalog 1132 594 6 B)

## 8. Units and Accessories

### C. J. WINTER 234SA SERIES RADIAL THREAD ROLLING ATTACHMENT

#### Preparation and Installation

With the exception of the Thread Rolls, your 234SA will be shipped with everything you need to install and operate on a Standard Hydromat 36/100 Recessing Spindle. The 234SA is packaged as 2 sub-assemblies. The Inner Assembly contains the working mechanisms of the thread-rolling head, including the Body, Slide Arms, and gear train components. The Outer Assembly consists of the Shell and a pair of Wedges. For maximum versatility, a complete set of wedges, chains, and springs has been included to cover the entire range of the attachment.

#### *Recessing Unit Preparation*

While a standard Hydromat 36/100 recessing unit is off the machine, remove the drawbar, disassemble the T-Nut and slip the included drawbar spacer over the short threaded end, and seat it against the shoulder. Re-install the drawbar.

If needed install a 50mm or 100mm spacer between the machine casting and the unit mounting flange to allow clearance for longer parts to index, and to insure that the unit adjusting screw is engaged in the unit mounting flange casting.

Center the unit to the work collets, and adjust for runout and alignment as needed. Tighten the flange clamping nuts fully as you learned in a previous lesson.

Attach the four M6 mounting screws to the outermost tapped holes on the unit's quill face. Leave these screws loose, protruding about 25mm from the quill face.

#### *Preparing the Outer Sub-Assembly*

Using the Data Reference Sheets provided, select the proper wedge, spring and chain combination to roll the desired thread.

Install the wedges into the wedge pockets on the shell. The Wedge retaining screws should be slightly loose at this point to allow the wedges to float in the radial pocket.

Mount the Shell onto your unit's quill. The 4 screw keyholes are not evenly spaced, so you may need to rotate your shell 90° to get the screws to align properly. Tighten all 4 screws in a cross pattern.

#### *Preparing the Inner Sub-Assembly*

##### 1. Taper Adjustment

The first step is to pre-set the taper of the roll pins. This procedure, as well as the installation of the Thread Rolling Dies, is best accomplished if you first remove the Slide Arms from the Base. To do this, disengage the chain from both of the tensioner's, and slip the arms out from one end of the Base. Refer to the drawing included in the back of the C. J. Winters manual.

- A. Before installing rolls, on a surface plate indicate across the roll pins, using an angle plate and height gage to adjust the taper setting screw so the roll pin is about .005" higher on the collet side. This pre-load usually results in near zero taper on the average threaded part. However, taper may require an additional adjustment after inspection of the first part.
- B. To adjust taper, loosen the Roll Pin Retention Screw, and take the roll pin out.
- C. For parts that are tapered too big on the collet side, turn the taper setting screw CCW in each arm, in full turn, 360 degree increments.

- D. For parts that are tapered too small on the collet side, turn the taper setting screw CW on each arm, in full turn, 360 degree increments.

**NOTE:** Each full turn of both Taper Setting Screws will change taper by approximately .0005" on diameter.

- E. Re-install the Roll Pin to its original position, rocking the taper setting screw to seat the flat on the roll pin properly, and tighten the Retention Screw.
- F. Check taper condition with an indicator and adjust as needed.
- G. Repeat this procedure with the other slide.

### 2. Install the Thread Rolling Dies and Roll Sprockets.

- A. Loosen the Roll Pin Retention Screw and completely remove the Roll Pin.
- B. Place the tangs of a roll sprocket sub-assembly into the drive slots on the Thread Rolls, roughly aligning the roll pin holes.
- C. Using the 234 Data Reference Sheet, select the proper chain, and wrap it around the Roll Sprocket. Slip the Roll and Sprocket into the Slide Arm, with the chain engaging the sprocket teeth.

**NOTE:** Install the chain with the master link up (facing the thread rolls). Installing the chain incorrectly will cause the master link to hit the hub of the roll sprocket, and may cause thread rolling problems.

- D. Lube the roll pin with full synthetic oil, like Mobile 1, and replace the roll pin. Tighten the roll pin retention screw.
- E. Repeat this procedure with the second Slide Arm.

### 3. Slide Arm Assembly

- A. Consult the 234 Data Reference Sheet, and select the recommended return spring for your application.
- B. Loosen the gib screw to ease assembly if necessary.
- C. Lube all way surfaces on both the arms and base with full synthetic oil (Mobile 1).
- D. Carefully insert slides between base and keepers. **Do Not Force.** If the slides are difficult to insert, check for burrs on the leading edges of the slides, body and keepers. These edges are kept sharp to avoid pulling debris into the slideways. Stone any burrs.
- E. With the 2 slides separated slightly, slip the recommended return spring into the pocket created between the slides.
- F. Pull the chain over the tensioner sprockets.
- G. The gib should be tightened enough to remove excessive play in the slideway, but loose enough for the return springs to force them open freely.

## 8. Units and Accessories

### 4. Timing adjustment

- A. Each roll has a timing mark etched on its face. These marks need to be pointed towards each other for proper timing. This can be accomplished one of two ways.
  - Loosen the M2.5 screw in the adjusting collar on the roll gear sub assembly. This unlocks timing, and allows the rolls to turn independently. Bring the two slide arms together until the thread rolls align. Tighten the adjusting collar M2.5 screws. Do not exceed 1.3 N-m (11 in-lb) of torque when tightening this screw. Excessive torque may cause gears to bind against Roll Pin.
  - Alternately, squeezing the tensioner sprockets together puts slack in the timing chain, which permits skipping a tooth on the roll sprockets. This is easier to do once the attachment is installed horizontally in the Hydromat machine, and the loose chain hangs aligned with the roll sprocket.

### 5. Final Assembly

- A. Partially back the flat head screw, (detail #2) out of the shell mounted in your machine.
- B. Slip the Inner sub-assembly into the shell. It is keyed to only go in one orientation. If it does not assemble freely, then rotate the inner sub-assembly 180°, and re-insert.
- C. Screw the drawbar into the inner sub-assembly and hand tighten.
- D. Push the inner sub assembly back into the outer shell, and while the wedge rollers are making solid contact with the wedge, float the wedges side to side slightly. Find the position where the roller seats best, and then push the wedge down into the shell. Tighten the wedge retaining screws.

## Maintenance

### *Regular Cleaning*

In-between jobs, and during tooling changes, disassemble the major components of the head and clean any accumulations of chips or debris. Pay particular attention to timing components, chains, sprockets, roll pockets, and slideways to be sure they are clear of foreign materials.

### *Lubrication*

Lube all way surfaces, and moving components with full synthetic oil, like Mobile 1 Oil. This oil has been recommended because of its superior film strength and lubricity. Using other oils may result in galling of components under the working loads of thread rolling.

### *Wear*

Check all moving surfaces for wear. Areas to pay particular attention to are:

- Gib: If the gib thickness is less than 6.15mm (.242"), especially along the two wear pads, then it is reaching the end of its usable life, and should be replaced. Continued use of the gib will result in tearing of the low-friction laminate, and possible permanent damage to the thread-rolling head.
- Roll Sprocket: If the hub on the roll sprocket has excessive wear, it will allow too much side play in the roll pocket. It should be replaced.
- Roll and Tensioner Sprockets: Check for chipped or missing teeth. Replace if needed.
- Chain: Check for excessive wear or stretch, and replace if needed.



### Setup Procedure for 234 Head

The following step by step procedure will decrease your setup time, and get you the best thread rolling results. This procedure is only an outline. For more detailed information, see the referenced sections in each step.

1. Index a part with the recommended blank diameter and configuration, prepared in the previous stations, into the threading station.
2. Remove the flat head screw from the outer shell.
3. With a blank part in the collet, and the Hydromat unit in home position, manually push the drawbar forward until the thread rolls are in the area to be threaded. Adjust the knurled stop nut against the back of the unit housing when the rolls are in position over your blank. To maximize roll life, the face of the rolls closest to the collet should be 1 pitch past the back chamfer of the blank diameter of the part.
4. Push the drawbar forward manually, and measure the distance between the front face of the shell (in the retracted position) and the center line of the rollers on the back of the slide arms.
5. Set the Hydromat unit to about 10mm more than the measurement taken in step #7. This roughly corresponds to the point where the rolls approach the blank diameter. It is also where the quill's rapid approach should end.
6. Push the inner sub assembly back into the outer shell. Tighten the flat-head "retention" screw.
7. At this point the Hydromat unit should be cycled manually, adjusting first the rapid approach so that it ends before the draw bar knurled nut strikes the back of the unit housing. RPM and feed rate for cycle time should also be adjusted at this point. (dry run)
8. With a blank in the collet, turn on the recessing unit and try rolling a single part.
9. Increase the length of quill stroke, 2 full turns at a time, until rolls leave a mark on blank.
10. Check pitch diameter, and adjust stroke in ½ turn increments until pitch diameter falls into tolerance range (see setting). **Minute adjustments to the pitch dia. can be made by fine adjusting the draw bar stop knurled nut. Unit position may have to be adjusted if shoulders are a consideration.**
11. At this point, you may need to adjust the taper of the roll pins to get a straight pitch diameter.
12. Once the pitch diameter is straight, adjust the prepared blank size to bring the Major diameter of the thread into tolerance. Each .0001" on the blank diameter will affect the major diameter of the thread by approximately .0003". Make adjustments in small increments to avoid filling the rolls, or over-rolling. *Severe over-rolling can cause thread roll failure.*

After adjusting the blank diameter, small corrections may be needed to the pitch diameter and taper settings.

# 8. Units and Accessories

## C.J. Winter Rotary Radial Attachment Parts Drawing

REV	DATE	BY	REVISION DESCRIPTION	DATE	CHK
A	.	.	Released	XX/XX/PA	

Item	Part #	QTY	Description
1	234925	2	Rolling Screws
2	234925-01	1	Slide Compression, CS30 x .2500 x 1.50
3	234925	2	Slide Pin
4	234925-01	1	Blank Hydraulic Rotating Spindle
5	234925	2	Washer
6	234925	2	Washer
7	234925	2	Carriage Roll Pin
8	234925	2	Carriage Wedge Roller Pin
9	234925	2	Transfer Roller Pin
10	234925	2	Wedge Roll Pin
11	234925	1	Hydraulic Collar
12	234925	1	Roll Spacers
13	234925	2	Transfer Spacers
14	234925	4	Roller Springs
15	234925	2	Roller Springs - 1/4-20 (Starts)
16	234925-130	1	Roller Compression, 130H, .2500 x 1.50
17	234925-01	1	Roller Compression, 130H, .2500 x 2.00
18	234925-24	1	Roller Roller, .1475 x .54
19	234925-24	1	Roller Roller, .1475 x .54
20	234925-24	1	Roller Roller, .1475 x .54
21	234925-24	1	Roller Roller, .1475 x .54
22	234925-24	1	Roller Roller, .1475 x .54
23	234925	1	Roller Pin, .1875 x .75 x 1.00H
24	234925	2	Roller Pin, .1875 x .75 x 1.00H
25	234925	4	Roller Pin, .1875 x .75 x 1.00H
26	234925	2	Roller Pin, .1875 x .75 x 1.00H
27	234925	2	Roller Pin, .1875 x .75 x 1.00H
28	234925	2	Roller Pin, .1875 x .75 x 1.00H
29	234925	2	Roller Pin, .1875 x .75 x 1.00H
30	234925	2	Roller Pin, .1875 x .75 x 1.00H
31	234925	1	Gib

THIS DRAWING IS THE CONFIDENTIAL AND EXCLUSIVE PROPERTY OF C.J. WINTER MACHINE TECHNOLOGIES, INC. AND IS NOT TO BE REPRODUCED OR COPIED IN ANY MANNER WITHOUT THE EXPRESS WRITTEN PERMISSION OF C.J. WINTER MACHINE TECHNOLOGIES, INC. VIOLATION IS PROHIBITED BY LAW.

UNLESS OTHERWISE SPECIFIED: DIMENSIONS SHALL BE IN INCHES UNLESS OTHERWISE SPECIFIED. DIMENSIONS IN PARENTHESES ARE FOR INFORMATION ONLY.

DESIGNED BY: J. Christ  
 DATE: 8/2/00  
 DRAWN BY: P. Altieri  
 DATE: 8/28/00

C. J. WINTER MACHINE TECHNOLOGIES, INC.  
 Rotary Radial Attachment Slide

REV. B  
 SHEET 1 OF 1  
 DATE: 6/00/PA

REV	DATE	BY	REVISION DESCRIPTION	DATE	CHK
A	.	.	Released	6/00/PA	

Item	Part #	QTY	Description
1	234925-01	1	Shell (Hydraulic Rotating Spindle)
2	234925-01	1	Screw: PHSS, M4 x .75 x 1.00H
3	234925-01	2	Wedge: 1.0 deg Rapid x 6 deg Power x .300
4	234925-02	2	Wedge: 1.0 deg Rapid x 6 deg Power x .350
5	234925-03	2	Wedge: 1.0 deg Rapid x 6 deg Power x .371
6	234925-04	2	Wedge: 1.0 deg Rapid x 6 deg Power x .403
7	234925-05	2	Wedge: 1.0 deg Rapid x 6 deg Power x .434
8	234925-06	2	Wedge: 1.0 deg Rapid x 6 deg Power x .465
9	234925-07	2	Wedge: 1.0 deg Rapid x 6 deg Power x .496
10	234925-08	2	Wedge: 1.0 deg Rapid x 6 deg Power x .527
11	234925-09	2	Wedge: 1.0 deg Rapid x 6 deg Power x .558
12	234925-10	2	Wedge: 1.0 deg Rapid x 6 deg Power x .589
13	234925-11	2	Wedge: 1.0 deg Rapid x 6 deg Power x .620
14	234925-12	2	Wedge: 1.0 deg Rapid x 6 deg Power x .651
15	234925	1	Pin: Dowel, SM Dia x 1.24H
16	234925	2	Screw: SHCS, M4 x .75 x .84H
17	234925	1	Blushring For Hydraulic Rotating Spindle
18	234925	4	Screw: SHCS, M8 x 1.0 x .30H
19	234925-01	1	Rotary Radial Attachment Inner Assembly

THIS DRAWING IS THE CONFIDENTIAL AND EXCLUSIVE PROPERTY OF C.J. WINTER MACHINE TECHNOLOGIES, INC. AND IS NOT TO BE REPRODUCED OR COPIED IN ANY MANNER WITHOUT THE EXPRESS WRITTEN PERMISSION OF C.J. WINTER MACHINE TECHNOLOGIES, INC. VIOLATION IS PROHIBITED BY LAW.

UNLESS OTHERWISE SPECIFIED: DIMENSIONS SHALL BE IN INCHES UNLESS OTHERWISE SPECIFIED. DIMENSIONS IN PARENTHESES ARE FOR INFORMATION ONLY.

DESIGNED BY: J. Christ  
 DATE: 8/2/00  
 DRAWN BY: P. Altieri  
 DATE: 8/28/00

C. J. WINTER MACHINE TECHNOLOGIES, INC.  
 Rotary Radial Attachment For Hydraulic

REV. B  
 SHEET 1 OF 1  
 DATE: 6/00/PA

## INVERTING UNIT

### Not Used on Machines With Indexable Satellite Chucks

The Inverting Unit offers the unique capability of removing the workpiece from the Index Table Collet, inverting it end to end, and replacing it back into the same Collet. This feature allows machining from both ends of the workpiece, therefore eliminating secondary operations.

### TECHNICAL DETAILS OF INVERTING UNIT WDE-30

Total Unit stroke .....	3.150
Maximum inverting diameter .....	1.250"
Maximum inverting size hex .....	1 1/16"
Maximum inverting size square.....	7/8"
Maximum inverting length (standard) .....	5"
Maximum inverting length (modification required) ..	6"
Minimum inverting time .....	3.0 sec.

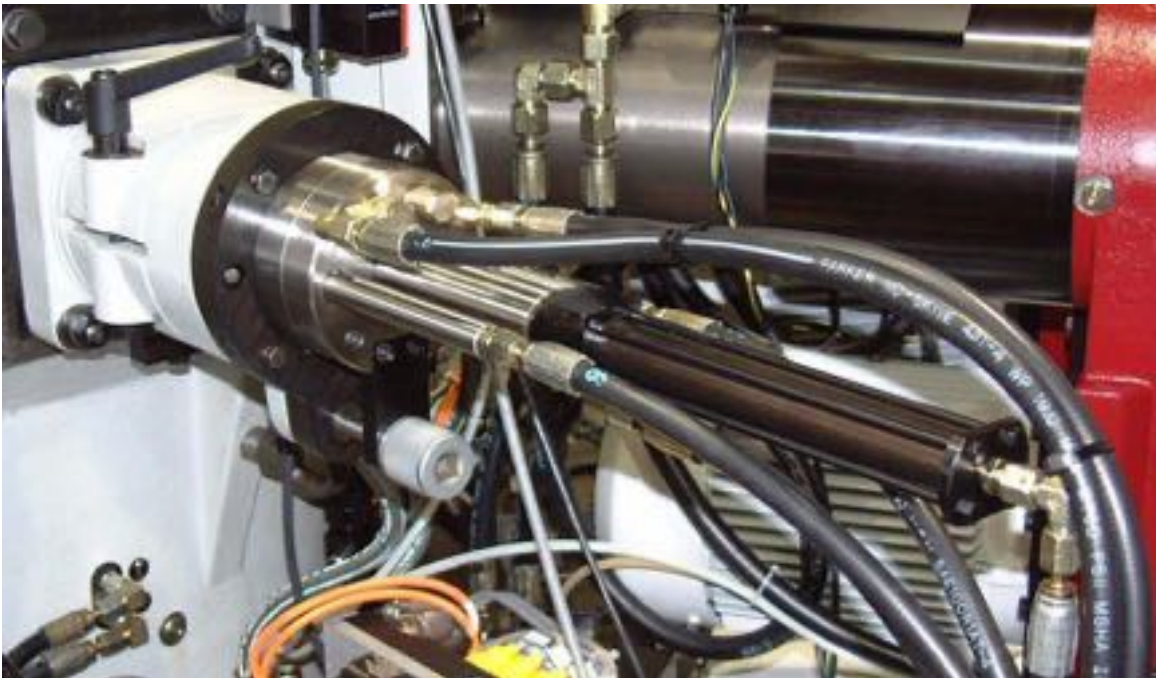

**Inverting Unit WDE-30**

## 8. Units and Accessories

### INVERTING UNIT WDE-30

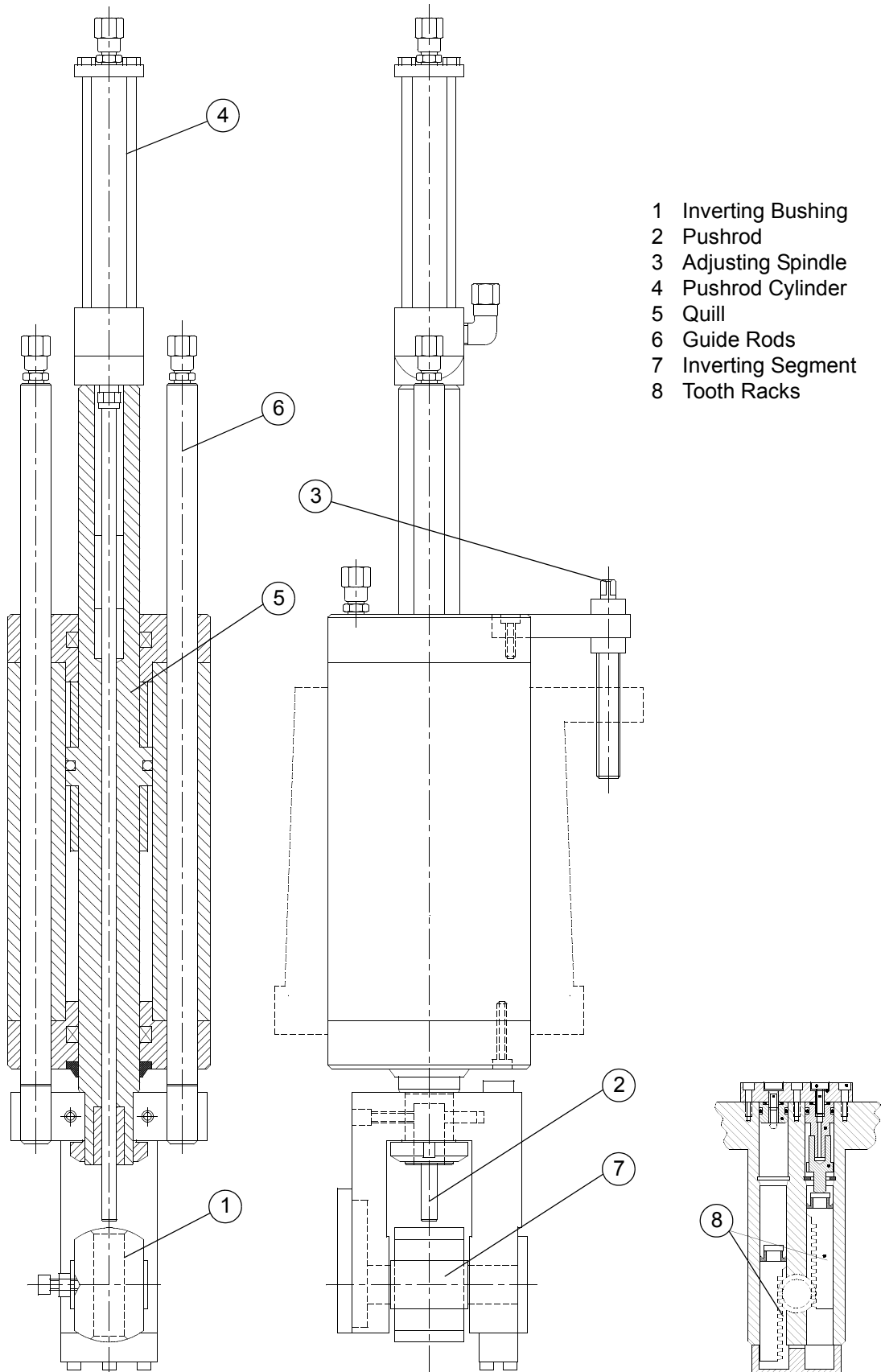

INVERTING BUSHING WDE-30/60

SYN.

REVISION RECORD

DATE

BY

DASH NUMBER	BUSHING TYPE	DIM. "A"	+0.003	-0

**TYPE B**

**GUARDS**

I.D.	HUG NO.
2.859	5.15.128-1
3.543	5.15.128-2
4.724	5.15.128-3
4.331	5.15.128-4
2.756	5.15.128-5

NOTE: DIMENSION "A" = MAXIMUM BARSTOCK SIZE + .004"

ITEM	QTY.	DESCRIPTION	MATERIAL	REMARKS
1	1	BUSHING	φ 1.248x2.40	A-2 HEAT TR. 58-62RC
NEXT ASSEMBLY				
Hydramat <sup>®</sup> Inc. <i>J. Lewis</i> Inc.				
INVERTING BUSHING WDE 30/60				

TOLERANCES - EXCEPT AS NOTED:		SCALE	DATE	7/24/90
X	± .015	FRACTIONAL	± 1/32	DRAWN BY
XX	± .010	DECIMAL	± 1/2	L. BENWELL
XXX	± .005	DECIMAL	± 1/2	CHK'D BY
				PERFORM

**TYPE C**

ALL OTHER DIMENSIONS TYP.

**TYPE D**

ALL OTHER DIMENSIONS TYP.

**TYPE E**

ALL OTHER DIMENSIONS TYP.

## 8. Units and Accessories

### DESCRIPTION OF INVERTING UNIT WDE-40

The HYDROMAT Inverting Unit offers the unique capability of removing the workpiece from the Index Table Collet, inverting it end for end, and replacing it back into the same Collet. This feature allows machining from both ends of the workpiece, therefore eliminating secondary operations.

### TECHNICAL DETAILS OF INVERTING UNIT WDE-40

Total Unit stroke .....	4.720
Maximum inverting diameter (6.15.001-4) .....	1.750"
Maximum inverting diameter (6.15.019-2) .....	2.25"
Maximum inverting size hex .....	1 1/2"
Maximum inverting size square.....	1 1/4"
Maximum inverting length (standard) .....	6"
Maximum inverting length (modification required) ..	7"
Minimum inverting time .....	4.0 sec.

**INVERTING UNIT WDE-40**

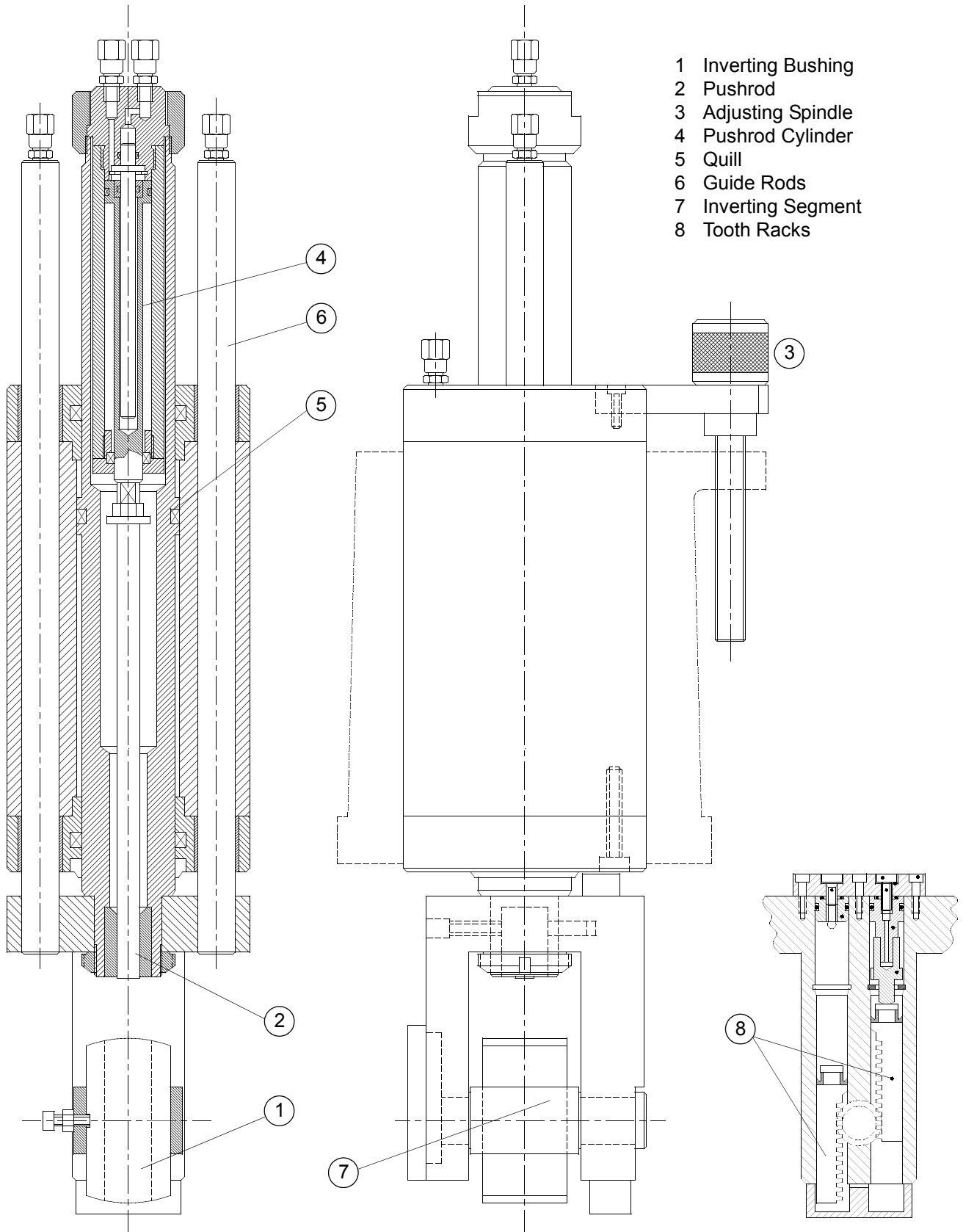

## 8. Units and Accessories

### INVERTING UNIT WDE-40 LARGE DIA.

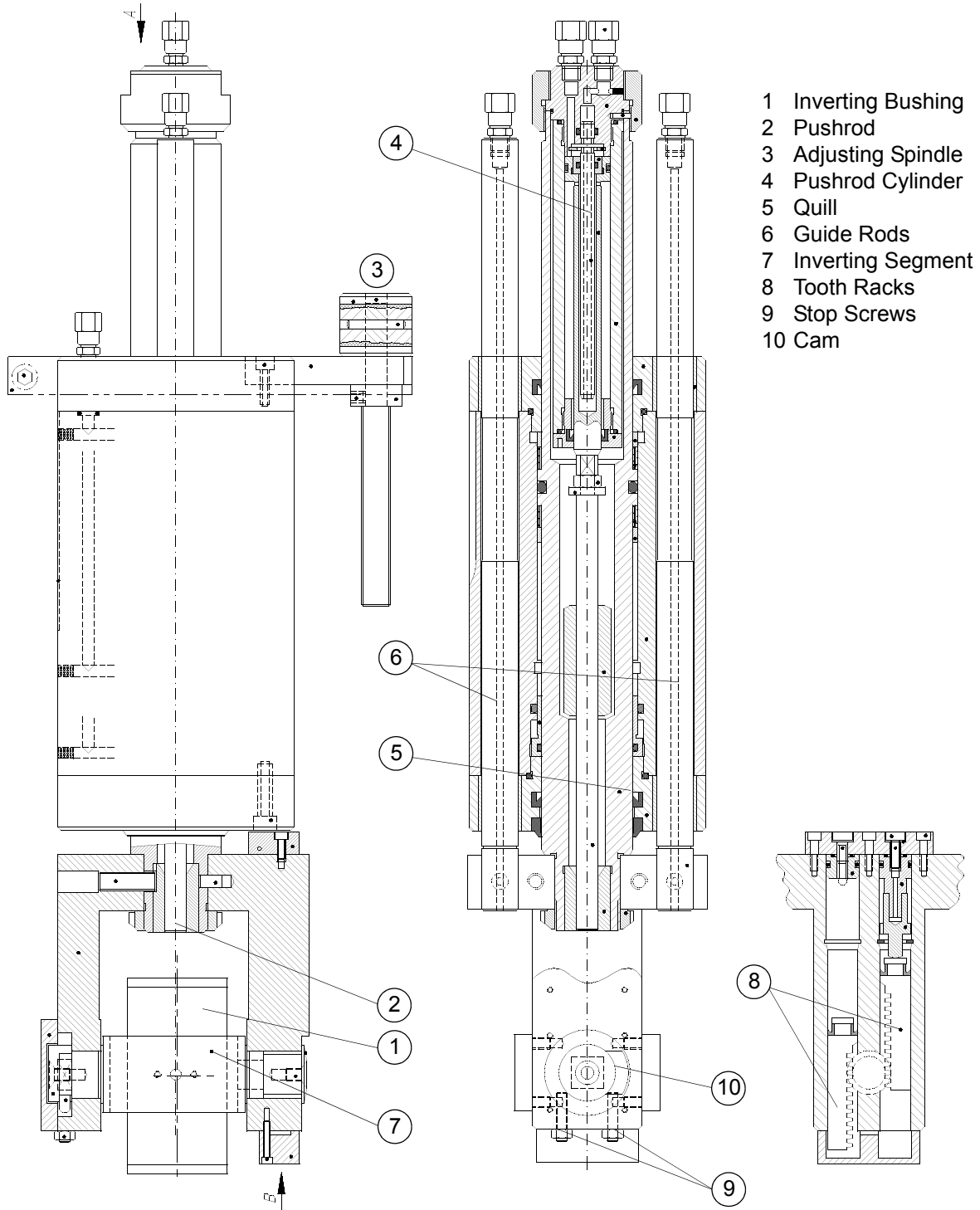





## 8. Units and Accessories

### SETUP OF THE INVERTING UNIT PUSHROD LENGTH

The following instructions describe the procedure for fine adjusting the pushrod length to determine short part length and fault the machine due to unit cycle overtime.

To determine exact length of pushrod sleeve for setups:

1. Determine the length of the part being inverted, using a part in the middle of the tolerance, from previous station facing the first end.
2. When using the inverting cage procedure described, be sure the cage halves have been placed in the forward and rearward positions as instructed. Position the unit to achieve correct clearance with the extended ejector.
3. Overall pushrod length can now be established to just clear the rotating inverting bushing, with the pushrod cylinder retracted.
4. Place the sample part of the middle of the tolerance length in the inverting station collet, determine pushrod spacer length to allow the pushrod cylinder to have .005 overtravel before bottoming in the extended position.
5. Final position adjustment should be made with the Unit Adjusting Screw and the pushrod cylinder forward, this will insure that parts from previous stations will be inverted and gaged to a tolerance of minus .005. Parts having a length shorter than this will not push the ejector completely back, returning the inverting unit home.
6. The same procedure can be used without an inverting cage, by bringing the inverting bushing rotating radius to within .010 of the extended ejector pin to set unit position, and adjusting the pushrod spacer as described for each part number.

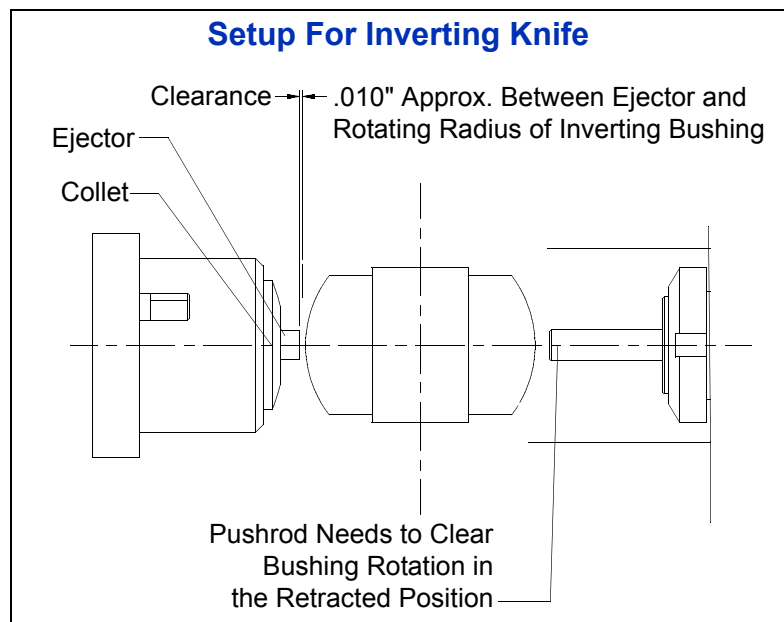
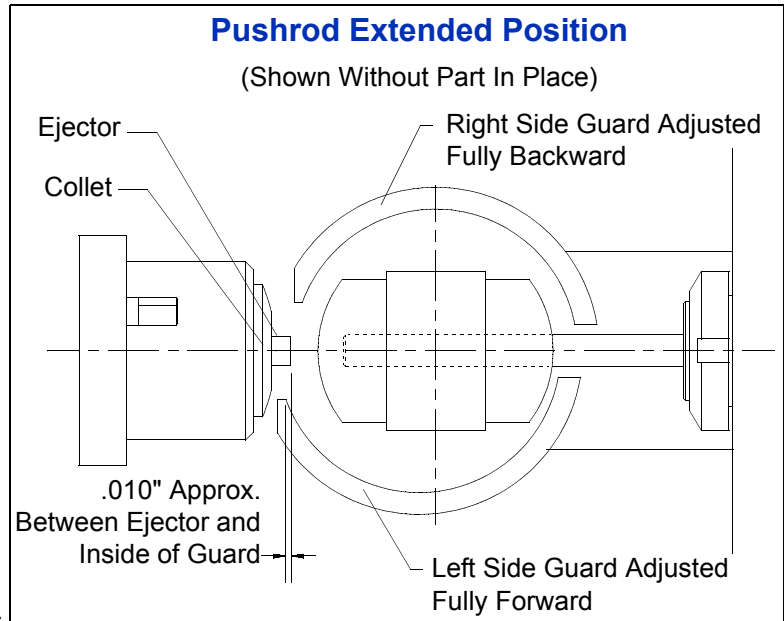

## LUBRICATION ASSEMBLY WITH BASIC AIR SUPPLY

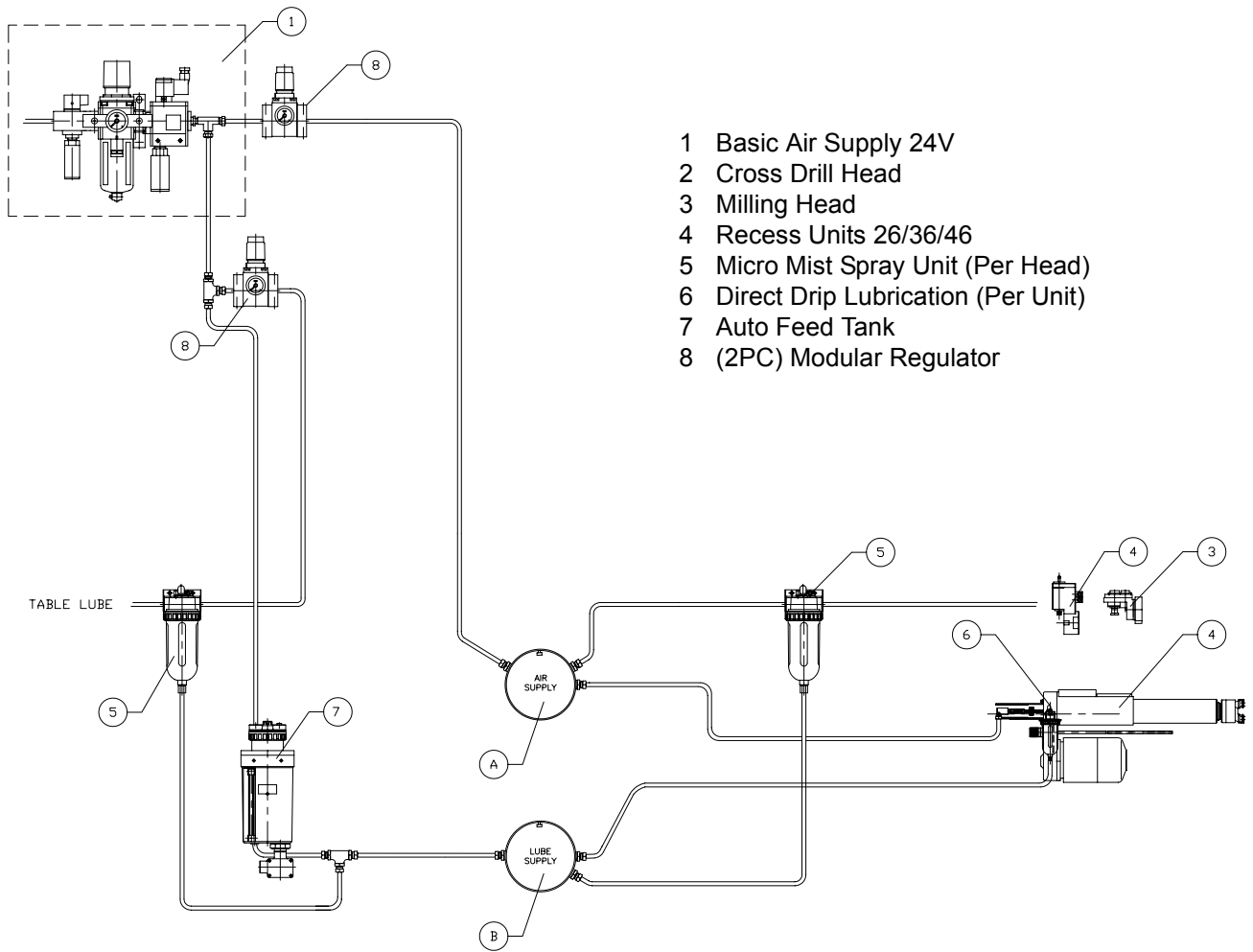

**Filter Regulator Package  
(Located on Barfeeder)**

## 8. Units and Accessories

### LUBRICATION AND LEAK OIL CONNECTIONS

If a Water Soluble Coolant is used, a Leak Oil Pressurizing System must be installed. This system provides a positive pressure inside each Toolspindle Unit, as well as the Index Table, to prevent Water Soluble Coolant from being drawn into the Machining Units past the seals. This system is available in kit form from HYDROMAT INC., and may be installed by the machine operator. (see fig.).

- 1 P2-Line Oil (Unit Lube)
- 2 T-Line Oil (Leak Oil)
- 3 T-Line Oil w/Check Valve (Unit Lube)

- 1 P2-Line Oil (Unit Lube)
- 2 T-Line Oil (Leak Oil)
- 3 T-Line Oil w/Check Valve (Unit Lube)
- 4 P1-Line Oil (Recess Head)
- 5 P-Line Air (Recess Head)



**Unit Lubrication and Leak Oil Connections**



**Valve Plate Lubrication and Leak Oil Connections**

# LUBRICATION AND PRESSURIZED LEAK OIL ASSEMBLY

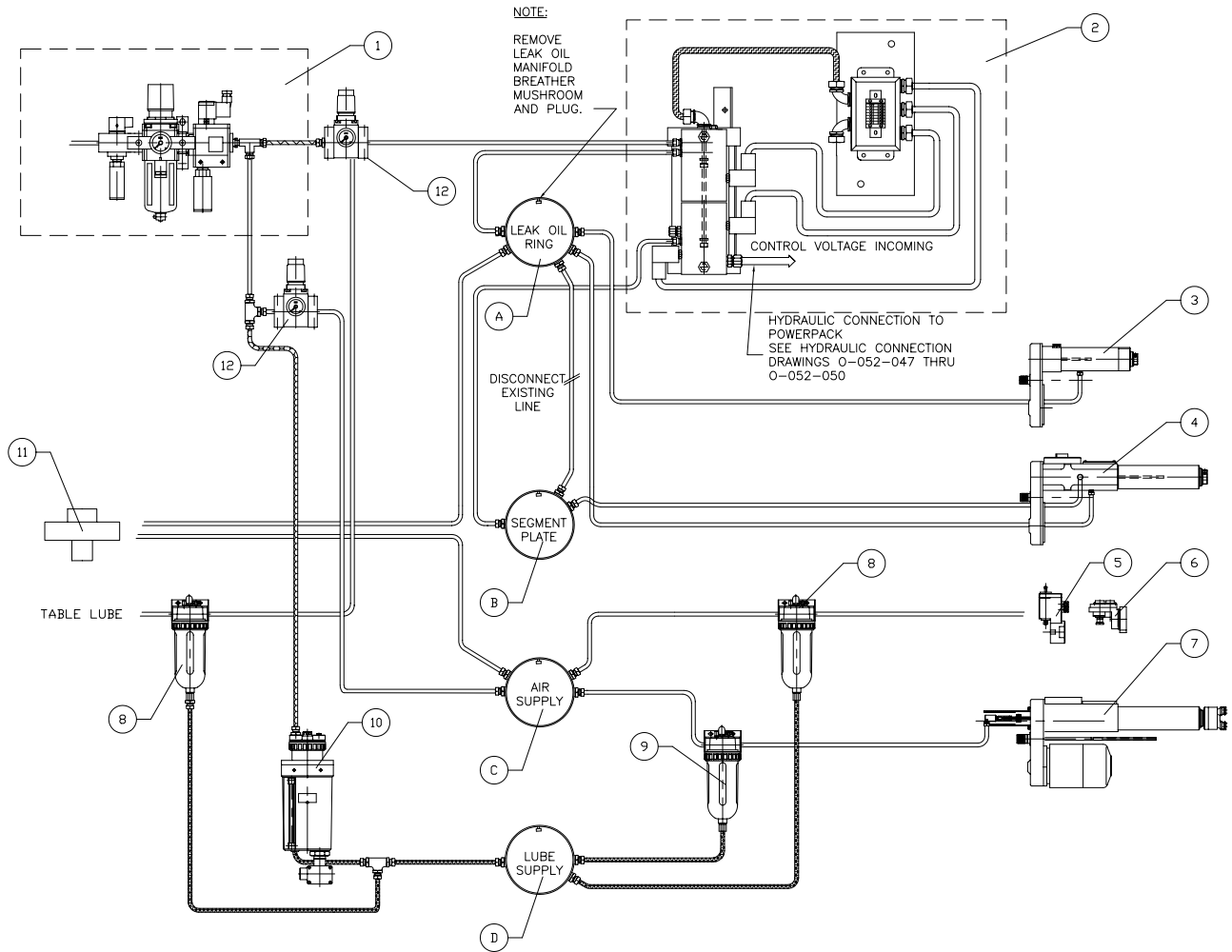

- |                            |                           |
|----------------------------|---------------------------|
| 1 Basic Air Supply         | 7 Recess Units 26/36/46   |
| 2 Leak Oil Pressure System | 8 Micro Mist Spray Unit   |
| 3 Units 20/30/40           | 9 Lubricator In Line Drip |
| 4 Units 26/36/46           | 10 Auto Feed Tank         |
| 5 Cross Drill              | 11 Index Drives           |
| 6 Milling Head             | 12 Regulator              |

## 8. Units and Accessories

### QUILL LUBRICATION OF NC UNITS

The Quill on NC units is lubricated every cycle with .5 second pulse of hydraulic oil from the ST1 line. The ring line plate connections are always on. This oil is later recovered from the unit through the clear plastic Leak Oil Line.

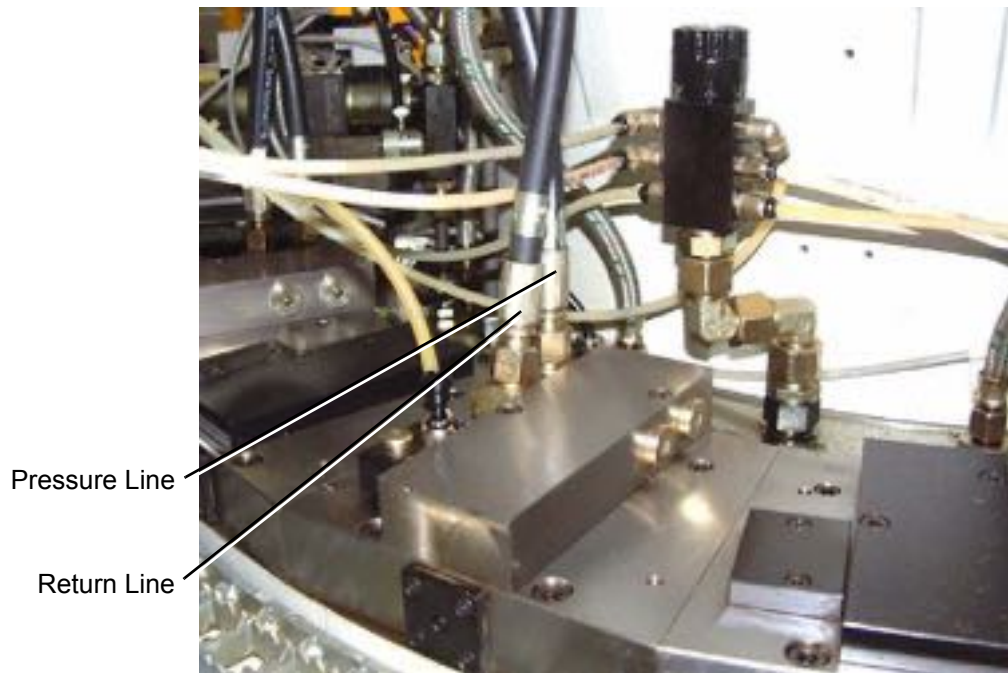

**NC Machine Ring Line Plate Connections**

**VOGEL LUBRICATION UNIT FOR CNC 50/100 2-AXIS, RECESS, RECESS TURN UNITS AND CROSS SLIDE FLANGES**

On NC50/100 2-Axis units the CNC Head is automatically lubricated by a Vogel lubrication unit. This unit is programmed to send a pulse of oil to unit periodically. This unit is also used to lubricate the head on any Recess, Recess Turn units or Cross Slide Flanges.

The oil is routed through a Rotary coupling that is attached to the back of the unit and travels to the CNC Head through the units Drawbar. The Vogel unit reservoir contains a float switch to monitor low level. A low oil condition will generate a fault on the CNC Controller.



**Recommended Oil**

Hydraulic CNC 2-Axis Units (With Vogel Lube Unit)

Engineered Lubricants .....ENLUBOL 98-5EP

# 8. Units and Accessories

## Vogel Unit Lubrication

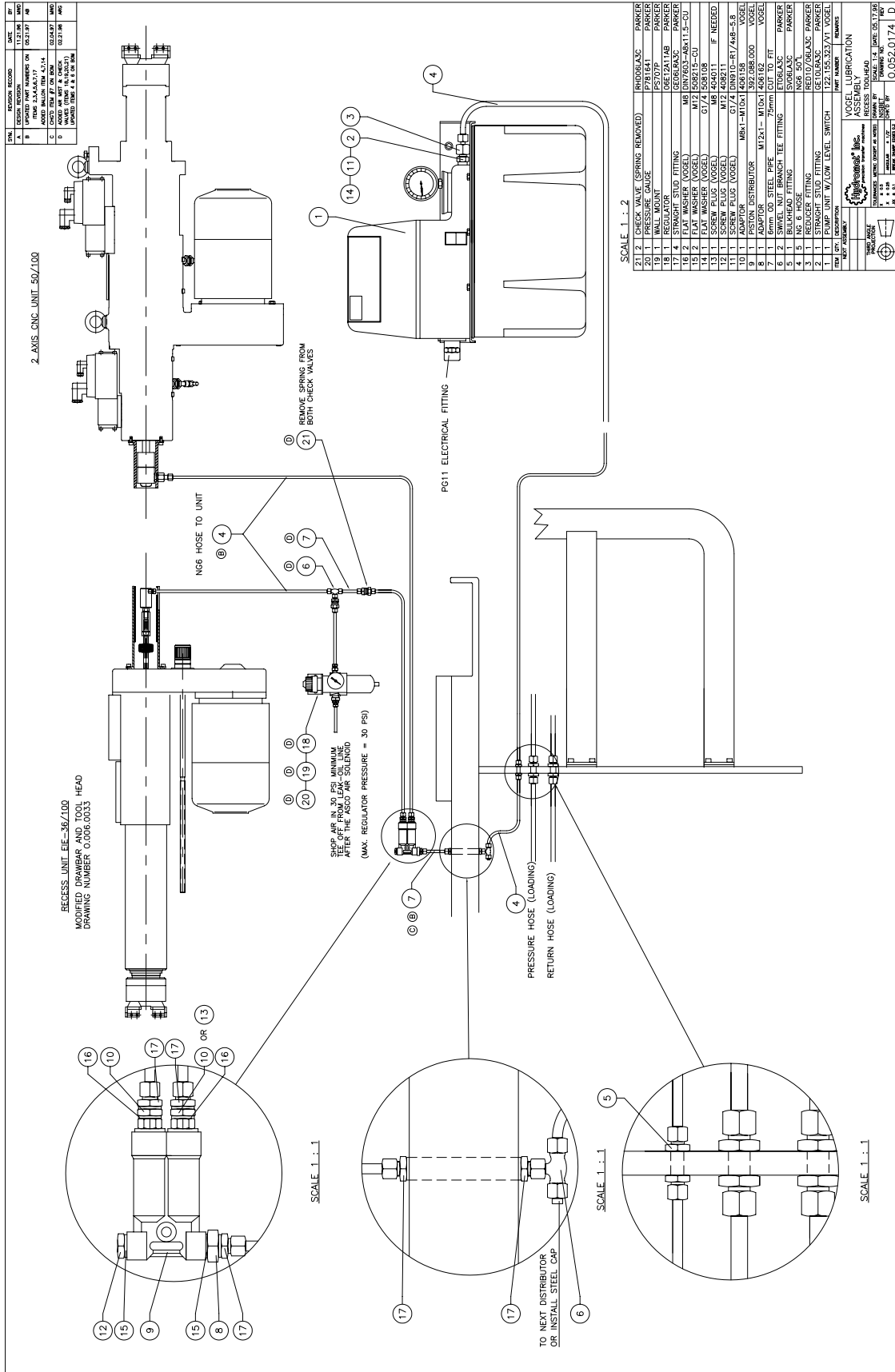



Vogel Cross Slide Lubrication

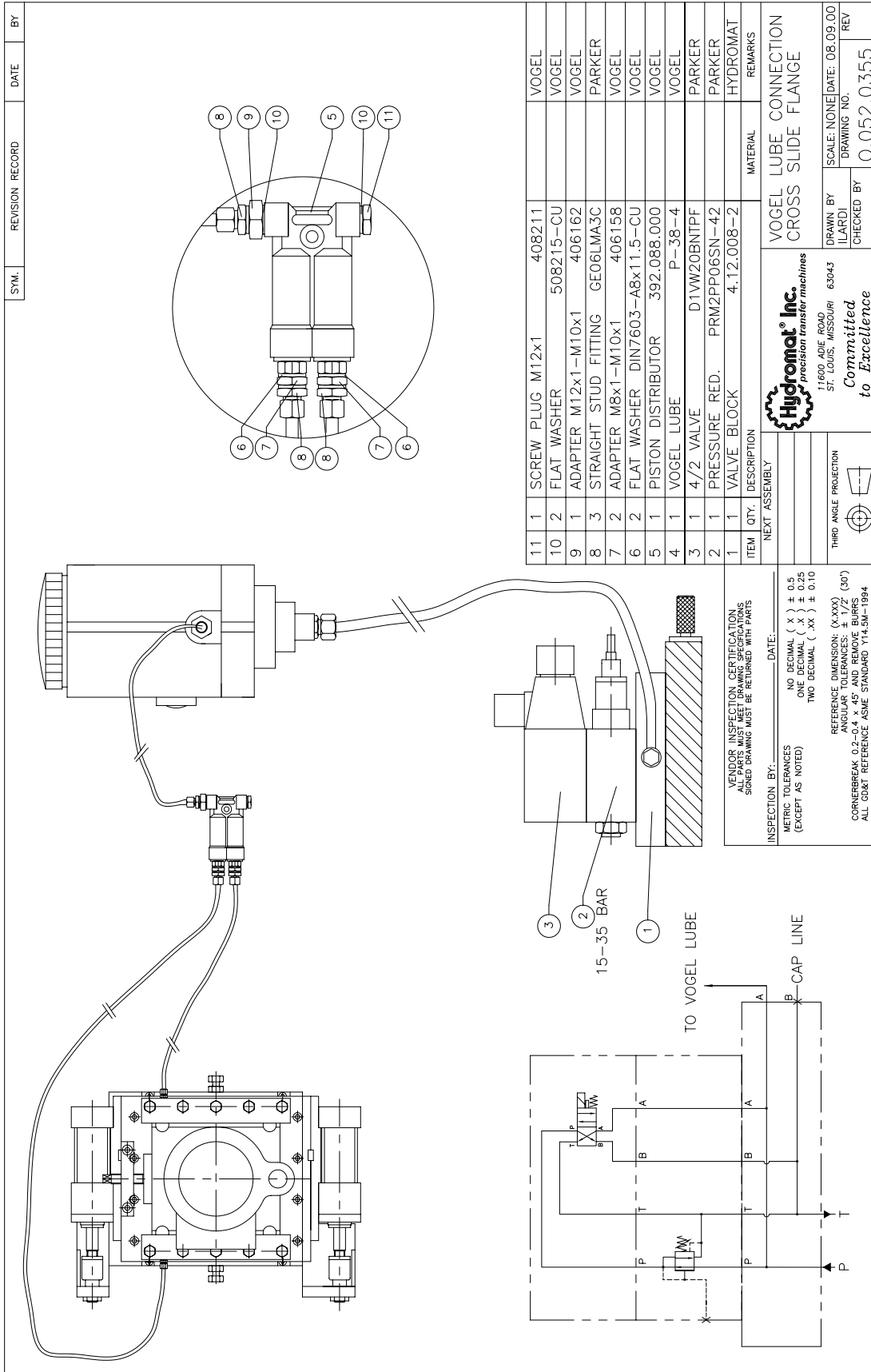

**9. CUTOFF UNIT**

NC 2-AXIS AE-250 CUTOFF UNIT ..... 9-1  
PROCEDURE FOR REPLACING COMPONENTS OF THE QUICK CHANGE SAW ARBOR ..... 9-2  
TECHNICAL DETAILS - AE-250 ..... 9-3  
SAW BLADE RECOMMENDATIONS - AE-250..... 9-3  
SPEEDS AND FEEDS - AE-250 ..... 9-4  
GUIDE BUSHING - AE-250 ..... 9-5  
GUIDE TUBE - AE-250..... 9-6  
RPM CHART AE-250 CUTOFF UNIT ..... 9-7  
RPM CHART FOR AE-250 CUTOFF UNIT WITH 1:1 OR 10:1 GEAR BOX..... 9-7  
MACHINING CYCLE TIME ..... 9-7

## CUTOFF UNIT

### NC 2-AXIS AE-250 CUTOFF UNIT

The Cutoff Unit has three major purposes: It guides the Barstock into the Index Table Collet, clamps the Barstock for cutoff, and saws off the Workpiece.

The RPM and saw position is set at the CNC controller screen.

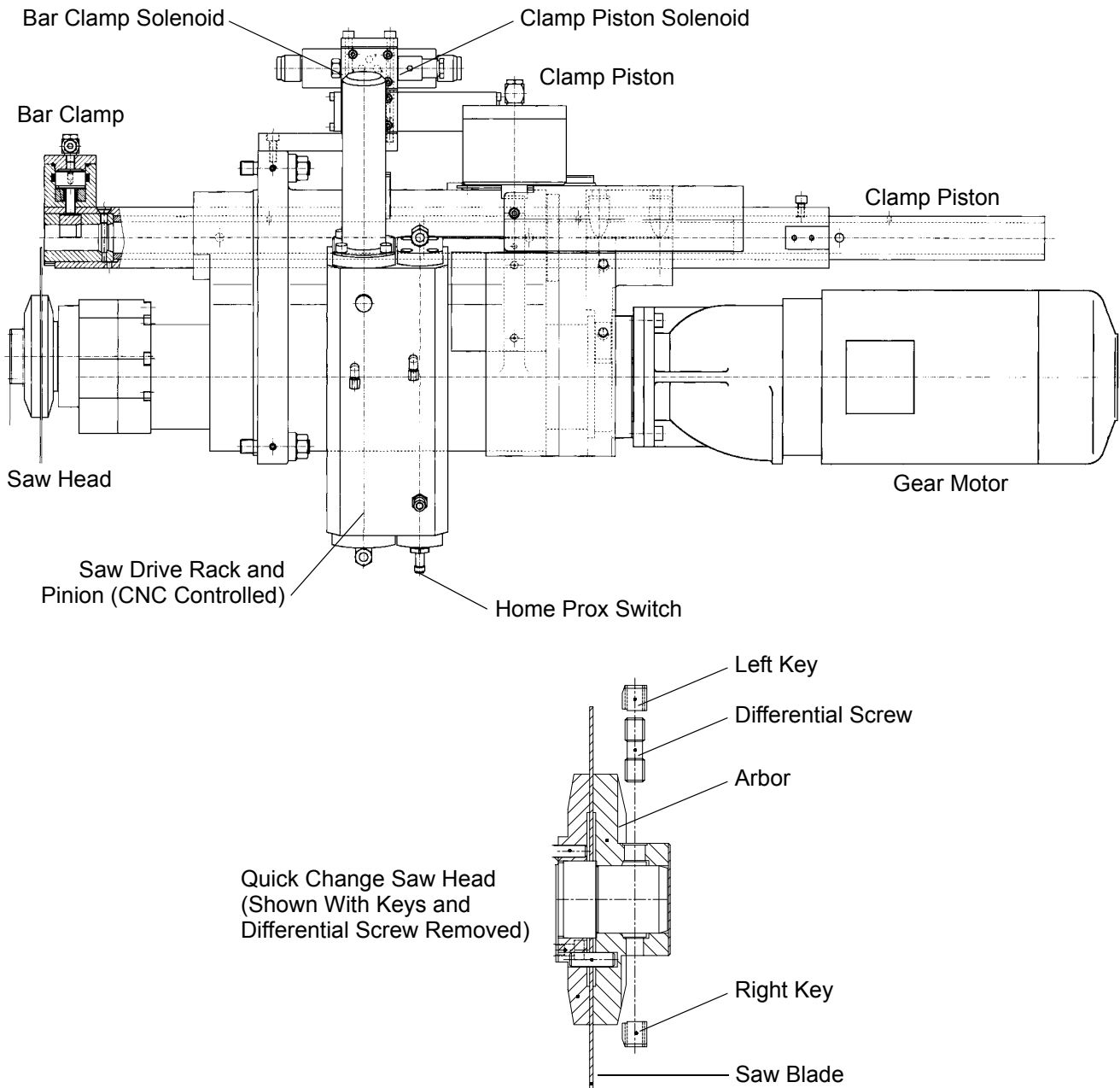

The Cutoff Saw utilizes a Quick Change Saw Head as a standard feature. This allows quick removal and replacement of Sawblades eliminating down time.

### **PROCEDURE FOR REPLACING COMPONENTS OF THE QUICK CHANGE SAW ARBOR**

Normal maintenance of the Cutoff saw unit includes inspection and periodically replacing wear items.

1. With the Valenite Quick Change Saw Arbor Torque Wrench, loosen the Differential Bolt by turning counter-clockwise. If the hex socket is damaged in the differential bolt on the side normally used to remove the flange, rotate the arbor to the opposite side.
2. By removing the setscrew in this position, access to the differential bolt and unused hex socket can be obtained. By turning the wrench clockwise in this position, the locking keys will be loosened.
3. Remove the Front Arbor Disk and the saw blade.
4. With the front arbor disk removed, a roll pin can be seen through the spindle diameter, 90 degrees around from the differential bolt location, and holds the differential bolt from slipping out.
5. With the proper size pin punch and hammer, drive the roll pin out, far enough to allow the differential bolt and the right and left hand locking keys to slip out.
6. Using new components to replace the damaged items, reverse the procedure to install these items into the spindle, making sure the differential bolt is installed with the right hand thread and locking key in the side of the spindle marked "R".
7. Replace the roll pin to it's full depth, making sure the relief in the differential bolt is engaged and that the pin is completely below the diameter of the spindle.
8. Test the locking ability of the differential bolt before replacing the saw blade and arbor disk, by turning the hex socket with the torque wrench in the side marked "R". Turn clockwise and the locking keys should extend out of the spindle diameter.
9. Replace the saw blade and the arbor disk, and then tighten the differential bolt with the torque wrench until the wrench clicks once. Replace the setscrew in the unused side of the arbor disk over the differential bolt socket.

**TECHNICAL DETAILS - AE-250**

## Cutoff Capacity:

Free Machining Steel	1 3/4"
Alloy Steel	1 1/2"
Stainless Steel	1 1/2"
Brass	1 3/4"
Aluminum	1 3/4"
Guide Bushing	S-O-022-056-
Guide Tube	S-O-022-055-
Gear Ratios	Determined by Gear Motor
Gear Ratio In Cutoff Head	2.18 = 1
Pulleys	None (Direct Drive)
Motor Size	
Standard	BG 100, FZ 100
Special Applications	BG 112, FZ 112
Motor RPM (Standard)	1100, 810, 223, 216, 174, 140, 98, 78

For actual RPM, refer to the "RPM Charts" at the end of this chapter.

**SAW BLADE RECOMMENDATIONS - AE-250**

Material Dia.		Sawblade Dia. 9.8"/8.8"	Bore Size 1.575"
Steel	Up to 1" Dia.	Saw Width .080"	160-200 Teeth
	Up to 1 3/4" Dia.	Saw Width .100"	120-180 Teeth
Brass and Aluminum	Up to 1" Dia.	Saw Width .080"	160-200 Teeth
	Up to 1 3/4" Dia.	Saw Width .100"	120-180 Teeth

## 9. Cut Off Unit

### SPEEDS AND FEEDS - AE-250

Recommended speeds and feeds for Cutoff Unit with Direct Drive Motor, all speeds are for High Speed Steel Saw Blades dia. 9.8”.

Material	Material Specs.	SFM	Feed/Rev.	RPM Saw	Gear Ratio Pulleys
Best Machining Steel High Lead, Low Carbon	la-led x	174	.06	148	68
Free Cutting Steel	12L13 12L14	136	.06	115	53
High Carbon Steel (Lead and Sulfur)	11L44 11L51	85	.05	72	33
High Carbon/Low Alloy (Without Ni and Cr)	1144	59	.05	50	23
Alloy Steel (Low Cr + Ni + Mo)	4140 4142	59	.05	50	23
Stainless Steel	416	59	.04	50	23
Stainless Steel	303	51	.04	40	20
Brass Free Cutting (Leaded)	360	577	.06	490	225
Commercial Bronze (Leaded)	316	416	.06	354	162
Aluminum (Leaded)	2011 6262	578	.06	490	225
Aluminum	2017 2024	578	.06	490	225
Aluminum	6061	416	.06	354	162

**NOTE:** In order to achieve the best tool life on the Sawblade, it is essential that they are properly reground and have the proper amount of teeth as recommended earlier in this chapter.

\* For materials requiring below 60 sfm, a Gear Motor may be required.



# 9. Cut Off Unit

SYML	REVISION RECORD	DATE	BY

DIA. "X" = BARSTOCK SIZE + .125"

DASH NO.	DIM "X"

$\frac{64}{\nabla} \left( \frac{32}{\nabla} \text{ GROUND} \right)$   
 CORNERBREAK .020 x 45°

ITEM	QTY.	DESCRIPTION	MATERIAL	1018	COLD DRAWN
1	3	GUIDE TUBE $\phi 2" \times 14-1/8$	Hydromat <sup>®</sup> Inc. St. Louis Mo.		

NEXT ASSEMBLY	REMARKS

DRAWN BY	SCALE
L. BENWELL	DATE: 4/10/91
	DRAWING NO.
	S-O-022-055

TOLERANCES - UNLESS NOTED	SCALE
X = ± .015	DATE: 4/10/91
XX = ± .010	DRAWING NO.
XXX = ± .005	BRK/SHIP DIMS: .010



## RPM CHART AE-250 CUTOFF UNIT

AE-250 Cutoff Unit				
Ratio: 1:2.18	Motor RPM	Output RPM	SFM DIA 225 MM	SFM DIA 250 MM
Motor Size				
BG-112 / BG-100	1100	505	1176	1295
BG-112 / BG-100	840	385	898	989
FZOLD 100L 24-4,3.0 KW	538	247	575	633
FZOLD 100L 24-4,3.0 KW	455	209	486	535
FZOLD 100L 24-4,3.0 KW	320	147	342	377
FZOLD 100L 24-4,3.0 KW	240	110	257	282
FZ1LD 100L 24-4,3.0 KW	171	78	183	201
FZ1LD 100L 24-4,3.0 KW	95	44	102	112
FZ1LD 100L 18-4,2.2 KW	68	31	73	80

## RPM CHART AE-250 CUTOFF UNIT WITH 1:1 OR 10:1 GEAR BOX

AE-250 Cutoff Unit With Gear Box									
Pulley Set		Selector in Position 1 - 1 = 1:1				Selector in Position 2- 1 = 10:1			
Spindle	Motor	Ratio	Motor RPM			Ratio	Motor RPM		
			1150	1740	3480		1150	1740	3480
1	8	2.75	1451	2195	4390	2.75	145	219	439
2	7	2	1055	1596	3193	2	106	160	319
3	6	1.5	791	1197	2394	1.5	79	120	239
4	5	1.14	601	910	1820	1.14	60	91	182
5	4	0.88	464	702	1405	0.88	46	70	140
6	3	0.67	353	535	1070	0.67	35	53	107
7	2	0.5	264	399	798	0.5	26	40	80
8	1 (181-4)	0.36	190	287	575	0.36	19	29	57
8	178								

## MACHINING CYCLE TIME

$$\text{RPM} = 3.82 \times \text{SFM} / \text{Dia}''$$

$$\text{SFM} = \text{Dia}'' \times \text{RPM} \times .262$$

$$\text{Feed per Rev.} = \frac{\text{Length} \times 60}{\text{RPM} \times \text{Time Sec.}}$$

$$\text{Time Sec.} = \frac{\text{Length} \times 60}{\text{RPM} \times \text{FPR}}$$

**10. BARFEEDER MAGAZINE**

ELECTRONIC BARFEEDER MAGAZINE WITH BARCHANGE CYCLE .....	10-1
THE BARCHANGE SEQUENCE .....	10-1
ELECTRONIC BARFEEDER COMPONENTS .....	10-2
ELECTRONIC BARCHANGE SEQUENCE STEP BY STEP .....	10-3
STANDARD ELECTRONIC BARFEEDER .....	10-4
ELECTRONIC BARFEEDER MANIFOLD - O.055.120 .....	10-5
SETUP OF THE STANDARD ELECTRONIC BARCHANGE .....	10-6
GENERAL TROUBLESHOOTING STEPS FOR BARFEEDER AND BARCHANGE .....	10-7
SELECTABLE COLLET/EJECTOR LOADING OPTION .....	10-10
LOADING SELECTION .....	10-10
COLLET LOADING FUNCTION .....	10-10
SETUP PROCEDURES .....	10-10
CONTROL PIVOT MODIFICATION FOR COLLET LOAD .....	10-11
IEMCA T560 BUNDLE BAR LOADER (OPTIONAL) .....	10-12
LOADING THE BUNDLE BAR LOADER .....	10-12
AUTOMATIC OPERATION OF THE BUNDLE LOADER .....	10-12
IEMCA T560/51 BUNDLE BAR LOADER LOCATION OF ELECTRICAL PARTS .....	10-13
ELECTRICAL PARTS LIST OF IEMCA BUNDLE BAR LOADER T560/51 .....	10-14
BUNDLE BELT TENSIONER .....	10-15
DESCRIPTION OF BELT TENSIONER .....	10-15
BELT TENSIONER ADJUSTMENTS .....	10-15
ADJUSTMENT OF ELEVATOR TROLLEYS .....	10-16
DESCRIPTION OF THE BAR MAGAZINE STOPPER .....	10-17
BAR MAGAZINE STOPPER ADJUSTMENTS .....	10-17
DESCRIPTION OF BARRIER FOR BARS 7MM (9/32") AND SMALLER .....	10-18
REGULATION OF SQUARE BARSTOCK .....	10-19
REGULATION OF ROUND BARSTOCK .....	10-20
DESCRIPTION OF THE BAR PRESSURE FOOT .....	10-21
BAR PRESSURE FOOT ADJUSTMENTS .....	10-21

## BARFEEDER MAGAZINE

---

### ELECTRONIC BARFEEDER MAGAZINE WITH BARCHANGE CYCLE

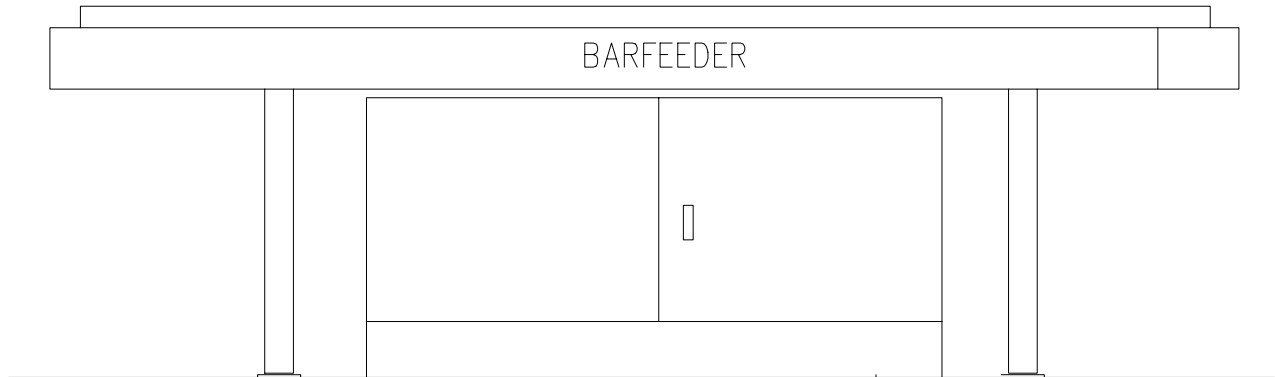

The Electronic Barfeeder is designed to allow the quick changeover and setup of the automatic barchange. The Electronic Barfeeder eliminates the extensive setup procedure required with Standard Barfeeder types, enhancing the Machines quick change capabilities.

The Barfeeder feeds the Barstock at the Loading Station through a Guide Bushing into the Index Table collet and provides automatic loading. It is activated by the Loading Valve as explained in chapter 7.

### THE BARCHANGE SEQUENCE

1. Determines in which position the Machine will start the actual change.
2. Drops the Rest Piece into the Chip Conveyer.
3. Cuts off the uneven beginning of each new bar.

## **ELECTRONIC BARFEEDER COMPONENTS**

### **ELECTRONIC BARFEEDER TYPES**

- Standard Electronic Tray Type
- Bundle Type Barfeeder

The procedures for the settings of individual items vary slightly within the different Barfeeder Types, although all the dimensions are the same. (Refer to the notes for individual settings).

### **INDEX TABLE**

Moves into a Half Index Position to allow enough space for dropping out the Rest Piece and for Cutting Off the new bar

### **THE CUTOFF SAW**

The Saw cuts off the beginning of the new bar activated through the Lucifer Solenoid on the Loading Valve (this is the only time the Solenoid is used).

### **BAR END LIMIT SWITCH**

This limit switch signals the PLC that a new bar has loaded into the channel and is pushing the bar end into the guide tube.

### **SLOW FEED LIMIT SWITCH**

This limit switch signals the PLC to de-energize the High Feed Solenoid and decrease chain feed to 2 to 2.5 inches per second. This ensures an accurate bar feed out for the face cut of the new bar.

### **BAR FEED ENCODER**

The rotary shaft encoder provides chain position feedback to the High Speed Counter board in the PLC control. This feedback is compared to the cut off unit position value entered into the thumbwheel switch, to determine when to 1/2 index the Table and initiate the face cut of the new bar.

### **PRESSURE ADJUSTMENT**

This adjustable pressure relief valve controls the hydraulic pressure of the Fast Speed cycle of the Hydraulic Motor.

### **FAST SPEED ADJUSTMENT**

This flow control valve is used to regulate the chain speed when the barfeeder is not in bar change.

### **FORWARD / REVERSE SOLENOID VALVE**

This 4/3 Vickers Directional Control Valve controls the rotational direction of the Barfeeder motor.

### **HIGH SPEED SOLENOID VALVE**

This 4/2 Vickers Directional Control Valve activates the High Speed cycle of the Barfeeder motor. It will be triggered from the Bar Rack, which is pushed forward by the Pusher Dog and attached to the Feed Chain. It starts the Saw immediately as well as stops the Barfeeder Motor.

### **THUMBWHEEL SWITCH**

The dimension off of the Bar Feeder Scale is entered into the thumbwheel switch. This value is used in the PLC program to establish the point at which the Barchange cycle begins.

## ELECTRONIC BARCHANGE SEQUENCE STEP BY STEP

1. The Pusher Dog hits the Slow Speed Limit Switch in the front of the Barfeeder.
2. A few parts later the Pusher Dog hits the Bar End Limit Switch. This references the encoder counter in the PLC program.
3. The first Pusher Dog continues to push the remaining bar into the guide tube until the Dog arcs around the front chain sprocket.
4. The second Pusher Dog then contacts the end of the new bar and pushes it up against the remaining portion of the old bar.
5. The new bar then continues to feed the old bars remnant until the PLC program determines that a barchange cycle is appropriate. This is done by comparing the Encoder position counts to the Thumbwheel setting.
6. The Table moves into the Half Index Position. At this time the bar end, which is approximately 10mm (.4") long, is dropped into the chip conveyor and the new bar is fed in, as much as necessary, to face off the new bar.
7. The Cutoff Saw is activated by the Lucifer solenoid and faces off the new bar. At the same time the Barfeeder stops feeding.
8. The Table moves forward into the next Full Index Position.
9. The Machine then runs a Units cycle and the Barfeeder loads the first part of the new bar.
10. The Machine then returns to continuous Automatic operation.

## 10. Barfeeder Magazine

### STANDARD ELECTRONIC BARFEEDER

Refer to your Unit Parts Book for specific model of Barfeeder.

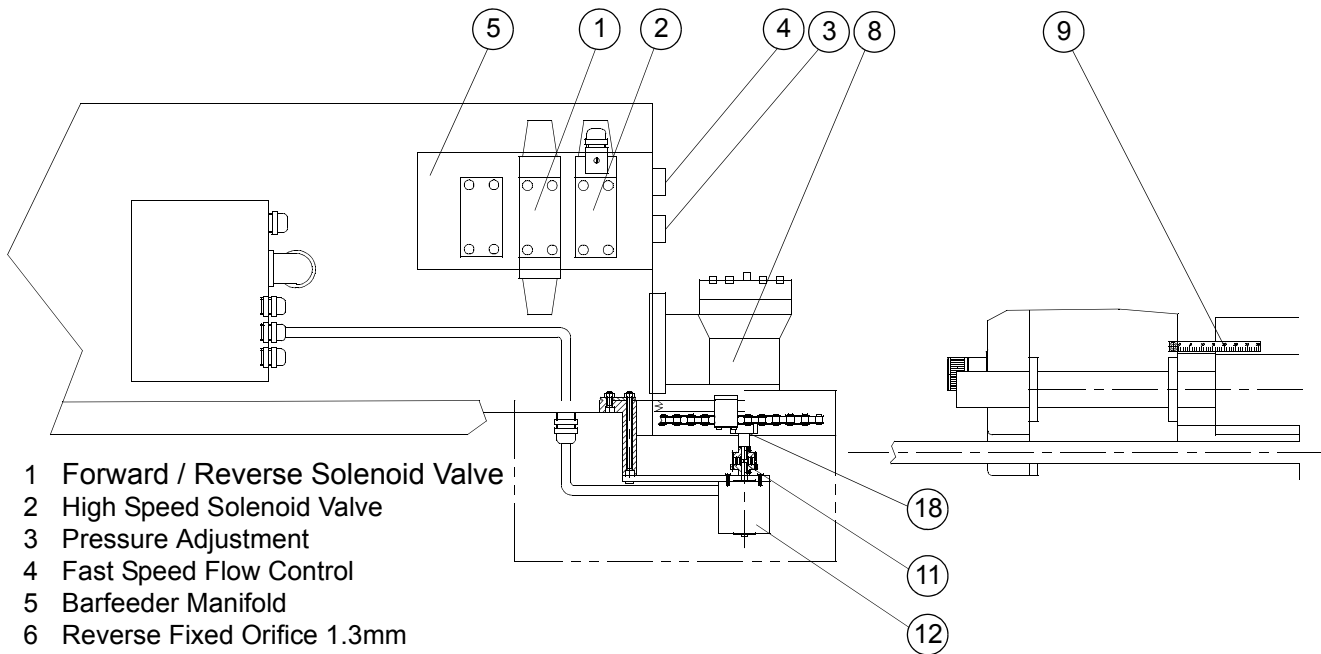

- 1 Forward / Reverse Solenoid Valve
- 2 High Speed Solenoid Valve
- 3 Pressure Adjustment
- 4 Fast Speed Flow Control
- 5 Barfeeder Manifold
- 6 Reverse Fixed Orifice 1.3mm
- 7 Slow Feed Fixed Orifice .5mm
- 8 Barfeeder Motor
- 9 Cutoff Unit Scale

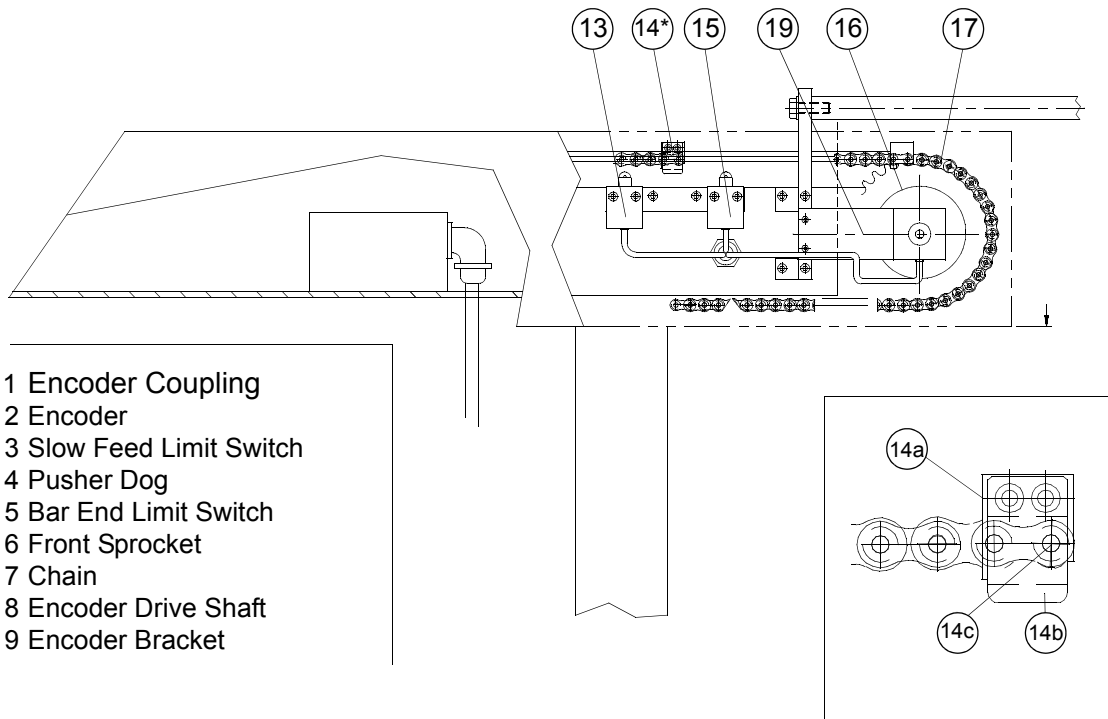

- 11 Encoder Coupling
- 12 Encoder
- 13 Slow Feed Limit Switch
- 14 Pusher Dog
- 15 Bar End Limit Switch
- 16 Front Sprocket
- 17 Chain
- 18 Encoder Drive Shaft
- 19 Encoder Bracket

ELECTRONIC BARFEEDER MANIFOLD - O.055.120

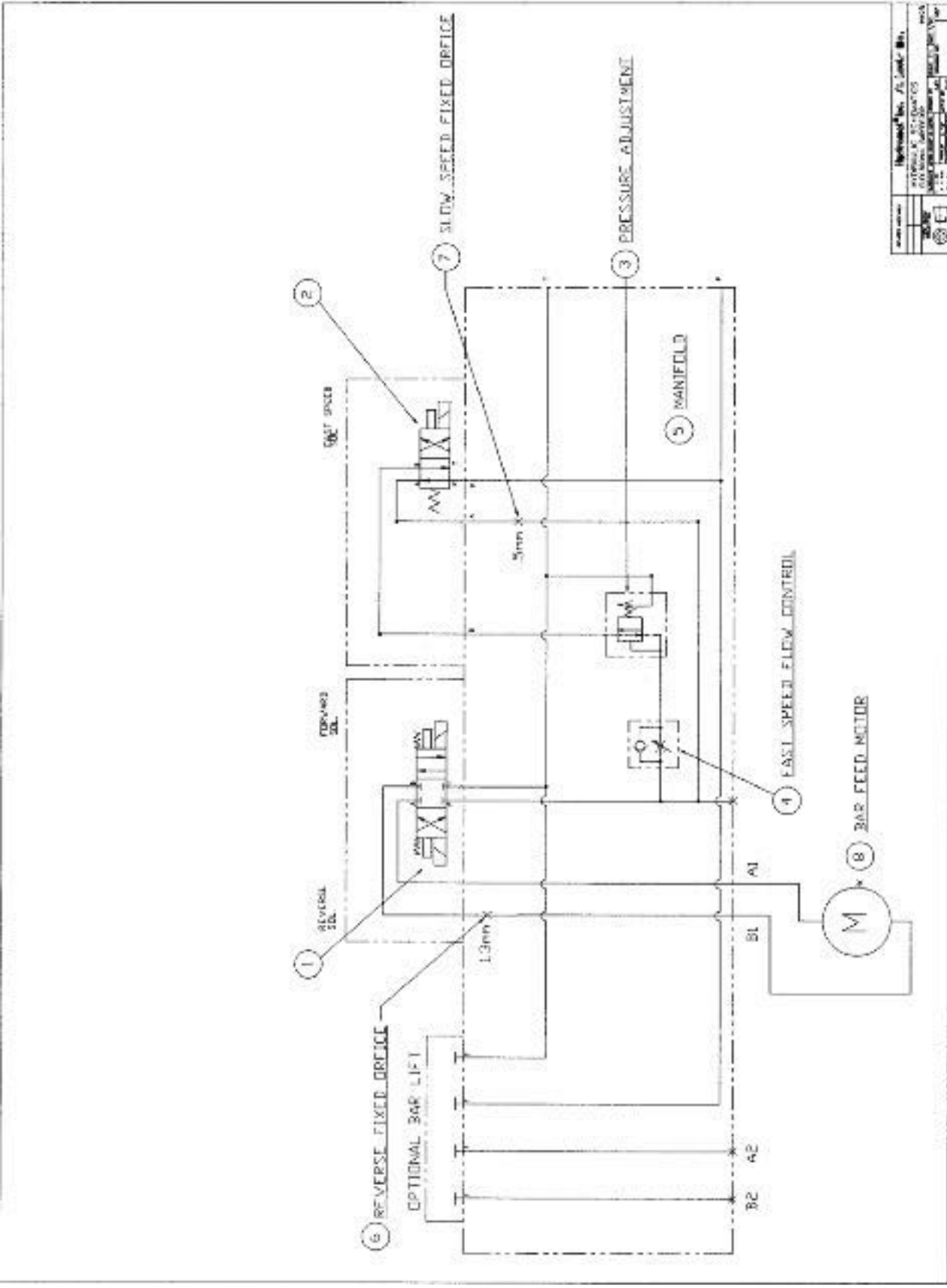

## 10. Barfeeder Magazine

### SETUP OF THE STANDARD ELECTRONIC BARCHANGE

The setup of the barchange on Electronic Barfeeders can be simply accomplished using the following sequence:

1. Adjust the cutoff length of the Cutoff Unit to the proper blank dimension.
2. Read the measurement from the scale at the back of the Cutoff Flange. (See Figure)
3. Using the thumbwheel, enter the measurement from the scale. (See Figure)
4. Lay a new bar on the Barfeeder, slide the bar forward until it exceeds the Cutoff saw by approximately 1/4".
5. Manually cycle the Cutoff Unit to face off the new bar.
6. Start the Automatic Cycle.

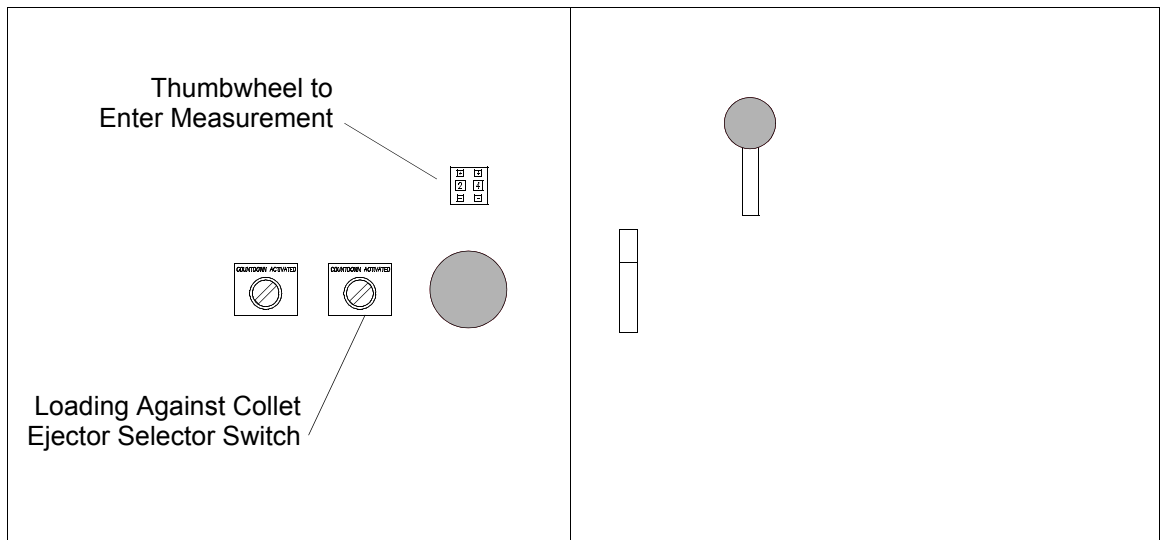
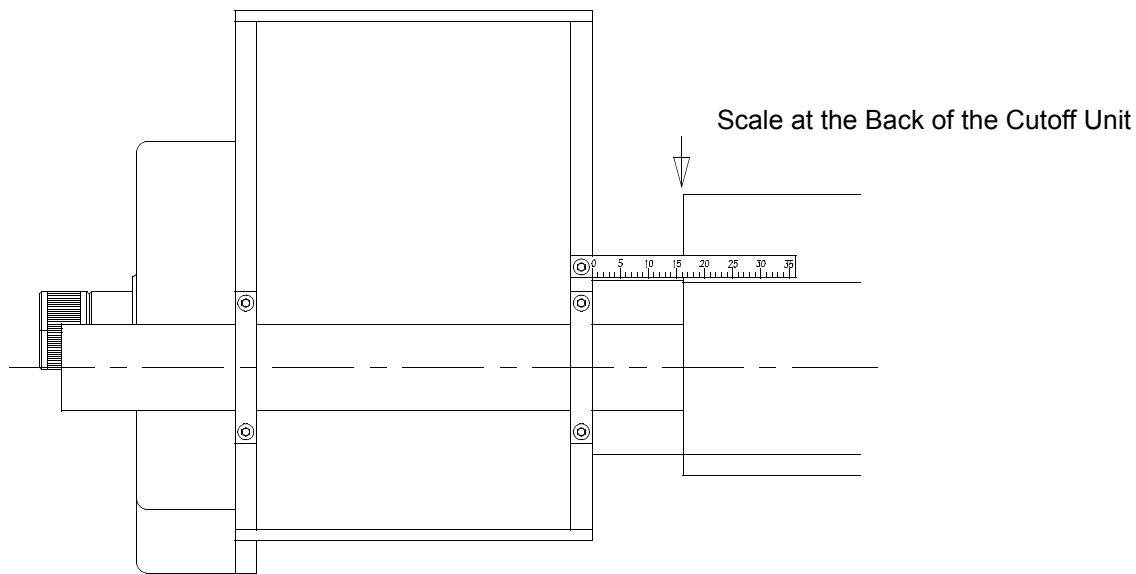



## GENERAL TROUBLESHOOTING STEPS FOR BARFEEDER AND BARCHANGE

### General items to check when bar change is failing.

1. **For Pushbutton Pendant** - Check the Binary Coded Decimal (BCD) Thumbwheel settings. Thumbwheel must be set at the saw to collet distance in tenths of an inch.  
**For Quickpanel Pendant** - Enter saw to collet distance.
2. Check the Encoder Linkage. Linkage should not slip on shafts and should be within an 1/8" of center alignment.
3. Check the barfeeder Slow Feed Limit Switch and the Bar End Limit Switch. Make sure they are tight and that both pusher dogs trigger the appropriate input on the PLC.
4. Check to see if barfeeder slows down when pusher dog triggers the Slow Feed Limit Switch, if not, check the slow speed valve for proper operation.
5. Check the 5 volt supply for proper operation; if it is not functioning, check associated fuses. Check the encoder.

### Machine goes into bar change too early. Remnant is 2 inches larger than part length.

1. **For Pushbutton Pendant** - Check the Binary Coded Decimal (BCD) Thumbwheel settings. Thumbwheel must be set at the saw to collet distance in tenths of an inch.  
**For Quickpanel Pendant** - Enter saw to collet distance.
2. Check the Encoder Linkage. Linkage should not slip on shafts and coupling should be within an 1/8" of center alignment.
3. Make sure the barfeeder has the proper spacing between the Bar End Limit Switch and the face of the collet. This is typically 48 3/4" for the PRO-20 and the HW25, and 72" for the HB32 and the HB45. This length may vary for special applications. Call Hydromat Electrical Engineers if these measurements are different.
4. Check Bar End Limit Switch and pusher dogs. Pusher dogs must be equally spaced 180° apart to each other, and if they do not match, the bar change will vary by the difference between them.

### Machine goes into bar change too late. First part in machine was not faced off or faced off piece is less than 3/8 inch.

1. **For Pushbutton Pendant** - Check the Binary Coded Decimal (BCD) Thumbwheel settings. Thumbwheel must be set at the saw to collet distance in tenths of an inch.  
**For Quickpanel Pendant** - Enter saw to collet distance.
2. Check the Encoder Linkage. Linkage should not slip on shafts and should be within an 1/8" of center alignment.
3. Make sure the barfeeder has the proper spacing between the Bar End Limit Switch and the face of the collet. This is typically 48 3/4" for the PRO-20 and the HW25, and 72" for the HB32 and the HB45. This length may vary for special applications. Call Hydromat Electrical Engineers if these measurements are different.
4. Check Bar End Limit Switch and pusher dogs. Pusher dogs must be identical to each other, and if they do not match, the bar change will vary by the difference between them.

## 10. Barfeeder Magazine

5. Verify that machine is going into Slow Feed mode when the Slow Feed Limit Switch is triggered. If not, check Fuse for the Slow Feed Solenoid and verify that the Slow Feed Limit Switch is being triggered and that the input is being received by the PLC.

### Face off piece of new bar varies, barchange works only intermittently.

1. Check all wiring for good connections.
2. Check the Encoder Linkage. Linkage should not slip on shafts and should be within an 1/8" of center alignment.
3. Check the barfeeder Slow Feed Limit Switch and the Bar End Limit Switch. Make sure they are tight and that both pusher dogs trigger the appropriate input on the PLC.
4. Check Bar End Limit Switch and pusher dogs. Pusher dogs must be identical to each other, and if they do not match, the bar change will vary by the difference between them.

### Bar stock spins in guide tube.

1. **For Pushbutton Pendant** - Check the Binary Coded Decimal (BCD) Thumbwheel settings. Thumbwheel must be set at the saw to collet distance in tenths of an inch.  
**For Quickpanel Pendant** - Enter saw to collet distance.
2. Check the Encoder Linkage. Linkage should not slip on shafts and should be within an 1/8" of center alignment.
3. Check the barfeeder Slow Feed Limit Switch and the Bar End Limit Switch. Make sure they are tight and that both pusher dogs trigger the appropriate input on the PLC.
4. Check Bar End Limit Switch and pusher dogs. Pusher dogs must be identical to each other, and if they do not match, the bar change will vary by the difference between them.
5. Make sure the barfeeder has the proper spacing between the Bar End Limit Switch and the face of the collet. This is typically 48 3/4" for the PRO-20 and the HW25, and 72" for the HB32 and the HB45. This length may vary for special applications. Call Hydromat Electrical Engineers if these measurements are different.
6. Check bar clamp for proper operation.

### Bar stock hits face of collet.

1. Check Bar Stock. Bar Stock must be straight and free of damage in order to feed reliably.
2. Check Guide Tube for wear. If guide tube is worn bar stock will not feed properly.
3. Check excess pivot adjustment. Check alignment of barfeeder.

### Bar stock feeds against table.

1. **For Pushbutton Pendant** - Check the Binary Coded Decimal (BCD) Thumbwheel settings. Thumbwheel must be set at the saw to collet distance in tenths of an inch.  
**For Quickpanel Pendant** - Enter saw to collet distance.
2. Check the Encoder Linkage. Linkage should not slip on shafts and should be within an 1/8" of center alignment.
3. Make sure the barfeeder has the proper spacing between the Bar End Limit Switch and the face of the collet. This is typically 48 3/4" for the PRO-20 and the HW25, and 72" for the HB32 and the HB45. This length may vary for special applications. Call Hydromat Electrical Engineers if these measurements are different.

4. Check Bar End Limit Switch and pusher dogs. Pusher dogs must be identical to each other, and if they do not match, the bar change will vary by the difference between them.
5. Verify that machine is going into Slow Feed mode when the Slow Feed Limit Switch is triggered. If not, check Fuse for the Slow Feed Solenoid and verify that the Slow Feed Limit Switch is being triggered and that the input is being received by the PLC.
6. Check to see if the barfeeder is feeding too fast. It is not necessary to feed fast unless your Cutoff Saw is the slowest unit on the machine. Feeding fast can result in the machine failing to see the pusher dogs wrap around to catch the new bar. This results in the machine beginning the face-off procedure immediately after the new bar is picked up by the pusher dogs.
7. Verify that the Encoder is wired properly. If it is wired wrong, it may be counting backwards resulting in the machine trying to face off a new bar as soon as the two parts after the Bar End Limit Switch is triggered.

### **Machine goes into bar change immediately after pusher dog wraps around for new bar.**

1. Check to see if the barfeeder is feeding too fast. It is not necessary to feed fast unless your Cutoff Saw is the slowest unit on the machine. Feeding fast can result in the machine failing to see the pusher dogs wrap around to catch the new bar. This results in the machine beginning the face-off procedure immediately after the new bar is picked up by the pusher dogs.
2. Verify that the Encoder is wired properly. If it is wired wrong it may be counting backwards, resulting in the machine trying to face off a new bar as soon as the two parts after the End of Bar Limit switch is triggered.

### **Machine does not go into bar change mode.**

1. Check the barfeeder Slow Feed Limit Switch and the Bar End Limit Switch. Make sure they are tight and that both pusher dogs trigger the appropriate input on the PLC.
2. Check 5 volt supply for proper operation and if it is not functioning, check associated fuses.

### **Machine detects Bar End (Amber light turns on) but never faces the new bar off.**

1. **For Pushbutton Pendant** - Check the Binary Coded Decimal (BCD) Thumbwheel settings. Thumbwheel must be set at the saw to collet distance in tenths of an inch.  
**For Quickpanel Pendant** - Enter saw to collet distance.
2. Check the Encoder Linkage. Linkage should not slip on shafts and should be within an 1/8" of center alignment.
3. Check the barfeeder Slow Feed Limit Switch and the Bar End Limit Switch. Make sure they are tight and that both pusher dogs trigger the appropriate input on the PLC.
4. Check 5 volt supply for proper operation and if it is not functioning, check associated fuses.
5. Verify that the Encoder is wired properly. If it is wired wrong, it may be counting incorrectly resulting in the machine failing to face off a new bar.

### **Machine always feeds bar in slow mode.**

1. Check the barfeeder Slow Feed Limit Switch and the Bar End Limit Switch. Make sure they are tight and that both pusher dogs trigger the appropriate input on the PLC.

## 10. Barfeeder Magazine

### Pusher dogs will not move.

1. Check PLC outputs for blown fuses.
2. Check for bad bar stock causing binding in guide tube.
3. Check for mechanical problems such as loose chains, bad hydraulic motor or improperly installed safety guards.
4. Check Loading valve prox. Input should turn on when units fire and no part is in station ones collet.

## SELECTABLE COLLET/EJECTOR LOADING OPTION

This option applies to Rotary Machines with collets and does not apply to the Rismat HT125 or any Rotary Machine with chucks.

### LOADING SELECTION

The Machines equipped with this option can load bar stock into a Step Collet with the Ejector sensing bypassed. Standard loading using the Ejector as the Stop is still functional. The type of loading can be selected with the LOADING AGAINST COLLET/ELECTOR selector switch on the control cabinet. A set screw (Item 9) must be installed into the Control Pivot for part ejection in the Step Collet mode.

### COLLET LOADING FUNCTION

1. The Bar is loaded into the Station #1 Collet, stopping on a step in the collet.
2. The Close Station 1 Collet solenoid valve is de-energized by the PLC when the following conditions have been met in sequence.
  - Loading Valve has been activated.
  - Minimum feed distance has been made.
  - Feed Motion has Stopped.
1. The Loading Valve is the activated by the closing collet and the saw then cycles.
2. The Control Pivot controls ejection of the part between the last and first station.

### SETUP PROCEDURES

1. Enter the measurement from the scale on the saw into the thumbwheels.
2. Clear the Count Down Mode. The Bar Change Count Down Mode MUST be Cleared if active. Press and hold the Loader Reset push button until the Orange Pendent Light turns off. If it's off then go to step 2.
3. Move the new bar 1/4 inch past the saw.
4. Cutoff the end piece.
5. Turn key switch to EJECTOR position, then to COLLET position to activate the LEARN MODE. The System must teach itself a minimum acceptable amount of feed distance. This process shall be referred to as the LEARN MODE.
6. Load and cutoff two pieces. During the LEARN MODE the Cutoff Saw will have a minimum of a five second delay once feeding has started.
7. Start Automatic Cycle.

# CONTROL PIVOT MODIFICATION FOR COLLET LOAD

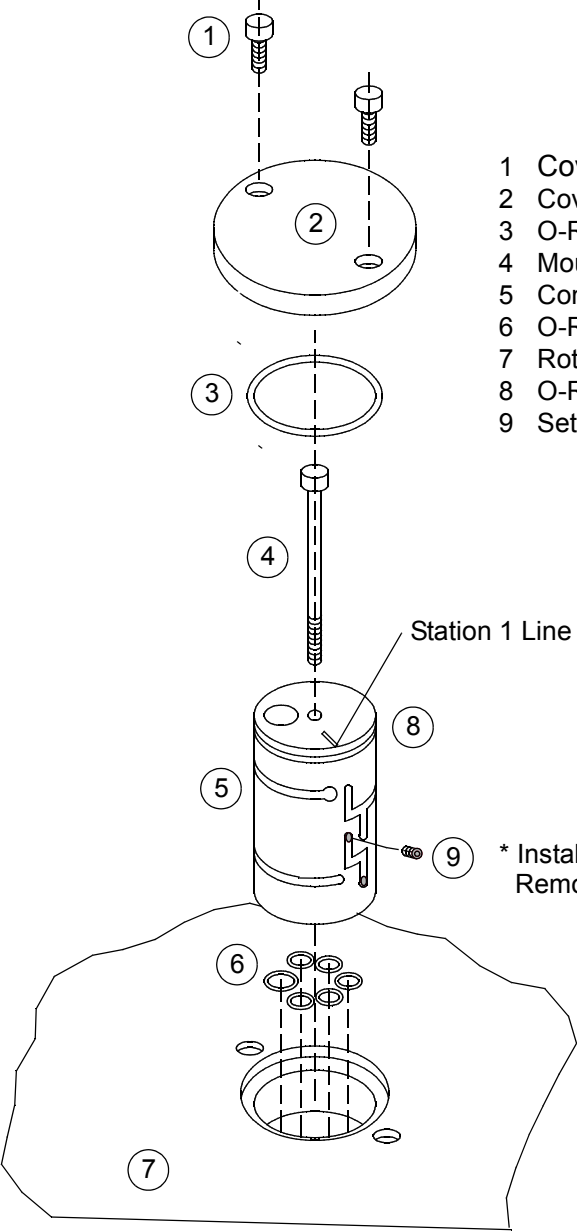

- 1 Cover Bolts
- 2 Cover
- 3 O-Ring
- 4 Mounting Bolt
- 5 Control Pivot
- 6 O-Rings
- 7 Rotary Table
- 8 O-Ring
- 9 Set Screw\*

\* Install M4 Set Screw for Step Collet Load.  
Remove M4 Set Screw for Ejector Load.



**WARNING!**  
Set Screw must be secured below the surface of Control Pivot to avoid damage to the Corner Block.

## 10. Barfeeder Magazine

### LEMCA T560 BUNDLE BAR LOADER (OPTIONAL)

The Model T560 Bundle Bar Loader is an efficient solution to loading Bars, Tubes, and profile shaped stock of virtually any configuration. The construction of this Loader is extremely rugged and heavy in order to maintain perfect alignment barchange after barchange.

The Loader also gives some of the following advantages:

- Convenience of loading an entire Bundle of material up to 2 1/2 tons
- Compact overall dimensions
- Fast change overs from one bar diameter to another
- Stock is placed well below the center of gravity for stability with heavier Bar stock.

#### LOADING THE BUNDLE BAR LOADER

1. Place the “BUNDLE MAGAZINE” selector switch in the “MANUAL” position.
2. Load Bars into the Magazine. If necessary, press the “MAGAZINE BELTS DOWN” push-button to loosen the Belts and create room for more Bars.
3. If the Elevator trolleys are not in the Down position, hold the “ELEVATOR” selector switch in the “DOWN” position.
4. Place the “BUNDLE MAGAZINE” selector switch in the “AUTO” position.

#### AUTOMATIC OPERATION OF THE BUNDLE LOADER

- The Magazine Belts lift the Bar Bundle until some of the Bars fall onto the Alignment Belt. The Stopper arm and Bar Present from Magazine limit switch are tripped, the Magazine Belt Motor stops, and the stopper arms retract.
- The Bar Alignment Belts roll the bars under the Bar Alignment Foot until the Bar Ready to Load limit switch is tripped. The number of discharged Bars depends on the diameter or the shape of the Bars.
- When the End of Bar limit switch is tripped, a Bar is separated and discharged into the Elevator and the trolleys carry it up to load the Feeder.
- The Elevator trolley then descends dropping the Bar into Bar Feeder channel.

**IEMCA T560/51 BUNDLE BAR LOADER LOCATION OF ELECTRICAL PARTS**

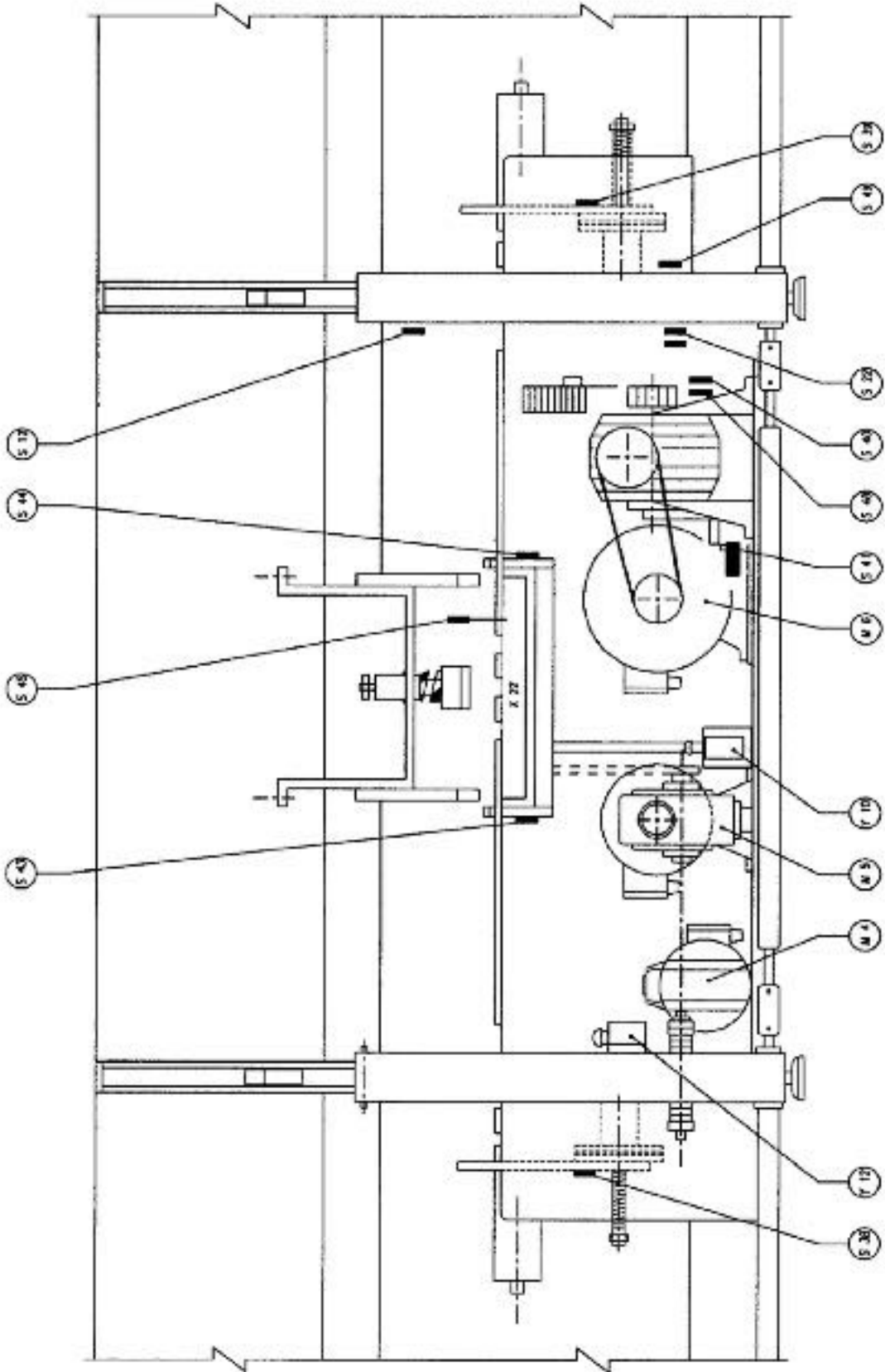

**10. Barfeeder Magazine**

**ELECTRICAL PARTS LIST OF IEMCA BUNDLE BAR LOADER T560/51**

<u>Item</u>	<u>Description and Function</u>	<u>Part #</u>	<u>Vendor</u>
S11A.....	Elevators Down limit switch.....	AZ 3513.....	National
S11C.....	Elevators Down limit switch.....	AZ 3513.....	National
S12A.....	Elevators Up limit switch.....	AZ 3513.....	National
S12C.....	Elevators Up limit switch.....	AZ 3513.....	National
S38.....	Bar Present from Mag. limit switch.....	Z15 GW 22.....	Omron
S39.....	Bar Present from Mag. limit switch.....	Z15 GW 22.....	Omron
S40.....	Belts Too Tight limit switch.....	ZE 022 2G.....	Omron
S41.....	Belts Too Tight limit switch.....	ZE 022 2G.....	Omron
S43.....	Bar on Alignment Plane limit sw.....	Z15 GW 22.....	Omron
S44.....	Bar on Alignment Plane limit sw.....	Z15 GW 22.....	Omron
S45.....	Bar Ready to Load limit switch.....	Z15 GW 22.....	Omron
S48.....	Belts Too Loose limit switch.....	ZE 022 2G.....	Omron
S49.....	Belts Too Loose limit switch.....	ZE 022 2G.....	Omron
Y10.....	Raise Stop Levers Solenoid.....	LM 70.....	IEMCA
Y12.....	Raise Bar Separator Solenoid.....	LM 70.....	IEMCA
M4.....	Elevator Drive Motor.....	1LA5070 4AB22.....	Siemens
.....	Gear Drive.....	VF49A 1:45.....	Bonfigioli
M5.....	Bar Alignment Motor.....	1LA5063 4AB22.....	Siemens
.....	Gear Drive.....	VF49A 1:70.....	Bonfigioli
M6.....	Magazine Belt Motor.....	1LA5083 4AA20.....	Siemens
.....	Gear Drive.....	VF86N 1:100.....	Bonfigioli



## BUNDLE BELT TENSIONER

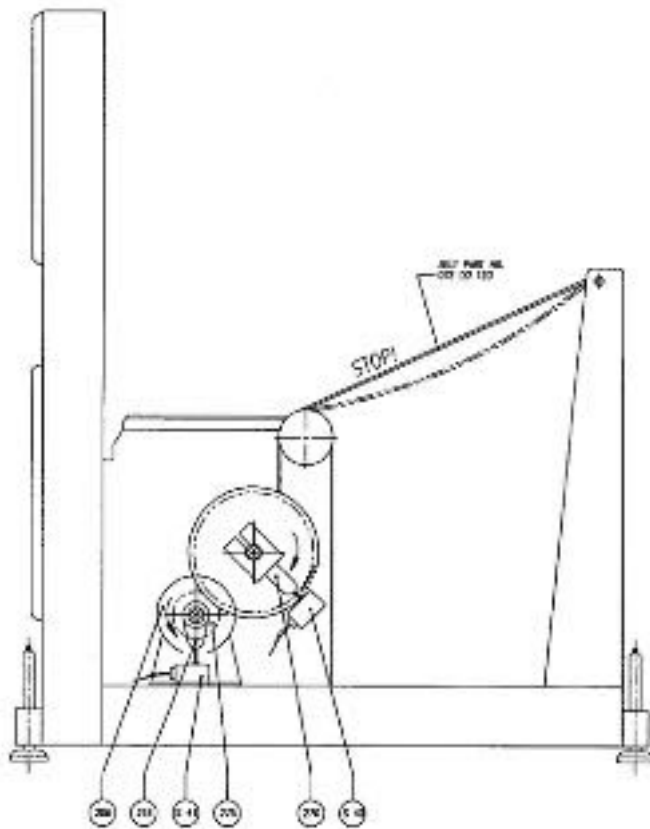

- 206 Gear
- 218 Lever
- 270 Lever
- 275 Ring Nut
- S 40 Belts Too Tight Limit Switch
- S 41 Belts Too Tight Limit Switch

### DESCRIPTION OF BELT TENSIONER

As Bars are discharged from the Loader Magazine, the Belt length is progressively reduced. When the last few Bars are left, the Belt tension becomes taunt to ensure that the last Bar is discharged.

Once this point is reached, limit switch S40 and S41 signal the PLC and the Belt Tension Motor M6 is stopped. The Motor then reverses until limit switches S48 and S49 signal the PLC and the Motor stops.

The Belts can be relaxed by placing the Bundle Magazine selector in the Manual position and then pushing the “Magazine Belts Down” pushbutton.

### BELT TENSIONER ADJUSTMENTS

1. With the Magazine empty, let the Belts draw up to a moderate tension and press the E-Stop pushbutton on the Bar Loader Operator Panel before maximum tension is reached.
2. Loosen and adjust lever 270 until it depresses limit switch S40 and retighten the lever lock screw.
3. Loosen Ring Nut 275 and set lever 218 until it depresses limit switch S41. Retighten the Ring Nut lock screw.
4. Restart the Machine and press the Magazine Belts Down pushbutton to loosen the Belts. Start the loader without Bars and check that the Belts tighten up to the correct tension. If not, repeat the procedure.

## 10. Barfeeder Magazine

### ADJUSTMENT OF ELEVATOR TROLLEYS

With Adjusting Screw (8), set the Booms of the Bar Trolley (7) so that only one Bar is picked up during the lifting cycle.

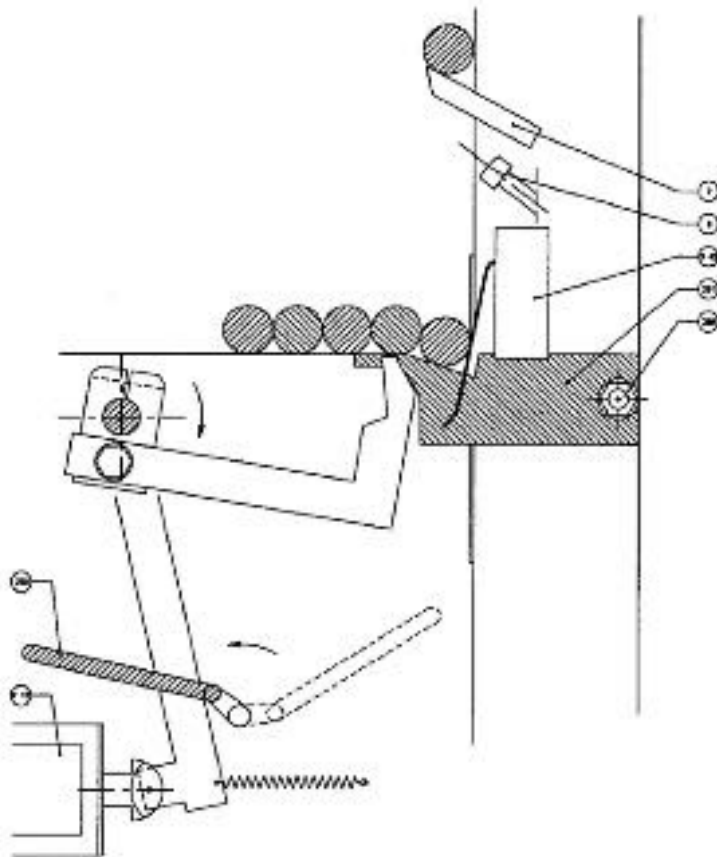

- 7 Bar Trolley
- 8 Adjusting Screw
- 250 Lever
- 289 Bolt and Nut
- 291 Bar Carriers
- S 45 Bar Ready to Load Limit Switch
- Y 12 Raise Bar Separator Solenoid

## DESCRIPTION OF THE BAR MAGAZINE STOPPER

During a Magazine Discharge the Raise Stop levers solenoid energizes lifting the Levers against the Stop Screw (255).

The Bars push up against the Levers tripping the Bar Present From Magazine limit switch which signals the PLC to stop the Magazine Belt Motor. The Raise Stop Levers solenoid de-energizes dropping the Levers back down.

### BAR MAGAZINE STOPPER ADJUSTMENTS

1. Set the stopping point of the Lever (257) with Stop Screw (255) to give an appropriate quantity of Bars that can be distributed evenly by the Alignment Plane conveyor Belts. this will vary with stock diameter and shape.
2. If the Levers tend to fall down from the force of the Bars being loaded the Retention Clutch (256) needs to be adjusted. The clutch can be tightened by turning the Lock Nut (276) clockwise.

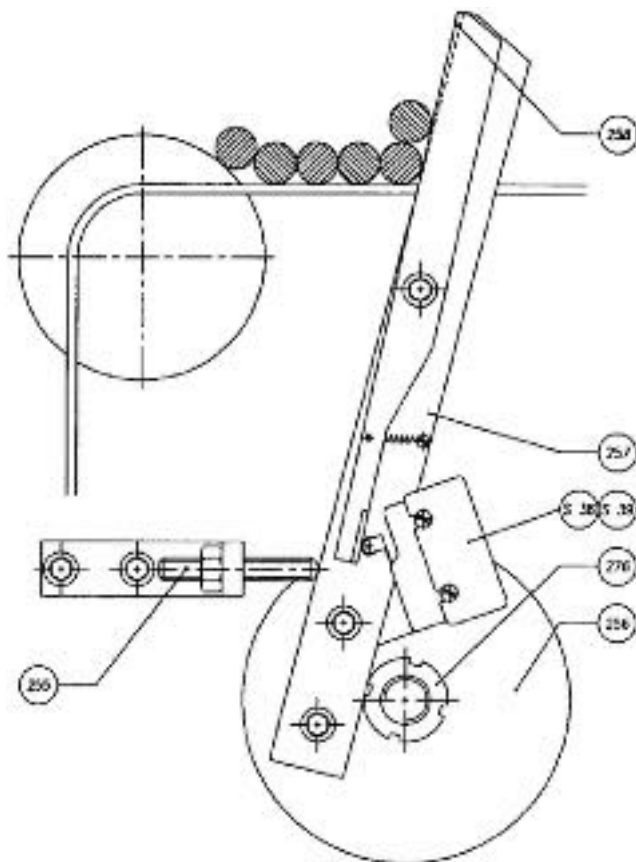

- 255 Stop Screw
- 256 Retention Clutch
- 257 Lever
- 258 Trip Lever
- 276 Lock Nut
- S 38 Bar Present From Magazine Limit Switch
- S 39 Bar Present From Magazine Limit Switch

## 10. Barfeeder Magazine

### DESCRIPTION OF BARRIER FOR BARS 7MM (9/32") AND SMALLER

When using barstock that is 7mm (9/32") or less, position the Bar Barrier next to the Alignment Belts. Set the Barrier by loosening the Adjusting Bolts (287) and positioning the Barrier (286) until it is approximately .5mm (.020") above the Belt surface.

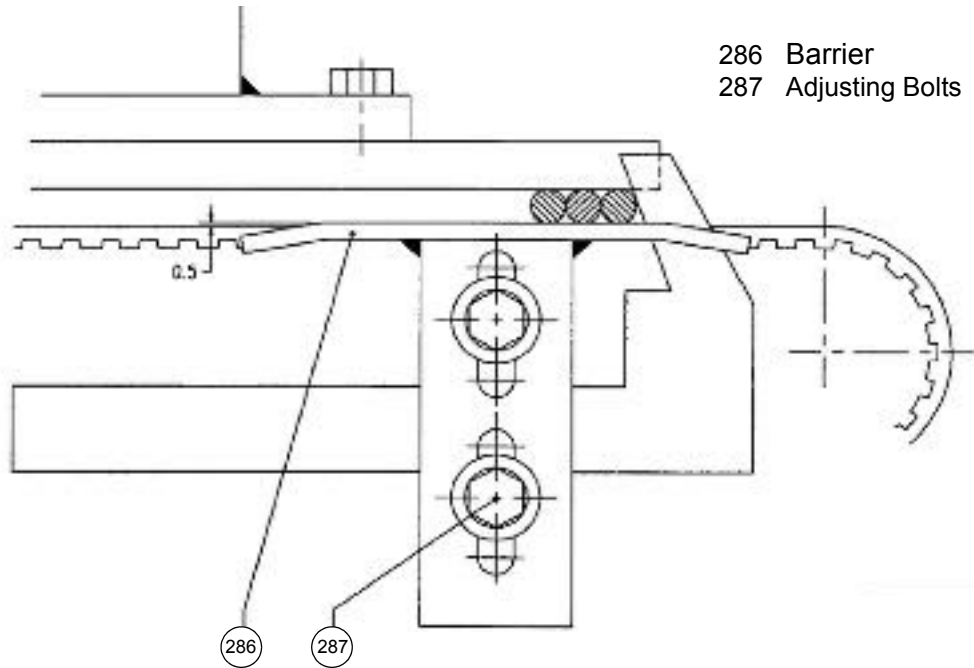

### REGULATION OF SQUARE BARSTOCK

When using Square Barstock, position the Upper Push-Rod (284) so that it sits on the second Bar, leaving the first one free.

The Lower Push-Rod (283) must be positioned so that it lifts the Bar to be loaded, only slightly touching the second Bar.

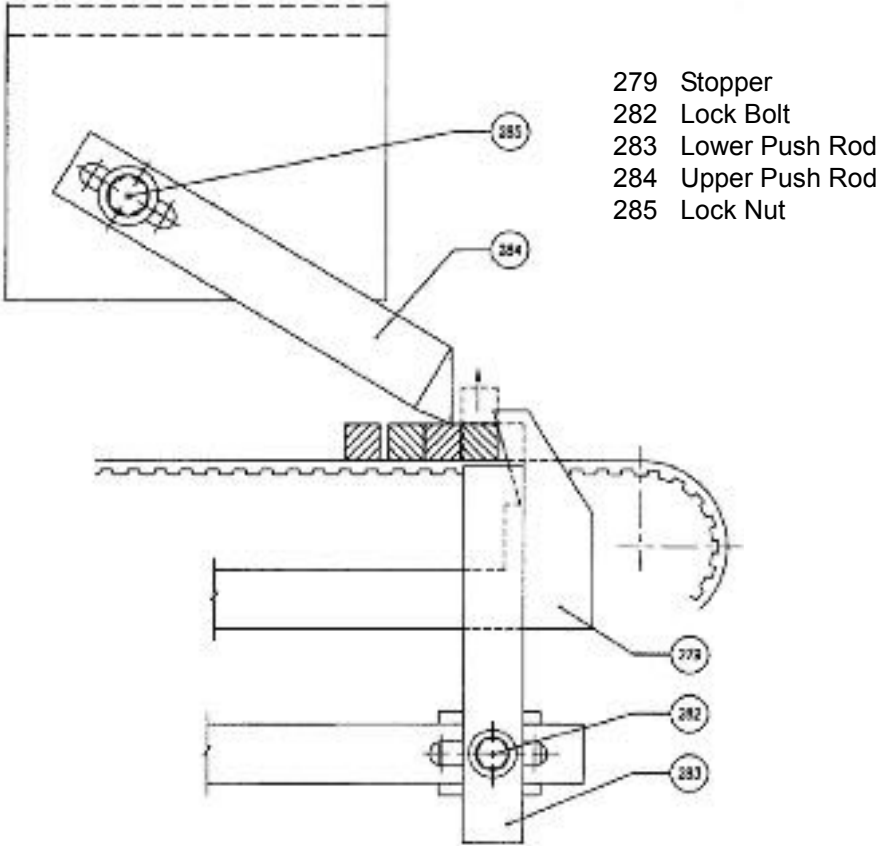

## 10. Barfeeder Magazine

### REGULATION OF ROUND BARSTOCK

When using Round Barstock, position the Upper Push-Rod (284) so that it touches the first Bar.

The Lower Push-Rod (283) must be positioned so that it fits between the first and second Bar without applying any force to either.

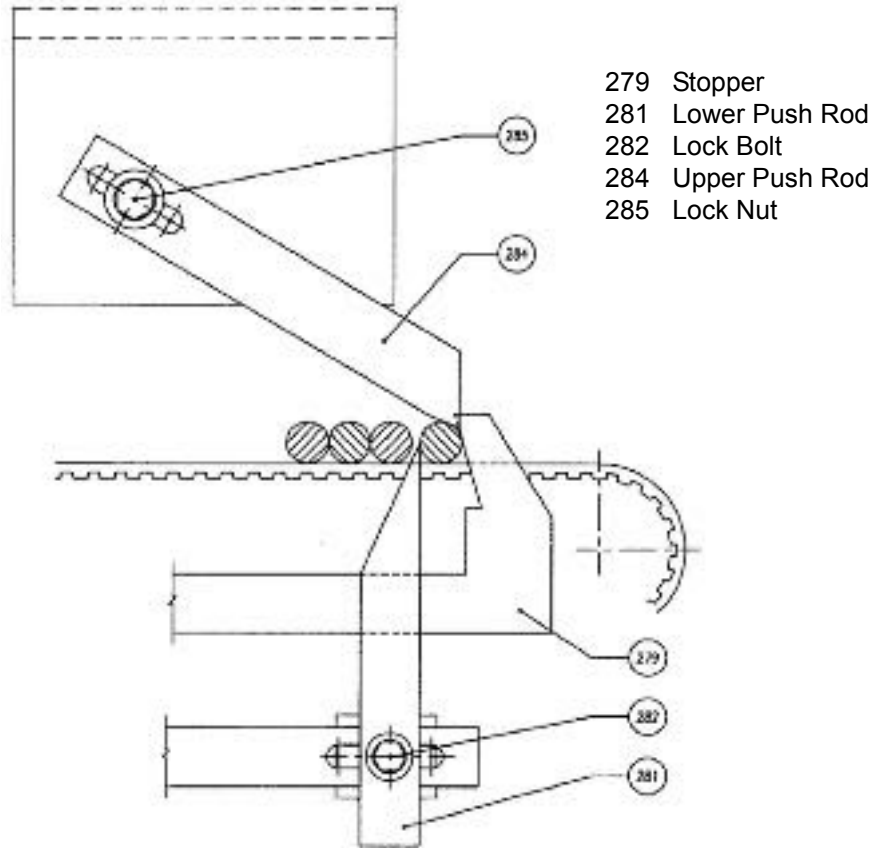

## DESCRIPTION OF THE BAR PRESSURE FOOT

When the Bar Pressure Foot is set properly, the Bars should be moved freely towards the loading Elevator by the Bar Alignment Belts, without jamming or rolling over each other.

### BAR PRESSURE FOOT ADJUSTMENTS

1. Loosen the Lock Nuts (295 and 296) and adjust for a gap of 2-5mm (.078" to .196") between the Washer and the Sleeve (297) when the Foot is resting on the Barstock.
2. Set the Pressure Foot "Y" position as shown in the drawing. With Round Bars, the Foot must keep all the Bars down, including the one closest to the Stopper. With Square Barstock, set the Foot so that the first Bar is "free".

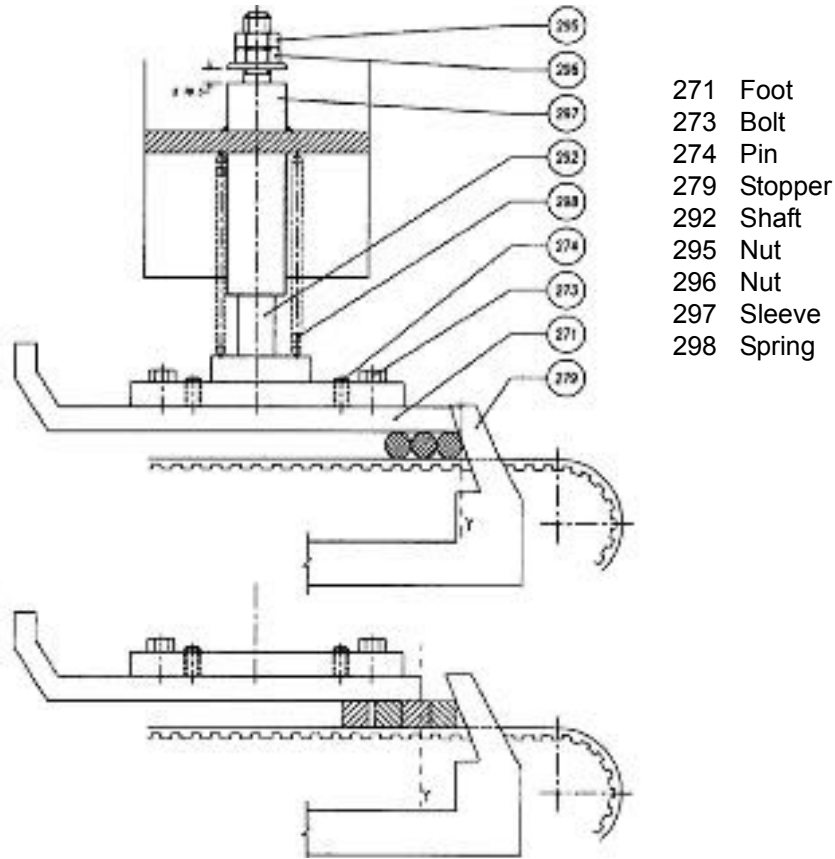

**11. ROTARY INDEX TABLE**

ROTARY INDEX TABLE - EPIC R/T 25-12 .....	11-1
CROSS SECTION OF ROTARY TABLE - EPIC R/T 25-12 .....	11-2
HYDRAULIC DIAGRAM FOR TABLE INDEXING.....	11-3
FULL TABLE INDEX SEQUENCE .....	11-3
1/2 TABLE INDEX SEQUENCE .....	11-3
ADJUSTMENTS ON THE ROTARY INDEXING TABLE.....	11-4
INDEX TABLE DOWN PROXIMITY SWITCH .....	11-5
TABLE MANIFOLD HOSE CONNECTIONS - EPIC R/T 25-12 .....	11-6
DESCRIPTION OF THE CONTROL PIVOT - EPIC R/T 25-12 .....	11-7
CHANGING THE CONTROL PIVOT .....	11-7
INSTRUCTIONS FOR REMOVING TABLE LIFT PISTON - EPIC R/T 25-12 .....	11-8
CHANGING THE COLLETS IN THE ROTARY INDEXING TABLE - EPIC R/T 25-12 .....	11-9
REMOVING THE COLLETS.....	11-9
SETTING THE GRIPPING DIAMETER OF THE COLLETS .....	11-9
CALCULATING THE EJECTOR DIMENSIONS - EPIC R/T 25-12 .....	11-11
WHEN USING EJECTOR TYPE T:.....	11-11
WHEN USING EJECTOR TYPE S:.....	11-11
DETERMINING THE COLLET DIMENSION “X” - EPIC R/T 25-12 .....	11-12
ROTARY INDEX TABLE WITH CHUCKS (OPTIONAL) .....	11-13



# ROTARY INDEX TABLE

## ROTARY INDEX TABLE - EPIC R/T 32/45-16

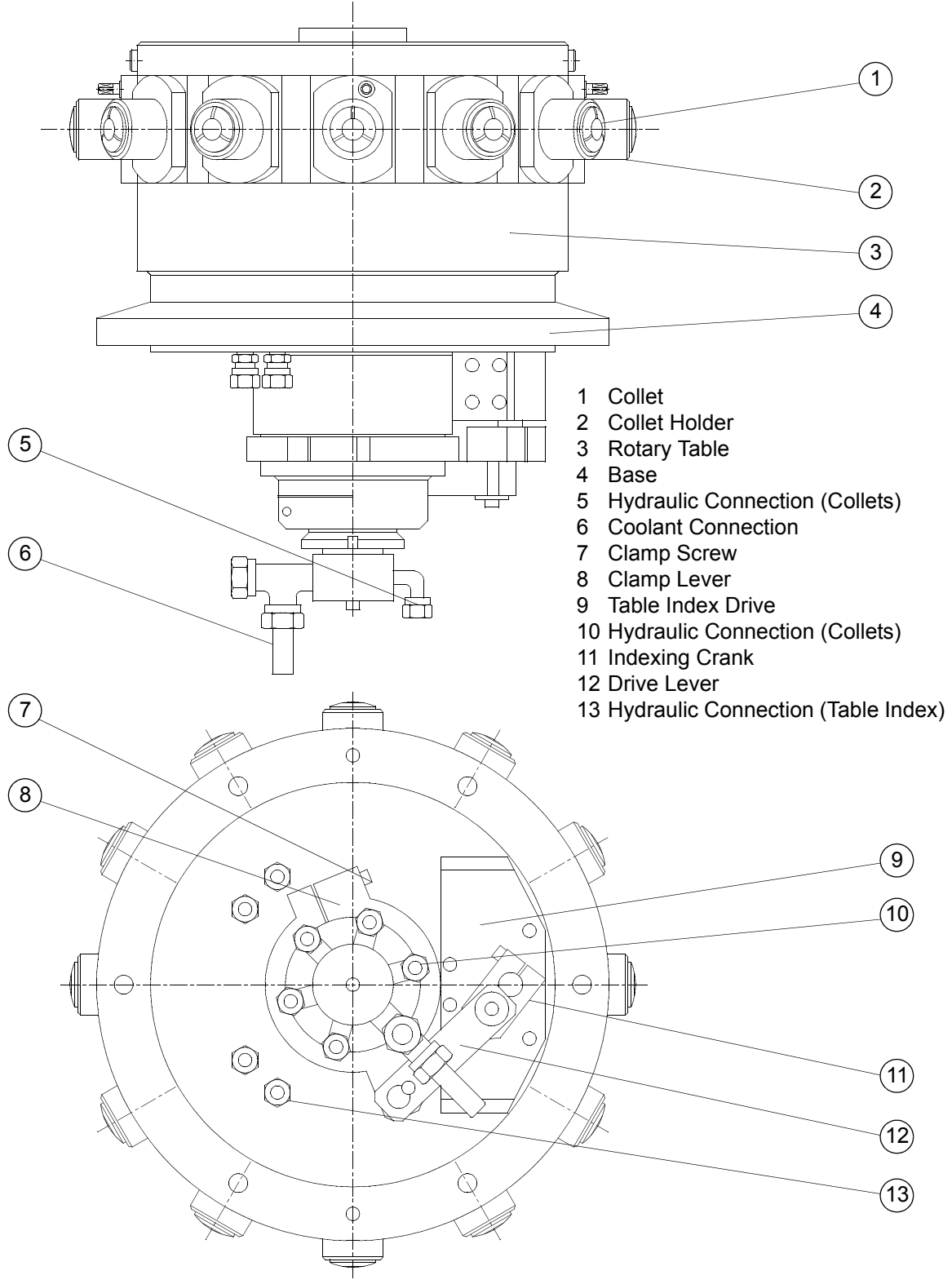

# 11. Rotary Index Table

## CROSS SECTION OF ROTARY TABLE - EPIC R/T 32/45-16

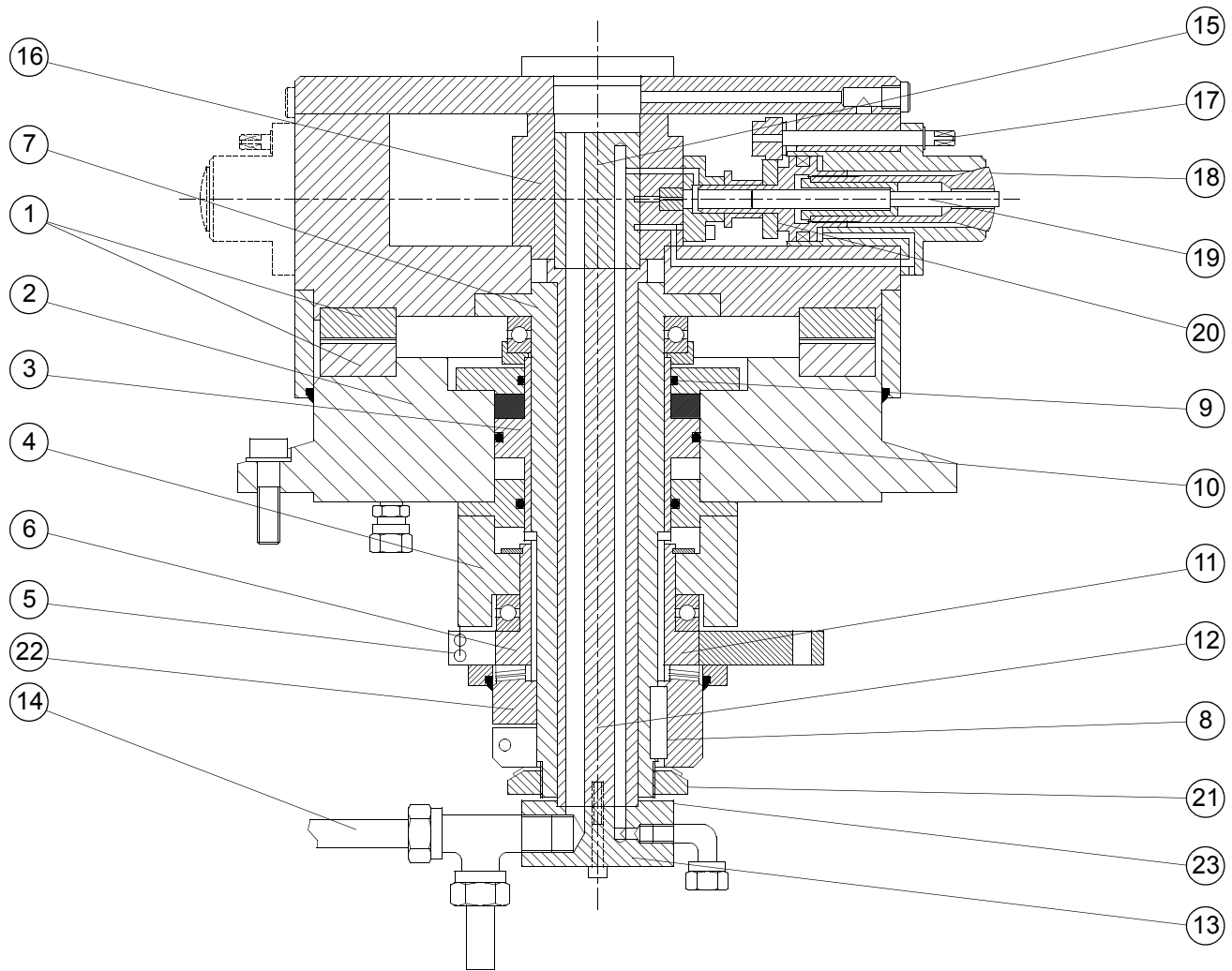

- |                     |                      |
|---------------------|----------------------|
| 1 Hirth Coupling    | 13 Manifold          |
| 2 Base              | 14 Rod               |
| 3 Piston            | 15 Control Pivot     |
| 4 Flange            | 16 12 Corner Block   |
| 5 Clamp Lever       | 17 Adj. Spindle      |
| 6 Upper Coupling    | 18 Collet            |
| 7 Quill             | 19 Ejector           |
| 8 Key               | 20 Collet Piston     |
| 9 2 x O-Ring        | 21 Lock Nut          |
| 10 Piston O-Ring    | 22 Lower Coupling    |
| 11 Upper Coupling   | 23 Connection Flange |
| 12 Connection Shaft |                      |

**NOTE:** Refer to the Unit Parts Book for actual part numbers.

## HYDRAULIC DIAGRAM FOR TABLE INDEXING

### FULL TABLE INDEX SEQUENCE

1. ST2 pressure must be HIGH (>80% P) and the ST2 prox must be ON. The 1/2 Reset solenoid (15) must be ON. Table Down prox is ON.
2. Table Index sol. (14) is energized for .5 seconds.
3. Table Valve (7) cycles Table to lift, Table drive (8) turns crank (12) 180 deg., Table sits down and Table drive is reset (as shown). ST2 pressure goes to zero during Index Valve (7) cycle and returns HIGH when Table drive resets. The Table Down prox turns OFF when Table lifts and ON when Table sits down.

### 1/2 TABLE INDEX SEQUENCE

1. ST2 pressure must be HIGH (>80% P) and the ST2 prox must be ON. The 1/2 Reset solenoid (15) must be ON. Table Down prox is ON
2. Table Index sol. (14) is energized for .5 seconds.
3. Table Valve (7) cycles Table to lift.
4. As soon as Table Down prox turns OFF.
  - 1/2 Reset sol. (15) turns OFF.
  - 1/2 Index sol. (13) turns ON.
5. Table Index Valve shifts function to 1/2 Index Valve (16) and Table turns to 1/2 position.
6. ST2 is zero and Table Down prox stays OFF.

- 1 Table Collets (1-10)
- 2 Table Down Flow Valve (Parker #F400-S)
- 3 Table Lift Flow Valve (Parker #F400-S)
- 4 Table Turn Flow Valve (Parker #F400-S)
- 5 Knurl Knob for Speed Setting (Typical)
- 6 Locking Knurl Knob (Typical)
- 7 Table Indexing Valve
- 8 Table Index Drive
- 9 Clamp Screw
- 10 Clamping Lever
- 11 Drive Lever
- 12 Index Crank
- 13 Table 1/2 Index Solenoid
- 14 Table Index Solenoid
- 15 Table 1/2 Reset Solenoid
- 16 1/2 Index Valve

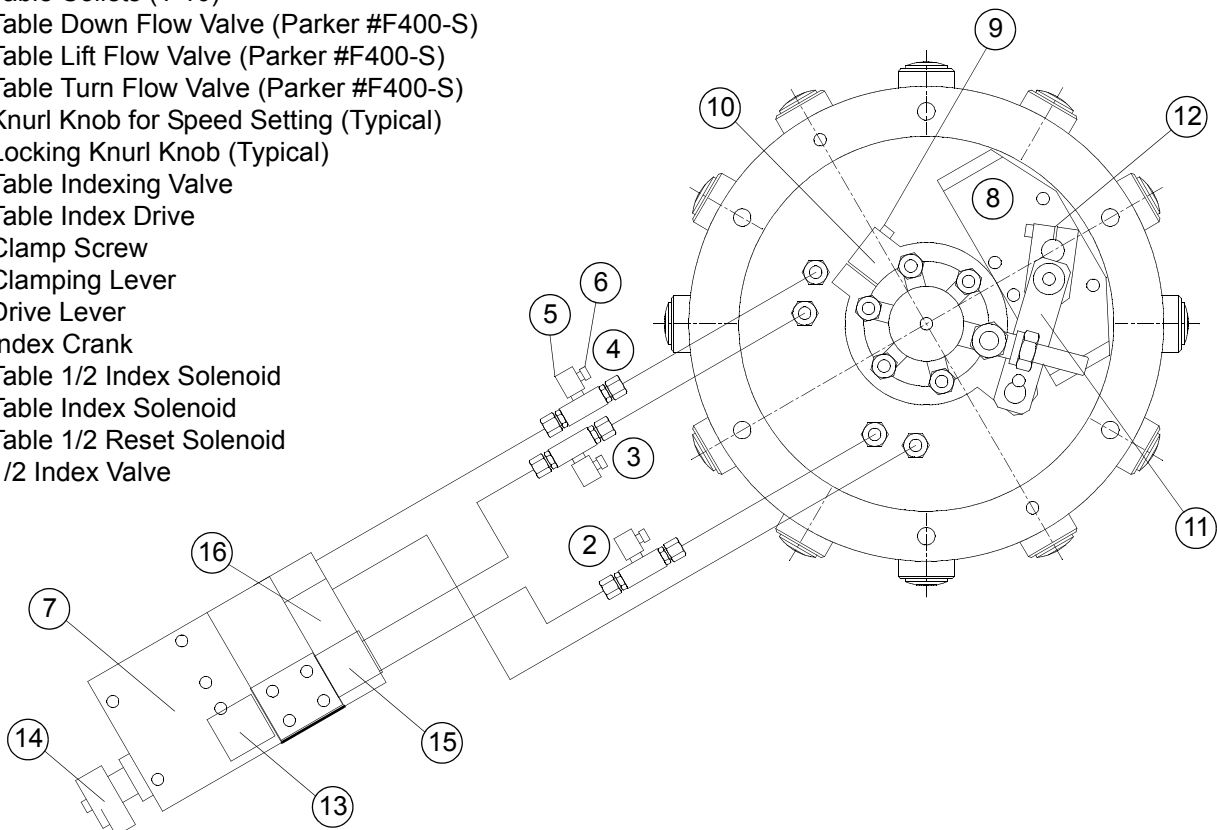

## 11. Rotary Index Table

### ADJUSTMENTS ON THE ROTARY INDEXING TABLE

The movements of the Rotary Indexing Table for; lifting, turning, and sitting down, can be adjusted by the Flow Control Valves 2, 3, and 4 (see previous page). If these movements need to be adjusted, make sure that the Locking Knurl Knob is securely tightened after the adjustment has been completed. If the movements are adjusted too slow, it is possible that the Table will not Index properly, and may sit down in the 1/2 Index Position, or on top of the Hirth Ring Coupling.

**THE PROPER INDEXING SPEED IS .7 SECOND ON EPIC R/T 32/45-16 MACHINES.**

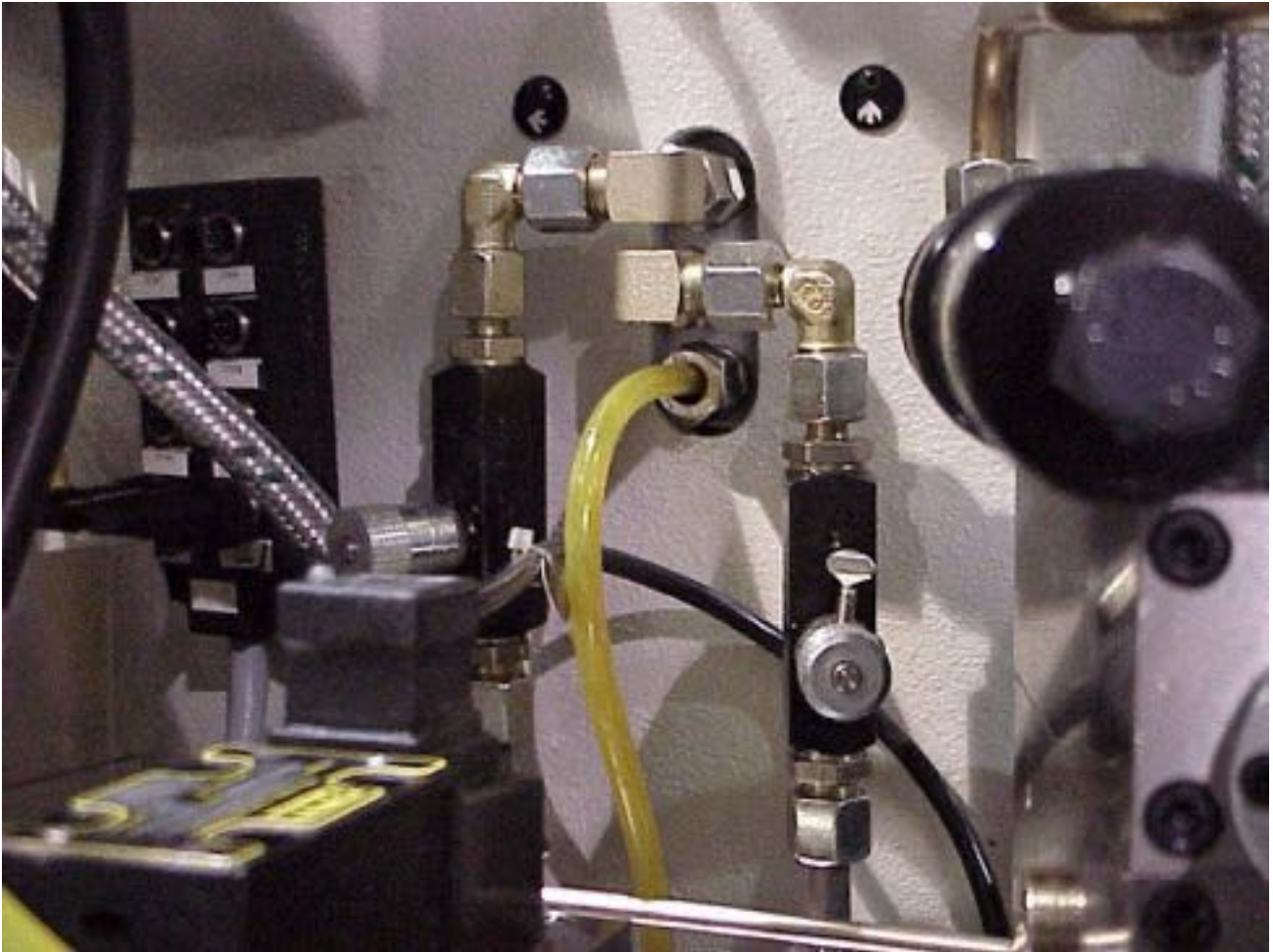

**Table Index Flow Control Valves Below Stations 10 and 11**

## INDEX TABLE DOWN PROXIMITY SWITCH

The Table Index Proximity Switch is an Input into the PLC controller that confirms that the Table has set down at the completion of a Table index.

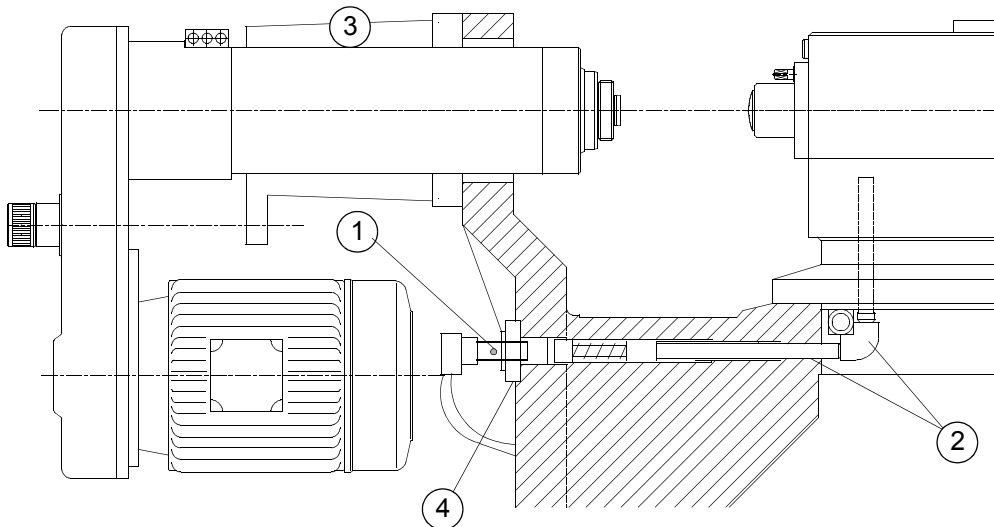

- 1 Table Down Proximity Switch
- 2 Lever and Push Rod
- 3 Toolspindle at Station 2
- 4 Adjustment Dial



**Table Down Proximity Switch  
(With Indicating LED)**

The Index Control Proximity Switch is covered by the Switch Housing and Adjustment Dial, and is located below Station #2 as shown above.

The Switch must be adjusted so that the Proximity Switch is made in the last movement of the Table sitting down. This eliminates the possibility that the Toolspindles will be actuated while the Table is Indexing. the Adjustment Dial allows an accurate setting of the Proximity Switch to avoid malfunction of the Table Index.

## 11. Rotary Index Table

### TABLE MANIFOLD HOSE CONNECTIONS - EPIC R/T 32/45-16

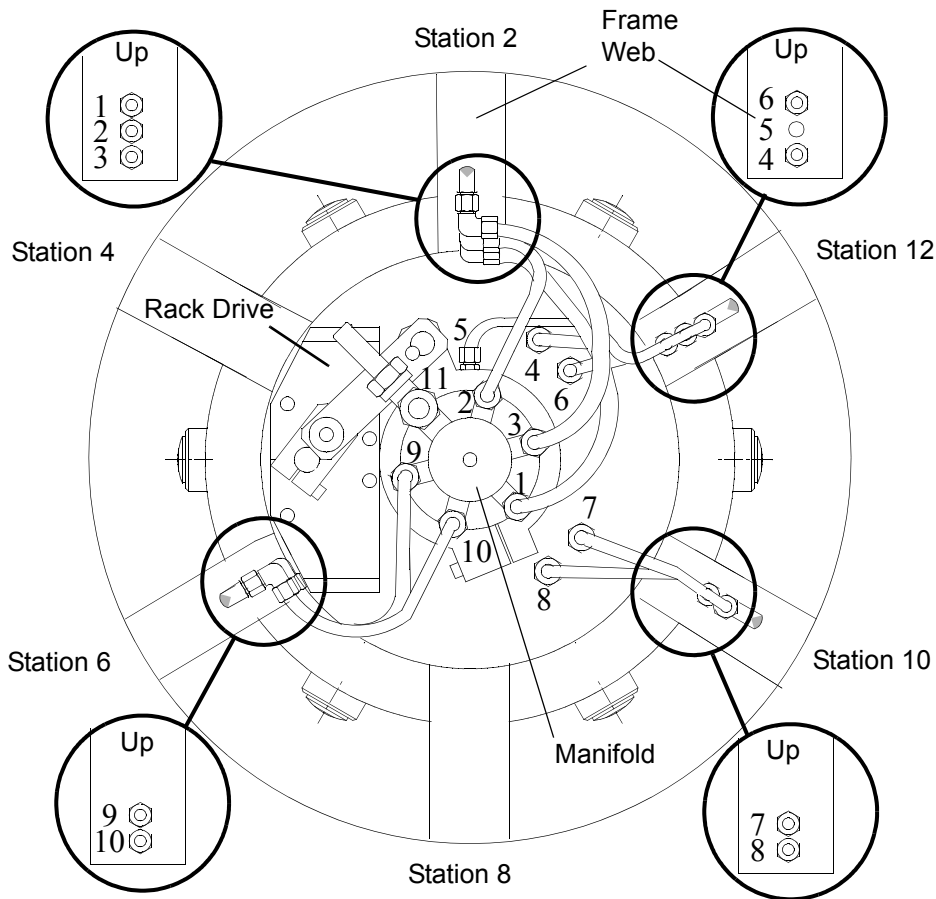

**View From Under Machine**

Line	Hose Size	Function	Manifold Fitting	Frame Fitting
1	NG10 x 22"	Loading Valve	W10-PLR-S	W10-PL-S
2	NG10 x 19"	Loading Valve	W10-PLR-S	W10-PL-S
3	NG10 x 16"	Collet Release	W10-PLR-S	W10-PL-S
4	10mm Pipe	Rack Drive Return	EVW10PL	W10-PL
5	Tygon Tubing	Leak Oil	CK 1/4" PK6	CK 1/4" PK6
6	10mm Pipe	Rack Drive Forward	EVW10PL	W10-PL
7	10mm Pipe	Table Down	EVW10PL	W10-PL
8	10mm Pipe	Table Up	EVW10PL	W10-PL
9	NG10 x 16"	Inverting Valve Line #5	W10-PLR-S	W10-PL-S
10	NG10 x 16"	Inverting Valve Line #2	W10-PLR-S	W10-PL-S
11	NG22 x 30"	Coolant Flush	EVL-22LR	

## DESCRIPTION OF THE CONTROL PIVOT - EPIC R/T 32/45-16

The Control Pivot in the center of the Rotary Index Table distributes the hydraulic pressure oil to the Collets. Filtered Machine Coolant is also distributed to the Collets through the Control Pivot. The channels on the outside of the Control Pivot allow the various Collet functions to be performed at the proper Stations, these functions include:

1. Closes the Collet
2. Controls the Ejector and closes the Collet at the Loading Station
3. Opens the Collet at the Inverting Station
4. Opens the Collet and actuates the Ejector between Stations 12 and 1.

The connections from the Inverting Valve to the Control Pivot are marked A and Z.

From the Loading Valve on Station 1 three hoses are connected to the Control Pivot:

- One for Pressure Oil
- One for Return Oil
- One for Control Oil

If the Inverting Station is relocated, it requires another Control Pivot. Control Pivots are available as a standard item to Invert at Stations 3 through 11. Special Control Pivots are also available for applications requiring unique functions.

Adjustment of the Control Pivot's location (to readjust the Loading, Inverting, and Ejecting position) is accomplished by rotating it either clockwise or counterclockwise. The Control Pivot Adjustment Block is located below Station 4 on the Machine Base. First loosen the Locking Screw on top of the Adjustment Block with an allen wrench. Make the adjustment on the side of the Adjustment Block with an allen wrench, then retighten the locking screw.



**Control Pivot Adjustment Block Window Below Station 4**

## CHANGING THE CONTROL PIVOT

1. Clean the area around the Table Cover, remove the Cover (2). Loosen and remove the Mounting Bolt (4) and thread an M8 Bolt into the same hole. Using the Bolt, pull the Pivot upwards and remove it.
2. Check to make sure that all the O-rings (6) are in place. Align the Pivot so the Locating Pin in the Table will engage the Pin Hole on the Pivot. Slide the Control Pivot into place, and check that it is all the way seated in the Table. **DO NOT FORCE!**
3. Install and tighten the Mounting Bolt (4). replace the O-ring (3), install and tighten the Cover (2).

## 11. Rotary Index Table

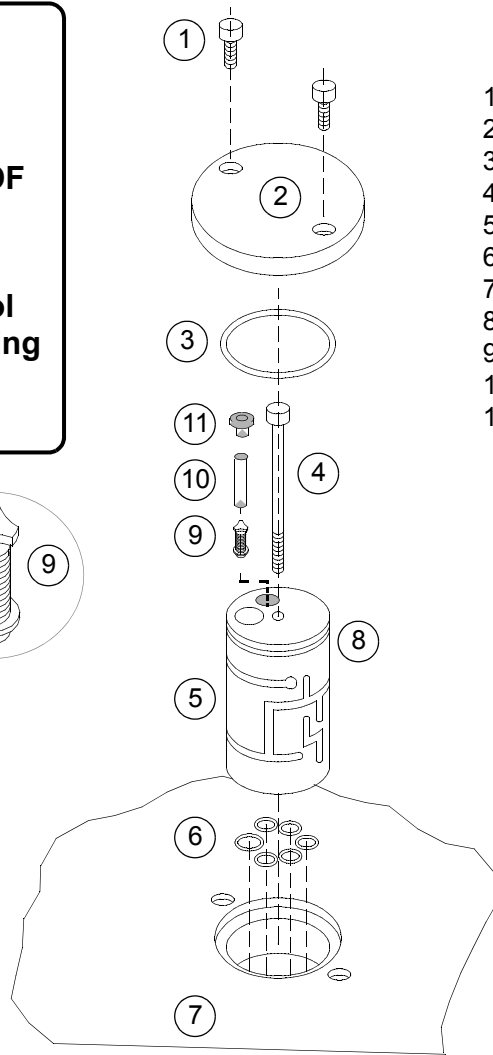
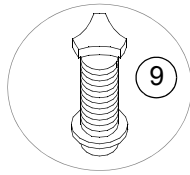

- 1 Cover Bolts
- 2 Cover
- 3 O-Ring (OR-3187)
- 4 Mounting Bolt
- 5 Control Pivot
- 6 O-Rings (1 x OR-2050, 5 x OR-106)
- 7 Rotary Table
- 8 O-Ring (1 x OR-4150)
- 9 Check Valve (6-L/6+8-5)
- 10 Distance Pin
- 11 Plug (1/8" G)

### Collet Load Option

When Collet Load Option is activated, Set Screw is installed in side of Control Pivot. See Ch. 10.



### WARNING!

**Set screw must be secured below the surface of the Control Pivot to avoid damage to the Corner Block.**

## ADJUSTING PART EJECTION PRESSURE

Remove the Cover (2). Loosen the Ejection pressure adjustment lock nut (12) and using a hex wrench, turn the adjustment clockwise to decrease or counter-clockwise to increase ejection force. Replace the Cover. This can be performed with the Cover removed.

## INSTRUCTIONS FOR REMOVING TABLE LIFT PISTON - EPIC R/T 32/45-16

See cross section of Rotary Table drawing earlier in this chapter for reference.

1. Remove the Connection Flange (23).
2. Bend the Lock washer tang and remove the Nut (21).
3. Loosen the lock screw on the Lower Coupling (22) and remove.
4. Remove the Key (8).
5. The Table and Piston assembly can now be lifted out from the top.
6. Replace the O-Rings and inspect the Axial Bearings and replace if necessary.
7. Re-assemble the Table assembly in the reverse order.



### WARNING: RISK OF INJURY!

- Make sure the Machine is turned off before servicing.
- Securely strap the Table when lifting.



## CHANGING THE COLLETS IN THE ROTARY INDEXING TABLE - EPIC R/T 32/45-16

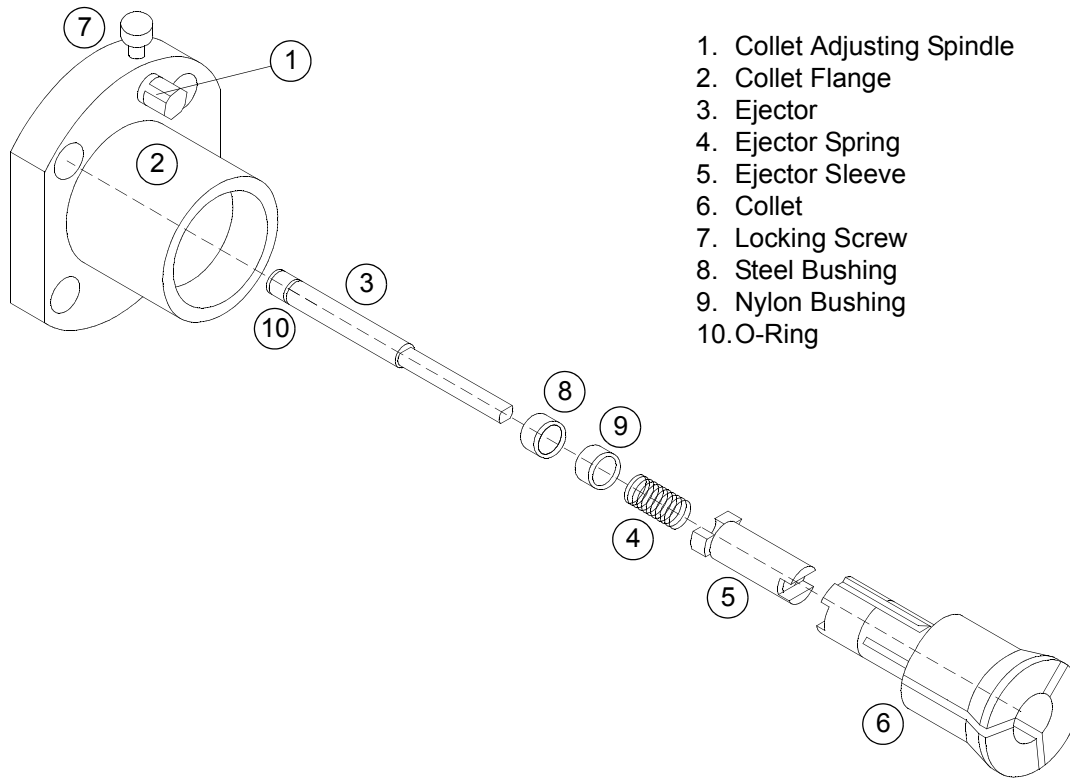

1. Collet Adjusting Spindle
2. Collet Flange
3. Ejector
4. Ejector Spring
5. Ejector Sleeve
6. Collet
7. Locking Screw
8. Steel Bushing
9. Nylon Bushing
10. O-Ring

### REMOVING THE COLLETS

1. Index the Table into the 1/2 Index Position.
2. Shut off the Machine by pressing the Emergency Stop Button.
3. Open the Locking Screw.
4. Remove the Collet by turning the Collet Adjusting Spindle counter clockwise.
5. Remove the Collet, Ejector, Ejector Sleeve, and Ejector Spring.

INSTALL THE COLLETS AND EJECTORS IN THE REVERSE ORDER SHOWN ABOVE

### SETTING THE GRIPPING DIAMETER OF THE COLLETS

1. Turn on the Hydraulics (all Collets and Ejectors must be installed).
2. Move the Table into the 1/2 Index Position.
3. While pressing the "RELEASE" Button, chuck a Master Piece into the Collet. With the button released, check the gripping on the part.
4. Pressing the "RELEASE" Button the Collet can be tightened. Adjust the Collet to a point that the Master Piece is held barely snug in the Collet.
5. Turn the Collet Adjusting Spindle 1/2 turn clockwise. This automatically adjusts the Collet to a pre-grip of .012".
6. Secure the Collet Adjusting Spindle with the Locking Screw.

**NOTE:** DO NOT adjust the Collets under pressure, always use the "RELEASE" Button or turn off the hydraulics.



### CALCULATING THE EJECTOR DIMENSIONS - EPIC R/T 32/45-16

Using the Master Drawing S-B-057-031 and the Chart to determine dimension “B” all calculations for Ejector length can be made.

The following descriptions and formulas will help in determining the variable dimensions.

**WHEN USING EJECTOR TYPE C:**

- 1. Determine the Clamp Depth required X = \_\_\_\_\_
- 2. Determine Distance “B” from following Chart B = \_\_\_\_\_
- 3. Calculate Total Ejector Length “F+K” = 9.882 + B -X F+K = \_\_\_\_\_
- 4. Calculate Ejector Body Length “E” = 5.787 - X - .078 E = \_\_\_\_\_
- 5. Determine Head Dimensions K, L, and M according to part requirements
- 6. Determine Ejector Shaft Length “F” = O.A.L.-K F = \_\_\_\_\_

**WHEN USING EJECTOR TYPE D:**

- 1. Determine the Clamp Depth required X = \_\_\_\_\_
- 2. Determine distance “B” from the following Chart B = \_\_\_\_\_
- 3. Calculate Total Ejector Length “G” = 9.882 + B -X G = \_\_\_\_\_
- 4. Calculate Dimension “E” = 5.787 - X - .078 E = \_\_\_\_\_
- 5. Calculate Dimension “F” = .748 min. F = \_\_\_\_\_
- 6. Determine Diameter “H” according to part requirements H = \_\_\_\_\_

## 11. Rotary Index Table

### DETERMINING THE COLLET DIMENSION "X" - EPIC R/T 32/45-16

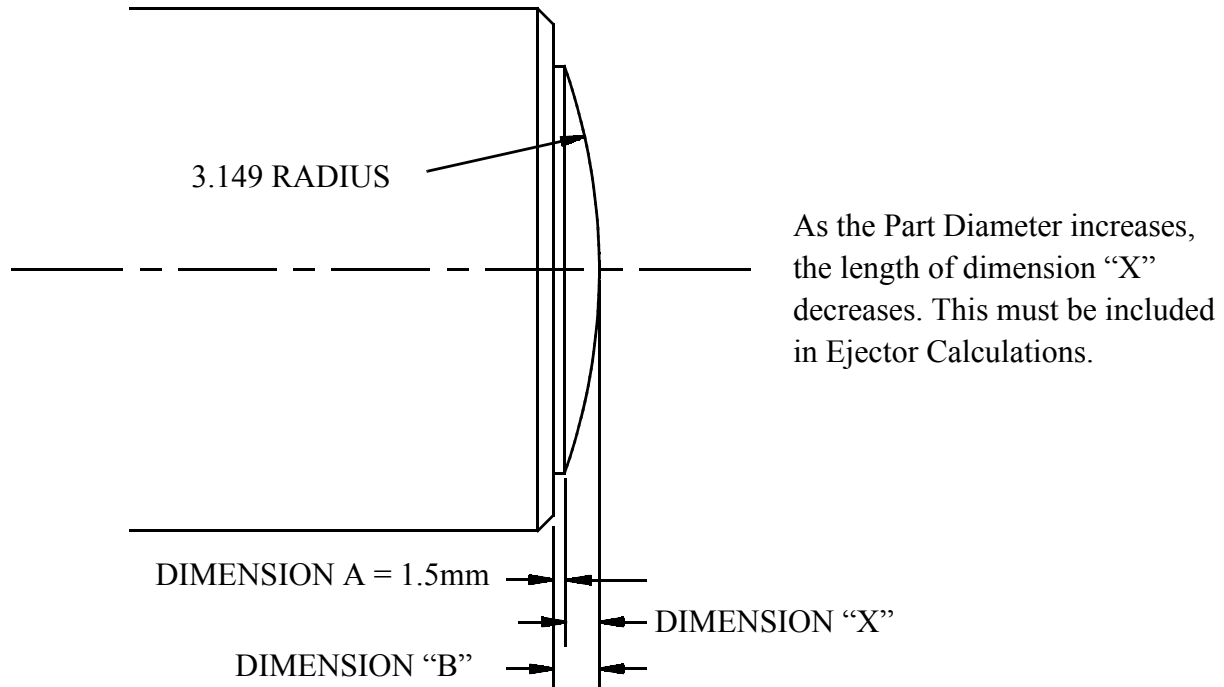

#### Formula:

$$A = 1.5\text{mm} \times 0.039375 = .059$$

$$B - A(.059) = X$$

Bar Diameter	Dimension "B"	Dimension "X"
1/8" (.125")	5.993mm (.236")	4.495mm (.177")
1/4" (.250")	5.892mm (.232")	4.393mm (.173")
3/8" (.375")	5.892mm (.232")	4.393mm (.173")
1/2" (.500")	5.790mm (.228")	4.292mm (.169")
5/8" (.625")	5.587mm (.220")	4.088mm (.161")
3/4" (.750")	5.384mm (.212")	3.885mm (.153")
7/8" (.875")	5.180mm (.204")	3.682mm (.145")
1" (1.00")	5.003mm (.197")	3.504mm (.138")
1 1/8" (1.1250")	4.698mm (.185")	3.2mm (.126")
1 1/4" (1.1250")	4.393mm (.173")	2.895mm (.114")
1 3/8" (1.375")	4.088mm (.161")	2.590mm (.102")
1 1/2" (1.500")	3.707mm (.146")	2.209mm (.087")
1 5/8" (1.625")	3.301mm (.130")	1.803mm (.071")

## ROTARY INDEX TABLE WITH CHUCKS (OPTIONAL)

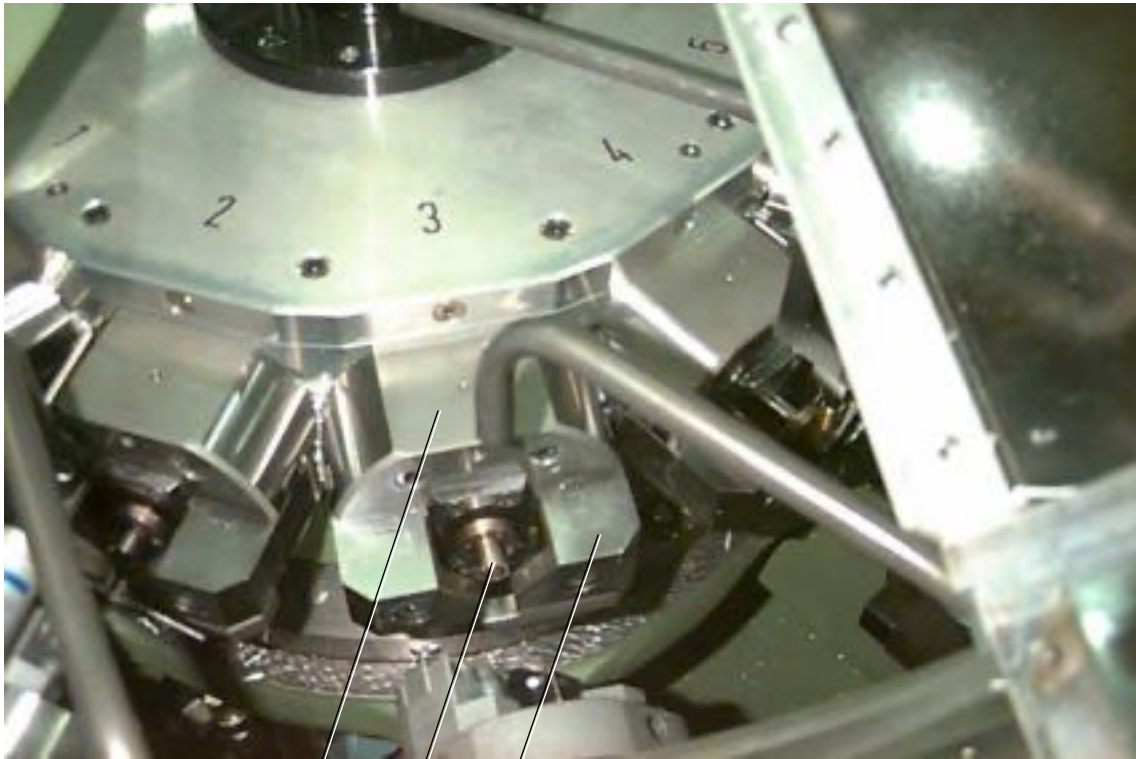

- 1 Chuck
- 2 Ejector
- 3 Chuck Jaw

①

②

③

For certain part applications such as extruded slugs, castings or long shafts, Chucks are used in place of the standard Collet / Ejector assemblies. The two jaw, self centering, Chucks hold the part with a strong gripping force and can handle heavy machining operations with consistent accuracy.

The Part is loaded against an Ejector and Chuck jaw pressure is controlled by the Hydraulic Powerpack High Pressure Clamp system (see Chapter 12).

The Chucks, chuck jaws and ejectors are designed specific to the part being produced. Drawings for the Chucks, Ejectors, and Jaws can be found in the Unit Parts Book that was supplied with your Machine.

**12. HYDRAULIC SYSTEMS**

PARKER HYDRAULIC POWERPACK - HPU12262 .....	12-1
BILL OF MATERIAL: PARKER POWERPACK - HPU12262 .....	12-3
POWERPACK OPERATING INSTRUCTIONS .....	12-4
SYSTEM PRESSURE PISTON PUMP (9) .....	12-4
SAFETY RELIEF VALVE (17).....	12-4
4/3 DIRECTIONAL CONTROL VALVE (16) .....	12-4
HEATING CYCLE RELIEF VALVE (13).....	12-4
CHECK VALVE (14).....	12-4
ELECTRIC MOTOR (3) .....	12-4
TEMPERATURE SWITCH (23) .....	12-4
HYDRAULIC OIL RETURN FILTER (26).....	12-4
HYDRAULIC OIL FILLER AND BREATHER (27) .....	12-5
ACCUMULATOR (21).....	12-5
POWERPACK SYSTEM PRESSURE ADJUSTMENTS.....	12-6
RETURN FILTER - PARKER #FTC1A10QV25S24X.....	12-7
ELEMENT SERVICE (HYDRAULIC).....	12-7
ELEMENT SERVICE (BREATHER) .....	12-7
POWERPACK HYDRAULIC SCHEMATIC - HPU12262.....	12-8
POWERPACK ELECTRICAL SCHEMATIC - HPU12262.....	12-9
GENERAL HYDRAULIC SYSTEMS INFORMATION .....	12-10
PARKER PISTON PUMP START-UP PROCEDURE.....	12-15
PARKER SERIES “AB” BLADDER ACCUMULATORS .....	12-16
PROCEDURE FOR RECHARGING OLAER AND BOSCH ACCUMULATORS (USING OLAER KIT #201381).....	12-17
TURN OFF THE POWERPACK! .....	12-17
POWERPACK GENERAL TROUBLE SHOOTING .....	12-18
HOW HOT IS “TOO HOT”? .....	12-18
MEASURING OIL TEMPERATURE.....	12-18
ISOLATING TROUBLE-SPOTS .....	12-18
LOOK, SMELL AND FEEL .....	12-18
HYDRAULIC MANIFOLD RING LINES.....	12-19

# HYDRAULIC POWERPACK

## PARKER HYDRAULIC POWERPACK - HPU12262

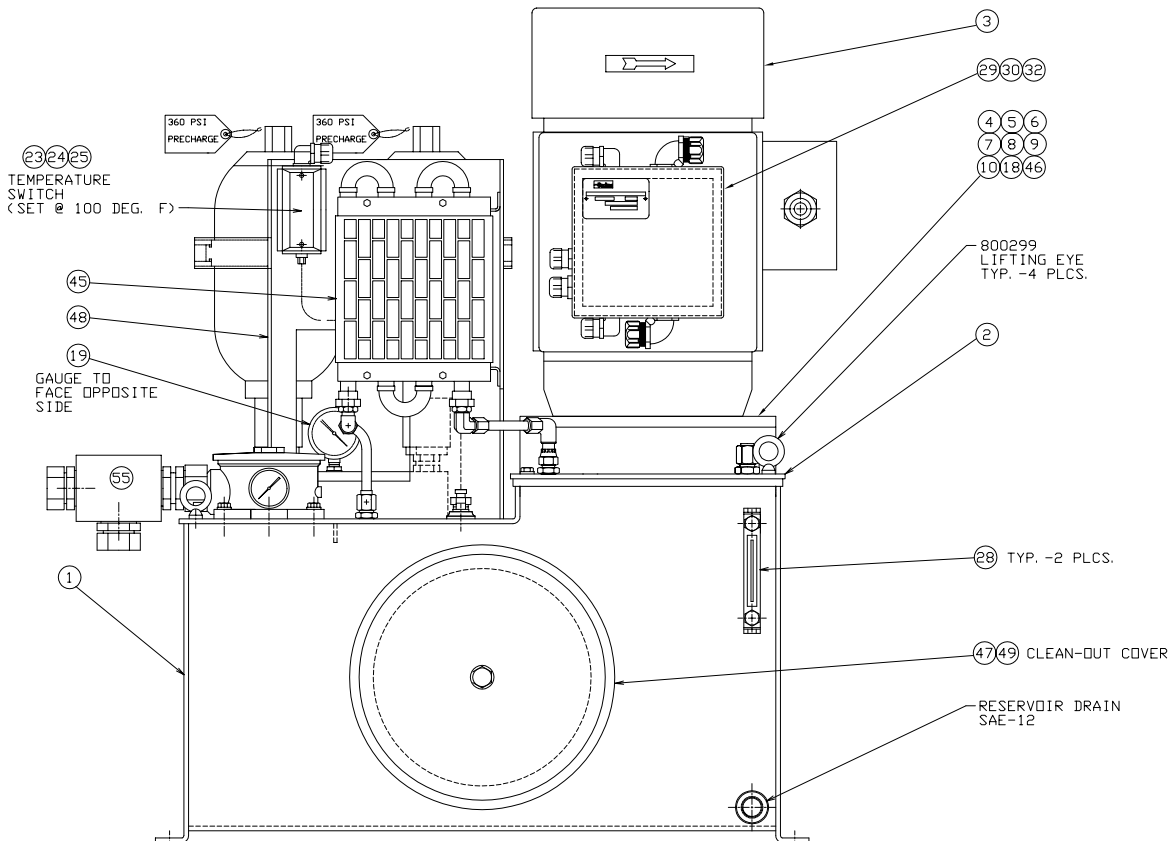
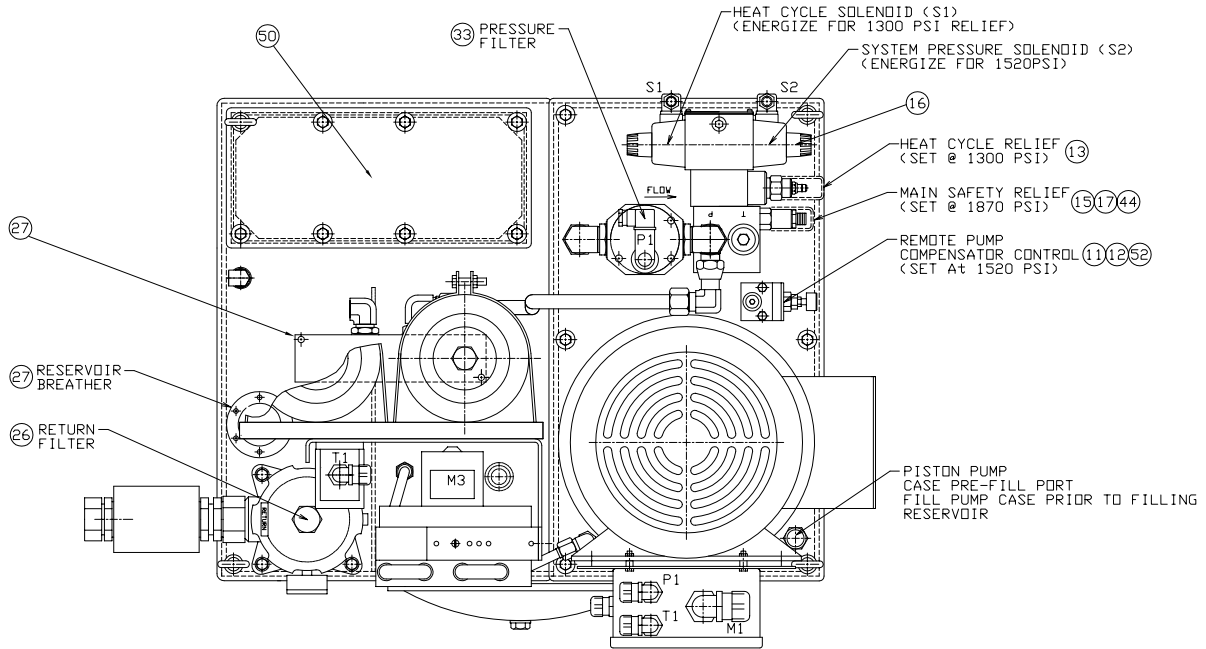

## 12. Hydraulic Powerpack

### PARKER HYDRAULIC POWERPACK - HPU12262 (CONTINUED)

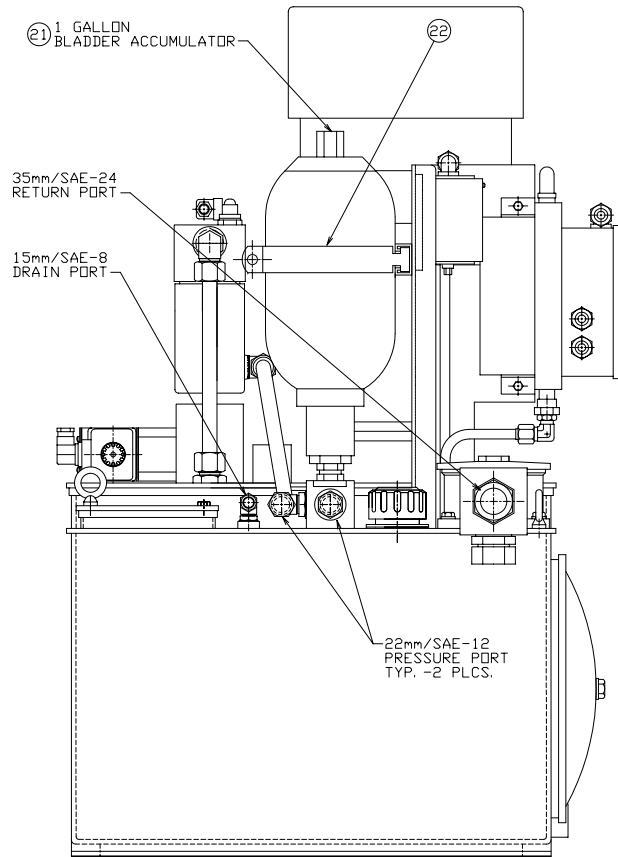



**BILL OF MATERIAL: PARKER POWERPACK - HPU12262**

<u>Item</u>	<u>Qty.</u>	<u>Description</u>	<u>Item</u>	<u>Qty.</u>	<u>Description</u>
1	1	50 Gal. Reservoir	32	1	Enclosure Bracket
2	1	Top Plate	33	1	Pressure Filter
3	1	20 HP - 1800RPM-256TC	34	2	Safety Relief Label
4	1	Bell Housing	35	1	Comp. Label
5	1	Dampening Ring	36	2	Pressure Label
6	1	Pump Coupling	37	2	Return Label
7	1	Motor Coupling	38	1	Rotation Arrow
8	1	Coupling Insert	39	1	Name Plate
9	1	Piston Pump	40	2	EO Return Fitting
10	1	Suction Strainer	41	1	EO Drain Fitting
11	1	Univ. Pilot Cart.	42	1	EO Pressure Fitting
12	1	Remote Gasket	43	1	Pre-Fill Label
13	1	Sandwich Relief	44	1	DO5 Manifold Gasket
14	1	Check Valve	45	1	Air Oil Heat Exchanger
15	1	DO5 Manifold	46	1	Suction Str. Gear Pump
16	1	DCV	47	1	Clean Out Cover
17	1	Safety Relief Valve	48	1	Accumulator Bracket
18	1	Gear Pump	49	1	Clean Out Cover Cross Bar
19	1	2000 PSI Pressure Gauge	50	1	Cover Plate
20	1	Header Block	51	1	PVP23 Pressure Hose
21	2	1 Gallon Accumulator	52	1	Remote Comp. Body
22	2	Accumulator Clamp	53	1	Gear Pump Hose
23	1	Temperature Switch	54	1	Remote Comp. Hose
24	1	Bulbwell	55	1	Manifold-Return
25	1	Packing Gland	56	1	End Barrier
26	1	Return Filter	57	4	End Anchor
27	1	Filler Breather	58	1	Mounting Channel
28	2	Level Sight Gauge	59	5	Jumper
29	1	Terminal Enclosure	60	11	Terminal
30	1	Enclosure Panel	61	1	End Anchor
31	18	Terminal Blocks			

## 12. Hydraulic Powerpack

### POWERPACK OPERATING INSTRUCTIONS

#### SYSTEM PRESSURE PISTON PUMP (9)

This standard Pump is set to 105 bar (1520 psi). If the Pump Pressure exceeds 105 bar, the Pump starts to idle and lowers its output volume down to 1 l/min. until the pressure drops below 105 bar in the Machine.

The Pump pre-fill port can be used to prime a new pump with an empty reservoir

1. Remove the Plug and fill with 2 cups of Hydraulic oil
2. Fill the Reservoir to the fill line with Hydraulic oil (see specs Chapter 4)
3. Start the pump and wait one minute for all air to be purged.

**Failure to observe this start up procedure will result in pump cavitation!**

#### SAFETY RELIEF VALVE (17)

Standard Setting is 130 bar (1870 psi). The pressure setting **must exceed** in all circumstances the Pump Pressure by at least 10 bar (145 psi).

#### 4/3 DIRECTIONAL CONTROL VALVE (16)

In the Middle Position of the Solenoid (both Coils deactivated) the Unit is able to start up without pressure. The Oil flows without pressure directly back into the Tank. The Accumulator (10) is empty or is going to empty out at this point. The position A of the 4/3 way Solenoid (Coil B activated) is the regular Operating Position. In position B (Coil A activated) the pressure flow is directed through the Pressure Relief Valve. This circuit allows the Oil to heat up rapidly to the Preset Operating Temperature of the Hydraulic Oil. This is accomplished by routing the oil to the Relief Valve.

#### HEATING CYCLE RELIEF VALVE (13)

Standard setting is 90 bar (1300 psi). The Pressure Setting of this Relief Valve must be at least 5 to 10 bar (145 psi) lower than the Pump Pressure.

#### CHECK VALVE (14)

This Check Valve prevents Oil back flow through the Hydraulic Pump and into the Tank when the powerpack is turned off. It is located in line directly below the manifold for normal/heat solenoid.

#### ELECTRIC MOTOR (3)

Upon installation make sure that the Motor turns in the direction marked by the Arrow on the Motor Housing.

#### TEMPERATURE SWITCH (23)

This Temperature Switch maintains a minimum hydraulic oil temperature and through the PLC activates the Heat and Normal coils of the Directional Control Valve (16).

The Standard Temperature setting of the Temperature Switch is **38°C (100°F)**.

#### HYDRAULIC OIL RETURN FILTER (26)

This Hydraulic Oil Filter cleans the back-flow of Hydraulic Oil from the Machine. The Filter Element must be changed every 1000 hours or at least when the Filter indicator gauge shows in the **Red**. The gauge should never be allowed to reach the **Red** zone!

### HYDRAULIC OIL FILLER AND BREATHER (27)

When filling the Powerpack, make sure that no dirt particles are allowed into the Hydraulic System. Preferably a Pump with a Filtration Station should be used to fill the Hydraulic Powerpack.

### ACCUMULATOR (21)

This Accumulator has the following functions:

- It equalizes pressure variations in the Hydraulic System.
- It provides the Machine with Pressurized Oil Volume during high peaks of usage.

The pre-charge of the Accumulator is 25 bars (360 psi) with Nitrogen.

**NOTE:** Every 1000 cycle hours it is essential to check the pre-charge of the Accumulators. Please contact a Hydraulic Specialist, if sufficient equipment is not available. Failure to maintain the accumulators will result in possible machine unit malfunction (inverter unit).

**NOTE:** It is **Important** that if you make any adjustment on the Hydraulic Powerpack, make sure that the Accumulator(s) are empty. Be sure that Directional Control Valve is in the Middle Position (float center).

### POWERPACK SYSTEM PRESSURE ADJUSTMENTS

This procedure assumes a system pressure setting of 105 Bar (1520 Psi.). If a higher setting is desired then set the Safety Relief Valve 10 Bar (145 Psi.) higher and the Heating Relief Valve 10 Bar (145 Psi.) lower than the new system pressure. System pressure should not exceed 115 Bar (1670 Psi.)

1. While the powerpack is running set the system pressure to 105 Bar (1520 Psi) on gauge. To increase system pressure turn the system pressure compensator adjustment clockwise or counter-clockwise to decrease the pressure setting.
2. Remove the cover boot from Relief Valve. Loosen the lock nut and put a 1/4" hex wrench into the threaded rod of Relief Valve and turn two turns C.C.W.
3. Adjust the system pressure pump compensator until about 80 Bar (1160 Psi) is read on the gauge. **Do not exceed 100 Bar or 1450 Psi!**
4. Turn the threaded rod of Relief Valve C.W. until 115 Bar (1670 Psi), or at least 10 Bar (145 Psi) above the final system pressure setting read on gauge. Tighten the lock nut and reinstall the Relief Valve boot.
5. Return the system pressure pump compensator to 105 Bar (1520 Psi), or the final system pressure setting, on gauge.
6. Check which coil is energized the 4/3 directional control valve **Heat or Normal**. If the **Heat** coil is already energized, proceed to step 8, if not remove the cover from the A-B thermostat. While watching the Fahrenheit scale on the left side of the thermostat, take a screwdriver and increase the temperature setting (upper screw) of the thermostat until the 4/3 directional control valve switches from coil **Normal** to coil **Heat**. There are two adjusting screws on the thermostat. The lower screw is the anticipator which should be set at mid position. The **upper screw** is the temperature setting.
7. Remove the cover boot from Relief Valve. Loosen the lock nut and put a 1/4" hex wrench into the threaded rod of Relief Valve and adjust until 54 Bar (725 Psi), or at least 5 to 10 Bar (145 Psi) below system, is read on the gauge and lock the Relief Valve and reinstall the cover.
8. **Return the Thermostat setting to 100°F. Failure to do this will cause Hydraulic oil overheating!** The system pressure will return to 105 Bar (1520 Psi.) or the final system pressure setting.
9. Replace the cover boot.

## RETURN FILTER - PARKER #FTC1A10QV25S24X

Index	Description	FTA	FTB	FTC
1	<b>Head</b>	Consult Factory	Consult Factory	Consult Factory
2	<b>Cover Without Fill Port</b> <b>Cover With Fill Port</b>	102770-001 Consult Factory	102772-001 Consult Factory	101768 Consult Factory
3	<b>Spring</b>	10152325	10152325	10152325
4	<b>Spring Retainer</b>	101789	101789	101789
5	<b>Seal Kit</b> Seal Kit - Nitrile Seal Kit - Fluorocarbon	FTS-0001 FTS-0002	FTS-0003 FTS-0004	FTS-0005 FTS-0006
6	<b>Bypass Assembly</b>	S02101	S02102	S02103
7	<b>Element</b>			FTCE1B10Q
8	<b>Bowl</b> Single Length Double Length	102812-001 102812-003	102812-002 102812-004	929716 929717
9	<b>Breather Replacement Kit</b>	FTS-0011	FTS-0011	N/A
N/S	<b>Bowl Adapter</b>	FTS-0012	FTS-0013	N/A
N/S	<b>Fill Port</b>	FTS-0015	FTS-0015	N/A
N/S	<b>Dipstick</b>	FTS-0014	FTS-0014	FTS-0014
N/S	<b>Gauge - 25 psi</b>	934237	934237	934237
N/S	<b>Pressure Switch - 25 psi</b>	926923	926923	926923
N/S	<b>Gauge Adapter</b>	935266	935266	N/A

N/S - Not Shown    N/A - Not Available

### ELEMENT SERVICE (HYDRAULIC)

1. Stop the system's power unit.
2. Rotate the cover counter clockwise and remove.
3. Element and bowl are removable through the head by using the element pull tab.
4. Discard the element and clean the inside of the bowl.
5. Check the integrity of the bowl o-ring and replace if necessary.
6. Insert new element assembly into bowl and place into head, be sure element and bowl are seated securely.
7. Check integrity of the cover o-ring and replace if necessary.
8. Center the cover spring over the bypass assembly and rotate the cover clockwise until hand tight.

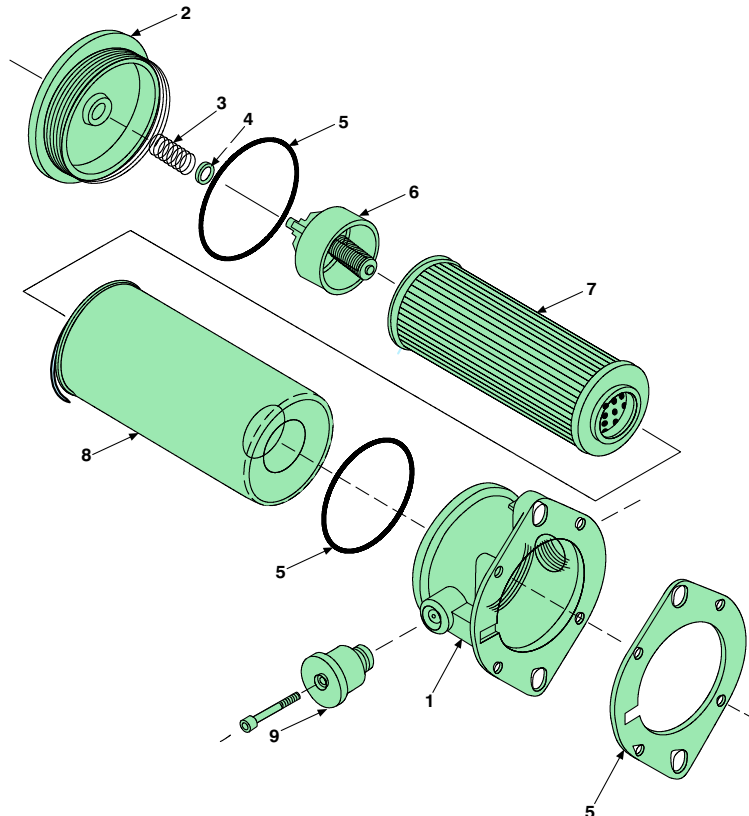

### ELEMENT SERVICE (BREATHER)

1. Stop the system's power unit.
2. Loosen socket hood cap screw (SHCS).
3. Discard complete breather assembly and replace.
4. Rotate SHCS clockwise until hand tight.

# 12. Hydraulic Powerpack

## POWERPACK HYDRAULIC SCHEMATIC - HPU12262

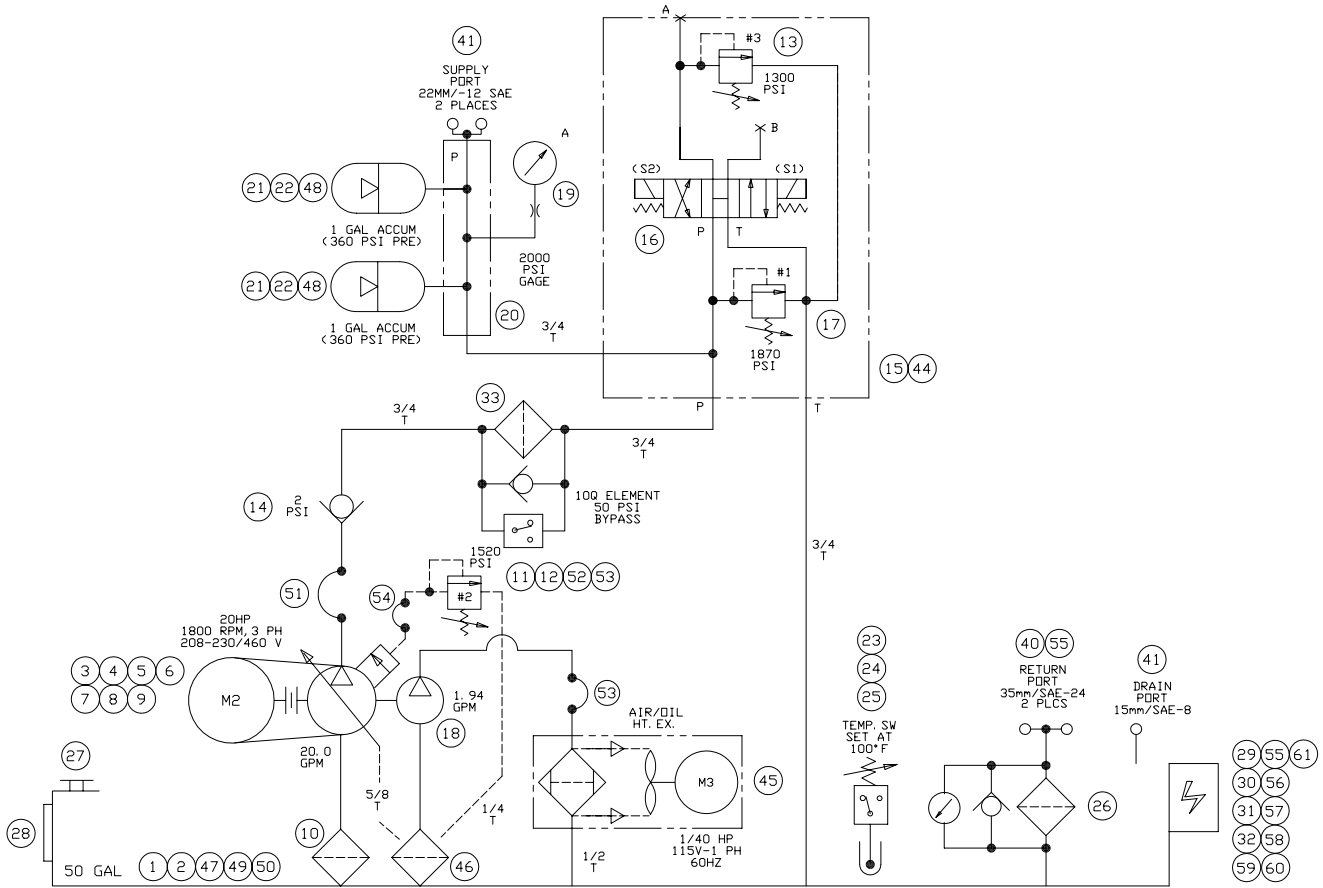

# POWERPACK ELECTRICAL SCHEMATIC - HPU12262

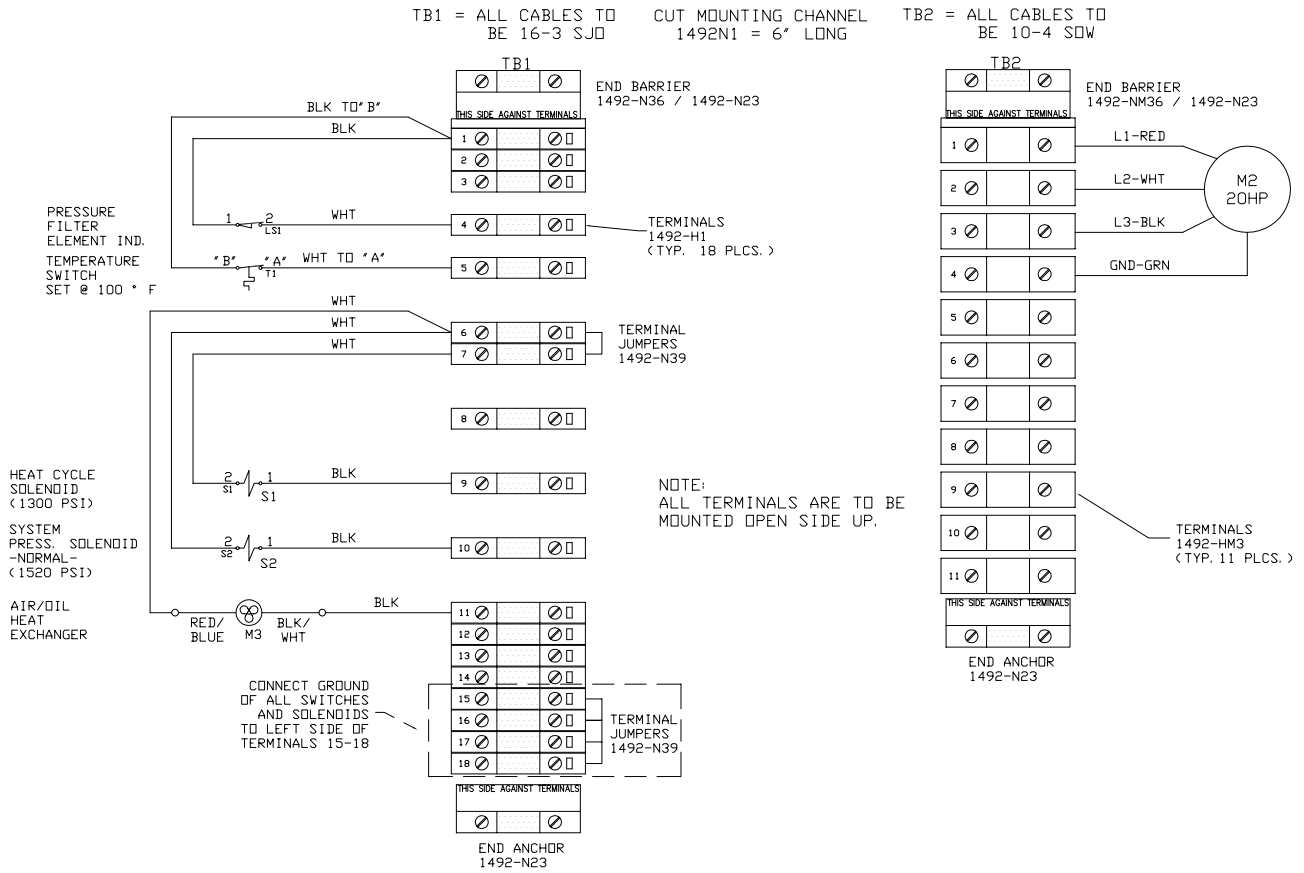

# GENERAL HYDRAULIC SYSTEMS INFORMATION

### Installation

Your packaged system is provided with lifting points, but make sure that slings do not strain the pipework and never lift a system by the pipework, or the motor.

The location of the packaged system should be indicated on the machine layout, but make sure that there will be good access for maintenance when all adjacent equipment and pipework is finally installed. Pay particular attention to access for routine maintenance such as checking and maintaining fluid level, changing filter elements and, if a water cooler is lifted, leave enough room for the pipe fitter who has to install the water pipes and control valves.

Try to keep your packaged system clean and in a well ventilated atmosphere. In difficult environments where it could be subjected to coolant spray, dirt or radiated heat, some special protection may be necessary, and be sure that mountings for the tank and pipework do not amplify noise.

When the packaged system is finally located in position make quite sure that it is on a level and firm foundation and that it is not distorted. Only use shims or wedges that cannot work loose.

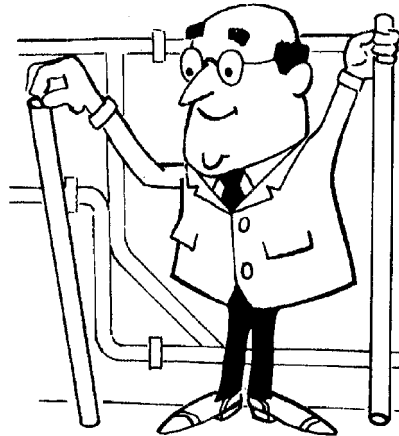

### Piping-up

The pipework connecting the Package System to the machine actuators should be undertaken by skilled hydraulic pipe fitters. The piping and fittings used must be suitable for the pressure rating of the equipment and all pipework must be securely supported by properly designed mounting brackets which must not impose unnecessary stresses on the pipework.

Piping should be kept short and direct and unnecessary elbows and bends should be avoided. Always keep the numbers of fittings to a minimum as each fitting is a possible leak point. The length and size of all connecting pipes must be in line with the requirements specified on the circuit diagram. The use of pipes with too small a bore or which are longer than specified will create power losses which will detract from the efficiency of the system.

### Preparation of pipes

It is most important that all pipework used in a hydraulic system is Internally clean and completely free from rust or scale and tubing must not be welded or brazed after assembly. All piping must be accurately fitted so that it will not be necessary to spring it into place and all sharp edges and burrs must be removed from the ends of pipes. Threaded fittings should be inspected for cleanliness and when a tape or liquid sealant is used, the two end

threads should be left bare. PTFE tape is an excellent lubricant so be careful that fittings sealed with this material are not over-tightened, producing distortions of the unit into which they are fitted.

Always leave the temporary seals that we have provided in the ports of the Package System until you are just ready to fit the appropriate pipework. This will help to keep the system clean.

### Commissioning

#### Alignment

If you are fitting your own electric motor, make sure that the pump half of the coupling is a push fit on the pump shaft. Hammering or pressing it on to the shaft will damage the pump. When we have fitted the motor, the coupling will have been correctly aligned at our factory, but, unless the pump is mounted on a bell housing, this alignment could have been disturbed during transit. So before running the system, check that the alignment is correct. For most couplings the alignment should be within 0.05 mm to 0.1 mm and this should be checked with all the pipework in position and tightened up.

#### Electric Supply

Check that the voltage and current specified on the electric motor and other electro-hydraulic





components correspond with the supply.

Running the pump dry or turning the wrong way for more than a few seconds can severely damage the pump, so jog the motor for the shortest practical time to check the direction of rotation and correct if necessary.

### Accumulators

Before starting up a system, gas loaded accumulators must be precharged to the correct pressure, and their venting and isolating valves correctly set, as shown on the circuit diagram. Unless otherwise specified, use nitrogen as the charging medium and adhere strictly to the manufacturer's recommendations for methods of filling, mounting and servicing accumulators.

### Filling the system

#### Cleanliness

Ensure that the system is thoroughly cleaned internally, before filling it with oil. Examine the tank, the suction line strainer or filter, if one is fitted, and the suction line, especially between the filter and the pump inlet.

Ensure that the tank cover and the air filter are mounted in such a way that unfiltered air

cannot enter the hydraulic system. The cleaner a system is when it is put into service, the greater will be the life expectancy of the parts liable to wear.

The hydraulic fluid is the lifeblood of your system, treat it with the respect it deserves. Be sure that you have the correct fluid and that it is really clean. Dirt that you can see and feel can become completely invisible when it is mixed with oil, so do not be misled by the appearance of the fluid. Large particles of dirt can cause sudden and catastrophic failure but even very fine dust, too fine to be seen by the naked eye, may cause slow wear in pumps and erratic operation of valves. Do not take chances. No system ever failed because it was too clean.

When transferring fluid from the barrel to the system every possible precaution should be taken to prevent dirt entering the system. Start off by cleaning around the end of the barrel before removing the plug and then inspect the contents to see that it has not already been contaminated, by condensation for example. See that the tank filler entry and the equipment to be used for the fluid transfer are scrupulously clean. Wherever practical, the transfer of fluid is best accomplished by using a portable pumping unit incorporating an efficient and fine filter. After filling make sure, that the filler caps are correctly replaced.

### Flushing the system

Flush all parts of the system thoroughly before puffing the equipment on full load.

Ideally, flushing should be carried out with the same type of fluid that is going to be used when the system is in normal use and, if possible, a flushing pump should be used which will create fluid velocities higher than those which would normally be present in the system. In a newly built system, no matter how carefully

constructed, most of the dirt will be in the pipework and during the process of flushing this out, temporary bridging loops must be used at the actuator ends, and sensitive valves should be replaced by bridging plates so that the contaminant is not flushed into these units. If it is possible, installing temporary filters in the bridging loops will help to speed up the flushing process.

If the Package System pump has to be used for the flushing operation, make sure that it pumps only clean fluid and operates at low pressure. If a flushing fluid, compatible with the working fluid, has been used, the majority of it must be drained from the system, but if the correct working fluid has been used for flushing, once the system is clean there is no need to change the fluid again as this could introduce additional contaminant into the tank. During flushing make sure that the clean-up filters are not by-passing and after flushing fit new filter elements, making sure that there is no dirty fluid left in the bottom of the filter bowl.

### Fluid Level

When a system is first started, the fluid level will fall as the pipework and actuators are filled up, and the fluid should be replenished as soon as possible. Subsequently, the fluid level should be checked at regular intervals, it should never be allowed to fall below the minimum level.

### The hydraulic fluid

#### Hydraulic oil

High quality oil kept clean and operated within the recommended temperature range will give long trouble free life to your hydraulic equipment and any reputable oil producer will help you select the correct premium grade for your application.

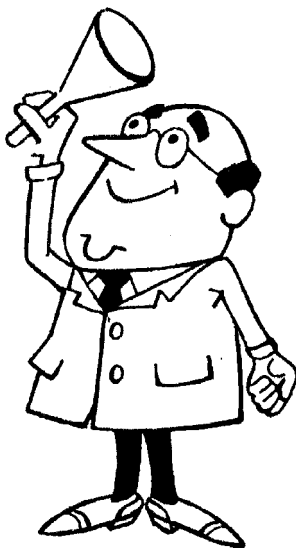

## 12. Hydraulic Powerpack

These high quality hydraulic oils contain many additives, but the most important is the anti wear additive which should have a level of effectiveness equivalent to the SAE JI 83 classification SC, SD or SE (these new classifications supersede the API MS grade).

The viscosity of the oil will depend on the exact type of equipment and the starting and working temperatures, but as a general guide the viscosity at working temperature should be between 13 and 55 centistokes (70 to 250 SUS). More specific recommendations are given in Vickers leaflet 1-286-S.

Store your oil in a clean undercover environment preferably at a workshop temperature to avoid the formation of condensation.

Barrels should rest on their side to avoid collecting contamination on the barrel end.

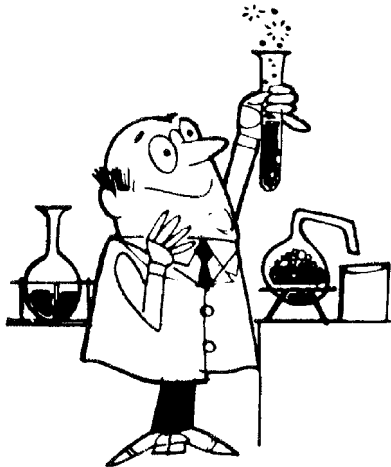

### Fire resistant fluids

*If your packaged system has been designed to run on mineral oil it is unlikely that it will adapt to any fire resistant fluid without significant alteration.*

Packaged systems designed for use on a specific type of fire resistant fluid will probably not be suitable for use on a different fluid and the fluids must not be mixed.

Water containing fluids will need careful and regular check on the percentage of water in the fluid.

If you intended to use a fire resistant fluid, obtain advice from your fluid supplier and the makers of the equipment to help you select the right grade, give advice on its compatibility with all your existing equipment and guidance regarding maintenance of the fluid.

It is good practice to fix a permanent instruction plate close to the reservoir filling point which gives clear directions for filling and maintaining the fluid level and which states the correct fluid to be used.

### Starting-up

#### Prior to starting-up

1. Check the fluid level in the tank.
2. If there are shut off valves in the suction lines, check that these valves are fully open.
3. Fill the casings of all piston units with clean hydraulic fluid.
4. Make sure that the machine is safe to start and that personnel are clear of possible hazard areas.

### Starting

1. Jog start the electric motor and check that the direction of rotation is correct for the pumps.
2. If automatic air bleed is not fitted, loosen a joint in the pump discharge line or open bleed valves to facilitate pump priming and bleeding of air from the system.
3. Operate the system manually at low pressure to expel air. Bleed points should emit a steady stream of fluid free from bubbles.
4. Allow the system to run in for a period at low pressure. This will be a final cleansing operation

before putting the pump on full load, providing that during the running in period fluid is flowing through the system filter.

5. Set pressure controls at the lowest possible setting compatible with satisfactory operation. On systems with compensated pumps and relief valves ensure that relief valves are set at least 10 bar above the compensator settings.

6. Re-check the fluid level in the tank..

7. When normal operating temperature is reached, check all pipework couplings and bolts, and tighten where necessary. Some of the equipment on the packages system may have become slack during transport and handling.

8. When the system has been running for a short period check that the filters are still clean. If they are by-passing, change the elements. Once a system is properly cleaned, the time between element changes will be greatly increased.

9. Record timings, temperature, pressure and any other information which will be required for future maintenance records.

10. After taking pressure readings it is good practice to shutoff pressure gauge valves when the gauges read zero, to prolong the gauge life.

### Trouble shooting

#### Excessive noise

In a new system the most likely cause of a noisy pump is the presence of air in the fluid. Aeration may be caused by:

1. The fluid level being too low.
2. Inadequate bleeding allowing air bubbles to circulate. Air is sometimes trapped in external suction line strainers.

3. Small air leaks into suction lines. Look first at the pipe joints, particularly if an external strainer is fitted. A temporary check can be made by covering suspect joints with heavy grease.

4. During start-up, pockets of air will gradually be cleared from the system and will enter the tank as fine bubbles. These can usually be seen. Allow time for them to settle out.

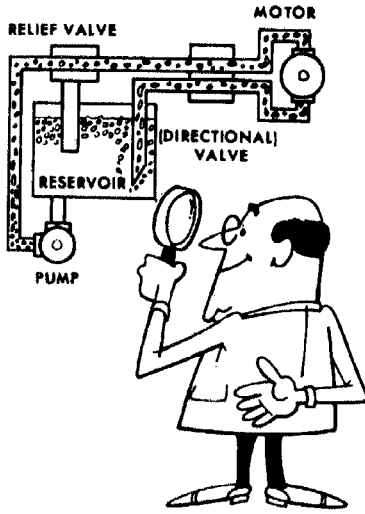

Pump cavitation or starvation can also cause noise. The likely causes are:

1. The fluid is too viscous. This could be caused by the selection of the wrong viscosity grade or because the fluid temperature in the tank is too low for a satisfactory start-up.

2. With water based fluids the viscosity can be adversely affected if the oil-to-water ratio is incorrect.

3. If inadequate precautions are taken during commissioning, the suction strainers can easily become heavily contaminated, remove them and clean them and be sure you replace them properly.

Noise may also be caused by a misaligned or out-of-balance coupling, and loose coupling guards can produce a rattle that is sometimes difficult to trace.

Relief valves blowing continuously can cause unnecessary noise which can be due to incorrect setting.

### Lack of pressure

1. Re-check the direction of rotation of the pump.

2. Check that the pump has been correctly primed and that the relief or pump compensator settings are correct.

3. A pump can only generate pressure if there is a resistance to its output flow. Many systems contain open center valves which allow fluid circulation at very low pressure, regardless of relief valve or compensator settings.

4. Make sure that you are reading pressure from the correct part of the system.

### Excessive temperature

1. If a water cooler is fitted make sure the water supply is flowing through it. The water outlet pipe should feel warmer than the inlet, and the fluid outlet pipes should feel cooler than the fluid inlet.

2. If an air cooler is fitted, is the fan rotating in the right direction, and check that the air ducts are not blocked.

3. The fluid pressure may be unnecessarily high. Check that all pressure control valves are set correctly to the pressures shown on the circuit diagram.

4. Make sure that any unloading system, such as a vented relief valve, is working properly.

5. When compensated pump systems are fitted with a relief valve the relief must be set at least 10 bar above the compensator.

6. Check that the fluid viscosity is correct to specification.

### Routine maintenance

The practice of planned maintenance at fixed intervals

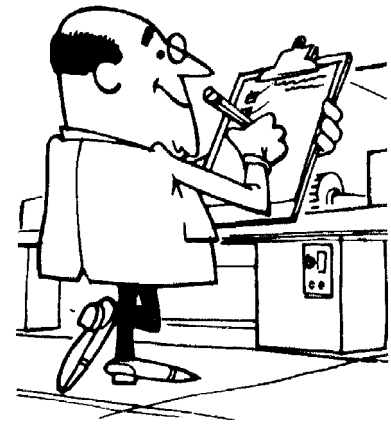

using a log book is strongly recommended.

The following list suggests some of the items which should be checked regularly.

### Check and record:

1. The machine time cycle.

2. The running temperature of the fluid.

3. The readings of the various pressure gauges.

4. Unusual noise.

5. Measure the leakage rate from piston unit casings under identical pressure and temperature conditions. Changes in this leakage give a good indication of the condition of the unit.

Significant changes in any of the above five items may require further investigation regarding their cause and the service necessary to correct them.

6. Clean the exterior of all equipment to check for leakage. Tighten joints where necessary and replace any fittings and associated pipes which leak persistently.

7. Check the cooling system for cleanliness and leakage,

8. Sample the hydraulic fluid and check for chemical condition and level of contamination.

## 12. Hydraulic Powerpack

9. Clean or replace filters as necessary.

10. Inspect air breather elements for build-up of contaminant and clean or replace.

11. If gas loaded accumulators are used, check that the gas Precharge pressure is correct. Always follow the accumulator manufacturer's instructions if you need to add more gas.

Periodic maintenance if after several years of use, routine service inspections show that the equipment performance is not quite up to the specified standard, a thorough overhaul of the equipment may prove economically desirable.

This is a good opportunity for a really thorough clean up of all the equipment, especially the inside of the tank. The use of a soft plastic scraper is to be recommended for cleaning flat surfaces, as cloth can leave particles of lint which will clog up strainers and generally cause trouble when the system is refilled.

Before undertaking a major overhaul, it may be prudent to contact your local Vickers organization to obtain advice on the servicing or replacement of suspect equipment and to obtain a new set of seals as, after several years these tend to harden, and their replacement will greatly reduce the risk of future leaks.

Hoses in pump inlet lines and seals preventing the entry of dirt around pipes returning to unit, are often overlooked and can have worn or contain surface cracks.

When reassembling the equipment make sure you follow all the service instructions and take every possible precaution to keep the inside of your hydraulic equipment spotlessly clean.

### Safety

When starting or servicing any machinery always take every reasonable safety precaution.

The following hints may serve as reminders.

- Be sure that lifting tackle is strong enough for the job and is safely applied.
- See that coupling or belt guards are in place and securely fastened.
- Securely prop or wedge slides or weights that could fall or move when hydraulic power or pipe work is removed.
- Removing the main fuses removes many risks during servicing.
- Make certain that an accumulator has been completely vented before removing any associated pipework.

## PARKER PISTON PUMP START-UP PROCEDURE

1. Open any ball or gate valve (if applicable) located in the pump suction line.
2. Back the system relief valve and / or pump pressure compensator adjustment knob out, so that the pressure will be near zero during the initial start.  
**NOTE:** If the system has been provided with a pressure compensated pump and a relief valve, adjust the relief valve approximately 10% higher than the compensator so that excessive heat is not generated by the relief valve.
3. If the system has been provided with an open center directional valve, the oil during start-up will flow directly back to tank. If the system has a closed centered valve, it may be necessary to loosen a fitting momentarily at the pump discharge, to bleed any air in the pump during the priming operation.
4. Jog the pump motor once, and verify that the pump is rotating in the same direction as the arrow tag on the pump case. If the direction is incorrect, reverse two (2) of the three (3) motor leads, and recheck the rotation.
5. Jog the pump motor (3) to (6) times to prime the pump and allow the pump to run for several minutes at zero pressure. Check the piping for any leaks and correct immediately. (Leaks in fittings and tubing can be the result of vibration during shipping.)
6. Begin adjusting the relief valve and/or pump compensator to increase the pressure gradually.  
**NOTE:** On systems with open center directional valves, it will be necessary to actuate the valve to build pressure.
7. Continue increasing pressure until normal operating pressure is obtained, and recheck system for leaks. Lock adjustment screws in place.
8. During the start-up sequence, all filters should be monitored closely. Replace any filters element immediately, as soon as they begin to go into by-pass as indicated on the visual indicator.
9. After the entire system has been wetted with fluid, refill the reservoir to the normal operating level.
10. Verify that the cooling water to the heat exchanger (if applicable) is flowing. If the power unit has been provided with a water control valve (Model WTC\*\*), and the oil temperature is exceeding 135°F, adjust the valve to increase the water flow.

## 12. Hydraulic Powerpack

### PARKER SERIES "AB" BLADDER ACCUMULATORS

Parker Bladder-Type Accumulators provide efficient and reliable pressure for hydraulic system requirements. They are a valuable tool for supplying and maintaining pressure efficiently, effectively, and economically.

#### FEATURES:

- absorbing system shock
- supplementing pump delivery
- energy storage
- piston pump pulsation dampening
- dispensing fluid
- acts as a fluid barrier

- 1 Protective Cap
- 2 Valve Cap
- 3 Valve Core
- 4 Bladder Valve (Part Of 4a)
- 4a Bladder
- 5 Name Plate
- 6 Shell
- 7 Valve Poppet
- 8 Bleeder Plug
- 9 Nut
- 10 Spring
- 11 Piston Poppet
- 12 Lock Nut
- 13 Anti-Extrusion Ring Assy.
- 14 Spacer
- 15 Lock Nut Outer
- 16 O-Ring Backup Metal
- 17 O-Ring
- 18 O-Ring Backup

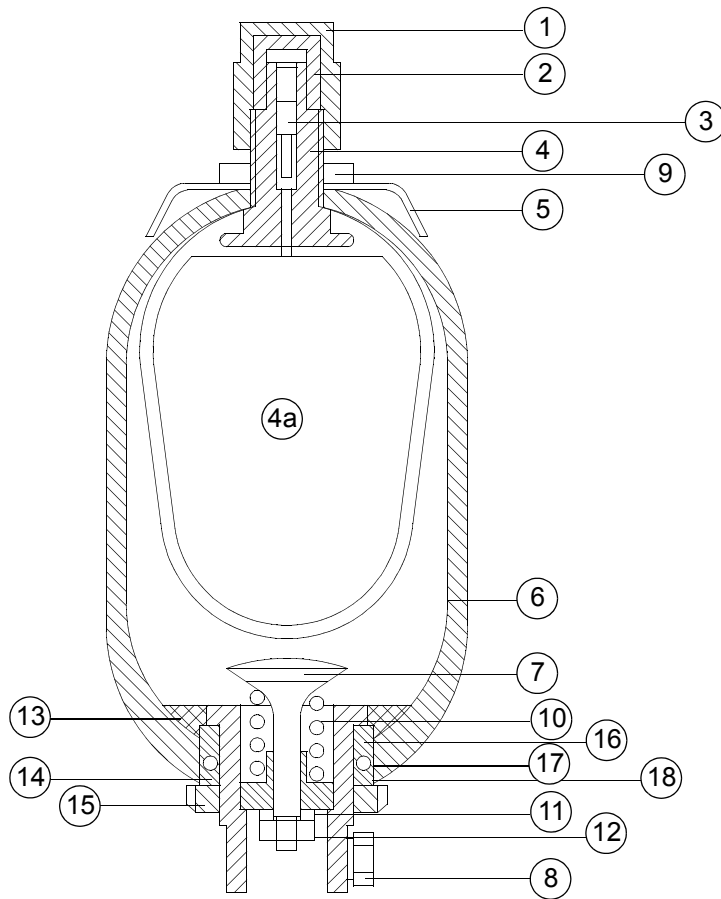

**Accumulator #AB04B3TA1**

## PROCEDURE FOR RECHARGING OLAER AND BOSCH ACCUMULATORS (USING OLAER KIT #201381)

### TURN OFF THE POWERPACK!

1. Connect hose fitting “E” to Nitrogen Tank.
2. Open adjusting nut “A” fully counter-clockwise.
3. Turn Exhaust valve “B” fully clockwise.
4. Thread nut “C” onto Accumulator stem (for BOSCH use adaptor provided with kit).
5. Loosen nut “D” slightly to allow the Bladder to align itself (only if replacing Bladder).
6. Turn adjusting nut “A” C.W. until you feel a slight resistance.
7. **Slowly** open valve “F” until 360 psi. (25 BAR) is read on the gauge and close.
8. If 360 psi. is exceeded, slowly open Exhaust valve "B" to reduce the pressure and close.
9. Turn adjusting nut “A” counter-clockwise until it stops.
10. Turn nut “C” counter-clockwise until the valve comes off the accumulator stem.
11. Tighten nut “D” clockwise with a light torque (2 ft./lb.).
12. Reinstall the valve cap and seal onto the accumulator stem.

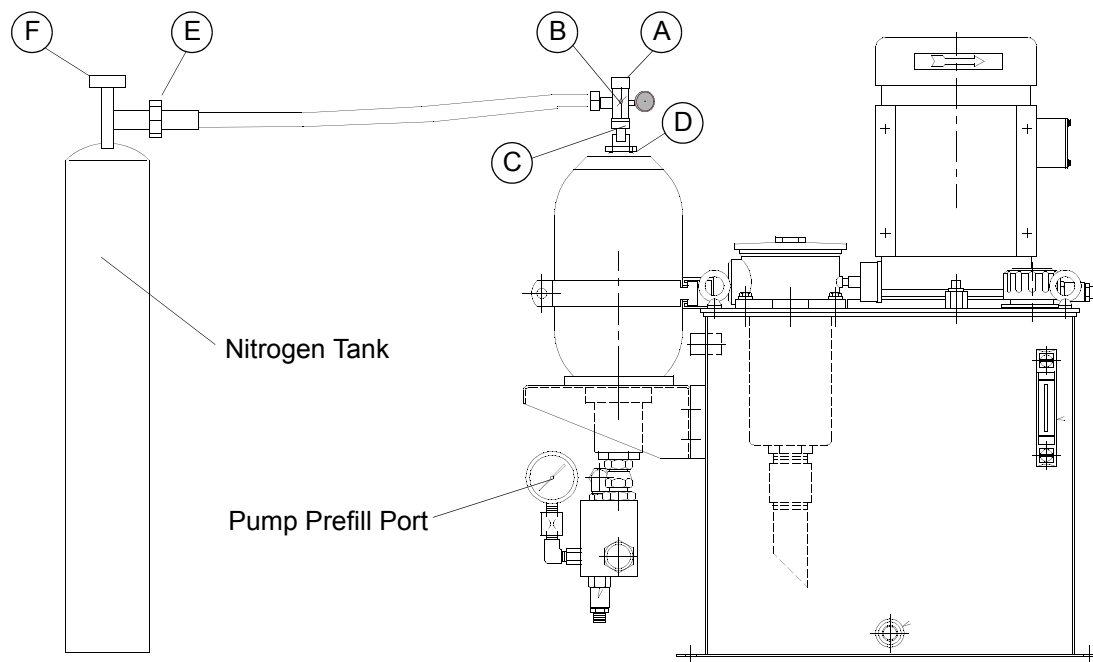

### WARNING:

**Extreme caution should be used whenever servicing accumulators. Power must be turned off and accumulators must be purged of all hydraulic pressure! Pressure gauge must read 0 bar (0 psi). Accumulators must be charged with pure Nitrogen only.**

### POWERPACK GENERAL TROUBLE SHOOTING

#### HOW HOT IS “TOO HOT”?

“Hot oil” is a relative term. In most cases, 120°F at the reservoir is considered an ideal operating temperature. Always take an oil temperature reading, at the reservoir, not at a component or any of the piping. Some hydraulic systems are designed to operate at 130°F, or higher. If you don't know the maximum operating temperature for your equipment, check your component manual for temperature and viscosity limitations.

#### MEASURING OIL TEMPERATURE

There are several ways to check the temperature of the oil. The best, most accurate method is by means of a thermometer. On some machines, this is mounted on the reservoir. Make it a habit to check the thermometer periodically, after the equipment has been running for more than an hour. If your machine doesn't have a reservoir thermometer, use the “palm test.” First check the tank with your fingertip; if it's not too hot to touch, place your palm on the tank. You'll be able to hold it there without discomfort if the oil temperature is about 130°F or below.

#### ISOLATING TROUBLE-SPOTS

To determine which components are “running hot” and overheating the oil, feel the outlet fittings and lines at the valves, pumps and motors. If the oil is normal going into a component but hot coming out, that could be one of the troublemakers. A sticking valve can cause excessive heat. If a spool does not return promptly to the neutral position, the pump flow will be dumped continuously. This builds up heat rapidly. If a relief valve is set too low, part of the oil will be dumped across the valve with every cycle. This generates excessive heat. Even when all valves are set properly, they may not be operating well because of worn orifices or seals. Always remove and check the hot components first, before the others.

#### LOOK, SMELL AND FEEL

Checking oil temperature periodically is good preventive maintenance. So too is the practice of periodically siphoning an oil sample from the reservoir, and comparing it with a sample of clean, new oil. Oil that has been running too hot will look darker and feel thinner than new oil. It will also smell burned. Chances are, it will contain more contaminants, because hot oil leads to accelerated wear of component parts.



## HYDRAULIC MANIFOLD RING LINES

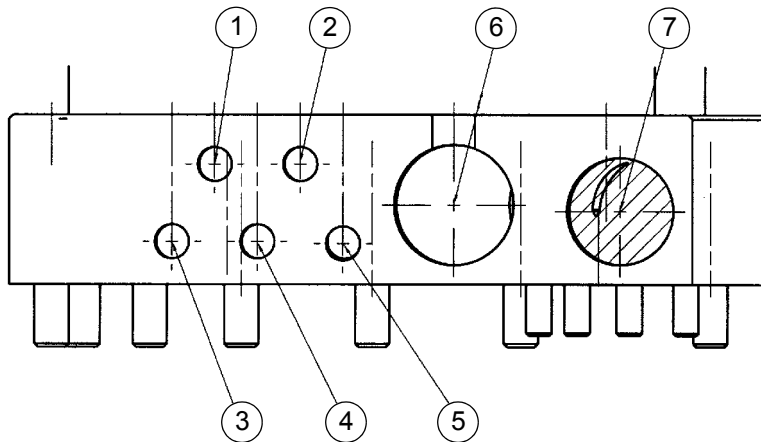

- 1 Recess Head Lube Line
- 2 Unit Lube Line
- 3 Lube Return Line
- 4 Air Line
- 5 Leak Oil Line
- 6 Return Line
- 7 Pressure Line

### 1. RECESS HEAD LUBE LINE

This line is used for Recess Head or Berger Head air mist lube.

### 2. UNIT LUBE LINE

This line is used for Unit lubrication.

### 3. LUBE RETURN LINE

Returns contaminated oil to the Contamination Tank.

### 4. AIR LINE

This line can be used for air purging or in conjunction with air mist.

### 5. LEAK OIL LINE

This line returns leak oil, from the Units and the Table, to the Hydraulic Powerpack. On Machines with the Leak Oil Pressurization option (see Chapter 5), the line has 5 psi. of air pressure, to prevent water soluble coolants from entering the Table and any Units with a leak oil line.

### 6. RETURN LINE

This line returns hydraulic oil back to the Powerpack.

### 7. PRESSURE LINE

This line supplies hydraulic oil from the Powerpack at 100 to 105 bar (1450 to 1522 psi.).

**13. TROUBLE SHOOTING**

MACHINE FAULTS AND ALARMS ..... 13-1  
FAULT GROUPS ..... 13-2  
MAJOR FAULTS ..... 13-2  
INSTANT FAULTS ..... 13-3  
DELAYED FAULTS ..... 13-8

# TROUBLESHOOTING

The Epic Hydromat incorporates a series of status messages that display on the HMI Controller to alert the machine operator about Machine Faults and Alarms. These messages simplify the operation and troubleshooting of the machine. This Chapter is designed to guide the machine operator in taking corrective action as described by the specific Fault Procedures.

## MACHINE FAULTS AND ALARMS

When a Fault or Alarm occurs, a message appears in a message banner at the top of the screen and indicates the date and time it occurred. The Machine will also have shut down while running in automatic and the red and green lights will be flashing. From the lists provided, find the Fault/Alarm to see what, if any corrective action is required. Pressing the "Fault Reset" button on the HMI Controller keypad will reset some Faults and Alarms. In other cases, the operator must follow a Corrective Action procedure to solve the problem before pressing the "Fault Reset" button.

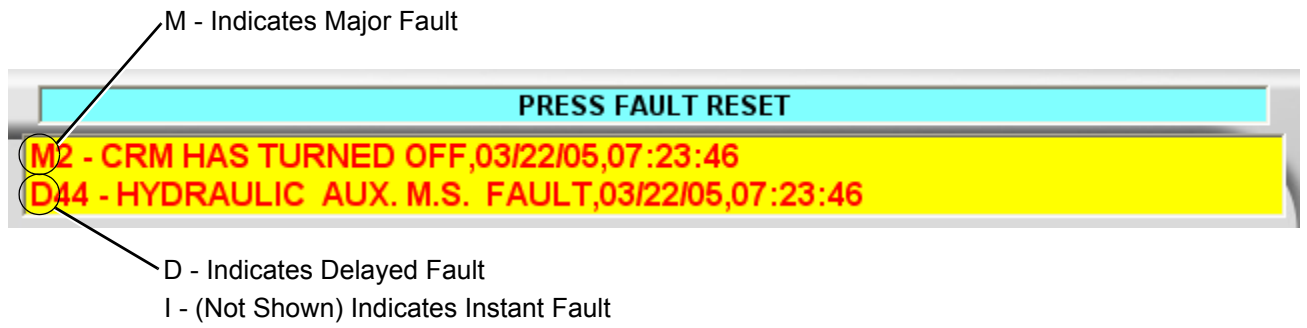

### Message Banner

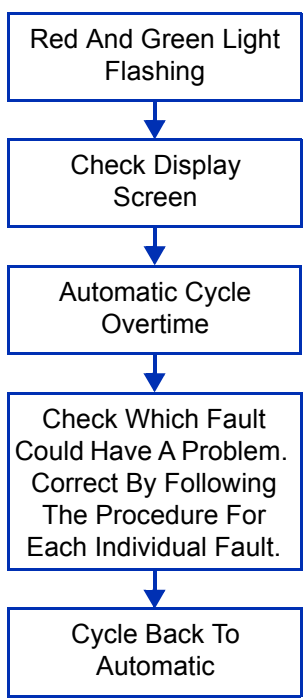

### Fault Condition

## 13. Troubleshooting

### FAULT GROUPS

Faults can be broken down into three main groups: Major, Instant, and Delayed. See each Fault Group for a list of the faults and a description of what corrective action needs to be performed.

#### Major Faults

When a Major Fault occurs, it is displayed in the message banner at the top of the screen. The Fault will be preceded by a M# indicating that this is a Major Fault. This kind of Fault causes the hydraulics and the entire machine to shut down. Following is a list of Major Faults and the corrective action that is required.

#### **M1 - MAIN HYDRAULIC PUMP M.S. OVERLOAD OR FAILURE**

Specifier: FLT.M\_FLT[0].0

Fault: The Hydraulic Motor Starter overload has tripped or the motor starter has failed.

Action: Correct overload condition, repair motor starter and reset overload. Any parts left in the Table must be removed! Consult the electrical schematics for location of the overload.

#### **M2 - CRM HAS TURNED OFF**

Specifier: FLT.M\_FLT[0].1

Fault: The Control Relay Master is off. Caused by an E-Stop being pressed or loss of supply power.

Action: Reset all E-Stop pushbuttons to apply power to the CRM contactor.

#### **M3 - PLC HAS RESTARTED**

Specifier: FLT.M\_FLT[0].2

Fault: The system detected the first scan of the PLC indicating that the PLC is restarting.

Action: Restart system

#### **M4 through M6 - OPEN FAULTS**

Specifier: FLT.M\_FLT[0].3 to FLT.M\_FLT[0].5

#### **M7 - INPUT DATA STRUCTURE MISMATCH FAULT**

Specifier: FLT.M\_FLT[0].6

Fault: A File Length error has occurred in the Input data transfer. The system is shutdown because of bad input data.

Action: Restart system

#### **M8 - OUTPUT DATA STRUCTURE MISMATCH FAULT**

Specifier: FLT.M\_FLT[0].7

Fault: A File Length error has occurred in the Output data transfer. The system is shutdown because of bad output data.

Action: Restart system

## Instant Faults

When an Instant Fault occurs, it is displayed in the message banner at the top of the screen. The Fault will be preceded by an I# indicating that this is an Instant Fault. This kind of Fault causes the Cycle to abort. Following is a list of Instant Faults and the corrective action that is required.

### I1 - HYDRAULIC PRESSURE ALARM

Specifier: FLT.I\_FLT[0].0

Fault: The system has detected a loss of Main hydraulic pressure.

Action: Verify proper hydraulic fluid level and operation of main hydraulic pump and motor.

### I2 - HYDRAULICS HIGH PRESSURE LOW FAULT

Specifier: FLT.I\_FLT[0].1

Fault: The system has detected a loss of High Pressure hydraulic.

Action: Verify proper hydraulic fluid level and operation of High Pressure hydraulic pump and motor.

### I3 - AUTOMATIC CYCLE OVERTIME FAULT

Specifier: FLT.I\_FLT[0].2

Fault: The system has detected a loss of High Pressure hydraulic.

Action: Verify proper hydraulic fluid level and operation of High Pressure hydraulic pump and motor.

### I4 - SAFETY COVERS OPENED WHILE SPINDLES WERE ON FAULT

Specifier: FLT.I\_FLT[0].3

Fault: The system has detected a break in the Safety Cover switch system while spindles were on.

Action: Verify proper operation of the Safety Switches and restart system.

### I5 - UNITS DID NOT CYCLE

Specifier: FLT.I\_FLT[0].4

Fault: The system has detected that some or all of the machines units did not cycle.

Action: Verify proper operation of the machining units and restart system.

### I6 - SOME UNITS ARE NOT HOME

Specifier: FLT.I\_FLT[0].5

Fault: The system has detected that some or all of the machines units did not complete their cycle and return to the home position.

Action: Check the motion program of the effected units and verify proper operation of the machining units and restart system.

### I7 and I8 - OPEN FAULTS

Specifier: FLT.I\_FLT[0].6 and FLT.I\_FLT[0].7

### I9 - SPINDLE MOTOR STARTER OVERLOAD OR FAILURE CB4

Specifier: FLT.I\_FLT[1].0

Fault: The spindle motor starter overload has tripped or the motor starter has failed.

Action: Correct overload condition by, checking the cutting tool sharpness, verify that the spindle turns smoothly, it rotates freely and check the motor operation. If required, repair motor starter and reset overload.

### **13. Troubleshooting**

#### **I10 - SPINDLE MOTOR STARTER OVERLOAD OR FAILURE CB5**

Specifier: FLT.I\_FLT[1].1

See I9 for Fault and Action for I10

#### **I11 - SPINDLE MOTOR STARTER OVERLOAD OR FAILURE CB6**

Specifier: FLT.I\_FLT[1].2

See I9 for Fault and Action for I11

#### **I12 - SPINDLE MOTOR STARTER OVERLOAD OR FAILURE CB7**

Specifier: FLT.I\_FLT[1].3

See I9 for Fault and Action for I12

#### **I13 - SPINDLE MOTOR STARTER OVERLOAD OR FAILURE CB8**

Specifier: FLT.I\_FLT[1].4

See I9 for Fault and Action for I13

#### **I14 - SPINDLE MOTOR STARTER OVERLOAD OR FAILURE CB9**

Specifier: FLT.I\_FLT[1].5

See I9 for Fault and Action for I14

#### **I15 - SPINDLE MOTOR STARTER OVERLOAD OR FAILURE CB10**

Specifier: FLT.I\_FLT[1].6

See I9 for Fault and Action for I15

#### **I16 - SPINDLE MOTOR STARTER OVERLOAD OR FAILURE CB11**

Specifier: FLT.I\_FLT[1].7

See I9 for Fault and Action for I16

#### **I17 - SPINDLE MOTOR STARTER OVERLOAD OR FAILURE CB12**

Specifier: FLT.I\_FLT[2].0

See I9 for Fault and Action for I17

#### **I18 - SPINDLE MOTOR STARTER OVERLOAD OR FAILURE CB13**

Specifier: FLT.I\_FLT[2].1

See I9 for Fault and Action for I18

#### **I19 - SPINDLE MOTOR STARTER OVERLOAD OR FAILURE CB14**

Specifier: FLT.I\_FLT[2].2

See I9 for Fault and Action for I19

#### **I20 - SPINDLE MOTOR STARTER OVERLOAD OR FAILURE CB15**

Specifier: FLT.I\_FLT[2].3

See I9 for Fault and Action for I20

#### **I21 - SPINDLE MOTOR STARTER OVERLOAD OR FAILURE CB16**

Specifier: FLT.I\_FLT[2].4

See I9 for Fault and Action for I21

**I22 - SPINDLE MOTOR STARTER OVERLOAD OR FAILURE CB17**

Specifier: FLT.I\_FLT[2].5

See I9 for Fault and Action for I22

**I23 - SPINDLE MOTOR STARTER OVERLOAD OR FAILURE CB18**

Specifier: FLT.I\_FLT[2].6

See I9 for Fault and Action for I23

**I24 - SPINDLE MOTOR STARTER OVERLOAD OR FAILURE CB19**

Specifier: FLT.I\_FLT[2].7

See I9 for Fault and Action for I24

**I25 - SPINDLE MOTOR STARTER OVERLOAD OR FAILURE CB20**

Specifier: FLT.I\_FLT[3].0

See I9 for Fault and Action for I25

**I26 - SPINDLE MOTOR STARTER OVERLOAD OR FAILURE CB21**

Specifier: FLT.I\_FLT[3].1

See I9 for Fault and Action for I26

**I27 - SPINDLE MOTOR STARTER OVERLOAD OR FAILURE CB22**

Specifier: FLT.I\_FLT[3].2

See I9 for Fault and Action for I27

**I28 - SPINDLE MOTOR STARTER OVERLOAD OR FAILURE CB23**

Specifier: FLT.I\_FLT[3].3

See I9 for Fault and Action for I28

**I29 - SPINDLE MOTOR STARTER OVERLOAD OR FAILURE CB24**

Specifier: FLT.I\_FLT[3].4

See I9 for Fault and Action for I29

**I30 - SPINDLE MOTOR STARTER OVERLOAD OR FAILURE CB25**

Specifier: FLT.I\_FLT[3].5

See I9 for Fault and Action for I30

**I31 - SPINDLE MOTOR STARTER OVERLOAD OR FAILURE CB26**

Specifier: FLT.I\_FLT[3].6

See I9 for Fault and Action for I31

**I32 - SPINDLE MOTOR STARTER OVERLOAD OR FAILURE CB27**

Specifier: FLT.I\_FLT[3].7

See I9 for Fault and Action for I32

**I33 - SPINDLE MOTOR STARTER OVERLOAD OR FAILURE CB28**

Specifier: FLT.I\_FLT[4].0

See I9 for Fault and Action for I33

## **13. Troubleshooting**

### **I34 - SPINDLE MOTOR STARTER OVERLOAD OR FAILURE CB29**

Specifier: FLT.I\_FLT[4].1

See I9 for Fault and Action for I34

### **I35 - SPINDLE MOTOR STARTER OVERLOAD OR FAILURE CB30**

Specifier: FLT.I\_FLT[4].2

See I9 for Fault and Action for I35

### **I36 - SPINDLE MOTOR STARTER OVERLOAD OR FAILURE CB31**

Specifier: FLT.I\_FLT[4].3

See I9 for Fault and Action for I36

### **I37 - SPINDLE MOTOR STARTER OVERLOAD OR FAILURE CB32**

Specifier: FLT.I\_FLT[4].4

See I9 for Fault and Action for I37

### **I38 - SPINDLE MOTOR STARTER OVERLOAD OR FAILURE CB33**

Specifier: FLT.I\_FLT[4].5

See I9 for Fault and Action for I38

### **I39 - SPINDLE MOTOR STARTER OVERLOAD OR FAILURE CB34**

Specifier: FLT.I\_FLT[4].6

See I9 for Fault and Action for I39

### **I40 - SPINDLE MOTOR STARTER OVERLOAD OR FAILURE CB35**

Specifier: FLT.I\_FLT[4].7

See I9 for Fault and Action for I40

### **I41 - FUSE ALARM CB4-CB9**

Specifier: FLT.I\_FLT[5].0

Fault: The fuse which supplies spindle motor starter CB4 – CB9 has failed.

Action: Check fuses for failure and determine source of overload. Correct overload condition and replace fuse with same type and rating.

### **I42 - FUSE ALARM CB10-CB15**

Specifier: FLT.I\_FLT[5].1

See I41 for Fault and Action

### **I43 - FUSE ALARM CB16-CB18**

Specifier: FLT.I\_FLT[5].2

See I41 for Fault and Action

### **I44 - FUSE ALARM HYDRAULIC POWER PACK**

Specifier: FLT.I\_FLT[5].3

Fault: The fuse/fuse indicator which supplies the hydraulic power pack has failed.

Action: Check fuses for failure and determine source of overload. Correct overload condition and replace fuse with same type and rating.



**I45 through I80 - OPEN FAULTS**

Specifier: FLT.I\_FLT[5].4 through FLT.I\_FLT[9].7

**I81 - HIGH SPEED SPINDLE MOTOR 1 M.S. 2 OVERLOAD**

Specifier: FLT.I\_FLT[10].0

Fault: The spindle motor starter overload has tripped or the motor starter has failed.

Action: Correct overload condition by, checking the cutting tool sharpness, verify that the spindle turns smoothly, it rotates freely and check the motor operation. If required, repair motor starter and reset overload.

Note: Only used on machines with optional High Speed spindles.

**I82 - HIGH SPEED SPINDLE MOTOR 2 M.S. 3 OVERLOAD**

Specifier: FLT.I\_FLT[10].1

See I81 for Fault and Action for I82

**I83 - HIGH SPEED SPINDLE MOTOR 3 M.S. 4 OVERLOAD**

Specifier: FLT.I\_FLT[10].2

See I81 for Fault and Action for I83

**I84 - HIGH SPEED SPINDLE MOTOR 4 M.S. 5 OVERLOAD**

Specifier: FLT.I\_FLT[10].3

See I81 for Fault and Action for I84

**I85 - HIGH SPEED SPINDLE MOTOR 5 M.S. 6 OVERLOAD**

Specifier: FLT.I\_FLT[10].4

See I81 for Fault and Action for I85

**I86 - HIGH SPEED SPINDLE MOTOR 6 M.S. 7 OVERLOAD**

Specifier: FLT.I\_FLT[10].5

See I81 for Fault and Action for I86

**I87 - HIGH SPEED SPINDLE MOTOR 7 M.S. 8 OVERLOAD**

Specifier: FLT.I\_FLT[10].6

See I81 for Fault and Action for I87

**I88 - HIGH SPEED SPINDLE MOTOR 8 M.S. 9 OVERLOAD**

Specifier: FLT.I\_FLT[10].7

See I81 for Fault and Action for I88

**I89 - HIGH SPEED 3 PHASE POWER ALARM M.S.40**

Specifier: FLT.I\_FLT[11].0

Fault: The power contactor overload for the high speed spindles has tripped or the motor starter has failed.

Action: Correct overload condition by checking the power distribution in the high speed spindle control cabinet. If required, repair motor starter and reset overload.

Note: Only used on machines with optional High Speed spindles.

## 13. Troubleshooting

### Delayed Faults

When a Delayed Fault occurs, it is displayed in the message banner at the top of the screen. The Fault will be preceded by a D# indicating that this is a Delayed Fault. This kind of Fault causes the Automatic Cycle to shut off. Following is a list of Delayed Faults and the corrective action that is required.

#### D1 - HYDRAULIC PRESSURE ALARM

Specifier: FLT.D\_FLT[0].0

Fault: The system has excessive backpressure in one of the hydraulic filters.

Action: Check power pack return and supply filters and replace as necessary.

#### D2 - TABLE DID NOT LIFT UP

Specifier: FLT.D\_FLT[0].1

Fault: The Table Down prox did not turn off, or the Table Up prox did not turn on when the Table Up solenoid was energized during the last table index sequence.

Action: Check prox switch and solenoid operation and adjust, repair or replace as needed.

#### D3 - TABLE DID NOT GO DOWN

Specifier: FLT.D\_FLT[0].2

Fault: The Table Up prox did not turn off, or the Table Down prox did not turn on when the Table Down solenoid was energized during the last table index sequence.

Action: Check prox switch and solenoid operation and adjust, repair or replace as needed.

#### D4 - TABLE DID NOT ROTATE CLOCKWISE

Specifier: FLT.D\_FLT[0].3

Fault: The Table Ratchet Retracted prox did not turn off or, the Table ½ Index Position prox and/or the Table Ratchet Extend prox did not turn on when the Table Ratchet Extend solenoid was energized during the last Full Table index sequence.

Action: Check prox switch and solenoid operation and adjust, repair or replace as needed.

#### D5 - TABLE DID NOT ROTATE COUNTER-CLOCKWISE

Specifier: FLT.D\_FLT[0].4

Fault: The Table Ratchet Retracted prox did not turn on, or the Table ½ Index Position prox and/or the Table Ratchet Extend prox did not turn off when the Table Ratchet Retract solenoid was energized during the last Full Table index sequence.

Action: Check prox switch and solenoid operation and adjust, repair or replace as needed.

#### D6 - TABLE DID NOT ROTATE TO 1/2 POSITION

Specifier: FLT.D\_FLT[0].5

Fault: The Table ½ Index Position prox did not turn on, or the Table Ratchet Retracted prox and/or the Table Ratchet Extend prox did not turn off when the ½ Table Index Mode solenoid was energized during the last ½ Table index sequence.

Action: Check prox switch and solenoid operation and adjust, repair or replace as needed.

#### D7 - TABLE RATCHET DID NOT RETURN

Specifier: FLT.D\_FLT[0].6

Fault: The Table Ratchet Retracted prox did not turn on, or the Table ½ Index Position prox and/or the Table Ratchet Extend prox did not turn off when the Table Ratchet Retract solenoid was energized during the last Table index sequence.

Action: Check prox switch and solenoid operation and adjust, repair or replace as needed.

**D8 - TABLE OVERTIME ALARM**

Specifier: FLT.D\_FLT[0].7

Fault: The Table index sequence was active for an extended amount of time. Caused by one of the steps in the sequence which did not complete.

Action: Check Table sequencer to determine which step/condition did not complete. Verify prox switches and solenoid operation and adjust, repair or replace as needed.

**D9 - AIR PRESSURE LOW FAULT**

Specifier: FLT.D\_FLT[1].0

Fault: The Air Pressure OK switch is off for 5 seconds while the Main Air Supply solenoid is energized.

Action: Check machine air supply, Air Pressure OK switch, Main Air Supply solenoid operation and adjust, repair or replace as needed.

**D10 - VOGEL LUBE ALARM**

Specifier: FLT.D\_FLT[1].1

Fault: The Vogel alarm Input is off for 5 seconds during a lubrication cycle.

Action: Check Vogel lubricator reservoir level, lubrication pump/control and/or supply power to pump. Fill reservoir, repair or replace as needed.

Note: If the Vogel lubricator operation is correct and the lube pressure remains low check the lines and fittings to the machine for leaks.

**D11 - LOW LUBE LEVEL ALARM**

Specifier: FLT.D\_FLT[1].2

Fault: The Lube Level OK switch is off for 10 seconds while the Main Air Supply solenoid is energized.

Action: Check machine air lubricator reservoir level and Lube Level OK switch, adjust, repair or replace as needed.

**D12 - CHIP CONVEYOR OVERLOAD**

Specifier: FLT.D\_FLT[1].3

Fault: The Chip Conveyor motor starter overload has tripped or the motor starter has failed.

Action: Correct overload condition by, checking the chip conveyor for blockage, verify that the conveyor turns freely and check the motor operation. If required, repair motor starter and reset overload.

**D13 - CHIP CONVEYOR ROTATION JAM**

Specifier: FLT.D\_FLT[1].4

Fault: The Chip Conveyor clutch has slipped or the motor/gearbox has failed.

Action: Correct overload condition by, checking the chip conveyor for blockage, verify that the conveyor turns freely and check the Rotation Jam switch operation. If adjust or replace prox switch as needed.

**D14 - CHIP CONVEYOR ENABLE FUSE ALARM**

Specifier: FLT.D\_FLT[1].5

Fault: The fuse which supplies Chip Conveyor control has failed.

Action: Check fuses for failure and determine source of overload. Correct overload condition and replace fuse with same type and rating.

## 13. Troubleshooting

### D15 - CHIP CONVEYOR CONTACTOR FAILURE

Specifier: FLT.D\_FLT[1].6

Fault: The power contactor overload for the chip conveyor has tripped or the contactor has failed.

Action: Correct overload condition by checking the power distribution to the Chip Conveyor control. If required, repair power contactor and reset overload.

### D16 - COOLANT PUMP #1 OVERLOAD OR CONTACTOR FAILURE

Specifier: FLT.D\_FLT[1].7

Fault: The Coolant Pump #1 motor starter overload has tripped or the motor starter has failed.

Action: Correct overload condition by, checking the #1 Coolant Pump for blockage, verify that the pump turns freely and check the motor operation. If required, repair motor starter and reset overload.

### D17 - COOLANT PUMP #2 OVERLOAD OR CONTACTOR FAILURE

Specifier: FLT.D\_FLT[2].0

Fault: The Coolant Pump #2 motor starter overload has tripped or the motor starter has failed.

Action: Correct overload condition by, checking the #2 Coolant Pump for blockage, verify that the pump turns freely and check the motor operation. If required, repair motor starter and reset overload.

### D18 - COOLANT PUMP #3 OVERLOAD OR CONTACTOR FAILURE

Specifier: FLT.D\_FLT[2].1

Fault: The Coolant Pump #3 motor starter overload has tripped or the motor starter has failed.

Action: Correct overload condition by, checking the #3 Coolant Pump for blockage, verify that the pump turns freely and check the motor operation. If required, repair motor starter and reset overload.

### D19 - CHIP CONV. AUX. STARTER OVERLOAD OR CONTACTOR FAILURE

Specifier: FLT.D\_FLT[2].2

Fault: The Chip Conveyor Auxiliary motor starter overload has tripped or the motor starter has failed.

Action: Correct overload condition by, checking the motor operation assigned to the auxiliary starter. If required, repair motor starter and reset overload.

### D20 - HIGH PRESSURE COOLANT OVERLOAD OR CONTACTOR FAILURE

Specifier: FLT.D\_FLT[2].3

Fault: The High Pressure Coolant Pump motor starter overload has tripped or the motor starter has failed.

Action: Correct overload condition by, checking the High Pressure Coolant Pump for blockage, verify that the pump turns freely and check the motor operation. If required, repair motor starter and reset overload.

### D21 - COOLANT CLEAN TANK LEVEL LOW

Specifier: FLT.D\_FLT[2].4

Fault: The Coolant Level Not Low float switch is off for 10 seconds while the Coolant system is running.

Action: Check machine coolant level and operation of the Coolant Level Not Low float switch, adjust, repair or replace as needed.

**D22 - BATCH COUNTER 1 FINISHED**

Specifier: FLT.D\_FLT[2].5

Fault: The first Batch Counter has reached it's preset count value.

Action: Reset counter

**D23 - BATCH COUNTER 2 FINISHED**

Specifier: FLT.D\_FLT[2].6

Fault: The second Batch Counter has reached it's preset count value.

Action: Reset counter

**D24 - MIST COLLECTOR OVERLOAD**

Specifier: FLT.D\_FLT[2].7

Fault: The Mist Collector motor starter overload has tripped or the motor starter has failed.

Action: Correct overload condition by, checking the Mist Collector for blockage, verify that the blower turns freely and check the motor operation. If required, repair motor starter and reset overload.

**D25 - VRF FLUSH PUMP OVERLOAD OR CONTACTOR FAILURE**

Specifier: FLT.D\_FLT[3].0

Fault: The VRF Flush Pump motor starter overload has tripped or the motor starter has failed.

Action: Correct overload condition by, checking the VRF Flush Pump for blockage, verify that the pump turns freely and check the motor operation. If required, repair motor starter and reset overload.

**D26 - VRF VACUUM PUMP OVERLOAD OR CONTACTOR FAILURE**

Specifier: FLT.D\_FLT[3].1

Fault: The VRF Vacuum Pump motor starter overload has tripped or the motor starter has failed.

Action: Correct overload condition by, checking the VRF Vacuum Pump for blockage, verify that the pump turns freely and check the motor operation. If required, repair motor starter and reset overload.

**D27 - VACUUM DRUM COOLANT LEVEL LOW**

Specifier: FLT.D\_FLT[3].2

Fault: The VRF Drum Coolant Not High float switch is on for 45 seconds while the Coolant system is running.

Action: Check machine coolant level and operation of the VRF Drum Coolant Not High float switch, adjust, repair or replace as needed.

**D28 - VRF COOLANT RETURN OVERFLOW**

Specifier: FLT.D\_FLT[3].3

Fault: The VRF Coolant Return Overflow float switch is on for 4 seconds while the Coolant system is running.

Action: Check machine coolant level, operation of the VRF Transfer pump and the VRF Coolant Return Overflow float switch, adjust, repair or replace as needed.

## 13. Troubleshooting

### D29 - AUXILIARY HIGH PRESSURE COOLANT FUSE ALARM

Specifier: FLT.D\_FLT[3].4

Fault: The fuse which supplies Auxiliary High Pressure Pump control has failed.

Action: Check fuses for failure and determine source of overload. Correct overload condition and replace fuse with same type and rating.

### D30 - AUXILIARY HIGH PRESSURE COOLANT CONTACTOR ALARM

Specifier: FLT.D\_FLT[3].5

Fault: The power contactor overload for the Auxiliary High Pressure Coolant Pump has tripped or the contactor has failed.

Action: Correct overload condition by checking the power distribution to the Auxiliary High Pressure Coolant Pump control. If required, repair power contactor and reset overload.

### D31 - AUXILIARY HIGH PRESSURE COOLANT SYSTEM ALARM FLT.D\_FLT[3].6

Fault: The Auxiliary Coolant System OK input is off for 5 seconds while the Auxiliary Coolant System is active.

Action: Check input's source for failure and determine fault condition. Correct fault condition.

### D32 - SUMP PUMP OVERTIME ALARM

Specifier: FLT.D\_FLT[3].7

Fault: The Waste Oil Sump Pump is running for 600 seconds while the Sump Pump Float Switch input remains on.

Action: Check Waste Oil Sump Pump for blockage, verify that the pump turns freely and check the motor operation. If required, replace float switch or Waste Oil Sump Pump.

### D33 - OUT OF STOCK OR BAR NOT IN POSITION

Specifier: FLT.D\_FLT[4].0

Fault: The Bar Feeder logic has detected the Bar Feeder First limit switch while in the Wrap-A-Round mode.

Action: Check the stock on the barfeeder, if a new bar is not present then cycle the Bar Lift to load a new bar. If the fault occurs at the beginning of Wrap-A-Round check the Bar Feeder First limit switch operation.

### D34 - SAW DID NOT CYCLE

Specifier: FLT.D\_FLT[4].1

Fault: The loading sequence is active for 40 seconds without the Saw Finished timer complete.

Action: Check the Cutoff Saw operation and Cutoff Saw extend prox operation. Turn on spindles and manually cycle the Cutoff Saw.

### D35 - BAR NOT FEEDING

Specifier: FLT.D\_FLT[4].2

Fault: The Bar Forward solenoid is active for 40 seconds during a loading cycle.

Action: Inspect bar stock for bends or dings that would cause the bar to jam in the guide tube. Check the flow and pressure feed controls, Bar Forward solenoid and hydraulic motor driven chain for operation.

**D36 - BAR END LIMIT SWITCH 2 FAILURE**

Specifier: FLT.D\_FLT[4].3

Fault: The Bar Feeder logic detects the High Speed Counters current position has exceeded 2000 counts from the Barfeed First Limit Switch while the Bar End Limit Switch 2 input has not turned on.

Action: Check the operation of Bar End Limit Switch 2 and verify the function of its input signal. Cancel the Bar Change sequence and use the Bar Lift to load a new bar.

**D37 - BARFEEDER LIMIT SWITCH 1 FAILURE**

Specifier: FLT.D\_FLT[4].4

Fault: The Bar Feeder logic detects the Bar End Limit Switch 2 input has turned on before the latch for the Barfeed First Limit Switch is set.

Action: Check the operation of Barfeed First Limit Switch and verify the function of its input signal. Cancel the Bar Change sequence and use the Bar Lift to load a new bar.

**D38 - BARCHANGE OVERTIME**

Specifier: FLT.D\_FLT[4].5

Fault: The Bar Feeder logic detects the Barchange Sequence has been active for 39 seconds without completing.

Action: Check Barchange sequencer to determine which step/condition did not complete. Verify prox switches and solenoid operation and adjust, repair or replace as needed. Cancel the Bar Change sequence and use the Bar Lift to load a new bar.

**D39 - LOADER/UNLOADER AUXILIARY AIR ALARM**

Specifier: FLT.D\_FLT[41].6

Fault: The Loader Air OK Pressure switch is off for 5 seconds while the Loader Air Supply solenoid is energized.

Action: Check machine air supply, Loader Air OK Pressure switch, Loader Air Supply solenoid operation and adjust, repair or replace as needed.

**D40 - HIGH PRESSURE COOLANT TANK LEVEL LOW**

Specifier: FLT.D\_FLT[4].7

Fault: The High Pressure Coolant Low Level float switch is off for 10 seconds while the Coolant system is running.

Action: Check machine coolant level and operation of the High Pressure Coolant Low Level float switch, adjust, repair or replace as needed.

**D41 - COOLANT CHILLER FUSE ALARM**

Specifier: FLT.D\_FLT[5].0

Fault: The fuse that supplies Coolant Chiller control has failed.

Action: Check fuses for failure and determine source of overload. Correct overload condition and replace fuse with same type and rating.

**D42 - COOLANT CHILLER CONTACTOR ALARM**

Specifier: FLT.D\_FLT[5].1

Fault: The power contactor overload for the Coolant Chiller Power has tripped or the contactor has failed.

Action: Correct overload condition by checking the power distribution to the Coolant Chiller control. If required, repair power contactor and reset overload.

## 13. Troubleshooting

### D43 - COOLANT CHILLER TEMPERATURE ALARM

Specifier: FLT.D\_FLT[5].2

Fault: The Coolant Chiller Temperature OK input is off for 2 seconds while  
The chiller system is enabled.

Action: Check coolant flow through the chiller. Verify proper operation of Chiller system. Test input  
for Coolant Chiller Temperature OK.

### D44 - HYDRAULIC AUX. MS FAULT

Specifier: FLT.D\_FLT[5].3

Fault: The Hydraulic Auxiliary motor starter overload has tripped or the motor starter has failed.

Action: Correct overload condition by, checking the motor operation assigned to the auxiliary starter.  
If required, repair motor starter and reset overload.

### D45 - MACHINE EMPTY AND NO UNITS ARE CYCLEING ASC STOP

Specifier: FLT.D\_FLT[5].4

Fault: The System has detected that the Automatic cycle is active with no parts in the machine and  
no units are active to cycle.

Action: Enable the Loader or disable part tracking on units to continue cycling the machine.

### D46 - MS 40 OVERLOAD OR FAILURE

Specifier: FLT.D\_FLT[5].5

Fault: The MS 40 motor starter overload has tripped or the motor starter has failed.

Action: Correct overload condition by, checking the motor operation assigned to the MS 40 starter. If  
required, repair motor starter and reset overload.

Note: This fault is used for Auxiliary High Pressure Coolant Pump #1

### D47 - MS 41 OVERLOAD OR FAILURE

Specifier: FLT.D\_FLT[5].6

Fault: The MS 41 motor starter overload has tripped or the motor starter has failed.

Action: Correct overload condition by, checking the motor operation assigned to the MS 41 starter. If  
required, repair motor starter and reset overload.

Note: This fault is used for Auxiliary High Pressure Coolant Pump #2

### D48 - OPEN FAULT

Specifier: FLT.D\_FLT[5].7

### D49 - PMAC ETHERNET COMM ALARM

Specifier: FLT.D\_FLT[6].0

Fault: The system detected an error in the Ethernet communications to one or more of the PMAC  
controllers.

Action: Power down the machine and restart the system.

### D50 - PMAC POSITION BIAS ALARM

Specifier: FLT.D\_FLT[6].1

Fault: The system detected an error in the Position Bias control communications to one or more of  
the PMAC controllers.

Action: Power down the machine and restart the system.



**D51 - HOME PROX DID NOT TRANSITION**

Specifier: FLT.D\_FLT[6].2

Fault: The system detected that one or more of the CNC units Home prox's did not change state during the homing sequence.

Action: Check the Home prox switches and wiring for the indicated unit number and re-home the machine.

**D52 - TABLE FIXTURE #1 TRACKING FAULT**

Specifier: FLT.D\_FLT[6].3

Fault: The system detects that Chuck #1 is at station 1 and the Table Chuck/Collet1 At Station1 prox is off or the system detects that Chuck #1 is not at station 1 and the Table Chuck/Collet1 At Station1 prox is on

Action: Check the Table Chuck/Collet1 At Station1 prox switch operation and wiring. Reset the Table Chuck Number tracking to the correct chuck number.

**D53 - CUTOFF UNIT EXTEND FAULT**

Specifier: FLT.D\_FLT[6].4

Fault: The Cutoff Unit Extend prox did not turn on or the Cutoff Unit Retract prox did not turn off when the Cutoff Extend solenoid is energized.

Action: Check prox switch and solenoid operation and adjust, repair or replace as needed.

**D54 - CUTOFF UNIT RETRACT FAULT**

Specifier: FLT.D\_FLT[6].5

Fault: The Cutoff Unit Retract prox did not turn on or the Cutoff Unit Extend prox did not turn off when the Cutoff Retract solenoid is energized.

Action: Check prox switch and solenoid operation and adjust, repair or replace as needed.

**D55 - BAR STOP EXTEND FAULT**

Specifier: FLT.D\_FLT[6].6

Fault: The Bar Stop Extend prox did not turn on or the Bar Stop Retract prox did not turn off when the Bar Stop Extend solenoid is energized.

Action: Check prox switch and solenoid operation and adjust, repair or replace as needed.

**D56 - BAR STOP RETRACT FAULT**

Specifier: FLT.D\_FLT[6].7

Fault: The Bar Stop Retract prox did not turn on or the Bar Stop Extend prox did not turn off when the Bar Stop Retract solenoid is energized.

Action: Check prox switch and solenoid operation and adjust, repair or replace as needed.

**D57 - BUNDLE BAR ALIGNMENT BELTS M.S. FAILURE**

Specifier: FLT.D\_FLT[7].0

Fault: The Bundle Bar Alignment Belts motor starter overload has tripped or the motor starter has failed.

Action: Correct overload condition by, checking the Alignment Belts for binding, verify that the Alignment Belts turns freely and check the motor operation. If required, repair motor starter and reset overload.

## 13. Troubleshooting

### D58 - BUNDLE BAR MAGAZINE BELTS M.S. FAILURE

Specifier: FLT.D\_FLT[7].1

Fault: The Bundle Bar Magazine Belts motor starter overload has tripped or the motor starter has failed.

Action: Correct overload condition by, checking the Magazine Belts for binding, verify that the Magazine Belts turns freely and check the motor operation. If required, repair motor starter and reset overload.

### D59 - BUNDLE BAR ELEVATOR M.S. FAILURE

Specifier: FLT.D\_FLT[7].2

Fault: The Bundle Bar Elevator motor starter overload has tripped or the motor starter has failed.

Action: Correct overload condition by, checking the Elevator for binding, verify that the Elevator turns freely and check the motor operation. If required, repair motor starter and reset overload.

### D60 - BUNDLE BAR FEEDER 3 PHASE FUSE ALARM

Specifier: FLT.D\_FLT[7].3

Fault: The fuse which supplies Bundle Bar Feeder control has failed.

Action: Check fuses for failure and determine source of overload. Correct overload condition and replace fuse with same type and rating.

### D61 - BUNDLE BAR FEEDER 3 PHASE CONTACTOR FAILURE

Specifier: FLT.D\_FLT[7].4

Fault: The power contactor overload for the Bundle Bar Feeder 3 Phase power has tripped or the contactor has failed.

Action: Correct overload condition by checking the power distribution to the Bundle Bar Feeder control. If required, repair power contactor and reset overload.

### D62 to D64 - OPEN FAULTS

Specifier: FLT.D\_FLT[7].5 to FLT.D\_FLT[7].7

### D65 - INVERTER SAFETY COVER FAULT

Specifier: FLT.D\_FLT[8].0

Fault: The safety cover switch opened while the Inverter is in cycle.

Action: Close the safety cover and reset/restart the Inverter cycle.

### D66 - INVERTER OVERTIME FAULT

Specifier: FLT.D\_FLT[8].1

Fault: The Inverter logic detects the Inverting Sequence has been active for 39 seconds without completing.

Action: Check Inverter sequencer to determine which step/condition did not complete. Verify prox switches and solenoid operation and adjust, repair or replace as needed. Reset/Restart the Inverter sequence to complete the cycle

Note: Verify the part orientation in the inverting station before continuing.

### D67 - INVERTER UNIT EXTEND FAULT

Specifier: FLT.D\_FLT[8].2

Fault: The Inverter Extend prox did not turn on or the Inverter Retract prox did not turn off when the Inverter Extend solenoid is energized.

Action: Check prox switch and solenoid operation and adjust, repair or replace as needed.

**D68 - INVERTER UNIT RETRACT FAULT**

Specifier: FLT.D\_FLT[8].3

Fault: The Inverter Retract prox did not turn on or the Inverter Extend prox did not turn off when the Inverter Retract solenoid is energized.

Action: Check prox switch and solenoid operation and adjust, repair or replace as needed.

**D69 - INVERTER TABLE COLLET OPEN FAULT**

Specifier: FLT.D\_FLT[8].4

Fault: The Inverter Table Collet Open prox did not turn on or the Inverter Table Collet Closed prox did not turn off when the Inverter Table Collet Open solenoid is energized.

Action: Check prox switch and solenoid operation and adjust, repair or replace as needed.

**D70 - INVERTER TABLE COLLET CLOSED FAULT**

Specifier: FLT.D\_FLT[8].5

Fault: The Inverter Table Collet Closed prox did not turn on or the Inverter Table Collet Open prox did not turn off when the Inverter Table Collet Close solenoid is energized.

Action: Check prox switch and solenoid operation and adjust, repair or replace as needed.

**D71 - INVERTER CAGE ROTATE TO 0 FAULT**

Specifier: FLT.D\_FLT[8].6

Fault: The Inverter Cage Rotate To 0 prox did not turn on or the Inverter Cage Rotate To 180 prox did not turn off when the Inverter Cage To 0 solenoid is energized.

Action: Check prox switch and solenoid operation and adjust, repair or replace as needed.

**D72 - INVERTER CAGE ROTATE TO 180 FAULT**

Specifier: FLT.D\_FLT[8].7

Fault: The Inverter Cage Rotate To 180 prox did not turn on or the Inverter Cage Rotate To 0 prox did not turn off when the Inverter Cage To 180 solenoid is energized.

Action: Check prox switch and solenoid operation and adjust, repair or replace as needed.

**D73 - INVERTER PUSHROD RETRACT FAULT**

Specifier: FLT.D\_FLT[9].0

Fault: The Inverter Pushrod Retract prox did not turn on or the Inverter Pushrod Extend prox did not turn off when the Inverter Pushrod Retract solenoid is energized.

Action: Check prox switch and solenoid operation and adjust, repair or replace as needed.

**D74 - INVERTER PUSHROD EXTEND FAULT**

Specifier: FLT.D\_FLT[9].1

Fault: The Inverter Pushrod Extend prox did not turn on or the Inverter Pushrod Retract prox did not turn off when the Inverter Pushrod Extend solenoid is energized.

Action: Check prox switch and solenoid operation and adjust, repair or replace as needed.

**D75 - INVERTER COLLET DID NOT OPEN FAULT**

Specifier: FLT.D\_FLT[9].2

Fault: The Inverter Collet Open prox did not turn on or the Inverter Collet Closed prox did not turn off when the Inverter Collet Open solenoid is energized.

Action: Check prox switch and solenoid operation and adjust, repair or replace as needed.

## 13. Troubleshooting

### D76 - INVERTER COLLET DID NOT CLOSED FAULT

Specifier: FLT.D\_FLT[9].3

Fault: The Inverter Collet Closed prox did not turn on or the Inverter Collet Open prox did not turn off when the Inverter Collet Close solenoid is energized.

Action: Check prox switch and solenoid operation and adjust, repair or replace as needed.

### D77 to D80 - OPEN FAULTS

Specifier: FLT.D\_FLT[9].4 to FLT.D\_FLT[9].7

### D81 - STATION 1 COLLET DID NOT OPEN FAULT

Specifier: FLT.D\_FLT[10].0

Fault: During the Loading sequence the Station 1 Collet Closed prox did not turn off the Station 1 Collet Closed solenoid is de-energized during step 1 of the loading sequence.

Action: Check prox switch and solenoid operation and adjust, repair or replace as needed.

### D82 - STATION 1 COLLET DID NOT CLOSED FAULT

Specifier: FLT.D\_FLT[10].1

Fault: During the Loading sequence the Station 1 Collet Closed prox did not turn on the Station 1 Collet Closed solenoid is energized during step 3 of the loading sequence.

Action: Check prox switch and solenoid operation and adjust, repair or replace as needed.

### D83 - CUTOFF SAW DID NOT CYCLE

Specifier: FLT.D\_FLT[10].2

Fault: During the Loading sequence, the Cutoff Saw motion program did not finish or the Cutoff Saw Home prox not turn on during step 5 of the loading sequence.

Action: Check prox switch operation and adjust, repair or replace as needed. Verify the Cutoff Saw programming.

### D84 - CUTOFF CYCLE OVERTIME

Specifier: FLT.D\_FLT[10].2

Fault: The Loading sequence has been active for 39 second without completing.

Action: Check Loading sequencer to determine which step/condition did not complete. Verify prox switches and solenoid operation and adjust, repair or replace as needed. Reset/Restart the Loading sequence to complete the cycle

### D85 to D88 - OPEN FAULTS

Specifier: FLT.D\_FLT[10].4 to FLT.D\_FLT[10].7

### D89 - EXIT CHUTE GOOD POSITION ALARM

Specifier: FLT.D\_FLT[11].0

Fault: The Exit Chute is commanded to the Good position and the Exit Chute Good Position prox is not on or the Exit Chute Inspection Position prox and/or the Exit Chute Scrap Position prox are not off

Action: Check prox switch and solenoid operation and adjust, repair or replace as needed.

**D90 - EXIT CHUTE INSPECTION POSITION ALARM**

Specifier: FLT.D\_FLT[11].1

Fault: The Exit Chute is commanded to the Inspection position and the Exit Chute Inspection Position prox is not on or the Exit Chute Good Position prox and/or the Exit Chute Scrap Position prox are not off

Action: Check prox switch and solenoid operation and adjust, repair or replace as needed.

**D91 - EXIT CHUTE SCRAP POSITION ALARM**

Specifier: FLT.D\_FLT[11].2

Fault: The Exit Chute is commanded to the Scrap position and the Exit Chute Scrap Position prox is not on or the Exit Chute Inspection Position prox and/or the Exit Chute Good Position prox are not off

Action: Check prox switch and solenoid operation and adjust, repair or replace as needed.

**D92 - UNIT SAFETY COVER CONFLICT**

Specifier: FLT.D\_FLT[11].3

Fault: For Type 210 Extend/Retract units the system detected the Safety Cover Switch is off or the cover was opened while the units cycle is active.

Action: Close cover and re-cycle the unit. Check Safety cover switch and solenoid operation and adjust, repair or replace as needed.

**D93 to D96 - OPEN FAULTS**

Specifier: FLT.D\_FLT[11].4 to FLT.D\_FLT[11].7

**D97 - LOADER SAFETY COVER CONFLICT**

Specifier: FLT.D\_FLT[12].0

Fault: The system detected the Safety Cover Switch is off or the Safety Cover was opened while the Loader cycle is active.

Action: Close cover and re-cycle the Loader. Check Safety cover switch and solenoid operation and adjust, repair or replace as needed.

Note: Applies to Type 220 Loaders only.

**D98 - LOADER CYLINDER EXTEND FAULT**

Specifier: FLT.D\_FLT[12].1

Fault: The Loader Cylinder Retracted prox did not turn off when the Loader Cylinder Extend solenoid is energized.

Action: Check prox switch and solenoid operation and adjust, repair or replace as needed.

Note: Applies to Type 220 Loaders only.

**D99 - LOADER CYLINDER RETRACT FAULT**

Specifier: FLT.D\_FLT[12].2

Fault: The Loader Cylinder Retracted prox did not turn on when the Loader Cylinder Loader Cylinder Retract solenoid is energized.

Action: Check prox switch and solenoid operation and adjust, repair or replace as needed.

Note: Applies to Type 220 Loaders only.

## 13. Troubleshooting

### D100 - LOADER TABLE COLLET/CHUCK OPEN FAULT

Specifier: FLT.D\_FLT[12].3

Fault: The Loader Table Collet Closed prox did not turn off when the Loader Table Collet Open solenoid is energized while the Loading sequence is active.

Action: Check prox switch and solenoid operation and adjust, repair or replace as needed.

Note: Applies to Type 220 Loaders only.

### D101 - LOADER TABLE COLLET/CHUCK CLOSED FAULT

Specifier: FLT.D\_FLT[12].4

Fault: The Loader Table Collet Closed prox did not turn on when the Loader Table Collet Close solenoid is energized while the Loading sequence is active.

Action: Check prox switch and solenoid operation and adjust, repair or replace as needed.

Note: Applies to Type 220 Loaders only.

### D102 - LOADER ESCAPEMENT RETRACT FAULT

Specifier: FLT.D\_FLT[12].5

Fault: The Loader Escapement Retracted prox did not turn on or the Loader Escapement Extended prox did not turn off when the Loader Escapement Retract solenoid is energized.

Action: Check prox switch and solenoid operation and adjust, repair or replace as needed.

Note: Applies to Type 220 Loaders only.

### D103 - LOADER ESCAPEMENT EXTEND FAULT

Specifier: FLT.D\_FLT[12].6

Fault: The Loader Escapement Extended prox did not turn on or the Loader Escapement Retracted prox did not turn off when the Loader Escapement Extend solenoid is energized.

Action: Check prox switch and solenoid operation and adjust, repair or replace as needed.

Note: Applies to Type 220 Loaders only.

### D104 - CUTOFF SAW NOT IN POSITION CHECK PROX FAULT

Specifier: FLT.D\_FLT[12].7

Fault: The Cutoff Saw Position Check prox is not on when the Cutoff Saw unit is active.

Action: Check prox switch and solenoid operation and adjust, repair or replace as needed.

Note: Applies to the Special for HW25-862 machine only.

### D105 - LOADER SLIDE CYLINDER EXTEND ALARM

Specifier: FLT.D\_FLT[13].0

Fault: The Loader Slide Cylinder Ext. prox did not turn on or the Loader Slide Cylinder Ret. prox did not turn off when the Loader Slide Cylinder Ext.solenoid is energized.

Action: Check prox switch and solenoid operation and adjust, repair or replace as needed.

Note: Applies to Type 220 Loaders only.

### D106 - LOADER SLIDE CYLINDER RETRACT ALARM

Specifier: FLT.D\_FLT[13].1

Fault: The Loader Slide Cylinder Ret. prox did not turn on or the Loader Slide Cylinder Ext. prox did not turn off when the Loader Slide Cylinder Ret. solenoid is energized.

Action: Check prox switch and solenoid operation and adjust, repair or replace as needed.

Note: Applies to Type 220 Loaders only.

**D107 and D108 - OPEN FAULTS**

Specifier: FLT.D\_FLT[13].2 to FLT.D\_FLT[13].3

**D109 - LOADER LOWER NEST PIVOT RETRACT ALARM**

Specifier: FLT.D\_FLT[13].4

Fault: The Loader Pickup Cylinder Extended prox did not turn off when the Loader Pickup Cylinder Retract solenoid is energized.

Action: Check prox switch and solenoid operation and adjust, repair or replace as needed.

Note: Applies to Type 220 Loaders only.

**D110 - LOADER LOWER NEST PIVOT EXTEND ALARM**

Specifier: FLT.D\_FLT[13].5

Fault: The Loader Pickup Cylinder Extended prox did not turn on when the Loader Pickup Cylinder Extend solenoid is energized.

Action: Check prox switch and solenoid operation and adjust, repair or replace as needed.

Note: Applies to Type 220 Loaders only.

**D111 - LOADER PART ALIGNMENT SLIDE RET PX ALARM**

Specifier: FLT.D\_FLT[13].6

Fault: The Upper Escapement Part In Place prox did not turn off, except in step 7 of the Loader sequence or the Upper Escapement Part In Place prox did not turn on, in step 7 of the Loader sequence, while the Loader Escapement Extend solenoid is energized.

Action: Check prox switch and solenoid operation and adjust, repair or replace as needed.

Note: Applies to Type 220 Loaders only.

**D112 - LOADER PART PRESENT IN NEST PX ALARM**

Specifier: FLT.D\_FLT[13].7

Fault: The Lower Nest Part In Place prox did not turn off in step 2 or the Lower Nest Part In Place prox did not turn on in step 7 of the Loader sequence while the Loader Pickup Cylinder Retract solenoid is energized.

Action: Check prox switch and solenoid operation and adjust, repair or replace as needed.

Note: Applies to Type 220 Loaders only.

**D113 - LOADER OVERTIME FAULT**

Specifier: FLT.D\_FLT[14].0

Fault: The Loader logic detects the Loading Sequence has been active for 15 second without completing.

Action: Check Loader sequencer to determine which step/condition did not complete. Verify prox switches and solenoid operation and adjust, repair or replace as needed. Reset/Restart the Inverter sequence to complete the cycle

Note: Applies to Type 220 Loaders only.

**D114 - LOADER SLIDE CYLINDER MID ALARM**

Specifier: FLT.D\_FLT[14].1

Fault: The Loader Slide Cylinder Mid prox did not turn on or Loader Slide Cylinder Ext. prox and/or Loader Slide Cylinder Ret. prox did not turn off while the Loader Slide Cylinder Mid solenoid is energized.

Action: Check prox switch and solenoid operation and adjust, repair or replace as needed.

Note: Applies to Type 220 Loaders only.

## 13. Troubleshooting

### D115 - UNLOADER GRIPPER OPEN FAULT

Specifier: FLT.D\_FLT[14].2

Closed prox did not turn off when the Unloader Gripper Open solenoid isFault: The Unloader Gripper Open prox did not turn on or the Unloader Gripper energized.

Action: Check prox switch and solenoid operation and adjust, repair or replace as needed.

Note: Applies to Type 222 Unloaders only.

### D116 - UNLOADER GRIPPER CLOSE FAULT

Specifier: FLT.D\_FLT[14].3

Fault: The Unloader Gripper Close prox did not turn on or the Unloader Gripper Open prox did not turn off when the Unloader Gripper Close solenoid is energized.

Action: Check prox switch and solenoid operation and adjust, repair or replace as needed.

Note: Applies to Type 222 Unloaders only.

### D117 - UNLOADER CYLINDER EXTEND FAULT

Specifier: FLT.D\_FLT[14].4

Fault: The Unloader Cylinder Extend prox did not turn on or the Unloader Slide Cylinder Ret prox did not turn off when the Unloader Cylinder Ext. solenoid is energized.

Action: Check prox switch and solenoid operation and adjust, repair or replace as needed.

Note: Applies to Type 222 Unloaders only.

### D118 - UNLOADER CYLINDER RETRACT FAULT

Specifier: FLT.D\_FLT[14].5

Fault: The Unloader Cylinder Ret. prox did not turn on or the Unloader Cylinder Ext. prox did not turn off when the Unloader Cylinder Ret. solenoid is energized.

Action: Check prox switch and solenoid operation and adjust, repair or replace as needed.

Note: Applies to Type 222 Unloaders only.

### D119 - UNLOADER TABLE COLLET OPEN FAULT

Specifier: FLT.D\_FLT[14].6

Fault: The Unloader Table Collet Closed prox did not turn off when the Unloader Table Collet Open solenoid is energized while the Unloading sequence is active.

Action: Check prox switch and solenoid operation and adjust, repair or replace as needed.

Note: Applies to Type 222 Unloaders only.

### D120 - UNLOADER TABLE COLLET CLOSED FAULT

Specifier: FLT.D\_FLT[14].7

Fault: The Unloader Table Collet Closed prox did not turn on when the Unloader Table Collet Close solenoid is energized while the Loading sequence is active.

Action: Check prox switch and solenoid operation and adjust, repair or replace as needed.

Note: Applies to Type 222 Unloaders only.



**D121 - UNLOADER OVERTIME TIMER FAULT**

Specifier: FLT.D\_FLT[15].0

Fault: The Unloader logic detects the Unloading Sequence has been active for 15 seconds without completing.

Action: Check Unloader sequencer to determine which step/condition did not complete. Verify prox switches and solenoid operation and adjust, repair or replace as needed. Reset/Restart the Inverter sequence to complete the cycle

Note: Applies to Type 222 Unloaders only.

**D122 - UNLOADER SAFETY COVER FAULT**

Specifier: FLT.D\_FLT[15].1

Fault: The system detected the Safety Cover Switch is off or the Safety Cover was opened while the Unloader cycle is active.

Action: Close cover and re-cycle the Unloader. Check Safety cover switch and solenoid operation and adjust, repair or replace as needed.

Note: Applies to Type 222 Loaders only.

**D123 - PART LEVEL LOW AT LOADING DEVICE FAULT**

Specifier: FLT.D\_FLT[15].2

Fault: The Loader logic detects the Loader Magazine Parts High Level prox and the Magazine Parts Low Level prox are both off for 20 seconds.

Action: Check prox switch operation and adjust, repair or replace as needed.

Note: Applies to Type 220 Loaders only.

**D124 - LOADER BACK PRESSURE EXTEND FAULT**

Specifier: FLT.D\_FLT[15].3

Fault: The Loader Back Pressure Ext prox did not turn on or the Loader Back Pressure Ret prox did not turn off when the Loader Back Pressure Ext. solenoid is energized.

Action: Check prox switch and solenoid operation and adjust, repair or replace as needed.

Note: Applies to Type 220 Loaders only.

**D125 - LOADER SLIDE CYLINDER RETRACT ALARM**

Specifier: FLT.D\_FLT[15].4

Fault: The Loader Back Pressure Ret. prox did not turn on or the Loader Back Pressure Ext. prox did not turn off when the Loader Back Pressure Ret. solenoid is energized.

Action: Check prox switch and solenoid operation and adjust, repair or replace as needed.

Note: Applies to Type 220 Loaders only.

**D126 - OPEN FAULT**

Specifier: FLT.D\_FLT[15].5

**D127 - PART SUPPORT AIR EXTEND FAULT**

Specifier: FLT.D\_FLT[15].6

Fault: The Part Support Air Sol. Extend pressure switch did not turn on when the Part Support Extend Sol. solenoid is energized.

Action: Check prox switch and solenoid operation and adjust, repair or replace as needed.

Note: Applies to machines with PART\_SUPPORT logic option only.

## 13. Troubleshooting

### D128 - PART SUPPORT HYDRAULIC EXTEND FAULT

Specifier: FLT.D\_FLT[15].7

Fault: The Part Support Hydraulic Lock pressure switch did not turn on when the Part Support Lock Sol. solenoid is energized.

Action: Check prox switch and solenoid operation and adjust, repair or replace as needed.

Note: Applies to machines with PART\_SUPPORT logic option only.

### D129 to D216 - OPEN FAULTS

Specifier: FLT.D\_FLT[16].0 to FLT.D\_FLT[26].7

### D217 - HIGH SPEED SPINDLE LUBE LEVEL LOW

Specifier: FLT.D\_FLT[27].0

Fault: The PRECISE\_SPINDLE logic detects the High Speed Spindle Lube Level F.S. is off for 30 seconds while any one of the Start High Speed Spindle Motor 1 to 8 control relays are energized.

Action: Check air lubricator lube level and fill if required. If level is OK check the Lube level switch operation and adjust, repair or replace as needed.

Note: Applies to machines with PRECISE\_SPINDLE logic option only.

### D218 - HIGH SPEED SPINDLE LOW AIR PRESSURE

Specifier: FLT.D\_FLT[27].1

Fault: The PRECISE\_SPINDLE logic detects the Air Pressure OK For Drive 1 to 8 p.s. off for 10 seconds while any one of the Start High Speed Spindle Motor 1 to 8 control relays are energized.

Action: Check air lubricator lube level and fill if required. If level is OK check the Lube level switch operation and adjust, repair or replace as needed.

Note: Applies to machines with PRECISE\_SPINDLE logic option only.

### D219 - HIGH SPEED SPINDLE COOLANT FLOW ALARM

Specifier: FLT.D\_FLT[27].2

Fault: The PRECISE\_SPINDLE logic detects the Chiller Flow Switch For Drive #1 to 8 p.s. off for 10 seconds while any one of the Start High Speed Spindle Motor 1 to 8 control relays are energized.

Action: Check Chiller coolant flow to the High Speed Spindle and fill if required. If the flow is OK check the Chiller Flow Switch For Drive #1 to #8 switch operation and adjust, repair or replace as needed.

Note: Applies to machines with PRECISE\_SPINDLE logic option only.

### D220 - HIGH SPEED SPINDLE CHILLER SYSTEM ALARM

Specifier: FLT.D\_FLT[27].3

Fault: The PRECISE\_SPINDLE logic detects the Chiller Not Faulted signal is off for 5 seconds while High Speed Spindles Chiller 3 Phase Enable power contactor is energized.

Action: Check Chiller control for the source of the fault (I.E. coolant flow, coolant level, control cabinet door interlock...) and adjust, repair or replace as needed.

Note: Applies to machines with PRECISE\_SPINDLE logic option only.

**D221 - CHILLER 3 PHASE BLOWN FUSE ALARM**

Specifier: FLT.D\_FLT[27].4

Fault: The fuse which supplies 3 phase power the Chiller system control has failed.

Action: Check fuses for failure and determine source of overload. Correct overload condition and replace fuse with same type and rating.

Note: Applies to machines with PRECISE\_SPINDLE logic option only.

**D222 to D224 - OPEN FAULTS**

Specifier: FLT.D\_FLT[27].5 to FLT.D\_FLT[27].7

**D225 - UNLOADER DID NOT EXTEND**

Specifier: FLT.D\_FLT[28].0

Fault: The Unloader Unit Extend prox did not turn on or the Unloader Unit Retract prox did not turn off when the Unloader Unit Extend solenoid is energized.

Action: Check prox switch and solenoid operation and adjust, repair or replace as needed.

Note: Applies to Type 222 Unloaders only.

**D226 - UNLOADER DID NOT RETRACT**

Specifier: FLT.D\_FLT[28].1

Fault: The Unloader Unit Retract prox did not turn on or the Unloader Unit Extend prox did not turn off when the Unloader Unit Retract solenoid is energized.

Action: Check prox switch and solenoid operation and adjust, repair or replace as needed.

Note: Applies to Type 222 Unloaders only.

**D227 - UNLOADER GRIPPER OPEN ALARM**

Specifier: FLT.D\_FLT[28].2

Fault: The Unloader Part Gripper Open Pressure Switch did not turn on or the Unloader Part Gripper Closed Pressure Switch did not turn off when the Unloader Part Gripper Open Sol solenoid is energized.

Action: Check prox switch and solenoid operation and adjust, repair or replace as needed.

Note: Applies to Type 222 Unloaders only.

**D228 - UNLOADER GRIPPER CLOSE ALARM**

Specifier: FLT.D\_FLT[28].3

Fault: The Unloader Part Gripper Closed Pressure Switch did not turn on or the Unloader Part Gripper Open Pressure Switch not turn off when the Unloader Part Gripper Close Sol solenoid is energized.

Action: Check prox switch and solenoid operation and adjust, repair or replace as needed.

Note: Applies to Type 222 Unloaders only.

**D229 to D232 - OPEN FAULTS**

Specifier: FLT.D\_FLT[28].4 to FLT.D\_FLT[28].7

**D233 to D240 - OPEN FAULTS**

Specifier: FLT.D\_FLT[29].0 to FLT.D\_FLT[29].7

## 13. Troubleshooting

### D241 - STATION 1H SPINDLE DRIVE FAULT

Specifier: FLT.D\_FLT[30].0

Fault: While the Spindles are running and Station 1H is active, the Spindle Control assigned to the configured plug number for Station 1H has detected:

1. The Spindle Control Drive Not Faulted signal is off

OR

2. The Spindle Drive Number is 0 in the setup for Station 1H

Action: Check the frequency drive or servo drive assigned to Station 1H plug number reset, repair or replace as needed.

### D242 - STATION 1H SPINDLE NOT AT SPEED

Specifier: FLT.D\_FLT[30].1

Fault: While the Spindles are running and Station 1H is active, the Spindle Control assigned to the configured plug number for Station 1H has detected the Spindle Control Drive At Speed signal is off for Station 1H.

Action: Check the frequency drive assigned to Station 1H plug number reset, repair or replace as needed.

### D243 - STATION 1H DID NOT CYCLE

Specifier: FLT.D\_FLT[30].2

Fault: While the machine cycle is active and Station 1H is active, the Unit Control assigned to the configured plug number for Station 1H has detected that the Unit Home Prox did not change state during the units cycle.

Action: Check the motion program for Station 1H and verify its cycle. Verify in position Checks and units hard stop settings.

### D244 - STATION 1H TOOL CYCLE COUNTER FINISHED

Specifier: FLT.D\_FLT[30].3

Fault: The Tool Counter for the plug number assigned to Station 1H has exceeded it's preset value.

Action: Check and/or replace the tool in Station 1H and reset the Cycle Counter for Station 1H.

### D245 - STATION 1H CYCLE OVERTIME

Specifier: FLT.D\_FLT[30].4

Fault: While the machine cycle is active and Station 1H is active, the Unit Control assigned to the configured plug number for Station 1H has detected that the Unit Cycle Active is set when the Automatic Cycle Overtime Fault sets.

Action: Check the motion program for Station 1H and verify its cycle. Verify in position Checks and units hard stop settings.

### D246 - STATION 1H NOT HOME

Specifier: FLT.D\_FLT[30].5

Fault: The Unit Control assigned to the configured plug number for Station 1H has detected that during the homing cycle the unit did not complete homing or when the Automatic Cycle Overtime Fault sets the unit is not home.

Action: Check the units operation for source of fault. If fault occurs during cycle check the motion program for Station 1H and verify its cycle. Verify in position checks and units hard stop settings.

**D247 - STATION 1H AMP FAULT**

Specifier: FLT.D\_FLT[30].6

Fault: The Unit Control assigned to the configured plug number for Station 1H has detected that one or more of the Axis Amp Fault signals are on.

Action: Check the Unit Axis Controller (Bosch or Pmac) operation for source of fault.

**D248 - STATION 1H FOLLOWING ERROR ALARM**

Specifier: FLT.D\_FLT[30].7

Fault: The Unit Control assigned to the configured plug number for Station 1H has detected that one or more of the Axis Fatal Following Error signals are on.

Action: Check the Unit Axis Controller (Bosch or Pmac) operation for source of fault.

**D249, D250, D251, D252, D253, D254, D255, AND D256 ARE STATION 2H FAULTS**

Specifier: FLT.D\_FLT[31].0 to FLT.D\_FLT[31].7

See corresponding fault D241 to D248 for Fault and Action for Station 2H

**D257, D258, D259, D260, D261, D262, D263, AND D264 ARE STATION 3H FAULTS**

Specifier: FLT.D\_FLT[32].0 to FLT.D\_FLT[32].7

See corresponding fault D241 to D248 for Fault and Action for Station 3H

**D265, D266, D267, D268, D269, D270, D271, AND D272 ARE STATION 4H FAULTS**

Specifier: FLT.D\_FLT[33].0 to FLT.D\_FLT[33].7

See corresponding fault D241 to D248 for Fault and Action for Station 4H

**D273, D274, D275, D276, D277, D278, D279, AND D280 ARE STATION 5H FAULTS**

Specifier: FLT.D\_FLT[34].0 to FLT.D\_FLT[34].7

See corresponding fault D241 to D248 for Fault and Action for Station 5H

**D281, D282, D283, D284, D285, D286, D289, AND D288 ARE STATION 6H FAULTS**

Specifier: FLT.D\_FLT[35].0 to FLT.D\_FLT[35].7

See corresponding fault D241 to D248 for Fault and Action for Station 6H

**D289, D290, D291, D292, D293, D294, D295, AND D296 ARE STATION 7H FAULTS**

Specifier: FLT.D\_FLT[36].0 to FLT.D\_FLT[36].7

See corresponding fault D241 to D248 for Fault and Action for Station 7H

**D297, D298, D299, D300, D301, D302, D303, AND D304 ARE STATION 8H FAULTS**

Specifier: FLT.D\_FLT[37].0 to FLT.D\_FLT[37].7

See corresponding fault D241 to D248 for Fault and Action for Station 8H

**D305, D306, D307, D308, D309, D310, D311, AND D312 ARE STATION 9H FAULTS**

Specifier: FLT.D\_FLT[38].0 to FLT.D\_FLT[38].7

See corresponding fault D241 to D248 for Fault and Action for Station 9H

**D313, D314, D315, D316, D317, D318, D319, AND D320 ARE STATION 10H FAULTS**

Specifier: FLT.D\_FLT[39].0 to FLT.D\_FLT[39].7

See corresponding fault D241 to D248 for Fault and Action for Station 10H

### 13. Troubleshooting

#### **D321, D322, D323, D324, D325, D326, D327, AND D328 ARE STATION 11H FAULTS**

Specifier: FLT.D\_FLT[40].0 to FLT.D\_FLT[40].7

See corresponding fault D241 to D248 for Fault and Action for Station 11H

#### **D329, D330, D331, D332, D333, D334, D335, AND D336 ARE STATION 12H FAULTS**

Specifier: FLT.D\_FLT[41].0 to FLT.D\_FLT[41].7

See corresponding fault D241 to D248 for Fault and Action for Station 12H

#### **D337, D338, D339, D340, D341, D342, D343, AND D344 ARE STATION 13H FAULTS**

Specifier: FLT.D\_FLT[42].0 to FLT.D\_FLT[42].7

See corresponding fault D241 to D248 for Fault and Action for Station 13H

#### **D345, D346, D347, D348, D349, D350, D351, AND D352 ARE STATION 14H FAULTS**

Specifier: FLT.D\_FLT[43].0 to FLT.D\_FLT[43].7

See corresponding fault D241 to D248 for Fault and Action for Station 14H

#### **D353, D354, D355, D356, D357, D358, D359, AND D360 ARE STATION 15H FAULTS**

Specifier: FLT.D\_FLT[44].0 to FLT.D\_FLT[44].7

See corresponding fault D241 to D248 for Fault and Action for Station 15H

#### **D361, D362, D363, D364, D365, D366, D367, AND D368 ARE STATION 16H FAULTS**

Specifier: FLT.D\_FLT[45].0 to FLT.D\_FLT[45].7

See corresponding fault D241 to D248 for Fault and Action for Station 16H

#### **D369, D370, D371, D372, D373 D374, D375, AND D376 ARE STATION 1V FAULTS**

Specifier: FLT.D\_FLT[46].0 to FLT.D\_FLT[46].7

See corresponding fault D241 to D248 for Fault and Action for Station 1V

#### **D377, D378, D379, D380, D381, D382, D383, AND D384 ARE STATION 2V FAULTS**

Specifier: FLT.D\_FLT[47].0 to FLT.D\_FLT[47].7

See corresponding fault D241 to D248 for Fault and Action for Station 2V

#### **D385, D386, D387, D388, D389, D390, D391, AND D392 ARE STATION 3V FAULTS**

Specifier: FLT.D\_FLT[48].0 to FLT.D\_FLT[48].7

See corresponding fault D241 to D248 for Fault and Action for Station 3V

#### **D393, D394, D395, D396, D397, D398, D399, AND D400 ARE STATION 4V FAULTS**

Specifier: FLT.D\_FLT[49].0 to FLT.D\_FLT[49].7

See corresponding fault D241 to D248 for Fault and Action for Station 4V

#### **D401, D402, D403, D404, D405, D406, D407, AND D408 ARE STATION 5V FAULTS**

Specifier: FLT.D\_FLT[50].0 to FLT.D\_FLT[50].7

See corresponding fault D241 to D248 for Fault and Action for Station 5V

#### **D409, D410, D411, D412, D413, D414, D415, AND D416 ARE STATION 6V FAULTS**

Specifier: FLT.D\_FLT[51].0 to FLT.D\_FLT[51].7

See corresponding fault D241 to D248 for Fault and Action for Station 6V

**D417, D418, D419, D420, D421, D422, D423, AND D424 ARE STATION 7V FAULTS**

Specifier: FLT.D\_FLT[52].0 to FLT.D\_FLT[52].7

See corresponding fault D241 to D248 for Fault and Action for Station 7V

**D425, D426, D427, D428, D429, D430, D431, AND D432 ARE STATION 8V FAULTS**

Specifier: FLT.D\_FLT[53].0 to FLT.D\_FLT[53].7

See corresponding fault D241 to D248 for Fault and Action for Station 8V

**D433, D434, D435, D436, D437, D438, D439, AND D440 ARE STATION 9V FAULTS**

Specifier: FLT.D\_FLT[54].0 to FLT.D\_FLT[54].7

See corresponding fault D241 to D248 for Fault and Action for Station 9V

**D441, D442, D443, D444, D445, D446, D447, AND D448 ARE STATION 10V FAULTS**

Specifier: FLT.D\_FLT[55].0 to FLT.D\_FLT[55].7

See corresponding fault D241 to D248 for Fault and Action for Station 10V

**D449, D450, D451, D452 D453, D454, D455, AND D456 ARE STATION 11V FAULTS**

Specifier: FLT.D\_FLT[56].0 to FLT.D\_FLT [56].7

See corresponding fault D241 to D248 for Fault and Action for Station 11V

**D457, D458, D459, D460, D461, D462, D463, AND D464 ARE STATION 12V FAULTS**

Specifier: FLT.D\_FLT[57].0 to FLT.D\_FLT[57].7

See corresponding fault D241 to D248 for Fault and Action for Station 12V

**D465, D466, D467, D468, D469, D470, D471, AND D472 ARE STATION 13V FAULTS**

Specifier: FLT.D\_FLT[58].0 to FLT.D\_FLT[58].7

See corresponding fault D241 to D248 for Fault and Action for Station 13V

**D473, D474, D475 D476, D477, D478, D479, AND D480 ARE STATION 14V FAULTS**

Specifier: FLT.D\_FLT[59].0 to FLT.D\_FLT[59].7

See corresponding fault D241 to D248 for Fault and Action for Station 14V

**D481, D482, D483, D484, D485, D486, D487, AND D488 ARE STATION 15V FAULTS**

Specifier: FLT.D\_FLT[60].0 to FLT.D\_FLT[60].7

See corresponding fault D241 to D248 for Fault and Action for Station 15V

**D489, D490, D491, D492, D493, D494, D495, AND D496 ARE STATION 16V FAULTS**

Specifier: FLT.D\_FLT[61].0 to FLT.D\_FLT[61].7

See corresponding fault D241 to D248 for Fault and Action for Station 16V

**D497 - STATION 1 HORIZONTAL ALARM**

Specifier: FLT.D\_FLT[62].0

Fault: This fault is used as a pointer for other alarms and faults. It will be displayed as Station 1H information for these other faults.

Action: No action is required, refer to additional displayed alarms and faults for corrective actions.

**D498 - STATION 2 HORIZONTAL ALARM**

Specifier: FLT.D\_FLT[62].1

See corresponding fault D497 or Fault and Action for Station 2H

## 13. Troubleshooting

### **D499 - STATION 3 HORIZONTAL ALARM**

Specifier: FLT.D\_FLT[62].2

See corresponding fault D497 for Fault and Action for Station 3H

### **D500 - STATION 4 HORIZONTAL ALARM**

Specifier: FLT.D\_FLT[62].3

See corresponding fault D497 for Fault and Action for Station 4H

### **D501 - STATION 5 HORIZONTAL ALARM**

Specifier: FLT.D\_FLT[62].4

See corresponding fault D497 for Fault and Action for Station 5H

### **D502 - STATION 6 HORIZONTAL ALARM**

Specifier: FLT.D\_FLT[62].5

See corresponding fault D497 for Fault and Action for Station 6H

### **D503 - STATION 7 HORIZONTAL ALARM**

Specifier: FLT.D\_FLT[62].6

See corresponding fault D497 for Fault and Action for Station 7H

### **D504 - STATION 8 HORIZONTAL ALARM**

Specifier: FLT.D\_FLT[62].7

See corresponding fault D497 for Fault and Action for Station 8H

### **D505 - STATION 9 HORIZONTAL ALARM**

Specifier: FLT.D\_FLT[63].0

See corresponding fault D497 for Fault and Action for Station 9H

### **D506 - STATION 10 HORIZONTAL ALARM**

Specifier: FLT.D\_FLT[63].1

See corresponding fault D497 for Fault and Action for Station 10H

### **D507 - STATION 11 HORIZONTAL ALARM**

Specifier: FLT.D\_FLT[63].2

See corresponding fault D497 for Fault and Action for Station 11H

### **D508 - STATION 12 HORIZONTAL ALARM**

Specifier: FLT.D\_FLT[63].3

See corresponding fault D497 for Fault and Action for Station 12H

### **D509 - STATION 13 HORIZONTAL ALARM**

Specifier: FLT.D\_FLT[63].4

See corresponding fault D497 for Fault and Action for Station 13H

### **D510 - STATION 14 HORIZONTAL ALARM**

Specifier: FLT.D\_FLT[63].5

See corresponding fault D497 for Fault and Action for Station 14H



**D511 - STATION 15 HORIZONTAL ALARM**

Specifier: FLT.D\_FLT[63].6

See corresponding fault D497 for Fault and Action for Station 15H

**D512 - STATION 16 HORIZONTAL ALARM**

Specifier: FLT.D\_FLT[63].7

See corresponding fault D497 for Fault and Action for Station 16H

**D513 - STATION 1 VERTICAL ALARM**

Specifier: FLT.D\_FLT[64].0

See corresponding fault D497 for Fault and Action for Station 1V

**D514 - STATION 2 VERTICAL ALARM**

Specifier: FLT.D\_FLT[64].1

See corresponding fault D497 for Fault and Action for Station 2V

**D515 - STATION 3 VERTICAL ALARM**

Specifier: FLT.D\_FLT[64].2

See corresponding fault D497 for Fault and Action for Station 3V

**D516 - STATION 4 VERTICAL ALARM**

Specifier: FLT.D\_FLT[64].3

See corresponding fault D497 for Fault and Action for Station 4V

**D517 - STATION 5 VERTICAL ALARM**

Specifier: FLT.D\_FLT[64].4

See corresponding fault D497 for Fault and Action for Station 5V

**D518 - STATION 6 VERTICAL ALARM**

Specifier: FLT.D\_FLT[64].5

See corresponding fault D497 for Fault and Action for Station 6V

**D519 - STATION 7 VERTICAL ALARM**

Specifier: FLT.D\_FLT[64].6

See corresponding fault D497 for Fault and Action for Station 7V

**D520 - STATION 8 VERTICAL ALARM**

Specifier: FLT.D\_FLT[64].7

See corresponding fault D497 for Fault and Action for Station 8V

**D521 - STATION 9 VERTICAL ALARM**

Specifier: FLT.D\_FLT[65].0

See corresponding fault D497 for Fault and Action for Station 9V

**D522 - STATION 10 VERTICAL ALARM**

Specifier: FLT.D\_FLT[65].1

See corresponding fault D497 for Fault and Action for Station 10V

## 13. Troubleshooting

### **D523 - STATION 11 VERTICAL ALARM**

Specifier: FLT.D\_FLT[65].2

See corresponding fault D497 for Fault and Action for Station 11V

### **D524 - STATION 12 VERTICAL ALARM**

Specifier: FLT.D\_FLT[65].3

See corresponding fault D497 for Fault and Action for Station 12V

### **D525 - STATION 13 VERTICAL ALARM**

Specifier: FLT.D\_FLT[65].4

See corresponding fault D497 for Fault and Action for Station 13V

### **D526 - STATION 14 VERTICAL ALARM**

Specifier: FLT.D\_FLT[65].5

See corresponding fault D497 for Fault and Action for Station 14V

### **D527 - STATION 15 VERTICAL ALARM**

Specifier: FLT.D\_FLT[65].6

See corresponding fault D497 for Fault and Action for Station 15V

### **D528 - STATION 16 VERTICAL ALARM**

See corresponding fault D497 for Fault and Action for Station 16V

Specifier: FLT.D\_FLT[65].7

### **D529 to D536 - OPEN FAULTS**

Specifier: FLT.D\_FLT[66].0 to FLT.D\_FLT[66].7

### **D537 to D544 - OPEN FAULTS**

Specifier: FLT.D\_FLT[67].0 to FLT.D\_FLT[67].7

### **D545 to D552 - OPEN FAULTS**

Specifier: FLT.D\_FLT[68].0 to FLT.D\_FLT[68].7

### **D553 to D560 - OPEN FAULTS**

Specifier: FLT.D\_FLT[69].0 to FLT.D\_FLT[69].7

### **D561 - BROKEN TOOL DETECTED STATION 1H**

Specifier: FLT.D\_FLT[70].0

**Fault:** While the machine cycle is active and Station 1H is active, the Unit Control assigned to the configured plug number for Station 1H has detected that the Broken Tool Monitor fault output is on.

**Action:** Check the tool used for Station 1H and replace if required. Also check the part being machined and remove it from Part Tracking if it is scrap. If the fault returns check the tool detector setup and verify the I/O to the Epic system.

**D562 BLUNT TOOL DETECTED STATION 1H**

Specifier: FLT.D\_FLT[70].1

Fault: While the machine cycle is active and Station 1H is active, the Unit Control assigned to the configured plug number for Station 1H has detected that the Blunt Tool Monitor fault output is on.

Action: Check the tool used for Station 1H and replace if required. Also check the part being machined and remove it from Part Tracking if it is scrap. If the fault returns check the tool monitor setup and verify the I/O to the Epic system.

**D563 - BROKEN/MISSING TOOL DETECTED STATION 1H**

Specifier: FLT.D\_FLT[70].2

Fault: While the machine cycle is active and Station 1H is active, the Unit Control assigned to the configured plug number for Station 1H has detected that the Broken/Missing Tool Monitor fault output is on.

Action: Check the tool used for Station 1H and replace if required. Also check the part being machined and remove it from Part Tracking if it is scrap. If the fault returns check the tool monitor setup and verify the I/O to the Epic system.

**D564 to D568 - OPEN FAULTS**

Specifier: FLT.D\_FLT[70].3 to FLT.D\_FLT[70].7

**D569, D570, D571, D572, D573, D574, D575, AND D576 ARE STATION 2H FAULTS**

Specifier: FLT.D\_FLT[71].0 to FLT.D\_FLT[71].7

See corresponding fault D561 to D568 for Fault and Action for Station 2H

**D577, D578, D579, D580, D581, D582, D583, AND D584 ARE STATION 3H FAULTS**

Specifier: FLT.D\_FLT[72].0 to FLT.D\_FLT[72].7

See corresponding fault D561 to D568 for Fault and Action for Station 3H

**D585, D586, D587, D588, D589, D590, D591, AND D592 ARE STATION 4H FAULTS**

Specifier: FLT.D\_FLT[73].0 to FLT.D\_FLT[73].7

See corresponding fault D561 to D568 for Fault and Action for Station 4H

**D593, D594, D595, D596, D597, D598, D599, AND D600 ARE STATION 5H FAULTS**

Specifier: FLT.D\_FLT[74].0 to FLT.D\_FLT[74].7

See corresponding fault D561 to D568 for Fault and Action for Station 5H

**D601, D602, D603, D604, D605, D606, D607, AND D608 ARE STATION 6H FAULTS**

Specifier: FLT.D\_FLT[75].0 to FLT.D\_FLT[75].7

See corresponding fault D561 to D568 for Fault and Action for Station 6H

**D609, D610, D611, D612, D613, D614, D615, AND D616 ARE STATION 7H FAULTS**

Specifier: FLT.D\_FLT[76].0 to FLT.D\_FLT[76].7

See corresponding fault D561 to D568 for Fault and Action for Station 7H

**D617, D618, D619, D620, D621, D622, D623, AND D624 ARE STATION 8H FAULTS**

Specifier: FLT.D\_FLT[77].0 to FLT.D\_FLT[77].7

See corresponding fault D561 to D568 for Fault and Action for Station 8H

### 13. Troubleshooting

#### **D625, D626, D627, D628, D629, D630, D631, AND D632 ARE STATION 9 FAULTS**

Specifier: FLT.D\_FLT[78].0 to FLT.D\_FLT[78].7

See corresponding fault D561 to D568 for Fault and Action for Station 9H

#### **D633, D634, D635, D636, D637, D638, D639, AND D640 ARE STATION 10H FAULTS**

Specifier: FLT.D\_FLT[79].0 to FLT.D\_FLT[79].7

See corresponding fault D561 to D568 for Fault and Action for Station 10H

#### **D641, D642, D643, D644, D645, D646, D647, AND D648 ARE STATION 11H FAULTS**

Specifier: FLT.D\_FLT[80].0 to FLT.D\_FLT[80].7

See corresponding fault D561 to D568 for Fault and Action for Station 11H

#### **D649, D650, D651, D652, D653, D654, D655, AND D656 ARE STATION 12H FAULTS**

Specifier: FLT.D\_FLT[81].0 to FLT.D\_FLT[81].7

See corresponding fault D561 to D568 for Fault and Action for Station 12H

#### **D657, D658, D659, D660, D661, D662, D663, AND D664 ARE STATION 13H FAULTS**

Specifier: FLT.D\_FLT[82].0 to FLT.D\_FLT[82].7

See corresponding fault D561 to D568 for Fault and Action for Station 13H

#### **D665, D666, D667, D668, D669, D670, D671, AND D672 ARE STATION 14H FAULTS**

Specifier: FLT.D\_FLT[83].0 to FLT.D\_FLT[83].7

See corresponding fault D561 to D568 for Fault and Action for Station 14H

#### **D673, D674, D675, D676, D677, D678, D679, AND D680 ARE STATION 15H FAULTS**

Specifier: FLT.D\_FLT[84].0 to FLT.D\_FLT[84].7

See corresponding fault D561 to D568 for Fault and Action for Station 15H

#### **D681, D682, D683, D684, D685, D686, D687, AND D688 ARE STATION 16H FAULTS**

Specifier: FLT.D\_FLT[85].0 to FLT.D\_FLT[85].7

See corresponding fault D561 to D568 for Fault and Action for Station 16H

#### **D689, D690, D691, D692, D693, D694, D695, AND D696 ARE STATION 1V FAULTS**

Specifier: FLT.D\_FLT[86].0 to FLT.D\_FLT[86].7

See corresponding fault D561 to D568 for Fault and Action for Station 1V

#### **D697, D698, D699, D700, D701, D702, D703, AND D704 ARE STATION 2V FAULTS**

Specifier: FLT.D\_FLT[87].0 to FLT.D\_FLT[87].7

See corresponding fault D561 to D568 for Fault and Action for Station 2V

#### **D705, D706, D707, D708, D709, D710, D711, AND D712 ARE STATION 3V FAULTS**

Specifier: FLT.D\_FLT[88].0 to FLT.D\_FLT[88].7

See corresponding fault D561 to D568 for Fault and Action for Station 3V

#### **D713, D714, D715, D716, D717, D718, D719, AND D720 ARE STATION 4V FAULTS**

Specifier: FLT.D\_FLT[89].0 to FLT.D\_FLT[89].7

See corresponding fault D561 to D568 for Fault and Action for Station 4V

**D721, D722, D723, D724, D725, D726, D727, AND D728 ARE STATION 5V FAULTS**

Specifier: FLT.D\_FLT[90].0 to FLT.D\_FLT[90].7

See corresponding fault D561 to D568 for Fault and Action for Station 5V

**D729, D730, D731, D732, D733, D734, D735, AND D736 ARE STATION 6V FAULTS**

Specifier: FLT.D\_FLT[91].0 to FLT.D\_FLT[91].7

See corresponding fault D561 to D568 for Fault and Action for Station 6V

**D737, D738, D739, D740, D741, D742, D743, AND D744 ARE STATION 7V FAULTS**

Specifier: FLT.D\_FLT[92].0 to FLT.D\_FLT[92].7

See corresponding fault D561 to D568 for Fault and Action for Station 7V

**D745, D746, D747, D748, D749, D750, D751, AND D752 ARE STATION 8V FAULTS**

Specifier: FLT.D\_FLT[93].0 to FLT.D\_FLT[93].7

See corresponding fault D561 to D568 for Fault and Action for Station 8V

**D753, D754, D755, D756, D757, D758, D759, AND D760 ARE STATION 9V FAULTS**

Specifier: FLT.D\_FLT[94].0 to FLT.D\_FLT[94].7

See corresponding fault D561 to D568 for Fault and Action for Station 9V

**D761, D762, D763, D764, D765, D766, D767, AND D768 ARE STATION 10V FAULTS**

FLT.D\_FLT[95].0 to FLT.D\_FLT[95].7

See corresponding fault D561 to D568 for Fault and Action for Station 10V

**D769, D770, D771, D772, D773, D774, D775, AND D776 ARE STATION 11V FAULTS**

Specifier: FLT.D\_FLT[96].0 to FLT.D\_FLT[96].7

See corresponding fault D561 to D568 for Fault and Action for Station 11V

**D777, D778, D779, D780, D781, D782, D783, AND D784 ARE STATION 12V FAULTS**

Specifier: FLT.D\_FLT[97].0 to FLT.D\_FLT[97].7

See corresponding fault D561 to D568 for Fault and Action for Station 12V

**D785, D786, D787, D788, D789, D790, D791, AND D792 ARE STATION 13V FAULTS**

Specifier: FLT.D\_FLT[98].0 to FLT.D\_FLT[98].7

See corresponding fault D561 to D568 for Fault and Action for Station 13V

**D793, D794, D795, D796, D797, D798, D799, AND D800 ARE STATION 14V FAULTS**

Specifier: FLT.D\_FLT[99].0 to FLT.D\_FLT[99].7

See corresponding fault D561 to D568 for Fault and Action for Station 14V

**D801, D802, D803, D804, D805, D806, D807, AND D808 ARE STATION 15V FAULTS**

Specifier: FLT.D\_FLT[100].0 to FLT.D\_FLT[100].7

See corresponding fault D561 to D568 for Fault and Action for Station 14V

**D809, D810, D811, D812, D813, D814, D815, AND D816 ARE STATION 16V FAULTS**

Specifier: FLT.D\_FLT[101].0 to FLT.D\_FLT[101].7

See corresponding fault D561 to D568 for Fault and Action for Station 16V

## 13. Troubleshooting

### D817 to D824 - OPEN FAULTS

Specifier: FLT.D\_FLT[102].0 to FLT.D\_FLT[102].7

### D825 to D832 - OPEN FAULTS

Specifier: FLT.D\_FLT[103].0 to FLT.D\_FLT[103].7

### D833 to D840 - OPEN FAULTS

Specifier: FLT.D\_FLT[104].0 to FLT.D\_FLT[104].7

### D841 to D848 - OPEN FAULTS

Specifier: FLT.D\_FLT[105].0 to FLT.D\_FLT[105].7

### D849 to D856 - OPEN FAULTS

Specifier: FLT.D\_FLT[106].0 to FLT.D\_FLT[106].7

### D857 to D864 - OPEN FAULT

Specifier: FLT.D\_FLT[107].0 to FLT.D\_FLT[107].7

### D865 to D872 - OPEN FAULT

Specifier: FLT.D\_FLT[108].0 to FLT.D\_FLT[108].7

### D873 to D880 - OPEN FAULT

Specifier: FLT.D\_FLT[109].0 to FLT.D\_FLT[109].7

### D881 to D888 - OPEN FAULT

Specifier: FLT.D\_FLT[110].0 to FLT.D\_FLT[110].7

### D889 - POSITION BIAS DOWNLOAD FAULT ON STATION 1 HORIZONTAL

Specifier: FLT.D\_FLT[111].0

Fault: Bosch JXR Alarm.

Action: Reset the fault and reload the program for this station.

### D890 - R VARIABLE UPDATE ALARM STATION 1 HORIZONTAL

Specifier: FLT.D\_FLT[111].1

Fault: Bosch JXR Alarm.

Action: Reset the fault and reload the program for this station.

### D891 - STATION 1H BOSCH PROGRAM DOWNLOAD ERROR

Specifier: FLT.D\_FLT[111].2

Fault: Bosch JXR Alarm.

Action: Reset the fault and reload the program for this station.

### D892 - STATION 1H BOSCH JOG SETTING ALARM

Specifier: FLT.D\_FLT[111].3

Fault: Bosch JXR Alarm.

Action: Exit jog mode and home the valve. Once the valve is home jogging should function.

### D893 to D896 - OPEN FAULTS

Specifier: FLT.D\_FLT[111].3 to FLT.D\_FLT[111].7

**D897, D898, D899, D900, D901, D902, D902, AND D904 ARE STATION 2H FAULTS**

Specifier: FLT.D\_FLT[112].0 to FLT.D\_FLT[112].7

See corresponding fault D889 to D896 for Fault and Action for Station 2H

**D905, D906, D907, D908, D909, D910, D911, AND D912 ARE STATION 3H FAULTS**

Specifier: FLT.D\_FLT[113].0 to FLT.D\_FLT[113].7

See corresponding fault D889 to D896 for Fault and Action for Station 3H

**D913, D914, D915, D916, D917, D918, D919, AND D920 ARE STATION 4H FAULTS**

Specifier: FLT.D\_FLT[114].0 to FLT.D\_FLT[114].7

See corresponding fault D889 to D896 for Fault and Action for Station 4H

**D921, D922, D923, D924, D925, D926, D927, AND D928 ARE STATION 5H FAULTS**

Specifier: FLT.D\_FLT[115].0 to FLT.D\_FLT[115].7

See corresponding fault D889 to D896 for Fault and Action for Station 5H

**D929, D930, D931, D932, D933, D934, D935, AND D936 ARE STATION 6H FAULTS**

Specifier: FLT.D\_FLT[116].0 to FLT.D\_FLT[116].7

See corresponding fault D889 to D896 for Fault and Action for Station 6H

**D937, D938, D939, D940, D941, D942, D943, AND D944 ARE STATION 7H FAULTS**

Specifier: FLT.D\_FLT[117].0 to FLT.D\_FLT[117].7

See corresponding fault D889 to D896 for Fault and Action for Station 7H

**D945, D946, D947, D948, D949, D950, D951, AND D952 ARE STATION 8H FAULTS**

Specifier: FLT.D\_FLT[118].0 to FLT.D\_FLT[118].7

See corresponding fault D889 to D896 for Fault and Action for Station 8H

**D953, D954, D955, D956, D957, D958, D959, AND D960 ARE STATION 9H FAULTS**

Specifier: FLT.D\_FLT[119].0 to FLT.D\_FLT[119].7

See corresponding fault D889 to D896 for Fault and Action for Station 9H

**D961, D962, D963, D964, D965, D966, D967, AND D968 ARE STATION 10H FAULTS**

Specifier: FLT.D\_FLT[120].0 to FLT.D\_FLT[120].7

See corresponding fault D889 to D896 for Fault and Action for Station 10H

**D969, D970, D971, D972, D973, D974, D975, AND D976 ARE STATION 11H FAULTS**

Specifier: FLT.D\_FLT[121].0 to FLT.D\_FLT[121].7

See corresponding fault D889 to D896 for Fault and Action for Station 11H

**D977, D978, D979, D980, D981, D982, D983, AND D984 ARE STATION 12H FAULTS**

Specifier: FLT.D\_FLT[122].0 to FLT.D\_FLT[122].7

See corresponding fault D889 to D896 for Fault and Action for Station 12H

**D985, D986, D987, D988, D989, D990, D991, AND D992 ARE STATION 13H FAULTS**

Specifier: FLT.D\_FLT[123].0 to FLT.D\_FLT[123].7

See corresponding fault D889 to D896 for Fault and Action for Station 13H

### **13. Troubleshooting**

#### **D993, D994, D995, D996, D997, D998, D999, AND D1000 ARE STATION 14H FAULTS**

Specifier: FLT.D\_FLT[124].0 to FLT.D\_FLT[124].7

See corresponding fault D889 to D896 for Fault and Action for Station 14H

#### **D1001, D1002, D1003, D1004, D1005, D1006, D1007, AND D1008 ARE STATION 15H FAULTS**

Specifier: FLT.D\_FLT[125].0 to FLT.D\_FLT[125].7

See corresponding fault D889 to D896 for Fault and Action for Station 15H

#### **D1009, D1010, D1011, D1012, D1013, D1014, D1015, AND D1016 ARE STATION 16H FAULTS**

Specifier: FLT.D\_FLT[126].0 to FLT.D\_FLT[126].7

See corresponding fault D889 to D896 for Fault and Action for Station 16H

#### **D1017, D1018, D1019, D1020, D1021, D1022, D1023, AND D1024 ARE STATION 1V FAULTS**

Specifier: FLT.D\_FLT[127].0 to FLT.D\_FLT[127].7

See corresponding fault D889 to D896 for Fault and Action for Station 1V

#### **D1025, D1026, D1027, D1028, D1029, D1030, D1031, AND D1032 ARE STATION 2V FAULTS**

Specifier: FLT.D\_FLT[128].0 to FLT.D\_FLT[128].7

See corresponding fault D889 to D896 for Fault and Action for Station 2V

#### **D1033, D1034, D1035, D1036, D1037, D1038, D1039, AND D1040 ARE STATION 3V FAULTS**

Specifier: FLT.D\_FLT[129].0 to FLT.D\_FLT[129].7

See corresponding fault D889 to D896 for Fault and Action for Station 3V

#### **D1041, D1042, D1043, D1044, D1045, D1046, D1047, AND D1048 ARE STATION 4V FAULTS**

Specifier: FLT.D\_FLT[130].0 to FLT.D\_FLT[130].7

See corresponding fault D889 to D896 for Fault and Action for Station 4V

#### **D1049, D1050, D1051, D1052, D1053, D1054, D1055, AND D1056 ARE STATION 5V FAULTS**

Specifier: FLT.D\_FLT[131].0 to FLT.D\_FLT[131].7

See corresponding fault D889 to D896 for Fault and Action for Station 5V

#### **D1057, D1058, D1059, D1060, D1061, D1062, D1063, AND D1064 ARE STATION 6V FAULTS**

Specifier: FLT.D\_FLT[132].0 to FLT.D\_FLT[132].7

See corresponding fault D889 to D896 for Fault and Action for Station 6V

#### **D1065, D1066, D1067, D1068, D1069, D1070, D1071, AND D1072 ARE STATION 7V FAULTS**

Specifier: FLT.D\_FLT[133].0 to FLT.D\_FLT[133].7

See corresponding fault D889 to D896 for Fault and Action for Station 7V

#### **D1073, D1074, D1075, D1076, D1077, D1078, D1079, AND D1080 ARE STATION 8V FAULTS**

Specifier: FLT.D\_FLT[134].0 to FLT.D\_FLT[134].7

See corresponding fault D889 to D896 for Fault and Action for Station 8V

#### **D1081, D1082, D1083, D1084, D1085, D1086, D1087, AND D1088 ARE STATION 9V FAULTS**

Specifier: FLT.D\_FLT[135].0 to FLT.D\_FLT[135].7

See corresponding fault D889 to D896 for Fault and Action for Station 9V



**D1089, D1090, D1091, D1092, D1093, D1094, D1095, AND D1096 ARE STATION 10V FAULTS**

Specifier: FLT.D\_FLT[136].0 to FLT.D\_FLT[136].7

See corresponding fault D889 to D896 for Fault and Action for Station 10V

**D1097, D1098, D1099, D1100, D1101, D1102, D1103, AND D1104 ARE STATION 11V FAULTS**

Specifier: FLT.D\_FLT[137].0 to FLT.D\_FLT[137].7

See corresponding fault D889 to D896 for Fault and Action for Station 11V

**D1105, D1106, D1107, D1108, D1109, D1110, D1111, AND D1112 ARE STATION 12V FAULTS**

Specifier: FLT.D\_FLT[138].0 to FLT.D\_FLT[138].7

See corresponding fault D889 to D896 for Fault and Action for Station 12V

**D1113, D1114, D1115, D1116, D1117, D1118, D1119, AND D1120 ARE STATION 13V FAULTS**

Specifier: FLT.D\_FLT[139].0 to FLT.D\_FLT[139].7

See corresponding fault D889 to D896 for Fault and Action for Station 13V

**D1121, D1122, D1123, D1124, D1125, D1126, D1127, AND D1128 ARE STATION 14V FAULTS**

Specifier: FLT.D\_FLT[140].0 to FLT.D\_FLT[140].7

See corresponding fault D889 to D896 for Fault and Action for Station 14V

**D1129, D1130, D1131, D1132, D1133, D1134, D1135, AND D1136 ARE STATION 15V FAULTS**

Specifier: FLT.D\_FLT[141].0 to FLT.D\_FLT[141].7

See corresponding fault D889 to D896 for Fault and Action for Station 15V

**D1137, D1138, D1139, D1140, D1141, D1142, D1143, AND D1144 ARE STATION 16V FAULTS**

Specifier: FLT.D\_FLT[142].0 to FLT.D\_FLT[142].7

See corresponding fault D889 to D896 for Fault and Action for Station 16V

**D1145 - STATION 1H PMAC OPEN SOCKET ALARM**

Specifier: FLT.D\_FLT[143].0

Fault: PMAC data Alarm.

Action: Check the Ethernet connections to the unit and reboot the system. If alarm returns, repair or replace the Epic control box on the unit.

**D1146 - STATION 1H PMAC CLOSE SOCKET ALARM**

Specifier: FLT.D\_FLT[143].1

Fault: PMAC data Alarm.

Action: Check the Ethernet connections to the unit and reboot the system. If alarm returns, repair or replace the Epic control box on the unit.

**D1147 - STATION 1H PMAC CYCLICAL COMMUNICATIONS ALARM**

Specifier: FLT.D\_FLT[143].2

Fault: PMAC data Alarm.

Action: Check the Ethernet connections to the unit and reboot the system. If alarm returns, repair or replace the Epic control box on the unit.

## 13. Troubleshooting

### **D1148 - STATION 1H PMAC SEND BUFFER FAILURE**

Specifier: FLT.D\_FLT[143].3

Fault: PMAC data Alarm.

Action: Check the Ethernet connections to the unit and reboot the system. If alarm returns, repair or replace the Epic control box on the unit.

### **D1149 - STATION 1H PMAC SEND LINE FAILURE**

Specifier: FLT.D\_FLT[143].4

Fault: PMAC data Alarm.

Action: Check the Ethernet connections to the unit and reboot the system. If alarm returns, repair or replace the Epic control box on the unit.

### **D1150 - STATION 1H PMAC READ LINE FAILURE**

Specifier: FLT.D\_FLT[143].5

Fault: PMAC data Alarm.

Action: Check the Ethernet connections to the unit and reboot the system. If alarm returns, repair or replace the Epic control box on the unit.

### **D1151 - STATION 1H SERVO MOTOR PHASING ERROR**

Specifier: FLT.D\_FLT[143].6

Fault: PMAC data Alarm.

Action: Check the Servo Motor connections to the unit and home the unit. If alarm returns, repair or replace the Epic control box on the unit.

### **D1152 - OPEN FAULT**

Specifier: FLT.D\_FLT[143].7

### **D1153, D1154, D1155, D1156, D1157, D1158, D1159, AND D1160 ARE STATION 2H FAULTS**

Specifier: FLT.D\_FLT[144].0 to FLT.D\_FLT[144].7

See corresponding fault D1145 to D1152 for Fault and Action for Station 2H

### **D1161, D1162, D1163, D1164, D1165, D1166, D1167, AND D1168 ARE STATION 3H FAULTS**

Specifier: FLT.D\_FLT[145].0 to FLT.D\_FLT[145].7

See corresponding fault D1145 to D1152 for Fault and Action for Station 3H

### **D1169, D1170, D1171, D1172, D1173, D1174, D1175, AND D1176 ARE STATION 4H FAULTS**

Specifier: FLT.D\_FLT[146].0 to FLT.D\_FLT[146].7

See corresponding fault D1145 to D1152 for Fault and Action for Station 4H

### **D1177, D1178, D1179, D1180, D1181, D1182, D1183, AND D1184 ARE STATION 5H FAULTS**

Specifier: FLT.D\_FLT[147].0 to FLT.D\_FLT[147].7

See corresponding fault D1145 to D1152 for Fault and Action for Station 5H

### **D1185, D1186, D1187, D1188, D1189, D1190, D1191, AND D1192 ARE STATION 6H FAULTS**

Specifier: FLT.D\_FLT[148].0 to FLT.D\_FLT[148].7

See corresponding fault D1145 to D1152 for Fault and Action for Station 76

**D1193, D1194, D1195, D1196, D1197, D1198, D1199, AND D1200 ARE STATION 7H FAULTS**

Specifier: FLT.D\_FLT[149].0 to FLT.D\_FLT[149].7

See corresponding fault D1145 to D1152 for Fault and Action for Station 7H

**D1201, D1202, D1203, D1204, D1205, D1206, D1207, AND D1208 ARE STATION 8H FAULTS**

Specifier: FLT.D\_FLT[150].0 to FLT.D\_FLT[150].7

See corresponding fault D1145 to D1152 for Fault and Action for Station 8H

**D1209, D1210, D1211, D1212, D1213, D1214, D1215, AND D1216 ARE STATION 9H FAULTS**

Specifier: FLT.D\_FLT[151].0 to FLT.D\_FLT[151].7

See corresponding fault D1145 to D1152 for Fault and Action for Station 9H

**D1217, D1218, D1219, D1220, D1221, D1222, D1223, AND D1224 ARE STATION 10H FAULTS**

Specifier: FLT.D\_FLT[152].0 to FLT.D\_FLT[152].7

See corresponding fault D1145 to D1152 for Fault and Action for Station 10H

**D1225, D1226, D1227, D1228, D1229, D1230, D1231, AND D1232 ARE STATION 11H FAULTS**

Specifier: FLT.D\_FLT[153].0 to FLT.D\_FLT[153].7

See corresponding fault D1145 to D1152 for Fault and Action for Station 11H

**D1233, D1234, D1235, D1236, D1237, D1238, D1239, AND D1240 ARE STATION 12H FAULTS**

Specifier: FLT.D\_FLT[154].0 to FLT.D\_FLT[154].7

See corresponding fault D1145 to D1152 for Fault and Action for Station 12H

**D1241, D1242, D1243, D1244, D1245, D1246, D1247, AND D1248 ARE STATION 13H FAULTS**

Specifier: FLT.D\_FLT[155].0 to FLT.D\_FLT[155].7

See corresponding fault D1145 to D1152 for Fault and Action for Station 13H

**D1249, D1250, D1251, D1252, D1253, D1254, D1255, AND D1256 ARE STATION 14H FAULTS**

Specifier: FLT.D\_FLT[156].0 to FLT.D\_FLT[156].7

See corresponding fault D1145 to D1152 for Fault and Action for Station 14H

**D1257, D1258, D1259, D1260, D1261, D1262, D1263, AND D1264 ARE STATION 15H FAULTS**

Specifier: FLT.D\_FLT[157].0 to FLT.D\_FLT[157].7

See corresponding fault D1145 to D1152 for Fault and Action for Station 15H

**D1265, D1266, D1267, D1268, D1269, D1270, D1271, AND D1272 ARE STATION 16H FAULTS**

Specifier: FLT.D\_FLT[158].0 to FLT.D\_FLT[158].7

See corresponding fault D1145 to D1152 for Fault and Action for Station 16H

**D1273, D1274, D1275, D1276, D1277, D1278, D1278, AND D1280 ARE STATION 1V FAULTS**

Specifier: FLT.D\_FLT[159].0 to FLT.D\_FLT[159].7

See corresponding fault D1145 to D1152 for Fault and Action for Station 1V

**D1281, D1282, D1283, D1284, D1285, D1286, D1287, AND D1288 ARE STATION 2V FAULTS**

Specifier: FLT.D\_FLT[160].0 to FLT.D\_FLT[160].7

See corresponding fault D1145 to D1152 for Fault and Action for Station 2V

### 13. Troubleshooting

#### **D1289, D1290, D1291, D1292, D1293, D1294, D1295, AND D1296 ARE STATION 3V FAULTS**

Specifier: FLT.D\_FLT[161].0 to FLT.D\_FLT[161].7

See corresponding fault D1145 to D1152 for Fault and Action for Station 3V

#### **D1297, D1298, D1299, D1300, D1301, D1302, D1303, AND D1304 ARE STATION 4V FAULTS**

Specifier: FLT.D\_FLT[162].0 to FLT.D\_FLT[162].7

See corresponding fault D1145 to D1152 for Fault and Action for Station 4V

#### **D1305, D1306, D1307, D1308, D1309, D1310, D1311, AND D1312 ARE STATION 5V FAULTS**

Specifier: FLT.D\_FLT[163].0 to FLT.D\_FLT[163].7

See corresponding fault D1145 to D1152 for Fault and Action for Station 5V

#### **D1313, D1314, D1315, D1316, D1317, D1318, D1319, AND D1320 ARE STATION 6V FAULTS**

Specifier: FLT.D\_FLT[164].0 to FLT.D\_FLT[164].7

See corresponding fault D1145 to D1152 for Fault and Action for Station 6V

#### **D1321, D1322, D1323, D1324, D1325, D1326, D1327, AND D1328 ARE STATION 7V FAULTS**

Specifier: FLT.D\_FLT[165].0 to FLT.D\_FLT[165].7

See corresponding fault D1145 to D1152 for Fault and Action for Station 7V

#### **D1329, D1330, D1331, D1332, D1333, D1334, D1335, AND D1336 ARE STATION 8V FAULTS**

Specifier: FLT.D\_FLT[166].0 to FLT.D\_FLT[166].7

See corresponding fault D1145 to D1152 for Fault and Action for Station 8V

#### **D1337, D1338, D1339, D1340, D1341, D1342, D1343, AND D1344 ARE STATION 9V FAULTS**

Specifier: FLT.D\_FLT[167].0 to FLT.D\_FLT[167].7

See corresponding fault D1145 to D1152 for Fault and Action for Station 9V

#### **D1345, D1346, D1347, D1348, D1349, D1350, D1351, AND D1352 ARE STATION 10V FAULTS**

Specifier: FLT.D\_FLT[168].0 to FLT.D\_FLT[168].7

See corresponding fault D1145 to D1152 for Fault and Action for Station 10V

#### **D1353, D1354, D1355, D1356, D1357, D1358, D1359, AND D1360 ARE STATION 11V FAULTS**

Specifier: FLT.D\_FLT[169].0 to FLT.D\_FLT[169].7

See corresponding fault D1145 to D1152 for Fault and Action for Station 11V

#### **D1361, D1362, D1363, D1364, D1365, D1366, D1367, AND D1368 ARE STATION 12V FAULTS**

Specifier: FLT.D\_FLT[170].0 to FLT.D\_FLT[170].7

See corresponding fault D1145 to D1152 for Fault and Action for Station 12V

#### **D1369, D1370, D1371, D1372, D1373, D1374, D1375, AND D1376 ARE STATION 13V FAULTS**

Specifier: FLT.D\_FLT[171].0 to FLT.D\_FLT[171].7

See corresponding fault D1145 to D1152 for Fault and Action for Station 13V

#### **D1377, D1378, D1379, D1380, D1381, D1382, D1383, AND D1384 ARE STATION 14V FAULTS**

Specifier: FLT.D\_FLT[172].0 to FLT.D\_FLT[172].7

See corresponding fault D1145 to D1152 for Fault and Action for Station 14V

**D1385, D1386, D1387, D1388, D1389, D1390, D1391, AND D1392 ARE STATION 15V FAULTS**

Specifier: FLT.D\_FLT[173].0 to FLT.D\_FLT[173].7

See corresponding fault D1145 to D1152 for Fault and Action for Station 15V

**D1393, D1394, D1395, D1396, D1397, D1398, D1399, AND D1400 ARE STATION 16V FAULTS**

Specifier: FLT.D\_FLT[174].0 to FLT.D\_FLT[174].7

See corresponding fault D1145 to D1152 for Fault and Action for Station 16V

**D1401 to D1408 - OPEN FAULTS**

Specifier: FLT.D\_FLT[175].0 to FLT.D\_FLT[175].7

**D1409 to D1416 - OPEN FAULTS**

Specifier: FLT.D\_FLT[176].0 to FLT.D\_FLT[176].7

**D1417 to D1424 - OPEN FAULTS**

Specifier: FLT.D\_FLT[177].0 to FLT.D\_FLT[177].7

**D1425 to D1432 - OPEN FAULTS**

Specifier: FLT.D\_FLT[178].0 to FLT.D\_FLT[178].7

**D1433 to D1440 - OPEN FAULTS**

Specifier: FLT.D\_FLT[179].0 to FLT.D\_FLT[179].7

**D1441 to D1448 - OPEN FAULTS**

Specifier: FLT.D\_FLT[180].0 to FLT.D\_FLT[180].7

**D1449 to D1456 - OPEN FAULTS**

Specifier: FLT.D\_FLT[181].0 to FLT.D\_FLT[181].7

**D1457 - CHUCK INDEXER 1 REFERENCE PROX FAULT**

Specifier: FLT.D\_FLT[182].0

Fault: The CHUCK INDEXER logic detects its Reference Prox is off when the current position of the chuck is not at zero, or the Reference Prox is on when the current position of the chuck is zero.

Action: Check prox switch operation and adjust, repair or replace as needed. Verify the current physical position of the chuck at CHUCK INDEXER 1 and set the actual position in the INDEXER control screen. This position must be a value that can be reached with the stroke of the index drive. (I.E. A 90 degree index drive can only reach the 0, 90, 180, or 270 degree absolute positions.)

**D1458 - CHUCK INDEXER 1 STEP 1 FAULT**

Specifier: FLT.D\_FLT[182].1

Fault: Step 1 of the CHUCK INDEXER LOGIC did not complete within 5 seconds.

Action: Step 1 for the indexer is to pre-position the rack drive. Check the rack EXTEND/RETRACT solenoid and prox operation and adjust, repair or replace as needed.

## 13. Troubleshooting

### **D1459 - CHUCK INDEXER 1 STEP 2 FAULT**

Specifier: FLT.D\_FLT[182].2

Fault: Step 2 of the CHUCK INDEXER LOGIC did not complete within 5 seconds.

Action: Step 2 for the indexer is to unlock the chuck. Check the chuck LOCK/UNLOCK solenoid and prox operation and adjust, repair or replace as needed.

### **D1460 - CHUCK INDEXER 1 STEP 3 FAULT**

Specifier: FLT.D\_FLT[182].3

Fault: Step 3 of the CHUCK INDEXER LOGIC did not complete within 5 seconds.

Action: Step 3 for the indexer is to position the rack drive to its end position. Check the rack EXTEND/RETRACT solenoid and prox operation and adjust, repair or replace as needed.

### **D1461 - CHUCK INDEXER 1 STEP 4 FAULT**

Specifier: FLT.D\_FLT[182].4

Fault: Step 4 of the CHUCK INDEXER LOGIC did not complete within 5 seconds.

Action: Step 4 for the indexer is to lock the chuck down. Check the chuck LOCK/UNLOCK solenoid and prox operation and adjust, repair or replace as needed.

### **D1462 - CHUCK INDEXER 1 RACK PROX PARITY FAULT**

Specifier: FLT.D\_FLT[182].5

Fault: The CHUCK INDEXER logic detects the combination of rack EXTEND/RETRACT solenoid and corresponding prox is invalid.

Action: Check the rack EXTEND/RETRACT solenoid and prox operation and adjust, repair or replace as needed.

### **D1463 - CHUCK INDEXER 1 LOCK/UNLOCK PROX FAULT**

Specifier: FLT.D\_FLT[182].6

Fault: The CHUCK INDEXER logic detects the combination of rack LOCK/UNLOCK solenoid and corresponding prox is invalid.

Action: Check the chuck LOCK/UNLOCK solenoid and prox operation and adjust, repair or replace as needed.

### **D1464 - OPEN FAULT**

Specifier: FLT.D\_FLT[182].7

### **D1465, D1466, D1467, D1468, D1469, D1470, D1471, AND D1472 ARE INDEXER 2 FAULTS**

Specifier: FLT.D\_FLT[183].0 to FLT.D\_FLT[183].7

See corresponding fault D1457 to D1464 for Fault and Action for Indexer 2.

### **D1473 D1474, D1475, D1476, D1477, D1478, D1479, AND D1480 ARE INDEXER 3 FAULTS**

Specifier: FLT.D\_FLT[184].0 to FLT.D\_FLT[184].7

See corresponding fault D1457 to D1464 for Fault and Action for Indexer 3.

### **D1481, D1482, D1483, D1484, D1485, D1486, D1487, AND D1488 ARE INDEXER 4 FAULTS**

Specifier: FLT.D\_FLT[185].0 to FLT.D\_FLT[185].7

See corresponding fault D1457 to D1464 for Fault and Action for Indexer 4.

**D1489, D1490, D1491, D1492, D1493, D1494, D1495, AND D1496 ARE INDEXER 5 FAULTS**

Specifier: FLT.D\_FLT[186].0 to FLT.D\_FLT[186].7

See corresponding fault D1457 to D1464 for Fault and Action for Indexer 5.

**D1497, D1498, D1499, D1500, D1501, D1502, D1503, AND D1504 ARE INDEXER 6 FAULTS**

Specifier: FLT.D\_FLT[187].0 to FLT.D\_FLT[187].7

See corresponding fault D1457 to D1464 for Fault and Action for Indexer 6.

**D1505, D1506, D1507, D1508, D1509, D1510, D1511, AND D1512 ARE INDEXER 7 FAULTS**

Specifier: FLT.D\_FLT[188].0 to FLT.D\_FLT[188].7

See corresponding fault D1457 to D1464 for Fault and Action for Indexer 7.

**D1513, D1514, D1515, D1516, D1517, D1518, D1519, AND D1520 ARE INDEXER 8 FAULTS**

Specifier: FLT.D\_FLT[189].0 to FLT.D\_FLT[189].7

See corresponding fault D1457 to D1464 for Fault and Action for Indexer 8.

**D1521, D1522, D1523, D1524, D1525, D1526, D1527, AND D1528 ARE INDEXER 9 FAULTS**

Specifier: FLT.D\_FLT[190].0 to FLT.D\_FLT[190].7

See corresponding fault D1457 to D1464 for Fault and Action for Indexer 9.

**D1529, D1530, D1531, D1532, D1533, D1534, D1535, AND D1536 ARE INDEXER 10 FAULTS**

Specifier: FLT.D\_FLT[191].0 to FLT.D\_FLT[191].7

See corresponding fault D1457 to D1464 for Fault and Action for Indexer 10.

**D1537, D1538, D1539, D1540, D1541, D1542, D1543, AND D1544 ARE INDEXER 11 FAULTS**

Specifier: FLT.D\_FLT[192].0 to FLT.D\_FLT[192].7

See corresponding fault D1457 to D1464 for Fault and Action for Indexer 11.

**D1545, D1546, D1547, D1548, D1549, D1550, D1551, AND D1552 ARE INDEXER 12 FAULTS**

Specifier: FLT.D\_FLT[193].0 to FLT.D\_FLT[193].7

See corresponding fault D1457 to D1464 for Fault and Action for Indexer 12.

**D1553, D1554, D1555, D1556, D1557, D1558, D1559, AND D1560 ARE INDEXER 13 FAULTS**

Specifier: FLT.D\_FLT[194].0 to FLT.D\_FLT[194].7

See corresponding fault D1457 to D1464 for Fault and Action for Indexer 13.

**D1561, D1562, D1563, D1564, D1565, D1566, D1567, AND D1568 ARE INDEXER 14 FAULTS**

Specifier: FLT.D\_FLT[195].0 to FLT.D\_FLT[195].7

See corresponding fault D1457 to D1464 for Fault and Action for Indexer 14.

**D1569, D1570, D1571, D1572, D1573, D1574, D1575, AND D1576 ARE INDEXER 15 FAULTS**

Specifier: FLT.D\_FLT[196].0 to FLT.D\_FLT[196].7

See corresponding fault D1457 to D1464 for Fault and Action for Indexer 15.

**D1577, D1578, D1579, D1580, D1581, D1582, D1583, AND D1584 ARE INDEXER 16 FAULTS**

Specifier: FLT.D\_FLT[197].0 to FLT.D\_FLT[197].7

See corresponding fault D1457 to D1464 for Fault and Action for Indexer 16.

## 13. Troubleshooting

### D1585 to D1520 - OPEN FAULTS

Specifier: FLT.D\_FLT[198].0 to FLT.D\_FLT[198].7

### D1593 to D1600 - OPEN FAULTS

Specifier: FLT.D\_FLT[199].0 to FLT.D\_FLT[199].7

### D1601 to D1608 - OPEN FAULTS

Specifier: FLT.D\_FLT[200].0 to FLT.D\_FLT[200].7

### D1609 - STA. 1H MECHANICAL UNIT NOT HOME

Specifier: FLT.D\_FLT[201].0

Fault: The mechanical impulse unit on station 1H did not complete its cycle. The Home switch is not on.

Action: Verify the operation of the impulse valve and solenoid, check the home prox switch operation. Adjust, repair or replace as needed.

### D1610 - STA. 1H MECHANICAL UNIT DIDN'T CYCLE

Specifier: FLT.D\_FLT[201].1

Fault: The mechanical impulse unit on station 1H did not cycle. The Home switch did not turn off during the unit's cycle.

Action: Verify the operation of the impulse valve and solenoid, check the home prox switch operation. Adjust, repair or replace as needed.

### D1611 - OPEN FAULT

Specifier: FLT.D\_FLT[201].2

### D1612 - OPEN FAULT

Specifier: FLT.D\_FLT[201].3

### D1613 - STA. 1V MECHANICAL UNIT NOT HOME

Specifier: FLT.D\_FLT[201].4

Fault: The mechanical impulse unit on station 1V did not complete its cycle. The Home switch is not on.

Action: Verify the operation of the impulse valve and solenoid, check the home prox switch operation. Adjust, repair or replace as needed.

### D1614 - STA. 1V MECHANICAL UNIT DIDN'T CYCLE

Specifier: FLT.D\_FLT[201].5

Fault: The mechanical impulse unit on station 1V did not cycle. The Home switch did not turn off during the unit's cycle.

Action: Verify the operation of the impulse valve and solenoid, check the home prox switch operation. Adjust, repair or replace as needed.

### D1615 - OPEN FAULT

Specifier: FLT.D\_FLT[201].6

### D1616 - OPEN FAULT

Specifier: FLT.D\_FLT[201].7



**D1617, D1618, D1619, D1620, D1621, D1622, D1623, AND D1624 ARE STATION 2 FAULTS**

Specifier: FLT.D\_FLT[202].0 to FLT.D\_FLT[202].7

See corresponding fault D1145 to D1152 for Fault and Action for Station 2

**D1625, D1626, D1627, D1628, D1629, D1630, D1631, AND D1632 ARE STATION 3 FAULTS**

Specifier: FLT.D\_FLT[203].0 to FLT.D\_FLT[203].7

See corresponding fault D1609 to D1616 for Fault and Action for Station 3

**D1633, D1634, D1635, D1636, D1637, D1638, D1639, AND D1640 ARE STATION 4 FAULTS**

Specifier: FLT.D\_FLT[204].0 to FLT.D\_FLT[204].7

See corresponding fault D1609 to D1616 for Fault and Action for Station 4

**D1641, D1641, D1643, D1644, D1645, D1646, D1647, AND D1648 ARE STATION 5 FAULTS**

Specifier: FLT.D\_FLT[205].0 to FLT.D\_FLT[205].7

See corresponding fault D1609 to D1616 for Fault and Action for Station 5

**D1649, D1650, D1651, D1652, D1653, D1654, D1655, AND D1656 ARE STATION 6 FAULTS**

Specifier: FLT.D\_FLT[206].0 to FLT.D\_FLT[206].7

See corresponding fault D1609 to D1616 for Fault and Action for Station 6

**D1657, D1658, D1659, D1660, D1661, D1662, D1663, AND D1664 ARE STATION 7 FAULTS**

Specifier: FLT.D\_FLT[207].0 to FLT.D\_FLT[207].7

See corresponding fault D1609 to D1616 for Fault and Action for Station 7

**D1665, D1666, D1667, D1668, D1669, D1670, D1671, AND D1672 ARE STATION 8 FAULTS**

Specifier: FLT.D\_FLT[208].0 to FLT.D\_FLT[208].7

See corresponding fault D1609 to D1616 for Fault and Action for Station 8

**D1673, D1674, D1675, D1676, D1677, D1678, D1679, AND D1680 ARE STATION 9 FAULTS**

Specifier: FLT.D\_FLT[209].0 to FLT.D\_FLT[209].7

See corresponding fault D1609 to D1616 for Fault and Action for Station 9

**D1681, D1682, D1683, D1684, D1685, D1686, D1687, AND D1688 ARE STATION 10 FAULTS**

Specifier: FLT.D\_FLT[210].0 to FLT.D\_FLT[210].7

See corresponding fault D1609 to D1616 for Fault and Action for Station 10

**D1689, D1690, D1691, D1692, D1693, D1694, D1956, AND D1696 ARE STATION 11 FAULTS**

Specifier: FLT.D\_FLT[211].0 to FLT.D\_FLT[211].7

See corresponding fault D1609 to D1616 for Fault and Action for Station 11

**D1697, D1698, D1699, D1700, D1701, D1702, D1703, AND D1704 ARE STATION 12 FAULTS**

Specifier: FLT.D\_FLT[212].0 to FLT.D\_FLT[212].7

See corresponding fault D1609 to D1616 for Fault and Action for Station 12

**D1705, D1706, D1707, D1708, D1709, D1710, D1711, AND D1712 ARE STATION 13 FAULTS**

Specifier: FLT.D\_FLT[213].0 to FLT.D\_FLT[213].7

See corresponding fault D1609 to D1616 for Fault and Action for Station 13

### **13. Troubleshooting**

#### **D1713, D1714, D1715, D1716, D1717, D1718, D1719, AND D1720 ARE STATION 14 FAULTS**

Specifier: FLT.D\_FLT[214].0 to FLT.D\_FLT[214].7

See corresponding fault D1609 to D1616 for Fault and Action for Station 14

#### **D1721, D1722, D1723, D1724, D1725, D1726, D1727, AND D1728 ARE STATION 15 FAULTS**

Specifier: FLT.D\_FLT[215].0 to FLT.D\_FLT[215].7

See corresponding fault D1609 to D1616 for Fault and Action for Station 15

#### **D1729, D1730, D1731, D1732, D1733, D1734, D1735, AND D1736 ARE STATION 16 FAULTS**

Specifier: FLT.D\_FLT[216].0 to FLT.D\_FLT[216].7

See corresponding fault D1609 to D1616 for Fault and Action for Station 16

**14. TECHNACHECK®/BK MIKRO**

TECHNACHECK® .....	TC-1
BK MIKRO.....	BK-1

# TECHNA-CHECK<sup>®</sup>

# MODEL 3200

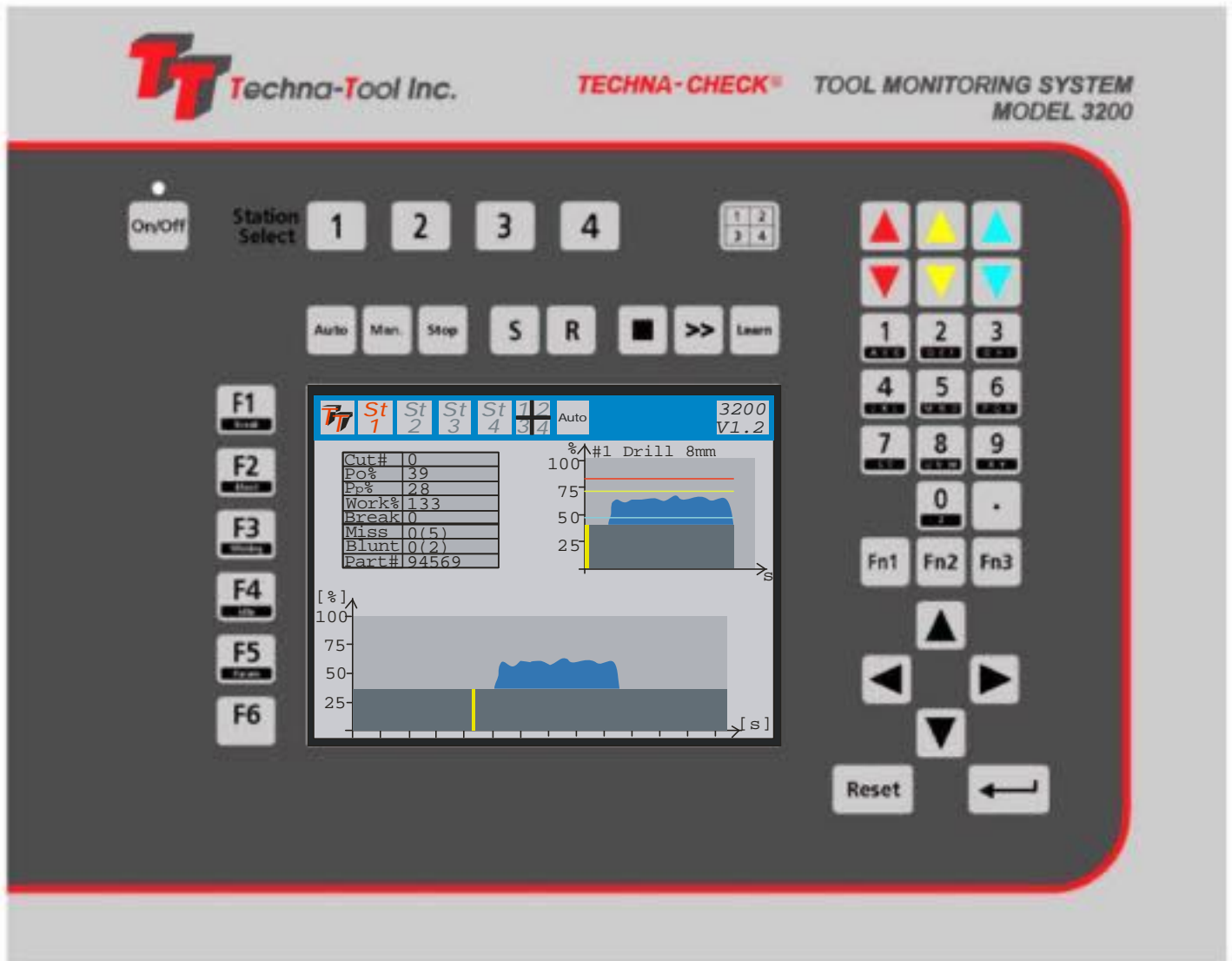

**Tool Monitoring System**  
**Technical Documentation**  
**Released: October 2003**

© Copyright 2003, Techna-Tool Inc., Hartland, Wisconsin, USA.

The information in this document is subject to change without notice.

**TECHNA-CHECK®** is a registered trademark of Techna-Tool Inc.

Table Of Contents:

1. The Concept.....	4
2. Key Benefits.....	5
3. Operating the unit.....	6
3.1 On/Off Key.....	6
3.2 Station Select.....	6
3.3 Auto Man. and Stop mode select.....	6
3.4 Spindle and Roll Mode.....	8
3.5 Spindle expand mode.....	8
3.6 F1-Break Parameters.....	9
3.7 F2-Blunt Parameters.....	10
3.8 F3-Missing Parameters.....	11
3.9 F4-Idle Parameters.....	12
3.10 F5-Measurement Parameters.....	13
3.11 F6-Miscellaneous Parameters.....	14
3.12 Stop Mode.....	15
3.13 Learn Command.....	16
3.14 Reset Command.....	17
3.15 Password Protection.....	18
4. Wiring of the PWM325 Module.....	19
4.1 Current Measurement Range.....	19
4.2 Filter Time Constants.....	19
4.3 PWM350 Technical Specifications.....	20
Appendix A-Interface to 3-Phase Transducer-PWM350.....	21
Appendix B-Interface to Single-Phase Transducer-UG105.....	22
Appendix C-TC3200 Back Side Print.....	23
Appendix D-Dip. Switch Usage.....	24
Appendix E-Cut Select Chart.....	25
Appendix F-Panel Cut-Out Profile.....	26

## 1. The Concept

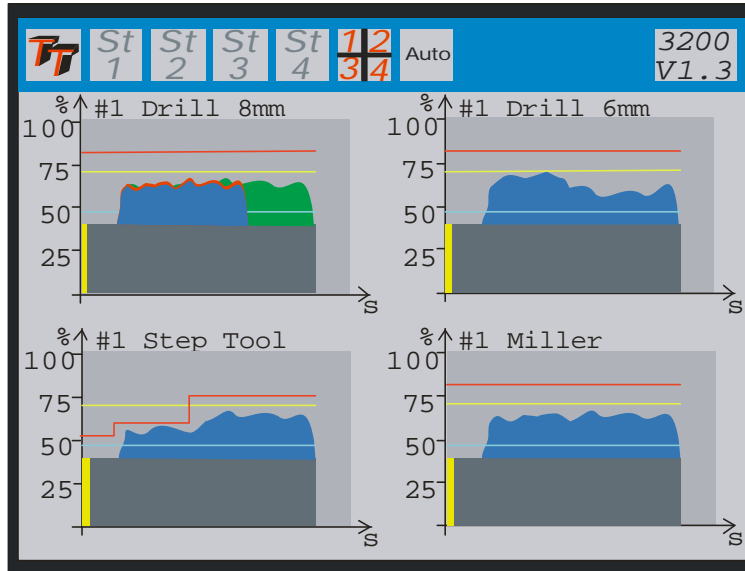

The **Techna Check**<sup>®</sup> TC3200 is a modular Tool Monitoring system.

The TC3200 is hardware configurable and is able to monitor 1/2/3 or 4 tooling spindles (stations). The stations are electrically isolated and can be used with (4) machines in a cell.

The Techna Check TC3200 has been exclusively developed for the **supervision of cutting tools on single spindle automatic machine tools. It is capable of detecting missing, blunt, and broken or damaged tooling.** The TC3200 measures, from external measurement transducer(s), the electrical power consumption of the spindle motor. A blunt (or worn) tool needs more energy to complete a machining cycle, and when a tool breaks a short energy peak or spike is created. If no tool is present, the power consumption drops back to the idle power of the spindle.

The TC3200 is designed to monitor motor power in the primary or secondary of a variable frequency motor drive (see the specification of the external measurement transducer PWM 325). It is also capable of storing 32 complete sets of monitoring parameters. These features make it ideal for monitoring flexible transfer machines utilizing single spindle CNC heads.

The unit may be interfaced and operated from a PC through its RS232 or RS485 interface. The TOOLMON application adds statistic features to the tool monitoring. The function of the TOOLMON application is covered by a separate manual.

## 2. Key Benefits

### ***Improved part quality***

The detection of missing or broken tools helps insure that the proper machining is being performed. Detection of tool wear and damage can help improve surface finish and tolerances.

### ***Maximized tool life***

By detecting for tool wear and damage, expensive tooling can be changed before the damage gets too severe. This detection also reduces dependence on hit or miss part counting schemes.

### ***Protection of spindle and feed mechanism***

By detecting catastrophic tool failures, the TC3200 can prevent serious damage to your head and feed mechanisms, not just at the station being monitored, but at down-stream stations where "chain reaction" effects can occur.

### ***Improved up time***

By creating the process improvements listed above, TC3200 keeps your machine running longer.

### ***Easy installation***

No mechanical modification of the machinery is necessary. The entire system mounts easily in your electrical cabinet.



### 3. Operating the unit

#### 3.1 On/Off key



The On/Off key may be used to switch the display On/Off, only if the machine is not running. If the display is turned off, it will be switched on again as soon as one of the stations is activated (start-signal active). A parameter 'Backlight On Period' is used to program how long the display will stay on after the start signal has been removed or a key has been activated. Switching of the display, when the machine is not running, increases the lifetime of the display. When the display is switched off (black) the green On/Off LED will be flashing.

#### 3.2 Station Select



The 4 station select keys are used to select the station, which will be displayed. If a channel is not hardware activated (not present), it cannot be selected. There also is a button for selecting a display of all channels simultaneously. Some of the actions that are carried out from the keyboard require a single station to be displayed. The 'Reset' command can only be issued while a single station is selected, while the reset will only apply to the currently displayed channel. The same is true for the 'Learn' command and the 'Parameter Modify' command.

#### 3.3 Auto, Man. and Stop mode select



In Auto mode the display follows the current operation cycle of the tooling machine. When the machine selects a new tool (cut) the display **Automatically** displays this cut. In manual mode the user is allowed to select/display and alter other cuts rather than the currently active cut. When Manual mode is selected the bottom half of the display is used to select the cut.

The screenshot shows the following data:

Cut#	0
Po%	39
Pp%	28
Work%	133
Break	0
Miss	0(5)
Blunt	0(2)
Part#	94569

**Manual Cut Select - Station 1, 32 Cuts**

Cut #00	Cut #08	Cut #16
Cut #01	Cut #09	Cut #17
Cut #02	Cut #10	Cut #18
Cut #03	<b>Cut #11</b>	Cut #19
Cut #04	Cut #12	Cut #20
Cut #05	Cut #13	Cut #21
Cut #06	Cut #14	Cut #22
Cut #07	Cut #15	Cut #23

Function keys and controls on the right:

- F1: Break
- F2: Blunt
- F3: Missing
- F4: Idle
- F5: Param
- F6: (unlabeled)

In **Manual** mode the arrow keys are used to select a cut. As soon as a cut is selected its last profile is displayed in the spindle window in the upper half of the screen. If a Parameter key is activated the parameter for the cut selected may be viewed or modified. In manual mode it is possible to display the LAST ALARM cut also.

### 3.4 Spindle and Roll mode

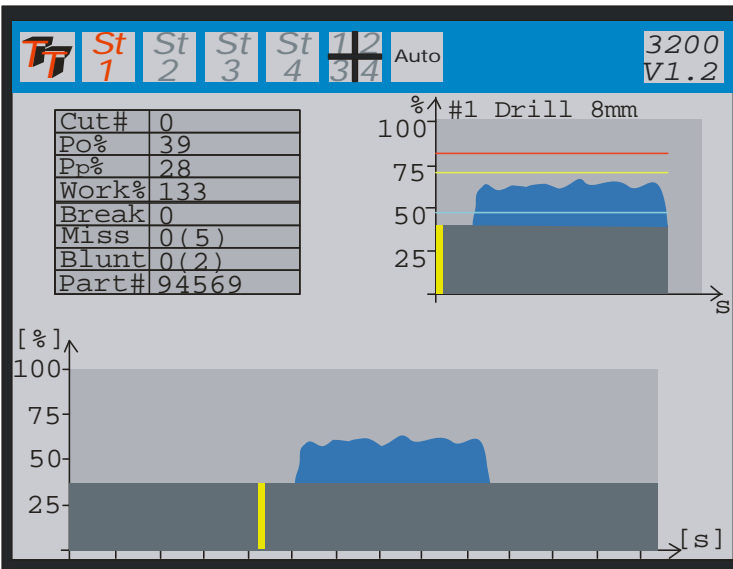

R

■ >>

The 'R' key is used to select this display mode. The bottom of the screen shows all measurement in a 'Rolling' fashion. This display may be used when analyzing, if the start signal appears at the right point. The rolling may be stopped and started again by two keys on the panel.

### 3.5 Spindle expand mode

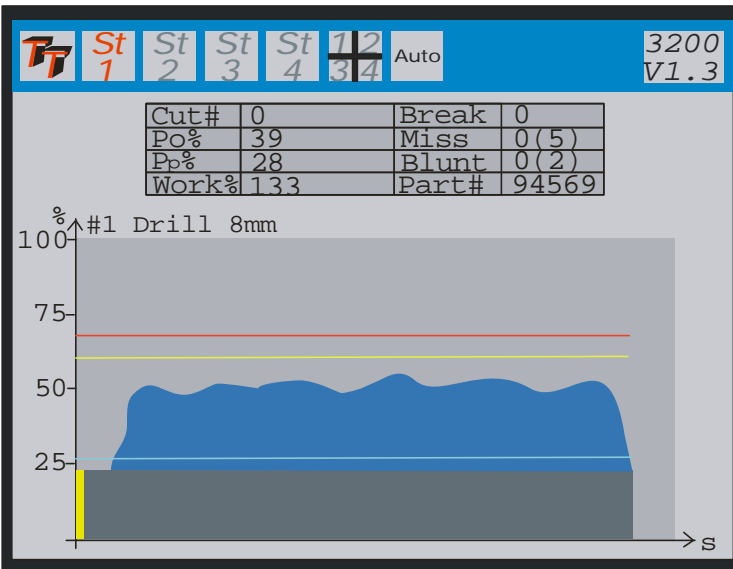

S

The 'S' key is used to select this display mode. The whole screen displays the current cycle (zoom mode).

3.6 F1—Break Parameters

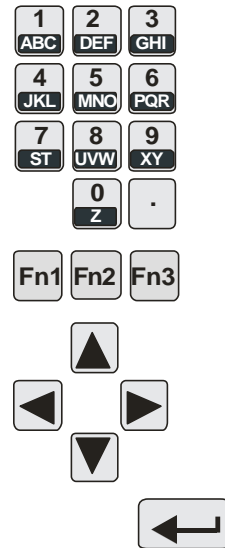
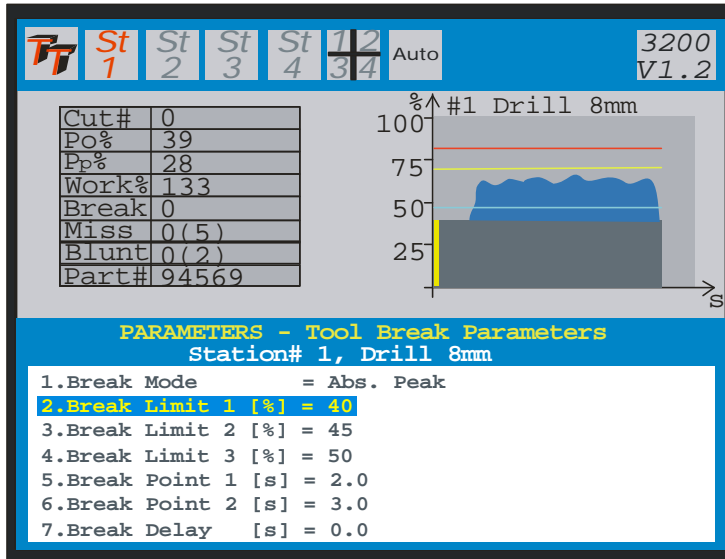

A parameter is selected by the arrow-up and down keys. The enter key may be pushed to activate the parameter. When activated the arrow-up and down key may be used to alter the variable. When the enter-key is activated again the modification is made permanent. The numerical keys may also be used to alter a variable. The enter-key or the arrow-up/down keys are used to make the change permanent.

Parameter	Range
1. Break Mode	Abs. Peak Learn Peak Abs. Peak Curve
2. Break Limit1 [%]	Break Limit 1 (0-100)%, 0 = Off
3. Break Limit2 [%]	Break Limit 2 (0-100)%, 0 = Off Active only in Abs. Peak Curve mode
4. Break Limit3 [%]	Break Limit 3 (0-100)%, 0 = Off Active only in Abs. Peak Curve mode
5. Break Point 1 [s]	Break Point 1 (0.0-999.9 seconds) Active only in Abs. Peak Curve mode
6. Break Point 2 [s]	Break Point 2 (0.0-999.9 seconds) Active only in Abs. Peak Curve mode
7. Break Delay [s]	Break Delay (0.0-25.0 seconds) Break Reaction Time-Keep as low as possible

3.7 F2—Blunt Parameters

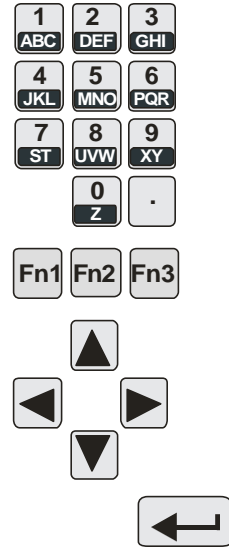

A parameter is selected by the arrow-up and down keys. The enter key may be pushed to activate the parameter. When activated the arrow-up and down key may be used to alter the variable. When the enter-key is activated again the modification is made permanent. The numerical keys may also be used to alter a variable. The enter-key or the arrow-up/down keys are used to make the change permanent.

Parameter	Range
1. Blunt Mode	Abs. Peak Learn Peak Learn Work
2. Blunt Limit [%]	Blunt Limit (0-100%), 0 = Off Blunt Limit (101-999%), Learn Work Mode
3. Blunt Delay [s]	Blunt Delay (0.0-25.0 seconds) Active only in Abs. Peak and Learn Peak mode
4. Blunt Count	Blunt Count (1-15 cont. cycles)
5. Blunt Duration [s]	Blunt Duration (0.0-999.9 seconds), 0.0 = Off
6. Blunt On Part#	Enable Disable
7. Blunt Part# Limit	(100-1000000)

3.8 F3—Missing Parameters

Cut# 0  
 Po% 39  
 Pp% 28  
 Work% 133  
 Break 0  
 Miss 0(5)  
 Blunt 0(2)  
 Part# 94569

100% #1 Drill 8mm  
 75  
 50  
 25

**PARAMETERS - Tool Missing Parameters**  
 Station# 1, Drill 8mm

1. Missing Mode = Absolute  
**2. Missing Limit [%] = 5**  
 3. Missing Delay [s] = 1.0  
 4. Missing Count = 1  
 5. Missing Tw [s] = 0.0



A parameter is selected by the arrow-up and down keys. The enter key may be pushed to activate the parameter. When activated the arrow-up and down key may be used to alter the variable. When the enter-key is activated again the modification is made permanent. The numerical keys may also be used to alter a variable. The enter-key or the arrow-up/down keys are used to make the change permanent.

Parameter	Range
1. Missing Mode	Absolute Learn Work
2. Missing Limit [%]	Missing Limit (0-99%), 0 = Off
3. Missing Delay [s]	Missing Delay (0.1-25.0 seconds) Active only in Absolute mode
4. Missing Count	Missing Count (1-15 cont. cycles)
5. Missing Tw [s]	(0.0-999.9 seconds), 0.0 = Off

3.9 F4—Idle Parameters

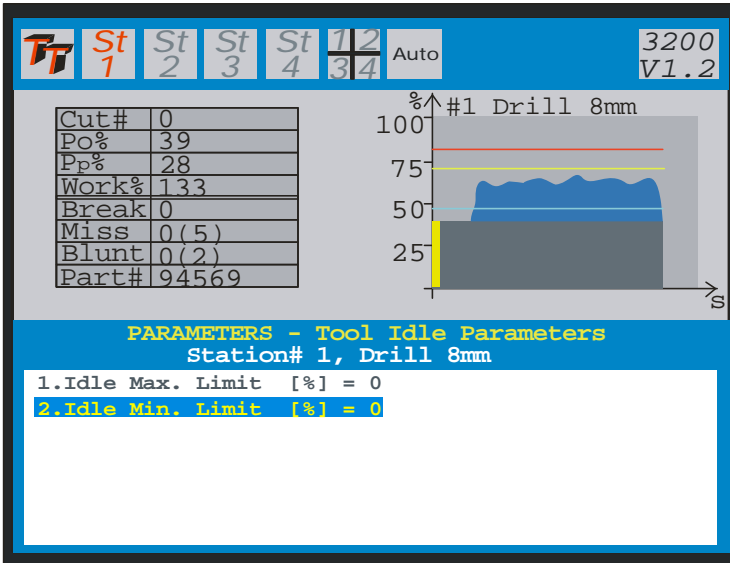

A parameter is selected by the arrow-up and down keys. The enter key may be pushed to activate the parameter. When activated the arrow-up and down key may be used to alter the variable. When the enter-key is activated again the modification is made permanent. The numerical keys may also be used to alter a variable. The enter-key or the arrow-up/down keys are used to make the change permanent.

Parameter	Range
1. Idle Max. Limit [%]	Idle Max. Limit (0-100%), 0 = Off
2. Idle Min. Limit [%]	Idle Min. Limit (0-100%), 0 = Off

3.10 F5—Measurement Parameters

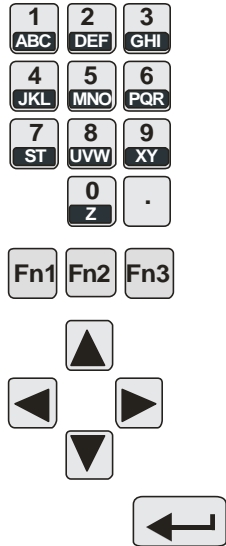
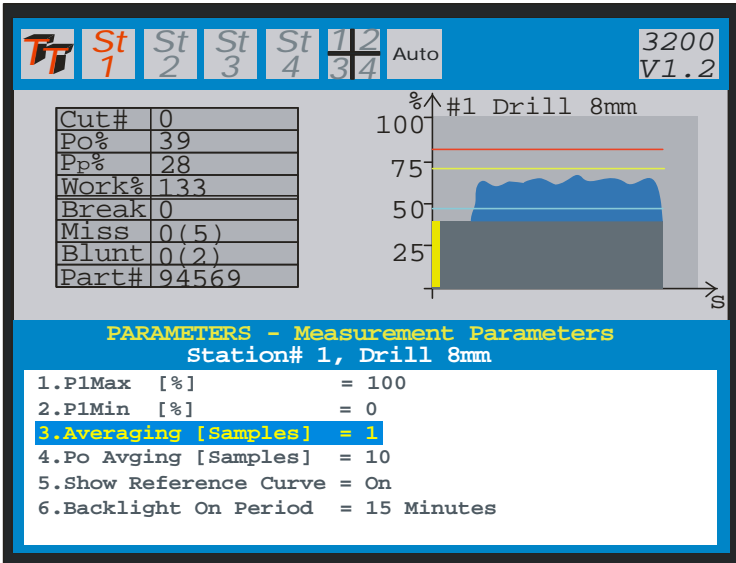

A parameter is selected by the arrow-up and down keys. The enter key may be pushed to activate the parameter. When activated the arrow-up and down key may be used to alter the variable. When the enter-key is activated again the modification is made permanent. The numerical keys may also be used to alter a variable. The enter-key or the arrow-up/down keys are used to make the change permanent.

Parameter	Range
1. PlMax [%]	PlMax ((PlMin+10)-100%) Measurement zoom function
2. PlMin [%]	PlMin (0-(PlMax-10)%) Measurement zoom function
3. Averaging	(1-10 samples) Keep as low as possible
4. Po Avging [Samples]	(0-250 samples), 0 = Off (no Po measurement)
5. Show Reference Curve	On Off
6. Backlight On Period	15 Minutes 30 Minutes 1 Hour 2 Hour



3.11 F6—Miscellaneous Parameters

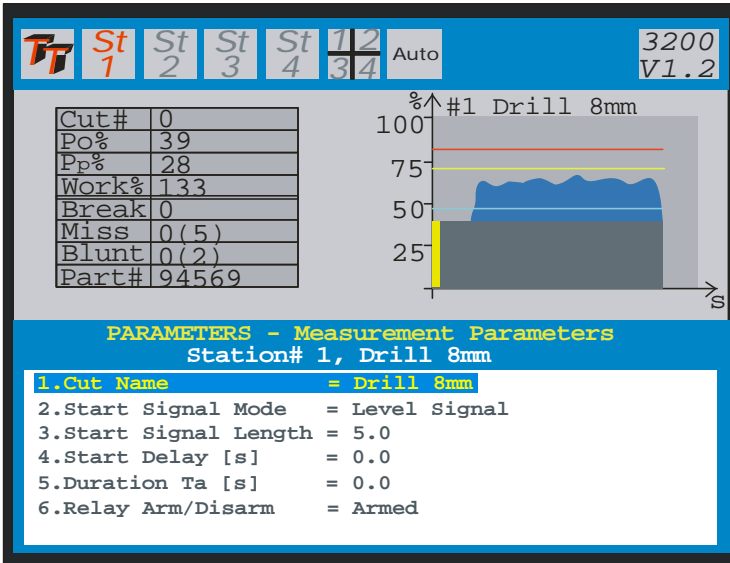

A parameter is selected by the arrow-up and down keys. The enter key may be pushed to activate the parameter. When activated the arrow-up and down key may be used to alter the variable. When the enter-key is activated again the modification is made permanent. The numerical keys may also be used to alter a variable. The enter-key or the arrow-up/down keys are used to make the change permanent.

Parameter	Range
1. Cut Name	Drill 8mm
2. Start Signal Mode	Level Signal Strobe Signal (Pulse)
3. Start Signal length	(0.0-999.9 seconds) Only used in strobe signal mode
4. Start Delay [s]	(0.0-25.0 seconds)
5. Duration Ta [s]	(0.0-999.9 seconds), 0.0 = Off
6. Relay Arm/Disarm	Armed Disarmed

The Cut name has a maximum of 14 characters. Letters are entered by first pressing a Fn1,Fn2 or Fn3 key followed by a numerical key. Arrow right is the space character and arrow left is the delete key.

3.12 Stop Mode

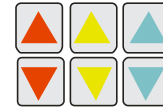
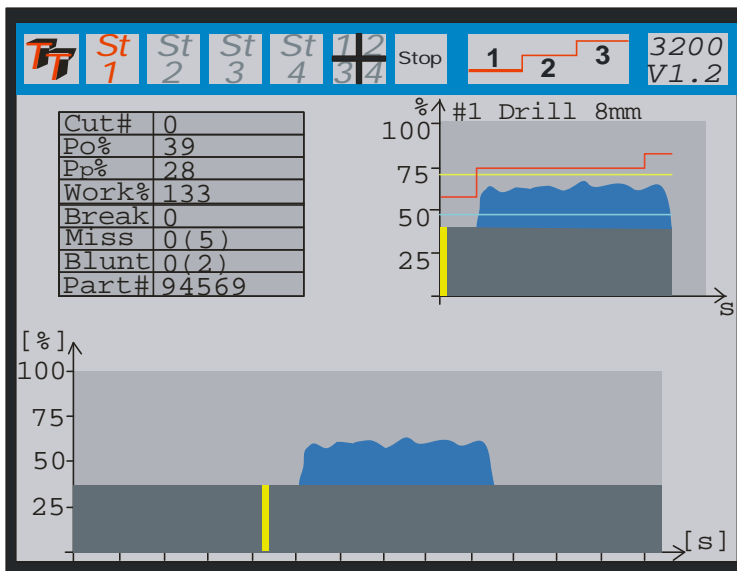

When stop mode is selected the current cut is latched in the window and only updated at the end of the cut cycle. When stop mode is selected the limits may be changed by the arrow keys in the upper right corner. If step curve is selected the step to modify is selected by the three function keys Fn1, Fn2 and Fn3.

### 3.13 Learn Command

The screenshot shows a CNC control interface with the following elements:

- Top Bar:** Includes a tool icon, station indicators (St 1, St 2, St 3, St 4, St 1/2, St 3/4), 'Auto' mode, and parameters '3200' and 'V1.2'.
- Table:** A table with the following data:

Cut#	0
Po%	39
Pp%	28
Work%	133
Break	0
Miss	0(5)
Blunt	0(2)
Part#	94569
- Graph:** A graph titled '#1 Drill 8mm' showing a blue area representing the cut profile. The y-axis is labeled '%' and ranges from 25 to 100. The x-axis is labeled 'S'.
- Learn Command Section:** A blue header reads 'LEARN COMMAND Station# 1, Drill 8mm'. Below it, a yellow box contains the text 'Press Enter Key To Learn Current Cut'. At the bottom, it says 'Use Arrow Keys to Change Mode'.

Learn

The learn command is used to cause the station selected to learn a cut. It is possible to learn the current cut or to learn all cuts.

## 3.14 Reset Command

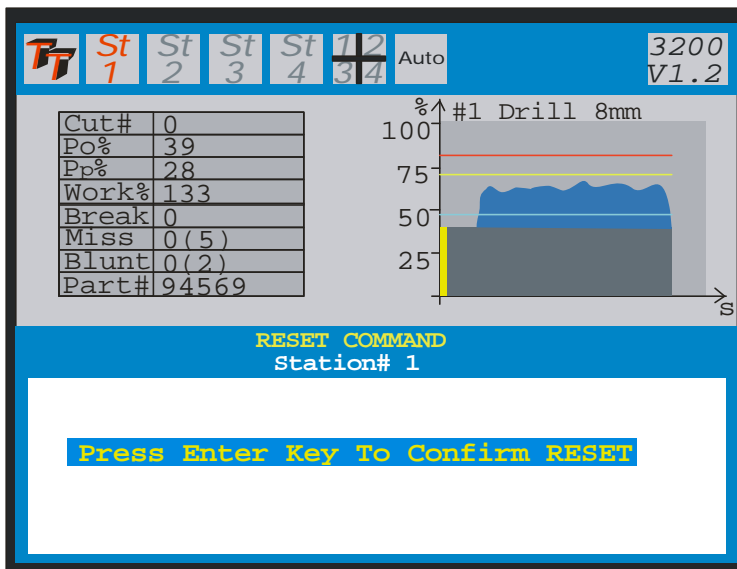

An alarm is signaled by a flashing station number.  
The reset command resets the alarm on the selected station.

### 3.15 Password Protection

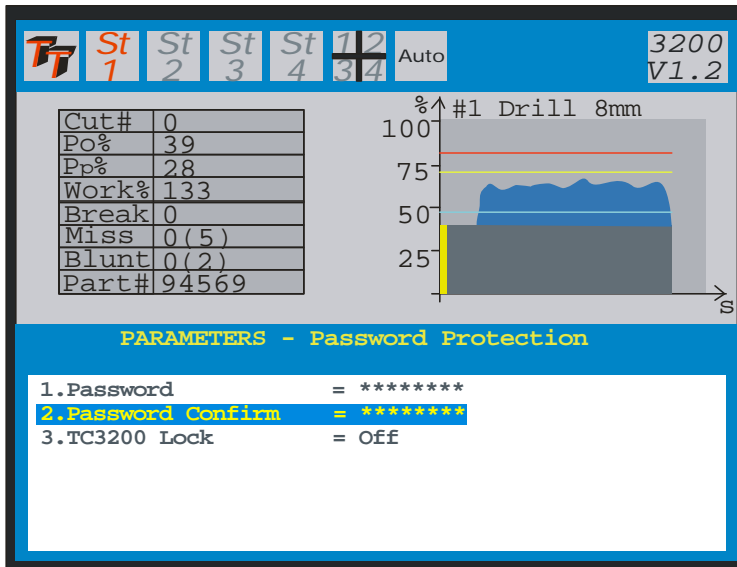

The password menu is activated by first pressing Fn1 followed by F6. In order to enter a password a password must be entered and confirmed also. When a valid password is entered it is possible to lock the TC3200.

When locked it must be unlocked before the parameter functions are accessible. Unlocking is done by entering the password followed by the enter key. The password dialog appears when one of the F-keys is activated.

When the unit is unlocked it may be locked again from the password menu.

## 4. Wiring of the PWM350 Module

For proper operation of the system, it is important that the PWM350 be set up properly (see Appendix A). Incorrect settings of **Current Measurement Range** or **Filter Time Constant** may severely reduce the functionality of the system.

### 4.1 Current Measurement Range

The current measurement range is set by applying 24 VDC input signals to pins 13 and 14, according to the logic diagram shown on page 20. The appropriate measuring range is selected by determining the Full Load Current (FLA) of the motor, which should be marked on the motor housing. Then the percentage of the rating of the PWM350 should be calculated. For example, when using a motor with an FLA rating of 5 Amps with a PWM350 rated at 25 A, the percentage of the PWM350 rating would be 20%. In this case, the 20% range on the PWM350 would be used. In cases where the percentage does not exactly correspond to one of the current ranges on the unit, the next larger range should be used.

It should also be noted that it is permissible to use external current transformers (CT's) in cases where the motor current is above the rating of the PWM350. As an example, if it was desired to monitor a motor having an FLA of 100 Amps, a 20:1 current transformer might be employed. Since the CT has a ratio of 20:1, the maximum current on its secondary would be 5 Amps. Applying the example above, the current measurement range would be set to 20%.

### 4.2 Filter Time Constant

The Filter Time Constant is set by applying a 24 VDC control signal to pins 11 and 12 of the PWM350, according to the logic diagram shown on page 20. The Filter Time Constant sets the sampling and averaging characteristics of the PWM350 module. For most tool monitoring applications, since it is desirable to try to catch very short duration power spikes caused by a tool breaking, the Filter Time Constant should initially be set to its minimum level of 20ms. This is accomplished simply by leaving pins 11 and 12 without connection.

If the system experiences nuisance faults due to short duration power transients, it may be necessary to raise the time constant to filter out these transients. In these cases, consideration should also be given to adjusting the **Power Averaging** feature of the TC3200 to attempt to filter these transients out of the monitoring.

### 4.3 PWM350 Technical Specifications

#### ***Mechanical***

Housing: Polycarbonate.  
Mounting: 35 mm DIN-rail.  
Protection Class: IP40.  
Temp. Range: -15 to + 50 C.  
Weight: App. 500g (1 lb).  
Dimensions: D 118 x B 45 x H 137,5 mm.  
Connections: Max 2,5 mm<sup>2</sup> (AVG 24).

#### ***Electrical***

Voltage Input: 3 x 0-500 V PWM (0-600V max).  
Current Input: 3 x 50 Amp. 5Hz - 5kHz.  
Power Range: 0 - 43.3 kW.  
Supply: 9-36 V DC max. 2.5 Watt.  
Analogue output: 0 - 20mA, 0 - 400 ohm isolated.  
Digital Inputs: 10-30 VDC.  
CE marked to: EN50081-1, EN50082-2,  
EN61010-1.

#### ***Measurement Ranges***

PLC control of the two inputs S1 and S2.  
100% 43.3 kW  
50% 21.7 kW  
20% 8.66 kW  
10% (1 CT turn) 4.33 kW  
10% (2 CT turns) 2.17 kW  
10% (3 CT turns) 1.44 kW  
The 10% measurement range must be selected when the PWM350 is used with external (cascading) N/5 current transducers.

A special PWM350 version where the 10% range is modified to 5% may be provided for ultra small motors.

Appendix A-Interface to 3-Phase Transducer—PWM350

**PWM350 Connection to TC3200**

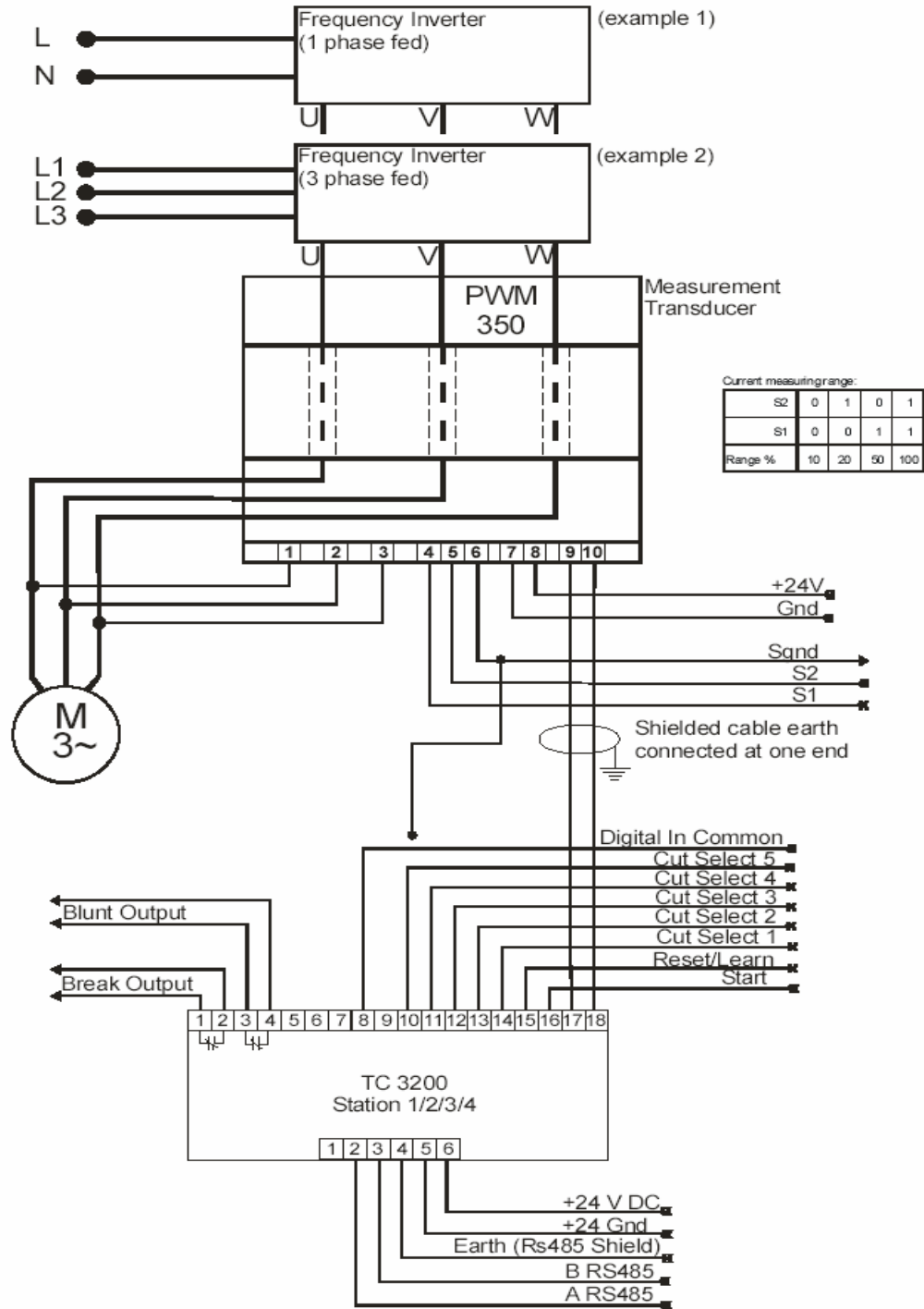

Note! Earth connected to housing inside TC3200



## Appendix B-Interface to Single-Phase Transducer—UG 105

Note! The wire that feeds through the UniGuard device *must* be the wire which connects to L3.

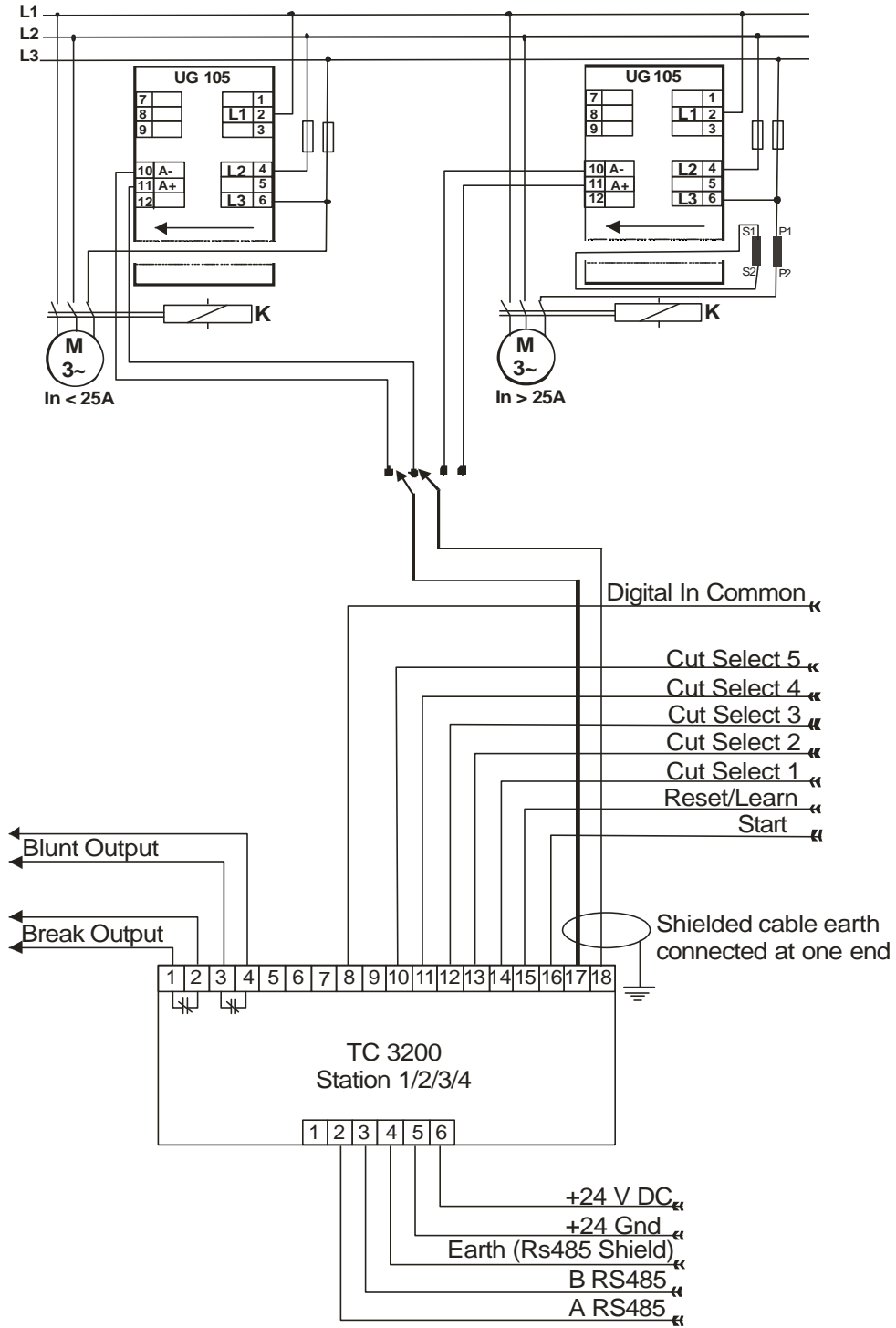

Note! Earth connected to housing inside TC3200

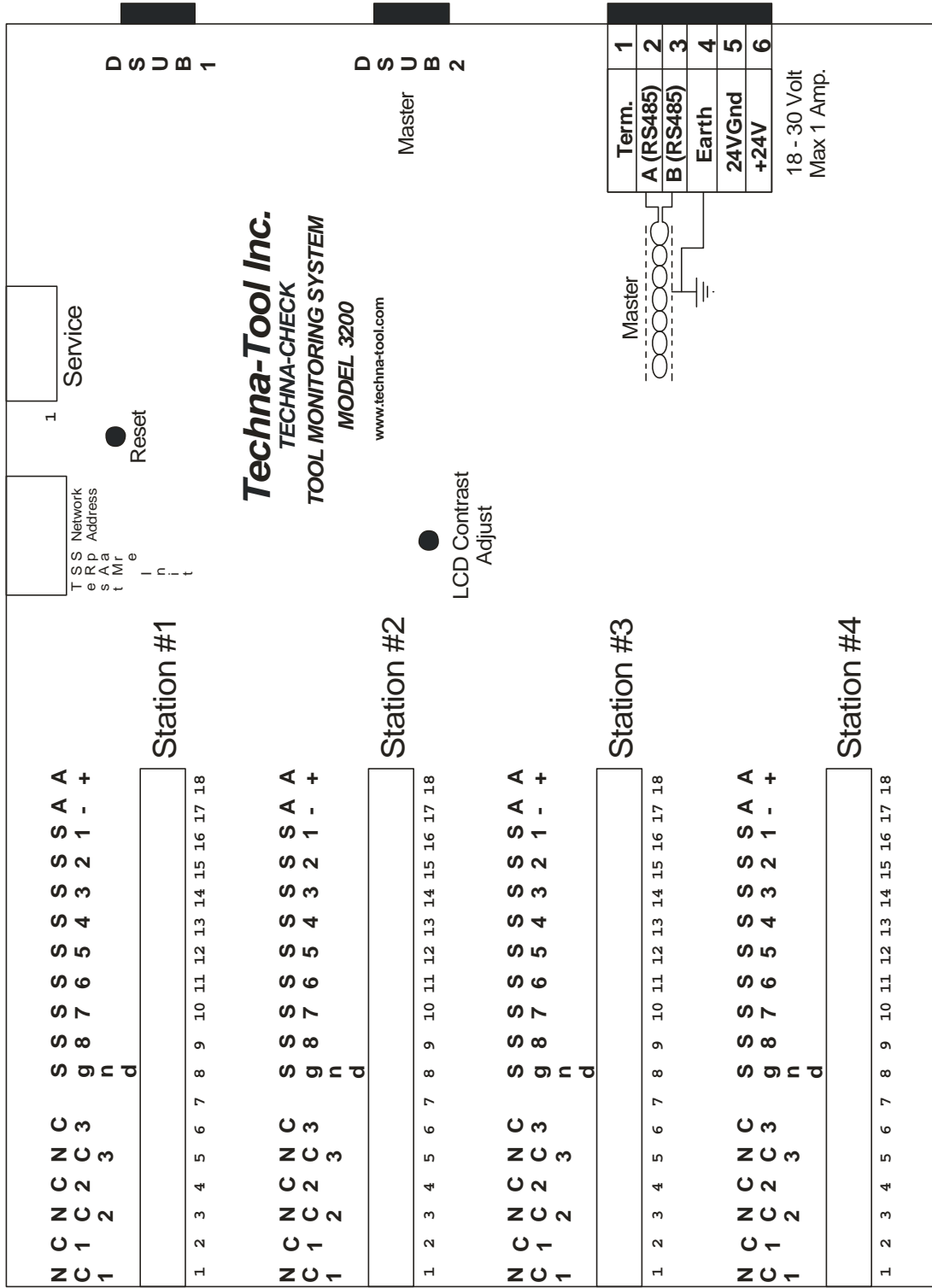

Dip Switch #	Function	Default
S1	Factory Test Only	On
S2	SRAM Initialize On Power On	On
S3	Spare	On
S4	Network Address	On
S5	Network Address	On
S6	Network Address	On
S7	Network Address	On
S8	Network Address	On

S4	S5	S6	S7	S8	Network Address
On	On	On	On	On	1
Off	On	On	On	On	2
On	Off	On	On	On	3
Off	Off	On	On	On	4
On	On	Off	On	On	5
Off	On	Off	On	On	6
On	Off	Off	On	On	7
Off	Off	Off	On	On	8
On	On	On	Off	On	9
Off	On	On	Off	On	10
On	Off	On	Off	On	11
Off	Off	On	Off	On	12
On	On	Off	Off	On	13
Off	On	Off	Off	On	14
On	Off	Off	Off	On	15
Off	Off	Off	Off	On	16
On	On	On	On	Off	17
Off	On	On	On	Off	18
On	Off	On	On	Off	19
Off	Off	On	On	Off	20
On	On	Off	On	Off	21
Off	On	Off	On	Off	22
On	Off	Off	On	Off	23
Off	Off	Off	On	Off	24
On	On	On	Off	Off	25(Outside Range)
Off	On	On	Off	Off	26(Outside Range)
On	Off	On	Off	Off	27(Outside Range)
Off	Off	On	Off	Off	28(Outside Range)
On	On	Off	Off	Off	29(Outside Range)
Off	On	Off	Off	Off	30(Outside Range)
On	Off	Off	Off	Off	31(Outside Range)
Off	Off	Off	Off	Off	32(Outside Range)

CUT SELECT INPUT 5	CUT SELECT INPUT 4	CUT SELECT INPUT 3	CUT SELECT INPUT 2	CUT SELECT INPUT 1	CUT #
Off	Off	Off	Off	Off	1
Off	Off	Off	Off	On	1
Off	Off	Off	On	Off	2
Off	Off	Off	On	On	3
Off	Off	On	Off	Off	4
Off	Off	On	Off	On	5
Off	Off	On	On	Off	6
Off	Off	On	On	On	7
Off	On	Off	Off	Off	8
Off	On	Off	Off	On	9
Off	On	Off	On	Off	10
Off	On	Off	On	On	11
Off	On	On	Off	Off	12
Off	On	On	Off	On	13
Off	On	On	On	Off	14
Off	On	On	On	On	15
On	Off	Off	Off	Off	16
On	Off	Off	Off	On	17
On	Off	Off	On	Off	18
On	Off	Off	On	On	19
On	Off	On	Off	Off	20
On	Off	On	Off	On	21
On	Off	On	On	Off	22
On	Off	On	On	On	23
On	On	Off	Off	Off	24
On	On	Off	Off	On	25
On	On	Off	On	Off	26
On	On	Off	On	On	27
On	On	On	Off	Off	28
On	On	On	Off	On	29
On	On	On	On	Off	30
On	On	On	On	On	31

Appendix F-Panel Cut-Out Profile

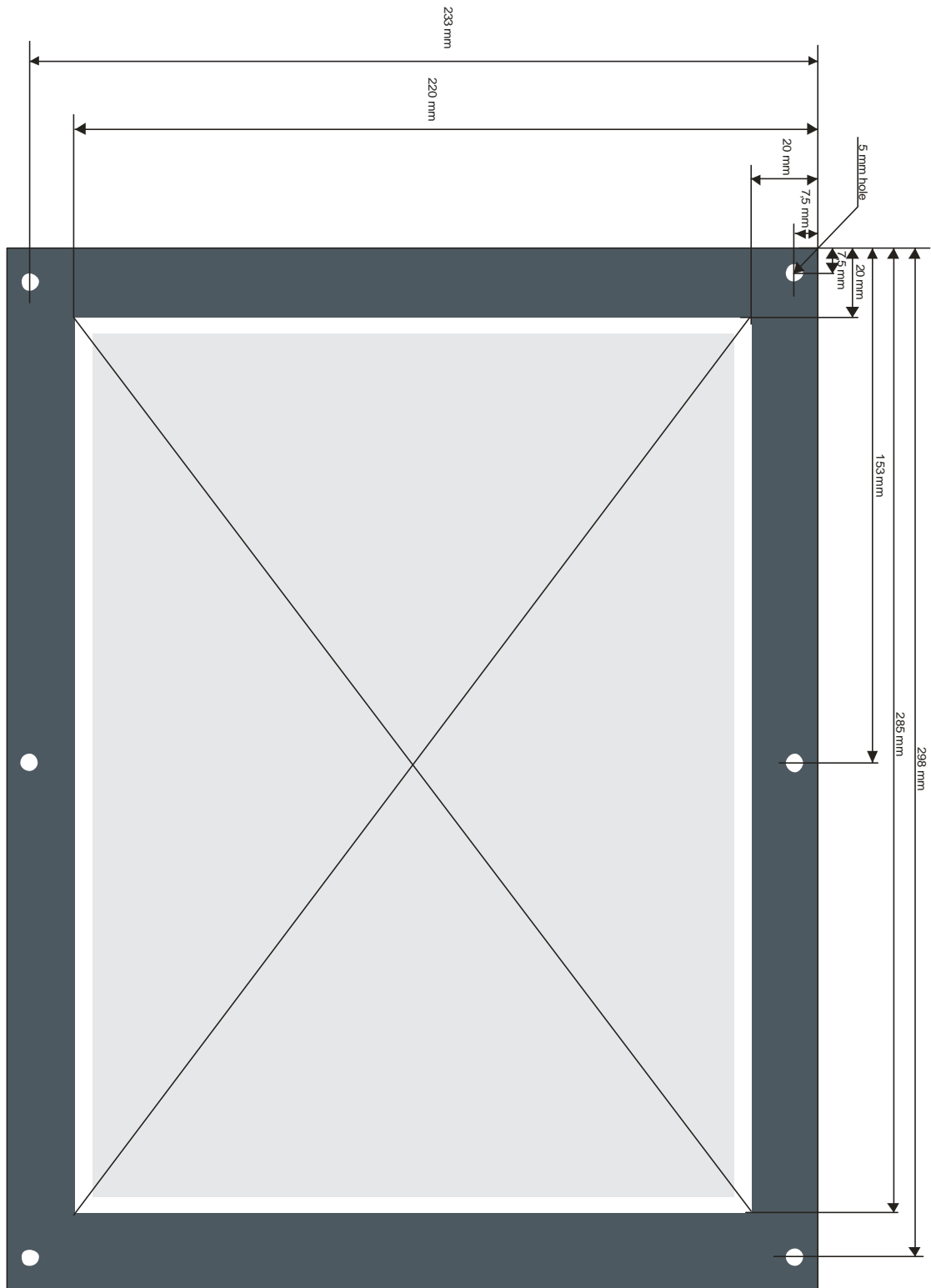

TC-26

# BK MIKRO 4

Monitoring System for Objects and Tools

Technical Documentation - North American Edition

Issue 02.00

Released: January, 1997



553 Industrial Dr. Hartland, WI 53029 262-367-8665 fax 262-367-0208  
web-site [www.techna-tool.com](http://www.techna-tool.com) email [techtool@techna-tool.com](mailto:techtool@techna-tool.com)

## Contents

<b>1. Description</b> .....	<b>2</b>
<b>2. System Components</b> .....	<b>3</b>
2.1. Control Unit .....	3
2.1.1. Characteristic Properties .....	3
2.1.2. Technical Data .....	4
2.1.3. Screw Terminals.....	5
2.1.3.1. Power Supply .....	6
2.1.3.2. Control Inputs .....	7
2.1.3.3. Scanner Connections.....	7
2.1.3.4. Relay Outputs.....	7
2.1.4. Light-Emitting Diodes .....	8
2.1.5. Toggle Switches .....	9
2.1.5.1. "Clockwise/Counter-Clockwise" Switch .....	9
2.1.5.2. "Object/Free Space Monitoring" Switch .....	9
2.1.5.3. "Normally Open Contact/Normally Closed Contact" Switch .....	9
2.1.5.4. "Decel" Switch .....	9
2.1.6. Rotary Switches .....	10
2.1.7. Notes on Technical Safety .....	11
2.2. Scanner TK 4 .....	12
2.2.1. Characteristic Properties .....	12
2.2.2. Technical Data .....	13
2.3. Connection Cable.....	13
<b>3. Function</b> .....	<b>14</b>
3.1. Mode of Operation.....	14
3.1.1. Scanning Process .....	14
3.1.2. Return Travel Monitoring.....	14
3.1.3. Output of Results.....	15
3.2. Monitoring with learn function .....	16
3.2.1. Teach-In .....	16
3.2.2. Start .....	16
3.3. Monitoring by Setting a Scanning Range.....	17
3.3.1. Setting Range.....	17
3.3.2. Control Operation "Object Monitoring" .....	18
3.3.3. Control Operation "Free Space Monitoring".....	18
3.4. Scanning Times.....	18
3.5. Deflection of Wand .....	19
3.6. Status Indication.....	19
3.6.1. Yellow LED .....	19
3.6.2. Red/Green LED.....	19
<b>4. Installation Notes</b> .....	<b>20</b>
4.1. Control Voltage Connection .....	20
4.2. Interference Prevention .....	21

## 1. Description

BK MIKRO 4 is a control system suitable for both tool and free space monitoring applications.

The complete BK MIKRO 4 system comprises

- a control unit,
- a sensor (scanner),
- a connection cable.

BK MIKRO 4 can be used for two different types of monitoring:

- Monitoring of a **scanning position** whose precise location has been previously entered by "teach-in", e.g. to carry out a tool check before each working cycle.
- Monitoring a **scanning range** freely selectable via two adjusting switches, e.g. to carry out tool checks for tools with varying diameters, or for ejection checks (free space monitoring).

Further features enabling customized system configuration include:

- Relay contacts switch-selectable as normally open or normally closed.
- Selection of clockwise or counter-clockwise travel direction for the scanner.
- Two settings of controlled acceleration and deceleration.
- Detection of cable breaks.

### Principle of Operation

When given the signal to "scan," the system will monitor the presence of a particular tool or check a certain area for obstacles.

Two different monitoring methods may be selected:

- **Monitoring with Learn Cycle**  
The monitoring system will first determine the exact position of the tool by a "teach-in" cycle. This cycle is followed by sensor-mode, during which the wand will be moved into the position "just learned", and a comparison takes place.
- **Monitoring by Setting a Range**  
A scanning range will be set via two rotary switches. Following each start signal, the wand will travel through this angle to determine monitoring results.

All output to the machine will be via two relay contacts, configurable as normally closed or normally open. For evaluation, the "O.K." relay, the "K.O." relay, or both may be used.



## 2. System Components

### 2.1. Control Unit

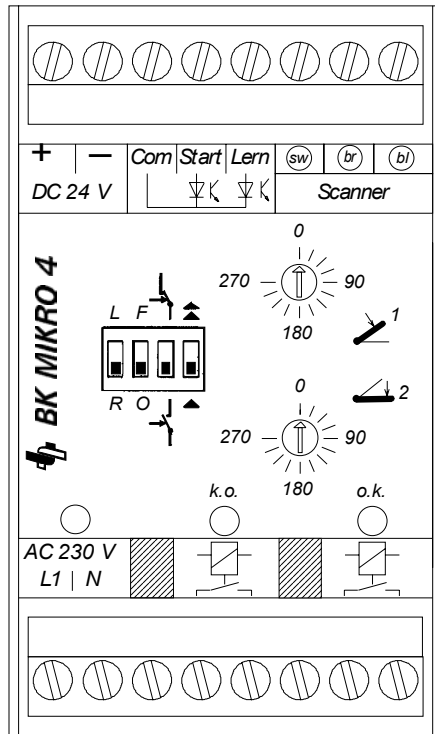

AC 230 V  
L1 | N

AC 120 V  
L1 | N

*Supply Voltage  
(optional)*

#### 2.1.1. Characteristic Properties

The BK MIKRO 4 system control unit is housed in an insulating material housing. On its front panel, the control unit is fitted with screw terminals to connect all machine inputs and outputs, supply voltage, and the scanner.

**Note:**

The unit is available in three different models for three different supply voltages: 24 VDC, 120 VAC, 230 VAC.

**2.1.2. Technical Data**

Housing .....	Insulated Material Housing, Protection Class II
Protection Type .....	IP 20
Dimensions (W x H x D).....	45 mm x 75 mm x 107.5 mm
Case Mountings .....	DIN Rail, 35 mm, to DIN EN 50022
Power Supply Voltage.....	Depending on Model: 24 VDC 120 VAC 230 VAC
Power Consumption.....	6 VA max.
Control Voltage.....	24 VDC (internal/external)
Inputs.....	Galvanically Isolated
Switched Outputs .....	2 x 250 VAC / 30 VDC
Making/Breaking Capacity .....	500 VA / 60 W (max.) 10 mA min. at 10 V
Operational Life of Relay.....	5 x 10 <sup>7</sup> switching cycles
Connections .....	plug-in screw terminals for connecting - power supply - control inputs - relay outputs - scanner
Temperature Range .....	0°C to +50°C

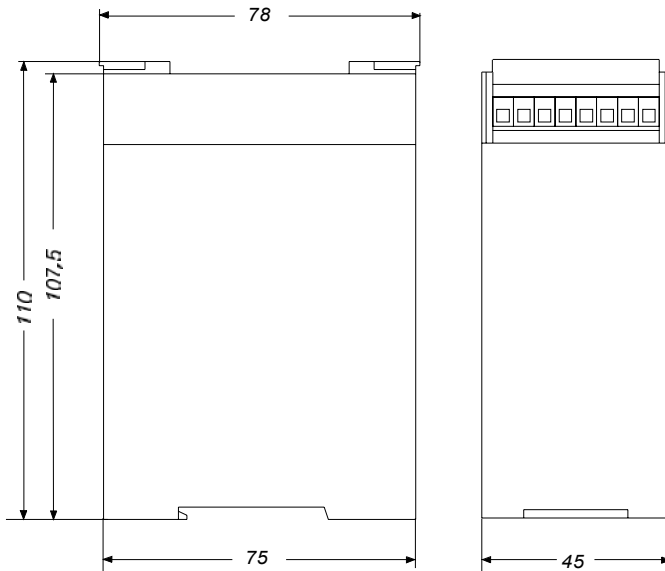

### 2.1.3. Screw Terminals

The screw terminals have been arranged on two plug-in terminal blocks. These blocks are keyed so that they cannot be accidentally plugged into the wrong socket. When in operation, plastic caps cover the screws in the front. Wires to be connected are routed from the top or bottom of the unit. Power supply, control inputs, relay outputs, and the scanner are all connected via these screw terminals.

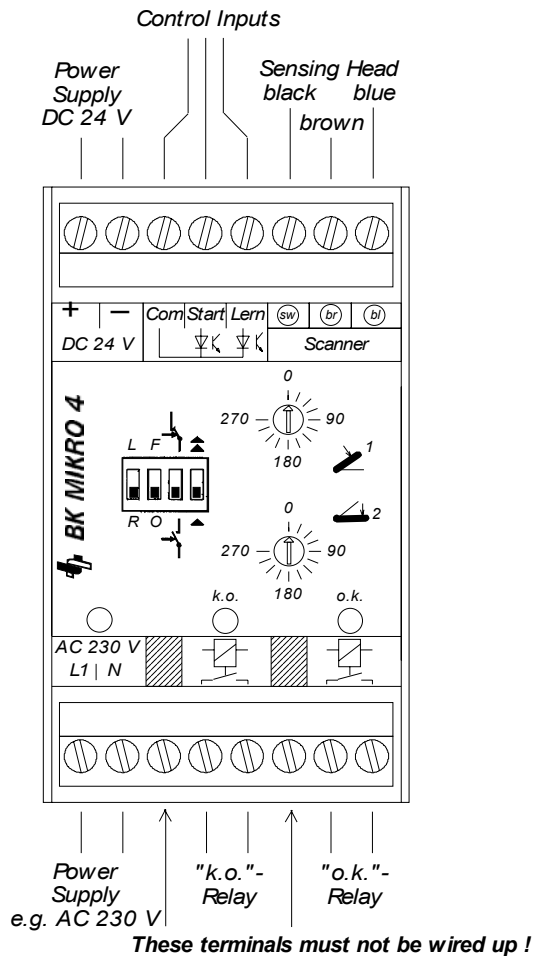

**Note:**

These plugs may only be inserted or removed when the power supply has been disconnected.

Unmarked terminals must not be connected.

### 2.1.3.1. Power Supply

#### "24 VDC" Model

- Terminal "+" 24 VDC  
Supply Voltage Input 24 VDC  $\pm$  20%  
Input Current 0.25 A max.
- Terminal "-" 24 VDC  
Reference potential of 24 VDC supply voltage.

#### "120 VAC" and "230 VAC" Models

Depending on the specific model, the unit will be supplied preconfigured for "120 VAC" or "230 VAC". The relevant version will be marked on the unit type plate next to the supply connections on the front panel.

- Terminals "L1" and "N"  
Supply Voltage Input, depending on model:  
120 VAC ( $I_{\max} = 0.05$  A) or  
230 VAC ( $I_{\max} = 0.025$  A)
- Terminal "+" 24 VDC  
Control voltage output for controlling inputs "Start" and "Learn," 24 VDC (16 V ... 32 V) unregulated.  
The control voltage meets the requirements for an extra low function potential with safe disconnection.  
Output Current 0.1 A max.  
If an external control voltage is applied, this terminal is not connected.
- Terminal "-" 24 VDC  
When using the internal control voltage, this terminal must be connected to the control inputs terminal "Com".  
If an external control voltage is applied, this terminal is not connected.

#### Note:

Alternatively, "120 VAC" and "230 VAC" models may also be supplied with 24 VDC. In this case, terminals "L1" and "N" must not be connected. Terminals "+24 V" and "-24 V" are to be connected as described above for "24 VDC" model.

### 2.1.3.2. Control Inputs

- "Com" Terminal  
Reference potential for control inputs
- "Start" Terminal  
An input level of +24 VDC will trigger a "sensing" cycle.  
The input current is approximately 5 mA; pulses lasting less than 6 ms will be disregarded.
- "Lern" Terminal  
An input level of +24 VDC will trigger a "learning" cycle (the "teach-in").  
The input current is approximately 5 mA; pulses lasting less than 6 ms will be disregarded.  
The position stored during the learning cycle will remain stored even after the unit has been switched off. Therefore, a new "teach-in" session is required only when your tool geometry changes, or the scanner is changed.  
If a range is set via a switch, any signal to the "Lern" terminal will be ignored.

### 2.1.3.3. Scanner Connections

Three screw terminals are used to connect scanner TK 4. The connections are marked according to the color-coding of the cable wires.

**Note:**

Using a different scanner may damage the scanner and control unit.

### 2.1.3.4. Relay Outputs

The terminals have been designed as dry relay contacts. By switch selection, they may be configured as either normally open or normally closed. (Note that when using the relays as normally closed, the contacts will be open when there is no power to the unit.) The contacts have been designed for 250 V and protected against inductive switch-off peaks of up to 19 W (2 ms).

Maximum switching power is 500 VA.

Maximum switching current may not exceed 2 A.

- "K.O." Relay Terminals  
These two terminals are used to indicate a fault message (K.O.).
- "O.K." Relay Terminals  
These two terminals are used to indicate a good cycle (O.K.).

### 2.1.4. Light-Emitting Diodes

Three light-emitting diodes (LEDs) on the front panel provide information about the current status of the BK MIKRO 4 monitoring system:

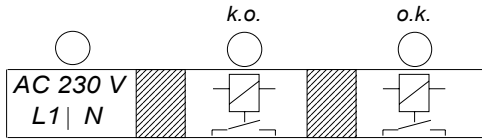

- Power Supply / Status  
yellow LED to indicate supply voltage or status
- "K.O." Relay  
red LED to indicate fault message
- "O.K." Relay  
green LED to indicate no fault message

### 2.1.5. Toggle Switches

Using the four toggle switches arranged next to each other on the control unit front panel, the following functions may be set.

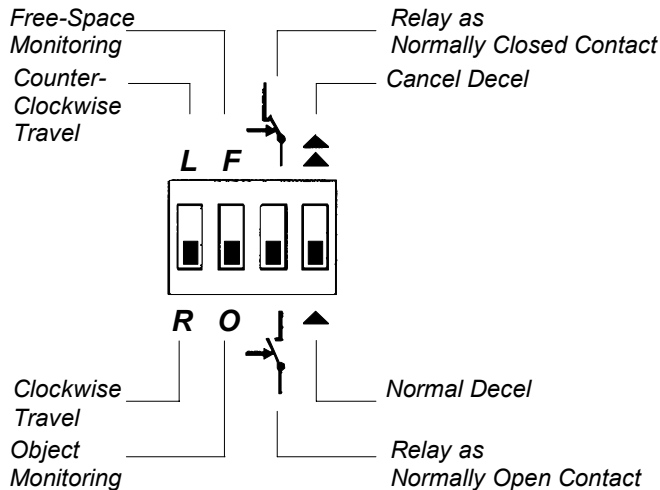

**Note - Setup on Delivery:**

**All switches are toggled downwards !**

#### 2.1.5.1. "Clockwise/Counter-Clockwise" Switch

The "Clockwise/Counter-Clockwise" switch determines the direction of rotation for the scanner.

Clockwise rotation is effected when rotating to the right (scanner viewed from behind, looking up length of scanner).

#### 2.1.5.2. "Object/Free Space Monitoring" Switch

This switch selects whether finding an object in the scanning window or not finding an object results in an OK result.

The "Free Space Monitoring" function is permitted only if a scanning range has been set via the rotary switches (it is not possible to "learn" an empty space).

#### 2.1.5.3. "Normally Open Contact/Normally Closed Contact" Switch

The "Normally Open Contact/Normally Closed Contact" switch determines the mode of operation for the two output relays.

#### 2.1.5.4. "Decel" Switch

The "Decel" switch determines whether the scanner will slow down while in its scanning range.

**Note:**

For normal tool detection applications, this switch should be in the "Normal Decel" position, as the normal deceleration of the unit is designed to protect the unit from wear and tear.

### 2.1.6. Rotary Switches

The two rotary switches are used to set a mode of operation and a scanning range. Switch positions from 0° to 270° (in 22.5° steps) are possible.

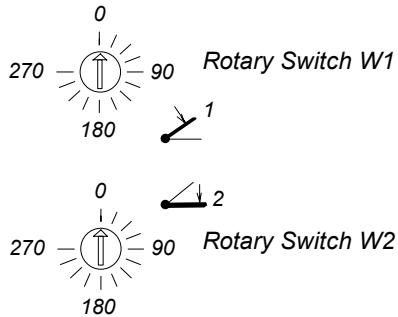

**Note:**

- W1 = 0            Return travel monitoring is switched off.
- W1 > 0           Return travel monitoring possible depending on start signal length.
- W2 = 0            Monitoring a scanning position following "teach-in".
- W2 > W1           Monitoring by setting a scanning range:
  - W1 defines where a scanning range starts, W2 where it ends; rotary direction is set by toggle switch.
  - W1 = 0 is possible (return travel monitoring is switched off).
  - $W2 \leq 270$ ; positions  $> 270^\circ$  are not permitted.
  - Monitoring range starts at approximately  $10^\circ$ .  
Smaller angles will be interpreted as a "sticking scanner" problem.



**2.1.7. Notes on Technical Safety**

The control unit comprises the following **circuits, all isolated** from each other:

K.O. Output (2 terminals)	safely isolated from all other circuits
O.K. Output (2 terminals)	safely isolated from all other circuits
AC power supply (L1, N)	safely isolated from all other circuits
DC power supply (+24 V, -24 V)	safely isolated from K.O. output, O.K. output, and AC power supply  simply isolated from control inputs no isolation from scanner connections
Control Inputs (Com, Start, Lern)	safely isolated from K.O. output, O.K. output, and AC power supply  simply isolated from DC power supply and scanner connections
Scanner Connections (black, br, blue)	safely isolated from K.O. output, O.K. output, and AC power supply  simply isolated from control inputs no isolation from DC power supply

## 2.2. Scanner TK 4

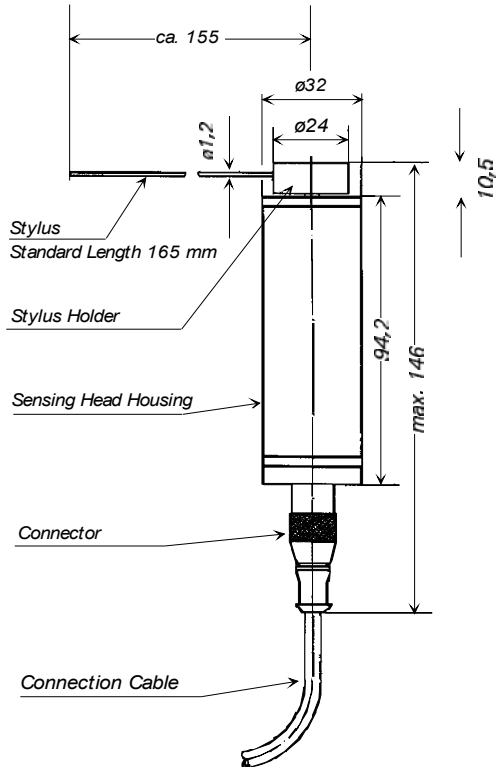

### 2.2.1. Characteristic Properties

The scanner housing is cylindrical and smooth, thus permitting easy installation, e.g. using a collet chuck. The scanner is designed for easy access for servicing and changing the wand.

Aligning the scanner is easy and requires no additional instruments or aids. Initial wand position is defined by an internal mechanical stop of the wand holder.

When a supply voltage is applied, the scanner will always move into its mechanically set initial position. The scanner will be held in this position until a start pulse triggers a scanning cycle.

#### Note:

Using scanner TK 4 with a different control unit than BK MIKRO 4 may damage the scanner and control unit.

#### Your wand is a wearing part!

Each contact with a rotating object will cause corresponding wear on the wand. This may even lead to the metal wand breaking. Due to the injury hazard this causes, users should exercise particular caution within any BK MIKRO 4 rotating area.

### 2.2.2. Technical Data

Housing .....	Anodized Aluminum
Protection Type .....	IP 67
Wand Length .....	165 mm (standard)
Scanning Angle .....	0° to 270°
Control Unit Connection .....	Connector, M12x1, 3 pins
Temperature Range .....	0°C to +80°C
Sensing Cycles .....	> 10 million with normal decel

#### **Option: Wand Holder for Small Chips**

If BK MIKRO 4 is used to monitor manufacturing processes where materials with small chips are processed (e.g. cast iron, diecast aluminum, brass), we recommend the use of our specially designed wand holder for this purpose.

### 2.3. Connection Cable

Control unit and scanner are connected by a 3-wire cable:

- pig-tail leads for connecting to the screw terminals on the control unit (note color coding of wires!)
- molded plug at the scanner end
- length 5 m, can be extended to a maximum length of approximately 25 m.

#### **Note:**

To avoid unnecessarily reducing the operational life of this cable, it should not be subject to more than a minimum amount of movement during operating cycles. Only the black, brown, and blue conductors in the cable are connected. Any additional wires, such as white, should be left disconnected.

### **3. Function**

The BK MIKRO 4 can be operated in two different ways:

- monitoring with learn function
- monitoring by setting a scanning range

Both modes of operation allow return travel monitoring.

#### **3.1. Mode of Operation**

##### **3.1.1. Scanning Process**

By applying a low voltage, the scanner will be held at rest in its mechanical stop position. Applying a start pulse will trigger a scanning cycle.

Initially, the scanner will travel at maximum speed to the start of a given monitoring range. However, its motor will slow down to a preselected scanning speed in time before a learned position or a preselected angle set by rotary switch W1 is reached.

The monitoring range will then be traversed at the preset scanning speed and its related force which is to be used to scan an object or range. During the entire operation, all pulses generated by the scanner's internal encoder will be continuously processed. If the system detects that the scanner no longer moves or has exceeded the end of the monitoring range (W2 setting), the direction of rotation immediately changes, and the scanner will return at maximum speed into its stop position.

##### **3.1.2. Return Travel Monitoring**

BK MIKRO 4 allows users to select whether or not return travel monitoring is desired.

- If rotary switch W1 = 0, return travel monitoring is off.
- If rotary switch W1 > 0, return travel monitoring is enabled.

The start signal length then determines whether the return travel will be monitored:

Before return travel begins, i.e. at the reversing point of the scanner, the system will re-read the current start signal status. If the start signal is still present, return travel monitoring begins. If the start signal has already been removed, an immediate output of results will follow. Return travel monitoring will not be performed.

---

### 3.1.3. Output of Results

- Fault message (K.O.)

A fault message will be output immediately on detection. The scanner will return to its stop position.

- Good cycle message (O.K.)

- with return travel monitoring:

On reaching the stop position, scanning process results will be indicated. This ensures that the scanner will have left the monitoring range at the time the results are output.

- without return travel monitoring:

Results will be indicated on reaching the scanner reversing point, as its return travel will not influence scanning results.

**Note:**

"K.O." will not only be indicated when a tool has broken but also when the scanner cannot leave its stop position for any reason (e.g. mechanical "sticking", cable break, etc.).

In the "O.K." state, the "O.K." relay will be active, while the "K.O." relay remains inactive.

In all other cases, "K.O." will be indicated, i.e. the "O.K." relay will be inactive, the "K.O." relay will be active.

The results of a scanning cycle will remain latched until the following cycle starts.

### 3.2. Monitoring with learn function

#### **Requirement: rotary switch W2 = 0**

The scanning range will be determined by a learning cycle (external control signal). This mode of operation is the typical mode for tool detection applications. The system will check for the presence of the tool at the learned position.

#### 3.2.1. Teach-In

The "teach-in" cycle will be started by an active input signal on the "Learn" terminal. Both relay outputs for "O.K." and "K.O." will become inactive. The scanner will travel in its preset direction of rotation.

- If a tool is detected, its position will be stored, and the scanner returns to its initial position. In addition, the "O.K." relay will be activated.
- If the scanner rotates to a maximum of 270° without detecting any tool, the "K.O." relay will be activated.

In this case, i.e. following a faulty learning action, the previously stored position will remain in force.

The LEDs "O.K." and "K.O." will indicate the result.

**Note:**

**A position learned during "teach-in" will remain stored, even after removal of power to the unit.**

**Ensure that tool geometry (layout and dimensions) at "teach-in" corresponds to the geometry used during monitoring in the "Start" mode.**

#### 3.2.2. Start

A "Start" cycle will be triggered by an active input signal on the "Start" terminal. Both relay outputs for "O.K." and "K.O." will become inactive. The scanner will travel to the previously "learned" position of the object to check for its presence.

- If the tool is in its "correct" position, the "O.K." relay will be activated. Angle tolerance for a good signal (O.K.) is  $\pm 10^\circ$  in relation to the learned position of this tool.
- If the tool is not detected, i.e. either it is missing or there is an obstacle within the scanner rotating area, the "K.O." relay will be activated.

In addition, the LEDs on the control unit will indicate the result.

### 3.3. Monitoring by Setting a Scanning Range

#### Requirement: rotary switch W2 $\neq$ 0

Rotary switch W1 and W2 settings will define the scanning range.

In this mode of operation, BK MIKRO 4 is suitable for **monitoring tools** with differing diameters as well as for **ejection monitoring** (free space monitoring).

Two rotary switches are used to define a scanning range which is to be monitored before each working cycle.

#### 3.3.1. Setting Range

The desired scanning range must be defined using rotary switches W1 and W2. W1 marks where the range starts, W2 where it ends.

Each rotary switch can be adjusted in 12 steps where each step represents an angle of  $22.5^\circ$  respectively. The direction of rotation is set by the toggle switch.

Illegal settings will be indicated to users by both LEDs flashing. The two relays, however, will remain in their rest positions.

#### Examples for Range Settings

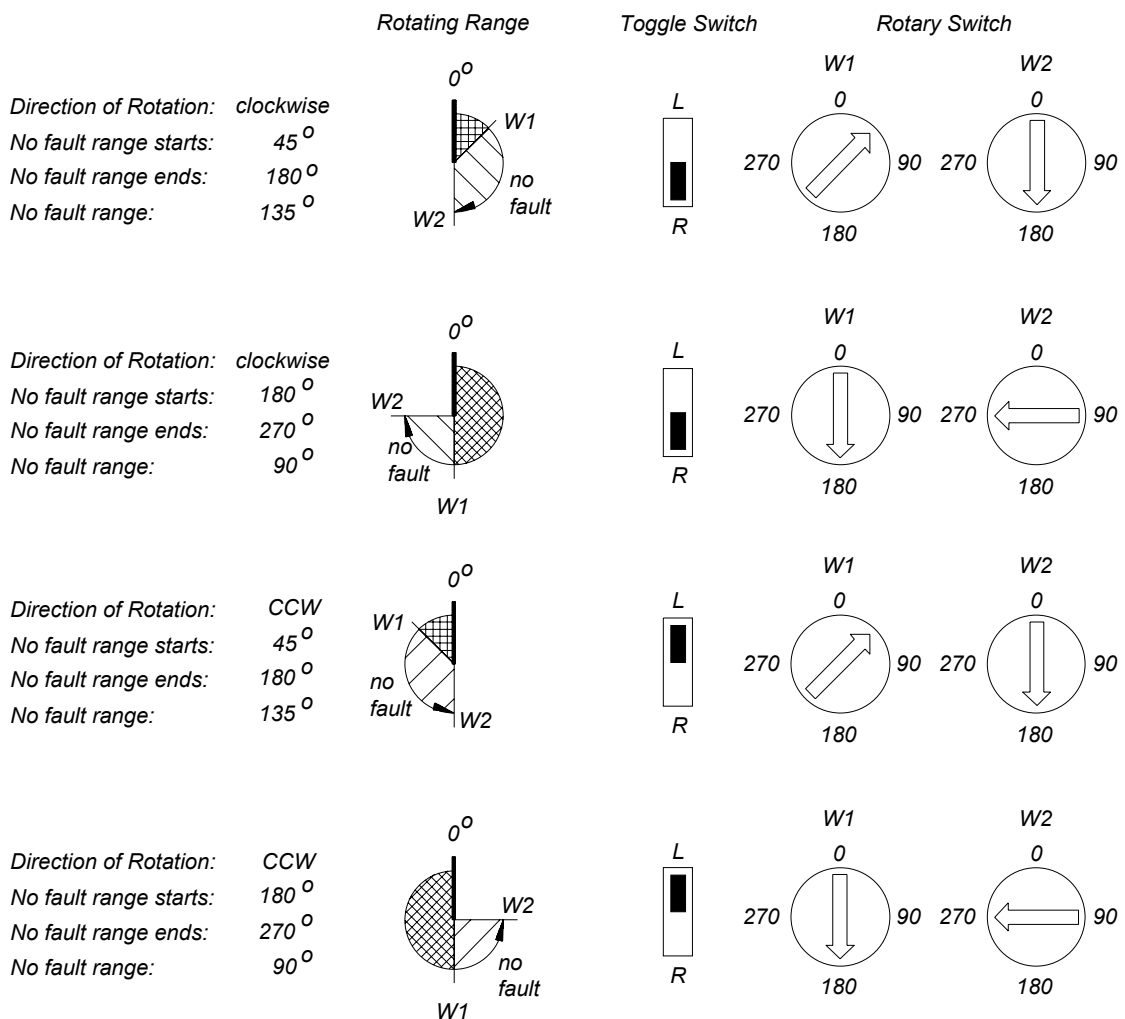

### 3.3.2. Control Operation "Object Monitoring"

During scanning, both relay outputs will be inactive (LEDs "O.K." and "K.O." not illuminated).

The control unit will change into an "O.K." state, i.e. it will issue a good message, if during a scanning cycle the operation sequence described below is followed:

- The scanner leaves its stop position.
- The angle preset via rotary switch W1 has been exceeded.
- The angle preset via rotary switch W2 has not been reached.

### 3.3.3. Control Operation "Free Space Monitoring"

The control operation "Free Space Monitoring" differs from the object monitoring mode in that within its monitoring range no object must be detected. Its "O.K." state is characterized by:

- The scanner leaves its rest position.
- The angle preset via rotary switch W2 has been exceeded.

During "Free Space Monitoring" it is typical to set the fourth toggle switch to the "No Deceleration" position. This setting will enable the unit to scan at a higher speed, and, since the unit will rarely contact a part, not reduce the life expectancy of the unit.

**Caution:**

When performing Free Space Monitoring, a broken wand will always trigger an "O.K." signal.

### 3.4. Scanning Times

Depending on the length of the path to be traveled, different scanning times will result. Several test series produced the following typical results:

Angle	at Teach-In		at Switch Setting	
	Measuring Time	Scanning Time	Measuring Time	Scanning Time
15°	125 ms	250 ms	125 ms	250 ms
270°	425 ms	850 ms	850 ms	1400 ms

As this shows: Scanning time  $\approx$  double measuring time (advance and return travel).



### 3.5. Deflection of Wand

Rotation angles will be detected by scanner encoder pulses. These pulses are derived from the rotation of the motor. For scanning, a metal needle (wand) is used which, depending on the scanning force, can be deflected. As the scanner motor is still turning when the end of this wand has already come to a stop, differences between the set and actual rotation ranges will result.

For all speeds, wand deflection is compensated to a range of less than 10°. Deflection will depend, however, on wand length.

### 3.6. Status Indication

#### 3.6.1. Yellow LED

##### **Fast Flashing = Self-Test**

After power-up, the system will carry out a self-test indicated by fast flashing of this yellow LED.

##### **Steady Illumination = Ready to Operate**

Following its self-test, the system is ready to operate. The LED stops flashing and remains steady.

##### **Slow Flashing = Motor Fault / Cable Break**

The system has detected a motor fault or cable break. Outputs will be switched inactive, the unit will remain in its present state, indicated by slow flashing of this yellow LED.

#### 3.6.2. Red/Green LED

##### **Steady Illumination = Indication following Scanning Cycle**

The red LED indicates a fault message.

The green LED indicates a no fault message.

##### **Flashing = Illegal Settings**

A flashing red and green LED simultaneously indicates that one or both of the rotary switches is incorrectly set, and/or that the "Freespace" monitoring mode has been selected without setting the rotary switches.

## 4. Installation Notes

### 4.1. Control Voltage Connection

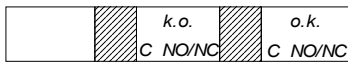
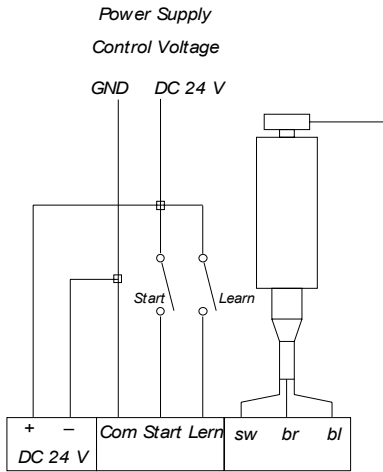

**BK MIKRO 4**  
DC 24 V  
common power and control voltage supply

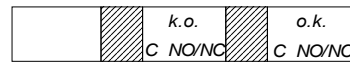
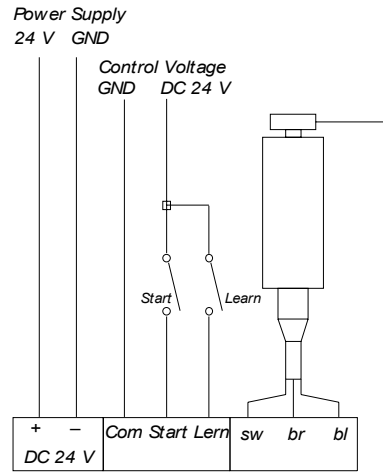

**BK MIKRO 4**  
DC 24 V  
separate control voltage

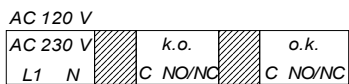
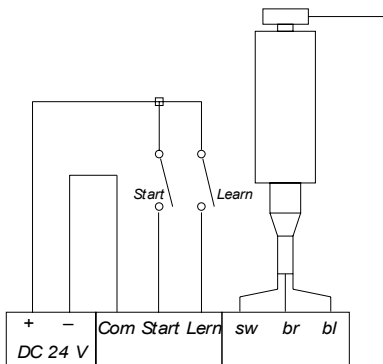

**BK MIKRO 4**  
AC 230 V (AC 120 V)  
internal control voltage

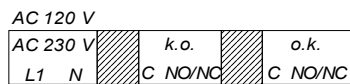
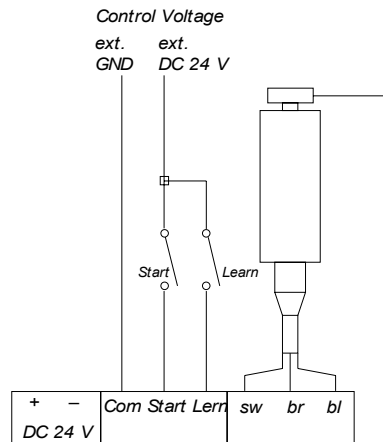

**BK MIKRO 4**  
AC 230 V (AC 120 V)  
external control voltage

**Note:**

Any connections to the "Lern" terminal in the mode where ranges are switch-selected will be ignored.

## 4.2. Interference Prevention

All inputs are opto-decoupled and thus maximally protected against interference voltage peaks, as caused, for example, by inductive sources.

Relay outputs are protected by varistors against inductive interference voltage peaks. Depending on the type of load used, further interference suppression measures may be necessary.

To ensure optimum operational safety, suppression measures, if required, must be taken at the source, i.e. directly where interference is caused.

### **Possible additional noise filters:**

- RC combination (included in the contactor suppliers' product ranges)
- Varistors
- Diodes

**15. MAINTENANCE REQUIREMENTS**

PREVENTIVE MAINTENANCE .....	15-1
PENDANT CONTROL SAFETY LABEL .....	15-2
PERIODIC MAINTENANCE .....	15-3
BASIC MACHINE .....	15-3
TABLE DOWN PROXIMITY SWITCH .....	15-3
TABLE MANIFOLD HOSE CONNECTIONS .....	15-3
COLLET TABLE .....	15-4
REMOVING THE COLLET EJECTOR ASSEMBLIES .....	15-4
REMOVING THE CONTROL PIVOT .....	15-4
SEAL KITS FOR COLLET TABLES .....	15-4
INSTRUCTIONS FOR REMOVING TABLE LIFT PISTON .....	15-4
SOLENOID VALVES .....	15-4
CHUCK TABLE (OPTIONAL) .....	15-4
HYDRAULIC POWERPACK .....	15-5
NC TOOLSPINDLE UNITS .....	15-6
COMPLETE SEAL KITS FOR UNITS .....	15-6
CHANGING THE BELT ON SINGLE AXIS NC UNITS .....	15-7
CHANGING THE BELT ON 2-AXIS NC UNITS .....	15-7
CROSS SECTION VIEW OF TYPICAL NC TOOLSPINDLE UNIT .....	15-8
2-AXIS NC UNITS .....	15-9
2-AXIS NC UNIT SCALE MAINTENANCE .....	15-9
CNC SLIDE FLANGE .....	15-9
INVERTING AND TRANSFER UNITS .....	15-10
INVERTING UNIT 30 .....	15-10
RECESS UNIT .....	15-11
CROSS DRILL AND MILLING UNITS .....	15-11
CROSS DRILL AND MILLING HEAD LUBRICATION .....	15-11
CUTOFF UNIT .....	15-12
AE160 CUT OFF UNIT MAINTENANCE .....	15-12
AE250 CUT OFF UNIT MAINTENANCE .....	15-13
AE250 SAW HEAD WITH QC ARBOR .....	15-13
CHIP CONVEYOR/BAG FILTERS .....	15-14
BAG FILTERS .....	15-14
CHIP CONVEYOR .....	15-14
TURMOIL COOLER (OPTIONAL) .....	15-16
BARFEEDER .....	15-17
ENCODER PERIODIC MAINTENANCE (4000 HRS.) .....	15-18
IEMCA BUNDLE BAR LOADER .....	15-19
ELECTRICAL .....	15-19
PERIODIC MACHINE SAFETY CHECKS .....	15-20
SEAL KITS .....	15-20
SPARE PARTS .....	15-20
SOLENOID VALVES - 110V .....	15-20
SOLENOID VALVES - 24V .....	15-21
HYDRAULIC HOSES .....	15-21
BELTS .....	15-21
HYDRAULIC POWERPACK .....	15-21
ELECTRICAL .....	15-21
HYDROMAT PREVENTIVE MAINTENANCE SUMMARY AND LOG SHEET .....	15-22

## MAINTENANCE REQUIREMENTS

---

### PREVENTIVE MAINTENANCE

Your EPIC R/T HYDROMAT is a high production Machine Tool engineered for many years of trouble free production. However, many of the service problems that can occur over the life of any Machine can be avoided through the application of proper preventive maintenance practices. The purpose of this chapter is to help you set up a regular schedule of periodic preventive maintenance for your HYDROMAT machine.

Keeping the machine clean is an important part of preventive maintenance. Cleaning the machine takes only a few minutes each shift when done on a regular basis. Wipe the machine thoroughly with a rag soaked in kerosene. If the machine is in an atmosphere where exposed metals rust quickly, wipe them with a rag soaked in a clear mineral oil.

Never use Acetone, Phenol, Benzole, concentrated acids, caustic or abrasive cleaners as these may ruin the finish on machine components. Never use water or steam to clean Machine surfaces. Avoid the use of compressed air for cleaning purposes. The pressure will drive dirt and chips into seals and bearing surfaces. Attach a hose to a coolant fitting and turn on the coolant to clean chips from the table and machining areas. Pay special attention to the Toolspindle Units with Cross Drilling or Milling Heads mounted since chips tend to build up behind these heads.

Before performing any of the procedures in this chapter, make sure the surrounding areas are clean and exposed hydraulic lines are capped or covered. If possible the unit should be removed and placed on a clean work bench where disassembly can be done in a clean and orderly fashion. Always have a print of the unit nearby for reference.

Use the proper tools when performing repair work. Avoid the use of a punch and hammer to remove lock nuts. Use the appropriate face or hook spanner. Never beat mating parts back together with a steel hammer. If you must use persuasion, use a nylon hammer with light blows. Inspect all parts for wear or damage. Avoid re-using worn or questionable parts.

Never use a punch and hammer when installing bearings. Always use a suitable arbor press. When installing angular contact bearings, be sure the bearings are placed in the correct direction. Bearing sets will have scribed arrows on the outer race that represent the bearing's orientation. Refer to the unit drawing for correct bearing directions. Never over-grease permanently greased bearings. Evenly distribute the recommended volume of grease with a syringe. Always use the HYDROMAT recommended grease.

Call or fax the HYDROMAT Service Dept. with any questions or comments regarding these preventive maintenance procedures.

## PENDANT CONTROL SAFETY LABEL

**NOTE:** Please ensure, whenever Preventive Maintenance is performed, that safe work habits are exercised (refer to Chapter 3 for further information).

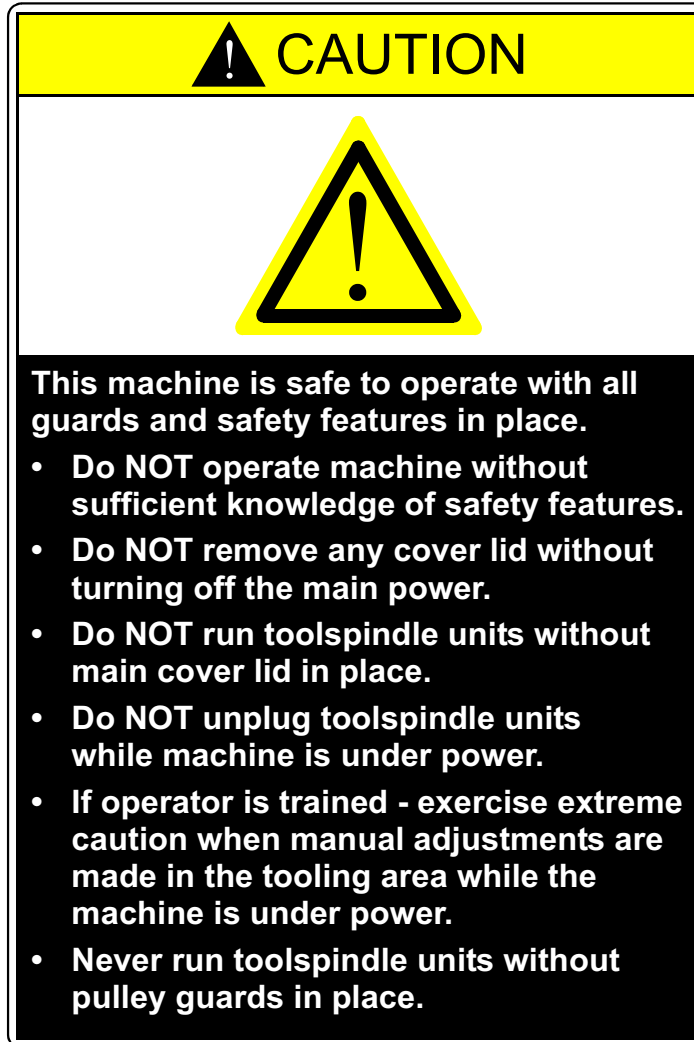

## PERIODIC MAINTENANCE

### BASIC MACHINE

ITEM	INTERVAL HOURS	TIME EST. HOURS	PROCEDURE
1.	4000 6000 (24V)	0.5 0.5	Replace the Emergency Solenoid valve (Parker part# D1VW2CNYPF). The valve is mounted on the manifold below station 2. Also replace the 1/2 Index/Reset Solenoid valve (Parker part# D1VW20BNYPF). These components correlate directly with your safety and their replacement is imperative.
2.	4000	1.5	Remove and inspect the Table Down proximity switch rod assembly, clean and regrease before reassembly. See Ch. 11.
3.	4000	4	Replace the Hydraulic Manifold supply hoses.
4.	8000	1.5	Replace the Table Down Proximity switch (Balluff Proximity Switch part #BES516207S27-E). See Chapter 7 for details.

### Table Down Proximity Switch

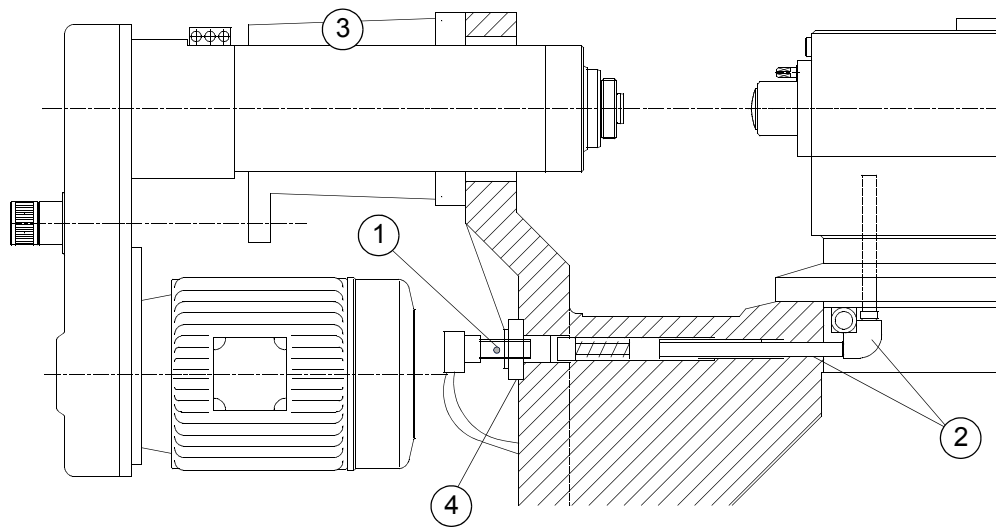

1. Table Down Proximity Switch
2. Lever and Push Rod
3. Toolspindle at Station 2
4. Adjustment dial

### Table Manifold Hose Connections

Refer to Chapter 11 for detailed instructions.

## 15. Maintenance Requirements

### COLLET TABLE

ITEM	INTERVAL HOURS	TIME EST. HOURS	PROCEDURE
1.	1000	1	Clean all Collet and Ejector assemblies of Coolant and Chips.
2.	4000	1	Remove the Control Pivot and replace all O-rings.
3.	4000	1	Remove all Collet ejector assemblies and replace all O-rings.
4.	8000	4	Pull the Table Lift Piston and replace all O-rings.
5.	8000	2	Remove the Index Drive (Rack and Pinion) and replace all seals and the Bearing bushing.

**Note:** The preferred way to remove collet and ejector assemblies is to use a screw air ratchet, speed wrench, or standard ratchet. Do not use a standard air ratchet.

### Removing The Collet Ejector Assemblies

Refer to Chapter 11 for detailed instructions.

### Removing The Control Pivot

Refer to Chapter 11 for detailed instructions.

### Seal Kits For Collet Tables

Refer to your Unit Parts Book.

### Instructions For Removing Table Lift Piston

Refer to Chapter 11 for detailed instructions.

### SOLENOID VALVES

ITEM	INTERVAL HOURS	TIME EST. HOURS	PROCEDURE
1.	6000 (110V) 8000 (24V)	0.3 0.3	Change 3 4/3 Way Solenoid Valves

### CHUCK TABLE (OPTIONAL)

ITEM	INTERVAL HOURS	TIME EST. HOURS	PROCEDURE
1.	1000	0.5	Inspect the Chuck Assemblies for worn or damaged jaws. Repair as needed.
2.	4000	1	Remove the Control Pivot and replace all O-rings.
3.	4000	8	Remove the individual Chuck assemblies and replace all O-Rings.
4.	8000	8	Pull the Table Lift Piston and replace all O-rings.
5.	8000	3	Remove the Index Drive (Rack and Pinion) and replace all seals and the Bearing bushing.



## HYDRAULIC POWERPACK

ITEM	INTERVAL HOURS	TIME EST. HOURS	PROCEDURE
1.	500 (Once)	2	After the initial break in period, drain the Powerpack oil and thoroughly wipe out the tank.
2.	1000	0.3	Change the Filter on the Powerpack.
3.	2000	0.25	Check the nitrogen charge on the Accumulators. See Chapter 12 for instructions.
4.	2000	2	Drain the Powerpack oil and thoroughly wipe out the tank. Remove the side cover for access.
5.	8000	2	Replace the Pump Motor Drive Coupling.

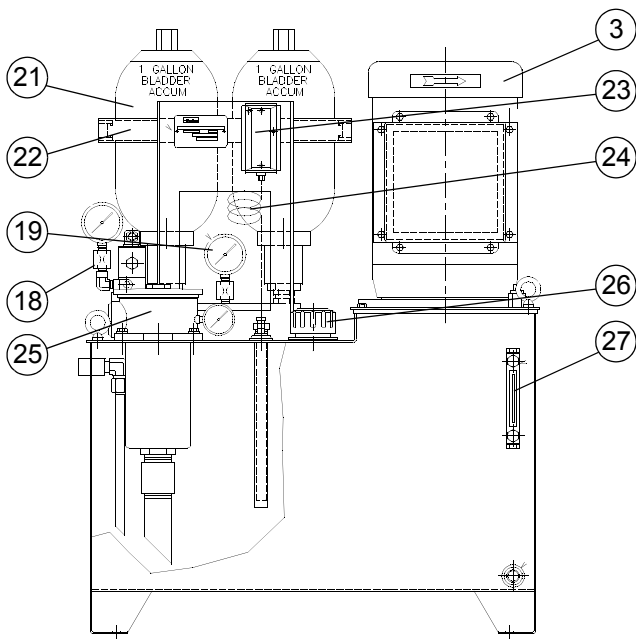

- 3 5 HP System Pressure Pump Motor
- 10 Pump Compensator Control
- 13 Heating Relief Valve (50 Bar/725 Psi)
- 15 Single Station manifold
- 16 Safety Relief Valve (70 Bar/1015 Psi)
- 17 4/3 Directional Control Valve (Heat/Normal)
- 18 Gauge Snubber
- 19 System Pressure Gauge
- 19a Collet or Chuck High Pressure Gauge
- 21 One Gallon Parker Accumulator x 2
- 22 Accumulator Clamp
- 23 A-B Thermostat (100 deg. F)
- 24 Bulbwell A-B
- 25 Return Line Filter
- 26 Filler Breather

**NOTE:** Refer to the Unit Parts Book for Part Numbers and procedures.

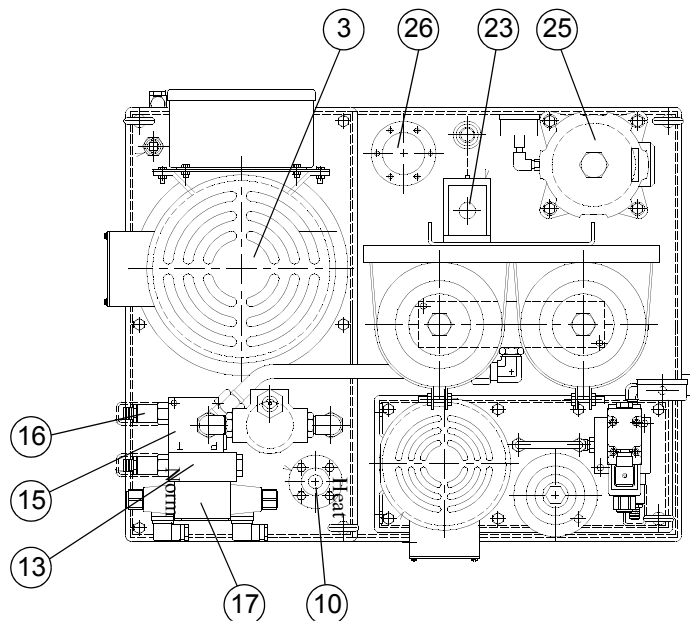

## 15. Maintenance Requirements

### NC TOOLSPINDLE UNITS

ITEM	INTERVAL HOURS	TIME EST. HOURS	PROCEDURE
1.	4000	1	Inspect all unit Belts and replace if necessary.
2.	4000	0.5	Inspect all unit Hoses and replace if necessary.
3.	8000	10	Analyze the condition of all unit bearings with a Digital Bearing Analyzer (comparable to a SPM Bearing Analyzer BAS-10). The information provided will determine if a rebuild is necessary. If a rebuild is performed replace all Seals, O-Rings, and Bearings. If the unit contains permanently greased Spindle bearings call the Hydromat Service Dept. for recommendations or pricing on exchange units. Refer to the HYDROMAT Units Part Book specific unit drawings.

### COMPLETE SEAL KITS FOR UNITS

To order a Seal Kit for a particular Toolspindle unit, refer to the unit parts book for the machine it belongs to. Look up the unit part # on page 3 of the table of contents and you will find the appropriate seal kit.

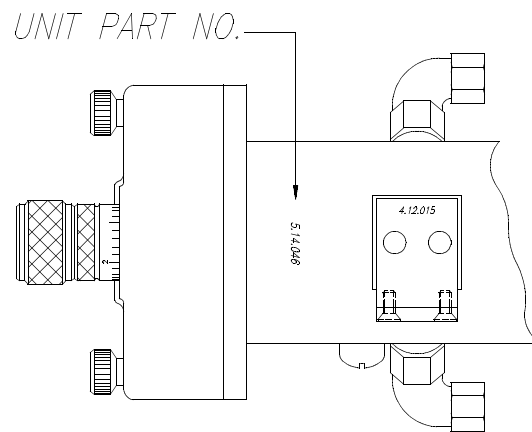

**CHANGING THE BELT ON SINGLE AXIS NC UNITS**

1. Turn off the Machine power.
2. Remove the Belt Cover.
3. Loosen the Belt Tension Locking Screw (2) to loosen the Belt Tension.
4. Remove the Belt (1) and install a new one.
5. Set the Belt tension to allow about 1/2" deflection.
6. Reinstall the Belt Cover.

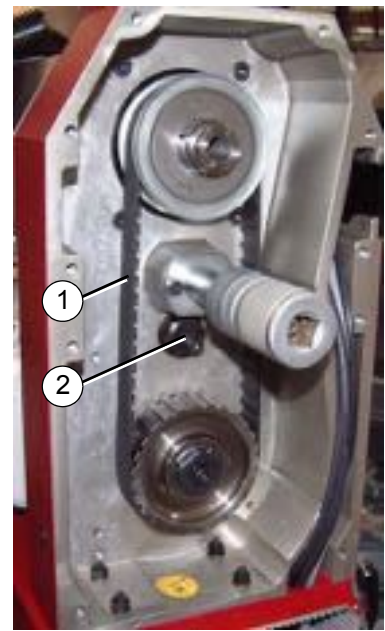

**Single Axis NC Unit  
With Belt Cover Removed**

**CHANGING THE BELT ON 2-AXIS NC UNITS**

1. Turn off the Machine power.
2. Remove the Belt Cover.
3. Loosen eight 13mm Hex Head Cap Screws (3) on the Motor Plate Slide.
4. Turn the Tension Wheel (2) to loosen the Belt Tension.
5. Place a wrench on the Motor Hub (5) and loosen Cap Screw (6).
6. Remove the Motor Pulley (4).
7. Take apart the upper back end of the Unit and remove the Belt (1).
8. Install a new belt and reassemble the upper back end of the Unit.
9. Reassemble Motor Hub and set the Belt tension to allow about 1/2" deflection.
10. Retighten eight Cap Screws (3).
11. Reinstall the Belt Cover.

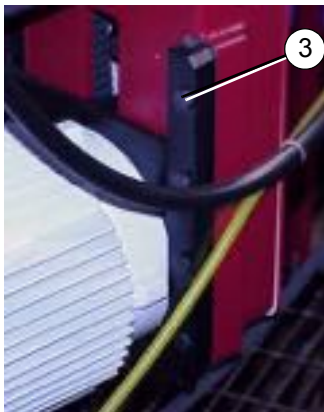

- 1 Belt
- 2 Tension Wheel
- 3 Cap Screw
- 4 Motor Pulley
- 5 Motor Hub
- 6 Cap Screw

**CAUTION**

- Do not over-tighten the Timing Belt. Only tighten enough to eliminate the play.



**WARNING: RISK OF INJURY!**  
Do not run Toolspindle Units without cover.

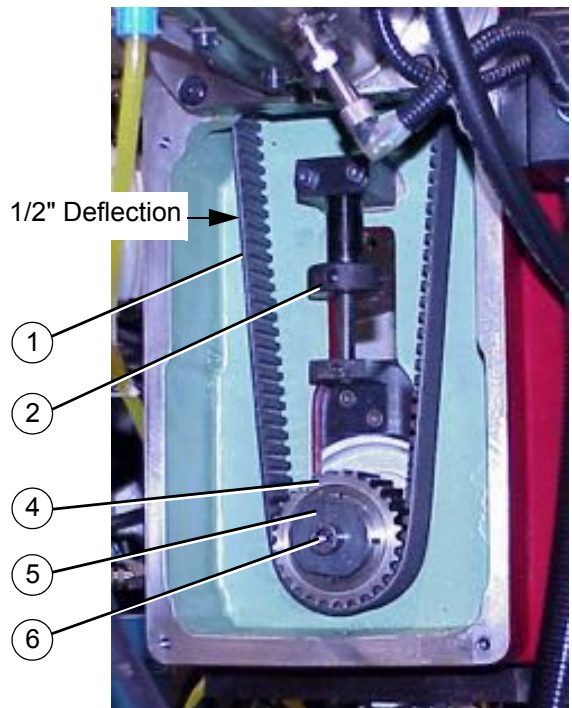

**2-Axis NC Unit  
With Belt Cover Removed**

## 15. Maintenance Requirements

### CROSS SECTION VIEW OF TYPICAL NC TOOLSPINDLE UNIT

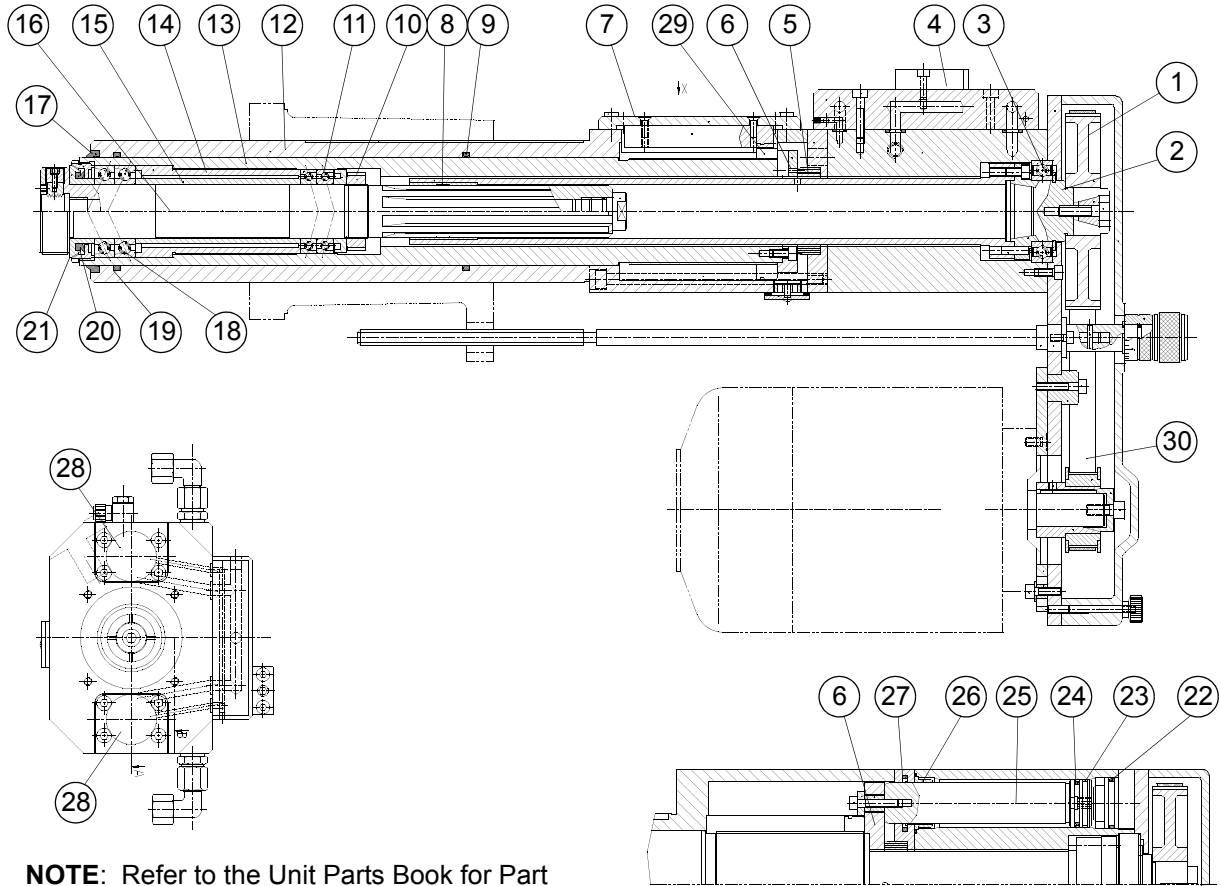

**NOTE:** Refer to the Unit Parts Book for Part Numbers and procedures.

- |                        |                                |
|------------------------|--------------------------------|
| 1 Spindle Pulley       | 16 Spindle                     |
| 2 Spindle Drive        | 17 Dirt Seal                   |
| 3 Ball Bearing         | 18 Angular Contact Set         |
| 4 Bleed Valve          | 19 Lip Seal                    |
| 5 Dampening Ring       | 20 Slinger Seal                |
| 6 Brille plate         | 21 Holding Ring (left h.)      |
| 7 Cover                | 22 O-Ring                      |
| 8 Keyed Hub            | 23 Guide Ring Seal             |
| 9 Lip Seal             | 24 Turcon Step Seal            |
| 10 Lock Nut            | 25 Piston                      |
| 11 Angular Contact Set | 26 Bushing                     |
| 12 Unit Body           | 27 O-Ring                      |
| 13 Quill               | 28 Cylinder lids               |
| 14 Spacer              | 29 Stroke Adjustment Stop Ring |
| 15 Spanner Tube        | 30 Belt                        |

## 2-AXIS NC UNITS

ITEM	INTERVAL HOURS	TIME EST. HOURS	PROCEDURE
1.	8	0.1	Check level in Willey Vogel Lube unit and refill if necessary.
2.	2000	0.1	Check the scale for loose screws and tighten accordingly.

**NOTE:** Refer to NC Unit section earlier in this chapter for additional maintenance.

### 2-AXIS NC UNIT SCALE MAINTENANCE



**WARNING: RISK OF INJURY!**  
Turn off Machine power or unplug before servicing the Unit Scale.

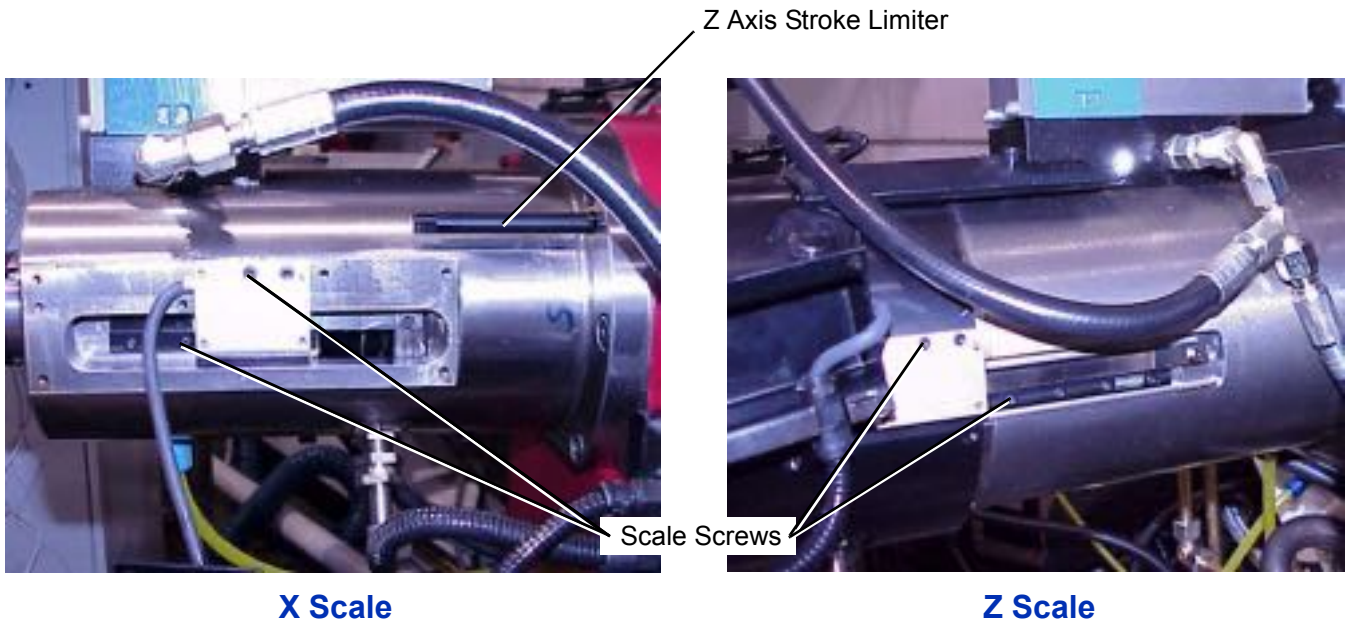

**CNC 50/100 2-Axis Servo Unit X & Z Scale Locations With Covers Removed**

## CNC SLIDE FLANGE

ITEM	INTERVAL HOURS	TIME EST. HOURS	PROCEDURE
1.	2000	0.1	Grease the (Optional) CNC Slide Flange.

## 15. Maintenance Requirements

### INVERTING AND TRANSFER UNITS

ITEM	INTERVAL HOURS	TIME EST. HOURS	PROCEDURE
1.	6000	3	Replace all seals and replace any worn parts.
2.	6000	3	Disassemble and inspect the Rotation Rack and Pinion and replace if necessary.

#### INVERTING UNIT 30

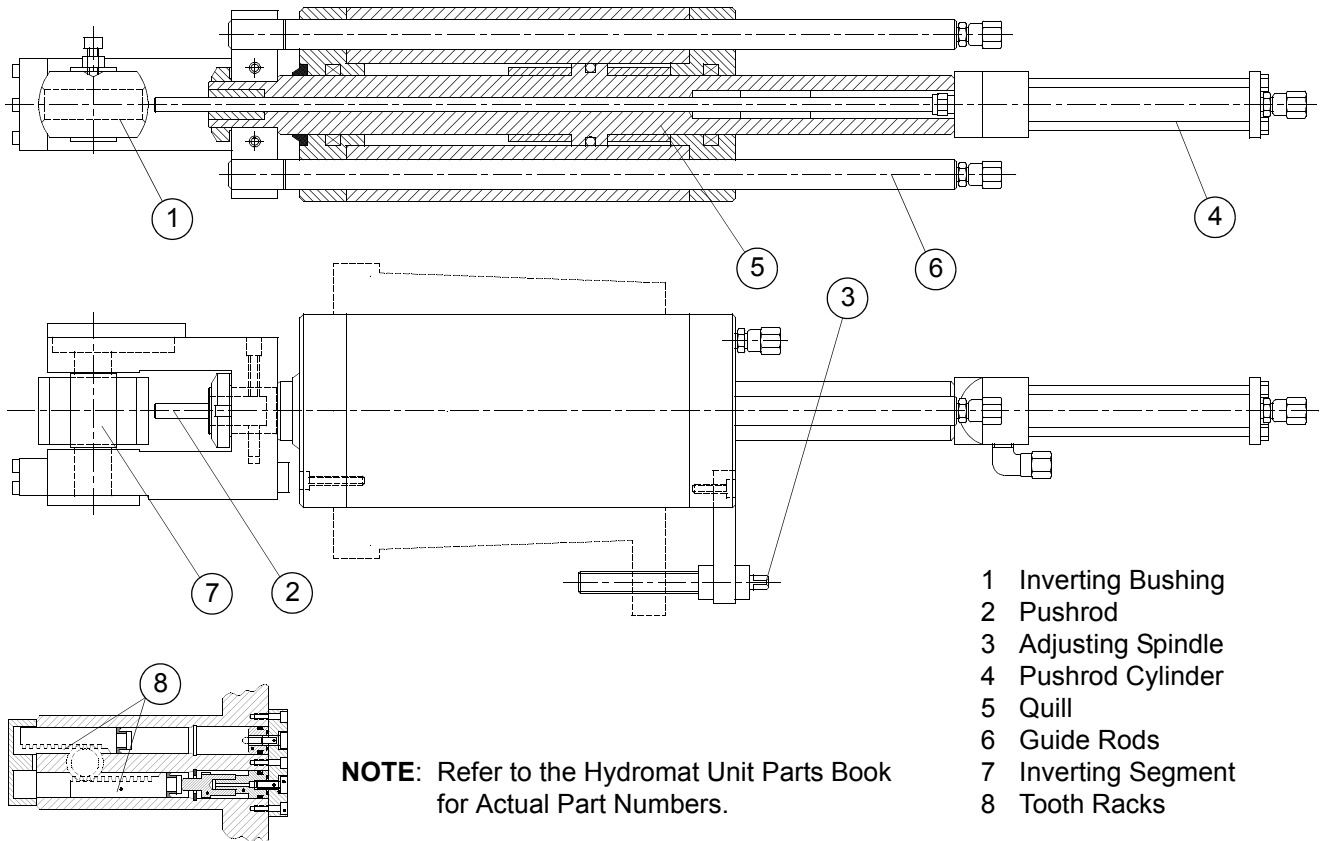

**NOTE:** Refer to the Hydromat Unit Parts Book for Actual Part Numbers.

## RECESS UNIT

ITEM	INTERVAL HOURS	TIME EST. HOURS	PROCEDURE
1.	1000	1	Disassemble, inspect and clean the Recess Head.
2.	4000	1	Inspect all unit Belts and replace if necessary.
3.	4000	0.5	Inspect all unit Hoses and replace if necessary.
4.	8000	10	Analyze the condition of all unit bearings with a Digital Bearing Analyzer (comparable to a SPM Bearing Analyzer BAS-10). The information provided will determine if a rebuild is necessary. If a rebuild is performed replace all Seals, O-Rings, and Bearings. If the unit contains permanently greased Spindle bearings call the Hydromat Service Dept. for recommendations or pricing on exchange units. Refer to the HYDROMAT Units Part Book specific unit drawings.

## CROSS DRILL AND MILLING UNITS

ITEM	INTERVAL HOURS	TIME EST. HOURS	PROCEDURE
1.	50	0.1 each	Grease all Cross Drill and Milling Heads with either the Hydromat type or regular grease gun (whichever is appropriate).
2.	2000	3	Replace all seals and replace any worn parts.

### CROSS DRILL AND MILLING HEAD LUBRICATION

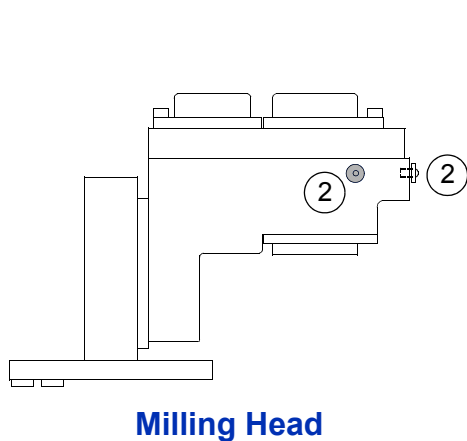

- 1 Regular (Zert) type fittings
- 2 Hydromat type fittings

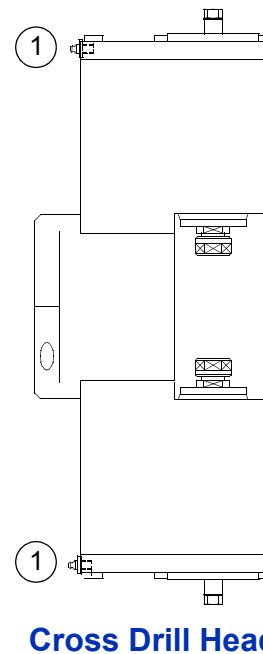

Lubricate the Cross Drill and Milling Heads every week using the HYDROMAT or regular style grease gun.

## 15. Maintenance Requirements

### CUTOFF UNIT

ITEM	INTERVAL HOURS	TIME EST. HOURS	PROCEDURE
1.	50	0.1	Grease the Cut Off Unit fittings with the Hydromat Grease gun (see grease specs).
2.	200	0.1	Grease the Saw Head.
3.	2000	1	Change the oil in the Direct Drive Motor Gear Box AE250 unit only (see oil specs).
4.	4000	2	Replace the Saw Drive Rack and Pinion Drive Seals (Refer to the HYDROMAT Unit Parts book for drawings).
5.	8000	4	Replace all Saw Head Seals and O-Rings and inspect all Bearings (Refer to the HYDROMAT Unit Parts book for drawings).
6.	8000	1	Inspect and replace if necessary the Guide Bushing Clamp and Hydraulic hose.

### AE160 CUT OFF UNIT MAINTENANCE

Applicable Machines - PRO 20, HW25-12

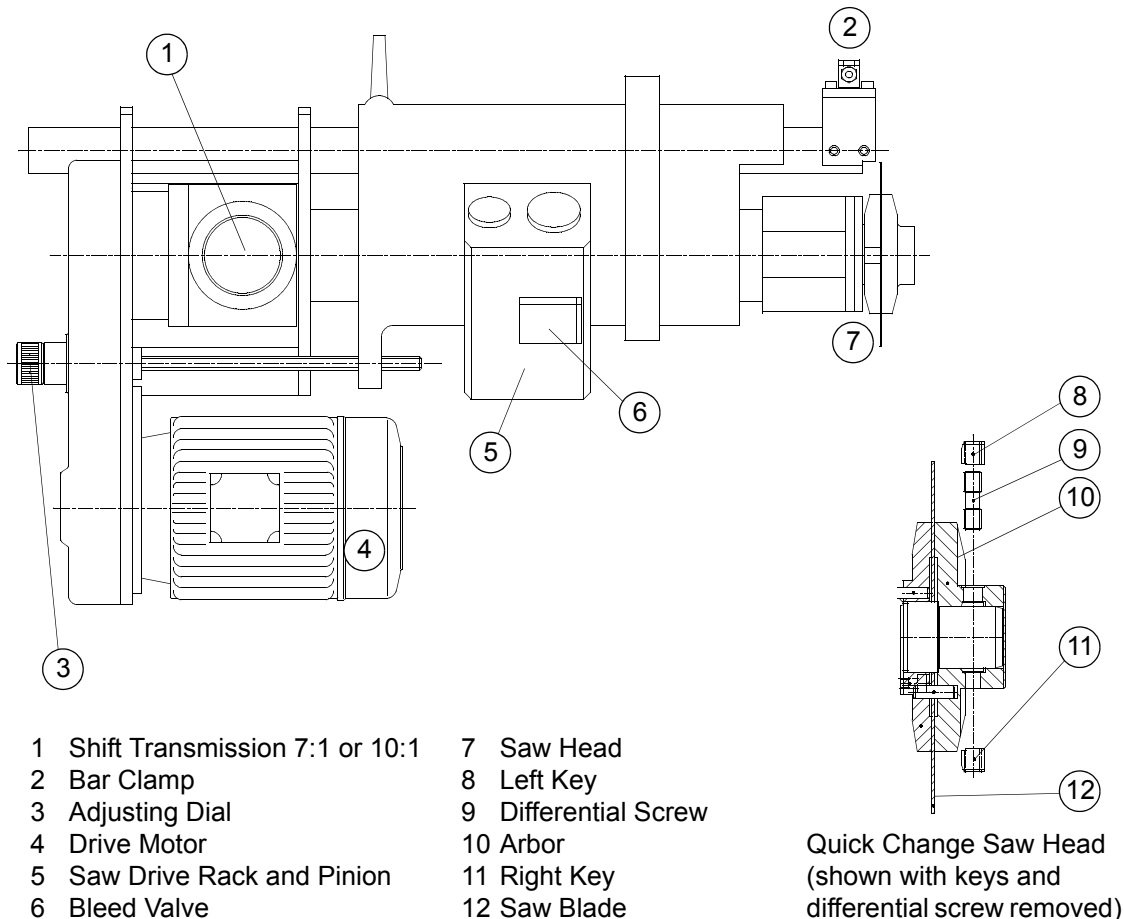



**AE250 CUT OFF UNIT MAINTENANCE**

Applicable Machines - HB32, HB32/45, HB45

- 1. Motor Gearbox Drain
- 2. Motor Gearbox Fill
- 3. Grease Fittings
- 4. Saw Head Oil Fill
- 5. Clamp Bushing
- 6. Rack Drive
- 7. Swing Tube (internal)

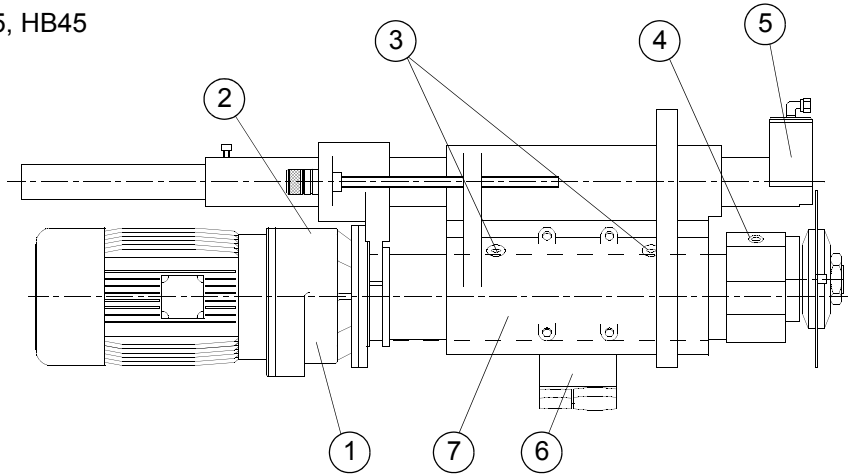

**AE250 SAW HEAD WITH QC ARBOR**

- 1. Piston Body
- 2. Spring
- 3. Clamp
- 4. Guide Bushing
- 5. Needle Bearing
- 6. Left Hand Key
- 7. Differential Screw
- 8. Valenite Arbour
- 9. Spindle
- 10. Shaft Seal
- 11. Right Hand Key
- 12. Pinion Shaft
- 13. Taper Roller Bearing
- 14. Taper Roller Bearing
- 15. Key
- 16. Spindle Washer
- 17. Gear

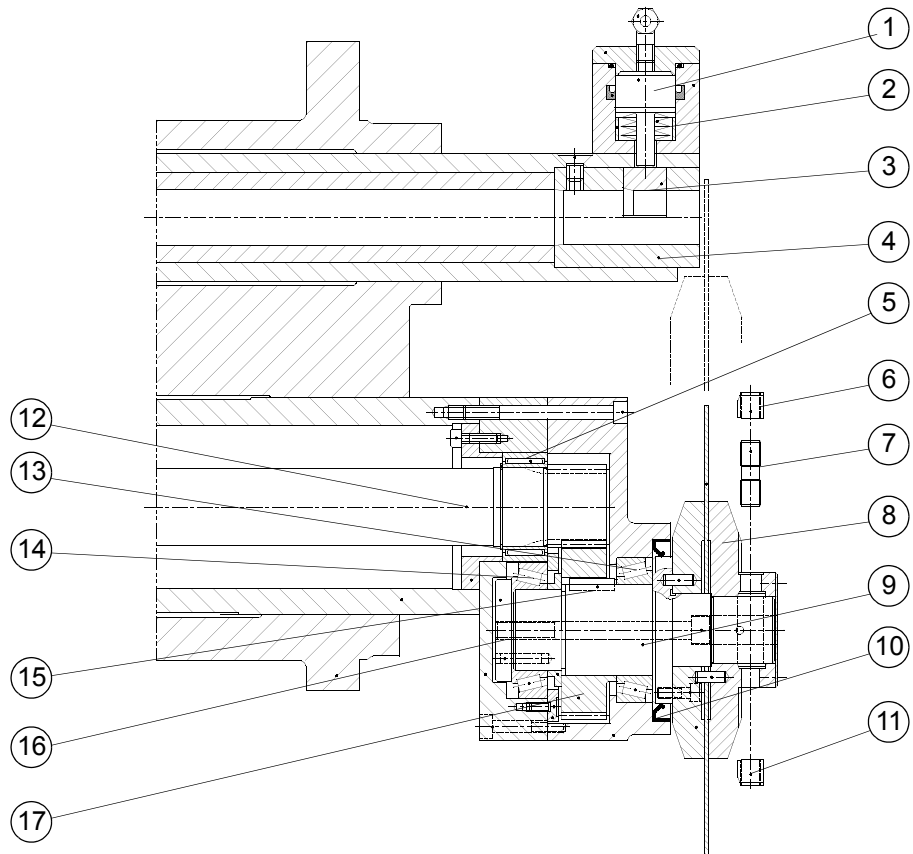

## 15. Maintenance Requirements

### CHIP CONVEYOR/BAG FILTERS

#### BAG FILTERS

ITEM	INTERVAL HOURS	TIME EST. HOURS	PROCEDURE
1.	8	1	Clean the Bag Filters thoroughly of chips.
2.	50	0.25	Replace the Bag Filter (refer to Chapter 5).



#### **WARNING: RISK OF INJURY!**

Always check that the gauge pressure on the Filter Vessel, you are about to service, is “ZERO” before loosening the band clamp bolt. Open the petcock on the vessel to release any residual pressure.



**Double Bag Filter System**

#### CHIP CONVEYOR

ITEM	INTERVAL HOURS	TIME EST. HOURS	PROCEDURE
1.	2000	4	Pull the Chip Conveyor and clean thoroughly.
2.	4000	2	Change or recycle the cutting oil.
3.	4000	2	Repack the Conveyor and Magnetic Filter Gearbox with grease.
4.	4000	0.5	Inspect the conveyor belt for wear and repair if necessary.
5.	4000	0.5	Inspect the Bearing Sleeve and Chain Sprocket for wear and repair/replace if necessary.

**NOTE:** Refer to the Knoll Spare Parts Manual for actual part numbers.

**NOTE:** For special systems such as Vacuum or Paper Filter, refer to chapter 5 in the Machine Manual for procedures and PM recommendations.



**Chip Conveyor/Coolant Tank**

## 15. Maintenance Requirements

### TURMOIL COOLER (OPTIONAL)

ITEM	INTERVAL HOURS	TIME EST. HOURS	PROCEDURE
1.	50	0.25	Inspect Air Filters for dust and dirt, clean if necessary.
2.	50	0.25	Inspect Condenser fins for dust and dirt, clean if necessary.



**Turmoil Cooler**

## BARFEEDER

ITEM	INTERVAL HOURS	TIME EST. HOURS	PROCEDURE
1.	4000	0.1	Check the Chain tension and Grease.
2.	4000	0.1	Check the Encoder coupling for excessive play on Machines with Electronic Bar Feeders.
3.	4000	0.3	Check the Slow Speed setting on Machines with the Electronic Bar Feeder. Remove the Bar from the channel and trip the Slow Speed limit switch. Time the feed of the chain. It should feed at 2 to 2.5 inches per second.

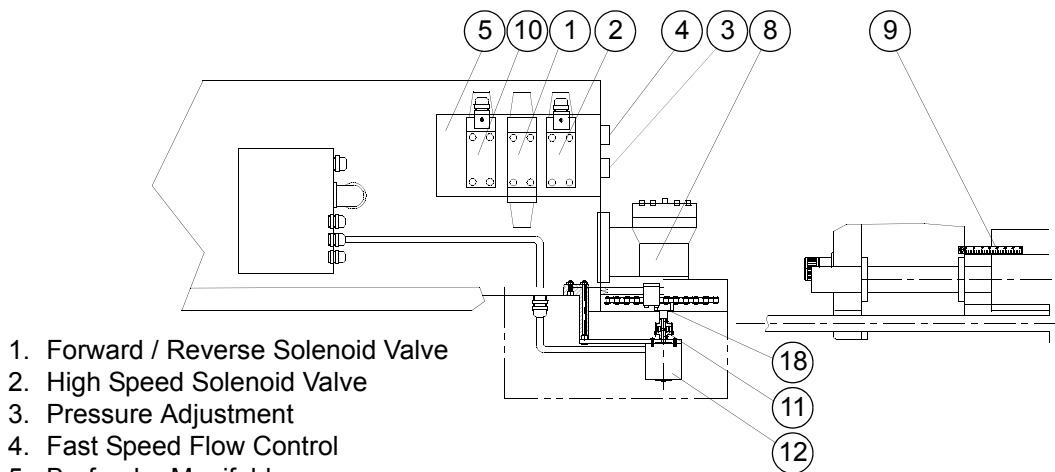

1. Forward / Reverse Solenoid Valve
2. High Speed Solenoid Valve
3. Pressure Adjustment
4. Fast Speed Flow Control
5. Barfeeder Manifold
6. Reverse Fixed Orifice 1.3mm
7. Slow Feed Fixed Orifice .5mm
8. Barfeeder Motor
9. Cut Off Unit Scale



**WARNING: RISK OF INJURY!**

- Make sure the Machine is turned off before servicing.
- Do not feed the Barfeeder Chain without all covers in place.

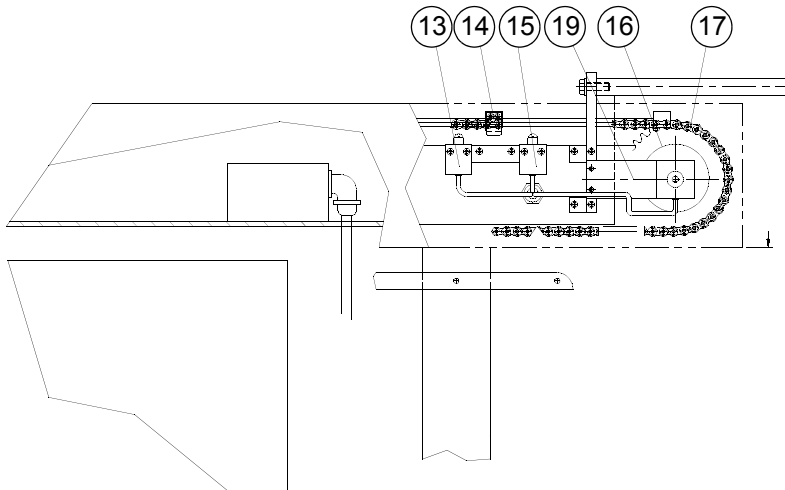

10. Bar Lift Solenoid (optional)
11. Encoder Coupling
12. Encoder
13. Slow Feed Limit Switch
14. Pusher Dog
15. Bar End Limit Switch
16. Front Sprocket
17. Chain
18. Encoder Drive Shaft
19. Encoder Bracket

**Electronic Barfeeder**

## 15. Maintenance Requirements

### ENCODER PERIODIC MAINTENANCE (4000 HRS.)

1. Check for 5 mm (.196") gap between the two coupling halves.
2. Check the Set Screws for tightness.
3. Make sure all of the Rubber Fingers are positioned properly into the other coupling half. Replace the coupling if any Fingers are missing.
4. If rubber fingers appear to be loose. Install a small "Tie Wrap" around where the fingers engage into the coupling teeth.

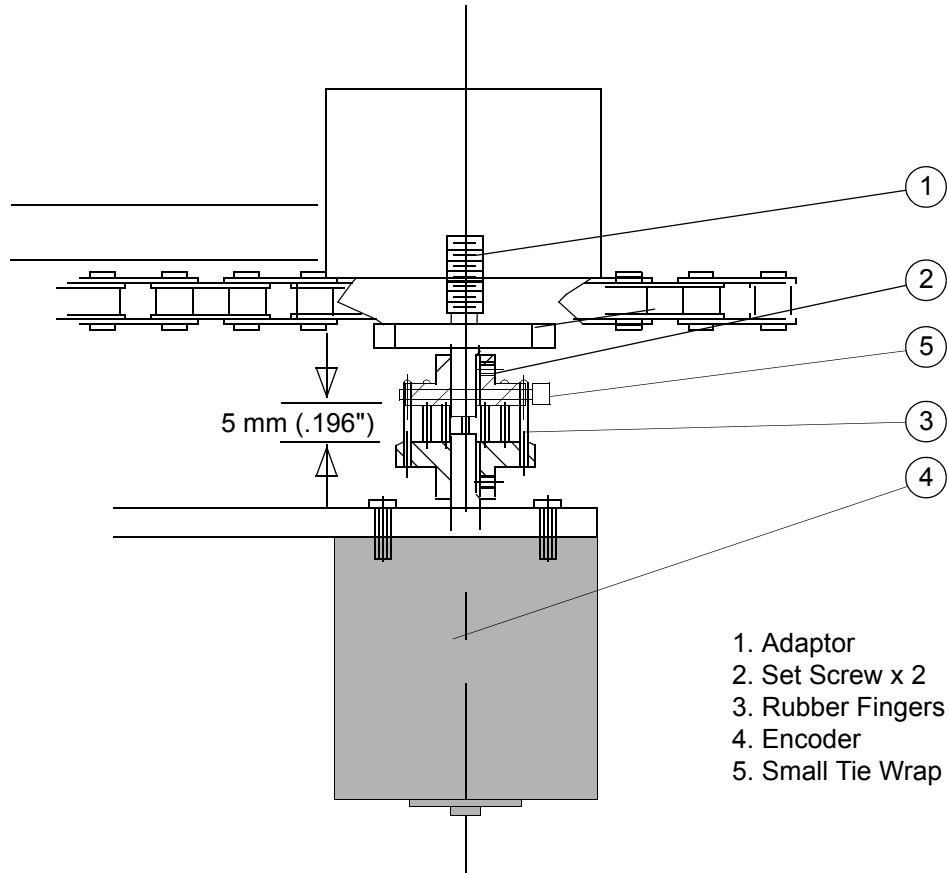

1. Adaptor
2. Set Screw x 2
3. Rubber Fingers
4. Encoder
5. Small Tie Wrap

**Barfeeder Encoder Coupling**

## BUNDLE BAR LOADER

ITEM	INTERVAL HOURS	TIME EST. HOURS	PROCEDURE
1.	4000	0.2	Inspect the Bar Lifting Straps for wear and replace all 4 belts if worn.
1.	4000		Check the Belt Tension Limit switch adjustments. Refer to the IEMCA Service Manual for instructions.

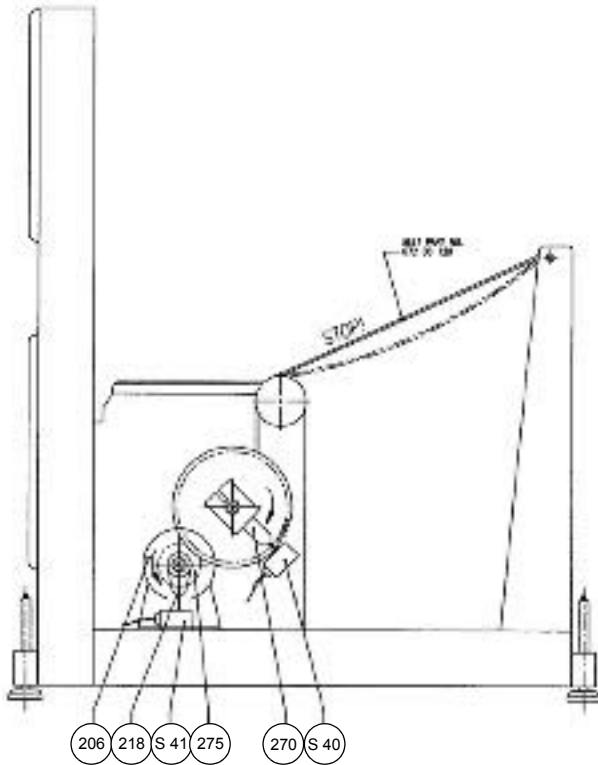

- 206 Gear
- 218 Lever
- 270 Lever
- 275 Ring Nut
- S 40 Belts Too Tight Limit Switch
- S 41 Belts Too Tight Limit Switch



**WARNING: RISK OF INJURY!**  
**Make sure the Machine is turned off before servicing.**

### Safety Device For Belt Tension

## ELECTRICAL

ITEM	INTERVAL HOURS	TIME EST. HOURS	PROCEDURE
1.	2000	1	Check the tightness of all component screw connections in all Electrical Cabinets. (See Chapter 2)

## 15. Maintenance Requirements

### PERIODIC MACHINE SAFETY CHECKS

**NOTE:** These checks are mandatory for safe operation of the HYDROMAT Machine. Omission could result in serious bodily injury.

ITEM	INTERVAL HOURS	TIME EST. HOURS	PROCEDURE
1.	2000	0.1	Verify that all unit covers have a Safety Label. If any are missing, contact the HYDROMAT Order Dept. for replacements. Verify that the Pendant Control Safety Label is in place and that all pushbutton labels are legible.
2.	2000	0.25	Check the function of all <b>Safety Cover Lid Switches</b> . Lift each cover one at a time and verify the following: <ul style="list-style-type: none"><li>• Spindles and Coolant turn off.</li><li>• All Units return to their home position.</li><li>• A Fault Message is displayed on Machines with the "smart screen" display.</li></ul>
3.	2000	0.25	Check the function of all Emergency Stop pushbuttons.
4.	2000	0.1	Verify that all Unit and Barfeeder covers are in place.
5.	2000		All Electrical Cabinet doors must be closed while the Machine is running in production.
6.	2000	0.5	Inspect the Platform and Chip Conveyor for any unsafe or slippery surfaces and repair or replace if necessary.
7.	2000	1	Check all electrical cables for proper connection. Inspect connections for any oil residue and clean with electrical cleaner if necessary. Repair or replace any exposed wires.

### SEAL KITS

Refer to your Unit Parts Book.

### SPARE PARTS

#### SOLENOID VALVES - 110V

ITEM	DESCRIPTION	PART NUMBER
1	..... Parker 4/2 Solenoid Valve.....	D1VW20BNYPF
2	..... Parker 4/3 Solenoid Valve.....	D1VW1CNYPF
3	..... Parker 4/3 Solenoid Valve.....	D1VW2CNYPF
4	..... Parker 4/3 Solenoid Valve.....	D1VW4CNYWH
5	..... Lucifer 2/2 Solenoid Valve .....	E121F44-110V
6	..... Bosch 4/2 Solenoid Valve .....	9.810.231.011



**SOLENOID VALVES - 24V**

ITEM	DESCRIPTION	PART NUMBER
1	Parker 4/2 Solenoid Valve.....	D1VW20BNJWL
2	Parker 4/3 Solenoid Valve.....	D1VW4CNJPL
3	Parker 4/3 Solenoid Valve.....	D1VW1CNJWL
4	Parker 4/3 Solenoid Valve.....	D1VW2CNJWL
5	Bosch 4/2 Solenoid Valve.....	0.810.091.227
6	Bosch 4/3 Solenoid Valve.....	0.810.091.212
7	Bosch 4/3 Solenoid Valve.....	0.810.091.203
8	Bosch 4/3 Solenoid Valve.....	9.810.231.438
9	Bosch 4/3 Solenoid Valve.....	0.810.091.201

**HYDRAULIC HOSES**

ITEM	DESCRIPTION	PART NUMBER
1	NG6 22" Long.....	NG6 22" Long
2	NG6 34" Long.....	NG6 34" Long
3	NG10 22" Long.....	NG10 22" Long
4	NG10 35" Long.....	NG10 35" Long
5	NG10 50" Long.....	NG10 50" Long

**BELTS**

ITEM	DESCRIPTION	PART NUMBER
1	20/80 & 26/80.....	240L075
2	30/60, 35/60 & 36/100.....	300H075
3	45/80.....	360H100
4	Bundle Barfeeder.....	345L100

**HYDRAULIC POWERPACK**

Refer to your Unit Parts Book.

**ELECTRICAL**

ITEM	DESCRIPTION	PART NUMBER
1	Balluff Proximity Switch.....	BES516207S27-E
2	Balluff Proximity Switch Cable.....	70220
3	Hirshman Plug for Solenoid Coils.....	GDM-2009J
4	Lutze Suppressor for Solenoid Coils.....	LRC-V8-0910
5	Allen-Bradley Thermostat for Powerpk.....	837-A4
6	Micro Switch.....	914CE2-3
7	Electric Plug Insert for 5 pin male.....	10.2100
8	Electric Plug Insert for 5 pin female.....	10.2111
9	Telemecanique Limit Switch.....	XCMA.110
10	Threading Control	
	4 Pole Relay (IDEC).....	RY4SULAC120V
	Time Delay (Telemecanique).....	RE1-LA001
	Reversing Motor Starter (Allen-Bradley).....	100-C23D10

## 15. Maintenance Requirements

### HYDROMAT PREVENTIVE MAINTENANCE SUMMARY AND LOG SHEET

This Maintenance Log Sheet has been developed to assist the customer in establishing their own preventive maintenance records. Whenever “PM” (Preventive Maintenance) is performed, it should be dated, initialed and hour counter cycle hours noted by the maintenance person. Keeping accurate records will assist in diagnosing machine problem areas and help to ensure a productive and safe HYDROMAT machine. If your company does not currently have a “PM” schedule, feel free to make several copies of the following two pages and place them in a folder near the machine. Please feel free to contact the HYDROMAT Service Dept., at 314-432-0070, with any questions regarding these recommendations.

**Note:** Refer to the Unit Parts Book for cross-sectional drawings of Units and Components.

UPB\* - Unit Parts Book

Interval Hours	Maintenance Performed	Reference Page	Date	Name	Hours
8	1. Clean Bag Filter	15-14, Ch. 5			
	2. Check Level in Willey Vogel Lube Unit and Refill if Necessary	15-9, Ch. 8			
50	1. Grease All Cut Off Units	15-12, Ch. 4			
	2. Grease All Cross Drill and Milling Heads	15-11, Ch. 4			
	3. Check (Optional) Turmoil Filter/Condenser Fin	15-16, Ch. 5			
1,000	1. Clean All Collet and Ejector Assemblies	15-4, Ch. 11			
	2. Inspect (Optional) Chuck Assemblies For Leaks & Worn or Damaged Jaws. Repair as Needed	15-4, Ch. 11			
	3. Replace Hydraulic Powerpack Filters	15-5, Ch. 12			
	4. Disassemble and Clean All Recess Heads	15-11, Ch. 8			
2,000	1. Check Accumulator Charge	15-5, Ch. 12			
	2. Replace Powerpack Oil (Wipe Out Tank)	15-5, Ch. 4, Ch. 12			
	3. Change Saw Head Oil	15-12, Ch. 4			
	4. Change Oil in Gear Motor & Grease Unit	15-12, 13, Ch. 4			
	5. Clean Chip Conveyor	15-14, Ch. 5			
	6. Check NC Scale Screws for tightness	15-9, Ch. 8			
	7. Perform Periodic Safety Checks	15-20, Ch. 3			
	8. Grease the (Optional) CNC Slide Flange	15-9, Ch. 4			

## 15. Maintenance Requirements

Interval Hours	Maintenance Performed	Reference Page	Date	Name	Hours
4,000	1. Replace Emergency & 1/2 Index Solenoids	15-3			
	2. Remove & Regrease the Table Down Rod	15-3, Ch. 11			
	3. Replace the Hydraulic Manifold Hoses	15-3, Ch. 11			
	4. Replace Control Pivot O-Rings	15-4, Ch. 11			
	5. Replace Collet Ejector Assembly O-Rings	15-4, Ch. 11			
	6. Remove the (Optional) Individual Chuck Assemblies and Replace All O-Rings	15-4, Ch. 11			
	7. Inspect All Unit Belts for Wear	15-6, 7			
	8. Inspect All Unit Hoses for Leaks or Wear	15-6, Ch. 11			
	9. Rebuild the Cut Off Unit Rack Drive	15-16, 17, UPB*			
	10. Replace Cutting Oil	15-12, Ch. 4			
	11. Regrease Chip Conveyor Gearbox	15-14, Ch. 5			
	12. Regrease Magnetic Filter Gearbox	15-14, Ch. 5			
	13. Inspect Chip Conveyor for Wear	15-14, Ch. 5			
	14. Inspect Chip Conveyor Bearing Sleeve and Chain Sprocket	15-14, Ch. 5			
	15. Check Barfeeder Chain Tension & Grease	15-17, Ch. 10			
	16. Inspect Barfeeder Encoder Coupling	15-17, 18, Ch. 10			
	17. Inspect Lifting Belts on Bundle Bar Loader	15-19, Ch. 10			
	18. Check Lift Belt Tension Switch Adjustments	15-19, Ch. 10			
6,000	1. Replace All Inverting Unit Seals & O-Rings	15-10, Ch. 8, UPB*			
	2. Rebuild the Inverting Unit Rack & Pinion	15-10, Ch. 8, UPB*			
6,000-8,000	1. Change 4/3 Way Solenoid Valve	15-4			
	2. Change 2/2 Index Lucifer Solenoid Valve	15-4			
8,000-10,000	1. Replace Table Down Proximity Switch	15-3, Ch. 11			
	2. Pull the Table & Replace Lift Piston Seals	15-4, Ch. 11, UPB*			
	3. Rebuild the Index Rack and Pinion Drive	15-4, Ch. 9, UPB*			
	4. Check NC Toolspindle Bearings	15-6, UPB*			
	5. Rebuild Cut Off Unit Saw Head	15-12, UPB*			
	6. Replace Hydraulic Pump Coupling	15-5, Ch. 12			
	7. Inspect the Guide Bushing Clamp & Hose	15-12, UPB*			