

STATE OF UTAH
DEPARTMENT OF NATURAL RESOURCES
DIVISION OF OIL, GAS AND MINING

FORM 3

AMENDED REPORT

APPLICATION FOR PERMIT TO DRILL		1. WELL NAME and NUMBER LC Fee 9-11D-56
2. TYPE OF WORK DRILL NEW WELL <input checked="" type="checkbox"/> REENTER P&A WELL <input type="checkbox"/> DEEPEN WELL <input type="checkbox"/>		3. FIELD OR WILDCAT LAKE CANYON
4. TYPE OF WELL Oil Well Coalbed Methane Well: NO		5. UNIT or COMMUNITIZATION AGREEMENT NAME
6. NAME OF OPERATOR LINN OPERATING, INC.		7. OPERATOR PHONE 303 999-4275
8. ADDRESS OF OPERATOR Rt. 2 Box 7735, Roosevelt, UT, 84066		9. OPERATOR E-MAIL rdescognets@linnenergy.com
10. MINERAL LEASE NUMBER (FEDERAL, INDIAN, OR STATE) Fee	11. MINERAL OWNERSHIP FEDERAL <input type="checkbox"/> INDIAN <input type="checkbox"/> STATE <input type="checkbox"/> FEE <input checked="" type="checkbox"/>	12. SURFACE OWNERSHIP FEDERAL <input type="checkbox"/> INDIAN <input type="checkbox"/> STATE <input type="checkbox"/> FEE <input checked="" type="checkbox"/>
13. NAME OF SURFACE OWNER (if box 12 = 'fee') Douglas Nielson		14. SURFACE OWNER PHONE (if box 12 = 'fee')
15. ADDRESS OF SURFACE OWNER (if box 12 = 'fee') PO Box 114, Duchesne, UT 84021		16. SURFACE OWNER E-MAIL (if box 12 = 'fee')
17. INDIAN ALLOTTEE OR TRIBE NAME (if box 12 = 'INDIAN')	18. INTEND TO COMMINGLE PRODUCTION FROM MULTIPLE FORMATIONS YES <input checked="" type="checkbox"/> (Submit Commingling Application) NO <input type="checkbox"/>	19. SLANT VERTICAL <input type="checkbox"/> DIRECTIONAL <input checked="" type="checkbox"/> HORIZONTAL <input type="checkbox"/>

20. LOCATION OF WELL	FOOTAGES	QTR-QTR	SECTION	TOWNSHIP	RANGE	MERIDIAN
LOCATION AT SURFACE	936 FSL 663 FEL	SESE	11	5.0 S	6.0 W	U
Top of Uppermost Producing Zone	1775 FSL 659 FEL	NESE	11	5.0 S	6.0 W	U
At Total Depth	1960 FSL 660 FEL	NESE	11	5.0 S	6.0 W	U

21. COUNTY DUCHEсне	22. DISTANCE TO NEAREST LEASE LINE (Feet) 660	23. NUMBER OF ACRES IN DRILLING UNIT 640
25. DISTANCE TO NEAREST WELL IN SAME POOL (Applied For Drilling or Completion) 2	26. PROPOSED DEPTH MD: 6295 TVD: 6166	29. SOURCE OF DRILLING WATER / WATER RIGHTS APPROVAL NUMBER IF APPLICABLE 43-12400
27. ELEVATION - GROUND LEVEL 6365	28. BOND NUMBER RLB0005651	

Hole, Casing, and Cement Information										
String	Hole Size	Casing Size	Length	Weight	Grade & Thread	Max Mud Wt.	Cement	Sacks	Yield	Weight
Surf	12.25	8.625	0 - 630	24.0	J-55 ST&C	9.5	Class G	350	1.15	15.8
Prod	7.875	5.5	0 - 6295	17.0	N-80 LT&C	9.5	Type V	210	3.82	11.0
							Class G	370	1.7	13.1

ATTACHMENTS

VERIFY THE FOLLOWING ARE ATTACHED IN ACCORDANCE WITH THE UTAH OIL AND GAS CONSERVATION GENERAL RULES

<input checked="" type="checkbox"/> WELL PLAT OR MAP PREPARED BY LICENSED SURVEYOR OR ENGINEER	<input checked="" type="checkbox"/> COMPLETE DRILLING PLAN
<input checked="" type="checkbox"/> AFFIDAVIT OF STATUS OF SURFACE OWNER AGREEMENT (IF FEE SURFACE)	<input type="checkbox"/> FORM 5. IF OPERATOR IS OTHER THAN THE LEASE OWNER
<input checked="" type="checkbox"/> DIRECTIONAL SURVEY PLAN (IF DIRECTIONALLY OR HORIZONTALLY DRILLED)	<input checked="" type="checkbox"/> TOPOGRAPHICAL MAP

NAME	TITLE	PHONE
SIGNATURE	DATE 09/18/2013	EMAIL
API NUMBER ASSIGNED 43013524790000		APPROVAL

Received: July 16, 2014

BERRY PETROLEUM COMPANY
 LC Fee 9-11D-56
 Section 11, T5S, R6W, U.S.B.&M.
 Surface: 936' FSL & 663' FEL (SE/4SE/4)
 BHL: 1960' FSL & 660' (NE/4SE/4)
 Duchesne County, Utah

ONSHORE ORDER NO. 1

DRILLING PROGRAM

A,B Estimated Tops of Geological Markers and Formations Expected to Contain Water, Oil and Gas and Other Minerals

FORMATION	DRILL DEPTH * @ SHL (TVD)	DRILL DEPTH* @ BHL (TVD)	Measured Depth
Uinta Fm	Surface	Surface	Surface
Green River	470'	472'	471'
Green River Fouch Marker	1015'	1039'	4038'
Mahogany	1614'	1645'	1665'
Tgr3	2631'	2679'	2732'
*Douglas Creek	3407'	3455'	3545'
Black Shale	4066'	4113'	4220'
*Castle Peak	4338'	4382'	4494'
Uteland Butte	4692'	4734'	4849'
*Wasatch	4938'	4966'	5095'
CR-6	5138'	6166'	6295'
TD	6138'	6166'	6295'
Base of Moderate Saline Water	2940'	2817'	

*PROSPECTIVE PAY

Berry is locating the well at the proposed surface location and directionally drilling to the proposed bottom hole location. By drilling directionally, Berry Petroleum Company will improve field development efficiency by potentially combining multiple surface hole locations together. This will significantly reduce total surface disturbance plus combine the use of access roads and existing pipelines.

Furthermore, Berry hereby certifies that it is the sole working interest owner with 460 feet of the entire directional well bore and the remainder of the Ute Tribal section.

C Pressure Control Equipment : (Schematic Attached)

The BOP and related equipment shall meet the minimum requirements of Onshore Oil and Gas Order No. 2 for equipment and testing requirements, procedures, etc. A 3M system will be utilized. The attached diagram depicts the use of an annular in conjunction with double rams. However, an annular, double rams or both may be used depending on the drilling rig contracted.

Chart recorders will be used for all pressure tests.

Test charts, with individual test results identified, shall be maintained on location while drilling and shall be made available to a representative upon request.

Mud volumes will be monitored visually.
Upper and Lower Kelly cocks will be utilized.
A gas buster will be utilized, if necessary.

<u>Depth Intervals</u>	<u>BOP Equipment</u>
0 – 650'	No Pressure Control
650' – 6295'	11" 3000# Ram Type BOP 11" 3000# Annular BOP

D,E Proposed Casing and Cementing Program

<u>Purpose</u>	<u>Depth</u>	<u>Hole Size</u>	<u>Casing Size</u>	<u>Type</u>	<u>Connection</u>	<u>Weight</u>
Conductor will be run as needed with cement set the surface.						
Surface	650'	12.25"	3-5/8"	J-55	ST&C	24#
Production	6295'	7.875"	3-1/2"	N-80 or LIDA-80	LT&C	17#

Surface Type & Amount

0' – 650' Approx. 350 SX Premium Class G, plus additives or a similar slurry with a minimum weight of 15.8 #/gal and approximate yield of 1.15 cuft/sx, minimum 24 hr compressive strength = 500 psi (Cement will be circulated to surface and topped off, if necessary.)

Production Type & Amount

0' – 3500' Lead: +/- 210 sx Premium Type V + additives or similar slurry with a minimum weight of 11.0 #/gal and approximate yield of 3.82 cuft/sx

3500' – 6295' Tail: +/- 370 sx Premium Class G + additives or similar slurry with a minimum weight of 13.1 #/gal and approximate yield of 1.70cuft/sk.

For production casing, actual cement volumes will be determined from the caliper log plus a minimum of 15% excess.

F Drilling Fluids Program

Interval	Weight	Viscosity	Fluid Loss	Remarks
0' – 650'	8.4 – 9.5	27	NC	Mud or Air (see attached variance)
650' -6295'	8.4 – 9.5	27	NC	DAP Water

G Evaluation Program

Logging Program:	HRI-GR-SP with SDL-DSN-PE: surface casing to TD. Preserve samples from all show intervals.
Sampling:	10' dry cut samples: Douglas Creek to TD. Preserve samples From all show intervals.
Surveys:	As deemed necessary
Mud Logger:	As deemed necessary
Drill Stem Tests:	As deemed necessary
Cores:	As deemed necessary

H Anticipated Abnormal Pressures or Temperatures

No abnormal temperatures or pressures or other hazards are anticipated.

Shallow gas and/or water flows are possible below surface casing.

Maximum anticipated bottom hole pressure equals approximately 3110 psi* and maximum anticipated surface pressure equals approximately 1725**psi (bottom hole pressure minus the pressure of a partially evacuated hole calculated at 0.22 psi/foot).

*Max Mud Wt x 0.052 x TD = A (bottom hole pressure)

**Maximum surface pressure = A – (0.22xTD)

I Anticipated Starting Dates and Notification of Operations

Drilling Activity:

Anticipated Commencement Date:	Upon approval of the APD.
Drilling Days:	Approximately 10 days.
Completion Days:	Approximately 7 days.

Berry Petroleum requests variances shown below to Onshore Order 2 III . Section E Special Drilling Operations as they apply to our air drilling of surface holes in the Uintah Formation.

Berry Petroleum requests permission to use a diverter bowl in place of a rotating head. The diverter bowl safely forces the air and cutting returns to the surface blooie line and then diverted away from the rig. Gas is very rarely encountered in small amounts in the Uintah formation. The diverter bowl is sufficient to divert such flows safely away from the rig.

Berry Petroleum requests permission to use a blooie line that discharges less than 100' from the wellbore. The location footprint, size and configuration does not allow for a 100' line to the flare or blooie pit for surface hole drilling. The lengths will be 30-60' depending on the location. Gas is very rarely encountered in small amounts in the Uintah formation, and the shorter blooie line lengths are capable of handling such flows.

Berry Petroleum requests permission to operate without an automatic igniter or continuous pilot light on the blooie line. Gas is very rarely encountered in small amounts in the Uintah Formation. If encountered, the drilling rig will have the ability to safely ignite the flare as needed.

Berry Petroleum requests permission to use a trailer mounted air compressor located less than 100 feet from the well bore. The location footprint, size and/or configuration of the surface hole drilling equipment does not practically allow for a 100' offset. Gas is very rarely encountered in small amounts in the Uintah Formation. If encountered, the following configuration will allow safe operations. The compressor itself it is located a minimum distance of 30' from the wellbore and is in an opposite direction from the blooie line. The compressor has the following safety features; (1) shut off valve on the trailer that is physically located no more than 20' from the air rig. (2) pressure relief valve on the air compressor discharge cylinder/piping. (3) Spark arrestors on the motors.

Berry Petroleum requests permission to not be required for the staging of mud circulating equipment, water and mud materials sufficient to maintain the capacity of the hole and circulating tank or pits on the air drilling location. Gas is very rarely encountered in small amounts in the Uintah Formation. Berry will have a water truck on location available to fill the hole as needed should gas be encountered.

T5S, R6W, U.S.B.&M.

S89°33'20"W - 5282.59' (Measured)

BERRY PETROLEUM COMPANY

WELL LOCATION, LC FEE 9-11D-56,
LOCATED AS SHOWN IN THE SE 1/4 SE
1/4 OF SECTION 11, T5S, R6W,
U.S.B.&M. DUCHESNE COUNTY, UTAH.

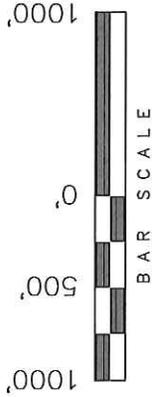

WELL LOCATION:
LC FEE 9-11D-56
ELEV. UNGRAD. GROUND = 6365.7'

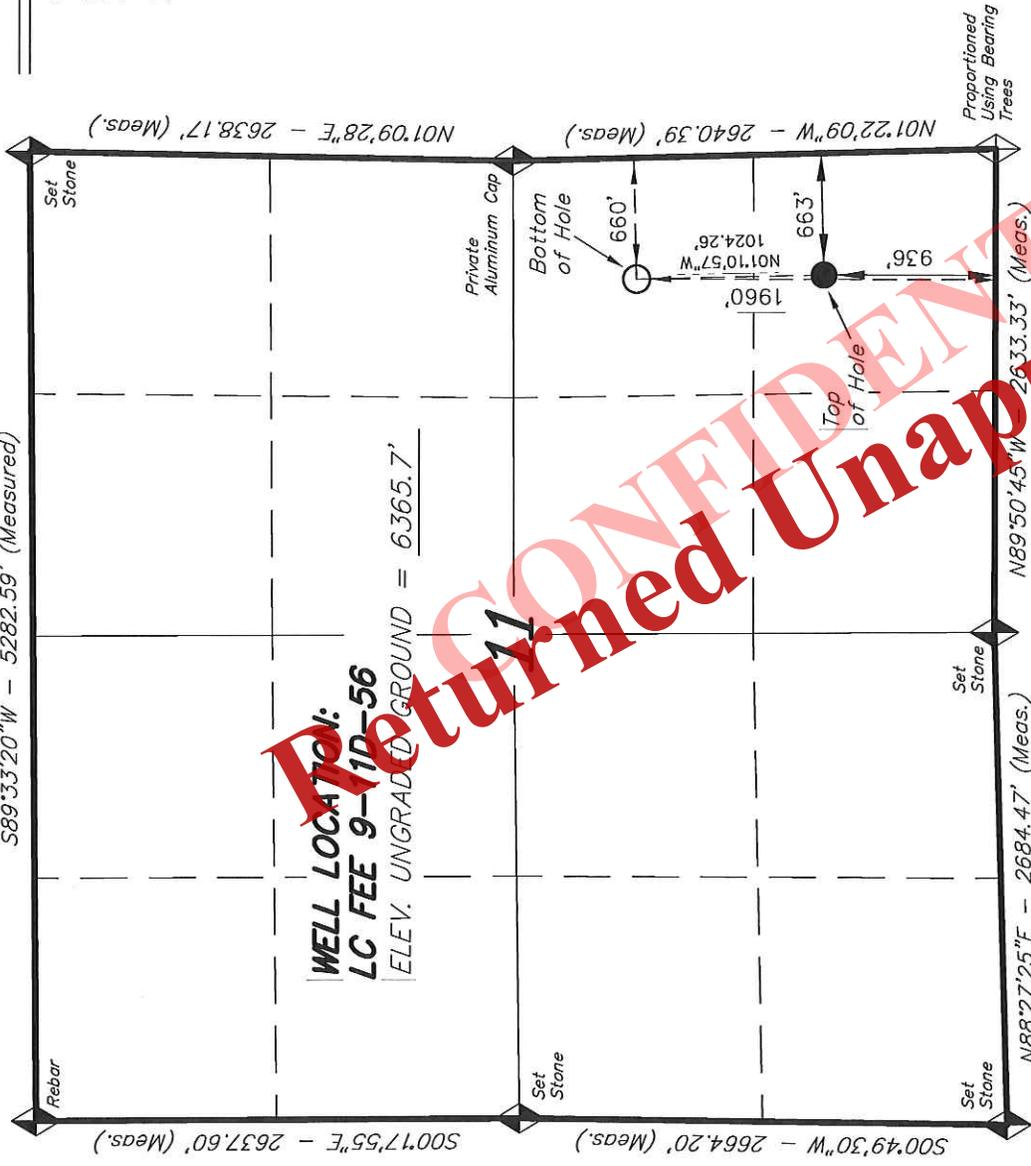

- NOTES:**
- Well footages are measured at right angles to the Section Lines.
 - Bearings are based on Global Positioning Satellite observations.

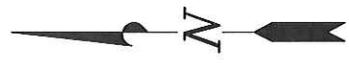

THIS IS TO CERTIFY THAT THE ABOVE REPORT WAS PREPARED FROM FIELD NOTES OF AGRICULTURAL SURVEYS MADE BY ME OR UNDER MY SUPERVISION AND THAT THE SAME ARE TRUE AND CORRECT TO THE BEST OF MY KNOWLEDGE AND BELIEF.

DATE 08-03-12
BY STACY W.
REGISTERED LAND SURVEYOR
REGISTRATION NO. 6189377
STATE OF UTAH

TRI STATE LAND SURVEYING & CONSULTING
180 NORTH VERNAL AVE. - VERNAL, UTAH 84078
(435) 781-2501

DATE SURVEYED: 07-31-12	SURVEYED BY: M.C.
DATE DRAWN: 08-03-12	DRAWN BY: L.C.S.
REVISED:	SCALE: 1" = 1000'

NAD 83 (SURFACE LOCATION)	LATITUDE = 40°03'22.89"	(40.056359)
	LONGITUDE = 110°31'12.46"	(110.520127)
NAD 83 (SURFACE LOCATION)	LATITUDE = 40°03'23.04"	(40.056399)
	LONGITUDE = 110°31'09.90"	(110.519417)
NAD 83 (BOTTOM HOLE LOCATION)	LATITUDE = 40°03'33.01"	(40.059170)
	LONGITUDE = 110°31'12.59"	(110.520163)
NAD 27 (BOTTOM HOLE LOCATION)	LATITUDE = 40°03'33.16"	(40.059210)
	LONGITUDE = 110°31'10.03"	(110.519452)

◆ = SECTION CORNERS LOCATED
BASIS OF ELEV; Elevations are base on an N.G.S. OPUS Correction. LOCATION: LAT. 39°58'55.06" LONG. 110°22'05.00" (Tristate Aluminum Cap) Elev. 7307.99'

CONFIDENTIAL
Returned Unapproved

Access Road Map

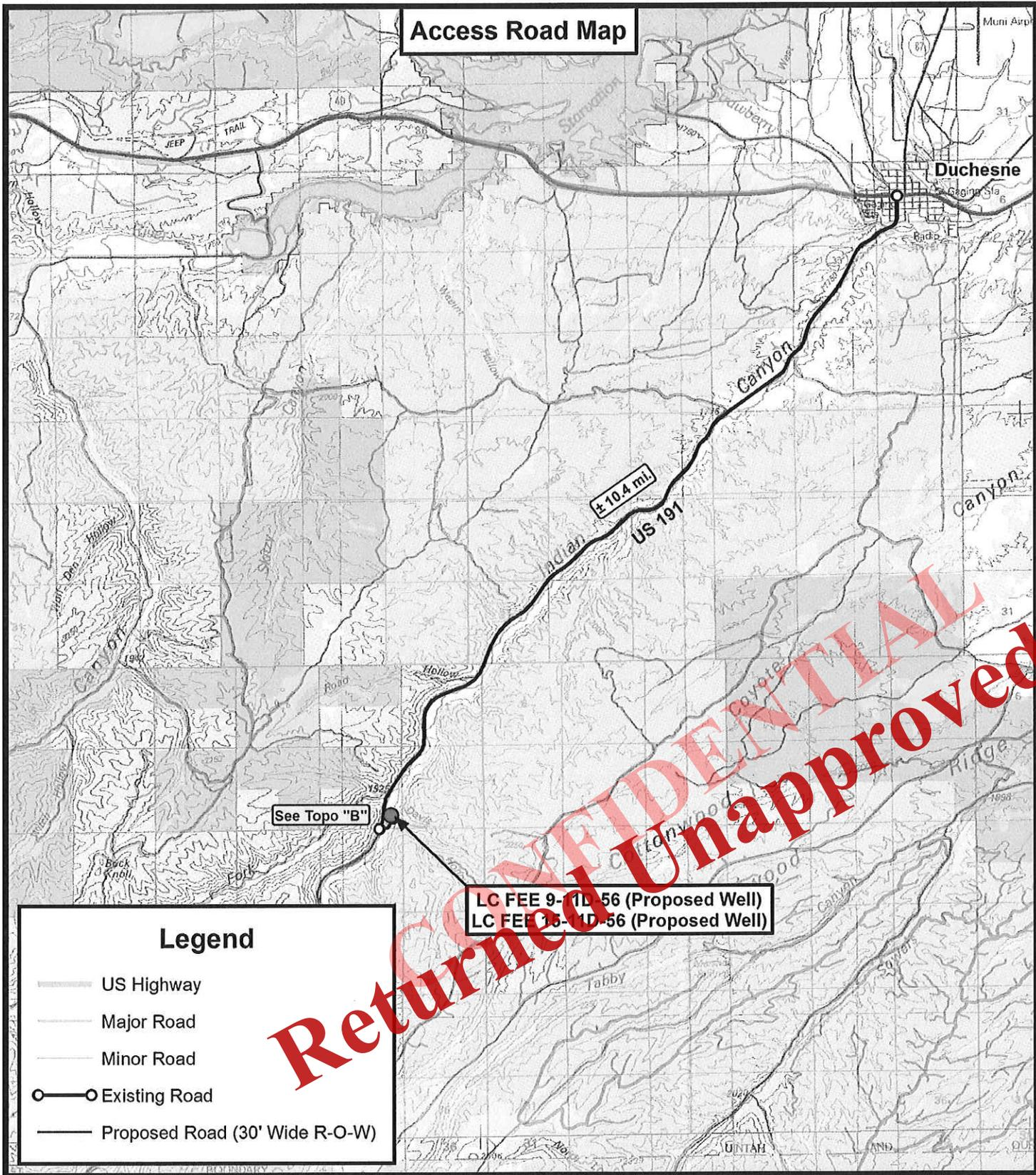

Returned to Confidential Unapproved

LC FEE 9-11D-56 (Proposed Well)
 LC FEE 15-11D-56 (Proposed Well)

See Topo "B"

± 10.4 mi

US 191

Duchesne

Legend

- US Highway
- Major Road
- Minor Road
- Existing Road
- Proposed Road (30' Wide R-O-W)



**Tri State
 Land Surveying, Inc.**
 180 NORTH VERNAL AVE. VERNAL, UTAH 84078

P: (435) 781-2501
 F: (435) 781-2518



BERRY PETROLEUM COMPANY

LC FEE 9-11D-56 (Proposed Well)
 LC FEE 15-11D-56 (Proposed Well)
 SEC. 11, T5S, R6W, U.S.B.&M.
 Duchesne County, UT.

DRAWN BY:	D.C.R.	REVISED:	12-19-2012 J.A.S.
DATE:	11-22-2011		
SCALE:	1:100,000		

TOPOGRAPHIC MAP

SHEET
A

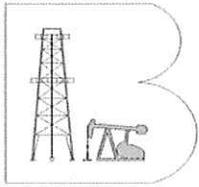

Berry Petroleum Company

Duchesne Co., UT (UT27C)

Sec.11-T5S-R6W

LC FEE 9-11D-56

Wellbore #1

Plan: Design #2

Standard Planning Report

18 October, 2012

CONFIDENTIAL
Returned Unapproved



Received: September 18, 2013



Database:	EDM 5000.1 Single User Db	Local Co-ordinate Reference:	Well LC FEE 9-11D-56
Company:	Berry Petroleum Company	TVD Reference:	WELL @ 6385.00usft (Original Well Elev)
Project:	Duchesne Co., UT (UT27C)	MD Reference:	WELL @ 6385.00usft (Original Well Elev)
Site:	Sec.11-T5S-R6W	North Reference:	True
Well:	LC FEE 9-11D-56	Survey Calculation Method:	Minimum Curvature
Wellbore:	Wellbore #1		
Design:	Design #2		

Project	Duchesne Co., UT (UT27C)		
Map System:	US State Plane 1927 (Exact solution)	System Datum:	Mean Sea Level
Geo Datum:	NAD 1927 (NADCON CONUS)		
Map Zone:	Utah Central 4302		

Site	Sec.11-T5S-R6W				
Site Position:		Northing:	629,075.375 usft	Latitude:	40° 3' 22.864 N
From:	Lat/Long	Easting:	2,274,463.604 usft	Longitude:	110° 31' 10.024 W
Position Uncertainty:	0.00 usft	Slot Radius:	13-3/16"	Grid Convergence:	0.63 °

Well	LC FEE 9-11D-56					
Well Position	+N/-S	17.48 usft	Northing:	629,092.954 usft	Latitude:	40° 3' 23.036 N
	+E/-W	9.52 usft	Easting:	2,274,472.929 usft	Longitude:	110° 31' 9.901 W
Position Uncertainty		0.00 usft	Wellhead Elevation:	usft	Ground Level:	6,365.00 usft

Wellbore	Wellbore #1				
Magnetics	Model Name	Sample Date	Declination (°)	Dip Angle (°)	Field Strength (nT)
	IGRF2010	2012/10/15	11.33	65.68	52,073

Design	Design #2				
Audit Notes:					
Version:	Phase:	PLAN	Tie On Depth:	0.00	
Vertical Section:	Depth From (TVD) (usft)	+N/-S (usft)	+E/-W (usft)	Direction (°)	
	0.00	0.00	0.00	358.80	

Plan Sections										
Measured Depth (usft)	Inclination (°)	Azimuth (°)	Vertical Depth (usft)	+N/-S (usft)	+E/-W (usft)	Dogleg Rate (°/100usft)	Build Rate (°/100usft)	Turn Rate (°/100usft)	TFO (°)	Target
0.00	0.00	0.00	0.00	0.00	0.00	0.00	0.00	0.00	0.00	
750.00	0.00	0.00	750.00	0.00	0.00	0.00	0.00	0.00	0.00	
1,442.67	20.78	358.80	1,427.58	124.21	-2.60	3.00	3.00	0.00	358.80	
2,929.02	20.78	358.80	2,817.22	651.43	-13.66	0.00	0.00	0.00	0.00	
5,007.03	0.00	0.00	4,868.00	1,024.06	-21.47	1.00	-1.00	0.00	180.00	
6,323.03	0.00	0.00	6,166.00	1,024.06	-21.47	0.00	0.00	0.00	0.00	



Database:	EDM 5000.1 Single User Db	Local Co-ordinate Reference:	Well LC FEE 9-11D-56
Company:	Berry Petroleum Company	TVD Reference:	WELL @ 6385.00usft (Original Well Elev)
Project:	Duchesne Co., UT (UT27C)	MD Reference:	WELL @ 6385.00usft (Original Well Elev)
Site:	Sec.11-T5S-R6W	North Reference:	True
Well:	LC FEE 9-11D-56	Survey Calculation Method:	Minimum Curvature
Wellbore:	Wellbore #1		
Design:	Design #2		

Planned Survey

Measured Depth (usft)	Inclination (°)	Azimuth (°)	Vertical Depth (usft)	+N/-S (usft)	+E/-W (usft)	Vertical Section (usft)	Dogleg Rate (°/100usft)	Build Rate (°/100usft)	Turn Rate (°/100usft)
0.00	0.00	0.00	0.00	0.00	0.00	0.00	0.00	0.00	0.00
100.00	0.00	0.00	100.00	0.00	0.00	0.00	0.00	0.00	0.00
200.00	0.00	0.00	200.00	0.00	0.00	0.00	0.00	0.00	0.00
300.00	0.00	0.00	300.00	0.00	0.00	0.00	0.00	0.00	0.00
400.00	0.00	0.00	400.00	0.00	0.00	0.00	0.00	0.00	0.00
Green River									
470.00	0.00	0.00	470.00	0.00	0.00	0.00	0.00	0.00	0.00
500.00	0.00	0.00	500.00	0.00	0.00	0.00	0.00	0.00	0.00
600.00	0.00	0.00	600.00	0.00	0.00	0.00	0.00	0.00	0.00
8 5/8" Csg.									
650.00	0.00	0.00	650.00	0.00	0.00	0.00	0.00	0.00	0.00
700.00	0.00	0.00	700.00	0.00	0.00	0.00	0.00	0.00	0.00
Start Build 3.00									
750.00	0.00	0.00	750.00	0.00	0.00	0.00	0.00	0.00	0.00
800.00	1.50	358.80	799.99	0.65	-0.01	0.65	3.00	3.00	0.00
900.00	4.50	358.80	899.85	5.89	-0.12	5.89	3.00	3.00	0.00
1,000.00	7.50	358.80	999.29	16.34	-0.34	16.34	3.00	3.00	0.00
Green River Fouch Mkr									
1,016.37	7.99	358.80	1,015.51	18.54	-0.39	18.55	3.00	3.00	0.00
1,100.00	10.50	358.80	1,098.04	31.97	-0.67	31.98	3.00	3.00	0.00
1,200.00	13.50	358.80	1,195.85	52.76	-1.11	52.77	3.00	3.00	0.00
1,300.00	16.50	358.80	1,292.43	78.63	-1.65	78.65	3.00	3.00	0.00
1,400.00	19.50	358.80	1,387.52	109.52	-2.30	109.55	3.00	3.00	0.00
Start 1486.35 hold at 1442.67 MD									
1,442.67	20.78	358.80	1,427.58	124.21	-2.60	124.24	3.00	3.00	0.00
1,500.00	20.78	358.80	1,481.18	144.55	-3.03	144.58	0.00	0.00	0.00
1,600.00	20.78	358.80	1,574.68	180.02	-3.77	180.06	0.00	0.00	0.00
Mahogany									
1,647.83	20.78	358.80	1,619.40	196.98	-4.03	197.03	0.00	0.00	0.00
1,700.00	20.78	358.80	1,668.17	215.49	-4.62	215.53	0.00	0.00	0.00
1,800.00	20.78	358.80	1,761.67	250.96	-5.26	251.01	0.00	0.00	0.00
1,900.00	20.78	358.80	1,855.16	286.43	-6.01	286.49	0.00	0.00	0.00
2,000.00	20.78	358.80	1,948.66	321.90	-6.75	321.97	0.00	0.00	0.00
2,100.00	20.78	358.80	2,042.15	357.37	-7.49	357.45	0.00	0.00	0.00
2,200.00	20.78	358.80	2,135.65	392.84	-8.24	392.93	0.00	0.00	0.00
2,300.00	20.78	358.80	2,229.15	428.31	-8.98	428.40	0.00	0.00	0.00
2,400.00	20.78	358.80	2,322.64	463.78	-9.72	463.88	0.00	0.00	0.00
2,500.00	20.78	358.80	2,416.13	499.25	-10.47	499.36	0.00	0.00	0.00
2,600.00	20.78	358.80	2,509.63	534.72	-11.21	534.84	0.00	0.00	0.00
2,700.00	20.78	358.80	2,603.12	570.19	-11.95	570.32	0.00	0.00	0.00
Tgr3 Mkr									
2,747.02	20.78	358.80	2,647.09	586.87	-12.30	587.00	0.00	0.00	0.00
2,800.00	20.78	358.80	2,696.62	605.66	-12.70	605.80	0.00	0.00	0.00
2,900.00	20.78	358.80	2,790.11	641.13	-13.44	641.27	0.00	0.00	0.00
Start Drop -1.00									
2,929.02	20.78	358.80	2,817.25	651.43	-13.66	651.57	0.00	0.00	0.00
3,000.00	20.07	358.80	2,883.76	676.19	-14.18	676.34	1.00	-1.00	0.00
3,100.00	19.07	358.80	2,977.98	709.68	-14.88	709.84	1.00	-1.00	0.00
3,200.00	18.07	358.80	3,072.78	741.52	-15.55	741.68	1.00	-1.00	0.00
3,300.00	17.07	358.80	3,168.11	771.70	-16.18	771.87	1.00	-1.00	0.00
3,400.00	16.07	358.80	3,263.96	800.21	-16.78	800.39	1.00	-1.00	0.00
3,500.00	15.07	358.80	3,360.28	827.05	-17.34	827.23	1.00	-1.00	0.00
Douglas Creek									

RETURNED Unapproved



Database:	EDM 5000.1 Single User Db	Local Co-ordinate Reference:	Well LC FEE 9-11D-56
Company:	Berry Petroleum Company	TVD Reference:	WELL @ 6385.00usft (Original Well Elev)
Project:	Duchesne Co., UT (UT27C)	MD Reference:	WELL @ 6385.00usft (Original Well Elev)
Site:	Sec.11-T5S-R6W	North Reference:	True
Well:	LC FEE 9-11D-56	Survey Calculation Method:	Minimum Curvature
Wellbore:	Wellbore #1		
Design:	Design #2		

Planned Survey										
Measured Depth (usft)	Inclination (°)	Azimuth (°)	Vertical Depth (usft)	+N/-S (usft)	+E/-W (usft)	Vertical Section (usft)	Dogleg Rate (°/100usft)	Build Rate (°/100usft)	Turn Rate (°/100usft)	
3,572.26	14.35	358.80	3,430.18	845.39	-17.72	845.58	1.00	-1.00	0.00	
3,600.00	14.07	358.80	3,457.07	852.20	-17.87	852.39	1.00	-1.00	0.00	
3,700.00	13.07	358.80	3,554.27	875.66	-18.36	875.85	1.00	-1.00	0.00	
3,800.00	12.07	358.80	3,651.88	897.42	-18.81	897.61	1.00	-1.00	0.00	
3,900.00	11.07	358.80	3,749.84	917.47	-19.24	917.67	1.00	-1.00	0.00	
4,000.00	10.07	358.80	3,848.14	935.81	-19.62	936.01	1.00	-1.00	0.00	
4,100.00	9.07	358.80	3,946.75	952.43	-19.97	952.64	1.00	-1.00	0.00	
4,200.00	8.07	358.80	4,045.63	967.33	-20.28	967.54	1.00	-1.00	0.00	
Upr Black Shale										
4,247.51	7.60	358.80	4,092.70	973.80	-20.42	974.02	1.00	-1.00	0.00	
4,300.00	7.07	358.80	4,144.76	980.50	-20.56	980.72	1.00	-1.00	0.00	
4,400.00	6.07	358.80	4,244.10	991.94	-20.80	992.16	1.00	-1.00	0.00	
4,500.00	5.07	358.80	4,343.63	1,001.64	-21.00	1,001.87	1.00	-1.00	0.00	
Castle Peak										
4,521.96	4.85	358.80	4,365.51	1,003.54	-21.04	1,003.76	1.00	-1.00	0.00	
4,600.00	4.07	358.80	4,443.31	1,009.61	-21.17	1,009.83	1.00	-1.00	0.00	
4,700.00	3.07	358.80	4,543.11	1,015.84	-21.30	1,016.06	1.00	-1.00	0.00	
4,800.00	2.07	358.80	4,643.01	1,020.32	-21.39	1,020.55	1.00	-1.00	0.00	
Uteland Butte										
4,877.05	1.30	358.80	4,720.03	1,022.59	-21.44	1,022.81	1.00	-1.00	0.00	
4,900.00	1.07	358.80	4,742.97	1,023.06	-21.45	1,023.29	1.00	-1.00	0.00	
Start 1316.00 hold at 5007.03 MD										
5,007.03	0.00	0.00	4,850.00	1,024.06	-21.47	1,024.29	1.00	0.00	0.00	
5,100.00	0.00	0.00	4,942.97	1,024.06	-21.47	1,024.29	0.00	0.00	0.00	
Wasatch										
5,123.11	0.00	0.00	4,966.07	1,024.06	-21.47	1,024.29	0.00	0.00	0.00	
5,200.00	0.00	0.00	5,042.97	1,024.06	-21.47	1,024.29	0.00	0.00	0.00	
5,300.00	0.00	0.00	5,142.97	1,024.06	-21.47	1,024.29	0.00	0.00	0.00	
5,400.00	0.00	0.00	5,242.97	1,024.06	-21.47	1,024.29	0.00	0.00	0.00	
5,500.00	0.00	0.00	5,342.97	1,024.06	-21.47	1,024.29	0.00	0.00	0.00	
5,600.00	0.00	0.00	5,442.97	1,024.06	-21.47	1,024.29	0.00	0.00	0.00	
5,700.00	0.00	0.00	5,542.97	1,024.06	-21.47	1,024.29	0.00	0.00	0.00	
5,800.00	0.00	0.00	5,642.97	1,024.06	-21.47	1,024.29	0.00	0.00	0.00	
5,900.00	0.00	0.00	5,742.97	1,024.06	-21.47	1,024.29	0.00	0.00	0.00	
6,000.00	0.00	0.00	5,842.97	1,024.06	-21.47	1,024.29	0.00	0.00	0.00	
6,100.00	0.00	0.00	5,942.97	1,024.06	-21.47	1,024.29	0.00	0.00	0.00	
6,200.00	0.00	0.00	6,042.97	1,024.06	-21.47	1,024.29	0.00	0.00	0.00	
6,300.00	0.00	0.00	6,142.97	1,024.06	-21.47	1,024.29	0.00	0.00	0.00	
TD at 6323.03 - LCF 9-11D-56 Box - LCF 9-11D-56 Tgt										
6,323.03	0.00	0.00	6,166.00	1,024.06	-21.47	1,024.29	0.00	0.00	0.00	

CONFIDENTIAL
 Returned Unapproved



Database:	EDM 5000.1 Single User Db	Local Co-ordinate Reference:	Well LC FEE 9-11D-56
Company:	Berry Petroleum Company	TVD Reference:	WELL @ 6385.00usft (Original Well Elev)
Project:	Duchesne Co., UT (UT27C)	MD Reference:	WELL @ 6385.00usft (Original Well Elev)
Site:	Sec.11-T5S-R6W	North Reference:	True
Well:	LC FEE 9-11D-56	Survey Calculation Method:	Minimum Curvature
Wellbore:	Wellbore #1		
Design:	Design #2		

Design Targets									
Target Name	Dip Angle	Dip Dir.	TVD	+N/-S	+E/-W	Northing	Easting	Latitude	Longitude
- hit/miss target	(°)	(°)	(usft)	(usft)	(usft)	(usft)	(usft)		
- Shape									
LCF 9-11D-56 Box	0.00	0.00	6,166.00	1,036.16	1.03	630,129.063	2,274,462.599	40° 3' 33.277 N	110° 31' 9.888 W
- plan misses target center by 25.55usft at 6323.03usft MD (6166.00 TVD, 1024.06 N, -21.47 E)									
- Polygon									
Point 1			6,166.00	199.30	-177.70	630,326.40	2,274,282.73		
Point 2			6,166.00	202.10	172.40	630,333.04	2,274,632.77		
Point 3			6,166.00	-198.90	182.00	629,932.17	2,274,646.77		
Point 4			6,166.00	-202.50	-176.70	629,924.64	2,274,288.13		
LCF 9-11D-56 Tgt	0.00	0.00	6,166.00	1,024.06	-21.47	630,116.717	2,274,440.233	40° 3' 33.157 N	110° 31' 10.177 W
- plan hits target center									
- Point									

Casing Points				
Measured Depth	Vertical Depth	Name	Casing Diameter	Hole Diameter
(usft)	(usft)		(")	(")
650.00	650.00	8 5/8" Csg.	8-5/8	12-1/4

Formations					
Measured Depth	Vertical Depth	Name	Lithology	Dip	Dip Direction
(usft)	(usft)			(°)	(°)
470.00	470.00	Green River		1.57	358.80
1,016.37	1,015.00	Green River Fouch Mkr		1.57	358.80
1,647.83	1,614.00	Mahogany		1.57	358.80
2,747.02	2,631.00	Tgr3 Mkr		1.57	358.80
3,572.26	3,407.00	Douglas Creek		1.57	358.80
4,247.51	4,066.00	Upr Black Shale		1.57	358.80
4,521.96	4,338.00	Castle Peak		1.57	358.80
4,877.05	4,692.00	Uteland Butte		1.57	358.80
5,123.11	4,938.00	Wasatch		1.57	358.80

Plan Annotations					
Measured Depth	Vertical Depth	Local Coordinates		Comment	
(usft)	(usft)	+N/-S	+E/-W		
		(usft)	(usft)		
750.00	750.00	0.00	0.00	Start Build 3.00	
1,442.67	1,427.58	124.21	-2.60	Start 1486.35 hold at 1442.67 MD	
2,929.02	2,817.25	651.43	-13.66	Start Drop -1.00	
5,007.03	4,850.00	1,024.06	-21.47	Start 1316.00 hold at 5007.03 MD	
6,323.03	6,166.00	1,024.06	-21.47	TD at 6323.03	

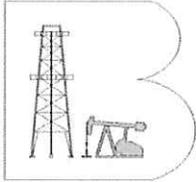

Berry Petroleum Company

Duchesne Co., UT (UT27C)

Sec.11-T5S-R6W

LC FEE 9-11D-56

Wellbore #1

Design #2

Anticollision Report

18 October, 2012

CONFIDENTIAL
Returned Unapproved



Received: September 18, 2013



Sharewell Energy Services
Anticollision Report



Company:	Berry Petroleum Company	Local Co-ordinate Reference:	Well LC FEE 9-11D-56
Project:	Duchesne Co., UT (UT27C)	TVD Reference:	WELL @ 6385.00usft (Original Well Elev)
Reference Site:	Sec.11-T5S-R6W	MD Reference:	WELL @ 6385.00usft (Original Well Elev)
Site Error:	0.00 usft	North Reference:	True
Reference Well:	LC FEE 9-11D-56	Survey Calculation Method:	Minimum Curvature
Well Error:	0.00 usft	Output errors are at	2.00 sigma
Reference Wellbore	Wellbore #1	Database:	EDM 5000.1 Single User Db
Reference Design:	Design #2	Offset TVD Reference:	Offset Datum

Reference	Design #2
Filter type:	NO GLOBAL FILTER: Using user defined selection & filtering criteria
Interpolation Method:	Stations
Depth Range:	Unlimited
Results Limited by:	Maximum center-center distance of 9,999.98 usft
Warning Levels Evaluated at:	2.00 Sigma
Error Model:	ISCWSA
Scan Method:	Closest Approach 3D
Error Surface:	Elliptical Conic
Casing Method:	Not applied

Survey Tool Program	Date	2012/10/18
From (usft)	To (usft)	Survey (Wellbore)
0.00	6,323.03	Design #2 (Wellbore #1)
Tool Name	Description	
MWD	MWD - Standard	

Summary						
Site Name	Reference Measured Depth (usft)	Offset Measured Depth (usft)	Distance Between Centres (usft)	Distance Between Ellipses (usft)	Separation Factor	Warning
Offset Well - Wellbore - Design						
Sec.11-T5S-R6W						
LC Tribal 12H-11-56 - Wellbore #1 - Design #1	750.00	750.00	19.90	16.80	6.416	CC, ES
LC Tribal 12H-11-56 - Wellbore #1 - Design #1	800.00	799.99	20.47	17.15	6.154	SF

Offset Design													Offset Site Error:	0.00 usft
Sec.11-T5S-R6W - LC Tribal 12H-11-56 - Wellbore #1 - Design #1													Offset Well Error:	0.00 usft
Survey Program: 0-MWD														
Reference	Offset	Semi Major Axis		Distance		Minimum Separation	Separation Factor	Warning						
Measured Depth (usft)	Vertical Depth (usft)	Measured Depth (usft)	Vertical Depth (usft)	Reference (usft)	Offset (usft)	Highside Toolface (°)	Offset Wellbore Centre +N/-S (usft)	+E/-W (usft)	Between Centres (usft)	Between Ellipses (usft)	Minimum Separation (usft)	Separation Factor	Warning	
0.00	0.00	0.00	0.00	0.00	0.00	-151.43	-17.48	-9.52	19.90	19.72	0.18	110.684		
100.00	100.00	100.00	100.00	0.09	0.09	-151.43	-17.48	-9.52	19.90	19.27	0.63	31.624		
200.00	200.00	200.00	200.00	0.31	0.31	-151.43	-17.48	-9.52	19.90	19.27	0.63	31.624		
300.00	300.00	300.00	300.00	0.54	0.54	-151.43	-17.48	-9.52	19.90	18.82	1.08	18.447		
400.00	400.00	400.00	400.00	0.76	0.76	-151.43	-17.48	-9.52	19.90	18.37	1.53	13.022		
500.00	500.00	500.00	500.00	0.99	0.99	-151.43	-17.48	-9.52	19.90	17.92	1.98	10.062		
600.00	600.00	600.00	600.00	1.21	1.21	-151.43	-17.48	-9.52	19.90	17.48	2.43	8.199		
700.00	700.00	700.00	700.00	1.44	1.44	-151.43	-17.48	-9.52	19.90	17.03	2.88	6.918		
750.00	750.00	750.00	750.00	1.55	1.55	-151.43	-17.48	-9.52	19.90	16.80	3.10	6.416	CC, ES	
800.00	799.99	799.99	799.99	1.66	1.66	-151.13	-17.48	-9.52	20.47	17.15	3.33	6.154	SF	
899.85	899.85	899.85	899.85	1.88	1.88	-156.83	-17.48	-9.52	25.18	21.41	3.78	6.667		
1,000.00	999.29	999.29	999.29	2.13	2.11	-163.49	-17.48	-9.52	35.04	30.81	4.22	8.295		
1,100.00	1,098.04	1,098.04	1,098.04	2.39	2.33	-168.47	-17.48	-9.52	50.24	45.58	4.66	10.774		
1,200.00	1,195.85	1,195.85	1,195.85	2.71	2.55	-171.76	-17.48	-9.52	70.74	65.65	5.09	13.890		
1,300.00	1,292.43	1,292.43	1,292.43	3.09	2.77	-173.87	-17.48	-9.52	96.43	90.92	5.51	17.488		
1,400.00	1,387.52	1,387.52	1,387.52	3.57	2.98	-175.27	-17.48	-9.52	127.21	121.28	5.93	21.457		
1,442.67	1,427.58	1,427.58	1,427.58	3.79	3.07	-175.73	-17.48	-9.52	141.86	135.76	6.10	23.244		
1,500.00	1,481.18	1,481.18	1,481.18	4.12	3.19	-176.26	-17.48	-9.52	162.16	155.78	6.37	25.444		
1,600.00	1,574.68	1,574.68	1,574.68	4.72	3.40	-176.93	-17.48	-9.52	197.58	190.73	6.85	28.834		
1,700.00	1,668.17	1,668.17	1,668.17	5.34	3.61	-177.40	-17.48	-9.52	233.02	225.68	7.34	31.745		
1,800.00	1,761.67	1,761.67	1,761.67	5.97	3.82	-177.74	-17.48	-9.52	268.47	260.64	7.84	34.263		
1,900.00	1,855.16	1,855.16	1,855.16	6.62	4.03	-178.01	-17.48	-9.52	303.93	295.59	8.34	36.459		
2,000.00	1,948.66	1,948.66	1,948.66	7.27	4.25	-178.22	-17.48	-9.52	339.39	330.55	8.84	38.386		
2,100.00	2,042.15	2,042.15	2,042.15	7.93	4.46	-178.38	-17.48	-9.52	374.85	365.50	9.35	40.090		
2,200.00	2,135.65	2,135.65	2,135.65	8.60	4.67	-178.52	-17.48	-9.52	410.32	400.46	9.86	41.604		

CC - Min centre to center distance or convergent point, SF - min separation factor, ES - min ellipse separation



Sharewell Energy Services
Anticollision Report



Company:	Berry Petroleum Company	Local Co-ordinate Reference:	Well LC FEE 9-11D-56
Project:	Duchesne Co., UT (UT27C)	TVD Reference:	WELL @ 6385.00usft (Original Well Elev)
Reference Site:	Sec.11-T5S-R6W	MD Reference:	WELL @ 6385.00usft (Original Well Elev)
Site Error:	0.00 usft	North Reference:	True
Reference Well:	LC FEE 9-11D-56	Survey Calculation Method:	Minimum Curvature
Well Error:	0.00 usft	Output errors are at	2.00 sigma
Reference Wellbore	Wellbore #1	Database:	EDM 5000.1 Single User Db
Reference Design:	Design #2	Offset TVD Reference:	Offset Datum

Offset Design													Offset Site Error:	0.00 usft
Survey Program: 0-MWD													Offset Well Error:	0.00 usft
Reference													Warning	
Measured Depth (usft)	Vertical Depth (usft)	Offset		Semi Major Axis		Highside Toolface (°)	Offset Wellbore Centre		Distance			Separation Factor	Warning	
		Measured Depth (usft)	Vertical Depth (usft)	Reference (usft)	Offset (usft)		+N/-S (usft)	+E/-W (usft)	Between Centres (usft)	Between Ellipses (usft)	Minimum Separation (usft)			
2,300.00	2,229.14	2,229.14	2,229.14	9.27	4.88	-178.64	-17.48	-9.52	445.79	435.41	10.38	42.958		
2,400.00	2,322.64	2,322.64	2,322.64	9.95	5.09	-178.74	-17.48	-9.52	481.26	470.37	10.89	44.176		
2,500.00	2,416.13	2,416.13	2,416.13	10.62	5.30	-178.83	-17.48	-9.52	516.73	505.32	11.41	45.275		
2,600.00	2,509.63	2,509.63	2,509.63	11.30	5.51	-178.90	-17.48	-9.52	552.20	540.27	11.93	46.272		
2,700.00	2,603.12	2,603.12	2,603.12	11.98	5.72	-178.97	-17.48	-9.52	587.68	575.22	12.46	47.181		
2,800.00	2,696.62	2,696.62	2,696.62	12.66	5.93	-179.03	-17.48	-9.52	623.15	610.17	12.98	48.012		
2,900.00	2,790.11	2,790.11	2,790.11	13.34	6.14	-179.08	-17.48	-9.52	658.62	645.12	13.50	48.774		
2,929.02	2,817.25	2,817.25	2,817.25	13.54	6.20	-179.09	-17.48	-9.52	668.92	655.26	13.66	48.984		
3,000.00	2,883.76	2,883.76	2,883.76	13.97	6.35	-179.13	-17.48	-9.52	693.69	679.65	14.04	49.403		
3,100.00	2,977.98	2,977.98	2,977.98	14.49	6.56	-179.18	-17.48	-9.52	727.18	712.62	14.56	49.943		
3,200.00	3,072.78	3,072.78	3,072.78	15.00	6.77	-179.22	-17.48	-9.52	759.02	743.95	15.07	50.350		
3,300.00	3,168.11	3,168.11	3,168.11	15.50	6.99	-179.25	-17.48	-9.52	789.21	773.62	15.58	50.640		
3,400.00	3,263.96	3,263.96	3,263.96	15.98	7.20	-179.28	-17.48	-9.52	817.72	801.64	16.09	50.827		
3,500.00	3,360.28	3,360.28	3,360.28	16.44	7.42	-179.31	-17.48	-9.52	844.56	827.98	16.59	50.921		
3,600.00	3,457.07	3,457.07	3,457.07	16.88	7.64	-179.33	-17.48	-9.52	869.72	852.64	17.08	50.933		
3,700.00	3,554.27	3,554.27	3,554.27	17.30	7.85	-179.35	-17.48	-9.52	893.18	875.62	17.56	50.871		
3,800.00	3,651.88	3,651.88	3,651.88	17.70	8.07	-179.37	-17.48	-9.52	914.94	896.91	18.03	50.742		
3,900.00	3,749.84	3,749.84	3,749.84	18.08	8.29	-179.38	-17.48	-9.52	935.00	916.50	18.50	50.551		
4,000.00	3,848.14	3,848.14	3,848.14	18.43	8.51	-179.40	-17.48	-9.52	953.34	934.39	18.95	50.304		
4,100.00	3,946.75	3,946.75	3,946.75	18.76	8.74	-179.41	-17.48	-9.52	969.97	950.57	19.40	50.006		
4,200.00	4,045.63	4,045.63	4,045.63	19.07	8.96	-179.42	-17.48	-9.52	984.87	965.04	19.83	49.659		
4,300.00	4,144.76	4,144.76	4,144.76	19.35	9.18	-179.43	-17.48	-9.52	998.04	977.78	20.26	49.262		
4,400.00	4,244.10	4,244.10	4,244.10	19.61	9.40	-179.44	-17.48	-9.52	1,009.48	988.81	20.67	48.833		
4,500.00	4,343.63	4,423.75	4,421.66	19.85	9.80	-178.31	-12.03	-29.81	1,016.72	995.46	21.25	47.440		
4,600.00	4,443.31	4,606.30	4,581.84	20.06	10.40	-173.65	10.05	-112.11	1,013.20	991.04	22.15	45.724		
4,700.00	4,543.11	4,721.92	4,662.10	20.25	11.19	-169.01	31.53	-192.11	1,008.08	982.70	23.21	43.035		
4,800.00	4,643.01	4,793.34	4,700.83	20.41	11.95	-165.60	47.06	-249.99	1,001.41	976.85	24.56	40.770		
4,838.81	4,681.80	4,813.55	4,710.12	20.46	12.20	-164.58	51.72	-267.41	1,000.88	976.00	24.97	40.091		
4,900.00	4,742.97	4,839.60	4,720.97	20.55	12.56	-163.23	57.86	-290.20	1,002.10	976.63	25.54	39.243		
5,007.03	4,850.00	4,875.00	4,733.60	20.67	13.08	-162.57	66.43	-320.13	1,010.45	984.06	26.39	38.295		
5,100.00	4,942.97	4,894.07	4,739.38	20.76	13.39	-161.53	71.14	-339.88	1,025.07	998.12	26.95	38.036		
5,200.00	5,042.97	4,911.32	4,743.98	20.87	13.69	-160.59	75.40	-355.74	1,049.28	1,021.78	27.50	38.156		
5,300.00	5,142.97	4,925.00	4,747.20	20.97	13.92	-159.83	78.89	-368.58	1,081.88	1,053.90	27.97	38.674		
5,400.00	5,242.97	4,935.59	4,749.43	21.08	14.11	-159.25	81.58	-378.57	1,122.22	1,093.83	28.39	39.533		
5,500.00	5,342.97	4,950.00	4,752.09	21.19	14.37	-158.45	83.45	-392.25	1,169.61	1,140.72	28.89	40.483		
5,600.00	5,442.97	4,950.00	4,752.09	21.30	14.37	-158.45	85.25	-392.25	1,223.18	1,194.12	29.05	42.103		
5,700.00	5,542.97	4,958.01	4,753.39	21.41	14.53	-158.00	87.30	-399.88	1,282.25	1,252.84	29.41	43.598		
5,800.00	5,642.97	4,963.33	4,754.18	21.52	14.69	-157.71	88.66	-404.97	1,346.10	1,316.40	29.70	45.317		
5,900.00	5,742.97	4,975.00	4,755.70	21.65	14.85	-157.06	91.66	-416.14	1,414.16	1,384.01	30.15	46.901		
6,000.00	5,842.97	4,975.00	4,755.70	21.77	14.85	-157.06	91.66	-416.14	1,485.70	1,455.38	30.32	49.004		
6,100.00	5,942.97	4,975.00	4,755.70	21.89	14.85	-157.06	91.66	-416.14	1,560.37	1,529.88	30.49	51.185		
6,200.00	6,042.97	4,975.00	4,755.70	22.01	14.85	-157.06	91.66	-416.14	1,637.74	1,607.09	30.65	53.427		
6,300.00	6,142.97	4,975.00	4,755.70	22.14	14.85	-157.06	91.66	-416.14	1,717.46	1,686.63	30.82	55.719		
6,323.03	6,166.00	4,975.00	4,755.70	22.17	14.85	-157.06	91.66	-416.14	1,736.11	1,705.25	30.86	56.252		

CC - Min centre to center distance or convergent point, SF - min separation factor, ES - min ellipse separation



Company:	Berry Petroleum Company	Local Co-ordinate Reference:	Well LC FEE 9-11D-56
Project:	Duchesne Co., UT (UT27C)	TVD Reference:	WELL @ 6385.00usft (Original Well Elev)
Reference Site:	Sec.11-T5S-R6W	MD Reference:	WELL @ 6385.00usft (Original Well Elev)
Site Error:	0.00 usft	North Reference:	True
Reference Well:	LC FEE 9-11D-56	Survey Calculation Method:	Minimum Curvature
Well Error:	0.00 usft	Output errors are at	2.00 sigma
Reference Wellbore	Wellbore #1	Database:	EDM 5000.1 Single User Db
Reference Design:	Design #2	Offset TVD Reference:	Offset Datum

Reference Depths are relative to WELL @ 6385.00usft (Original Well E
 Offset Depths are relative to Offset Datum
 Central Meridian is 111° 30' 0.000 W

Coordinates are relative to: LC FEE 9-11D-56
 Coordinate System is US State Plane 1927 (Exact solution), Utah Central 4302
 Grid Convergence at Surface is: 0.63°

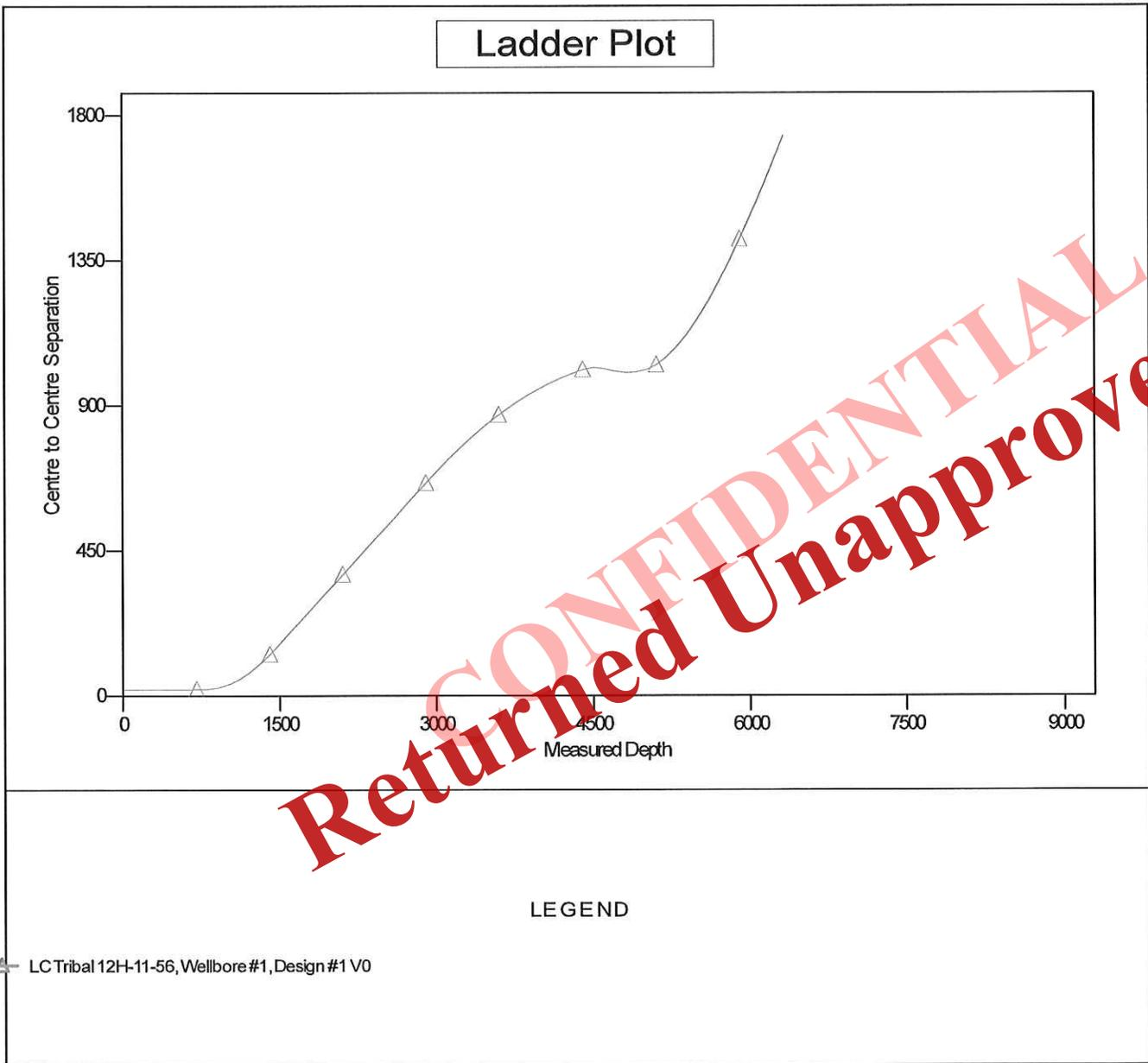



Company:	Berry Petroleum Company	Local Co-ordinate Reference:	Well LC FEE 9-11D-56
Project:	Duchesne Co., UT (UT27C)	TVD Reference:	WELL @ 6385.00usft (Original Well Elev)
Reference Site:	Sec.11-T5S-R6W	MD Reference:	WELL @ 6385.00usft (Original Well Elev)
Site Error:	0.00 usft	North Reference:	True
Reference Well:	LC FEE 9-11D-56	Survey Calculation Method:	Minimum Curvature
Well Error:	0.00 usft	Output errors are at	2.00 sigma
Reference Wellbore	Wellbore #1	Database:	EDM 5000.1 Single User Db
Reference Design:	Design #2	Offset TVD Reference:	Offset Datum

Reference Depths are relative to WELL @ 6385.00usft (Original Well E
Offset Depths are relative to Offset Datum
Central Meridian is 111° 30' 0.000 W

Coordinates are relative to: LC FEE 9-11D-56
Coordinate System is US State Plane 1927 (Exact solution), Utah Central 4302
Grid Convergence at Surface is: 0.63°

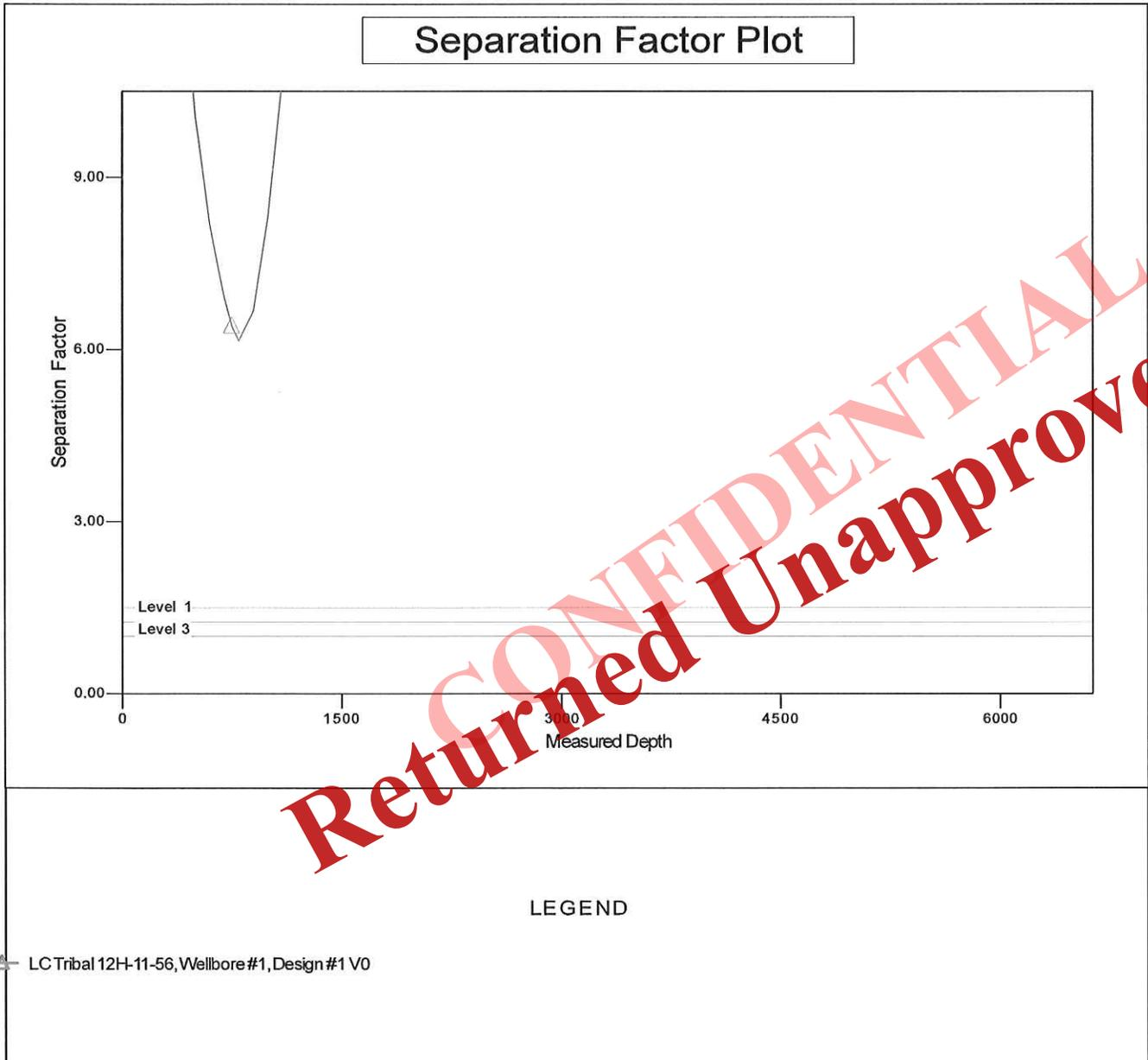

AFFIDAVIT OF SURFACE DAMAGE AGREEMENT

SHAWN HAWK, the Affiant herein, is a Field Landman for Berry Petroleum Company, a Delaware corporation, with an office located at 4000 S 4028 W, Rt 2 Box 7735, Roosevelt, Utah 84066, being of lawful age and duly sworn upon his oath and being duly authorized to make this affidavit on behalf of said corporation hereby deposes and states to the best of his knowledge as follows:

That Berry Petroleum Company has a Surface Damage Agreement signed by the current surface owner covering the following described property, hereinafter referred to as the Land:

TOWNSHIP 5 SOUTH, RANGE 6 WEST, USB&M
Section 11, SE ¼ SE ¼

Affiant further states said Surface Damage Agreement GRANTS, SELLS, and CONVEYS unto Berry Petroleum Company an easement for ingress and egress to, along with a right to use, that portion of the herein described property as may be necessary to construct, use, and maintain a well site or well sites (including location of additional wells on each well site in the case of directional or horizontal drilling) for the drilling, completion and operation of an oil and gas well or wells (including but not limited to pumping facilities and tank batteries) over, under and through the herein described Land.

Affiant further states said Surface Damage Agreement GRANTS, SELLS, and CONVEYS unto Berry Petroleum Company the right to construct, entrench, maintain, operate, replace, remove, protect, or abandon a pipeline or pipelines for water or gas with appurtenances thereto, including, but not limited to, valves, metering equipment, and cathodic equipment; to construct, maintain, relocate, or abandon a road (said well sites, pipelines, appurtenance, valves, metering equipment, cathodic equipment and road being sometimes collectively call the "facilities") over, under, and through the herein described Land.

Executed and effective as of this 16th day of September, 2013.

Berry Petroleum Company

By: Shawn Hawk
Shawn Hawk
Field Landman

SURFACE USE PLAN of OPERATIONS

Attachment for Permit to Drill:

Name of Operator: Berry Petroleum Company
Address: 4000 South 4028 West/Rt. 2 Box 7735
Roosevelt, Utah 80466
Well Location: LC Fee 9-11D-56
Surface: 936' FSL & 663' FEL
Target: 1960' FSL & 660' FEL
SESE of Sec. 11, T5S, R6W.

The surface owner or surface owner representative and dirt contractor will be proved with an approved copy of the surface use plan of operations and approved conditions of approval before initiating construction.

The onsite inspection for the referenced well will be conducted per UDOGM.

A Existing Roads

To reach the Berry Petroleum Company well, LC Fee 9-11D-56, in Section 11-T5S-R6W:

The proposed well site is approximately 10.6 miles southwest of Duchesne, Utah.

Proceed in a southerly direction from Duchesne, Utah, along US Highway 191 for approximately 10.4 miles. Turn east onto the existing access road and proceed in a northerly by north easterly direction for approximately 0.2 miles. Follow the road flags in a westerly direction for approximately 91 feet to the proposed LC Fee 9-11D-56 and 15-11D-56 location.

Berry Petroleum Company will improve or maintain existing roads in a condition the same or better than before operations began. Best Management Practices will be considered when improving or maintaining existing roads. In general this would involve the need for some surface material or fill to prevent or repair holes in the road due to heavy truck traffic during the drilling and completion operations. If repairs are made the operator will secure the appropriate material from private sources.

B New or Reconstructed Access Roads

See Topographic Map "A & B" for the location of the proposed access road. Berry Petroleum Company will construct a new access road for approximately 91 feet to access the LC Fee 9-11D-56 and 15-11D-56.

C Location of Existing Wells

See Topographic Map "D" for the location of existing wells within a 1 mile radius.

D Location of Tank Batteries, Production Facilities and Production Gathering and Service Lines

A containment dike will be constructed completely around those production facilities which contain fluids (i.e., production tanks, produced water tanks). This dike will be constructed of compacted subsoil, be impervious, hold 100% of the capacity of the largest tank. The site specific APD will address additional capacity if such is needed due to environmental concerns. The use of topsoil for the construction of dikes will not be allowed. If a Spill Prevention, Control, and Countermeasure (SPCC) Plan is required by the Environmental Protection Agency, the containment dike may be expanded with the Authorized Agency Officer's approval to meet SPCC requirements.

The proposed pipeline will tie in at an existing pipeline. Map "C" illustrating the proposed route is attached. The proposed pipeline will be 4"-6" polypipe and be placed above ground. The pipeline will run in the same corridor as the above proposed access road.

All site security guidelines identified in Federal regulation 43 CFR 3126.7, will be adhered to. All off-lease storage, off-lease measurement, or commingling on-lease or off-lease production will have prior written approval from the Authorized Agency Officer.

Gas meter runs will be located approximately 100 feet from the wellhead. Where necessary, the gas line will be anchored down from the wellhead to the meter.

E Location and Type of Water Supply

Water for the drilling and completion will be pumped or trucked from one of the following Berry source wells:

- Water Permit # 43-12400, Sec. 23, T5S, R5W
- Water Permit # 43-12400, Sec. 24, T5S, R5W
- Water Permit # 43-1221, Sec. 30, T3S, R8W
- Water Permit # 43-1226, Sec. 30, T3S, R8W
- Water Permit # 43-1627, Sec. 30, T3S, R8W
- Water Permit # 43-1628, Sec. 12, T5S, R6W (Douglas E. & Yordis Nielsen)
- Duchesne City Culinary Water Dock located in Sec. 1, T4S, R5W
- East Duchesne Water, Arcadia Feedlot, Sec. 28, T3S, R3W
- Petroglyph Operating Company 08-04 Waterplant, Sec. 1, T5S, R3W

F Source of Construction Materials

All construction materials for this location site and access road shall be borrow material accumulated during the construction of the location site and access road.

Additional gravel or pit lining material will be obtained from a private source.

The use of materials under Authorized Agency jurisdiction will conform to 43 CFR 3610.2-3.

G Methods of Handling Waste Materials

Drill fluids will be contained in a closed loop system. Cuttings will be contained on site and buried in a pit or used on location and/or access roads, whichever is deemed appropriate by the authorized agency.

After first production, produced wastewater from Berry Petroleum Company wells will be used for injection in our enhanced oil recovery project(s) in the Brundage Canyon Field or they will be trucked to one of the following approved waste water disposal sites:

- R.N. Industries, Inc. Sec. 4, T2S, R2W, Bluebell
- MC & MC Disposal Sec. 12, T6S, R19E, Vernal
- LaPoint Recycle & Storage Sec. 12, T5S, R19E, LaPoint
- Water Disposal Inc. Sec. 32, T1S, R1W, Roosevelt
- ITL 4461 W 3000 So Roosevelt Location Pleasant Valley
- IWM PO Box 430 Altamont or 20250 W 2000 S Duchesne Location – Blue Bench
- Pro Water 12223 Highland Ave Ste B503 Rancho Cucamonga CA 91739 Location – Blue Bench

Should operations of the field be prohibited by the Authorized Officer, the wastewater shall be confined to the approved pit or storage tank for a period not to exceed 90 days. The use of such pit is hereby approved as part of this Application for Permit to Drill.

Production fluids will be contained in leak-proof tanks. All production fluids will be disposed of at approved disposal sites. Produced water, oil, and other byproducts will not be applied to roads or well pads for control of dust or weeds. The indiscriminate dumping of produced fluids on roads, well sites, or other areas will not be allowed.

Any spills of oil, gas, salt water, or other noxious fluids will be immediately cleaned up and removed to an approved disposal site.

A chemical portable toilet will be furnished with the drilling rig.

Garbage, trash, and other waste materials will be collected in a portable, self-contained, fully enclosed trash cage during operations. Trash will not be burned on location.

All debris and other waste materials not contained in the trash cage will be cleaned up and removed from the location promptly after removal of the completion rig (weather permitting).

Any open pits will be fenced during the operations. The fencing will be maintained with best efforts until such time as the pits are backfilled.

No chemicals subject to reporting under SARA Title III (hazardous materials) in an amount equal to or greater than 10,000 pounds will be used, produced, stored, transported, or disposed of annually in association with the drilling, testing, or completing of wells. Furthermore, extremely hazardous substances, as defined in 40 CFR 355, in threshold planning quantities, will not be used, produced, stored, transported, or disposed of in association with the drilling, testing, or completing of wells within these areas.

H Ancillary Facilities

There are no ancillary facilities planned for at this time and none are foreseen in the future.

I Well site Layout

The attached Location Layout diagram describes drill pad cross-sections, cuts and fills, and locations of the mud tanks, reserve pipe racks, trailer parking, spoil dirt stockpile(s) and surface material stockpile(s)

J Plans for Restoration of the Surface

Interim

The dirt contractor will be provided with approved copies of the Surface Use Plan prior to construction activities.

Upon well completion, within a reasonable time, the location and surrounding area will be cleared of all unused tubing, materials, trash, and debris not required for production.

Abandoned well sites, roads, and other disturbed areas will be restored as near as practical to their original condition. Where applicable, these conditions may include the re-establishment of irrigation systems, the re-establishment of appropriate soil conditions, and the re-establishment of vegetation as specified.

All disturbed areas will be re-contoured to the approximate natural contours.

Any drainage rerouted during the construction activities shall be restored to its original line of flow or as near as possible.

All areas of disturbance (including surface pipelines) must have appropriate surface use agreements or approvals in place with the proper owner and/or agency before such action is started.

The conditions of approval, as set forth by those owners and/or agencies, shall be adhered to.

Interim Reclamation consisting of minimizing the footprint of disturbance shall be accomplished by reclaiming all portions of the well site not needed for safe production operations. The portions of the well site not needed for operational and safety purposes will be recontoured to a final appearance that blends with the surrounding topography. Topsoil will be spread over these areas. The operator will spread the topsoil over the entire location except where an all-weather surface, access route or turnaround is needed. Production facilities should be clustered or placed offsite to maximize the opportunity for interim reclamation. Any incidental use on interim reclamation may require restoration of damage. This may require recontouring and seeding of the damaged area.

Paint all production facilities and equipment, not otherwise regulated (OSHA, etc.), a uniform, non-contrasting, non-reflective color tone, matched to the land and not the sky, slightly darker than the adjacent landscape.

Install Hospital muffler to the Pump-jack to minimize engine noise.

Final

Prior to the construction of the location, the top 12 inches of soil material (if present) will be stripped and stockpiled. Placement of the topsoil is noted on the location plat attached. Topsoil shall be stockpiled separately from subsoil materials. Topsoil salvaged from the reserve pit shall be stockpiled separately near the reserve pit.

When restoration activities have been completed, the location site and new access road cuts and shoulders shall be reseeded. Prior to reseeding, all disturbed areas, including the old access road will be scarified and left with a rough surface.

The Authorized Agency Officer shall be contacted for the required seed mixture. Seed will be broadcast and the amount of seed mixture per acre will be doubled. The seeded area will then be "walked" with a dozer to assure coverage of the seeds. The seed mixture will reflect the recommendation from the Archeology study done.

At final abandonment, all casing shall be cut off at the base of the cellar or 3 feet below final restored ground level, whichever is deeper, and cap the casing with a metal plate a minimum of 0.25 inches thick. The cap will be welded in place and the well location and identity will be permanently inscribed on the cap. The cap also will be constructed with a weep hole.

K Well Surface & Access Ownership:

Douglas E. Nielsen
PO Box 114
Duchesne, UT 84021

L Other information

All lease and/or unit operations will be conducted in such a manner that full compliance is made with all applicable laws, regulations, Onshore Oil and Gas Orders, the approved Plan of Operations, and any applicable Notice to Lessees. The operator is fully responsible for the actions of his subcontractors. A copy of these conditions will be furnished to the field representative to ensure compliance.

Berry will control noxious weeds along access road use authorizations, pipeline route authorizations, well sites or other applicable facilities. A list of noxious weeds may be obtained from the Authorized Agency or the appropriate County Extension Office.

Drilling rigs and/or equipment used during drilling operations on this location will not be stacked or stored on administered lands after the conclusion of drilling operations or at any other time without authorization by the Authorized Agency Officer. If authorization is obtained, such storage is only a temporary measure.

Travel is restricted to approved routes only.

All personnel will refrain from collecting artifacts and from disturbing any significant cultural resources in the area. The operator is responsible for informing all persons in the area who are associated with this project that they may be subject to prosecution for knowingly disturbing historic or archaeological sites or for collecting artifacts. All vehicular traffic, personnel movement, construction, and restoration activities shall be confined to the areas examined, as referenced in the archaeological report, and to the existing roadways and/or evaluated access routes. If historic or archaeological materials are uncovered during construction, Berry Petroleum Company is to immediately stop work that might further disturb such materials and contact the Authorized Agency Officer.

Within five working days, the Authorized Agency Officer will inform the operator as to:

- Whether the materials appear eligible for the National Historic Register of Historic Places;
- The mitigation measures Berry will likely have to undertake before the site can be used (assuming in-situ preservation is not necessary); and a time frame for the Authorized Officer to complete an expedited review under 36 CFR 800.11 to confirm, through the State Historic Preservation Officer, that the findings of the Authorized Officer are correct and that the mitigation measures are appropriate.

If Berry wishes, at any time, to relocate activities to avoid the expense of mitigation and/or the delays associated with this process, the Authorized Agency Officer and/or the surface owner will assume responsibility for whatever reexcavation and stabilization of the exposed materials may be required. Otherwise the operator will be responsible for mitigation costs. The Authorized Agency Officer and/or the surface owner will provide technical and procedural guidelines for the conduct of mitigation. Upon verification from the Authorized Agency Officer that required mitigation has been completed, Berry will then be allowed to resume construction.

All Surface Use Conditions of Approval associated with the Landowner Surface Use Agreement and Environmental Analysis Mitigation Stipulations will be adhered to.

All well site locations will have appropriate signs indicating the name of the operator, the lease serial number, the well name and number, the survey description of the well (footages or the quarter/quarter section, the section, township, and range).

BERRY PETROLEUM COMPANY

WELL PAD INTERFERENCE PLAT

LC FEE 9-11D-56 (Proposed Well)

LC FEE 15-11D-56 (Proposed Well)

Pad Location: SESE Section 11, T5S, R6W, U.S.B.&M.

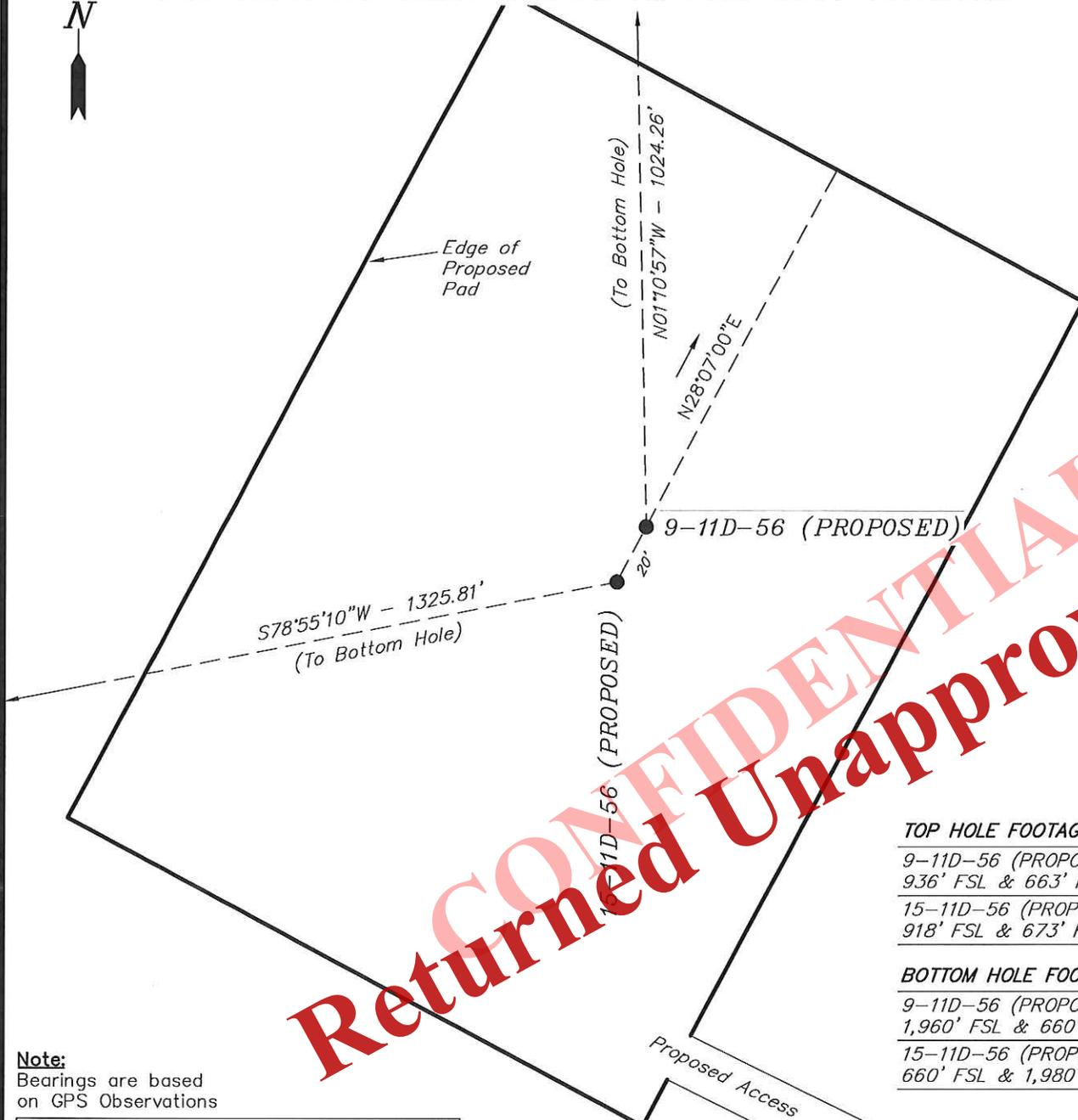

CONFIDENTIAL
 Returned Unapproved

TOP HOLE FOOTAGES

9-11D-56 (PROPOSED)
936' FSL & 663' FEL

15-11D-56 (PROPOSED)
918' FSL & 673' FEL

BOTTOM HOLE FOOTAGES

9-11D-56 (PROPOSED)
1,960' FSL & 660' FEL

15-11D-56 (PROPOSED)
660' FSL & 1,980' FEL

Note:
Bearings are based
on GPS Observations

RELATIVE COORDINATES
From top hole to bottom hole

WELL	NORTH	EAST
9-11D-56	1,024'	-21'
15-11D-56	-255'	-1,301'

LATITUDE & LONGITUDE
Surface position of Wells (NAD 27)

WELL	LATITUDE	LONGITUDE
9-11D-56	40.056399°	110.519417°
15-11D-56	40.056351°	110.519451°

SURVEYED BY: Q.M.	DATE SURVEYED: 11-14-11
DRAWN BY: R.B.T.	DATE DRAWN: 11-15-11
SCALE: 1" = 50'	REVISED: L.C.S. 12-07-12

(435) 781-2501

Tri State
Land Surveying, Inc.

180 NORTH VERNAL AVE. VERNAL, UTAH 84078

BERRY PETROLEUM COMPANY

LOCATION LAYOUT

LC FEE 9-11D-56 (Proposed Well)

LC FEE 15-11D-56 (Proposed Well)

Pad Location: SESE Section 11, T5S, R6W, U.S.B.&M.

Existing Pipeline Right-of-Way

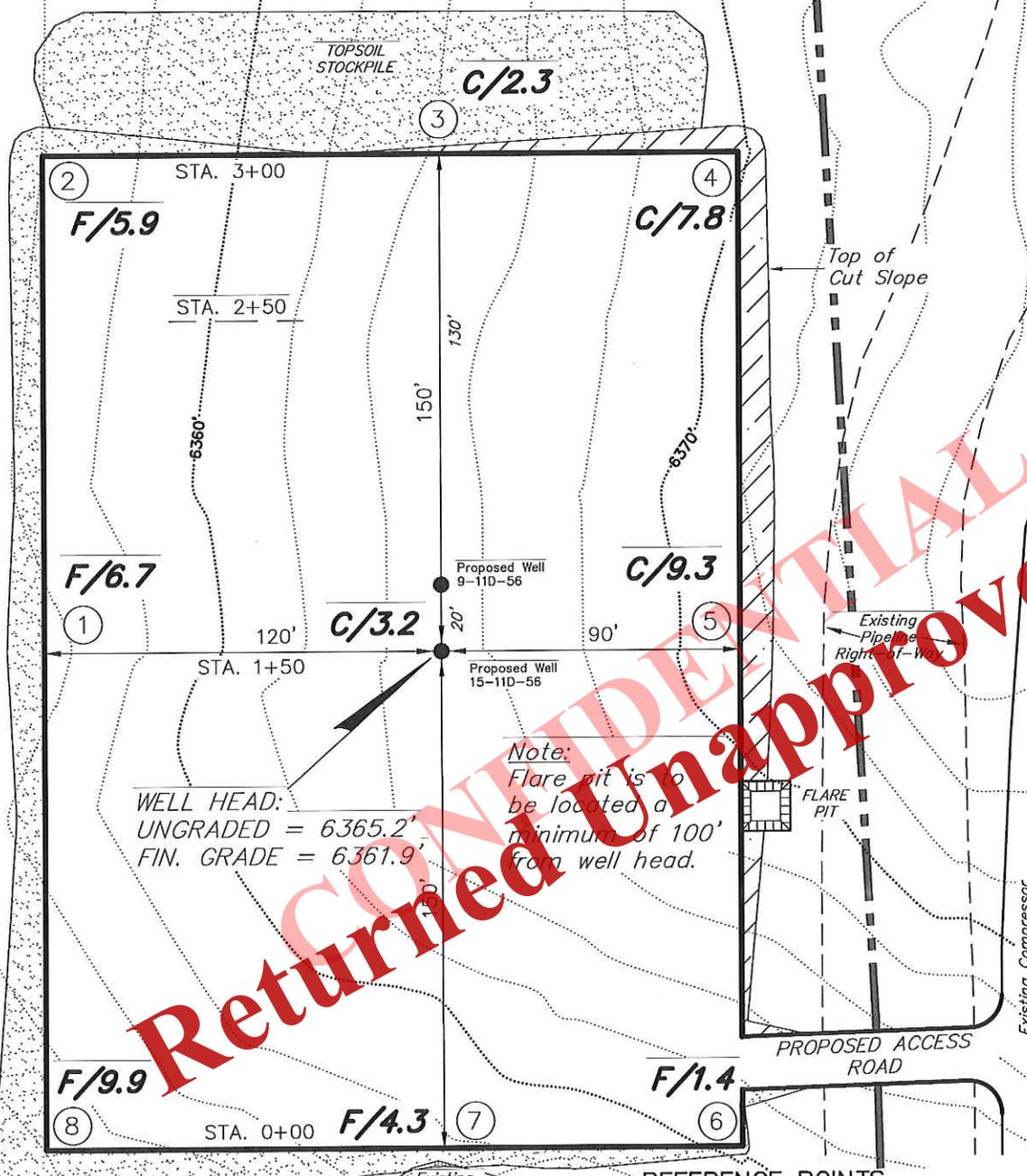
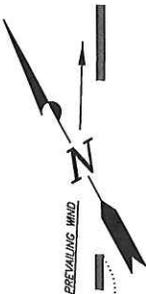

Returned Unapproved

WELL HEAD:
UNGRADED = 6365.2'
FIN. GRADE = 6361.9'

Note:
Flare pit is to be located a minimum of 100' from well head.

REFERENCE POINTS

- 170' NORTHWESTERLY - 6351.5'
- 200' NORTHWESTERLY - 6348.9'
- 200' SOUTHWESTERLY - 6354.0'
- 230' SOUTHWESTERLY - 6351.9'

SURVEYED BY: Q.M.	DATE SURVEYED: 11-14-11
DRAWN BY: R.B.T.	DATE DRAWN: 11-15-11
SCALE: 1" = 50'	REVISED: L.C.S. 12-07-12

Tri State (435) 781-2501
Land Surveying, Inc.
180 NORTH VERNAL AVE. VERNAL, UTAH 84078

BERRY PETROLEUM COMPANY

CROSS SECTIONS

LC FEE 9-11D-56 (Proposed Well)

LC FEE 15-11D-56 (Proposed Well)

Pad Location: SESE Section 11, T5S, R6W, U.S.B.&M.

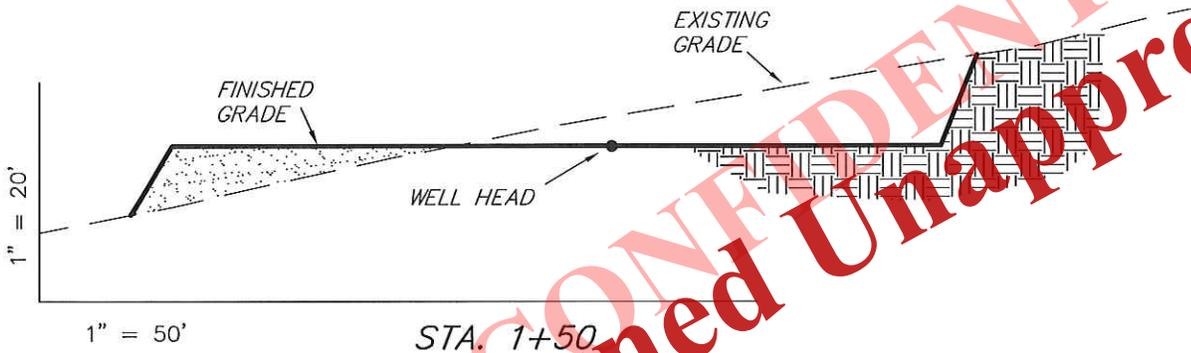
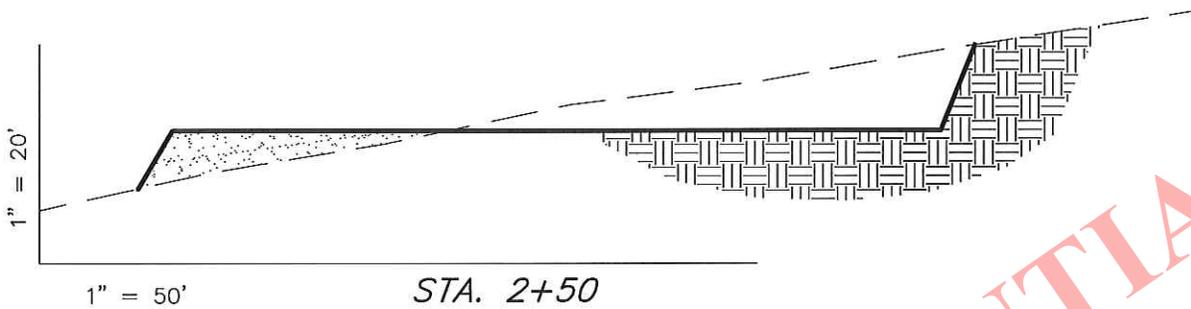
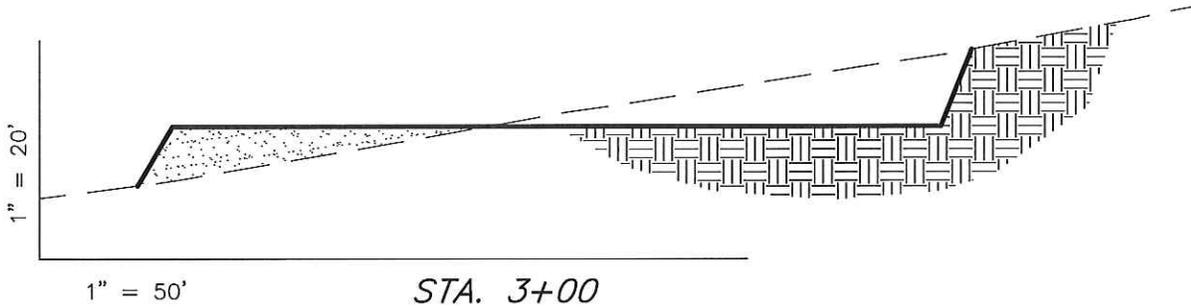

CONFIDENTIAL
Returned Unapproved

NOTE:
UNLESS OTHERWISE NOTED
CUT SLOPES ARE AT 1:1
FILL SLOPES ARE AT 1.5:1

ESTIMATED EARTHWORK QUANTITIES (No Shrink or swell adjustments have been used) (Expressed in Cubic Yards)				
ITEM	CUT	FILL	6" TOPSOIL	EXCESS
PAD	4,790	4,790	Topsail is not included in Pad Cut	0
PIT	0	0		0
TOTALS	4,790	4,790	1,320	0

SURVEYED BY: Q.M.	DATE SURVEYED: 11-14-11
DRAWN BY: R.B.T.	DATE DRAWN: 11-15-11
SCALE: 1" = 50'	REVISED: L.C.S. 12-07-12

Tri State (435) 781-2501
Land Surveying, Inc.
180 NORTH VERNAL AVE. VERNAL, UTAH 84078

BERRY PETROLEUM COMPANY

TYPICAL RIG LAYOUT

LC FEE 9-11D-56 (Proposed Well)

LC FEE 15-11D-56 (Proposed Well)

Pad Location: SESE Section 11, T5S, R6W, U.S.B.&M.

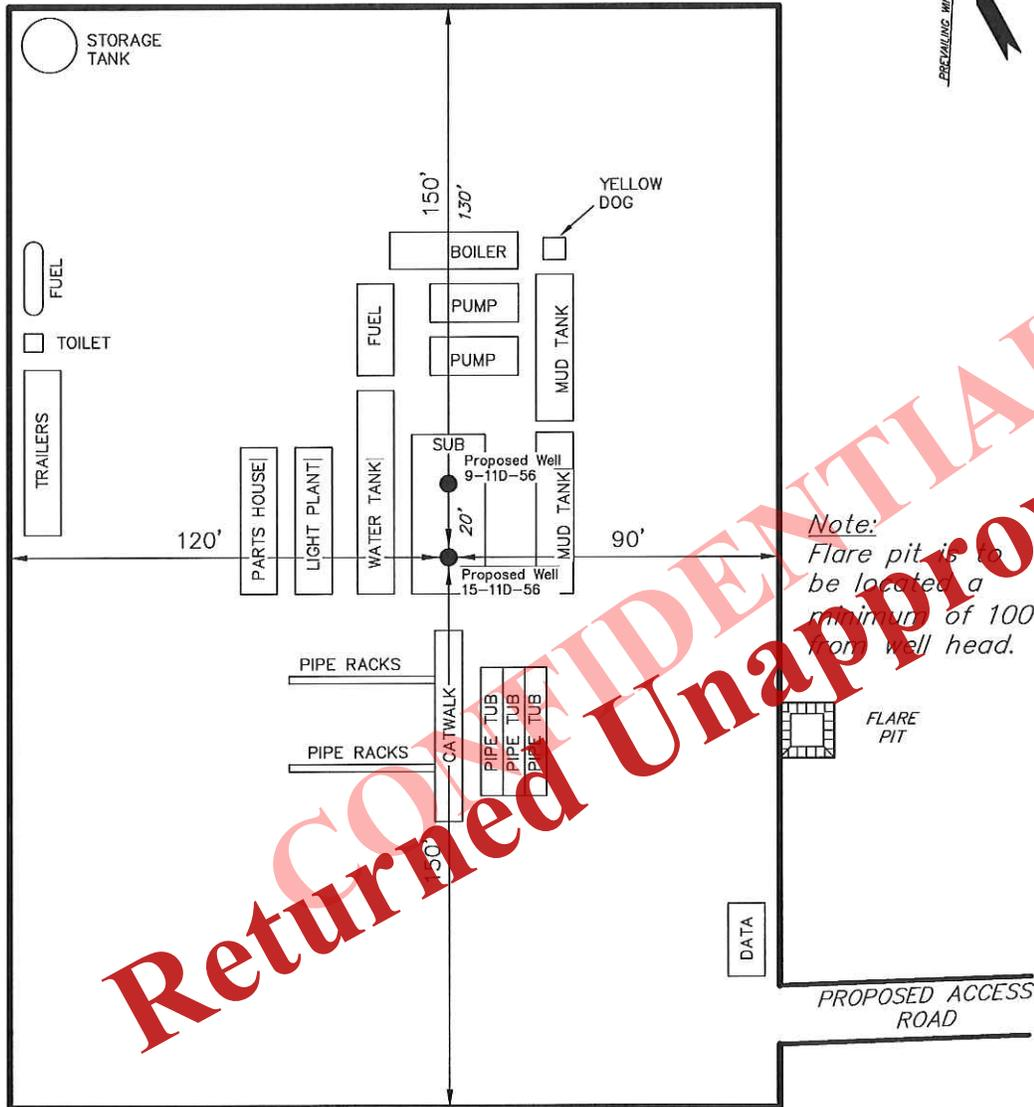
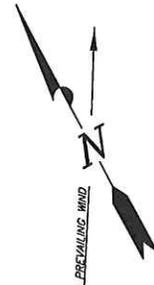

CONFIDENTIAL
 Returned Unapproved

SURVEYED BY: Q.M.	DATE SURVEYED: 11-14-11
DRAWN BY: R.B.T.	DATE DRAWN: 11-15-11
SCALE: 1" = 50'	REVISED: L.C.S. 12-07-12

Tri State (435) 781-2501
 Land Surveying, Inc.
 180 NORTH VERNAL AVE. VERNAL, UTAH 84078

Access Road Map

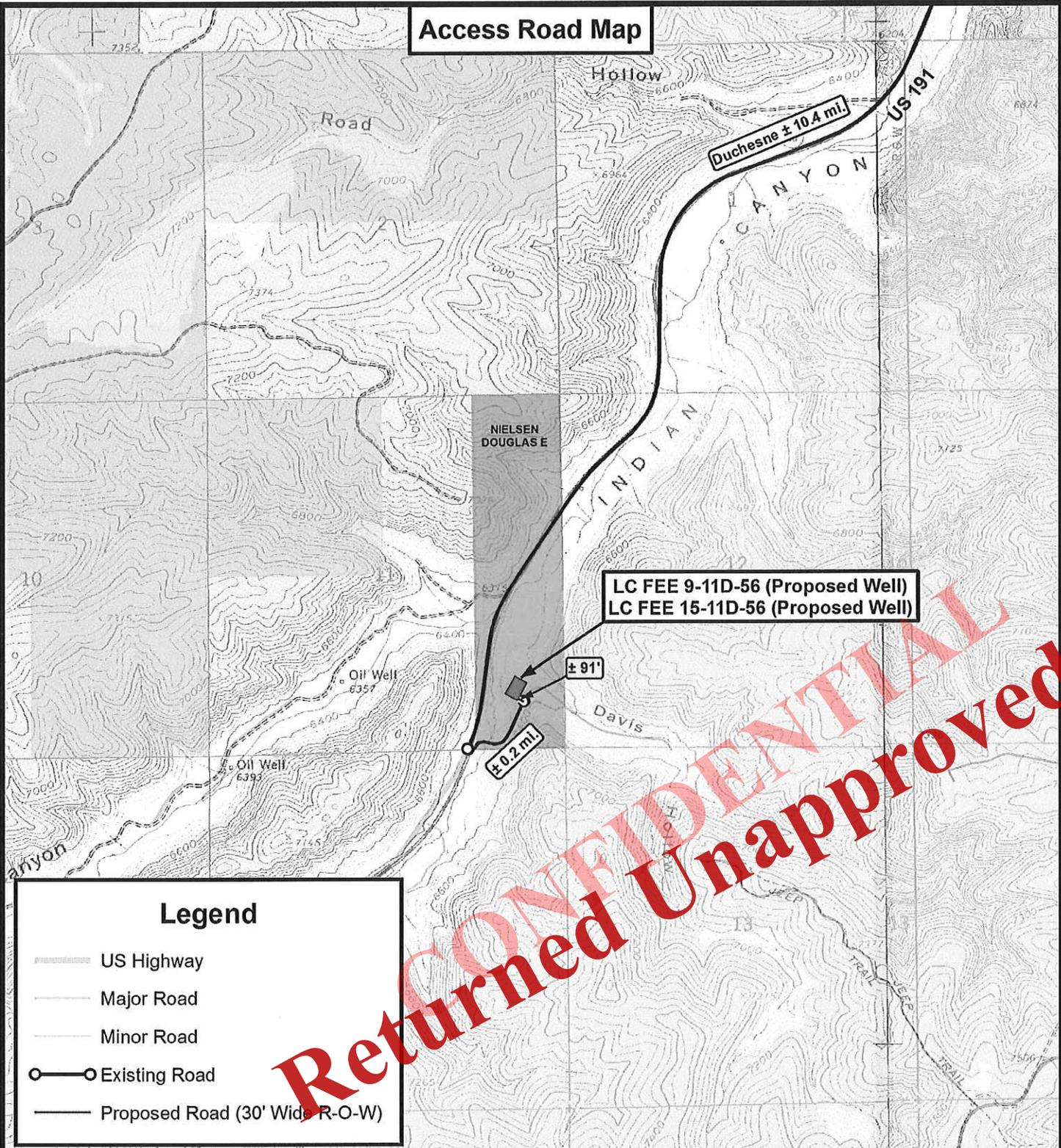

Legend

- US Highway
- Major Road
- Minor Road
- Existing Road
- Proposed Road (30' Wide R-O-W)

THE PARCEL INFORMATION SHOWN HAS NOT BEEN SURVEYED BY TRI-STATE LAND SURVEYING, INC. - TRI-STATE DOES NOT WARRANTY PROPERTY PARCEL DATA OR ANY ASSOCIATED INFORMATION. A PROPERTY SURVEY IS REQUIRED TO DETERMINE THE ACTUAL LOCATION OF PROPERTY LINES AND SHOW ACCURATE DISTANCES ACROSS PARCELS.



**Tri State
Land Surveying, Inc.**

180 NORTH VERNAL AVE. VERNAL, UTAH 84078

P: (435) 781-2501
F: (435) 781-2518



BERRY PETROLEUM COMPANY

LC FEE 9-11D-56 (Proposed Well)
LC FEE 15-11D-56 (Proposed Well)
SEC. 11, T5S, R6W, U.S.B.&M.
Duchesne County, UT.

DRAWN BY: D.C.R. REVISED: 12-19-2012 J.A.S.

DATE: 11-22-2011

SCALE: 1" = 2,000'

TOPOGRAPHIC MAP

SHEET

B

Access Road Map

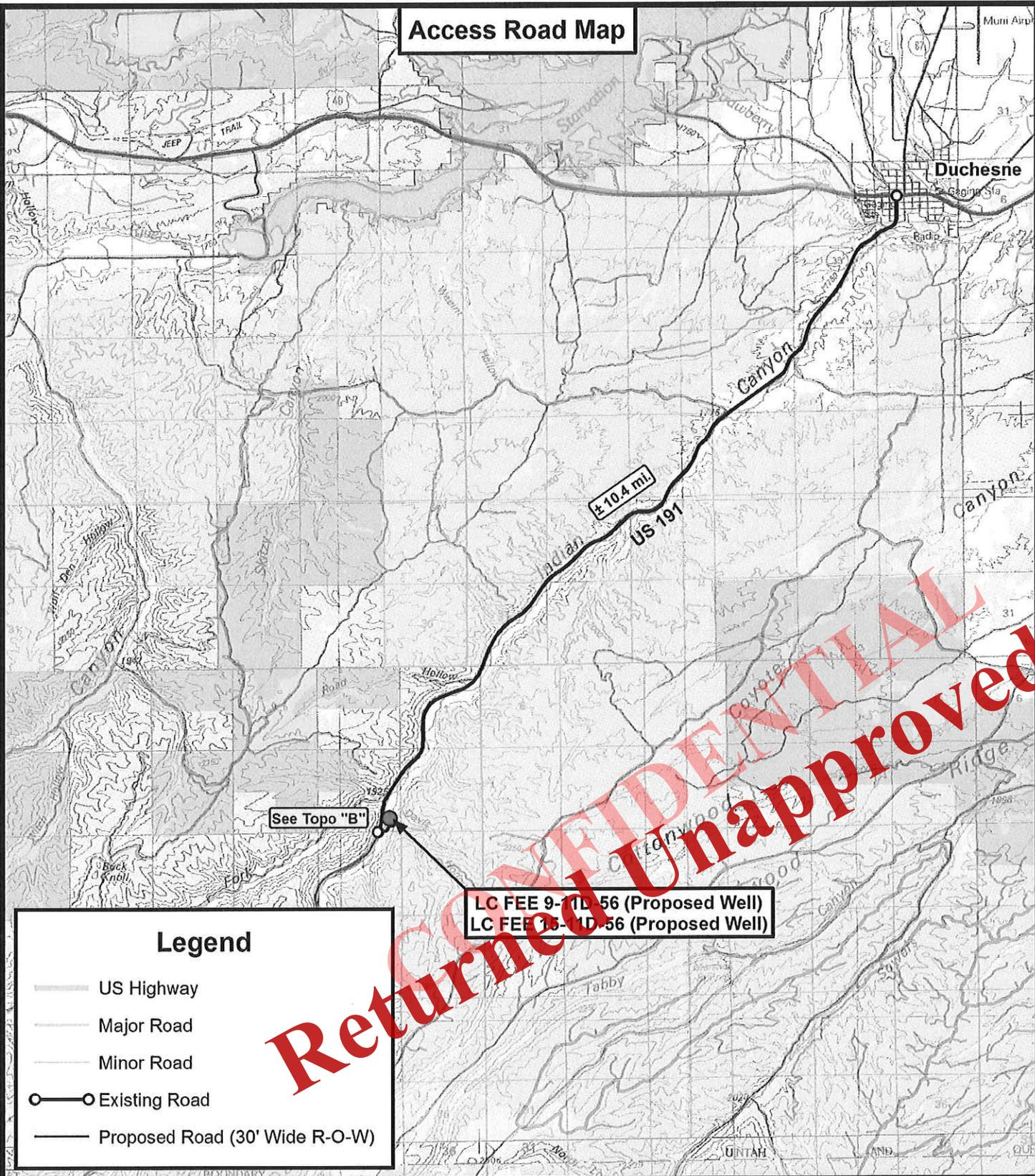

CONFIDENTIAL
 Returned Unapproved

Legend

- US Highway
- Major Road
- Minor Road
- Existing Road
- Proposed Road (30' Wide R-O-W)

LC FEE 9-11D-56 (Proposed Well)
 LC FEE 15-11D-56 (Proposed Well)



**Tri State
Land Surveying, Inc.**

180 NORTH VERNAL AVE. VERNAL, UTAH 84078

P: (435) 781-2501
F: (435) 781-2518



BERRY PETROLEUM COMPANY

LC FEE 9-11D-56 (Proposed Well)
 LC FEE 15-11D-56 (Proposed Well)
 SEC. 11, T5S, R6W, U.S.B.&M.
 Duchesne County, UT.

DRAWN BY:	D.C.R.	REVISED:	12-19-2012 J.A.S.
DATE:	11-22-2011		
SCALE:	1:100,000		

TOPOGRAPHIC MAP

SHEET
A

Proposed Pipeline Map

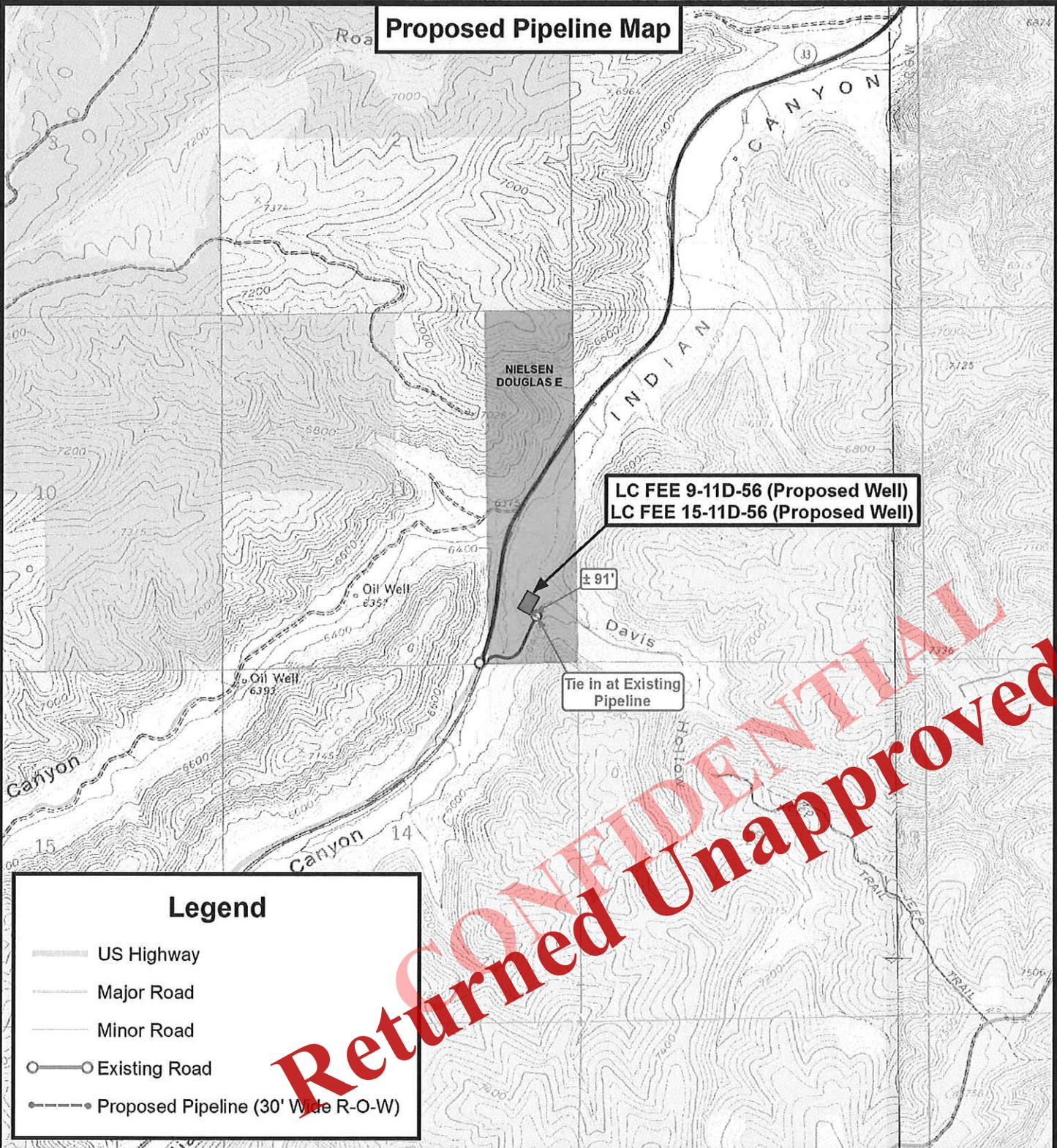

Legend

- US Highway
- Major Road
- Minor Road
- Existing Road
- Proposed Pipeline (30' Wide R-O-W)

THE PARCEL INFORMATION SHOWN HAS NOT BEEN SURVEYED BY TRI-STATE LAND SURVEYING, INC. - TRI-STATE DOES NOT WARRANTY PROPERTY PARCEL DATA OR ANY ASSOCIATED INFORMATION. A PROPERTY SURVEY IS REQUIRED TO DETERMINE THE ACTUAL LOCATION OF PROPERTY LINES AND SHOW ACCURATE DISTANCES ACROSS PARCELS.



**Tri State
Land Surveying, Inc.**
180 NORTH VERNAL AVE. VERNAL, UTAH 84078

P: (435) 781-2501
F: (435) 781-2518

DRAWN BY:	D.C.R.	REVISED:	12-19-2012 J.A.S.
DATE:	11-22-2011		
SCALE:	1" = 2,000'		



BERRY PETROLEUM COMPANY

LC FEE 9-11D-56 (Proposed Well)
LC FEE 15-11D-56 (Proposed Well)
SEC. 11, T5S, R6W, U.S.B.&M.
Duchesne County, UT.

TOPOGRAPHIC MAP	SHEET C
------------------------	-------------------

Exhibit "B" Map

LC FEE 9-11D-56 (Proposed Well)
LC FEE 15-11D-56 (Proposed Well)

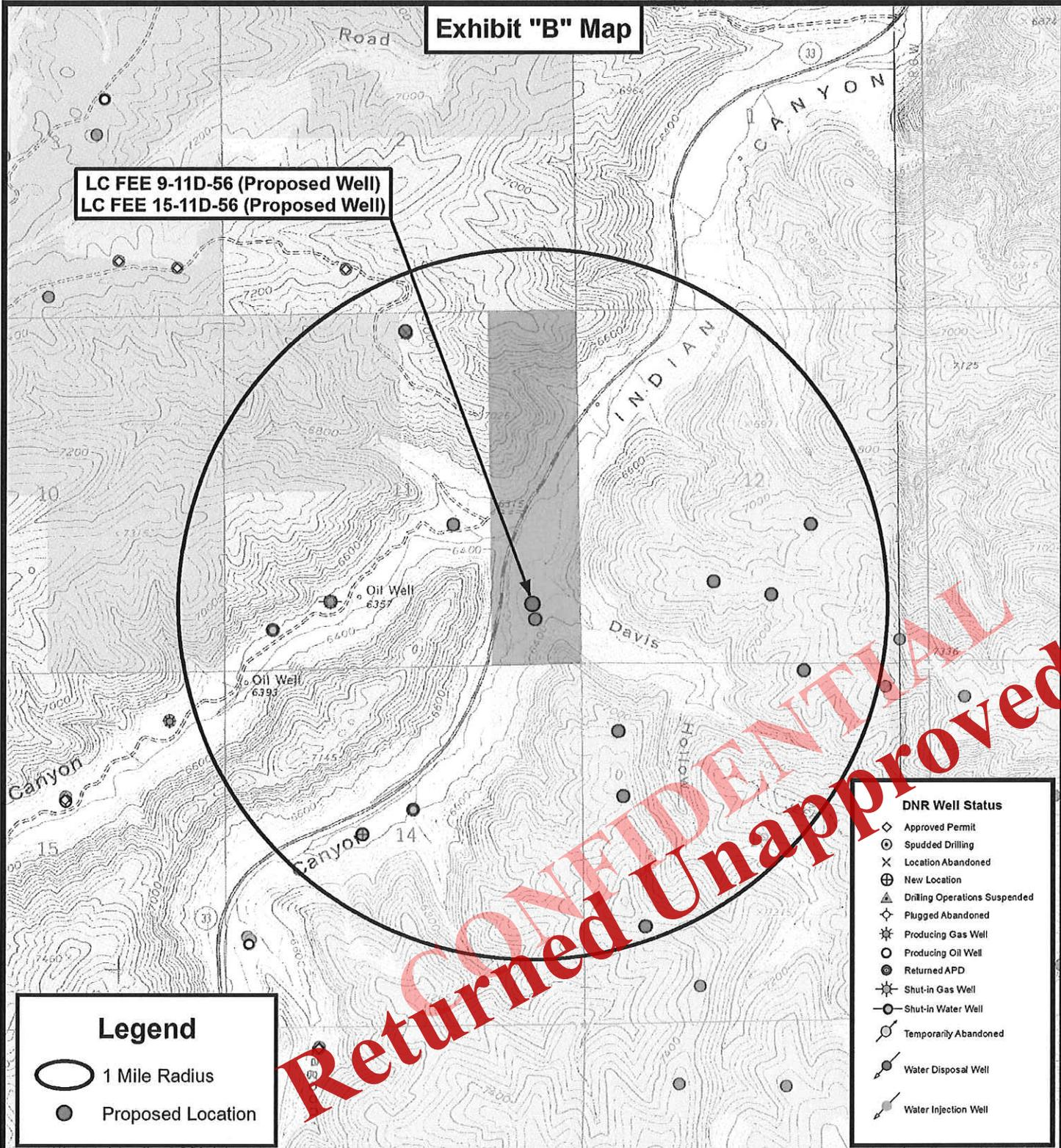

DNR Well Status

- ◇ Approved Permit
- ⊙ Spudded Drilling
- × Location Abandoned
- ⊕ New Location
- ⚠ Drilling Operations Suspended
- ⊖ Plugged Abandoned
- ☀ Producing Gas Well
- ⊙ Producing Oil Well
- ⊙ Returned APD
- ⊖ Shut-in Gas Well
- ⊖ Shut-in Water Well
- ⊖ Temporarily Abandoned
- ⚡ Water Disposal Well
- ⚡ Water Injection Well

Legend

- 1 Mile Radius
- Proposed Location

THE PARCEL INFORMATION SHOWN HAS NOT BEEN SURVEYED BY TRI-STATE LAND SURVEYING, INC. - TRI-STATE DOES NOT WARRANTY PROPERTY PARCEL DATA OR ANY ASSOCIATED INFORMATION. A PROPERTY SURVEY IS REQUIRED TO DETERMINE THE ACTUAL LOCATION OF PROPERTY LINES AND SHOW ACCURATE DISTANCES ACROSS PARCELS.



**Tri State
Land Surveying, Inc.**
180 NORTH VERNAL AVE. VERNAL, UTAH 84078

P: (435) 781-2501
F: (435) 781-2518

DRAWN BY:	D.C.R.	REVISED:	12-19-2012 J.A.S.
DATE:	11-22-2011		
SCALE:	1" = 2,000'		

BERRY PETROLEUM COMPANY

LC FEE 9-11D-56 (Proposed Well)
 LC FEE 15-11D-56 (Proposed Well)
 SEC. 11, T5S, R6W, U.S.B.&M.
 Duchesne County, UT.



TOPOGRAPHIC MAP

SHEET
D

**Location
Photos**

**Center Stake
Looking Northerly**

Date Photographed:	11/14/2011
Photographed By :	Q. Miller



**Access
Looking Westerly**

Date Photographed:	11/22/2011
Photographed By :	Q. Miller



**Tri State
Land Surveying, Inc.**

180 NORTH VERNAL AVE. VERNAL, UTAH 84078

P: (435) 781-2501
F: (435) 781-2518

BERRY PETROLEUM COMPANY

LC FEE 9-11D-56 (Proposed Well)
LC FEE 15-11D-56 (Proposed Well)
SEC. 11, T5S, R6W, U.S.B.&M.
Duchesne County, UT.

DRAWN BY:	D.C.R.	REVISED:	12-19-2012 J.A.S.
DATE:	11-22-2011		

COLOR PHOTOGRAPHS

SHEET
P

SCHEMATIC DIAGRAM OF 3,000 PSI BOP STACK

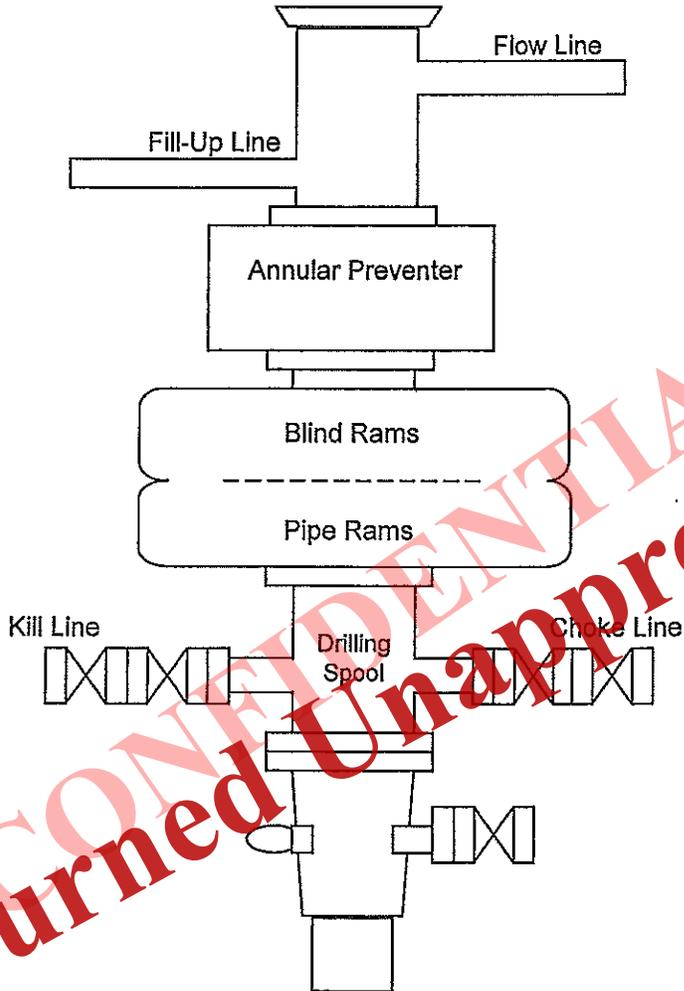

CONFIDENTIAL
Returned Unapproved

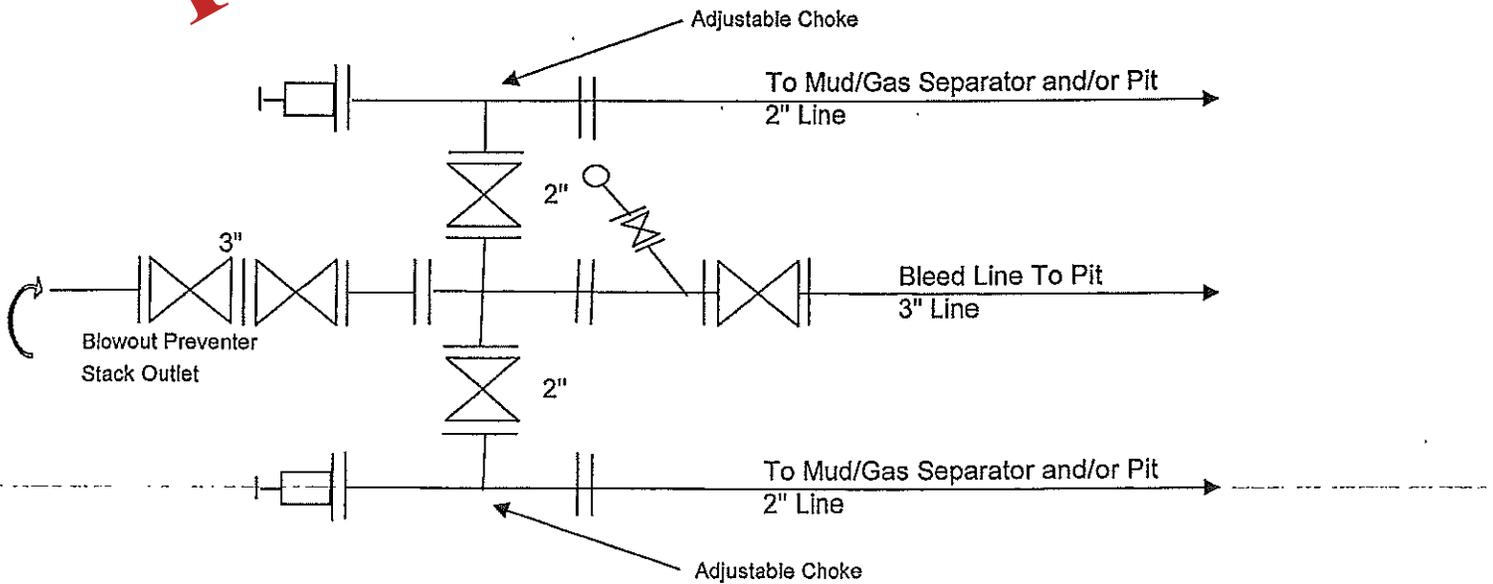

AFFIDAVIT OF NOTICE

I, Krista Mecham, the affiant herein, being of lawful age and duly sworn upon his oath deposes and states as follows:

Krista Mecham is a Sr. Permitting Tech for **Berry Petroleum Company**, a Delaware Corporation, with headquarters located at 1999 Broadway, Suite 3700, Denver, Colorado 80202, and is duly authorized to make this affidavit on behalf of said corporation.

Berry Petroleum Company has submitted notices to commingle production from the Wasatch and Green River formations in the following wells:

LC Fee 9-11D-56
LC Fee 15-11D-56

This Affidavit is made in accordance with Utah's Oil, Gas and Mining regulation R649-3-22. As operator, Berry Petroleum Company has provided notices to the owner(s) of all contiguous oil and gas leases or drilling units overlying the pool for the aforementioned wells to the parties listed below:

BIA - Uintah & Ouray Agency
RES, Minerals and Mining
P.O. Box 130
988 South 7500 East
Fort Duchesne, UT 84026
Attn: Paula C Black, Realty Specialist

This instrument is executed this 18th day of September, 2013.

Berry Petroleum Company

By: Krista Mecham

CONFIDENTIAL
Returned Unapproved

Berry Petroleum Company

Statewide Utah

Commingle Map

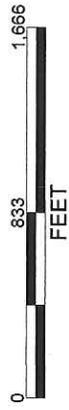

September 16, 2013

Well of Interest

- Berry Ute Tribal Leases
- Berry Fee Leases
- Berry Fee <100% Leases
- Drilling Units to Commingle
- Drilling Units to Commingle #2

09-11D-56



13-11D-56

CONFIDENTIAL
Returned Unapproved

SELF-CERTIFICATION STATEMENT

The following self -certification statement is provided per federal requirements dated May 7, 2007.

Please be advised that Berry Petroleum Company is considered to be the operator of the following well.

LC Fee 9-11D-56
Section 11, T5S, R6W, U.S.B.& M.
Surface: 936' FSL & 663' (SE/4SE/4)
BHL: 1960' FSL & 660' FEL (NE/4SE/4)
Duchesne, County, Utah

Berry Petroleum Company is responsible under the terms of the lease for the operations conducted upon the lease lands.

Operator's Representative and Certification

A) Representative
NAME: Krista M. Mecham
ADDRESS: Berry Petroleum Company
4000 South 4028 West
Route 2, Box 7735
Roosevelt, Utah 84066
PHONE: 435-722-1325

All lease and/or unit operations will be conducted in such a manner that full compliance is made with all applicable laws, regulations and onshore oil and gas orders. Berry Petroleum Company is fully responsible for the actions of its subcontractors. A copy of these conditions will be furnished to the field representative to ensure compliance.

The drilling permit will be valid for a period of two years from the date of approval. After permit termination, a new application will be filed for approval for any future operations.

B) Certification:

I hereby certify that I, or persons under my direct supervision, have inspected the proposed drill site and access route; that I am familiar with the conditions which presently exist; that the statements made in this plan are, to the best of my knowledge and belief, true and correct; and that the work associated with the operations proposed herein will be performed by Berry Petroleum Company and its contractors and subcontractors in conformity with this plan and the terms and conditions under which it is approved. This statement is subject to the provisions of 18 U.S.C. 1001 for the filing of a false statement.

9/18/2013

DATE

Krista Mecham

Krista M. Mecham
Sr. Regulatory & Permitting Tech.

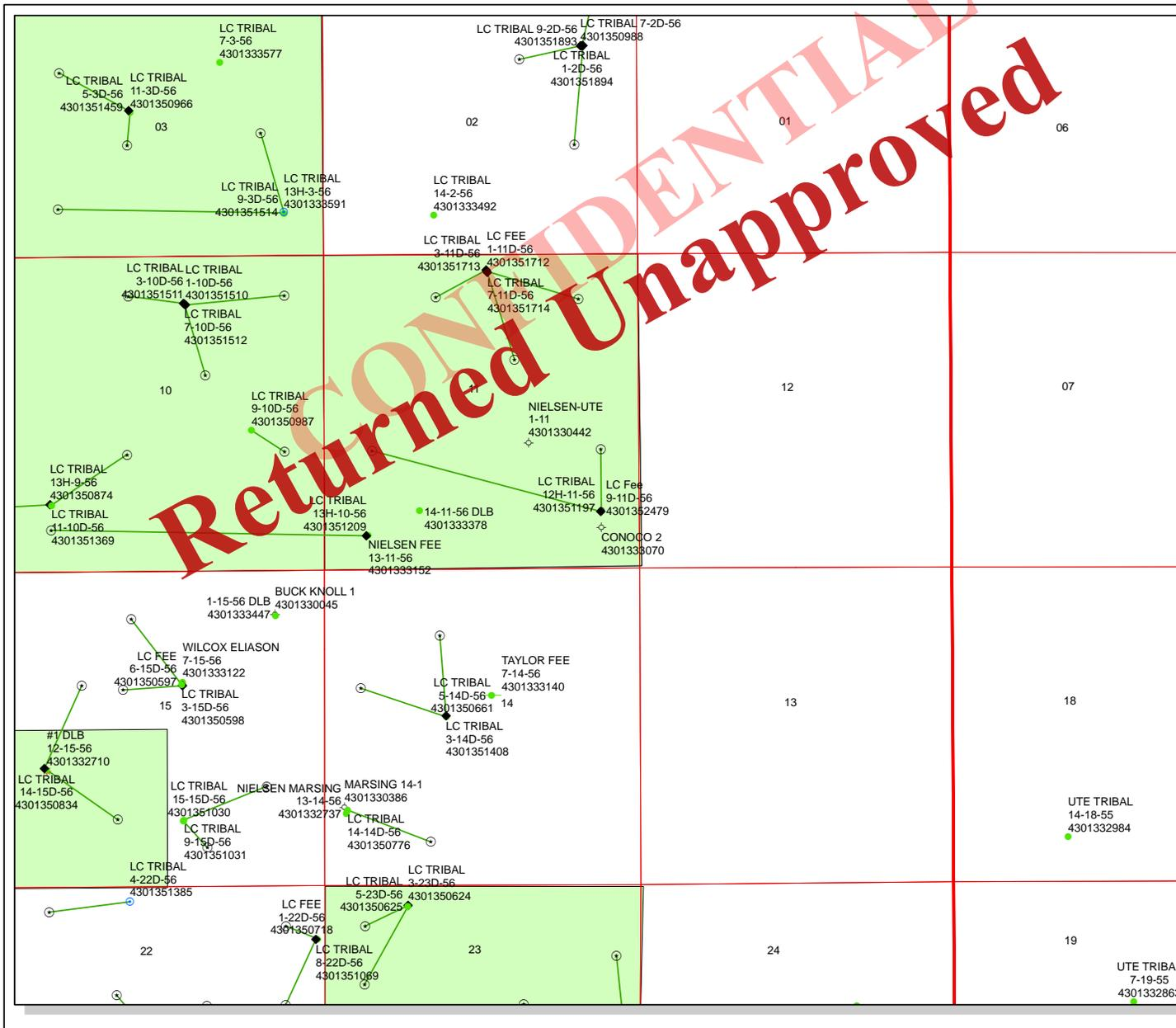

API Number: 4301352479

Well Name: LC Fee 9-11D-56

Township: T05.0S Range: R06.0W Section: 11 Meridian: U

Operator: BERRY PETROLEUM COMPANY

Map Prepared: 9/25/2013
Map Produced by Diana Mason

Wells Query		Units STATUS	
◆	APD - Aproved Permit	▨	ACTIVE
⊙	DRL - Spuded (Drilling Commenced)	▨	EXPLORATORY
⊕	GIW - Gas Injection	▨	GAS STORAGE
⊕	GS - Gas Storage	▨	NF PP OIL
⊕	LOC - New Location	▨	NF SECONDARY
⊕	OPS - Operation Suspended	▨	PI OIL
⊕	PA - Plugged Abandoned	▨	PP GAS
⊕	PGW - Producing Gas Well	▨	PP GEOTHERML
⊕	POW - Producing Oil Well	▨	PP OIL
⊕	SGW - Shut-in Gas Well	▨	SECONDARY
⊕	SOW - Shut-in Oil Well	▨	TERMINATED
⊕	TA - Temp. Abandoned		
○	TW - Test Well		
⊕	WDW - Water Disposal		
⊕	WW - Water Injection Well		
●	WSW - Water Supply Well		

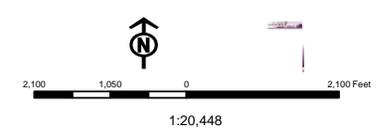
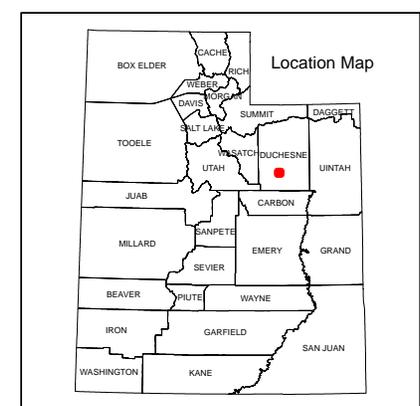



GARY R. HERBERT
Governor

SPENCER J. COX
Lieutenant Governor

State of Utah

DEPARTMENT OF NATURAL RESOURCES

MICHAEL R. STYLER
Executive Director

Division of Oil, Gas and Mining

JOHN R. BAZA
Division Director

September 17, 2015

LINN OPERATING, INC.
Rt. 2 Box 7735
Roosevelt, UT 84066

Re: Application for Permit to Drill - DUCHESNE County, Utah

Ladies and Gentlemen:

The Application for Permit to Drill (APD) for the LC Fee 9-11D-56 well, API 43013524790000 that was submitted September 18, 2013 is being returned unapproved. If you plan on drilling this well in the future, you must first submit a new application.

Should you have any questions regarding this matter, please call me at (801) 538-5312.

Sincerely,

Diana Mason
Environmental Scientist

Enclosure

cc: Bureau of Land Management, Vernal, Utah



Division of Oil, Gas and Mining
 Operator Change/Name Change Worksheet-for State use only

Effective Date: 3/1/2017

FORMER OPERATOR:	NEW OPERATOR:
Linn Operating, Inc. 600 Travis Street, Suite 140 Houston, TX 77002	Linn Operating, LLC 600 Travis Street, Suite 140 Houston, TX 77002
CA Number(s):	Unit(s): Bradford Canyon Berry Pilot EOR 246-02 Brundage Canyon

WELL INFORMATION:

Well Name	Sec	TWN	RNG	API	Entity	Mineral	Surface	Type	Status
See Attached List									

OPERATOR CHANGES DOCUMENTATION:

- Sundry or legal documentation was received from the **FORMER** operator on: 4/11/2017
- Sundry or legal documentation was received from the **NEW** operator on: 4/11/2017
- New operator Division of Corporations Business Number: 9031632-0161

REVIEW:

- Surface Agreement Sundry from **NEW** operator on Fee Surface wells received on: 4/11/2017
- Receipt of Acceptance of Drilling Procedures for APD on: 4/11/2017
- Reports current for Production/Disposition & Sundries: 6/13/2017
- OPS/SI/TA well(s) reviewed for full cost bonding: 6/13/2017
- UIC5 on all disposal/injection/storage well(s) approved on: Per DJJ, not required
- Surface Facility(s) included in operator change: See Attached List
- Inspections of PA state/fee well sites complete on (only upon operators request): 6/13/2017

NEW OPERATOR BOND VERIFICATION:

- Federal well(s) covered by Bond Number: LPM8898781
- Indian well(s) covered by Bond Number: LPM9149926
- State/fee well(s) covered by Bond Number(s): K0915367-Blanket
K09515434
K09515409
K09515392
K09622597
K09622615
K09622603
K09622627

DATA ENTRY:

- Well(s) moved in RBDMS on: 6/14/2017
- Entity Number(s) updated in **RBDMS** on: 6/14/2017
- Unit(s) update in **RBDMS** on: 6/14/2017
- Surface Facilities moved in RBDMS on: 6/14/2017
- State/Fee well(s) attached to bond(s) in **RBDMS** on: 6/14/2017
- Surface Facilities attached to bond(s) in **RBDMS** on: 6/14/2017

COMMENTS:

Well Transfer
 From: Linn Operating, Inc.
 To: Linn Operation, LLC
 Effective: 3/1/2017

Well Name	Sec	Town	Twp Dir	Range	Rng Dir	API	Entity Number	Well Type	Well Status
SWD 4-11A2	11	1	S	2	W	4301320255	99990	Water Disposal Well	Active
VIRGIL MECHAM 1-11A2	11	1	S	2	W	4301330009	5760	Water Disposal Well	Active
1-3A2	3	1	S	2	W	4301330021	99990	Water Disposal Well	Active
BLUEBELL 2-28A2	28	1	S	2	W	4301330346	99990	Water Disposal Well	Active
SALERATUS 2-17C5	17	3	S	5	W	4301330388	99990	Water Disposal Well	Active
CENTRAL BLUEBELL 2-26A2	26	1	S	2	W	4301330389	99990	Water Disposal Well	Active
Z and T UTE TRIBAL 2-21	21	5	S	4	W	4301331280	11130	Water Injection Well	Active
Z and T UTE TRIBAL 10-21	21	5	S	4	W	4301331283	11133	Water Injection Well	Active
UTE TRIBAL 16-21-54	21	5	S	4	W	4301332381	13912	Water Injection Well	Active
UTE TRIBAL 7-21-54	21	5	S	4	W	4301332623	14383	Water Injection Well	Active
UTE TRIBAL 12-30-54	30	5	S	4	W	4301332747	14747	Water Injection Well	Active
UTE TRIBAL 14-30-54	30	5	S	4	W	4301332748	14778	Water Injection Well	Active
UTE TRIBAL 10-30D-54	30	5	S	4	W	4301332893	15246	Water Injection Well	Active
UTE TRIBAL 6-30-54	30	5	S	4	W	4301332975	15300	Water Injection Well	Active
UTE TRIBAL 9-21-54	21	5	S	4	W	4301333040	15360	Water Injection Well	Active
UTE TRIBAL 15-21-54	21	5	S	4	W	4301333114	15441	Water Injection Well	Active
UTE TRIBAL 1-21-54	21	5	S	4	W	4301333388	15937	Water Injection Well	Active
BALLARD 2-15B1	15	2	S	1	W	4304732351	11476	Water Disposal Well	Active
UTE TRIBAL 15-28D-55	28	5	S	5	W	4301333623		Oil Well	Approved Permit
LC TRIBAL 13H-9-56	10	5	S	6	W	4301350874		Oil Well	Approved Permit
LC TRIBAL 4H-26-56	26	5	S	6	W	4301350951		Oil Well	Approved Permit
LC TRIBAL 5H-34-45	34	4	S	5	W	4301350974		Oil Well	Approved Permit
LC TRIBAL 11-34-45	34	4	S	5	W	4301350975		Oil Well	Approved Permit
CC TRIBAL 4-30D-38	19	3	S	8	W	4301350993		Oil Well	Approved Permit
FEDERAL 4-1-65	1	6	S	5	W	4301351016		Oil Well	Approved Permit
LC TRIBAL 13H-28-45	28	4	S	5	W	4301351061		Oil Well	Approved Permit
LC TRIBAL 5H-23-45	23	4	S	5	W	4301351071		Oil Well	Approved Permit
LC TRIBAL 4H-27-45	27	4	S	5	W	4301351072		Oil Well	Approved Permit
LC TRIBAL 16-27-45	27	4	S	5	W	4301351074		Oil Well	Approved Permit
LC TRIBAL 12-27-45	27	4	S	5	W	4301351075		Oil Well	Approved Permit
LC TRIBAL 16-23-45	23	4	S	5	W	4301351077		Oil Well	Approved Permit
LC TRIBAL 12H-30-56	30	5	S	6	W	4301351133		Oil Well	Approved Permit
LC TRIBAL 5H-33-45	33	4	S	5	W	4301351338		Oil Well	Approved Permit
LC TRIBAL 6-16D-56	16	5	S	6	W	4301351406		Oil Well	Approved Permit
LC TRIBAL 3-14D-56	14	5	S	6	W	4301351408		Oil Well	Approved Permit
LC TRIBAL 13-6D-57	6	5	S	7	W	4301351417		Oil Well	Approved Permit
LC TRIBAL 9-23-45	23	4	S	5	W	4301351432		Oil Well	Approved Permit
LC TRIBAL 5-28D-56	29	5	S	6	W	4301351441		Oil Well	Approved Permit
LC TRIBAL 15-20D-56	29	5	S	6	W	4301351443		Oil Well	Approved Permit
LC Tribal 16-33-45	33	4	S	5	W	4301351463		Oil Well	Approved Permit
LC TRIBAL 7-23D-56	23	5	S	6	W	4301351479		Oil Well	Approved Permit
LC TRIBAL 4-7-56	7	5	S	6	W	4301351482		Oil Well	Approved Permit
LC TRIBAL 3-2-56	2	5	S	6	W	4301351483		Oil Well	Approved Permit
CC TRIBAL 15-34D-38	2	4	S	8	W	4301351490		Oil Well	Approved Permit

Well Transfer
 From: Linn Operating, Inc.
 To: Linn Operation, LLC
 Effective: 3/1/2017

CC TRIBAL 14-35D-38	2	4	S	8	W	4301351491	Oil Well	Approved Permit
CC TRIBAL 8-3D-48	2	4	S	8	W	4301351493	Oil Well	Approved Permit
LC TRIBAL 1-10D-56	10	5	S	6	W	4301351510	Oil Well	Approved Permit
LC TRIBAL 3-10D-56	10	5	S	6	W	4301351511	Oil Well	Approved Permit
LC TRIBAL 7-10D-56	10	5	S	6	W	4301351512	Oil Well	Approved Permit
LC TRIBAL 9-29D-56	29	5	S	6	W	4301351513	Oil Well	Approved Permit
UTE TRIBAL 1-16-55	16	5	S	5	W	4301351519	Oil Well	Approved Permit
LC TRIBAL 1-17-56	17	5	S	6	W	4301351704	Oil Well	Approved Permit
LC Tribal 4HW-8-56	8	5	S	6	W	4301351710	Oil Well	Approved Permit
LC TRIBAL 3-11D-56	11	5	S	6	W	4301351713	Oil Well	Approved Permit
LC TRIBAL 7-11D-56	11	5	S	6	W	4301351714	Oil Well	Approved Permit
LC TRIBAL 9-34D-45	34	4	S	5	W	4301351717	Oil Well	Approved Permit
LC TRIBAL 4-34D-45	34	4	S	5	W	4301351723	Oil Well	Approved Permit
LC TRIBAL 7-34D-45	34	4	S	5	W	4301351724	Oil Well	Approved Permit
LC TRIBAL 13-34D-45	34	4	S	5	W	4301351747	Oil Well	Approved Permit
LC TRIBAL 12-31D-56	31	5	S	6	W	4301351799	Oil Well	Approved Permit
LC TRIBAL 8-20D-56	20	5	S	6	W	4301351800	Oil Well	Approved Permit
LC TRIBAL 6-31D-56	31	5	S	6	W	4301351801	Oil Well	Approved Permit
LC Tribal 11-7D-57	7	5	S	7	W	4301351814	Oil Well	Approved Permit
LC Tribal 5-7D-57	7	5	S	7	W	4301351815	Oil Well	Approved Permit
LC Tribal 11-6D-57	6	5	S	7	W	4301351817	Oil Well	Approved Permit
LC Tribal 8-33-45	33	4	S	5	W	4301351859	Oil Well	Approved Permit
LC Tribal 7-23D-45	23	4	S	5	W	4301351865	Oil Well	Approved Permit
LC Tribal 1-23D-56	23	5	S	6	W	4301351866	Oil Well	Approved Permit
LC TRIBAL 1-19-56	19	5	S	6	W	4301351867	Oil Well	Approved Permit
LC TRIBAL 7-19D-56	19	5	S	6	W	4301351868	Oil Well	Approved Permit
LC TRIBAL 9-4D-56	4	5	S	6	W	4301351869	Oil Well	Approved Permit
LC Tribal 14-32D-45	32	4	S	5	W	4301351879	Oil Well	Approved Permit
LC TRIBAL 7-17D-56	17	5	S	6	W	4301351886	Oil Well	Approved Permit
LC TRIBAL 5-17D-56	17	5	S	6	W	4301351887	Oil Well	Approved Permit
LC TRIBAL 9-2D-56	2	5	S	6	W	4301351893	Oil Well	Approved Permit
LC TRIBAL 1-2D-56	2	5	S	6	W	4301351894	Oil Well	Approved Permit
LC Tribal 15-23D-45	23	4	S	5	W	4301351895	Oil Well	Approved Permit
LC TRIBAL 11-34D-56	34	5	S	6	W	4301351900	Oil Well	Approved Permit
LC TRIBAL 9-5D-56	4	5	S	6	W	4301351901	Oil Well	Approved Permit
LC Tribal 10-28D-45	28	4	S	5	W	4301351903	Oil Well	Approved Permit
LC TRIBAL 13-20D-56	20	5	S	6	W	4301351904	Oil Well	Approved Permit
Ute Tribal 14-17-55	17	5	S	5	W	4301351908	Oil Well	Approved Permit
Federal 14-7D-65	31	5	S	6	W	4301351910	Oil Well	Approved Permit
LC Tribal 3-27D-45	27	4	S	5	W	4301351911	Oil Well	Approved Permit
LC TRIBAL 9-34D-56	34	5	S	6	W	4301351914	Oil Well	Approved Permit
LC Tribal 10-33D-45	33	4	S	5	W	4301351939	Oil Well	Approved Permit
LC Tribal 14-33D-45	33	4	S	5	W	4301351940	Oil Well	Approved Permit
LC Tribal 10-27D-45	27	4	S	5	W	4301351941	Oil Well	Approved Permit
LC Tribal 14-27D-45	27	4	S	5	W	4301351951	Oil Well	Approved Permit

Well Transfer
 From: Linn Operating, Inc.
 To: Linn Operation, LLC
 Effective: 3/1/2017

LC Tribal 6-33D-45	33	4	S	5	W	4301351955	Oil Well	Approved Permit
LC Tribal 6-32D-45	32	4	S	5	W	4301351956	Oil Well	Approved Permit
Federal 3-11D-65	11	6	S	5	W	4301351982	Oil Well	Approved Permit
Federal 2-4-64	4	6	S	4	W	4301351983	Oil Well	Approved Permit
Federal 5-11D-65	11	6	S	5	W	4301351984	Oil Well	Approved Permit
Federal 7-4D-64	4	6	S	4	W	4301351985	Oil Well	Approved Permit
Federal 3-4D-64	4	6	S	4	W	4301351986	Oil Well	Approved Permit
Federal 8-4D-64	4	6	S	4	W	4301351988	Oil Well	Approved Permit
Federal 6-4D-64	4	6	S	4	W	4301351989	Oil Well	Approved Permit
Federal 4-4D-64	4	6	S	4	W	4301351991	Oil Well	Approved Permit
Federal 9-4D-64	4	6	S	4	W	4301352004	Oil Well	Approved Permit
Federal 10-4D-64	4	6	S	4	W	4301352011	Oil Well	Approved Permit
Federal 1-4D-64	4	6	S	4	W	4301352025	Oil Well	Approved Permit
Federal 16-4D-64	4	6	S	4	W	4301352026	Oil Well	Approved Permit
LC Tribal 10-23D-45	23	4	S	5	W	4301352029	Oil Well	Approved Permit
Federal 15-4D-64	4	6	S	4	W	4301352032	Oil Well	Approved Permit
Federal 9-9D-64	9	6	S	4	W	4301352036	Oil Well	Approved Permit
Federal 10-9D-64	9	6	S	4	W	4301352041	Oil Well	Approved Permit
Federal 15-9D-64	9	6	S	4	W	4301352043	Oil Well	Approved Permit
Federal 16-9D-64	9	6	S	4	W	4301352044	Oil Well	Approved Permit
LC Tribal 10-32D-45	32	4	S	5	W	4301352065	Oil Well	Approved Permit
LC Tribal 16-28D-45	28	4	S	5	W	4301352073	Oil Well	Approved Permit
LC Tribal 15-24D-45	24	4	S	5	W	4301352074	Oil Well	Approved Permit
LC Tribal 13-17D-56	17	5	S	6	W	4301352076	Oil Well	Approved Permit
LC Tribal 15-17D-56	17	5	S	6	W	4301352077	Oil Well	Approved Permit
LC Tribal 5-26D-56	26	5	S	6	W	4301352097	Oil Well	Approved Permit
LC Tribal 11-26D-56	26	5	S	6	W	4301352098	Oil Well	Approved Permit
LC Tribal 4-9D-56	9	5	S	6	W	4301352102	Oil Well	Approved Permit
LC Tribal 8-32D-45	32	4	S	5	W	4301352135	Oil Well	Approved Permit
UTE Tribal 15-24D-54	24	5	S	4	W	4301352156	Gas Well	Approved Permit
UTE Tribal 9-24D-54	24	5	S	4	W	4301352157	Gas Well	Approved Permit
UTE Tribal 1-25D-54	25	5	S	4	W	4301352173	Gas Well	Approved Permit
UTE Tribal 9-25D-54	25	5	S	4	W	4301352177	Gas Well	Approved Permit
Myrin Tribal 9-10D-55	10	5	S	5	W	4301352189	Oil Well	Approved Permit
Myrin Tribal 16-10D-55	10	5	S	5	W	4301352190	Oil Well	Approved Permit
Myrin Tribal 10-10D-55	10	5	S	5	W	4301352191	Oil Well	Approved Permit
UTE Tribal 1-24D-54	24	5	S	4	W	4301352304	Gas Well	Approved Permit
UTE Tribal 7-24D-54	24	5	S	4	W	4301352306	Gas Well	Approved Permit
UTE Tribal 12-25D-54	25	5	S	4	W	4301352308	Gas Well	Approved Permit
UTE Tribal 4-13D-54	13	5	S	4	W	4301352321	Gas Well	Approved Permit
UTE Tribal 13-25D-54	25	5	S	4	W	4301352322	Gas Well	Approved Permit
UTE Tribal 3-24D-54	24	5	S	4	W	4301352347	Gas Well	Approved Permit
UTE Tribal 5-24D-54	24	5	S	4	W	4301352348	Gas Well	Approved Permit
State Tribal 14-1D-55	1	5	S	5	W	4301352372	Oil Well	Approved Permit
State Tribal 11-1D-55	1	5	S	5	W	4301352373	Oil Well	Approved Permit

Well Transfer
 From: Linn Operating, Inc.
 To: Linn Operation, LLC
 Effective: 3/1/2017

State Tribal 13-1D-55	1	5	S	5	W	4301352374	Oil Well	Approved Permit
State Tribal 12-2D-55	2	5	S	5	W	4301352391	Oil Well	Approved Permit
State Tribal 14-2D-55	2	5	S	5	W	4301352392	Oil Well	Approved Permit
State Tribal 13-2D-55	2	5	S	5	W	4301352393	Oil Well	Approved Permit
State Tribal 14-3D-55	3	5	S	5	W	4301352430	Oil Well	Approved Permit
State Tribal 11-3D-55	3	5	S	5	W	4301352434	Oil Well	Approved Permit
State Tribal 13-3D-55	3	5	S	5	W	4301352435	Oil Well	Approved Permit
UTE TRIBAL 2-5D-55	5	5	S	5	W	4301352450	Oil Well	Approved Permit
Ute Tribal 1-5D-55	5	5	S	5	W	4301352456	Oil Well	Approved Permit
Ute Tribal 7-5-55	5	5	S	5	W	4301352459	Oil Well	Approved Permit
Ute Tribal 3-16D-54	9	5	S	4	W	4301352467	Oil Well	Approved Permit
State Tribal 1-3D-55	3	5	S	5	W	4301352471	Oil Well	Approved Permit
State Tribal 2-3D-55	3	5	S	5	W	4301352472	Oil Well	Approved Permit
State Tribal 7-3D-55	3	5	S	5	W	4301352473	Oil Well	Approved Permit
State Tribal 8-3D-55	3	5	S	5	W	4301352474	Oil Well	Approved Permit
Ute Tribal 2-16D-54	9	5	S	4	W	4301352481	Oil Well	Approved Permit
State Tribal 3-3D-55	3	5	S	5	W	4301352532	Oil Well	Approved Permit
State Tribal 4-3D-55	3	5	S	5	W	4301352533	Oil Well	Approved Permit
State Tribal 5-3D-55	3	5	S	5	W	4301352535	Oil Well	Approved Permit
State Tribal 6-3D-55	3	5	S	5	W	4301352536	Oil Well	Approved Permit
UTE TRIBAL 15-12D-55	12	5	S	5	W	4301352549	Oil Well	Approved Permit
Ute Tribal 9-11D-55	11	5	S	5	W	4301352564	Oil Well	Approved Permit
UTE TRIBAL 10-11D-55	11	5	S	5	W	4301352566	Oil Well	Approved Permit
UTE TRIBAL 15-11D-55	11	5	S	5	W	4301352567	Oil Well	Approved Permit
UTE TRIBAL 14-12D-55	12	5	S	5	W	4301352592	Oil Well	Approved Permit
UTE TRIBAL 13-12D-55	12	5	S	5	W	4301352593	Oil Well	Approved Permit
UTE TRIBAL 10-11D-54	11	5	S	4	W	4301352603	Oil Well	Approved Permit
UTE TRIBAL 9-11D-54	11	5	S	4	W	4301352604	Oil Well	Approved Permit
UTE TRIBAL 15-11-54	11	5	S	4	W	4301352605	Oil Well	Approved Permit
UTE TRIBAL 16-11D-54	11	5	S	4	W	4301352606	Oil Well	Approved Permit
UTE TRIBAL 14-11D-55	11	5	S	5	W	4301352610	Oil Well	Approved Permit
UTE TRIBAL 13-11D-55	11	5	S	5	W	4301352611	Oil Well	Approved Permit
UTE TRIBAL 12-11D-55	11	5	S	5	W	4301352612	Oil Well	Approved Permit
UTE TRIBAL 11-11D-55	11	5	S	5	W	4301352613	Oil Well	Approved Permit
Federal 6-7D-65	7	6	S	5	W	4301352682	Oil Well	Approved Permit
Federal 11-7D-65	7	6	S	5	W	4301352683	Oil Well	Approved Permit
Federal 10-7D-65	7	6	S	5	W	4301352684	Oil Well	Approved Permit
Federal 7-7D-65	7	6	S	5	W	4301352685	Oil Well	Approved Permit
UTE TRIBAL 4-17D-55	17	5	S	5	W	4301352695	Oil Well	Approved Permit
UTE TRIBAL 14-13D-54	13	5	S	4	W	4301352702	Oil Well	Approved Permit
State Tribal 3-11D-55	11	5	S	5	W	4301352704	Oil Well	Approved Permit
State Tribal 4-11D-55	11	5	S	5	W	4301352705	Oil Well	Approved Permit
State Tribal 5-11D-55	11	5	S	5	W	4301352706	Oil Well	Approved Permit
State Tribal 6-11D-55	11	5	S	5	W	4301352707	Oil Well	Approved Permit
State Tribal 8-11D-55	11	5	S	5	W	4301352708	Oil Well	Approved Permit

Well Transfer
 From: Linn Operating, Inc.
 To: Linn Operation, LLC
 Effective: 3/1/2017

State Tribal 7-11D-55	11	5	S	5	W	4301352709	Oil Well	Approved Permit
State Tribal 2-11D-55	11	5	S	5	W	4301352710	Oil Well	Approved Permit
State Tribal 1-11D-55	11	5	S	5	W	4301352711	Oil Well	Approved Permit
UTE TRIBAL 9-4D-55	4	5	S	5	W	4301352713	Oil Well	Approved Permit
State Tribal 2-10D-55	10	5	S	5	W	4301352714	Oil Well	Approved Permit
State Tribal 7-10D-55	10	5	S	5	W	4301352715	Oil Well	Approved Permit
State Tribal 8-10D-55	10	5	S	5	W	4301352716	Oil Well	Approved Permit
UTE TRIBAL 10-4D-55	4	5	S	5	W	4301352717	Oil Well	Approved Permit
UTE TRIBAL 15-4D-55	4	5	S	5	W	4301352718	Oil Well	Approved Permit
State Tribal 1-10D-55	10	5	S	5	W	4301352720	Oil Well	Approved Permit
UTE TRIBAL 16-4D-55	4	5	S	5	W	4301352721	Oil Well	Approved Permit
State Tribal 3-10D-55	10	5	S	5	W	4301352723	Oil Well	Approved Permit
State Tribal 4-10D-55	10	5	S	5	W	4301352724	Oil Well	Approved Permit
State Tribal 5-10D-55	10	5	S	5	W	4301352725	Oil Well	Approved Permit
State Tribal 6-10D-55	10	5	S	5	W	4301352726	Oil Well	Approved Permit
UTE TRIBAL 11-5D-55	5	5	S	5	W	4301352727	Oil Well	Approved Permit
UTE TRIBAL 12-5D-55	5	5	S	5	W	4301352728	Oil Well	Approved Permit
UTE TRIBAL 13-5D-55	5	5	S	5	W	4301352729	Oil Well	Approved Permit
UTE TRIBAL 14-5D-55	5	5	S	5	W	4301352730	Oil Well	Approved Permit
State Tribal 15-2D-55	2	5	S	5	W	4301352732	Oil Well	Approved Permit
State Tribal 16-2D-55	2	5	S	5	W	4301352733	Oil Well	Approved Permit
State Tribal 9-2D-55	2	5	S	5	W	4301352735	Oil Well	Approved Permit
UTE TRIBAL 16-30D-55	30	5	S	5	W	4301352738	Oil Well	Approved Permit
Myrin Tribal 9-19D-55	19	5	S	5	W	4301352739	Oil Well	Approved Permit
State Tribal 16-3D-55	3	5	S	5	W	4301352740	Oil Well	Approved Permit
State Tribal 15-3D-55	3	5	S	5	W	4301352741	Oil Well	Approved Permit
State Tribal 10-3D-55	3	5	S	5	W	4301352742	Oil Well	Approved Permit
State Tribal 9-3D-55	3	5	S	5	W	4301352743	Oil Well	Approved Permit
Myrin Tribal 15-19D-55	19	5	S	5	W	4301352744	Oil Well	Approved Permit
Myrin Tribal 13-19D-55	19	5	S	5	W	4301352745	Oil Well	Approved Permit
Myrin Tribal 12-19D-55	19	5	S	5	W	4301352746	Oil Well	Approved Permit
UTE TRIBAL 5-4D-55	4	5	S	5	W	4301352747	Oil Well	Approved Permit
UTE TRIBAL 4-4D-55	4	5	S	5	W	4301352748	Oil Well	Approved Permit
UTE TRIBAL 3-4D-55	4	5	S	5	W	4301352749	Oil Well	Approved Permit
UTE TRIBAL 6-4D-55	4	5	S	5	W	4301352754	Oil Well	Approved Permit
UTE TRIBAL 7-31D-55	31	5	S	5	W	4301352764	Oil Well	Approved Permit
Myrin Tribal 11-19D-55	19	5	S	5	W	4301352765	Oil Well	Approved Permit
UTE TRIBAL 4-30D-55	30	5	S	5	W	4301352796	Oil Well	Approved Permit
UTE TRIBAL 5-30D-55	30	5	S	5	W	4301352797	Oil Well	Approved Permit
UTE TRIBAL 7-30D-55	30	5	S	5	W	4301352799	Oil Well	Approved Permit
UTE TRIBAL 1-30D-55	30	5	S	5	W	4301352809	Oil Well	Approved Permit
LC TRIBAL 6-25D-56	25	5	S	6	W	4301352810	Oil Well	Approved Permit
LC TRIBAL 4-25D-56	25	5	S	6	W	4301352812	Oil Well	Approved Permit
Federal 6-13D-65	13	6	S	5	W	4301352813	Oil Well	Approved Permit
Federal 4-13D-65	13	6	S	5	W	4301352814	Oil Well	Approved Permit

Well Transfer
 From: Linn Operating, Inc.
 To: Linn Operation, LLC
 Effective: 3/1/2017

Federal 3-13D-65	13	6	S	5	W	4301352815	Oil Well	Approved Permit
Federal 3-16D-64	16	6	S	4	W	4301352823	Oil Well	Approved Permit
Federal 4-16D-64	16	6	S	4	W	4301352824	Oil Well	Approved Permit
Federal 5-16D-64	16	6	S	4	W	4301352825	Oil Well	Approved Permit
Federal 6-16D-64	16	6	S	4	W	4301352826	Oil Well	Approved Permit
Federal 5-13D-65	13	6	S	5	W	4301352827	Oil Well	Approved Permit
LC TRIBAL 1-25D-56	25	5	S	6	W	4301352835	Oil Well	Approved Permit
LC TRIBAL 2-25D-56	25	5	S	6	W	4301352836	Oil Well	Approved Permit
LC TRIBAL 8-25D-56	25	5	S	6	W	4301352837	Oil Well	Approved Permit
LC TRIBAL 9-25D-56	25	5	S	6	W	4301352840	Oil Well	Approved Permit
LC TRIBAL 15-25-56	25	5	S	6	W	4301352844	Oil Well	Approved Permit
Federal 9-5D-65	5	6	S	5	W	4301352846	Oil Well	Approved Permit
Federal 10-5D-65	5	6	S	5	W	4301352847	Oil Well	Approved Permit
LC TRIBAL 16-25D-56	25	5	S	6	W	4301352848	Oil Well	Approved Permit
LC TRIBAL 10-25D-56	25	5	S	6	W	4301352849	Oil Well	Approved Permit
UTE TRIBAL 8-30D-55	29	5	S	5	W	4301352855	Oil Well	Approved Permit
UTE TRIBAL 9-29D-55	29	5	S	5	W	4301352870	Oil Well	Approved Permit
UTE TRIBAL 6-24D-55	24	5	S	5	W	4301352871	Oil Well	Approved Permit
UTE TRIBAL 16-17D-55	17	5	S	5	W	4301352872	Oil Well	Approved Permit
Federal 9-8D-64	9	6	S	4	W	4301352880	Oil Well	Approved Permit
Federal 16-8D-64	9	6	S	4	W	4301352881	Oil Well	Approved Permit
UTE TRIBAL 13-27D-55	27	5	S	5	W	4301352882	Oil Well	Approved Permit
UTE TRIBAL 4-29D-55	29	5	S	5	W	4301352883	Oil Well	Approved Permit
UTE TRIBAL 1-29D-55	29	5	S	5	W	4301352884	Oil Well	Approved Permit
Federal 4-2D-65	2	6	S	5	W	4301352885	Oil Well	Approved Permit
Federal 5-2D-65	2	6	S	5	W	4301352886	Oil Well	Approved Permit
Federal 12-2D-65	2	6	S	5	W	4301352887	Oil Well	Approved Permit
LC TRIBAL 12-25D-56	25	5	S	6	W	4301352888	Oil Well	Approved Permit
LC TRIBAL 13-25D-56	25	5	S	6	W	4301352890	Oil Well	Approved Permit
LC TRIBAL 14-25D-56	25	5	S	6	W	4301352891	Oil Well	Approved Permit
Federal 15-3D-65	3	6	S	5	W	4301352892	Oil Well	Approved Permit
Federal 9-3D-65	3	6	S	5	W	4301352893	Oil Well	Approved Permit
Federal 8-3D-65	3	6	S	5	W	4301352894	Oil Well	Approved Permit
Federal 6-3D-65	3	6	S	5	W	4301352895	Oil Well	Approved Permit
LC Nielsen Tribal 6-33D-56	33	5	S	6	W	4301352896	Oil Well	Approved Permit
LC Nielsen Tribal 2-33D-56	33	5	S	6	W	4301352897	Oil Well	Approved Permit
LC Nielsen Tribal 4-33D-56	33	5	S	6	W	4301352898	Oil Well	Approved Permit
LC Nielsen Tribal 5-33D-56	33	5	S	6	W	4301352899	Oil Well	Approved Permit
UTE FEE 13-9D-54	9	5	S	4	W	4301352906	Oil Well	Approved Permit
UTE FEE 2-34D-55	27	5	S	5	W	4301352971	Oil Well	Approved Permit
Federal 13-7D-65	7	6	S	5	W	4301352974	Oil Well	Approved Permit
Federal 14-7D-65	7	6	S	5	W	4301352975	Oil Well	Approved Permit
UTE TRIBAL 6-27D-55	27	5	S	5	W	4301352976	Oil Well	Approved Permit
LC Nielsen Tribal 12-27D-56	27	5	S	6	W	4301352977	Oil Well	Approved Permit
LC Nielsen Tribal 13-27D-56	27	5	S	6	W	4301352978	Oil Well	Approved Permit

Well Transfer
 From: Linn Operating, Inc.
 To: Linn Operation, LLC
 Effective: 3/1/2017

LC Nielsen Tribal 16-28D-56	27	5	S	6	W	4301352979		Oil Well	Approved Permit
LC Nielsen Fee 9-28D-56	27	5	S	6	W	4301352980		Oil Well	Approved Permit
LC FEE 9-36D-56	36	5	S	6	W	4301352982		Oil Well	Approved Permit
LC FEE 15-36D-56	36	5	S	6	W	4301352983		Oil Well	Approved Permit
LC TRIBAL 6-36D-56	36	5	S	6	W	4301352984		Oil Well	Approved Permit
LC TRIBAL 5-36D-56	36	5	S	6	W	4301352985		Oil Well	Approved Permit
LC TRIBAL 4-36D-56	36	5	S	6	W	4301352986		Oil Well	Approved Permit
LC TRIBAL 3-36D-56	36	5	S	6	W	4301352987		Oil Well	Approved Permit
LC TRIBAL 2-35D-56	35	5	S	6	W	4301352988		Oil Well	Approved Permit
LC TRIBAL 1-35D-56	35	5	S	6	W	4301352989		Oil Well	Approved Permit
LC TRIBAL 9-35D-56	35	5	S	6	W	4301353018		Oil Well	Approved Permit
LC TRIBAL 6-35D-56	35	5	S	6	W	4301353019		Oil Well	Approved Permit
LC TRIBAL 10-35D-56	35	5	S	6	W	4301353020		Oil Well	Approved Permit
UTE TRIBAL 9-17D-55	17	5	S	5	W	4301353022		Oil Well	Approved Permit
LC TRIBAL 8-35D-56	35	5	S	6	W	4301353023		Oil Well	Approved Permit
UTE TRIBAL 10-17D-55	17	5	S	5	W	4301353024		Oil Well	Approved Permit
LC TRIBAL 7-35D-56	35	5	S	6	W	4301353025		Oil Well	Approved Permit
LC TRIBAL 5-35D-56	35	5	S	6	W	4301353026		Oil Well	Approved Permit
LC TRIBAL 15-35D-56	35	5	S	6	W	4301353027		Oil Well	Approved Permit
LC TRIBAL 16-35D-56	35	5	S	6	W	4301353028		Oil Well	Approved Permit
LC TRIBAL 3-35D-56	35	5	S	6	W	4301353029		Oil Well	Approved Permit
LC TRIBAL 4-35D-56	35	5	S	6	W	4301353030		Oil Well	Approved Permit
LC TRIBAL 14-35D-56	35	5	S	6	W	4301353036		Oil Well	Approved Permit
LC TRIBAL 13-35D-56	35	5	S	6	W	4301353038		Oil Well	Approved Permit
LC TRIBAL 12-35D-56	35	5	S	6	W	4301353039		Oil Well	Approved Permit
LC TRIBAL 11-35D-56	35	5	S	6	W	4301353040		Oil Well	Approved Permit
UTE TRIBAL 8-14D-55	14	5	S	5	W	4301353099		Oil Well	Approved Permit
LC FEE 13-36D-56	36	5	S	6	W	4301353114		Oil Well	Approved Permit
LC FEE 11-36D-56	36	5	S	6	W	4301353115		Oil Well	Approved Permit
LC Nielsen Fee 15-28D-56	28	5	S	6	W	4301353131		Oil Well	Approved Permit
UTE TRIBAL 3-20D-55	20	5	S	5	W	4301333280	18424	Oil Well	Drilling Operations Suspended
LC TRIBAL 4H-17-56	17	5	S	6	W	4301333540	18067	Oil Well	Drilling Operations Suspended
UTE TRIBAL 8-20D-55	20	5	S	5	W	4301333676	17308	Oil Well	Drilling Operations Suspended
UTE TRIBAL 14-14D-55	14	5	S	5	W	4301333699	18409	Oil Well	Drilling Operations Suspended
UTE TRIBAL 5-29D-55	29	5	S	5	W	4301333740	17306	Oil Well	Drilling Operations Suspended
UTE TRIBAL 7-32D-55	32	5	S	5	W	4301333794	18359	Oil Well	Drilling Operations Suspended
UTE TRIBAL 12-27D-55	27	5	S	5	W	4301333798	18360	Oil Well	Drilling Operations Suspended
BERRY TRIBAL 2-23D-54	23	5	S	4	W	4301333805	18546	Oil Well	Drilling Operations Suspended
UTE TRIBAL 13-29D-55	29	5	S	5	W	4301333807	18378	Oil Well	Drilling Operations Suspended
UTE TRIBAL 16-28D-55	28	5	S	5	W	4301333887	18594	Oil Well	Drilling Operations Suspended
FEDERAL 10-10D-65	10	6	S	5	W	4301350523	19773	Oil Well	Drilling Operations Suspended
LC FEE 8-15D-56	15	5	S	6	W	4301350597	19347	Oil Well	Drilling Operations Suspended
SFW FEE 13-10D-54	10	5	S	4	W	4301350892	19186	Oil Well	Drilling Operations Suspended
SFW TRIBAL 11-10D-54	10	5	S	4	W	4301350893	19215	Oil Well	Drilling Operations Suspended
LC TRIBAL 16-34D-45	34	4	S	5	W	4301350977	18658	Oil Well	Drilling Operations Suspended

Well Transfer
 From: Linn Operating, Inc.
 To: Linn Operation, LLC
 Effective: 3/1/2017

LC TRIBAL 5-29D-56	29	5	S	6	W	4301351184		Oil Well	Drilling Operations Suspended
LC TRIBAL 2-33D-45	33	4	S	5	W	4301351402	18854	Oil Well	Drilling Operations Suspended
LC TRIBAL 9-24D-45	24	4	S	5	W	4301351431	18861	Oil Well	Drilling Operations Suspended
LC TRIBAL 9-3D-56	3	5	S	6	W	4301351514	18948	Oil Well	Drilling Operations Suspended
GALLOWAY #2-14B2	14	2	S	2	W	4301351739	19044	Oil Well	Drilling Operations Suspended
LC Tribal 3-34D-56	34	5	S	6	W	4301352087	19234	Oil Well	Drilling Operations Suspended
LC Tribal 7-34D-56	34	5	S	6	W	4301352088	19235	Oil Well	Drilling Operations Suspended
Ute Tribal 5-9D-54	9	5	S	4	W	4301352463	19354	Oil Well	Drilling Operations Suspended
Ute Tribal 3-9D-54	9	5	S	4	W	4301352464	19355	Oil Well	Drilling Operations Suspended
UTE TRIBAL 7-17D-55	17	5	S	5	W	4301352691	19691	Oil Well	Drilling Operations Suspended
UTE TRIBAL 6-17D-55	17	5	S	5	W	4301352692	19708	Oil Well	Drilling Operations Suspended
UTE TRIBAL 3-17D-55	17	5	S	5	W	4301352693	19709	Oil Well	Drilling Operations Suspended
UTE TRIBAL 2-17D-55	17	5	S	5	W	4301352694	19692	Oil Well	Drilling Operations Suspended
State Tribal 3-12D-55	12	5	S	5	W	4301352697	19667	Oil Well	Drilling Operations Suspended
State Tribal 4-12D-55	12	5	S	5	W	4301352698	19668	Oil Well	Drilling Operations Suspended
State Tribal 10-2D-55	2	5	S	5	W	4301352734	19710	Oil Well	Drilling Operations Suspended
LC TRIBAL 1-36D-56	36	5	S	6	W	4301353021		Oil Well	Drilling Operations Suspended
LC TRIBAL 8-36D-56	36	5	S	6	W	4301353034		Oil Well	Drilling Operations Suspended
LC TRIBAL 7-36D-56	36	5	S	6	W	4301353035		Oil Well	Drilling Operations Suspended
LC TRIBAL 2-36D-56	36	5	S	6	W	4301353037		Oil Well	Drilling Operations Suspended
UTE TRIBAL 13-17D-55	17	5	S	5	W	4301333550		Oil Well	Location Abandoned
UTE TRIBAL 11-14D-54	14	5	S	4	W	4301333596		Oil Well	Location Abandoned
UTE TRIBAL 16-17D-55	17	5	S	5	W	4301333622		Oil Well	Location Abandoned
LC TRIBAL 14-16D-56	16	5	S	6	W	4301334283		Oil Well	Location Abandoned
LC TRIBAL 3-23D-56	23	5	S	6	W	4301350624		Oil Well	Location Abandoned
FEDERAL 2-1D-64	1	6	S	4	W	4301350765		Oil Well	Location Abandoned
FEDERAL 7-1D-64	1	6	S	4	W	4301350766		Oil Well	Location Abandoned
FEDERAL 9-1D-64	1	6	S	4	W	4301350767		Oil Well	Location Abandoned
CC FEE 8-24-38	24	3	S	8	W	4301350885		Oil Well	Location Abandoned
LC FEE 4H-12-57	12	5	S	7	W	4301350952		Oil Well	Location Abandoned
CC TRIBAL 4-2-48	2	4	S	8	W	4301350964		Oil Well	Location Abandoned
LC TRIBAL 7-2D-56	2	5	S	6	W	4301350988		Oil Well	Location Abandoned
LC TRIBAL 10-18D-56	18	5	S	6	W	4301350989		Oil Well	Location Abandoned
LC TRIBAL 3-16D-56	16	5	S	6	W	4301351032		Oil Well	Location Abandoned
CC FEE 6-21-38	21	3	S	8	W	4301351059		Oil Well	Location Abandoned
LC TRIBAL 12H-19-56	19	5	S	6	W	4301351193		Oil Well	Location Abandoned
LC FEE 15-11D-56	11	5	S	6	W	4301351197		Oil Well	Location Abandoned
LC TRIBAL 13H-10-56	11	5	S	6	W	4301351209		Oil Well	Location Abandoned
LC TRIBAL 2-31D-45	31	4	S	5	W	4301351261		Oil Well	Location Abandoned
LC TRIBAL 13H-24-45	24	4	S	5	W	4301351273		Oil Well	Location Abandoned
UTE TRIBAL 6-21D-55	21	5	S	5	W	4301351274		Oil Well	Location Abandoned
UTE TRIBAL 15-16D-55	16	5	S	5	W	4301351284		Oil Well	Location Abandoned
UTE TRIBAL 4H-15-55	15	5	S	5	W	4301351292		Oil Well	Location Abandoned
UTE TRIBAL 13H-14-54	14	5	S	4	W	4301351297		Oil Well	Location Abandoned
UTE TRIBAL 1-32-55	32	5	S	5	W	4301351298		Oil Well	Location Abandoned

Well Transfer
 From: Linn Operating, Inc.
 To: Linn Operation, LLC
 Effective: 3/1/2017

UTE TRIBAL 4-21D-55	21	5	S	5	W	4301351299	Oil Well	Location Abandoned
LC TRIBAL 12-33-45	33	4	S	5	W	4301351301	Oil Well	Location Abandoned
UTE TRIBAL 16-15D-55	15	5	S	5	W	4301351302	Oil Well	Location Abandoned
UTE TRIBAL 2-24-55	24	5	S	5	W	4301351304	Oil Well	Location Abandoned
LC TRIBAL 11-32D-56	32	5	S	6	W	4301351315	Oil Well	Location Abandoned
LC TRIBAL 1-32D-56	32	5	S	6	W	4301351317	Oil Well	Location Abandoned
LC TRIBAL 5H-32-56	32	5	S	6	W	4301351318	Oil Well	Location Abandoned
LC TRIBAL 14-28-45	28	4	S	5	W	4301351339	Oil Well	Location Abandoned
LC TRIBAL 16-32D-45	32	4	S	5	W	4301351340	Oil Well	Location Abandoned
LC TRIBAL 3-31-45	31	4	S	5	W	4301351347	Oil Well	Location Abandoned
LC TRIBAL 1-18D-56	18	5	S	6	W	4301351367	Oil Well	Location Abandoned
LC TRIBAL 9-18D-56	18	5	S	6	W	4301351368	Oil Well	Location Abandoned
LC FEE 9-23D-56	23	5	S	6	W	4301351380	Oil Well	Location Abandoned
LC TRIBAL 1-34D-45	34	4	S	5	W	4301351382	Oil Well	Location Abandoned
LC TRIBAL 12-21D-56	21	5	S	6	W	4301351383	Oil Well	Location Abandoned
LC TRIBAL 7-29D-56	29	5	S	6	W	4301351386	Oil Well	Location Abandoned
UTE TRIBAL 6-15-55	15	5	S	5	W	4301351399	Oil Well	Location Abandoned
UTE TRIBAL7-21D-55	21	5	S	5	W	4301351403	Oil Well	Location Abandoned
CC FEE 13-9D-37	9	3	S	7	W	4301351409	Oil Well	Location Abandoned
CC FEE 16-21D-38	21	3	S	8	W	4301351410	Oil Well	Location Abandoned
UTE TRIBAL 5H-10-54	10	5	S	4	W	4301351415	Oil Well	Location Abandoned
LC FEE 14-1-56	1	5	S	6	W	4301351457	Oil Well	Location Abandoned
LC TRIBAL 5-3D-56	3	5	S	6	W	4301351459	Oil Well	Location Abandoned
LC TRIBAL 12H-23-56	23	5	S	6	W	4301351488	Oil Well	Location Abandoned
LC TRIBAL 12HH-31-45	32	4	S	5	W	4301351499	Oil Well	Location Abandoned
CC Tribal 3-27D-38	27	3	S	8	W	4301351604	Oil Well	Location Abandoned
Myrin Fee 3-16D-55	16	5	S	5	W	4301351633	Oil Well	Location Abandoned
LC TRIBAL 12H-34-56	34	5	S	6	W	4301351634	Oil Well	Location Abandoned
UTE FEE 12-16D-55	16	5	S	5	W	4301351635	Oil Well	Location Abandoned
LC Tribal 13-11D-58	11	5	S	8	W	4301351708	Oil Well	Location Abandoned
LC Tribal 15-11D-58	11	5	S	8	W	4301351709	Oil Well	Location Abandoned
LC FEE 1-11D-56	11	5	S	6	W	4301351712	Oil Well	Location Abandoned
LC Tribal 8M-23-45	23	4	S	5	W	4301351722	Oil Well	Location Abandoned
LC Tribal 3-14D-58	11	5	S	8	W	4301351726	Oil Well	Location Abandoned
LC Tribal 11-11D-58	11	5	S	8	W	4301351729	Oil Well	Location Abandoned
GALLOWAY #3-12B2	12	2	S	2	W	4301351742	Oil Well	Location Abandoned
LC TRIBAL 8-31D-56	31	5	S	6	W	4301351746	Oil Well	Location Abandoned
LC Fee 2-6D-57	6	5	S	7	W	4301351749	Oil Well	Location Abandoned
LC Tribal 15-12D-58	12	5	S	8	W	4301351783	Oil Well	Location Abandoned
LC Tribal 9-12D-58	12	5	S	8	W	4301351784	Oil Well	Location Abandoned
LC Tribal 1-13D-58	12	5	S	8	W	4301351785	Oil Well	Location Abandoned
LC Tribal 13-7D-57	12	5	S	8	W	4301351786	Oil Well	Location Abandoned
LC Tribal 9-2D-58	2	5	S	8	W	4301351788	Oil Well	Location Abandoned
LC Tribal 1-2D-58	2	5	S	8	W	4301351789	Oil Well	Location Abandoned
LC Tribal 5-1D-58	2	5	S	8	W	4301351790	Oil Well	Location Abandoned

Well Transfer
 From: Linn Operating, Inc.
 To: Linn Operation, LLC
 Effective: 3/1/2017

LC Fee 15-6D-57	6	5	S	7	W	4301351816		Oil Well	Location Abandoned
GALLOWAY 4-14B2	14	2	S	2	W	4301351818		Oil Well	Location Abandoned
MORRIS #3-8B1	8	2	S	1	W	4301351836		Oil Well	Location Abandoned
FRITZ #3-24A2	24	1	S	2	W	4301351837		Oil Well	Location Abandoned
LC Fee 7-31D-45	31	4	S	5	W	4301351857		Oil Well	Location Abandoned
LC Tribal 5-31D-45	31	4	S	5	W	4301351858		Oil Well	Location Abandoned
LC Tribal 16-31-45	31	4	S	5	W	4301351863		Oil Well	Location Abandoned
LC FEE 4-32D-45	31	4	S	5	W	4301351892		Oil Well	Location Abandoned
CC Fee 8R-9-37	9	3	S	7	W	4301351937		Oil Well	Location Abandoned
LC Tribal 13-26D-56	26	5	S	6	W	4301352099		Oil Well	Location Abandoned
LC Tribal 2-27D-45	27	4	S	5	W	4301352100		Oil Well	Location Abandoned
LC Tribal 8-27D-45	27	4	S	5	W	4301352101		Oil Well	Location Abandoned
Abbott Fee 1-6D-54	6	5	S	4	W	4301352324		Oil Well	Location Abandoned
Abbott Fee 7-6D-54	6	5	S	4	W	4301352327		Oil Well	Location Abandoned
UTE FEE 10-9D-54	9	5	S	4	W	4301352475		Oil Well	Location Abandoned
UTE FEE 12-9D-54	9	5	S	4	W	4301352476		Oil Well	Location Abandoned
UTE FEE 16-9D-54	9	5	S	4	W	4301352478		Oil Well	Location Abandoned
UTE FEE 11-9D-54	9	5	S	4	W	4301352544		Oil Well	Location Abandoned
UTE TRIBAL 6-5D-55	5	5	S	5	W	4301352556		Oil Well	Location Abandoned
UTE TRIBAL 5-5D-55	5	5	S	5	W	4301352557		Oil Well	Location Abandoned
UTE TRIBAL 4-5D-55	5	5	S	5	W	4301352558		Oil Well	Location Abandoned
UTE TRIBAL 3-5D-55	5	5	S	5	W	4301352559		Oil Well	Location Abandoned
UTE TRIBAL 10-30D-55	30	5	S	5	W	4301352736		Oil Well	Location Abandoned
UTE TRIBAL 8-5D-55	5	5	S	5	W	4301352773		Oil Well	Location Abandoned
UTE FEE 1-13D-55	13	5	S	5	W	4301352838		Oil Well	Location Abandoned
SCOFIELD-THORPE 26-31	26	12	S	7	E	4300730987		Dry Hole	Plugged & Abandoned
SCOFIELD-THORPE 26-43	26	12	S	7	E	4300730990		Dry Hole	Plugged & Abandoned
SCOFIELD CHRISTIANSEN 8-23	8	12	S	7	E	4300730999		Dry Hole	Plugged & Abandoned
MAUREL TAYLOR FEE 1-36A2	36	1	S	2	W	4301330143	5525	Oil Well	Plugged & Abandoned
NUTTERS RIDGE FED 5-1	5	6	S	4	W	4301330403	8231	Oil Well	Plugged & Abandoned
ANTELOPE RIDGE 24-1	24	6	S	5	W	4301330426		Dry Hole	Plugged & Abandoned
B C UTE TRIBAL 8-21	21	5	S	4	W	4301330829	8414	Water Injection Well	Plugged & Abandoned
LC TRIBAL 16-21-46	21	4	S	6	W	4301333575		Dry Hole	Plugged & Abandoned
LC TRIBAL 8-4-56	4	5	S	6	W	4301333605	17046	Oil Well	Plugged & Abandoned
FOY 9-33D-55	33	5	S	5	W	4301333802		Dry Hole	Plugged & Abandoned
EMERALD 2-32A1	32	1	S	1	W	4301350059		Dry Hole	Plugged & Abandoned
CC FEE 7-28-38	28	3	S	8	W	4301350887		Dry Hole	Plugged & Abandoned
CC FEE 8-9-37	9	3	S	7	W	4301350896		Dry Hole	Plugged & Abandoned
LC TRIBAL 5HH-5-56	4	5	S	6	W	4301350927		Dry Hole	Plugged & Abandoned
LC TRIBAL 3-4D-56	4	5	S	6	W	4301351000		Dry Hole	Plugged & Abandoned
GALLOWAY #3-14B2	14	2	S	2	W	4301351741		Dry Hole	Plugged & Abandoned
ST LOST CREEK 32-44	32	11	S	7	E	4304930023		Dry Hole	Plugged & Abandoned
CLYDE MURRAY 1-2A2	2	1	S	2	W	4301330005	5876	Oil Well	Producing
VICTOR C BROWN 1-4A2	4	1	S	2	W	4301330011	5780	Oil Well	Producing
L BOREN U 3-15A2	15	1	S	2	W	4301330086	5755	Oil Well	Producing

Well Transfer
 From: Linn Operating, Inc.
 To: Linn Operation, LLC
 Effective: 3/1/2017

LAMICQ-URTY U 3-17A2	17	1	S	2	W	4301330099	5745	Oil Well	Producing
L BOREN U 4-23A2	23	1	S	2	W	4301330115	5905	Oil Well	Producing
TOMLINSON FED 1-25A2	25	1	S	2	W	4301330120	5535	Oil Well	Producing
WOODWARD 1-21A2	21	1	S	2	W	4301330130	5665	Oil Well	Producing
LAMICQ 1-20A2	20	1	S	2	W	4301330133	5400	Gas Well	Producing
L RBRTSN ST 1-1B2	1	2	S	2	W	4301330200	5410	Oil Well	Producing
SMITH ALBERT 1-8C5	8	3	S	5	W	4301330245	5490	Oil Well	Producing
FRESTON ST 1-8B1	8	2	S	1	W	4301330294	5345	Oil Well	Producing
GEORGE MURRAY 1-16B1	16	2	S	1	W	4301330297	5950	Oil Well	Producing
LAMICQ-URTY U 4-5A2	5	1	S	2	W	4301330347	5845	Oil Well	Producing
H G COLTHARP 1-15B1	15	2	S	1	W	4301330359	5945	Oil Well	Producing
STATE 3-18A1	18	1	S	1	W	4301330369	5810	Oil Well	Producing
BC UTE TRIBAL 4-22	22	5	S	4	W	4301330755	2620	Oil Well	Producing
DILLMAN 2-28A2	28	1	S	2	W	4301330821	5666	Oil Well	Producing
B C UTE TRIBAL 16-16	16	5	S	4	W	4301330841	9489	Oil Well	Producing
B C UTE TRIBAL 14-15	15	5	S	4	W	4301330842	9440	Oil Well	Producing
UTE TRIBAL 1-32R	32	5	S	4	W	4301330872	13020	Oil Well	Producing
UTE TRIBAL 23-3R	23	5	S	4	W	4301330886	13034	Oil Well	Producing
UTE TRIBAL 13-3R-54	3	5	S	4	W	4301330924	9488	Oil Well	Producing
S COTTONWOOD RIDGE UTE TRIBAL 1-19	19	5	S	4	W	4301330933	9845	Oil Well	Producing
TABBY CYN UTE TRIBAL 1-25	25	5	S	5	W	4301330945	9722	Oil Well	Producing
S BRUNDAGE UTE TRIBAL 1-30	30	5	S	4	W	4301330948	9850	Oil Well	Producing
SOWERS CYN UTE TRIBAL 3-26	26	5	S	5	W	4301330955	10423	Oil Well	Producing
UTE TRIBAL 3-24R-55 (REENTRY)	24	5	S	5	W	4301330960	15173	Oil Well	Producing
UTE TRIBAL 1-20	20	5	S	4	W	4301330966	9925	Oil Well	Producing
JOHN 2-3-B2	3	2	S	2	W	4301330975	5387	Oil Well	Producing
LAMICQ-ROBERTSON ST 2-1B2	1	2	S	2	W	4301330995	5412	Oil Well	Producing
T C UTE TRIBAL 9-23X	23	5	S	5	W	4301330999	9720	Oil Well	Producing
UTE TRIBAL 2-7A2	7	1	S	2	W	4301331009	5836	Oil Well	Producing
UTE TRIBAL 15-24R	24	5	S	5	W	4301331129	11985	Oil Well	Producing
S BRUNDAGE CYN UTE TRIBAL 4-27	27	5	S	4	W	4301331131	9851	Oil Well	Producing
HATCH 2-3B1	3	2	S	1	W	4301331147	10615	Oil Well	Producing
NORLING 2-9B1	9	2	S	1	W	4301331151	10616	Oil Well	Producing
UTE TRIBAL 5-13	13	5	S	5	W	4301331152	10421	Oil Well	Producing
SHAW 2-27A2	27	1	S	2	W	4301331184	10753	Oil Well	Producing
LAMICQ-URRITY 4-17A2	17	1	S	2	W	4301331190	10764	Oil Well	Producing
FRESTON 2-8B1	8	2	S	1	W	4301331203	10851	Oil Well	Producing
WISSE 3-35A2	35	1	S	2	W	4301331215	10925	Oil Well	Producing
MECCA 2-8A2	8	1	S	2	W	4301331231	10981	Oil Well	Producing
SWYKES 2-21A2	21	1	S	2	W	4301331235	10998	Oil Well	Producing
SHERMAN 2-12B2	12	2	S	2	W	4301331238	11009	Oil Well	Producing
DUNCAN 4-2A2	2	1	S	2	W	4301331276	11258	Gas Well	Producing
HAMBLIN 3-9A2	9	1	S	2	W	4301331278	11094	Gas Well	Producing
UTE TRIBAL 7-20R-54	20	5	S	4	W	4301331281	14088	Oil Well	Producing
Z and T UTE TRIBAL 7-19	19	5	S	4	W	4301331282	11131	Oil Well	Producing

Well Transfer
 From: Linn Operating, Inc.
 To: Linn Operation, LLC
 Effective: 3/1/2017

UTE TRIBAL 13-19	19	5	S	4	W	4301331284	11134	Oil Well	Producing
BAR-F 2-5B1	5	2	S	1	W	4301331286	11113	Oil Well	Producing
Z and T UTE TRIBAL 7-25	25	5	S	5	W	4301331310	11416	Oil Well	Producing
SMITH 2-9C5	9	3	S	5	W	4301331321	11245	Oil Well	Producing
LORANGER 2-24A2	24	1	S	2	W	4301331322	11244	Oil Well	Producing
UTE 2-6B3	6	2	S	3	W	4301331325	11446	Oil Well	Producing
MCELPRANG 2-30A1	30	1	S	1	W	4301331326	11252	Oil Well	Producing
SMITH 2-7C5	7	3	S	5	W	4301331327	11324	Oil Well	Producing
SMITH 2-18C5	18	3	S	5	W	4301331328	11336	Oil Well	Producing
UTE 2-24A3	24	1	S	3	W	4301331329	11339	Oil Well	Producing
UTE 5-19A2	19	1	S	2	W	4301331330	11277	Oil Well	Producing
EDWARDS 3-10B1	10	2	S	1	W	4301331332	11264	Oil Well	Producing
SUNDANCE 4-15A2	15	1	S	2	W	4301331333	11269	Oil Well	Producing
LORANGER 6-22A2	22	1	S	2	W	4301331334	11335	Oil Well	Producing
COX 2-36A2	36	1	S	2	W	4301331335	11330	Oil Well	Producing
SMITH 2-6C5	6	3	S	5	W	4301331338	11367	Oil Well	Producing
FRESTON 2-7B1	7	2	S	1	W	4301331341	11338	Oil Well	Producing
PEARSON 2-11B2	11	2	S	2	W	4301331356	11359	Oil Well	Producing
LAMB 2-16A2	16	1	S	2	W	4301331390	11487	Oil Well	Producing
LABRUM 2-23A2	23	1	S	2	W	4301331393	11514	Oil Well	Producing
UTE TRIBAL 13-17	17	5	S	4	W	4301331546	11921	Oil Well	Producing
UTE TRIBAL 11-19	19	5	S	4	W	4301331547	11920	Oil Well	Producing
UTE TRIBAL 13-22	22	5	S	4	W	4301331548	11926	Oil Well	Producing
UTE TRIBAL 1-28	28	5	S	4	W	4301331549	11925	Oil Well	Producing
UTE TRIBAL 4-30	30	5	S	4	W	4301331550	11914	Oil Well	Producing
UTE TRIBAL 15-16	16	5	S	4	W	4301331648	11951	Oil Well	Producing
UTE TRIBAL 16-18	18	5	S	4	W	4301331650	11946	Oil Well	Producing
UTE TRIBAL 5-20	20	5	S	4	W	4301331651	11957	Oil Well	Producing
UTE TRIBAL 15-23	23	5	S	5	W	4301331671	11989	Oil Well	Producing
TABBY CANYON 1-21	21	5	S	5	W	4301331699	12225	Oil Well	Producing
TABBY CANYON 8-22	22	5	S	5	W	4301331700	12008	Oil Well	Producing
SOWERS CANYON 9-27	27	5	S	5	W	4301331701	11997	Oil Well	Producing
UTE TRIBAL 9-19	19	5	S	4	W	4301331831	12175	Oil Well	Producing
UTE TRIBAL 15-19	19	5	S	4	W	4301331832	12180	Oil Well	Producing
UTE TRIBAL 2-25	25	5	S	5	W	4301331833	12153	Oil Well	Producing
UTE TRIBAL 3-25	25	5	S	5	W	4301331834	12152	Oil Well	Producing
UTE TRIBAL 11-24	24	5	S	5	W	4301331909	12190	Oil Well	Producing
UTE TRIBAL 13-24	24	5	S	5	W	4301331910	12217	Oil Well	Producing
UTE TRIBAL 11-25	25	5	S	5	W	4301331911	12182	Oil Well	Producing
UTE TRIBAL 1-26	26	5	S	5	W	4301331912	12235	Oil Well	Producing
UTE TRIBAL 2-19	19	5	S	4	W	4301332140	12795	Oil Well	Producing
UTE TRIBAL 6-25H	25	5	S	5	W	4301332143	12750	Oil Well	Producing
UTE TRIBAL 9-18	18	5	S	4	W	4301332144	12746	Oil Well	Producing
UTE TRIBAL 11-17	17	5	S	4	W	4301332145	12747	Oil Well	Producing
UTE TRIBAL 12-17	17	5	S	4	W	4301332146	12745	Oil Well	Producing

Well Transfer
 From: Linn Operating, Inc.
 To: Linn Operation, LLC
 Effective: 3/1/2017

UTE TRIBAL 15-18	18	5	S	4	W	4301332148	12794	Oil Well	Producing
UTE TRIBAL 6-22	22	5	S	4	W	4301332163	12974	Oil Well	Producing
UTE TRIBAL 6-21	21	5	S	4	W	4301332164	12994	Oil Well	Producing
UTE TRIBAL 7-28	28	5	S	4	W	4301332166	12995	Oil Well	Producing
UTE TRIBAL 11-20	20	5	S	4	W	4301332168	12946	Oil Well	Producing
UTE TRIBAL 13-25	25	5	S	5	W	4301332169	12857	Oil Well	Producing
UTE TRIBAL 2-27	27	5	S	4	W	4301332179	12975	Oil Well	Producing
UTE TRIBAL 1-34	34	5	S	4	W	4301332186	13121	Oil Well	Producing
UTE TRIBAL 2-35	35	5	S	5	W	4301332187	13021	Oil Well	Producing
UTE TRIBAL 4-36	36	5	S	5	W	4301332188	13063	Oil Well	Producing
UTE TRIBAL 5-28	28	5	S	4	W	4301332189	13026	Oil Well	Producing
UTE TRIBAL 5-31	31	5	S	4	W	4301332190	13080	Oil Well	Producing
UTE TRIBAL 9-26	26	5	S	4	W	4301332191	13101	Oil Well	Producing
UTE TRIBAL 11-28	28	5	S	4	W	4301332192	13022	Oil Well	Producing
UTE TRIBAL 3-29	29	5	S	4	W	4301332193	13042	Oil Well	Producing
BOWMAN 5-5A2	5	1	S	2	W	4301332202	13043	Oil Well	Producing
BOREN 4-9A2	9	1	S	2	W	4301332203	13079	Oil Well	Producing
UTE TRIBAL 5-19	19	5	S	4	W	4301332204	13090	Oil Well	Producing
UTE TRIBAL 12-15	15	5	S	4	W	4301332205	13100	Oil Well	Producing
UTE TRIBAL 13-20	20	5	S	4	W	4301332206	13048	Oil Well	Producing
BLANCHARD 3-10A2	10	1	S	2	W	4301332223	13149	Oil Well	Producing
SQUIRES 3-8A2	8	1	S	2	W	4301332227	13176	Oil Well	Producing
UTE TRIBAL 1-24-55	24	5	S	5	W	4301332259	13618	Oil Well	Producing
UTE TRIBAL 3-28-54	28	5	S	4	W	4301332261	13644	Oil Well	Producing
UTE TRIBAL 5-26-55	26	5	S	5	W	4301332264	13642	Oil Well	Producing
UTE TRIBAL 6-36-55	36	5	S	5	W	4301332265	13600	Oil Well	Producing
UTE TRIBAL 8-35-55	35	5	S	5	W	4301332267	13571	Oil Well	Producing
UTE TRIBAL 9-24-55	24	5	S	5	W	4301332268	13620	Oil Well	Producing
UTE TRIBAL 11-23-55	23	5	S	5	W	4301332269	13572	Oil Well	Producing
UTE TRIBAL 15-25-55	25	5	S	5	W	4301332271	13566	Oil Well	Producing
UTE TRIBAL 16-14-55	14	5	S	5	W	4301332272	13567	Oil Well	Producing
UTE TRIBAL 15-27-55	27	5	S	5	W	4301332339	14020	Oil Well	Producing
UTE TRIBAL 5-15-55	15	5	S	5	W	4301332344	13606	Oil Well	Producing
UTE TRIBAL 7-20-55	20	5	S	5	W	4301332346	13607	Oil Well	Producing
MOON TRIBAL 12-23-54	23	5	S	4	W	4301332347	14008	Oil Well	Producing
UTE TRIBAL 14-28-55	28	5	S	5	W	4301332348	13580	Oil Well	Producing
UTE TRIBAL 16-29-55	29	5	S	5	W	4301332349	13581	Oil Well	Producing
UTE TRIBAL 2-32-55	32	5	S	5	W	4301332350	13695	Oil Well	Producing
FOY TRIBAL 11-34-55	34	5	S	5	W	4301332351	13648	Oil Well	Producing
UTE TRIBAL 16-35-55	35	5	S	5	W	4301332352	14267	Oil Well	Producing
UTE TRIBAL 10-35-55	35	5	S	5	W	4301332353	13645	Oil Well	Producing
UTE TRIBAL 12-36-55	36	5	S	5	W	4301332354	13643	Oil Well	Producing
UTE TRIBAL 14-36-55	36	5	S	5	W	4301332355	14262	Oil Well	Producing
UTE TRIBAL 16-36-55	36	5	S	5	W	4301332356	14122	Oil Well	Producing
UTE TRIBAL 4-33-55	33	5	S	5	W	4301332357	13685	Oil Well	Producing

Well Transfer
 From: Linn Operating, Inc.
 To: Linn Operation, LLC
 Effective: 3/1/2017

UTE TRIBAL 15-17-55	17	5	S	5	W	4301332358	13698	Oil Well	Producing
UTE TRIBAL 12-14-54	14	5	S	4	W	4301332369	13647	Oil Well	Producing
UTE TRIBAL 3-20-54	20	5	S	4	W	4301332377	13955	Oil Well	Producing
UTE TRIBAL 4-21-54	21	5	S	4	W	4301332378	13907	Oil Well	Producing
UTE TRIBAL 9-20-54	20	5	S	4	W	4301332379	13906	Oil Well	Producing
UTE TRIBAL 5-30-54	30	5	S	4	W	4301332380	13905	Oil Well	Producing
UTE TRIBAL 9-30-54	30	5	S	4	W	4301332383	14050	Oil Well	Producing
UTE TRIBAL 12-21-54	21	5	S	4	W	4301332385	13928	Oil Well	Producing
UTE TRIBAL 15-20-54	20	5	S	4	W	4301332386	13911	Oil Well	Producing
UTE TRIBAL 13-28-54	28	5	S	4	W	4301332387	13908	Oil Well	Producing
UTE TRIBAL 9-28-54	28	5	S	4	W	4301332388	13910	Oil Well	Producing
UTE TRIBAL 15-28-54	28	5	S	4	W	4301332389	13909	Oil Well	Producing
UTE TRIBAL 9-25-55	25	5	S	5	W	4301332390	13715	Oil Well	Producing
MOON TRIBAL 6-27-54	27	5	S	4	W	4301332407	13969	Oil Well	Producing
MOON TRIBAL 14-27-54	27	5	S	4	W	4301332408	13998	Oil Well	Producing
UTE TRIBAL 3-32-54	32	5	S	4	W	4301332410	13949	Oil Well	Producing
UTE TRIBAL 7-32-54	32	5	S	4	W	4301332411	13936	Oil Well	Producing
UTE TRIBAL 7-33-54	33	5	S	4	W	4301332413	13945	Oil Well	Producing
UTE TRIBAL 11-20-55	20	5	S	5	W	4301332415	14269	Oil Well	Producing
UTE TRIBAL 1-27-55	27	5	S	5	W	4301332416	13947	Oil Well	Producing
UTE TRIBAL 3-27-55	27	5	S	5	W	4301332417	14022	Oil Well	Producing
UTE TRIBAL 7-27-55	27	5	S	5	W	4301332418	13948	Oil Well	Producing
UTE TRIBAL 10-28-55	28	5	S	5	W	4301332419	14580	Oil Well	Producing
UTE TRIBAL 6-32-55	32	5	S	5	W	4301332420	14895	Oil Well	Producing
UTE TRIBAL 8-32-55	32	5	S	5	W	4301332421	14896	Oil Well	Producing
UTE TRIBAL 2-36-55	36	5	S	5	W	4301332422	13937	Oil Well	Producing
UTE TRIBAL 8-36-55	36	5	S	5	W	4301332423	14021	Oil Well	Producing
UTE TRIBAL 13-16-54	16	5	S	4	W	4301332511	13981	Oil Well	Producing
UTE TRIBAL 11-30-54	30	5	S	4	W	4301332512	13982	Oil Well	Producing
UTE TRIBAL 13-23-55	23	5	S	5	W	4301332513	13975	Oil Well	Producing
UTE TRIBAL 7-23-55	23	5	S	5	W	4301332514	13976	Oil Well	Producing
UTE TRIBAL 5-33-54	33	5	S	4	W	4301332521	14060	Oil Well	Producing
UTE TRIBAL 11-33-54	33	5	S	4	W	4301332522	14061	Oil Well	Producing
UTE TRIBAL 14-32-54	32	5	S	4	W	4301332523	14062	Oil Well	Producing
UTE TRIBAL 1-23-55	23	5	S	5	W	4301332524	14044	Oil Well	Producing
UTE TRIBAL 5-29-54	29	5	S	4	W	4301332525	14045	Oil Well	Producing
UTE TRIBAL 1-31-54	31	5	S	4	W	4301332526	14116	Oil Well	Producing
UTE TRIBAL 3-31-54	31	5	S	4	W	4301332527	14109	Oil Well	Producing
UTE TRIBAL 7-31-54	31	5	S	4	W	4301332528	14160	Oil Well	Producing
UTE TRIBAL 9-31-54	31	5	S	4	W	4301332529	14177	Oil Well	Producing
UTE TRIBAL 11-31-54	31	5	S	4	W	4301332530	14163	Oil Well	Producing
UTE TRIBAL 3-23-55	23	5	S	5	W	4301332536	14077	Oil Well	Producing
UTE TRIBAL 5-23-55	23	5	S	5	W	4301332537	14108	Oil Well	Producing
UTE TRIBAL 9-32-54	32	5	S	4	W	4301332538	14199	Oil Well	Producing
UTE TRIBAL 5-32-54	32	5	S	4	W	4301332539	14112	Oil Well	Producing

Well Transfer
 From: Linn Operating, Inc.
 To: Linn Operation, LLC
 Effective: 3/1/2017

MOON TRIBAL 10-27-54	27	5	S	4	W	4301332540	14195	Oil Well	Producing
MOON TRIBAL 12-27-54	27	5	S	4	W	4301332541	14161	Oil Well	Producing
MOON TRIBAL 8-27-54	27	5	S	4	W	4301332543	14139	Oil Well	Producing
UTE TRIBAL 9-33-54	33	5	S	4	W	4301332549	14162	Oil Well	Producing
WILLIAMSON TRIBAL 3-34-54	34	5	S	4	W	4301332550	14222	Oil Well	Producing
WILLIAMSON TRIBAL 5-34-54	34	5	S	4	W	4301332551	14235	Oil Well	Producing
FEDERAL 6-2-65	2	6	S	5	W	4301332557	14655	Oil Well	Producing
UTE TRIBAL 15-29-54	29	5	S	4	W	4301332561	14316	Oil Well	Producing
UTE TRIBAL 7-29-54	29	5	S	4	W	4301332562	14354	Oil Well	Producing
UTE TRIBAL 11-29-54	29	5	S	4	W	4301332563	14337	Oil Well	Producing
UTE TRIBAL 13-29-54	29	5	S	4	W	4301332564	14315	Oil Well	Producing
UTE TRIBAL 4-29-54	29	5	S	4	W	4301332565	14367	Oil Well	Producing
UTE TRIBAL 1-35-54	35	5	S	4	W	4301332567	14266	Oil Well	Producing
UTE TRIBAL 11-13-54	13	5	S	4	W	4301332568	14281	Oil Well	Producing
UTE TRIBAL 2-24-54	24	5	S	4	W	4301332569	14314	Oil Well	Producing
UTE TRIBAL 13-18-54	18	5	S	4	W	4301332571	14388	Oil Well	Producing
UTE TRIBAL 12-29-54	29	5	S	4	W	4301332572	14336	Oil Well	Producing
UTE TRIBAL 4-24-54	24	5	S	4	W	4301332573	14247	Oil Well	Producing
UTE TRIBAL 6-14-54	14	5	S	4	W	4301332586	15270	Oil Well	Producing
UTE TRIBAL 10-15-54	15	5	S	4	W	4301332587	14194	Oil Well	Producing
UTE TRIBAL 16-15-54	15	5	S	4	W	4301332588	14311	Oil Well	Producing
UTE TRIBAL 11-16-54	16	5	S	4	W	4301332589	14178	Oil Well	Producing
UTE TRIBAL 8-22-54	22	5	S	4	W	4301332590	14219	Oil Well	Producing
UTE TRIBAL 2-22-54	22	5	S	4	W	4301332591	14328	Oil Well	Producing
UTE TRIBAL 10-22-54	22	5	S	4	W	4301332592	14218	Oil Well	Producing
UTE TRIBAL 14-22-54	22	5	S	4	W	4301332593	14220	Oil Well	Producing
UTE TRIBAL 13-13-55	13	5	S	5	W	4301332599	15134	Oil Well	Producing
UTE TRIBAL 13-14-55	14	5	S	5	W	4301332600	14236	Oil Well	Producing
UTE TRIBAL 13-15-55	15	5	S	5	W	4301332602	14263	Oil Well	Producing
UTE TRIBAL 10-21-55	21	5	S	5	W	4301332603	14385	Oil Well	Producing
UTE TRIBAL 2-22-55	22	5	S	5	W	4301332604	14268	Oil Well	Producing
UTE TRIBAL 3-22-55	22	5	S	5	W	4301332605	14298	Oil Well	Producing
UTE TRIBAL 9-22-55	22	5	S	5	W	4301332606	14330	Oil Well	Producing
UTE TRIBAL 11-22-55	22	5	S	5	W	4301332607	14329	Oil Well	Producing
MOON TRIBAL 3-27-54	27	5	S	4	W	4301332613	14416	Oil Well	Producing
UTE TRIBAL 5-27-55	27	5	S	5	W	4301332614	14881	Oil Well	Producing
UTE TRIBAL 11-27-55	27	5	S	5	W	4301332615	14882	Oil Well	Producing
UTE TRIBAL 12-22-55	22	5	S	5	W	4301332616	14370	Oil Well	Producing
UTE TRIBAL 15-22-55	22	5	S	5	W	4301332617	14921	Oil Well	Producing
UTE TRIBAL 8-25-55	25	5	S	5	W	4301332620	14365	Oil Well	Producing
UTE TRIBAL 4-20-54	20	5	S	4	W	4301332621	14518	Oil Well	Producing
UTE TRIBAL 6-20-54	20	5	S	4	W	4301332622	14382	Oil Well	Producing
UTE TRIBAL 5-22-54	22	5	S	4	W	4301332624	14547	Oil Well	Producing
UTE TRIBAL 3-30-54	30	5	S	4	W	4301332625	14364	Oil Well	Producing
UTE TRIBAL 3-10-54	10	5	S	4	W	4301332663	14414	Oil Well	Producing

Well Transfer
 From: Linn Operating, Inc.
 To: Linn Operation, LLC
 Effective: 3/1/2017

UTE TRIBAL 15-32-54	32	5	S	4	W	4301332666	14460	Oil Well	Producing
UTE TRIBAL 8-31-55	31	5	S	5	W	4301332673	14407	Oil Well	Producing
UTE TRIBAL 3-35-54	35	5	S	4	W	4301332675	14656	Oil Well	Producing
UTE TRIBAL 2-30-55	30	5	S	5	W	4301332680	14427	Oil Well	Producing
BROWN 3-4A2	4	1	S	2	W	4301332684	14673	Oil Well	Producing
UTE TRIBAL 9-17-54	17	5	S	4	W	4301332687	15309	Oil Well	Producing
UTE TRIBAL 13-31-54	31	5	S	4	W	4301332688	14517	Oil Well	Producing
UTE TRIBAL 14-19-54	19	5	S	4	W	4301332690	14546	Oil Well	Producing
UTE TRIBAL 16-19-54	19	5	S	4	W	4301332691	14491	Oil Well	Producing
UTE TRIBAL 13-32-54	32	5	S	4	W	4301332692	14490	Oil Well	Producing
UTE TRIBAL 11-14-55	14	5	S	5	W	4301332693	15136	Oil Well	Producing
UTE TRIBAL 8-28-55	28	5	S	5	W	4301332694	14574	Oil Well	Producing
FEDERAL 6-1-65	1	6	S	5	W	4301332699	15776	Oil Well	Producing
UTE TRIBAL 9-15-55	15	5	S	5	W	4301332701	14573	Oil Well	Producing
UTE TRIBAL 14-20-54	20	5	S	4	W	4301332702	14459	Oil Well	Producing
#1 DLB 12-15-56	15	5	S	6	W	4301332710	14943	Gas Well	Producing
UTE TRIBAL 12-19-54	19	5	S	4	W	4301332716	14627	Oil Well	Producing
UTE TRIBAL 10-19-54	19	5	S	4	W	4301332717	14628	Oil Well	Producing
UTE TRIBAL 16-30-54	30	5	S	4	W	4301332718	14604	Oil Well	Producing
UTE TRIBAL 11-12-55	12	5	S	5	W	4301332721	14605	Oil Well	Producing
NIELSEN MARSING 13-14-56	14	5	S	6	W	4301332737	15060	Oil Well	Producing
TAYLOR HERRICK 10-22-56	22	5	S	6	W	4301332738	15058	Oil Well	Producing
UTE TRIBAL 16-20-54	20	5	S	4	W	4301332739	14671	Oil Well	Producing
UTE TRIBAL 10-20-54	20	5	S	4	W	4301332740	14691	Oil Well	Producing
UTE TRIBAL 4-28-54	28	5	S	4	W	4301332741	14672	Oil Well	Producing
UTE TRIBAL 13-33-54	33	5	S	4	W	4301332742	14736	Oil Well	Producing
UTE TRIBAL 15-31-54	31	5	S	4	W	4301332743	14690	Oil Well	Producing
UTE TRIBAL 8-30-54	30	5	S	4	W	4301332746	15583	Oil Well	Producing
UTE TRIBAL 10-25-55	25	5	S	5	W	4301332749	14758	Oil Well	Producing
UTE TRIBAL 14-25-55	25	5	S	5	W	4301332750	14798	Oil Well	Producing
UTE TRIBAL 3-36-55	36	5	S	5	W	4301332751	14842	Oil Well	Producing
UTE TRIBAL 16-16-55	16	5	S	5	W	4301332757	14865	Oil Well	Producing
UTE TRIBAL 3-21-55	21	5	S	5	W	4301332758	15112	Oil Well	Producing
UTE TRIBAL 16-25-55	25	5	S	5	W	4301332759	14821	Oil Well	Producing
UTE TRIBAL 1-36-55	36	5	S	5	W	4301332760	14822	Oil Well	Producing
UTE TRIBAL 7-22-54	22	5	S	4	W	4301332761	15661	Oil Well	Producing
UTE TRIBAL 2-31-54	31	5	S	4	W	4301332762	14845	Oil Well	Producing
UTE TRIBAL 2-28-54	28	5	S	4	W	4301332763	14723	Oil Well	Producing
UTE TRIBAL 10-28-54	28	5	S	4	W	4301332764	14722	Oil Well	Producing
UTE TRIBAL 12-28-54	28	5	S	4	W	4301332765	14701	Oil Well	Producing
UTE TRIBAL 8-28-54	28	5	S	4	W	4301332766	14777	Oil Well	Producing
UTE TRIBAL 4-31-54	31	5	S	4	W	4301332767	14494	Oil Well	Producing
UTE TRIBAL 15-33-54	33	5	S	4	W	4301332768	15210	Oil Well	Producing
UTE TRIBAL 12-25-55	25	5	S	5	W	4301332769	14799	Oil Well	Producing
UTE TRIBAL 7-35-54	35	5	S	4	W	4301332774	15019	Oil Well	Producing

Well Transfer
 From: Linn Operating, Inc.
 To: Linn Operation, LLC
 Effective: 3/1/2017

UTE TRIBAL 16-24-54	24	5	S	4	W	4301332775	14762	Oil Well	Producing
UTE TRIBAL 14-25-54	25	5	S	4	W	4301332776	14753	Oil Well	Producing
UTE TRIBAL 16-25-54	25	5	S	4	W	4301332779	15078	Oil Well	Producing
UTE TRIBAL 8-25-54	25	5	S	4	W	4301332780	15280	Oil Well	Producing
UTE TRIBAL 9-35-54	35	5	S	4	W	4301332781	15535	Oil Well	Producing
UTE TRIBAL 6-30-55	30	5	S	5	W	4301332783	15163	Oil Well	Producing
MOON TRIBAL 4-23-54	23	5	S	4	W	4301332800	14985	Oil Well	Producing
MOON TRIBAL 5-27-54	27	5	S	4	W	4301332802	14984	Oil Well	Producing
UTE TRIBAL 2-32-54	32	5	S	4	W	4301332803	15151	Oil Well	Producing
UTE TRIBAL 15-35-54	35	5	S	4	W	4301332804	15185	Oil Well	Producing
UTE TRIBAL 5-35-54	35	5	S	4	W	4301332805	15485	Oil Well	Producing
UTE TRIBAL 13-35-54	35	5	S	4	W	4301332806	15292	Oil Well	Producing
UTE TRIBAL 11-35-54	35	5	S	4	W	4301332807	15317	Oil Well	Producing
UTE TRIBAL 8-19-54	19	5	S	4	W	4301332840	14946	Oil Well	Producing
UTE TRIBAL 13-20-55	20	5	S	5	W	4301332841	15097	Oil Well	Producing
UTE TRIBAL 16-22-54	22	5	S	4	W	4301332842	15015	Oil Well	Producing
MOON TRIBAL 6-23-54	23	5	S	4	W	4301332843	15113	Oil Well	Producing
UTE TRIBAL 11-26-54	26	5	S	4	W	4301332844	15233	Oil Well	Producing
MOON TRIBAL 15-27-54	27	5	S	4	W	4301332846	15115	Oil Well	Producing
UTE TRIBAL 10-31-54	31	5	S	4	W	4301332847	14956	Oil Well	Producing
ST TRIBAL 6-15-54	15	5	S	4	W	4301332848	16656	Oil Well	Producing
ST TRIBAL 2-15-54	15	5	S	4	W	4301332849	16959	Oil Well	Producing
ST TRIBAL 4-15-54	15	5	S	4	W	4301332850	17478	Oil Well	Producing
ST TRIBAL 8-15-54	15	5	S	4	W	4301332851	16279	Oil Well	Producing
UTE TRIBAL 11-25-54	25	5	S	4	W	4301332856	15430	Oil Well	Producing
UTE TRIBAL 3-30-55	30	5	S	5	W	4301332862	15340	Oil Well	Producing
UTE TRIBAL 7-19-55	19	5	S	5	W	4301332863	15279	Oil Well	Producing
UTE TRIBAL 8-19-55	19	5	S	5	W	4301332864	15241	Oil Well	Producing
UTE TRIBAL 6-19-54	19	5	S	4	W	4301332865	14947	Oil Well	Producing
UTE TRIBAL 12-20-54	20	5	S	4	W	4301332866	14924	Oil Well	Producing
UTE TRIBAL 3-21-54	21	5	S	4	W	4301332867	15554	Oil Well	Producing
UTE TRIBAL 2-26-54	26	5	S	4	W	4301332868	15231	Oil Well	Producing
UTE TRIBAL 8-31-54	31	5	S	4	W	4301332869	14970	Oil Well	Producing
UTE TRIBAL 8-32-54	32	5	S	4	W	4301332870	15152	Oil Well	Producing
UTE TRIBAL 4-33-54	33	5	S	4	W	4301332871	15040	Oil Well	Producing
UTE TRIBAL 6-33-54	33	5	S	4	W	4301332872	15059	Oil Well	Producing
UTE TRIBAL 9-22-54	22	5	S	4	W	4301332889	15607	Oil Well	Producing
UTE TRIBAL 5-26-54	26	5	S	4	W	4301332890	15268	Oil Well	Producing
UTE TRIBAL 13-26-54	26	5	S	4	W	4301332891	15287	Oil Well	Producing
UTE TRIBAL 6-28D-54	28	5	S	4	W	4301332892	15232	Oil Well	Producing
UTE TRIBAL 2-30D-54	30	5	S	4	W	4301332894	15298	Oil Well	Producing
UTE TRIBAL 4-32-54	32	5	S	4	W	4301332896	15555	Oil Well	Producing
UTE TRIBAL 6-32D-54	32	5	S	4	W	4301332897	15312	Oil Well	Producing
UTE TRIBAL 2-33D-54	33	5	S	4	W	4301332898	15271	Oil Well	Producing
UTE TRIBAL 12-32-54	32	5	S	4	W	4301332925	15503	Oil Well	Producing

Well Transfer
 From: Linn Operating, Inc.
 To: Linn Operation, LLC
 Effective: 3/1/2017

UTE TRIBAL 16-32D-54	32	5	S	4	W	4301332926	16971	Oil Well	Producing
MOON TRIBAL 16-23-54	23	5	S	4	W	4301332927	15219	Oil Well	Producing
UTE TRIBAL 4-25-55	25	5	S	5	W	4301332928	15421	Oil Well	Producing
UTE TRIBAL 7-36-55	36	5	S	5	W	4301332929	15341	Oil Well	Producing
UTE TRIBAL 5-36-55	36	5	S	5	W	4301332930	15301	Oil Well	Producing
MOON TRIBAL 10-2-54	2	5	S	4	W	4301332931	15429	Oil Well	Producing
MYRIN TRIBAL 16-19-55	19	5	S	5	W	4301332934	15339	Oil Well	Producing
UTE TRIBAL 2-31-55	31	5	S	5	W	4301332935	15428	Oil Well	Producing
UTE TRIBAL 10-31-55	31	5	S	5	W	4301332936	15354	Oil Well	Producing
MOON TRIBAL 1-27-54	27	5	S	4	W	4301332937	15308	Oil Well	Producing
MOON TRIBAL 5-23-54	23	5	S	4	W	4301332938	15584	Oil Well	Producing
ST TRIBAL 7-18-54	18	5	S	4	W	4301332952	15724	Oil Well	Producing
ST TRIBAL 5-18-54	18	5	S	4	W	4301332953	15781	Oil Well	Producing
UTE TRIBAL 15-15-54	15	5	S	4	W	4301332971	15310	Oil Well	Producing
UTE TRIBAL 4-19-54	19	5	S	4	W	4301332972	15382	Oil Well	Producing
UTE TRIBAL 8-20-54	20	5	S	4	W	4301332973	15245	Oil Well	Producing
UTE TRIBAL 2-20-54	20	5	S	4	W	4301332974	15269	Oil Well	Producing
UTE TRIBAL 7-15-55	15	5	S	5	W	4301332976	15311	Oil Well	Producing
UTE TRIBAL 10-15-55	15	5	S	5	W	4301332977	15380	Oil Well	Producing
UTE TRIBAL 1-15-55	15	5	S	5	W	4301332978	15299	Oil Well	Producing
UTE TRIBAL 14-15-55	15	5	S	5	W	4301332979	15369	Oil Well	Producing
UTE TRIBAL 11-15-55	15	5	S	5	W	4301332980	15342	Oil Well	Producing
UTE TRIBAL 14-18-55	18	5	S	5	W	4301332984	15671	Oil Well	Producing
UTE TRIBAL 14-24-56	24	5	S	6	W	4301332988	15740	Oil Well	Producing
UTE TRIBAL 7-24-56	24	5	S	6	W	4301332989	15782	Oil Well	Producing
UTE TRIBAL 11-25-56	25	5	S	6	W	4301332990	15627	Oil Well	Producing
UTE TRIBAL 7-25-56	25	5	S	6	W	4301332991	15617	Oil Well	Producing
UTE TRIBAL 5-25-56	25	5	S	6	W	4301332992	15648	Oil Well	Producing
UTE TRIBAL 3-25-56	25	5	S	6	W	4301332993	15561	Oil Well	Producing
UTE TRIBAL 13-15D-54	15	5	S	4	W	4301333039	15368	Oil Well	Producing
UTE TRIBAL 16-28D-54	28	5	S	4	W	4301333041	15377	Oil Well	Producing
UTE TRIBAL 14-31D-54	31	5	S	4	W	4301333042	15419	Oil Well	Producing
UTE TRIBAL 4-22-55	22	5	S	5	W	4301333044	15381	Oil Well	Producing
UTE TRIBAL 16-23-55	23	5	S	5	W	4301333046	15211	Oil Well	Producing
UTE TRIBAL 9-35-55	35	5	S	5	W	4301333047	15378	Oil Well	Producing
UTE TRIBAL 7-35-55	35	5	S	5	W	4301333048	15367	Oil Well	Producing
UTE TRIBAL 15-36-55	36	5	S	5	W	4301333049	15379	Oil Well	Producing
UTE TRIBAL 10-12-55	12	5	S	5	W	4301333055	15618	Oil Well	Producing
UTE TRIBAL 5-13-54	13	5	S	4	W	4301333075	15873	Oil Well	Producing
UTE TRIBAL 16-29-54	29	5	S	4	W	4301333076	17074	Oil Well	Producing
UTE TRIBAL 12-18-54	18	5	S	4	W	4301333077	15575	Oil Well	Producing
UTE TRIBAL 8-33-54	33	5	S	4	W	4301333089	15398	Oil Well	Producing
UTE TRIBAL 12-33-54	33	5	S	4	W	4301333090	15417	Oil Well	Producing
UTE TRIBAL 16-33-54	33	5	S	4	W	4301333091	15397	Oil Well	Producing
UTE TRIBAL 10-33-54	33	5	S	4	W	4301333092	15418	Oil Well	Producing

Well Transfer
 From: Linn Operating, Inc.
 To: Linn Operation, LLC
 Effective: 3/1/2017

UTE TRIBAL 14-33-54	33	5	S	4	W	4301333093	15399	Oil Well	Producing
UTE TRIBAL 2-14-54	14	5	S	4	W	4301333111	16832	Oil Well	Producing
UTE TRIBAL 14-14-54	14	5	S	4	W	4301333112	15440	Oil Well	Producing
UTE TRIBAL 13-21-54	21	5	S	4	W	4301333113	15471	Oil Well	Producing
UTE TRIBAL 11-21-54	21	5	S	4	W	4301333115	15470	Oil Well	Producing
UTE TRIBAL 11-22-54	22	5	S	4	W	4301333116	15662	Oil Well	Producing
UTE TRIBAL 2-21-55	21	5	S	5	W	4301333117	15582	Oil Well	Producing
UTE TRIBAL 4-28-55	28	5	S	5	W	4301333118	15506	Oil Well	Producing
UTE TRIBAL 8-29-55	29	5	S	5	W	4301333119	15507	Oil Well	Producing
UTE TRIBAL 6-29-55	29	5	S	5	W	4301333120	15504	Oil Well	Producing
TAYLOR FEE 13-22-56	22	5	S	6	W	4301333121	15525	Oil Well	Producing
WILCOX ELIASON 7-15-56	15	5	S	6	W	4301333122	15526	Oil Well	Producing
UTE TRIBAL 14-16-54	16	5	S	4	W	4301333123	15639	Oil Well	Producing
UTE TRIBAL 1-16-54	16	5	S	4	W	4301333128	15420	Oil Well	Producing
UTE TRIBAL 10-16-54	16	5	S	4	W	4301333129	15454	Oil Well	Producing
UTE TRIBAL 7-16-54	16	5	S	4	W	4301333130	15455	Oil Well	Producing
UTE TRIBAL 12-16-54	16	5	S	4	W	4301333131	15456	Oil Well	Producing
UTE TRIBAL 16-17-54	17	5	S	4	W	4301333132	15524	Oil Well	Producing
UTE TRIBAL 10-17-54	17	5	S	4	W	4301333133	15581	Oil Well	Producing
UTE TRIBAL 12-24D-55	24	5	S	5	W	4301333134	15567	Oil Well	Producing
WILCOX FEE 1-20-56	20	5	S	6	W	4301333150	15745	Oil Well	Producing
NIELSEN FEE 13-11-56	11	5	S	6	W	4301333152	15600	Oil Well	Producing
UTE TRIBAL 2-29-54	29	5	S	4	W	4301333153	15919	Oil Well	Producing
UTE TRIBAL 14-29-54	29	5	S	4	W	4301333154	15831	Oil Well	Producing
UTE TRIBAL 10-29-54	29	5	S	4	W	4301333155	15847	Oil Well	Producing
UTE TRIBAL 10-24D-55	24	5	S	5	W	4301333156	15556	Oil Well	Producing
UTE TRIBAL 10-29D-55	29	5	S	5	W	4301333157	15505	Oil Well	Producing
UTE TRIBAL 6-29-54	29	5	S	4	W	4301333172	15846	Oil Well	Producing
UTE TRIBAL 12Q-25-55	25	5	S	5	W	4301333184	15744	Oil Well	Producing
UTE TRIBAL 3G-31-54	31	5	S	4	W	4301333185	15746	Oil Well	Producing
UTE TRIBAL 11-36-55	36	5	S	5	W	4301333186	15865	Oil Well	Producing
UTE TRIBAL 6-23D-55	23	5	S	5	W	4301333187	15996	Oil Well	Producing
UTE TRIBAL 8-14-54	14	5	S	4	W	4301333204	15656	Oil Well	Producing
UTE TRIBAL 10-14-54	14	5	S	4	W	4301333205	15680	Oil Well	Producing
UTE TRIBAL 11-15-54	15	5	S	4	W	4301333206	15643	Oil Well	Producing
UTE TRIBAL 9-16-54	16	5	S	4	W	4301333207	15660	Oil Well	Producing
UTE TRIBAL 3-22-54	22	5	S	4	W	4301333208	15640	Oil Well	Producing
UTE TRIBAL 15-13D-55	13	5	S	5	W	4301333212	15642	Oil Well	Producing
UTE TRIBAL 6-22D-55	22	5	S	5	W	4301333213	16831	Oil Well	Producing
UTE TRIBAL 11-36D-55	36	5	S	5	W	4301333214	15702	Oil Well	Producing
UTE TRIBAL 1-22D-54	22	5	S	4	W	4301333215	15641	Oil Well	Producing
BERRY TRIBAL 1-23-54	23	5	S	4	W	4301333216	15931	Oil Well	Producing
BERRY TRIBAL 15-23-54	23	5	S	4	W	4301333217	15932	Oil Well	Producing
UTE TRIBAL 9-36D-55	36	5	S	5	W	4301333239	15933	Oil Well	Producing
UTE TRIBAL 9S-25-55	25	5	S	5	W	4301333245	15962	Oil Well	Producing

Well Transfer
 From: Linn Operating, Inc.
 To: Linn Operation, LLC
 Effective: 3/1/2017

UTE TRIBAL 12-32-55	32	5	S	5	W	4301333266	15681	Oil Well	Producing
UTE TRIBAL 16-22D-55	22	5	S	5	W	4301333267	15703	Oil Well	Producing
UTE TRIBAL 4-14D-54	14	5	S	4	W	4301333270	15679	Oil Well	Producing
UTE TRIBAL 9S-19-54	19	5	S	4	W	4301333276	16153	Oil Well	Producing
UTE TRIBAL 14Q-28-54	28	5	S	4	W	4301333277	15818	Oil Well	Producing
UTE TRIBAL 14-28D-54	28	5	S	4	W	4301333278	15817	Oil Well	Producing
UTE TRIBAL 1-14D-55	14	5	S	5	W	4301333279	18408	Oil Well	Producing
UTE TRIBAL 10-18-54	18	5	S	4	W	4301333300	15747	Oil Well	Producing
UTE TRIBAL 5-21-54	21	5	S	4	W	4301333324	15748	Oil Well	Producing
UTE TRIBAL 6-31D-54	31	5	S	4	W	4301333325	16185	Oil Well	Producing
UTE TRIBAL 16-31D-54	31	5	S	4	W	4301333326	15800	Oil Well	Producing
UTE TRIBAL 16-13D-55	13	5	S	5	W	4301333327	15891	Oil Well	Producing
UTE TRIBAL 9-13D-55	13	5	S	5	W	4301333328	15892	Oil Well	Producing
UTE TRIBAL 15-21-55	21	5	S	5	W	4301333357	15791	Oil Well	Producing
UTE TRIBAL 10-23D-55	23	5	S	5	W	4301333358	15799	Oil Well	Producing
UTE TRIBAL 9-26D-55	26	5	S	5	W	4301333359	15853	Oil Well	Producing
UTE TRIBAL 10-26D-55	26	5	S	5	W	4301333360	15852	Oil Well	Producing
UTE TRIBAL 14-26D-55	26	5	S	5	W	4301333361	15938	Oil Well	Producing
UTE TRIBAL 15-26D-55	26	5	S	5	W	4301333362	15869	Oil Well	Producing
UTE TRIBAL 3-32D-55	32	5	S	5	W	4301333363	15936	Oil Well	Producing
UTE TRIBAL 13-14-54	14	5	S	4	W	4301333364	15790	Oil Well	Producing
MOON TRIBAL 7-27D-54	27	5	S	4	W	4301333365	15935	Oil Well	Producing
UTE TRIBAL 4-32-55	32	5	S	5	W	4301333379	15819	Oil Well	Producing
UTE TRIBAL 13H-16-55	16	5	S	5	W	4301333380	18357	Oil Well	Producing
BERRY TRIBAL 7-23-54	23	5	S	4	W	4301333381	15934	Oil Well	Producing
BERRY TRIBAL 9-34-54	34	5	S	4	W	4301333382	16024	Oil Well	Producing
BERRY TRIBAL 7-34-54	34	5	S	4	W	4301333383	16102	Oil Well	Producing
BERRY TRIBAL 4-34-54	34	5	S	4	W	4301333384	16588	Oil Well	Producing
FEDERAL 2-2-65	2	6	S	5	W	4301333385	16150	Oil Well	Producing
FEDERAL 5-4-65	4	6	S	5	W	4301333387	17599	Oil Well	Producing
UTE TRIBAL 1A-29-54	29	5	S	4	W	4301333393	17075	Oil Well	Producing
BERRY TRIBAL 15-34-54	34	5	S	4	W	4301333411	16037	Oil Well	Producing
BERRY TRIBAL 8-23D-54	23	5	S	4	W	4301333417	16101	Oil Well	Producing
UTE TRIBAL 12-29D-55	29	5	S	5	W	4301333418	17307	Oil Well	Producing
UTE TRIBAL 8-24-55	24	5	S	5	W	4301333420	15997	Oil Well	Producing
UTE TRIBAL 5-25D-55	25	5	S	5	W	4301333421	16589	Oil Well	Producing
BERRY TRIBAL 10-34D-54	34	5	S	4	W	4301333422	16038	Oil Well	Producing
1-15-56 DLB	15	5	S	6	W	4301333447	15854	Oil Well	Producing
FEDERAL 5-3-64	3	6	S	4	W	4301333448	16098	Oil Well	Producing
FEDERAL 8-1-64	1	6	S	4	W	4301333449	16152	Oil Well	Producing
FEDERAL 5-4-64	4	6	S	4	W	4301333450	17851	Oil Well	Producing
FEDERAL 11-10-65	10	6	S	5	W	4301333451	16281	Oil Well	Producing
BERRY TRIBAL 9-23-54	23	5	S	4	W	4301333465	16590	Oil Well	Producing
UTE TRIBAL 6-26D-55	26	5	S	5	W	4301333476	16657	Oil Well	Producing
UTE TRIBAL 7-26D-55	26	5	S	5	W	4301333477	16658	Oil Well	Producing

Well Transfer
 From: Linn Operating, Inc.
 To: Linn Operation, LLC
 Effective: 3/1/2017

UTE TRIBAL 11-26D-55	26	5	S	5	W	4301333478	16659	Oil Well	Producing
UTE TRIBAL 14Q-30-54	30	5	S	4	W	4301333479	16151	Oil Well	Producing
FEDERAL 5-6-65	6	6	S	5	W	4301333489	17852	Oil Well	Producing
FEDERAL 16-5-65	5	6	S	5	W	4301333490	16833	Oil Well	Producing
FEDERAL 6-11-65	11	6	S	5	W	4301333491	16335	Oil Well	Producing
LC TRIBAL 14-2-56	2	5	S	6	W	4301333492	18358	Oil Well	Producing
UTE TRIBAL 1-31-55	31	5	S	5	W	4301333501	17104	Oil Well	Producing
UTE TRIBAL 9-31-55	31	5	S	5	W	4301333508	17103	Oil Well	Producing
BERRY TRIBAL 11-34D-54	34	5	S	4	W	4301333529	16099	Oil Well	Producing
LC TRIBAL 2-16D-56	16	5	S	6	W	4301333538	17305	Oil Well	Producing
LC TRIBAL 4-16-56	16	5	S	6	W	4301333539	16272	Oil Well	Producing
LC TRIBAL 3-17-56	17	5	S	6	W	4301333541	16459	Oil Well	Producing
UTE TRIBAL 4-20D-55	20	5	S	5	W	4301333549	18075	Oil Well	Producing
UTE TRIBAL 8-23D-55	23	5	S	5	W	4301333552	16662	Oil Well	Producing
LC TRIBAL 8-28-46	28	4	S	6	W	4301333576	16155	Oil Well	Producing
LC TRIBAL 7-3-56	3	5	S	6	W	4301333577	16379	Oil Well	Producing
LC TRIBAL 3-5-56	5	5	S	6	W	4301333580	17082	Oil Well	Producing
FEDERAL 8-2D-64	2	6	S	4	W	4301333581	16100	Oil Well	Producing
LC TRIBAL 13H-3-56	3	5	S	6	W	4301333591	18129	Oil Well	Producing
LC FEE 6-12-57	12	5	S	7	W	4301333593	17083	Oil Well	Producing
UTE TRIBAL 4-26D-54	26	5	S	4	W	4301333595	16591	Oil Well	Producing
LC FEE 12H-6-56	6	5	S	6	W	4301333606	18037	Oil Well	Producing
LC TRIBAL 7-7D-56	7	5	S	6	W	4301333607	18038	Oil Well	Producing
LC TRIBAL 1-9-56	9	5	S	6	W	4301333608	16380	Oil Well	Producing
UTE TRIBAL 5-14-54	14	5	S	4	W	4301333619	16945	Oil Well	Producing
UTE TRIBAL 10-26D-54	26	5	S	4	W	4301333620	16663	Oil Well	Producing
UTE TRIBAL 7-26D-54	26	5	S	4	W	4301333621	16664	Oil Well	Producing
UTE TRIBAL 13-36D-55	36	5	S	5	W	4301333624	17744	Oil Well	Producing
UTE TRIBAL 6-26D-54	26	5	S	4	W	4301333625	16619	Oil Well	Producing
UTE TRIBAL 1-22D-55	22	5	S	5	W	4301333626	16777	Oil Well	Producing
UTE TRIBAL 4-23D-55	23	5	S	5	W	4301333627	16818	Oil Well	Producing
UTE TRIBAL 2-27D-55	27	5	S	5	W	4301333628	16746	Oil Well	Producing
UTE TRIBAL 12-28D-55	28	5	S	5	W	4301333645	17999	Oil Well	Producing
UTE TRIBAL 13-28D-55	28	5	S	5	W	4301333646	18000	Oil Well	Producing
UTE TRIBAL 14-26D-54	26	5	S	4	W	4301333673	16299	Oil Well	Producing
UTE FEE 7-13D-55	13	5	S	5	W	4301333674	18089	Oil Well	Producing
UTE TRIBAL 9-20D-55	20	5	S	5	W	4301333675	17309	Oil Well	Producing
LC TRIBAL 11-17-56	17	5	S	6	W	4301333677	17600	Oil Well	Producing
UTE TRIBAL 1-26D-54	26	5	S	4	W	4301333680	16638	Oil Well	Producing
UTE TRIBAL 3-26D-54	26	5	S	4	W	4301333681	16665	Oil Well	Producing
UTE TRIBAL 8-26D-54	26	5	S	4	W	4301333682	17031	Oil Well	Producing
UTE TRIBAL 10-27D-55	27	5	S	5	W	4301333683	16666	Oil Well	Producing
UTE TRIBAL 14-27D-55	27	5	S	5	W	4301333684	16667	Oil Well	Producing
UTE TRIBAL 12-21D-55	21	5	S	5	W	4301333694	16296	Oil Well	Producing
UTE TRIBAL 5-21D-55	21	5	S	5	W	4301333706	16298	Oil Well	Producing

Well Transfer
 From: Linn Operating, Inc.
 To: Linn Operation, LLC
 Effective: 3/1/2017

UTE TRIBAL 2-29D-55	29	5	S	5	W	4301333714	16854	Oil Well	Producing
UTE TRIBAL 7-29D-55	29	5	S	5	W	4301333715	16853	Oil Well	Producing
UTE TRIBAL 13-22D-55	22	5	S	5	W	4301333716	16668	Oil Well	Producing
UTE TRIBAL 14-22D-55	22	5	S	5	W	4301333717	16669	Oil Well	Producing
UTE TRIBAL 7-22D-55	22	5	S	5	W	4301333721	16670	Oil Well	Producing
UTE TRIBAL 10-22D-55	22	5	S	5	W	4301333722	16671	Oil Well	Producing
UTE TRIBAL 3-29-55	29	5	S	5	W	4301333723	16857	Oil Well	Producing
BERRY TRIBAL 10-23D-54	23	5	S	4	W	4301333724	16592	Oil Well	Producing
BERRY TRIBAL 11-23D-54	23	5	S	4	W	4301333725	16672	Oil Well	Producing
UTE TRIBAL 4-24D-55	24	5	S	5	W	4301333726	16673	Oil Well	Producing
FEDERAL 6-6D-64	6	6	S	4	W	4301333745	17084	Oil Well	Producing
UTE TRIBAL 15-26D-54	26	5	S	4	W	4301333768	17450	Oil Well	Producing
UTE TRIBAL 1-14D-54	14	5	S	4	W	4301333769	17483	Oil Well	Producing
UTE TRIBAL 12-35D-55	35	5	S	5	W	4301333782	16856	Oil Well	Producing
UTE TRIBAL 11-35-55	35	5	S	5	W	4301333783	16855	Oil Well	Producing
UTE TRIBAL 1-28D-55	28	5	S	5	W	4301333784	16852	Oil Well	Producing
UTE TRIBAL 16-27D-55	27	5	S	5	W	4301333786	17800	Oil Well	Producing
UTE TRIBAL 9-28D-55	28	5	S	5	W	4301333787	16887	Oil Well	Producing
UTE TRIBAL 7-28D-55	28	5	S	5	W	4301333788	16886	Oil Well	Producing
UTE TRIBAL 11-32D-54	32	5	S	4	W	4301333793	17003	Oil Well	Producing
UTE TRIBAL 9-14D-54	14	5	S	4	W	4301333796	17482	Oil Well	Producing
UTE TRIBAL 4-27D-55	27	5	S	5	W	4301333797	16700	Oil Well	Producing
FOY TRIBAL 12H-33-55	33	5	S	5	W	4301333799	18232	Oil Well	Producing
UTE TRIBAL 9-32D-55	32	5	S	5	W	4301333800	18361	Oil Well	Producing
UTE TRIBAL 12-26D-54	26	5	S	4	W	4301333801	16639	Oil Well	Producing
UTE TRIBAL 8-26D-55	26	5	S	5	W	4301333859	17859	Oil Well	Producing
BERRY TRIBAL 2-34D-54	34	5	S	4	W	4301333867	17889	Oil Well	Producing
UTE TRIBAL 3-35D-55	35	5	S	5	W	4301333888	17421	Oil Well	Producing
UTE TRIBAL 10-32-54	32	5	S	4	W	4301333902	16819	Oil Well	Producing
UTE TRIBAL 12-31D-54	31	5	S	4	W	4301333907	17480	Oil Well	Producing
UTE TRIBAL 12-23D-55	23	5	S	5	W	4301333908	17814	Oil Well	Producing
UTE TRIBAL 14-20D-55	20	5	S	5	W	4301333909	18559	Oil Well	Producing
UTE TRIBAL 6-20D-55	20	5	S	5	W	4301333910	18481	Oil Well	Producing
UTE TRIBAL 12-20-55	20	5	S	5	W	4301333911	18520	Oil Well	Producing
UTE TRIBAL 14-24D-55	24	5	S	5	W	4301333912	16943	Oil Well	Producing
UTE TRIBAL 14-23D-55	23	5	S	5	W	4301333915	17457	Oil Well	Producing
ST TRIBAL 1-15D-54	15	5	S	4	W	4301333916	16889	Oil Well	Producing
ST TRIBAL 7-15D-54	15	5	S	4	W	4301333950	16972	Oil Well	Producing
ST TRIBAL 9-15D-54	15	5	S	4	W	4301333951	16973	Oil Well	Producing
UTE TRIBAL 15-35D-55	35	5	S	5	W	4301333954	17417	Oil Well	Producing
UTE TRIBAL 14-35D-55	35	5	S	5	W	4301333955	17416	Oil Well	Producing
UTE TRIBAL 16-26D-55	26	5	S	5	W	4301333965	17418	Oil Well	Producing
FEDERAL 1-2D-65	2	6	S	5	W	4301333966	16888	Oil Well	Producing
UTE TRIBAL 1-35D-55	35	5	S	5	W	4301333967	17420	Oil Well	Producing
UTE TRIBAL 10-36D-55	36	5	S	5	W	4301333968	17743	Oil Well	Producing

Well Transfer

From: Linn Operating, Inc.

To: Linn Operation, LLC

Effective: 3/1/2017

UTE TRIBAL 4-26D-55	26	5	S	5	W	4301333978	17455	Oil Well	Producing
UTE TRIBAL 2-26D-55	26	5	S	5	W	4301333979	17456	Oil Well	Producing
BERRY TRIBAL 14-23D-54	23	5	S	4	W	4301333989	17903	Oil Well	Producing
FEDERAL 3-2D-65	2	6	S	5	W	4301334001	16944	Oil Well	Producing
UTE TRIBAL 13-26D-55	26	5	S	5	W	4301334002	17481	Oil Well	Producing
FEDERAL 7-1D-65	1	6	S	5	W	4301334015	17775	Oil Well	Producing
FEDERAL 2-2D-64	2	6	S	4	W	4301334018	17086	Oil Well	Producing
FEDERAL 7-6D-64	6	6	S	4	W	4301334020	17085	Oil Well	Producing
UTE TRIBAL 6-35D-55	35	5	S	5	W	4301334028	17785	Oil Well	Producing
UTE TRIBAL 16-26-54	26	5	S	4	W	4301334042	17413	Oil Well	Producing
BERRY TRIBAL 13-23-54	23	5	S	4	W	4301334043	17100	Oil Well	Producing
UTE TRIBAL 6-28D-55	28	5	S	5	W	4301334056	18593	Oil Well	Producing
UTE TRIBAL 11-28-55	28	5	S	5	W	4301334057	18001	Oil Well	Producing
UTE TRIBAL 8-27D-55	27	5	S	5	W	4301334058	17842	Oil Well	Producing
ST TRIBAL 3-15D-54	15	5	S	4	W	4301334059	17477	Oil Well	Producing
ST TRIBAL 5-15D-54	15	5	S	4	W	4301334060	17479	Oil Well	Producing
FEDERAL 7-11D-65	11	6	S	5	W	4301334061	17776	Oil Well	Producing
FEDERAL 7-3D-65	3	6	S	5	W	4301334065	17124	Oil Well	Producing
MOON TRIBAL 9-27D-54	27	5	S	4	W	4301334108	19095	Oil Well	Producing
MOON TRIBAL 16-27D-54	27	5	S	4	W	4301334109	17414	Oil Well	Producing
UTE TRIBAL 15-22D-54	22	5	S	4	W	4301334116	17415	Oil Well	Producing
UTE TRIBAL 13-35D-55	35	5	S	5	W	4301334117	18442	Oil Well	Producing
UTE TRIBAL 12-26D-55	26	5	S	5	W	4301334118	17786	Oil Well	Producing
FEDERAL 11-6D-64	6	6	S	4	W	4301334284	17615	Oil Well	Producing
FEDERAL 14-6D-64	6	6	S	4	W	4301334285	17616	Oil Well	Producing
FEDERAL 2-6D-64	6	6	S	4	W	4301334286	17663	Oil Well	Producing
FEDERAL 3-5D-64	5	6	S	4	W	4301334287	17617	Oil Well	Producing
FEDERAL 6-5D-64	5	6	S	4	W	4301334288	17649	Oil Well	Producing
SFW TRIBAL 10-10D-54	10	5	S	4	W	4301334295	17564	Oil Well	Producing
SFW TRIBAL 9-10D-54	10	5	S	4	W	4301334296	17565	Oil Well	Producing
GALLOWAY 3-11B2	11	2	S	2	W	4301334304	18527	Oil Well	Producing
STATE TRIBAL 16-10-54	10	5	S	4	W	4301350245	17553	Oil Well	Producing
UTE TRIBAL 6-14D-55	14	5	S	5	W	4301350246	17602	Oil Well	Producing
SFW FEE 15-10-54	10	5	S	4	W	4301350247	17566	Oil Well	Producing
FEDERAL 5-5D-64	5	6	S	4	W	4301350259	17648	Oil Well	Producing
LC TRIBAL 6-22D-56	22	5	S	6	W	4301350260	17567	Oil Well	Producing
FEDERAL 12-6D-64	6	6	S	4	W	4301350261	17618	Oil Well	Producing
FEDERAL 4-5D-64	5	6	S	4	W	4301350263	17661	Oil Well	Producing
FEDERAL 1-6-64	6	6	S	4	W	4301350266	17662	Oil Well	Producing
FEDERAL 4-6D-64	6	6	S	4	W	4301350267	17651	Oil Well	Producing
FEDERAL 3-6D-64	6	6	S	4	W	4301350268	17650	Oil Well	Producing
FEDERAL 5-6D-64	6	6	S	4	W	4301350269	17652	Oil Well	Producing
FEDERAL 8-6D-64	6	6	S	4	W	4301350325	17664	Oil Well	Producing
FEDERAL 10-1D-65	1	6	S	5	W	4301350326	18027	Oil Well	Producing
FEDERAL 11-1D-65	1	6	S	5	W	4301350327	18039	Oil Well	Producing

Well Transfer
 From: Linn Operating, Inc.
 To: Linn Operation, LLC
 Effective: 3/1/2017

FEDERAL 12-1D-65	1	6	S	5	W	4301350328	18040	Oil Well	Producing
FEDERAL 13-1D-65	1	6	S	5	W	4301350329	18042	Oil Well	Producing
FEDERAL 14-1D-65	1	6	S	5	W	4301350330	18041	Oil Well	Producing
FEDERAL 13-5D-64	5	6	S	4	W	4301350337	17714	Oil Well	Producing
FEDERAL 14-5D-64	5	6	S	4	W	4301350338	17715	Oil Well	Producing
FEDERAL 9-1D-65	1	6	S	5	W	4301350342	18026	Oil Well	Producing
FEDERAL 13-6D-64	6	6	S	4	W	4301350347	17619	Oil Well	Producing
FEDERAL 11-5D-64	5	6	S	4	W	4301350348	17690	Oil Well	Producing
FEDERAL 12-5D-64	5	6	S	4	W	4301350349	17713	Oil Well	Producing
FEDERAL 8-1D-65	1	6	S	5	W	4301350350	18025	Oil Well	Producing
UTE TRIBAL 3-14D-54	14	5	S	4	W	4301350389	17904	Oil Well	Producing
UTE TRIBAL 1-34D-55	34	5	S	5	W	4301350408	17931	Oil Well	Producing
UTE TRIBAL 7-14-54	14	5	S	4	W	4301350409	17924	Oil Well	Producing
UTE TRIBAL 8-21D-55	21	5	S	5	W	4301350435	17963	Oil Well	Producing
UTE TRIBAL 8-34D-55	34	5	S	5	W	4301350436	17952	Oil Well	Producing
UTE TRIBAL 5-16D-54	16	5	S	4	W	4301350475	17991	Oil Well	Producing
UTE TRIBAL 12-14D-55	14	5	S	5	W	4301350476	17973	Oil Well	Producing
UTE TRIBAL 8-15D-55	15	5	S	5	W	4301350477	17974	Oil Well	Producing
UTE TRIBAL 3-14-55	14	5	S	5	W	4301350478	18002	Oil Well	Producing
UTE TRIBAL 5-14-55	14	5	S	5	W	4301350479	18021	Oil Well	Producing
UTE TRIBAL 8-10D-54	10	5	S	4	W	4301350488	18099	Oil Well	Producing
UTE TRIBAL 7-34-55	34	5	S	5	W	4301350510	17949	Oil Well	Producing
FEDERAL 4-4D-65	4	6	S	5	W	4301350521	18557	Oil Well	Producing
FEDERAL 6-3D-64	3	6	S	4	W	4301350522	18073	Oil Well	Producing
FEDERAL 1-1D-64	1	6	S	4	W	4301350524	18088	Oil Well	Producing
FEDERAL 7-2D-65	2	6	S	5	W	4301350525	18100	Oil Well	Producing
BERRY TRIBAL 12-34D-54	34	5	S	4	W	4301350527	17998	Oil Well	Producing
FEDERAL 15-5D-65	5	6	S	5	W	4301350553	18537	Oil Well	Producing
FEDERAL 11-4D-64	4	6	S	4	W	4301350565	18043	Oil Well	Producing
FEDERAL 6-6D-65	6	6	S	5	W	4301350566	18521	Oil Well	Producing
LC TRIBAL 3-15D-56	15	5	S	6	W	4301350598	18097	Oil Well	Producing
LC TRIBAL 9-16D-56	16	5	S	6	W	4301350600	19544	Oil Well	Producing
LC FEE 16-16D-56	16	5	S	6	W	4301350601	18165	Oil Well	Producing
LC TRIBAL 10-16D-56	16	5	S	6	W	4301350602	18586	Oil Well	Producing
LC TRIBAL 15-22D-56	22	5	S	6	W	4301350606	18278	Oil Well	Producing
LC TRIBAL 5-23D-56	23	5	S	6	W	4301350625	18285	Oil Well	Producing
LC TRIBAL 5-14D-56	14	5	S	6	W	4301350661	18219	Oil Well	Producing
SFW FEE 14-10D-54	10	5	S	4	W	4301350686	18070	Oil Well	Producing
LC FEE 1-22D-56	22	5	S	6	W	4301350718	18101	Oil Well	Producing
FEDERAL 8-2D-65	2	6	S	5	W	4301350719	18614	Oil Well	Producing
FEDERAL 1-2D-64	2	6	S	4	W	4301350730	18585	Oil Well	Producing
FEDERAL 7-2D-64	2	6	S	4	W	4301350734	18584	Oil Well	Producing
FEDERAL 10-6D-64	6	6	S	4	W	4301350735	18162	Oil Well	Producing
FEDERAL 4-3D-64	3	6	S	4	W	4301350736	18621	Oil Well	Producing
FEDERAL 12-3D-64	3	6	S	4	W	4301350737	18620	Oil Well	Producing

Well Transfer
 From: Linn Operating, Inc.
 To: Linn Operation, LLC
 Effective: 3/1/2017

LC TRIBAL 3-21D-56	21	5	S	6	W	4301350751	18462	Oil Well	Producing
LC TRIBAL 5-21D-56	21	5	S	6	W	4301350752	18286	Oil Well	Producing
FEDERAL 2-1D-65	1	6	S	5	W	4301350759	18172	Oil Well	Producing
FEDERAL 3-1D-65	1	6	S	5	W	4301350760	18173	Oil Well	Producing
FEDERAL 5-1D-65	1	6	S	5	W	4301350761	18174	Oil Well	Producing
FEDERAL 9-2D-65	2	6	S	5	W	4301350762	18245	Oil Well	Producing
FEDERAL 11-2D-65	2	6	S	5	W	4301350763	18589	Oil Well	Producing
FEDERAL 15-2D-65	2	6	S	5	W	4301350764	18590	Oil Well	Producing
LC TRIBAL 14-14D-56	14	5	S	6	W	4301350776	18287	Oil Well	Producing
LC FEE 2-20D-56	20	5	S	6	W	4301350777	18622	Oil Well	Producing
LC TRIBAL 12-22D-56	22	5	S	6	W	4301350780	18341	Oil Well	Producing
FEDERAL 3-4D-65	4	6	S	5	W	4301350782	18556	Oil Well	Producing
FEDERAL 6-4D-65	4	6	S	5	W	4301350783	19162	Oil Well	Producing
FEDERAL 12-4D-65	4	6	S	5	W	4301350784	19171	Oil Well	Producing
LC TRIBAL 14-15D-56	15	5	S	6	W	4301350834	18362	Oil Well	Producing
UTE TRIBAL 7I-21D-54	21	5	S	4	W	4301350852	18423	Oil Well	Producing
UTE TRIBAL 8L-21D-54	21	5	S	4	W	4301350853	18423	Oil Well	Producing
UTE TRIBAL 10S-21D-54	21	5	S	4	W	4301350854	18423	Oil Well	Producing
UTE TRIBAL 11-11-54	11	5	S	4	W	4301350861	18775	Oil Well	Producing
LC TRIBAL 1-28D-56	28	5	S	6	W	4301350865	19575	Oil Well	Producing
LC TRIBAL 2-28D-56	28	5	S	6	W	4301350866	18592	Oil Well	Producing
LC FEE 8-28D-56	28	5	S	6	W	4301350867	18342	Oil Well	Producing
LC TRIBAL 6-27D-56	27	5	S	6	W	4301350868	18480	Oil Well	Producing
LC FEE 15-23D-56	23	5	S	6	W	4301350870	18410	Oil Well	Producing
LC TRIBAL 15-26-56	26	5	S	6	W	4301350871	18377	Oil Well	Producing
UTE TRIBAL 16-11-55	11	5	S	5	W	4301350888	18707	Oil Well	Producing
LC TRIBAL 2-5D-56	5	5	S	6	W	4301350925	18568	Oil Well	Producing
LC TRIBAL 2-9D-56	9	5	S	6	W	4301350926	18425	Oil Well	Producing
LC FEE 8-29-45	29	4	S	5	W	4301350928	18313	Oil Well	Producing
LC FEE 13-29-45	29	4	S	5	W	4301350929	18426	Oil Well	Producing
LC FEE 9-12D-57	12	5	S	7	W	4301350963	18541	Oil Well	Producing
LC FEE 1-22-57	22	5	S	7	W	4301350965	18558	Oil Well	Producing
LC TRIBAL 11-3D-56	3	5	S	6	W	4301350966	18464	Oil Well	Producing
LC TRIBAL 3-34-45	34	4	S	5	W	4301350976	18661	Oil Well	Producing
LC TRIBAL 9-10D-56	10	5	S	6	W	4301350987	18944	Oil Well	Producing
LC TRIBAL 10-9D-56	9	5	S	6	W	4301350990	18864	Oil Well	Producing
LC FEE 10-31D-45	31	4	S	5	W	4301350994	18443	Oil Well	Producing
VIEIRA TRIBAL 4-4-54	4	5	S	4	W	4301350997	18747	Oil Well	Producing
LC TRIBAL 10-21-56	21	5	S	6	W	4301350999	18439	Oil Well	Producing
FEDERAL 1-5D-64	5	6	S	4	W	4301351012	18720	Oil Well	Producing
FEDERAL 2-5D-64	5	6	S	4	W	4301351013	18723	Oil Well	Producing
FEDERAL 7-5D-64	5	6	S	4	W	4301351014	18722	Oil Well	Producing
FEDERAL 8-5D-64	5	6	S	4	W	4301351015	18721	Oil Well	Producing
MYRIN TRIBAL 15-10-55	10	5	S	5	W	4301351024	18771	Oil Well	Producing
LC TRIBAL 15-15D-56	15	5	S	6	W	4301351030	18440	Oil Well	Producing

Well Transfer
 From: Linn Operating, Inc.
 To: Linn Operation, LLC
 Effective: 3/1/2017

LC TRIBAL 9-15D-56	15	5	S	6	W	4301351031	18441	Oil Well	Producing
LC TRIBAL 6-28-45	28	4	S	5	W	4301351034	18700	Oil Well	Producing
FEDERAL 1-12D-65	12	6	S	5	W	4301351055	18739	Oil Well	Producing
FEDERAL 8-12D-65	12	6	S	5	W	4301351056	18718	Oil Well	Producing
FEDERAL 2-12D-65	12	6	S	5	W	4301351057	18738	Oil Well	Producing
FEDERAL 7-12D-65	12	6	S	5	W	4301351058	18717	Oil Well	Producing
LC TRIBAL 8-22D-56	22	5	S	6	W	4301351069	19233	Oil Well	Producing
LC TRIBAL 9-17D-56	17	5	S	6	W	4301351070	18945	Oil Well	Producing
LC TRIBAL 7-27-45	27	4	S	5	W	4301351073	18685	Oil Well	Producing
LC TRIBAL 11-24-45	24	4	S	5	W	4301351076	18745	Oil Well	Producing
FEDERAL 3-12D-65	12	6	S	5	W	4301351093	18705	Oil Well	Producing
FEDERAL 4-12D-65	12	6	S	5	W	4301351094	18704	Oil Well	Producing
FEDERAL 5-12D-65	12	6	S	5	W	4301351095	18702	Oil Well	Producing
FEDERAL 6-12D-65	12	6	S	5	W	4301351096	18703	Oil Well	Producing
UTE TRIBAL 9-5-54	5	5	S	4	W	4301351111	18909	Oil Well	Producing
LC TRIBAL 9-8D-56	8	5	S	6	W	4301351112	18522	Oil Well	Producing
UTE TRIBAL 4-9-54	9	5	S	4	W	4301351126	19059	Oil Well	Producing
UTE TRIBAL 2-9-54	9	5	S	4	W	4301351128	18946	Oil Well	Producing
UTE TRIBAL 1-10-54	10	5	S	4	W	4301351129	18879	Oil Well	Producing
LC TRIBAL 8-30D-56	30	5	S	6	W	4301351131	18539	Oil Well	Producing
FEDERAL 1-1D-65	1	6	S	5	W	4301351142	18623	Oil Well	Producing
UTE TRIBAL 8-9-54	9	5	S	4	W	4301351143	18947	Oil Well	Producing
FEDERAL 15-1D-65	1	6	S	5	W	4301351175	18654	Oil Well	Producing
FEDERAL 16-1D-65	1	6	S	5	W	4301351176	18655	Oil Well	Producing
LC TRIBAL 11-29D-56	29	5	S	6	W	4301351183	18873	Oil Well	Producing
STATE TRIBAL 8-12-55	12	5	S	5	W	4301351188	18986	Oil Well	Producing
LC TRIBAL 11-20D-56	20	5	S	6	W	4301351189	18819	Oil Well	Producing
LC FEE 5-20D-56	20	5	S	6	W	4301351190	18818	Oil Well	Producing
LC FEE 9-19-56	19	5	S	6	W	4301351192	18596	Oil Well	Producing
LC TRIBAL 9-9D-56	9	5	S	6	W	4301351198	18595	Oil Well	Producing
OWL AND THE HAWK 3-9C5	9	3	S	5	W	4301351214	18649	Oil Well	Producing
FEDERAL 16-6-64	6	6	S	4	W	4301351217	18792	Oil Well	Producing
FEDERAL 9-6D-64	6	6	S	4	W	4301351218	18791	Oil Well	Producing
FEDERAL 15-6D-64	6	6	S	4	W	4301351219	18793	Oil Well	Producing
UTE TRIBAL 5-17-55	17	5	S	5	W	4301351220	18841	Oil Well	Producing
UTE TRIBAL 16-3-54	3	5	S	4	W	4301351226	18664	Oil Well	Producing
STATE TRIBAL 8-7-54	7	5	S	4	W	4301351228	18743	Oil Well	Producing
STATE TRIBAL 12-1-55	1	5	S	5	W	4301351229	18741	Oil Well	Producing
STATE TRIBAL 11-2-55	2	5	S	5	W	4301351230	18742	Oil Well	Producing
FEDERAL 1-11-65	11	6	S	5	W	4301351231	18689	Oil Well	Producing
FEDERAL 8-11D-65	11	6	S	5	W	4301351232	18688	Oil Well	Producing
FEDERAL 2-11D-65	11	6	S	5	W	4301351233	18690	Oil Well	Producing
STATE TRIBAL 12-3-55	3	5	S	5	W	4301351236	18744	Oil Well	Producing
UTE TRIBAL 11-4-55	4	5	S	5	W	4301351237	18663	Oil Well	Producing
UTE TRIBAL 4-9-55	9	5	S	5	W	4301351238	18796	Oil Well	Producing

Well Transfer
 From: Linn Operating, Inc.
 To: Linn Operation, LLC
 Effective: 3/1/2017

UTE TRIBAL 15-5-55	5	5	S	5	W	4301351239	18740	Oil Well	Producing
UTE TRIBAL 9-21D-55	21	5	S	5	W	4301351258	19401	Oil Well	Producing
UTE FEE 9-9-54	9	5	S	4	W	4301351259	18642	Oil Well	Producing
LC TRIBAL 4-29-45	29	4	S	5	W	4301351260	18719	Oil Well	Producing
UTE FEE 14-9D-54	9	5	S	4	W	4301351271	18684	Oil Well	Producing
UTE FEE 15-9D-54	9	5	S	4	W	4301351272	18687	Oil Well	Producing
LC FEE 10-28D-56	28	5	S	6	W	4301351288	18591	Oil Well	Producing
UTE TRIBAL 8-16D-54	16	5	S	4	W	4301351295	19003	Oil Well	Producing
FEE TRIBAL 4-5-54	5	5	S	4	W	4301351303	19187	Oil Well	Producing
LC TRIBAL 1-26-56	26	5	S	6	W	4301351306	18816	Oil Well	Producing
UTE TRIBAL 6-16D-54	16	5	S	4	W	4301351307	19060	Oil Well	Producing
LC TRIBAL 7-22D-56	22	5	S	6	W	4301351308	18795	Oil Well	Producing
LC TRIBAL 9-22D-56	22	5	S	6	W	4301351309	18794	Oil Well	Producing
STATE TRIBAL 2-12D-55	12	5	S	5	W	4301351310	19444	Oil Well	Producing
LC TRIBAL 9-32D-56	32	5	S	6	W	4301351316	19228	Oil Well	Producing
LC TRIBAL 7-26D-56	26	5	S	6	W	4301351319	18817	Oil Well	Producing
LC FEE 8-6D-56	6	5	S	6	W	4301351342	18657	Oil Well	Producing
LC FEE 10-29D-45	29	4	S	5	W	4301351343	18850	Oil Well	Producing
LC TRIBAL 1-7D-56	7	5	S	6	W	4301351344	18774	Oil Well	Producing
LC TRIBAL 9-7D-56	7	5	S	6	W	4301351346	18773	Oil Well	Producing
UTE TRIBAL 7-10D-54	10	5	S	4	W	4301351365	19391	Oil Well	Producing
LC TRIBAL 11-10D-56	10	5	S	6	W	4301351369	18840	Oil Well	Producing
LC FEE 1-31D-45	31	4	S	5	W	4301351371	18686	Oil Well	Producing
LC TRIBAL 9-26D-56	26	5	S	6	W	4301351381	19433	Oil Well	Producing
LC TRIBAL 14-21D-56	21	5	S	6	W	4301351384	18877	Oil Well	Producing
LC TRIBAL 4-22D-56	22	5	S	6	W	4301351385	18878	Oil Well	Producing
LC TRIBAL 8-21D-56	21	5	S	6	W	4301351392	18874	Oil Well	Producing
UTE TRIBAL 1-17-55	17	5	S	5	W	4301351393	18848	Oil Well	Producing
LC TRIBAL 4-33D-45	33	4	S	5	W	4301351401	18853	Oil Well	Producing
LC TRIBAL 16-21D-56	21	5	S	6	W	4301351407	18875	Oil Well	Producing
UTE TRIBAL 2-10D-54	10	5	S	4	W	4301351411	19172	Oil Well	Producing
UTE TRIBAL 8-17D-55	17	5	S	5	W	4301351413	19388	Oil Well	Producing
UTE TRIBAL 4-10D-54	10	5	S	4	W	4301351414	19069	Oil Well	Producing
LC TRIBAL 2-21D-56	16	5	S	6	W	4301351418	19252	Oil Well	Producing
LC TRIBAL 1-23D-45	23	4	S	5	W	4301351425	18855	Oil Well	Producing
LC TRIBAL 2-28D-45	28	4	S	5	W	4301351429	18701	Oil Well	Producing
LC TRIBAL 9-28D-45	28	4	S	5	W	4301351430	18656	Oil Well	Producing
LC FEE 1-1-56	1	5	S	6	W	4301351458	18829	Oil Well	Producing
Bingham #3-4B1	4	2	S	1	W	4301351464	18825	Oil Well	Producing
LC Tribal 12-32-45	32	4	S	5	W	4301351465	18772	Oil Well	Producing
UTE TRIBAL 2-5-54	5	5	S	4	W	4301351520	18880	Oil Well	Producing
LC Tribal 3-32D-45	32	4	S	5	W	4301351561	18842	Oil Well	Producing
LC TRIBAL 5-15D-56	15	5	S	6	W	4301351562	19253	Oil Well	Producing
LC FEE 16-36-56	36	5	S	6	W	4301351611	19096	Oil Well	Producing
LC FEE 10-36D-56	36	5	S	6	W	4301351622	19583	Oil Well	Producing

Well Transfer
 From: Linn Operating, Inc.
 To: Linn Operation, LLC
 Effective: 3/1/2017

RED MOUNTAIN 3-5B1	5	2	S	1	W	4301351632	18954	Oil Well	Producing
LC TRIBAL 15-34-56	34	5	S	6	W	4301351647	18962	Oil Well	Producing
LC TRIBAL 15-27-56	27	5	S	6	W	4301351649	19605	Oil Well	Producing
LC TRIBAL 11-27D-56	27	5	S	6	W	4301351650	19606	Oil Well	Producing
LC TRIBAL 1-34D-56	34	5	S	6	W	4301351660	18988	Oil Well	Producing
LC TRIBAL 2-29D-45	29	4	S	5	W	4301351705	19545	Oil Well	Producing
LC FEE 13-23-56	23	5	S	6	W	4301351706	18994	Oil Well	Producing
LC FEE 11-23D-56	23	5	S	6	W	4301351707	18995	Oil Well	Producing
LC TRIBAL 3-33-56	33	5	S	6	W	4301351711	19242	Oil Well	Producing
LC FEE 11-29D-45	29	4	S	5	W	4301351743	19188	Oil Well	Producing
LC TAYLOR FEE 14-22D-56	22	5	S	6	W	4301351744	19508	Oil Well	Producing
LC FEE 4-28D-45	29	4	S	5	W	4301351745	18849	Oil Well	Producing
LC FEE 14-6D-56	6	5	S	6	W	4301351787	18910	Oil Well	Producing
LC FEE 15-6-56	6	5	S	6	W	4301351792	19334	Oil Well	Producing
LC TRIBAL 9-27-56	27	5	S	6	W	4301351822	19607	Oil Well	Producing
LC TRIBAL 7-27D-56	27	5	S	6	W	4301351823	19608	Oil Well	Producing
MECHAM #3-1B2	1	2	S	2	W	4301351844	19082	Oil Well	Producing
MIKE AND SHELLEY #3-4B2	4	2	S	2	W	4301351845	19083	Oil Well	Producing
LC Fee 14-36D-56	36	5	S	6	W	4301351878	19376	Oil Well	Producing
LC Fee 12-36-56	36	5	S	6	W	4301351883	19377	Oil Well	Producing
LC Tribal 6-29D-45	29	4	S	5	W	4301351902	19402	Oil Well	Producing
FEDERAL 6-7-64	7	6	S	4	W	4301351915	19117	Oil Well	Producing
FEDERAL 3-7D-64	7	6	S	4	W	4301351916	19115	Oil Well	Producing
FEDERAL 4-7D-64	7	6	S	4	W	4301351917	19110	Oil Well	Producing
FEDERAL 5-7D-64	7	6	S	4	W	4301351918	19111	Oil Well	Producing
FEDERAL 2-7-64	7	6	S	4	W	4301351919	19139	Oil Well	Producing
FEDERAL 1-7D-64	7	6	S	4	W	4301351920	19140	Oil Well	Producing
FEDERAL 12-7D-64	7	6	S	4	W	4301351924	19025	Oil Well	Producing
FEDERAL 11-7D-64	7	6	S	4	W	4301351925	19039	Oil Well	Producing
FEDERAL 13-7D-64	7	6	S	4	W	4301351926	19026	Oil Well	Producing
FEDERAL 14-7D-64	7	6	S	4	W	4301351927	19040	Oil Well	Producing
FEDERAL 7-7D-64	7	6	S	4	W	4301351933	19141	Oil Well	Producing
FEDERAL 8-7D-64	7	6	S	4	W	4301351934	19142	Oil Well	Producing
FEDERAL 9-7D-64	7	6	S	4	W	4301351935	19143	Oil Well	Producing
FEDERAL 10-7D-64	7	6	S	4	W	4301351936	19144	Oil Well	Producing
ABBOTT FEE 6-6-54	6	5	S	4	W	4301351948	18963	Oil Well	Producing
ABBOTT FEE 2-6D-54	6	5	S	4	W	4301351949	18974	Oil Well	Producing
ABBOTT FEE 4-6-54	6	5	S	4	W	4301351952	18965	Oil Well	Producing
Federal 7-9D-64	9	6	S	4	W	4301351990	19721	Oil Well	Producing
Federal 15-12D-65	12	6	S	5	W	4301351992	19051	Oil Well	Producing
Federal 10-12D-65	12	6	S	5	W	4301351999	19052	Oil Well	Producing
Federal 9-12D-65	12	6	S	5	W	4301352000	19053	Oil Well	Producing
Federal 16-12D-65	12	6	S	5	W	4301352003	19054	Oil Well	Producing
Federal 4-6D-65	6	6	S	5	W	4301352005	19173	Oil Well	Producing
Federal 12-6D-65	6	6	S	5	W	4301352006	19174	Oil Well	Producing

Well Transfer
 From: Linn Operating, Inc.
 To: Linn Operation, LLC
 Effective: 3/1/2017

Federal 1-6D-65	6	6	S	5	W	4301352012	19189	Oil Well	Producing
Federal 3-6D-65	6	6	S	5	W	4301352014	19190	Oil Well	Producing
Federal 3-9D-64	9	6	S	4	W	4301352015	19678	Oil Well	Producing
Federal 2-6-65	6	6	S	5	W	4301352017	19191	Oil Well	Producing
Federal 7-6D-65	6	6	S	5	W	4301352018	19192	Oil Well	Producing
Federal 6-9-64	9	6	S	4	W	4301352021	19679	Oil Well	Producing
Federal 8-9D-64	9	6	S	4	W	4301352023	19723	Oil Well	Producing
Federal 5-9D-64	9	6	S	4	W	4301352035	19680	Oil Well	Producing
Federal 11-9D-64	9	6	S	4	W	4301352037	19687	Oil Well	Producing
Federal 12-9D-64	9	6	S	4	W	4301352038	19688	Oil Well	Producing
Federal 13-9D-64	9	6	S	4	W	4301352039	19689	Oil Well	Producing
Federal 2-9D-64	9	6	S	4	W	4301352042	19724	Oil Well	Producing
Federal 16-11D-65	11	6	S	5	W	4301352045	19070	Oil Well	Producing
Federal 15-11D-65	11	6	S	5	W	4301352046	19076	Oil Well	Producing
Federal 10-11D-65	11	6	S	5	W	4301352047	19077	Oil Well	Producing
Federal 9-11D-65	11	6	S	5	W	4301352048	19071	Oil Well	Producing
Federal 11-12D-65	12	6	S	5	W	4301352049	19121	Oil Well	Producing
Federal 12-12D-65	12	6	S	5	W	4301352050	19122	Oil Well	Producing
Federal 13-12D-65	12	6	S	5	W	4301352052	19123	Oil Well	Producing
Federal 14-12D-65	12	6	S	5	W	4301352053	19124	Oil Well	Producing
LC Tribal 12-28D-45	28	4	S	5	W	4301352089	19378	Oil Well	Producing
LC Tribal 2-32D-45	32	4	S	5	W	4301352113	19348	Oil Well	Producing
LC Tribal 16-29D-45	32	4	S	5	W	4301352114	19349	Oil Well	Producing
Vieira Tribal 3-4D-54	4	5	S	4	W	4301352145	19210	Oil Well	Producing
Vieira Tribal 5-4D-54	4	5	S	4	W	4301352146	19193	Oil Well	Producing
Vieira Tribal 6-4D-54	4	5	S	4	W	4301352147	19216	Oil Well	Producing
Lamplugh Tribal 6-3D-54	3	5	S	4	W	4301352148	19289	Oil Well	Producing
Lamplugh Tribal 5-3D-54	3	5	S	4	W	4301352149	19290	Gas Well	Producing
Lamplugh Tribal 4-3D-54	3	5	S	4	W	4301352150	19291	Oil Well	Producing
Lamplugh Tribal 3-3D-54	3	5	S	4	W	4301352151	19292	Oil Well	Producing
UTE Tribal 6-35D-54	35	5	S	4	W	4301352158	19254	Gas Well	Producing
UTE Tribal 4-35D-54	35	5	S	4	W	4301352159	19255	Gas Well	Producing
Heiner Tribal 3-11D-54	11	5	S	4	W	4301352165	19194	Oil Well	Producing
Heiner Tribal 4-11-54	11	5	S	4	W	4301352166	19195	Oil Well	Producing
Heiner Tribal 5-11D-54	11	5	S	4	W	4301352167	19196	Oil Well	Producing
Conolly Tribal 1-11D-54	11	5	S	4	W	4301352168	19270	Oil Well	Producing
Conolly Tribal 2-11D-54	11	5	S	4	W	4301352169	19197	Oil Well	Producing
Conolly Tribal 7-11D-54	11	5	S	4	W	4301352170	19280	Oil Well	Producing
Conolly Tribal 8-11D-54	11	5	S	4	W	4301352171	19281	Oil Well	Producing
Casper Tribal 1-5D-54	5	5	S	4	W	4301352180	19198	Oil Well	Producing
Fee Tribal 6-5D-54	5	5	S	4	W	4301352181	19199	Oil Well	Producing
Fee Tribal 5-5D-54	5	5	S	4	W	4301352182	19200	Oil Well	Producing
Fee Tribal 3-5D-54	5	5	S	4	W	4301352184	19201	Oil Well	Producing
Casper Tribal 7-5D-54	5	5	S	4	W	4301352185	19202	Oil Well	Producing
UTE Tribal 10-35D-54	35	5	S	4	W	4301352198	19320	Oil Well	Producing

Well Transfer
 From: Linn Operating, Inc.
 To: Linn Operation, LLC
 Effective: 3/1/2017

UTE Tribal 14-35D-54	35	5	S	4	W	4301352199	19311	Gas Well	Producing
UTE Tribal 12-35D-54	35	5	S	4	W	4301352200	19312	Oil Well	Producing
UTE Tribal 14-18D-54	18	5	S	4	W	4301352213	19509	Gas Well	Producing
UTE Tribal 16-35D-54	35	5	S	4	W	4301352230	19321	Oil Well	Producing
Evans Tribal 1-3-54	3	5	S	4	W	4301352234	19264	Oil Well	Producing
Evans Tribal 2-3D-54	3	5	S	4	W	4301352235	19265	Oil Well	Producing
Evans Tribal 7-3D-54	3	5	S	4	W	4301352236	19256	Oil Well	Producing
Evans Tribal 8-3D-54	3	5	S	4	W	4301352237	19257	Oil Well	Producing
Ute Tribal 9-3D-54	3	5	S	4	W	4301352249	19236	Oil Well	Producing
Ute Tribal 15-3D-54	3	5	S	4	W	4301352250	19237	Oil Well	Producing
Ute Tribal 10-3-54	3	5	S	4	W	4301352251	19238	Oil Well	Producing
Ute Tribal 14-3D-54	3	5	S	4	W	4301352298	19258	Oil Well	Producing
Ute Tribal 12-3D-54	3	5	S	4	W	4301352299	19259	Oil Well	Producing
Ute Tribal 11-3D-54	3	5	S	4	W	4301352300	19260	Oil Well	Producing
Ute Tribal 16-4D-54	4	5	S	4	W	4301352302	19350	Oil Well	Producing
Ute Tribal 15-4D-54	4	5	S	4	W	4301352303	19293	Oil Well	Producing
Ute Tribal 9-4D-54	4	5	S	4	W	4301352305	19304	Oil Well	Producing
Ute Tribal 10-4D-54	4	5	S	4	W	4301352307	19294	Oil Well	Producing
UTE Tribal 15-31D-55	31	5	S	5	W	4301352309	19472	Gas Well	Producing
UTE Tribal 16-31D-55	31	5	S	5	W	4301352318	19473	Gas Well	Producing
UTE Tribal 2-35D-54	35	5	S	4	W	4301352319	19322	Oil Well	Producing
UTE Tribal 8-35D-54	35	5	S	4	W	4301352320	19323	Oil Well	Producing
Abbott Fee 5-6D-54	6	5	S	4	W	4301352326	19351	Oil Well	Producing
Ute Tribal 6-11D-54	11	5	S	4	W	4301352330	19243	Oil Well	Producing
Ute Tribal 12-11D-54	11	5	S	4	W	4301352331	19244	Oil Well	Producing
Ute Tribal 14-11D-54	11	5	S	4	W	4301352332	19245	Oil Well	Producing
Ute Tribal 11-4D-54	4	5	S	4	W	4301352343	19305	Oil Well	Producing
Ute Tribal 13-4D-54	4	5	S	4	W	4301352345	19353	Oil Well	Producing
Ute Tribal 14-4D-54	4	5	S	4	W	4301352346	19306	Oil Well	Producing
State Tribal 7-12D-55	12	5	S	5	W	4301352369	19651	Oil Well	Producing
State Tribal 1-12D-55	12	5	S	5	W	4301352390	19445	Oil Well	Producing
State Tribal 16-6D-54	6	5	S	4	W	4301352394	19424	Oil Well	Producing
State Tribal 9-6D-54	6	5	S	4	W	4301352396	19426	Oil Well	Producing
State Tribal 7-7D-54	7	5	S	4	W	4301352426	19496	Oil Well	Producing
State Tribal 1-7D-54	7	5	S	4	W	4301352427	19497	Oil Well	Producing
State Tribal 2-7D-54	7	5	S	4	W	4301352428	19498	Oil Well	Producing
State Tribal 3-7D-54	7	5	S	4	W	4301352429	19517	Oil Well	Producing
State Tribal 4-7D-54	7	5	S	4	W	4301352431	19546	Oil Well	Producing
State Tribal 5-7D-54	7	5	S	4	W	4301352432	19547	Oil Well	Producing
State Tribal 6-7D-54	7	5	S	4	W	4301352433	19518	Oil Well	Producing
State Tribal 11-6D-54	6	5	S	4	W	4301352452	19474	Oil Well	Producing
State Tribal 12-6D-54	6	5	S	4	W	4301352453	19475	Oil Well	Producing
State Tribal 13-6D-54	6	5	S	4	W	4301352454	19476	Oil Well	Producing
Ute Tribal 1-9D-54	9	5	S	4	W	4301352465	19356	Oil Well	Producing
Ute Tribal 7-9D-54	9	5	S	4	W	4301352466	19357	Oil Well	Producing

Well Transfer
 From: Linn Operating, Inc.
 To: Linn Operation, LLC
 Effective: 3/1/2017

UTE TRIBAL 12-5D-54	5	5	S	4	W	4301352480	19499	Oil Well	Producing
UTE TRIBAL 13-5D-54	5	5	S	4	W	4301352484	19500	Oil Well	Producing
UTE TRIBAL 14-5D-54	5	5	S	4	W	4301352493	19510	Oil Well	Producing
Federal 14-6D-65	6	6	S	5	W	4301352495	19610	Oil Well	Producing
Federal 13-6D-65	6	6	S	5	W	4301352496	19611	Oil Well	Producing
Federal 11-6D-65	6	6	S	5	W	4301352497	19591	Oil Well	Producing
Ute Tribal 16-5D-54	5	5	S	4	W	4301352545	19335	Oil Well	Producing
Ute Tribal 15-5D-54	5	5	S	4	W	4301352546	19358	Oil Well	Producing
Ute Tribal 10-5D-54	5	5	S	4	W	4301352547	19359	Oil Well	Producing
Ute Tribal 8-5D-54	5	5	S	4	W	4301352548	19336	Oil Well	Producing
State Tribal 13-11D-54	10	5	S	4	W	4301352561	19519	Oil Well	Producing
State Tribal 1-18D-54	18	5	S	4	W	4301352568	19434	Oil Well	Producing
State Tribal 2-18D-54	18	5	S	4	W	4301352576	19427	Oil Well	Producing
State Tribal 8-18D-54	18	5	S	4	W	4301352577	19428	Oil Well	Producing
Federal 16-6D-65	6	6	S	5	W	4301352590	19616	Oil Well	Producing
Federal 15-6D-65	6	6	S	5	W	4301352591	19617	Oil Well	Producing
State Tribal 4-18D-54	18	5	S	4	W	4301352607	19435	Oil Well	Producing
State Tribal 3-18D-54	18	5	S	4	W	4301352608	19436	Oil Well	Producing
State Tribal 6-18D-54	18	5	S	4	W	4301352609	19437	Oil Well	Producing
State Tribal 5-12-55	12	5	S	5	W	4301352643	19446	Oil Well	Producing
State Tribal 12-12D-55	12	5	S	5	W	4301352644	19447	Oil Well	Producing
State Tribal 6-12D-55	12	5	S	5	W	4301352645	19438	Oil Well	Producing
State Tribal 16-1D-55	1	5	S	5	W	4301352646	19483	Oil Well	Producing
State Tribal 15-1D-55	1	5	S	5	W	4301352647	19484	Oil Well	Producing
State Tribal 10-1D-55	1	5	S	5	W	4301352648	19485	Oil Well	Producing
State Tribal 9-1D-55	1	5	S	5	W	4301352649	19486	Oil Well	Producing
LC FEE 16-15D-56	14	5	S	6	W	4301352655	19520	Oil Well	Producing
LC Tribal 2-22D-56	22	5	S	6	W	4301352663	19548	Oil Well	Producing
LC Tribal 3-22D-56	22	5	S	6	W	4301352664	19549	Oil Well	Producing
UTE TRIBAL 14-30D-55	30	5	S	5	W	4301352687	19836	Oil Well	Producing
UTE TRIBAL 13-30D-55	30	5	S	5	W	4301352688	19743	Oil Well	Producing
UTE TRIBAL 12-30D-55	30	5	S	5	W	4301352689	19744	Oil Well	Producing
UTE TRIBAL 11-30D-55	30	5	S	5	W	4301352690	19745	Oil Well	Producing
UTE TRIBAL 12-31D-55	31	5	S	5	W	4301352699	19774	Oil Well	Producing
UTE TRIBAL 13-31D-55	31	5	S	5	W	4301352700	19775	Oil Well	Producing
UTE TRIBAL 14-31D-55	31	5	S	5	W	4301352701	19776	Oil Well	Producing
UTE TRIBAL 11-31-55	31	5	S	5	W	4301352703	19777	Oil Well	Producing
UTE TRIBAL 9-30D-55	30	5	S	5	W	4301352731	19732	Oil Well	Producing
UTE TRIBAL 15-30D-55	30	5	S	5	W	4301352737	19725	Oil Well	Producing
UTE TRIBAL 3-31D-55	31	5	S	5	W	4301352757	19778	Oil Well	Producing
UTE TRIBAL 5-31D-55	31	5	S	5	W	4301352758	19779	Oil Well	Producing
UTE TRIBAL 6-31D-55	31	5	S	5	W	4301352759	19746	Oil Well	Producing
Federal 8-14D-65	14	6	S	5	W	4301352767	19592	Oil Well	Producing
Federal 7-14D-65	14	6	S	5	W	4301352768	19593	Oil Well	Producing
Federal 2-14D-65	14	6	S	5	W	4301352769	19594	Oil Well	Producing

Well Transfer
 From: Linn Operating, Inc.
 To: Linn Operation, LLC
 Effective: 3/1/2017

Federal 1-14D-65	14	6	S	5	W	4301352770	19595	Oil Well	Producing
UTE TRIBAL 4-31D-55	31	5	S	5	W	4301352795	19780	Oil Well	Producing
Federal 1-13D-65	13	6	S	5	W	4301352800	19596	Oil Well	Producing
Federal 2-13-65	13	6	S	5	W	4301352801	19501	Oil Well	Producing
Federal 7-13D-65	13	6	S	5	W	4301352802	19597	Oil Well	Producing
Federal 8-13D-65	13	6	S	5	W	4301352803	19502	Oil Well	Producing
Federal 12-8D-64	7	6	S	4	W	4301352832	19550	Oil Well	Producing
Federal 5-8D-64	7	6	S	4	W	4301352833	19551	Oil Well	Producing
Federal 4-8D-64	7	6	S	4	W	4301352834	19552	Oil Well	Producing
Federal 3-8D-64	5	6	S	4	W	4301352845	19503	Oil Well	Producing
MAY UTE FED 1-13B1	13	2	S	1	W	4304730176	5435	Oil Well	Producing
COOK 1-26B1	26	2	S	1	W	4304731981	11212	Oil Well	Producing
CHRISTIANSEN 2-12B1	12	2	S	1	W	4304732178	11350	Oil Well	Producing
RICH 2-13B1	13	2	S	1	W	4304732744	12046	Oil Well	Producing
THOMAS 4-10B1	10	2	S	1	W	4304734080	13284	Oil Well	Producing
HAMAKER 3-12B1	12	2	S	1	W	4304752294	18650	Oil Well	Producing
BETTS 2-26B1	26	2	S	1	W	4304752435	18698	Oil Well	Producing
LC TRIBAL 4H-31-56	31	5	S	6	W	4301351738		Oil Well	Returned APD (Unapproved)
LC Fee 11-22-57	22	5	S	7	W	4301352127		Oil Well	Returned APD (Unapproved)
LC Fee 13-22D-57	22	5	S	7	W	4301352131		Oil Well	Returned APD (Unapproved)
LC Tribal 5-22D-57	22	5	S	7	W	4301352133		Oil Well	Returned APD (Unapproved)
LC Tribal 15-22D-57	22	5	S	7	W	4301352134		Oil Well	Returned APD (Unapproved)
LC Tribal 11-18D-56	18	5	S	6	W	4301352140		Oil Well	Returned APD (Unapproved)
LC Tribal 13-18D-56	18	5	S	6	W	4301352141		Oil Well	Returned APD (Unapproved)
LC Tribal 15-18D-56	18	5	S	6	W	4301352142		Oil Well	Returned APD (Unapproved)
LC Tribal 7-18D-56	18	5	S	6	W	4301352153		Oil Well	Returned APD (Unapproved)
LC Tribal 5-18D-56	18	5	S	6	W	4301352154		Oil Well	Returned APD (Unapproved)
LC Tribal 3-18-56	18	5	S	6	W	4301352155		Oil Well	Returned APD (Unapproved)
LC Tribal 6-19D-56	19	5	S	6	W	4301352247		Oil Well	Returned APD (Unapproved)
LC Tribal 4-19D-56	19	5	S	6	W	4301352248		Oil Well	Returned APD (Unapproved)
Abbott Fee 3-6D-54	6	5	S	4	W	4301352325		Oil Well	Returned APD (Unapproved)
LC Fee 9-11D-56	11	5	S	6	W	4301352479		Oil Well	Returned APD (Unapproved)
Williams Tribal 8-4D-54	4	5	S	4	W	4301352650		Oil Well	Returned APD (Unapproved)
Williams Tribal 7-4D-54	4	5	S	4	W	4301352651		Oil Well	Returned APD (Unapproved)
Williams Tribal 2-4D-54	4	5	S	4	W	4301352652		Oil Well	Returned APD (Unapproved)
Williams Tribal 1-4D-54	4	5	S	4	W	4301352653		Oil Well	Returned APD (Unapproved)
Foy Fee 12-34D-55	34	5	S	5	W	4301353087		Oil Well	Returned APD (Unapproved)
Foy Fee 6-34D-55	34	5	S	5	W	4301353088		Oil Well	Returned APD (Unapproved)
Foy Fee 5-34D-55	34	5	S	5	W	4301353089		Oil Well	Returned APD (Unapproved)
Foy Fee 3-34D-55	34	5	S	5	W	4301353090		Oil Well	Returned APD (Unapproved)
Foy Tribal 13-34D-55	34	5	S	5	W	4301353119		Oil Well	Returned APD (Unapproved)
Foy Tribal 14-34-55	34	5	S	5	W	4301353120		Oil Well	Returned APD (Unapproved)
UTE FEE 10-13D-55	13	5	S	5	W	4301353129		Oil Well	Returned APD (Unapproved)
LC Tribal 10-15D-56	15	5	S	6	W	4301353163		Oil Well	Returned APD (Unapproved)
LC Tribal 9-21D-56	21	5	S	6	W	4301353164		Oil Well	Returned APD (Unapproved)

Well Transfer
 From: Linn Operating, Inc.
 To: Linn Operation, LLC
 Effective: 3/1/2017

LC Tribal 7-21D-56	21	5	S	6	W	4301353165		Oil Well	Returned APD (Unapproved)
LC Tribal 11-15D-56	15	5	S	6	W	4301353189		Oil Well	Returned APD (Unapproved)
SCOFIELD THORPE 22-41X RIG SKID	22	12	S	7	E	4300730890	13719	Gas Well	Shut-in
SCOFIELD-THORPE 35-13	35	12	S	7	E	4300730991	14846	Gas Well	Shut-in
SCOFIELD-THORPE 23-31	23	12	S	7	E	4300731001	14923	Gas Well	Shut-in
STATE 1-10A2 (3-10C)	10	1	S	2	W	4301330006	5860	Gas Well	Shut-in
DOUG BROWN 2-4A2	4	1	S	2	W	4301330017	5840	Oil Well	Shut-in
L BOREN U 5-22A2	22	1	S	2	W	4301330107	5900	Oil Well	Shut-in
L BOREN U 6-16A2	16	1	S	2	W	4301330123	5750	Oil Well	Shut-in
UTE TRIBAL 1-6B3	6	2	S	3	W	4301330136	5705	Oil Well	Shut-in
CAMPBELL UTE ST 1-7B1	7	2	S	1	W	4301330236	5295	Oil Well	Shut-in
WIRE FENCE CYN FED 15-1	15	6	S	5	W	4301330404	8233	Gas Well	Shut-in
R FORK ANTELOPE CYN FED 25-1	25	6	S	5	W	4301330406	8234	Oil Well	Shut-in
WOLF HOLLOW 22-1	22	6	S	5	W	4301330425	10370	Gas Well	Shut-in
D L GALLOWAY 1-14B2	14	2	S	2	W	4301330564	5965	Oil Well	Shut-in
LAMICQ 2-6B1	6	2	S	1	W	4301330809	2301	Oil Well	Shut-in
HAMBLIN 2-26-A2	26	1	S	2	W	4301330903	5361	Oil Well	Shut-in
LAMICQ 2-20A2	20	1	S	2	W	4301331191	10794	Oil Well	Shut-in
MARK 2-25A2	25	1	S	2	W	4301331232	10986	Oil Well	Shut-in
Z and T UTE TRIBAL 12-22	22	5	S	4	W	4301331311	11421	Oil Well	Shut-in
MITCHELL 2-4B1	4	2	S	1	W	4301331317	11231	Oil Well	Shut-in
CHAPMAN 2-4B2	4	2	S	2	W	4301331378	11485	Oil Well	Shut-in
UTE TRIBAL 15-17	17	5	S	4	W	4301331649	11956	Oil Well	Shut-in
POWELL 2-16B1	16	2	S	1	W	4301331820	12342	Oil Well	Shut-in
UTE TRIBAL 3-19	19	5	S	4	W	4301331830	12197	Oil Well	Shut-in
UTE TRIBAL 14-17	17	5	S	4	W	4301332147	12755	Oil Well	Shut-in
UTE TRIBAL 7-30	30	5	S	4	W	4301332167	12945	Oil Well	Shut-in
UTE TRIBAL 1-33	33	5	S	4	W	4301332185	13024	Oil Well	Shut-in
UTE TRIBAL 5-24-55	24	5	S	5	W	4301332263	13621	Oil Well	Shut-in
UTE TRIBAL 10-16-55	16	5	S	5	W	4301332345	13693	Oil Well	Shut-in
UTE TRIBAL 15-30-54	30	5	S	4	W	4301332382	13944	Oil Well	Shut-in
UTE TRIBAL 14-21-54	21	5	S	4	W	4301332384	13946	Oil Well	Shut-in
UTE TRIBAL 13-30-54	30	5	S	4	W	4301332409	13968	Oil Well	Shut-in
UTE TRIBAL 3-33-54	33	5	S	4	W	4301332412	13938	Oil Well	Shut-in
UTE TRIBAL 1-20-55	20	5	S	5	W	4301332414	14548	Oil Well	Shut-in
UTE TRIBAL 9-29-54	29	5	S	4	W	4301332566	14369	Oil Well	Shut-in
UTE TRIBAL 6-24-54	24	5	S	4	W	4301332570	14299	Oil Well	Shut-in
UTE TRIBAL 10-14-55	14	5	S	5	W	4301332601	14331	Oil Well	Shut-in
UTE TRIBAL 11-5-54	5	5	S	4	W	4301332664	14415	Oil Well	Shut-in
UTE TRIBAL 16-24-55	24	5	S	5	W	4301332672	14384	Gas Well	Shut-in
MYRIN TRIBAL 14-19-55	19	5	S	5	W	4301332782	15184	Oil Well	Shut-in
MOON TRIBAL 13-27-54	27	5	S	4	W	4301332801	15057	Oil Well	Shut-in
MOON TRIBAL 11-27-54	27	5	S	4	W	4301332845	15135	Oil Well	Shut-in
UTE TRIBAL 15-15-55	15	5	S	5	W	4301332855	15114	Oil Well	Shut-in
UTE TRIBAL 10-24-54	24	5	S	4	W	4301332932	15364	Oil Well	Shut-in

Well Transfer
 From: Linn Operating, Inc.
 To: Linn Operation, LLC
 Effective: 3/1/2017

UTE TRIBAL 8-24-54	24	5	S	4	W	4301332933	15402	Oil Well	Shut-in
UTE TRIBAL 12-15-55	15	5	S	5	W	4301332981	15348	Oil Well	Shut-in
UTE TRIBAL 2-23-55	23	5	S	5	W	4301333045	15416	Oil Well	Shut-in
TAYLOR FEE 7-14-56	14	5	S	6	W	4301333140	15601	Oil Well	Shut-in
WILCOX FEE 15-16-56	16	5	S	6	W	4301333151	15527	Oil Well	Shut-in
UTE TRIBAL 11-13-55	13	5	S	5	W	4301333268	15692	Oil Well	Shut-in
UTE TRIBAL 7-14-55	14	5	S	5	W	4301333269	15693	Oil Well	Shut-in
14-11-56 DLB	11	5	S	6	W	4301333378	15801	Oil Well	Shut-in
FEDERAL 10-3-65	3	6	S	5	W	4301333386	16297	Oil Well	Shut-in
BERRY TRIBAL 16-34D-54	34	5	S	4	W	4301333464	16280	Oil Well	Shut-in
FEDERAL 10-2-65	2	6	S	5	W	4301333542	16181	Oil Well	Shut-in
UTE FEE 2-13-55	13	5	S	5	W	4301333720	18659	Oil Well	Shut-in
LC TRIBAL 13-16D-56	16	5	S	6	W	4301334282	17601	Oil Well	Shut-in
LC TRIBAL 4-27D-56	27	5	S	6	W	4301350262	17568	Oil Well	Shut-in
LC TRIBAL 8-16D-56	16	5	S	6	W	4301350599	18161	Oil Well	Shut-in
LC TRIBAL 15-8D-56	8	5	S	6	W	4301351060	18862	Oil Well	Shut-in
UTE TRIBAL 6-9-54	9	5	S	4	W	4301351127	19017	Oil Well	Shut-in
LC TRIBAL 16-30D-56	30	5	S	6	W	4301351132	18540	Oil Well	Shut-in
STATE TRIBAL 15-6-54	6	5	S	4	W	4301351227	18746	Oil Well	Shut-in
LC TRIBAL 1-29-56	29	5	S	6	W	4301351442	18876	Oil Well	Shut-in
CC Fee 7R-28-38	28	3	S	8	W	4301351852	18863	Oil Well	Shut-in
ABBOTT FEE 8-6D-54	6	5	S	4	W	4301351950	18964	Oil Well	Shut-in
Federal 1-9D-64	9	6	S	4	W	4301352020	19722	Oil Well	Shut-in
FEDERAL 14-9D-64	9	6	S	4	W	4301352040	19690	Oil Well	Shut-in
Ute Tribal 12-4D-54	4	5	S	4	W	4301352344	19352	Oil Well	Shut-in
State Tribal 10-6D-54	6	5	S	4	W	4301352395	19425	Oil Well	Shut-in
State Tribal 14-6D-54	6	5	S	4	W	4301352455	19477	Oil Well	Shut-in
Federal 10-6D-65	6	6	S	5	W	4301352498	19612	Oil Well	Shut-in
Federal 2-7D-65	7	6	S	5	W	4301352537	19630	Oil Well	Shut-in
Federal 5-7D-65	7	6	S	5	W	4301352538	19613	Oil Well	Shut-in
Federal 4-7D-65	7	6	S	5	W	4301352541	19614	Oil Well	Shut-in
Federal 3-7-65	7	6	S	5	W	4301352560	19609	Oil Well	Shut-in
Federal 1-7D-65	6	6	S	5	W	4301352589	19615	Oil Well	Shut-in
RBRTSN UTE ST 1-12B1	12	2	S	1	W	4304730164	5475	Oil Well	Shut-in

Facility Transfer
 From: Linn Operating, Inc.
 To: Linn Operating, LLC
 Effective: March 1, 2017

Facility Name	Facility Status	Facility Type	Sec	TWN	RNG	Qtr/Qtr
Boren	Active	Tank Battery	23	1	2	NENW
Chevron Pump Station	Active	Tank Battery	22	1	2	
Davis Hollow	Active	Compressor Station		5	6	SESW
LINN ENERGY, LLC	Active	Gas Plant				
Scofield	Active	Compressor Station	26	12	7	
Section 21	Active	Compressor Station	21	5	5	NENE
Section 22	Active	Compressor Station	22	5	4	NWSW
Section 23	Active	Compressor Station	23	5	4	NESE
Section 34	Active	Compressor Station	34	5	4	NENW
Section 7	Active	Compressor Station	7	5	4	NWSW
Skitzzy	Active	Compressor Station	3	5	6	SWSW
Ute Pipeline	Active	Compressor Station	22	5	4	NWSW
Ute Pipeline 21	Active	Compressor Station	21	5	5	NENE
Ute Pipeline 7	Active	Compressor Station	7	5	5	NESW

STATE OF UTAH
DEPARTMENT OF NATURAL RESOURCES
DIVISION OF OIL, GAS AND MINING

FORM 9

SUNDRY NOTICES AND REPORTS ON WELLS

Do not use this form for proposals to drill new wells, significantly deepen existing wells below current bottom-hole depth, reenter plugged wells, or to drill horizontal laterals. Use APPLICATION FOR PERMIT TO DRILL form for such proposals.

1. TYPE OF WELL OIL WELL <input type="checkbox"/> GAS WELL <input type="checkbox"/> OTHER <u>see attached</u>		5. LEASE DESIGNATION AND SERIAL NUMBER: <u>see attached list</u>
2. NAME OF OPERATOR: LINN OPERATING, LLC <u>N4365</u>		6. IF INDIAN, ALLOTTEE OR TRIBE NAME:
3. ADDRESS OF OPERATOR: 600 TRAVIS ST., SUITE 140 CITY HOUSTON STATE TX ZIP 77002		7. UNIT or CA AGREEMENT NAME:
PHONE NUMBER: (281) 840-4000		8. WELL NAME and NUMBER: <u>see attached list</u>
4. LOCATION OF WELL FOOTAGES AT SURFACE:		9. API NUMBER:
QTR/QTR, SECTION, TOWNSHIP, RANGE, MERIDIAN:		10. FIELD AND POOL, OR WILDCAT:
COUNTY: <u>Duchesne</u>		
STATE: <u>UTAH</u>		

11. CHECK APPROPRIATE BOXES TO INDICATE NATURE OF NOTICE, REPORT, OR OTHER DATA			
TYPE OF SUBMISSION	TYPE OF ACTION		
<input checked="" type="checkbox"/> NOTICE OF INTENT (Submit in Duplicate) Approximate date work will start: _____	<input type="checkbox"/> ACIDIZE	<input type="checkbox"/> DEEPEN	<input type="checkbox"/> REPERFORATE CURRENT FORMATION
<input type="checkbox"/> SUBSEQUENT REPORT (Submit Original Form Only) Date of work completion: _____	<input type="checkbox"/> ALTER CASING	<input type="checkbox"/> FRACTURE TREAT	<input type="checkbox"/> SIDETRACK TO REPAIR WELL
	<input type="checkbox"/> CASING REPAIR	<input type="checkbox"/> NEW CONSTRUCTION	<input type="checkbox"/> TEMPORARILY ABANDON
	<input type="checkbox"/> CHANGE TO PREVIOUS PLANS	<input checked="" type="checkbox"/> OPERATOR CHANGE	<input type="checkbox"/> TUBING REPAIR
	<input type="checkbox"/> CHANGE TUBING	<input type="checkbox"/> PLUG AND ABANDON	<input type="checkbox"/> VENT OR FLARE
	<input type="checkbox"/> CHANGE WELL NAME	<input type="checkbox"/> PLUG BACK	<input type="checkbox"/> WATER DISPOSAL
	<input type="checkbox"/> CHANGE WELL STATUS	<input type="checkbox"/> PRODUCTION (START/RESUME)	<input type="checkbox"/> WATER SHUT-OFF
	<input type="checkbox"/> COMMINGLE PRODUCING FORMATIONS	<input type="checkbox"/> RECLAMATION OF WELL SITE	<input type="checkbox"/> OTHER: _____
	<input type="checkbox"/> CONVERT WELL TYPE	<input type="checkbox"/> RECOMPLETE - DIFFERENT FORMATION	

12. DESCRIBE PROPOSED OR COMPLETED OPERATIONS. Clearly show all pertinent details including dates, depths, volumes, etc.
Effective March 1, 2017, we respectfully submit for your review a Change of Operator from Linn Operating, Inc. to Linn Operating, LLC.

Attached is a list of wells that are associated with this Change of Operator. The bonds covering these wells are State of Utah Surety Bond #K09515367, BIA Bond #B004292, BLM Bond #K09515124. All lease agreements remain in place, unchanged.

Linn Operating, Inc. (N4115)
600 Travis St., Suite 1400
Houston, Texas 77002
281-840-4000

RECEIVED

APR 11 2017

DIV. OF OIL, GAS & MINING

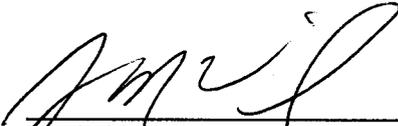

Jamin McNeil
Vice President, Sr. Operations

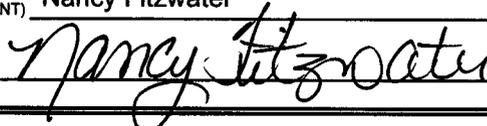
NAME (PLEASE PRINT) <u>Nancy Fitzwater</u>	TITLE <u>Regulatory Supervisor</u>
SIGNATURE 	DATE <u>4/6/2017</u>

(This space for State use only)

APPROVED

JUN 14 2017

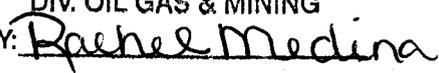
DIV. OIL GAS & MINING
BY: 

STATE OF UTAH
DEPARTMENT OF NATURAL RESOURCES
DIVISION OF OIL, GAS AND MINING

FORM 9

SUNDRY NOTICES AND REPORTS ON WELLS

Do not use this form for proposals to drill new wells, significantly deepen existing wells below current bottom-hole depth, reenter plugged wells, or to drill horizontal laterals. Use APPLICATION FOR PERMIT TO DRILL form for such proposals.

1. TYPE OF WELL OIL WELL <input type="checkbox"/> GAS WELL <input type="checkbox"/> OTHER <u>see attached</u>		5. LEASE DESIGNATION AND SERIAL NUMBER: see attached list
2. NAME OF OPERATOR: LINN OPERATING, LLC (N4365)		6. IF INDIAN, ALLOTTEE OR TRIBE NAME:
3. ADDRESS OF OPERATOR: 600 TRAVIS ST., SUITE 140 CITY HOUSTON STATE TX ZIP 77002		7. UNIT or CA AGREEMENT NAME:
4. LOCATION OF WELL FOOTAGES AT SURFACE:		8. WELL NAME and NUMBER: see attached list
QTR/QTR, SECTION, TOWNSHIP, RANGE, MERIDIAN:		9. API NUMBER:
COUNTY: Duchesne		10. FIELD AND POOL, OR WILDCAT:
STATE: UTAH		

11. CHECK APPROPRIATE BOXES TO INDICATE NATURE OF NOTICE, REPORT, OR OTHER DATA

TYPE OF SUBMISSION	TYPE OF ACTION		
<input checked="" type="checkbox"/> NOTICE OF INTENT (Submit in Duplicate) Approximate date work will start: _____	<input type="checkbox"/> ACIDIZE	<input type="checkbox"/> DEEPEN	<input type="checkbox"/> REPERFORATE CURRENT FORMATION
<input type="checkbox"/> SUBSEQUENT REPORT (Submit Original Form Only) Date of work completion: _____	<input type="checkbox"/> ALTER CASING	<input type="checkbox"/> FRACTURE TREAT	<input type="checkbox"/> SIDETRACK TO REPAIR WELL
	<input type="checkbox"/> CASING REPAIR	<input type="checkbox"/> NEW CONSTRUCTION	<input type="checkbox"/> TEMPORARILY ABANDON
	<input type="checkbox"/> CHANGE TO PREVIOUS PLANS	<input checked="" type="checkbox"/> OPERATOR CHANGE	<input type="checkbox"/> TUBING REPAIR
	<input type="checkbox"/> CHANGE TUBING	<input type="checkbox"/> PLUG AND ABANDON	<input type="checkbox"/> VENT OR FLARE
	<input type="checkbox"/> CHANGE WELL NAME	<input type="checkbox"/> PLUG BACK	<input type="checkbox"/> WATER DISPOSAL
	<input type="checkbox"/> CHANGE WELL STATUS	<input type="checkbox"/> PRODUCTION (START/RESUME)	<input type="checkbox"/> WATER SHUT-OFF
	<input type="checkbox"/> COMMINGLE PRODUCING FORMATIONS	<input type="checkbox"/> RECLAMATION OF WELL SITE	<input type="checkbox"/> OTHER: _____
	<input type="checkbox"/> CONVERT WELL TYPE	<input type="checkbox"/> RECOMPLETE - DIFFERENT FORMATION	

12. DESCRIBE PROPOSED OR COMPLETED OPERATIONS. Clearly show all pertinent details including dates, depths, volumes, etc.

Effective March 1, 2017, we respectfully submit for your review a Change of Operator from Linn Operating, Inc. to Linn Operating, LLC.

Attached is a list of surface facilities that are associated with this Change of Operator. The bonds covering these facilities are State of Utah Surety Bond #K09515367, BIA Bond #B004292, BLM Bond #K09515124. All lease agreements remain in place, unchanged.

Linn Operating, Inc. (N4115)
600 Travis St., Suite 1400
Houston, Texas 77002
281-840-4000

RECEIVED
APR 11 2017
DIV. OF OIL, GAS & MINING

Jamin McNeil
Jamin McNeil
Vice President, Sr. Operations

NAME (PLEASE PRINT) <u>Nancy Fitzwater</u>	TITLE <u>Regulatory Supervisor</u>
SIGNATURE <i>Nancy Fitzwater</i>	DATE <u>4/6/2017</u>

(This space for State use only)

APPROVED

JUN 14 2017

DIV. OIL GAS & MINING

BY: *Rachel Medina*

(5/2000) (See Instructions on Reverse Side)

UPDATE ON SI WELLS FOR NAME CHANGE

4/10/17

Future Berry Petroleum Wells

Scofield Thorpe 22-41X Rig Skid:

Future Berry Petroleum well as of May 1st, 2017.

Scofield Thorpe 35-13

Future Berry Petroleum well as of May 1st, 2017.

Scofield Thorpe 23-31

Future Berry Petroleum well as of May 1st, 2017.

Wilcox Fee 15-16-56

Future Berry Petroleum well as of May 1st, 2017.

LC Fee 8-15D-56

Future Berry Petroleum well as of May 1st, 2017.

CC Fee 7R-28-38

Future Berry Petroleum well as of May 1st, 2017.

Taylor Fee 7-14-56

Future Berry Petroleum well as of May 1st, 2017.

SFW Fee 13-10D-54

Future Berry Petroleum well as of May 1st, 2017.

LINN Energy Wells

Mark 2-25A2

Received approved LINN Energy budget this month. Repair work under review.

Mitchell 2-4B1

Received approved LINN Energy budget this month. Repair work under review.

Galloway #2-14B2

Reclaim existing pit in Q2 2017. Project delayed due to winter weather.

Hamblin 2-26-A2

Received approved LINN Energy budget this month. Repair work under review.



STATE OF UTAH SHUT IN LIST ESTIMATED P/A COSTS

4/10/2017

WELLNAME	FUTURE OPERATOR	ESTIMATED P/A COSTS
Scofield Thorpe 22-41X Rig Skid	Berry Petroleum Company	\$ 45,000
Scofield Thorpe 35-13	Berry Petroleum Company	\$ 45,000
Scofield Thorpe 23-31	Berry Petroleum Company	\$ 45,000
SFW Fee 13-10D-54	Berry Petroleum Company	\$ 35,000
Wilcox Fee 15-16-56	Berry Petroleum Company	\$ 35,000
LC Fee 8-15D-56	Berry Petroleum Company	\$ 35,000
CC Fee 7R-28-38	Berry Petroleum Company	\$ 75,000
Taylor Fee 7-14-56	Berry Petroleum Company	\$ 35,000
Berry Petroleum Company TOTAL		\$ 350,000
Mark 2-25A2	LINN Operating	\$ 75,000
Mitchell 2-4B1	LINN Operating	\$ 75,000
Galloway 2-14B2	LINN Operating	\$ 30,000
Hamblin 2-26A2	LINN Operating	\$ 75,000
LINN Operating TOTAL		\$ 255,000



Rachel Medina <rachelmedina@utah.gov>

Linn Name Change and Berry Operator Change

2 messages

Rachel Medina <rachelmedina@utah.gov>

Thu, Apr 20, 2017 at 11:58 AM

To: Dustin Doucet <dustindoucet@utah.gov>, Randy Thackeray <randythackeray@utah.gov>

Dustin,

Linn is planning on moving all the wells from Linn Inc. to Linn LLC, then complete an operator change for the Berry wells. Eight of the wells on the non-compliance list will be move to Berry. Are you okay with us moving all the wells to Berry, putting the eight wells on the blanket bond, then getting the shut in plans and full cost bond when the move to Berry is complete?

The blanket bond and full cost bonding for the Linn wells will of course be in place before we complete the move.

Attached is the plugging estimates for all twelve wells, as well as a list of which wells are going to the new Linn and Berry. They have some details on what they plan to do with the wells on the Update list. Will this be acceptable for a shut in plan and plugging estimates?

--
Rachel Medina
Division of Oil, Gas & Mining
Bonding Technician
801-538-5260

 **20170420110137.pdf**
58K**Dustin Doucet** <dustindoucet@utah.gov>

Thu, Apr 27, 2017 at 10:40 AM

To: Rachel Medina <rachelmedina@utah.gov>

Cc: Randy Thackeray <randythackeray@utah.gov>

I'm o.k. with those amounts. They should send in their plans for the wells.

[Quoted text hidden]

--
Dustin K. Doucet
Petroleum Engineer
Division of Oil, Gas and Mining
1594 West North Temple, Ste 1210
Salt Lake City, Utah 84116
801.538.5281 (ofc)
801.359.3940 (fax)

web: www.ogm.utah.gov



600 TRAVIS, SUITE 1400
HOUSTON, TX 77002
PHONE: (281) 840-4000
FAX: (281) 840-4001

RECEIVED

MAY 30 2017

DIV. OF OIL, GAS & MINING

May 25, 2017

Mr. Dustin Doucet
State of Utah – DNR
Division of Oil, Gas and Mining
1594 West North Temple
Salt Lake City, Utah 84116

Re: Extended Shut-in and Temporary Abandoned Well Requirements for Fee or State Leases
Four (4) Fee Lease Wells (see attachment A)

Dear Mr. Doucet:

In response to your request for more detailed six (6) month plans, Linn respectfully submits the following plans to bring these wells into compliance:

Mark 2-25A2

Plan to P/A this well. A sundry will be submitted in June 2017 and the P/A work will be completed by September 30, 2017.

Mitchell 2-4B1

Plan to return well to production. This repair work will be completed by June 30, 2017.

Galloway #2-14B2

The existing pit will be reclaimed in May 2017. We are requesting a T/A extension through December 2018 on this well to maintain the constructed surface location and surface pipe. This will allow for review of results from planned horizontal drilling this year to provide a detailed plan for this wellbore.

Hamblin 2-26-A2

Plan to P/A this well. A sundry will be submitted in June 2017 and the P/A work will be completed by September 30, 2017.

Linn appreciates your time and consideration. If you require any additional information please do not hesitate to contact me at 281-840-4266 or by e-mail at nfitzwater@linnenergy.com.

LINN OPERATING, LLC

Nancy Fitzwater
Regulatory Supervisor



Rachel Medina <rachelmedina@utah.gov>

Linn's Shut-In Plan

2 messages

Rachel Medina <rachelmedina@utah.gov>
To: Dustin Doucet <dustindoucet@utah.gov>

Fri, Jun 2, 2017 at 9:56 AM

Hi Dustin,

Attached is the shut in plan that Linn has for the four wells they will be keeping. Is this enough for me to complete the Linn, Inc, to Linn, LLC operator change?

—
Rachel Medina
Division of Oil, Gas & Mining
Bonding Technician
801-538-5260

 **20170602090508.pdf**
56K

Dustin Doucet <dustindoucet@utah.gov>
To: Rachel Medina <rachelmedina@utah.gov>

Mon, Jun 5, 2017 at 11:26 AM

Looks good.
[Quoted text hidden]

—
Dustin K. Doucet
Petroleum Engineer
Division of Oil, Gas and Mining
1594 West North Temple, Ste 1210
Salt Lake City, Utah 84116
801.538.5281 (ofc)
801.359.3940 (fax)

web: www.ogm.utah.gov

Division of Oil, Gas and Mining
 Operator Change/Name Change Worksheet-for State use only

Effective Date: 5/1/2017

FORMER OPERATOR: Linn Operating, LLC 600 Travis Street, Suite 1400 Houston, TX 77002	NEW OPERATOR: Berry Petroleum Company, LLC 5201 Truxtun Avenue Bakersfield, CA 93309
CA Number(s):	Unit(s): Bradford Canyon, Berry Pilot EOR, Brundage Canyon

WELL INFORMATION:

Well Name	Sec	TWN	RNG	API	Entity	Mineral	Surface	Type	Status
See Attached List									

OPERATOR CHANGES DOCUMENTATION:

- Sundry or legal documentation was received from the **FORMER** operator on: 4/21/2017
- Sundry or legal documentation was received from the **NEW** operator on: 4/21/2017
- New operator Division of Corporations Business Number: 9783541-0161

REVIEW:

- Surface Agreement Sundry from **NEW** operator on Fee Surface wells received on: 4/21/2017
- Receipt of Acceptance of Drilling Procedures for APD on: 4/21/2017
- Reports current for Production/Disposition & Sundries: 6/27/2017
- OPS/SI/TA well(s) reviewed for full cost bonding: 4/22/2017
- UIC5 on all disposal/injection/storage well(s) approved on: 5/25/2017
- Surface Facility(s) included in operator change:

Section 23
~~Unnamed~~ Section 7
 Section 22
 Section 21
 Davis Hollow
 Scofield
 Section 34
 Ute Pipeline
 Ute Pipeline 21
 Ute Pipeline 7
 Skitzy
 Linn Energy, LLC-Gas Plant

- Inspections of PA state/fee well sites complete on (only upon operators request): All bonded

NEW OPERATOR BOND VERIFICATION:

- State/fee well(s) covered by Bond Number(s):
 B010538-Blanket
 B010630
 B010629
 B010628
 B010627
 B010626
 B010625
 B010624
 B010623

DATA ENTRY:

- Well(s) update in the RBDMS on: 6/27/2017
- Group(s) update in RDBMS on: 6/27/2017
- Surface Facilities update in RBDMS on: 6/29/2017

COMMENTS:

STATE OF UTAH
DEPARTMENT OF NATURAL RESOURCES
DIVISION OF OIL, GAS AND MINING

FORM 9

SUNDRY NOTICES AND REPORTS ON WELLS		5 LEASE DESIGNATION AND SERIAL NUMBER see attached list
		6. IF INDIAN, ALLOTTEE OR TRIBE NAME
Do not use this form for proposals to drill new wells, significantly deepen existing wells below current bottom-hole depth, reenter plugged wells, or to drill horizontal laterals. Use APPLICATION FOR PERMIT TO DRILL form for such proposals.		7 UNIT or CA AGREEMENT NAME
1 TYPE OF WELL OIL WELL <input type="checkbox"/> GAS WELL <input type="checkbox"/> OTHER see attached		8 WELL NAME and NUMBER see attached list
2 NAME OF OPERATOR BERRY PETROLEUM COMPANY, LLC		9 API NUMBER
3 ADDRESS OF OPERATOR 5201 TRUXTUN AVENUE BAKERSFIELD CA 93309	PHONE NUMBER (661) 616-3900	10 FIELD AND POOL, OR WILDCAT
4 LOCATION OF WELL FOOTAGES AT SURFACE		COUNTY Duchesne
QTR/QTR, SECTION TOWNSHIP RANGE MERIDIAN		STATE UTAH

11 CHECK APPROPRIATE BOXES TO INDICATE NATURE OF NOTICE, REPORT, OR OTHER DATA			
TYPE OF SUBMISSION	TYPE OF ACTION		
<input checked="" type="checkbox"/> NOTICE OF INTENT (Submit in Duplicate) Approximate date work will start: _____	<input type="checkbox"/> ACIDIZE	<input type="checkbox"/> DEEPEN	<input type="checkbox"/> REPERFORATE CURRENT FORMATION
<input type="checkbox"/> SUBSEQUENT REPORT (Submit Original Form Only) Date of work completion _____	<input type="checkbox"/> ALTER CASING	<input type="checkbox"/> FRACTURE TREAT	<input type="checkbox"/> SIDETRACK TO REPAIR WELL
	<input type="checkbox"/> CASING REPAIR	<input type="checkbox"/> NEW CONSTRUCTION	<input type="checkbox"/> TEMPORARILY ABANDON
	<input type="checkbox"/> CHANGE TO PREVIOUS PLANS	<input checked="" type="checkbox"/> OPERATOR CHANGE	<input type="checkbox"/> TUBING REPAIR
	<input type="checkbox"/> CHANGE TUBING	<input type="checkbox"/> PLUG AND ABANDON	<input type="checkbox"/> VENT OR FLARE
	<input type="checkbox"/> CHANGE WELL NAME	<input type="checkbox"/> PLUG BACK	<input type="checkbox"/> WATER DISPOSAL
	<input type="checkbox"/> CHANGE WELL STATUS	<input type="checkbox"/> PRODUCTION (START/RESUME)	<input type="checkbox"/> WATER SHUT-OFF
	<input type="checkbox"/> COMMINGLE PRODUCING FORMATIONS	<input type="checkbox"/> RECLAMATION OF WELL SITE	<input type="checkbox"/> OTHER: _____
	<input type="checkbox"/> CONVERT WELL TYPE	<input type="checkbox"/> RECOMPLETE - DIFFERENT FORMATION	

12 DESCRIBE PROPOSED OR COMPLETED OPERATIONS. Clearly show all pertinent details including dates depths volumes, etc.
Effective May 1, 2017, we respectfully submit for your review a Change of Operator from Linn Operating, LLC (N4365) to Berry Petroleum Company, LLC (N4075).

Attached is a list of surface facilities that are associated with this Change of Operator. The bonds covering these facilities are State of Utah Surety Bond #B010538, BIA Bond #B010546, BLM Bond #B010580.

Linn Operating, LLC (N4365)
600 Travis St., Suite 1400
Houston, Texas 77002
281-840-4000

RECEIVED
APR 21 2017
DIV. OF OIL, GAS & MINING

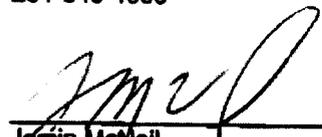
Jamin McNeil
Vice President, Sr. Operations

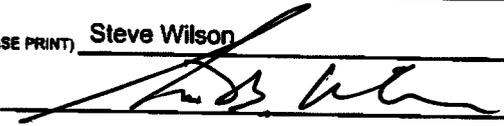
NAME (PLEASE PRINT) Steve Wilson TITLE CFO
SIGNATURE  DATE April 20 2017

(This space for State use only)

APPROVED
JUN 27 2017

From: Linn Operating, LLC
 To: Berry Petroleum Company, LLC
 Effective: May 1, 2017

Well Name	API	Town	Twp Dir	Range	Rng Dir	Sec	Entity Number	Well Type	Well Status
Z and T UTE TRIBAL 2-21	4301331280	5	S	4	W	21	11130	Water Injection Well	Active
Z and T UTE TRIBAL 10-21	4301331283	5	S	4	W	21	11133	Water Injection Well	Active
UTE TRIBAL 16-21-54	4301332381	5	S	4	W	21	13912	Water Injection Well	Active
UTE TRIBAL 7-21-54	4301332623	5	S	4	W	21	14383	Water Injection Well	Active
UTE TRIBAL 12-30-54	4301332747	5	S	4	W	30	14747	Water Injection Well	Active
UTE TRIBAL 14-30-54	4301332748	5	S	4	W	30	14778	Water Injection Well	Active
UTE TRIBAL 10-30D-54	4301332893	5	S	4	W	30	15246	Water Injection Well	Active
UTE TRIBAL 6-30-54	4301332975	5	S	4	W	30	15300	Water Injection Well	Active
UTE TRIBAL 9-21-54	4301333040	5	S	4	W	21	15360	Water Injection Well	Active
UTE TRIBAL 15-21-54	4301333114	5	S	4	W	21	15441	Water Injection Well	Active
UTE TRIBAL 1-21-54	4301333388	5	S	4	W	21	15937	Water Injection Well	Active
UTE TRIBAL 15-28D-55	4301333623	5	S	5	W	28		Oil Well	Approved Permit
LC TRIBAL 13H-9-56	4301350874	5	S	6	W	10		Oil Well	Approved Permit
LC TRIBAL 4H-26-56	4301350951	5	S	6	W	26		Oil Well	Approved Permit
LC TRIBAL 5H-34-45	4301350974	4	S	5	W	34		Oil Well	Approved Permit
LC TRIBAL 11-34-45	4301350975	4	S	5	W	34		Oil Well	Approved Permit
CC TRIBAL 4-30D-38	4301350993	3	S	8	W	19		Oil Well	Approved Permit
FEDERAL 4-1-65	4301351016	6	S	5	W	1		Oil Well	Approved Permit
LC TRIBAL 13H-28-45	4301351061	4	S	5	W	28		Oil Well	Approved Permit
LC TRIBAL 5H-23-45	4301351071	4	S	5	W	23		Oil Well	Approved Permit
LC TRIBAL 4H-27-45	4301351072	4	S	5	W	27		Oil Well	Approved Permit
LC TRIBAL 16-27-45	4301351074	4	S	5	W	27		Oil Well	Approved Permit
LC TRIBAL 12-27-45	4301351075	4	S	5	W	27		Oil Well	Approved Permit
LC TRIBAL 16-23-45	4301351077	4	S	5	W	23		Oil Well	Approved Permit
LC TRIBAL 12H-30-56	4301351133	5	S	6	W	30		Oil Well	Approved Permit
LC TRIBAL 5H-33-45	4301351338	4	S	5	W	33		Oil Well	Approved Permit
LC TRIBAL 6-16D-56	4301351406	5	S	6	W	16		Oil Well	Approved Permit
LC TRIBAL 3-14D-56	4301351408	5	S	6	W	14		Oil Well	Approved Permit
LC TRIBAL 13-6D-57	4301351417	5	S	7	W	6		Oil Well	Approved Permit
LC TRIBAL 9-23-45	4301351432	4	S	5	W	23		Oil Well	Approved Permit
LC TRIBAL 5-28D-56	4301351441	5	S	6	W	29		Oil Well	Approved Permit
LC TRIBAL 15-20D-56	4301351443	5	S	6	W	29		Oil Well	Approved Permit
LC Tribal 16-33-45	4301351463	4	S	5	W	33		Oil Well	Approved Permit
LC TRIBAL 7-23D-56	4301351479	5	S	6	W	23		Oil Well	Approved Permit
LC TRIBAL 4-7-56	4301351482	5	S	6	W	7		Oil Well	Approved Permit
LC TRIBAL 3-2-56	4301351483	5	S	6	W	2		Oil Well	Approved Permit
CC TRIBAL 15-34D-38	4301351490	4	S	8	W	2		Oil Well	Approved Permit
CC TRIBAL 14-35D-38	4301351491	4	S	8	W	2		Oil Well	Approved Permit
CC TRIBAL 8-3D-48	4301351493	4	S	8	W	2		Oil Well	Approved Permit
LC TRIBAL 1-10D-56	4301351510	5	S	6	W	10		Oil Well	Approved Permit
LC TRIBAL 3-10D-56	4301351511	5	S	6	W	10		Oil Well	Approved Permit
LC TRIBAL 7-10D-56	4301351512	5	S	6	W	10		Oil Well	Approved Permit
LC TRIBAL 9-29D-56	4301351513	5	S	6	W	29		Oil Well	Approved Permit

From: Linn Operating, LLC
 To: Berry Petroleum Company, LLC
 Effective: May 1, 2017

UTE TRIBAL 1-16-55	4301351519	5	S	5	W	16	Oil Well	Approved Permit
LC TRIBAL 1-17-56	4301351704	5	S	6	W	17	Oil Well	Approved Permit
LC Tribal 4HW-8-56	4301351710	5	S	6	W	8	Oil Well	Approved Permit
LC TRIBAL 3-11D-56	4301351713	5	S	6	W	11	Oil Well	Approved Permit
LC TRIBAL 7-11D-56	4301351714	5	S	6	W	11	Oil Well	Approved Permit
LC TRIBAL 9-34D-45	4301351717	4	S	5	W	34	Oil Well	Approved Permit
LC TRIBAL 4-34D-45	4301351723	4	S	5	W	34	Oil Well	Approved Permit
LC TRIBAL 7-34D-45	4301351724	4	S	5	W	34	Oil Well	Approved Permit
LC TRIBAL 13-34D-45	4301351747	4	S	5	W	34	Oil Well	Approved Permit
LC TRIBAL 12-31D-56	4301351799	5	S	6	W	31	Oil Well	Approved Permit
LC TRIBAL 8-20D-56	4301351800	5	S	6	W	20	Oil Well	Approved Permit
LC TRIBAL 6-31D-56	4301351801	5	S	6	W	31	Oil Well	Approved Permit
LC Tribal 11-7D-57	4301351814	5	S	7	W	7	Oil Well	Approved Permit
LC Tribal 5-7D-57	4301351815	5	S	7	W	7	Oil Well	Approved Permit
LC Tribal 11-6D-57	4301351817	5	S	7	W	6	Oil Well	Approved Permit
LC Tribal 8-33-45	4301351859	4	S	5	W	33	Oil Well	Approved Permit
LC Tribal 7-23D-45	4301351865	4	S	5	W	23	Oil Well	Approved Permit
LC Tribal 1-23D-56	4301351866	5	S	6	W	23	Oil Well	Approved Permit
LC TRIBAL 1-19-56	4301351867	5	S	6	W	19	Oil Well	Approved Permit
LC TRIBAL 7-19D-56	4301351868	5	S	6	W	19	Oil Well	Approved Permit
LC TRIBAL 9-4D-56	4301351869	5	S	6	W	4	Oil Well	Approved Permit
LC Tribal 14-32D-45	4301351879	4	S	5	W	32	Oil Well	Approved Permit
LC TRIBAL 7-17D-56	4301351886	5	S	6	W	17	Oil Well	Approved Permit
LC TRIBAL 5-17D-56	4301351887	5	S	6	W	17	Oil Well	Approved Permit
LC TRIBAL 9-2D-56	4301351893	5	S	6	W	2	Oil Well	Approved Permit
LC TRIBAL 1-2D-56	4301351894	5	S	6	W	2	Oil Well	Approved Permit
LC Tribal 15-23D-45	4301351895	4	S	5	W	23	Oil Well	Approved Permit
LC TRIBAL 11-34D-56	4301351900	5	S	6	W	34	Oil Well	Approved Permit
LC TRIBAL 9-5D-56	4301351901	5	S	6	W	4	Oil Well	Approved Permit
LC Tribal 10-28D-45	4301351903	4	S	5	W	28	Oil Well	Approved Permit
LC TRIBAL 13-20D-56	4301351904	5	S	6	W	20	Oil Well	Approved Permit
Ute Tribal 14-17-55	4301351908	5	S	5	W	17	Oil Well	Approved Permit
Federal 14-7D-65	4301351910	5	S	6	W	31	Oil Well	Approved Permit
LC Tribal 3-27D-45	4301351911	4	S	5	W	27	Oil Well	Approved Permit
LC TRIBAL 9-34D-56	4301351914	5	S	6	W	34	Oil Well	Approved Permit
LC Tribal 10-33D-45	4301351939	4	S	5	W	33	Oil Well	Approved Permit
LC Tribal 14-33D-45	4301351940	4	S	5	W	33	Oil Well	Approved Permit
LC Tribal 10-27D-45	4301351941	4	S	5	W	27	Oil Well	Approved Permit
LC Tribal 14-27D-45	4301351951	4	S	5	W	27	Oil Well	Approved Permit
LC Tribal 6-33D-45	4301351955	4	S	5	W	33	Oil Well	Approved Permit
LC Tribal 6-32D-45	4301351956	4	S	5	W	32	Oil Well	Approved Permit
Federal 3-11D-65	4301351982	6	S	5	W	11	Oil Well	Approved Permit
Federal 2-4-64	4301351983	6	S	4	W	4	Oil Well	Approved Permit
Federal 5-11D-65	4301351984	6	S	5	W	11	Oil Well	Approved Permit

Federal 7-4D-64	4301351985	6	S	4	W	4		Oil Well	Approved Permit
Federal 3-4D-64	4301351986	6	S	4	W	4		Oil Well	Approved Permit
Federal 8-4D-64	4301351988	6	S	4	W	4		Oil Well	Approved Permit
Federal 6-4D-64	4301351989	6	S	4	W	4		Oil Well	Approved Permit
Federal 4-4D-64	4301351991	6	S	4	W	4		Oil Well	Approved Permit
Federal 9-4D-64	4301352004	6	S	4	W	4		Oil Well	Approved Permit
Federal 10-4D-64	4301352011	6	S	4	W	4		Oil Well	Approved Permit
Federal 1-4D-64	4301352025	6	S	4	W	4		Oil Well	Approved Permit
Federal 16-4D-64	4301352026	6	S	4	W	4		Oil Well	Approved Permit
LC Tribal 10-23D-45	4301352029	4	S	5	W	23		Oil Well	Approved Permit
Federal 15-4D-64	4301352032	6	S	4	W	4		Oil Well	Approved Permit
Federal 9-9D-64	4301352036	6	S	4	W	9		Oil Well	Approved Permit
Federal 10-9D-64	4301352041	6	S	4	W	9		Oil Well	Approved Permit
Federal 15-9D-64	4301352043	6	S	4	W	9		Oil Well	Approved Permit
Federal 16-9D-64	4301352044	6	S	4	W	9		Oil Well	Approved Permit
LC Tribal 10-32D-45	4301352065	4	S	5	W	32		Oil Well	Approved Permit
LC Tribal 16-28D-45	4301352073	4	S	5	W	28		Oil Well	Approved Permit
LC Tribal 15-24D-45	4301352074	4	S	5	W	24		Oil Well	Approved Permit
LC Tribal 13-17D-56	4301352076	5	S	6	W	17		Oil Well	Approved Permit
LC Tribal 15-17D-56	4301352077	5	S	6	W	17		Oil Well	Approved Permit
LC Tribal 5-26D-56	4301352097	5	S	6	W	26		Oil Well	Approved Permit
LC Tribal 11-26D-56	4301352098	5	S	6	W	26		Oil Well	Approved Permit
LC Tribal 4-9D-56	4301352102	5	S	6	W	9		Oil Well	Approved Permit
LC Tribal 8-32D-45	4301352135	4	S	5	W	32		Oil Well	Approved Permit
UTE Tribal 15-24D-54	4301352156	5	S	4	W	24		Gas Well	Approved Permit
UTE Tribal 9-24D-54	4301352157	5	S	4	W	24		Gas Well	Approved Permit
UTE Tribal 1-25D-54	4301352173	5	S	4	W	25		Gas Well	Approved Permit
UTE Tribal 9-25D-54	4301352177	5	S	4	W	25		Gas Well	Approved Permit
Myrin Tribal 9-10D-55	4301352189	5	S	5	W	10		Oil Well	Approved Permit
Myrin Tribal 16-10D-55	4301352190	5	S	5	W	10		Oil Well	Approved Permit
Myrin Tribal 10-10D-55	4301352191	5	S	5	W	10		Oil Well	Approved Permit
UTE Tribal 1-24D-54	4301352304	5	S	4	W	24		Gas Well	Approved Permit
UTE Tribal 7-24D-54	4301352306	5	S	4	W	24		Gas Well	Approved Permit
UTE Tribal 12-25D-54	4301352308	5	S	4	W	25		Gas Well	Approved Permit
UTE Tribal 4-13D-54	4301352321	5	S	4	W	13		Gas Well	Approved Permit
UTE Tribal 13-25D-54	4301352322	5	S	4	W	25		Gas Well	Approved Permit
UTE Tribal 3-24D-54	4301352347	5	S	4	W	24		Gas Well	Approved Permit
UTE Tribal 5-24D-54	4301352348	5	S	4	W	24		Gas Well	Approved Permit
State Tribal 14-1D-55	4301352372	5	S	5	W	1		Oil Well	Approved Permit
State Tribal 11-1D-55	4301352373	5	S	5	W	1		Oil Well	Approved Permit
State Tribal 13-1D-55	4301352374	5	S	5	W	1		Oil Well	Approved Permit
State Tribal 12-2D-55	4301352391	5	S	5	W	2		Oil Well	Approved Permit
State Tribal 14-2D-55	4301352392	5	S	5	W	2		Oil Well	Approved Permit
State Tribal 13-2D-55	4301352393	5	S	5	W	2		Oil Well	Approved Permit

From: Linn Operating, LLC
 To: Berry Petroleum Company, LLC
 Effective: May 1, 2017

State Tribal 14-3D-55	4301352430	5	S	5	W	3		Oil Well	Approved Permit
State Tribal 11-3D-55	4301352434	5	S	5	W	3		Oil Well	Approved Permit
State Tribal 13-3D-55	4301352435	5	S	5	W	3		Oil Well	Approved Permit
UTE TRIBAL 2-5D-55	4301352450	5	S	5	W	5		Oil Well	Approved Permit
Ute Tribal 1-5D-55	4301352456	5	S	5	W	5		Oil Well	Approved Permit
Ute Tribal 7-5-55	4301352459	5	S	5	W	5		Oil Well	Approved Permit
Ute Tribal 3-16D-54	4301352467	5	S	4	W	9		Oil Well	Approved Permit
State Tribal 1-3D-55	4301352471	5	S	5	W	3		Oil Well	Approved Permit
State Tribal 2-3D-55	4301352472	5	S	5	W	3		Oil Well	Approved Permit
State Tribal 7-3D-55	4301352473	5	S	5	W	3		Oil Well	Approved Permit
State Tribal 8-3D-55	4301352474	5	S	5	W	3		Oil Well	Approved Permit
Ute Tribal 2-16D-54	4301352481	5	S	4	W	9		Oil Well	Approved Permit
State Tribal 3-3D-55	4301352532	5	S	5	W	3		Oil Well	Approved Permit
State Tribal 4-3D-55	4301352533	5	S	5	W	3		Oil Well	Approved Permit
State Tribal 5-3D-55	4301352535	5	S	5	W	3		Oil Well	Approved Permit
State Tribal 6-3D-55	4301352536	5	S	5	W	3		Oil Well	Approved Permit
UTE TRIBAL 15-12D-55	4301352549	5	S	5	W	12		Oil Well	Approved Permit
Ute Tribal 9-11D-55	4301352564	5	S	5	W	11		Oil Well	Approved Permit
UTE TRIBAL 10-11D-55	4301352566	5	S	5	W	11		Oil Well	Approved Permit
UTE TRIBAL 15-11D-55	4301352567	5	S	5	W	11		Oil Well	Approved Permit
UTE TRIBAL 14-12D-55	4301352592	5	S	5	W	12		Oil Well	Approved Permit
UTE TRIBAL 13-12D-55	4301352593	5	S	5	W	12		Oil Well	Approved Permit
UTE TRIBAL 10-11D-54	4301352603	5	S	4	W	11		Oil Well	Approved Permit
UTE TRIBAL 9-11D-54	4301352604	5	S	4	W	11		Oil Well	Approved Permit
UTE TRIBAL 15-11-54	4301352605	5	S	4	W	11		Oil Well	Approved Permit
UTE TRIBAL 16-11D-54	4301352606	5	S	4	W	11		Oil Well	Approved Permit
UTE TRIBAL 14-11D-55	4301352610	5	S	5	W	11		Oil Well	Approved Permit
UTE TRIBAL 13-11D-55	4301352611	5	S	5	W	11		Oil Well	Approved Permit
UTE TRIBAL 12-11D-55	4301352612	5	S	5	W	11		Oil Well	Approved Permit
UTE TRIBAL 11-11D-55	4301352613	5	S	5	W	11		Oil Well	Approved Permit
Federal 6-7D-65	4301352682	6	S	5	W	7		Oil Well	Approved Permit
Federal 11-7D-65	4301352683	6	S	5	W	7		Oil Well	Approved Permit
Federal 10-7D-65	4301352684	6	S	5	W	7		Oil Well	Approved Permit
Federal 7-7D-65	4301352685	6	S	5	W	7		Oil Well	Approved Permit
UTE TRIBAL 4-17D-55	4301352695	5	S	5	W	17		Oil Well	Approved Permit
UTE TRIBAL 14-13D-54	4301352702	5	S	4	W	13		Oil Well	Approved Permit
State Tribal 3-11D-55	4301352704	5	S	5	W	11		Oil Well	Approved Permit
State Tribal 4-11D-55	4301352705	5	S	5	W	11		Oil Well	Approved Permit
State Tribal 5-11D-55	4301352706	5	S	5	W	11		Oil Well	Approved Permit
State Tribal 6-11D-55	4301352707	5	S	5	W	11		Oil Well	Approved Permit
State Tribal 8-11D-55	4301352708	5	S	5	W	11		Oil Well	Approved Permit
State Tribal 7-11D-55	4301352709	5	S	5	W	11		Oil Well	Approved Permit
State Tribal 2-11D-55	4301352710	5	S	5	W	11		Oil Well	Approved Permit
State Tribal 1-11D-55	4301352711	5	S	5	W	11		Oil Well	Approved Permit

From: Linn Operating, LLC
 To: Berry Petroleum Company, LLC
 Effective: May 1, 2017

UTE TRIBAL 9-4D-55	4301352713	5	S	5	W	4	Oil Well	Approved Permit
State Tribal 2-10D-55	4301352714	5	S	5	W	10	Oil Well	Approved Permit
State Tribal 7-10D-55	4301352715	5	S	5	W	10	Oil Well	Approved Permit
State Tribal 8-10D-55	4301352716	5	S	5	W	10	Oil Well	Approved Permit
UTE TRIBAL 10-4D-55	4301352717	5	S	5	W	4	Oil Well	Approved Permit
UTE TRIBAL 15-4D-55	4301352718	5	S	5	W	4	Oil Well	Approved Permit
State Tribal 1-10D-55	4301352720	5	S	5	W	10	Oil Well	Approved Permit
UTE TRIBAL 16-4D-55	4301352721	5	S	5	W	4	Oil Well	Approved Permit
State Tribal 3-10D-55	4301352723	5	S	5	W	10	Oil Well	Approved Permit
State Tribal 4-10D-55	4301352724	5	S	5	W	10	Oil Well	Approved Permit
State Tribal 5-10D-55	4301352725	5	S	5	W	10	Oil Well	Approved Permit
State Tribal 6-10D-55	4301352726	5	S	5	W	10	Oil Well	Approved Permit
UTE TRIBAL 11-5D-55	4301352727	5	S	5	W	5	Oil Well	Approved Permit
UTE TRIBAL 12-5D-55	4301352728	5	S	5	W	5	Oil Well	Approved Permit
UTE TRIBAL 13-5D-55	4301352729	5	S	5	W	5	Oil Well	Approved Permit
UTE TRIBAL 14-5D-55	4301352730	5	S	5	W	5	Oil Well	Approved Permit
State Tribal 15-2D-55	4301352732	5	S	5	W	2	Oil Well	Approved Permit
State Tribal 16-2D-55	4301352733	5	S	5	W	2	Oil Well	Approved Permit
State Tribal 9-2D-55	4301352735	5	S	5	W	2	Oil Well	Approved Permit
UTE TRIBAL 16-30D-55	4301352738	5	S	5	W	30	Oil Well	Approved Permit
Myrin Tribal 9-19D-55	4301352739	5	S	5	W	19	Oil Well	Approved Permit
State Tribal 16-3D-55	4301352740	5	S	5	W	3	Oil Well	Approved Permit
State Tribal 15-3D-55	4301352741	5	S	5	W	3	Oil Well	Approved Permit
State Tribal 10-3D-55	4301352742	5	S	5	W	3	Oil Well	Approved Permit
State Tribal 9-3D-55	4301352743	5	S	5	W	3	Oil Well	Approved Permit
Myrin Tribal 15-19D-55	4301352744	5	S	5	W	19	Oil Well	Approved Permit
Myrin Tribal 13-19D-55	4301352745	5	S	5	W	19	Oil Well	Approved Permit
Myrin Tribal 12-19D-55	4301352746	5	S	5	W	19	Oil Well	Approved Permit
UTE TRIBAL 5-4D-55	4301352747	5	S	5	W	4	Oil Well	Approved Permit
UTE TRIBAL 4-4D-55	4301352748	5	S	5	W	4	Oil Well	Approved Permit
UTE TRIBAL 3-4D-55	4301352749	5	S	5	W	4	Oil Well	Approved Permit
UTE TRIBAL 6-4D-55	4301352754	5	S	5	W	4	Oil Well	Approved Permit
UTE TRIBAL 7-31D-55	4301352764	5	S	5	W	31	Oil Well	Approved Permit
Myrin Tribal 11-19D-55	4301352765	5	S	5	W	19	Oil Well	Approved Permit
UTE TRIBAL 4-30D-55	4301352796	5	S	5	W	30	Oil Well	Approved Permit
UTE TRIBAL 5-30D-55	4301352797	5	S	5	W	30	Oil Well	Approved Permit
UTE TRIBAL 7-30D-55	4301352799	5	S	5	W	30	Oil Well	Approved Permit
UTE TRIBAL 1-30D-55	4301352809	5	S	5	W	30	Oil Well	Approved Permit
LC TRIBAL 6-25D-56	4301352810	5	S	6	W	25	Oil Well	Approved Permit
LC TRIBAL 4-25D-56	4301352812	5	S	6	W	25	Oil Well	Approved Permit
Federal 6-13D-65	4301352813	6	S	5	W	13	Oil Well	Approved Permit
Federal 4-13D-65	4301352814	6	S	5	W	13	Oil Well	Approved Permit
Federal 3-13D-65	4301352815	6	S	5	W	13	Oil Well	Approved Permit
Federal 3-16D-64	4301352823	6	S	4	W	16	Oil Well	Approved Permit

From: Linn Operating, LLC
 To: Berry Petroleum Company, LLC
 Effective: May 1, 2017

Federal 4-16D-64	4301352824	6	S	4	W	16	Oil Well	Approved Permit
Federal 5-16D-64	4301352825	6	S	4	W	16	Oil Well	Approved Permit
Federal 6-16D-64	4301352826	6	S	4	W	16	Oil Well	Approved Permit
Federal 5-13D-65	4301352827	6	S	5	W	13	Oil Well	Approved Permit
LC TRIBAL 1-25D-56	4301352835	5	S	6	W	25	Oil Well	Approved Permit
LC TRIBAL 2-25D-56	4301352836	5	S	6	W	25	Oil Well	Approved Permit
LC TRIBAL 8-25D-56	4301352837	5	S	6	W	25	Oil Well	Approved Permit
LC TRIBAL 9-25D-56	4301352840	5	S	6	W	25	Oil Well	Approved Permit
LC TRIBAL 15-25-56	4301352844	5	S	6	W	25	Oil Well	Approved Permit
Federal 9-5D-65	4301352846	6	S	5	W	5	Oil Well	Approved Permit
Federal 10-5D-65	4301352847	6	S	5	W	5	Oil Well	Approved Permit
LC TRIBAL 16-25D-56	4301352848	5	S	6	W	25	Oil Well	Approved Permit
LC TRIBAL 10-25D-56	4301352849	5	S	6	W	25	Oil Well	Approved Permit
UTE TRIBAL 8-30D-55	4301352855	5	S	5	W	29	Oil Well	Approved Permit
UTE TRIBAL 9-29D-55	4301352870	5	S	5	W	29	Oil Well	Approved Permit
UTE TRIBAL 6-24D-55	4301352871	5	S	5	W	24	Oil Well	Approved Permit
UTE TRIBAL 16-17D-55	4301352872	5	S	5	W	17	Oil Well	Approved Permit
Federal 9-8D-64	4301352880	6	S	4	W	9	Oil Well	Approved Permit
Federal 16-8D-64	4301352881	6	S	4	W	9	Oil Well	Approved Permit
UTE TRIBAL 13-27D-55	4301352882	5	S	5	W	27	Oil Well	Approved Permit
UTE TRIBAL 4-29D-55	4301352883	5	S	5	W	29	Oil Well	Approved Permit
UTE TRIBAL 1-29D-55	4301352884	5	S	5	W	29	Oil Well	Approved Permit
Federal 4-2D-65	4301352885	6	S	5	W	2	Oil Well	Approved Permit
Federal 5-2D-65	4301352886	6	S	5	W	2	Oil Well	Approved Permit
Federal 12-2D-65	4301352887	6	S	5	W	2	Oil Well	Approved Permit
LC TRIBAL 12-25D-56	4301352888	5	S	6	W	25	Oil Well	Approved Permit
LC TRIBAL 13-25D-56	4301352890	5	S	6	W	25	Oil Well	Approved Permit
LC TRIBAL 14-25D-56	4301352891	5	S	6	W	25	Oil Well	Approved Permit
Federal 15-3D-65	4301352892	6	S	5	W	3	Oil Well	Approved Permit
Federal 9-3D-65	4301352893	6	S	5	W	3	Oil Well	Approved Permit
Federal 8-3D-65	4301352894	6	S	5	W	3	Oil Well	Approved Permit
Federal 6-3D-65	4301352895	6	S	5	W	3	Oil Well	Approved Permit
LC Nielsen Tribal 6-33D-56	4301352896	5	S	6	W	33	Oil Well	Approved Permit
LC Nielsen Tribal 2-33D-56	4301352897	5	S	6	W	33	Oil Well	Approved Permit
LC Nielsen Tribal 4-33D-56	4301352898	5	S	6	W	33	Oil Well	Approved Permit
LC Nielsen Tribal 5-33D-56	4301352899	5	S	6	W	33	Oil Well	Approved Permit
UTE FEE 13-9D-54	4301352906	5	S	4	W	9	Oil Well	Approved Permit
UTE FEE 2-34D-55	4301352971	5	S	5	W	27	Oil Well	Approved Permit
Federal 13-7D-65	4301352974	6	S	5	W	7	Oil Well	Approved Permit
Federal 14-7D-65	4301352975	6	S	5	W	7	Oil Well	Approved Permit
UTE TRIBAL 6-27D-55	4301352976	5	S	5	W	27	Oil Well	Approved Permit
LC Nielsen Tribal 12-27D-56	4301352977	5	S	6	W	27	Oil Well	Approved Permit
LC Nielsen Tribal 13-27D-56	4301352978	5	S	6	W	27	Oil Well	Approved Permit
LC Nielsen Tribal 16-28D-56	4301352979	5	S	6	W	27	Oil Well	Approved Permit

From: Linn Operating, LLC
 To: Berry Petroleum Company, LLC
 Effective: May 1, 2017

LC Nielsen Fee 9-28D-56	4301352980	5	S	6	W	27		Oil Well	Approved Permit
LC FEE 9-36D-56	4301352982	5	S	6	W	36		Oil Well	Approved Permit
LC FEE 15-36D-56	4301352983	5	S	6	W	36		Oil Well	Approved Permit
LC TRIBAL 6-36D-56	4301352984	5	S	6	W	36		Oil Well	Approved Permit
LC TRIBAL 5-36D-56	4301352985	5	S	6	W	36		Oil Well	Approved Permit
LC TRIBAL 4-36D-56	4301352986	5	S	6	W	36		Oil Well	Approved Permit
LC TRIBAL 3-36D-56	4301352987	5	S	6	W	36		Oil Well	Approved Permit
LC TRIBAL 2-35D-56	4301352988	5	S	6	W	35		Oil Well	Approved Permit
LC TRIBAL 1-35D-56	4301352989	5	S	6	W	35		Oil Well	Approved Permit
LC TRIBAL 9-35D-56	4301353018	5	S	6	W	35		Oil Well	Approved Permit
LC TRIBAL 6-35D-56	4301353019	5	S	6	W	35		Oil Well	Approved Permit
LC TRIBAL 10-35D-56	4301353020	5	S	6	W	35		Oil Well	Approved Permit
UTE TRIBAL 9-17D-55	4301353022	5	S	5	W	17		Oil Well	Approved Permit
LC TRIBAL 8-35D-56	4301353023	5	S	6	W	35		Oil Well	Approved Permit
UTE TRIBAL 10-17D-55	4301353024	5	S	5	W	17		Oil Well	Approved Permit
LC TRIBAL 7-35D-56	4301353025	5	S	6	W	35		Oil Well	Approved Permit
LC TRIBAL 5-35D-56	4301353026	5	S	6	W	35		Oil Well	Approved Permit
LC TRIBAL 15-35D-56	4301353027	5	S	6	W	35		Oil Well	Approved Permit
LC TRIBAL 16-35D-56	4301353028	5	S	6	W	35		Oil Well	Approved Permit
LC TRIBAL 3-35D-56	4301353029	5	S	6	W	35		Oil Well	Approved Permit
LC TRIBAL 4-35D-56	4301353030	5	S	6	W	35		Oil Well	Approved Permit
LC TRIBAL 14-35D-56	4301353036	5	S	6	W	35		Oil Well	Approved Permit
LC TRIBAL 13-35D-56	4301353038	5	S	6	W	35		Oil Well	Approved Permit
LC TRIBAL 12-35D-56	4301353039	5	S	6	W	35		Oil Well	Approved Permit
LC TRIBAL 11-35D-56	4301353040	5	S	6	W	35		Oil Well	Approved Permit
UTE TRIBAL 8-14D-55	4301353099	5	S	5	W	14		Oil Well	Approved Permit
LC FEE 13-36D-56	4301353114	5	S	6	W	36		Oil Well	Approved Permit
LC FEE 11-36D-56	4301353115	5	S	6	W	36		Oil Well	Approved Permit
LC Nielsen Fee 15-28D-56	4301353131	5	S	6	W	28		Oil Well	Approved Permit
UTE TRIBAL 3-20D-55	4301333280	5	S	5	W	20	18424	Oil Well	Drilling Operations Suspended
LC TRIBAL 4H-17-56	4301333540	5	S	6	W	17	18067	Oil Well	Drilling Operations Suspended
UTE TRIBAL 8-20D-55	4301333676	5	S	5	W	20	17308	Oil Well	Drilling Operations Suspended
UTE TRIBAL 14-14D-55	4301333699	5	S	5	W	14	18409	Oil Well	Drilling Operations Suspended
UTE TRIBAL 5-29D-55	4301333740	5	S	5	W	29	17306	Oil Well	Drilling Operations Suspended
UTE TRIBAL 7-32D-55	4301333794	5	S	5	W	32	18359	Oil Well	Drilling Operations Suspended
UTE TRIBAL 12-27D-55	4301333798	5	S	5	W	27	18360	Oil Well	Drilling Operations Suspended
BERRY TRIBAL 2-23D-54	4301333805	5	S	4	W	23	18546	Oil Well	Drilling Operations Suspended
UTE TRIBAL 13-29D-55	4301333807	5	S	5	W	29	18378	Oil Well	Drilling Operations Suspended
UTE TRIBAL 16-28D-55	4301333887	5	S	5	W	28	18594	Oil Well	Drilling Operations Suspended
FEDERAL 10-10D-65	4301350523	6	S	5	W	10	19773	Oil Well	Drilling Operations Suspended
LC FEE 8-15D-56	4301350597	5	S	6	W	15	19347	Oil Well	Drilling Operations Suspended
SFW FEE 13-10D-54	4301350892	5	S	4	W	10	19186	Oil Well	Drilling Operations Suspended
SFW TRIBAL 11-10D-54	4301350893	5	S	4	W	10	19215	Oil Well	Drilling Operations Suspended
LC TRIBAL 16-34D-45	4301350977	4	S	5	W	34	18658	Oil Well	Drilling Operations Suspended

From: Linn Operating, LLC
 To: Berry Petroleum Company, LLC
 Effective: May 1, 2017

LC TRIBAL 5-29D-56	4301351184	5	S	6	W	29		Oil Well	Drilling Operations Suspended
LC TRIBAL 2-33D-45	4301351402	4	S	5	W	33	18854	Oil Well	Drilling Operations Suspended
LC TRIBAL 9-24D-45	4301351431	4	S	5	W	24	18861	Oil Well	Drilling Operations Suspended
LC TRIBAL 9-3D-56	4301351514	5	S	6	W	3	18948	Oil Well	Drilling Operations Suspended
LC Tribal 3-34D-56	4301352087	5	S	6	W	34	19234	Oil Well	Drilling Operations Suspended
LC Tribal 7-34D-56	4301352088	5	S	6	W	34	19235	Oil Well	Drilling Operations Suspended
Ute Tribal 5-9D-54	4301352463	5	S	4	W	9	19354	Oil Well	Drilling Operations Suspended
Ute Tribal 3-9D-54	4301352464	5	S	4	W	9	19355	Oil Well	Drilling Operations Suspended
UTE TRIBAL 7-17D-55	4301352691	5	S	5	W	17	19691	Oil Well	Drilling Operations Suspended
UTE TRIBAL 6-17D-55	4301352692	5	S	5	W	17	19708	Oil Well	Drilling Operations Suspended
UTE TRIBAL 3-17D-55	4301352693	5	S	5	W	17	19709	Oil Well	Drilling Operations Suspended
UTE TRIBAL 2-17D-55	4301352694	5	S	5	W	17	19692	Oil Well	Drilling Operations Suspended
State Tribal 3-12D-55	4301352697	5	S	5	W	12	19667	Oil Well	Drilling Operations Suspended
State Tribal 4-12D-55	4301352698	5	S	5	W	12	19668	Oil Well	Drilling Operations Suspended
State Tribal 10-2D-55	4301352734	5	S	5	W	2	19710	Oil Well	Drilling Operations Suspended
LC TRIBAL 1-36D-56	4301353021	5	S	6	W	36		Oil Well	Drilling Operations Suspended
LC TRIBAL 8-36D-56	4301353034	5	S	6	W	36		Oil Well	Drilling Operations Suspended
LC TRIBAL 7-36D-56	4301353035	5	S	6	W	36		Oil Well	Drilling Operations Suspended
LC TRIBAL 2-36D-56	4301353037	5	S	6	W	36		Oil Well	Drilling Operations Suspended
UTE TRIBAL 13-17D-55	4301333550	5	S	5	W	17		Oil Well	Location Abandoned
UTE TRIBAL 11-14D-54	4301333596	5	S	4	W	14		Oil Well	Location Abandoned
UTE TRIBAL 16-17D-55	4301333622	5	S	5	W	17		Oil Well	Location Abandoned
LC TRIBAL 14-16D-56	4301334283	5	S	6	W	16		Oil Well	Location Abandoned
LC TRIBAL 3-23D-56	4301350624	5	S	6	W	23		Oil Well	Location Abandoned
FEDERAL 2-1D-64	4301350765	6	S	4	W	1		Oil Well	Location Abandoned
FEDERAL 7-1D-64	4301350766	6	S	4	W	1		Oil Well	Location Abandoned
FEDERAL 9-1D-64	4301350767	6	S	4	W	1		Oil Well	Location Abandoned
CC FEE 8-24-38	4301350885	3	S	8	W	24		Oil Well	Location Abandoned
LC FEE 4H-12-57	4301350952	5	S	7	W	12		Oil Well	Location Abandoned
CC TRIBAL 4-2-48	4301350964	4	S	8	W	2		Oil Well	Location Abandoned
LC TRIBAL 7-2D-56	4301350988	5	S	6	W	2		Oil Well	Location Abandoned
LC TRIBAL 10-18D-56	4301350989	5	S	6	W	18		Oil Well	Location Abandoned
LC TRIBAL 3-16D-56	4301351032	5	S	6	W	16		Oil Well	Location Abandoned
CC FEE 6-21-38	4301351059	3	S	8	W	21		Oil Well	Location Abandoned
LC TRIBAL 12H-19-56	4301351193	5	S	6	W	19		Oil Well	Location Abandoned
LC FEE 15-11D-56	4301351197	5	S	6	W	11		Oil Well	Location Abandoned
LC TRIBAL 13H-10-56	4301351209	5	S	6	W	11		Oil Well	Location Abandoned
LC TRIBAL 2-31D-45	4301351261	4	S	5	W	31		Oil Well	Location Abandoned
LC TRIBAL 13H-24-45	4301351273	4	S	5	W	24		Oil Well	Location Abandoned
UTE TRIBAL 6-21D-55	4301351274	5	S	5	W	21		Oil Well	Location Abandoned
UTE TRIBAL 15-16D-55	4301351284	5	S	5	W	16		Oil Well	Location Abandoned
UTE TRIBAL 4H-15-55	4301351292	5	S	5	W	15		Oil Well	Location Abandoned
UTE TRIBAL 13H-14-54	4301351297	5	S	4	W	14		Oil Well	Location Abandoned
UTE TRIBAL 1-32-55	4301351298	5	S	5	W	32		Oil Well	Location Abandoned

From: Linn Operating, LLC
 To: Berry Petroleum Company, LLC
 Effective: May 1, 2017

UTE TRIBAL 4-21D-55	4301351299	5	S	5	W	21	Oil Well	Location Abandoned
LC TRIBAL 12-33-45	4301351301	4	S	5	W	33	Oil Well	Location Abandoned
UTE TRIBAL 16-15D-55	4301351302	5	S	5	W	15	Oil Well	Location Abandoned
UTE TRIBAL 2-24-55	4301351304	5	S	5	W	24	Oil Well	Location Abandoned
LC TRIBAL 11-32D-56	4301351315	5	S	6	W	32	Oil Well	Location Abandoned
LC TRIBAL 1-32D-56	4301351317	5	S	6	W	32	Oil Well	Location Abandoned
LC TRIBAL 5H-32-56	4301351318	5	S	6	W	32	Oil Well	Location Abandoned
LC TRIBAL 14-28-45	4301351339	4	S	5	W	28	Oil Well	Location Abandoned
LC TRIBAL 16-32D-45	4301351340	4	S	5	W	32	Oil Well	Location Abandoned
LC TRIBAL 3-31-45	4301351347	4	S	5	W	31	Oil Well	Location Abandoned
LC TRIBAL 1-18D-56	4301351367	5	S	6	W	18	Oil Well	Location Abandoned
LC TRIBAL 9-18D-56	4301351368	5	S	6	W	18	Oil Well	Location Abandoned
LC FEE 9-23D-56	4301351380	5	S	6	W	23	Oil Well	Location Abandoned
LC TRIBAL 1-34D-45	4301351382	4	S	5	W	34	Oil Well	Location Abandoned
LC TRIBAL 12-21D-56	4301351383	5	S	6	W	21	Oil Well	Location Abandoned
LC TRIBAL 7-29D-56	4301351386	5	S	6	W	29	Oil Well	Location Abandoned
UTE TRIBAL 6-15-55	4301351399	5	S	5	W	15	Oil Well	Location Abandoned
UTE TRIBAL 7-21D-55	4301351403	5	S	5	W	21	Oil Well	Location Abandoned
CC FEE 13-9D-37	4301351409	3	S	7	W	9	Oil Well	Location Abandoned
CC FEE 16-21D-38	4301351410	3	S	8	W	21	Oil Well	Location Abandoned
UTE TRIBAL 5H-10-54	4301351415	5	S	4	W	10	Oil Well	Location Abandoned
LC FEE 14-1-56	4301351457	5	S	6	W	1	Oil Well	Location Abandoned
LC TRIBAL 5-3D-56	4301351459	5	S	6	W	3	Oil Well	Location Abandoned
LC TRIBAL 12H-23-56	4301351488	5	S	6	W	23	Oil Well	Location Abandoned
LC TRIBAL 12HH-31-45	4301351499	4	S	5	W	32	Oil Well	Location Abandoned
CC Tribal 3-27D-38	4301351604	3	S	8	W	27	Oil Well	Location Abandoned
Myrin Fee 3-16D-55	4301351633	5	S	5	W	16	Oil Well	Location Abandoned
LC TRIBAL 12H-34-56	4301351634	5	S	6	W	34	Oil Well	Location Abandoned
UTE FEE 12-16D-55	4301351635	5	S	5	W	16	Oil Well	Location Abandoned
LC Tribal 13-11D-58	4301351708	5	S	8	W	11	Oil Well	Location Abandoned
LC Tribal 15-11D-58	4301351709	5	S	8	W	11	Oil Well	Location Abandoned
LC FEE 1-11D-56	4301351712	5	S	6	W	11	Oil Well	Location Abandoned
LC Tribal 8M-23-45	4301351722	4	S	5	W	23	Oil Well	Location Abandoned
LC Tribal 3-14D-58	4301351726	5	S	8	W	11	Oil Well	Location Abandoned
LC Tribal 11-11D-58	4301351729	5	S	8	W	11	Oil Well	Location Abandoned
LC TRIBAL 8-31D-56	4301351746	5	S	6	W	31	Oil Well	Location Abandoned
LC Fee 2-6D-57	4301351749	5	S	7	W	6	Oil Well	Location Abandoned
LC Tribal 15-12D-58	4301351783	5	S	8	W	12	Oil Well	Location Abandoned
LC Tribal 9-12D-58	4301351784	5	S	8	W	12	Oil Well	Location Abandoned
LC Tribal 1-13D-58	4301351785	5	S	8	W	12	Oil Well	Location Abandoned
LC Tribal 13-7D-57	4301351786	5	S	8	W	12	Oil Well	Location Abandoned
LC Tribal 9-2D-58	4301351788	5	S	8	W	2	Oil Well	Location Abandoned
LC Tribal 1-2D-58	4301351789	5	S	8	W	2	Oil Well	Location Abandoned
LC Tribal 5-1D-58	4301351790	5	S	8	W	2	Oil Well	Location Abandoned

From: Linn Operating, LLC
 To: Berry Petroleum Company, LLC
 Effective: May 1, 2017

LC Fee 15-6D-57	4301351816	5	S	7	W	6		Oil Well	Location Abandoned
LC Fee 7-31D-45	4301351857	4	S	5	W	31		Oil Well	Location Abandoned
LC Tribal 5-31D-45	4301351858	4	S	5	W	31		Oil Well	Location Abandoned
LC Tribal 16-31-45	4301351863	4	S	5	W	31		Oil Well	Location Abandoned
LC FEE 4-32D-45	4301351892	4	S	5	W	31		Oil Well	Location Abandoned
CC Fee 8R-9-37	4301351937	3	S	7	W	9		Oil Well	Location Abandoned
LC Tribal 13-26D-56	4301352099	5	S	6	W	26		Oil Well	Location Abandoned
LC Tribal 2-27D-45	4301352100	4	S	5	W	27		Oil Well	Location Abandoned
LC Tribal 8-27D-45	4301352101	4	S	5	W	27		Oil Well	Location Abandoned
Abbott Fee 1-6D-54	4301352324	5	S	4	W	6		Oil Well	Location Abandoned
Abbott Fee 7-6D-54	4301352327	5	S	4	W	6		Oil Well	Location Abandoned
UTE FEE 10-9D-54	4301352475	5	S	4	W	9		Oil Well	Location Abandoned
UTE FEE 12-9D-54	4301352476	5	S	4	W	9		Oil Well	Location Abandoned
UTE FEE 16-9D-54	4301352478	5	S	4	W	9		Oil Well	Location Abandoned
UTE FEE 11-9D-54	4301352544	5	S	4	W	9		Oil Well	Location Abandoned
UTE TRIBAL 6-5D-55	4301352556	5	S	5	W	5		Oil Well	Location Abandoned
UTE TRIBAL 5-5D-55	4301352557	5	S	5	W	5		Oil Well	Location Abandoned
UTE TRIBAL 4-5D-55	4301352558	5	S	5	W	5		Oil Well	Location Abandoned
UTE TRIBAL 3-5D-55	4301352559	5	S	5	W	5		Oil Well	Location Abandoned
UTE TRIBAL 10-30D-55	4301352736	5	S	5	W	30		Oil Well	Location Abandoned
UTE TRIBAL 8-5D-55	4301352773	5	S	5	W	5		Oil Well	Location Abandoned
UTE FEE 1-13D-55	4301352838	5	S	5	W	13		Oil Well	Location Abandoned
SCOFIELD-THORPE 26-31	4300730987	12	S	7	E	26		Dry Hole	Plugged & Abandoned
SCOFIELD-THORPE 26-43	4300730990	12	S	7	E	26		Dry Hole	Plugged & Abandoned
SCOFIELD CHRISTIANSEN 8-23	4300730999	12	S	7	E	8		Dry Hole	Plugged & Abandoned
NUTTERS RIDGE FED 5-1	4301330403	6	S	4	W	5	8231	Oil Well	Plugged & Abandoned
ANTELOPE RIDGE 24-1	4301330426	6	S	5	W	24		Dry Hole	Plugged & Abandoned
B C UTE TRIBAL 8-21	4301330829	5	S	4	W	21	8414	Water Injection Well	Plugged & Abandoned
LC TRIBAL 16-21-46	4301333575	4	S	6	W	21		Dry Hole	Plugged & Abandoned
LC TRIBAL 8-4-56	4301333605	5	S	6	W	4	17046	Oil Well	Plugged & Abandoned
FOY 9-33D-55	4301333802	5	S	5	W	33		Dry Hole	Plugged & Abandoned
CC FEE 7-28-38	4301350887	3	S	8	W	28		Dry Hole	Plugged & Abandoned
CC FEE 8-9-37	4301350896	3	S	7	W	9		Dry Hole	Plugged & Abandoned
LC TRIBAL 5HH-5-56	4301350927	5	S	6	W	4		Dry Hole	Plugged & Abandoned
LC TRIBAL 3-4D-56	4301351000	5	S	6	W	4		Dry Hole	Plugged & Abandoned
ST LOST CREEK 32-44	4304930023	11	S	7	E	32		Dry Hole	Plugged & Abandoned
BC UTE TRIBAL 4-22	4301330755	5	S	4	W	22	2620	Oil Well	Producing
B C UTE TRIBAL 16-16	4301330841	5	S	4	W	16	9489	Oil Well	Producing
B C UTE TRIBAL 14-15	4301330842	5	S	4	W	15	9440	Oil Well	Producing
UTE TRIBAL 1-32R	4301330872	5	S	4	W	32	13020	Oil Well	Producing
UTE TRIBAL 23-3R	4301330886	5	S	4	W	23	13034	Oil Well	Producing
UTE TRIBAL 13-3R-54	4301330924	5	S	4	W	3	9488	Oil Well	Producing
S COTTONWOOD RIDGE UTE TRIBAL 1-19	4301330933	5	S	4	W	19	9845	Oil Well	Producing
TABBY CYN UTE TRIBAL 1-25	4301330945	5	S	5	W	25	9722	Oil Well	Producing

From: Linn Operating, LLC
 To: Berry Petroleum Company, LLC
 Effective: May 1, 2017

S BRUNDAGE UTE TRIBAL 1-30	4301330948	5	S	4	W	30	9850	Oil Well	Producing
SOWERS CYN UTE TRIBAL 3-26	4301330955	5	S	5	W	26	10423	Oil Well	Producing
UTE TRIBAL 3-24R-55 (REENTRY)	4301330960	5	S	5	W	24	15173	Oil Well	Producing
UTE TRIBAL 1-20	4301330966	5	S	4	W	20	9925	Oil Well	Producing
T C UTE TRIBAL 9-23X	4301330999	5	S	5	W	23	9720	Oil Well	Producing
UTE TRIBAL 15-24R	4301331129	5	S	5	W	24	11985	Oil Well	Producing
S BRUNDAGE CYN UTE TRIBAL 4-27	4301331131	5	S	4	W	27	9851	Oil Well	Producing
UTE TRIBAL 5-13	4301331152	5	S	5	W	13	10421	Oil Well	Producing
UTE TRIBAL 7-20R-54	4301331281	5	S	4	W	20	14088	Oil Well	Producing
Z and T UTE TRIBAL 7-19	4301331282	5	S	4	W	19	11131	Oil Well	Producing
UTE TRIBAL 13-19	4301331284	5	S	4	W	19	11134	Oil Well	Producing
Z and T UTE TRIBAL 7-25	4301331310	5	S	5	W	25	11416	Oil Well	Producing
UTE TRIBAL 13-17	4301331546	5	S	4	W	17	11921	Oil Well	Producing
UTE TRIBAL 11-19	4301331547	5	S	4	W	19	11920	Oil Well	Producing
UTE TRIBAL 13-22	4301331548	5	S	4	W	22	11926	Oil Well	Producing
UTE TRIBAL 1-28	4301331549	5	S	4	W	28	11925	Oil Well	Producing
UTE TRIBAL 4-30	4301331550	5	S	4	W	30	11914	Oil Well	Producing
UTE TRIBAL 15-16	4301331648	5	S	4	W	16	11951	Oil Well	Producing
UTE TRIBAL 16-18	4301331650	5	S	4	W	18	11946	Oil Well	Producing
UTE TRIBAL 5-20	4301331651	5	S	4	W	20	11957	Oil Well	Producing
UTE TRIBAL 15-23	4301331671	5	S	5	W	23	11989	Oil Well	Producing
TABBY CANYON 1-21	4301331699	5	S	5	W	21	12225	Oil Well	Producing
TABBY CANYON 8-22	4301331700	5	S	5	W	22	12008	Oil Well	Producing
SOWERS CANYON 9-27	4301331701	5	S	5	W	27	11997	Oil Well	Producing
UTE TRIBAL 9-19	4301331831	5	S	4	W	19	12175	Oil Well	Producing
UTE TRIBAL 15-19	4301331832	5	S	4	W	19	12180	Oil Well	Producing
UTE TRIBAL 2-25	4301331833	5	S	5	W	25	12153	Oil Well	Producing
UTE TRIBAL 3-25	4301331834	5	S	5	W	25	12152	Oil Well	Producing
UTE TRIBAL 11-24	4301331909	5	S	5	W	24	12190	Oil Well	Producing
UTE TRIBAL 13-24	4301331910	5	S	5	W	24	12217	Oil Well	Producing
UTE TRIBAL 11-25	4301331911	5	S	5	W	25	12182	Oil Well	Producing
UTE TRIBAL 1-26	4301331912	5	S	5	W	26	12235	Oil Well	Producing
UTE TRIBAL 2-19	4301332140	5	S	4	W	19	12795	Oil Well	Producing
UTE TRIBAL 6-25H	4301332143	5	S	5	W	25	12750	Oil Well	Producing
UTE TRIBAL 9-18	4301332144	5	S	4	W	18	12746	Oil Well	Producing
UTE TRIBAL 11-17	4301332145	5	S	4	W	17	12747	Oil Well	Producing
UTE TRIBAL 12-17	4301332146	5	S	4	W	17	12745	Oil Well	Producing
UTE TRIBAL 15-18	4301332148	5	S	4	W	18	12794	Oil Well	Producing
UTE TRIBAL 6-22	4301332163	5	S	4	W	22	12974	Oil Well	Producing
UTE TRIBAL 6-21	4301332164	5	S	4	W	21	12994	Oil Well	Producing
UTE TRIBAL 7-28	4301332166	5	S	4	W	28	12995	Oil Well	Producing
UTE TRIBAL 11-20	4301332168	5	S	4	W	20	12946	Oil Well	Producing
UTE TRIBAL 13-25	4301332169	5	S	5	W	25	12857	Oil Well	Producing
UTE TRIBAL 2-27	4301332179	5	S	4	W	27	12975	Oil Well	Producing

From: Linn Operating, LLC
 To: Berry Petroleum Company, LLC
 Effective: May 1, 2017

UTE TRIBAL 1-34	4301332186	5	S	4	W	34	13121	Oil Well	Producing
UTE TRIBAL 2-35	4301332187	5	S	5	W	35	13021	Oil Well	Producing
UTE TRIBAL 4-36	4301332188	5	S	5	W	36	13063	Oil Well	Producing
UTE TRIBAL 5-28	4301332189	5	S	4	W	28	13026	Oil Well	Producing
UTE TRIBAL 5-31	4301332190	5	S	4	W	31	13080	Oil Well	Producing
UTE TRIBAL 9-26	4301332191	5	S	4	W	26	13101	Oil Well	Producing
UTE TRIBAL 11-28	4301332192	5	S	4	W	28	13022	Oil Well	Producing
UTE TRIBAL 3-29	4301332193	5	S	4	W	29	13042	Oil Well	Producing
UTE TRIBAL 5-19	4301332204	5	S	4	W	19	13090	Oil Well	Producing
UTE TRIBAL 12-15	4301332205	5	S	4	W	15	13100	Oil Well	Producing
UTE TRIBAL 13-20	4301332206	5	S	4	W	20	13048	Oil Well	Producing
UTE TRIBAL 1-24-55	4301332259	5	S	5	W	24	13618	Oil Well	Producing
UTE TRIBAL 3-28-54	4301332261	5	S	4	W	28	13644	Oil Well	Producing
UTE TRIBAL 5-26-55	4301332264	5	S	5	W	26	13642	Oil Well	Producing
UTE TRIBAL 6-36-55	4301332265	5	S	5	W	36	13600	Oil Well	Producing
UTE TRIBAL 8-35-55	4301332267	5	S	5	W	35	13571	Oil Well	Producing
UTE TRIBAL 9-24-55	4301332268	5	S	5	W	24	13620	Oil Well	Producing
UTE TRIBAL 11-23-55	4301332269	5	S	5	W	23	13572	Oil Well	Producing
UTE TRIBAL 15-25-55	4301332271	5	S	5	W	25	13566	Oil Well	Producing
UTE TRIBAL 16-14-55	4301332272	5	S	5	W	14	13567	Oil Well	Producing
UTE TRIBAL 15-27-55	4301332339	5	S	5	W	27	14020	Oil Well	Producing
UTE TRIBAL 5-15-55	4301332344	5	S	5	W	15	13606	Oil Well	Producing
UTE TRIBAL 7-20-55	4301332346	5	S	5	W	20	13607	Oil Well	Producing
MOON TRIBAL 12-23-54	4301332347	5	S	4	W	23	14008	Oil Well	Producing
UTE TRIBAL 14-28-55	4301332348	5	S	5	W	28	13580	Oil Well	Producing
UTE TRIBAL 16-29-55	4301332349	5	S	5	W	29	13581	Oil Well	Producing
UTE TRIBAL 2-32-55	4301332350	5	S	5	W	32	13695	Oil Well	Producing
FOY TRIBAL 11-34-55	4301332351	5	S	5	W	34	13648	Oil Well	Producing
UTE TRIBAL 16-35-55	4301332352	5	S	5	W	35	14267	Oil Well	Producing
UTE TRIBAL 10-35-55	4301332353	5	S	5	W	35	13645	Oil Well	Producing
UTE TRIBAL 12-36-55	4301332354	5	S	5	W	36	13643	Oil Well	Producing
UTE TRIBAL 14-36-55	4301332355	5	S	5	W	36	14262	Oil Well	Producing
UTE TRIBAL 16-36-55	4301332356	5	S	5	W	36	14122	Oil Well	Producing
UTE TRIBAL 4-33-55	4301332357	5	S	5	W	33	13685	Oil Well	Producing
UTE TRIBAL 15-17-55	4301332358	5	S	5	W	17	13698	Oil Well	Producing
UTE TRIBAL 12-14-54	4301332369	5	S	4	W	14	13647	Oil Well	Producing
UTE TRIBAL 3-20-54	4301332377	5	S	4	W	20	13955	Oil Well	Producing
UTE TRIBAL 4-21-54	4301332378	5	S	4	W	21	13907	Oil Well	Producing
UTE TRIBAL 9-20-54	4301332379	5	S	4	W	20	13906	Oil Well	Producing
UTE TRIBAL 5-30-54	4301332380	5	S	4	W	30	13905	Oil Well	Producing
UTE TRIBAL 9-30-54	4301332383	5	S	4	W	30	14050	Oil Well	Producing
UTE TRIBAL 12-21-54	4301332385	5	S	4	W	21	13928	Oil Well	Producing
UTE TRIBAL 15-20-54	4301332386	5	S	4	W	20	13911	Oil Well	Producing
UTE TRIBAL 13-28-54	4301332387	5	S	4	W	28	13908	Oil Well	Producing

From: Linn Operating, LLC
 To: Berry Petroleum Company, LLC
 Effective: May 1, 2017

UTE TRIBAL 9-28-54	4301332388	5	S	4	W	28	13910	Oil Well	Producing
UTE TRIBAL 15-28-54	4301332389	5	S	4	W	28	13909	Oil Well	Producing
UTE TRIBAL 9-25-55	4301332390	5	S	5	W	25	13715	Oil Well	Producing
MOON TRIBAL 6-27-54	4301332407	5	S	4	W	27	13969	Oil Well	Producing
MOON TRIBAL 14-27-54	4301332408	5	S	4	W	27	13998	Oil Well	Producing
UTE TRIBAL 3-32-54	4301332410	5	S	4	W	32	13949	Oil Well	Producing
UTE TRIBAL 7-32-54	4301332411	5	S	4	W	32	13936	Oil Well	Producing
UTE TRIBAL 7-33-54	4301332413	5	S	4	W	33	13945	Oil Well	Producing
UTE TRIBAL 11-20-55	4301332415	5	S	5	W	20	14269	Oil Well	Producing
UTE TRIBAL 1-27-55	4301332416	5	S	5	W	27	13947	Oil Well	Producing
UTE TRIBAL 3-27-55	4301332417	5	S	5	W	27	14022	Oil Well	Producing
UTE TRIBAL 7-27-55	4301332418	5	S	5	W	27	13948	Oil Well	Producing
UTE TRIBAL 10-28-55	4301332419	5	S	5	W	28	14580	Oil Well	Producing
UTE TRIBAL 6-32-55	4301332420	5	S	5	W	32	14895	Oil Well	Producing
UTE TRIBAL 8-32-55	4301332421	5	S	5	W	32	14896	Oil Well	Producing
UTE TRIBAL 2-36-55	4301332422	5	S	5	W	36	13937	Oil Well	Producing
UTE TRIBAL 8-36-55	4301332423	5	S	5	W	36	14021	Oil Well	Producing
UTE TRIBAL 13-16-54	4301332511	5	S	4	W	16	13981	Oil Well	Producing
UTE TRIBAL 11-30-54	4301332512	5	S	4	W	30	13982	Oil Well	Producing
UTE TRIBAL 13-23-55	4301332513	5	S	5	W	23	13975	Oil Well	Producing
UTE TRIBAL 7-23-55	4301332514	5	S	5	W	23	13976	Oil Well	Producing
UTE TRIBAL 5-33-54	4301332521	5	S	4	W	33	14060	Oil Well	Producing
UTE TRIBAL 11-33-54	4301332522	5	S	4	W	33	14061	Oil Well	Producing
UTE TRIBAL 14-32-54	4301332523	5	S	4	W	32	14062	Oil Well	Producing
UTE TRIBAL 1-23-55	4301332524	5	S	5	W	23	14044	Oil Well	Producing
UTE TRIBAL 5-29-54	4301332525	5	S	4	W	29	14045	Oil Well	Producing
UTE TRIBAL 1-31-54	4301332526	5	S	4	W	31	14116	Oil Well	Producing
UTE TRIBAL 3-31-54	4301332527	5	S	4	W	31	14109	Oil Well	Producing
UTE TRIBAL 7-31-54	4301332528	5	S	4	W	31	14160	Oil Well	Producing
UTE TRIBAL 9-31-54	4301332529	5	S	4	W	31	14177	Oil Well	Producing
UTE TRIBAL 11-31-54	4301332530	5	S	4	W	31	14163	Oil Well	Producing
UTE TRIBAL 3-23-55	4301332536	5	S	5	W	23	14077	Oil Well	Producing
UTE TRIBAL 5-23-55	4301332537	5	S	5	W	23	14108	Oil Well	Producing
UTE TRIBAL 9-32-54	4301332538	5	S	4	W	32	14199	Oil Well	Producing
UTE TRIBAL 5-32-54	4301332539	5	S	4	W	32	14112	Oil Well	Producing
MOON TRIBAL 10-27-54	4301332540	5	S	4	W	27	14195	Oil Well	Producing
MOON TRIBAL 12-27-54	4301332541	5	S	4	W	27	14161	Oil Well	Producing
MOON TRIBAL 8-27-54	4301332543	5	S	4	W	27	14139	Oil Well	Producing
UTE TRIBAL 9-33-54	4301332549	5	S	4	W	33	14162	Oil Well	Producing
WILLIAMSON TRIBAL 3-34-54	4301332550	5	S	4	W	34	14222	Oil Well	Producing
WILLIAMSON TRIBAL 5-34-54	4301332551	5	S	4	W	34	14235	Oil Well	Producing
FEDERAL 6-2-65	4301332557	6	S	5	W	2	14655	Oil Well	Producing
UTE TRIBAL 15-29-54	4301332561	5	S	4	W	29	14316	Oil Well	Producing
UTE TRIBAL 7-29-54	4301332562	5	S	4	W	29	14354	Oil Well	Producing

From: Linn Operating, LLC
 To: Berry Petroleum Company, LLC
 Effective: May 1, 2017

UTE TRIBAL 11-29-54	4301332563	5	S	4	W	29	14337	Oil Well	Producing
UTE TRIBAL 13-29-54	4301332564	5	S	4	W	29	14315	Oil Well	Producing
UTE TRIBAL 4-29-54	4301332565	5	S	4	W	29	14367	Oil Well	Producing
UTE TRIBAL 1-35-54	4301332567	5	S	4	W	35	14266	Oil Well	Producing
UTE TRIBAL 11-13-54	4301332568	5	S	4	W	13	14281	Oil Well	Producing
UTE TRIBAL 2-24-54	4301332569	5	S	4	W	24	14314	Oil Well	Producing
UTE TRIBAL 13-18-54	4301332571	5	S	4	W	18	14388	Oil Well	Producing
UTE TRIBAL 12-29-54	4301332572	5	S	4	W	29	14336	Oil Well	Producing
UTE TRIBAL 4-24-54	4301332573	5	S	4	W	24	14247	Oil Well	Producing
UTE TRIBAL 6-14-54	4301332586	5	S	4	W	14	15270	Oil Well	Producing
UTE TRIBAL 10-15-54	4301332587	5	S	4	W	15	14194	Oil Well	Producing
UTE TRIBAL 16-15-54	4301332588	5	S	4	W	15	14311	Oil Well	Producing
UTE TRIBAL 11-16-54	4301332589	5	S	4	W	16	14178	Oil Well	Producing
UTE TRIBAL 8-22-54	4301332590	5	S	4	W	22	14219	Oil Well	Producing
UTE TRIBAL 2-22-54	4301332591	5	S	4	W	22	14328	Oil Well	Producing
UTE TRIBAL 10-22-54	4301332592	5	S	4	W	22	14218	Oil Well	Producing
UTE TRIBAL 14-22-54	4301332593	5	S	4	W	22	14220	Oil Well	Producing
UTE TRIBAL 13-13-55	4301332599	5	S	5	W	13	15134	Oil Well	Producing
UTE TRIBAL 13-14-55	4301332600	5	S	5	W	14	14236	Oil Well	Producing
UTE TRIBAL 13-15-55	4301332602	5	S	5	W	15	14263	Oil Well	Producing
UTE TRIBAL 10-21-55	4301332603	5	S	5	W	21	14385	Oil Well	Producing
UTE TRIBAL 2-22-55	4301332604	5	S	5	W	22	14268	Oil Well	Producing
UTE TRIBAL 3-22-55	4301332605	5	S	5	W	22	14298	Oil Well	Producing
UTE TRIBAL 9-22-55	4301332606	5	S	5	W	22	14330	Oil Well	Producing
UTE TRIBAL 11-22-55	4301332607	5	S	5	W	22	14329	Oil Well	Producing
MOON TRIBAL 3-27-54	4301332613	5	S	4	W	27	14416	Oil Well	Producing
UTE TRIBAL 5-27-55	4301332614	5	S	5	W	27	14881	Oil Well	Producing
UTE TRIBAL 11-27-55	4301332615	5	S	5	W	27	14882	Oil Well	Producing
UTE TRIBAL 12-22-55	4301332616	5	S	5	W	22	14370	Oil Well	Producing
UTE TRIBAL 15-22-55	4301332617	5	S	5	W	22	14921	Oil Well	Producing
UTE TRIBAL 8-25-55	4301332620	5	S	5	W	25	14365	Oil Well	Producing
UTE TRIBAL 4-20-54	4301332621	5	S	4	W	20	14518	Oil Well	Producing
UTE TRIBAL 6-20-54	4301332622	5	S	4	W	20	14382	Oil Well	Producing
UTE TRIBAL 5-22-54	4301332624	5	S	4	W	22	14547	Oil Well	Producing
UTE TRIBAL 3-30-54	4301332625	5	S	4	W	30	14364	Oil Well	Producing
UTE TRIBAL 3-10-54	4301332663	5	S	4	W	10	14414	Oil Well	Producing
UTE TRIBAL 15-32-54	4301332666	5	S	4	W	32	14460	Oil Well	Producing
UTE TRIBAL 8-31-55	4301332673	5	S	5	W	31	14407	Oil Well	Producing
UTE TRIBAL 3-35-54	4301332675	5	S	4	W	35	14656	Oil Well	Producing
UTE TRIBAL 2-30-55	4301332680	5	S	5	W	30	14427	Oil Well	Producing
UTE TRIBAL 9-17-54	4301332687	5	S	4	W	17	15309	Oil Well	Producing
UTE TRIBAL 13-31-54	4301332688	5	S	4	W	31	14517	Oil Well	Producing
UTE TRIBAL 14-19-54	4301332690	5	S	4	W	19	14546	Oil Well	Producing
UTE TRIBAL 16-19-54	4301332691	5	S	4	W	19	14491	Oil Well	Producing

From: Linn Operating, LLC
 To: Berry Petroleum Company, LLC
 Effective: May 1, 2017

UTE TRIBAL 13-32-54	4301332692	5	S	4	W	32	14490	Oil Well	Producing
UTE TRIBAL 11-14-55	4301332693	5	S	5	W	14	15136	Oil Well	Producing
UTE TRIBAL 8-28-55	4301332694	5	S	5	W	28	14574	Oil Well	Producing
FEDERAL 6-1-65	4301332699	6	S	5	W	1	15776	Oil Well	Producing
UTE TRIBAL 9-15-55	4301332701	5	S	5	W	15	14573	Oil Well	Producing
UTE TRIBAL 14-20-54	4301332702	5	S	4	W	20	14459	Oil Well	Producing
#1 DLB 12-15-56	4301332710	5	S	6	W	15	14943	Gas Well	Producing
UTE TRIBAL 12-19-54	4301332716	5	S	4	W	19	14627	Oil Well	Producing
UTE TRIBAL 10-19-54	4301332717	5	S	4	W	19	14628	Oil Well	Producing
UTE TRIBAL 16-30-54	4301332718	5	S	4	W	30	14604	Oil Well	Producing
UTE TRIBAL 11-12-55	4301332721	5	S	5	W	12	14605	Oil Well	Producing
NIELSEN MARSING 13-14-56	4301332737	5	S	6	W	14	15060	Oil Well	Producing
TAYLOR HERRICK 10-22-56	4301332738	5	S	6	W	22	15058	Oil Well	Producing
UTE TRIBAL 16-20-54	4301332739	5	S	4	W	20	14671	Oil Well	Producing
UTE TRIBAL 10-20-54	4301332740	5	S	4	W	20	14691	Oil Well	Producing
UTE TRIBAL 4-28-54	4301332741	5	S	4	W	28	14672	Oil Well	Producing
UTE TRIBAL 13-33-54	4301332742	5	S	4	W	33	14736	Oil Well	Producing
UTE TRIBAL 15-31-54	4301332743	5	S	4	W	31	14690	Oil Well	Producing
UTE TRIBAL 8-30-54	4301332746	5	S	4	W	30	15583	Oil Well	Producing
UTE TRIBAL 10-25-55	4301332749	5	S	5	W	25	14758	Oil Well	Producing
UTE TRIBAL 14-25-55	4301332750	5	S	5	W	25	14798	Oil Well	Producing
UTE TRIBAL 3-36-55	4301332751	5	S	5	W	36	14842	Oil Well	Producing
UTE TRIBAL 16-16-55	4301332757	5	S	5	W	16	14865	Oil Well	Producing
UTE TRIBAL 3-21-55	4301332758	5	S	5	W	21	15112	Oil Well	Producing
UTE TRIBAL 16-25-55	4301332759	5	S	5	W	25	14821	Oil Well	Producing
UTE TRIBAL 1-36-55	4301332760	5	S	5	W	36	14822	Oil Well	Producing
UTE TRIBAL 7-22-54	4301332761	5	S	4	W	22	15661	Oil Well	Producing
UTE TRIBAL 2-31-54	4301332762	5	S	4	W	31	14845	Oil Well	Producing
UTE TRIBAL 2-28-54	4301332763	5	S	4	W	28	14723	Oil Well	Producing
UTE TRIBAL 10-28-54	4301332764	5	S	4	W	28	14722	Oil Well	Producing
UTE TRIBAL 12-28-54	4301332765	5	S	4	W	28	14701	Oil Well	Producing
UTE TRIBAL 8-28-54	4301332766	5	S	4	W	28	14777	Oil Well	Producing
UTE TRIBAL 4-31-54	4301332767	5	S	4	W	31	14494	Oil Well	Producing
UTE TRIBAL 15-33-54	4301332768	5	S	4	W	33	15210	Oil Well	Producing
UTE TRIBAL 12-25-55	4301332769	5	S	5	W	25	14799	Oil Well	Producing
UTE TRIBAL 7-35-54	4301332774	5	S	4	W	35	15019	Oil Well	Producing
UTE TRIBAL 16-24-54	4301332775	5	S	4	W	24	14762	Oil Well	Producing
UTE TRIBAL 14-25-54	4301332776	5	S	4	W	25	14753	Oil Well	Producing
UTE TRIBAL 16-25-54	4301332779	5	S	4	W	25	15078	Oil Well	Producing
UTE TRIBAL 8-25-54	4301332780	5	S	4	W	25	15280	Oil Well	Producing
UTE TRIBAL 9-35-54	4301332781	5	S	4	W	35	15535	Oil Well	Producing
UTE TRIBAL 6-30-55	4301332783	5	S	5	W	30	15163	Oil Well	Producing
MOON TRIBAL 4-23-54	4301332800	5	S	4	W	23	14985	Oil Well	Producing
MOON TRIBAL 5-27-54	4301332802	5	S	4	W	27	14984	Oil Well	Producing

From: Linn Operating, LLC
 To: Berry Petroleum Company, LLC
 Effective: May 1, 2017

UTE TRIBAL 2-32-54	4301332803	5	S	4	W	32	15151	Oil Well	Producing
UTE TRIBAL 15-35-54	4301332804	5	S	4	W	35	15185	Oil Well	Producing
UTE TRIBAL 5-35-54	4301332805	5	S	4	W	35	15485	Oil Well	Producing
UTE TRIBAL 13-35-54	4301332806	5	S	4	W	35	15292	Oil Well	Producing
UTE TRIBAL 11-35-54	4301332807	5	S	4	W	35	15317	Oil Well	Producing
UTE TRIBAL 8-19-54	4301332840	5	S	4	W	19	14946	Oil Well	Producing
UTE TRIBAL 13-20-55	4301332841	5	S	5	W	20	15097	Oil Well	Producing
UTE TRIBAL 16-22-54	4301332842	5	S	4	W	22	15015	Oil Well	Producing
MOON TRIBAL 6-23-54	4301332843	5	S	4	W	23	15113	Oil Well	Producing
UTE TRIBAL 11-26-54	4301332844	5	S	4	W	26	15233	Oil Well	Producing
MOON TRIBAL 15-27-54	4301332846	5	S	4	W	27	15115	Oil Well	Producing
UTE TRIBAL 10-31-54	4301332847	5	S	4	W	31	14956	Oil Well	Producing
ST TRIBAL 6-15-54	4301332848	5	S	4	W	15	16656	Oil Well	Producing
ST TRIBAL 2-15-54	4301332849	5	S	4	W	15	16959	Oil Well	Producing
ST TRIBAL 4-15-54	4301332850	5	S	4	W	15	17478	Oil Well	Producing
ST TRIBAL 8-15-54	4301332851	5	S	4	W	15	16279	Oil Well	Producing
UTE TRIBAL 11-25-54	4301332856	5	S	4	W	25	15430	Oil Well	Producing
UTE TRIBAL 3-30-55	4301332862	5	S	5	W	30	15340	Oil Well	Producing
UTE TRIBAL 7-19-55	4301332863	5	S	5	W	19	15279	Oil Well	Producing
UTE TRIBAL 8-19-55	4301332864	5	S	5	W	19	15241	Oil Well	Producing
UTE TRIBAL 6-19-54	4301332865	5	S	4	W	19	14947	Oil Well	Producing
UTE TRIBAL 12-20-54	4301332866	5	S	4	W	20	14924	Oil Well	Producing
UTE TRIBAL 3-21-54	4301332867	5	S	4	W	21	15554	Oil Well	Producing
UTE TRIBAL 2-26-54	4301332868	5	S	4	W	26	15231	Oil Well	Producing
UTE TRIBAL 8-31-54	4301332869	5	S	4	W	31	14970	Oil Well	Producing
UTE TRIBAL 8-32-54	4301332870	5	S	4	W	32	15152	Oil Well	Producing
UTE TRIBAL 4-33-54	4301332871	5	S	4	W	33	15040	Oil Well	Producing
UTE TRIBAL 6-33-54	4301332872	5	S	4	W	33	15059	Oil Well	Producing
UTE TRIBAL 9-22-54	4301332889	5	S	4	W	22	15607	Oil Well	Producing
UTE TRIBAL 5-26-54	4301332890	5	S	4	W	26	15268	Oil Well	Producing
UTE TRIBAL 13-26-54	4301332891	5	S	4	W	26	15287	Oil Well	Producing
UTE TRIBAL 6-28D-54	4301332892	5	S	4	W	28	15232	Oil Well	Producing
UTE TRIBAL 2-30D-54	4301332894	5	S	4	W	30	15298	Oil Well	Producing
UTE TRIBAL 4-32-54	4301332896	5	S	4	W	32	15555	Oil Well	Producing
UTE TRIBAL 6-32D-54	4301332897	5	S	4	W	32	15312	Oil Well	Producing
UTE TRIBAL 2-33D-54	4301332898	5	S	4	W	33	15271	Oil Well	Producing
UTE TRIBAL 12-32-54	4301332925	5	S	4	W	32	15503	Oil Well	Producing
UTE TRIBAL 16-32D-54	4301332926	5	S	4	W	32	16971	Oil Well	Producing
MOON TRIBAL 16-23-54	4301332927	5	S	4	W	23	15219	Oil Well	Producing
UTE TRIBAL 4-25-55	4301332928	5	S	5	W	25	15421	Oil Well	Producing
UTE TRIBAL 7-36-55	4301332929	5	S	5	W	36	15341	Oil Well	Producing
UTE TRIBAL 5-36-55	4301332930	5	S	5	W	36	15301	Oil Well	Producing
MOON TRIBAL 10-2-54	4301332931	5	S	4	W	2	15429	Oil Well	Producing
MYRIN TRIBAL 16-19-55	4301332934	5	S	5	W	19	15339	Oil Well	Producing

From: Linn Operating, LLC
 To: Berry Petroleum Company, LLC
 Effective: May 1, 2017

UTE TRIBAL 2-31-55	4301332935	5	S	5	W	31	15428	Oil Well	Producing
UTE TRIBAL 10-31-55	4301332936	5	S	5	W	31	15354	Oil Well	Producing
MOON TRIBAL 1-27-54	4301332937	5	S	4	W	27	15308	Oil Well	Producing
MOON TRIBAL 5-23-54	4301332938	5	S	4	W	23	15584	Oil Well	Producing
ST TRIBAL 7-18-54	4301332952	5	S	4	W	18	15724	Oil Well	Producing
ST TRIBAL 5-18-54	4301332953	5	S	4	W	18	15781	Oil Well	Producing
UTE TRIBAL 15-15-54	4301332971	5	S	4	W	15	15310	Oil Well	Producing
UTE TRIBAL 4-19-54	4301332972	5	S	4	W	19	15382	Oil Well	Producing
UTE TRIBAL 8-20-54	4301332973	5	S	4	W	20	15245	Oil Well	Producing
UTE TRIBAL 2-20-54	4301332974	5	S	4	W	20	15269	Oil Well	Producing
UTE TRIBAL 7-15-55	4301332976	5	S	5	W	15	15311	Oil Well	Producing
UTE TRIBAL 10-15-55	4301332977	5	S	5	W	15	15380	Oil Well	Producing
UTE TRIBAL 1-15-55	4301332978	5	S	5	W	15	15299	Oil Well	Producing
UTE TRIBAL 14-15-55	4301332979	5	S	5	W	15	15369	Oil Well	Producing
UTE TRIBAL 11-15-55	4301332980	5	S	5	W	15	15342	Oil Well	Producing
UTE TRIBAL 14-18-55	4301332984	5	S	5	W	18	15671	Oil Well	Producing
UTE TRIBAL 14-24-56	4301332988	5	S	6	W	24	15740	Oil Well	Producing
UTE TRIBAL 7-24-56	4301332989	5	S	6	W	24	15782	Oil Well	Producing
UTE TRIBAL 11-25-56	4301332990	5	S	6	W	25	15627	Oil Well	Producing
UTE TRIBAL 7-25-56	4301332991	5	S	6	W	25	15617	Oil Well	Producing
UTE TRIBAL 5-25-56	4301332992	5	S	6	W	25	15648	Oil Well	Producing
UTE TRIBAL 3-25-56	4301332993	5	S	6	W	25	15561	Oil Well	Producing
UTE TRIBAL 13-15D-54	4301333039	5	S	4	W	15	15368	Oil Well	Producing
UTE TRIBAL 16-28D-54	4301333041	5	S	4	W	28	15377	Oil Well	Producing
UTE TRIBAL 14-31D-54	4301333042	5	S	4	W	31	15419	Oil Well	Producing
UTE TRIBAL 4-22-55	4301333044	5	S	5	W	22	15381	Oil Well	Producing
UTE TRIBAL 16-23-55	4301333046	5	S	5	W	23	15211	Oil Well	Producing
UTE TRIBAL 9-35-55	4301333047	5	S	5	W	35	15378	Oil Well	Producing
UTE TRIBAL 7-35-55	4301333048	5	S	5	W	35	15367	Oil Well	Producing
UTE TRIBAL 15-36-55	4301333049	5	S	5	W	36	15379	Oil Well	Producing
UTE TRIBAL 10-12-55	4301333055	5	S	5	W	12	15618	Oil Well	Producing
UTE TRIBAL 5-13-54	4301333075	5	S	4	W	13	15873	Oil Well	Producing
UTE TRIBAL 16-29-54	4301333076	5	S	4	W	29	17074	Oil Well	Producing
UTE TRIBAL 12-18-54	4301333077	5	S	4	W	18	15575	Oil Well	Producing
UTE TRIBAL 8-33-54	4301333089	5	S	4	W	33	15398	Oil Well	Producing
UTE TRIBAL 12-33-54	4301333090	5	S	4	W	33	15417	Oil Well	Producing
UTE TRIBAL 16-33-54	4301333091	5	S	4	W	33	15397	Oil Well	Producing
UTE TRIBAL 10-33-54	4301333092	5	S	4	W	33	15418	Oil Well	Producing
UTE TRIBAL 14-33-54	4301333093	5	S	4	W	33	15399	Oil Well	Producing
UTE TRIBAL 2-14-54	4301333111	5	S	4	W	14	16832	Oil Well	Producing
UTE TRIBAL 14-14-54	4301333112	5	S	4	W	14	15440	Oil Well	Producing
UTE TRIBAL 13-21-54	4301333113	5	S	4	W	21	15471	Oil Well	Producing
UTE TRIBAL 11-21-54	4301333115	5	S	4	W	21	15470	Oil Well	Producing
UTE TRIBAL 11-22-54	4301333116	5	S	4	W	22	15662	Oil Well	Producing

From: Linn Operating, LLC
 To: Berry Petroleum Company, LLC
 Effective: May 1, 2017

UTE TRIBAL 2-21-55	4301333117	5	S	5	W	21	15582	Oil Well	Producing
UTE TRIBAL 4-28-55	4301333118	5	S	5	W	28	15506	Oil Well	Producing
UTE TRIBAL 8-29-55	4301333119	5	S	5	W	29	15507	Oil Well	Producing
UTE TRIBAL 6-29-55	4301333120	5	S	5	W	29	15504	Oil Well	Producing
TAYLOR FEE 13-22-56	4301333121	5	S	6	W	22	15525	Oil Well	Producing
WILCOX ELIASON 7-15-56	4301333122	5	S	6	W	15	15526	Oil Well	Producing
UTE TRIBAL 14-16-54	4301333123	5	S	4	W	16	15639	Oil Well	Producing
UTE TRIBAL 1-16-54	4301333128	5	S	4	W	16	15420	Oil Well	Producing
UTE TRIBAL 10-16-54	4301333129	5	S	4	W	16	15454	Oil Well	Producing
UTE TRIBAL 7-16-54	4301333130	5	S	4	W	16	15455	Oil Well	Producing
UTE TRIBAL 12-16-54	4301333131	5	S	4	W	16	15456	Oil Well	Producing
UTE TRIBAL 16-17-54	4301333132	5	S	4	W	17	15524	Oil Well	Producing
UTE TRIBAL 10-17-54	4301333133	5	S	4	W	17	15581	Oil Well	Producing
UTE TRIBAL 12-24D-55	4301333134	5	S	5	W	24	15567	Oil Well	Producing
WILCOX FEE 1-20-56	4301333150	5	S	6	W	20	15745	Oil Well	Producing
NIELSEN FEE 13-11-56	4301333152	5	S	6	W	11	15600	Oil Well	Producing
UTE TRIBAL 2-29-54	4301333153	5	S	4	W	29	15919	Oil Well	Producing
UTE TRIBAL 14-29-54	4301333154	5	S	4	W	29	15831	Oil Well	Producing
UTE TRIBAL 10-29-54	4301333155	5	S	4	W	29	15847	Oil Well	Producing
UTE TRIBAL 10-24D-55	4301333156	5	S	5	W	24	15556	Oil Well	Producing
UTE TRIBAL 10-29D-55	4301333157	5	S	5	W	29	15505	Oil Well	Producing
UTE TRIBAL 6-29-54	4301333172	5	S	4	W	29	15846	Oil Well	Producing
UTE TRIBAL 12Q-25-55	4301333184	5	S	5	W	25	15744	Oil Well	Producing
UTE TRIBAL 3G-31-54	4301333185	5	S	4	W	31	15746	Oil Well	Producing
UTE TRIBAL 11-36-55	4301333186	5	S	5	W	36	15865	Oil Well	Producing
UTE TRIBAL 6-23D-55	4301333187	5	S	5	W	23	15996	Oil Well	Producing
UTE TRIBAL 8-14-54	4301333204	5	S	4	W	14	15656	Oil Well	Producing
UTE TRIBAL 10-14-54	4301333205	5	S	4	W	14	15680	Oil Well	Producing
UTE TRIBAL 11-15-54	4301333206	5	S	4	W	15	15643	Oil Well	Producing
UTE TRIBAL 9-16-54	4301333207	5	S	4	W	16	15660	Oil Well	Producing
UTE TRIBAL 3-22-54	4301333208	5	S	4	W	22	15640	Oil Well	Producing
UTE TRIBAL 15-13D-55	4301333212	5	S	5	W	13	15642	Oil Well	Producing
UTE TRIBAL 6-22D-55	4301333213	5	S	5	W	22	16831	Oil Well	Producing
UTE TRIBAL 11-36D-55	4301333214	5	S	5	W	36	15702	Oil Well	Producing
UTE TRIBAL 1-22D-54	4301333215	5	S	4	W	22	15641	Oil Well	Producing
BERRY TRIBAL 1-23-54	4301333216	5	S	4	W	23	15931	Oil Well	Producing
BERRY TRIBAL 15-23-54	4301333217	5	S	4	W	23	15932	Oil Well	Producing
UTE TRIBAL 9-36D-55	4301333239	5	S	5	W	36	15933	Oil Well	Producing
UTE TRIBAL 9S-25-55	4301333245	5	S	5	W	25	15962	Oil Well	Producing
UTE TRIBAL 12-32-55	4301333266	5	S	5	W	32	15681	Oil Well	Producing
UTE TRIBAL 16-22D-55	4301333267	5	S	5	W	22	15703	Oil Well	Producing
UTE TRIBAL 4-14D-54	4301333270	5	S	4	W	14	15679	Oil Well	Producing
UTE TRIBAL 9S-19-54	4301333276	5	S	4	W	19	16153	Oil Well	Producing
UTE TRIBAL 14Q-28-54	4301333277	5	S	4	W	28	15818	Oil Well	Producing

From: Linn Operating, LLC
 To: Berry Petroleum Company, LLC
 Effective: May 1, 2017

UTE TRIBAL 14-28D-54	4301333278	5	S	4	W	28	15817	Oil Well	Producing
UTE TRIBAL 1-14D-55	4301333279	5	S	5	W	14	18408	Oil Well	Producing
UTE TRIBAL 10-18-54	4301333300	5	S	4	W	18	15747	Oil Well	Producing
UTE TRIBAL 5-21-54	4301333324	5	S	4	W	21	15748	Oil Well	Producing
UTE TRIBAL 6-31D-54	4301333325	5	S	4	W	31	16185	Oil Well	Producing
UTE TRIBAL 16-31D-54	4301333326	5	S	4	W	31	15800	Oil Well	Producing
UTE TRIBAL 16-13D-55	4301333327	5	S	5	W	13	15891	Oil Well	Producing
UTE TRIBAL 9-13D-55	4301333328	5	S	5	W	13	15892	Oil Well	Producing
UTE TRIBAL 15-21-55	4301333357	5	S	5	W	21	15791	Oil Well	Producing
UTE TRIBAL 10-23D-55	4301333358	5	S	5	W	23	15799	Oil Well	Producing
UTE TRIBAL 9-26D-55	4301333359	5	S	5	W	26	15853	Oil Well	Producing
UTE TRIBAL 10-26D-55	4301333360	5	S	5	W	26	15852	Oil Well	Producing
UTE TRIBAL 14-26D-55	4301333361	5	S	5	W	26	15938	Oil Well	Producing
UTE TRIBAL 15-26D-55	4301333362	5	S	5	W	26	15869	Oil Well	Producing
UTE TRIBAL 3-32D-55	4301333363	5	S	5	W	32	15936	Oil Well	Producing
UTE TRIBAL 13-14-54	4301333364	5	S	4	W	14	15790	Oil Well	Producing
MOON TRIBAL 7-27D-54	4301333365	5	S	4	W	27	15935	Oil Well	Producing
UTE TRIBAL 4-32-55	4301333379	5	S	5	W	32	15819	Oil Well	Producing
UTE TRIBAL 13H-16-55	4301333380	5	S	5	W	16	18357	Oil Well	Producing
BERRY TRIBAL 7-23-54	4301333381	5	S	4	W	23	15934	Oil Well	Producing
BERRY TRIBAL 9-34-54	4301333382	5	S	4	W	34	16024	Oil Well	Producing
BERRY TRIBAL 7-34-54	4301333383	5	S	4	W	34	16102	Oil Well	Producing
BERRY TRIBAL 4-34-54	4301333384	5	S	4	W	34	16588	Oil Well	Producing
FEDERAL 2-2-65	4301333385	6	S	5	W	2	16150	Oil Well	Producing
FEDERAL 5-4-65	4301333387	6	S	5	W	4	17599	Oil Well	Producing
UTE TRIBAL 1A-29-54	4301333393	5	S	4	W	29	17075	Oil Well	Producing
BERRY TRIBAL 15-34-54	4301333411	5	S	4	W	34	16037	Oil Well	Producing
BERRY TRIBAL 8-23D-54	4301333417	5	S	4	W	23	16101	Oil Well	Producing
UTE TRIBAL 12-29D-55	4301333418	5	S	5	W	29	17307	Oil Well	Producing
UTE TRIBAL 8-24-55	4301333420	5	S	5	W	24	15997	Oil Well	Producing
UTE TRIBAL 5-25D-55	4301333421	5	S	5	W	25	16589	Oil Well	Producing
BERRY TRIBAL 10-34D-54	4301333422	5	S	4	W	34	16038	Oil Well	Producing
1-15-56 DLB	4301333447	5	S	6	W	15	15854	Oil Well	Producing
FEDERAL 5-3-64	4301333448	6	S	4	W	3	16098	Oil Well	Producing
FEDERAL 8-1-64	4301333449	6	S	4	W	1	16152	Oil Well	Producing
FEDERAL 5-4-64	4301333450	6	S	4	W	4	17851	Oil Well	Producing
FEDERAL 11-10-65	4301333451	6	S	5	W	10	16281	Oil Well	Producing
BERRY TRIBAL 9-23-54	4301333465	5	S	4	W	23	16590	Oil Well	Producing
UTE TRIBAL 6-26D-55	4301333476	5	S	5	W	26	16657	Oil Well	Producing
UTE TRIBAL 7-26D-55	4301333477	5	S	5	W	26	16658	Oil Well	Producing
UTE TRIBAL 11-26D-55	4301333478	5	S	5	W	26	16659	Oil Well	Producing
UTE TRIBAL 14Q-30-54	4301333479	5	S	4	W	30	16151	Oil Well	Producing
FEDERAL 5-6-65	4301333489	6	S	5	W	6	17852	Oil Well	Producing
FEDERAL 16-5-65	4301333490	6	S	5	W	5	16833	Oil Well	Producing

From: Linn Operating, LLC
 To: Berry Petroleum Company, LLC
 Effective: May 1, 2017

FEDERAL 6-11-65	4301333491	6	S	5	W	11	16335	Oil Well	Producing
LC TRIBAL 14-2-56	4301333492	5	S	6	W	2	18358	Oil Well	Producing
UTE TRIBAL 1-31-55	4301333501	5	S	5	W	31	17104	Oil Well	Producing
UTE TRIBAL 9-31-55	4301333508	5	S	5	W	31	17103	Oil Well	Producing
BERRY TRIBAL 11-34D-54	4301333529	5	S	4	W	34	16099	Oil Well	Producing
LC TRIBAL 2-16D-56	4301333538	5	S	6	W	16	17305	Oil Well	Producing
LC TRIBAL 4-16-56	4301333539	5	S	6	W	16	16272	Oil Well	Producing
LC TRIBAL 3-17-56	4301333541	5	S	6	W	17	16459	Oil Well	Producing
UTE TRIBAL 4-20D-55	4301333549	5	S	5	W	20	18075	Oil Well	Producing
UTE TRIBAL 8-23D-55	4301333552	5	S	5	W	23	16662	Oil Well	Producing
LC TRIBAL 8-28-46	4301333576	4	S	6	W	28	16155	Oil Well	Producing
LC TRIBAL 7-3-56	4301333577	5	S	6	W	3	16379	Oil Well	Producing
LC TRIBAL 3-5-56	4301333580	5	S	6	W	5	17082	Oil Well	Producing
FEDERAL 8-2D-64	4301333581	6	S	4	W	2	16100	Oil Well	Producing
LC TRIBAL 13H-3-56	4301333591	5	S	6	W	3	18129	Oil Well	Producing
LC FEE 6-12-57	4301333593	5	S	7	W	12	17083	Oil Well	Producing
UTE TRIBAL 4-26D-54	4301333595	5	S	4	W	26	16591	Oil Well	Producing
LC FEE 12H-6-56	4301333606	5	S	6	W	6	18037	Oil Well	Producing
LC TRIBAL 7-7D-56	4301333607	5	S	6	W	7	18038	Oil Well	Producing
LC TRIBAL 1-9-56	4301333608	5	S	6	W	9	16380	Oil Well	Producing
UTE TRIBAL 5-14-54	4301333619	5	S	4	W	14	16945	Oil Well	Producing
UTE TRIBAL 10-26D-54	4301333620	5	S	4	W	26	16663	Oil Well	Producing
UTE TRIBAL 7-26D-54	4301333621	5	S	4	W	26	16664	Oil Well	Producing
UTE TRIBAL 13-36D-55	4301333624	5	S	5	W	36	17744	Oil Well	Producing
UTE TRIBAL 6-26D-54	4301333625	5	S	4	W	26	16619	Oil Well	Producing
UTE TRIBAL 1-22D-55	4301333626	5	S	5	W	22	16777	Oil Well	Producing
UTE TRIBAL 4-23D-55	4301333627	5	S	5	W	23	16818	Oil Well	Producing
UTE TRIBAL 2-27D-55	4301333628	5	S	5	W	27	16746	Oil Well	Producing
UTE TRIBAL 12-28D-55	4301333645	5	S	5	W	28	17999	Oil Well	Producing
UTE TRIBAL 13-28D-55	4301333646	5	S	5	W	28	18000	Oil Well	Producing
UTE TRIBAL 14-26D-54	4301333673	5	S	4	W	26	16299	Oil Well	Producing
UTE FEE 7-13D-55	4301333674	5	S	5	W	13	18089	Oil Well	Producing
UTE TRIBAL 9-20D-55	4301333675	5	S	5	W	20	17309	Oil Well	Producing
LC TRIBAL 11-17-56	4301333677	5	S	6	W	17	17600	Oil Well	Producing
UTE TRIBAL 1-26D-54	4301333680	5	S	4	W	26	16638	Oil Well	Producing
UTE TRIBAL 3-26D-54	4301333681	5	S	4	W	26	16665	Oil Well	Producing
UTE TRIBAL 8-26D-54	4301333682	5	S	4	W	26	17031	Oil Well	Producing
UTE TRIBAL 10-27D-55	4301333683	5	S	5	W	27	16666	Oil Well	Producing
UTE TRIBAL 14-27D-55	4301333684	5	S	5	W	27	16667	Oil Well	Producing
UTE TRIBAL 12-21D-55	4301333694	5	S	5	W	21	16296	Oil Well	Producing
UTE TRIBAL 5-21D-55	4301333706	5	S	5	W	21	16298	Oil Well	Producing
UTE TRIBAL 2-29D-55	4301333714	5	S	5	W	29	16854	Oil Well	Producing
UTE TRIBAL 7-29D-55	4301333715	5	S	5	W	29	16853	Oil Well	Producing
UTE TRIBAL 13-22D-55	4301333716	5	S	5	W	22	16668	Oil Well	Producing

From: Linn Operating, LLC
 To: Berry Petroleum Company, LLC
 Effective: May 1, 2017

UTE TRIBAL 14-22D-55	4301333717	5	S	5	W	22	16669	Oil Well	Producing
UTE TRIBAL 7-22D-55	4301333721	5	S	5	W	22	16670	Oil Well	Producing
UTE TRIBAL 10-22D-55	4301333722	5	S	5	W	22	16671	Oil Well	Producing
UTE TRIBAL 3-29-55	4301333723	5	S	5	W	29	16857	Oil Well	Producing
BERRY TRIBAL 10-23D-54	4301333724	5	S	4	W	23	16592	Oil Well	Producing
BERRY TRIBAL 11-23D-54	4301333725	5	S	4	W	23	16672	Oil Well	Producing
UTE TRIBAL 4-24D-55	4301333726	5	S	5	W	24	16673	Oil Well	Producing
FEDERAL 6-6D-64	4301333745	6	S	4	W	6	17084	Oil Well	Producing
UTE TRIBAL 15-26D-54	4301333768	5	S	4	W	26	17450	Oil Well	Producing
UTE TRIBAL 1-14D-54	4301333769	5	S	4	W	14	17483	Oil Well	Producing
UTE TRIBAL 12-35D-55	4301333782	5	S	5	W	35	16856	Oil Well	Producing
UTE TRIBAL 11-35-55	4301333783	5	S	5	W	35	16855	Oil Well	Producing
UTE TRIBAL 1-28D-55	4301333784	5	S	5	W	28	16852	Oil Well	Producing
UTE TRIBAL 16-27D-55	4301333786	5	S	5	W	27	17800	Oil Well	Producing
UTE TRIBAL 9-28D-55	4301333787	5	S	5	W	28	16887	Oil Well	Producing
UTE TRIBAL 7-28D-55	4301333788	5	S	5	W	28	16886	Oil Well	Producing
UTE TRIBAL 11-32D-54	4301333793	5	S	4	W	32	17003	Oil Well	Producing
UTE TRIBAL 9-14D-54	4301333796	5	S	4	W	14	17482	Oil Well	Producing
UTE TRIBAL 4-27D-55	4301333797	5	S	5	W	27	16700	Oil Well	Producing
FOY TRIBAL 12H-33-55	4301333799	5	S	5	W	33	18232	Oil Well	Producing
UTE TRIBAL 9-32D-55	4301333800	5	S	5	W	32	18361	Oil Well	Producing
UTE TRIBAL 12-26D-54	4301333801	5	S	4	W	26	16639	Oil Well	Producing
UTE TRIBAL 8-26D-55	4301333859	5	S	5	W	26	17859	Oil Well	Producing
BERRY TRIBAL 2-34D-54	4301333867	5	S	4	W	34	17889	Oil Well	Producing
UTE TRIBAL 3-35D-55	4301333888	5	S	5	W	35	17421	Oil Well	Producing
UTE TRIBAL 10-32-54	4301333902	5	S	4	W	32	16819	Oil Well	Producing
UTE TRIBAL 12-31D-54	4301333907	5	S	4	W	31	17480	Oil Well	Producing
UTE TRIBAL 12-23D-55	4301333908	5	S	5	W	23	17814	Oil Well	Producing
UTE TRIBAL 14-20D-55	4301333909	5	S	5	W	20	18559	Oil Well	Producing
UTE TRIBAL 6-20D-55	4301333910	5	S	5	W	20	18481	Oil Well	Producing
UTE TRIBAL 12-20-55	4301333911	5	S	5	W	20	18520	Oil Well	Producing
UTE TRIBAL 14-24D-55	4301333912	5	S	5	W	24	16943	Oil Well	Producing
UTE TRIBAL 14-23D-55	4301333915	5	S	5	W	23	17457	Oil Well	Producing
ST TRIBAL 1-15D-54	4301333916	5	S	4	W	15	16889	Oil Well	Producing
ST TRIBAL 7-15D-54	4301333950	5	S	4	W	15	16972	Oil Well	Producing
ST TRIBAL 9-15D-54	4301333951	5	S	4	W	15	16973	Oil Well	Producing
UTE TRIBAL 15-35D-55	4301333954	5	S	5	W	35	17417	Oil Well	Producing
UTE TRIBAL 14-35D-55	4301333955	5	S	5	W	35	17416	Oil Well	Producing
UTE TRIBAL 16-26D-55	4301333965	5	S	5	W	26	17418	Oil Well	Producing
FEDERAL 1-2D-65	4301333966	6	S	5	W	2	16888	Oil Well	Producing
UTE TRIBAL 1-35D-55	4301333967	5	S	5	W	35	17420	Oil Well	Producing
UTE TRIBAL 10-36D-55	4301333968	5	S	5	W	36	17743	Oil Well	Producing
UTE TRIBAL 4-26D-55	4301333978	5	S	5	W	26	17455	Oil Well	Producing
UTE TRIBAL 2-26D-55	4301333979	5	S	5	W	26	17456	Oil Well	Producing

From: Linn Operating, LLC
 To: Berry Petroleum Company, LLC
 Effective: May 1, 2017

BERRY TRIBAL 14-23D-54	4301333989	5	S	4	W	23	17903	Oil Well	Producing
FEDERAL 3-2D-65	4301334001	6	S	5	W	2	16944	Oil Well	Producing
UTE TRIBAL 13-26D-55	4301334002	5	S	5	W	26	17481	Oil Well	Producing
FEDERAL 7-1D-65	4301334015	6	S	5	W	1	17775	Oil Well	Producing
FEDERAL 2-2D-64	4301334018	6	S	4	W	2	17086	Oil Well	Producing
FEDERAL 7-6D-64	4301334020	6	S	4	W	6	17085	Oil Well	Producing
UTE TRIBAL 6-35D-55	4301334028	5	S	5	W	35	17785	Oil Well	Producing
UTE TRIBAL 16-26-54	4301334042	5	S	4	W	26	17413	Oil Well	Producing
BERRY TRIBAL 13-23-54	4301334043	5	S	4	W	23	17100	Oil Well	Producing
UTE TRIBAL 6-28D-55	4301334056	5	S	5	W	28	18593	Oil Well	Producing
UTE TRIBAL 11-28-55	4301334057	5	S	5	W	28	18001	Oil Well	Producing
UTE TRIBAL 8-27D-55	4301334058	5	S	5	W	27	17842	Oil Well	Producing
ST TRIBAL 3-15D-54	4301334059	5	S	4	W	15	17477	Oil Well	Producing
ST TRIBAL 5-15D-54	4301334060	5	S	4	W	15	17479	Oil Well	Producing
FEDERAL 7-11D-65	4301334061	6	S	5	W	11	17776	Oil Well	Producing
FEDERAL 7-3D-65	4301334065	6	S	5	W	3	17124	Oil Well	Producing
MOON TRIBAL 9-27D-54	4301334108	5	S	4	W	27	19095	Oil Well	Producing
MOON TRIBAL 16-27D-54	4301334109	5	S	4	W	27	17414	Oil Well	Producing
UTE TRIBAL 15-22D-54	4301334116	5	S	4	W	22	17415	Oil Well	Producing
UTE TRIBAL 13-35D-55	4301334117	5	S	5	W	35	18442	Oil Well	Producing
UTE TRIBAL 12-26D-55	4301334118	5	S	5	W	26	17786	Oil Well	Producing
FEDERAL 11-6D-64	4301334284	6	S	4	W	6	17615	Oil Well	Producing
FEDERAL 14-6D-64	4301334285	6	S	4	W	6	17616	Oil Well	Producing
FEDERAL 2-6D-64	4301334286	6	S	4	W	6	17663	Oil Well	Producing
FEDERAL 3-5D-64	4301334287	6	S	4	W	5	17617	Oil Well	Producing
FEDERAL 6-5D-64	4301334288	6	S	4	W	5	17649	Oil Well	Producing
SFW TRIBAL 10-10D-54	4301334295	5	S	4	W	10	17564	Oil Well	Producing
SFW TRIBAL 9-10D-54	4301334296	5	S	4	W	10	17565	Oil Well	Producing
STATE TRIBAL 16-10-54	4301350245	5	S	4	W	10	17553	Oil Well	Producing
UTE TRIBAL 6-14D-55	4301350246	5	S	5	W	14	17602	Oil Well	Producing
SFW FEE 15-10-54	4301350247	5	S	4	W	10	17566	Oil Well	Producing
FEDERAL 5-5D-64	4301350259	6	S	4	W	5	17648	Oil Well	Producing
LC TRIBAL 6-22D-56	4301350260	5	S	6	W	22	17567	Oil Well	Producing
FEDERAL 12-6D-64	4301350261	6	S	4	W	6	17618	Oil Well	Producing
FEDERAL 4-5D-64	4301350263	6	S	4	W	5	17661	Oil Well	Producing
FEDERAL 1-6-64	4301350266	6	S	4	W	6	17662	Oil Well	Producing
FEDERAL 4-6D-64	4301350267	6	S	4	W	6	17651	Oil Well	Producing
FEDERAL 3-6D-64	4301350268	6	S	4	W	6	17650	Oil Well	Producing
FEDERAL 5-6D-64	4301350269	6	S	4	W	6	17652	Oil Well	Producing
FEDERAL 8-6D-64	4301350325	6	S	4	W	6	17664	Oil Well	Producing
FEDERAL 10-1D-65	4301350326	6	S	5	W	1	18027	Oil Well	Producing
FEDERAL 11-1D-65	4301350327	6	S	5	W	1	18039	Oil Well	Producing
FEDERAL 12-1D-65	4301350328	6	S	5	W	1	18040	Oil Well	Producing
FEDERAL 13-1D-65	4301350329	6	S	5	W	1	18042	Oil Well	Producing

From: Linn Operating, LLC
 To: Berry Petroleum Company, LLC
 Effective: May 1, 2017

FEDERAL 14-1D-65	4301350330	6	S	5	W	1	18041	Oil Well	Producing
FEDERAL 13-5D-64	4301350337	6	S	4	W	5	17714	Oil Well	Producing
FEDERAL 14-5D-64	4301350338	6	S	4	W	5	17715	Oil Well	Producing
FEDERAL 9-1D-65	4301350342	6	S	5	W	1	18026	Oil Well	Producing
FEDERAL 13-6D-64	4301350347	6	S	4	W	6	17619	Oil Well	Producing
FEDERAL 11-5D-64	4301350348	6	S	4	W	5	17690	Oil Well	Producing
FEDERAL 12-5D-64	4301350349	6	S	4	W	5	17713	Oil Well	Producing
FEDERAL 8-1D-65	4301350350	6	S	5	W	1	18025	Oil Well	Producing
UTE TRIBAL 3-14D-54	4301350389	5	S	4	W	14	17904	Oil Well	Producing
UTE TRIBAL 1-34D-55	4301350408	5	S	5	W	34	17931	Oil Well	Producing
UTE TRIBAL 7-14-54	4301350409	5	S	4	W	14	17924	Oil Well	Producing
UTE TRIBAL 8-21D-55	4301350435	5	S	5	W	21	17963	Oil Well	Producing
UTE TRIBAL 8-34D-55	4301350436	5	S	5	W	34	17952	Oil Well	Producing
UTE TRIBAL 5-16D-54	4301350475	5	S	4	W	16	17991	Oil Well	Producing
UTE TRIBAL 12-14D-55	4301350476	5	S	5	W	14	17973	Oil Well	Producing
UTE TRIBAL 8-15D-55	4301350477	5	S	5	W	15	17974	Oil Well	Producing
UTE TRIBAL 3-14-55	4301350478	5	S	5	W	14	18002	Oil Well	Producing
UTE TRIBAL 5-14-55	4301350479	5	S	5	W	14	18021	Oil Well	Producing
UTE TRIBAL 8-10D-54	4301350488	5	S	4	W	10	18099	Oil Well	Producing
UTE TRIBAL 7-34-55	4301350510	5	S	5	W	34	17949	Oil Well	Producing
FEDERAL 4-4D-65	4301350521	6	S	5	W	4	18557	Oil Well	Producing
FEDERAL 6-3D-64	4301350522	6	S	4	W	3	18073	Oil Well	Producing
FEDERAL 1-1D-64	4301350524	6	S	4	W	1	18088	Oil Well	Producing
FEDERAL 7-2D-65	4301350525	6	S	5	W	2	18100	Oil Well	Producing
BERRY TRIBAL 12-34D-54	4301350527	5	S	4	W	34	17998	Oil Well	Producing
FEDERAL 15-5D-65	4301350553	6	S	5	W	5	18537	Oil Well	Producing
FEDERAL 11-4D-64	4301350565	6	S	4	W	4	18043	Oil Well	Producing
FEDERAL 6-6D-65	4301350566	6	S	5	W	6	18521	Oil Well	Producing
LC TRIBAL 3-15D-56	4301350598	5	S	6	W	15	18097	Oil Well	Producing
LC TRIBAL 9-16D-56	4301350600	5	S	6	W	16	19544	Oil Well	Producing
LC FEE 16-16D-56	4301350601	5	S	6	W	16	18165	Oil Well	Producing
LC TRIBAL 10-16D-56	4301350602	5	S	6	W	16	18586	Oil Well	Producing
LC TRIBAL 15-22D-56	4301350606	5	S	6	W	22	18278	Oil Well	Producing
LC TRIBAL 5-23D-56	4301350625	5	S	6	W	23	18285	Oil Well	Producing
LC TRIBAL 5-14D-56	4301350661	5	S	6	W	14	18219	Oil Well	Producing
SFW FEE 14-10D-54	4301350686	5	S	4	W	10	18070	Oil Well	Producing
LC FEE 1-22D-56	4301350718	5	S	6	W	22	18101	Oil Well	Producing
FEDERAL 8-2D-65	4301350719	6	S	5	W	2	18614	Oil Well	Producing
FEDERAL 1-2D-64	4301350730	6	S	4	W	2	18585	Oil Well	Producing
FEDERAL 7-2D-64	4301350734	6	S	4	W	2	18584	Oil Well	Producing
FEDERAL 10-6D-64	4301350735	6	S	4	W	6	18162	Oil Well	Producing
FEDERAL 4-3D-64	4301350736	6	S	4	W	3	18621	Oil Well	Producing
FEDERAL 12-3D-64	4301350737	6	S	4	W	3	18620	Oil Well	Producing
LC TRIBAL 3-21D-56	4301350751	5	S	6	W	21	18462	Oil Well	Producing

From: Linn Operating, LLC
 To: Berry Petroleum Company, LLC
 Effective: May 1, 2017

LC TRIBAL 5-21D-56	4301350752	5	S	6	W	21	18286	Oil Well	Producing
FEDERAL 2-1D-65	4301350759	6	S	5	W	1	18172	Oil Well	Producing
FEDERAL 3-1D-65	4301350760	6	S	5	W	1	18173	Oil Well	Producing
FEDERAL 5-1D-65	4301350761	6	S	5	W	1	18174	Oil Well	Producing
FEDERAL 9-2D-65	4301350762	6	S	5	W	2	18245	Oil Well	Producing
FEDERAL 11-2D-65	4301350763	6	S	5	W	2	18589	Oil Well	Producing
FEDERAL 15-2D-65	4301350764	6	S	5	W	2	18590	Oil Well	Producing
LC TRIBAL 14-14D-56	4301350776	5	S	6	W	14	18287	Oil Well	Producing
LC FEE 2-20D-56	4301350777	5	S	6	W	20	18622	Oil Well	Producing
LC TRIBAL 12-22D-56	4301350780	5	S	6	W	22	18341	Oil Well	Producing
FEDERAL 3-4D-65	4301350782	6	S	5	W	4	18556	Oil Well	Producing
FEDERAL 6-4D-65	4301350783	6	S	5	W	4	19162	Oil Well	Producing
FEDERAL 12-4D-65	4301350784	6	S	5	W	4	19171	Oil Well	Producing
LC TRIBAL 14-15D-56	4301350834	5	S	6	W	15	18362	Oil Well	Producing
UTE TRIBAL 7I-21D-54	4301350852	5	S	4	W	21	18423	Oil Well	Producing
UTE TRIBAL 8L-21D-54	4301350853	5	S	4	W	21	18423	Oil Well	Producing
UTE TRIBAL 10S-21D-54	4301350854	5	S	4	W	21	18423	Oil Well	Producing
UTE TRIBAL 11-11-54	4301350861	5	S	4	W	11	18775	Oil Well	Producing
LC TRIBAL 1-28D-56	4301350865	5	S	6	W	28	19575	Oil Well	Producing
LC TRIBAL 2-28D-56	4301350866	5	S	6	W	28	18592	Oil Well	Producing
LC FEE 8-28D-56	4301350867	5	S	6	W	28	18342	Oil Well	Producing
LC TRIBAL 6-27D-56	4301350868	5	S	6	W	27	18480	Oil Well	Producing
LC FEE 15-23D-56	4301350870	5	S	6	W	23	18410	Oil Well	Producing
LC TRIBAL 15-26-56	4301350871	5	S	6	W	26	18377	Oil Well	Producing
UTE TRIBAL 16-11-55	4301350888	5	S	5	W	11	18707	Oil Well	Producing
LC TRIBAL 2-5D-56	4301350925	5	S	6	W	5	18568	Oil Well	Producing
LC TRIBAL 2-9D-56	4301350926	5	S	6	W	9	18425	Oil Well	Producing
LC FEE 8-29-45	4301350928	4	S	5	W	29	18313	Oil Well	Producing
LC FEE 13-29-45	4301350929	4	S	5	W	29	18426	Oil Well	Producing
LC FEE 9-12D-57	4301350963	5	S	7	W	12	18541	Oil Well	Producing
LC FEE 1-22-57	4301350965	5	S	7	W	22	18558	Oil Well	Producing
LC TRIBAL 11-3D-56	4301350966	5	S	6	W	3	18464	Oil Well	Producing
LC TRIBAL 3-34-45	4301350976	4	S	5	W	34	18661	Oil Well	Producing
LC TRIBAL 9-10D-56	4301350987	5	S	6	W	10	18944	Oil Well	Producing
LC TRIBAL 10-9D-56	4301350990	5	S	6	W	9	18864	Oil Well	Producing
LC FEE 10-31D-45	4301350994	4	S	5	W	31	18443	Oil Well	Producing
VIEIRA TRIBAL 4-4-54	4301350997	5	S	4	W	4	18747	Oil Well	Producing
LC TRIBAL 10-21-56	4301350999	5	S	6	W	21	18439	Oil Well	Producing
FEDERAL 1-5D-64	4301351012	6	S	4	W	5	18720	Oil Well	Producing
FEDERAL 2-5D-64	4301351013	6	S	4	W	5	18723	Oil Well	Producing
FEDERAL 7-5D-64	4301351014	6	S	4	W	5	18722	Oil Well	Producing
FEDERAL 8-5D-64	4301351015	6	S	4	W	5	18721	Oil Well	Producing
MYRIN TRIBAL 15-10-55	4301351024	5	S	5	W	10	18771	Oil Well	Producing
LC TRIBAL 15-15D-56	4301351030	5	S	6	W	15	18440	Oil Well	Producing

From: Linn Operating, LLC
 To: Berry Petroleum Company, LLC
 Effective: May 1, 2017

LC TRIBAL 9-15D-56	4301351031	5	S	6	W	15	18441	Oil Well	Producing
LC TRIBAL 6-28-45	4301351034	4	S	5	W	28	18700	Oil Well	Producing
FEDERAL 1-12D-65	4301351055	6	S	5	W	12	18739	Oil Well	Producing
FEDERAL 8-12D-65	4301351056	6	S	5	W	12	18718	Oil Well	Producing
FEDERAL 2-12D-65	4301351057	6	S	5	W	12	18738	Oil Well	Producing
FEDERAL 7-12D-65	4301351058	6	S	5	W	12	18717	Oil Well	Producing
LC TRIBAL 8-22D-56	4301351069	5	S	6	W	22	19233	Oil Well	Producing
LC TRIBAL 9-17D-56	4301351070	5	S	6	W	17	18945	Oil Well	Producing
LC TRIBAL 7-27-45	4301351073	4	S	5	W	27	18685	Oil Well	Producing
LC TRIBAL 11-24-45	4301351076	4	S	5	W	24	18745	Oil Well	Producing
FEDERAL 3-12D-65	4301351093	6	S	5	W	12	18705	Oil Well	Producing
FEDERAL 4-12D-65	4301351094	6	S	5	W	12	18704	Oil Well	Producing
FEDERAL 5-12D-65	4301351095	6	S	5	W	12	18702	Oil Well	Producing
FEDERAL 6-12D-65	4301351096	6	S	5	W	12	18703	Oil Well	Producing
UTE TRIBAL 9-5-54	4301351111	5	S	4	W	5	18909	Oil Well	Producing
LC TRIBAL 9-8D-56	4301351112	5	S	6	W	8	18522	Oil Well	Producing
UTE TRIBAL 4-9-54	4301351126	5	S	4	W	9	19059	Oil Well	Producing
UTE TRIBAL 2-9-54	4301351128	5	S	4	W	9	18946	Oil Well	Producing
UTE TRIBAL 1-10-54	4301351129	5	S	4	W	10	18879	Oil Well	Producing
LC TRIBAL 8-30D-56	4301351131	5	S	6	W	30	18539	Oil Well	Producing
FEDERAL 1-1D-65	4301351142	6	S	5	W	1	18623	Oil Well	Producing
UTE TRIBAL 8-9-54	4301351143	5	S	4	W	9	18947	Oil Well	Producing
FEDERAL 15-1D-65	4301351175	6	S	5	W	1	18654	Oil Well	Producing
FEDERAL 16-1D-65	4301351176	6	S	5	W	1	18655	Oil Well	Producing
LC TRIBAL 11-29D-56	4301351183	5	S	6	W	29	18873	Oil Well	Producing
STATE TRIBAL 8-12-55	4301351188	5	S	5	W	12	18986	Oil Well	Producing
LC TRIBAL 11-20D-56	4301351189	5	S	6	W	20	18819	Oil Well	Producing
LC FEE 5-20D-56	4301351190	5	S	6	W	20	18818	Oil Well	Producing
LC FEE 9-19-56	4301351192	5	S	6	W	19	18596	Oil Well	Producing
LC TRIBAL 9-9D-56	4301351198	5	S	6	W	9	18595	Oil Well	Producing
OWL AND THE HAWK 3-9C5	4301351214	3	S	5	W	9	18649	Oil Well	Producing
FEDERAL 16-6-64	4301351217	6	S	4	W	6	18792	Oil Well	Producing
FEDERAL 9-6D-64	4301351218	6	S	4	W	6	18791	Oil Well	Producing
FEDERAL 15-6D-64	4301351219	6	S	4	W	6	18793	Oil Well	Producing
UTE TRIBAL 5-17-55	4301351220	5	S	5	W	17	18841	Oil Well	Producing
UTE TRIBAL 16-3-54	4301351226	5	S	4	W	3	18664	Oil Well	Producing
STATE TRIBAL 8-7-54	4301351228	5	S	4	W	7	18743	Oil Well	Producing
STATE TRIBAL 12-1-55	4301351229	5	S	5	W	1	18741	Oil Well	Producing
STATE TRIBAL 11-2-55	4301351230	5	S	5	W	2	18742	Oil Well	Producing
FEDERAL 1-11-65	4301351231	6	S	5	W	11	18689	Oil Well	Producing
FEDERAL 8-11D-65	4301351232	6	S	5	W	11	18688	Oil Well	Producing
FEDERAL 2-11D-65	4301351233	6	S	5	W	11	18690	Oil Well	Producing
STATE TRIBAL 12-3-55	4301351236	5	S	5	W	3	18744	Oil Well	Producing
UTE TRIBAL 11-4-55	4301351237	5	S	5	W	4	18663	Oil Well	Producing

From: Linn Operating, LLC
 To: Berry Petroleum Company, LLC
 Effective: May 1, 2017

UTE TRIBAL 4-9-55	4301351238	5	S	5	W	9	18796	Oil Well	Producing
UTE TRIBAL 15-5-55	4301351239	5	S	5	W	5	18740	Oil Well	Producing
UTE TRIBAL 9-21D-55	4301351258	5	S	5	W	21	19401	Oil Well	Producing
UTE FEE 9-9-54	4301351259	5	S	4	W	9	18642	Oil Well	Producing
LC TRIBAL 4-29-45	4301351260	4	S	5	W	29	18719	Oil Well	Producing
UTE FEE 14-9D-54	4301351271	5	S	4	W	9	18684	Oil Well	Producing
UTE FEE 15-9D-54	4301351272	5	S	4	W	9	18687	Oil Well	Producing
LC FEE 10-28D-56	4301351288	5	S	6	W	28	18591	Oil Well	Producing
UTE TRIBAL 8-16D-54	4301351295	5	S	4	W	16	19003	Oil Well	Producing
FEE TRIBAL 4-5-54	4301351303	5	S	4	W	5	19187	Oil Well	Producing
LC TRIBAL 1-26-56	4301351306	5	S	6	W	26	18816	Oil Well	Producing
UTE TRIBAL 6-16D-54	4301351307	5	S	4	W	16	19060	Oil Well	Producing
LC TRIBAL 7-22D-56	4301351308	5	S	6	W	22	18795	Oil Well	Producing
LC TRIBAL 9-22D-56	4301351309	5	S	6	W	22	18794	Oil Well	Producing
STATE TRIBAL 2-12D-55	4301351310	5	S	5	W	12	19444	Oil Well	Producing
LC TRIBAL 9-32D-56	4301351316	5	S	6	W	32	19228	Oil Well	Producing
LC TRIBAL 7-26D-56	4301351319	5	S	6	W	26	18817	Oil Well	Producing
LC FEE 8-6D-56	4301351342	5	S	6	W	6	18657	Oil Well	Producing
LC FEE 10-29D-45	4301351343	4	S	5	W	29	18850	Oil Well	Producing
LC TRIBAL 1-7D-56	4301351344	5	S	6	W	7	18774	Oil Well	Producing
LC TRIBAL 9-7D-56	4301351346	5	S	6	W	7	18773	Oil Well	Producing
UTE TRIBAL 7-10D-54	4301351365	5	S	4	W	10	19391	Oil Well	Producing
LC TRIBAL 11-10D-56	4301351369	5	S	6	W	10	18840	Oil Well	Producing
LC FEE 1-31D-45	4301351371	4	S	5	W	31	18686	Oil Well	Producing
LC TRIBAL 9-26D-56	4301351381	5	S	6	W	26	19433	Oil Well	Producing
LC TRIBAL 14-21D-56	4301351384	5	S	6	W	21	18877	Oil Well	Producing
LC TRIBAL 4-22D-56	4301351385	5	S	6	W	22	18878	Oil Well	Producing
LC TRIBAL 8-21D-56	4301351392	5	S	6	W	21	18874	Oil Well	Producing
UTE TRIBAL 1-17-55	4301351393	5	S	5	W	17	18848	Oil Well	Producing
LC TRIBAL 4-33D-45	4301351401	4	S	5	W	33	18853	Oil Well	Producing
LC TRIBAL 16-21D-56	4301351407	5	S	6	W	21	18875	Oil Well	Producing
UTE TRIBAL 2-10D-54	4301351411	5	S	4	W	10	19172	Oil Well	Producing
UTE TRIBAL 8-17D-55	4301351413	5	S	5	W	17	19388	Oil Well	Producing
UTE TRIBAL 4-10D-54	4301351414	5	S	4	W	10	19069	Oil Well	Producing
LC TRIBAL 2-21D-56	4301351418	5	S	6	W	16	19252	Oil Well	Producing
LC TRIBAL 1-23D-45	4301351425	4	S	5	W	23	18855	Oil Well	Producing
LC TRIBAL 2-28D-45	4301351429	4	S	5	W	28	18701	Oil Well	Producing
LC TRIBAL 9-28D-45	4301351430	4	S	5	W	28	18656	Oil Well	Producing
LC FEE 1-1-56	4301351458	5	S	6	W	1	18829	Oil Well	Producing
LC Tribal 12-32-45	4301351465	4	S	5	W	32	18772	Oil Well	Producing
UTE TRIBAL 2-5-54	4301351520	5	S	4	W	5	18880	Oil Well	Producing
LC Tribal 3-32D-45	4301351561	4	S	5	W	32	18842	Oil Well	Producing
LC TRIBAL 5-15D-56	4301351562	5	S	6	W	15	19253	Oil Well	Producing
LC FEE 16-36-56	4301351611	5	S	6	W	36	19096	Oil Well	Producing

From: Linn Operating, LLC
 To: Berry Petroleum Company, LLC
 Effective: May 1, 2017

LC FEE 10-36D-56	4301351622	5	S	6	W	36	19583	Oil Well	Producing
LC TRIBAL 15-34-56	4301351647	5	S	6	W	34	18962	Oil Well	Producing
LC TRIBAL 15-27-56	4301351649	5	S	6	W	27	19605	Oil Well	Producing
LC TRIBAL 11-27D-56	4301351650	5	S	6	W	27	19606	Oil Well	Producing
LC TRIBAL 1-34D-56	4301351660	5	S	6	W	34	18988	Oil Well	Producing
LC TRIBAL 2-29D-45	4301351705	4	S	5	W	29	19545	Oil Well	Producing
LC FEE 13-23-56	4301351706	5	S	6	W	23	18994	Oil Well	Producing
LC FEE 11-23D-56	4301351707	5	S	6	W	23	18995	Oil Well	Producing
LC TRIBAL 3-33-56	4301351711	5	S	6	W	33	19242	Oil Well	Producing
LC FEE 11-29D-45	4301351743	4	S	5	W	29	19188	Oil Well	Producing
LC TAYLOR FEE 14-22D-56	4301351744	5	S	6	W	22	19508	Oil Well	Producing
LC FEE 4-28D-45	4301351745	4	S	5	W	29	18849	Oil Well	Producing
LC FEE 14-6D-56	4301351787	5	S	6	W	6	18910	Oil Well	Producing
LC FEE 15-6-56	4301351792	5	S	6	W	6	19334	Oil Well	Producing
LC TRIBAL 7-27D-56	4301351823	5	S	6	W	27	19608	Oil Well	Producing
LC Fee 14-36D-56	4301351878	5	S	6	W	36	19376	Oil Well	Producing
LC Fee 12-36-56	4301351883	5	S	6	W	36	19377	Oil Well	Producing
LC Tribal 6-29D-45	4301351902	4	S	5	W	29	19402	Oil Well	Producing
FEDERAL 6-7-64	4301351915	6	S	4	W	7	19117	Oil Well	Producing
FEDERAL 3-7D-64	4301351916	6	S	4	W	7	19115	Oil Well	Producing
FEDERAL 4-7D-64	4301351917	6	S	4	W	7	19110	Oil Well	Producing
FEDERAL 5-7D-64	4301351918	6	S	4	W	7	19111	Oil Well	Producing
FEDERAL 2-7-64	4301351919	6	S	4	W	7	19139	Oil Well	Producing
FEDERAL 1-7D-64	4301351920	6	S	4	W	7	19140	Oil Well	Producing
FEDERAL 12-7D-64	4301351924	6	S	4	W	7	19025	Oil Well	Producing
FEDERAL 11-7D-64	4301351925	6	S	4	W	7	19039	Oil Well	Producing
FEDERAL 13-7D-64	4301351926	6	S	4	W	7	19026	Oil Well	Producing
FEDERAL 14-7D-64	4301351927	6	S	4	W	7	19040	Oil Well	Producing
FEDERAL 7-7D-64	4301351933	6	S	4	W	7	19141	Oil Well	Producing
FEDERAL 8-7D-64	4301351934	6	S	4	W	7	19142	Oil Well	Producing
FEDERAL 9-7D-64	4301351935	6	S	4	W	7	19143	Oil Well	Producing
FEDERAL 10-7D-64	4301351936	6	S	4	W	7	19144	Oil Well	Producing
ABBOTT FEE 6-6-54	4301351948	5	S	4	W	6	18963	Oil Well	Producing
ABBOTT FEE 2-6D-54	4301351949	5	S	4	W	6	18974	Oil Well	Producing
ABBOTT FEE 4-6-54	4301351952	5	S	4	W	6	18965	Oil Well	Producing
Federal 7-9D-64	4301351990	6	S	4	W	9	19721	Oil Well	Producing
Federal 15-12D-65	4301351992	6	S	5	W	12	19051	Oil Well	Producing
Federal 10-12D-65	4301351999	6	S	5	W	12	19052	Oil Well	Producing
Federal 9-12D-65	4301352000	6	S	5	W	12	19053	Oil Well	Producing
Federal 16-12D-65	4301352003	6	S	5	W	12	19054	Oil Well	Producing
Federal 4-6D-65	4301352005	6	S	5	W	6	19173	Oil Well	Producing
Federal 12-6D-65	4301352006	6	S	5	W	6	19174	Oil Well	Producing
Federal 1-6D-65	4301352012	6	S	5	W	6	19189	Oil Well	Producing
Federal 3-6D-65	4301352014	6	S	5	W	6	19190	Oil Well	Producing

From: Linn Operating, LLC
 To: Berry Petroleum Company, LLC
 Effective: May 1, 2017

Federal 3-9D-64	4301352015	6	S	4	W	9	19678	Oil Well	Producing
Federal 2-6-65	4301352017	6	S	5	W	6	19191	Oil Well	Producing
Federal 7-6D-65	4301352018	6	S	5	W	6	19192	Oil Well	Producing
Federal 6-9-64	4301352021	6	S	4	W	9	19679	Oil Well	Producing
Federal 8-9D-64	4301352023	6	S	4	W	9	19723	Oil Well	Producing
Federal 5-9D-64	4301352035	6	S	4	W	9	19680	Oil Well	Producing
Federal 11-9D-64	4301352037	6	S	4	W	9	19687	Oil Well	Producing
Federal 12-9D-64	4301352038	6	S	4	W	9	19688	Oil Well	Producing
Federal 13-9D-64	4301352039	6	S	4	W	9	19689	Oil Well	Producing
Federal 2-9D-64	4301352042	6	S	4	W	9	19724	Oil Well	Producing
Federal 16-11D-65	4301352045	6	S	5	W	11	19070	Oil Well	Producing
Federal 15-11D-65	4301352046	6	S	5	W	11	19076	Oil Well	Producing
Federal 10-11D-65	4301352047	6	S	5	W	11	19077	Oil Well	Producing
Federal 9-11D-65	4301352048	6	S	5	W	11	19071	Oil Well	Producing
Federal 11-12D-65	4301352049	6	S	5	W	12	19121	Oil Well	Producing
Federal 12-12D-65	4301352050	6	S	5	W	12	19122	Oil Well	Producing
Federal 13-12D-65	4301352052	6	S	5	W	12	19123	Oil Well	Producing
Federal 14-12D-65	4301352053	6	S	5	W	12	19124	Oil Well	Producing
LC Tribal 12-28D-45	4301352089	4	S	5	W	28	19378	Oil Well	Producing
LC Tribal 2-32D-45	4301352113	4	S	5	W	32	19348	Oil Well	Producing
LC Tribal 16-29D-45	4301352114	4	S	5	W	32	19349	Oil Well	Producing
Vieira Tribal 3-4D-54	4301352145	5	S	4	W	4	19210	Oil Well	Producing
Vieira Tribal 5-4D-54	4301352146	5	S	4	W	4	19193	Oil Well	Producing
Vieira Tribal 6-4D-54	4301352147	5	S	4	W	4	19216	Oil Well	Producing
Lamplugh Tribal 6-3D-54	4301352148	5	S	4	W	3	19289	Oil Well	Producing
Lamplugh Tribal 5-3D-54	4301352149	5	S	4	W	3	19290	Gas Well	Producing
Lamplugh Tribal 4-3D-54	4301352150	5	S	4	W	3	19291	Oil Well	Producing
Lamplugh Tribal 3-3D-54	4301352151	5	S	4	W	3	19292	Oil Well	Producing
UTE Tribal 6-35D-54	4301352158	5	S	4	W	35	19254	Gas Well	Producing
UTE Tribal 4-35D-54	4301352159	5	S	4	W	35	19255	Gas Well	Producing
Heiner Tribal 3-11D-54	4301352165	5	S	4	W	11	19194	Oil Well	Producing
Heiner Tribal 4-11-54	4301352166	5	S	4	W	11	19195	Oil Well	Producing
Heiner Tribal 5-11D-54	4301352167	5	S	4	W	11	19196	Oil Well	Producing
Conolly Tribal 1-11D-54	4301352168	5	S	4	W	11	19270	Oil Well	Producing
Conolly Tribal 2-11D-54	4301352169	5	S	4	W	11	19197	Oil Well	Producing
Conolly Tribal 7-11D-54	4301352170	5	S	4	W	11	19280	Oil Well	Producing
Conolly Tribal 8-11D-54	4301352171	5	S	4	W	11	19281	Oil Well	Producing
Casper Tribal 1-5D-54	4301352180	5	S	4	W	5	19198	Oil Well	Producing
Fee Tribal 6-5D-54	4301352181	5	S	4	W	5	19199	Oil Well	Producing
Fee Tribal 5-5D-54	4301352182	5	S	4	W	5	19200	Oil Well	Producing
Fee Tribal 3-5D-54	4301352184	5	S	4	W	5	19201	Oil Well	Producing
Casper Tribal 7-5D-54	4301352185	5	S	4	W	5	19202	Oil Well	Producing
UTE Tribal 10-35D-54	4301352198	5	S	4	W	35	19320	Oil Well	Producing
UTE Tribal 14-35D-54	4301352199	5	S	4	W	35	19311	Gas Well	Producing

From: Linn Operating, LLC
 To: Berry Petroleum Company, LLC
 Effective: May 1, 2017

UTE Tribal 12-35D-54	4301352200	5	S	4	W	35	19312	Oil Well	Producing
UTE Tribal 14-18D-54	4301352213	5	S	4	W	18	19509	Gas Well	Producing
UTE Tribal 16-35D-54	4301352230	5	S	4	W	35	19321	Oil Well	Producing
Evans Tribal 1-3-54	4301352234	5	S	4	W	3	19264	Oil Well	Producing
Evans Tribal 2-3D-54	4301352235	5	S	4	W	3	19265	Oil Well	Producing
Evans Tribal 7-3D-54	4301352236	5	S	4	W	3	19256	Oil Well	Producing
Evans Tribal 8-3D-54	4301352237	5	S	4	W	3	19257	Oil Well	Producing
Ute Tribal 9-3D-54	4301352249	5	S	4	W	3	19236	Oil Well	Producing
Ute Tribal 15-3D-54	4301352250	5	S	4	W	3	19237	Oil Well	Producing
Ute Tribal 10-3-54	4301352251	5	S	4	W	3	19238	Oil Well	Producing
Ute Tribal 14-3D-54	4301352298	5	S	4	W	3	19258	Oil Well	Producing
Ute Tribal 12-3D-54	4301352299	5	S	4	W	3	19259	Oil Well	Producing
Ute Tribal 11-3D-54	4301352300	5	S	4	W	3	19260	Oil Well	Producing
Ute Tribal 16-4D-54	4301352302	5	S	4	W	4	19350	Oil Well	Producing
Ute Tribal 15-4D-54	4301352303	5	S	4	W	4	19293	Oil Well	Producing
Ute Tribal 9-4D-54	4301352305	5	S	4	W	4	19304	Oil Well	Producing
Ute Tribal 10-4D-54	4301352307	5	S	4	W	4	19294	Oil Well	Producing
UTE Tribal 15-31D-55	4301352309	5	S	5	W	31	19472	Gas Well	Producing
UTE Tribal 16-31D-55	4301352318	5	S	5	W	31	19473	Gas Well	Producing
UTE Tribal 2-35D-54	4301352319	5	S	4	W	35	19322	Oil Well	Producing
UTE Tribal 8-35D-54	4301352320	5	S	4	W	35	19323	Oil Well	Producing
Abbott Fee 5-6D-54	4301352326	5	S	4	W	6	19351	Oil Well	Producing
Ute Tribal 6-11D-54	4301352330	5	S	4	W	11	19243	Oil Well	Producing
Ute Tribal 12-11D-54	4301352331	5	S	4	W	11	19244	Oil Well	Producing
Ute Tribal 14-11D-54	4301352332	5	S	4	W	11	19245	Oil Well	Producing
Ute Tribal 11-4D-54	4301352343	5	S	4	W	4	19305	Oil Well	Producing
Ute Tribal 13-4D-54	4301352345	5	S	4	W	4	19353	Oil Well	Producing
Ute Tribal 14-4D-54	4301352346	5	S	4	W	4	19306	Oil Well	Producing
State Tribal 7-12D-55	4301352369	5	S	5	W	12	19651	Oil Well	Producing
State Tribal 1-12D-55	4301352390	5	S	5	W	12	19445	Oil Well	Producing
State Tribal 16-6D-54	4301352394	5	S	4	W	6	19424	Oil Well	Producing
State Tribal 9-6D-54	4301352396	5	S	4	W	6	19426	Oil Well	Producing
State Tribal 7-7D-54	4301352426	5	S	4	W	7	19496	Oil Well	Producing
State Tribal 1-7D-54	4301352427	5	S	4	W	7	19497	Oil Well	Producing
State Tribal 2-7D-54	4301352428	5	S	4	W	7	19498	Oil Well	Producing
State Tribal 3-7D-54	4301352429	5	S	4	W	7	19517	Oil Well	Producing
State Tribal 4-7D-54	4301352431	5	S	4	W	7	19546	Oil Well	Producing
State Tribal 5-7D-54	4301352432	5	S	4	W	7	19547	Oil Well	Producing
State Tribal 6-7D-54	4301352433	5	S	4	W	7	19518	Oil Well	Producing
State Tribal 11-6D-54	4301352452	5	S	4	W	6	19474	Oil Well	Producing
State Tribal 12-6D-54	4301352453	5	S	4	W	6	19475	Oil Well	Producing
State Tribal 13-6D-54	4301352454	5	S	4	W	6	19476	Oil Well	Producing
Ute Tribal 1-9D-54	4301352465	5	S	4	W	9	19356	Oil Well	Producing
Ute Tribal 7-9D-54	4301352466	5	S	4	W	9	19357	Oil Well	Producing

From: Linn Operating, LLC
 To: Berry Petroleum Company, LLC
 Effective: May 1, 2017

UTE TRIBAL 12-5D-54	4301352480	5	S	4	W	5	19499	Oil Well	Producing
UTE TRIBAL 13-5D-54	4301352484	5	S	4	W	5	19500	Oil Well	Producing
UTE TRIBAL 14-5D-54	4301352493	5	S	4	W	5	19510	Oil Well	Producing
Federal 14-6D-65	4301352495	6	S	5	W	6	19610	Oil Well	Producing
Federal 13-6D-65	4301352496	6	S	5	W	6	19611	Oil Well	Producing
Federal 11-6D-65	4301352497	6	S	5	W	6	19591	Oil Well	Producing
Ute Tribal 16-5D-54	4301352545	5	S	4	W	5	19335	Oil Well	Producing
Ute Tribal 15-5D-54	4301352546	5	S	4	W	5	19358	Oil Well	Producing
Ute Tribal 10-5D-54	4301352547	5	S	4	W	5	19359	Oil Well	Producing
Ute Tribal 8-5D-54	4301352548	5	S	4	W	5	19336	Oil Well	Producing
State Tribal 13-11D-54	4301352561	5	S	4	W	10	19519	Oil Well	Producing
State Tribal 1-18D-54	4301352568	5	S	4	W	18	19434	Oil Well	Producing
State Tribal 2-18D-54	4301352576	5	S	4	W	18	19427	Oil Well	Producing
State Tribal 8-18D-54	4301352577	5	S	4	W	18	19428	Oil Well	Producing
Federal 16-6D-65	4301352590	6	S	5	W	6	19616	Oil Well	Producing
Federal 15-6D-65	4301352591	6	S	5	W	6	19617	Oil Well	Producing
State Tribal 4-18D-54	4301352607	5	S	4	W	18	19435	Oil Well	Producing
State Tribal 3-18D-54	4301352608	5	S	4	W	18	19436	Oil Well	Producing
State Tribal 6-18D-54	4301352609	5	S	4	W	18	19437	Oil Well	Producing
State Tribal 5-12-55	4301352643	5	S	5	W	12	19446	Oil Well	Producing
State Tribal 12-12D-55	4301352644	5	S	5	W	12	19447	Oil Well	Producing
State Tribal 6-12D-55	4301352645	5	S	5	W	12	19438	Oil Well	Producing
State Tribal 16-1D-55	4301352646	5	S	5	W	1	19483	Oil Well	Producing
State Tribal 15-1D-55	4301352647	5	S	5	W	1	19484	Oil Well	Producing
State Tribal 10-1D-55	4301352648	5	S	5	W	1	19485	Oil Well	Producing
State Tribal 9-1D-55	4301352649	5	S	5	W	1	19486	Oil Well	Producing
LC FEE 16-15D-56	4301352655	5	S	6	W	14	19520	Oil Well	Producing
LC Tribal 2-22D-56	4301352663	5	S	6	W	22	19548	Oil Well	Producing
LC Tribal 3-22D-56	4301352664	5	S	6	W	22	19549	Oil Well	Producing
UTE TRIBAL 14-30D-55	4301352687	5	S	5	W	30	19836	Oil Well	Producing
UTE TRIBAL 13-30D-55	4301352688	5	S	5	W	30	19743	Oil Well	Producing
UTE TRIBAL 12-30D-55	4301352689	5	S	5	W	30	19744	Oil Well	Producing
UTE TRIBAL 11-30D-55	4301352690	5	S	5	W	30	19745	Oil Well	Producing
UTE TRIBAL 12-31D-55	4301352699	5	S	5	W	31	19774	Oil Well	Producing
UTE TRIBAL 13-31D-55	4301352700	5	S	5	W	31	19775	Oil Well	Producing
UTE TRIBAL 14-31D-55	4301352701	5	S	5	W	31	19776	Oil Well	Producing
UTE TRIBAL 11-31-55	4301352703	5	S	5	W	31	19777	Oil Well	Producing
UTE TRIBAL 9-30D-55	4301352731	5	S	5	W	30	19732	Oil Well	Producing
UTE TRIBAL 15-30D-55	4301352737	5	S	5	W	30	19725	Oil Well	Producing
UTE TRIBAL 3-31D-55	4301352757	5	S	5	W	31	19778	Oil Well	Producing
UTE TRIBAL 5-31D-55	4301352758	5	S	5	W	31	19779	Oil Well	Producing
UTE TRIBAL 6-31D-55	4301352759	5	S	5	W	31	19746	Oil Well	Producing
Federal 8-14D-65	4301352767	6	S	5	W	14	19592	Oil Well	Producing
Federal 7-14D-65	4301352768	6	S	5	W	14	19593	Oil Well	Producing

From: Linn Operating, LLC
 To: Berry Petroleum Company, LLC
 Effective: May 1, 2017

Federal 2-14D-65	4301352769	6	S	5	W	14	19594	Oil Well	Producing
Federal 1-14D-65	4301352770	6	S	5	W	14	19595	Oil Well	Producing
UTE TRIBAL 4-31D-55	4301352795	5	S	5	W	31	19780	Oil Well	Producing
Federal 1-13D-65	4301352800	6	S	5	W	13	19596	Oil Well	Producing
Federal 2-13-65	4301352801	6	S	5	W	13	19501	Oil Well	Producing
Federal 7-13D-65	4301352802	6	S	5	W	13	19597	Oil Well	Producing
Federal 8-13D-65	4301352803	6	S	5	W	13	19502	Oil Well	Producing
Federal 12-8D-64	4301352832	6	S	4	W	7	19550	Oil Well	Producing
Federal 5-8D-64	4301352833	6	S	4	W	7	19551	Oil Well	Producing
Federal 4-8D-64	4301352834	6	S	4	W	7	19552	Oil Well	Producing
Federal 3-8D-64	4301352845	6	S	4	W	5	19503	Oil Well	Producing
LC TRIBAL 4H-31-56	4301351738	5	S	6	W	31		Oil Well	Returned APD (Unapproved)
LC Fee 11-22-57	4301352127	5	S	7	W	22		Oil Well	Returned APD (Unapproved)
LC Fee 13-22D-57	4301352131	5	S	7	W	22		Oil Well	Returned APD (Unapproved)
LC Tribal 5-22D-57	4301352133	5	S	7	W	22		Oil Well	Returned APD (Unapproved)
LC Tribal 15-22D-57	4301352134	5	S	7	W	22		Oil Well	Returned APD (Unapproved)
LC Tribal 11-18D-56	4301352140	5	S	6	W	18		Oil Well	Returned APD (Unapproved)
LC Tribal 13-18D-56	4301352141	5	S	6	W	18		Oil Well	Returned APD (Unapproved)
LC Tribal 15-18D-56	4301352142	5	S	6	W	18		Oil Well	Returned APD (Unapproved)
LC Tribal 7-18D-56	4301352153	5	S	6	W	18		Oil Well	Returned APD (Unapproved)
LC Tribal 5-18D-56	4301352154	5	S	6	W	18		Oil Well	Returned APD (Unapproved)
LC Tribal 3-18-56	4301352155	5	S	6	W	18		Oil Well	Returned APD (Unapproved)
LC Tribal 6-19D-56	4301352247	5	S	6	W	19		Oil Well	Returned APD (Unapproved)
LC Tribal 4-19D-56	4301352248	5	S	6	W	19		Oil Well	Returned APD (Unapproved)
Abbott Fee 3-6D-54	4301352325	5	S	4	W	6		Oil Well	Returned APD (Unapproved)
LC Fee 9-11D-56	4301352479	5	S	6	W	11		Oil Well	Returned APD (Unapproved)
Williams Tribal 8-4D-54	4301352650	5	S	4	W	4		Oil Well	Returned APD (Unapproved)
Williams Tribal 7-4D-54	4301352651	5	S	4	W	4		Oil Well	Returned APD (Unapproved)
Williams Tribal 2-4D-54	4301352652	5	S	4	W	4		Oil Well	Returned APD (Unapproved)
Williams Tribal 1-4D-54	4301352653	5	S	4	W	4		Oil Well	Returned APD (Unapproved)
Foy Fee 12-34D-55	4301353087	5	S	5	W	34		Oil Well	Returned APD (Unapproved)
Foy Fee 6-34D-55	4301353088	5	S	5	W	34		Oil Well	Returned APD (Unapproved)
Foy Fee 5-34D-55	4301353089	5	S	5	W	34		Oil Well	Returned APD (Unapproved)
Foy Fee 3-34D-55	4301353090	5	S	5	W	34		Oil Well	Returned APD (Unapproved)
Foy Tribal 13-34D-55	4301353119	5	S	5	W	34		Oil Well	Returned APD (Unapproved)
Foy Tribal 14-34-55	4301353120	5	S	5	W	34		Oil Well	Returned APD (Unapproved)
UTE FEE 10-13D-55	4301353129	5	S	5	W	13		Oil Well	Returned APD (Unapproved)
LC Tribal 10-15D-56	4301353163	5	S	6	W	15		Oil Well	Returned APD (Unapproved)
LC Tribal 9-21D-56	4301353164	5	S	6	W	21		Oil Well	Returned APD (Unapproved)
LC Tribal 7-21D-56	4301353165	5	S	6	W	21		Oil Well	Returned APD (Unapproved)
LC Tribal 11-15D-56	4301353189	5	S	6	W	15		Oil Well	Returned APD (Unapproved)
SCOFIELD THORPE 22-41X RIG SKID	4300730890	12	S	7	E	22	13719	Gas Well	Shut-in
SCOFIELD-THORPE 35-13	4300730991	12	S	7	E	35	14846	Gas Well	Shut-in
SCOFIELD-THORPE 23-31	4300731001	12	S	7	E	23	14923	Gas Well	Shut-in

From: Linn Operating, LLC
 To: Berry Petroleum Company, LLC
 Effective: May 1, 2017

WIRE FENCE CYN FED 15-1	4301330404	6	S	5	W	15	8233	Gas Well	Shut-in
R FORK ANTELOPE CYN FED 25-1	4301330406	6	S	5	W	25	8234	Oil Well	Shut-in
WOLF HOLLOW 22-1	4301330425	6	S	5	W	22	10370	Gas Well	Shut-in
Z and T UTE TRIBAL 12-22	4301331311	5	S	4	W	22	11421	Oil Well	Shut-in
UTE TRIBAL 15-17	4301331649	5	S	4	W	17	11956	Oil Well	Shut-in
UTE TRIBAL 3-19	4301331830	5	S	4	W	19	12197	Oil Well	Shut-in
UTE TRIBAL 14-17	4301332147	5	S	4	W	17	12755	Oil Well	Shut-in
UTE TRIBAL 7-30	4301332167	5	S	4	W	30	12945	Oil Well	Shut-in
UTE TRIBAL 1-33	4301332185	5	S	4	W	33	13024	Oil Well	Shut-in
UTE TRIBAL 5-24-55	4301332263	5	S	5	W	24	13621	Oil Well	Shut-in
UTE TRIBAL 10-16-55	4301332345	5	S	5	W	16	13693	Oil Well	Shut-in
UTE TRIBAL 15-30-54	4301332382	5	S	4	W	30	13944	Oil Well	Shut-in
UTE TRIBAL 14-21-54	4301332384	5	S	4	W	21	13946	Oil Well	Shut-in
UTE TRIBAL 13-30-54	4301332409	5	S	4	W	30	13968	Oil Well	Shut-in
UTE TRIBAL 3-33-54	4301332412	5	S	4	W	33	13938	Oil Well	Shut-in
UTE TRIBAL 1-20-55	4301332414	5	S	5	W	20	14548	Oil Well	Shut-in
UTE TRIBAL 9-29-54	4301332566	5	S	4	W	29	14369	Oil Well	Shut-in
UTE TRIBAL 6-24-54	4301332570	5	S	4	W	24	14299	Oil Well	Shut-in
UTE TRIBAL 10-14-55	4301332601	5	S	5	W	14	14331	Oil Well	Shut-in
UTE TRIBAL 11-5-54	4301332664	5	S	4	W	5	14415	Oil Well	Shut-in
UTE TRIBAL 16-24-55	4301332672	5	S	5	W	24	14384	Gas Well	Shut-in
MYRIN TRIBAL 14-19-55	4301332782	5	S	5	W	19	15184	Oil Well	Shut-in
MOON TRIBAL 13-27-54	4301332801	5	S	4	W	27	15057	Oil Well	Shut-in
MOON TRIBAL 11-27-54	4301332845	5	S	4	W	27	15135	Oil Well	Shut-in
UTE TRIBAL 15-15-55	4301332855	5	S	5	W	15	15114	Oil Well	Shut-in
UTE TRIBAL 10-24-54	4301332932	5	S	4	W	24	15364	Oil Well	Shut-in
UTE TRIBAL 8-24-54	4301332933	5	S	4	W	24	15402	Oil Well	Shut-in
UTE TRIBAL 12-15-55	4301332981	5	S	5	W	15	15348	Oil Well	Shut-in
UTE TRIBAL 2-23-55	4301333045	5	S	5	W	23	15416	Oil Well	Shut-in
TAYLOR FEE 7-14-56	4301333140	5	S	6	W	14	15601	Oil Well	Shut-in
WILCOX FEE 15-16-56	4301333151	5	S	6	W	16	15527	Oil Well	Shut-in
UTE TRIBAL 11-13-55	4301333268	5	S	5	W	13	15692	Oil Well	Shut-in
UTE TRIBAL 7-14-55	4301333269	5	S	5	W	14	15693	Oil Well	Shut-in
FEDERAL 10-3-65	4301333386	6	S	5	W	3	16297	Oil Well	Shut-in
BERRY TRIBAL 16-34D-54	4301333464	5	S	4	W	34	16280	Oil Well	Shut-in
FEDERAL 10-2-65	4301333542	6	S	5	W	2	16181	Oil Well	Shut-in
UTE FEE 2-13-55	4301333720	5	S	5	W	13	18659	Oil Well	Shut-in
LC TRIBAL 13-16D-56	4301334282	5	S	6	W	16	17601	Oil Well	Shut-in
LC TRIBAL 4-27D-56	4301350262	5	S	6	W	27	17568	Oil Well	Shut-in
LC TRIBAL 8-16D-56	4301350599	5	S	6	W	16	18161	Oil Well	Shut-in
LC TRIBAL 15-8D-56	4301351060	5	S	6	W	8	18862	Oil Well	Shut-in
UTE TRIBAL 6-9-54	4301351127	5	S	4	W	9	19017	Oil Well	Shut-in
LC TRIBAL 16-30D-56	4301351132	5	S	6	W	30	18540	Oil Well	Shut-in
STATE TRIBAL 15-6-54	4301351227	5	S	4	W	6	18746	Oil Well	Shut-in

From: Linn Operating, LLC
 To: Berry Petroleum Company, LLC
 Effective: May 1, 2017

LC TRIBAL 1-29-56	4301351442	5	S	6	W	29	18876	Oil Well	Shut-in
CC Fee 7R-28-38	4301351852	3	S	8	W	28	18863	Oil Well	Shut-in
ABBOTT FEE 8-6D-54	4301351950	5	S	4	W	6	18964	Oil Well	Shut-in
Federal 1-9D-64	4301352020	6	S	4	W	9	19722	Oil Well	Shut-in
FEDERAL 14-9D-64	4301352040	6	S	4	W	9	19690	Oil Well	Shut-in
Ute Tribal 12-4D-54	4301352344	5	S	4	W	4	19352	Oil Well	Shut-in
State Tribal 10-6D-54	4301352395	5	S	4	W	6	19425	Oil Well	Shut-in
State Tribal 14-6D-54	4301352455	5	S	4	W	6	19477	Oil Well	Shut-in
Federal 10-6D-65	4301352498	6	S	5	W	6	19612	Oil Well	Shut-in
Federal 2-7D-65	4301352537	6	S	5	W	7	19630	Oil Well	Shut-in
Federal 5-7D-65	4301352538	6	S	5	W	7	19613	Oil Well	Shut-in
Federal 4-7D-65	4301352541	6	S	5	W	7	19614	Oil Well	Shut-in
Federal 3-7-65	4301352560	6	S	5	W	7	19609	Oil Well	Shut-in
Federal 1-7D-65	4301352589	6	S	5	W	6	19615	Oil Well	Shut-in

UPDATE ON SI WELLS FOR NAME CHANGE

4/10/17

Future Berry Petroleum Wells

Scofield Thorpe 22-41X Rig Skid:

Future Berry Petroleum well as of May 1st, 2017.

Scofield Thorpe 35-13

Future Berry Petroleum well as of May 1st, 2017.

Scofield Thorpe 23-31

Future Berry Petroleum well as of May 1st, 2017.

Wilcox Fee 15-16-56

Future Berry Petroleum well as of May 1st, 2017.

LC Fee 8-15D-56

Future Berry Petroleum well as of May 1st, 2017.

CC Fee 7R-28-38

Future Berry Petroleum well as of May 1st, 2017.

Taylor Fee 7-14-56

Future Berry Petroleum well as of May 1st, 2017.

SFW Fee 13-10D-54

Future Berry Petroleum well as of May 1st, 2017.

LINN Energy Wells

Mark 2-25A2

Received approved LINN Energy budget this month. Repair work under review.

Mitchell 2-4B1

Received approved LINN Energy budget this month. Repair work under review.

Galloway #2-14B2

Reclaim existing pit in Q2 2017. Project delayed due to winter weather.

Hamblin 2-26-A2

Received approved LINN Energy budget this month. Repair work under review.

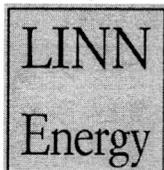

STATE OF UTAH SHUT IN LIST ESTIMATED P/A COSTS

4/10/2017

WELLNAME	FUTURE OPERATOR	ESTIMATED P/A COSTS	
Scofield Thorpe 22-41X Rig Skid	Berry Petroleum Company	\$	45,000
Scofield Thorpe 35-13	Berry Petroleum Company	\$	45,000
Scofield Thorpe 23-31	Berry Petroleum Company	\$	45,000
SFW Fee 13-10D-54	Berry Petroleum Company	\$	35,000
Wilcox Fee 15-16-56	Berry Petroleum Company	\$	35,000
✓LC Fee 8-15D-56	Berry Petroleum Company	\$	35,000
✓CC Fee 7R-28-38	Berry Petroleum Company	\$	75,000
✓Taylor Fee 7-14-56	Berry Petroleum Company	\$	35,000
	Berry Petroleum Company TOTAL	\$	350,000
Mark 2-25A2	LINN Operating	\$	75,000
Mitchell 2-4B1	LINN Operating	\$	75,000
Galloway 2-14B2	LINN Operating	\$	30,000
Hamblin 2-26A2	LINN Operating	\$	75,000
	LINN Operating TOTAL	\$	255,000



Rachel Medina <rachelmedina@utah.gov>

Linn Name Change and Berry Operator Change

2 messages

Rachel Medina <rachelmedina@utah.gov>

Thu, Apr 20, 2017 at 11:58 AM

To: Dustin Doucet <dustindoucet@utah.gov>, Randy Thackeray <randythackeray@utah.gov>

Dustin,

Linn is planning on moving all the wells from Linn Inc. to Linn LLC, then complete an operator change for the Berry wells. Eight of the wells on the non-compliance list will be move to Berry. Are you okay with us moving all the wells to Berry, putting the eight wells on the blanket bond, then getting the shut in plans and full cost bond when the move to Berry is complete?

The blanket bond and full cost bonding for the Linn wells will of course be in place before we complete the move.

Attached is the plugging estimates for all twelve wells, as well as a list of which wells are going to the new Linn and Berry. They have some details on what they plan to do with the wells on the Update list. Will this be acceptable for a shut in plan and plugging estimates?

—
Rachel Medina
Division of Oil, Gas & Mining
Bonding Technician
801-538-5260

 20170420110137.pdf
58K

Dustin Doucet <dustindoucet@utah.gov>

Thu, Apr 27, 2017 at 10:40 AM

To: Rachel Medina <rachelmedina@utah.gov>

Cc: Randy Thackeray <randythackeray@utah.gov>

I'm o.k. with those amounts. They should send in their plans for the wells.
[Quoted text hidden]

—
Dustin K. Doucet
Petroleum Engineer
Division of Oil, Gas and Mining
1594 West North Temple, Ste 1210
Salt Lake City, Utah 84116
801.538.5281 (ofc)
801.359.3940 (fax)

web: www.ogm.utah.gov



June 14, 2017

Mr. Dustin Doucet
State of Utah – DNR
Division of Oil, Gas and Mining
1594 West North Temple
Salt Lake City, Utah 84116

Re: Extended Shut-in and Temporary Abandoned requirements for eight (8) Fee Leases

Dear Mr. Doucet:

Berry Petroleum Company, LLC., and Linn Operating, LLC. emerged from bankruptcy as two standalone companies on May 1, 2017. Due to this recent action, Berry Petroleum Company, LLC. is currently evaluating the potential for eight (8) wells, and respectfully submits the following plans to bring these wells into compliance as follows:

Scofield Thorpe 22-41X Rig Skid

API # 43-007-30890

Berry Petroleum Company, LLC is currently evaluating the entire Scofield acreage block for potential and would like to respectfully request a 90-day shut- in extension to September 15, 2017. After the well review is complete, Berry Petroleum Company, LLC. will follow up with 1 of the 2 following procedures prior to August 15, 2017: (1) File for approval to PA well with a completion date prior to October 1, 2017, or (2) Berry will commit to return the well to production prior to June 1, 2018. The roads to this well are not open in the winter, so this well is not operated during winter months.

Scofield Thorpe 35-13

API # 43-007-30991

Berry Petroleum Company, LLC is currently evaluating the entire Scofield acreage block for potential and would like to respectfully request a 90-day shut- in extension to September 15, 2017. After the well review is complete, Berry Petroleum Company, LLC. will follow up with 1 of the 2 following procedures prior to August 15, 2017: (1) File for approval to PA well with a completion date prior to October 1, 2017, or (2) Berry will commit to return the well to production prior to June 1, 2018. The roads to this well are not open in the winter, so this well is not operated during winter months.

Scofield Thorpe 23-31

API # 43-007-31001

Berry Petroleum Company, LLC is currently evaluating the entire Scofield acreage block for potential and would like to respectfully request a 90-day shut- in extension to September 15, 2017. After the well review is complete, Berry Petroleum Company, LLC. will follow up with 1 of the 2 following procedures prior to August 15, 2017: (1) File for approval to PA well with a completion date prior to October 1, 2017, or (2) Berry will commit to return the well to production prior to June 1, 2018. The roads to this well are not open in the winter, so this well is not operated during winter months.

SWF Fee 13-10D-54

API# 43-013-50892

Berry Petroleum Company, LLC proposes to Plug and Abandon in Q3 of 2017. We will be submitting sundry/procedures for approval prior to September 15, 2017. Due to this, Berry Petroleum Company, LLC respectfully requests a 90-day shut-in extension to September 15, 2017.

Wilcox Fee 15-16-56

API # 43-013-50597



Berry Petroleum Company, LLC proposes to return this well to production prior to September 1, 2017, following the end of raptor stipulations in August 2017. Berry respectfully requests a shut-in extension to September 1, 2017.

LC Fee 8-15D-56

API # 43-013-50597

Berry Petroleum Company, LLC proposes to complete this well in Q3 of 2017, following raptor stipulations in August 2017. Berry respectfully requests a shut-in extension to September 30, 2017.

CC Fee 7R-28-38

API# 43-013-51852

Plan to return to production in Q4 of 2017. Linn had submitted for a preconstruction permit with UDAQ to operate well below flaring limits, and we are currently transferring this documentation to Berry Petroleum Company, LLC. Due to this, Berry respectfully requests a 6-month Temporary Abandonment extension thru December 31, 2017.

Taylor Fee 7-14-56

API# 43-013-33140

Berry Petroleum Company, LLC proposes to return this well to production prior to July 15, 2017, and respectfully requests a shut-in extension to July 15, 2017.

Sincerely,

A handwritten signature in black ink that reads 'Andrea Gurr'.



Andrea Gurr
Regulatory Specialist 2
4028 W. 4000 S
Roosevelt, UT 84066
T: 435.722.0065
C. 435.823.1846
ang@bry.com

Well Name: SCOFIELD THORPE 22-41X RIG SKID

API Well 43007308900000	Field Name UNTA - AREA A - SCOFIELD	County Carbon	State/Province UT	Section 22	Township 012-S	Range 007-E	Survey	Block
Ground Elevation (ft) 8,457.00	Orig KB Elev (ft) 8,472.00	KB-Grid ft 15.00	Initial Spud Date 9/24/2002	Rig Release Date 11/28/2002	TD Date 11/24/2002	Latitude (°) 39° 45' 40.859" N	Longitude (°) 111° 7' 11.829" W	Operated? YES

Most Recent Job

Job Category Workover/Maint	Primary Job Type Tubing	Secondary Job Type Repair / Replace	Start Date 9/11/2007	End Date 9/13/2007
--------------------------------	----------------------------	--	-------------------------	-----------------------

TD: 6,247.0

Vertical - Original Hole, 5/3/2017 10:09:24 AM

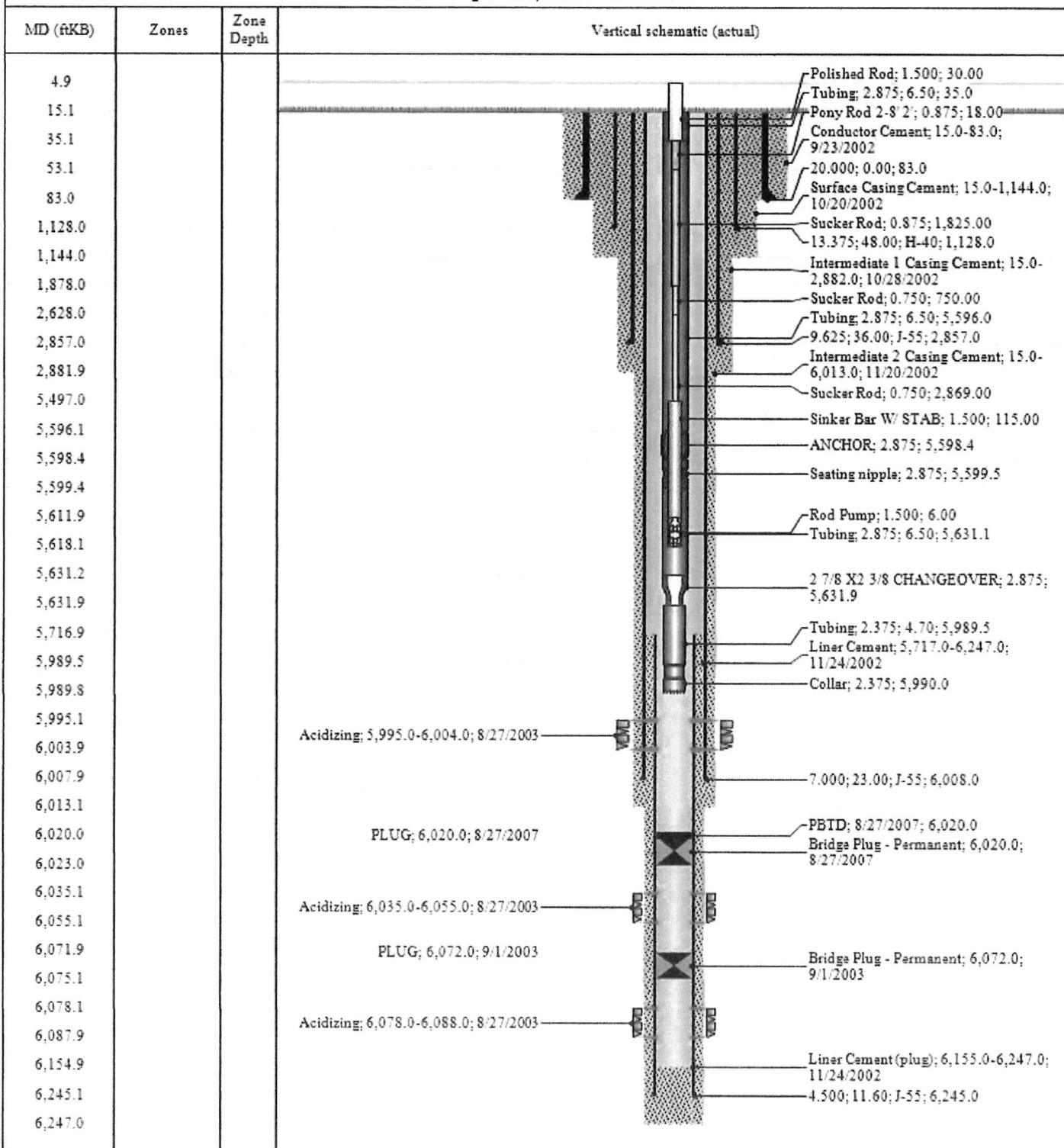

Well Name: SCOFIELD-THORPE 35-13

API Well 43007309910000	Field Name UNTA - AREA A - SCOFIELD	County Carbon	State/Province UT	Section 35	Township 012-S	Range 007-E	Survey	Block
Ground Elevation (ft) 9,018.00	Orig KB Elev (ft) 9,032.00	KS-Grid (ft) 14.00	Initial Spud Date 7/30/2005	Rig Release Date 8/31/2005	TD Date 8/25/2005	Latitude 39° 44' 8.922" N	Longitude 111° 6' 16.96" W	Operated Yes

Most Recent Job

Job Category Workover/Maint	Primary Job Type Swabbing	Secondary Job Type Swabbing	Start Date 11/8/2010	End Date 11/10/2010
--------------------------------	------------------------------	--------------------------------	-------------------------	------------------------

TD: 7,045.0

Vertical - Original Hole, 5/3/2017 10:14:14 AM

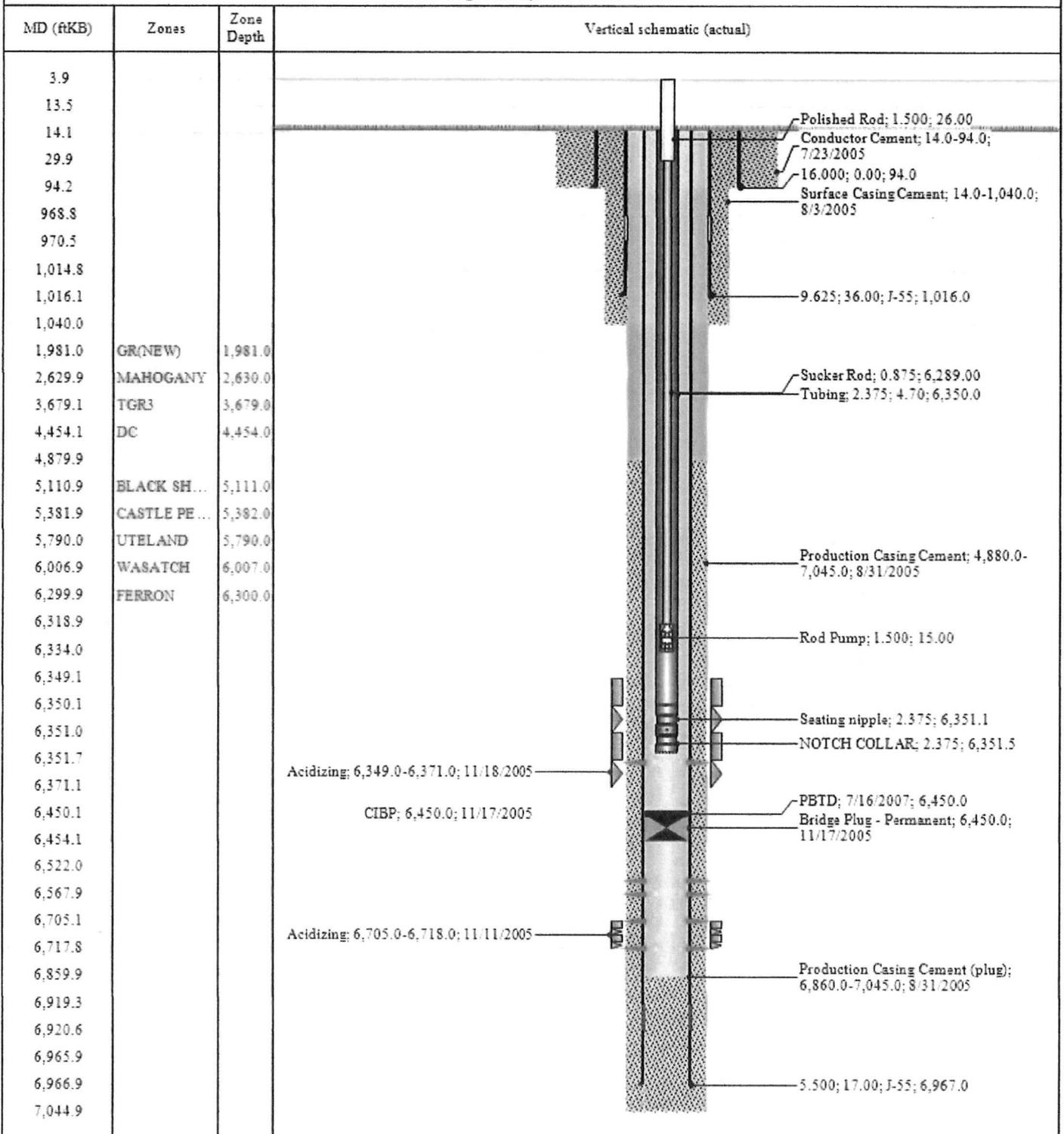

Well Name: SCOFIELD-THORPE 23-31

API Well 43007310010000	Field Name LINTA - AREA A - SCOFIELD	County Carbon	State/Province UT	Section 23	Township 012-S	Range 007-E	Survey	Block
Ground Elevation (ft) 8,991.00	Orig KB Elev (ft) 9,005.00	KB-Grid (ft) 14.00	Initial Spud Date 9/20/2005	Rig Release Date 12/21/2005	TD Date 12/15/2005	Latitude 39° 46' 39.388" N	Longitude 111° 6' 38.25" W	Operated Yes

Most Recent Job				
Job Category Completion	Primary Job Type Initial Completion	Secondary Job Type	Start Date 1/5/2006	End Date 3/25/2006

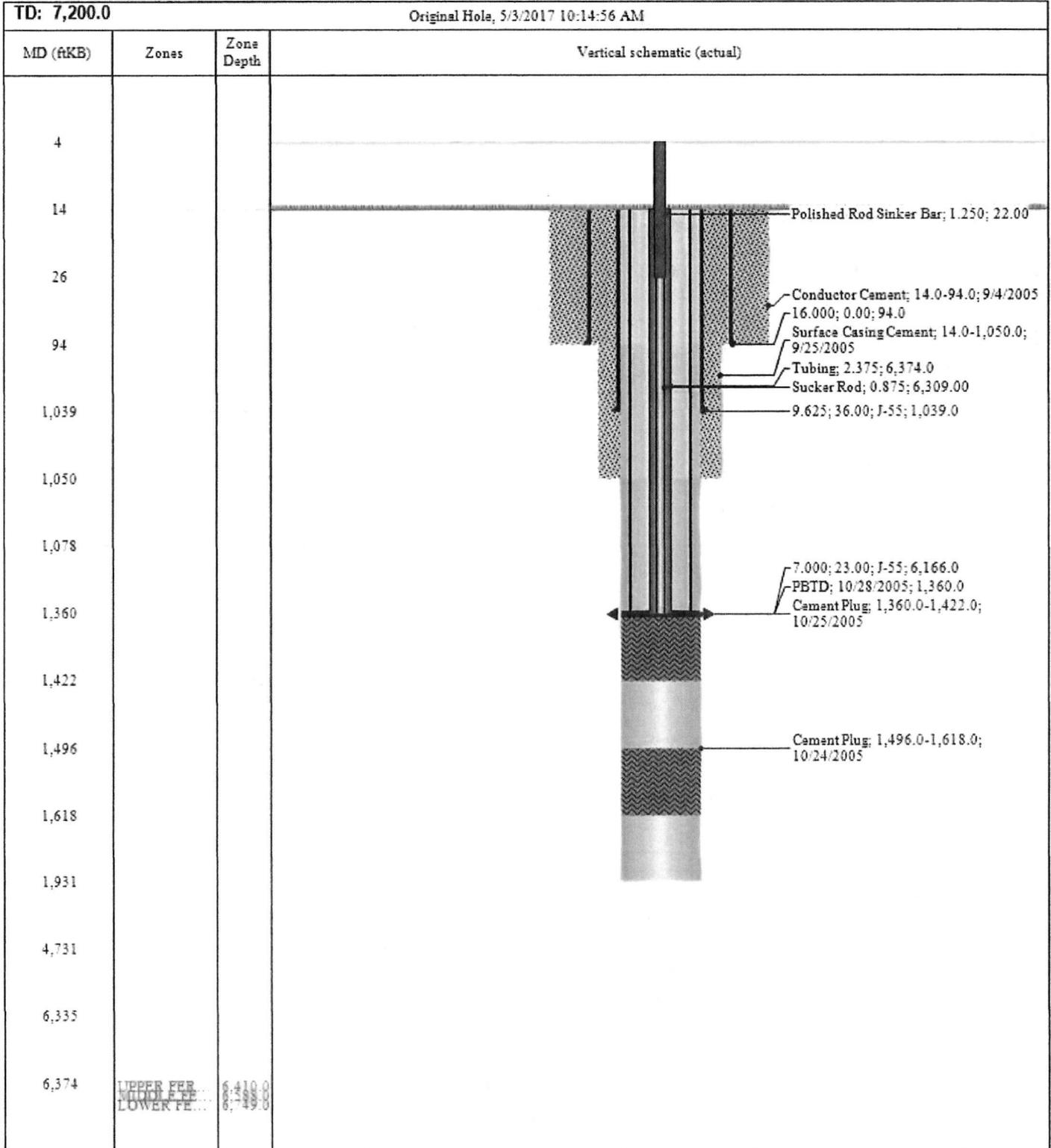

Schematic - Current

Well Name: WILCOX FEE 15-16-56

API Well 43013331510000	Field Name UNTA - AREA A - LAKE CANYON	County Duchesne	State/Province UT	Section 18	Township 006-S	Range 006-W	Survey	Block
Ground Elevation (ft) 6,612.00	Orig KB Elev (ft) 6,626.00	KB-Grid (ft) 14.00	Initial Spud Date 8/17/2006	Rig Release Date 8/26/2006	TD Date 8/25/2006	Latitude 40° 2' 31.488" N	Longitude 110° 33' 47.524" W	Operated Yes

Most Recent Job

Job Category Workover/Maint	Primary Job Type Tubing	Secondary Job Type Repair/Replace	Start Date 11/3/2007	End Date 11/5/2007
--------------------------------	----------------------------	--------------------------------------	-------------------------	-----------------------

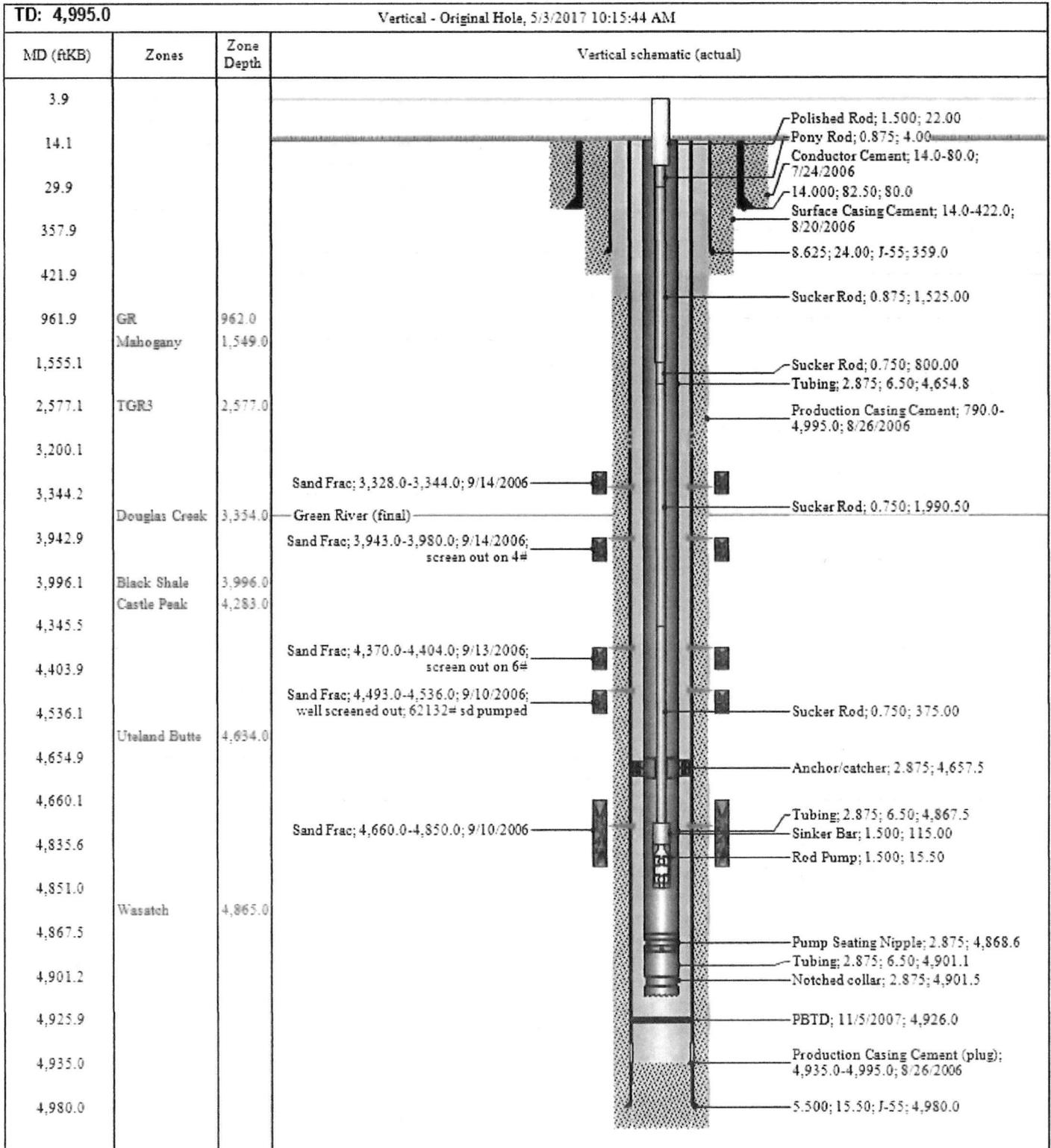

Well Name: LC FEE 8-15D-56

API No: 430135069700	Field Name: UNTA-AREA A-LAKE CANYON	County: Duchesne	State/Province: UT	Section: 15	Township: 005-S	Range: 006-W	Survey:	Block:
Ground Elevation (ft): 6,483.00	Orig KB Elev (ft): 6,502.00	KB-Grid (ft): 19.00	Initial Spud Date: 1/4/2015	Rig Release Date: 1/16/2015	TD Date: 1/10/2015	Latitude (°): 40° 2' 55.076" N	Longitude (°): 110° 32' 43.157" W	Operated? Yes

Most Recent Job

Job Category: Completion	Primary Job Type: Initial Completion	Secondary Job Type: AFE	Start Date: 1/23/2015	End Date: 1/27/2015
-----------------------------	---	----------------------------	--------------------------	------------------------

TD: 6,256.0 Directional - Original Hole, 5/3/2017 10:16:27 AM

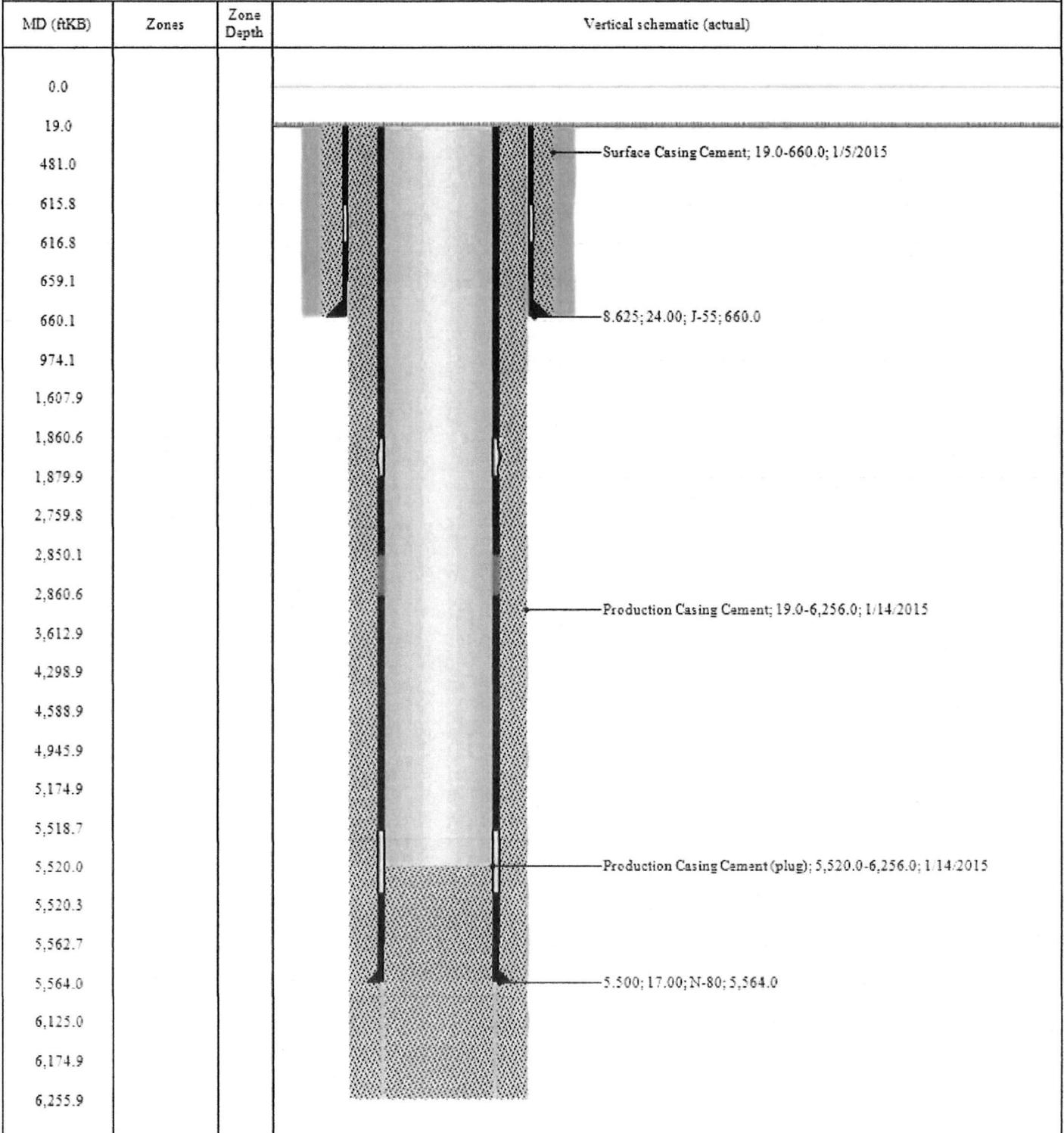

Schematic - Current

Well Name: CC FEE 7R-28-38

API Well 43013518520000	Field Name LINTA - AREA A - CURRENT CREEK	County Duchesne	State/Province UT	Section	Township	Range	Survey	Block
Ground Elevation (ft) 6,543.00	Orig KB Elev (ft) 6,562.00	KB-Grid (ft) 19.00	Initial Spud Date 2/3/2013	Rig Release Date 3/24/2013	TD Date 3/19/2013	Latitude 40° 11' 34.505" N	Longitude 110° 47' 21.343" W	Operated Yes

Most Recent Job

Job Category Workover/Maint	Primary Job Type Artificial Lift	Secondary Job Type Repair/Replace Rod	Start Date 3/4/2014	End Date 3/5/2014
--------------------------------	-------------------------------------	--	------------------------	----------------------

TD: 11,382.0

Vertical - Original Hole, 5/3/2017 10:17:26 AM

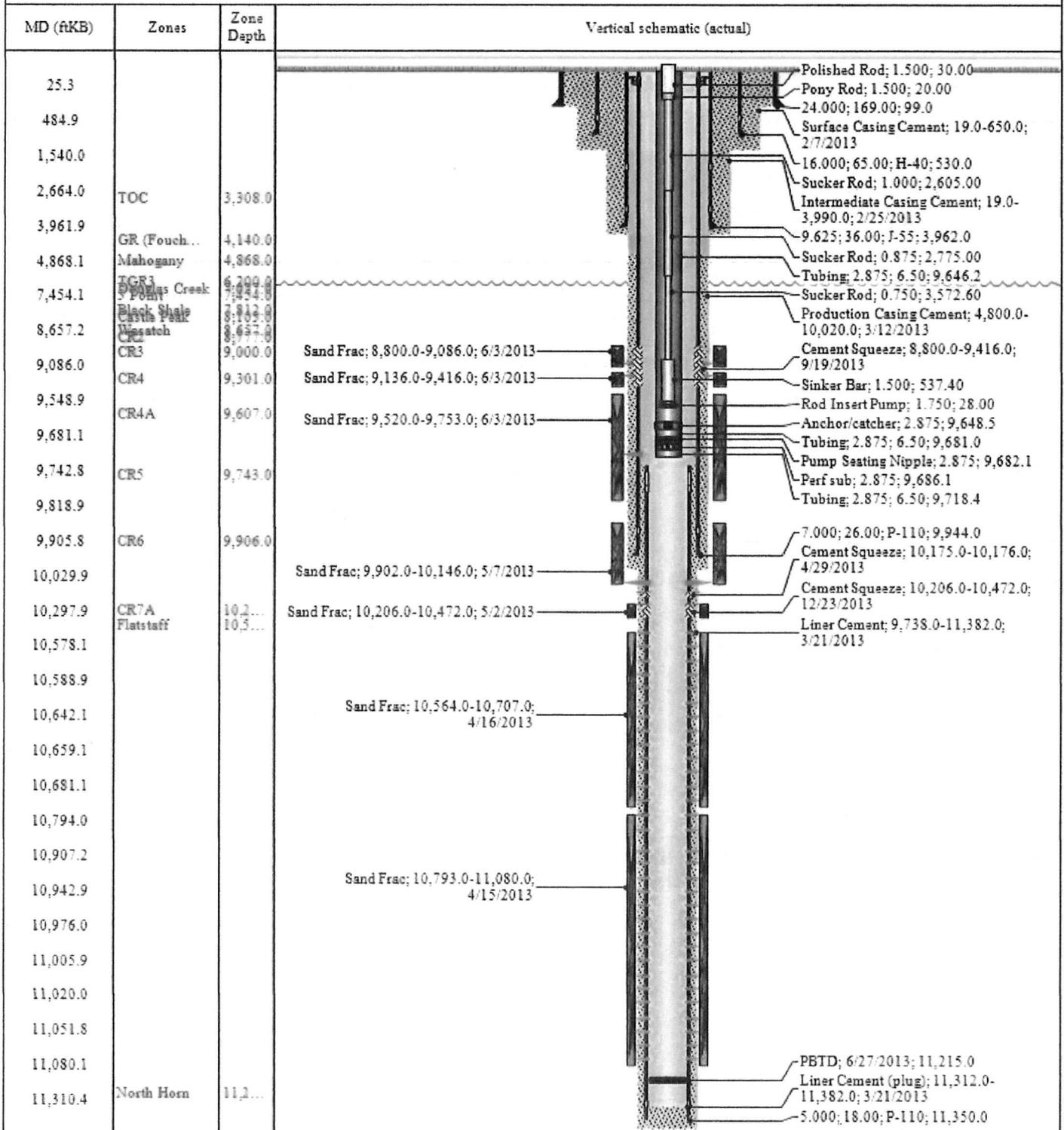

Well Name: TAYLOR FEE 7-14-56

API Well: 43013331400000	Field Name: LANTA-AREA A-LAKE CANYON	County: Duchesne	State/Province: UT	Section: 14	Township: 006-S	Range: 006-W	Survey:	Block:
Ground Elevation (ft): 6,415.00	Orig KB Elev (ft): 6,429.00	KB-Grid (ft): 14.00	Initial Spud Date: 8/6/2006	Rig Release Date: 8/15/2006	TD Date: 8/13/2006	Latitude: 40° 2' 52.606" N	Longitude: 110° 31' 36.911" W	Completed: Yes

Most Recent Job

Job Category: Workover/Maint	Primary Job Type: Tubing	Secondary Job Type: Repair/Replace	Start Date: 6/22/2007	End Date: 6/26/2007
------------------------------	--------------------------	------------------------------------	-----------------------	---------------------

TD: 5,020.0 Vertical - Original Hole, 5/3/2017 10:18:05 AM

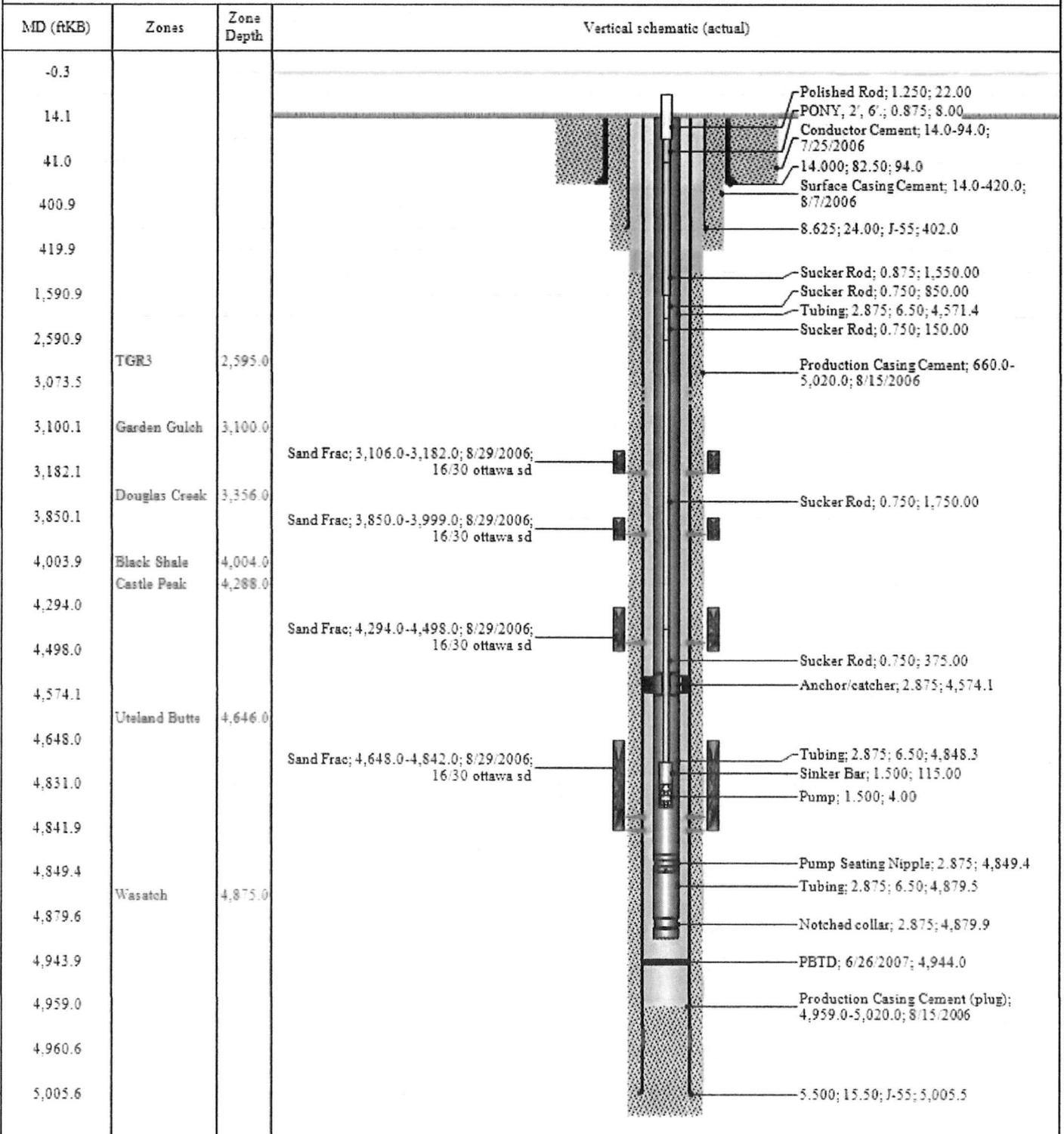



Rachel Medina <rachelmedina@utah.gov>

RE: Follow up to VM I left you re Berry Petroleum Company, LLC non compliant wells

3 messages

Gurr, Andrea N. <ang@bry.com>

Thu, Jun 15, 2017 at 7:55 AM

To: Rachel Medina <rachelmedina@utah.gov>

Cc: "Hyder, John W." <jwh@bry.com>, "Rosenlieb, Trent R." <trr@bry.com>

Rachel,

Thank you for your suggestions yesterday-- per your response below, Berry has chosen to submit a letter. Please submit the attached letter & wellbore diagrams re the 8 non-compliant wells for Dustin's review.

As I mentioned yesterday, Trent Rosenlieb @ Bakersfield office will be meeting with your team on Tuesday to discuss.

Thank you,

**Andrea Gurr***Regulatory Specialist II*

4028 W. 4000 S.

Roosevelt, UT 84066

T: 435.722.0065

C. 435.823.1846

From: Rachel Medina [mailto:rachelmedina@utah.gov]**Sent:** Wednesday, June 14, 2017 2:27 PM**To:** Gurr, Andrea N. <ang@bry.com>**Cc:** Hyder, John W. <jwh@bry.com>; Rosenlieb, Trent R. <trr@bry.com>**Subject:** Re: Follow up to VM I left you re Berry Petroleum Company, LLC non compliant wells

Hi Andrea,

Berry's inactive status is due to the fact that they currently have no open well-bores attached to the company. Once the operator change is complete that status will move to active.

As for the 8 non-compliance wells, you can either do a sundry for each well, or you can do a letter covering each well individually. Dustin will want the plans to be detailed so please be sure to include as much information as possible.

Either way (sundries or letter) you can email the plans to me for Dustin's review.

Thanks!

On Wed, Jun 14, 2017 at 10:25 AM, Gurr, Andrea N. <ang@bry.com> wrote:

Rachel,

I left you a voicemail, but wanted to follow up with an email to a question I have. Currently, Berry Petroleum Company, LLC operator status is inactive & being held up by 8 non-compliant wells. When Berry applied for active operator status it was believed to PA these wells, however, after a review has been conducted upper management has suggested alternate options. I would like to submit the new proposals for review, so my question to you is, should I prepare each proposal on a Form 9 (old school paper form), and send them to Dayne, Dustin, and yourself? Or should I submit electronically, selecting one of the Berry Petroleum options as operator in the E-permitting system?

Trent Rosenlieb will be traveling to Utah next week and plans to visit your office, so I would like to get these to your team and in review for discussion when he is there. Let me know your thoughts, I am happy to submit as you think will work best.

Thank you,

Andi



Andrea Gurr

Regulatory Specialist II

4028 W. 4000 S.

Roosevelt, UT 84066

T: 435.722.0065

C. 435.823.1846

—
Rachel Medina

Division of Oil, Gas & Mining

Bonding Technician

801-538-5260

 **2017_06-15_UDOGM letter re 8 non compliant wells.pdf**
2304K

Rachel Medina <rachelmedina@utah.gov>
To: Dustin Doucet <dustindoucet@utah.gov>

Thu, Jun 15, 2017 at 12:46 PM

Here is Berry's shut in plans for the 8 non-compliance wells they will be taking, Can we complete the operator change?
[Quoted text hidden]

 **2017_06-15_UDOGM letter re 8 non compliant wells.pdf**
2304K

Dustin Doucet <dustindoucet@utah.gov>
To: Rachel Medina <rachelmedina@utah.gov>

Mon, Jun 19, 2017 at 3:43 PM

Looks o.k. on any they are proposing to plug by Sept 15th and decide not to to put online by 2018, they will need MIT to get an extension beyond sept
[Quoted text hidden]

—
Dustin K. Doucet
Petroleum Engineer
Division of Oil, Gas and Mining
1594 West North Temple, Ste 1210
Salt Lake City, Utah 84116
801.538.5281 (ofc)
801.359.3940 (fax)

web: www.ogm.utah.gov

STATE OF UTAH
DEPARTMENT OF NATURAL RESOURCES
DIVISION OF OIL, GAS AND MINING

UIC FORM 5

TRANSFER OF AUTHORITY TO INJECT

Well Name and Number Z and T Ute Tribal 2-21	API Number 4301331280
Location of Well Footage : 759' FNL, 1978' FEL County : Duchesne QQ, Section, Township, Range: NWNE 21 5S 4W State : UTAH	Field or Unit Name Brundage Canyon Lease Designation and Number 14-20-H62-3414

EFFECTIVE DATE OF TRANSFER: 5/1/2017

CURRENT OPERATOR

Company: <u>Linn Operating, LLC</u>	Name: <u>Debra Gordon</u>
Address: <u>600 Travis Street, Suite 1400</u>	Signature: <u><i>Debra Gordon</i></u>
<u>city Houston state TX zip 77002</u>	Title: <u>Regulatory Manager</u>
Phone: <u>(281) 840-4010</u>	Date: <u>4-13-17</u>
Comments:	

NEW OPERATOR

Company: <u>Berry Petroleum Company, LLC</u>	Name: <u>Arthur T. Smith</u>
Address: <u>5201 Truxtun Avenue</u>	Signature: <u><i>A. T. Smith</i></u>
<u>city Bakersfield state CA zip 93309</u>	Title: <u>Chief Executive Officer</u>
Phone: _____	Date: <u>12 April 2017</u>
Comments:	

(This space for State use only)
Transfer approved by: *Don Jones*
Title: *Geologist*

Approval Date: 5/25/17

Comments: EPA approval needed.

RECEIVED
MAY 03 2017
DIV. OF OIL, GAS & MINING