

Plug fan ER..C, ventilation unit GR..C

Product overview	Page
Size 225	54
Size 250	56
Size 280	58
Size 315	60
Size 355	62
Size 400	64
Size 450	66
Size 500	68
Size 560	70
Size 630	72
Size 710	74
Size 800	76
Size 900	78
Size 1000	80
Size 1120 - version 4R	82
Size 1120 - version 1R	84

Information

RH..Cpro
RH..CSeries
ER / GRER..Cpro
GR..CproER..C
GR..CEx-
DesignSystem
Components

Appendix

Plug fan, ventilation unit

ER22C, GR22C

Motor IE2

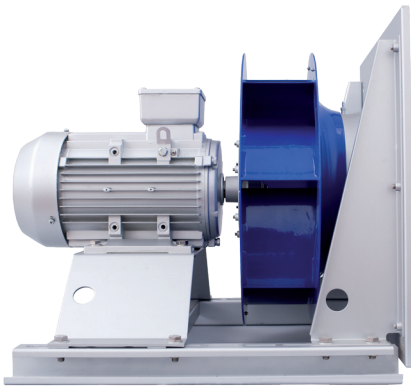

Description

- Number of blades: 7
- Max. permissible media temperature: 40°C
- Min. permissible media temperature: -20°C
- Motor protection: PTC thermistor (PTC)
- Impeller: Welded sheet steel coated / painted in RAL 5002 (ultramarine blue)
- ER-plug fan made as rugged bolted construction built with galvanised sheet steel
- Inlet ring for optimum impeller inflow with measurement device for determining flow rate

- Inlet guard Page 109
- Rubber dampers Page 109
- Spring vibration damper Page 109
- Flexible air intakes Page 110
- Frequency inverter Icontrol Page 92
- Sensors Page 96

Fan curve RH..C

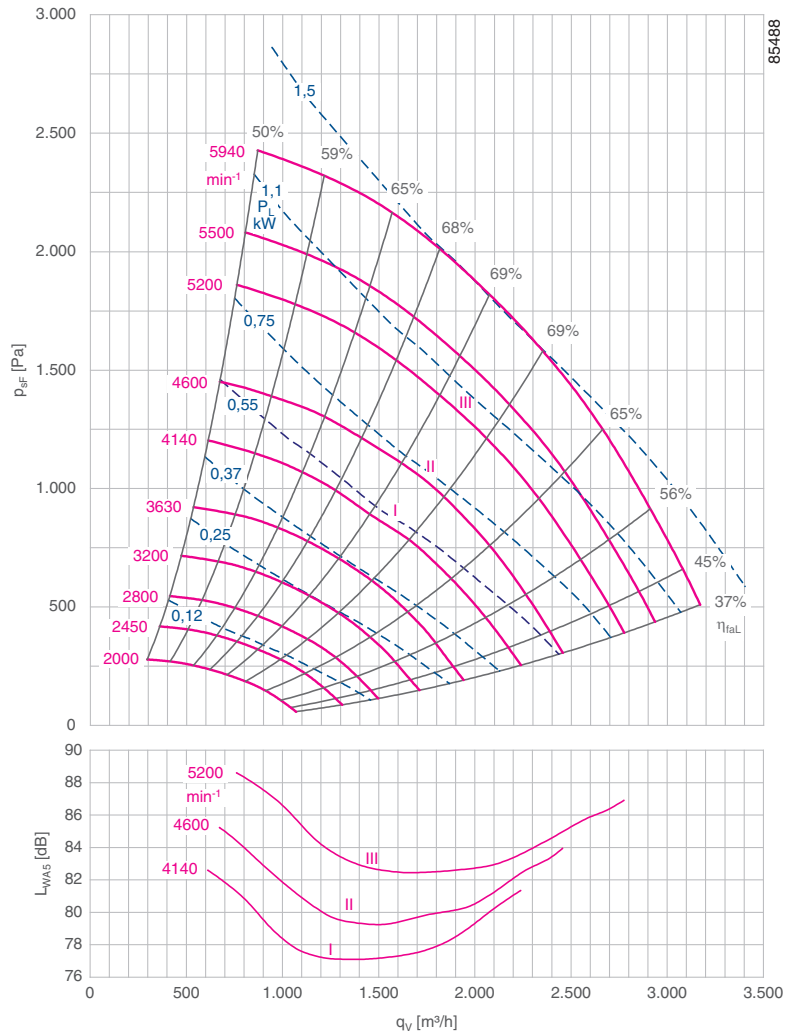

Technical data

Rated power P_N kW	Type ER / GR*	Motor size	Fan curve no.	Rated speed n_N min^{-1}	Rated current I_N A	Max. speed n_{max} min^{-1}	Max. frequency f_{max} Hz
0.55	ER22C-2DN.A7.1R	71M	I	2800	1.31	4140	74
0.75	ER22C-2DN.B7.1R	80M	II	2825	1.62	4600	81
1.10	ER22C-2DN.B7.1R	80M	III	2825	2.28	5200	92

* Identical performance data for ER..C and GR..C

Basic version ER				Basic version GR				
Rated power P_N kW	Type ER..C	Article no. ER..C	max.	Type GR..C	Installation position H Article no. GR..C	Installation position Vu Article no. GR..C	Installation position Vo Article no. GR..C	max.
0.55	ER22C-2DN.A7.1R	130613/0F01	15	GR22C-2DN.B5.1R	113732/H01	113732/U01	113732/O01	19
0.75	ER22C-2DN.B7.1R	130614/0F01	20	GR22C-2DN.B5.1R	113733/H01	113733/U01	113733/O01	21
1.10	ER22C-2DN.B7.1R	130615/0F01	21					



Dimensions in mm

Plug fan ER in installation position H

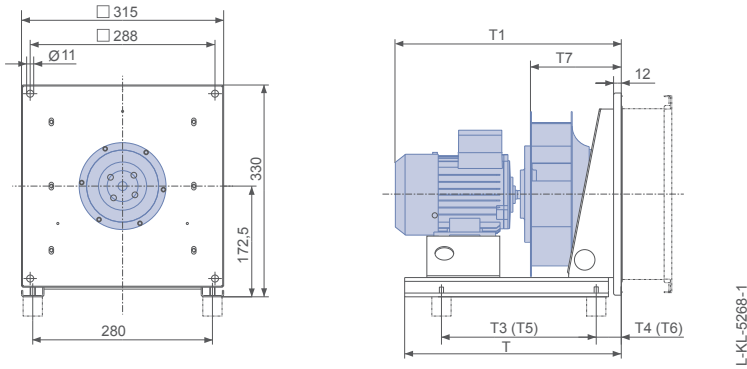

Rated power	Type	T	T1	T3	T4	T5	T6	T7	Spring vibration damper	Rubber dampers
P_N kW		mm	mm	mm	mm	mm	mm	mm		
0.55	ER22C-2DN.A7.1R	460	377	316	39	224	56	142	MSN 3	30x30 / 40
0.75	ER22C-2DN.B7.1R	460	422	348	52	266	69	142	MSN 4	30x30 / 55
1.10	ER22C-2DN.B7.1R	460	422	358	50	256	79	142	MSN 4	30x30 / 55

T5 and T6 apply to attachment of Ziehl-Abegg intake flanges.

Ventilation unit GR in installation position H

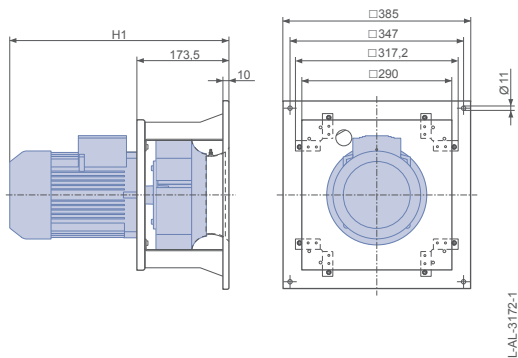

Ventilation unit GR in installation position Vu/Vo

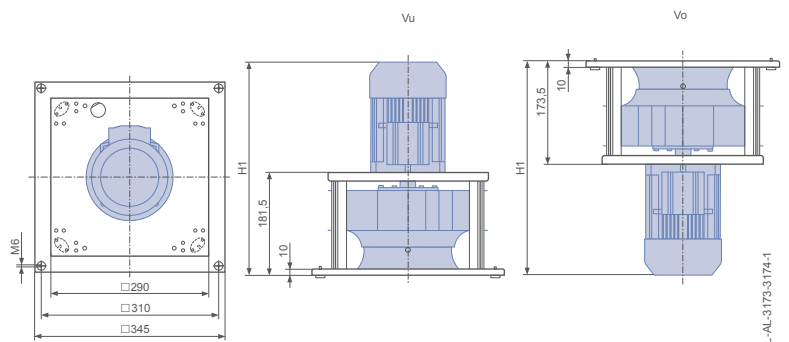

Rated power	Type	Installation position		
		H	Vu	Vo
P_N kW		H1 mm	H1 mm	H1 mm
0.75	GR22C-2DN.B5.1R	410	418	410
1.10	GR22C-2DN.B5.1R	410	418	410

Plug fan, ventilation unit

ER25C, GR25C

Motor IE2

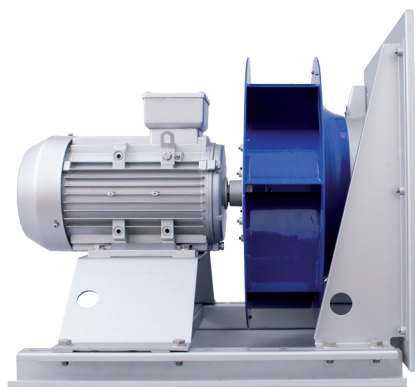

Description

- Number of blades: 7
- Max. permissible media temperature: 40 °C
- Min. permissible media temperature: -20 °C
- Motor protection: PTC thermistor (PTC)
- Impeller: Welded sheet steel coated / painted in RAL 5002 (ultramarine blue)
- ER-plug fan made as rugged bolted construction built with galvanised sheet steel
- Inlet ring for optimum impeller inflow with measurement device for determining flow rate

- Dimensions of explosion protected design Page 88
- Inlet guard Page 109
- Rubber dampers Page 109
- Spring vibration damper Page 109
- Flexible air intakes Page 110
- Frequency inverter Icontrol Page 92
- Sensors Page 96

Fan curve RH..C

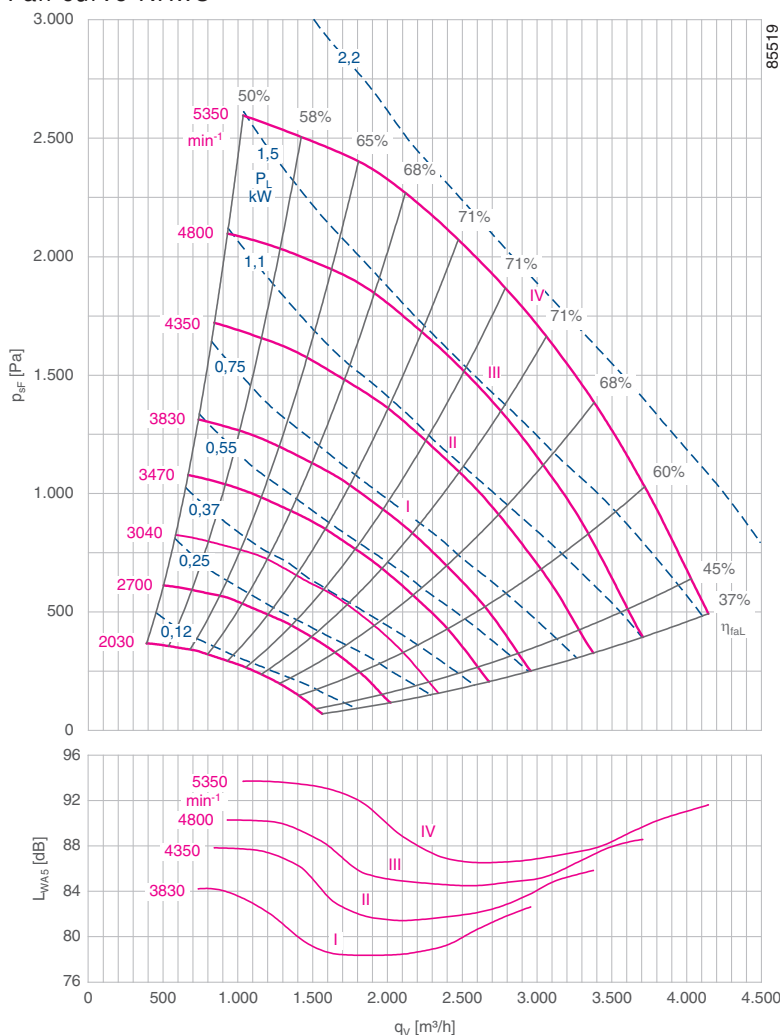

Technical data

Rated power P_N kW	Type ER / GR*	Motor size	Fan curve no.	Rated speed n_N min^{-1}	Rated current I_N A	Max. speed n_{max} min^{-1}	Max. frequency f_{max} Hz
0.75	ER25C-2DN.B7.1R	80M	I	2825	1.62	3830	68
1.10	ER25C-2DN.B7.1R	80M	II	2825	2.28	4350	77
1.50	ER25C-2DN.C7.1R	90S	III	2840	3.06	4800	85
2.20	ER25C-2DN.D7.1R	90L	IV	2840	4.36	5350	94

* Identical performance data for ER..C and GR..C

Basic version ER				Basic version GR			
Rated power				Installation position			
P_N kW	Type ER..C	Article no. ER..C	\bar{h} max.	Type GR..C	Article no. GR..C	Article no. GR..C	\bar{h} max.
0.75	ER25C-2DN.B7.1R	130609/0F01	23	GR25C-2DN.B5.1R	113734/H01	113734/U01	113734/O01
1.10	ER25C-2DN.B7.1R	130610/0F01	25	GR25C-2DN.B5.1R	113735/H01	113735/U01	113735/O01
1.50	ER25C-2DN.C7.1R	130611/0F01	29	GR25C-2DN.C5.1R	113736/H01	113736/U01	113736/O01
2.20	ER25C-2DN.D7.1R	130612/0F01	33	GR25C-2DN.D5.1R	113737/H01	113737/U01	113737/O01



Dimensions in mm

Plug fan ER in installation position H

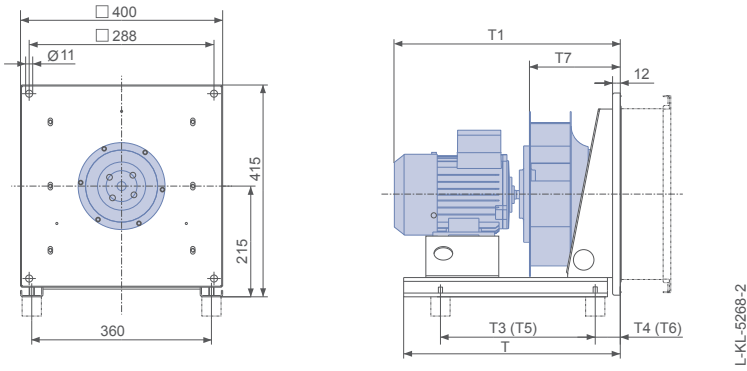

Rated power	Type	T	T1	T3	T4	T5	T6	T7	Spring vibration damper	Rubber dampers
P_N kW		mm	mm	mm	mm	mm	mm	mm		
0.75	ER25C-2DN.B7.1R	460	439	330	61	252	80	158	MSN 4	30x30 / 55
1.10	ER25C-2DN.B7.1R	460	439	342	59	296	63	158	MSN 4	30x30 / 55
1.50	ER25C-2DN.C7.1R	460	464	362	63	322	65	158	MSN 4	30x30 / 55
2.20	ER25C-2DN.D7.1R	460	489	334	91	292	96	158	MSN 5	40x30 / 55

T5 and T6 apply to attachment of Ziehl-Abegg intake flanges.

Ventilation unit GR in installation position H

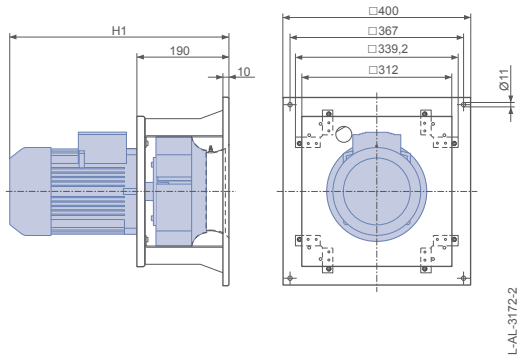

Ventilation unit GR in installation position Vu/Vo

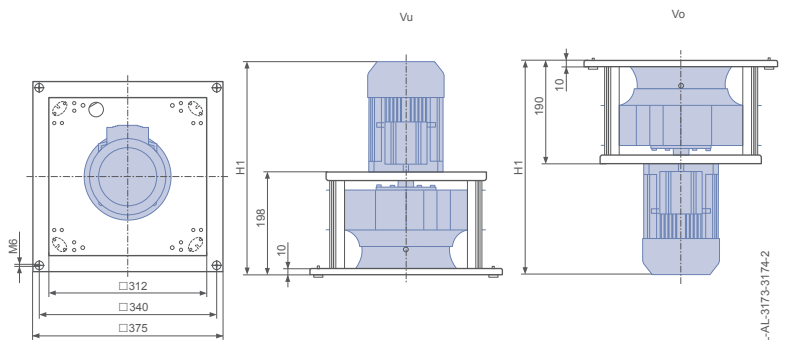

Rated power	Type	Installation position		
		H	Vu	Vo
P_N kW		H1 mm	H1 mm	H1 mm
0.75	GR25C-2DN.B5.1R	427	435	427
1.10	GR25C-2DN.B5.1R	427	435	427
1.50	GR25C-2DN.C5.1R	452	460	452
2.20	GR25C-2DN.D5.1R	477	485	477

Plug fan, ventilation unit

ER28C, GR28C

Motor IE2

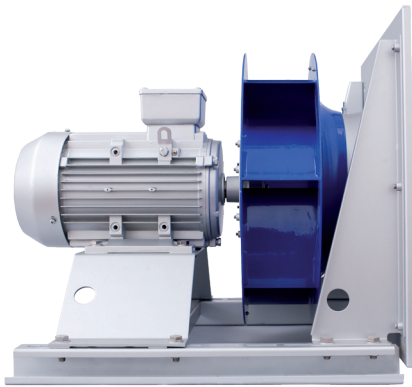

Description

- Number of blades: 7
- Max. permissible media temperature: 40°C
- Min. permissible media temperature: -20°C
- Motor protection: PTC thermistor (PTC)
- Impeller: Welded sheet steel coated / painted in RAL 5002 (ultramarine blue)
- ER-plug fan made as rugged bolted construction built with galvanised sheet steel
- Inlet ring for optimum impeller inflow with measurement device for determining flow rate

- Dimensions of explosion protected design Page 88
- Inlet guard Page 109
- Rubber dampers Page 109
- Spring vibration damper Page 109
- Flexible air intakes Page 110
- Frequency inverter Icontrol Page 92
- Sensors Page 96

Fan curve RH..C

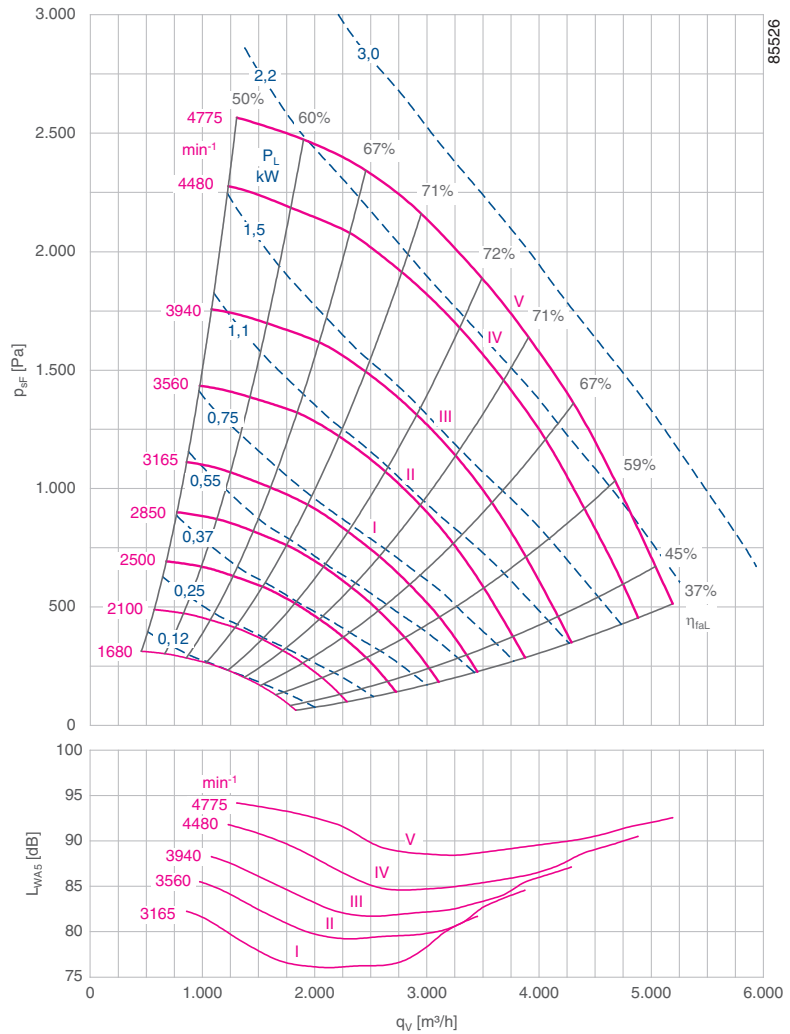

Technical data

Rated power P_N kW	Type ER / GR*	Motor size	Fan curve no.	Rated speed n_N min ⁻¹	Rated current I_N A	Max. speed n_{max} min ⁻¹	Max. frequency f_{max} Hz
0.75	ER28C-2DN.B7.1R	80M	I	2825	1.62	3165	56
1.10	ER28C-2DN.B7.1R	80M	II	2825	2.28	3560	63
1.50	ER28C-2DN.C7.1R	90S	III	2840	3.06	3940	69
2.20	ER28C-2DN.D7.1R	90L	IV	2840	4.36	4480	79
3.00	ER28C-2DN.E7.1R	100L	V	2880	5.73	4775	83

* Identical performance data for ER..C and GR..C

Basic version ER				Basic version GR				
Rated power P_N kW	Type ER..C	Article no. ER..C	max.	Type GR..C	Installation position H Article no. GR..C	Installation position Vu Article no. GR..C	Installation position Vo Article no. GR..C	max.
0.75	ER28C-2DN.B7.1R	130604/0F01	24	GR28C-2DN.B5.1R	113738/H01	113738/U01	113738/O01	23
1.10	ER28C-2DN.B7.1R	130605/0F01	26	GR28C-2DN.B5.1R	113739/H01	113739/U01	113739/O01	24
1.50	ER28C-2DN.C7.1R	130606/0F01	30	GR28C-2DN.C5.1R	113740/H01	113740/U01	113740/O01	28
2.20	ER28C-2DN.D7.1R	130607/0F01	34	GR28C-2DN.D5.1R	113741/H01	113741/U01	113741/O01	32
3.00	ER28C-2DN.E7.1R	130608/0F01	41	GR28C-2DN.E5.1R	113742/H01	113742/U01	113742/O01	38



Dimensions in mm

Plug fan ER in installation position H

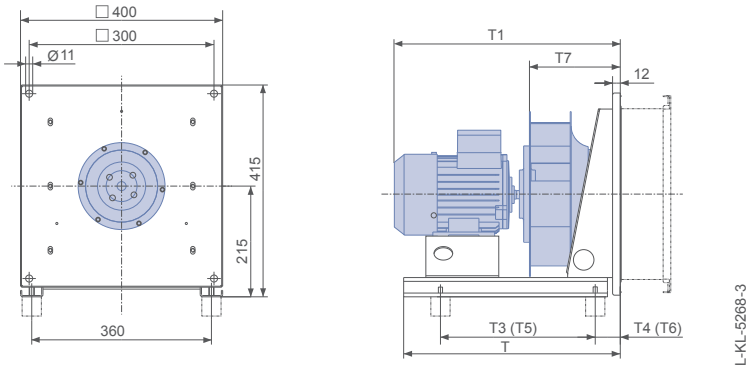

Rated power	Type	T	T1	T3	T4	T5	T6	T7	Spring vibration damper	Rubber dampers
P_N kW		mm	mm	mm	mm	mm	mm	mm		
0.75	ER28C-2DN.B7.1R	460	455	350	61	302	63	174	MSN 4	30x30 / 40
1.10	ER28C-2DN.B7.1R	460	455	362	59	308	65	174	MSN 4	30x30 / 55
1.50	ER28C-2DN.C7.1R	460	480	350	80	306	82	174	MSN 4	30x30 / 55
2.20	ER28C-2DN.D7.1R	460	505	320	110	342	81	174	MSN 5	30x30 / 55
3.00	ER28C-2DN.E7.1R	570	543	468	59	428	64	174	MSN 5	40x30 / 55

T5 and T6 apply to attachment of Ziehl-Abegg intake flanges.

Ventilation unit GR in installation position H

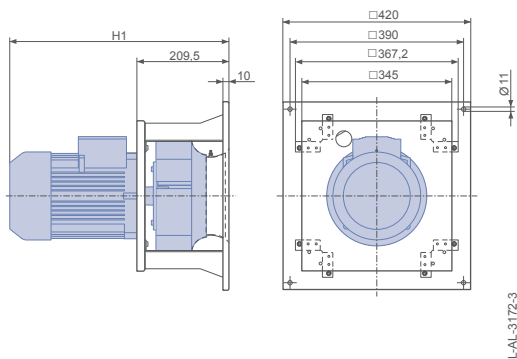

Ventilation unit GR in installation position Vu/Vo

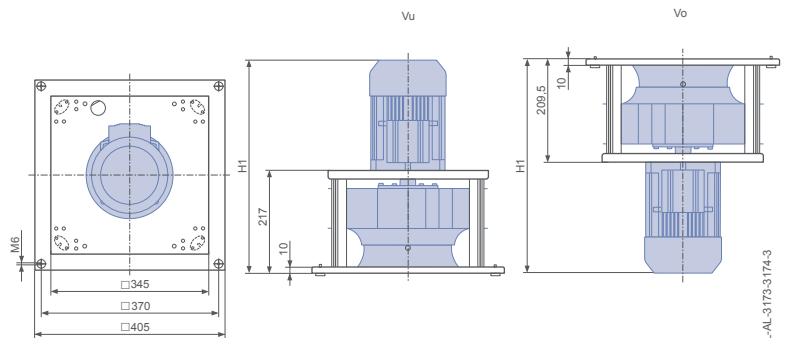

Rated power	Type	Installation position H	Installation position Vu	Installation position Vo
P_N kW		H1 mm	H1 mm	H1 mm
0.75	GR28C-2DN.B5.1R	443	450	443
1.10	GR28C-2DN.B5.1R	443	450	443
1.50	GR28C-2DN.C5.1R	468	475	468
2.20	GR28C-2DN.D5.1R	493	500	493
3.00	GR28C-2DN.E5.1R	531	538	531

Plug fan, ventilation unit

ER31C, GR31C

Motor IE2

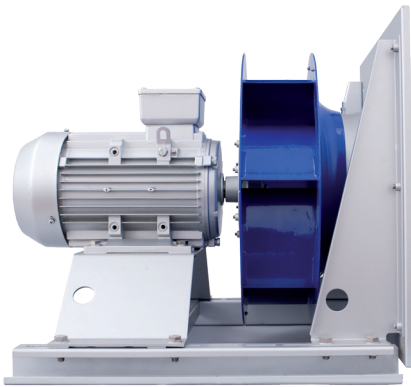

Fan curve RH..C

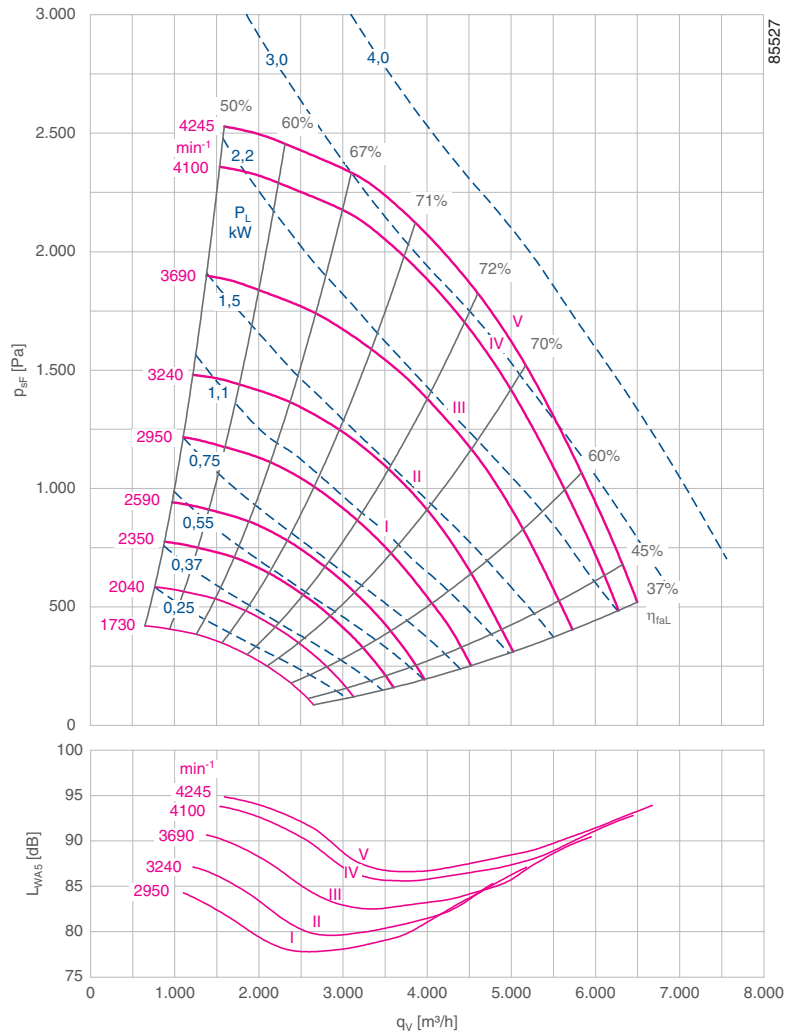

Description

- Number of blades: 7
- Max. permissible media temperature: 40°C
- Min. permissible media temperature: -20°C
- Motor protection: PTC thermistor (PTC)
- Impeller: Welded sheet steel coated / painted in RAL 5002 (ultramarine blue)
- ER-plug fan made as rugged bolted construction built with galvanised sheet steel
- Inlet ring for optimum impeller inflow with measurement device for determining flow rate

- Dimensions of explosion protected design Page 88
- Inlet guard Page 109
- Rubber dampers Page 109
- Spring vibration damper Page 109
- Flexible air intakes Page 110
- Frequency inverter Icontrol Page 92
- Sensors Page 96

Technical data

Rated power P_N kW	Type ER / GR*	Motor size	Fan curve no.	Rated speed n_N min^{-1}	Rated current I_N A	Max. speed n_{max} min^{-1}	Max. frequency f_{max} Hz
1.10	ER31C-2DN.B7.1R	80M	I	2825	2.28	2950	52
1.50	ER31C-2DN.C7.1R	90S	II	2840	3.06	3240	57
2.20	ER31C-2DN.D7.1R	90L	III	2840	4.36	3690	65
3.00	ER31C-2DN.E7.1R	100L	IV	2880	5.73	4100	71
4.00	ER31C-2DN.F7.1R	112M	V	2875	7.48	4245	74

* Identical performance data for ER..C and GR..C

Basic version ER				Basic version GR				
Rated power P_N kW	Type ER..C	Article no. ER..C	max.	Type GR..C	Installation position H Article no. GR..C	Installation position Vu Article no. GR..C	Installation position Vo Article no. GR..C	max.
1.10	ER31C-2DN.B7.1R	130599/0F01	27	GR31C-2DN.B5.1R	113743/H01	113743/U01	113743/O01	28
1.50	ER31C-2DN.C7.1R	130600/0F01	32	GR31C-2DN.C5.1R	113744/H01	113744/U01	113744/O01	32
2.20	ER31C-2DN.D7.1R	130601/0F01	36	GR31C-2DN.D5.1R	113745/H01	113745/U01	113745/O01	36
3.00	ER31C-2DN.E7.1R	130602/0F01	42	GR31C-2DN.E5.1R	113746/H01	113746/U01	113746/O01	41
4.00	ER31C-2DN.F7.1R	130603/0F01	45	GR31C-2DN.F5.1R	113747/H01	113747/U01	113747/O01	44



Dimensions in mm

Plug fan ER in installation position H

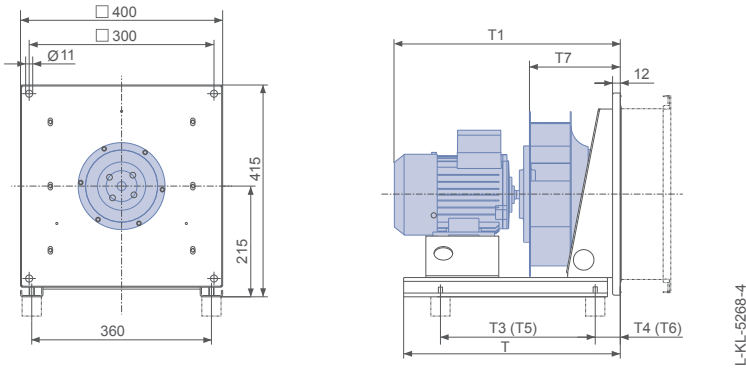

Rated power	Type	T	T1	T3	T4	T5	T6	T7	Spring vibration damper	Rubber dampers
P_N kW		mm	mm	mm	mm	mm	mm	mm		
1.10	ER31C-2DN.B7.1R	460	475	360	70	316	71	194	MSN 4	30x30 / 40
1.50	ER31C-2DN.C7.1R	570	500	414	63	372	65	194	MSN 4	30x30 / 55
2.20	ER31C-2DN.D7.1R	570	525	412	79	350	93	194	MSN 5	30x30 / 55
3.00	ER31C-2DN.E7.1R	570	563	460	75	452	63	194	MSN 5	40x30 / 55
4.00	ER31C-2DN.F7.1R	570	612	434	97	472	63	194	MSN 5	40x30 / 55

T5 and T6 apply to attachment of Ziehl-Abegg intake flanges.

Ventilation unit GR in installation position H

Ventilation unit GR in installation position Vu/Vo

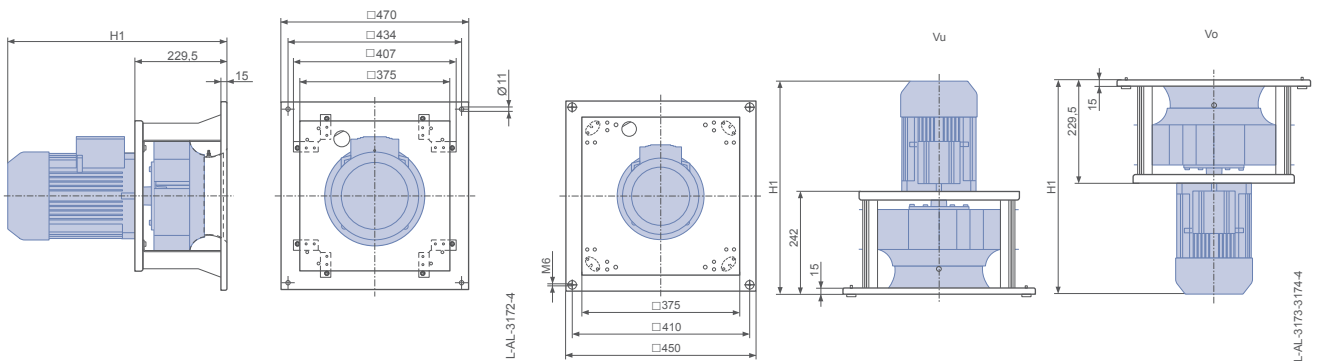

Rated power	Type	Installation position H	Installation position Vu	Installation position Vo
P_N kW		H1 mm	H1 mm	H1 mm
1.10	GR31C-2DN.B5.1R	463	475	463
1.50	GR31C-2DN.C5.1R	488	500	488
2.20	GR31C-2DN.D5.1R	513	525	513
3.00	GR31C-2DN.E5.1R	551	563	551
4.00	GR31C-2DN.F5.1R	600	612	600

Plug fan, ventilation unit

ER35C, GR35C

Motor IE2

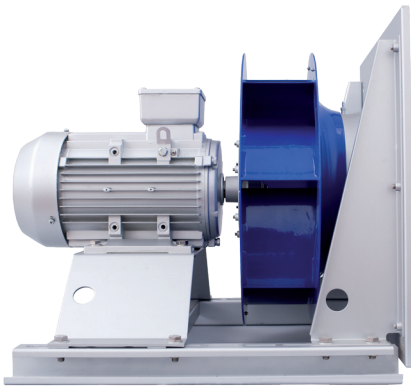

Description

- Number of blades: 7
- Max. permissible media temperature: 40°C
- Min. permissible media temperature: -20°C
- Motor protection: PTC thermistor (PTC)
- Impeller: Welded sheet steel coated / painted in RAL 5002 (ultramarine blue)
- ER-plug fan made as rugged bolted construction built with galvanised sheet steel
- Inlet ring for optimum impeller inflow with measurement device for determining flow rate

- Dimensions of explosion protected design Page 88
- Inlet guard Page 109
- Rubber dampers Page 109
- Spring vibration damper Page 109
- Flexible air intakes Page 110
- Frequency inverter Icontrol Page 92
- Sensors Page 96

Fan curve RH..C

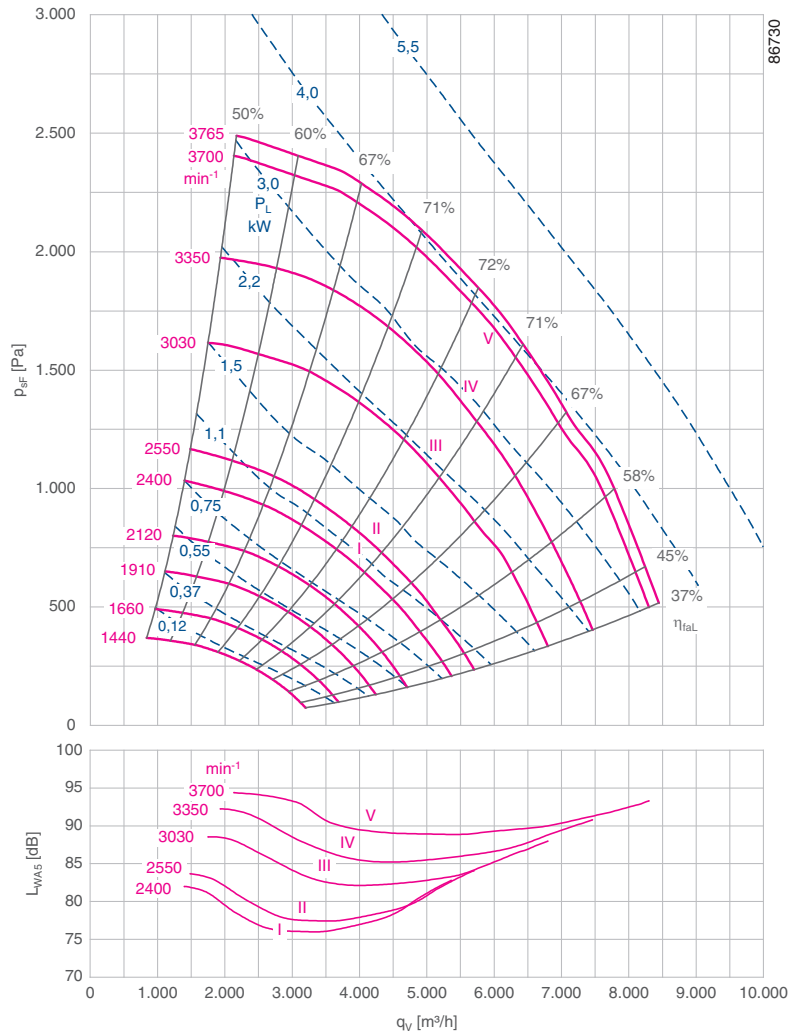

Technical data

Rated power P_N kW	Type ER / GR*	Motor size	Fan curve no.	Rated speed n_N min^{-1}	Rated current I_N A	Max. speed n_{max} min^{-1}	Max. frequency f_{max} Hz
1.10	ER35C-4DN.C7.1R	90S	I	1400	2.46	2400	86
1.50	ER35C-4DN.D7.1R	90L	II	1400	3.22	2550	91
2.20	ER35C-2DN.D7.1R	90L	III	2840	4.36	3030	53
3.00	ER35C-2DN.E7.1R	100L	IV	2880	5.73	3350	58
4.00	ER35C-2DN.F7.1R	112M	V	2875	7.48	3700	64

* Identical performance data for ER..C and GR..C

Basic version ER				Basic version GR				
Rated power P_N kW	Type ER..C	Article no. ER..C	max.	Type GR..C	Installation position H Article no. GR..C	Installation position Vu Article no. GR..C	Installation position Vo Article no. GR..C	max.
1.10	ER35C-4DN.C7.1R	131399/0F01	36	GR35C-4DN.C5.1R	113748/H01	113748/U01	113748/O01	36
1.50	ER35C-4DN.D7.1R	130595/0F01	39	GR35C-4DN.D5.1R	113749/H01	113749/U01	113749/O01	38
2.20	ER35C-2DN.D7.1R	130596/0F01	39	GR35C-2DN.D5.1R	113750/H01	113750/U01	113750/O01	39
3.00	ER35C-2DN.E7.1R	130597/0F01	46	GR35C-2DN.E5.1R	113751/H01	113751/U01	113751/O01	44
4.00	ER35C-2DN.F7.1R	130598/0F01	49	GR35C-2DN.F5.1R	113752/H01	113752/U01	113752/O01	47



Dimensions in mm

Plug fan ER in installation position H

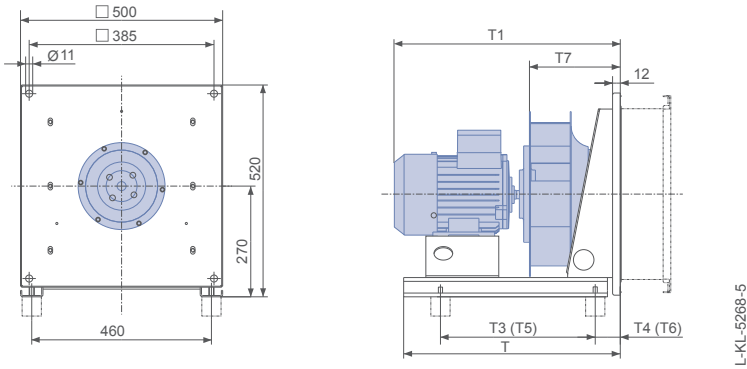

Rated power	Type	T	T1	T3	T4	T5	T6	T7	Spring vibration damper	Rubber dampers
P_N kW		mm	mm	mm	mm	mm	mm	mm		
1.10	ER35C-4DN.C7.1R	570	522	404	71	360	75	217	MSN 5	30x30 / 40
1.50	ER35C-4DN.D7.1R	570	547	412	79	350	93	217	MSN 5	30x30 / 55
2.20	ER35C-2DN.D7.1R	570	547	410	81	348	95	217	MSN 6	30x30 / 55
3.00	ER35C-2DN.E7.1R	570	585	452	83	444	71	217	MSN 6	30x30 / 55
4.00	ER35C-2DN.F7.1R	570	634	434	101	464	71	217	MSN 6	40x30 / 55

T5 and T6 apply to attachment of Ziehl-Abegg intake flanges.

Ventilation unit GR in installation position H

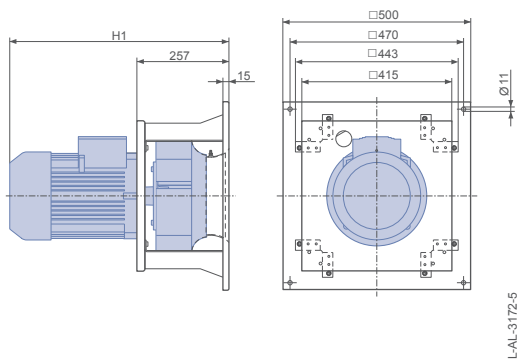

Ventilation unit GR in installation position Vu/Vo

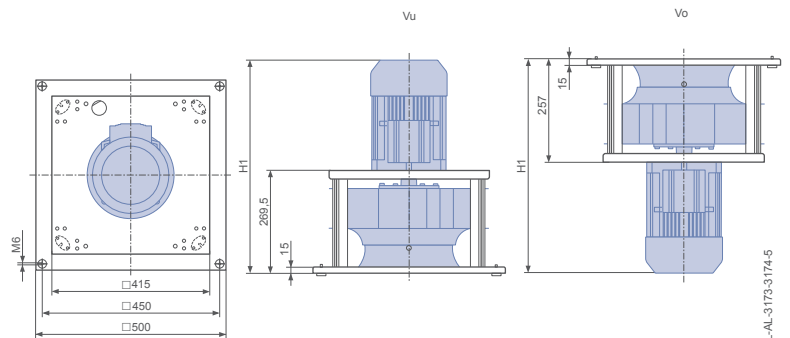

Rated power	Type	Installation position H	Installation position Vu	Installation position Vo
P_N kW		H1 mm	H1 mm	H1 mm
1.10	GR35C-4DN.C5.1R	510	523	510
1.50	GR35C-4DN.D5.1R	535	548	535
2.20	GR35C-2DN.D5.1R	535	548	535
3.00	GR35C-2DN.E5.1R	573	586	573
4.00	GR35C-2DN.F5.1R	622	635	622

Plug fan, ventilation unit

ER40C, GR40C

Motor IE2

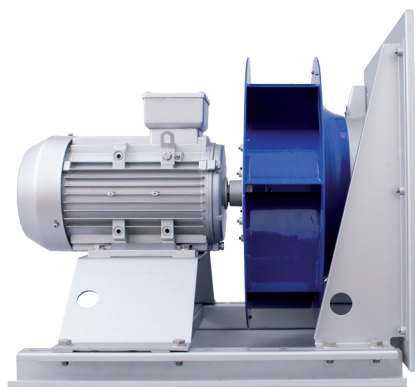

Description

- Number of blades: 7
- Max. permissible media temperature: 40°C
- Min. permissible media temperature: -20°C
- Motor protection: PTC thermistor (PTC)
- Impeller: Welded sheet steel coated / painted in RAL 5002 (ultramarine blue)
- ER-plug fan made as rugged bolted construction built with galvanised sheet steel
- Inlet ring for optimum impeller inflow with measurement device for determining flow rate

- Dimensions of explosion protected design Page 88
- Inlet guard Page 109
- Rubber dampers Page 109
- Spring vibration damper Page 109
- Flexible air intakes Page 110
- Frequency inverter Icontrol Page 92
- Sensors Page 96

Fan curve RH..C

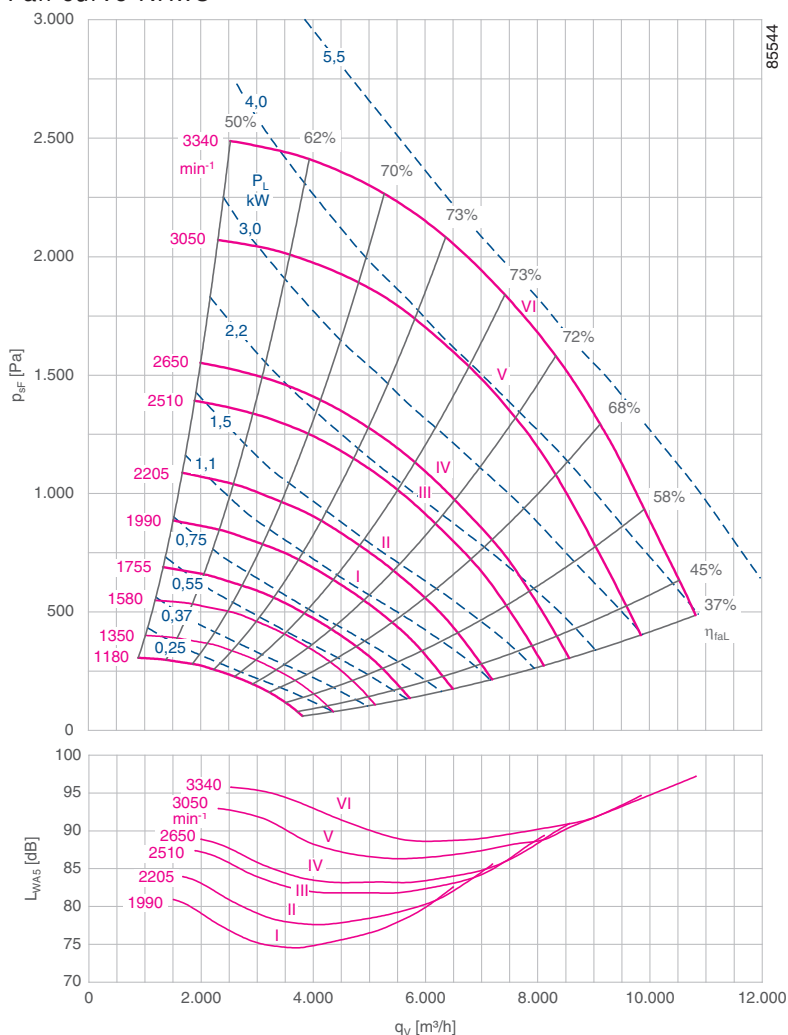

Technical data

Rated power P_N kW	Type ER / GR*	Motor size	Fan curve no.	Rated speed n_N min ⁻¹	Rated current I_N A	Max. speed n_{max} min ⁻¹	Max. frequency f_{max} Hz
1.10	ER40C-4DN.C7.1R	90S	I	1400	2.46	1990	71
1.50	ER40C-4DN.D7.1R	90L	II	1400	3.22	2205	79
2.20	ER40C-4DN.E7.1R	100L	III	1440	4.53	2510	87
3.00	ER40C-4DN.E7.1R	100L	IV	1420	6.04	2650	93
4.00	ER40C-2DN.F7.1R	112M	V	2875	7.48	3050	53
5.50	ER40C-2DN.G7.1R	132S	VI	2890	10.20	3340	58

* Identical performance data for ER..C and GR..C

Basic version ER				Basic version GR				
Rated power P_N kW	Type ER..C	Article no. ER..C	\bar{h} max.	Type GR..C	Installation position H Article no. GR..C	Installation position Vu Article no. GR..C	Installation position Vo Article no. GR..C	\bar{h} max.
1.10	ER40C-4DN.C7.1R	130589/0F01	40	GR40C-4DN.C5.1R	113753/H01	113753/U01	113753/O01	44
1.50	ER40C-4DN.D7.1R	130590/0F01	42	GR40C-4DN.D5.1R	113754/H01	113754/U01	113754/O01	46
2.20	ER40C-4DN.E7.1R	130591/0F01	52	GR40C-4DN.E5.1R	113755/H01	113755/U01	113755/O01	54
3.00	ER40C-4DN.E7.1R	130592/0F01	57	GR40C-4DN.E5.1R	113756/H01	113756/U01	113756/O01	59
4.00	ER40C-2DN.F7.1R	130593/0F01	53	GR40C-2DN.F5.1R	113757/H01	113757/U01	113757/O01	55
5.50	ER40C-2DN.G7.1R	130594/0F01	69	GR40C-2DN.G5.1R	113758/H01	113758/U01	113758/O01	71



Dimensions in mm

Plug fan ER in installation position H

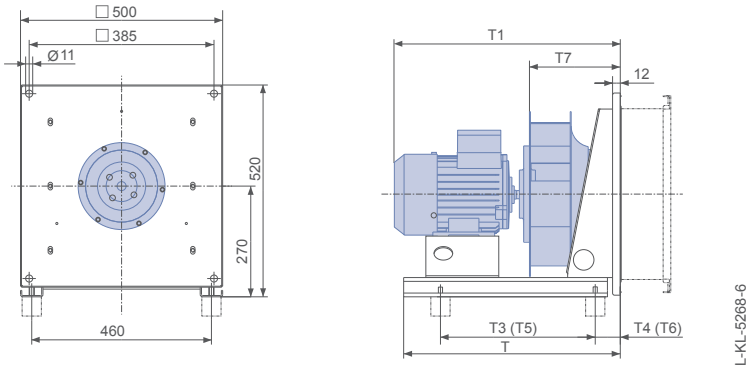

Rated power	Type	T	T1	T3	T4	T5	T6	T7	Spring vibration damper	Rubber dampers
P_N kW		mm	mm	mm	mm	mm	mm	mm		
1.10	ER40C-4DN.C7.1R	570	548	406	75	364	79	243	MSN 5	30x30 / 40
1.50	ER40C-4DN.D7.1R	570	573	408	87	382	83	243	MSN 5	30x30 / 40
2.20	ER40C-4DN.E7.1R	570	611	428	107	418	97	243	MSN 5	30x30 / 55
3.00	ER40C-4DN.E7.1R	570	611	412	123	440	95	243	MSN 6	30x30 / 55
4.00	ER40C-2DN.F7.1R	720	660	520	70	508	62	243	MSN 6	30x30 / 55
5.50	ER40C-2DN.G7.1R	720	673	578	71	560	68	243	MSN 6	40x30 / 55

T5 and T6 apply to attachment of Ziehl-Abegg intake flanges.

Ventilation unit GR in installation position H

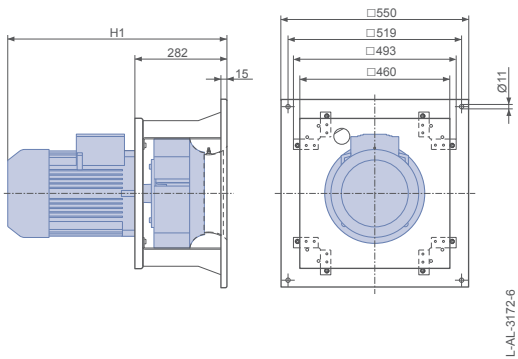

Ventilation unit GR in installation position Vu/Vo

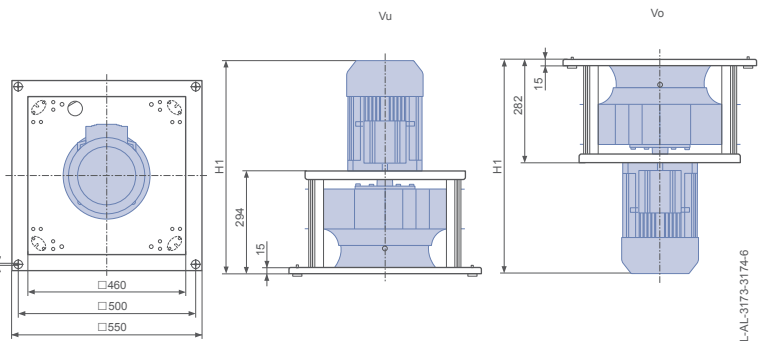

Rated power	Type	Installation position H	Installation position Vu	Installation position Vo
P_N kW		H1 mm	H1 mm	H1 mm
1.10	GR40C-4DN.C5.1R	536	548	536
1.50	GR40C-4DN.D5.1R	561	573	561
2.20	GR40C-4DN.E5.1R	599	611	599
3.00	GR40C-4DN.E5.1R	599	611	599
4.00	GR40C-2DN.F5.1R	648	660	648
5.50	GR40C-2DN.G5.1R	656	668	656

Plug fan, ventilation unit

ER45C, GR45C

Motor IE2

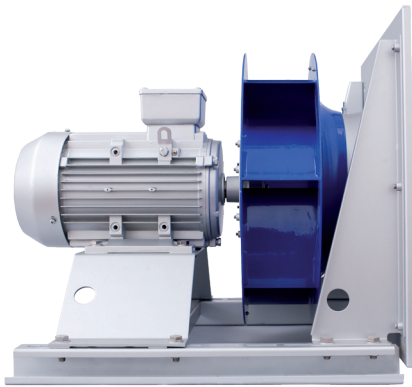

Description

- Number of blades: 7
- Max. permissible media temperature: 40 °C
- Min. permissible media temperature: -20 °C
- Motor protection: PTC thermistor (PTC)
- Impeller: Welded sheet steel coated / painted in RAL 5002 (ultramarine blue)
- ER-plug fan made as rugged bolted construction built with galvanised sheet steel
- Inlet ring for optimum impeller inflow with measurement device for determining flow rate

- Dimensions of explosion protected design Page 88
- Inlet guard Page 109
- Rubber dampers Page 109
- Spring vibration damper Page 109
- Flexible air intakes Page 110
- Frequency inverter Icontrol Page 92
- Sensors Page 96

Fan curve RH..C

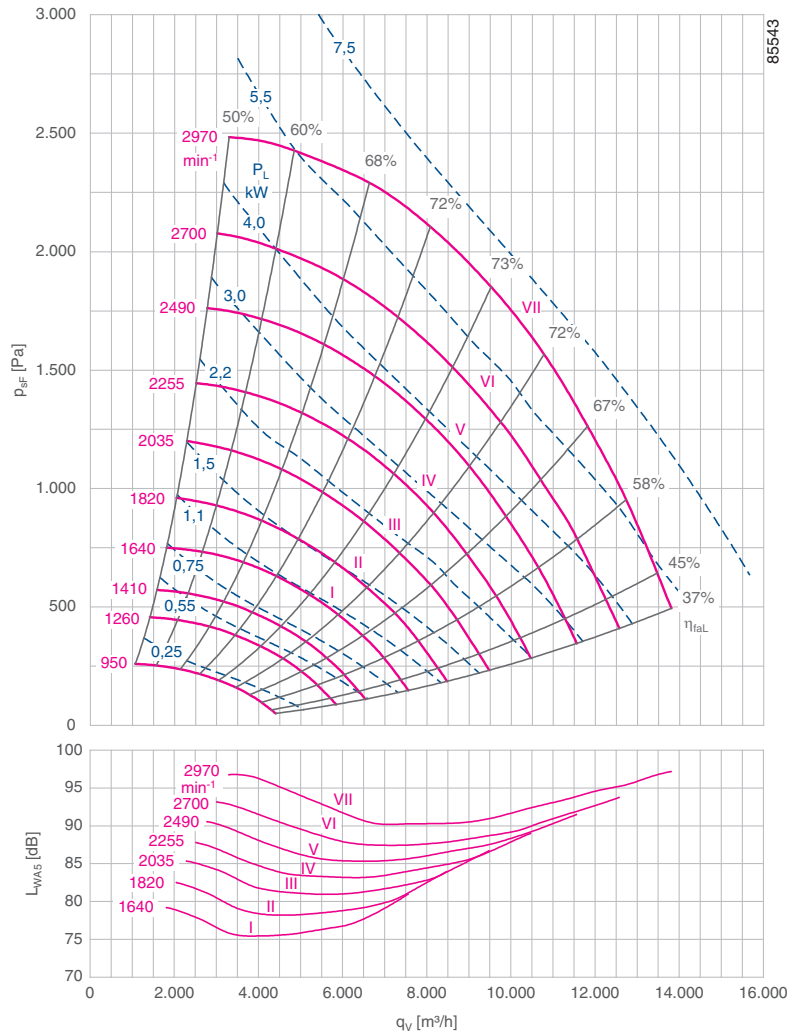

Technical data

Rated power P_N kW	Type ER / GR*	Motor size	Fan curve no.	Rated speed n_N min ⁻¹	Rated current I_N A	Max. speed n_{max} min ⁻¹	Max. frequency f_{max} Hz
1.10	ER45C-4DN.C7.1R	90S	I	1400	2.46	1640	59
1.50	ER45C-4DN.D7.1R	90L	II	1400	3.22	1820	65
2.20	ER45C-4DN.E7.1R	100L	III	1440	4.53	2035	71
3.00	ER45C-4DN.E7.1R	100L	IV	1420	6.04	2255	79
4.00	ER45C-4DN.F7.1R	112M	V	1450	7.96	2490	86
5.50	ER45C-4DN.G7.1R	132S	VI	1440	10.70	2770	96
7.50	ER45C-2DN.G7.1R	132S	VII	2915	13.70	2970	51

* Identical performance data for ER..C and GR..C

Basic version ER				Basic version GR				
Rated power P_N kW	Type ER..C	Article no. ER..C	\bar{h} max.	Type GR..C	Installation position H Article no. GR..C	Installation position Vu Article no. GR..C	Installation position Vo Article no. GR..C	\bar{h} max.
1.10	ER45C-4DN.C7.1R	130582/0F01	50	GR45C-4DN.C5.1R	113759/H01	113759/U01	113759/O01	54
1.50	ER45C-4DN.D7.1R	130583/0F01	53	GR45C-4DN.D5.1R	113760/H01	113760/U01	113760/O01	57
2.20	ER45C-4DN.E7.1R	130584/0F01	62	GR45C-4DN.E5.1R	113761/H01	113761/U01	113761/O01	65
3.00	ER45C-4DN.E7.1R	130585/0F01	67	GR45C-4DN.E5.1R	113762/H01	113762/U01	113762/O01	70
4.00	ER45C-4DN.F7.1R	130586/0F01	72	GR45C-4DN.F5.1R	113763/H01	113763/U01	113763/O01	74
5.50	ER45C-4DN.G7.1R	130587/0F01	82	GR45C-4DN.G5.1R	113764/H01	113764/U01	113764/O01	83
7.50	ER45C-2DN.G7.1R	130588/0F01	82	GR45C-2DN.G5.1R	113765/H01	113765/U01	113765/O01	83



Dimensions in mm

Plug fan ER in installation position H

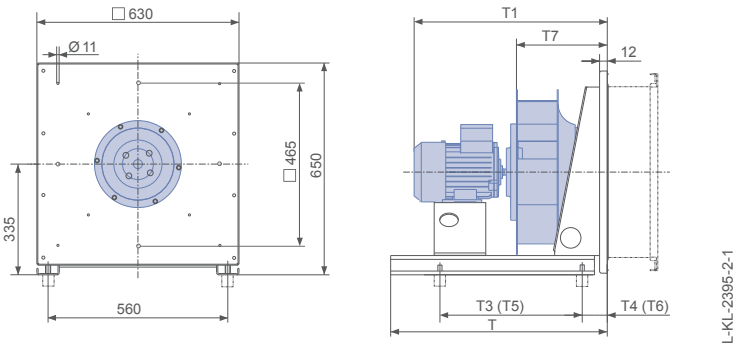

Rated power	Type	T	T1	T3	T4	T5	T6	T7	Spring vibration damper	Rubber dampers
P_N kW		mm	mm	mm	mm	mm	mm	mm		
1.10	ER45C-4DN.C7.1R	570	582	414	75	350	92	271	MSN 5	30x30 / 40
1.50	ER45C-4DN.D7.1R	570	607	404	91	394	81	271	MSN 5	30x30 / 40
2.20	ER45C-4DN.E7.1R	570	645	424	111	422	98	271	MSN 6	30x30 / 55
3.00	ER45C-4DN.E7.1R	570	645	408	127	434	101	271	MSN 6	30x30 / 55
4.00	ER45C-4DN.F7.1R	720	694	572	58	496	84	271	MSN 6	30x30 / 55
5.50	ER45C-4DN.G7.1R	720	702	596	74	576	72	271	MSN 6	40x30 / 55
7.50	ER45C-2DN.G7.1R	720	702	616	64	588	66	271	MSN 7	40x30 / 55

T5 and T6 apply to attachment of Ziehl-Abegg intake flanges.

Ventilation unit GR in installation position H

Ventilation unit GR in installation position Vu/Vo

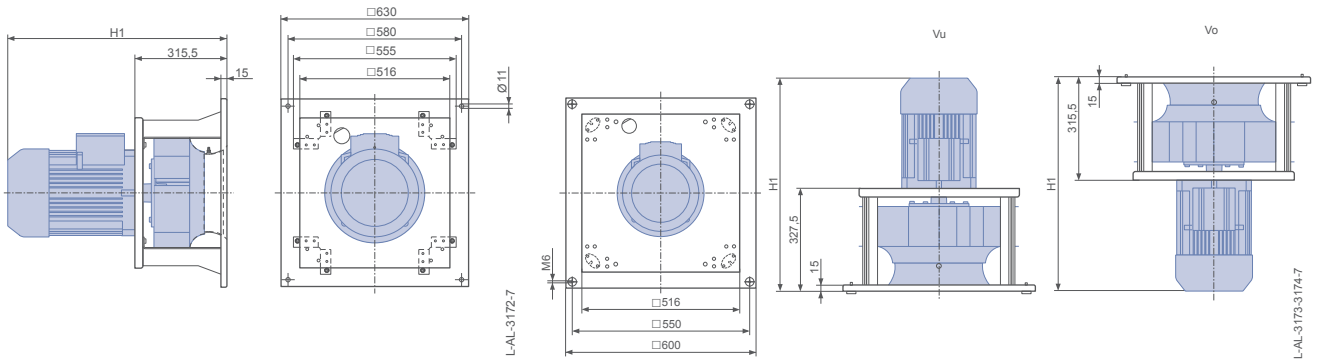

Rated power	Type	Installation position H	Installation position Vu	Installation position Vo
P_N kW		H1 mm	H1 mm	H1 mm
1.10	GR45C-4DN.C5.1R	570	582	570
1.50	GR45C-4DN.D5.1R	595	607	595
2.20	GR45C-4DN.E5.1R	633	645	633
3.00	GR45C-4DN.E5.1R	633	645	633
4.00	GR45C-4DN.F5.1R	682	694	682
5.50	GR45C-4DN.G5.1R	690	702	690
7.50	GR45C-2DN.G5.1R	690	702	690

Plug fan, ventilation unit

ER50C, GR50C

Motor IE2

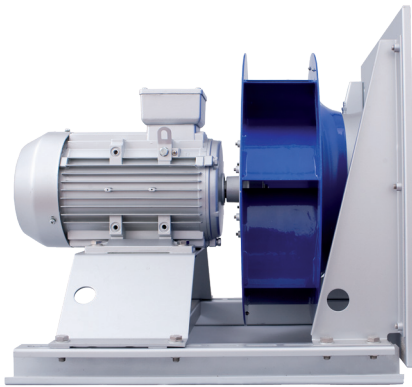

Description

- Number of blades: 7
- Max. permissible media temperature: 40°C
- Min. permissible media temperature: -20°C
- Motor protection: PTC thermistor (PTC)
- Impeller: Welded sheet steel coated / painted in RAL 5002 (ultramarine blue)
- ER-plug fan made as rugged bolted construction built with galvanised sheet steel
- Inlet ring for optimum impeller inflow with measurement device for determining flow rate

- Dimensions of explosion protected design Page 88
- Inlet guard Page 109
- Rubber dampers Page 109
- Spring vibration damper Page 109
- Flexible air intakes Page 110
- Frequency inverter Icontrol Page 92
- Sensors Page 96

Fan curve RH..C

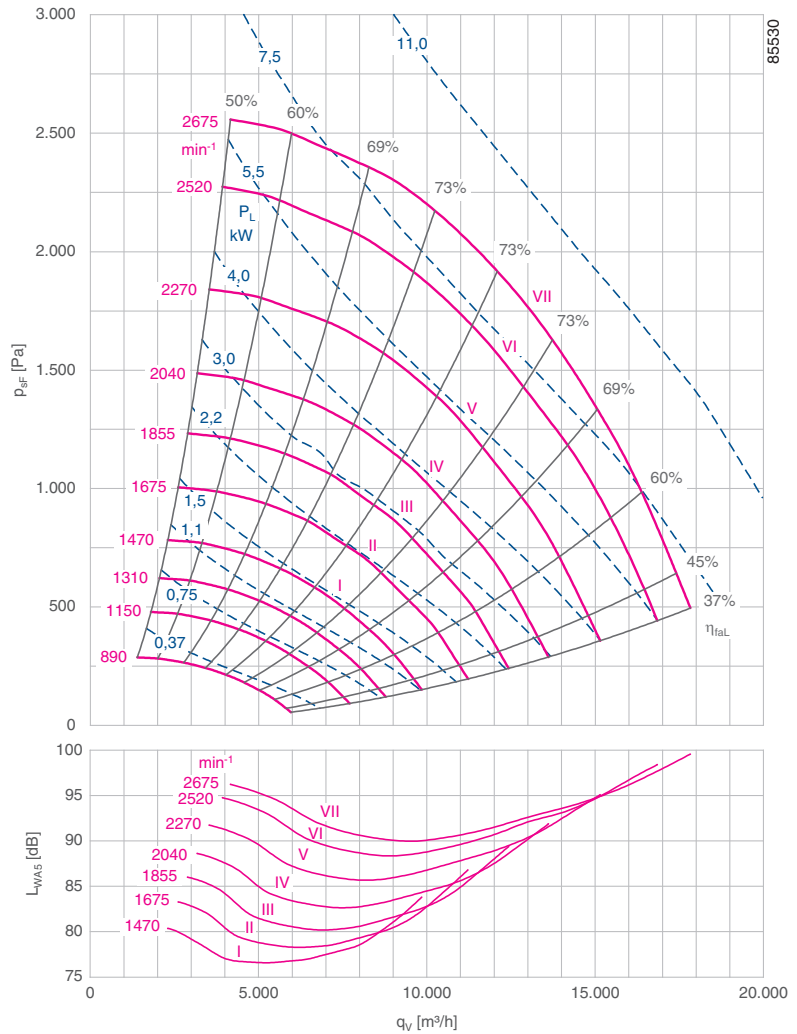

Technical data

Rated power P_N kW	Type ER / GR*	Motor size	Fan curve no.	Rated speed n_N min^{-1}	Rated current I_N A	Max. speed n_{max} min^{-1}	Max. frequency f_{max} Hz
1.50	ER50C-4DN.D7.1R	90L	I	1400	3.22	1470	53
2.20	ER50C-4DN.E7.1R	100L	II	1440	4.53	1675	58
3.00	ER50C-4DN.E7.1R	100L	III	1420	6.04	1855	65
4.00	ER50C-4DN.F7.1R	112M	IV	1450	7.96	2040	70
5.50	ER50C-4DN.G7.1R	132S	V	1440	10.70	2270	79
7.50	ER50C-4DN.H7.1R	132M	VI	1440	14.30	2520	88
11.00	ER50C-4DN.I7.1R	160M	VII	1460	20.70	2675	92

* Identical performance data for ER..C and GR..C

Basic version ER				Basic version GR				
Rated power P_N kW	Type ER..C	Article no. ER..C	max.	Type GR..C	Installation position H Article no. GR..C	Installation position Vu Article no. GR..C	Installation position Vo Article no. GR..C	max.
1.50	ER50C-4DN.D7.1R	130575/0F01	59	GR50C-4DN.D5.1R	113766/H01	113766/U01	113766/O01	71
2.20	ER50C-4DN.E7.1R	130576/0F01	68	GR50C-4DN.E5.1R	113767/H01	113767/U01	113767/O01	79
3.00	ER50C-4DN.E7.1R	130577/0F01	73	GR50C-4DN.E5.1R	113768/H01	113768/U01	113768/O01	84
4.00	ER50C-4DN.F7.1R	130578/0F01	77	GR50C-4DN.F5.1R	113769/H01	113769/U01	113769/O01	88
5.50	ER50C-4DN.G7.1R	130579/0F01	88	GR50C-4DN.G5.1R	113770/H01	113770/U01	113770/O01	97
7.50	ER50C-4DN.H7.1R	130580/0F01	98	GR50C-4DN.H5.1R	113771/H01	113771/U01	113771/O01	108
11.00	ER50C-4DN.I7.1R	130581/0F01	168	GR50C-4DN.I5.1R	113772/H01	113772/U01	113772/O01	172



Dimensions in mm

Plug fan ER in installation position H

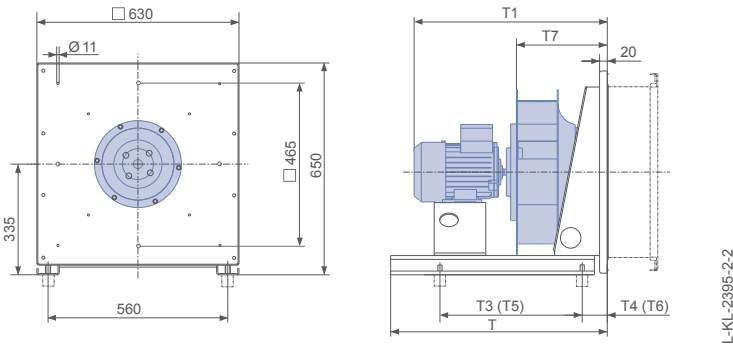

Rated power	Type	T	T1	T3	T4	T5	T6	T7	Spring vibration damper	Rubber dampers
P_N kW		mm	mm	mm	mm	mm	mm	mm		
1.50	ER50C-4DN.D7.1R	728	648	508	67	438	87	313	MSN 6	30x30 / 40
2.20	ER50C-4DN.E7.1R	728	686	582	59	454	109	313	MSN 6	30x30 / 40
3.00	ER50C-4DN.E7.1R	728	686	600	59	480	105	313	MSN 6	30x30 / 40
4.00	ER50C-4DN.F7.1R	728	735	602	68	514	99	313	MSN 6	30x30 / 55
5.50	ER50C-4DN.G7.1R	728	743	594	99	598	85	313	MSN 7	30x30 / 55
7.50	ER50C-4DN.H7.1R	728	781	546	147	564	126	313	MSN 7	40x30 / 55
11.00	ER50C-4DN.I7.1R	888	853	718	135	686	144	313	MSN 7	40x30 / 55

T5 and T6 apply to attachment of Ziehl-Abegg intake flanges.

Ventilation unit GR in installation position H

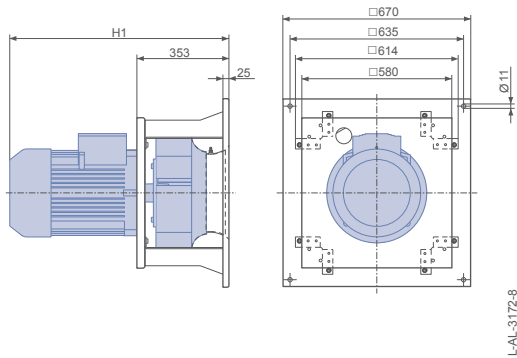

Ventilation unit GR in installation position Vu/Vo

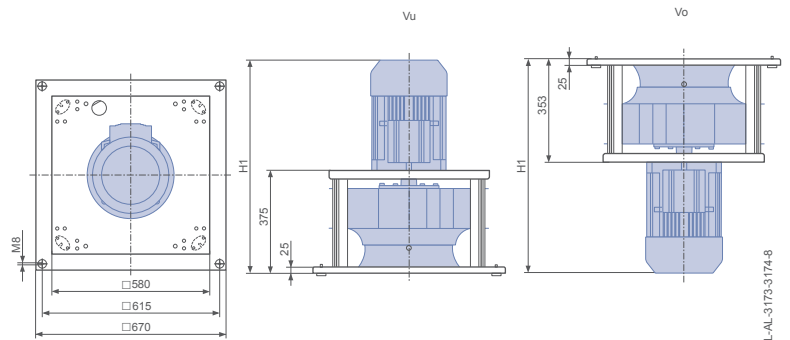

Rated power	Type	Installation position H	Installation position Vu	Installation position Vo
P_N kW		H1 mm	H1 mm	H1 mm
1.50	GR50C-4DN.D5.1R	628	650	628
2.20	GR50C-4DN.E5.1R	666	688	666
3.00	GR50C-4DN.E5.1R	666	688	666
4.00	GR50C-4DN.F5.1R	715	737	715
5.50	GR50C-4DN.G5.1R	723	745	723
7.50	GR50C-4DN.H5.1R	761	783	761
11.00	GR50C-4DN.I5.1R	833	855	833

Plug fan, ventilation unit

ER56C, GR56C

Motor IE2

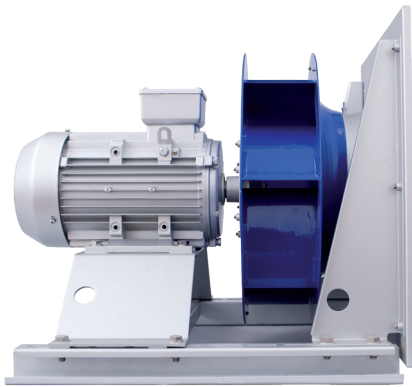

Description

- Number of blades: 7
- Max. permissible media temperature: 40°C
- Min. permissible media temperature: -20°C
- Motor protection: PTC thermistor (PTC)
- Impeller: Welded sheet steel coated / painted in RAL 5002 (ultramarine blue)
- ER-plug fan made as rugged bolted construction built with galvanised sheet steel
- Inlet ring for optimum impeller inflow with measurement device for determining flow rate

- Dimensions of explosion protected design Page 88
- Inlet guard Page 109
- Rubber dampers Page 109
- Spring vibration damper Page 109
- Flexible air intakes Page 110
- Frequency inverter Icontrol Page 92
- Sensors Page 96

Fan curve RH..C

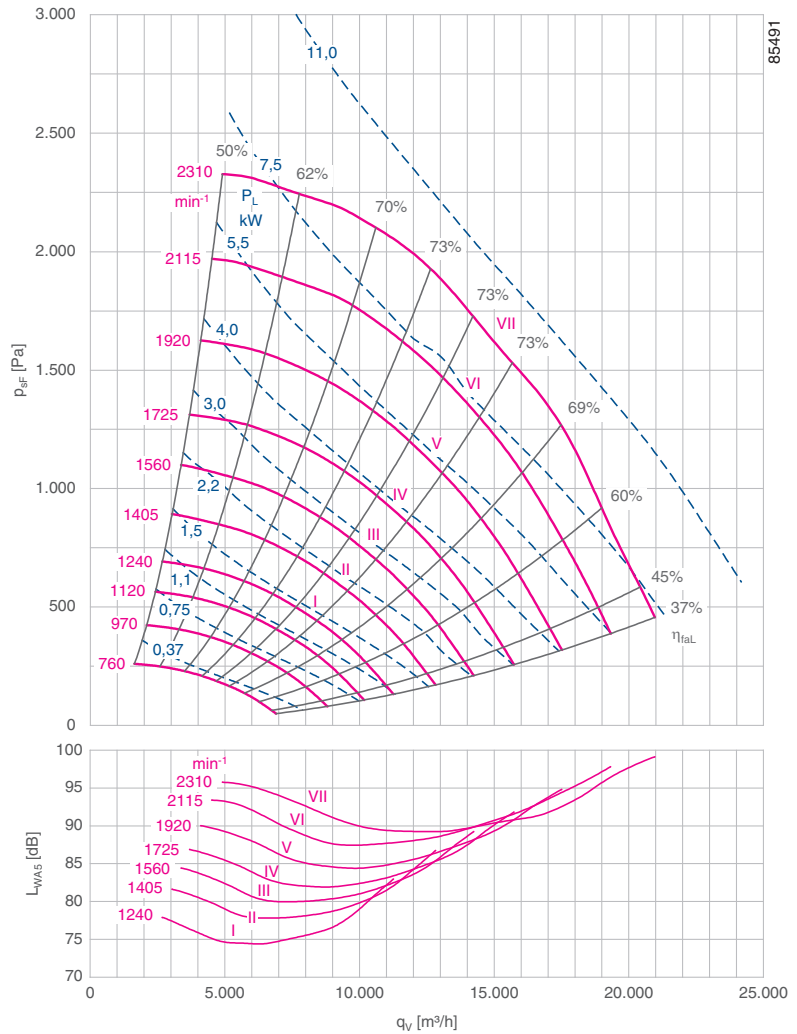

Technical data

Rated power P_N kW	Type ER / GR*	Motor size	Fan curve no.	Rated speed n_N min ⁻¹	Rated current I_N A	Max. speed n_{max} min ⁻¹	Max. frequency f_{max} Hz
1.50	ER56C-6DN.E7.1R	100L	I	940	3.53	1240	66
2.20	ER56C-4DN.E7.1R	100L	II	1440	4.53	1405	49
3.00	ER56C-4DN.E7.1R	100L	III	1420	6.04	1560	55
4.00	ER56C-4DN.F7.1R	112M	IV	1450	7.96	1725	59
5.50	ER56C-4DN.G7.1R	132S	V	1440	10.70	1920	67
7.50	ER56C-4DN.H7.1R	132M	VI	1440	14.30	2115	73
11.00	ER56C-4DN.I7.1R	160M	VII	1460	20.70	2310	79

* Identical performance data for ER..C and GR..C

Basic version ER				Basic version GR				
Rated power P_N kW	Type ER..C	Article no. ER..C	max.	Type GR..C	Installation position H Article no. GR..C	Installation position Vu Article no. GR..C	Installation position Vo Article no. GR..C	max.
1.50	ER56C-6DN.E7.1R	130568/0F01	77	GR56C-6DN.E5.1R	113773/H01	113773/U01	113773/O01	91
2.20	ER56C-4DN.E7.1R	130569/0F01	79	GR56C-4DN.E5.1R	113774/H01	113774/U01	113774/O01	92
3.00	ER56C-4DN.E7.1R	130570/0F01	84	GR56C-4DN.E5.1R	113775/H01	113775/U01	113775/O01	97
4.00	ER56C-4DN.F7.1R	130571/0F01	88	GR56C-4DN.F5.1R	113776/H01	113776/U01	113776/O01	101
5.50	ER56C-4DN.G7.1R	130572/0F01	101	GR56C-4DN.G5.1R	113777/H01	113777/U01	113777/O01	111
7.50	ER56C-4DN.H7.1R	130573/0F01	111	GR56C-4DN.H5.1R	113778/H01	113778/U01	113778/O01	121
11.00	ER56C-4DN.I7.1R	130574/0F01	182	GR56C-4DN.I5.1R	113779/H01	113779/U01	113779/O01	185



Dimensions in mm

Plug fan ER in installation position H

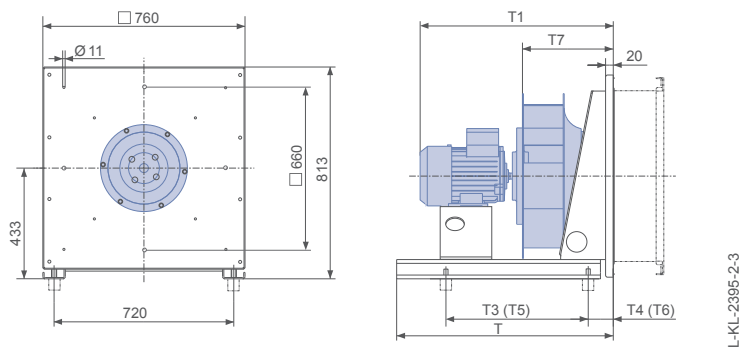

Rated power	Type	T	T1	T3	T4	T5	T6	T7	Spring vibration damper	Rubber dampers
P_N kW		mm	mm	mm	mm	mm	mm	mm		
1.50	ER56C-6DN.E7.1R	720	718	586	54	464	98	345	MSN 6	30x30 / 40
2.20	ER56C-4DN.E7.1R	720	718	600	50	444	112	345	MSN 6	30x30 / 40
3.00	ER56C-4DN.E7.1R	720	718	620	50	468	110	345	MSN 7	30x30 / 40
4.00	ER56C-4DN.F7.1R	720	767	618	62	506	102	345	MSN 7	30x30 / 55
5.50	ER56C-4DN.G7.1R	880	775	684	62	602	88	345	MSN 7	30x30 / 55
7.50	ER56C-4DN.H7.1R	880	813	730	62	630	98	345	SD 4	40x30 / 55
11.00	ER56C-4DN.I7.1R	880	885	686	164	690	152	345	SD 4	40x30 / 55

T5 and T6 apply to attachment of Ziehl-Abegg intake flanges.

Ventilation unit GR in installation position H

Ventilation unit GR in installation position Vu/Vo

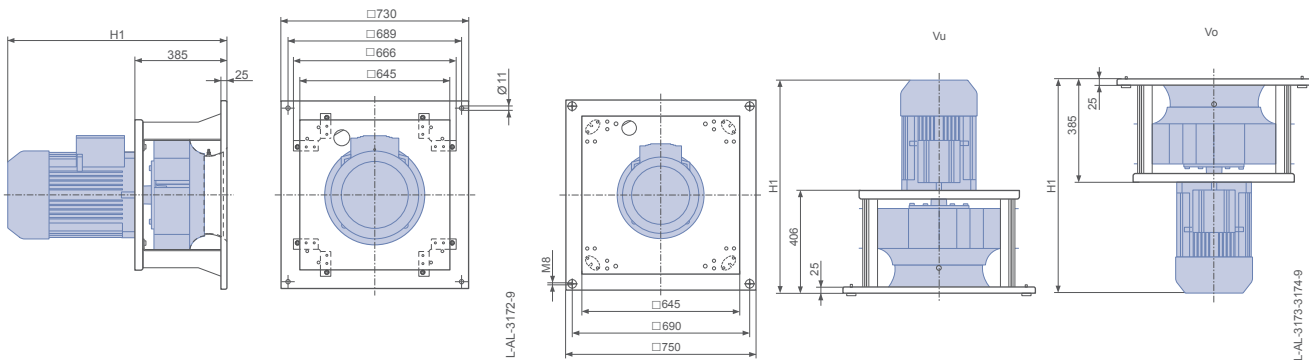

Rated power	Type	Installation position H	Installation position Vu	Installation position Vo
P_N kW		H1 mm	H1 mm	H1 mm
1.50	GR56C-6DN.E5.1R	698	719	698
2.20	GR56C-4DN.E5.1R	698	719	698
3.00	GR56C-4DN.E5.1R	698	719	698
4.00	GR56C-4DN.F5.1R	747	768	747
5.50	GR56C-4DN.G5.1R	755	776	755
7.50	GR56C-4DN.H5.1R	793	814	793
11.00	GR56C-4DN.I5.1R	865	886	865

Plug fan, ventilation unit

ER63C, GR63C

Motor IE2

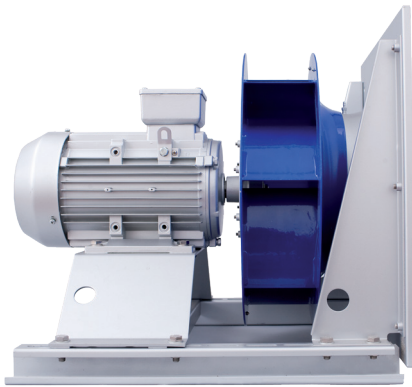

Description

- Number of blades: 7
- Max. permissible media temperature: 40°C
- Min. permissible media temperature: -20°C
- Motor protection: PTC thermistor (PTC)
- Impeller: Welded sheet steel coated / painted in RAL 5002 (ultramarine blue)
- ER-plug fan made as rugged bolted construction built with galvanised sheet steel
- Inlet ring for optimum impeller inflow with measurement device for determining flow rate

- Dimensions of explosion protected design Page 88
- Inlet guard Page 109
- Rubber dampers Page 109
- Spring vibration damper Page 109
- Flexible air intakes Page 110
- Frequency inverter Icontrol Page 92
- Sensors Page 96

Fan curve RH..C

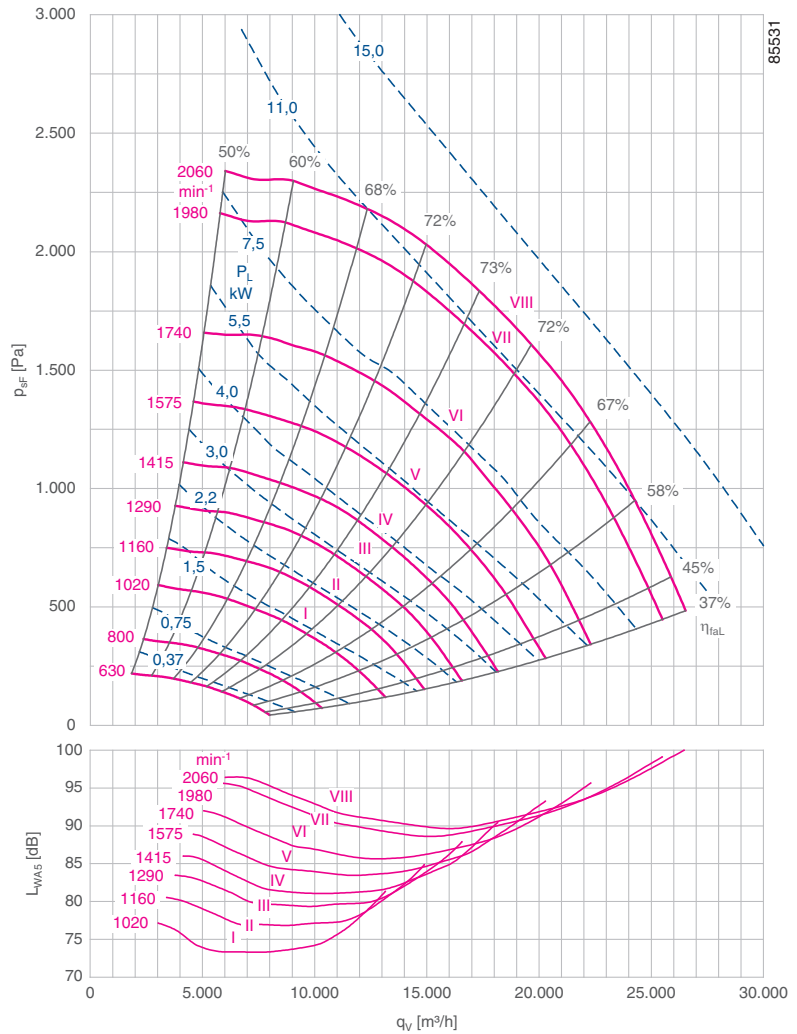

Technical data

Rated power P_N kW	Type ER / GR*	Motor size	Fan curve no.	Rated speed n_N min^{-1}	Rated current I_N A	Max. speed n_{max} min^{-1}	Max. frequency f_{max} Hz
1.50	ER63C-6DN.E7.1R	100L	I	940	3.53	1020	54
2.20	ER63C-6DN.F7.1R	112M	II	945	5.00	1160	61
3.00	ER63C-6DN.G7.1R	132S	III	960	6.70	1290	67
4.00	ER63C-4DN.F7.1R	112M	IV	1450	7.96	1415	49
5.50	ER63C-4DN.G7.1R	132S	V	1440	10.70	1575	55
7.50	ER63C-4DN.H7.1R	132M	VI	1440	14.30	1740	60
11.00	ER63C-4DN.I7.1R	160M	VII	1460	20.70	1980	68
15.00	ER63C-4DN.K7.1R	160L	VIII	1460	27.70	2060	71

* Identical performance data for ER..C and GR..C

Basic version ER				Basic version GR				
Rated power P_N kW	Type ER..C	Article no. ER..C	\bar{h} max.	Type GR..C	Installation position H Article no. GR..C	Installation position Vu Article no. GR..C	Installation position Vo Article no. GR..C	\bar{h} max.
1.50	ER63C-6DN.E7.1R	130560/0F01	92	GR63C-6DN.E5.1R	113780/H01	113780/U01	113780/O01	118
2.20	ER63C-6DN.F7.1R	130561/0F01	95	GR63C-6DN.F5.1R	113781/H01	113781/U01	113781/O01	121
3.00	ER63C-6DN.G7.1R	130562/0F01	107	GR63C-6DN.G5.1R	113782/H01	113782/U01	113782/O01	129
4.00	ER63C-4DN.F7.1R	130563/0F01	102	GR63C-4DN.F5.1R	113783/H01	113783/U01	113783/O01	128
5.50	ER63C-4DN.G7.1R	130564/0F01	115	GR63C-4DN.G5.1R	113784/H01	113784/U01	113784/O01	137
7.50	ER63C-4DN.H7.1R	130565/0F01	126	GR63C-4DN.H5.1R	113785/H01	113785/U01	113785/O01	148
11.00	ER63C-4DN.I7.1R	130566/0F01	196	GR63C-4DN.I5.1R	113786/H01	113786/U01	113786/O01	212
15.00	ER63C-4DN.K7.1R	130567/0F01	208	GR63C-4DN.K5.1R	113787/H01	113787/U01	113787/O01	224

Dimensions in mm

Plug fan ER in installation position H

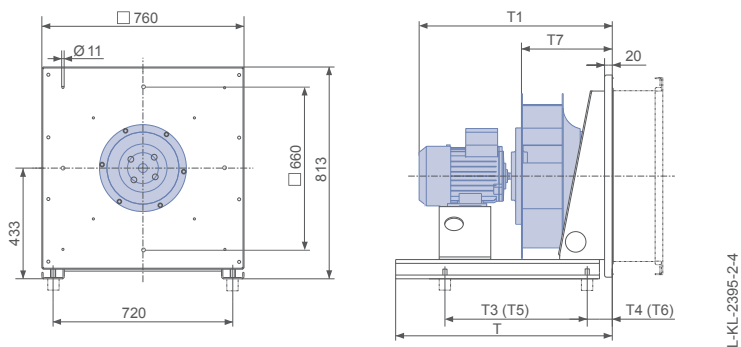

Rated power	Type	T	T1	T3	T4	T5	T6	T7	Spring vibration damper	Rubber dampers
P_N kW		mm	mm	mm	mm	mm	mm	mm		
1.50	ER63C-6DN.E7.1R	720	758	606	64	526	84	384	MSN 6	30x30 / 40
2.20	ER63C-6DN.F7.1R	720	807	608	72	576	68	384	MSN 6	30x30 / 40
3.00	ER63C-6DN.G7.1R	880	815	684	66	648	66	384	MSN 7	30x30 / 40
4.00	ER63C-4DN.F7.1R	720	807	602	88	556	93	384	MSN 7	30x30 / 40
5.50	ER63C-4DN.G7.1R	880	815	680	80	646	79	384	MSN 7	30x30 / 55
7.50	ER63C-4DN.H7.1R	880	853	704	90	670	90	384	MSN 7	30x30 / 55
11.00	ER63C-4DN.I7.1R	880	925	650	195	666	179	384	SD 4	40x30 / 55
15.00	ER63C-4DN.K7.1R	880	980	608	237	624	221	384	SD 4	40x30 / 55

T5 and T6 apply to attachment of Ziehl-Abegg intake flanges.

Ventilation unit GR in installation position H

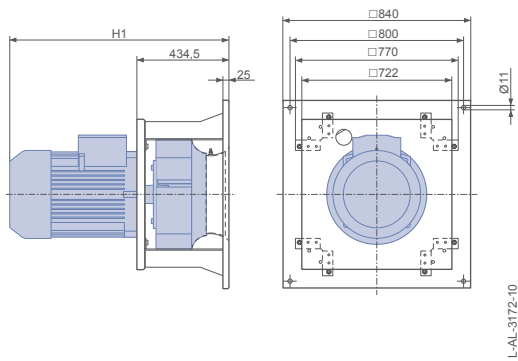

Ventilation unit GR in installation position Vu/Vo

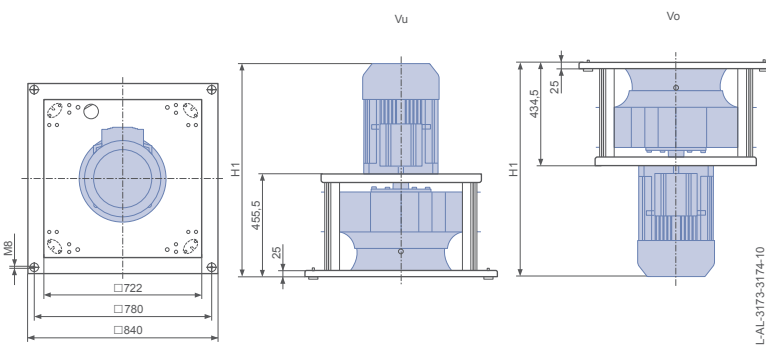

Rated power	Type	Installation position		
		H	Vu	Vo
P_N kW		H1 mm	H1 mm	H1 mm
1.50	GR63C-6DN.E5.1R	738	759	738
2.20	GR63C-6DN.F5.1R	787	808	787
3.00	GR63C-6DN.G5.1R	795	816	795
4.00	GR63C-4DN.F5.1R	787	808	787
5.50	GR63C-4DN.G5.1R	795	816	795
7.50	GR63C-4DN.H5.1R	833	854	833
11.00	GR63C-4DN.I5.1R	905	926	905
15.00	GR63C-4DN.K5.1R	960	981	960

Information
RH..Cpro
RH..C
Series
ER / GR
ER..Cpro
GR..Cpro
ER..C
GR..C
Ex-
Design
System
Components
Appendix

Plug fan, ventilation unit

ER71C, GR71C

Motor IE2

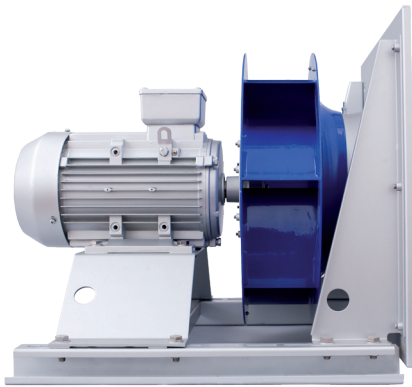

Description

- Number of blades: 7
- Max. permissible media temperature: 40°C
- Min. permissible media temperature: -20°C
- Motor protection: PTC thermistor (PTC)
- Impeller: Welded sheet steel coated / painted in RAL 5002 (ultramarine blue)
- ER-plug fan made as rugged bolted construction built with galvanised sheet steel
- Inlet ring for optimum impeller inflow with measurement device for determining flow rate

- Dimensions of explosion protected design Page 88
- Inlet guard Page 109
- Rubber dampers Page 109
- Spring vibration damper Page 109
- Flexible air intakes Page 110
- Frequency inverter Icontrol Page 92
- Sensors Page 96

Fan curve RH..C

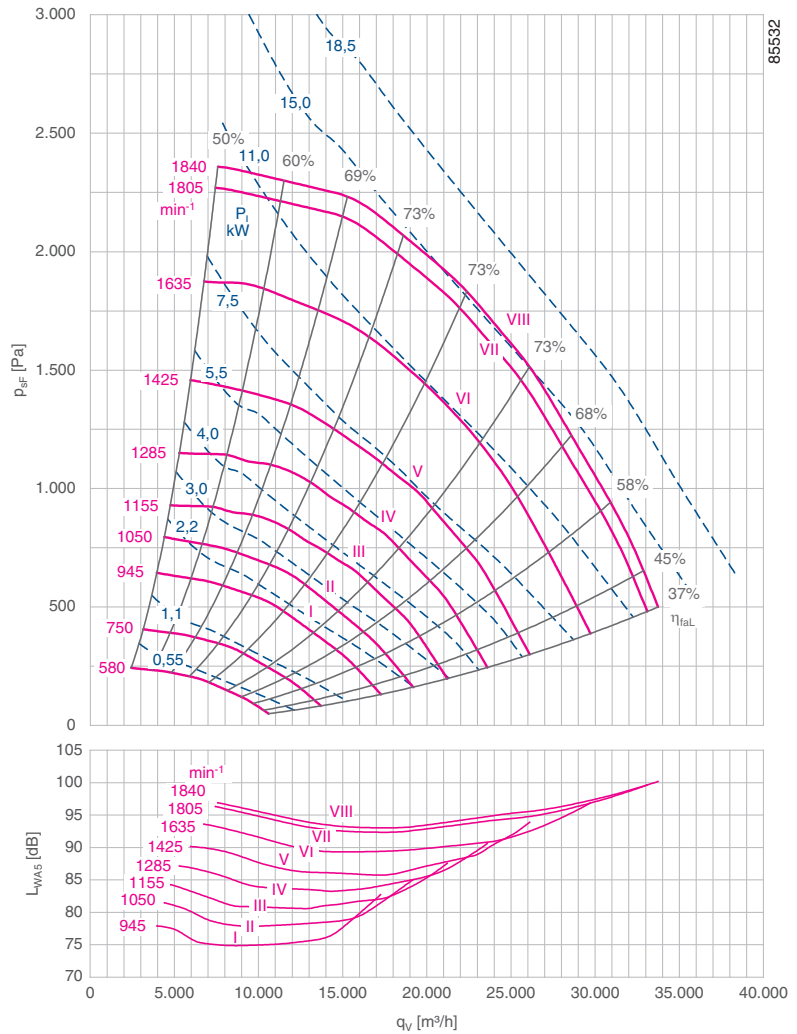

Technical data

Rated power P_N kW	Type ER / GR*	Motor size	Fan curve no.	Rated speed n_N min ⁻¹	Rated current I_N A	Max. speed n_{max} min ⁻¹	Max. frequency f_{max} Hz
2.20	ER71C-6DN.F7.1R	112M	I	945	5.00	945	50
3.00	ER71C-6DN.G7.1R	132S	II	960	6.70	1050	55
4.00	ER71C-6DN.H7.1R	132M	III	960	8.10	1155	60
5.50	ER71C-6DN.H7.1R	132M	IV	960	11.80	1285	67
7.50	ER71C-4DN.H7.1R	132M	V	1440	14.30	1425	49
11.00	ER71C-4DN.I7.1R	160M	VI	1460	20.70	1635	56
15.00	ER71C-4DN.K7.1R	160L	VII	1460	27.70	1805	62
18.50	ER71C-4DN.L7.1R	180M	VIII	1470	33.60	1840	63

* Identical performance data for ER..C and GR..C

Basic version ER				Basic version GR			
Rated power P_N kW	Type ER..C	Article no. ER..C	\bar{h} max.	Type GR..C	Installation position Vu Article no. GR..C	Installation position Vo Article no. GR..C	\bar{h} max.
2.20	ER71C-6DN.F7.1R	130552/0F01	126	GR71C-6DN.F5.1R	113809/U01	113809/O01	147
3.00	ER71C-6DN.G7.1R	130553/0F01	137	GR71C-6DN.G5.1R	113810/U01	113810/O01	156
4.00	ER71C-6DN.H7.1R	130554/0F01	146	GR71C-6DN.H5.1R	113811/U01	113811/O01	164
5.50	ER71C-6DN.H7.1R	130555/0F01	155	GR71C-6DN.H5.1R	113812/U01	113812/O01	174
7.50	ER71C-4DN.H7.1R	130556/0F01	156	GR71C-4DN.H5.1R	113813/U01	113813/O01	174
11.00	ER71C-4DN.I7.1R	130557/0F01	224	GR71C-4DN.I5.1R	113814/U01	113814/O01	238
15.00	ER71C-4DN.K7.1R	130558/0F01	236	GR71C-4DN.K5.1R	113815/U01	113815/O01	250
18.50	ER71C-4DN.L7.1R	130559/0F01	273	GR71C-4DN.L5.1R	113816/U01	113816/O01	285



Dimensions in mm

Plug fan ER in installation position H

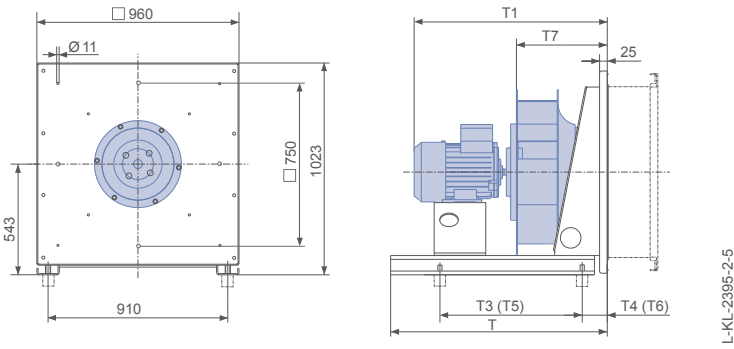

Rated power	Type	T	T1	T3	T4	T5	T6	T7	Spring vibration damper	Rubber dampers
P_N kW		mm	mm	mm	mm	mm	mm	mm		
2.20	ER71C-6DN.F7.1R	885	858	636	84	608	82	435	MSN 7	40x40 / 40
3.00	ER71C-6DN.G7.1R	885	866	690	85	662	83	435	MSN 7	40x40 / 40
4.00	ER71C-6DN.H7.1R	885	904	708	94	680	92	435	SD 4	40x40 / 40
5.50	ER71C-6DN.H7.1R	885	904	740	90	710	90	435	SD 4	40x40 / 40
7.50	ER71C-4DN.H7.1R	885	904	712	105	686	102	435	SD 4	40x40 / 40
11.00	ER71C-4DN.I7.1R	1045	976	756	169	722	173	435	SD 4	50x50 / 55
15.00	ER71C-4DN.K7.1R	1045	1031	802	165	772	168	435	SD 5	50x50 / 55
18.50	ER71C-4DN.L7.1R	1045	1101	836	174	858	152	435	SD 5	50x50 / 55

T5 and T6 apply to attachment of Ziehl-Abegg intake flanges.

Ventilation unit GR in installation position Vu/Vo

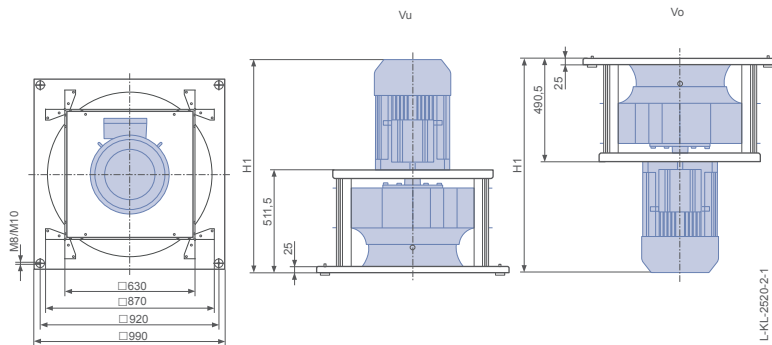

Rated power	Type	Installation position	
		Vu	Vo
P_N kW		H1 mm	H1 mm
2.20	GR71C-6DN.F5.1R	854	833
3.00	GR71C-6DN.G5.1R	862	841
4.00	GR71C-6DN.H5.1R	900	879
5.50	GR71C-6DN.H5.1R	900	879
7.50	GR71C-4DN.H5.1R	900	879
11.00	GR71C-4DN.I5.1R	972	951
15.00	GR71C-4DN.K5.1R	1027	1006
18.50	GR71C-4DN.L5.1R	1057	1036

Plug fan, ventilation unit

ER80C, GR80C

Motor IE2

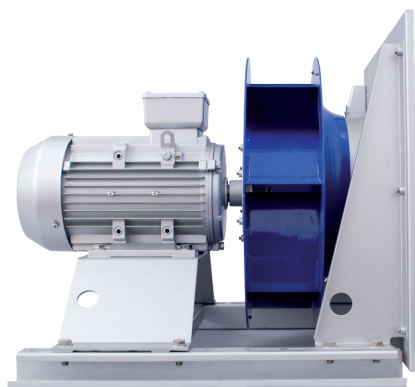

Description

- Number of blades: 7
- Max. permissible media temperature: 40 °C
- Min. permissible media temperature: -20 °C
- Motor protection: PTC thermistor (PTC)
- Impeller: Welded sheet steel coated / painted in RAL 5002 (ultramarine blue)
- ER-plug fan made as rugged bolted construction built with galvanised sheet steel
- Inlet ring for optimum impeller inflow with measurement device for determining flow rate

- Dimensions of explosion protected design Page 88
- Inlet guard Page 109
- Rubber dampers Page 109
- Spring vibration damper Page 109
- Flexible air intakes Page 110
- Frequency inverter Icontrol Page 92
- Sensors Page 96

Fan curve RH..C

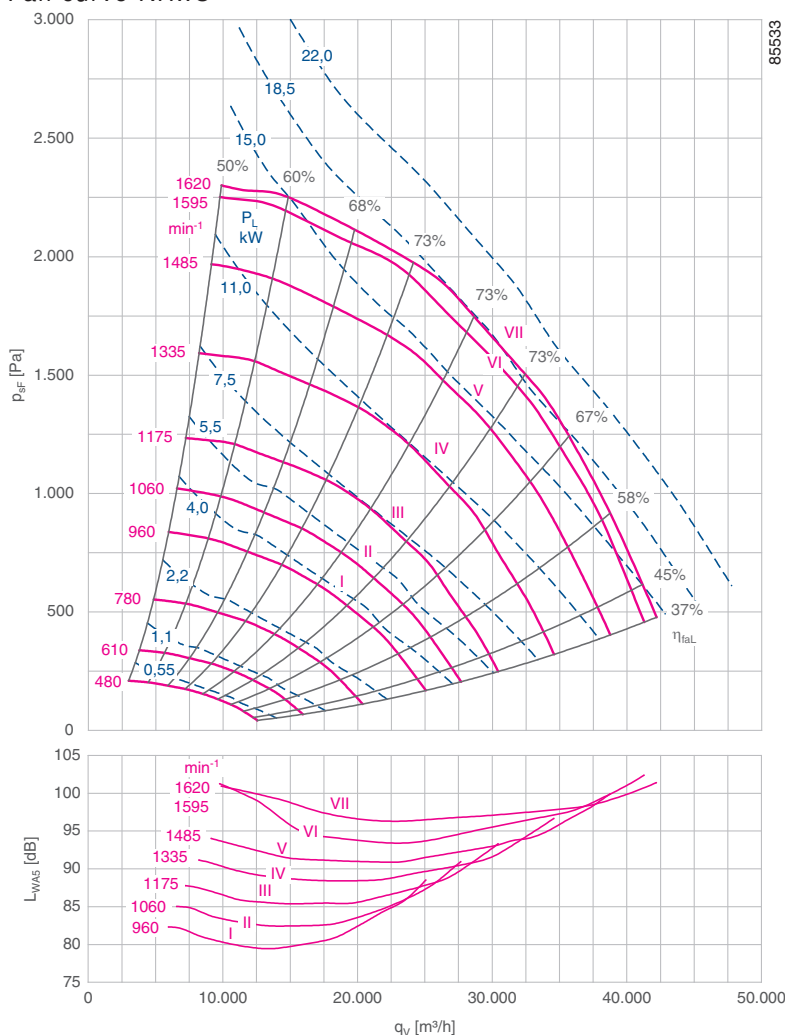

Technical data

Rated power P_N kW	Type ER / GR*	Motor size	Fan curve no.	Rated speed n_N min ⁻¹	Rated current I_N A	Max. speed n_{max} min ⁻¹	Max. frequency f_{max} Hz
4.00	ER80C-6DN.H7.1R	132M	I	960	8.10	960	50
5.50	ER80C-6DN.H7.1R	132M	II	960	11.80	1060	55
7.50	ER80C-6DN.I7.1R	160M	III	970	15.80	1175	61
11.00	ER80C-6DN.K7.1R	160L	IV	970	22.60	1335	69
15.00	ER80C-4DN.K7.1R	160L	V	1460	27.70	1485	51
18.50	ER80C-4DN.L7.1R	180M	VI	1470	33.60	1595	54
22.00	ER80C-4DN.M7.1R	180L	VII	1470	39.80	1620	55

* Identical performance data for ER..C and GR..C

Basic version ER				Basic version GR			
Rated power				Installation position			
P_N kW	Type ER..C	Article no. ER..C	$\frac{h}{D}$ max.	Type GR..C	Article no. GR..C	Article no. GR..C	$\frac{h}{D}$ max.
4.00	ER80C-6DN.H7.1R	130545/0F01	173	GR80C-6DN.H5.1R	113817/U01	113817/O01	198
5.50	ER80C-6DN.H7.1R	130546/0F01	182	GR80C-6DN.H5.1R	113818/U01	113818/O01	207
7.50	ER80C-6DN.I7.1R	130547/0F01	263	GR80C-6DN.I5.1R	113819/U01	113819/O01	284
11.00	ER80C-6DN.K7.1R	130548/0F01	277	GR80C-6DN.K5.1R	113820/U01	113820/O01	298
15.00	ER80C-4DN.K7.1R	130549/0F01	263	GR80C-4DN.K5.1R	113821/U01	113821/O01	284
18.50	ER80C-4DN.L7.1R	130550/0F01	300	GR80C-4DN.L5.1R	113822/U01	113822/O01	319
22.00	ER80C-4DN.M7.1R	130551/0F01	314	GR80C-4DN.M5.1R	113823/U01	113823/O01	333



Dimensions in mm

Plug fan ER in installation position H

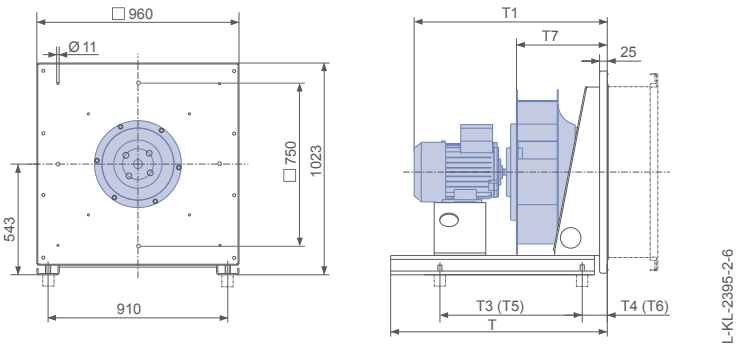

Rated power	Type	T	T1	T3	T4	T5	T6	T7	Spring vibration damper	Rubber dampers
P_N kW		mm	mm	mm	mm	mm	mm	mm		
4.00	ER80C-6DN.H7.1R	885	956	738	92	708	92	487	SD 4	40x40 / 40
5.50	ER80C-6DN.H7.1R	885	956	752	98	742	88	487	SD 4	40x40 / 40
7.50	ER80C-6DN.I7.1R	1045	1028	882	128	766	174	487	SD 4	50x50 / 55
11.00	ER80C-6DN.K7.1R	1045	1083	842	168	846	154	487	SD 4	50x50 / 55
15.00	ER80C-4DN.K7.1R	1045	1083	860	150	784	176	487	SD 5	50x50 / 55
18.50	ER80C-4DN.L7.1R	1045	1153	804	206	826	184	487	SD 5	50x50 / 55
22.00	ER80C-4DN.M7.1R	1045	1153	768	242	790	220	487	SD 5	50x50 / 55

T5 and T6 apply to attachment of Ziehl-Abegg intake flanges.

Ventilation unit GR in installation position Vu/Vo

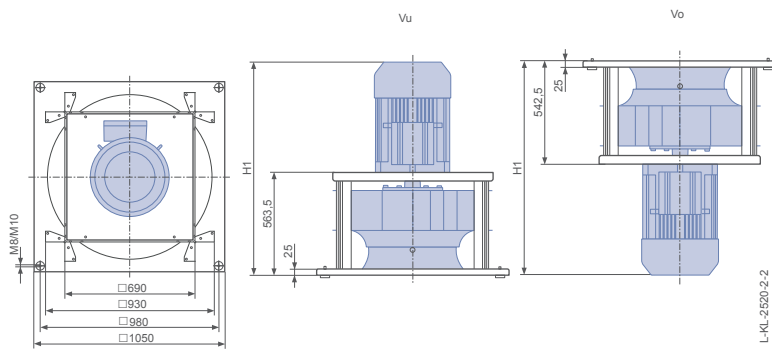

Rated power	Type	Installation position	
		Vu	Vo
P_N kW		H1 mm	H1 mm
4.00	GR80C-6DN.H5.1R	952	931
5.50	GR80C-6DN.H5.1R	952	931
7.50	GR80C-6DN.I5.1R	1024	1003
11.00	GR80C-6DN.K5.1R	1079	1058
15.00	GR80C-4DN.K5.1R	1079	1058
18.50	GR80C-4DN.L5.1R	1109	1088
22.00	GR80C-4DN.M5.1R	1149	1128

Plug fan, ventilation unit

ER90C, GR90C

Motor IE2

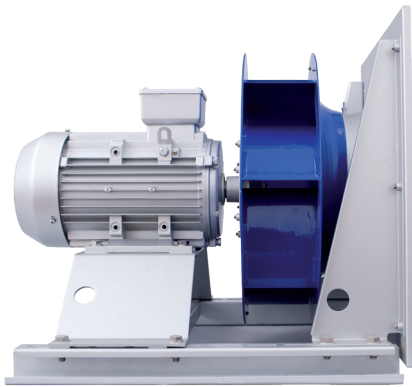

Fan curve RH..C

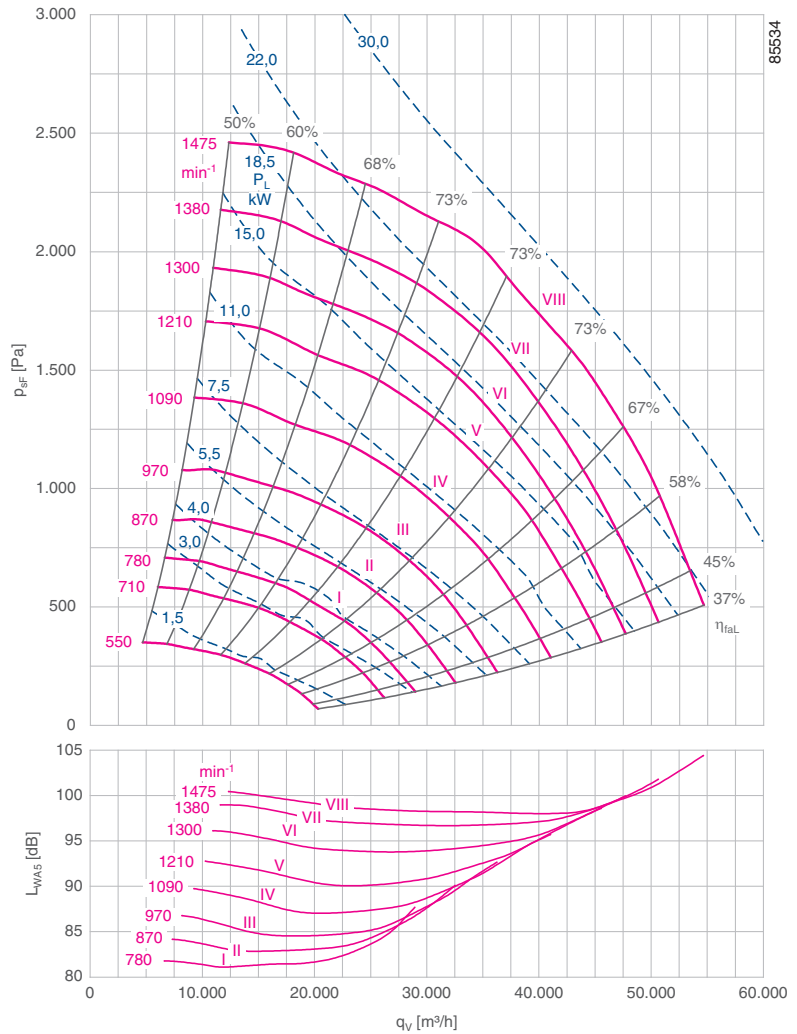

Description

- Number of blades: 7
- Max. permissible media temperature: 40°C
- Min. permissible media temperature: -20°C
- Motor protection: PTC thermistor (PTC)
- Impeller: Welded sheet steel coated / painted in RAL 5002 (ultramarine blue)
- ER-plug fan made as rugged bolted construction built with galvanised sheet steel
- Inlet ring for optimum impeller inflow with measurement device for determining flow rate

- Dimensions of explosion protected design Page 88
- Inlet guard Page 109
- Rubber dampers Page 109
- Spring vibration damper Page 109
- Flexible air intakes Page 110
- Frequency inverter Icontrol Page 92
- Sensors Page 96

Technical data

Rated power P_N kW	Type ER / GR*	Motor size	Fan curve no.	Rated speed n_N min⁻¹	Rated current I_N A	Max. speed n_{max} min⁻¹	Max. frequency f_{max} Hz
4.00	ER90C-8DN.I7.1R	160M	I	720	9.37	780	54
5.50	ER90C-8DN.I7.1R	160M	II	720	12.50	870	60
7.50	ER90C-6DN.I7.1R	160M	III	970	15.80	970	50
11.00	ER90C-6DN.K7.1R	160L	IV	970	22.60	1090	56
15.00	ER90C-6DN.M7.1R	180L	V	970	29.30	1210	62
18.50	ER90C-6DN.N7.1R	200L	VI	970	35.90	1300	67
22.00	ER90C-6DN.N7.1R	200L	VII	970	41.50	1380	71
30.00	ER90C-4DN.N7.1R	200L	VIII	1480	54.00	1475	50

* Identical performance data for ER..C and GR..C

Basic version ER				Basic version GR			
Rated power P_N kW	Type ER..C	Article no. ER..C	\bar{h} max.	Type GR..C	Installation position Vu Article no. GR..C	Installation position Vo Article no. GR..C	\bar{h} max.
4.00	ER90C-8DN.I7.1R	130537/0F01	324	GR90C-8DN.I5.1R	113824/U01	113824/O01	340
5.50	ER90C-8DN.I7.1R	130538/0F01	346	GR90C-8DN.I5.1R	113825/U01	113825/O01	362
7.50	ER90C-6DN.I7.1R	130539/0F01	326	GR90C-6DN.I5.1R	113826/U01	113826/O01	342
11.00	ER90C-6DN.K7.1R	130540/0F01	340	GR90C-6DN.K5.1R	113827/U01	113827/O01	356
15.00	ER90C-6DN.M7.1R	130541/0F01	378	GR90C-6DN.M5.1R	113828/U01	113828/O01	390
18.50	ER90C-6DN.N7.1R	130542/0F01	416	GR90C-6DN.N5.1R	113829/U01	113829/O01	425
22.00	ER90C-6DN.N7.1R	130543/0F01	430	GR90C-6DN.N5.1R	113830/U01	113830/O01	439
30.00	ER90C-4DN.N7.1R	130544/0F01	447	GR90C-4DN.N5.1R	113831/U01	113831/O01	456



Dimensions in mm

Plug fan ER in installation position H

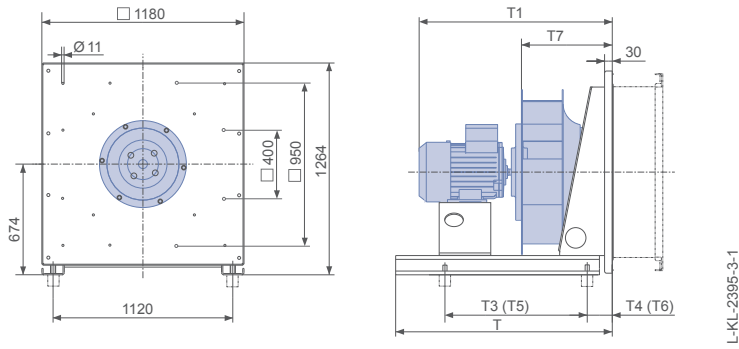

L-KL-2395-3-1

Rated power	Type	T	T1	T3	T4	T5	T6	T7	Spring vibration damper	Rubber dampers
P_N kW		mm	mm	mm	mm	mm	mm	mm		
4.00	ER90C-8DN.I7.1R	1160	1091	1026	74	760	190	551	SD 4	75x50 / 40
5.50	ER90C-8DN.I7.1R	1160	1091	1000	100	780	195	551	SD 4	75x50 / 40
7.50	ER90C-6DN.I7.1R	1160	1091	1024	76	806	169	551	SD 5	75x50 / 40
11.00	ER90C-6DN.K7.1R	1160	1146	988	112	870	155	551	SD 5	75x50 / 40
15.00	ER90C-6DN.M7.1R	1320	1216	1112	88	1012	123	551	SD 5	75x50 / 40
18.50	ER90C-6DN.N7.1R	1320	1255	1202	78	1050	140	551	SD 6	75x50 / 40
22.00	ER90C-6DN.N7.1R	1320	1255	1182	95	1104	119	551	SD 6	75x50 / 40
30.00	ER90C-4DN.N7.1R	1320	1255	1168	109	1088	135	551	SD 6	75x50 / 40

T5 and T6 apply to attachment of Ziehl-Abegg intake flanges.

Ventilation unit GR in installation position Vu/Vo

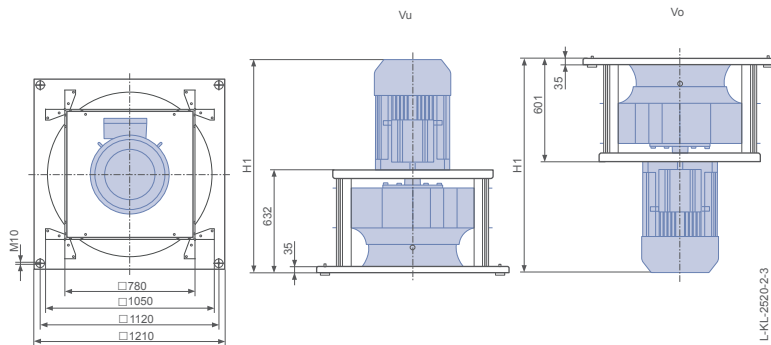

L-KL-2520-2-3

Rated power	Type	Installation position Vu	Installation position Vo
P_N kW		H1 mm	H1 mm
4.00	GR90C-8DN.I5.1R	1097	1066
5.50	GR90C-8DN.I5.1R	1097	1066
7.50	GR90C-6DN.I5.1R	1097	1066
11.00	GR90C-6DN.K5.1R	1152	1121
15.00	GR90C-6DN.M5.1R	1222	1191
18.50	GR90C-6DN.N5.1R	1261	1230
22.00	GR90C-6DN.N5.1R	1261	1230
30.00	GR90C-4DN.N5.1R	1261	1230

Plug fan, ventilation unit

ER10C, GR10C

Motor IE2

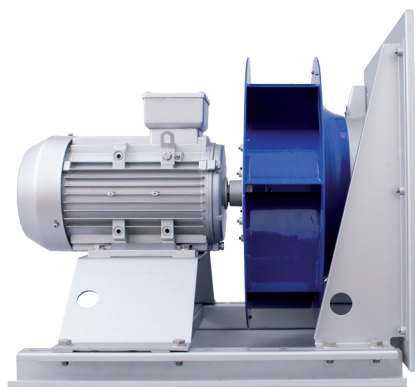

Fan curve RH..C

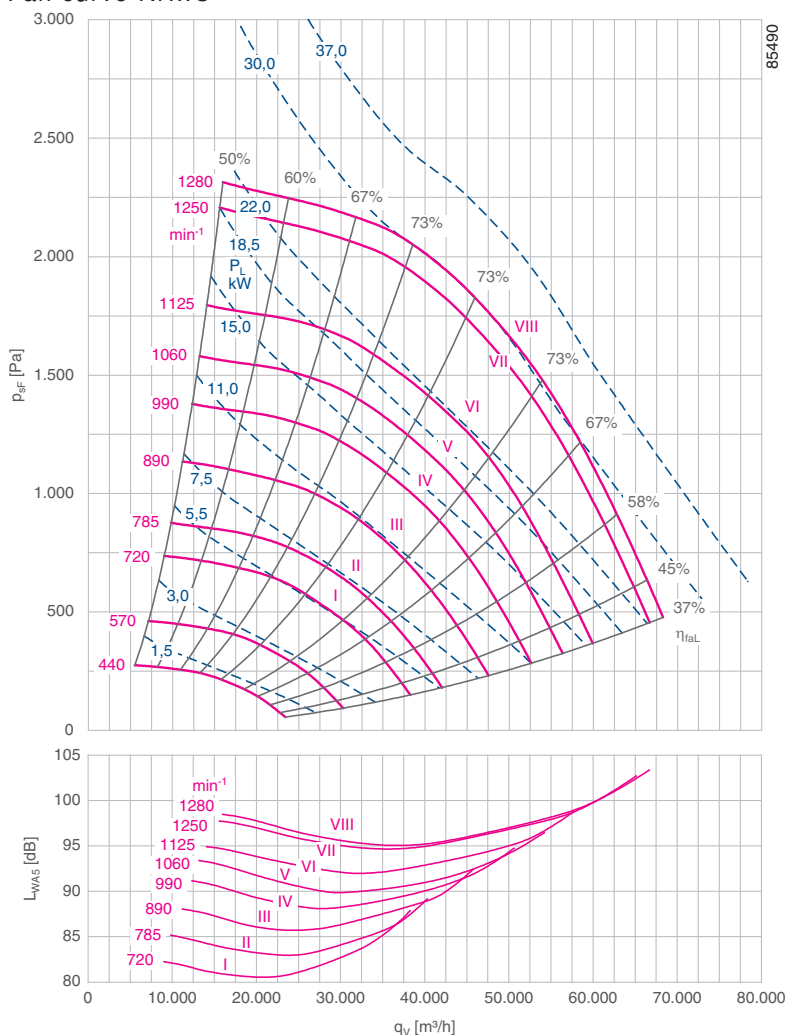

Description

- Number of blades: 7
- Max. permissible media temperature: 40°C
- Min. permissible media temperature: -20°C
- Motor protection: PTC thermistor (PTC)
- Impeller: Welded sheet steel coated / painted in RAL 5002 (ultramarine blue)
- ER-plug fan made as rugged bolted construction built with galvanised sheet steel
- Inlet ring for optimum impeller inflow with measurement device for determining flow rate

- Dimensions of explosion protected design Page 88
- Inlet guard Page 109
- Rubber dampers Page 109
- Spring vibration damper Page 109
- Flexible air intakes Page 110
- Frequency inverter Icontrol Page 92
- Sensors Page 96

Technical data

Rated power P_N kW	Type ER / GR*	Motor size	Fan curve no.	Rated speed n_N min^{-1}	Rated current I_N A	Max. speed n_{max} min^{-1}	Max. frequency f_{max} Hz
5.50	ER10C-8DN.I7.1R	160M	I	720	12.50	720	50
7.50	ER10C-8DN.K7.1R	160L	II	720	16.50	785	55
11.00	ER10C-8DN.M7.1R	180L	III	720	23.50	890	62
15.00	ER10C-6DN.M7.1R	180L	IV	970	29.30	990	51
18.50	ER10C-6DN.N7.1R	200L	V	970	35.90	1060	55
22.00	ER10C-6DN.N7.1R	200L	VI	970	41.50	1125	58
30.00	ER10C-6DN.R7.1R	225M	VII	980	55.70	1250	64
37.00	ER10C-6DN.S7.1R	250M	VIII	980	66.60	1280	65

* Identical performance data for ER..C and GR..C

Basic version ER				Basic version GR			
Rated power P_N kW	Type ER..C	Article no. ER..C	\bar{h} max.	Type GR..C	Installation position Vu Article no. GR..C	Installation position Vo Article no. GR..C	\bar{h} max.
5.50	ER10C-8DN.I7.1R	130528/0F01	389	GR10C-8DN.I5.1R	113832/U01	113832/O01	429
7.50	ER10C-8DN.K7.1R	130529/0F01	394	GR10C-8DN.K5.1R	113833/U01	113833/O01	434
11.00	ER10C-8DN.M7.1R	130530/0F01	410	GR10C-8DN.M5.1R	113834/U01	113834/O01	447
15.00	ER10C-6DN.M7.1R	130531/0F01	420	GR10C-6DN.M5.1R	113835/U01	113835/O01	457
18.50	ER10C-6DN.N7.1R	130532/0F01	459	GR10C-6DN.N5.1R	113836/U01	113836/O01	492
22.00	ER10C-6DN.N7.1R	130533/0F01	473	GR10C-6DN.N5.1R	113837/U01	113837/O01	506
30.00	ER10C-6DN.R7.1R	130534/0F01	534	GR10C-6DN.R5.1R	113838/U01	113838/O01	568
37.00	ER10C-6DN.S7.1R	130535/0F01	621	GR10C-6DN.S5.1R	113839/U01	113839/O01	648



Dimensions in mm

Plug fan ER in installation position H

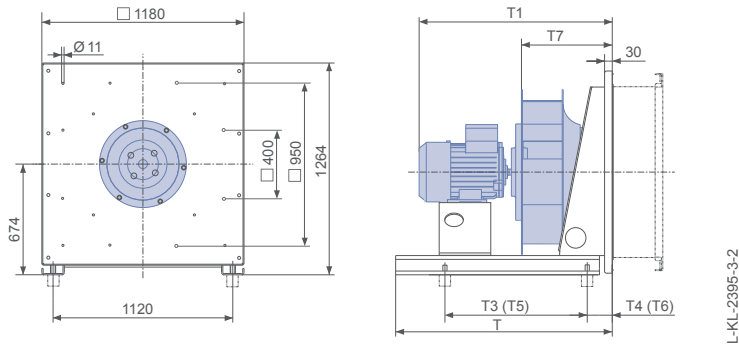

Rated power	Type	T	T1	T3	T4	T5	T6	T7	Spring vibration damper	Rubber dampers
P_N kW		mm	mm	mm	mm	mm	mm	mm		
5.50	ER10C-8DN.I7.1R	1160	1157	936	165	828	202	616	SD 4	75x50 / 40
7.50	ER10C-8DN.K7.1R	1160	1212	960	165	884	186	616	SD 5	75x50 / 40
11.00	ER10C-8DN.M7.1R	1320	1282	1134	87	1104	86	616	SD 5	75x50 / 40
15.00	ER10C-6DN.M7.1R	1320	1282	1092	129	1062	128	616	SD 5	75x50 / 40
18.50	ER10C-6DN.N7.1R	1320	1321	1152	133	1096	146	616	SD 6	75x50 / 40
22.00	ER10C-6DN.N7.1R	1320	1321	1138	147	1160	121	616	SD 6	75x50 / 40
30.00	ER10C-6DN.R7.1R	1320	1357	1062	223	1090	195	616	SD 6	75x50 / 40
37.00	ER10C-6DN.S7.1R	1320	1427	954	331	980	305	616	SD 7	75x50 / 40

T5 and T6 apply to attachment of Ziehl-Abegg intake flanges.

Ventilation unit GR in installation position Vu/Vo

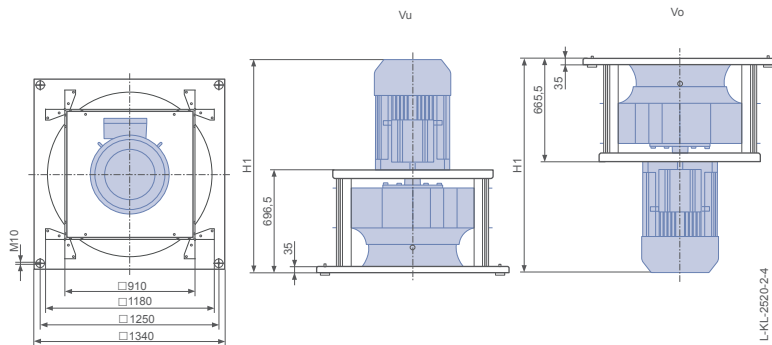

Rated power	Type	Installation position Vu	Installation position Vo
P_N kW		H1 mm	H1 mm
5.50	GR10C-8DN.I5.1R	1162	1131
7.50	GR10C-8DN.K5.1R	1217	1186
11.00	GR10C-8DN.M5.1R	1287	1256
15.00	GR10C-6DN.M5.1R	1287	1256
18.50	GR10C-6DN.N5.1R	1326	1295
22.00	GR10C-6DN.N5.1R	1326	1295
30.00	GR10C-6DN.R5.1R	1362	1331
37.00	GR10C-6DN.S5.1R	1432	1401

Plug fan

ER11C.4R

Motor IE2

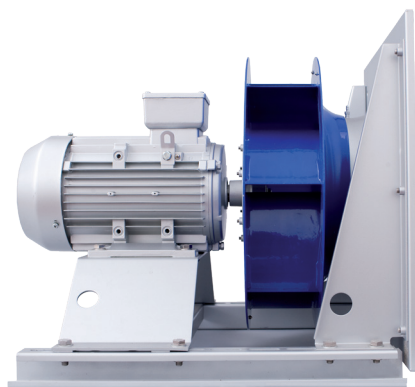

Description

- Number of blades: 7
- Max. permissible media temperature: 40°C
- Min. permissible media temperature: -20°C
- Motor protection: PTC thermistor (PTC)
- Impeller: Welded sheet steel coated / painted in RAL 5002 (ultramarine blue)
- ER-plug fan made as rugged bolted construction built with galvanised sheet steel
- Inlet ring for optimum impeller inflow with measurement device for determining flow rate

- Inlet guard Page 109
- Rubber dampers Page 109
- Spring vibration damper Page 109
- Flexible air intakes Page 110
- Frequency inverter Icontrol Page 92
- Sensors Page 96

Fan curve RH..C

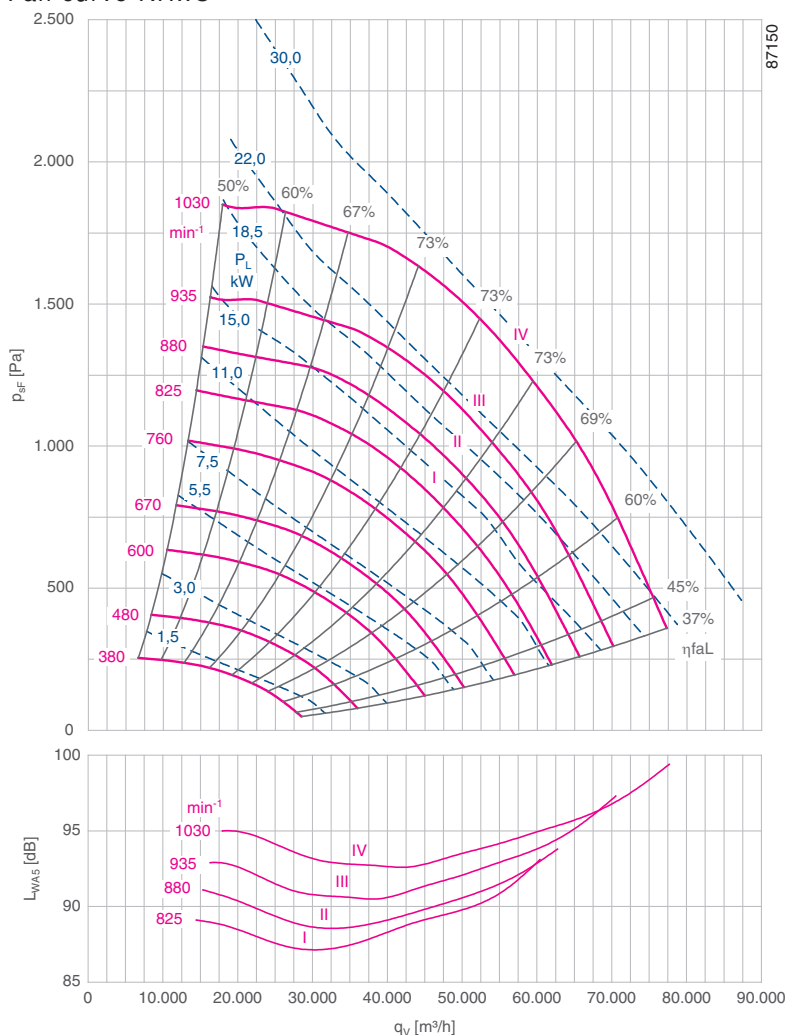

Technical data

Rated power P_N kW	Type ER	Motor size	Fan curve no.	Rated speed n_N min^{-1}	Rated current I_N A	Max. speed n_{max} min^{-1}	Max. frequency f_{max} Hz
15.00	ER11C-8DN.N7.4R	220L	I	730	31.60	825	57
18.50	ER11C-8DN.P7.4R	225S	II	730	38.70	880	60
22.00	ER11C-8DN.R7.4R	225M	III	730	44.50	935	64
30.00	ER11C-6DN.R7.4R	225M	IV	980	55.70	1030	72

Basic version ER

Rated power P_N kW	Type ER..C	Article no. ER..C	max.
15.00	ER11C-8DN.N7.4R	114326/0F01	581
18.50	ER11C-8DN.P7.4R	114327/0F01	622
22.00	ER11C-8DN.R7.4R	114328/0F01	644
30.00	ER11C-6DN.R7.4R	114329/0F01	642



Dimensions in mm

Plug fan ER in installation position H

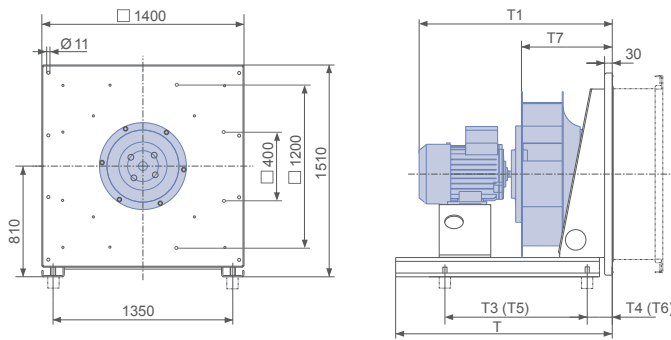

L-KL-2395-3-3

Rated power P_N kW	Type	T	T1	T3	T4	T5	T6	T7	Spring vibration damper	Rubber dampers
		mm	mm	mm	mm	mm	mm	mm		
15.00	ER11C-8DN.N7.4R	1380	1398	1210	130	1210	130	683	SD 6	75x50 / 40
18.50	ER11C-8DN.P7.4R	1380	1404	1210	130	1210	130	683	SD 6	75x50 / 40
22.00	ER11C-8DN.R7.4R	1380	1434	1210	130	1210	130	683	SD 6	75x50 / 40
30.00	ER11C-6DN.R7.4R	1380	1434	1210	130	1210	130	683	SD 7	75x50 / 40

T5 and T6 apply to attachment of Ziehl-Abegg intake flanges.

Plug fan

ER11C.1R

Motor IE2

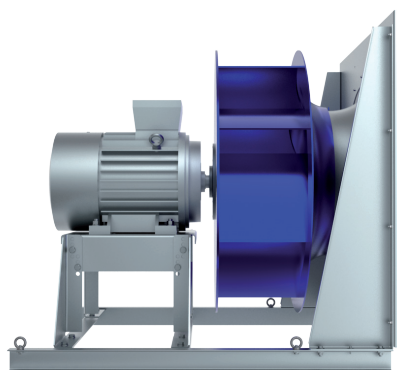

Fan curve RH..C

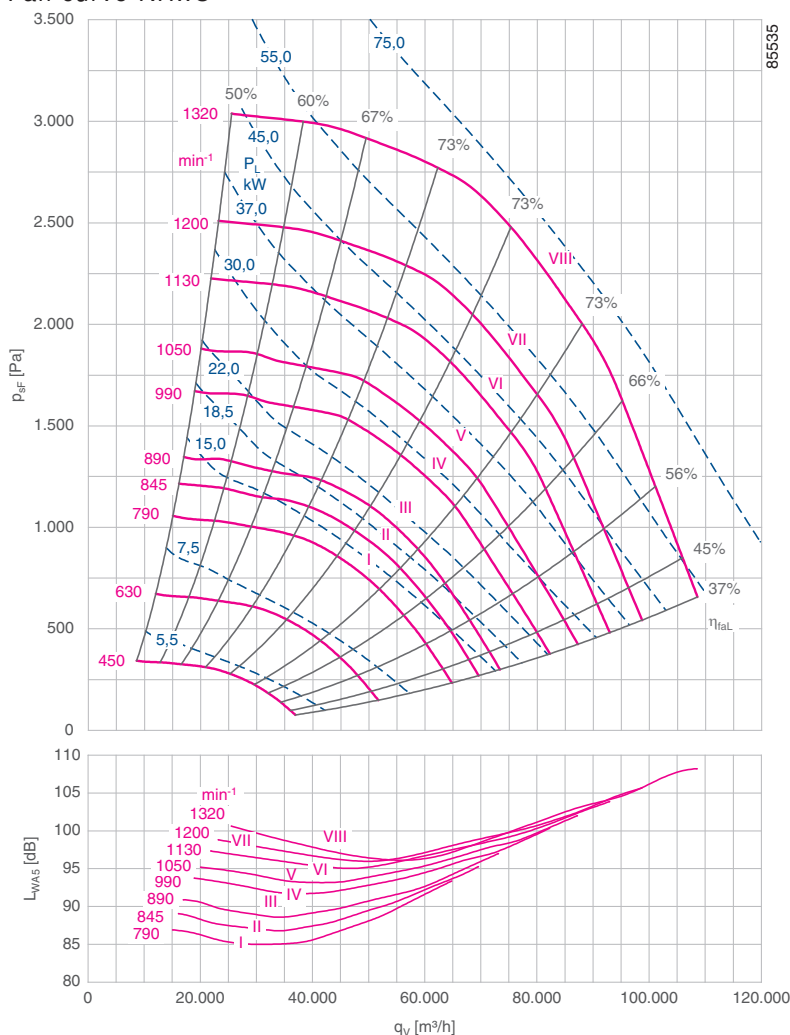

Description

- Number of blades: 7
- Max. permissible media temperature: 40°C
- Min. permissible media temperature: -20°C
- Motor protection: PTC thermistor (PTC)
- Impeller: Welded sheet steel coated / painted in RAL 5002 (ultramarine blue)
- ER-plug fan made as rugged bolted construction built with galvanised sheet steel
- Inlet ring for optimum impeller inflow with measurement device for determining flow rate

- Inlet guard Page 109
- Rubber dampers Page 109
- Spring vibration damper Page 109
- Flexible air intakes Page 110
- Frequency inverter Icontrol Page 92
- Sensors Page 96

Technical data

Rated power P_N kW	Type ER	Motor size	Fan curve no.	Rated speed n_N min^{-1}	Rated current I_N A	Max. speed n_{max} min^{-1}	Max. frequency f_{max} Hz
15.00	ER11C-8DN.N7.1R	200L	I	730	31.60	790	54
18.50	ER11C-8DN.P7.1R	225S	II	730	38.70	845	58
22.00	ER11C-8DN.R7.1R	225M	III	730	44.50	890	61
30.00	ER11C-6DN.R7.1R	225M	IV	980	55.70	990	51
37.00	ER11C-6DN.S7.1R	250M	V	980	66.60	1050	54
45.00	ER11C-6DN.T7.1R	280S	VI	980	80.60	1130	58
55.00	ER11C-6DN.U7.1R	280M	VII	980	98.20	1200	61
75.00	ER11C-6DN.W7.1R	315S	VIII	980	133.00	1320	67

Basic version ER

Rated power P_N kW	Type ER..C	Article no. ER..C	L_{wA} max.
15.00	ER11C-8DN.N7.1R	112463/0F01	675
18.50	ER11C-8DN.P7.1R	112464/0F01	717
22.00	ER11C-8DN.R7.1R	112465/0F01	739
30.00	ER11C-6DN.R7.1R	112466/0F01	737
37.00	ER11C-6DN.S7.1R	112467/0F01	821
45.00	ER11C-6DN.T7.1R	112468/0F01	939
55.00	ER11C-6DN.U7.1R	113408/0F01	981
75.00	ER11C-6DN.W7.1R	113405/0F01	1467



Dimensions in mm

Plug fan ER in installation position H

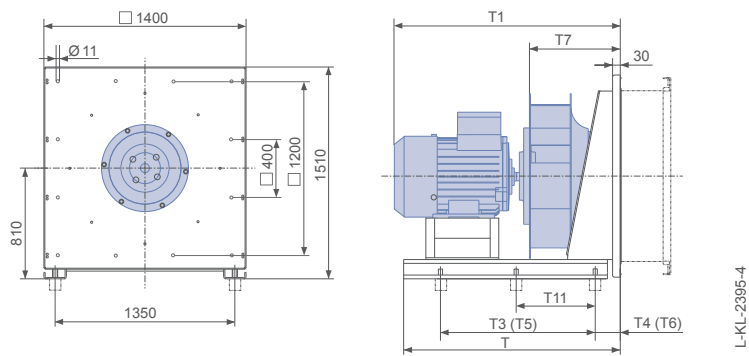

Rated power P_N kW	Type	T	T1	T3	T4	T5	T6	T7	T11	Spring vibration damper	Rubber dampers
		mm	mm	mm	mm	mm	mm	mm	mm		
15.00	ER11C-8DN.N7.1R	1630	1475	1385	70	1385	70	760		SD 6	75x50 / 40
18.50	ER11C-8DN.P7.1R	1630	1481	1450	70	1385	70	760		SD 6	75x50 / 40
22.00	ER11C-8DN.R7.1R	1630	1511	1450	70	1450	70	760		SD 6	75x50 / 40
30.00	ER11C-6DN.R7.1R	1630	1511	1450	70	1450	70	760		SD 7	75x50 / 40
37.00	ER11C-6DN.S7.1R	1630	1581	1520	70	1520	70	760		SD 7	75x50 / 40
45.00	ER11C-6DN.T7.1R	1630	1651	1430	160	1430	160	760		SD 8	75x50 / 55
55.00	ER11C-6DN.U7.1R	1630	1701	1430	160	1430	160	760		SD 8	75x50 / 55
75.00	ER11C-6DN.W7.1R	1795	1860	1460	276	1460	276	760	730	SD 8*	100x75 / 40*

T5 and T6 apply to attachment of Ziehl-Abegg intake flanges.

* 6 dampers required

Plug fan ER..C

Explosion protected design



RH..C in Ex-versions

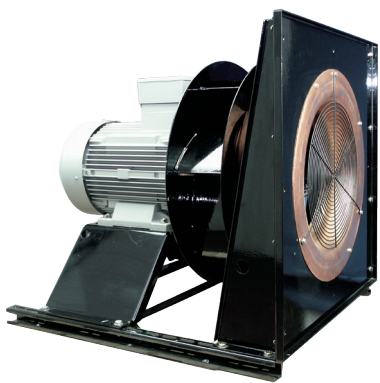

ER..C in Ex-versions

Description

RH..C centrifugal impellers and ER..C plug fans in explosion protected design (deliverable only as steel wheel) fulfill the requirements of the 94/9/EU directive (ATEX 95, former short designation ATEX 100a), in accordance with the device group II, device group 2G and 3G, explosion group IIB, and can be utilised in zone 1 and zone 2.

RH..C impellers

- Available in form sizes 250 to 1000
- The design corresponds to standard impellers, additionally with fixed hub, blades continuously welded on both sides, and electrically conductive special coating RAL 9005
- Inlet ring made of copper with measuring device

ER..C plug fans

- Available in form sizes 250 to 1000
- Speed controllable through a frequency inverter
- With three phase motor ignition protection class, Ex de IIC T4 pressure-proof housing; temperature monitoring through 3 PTC thermistors-temperature sensor in the motor winding and 1 PTC in the motor terminal box for disconnection IE1
- A type U-EK230E explosion-protected design triggering-device with the II (2) G 03 ATEX 3045 approval mark is needed as a safeguard.
- Flexible intake flanges in Ex-version according to ATEX 95 can be supplied
- Installation only allowed with horizontal motor shaft; motor feet on button

Application

RH..C impellers and ER..C plug fans in Ex-versions are not ready-for-use products but are conceived as components for air conditioning, ventilation, and exhaust air removal. They may only be put into operation when they are installed in accordance with their intended use and the safety has been ensured through protective devices in accordance with DIN EN ISO 13857, DIN EN 60529, and the required structural explosion-protective measures in accordance with DIN EN 14986. The fans correspond to the choice of materials in accordance with the filing at the BAM (Federal Institute for Materials Research and Testing), TGB (journal) no.: II-2851/2008 of the 94/9/EU directive (ATEX 95, former designation ATEX 100a).

Suitable system components



Triggering-device U-EK230E, Art. no. 382000

- | | |
|---|----------|
| ➤ Measuring device for determining air volume | Page 19 |
| ➤ Rubber or spring dampers | Page 109 |
| ➤ Description of high-performance impeller | Page 20 |
| ➤ Standard version | Page 28 |
| ➤ Frequency inverter Icontrol | Page 92 |

Plug fans / centrifugal impellers

Fan Labeling

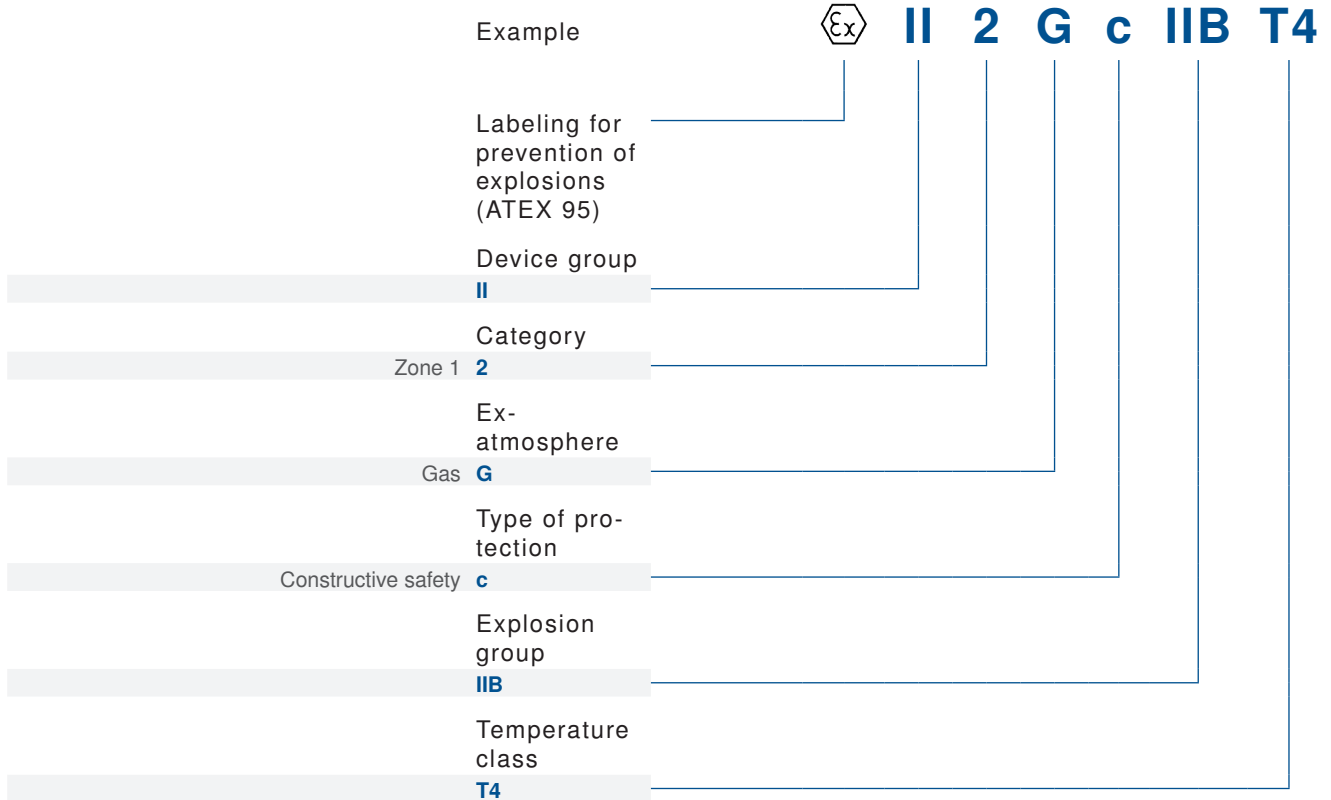

Safety information:

The use of impellers and plug-fans in **Ex-versions** assumes that regarding material selection and dimensioning of the surrounding components, the planner, operator, or end user of the device or the system acts on their own authority in accordance with the state-of-the-art of technology for safety relevant requirements, for example according to DIN EN 1127-1, EN 13237, DIN EN 60079-10, DIN EN 60079-14, DIN EN 60079-17, DIN EN 13463-1 and especially according to DIN EN 14986.

The relevant assembly instructions L-BAL-019 can be downloaded from the download area of our website at www.ziehl-abegg.com.

Physikalisch-Technische Bundesanstalt Braunschweig und Berlin



EG-Baumusterprüfbescheinigung

- (1) Geräte und Schutzsysteme zur bestimmungsgemäßen Verwendung in explosionsgefährdeten Bereichen - **Richtlinie 94/9/EG**
- (2) EG-Baumusterprüfbescheinigungsnummer
- (3) **PTB 07 ATEX 1034 X**
- (4) Gerät: Drehstromasynchronmotoren Typen 1MJ6 07... bis 1MJ6 20... ..
- (5) Hersteller: Siemens Aktiengesellschaft Automatisierungs- und Antriebstechnik Standardantriebe
- (6) Anschrift: 91056 Erlangen, Deutschland
- (7) Die Bauart dieses Gerätes sowie die verschiedenen zulässigen Ausführungen sind in der Anlage und den darin aufgeführten Unterlagen zu dieser Baumusterprüfbescheinigung festgelegt.
- (8) Die Physikalisch-Technische Bundesanstalt bescheinigt als benannte Stelle Nr. 0102 nach Artikel 9 der Richtlinie des Rates der Europäischen Gemeinschaften vom 23. März 1994 (94/9/EG) die Erfüllung der grundlegenden Sicherheits- und Gesundheitsanforderungen für die Konzeption und den Bau von Geräten und Schutzsystemen zur bestimmungsgemäßen Verwendung in explosionsgefährdeten Bereichen gemäß Anhang II der Richtlinie.
Die Ergebnisse der Prüfung sind in dem vertraulichen Prüfbericht PTB Ex 07-17171 festgehalten.
- (9) Die grundlegenden Sicherheits- und Gesundheitsanforderungen werden erfüllt durch Übereinstimmung mit
EN 60079-0:2004 EN 60079-1:2004 EN 60079-7:2003
EN 61241-0:2006 EN 61241-1:2004
- (10) Falls das Zeichen „X“ hinter der Bescheinigungsnummer steht, wird auf besondere Bedingungen für die sichere Anwendung des Gerätes in der Anlage zu dieser Bescheinigung hingewiesen.
- (11) Diese EG-Baumusterprüfbescheinigung bezieht sich nur auf Konzeption und Prüfung des festgelegten Gerätes gemäß Richtlinie 94/9/EG. Weitere Anforderungen dieser Richtlinie gelten für die Herstellung und das Inverkehrbringen dieses Gerätes. Diese Anforderungen werden nicht durch diese Bescheinigung abgedeckt.
- (12) Die Kennzeichnung des Gerätes muß die folgenden Angaben enthalten:

Ex II 2 G Ex d IIC T1 - T4 bzw. Ex de IIC T1 - T4 bzw. Ex tD A21 IP65 TXXX °C

Zertifizierungsstelle: Explosionsschutz
Im Auftrag

Braunschweig, 5. Dezember 2007



Dr.-Ing. M. J. Peters
Oberregierungsrat

EG-Baumusterprüfbescheinigungen ohne Unterschrift und ohne Siegel haben keine Gültigkeit.
Diese EG-Baumusterprüfbescheinigung darf nur unverändert weiterverbreitet werden.
Auszug oder Änderungen bedürfen der Genehmigung der Physikalisch-Technischen Bundesanstalt.
Physikalisch-Technische Bundesanstalt • Bundesallee 100 • D-38116 Braunschweig