



# User Manual

## Full HD Wi-Fi Camera

DCS-2230L

---

# Preface

D-Link reserves the right to revise this publication and to make changes in the content hereof without obligation to notify any person or organization of such revisions or changes. Information in this document may become obsolete as our services and websites develop and change. Please refer to the [www.mydlink.com](http://www.mydlink.com) website for the most current information.

## Manual Revisions

Revision	Date	Description
1.00	January 11, 2017	• Initial release

## Trademarks

D-Link and the D-Link logo are trademarks or registered trademarks of D-Link Corporation or its subsidiaries in the United States or other countries. All other company or product names mentioned herein are trademarks or registered trademarks of their respective companies.

Apple®, Apple logo®, Safari®, iPhone®, iPad®, iPod touch® and Macintosh® are trademarks of Apple Inc., registered in the U.S. and other countries. App Store<sup>SM</sup> is a service mark of Apple Inc.

Chrome™ browser, Google Play™ and Android™ are trademarks of Google Inc.

Internet Explorer®, Windows® and the Windows logo are trademarks of the Microsoft group of companies.

Copyright © 2017 by D-Link Corporation, Inc.

All rights reserved. This publication may not be reproduced, in whole or in part, without prior expressed written permission from D-Link Corporation, Inc.

---

# Table of Contents

<b>Product Overview</b> .....	<b>4</b>	Time and Date.....	41
Package Contents.....	4	Event Setup.....	42
System Requirements .....	5	SD Card.....	51
Introduction.....	6	Advanced.....	52
Features.....	7	Digital Input/Output.....	52
Hardware Overview .....	8	ICR and IR.....	53
Front View.....	8	HTTPS.....	54
Rear View .....	9	Access List.....	55
Side View.....	10	SNMP .....	56
<b>Installation</b> .....	<b>11</b>	Maintenance.....	57
Wireless Installation Considerations.....	12	Admin.....	57
Mobile App Setup.....	13	System .....	58
Zero Configuration Setup.....	14	Firmware Upgrade.....	59
Mount the Camera .....	18	Status .....	60
<b>mydlink</b> .....	<b>19</b>	Device Info .....	60
<b>Configuration</b> .....	<b>20</b>	Logs .....	61
Using the Configuration Interface.....	20	Help.....	62
Live Video .....	21	<b>DI/DO Specifications</b> .....	<b>63</b>
Setup .....	23	<b>Technical Specifications</b> .....	<b>64</b>
Setup Wizard .....	23	<b>Contacting Technical Support</b> .....	<b>67</b>
Network Setup.....	29	<b>Warranty</b> .....	<b>68</b>
Wireless Setup.....	32	<b>Registration</b> .....	<b>73</b>
Dynamic DNS .....	33		
Image Setup .....	34		
Audio and Video.....	36		
Preset.....	38		
Motion Detection .....	40		

# Product Overview

## Package Contents



DCS-2230L Full HD Wi-Fi Camera



CAT5 Ethernet Cable



Power Adapter



Quick Install Guide

If any of the above items are missing, please contact your reseller.

**Note:** Using a power supply with a different voltage than the one included with your product will cause damage and void the warranty for this product.

# System Requirements

<b>Hardware Requirements</b>	<ul style="list-style-type: none"><li>• A microSD memory card (optional) is required for recording to onboard storage. SDHC Class 6 or above is recommended.</li></ul>
<b>Network Requirements</b>	<ul style="list-style-type: none"><li>• An Ethernet-based cable or DSL modem</li><li>• IEEE 802.11n/g wireless clients</li><li>• 10/100 Ethernet</li><li>• Broadband Internet connection</li></ul>
<b>Web-based Configuration Utility Requirements</b>	<p><b>Computer with the following:</b></p> <ul style="list-style-type: none"><li>• Windows® 10/8/7/Vista®, macOS™ (10.6 or higher)</li><li>• An installed Ethernet adapter or wireless adapter</li></ul> <p><b>Browser Requirements:</b></p> <ul style="list-style-type: none"><li>• Internet Explorer 7 or higher</li><li>• Firefox 12 or higher</li><li>• Safari 7 or higher</li><li>• Chrome 20 or higher</li></ul> <p><b>Windows® Users:</b> Make sure you have the latest version of Java installed. Visit <a href="http://www.java.com">www.java.com</a> to download the latest version.</p>

## Introduction

Congratulations on your purchase of the DCS-2230L Full HD Wi-Fi Camera. The DCS-2230L is a versatile surveillance solution for your small office or home. The full HD 1920 x 1080 resolution 2 megapixel progressive scan CMOS sensor lets you capture details like never before – especially important for face recognition. A built-in IR-cut filter and IR LED makes sure you don't miss an event no matter how bright or dark your surroundings are. To make things convenient, support for Wireless N means you can easily connect it to your network when setting up your camera on location.

Unlike a standard webcam, the DCS-2230L is a complete system with a built-in CPU and web server that transmits high quality video images for security and surveillance. The DCS-2230L can be accessed remotely, and controlled from any PC over your local network or through the Internet via a web browser. It also comes with the D-Link D-ViewCam™ software bundle that allows you to manage multiple network cameras using remote monitoring, scheduling, recording, motion detection, and notifications for a complete and cost-effective home security solution.

## Features

### **Full HD Resolution**

The DCS-2230L Full HD Wi-Fi Camera is equipped with a 2 megapixel progressive scan CMOS sensor that provides full HD 1920x1080 resolution, the video stream captures a larger scene and provides more details than an analog CCTV camera – so you can identify criminals more easily in critical surveillance applications.

### **Wireless N for Convenience**

The DCS-2230L supports Wireless N, which lets you connect your camera to your network without using an Ethernet cable. This feature lets you set up your camera anywhere without worrying about running network cables to your location.

### **IR LED for Day and Night Functionality**

The built-in IR-cut filter and IR LED enable night time viewing or recording in dark environments at ranges up to 16 feet (5 meters).

### **DI/DO for Connecting External Devices**

Rounding out the flexibility of the DCS-2230L, you can connect an alarm or trigger to its DI/DO port for integration into a surveillance solution.

### **Remote Monitoring Utility**

The D-ViewCam™ application adds enhanced features and functionality for the DCS-2230L and allows administrators to configure and access the DCS-2230L from a remote site via Intranet or Internet. Other features include image monitoring, recording images to a hard drive, viewing up to 32 cameras on one screen, and taking snapshots.

### **Built-in Mic and Speaker**

Covering all the visual components, the DCS-2230L also has a built-in microphone and speaker, so you can transmit two-way audio easily.

### **mydlink Support**

Embrace the power of the cloud by adding your DCS-2230L to the list of devices manageable via the free mydlink web portal.

### **Web Configuration**

Using a standard web browser, administrators can configure and manage the DCS-2230L directly from its own web page via Intranet or Internet. This means you can access your DCS-2230L anytime, anywhere in the world.

### **Broad Range of Applications**

With today's high-speed Internet services, the DCS-2230L can provide the ideal solution for delivering live video images over the Intranet and Internet for remote monitoring. The DCS-2230L allows remote access using a web browser for live image viewing, and allows the administrator to manage and control the DCS-2230L anytime, anywhere in the world.

# Hardware Overview

## Front View



1	<b>Status LED</b>	Indicates the camera's current status
2	<b>WPS Status LED</b>	Indicates the WPS connection status of the camera
3	<b>Infrared LED</b>	Used to illuminate the camera's field of view at night
4	<b>PIR Sensor</b>	Passive Infrared sensor for motion detection
5	<b>Camera Lens</b>	Records video of the surrounding area
6	<b>Light Sensor</b>	The IR-Cut Removable sensor monitors lighting conditions and switches between color and infrared accordingly
7	<b>Microphone</b>	Records audio from the surrounding area



## Rear View

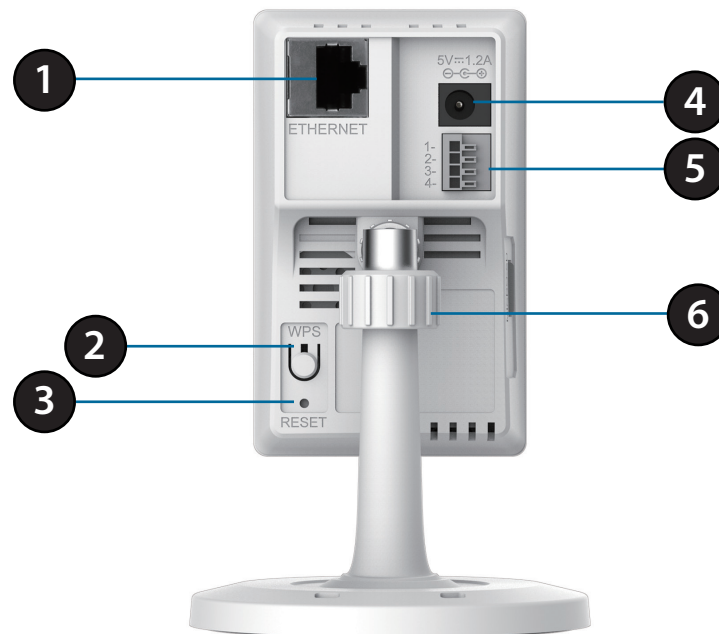

1	<b>Ethernet Port</b>	RJ45 connector for Ethernet
2	<b>WPS Button</b>	Press this button, then press the WPS button for 5 seconds on your router to set up a wireless connection automatically
3	<b>Reset Button</b>	Press and hold this button for 10 seconds to reset the camera
4	<b>Power Connector</b>	Connects to the included DC 5 V power adapter
5	<b>DI/DO Connector</b>	I/O connectors for external devices
6	<b>Adjustment Ring</b>	Tighten or loosen the adjustment ring to adjust the camera's position

## Side View

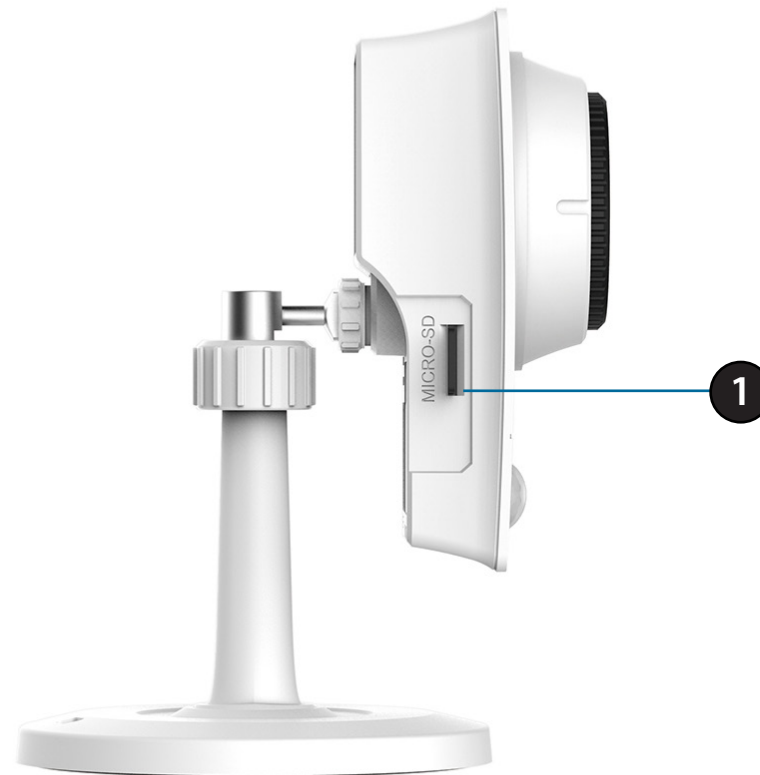

1	<b>microSD Card Slot</b>	Insert a microSD card for Local storage for storing recorded image and video
---	--------------------------	--

# Installation

There are two ways to set up your camera:

**mydlink Lite Mobile App:** You can use the mydlink Lite mobile app to guide you through setup and initial configuration of your camera. Refer to Mobile App Setup on page 13.

**Zero Configuration Setup:** If you have a mydlink-enabled router (D-Link Wi-Fi router), this is the easiest way to set up your camera. Refer to Zero Configuration Setup on page 14.

**Note:** To ensure your product has the latest security updates and operates at optimal performance, it is recommended you update your product to the latest firmware after installation and to periodically check for new firmware releases. Updates can be found by searching your model name at <http://support.dlink.com> or through the mydlink mobile apps for mydlink registered devices.

## Wireless Installation Considerations

This D-Link device can connect to your wireless network from anywhere within the operating range of your wireless network. However, the number, thickness and location of walls, ceilings, or other objects that the wireless signals must pass through, may limit the range. Typical ranges vary depending on the types of materials and background RF (radio frequency) noise in your home or business. The key to maximizing wireless range is to follow these basic guidelines:

1. Minimize the number of walls and ceilings between your adapter and other network devices (such as your DCS-2230L) - each wall or ceiling can reduce your adapter's range from 3-90 feet (1-30 meters).
2. Be aware of the direct line between network devices. A wall that is 1.5 feet thick (.5 meters), at a 45-degree angle appears to be almost 3 feet (1 meter) thick. At a 2-degree angle, it looks over 42 feet (14 meters) thick. Position your devices so that the signal will travel straight through a wall or ceiling (instead of at an angle) for better reception.
3. Building materials make a difference. A solid metal door or aluminum studs may weaken the wireless signal. Try to position your access points, wireless routers, and other networking devices where the signal passes through drywall or open doorways. Materials and objects such as glass, steel, metal, walls with insulation, water (fish tanks), mirrors, file cabinets, brick, and concrete will degrade your wireless signal.
4. Keep your product at least 3-6 feet or 1-2 meters away from electrical devices or appliances that generate RF noise.
5. If you are using 2.4 GHz cordless phones or other radio frequency sources (such as microwave ovens), your wireless connection may degrade dramatically or drop completely. Make sure your 2.4 GHz phone base is as far away from your wireless devices as possible. The base transmits a signal even if the phone is not in use.

## Mobile App Setup

You can configure your camera through the mydlink Lite mobile app. On your mobile device, download mydlink Lite by searching for **mydlink Lite** in the iTunes App Store, Google Play, or the Windows Store.



Launch the mydlink Lite app and create a new account or sign in to your existing account. Follow the onscreen instructions to set up your camera.

When you are asked to scan a QR code, use the code on the Quick Install Card in your package, or on the label attached to your device. If your camera does not have a QR code or does not include a Quick Install Card, you may choose your DCS-2230L from the list of D-Link models on the app.

Congratulations, your DCS-2230L camera is now ready to use! Be sure to accept any firmware update to keep your product secure and up to date with the latest features.

## Zero Configuration Setup

**If you have a D-Link Wi-Fi Router**, you can take advantage of Zero Configuration Setup. Zero Configuration automatically configures your camera's settings for you, and adds it to your mydlink account automatically. This type of setup allows you to set up your camera by simply plugging it in and connecting it to your router.

Connect your camera to your mydlink-enabled Wi-Fi Router (cloud router) and Zero Configuration will automatically configure your DCS-2230L and automatically add the camera to your mydlink account. You can now remotely access your camera from the mydlink.com website to manage and monitor your DCS-2230L.

### Connect the Ethernet Cable

If using an Ethernet connection: Connect the included Ethernet cable to the Ethernet port located on the back of the DCS-2230L and connect it to your router.

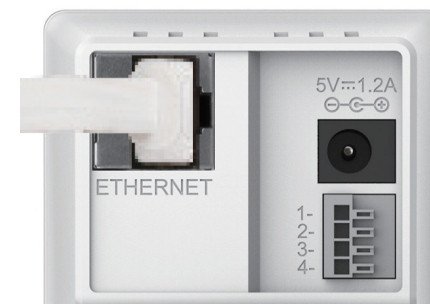

### Attach the External Power Supply

Attach the external power supply to the DC Power receptor located on the rear panel of the DCS-2230L and connect it to your wall outlet or power strip.

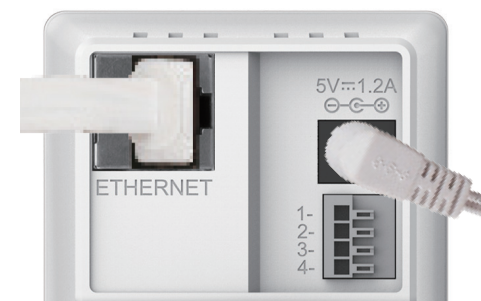

## Optional: WPS Wireless Connection

Alternatively, if your router supports WPS, you can use the WPS button on the camera to easily create a secure wireless connection to your network.

### To create a WPS connection:

#### Step 1

Press and hold the WPS button for approximately 5-6 seconds. The blue WPS status LED above the button will blink.

#### Step 2

Within 60 seconds press the WPS button on your router. On some routers, you may need to log in to the web interface and click on an on-screen button to activate the WPS feature. If you are not sure where the WPS button is on your router, please refer to your router's user manual.

The DCS-2230L will automatically create a wireless connection to your router. While connecting, the status LED will flash. When the connection process is complete, the status LED will turn solid.

**Note:** If your router does not support WPS, you can still use the wired connection method on the previous page. After Zero Configuration setup is complete, your router's wireless settings will be automatically transferred to the camera.

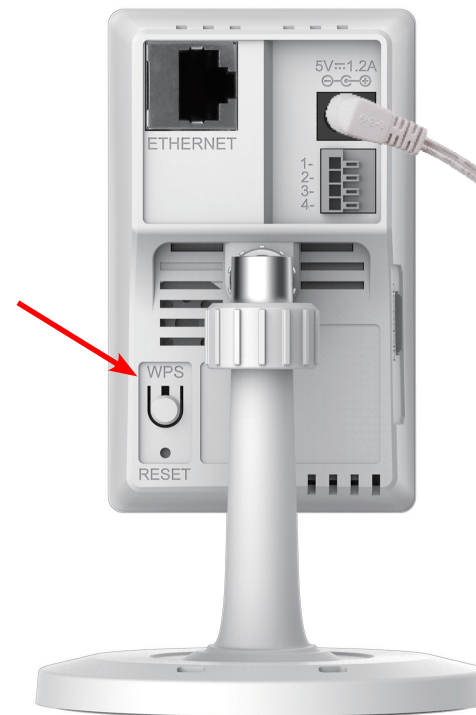

## Check Your mydlink Account

From any computer, open a web browser, go to <http://www.mydlink.com> and log in to your account. Once mydlink detects your camera, a **New Device Found!** notice will appear in the bottom-left corner. Click on the device name to continue.

The screenshot shows the mydlink web interface. At the top, there's a navigation bar with 'My Devices', 'Shared Devices', 'My Services', and 'My Profile'. The main content area is titled 'Router Status' and 'Settings'. It displays the following information:

- Model Name:** DIR-605L
- Network Name(SSID):** Taonet
- Internet IP:** 192.168.1.103
- LAN IP:** 192.168.0.1
- Connected Devices:** 5 device(s)

Below this, there's a 'Connection List' table:

Device	Device Name	IP Address	MAC Address	Block
	CardboardBox	192.168.0.110	00:26:2D:02:FE:FA	<input type="checkbox"/>
	--	192.168.0.120	04:54:53:50:53:18	<input type="checkbox"/>
	HeiGuy	192.168.0.100	00:1A:92:E2:4D:C9	<input type="checkbox"/>
	--	192.168.0.121	28:E0:2C:DC:0A:BE	<input type="checkbox"/>
	--	192.168.0.101	F0:A2:25:AA:8C:C3	<input type="checkbox"/>

At the bottom left, there's a notification box that says 'New Devices!' and lists 'DCS-2230L'.

A summary and confirmation notification will appear with the automatically configured details. Make a note of the details and click **Yes** to add the camera to your account.

The screenshot shows a dialog box titled 'Confirming New Device'. It contains the following text:

Do you want to add this new device to your mydlink account?

**Device Name: DCS-2230L**  
**mydlink Number: 30034971**  
**Network name (SSID): dlink-07725**  
**Admin Password: 7D5XLBUX**

You can change these default settings by going to **Advanced Settings** after add it to your device list.

At the bottom, there are two buttons: 'Not now' and 'Yes'.



## Section 2: Installation

Zero Configuration is now complete and your camera has been added to your mydlink account. You can now view your camera on the mydlink Live View tab.

Your camera is now set up, and you can skip to **mydlink on page 19** to learn more about the mydlink features of this camera, or to **Configuration on page 20** for advanced configuration of your camera.

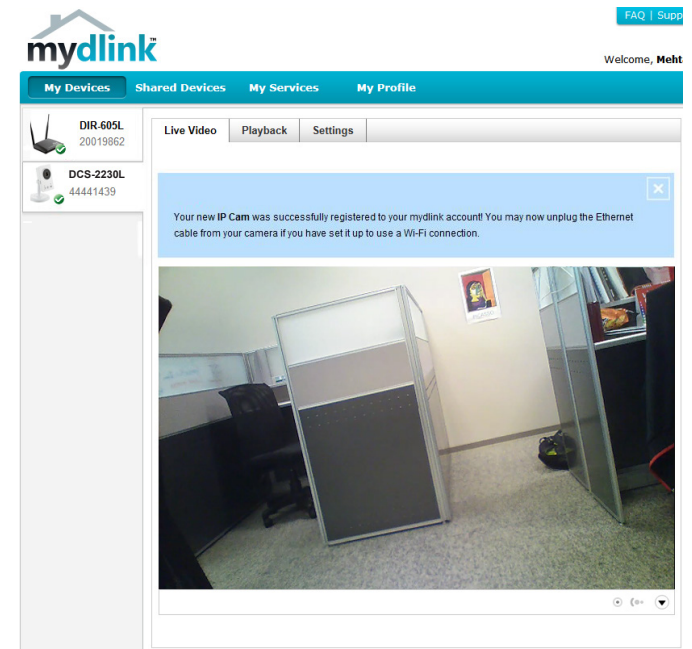

## Mount the Camera

Please refer to the steps below to assist you with mounting the camera.

**i** We suggest that you configure the camera before mounting.

1. Place the mounting base where you want to position the camera and use a pencil to mark the holes.

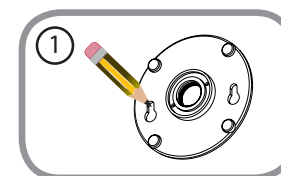

2. Depending on the material of the wall or ceiling, use proper tools to drill two holes or screws where you marked. If the wall is made out of concrete, drill the holes first, insert the plastic anchors and then the screws.

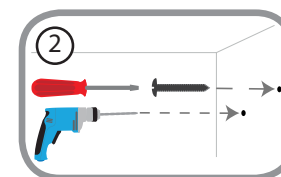

**!** The space between the camera and the screwheads should be 3mm.

3. Place the mounting base over the screw that is mounted on the wall. Make sure to fit the screw-heads over the big holes and slide it downward to lock firmly. Lightly pull the base forward to make sure that it is locked.

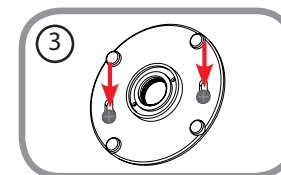

4. Place the base cover on the base and screw the camera stem clockwise into the mounting base.

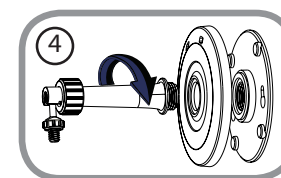

5. Adjust the angle of the camera as desired, then tighten the collar on the camera stem to lock it in place.

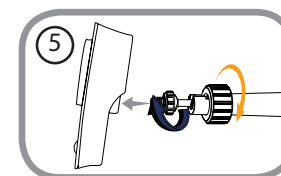

# mydlink

After registering your DCS-2230L camera with a mydlink account in the Camera Installation Wizard, you will be able to remotely access your camera from the [www.mydlink.com](http://www.mydlink.com) website. After signing in to your mydlink account, you will see a screen similar to the following:

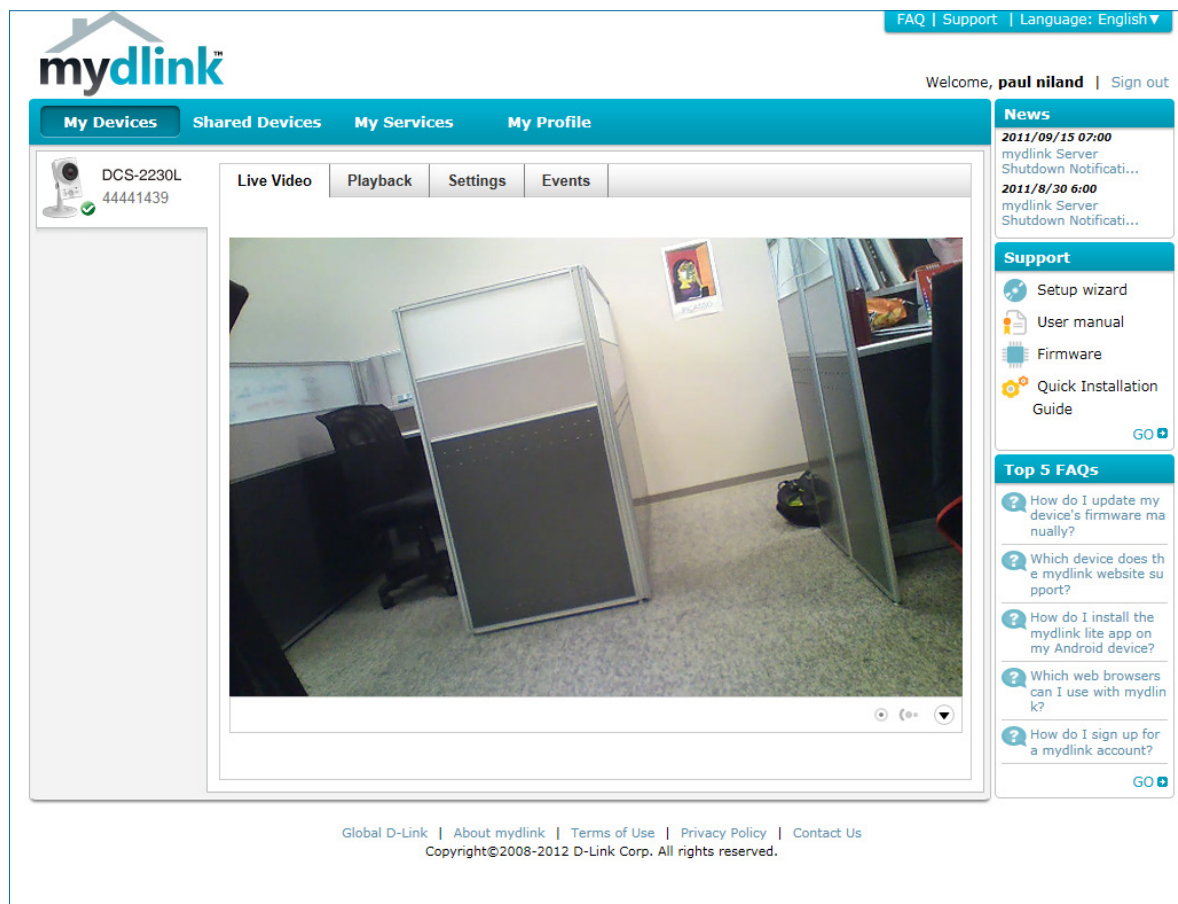

# Configuration

## Using the Configuration Interface

After completing the Camera Installation Wizard, you are ready to use your camera. The camera's built-in web configuration utility is designed to allow you to easily access and configure your DCS-2230L. At the end of the wizard, enter the IP address of your camera into a web browser, such as Mozilla Firefox. To log in, use the username **admin** and the password you created in the Installation Wizard. If you did not create a password, the default password is blank. After entering your password, click **OK**.

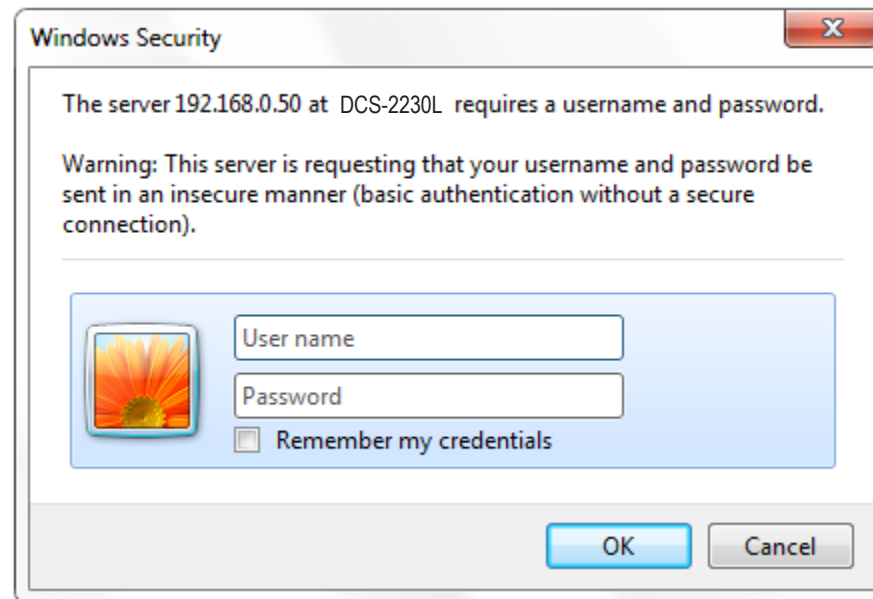







## Live Video

This section shows your camera's live video. You may select any of the available icons listed below to operate the camera. You may also select your language using the drop-down menu on the left side of the screen.

You can zoom in and out on the live video image using your mouse. Right-click to zoom out or left-click to zoom in on the image.

**SD Status:** This option displays the status of the SD card. If no SD card has been inserted, this screen will display the message "Card Invalid."

**IO Status:** This option displays the status of your I/O device if a device has been connected.

	<b>Digital Input Indicator</b>	This indicator will change color when a digital input signal is detected.
	<b>Motion Trigger Indicator</b>	This indicator will change color when a trigger event occurs. <b>Note:</b> The video motion feature for your camera must be enabled.
	<b>Recording Indicator</b>	When a recording is in progress, this indicator will change color.
	<b>Control Pad</b>	This control pad can be used to electronically pan, tilt, and zoom (ePTZ) within the camera's predefined view area, if one has been defined.
	<b>Auto Pan</b>	Starts the automatic panning function. The ROI will pan from back and forth within the FOV.
	<b>Stop</b>	Stops automatic panning.
	<b>Preset Path</b>	Starts the camera's motion along the predefined path.



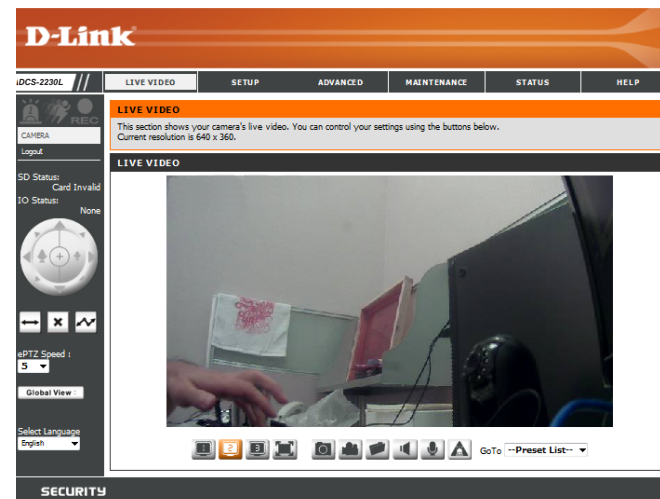







**ePTZ Speed:** You may select a value between 0 and 64. 0 is the slowest and 64 is the fastest.



**Note:** Presets must be set in order for the control pad and panning options to function. The view window size must be smaller than the frame size in order for Presets to be configured. Refer to page 36-38 for more information.

**Global View:** This window indicates the total field of view (FOV) of the camera. The red box indicates the visible region of interest (ROI).

**Language:** You may select the interface language using this menu.

- |   |  |
|---|--|
|  Video Profile 1   |  Record a Video Clip                    |
|  Video Profile 2   |  Set a Storage Folder                   |
|  Video Profile 3   |  Listen/Stop Audio In (from microphone) |
|  Full screen mode  |  Start/Stop Audio Out (to speaker)      |
|  Taking a Snapshot |  Start/Stop Digital Output              |

**Go To:** If any presets have been defined, selecting a preset from this list will (**Preset List**) display it.

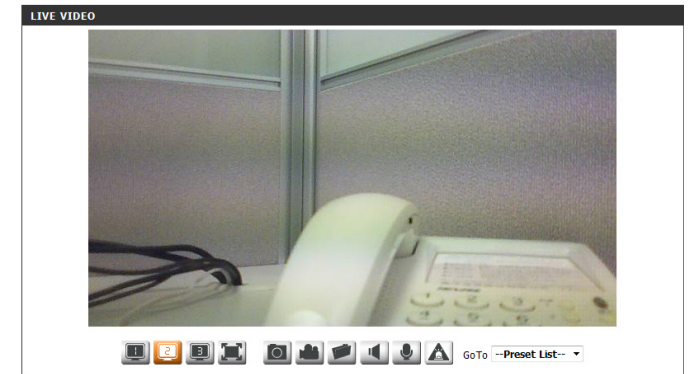

# Setup Setup Wizard

To configure your DCS-2230L, click **Internet Connection Setup Wizard**. Alternatively, you may click **Manual Internet Connection Setup** to manually configure your DCS-2230L and skip to **Network Setup** on page 29.

To quickly configure your DCS-2230L's motion detection settings, click **Motion Detection Setup Wizard**. If you want to enter your settings without running the wizard, click **Manual Motion Detection Setup** and skip to **Motion Detection** on page 40.

**INTERNET CONNECTION SETTINGS**

In this section, you can setup the IP camera's wired network interface settings. If you are configuring this device for the first time, D-Link recommends that you click the Setup Wizard button, and follow the instructions on screen. If you wish to modify or configure the IP camera settings manually, click manual setup to enable the IP camera connection setup.

**IP CAMERA MOTION DETECTION SETTINGS**

In this section, you can setup the IP camera's Motion Detection settings. If you are configuring this device for the first time, D-Link recommends that you click the Setup Wizard button, and follow the instructions on screen. If you wish to modify or configure the Motion Detection manually, click manual setup to enable the Motion Detection setup.

## Internet Connection Setup Wizard

This wizard will guide you through a step-by-step process to configure your new D-Link Camera and connect the camera to the Internet. Click **Next** to continue.

**Note:** Select **DHCP** if you are unsure of which settings to choose.

Click **Next** to continue.

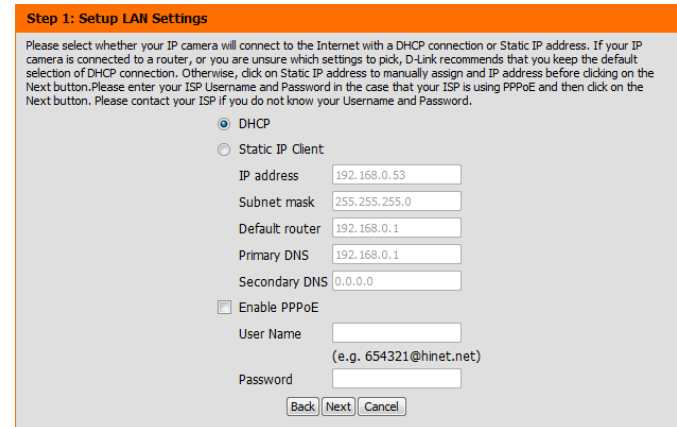
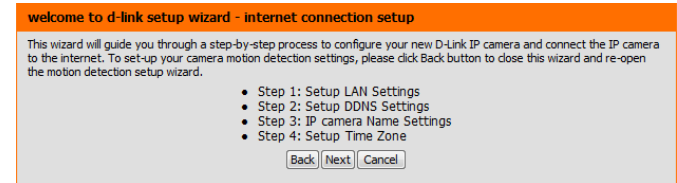



## Section 4: Configuration

Select **Static IP** if your Internet Service Provider has provided you with connection settings, or if you wish to set a static address within your home network. Enter the correct configuration information and click **Next** to continue.

If you are using PPPoE, select **Enable PPPoE** and enter your User Name and Password, otherwise click **Next** to continue.

**Step 1: Setup LAN Settings**

Please select whether your IP camera will connect to the Internet with a DHCP connection or Static IP address. If your IP camera is connected to a router, or you are unsure which settings to pick, D-Link recommends that you keep the default selection of DHCP connection. Otherwise, click on Static IP address to manually assign and IP address before clicking on the Next button. Please enter your ISP Username and Password in the case that your ISP is using PPPoE and then click on the Next button. Please contact your ISP if you do not know your Username and Password.

DHCP

Static IP Client

IP address

Subnet mask

Default router

Primary DNS

Secondary DNS

Enable PPPoE

User Name   
(e.g. 654321@hinet.net)

Password

If you have a Dynamic DNS account and would like the camera to update your IP address automatically, Select **Enable DDNS** and enter your host information. Click **Next** to continue.

**Step 2: Setup DDNS Settings**

If you have a Dynamic DNS account and would like the IP camera to update your IP address automatically, enable DDNS and enter in your host information below. Please click on the Next button to continue.

Enable DDNS

Server Address  <<

Host Name

User Name

Password

Verify Password

Timeout  (hours)

Enter a name for your camera and click **Next** to continue.

**Step 3: IP camera Name Settings**

D-Link recommends that you rename your IP camera for easy accessibility. You can then identify and connect to your IP camera via this name. Please assign a name of your choice before clicking on the Next button.

IP camera Name

## Section 4: Configuration

---

Configure the correct time to ensure that all events will be triggered as scheduled. Click **Next** to continue.

**Step 4: Setup Time Zone**

Please configure the correct time to ensure that all events are triggered, captured and scheduled at the correct time and day and then click on the Next button.

Time Zone (GMT+08:00) Taipei

Enable Daylight Saving

Back Next Cancel

If you have selected DHCP, you will see a summary of your settings, including the camera's IP address. Please write down all of this information as you will need it in order to access your camera.

Click **Apply** to save your settings.

**Step 5: Setup complete**

Below is a summary of your IP camera settings. Click on the Back button to review or modify settings or click on the Apply button if all settings are correct. It is recommended to note down these settings in order to access your IP camera on the network or via your web browser.

IP Address	DHCP
IP camera Name	DCS-2230L
Time Zone	(UTC+08:00) Taipei
DDNS	Enable
PPPoE	Disable

Back Apply Cancel

## Motion Detection Setup Wizard

This wizard will guide you through a step-by-step process to configure your camera's motion detection functions.

Click **Next** to continue.

### Step 1

This step will allow you to enable or disable motion detection, specify the detection sensitivity, and adjust the camera's ability to detect movement.

You may specify whether the camera should capture a snapshot or a video clip when motion is detected.

Please refer to **Motion Detection** on page 40 for information about how to configure motion detection.

### Step 2

This step allows you to enable motion detection based on a customized schedule. Specify the day and hours. You may also choose to always record whenever motion is detected.

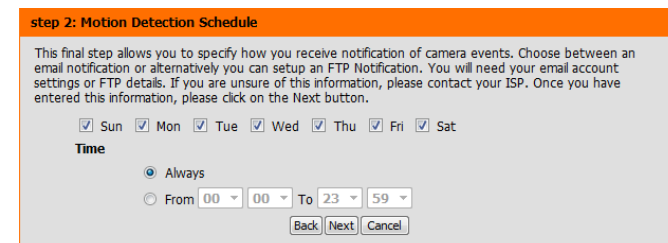
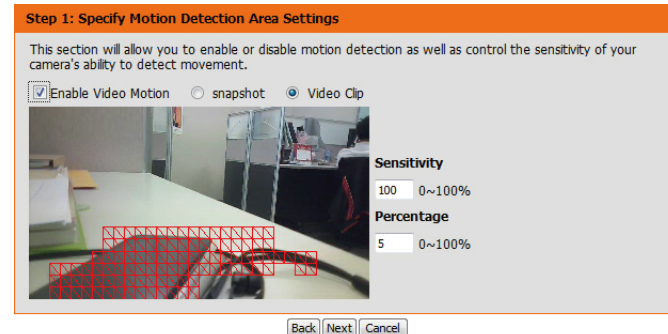
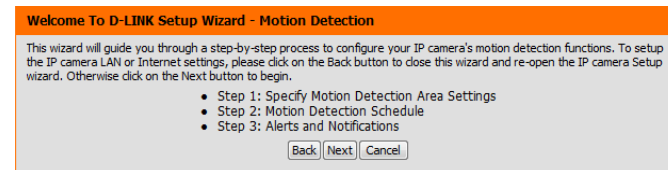

## Section 4: Configuration

### Step 3

This step allows you to specify how you will receive event notifications from your camera. You may choose not to receive notifications, or to receive notifications via e-mail or FTP.

Please enter the relevant information for your e-mail or FTP account.

Click **Next** to continue.

**Step 3: Alerts and Notification**

This final step allows you to specify how you receive notification of camera events. Choose between an email notification or alternatively you can setup an FTP Notification. You will need your email account settings or FTP details. If you are unsure of this information, please contact your ISP. Once you have entered this information, please click on the Next button.

Do not notify me

Email

Sender email address

Recipient email address

Server address

User name

Password

Port

FTP

Server address

Port

User name

Password

Remote folder name

### Step 4

You have completed the Motion Detection Wizard.

Please verify your settings and click **Apply** to save them.

**Step 4: Setup Complete**

You have completed your IP camera setup. Please click the Back button if you want to review or modify your settings or click on the Apply button to save and apply your settings.

Motion Detection : Enable

EVENT : Video Clip

Schedule Day : Sun ,Mon ,Tue ,Wed ,Thu ,Fri ,Sat ,

Schedule Time : Always

Alerts and Notification : Email

Please wait a few moments while the camera saves your settings and restarts.

**Step 4: Setup Complete**

You have completed your IP camera setup. Please click the Back button if you want to review or modify your settings or click on the Apply button to save and apply your settings.

Changes saved.IP camera's network is restarting, please wait for 5 seconds ...

## Network Setup

Use this section to configure the network connections for your camera. All relevant information must be entered accurately. After making any changes, click the **Save Settings** button to save your changes.

**LAN Settings:** This section lets you configure settings for your local area network.

**DHCP:** Select this connection if you have a DHCP server running on your network and would like your camera to obtain an IP address automatically.

If you choose DHCP, you do not need to fill out the IP address settings.

**Static IP Address:** You may obtain a static or fixed IP address and other network information from your network administrator for your camera. A static IP address may simplify access to your camera in the future.

**IP Address:** Enter the fixed IP address in this field.

**Subnet Mask:** This number is used to determine if the destination is in the same subnet. The default value is 255.255.255.0.

**Default Gateway:** The gateway used to forward frames to destinations in a different subnet. Invalid gateway settings may cause the failure of transmissions to a different subnet.

**Primary DNS:** The primary domain name server translates names to IP addresses.

**Secondary DNS:** The secondary DNS acts as a backup to the primary DNS.

**NETWORK SETUP**

You can configure your LAN and Internet settings here.

**LAN SETTINGS**

DHCP

Static IP Client

IP address   
 Subnet mask   
 Default router   
 Primary DNS   
 Secondary DNS

Enable UPnP presentation

Enable UPnP port forwarding

Forwarding Port    
 Forwarding Status UPnP forwarding is inactive

**PPPOE SETTINGS**

Enable  Disable

User Name   
 Password   
 Confirm password   
 PPPoE Status PPPoE is inactive.

**HTTP**

HTTP port

Access name for stream1

Access name for stream2

Access name for stream3

**HTTPS**

HTTPS port

**Enable UPnP Presentation:** Enabling this setting allows your camera to be configured as a UPnP device on your network.

**Enable UPnP Port Forwarding:** Enabling this setting allows the camera to add port forwarding entries into the router automatically on a UPnP capable network.

**Enable PPPoE:** Enable this setting if your network uses PPPoE.

**User Name / Password:** Enter the username and password for your PPPoE account. Re-enter your password in the Confirm Password field. You may obtain this information from your ISP.

**HTTP Port:** The default port number is 80.

**Access Name for Stream 1~3:** The default name is video#.mjpg, where # is the number of the stream.

**HTTPS Port:** You may use a PC with a secure browser to connect to the HTTPS port of the camera. The default port number is 443.

**RTSP Port:** The port number that you use for RTSP streaming to mobile devices, such as mobile phones or PDAs. The default port number is 554. You may specify the address of a particular stream. For instance, live1.sdp can be accessed at rtsp://x.x.x.x/video1.sdp where the x.x.x.x represents the IP address of your camera.

LAN SETTINGS	
<input checked="" type="radio"/> DHCP	
<input type="radio"/> Static IP Client	
IP address	<input type="text" value="192.168.0.53"/>
Subnet mask	<input type="text" value="255.255.255.0"/>
Default router	<input type="text" value="192.168.0.1"/>
Primary DNS	<input type="text" value="192.168.0.1"/>
Secondary DNS	<input type="text" value="0.0.0.0"/>
<input checked="" type="checkbox"/> Enable UPnP presentation	
<input type="checkbox"/> Enable UPnP port forwarding	
Forwarding Port	<input type="text" value="1024"/> <input type="button" value="Test"/>
Forwarding Status	UPnP forwarding is inactive
PPPOE SETTINGS	
<input type="radio"/> Enable <input checked="" type="radio"/> Disable	
User Name	<input type="text"/>
Password	<input type="text"/>
Confirm password	<input type="text"/>
PPPoE Status	PPPoE is inactive.
HTTP	
HTTP port	<input type="text" value="80"/>
Access name for stream1	<input type="text" value="video1.mjpg"/>
Access name for stream2	<input type="text" value="video2.mjpg"/>
Access name for stream3	<input type="text" value="video3.mjpg"/>
HTTPS	
HTTPS port	<input type="text" value="443"/>
RTSP	
Authentication	<input type="text" value="Disable"/>
RTSP port	<input type="text" value="554"/>
Access name for stream1	<input type="text" value="live1.sdp"/>
Access name for stream2	<input type="text" value="live2.sdp"/>
Access name for stream3	<input type="text" value="live3.sdp"/>

**Enable CoS:** Enabling the Class of Service setting implements a best-effort policy without making any bandwidth reservations.

**Enable QoS:** Enabling QoS allows you to specify a traffic priority policy to ensure a consistent Quality of Service during busy periods. If the DCS-2230L is connected to a router that itself implements QoS, the router's settings will override the QoS settings of the camera.

**Enable IPv6:** Enable the IPv6 setting to use the IPv6 protocol. Enabling the option allows you to manually set up the address, specify an optional IP address, specify an optional router and an optional primary DNS.

**Enable Multicast for stream:** The DCS-2230L allows you to multicast each of the available streams via group address and specify the TTL value for each stream. Enter the port and TTL settings you wish to use if you do not want to use the defaults.

**Enable Bonjour:** Enable Bonjour to broadcast to network devices (such as iPhones) using this protocol. You can enter a custom Bonjour Name for the router in the text box for identification.

**COS SETTINGS**

Enable CoS  
 VLAN ID  [0~4095]  
 Live video   
 Live audio   
 Event/Alarm   
 Management

**QOS SETTINGS**

Enable QoS  
 Live video   
 Live audio   
 Event/Alarm   
 Management

**IPv6**

Enable IPv6  
  
 Manually setup the IP address  
 Optional IP address / Prefix length  /   
 Optional default router   
 Optional primary DNS

**MULTICAST**

Enable multicast for stream 1  
 Multicast group address   
 Multicast video port   
 Multicast RTCP video port   
 Multicast audio port   
 Multicast RTCP audio port   
 Multicast TTL [1~255]   
 Enable multicast for stream 2  
 Multicast group address   
 Multicast video port   
 Multicast RTCP video port   
 Multicast audio port   
 Multicast RTCP audio port   
 Multicast TTL [1~255]   
 Enable multicast for stream 3  
 Multicast group address   
 Multicast video port   
 Multicast RTCP video port   
 Multicast audio port   
 Multicast RTCP audio port   
 Multicast TTL [1~255]

## Wireless Setup

This section allows you to set up and configure the wireless settings on your camera. After making any changes, click the **Save Settings** button to save your changes.

**Site Survey:** Click the **Rescan** button to scan for available wireless networks. After scanning, you can use the drop-down box to select an available wireless network. The related information (SSID, Wireless Mode, Channel, Authentication, Encryption) will be automatically filled in for you.

**SSID:** Enter the SSID of the wireless access point you wish to use.

**Wireless Mode:** Use the drop-down box to select the mode of the wireless network you wish to connect to. Infrastructure is normally used to connect to an access point or router. Ad-Hoc is usually used to connect directly to another computer.

**Channel:** If you are using Ad Hoc mode, select the channel of the wireless network you wish to connect to, or select Auto.

**Authentication:** Select the authentication you use on your wireless network - Open, Shared, WPA-PSK, or WPA2-PSK.

**Encryption:** If you use WPA-PSK or WPA2-PSK authentication, you will need to specify whether your wireless network uses TKIP or AES encryption. If you use Open or Shared authentication, WEP encryption should be the setting.

**Key:** If you use WEP, WPA-PSK, or WPA2-PSK authentication, enter the Key (also known as password) used for your wireless network.

**WIRELESS SETUP**

In this section, you can setup and configure the wireless settings on your camera.

---

**WIRELESS CONFIGURATION**

Enable Wireless	<input type="checkbox"/>
Site Survey	<input type="text" value="===SSID List==="/> <input type="button" value="Rescan"/>
SSID	<input type="text" value="default"/>
Wireless Mode	<input type="text" value="Infrastructure"/>
Channel	<input type="text" value="Auto"/>
Authentication	<input type="text" value="Open"/>
Encryption	<input type="text" value="Disable"/>
Default Key	<input type="text" value="1"/>
Key 1	<input type="text" value="*****"/>
Key 2	<input type="text" value="*****"/>
Key 3	<input type="text" value="*****"/>
Key 4	<input type="text" value="*****"/>

(5 or 13 ASCII, 10 or 26 HEX characters)



## Dynamic DNS

DDNS (Dynamic Domain Name Server) will hold a DNS host name and synchronize the public IP address of the modem when it has been modified. A user name and password are required when using the DDNS service. After making any changes, click the **Save Settings** button to save your changes.

**Enable DDNS:** Select this checkbox to enable the DDNS function.

**Server Address:** Select your Dynamic DNS provider from the drop-down menu or enter the server address manually.

**Host Name:** Enter the host name of the DDNS server.

**User Name:** Enter the user name or e-mail used to connect to your DDNS account.

**Password:** Enter the password used to connect to your DDNS server account.

**Timeout:** Enter the DNS timeout values you wish to use.

**Status:** Indicates the connection status, which is automatically determined by the system.

**DYNAMIC DNS**

The Dynamic DNS feature allows you to use a domain name that you have purchased (www.yourdomain.com) to access your IP camera with a dynamically assigned IP address. Most broadband Internet service providers assign dynamic (changing) IP addresses. By using a DDNS service, you can enter your domain name to connect to your IP camera no matter what your IP address is.

[Sign up for D-Link's Free DDNS service at www.DLinkDDNS.com.](http://www.DLinkDDNS.com)

Save Settings Don't Save Settings

**DYNAMIC DNS SETTING**

Enable DDNS

Server Address  <<    
Select Dynamic DNS Server   
www.dlinkddns.com   
www.DynDNS.org

Host Name

User Name

Password

Verify Password

Timeout  (hours)

Status Active

Save Settings Don't Save Settings

## Image Setup

In this section, you may configure the video image settings for your camera. A preview of the image will be shown in Live Video.

**Enable Privacy Mask:** The Privacy Mask setting allows you to specify up to 3 rectangular areas on the camera's image to be blocked/excluded from recordings and snapshots.

You may click and drag the mouse cursor over the camera image to draw a mask area. Right clicking on the camera image brings up the following menu options:

**Disable All:** Disables all mask areas

**Enable All:** Enables all mask areas

**Reset All:** Clears all mask areas.

Click **Save** for the mask to take effect.

**Anti Flicker:** If the video flickers, try enabling this setting.

**Mirror:** This will mirror the image horizontally.

**Flip:** This will flip the image vertically. When turning Flip on, you may want to consider turning Mirror on as well.

**Power Line:** Select the frequency used by your power lines to avoid interference or distortion.

**White Balance:** Use the drop-down box to change white balance settings to help balance colors for different environments. You can choose from **Auto**, **Outdoor**, **Indoor**, **Fluorescent**, and **Push Hold**.

**IMAGE SETUP**

Changes to your IP camera settings are made immediately.

**PRIVACY MASK AREA OF VIDEO SETTING**

Enable Privacy Mask Setting
 

- Privacy mask: mask 3 privacy area(s) on video.
- Click the right mouse button on the video control to show the popmenu.
- Press the left mouse button, drag and drop to set the privacy area.
- Privacy area can be enabled or disabled.
- After you finish all privacy mask settings, click the Save button.



**IMAGE SETTINGS**

Anti Flicker	<input type="radio"/> On	<input checked="" type="radio"/> Off
Mirror	<input type="radio"/> On	<input checked="" type="radio"/> Off
Flip	<input type="radio"/> On	<input checked="" type="radio"/> Off
Power Line	<input type="radio"/> 60 Hz	<input checked="" type="radio"/> 50 Hz
White Balance	Auto ▾	
Exposure Mode	Auto ▾	Max Gain 24 ▾ dB
Denoise	0 ▾	
Brightness	4 ▾	
Contrast	4 ▾	
Saturation	128 ▾	
Sharpness	4 ▾	

**Exposure Mode:** Changes the exposure mode. Use the drop-down box to set the camera for **Indoor**, **Outdoor**, or **Night** environments, or to **Moving** to capture moving objects. The **Low Noise** option will focus on creating a high-quality picture without noise. You can also create 3 different custom exposure modes. The Max Gain setting will allow you to control the maximum amount of gain to apply to brighten the picture.

**Denoise:** This setting controls the amount of noise reduction that will be applied to the picture.

**Brightness:** Adjust this setting to compensate for backlit subjects.

**Contrast:** Adjust this setting to alter the color intensity/strength.

**Saturation:** This setting controls the amount of coloration, from grayscale to fully saturated.

**Sharpness:** Specify a value from 0 to 8 to specify how much sharpening to apply to the image.

**Reset Default:** Click this button to reset the image to factory default settings.

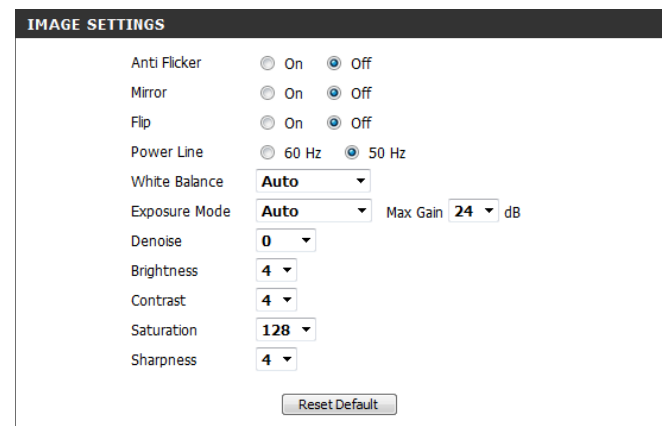

The screenshot shows the 'IMAGE SETTINGS' menu with the following options and values:

Setting	Value
Anti Flicker	Off
Mirror	Off
Flip	Off
Power Line	50 Hz
White Balance	Auto
Exposure Mode	Auto
Max Gain	24 dB
Denoise	0
Brightness	4
Contrast	4
Saturation	128
Sharpness	4

A 'Reset Default' button is located at the bottom right of the settings panel.

## Audio and Video

You may configure up to 2 video profiles with different settings for your camera. Hence, you may set up different profiles for your computer and mobile display. In addition, you may also configure the two-way audio settings for your camera. After making any changes, click the **Save Settings** button to save your changes.

**Aspect ratio:** Set the aspect ratio of the video to 4:3 standard or 16:9 widescreen.

**Mode:** Set the video codec to be used to MJPEG or H.264. JPEG can be selected for image mode.

**Frame size / View window area:** Frame size determines the total capture resolution, and View window area determines the Live Video viewing window size. If the Frame size is larger than the Live Video size, you can use the ePTZ controls to look around.

16:9 1920x1080, 1280x720, 800x450, 640x360,  
480x270, 320x176

4:3 1440x1080, 1280x920, 800x600, 640x480,  
480x360, 320x240

**Note:** If your View window area is the same as your Frame size, you will not be able to use the ePTZ function.

**Maximum frame rate:** A higher frame rate provides smoother motion for videos, and requires more bandwidth. Lower frame rates will result in stuttering motion, and requires less bandwidth.

**AUDIO AND VIDEO**

This section allows you to configure the sound and video of your camera. You can configure different settings depending on whether you are viewing content from a PC or a Mobile Phone / PDA.

---

**VIDEO SETTINGS**

Aspect ratio 16:9 Warning: Change the aspect ratio will clear the settings of privacy mask and preset and motion detection.

---

**VIDEO PROFILE 1**

Mode H.264

Frame size 1280x720

View window area 1280x720

Maximum frame rate 25

Video quality

Constant bit rate 1M

Fixed quality Excellent

---

**VIDEO PROFILE 2**

Mode JPEG

Frame size 800x450

View window area 640x360

Maximum frame rate 25

Video quality Excellent

---

**VIDEO PROFILE 3**

Mode MPEG4

Frame size 640x360

View window area 640x360

Maximum frame rate 25

Video quality

Constant bit rate 1M

Fixed quality Excellent

---

**AUDIO SETTINGS**

Audio in off

Audio in gain level 20dB

Audio out off

Audio out volume level 10

**Video Quality:** This limits the maximum frame rate, which can be combined with the "Fixed quality" option to optimize the bandwidth utilization and video quality. If fixed bandwidth utilization is desired regardless of the video quality, choose "Constant bit rate" and select the desired bandwidth.

**Constant bit rate:** The bps will affect the bit rate of the video recorded by the camera. Higher bit rates result in higher video quality.

**Fixed quality:** Select the image quality level for the camera to try to maintain. High quality levels will result in increased bit rates.

**Audio in off:** Selecting this checkbox will mute incoming audio.

**Audio in gain level:** This setting controls the amount of gain applied to incoming audio to increase its volume.

**Audio out off:** Selecting this checkbox will mute outgoing audio.

**Audio out volume level:** This setting controls the amount of gain applied to outgoing audio to increase its volume.

VIDEO PROFILE 1	
Mode	H.264
Frame size	1280x720
View window area	1280x720
Maximum frame rate	25
Video quality	<input type="radio"/> Constant bit rate 1M <input checked="" type="radio"/> Fixed quality Excellent

VIDEO PROFILE 2	
Mode	JPEG
Frame size	800x450
View window area	640x360
Maximum frame rate	25
Video quality	Excellent

VIDEO PROFILE 3	
Mode	MPEG4
Frame size	640x360
View window area	640x360
Maximum frame rate	25
Video quality	<input type="radio"/> Constant bit rate 1M <input checked="" type="radio"/> Fixed quality Excellent

AUDIO SETTINGS	
<input type="checkbox"/> Audio in off	
Audio in gain level	20dB
<input type="checkbox"/> Audio out off	
Audio out volume level	10

## Preset

This screen allows you to set preset points for the ePTZ function of the camera, which allows you to look around the camera's viewable area by using a zoomed view. Presets allow you to quickly go to and view a specific part of the area your camera is covering, and you can create preset sequences, which will automatically change the camera's view between the different presets according to a defined order and timing you can set.

**Note:** If your View window area is the same as your Frame size, you will not be able to use the ePTZ function.

**Video Profile:** This selects which video profile to use.

**ePTZ Speed:** You may select a value between 1 and 10. 0 is the slowest and 10 is the fastest.

**Arrow Buttons and Home Button:** Use these buttons to move to a specific part of the viewing area, which you can then set as a preset. Click the Home button to return to the center of the viewing area.

**Input Preset Name:** Enter the name of the preset you want to create, then click the **Add** button to make a new preset. If an existing preset has been selected from the Preset List, you can change its name by typing in a new name, then clicking the **Rename** button.

**Preset List:** Click this drop-down box to see a list of all the presets that have been created. You can select one, then click the **GoTo** button to change the displayed camera view to the preset. Clicking the **Remove** button will delete the currently selected preset.

**Preset Sequence:** This section allows you to create a preset sequence, which automatically moves the camera's view between a set of preset views.

**PRESET CONTROL**  
Using the Pan and Tilt controls, move the camera view to the required position. There are provides the tools for creating and saving Preset positions & Preset Sequence.

**PRESET CONTROL**  
VIDEO PROFILE : 1  
ePTZ Speed : 5

**PRESET**  
Input Preset Name :  Add Rename  
Support(0~9,A~Z,a~z,-,\*,/,\_)  
Preset List : --Preset List-- GoTo Remove

**PRESET SEQUENCE**  
Preset Name : Dwell time  
Preset List : --Preset List-- Add  
Dwell time : 10 Update Second(s)[3~30]

**Preset List:** To add a preset to the sequence, select it from the drop-down box at the bottom of this window, set the **Dwell time** to determine how long the camera view will stay at that preset, then click the **Add** button. The preset name will appear in the list, followed by the dwell time to view that preset for.

You can rearrange your presets in the sequence by selecting a preset in the sequence, then clicking the arrow buttons to move it higher or lower in the current sequence.

Clicking the trash can button will remove the currently selected preset from the sequence.

If you want to change the dwell time for a preset, select it from the list, enter a new dwell time, then click the **Update** button.

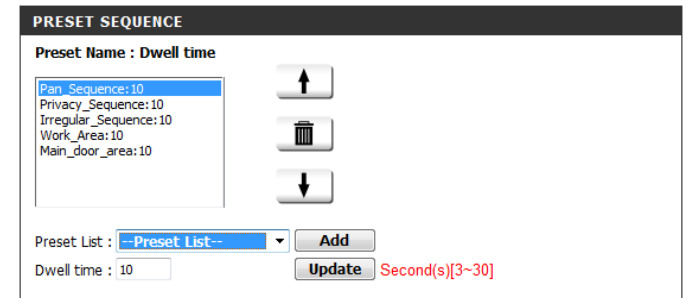

The screenshot shows a window titled "PRESET SEQUENCE". At the top, it says "Preset Name : Dwell time". Below this is a list of presets: "Pan\_Sequence:10", "Privacy\_Sequence:10", "Irregular\_Sequence:10", "Work\_Area:10", and "Main\_door\_area:10". To the right of the list are three buttons: an up arrow, a trash can, and a down arrow. Below the list is a dropdown menu labeled "Preset List" with "--Preset List--" selected, and an "Add" button. Below that is a "Dwell time" input field with "10" entered, and an "Update" button. To the right of the "Update" button, the text "Second(s)[3~30]" is displayed in red.

## Motion Detection

Enabling Video Motion will allow your camera to use the motion detection feature. You may draw a finite motion area that will be used for monitoring. After making any changes, click the **Save Settings** button to save your changes.

**Enable Video Motion:** Select this box to enable the motion detection feature of your camera.

**Enable PIR:** Select this box to enable Passive Infrared detection.

**Sensitivity:** Specifies the measurable difference between two sequential images that would indicate motion. Please enter a value between 0 and 100.

**Percentage:** Specifies the amount of motion in the window being monitored that is required to initiate an alert. If this is set to 100%, motion is detected within the whole window will trigger a snapshot.

**Draw Motion Area:** Draw the motion detection area by dragging your mouse in the window (indicated by the red square).

**Erase Motion Area:** To erase a motion detection area, simply click on the red square that you wish to remove.

Right-clicking on the camera image brings up the following menu options:

**Select All:** Draws a motion detection area over the entire screen.

**Clear All:** Clears any motion detection areas that have been drawn.

**Restore:** Restores the previously specified motion detection areas.

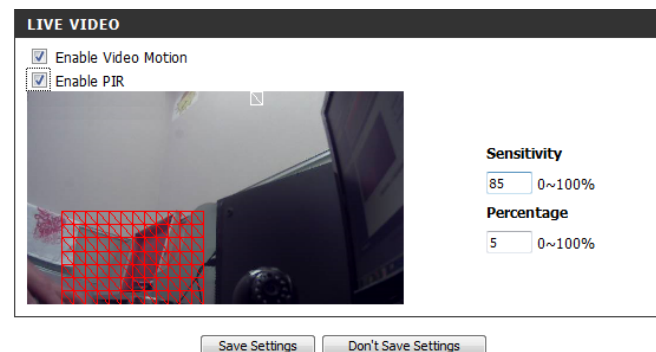
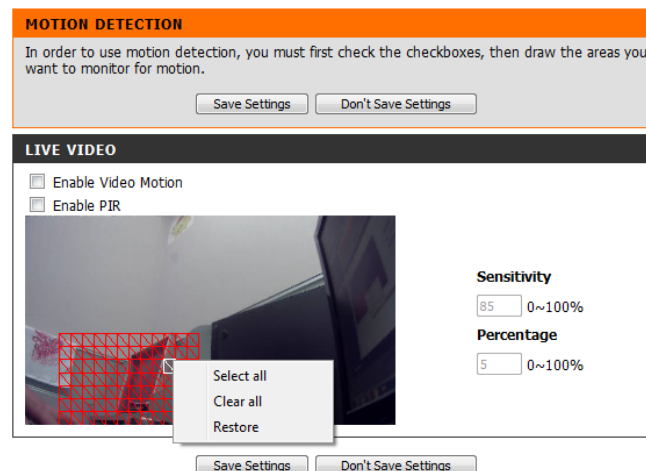



## Time and Date

This section allows you to automatically or manually configure, update, and maintain the internal system clock for your camera. After making any changes, click the **Save Settings** button to save your changes.

**Time Zone:** Select your time zone from the drop-down menu.

**Enable Daylight Saving:** Select this to enable Daylight Saving Time.

**Auto Daylight Saving:** Select this option to allow your camera to configure the Daylight Saving settings automatically.

**Set Date and Time Manually:** Selecting this option allows you to configure the Daylight Saving date and time manually.

**Offset:** Sets the amount of time to be added or removed when Daylight Saving is enabled.

**Synchronize with NTP Server:** Enable this feature to obtain time automatically from an NTP server.

**NTP Server:** Network Time Protocol (NTP) synchronizes the DCS-2230L with an Internet time server. Choose the one that is closest to your location.

**Set the Date and Time Manually:** This option allows you to set the time and date manually.

**Copy Your Computer's Time Settings:** This will synchronize the time information from your PC.

**TIME AND DATE**

You can set the current time for the IP camera.

Save Settings Don't Save Settings

**TIME CONFIGURATION**

Time Zone (GMT+08:00) Taipei

Enable Daylight Saving

Auto Daylight Saving

Set date and time manually

Offset +2:00

Month Week Day of week Hour Minutes

Start time 5 1 Sunday 00 00

End time 10 1 Sunday 00 00

**AUTOMATIC TIME CONFIGURATION**

Synchronize with NTP Server

NTP Server ntp.dlink.com.tw << Select NTP Server

**SET DATE AND TIME MANUALLY**

Set date and time manually

Year 2011 Month 1 Day 1

Hour 18 Minute 30 Second 55

Copy Your Computer's Time Settings

Save Settings Don't Save Settings

## Event Setup

In a typical application, when motion is detected, the DCS-2230L sends images to a FTP server or via e-mail as notifications. As shown in the illustration below, an event can be triggered by many sources, such as motion detection or external digital input devices. When an event is triggered, a specified action will be performed. You can configure the DCS-2230L to send snapshots or videos to your e-mail address or FTP site.

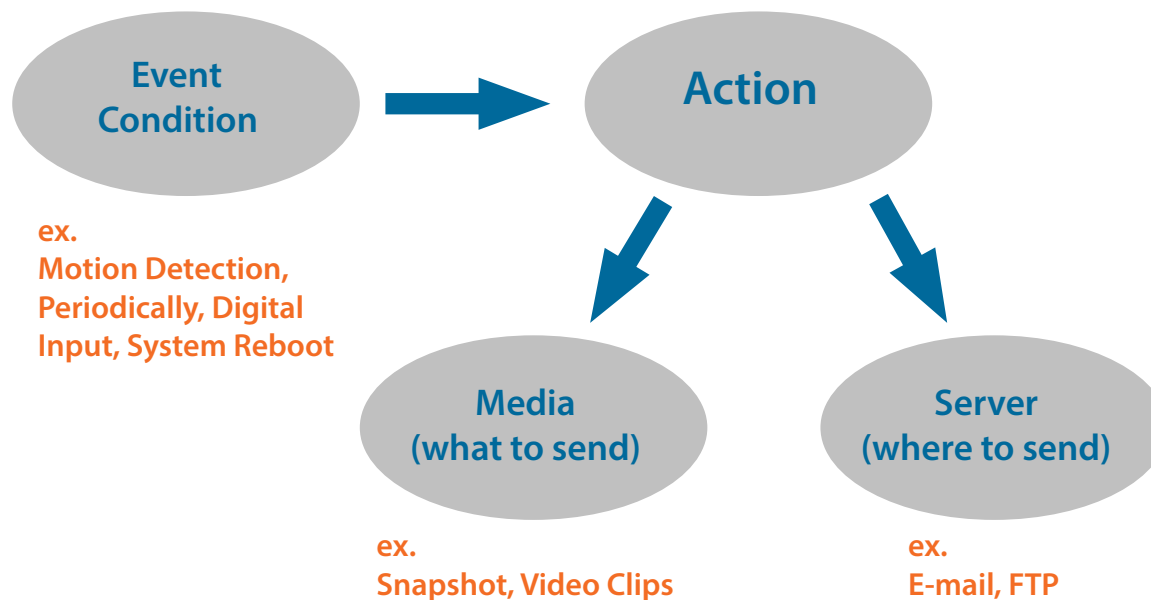

To start plotting an event, it is suggested to configure server and media columns first so that the DCS-2230L will know what action shall be performed when a trigger is activated.

## Section 4: Configuration

The Event Setup page includes four different sections:

- Server
- Media
- Event
- Recording

1. To add a new item - "event, server or media," click **Add**. A screen will appear and allow you to update the fields accordingly.
2. To delete the selected item from the pull-down menu of event, server or media, click **Delete**.
3. Click on the item name to pop up a window for modifying.

**EVENT SETUP**

There are four sections in Event Setup page. They are event, server, media and recording. Click Add to pop a window to add a new item of event, server, media or recording. Click Delete to delete the selected item from event, server, media or recording. Click on the item name to pop a window to edit it. There can be at most 2 events and 1 recording. There can be at most 5 server and 5 media configurations.

**SERVER**

Name	Type	Address/Location
<a href="#">Server1</a>	Email	mail.gandi.net

**MEDIA**

Media freespace: 6700KB

Name	Type	Source
<a href="#">Media1</a>	Video clip	Profile 1

**EVENT**

Name	Status	Sun	Mon	Tue	Wed	Thu	Fri	Sat	Time	Trigger
<a href="#">Event1</a>	OFF	V	V	V	V	V	V	V	00:00~23:59	Motion

**RECORDING**

Name	Status	Sun	Mon	Tue	Wed	Thu	Fri	Sat	Time	Source	Destination
------	--------	-----	-----	-----	-----	-----	-----	-----	------	--------	-------------

## Add Server

You can configure up to 5 servers to save snapshots and/or video to. After making any changes, click the **Save Settings** button to save your changes. You can click **Test** to test your configurations.

**Server Name:** Enter the unique name of your server.

**E-mail:** Enter the configuration for the target e-mail server account.

**FTP:** Enter the configuration for the target FTP server account.

**Network Storage:** Specify a network storage device. Only one network storage device is supported.

**SD Card:** Use the camera's onboard SD card storage.

**SERVER**

You can set at most 5 different servers here for different event.

**SERVER TYPE**

**Server Name:**

**Email**

Sender email address

Recipient email address

Server address

User name

Password

Port

This server requires a secure connection (StartTLS)

**FTP**

Server address

Port

User name

Password

Remote folder name

Passive mode

**Network storage**

Network storage location   
(for example: \\my\_nas\disk\folder)

Workgroup

User name

Password

Primary WINS server

**SD Card**

## Add Media

There are three types of media: **Snapshot**, **Video Clip**, and **System Log**. After making any changes, click the **Save Settings** button to save your changes.

**Media Name:** Enter a unique name for media type you want to create.

**Snapshot:** Select this option to set the media type to snapshots.

**Source:** Set the video profile to use as the media source. Refer to **Audio and Video on page 36** for more information on video profiles.

**Send pre-event image(s) [0~4]:** Set the number of pre-event images to take. Pre-event images are images taken before the main event snapshot is taken.

**Send post-event image(s) [0~7]:** Set the number of post-event images to take. Post-event images are images taken after the main event snapshot is taken. You can set up to 7 post-event images to be taken.

**File name prefix:** The prefix name will be added on the file name.

**Add date and time suffix to file name:** Check it to add timing information as file name suffix.

**MEDIA**

You can set at most 5 different media here for different event.

**MEDIA TYPE**

**Media name:**

**Snapshot**  
 Source:

Send  pre-event image(s) [0~4]

Send  post-event image(s) [0~7]

File Name Prefix:

Add date and time suffix to file name

**Video Clip**  
 Source:

Pre-event recording:  Second(s) [0~4]

Maximum duration:  Second(s) [1~100]

Maximum file size:  Kbytes [100~5000]

File Name Prefix:

**System log**

**Video clip:** Select this option to set the media type to video clips.

**Source:** Set the video profile to use as the media source. Refer to **Audio and Video on page 36** for more information on video profiles.

**Pre-event recording:** This sets how many seconds to record before the main event video clip starts. You can record up to 4 seconds of pre-event video.

**Maximum duration:** Set the maximum length of video to record for your video clips.

**Maximum file size:** Set the maximum file size to record for your video clips.

**File name prefix:** This is the prefix that will be added to the filename of saved video clips.

**System log:** Select this option to set the media type to system logs. This will save the event to the camera system log, but will not record any snapshots or video.

The screenshot shows a configuration window titled "MEDIA" with an orange header. Below the header, a grey box contains the text "You can set at most 5 different media here for different event." and two buttons: "Save Settings" and "Don't Save Settings". The main area is titled "MEDIA TYPE" and contains the following options:

- Media name:** A text input field.
- Snapshot:** Selected with a radio button. Includes:
  - Source: Profile 1 (dropdown)
  - Send 1 pre-event image(s) [0~4] (input field)
  - Send 1 post-event image(s) [0~7] (input field)
  - File Name Prefix: (input field)
  - Add date and time suffix to file name
- Video Clip:** Unselected with a radio button. Includes:
  - Source: Profile 1 (dropdown)
  - Pre-event recording: (input field) Second(s) [0~4]
  - Maximum duration: (input field) Second(s) [1~100]
  - Maximum file size: (input field) Kbytes [100~5000]
  - File Name Prefix: (input field)
- System log:** Unselected with a radio button.

At the bottom of the window, there are two buttons: "Save Settings" and "Don't Save Settings".

## Add Event

Create and schedule up to three events with their own settings here. After making any changes, click the **Save Settings** button to save your changes.

**Event name:** Enter a name for the event.

**Enable this event:** Select this box to activate this event.

**Priority:** Set the priority for this event. The event with higher priority will be executed first.

**Delay:** Select the delay time before checking the next event. It is being used for events of motion detection, digital input, and PIR triggers.

**Video Motion Detection:** Motion is detected during live video monitoring. Select the window that needs to be monitored.

**Periodic:** The event is triggered in specified intervals. The trigger interval unit is in minutes.

**Digital input:** The external trigger input to the camera.

**System Boot:** Triggers an event when the system boots up.

**Network Lost:** Triggers an event when the network connection is lost.

**Passive Infrared Sensor:** Triggers an event when the PIR sensor is activated by moving infrared objects even in dark environment. Select **Always** or enter the time interval.

**Time:** Select the days and times when events will be detected.

**EVENT**

You can set at most 2 events like motion detection or digital input trigger here and arrange the detection schedule at the same time.

---

**EVENT**

**Event name:**

Enable this event

Priority: normal

Delay for  seconds before detecting next event [For motion detection and digital input and Passive Infrared sensor]

---

**TRIGGER**

Video motion detection

Periodic  
Trigger every  minutes

Digital input

System boot

Network lost

Passive Infrared sensor

---

**EVENT SCHEDULE**

Sun  Mon  Tue  Wed  Thu  Fri  Sat

**Time**

Always

From 00 00 To 23 59

---

**ACTION**

Trigger D/O for  seconds

Server1  
Attached media: Media 1

**Trigger D/O:** Select to trigger the digital output for a specific number of seconds when an event occurs.

**Server:** Specify the location where the event information should be saved to.

### EVENT

Event name:

Enable this event

Priority: normal ▾

Delay for  seconds before detecting next event [For motion detection and digital input and Passive Infrared sensor]

### TRIGGER

Video motion detection

Periodic  
Trigger every  minutes

Digital input

System boot

Network lost

Passive Infrared sensor

### EVENT SCHEDULE

Sun  Mon  Tue  Wed  Thu  Fri  Sat

**Time**

Always

From   To

### ACTION

Trigger D/O for  seconds

Server1  
Attached media: Media1 ▾



## Add Recording

Here you can configure and schedule the recording settings. After making any changes, click the **Save Settings** button to save your changes.

**Recording entry name:** The unique name of the entry.

**Enable this recording:** Select this to enable the recording function.

**Priority:** Set the priority for this entry. The entry with a higher priority value will be executed first.

**Source:** The source of the stream.

**Recording schedule:** Schedule the recording entry via days and times.

**Recording settings:** Configuring the setting for the recording.

**Destination:** Select the folder where the recording file will be stored.

**Total cycling recording size:** Please input a HDD volume between 200 MB and 2 TB for recording space. The recording data will replace the oldest record when the total recording size exceeds this value. For example, if each recording file is 6 MB, and the total cyclical recording size is 600 MB, then the camera will record 100 files in the specified location (folder) and then will delete the oldest file and create a new file for cyclical recording.

Please note that if the free HDD space is not enough, the recording will stop. Before you set up this option please make sure your HDD has enough space, and it is better to not save other files in the same folder as recording files.

The screenshot displays the recording configuration interface, organized into three main sections:

- RECORDING:** This section includes a header with the text "You can setup schedule recording to network storage with your specify week day and time period." Below this are two buttons: "Save Settings" and "Don't Save Settings".
- RECORDING:** This section contains a text input field for "Recording entry name:", a checkbox for "Enable this recording", a "Priority" dropdown menu set to "normal", and a "Source" dropdown menu set to "Profile 1".
- RECORDING SCHEDULE:** This section features a row of checkboxes for days of the week (Sun, Mon, Tue, Wed, Thu, Fri, Sat), all of which are checked. Below this is a "Time" section with a radio button selected for "Always" and another radio button for "From" followed by time selection fields (From 00:00 To 23:59).
- RECORDING SETTINGS:** This section includes a "Destination" dropdown menu set to "None", a "Total cycling recording size" field set to "1000" Mbytes [200~2000000], a radio button selected for "Size of each file for recording" set to "10" Mbytes, another radio button for "Time of each file for recording" set to "10" seconds, and a "File Name Prefix" text input field. At the bottom of this section are two buttons: "Save Settings" and "Don't Save Settings".

**Size of each file for recording:** If this is selected, files will be separated based on the file size you specify.

**Time of each file for recording:** If this is selected, files will be separated based on the maximum length you specify.

**File Name Prefix:** The prefix name will be added on the file name of the recording file(s).

### RECORDING

Recording entry name:

Enable this recording

Priority: normal

Source: Profile 1

### RECORDING SCHEDULE

Sun  Mon  Tue  Wed  Thu  Fri  Sat

**Time**

Always

From   To

### RECORDING SETTINGS

Destination: None

Total cycling recording size:  Mbytes [200~2000000]

Size of each file for recording:  Mbytes

Time of each file for recording:  seconds

File Name Prefix:

## SD Card

Here you may browse and manage the recorded files which are stored on the SD card.

**Format SD Card:** Click this icon to automatically format the SD card and create "picture" & "video" folders.

**View Recorded Picture:** If the picture files are stored on the SD card, click on the picture folder and choose the picture file you would like to view.

**Playback Recorded Video:** If video files are stored on the SD card, click on the video folder and choose the video file you would like to view.

**Refresh:** Reloads the file and folder information from the SD card.

The screenshot displays the SD Card management interface. At the top, there is an orange header with the text "SD CARD". Below this, a grey bar contains the instruction: "Here you could browse and manage the record files which stored in SD card." The main content area has a dark grey header with "SD CARD" in white. Below the header, it shows "SD Card: /" and "SD Status : Ready". There are controls for "Files per Page: 10" and a "Refresh" link. A table lists the contents of the SD card:

<input type="checkbox"/> Delete	File	Num of files	Size
<input type="checkbox"/>	<a href="#">Picture</a>	8	
<input type="checkbox"/>	<a href="#">Video</a>	1	

Below the table, there is a "Format SD Card" button and a status bar showing "Total:119247KB, Used:31848KB, Free:87399KB". An "OK" button is located at the bottom right of the interface.

## Advanced Digital Input/Output

This screen allows you to control the behavior of digital input and digital output devices. The I/O connector provides the physical interface for digital output (DO) and digital input (DI) that is used for connecting a variety of external alarm devices such as IR sensors and alarm relays. The digital input is used for connecting external alarm devices and once triggered images will be taken and e-mailed. After making any changes, click the **Save Settings** button to save your changes.

**Select D/I or D/O Mode:** The camera will send a signal when an event is triggered, depending upon the type of device connected to the DI circuit.

N.C. stands for **Normally Closed**. This means that the normal state of the circuit is closed. Therefore events are triggered when the device status changes to "Open."

N.O. stands for **Normally Open**. This means that the normal state of the circuit is open. Therefore events are triggered when the device status changes to "Closed."

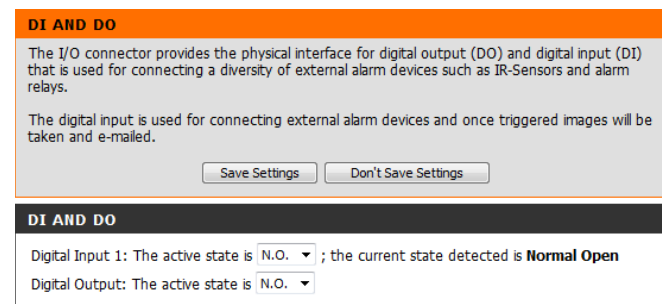

## ICR and IR

Here you can configure the ICR and IR settings. An IR (Infrared) Cut-Removable (ICR) filter can be disengaged for increased sensitivity in low light environments.

**Automatic:** The Day/Night mode is set automatically. Generally, the camera uses Day mode and switches to Night mode when needed.

**Day Mode:** Day mode enables the IR Cut Filter.

**Night Mode:** Night mode disables the IR Cut Filter.

**Schedule Mode:** Set up the Day/Night mode using a schedule. The camera will enter Day mode at the starting time and return to Night mode at the ending time.

**IR Light Control:** The camera can enable or disable the IR (infrared) light according to your preferences. This setting lets you adjust IR strength depending on your specific application.

**Off:** The IR light will always be off.

**On:** The IR light will always be on.

**Sync:** The IR light will turn on when the ICR sensor is on.

**Schedule:** The IR light will turn on or off according to the schedule that you specify below.

**ICR AND IR**

An IR(Infrared) Cut-Removable(ICR) filter can be disengaged from the image path for increased sensitivity in low light environments. The ICR filter will automatically engage depending on the ambient light, allowing the camera to be effective in day/night environments.

1. Select the Day/Night from the radio button. The available options are Automatic, Schedule mode, Day mode and Night mode.
2. The default value is Automatic.

**IR Light**  
The built-in IR light illuminators will be activated automatically or manually so as to supplement the low light situation without additional equipment.

---

**ICR**

Removable IR-Cut filter trigger condition:

Automatic  
 Day mode  
 Night mode  
 Schedule mode

Day mode(24hr)  
 From   To

---

**IR LIGHT**

IR Light Control

Off  
 On  
 Sync. With ICR  
 Schedule

IR Light Control On(24hr)  
 From   To

## HTTPS

This page allows you to install and activate an SSL certificate for secure HTTPS access to your camera. After making any changes, click the **Save Settings** button to save your changes.

**Enable HTTPS Secure Connection:** Enable the HTTPS service.

**Create Certificate Method:** Choose the way the certificate should be created. Three options are available:

- Create a self-signed certificate automatically
- Create a self-signed certificate manually
- Create a certificate request and install

**Certificate Information:** Displays the status and details of the certificate. Click on **CSR Property** and **Certificate Property** to view details of the certificates.

**Note:** The certificate cannot be removed while the HTTPS is still enabled. To remove the certificate, you must first uncheck **Enable HTTPS secure connection**.

**HTTPS**

To enable HTTPS, you have to create and install certificate first.

**HTTPS**

Enable HTTPS secure connection

Create certificate method
 

- Create self-signed certificate automatically
- Create self-signed certificate manually
- Create certificate request and install

Create certificate:  Private key existed

**CERTIFICATE INFORMATION**

Status	Active
Country	TW
State or province	Taiwan
Locality	Taipei
Organization	D-Link Taiwan
Organization Unit	R&D Dept.
Common Name	www.dlink.com.tw

## Access List

Here you can set access permissions for users to view your DCS-2230L.

**Allow list:** The list of IP addresses that have the right to access the camera.

**Start IP address:** The starting IP Address of the devices (such as a computer) that have permission to access the video of the camera.

**Note:** A total of seven lists can be configured for both columns.

**End IP address:** The ending IP Address of the devices (such as a computer) that have permission to access the video of the camera. Click **Add** to save the changes made.

**Delete allow list:** Remove the customized setting from the Allow List.

**Deny list:** The list of IP addresses that have no access rights to the camera.

**Delete deny list:** Remove the customized setting from the Delete List.

**For example:**

When the range of the Allowed List is set from 1.1.1.0 to 192.255.255.255 and the range of the Denied List is set from 1.1.1.0 to 170.255.255.255. Only users with IPs located between 171.0.0.0 and 192.255.255.255 can access the DCS-2230L.

ACCESS LIST	
Here you can set access permissions for users to view your IP camera.	
ALLOW LIST	
Start IP address	<input type="text"/>
End IP address	<input type="text"/> <input type="button" value="Add"/>
Delete allow list	<input type="button" value="Delete"/>
DENY LIST	
Start IP address	<input type="text"/>
End IP address	<input type="text"/> <input type="button" value="Add"/>
Delete deny list	<input type="button" value="Delete"/>

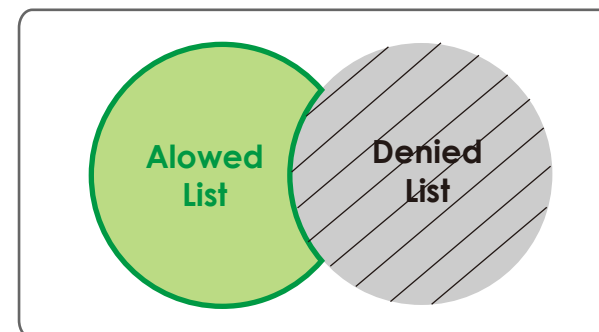

# SNMP

The Simple Network Management Protocol is an application layer protocol that facilitates the exchange of management information between network devices. It helps network administrators to remotely manage network devices and find, solve network problems with ease.

**Enable SNMPv1, SNMPv2c:** Select this to enable SNMPv1 and 2.

**Read/Write Community:** Enter a name for the read community of your SNMP server.

**Read Only Community:** Enter a name for the write community of your SNMP server.

**Enable SNMPv3:** Select this to enable SNMPv3. You will need to ask your network administrator for the SNMP authentication information and input them into the fields below.

**Read/Write and Read Only Security Names:** Enter custom names for your read/write and read only SNMP accounts in the text boxes.

**Authentication Type:** Select the authentication protocol used for SNMP exchanges between this user and the local SNMP engine. SHA and MD5 protocols are supported.

**Authentication/Encryption Password:** Enter the authentication and encryption passwords for your read/write and read only SNMP accounts in these boxes.

**SNMP**

The Simple Network Management Protocol is an application layer protocol that facilitates the exchange of management information between network devices. It helps network administrators to remotely manage network devices and find, solve network problems with ease.

---

**SNMP CONFIGURATION**

Enable SNMPv1, SNMPv2c

Read/Write community

Read only community

Enable SNMPv3

Read/Write Security name

Authentication type

Authentication password

Encryption password

Read only security name

Authentication type

Authentication password

Encryption password



# Maintenance

## Admin

You may modify the name and administrator's password of your camera, as well as add and manage the user accounts for accessing the camera. You may also use this section to create a unique name and configure the OSD settings for your camera.

**Admin Password Setting:** Set a new password for the administrator's account. Retype it and click **Save** for it to take effect.

**Add User Account:** Add new user account. Click **Add** to save the account.

**User Name:** The user name for the new account.

**Password:** The password for the new account.

**User List:** All the existing user accounts will be displayed here. You may delete accounts included in the list, but you may want to reserve at least one as a guest account.

**IP Camera Name:** Create a unique name for your camera that will be added to the file name prefix when creating a snapshot or a video clip.

**Enable OSD:** Select this option to enable the On-Screen Display feature for your camera.

**Label:** Enter a label for the camera, which will be shown on the OSD when it is enabled.

**Show Time:** Select this option to enable the time-stamp display on the video screen. Click **Save** when you are done.

**LED:** You may specify whether or not to illuminate the status LED on the camera. Click **Save** when you are done.

**ADMIN**

Here you can change the administrator's password for your IP camera as well as add and/or delete user account(s). You can configure the information, such as IP camera's name and time via this page. You can also enable the OSD (On-Screen Display) feature in order to display the IP camera name and time stamp for your video recordings.

**ADMIN PASSWORD SETTING**

New Password  32 characters maximum  
 Retype Password

**ADD USER ACCOUNT**

User Name  20 users maximum  
 New Password  32 characters maximum  
 Retype Password

**USER LIST**

User Name

**DEVICE SETTING**

IP camera Name  63 characters maximum  
 Enable OSD  
 Label  30 characters maximum  
 Show Time

**LED**

LED  On  Off

# System

In this section, you may backup, restore and reset the camera configuration, or reboot the camera.

**Save To Local Hard Drive:** You may save your current camera configuration as a file on your computer.

**Load From Local Hard Drive:** Locate a pre-saved configuration by clicking **Browse** and then restore the pre-defined settings to your camera by clicking **Load Configuration**.

**Restore to Factory Default:** You may reset your camera and restore the factory settings by clicking **Restore Factory Defaults**.

**Reboot Device:** This will restart your camera.

**Enable Schedule Reboot:** Check to enable this feature and select the days and times your DCS-2230L will automatically reboot. Click **Save** for it to take effect.

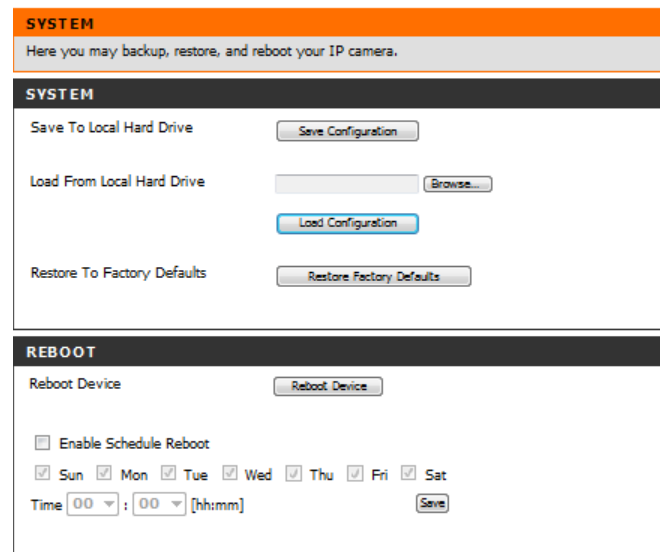

## Firmware Upgrade

The camera's current firmware version will be displayed on this screen. You may visit the D-Link Support Website to check for the latest available firmware version.

To upgrade the firmware on your DCS-2230L, please download and save the latest firmware version from the D-Link Support Page to your local hard drive. Locate the file on your local hard drive by clicking the **Browse** button. Select the file and click the **Upload** button to start upgrading the firmware.

**Current Firmware Version:** Displays the detected firmware version.

**Current Product Name:** Displays the camera model name.

**File Path:** Locate the file (upgraded firmware) on your hard drive by clicking **Browse**.

**Upload:** Uploads the new firmware to your camera.

The screenshot shows a web interface for firmware upgrade. It features an orange header with the text 'FIRMWARE UPGRADE'. Below the header, there is a paragraph of text: 'A new firmware upgrade may be available for your IP camera. It is recommended to keep your IP camera firmware up-to-date to maintain and improve the functionality and performance of your internet IP camera. Click here [D-Link Support Page](#) to check for the latest firmware version available.' This is followed by another paragraph: 'To upgrade the firmware on your IP camera, please download and save the latest firmware version from the D-Link Support Page to your local hard drive. Locate the file on your local hard drive by clicking the Browse button. Once you have found and opened the file using the browse button, click the "Upload" button to start the firmware upgrade.' Below this text is a section titled 'FIRMWARE INFORMATION' with a white background and a black border. It contains two rows of information: 'Current Firmware Version: 0.03.00' and 'Current Product Name: DCS-2230L'. At the bottom of the screenshot is another section titled 'FIRMWARE UPGRADE' with a black header and white background. It contains a 'File Path:' label followed by a text input field, a 'Browse...' button, and an 'Upload' button.

# Status

## Device Info

This page displays detailed information about your device and network connection.

### DEVICE INFO

All of your network connection details are displayed on this page. The firmware version is also displayed here.

### INFORMATION

IP camera Name	DCS-2230L
Time & Date	Wed Jan 1 20:32:56 2016
Firmware Version	0.03.00
MAC Address	0A:CA:CA:22:10:14
IP Address	192.168.0.101
IP Subnet Mask	255.255.255.0
Default Gateway	192.168.0.2
Primary DNS	192.168.0.2
Secondary DNS	0.0.0.0
PPPoE	Disable
DDNS	Enable
Agent Version	2.0.17-b76

## Logs

This page displays the log information of your camera. You may download the information by clicking **Download**. You may also click **Clear** to delete the saved log information.

**SYSTEM LOG**  
The system log records IP camera events that have occurred.

**CURRENT LOG**

1. 2011-01-01 19:01:11 Someone Create Certificate
2. 2011-01-01 18:47:55 admin LOGIN OK FROM 192.168.0.51
3. 2011-01-01 17:56:08 admin FROM 192.168.0.51 SET EVENT MEDIA 1 ; Name : Media1, Type : Video Clip
4. 2011-01-01 17:56:08 admin FROM 192.168.0.51 SET EVENT TYPE 1 ; Trigger : Motion Detection
5. 2011-01-01 17:55:47 admin FROM 192.168.0.51 SET EVENT SERVER 1 ; Name : Server1, Type : Email
6. 2011-01-01 17:55:47 admin FROM 192.168.0.51 SET EVENT TYPE 1 ; Trigger : Motion Detection
7. 2011-01-01 17:55:47 admin FROM 192.168.0.51 SET EVENT MEDIA 1 ; Name : Media1, Type : Video Clip
8. 2011-01-01 17:33:37 admin LOGIN OK FROM 192.168.0.51
9. 2011-01-01 17:32:45 SYSTEM SET IR LIGHT OFF
10. 2011-01-01 17:32:21 IP CAMERA ACQUIRE DHCP IP 192.168.0.53
11. 2011-01-01 17:32:17 NETWORK RECONNECT
12. 2011-01-01 17:30:18 SYSTEM SET IR LIGHT ON
13. 2011-01-01 17:28:51 NETWORK LOSS
14. 2011-01-01 17:28:50 SYSTEM SET IR LIGHT OFF
15. 2011-01-01 17:28:50 SYSTEM BOOTING
16. 2011-01-01 14:51:44 SYSTEM SET IR LIGHT OFF
17. 2011-01-01 08:35:12 SYSTEM SET IR LIGHT ON
18. 2011-01-01 07:36:18 admin LOGIN OK FROM 172.17.5.125
19. 2011-01-01 07:25:36 SYSTEM SET IR LIGHT OFF
20. 2011-01-01 07:25:33 IP CAMERA ACQUIRE DHCP IP 172.17.5.143

First Page Previous 20 Next 20

Clear Download

# Help

This page provides helpful information regarding camera operation.

<b>HELP</b> <ul style="list-style-type: none"><li>• <a href="#">LIVE VIDEO</a></li><li>• <a href="#">SETUP</a></li><li>• <a href="#">MAINTENANCE</a></li><li>• <a href="#">ADVANCED</a></li><li>• <a href="#">STATUS</a></li></ul>
<b>LIVE VIDEO</b> <ul style="list-style-type: none"><li>• <a href="#">Camera</a></li></ul>
<b>SETUP</b> <ul style="list-style-type: none"><li>• <a href="#">Setup Wizard</a></li><li>• <a href="#">Network Setup</a></li><li>• <a href="#">Dynamic DNS</a></li><li>• <a href="#">Image Setup</a></li><li>• <a href="#">Audio and Video</a></li><li>• <a href="#">Preset</a></li><li>• <a href="#">Motion Detection</a></li><li>• <a href="#">Time and Date</a></li><li>• <a href="#">Event Setup</a></li><li>• <a href="#">SD Card</a></li></ul>
<b>ADVANCED</b> <ul style="list-style-type: none"><li>• <a href="#">DI and DO</a></li><li>• <a href="#">ICR and IR</a></li><li>• <a href="#">HTTPS</a></li><li>• <a href="#">Access List</a></li><li>• <a href="#">SNMP</a></li></ul>
<b>MAINTENANCE</b> <ul style="list-style-type: none"><li>• <a href="#">Admin</a></li><li>• <a href="#">System</a></li><li>• <a href="#">Firmware Upgrade</a></li></ul>
<b>STATUS</b> <ul style="list-style-type: none"><li>• <a href="#">Device Info</a></li><li>• <a href="#">Log</a></li></ul>

# DI/DO Specifications

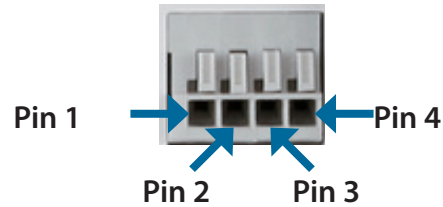

PIN	FUNCTION	NOTE
1	<b>Digital Out (DO)</b>	Uses an open-drain NFET transistor with the source connected to GND in camera. If used with an external relay, a diode must be connected in parallel with the load for protection against voltage transients. Max loading is 100 mA.
2	<b>Digital In (DI)</b>	A switch from DI to DC 5 V, activated by setting NO. or NC.
3	<b>DC 5V OUTPUT</b>	DC 5 V Output / Max. 100 mA
4	<b>GND</b>	GND

**Internal 5V Power**

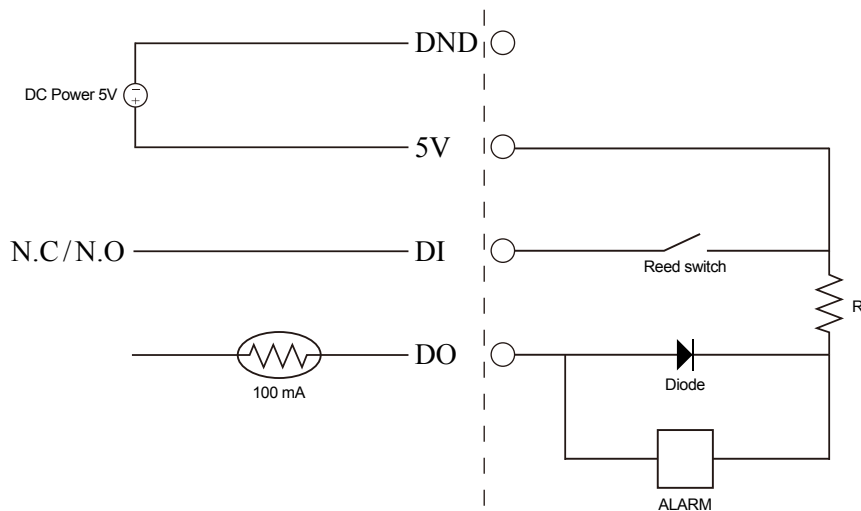

**External 3~12V Power**

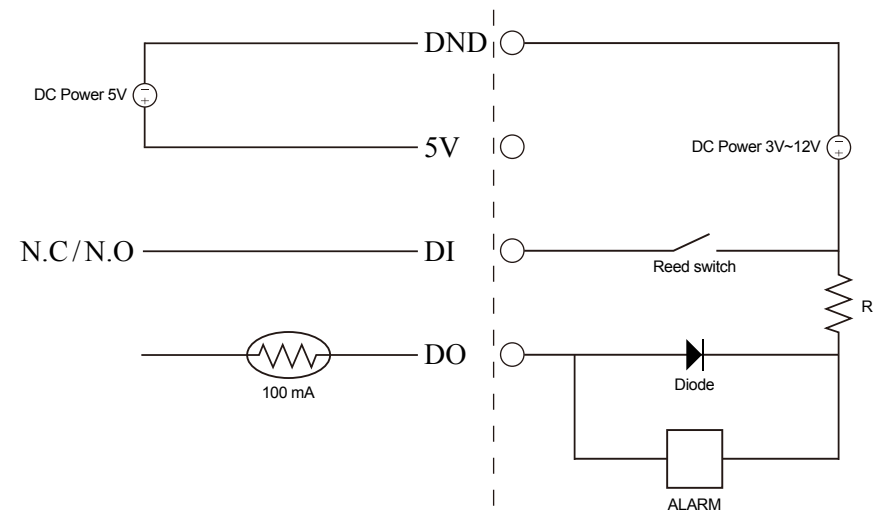

# Technical Specifications

<b>Camera</b>	Camera Hardware Profile	<ul style="list-style-type: none"> <li>▪ 1/2.7" 2 Megapixel CMOS sensor</li> <li>▪ 16 foot (5 meter) IR illumination distance</li> <li>▪ Minimum illumination: 0 lux with IR LED on</li> <li>▪ Built-in Infrared-Cut Removable (ICR) Filter module</li> <li>▪ Built-in PIR sensor (16 feet)</li> <li>▪ Built-in microphone and speaker</li> <li>▪ 10x digital zoom</li> </ul>	<ul style="list-style-type: none"> <li>▪ Focal length: 2.8 mm</li> <li>▪ Aperture: F1.8</li> <li>▪ Angle of view:               <ul style="list-style-type: none"> <li>▪ (H) 103°</li> <li>▪ (V) 55°</li> <li>▪ (D) 118°</li> </ul> </li> </ul>
	Image Features	<ul style="list-style-type: none"> <li>▪ Configurable image size, quality, frame rate, and bit rate</li> <li>▪ Time stamp and text overlays</li> <li>▪ Configurable motion detection windows</li> </ul>	<ul style="list-style-type: none"> <li>▪ Configurable privacy mask zones</li> <li>▪ Configurable shutter speed, brightness, saturation, contrast, and sharpness</li> </ul>
	Video Compression	<ul style="list-style-type: none"> <li>▪ Simultaneous H.264/MJPEG/MPEG-4 format compression</li> <li>▪ H.264/MPEG-4 multicast streaming</li> </ul>	<ul style="list-style-type: none"> <li>▪ JPEG for still images</li> <li>▪ MJPEG Streaming over HTTP</li> </ul>
	Video Resolution	16:9 - Up to 30 fps at 1920 x 1080, 1280 x 720, 800 x 450, 640 x 360, 480 x 270	4:3 - Up to 30 fps at 1440 x 1080, 1280 x 960, 1024 x 768, 800 x 600, 600 x 480, 320 x 240
	Audio Support	G.711, AAC	
	External Device Interface	<ul style="list-style-type: none"> <li>▪ 10/100 BASE-T Fast Ethernet port</li> <li>▪ IEEE 802.11n/b/g wireless with WPS</li> </ul>	<ul style="list-style-type: none"> <li>▪ DI/DO port</li> <li>▪ microSD/SDHC card slot</li> </ul>
<b>Network</b>	Network Protocols	IPv6 / IPv4 TCP/IP UDP ICMP DHCP client NTP client (D-Link) DNS client DDNS client (D-Link) SMTP client FTP client Bonjour	HTTP / HTTPS SNMP v1, v2c, v3 PPPoE UPnP port forwarding RTP / RTSP/ RTCP IP filtering QoS CoS Multicast IGMP ONVIF compliant
	Security	<ul style="list-style-type: none"> <li>▪ Administrator and user group protection</li> <li>▪ Password authentication</li> </ul>	<ul style="list-style-type: none"> <li>▪ HTTP and RTSP digest encryption</li> </ul>



## Appendix B: Technical Specifications

<b>System Management</b>	System Requirements for Web Interface	<ul style="list-style-type: none"> <li>Operating System: Microsoft Windows 10/8/7 (32/64-bit)/Vista (32/64-bit), macOS (10.6 or above)</li> </ul>	<ul style="list-style-type: none"> <li>Browser: Internet Explorer 9, Firefox 12, Safari 7, Chrome 20 and above</li> </ul>
	Event Management	<ul style="list-style-type: none"> <li>Motion detection, Periodic, Digital Input, System Boot, Network Lost, PIR</li> <li>Event notification and saving/uploading of snapshots/video clips via e-mail, FTP, network storage, or SD card</li> </ul>	<ul style="list-style-type: none"> <li>Supports multiple SMTP and FTP servers</li> <li>Multiple event notifications</li> <li>Multiple recording methods for easy backup</li> </ul>
	Remote Management	<ul style="list-style-type: none"> <li>Take snapshots/video clips and save to local hard drive or NAS via web browser</li> </ul>	<ul style="list-style-type: none"> <li>Configuration interface accessible via web browser</li> </ul>
	Mobile Support	mydlink mobile app for iOS and Android devices, and Windows 8 mobile phones	
	D-ViewCam™ System Requirements	<ul style="list-style-type: none"> <li>Operating System: Microsoft Windows 10/8/7 (32/64-bit)/Vista (32/64-bit)</li> </ul>	<ul style="list-style-type: none"> <li>Protocol: Standard TCP/IP</li> <li>Web Browser: Internet Explorer 9 and above</li> </ul>
	D-ViewCam™ Software Functions	<ul style="list-style-type: none"> <li>Remote management/control of up to 32 cameras</li> <li>Viewing of up to 32 cameras on one screen</li> </ul>	<ul style="list-style-type: none"> <li>Supports all management functions provided in web interface</li> <li>Scheduled motion triggered, or manual recording options</li> </ul>
<b>General</b>	Weight	DCS-2230L: 2.65 ounces / 0.17 lbs	
	External Power Adaptor	Input: 100 to 240 V AC, 50/60 Hz	Output: 5 V DC, 1.2 A, 50/60 Hz
	Power Consumption	DCS-2230L: 4.6 watts (Max)	
	Temperature	Operating: 0 to 40 °C (32 to 104 °F)	Storage: -20 to 70 °C (-4 to 158 °F)
	Humidity	Operating: 20% to 80% non-condensing	Storage: 5% to 95% non-condensing
	Certifications	CE IC	FCC C-Tick

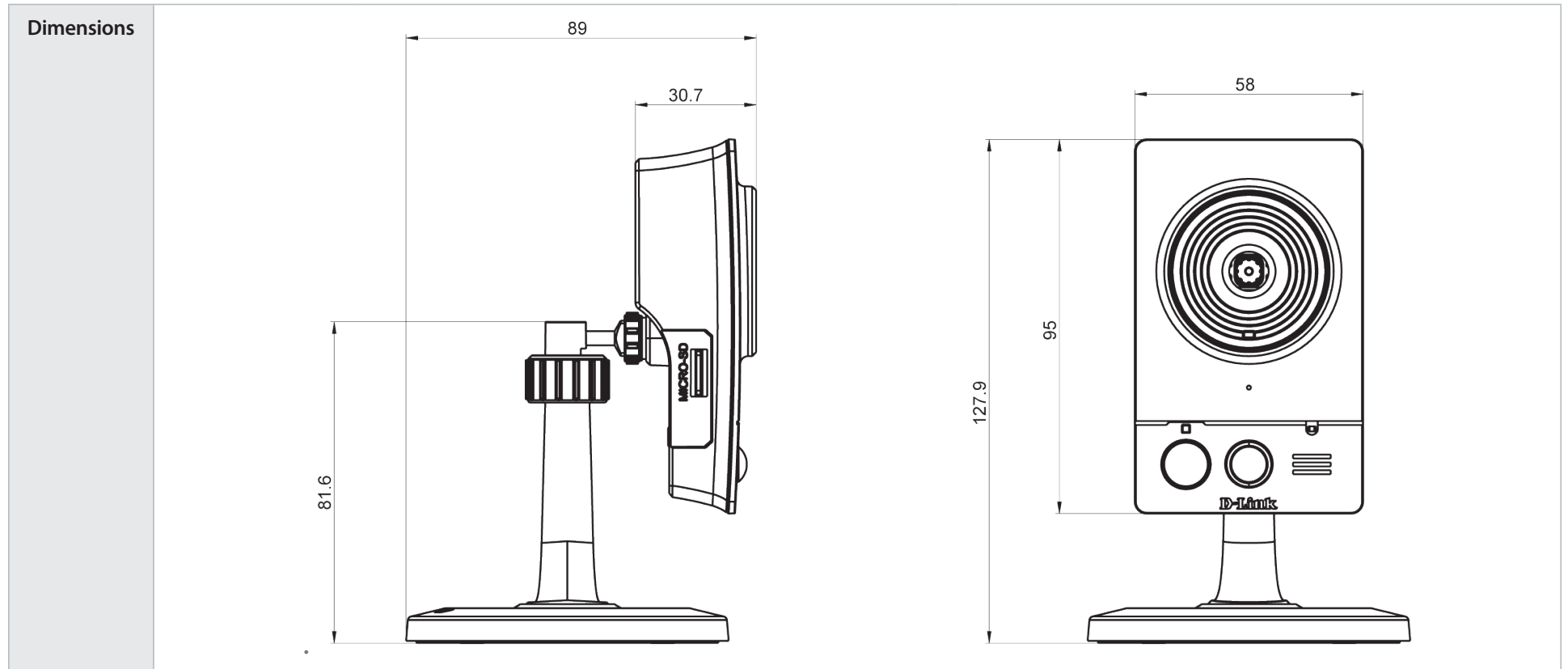

# Contacting Technical Support

U.S. and Canadian customers can contact D-Link technical support through our web site or by phone.

Before you contact technical support, please have the following ready:

- Model number of the product (e.g. DCS-2230L)
- Hardware Revision (located on the label on the bottom of the camera [e.g. rev A1])
- Serial Number (s/n number located on the label on the bottom of the camera).

You can find software updates and user documentation on the D-Link website as well as frequently asked questions and answers to technical issues.

## For customers within the United States:

### Phone Support:

(877) 453-5465

### Internet Support:

<http://support.dlink.com>

## For customers within Canada:

### Phone Support:

(800) 361-5265

### Internet Support:

<http://support.dlink.ca>

# Warranty

Subject to the terms and conditions set forth herein, D-Link Systems, Inc. (“D-Link”) provides this Limited Warranty:

- Only to the person or entity that originally purchased the product from D-Link or its authorized reseller or distributor, and
- Only for products purchased and delivered within the fifty states of the United States, the District of Columbia, U.S. Possessions or Protectorates, U.S. Military Installations, or addresses with an APO or FPO.

## Limited Warranty:

D-Link warrants that the hardware portion of the D-Link product described below (“Hardware”) will be free from material defects in workmanship and materials under normal use from the date of original retail purchase of the product, for the period set forth below (“Warranty Period”), except as otherwise stated herein.

- Hardware (excluding power supplies and fans): One (1) year
- Power supplies and fans: One (1) year
- Spare parts and spare kits: Ninety (90) days

The customer’s sole and exclusive remedy and the entire liability of D-Link and its suppliers under this Limited Warranty will be, at D-Link’s option, to repair or replace the defective Hardware during the Warranty Period at no charge to the original owner or to refund the actual purchase price paid. Any repair or replacement will be rendered by D-Link at an Authorized D-Link Service Office. The replacement hardware need not be new or have an identical make, model or part. D-Link may, at its option, replace the defective Hardware or any part thereof with any reconditioned product that D-Link reasonably determines is substantially equivalent (or superior) in all material respects to the defective Hardware. Repaired or replacement hardware will be warranted for the remainder of the original Warranty Period or ninety (90) days, whichever is longer, and is subject to the same limitations and exclusions. If a material defect is incapable of correction, or if D-Link determines that it is not practical to repair or replace the defective Hardware, the actual price paid by the original purchaser for the defective Hardware will be refunded by D-Link upon return to D-Link of the defective Hardware. All Hardware or part thereof that is replaced by D-Link, or for which the purchase price is refunded, shall become the property of D-Link upon replacement or refund.

### **Limited Software Warranty:**

D-Link warrants that the software portion of the product (“Software”) will substantially conform to D-Link’s then current functional specifications for the Software, as set forth in the applicable documentation, from the date of original retail purchase of the Software for a period of ninety (90) days (“Software Warranty Period”), provided that the Software is properly installed on approved hardware and operated as contemplated in its documentation. D-Link further warrants that, during the Software Warranty Period, the magnetic media on which D-Link delivers the Software will be free of physical defects. The customer’s sole and exclusive remedy and the entire liability of D-Link and its suppliers under this Limited Warranty will be, at D-Link’s option, to replace the non-conforming Software (or defective media) with software that substantially conforms to D-Link’s functional specifications for the Software or to refund the portion of the actual purchase price paid that is attributable to the Software. Except as otherwise agreed by D-Link in writing, the replacement Software is provided only to the original licensee, and is subject to the terms and conditions of the license granted by D-Link for the Software. Replacement Software will be warranted for the remainder of the original Warranty Period and is subject to the same limitations and exclusions. If a material non-conformance is incapable of correction, or if D-Link determines in its sole discretion that it is not practical to replace the non-conforming Software, the price paid by the original licensee for the non-conforming Software will be refunded by D-Link; provided that the non-conforming Software (and all copies thereof) is first returned to D-Link. The license granted respecting any Software for which a refund is given automatically terminates.

### **Non-Applicability of Warranty:**

The Limited Warranty provided hereunder for Hardware and Software portions of D-Link’s products will not be applied to and does not cover any refurbished product and any product purchased through the inventory clearance or liquidation sale or other sales in which D-Link, the sellers, or the liquidators expressly disclaim their warranty obligation pertaining to the product and in that case, the product is being sold “As-Is” without any warranty whatsoever including, without limitation, the Limited Warranty as described herein, notwithstanding anything stated herein to the contrary.

### **Submitting A Claim (USA):**

The customer shall return the product to the original purchase point based on its return policy. In case the return policy period has expired and the product is within warranty, the customer shall submit a claim to D-Link as outlined below:

- The customer must submit with the product as part of the claim a written description of the Hardware defect or Software nonconformance in sufficient detail to allow D-Link to confirm the same, along with proof of purchase of the product (such as a copy of the dated purchase invoice for the product) if the product is not registered.
- The customer must obtain a Case ID Number from D-Link Technical Support at 1-877-354-6555, who will attempt to assist the customer in resolving any suspected defects with the product. If the product is considered defective, the customer must obtain a Return Material Authorization (“RMA”) number by completing the RMA form and entering the assigned Case ID Number at <https://rma.dlink.com/>.

- After an RMA number is issued, the defective product must be packaged securely in the original or other suitable shipping package to ensure that it will not be damaged in transit, and the RMA number must be prominently marked on the outside of the package. Do not include any manuals or accessories in the shipping package. D-Link will only replace the defective portion of the product and will not ship back any accessories.
- The customer is responsible for all in-bound shipping charges to D-Link. No Cash on Delivery (“COD”) is allowed. Products sent COD will either be rejected by D-Link or become the property of D-Link. Products shall be fully insured by the customer and shipped to D-Link Systems, Inc., 17595 Mt. Herrmann, Fountain Valley, CA 92708. D-Link will not be held responsible for any packages that are lost in transit to D-Link. The repaired or replaced packages will be shipped to the customer via UPS Ground or any common carrier selected by D-Link. Return shipping charges shall be prepaid by D-Link if you use an address in the United States, otherwise we will ship the product to you freight collect. Expedited shipping is available upon request and provided shipping charges are prepaid by the customer. D-Link may reject or return any product that is not packaged and shipped in strict compliance with the foregoing requirements, or for which an RMA number is not visible from the outside of the package. The product owner agrees to pay D-Link’s reasonable handling and return shipping charges for any product that is not packaged and shipped in accordance with the foregoing requirements, or that is determined by D-Link not to be defective or non-conforming.

### **What Is Not Covered:**

The Limited Warranty provided herein by D-Link does not cover:

Products that, in D-Link’s judgment, have been subjected to abuse, accident, alteration, modification, tampering, negligence, misuse, faulty installation, lack of reasonable care, repair or service in any way that is not contemplated in the documentation for the product, or if the model or serial number has been altered, tampered with, defaced or removed; Initial installation, installation and removal of the product for repair, and shipping costs; Operational adjustments covered in the operating manual for the product, and normal maintenance; Damage that occurs in shipment, due to act of God, failures due to power surge, and cosmetic damage; Any hardware, software, firmware or other products or services provided by anyone other than D-Link; and Products that have been purchased from inventory clearance or liquidation sales or other sales in which D-Link, the sellers, or the liquidators expressly disclaim their warranty obligation pertaining to the product.

While necessary maintenance or repairs on your Product can be performed by any company, we recommend that you use only an Authorized D-Link Service Office. Improper or incorrectly performed maintenance or repair voids this Limited Warranty.

### **Disclaimer of Other Warranties:**

EXCEPT FOR THE LIMITED WARRANTY SPECIFIED HEREIN, THE PRODUCT IS PROVIDED “AS-IS” WITHOUT ANY WARRANTY OF ANY KIND WHATSOEVER INCLUDING, WITHOUT LIMITATION, ANY WARRANTY OF MERCHANTABILITY, FITNESS FOR A PARTICULAR PURPOSE AND NONINFRINGEMENT.

IF ANY IMPLIED WARRANTY CANNOT BE DISCLAIMED IN ANY TERRITORY WHERE A PRODUCT IS SOLD, THE DURATION OF SUCH IMPLIED WARRANTY SHALL BE LIMITED TO THE DURATION OF THE APPLICABLE WARRANTY PERIOD SET FORTH ABOVE. EXCEPT AS EXPRESSLY COVERED UNDER THE LIMITED WARRANTY PROVIDED HEREIN, THE ENTIRE RISK AS TO THE QUALITY, SELECTION AND PERFORMANCE OF THE PRODUCT IS WITH THE PURCHASER OF THE PRODUCT.

### **Limitation of Liability:**

TO THE MAXIMUM EXTENT PERMITTED BY LAW, D-LINK IS NOT LIABLE UNDER ANY CONTRACT, NEGLIGENCE, STRICT LIABILITY OR OTHER LEGAL OR EQUITABLE THEORY FOR ANY LOSS OF USE OF THE PRODUCT, INCONVENIENCE OR DAMAGES OF ANY CHARACTER, WHETHER DIRECT, SPECIAL, INCIDENTAL OR CONSEQUENTIAL (INCLUDING, BUT NOT LIMITED TO, DAMAGES FOR LOSS OF GOODWILL, LOSS OF REVENUE OR PROFIT, WORK STOPPAGE, COMPUTER FAILURE OR MALFUNCTION, FAILURE OF OTHER EQUIPMENT OR COMPUTER PROGRAMS TO WHICH D-LINK'S PRODUCT IS CONNECTED WITH, LOSS OF INFORMATION OR DATA CONTAINED IN, STORED ON, OR INTEGRATED WITH ANY PRODUCT RETURNED TO D-LINK FOR WARRANTY SERVICE) RESULTING FROM THE USE OF THE PRODUCT, RELATING TO WARRANTY SERVICE, OR ARISING OUT OF ANY BREACH OF THIS LIMITED WARRANTY, EVEN IF D-LINK HAS BEEN ADVISED OF THE POSSIBILITY OF SUCH DAMAGES. THE SOLE REMEDY FOR A BREACH OF THE FOREGOING LIMITED WARRANTY IS REPAIR, REPLACEMENT OR REFUND OF THE DEFECTIVE OR NONCONFORMING PRODUCT. THE MAXIMUM LIABILITY OF D-LINK UNDER THIS WARRANTY IS LIMITED TO THE PURCHASE PRICE OF THE PRODUCT COVERED BY THE WARRANTY. THE FOREGOING EXPRESS WRITTEN WARRANTIES AND REMEDIES ARE EXCLUSIVE AND ARE IN LIEU OF ANY OTHER WARRANTIES OR REMEDIES, EXPRESS, IMPLIED OR STATUTORY.

### **Governing Law:**

This Limited Warranty shall be governed by the laws of the State of California. Some states do not allow exclusion or limitation of incidental or consequential damages, or limitations on how long an implied warranty lasts, so the foregoing limitations and exclusions may not apply. This Limited Warranty provides specific legal rights and you may also have other rights which vary from state to state.

### **Trademarks:**

D-Link is a registered trademark of D-Link Corporation/D-Link Systems, Inc. Other trademarks or registered trademarks are the property of their respective owners.

### **Copyright Statement:**

No part of this publication or documentation accompanying this product may be reproduced in any form or by any means or used to make any derivative such as translation, transformation, or adaptation without permission from D-Link Corporation/D-Link Systems, Inc., as stipulated by the United States Copyright Act of 1976 and any amendments thereto. Contents are subject to change without prior notice.

Copyright ©2017 by D-Link Corporation/D-Link Systems, Inc. All rights reserved.

### **FCC Statement:**

This equipment has been tested and found to comply with the limits for a Class B digital device, pursuant to part 15 of the FCC Rules. These limits are designed to provide reasonable protection against harmful interference in a residential installation. This equipment generates, uses, and can radiate radio frequency energy and, if not installed and used in accordance with the instructions, may cause harmful interference to radio communication. However, there is no guarantee that interference will not occur in a particular installation. If this equipment does cause harmful interference to radio or television reception, which can be determined by turning the equipment off and on, the user is encouraged to try to correct the interference by one or more of the following measures:

- Reorient or relocate the receiving antenna.
- Increase the separation between the equipment and receiver.
- Connect the equipment into an outlet on a circuit different from that to which the receiver is connected.
- Consult the dealer or an experienced radio/TV technician for help.

### **FCC Caution:**

Any changes or modifications not expressly approved by the party responsible for compliance could void the user's authority to operate this equipment.

This device complies with Part 15 of the FCC Rules. Operation is subject to the following two conditions:

- (1) This device may not cause harmful interference, and
- (2) this device must accept any interference received, including interference that may cause undesired operation.

If this device is going to be operated in 5.15 ~ 5.25GHz frequency range, then it is restricted in indoor environment only.

### **IMPORTANT NOTICE:**

#### **FCC Radiation Exposure Statement:**

This equipment complies with FCC radiation exposure limits set forth for an uncontrolled environment. This equipment should be installed and operated with minimum distance 20cm between the radiator & your body. This transmitter must not be co-located or operating in conjunction with any other antenna or transmitter.

The availability of some specific channels and/or operational frequency bands are country dependent and are firmware programmed at the factory to match the intended destination. The firmware setting is not accessible by the end user.

For detailed warranty information applicable to products purchased outside the United States, please contact the corresponding local D-Link office.



# Registration

Register your product online at [registration.dlink.com](http://registration.dlink.com)



Product registration is entirely voluntary and failure to complete or return this form will not diminish your warranty rights.

Version 1.00 (US)  
January 11, 2017