

# NIST CALIBRATION SERVICES USERS GUIDE 1991



NIST SPECIAL PUBLICATION 250

DIMENSIONAL MEASUREMENTS

MECHANICAL MEASUREMENTS

THERMODYNAMIC QUANTITIES

OPTICAL RADIATION MEASUREMENTS

IONIZING RADIATION MEASUREMENTS

ELECTROMAGNETIC MEASUREMENTS

TIME AND FREQUENCY MEASUREMENTS

**FOR INFORMATION, PHONE (301) 975-2002**



# NIST CALIBRATION SERVICES USERS GUIDE 1991



Joe D. Simmons, Editor

**Physical Measurement Services Program**  
**National Institute of Standards and Technology**  
Gaithersburg, MD 20899

NIST Special Publication 250  
Revised October 1991  
(Supersedes 1989 Edition)



**U.S. Department of Commerce**

Robert A. Mosbacher, Secretary  
Robert M. White, Undersecretary for Technology

**National Institute of Standards and Technology**

John W. Lyons, Director

**FOR INFORMATION, PHONE (301) 975-2002**

---

National Institute of Standards and Technology  
Special Publication 250, 1991 Edition  
Natl. Inst. Stand. Technol., Spec. Publ. 250, 1991 Ed.,  
220 pages (Revised Oct. 1991)  
CODEN: NSPUE2

U.S. GOVERNMENT PRINTING OFFICE  
WASHINGTON: 1991

For sale by the Superintendent of Documents,  
U.S. Government Printing Office, Washington, DC 20402

U.S. Government Printing Office  
Washington: 1991

# Foreword

---

The NIST Calibration Services Users Guide provides detailed descriptions of the currently available NIST calibration services, special-test services, and measurement assurance programs. This document is a revised edition of NIST Special Publication 250. It describes the NIST services available as of the fourth quarter of 1990 and reflects a number of important changes since the 1989 edition was published. A detailed description is given of each measurement service, and a large number of NIST technical experts are cited (who may be contacted for further information concerning services or measurement problems). Future editions will be published periodically as NIST services change.

This document also presents a detailed description of a number of Measurement Assurance Program (MAP) services. These are carefully designed quality control programs for critical measurements that allow the user to achieve a high level of confidence that the measurements being made in the user's laboratory are consistent with national standards and adequate for intended use. MAP services are available for some basic measurement quantities (e.g., laser power and energy).

A Fee Schedule for the services described in this Users Guide is published annually. It lists current prices for the services described here. NIST will notify users of changes in services or proposed changes in services by means of announcements in the Fee Schedule. In addition, information about upcoming NIST Measurement Seminars is announced there. It is important that you refer to the current issue of the Fee Schedule in order to have up-to-date information with respect to NIST contacts.

A companion document to this guide is NIST Special Publication 260, NIST Standard Reference Materials Catalog. This document describes over 1,100 Standard Reference Materials (SRM's) certified by NIST for use in industrial quality control, materials testing, environmental testing, and clinical testing applications. A copy of SP 260 may be obtained by calling (301) 975-6776.

The Physical Measurement Services Program welcomes suggestions on how this publication can be made more useful to those who rely on NIST physical measurement services. Suggestions are also welcome concerning needs for new calibration services, measurement assurance programs, or other measurement services.

Joe D. Simmons  
Physical Measurement Services Program

---

# Abstract

---

The National Institute of Standards and Technology (NIST) Calibration Services Users Guide provides detailed descriptions of currently available NIST calibration services, measurement assurance programs, and special-test services. The following measurement areas are covered: (1) dimensional; (2) mechanical, including flow, acoustic, and ultrasonic; (3) thermodynamic; (4) optical radiation; (5) ionizing radiation; and (6) electromagnetic, including dc, ac, rf, and microwave. A separate Fee Schedule is issued annually, providing current prices for the services offered, updates on points-of-contact, and information on measurement seminars.

Key words: calibration; measurement assurance; measurement services; standards; traceability.

# Acknowledgments

---

Many NIST staff members contributed to the development and preparation of this guide. Over 50 members of the NIST technical staff contributed data and information that have been incorporated into the guide. Special thanks should go to the SP 250 committee, which included Dan Flynn, John Mayo-Wells, Arthur McCoubrey, William Ott, and Carolyn Stull. Joanne Marshall served as production manager and coordinated the preparation of the final document. Editorial assistance was provided by Armatha Osborne, who did an excellent job in typing. Kathy Hillen, NIST Boulder, arranged for the Boulder photographs and verifications. NIST Publications Production staff made many valuable suggestions and typeset the final draft.

The Editor

# List of Tables

---

Table	Page
1. Estimated Systematic Uncertainties of Piston Gage Calibrations in Gage Mode .....	55
2. Thermometer Calibration Uncertainties .....	61
3. NIST Two-Pressure Humidity Generator, Mark 2, Range and Uncertainty .....	72
4. Primary Standard Measurement Capabilities .....	88
5. Measurement Capabilities .....	89
6. Low-Level MAP Transfer Standards .....	90
7. Pulsed CO <sub>2</sub> Calibrations .....	91
8. Specifications for Calibration of Gamma-Ray Emitting Solutions Which Are Submitted for Calibration .....	96
9. Specifications for Calibration of Gamma-Ray Solution Sources .....	97
10. Specifications for Calibrations Using the 2 $\pi\alpha$ Proportional Counter and the 0.8 $\pi\alpha$ Defined Solid Angle Counter .....	97
11. Specifications for Special Tests of Beta-Particle-Emitting Solution Sources .....	98
12. Irradiation Parameters for Fission Spectra and Maxwellian Thermal Neutron Fields .....	101
13. X-Ray Beam-Quality Parameters .....	105
14. Calibration Uncertainties for DC Resistance Standards .....	115
15. AC-DC Difference Calibration Service .....	137
16. Specifications and Estimated Uncertainties for Low-Frequency TVC Services .....	139
17. Specifications and Estimated Uncertainties for High-Frequency TVC Services .....	139
18. Specifications and Estimated Uncertainties for Peak-to-Peak Detector Services .....	140
19. Specifications and Estimated Uncertainties for RF Micropotentiometer Calibrations .....	140
20. Specifications and Estimated Uncertainties for Data Converter Calibrations .....	144
21. Available Values of the Parameters for Routine Wattmeter, Watthour Varmeter and Varhour Testing .....	160
22. Summary of NIST Standard Field Strength Facilities .....	183
23. NIST Impulse Generator Spectrum Amplitude Measurement Service Capabilities .....	185
24. Limits of Uncertainty for Calibration of Fast Repetitive Baseband Pulse Parameters .....	185



# List of Figures

---

Figure	Page
1. Accuracy of Length Measurements at NIST.....	15
2. Precision of Angle Calibrations for Master Angle Gage Blocks and Polygons .....	22
3. Total Uncertainty for the NIST Airspeed Measurements Capability.....	35
4. NIST Precision of Weighing for Mass Standards Ranging from $10^{-8}$ to $10^{-4}$ Kilograms.....	38
5. Uncertainties of NIST Low Pressure and Vacuum Standards.....	58
6. Uncertainties for NIST Calibration of Temperature Measuring Instruments .....	61
7. Uncertainties for NIST Spectral Radiance Calibrations.....	81
8. Uncertainties for NIST Spectral Irradiance Calibrations of Type FEL Lamps .....	82
9. Uncertainties of NIST DC Voltage Measurements.....	128
10. Uncertainty for NIST Data Converter Test System for Resolutions from 12-18 Bits.....	144
11. Estimated Total Uncertainties of the NIST Phase Angle Calibration Standard .....	157

---

# Contents

---

---

## Chapter 1 – Policies

A. Introduction	1
B. Types of Services	1
C. Criteria for Quality Assurance	1
D. Fees	2
E. Reports of Test Results	2
F. Traceability	2
G. Reference to NIST Advertisements	2
H. Disclaimer	3
I. Questions and Inquiries	3

## Chapter 2 – Ordering Instructions – Domestic Customers

A. Turnaround Time	5
B. Prearrangements and Scheduling	5
C. Purchase Order	5
D. Shipping, Insurance, and Risk of Loss	6

## Chapter 3 – Special Instructions – Foreign Customers

A. Criteria for Providing Service	9
B. Special Instructions	9
C. Foreign Inquiries	10

---

## Chapter 4 – Dimensional Measurements

A. Length Measurements	13
10010C .....Gage Blocks	
10020C .....Line Standards	
10030C .....Surveying and Oil Gaging Tapes	
10040S .....Special Tests of Surveying Leveling Rods	
10050S .....Special Tests of Length Standards	
10060S .....Special Tests of Sieves	
<hr/>	
B. Diameter Measurements	17
11010S .....Special Tests for Plug Gages: External Diameter Standards	
11020C .....Measuring Wires for Threads and Gears	
11030S .....Special Tests for Spherical Diameter Standards: Balls	
11040S .....Special Tests for Internal Diameter Standards: Ring Gages	
11050S .....Special Tests of Length and Diameter	
11060S .....Special Tests of Step Gages	
11070S .....Special Diameter Measurement, by Prearrangement	

---

---

C. Complex Dimensional Standards	19
12010C .....API Threaded Plug and Ring Gages	
12020S .....Special Tests of Threaded Plug and Ring Gages	
12030S .....Special Tests of Two-Dimensional Gages	
12040S .....Special Complex Dimensional Tests, by Prearrangement	
D. Optical Reference Planes & Roundness Standards	21
13010S .....Special Tests of Optical Reference Planes (Flats)	
13020S .....Special Tests of Roundness	
13030S .....Special Tests of Roundness Calibration Specimens	
E. Angular Measurements	22
14010C .....Angle Gage Blocks	
14020S .....Special Tests of Optical Polygons	
14030S .....Special Tests of Rotary and Indexing Tables	
14040S .....Special Tests of Wedges	
14050S .....Special Angular Measurements, by Prearrangement	
F. Laser Measurements	24
14510S .....Laser Frequency/Wavelength	
G. Surface Texture	25
15010C .....Roughness Calibration Specimens	
15020C .....Surface Roughness Comparison Specimens	
15030C .....Step Height Measurements	
H. Hydrometers	27
16010C .....Reference Standard Hydrometers	
I. Volume and Density	28
17010C .....Volume Standards	
17020S .....Special Tests of Volume Standards	
17040S .....Special Tests of Density: Liquids	

---

## **Chapter 5— Mechanical Measurements**

A. Flow Rate Measurements	31
18010C .....Single Turbine Meters	
18020C .....Tandem Turbine Meters	
18030C .....Flow Rate Meters (Direct Reading in Flow Rate Units)	
18040C .....Head Class Flow Measurement Devices	
18050S .....Special Tests for Liquid and Gas Flow Rates	
B. Flow Measurements at Cryogenic Temperatures	34
18800S .....Special Tests of Cryogenic Liquid Flow	

---

C. Airspeed Measurements	35
19010C . . . . . Pitot-Static Tubes 1.3 to 67 m/s (3 to 150 mph)	
19020C . . . . . Low Airspeed Instruments 07.6 to 10.2 m/s (15 to 2,000 fpm)	
19030S . . . . . Meteorological Airspeed Instrumentation 1.3 to 67 m/s (3 to 150 mph)	
19040S . . . . . Special Tests of Airspeed Instruments	
D. Mass Standards	37
22010C-22030C . . . Single Weight Sets (1 mg to 30 kg)	
22040C-22110C . . . Single Weights (1 mg to 30,000 kg)	
22130C-22150C . . . Single Weights for Deadweight Pressure Testers	
22170S . . . . . Special Mass Measurement Services	
22180M . . . . . Measurement Assurance Program for Mass	
E. Force Measurements	41
23010C-23240C . . . Force Transducers (to 1,000,000 lbf, 1 or 2 Modes)	
23250C . . . . . Force Transducers (over 1,000,000 lbf)	
23260S . . . . . Special Tests of Force Transducer	
F. Vibration Measurements	43
24010C-24030C . . . Vibrations (Pickup Sensitivity, 2 to 10,000 Hz)	
24040S . . . . . Special Shock Measurement Services	
24050S . . . . . Special Tests of Pickup Sensitivity	
24060S . . . . . Special Vibration Tests	
G. Acoustic Measurements	45
25010C-25020C . . . Pressure Response: WE Type 640AA Microphones or Equivalent	
25030C-25040C . . . Pressure Response: Tokyo Riko Type ECL MR 112, or Equivalent Half-Inch Microphones	
25050C . . . . . Free-Field Response: Tokyo Riko Type ECL MR 112, B&K Types 4133, 4134, 4165, 4166, or 4180 Equivalent Half-Inch Microphone	
25060S . . . . . Special Tests of Acoustic Devices	
25070S . . . . . Special Tests of Earphones	
H. Ultrasonic Reference Block Measurements	48
26030S,26050S,26070S . . . Special Tests of Aluminum Reference Blocks	
26040S,26060S,26070S . . . Special Tests of Titanium or Steel Reference Blocks	
26080S . . . . . Special Tests of Velocity Reference Blocks	
I. Ultrasonic Transducer Measurements	50
26100C . . . . . Ultrasonic Transducer Power Output; Radiation Pressure	
26110C . . . . . Ultrasonic System Power Output; Calorimeter	
26120S . . . . . Special Tests of Ultrasonic Transducers	

---

J. Acoustic Emission Transducer Measurements	52
226200C . . . . .Acoustic Emission Transducer Amplitude and Phase Sensitivity versus Frequency	
26210S . . . . .Special Tests of Acoustic Emission Transducers and Sensors	

---

**Chapter 6—  
Thermodynamic Quantities**

A. Pressure Measurements	55
29010C . . . . .Deadweight Piston Gages	
29020C . . . . .Controlled Clearance Piston Gages	
29030C . . . . .Pressure Gages and Transducers	
29035C . . . . .Mercurial Barometers and Manometers	
29040S . . . . .Special Tests of Pressure Gages	

---

B. Low Pressure, Vacuum, and Leak Measurements	57
30010C–30011C . . . . .Absolute Low-Pressure Transducers	
30020C–30021C . . . . .Differential Low-Pressure Transducers	
30025C . . . . .Ball-Type Deadweight Tester	
30029C–30031C . . . . .Molecular Drag Gages	
30034C–30038C . . . . .Ionization Gages	
30040S . . . . .Special Tests of Low-Pressure Gages	
30050S . . . . .Special Tests of Vacuum Gages	
30060S . . . . .Special Tests of Leak Artifacts	

---

C. Laboratory Thermometers	60
31010C–31060C . . . . .Laboratory Thermometers	
31070C . . . . .Calorimetric Thermometers	
31080C . . . . .Beckmann Thermometers	
31100C . . . . .Quantity Tests of Liquid-in-Glass Thermometers	
31110S–31160S . . . . .Special Tests of Thermometers	
31260S . . . . .Special Thermometry Services, by Prearrangement	

---

D. Thermocouples, Thermocouple Materials, and Pyrometer Indicators	62
32010C–32044C . . . . .Type S, R, B, E, J, K, N, and T, Measured with Standard Thermocouples Covering 0–1750 °C	
32070C . . . . .Thermocouple Materials Tests against Pt Thermoelectric Standard with PRT (–100 to 300 °C)	
32090C . . . . .Type S Measured with Freezing-Point Standards (0–1450°C)	
32100C . . . . .Pyrometer Indicators (Portable Potentiometers, First Dial or Range)	
32110C–32147C . . . . .Thermocouple Materials Tested against PT Standard with PRT-Varian Temperature Ranges	
32150S . . . . .Special Tests of Thermocouples and Thermocouple Materials	

---

E. Resistance Thermometry	65
33010C–33130C...Capsule Platinum Resistance Thermometers	
33410C.....Germanium and Rhodium-Iron Resistance Thermometers	
33150C–33310C...Long Stem Platinum Resistance Thermometers	
33350S.....Special Tests of Resistance Thermometers	
33360S.....Special Tests of Thermometric Fixed-Point Devices	
33370M–33390M..Measurement Assurance Program for Temperature	
<hr/>	
F. Radiation Thermometry	69
35010C–35040C...Optical Pyrometers	
35050C–35060C...Ribbon Filament Lamps (800 to 2300 °C)	
35070S.....Special Tests of Radiation Pyrometers	
<hr/>	
G. Humidity Measurements	71
36010C–36020C...Dew-Point Hygrometers	
36030C.....Electric Hygrometers	
36040C.....Electrolytic Hygrometers	
36050C.....Aspirated Hygrometers	
36060C.....Pneumatic Bridge Hygrometers	
36070S.....Special Tests of Humidity	
<hr/>	
H. Total Heat Flux Gauges	73
36510S.....Special Tests of Total Heat Flux Gauges	

## Chapter 7 – Optical Radiation Measurements

A. Photometric Measurements	75
37015C.....Luminous Intensity Rental Program	
37025C.....Luminous Intensity-Submitted Lamp	
37035C.....Color Temperature Determination on Lamp Submitted for 37025C	
37080S.....Special Tests for Luminous Flux of Incandescent Lamps	
37140C.....Airway Beacon Lamps	
37170C.....Opal Glass Luminous Directional Transmittance Standards	
37180S.....Special Photometric Tests	
<hr/>	
B. Spectrophotometric Measurements	77
38010C–38040C...Spectral Transmittance Filters	
38050C.....Wavelength Standards (Holmium Oxide Glass)	
38060S.....Special Tests of Spectral Transmittance and Reflectance	
38070M–38074M..Measurement Assurance Program for Retroreflectance	
38080M.....Measurement Assurance Program for Transmittance	

---

38090S .....	Special Tests of X-Ray Photographic Step Tablets	
38100S .....	Special Tests of Microcopy Resolution Test Charts	
<hr/>		
C.	Radiometric Measurements	81
39010C–39030C...	Spectral Radiance Ribbon Filament Lamps	
39040C–39045C...	Spectral Irradiance Quartz-Halogen Lamps (250–2400 nm)	
39050C .....	Spectral Irradiance Deuterium Lamps (200–350 nm)	
39060S .....	Special Tests of Radiometric Sources	
39070C .....	Photodiode Spectral Response Rental Package	
39080S .....	Special Tests of Radiometric Detectors	
<hr/>		
D.	Radiometric Standards in the Far Ultraviolet	84
	<i>D.1 Standard Sources</i>	
40010C .....	Spectral Irradiance Standard, Argon Mini-Arc	
40020C .....	Spectral Radiance Standard, Argon Mini-Arc	
40030C .....	Spectral Irradiance Standard, Deuterium Arc Lamp	
40040S .....	Special Tests of Radiometric Devices in the Near and Vacuum Ultraviolet	
<hr/>		
	<i>D.2 Standard Detectors in the Far Ultraviolet</i>	86
40510C–40561C...	Detector Standard, Windowless Photodiode	
40599S .....	Special Tests on Detectors from the Near Ultraviolet to the Soft X-Ray Region	
<hr/>		
E.	Laser Power and Energy	88
42110C–42111C...	Laser Power and Energy Meter Calibrations	
42120M .....	Laser Power and Energy Measurement Assurance Program	
42130C–42131C...	Optical Fiber Power Meter Calibrations	
42140M .....	Optical Fiber Power Meter Measurement Assurance Program	
42150M .....	Low-Level Laser Measurement Assurance Program	
42160C .....	Pulsed 10.6- $\mu$ m Laser Calibrations	
42170S .....	Special Tests for Laser Power and Energy Meters	
42180S .....	Special Tests for Optical Fiber Power Meters	

---

## Chapter 8— Ionizing Radiation Measurements

A.	Radioactivity Sources	95
43010C–43020C...	Gamma-Ray-Emitting Radionuclides in Solution	
43030C–43050C...	Alpha-Particle-Emitting Solid Sources	
43060S–43070S ...	Special Tests of Beta-Particle-Emitting Solution Sources	
43090S .....	Special Tests of Alpha-Particle-Emitting Solid Sources	

---

<hr/>	
B. Neutron Sources and Neutron Dosimetry	100
44010C–44020C...Radioactive Neutron Sources	
44060C .....Personnel Protection Instrumentation, Californium Source Bare and Moderated	
44070C .....Activation Detector Dosimetry, Thermal Neutrons	
44080C .....Activation Detector Dosimetry, Californium Fission Neutrons	
44090C .....Activation Detector Dosimetry, <sup>235</sup> U Cavity Fission Source	
44100S .....Special Tests of Neutron Sources and Dosimeters	
<hr/>	
C. Dosimetry of X Rays, Gamma Rays, and Electrons	103
C.0 <i>Special Instructions for Using Electron and Photon Dosimetry                 Calibration and Test Services</i>	
C.1 <i>X-Ray and Gamma-Ray Measuring Instruments</i>	
46010C–46011C...Radiation Detectors – Calibration/Correction Factor	
46020C–46021C...Passive Dosimeters	
46030S .....Special Tests of High-Gain Electrometers – Charge Sensitivity	
46040S .....Special Tests of X-Ray Penetrimeters, Ardran-Crookes Type	
46050S .....Special Tests of X-Ray and Gamma-Ray Measuring Instruments	
<hr/>	
C.2 <i>Gamma-Ray Sources, Beta-Particle Sources, and Measuring Instruments</i>	107
47010C–47011C... Gamma-Ray Sources	
47030C–47035C... Beta-Particle Sources	
47036C ..... Ionization Chambers	
47040S .....Special Tests of Gamma-Ray and Beta-Particle Sources	
<hr/>	
C.3 <i>Dosimetry of High-Energy Electron Beams</i>	108
48010M–48011M..Irradiation of Ferrous-Ferric Dosimeters	
48020S .....Special Tests of Electron-Beam Dosimeters	
<hr/>	
D. Dosimetry for High-Dose Applications	110
49010C .....Calibration Irradiations of Customer-Supplied Dosimeters Irradiated with <sup>60</sup> Co Gamma Rays	
49020C–49030C...Dose Interpretation of NIST Transfer Dosimeters Irradiated by Customer	
49040S–49041S ...Special Tests of Dosimeters By Reading with Spectrophotometer	
49050S .....Special Measurement Services for Dosimeter Response and Dose Distributions	
<hr/>	

**Chapter 9 –  
Electromagnetic Measurements**

A. Resistance Measurements	113
A.1 <i>DC Resistance Standards and Measurements</i>	
51100S .....Special Resistance Measurement Services, by Prearrangement	



---

51110M.....	Measurement Assurance Program Services for Resistance	
51130C.....	Standard Resistor, Thomas-Type, 1 $\Omega$	
51131C.....	Standard Resistor, Evanohm Wirewound High Precision, 10 k $\Omega$	
51132C–51138C...	Standard Resistor, Four-Terminal, 0.001–100 $\Omega$	
51139C–51154C...	Standard Resistor, 1 k $\Omega$ –1 T $\Omega$	
51160C–51163C...	Standard Resistor, for Current Measurements (Shunts)	
A.2	<i>High-Voltage Standard Resistors</i>	117
51210C.....	High-Voltage Standard Resistors	
A.3	<i>High-Frequency Standard Resistors</i>	118
51310S.....	High-Frequency Standard Resistors, Two-Terminal	
A.4	<i>AC Resistors</i>	
51410S.....	Special Tests of AC Resistors, by Prearrangement	119

---

B.	<i>Impedance Measurements (Except Resistors)</i>	120
B.1	<i>Low-Frequency Capacitance and Inductance Measurements and Standards</i>	
52110S.....	Special LF Impedance Measurements, by Prearrangement	
52130C–52131C...	Standard Fixed, Fused-Silica, Dielectric Capacitor	
52140C–52141C...	Fixed Three-Terminal, High-Precision Standard Capacitor with Coaxial Connectors	
52150C.....	Physical Tests to Qualify Three-Terminal Air Capacitors for Measurement	
52160C–52161C...	Fixed Three-Terminal Standard Capacitor with Coaxial Connectors	
52170C–52171C...	Two- or Three-Terminal Solid Dielectric Standard Capacitor	
52180C–52181C...	Fixed Inductor, Self or Mutual	
B.2	<i>High-Frequency Standard Capacitors and Inductors</i>	124
52210S–52211C...	Two-Terminal, Low-Loss, Standard Capacitors	
52220S–52221C...	Three-Terminal, Low-Loss, Standard Capacitors	
52310S.....	Two-Terminal, High-Q Standard Inductors	
B.3	<i>Power-Frequency Capacitors</i>	126
52400C.....	Power-Frequency Capacitors	
B.4	<i>Q-Standards</i>	127
52710C–52711C...	Inductive Q-Standards	

---

C.	<i>Voltage Measurements</i>	
C.1	<i>DC Voltage Measurements and Standards</i>	128
53110S.....	Special DC Voltage Measurements, by Prearrangement	
53120M.....	Measurement Assurance Program for DC Voltage	
53130C–53131C...	Saturated Standard Cells	
53140C.....	Platinum Resistance Thermometer Temperature Determination for Standard Cell Calibration	

---

53150C .....	Unsaturated Standard Cells	
53160C–53161C...	Tests of Solid-State Voltage Reference Standard	
53180S–53190S ...	Special Handling	
C.2	<i>AC Voltage Measurements</i>	133
53200S .....	Special Tests of High-Accuracy Digital Multimeters, Multifunction Calibrators, by Prearrangement	
53201S .....	Special Tests of Low-Voltage AC–DC Transfer Standards, by Prearrangement	
C.3	<i>AC–DC Thermal Voltage and Current Converters (to 1 MHz)</i>	135
53310S .....	Special AC–DC Measurement Services, by Prearrangement	
53340C–53341C...	AC–DC Thermal Voltage and Current Converters	
C.4	<i>RF-DC Thermal Voltage and Current Converters (100 Hz–1 GHz)</i>	138
53405S .....	Special Tests of AC Thermal Voltage Converters, by Prearrangement	
53410C–53415C...	Low-Frequency TVC Calibrations	
53420C–53421C...	High-Frequency TVC Calibrations	
53430S–53431S ...	Peak-to-Peak Detector Calibrations	
53440S .....	Special Tests of RF Micropotentiometers, by Prearrangement	
53441C .....	RF Micropotentiometer Calibration	
53445S .....	Special Calibration of RF Micropotentiometer	
C.5	<i>Data Converters</i>	142
53500S .....	Special Data Converter Services, by Prearrangement	
53510C .....	A/D or D/A Converters, Linearity Errors, 10-Bit Correction Coefficients, and Superposition Errors	
53520C .....	A/D or D/A Converters, Differential Linearity Errors	
53530C .....	A/D Converter, Equivalent RMS Input Noise	
53540S .....	A/D or D/A Converters, Offset and Gain Errors Relative to Legal Volt	

---

D.	Precision Ratio Measurements	
D.1	<i>Inductive Dividers</i>	146
54110S .....	Special Ratio Measurements and Tests of Inductive Voltage Dividers, by Prearrangement	
54120C–54131C...	Inductive Voltage Dividers	
D.2	<i>Resistive Dividers</i>	148
54210C .....	Resistor and Resistive Dividers, Total Resistance or Voltage Ratio	
54211S .....	Special Tests of Resistor and Resistive Dividers at Direct Voltage Levels, by Prearrangement	

54212C . . . . .	Resistor and Resistive Dividers at 60 Hz, Voltage Ratio and Phase Angle	
54213S–54214S . . .	Special Tests of Resistor and Resistive Dividers	
<i>D.3 Capacitive Dividers</i>		151
54310S–54311S . . .	Special Tests of Capacitive Dividers	
<i>D.4 Mixed Dividers</i>		152
54410S . . . . .	Pulse Voltage Measuring Systems, Including Kerr Cells	
<i>D.5 Voltage and Current Transformers</i>		153
54510C–54513C . . .	Voltage Transformers, Ratio and Phase Angle	
54520C–54522C . . .	Current Transformers, Ratio and Phase Angle	
54600S . . . . .	Special Tests of Dividers and Transformers, by Prearrangement	
<hr/>		
<i>E. Phase Measurements and Air Navigation Aids</i>		156
<i>E.1 Phase Meters and Standards</i>		
55110S . . . . .	Special Tests of Phase Standards and Related Instruments, by Prearrangement	
55120C–55141C . . .	Phase Meters	
<i>E.2 Very-High-Frequency Omnidirectional Range (VOR) Measurements</i>		158
55210C–55211C . . .	VOR Bearing-Angle Indicators	
55220C–55221C . . .	VOR Generators	
55230S . . . . .	Special VOR Tests	
<hr/>		
<i>F. Power and Energy Measurements, Low Frequency</i>		160
56110S . . . . .	Special Tests of AC–DC Wattmeters, by Prearrangement	
56200C–56202C . . .	Watt, Watthour, Var, or Varhour Meter at 60 Hz	
56210M . . . . .	Measurement Assurance Program for Watthour Meters	
<hr/>		
<i>G. Microwave Measurements</i>		163
<i>G.1 Bolometer Units, RF and Microwave</i>		
61110S–61129S . . .	Coaxial Thermistor Mounts, Combinations of Calibration Factor, Effective Efficiency Factor, and Reflection Coefficient at Specified Frequencies in Range 0.1 MHz to 26 GHz	
61144S–61155S . . .	Rectangular-Waveguide Power Meters, Combinations of Effective Efficiency, Efficiency Factor and Reflection Coefficient within Specified Frequency Bands Covering 8.2–96 GHz	
61190S . . . . .	Special Microwave and RF Power Measurement Services, by Prearrangement	
<i>G.2 Attenuators, RF and Microwave</i>		167
61210S . . . . .	Coaxial Fixed and Variable Attenuators, 10 MHz to 26 GHz	

---

61211C	.....Coaxial Fixed and Variable Attenuators, Measured at 30 MHz	
61215C	.....Waveguide Circular (Below Cutoff) (Piston) Attenuator, Coaxial Connector, Measured at 30 MHz	
61230S	.....Rectangular Waveguide Fixed and Variable Attenuators, WR10-WR42 Waveguide Bands	
61240S	.....Special Attenuation Measurements of Three- Port and Two-Port Devices at 1.25 MHz	
61250S	.....Special Attenuation Measurements, by Prearrangement	
<i>G.3</i>	<i>Coaxial and Waveguide Terminations, Reflection Coefficients</i>	170
61310S	.....Complex Reflection Coefficient of Coaxial Terminations, 10 to 26 GHz	
61320S	.....Complex Reflection Coefficient of Rectangular Waveguide Terminations with Standard Flange Connectors at Frequencies within WR10-WR42 Waveguide Bands	
61340S	.....Special Reflection Coefficient Measurements, by Prearrangement	
<i>G.4</i>	<i>Phase Shifters, RF and Microwave</i>	172
61410S	.....Coaxial Fixed and Variable Phase Shifters; Characteristic Phase Shift Difference; Precision Connectors; Measured at 30 MHz, Range 0–360°	
61411S	.....Coaxial Fixed and Variable Phase Shifters; Phase Shift Difference; Precision Connectors; 1–26 GHz, Range 0–360°	
61420S	.....Variable Rectangular Waveguide Phase Shifters; Phase Shift Difference at Frequencies WR10-WR42 Waveguide Bands, Range 0–720°	
61450S	.....Special Tests of Phase Shifters, by Prearrangement	
<i>G.5</i>	<i>Dimensional Verification of Coaxial Air Line Standards</i>	174
61510S	.....Coaxial Air Lines	
<i>G.6</i>	<i>Dielectric Material Measurements</i>	175
61620S	.....Special Tests for Dielectric Materials, 0.05 to 18 GHz	

---

<i>H.</i>	<i>Noise Temperature Measurements</i>	176
62020S	.....Special Noise Temperature Measurements (Electromagnetic), by Prearrangement	
62100S-62111S	.... Noise Temperature of Coaxial Noise Sources, Type N Precision or 14-mm Connectors	
62112S-62113S	....Noise Temperature of Coaxial Noise Source, APC 3.5 Connector	

---

62115S-62116S...	Special Service for Waveguide Noise Sources at Frequencies within WR90-WR284 Waveguide Bands	
62120S-62121S...	Noise Temperature of Rectangular Waveguide Noise Sources at Specified Frequencies in WR62 and WR90 Waveguide Bands	
62130S-62131S...	Noise Temperature of WR10 Noise Sources	
62132S-62133S...	Noise Temperature of WR15 Noise Sources	

---

I.	Electromagnetic Field Strength and Antenna Measurements	179
I.1	<i>Microwave Antenna Parameter Measurements</i>	
63100S	Gain and Polarization of Standard Antennas Using Extrapolation Range	
63200S	Measurement of Pattern, Gain, and Polarization of Arbitrary Antennas Using Near-Field Scanning Techniques	
63300S	Special-Test Service for Calibration of Probes Used with Near-Field Scanning Techniques	
63400S	Special Consulting, Advisory, and Other Services	
I.2	<i>Field Strength Parameter Measurements</i>	182
64100S	Special-Test Service for Antennas/Field Strength Measurements, Utilizing Transverse Electromagnetic Cell Method	
64200S	Special-Test Service for Antennas/Field Strength Measurements, Utilizing the Open Field Method	
64300S	Special-Test Service for Antennas/Field Strength/Reflectivity Measurements, Utilizing the Anechoic-Chamber Method	

---

J.	Pulse Waveform Measurements	184
65100S	Impulse Generator Spectrum Amplitude (50 Ohm)	
65200S	Fast Repetitive Broadband Pulse Parameters (50 Ohm)	
65300S-65301S...	Network Impulse Response of Coaxial Networks, 10 MHz to 10.0 GHz	
65400S	Pulse Time Delay through Coaxial Transmission Lines	

---

**Chapter 10—  
Time and Frequency Measurements**

A.	Time and Frequency Dissemination	189
76100S	Special Frequency Measurement Service	
76110S	Special Global Time Service	

---

---

B. Oscillator Characterization	191
77100C.....Precision Oscillator Frequency Calibration	
77110C.....Characterization of Atomic Time and Frequency Standards	
77120C–77131C...Characterization of Precision Oscillators: Time and Frequency Domain	
77140S.....Special Time/Frequency Measurements	

---



---

# Chapter

# 1

- A** Introduction
- B** Types of Services
- C** Criteria for Quality Assurance
- D** Fees
- E** Reports of Test Results
- F** Traceability
- G** References to NIST in Advertisements
- H** Disclaimer
- I** Questions and Inquiries



## **A.** Introduction

The physical measurement services of the National Institute of Standards and Technology (NIST) are designed to help the makers and users of precision instruments achieve the highest possible levels of measurement quality and productivity. The hundreds of individual services you will find listed and described in this Users Guide constitute the highest order calibration services available in the United States. They directly link a customer's precision equipment or transfer standards to national measurement standards. These services are offered to public and private organizations and individuals alike.

## **B.** Types of Services

You will find three types of physical measurement services described in this guide: Calibration Services, Special Tests, and Measurement Assurance Programs.

Calibrations and Special Tests generally designate those NIST services that check, adjust, or characterize particular instruments, devices, and sets of standards on a one-time-per-request basis. The customer, in most cases, ships an item requiring calibration to the appropriate NIST laboratory in Gaithersburg, Maryland, or Boulder, Colorado, as noted in this Users Guide and in the separate Fee Schedule. The calibrated item is shipped back to the customer, followed, under separate cover, by a report of test procedures and results.

Measurement Assurance Programs, or MAPs, are quality control programs for calibrating a customer's entire measurement system. In a typical MAP, a stable artifact or set of artifacts—called transfer standards—are first measured by NIST and sent to a customer's laboratory for a series of measurements. The transfer standards are then returned to NIST for

remeasurement, along with the participating laboratory's results. NIST reports its comparative findings to the customer and, when necessary, offers guidance on how to achieve and maintain measurement quality.

Successful use of a NIST MAP requires that the customer make periodic measurements of in-house check standards to estimate the random error and to ensure that the measurement process remains in a state of statistical control. Unless a laboratory has a measurement quality control program to monitor continuously its own measurement process parameters, there is little point in participating in a MAP.

**PLEASE NOTE:** NIST does not audit, regulate, or accredit metrology laboratories as part of the MAP services. Whatever steps a participating laboratory may take to improve its measurement process are undertaken voluntarily.

## **C.** Criteria for Quality Assurance

All the measurement services described in this guide meet rigorous criteria for quality assurance. Calibration Services and MAPs satisfy the most demanding and explicit requirements in that these services are carried out regularly under pre-established and well-defined conditions; the measurement processes involved are well-characterized, stable, and statistically controlled; and quality-control procedures are well-defined and strictly followed. Furthermore, each Calibration Service or MAP is planned and documented to permit continuity of service over time.

A Special Test is so designated for one or more of the following reasons: 1) the specific type of calibration is seldom requested, thus precluding the maintenance of a large statistical base for controlling the measurement process, 2) the test requested is unique, or 3) the service is still under

development—meaning the measurement or calibration methods are still being perfected or all the quality-control documentation has yet to be completed.

## **D.** Fees

NIST recovers the cost of providing calibration services by charging a fee for each calibration performed. These fees range from a low of less than \$150 for calibration of a laboratory thermometer to \$50,000 or more for special tests of large microwave antenna systems.

The costs of services are not stated in the Users Guide. Instead, they are listed in a separate Fee Schedule, which is updated and published, effective January 1 annually to reflect changes in prices and services. Even so, many services are performed at cost and you must provide the technical contact with an exact description of work before receiving a price quote. Request a free copy of the current Fee Schedule by writing or calling the Physical Measurement Services Program (see section I).

## **E.** Reports of Test Results

Reports on calibrations or other services are regarded as the property of the customer. Copies are not supplied to other parties except as required by federal law or requested in writing by the customer. The results of calibrations and tests performed by NIST apply only to a particular instrument or standard at the time of test unless otherwise clearly stated.

## **F.** Traceability

Many Federal regulations and contracts require regulated organizations or contractees to verify that the mea-

surements they make are “traceable” and to support the claim of traceability by auditing records for equipment used in the calibration process. This regulatory requirement implies the ability to relate individual measurement results through an unbroken chain of calibrations to a common source, usually U.S. national standards as maintained by NIST, or intrinsic standards based on fundamental constants of nature with values assigned or accepted by NIST. To adequately establish an audit trail for traceability, a proper calibration result should include: the assigned value, a stated uncertainty, identification of the standard used in the calibration, and the specification of any environmental conditions of the calibration where correction factors should be applied if the standard or equipment were to be used under different environmental conditions.

NIST is supportive of the practice of making the user aware of traceability and providing the user details as to how traceability was established; however, at the same time NIST cannot condone the prominent display of its name on proprietary products or in the advertising of them. (See Sec. G).

NIST does not define nor enforce traceability. Moreover, NIST is not legally required to comply with traceability requirements of other federal agencies; nor do we determine what must be done to comply with another party's contract or regulation calling for such traceability. However, NIST can and does provide technical advice on how to make measurements consistent with national standards.

## **G.** Reference to NIST Advertisements

NIST test results or reports shall not be used to indicate or imply that the National Institute of Standards and Technology approves, recommends,

or endorses the manufacturer, supplier, or user of any instruments or standards or that NIST in any way guarantees or predicts the future performance of items after calibration or test. No reference shall be made to NIST or to reports or results furnished by NIST in any advertising or sales promotions which would indicate or imply that NIST approves, recommends, or endorses any proprietary product or proprietary material. (For more information, please request Letter Circular 1128).

## **H.** Disclaimer

Commercial products—materials and instruments—are identified in this document for the sole purpose of adequately describing experimental or test procedures. In no event does such identification imply recommendation or endorsement by the National Institute of Standards and Technology of a particular product; nor does it imply that a named material or instrument is necessarily the best available for the purpose it serves.

## **I.** Questions and Inquiries

This Users Guide is designed to make the task of selecting and ordering an appropriate calibration service as quick and easy as possible. Nevertheless, questions will arise. When they do, we urge you to call or write for immediate clarification. Address general questions and lengthy inquiries to:

Physical Measurement Services  
Program  
National Institute of Standards and  
Technology  
Building 411, Room A112  
Gaithersburg, MD 20899-0001  
Telephone: (301) 975-2002  
Telefax: (301) 975-2128

If you have a technical question concerning a specific service, contact directly one of the NIST staff members responsible for that calibration area. Consult the section of this guide that describes the service in question for names, addresses, and telephone numbers.

---

# Chapter

# 2

- A** Turnaround Time
- B** Prearrangements and Scheduling
- C** Purchase Order
- D** Shipping, Insurance, and Risk of Loss

# Ordering Instructions – Domestic Customers

## **A.** Turnaround Time

Normal turnaround time for NIST calibration services varies greatly—usually from several weeks to six months—depending on the type of service requested and fluctuations in workload. Some services are only provided on a scheduled basis with appointments made many months in advance of the service date. To avoid unnecessary scheduling or administrative delays in the calibration process, always make prearrangements with the technical contact for the service you intend to utilize. See section B for more information on Prearrangements.

## **B.** Prearrangements and Scheduling

Services are best arranged in advance, beginning with a call or letter from the customer to a NIST staff member directly responsible for the desired service. See the appropriate technical section of this Users Guide or the separate Fee Schedule to determine whom to call or write. This advance communication can clear up any questions you may have, clarify the policies and procedures briefly described here, and permit you to tentatively schedule a calibration date. Following the initial communication, you will immediately need to fill out and send in a purchase order and prepare and ship the item according to the procedures described below. If a calibration must be scheduled far in advance, you may arrange to delay shipment of the item until shortly before the scheduled date; you must however, submit the purchase order—complete with the name and number of the desired service—before a firm calibration date can be assigned. When NIST receives your valid purchase order and assigns a firm service date, you will be notified by mail to confirm the order.

## **C.** Purchase Order

Send a purchase order to the address listed in the appropriate technical section of this Users Guide, or in the separate Fee Schedule, before you ship an item for calibration. The purchase order must:

- 1) State both the name and number of the NIST service being requested. **FAILURE TO INCLUDE THE ORDER NUMBER WILL SERIOUSLY IMPEDE SCHEDULING AND SERVICE.**
- 2) Clearly identify the item(s) being sent for calibration, including any serial number(s).
- 3) Give the name, address, and telephone number of the requesting company's procurement officer.
- 4) Give the name, address, and telephone number of the requesting company's technical contact, if different from above.
- 5) List separately the instructions for return shipment, insurance, mailing of the test report, and billing. (Federal or state agency requests for calibration services should be accompanied by a document authorizing that the cost of the service be billed to the agency.)
- 6) Clearly state any special or necessary conditions of test—such as operating frequency or temperature.
- 7) Clearly state the customer identification number; i.e., social security number (EIN) for consumer customers; tax identification number (TIN) for commercial customers; or agency location code (ALC) for government customers.
- 8) Give instructions on the purchase order, if the final report is to be handled in a special manner.

**PLEASE NOTE:** Receipt of orders by NIST does not imply acceptance of any provisions set forth in the order that are contrary to the policy, practice, or regulations of the National Institute of Standards and Technology or the U.S. government. In general, NIST will not sign any affidavits, acknowledgment forms, or other documents that may be required by company policy governing the procurement of goods and services.

## **D.** Shipping, Insurance, and Risk of Loss

Ship an instrument or standard to the address to which you mailed your purchase order. Adhere rigorously to the following procedures:

- 1) Ship only items in good repair. Apparatus in disrepair will not be calibrated. If defects are found after calibration has begun, the procedure will be terminated, a report issued, and a charge levied for work completed.
- 2) Use strong, reusable packing materials and containers marked clearly and indelibly on the outside with the requestor's name, address, and the following notation: REUSABLE CONTAINER, DO NOT DESTROY.
- 3) Follow any special shipping procedures given in the technical sections of this guide, particularly those sections covering radiation and dosimetry measurements.
- 4) Insure the shipments to and from NIST and clearly state the method of return shipment. NIST will not assume liability for loss or damage unless such loss and damage result solely from the negligence of NIST personnel. If return shipment by parcel post is requested or is suitable, NIST will prepay

the return shipment but will not insure it. When no shipping or insurance instructions are furnished, NIST will return the shipment by common carrier, collect and uninsured.

**PLEASE NOTE:** Fees for NIST services do not include shipping costs.



---

# Chapter

# 3

- A** Criteria for Providing Service
- B** Special Instructions
- C** Foreign Inquiries



# Special Instructions – Foreign Customers

## **A.** Criteria for Providing Service

The National Institute of Standards and Technology is authorized to provide measurement services, including calibrations, for organizations or individuals located outside the United States. NIST policy requires that the Physical Measurement Services Program review each request to determine if such a service is available in the requestor's country. Foreign customers must provide the following information:

- 1) A justification why NIST should perform this service, if an official standards laboratory in the country of the requestor's provide such service.
- 2) A description of the instrument or standard to be tested, particularly if it is not manufactured in the U.S.
- 3) A detailed description of the measurements that are needed or indicate the test order number as given in the Calibration Services Users Guide (NIST SP 250) or the separate Fee Schedule (NIST SP 250 Appendix).
- 4) A description of any special requirements that might affect the decision to provide the service. For example, will a need exist for adjustments to the instrument or will the time period be restricted in which the device is available for measurement?

## **B.** Special Instructions

If the request for the measurement service is accepted by NIST, the requesting organization will be notified of the cost of service and will be given the identification of the NIST laboratory that will perform the measurements. The requesting

organization must then complete the following steps:

- 1) Contact the NIST technical unit that will provide the service to determine the schedule.
- 2) Send a purchase order to the Physical Measurement Services Program. Provide complete addresses for returning the instrument and for mailing the calibration or test report.
- 3) Send a check payable in U.S. dollars to the Physical Measurement Services Program for the full cost of the service. The check must be drawn on a U.S. bank. NIST cannot begin the service until full payment has been received.
- 4) Ship the instrument or standard to the appropriate NIST technical unit, as specified in the Calibration Services Users Guide (NIST SP 250) or the separate Fee Schedule (NIST SP 250 Appendix). You must prearrange shipment with a customs broker for entry of the instrument into the U.S. with prepaid transportation from the port of entry. Air freight is most satisfactory. Entry bond is required for instruments not manufactured in the U.S. If arrangements are made with a broker in the country of origin, that broker should, in turn, have a U.S. customs broker in or near the port of entry who must arrange for the entry of the instrument and its transportation to NIST. Direct arrangements can be made with customs brokers located in the Washington, DC/Baltimore, MD, metropolitan area or in the Denver, CO, area, as appropriate. These brokers must also arrange for transportation to the port of exit after testing is completed.

## **C.** Foreign Inquiries

Foreign customers requiring additional information or clarifications can get assistance by addressing all telephone calls or correspondence to:

Physical Measurement Services  
Program  
National Institute of Standards and  
Technology  
Building 411, Room A112  
Gaithersburg, MD 20899-0001  
United States of America  
Telephone (301) 975-2002  
Telefax (301) 975-2128  
Telex: TRT 197674NIST UT



*Visit our exhibit booth at the next meeting you attend.*



---

# Chapter

# 4

- A** Length Measurements
- B** Diameter Measurements
- C** Complex Dimensional Standards
- D** Optical Reference Planes & Roundness Standards
- E** Angular Measurements
- F** Laser Measurements
- G** Surface Texture
- H** Hydrometers
- I** Volume and Density

## A.

### Length Measurements

#### Technical Contacts:

Ralph Veale  
Tel: 301/975-3502



John R. Stoup  
10010C-10050S  
Tel: 301/975-3471



William B. Penzes  
10020C  
Tel: 301/975-3477



Ronald G. Hartsock  
10030C-10040C  
Tel: 301/975-3465



Theodore D. Doiron  
10060S  
Tel: 301/975-3468

**Mailing Address:** A107 Metrology, National Institute of Standards and Technology, Gaithersburg, MD 20899-0001

Test No.	Items
10010C	Gage Blocks
10020C	Line Standards
10030C	Surveying and Oil Gaging Tapes
10040S	Special Tests of Surveying Leveling Rods
10050S	Special Tests of Length Standards
10060S	Special Tests of Sieves

#### Gage Blocks (10010C)

This calibration service provides for measurement of the length of gage blocks by either comparison to NIST master gage blocks or by direct interferometry. Generally, the length is transferred from known master blocks by a systematic intercomparison procedure using mechanical comparators. Comparators with laser scales are also available.

All gage blocks submitted for test should be in substantially new block condition, and each block should be marked with an identification number. In shipping gage blocks, extreme care should be taken against both corrosion and damage by contact with other gage blocks. All defining steel surfaces should be greased and blocks padded with waxed paper or volatile rust inhibitor treated paper. A greased steel surface coming in contact with newspaper, wrapping paper (unwaxed), or excelsior is likely to

corrode. Sets of gage blocks should have packing inside the case and the case should be bound shut, as the clasps frequently open or break during shipment.

Square or rectangular blocks or lengths up to 20 inches are routinely calibrated and the lengths reported in English or metric units. For blocks longer than 20 inches, the NIST technical contact should be consulted in advance to discuss alternative measurement techniques, approximate costs, and scheduling.

The measurement uncertainty reported is the sum of the random error in the measurement of the block under test and the estimated systematic error in the measurement process. The process used to estimate this systematic error is documented in publications referenced in this catalog. Although the uncertainty varies slightly with each measurement, the variation is usually small. A reasonable estimate for the accuracy of the calibration is 2 microinches (0.05 micrometer) for blocks under 2 inches, and with accuracy decreasing with length to 10 microinches for the 20-inch blocks.

#### Line Standards (10020C)

Line standards of 1 meter or less are measured on an instrument called a line scale interferometer, which is used to measure the distance between suitable lines on a flat surface. The instrument employs a fixed photoelectric microscope to determine the position of the scale lines, a linearly mobile carriage in the focal plane of the microscope to carry the scales, a calibrated laser interferometer to measure carriage displacement, and a temperature-controlled housing enclosing the whole apparatus.

The system is now highly automated using a laboratory microcomputer, NIST-developed optical processing, and servo electronics. With the microscope focused on the scale zero line, a servo moves the

carriage until a null signal indicates the line is centered in the microscopic field. A stepping motor then drives the carriage until the next line on the scale is reached. Servoed line centering again takes place. The carriage is now moved precisely the distance between scale lines, and the interferometer has now measured this distance in laser light wavelengths. Proceeding down the scale in this manner results in the measurement of the line spacings.

The maximum length of line standards that can be measured is 1 meter, and the maximum width of any part of the piece being calibrated cannot exceed 150 millimeters. The accuracy of the calibration depends significantly on the shape and optical properties of the line, the background, and the geometric flatness of the artifact being calibrated. If the lines have straight edges and are 2 to 10 micrometers wide, if there is good contrast between the line and the background, and if the reference surface of the artifact is flat, then the accuracy of the calibration will be near

optimum. Uncertainties as low as 0.006 micrometer have been achieved on short intervals, and on 1-meter lengths uncertainties of 0.1 micrometer can be achieved. The current overall system accuracy is limited by imprecise knowledge of the refractive index of air.

#### **Surveying and Oil Gaging Tapes (10030C)**

The calibration of surveying tapes and oil gaging tapes is carried out in a laboratory that houses two permanent working standards, a laser interferometer, and a 50-meter (200-foot) stainless steel bench. For the most part measurements are performed using a laser system that is referenced against a cube-corner retroreflector attached to a microscope, which is used manually for line location. The laboratory is maintained at 20 °C, but a control system can vary the chamber temperature from 15 to 40 °C for special tests. Calibration of tapes will normally be made with the tape under tension and supported on a horizontal-flat surface. Unless otherwise requested, the total length and each 15-meter or 50-foot subinterval will be measured and reported. Each interval calibrated on a surveying tape will have computed lengths for two (single catenary), three, four, and five equidistant points of support.

The laser standard is capable of calibrating tapes with scribed graduations to an accuracy of 2 parts per million (ppm). Calibrations made with respect to the stainless steel tape bench are normally reported to an accuracy of 10 ppm. A NIST serial number will be engraved on each calibrated tape for identification.

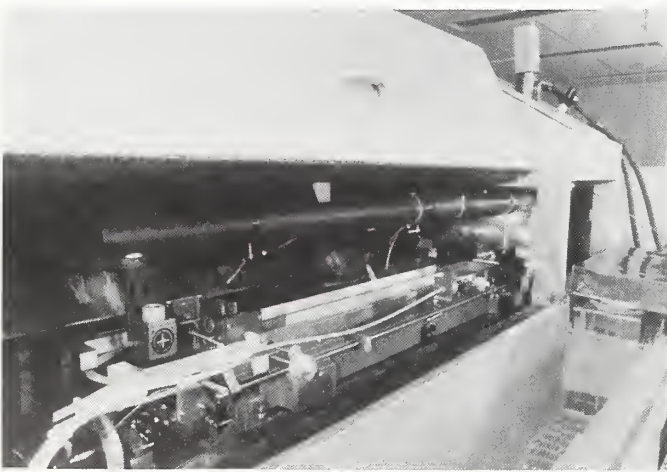

*Pictured above is the line scale interferometer used for calibrations of line standards up to 1 meter in length.*

Figure 1 summarizes the accuracy of length measurements at NIST. Included are the NIST 5-meter bar, gage block calibrations, end line standards, and geodetic/steel tapes.

Figure 1. Accuracy of Length Measurements at NIST

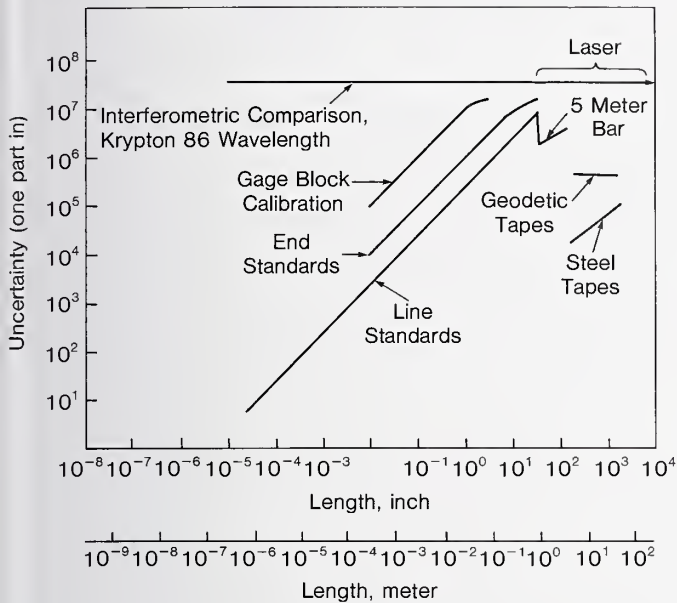

#### Special Tests of Surveying Leveling Rods (10040S)

Leveling rods are currently calibrated using two methods. One method involves the comparison of the rod to a 3-meter standard at the 1-, 2-, and 3-meter intervals. A second system provides measurement at multiple intervals and automatic report generation. This automated system incorporates a 7-meter one-dimensional measuring machine, a motorized carriage, a photoelectric microscope, and a helium-neon laser interferometer interfaced to a minicomputer. Measurements can be made on virtually any type of linear scale or leveling rod with scribed, engraved, or painted graduations. The random error of measuring high-quality leveling rods is plus or minus 6 micrometers for new rods and plus or minus 12 micrometers for used rods at the one

standard deviation level. The systematic errors are largely unevaluated, and to account for their existence the total error being reported by NIST at present is plus or minus 50 micrometers for new rods. The length of intervals will be reported as measured at 20 °C unless otherwise requested. The report can be supplied in either written or computer-readable form.

#### Special Tests of Length Standards (10050S)

Measurements on end standards with spherical ends, gage blocks of unusual shape or exotic materials, or measurement of standards between 24 and 240 inches can sometimes be done, but agreement with the technical contact should be made before sending material.

#### Special Tests of Sieves (10060S)

To determine conformity to ASTM E11 specifications.

#### References—Length Measurements

- Grid Plate Calibration at the National Bureau of Standards, T. D. Doiron, *J. Res. Natl. Bur. Stand. (U.S.)*, 93, No. 1 (Jan.-Feb. 1988).
- Interferometric Measurement of Length Scales at the National Bureau of Standards, J. S. Beers and K. B. Lee, *Prec. Eng.*, 4, No. 4, 205 (Oct. 1982).
- Contact Deformation of Gage Block Comparisons, J. S. Beers and J. E. Taylor, *Natl. Bur. Stand. (U.S.)*, Tech. Note 962 (May 1978).
- Intercomparison Procedures for Gage Blocks Using Electromechanical Comparators, J. S. Beers and C. D. Tucker, *Natl. Bur. Stand. (U.S.)*, NBSIR 76-979 (Jan. 1976).

A Gage Block Measurement Process Using Single Wavelength Interferometry, J. S. Beers, Natl. Bur. Stand. (U.S.), Monogr. 152 9Dec. 1975).

Preparations for Gage Block Comparison Measurements, C. D. Tucker, Natl. Bur. Stand. (U.S.), NBSIR 74-523 (July 1974).

Gage Block Flatness and Parallelism Measurement, J. S. Beers and C. D. Tucker, Natl. Bur. Stand. (U.S.), NBSIR 73-239 (Aug. 1973).

An Automatic Fringe Counting Interferometer for Use in the Calibration of Line Scales, H. D. Cook and L. A. Marzetta, J. Res. Natl. Bur. Stand. (U.S.), 65C, 129 (1961).



## 3. Diameter Measurements

### Technical Contacts:



**John R. Stoup**  
11010S-11070S  
Tel: 301/975-3471

**Ralph Veale**  
Tel: 301/975-3502

**Mailing Address:** A107 Metrology, National Institute of Standards and Technology, Gaithersburg, MD 20899-0001

Test No.	Items
11010S	Special Tests for Plug Gages: External Diameter Standards
11020C	Measuring Wires for Threads and Gears
11030S	Special Tests of Spherical Diameter Standards: Balls
11040S	Special Tests of Internal Diameter Standards: Ring Gages
11050S	Special Tests of Length and Diameter
11060S	Special Tests of Step Gages
11070S	Special Diameter Measurement, by Prearrangement

### General Information

For controlling dimensions in the manufacture of all products, various types of dimensional gages are used. The variety of such gages measured includes cylindrical plug gages, ring gages, balls for diameter, and screw thread gages. The diameter standards and gages, with the exception of thread and gear measuring wires, are generally intended to be used as comparison masters.

### Special Tests for Plug Gages: External Diameter Standards (11010S)

NIST will provide calibrations of external diameter standards by special arrangement. Please consult with the technical contacts listed above.

### Measuring Wires for Threads and Gears (11020C)

This service provides for measurement of the diameter of thread and gear measuring wires by intercomparison to NIST Master wires. The diameter is transferred from known Master wires using a systematized intercomparison sequence with a mechanical comparator.

All measuring wires submitted for test should be in substantially new condition, each wire should be appropriately bottled, and the bottle should be labeled with an identification number. In shipping thread wires, extreme care should be taken to prevent corrosion; all wires should be properly greased and their bottles rigidly contained inside an appropriate packing case.

Thread measuring wires for 60-degree and 29-degree threads are tested for compliance with the latest specifications in commercial use. These wires are calibrated, and the pitch diameter is computed. Gear measuring wires in the 1.92"/P, 1.728"/P, 1.68"/P, and 1.44"/P series are tested for compliance with the latest specifications in commercial use and the mean diameter reported. Accuracies are reported to a 3-sigma confidence level of 5 micrometers for English wires and 0.12 micrometer for metric wires.

### Special Tests of Spherical Diameter Standards: Balls (11030S)

Balls used in precision bearings and master balls used as transfer diameter standards are calibrated according to current commercial practice. The ball diameters reported are the undeformed sizes as calculated with the Hertz relations to maintain a consistency in reported sizes.

### Special Tests of Internal Diameter Standards: Ring Gages (11040S)

NIST will provide calibrations of ring gages by special arrangement. Please consult with the technical contacts listed.

### **Special Tests of Length and Diameter (11050S)**

NIST has a wide variety of state-of-the-art metrology equipment and can provide services associated with dimensional quality control as special tests. A three-dimensional measuring machine is available for calibration of two- and three-dimensional ball plates, two-dimensional grid plates, and other artifacts of complex shape. The machine has a working volume of 48×24×12 inches and can detect a length difference of 0.013 micrometer. Reference to the international standard of length is through interferometers. Uncertainties in the calibrations are variable. Spherical diameter standards, such as balls used in precision bearings and master balls used as transfer diameter standards, are calibrated using a laser-based mechanical comparator.

### **Special Tests of Step Gages (11060S)**

Step gages having flat parallel faces can be measured in lengths up to one meter.

### **Special Diameter Measurements, by Prearrangement (11070S)**

For requirements not covered by the services described above, special arrangements may be made by contacting Ralph Veale (301) 975-3468.

### **References – Diameter Measurements**

Federal Standard H-28, Screw Thread Standards for Federal Services. English and metric versions. These handbooks are available from the General Services Administration (GSA).

American National Standard B1.2, Amer. Natl. Stand. Inst., New York.

Designs for the Calibration of Small Groups of Standards in the Presence of Instrumental Drift, J. M. Cameron and G. E. Hieles, Natl. Bur. Stand. (U.S.) Tech. Note 844 (Aug. 1974).

On the Measurement of Thread Measuring Wires, B. N. Norden, Natl. Bur. Stand. (U.S.), Report 10987 (Jan. 1973).

Measurements of Cylindrical Standards, R.C. Veale, Natl. Bur. Stand. (U.S.), NBSIR 73-136 (1973).

On the Comparison of Cylinder in Contact with a Plane Surface, B. Norden, Natl. Bur. Stand. (U.S.), NBSIR 73-243 (1973).

## C. Complex Dimensional Standards

### Technical Contacts:



Edgar G. Erber  
12010C-12020S  
Tel: 301/975-3468



Theodore D.  
Doiron  
12030S  
Tel: 301/975-3468

Ralph Veale  
Tel: 301/975-3502

**Mailing Address:** A107 Metrology, National Institute of Standards and Technology, Gaithersburg, MD 20899-0001

Test No.	Items
12010C	API Threaded Plug and Ring Gages
12020S	Special Tests of Threaded Plug and Ring Gages
12030S	Special Tests of Two-Dimensional Gages
12040S	Special Complex Dimensional Tests, by Prearrangement

#### API Threaded Plug and Ring Gages (12010C)

NIST provides calibration and certification services for API threaded plug and ring gages, casing, tubing and line pipe plug and ring gages as well as sucker rod gages. NIST is the custodian of the American Petroleum Institute (API) Grand Master rotary thread gages. These Grand Master gages are maintained and have been recalibrated at NIST for more than 60 years. They can be considered an international standard since all API Regional Master Gages throughout the world are referenced to NIST. Foreign product manufacturers can have their Reference Master Gages calibrated and certified by NIST or by one of the other national standard laboratories listed below:

National Physical Laboratory,  
Teddington, England

National Research Laboratory of Metrology, Tokyo, Japan  
National Standards Laboratory, Chippendale, N.S.W., Australia  
Physikalisch Technische Bundesanstalt, Braunschweig, Germany  
Laboratoire National d'Essais, Paris, France  
Instituto Nacional de Tecnologia Industrial, San Martin, Argentina  
As required, the API lab is temperature controlled at 20 °C. Parameters measured for plug gages are length of plug, taper, pitch diameter, major diameter, thread lead, lead and following thread half-angles, depth of thread, pitch line width, and radius of curvature.

Parameters measured for ring gages are length of ring, taper, thread lead, minor diameter, lead and following thread half-angles, counter bore, depth of thread, pitch line width, radius of curvature, and standoff.

These calibrations are based on a three standard deviation confidence level and are accurate to plus or minus 0.0003 inch (8 mm).

All gages received must be marked with the API monogram and the API registration number. If not so marked the gages will be returned to the customer uncalibrated. Gages which meet the specifications will be marked as specified in the API Standards. All thread gages must be submitted in sets of plug and ring. The name of the gage owner should be given for inclusion in the Report of Calibration.

#### Special Tests of Threaded Plug and Ring Gages (12020S)

NIST will provide special tests of threaded plug and ring gages. Please consult the technical contact listed.

**Special Tests of Two-Dimensional Gages (12030S)**

NIST can provide special tests of two-dimensional gages, ball plates, or grid plates, with dimensions up to 24 inches by 24 inches (0.6×0.6 meters). The accuracy of such calibrations depends substantially on the quality of the gage, but accuracies of one micrometer or better are obtainable.

**Special Complex Dimensional Tests, by Prearrangement (12040S)**

For requirements not covered by the services described above, special

arrangements may be made by contacting Ralph Veale (301) 975-3502.

**References – Complex Dimensional Standards**

On Characterizing Measuring Machine Geometry, R. J. Hocken and B. R. Borchardt, Natl. Bur. Stand. (U.S.), NBSIR 79-1752 (1979).

Three-Dimensional Metrology, R. J. Hocken et al., Annals of the CIRP, 26-1 (1977).

Unified Three-Dimensional Program – Two Useful Non-Contacting Probes, J. A. Simpson, Natl. Bur. Stand. (U.S.), Report 10597 (1971).

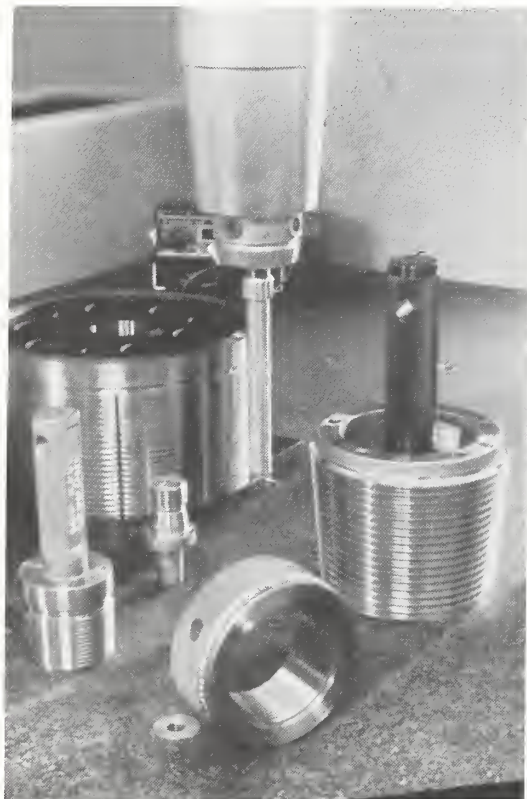

*NIST provides calibration and certification services for American Petroleum Institute (API) gages, including threaded plug and ring gages, casings, tubing and line pipe plug and ring gages, and sucker rod gages. NIST has maintained and recalibrated the API grand master rotary thread gages for more than 50 years.*

## D. Optical Reference Planes & Roundness Standards

### Technical Contacts:



John R. Stoup  
13010S  
Tel: 301/975-3741



Yun H. Queen  
13020S-13030S  
Tel: 301/975-3468

Ralph Veale  
Tel: 301/975-3502

**Mailing Address:** A107 Metrology, National Institute of Standards and Technology, Gaithersburg, MD 20899-0001

Test No.	Items
13010S	Special Tests of Optical Reference Planes (Flats)
13020S	Special Tests of Roundness
13030S	Special Tests of Roundness Calibration Specimens

### Special Tests of Optical Reference Planes (13010S)

Optical reference planes are tested interferometrically, horizontally supported with the test surface supported on three equally spaced pads located at 0.7 of the radius from the center. The measurement is performed along two marked diameters at 90° to each other on each surface when each diameter is parallel to two of the support pads.

### Roundness Calibration Specimens and Measurements, Special Tests of Roundness (13020S and 13030S)

The deviation from roundness at eight or more positions around nominally round standards is determined. The size of the calibration step or deviation from roundness on calibration standards is determined. The departure from roundness of components and gages is measured, and the results are reported in graphical form.

NIST will provide special tests of roundness calibration specimens by request. Please consult with the technical contacts listed.

### References—Optical Reference Planes

The Calibration of an Optical Flat by Interferometric Comparison to a Master Optical Flat, C. P. Reeve, Natl. Bur. Stand. (U.S.), NBSIR 75-975 (Dec. 1975).  
A Survey of the Stability of Optical Flats, C. P. Reeve and R. C. Veale, Natl. Bur. Stand. (U.S.), NBSIR 73-232 (June 1973).

# E. Angular Measurements

## Technical Contacts:



**Yun H. Queen**  
Tel: 301/975-3468

**Ralph Veale**  
Tel: 301/975-3502

**Mailing Address:** A107 Metrology, National Institute of Standards and Technology, Gaithersburg, MD 20899-0001

Test No.	Items
14010C	Angle Gage Blocks
14020S	Special Tests of Optical Polygons
14030S	Special Tests of Rotary and Indexing Tables
14040S	Special Tests of Wedges
14050S	Special Angular Measurements, by Prearrangement

### Angle Gage Blocks (14010C)

This service provides for the measurement of the angle of angle gage blocks by direct comparison to NIST master angle blocks using a dual-autocollimator system. Current autocollimators have resolution to 0.01 arc-second and electronic readout. The blocks are enclosed in a special chamber during intercomparison to minimize air currents, and the laboratory is maintained at 20 °C to within plus or minus 0.1 degree.

All angle gage blocks submitted for test should be in substantially new block condition, and each block should be marked with an identification number. In shipping angle blocks the same care as is exercised in gage block shipment should be used, as the surfaces are subject to corrosion.

All standard sizes of angle blocks can be calibrated in the NIST facilities. Blocks with angles ranging from 1 arc-second to 45 degrees are routinely handled; however, optical squares and other standards can also be accommodated. Accuracy at the 3-sigma level is approximately 0.4 arc-second; this value, however, varies with the condition of the gaging surface on the standard.

### Special Tests of Optical Polygons (14020S)

The calibration of polygons is done with autocollimation techniques. It consists of the determination of flatness of each face, variation of the angle between each face and the base (where possible the polygon will be adjusted for minimum variation), and the angle between faces. Figure 2 summarizes the precision of angle calibration for master angle gage blocks and polygons.

Figure 2. Precision of Angle Calibrations for Master Angle Gage Blocks and Polygons

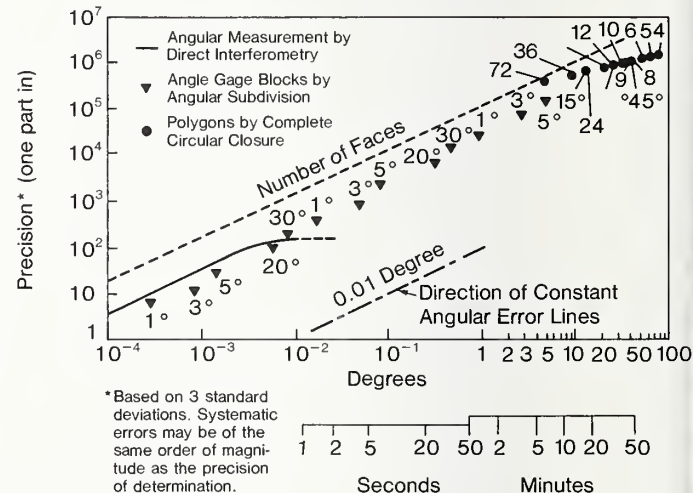

**Special Tests of Rotary and Indexing Tables (14030S)**

Instruments and tools used for the precise measurement of angle, such as precision angular rotary and indexing tables, autocollimating telescopes, or angle generating equipment, are calibrated at specific angular settings. Accuracy at the 3-sigma level is approximately 0.2 arc-second.

**Special Tests of Wedges (14040S)**

Solid angle calipers and step mirrors are calibrated by autocollimation or interferometric techniques as to the angle between faces. Wedges are calibrated by autocollimating or interferometric techniques at a specified wavelength for deviation angle. Mechanical angular references such as cylindrical squares and machinist's squares are usually calibrated by mechanical techniques.

**Special Angular Measurements, by Prearrangement (14050S)**

For requirements not covered by the services described above, special arrangements may be made by contacting Ralph Veale (301) 975-3502.

**References – Angular Measurements**

The Calibration of Angle Blocks by Intercomparison, C. P. Reeve, Natl. Bur. Stand. (U.S.), NBSIR 80-1967 (1980).

The Calibration of Indexing Tables by Subdivision, C. P. Reeve, Natl. Bur. Stand. (U.S.), NBSIR 75-750 (July 1975).

A Survey of the Temporal Stability of Angle Blocks, R. C. Veale and C. P. Reeve, Natl. Bur. Stand. (U.S.), NBSIR 74-601 (Nov. 1974).

## **F.** Laser Measurements

### Technical Contacts:



**Jack Stone**  
Tel: 301/975-5638

**Ralph Veale**  
Tel: 301/975-3502

**Mailing Address:** A107 Metrology, National Institute of Standards and Technology, Gaithersburg, MD 20899-0001

---

<b>Test No.</b>	<b>Items</b>
-----------------	--------------

---

14510S	Laser Frequency/Wavelength
--------	----------------------------

---

### **Laser Frequency/Wavelength (14510S)**

The frequency (or, equivalently, the vacuum wavelength) of a red He-Ne laser is determined by comparison to an iodine-stabilized He-Ne laser. The technique has a potential accuracy of about 6 parts in ten to the tenth. As a practical matter, however, accuracy is usually limited by the stability of the laser under test.



# G. Surface Texture

## Technical Contacts:



Arie Hartman  
Tel: 301/975-3475



Cynthia K. Rymes  
Tel: 301/975-4081

**Mailing Address:** A117 Metrology, National Institute of Standards and Technology, Gaithersburg, MD 20899-0001

Test No.	Items
15010C	Roughness Calibration Specimens
15020C	Surface Roughness Comparison Specimens
15030C	Step Height Measurements

### Roughness (15010C-15030C)

NIST provides measurement services in three categories: instrument calibration specimens (with regular geometric profiles), roughness comparison (and other types of roughness specimens), and step height specimens.

The property of surface roughness up to 10- $\mu\text{m}$   $R_a$  and of step heights up to 25  $\mu\text{m}$  are measured by means of a minicomputer/stylus instrument system. Using an interferometrically measured step, the system is calibrated at each value of magnification employed during a measurement.

In measurements of roughness, surface profiles are taken according to American National Standard B46.1-1985 using a 0.8-mm cutoff length and a traversing length of 4 mm. A number of other statistical parameters and functions may be calculated, including the rms roughness, average slope, average wavelength, skewness, amplitude density function, autocorrelation function, and power spectral density.

In step height measurements, a straight line is fitted by the method of least squares to each side of the profile of the step and to the middle, and the step height is calculated from the vertical difference between the middle area and each side.

The uncertainty in the NIST calibration for step height or  $R_a$  depends on a number of factors, the most important being the step or  $R_a$  value itself. The uncertainties range from approximately 0.4  $\mu\text{m}$  at a step height of 25  $\mu\text{m}$  to 0.002  $\mu\text{m}$  at the smallest step heights. Comparable uncertainties are achieved for measurements of  $R_a$ .

### References - Surface Texture

Characterization of Surface Topography, T. V. Vorburger and G. G. Hembree, in Navy Metrology R&D Prog. Conf. Report, Corona, CA (Apr. 1989).

Measurements of Roughness of Very Smooth Surfaces, T. V. Vorburger, Annals of the CIRP 36, No. 2, 503 (1987).

Direct Comparison of Mechanical and Optical Measurements of the Finish of Precision Machined Optical Surfaces, E. L. Church, T. V. Vorburger, and J. C. Wyant, Optical Engineering 24, 388 (1985).

Sinusoidal Profile Precision Roughness Specimens, E. C. Teague, F. E. Scire, and T. V. Vorburger, Wear, 83, 61 (1982).

Three-Dimensional Stylus Profilometry, E. C. Teague, F. E. Scire, S. M. Baker, and S. W. Jensen, Wear, 83, 1 (1982).

**FASTMENU:** A set of FORTRAN Programs for Analyzing Surface Texture, T. V. Vorburger, Natl. Bur. Stand. (U.S.), NBSIR 83-2703 (July 1982).

Optical Techniques for On-Line Measurement of Surface Topography, T. V. Vorburger and E. C. Teague, *Prec. Eng.*, 3, 611 (1981).

Uncertainties in Calibrating a Stylus Type Surface Texture Measuring Instrument with an Interferometrically Measured Step, E. C. Teague, *Metrologia*, 14, 39 (1979).

Measurements of Stylus Radii, T. V. Vorburger, E. C. Teague, F. E. Scire, and F. W. Rasberry, *Wear*, 57, 39 (1979).

**FAST Facility Available for Engineering Needs,** T. V. Vorburger, E. C. Teague, and F. E. Scire, *Dimensions/NBS*, 62, 18 (1978).

**Evaluation, Revision, and Application of the NBS Stylus/Computer System for the Measurement of Surface Roughness,** E. C. Teague, Natl. Bur. Stand. (U.S.), Tech. Note 902 (Apr. 1976).

**Precision Reference Specimens of Surface Roughness: Some Characteristics of the Cali-Block,** R. D. Young and F. E. Scire, *J. Res. Natl. Bur. Stand. (U.S.)*, 76C (Eng. and Instr.), Nos. 1 and 2, 21 (Jan.-June 1972).

## H. Hydrometers

### Technical Contacts:



John F. Houser  
Tel: 301/975-5956



George E. Mattingly  
Tel: 301/975-5939

**Mailing Address:** 105 Fluid Mechanics, National Institute of Standards and Technology, Gaithersburg, MD 20899-0001

---

#### Test No. Items

16010C Reference Standard Hydrometers

---

#### Reference Standard Hydrometers (16010C)

NIST provides measurement services for reference hydrometers. These reference standard hydrometers are generally used as laboratory standards to calibrate other hydrometers. Reference hydrometers submitted for test should be made of smooth, transparent glass, free of bubbles or other imperfections. The hydrometer should bear an inscription which indicates the purpose of the instrument. This inscription should denote the reference temperature at which it is to be used. The maker's name or trade mark and an identification number should be inscribed on the hydrometer scale. Hydrometers accepted for calibration must comply with ASTM (E100) specifications and the requirements of NBS Circular 555, "Testing of Hydrometers".

Reference Hydrometers accepted for calibration may include specific gravity proof spirit for alcohol solutions, API degrees for petroleum measurements, degrees Baume heavy and degrees Baume light, and other arbitrary scales; however, in all cases,

details regarding particular requirements must be arranged in advance. Specific gravity hydrometers cover the range of 0.65 to 2.0 specific gravity. The hydrometer scale should be divided into 0.001, 0.0005, 0.0002, or 0.0001 units of the density. Proof spirit hydrometers cover the range of 0 to 200 proof. The hydrometer scale should be divided in whole, half, fifth or tenth percents.

Visual inspection should be made by the customer before submitting the hydrometer for calibration. The hydrometer should be packed in a safe, reusable shipping container.

NIST will provide a three point calibration of these reference hydrometers. Additional points will be provided, if requested, for an additional charge. The calibration at NIST consists of comparing NIST master hydrometers with the customer's hydrometers in an appropriate liquid having low surface tension.

Readings and corrections to readings are reported to one-tenth of a scale division. The uncertainty of these values may vary with the instrument design and a general statement cannot be made. Considerations regarding uncertainty can be discussed at the time that arrangements are made for the calibration of any particular instrument; a statement of uncertainty for the NIST master hydrometers used in the calibration will be included in the calibration report.

## Volume and Density

### Technical Contacts:



John F. Houser  
Tel: 301/975-5956



George E. Mattingly  
Tel: 301/5939

**Mailing Address:** 105 Fluid Mechanics, National Institute of Standards and Technology, Gaithersburg, MD 20899-0001

Test No.	Items
17010C	Volume Standards
17020S	Special Tests of Volume Standards
17040S	Special Tests of Density: Liquids

### Volume Standards (17010C)

The procedure used for testing glass volumetric apparatus is to weigh the amount of distilled water contained or delivered with reference to the graduations marked on the instrument, the volume being computed from the density of the water. (References provided upon request.) The quality of the markings and the care exercised in reading or setting the liquid level are major factors in test calibration and usage. NIST does not provide routine calibration services for glassware; however, NIST will accept factory standards and replacement glassware for the State Weights and Measures Departments, in the range of  $10^{-2}$  L to 5 liters, which conform essentially to requirements contained in NBS Circular 602, "Testing of Glass Volumetric Apparatus," Federal Procurement Specifications NNN-B-00789 (Buret, straight, precision), NNN-F-00289a (Pipet, volumetric), NNN-P-0035a (Pipet, measuring), or NNN-F-00289a (Flask, volumetric), if such instruments

are to be used as reference or transfer standards.

NIST provides a calibration service for metal volumetric test measures. These volumetric test measures accepted for calibration should comply with the specifications contained in NBS Monograph 62, "Testing of Volumetric Standards." These test measures should be free from dents, rust, or scratches. Special care should be taken by the customers to insure the cleanliness of the inside of the test measures. Should the test measure be equipped with a bottom drain valve, it is the customer's responsibility to insure that the valve is in sound working condition. These test measures should bear an inscription which indicates the nominal volume at a reference temperature, the assumed thermal coefficient of expansion, and an identification number. The scale plate should be legible so that the scale division can be estimated to one-tenth of a single division. A scale calibration is provided as part of the calibration; however, NIST does not adjust scales. The zero index or the gage scale should, therefore, be adjusted prior to calibration. The slicker plate type volume standards should be adjusted by the manufacturer.

Normally NIST will accept for calibration test measures that have nominal volumes in the range of 1 gallon to 1500 gallons or 5 liters to 7500 liters. The calibration procedure for these test measures consists of determining the volume "to contain" or "to deliver" by either gravimetric determinations, which is the result of direct comparisons with mass standards, or by the use of transfer standards, for which volumes have been predetermined. NIST will perform two independent measurements for each volume standard submitted for calibration. An overall uncertainty of  $\pm 0.04$  percent is usually assigned to all metal volumetric standards at the present time. NIST is currently involved in a program to improve liquid volume measurement accuracies.

**Special Tests of Volume Standards  
(17020S)**

Special tests may be made of volume standards by prearrangement with technical contacts cited in this section.

**Special Tests of Density: Liquids  
(17040S)**

Currently NIST is involved in a liquid density measurement research project; The technical contacts cited in this section can be contacted regarding this project.

**References – Volume and Density  
Measurements**

Calibration of Small Volumetric Laboratory Glassware, J. Lembeck, Natl. Bur. Stand. (U.S.), NBSIR 74-461 (Oct. 1974).

The Equivalence of Gravimetric and Volumetric Test Measure Calibration, R. M. Schoonover, Natl. Bur. Stand. (U.S.), NBSIR 74-454 (Feb. 1974).

Procedures for the Calibration of Volumetric Test Measures, J. F. Houser, Natl. Bur. Stand. (U.S.), NBSIR 73-287 (Aug. 1973).

---

# Chapter

# 5

- A** Flow Rate Measurements
- B** Flow Measurements at Cryogenic Temperatures
- C** Airspeed Measurements
- D** Mass Standards
- E** Force Measurements
- F** Vibration Measurements
- G** Acoustic Measurements
- H** Ultrasonic Reference Block Measurements
- I** Ultrasonic Transducer Measurements
- J** Acoustic Emission Transducer Measurements

## A. Flow Rate Measurements

### Technical Contacts:



G. Paul  
Baumgarten  
Tel: 301/975-9057



George E.  
Mattingly  
Tel: 301/975-5939

**Mailing Address:** 105 Fluid Mechanics, National Institute of Standards and Technology, Gaithersburg, MD 20899-0001

Test No.	Items
18010C	Single Turbine Meters
18020C	Tandem Turbine Meters
18030C	Flow Rate Meters (Direct Reading in Flow Rate Units)
18040C	Head Class Flow Measurement Devices
18050S	Special Tests for Liquid and Gas Flow Rates

### Flowmeters (18010C-18040C)

NIST provides calibration services for liquid flowmeter systems that include a flowmeter and pertinent adjacent tubing, auxiliary measurement instrumentation, and readout equipment.

Flowmeter systems having demonstrated precision and temporal stability commensurate with the quality of the calibrations are accepted for calibration. Calibration tests usually include five different flow rates, although additional rates can be included on request. At each flow rate, five determinations of meter indication and flow rate are made; the entire test sequence is repeated—usually on the following day.

Meter systems submitted should have conventional connections, either A/N flare fittings up to 2-in (5 cm) nominal diameters, or National Pipe Thread fittings up to 3-in (7.6 cm)

nominal diameter. Larger meters must terminate with ASA 150-lb steel flanges, or grooved-end steel pipe compatible with Victaulic couplings (for water meters), or with adapters thereto. For air flow systems with flow rates above 100 ft<sup>3</sup>/min (2.8 m<sup>3</sup>/min), flanges must terminate with ASA 300-lb steel flanges except for laminar element flowmeters operated near ambient pressure levels. Connections other than these should not be submitted unless special arrangements have been made in advance.

NIST maintains a range of facilities that are capable of serving as national standards for fluid flow rate measurements for a wide range of fluid and flow conditions.

**Small Air Flow Facilities:** Calibration of devices in this laboratory covers the air flow range up to approximately 100 standard cubic feet per minute (SCFM) [2.8 standard cubic meters per minute (SCCM)]. The mass flow rate of gas passing through a metering device during its calibration is determined from pressure, temperature, volume, and transit time measurement of the displaced volumes of gas. Two types of displacers are used, bell gasometers and mercury-sealed piston/cylinder provers. Determination of the displaced volume in either case is based on diameter and stroke measurement. Currently, these are done using fixed switching positions of optical or mechanical switch mechanisms for eight provers with volumes ranging from  $3 \times 10^{-5}$  m<sup>3</sup> to 0.566 m<sup>3</sup>. Measurements of pressure are made using manometers and barometers. Temperature measurements are made using contacting techniques, i.e., thermocouples, thermistors, etc. The overall uncertainty for the air flow rate measurements is quoted to be  $\pm 0.25$  percent; this is determined by summing a three standard deviation uncertainty of  $\pm 0.15$  percent, and an estimated systematic error of

0.1 percent. Details on these facilities are given by Benson et al.

**Large Air Flow Facility:** The large air flow facility consists of a compressor as the pressure source, a dryer, settling chamber, meter runs (2- to 8-inch pipe sizes) (50–203 mm), and a collection tank. Flow rates from 35 to 3000 SCFM (0.99 to 84.95 m<sup>3</sup> min) are attainable at pressures up to 90 psig (620 KPa). Calibration measurements are based upon the use of a set of working standards, which are flow nozzles operated under critical conditions, i.e., at sonic velocity in the throat of the nozzle. These provide an extremely stable flow which is not influenced by variations in downstream pressure and temperature conditions. Determination of the mass flow rate through these nozzles is based upon measured discharge coefficients. Measurement of the discharge coefficient for each nozzle over the range of throat Reynolds numbers used is performed by diverting the gas flowing through the nozzle into the collection tank of the facility for a measured period of time. Once the gas has been collected, a PVT measurement is used to determine the mass of gas in the tank. This value of the mass of gas is used with the diversion time to compute the average mass flow rate through the nozzle. The overall uncertainty quoted for this flow system is  $\pm 0.25$  percent. This value is obtained as described above for the Small Air Flow Facilities.

**Water Flow Facility:** The water flow facility consists of reservoir, pumps, meter runs, and weigh tanks necessary to make primary flow measurements. Pipeline sizes up to 16 inches (406 mm) in diameter are available. The system operates as a constant flow rate facility using bypass and meter-run control valves to control the pressure and flow rate in the system.

Diversion into the weigh tanks is accomplished with pneumatically driven diverter valves fitted to each of the four weighing systems used. The overall uncertainty for the water flow facility is quoted to be  $\pm 0.13$  percent; this is determined by summing a three standard deviation uncertainty of  $\pm 0.03$  percent, and an estimated systematic error of  $\pm 0.1$  percent.

**Hydrocarbon Flow Facilities:** These facilities have the ability to handle a variety of hydrocarbon liquids. The majority of the calibration requests pertain to the use of a surrogate liquid for JP-4 and JP-5 jet fuels as the liquid used in the calibration. Both volumetric and gravimetric systems are used to calibrate flowmeters. The flow rate range of this laboratory extends from 0.01 to approximately 400 gallons per minute ( $3.5 - 10^{-5}$  to 1.5 m<sup>3</sup>/min). A variety of meter types are calibrated, although turbine meters predominate. The overall uncertainty quoted for these systems is as given above for the Water Flow Facility.

#### **Special Tests for Liquid and Gas Flow Rates (18050S)**

Special tests for liquid and gas flow rates can be arranged. Examples can include "in-situ" calibration of flowmeters, proving other fluid measurement systems, etc. Tests to establish and maintain more realistic traceability for flow measurement laboratories can be designed for specific situations. Details can be obtained and arrangements made through the technical contacts listed at the beginning of this section.



**References—Flow Rate Measurements**

- NBS Primary Calibration Facilities for Air Flow Rate, Air Speed, and Slurry Flow, K. R. Benson, N. E. Mease, G. Kulin, and G. E. Mattingly, Proc. Intl. Flow Meas. Symp., Washington, D.C., Nov. 1986, Amer. Gas Assoc., Arlington, VA.
- Gas Flow Measurement: Calibration Facilities and Fluid Metering Traceability at the National Bureau of Standards, G. E. Mattingly, Proc. Inst. for Gas Tech. Conf. on Energy Meas., Chicago, IL (May 1985) Fundamentals of Flow Measurements, J. P. DeCarlo, Instr. Soc. of America, Research Triangle Park, NC (1984).
- Flow Measurement Engineering Handbook, R. W. Miller, McGraw-Hill, New York (Jan. 1983).
- A Laboratory Study of Turbine Meter Uncertainty, G. E. Mattingly, P. E. Pontius, H. H. Allion, and E. F. Moore, Natl. Bur. Stand. (U.S.), Spec. Publ. 484 (Oct. 1977).
- The National Measurement System for Fluid Flow, W. C. Haight, P. S. Klebanoff, F. W. Ruegg, and G. Kulin, Natl. Bur. Stand. (U.S.), NBSIR 75-930 (Aug. 1976).
- Introduction to Liquid Flow Metering and Calibration of Liquid Flowmeters, L. O. Olsen, Natl. Bur. Stand. (U.S.), Tech. Note 831 (June 1974).
- Flow Measurement: Procedures and Facilities at the National Bureau of Standards, F. W. Ruegg and M. R. Shafer (Proc. Symp. Flow Measurement, San Francisco, CA, Jan. 19-22, 1970). Chapter in ASHRAE (Amer. Soc. Heat Refrig. Air-Cond. Eng.), Bull. Flow Measurement Part 1, SF70-7, 1 (1972).
- Gas Flow Measurement by Collection Time and Density in a Constant Volume, L. Olsen and G. Baumgarten, Symposium on Flow, Its Measurement and Control in Science and Industry, ISA, 1, Part 3, 1287 (1972).
- Evaluation of a Low Flow Generator and Calibrator as a Flow Measurement Standard, G. Baumgarten, Natl. Bur. Stand. (U.S.), Tech. Report 10921 (1972).
- Practical Considerations for Gas Flow Measurement, M. R. Shafer, Jr., and D. W. Baker, Proc. 3rd Annual Prec. Meas. Assoc. Metrology Conf., Natl. Bur. Stand., Gaithersburg, MD, June 17-18, 1970, 1, 187 Prec. Meas. Assoc., Burbank, CA (1970).
- Liquid-Flowmeter Calibration Techniques, M. R. Shafer and F. W. Ruegg, ASME Paper No. 57-A-70.
- Performance Characteristics of Turbine Flowmeters, M. R. Shafer, ASME Paper No. 61-WA-25.

## **B.** Flow Measurements at Cryogenic Temperature

### Technical Contacts:



James A.  
Brennan  
Tel: 303/497-3611



Kathy Hillen  
Administrative and Logistics  
Tel: 303/497-3753

**Mailing Address:** M.C. 832.02, National Institute of Standards and Technology, 325 Broadway, Boulder, CO 80303-3328

---

#### Test No. Items

---

18800S Special Tests of Cryogenic Liquid Flow

---

#### Special Tests of Cryogenic Liquid Flow (18800S)

Limited measurement services are provided for cryogenic liquid flow. Mass flow measurements are performed using liquid nitrogen flow rates of 1 to 10 Kg/s. Uncertainty within this flow range is 0.18 percent. For volumetric flow measurement the uncertainty in fluid density must also be included. Lower flow rates are possible but at increased uncertainty.

#### References—Flow Measurements at Cryogenic Temperature

Progress Report on Cryogenic Flowmetering at the National Bureau of Standards, J. A. Brennan, J. F. LaBreque, and C. H. Kneebone, Proc. 1st Biennial Symp. Instrumentation in the Cryogenic Industry, Houston, TX, Oct. 11-14, 1976, 1, 621, Instr. Soc. of America, Pittsburgh, PA (1976).

NBS-CGA Cryogenic Flow Measurement Program, J. A. Brennan, R. W. Stokes, C. H. Kneebone, and D. B. Mann (Proc. ISA Intl. Instrument. Automation Conf. and Exhibit, New York, NY, Oct. 28-31, 1974), Paper in Adv. in Instrument. 29, 612.1 (Instr. Soc. of America, Pittsburgh, PA, 1974).

Cryogenic Flow Research Facility Provisional Accuracy Statement, J. W. Dean, J. A. Brennan, D. B. Mann, and C. H. Kneebone, Natl. Bur. Stand. (U.S.), Tech. Note 606 (July 1971).

## C. Airspeed Measurements

### Technical Contacts:



Norman E.  
Mease  
Tel: 301/975-5959



J. Michael  
Hall  
Tel: 301/975-5947



George E.  
Mattingly  
Tel: 301/975-5939

**Mailing Address:** 105 Fluid Mechanics, National Institute of Standards and Technology, Gaithersburg, MD 20899-0001

Test No.	Items
19010C	Pitot-Static Tubes 1.3 to 67 m/s (3 to 150 mph)
19020C	Low Airspeed Instruments 0.76 to 10.2 m/s (15 to 2,000 fpm)
19030S	Meteorological Airspeed Instrumentation 1.3 to 67 m/s (3 to 150 mph)
19040S	Special Tests of Airspeed Instruments

### Airspeed Instruments (19010C-19040S)

Calibration of airspeed measuring devices is performed in one of two special wind tunnels (see Benson et al.). The pressure differential measured from ellipsoidal-nosed Pitot-static tubes provides the basis of airspeed measurement in these facilities. Pitot-static tubes and meteorological instruments are calibrated in the NIST Dual Test Section Wind Tunnel. Low velocity airspeed measurements are based upon laser velocimeter measurements in the NIST Low Velocity Airflow Facility. Calibration of the laser velocimeter is done using the Pitot-static tube at velocities which produce a sufficiently large pressure differential in the tube that the uncertainty in the pressure

measurement does not propagate a large error into the velocity determination. Extension of the laser velocimeter to the low velocity region, where the Pitot-static tube has large measurement errors due to the inability to measure accurately the extremely small pressure differentials produced by the Pitot-static tube, allows considerably improved measurement uncertainty. Air density values in the tunnels are computed from pressure, temperature, and humidity measurements in the settling chamber of the tunnel.

Total uncertainty levels for the range of airspeed currently offered are shown in Figure 3.

*Figure 3. Total Uncertainty for the NIST Airspeed Measurements Capability.*

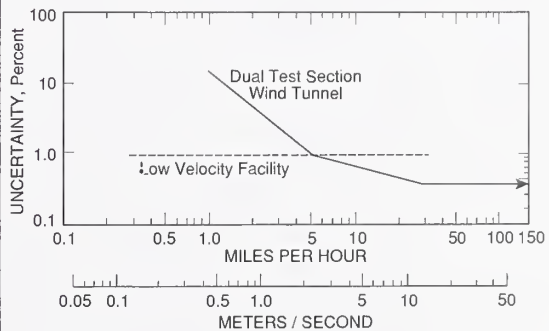

Special tests of airspeed instruments can be arranged. Examples include "in-situ" calibration of airspeed instrumentation, proving other airspeed measurement systems, and tests where appropriate scaling will allow the results to be applicable to fluids other than air. Details can be obtained and arrangements made through the technical contacts cited at the beginning of this section.

**References — Airspeed Measurements**

NBS Primary Calibration Facilities for Air Flow Rate, Airspeed, and Slurry Flow, K. R. Benson, N. E. Mease, G. Kulin, and G. E. Mattingly, Proc. Intl. Flow Symp., Washington, D.C. (Nov. 1986), Amer. Gas Assoc., Arlington, VA.

Experimental Investigation of Drag on a Compliant Surface, J. M. McMichael, P. S. Klebanoff, and N. E. Mease, Part of chapter 7 in Viscous Flow Drag Reduction, Gary R. Hough, Ed., Progress in Astronautics and Aeronautics, 72 (1980).

Low-Velocity Performance of Anemometers, L. P. Purtell, Natl. Bur. Stand. (U.S.), NBSIR 79-1759 (May 1979).

A Low-Velocity Airflow Calibration and Research Facility, L. P. Purtell and P. S. Klebanoff, Natl. Bur. Stand. (U.S.), Tech. Note 989 (Mar. 1979).

Low-Velocity Performance of a Magnetic Pick-up Vane Anemometer, L. P. Purtell, Natl. Bur. Stand. (U.S.), NBSIR 79-1566 (Dec. 1978).

Low-Velocity Performance of a Ball Bearing Vane Anemometer, L. P. Purtell, Natl. Bur. Stand. (U.S.), NBSIR 78-1485 (June 1978).

## D. Mass Standards

### Technical Contact:



Jerry G. Keller  
Tel: 301/975-4218

**Mailing Address:** A117 Metrology, National Institute of Standards and Technology, Gaithersburg, MD 20899-0001

**Shipping Address:** National Institute of Standards and Technology, I-270 at Quince Orchard Road, B33 Metrology, Gaithersburg, MD 20899-0001

Note: For weights larger than 50 lb (30 kg), contact J. G. Keller prior to shipment.

Test No.	Items
22010C	Weight Set (1 mg to 100 g)
22020C	Weight Set (1 mg to 1 kg)
22030C	Weight Set (2 to 30 kg)
22040C	Single Weights (1 mg to 1 kg)
22060C	Single Weights (2 kg to 30 kg)
22080C	Single Weights (> 30 kg to 1200 kg, 2 double substitution weighings)
22100C	Single Weights (> 1200 kg to 30,000 kg)
22110C	Single Weights (> 30 kg to 1200 kg, calibrated in a weighing design)
22130C	Single Weights for Deadweight Pressure Testers (13 lb-50 lb)
22140C	Single Weights for Deadweight Pressure Testers (> 50 lb)
22150C	Single Weights for Deadweight Pressure Testers (< 13 lb)
22170S	Special Mass Measurement Services
22180M	Measurement Assurance Program for Mass

### Mass (22010C-22110C)

NIST maintains the national standards for mass in the form of the prototype kilograms (K4 and K20) and provides services to support the parts of the national measurement system that rely directly or indirectly on mass measurements. These services include the calibration of suitable weight sets. A calibration consists of establishing a mass value and the appropriate uncertainty for that value for each weight that has been designated to be a reference standard. It is desirable, but not necessary, that a weight meet the adjustment tolerances established for Classes A, B, M, S, or S-1 prior to submission. Weights are available from manufacturers, many of whom can directly furnish documentation suitable for meeting quality assurance contracts and requirements.

For periodic recalibrations of reference mass standards, the user need measure only differences between weights or groups of weights within a set and compare them with computed differences. As long as the agreement is within allowable limits, the values can be considered constant within the precision of the comparison process. Mass standards submitted to NIST for recalibration frequently are tested in this manner. If these tests indicate that no significant changes have occurred, a continuation report so stating and referring to the previous NIST Report of Calibration will be issued.

NIST calibrates individual weights or sets in the range of 1 mg to 30 kg or 1 lb to 50 lb in decimal subdivisions. If the weights are designated as reference standards, they must be of design, material, and surface finish comparable to present Classes A, B, M, S, or S-1. These include ASTM Type I and II, grade S and O, and OIML E1, E2, and F1. NIST also calibrates large mass standards (60 to 60,000 lbs) if the design, material, and surface finish are compatible with the intended usage. For these large

mass standards, an adjustment with reference to a nominal or desired value can be included as a part of the calibration procedure.

The values of true mass (and an apparent mass correction) included in the report will be determined by using computed volumes based on the manufacturer's statement of density of the material, or on the density computed from measured volumes, or, in the absence of this information, on estimated density values. However, 1-kg mass standards fabricated from stainless steel and of one-piece construction will have their density determined as part of a "first-time" calibration at NIST. The apparent mass corrections are computed for 20 °C with reference to Normal Brass (density 8.4 g/cm<sup>3</sup> at 0 °C and volume coefficient of expansion 0.000054/°C) and to stainless steel (density 8.0 g/cm<sup>3</sup> at 20 °C) in a conventional air density of 1.2 mg/cm<sup>3</sup>. Apparent mass corrections to any other basis can be furnished if requested. Typical uncertainties range from 50 parts per billion at 1 kilogram up to 500 parts per million at one milligram and 1 part per million for weights from 2 to 30 kilograms. Figure 4 shows the NIST precision of weighing for mass standards over the range 10<sup>-8</sup> to 10<sup>4</sup> kilograms.

Figure 4. NIST Precision of Weighing for Mass Standards Ranging from 10<sup>-8</sup> to 10<sup>4</sup> Kilograms

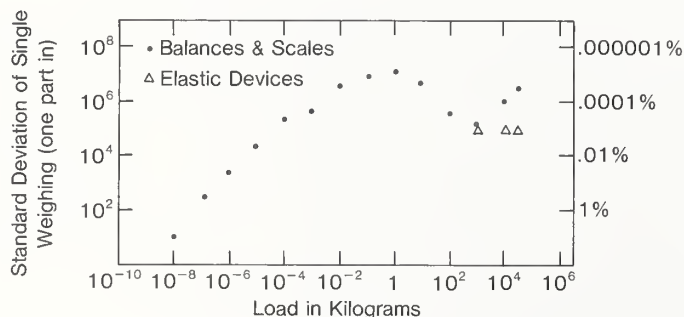

#### Single Weights for Deadweight Pressure Testers (22130C-22150C)

Weights less than six (6) pounds are determined by comparing them with calibrated built-in-weights of appropriate analytical balances by the double substitution method. Weights larger than six (6) pounds are compared to discrete standards by the method of double transposition or double substitution weighing.

#### Special Mass Measurement Services (22170S)

For tests not covered by the previous descriptions, the NIST technical contact cited at the beginning of this section should be consulted to determine whether a test can be performed and to negotiate a price for the test.

#### Measurement Assurance Program for Mass (22180M)

This service is most appropriate for primary calibration laboratories. Total uncertainties ranging from a few parts in 10<sup>7</sup> to a few parts in 10<sup>5</sup> for 1 kg can be obtained. Unlike most other NIST MAP services, the Mass MAP service does not involve the use of a NIST-owned transport standard that is shipped to participants for measurement. The transfer standards in the mass MAP are a set of mass standards owned by the participant and sent to NIST for calibration. These standards are referred to as the starting standards. In addition to the starting standards, the mass MAP participant must also furnish a set of much smaller weights called "sensitivity weights." The choice of both the starting standards and the sensitivity weights will depend on the particular mass range of interest to the participant; NIST staff can provide advice regarding suitable starting standards and sensitivity weights for a particular range of mass weighings. In addition to the starting standards and the sensitivity weights, the participating facility should have a working set of weights known as the "test set" and a set of weights to be used as check

standards. This set usually consists of weights in the range 1 to 1000 g.

This service, like other NIST MAP services, samples the participant's measurement process and establishes its uncertainty. Once the participant has become well-established in the Mass MAP, two options are possible:

(1) NIST personnel do all of the data analysis and record keeping for the participant and provide periodic reports on the uncertainty of the participant's mass measurements.

(2) The participant keeps all records and calculates the uncertainties of his measurements using NIST methods and computer codes.

The implementation of the Mass Measurement Assurance Program in its most complete form typically proceeds in four distinct phases, which may be abbreviated somewhat if the participant already has a suitable mass measurement quality control system.

**Phase I:** Each new participant completes a questionnaire on equipment and facilities and receives a written description of the NIST process, methods and procedure to be used, an introduction to the interpretation of results, and information on the use of these results in measurement decisions. At the participating laboratory, the suitability of the weighing equipment is verified, the starting standards selected or procured, and if the procedures are entirely new, operators are trained. The starting standards and sensitivity weights are sent to NIST for calibration. If the starting standards have a prior NIST calibration history, those data are reviewed, and if satisfactory, they are considered, along with the data from the more recent determinations, in arriving at assigned values for the starting standards. NIST will recommend a weighing design to be used for calibrating the test weight. This weighing design prescribes the set of observations for intercomparing the test weights with known weights. NIST will also supply data sheets that are used throughout the first three phases

of the program for recording data taken using the design. The objective of the first phase is to ensure that the new participant is familiar with good laboratory practices for high precision weighing. If the participating laboratory has an established mass measurement capability and an existing quality control procedure for mass measurements, Phase I is abbreviated considerably.

**Phase II:** The starting standards and sensitivity weights are returned to the participant and, following the prescribed procedures, measurements are made over a period of time by the participant to verify that a state of statistical control exists. The data sheets are sent to NIST for review, comments, and processing after each measurement. If there are unanticipated problems, or the procedure has not been followed exactly, more measurements may be required. After three or more successful calibrations in the user's facility, NIST analyzes the data to determine the values of the check standards.

**Phase III:** A comprehensive report is issued by NIST that contains a review of the actions and decisions in each of the phases, control charts for the check standards to be used in the participant's facility, and a comparison of the values assigned to the starting standards by NIST and by the participant. It is assumed at this point that the participating facility is now ready to extend the operation of the MAP to its regular workload.

**Phase IV:** Having thus established measurement comparability, the MAP user can then, in principle, operate independently of NIST. As long as there is no indication of a loss of statistical control of the process, no further checking with NIST should be necessary. Most participants request a recheck of the starting standards every few years to ensure that no undetected long-term drift has taken place.

For work that differs from the items normally calibrated by the participant, NIST can provide consulting help and assistance necessary to accommodate a greater range of weights, calibrate pound standards, and extend pound standards to large weights normally associated with force measurement. Although the usual Mass MAP service uses two one kilogram masses as the starting standards, the program is sufficiently flexible that the same methods can be used with other mass values.

#### References – Mass Standards

- New Assignment of Mass Values and Uncertainties to NIST Working Standards, R. S. Davis, *J. Res. Natl. Inst. Stand. Technol.*, 95, No. 1, 79 (Jan.-Feb. 1990).
- NIST Measurement Services: Mass Calibrations, R. S. Davis, *Natl. Inst. Stand. Technol. Spec. Publ.* 250-31 (Jan. 1989).
- A Primer for Mass Metrology, K. B. Jaeger and R. S. Davis, *Natl. Bur. Stand. (U.S.)*, Spec. Publ. 700-1 (Nov. 1984).
- Air Buoyancy Correction in High-Accuracy Weighing on Analytical Balances, R. M. Schoonover and F. E. Jones, *Anal. Chem.*, 53, No. 6, 900 (May 1981).
- National Bureau of Standards Mass Calibration Computer Software, R. N. Varner and R. C. Raybold, *Natl. Bur. Stand. (U.S.)*, Tech. Note 1127 (July 1980).
- Quick and Accurate Density Determination of Laboratory Weights, R. M. Schoonover and R. S. Davis, *Proceedings of the 8th Conference of IMEKO, Krakow, Poland* (1980).
- Precision Laboratory Standards of Mass and Laboratory Weights. A reprint of NBS Circular 547, Section 1, T. W. Lashof and L. B. Macurdy, August 1954, *Natl. Bur. Stand. (U.S.)*, NBSIR 78-1476 (Oct. 1978).
- The National Measurement System for Mass, Volume, and Density, P. E. Pontius, J. R. Whetstone, and J. A. Simpson, *Natl. Bur. Stand. (U.S.)*, NBSIR 75-928 (May 1978).
- Direct Determination of Air Density in a Balance through Artifacts Characterized in an Evacuated Weighing Chamber, W. F. Koch, R. S. Davis, and V. E. Bower, *J. Res. Natl. Bur. Stand. (U.S.)*, 83, No. 5, 407 (Sept.-Oct. 1978).
- The Air Density Equation and the Transfer of the Mass Unit, F. E. Jones, *J. Res. Natl. Bur. Stand. (U.S.)*, 83, No. 5, 419 (Sept.-Oct. 1978).
- Designs for the Calibration of Standards of Mass, J. M. Cameron, M.C. Croarkin, and R. C. Raybold, *Natl. Bur. Stand. (U.S.)*, Tech. Note 952 (June 1977).
- The Air Density Equation and the Transfer of the Mass Unit, F. E. Jones, *Natl. Bur. Stand. (U.S.)*, NBSIR 77-1278 (July 1977).
- Measurement Assurance, J. M. Cameron, *Natl. Bur. Stand. (U.S.)*, NBSIR 77-1240 (1977).
- Surveillance Test Procedures, H. W. Almer, *Natl. Bur. Stand. (U.S.)*, NBSIR 76-999 (Feb. 1976).
- Mass and Mass Values, P. E. Pontius, *Natl. Bur. Stand. (U.S.)*, Monogr. 133 (Jan. 1974).
- Weight Cleaning Procedures, H. E. Almer, *Natl. Bur. Stand. (U.S.)*, NBSIR 74-443 (Nov. 1973).
- On Uncertainty in Mass Measurement, J. R. Donaldson, *Natl. Bur. Stand. (U.S.)*, NBSIR 73-151 (Mar. 1973).
- Method of Calibrating Weights for Piston Gages, H. E. Almer, *Natl. Bur. Stand. (U.S.)*, Tech. Note 577 (May 1971).
- Realistic Uncertainties and the Mass Measurement Process, P. E. Pontius and J. M. Cameron, *Natl. Bur. Stand. (U.S.)*, Monogr. 103 (Aug. 1967).
- Introduction to Intercomparison Methods in Mass Measurement, H. E. Almer, *Natl. Bur. Stand. (U.S.)*, Report 9487 (Feb. 1967).
- Measurement Philosophy of the Pilot Program for Mass Calibration, P. E. Pontius, *Natl. Bur. Stand. (U.S.)*, Tech. Note 288 (May 1966).



## E. Force Measurements

### Technical Contacts:



Simone L.  
Yaniv  
Tel: 301/975-6655



Robert W.  
Peterson  
Tel: 301/975-6649

**Mailing Address:** 221 Engineering Mechanics, National Institute of Standards and Technology, Gaithersburg, MD 20899-0001

**Shipping Address:** National Institute of Standards and Technology, I-270 at Quince Orchard Road, Engineering Mechanics Building, Room 123, Gaithersburg, MD 20899-0001

Test No.	Items
23010C	Force Transducers (to 25,000 lbf, 1 mode)
23020C	Extra observation
23030C	Additional bridges
23040C	Force Transducers (to 25,000 lbf, 2 modes)
23050C	Extra observation
23060C	Additional bridges
23070C	Force Transducers (25,001 to 112,000 lbf, 1 mode)
23080C	Extra observation
23090C	Additional bridges
23100C	Force Transducers (25,001 to 112,000 lbf, 2 modes)
23110C	Extra observation
23120C	Additional bridges
23130C	Force Transducers (112,001 to 300,000 lbf, 1 mode)
23140C	Extra observation
23150C	Additional bridges
23160C	Force Transducers (112,001 to 300,000 lbf, 2 modes)
23170C	Extra observation
23180C	Additional bridges
23190C	Force Transducers (300,001 to 1,000,000 lbf, 1 mode)
23200C	Extra observation
23210C	Additional bridges
23220C	Force Transducers (300,001 to 1,000,000 lbf, 2 modes)
23230C	Extra observation
23240C	Additional bridges
23250C	Force Transducers (over 1,000,000 lbf)
23260S	Special Tests of Force Transducers

### Force Transducers (23010C-23250C)

NIST provides calibration services for force measuring devices by applying known forces, either tension or compression, to the elastic device and recording the sensed deformation.

Most of the devices calibrated are either proving rings or load cells. The deformation of proving rings is usually measured by means of a micrometer screw and vibrating reed, which are an integral part of the device.

Load cells, which utilize strain gauge bridges, produce an electrical output that is related to the applied force.

The calibration report describes the relationship between the applied force and the measured deformation, either in electrical or mechanical units. A load cell can be calibrated using (1) a readout device furnished by the customer, in which case the load cell and the readout device are calibrated as a system, and the calibration is valid only when the load cell and the readout device are used together; or (2) instrumentation furnished by NIST, in which case data are reported in terms of the ratio of the output voltage to the DC excitation voltage (mV/V). In the latter case, the customer must possess the necessary electrical instrumentation and expertise to utilize the calibration results.

Tension or compression calibrations in the range of 100 pounds-force (lbf) to 1,000,000 lbf are performed using deadweight machines. NIST has six such deadweight machines with maximum capacities of 500; 6,100; 25,300; 112,000; 300,000; and 1,000,000 lbf. The four larger machines allow the force applied to the unit being calibrated to be incremented or decremented without having to return to zero load between

force applications. When using the two smaller machines it is necessary to go to zero load before the load is changed. For all six deadweight machines, the estimated uncertainty of the vertical component of the applied force is 20 ppm.

Comparison calibrations in the range of 1,000,000 lbf to 12,000,000 lbf in compression only are performed in a universal testing machine. In this case, the system being calibrated is loaded in series with load cells that have been previously calibrated in a deadweight machine.

#### **Special Tests of Force Transducers (23260S)**

Temperature sensitivity, pressure sensitivity and creep tests of force transducers are measured. The ranges of test parameters and environmental conditions may be limited by the characteristics of the force transducer and the availability of special test fixtures. These special tests should be discussed with the designated NIST technical contact before the work is scheduled.

#### **References – Force Measurements**

- Interlaboratory Comparison of Force Calibrations Using ASTM Method E74-74, R. W. Peterson, L. Jenkins, and R. A. Mitchell, Natl. Bur. Stand. (U.S.), Tech. Note 1211 (Apr. 1985).
- Metrological Regulations for Load Cells, OIML International Recommendation No. 60, Intl. Org. for Legal Metrol., Paris (Oct. 1984).
- Progress in Force Measurement at NBS, R. A. Mitchell, Proc. 10th Conf. IMEKO TC-3 on Measurement of Force and Mass, Kobe, Japan (Sept. 1984).
- Inherent Problems in Force Measurements, P. E. Pontius and R. A. Mitchell, *Exper. Mech.*, 22, No. 3 (Mar. 1982).

Force Sensor-Machine Interaction, R. A. Mitchell and P. E. Pontius, Proceedings of the 27th International Instrumentation Symposium (ISA), Indianapolis, IN, Instrumentation in the Aerospace Industry, 27, 225 (1981).

Characterizing the Creep Response of Load Cells, R. A. Mitchell and S. M. Baker, VDI-Berichte 312, 43 (1978).

Interlaboratory Comparison of Force Calibrations Using ASTM Method E74-74, Phase I, R. W. Peterson and R. L. Bloss, Natl. Bur. Stand. (U.S.), NBSIR 76-1145 (Aug. 1976).

A Study of the National Force Measurement System, D. E. Marlowe, Natl. Bur. Stand. (U.S.), NBSIR 75-929 (June 1975).

Universal Testing Machine of 12-Million-lbf Capacity at the National Bureau of Standards, A. F. Kirstein, Natl. Bur. Stand. (U.S.), Spec. Publ. 355 (Sept. 1971).

Studies of Calibration Procedures for Load Cells and Proving Rings as Weighing Devices, G. B. Anderson and R. C. Raybold, Natl. Bur. Stand. (U.S.), Tech. Note 436 (Jan. 1969).

Gravity Measurements and the Standards Laboratory, D. R. Tate, Natl. Bur. Stand. (U.S.), Tech. Note 491 (Aug. 1969).

Uncertainties Associated with Proving Ring Calibration, T. E. Hockersmith and H. H. Ku, Preprint No. 12.3-2-64 ISA Conference, Instr. Soc. of America, Res. Triangle Park, NC (Oct. 1964).

## Vibration Measurements

### Technical Contacts:



Beverly F.  
Payne  
Tel: 301/975-6639



Donald C.  
Robinson  
Tel: 301/975-6643



Myroslav R.  
Serbyn  
Tel: 301/975-6646

**Mailing Address:** A149 Sound, National Institute of Standards and Technology, Gaithersburg, MD 20899-0001

Test No.	Items	Freq. Range	Peak Accel.	Uncer. in %
24010C	Pickup Sensitivity	2 to 160 Hz	0.2 to 2 g	±1 to ±2
24020C	Pickup Sensitivity	10 to 3500 Hz	2 to 10 g	±1 to ±2
24030C	Pickup Sensitivity	10 Hz to 10 kHz	2 to 10 g	±1 to ±2
24040S	Shock Measurement	10 Hz to 10 kHz	50 to 5000 g	±3 to ±5
24050S	Pickup Sensitivity	3 to 20 kHz	4 to 200 g	±1 to ±3
24060S	Special Vibration Tests, by Prearrangement			

#### Pickup Sensitivity (24010C-24030C)

NIST calibrations of vibration exciters and pickups are performed by comparison with the response characteristics of NIST standards or by absolute measurements. A calibration consists of measuring the transfer function of the instrument, usually referred to as the sensitivity. For a pickup it is the ratio of the electrical output to a mechanical input. The magnitude of the latter is set in accordance with the calibration method, the type of vibration exciter, and the frequency of vibration. The magnitude of the output depends, of course, on the nature of the test device. In the case of an accelerometer with signal conditioner, the practice has been to express the output in millivolts, and the input in units of  $g_n$ , the standard acceleration of free fall.

The acceleration sensitivity is then given in mV/g. For charge-output devices without signal conditioners, the acceleration sensitivity is stated in picocoulombs per g (pC/g). All measurements are performed at  $23 \pm 3^\circ\text{C}$  and  $50 \pm 10$  percent r.h.

The calibration of an accelerometer is reported in tabular form as the sensitivity magnitude at a set of discrete frequencies; the phase component can be furnished on request, at additional cost.

The NIST vibration standards are periodically calibrated by reciprocity and/or interferometric techniques, two independent and absolute methods. The use of these standards in the calibration of stable transducers furnishes calibration data with a typical uncertainty of one to two percent depending on the frequency range.

#### Special Shock Measurement Services (24040S)

The shock facility provides a comparison calibration of accelerometers by subjecting them to half-sinewave pulses with peak amplitudes of 50 to 5000 g and pulse widths from 0.2 to 40 milliseconds. Both time and frequency domain measurements can be performed.

#### Special Tests of Pickup Sensitivity (24050S)

This test measures the pickup sensitivity by the fringe-disappearance method, using an automated Michelson interferometer. As presently configured, the system operates between 3 kHz and 20 kHz. The method requires precise setting of vibration amplitude to 121.10 nm; consequently, the acceleration amplitude in the stated frequency range increases from about 4 to 200 g.

#### Special Vibration Tests (24060S)

Calibration of vibration and shock measuring instruments to specifications different from those above as

well as other measurements can be performed by prearrangement. For example, a comparison calibration for frequencies less than 2 Hz or greater than 10 kHz can be performed on request. Consult with the technical contacts cited at the beginning of this section.

#### References—Vibration Measurements

- An Application of Parameter Estimation Theory in Low Frequency Accelerometers, B. F. Payne and M. R. Serbyn, 14th Transducer Workshop, Telemetry Group, Range Commanders Council, Colorado Springs, CO (June 1987).
- A Description of NBS Calibration Services in Mechanical Vibration and Shock, D. C. Robinson, M. R. Serbyn, and B. F. Payne, Natl. Bur. Stand. (U.S.), Tech. Note 1232 (Feb. 1987).
- An Automated Fringe Counting Laser Interferometer for Low Frequency Vibration Measurements, B. F. Payne, Proc. ISA Symp., Seattle, WA (May 1986).
- Automation of Vibration Testing at the National Bureau of Standards, B. F. Payne, Proc. 30th Tech. Meeting, Inst. of Environ. Sciences (May 1984).
- An Automated System for the Measurement of Pickup Sensitivity, B. F. Payne and M. R. Serbyn, Proc. Natl. Conf. Stand. Lab. Ann. Workshop and Symp. II-11.1-II-11.22 (July 1983).
- The Application of Back-to-Back Accelerometers to Precision Vibration Measurements, B. F. Payne, J. Res. Natl. Bur. Stand. (U.S.), 88, No. 3, 171 (May-June 1983).
- A Real-Time Active Vibration Controller, M. R. Serbyn and W. B. Penzes, ISA Transactions, 21, No. 3, 55 (1982).
- Development of a Low-Frequency-Vibration Calibration System, R. S. Koyanagi, Exp. Mech., 15, 443 (Nov. 1975).
- Shock Calibration of Accelerometers, C. Federman, W. Walston, and J. Ramboz, Minutes of the 8th Transducer Workshop: Telemetry Group, Inter-Range Instrumentation Group, Range Commanders Council, Wright-Patterson AFB, OH (Apr. 1975).
- Piezoelectric Shakers for Wide-Frequency Calibration of Vibration Pickups, E. Jones, B. Yelon, and S. Edelman, J. Acoust. Soc. Am., 46, No. 6, 1556 (June 1969).
- Improved Transfer Standard for Vibration Pickups, E. Jones, D. Lee, and S. Edelman, J. Acoust. Soc. Am., 41, No. 2, 354 (Feb. 1967).
- Electrodynamic Vibration Standard with a Ceramic Moving Element, T. Dimoff, J. Acoust. Soc. Am., 40, No. 3, 671 (Sept. 1966).
- Calibration of Vibration Pickups at Large Amplitudes, E. Jones, S. Edelman, and K. S. Sizemore, J. Acoust. Soc. Am., 33, No. 11, 1462 (Nov. 1961).
- Calibration of Vibration Pickups by the Reciprocity Method, S. Levy and R. R. Bouche, J. Res. Natl. Bur. Stand. (U.S.), 57, No. 4, 227 (Oct. 1956).

# G. Acoustic Measurements

## Technical Contacts:



**Victor  
Nedzelitsky**  
Tel: 301/975-6638



**David J. Evans**  
Tel: 301/975-6637

**Mailing Address:** A147 Sound, National Institute of Standards and Technology, Gaithersburg, MD 20899-0001

Test No.	Items
25010C	Pressure Response: WE Type 640AA microphones or equivalent (e.g., Tokyo Riko Type ECL MR103, Bruel & Kjaer Type 4160, Bruel & Kjaer Types 4144 or 4132 with DB0111 adapter). 50 to 10,000 Hz.
25020C	Pressure Response: WE Type 640AA microphones or equivalent (e.g., Tokyo Riko Type ECL MR103; Bruel & Kjaer Type 4160; Bruel & Kjaer Types 4144 or 4132 with DB0111 adapter). 50 to 20,000 Hz.
25030C	Pressure Response: Tokyo Riko Type ECL MR112, Bruel & Kjaer Type 4134, or equivalent half-inch microphones, 50 to 10,000 Hz.
25040C	Pressure Response: Tokyo Riko Type ECL MR112, Bruel & Kjaer Type 4134, or equivalent half-inch microphones, 50 to 20,000 Hz.
25050C	Free-Field Response: Tokyo Riko Type ECL MR112, Bruel & Kjaer Types 4133, 4134, 4165, 4166, 4180, or equivalent half-inch microphones, 2,500 to 20,000 Hz.
25060S	Special Tests of Acoustic Devices
25070S	Special Tests of Earphones

### Pressure and Free-Field Response of Microphones (25010C-25050C)

Pressure calibrations (Test Nos. 25010C and 25020C) are performed on Type-L one-inch microphones satisfying the requirements of American National Standard S1.12-1967 (R1977), Specifications for Laboratory Standard Microphones and its impending revision. The microphones submitted for pressure calibration

must be suitable for use with the calibrating couplers shown in Figures 6 and 10 of the applicable American National Standard S1.10-1966 (R1986).

Pressure calibrations are reported in terms of open-circuit voltage per unit sound pressure applied uniformly to the diaphragm. The open-circuit voltage at the electrical terminals of a microphone may be influenced by stray capacitance evident at these terminals. For Type-L microphones, these capacitances are defined by the geometrical configuration of the ground shield shown in Figures 6 and 13 of S1.10-1966 (R1986). If the ground shield dimensions are not adhered to in making use of the response levels reported by NIST, errors may result. Pressure calibrations of Type-L microphones exhibit typical uncertainties of approximately 0.1 dB or less at frequencies from 50 Hz to 8 kHz, and 0.2 dB or less at frequencies from 8 kHz to 20 kHz. Further information is contained in the references for acoustic measurements.

Since American National Standards Institute publications S1.10-1966 (R1986) and S1.12-1967 (R1977) were issued, certain types of half-inch diameter precision microphones have attained widespread use. Therefore, NIST has developed procedures (Test Nos. 25030C and 25040C) for determining the pressure response levels of half-inch microphones by comparison with NIST-owned Type-L standard microphones, which in turn are calibrated periodically by the reciprocity technique. The technique used, precautions to be observed, and uncertainties of measurement are essentially the same as those given above for one-inch microphones. Significantly different aspects of the procedures for half-inch microphones, such as ground shield configuration, are described in the test report. Since several half-inch laboratory standard microphones have been available for

only a relatively short time, their long-term stability has yet to be determined.

The free-field response levels of certain Type-L microphones (e.g., Western Electric Type 640AA condenser microphones) can be computed from pressure response levels reported by NIST. However, certain precautions must be taken, and there is some degradation in accuracy. Therefore, for the most demanding free-field measurement requirements, NIST offers a calibration service (Test No. 25050C) for determining the free-field response levels for half-inch microphones. The calibrations are made over the frequency range of 2.5 kHz to 20 kHz at normal incidence. Response levels (sensitivity levels) are reported in terms of open-circuit voltage per unit sound pressure (in the absence of the microphone) of a plane progressive wave whose direction of propagation is normal to the plane of the diaphragm. The calibrations are performed in a well-characterized anechoic chamber. A typical uncertainty in this calibration is approximately 0.15 dB or less at each frequency within the range of 2.5 kHz to 20 kHz. Calibrations can be performed with or without protective grids on the microphone. For the most precise free-field measurements, the customer should contact the NIST staff person cited at the beginning of this section for recommendations prior to submitting the microphone to NIST for calibration.

#### **Special Tests of Acoustic Devices (25060S)**

Acoustical measurement services are available by special arrangement. These services include extended frequency ranges of calibration, additional data points, measurements at very low sound pressure levels, and calibration of certain pistonphones

and acoustic calibrators. NIST has a large general-purpose anechoic chamber available for special calibrations requiring such a facility. The frequency-dependent and position-dependent acoustical performance of this chamber, including extremely low background noise, was carefully controlled during design and construction and is documented in archival journal publications.

#### **Special Tests of Earphones (25070S)**

Earphones are tested on the NIST 9-A Coupler from 125 to 8000 Hz. Measurements of audiometer/earphone response and linearity can be made at very low sound pressure levels.

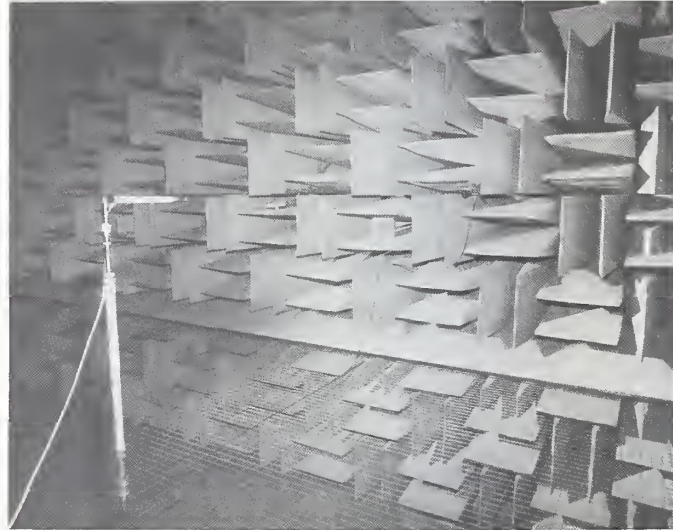

*A NIST-owned half-inch microphone, the free-field response level of which has been determined by the reciprocity method, is shown with a small electrodynamic source of sound in the NIST large general-purpose anechoic chamber.*

**References—Acoustic Measurements**

- Free-Field Reciprocity Calibration of Microphones, E. D. Burnett and V. Nedzelnitsky, *J. Res. Natl. Bur. Stand. (U.S.)*, 92, No. 2, 129 (Mar.-April 1987).
- Traceability of Acoustical Instrument Calibration to the National Bureau of Standards, V. Nedzelnitsky, *Proc. INTER-NOISE 80*, II, Dec. 8-10, 1980, Miami, FL, G. C. Maling, Jr., Ed., Poughkeepsie, NY: Noise Control Foundation, 1043 (1980).
- Calibration of Laboratory Condenser Microphones, V. Nedzelnitsky, E. D. Burnett, and W. B. Penzes, *Proceedings of the 10th Transducer Workshop*, Transducer Committee, Telemetry Group, Range Commanders Council, Colorado Springs, CO (June 1979).
- Acoustical Properties of the National Bureau of Standards Anechoic Chamber, W. Koidan and G. R. Hruska, *J. Acoust. Soc. Am.*, 64, No. 2, 501 (Aug. 1978).
- Specifications for Laboratory Standard Microphones, American National Standards Institute, S1.12-1967 (R1977), New York, NY.
- Method for Calibration of Microphones, *Amer. Natl. Stand. Inst.*, S1.10-1966 (R1986), New York, NY.
- Wedge Design for the National Bureau of Standards Anechoic Chamber, W. Koidan, G.R. Hruska, and M.A. Pickett, *J. Acoust. Soc. Am.*, 52, No. 4 (Part 1), 1071 (1972).
- Calibration of Standard Condenser Microphones: Coupler Versus Electrostatic Actuator, W. Koidan, *J. Acoust. Soc. Am.*, 44, No. 5, 1451 (Nov. 1968).
- Calibrations of Microphones, Vibration Pickups, and Earphones, R.K. Cook, S. Edelman, and W. Koidan, *J. Audio Eng. Soc.*, 13, No. 4 (Oct. 1965).
- Free-Field Correction for Condenser Microphones, W. Koidan and D.S. Siegel, *J. Acoust. Soc. Am.*, 36, No. 11, 2233 (Nov. 1964).
- Hydrogen Retention System for Pressure Calibration of Microphones in Small Couplers, W. Koidan, *J. Acoust. Soc. Am.*, 35, No. 4, 614 (Apr. 1963).
- Method of Measurement of  $E'/I'$  in the Reciprocity Calibration of Condenser Microphones, W. Koidan, *J. Acoust. Soc. Am.*, 32, No. 5, 611 (May 1960).

# H. Ultrasonic Reference Block Measurements

## Technical Contacts:



Gerald V.  
Blessing  
Tel: 301/975-6627



Donald G.  
Eitzen  
Tel: 301/975-6624

**Mailing Address:** A147 Sound, National Institute of Standards and Technology, Gaithersburg, MD 20899-0001

Test No.	Items
26030S	Special Tests of Area Amplitude Aluminum Reference Blocks—Set of Eight Blocks
26040S	Special Tests of Area Amplitude Titanium or Steel Ultrasonic Reference—Set of Eight Blocks
26050S	Special Tests of Distance Amplitude Aluminum Reference Blocks—Set of Fifteen Blocks
26060S	Special Tests of Distance Amplitude Titanium or Steel Ultrasonic Reference Blocks—Set of Fifteen Blocks
26070S	Special Tests of Distance Area Amplitude (Basic Set) Aluminum, Titanium or Steel Ultrasonic Reference Blocks—Set of Eight Blocks
26080S	Special Tests of Velocity Reference Blocks

### Special Tests of Aluminum Reference Blocks (26030S, 26050S, and 26070S)

The ultrasonic response of 7075 aluminum alloy ASTM E127 type flat-bottom-hole (FBH) reference blocks of 0.50 inch and greater metal path distances is determined relative to a NIST reference standard. The immersion, pulse-echo, longitudinal wave, 5 MHz quartz transducer testing system defined in the ASTM E127 calibration document is used with some procedural modifications. First, in the NIST-developed procedure, a 5-0050 block (rather than the steel balls called for in ASTM E127) acts as the NIST reference standard against which all other instrument gain settings are defined. Second, the relative

gain settings for blocks of different FBH sizes are determined by the ratios of their respective FBH areas (rather than by different diameter steel balls per ASTM E127). NIST research shows that these procedural differences yield improved measurement precision. A specific set of NIST FBH "check standard" blocks, acting as interim reference standards, are then calibrated along with the customer's block. System precision and stability over time are provided by measurement of this set of check standard blocks with FBH sizes of 3/64, 5/64, and 8/64 inch diameter. Standard deviation data, representing random errors associated with the NIST system, are provided for the respective block and hole sizes. The plus or minus two standard deviation uncertainty levels range from about 3 to 12 percent of block response, depending on the block and hole sizes of the respective check standards.

A comparison of the customer's block value to the data base of all blocks measured by NIST can be made available. Block response following the procedures of the ASTM Recommended Practice E-127 can also be determined.

Please note that for expedient turnaround of the customer's blocks, it is important that prior arrangements be made with the technical contacts before shipping the blocks to NIST.

### Special Tests of Titanium or Steel Reference Blocks (26040S, 26060S, and 26070S)

Steel and titanium ultrasonic reference blocks can be calibrated using procedures similar to those described in ASTM E428.

### Special Tests of Velocity Reference Blocks (26080S)

Ultrasonic transit-time measurements of the customer's supplied blocks can be determined, from which the material velocity may be calculated.



**References – Ultrasonic Reference Block Measurements**

- Standard Practice for Fabricating and Checking Aluminum Alloy Ultrasonic Standard Reference Blocks, E-127-82A, in Annual Book of ASTM Standards, Vol. 03.03, Philadelphia, PA, Amer. Soc. for Testing and Materials (1985).
- An Assessment of Ultrasonic Reference Block Calibration Methodology, G. V. Blessing, Natl. Bur. Stand. (U.S.), NBSIR 83-2710 (June 1983).
- Recent Improvements to the ASTM-Type Ultrasonic Reference Block System, D. J. Chwirut, Natl. Bur. Stand. (U.S.), NBSIR 79-1742 (Feb. 1979).
- The Evaluation of Search Units Used for Ultrasonic Reference Block Calibrations, D. J. Chwirut and G. D. Boswell, Natl. Bur. Stand. (U.S.), NBSIR 78-1454 (Feb. 1978).
- Improved Ultrasonic Standard Reference Blocks, G.F. Sushinsky, D. G. Eitzen, D. J. Chwirut, C. J. Bechtoldt, and A.W. Ruff, Natl. Bur. Stand. (U.S.), NBSIR 76-984 (Nov. 1976).
- Procedures for the Calibration of ASTM E127-Type Ultrasonic Reference Blocks, D. J. Chwirut, G. F. Sushinsky, and D. G. Eitzen, Natl. Bur. Stand. (U.S.), Tech. Note 924 (Sept. 1976).

## Ultrasonic Transducer Measurements

### Technical Contacts:



Steven E. Fick  
Tel: 301/975-6629



Donald G. Eitzen  
Tel: 301/975-6624

**Mailing Address:** A147 Sound, National Institute of Standards and Technology, Gaithersburg, MD 20899-0001

Test No.	Items
26100C	Ultrasonic Transducer Power Output; Radiation Pressure
26110C	Ultrasonic System Power Output; Calorimeter
26120S	Special Tests of Ultrasonic Transducers

### Ultrasonic Transducer Power and Frequency (26100C-26110C)

Measurements of total ultrasonic forward power radiated into a water load are offered for the purpose of characterizing ultrasonic systems and transducers. Ultrasonic systems are characterized by measurement of output under operating conditions specified by the customer. Transducers for which an amplitude-modulated continuous-wave electrical input voltage can accurately and reproducibly be measured are characterized by a radiation conductance determined from measurements of input voltage and output power. A typical calibration report for an ultrasonic system provides the results of at least three measurements of output power for each operating condition specified. Calibration reports for transducers typically present a single value of radiation conductance derived from at least 15 measurements spanning an appropriate range of power. Resonance frequencies of transducers are determined from the results of iterative

spot-frequency relative measurements of radiation conductance.

Continuous-wave ultrasonic power is measured using a radiation force balance which allows power to be determined from the force required to arrest the motion of a conical target that diverts the output beam of the transducer under test into a bank of absorbers. Absolute power can be measured at spot frequencies between 1 and 20 MHz. The overall uncertainty varies from 2.2 percent at 1 MHz to 7.6 percent at 20 MHz. These estimates of uncertainty apply to measurements made at power levels ranging from a few milliwatts to a few watts. The minimum detectable power is about 10 microwatts; high-power measurements are limited by the onset of cavitation in the water load. Transducers of diameter no greater than 45 mm can be tested in this apparatus.

Pulsed ultrasonic power is measured for the purpose of characterizing ultrasonic systems comprising a transducer and an electrical driver can be tested. Transducers by themselves cannot be independently characterized with nonsinusoidal drive wave-forms since the electrical input signals cannot at present be adequately measured or characterized. The radiation force balance just described is used to characterize pulsed ultrasonic systems capable of externally-triggered operation at pulse repetition frequencies near 30 Hz. Systems incapable of external triggering or of operation at 30 Hz p.r.f. are characterized using a specially designed calorimeter. Power levels ranging from 1 mW to several watts at frequencies between 1 and 15 MHz can be measured with an overall uncertainty less than 10 percent + 0.2 mW. Transducers with diameters as great as 26 mm can be accommodated. Measurements of continuous-wave power are also possible with the calorimeter; its response time precludes swept-frequency tests.

### Special Tests of Ultrasonic Transducer Power (26120S)

This service includes consultation, customized testing, and the lending of air-backed transducers for the purpose of transferring power measurements. Quartz transducers characterized by radiation conductance and thus suited for the reproduction of arbitrary power levels are available for frequencies of 2, 3, and 5 MHz and can be specially calibrated for operation at odd overtones. Lithium niobate transducers with built-in circuitry allowing the field user to reproduce prearranged power levels while measuring only dc voltage are available for use at frequencies below 20 MHz approximated by odd multiples of 0.5 MHz.

### References—Ultrasonic Transducer Measurements

- An Ultrasonic Absolute Power Transfer Standard, S. E. Fick, F. R. Breckenridge, C. E. Tschiegg, and D. G. Eitzen, *J. Res. Natl. Bur. Stand. (U.S.)*, 89, No. 2, 209 (Mar. 1984).
- Ultrasonic Transducer Characterization at the NBS, E. R. Miller and D. G. Eitzen, *IEEE Trans. Sonics and Ultrasonics*, SU-26, No. 1, 28 (Jan. 1979).

Ultrasonic Transducer Power Output by Modulated Radiation Pressure (with details), M. Greenspan, F. R. Breckenridge, and C. E. Tschiegg, *Natl. Bur. Stand. (U.S.)*, NBSIR 78-1520 (July 1978).

Ultrasonic Transducer Power Output by Modulated Radiation Pressure, M. Greenspan, F. R. Breckenridge, and C. E. Tschiegg, *J. Acoust. Soc. Am.*, 63, No. 4, 1031 (Apr. 1978).

Ultrasonic Calorimeter for Beam Power Measurements from 1 to 15 Megahertz, T. L. Zapf, M. E. Harvey, N. T. Larsen, and R. E. Stoltenberg, 1976 Ultrasonics Symposium Proceedings, *IEEE Cat. 76, CH1120-ISU*, Inst. for Electron. and Electric. Engrs., New York, NY (1976).

Ultrasonic Calorimeter for Beam Power Measurements, T. L. Zapf, M. E. Harvey, N. T. Larsen, and R. E. Stoltenberg, *Natl. Bur. Stand. (U.S.)*, Tech. Note 686 (Sept. 1976).

Calibration of Quartz Transducers as Ultrasonic Power Standards by an Electrical Method, T. L. Zapf, 1974 Ultrasonics Symposium Proceedings, *IEEE Cat. 74, CH0896-ISU*, Inst. for Electron. and Electric. Engrs., New York, NY (1974).

# J. Acoustic Emission Transducer Measurements

## Technical Contacts:

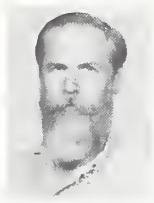

Franklin R.  
Breckenridge  
Tel: 301/975-6628



Donald G.  
Eitzen  
Tel: 301/975-6624

**Mailing Address:** A147 Sound, National Institute of Standards and Technology, Gaithersburg, MD 20899-0001

Test No.	Items
26200C	Acoustic Emission Transducer Amplitude and Phase Sensitivity versus Frequency
26210S	Special Tests of Acoustic Emission Transducers and Sensors

### Acoustic Emission Sensors (26200C)

The NIST acoustic emission transducer calibration provides the voltage output of a transducer per unit of motion (displacement or velocity) of the mounting surface as a function of frequency. The calibration is based upon the normal component of motion which would occur in the absence of the transducer. A choice of two different geometries for the test is offered as follows: the surface-pulse test in which the transducer under test and the source of sound are both on a common plane surface of the test block, and the through-pulse test in which the transducer under test and the source of sound are located on opposite faces of the test block.

The surface-pulse test method is as follows: a step function of "point" force is generated on the surface of a large steel block by breaking a glass capillary. The transducer under test and the NIST standard capacitive transducer are located on this same

surface and are equidistant from the source. Both transducers experience the motion of the seismic surface pulse generated by the step function force. The transient voltage outputs from both transducers are recorded and analyzed for frequency content. The frequency response of the transducer under test is obtained by dividing the spectral amplitude from it by that from the standard transducer, frequency by frequency. The calibration is absolute, since the sensitivity of the standard transducer is known. The magnitude and phase of the sensitivity of the transducer under test are obtained at discrete frequencies,  $f_n = 9765.625n$  (Hz), where  $n = 1, 2, 3, \dots$ . The customer is provided with the results in the form of graphs of magnitude and phase. These are piecewise linear functions constructed through the data points. Within the valid range of 0.1 to 1 MHz, the uncertainty is approximately 10 percent. At the option of the customer, the results will be given with respect to normal displacement or velocity of the mounting surface, on a linear scale or on a decibel scale.

The through-pulse test method is similar to the surface-pulse test, except that the transducer under test and the source of sound are located opposite each other on the top and bottom plane surfaces of the 43-cm-thick test block. For the through-pulse calibration, the reference signal is obtained not from the standard transducer but from a calculation based on the measured force of the capillary break.

**References – Acoustic Emission Transducer Measurements**

Acoustic Emission Transducer Calibration by Means of the Seismic Surface Pulse, F. R. Breckenridge, *J. Acoust. Emission*, 1, No. 2 (Apr. 1985).

Calibration and Sensor Activities, D. G. Eitzen, F. R. Breckenridge, R. B. Clough, E. R. Fuller, N. N. Hsu, and J. A. Simmons, Chapter 2.0 in *Fundamental Developments for Quantitative Acoustic Emission Measurements*, EPRI NP-2089, Research Project 608-1, Palo Alto, CA, Electric Power Research Institute, 2-1-2-52 (Oct. 1981).

**Surface-Wave Displacement:**

Absolute Measurements Using a Capacitive Transducer, F. R. Breckenridge and M. Greenspan, *J. Acoust. Soc. Am.*, 69, No. 4, 1177 (Apr. 1981).

Characterization and Calibration of Acoustic Emission Sensors, N. N. Hsu and F. R. Breckenridge, *Matls. Eval.*, 39, No. 1, 60 (Jan. 1981).

Acoustic Emission: Some Applications of Lamb's Problem, F. R. Breckenridge, C. E. Tschiegg, and M. Greenspan, *J. Acoust. Soc. Am.*, 57, No. 3, 626 (Mar. 1975).

---

# Chapter

# 6

- A** Pressure Measurements
- B** Low-Pressure, Vacuum,  
and Leak Measurements
- C** Laboratory Thermometers
- D** Thermocouples, Thermocouple  
Materials, and Pyrometer Indicators
- E** Resistance Thermometry
- F** Radiation Thermometry
- G** Humidity Measurements
- H** Total Heat Flux Gauges

## A. Pressure Measurements

### Technical Contacts:



Stephen W. Doty  
29010C, 29030C  
Tel: 301/975-4857



R. Gregory Driver  
29010C, 29030C,  
29040S  
Tel: 301/975-4832



Walter Markus  
29010C, 29030C  
Tel: 301/975-4827



Donald B. Ward  
29020C, 29035C  
Tel: 301/975-6561

**Mailing Address:** A55 Metrology, National Institute of Standards and Technology, Gaithersburg, MD 20899-0001

Test No.	Items
29010C	Deadweight Piston Gages
29020C	Controlled Clearance Piston Gages
29030C	Pressure Gages and Transducers
29035C	Mercurial Barometers and Manometers
29040S	Special Tests of Pressure Gages

### Piston Gages and Pressure Transducers (29010C-29035C)

NIST provides measurement services for the calibration of piston gages and transducers operating with gas in the range of 1.4 kPa to 17 MPa and with oil in the range of 700 kPa to 400 MPa. Calibrations of customer piston gages are done in the gage mode by the cross-floating technique using NIST working standard piston gages. NIST working standards for use with gas have been calibrated at the low end of the pressure range using the NIST gas thermometer manometer and at the high end of the range using a controlled-clearance piston gage. The NIST working standards for oil service have been calibrated using two controlled-clearance piston gages. Systematic uncertainties associated with such calibrations are shown in Table 1.

**Table 1:** Estimated Systematic Uncertainties of Piston Gage Calibrations in Gage Mode

Type of Instrument	Range	Approx. Systematic Uncertainty
Gas-operated PG	21 kPa to 103 kPa	$\pm 22$ ppm*
	83 kPa to 1 MPa	$\pm 27$ ppm*
	690 kPa to 5 MPa	$\pm 50$ ppm*
	690 kPa to 17 MPa	$\pm 50$ ppm*
Oil-operated PG	700 kPa to 100 MPa	$\pm 77$ ppm
	28 MPa to 280 MPa	$\pm 73$ to $\pm 150$ ppm
	40 MPa to 400 MPa	$\pm 186$ ppm

\* These uncertainties are based on recent evaluations of NIST "transfer" piston gage standards. These estimates are in the process of further evaluation and may be modified (look for announcements in SP250 Supplements).

Calibrations of transducers are performed in both the gage and absolute modes.

### Special Tests of Pressure Gages (29040S)

Special tests of pressure gages and other pressure measuring devices may be performed on request. This includes, as a complement to the special test described in Test No. 30040S for deadweight piston gages, an absolute mode test in the pressure range 21-103 kPa that can provide systematic uncertainties at a level below that which is available in Table 1. A minimum piston gage test will require data at five or more pressures for each gas desired. Call Mr. Driver or Dr. Ratnam for further information about this service.

### References—Pressure Measurements

The Reduction of Uncertainties for Absolute Piston Gage Pressure Measurements in the Atmospheric Pressure Range, B. E. Welch, R. E. Edsinger, V. E. Bean and C. D. Ehrlich, *J. Res. Natl. Inst. Stand. Technol.*, 94, 343 (Nov.-Dec. 1989).  
Observations of Gas Species and Mode of Operation Effects on Effective Areas of Gas-Operated Piston Gages, B. E. Welch, R. E. Edsinger, V. E. Bean, and C. D. Ehrlich, *High Pressure Metrology*, G. F. Molinar, ed., BIPM Monogr. 89/1, 81 (1989).

- Practical Uncertainty Limits to the Mass Determination of a Piston-Gage Weight, R. S. Davis and B. E. Welch, *J. Res. Natl. Bur. Stand. (U.S.)*, 93, No. 4 (July-Aug. 1988).
- Pressure Metrology: Primary Standard Piston Gages, V. E. Bean, *Proc. Xth Conf. of the Intl. Assoc. for the Advanc. of High Pressure Sci. and Tech.*, Amsterdam (July 1985).
- Elastic Distortion of Piston Gages, J. Lazos-Martinez and V. E. Bean, *Proc. Xth Conf. of the Intl. Assoc. for the Advanc. of High Pressure Sci. and Tech.*, Amsterdam (July 1985).
- Factors Affecting the Precision of Gas Operated Piston Gages at the Part Per Million Level, B. E. Welch, L. A. Guildner, and V. E. Bean, *Proc. 31st Intl. Instrum. Symp.*, San Diego, CA, 9 (May 1985).
- Note on the Results of the First Phase of an International Comparison in the Pressure Range 20-100 MPa Organized by the High Pressure Working Group of the Comité Consultatif pour la Masse, J. C. Legras, V. E. Bean, J. Jager, S. L. Lewis, and G. F. Molinar, *J. Phys. E: Sci. Instrum.* 18, 361 (1985).
- International Comparison in the Pressure Range 20-100 MPa Organized by the High Pressure Working Group of the Comité Consultatif pour la Masse, J. C. Legras, V. E. Bean, J. Jager, S. L. Lewis, and G. F. Molinar, *BIPM Internal Technical Report 84/2*, Intl. Bur. of Weights and Meas., Paris (1984).
- Pressure and Temperature Measurements in the Annulus between the Piston and Cylinder of a Simple Dead-Weight Piston Gauge, B. E. Welch and V. E. Bean, *Rev. Sci. Instrum.* 55, 1901 (1984).
- Effects of Viscosity, Temperature, and Rate of Rotation on Pressure Generated by a Controlled-Clearance Piston Gauge, J. K. N. Sharma, K. K. Jain, V. E. Bean, B. E. Welch, and R. J. Lazos, *Rev. Sci. Instrum.* 55, 563 (1984).
- A Method to Determine the Pressure Dependent Distortion of a Simple Piston Gauge Based on Dimensional Metrology, B. E. Welch and V. E. Bean, *High Pres. Sci. and Tech.*, 22, II, 261, C. Homan, R. K. MacCrone, and E. Whalley, Eds., Elsevier Science Publishing Co., Inc., New York (1984).
- An Intercomparison of Pressure Standards between IMGCC and NBS, J. C. Houck, G. F. Molinar, and R. Maghenzani, *J. Res. Natl. Bur. Stand. (U.S.)*, 88, 253 (1983).
- An Intercomparison of Pressure Standards between LNE and NBS, R. G. Driver, J. C. Houck, and B. E. Welch, *J. Res. Natl. Bur. Stand. (U.S.)*, 86, No. 3 (May-June 1981).
- Absolute High Pressure Measurements, V. E. Bean, *High Pressure Science and Technology*, B. Vodar and P. Mardeau, Eds., 231, Pergamon Press, Oxford, England (1980).
- Piston Gages, P. L. M. Heydemann and B. E. Welch, Chapter 4, *Experimental Thermodynamics, Vol. II, in Experimental Thermodynamics of Non-Reacting Fluids*, B. Le Neindre and B. Vodar, Eds., Part 3, 147, Butterworth and Co., London, England (1975).
- Reduction of Data for Piston Gauge Measurement, J. L. Cross, *Natl. Bur. Stand. (U.S.)*, Monogr. 65 (1963).



## B. Low-Pressure, Vacuum, and Leak Measurements

### Technical Contacts:



**Richard W. Hyland**  
30010C-30021C,  
30025C, 30040S,  
30050S  
Tel: 301/975-4829



**Sharrill Dittmann**  
30029C-30038C,  
30050S  
Tel: 301/975-4838



**Stuart A. Tison**  
30060S  
Tel: 301/975-2857

**Mailing Address:** A55 Metrology, National Institute of Standards and Technology, Gaithersburg, MD 20899-0001

**Shipping Address:** National Institute of Standards and Technology, I-270 at Quince Orchard Rd., A52 Metrology, Gaithersburg, MD 20899-0001

Test No.	Items
30010C	Absolute Low-Pressure Transducers
30011C	Up to Two Additional Transducers (cost per unit)
30020C	Differential Low-Pressure Transducers Relative to Vacuum
30021C	Up to Two Additional Transducers (cost per unit)
30025C	Ball-Type Deadweight Tester
30029C	Molecular Drag Gages, Without Customer Controller
30030C	Molecular Drag Gages, With Customer Controller
30031C	Molecular Drag Gages, Additional Ball or Gas
30034C	Ionization Gages, $10^{-4}$ to $10^{-1}$ Pa, Nitrogen Gas
30035C	Ionization Gages, $10^{-5}$ to $10^{-1}$ Pa, Nitrogen Gas
30036C	Ionization Gages, $10^{-7}$ to $10^{-1}$ Pa, Nitrogen Gas
30037C	Ionization Gages, Additional Filament or Gas for Above Tests
30038C	Ionization Gages, NIST Supplied Gage Tube for Above Tests
30040S	Special Tests of Low-Pressure Gages
30050S	Special Tests of Vacuum Gages
30060S	Special Tests of Leak Artifacts

### Low-Pressure Transducers (30010C-30011C, 30020C-30021C and 30025C)

Absolute low-pressure gages including capacitance diaphragm gages and quartz spiral gages are calibrated against the NIST Ultrasonic Interferometer Manometer. This standard

covers a range limited at the low end by its 10 mPa ( $10^{-4}$  Torr) imprecision and extending up to 360 kPa (2700 Torr, 53 psi). The uncertainty of the standard is 15 ppm of reading plus 10 mPa. This standard is also used for the calibration of low-range differential gages, including ball gages, and gas-operated piston gages (see 30040S). Calibrations are generally performed during February and July. Instruments scheduled for these regular calibration periods must be received in the calibration laboratory before the fifth working day of February or July, respectively. Calibrations can be performed at other times by special arrangement. A fee will be charged to cover time lost because of inoperative customer equipment.

### Molecular Drag and Ionization Gages (30029C-30038C)

A standard of the orifice flow type covers the range from  $10^{-1}$  to  $10^{-7}$  Pa ( $10^{-3}$  to  $10^{-9}$  Torr) for most gases with an uncertainty of 1 percent between  $10^{-2}$  and  $10^{-4}$  Pa increasing to 5 percent at  $10^{-7}$  Pa. Ionization gages and molecular drag or spinning rotor gages are accepted for calibration but all gages must be bakeable to 250 °C and should be welded to "Conflat" type flanges. Standard procedure is to calibrate the sensor and electronics as a package, although sensors may be calibrated using NIST electronics by special arrangement. Note that ionization gage controllers that do not regulate the emission current or controllers that deliberately change the current are not considered suitable as transfer standards. Calibration fees will depend on the pressure range. For any of the tests 30034C-30036C, additional filaments will be calibrated at the same time, or calibrations performed with additional gases, for a reduced charge (30037C). A fee will be charged to cover time lost because of inoperative customer equipment. Similarly, for tests 30029C and 30030C additional rotors will be calibrated, or calibrations will be performed with additional gases for a reduced charge (30031C).

For an additional fee NIST will provide tubulated Bayard-Alpert ionization gages with tungsten filaments and 2.75 in. "Conflat" type flanges (30038C). These will be calibrated with the user's electronics.

#### Special Tests of Low-Pressure Gages (30040S)

Instruments requiring special calibration procedures or prolonged testing can often be accommodated as a special test. This includes, as a complement to the 29000 series of tests, the determination of deadweight piston gage effective area using the NIST ultrasonic interferometer manometer as the reference standard. This test can be done in either the gage or absolute mode for a variety of gases. A minimum piston gage test will require data for at least one gas in the absolute mode at five or more pressures. For further information contact R. W. Hyland.

#### Special Tests of Vacuum Gages (30050S)

Instruments requiring special calibration procedures or prolonged testing can often be accommodated as a special test. Consult with S. Dittmann for further details.

#### Special Tests of Leak Artifacts (30060S)

A special-test service is offered for helium leak artifacts in the range  $10^{-8}$  to  $5 \times 10^{-14}$  mol/s ( $2 \times 10^{-4}$  to  $1 \times 10^{-9}$  atm cc/s at 0 °C). The Report of Test provides tabulated leak rates at 1 °C intervals from 0 °C to 50 °C, based on absolute measurements taken on the Primary Leak Standard (referenced to 23 °C), and temperature-dependence measurements taken on a controlled-temperature leak rate comparator system. Typical uncertainties for the calibrated leaks ( $3\sigma$ ) are between 3 and 10 percent. All leak artifacts submitted for measurement must be of ultrahigh vacuum compatible, clean and with all-metal construction except for the glass permeation element. The vacuum

connection must be a standard 2.75" "conflat" type flange. An easily observable customer identification number or code must be engraved on the circumference of the 2.75" flange. Special test of leaks for gases other than helium will be considered on a case-by-case basis. For further information contact S. A. Tison.

Figure 5 summarizes the uncertainties of the NIST low-pressure and vacuum standards. Dashed lines are target uncertainties expected from new standards under development or improvements to existing standards.

Figure 5. Uncertainties of NIST Low Pressure and Vacuum Standards

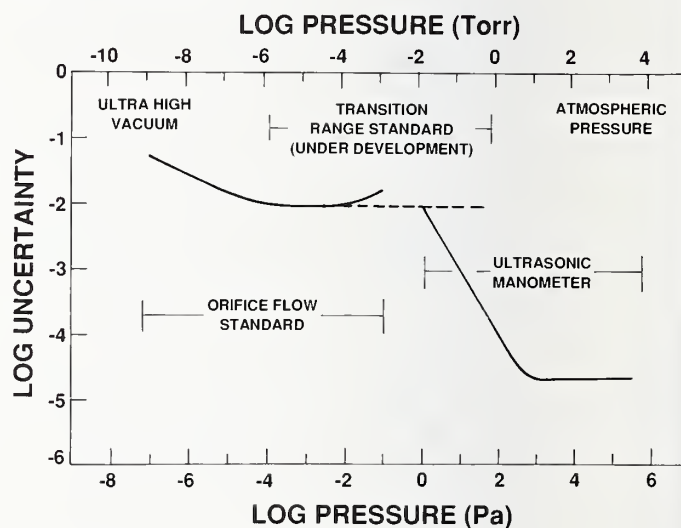

#### References – Low-Pressure, Vacuum, and Leak Measurements

- A Study of the Linearity of Transfer Leak Standards and a Helium Leak Detector, C. D. Ehrlich, S. A. Tison, H. Y. Hsiao, and D. B. Ward, *J. Vac. Sci. Technol.* (Nov. 1990).
- The Molecular Drag Gauge as a Calibration Standard, S. Dittmann, B. E. Lindenau, and C. R. Tilford, *J. Vac. Sci. Technol.*, A7, 3356 (1989).
- NIST Measurement Services: High Vacuum Standard and Its Use, S. Dittmann, *Natl. Inst. Stand. Technol. Spec. Publ.* 250-34 (1989).



*Sharrill Dittmann with the primary high vacuum standard used for the calibration of spinning rotor and ionization gages.*

The NBS Ultrasonic Interferometer Manometer and Studies of Gas-Operated Piston Gages, C. R. Tilford and R. W. Hyland, *Metrology*, Proc. 11th Triennial World Congress of the Int. Meas. Conf. (IMEKO), 277, Instrum. Soc. of America, Res. Triangle Park, NC, Houston, TX (Oct. 16-21 1988).  
 New Developments in Barometric Range Pressure Standards, C.R. Tilford, Proc. 1988 Natl Conf. Stand. Lab. Ann. Workshop and Symp., 35-1 to 35-15 (1988).  
 The NBS Primary High Vacuum Standard, C. R. Tilford, S. Dittmann, and K. E. McCulloh, *J. Vac. Sci. Technol.* A6, 2853 (1988).  
 The Speed of Sound in a Mercury Ultrasonic Interferometer Manometer, C. R. Tilford, *Metrologia* 24, 121 (1987).

Low-Range Flowmeters for Use with Vacuum and Leak Standards, K. E. McCulloh, C. R. Tilford, C. D. Ehrlich, and F. G. Long, *J. Vac. Sci. Technol.*, A5, 376 (1987).

Transfer Leak Studies and Comparisons of Primary Leak Standards at the National Bureau of Standards and Sandia National Laboratories, R. W. Hyland, C. D. Ehrlich, and C. R. Tilford, *J. Vac. Sci. Technol.*, A4, 334 (1986).

A Note on Flow Rate and Leak Rate Units, C. D. Ehrlich, *J. Vac. Sci. Technol.*, A4, 2384 (1986).

Zero Stability and Calibration Results for a Group of Capacitance Diaphragm Gages, R. W. Hyland and C. R. Tilford, *J. Vac. Sci. Technol.*, A3, 1731 (1985).

Zero Stability of Spinning Rotor Vacuum Gages, K. E. McCulloh, S. D. Wood, and C. R. Tilford, *J. Vac. Sci. Technol.*, A4, 1738 (1985).

Long-Term Stability of Two Types of Hot Cathode Ionization Gages, S. D. Wood and C. R. Tilford, *J. Vac. Sci. Technol.*, A3, 542 (1985).

Sensitivity of Hot Cathode Ionization Gages, C. R. Tilford, *J. Vac. Sci. Technol.*, A3, 546 (1985).

Reliability of High Vacuum Measurements, C. R. Tilford, *J. Vac. Sci. Technol.*, A1(2), 152 (Apr.-June 1983).

Ultrasonic Manometers for Low and Medium Vacua Under Development at NBS, P. L. M. Heydemann, C. R. Tilford, and R. W. Hyland, *J. Vac. Sci. Technol.*, 14, 597 (Jan.-Feb. 1977).

## C. Laboratory Thermometers

### Technical Contact:



Jacquelyn A. Wise  
Tel: 301/975-4822

**Mailing Address:** B126 Physics, National Institute of Standards and Technology, Gaithersburg, MD 20899-0001

**Shipping Address:** National Institute of Standards and Technology, 1-270 at Quince Orchard Rd., A242 Physics, Gaithersburg, MD 20899-0001

Attn: J. Wise

Test No.	Items
31010C	Laboratory Thermometers (0 to 150 °C) (32 to 302 °F)
31020C	Laboratory Thermometers (151 to 300 °C) (304 to 572 °F)
31030C	Laboratory Thermometers (301 to 550 °C) (574 to 1022 °F)
31040C	Laboratory Thermometers (-1 to -110 °C) (30 to -166 °F)
31050C	Laboratory Thermometers (Liquid N <sub>2</sub> ) (-196 °C or -321 °F)
31060C	Laboratory Thermometers (Liquid O <sub>2</sub> ) (-183 °C or -297 °F)
31070C	Calorimetric Thermometer
31080C	Beckmann Thermometer
31100C	Quantity Tests of Liquid-in-Glass Thermometers
31110S	Special Tests of Thermometers (0 to 150 °C) (32 to 302 °F)
31120S	Special Tests of Thermometers (151 to 300 °C) (304 to 572 °F)
31130S	Special Tests of Thermometers (301 to 550 °C) (574 to 1022 °F)
31140S	Special Tests of Thermometers (-1 to 110 °C) (30 to -166 °F)
31150S	Special Tests of Thermometers (Liquid N <sub>2</sub> ) (-196 °C or -321 °F)
31160S	Special Tests of Thermometers (Liquid O <sub>2</sub> ) (-183 °C or -297 °F)
31200S	Preliminary Exam or Ineligible Thermometer
31250S	Additional copy of report
31260S	Special Thermometry Services, by Prearrangement

### Laboratory Thermometers (31010C-31100C)

This service provides for the calibration of a variety of thermometers covering the range from -196 to +550 °C (-320 to +1022 °F).

Thermometers belonging to the large and varied group, which may be classed as laboratory or "chemical" thermometers, are regularly accepted. These are of the liquid-in-glass type with either solid-stem or enclosed scale. Ordinary household or meteorological thermometers will not, in general, be accepted unless the scale is graduated on the glass stem itself and the thermometer can be readily detached from its mounting for insertion in a liquid bath. Every thermometer submitted must be uniquely identified by a serial number and must pass a preliminary examination for fineness and uniformity of graduation; for cleanliness of the mercury and capillary bore; for freedom from moisture, gas bubbles, and cracks in the glass; for adequacy or omission of gas filling where needed; for insufficient annealing; and for misnumbered graduations. When these or other serious defects are found, the thermometer is returned untested.

The thermometers to be calibrated are placed in a constant temperature bath along with a NIST-calibrated standard platinum resistance thermometer (SPRT). The SPRT maintains calibrations traceable to the International Practical Temperature Scale of 1990 (ITS-90), with an uncertainty of  $\approx 1$  mK. (See Table 2.)

**Table 2: Thermometer Calibration Uncertainties**

Type of Thermometer (Total Immersion)	Range	Uncertainty
Mercury-in-glass (graduations: 0.1–0.2 °C)	0 to 100 °C	0.03 to 0.05 °C
Mercury-in-glass (graduations: 1–2 °C)	0 to 300 °C 300 to 550 °C	0.2 to 0.5 °C 0.5 to 1.0 °C
Organic liquid-in-glass	– 200 to 0 °C	0.2 to 0.5 °C

### Special Tests of Thermometers (31110S–31160S)

Special tests may be conducted on temperature-measuring devices such as industrial grade platinum resistance thermometers, digital thermometers, and thermistors. Laboratory personnel should be contacted before submitting items.

Figure 6 summarizes the relative NIST uncertainties for different types of temperature-measuring instruments, including thermometers, thermocouples, and pyrometers. See also following sections.

### References – Laboratory Thermometers

- The International Temperature Scale of 1990 (ITS-90), H. Preston-Thomas, *Metrologia* 27, 3–10 (1990); *Metrologia* 27, 107 (1990).  
 ASTM Standard E1-89, Specification for ASTM Thermometers, Annual Book of ASTM Standards 14.03, 1, Amer. Soc. for Test. and Matls., Philadelphia, PA (1990).  
 ASTM Standard E77-89, Methods of Verification and Calibration of Liquid-in-Glass Thermometers, Annual Book of ASTM Standards 14.03, 60, Amer. Soc. for Test. and Matls., Philadelphia, PA (1990).  
 NIST Measurement Services: Liquid-in-Glass Thermometer Calibration Service, J. A. Wise, Natl. Inst. Stand. Technol. Spec. Publ. 250-23 (Sept. 1988).  
 Thermometer Calibration: A Model for State Calibration Laboratories, J. A. Wise, R. J. Soulen, Natl. Bur. Stand. (U.S.), Monogr. 174 (Jan. 1986).

Figure 6. Uncertainties for NIST Calibration of Temperature Measuring Instruments

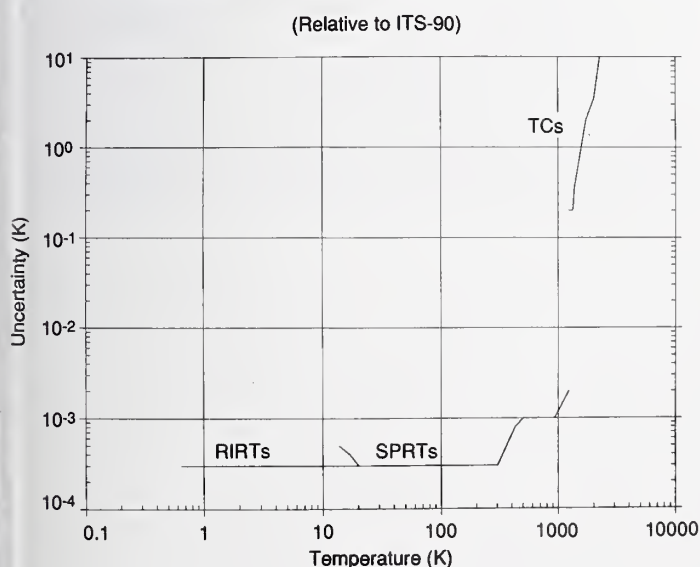

# D. Thermocouples, Thermocouple Materials, and Pyrometer Indicators

## Technical Contacts:



**George W. Burns**  
32010C-32101C,  
32150S  
Tel: 301/975-4817



**Margaret G. Scroger**  
32010C-32101C,  
32150S  
Tel: 301/975-4818



**Jacquelyn A. Wise**  
32110C-32147C  
Tel: 301/975-4822

**Mailing Address:** B126 Physics, National Institute of Standards and Technology, Gaithersburg, MD 20899-0001

**Shipping Address:** National Institute of Standards and Technology, I-270 at Quince Orchard Road, Gaithersburg, MD 20899-0001

For 32010C-32101C, 32150S  
[Attn: G. Burns or M. Scroger, Bldg. 221, Room B229]

For 32110C-32147C  
[Attn: J. Wise, Bldg. 221, Room A242]

*Comparison Calibrations, Temperature Measured with Thermocouple:*

Test No.	Items	Temp. TC Range Type °C	Points	Min. Length mm	Temp. °C	Est. Uncert. °C
32010C	S	0-1450	1° or 1°F Interv. Table	700	0-600 600-1100 1450	0.5 0.5 2
32020C	R	0-1450	" " "	700	0-600 600-1100 1450	0.5 0.7 2
32030C	B	0-1750	" " "	1000	0-600 (3 μV) 600-1100 1450 1750	0.5 2 3
32031C	B	800-1750	" " "	1000	800-1100 1450 1750	0.7 2 3

*Comparison Calibrations, Temperature Measured with Thermocouple:*

Test No.	Items	Temp. TC Range Type °C	Points	Min. Length mm	Temp. °C	Est. Uncert. °C
32040C	E	0-1000	4 to 15	700		1
32041C	J	0-760	4 to 15	700		1
32042C	K	0-1100	4 to 15	700		1
32043C	N	0-1100	4 to 15	700		1
32044C	T	0-400	4 to 15	700		1
32050C	Comparison calibration, 2 point minimum, per point, for all items above					
32060C	Each additional table of results at 1°C or 1°F intervals, for Type S, R, or B at later date					
32061C	Each additional table of results at 1°C or 1°F intervals, for Type S, R, or B at time of test					
32070C	Thermocouple materials tested against Pt thermoelectric standard, 4 to 15 points, 700 mm minimum lengths					
<i>Calibration at Metal Freezing Points, Minimum Diameter 0.4 mm, Freezing Point Determination at Au, Ag, Sb, and Zn</i>						
32090C	S	0-1450	Table, 1°C or 1°F interv. and equations to generate table	1000	at freezing points 0 to 700 700 to 1100 1450	0.2 0.3 0.4 2
32091C	Type S, freezing point determination, per point, 2 point minimum					

*Calibration of Pyrometer Indicators*

32100C	Portable Potentiometer, first dial or range
32101C	Portable Potentiometer, each additional dial or range

*Comparison Calibrations, Temperature Measured with Platinum Resistance Thermometer:*

**Test No. Items**

*Comparison Calibration of Thermocouples or Thermocouple Materials Tested against Pt Thermoelectric Standard, Temperature Measured with Platinum Resistance Thermometer, Minimum Length 36 Inches, 2 Point Minimum*

- 32110C Range -110 to +300 °C and Liquid N<sub>2</sub> (-196 °C) or -166 to 572 °F and Liquid N<sub>2</sub> (-321 °F)  
 32120C 301 to 550 °C or 574 to 1022 °F  
 32130C Liquid O<sub>2</sub> (-183 °C) or (-297 °F)

*Table at one degree intervals for Type T thermocouple for any of the following options:  
 (The cost of the table will be in addition to the calibration per point covered under fee schedule items numbered 32110C-32130C.)*

- 32141C Option 1: Table from -190 to +300 °C (-310 to +572 °F), calibration points at -183, -110, -50, +100, +200, +300 °C  
 32142C Option 2: Table from -190 to +100 °C (-310 to +212 °F), calibration points at -183, -110, -50, +50, +100 °C  
 32143C Option 3: Table from -110 to +300 °C (-166 to +572 °F), calibration points at -110, -50, +100, +200, +300 °C  
 32144C Option 4: Table from -110 to +100 °C (-166 to +212 °F), calibration points at -110, -50, +50, +100 °C  
 32145C Option 5: Table 0 to 300 °C (32 to 572 °F), calibration points at +100, +200, +300 °C  
 32146C Option 6: Table from -110 to 0 °C (-166 to +32 °F), calibration points at -110, -50 °C.  
 32147C Option 7: Table from -190 to 0 °C (-310 to +32 °F), calibration points at -183, -110, -50 °C  
 32150S Special Tests of Thermocouples and Thermocouple Materials

**Thermocouples, Thermocouple Materials, and Pyrometer Indicators (32010C-32147C)**

Calibration services for all commonly used types of thermocouples are provided by NIST from -196 to 1750 °C depending upon the wire or thermocouple type. The thermocouples are calibrated by one or a combination of three general methods, depending on the thermocouple type, the temperature range, and the accuracy required. All three methods provide traceability to the ITS-90. In the first method, thermocouples are calibrated by comparison with a standard thermocouple maintained at NIST. In the second method, thermocouples are calibrated by comparison with a standard platinum resistance thermometer. In the third method, thermocouples are calibrated at three defining temperatures on the ITS-90—the freezing points of Zn, Ag, and Au, as well as at the freezing point of Sb (≈630.62 °C). Below 0 °C the thermocouple calibration is carried out in a cryostat, while above 0 °C stirred liquid baths, metal freezing-point cells, and electric tube-type furnaces are employed for the calibrations. Vacuum or inert gas furnaces are also available for testing thermocouples.

Only the bare wires are required to perform the thermocouple calibrations. It is preferable not to send insulating and protecting tubes as the rate of breakage of these in shipment is high. If the thermocouple is furnished mounted (as in a protection tube assembly), a nominal charge will be made for dismantling the mounting and the various parts will be returned to the sender without reassembling them. Thermocouple length requirements listed in the appendix are exclusive of lead wire. Lead wires (for connections) need not be sent with thermocouples. All thermocouple calibration data furnished in reports will be on the basis of a reference junction temperature of 0 °C (32 °F). The calibration results will be given in degrees C or F, as requested by the customer.

The calibration of a thermocouple will not be undertaken if it will likely not yield the specified accuracy or if it possesses unusual characteristics that would prevent the carrying out of the calibration or test at a reasonable cost. Only unused base-metal thermocouples and thermocouple materials will be accepted for test.

#### **Special Tests of Thermocouples and Thermocouple Materials (32150S)**

For requirements not covered by calibrations described above, special arrangements may be made by contacting one of the specified staff members.

#### **References – Thermocouples**

The International Temperature Scale of 1990 (ITS-90), H. Preston-Thomas, *Metrologia* 27, 3-10 (1990).

NIST Measurement Services: The Calibration of Thermocouple and Thermocouple Materials, G. W. Burns and M.G. Scroger, *Natl. Inst. Stand. Technol. Spec. Publ. 250-35* (Apr. 1989).

ASTM Standard E220-86, Standard Method for Calibration of Thermocouples by Comparison Techniques, Annual Book of ASTM Standards, 14.01, 225, Amer. Soc. for Test. and Matls., Philadelphia, PA (1987).

ASTM Standard E230-87, Temperature-Electromotive Force (EMF) Tables for Thermocouples, Annual Book of ASTM Standards, 14.01, 242, Amer. Soc. for Test. and Matls., Philadelphia, PA (1987).

American National Standard, Temperature Measurement Thermocouples, ANSI-MC96.1-1982, Instr. Soc. of Amer., Res. Triangle Park, NC (1982).

Manual on the Use of Thermocouples in Temperature Measurement, ASTM STP 470B, Amer. Soc. for Test. and Matls., Philadelphia, PA (1981).

Accurate Thermocouple Thermometry, L. A. Guildner and G. W. Burns, *High Temperatures – High Pressures*, 11, 173 (1979).

International Electrotechnical Commission Standard, Thermocouples, Part I: Reference Tables, IEC Publication 584-1, Intl. Electrotech. Com., Geneva (1977).

Thermocouple Reference Tables Based on the IPTS-68, R. L. Powell, W. J. Hall, C. H. Hyink, Jr., L. L. Sparks, G. W. Burns, M. G. Scroger, and H. H. Plumb, *Natl. Bur. Stand. (U.S.), Monogr. 125* (1974).



## Resistance Thermometry

### Technical Contacts:

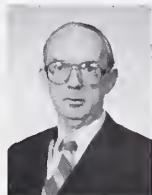

Earl R. Pfeiffer  
0.65 K to 84 K  
Tel: 301/975-4821



Gregory F. Strouse  
83 K to 962 °C  
Tel: 301/975-4803

**Mailing Address:** B126 Physics, National Institute of Standards and Technology, Gaithersburg, MD 20899-0001

**Shipping Address:** National Institute of Standards and Technology, 1-270 at Quince Orchard Road, B04 Physics, Gaithersburg, MD 20899-0001

Attn: E. R. Pfeiffer or G. F. Strouse

Test No.	Items
33010C	Capsule PRT (13.8 K to 30 °C)
33020C	Capsule PRT (13.8 K to 157 °C)
33030C	Capsule PRT (13.8 K to 232 °C)
33040C	Capsule PRT (54 K to 30 °C)
33050C	Capsule PRT (54 K to 157 °C)
33060C	Capsule PRT (54 K to 232 °C)
33070C	Capsule PRT (84 K to 30 °C) Ar to Ga
33080C	Capsule PRT (84 K to 157 °C) Ar to In
33090C	Capsule PRT (84 K to 232 °C) Ar to Sn
33100C	Capsule PRT (0 °C to 30 °C) TPW to Ga
33110C	Capsule PRT (0 °C to 157 °C) TPW to In
33120C	Capsule PRT (0 °C to 232 °C) TPW to Sn
33130C	Capsule PRT (234 K to 30 °C) Hg to Ga
33140C	Germanium and Rhodium-Iron Resistance Thermometers (0.65 K to 24.6 K)
33150C	Long Stem PRT (83 K to 0 °C) Ar to TPW
33160C	Long Stem PRT (83 K to 30 °C) Ar to Ga
33170C	Long Stem PRT (83 K to 157 °C) Ar to In
33180C	Long Stem PRT (83 K to 232 °C) Ar to Sn
33190C	Long Stem PRT (83 K to 420 °C) Ar to Zn
33200C	Long Stem PRT (83 K to 661 °C) Ar to Al
33210C	Long Stem PRT (234 K to 30 °C) Hg to Ga
33220C	Long Stem PRT (234 K to 157 °C) Hg to In
33230C	Long Stem PRT (234 K to 232 °C) Hg to Sn
33240C	Long Stem PRT (234 K to 420 °C) Hg to Zn
33250C	Long Stem PRT (234 K to 661 °C) Hg to Al
33260C	Long Stem PRT (0 °C to 30 °C) TPW to Ga

### Test No. Items

33280C	Long Stem PRT (0 °C to 232 °C) TPW to Sn
33290C	Long Stem PRT (0 °C to 420 °C) TPW to Zn
33270C	Long Stem PRT (0 °C to 157 °C) TPW to In
33300C	Long Stem PRT (0 °C to 661 °C) TPW to Al
33310C	Long Stem PRT (0 °C to 962 °C) TPW to Ag
33320C	Additional Copy of Table from Results of 33010C-33310C at Time of Test
33330C	Additional Copy of Table from Results of 33010C-33310C at a Later Date
33340C	Minimum Charge for Unsuitable Thermometer
33350S	Special Tests of Resistance Thermometers
33360S	Special Tests of Thermometric Fixed-Point Devices
33370M	Measurement Assurance Program for Temperature (83 K to 420 °C) Ar to Zn
33380M	Measurement Assurance Program for Temperature (83 K to 661 °C) Ar to Al
33390M	Measurement Assurance Program for Temperature (0 °C to 962 °C) TPW to Ag

### Resistance Thermometers (33010C-33310C)

NIST provides calibration services for standard platinum resistance thermometers (SPRTs) from 13.8 K to 1235 K. Both long-stem and capsule-type SPRTs are calibrated, providing direct access to the International Temperature Scale of 1990 (ITS-90). The reproducibility of the calibration measurements of SPRTs is better than  $\pm 0.3$  mK and the total uncertainty of calibration is  $\pm 1$  mK at temperatures below 661 °C. The reproducibility increases to about  $\pm 0.5$  mK and the uncertainty to about  $\pm 2$  mK at 962 °C. The reproducibility of triple point of water (TPW) cells used for calibration of SPRTs is  $\pm 50$   $\mu$ K or better while that for Ar, Hg, Ga, In, Sn, Zn, and Al triple-point or freezing-point cells is  $\pm 0.1$  mK; and that for Ag freezing-point cells is  $\pm 0.5$  mK. Presently, the NIST temperature scale in the range 13.8 K to 84 K is based on stable reference SPRTs of the capsule type that have uncertainties of about  $\pm 0.3$  mK down to about 20 K. Below 20 K, the uncertainty degrades to about  $\pm 0.5$  mK as the SPRTs become less sensitive.

For calibration of rhodium-iron resistance thermometers (RIRTs) and germanium resistance thermometers (GRTs) in the temperature range from 0.65 K to 24.6 K, the NIST scale is based presently on a set of reference capsule-type RIRTs. The uncertainty of those calibrations is about  $\pm 0.3$  mK.

To qualify for testing, either long-stem or capsule SPRTs must meet two conditions. They must reasonably be expected to meet the requirements of the ITS-90 for a standard interpolating instrument (i.e., a four lead resistor of high-purity platinum hermetically sealed in a protecting tube). Second, they must be compatible with the NIST calibration equipment. It is important that, insofar as possible, resistance thermometers be protected from any mechanical shock that could alter their calibration. For shipment, the thermometer should be softly supported within a case but not be free to rattle. This necessitates the use of packing material that does not become compacted. The thermometer case should be softly packed inside a shipping container. The shipping container must be sufficiently rigid and strong that it will not appreciably deform under the treatment usually given by common carriers. Styrofoam is not sufficiently rigid to be used as an outside container. Thermometers will not be returned in containers that are obviously unsuitable, such as those closed by nailing. Suitable containers will be provided, for a fee, when a thermometer shipping container is not satisfactory for re-use.

**Special Tests of Resistance Thermometers and Special Tests of Thermometric Fixed-Point Devices (33350S and 33360S)**

Special tests of various resistance thermometers and thermometric fixed point devices may be made by pre-arrangement with the specified technical contacts.

**Measurement Assurance Program for Temperature (33370M, 33380M, and 33390M)**

The purpose of this MAP service is to assure the accuracy of the calibration of temperature standards (83 K to either 420 °C or 661 °C, or 0 °C to 962 °C temperature ranges) made by participating laboratories when using platinum resistance thermometry.

The MAP transport standard consists of a set of three commercial glass-sheathed SPRTs packaged in a special shock-proof shipping container (mechanical shock may result in shifts in calibration). These SPRTs are used to assess both the reproducibility and the accuracy of calibrations performed by the participating laboratory.

MAP participants should use the techniques described in NIST Technical Note 1265 and the same fixed points as those used in the NIST calibrations, or use an SPRT previously calibrated by NIST. In order to achieve high accuracy, SPRTs used as standards should be of the matte-finish type to avoid systematic errors arising from light-pipe effects in the glass sheath. The participant must have a triple point of water cell and a calibrated resistance bridge.

After unpacking and inspecting the SPRTs for damage, the participant should measure the resistances of the SPRTs at the triple point of water (using the triple-point cell). This preliminary measurement of the resistances at the triple point of water is used as a "go/no go" check to ensure that the thermometers have not been damaged in shipment.

These preliminary measurements are reported by telephone to NIST; if the values are consistent with the data taken by NIST before shipment, the participant should proceed with further measurements at the fixed points of the ITS-90. NIST provides a worksheet on which the participant should record data. The participant then calculates the thermometer constants from experimental data,

records them, and prepares tables of either resistance ratio or resistance versus temperature.

The SPRTs are recalibrated upon return to NIST and the participant's data are compared with NIST's calibrations. NIST provides a plot of the participating laboratory's temperature deviation from NIST values and a written analysis of the data, including any pertinent observations. In a typical MAP transfer, the participant makes several measurements over a period of one to two months. A typical turnaround time from the date NIST receives the participant's data until a test report is sent to the participant is four to six weeks.

The best NIST SPRT calibrations have precisions of about 0.1 to 0.2 mK. Sources of error that may contribute to the total uncertainty include changes in the calibration of the measurement instruments, changes in the SPRT itself, and uncertainty of the degree of purity of the materials used as fixed-point references (e.g., zinc). As a result of quantifying these errors, NIST currently assigns an uncertainty of  $\pm 1$  mK to the values assigned to the MAP transport standards used below 661 °C. A standards laboratory conscientiously participating in this MAP and having suitable equipment should be able to closely approximate this uncertainty figure. Former participants in the MAP have had uncertainties that ranged from about 1 mK to several tens of millikelvin.

No rigid recommendations can be given concerning how often a participant should utilize the temperature MAP service. Experience has indicated that when temperature measurements are in a state of statistical control, as evidenced by in-house check standards and control charts used to monitor the measurement process, the participant should be able to go at least three years between transfers from NIST without significantly degrading the confidence in the correctness of the measurements.

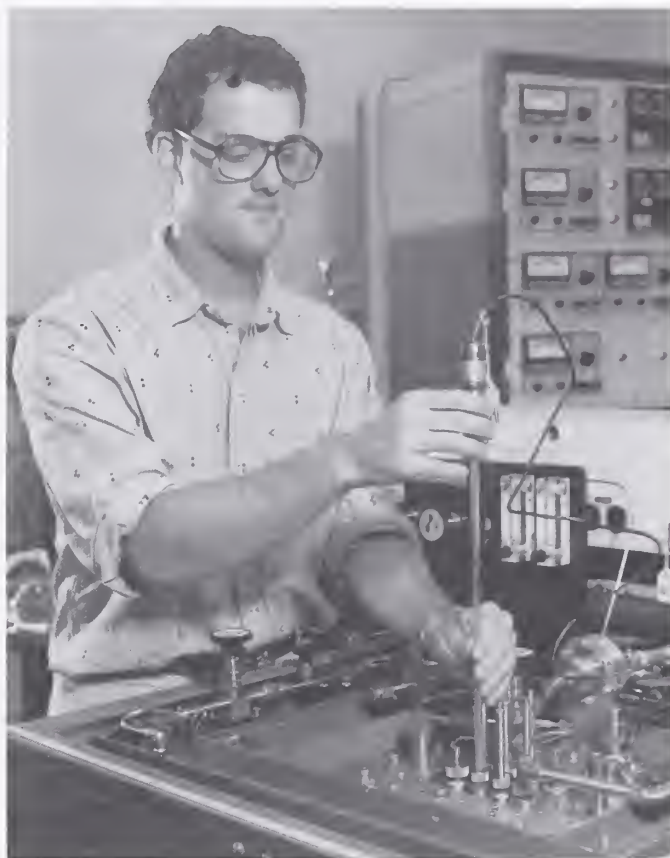

*Gregory Strouse is preparing to insert an SPRT into the argon triple-point apparatus. The argon Triple-point temperature is used in the calibration of SPRTs on the ITS-90.*

#### References—Resistance Thermometry

The International Temperature Scale of 1990 (ITS-90), H. Preston-Thomas, *Metrologia* 27, 3–10 (1990); *Metrologia* 27,107 (1990).

Special Report on the International Temperature Scale of 1990, Report on the 17th Session of the Consultative Committee on Thermometry, B. W. Mangum, *J. Res. Natl. Inst. Stand. Technol.* 95, 69 (1990).

Guidelines for Realizing the International Temperature Scale of 1990 (ITS-90), B.W. Mangum and G. T. Furukawa, *Natl. Inst. Stand. Technol.*, Tech. Note 1265 (Aug. 1990).

- NBS Measurement Services: Platinum Resistance Thermometer Calibrations, B. W. Mangum, Natl. Bur. Stand. (U.S.), Spec. Publ. 250-22 (1988).
- The Determination of the Triple-point and Freezing-point Temperatures of Indium, B. W. Mangum, *Metrologia* 26, 211-217 (1989).
- Reproducibility of Some Triple Point of Water Cells, G. T. Furukawa and W. R. Bigge, *Temperature, Its Measurement and Control in Science and Industry*, Vol. 5, 291, Amer. Inst. Phys., New York, NY (1982).
- Standard Reference Materials: Application of Some Metal SRM's as Thermometric Fixed Points, G. T. Furukawa, J. L. Riddle, W. R. Bigge, and E. R. Pfeiffer, Natl. Bur. Stand. (U.S.), Spec. Publ. 260-77 (Aug. 1982).
- A Measurement Assurance Program - Thermometer Calibration, G. T. Furukawa and W. R. Bigge, in *Testing Laboratory Performance, Evaluation, and Accreditation*, Natl. Bur. Stand. (U.S.), Spec. Publ. 591, 137 (Aug. 1980).
- Determination of the Triple-point Temperatures of Gallium, B. W. Mangum and D. D. Thornton, *Metrologia* 15, 201-215 (1979).
- Platinum Resistance Thermometry, J. L. Riddle, G. T. Furukawa, and H. H. Plumb, Natl. Bur. Stand. (U.S.), Monogr. 126 (Apr. 1973).

## F. Radiation Thermometry

### Technical Contacts:



Charles  
Gibson  
Tel: 301/975-2329



Robert D.  
Saunders  
Tel: 301/975-2328



Edward  
Hunter  
Tel: 301/975-2130

Mailing Address: A221 Physics, National Institute of Standards and Technology, Gaithersburg, MD 20899-0001

Test No.	Items
35010C	Optical Pyrometers (1 range between 800 to 2400 °C, 4 to 12 points)
35020C	Optical Pyrometers (per range in addition up to 4200 °C)
35030C	Additional Interpolated Values
35040C	Optical Pyrometers (3 or fewer points, 800 to 4200 °C)
35050C	Ribbon Filament Lamp (6 to 16 points, 800 to 2300 °C)
35060C	Ribbon Filament Lamp (5 or fewer points, 800 to 2300 °C)
35070S	Special Tests of Radiation Pyrometers

### Optical Pyrometers and Ribbon Filament Lamps (35010C-35060C)

These calibration services provide access to the ITS-90 as realized by NIST for the temperature range 800 °C to 4200 °C. High-precision monochromatic visual and automatic optical pyrometers are calibrated in that temperature range. Uncertainties in routine testing vary from  $\pm 3$  °C at 1064 °C, and  $\pm 8$  °C at 2800 °C, to  $\pm 30$  °C at 4200 °C. Ribbon filament lamps are calibrated using the NIST photoelectric pyrometer, and reports of brightness temperature at 655 nm versus direct current are issued. Uncertainties in routine testing vary from  $\pm 0.75$  °C at 1064 °C to  $\pm 2$  °C at 2300 °C.

The radiation thermometry portion of ITS-90 is defined in terms of a fixed temperature for the freezing point of gold (1064.18 °C) and the Planck equation for the radiation of a blackbody source. In practice, temperature scales are realized by constructing a gold point blackbody and a variable temperature blackbody, and then measuring spectral radiance ratio at a red wavelength (approximately 650 nm) in terms of the Planck equation. Gold point blackbodies are reproducible to  $\pm 0.02$  °C, but the temperature assignment of the freezing point of gold is uncertain by about  $\pm 0.4$  °C. The spectral radiance ratio measurements can be performed with an uncertainty of 0.2 to 0.3 percent. Higher accuracies than available in the routine tests described above can be provided as special tests subject to the ITS-90 uncertainties noted. Calibrations at wavelengths other than 650 nm can be provided in the wavelength range 250 to 2500 nm subject to an additional uncertainty due to the quality of the variable temperature blackbody.

### Special Tests of Radiation Pyrometers (35070S)

Calibrations at wavelengths other than 650 nm can be provided in the wavelength range 250 nm to 2500 nm subject to an additional uncertainty due to the quality of the variable temperature blackbody. Absorbing glass filters used for range changing in optical pyrometers can also be calibrated as special tests.

### References - Radiation Thermometry

Spectroradiometric Determination of the Freezing Temperature of Gold, K. D. Mielenz, R. D. Saunders and J. Shumaker, *J. Res. Natl. Inst. Stand. Technol.*, Vol. 95 (Jan.-Feb. 1990).

The International Temperature Scale of 1990 (ITS-90), H. Preston-Thomas, *Metrologia* 27, 3-10 (1990).

NBS Measurement Services: Radiance Temperature Calibrations, W. R. Waters, J. H. Walker, and A. T. Hattenburg, Natl. Bur. Stand. (U.S.), Spec. Publ. 250-7 (Oct. 1987).

The International Practical Temperature Scale of 1968, Amended Edition of 1975, Metrologia, 12, 7 (1976).

Corrections in Optical Pyrometry and Photometry for the Refractive Index of Air, W. R. Blevin, Metrologia, 8, 146 (1972).

Vacuum Tungsten Strip Lamps with Improved Stability as Radiance Temperature Standards, T. J. Quinn and R. D. Lee, 5th Symposium on Temperature, 395, Instr. Soc. Am., Res. Triangle Park, NC (1971).

High-Accuracy Spectral Radiance Calibration of Tungsten-Strip Lamps, H. J. Kostkowski, D. E. Erminy, and A. E. Hattenburg, Adv. Geophys. 14, 111 (1970).

The NBS Photoelectric Pyrometer and Its Use in Realizing the International Practical Temperature Scale above 1063 °C, R. D. Lee, Metrologia, 2, No. 4, 150 (Oct. 1966).

Theory and Methods of Optical Pyrometry, H. J. Kostkowski and R. D. Lee, Natl. Bur. Stand. (U.S.), Monogr. 41 (Mar. 1962).

## G. Humidity Measurements

### Technical Contacts:



Peter H. Huang  
Tel: 301/975-2621,2626



James R. Whetstone  
Tel: 301/975-2738

**Mailing Address:** A303 Physics, National Institute of Standards and Technology, Gaithersburg, MD 20899-0001

**Shipping Address:** National Institute of Standards and Technology, 1-270 at Quince Orchard Road, B349 Physics, Gaithersburg, MD 20899-0001

Test No.	Items
36010C	Dew-Point Hygrometers (+ 25 to - 15 °C)
36020C	Dew-Point Hygrometers (- 70 to - 15 °C)
36030C	Electric Hygrometers
36040C	Electrolytic Hygrometers
36050C	Aspirated Hygrometers
36060C	Pneumatic Bridge Hygrometers
36070S	Special Tests of Humidity

### Hygrometers (36010C-36060C)

NIST provides calibration services for a wide variety of humidity-measuring instruments. Calibrations are performed by subjecting the instrument under test to atmospheres of known moisture content produced by the NIST two-pressure humidity generator. The instruments and ranges of calibration are listed below:

A. Dew-Point Hygrometers calibrated over the dew/frost range of - 70 to + 60 °C.

B. Electric Hygrometers classified under this category are sensors which sorb water vapor as a function of relative humidity; associated with this sorption is a corresponding change in an electric parameter (that is, resistance, capacitance). The range of

calibration is 3 to 98 percent relative humidity over the temperature range - 55 to + 60 °C.

C. Psychrometers are wet-dry bulb hygrometers (aspirated psychrometers). The contact person should be consulted for the special features of the psychrometer which are necessary before the instrument can be calibrated at NIST.

D. Electrolytic Hygrometers are devices which electrolyze water into gaseous oxygen and hydrogen by the application of a voltage in excess of the thermodynamic decomposition voltage for water, and then measure the electrolysis current. The range of calibration is 1 to 31,000 ppm by volume.

E. Pneumatic Bridge Hygrometers are instruments that measure the variation of the pressure drop across two combinations of nozzles, operating at critical flow, with a desiccant between one pair of nozzles. The range of calibration in mixing ratio (grams of water vapor/grams of dry air) is 0.0005 to 0.015.

Table 3 illustrates typical NIST uncertainties for measurement of humidity standards with atmospheric air at atmospheric pressures.

**Special Tests of Humidity (36070S)**

Tests for response time, hysteresis, and stability can be provided upon request.

**Table 3: NIST Two-Pressure Humidity Generator, Mark 2, Range and Uncertainty**

Humidity Parameter	Range	Uncertainty*	
Mixing ratio, $r_w$ (g water vapor/ kg dry air)	$.0005 \leq r_w < 0.0015$	3.0% of value	
	$0.0015 \leq r_w < 0.005$	1.5% of value	
	$0.005 \leq r_w < 0.1$	1.0% of value	
	$0.1 \leq r_w < 0.3$	0.5% of value	
	$0.3 \leq r_w < 155$	0.3% of value	
Volume ratio, V (ppm)	$1 \leq V < 3$	3.0% of value	
	$3 \leq V < 10$	1.5% of value	
	$10 \leq V < 170$	1.0% of value	
	$170 \leq V < 500$	0.5% of value	
	$500 \leq V < 250,000$	0.3% of value	
Dew point temperature, $T_d$ °C	$-80 \leq T_d < -70$	0.2 °C	
	$-70 \leq T_d < -35$	0.1 °C	
	$-35 \leq T_d < +60$	0.04 °C	
Relative humidity, RH (%) at test chamber temperature, $T_c$ (°C)	$-55 \leq T_c < -40$	3-98	1.5%
	$-40 \leq T_c < -20$	3-98	0.8%
	$-20 \leq T_c < 0$	3-98	0.4%
	$0 \leq T_c < +60$	3-98	0.2%

\*The estimated bounds to systematic error plus three times the standard deviation.

**References—Humidity Measurements**

- Vapor Pressure Formulation for Ice, A. Wexler, J. Res. Natl. Bur. Stand. (U.S.), 81A (Phys. and Chem.), No. 1, 5 (Jan.-Feb. 1977).
- The NBS Two-Pressure Humidity Generator, Mark 2, S. Hasegawa and J. W. Little, J. Res. Natl. Bur. Stand. (U.S.), 81A (Phys. and Chem.), No. 1, 81 (Jan.-Feb. 1977).
- Vapor Pressure Formulation for Water in Range 0 to 100 °C, A revision, A. Wexler, J. Res. Natl. Bur. Stand. (U.S.), 80A (Phys. and Chem.), Nos. 5 and 6, 775 (Sept.-Dec. 1976).
- A Correlation for the Second Interaction Virial Coefficients and Enhancement Factors for Moist Air, R. W. Hyland, J. Res. Natl. Bur. Stand. (U.S.), 79A (Phys. and Chem.), No. 4, 551 (July-Aug. 1975).
- J. Res. Natl. Bur. Stand. (U.S.), 79A, (Phys. and Chem.), No. 4, 551 (July-Aug. 1975).
- The NBS Standard Hygrometer, A. Wexler and R. W. Hyland, Natl. Bur. Stand. (U.S.), Monogr. 73 (May 1964).



## H. Total Heat Flux Gauges

### Technical Contact:



**Kenneth D. Steckler**  
Tel: 301/975-6678

**Mailing Address:** A345 Polymers, National Institute of Standards and Technology, Gaithersburg, MD 20899-0001

Test No.	Items
36510S	Special Tests of Total Heat Flux Gauges

### Special Tests of Total Heat Flux Gauges (36510S)

NIST is offering a new special test service for total heat flux gauges used in fire experiments and standard fire tests.

A substitution technique is used to calibrate heat flux gauges in an infrared radiation field at flux levels to nominally 4 W/cm<sup>2</sup>. The radiant field is produced by a stable infrared electric heater. A reference radiometer is used to establish the flux level at the measurement point within the radiative field. A precision traversing carriage allows the rapid substitution of a heat flux gauge for the reference radiometer at the measurement position.

Current fixtures accommodate 2.54 cm diameter Gardon or Schmidt-Boelter total heat flux gauges that have coolant tubes emanating from their rear surfaces. Fixtures for other geometries can be fabricated at an additional cost.

Each heat flux gauge is calibrated at four flux levels which span the range 0.5–3.5 W/cm<sup>2</sup>. Accuracy of the reference radiometer is within 3 percent over the range 1 mW/cm<sup>2</sup> to 0.9 W/cm<sup>2</sup>. Based on assumptions of linearity of the standard flux gauges and system uncertainties we expect overall accuracy of within 5 percent for the calibration range.

The special test results are presented in a Report of Test which includes a plot of the measured incident flux (W/cm<sup>2</sup>) versus the measured response of the sensor (mV) at each of the four flux levels. The heat flux sensor will be calibrated and returned within 30 days of receipt of the device and purchase order.

---

# Chapter

# 7

- A** Photometric Measurements
- B** Spectrophotometric Measurements
- C** Radiometric Measurements
- D** Radiometric Standards in the Far Ultraviolet
- E** Laser Power and Energy

## A. Photometric Measurements

### Technical Contacts:



Jonathan E. Hardis  
Tel: 301/975-2373



George Eppeldauer  
Tel: 301/975-2338

**Mailing Address:** B306 Metrology, National Institute of Standards and Technology, Gaithersburg, MD 20899-0001

Test No.	Items
37015C	Luminous Intensity Rental Program
37025C	Luminous Intensity-Submitted Lamp
37035C	Color Temperature Determination on Lamp Submitted for 37025C
37080S	Special Tests for Luminous Flux of Incandescent Lamps
37140C	Airway Beacon Lamps for Color Temperature (500 W, 1 point in range, 2000-3000 K)
37150C	Each additional color temperature
37160C	Color temperature equation (4 points and interpolation equation)
37170C	Opal Glass Luminous Directional Transmittance Standards
37180S	Special Photometric Tests

### General Information

Calibration services in this area provide access to the photometric scales realized and maintained at NIST. Lamp standards of luminous intensity, luminous flux, and color temperature as described below are calibrated on a routine basis.

### Luminous Intensity Rental Program (37015C)

NIST will supply to the customer two 500-watt and one 300-watt luminous intensity lamps. These are inside-frosted bulb lamps with a C-13B tungsten filament and a medium bipost base. The luminous intensity of the lamps will be measured before and after the customer uses them and the data furnished to the customer for determining their calibration base in luminous intensity. The lamps will be calibrated at a color temperature of 2856 K. An additional calibration point at an approximate color temperature of 2700 K will be furnished for the 500-watt lamps. The approximate 3-sigma uncertainty of these calibrations is 1 percent relative to the SI units of luminous intensity and 0.8 percent relative to NIST standards.

### Luminous Intensity-Submitted Lamps (37025C)

Lamps that were furnished by NIST prior to October 1, 1986 as calibrated standards will be recertified with respect to NIST standards and returned to the customer with a calibration report specifying the luminous intensity of the lamp. Customer supplied lamps of types other than those traditionally issued by NIST will be accepted for calibration subject to a determination as to suitability. Customers should contact NIST before submitting such lamps. The approximate 3-sigma uncertainty of these calibrations is 1 percent relative to the SI units of luminous intensity and 0.8 percent relative to NIST standards.

### Color Temperature Determination on Lamps Submitted for 37025C (37035C)

The color temperature for given operating conditions will be measured and furnished for lamps submitted for luminous intensity testing on test 37025C. The uncertainty of these calibrations ranges from 10 K at a color temperature of 2000 K to 15 K at a color temperature of 3000 K.

**Special Tests for Luminous Flux of Incandescent Lamps (37080S)**

NIST will calibrate the luminous flux (geometrically total) of customer supplied lamps. These lamps must be base-up burning and rated at 120 V for operation. General purpose gas filled lamps in the range of 60 to 500 watts can be accommodated for testing. Approximate 3-sigma uncertainties are 1.4 percent relative to SI units and 1.2 percent relative to NIST standards. Customers should contact NIST prior to sending lamps to obtain schedule and price information.

**Airway Beacon Lamps (37140C-37160C)**

Color temperature standard lamps supplied by NIST (airway beacon 500-W medium bipost lamps) are calibrated for color temperature in the range 2000 to 3000 K with 3-sigma uncertainties ranging from 10 to 15 degrees.

**Opal Glass Luminous Directional Transmittance Standards (37170C)**

Flashed opal glasses, 51 mm × 51 mm, are calibrated for luminous directional transmittance (exitant luminance per incident illuminance). The glasses are masked with a diaphragm limiting the useful area to a circle 1.9 cm in diameter.

**Special Tests of Photometric Devices (37180S)**

Lamp standards of luminous intensity can be calibrated at any color temperature in the range 2000 K to 3200 K. Photometric values can be computed for special sources measured spectrally on the Facility for Automatic Spectral Calibrations (FASCAL). See test 39060S for details.

**Reference—Photometric Measurements**

NBS Measurement Services: Photometric Calibrations, R. L. Booker and D. A. McSparron, Natl. Bur. Stand. (U.S.), Spec. Publ. 250-15 (Oct. 1987).

## B. Spectrophotometric Measurements

### Technical Contact:



P. Yvonne Barnes  
Tel: 301/975-2345

**Mailing Address:** B306 Metrology, National Institute of Standards and Technology, Gaithersburg, MD 20899-0001

Test No.	Items
38010C	Spectral Transmittance Filters (Cobalt Blue Glass)
38020C	Spectral Transmittance Filters (Copper Green Glass)
38030C	Spectral Transmittance Filters (Carbon Yellow Glass)
38040C	Spectral Transmittance Filters (Selenium Orange Glass)
38050C	Wavelength Standards (Holmium Oxide Glass)
38060S	Special Tests of Spectral Transmittance and Reflectance
38070M	Measurement Assurance Program for Retroreflectance - Complete Package
38071M	Retroreflectance MAP - Sheeting Standards or Prismatic Standard with Colored Filters
38072M	Retroreflectance MAP - Sheeting Standards and Prismatic Standard without Colored Filters
38073M	Retroreflectance MAP - Sheeting Standards or Prismatic Standard without Colored Filters
38074M	Retroreflectance MAP - Colored Filters Only
38080M	Measurement Assurance Program for Transmittance
38090S	Special Tests of X-Ray and Photographic Step Tablets
38100S	Special Tests of Microcopy Resolution Test Charts

### Spectral Transmittance Filters (38010C-38040C)

NIST supplies standards of spectral transmittance for checking the photometric scale of spectrophotometers. These are either 30 mm polished glass disks or 51 mm polished glass squares, 2 to 3 mm thick, designated as cobalt blue, copper green, carbon

yellow, and selenium orange. The total uncertainty ranges from approximately 0.3 to 0.5 percent of the value at the  $3\sigma$  level. Information provided to the user includes values of transmittance at 25 °C at 10 nm intervals from 380 to 770 nm, the estimated uncertainty of each value, and data as to the effect of temperature change on transmittance at each wavelength.

### Wavelength Standards (38050C)

Holmium oxide glass standards are also supplied for checking the ultraviolet and visible wavelength calibrations of recording spectrophotometers having a bandpass less than 2 nm. These are made of polished Corning 3130 glass, 51 × 51 mm, 2.5 mm thick. A table of wavelengths of minimum transmittance is provided in the report to the user. The uncertainty is 0.5 nm at the  $3\sigma$  level.

### Special Tests of Spectral Transmittance and Reflectance (38060S)

Measurements of spectral transmittance can be made for the wavelength region 190 to 2500 nm. Measurements of absolute spectral reflectance factors and of spectral specular reflectance can be made for the wavelength region 250 to 2500 nm. However, arrangements for these measurements on submitted specimens must be made before shipment. The decision as to whether or not to perform the measurements and selection of the instruments to be used will rest with NIST. Specimens not accepted for measurement will be returned. Accuracy and precision estimates will be given. Estimates will be dependent upon the optical characteristics of the submitted specimens and whether a primary or transfer instrument is used to perform the measurement.

### Measurement Assurance Programs for Retroreflectance (38070M-38074M)

These Measurement Assurance Programs (MAP's) verify, within certain limits, how well a laboratory can measure coefficient of luminous intensity. The verification is accomplished by means of a MAP package. The MAP package contains two white bead sheeting retroreflectors, one colorless prismatic retroreflector, and seven colored glass filters. The elements in this package are measured by NIST, then by the participating laboratory, and finally by NIST. Quality control procedures are maintained by using NIST master standards.

The use of three retroreflectors enables determination of how well the participant can measure coefficient of luminous intensity for white or colorless samples of three kinds of geometries. The luminous transmittance of the seven colored glass filters can be used as a diagnostic tool to check measurements of coefficient of luminous intensity of colored retroreflectors. This is accomplished by checking the conformance of the source-receiver combination to CIE Illuminant A and CIE 2° standard observer respectively.

The coefficient of luminous intensity of each of the bead sheeting standards is measured at six combinations of observation and entrance angles. The coefficient of luminous intensity of the prismatic retroreflector is measured at 18 combinations of entrance and observation angles. The luminous transmittance of the filters is provided only for the spectral conditions of source and receiver specified above.

A general testing laboratory will probably need the service utilizing the complete MAP package. However, some laboratories may be specialized. For this reason, we list five options that offer not only the complete package, but also some selected components. These options are the following:

- A. Complete MAP package;
- B. Sheeting standards or prismatic standard with colored filters;
- C. Sheeting standards or prismatic standard without colored filters;
- D. Sheeting standards and prismatic standard without colored filters; and
- E. Colored filters only.

Measurement of even the complete MAP package achieves only part of the goal of a MAP service. To fully benefit from the MAP procedure, we suggest that the participant have on hand several check standards to be measured while also measuring the MAP package. These check standards can then be measured periodically to determine any gross error in measurement procedure, and a control chart can be constructed. A control chart is a plot of measurement result versus time, and normally the measurement process is considered to be under control if measurements fall within  $\pm 3$  standard deviations from the mean. For retroreflectance measurements where geometric errors are large, the standard deviation obtained after changing geometrical parameters may be large compared with that obtained from repeated measurements without changing the apparatus. Thus, the total variation for a given instrument can be obtained only by repetition over a period of time and realignment of the experimental apparatus.

The uncertainties of retroreflector measurements have three sources: uncertainties associated with values assigned by NIST to the MAP package, participant uncertainties, and uncertainties due to environment and sample interaction. Repeated measurements without changing the apparatus show that the NIST random error is small relative to the systematic errors. A large fraction of the latter arises when the retroreflector is rearranged and realigned for making measurements with different measurement parameters. The NIST

uncertainty for retroreflectance measurement ranges from 4 to 15 percent of the value depending on the geometry and the type of retroreflectors. The NIST uncertainty for luminous transmittance of the colored glass filters varies up to 0.002 at the  $3\sigma$  level.

#### **Measurement Assurance Program for Transmittance (38080M)**

The Transmittance Measurement Assurance Program (MAP) provides a means for a laboratory to assess the accuracy of its spectral transmittance measurement capabilities. A laboratory that participates in this program will be sent a package of transmittance filters, which have been measured at NIST. These are to be measured by the laboratory on its spectrophotometer(s) and returned, together with the measurement results, to NIST. NIST will then remeasure the filters and send a final analysis of the result to the participating laboratory. The range of filter measurements provided in the MAP package permits an evaluation of the accuracy of a laboratory's spectral transmission measurements and will often reveal the cause of any systematic errors that exist. The NIST uncertainty ranges from approximately 0.05 to 0.5 percent of the value at the  $3\sigma$  level for filters with nominal transmittance from 0.92 to 0.001.

The MAP package includes seven neutral density filters with nominal transmittances ranging from 0.92 to 0.001. The filters are available in three sizes. The filter holders are 51 × 51 mm, 51 × 38 mm, or standard cuvette. In addition, the package contains one didymium glass filter or cuvette-sized holmium oxide solution that is to be used for wavelength scale calibration. Several wavelengths of transmittance minima and points of inflection have been measured by NIST for the didymium filter. These wavelengths have been shown to be stable over long periods of time;

therefore, these didymium filters are not normally measured by NIST with every use of the MAP package. The didymium filter is useful for triangular bandpasses between 1.5 and 10.5 nm with an uncertainty up to 0.3 nm. The holmium oxide solution has been certified at several wavelengths for bandpasses up to 3.0 nm with an uncertainty of 0.1 nm.

It is strongly suggested that the participating laboratory acquire a set of check standards similar to the NIST filters for maintaining a control chart and measurement assurance.

#### **Special Tests of X-Ray and Photographic Step Tablets (38090S)**

Special tests for visual transmission of density ranges from 0 to 4 (by integrating sphere or by opal glass diffuser) and reflection optical density can be performed by prior arrangement. Tablets submitted must be free of scratches, fingerprints, abrasions, and foreign matter and must have steps of uniform density. The visual transmission density is measured in accordance with ANSI Standard PH2.19/ISO 5/2-1986 with an uncertainty of the greater of 0.01 or 1 percent of the value. The visual reflection density of  $45^\circ/0^\circ$  is measured in accordance with ANSI Standard PH2.17/ISO 5/4-1985 with an uncertainty of the greater of 0.02 or 2 percent of the value.

#### **Special Tests of Microcopy Resolution Test Charts (38100S)**

Test charts conforming to ISO Standard 3334, NMA Standard MS104-1972, and MIL-M-9868D, can be tested by special arrangement.

#### **References – Spectrophotometric Measurements**

National Scales of Spectrometry in the U.S., J. J. Hsia, *Advances in Standards and Methodology in Spectrophotometry 1987*, Elsevier Science Publishers, B. V., Amsterdam, pp. 99-109 (1987).

- NBS Measurement Services: Spectral Reflectance, V. R. Weidner and J. J. Hsia, *Natl. Bur. Stand. (U.S.)*, Spec. Publ. 250-8 (July 1987).
- NBS Measurement Services: Regular Spectral Transmittance, K. L. Eckerle, J. J. Hsia, K. D. Mielenz, and V. R. Weidner, *Natl. Bur. Stand. (U.S.)*, Spec. Publ. 250-6 (July 1987).
- White Opal Glass Diffuse Spectral Reflectance Standards for the Visible Spectrum (SRM's 2015 and 2016), V. R. Weidner, *Natl. Bur. Stand. (U.S.)*, Spec. Publ. 260-82 (1983).
- Extension of a Reference Spectrophotometer into the Near Infrared, K. L. Eckerle, V. R. Weidner, J. J. Hsia, and Z. W. Chao, *Natl. Bur. Stand. (U.S.)*, Tech. Note 1175 (Apr. 1983).
- Measurement Assurance Program—Transmittance Standards for Spectrophotometric Linearity Testing: Preparation and Calibration, K. L. Eckerle, V. R. Weidner, J. J. Hsia, and K. Kafadar, *J. Res. Natl. Bur. Stand. (U.S.)*, 88(1), 25 (1983).
- Second-Surface Mirror Standards of Spectral Specular Reflectance (SRM's 2023, 2024, 2025), J. C. Richmond, J. J. Hsia, V. R. Weidner, and D. B. Wilmering, *Natl. Bur. Stand. (U.S.)*, Spec. Publ. 260-79 (Oct. 1982).
- Proposed Standards for the NBS Retroreflectance MAP, K. L. Eckerle and J. J. Hsia, *Color Res. and Appl.*, 7(3), 235 (1982).
- NBS 45°/Normal Reflectometer for Absolute Reflectance Factors, J. J. Hsia and V. R. Weidner, *Metrologia*, 17, 97 (1981).
- NBS Specular Reflectometer—Spectrophotometer, V. R. Weidner and J. J. Hsia, *Appl. Opt.*, 19, 1268 (Apr. 1980).
- New Reference Retroreflectometer, K. L. Eckerle, J. J. Hsia, V. R. Weidner, and W. H. Venable, Jr., *Appl. Opt.*, 19(8), 1253 (1980).
- Photometry and Colorimetry of Retroreflection: State-of-Measurement Accuracy Report, K. L. Eckerle, *Natl. Bur. Stand. (U.S.)*, Tech. Note 1125 (July 1980).
- Inverse-Fourth Apparatus for Photometric Calibrations, D. A. Swyt and J. G. LaRock, *Rev. Sci. Instrum.*, 49(8), 1083 (Aug. 1978).
- Basic Considerations of Densitometer Adjustment and Calibration, R. E. Swing, *Natl. Bur. Stand. (U.S.)*, NBSIR 75-682 (Feb. 1975).
- Establishing a Scale of Directional-Hemispherical Reflectance Factor 1: The Van den Akker Method, W. H. Venable, Jr., J. J. Hsia, and V. R. Weidner, *J. Res. Natl. Bur. Stand. (U.S.)*, 82, 1, 29 (July-Aug. 1977).
- New Reference Spectrophotometer, K. D. Mielenz, K. L. Eckerle, R. P. Madden, and J. Reader, *Appl. Opt.*, 12, 7, 1630 (July 1973).
- The Optics of Densitometry, R. E. Swing, *Opt. Eng.*, 12, 6, 185 (Nov.-Dec. 1973).
- Basic Considerations of Densitometer Adjustment and Calibration, R. E. Swing, *Natl. Bur. Stand. (U.S.)*, Report 10970 (Dec. 1972).
- Permanence of Glass Standards of Spectral Transmittance, K. S. Gibson and M. A. Belknap, *J. Res. Natl. Bur. Stand. (U.S.)*, 44, 463 (May 1950).



## C. Radiometric Measurements

### Technical Contacts:



**John K. Jackson**  
39010C-39060S  
Tel: 301/975-2330



**Chris L. Cromer**  
39070C-39080S  
Tel: 301/975-3216



**Thomas C. Larason**  
39070C-39080S  
Tel: 301/975-2334



**Sally S. Bruce**  
39070C-39080S  
Tel: 301/975-2323

**Mailing Address:** A221 Physics, National Institute of Standards and Technology, Gaithersburg, MD 20899-0001

Test No.	Items
39010C	Spectral Radiance Ribbon Filament Lamps (225 to 2400 nm)
39020C	Spectral Radiance Ribbon Filament Lamps (225 to 800 nm)
39030C	Spectral Radiance Ribbon Filament Lamps (650 to 2400 nm)
39040C	Spectral Irradiance Quartz-Halogen Lamps (250 to 1600 nm)
39045C	Spectral Irradiance Quartz-Halogen Lamps (250 to 2400 nm)
39050C	Spectral Irradiance Deuterium Lamps (200 to 350 nm)
39060S	Special Tests of Radiometric Sources
39070C	Photodiode Spectral Response Rental Package
39080S	Special Tests of Radiometric Detectors

### Spectral Radiance Ribbon Filament Lamps (39010C-39030C)

These spectral radiance standards are supplied by NIST. Tungsten, ribbon filament lamps (30A/T24/13) are provided as lamp standards of spectral radiance. The lamps are calibrated at 34 wavelengths from 225 to 2400 nm, with a target area 0.6 mm wide by 0.8 mm high. Radiance temperature ranges from 2650 K at 225 nm, and 2475 K at 650 nm to 1610 K at 2400 nm, with corresponding uncertainties of 2, 0.6, and 0.4 percent. For spectral radiance lamps, errors are stated

as the quadrature sum of individual uncertainties at the three standard deviation level. See also related tests 40010C-40040S, next section.

Figure 7 summarizes the measurement uncertainty for NIST spectral radiance calibrations.

*Figure 7. Uncertainties for NIST Spectral Radiance Calibrations*

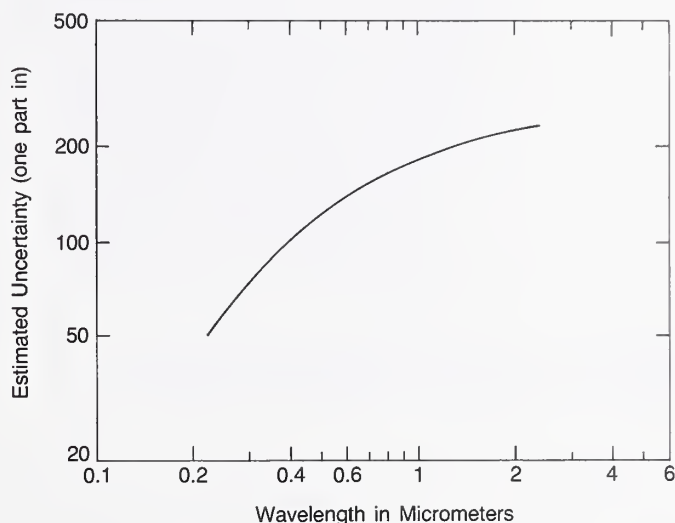

### Spectral Irradiance Lamps (39040C-39050C)

These spectral irradiance standards are supplied by NIST. Lamp standards of spectral irradiance are provided in two forms. Tungsten filament, 1000-watt quartz halogen type FEL lamps are calibrated at 31 wavelengths in the range 250 to 2400 nm. At the working distance of 50 cm, the lamps produce 0.2 W/cm<sup>2</sup> at 250 nm, 220 W/cm<sup>2</sup> at 900 nm, 115 W/cm<sup>2</sup> at 1600 nm, and 40 W/cm<sup>2</sup> at 2400 nm, with corresponding uncertainties of 2.2, 1.3, 1.9, and 6.5 percent. For spectral irradiance lamps, errors are stated as the quadrature sum of individual uncertainties at the three standard deviation level. Deuterium lamp standards of spectral irradiance are also provided and are calibrated at 16 wavelengths from 200 to 350 nm. At the working

distance of 50 cm, the spectral irradiance produced by the lamp ranges from about  $0.5 \text{ W/cm}^2$  at 200 nm and  $0.3 \text{ W/cm}^2$  at 250 nm to  $0.07 \text{ W/cm}^2$  at 350 nm. The deuterium lamps are intended primarily for the spectral region 200 to 250 nm. The approximate uncertainty relative to SI units is 7.5 percent at 200 nm and 5 percent at 250 nm. The approximate uncertainty in relative spectral distribution is 3 percent. It is strongly recommended that the deuterium standards be compared to an FEL tungsten standard over the range 250 to 300 nm each time the deuterium lamp is lighted to take advantage of the accuracy of the relative spectral distribution.

Figure 8 summarizes the measurement uncertainty for NIST spectral irradiance calibrations of type FEL lamps.

capability of performing spectral radiance measurements from 200 to 2500 nm, radiance temperatures from 1050 K to 2700 K, and adjustable spectral bandpass down to 0.1 nm. Spectral irradiance measurement capability from 200 to 2400 nm at flux levels down to  $0.1 \text{ W/cm}^2$  is also available. For both spectral radiance and irradiance measurements a wide variety of sources and measurement geometries are possible. Special tests utilizing the capabilities of FASCAL are occasionally performed depending on the availability of the equipment and associated personnel.

#### Photodiode Spectral Response Rental Package (39070C)

Photodiode response packages can be rented from NIST. Absolute spectral responsivity calibrations can be obtained by leasing one of the NIST Detector Response Transfer and Intercomparison Packages. This is a well-characterized radiometer that utilizes a silicon photodiode as the detector element. Its calibration is reported in units of  $\text{A/W}$  at a number of wavelengths in the 200 to 1100 nm range. A precision aperture is provided for calibrations in units of  $\text{A cm}^2/\text{W}$ . The duration of the lease is sufficient to enable the transfer of the calibration to a laboratory's own in-house standards. This calibration is based on an electrically calibrated high accuracy cryogenic radiometer. The absolute spectral response is reported at 5 nm intervals from 200 to 1100 nm. The estimated uncertainty ranges from 0.3 to 1 percent, depending on the wavelength. The radiometers cover a range of detector current from  $10^{-11}$  to  $10^{-3}$  A. This corresponds to a radiant power range of about 1 pW to 1 mW.

Figure 8. Uncertainties for NIST Spectral Irradiance Calibrations of Type FEL Lamps

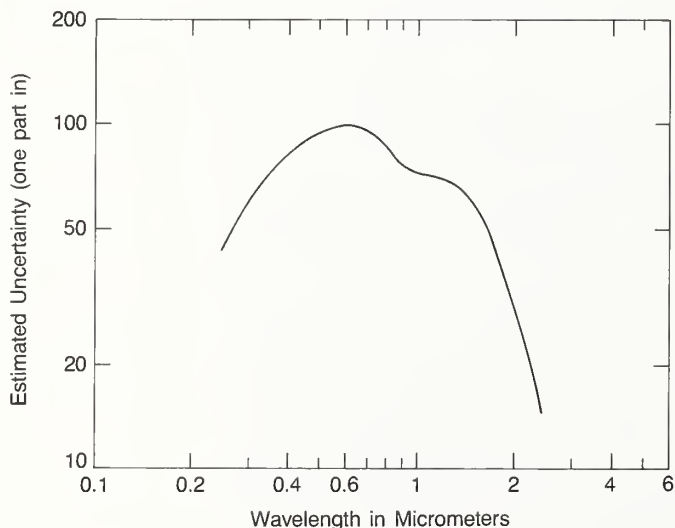

#### Special Tests of Radiometric Sources (39060S)

Spectroradiometric source calibrations are performed on the Facility for Automatic Spectral Calibrations (FASCAL). This instrument has the

### Special Tests of Radiometric Detectors(39080S)

Special tests of radiometric detectors generally used in the ultraviolet, visible, and infrared regions of the spectrum can be performed. Responsivity can be measured on detectors between 200 to 1800 nm at power levels of less than 10  $\mu$ W. Examples of detector characteristics that can be determined in a special test include spectral response (A/W), quantum efficiency (electrons/photon), linearity, and uniformity (over surface area). Since special tests of this type are unique, details of the tests should be discussed with C. Cromer prior to submitting a formal request. Also, characterized silicon detectors can be purchased from NIST that are calibrated in either the 200 to 450 nm or 400 to 1100 nm regions in 5 nm steps.



*Jeanne Houston and Christopher Cromer are aligning in the detector calibration facility.*

### References – Radiometric Measurements

Spectroradiometric Determination of the Freezing Temperature of Gold, K. D. Mielenz, R. D. Saunders and J. Shumaker, *J. Res. Natl. Inst. Stand. Technol.*, Vol. 95 (Jan-Feb. 1990).

The International Temperature Scale of 1990 (ITS-90), H. Preston-Thomas, *Metrologia* 27, 2-310 (1990).

NBS Measurement Services: The NBS Photodetector Spectral Response Calibration Transfer Program, E. F. Zalewski, *Natl. Bur. Stand. (U.S.)*, Spec. Publ. 250-17 (1988).

NBS Measurement Services: Spectral Irradiance Calibrations, J. H. Walker, R. D. Saunders, J. K. Jackson, and D. A. McSparron, *Natl. Bur. Stand. (U.S.)*, Spec. Publ. 250-20 (Sept. 1987).

NBS Measurement Services: Spectral Radiance Calibrations, J. H. Walker, R. D. Saunders, and A. T. Hattenburg, *Natl. Bur. Stand. (U.S.)*, Spec. Publ. 250-1 (Jan. 1987).

Spectral Response Self-Calibration and Interpolation of Silicon Photodiodes, J. Geist, E. F. Zalewski, and A. R. Schaefer, *Appl. Opt.* 20, 3795 (1980).

Spectral Irradiance Standard for the Ultraviolet: The Deuterium Lamp, R. D. Saunders, W. R. Ott, and J. M. Bridges, *Appl. Opt.* 17, 593 (1978).

The 1973 NBS Scale of Spectral Irradiance, R. D. Saunders and J. B. Shumaker, *Natl. Bur. Stand. (U.S.)*, Tech. Note 594-13 (1977).

Spectral Radiometry: A New Approach Based on Electro-Optics, J. Geist, M. A. Lind, A. R. Schaefer, and E. F. Zalewski, *Natl. Bur. Stand. (U.S.)*, Tech. Note 954 (1977).

Fundamental Principles of Absolute Radiometry and the Philosophy of This NBS Program (1968 to 1971), J. Geist, *Natl. Bur. Stand. (U.S.)*, Tech. Note 594-1 (1972).

High-Accuracy Spectral Radiance Calibration of Tungsten-Strip Lamps, H. J. Kostkowski, D. E. Erminy, and A. T. Hattenburg, *Adv. Geophys.*, 14, 111 (1970).

## D. Radiometric Standards in the Far Ultraviolet

### D.1 Standard Sources

#### Technical Contact:



Mervin Bridges  
Tel: 301/975-3228

**Mailing Address:** A167 Physics, National Institute of Standards and Technology, Gaithersburg, MD 20899-0001

Test No.	Items
40010C	Spectral Irradiance Standard, Argon Mini-Arc (140 to 330 nm)
40020C	Spectral Radiance Standard, Argon Mini-Arc (115 to 330 nm)
40030C	Spectral Irradiance Standard, Deuterium Arc Lamp (165 to 200 nm)
40040S	Special Tests of Radiometric Devices in the Near and Vacuum Ultraviolet

#### Source Calibrations in the Ultraviolet (40010C-40040S)

NIST maintains a collection of secondary standard sources such as argon maxi-arcs, argon mini-arcs, and deuterium arc lamps in the near and vacuum ultraviolet radiometric standards program to provide calibrations for user-supplied sources. The calibrations of these sources are traceable to a hydrogen arc whose radiance is calculable and which NIST maintains as a primary standard. The collection also includes tungsten strip lamps and tungsten halogen lamps whose calibrations are based on a blackbody rather than a hydrogen arc. Customer-supplied sources are calibrated in both radiance and irradiance by comparing them with NIST secondary standards.

Argon arcs are used to calibrate other sources in the wavelength range 115 nm to 330 nm for radiance and 140 nm to 330 nm for irradiance. The lower wavelength limit is determined in radiance by the cutoff of the magnesium fluoride windows used in the arcs and in irradiance by the decrease in signal produced by the addition of a diffuser. Deuterium arc lamps are used in the range 165 nm to 200 nm, with the low wavelength cutoff due to the onset of blended molecular lines. The high wavelength limit is the starting point of the range of another calibration group at NIST. (See tests 39010C-39050C, previous section.) The tungsten lamps are used at 250 nm and above, since their signals are too weak at shorter wavelengths. It should be noted that the wavelength range of the NIST arcs partially overlaps the range of tungsten lamps, thus providing an independent check on calibrations.

An argon mini-arc lamp supplied by the customer is calibrated for spectral irradiance at 10-nm intervals in the wavelength region 140 to 300 nm. Absolute values are obtained by comparison of the radiative output with laboratory standards of both spectral irradiance and spectral radiance. The spectral irradiance measurement is made at a distance of 50 cm from the field stop. Uncertainties are estimated to be less than  $\pm 10$  percent in the wavelength region 140 to 200 nm and within  $\pm 5$  percent in the wavelength region 200 to 330 nm. A measurement of the spectral transmission of the lamp window is included in order that the calibration be independent of possible window deterioration or damage. The uncertainties given here and below are taken to be two standard deviations ( $2\sigma$ ), i.e., as having a confidence limit of about 95 percent.

The spectral radiance of argon mini-arc radiation sources is determined to within an uncertainty of less than 7 percent over the wavelength range 140-330 nm and 20 percent over the wavelength range 115 to 140 nm.

The calibrated area of the 4-mm diameter radiation source is the central 0.3-mm diameter region. Typical values of the spectral radiance are: at 250 nm,  $L_\lambda = 30 \text{ mW cm}^{-2} \text{ nm}^{-1} \text{ sr}^{-1}$ ; and at 150 nm,  $L_\lambda = 3 \text{ mW cm}^{-2} \text{ nm}^{-1} \text{ sr}^{-1}$ . The transmission of the demountable lamp window and that of an additional  $\text{MgF}_2$  window are determined individually so that the user may check periodically for possible long-term variations.

The deuterium arc lamp is calibrated at 10 wavelengths from 165 to 200 nm, at a distance of 50 cm. Typical values of spectral irradiance are  $0.5 \text{ W/cm}^2$  at 165 nm,  $0.3 \text{ W/cm}^2$  at 170 nm, and  $0.5 \text{ W/cm}^2$  at 200 nm. The approximate uncertainty relative to SI units is estimated to be less than 10 percent. The lamp is normally supplied by NIST and requires 300 mA at about 100 V.

#### References—Source Calibrations in the Ultraviolet

Radiometric Calibrations of Portable Sources in the Vacuum Ultraviolet, J. Z. Klose, J. M. Bridges, and W. R. Ott, *J. Res. Natl. Bur. Stand. (U.S.)*, 93, 21 (1988).

NBS Measurement Services: Radiometric Standards in the Vacuum Ultraviolet, J. Z. Klose, J. M. Bridges, and W. R. Ott, *Natl. Bur. Stand. (U.S.)*, Spec. Publ. 250-3 (June 1987).

Radiance of a Pt/Cr-Ne Hollow Cathode Spectral Line Source, J. Z. Klose and J. M. Bridges, *Appl. Opt.*, 26, 5202 (1987).

VUV Spectral Irradiance Calibrations: Method and Applications, W. R. Ott, J. M. Bridges, and J. Z. Klose, *Opt. Lett.*, 5, 225 (1980).

Spectral Irradiance Standard for the Ultraviolet: The Deuterium Lamp, R. D. Saunders, W. R. Ott, and J. M. Bridges, *Appl. Opt.*, 17, 593 (1978).

Spectral Radiance Calibrations between 165-300 nm: An Interlaboratory Comparison, J. M. Bridges, W. R. Ott, E. Pitz, A. Schultz, D. Einfield, and D. Stuck, *Appl. Opt.*, 16, 1788 (1977).

VUV Radiometry, 3: The Argon Mini-Arc as a New Secondary Standard of Spectral Radiance, J. M. Bridges and W. R. Ott, *Appl. Opt.*, 16, 367 (1977).

NBS UV Radiometric Standards, W. R. Ott, *Natl. Bur. Stand. (U.S.)*, Spec. Publ. 456, 107 (1976).

# D. Radiometric Standards in the Far Ultraviolet

## D.2 Standard Detectors in the Far Ultraviolet

### Technical Contact:



L. Randall  
Canfield  
Tel: 301/975-3728

**Mailing Address:** B119 Radiation Physics, National Institute of Standards and Technology, Gaithersburg, MD 20899-0001

Test No.	Items
40510C	Detector Standard, Windowless Photodiode (5 to 122 nm)
40511C	Recalibration of Detector Standard (5 to 122 nm)
40520C	Detector Standard, Windowless Photodiode (18 to 122 nm)
40521C	Recalibration of Detector Standard (18 to 122 nm)
40530C	Detector Standard, Windowless Photodiode (52 to 122 nm)
40531C	Recalibration of Detector Standard (52 to 122 nm)
40540C	Uncalibrated Windowless Photodiode
40560C	Detector Standard, Windowed Photodiode (116 to 254 nm)
40561C	Recalibration of Detector Standard (116 to 254 nm)
40599S	Special Tests on Detectors from the Near Ultraviolet (320 nm) to the Soft X-Ray Region (5 nm)

### Detector Calibrations in the Ultraviolet (40510C-40599S)

Calibrated transfer standard detectors for the far ultraviolet are available from NIST to cover the spectral region 5 to 254 nm. Users are furnished with the quantum efficiency as a function of wavelength, with quantum efficiency defined as the number of photoelectrons per incident photon. Three detector types are available to cover this range: (1) a windowless silicon semiconductor photodiode for

the wavelength region 5-50 nm (Available Under Test No. 40599S); (2) a windowless photoemissive diode with an  $\text{Al}_2\text{O}_3$  photocathode for the wavelength region 5-122 nm; and (3) a  $\text{MgF}_2$ -windowed photodiode with a semi-transparent CsTe photocathode for the wavelength region 116-254 nm. The detectors have been extensively studied regarding radiometrically important parameters such as photocathode spatial uniformity and temporal stability of conversion efficiency. It should be noted that the silicon photodiode is not solar blind, while the windowless photoemissive diode is. Stray light considerations should be evaluated before making a choice for the 5-50 nm region.

The probable errors in the measured quantum efficiencies are 8 to 15 percent in the 5- to 122-nm windowless photodiode region and 6 to 10 percent in the 116- to 254-nm windowed photodiode region. Probable error means that there is a probability of 0.5 that the true quantum efficiency values lie within the stated error range about the values measured.

All calibrations are based on the rare gas ionization chamber as an absolute detector. In the windowless region 5 to 92 nm, working standards are calibrated directly against such a reference, while at longer wavelengths it is necessary to transfer the calibration derived from the ionization chamber at shorter wavelengths with the use of a special uniformly "gray" thermopile. The shortest portion of the windowless region involves the use of a beamline at the NIST electron storage ring facility, SURF-II, while the calibrations above 50 nm are conducted using plasma light sources in a laboratory environment.

Outgoing detectors are calibrated by direct intercomparison with precalibrated working standards that are periodically recalibrated. Windowless  $\text{Al}_2\text{O}_3$  photodiodes are fabricated in-house; the windowless Si photodiodes and the windowed CsTe photodiodes are procured commercially and tested for stability and spatial homogeneity.

Only those photodiodes meeting stringent NIST quality specifications are selected as transfer standards. The calibration costs include the cost of the detector and screening services unless a recalibration of previously used detectors is requested.

Special detectors that do not lend themselves to convenient on-site cross-calibration may also be calibrated at NIST if the detectors merit radiometric application and if the NIST calibration facilities are suitable and available for the particular device.

#### References – Detector Calibrations in the Ultraviolet

Far Ultraviolet Detector Standards, L. R. Canfield and N. Swanson, *J. Res. Natl. Bur. Stand. (U.S.)*, 92, 97 (1987).

NBS Measurement Services: Far Ultraviolet Detector Standards, L. R. Canfield and N. Swanson, *Natl. Bur. Stand. (U.S.)*, Spec. Publ. 250-2 (June 1987).

Time Response of NBS Windowless XUV Radiometric Transfer Standards, E. B. Saloman, *Appl. Opt.* 14, 1764 (1975).

## E. Laser Power and Energy

### Technical Contacts:



Thomas R. Scott  
Tel: 303/497-3651



Aaron A. Sanders  
Tel: 303/497-5341



Kathy Hillen  
Administrative  
and Logistics  
Tel: 303/497-3753

**Mailing Address:** M. C. 813.10, National Institute of Standards and Technology, 325 Broadway, Boulder, CO 80303-3328

Test No.	Items
42110C	Laser Power and Energy Meter Calibrations
42111C	Same as 42110C, Additional Wavelengths or Power Levels
42120M	Laser Power and Energy Measurement Assurance Program (MAP)
42130C	Optical Fiber Power Meter Calibrations
42131C	Same as 42130C, Additional Wavelengths
42140M	Optical Fiber Power Meter Measurement Assurance Program (MAP)
42150M	Low-Level Laser Measurement Assurance Program (MAP)
42160C	Pulsed 10.6- $\mu\text{m}$ Laser Calibrations
42170S	Special Tests for Laser Power and Energy Meters, by Prearrangement
42180S	Special Tests for Optical Fiber Power Meters, by Prearrangement

### Laser Power and Energy—General Information

The National Institute of Standards and Technology develops and maintains the U.S. national standards for the measurement of laser power and energy. These standards are realized in the form of several types of isoperibol (constant temperature environment) calorimeters. The calorimeters compare absorbed laser radiation to an equivalent quantity of electrical energy. Well-characterized transfer standards (calibrated against the primary standards) are also main-

tained as laboratory standards for calibrations and for use in Measurement Assurance Program (MAP) intercomparisons. The primary standards and secondary transfer standards are used in specially designed calibration systems that allow various power and energy meters to be compared to the standards. Table 4 summarizes the measurement capabilities of the primary standard measurement systems and lists typical calibration uncertainties.

**Table 4: Primary Standard Measurement Capabilities**

Primary Standard	Wavelength Range	Power Range	Typical Uncertainty
C-series	488.0, 514.5 nm	1 $\mu\text{W}$ - 1 W	$\pm 0.5$ -1.0%
	632.8 nm	1 $\mu\text{W}$ - 20 mW	$\pm 0.5$ -1.0%
	830 nm	100 $\mu\text{W}$ - 20 mW	$\pm 0.5$ -1.0%
	1.06 $\mu\text{m}$	1 mW - 1 W	$\pm 0.5$ -1.0%
	1.32 $\mu\text{m}$	100 $\mu\text{W}$ - 100 mW	$\pm 0.5$ -1.0%
	1.53 $\mu\text{m}$	100 $\mu\text{W}$ - 1 mW	$\pm 0.5$ -1.0%
Q-series	1.06 $\mu\text{m}$ (Q-switched)	< 110 mJ/pulse	$\pm 1.1$ -1.9%
K1-series	10.6 $\mu\text{m}$	1 W - 300 W	$\pm 1.6$ -2.5%
K2-series	10.6 $\mu\text{m}$	40 mW - 40 W	$\pm 2.5$ -3.5%

### Laser Power and Energy Meter Calibration (42110C-42111C)

Within the ranges listed in Table 4, NIST can perform calibrations at the power or energy and wavelength specified by the owner. The instrument is sent to NIST where it is then compared to the appropriate primary reference calorimeter using a calibrated beamsplitter measurement system. Normally, no adjustments are made to the test instrument. At the completion of the calibration measurements, the instrument and a calibration report are sent to the owner. The calibration report summarizes the results of the measurements and provides a detailed listing of the associated measurement uncertainties.

These calibration measurements are accomplished using a calibrated beamsplitter arrangement in which both the standard and the test meter are exposed to the laser beam



simultaneously. All the significant parameters (e.g., electrical calibration coefficient, absorptivity, window transmission) for each of the standard calorimeters used in these measurements have been evaluated for each laser wavelength used. Based on first principles of thermodynamics and linear system analysis, the characteristic voltage response of the standard isoperibol calorimeters can be correlated to the quantity of energy absorbed. Because the reference calorimeters measure energy, laser stability is not required when calibrating other energy detectors. However, when calibrating power meters, either a stable laser is used or else the voltage of the test meter is integrated to give an energy measurement. The data acquisition and analysis for these systems are computer controlled.

The laser sources used for these calibration measurements with the primary standards consists of the following types: (1) helium-neon (632.8 nm), (2) helium-neon (1.53  $\mu\text{m}$ ), (3) argon ion (488.0 & 514.5 nm), (4) Nd:YAG (1.064  $\mu\text{m}$ , cw & Q-switched), (5) Nd:YAG (1.32  $\mu\text{m}$ ), (6) diode laser (830 nm), and (7) carbon dioxide (10.6  $\mu\text{m}$ ).

#### Laser Power and Energy Measurement Assurance Programs (42120M)

The Measurement Assurance Program (MAP) service is available at the wavelengths and powers listed in Table 4. The laser MAP intercomparisons are implemented by means of transfer standards which have been evaluated and characterized relative to the national primary standards. The measurement system and primary standards discussed above are used to calibrate the transfer standards for the intercomparisons. The characteristics of these transfer standards are well understood, and their associated accuracies do not differ significantly from those associated with direct comparisons to the primary standards. For a specified wavelength

and power or energy, the appropriate transfer standard is selected and sent from NIST to the MAP participant. The participant calibrates the NIST transfer standard using his measurement system and then returns both his data and the transfer standard to NIST. Before and after the NIST transfer standard is shipped to the participant, NIST performs calibration measurements on the detector to provide continuity during the intercomparison process. At the completion of the intercomparison sequence, NIST evaluates the participant's measurement results relative to the NIST calibration results on this same meter. A MAP intercomparison report is then submitted to the participant summarizing the intercomparison and listing the associated measurement uncertainties.

#### Optical Fiber Power Meter Calibrations (42130C-42131C)

Optical fiber power meters are calibrated using an automated calibration system in which the test meter and the laboratory standard are alternately exposed to a stable laser source. Table 5 summarizes the current capabilities of this system. The laboratory standard used for these measurements is an electrically calibrated pyroelectric radiometer (ECPR), which has been calibrated against the C-series primary standard calorimeter. Various laser sources are used to provide collimated beams approximately 3 to 4 mm in diameter for the optical power meter calibrations.

Table 5: Measurement Capabilities

Laboratory Standard	Wavelength Window	Power Range	Typical Uncertainties
ECPR	850 nm	100 $\mu\text{W}$	$\pm 0.5-1.0\%$
ECPR	1300 nm	100 $\mu\text{W}$	$\pm 0.5-1.0\%$
ECPR	1550 nm	100 $\mu\text{W}$	$\pm 0.5-1.0\%$

**Optical Fiber Power Meter  
Measurement Assurance Program  
(MAP) (42140M)**

NIST maintains a set of calibrated transfer standards that are available for MAP intercomparisons of optical fiber power meters. These transfer standards are calibrated using the optical fiber power meter calibration system discussed above at the wavelengths listed in table 5.



*John B. Schlager uses soliton-like compression in the generation of very short pulses of light as part of work to measure the performance of lightwave system components used for optical-fiber telecommunications.*

**Low-Level Laser Measurement  
Assurance Program (MAP) (42150M)**

NIST has designed and constructed special silicon and germanium diode detectors to measure pulse energy and peak power of low-level, 1.064- $\mu\text{m}$  laser pulses of about 10- to 100-ns duration. These diode detectors have been evaluated for spatial uniformity, bandwidth, and linearity, and are used as transfer standards for intercomparison measurements. The output response of each detector has been calibrated against a transfer standard, which, in turn, has been calibrated against the C-series calorimeter. The system for calibrating these transfer standards uses a cw Nd:YAG laser beam, which is acousto-optically modulated to produce short, well-defined pulses. The beam intensity is attenuated to low levels using a multiple reflection precision wedge beamsplitter. The transfer standards are available for intercomparisons at the levels listed in table 6.

**Table 6: Low-Level MAP Transfer Standards**

Transfer Standard	Energy/Power Range	Typical Uncertainty
Silicon PIN	$10^{-14}$ - $10^{-11}$ J/cm <sup>2</sup> /pulse	$\pm 8$ -10%
Germanium PIN	$10^{-15}$ - $10^{-13}$ J/cm <sup>2</sup> /pulse	$\pm 15\%$
Silicon APD	$10^{-8}$ - $10^{-4}$ W/cm <sup>2</sup> (peak)	$\pm 9$ -12%

### Pulsed 10.6- $\mu\text{m}$ Laser Calibrations (42160C)

NIST can perform responsivity and energy calibrations on instruments designed to measure pulsed laser radiation at a wavelength of 10.6  $\mu\text{m}$ . For these measurements a transfer standard (calibrated against the K-series calorimeters) is used in a beamsplitter arrangement in which a transversely excited atmospheric pressure (TEA)  $\text{CO}_2$  laser is used as the radiation source. The TEA laser, surrounded by a shielded aluminum enclosure, is composed of both a high-pressure cell containing the gain medium (mixture of carbon dioxide, helium, and nitrogen) and a low-pressure gain cell also containing the same gain medium. The low-pressure cell causes the laser to operate at a single longitudinal mode (SLM). To determine responsivity, the output voltage waveform of the instrument being calibrated is acquired with a transient digitizer and numerically integrated with a computer. The voltage integral is then divided by the incident energy as measured by the transfer standard and beamsplitter system. At the completion of the responsivity or energy measurements, a calibration report is sent, along with the detector, to the owner. Table 7 summarizes the capability of this pulsed measurement system.

Table 7: Pulsed  $\text{CO}_2$  Calibrations

Measurement	Pulse Width	Pulse Energy	Typical Uncertainty
Responsivity	200 ns	5-60 mJ/pulse (SLM TEM <sub>00</sub> )	$\pm 5-15\%$
Energy	200 ns	5-300 mJ/pulse (multi-spatial mode)	$\pm 5\%$

### Special tests for Laser Power and Energy Meters, by Prearrangement (42170S)

Laser calibrations or measurements not specifically mentioned above may be arranged by contacting NIST and discussing the particular requirements with the appropriate NIST personnel. Special-test measurements could include, for example, calibrations at wavelengths or power levels not listed above or other unique measurements such as impulse response or linearity measurements. Low-level laser calibrations are also included in this category. All these measurements must be prearranged with NIST.

### Special Tests for Optical Fiber Power Meters, by Prearrangement (42180S)

The special tests in this category include optical fiber power meter measurements not listed above. For example, this category would be used for power meters using fiber connectors or meters that have small-area detectors. All these special-test measurements must be prearranged with NIST.

### References—Laser Power and Energy

- NBS Laser Power and Energy Measurements, T. R. Scott, Proc. SPIE O-E LASE '88, Optoelectronics and Laser Applications in Science and Engineering (1988).
- A System for Measuring Energy and Peak Power of Low-Level 1.064- $\mu\text{m}$  Laser Pulses, A. A. Sanders and A. L. Rasmussen, Natl. Bur. Stand. (U.S.), Tech. Note 1058 (Oct. 1982).
- Documentation of the NBS C, K, and Q Laser Calibration Systems, W. E. Case, Natl. Bur. Stand. (U.S.), NBSIR 82-1676 (Sept. 1982).
- A System for Measuring the Characteristics of High Peak Power Detectors of Pulsed  $\text{CO}_2$  Radiation, P. A. Simpson, Natl. Bur. Stand. (U.S.), Tech. Note 1023 (Sept. 1980).

- Quality Assurance Program for the NBS, C, K, and Q Laser Calibration Systems, W. E. Case, Natl. Bur. Stand. (U.S.), Int. Report, NBSIR 79-1619 (Aug. 1979).
- A System for Calibrating Laser Power Meters for the Range 5-1000 W., E. D. West and L. B. Schmidt, Natl. Bur. Stand. (U.S.), Tech. Note 685 (May 1977).
- An NBS Measurement Assurance Program, A. A. Sanders and A. R. Cook, Proc. Electro-Optics Laser Conference (1976).
- Absolute Reference Calorimeter for Measuring High-Power Laser Pulses, D. L. Franzen and L. B. Schmidt, Appl. Opt. 15, 3115 (Dec. 1976).
- A Calorimeter for High-Power CW Lasers, R. L. Smith, T. W. Russell, W. E. Case, and A. L. Rasmussen, IEEE Trans. Instr. Meas., Vol. IM-21, No. 4 (Nov. 1972).
- A Reference Calorimeter for Laser Energy Measurement, E. D. West, W. E. Case, A. L. Rasmussen, and L. B. Schmidt, J. Res. Natl. Bur. Stand. (U.S.), 76A, No. 1, 13 (Jan.-Feb. 1972).
- Data Analysis for Isoperibol Laser Calorimetry, E. D. West, Natl. Bur. Stand. (U.S.), Tech. Note 396 (Feb. 1971).
- Theory of Isoperibol Calorimetry for Laser Power and Energy Measurement, E. D. West and K. L. Churney, J. Appl. Phys. 41, No. 6, 2705 (May 1970).

#### References – Optical Fiber Power Meter Measurements

- Calibrated Optical Fiber Power Meters: Errors Due to Variations in Connectors, Xiaoyu Li and R. L. Gallawa, Fiber & Integrated Optics, Vol. 7 (Mar. 1988).
- Calibration of Optical Fiber Power Meters: The Effect of Connectors, R. L. Gallawa and Xiaoyu Li, Appl. Opt. 26, 1170 (Apr. 1987).
- Optical Fiber Power Meters: A Round Robin Test of Uncertainty, R. L. Gallawa and Shao Yang, Appl. Opt. 25, 1066 (Apr. 1986).



---

# Chapter

# 8

- A** Radioactivity Sources
- B** Neutron Sources and Neutron Dosimetry
- C** Dosimetry of X Rays, Gamma Rays, and Electrons
- D** Dosimetry for High-Dose Applications

## A. Radioactivity Sources

### Technical Contacts:



Jacqueline M.  
Calhoun  
Tel: 301/975-5538



Pamela A. Hodge  
43030C-43050C  
Tel: 301/975-5544



Cassandra Beck  
Administrative  
and Logistics  
Tel: 301/975-5531

**Mailing Address:** C114 Radiation Physics, National Institute of Standards and Technology, Gaithersburg, MD 20899-0001

Test No.	Items
43010C	Gamma-Ray-Emitting Radionuclides in Solution (Half Lives Greater Than 15 Days)
43020C	Gamma-Ray-Emitting Radionuclides in Solution (Half Lives Less Than 15 Days)
43030C	Alpha-Particle-Emitting Solid Sources, NIST 2 $\pi\alpha$ proportional counter
43040C	Alpha-Particle-Emitting Solid Sources, NIST 0.8 $\pi\alpha$ defined-solid-angle counter
43050C	Alpha-Particle-Emitting Solid Sources, using both counting systems
43060S	Special Tests of Beta-Particle-Emitting Solution Sources—Liquid Scintillation Counting
43070S	Special Tests of Beta-Particle-Emitting Solution Sources, Other Techniques
43090S	Special Tests of Alpha-Particle-Emitting Solid Sources

### Radioactivity Sources—General Information (43010C-43090S)

The National Institute of Standards and Technology offers calibration services for over 50 radionuclides. Calibrations are provided that meet the requirements of industry, research, environmental monitoring, and the life sciences. Radioactivity calibration services are available for alpha-particle solid sources, beta-particle solutions, and gamma-ray solutions.

In order to offer such a broad range of services, NIST must place stringent limitations on the physical and chemical form and activity range of sources that can be accepted. To ensure that these specifications are understood, it is essential that there be good communication between the technical user and the technical contact at NIST. When planning to have a source calibrated, the user should discuss the following points with the NIST contact:

A. Type of calibration: Often, more than one type of calibration is available for a given source. A cobalt-60 source, for example, may be calibrated in terms of total activity or gamma-ray-emission rate. (Inquiries regarding the calibration of radioactive sources for exposure rate should be directed to the Dosimetry Group. See tests 47010C to 47040S.) The required total uncertainty in the calibration should also be discussed.

B. General packaging and shipping requirements: Two general requirements apply to all sources submitted for calibration: (1) all shipments must conform to applicable Nuclear Regulatory Commission (NRC) and Department of Transportation (DOT) packaging and transport; and (2) source descriptions, including approximate activity, must be provided in advance. The NIST Health Physics Group must approve the receipt of radioactive material, and sources may be refused if the necessary information is not available.

C. Reports of Calibration: A Report of Calibration is sent upon completion of a radioactivity calibration service. If the user has particular requirements for documentation of the calibration, these should be discussed with the technical contact at NIST before the services are performed.

D. Sample Preparation, Packaging, and Shipping: All samples submitted for calibration must be chemically and physically stable. The

chemical form of solutions suggested for beta-particle emitters and gamma-ray emitters are described later in this document. A special lot of borosilicate-glass ampoules must be used for gamma-ray emitters. Empty ampoules are provided for this purpose. The volume of material in the ampoule should be  $5.0 \pm 0.2$  mL.

Packaging for all sources must be in compliance with DOT and NRC regulations. Copies of regulations may be obtained from Operations Division, Office of Hazardous Materials, Department of Transportation, Washington, DC 20950. Postal regulations prohibit the mailing of radioactive materials that require a caution label under DOT regulations.

Alpha-particle solid sources must be supplied in special source holders designed so that the active area is not touched by any material. For sources to be measured in the  $2\pi\alpha$  counter (calibration 43030C), the diameter of the source must be less than 10 cm and that of the active surface less than 9 cm. For the  $0.8\pi\alpha$  counter (calibration 43040C), the maximum diameter is 1.6 cm.

All sources arriving at NIST are checked by the Health Physics Group for radiation level and source integrity. Sources should be shipped to the attention of the technical contact at NIST, addressed, for example, as follows:

National Institute of Standards  
and Technology  
Attn: Jacqueline M. Calhoun  
Health Physics (Radioactivity  
Group)  
Quince Orchard and Clopper  
Roads  
Gaithersburg, MD 20899-0001

#### Gamma-Ray-Emitting Solution Sources (43010C-43020C)

Tables 8 and 9 list 41 radionuclide solutions that may be calibrated in the NIST " $4\pi$ "  $\gamma$  ionization chamber. The sources must be submitted flame-sealed in the special ampoules provided by NIST. The operation of this type of chamber is described in NCRP Report 58, A Handbook of

**Table 8:** Specifications for Calibration of Gamma-Ray Emitting Solutions Which Are Submitted for Calibration Radionuclides Having Half Lives Greater Than 15 Days

Radio-nuclide	Nominal " $3\sigma$ " Uncer. Limits of Ionization- Chamber Calibration <sup>(a)</sup> (%)	Activity Range <sup>(b)</sup> (MBq)	Suggested Chemical Form <sup>(c)</sup>	
			Carrier	Solution
<sup>22</sup> Na	1.6	0.4 - 40	NaCl	1 M HCl
<sup>46</sup> Sc	0.8	0.4 - 40	ScCl <sub>3</sub>	1 M HCl
<sup>51</sup> Cr	1.0	2 - 60	CrCl <sub>3</sub>	0.5 M HCl
<sup>54</sup> Mn	1.2	2 - 60	MnCl <sub>2</sub>	1 M HCl
<sup>57</sup> Co	0.8	2 - 60	CoCl <sub>2</sub>	1 M HCl
<sup>59</sup> Fe	1.4	0.4 - 40	FeCl <sub>3</sub>	1 M HCl
<sup>60</sup> Co	0.8	0.4 - 40	CoCl <sub>2</sub>	1 M HCl
<sup>75</sup> Se	2.4	2 - 60	H <sub>2</sub> SeO <sub>3</sub>	1 M HNO <sub>3</sub>
<sup>85</sup> Sr	2.0	2 - 60	SrCl <sub>2</sub>	1 M HCl
<sup>88</sup> Y	0.7	0.4 - 40	YCl <sub>3</sub>	1 M HCl
<sup>109</sup> Cd - <sup>109m</sup> Ag <sup>(d)</sup>	1.7	2 - 60	CdCl <sub>2</sub>	1.3 M HCl*
<sup>110m</sup> Ag - <sup>110</sup> Ag	0.9	0.4 - 40	AgNO <sub>3</sub>	1 M HNO <sub>3</sub>
<sup>113</sup> Sn - <sup>113m</sup> In	3.0	2 - 60	SnCl <sub>2</sub> or SnCl <sub>4</sub>	4 M HCl
<sup>114m</sup> In	1.0	2 - 200	InCl <sub>2</sub>	3 M HCl
<sup>123m</sup> Te	1.0	2 - 100	TeCl <sub>4</sub>	2 M HCl
<sup>133</sup> Ba	1.5	2 - 60	BaCl <sub>2</sub>	1 M HCl
<sup>134</sup> Cs	1.0	2 - 60	CsCl	1 M HCl
<sup>137</sup> Cs - <sup>137m</sup> Ba	1.5	2 - 60	CsCl	1 M HCl
<sup>139</sup> Ce	1.0	2 - 60	CeCl <sub>3</sub>	1 M HCl
<sup>141</sup> Ce	2.0	2 - 60	CeCl <sub>3</sub>	1 M HCl
<sup>144</sup> Ce	1.3	2 - 740	CeCl <sub>3</sub>	1 M HCl*
<sup>152</sup> Eu	1.6	0.4 - 40	EuCl <sub>3</sub>	1 M HCl
<sup>153</sup> Gd	1.9	2 - 60	GdCl <sub>3</sub>	1 M HCl*
<sup>154</sup> Eu	0.8	0.4 - 40	EuCl <sub>3</sub>	4 M HCl
<sup>155</sup> Eu	1.5	2 - 60	EuCl <sub>3</sub>	4 M HCl
<sup>169</sup> Yb	2.5	2 - 60	YbCl <sub>3</sub>	0.1 M HCl*
<sup>195</sup> Au	2.3	2 - 60	KAu(CN) <sub>4</sub>	10g L <sup>-1</sup> KCN* 10g L <sup>-1</sup> KCl*
<sup>203</sup> Hg	1.4	2 - 60	Hg(NO <sub>3</sub> ) <sub>2</sub>	0.1 M HNO <sub>3</sub>

<sup>(a)</sup> The total estimated uncertainty will depend upon the activity level and chemical form.

<sup>(b)</sup> The source activity should be in the indicated range when it arrives at NIST. The calibration scheduling must be coordinated with the NIST technical contact.

<sup>(c)</sup> This information is based in large part on the NIST Standard Reference Materials for these radionuclides. For those radionuclides marked with an asterisk, the carrier should be discussed with the NIST technical contact.

<sup>(d)</sup> The calibration for <sup>109</sup>Cd - <sup>109m</sup>Ag and <sup>113</sup>Sn - <sup>113m</sup>In are in terms of gamma-ray-emission rate rather than activity.

Radioactivity Measurements Procedures, Section 4.4 "Ionization Chambers," and in NBS SP 250-10, Radioactivity Calibrations with the " $4\pi$ " Gamma Ionization Chamber and other Radioactivity Calibration Capabilities (see references).



**Table 9: Specifications for Calibration of Gamma-Ray Solution Sources Radionuclides Having Half Lives Less Than 15 Days**

Radio-nuclide	Nominal "3 $\sigma$ " Uncer. Limits of Ionization- Chamber Calibration <sup>(a)</sup> (%)	Activity Range <sup>(b)</sup> (MBq)	Suggested Chemical Form <sup>(c)</sup>	
			Carrier	Solution
<sup>24</sup> Na	0.8	0.4-40	NaCl	1 M HCl
<sup>67</sup> Ga	1.4	0.4-40	GaCl <sub>3</sub>	2 M HCl
<sup>99m</sup> Mo - <sup>99m</sup> Tc	1.6	2-60	Molybdate	4 M HNO <sub>3</sub>
<sup>99m</sup> Tc	1.5	2-60	No carrier added/ pertechnetate	Saline
<sup>111</sup> In	1.3	2-60	InCl <sub>2</sub>	3 M HCl
<sup>123</sup> I	1.5	2-60	KI, Na <sub>2</sub> SO <sub>3</sub>	0.01 M LiOH*
<sup>131</sup> I	1.3	2-60	KI, Na <sub>2</sub> SO <sub>3</sub>	0.01 M LiOH*
<sup>140</sup> Ba - <sup>140</sup> La	3.4	0.4-40	Ba(NO <sub>3</sub> ) <sub>2</sub> , La(NO <sub>3</sub> ) <sub>3</sub>	1 M HCl
<sup>186</sup> Re	1.0	2-600	Re	Saline
<sup>197</sup> Hg	2.4	2-60	Hg(NO <sub>3</sub> ) <sub>2</sub>	0.1 M HNO <sub>3</sub>
<sup>198</sup> Au	1.3	2-60	KAu(CN) <sub>4</sub>	10 gL <sup>-1</sup> KCl, 10 gL <sup>-1</sup> KCN
<sup>201</sup> Tl	1.9	2-60	T(NO <sub>3</sub> ) <sub>3</sub>	0.9 M HNO <sub>3</sub>
<sup>203</sup> Pb	1.7	2-60	PbCl <sub>2</sub>	0.5 M HCl

<sup>(a)</sup> The total estimated uncertainty will depend upon the activity level and chemical form.

<sup>(b)</sup> The source activity should be in the indicated range when it arrives at NIST. The calibration scheduling must be coordinated with the NIST technical contact.

<sup>(c)</sup> This information is based in large part on the NIST Standard Reference Materials for these radionuclides. For those radionuclides marked with an asterisk, the carrier should be discussed with the NIST technical contact.

#### Alpha-Particle-Emitting Solid Sources (43030C-43050C)

Alpha-particle sources may be calibrated using the National Institute of Standards and Technology 2  $\pi\alpha$  proportional counter, or the National Institute of Standards and Technology 0.8  $\pi\alpha$  defined-solid-angle counter. The former calibration is in terms of alpha-particle-emission rate into 2  $\pi\alpha$  steradians, while the latter is in terms of total activity. A more detailed comparison of these counting systems is given in NCRP Report 58 (Section 3.7) and in NBS SP 250-5, Alpha-Particle Calibrations. Backscattering corrections for a variety of source-mount materials are discussed in the references given. The source thickness must be such that more than 99.5

percent of the emitted alpha particles have an energy greater than 400 keV. Further specifications for these calibration services are given in Table 10. Test 43050C includes calibration of the same source using both counting systems.

Large area sources of plutonium-238 may also be measured providing the source thickness is as above. The activity range is 10<sup>2</sup> to 10<sup>5</sup> Bq utilizing Large-Area Internal and External Counters.

**Table 10: Specifications for Calibrations Using the 2  $\pi\alpha$  Proportional Counter and the 0.8  $\pi\alpha$  Defined Solid Angle Counter**

	Calibration 43030C	Calibration 43040C
Counting System	NIST 2 $\pi\alpha$ proportional counter	NIST 0.8 $\pi\alpha$ defined-solid- angle-counter
Sources Calibrated For:	Alpha-particle- emission rate into 2 $\pi\alpha$ steradians either above 400 KeV or extrapolated to zero KeV (in s <sup>-1</sup> )	Total activity (in Bq)
Nominal Uncertainty (~3 $\sigma$ )	1.5 percent	1.5 percent
Activity Range	~(0.4-10 <sup>4</sup> )s <sup>-1</sup>	~(40-10 <sup>4</sup> )s <sup>-1</sup>
Maximum Source Diameter	10 cm (9 cm active surface)	1.6 cm

The total estimated uncertainty will depend upon the activity level and source geometry.



Jacqueline Calhoun places a gamma-ray emitting radionuclide sample into the NIST "4 $\pi$ "  $\alpha$  ionization chamber.

#### Special Tests of Beta-Particle-Emitting Solution Sources (43060S and 43070S)

Beta-particle-emitting solutions that conform to the physical, chemical, and activity specifications for measurement are assayed by liquid-scintillation counting. The specifications are shown in Table 11. Solutions should be approximately 5 mL in volume and flame-sealed in glass vials or ampoules. The suggested radioactivity concentration range is 20 to 2000 kBq/g.

**Table 11: Specifications for Special Tests of Beta-Particle-Emitting Solution Sources**

Radio-nuclide	Nominal Uncertainty <sup>(b)</sup> (%)	Suggested Chemical Composition <sup>(b)</sup>	
		Carrier	Solution
<sup>3</sup> H	1.0	H <sub>2</sub> O	H <sub>2</sub> O
<sup>14</sup> C	1.5	Na <sub>2</sub> CO <sub>3</sub>	0.001 M NaOH
<sup>32</sup> P <sup>(c)</sup>	1.0	H <sub>3</sub> PO <sub>4</sub>	0.0034 M H <sub>3</sub> PO <sub>4</sub>
<sup>33</sup> P	1.0	H <sub>3</sub> PO <sub>4</sub>	0.0034 M H <sub>3</sub> PO <sub>4</sub>
<sup>35</sup> S	1.0	Li <sub>2</sub> SO <sub>4</sub>	0.1 M HCl
<sup>36</sup> Cl	2.0	NaCl	H <sub>2</sub> O
<sup>89</sup> Sr	1.0	SrCl <sub>2</sub>	1 M HCl
<sup>90</sup> Sr - <sup>90</sup> Y	1.0	SrCl <sub>2</sub> /YCl <sub>3</sub>	1 M HCl
<sup>90</sup> Y	1.0	YCl <sub>3</sub>	1 M HCl
<sup>147</sup> Pm	1.0	PmCl <sub>3</sub>	1 M HCl
<sup>204</sup> Tl	2.0	Tl(NO <sub>3</sub> ) <sub>3</sub>	1 M HNO <sub>3</sub>

<sup>(a)</sup> The total estimated uncertainty will depend upon the activity level and chemical form.

<sup>(b)</sup> The chemical composition is critical for these calibrations and should be discussed before sending the source.

<sup>(c)</sup> This calibration includes a half-life fit to determine the <sup>33</sup>P impurity.

No examination is made for beta-particle-emitting impurities, except in the case of phosphorus-32 where a half-life fit is made. The sources will be examined for gamma-ray emitting impurities.

Measurement of beta-particle-emitting solutions by techniques other than liquid-scintillation may be made by special arrangement.

#### Special Alpha-Particle-Emitting Solid Sources (43090S)

Special arrangements may be made for measurements of solid alpha-particle-emitting sources with emission rates exceeding  $1.1 \times 10^4$  Bq.

#### References - Radioactivity Sources

NBS Measurement Services: Radioactivity Calibrations with the "4 $\pi$ " Gamma Ionization Chamber and Other Radioactivity Calibration Capabilities, J. M. Calhoun, Natl. Bur. Stand. (U.S.), Spec. Publ. 250-10 (Oct. 1987).

- NBS Measurement Services: Alpha-Particle Calibrations, J. M. R. Hutchinson, Natl. Bur. Stand. (U.S.), Spec. Publ. 250-5 (July 1987).
- NCRP Report 58, A Handbook of Radioactivity Measurements Procedures, Section 3.7—Alpha-Particle Counting, W. B. Mann, Ed., Natl. Council Rad. Protect. and Meas., Washington, DC (1985).
- Study of the Scattering Correction for Thick Uranium-Oxide and Other  $\alpha$ -Particle Sources, I: Theoretical, L. L. Lucas and J. M. R. Hutchinson, Int. J. Appl. Radiat. Isotopes, 27, 35 (1976).
- Study of the Scattering Correction for Thick Uranium-Oxide and Other  $\alpha$ -Particle Sources, II: Experimental, J. M. R. Hutchinson, L. L. Lucas, and P. A. Mullen, Int. J. Appl. Radiat. Isotopes, 27, 43 (1976).
- Backscattering of Alpha Particles from Thick Metal Backings as a Function of Atomic Weight, J. M. R. Hutchinson, C. R. Naas, D. H. Walker, and W. B. Mann, Int. J. Appl. Radiat. Isotopes, 19, 517 (1968).
- An Experimental Study of the Backscattering of 5.3 MeV-Alpha Particles from Platinum and Monel Metal, D. H. Walker, Int. J. Appl. Radiat. Isotopes, 16, 183 (1965).

## B. Neutron Sources and Neutron Dosimetry

### Technical Contacts:



E. Dale  
McGarry  
44010C, 44020C,  
44100S  
Tel: 301/975-6205



Robert B.  
Schwartz  
44060C, 44100S  
Tel: 301/975-6203



Edward W.  
Boswell  
44010C-44060C  
Tel: 301/975-6207

**Mailing Address:** A135 Reactor, National Institute of Standards and Technology, Gaithersburg, MD 20899-0001

---

### Test No. Items

44010C	Radioactive Neutron Sources ( $10^5$ to $10^8$ n/s)
44020C	Radioactive Neutron Sources ( $10^8$ to $10^{10}$ n/s)
44060C	Personnel Protection Instrumentation, Californium Source Bare and Moderated
44070C	Activation Detector Dosimetry, Thermal Neutrons
44080C	Activation Detector Dosimetry, Californium Fission Neutrons
44090C	Activation Detector Dosimetry, $^{235}\text{U}$ Cavity Fission Source
44100S	Special Tests of Neutron Sources and Dosimeters

---

### Radioactive Neutron Sources (44010C-44020C)

NIST provides calibration services for radioactive neutron sources with emission rates from  $5 \times 10^5$  to  $1 \times 10^{10}$  neutrons/second. Emission rates are determined by the Manganous Sulfate Bath Method to an accuracy of about 1.2 percent (one sigma) depending upon the details of source encapsulation. Sources to be calibrated are compared in the bath to the emission rate of NBS-1, the national standard Ra-Be photoneutron source. The emission rate of NBS-1 ( $1.2 \times 10^6$  n/s in January 1990) has an assigned uncertainty of  $\pm 0.85$  percent (one sigma).

### Personnel Protection Instrumentations (44060C)

Neutron personnel instruments, both passive (e.g., dosimeters) and active (e.g., remmeters) are calibrated on the basis of a certified free-field dose-equivalent or dose equivalent rate. Two  $^{252}\text{Cf}$  source-driven neutron fields are available on a routine basis for this purpose: bare source and heavy-water moderated  $^{252}\text{Cf}$  fission neutron sources. Thermal and filtered neutron beams are also available for special requirements under Test No. 44100S. For both bare and moderated  $^{252}\text{Cf}$  source exposures, maximum dose-equivalent rates are about 2 rem/h. The calibration uncertainty is in the range of  $\pm 5$  percent ( $1\sigma$ ), including a  $\pm 4$  percent component for the dose equivalent conversion factor.

### Activation Detector Dosimetry (44070C-44090C)

Passive neutron detectors, generally activation foils, can be irradiated to a certified neutron fluence (or average fluence rate) in a fission spectrum or a Maxwellian thermal neutron field. Irradiation parameters are given in Table 12.

**Table 12: Irradiation Parameters for Fission Spectra and Maxwellian Thermal Neutron Fields**

Neutron Field	Typical Maximum Fluence (n/s)	Typical Maximum Fluence Rate (n/cm <sup>2</sup> )	Accuracy (1 $\sigma$ ) (%)
<sup>252</sup> Cf Fission Source	$5 \times 10^{12}$	$2 \times 10^7$	$< \pm 1.3^{(b)}$
<sup>235</sup> U Cavity Fission Source <sup>(a)</sup>	$5 \times 10^{15}$	$4 \times 10^{10}$	$< \pm 2.3^{(b)}$
Thermal Neutrons Beam <sup>(c)</sup>	$1 \times 10^{13}$	$8 \times 10^7$	$\pm 2.5$
Isotropic	$> 1 \times 10^{16}$	$2 \times 10^{11}$	$\pm 2.5$

<sup>(a)</sup> Threshold detectors only. Maximum size of detector disks: 12.7 mm dia.  $\times$  about 3 mm thick. Radial gradient of fluence: about 20 percent center-to-edge.

<sup>(b)</sup> Uncertainty includes neutron scattering corrections.

<sup>(c)</sup> Maxwellian distribution corresponding to a temperature of about 40 °C.

### Special Tests of Neutron Sources and Dosimeters (44100S)

Other tests of dosimetry instrumentation may be undertaken by special arrangement with the Ionizing Radiation Division. In particular for personnel protection instruments, a thermal beam can provide dose equivalent rates of up to approximately 1 rem/h across a 30-cm diameter circle, and three monoenergetic filtered neutron beams may be used to investigate neutron response as a function of energy. Energies and typical dose equivalent rates for the filtered beams are 2 keV (8 mrem/h), 24 keV (15 mrem/h), and 144 keV (120 mrem/h).

### References – Radioactive Neutron Sources

NBS Measurement Services: Neutron Source Strength Calibrations at NBS by the Manganese Sulfate Bath Method, E. D. McGarry and E. W. Boswell, Natl. Bur. Stand. (U.S.), Spec. Publ. 250-18 (Mar. 1988).

Neutron Source Calibrations at NBS for Calibration Checks of Neutron Radiation Instruments, V. Spiegel, Jr., Proc. of Symp. on Meas. for the Safe Use of Radiation, Natl. Bur. Stand. (U.S.), Spec. Publ. 456, 87 (Nov. 1976).

Calibration of Thermal Neutron Absorption in Cylindrical and Spherical Neutron Sources, V. Spiegel, Jr., and W. M. Murphey, Metrologia, 7, 34 (Jan. 1971).

The Correction Factor for Fast Neutron Reactions on Sulphur and Oxygen in the Manganous-Sulfate-Bath Calibration of Neutron Sources, W. M. Murphey, Nucl. Instrum. Methods, 37, 13 (1965).

Absolute Calibration of the National Bureau of Standards Photoneutron Source: III. Absorption in a Heavy Water Solution of Manganous Sulfate, R. H. Noyce, E. R. Mosburg, Jr., S. B. Garfinkel, and R. S. Caswell, J. Nucl. Eng., 17, No. 7, 313 (1963).

Absolute Calibration of the National Bureau of Standards Photoneutron Standard: I, J. A. DeJuren, D. W. Padgett, and L. F. Curtiss, J. Res. Natl. Bur. Stand. (U.S.), 55, 63 (Aug. 1955).

### References – Personnel Protection Instrumentation

NBS Measurement Services: Neutron Personnel Dosimetry, R. B. Schwartz, Natl. Bur. Stand. (U.S.), Spec. Publ. 250-12 (July 1987).

Calibrations and Use of Filtered Beams, R. B. Schwartz, Proc. Intl. Specialists Symp. on Neut. Stand. and Applic., Gaithersburg, MD, Natl. Bur. Stand. (U.S.), Spec. Publ. 493, 250 (Oct. 1977).

The Design and Construction of a D<sub>2</sub>O-Moderated <sup>252</sup>Cf Source for Calibrating Neutron Personnel Dosimeters Used at Nuclear Power Reactors, R. B. Schwartz and C. M. Eisenhauer, U.S. Nucl. Reg. Com. Doc. NUREG/CR-1204 (Jan. 1980).

#### References—Activation Detector Dosimetry

NBS Measurement Services: Activation Foil Irradiations at NBS by Californium Fission Sources, G. P. Lamaze and J. A. Grundl, Natl. Bur. Stand. (U.S.), Spec. Publ. 250-13 (Mar. 1988).

NBS Measurement Services: Activation Foil Irradiations at NBS by Reactor Cavity Sources, G. P. Lamaze and J. A. Grundl, Natl. Bur. Stand. (U.S.), Spec. Publ. 250-14 (Mar. 1988).

Derivation of Neutron Exposure Parameters from Threshold Detector Measurements, J. A. Grundl, Proc. Sixth ASTM-Euratom Symp. on Reactor Dosimeter, Jackson, WY (June 1987).

Compendium of Benchmark Neutron Fields for Reactor Dosimetry, J. A. Grundl and C. M. Eisenhauer, Natl. Bur. Stand. (U.S.), NBSIR 85-3151 (Apr. 1985).

The U.S. <sup>235</sup>U Fission Spectrum Standard Neutron Field Revisited, E. D. McGarry, C. M. Eisenhauer, D. M. Gilliam, J. A. Grundl, G. P. Lamaze, and A. Fabry, Proc. Fifth ASTM-Euratom Symp. on Reactor Dosimetry, Geesthacht, Germany (Sept. 1984).

National Standards for Neutron Measurements, J. A. Grundl, Proc. of a Meeting on Traceability for Ionizing Radiation Measurements, Natl. Bur. Stand. (U.S.), NBS Spec. Publ. 609 (Feb. 1982).

Utilization of Standard and Reference Neutron Fields at NBS, C. M. Eisenhauer, D. M. Gilliam, J. A. Grundl, and V. Spiegel, Proc. Second ASTM-Euratom Symp. on Reactor Dosimetry, Palo Alto, CA (Oct. 1977).

A Californium-252 Fission Spectrum Irradiation Facility for Neutron Reaction Rate Measurements, J. A. Grundl, V. Spiegel, C. M. Eisenhauer, H. T. Heaton II, D. M. Gilliam (NBS), and J. Bigelow (ORNL), Nucl. Tech. 32, 315 (Mar. 1977).

# C. Dosimetry of X Rays, Gamma Rays, and Electrons

## Technical Contacts:



Christopher G. Soares  
Test 47030C-47036C, 47040S, 48010M-48020S  
Tel: 301/975-5589



Bert M. Coursey  
All Tests  
Tel: 301/975-5584



Paul G. Lamperti  
Tests 46010C-46050S  
Tel: 301/975-5591



Debra Bensen  
46010C  
Tel: 301/975-5556



James T. Weaver, Jr.  
Tests 47010C, 47011C, 47040S  
Tel: 301/975-5586

**Mailing Address:** C214 Radiation Physics, Center for Radiation Research, National Institute of Standards and Technology, Gaithersburg, MD 20899-0001

**Shipment of Instruments:** National Institute of Standards and Technology, I-270 at Quince Orchard Road, C214 Radiation Physics, Gaithersburg, MD 20899-0001

**For:** 46010C-46050S; **Attn:** P. J. Lamperti  
**For:** 48010M-48020S; **Attn:** C. G. Soares

**Shipment of Sources:** National Institute of Standards and Technology, I-270 at Quince Orchard Road, B131 Radiation Physics, Gaithersburg, MD 20899-0001

**For:** 47010C-47040S;  
**Attn:** Health Physics/J. T. Weaver  
(for Gamma-Ray Sources)  
**Attn:** Health Physics/C. G. Soares  
(for Beta-Particle Sources)

Test No.	Items
C.0	Special Instructions for Using Electron and Photon Dosimetry Calibration and Test Services (46010C-48020S)
C.1	X-Ray and Gamma-Ray Measuring Instruments
46010C	Radiation Detectors—Calibration/Correction Factor, One Beam Quality (See Table 13)
46011C	Each Additional Beam Quality or Condition
46020C	Passive Dosimeters—Irradiation of Up to Six, One Beam Quality at One Set-Up
46021C	Up to Six Additional Dosimeters at Same Set-Up and Beam Quality
46030S	Special Tests of High-Gain Electrometers—Charge Sensitivity, One Set of Switch Positions, with 46010C/46011C, by Prearrangement
46040S	Special Tests of X-Ray Penetrimeters, Ardran-Crookes Type
46050S	Special Tests of X-Ray and Gamma-Ray Measuring Instruments
C.2	Gamma-Ray Sources, Beta-Particle Sources, and Measuring Instruments
47010C	Gamma-Ray Sources Similar to NIST Standards— <sup>60</sup> Co or <sup>137</sup> Cs Having Air-Kerma Strengths 10 to 1500 $\mu\text{Gy m}^2/\text{h}$ , and <sup>125</sup> I or <sup>192</sup> Ir Sources: Same Type Seeds Used to Calibrate Reentrant Chamber Having Air-Kerma Strengths 0.1 to 30 $\mu\text{Gy m}^2/\text{h}$
47011C	Each Additional Gamma-Ray Source of Same Radionuclide
47030C	Beta-Particle Sources Calibrated for Surface Dose Rate
47035C	Beta-Particle Sources Calibrated for Radiation Protection
47036C	Ionization Chambers Calibrated with Beta-Particle Sources for Radiation Protection
47040S	Special Tests of Gamma-Ray and Beta-Particle Sources
C.3	Dosimetry of High-Energy Electron Beams
48010M	Dose Interpretation of NIST-Packaged Ferrous-Ferrie (Fricke) Dosimeters Irradiated by Customer—Three Dosimeters (Two for Irradiation, One Control)
48011M	Each Additional Dosimeter
48020S	Special Tests of Electron-Beam Dosimeters

### C.0 Special Instructions for Using Electron and Photon Dosimetry Calibration and Test Services (46010C-48020S)

The NIST dosimetry calibration and test services for x rays, gamma rays, beta particles, and electrons are performed in NIST's laboratories at Gaithersburg, Maryland. Inquiries

should be addressed to the appropriate technical contacts listed at the beginning of this section. The inquirer must provide the name and telephone number of an individual who can answer technical questions that may arise in any inquiry, order, or shipment.

Upon receipt of a purchase order, a report number is assigned. Calibrations are generally performed in the sequence established by those numbers, except when greater efficiency can be achieved by combining similar calibrations, or when work for a calibration laboratory is given a higher priority. Arrangements for calibration must be made in advance by letter or telephone, so that the instrument or source to be calibrated will not be shipped to NIST until the time of its scheduled calibration approaches. Inquiry should be made as to scheduling and turn-around time.

Except for negligence by its personnel, NIST assumes no responsibility for loss of or damage to the instruments or sources while in its possession. The risk should be covered by insurance.

The report of calibration or test will carry a DG number (e.g., DG 9876/89). Subsequent reference to that calibration or test should cite the DG number.

### **C.1 X-Ray and Gamma-Ray Measuring Instruments (46010C-46050S)**

X-ray measuring instruments are calibrated in terms of air kerma or exposure by a substitution method in an x-ray beam at a point where the rate has been determined by means of a standard free-air ionization chamber. In order to provide instrument calibrations over a wide range of x-ray beam qualities, many combinations of generating potential and filtration are available. These are listed in Table 13 as lightly (L), moderately (M), and heavily (H) filtered beams. Two beam qualities that do not fit into these categories are considered as special (S) qualities. Cobalt-60 and cesium-137 gamma-ray beams are also

available. The beam qualities are identified by beam codes given in the first column. The calibration beam qualities requested should be appropriate to the instrument submitted.

Gamma-ray measuring instruments are calibrated in terms of air kerma, exposure, or absorbed dose at points in the collimated cobalt-60 and cesium-137 gamma-ray beams that have been standardized by means of graphite cavity chambers or a graphite calorimeter. Rates at the time of calibration are computed from the original beam standardization data and appropriate decay corrections. Ionization chambers submitted for an air kerma or exposure calibration should have sufficient wall thickness to provide electron equilibrium for the gamma-ray energy selected. Ionization chambers submitted for an absorbed-dose calibration must be suitable for calibration in a phantom.

An ionization chamber and electrometer combination, with the electrometer marked in terms of air kerma, exposure, or absorbed dose, is calibrated by providing a dimensionless correction factor for the electrometer scale. An ionization chamber and electrometer combination marked in electrical units is calibrated as follows: (1) the chamber is calibrated in terms of air kerma, exposure, or absorbed dose per unit charge using a NIST electrometer; (2) the customer's electrometer is checked for linearity and charge measurement accuracy; and (3) the combination of chamber and electrometer is checked for consistency. An ionization chamber submitted without an electrometer is calibrated in terms of air kerma, exposure, or absorbed dose per unit charge. Calibration can be based on measurements for positive or negative polarizing potential, or on the mean of measurements for both potentials, as requested. The ratio of ionization currents for full and half polarizing potentials and the corresponding ionization current will be stated in the calibration certificate.



Table 13: X-Ray Beam-Quality Parameters

Beam Code	Added Filter				Half-Value Layer		Homogeneity Coefficient		Effective Energy (keV)	Exposure Min. ( $\mu\text{Gy/s}$ )	Rate Max. (mGy/s)
	Al (mm)	Cu (mm)	Sn (mm)	Pb (mm)	Al (mm)	Cu (mm)	Al (mm)	Cu (mm)			
L10	0.				0.029		79			0.009	15
L15	0.				0.050		74			0.009	37
L20	0.				0.071		76			0.009	29
L30	0.265				0.22		60			0.009	4
L40	0.50				0.49		57			0.009	4
L50	0.639				0.75		58			0.009	4
L80	1.284				1.83		58			0.009	4
L100	1.978				2.8		59			0.009	4
M20	0.230				0.152		79			0.009	4.4
M30	0.50				0.36		64			0.009	3
M40	0.786				0.73		66			0.009	4
M50	1.021				1.02	0.032	66	62		0.009	4
M60	1.51				1.68	0.052	68	64		7	2
M100	5.0				5.0	0.20	72	55		9	3
M150	5.0	0.25			10.2	0.67	87	62		9	4
M200	4.1	1.12			14.9	1.69	95	69		9	3
M250	5.0	3.2			18.5	3.2	98	86		9	2
M300	4.0		6.5		22.	5.3	100	97		4	0.7
H10	0.105				0.048		89			0.009	0.03
H15	0.500				0.152		87			0.009	0.03
H20	1.021				0.36		88			0.009	0.03
H30	4.13				1.23	0.038	93	94		0.009	0.03
H40	4.05	0.26			2.9	0.093	94	95		0.009	0.03
H50	4.0			0.10	4.2	0.142	92	90	38	3	0.6
H60	4.0	0.61			6.0	0.24	94	89	46	0.2	0.04
H100	4.0	5.2			13.5	1.14	100	94	80	0.04	0.02
H150	4.0	4.0	1.51		17.0	2.5	100	95	120	0.3	0.09
H200	4.0	0.60	4.16	0.77	19.8	4.1	100	99	166	0.2	0.05
H250	4.0	0.60	1.04	2.72	22	5.2	100	98	211	0.3	
H300	4.1		3.0	5.0	23	6.2	99	98	252	0.4	0.03
S75	1.504				1.86		63			0.009	4
S60	4.0				2.8	0.089	75	70		3	0.5
<sup>137</sup> Cs						10.8			662	13	0.9
<sup>60</sup> Co						14.9			1250	13	22

For the x-ray beam codes, the letter indicates light, moderate, heavy, and special filtration and the number is the constant potential in kilovolts.

The inherent filtration is approximately 1.0 mm Be for beam codes L10-L100, M20-M50, H10-H40, and S75; and 3.0 mm Be for beam codes M60-M300, H50-H300, and S60.

The half-value layers for <sup>137</sup>Cs and <sup>60</sup>Co are calculated.

The homogeneity coefficient is taken as  $100 \times (1\text{st HVL})/(2\text{nd HVL})$ .

The calibration distance is 25 cm for beam codes L10, L15, H10, and H15; 50 cm for beam codes L20-L100, M20-M50, H20-H40, and S75; and variable for the remaining beam codes.

To get exposure in R multiply air kerma in mGy by 8.76  
in mR  $\mu\text{Gy}$

Ionization chambers are tested, prior to calibration, for leakage, stabilization time, short-term stability, recombination loss, and connection to the atmosphere. Chambers found unsuitable for calibration will be returned with a statement of the reason for rejection. A charge may be made for time incurred on the tests.

Each instrument submitted to NIST for dosimetry calibration or test must be uniquely identified, usually by the manufacturer's name, model number, and instrument serial number. When the serial number is lacking, an alternative identifying mark should be provided. If none is found, NIST will mark the piece with an identification number. If the apparatus submitted has been calibrated previously by NIST, the serial number or identifying mark should be given on the new order so that a continuing record of stability can be maintained.

All shipments to NIST of instruments for dosimetry calibration must be in reusable containers. Even if properly packed, there can be no assurance that a calibrated instrument has maintained its calibration during shipment unless a method of verifying instrument stability has been established. Measurement should be made of the instrument response both before and after shipment, using a long-lived radioactive source and a highly reproducible measurement procedure. A long-term record of instrument stability using a suitable constancy check procedure is the most effective method for assuring the validity of the instrument calibration.

Irradiation of passive dosimeters, for readout by the customer, is available for most of the beam qualities listed in Table 13. These irradiations are generally in terms of air kerma or exposure; for passive dosimeters suitable for insertion in a phantom, irradiation in terms of absorbed dose can be provided by in-phantom irradiation using cobalt-60 gamma rays.

X-ray penetrameters, of the Ardran-Crookes type, can be calibrated using constant x-ray generating potentials up to 300 kV. These penetrameters are used for measurement of the generating potential of diagnostic x-ray units.



*Debbie Bensen sets up an ionization chamber for calibration. The calibrated chambers are used as standards for radiation exposure by medical industrial and research organizations.*

## **C.2 Gamma-Ray Sources, Beta-Particle Sources, and Measuring Instruments (47010C-47040S)**

Sources submitted to NIST for dosimetry calibration are subject to the following conditions:

A. Preparation: Sources submitted for calibration must be sealed so that there can be no escape of any radioactive material, including any gaseous decay products. The sources, shielding, and packaging must be free of contamination. Contaminated or leaking sources cannot be measured and may cause considerable loss of time and damage to laboratory facilities. Sources must have been sealed for a sufficient time to be substantially in radioactive equilibrium with their decay products when these contribute to the emitted radiation.

B. Packaging for shipment: Packages must be in compliance with the regulations of the Department of Transportation as specified in DOT 49CFR173.401-173.478. Radionuclides must be packaged as Limited Quantities (DOT 49CFR173.421) or in Type A packages (DOT 49CFR173.412 and 173.433). Type A packages must bear the appropriate radioactive-hazard labels (DOT 49CFR172.403). If the source is considered by the shipper to be in DOT Special Form, a Special Form certificate must be furnished to NIST in strict compliance with DOT 49CFR173.476. Copies of the codes are available from the Government Printing Office, Washington, DC 20402.

All shipments to NIST of gamma-ray and beta-particle sources should be in reusable containers. A drawing showing the source container and a description of the method of source removal should be provided before the shipment is received at NIST.

Postal regulations preclude shipment of dosimetry sources via the Postal Service.

If the nature of the shipment requires a Type B container subject to an NRC quality assurance program, documentation should be supplied to NIST certifying that the use of the container by NIST is part of the program of the shipper.

C. Possession of licensed materials: In submitting a source for calibration, it is necessary for the submitter to certify that he is duly authorized to possess the source under license by the applicable authority. In the case of individuals residing in a State that has entered into agreement with the Nuclear Regulatory Commission, State regulations are applicable to all sources. In the case of other individuals, NRC regulations are applicable. This certification may be by letter, by a suitable statement on the purchase order covering the calibration fee, or by a clear copy of the submitter's Possession License for the source.

Calibration in terms of air kerma strength (air kerma rate in free space times the square of the distance of the calibration point from the source center along the perpendicular bisector) is provided for gamma-ray sources of cobalt-60, cesium-137, iridium-192, and iodine-125.

Calibration in terms of absorbed-dose rate is provided for suitable encapsulated beta-particle sources; the dose rate to a low-atomic-number material (graphite or plastic) is determined by measurement with an extrapolation chamber. The beta-particle sources may be either small-area sources such as ophthalmic applicators, or large-area plaques, and will be calibrated for absorbed dose rate to water either at the source surface or at a specified distance.

Ionization chambers to be calibrated with beta-particle sources must be parallel-plate chambers with thin walls. They can be calibrated with the radionuclides  $^{90}\text{Sr} + ^{90}\text{Y}$ , or  $^{204}\text{Tl}$ , or  $^{147}\text{Pm}$ .

### C.3 Dosimetry of High-Energy Electron Beams (48010M-48020S)

Dosimeters are provided twice a year to users requesting assistance with absorbed-dose measurements in high-energy electron beams. The dosimeters consist of ferrous sulfate (Fricke) solution in radiation-resistant silica-glass spectrophotometer cells. The user irradiates all but one of the three furnished dosimeters to between 50 and 80 Gy (5000 and 8000 rad) to water at electron energies between 5 and 50 MeV, employing the irradiation geometry (field size, phantom, position of dosimeter in phantom) given in the "Protocol for Dosimetry of High-Energy Electrons," *Physics in Medicine and Biology* 11, 505 (1966).

After irradiation, the dosimeters are returned to NIST for spectrophotometric evaluation of the ferric-ion concentration in terms of absorbed dose in the phantom, using the  $\epsilon_G$  product given in "Radiation Dosimetry: Electron Beams with Energies between 1 and 50 MeV," ICRU Report 35 (1984).

#### References—Dosimetry of X Rays, Gamma Rays, and Electrons

##### C.1 X-Ray and Gamma-Ray Measuring Instruments

NBS Measurement Services: Calibration of X-Ray and Gamma-Ray Measuring Instruments, P. J. Lamperti, T. P. Loftus, and R. Loevinger, *Natl. Bur. Stand. (U.S.)*, Spec. Publ. 250-16 (Mar. 1988).

The Photon-Fluence Scaling Theorem for Compton-Scattered Radiation, J. S. Pruitt and R. Loevinger, *Med. Phys.*, 9, 176 (1982).

The Graphite Calorimeter as a Standard of Absorbed Dose for Cobalt-60 Gamma Radiation, J. S. Pruitt, S. R. Domen, and R. Loevinger, *J. Res. Natl. Bur. Stand. (U.S.)*, 86, 495 (1981).

Uncertainty in the Delivery of Absorbed Dose, R. Loevinger and T. P. Loftus, *Ionizing Radiation Metrology, International Course at Varenna, Italy, 1974*, E. Casnati, Ed., G-6, 459, Editrice Compositori, Bologna (1977).

Medical Dosimetry Standards Program of the National Bureau of Standards, R. Loevinger, *Proc. Symp. on Natl. and Intl. Standardization in Rad. Dosimetry*, Atlanta, GA, Dec. 5-9, 1977, Intl. Atomic Energy Agency, Vienna (1978).

(This article provides references for earlier publications on NBS exposure and absorbed-dose standards.)

Exposure Spectra from the NBS Vertical-Beam  $^{60}\text{Co}$  Gamma-Ray Source, M. Ehrlich and C. G. Soares, *Natl. Bur. Stand. (U.S.)*, NBSIR 76-1117 (1976).

Spectrometry of a  $^{60}\text{Co}$  Gamma-Ray Beam Used for Instrument Calibration, M. Ehrlich, S. M. Seltzer, M. J. Bielefeld, and J. I. Trombka, *Metrologia*, 12, 169 (1976).

##### C.2 Gamma-Ray Sources, Beta-Particle Sources, and Measuring Instruments

NBS Measurement Services: Calibration of Gamma-Ray-Emitting Brachytherapy Sources, J. T. Weaver, T. P. Loftus, and R. Loevinger, *Natl. Bur. Stand. (U.S.)*, Spec. Publ. 250-19 (1988).

NBS Measurement Services: Calibration of Beta-Particle Radiation Instrumentation and Sources, J. S. Pruitt, C. G. Soares, and M. Ehrlich, *Natl. Bur. Stand. (U.S.)*, Spec. Publ. 250-21 (Apr. 1988).

NBS Measurement Services: Calibration of Beta-Particle-Emitting Ophthalmic Applicators, J. S. Pruitt, *Natl. Bur. Stand. (U.S.)*, Spec. Publ. 250-9 (July 1987).

Calibration of Beta-Particle Ophthalmic Applicators at the National Bureau of Standards, J. S. Pruitt, *J. Res. Natl. Bur. Stand. (U.S.)*, 91, 165 (1986).

The Effect of Altitude on Beta-Ray Source Calibrations, J. S. Pruitt, *Rad. Protec. Dosim.* 11, 151 (1984).

Exposure Standardization of Iodine-125 Seeds Used for Brachytherapy, T. P. Loftus, *J. Res. Natl. Bur. Stand. (U.S.)*, 89, 295 (1984).

Standardization of Iridium-192 Gamma-Ray Sources in Terms of Exposure, T. P. Loftus, *J. Res. Natl. Bur. Stand. (U.S.)*, 85, 19 (1980).

Medical Dosimetry Standards Program of the National Bureau of Standards, R. Loevinger, *Proc. Symp. on Natl. and Intl. Standardization in Rad. Dosimetry*, Atlanta, GA, Dec. 5-9, 1977, Intl. Atomic Energy Agency, Vienna (1978). (This article provides references for earlier publications on NBS exposure and absorbed-dose standards.)

Standardization of Cesium-137 Gamma-Ray Sources in Terms of Exposure Units (Roentgens), T. P. Loftus, *J. Res. Natl. Bur. Stand. (U.S.)*, 74A, 1 (1970).

### *C.3 Dosimetry of High-Energy Electron Beams*

NBS Measurement Services: Fricke Dosimetry in High-Energy Electron Beams, C. G. Soares, E. L. Bright, and M. Ehrlich, *Natl. Bur. Stand. (U.S.)*, Spec. Publ. 250-4 (1987).

Uniformity of High-Energy Electron-Beam Calibrations, M. Ehrlich and P. J. Lamperti, *Phys. Med. Biol.* 14, 305 (1969).

Proposed National Bureau of Standards Program for the Calibration of Instruments Used in High-Energy Electron and X-Ray Beams, M. Ehrlich, *Ann. N.Y. Acad. Sci.* 161, 139 (1969).

## D. Dosimetry for High-Dose Applications

### Technical Contacts:



Jimmy C.  
Humphreys  
Tel: 301/975-5582



William L.  
McLaughlin  
Tel: 301/975-5559



James M.  
Puhl  
Tel: 301/975-5581

**Mailing Address:** C214 Radiation Physics, National Institute of Standards and Technology, Gaithersburg, MD 20899-0001

Test No.	Items
49010C	Calibration Irradiations of Customer-Supplied Dosimeters with $^{60}\text{Co}$ Gamma Rays
49020C	Dose Interpretation of NIST Transfer Dosimeters Irradiated by Customer
49030C	Dose Interpretation of Each NIST Transfer Dosimeter in Addition to Those Supplied under 49020C
49040S	Special Tests of Dosimeters by Reading with Spectrophotometer, Optical Density at One to Five Wavelengths (Each Dosimeter)
49041S	Spectrophotometric Readings of Dosimeters, Ultra-Violet and Visible Spectrum Scan (Each Dosimeter)
49050S	Special Measurement Services for Dosimeter Response and Dose Distributions

### Calibration Services and Special Tests of Dosimeters (49010C-49050S)

The following dosimetry services are for individual users of intense radiation fields, in particular large gamma-ray sources and electron accelerators up to approximately 10 MeV. These services include the administering of known absorbed doses of photons to customer-supplied dosimeters; supplying calibrated transfer standard dosimeters to customers for irradiation and subsequent readout and dose interpretation; and special measurement services such as

the determination of temperature dependence, dose-rate dependency or reproducibility of dosimeter response.

### Calibration of Dosimeters Irradiated with $^{60}\text{Co}$ Gamma Rays (49010C)

Calibration irradiations are available for customer-supplied dosimeters (such as solid radiochromic or liquid chemical types) or test samples that are sent to NIST, where they are packaged appropriately to provide electron equilibrium conditions. They are irradiated in the NIST standard cobalt-60 calibration facility to specific agreed-upon absorbed dose values in the nominal "high-dose" range of  $10-10^6$  grays ( $10^3-10^8$  rads). The dosimeters are then sent back to the customer for analysis and evaluation. Dosimeters should not exceed dimensions of  $1\text{ cm} \times 2\text{ cm} \times 5\text{ cm}$ . A detailed list of the various sources of uncertainty and estimates of the magnitude of those uncertainties that make up the overall uncertainty for these services may be obtained by requesting such information from NIST. The uncertainties are divided into two types: random and non-random. Typical values for these uncertainties for irradiations with the standard water-shielded source are:

**Random Uncertainties:** The total random uncertainty associated with these irradiations has been determined by statistical methods to be  $\pm 0.7$  percent at a 95 percent confidence level.

**Non-random Uncertainties:** These are estimates that include all uncertainties not derived by the statistical methods above. The total estimated non-random uncertainty is  $\pm 2.1$  percent at a 95 percent confidence level.

**Overall Uncertainty:** The random and non-random uncertainties have been combined in quadrature (that is, the square root of the sum of the squares) to yield an overall uncertainty of  $\pm 2.2$  percent at a 95 percent confidence level.

### **Transfer Reference Standard Dosimeters (49020C and 49030C)**

NIST provides transfer standards in the form of sets of calibrated radiochromic dosimeters packaged in appropriate equilibrium materials such as polystyrene or aluminum. The sealed, packaged dosimeters are sent to the customer for irradiation to nominal agreed-upon absorbed dose levels in a prescribed geometrical arrangement. The unopened packaged dosimeters are then returned to NIST to be read and evaluated and the results reported, thus providing calibration of the customer irradiator. The absorbed dose range that is suitable for use with the transfer dosimeters is 1 to 50 kGy (0.1 to 5 Mrad) in water, silicon, aluminum, graphite, or certain plastics. The absorbed dose rate should be greater than 30 Gy/min.

### **Special Tests of Dosimeters: Spectrophotometric Reading (49040S-49041S)**

Dosimeters may be read at several specific ultraviolet or visible optical wavelengths or as a spectral scan over an appropriate wavelength region of interest.

### **Special Measurement Services for Dosimeter Response and Dose Distributions (49050S)**

Tests of dosimeter response, such as temperature dependence, dose rate dependence, and dose distributions in specific irradiation geometries, can be provided as special measurement services. These dose distribution measurements can include dose profiles in heterogenous absorbers and at interfaces of different materials.

### **References — High-Dose Dosimetry**

- NBS Measurement Services: Dosimetry for High-Dose Applications, J. C. Humphreys, D. Hocken, and W. L. McLaughlin, Natl. Bur. Stand. (U.S.), Spec. Publ. 250-11 (Mar. 1988).
- Dosimetry for Industrial Radiation Processing, W. L. McLaughlin, J. C. Humphreys, and A. Miller, Natl. Bur. Stand. (U.S.), Spec. Publ. 609 (1982).
- A National Standardization Programme for High-Dose Measurements, W. L. McLaughlin, Technical Report No. 205, 17, Intl. Atomic Energy Agency, Vienna (1981).
- Dye Film Dosimetry for Radiation Processing, J. C. Humphreys and W. L. McLaughlin, IEEE Trans. Nucl. Sci., NS-28, 2, 1797 (Apr. 1981).
- The Measurement of Absorbed Dose and Dose Gradients, W. L. McLaughlin, Radiat. Phys. Chem., 15, 9 (1980).
- Dosimetry Standards for Industrial Radiation Processing, W. L. McLaughlin, National and International Standardization of Radiation Dosimetry, 1, Intl. Atomic Energy Agency, Vienna (1978).

---

# Chapter

# 9

- A** Resistance Measurements
- B** Impedance Measurements
- C** Voltage Measurements
- D** Precision Ratio Measurements
- E** Phase Measurements and  
Air Navigation Aids
- F** Power and Energy Measurements,  
Low-Frequency
- G** Microwave Measurements
- H** Noise Temperature Measurements
- I** Electromagnetic Field Strength and  
Antenna Measurements
- J** Pulse Waveform Measurements



## A. Resistance Measurements A.1 DC Resistance Standards and Measurements

### Technical Contacts:



Ronald F. Dziuba  
Tel: 301/975-4239



Norman B. Belecki  
Tel: 301/975-4223



Denise D. Prather  
Administrative and Logistics  
Tel: 301/975-4221

**Mailing Address:** B146 Metrology, National Institute of Standards and Technology, Gaithersburg, MD 20899-0001

Test No.	Items
51100S	Special Resistance Measurement Services, by Prearrangement
51110M	Measurement Assurance Program Services for Resistance
51130C	Standard Resistor, Thomas-Type, 1 $\Omega$
51131C	Standard Resistor, Evanohm Wirewound High Precision, 10 k $\Omega$
51132C	Standard Resistor, Four-Terminal, 0.0001 $\Omega$
51133C	Standard Resistor, Four-Terminal, 0.001 $\Omega$
51134C	Standard Resistor, Four-Terminal, 0.01 $\Omega$
51135C	Standard Resistor, Four-Terminal, 0.1 $\Omega$
51136C	Standard Resistor, Four-Terminal, 1 $\Omega$
51137C	Standard Resistor, Four-Terminal, 10 $\Omega$
51138C	Standard Resistor, Four-Terminal, 100 $\Omega$
51139C	Standard Resistor, 1 k $\Omega$
51140C	Standard Resistor, 10 k $\Omega$
51141C	Standard Resistor, 100 k $\Omega$
51142C	Standard Resistor, 1 M $\Omega$
51143C	Standard Resistor, 10 M $\Omega$
51144C	Additional Voltage
51145C	Standard Resistor, 100 M $\Omega$

Test No.	Items
51146C	Additional Voltage
51147C	Standard Resistor, 1 G $\Omega$
51148C	Additional Voltage
51149C	Standard Resistor, 10 G $\Omega$
51150C	Additional Voltage
51151C	Standard Resistor, 100 G $\Omega$
51152C	Additional Voltage
51153C	Standard Resistor, 1 T $\Omega$
51154C	Additional Voltage
51160C	Standard Resistor for Current Measurements (Shunts), One Range, One Current Not to Exceed 300 A
51161C	Standard Resistor for Current Measurements (Shunts), One Range, One Current between 300 A and 1000 A
51162C	Standard Resistor for Current Measurements (Shunts), Additional Range of a Multi-Range Resistor
51163C	Standard Resistor for Current Measurements (Shunts), Additional Determination at Another Current Level

### Special DC Resistance Measurements, by Prearrangement (51100S)

Testing or evaluation of prototype resistance standards or measuring instruments; unique resistance measurements; and other calibration services not specified below, such as the determination of the pressure coefficient of Thomas-type resistors, the determination of the temperature coefficient of standard resistors, and the calibration of resistance standards in oil at temperatures other than 25 °C, are carried out under this test number. Such measurements are made at the discretion of the NIST technical staff in a manner specifically agreed upon by the customer and the expert involved. Testing of component resistors will only be considered under the rare circumstance that the behavior of the resistors has been observed to approximate that of state-of-the-art standards under the same conditions.

### Measurement Assurance Program Services for Resistance (51110M)

Resistance MAP transfers are generally carried out at the 1-ohm and 10-kilohm levels. Four well-characterized commercial standard resistors are used as transport standards at each level. The suggested measurement schedule at the client laboratory consists of measurements on each transport resistor three times a week for a period of 4 to 6 weeks, depending upon the settling time of the resistors due to transportation effects.

Participation in this program is generally not advisable unless one is required to support resistance measurements at or near state-of-the-art accuracies and is willing to adopt a system for the continuous surveillance of standards during the intervals between NIST MAP transfers. A successful transfer requires a considerable amount of data collection and a willingness to become involved in the data analysis process. Data supplied in the course of routine NIST calibrations suffice for normal measurement requirements of standards laboratories if proper methods are used by the laboratory to quantify

the additional uncertainties caused by transportation and the laboratory's own measurement process.

### Special Standard Resistors 1 Ω and 10 kΩ (51130C and 51131C)

Thomas-type 1 ohm resistors or their equivalent are calibrated directly against the NIST 1 ohm reference group that is used to maintain the U.S. legal ohm. Special 10-kilohm standard resistors designed for air or oil use are calibrated directly against the NIST 10-kilohm working standards. The special 10-kilohm standard resistors (Evanohm wirewound high-precision or equivalent) are characterized by resistance corrections within 10 ppm of nominal value, temperature coefficients of  $0 \pm 1$  ppm/°C at the operating temperature, and drift rates of  $\leq 1$  ppm/year.

The customer resistors are acclimatized in their respective test environments for approximately 1 week prior to their calibration. Measurement parameters of temperature and current level are as follows:

Resistor	Medium	Temperature (°C)	Current
1 Ω	oil	25.00 ± 0.003	100 mA
10 kΩ	oil	25.00 ± 0.01	1 mA
10 kΩ	air	23.0 ± 1.0	1 mA

The temperature of the customer resistor at the time of the measurement is given in the report of calibration. Since the Thomas-type resistor exhibits a significant pressure coefficient, the barometric pressure at the time of the measurement is also reported. Uncertainties are based upon (1) the random behavior of the measurement process as characterized by data from a large population of individual calibrations, and (2) an estimate of the systematic errors arising from such sources as temperature inaccuracies, pressure inaccuracies, scaling errors, etc. Uncertainties are listed in Table 14 on the next page.

### Standard Resistors $10^{-4}$ – $10^6$ Ω (51132C–51142C)

Standard resistors with nominal decade values in the range between

$10^{-4}$  and  $10^6$  ohm are calibrated by comparison with NIST working standards of equivalent value. In general, these standards are characterized by (1) resistance corrections within 500 ppm of nominal value, (2) temperature coefficients of  $\leq 10$  ppm/ $^{\circ}\text{C}$  at the temperature of use, and (3) drift rates of  $\leq 5$  ppm/year. Normally, standard resistors are measured in an oil bath maintained at  $25.0 \pm 0.05$   $^{\circ}\text{C}$ , and at a power level of  $\leq 0.1$  W. Resistors in temperature-controlled enclosures with fixed terminations are also accepted for calibration. At the levels of accuracy involved, four-terminal measurements are required for resistors whose nominal values are 100 ohms or less. Uncertainties are based upon (1) the random behavior of the measurement process as characterized by data from a large population of individual calibrations, and (2) an estimate of the systematic errors. Uncertainties are given in Table 14.

**Table 14: Calibration Uncertainties for DC Resistance Standards**

Test Number	Nominal Resistance (ohms)	Terminal Connection	Maximum Power (mw)	Uncertainty (ppm)
51130C	1 (Thomas)	4	10	0.08
51131C	$10^4$ (Special)	5	10	2
51132C	$10^{-4}$	4	100	17
51133C	$10^{-3}$	4	100	7
51134C	$10^{-2}$	4	100	4
51135C	$10^{-1}$	4	100	3
51136C	1	4	50	2
51137C	10	4	50	2
51138C	$10^2$	2	10	1
51139C	$10^3$	2	10	1
51140C	$10^4$	2	10	1
51141C	$10^5$	2	10	3
51142C	$10^6$	2	10	5
51143C	$10^7$	3	*	20-1000
51145C	$10^8$	3	*	50-1000
51147C	$10^9$	3	*	20-1000
51149C	$10^{10}$	3	*	1000
51151C	$10^{11}$	3	*	1000
51153C	$10^{12}$	3	*	2000

\* Resistors at this level are tested at customer-specified voltages up to 1 kV.

#### High-Valued Standard Resistors: $10^7$ - $10^{12}$ $\Omega$ (51143C-51154C)

High-value standard resistors in the range between  $10^7$  and  $10^{12}$  ohms are calibrated in an air bath maintained at a temperature of  $23.0 \pm 0.5$   $^{\circ}\text{C}$  and at a relative humidity of  $35 \pm 5$  percent. Customer resistors are compared 1:1 with NIST working standards of the same nominal value up to and including the  $10^{10}$  ohms level. Above  $10^{10}$  ohms, 10:1 and 100:1 ratio techniques are employed. The maximum test voltage is 500 volts for resistors  $< 10^{10}$  ohms and 1000 volts for resistors  $\geq 10^{10}$  ohms. Uncertainties depend upon the stability and performance of the specific resistor involved and are given in Table 14. Only resistors that are mounted in a shielded enclosure with a permanent identifying number and have suitable terminations are accepted for calibration.

The resistance of thin-film, high-valued resistance standards is frequently highly voltage dependent. Hence, the magnitude of the test voltage should be specified by the customer when a resistor is submitted for calibration. The temperature, relative humidity, and test voltage of the resistor are given in the report of calibration.

#### High-Current Standard Resistors — Shunts (51160C-51163C)

Four-terminal standard resistors for use in the precise measurement of high direct currents (shunts) are calibrated by NIST only during May and November of the calendar year. Arrangements should be made with NIST prior to submitting a resistor for calibration. Normally only resistors of 0.04 percent accuracy or better are calibrated. The maximum test current available is 1000 amperes. The uncertainty of measurement depends largely upon the performance of the customer resistor involved.

NEW OHM VALUE  
NOW  
DETERMINED BY

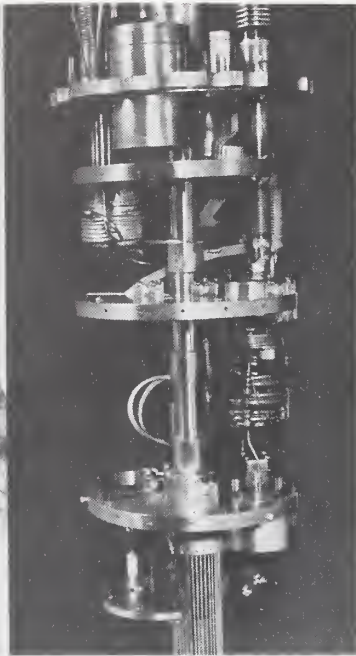

## QUANTUM HALL EFFECT

*The U.S. National Ohm, on which NIST services for d-c resistance are directly based, is now implemented in the form of a quantum Hall effect system.*

### References – DC Resistance

Guidelines for Implementing the New Representation of the Volt and Ohm Effective January 1, 1990, N. B. Belecki, R. F. Dziuba, B. F. Field, and B. N. Taylor, Natl. Inst. Stand. Technol. Tech. Note 1263 (June 1989).

New Realization of the Ohm and Farad Using the NBS Calculable Capacitor, J. Q. Shields, R. F. Dziuba, and H. P. Layer, Conf. Precision Electromagnetic Meas. (CPEM '88), June 7-10, 1988, Tsukuba Science City, Japan, Special Issue CPEM '88 IEEE Trans. Instrum. Meas., Vol. 38, No. 2, 249-251 (April 1989).

Determination of the Time-Dependence of  $\Omega_{\text{NBS}}$  Using the Quantized Hall Resistance, M. E. Cage, R. F. Dziuba, C. T. Van Degrift, and D. Yu Conf. Precision Electromagnetic

Meas. (CPEM '88), June 7-10, 1988, Tsukuba Science City, Japan, Special Issue CPEM '88 IEEE Trans. Instrum. Meas., Vol. 38, No. 2, 263-269 (April 1989).

Monitoring the U.S. Legal Unit of Resistance via the Quantum Hall Effect, M. E. Cage, R. F. Dziuba, B. F. Field, T. E. Kiess, and C. T. Van Degrift, IEEE Trans. Instrum. Meas., IM-36, 222 (June 1987).

The NBS Ohm Past-Present-Future, R. F. Dziuba, Proc. Meas. Science Conf., Irvine, CA (Jan. 1987).

A Test of the Quantum Hall Effect as a Resistance Standard, M. E. Cage, R. F. Dziuba, and B. F. Field, IEEE Trans. Instrum. Meas., IM-34, 301 (1985).

Automated NBS 1-Ohm Measurement System, K. R. Baker and R. F. Dziuba, IEEE Trans. Instrum. Meas., IM-32, 154 (1982).

An Integrated System for the Precision Calibration of Four-Terminal Standard Resistors, T. E. Wells and E. F. Gard, IEEE Trans. Instrum. Meas., IM-20, 253 (Nov. 1971).

Calibration Procedures for Direct Current Apparatus, P. Brooks, Natl. Bur. Stand. (U.S.), Monogr. 39 (Mar. 1962).

Measurement of Multimegohm Resistors, A. H. Scott, J. Res. Natl. Bur. Stand. (U.S.), 50, No. 3 (Mar. 1953).

Precision Resistors and Their Measurement, J. L. Thomas, Natl. Bur. Stand. (U.S.), Circular 470 (Oct. 1948).

Methods, Apparatus, and Procedures for the Comparison of Precision Standard Resistors, F. Wenner, J. Res. Natl. Bur. Stand. (U.S.), 25, Res. Paper RP1323 (Aug. 1940).

## A. Resistance Measurements

### A.2 High-Voltage Standard Resistors

#### Technical Contacts:



**Martin Misakian**  
Tel: 301/975-2426



**William E. Anderson**  
Tel: 301/975-2423

**Mailing Address:** B344 Metrology, National Institute of Standards and Technology, Gaithersburg, MD 20899-0001

**Shipping Address:** National Institute of Standards and Technology, I-270 at Quince Orchard Road, Gaithersburg, MD 20899-0001

[Attn: M. Misakian, Bldg. 220, Room B351]

---

#### Test No. Items

---

51210C High-Voltage Standard Resistors

---

#### High-Voltage Standard Resistors (51210C)

A routine calibration service is maintained for resistors designed for dc high-voltage applications. This service is for nearly corona-free resistors designed for dc operation between 10 kV and 150 kV.

Resistors can be hand-carried or shipped to NIST. If they are shipped, they should be packaged in sturdy reusable containers. The design of many high-voltage resistors makes them vulnerable to shear-type forces, so provisions should be made to minimize the likelihood of damage due to such forces when the device is in the shipping container.

#### References – High-Voltage Standard Resistors

High-Voltage Divider and Resistor Calibrations, M. Misakian, Natl. Bur. Stand. (U.S.), Tech. Note 1215 (July 1985).

Special Shielded Resistor for High-Voltage Measurements, J. H. Park, J. Res. Natl. Bur. Stand., 66C, No. 1, 1924 (Jan.-Mar. 1962).

# A. Resistance Measurements

## A.3 High-Frequency Standard Resistors

### Technical Contacts:



**George M. Free**  
Tel: 303/497-3609



**Kathy Hillen**  
Administrative  
and Logistics  
Tel: 303/497-3753

**Mailing Address:** M.C. 813.10, National Institute of Standards and Technology, 325 Broadway, Boulder, CO 80303-3328

---

### Test No. Items

---

51310S High-Frequency Standard Resistors; Two-Terminal

---

#### High-Frequency Standard Resistors (51310S)

The overall frequency range covered is 10 kHz to 250 MHz. The range of resistance that can be calibrated depends upon the measurement frequency, as follows:

Frequency Range	Resistance Range
10 kHz–2 MHz	0.1 $\Omega$ to 10 k $\Omega$
2 MHz–10 MHz	50 $\Omega$ to 10 k $\Omega$
10 MHz–100 MHz	20 $\Omega$ to 10 k $\Omega$
100 MHz–250 MHz	20 $\Omega$ to 10 k $\Omega$

Measurement uncertainties are given in the reference; the minimum uncertainty provided is  $\pm 0.1$  percent.

Reports of Calibration or Tests for resistors will include the inductance or capacitance associated with the resistor. Equivalent series values are normally given for inductive resistors and equivalent parallel values for capacitive resistors.

#### References – High-Frequency Standard Resistors

The Measurement of Lumped Parameter Impedance: A Metrology Guide, R. N. Jones, Natl. Bur. Stand. (U.S.), Monogr. 141 (June 1974).

Impedance of Lumped Circuits, L. E. Huntley and R. N. Jones, Proc. IEEE, 55(6), 900 (June 1967).

## A. Resistance Measurements

### A.4 AC Resistors

#### Technical Contacts:



**T. Michael  
Souders**  
Tel: 301/975-2406



**Barry A. Bell**  
Tel: 301/975-2419

**Mailing Address:** B162 Metrology, National Institute of Standards and Technology, Gaithersburg, MD 20899-0001

---

#### Test No. Items

---

51410S Special Tests of AC Resistors, by Prearrangement

---

#### Special Tests of AC Resistors (51410S)

Properly designed four-terminal ac resistors in the range of 0.1 ohm to 0.001 ohm can be measured at current ratings not to exceed 50A. The values for the ac resistance and phase angle (or time constant) can be reported for frequencies between 50 Hz and 10 kHz. To be accepted for test, resistors must have phase angles no greater than 0.01 radian at all requested test frequencies.

This service is offered as a special-test service; fees will be based on actual costs. Prior arrangements are essential.

#### References—AC Resistors

An Audio Frequency Four-Terminal Resistance Bridge, T. M. Souders, IEEE Trans. Instrum. Meas., IM-23, No. 4, 342 (Dec. 1974).

## **B.** Impedance Measurements (Except Resistors)

### **B.1** Low-Frequency Capacitance and Inductance Measurements and Standards

#### Technical Contacts:



Y. May Chang  
Tel: 301/975-4237



Norman B. Belecki  
Tel: 301/975-4223



Denise D. Prather  
Administrative  
and Logistics  
Tel: 301/975-4221

**Mailing Address:** B146 Metrology, National Institute of Standards and Technology, Gaithersburg, MD 20899-0001

Test No.	Items
52110S	Special LF Impedance Measurements, by Prearrangement
52130C	Standard Fixed, Fused-Silica Dielectric Capacitor (10 and 100 pF at 100, 400, or 1000 Hz)
52131C	Additional Frequency Points
52140C	Fixed Three-Terminal, High-Precision Standard Capacitor with Coaxial Connectors (1 frequency high accuracy under controlled conditions, 100, 400, or 1000 Hz)
52141C	Additional Frequency Points
52150C	Physical Tests to Qualify Three-Terminal Air Capacitor for Measurement under 52140C
52160C	Fixed Three-Terminal Standard Capacitor with Coaxial Connectors (1 frequency, laboratory conditions, 100, 400, or 1000 Hz)
52161C	Additional Frequencies
52170C	Two- or Three-Terminal Solid Dielectric Standard Capacitor (66-2/3, 100, 400, 1000, or 10,000 Hz)
52171C	Additional Frequencies and/or steps (for decade capacitors)
52180C	Fixed Inductor, Self or Mutual (100, 400, 1000, or 10,000 Hz)
52181C	Additional Points

### Low-Frequency Capacitance and Inductance Measurements and Standards (52110S-52181C)

These services cover the calibration of standard capacitors and inductors in the audio-frequency range. Three-terminal standard capacitors having fused-silica (10 and 100 pF), and gas (0.001 to 1000  $\mu$ F), dielectrics can be measured at 100, 400, and 1000 Hz. Two-terminal capacitors with either air, mica, or polystyrene dielectrics can be measured at 100, 400, 1000, and 10,000 Hz. Capacitors in the range from 1 microfarad to 100 microfarad, including decade (plug or rotary switch types—noninductive), can be calibrated at 66-2/3, 100, 120, 400, or 1000 Hz. Air-core standard inductors having nominal values between 0.01 mH and 10 H can be measured over the same frequency range. Standard inductors of 100 mH or less can also be measured at 10 kHz.

Calibration services for some types of capacitance standards at frequencies as low as 1 kHz can be provided by the NIST Boulder Laboratory provided the accuracy requirement does not exceed  $\pm 0.01$  percent. In some circumstances this can eliminate the necessity of sending a standard to both Gaithersburg and Boulder Laboratories for a complete calibration. See also tests 52210C-52310C for calibration services for capacitors at higher frequencies. For additional details please inquire at NIST/Boulder: Telephone (303) 497-3609.

### Special LF Impedance Measurements, by Prearrangement (52110S)

This service provides for the testing or evaluation of prototype impedance standards or measurement instrumentation at the state-of-the-art, and other impedance measurements (such as the calibration of decade or variable capacitance standards), at the discretion of NIST technical experts. Component capacitors, inductors, and



resistors are not considered for test by NIST unless their performance approximates that of the best available standards. Even under those conditions, only limited testing will be done to ascertain the possible use of the components in precision measurement applications.

**Standard Fixed, Fused-Silica Dielectric Capacitors (52130C-52131C)**

Fused-silica dielectric standard capacitors are generally submitted in temperature-controlled ovens due to their 10-ppm/degree temperature coefficient. Because of the magnitude of the temperature coefficient, it is recommended that a reliable temperature sensor having a resolution of 0.001 °C, or better be permanently mounted in the oven and thus included for the calibration. For baths not so equipped, the temperature is measured in terms of the International Temperature Scale of 1990 (ITS-90), using a standard platinum resistance thermometer.

Calibrations are carried out at 100, 400, or 1000 Hz, or any combination of these chosen by the client. A minimum of eight measurements are made over a 2-week or longer period, comparing the test capacitor directly with a NIST fused-silica standard at 10 pF. The number of readings taken depends on the stability of the temperature controller in the oven containing the test capacitors and can be as high as 14. The averages of the measured values of capacitance and temperature are reported. The uncertainty of the reported capacitance value depends on the stability of the temperature as well as on the performance of the capacitance standard itself. Because the temperature coefficients of individual standards are not known quantitatively, the results are not temperature corrected. Despite these factors, the uncertainty can be as low as 0.1 ppm.

Fused-silica dielectric standards not submitted in their own temperature-controlled oven are calibrated in

stirred oil at a temperature of 25 °C. If they are supplied with built-in sensors, the sensors and the bath temperature are both measured.

**Standard Capacitors (52140C-52171C)**

The following guidelines apply to the calibration of standard capacitors at NIST.

Calibrations are ordinarily performed at a normal laboratory ambient temperature of  $23 \pm 1$  °C except for high-stability gas dielectric capacitors. These are placed in a highly insulated chamber for 48 hours to achieve temperature stability during calibration. The calibration temperature of about 23 °C is reported to within  $\pm 0.1$  °C. Relative humidity is maintained at 50 percent or less in all cases.

Precision three-terminal gas dielectric capacitors, such as ESI Model SC1000 and GENRAD Model 1404, have been found to be variously affected by mechanical shock and orientation. Accordingly, two types of calibrations are offered. The higher accuracy calibration (52140C) requires a qualification test (52150C) to determine the effect on capacitance of various impacts and changes in orientation. Results of this test are coupled with the random error of the precision calibration which follows to provide a more complete uncertainty for the calibration process. For the lower accuracy test (52160C), a similar calibration, albeit with reduced resolution, is performed, but no physical testing is performed. The assigned uncertainty is fixed and has been deduced from an analysis of data taken from tests on a large population of standard capacitors.

The frequencies available for capacitance calibrations depend upon the type of capacitor and its connectors. In general, capacitors with coaxial connectors (Type 900) can be calibrated at 100, 400, and 1000 Hz. Capacitors with binding posts or PL 274 pins can be calibrated at 66-2/3, 100, 400, 1000, and 10,000 Hz.

The capacitance value given is the equivalent parallel capacitance. In general, an accurate determination of the equivalent parallel conductance with high accuracy is not feasible. However, for solid dielectric capacitors an approximate value is given without charge.

The uncertainty stated in the report of calibration is determined in part by the accuracy of NIST's measurements and in part by the characteristics of the capacitor itself. The uncertainty is sufficiently broad to allow for variations in the stray capacitance at the connectors, variations in temperature of a few degrees Celsius, considerable variation in relative humidity and atmospheric pressure, and frequency deviations of a few percent from the stated test conditions. Over the above frequency range, and in the capacitance range from 0.001 to 100  $\mu\text{F}$ , the uncertainty usually lies in the range 0.0003 to 0.5 percent. The uncertainties do not include allowances for effects of transportation; these must be determined by the owner using pre- and post-calibration data from his own facility.

Capacitors requiring terminal plugs (banana plugs) for parallel connection should be sent to NIST, together with the plugs that will be used with the capacitor after calibration. If such a capacitor arrives without plugs, NIST must attach plugs temporarily in order to calibrate the capacitor. The plugs used by NIST are GENRAD Type 274-P. If, after calibration with these plugs, the capacitor is used with plugs of even slightly different length and base, the capacitance can differ significantly from that reported. Unless otherwise requested, the measured value reported by NIST is the capacitance added when the standard is plugged directly into the binding posts of the NIST bridge. For two-terminal GENRAD capacitors Type 1401, Type 509, and Type 1409 (when used as a two-terminal capacitor), a capacitance increase ranging from 0.01 to 0.04 pF has been found for different plugs. No significant

change in conductance has been found in either the two-terminal or three-terminal value. The importance of terminal connection methods becomes extremely critical when capacitance values of 0.01  $\mu\text{F}$  or less are being measured. Improved accuracy in two-terminal measurement can be realized if standards are provided with precision coaxial connectors.

In the case of direct or three-terminal capacitance standards, the connectors are assumed to be coaxial. While the connectors available for this purpose are adequate, it should be noted that changes or instabilities in the impedance of the shield or guard connection of a three-terminal capacitor can change the capacitance significantly.

Unless otherwise specified in the customer's purchase order, capacitors with solid dielectric—except for fused-silica capacitors—will be calibrated as two-terminal capacitors (measurement of “grounded” capacitance, case connected to low terminal).

#### **Standard Inductors, Self or Mutual (52180C-52181C)**

Standard inductors for use in ac bridges are tested at a room temperature of 23 °C and a relative humidity of 50 percent or less. Measurements at 10,000 Hz are limited to standard inductors of 0.1 H or less. Most inductors used at 60 Hz can be tested at 100 Hz since the variation of inductance with frequency in this range is usually negligible. A metal-encased standard is calibrated with the case connected to the “low” terminal of the inductor unless other conditions are specified.

**References—Low-Frequency Capacitance and Inductance Standards**

New Realization of the Ohm and Farad Using the NBS Calculable Capacitor, J. Q. Shields, R. F. Dziuba, and H. P. Layer, Conf. Precision Electromagnetic Meas. (CPEM '88), June 7-10, 1988, Tsukuba Science City, Japan, Special Issue CPEM '88 IEEE Trans. Instrum. Meas., Vol. 38, No. 2, 249-251 (April 1989).

Testing to Quantify the Effects of Handling of Gas Dielectric Standard Capacitors, C. R. Levy, Natl. Bur. Stand. (U.S.), Tech. Note 1161 (1982).

Transportable 1000 pF Standard, G. M. Free and J. J. Morrow, Natl. Bur. Stand. (U.S.), Tech. Note 1162 (1982).

New Measurements of the Absolute Farad and Ohm, R. D. Cutkosky, IEEE Trans. Instrum. Meas., IM-23, No. 4, 305 (Dec. 1974).

Applications of Coaxial Chokes to AC Bridge Circuits, D. N. Homan, J. Res. Natl. Bur. Stand. (U.S.), 72C, No. 2 (June 1968).

Improved Ten-Picofarad Fused Silica Dielectric Capacitor, R. D. Cutkosky and H. L. Lee, J. Res. Natl. Bur. Stand. (U.S.), 69C, No. 3, 173 (Sept. 1965).

Calibration of Inductance Standards in the Maxwell-Wein Bridge Circuit, T. L. Zapf, J. Res. Natl. Bur. Stand. (U.S.), 65C, No. 3 (Sept. 1961).

Capacitance Bridge—NBS Type 2, R. D. Cutkosky, Natl. Bur. Stand. (U.S.), Report 7103 (Mar. 1961).

## B. Impedance Measurements (Except Resistors)

### B.2 High-Frequency Standard Capacitors and Inductors

#### Technical Contacts:



George M. Free  
Tel: 303/497-3609



Kathy Hillen  
Administrative  
and Logistics  
Tel: 303/497-3753

**Mailing Address:** M.C. 813.10, National Institute of Standards and Technology, 325 Broadway, Boulder, CO 80303-3328

Test No.	Items
52210S	Two-Terminal, Low-Loss Standard Capacitors—10 kHz to 250 MHz; 1 pF to 1 $\mu$ F
52211C	Two-Terminal, Low-Loss Standard Capacitors (High Accuracy)—1 MHz; 50, 100, 200, 500, and 1000 pF
52220S	Three-Terminal, Low-Loss Standard Capacitors—100 kHz, 1 MHz; $10^{-2}$ pF to $10^3$ pF
52221C	Three-Terminal, Low-Loss Standard Capacitors (High Accuracy)—100 kHz, 1 MHz; $10^{-2}$ , $10^{-1}$ , 1, 10, $10^2$ , and $10^3$ pF
52310S	Two-Terminal, High-Q Standard Inductors ( $10^{-2}$ $\mu$ H to 1 H)

#### High-Frequency Standard Capacitors and Inductors (52210S-52310S)

Services provided in this category (and also Test Nos. 51310S and 52700C) are for passive devices over the frequency range from 10 kHz to 250 MHz. Highest accuracy is obtained only for standards equipped with precision coaxial connectors. Standards submitted for calibration should be in good repair and, except for very minor cleaning of connector

surfaces, should require no pre-calibration maintenance. NIST does not provide repair services; items received that require maintenance will be returned to the sender and a handling fee charged.

Calibration services for some types of capacitance standards at frequencies as low as 1 kHz can be provided by the NIST Boulder Laboratory provided the accuracy requirement does not exceed  $\pm 0.01$  percent. In some circumstances this can eliminate the necessity of sending a standard to both the Gaithersburg and Boulder Laboratories for a complete calibration. For additional details please consult with the technical contact listed at the beginning of this section.

Calibration service for measuring instruments such as bridges or meters is not provided. The accuracy of these instruments should be verified by the owner through the use of stable standards especially selected for particular values and frequencies appropriate to the instrument in question.

All calibrations are performed under typical ambient laboratory conditions of 23 °C, and an atmospheric pressure of approximately  $8.4 \pm 0.2 \times 10^4$  Pa at Boulder, Colorado. Services at ambient conditions outside these limits are not provided. Also, the power applied to any device being calibrated does not exceed 1 W. Additional information pertaining to immittance (impedance and admittance) measurement and standards is contained in the references.

#### Two-Terminal, Low-Loss Standard Capacitors (52210S-52211C)

In the frequency range from 10 kHz to 250 MHz, capacitance calibrations to a minimum uncertainty of  $\pm 0.1$  percent are available from 1 pF to 1  $\mu$ F depending upon frequency. The upper capacitance limit for calibration decreases as the frequency increases and is 50 pF at 5 MHz and above.

At 1 MHz a special high-accuracy service is available for capacitors with nominal values of 50, 100, 200, 500, and 1000 pF provided they are equipped with 14-mm coaxial connectors.

Reports of calibration for capacitors normally do not give conductance values. This is because capacitors of standard quality, especially those with air-dielectric, have conductance values too small to be measured accurately at the present state-of-the-art.

A technique for extrapolating the 1-kHz values of capacitance standards to high frequencies is described by R. N. Jones (see references). This reference describes a technique for obtaining a high-frequency value of a capacitor equipped with an unshielded (banana plug) connector. The measurement technique yields effective capacitance values at high frequencies using the capacitance value at 1 kHz and the residual series inductance. The same technique, with some modifications, is usable for three-terminal and four-terminal pair capacitors. It is emphasized that these extrapolation procedures are only usable for air dielectric capacitors or capacitors with insulating materials whose dielectric constant does not change with frequency.

#### **Three-Terminal, Low-Loss Standard Capacitors (52220S-52221C)**

Fixed-value reference standards are maintained by NIST for values of 10, 100, and 1000 pF. High-quality three-terminal air dielectric capacitance standards should have low residual series inductance ( $<0.1 \mu\text{H}$ ). This being the case, it may be assumed that to an accuracy of  $\pm 0.10$  percent, the capacitances of standards of 1 pF or less with air dielectric is the same at 1 MHz as it is at 1 kHz. Thus, it is unnecessary to have capacitors smaller than 10 pF calibrated at 1 MHz.

#### **Two-Terminal, High-Q Standard Inductors (52310S)**

In the frequency range from 10 kHz to 250 MHz, inductance calibrations to a minimum uncertainty of  $\pm 0.1$  percent are available from  $0.01 \mu\text{H}$  to 1 H. The upper inductance limit for calibration decreases as the frequency increases and is  $1 \mu\text{H}$  at 250 MHz. In the Report of Calibration, the resistance of the inductor is also given. Service is available only for aircore inductors or inductors whose value is independent of current.

#### **References - High-Frequency Standard Capacitors and Inductors**

- Evaluation of Three-Terminal and Four-Terminal Pair Capacitors at High Frequencies, R. N. Jones, Natl. Bur. Stand. (U.S.), Tech. Note 1024 (Sept. 1980).
- The Measurements of Lumped Parameter Impedance: A Metrology Guide, R. N. Jones, Natl. Bur. Stand. (U.S.), Monogr. 141 (June 1974).
- A Precision High-Frequency Calibration Facility for Coaxial Capacitance Standards, R. N. Jones and L. E. Huntley, Natl. Bur. Stand. (U.S.), Tech. Note 386 (Mar. 1970).
- Impedance of Lumped Circuits, L. E. Huntley and R. N. Jones, Proc. IEEE 55(6), 900 (June 1967).
- A Technique for Extrapolating the 1 kc Values of Secondary Capacitance Standards to Higher Frequencies, R. N. Jones, Natl. Bur. Stand. (U.S.), Tech. Note 201 (Nov. 1963).

## **B.** Impedance Measurements (Except Resistors)

### **B.3** Power-Frequency Capacitors

#### Technical Contacts:



**James K.  
Olthoff**  
Tel: 301/975-2431



**William E.  
Anderson**  
Tel: 301/975-2423

**Mailing Address:** B344 Metrology, National Institute of Standards and Technology, Gaithersburg, MD 20899-0001

**Shipping Address:** National Institute of Standards and Technology, I-270 at Quince Orchard Road, Gaithersburg, MD 20899-0001

[Attn: J. K. Olthoff, Bldg. 202, Room 167]

---

#### Test No. Items

---

52400C Power-Frequency Capacitors

---

#### Power-Frequency Capacitors (52400C)

A calibration service is maintained for capacitors designed for 60-Hz operation, especially at voltages above 100 V. Typical uncertainties for a calibration are  $\pm 100$  ppm of the capacitance, and  $\pm 1$  percent of the dissipation factor  $\pm 1 \times 10^{-5}$ . Routine calibrations are limited to devices with a dissipation factor of 0.011 or smaller and which are operated at sufficient voltages that at least 40  $\mu$ A passes through the device under test.

The high-power limit for routine tests is 10 kVA. Some capability to perform tests outside of these limits exists, and NIST should be contacted to discuss special arrangements for such tests.

#### References—Power-Frequency Capacitors

- A Calibration Service for Voltage Transformers and High-Voltage Capacitors, W. E. Anderson, Natl. Bur. Stand. (U.S.), Spec. Publ. 250-33 (June 1988).
- An International Comparison of High-Voltage Capacitor Calibrations, W. E. Anderson, R. S. Davis, O. Petersons, and W. J. M. Moore, IEEE Trans. Power Appar. Syst., 97, 4, 1217 (July 1978).
- A Wide Range High-Voltage Capacitance Bridge with One-ppm Accuracy, O. Petersons and W. E. Anderson, IEEE Trans. Instrum. Meas., IM-24, 4, 336 (Dec. 1975).

## B. Impedance Measurements (Except Resistors)

### B.4 Q-Standards

#### Technical Contacts:



George M. Free  
Tel: 303/497-3609



Kathy Hillen  
Administrative  
and Logistics  
Tel: 303/497-3753

Mailing Address: M.C. 813.10, National Institute of Standards and Technology, 325 Broadway, Boulder, CO 80303-3328

Test No.	Items
52710C	Inductive Q-Standards; 50 kHz-45 MHz, 0.25 $\mu$ H to 25 mH
52711C	Each Additional Frequency for 52710C

#### Q-Standards (52710C-52711C)

Standards for Q-measurements are maintained at NIST. These are high-Q inductors equipped with banana plug connectors at a spacing of 1 inch on centers. These standards have inductance values of 0.25, 2.5, 25, 250, 2500, and 25,000  $\mu$ H, and effective Q-values from 100 to approximately 600. These serve as working standards for calibration of Q-standards of a similar type. Calibration frequencies range from 50 kHz to 45 MHz. The calibration report includes effective resonating capacitance and effective Q. Uncertainties are of the order of  $\pm 0.2$  percent for capacitance and 2 percent for Q. Provisions are made for calibrating each Q-standard at three frequencies; however, adequate assurance of stability is usually provided by recalibrating only at the center frequency.

Estimated limits of uncertainty are based upon a statistical analysis of previously obtained calibration data. These uncertainties are believed to result solely from sources of random error as opposed to known systematic errors.

#### References—Q-Standards

Standards for the Calibration of Q-Meters, 50 kHz to 45 MHz, R. N. Jones, J. Res. Natl. Bur. Stand. (U.S.), 58C, No. 4, 243 (Oct.-Dec. 1964).

# C. Voltage Measurements

## C.1 DC Voltage Measurements and Standards

### Technical Contacts:



June E. Sims  
Tel: 301/975-4238



Richard L. Stelner  
Tel: 301/975-4226



Norman B. Belecki  
Tel: 301/975-4223



Denise D. Prather  
Administrative and Logistics  
Tel: 301/975-4221

**Mailing Address:** B146 Metrology, National Institute of Standards and Technology, Gaithersburg, MD 20899-0001

Test No.	Items
53110S	Special DC Voltage Measurements, by Prearrangement
53120M	Measurement Assurance Program for DC Voltage
53130C	First Saturated Standard Cell in a Group
53131C	Each Additional Cell
53140C	Platinum Resistance Thermometer Temperature Determination for Standard Cell Calibration
53150C	Unsaturated Standard Cells
53160C	Tests of Solid-State Voltage Reference Standard (1 Output, 1-10 V)
53161C	Each Additional Output
53180S	Special Handling (Equipment Pickup or Delivery)
53190S	Special Handling (Cleaning, Minor Repair, Return Service Charge)

### General Information—DC Voltage Measurement Standards

The service described in this section provides for the calibration of standards of direct voltage, saturated and unsaturated standard cells, and solid-state standards, and for dc voltage MAP services at the 1.02-volt level. The U.S. Representation of the Volt is maintained by monitoring the emf's of several groups of saturated standard cells in ovens on a monthly basis using the ac Josephson effect.

Customer cells are calibrated by measuring the difference between their emf's and those of working groups of standard cells using automated systems comprised of low thermal emf, computer-controlled switches and high-resolution digital voltmeters.

Figure 9 summarizes the uncertainty of NIST dc voltage measurements for the primary standards, standard cells, and Zener diodes.

Figure 9. Uncertainties of NIST DC Voltage Measurements

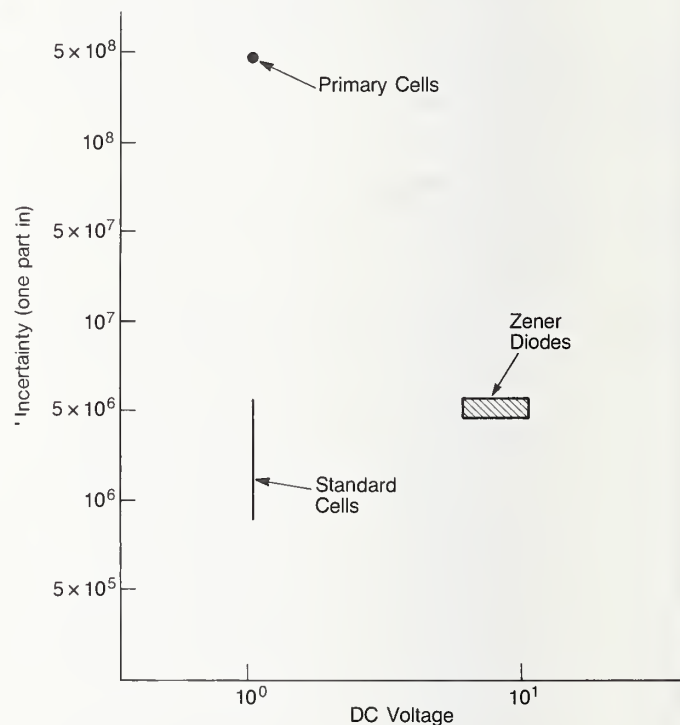

### Special DC Voltage Measurements, by Prearrangement (53110S)

The evaluation, testing, or calibration of prototype dc voltage standards and measuring apparatus or unique voltage measurements are provided for in this service. These measurements are performed only when deemed reasonable by the appropriate technical staff and serving the best long-term interests of the client, the measurement community, and NIST.



### Measurement Assurance Program Service (53120M)

This MAP service provides a measurement of the error of dc voltage measurements in the customer laboratory at the 1.02-volt level, the uncertainty of the results, and an updated assigned value for the client's reference standards. A transport standard, which consists of a standard cell enclosure containing four saturated standard cells, maintaining constant temperature via line and battery power, is used. It is preferentially hand-carried between NIST and the client laboratory, but arrangements may be made for air shipment. The standard is calibrated by NIST, the customer laboratory, and again by NIST to obtain the required data. The transport standard is capable of performing at the 0.2- to 0.3-ppm level of reproducibility when hand-carried, 0.5 to 0.8 ppm otherwise.

The measurement uncertainty achieved in this service contains primarily random errors. The major components of random error can be attributed to:

A. Day-to-day fluctuations in temperature-corrected cell emf's caused by temperature-hysteresis effects;

B. The finite resolution of the measurement apparatus at both the client laboratory and NIST;

C. Thermal emf's, unstable with time, which occur in the measuring circuit due to room temperature and humidity changes and drafts;

D. Temperature coefficients of the enclosures as a whole, not compensated for by temperature corrections;

E. Lack of resolution or instability of the apparatus used to monitor the cell temperatures;

F. Slow changes in temperature gradients or enclosure temperatures possibly due to atmospheric "pumping" of cool air into the enclosures, or vibration effects on the control circuitry;

G. Controller instability caused by power-line noise;

H. Effects of electrostatic or electromagnetic pick-up on the measuring system;

I. Detector drift; and

J. Momentary upsets in cell emf's caused by small electrical currents passing through the cells.

The experimental design described for making the intercomparison measurements removes the effects of average "left-right" or offset errors. One potentially significant source of error not corrected for or quantified in the MAP service is that caused by scale-factor errors in the instrumentation used to measure the differences between cell emf's. An error from this source can be eliminated by using calibrated instruments and applying the appropriate calibration corrections to the results.

The transport standard is normally kept in the client's laboratory for about 4 weeks, as 8 to 12 measurement sets are generally required. Data analysis and issuance of the test report by NIST takes 4 to 5 weeks following the return of the transfer standards.

If the participating laboratory has a quality instrument that has been accurately calibrated and also has quality standards, the uncertainty of a single transfer of the unit of voltage using NIST transport standards is generally of the order of 0.5 ppm or better. The best achievable long-term uncertainty, resulting from five or more transfers over an extended time, is of the order of 0.2 to 0.3 ppm.

In this service, NIST provides detailed instructions for carrying out the transfer and making the required measurements. The participant must have in-house standards and instrumentation capable of sustained performance at the 0.1-ppm level. When a new participant (or group of participants) expresses a desire to use the

voltage MAP service, NIST requests that a complete description of the participant's measurement system, including instruments, standards, wires, switches, and their use, be sent to the NIST technical staff. This description enables NIST personnel to assist in resolving measurement problems by telephone.

NIST requires evidence in the form of control charts of the existence of a formal quality-control program in the laboratory as a prerequisite to participation in the service. This requirement has been established to enable problems to be addressed in advance of the transfer and to reduce delays in returning the standards to NIST.

#### **Saturated Standard Cells (53130C-53140C)**

Routine calibrations of saturated standard cells involve the following considerations:

A. Saturated standard cells of the unshippable type should always be transported by messenger because such cells should never be tipped from an upright position by more than 45° in any direction. Unshippable saturated cells contained in portable, temperature-regulated enclosures should also be transported by messenger and with the enclosure activated or under power if possible.

B. Saturated standard cells of the shippable type housed in portable thermoregulated enclosures should be packed carefully and shipped under power if possible. Any liquid-in-glass thermometer mounted in such a device should be removed and provided with additional rigid packing for protection against breakage. Enclosures having a nominal cell temperature of 28 °C or lower should not be transported during the summer due to the danger of overheating. Enclosures should not be energized by using the ac power mains while they are in shipping containers as heat from the transformer will cause them to go over-temperature.

C. Saturated standard cells, which are maintained continuously at their nominal temperature of use during shipment, will undergo test starting 1 week after receipt for a period not to exceed 6 weeks, unless other arrangements are made. If such cells perform abnormally, the owner will be notified. Arrangements for further testing may be made at that time if desired. Cells will be returned as soon as possible after calibration.

D. Saturated cells arriving at a temperature other than their nominal temperature of use will be brought to their use temperature as soon as possible after receipt. Starting 1 month after they initially attain use temperature, daily readings will be taken to observe the stability of the cells. When the cells stabilize, 10 daily readings will be taken and averaged to assign values to them. This process will not exceed 90 days without special arrangements being made.

E. For an additional fee, the temperature of air bath enclosures for saturated standard cells will be determined using a calibrated NIST platinum resistance thermometer (test 53140C). Daily readings are taken and reported. The reported cell emf's are assumed to correspond to the mean of the temperatures measured on the same days as the emf readings were taken. The client must understand that, when this is done, the uncertainties of the reported emf's include the emf equivalent of the uncertainty of the measured temperatures in terms of the International Temperature Scale of 1990 (ITS-90). Moreover, estimates of the uncertainties of any voltage measurements made by clients using these cells as a reference must include corresponding uncertainties of their own temperature measurements.

F. NIST accepts cells used in oil baths for calibration in NIST oil baths maintained at 28 and 30 °C. Cells used in oil baths operating at other nominal temperatures can best

be calibrated using transport standards as in the MAP service. (See 53120M above.)

Calibration uncertainties generally range from 0.3 to 0.75 ppm. The stated uncertainties are those of the NIST-measured average values, i.e., they do not reflect long-term behavior of the cells, transportation effects, etc.

#### Unsaturated Standard Cells (53150C)

Unsaturated cells require approximately 3 weeks for a complete calibration. The emf's of such cells are read daily for a minimum period of 10 days. These cells are compared with NIST saturated cells using a precision digital voltmeter to measure the difference emf directly. The calibration uncertainty is 0.005 percent of the measured voltage unless the cell is abnormal. If the measured emf fluctuates unduly or is unusually low, or if the cell behaves abnormally, the reported uncertainty will be increased appropriately. Unsaturated cells are not likely to be injured by normal transportation (mail or express) if they are packed carefully. Because of the possible hazard from freezing, shipment during extremely cold weather should be avoided.

#### Solid-State Voltage Reference Standards (53160C and 53161C)

Solid-state voltage standards with outputs in the range from 1 to 10 volts are calibrated using a self-calibrating automated system which scales to any multiple up to 10 of 1.018 volts from the emf of a working group of NIST saturated standard cells. It then measures the difference between the emf of the standard under test and the emf of its own output closest in voltage to that of the standard being measured and computes its emf. Measurements are taken daily for 12 to 15 working days and the mean value of the results reported.

Because of the limited battery life of many commercial standards, special shipping arrangements are advisable and can be made by contacting the Electricity Division.

Many solid-state standards have multiple outputs; the outputs to be calibrated should be specified on the shipping papers as well as on the purchase order to ensure proper testing.

Voltmeter calibrators, multirange instruments with up to eight decimal digits of adjustability, are not considered by NIST to be standards and are not to be submitted routinely for calibration under this test category. Likewise, NIST will not accept component solid-state devices for routine calibration. However, new, state-of-the-art devices and instruments may be accepted for test under special circumstances (see test 53110S) at the discretion of NIST technical staff.

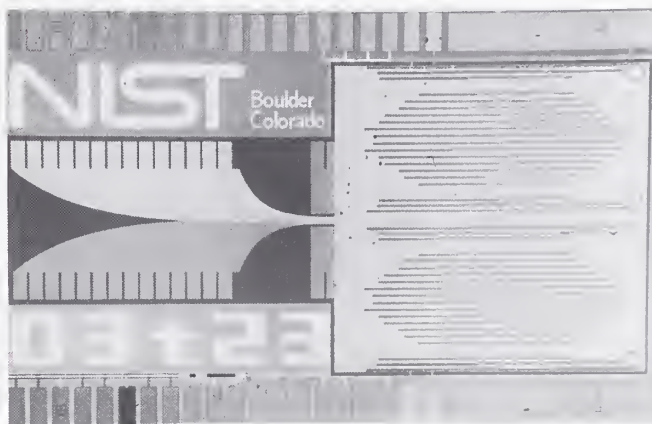

*The NIST calibration service for voltage is directly tied to NIST Josephson-junction voltage-standard arrays. This 1-V standard fabricated from niobium trilayer resists the effects of cycling between its operating temperature of liquid helium and room temperature better than previous designs.*

**References – Voltage Measurements and Standards**

- Guidelines for Implementing the New Representation of the Volt and Ohm Effective January 1, 1990, N. B. Belecki, R. F. Dzuiba, B. F. Field, and B. W. Taylor, Natl. Inst. Technol., Tech. Note 1263 (June 1989).
- NBS Measurement Services: Solid-State DC Voltage Standard Calibrations, B. F. Field, Natl. Bur. Stand. (U.S.), Spec. Publ. 250-28 (Jan. 1988).
- NBS Measurement Services: Standard Cell Calibrations, B. F. Field, Natl. Bur. Stand. (U.S.), Spec. Publ. 250-24 (Oct. 1987).
- The NBS Josephson Array Voltage Standard, C. A. Hamilton, R. L. Kautz, F. L. Lloyd, R. L. Steiner, and B. F. Field, IEEE Trans. Instrum. Meas., IM-36, 258 (June 1987).
- A Sub-PPM Automated One-to-Ten Volt Measuring System, B. F. Field, IEEE Trans. Instrum. Meas., IM-34, 327 (1985).
- Volt Transfer Program Instructions, NBS Internal Document, Unpublished, Revised (1983).
- A High-Resolution Prototype System for Automatic Measurement of Standard Cell Voltages, D. W. Braudaway and R.E. Kleinmann, IEEE Trans. Instrum. Meas., IM-23, 282 (1974).
- Volt Maintenance at NBS via  $2e/h$ : A New Definition of the NBS Volt, B. F. Field, T. F. Finnegan, and J. Toots, Metrologia, 9, 155 (1973).
- Designs for Surveillance of the Volt Maintained by a Small Group of Saturated Standard Cells, W. G. Eicke and J. M. Cameron, Natl. Bur. Stand. (U.S.), Tech. Note 430 (Oct. 1967).
- Standard Cells—Their Construction, Maintenance, and Characteristics, W. J. Hamer, Natl. Bur. Stand. (U.S.), Monogr. 84 (Jan. 1965)

## C. Voltage Measurements

### C.2 AC Voltage Measurements

#### Technical Contacts:



Nile M. Oldham  
Tel: 301/975-2408



Barry A. Bell  
Tel: 301/975-2419



Mark E. Parker  
Tel: 301/975-2413

**Mailing Address:** B162 Metrology, National Institute of Standards and Technology, Gaithersburg, MD 20899-0001

Test No.	Items
53200S	Special Tests of High-Accuracy AC Digital Multimeters, Multifunction Calibrators, by Prearrangement
53201S	Special Tests of Low-Voltage AC-DC Transfer Standards, by Prearrangement

#### Digital Multimeters (DMMs) and Multifunction Calibrators (53200S)

AC Voltage measurements are performed at frequencies between 0.1 Hz and 30 MHz at amplitudes between 1 mV and 1 kV in the mid-frequency range.

Low-frequency measurements (0.1 to 10 Hz) are made using a NIST-developed calculable voltage standards in which waveforms are digitally synthesized using a sine lookup table and a pair of digital-to-analog converters. The resulting "stepped" waveform is measured at very low frequencies using a precision dc voltmeter. This source may be used in conjunction with external attenuators to calibrate DMMs between 1 mV and 7 V.

Wideband measurements between 10 Hz and 30 MHz are made using a thermal voltage converter (TVC) based automatic calibration system. Using this system, ac calibrators and DMMs are tested from 100 mV to 1 kV. At lower levels, a micropotentiometer is used (as an ac-dc transfer

standard) to generate voltages between 1 and 100 mV that are used to calibrate DMMs (calibrators are tested using a characterized DMM).

The estimated uncertainties associated with both measurement systems range from  $\pm 10$  ppm in the mid-voltage and mid-frequency range to  $\pm 0.2$  percent for a 1 mV measurement at 1 MHz.

AC current measurements are performed on the same system using a set of characterized thermal current converters. Current sources can be measured from 10 Hz to 100 kHz at current levels between 1 mA and 2 A. Due to limitations in the present NIST sources, DMM tests are normally limited to an upper frequency of 5 kHz; however, special arrangements may be made for tests at higher frequencies and currents. The best uncertainties available for ac current measurements are less than  $\pm 100$  ppm.

Measurements of dc voltage (1 mV – 1 kV), dc current (10  $\mu$ A – 2 A), and resistance (10  $\Omega$  – 10 M $\Omega$ ), for both DMMs and calibrators, are being offered on a trial basis. These tests are performed using calibrators and DMMs which have been carefully characterized using standards maintained in the Electricity Division. The best uncertainties are less than  $\pm 3$  ppm for certain values of dc voltage and resistance.

#### Low-Voltage AC-DC Transfer Standards (53201S)

Measurements of the ac-dc difference of low-voltage thermal transfer standards, micropotentiometers, and voltage dividers is also offered on a trial basis. High-accuracy tests on these devices are performed, using a procedure described in New Low-Voltage Standards in the DC to 1 MHz Frequency Range (see references), between 1 and 200 mV from dc to 1 MHz where uncertainties of  $\pm 20$  ppm are possible in the audio-frequency range at 100 mV.

**References—AC Voltmeters and Sources**

- New Low-Voltage Standards in the DC to 1 MHz Frequency Range, N. M. Oldham and R. M. Henderson, Conf. Record of CPEM '90, Ottawa, Canada (June 1990).
- A Calculable, Transportable Audio-Frequency AC Reference Standard, N. M. Oldham, P. S. Hetrick, and X. Zeng, IEEE Trans. Instrum. Meas., Vol. 38, No. 2, pp. 368-371 (April 1989).
- A High-Accuracy, 10 Hz-1 MHz Automatic AC Voltage Calibration System, N. M. Oldham, M. E. Parker, A. Young, and A. G. Smith, IEEE Trans. Instrum. Meas., IM-36, pp. 883-887 (Dec. 1987).

## C. Voltage Measurements

### C.3 AC-DC Thermal Voltage and Current Converters (to 1 MHz)

#### Technical Contacts:



Joseph R. Kinard  
Tel: 301/975-4250



Norman B. Belecki  
Tel: 301/975-4223



Denise D. Prather  
Administrative  
and Logistics  
Tel: 301/975-4221

**Mailing Address:** B146 Metrology, National Institute of Standards and Technology, Gaithersburg, MD 20899-0001

Test No.	Items
53310S	Special AC-DC Measurement Services, by Prearrangement
53340C	AC-DC Thermal Voltage and Current Converters (1 voltage, 1 frequency from 2 Hz to 1 MHz)
53341C	Additional Determination at 1 Frequency (from 2 Hz to 1 MHz)

#### General Information—Thermal Voltage and Current Converters

Routine calibrations of thermal voltage and current converters generally are carried out on a demand basis. However, occasional extensive calibration requests may create scheduling problems; therefore, to facilitate rapid turnaround, please advise D. D. Prather at the telephone number/address cited above before sending the equipment.

Calibration services for wide-frequency range thermal voltage converters, such as John Fluke Model A55 or HP 11000 series, have been extended in the NIST Boulder Laboratory to cover frequencies down to 100 Hz with uncertainties as low as 0.05 percent (see tests 53405S-53420C). This means thermal converters of this type can be completely

calibrated at NIST Boulder if the 0.05 percent uncertainty is acceptable. Calibration requiring uncertainties less than 0.05 percent in the range below 1 MHz continue to be done in NIST Gaithersburg (53310S-53341C).

#### Special AC-DC Measurement Services, by Prearrangement (53310S)

This service provides for the measurement or evaluation of prototype ac voltage or current standards, sources, or measurement instrumentation, and for other measurements of alternating voltage, alternating current, or ac-dc difference not provided for below, at the discretion of NIST technical experts. Components used for ac-dc conversions will generally not be tested unless they show promise of standards-level behavior. Even then, such components will only be tested in very limited numbers to explore their possible use for precision measurements.

Special ac-dc difference calibrations of appropriate thermal voltage and thermal current converters are now offered with an uncertainty of 0.8 ppm. This sub-part-per-million calibration service is the result of an extensive study of the group of multijunction thermal converters that make up the NIST primary standards. Thermal converters will be accepted for calibration with the 0.8 ppm uncertainty providing their performance, including stability and square-law response, is compatible with the NIST standards and high-precision comparator system. In general, the sub-ppm uncertainty is available for voltages from 2 to 12 V, currents from 5 to 20 mA, and frequencies from 30 to 10 kHz. As in the case of the other special ac-dc difference calibrations with reduced uncertainty, an additional cost and a longer-than-usual turnaround time at NIST are required. Prospective clients are asked to contact Joseph Kinard, phone (301) 975-4250, to discuss the requirements and arrangements related to this service.

**AC-DC Thermal Voltage and Current Converters (Up to 1 MHz)  
(53340C-53341C)**

This service covers the calibration of thermal voltage and current converters, ac shunts, and primary thermoelements covering the ranges 2 Hz to 1 MHz, 1 mA to 20 A, and 0.5 to 1000 V. These are used to make measurements of alternating current and voltage in terms of direct current standards of voltage and resistance and are calibrated at NIST by comparison with similar NIST devices. Ordinarily only ac-dc transfer standards and thermal converters of 0.05 percent or better rated accuracy are accepted for test. AC-DC difference tests consist of determinations of the differences between the current or voltage, required to give the same response (output) of the transfer standard for alternating current and for the average of the two directions of direct current. Tests are recommended at rated voltage or current on each range up to the highest frequency of interest. For 1000-V ranges, a second test at 600 V is recommended because these ranges may be affected by self-heating. In addition to the high-frequency tests, an ac-dc difference test (ordinarily at 20 Hz) is recommended for one range, to verify the low-frequency accuracy. Thermoelements have a low-frequency limit, below which they fail to integrate properly. The ac-dc difference may approach 0.02 percent at frequencies ranging from about 5 Hz, for most low-range thermoelements, to about 60 Hz, for some thermoelements with ratings above 1 A. This low-frequency ac-dc difference is nearly the same for all ranges of a multirange converter in which a single thermoelement is used with shunts or multipliers. For convenience, usually a low-voltage or current range is chosen for the test. Unless the test points have been firmly established in prior practice,

the user is strongly advised to contact the appropriate NIST technical staff prior to submission of the standards to NIST for calibration.

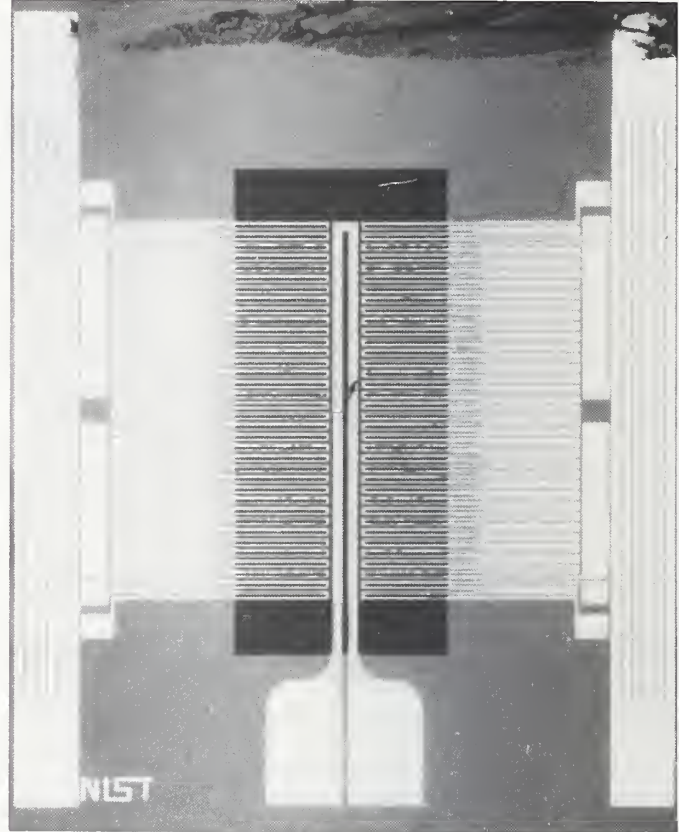

*Thermal voltage and converters are used to make accurate ac to dc transfer measurements. To improve the Nation's capability to make these measurements, NIST is investigating multijunction thermal converters made using thin-film technology developed for the semiconductor industry. An experimental NIST device is shown.*



Table 15: AC-DC Difference Calibration Service

Frequency:	2-5 Hz	5-20 Hz	20-20k Hz	20-50 kHz	50-100 kHz	0.1-1 MHz
Voltage Limits (V)	50	100	1000	1000	1000	100
Current Limits (A)	0.05	0.05	20	20	20 <sup>[a]</sup>	
<i>Uncertainty (parts per million)<sup>[b]</sup></i>						
Multirange TVC's						
> 100 V			30	50	70	
≤ 100 V	200 <sup>[c]</sup>	100 <sup>[c]</sup>	20	30	50	100
Coax Single Range						
TVC's > 100 V			20	30	50	
5 V ≤ x ≤ 100 V	200 <sup>[c]</sup>	100 <sup>[c]</sup>	15 <sup>[c]</sup>	25	40	70
Special <sup>[d]</sup>						
10 V ≤ x ≤ 100 V			10			
2 V ≤ x ≤ 10 V			5			
TCC's						
> 5 A			100	150		
50 mA < x ≤ 5 A			50	70		
≤ 50 mA <sup>[e]</sup>	200	100	50	70		

<sup>[a]</sup> Available as a special test with uncertainty determined on an individual basis.

<sup>[b]</sup> The lower uncertainty applies at the crossover frequencies. Uncertainties may be increased if the ac-dc differences are large or affected by self-heating or other instability.

<sup>[c]</sup> 20 ppm from 20 Hz to 100 Hz, 15 ppm at 100 Hz and above.

<sup>[d]</sup> Normally available by prearrangement for coaxial, single-range TVC's between 100 Hz and 20 kHz. An additional cost and a longer turnaround time at NIST are required.

<sup>[e]</sup> This area is currently under study and improvements are expected from time to time. The laboratory staff should be contacted for up-to-date information.

#### References—AC-DC Thermal Converters (to 1 MHz)

Determination of AC-DC Difference in the 0.1–100 MHz Frequency Range, J. R. Kinard and T. X. Cai, IEEE Trans. Instrum. Meas., IM-38, No. 2, 360 (April 1989).

Recharacterization of Thermal Voltage Converters after Thermoelement Replacement, J. R. Kinard and T. E. Lipe, IEEE Trans. Instrum. Meas., IM-38, No. 2, 351 (April 1989).

NIST Measurement Services: AC-DC Difference Calibrations, J. R. Kinard, J. R. Hastings, T. E. Lipe, and C. B. Childers, Natl. Inst. Stand. Technol., Spec. Publ. 250-27 (May 1989).

# C. Voltage Measurements

## C.4 RF-DC Thermal Voltage and Current Converters (100 Hz-1 GHz)

### Technical Contacts:



**Gregorio  
Rebuldela**  
Tel: 303/497-3561



**Kathy Hillen**  
Administrative  
and Logistics  
Tel: 303/497-3753

**Mailing Address:** M.C. 813.10, National Institute of Standards and Technology, 325 Broadway, Boulder, CO 80303-3328

Test No.	Items
53405S	Special Tests of AC Thermal Voltage Converters, by Prearrangement
53410C	Low-Frequency TVC Calibration at One Frequency Selected from Those Given in Table 16 at Rated Voltage in the Range 0.1-50 V
53411C	Additional Frequency Selected from Table 16 for Same TVC as in 53410C
53412S	Same as 53410C, Except Customer Designates a Single Frequency (in Same Frequency Range) Other Than Those Given in Table 16
53413C	Low-Frequency TVC Calibration at One Frequency Selected from Those Given in Table 16 at Rated Voltage in the Range 50-200 V
53414C	Additional Frequency Selected from Table 16 for Same TVC as in 53413C
53415S	Same as 53413C, Except Customer Designates a Single Frequency (in Same Frequency Range) Other Than Those Given in Table 16

Test No.	Items
53420C	High-Frequency TVC Calibration at One Frequency Selected from Those Given in Table 17 at Rated Voltage in the Range 0.1-7.5 V
53421C	Additional Frequency Selected from Table 17 for Same TVC as in 53420C
53430S	Peak-to-Peak Detector Calibration at One Frequency Selected from Those Given in Table 18 at 1.2 V Applied RF Voltage
53431S	Additional Frequency for Peak-to-Peak Detector in Test 53430S
53440S	Special Tests of RF Micropotentiometers, by Prearrangement
53441C	RF Micropotentiometer Calibration at One Frequency Selected from the Frequency Bands Given in Table 19
53445S	Special Calibration of RF Micropotentiometer (Output Voltage Range, 200 to 200,000 $\mu$ V at Frequency Range, 0.05 to 1000 MHz) with Reduced Limits of Uncertainty

### General Information—RF-DC Thermal Voltage and Current Converters, 100 Hz to 1 GHz (53405S-53445S)

Services are available for three types of electromagnetic voltage measuring

devices: (1) Thermal Voltage Converters (TVC's), (2) Peak-to-Peak Detectors, and (3) Voltage Comparators and one type of electromagnetic generating device: RF Micropotentiometers.

Past calibrations of micropots and TVC's have shown that these devices are very stable for periods up to 10 years. Thus, in most cases, a 2-year or longer recalibration cycle is recommended. An exception might be micropots whose rated output voltages are 100  $\mu$ V or less.

Assurance of device stability can be obtained by intercomparing a micropot or TVC with another similar device where voltage ranges overlap. For example, a 1 V TVC can be compared with a 3 V TVC at 1 V, etc.

TVC calibrations requiring uncertainties less than 0.05 percent below 1 MHz are performed at NIST Gaithersburg. See tests 53310S-53341C.

#### RF Voltage Comparators (53405S)

Special tests are performed on rf voltage comparators using TVC's and micropotentiometers at selected frequencies from 100 kHz to 1 GHz at voltages ranging from 10 mV to 20 V. Several calibration options are available to the customer. Therefore, consultation by telephone or written correspondence is recommended before the comparator is submitted for calibration.

#### Thermal Voltage Converters (53410C-53421C)

Thermal voltage converters also include other devices such as Rawson rf voltmeters, thermal transfer standards, rf voltage standards, and ac-dc transfer standards.

Most converters have rf-dc differences within  $\pm 0.01$  percent of zero at 1 MHz and below. Converters with previous calibration history that are submitted for recalibration should be evaluated at 1 MHz and results compared to prior data. If the difference is negligible, no further calibrations are usually necessary below 1 MHz.

The quantity measured by this calibration service is the rf-dc difference, defined as the percentage difference

between the rf and dc input voltages required to produce the same thermocouple output, e.g.,

$$\text{rf-dc difference (\%)} = \left( \frac{V_{\text{rf}} - V_{\text{dc}}}{V_{\text{dc}}} \right) \times 100.$$

Services available for low-frequency TVC's without a built-in "T" connector are given in Table 16. For high-frequency TVC's with a built-in "T" connector, the services available are given in Table 17. Calibrations above 100 MHz are performed only on the new high-frequency thermal voltage converters with a "T" connector as an integral part of the converter housing. The measurement reference plane is at the Type "N" male output connector.

**Table 16: Specifications and Estimated Uncertainties for Low-Frequency TVC Services**

Recommended Frequencies	RF Voltage Range (V)	Estimated Limits of Uncertainty* ( $\pm\%$ )
0.03, 0.1, 0.3, 1 MHz	0.1 to 200	0.05
3 and 10 MHz	0.1 to 200	0.1
30 MHz	0.1 to 200	0.2
100 MHz	0.1 to 200	1.0

\* Rf-dc differences greater than  $\pm 20$  percent will not be reported. This normally limits the calibrations to 100 MHz and below.

**Table 17: Specifications and Estimated Uncertainties for High-Frequency TVC Services**

Frequency (MHz)	RF Voltage Range (V)	Estimated Limits of Uncertainty* ( $\pm\%$ )
10	0.1 to 7.5	0.1
30	0.1 to 7.5	0.2
100, 200, 300, 400	0.1 to 7.5	1
500, 600, 700	0.1 to 7.5	1
900, 900, 1000	0.1 to 7.5	1

\* Rf-dc differences greater than  $\pm 20$  percent will not be reported.

### Peak-to-Peak Detectors (53430S-53431S)

Measurements on peak-to-peak detectors are performed from 100 kHz to 500 MHz and are referenced to the center of a GR 874 "T" connector. A 50-kHz ac reference signal is applied instead of dc. The services available are specified in Table 18.

**Table 18: Specifications and Estimated Uncertainties for Peak-to-Peak Detector Services**

Frequency (MHz)	Applied RF Voltage for "0" Detector Output (V <sub>p-p</sub> )	Estimated Limits of Uncertainty (%)
0.1, 0.3, 1.0	1.2	0.15
3, 10	1.2	0.20
30	1.2	0.30
50	1.2	0.60
100, 200, 300, 400, 500	1.2	1.10

### RF Micropotentiometers (53440S-53445S)

Radiofrequency micropotentiometers are usually calibrated at their nominal rated output voltages. Frequencies suggested for a normal calibration are 5, 100, 300, 400, 500, 700, and 900 MHz. Special arrangements may be made for calibrations up to 1000 MHz with reduced limits of uncertainty.

Radiofrequency micropotentiometers having resistive elements greater than 10 milliohms in combination with thermoelement housings between 5 and 100 mA, usually have rf-dc differences within  $\pm 1$  percent at 5 MHz. Since the rf-dc difference approaches zero below 5 MHz, calibrations at 50 kHz and 5 MHz would suffice to determine interpolated points of interest between 50 kHz and 5 MHz, with no appreciable loss of accuracy. Estimated uncertainties are shown in Table 19.

An rf-dc difference of about  $\pm 5$  percent at 1 MHz usually results from a combination consisting of a 1 milliohm resistive element with a thermoelement rated between 5 and 100 mA inclusive. Interpolation below 1 MHz is not recommended in this case.

**Table 19: Specifications and Estimated Uncertainties for RF Micropotentiometer Calibrations**

Any Frequency within Band (MHz)	RF Voltage Range ( $\mu$ V)	Estimated Limits of Uncertainty* ( $\pm$ %)
0.05 to 100	1 to 100,000	2
100 to 500	1 to 100,000	3
500 to 900	1 to 100,000	5

\* For rf-dc differences greater than  $\pm 20$  percent, the estimated limits of uncertainty are larger than those listed.

The rf-dc difference is defined as the percentage difference between the rf and dc output voltages required to produce the same thermocouple output, with the resistive element terminated in 50 ohms, e.g.,

$$\text{rf-dc difference (\%)} = \left( \frac{V_{\text{rf}} - V_{\text{dc}}}{V_{\text{dc}}} \right) \times 100.$$

As a special service, rf micropotentiometers with rated output voltage greater than 200  $\mu$ V can be calibrated from 0.05 to 1000 MHz, with reduced limits of uncertainty from  $\pm 0.2$  percent to  $\pm 2$  percent. This uncertainty is dependent on frequency, output voltage level, and the rf-dc difference vs. frequency response. For further details, consult with the technical contact cited at the beginning of this section.

**References—RF-DC Voltage and Current Converters (100 Hz–1 GHz)**

NBS RF Voltage Comparator, L. D. Driver, F. X. Ries, G. Rebuldela, Natl. Bur. Stand. (U.S.), NBSIR 78-871 (Dec. 1978).

High-Frequency Microvolt Measurements, F. X. Ries and G. Rebuldela, ISA Proc., 18, 1, 37.2.63, Instrum. Soc. of Amer., Res. Triangle Park, NC (Sept. 1963).

Thermal Voltage Converters for Accurate Voltage Measurements to 30 Megacycles Per Second, F. L. Hermach and E. S. Williams, Trans. AIEE, Pt. 1, Commun. Elect., 72, 200 (July 1960).

**Thermal Converters as AC-DC**

Transfer Standards for Current and Voltage Measurements at Audio Frequencies, F. L. Hermach, J. Res. Natl. Bur. Stand. (U.S.), 48, 121 (1952).

Accurate Radio Frequency Microvoltages, M. C. Selby, Trans. AIEE, Pt. 1, Commun. Elect., 72, 158 (May 1953).

## C. Voltage Measurements

### C.5 Data Converters

#### Technical Contacts:



**T. Michael Souders**  
Tel: 301/975-2406



**Barry A. Bell**  
Tel: 301/975-2419

**Mailing Address:** B162 Metrology, National Institute of Standards and Technology, Gaithersburg, MD 20899-0001

Test No.	Items
53500S	Special Data Converter Services, by Prearrangement
53510C	A/D or D/A Converter, Linearity Errors at 1024 Points, 10-Bit Correction Coefficients, and Superposition Errors
53520C	A/D or D/A Converter, Differential Linearity Errors at $2(N-1)$ Points ( $N = \text{No. of Bits}$ )
53530C	A/D Converter, Equivalent RMS Input Noise
53540S	A/D or D/A Converter, Offset and Gain Errors Relative to U.S. Legal Volt

#### Data Converters (53500S-53540S)

NIST maintains a calibration service for static testing of high-resolution (12 to 18 bit) analog-to-digital (ADC) and digital-to-analog (DAC) converters. Routine measurements, for which calibration reports are issued, are made of the static parameters listed below. However, NIST has recently developed the capability to measure the dynamic response of ADC's to well-defined, programmable input voltage steps characteristic of typical input signals. These dynamic measurements can be made as a special test. Until further analysis of systematic and random errors of the test procedure is completed and until additional operating experience is ob-

tained, the customer will receive the test results with appropriate error analysis, but no calibration report will be issued.

There is no standard data-converter terminology, but NIST uses the following definitions of parameters to describe its calibration service:

A. **Linearity Error:** The difference between the actual and ideal levels of the static input/output characteristic after corrections have been made for offset and gain errors.

B. **Differential Linearity Error:** The difference between the actual and the ideal separation between adjacent levels.

C. **Offset Error:** The difference between the actual and the ideal levels, measured at the most negative level of the input/output characteristic. Due to practical considerations, this definition is modified to the second most negative level (i.e., with the least significant bit (LSB) on).

D. **Gain Error:** The difference between actual and ideal levels, measured at the most positive level of the input/output characteristic, after correction for offset error. Again, in practice, a defining level is chosen slightly below the one stated here.

E. **Equivalent RMS Input Noise:** The rms value of the effective internal noise of an ADC, referred to its input terminals.

In these definitions, the specified levels for DAC's are taken to be the discrete output levels, and for ADC's the analog input levels are those at which the digital output transitions between adjacent codes occur. In this latter case, the transition levels are defined by the upper digital code of the transition in question.

The principal error parameters are usually those of linearity and differential linearity. Nevertheless, gain and offset errors may also be measured when appropriate, and the equivalent rms input noise of ADC's can be

measured as well, provided it has approximately a Gaussian distribution. Determination of monotonicity in DAC's and missing codes in ADC's is not generally performed since these tests require excessive measurement time for high-resolution converters. These characteristics can often be inferred, however, from the available linearity data. Sensitivity of the various parameters to changes in temperature and power supply voltage, for example, is also not generally determined.

*Description of Static Tests:*

A. **Linearity:** For the linearity test, all 1024 digital codeword combinations of the 10 most significant bits are measured. Errors contributed by the remaining, less significant bits are generally insignificant, a premise which is tested during the calibration process. The data are numerically processed to determine the maximum, minimum, and rms errors of the 1024 tested codes, and to determine, on a least-squares basis, individual correction coefficients for the 10 most significant bits. The residuals from the computation of correction coefficients are a direct measure of the converter's superposition errors. These are computed as well.

B. **Differential Linearity:** Differential linearity errors are measured at  $2(N-1)$  major codeword transitions, for an N-bit converter.

C. **Offset & Gain:** In general, converter offset and gain measurements are not required, since it is common practice to provide adjustable trimmer circuits, which are periodically set to suit individual system requirements. However, accurate

voltage measurements directly traceable to legal standards can be provided if required. Offset and gain errors are measured directly by setting the test converter to the designated code and measuring the input (or output) voltage by direct comparison with a transfer standard calibrated by NIST.

D. **RMS Input Noise:** The equivalent rms input noise of ADC's can be measured either as an average value over the entire full-scale range of the converter, or as a function of codeword, at 64 randomly selected points. The measurement technique relies upon the assumptions that the noise has a Gaussian distribution and that, at a given sampling rate, successive values are uncorrelated. The validity of these assumptions is tested prior to performing the measurements.

E. **Specification for Test Converters:** To be compatible with the NIST data converter test set, test units must conform to the following general specifications:

1. Nominal resolution from 12 to 18 bits,
2. Conversion rate of at least 10 kHz,
3. Binary coding format, including binary sign-magnitude, offset binary, 2's complement, 1's complement, and complemented versions of these,
4. TTL compatibility,
5. Voltage ranges of 0-5 V,  $\pm 5$  V; 0-10 V,  $\pm 10$  V,
6. Maximum error, including offset and gain, not to exceed 500 ppm.

*Systematic Uncertainties:*

The estimated limits of the systematic uncertainties in measuring the various converter error parameters are summarized in Table 20 for a  $\pm 10$  V range.

**Table 20: Specifications and Estimated Uncertainties for Data Converter Calibrations**

Parameter	Estimated Systematic Uncertainty			
	DAC's		ADC's	
Linearity Error	2.7 ppm	+0.04 LSB	4.7 ppm	+0.16 LSB
Differential Linearity Error	3.2 ppm	+0.04 LSB	5.2 ppm	+0.16 LSB
Offset Error <sup>(a)</sup>	3 ppm		3 ppm	+0.07 LSB
Gain Error <sup>(a)</sup>	6 ppm		6 ppm	+0.13 LSB
RMS Input Noise <sup>(b)</sup>			- 100%; + (20% + 10 $\mu$ V) Noise introduced by the Test Set is approximately 30 nV/(Hz) <sup>1/2</sup> in a 1-MHz bandwidth	

<sup>(a)</sup> Measured upon special request only, if no adjustable trimmers are provided for these parameters.

<sup>(b)</sup> Since the effective bandwidth of the test converter is generally unknown, the noise contribution from the test set cannot be determined. Therefore, only an upper limit can be accurately placed on the noise measurements.

Random errors of the measurement process necessarily include random variations in the test converter and are, therefore, individually evaluated for each test. Nevertheless, measurements on very stable (check standard) converters indicate the random errors contributed by the test set itself are substantially less than the respective systematic uncertainties listed in the table. Figure 10 shows the estimated systematic uncertainty of the NIST data converter test system for resolutions from 12 to 18 bits.

#### Dynamic Tests of ADC's:

Dynamic errors in ADC's are defined as any deviations from the static transfer characteristic resulting from prior exercise (i.e., previous changes in input). The test converter is exercised with stepped input changes typical of the conditions of actual use. The dynamic errors are measured in terms of the changes in the test converter's code transition levels resulting from prior exercise. A more complete description of the dynamic

testing now provided for ADC's on a Special Test basis is provided in Souders et al., "An Automated Test Set for the Dynamic Characterization of A/D Converters" (see references).

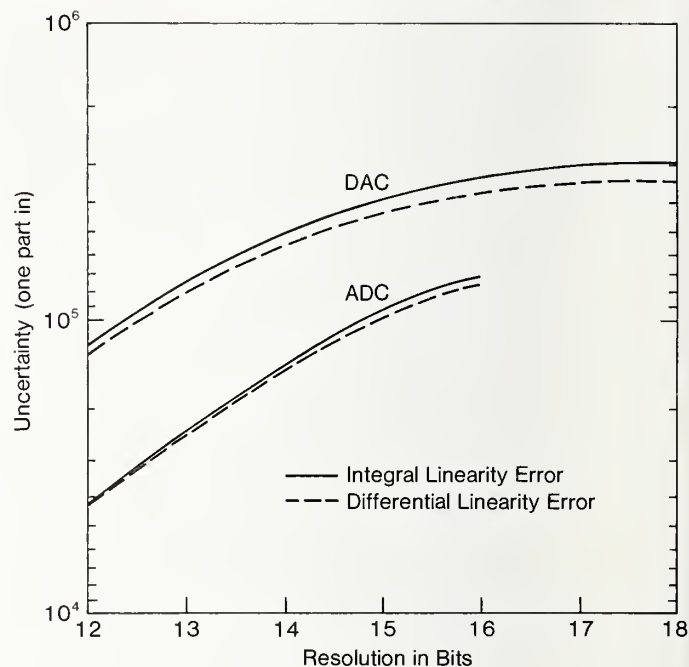
**Figure 10. Uncertainty for NIST Data Converter Test System for Resolutions from 12-18 Bits**

#### Preparation of Test Boards:

In general, the customer is responsible for mounting the integrated circuit, hybrid, or modular test converters on suitable test boards, and for providing all required trimmer circuits, voltage references, input or output amplifiers, recommended power supply decoupling capacitors, and connectors for interfacing to the input/output lines. Fully self-contained converters need only be fitted with the necessary interfacing connectors. In so doing, the customer gains significant performance advantages while at the same time saving the additional fee that would otherwise be charged by NIST for performing this service. High-performance converters are often susceptible to small changes



in grounding, routing of dynamic signal lines, capacitive loading, etc. Particularly with ADC's, signal dynamics are quite important, even for static testing, because the converter itself always operates at high speeds. When mounted by the customer, the test converter and its support circuitry can be laid out to simulate more closely the way it will be used, according to the specific manufacturer's recommendations. Therefore, the test results should more closely describe the converter's in situ performance. Detailed type and wiring requirements for the interfacing connectors are available upon request.

#### References—Data Converters

An Automated Test Set for the Dynamic Characterization of A/D Converters, T. M. Souders, D. R. Flach, and T. C. Wong, IEEE Trans. Instrum. Meas., IM-32, No. 1, 180 (Mar. 1983).

A Calibration Service for Analog-to-Digital and Digital-to-Analog Converters, T. M. Souders, D. R. Flach, and B. A. Bell, Natl. Bur. Stand. (U.S.), Tech. Note 1145 (July 1981). (Provides a complete description of the calibration service.)

A Technique for Measuring the Equivalent RMS Input Noise of A/D Converters, T. M. Souders and J. A. Lechner, IEEE Trans. Instrum. Meas., IM-29, No. 4, 251 (Dec. 1980).

A 20-Bit + Sign Relay Switched D/A Converter, T. M. Souders and D. R. Flach, Natl. Bur. Stand. (U.S.), Tech. Note 1105 (Oct. 1979). (Describes the reference standard used in the calibration service.)

A High-Speed Low-Noise 18-Bit Digital-to-Analog Converter, H. K. Schoenwetter, IEEE Trans. Instrum. Meas., IM-27, No. 4, 413 (Dec. 1978).

## D. Precision Ratio Measurements

### D.1 Inductive Dividers

#### Technical Contacts:



Norman B.  
Belecki  
Tel: 301/975-4223



Denise B.  
Prather  
Administrative  
and Logistics  
Tel: 301/975-4221

**Mailing Address:** B146 Metrology, National Institute of Standards and Technology, Gaithersburg, MD 20899-0001

Test No.	Items
54110S	Special Ratio Measurements and Tests of Inductive Voltage Dividers, by Prearrangement
54120C	Inductive Voltage Dividers—(Single Frequency, Voltage To Be Specified, Each Setting of 3 Most Significant Dials)
54121C	Additional Frequency Points
54130C	Inductive Voltage Dividers—(Single Frequency, Voltage To Be Specified, Each Setting of Most Significant Dial Only)
54131C	Additional Frequency Points

#### Special Ratio Measurements and Tests of Inductive Voltage Dividers, by Prearrangement (54110S)

This service category provides for the measurement and/or evaluation of prototype ratio devices and inductive voltage dividers based on new principles, and for unique ratio measurements at the highest accuracy levels, such as the determination of the ratios of Hamon resistance transfer devices or Silsbee-type voltage ratio standards. Such measurements are undertaken at the discretion of NIST technical staff and only when the need for them can be clearly demonstrated.

#### Inductive Voltage Dividers (54120C-54131C)

Inductive voltage dividers (decade transformer dividers) are accepted for calibration only at 50, 60, 100, 120, 400, 1000, 5000, and 10,000 Hz. The most significant dial only can be calibrated at 15 and 20 kHz.

Calibration voltages may be specified up to 100 V or the manufacturer's specified limit, whichever is lower. The largest contribution to instability in undamaged inductive voltage dividers is wear or dirt in the decade switches. Variable contact resistance in these switches sometimes affects the stability of voltage-ratio measurements to a significant extent but is most evident by its effect on the phase angle. When a decade inductive voltage divider exhibits large changes in phase angle for repeated measurements after the switches have been disturbed, the divider should no longer be considered satisfactory for use as a voltage-ratio reference standard. Inductive voltage dividers that use pushbutton switching or incorporate a resistive divider as a fine adjustment usually are not accepted for calibration.

Corrections to the separate decades of an inductive divider, in general, cannot be simply combined. However, the correction to a step setting of one of the higher decades usually is independent of the setting of the lower decades. The effects of stray impedances must be corrected by connecting the case to the divider at one point, and unless otherwise specified, the case will be connected to one of the "common" terminals, typically marked "GRD," "Case GND," or "Case GRD." Decade inductive voltage dividers are calibrated at NIST at room temperature (22 to 24 °C) by comparison with a two-stage, three-decade transformer of known ratios.

**References-- Inductive Dividers**

American National Standard for Decade Transformer Dividers (Voltage Type), ANSI C100, 1-1972 Amer. Natl. Stand. Inst., New York, NY (Jan. 1972).

Instructions for the Use of the NBS Reference Inductive Divider, Wilbur C. Sze, Natl. Bur. Stand. (U.S.), NBSIR, unpublished (1970). (Available from NIST.)

Two-Stage, Guarded Inductive Voltage Divider for Use at 100 kHz, D. H. Hamon and T. L. Zaf, ISA Transactions, 9, 3, Instrum. Soc. of Amer., Res. Triangle Park, NC (1970).

Comparator for Calibration of Inductive Voltage Dividers from 1 to 10 kHz, W. C. Sze, ISA Transactions, 6, 4, Instrum. Soc. of America, Res. Triangle Park, NC (1967).

## D. Precision Ratio Measurements

### D.2 Resistive Dividers

#### Technical Contacts:



**Martin Misakian**  
(DC Measurements)  
Tel: 301/975-2426



**Richard J. Van Brunt**  
(60-Hz Measurements)  
Tel: 301/975-2425



**Gerald J. Fitzpatrick**  
(Pulsed Measurements)  
Tel: 301/975-2737

**Mailing Address:** B344 Metrology, National Institute of Standards and Technology, Gaithersburg, MD 20899-0001

**Shipping Address:** National Institute of Standards and Technology, I-270 at Quince Orchard Road, Gaithersburg, MD 20899-0001

**For 54210C-54211S:**  
[Attn: M. Misakian, Bldg. 220, Room B351]

**For 54212C-54213S:**  
[Attn: R. J. Van Brunt, Bldg. 202, Room 167]

**For 54214S:**  
[Attn: G. J. Fitzpatrick, Bldg. 202, Room 106]

Test No.	Items
54210C	Resistor and Resistive Dividers, Total Resistance or Voltage Ratio, Two Direct Voltage Levels between 10 kV and 150 kV
54211S	Special Tests of Resistor and Resistive Dividers at Direct Voltage Levels, by Prearrangement
54212C	Resistor and Resistive Dividers at 60 Hz, Voltage Ratio and Phase Angle, between 10 kV and 100 kV rms
54213S	Special Tests of Resistor and Resistive Dividers at 60 Hz, by Prearrangement
54214S	Special Tests of Resistor and Resistive Dividers Under Pulsed High-Voltage Conditions, by Prearrangement

#### Resistor and Resistive Dividers, DC Measurements (54210C-54211S)

A calibration service is maintained at NIST to determine the dc voltage ratio of resistive dividers. The routine calibration service is available for applied voltages from 10 kV to 150 kV. The calibrations are performed with a measurement system which has an uncertainty of  $\pm 0.01$  percent of the voltage ratio. To assure adequate sensitivity at the lowest applied voltage levels, calibrations are performed routinely only on dividers with ratios of 100,000:1 or smaller. The routine calibration service is also restricted to dividers with nominal ratios of 100,000:1, 10,000:1, or 1,000:1.

Resistive dividers are acceptable for calibration only if they are nearly corona free at the rated operating voltage and are designed to have small temperature and voltage coefficients. Specifically, a device is not generally suitable for calibration by NIST if these coefficients produce a change in the ratio of  $\pm 0.1$  percent over the normal range of operating voltages. At a given voltage, dividers should not exhibit instabilities in their ratio value in excess of 0.005 percent. NIST staff can provide some assistance in the identification of other calibration laboratories capable of certifying the response of less accurate dividers.

#### Resistor and Resistive Dividers, 60-Hz Measurements (54212C-54213S)

Resistive dividers of sufficient quality to be considered as transfer standards are calibrated at 60 Hz for applied voltages between 10 kV and 100 kV rms. High-voltage dividers may perform satisfactorily as standards under dc voltages but do not perform well enough to be considered as standards when excited by 60-Hz voltages. The design of an ac divider requires special features, beyond those of a dc divider. In particular, ac dividers designed to be used as transfer standards may have to be equipped with external shielding to minimize the effects of capacitive coupling to surrounding objects.

If the device is not properly shielded, the effects of proximity to surrounding objects and pickup from high-voltage conductors can introduce large uncertainties into the measured value of the divider ratio. In such cases, the measurement of the ratio for one configuration would not necessarily be valid for another configuration. Consequently, a meaningful calibration of the device is difficult or impossible.

Therefore, we recommend that the following two preliminary proximity tests be performed before an ac divider is submitted for test to determine the suitability of the device as a transfer standard. Place the divider about 2.0 m from a vertical ground plane as measured from the center of the device. Energize the divider to some safe high-voltage level and measure the divider ratio. Repeat the measurement with the same applied high voltage but with the vertical ground plane (or divider) moved into a position 1.2 m from the center of the divider. If the measured divider ratio changes by 0.1 percent or more, the device has excessive capacitive coupling and is not suitable as a transfer standard.

To test for pickup, remove the high-voltage connection to the top of the divider and then connect the top of the divider to ground with a thin wire. Measure the output voltage of the divider under these conditions both with and without the high-voltage source energized. If the resulting change in the output voltage exceeds 0.1 percent of the expected output voltage when the high voltage is connected to the divider, then again there is excessive coupling indicating that the device is not suitable as a transfer standard.

High-voltage ac dividers sent to NIST are first subjected to tests like those described above before any measurements are attempted. If such tests show variations in the measured ratio of more than 0.1 percent for

either proximity or pickup, then no further tests will be performed and the device will be returned. Prior to performing any measurements, dividers sent to NIST will also be subjected to a breakdown test at the highest voltage for which measurements are requested. The customer will be charged for the cost of these tests.

NIST calibration of voltage transformers at 60 Hz is generally more accurate than its calibration of dividers at the same frequency. Therefore, customers having a requirement for a calibrated divider may find it advantageous to use a voltage transformer as the transfer standard and to use that transformer to calibrate the divider in their own facilities.

Routine tests are carried out for voltages between 10 kV and 100 kV rms and are performed with a measurement system having an uncertainty of 0.05 percent in the determination of the ratio and  $\pm 0.5$  milliradian in the determination of the phase angle.

#### **Resistor and Resistive Dividers, Pulsed High-Voltage Conditions (54214S)**

Resistive divider ratios are also determined under pulsed high-voltage conditions. All pulsed measurements are by prearrangement. Determinations employ special-design pulse dividers and calibrated Kerr cells as reference standards. A variety of pulses may be applied to simulate the conditions under which the divider will be used. Calibrations are made at selected voltage intervals from 20 kV to 300 kV as requested and up to 500 kV with certain pulse shapes. The typical uncertainty is  $\pm 3$  percent of the voltage ratio although smaller uncertainties can occasionally be reported as a special test.

#### **Shipping:**

Dividers can be hand-carried or shipped to NIST. Shipped dividers should be packaged in sturdy reusable

containers. The design of many high-voltage dividers makes them vulnerable to shear-type forces, so provisions should be made to minimize the likelihood of damage due to such forces when the device is in the shipping container.

#### References—Resistive Dividers

High-Voltage Divider and Resistor Calibrations, M. Misakian, Natl. Bur. Stand. (U.S.), Tech. Note 1215 (July 1985).

Evaluation of a Multimegavolt Impulse Measurement System, R. E. Hebner, D. L. Hillhouse, and R. A. Bullock, Natl. Bur. Stand. (U.S.), NBSIR 77-1933 (Nov. 1979).

Calibration of High-Voltage Pulse Measurement Systems Based on the Kerr Effect, Natl. Bur. Stand. (U.S.), NBSIR 77-1317 (Sept. 1977).

Special Shielded Resistor for High-Voltage Measurements, J. H. Park, J. Res. Natl. Bur. Stand. (U.S.), 66C, No. 1, 19 (Jan.-Mar. 1962).

## D. Precision Ratio Measurements

### D.3 Capacitive Dividers

#### Technical Contacts:



Robert E.  
Hebner, Jr.  
Tel: 301/975-2403



Richard J.  
Van Brunt  
(60-Hz Mea-  
surements)  
301/975-2425



Gerald J.  
Fitzpatrick  
(Pulsed Mea-  
surements)  
Tel: 301/975-2737

**Mailing Address:** B344 Metrology, National Institute of Standards and Technology, Gaithersburg, MD 20899-0001

**Shipping Address:** National Institute of Standards and Technology, I-270 at Quince Orchard Road, Gaithersburg, MD 20899-0001

#### For 54310S:

[Attn: R. J. Van Brunt, Bldg. 202, Room 167]

#### For 54311S:

[Attn: G. J. Fitzpatrick, Bldg. 202, Room 106]

Test No.	Items
54310S	Special Tests of Capacitive Dividers at 60-Hz, by Prearrangement
54311S	Special Tests of Capacitive Dividers Under Pulsed High-Voltage Conditions, by Prearrangement

#### Capacitive Dividers, 60-Hz Measurements (54310S)

Determinations of capacitive divider ratios at 60-Hz ac employ the same equipment used for the calibration of ac resistive dividers (see 54212C).

The same limitations pertain to shielding (proximity and pickup effects). The NIST measurement system imposes a negligible burden on the divider if its output voltage is 100 volts or less. Otherwise, the burden is equivalent to a 1000-picofarad capacitor.

#### Capacitive Dividers, Pulsed High-Voltage Conditions (54311S)

Determinations of capacitive divider ratios under high-voltage pulse conditions employ special-design pulse dividers and calibrated Kerr cells as reference standards. A variety of pulses may be applied to simulate the conditions under which the divider will be used. Calibrations are made at selected voltage intervals from 20 kV to 300 kV as requested and up to 500 kV with certain pulse shapes. The typical uncertainty is  $\pm 3$  percent of the voltage ratio although smaller uncertainties occasionally may be negotiated.

#### References – Capacitive Dividers

High-Voltage Divider and Resistor Calibrations, M. Misakian, Natl. Bur. Stand. (U.S.), Tech. Note 1215 (July 1985).

Evaluation of a Multimegavolt Impulse Measurement System, R. E. Hebner, D. L. Hillhouse, and R.A. Bullock, Natl. Bur. Stand. (U.S.), NBSIR 79-1933 (Nov. 1979).

Calibration of High-Voltage Pulse Measurement Systems Based on the Kerr Effect, Natl. Bur. Stand. (U.S.), NBSIR 77-1317 (Sept. 1977).

Special Shielded Resistor for High-Voltage Measurements, J. H. Park, J. Res. Natl. Bur. Stand. (U.S.), 66C, No. 1, 19 (Jan.-Mar. 1962).

## D. Precision Ratio Measurements

### D.4 Mixed Dividers

#### Technical Contact:



Gerald J.  
Fitzpatrick  
Tel: 301/975-2737

Mailing Address: B344 Metrology, National Institute of Standards and Technology, Gaithersburg, MD 20899-0001

---

#### Test No. Items

---

54410S	Pulse Voltage Measuring Systems, Including Kerr Cells
--------	--

---

#### Mixed Dividers (54410S)

A mixed divider is one constructed of resistors and capacitors. Ratios of mixed-voltage dividers are determined under pulsed, high-voltage transient conditions. Determinations employ specially-designed pulse voltage dividers and calibrated Kerr cells as reference standards. A variety of pulse waveshapes may be applied to simulate the conditions under which the divider will be used. Calibrations are made at selected voltage intervals from 20 kV to 300 kV as requested and up to 500 kV with certain pulse shapes. The typical uncertainty is  $\pm 3$  percent of the voltage ratio although smaller uncertainties can occasionally be reported as a special test.

#### References – Mixed Dividers

- Evaluation of a Multimegavolt Impulse Measurement System, R. E. Hebner, D. L. Hillhouse, and R. A. Bullock, Natl. Bur. Stand. (U.S.), NBSIR 79-1933 (Nov. 1979).
- Calibration of High-Voltage Pulse Measurement Systems Based on the Kerr Effect, Natl. Bur. Stand. (U.S.), NBSIR 77-1317 (Sept. 1977).
- Special Shielded Resistor for High-Voltage Measurements, J. H. Park, J. Res. Natl. Bur. Stand. (U.S.), 66C, No. 1, 19 (Jan.-Mar. 1962).



## D. Precision Ratio Measurements

### D.5 Voltage and Current Transformers

#### Technical Contacts:



**James K. Olthoff**  
(Voltage Transformers)  
Tel: 301/975-2431

**Thomas L. Nelson**  
(Current Transformers)  
Tel: 301/975-2416

**Mailing Address:** B344 Metrology, National Institute of Standards and Technology, Gaithersburg, MD 20899-0001

**Shipping Address:** National Institute of Standards and Technology, I-270 at Quince Orchard Road, Gaithersburg, MD 20899-0001

#### For 54510C-54513C:

[Attn: J. K. Olthoff, Bldg. 202, Room 167]

#### For 54520C-54522C:

[Attn: T. L. Nelson, Bldg. 220, Room B165]

Test No.	Items
54510C	Voltage Transformer, Ratio & Phase Angle, at 60 Hz on 1 Range, 1 Secondary Voltage, 1 Burden Primary $V_{rms} \leq 150$ kV
54511C	Same as 54510C, Additional Similar Transformer at Same Time
54512C	Same as 54510C and 54511C, Additional Burden or Range
54513C	Same as 54510C-54512C, at Each Additional Secondary Voltage
54520C	Current Transformer, Ratio & Phase Angle, 1 Range at 1 Frequency and 1 Burden, Secondary Currents 0.5, 1, 2, 3, 4, 5 A, Primary Current Not Over 12,000 A
54521C	Current Transformer, Ratio & Phase, 1 Secondary Current, Additional Combination of Range, Frequency, and Burden, Primary Current Not Over 12,000 A
54522C	Current Transformer, Ratio & Phase at Each Additional Secondary Current, Same Combination of Range, Frequency, and Burden as 54520C or 54521C
54600S	Special Tests of Dividers and Transformers, by Prearrangement

#### Voltage Transformers (54510C-54513C)

NIST provides routine services for the measurement of complex voltage ratios (magnitude and phase angle) of transformers for primary voltages up to 150 kV and for secondary voltages above 50 V, subject to some constraints as to the maximum physical size of the device. Results of these routine tests are reported with an uncertainty of  $\pm 0.03$  percent for ratio and 0.3 mrad (1 mrad = 3.438 min) for phase angle. If the test conditions and the device under test warrant, special tests with smaller uncertainties can be performed. These special tests may require an extra fee.

The customer must specify the secondary voltage and the secondary burden for each transformer or for each range of a multirange transformer. Ambiguity can be avoided if the impedance and power factor, or the resistance and reactance, are specified rather than the volt-ampere rating of each burden. The customer should note that the NIST calibration system represents a minimum burden of 1000 pF for routine calibrations. The customer should give some care to the specification of a burden recognizing that the use of the transformer with a burden different from that used in the calibration can result in significant error.

Calibrations of voltage transformers are performed routinely only at 60 Hz. Measurements are made with one side of both the primary and secondary windings connected to ground.

NIST does have some capability to perform measurements at voltages, frequencies, and burdens outside of the ranges described above. Calibrations can occasionally be provided at these nonroutine test points as a special test for an increased fee.

### **Current Transformers (54520C-54522C)**

Normally NIST calibrates only current transformers of high quality for use as reference standards. The NIST equipment is designed to test current transformers with a rated secondary current of 5 A, with test points chosen to be one or more of the following values: 0.5, 1, 2, 3, 4, 5 A.

Routine tests are carried out at 50, 60, and 400 Hz. For measurements at 50 or 60 Hz, the results are generally reported with an uncertainty of  $\pm 0.01$  percent in ratio and  $\pm 0.1$  mrad in phase angle. For measurements at 400 Hz, the reported uncertainty is  $\pm 0.03$  percent in ratio and  $\pm 0.3$  mrad in phase angle.

The customer must specify the test frequency, the secondary currents, and the secondary burdens for each transformer or for each range of a multirange transformer. Current transformers should be tested with burdens equivalent to those which are imposed when the device is used as a transfer standard. Routine calibration using the burdens specified in the American National Standards Institute (ANSI) Standard C-57.13 is not recommended unless these burdens are subsequently used in the customer's factory or laboratory. Large errors can result if the values of ratio and phase angle obtained with an ANSI recommended burden are used for the transformer when it is connected to a different burden.

Preferably the burden should be specified in terms of the measured resistance and inductance. These values should include the effects of the leads used to make a connection to the transformer secondary. An alternative, which is sometimes feasible, is to submit the transformer together with its normal leads and connected burden for calibration as a unit. If neither of the above are possible, the burden may be stated in terms of the voltampere product and the power factor of the secondary circuit at the test frequency. For reference, it

should be noted that the test equipment regularly used at NIST represents a minimum test burden of about 0.03 ohms with a inductance of about 10  $\mu$ H.

Because of contact resistance and current rectification, loose or dirty primary and secondary terminations may affect the measurement results. These surfaces should be tight and clean when the transformer is shipped to NIST to minimize this source of error.

Unless otherwise specified, current transformers are demagnetized prior to calibration. If it is desired to have a transformer tested as submitted (without demagnetization), this requirement should be stated on the purchase order and NIST staff should be informed by telephone before the transformer is shipped.

Many current transformers are not designed to be used as transfer standards, and most of these do not require calibration at NIST. NIST staff can provide some assistance in the assessment of the appropriateness of the device for NIST calibration and in the identification of alternative calibration sources. If NIST is required to perform laboratory measurements to determine whether or not a particular device can be calibrated, a charge for the cost of these measurements will be made.

### **Special Tests of Dividers and Transformers (54600S)**

The Electricity Division maintains an active program of research and development in the area of electrical measurements at high-voltage levels. For this reason, NIST often is able to provide measurement support for high-voltage devices other than those listed above in this section. Special tests will generally be conducted by NIST, if the following criteria are met:

A. The requested tests are fully developed and documented.

B. There is a significant technical or economic justification for traceability of the test on the item to national standards.

C. There has not been a routine or recurrent need for the test.

#### **References-- Voltage and Current Transformers**

A Calibration Service for Voltage Transformers and High-Voltage Capacitors, W. E. Anderson, Natl. Bur. Stand (U.S.), Spec. Publ. 250-33 (June 1988).

An Electronic Ratio Error Set for Current Transformer Calibrations, R. L. Kahler, IEEE Trans. Instrum. Meas., IM-28, No. 2, 162 (June 1979).

A Wide-Range High-Voltage Capacitance Bridge with One-ppm Accuracy, O. Petersons and W. E. Anderson, IEEE Trans. Instrum. Meas., IM-24, No. 4, 336 (Dec. 1975).

Wide-Band Two-Stage Current Transformers of High Accuracy, T. M. Souders, IEEE Trans. Instrum. Meas., IM-21, No. 4, 340 (Nov. 1972).

A Wide-Range Current Comparator System for Calibrating Current Transformers, T. M. Souders, IEEE Trans. Power Appar. Syst. PAS-90 No. 1, 318 (Jan.-Feb. 1971).

## E. Phase Measurements

### E.1 Phase Meters and Standards

#### Technical Contacts:



Raymond S.  
Turgel  
Tel: 301/975-2420

Barry A. Bell  
Tel: 301/975-2419

Mark E. Parker  
Tel: 301/975-2413

Mailing Address: B162 Metrology, National Institute of Standards and Technology, Gaithersburg, MD 20899-0001

Test No.	Items
55110S	Special Tests of Phase Standards and Related Instruments, by Prearrangement
55120C	Phase Meters—One Combination of Input Voltages (0.5 V to 100 V rms) at one Frequency (2 Hz to 50 kHz)—the Input Voltage Ratio Shall Not Exceed 10
55121C	Phase Meters—Each Additional Combination of Input Voltages (0.5 V to 100 V rms) at the Same or at a Different Frequency (2 Hz to 50 kHz)—the Input Voltage Ratio Shall Not Exceed 10
55130C	Phase Meters—One Combination of One Input Voltage (0.5 V to 120 V rms) and One Input Current (1 to 5 A rms) at One Frequency (2 Hz to 5 kHz)
55131C	Phase Meters—Each Additional Combination of One Input Voltage (0.5 V to 120 V rms) and One Input Current (1 to 5 A rms)
55140C	Phase Meters—One Input Voltage (0.5 V to 120 V rms) and Another Input Voltage (0.5 V to 100 V rms) at One Frequency (2 Hz to 5 kHz)
55141C	Phase Meters—Each Additional Combination of One Input Voltage (0.5 V to 120 V rms) and Another Input Voltage (0.5 V to 100 V rms) at the Same or at a Different Frequency (2 Hz to 5 kHz)

#### Special Tests of Phase Standards and Related Instruments, by Prearrangement (55110S)

NIST will perform special-test phase angle measurements on phase angle generators, quadrature detectors, and phase bridge-networks. Restrictions apply, and technical limitations and

arrangements for these tests should be discussed with NIST; prior arrangements are essential.

#### Phase Meters (55120C-55141C)

NIST has a capability for characterizing audio frequency phase meters over a frequency range of 2 Hz to 50 kHz. The standard used is a micro-computer-based system that synthesizes two sinusoidal voltages by means of digital techniques. The two signals are displaced relative to one another by a precisely known phase angle. Phase angles can be set with a resolution of 0.002 degree up to 5 kHz and 0.005 degree above 5 kHz. The amplitude of the two output signals can be varied independently from 0.5 volt to 100 volts rms. At power frequencies, one of the signals can be a current from 0.5 to 5 amperes. The uncertainty in setting the standard is less than  $\pm 0.01$  degree below 5 kHz and increases to  $\pm 0.04$  degree at 50 kHz if the two output signals have the same amplitude. For unequal outputs, this uncertainty increases to  $\pm 0.015$  degree and  $\pm 0.090$  degree respectively, if the amplitude ratio is less than 10:1.

Although the accuracy of the phase angle standard does not rely on the stability of the frequency, the generated output, which can be varied in steps of 1 Hz, is locked to a crystal-controlled frequency synthesizer.

Figure 11 shows a plot of the total estimated uncertainty of the NIST Phase Angle Calibration Standard as a function of frequency for two limiting amplitude ratios.

Figure 11. Estimated Total Uncertainties of the NIST Phase Angle Calibration Standard

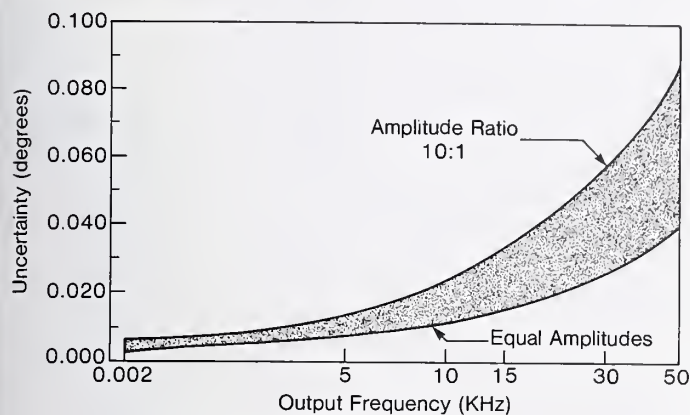

Special requirements for this service are as follows:

A. The voltage inputs of phase meter to be tested must have impedances such that the current is limited to a few milliamperes at any applied voltage requested. Current inputs must have impedances low enough so that the compliance voltage does not exceed 2 volts.

B. NIST will test the instrument in the as-received condition, without making any zero or gain adjustments.

C. In some cases, the response of phase meters involves significant time constants; in these cases, readings will be taken 30 seconds after the setting of the standard.

D. For given voltage and frequency settings, at least three readings will be taken at each specified phase angle. The order of readings will be randomized.

E. The experimental data are fitted to a mathematical model from which the phase meter response can be predicted. From the closeness of fit to the model, it can be determined whether observed deviations from the predicted values are significant.

F. Each phase meter will be operated under power for at least 2 hours before test data are taken.

G. Meters that are not in operating condition upon receipt at NIST will be returned to the owner without repairs.

#### References—Phase Meters

- NBS Measurement Services: Phase Angle Calibration Services, R. S. Turgel, J. M. Mulrow, and D. F. Vecchia, Natl. Bur. Stand. (U.S.), Spec. Publ. 250-26 (May 1988).
- Phase Meter Calibrations at NBS, R. S. Turgel, J. Res. Natl. Bur. Stand. (U.S.), 93, No. 1, 53-59 (Jan. 1988).
- Precision Calibration of Phase Meters, R. S. Turgel and D. F. Vecchia, IEEE Trans. Instrum. Meas., IM-36, No. 4, 915-922 (Dec. 1987).
- NBS 50-kHz Phase Angle Calibration Standard, R. S. Turgel, Natl. Bur. Stand. (U.S.), Tech. Note 1220 (Apr. 1986).
- A Wideband Transconductance Amplifier for Current Calibrations, O. B. Laug, IEEE Trans. Instrum. Meas., IM-34, No. 4, 639-643 (Dec. 1985).
- A Precision Phase Angle Calibration Standard for Frequencies Up to 50 kHz, R. S. Turgel, IEEE Trans. Instrum. Meas., IM-34, No. 4, 509-516 (Dec. 1985).
- NBS Phase Angle Calibration Standard, R. S. Turgel, N. M. Oldham, G. N. Stenbakken, and T. H. Kibalo, Natl. Bur. Stand. (U.S.), Tech. Note 1144 (July 1981).
- A High-Performance Phase-Sensitive Detector, L. A. Marzetta, IEEE Trans. Instrum. Meas., IM-27, No. 4, 460-464 (Dec. 1978).
- High-Precision Audio-Frequency Phase Calibration Standard, R. S. Turgel and N. M. Oldham, IEEE Trans. Instrum. Meas., IM-27, No. 4, 460-464 (Dec. 1978).

# E. Phase Angle Measurements and Air Navigation Aids

## E.2 Very-High-Frequency Omnidirectional Range (VOR) Measurements

### Technical Contacts:



Neil T. Larsen  
Tel: 303/497-3711



David H. Russell  
Tel: 303/497-3148



Kathy Hillen  
Administrative  
and Logistics  
Tel: 303/497-3753

**Mailing Address:** M.C. 813.10, National Institute of Standards and Technology, 325 Broadway, Boulder, CO 80303-3328

Test No.	Items
55210C	VOR Bearing-Angle Indicators, 12 Bearing Angles Over the Range 0 to 330 Degrees
55211C	Calibration of VOR Bearing-Angle Indicator at Each Additional Angle
55220C	VOR Generators, 12 Bearing-Angle Equivalent Signals Over the Range 0 to 330 Degrees
55221C	Calibration of VOR Generator at Each Additional Angle
55230S	Special VOR Tests

### VOR Measurements – General Information

The NIST calibration services for VOR air navigation signals are described in detail in VOR Calibration Service, NBS Technical Note 1069 (see references).

Two services are offered to support the calibration of VOR (Very-high-frequency Omnidirectional Range) instruments. NIST has designed and built a standard VOR audio generator, used to calibrate unknown VOR bearing-angle indicators, and a standard VOR bearing-angle indicator, used to calibrate unknown audio generators. Direct generation or

measurement of standard VOR rf signals are not a part of the service.

Quality control of the NIST standards is accomplished by using each to measure the other. As a result of these measurements, the uncertainty of a calibration of either a generator or a bearing-angle indicator is given by the following statement, which is part of the calibration report:

“The assigned values of VOR bearing angles are the nominal bearings from 0 to 360 degrees in increments of 0.01 degrees. The overall uncertainty of these values has been estimated from test data at bearings from 0 degrees to 360 degrees at 30-degree increments. Thus, each of the nominal bearings has been assigned a provisional overall uncertainty of  $\pm 0.0017$  degrees, based on estimated bounds of 0.00065 degrees on the systematic error and a computed standard error of 0.00105 degrees.”

### VOR Bearing-Angle Indicators (55210C and 55211C)

An unknown bearing-angle indicator is calibrated by connecting its input to the output of the NIST standard generator. The generator provides a composite audio signal that is the sum of two signals, each 1 volt rms ( $\pm 1$  percent) in amplitude. The first signal is a 30-Hz sinusoid and represents the variable phase signal recovered from the VHF carrier. The second is the frequency-modulated 9960-Hz subcarrier. NIST will calibrate at any set of 12 bearing angles specified by the customer (if not specified, at 30-degree intervals over the inclusive range 0 to 330 degrees).

**VOR Generator (55220C and 55221C)**

Only certain commercial VOR generators are suitable for calibration. They should provide a composite audio signal of nominally 1 volt rms, per tone. They must have a short-term phase jitter of less than 10 nsec. The modulation index for the 9960-Hz subcarrier must be equal to  $16 \pm 1$  percent. Most commercial generators do not meet these requirements and can best be calibrated by submitting a bearing-angle indicator for calibration instead. This can then be used to transfer the NIST calibration to the unknown generator with some loss of accuracy. An uncertainty statement for this transfer has not been developed due to lack of history. NIST will calibrate at any set of 12 bearing-angle equivalent signals corresponding to bearing-angles specified by the customer (if not specified, at 30-degree intervals over the inclusive range 0 to 330 degrees).

**Special VOR Tests (55230S)**

The NIST standard bearing-angle indicator lends itself to the measurement of audio frequency periodic waveforms through the use of sampling techniques and time series analysis. It has been used for the accurate measurement of phase angles between two sinusoids. Special tests of this nature may be provided by prearrangement. The uncertainty depends upon the frequency; at 30 Hz it is about 0.0006 degrees (3 standard deviations).

**References – VOR Measurements**

VOR Calibration Services, N. T. Larsen, D. F. Vecchia, and G. R. Sugar, Natl. Bur. Stand. (U.S.), Tech. Note 1069 (April 1985).  
Fourier Transformation of the Non-linear VOR Model to Approximate Linear Form, D. F. Vecchia, Natl. Bur. Stand. (U.S.), Tech. Note 1021 (June 1980).

## F. Power and Energy Measurements, Low-Frequency

### Technical Contacts:



Andrew J.  
Secula  
Tel: 301/975-2416

Thomas L.  
Nelson  
Tel: 301/975-2427

**Mailing Address:** B344 Metrology, National Institute of Standards and Technology, Gaithersburg, MD 20899-0001

**Shipping Address:** National Institute of Standards and Technology, I-270 at Quince Orchard Road, Gaithersburg, MD 20899-0001  
[Attn: A. J. Secula, Bldg. 220, Room B165]

Test No.	Items
56110S	Special Tests of AC-DC Wattmeters, by Prearrangement
56200C	Watt, Watthour Var or Varhour Meter, Initial Two Determinations of Percentage Registration of Same Meter at 60 Hz
56201C	Each Additional Determination of Percentage Registration of Same Meter at 50/60 Hz
56202C	Initial Two Determinations of One or Two Meters Run Simultaneously with the First (56200C)
56210M	Measurement Assurance Program for Watthour Meters

### Power and Energy Measurements, Low-Frequency (56110S-56210M)

Only standard electronic-type watt, watthour, var and varhour meters are accepted for test. Rotating types are no longer accepted except by special arrangement. If necessary, the meters should be cleaned or adjusted by the customer before they are shipped to NIST. NIST does not adjust meters and does not knowingly begin tests of faulty meters.

The test conditions must be specified by the customer. These include the current and voltage ranges to be tested, the frequency, the applied voltages, the applied currents, and the power factors. Values of these parameters which are available for routine testing are summarized in Table 21.

**Table 21:** Available Values of the Parameters for Routine Wattmeter, Watthour Varmeter and Varhour Testing

Parameter	Available Values
Voltage (V)	69 to 480
Current (A)	0.5 to 30
Power Factor	0 to 1.0
Phase Angle	0 to 360°
Frequency (Hz)	50*, 60, 400*

\* Tests at 50 and 400 Hz are limited to voltages of 240 V or less and currents of 5 A or less.

If necessary, measurements can sometimes be made at other values of these parameters. These would, however, be considered special tests. Separate, specific arrangements and a higher fee will be charged than for a routine calibration.

Prior to the calibration, the meters are energized for between 1 and 4 hours at rated voltage and current on one range. A calibration consists of at least two sets of measurements taken over a minimum period of 2 days.



For wattmeters, the values of the reported corrections (in watts) generally have uncertainties of  $\pm 0.05$  percent of the full scale range in volt-amperes. For watthour meters, the reported values of the percentage registration generally have uncertainties of  $\pm 0.05$  percent of the indicated value. Special, higher accuracy tests can be arranged for an additional fee. The uncertainties for power or energy measurements in these special tests may be as low as  $\pm 0.01$  percent if the short-term standard deviation of the device under test is appropriately small. For the highest accuracy, voltages are limited to 120 V and currents to 5 A.

Wattmeter calibrations at other than power frequencies are considered Special Tests and must be arranged on an individual basis. The following limitations apply:

A. Instruments must have separate voltage and current input terminals.

B. The instrument must have a self-contained power indicator, or provide a direct current or voltage signal which is proportional to power, or provide an output frequency which is proportional to the power.

C. Measurements are generally limited to sinusoidal signals at frequencies between dc and 100 kHz. Input signal levels should not exceed 240 V and 5 A.

D. Instruments will be tested in the as-received condition, and test uncertainties will be based in part on the performance of the instrument during the test.

The Measurement Assurance Program for electric energy is designed to evaluate the performance of energy-measuring systems at the customer's laboratory. A NIST-owned, transport standard watthour meter of

known stability is measured by NIST. It is then shipped to and measured by the customer, and shipped back to NIST. NIST analyzes the data and provides a report to the customer indicating the total uncertainty of his measurement. This procedure enables the customer's standards to be measured relative to NIST standards without the downtime encountered when the customer's standards are shipped to and calibrated by NIST. In addition, and more important to those who calibrate standard watthour meters, the NIST MAP standard can be used by customers to evaluate their measurement process in a convenient and cost-effective way.

The uncertainty of a MAP includes the effects of the long-term and short-term instabilities of the NIST calibration system, the customer's calibration system, and the transport standard. Typically, the uncertainty in a well-controlled comparison ranges between  $\pm 0.03$  percent and  $\pm 0.05$  percent.

The Electricity Division maintains an active program of research and development in the area of electric power and energy measurements. This program often enables NIST to provide measurement support for watt and watthour meters beyond that listed in this section. Special tests will generally be conducted when the following conditions prevail:

A. The requested tests are fully developed and documented.

B. There is a significant technical or economic justification for traceability of the test on the item to national standards.

C. There has not been a routine or recurrent need for the test.

**References—Power and Energy Measurements, Low Frequency**

- Digitally Synthesized Power Calibration Source, N. M. Oldham, O. B. Laug, and B. C. Waltrip, IEEE Trans. Instrum. Meas., IM-36, No. 2, 341 (June 1987).
- NBS Wideband Sampling Wattmeter, G. N. Stenbakken, O. B. Laug, A. G. Perry, B. A. Bell, and T. H. Kibalo, Natl. Bur. Stand. (U.S.), Tech. Note 1221 (May 1987).
- A Wideband Sampling Wattmeter, G. N. Stenbakken, IEEE Trans. Power Appar. Syst., PAS-103, No. 10, 2919 (Oct. 1984).
- A Calibration Service for Wattmeters and Watthour Meters, J. D. Ramboz and R. C. McAuliff, Natl. Bur. Stand. (U.S.), Tech. Note 1179 (July 1983).
- A Measurement Assurance Program for Electric Energy, N. M. Oldham, Natl. Bur. Stand. (U.S.), Tech. Note 930 (Sept. 1976).
- Transfer of the Kilowatthour, S. R. Houghton, IEEE Trans. Power Appar. Syst., PAS-94, No. 4, 1232 (July-Aug. 1975).
- Sampling Techniques for Electric Power Measurement, R. S. Turgel, Natl. Bur. Stand. (U.S.), Tech. Note 870 (June 1975).
- A Current Comparator System to Establish the Unit of Electrical Energy at 60 Hz, K. J. Lentner, IEEE Trans. Instrum. Meas., IM-23, No. 4, 334 (Dec. 1974).

# G. Microwave Measurements

## G.1 Bolometer Units, RF and Microwave

### Technical Contacts:



**Ronald A. Glnley**  
Tel: 303/497-3634



**Manley P. Weidman**  
Tel: 303/497-3516



**Kathy Hillen**  
Administrative  
and Logistics  
Tel: 303/497-3753

**Mailing Address:** M.C. 813.10, National Institute of Standards and Technology, 325 Broadway, Boulder, CO 80303-3328.

Test No.	Items
61110S	Effective Efficiency and Reflection Coefficient of Coaxial Thermistor Mounts at Specified Frequency in Range 0.1 to 10 MHz
61111S	Each Additional Frequency for 61110S
61120S	Calibration Factor, Effective Efficiency, and Reflection Coefficient of Coaxial Thermistor Mounts at 10 MHz intervals within 10-100 MHz
61121S	Calibration Factor, Effective Efficiency, and Reflection Coefficient of Coaxial Thermistor Mounts at 25 MHz intervals within 100-500 MHz and 1000 MHz
61122S	Calibration Factor, Effective Efficiency, and Reflection Coefficient of Coaxial Thermistor Mounts at 10 MHz intervals within 10-100 MHz and 25 MHz intervals within 100-500 MHz and 1000 MHz
61123S	Calibration Factor, Effective Efficiency, and Reflection Coefficient of Coaxial Thermistor Mounts at 50-MHz Intervals within 1-2 GHz
61124S	Calibration Factor, Effective Efficiency, and Reflection Coefficient of Coaxial Thermistor Mounts at 100-MHz Intervals within 2-4 GHz
61125S	Calibration Factor, Effective Efficiency, and Reflection Coefficient of Coaxial Thermistor Mounts at 200-MHz Intervals within 4-8 GHz

Test No.	Items
61126S	Calibration Factor, Effective Efficiency, and Reflection Coefficient of Coaxial Thermistor Mounts at 200-MHz Intervals in the Range 8-12.4 GHz
61127S	Calibration Factor, Effective Efficiency, and Reflection Coefficient of Coaxial Thermistor Mounts at 250-MHz Intervals in the Range 12.4-18 GHz
61128S	Calibration Factor, Effective Efficiency, and Reflection Coefficient of Coaxial Thermistor Mounts at 1-GHz Intervals in the Range 1-18 GHz
61129S	Calibration Factor, Effective Efficiency, and Reflection Coefficient of Coaxial Thermistor Mounts at 1-GHz Intervals in the Range 18-26 GHz
61144S	Calibration Factor, Effective Efficiency, and Reflection Coefficient of Rectangular-Waveguide Thermistor Mounts at 200-MHz Intervals within 8.2-12.4 GHz (WR90)
61146S	Calibration Factor, Effective Efficiency, and Reflection Coefficient of Rectangular-Waveguide Thermistor Mounts at 250-MHz Intervals within 12.4-18.0 GHz (WR62)
61147S	Calibration Factor, Effective Efficiency, and Reflection Coefficient of Rectangular-Waveguide Thermistor Mounts at a Specified Frequency within 18-26.5 GHz (WR42)
61148S	Calibration Factor, Effective Efficiency, and Reflection Coefficient of Rectangular-Waveguide Thermistor Mounts at a Specified Frequency within 26.5-40 GHz (WR28)
61149S	Calibration Factor, Effective Efficiency, and Reflection Coefficient of Rectangular-Waveguide Thermistor Mounts at a Specified Frequency within 42-46 GHz (WR22)
61155S	Calibration Factor, Effective Efficiency, and Reflection Coefficient of Rectangular-Waveguide Thermistor Mounts of Specified Frequency within 94-96 GHz (WR10)
61190S	Special Microwave and RF Power Measurement Services, by Prearrangement

### Coaxial Thermistor Mounts, RF and Microwave (61110S-61190S)

Calibration services are available for thermistor mounts with 7 mm, Type N, and 3.5 mm connectors. Thermistor-type bolometer units have shown adequate stability over long periods of time (approximately 10 years) and warrant long recalibration intervals. Three to five year recalibration intervals are recommended once the stability of a bolometer unit has been verified.

Assistance is available for applying published, technically valid measurement techniques in lieu of previously available NIST calibration services for coaxial and waveguide calorimeters, thermoelectric power meters, and bolometer coupler units. The attainable limits of measurement uncertainty using these techniques are comparable to those of the previously available calibration services for these devices.

The calibration reports give the magnitude of the reflection coefficient, effective efficiency, and calibration factor of the bolometer unit.

#### *Definitions:*

Calibration results are reported in the following quantities:

#### Effective Efficiency $\eta_e$

The effective efficiency  $\eta_e$  is the ratio of the bolometrically substituted dc power in the bolometer unit to the net cw rf microwave power absorbed by the bolometer unit.

### Bolometrically Substituted dc Power

The bolometrically substituted dc power is the change in dc (or audio frequency) bias power required to maintain the resistance of the bolometer element at a constant value following the application of rf or microwave power.

#### Calibration Factor, $K_B$

The calibration factor is the ratio of the bolometrically substituted dc power in the bolometer unit to the cw rf microwave power incident upon the bolometer unit.

$$K_B = \eta_e(1 - |\Gamma|^2).$$

#### Reflection Coefficient Magnitude, $|\Gamma|$

The reflection coefficient magnitude is the ratio of the reflected wave voltage amplitude to the incident wave voltage amplitude. The reflection coefficient magnitude is included in the Report of Calibration for all power measurements. All calibrations are performed under typical ambient laboratory conditions at 23 °C, and an atmospheric pressure of approximately  $8.4 \pm 0.2 \times 10^4$  Pa at Boulder, Colorado.

### Coaxial Thermistor Mounts (61110S-61129S)

Only bolometer units designed for low-frequency operation will be calibrated below 100 MHz.

Specify frequency in range 0.1 to 10 MHz for special low-frequency bolometer units (Test No. 61111S). Values for  $\eta_e$  and  $|\Gamma|$  are calculated from voltage and resistance measurements.

$\eta_e = (P_{dc})/(P_{rf})$ , where  $P_{rf} = V^2/R_P$ , where  $R_P$  is the parallel equivalent resistance and  $P_{dc}$  is the bolometrically substituted dc power in the bolometer. The uncertainty in measuring  $\eta_e$  is  $\pm 0.3$  percent.

Measurements are made at the following frequencies:

Range	Frequency or Interval
10-100 MHz	10 MHz intervals
100-500 MHz	25 MHz intervals
1000 MHz	1000 MHz
1-2 GHz	50-MHz intervals
2-4 GHz	100-MHz intervals
4-8 GHz	200-MHz intervals
8-12.4 GHz	200-MHz intervals
12.4-18 GHz	250-MHz intervals
18-26.5 GHz	1 GHz intervals

Measurement uncertainties for effective efficiency and calibration factor will vary from approximately 1.0 to 3.5 percent depending on the frequency and the characteristics of the unit being calibrated such as connector type, reflection coefficient, and repeatability.

### Waveguide Thermistor Mounts (61144S-61155S)

Measurements of effective efficiency, efficiency factor, and reflection coefficient are made for various waveguide sizes as follows:

Waveguide	Frequency Range (GHz)	Measurement Frequency or Interval
WR90	8.2-12.4	200-MHz intervals
WR62	12.4-18.0	250-MHz intervals
WR42	18-26.5	Specify frequency
WR28	26.5-40	Specify frequency
WR22	42-46	Specify frequency
WR10	94-96	Specify frequency

The measurement uncertainty of effective efficiency will vary from 1 to 3.5 percent depending on the frequency and the characteristics of the unit being calibrated.

### References - Power Meters, RF and Microwave

- WR-10 Millimeter Wave Microcalorimeter, M. Weidman and P. Hudson, Natl. Bur. Stand. (U.S.), Tech. Note 1044 (June 1981).
- A Semiautomated Six-Port for Measuring Millimeter-Wave Power and Complex Reflection Coefficient, M. Weidman, IEEE Trans. Micro. Theory Tech., MTT-25, 12 (Dec. 1977).
- Performance Characteristics of an Automated Broad-Band Bolometer Unit Calibration System, E. Komarek, IEEE Trans. Micro. Theory Tech., MTT-25, 12 (Dec. 1977).
- Theory of UHF and Microwave Measurements Using the Power Equation Concept, G. Engen, Natl. Bur. Stand. (U.S.), Tech. Note 637 (Apr. 1973).

- Application of an Arbitrary Six-Port Junction to Power Measurement Problems, G. Engen and C. Hoer, IEEE Trans. Instrum. Meas., IM-21, 470 (Nov. 1972).
- WR-15 Microwave Calorimeter and Bolometer Unit, M. Harvey, Natl. Bur. Stand. (U.S.), Tech. Note 618 (May 1972).
- Accurate Microwave High-Power Measurements Using a Cascaded Coupler Method, K. E. Bramall, J. Res. Natl. Bur. Stand. (U.S.), 75C, Nos. 3 and 4, 185 (July-Dec. 1971).
- A Method of Determining the Mismatch Correction in Microwave Power Measurements, G. Engen, IEEE Trans. Instrum. Meas., IM-17, 4 (Dec. 1968).
- Bolometric Microwave Power Calibration Techniques at the National Bureau of Standards, R. F. Desch and R. E. Larson, IEEE Trans. Instrum. Meas., IM-12, 1 (June 1963).
- A Bolometer Mount Efficiency Measurement Technique, G. Engen, J. Res. Natl. Bur. Stand. (U.S.), 65C, 113 (Apr.-June 1961).
- A Transfer Instrument for the Intercomparison of Microwave Power Meters, G. Engen, IRE Trans. Instrum. Meas. 19, 202 (Sept. 1960).
- A Refined X-Band Microwave Microcalorimeter, G. Engen, J. Res. Natl. Bur. Stand. (U.S.), 63C, 77 (1959).

## G. Microwave Measurements

### G.2 Attenuators, RF and Microwave

#### Technical Contacts:



Ronald A. Ginley  
Tel: 303/497-3634



Manley P.  
Weidman  
Tel: 303/497-3516



John R. Juroshek  
Tel: 303/497-5362



Kathy Hillen  
Administrative  
and Logistics  
Tel: 303/497-3753

**Mailing Address:** M.C. 813.10, National Institute of Standards and Technology, 325 Broadway, Boulder, CO 80303-3328

Test No.	Items
61210S	Coaxial Fixed and Variable Attenuators, Frequency Range 10 MHz to 26 GHz, Attenuation 0 to 50 dB
61211C	Coaxial Fixed and Variable Attenuators, Measured at 30 MHz, Attenuation 0 to 120 dB
61215C	Waveguide-Below Cutoff (Piston) Attenuators, Coaxial Connector, Measured at 30 MHz, Attenuation 0-120 dB (Total Insertion Loss)
61230S	Rectangular Waveguide Fixed and Variable Attenuators, Specify Frequencies for Waveguide Sizes WR10, WR22, WR28, and WR42, 0-50 dB
61240S	Attenuation Measurements of Three-Port and Two-Port Devices at 1.25 MHz, 0-6 dB
61250S	Special Attenuation Measurements, by Prearrangement

#### Attenuators, RF and Microwave (61210S-61250S)

Specific attenuation measurements are available for 14 mm, 7 mm, Type N, and 3.5 mm connectors. Measurements not listed may possibly be provided (61250S) if sufficient advance notice is given and resources permit. The cost of such services must be negotiated and will, in general, be higher than other established services. Consultation by telephone

or written correspondence is suggested. Often a measurement technique can be suggested that will permit the customer to perform his calibrations in-house with appropriate reference to other NIST-supported standards.

#### Fixed and Variable Coaxial Attenuators (61210S and 61211C)

Coaxial fixed and variable attenuators are measured on the NIST Dual Six-Port Automatic Network Analyzer (DSPANA) over the frequency range 10 MHz to 26.5 GHz.

In addition to measurements performed on the DSPANA, measurements at a fixed frequency of 30 MHz are available referenced to the NIST waveguide below cutoff standard at this frequency.

Coaxial attenuators are normally measured in a system having a characteristic impedance of 50 ohms. Typical uncertainties range from 0.01 dB to 1 dB depending on the nominal attenuation, connector repeatability, and frequency.

#### Waveguide Below-Cutoff Piston Attenuator Measurements at 30 MHz (61215C)

Incremental attenuation is the change in attenuation of an adjustable attenuator between a reference setting (usually zero) and any other setting. The same restraints on system conditions apply as for attenuation. The term "attenuation difference" is sometimes applied to this case and usually refers to two nonzero settings.

Measurements on waveguide-below-cutoff (piston) attenuators are performed at 30 MHz. These attenuators are normally quite stable and seldom need recalibration unless damaged or mechanically worn. Since any laboratory can perform independent checks to determine continuing repeatability and linearity of attenuation, we do not recommend

periodic NIST recalibrations. This recommendation is also made because more damage can be suffered in transit than in daily use. In any measurement, the maximum power delivered to the test attenuator will not exceed 400 mW. If the attenuator cannot tolerate this power level, some reduction of measurement range will be required.

Piston attenuators are normally calibrated in a system having a characteristic impedance of 50 ohms. Since only measurements of incremental attenuation are made on this type of attenuator, Type BNC, C, TNC, and similar connectors are acceptable, but precision connectors are preferred to reduce leakage. Limits of uncertainty depend upon the quality of the attenuator and connectors, as well as upon the VSWR of the attenuator, and the magnitude of attenuation. Typical systematic uncertainties range from 0.003 to 0.005 dB/10 dB of attenuation. Total insertion loss must be less than 120 dB.

#### Rectangular Waveguide Fixed and Variable Attenuators (61230S)

Fixed and variable (usually rotary vane) waveguide attenuators are calibrated on the NIST DSPANA. Service is available for frequencies corresponding to waveguide sizes WR10, WR22, WR28, and WR42.

Requested measurements for variable attenuators should be for a minimum number of settings at a single band-center frequency and be sufficient to determine the characteristics of the device. Previously calibrated units should not be resubmitted unless tests performed by the user indicate a shift in values.

The uncertainty is a function of re-settability, internal leakage, and quality of flanges. Except for measurements made on the NIST Dual Six-Port Automatic Network Analyzer, the uncertainty is also a

function of the VSWR of the waveguide ports. Devices submitted should be in the best possible condition to justify calibration and to ensure long-term stability of measured values. Typical uncertainties range from 0.01 to 0.10 dB.

#### Attenuation Measurements at 1.25 MHz (61240S)

An additional measurement service is available for attenuation measurements of special three-port devices at 1.25 MHz. A measurement system has been developed to measure the change in the ratio  $S_{21}/S_{31}$  of special stable two-position three-port devices, sometimes called voltage doublers, at 1.25 MHz. The device must have an input for a 1.25-MHz source (port 1), a reference output (port 3), and an output (port 2) with a level switchable to two different values. The two levels of the bi-level output have a nominal ratio of 6.0206 dB.

If  $P_{r1}$  is the reference power level when the bi-level output is at level 1 ( $P_{b1}$ ), and  $P_{r2}$  is the reference power level when the bi-level output is at level 2 ( $P_{b2}$ ), then parameter measured is given by the following equation:

$$10 \text{ Log}_{10} \left( \frac{P_{b1}}{P_{r1}} \right) - 10 \text{ Log}_{10} \left( \frac{P_{b2}}{P_{r2}} \right) \text{ dB}$$

where the subscripts (1) and (2) refer to the switch positions 1 and 2, respectively. The above is equivalent to

$$10 \log_{10} \left| \frac{S_{21}(1)/S_{31}(1)}{S_{21}(2)/S_{31}(2)} \right|^2 .$$



The loads presented to the two outputs are 50 ohms. The device must allow the signal input to be of such strength that the bi-level output is at least 10 mW in the high-level position.

The total uncertainty of the measurement system in measuring a 6-dB change in attenuation is estimated to have a systematic error no greater than 5  $\mu$ B and a random error of about 3  $\mu$ B, where 1  $\mu$ B =  $10^{-5}$  dB or about 2.3 ppm of the power ratio. Two-port step attenuators having a nominal change in attenuation of 6 dB can also be measured by this system at 1.25 MHz.

#### References – Attenuators, RF and Microwave

1.25 MHz Attenuation Measurement System, R. A. Ginley and C. M. Allred, IEEE Trans. Instrum. Meas., IM-35, No. 4, Pt. 1 (Dec. 1986).

Effects of Connectors and Adapters on Accurate Attenuation Measurements at Microwave Frequencies, R. W. Beatty, IEEE Trans. Instrum., IM-13, 272 (Dec. 1984).

“Thru-Reflect-Line”: An Improved Technique for Calibrating the Dual Six-Port Automatic Network Analyzer, G. F. Engen and C. A. Hoer, IEEE Trans. Micr. Theory Tech., MTT-27, 987 (Dec. 1979).

A Network Analyzer Incorporating Two Six-Port Reflectometers, C. A. Hoer, IEEE Trans. Micr. Theory Tech., MTT-25, 1070 (Dec. 1977).

The Six-Port Reflectometer: An Alternative Network Analyzer, G. F. Engen, IEEE Trans. Micr. Theory Tech., MTT-25, 1075 (Dec. 1977).

Insertion Loss Concepts, R. W. Beatty, Proc. IEEE 55, 6, 663 (June 1964).

RF Attenuation, D. Russell, Proc. IEEE 55, 6, 942 (June 1967).

Application of Waveguide and Circuit Theory to the Development of Accurate Microwave Measurement Methods and Standards, R. W. Beatty, Natl. Bur. Stand. (U.S.), Monogr. 137 (Aug. 1973).

Specifications and Test Methods for Fixed and Variable Attenuators, dc to 40 GHz, IEEE Standard 474 (1973).

Basic Theory of Waveguide Junctions and Introductory Microwave Network Analysis, D. M. Kearns and R. W. Beatty, Intl. Ser. of Monogr. in Electromag. Waves, 13, 59, Pergamon Press, New York, NY (1967).

## G. Microwave Measurements

### G.3 Coaxial and Waveguide Terminations, Reflection Coefficients

#### Technical Contacts:



Ronald A. Ginley  
Tel: 303/497-3634



Manly P. Weidman  
Tel: 303/497-3516



John R. Juroshek  
Tel: 303/497-5362



Kathy Hillen  
Administrative  
and Logistics  
Tel: 303/497-3753

**Mailing Address:** M.C. 813.10, National Institute of Standards and Technology, 325 Broadway, Boulder, CO 80303-3328

Test No.	Items
61310S	Complex Reflection Coefficient of Coaxial Terminations, Frequency Range 10 MHz to 26 GHz
61320S	Complex Reflection Coefficient of Rectangular Waveguide Terminations with Standard Flange Connectors, Specify Frequency for Waveguide Sizes WR10, WR22, WR28, and WR42
61340S	Special Reflection Coefficient Measurements, by Prearrangement

#### Coaxial and Waveguide Terminations, Reflection Coefficient (61310S-61320S)

Services provided in this category are for passive devices over the frequency range from 10 MHz to 95 GHz. Available calibration frequencies are listed in the test descriptions. Highest accuracy is obtained only for standards equipped with precision coaxial connectors or waveguide flanges. Standards submitted for calibration should be in good repair and, except for very minor cleaning of connector surfaces, should require no recalibration maintenance. NIST does not provide repair services. Items received requiring maintenance will be returned to the customer, and a handling fee will be charged.

#### Coaxial Terminations (61310S)

Services are available for complex coefficient of devices with 14 mm, 7 mm, Type N, and 3.5 mm connectors. Measurements on coaxial devices in the frequency range 10 MHz to 26 GHz are made on the NIST Dual Six-Port Automatic Network Analyzer (DSPANA). Typical uncertainties are  $\pm 0.005$  to  $0.015$  depending on the frequency and connector repeatability.

#### Waveguide Terminations (61320S)

Waveguide terminations are measured on the NIST DSPANA's.

Waveguide terminations are usually quite stable and need not be resubmitted unless tests performed by the user indicate a shift in values. The terminations must be fitted with standard waveguide flange connectors. The faces of these flanges should be machined flat and smooth and should not contain protrusions or indentations. Considerable care must be exercised in keeping the mating connector flange surfaces smooth and clean. Accurate alignment of the interior surfaces of the joining waveguides at the flange junction also is very important. The back of the flange which makes contact with the connecting bolts should be nominally flat and free of soft materials, including paint. The connecting holes of the flange should be symmetrically and accurately aligned to the rectangular waveguide opening. These precautions must be observed when using a waveguide termination in a precision measurement system.

Assigned limits of uncertainty depend upon the quality of the flanges and the frequency range. Typical uncertainties are  $0.001$  to  $0.015$ .

**References – Coaxial and Waveguide Terminations, Reflection Coefficients**

“Thru-Reflect-Line”: An Improved Technique for Calibrating the Dual Six-Port Automatic Network Analyzer, G. F. Engen and C. A. Hoer, IEEE Trans. Micr. Theory Tech., MTT-27, 987 (Dec. 1979).

A Network Analyzer Incorporating Two Six-Port Reflectometers, C. A. Hoer, IEEE Trans. Micr. Tech., MTT-25, 1070 (Dec. 1977).

The Six-Port Reflectometer: An Alternative Network Analyzer, G. F. Engen, IEEE Trans. Micr. Theory Tech., MTT-25, 1075 (Dec. 1977).

Millimeter Attenuation and Reflection Coefficient Measurement System, B. C. Yates and W. Larson, Natl. Bur. Stand. (U.S.), Tech. Note 619 (1972).

A Guide to the Use of the Modified Reflectometer Technique of VSWR Measurement, W. J. Anson, J. Res. Natl. Bur. Stand. (U.S.), 65C, 4, 217 (Oct.-Dec. 1961). (The measurement technique utilized in reflection measurements is described in this paper.)

## **G.** Microwave Measurements G.4 Phase Shifters, RF and Microwave

### Technical Contacts:



**Ronald A. Ginley**  
Tel: 303/497-3634



**Manley P. Weidman**  
Tel: 303/497-3516



**Gene Marler**  
Tel: 303/497-5455



**Kathy Hillen**  
Administrative  
and Logistics  
Tel: 303/497-3753

**Mailing Address:** M.C. 813.10, National Institute of Standards and Technology, 325 Broadway, Boulder, CO 80303-3328

---

### Test No. Items

---

61410S	Coaxial Fixed and Variable Phase Shifters; Characteristic Phase Shift Difference; Precision Connectors; Measured at 30 MHz, Range 0-360°
61411S	Coaxial Fixed and Variable Phase Shifters; Phase Shift Difference; Precision Connectors; Frequency Range 1-26 GHz, Phase Range 0-360°
61420S	Variable Rectangular Waveguide Phase Shifters; Phase Shift Difference; Specify Frequencies for Waveguide Sizes WR10, WR22, WR28, WR42, Range 0-720°
61450S	Special Tests of Phase Shifters, by Prearrangement

---

### Phase Shifters, RF and Microwave (61410S-61450S)

The specific phase shift services listed below are available on a limited basis depending on other demands and staff availability. Measurements not listed may possibly be provided if sufficient advance notice is given. The cost of such services must be negotiated and will, in general, be higher

than the established phase shift services. Consultation by telephone or written correspondence is suggested. Often a measurement technique can be suggested that will permit the customer to perform calibrations in-house with appropriate reference to other NIST-supported standards.



*Microwave devices made on gallium arsenide microelectronic chips MMICs (monolithic microwave/millimeter-wave integrated circuits) offer the potential of greatly reduced costs compared to conventional "plumbing" if produced in large numbers for civilian applications. NIST supports the emerging MMIC industry by providing measurements and standards for evaluating the performance of wafer probe stations such as this one.*

### Coaxial Phase Shifters (61410S and 61411S)

Fixed and variable coaxial two-ports are measured on the NIST Dual Six-Port Automatic Network Analyzer over the frequency range 10 MHz to 26 GHz. In addition, measurements can be performed with reference to a precision variable air line at 30 MHz. Because of the specialized nature of coaxial phase shifting components, prior discussions should be held with NIST staff before submission of any devices to NIST. Items to be calibrated must be fitted with connectors having a known plane of reference, such as sexless precision connectors, or Type N connectors meeting Mil. Std. C39012. The phase angle measured is  $\Psi + 360n$ , where  $n$  is an integer. The value of  $n$  is not determined.

Limits of uncertainty are:

Frequency	Range	Uncertainty
30 MHz	0-360°	0.1-0.5°
0.1-26 GHz	0-360°	0.5°

### Phase Shifters (61420S)

For a rectangular waveguide, the measurement services are limited to phase shift difference at frequencies below 18 GHz. Measurements are made on continuously variable waveguide phase shifters with the zero value of the scale as the normal reference position. Since 360 mechanical degrees of rotation represent 720 electrical degrees, attention should be given to the relationship between dial indication and actual mechanical position of the rotating vane assembly.

The uncertainty is approximately the same as for coaxial devices.

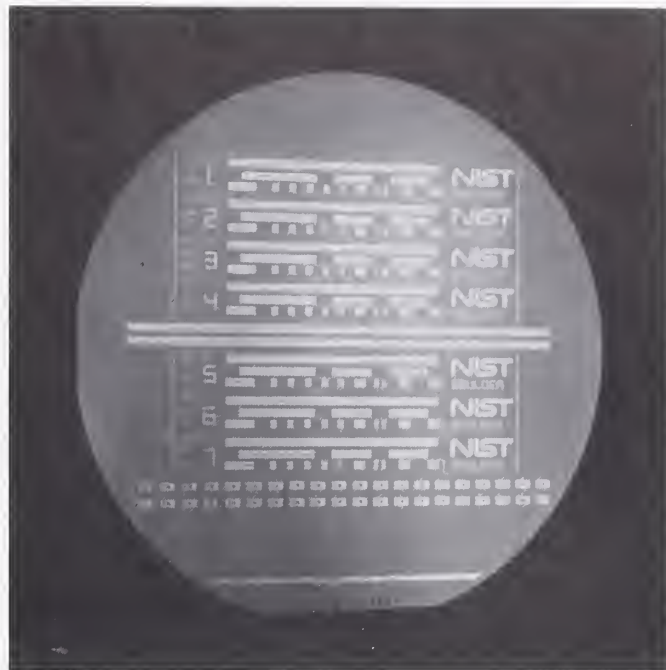

*Gallium arsenide wafer on which NIST has fabricated standard transmission lines for the calibration of MMIC (monolithic microwave/millimeter-wave integrated circuit) wafer probe stations from 50 MHz to 40 GHz. The lines are of coplanar configuration from gold films patterned on the wafer surface.*

### References—Phase Shifters, RF and Microwave

UHF and Microwave Phase Shift Measurements, D. A. Ellerbach, Proc. IEEE 55, 6, 960 (June 1967).

# G. Microwave Measurements

## G.5 Dimensional Verification of Coaxial Air Line Standards

### Technical Contacts:



**John R. Juroshek**  
Tel: 303/497-5362



**Ronald A. Ginley**  
Tel: 303/497-3634



**Manley P. Weidman**  
Tel: 303/497-3516



**Kathy Hillen**  
Administrative  
and Logistics  
Tel: 303/497-3753

**Mailing Address:** M.C. 813.10, National Institute of Standards and Technology, 325 Broadway, Boulder, CO 80303-3328

---

#### Test No. Items

---

61510S Dimensional Measurement of Air Lines and Verification of Characteristic Impedance from Dimensional Measurements 18 GHz

---

#### Coaxial Air lines (61510S)

Dimensional measurements are made on the inner and outer conductors of a beadless, coaxial, air line standard. The characteristic impedance of the air line standard is then computed from these dimensional measurements. The service is currently available for 14 mm, 7 mm, Type N, and 3.5 mm air line standards. The computations for characteristic impedance is made over the normal operating frequency range of the air line standard.

# G. Microwave Measurements

## G.6 Dielectric Material Measurements

### Technical Contacts:



Claude M. Weil  
Tel: 303/497-5305



William A. Kissick  
Tel: 303/497-3339



Kathy Hillen  
Administrative  
and Logistics  
Tel: 303/497-3753

**Mailing Address:** M.C. 813.10, National Institute of Standards and Technology, 325 Broadway, Boulder, CO 80303-3328

---

#### Test No. Items

---

61620S Special Tests for Dielectric Materials 0.05 to 18 GHz

---

#### Special Tests for Dielectric Materials (61620S)

A provisional service is now available for complex dielectric permittivity measurements of low-loss dielectric materials.

The service is currently limited to solid materials that are linear, homogeneous, isotropic and non-magnetic; measurements can only be performed at room temperature (23 °C), currently.

Measurements will be performed on materials meeting the above criteria, that are supplied by the customer; the customer has the option of machining the material to the required sample specifications or leaving this task to NIST to perform. Alternatively, NIST can supply machined samples of certain dielectric reference materials, such as cross-linked polystyrene (rexolite), together with the dielectric data that characterizes these materials.

Two kinds of measurement services are available: either a) a high accuracy ( $\Delta\epsilon_r = 0.5\%$ ) measurement performed in a resonant cavity at the single frequency of 10 GHz, or b) a measurement of lesser accuracy performed in a 7 mm coaxial transmission line covering the frequency range 0.05 to 18 GHz. A measurement service, similar to the latter, and performed in WR-284 waveguide (2.6–3.95 GHz) and WR-90 waveguide (8.2–12.4 GHz) is also provided. For broadband measurements, the number of frequencies at which dielectric measurement data are provided, shall be selected by the customer.

#### References – Dielectric Material Measurements

Advances in NIST Dielectric Measurement Capability Using a Mode-filtered Cylindrical Cavity, E. Vanzura and W. A. Kissick, IEEE Intl. Micr. Symp. Digest, MTT-S, Vol. 3, 901 (1989).

# H. Noise Temperature Measurements

## Technical Contacts:



**J. Wayne Allen**  
Tel: 303/497-5871



**Sunchanna Perera**  
Tel: 303/497-3546



**Kathy Hillen**  
Administrative  
and Logistics  
Tel: 303/497-3753

**Mailing Address:** M.C. 813.10, National Institute of Standards and Technology, 325 Broadway, Boulder, CO 80303-3328

Test No.	Items
62020S	Special Noise Temperature Measurements (Electromagnetic), by Prearrangement
62100S	Noise Temperature of Coaxial Noise Source, Type N Precision, APC 3.5, or 14-mm Connectors, at 30 MHz or 60 MHz; VSWR <1.2, Temperature: 77 K-15,000 K, ENR <17 dB
62101S	Each Additional 62100S Item Tested at Same Frequency within the Same System
62110S	Noise Temperature of Coaxial Noise Source, Type N Precision, 14 mm, or APC 7 Connectors; Continuous Frequencies 2.0-12.0 GHz, Reflection Coefficient <0.2, Temperature: 77 K-15,000 K, ENR <17 dB
62111S	Each Additional 62110S Item Tested at Same Frequency within the Same System
62112S	Noise Temperature of Coaxial Noise Source, APC 3.5 Connector; Continuous Frequencies 2.0-12.0 GHz, Reflection Coefficient <0.2, Temperature: 77 K-15,000 K, <17 dB
62113S	Each Additional 62112S Item Tested at Same Frequency within the Same System
62115S	Special Service for Waveguide Noise Sources in WR284, WR187, WR137, WR112, and WR90; Continuous Frequencies within the Bands from 2.6 to 12.0 GHz; Reflection Coefficient <0.2, Temperature: 77 K-15,000 K, ENR <17 dB

Test No.	Items
62116S	Each Additional 62115S Item Tested at the Same Frequency within the Same System
62120S	Noise Temperature of Rectangular Waveguide Noise Sources at Specific Frequencies in WR62 (12.4, 13.5, 14.0, 15.0, 16.0, 16.5, 17.0, 18.0 GHz) and WR90 (8.2, 9.0, 9.5, 9.8, 10.0, 10.5, 11.2, 11.8, 12.4 GHz); Reflection Coefficient <0.09, Temperature: 9,000 K-17,000 K, ENR <17.6 dB
62121S	Each Additional 62120S Item Tested at Same Frequency within the Same System
62130S	Noise Temperature of WR10 Noise Sources, Continuous Frequencies between 94.5 GHz and 96.6 GHz, Reflection Coefficient <0.2, Temperature 77 K-15,000 K, ENR <17 dB
62131S	Each Additional 62130S Item Tested at the Same Frequency
62132S	Noise Temperature of WR15 Noise Sources, Continuous Frequencies between 55.0 GHz and 64.5 GHz, Reflection Coefficient <0.09, Temperature 300 K-15,000 K, ENR <17 dB
62133S	Each Additional 62132S Item Tested at the Same Frequency



**Noise Temperature Measurements – Electromagnetic (62020S)**

Special-test services for the measurement of electromagnetic thermal noise are offered in limited frequency coverage from 30 MHz to 96.5 GHz and include measurements through adaptors and out-of-range noise temperatures. Some gaps in the frequency coverage exist. In some frequency regions, only spot frequency measurements are available. Depending on the frequency coverage available, noise sources submitted for measurement will be compared, via one of three different types of radiometers, against a hot or cold primary reference standard or a transfer standard. Since there are limitations which are a function of the noise standards and radiometer available, the customer should check with the technical contacts listed at the beginning of this section before submitting a device for calibration.

**Noise Sources (62100S-62133S)**

Noise temperature measurements are available on single-port, coaxial, and rectangular waveguide noise sources under conditions of continuous, unmodulated operation. Precision coaxial connectors or clean, smooth, and flat standard EIA waveguide flanges are required. Complete operating instructions and special electronic connectors should be supplied, and pertinent operating conditions (voltages, circuits, etc.) specified for the noise source to be measured.

Devices submitted that are not of sufficient quality or not mechanically compatible with the measuring system will be rejected and an appropriate fee charged. Availability of measurements at specific frequencies and for various connector types are specified above. Generally, an attempt is being made to expand services to include more types of precision connectors and waveguide sizes. However, the cost of measurements requiring the use of adaptors as part of the measurement process can be substantially greater than the cost of measurements on sources with connectors mating directly to the measurement system. Furthermore, measurement results on devices submitted with adaptors attached may apply only to the source/adaptor combination.

The limits of uncertainty vary with noise temperature, reflection coefficient, and source and connector stability, but typically lie between 1 percent and 3 percent of the noise temperature.

**References — Noise Temperature Measurements**

- A Derivation for the Noise Temperature of Horn-Type Noise Standards, W. C. Daywitt, *Metrologia* 21, 127 (Sept. 1985).
- A Coaxial Noise Standard for the 1-GHz to 12.4-GHz Frequency Range, W. C. Daywitt, *Natl. Bur. Stand. (U.S.)*, Tech. Note 1074 (Mar. 1984).
- The NBS WR62 and WR90 Reference Noise Standards, C. K. S. Miller and W. C. Daywitt, *Natl. Bur. Stand. (U.S.)*, NBSIR 84-3005 (May 1984).
- The NBS Switching Radiometers, C. K. S. Miller and W. C. Daywitt, *Natl. Bur. Stand. (U.S.)*, NBSIR 84-3004 (May 1984).
- Design and Error Analysis for the WR10 Thermal Noise Standard, W. C. Daywitt, *Natl. Bur. Stand. (U.S.)*, Tech. Note 1071 (Dec. 1983).
- Precision Measurement of Antenna System Noise Using Radio Stars, D. F. Wait, *IEEE Trans. Instrum. Meas.*, IM-32, 1 (Mar. 1983).
- WR15 Thermal Noise Standard, W. C. Daywitt, W. J. Foote, and E. Campbell, *Natl. Bur. Stand. (U.S.)*, Tech. Note 615 (Mar. 1972).

## Electromagnetic Field Strength and Antenna Measurements

### 1.1 Microwave Antenna Parameter Measurements

#### Technical Contacts:



Allen C. Newell  
63100S-63400S  
Tel: 303/497-3743



Katie MacReynolds  
63100S  
Tel: 303/497-3471



Andrew G. Repjar  
63200S  
Tel: 303/497-5703



Kathy Hillen  
Administrative  
and Logistics  
Tel: 303/497-3753

**Mailing Address:** M.C. 813.05, National Institute of Standards and Technology, 325 Broadway, Boulder, CO 80303-3328

**Shipping Address:** Room 1300, Bldg. 24, National Institute of Standards and Technology, 325 Broadway, Boulder, CO 80303-3328

Test No.	Items
63100S	Gain and Polarization Calibrations of Standard Antennas Using Extrapolation Range
63200S	Measurement of Pattern, Gain, and Polarization of Arbitrary Antennas Using Near-Field Scanning Techniques
63300S	Special-Test Service for Calibration of Probes Used with Near-Field Scanning Facilities
63400S	Special Consulting, Advisory, and Other Services

#### Antenna Parameter Measurements (Microwave) – General Information

Accurate measurements of antenna gain, pattern, and polarization are generally available from about 1.0 GHz to about 65 GHz. However, because the measurement accuracy, capability, and cost depend on the frequency, type, and size of antenna, and the parameters to be measured, a particular measurement service must

be negotiated in advance. Antennas submitted for evaluation should be mechanically and electrically stable in order to retain a calibration for a significant length of time. Antennas with either coaxial or waveguide connectors can be measured; however, if coaxial connectors are employed, they should be precision connectors to minimize uncertainties due to a lack of connector repeatability. In particular, the use of SMA connectors is strongly discouraged because of poor connector repeatability. The following methods and facilities are used for these measurements.

#### Gain and Polarization Calibrations of Standard Antennas Using Extrapolation Range (63100S)

This calibration service is offered primarily for determining the absolute on-axis gain and polarization of standard gain horns, which, in turn, are used as reference standards in determining the gain and polarization of other antennas by the gain comparison technique. In the extrapolation method three antennas are normally utilized, and three pairwise combinations are determined. The received signal transmitted between each pair of antennas is measured as a function of the separation distance between the antennas. The antennas need not be identical, and no assumptions concerning the polarization are required. The method is not well suited for pattern measurements but is the most accurate technique known for absolute gain and polarization measurements. Above 1 GHz, the accuracies are typically  $\pm 0.10$  dB for gain measurements and  $\pm 0.05$  dB/dB for polarization axial ratio measurements. There are antenna size limitations associated with existing NIST extrapolation ranges. These limitations depend on the type of antenna, the frequency, and the desired measurements and accuracies. Therefore, negotiations must be conducted prior to submitting antennas for calibration to ascertain whether all requirements can be met.

**Measurement of Pattern, Gain, and Polarization of Arbitrary Antennas Using Near-Field Scanning Techniques (63200S)**

With this technique, gain, pattern, and polarization parameters are calculated from near-field amplitude and phase measurements taken over a surface close to the test antenna. The absolute gain can be determined to within about 0.15 dB, the polarization axial ratio to within about 0.10 dB/dB, and side lobe levels can be obtained down to  $-50$  or  $-60$  dB. The exact uncertainties in these parameters will depend on such factors as the frequency, type, and size of antenna. Antennas with apertures up to about 3.5 meters in diameter can be managed. Measurements can be made from about 1.0 GHz to about 65 GHz. Measurements are most commonly made over a plane surface in front of the antenna being evaluated, but the capability also exists for measuring over a cylindrical or spherical surface surrounding the antenna when it is advantageous to do so. Calibrated probes are normally required for these measurements. These near-field scanning measurements are offered as a special-test service because nearly every measurement is unique and it is difficult to build up a statistical history as required for a regular calibration service.

**Special-Test Service for Calibrating Probes Used with Near-Field Scanning Facilities (63300S)**

This special-test service is available to support those organizations that have established their own near-field measurement facilities and need to characterize the probes used in performing the near-field measurements. In order to achieve accurate results with either the planar, cylindrical, or spherical near-field method, the transmitting or receiving properties of the probe must be known. With this information, the measured data can be corrected for the nonideal pattern and polarization properties of the probe. Probes are characterized by a

three-step process: (1) The on-axis gain and polarization properties are measured using the extrapolation technique described above; (2) the far-field amplitude and phase patterns are measured for two nominally orthogonal polarizations of the incident field; and (3) the on-axis and pattern data are combined to obtain the probe correction coefficients at the desired lattice points for the measurement surface specified by the customer. The final output consists of a computer tape containing the measured far-field patterns and the calculated probe coefficients. Typical types of probes are open-ended waveguides and small horns. Both linearly and circularly polarized probes can be evaluated.

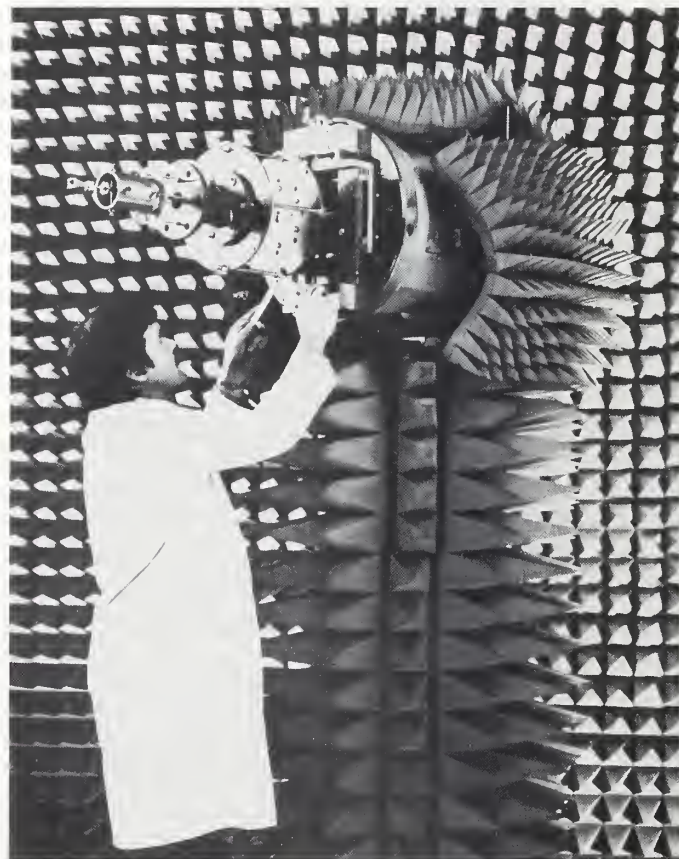

*Douglas Kremer makes adjustments before evaluating and calibrating the performance of large, complex antennas.*

### Special Consulting, Advisory, and Other Services (63400S)

A variety of special consultation and advisory services related to the measurements described above are available upon request. These services are offered to disseminate NIST technologies and to assist other organizations in establishing their own measurement facilities and capabilities. Included are cooperative measurement programs. A customer actually participates directly in the measurement of his device in order to become familiar with the measurement methods and assist in the analysis of the results. This is a useful approach when one is attempting to establish a new measurement capability that is related to or based upon NIST measurement techniques.

### References—Microwave Antenna Parameter Measurements

- Accurate Determination of Planar Near-Field Correction Parameters for Linearly Polarized Probes, A. G. Repjar, A. C. Newell, and M. H. Francis, *IEEE Trans. Antennas Propagat.*, Vol. 36, No. 6 (June 1988).
- Improved Polarization Measurements Using a Modified Three-Antenna Technique, A. C. Newell, *IEEE Trans. Antennas Propagat.*, Vol. 36, No. 6 (June 1988).
- Gain and Power Parameter Measurements Using Planar Near-Field Techniques, A. C. Newell, Robert Ward, and Edward McFarlane, *IEEE Trans. Antennas Propagat.*, Vol. 36, No. 6 (June 1988).
- Error Analysis Techniques for Planar Near-Field Measurements, A. C. Newell, *IEEE Trans. Antennas Propagat.*, Vol. 36, No. 6 (June 1988).
- Effect of Random Errors in Planar Near-Field Measurement, A. C. Newell and C. F. Stubenrauch, *IEEE Trans. Antennas Propagat.*, Vol. 36, No. 6 (June 1988).
- An Efficient and Accurate Method for Calculating and Representing Power Density in the Near Zone of Microwave Antennas, R. L. Lewis and A. C. Newell, *IEEE Trans. Antennas Propagat.*, Vol. 36, No. 6 (June 1988).
- Plane-Wave Scattering-Matrix Theory of Antennas and Antenna-Antenna Interactions, D. M. Kerns, *Natl. Bur. Stand. (U.S.)*, Monograph 162 (June 1981).
- Plane-Wave Scattering-Matrix Theory of Antennas and Antenna-Antenna Interactions: Formulation and Applications, D. M. Kerns, *J. Res. Natl. Bur. Stand. (U.S.)*, 80B, 1, 5051 (Jan.-Mar. 1976).
- Upper-Bound Errors in Far-Field Antenna Parameters Determined from Planar Near-Field Measurements, A. D. Yaghjian, *Natl. Bur. Stand. (U.S.)*, Tech. Note 667 (Oct. 1975).
- Accurate Measurement of Antenna Gain and Polarization at Reduced Distances by an Extrapolation Technique, A. C. Newell, R. C. Baird, and P. F. Wacker, *IEEE Trans. Antennas Propagat.*, AP-21, 4, 418 (July 1973).
- Determination of Both Polarization and Power Gain of Antennas by a Generalized 3-Antenna Measurement Method, A. C. Newell and D. M. Kerns, *Electronics Letters*, 7, 7, 68 (Feb. 1971).
- Correction of Near-Field Antenna Measurements Made with an Arbitrary but Known Measuring Antenna, D. M. Kerns, *Electronics Letters*, 6, 11, 346 (May 1970).
- New Method of Gain Measurement Using Two Identical Antennas, D. M. Kerns, *Electronics Letters* 6, 11, 348 (May 1970).

## Electromagnetic Field Strength and Antenna Measurements

### 1.2 Field Strength Parameter Measurements

#### Technical Contacts:



Galen H. Koepke  
Tel: 303/497-5766



Motohisa Kanda  
Tel: 303/497-5320



Kathy Hillen  
Administrative  
and Logistics  
Tel: 303/497-3753

**Mailing Address:** M.C. 813.10, National Institute of Standards and Technology, 325 Broadway, Boulder, CO 80303-3328

Test No.	Items
64100S	Special-Test Service for Antennas/Field Strength Measurements, Utilizing the Transverse Electromagnetic (TEM) Cell Method (10 kHz-300 MHz)
64200S	Special-Test Service for Antennas/Field Strength Measurements, Utilizing the Open-Field Method
64300S	Special-Test Service for Antennas/Field Strength/Reflectivity Measurements, Utilizing the Anechoic-Chamber Method

#### Special-Test Service for Antennas/ Field Strength Measurements, Utilizing the Transverse Electromagnetic (TEM) Cell Method (64100S)

Standard electromagnetic fields are generated in TEM cells and used to calibrate electrically small antennas and antenna systems used for electromagnetic field probes in the frequency range 10 kHz to 300 MHz.

#### Special-Test Service for Antennas/ Field Strength Measurements, Utilizing the Open-Field Method (64200S)

These measurements include calibration of antenna factor and gain of antennas used in conjunction with field strength meters, and of electrically small antennas used in electromagnetic field probes. The following methods and facilities are used for these measurements:

A. Dipoles, log-periodic, and other antennas (25 to 1000 MHz) are used to generate electromagnetic fields which are used for calibrating various antennas and electromagnetic field probes. The field strength is established using the standard receiving antenna method.

B. Monopoles (30 kHz to 300 MHz) are used to generate standard electric fields for calibrating antennas and electromagnetic field probes.

C. Loop antennas (14 kHz to 50 MHz) are used to generate standard magnetic fields for calibrating loop antennas used in conjunction with field strength meters.

#### Special-Test Service for Antennas/ Field Strength Measurements, Utilizing the Anechoic-Chamber Method (64300S)

A. Open-end waveguides (200 to 450 MHz) are used to generate standard electromagnetic fields for calibrating antennas and electromagnetic field probes.

B. Pyramidal horns (0.45 to 40 GHz) are used to generate standard electromagnetic fields for calibrating antennas and electromagnetic field probes.

Table 22 summarizes the field parameters, frequency ranges, and radiating antenna sources for the various NIST field strength measurement facilities.

**Table 22: Summary of NIST Standard Field Strength Facilities**

Field Parameter	Type of Measurement Facility	Frequency Range	Radiating Antenna Source
H	Wood building	14 kHz to 50 MHz	Loop (20 cm)
E (vertical screen)	Open site 30 MHz	30 kHz to 300 MHz	Short (ground)
E (vertical)	Open site (ground screen)	30 to 300 MHz	Quarter wave length monopole
E (horizontal)	Open site	25 to 1000 MHz	Dipole, log-periodic antenna, etc.
E and H	TEM cell	10 kHz to 300 MHz	
Power Density	Anechoic chamber	200 to 450 MHz	Open-end waveguide
Power Density	Anechoic chamber	0.45 to 40 GHz	Pyramidal horn

**References – Electromagnetic Field Strength Parameter Measurements**

- Methodology for Standard Electromagnetic Field Measurements, N. S. Nahman, M. Kanda, E. B. Larsen, and M. L. Crawford, IEEE Trans. Instrum. Meas., IM-34, 4 (Dec. 1985).
- A Review of Electromagnetic Compatibility/Interference Measurement Methodologies, M. T. Ma, M. Kanda, M. L. Crawford, and E. B. Larsen, Proc. IEEE, 73, 3, 388 (Mar. 1985).

## J. Pulse Waveform Measurements

### Technical Contacts:



William L. Gans  
Tel: 303/497-3538



William A. Kissick  
Tel: 303/487-3339



S. Michelle Chesnut  
Tel: 303/497-3456



Kathy Hillen  
Administrative  
and Logistics  
Tel: 303/497-3753

**Mailing Address:** M.C. 813.10, National Institute of Standards and Technology, 325 Broadway, Boulder, CO 80303-3328

Test No.	Items
65100S	Impulse Generator Spectrum Amplitude (50 Ohm)
65200S	Fast Repetitive Broadband Pulse Parameters (50 Ohm)
65300S	Network Impulse Response (Frequency Domain Parameter $S_{21}$ ) of Coaxial Networks, 10 MHz to 10.0 GHz, 0 to $\pm 40$ dB
65301S	Additional 65300S Item Tested at Same Time as First
65400S	Pulse Time Delay through Coaxial Transmission Lines

### Pulse Waveform Measurements— General Information

NIST offers special-test services for a number of baseband pulse parameters. These are broken down into four categories: impulse generator spectrum amplitude, fast repetitive baseband pulse parameters, network impulse response, and pulse time delay. All of these special-test services are performed on the NIST Automatic Wave Analysis and Measurement System (AWAMS), which consists of a sampling oscilloscope interfaced to a minicomputer. In addition, all of these special tests are performed at cost. References pertaining to these four services are located at the end of this section.

### Impulse Generator Spectrum Amplitude, 50 Ohms (65100S)

In response to calibration needs from the electromagnetic interference (EMI) community, NIST has developed a special-test service to calibrate the broadband spectrum amplitude output from impulse generators. Such a generator can then be used as a transfer standard of broadband impulsive noise for field calibration of spectrum analyzers and field intensity meters. The NIST special-test service uses the time-domain measurement/frequency-domain deconvolution computational method for calibration of impulse generators. A wideband (dc-20 GHz) sampling oscilloscope is used to measure the time-domain waveform from the impulse generator. A dedicated minicomputer then computes the spectrum amplitude,  $S(f)$ , versus frequency using the fast Fourier transform (FFT). NIST will provide 50 to 200 data points over a wide frequency range for a single fee.

NIST impulse generator spectrum amplitude measurement service capabilities are shown in Table 23.

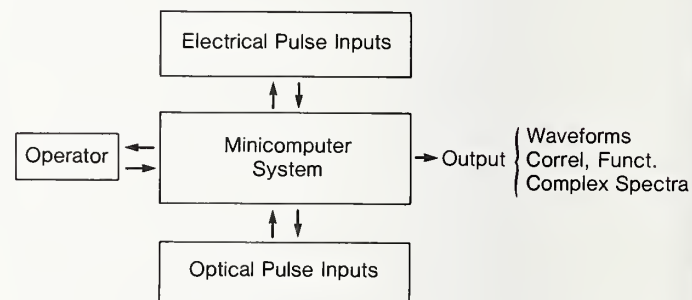



**Table 23: NIST Impulse Generator Spectrum Amplitude Measurement Service Capabilities**

Parameter	Limits	Notes
Maximum impulse amplitude without attenuators	$\pm 600$ mV	1, 2, 3
Maximum impulse amplitude with external attenuators	$\pm 1.2$ kV	3, 4
Spectrum amplitude	$-15 \text{ dB}\mu\text{V}/\text{MHz} < [S(f) - S_0] < +5 \text{ dB}\mu\text{V}/\text{MHz}$	5, 6, 7
S(f) uncertainty	Nominally $f < 1$ GHz, $\pm 0.6$ dB $1 \text{ GHz} < f < 4 \text{ GHz}$ , $\pm 1.2$ dB $4 \text{ GHz} < f < 10 \text{ GHz}$ , $\pm 2.0$ dB	5, 6, 7 8 & 9
Frequency range GHz	5 MHz to 10 GHz	5, 6, 7, & 10
Frequency spacing	$\Delta f = 5, 10, 20, 50,$ or 100 MHz	5, 10
Frequency uncertainty	of the order of $\pm 1\%$	7
Load impedance	50.0 $\Omega$	
Load impedance uncertainty	Nominally $\pm 0.1 \Omega$ at dc VSWR $< 1.3$ up to 10 GHz	8, 11
Trigger pulse amplitude	$> 100$ mV	12
Trigger pulse transition duration	$< 5$ ns	12
Trigger to impulse delay	$75 \text{ ns} < t_1 < 100 \text{ ns}$	12
Trigger to impulse jitter	$< 20$ ps	12

Notes: 1. The impulse generator is characterized by its impulse output waveform into 50 ohms of peak amplitude ( $V_{pk}$ ), 50 percent level duration ( $\tau$ ), and low-frequency spectrum amplitude ( $S_0 \approx 2V_{pk}\tau$ ).

2. Impulse generator with an adjustable amplitude impulse output will be calibrated with the generator adjusted to give a peak amplitude in the range of 200 to 400 mV.

3. Impulse generators with fixed outputs greater than  $\pm 400$  mV must have the impulse attenuated to the 200-400 mV level by 50-ohm wideband coaxial attenuators.

4. Either customer-supplied or NIST attenuators may be used.

5. Depends upon actual generator characteristics.

6. Data will not be given in the first spectrum null or at frequencies above. Typically 100 data points are supplied.

7. Subject to revision.

8. Only for impulse amplitudes less than  $\pm 400$  mV.

9. If external attenuators and/or a 6-dB tee and delay line are used, then the uncertainty associated with the attenuator calibration is added to these values.

10. Lower frequencies ( $< 5$  MHz) are available as a special test.

11. Depends upon input impedance of external attenuators when used.

12. If the impulse generator does not supply a trigger output or if the trigger output does not have the proper characteristics, then a 6-dB tee and a delay line will be used to provide a suitable trigger pulse.

### Fast Repetitive Baseband Pulse Parameters, 50 Ohms (65200S)

NIST offers a special-test service for selected pulse parameters. These parameters are measured with the NIST Automatic Wave Analysis and Measurement System (AWAMS), which consists of a calibrated wide-band (nominally dc-20 GHz) equivalent-time sampling oscilloscope custom interfaced to a dedicated minicomputer system. The parameters, ranges, and estimated uncertainty limits for this service are listed in Table 24.

**Table 24: Limits of Uncertainty for Calibration of Fast Repetitive Baseband Pulse Parameters**

Parameter	Range	Typical Limits of Uncertainty*
Pulse Baseline (0% level)	$\pm 500$ mV	$\pm (0.5\% + 1 \text{ mV})$
Pulse Topline (100% level)	$\pm 500$ mV	$\pm (0.5\% + 1 \text{ mV})$
Pulse Amplitude	$\pm 500$ mV	$\pm (0.5\% + 1 \text{ mV})$
Pulse Overshoot/ Undershoot	$\pm 500$ mV	$\pm (0.5\% + 1 \text{ mV})$
Pulse First Transition Duration (Rise Time)	10 ps-100 ns	$\pm (0.5\% + 2 \text{ ps})$
Pulse Second Transition Duration (Fall Time)	10 ps-100 ns	$\pm (0.5\% + 2 \text{ ps})$
Pulse Duration (between 50% levels)	10 ps-100 ns	$\pm (0.5\% + 2 \text{ ps})$

\* Smaller limits of uncertainty are achievable in some cases.

**Restrictions:**

1. Customer's device must generate a repetitive pulse with repetition rate between 100 Hz and 1 GHz.
2. Customer's device must have a 50-ohms nominal output impedance.
3. Customer's device should have a precision coaxial output connector, e.g., SMA, APC-7, Type "N," APC-3.5, etc.
4. Pulse topline is only measured for "step-like" pulses.
5. Pulse second transition duration and pulse duration are only measured for "impulse-like" pulses.
6. Pulse overshoot/undershoot is estimated as a percent of pulse amplitude.

This measurement service includes the previously offered measurement service referred to in prior editions of the SP250 Appendix as "Low-Pass Filter Transition Duration."

Measurements of other pulse parameters or parameter ranges may be provided by special arrangement. Consulting and advisory services also are available.

**Network Impulse Response (65300S)**

A network time-domain impulse response measurement service for coaxial networks is offered at NIST. The resulting data are in the form of a discrete waveform vector, normally 1024 points in length, with a time window range of from 2 ns to 100 ns. Also, using discrete Fourier transforms, the associated frequency-domain data ( $S_{21}[f]$ ) are provided over a frequency range of 10 MHz to 10 GHz and a gain or loss range of 0 to 40 dB.

These measurements are accomplished by use of the NIST Automatic Wave Analysis and Measurement System, which consists of a fast transition duration pulse generator, a 17.5-ps, 50-ohm sampling oscilloscope and a minicomputer. Two waveforms are measured, one with the pulse generator connected directly to the

oscilloscope, and the other with the unknown network inserted between the generator and the oscilloscope. The time-domain impulse response function and/or the frequency domain scattering parameter,  $S_{21}(f)$ , are then calculated using an NIST-developed deconvolution algorithm. A wide variety of connectors can be accommodated. The approximate limits of uncertainty are less than  $\pm 2$  percent for all parameters.

This measurement service includes the previously offered measurement service referred to in prior editions of SP250 as "Wideband Attenuation or Gain of Coaxial Networks."

**Pulse Time Delay through Coaxial Transmission Lines (65400S)**

NIST offers a special-test service for pulse time delay using the same measurement system described in item 65300S above. The pulse time delay is measured in the range of 100 ps-100 ns with typical limits of uncertainty of  $\pm(0.5\% + 2 \text{ ps})$ . Smaller limits of uncertainty are achievable in some cases.

**Restrictions:**

1. Customer's device must utilize precision coaxial connectors for both delay ports.
2. Customer should provide driving pulse generator if possible. First transition duration (rise time) of driving pulse generator should not exceed 10 percent of pulse time delay to be measured.
3. Customer's device should have nominal input and output impedances of 50 ohms.

Measurements for other ranges and configurations may be made by special arrangement. Consulting and advisory services are available.

### References—Pulse Waveform Measurements

- Calibration and Error Analysis of a Picosecond Pulse Waveform Measurement System at NBS, W. L. Gans, Proc. of the IEEE, Vol. 74, No. 1, 86 (Jan. 1986).
- The Measurement and Deconvolution of Time Jitter in Equivalent-Time Waveform Samplers, W. L. Gans, IEEE Trans. Instrum. Meas., IM-32, 1, 126 (March 1983).
- Deconvolution of Time Domain Waveforms in the Presence of Noise, N. S. Nahman and M. E. Guillaume, Natl. Bur. Stand. (U.S.), Tech. Note 1047 (Oct. 1981).
- Modeling of the Feed-through Wideband (dc to 12.4 GHz) Sampling Head, S. M. Riad and N. S. Nahman, Digest, 1978 IEEE-MTT-S Intl. Microwave Symp., Ottawa, Canada (June 1978).
- Spectrum Amplitude Definition, Generation, and Measurement, J. R. Andrews and M. G. Arthur, Natl. Bur. Stand. (U.S.), Tech. Note 699 (Oct. 1977).
- IEEE Standard Pulse Terms and Definitions, IEEE Std. 194-1977; and IEEE Standard on Pulse Measurement and Analysis by Objective Techniques, IEEE Std. 181-1977, Inst. Electrical and Electronic Engrs., New York, NY (July 1977).
- Impulse Generator Spectrum Amplitude Measurement Techniques, J. R. Andrews, IEEE Trans. Instrum. Meas., IM-25, 4, 280 (Dec. 1976).
- Present Capabilities of the NBS Automatic Pulse Measurement System, W. L. Gans, IEEE Trans. Instrum. Meas., IM-25, 384 (Dec. 1976).
- Time Domain Automatic Network Analyzer for Measurement of RF and Microwave Components, W. L. Gans and J. R. Andrews, Natl. Bur. Stand. (U.S.), Tech. Note 672 (Sept. 1975).
- Pulsed Wavemeter Timing Reference for Sampling Oscilloscope Calibration, J. R. Andrews and W. L. Gans, IEEE Trans. Instrum. Meas., IM-24, 82 (Mar. 1975).
- Pulse Techniques and Apparatus, Part 1: Pulse Terms and Definitions; Part 2: Pulse Measurements and Analysis, General Considerations, IEC Publications 469-1 and 469-2, Intl. Electrotech. Com. (IEC), Geneva, Switzerland (1974).

---

# Chapter

# 10

- A** Time and Frequency Dissemination
- B** Oscillator Characterization

## A. Time and Frequency Dissemination

### Technical Contacts:



**George Kamas**  
(Frequency)  
Tel: 303/497-3378



**David W. Allan**  
(Time)  
Tel: 303/497-5637

**Kathy Hillen**  
Administrative  
and Logistics  
Tel: 303/497-3753

**Mailing Address:** M.C. 847.40, National Bureau of Standards and Technology, 325 Broadway, Boulder, CO 80303-3328

**Shipping Address:** M.C. 847.40, Room 4039, National Institute of Standards and Technology, 325 Broadway, Boulder, CO 80303-3328

---

Test No.	Items
----------	-------

76100S	Special Tests of Time and Frequency; Frequency Measurement Service (Frequency delivered to user's site)
76110S	Special Tests of Time and Frequency; Global Time Service (Frequency and Time delivered to user's site)

---

### NIST Broadcast of Time and Frequency Signals (No Test No.)

NIST offers several continuous time and frequency dissemination services that are freely available to the general public. These services are provided via the radio broadcasts of stations WWV, WWVH, and WWVB, and a time-code disseminated from the GOES satellites. WWV's signal is also available by dialing (303) 499-7111. A similar service from WWVH is available by dialing (808) 335-4363. (These numbers are not toll free.)

Broadcasts from WWV (Fort Collins, Colorado) and WWVH (Kauai, Hawaii) can be received on

conventional shortwave receivers nearly anywhere in the world. Broadcast frequencies are 2.5, 5, 10, and 15 MHz for both stations and 20 MHz for WWV only. Accuracies of 1 to 10 milliseconds in time and  $1 \times 10^{-6}$  in frequency are typical from these broadcasts. These stations provide standard frequencies, standard time intervals, time-of-day announcements, a binary-coded-decimal (BCD) time code, astronomical time corrections, and certain public service announcements for other government agencies. For individuals without receivers, the telephone service provides the same NIST time and frequency signals. The time signal by telephone is accurate to only 30 milliseconds or better due to unpredictable delays in cross-country telephone line routings.

WWVB (Fort Collins, Colorado) offers accuracies of 0.5 millisecond in time and  $1 \times 10^{-11}$  in frequency but requires a special 60-KHz low-frequency receiver. WWVB's time-code signal is a BCD type needing special decoding equipment. The GOES satellites broadcast an NIST time code accurate to 100 microseconds to the western hemisphere. These are geostationary weather satellites located at nominally 75° west and 135° west longitude.

NIST broadcast services are coordinated with similar operations in other countries. Commercial receivers designed to receive (and decode) NIST broadcasts are available from several manufacturers. A number of publications are available to assist users to record properly the time and frequency information available from these broadcast services.

### Special Frequency Measurement Service (76100S)

Frequency calibration requirements at the part in  $10^{11}$  to a part in  $10^{12}$  level can be satisfied using low-frequency radio signals from broadcast stations such as WWVB or Loran-C. This service involves a low-frequency receiver and data logger system at the user's site. The typical system contains a receiver, microcomputer, disc units, and printer-plotter. A dedicated phone line and modem must be provided by the user so that his data can be compared with that obtained at NIST, thus providing measurement assurance. The user will also receive a bulletin, either by telephone transfer or by mail, which reports the performance of many of the accurate signal sources accessible by the system. To assist the user in getting the maximum benefit from the service, NIST provides specific training on the actual equipment.

### Special Global Time Service (76110S)

This service uses the Global Positioning System (GPS) satellites compatible with the common-view technique receiver, which provides much higher precision time and frequency data and a high degree of automation. The data from a receiver, which is located at the user's facility, are automatically sent to a NIST computer. The NIST computer then stores the raw data, determines which data are suitable for time transfer calculations, and provides an optimally filtered value for the time and frequency of the user's clock with respect to the NIST atomic time scale. The results are communicated to the user in a monthly report. The user is also given an account on one of the NIST

computers through which he may access a preliminary NIST analysis, which is calculated daily. Tests between receivers in California, Colorado, Washington, D.C., France, Germany, Spain, and Canada have demonstrated an ability to perform time comparisons with a precision of  $1 \times 10^{-14}$  or better ( $1\sigma$ ) for averaging times of 4 days and longer. While useful characterization of frequency stability is available to at least this latter level, frequency accuracy is limited to  $8 \times 10^{-14}$ , the accuracy of the NIST primary frequency standard.

### References - Time and Frequency Dissemination

- NBS Measurement Services: GOES Satellite Time Code Dissemination: Description and Operation, R. E. Beehler, D. Davis, and J. B. Milton, Natl. Bur. Stand. (U.S.), Spec. Publ. 250-30 (Jan. 1988).
- NBS Measurement Services: Traceable Frequency Calibrations, G. Kamas and M. A. Lombardi, Natl. Bur. Stand. (U.S.), Spec. Publ. 250-29 (Jan. 1988).
- Accuracy of International Time and Frequency via Global Positioning System Satellites in Common View, D. W. Allan et al., IEEE Trans. Instrum. and Meas., IM-34, 2, 118 (June 1985).
- New Time and Frequency Services at the National Bureau of Standards, S. R. Stein, G. Kamas, and D. W. Allan, Proc. 15th Annual Precise Time and Time Interval (PTTI) Applications and Planning Meeting, 17 (Dec. 1983).
- NBS Time and Frequency Dissemination Services, Natl. Bur. Stand. (U.S.), Spec. Publ. 432 (Sept. 1979).

## B. Oscillator Characterization

### Technical Contacts:

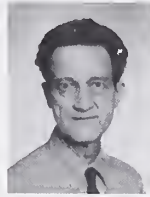

James E. Gray  
Tel: 303/497-3209



Kathy Hillen  
Administrative  
and Logistics  
Tel: 303/497-3753

**Mailing Address:** M.C. 847.50, National Institute of Standards and Technology, 325 Broadway, Boulder, CO 80303-3328

**Shipping Address:** M.C. 847.50, Room 2019, National Institute of Standards and Technology, 325 Broadway, Boulder, CO 80303-3328

Test No.	Items
77100C	Precision Oscillator Frequency Calibration
77110C	Characterization of Atomic Time and Frequency Standards
77120C	Characterization of Precision Oscillators: Time Domain
77130C	Characterization of Precision Oscillators: Frequency Domain
77131C	Characterization of Precision Oscillators: Frequency Domain, High-Accuracy Option
77140S	Special Time/Frequency Measurements: Oscillators and Other Components

### Precision Oscillator Frequency Calibration (77100C)

Precision oscillators can be readily calibrated in the frequency range from 1 to 100 MHz. Reference calibration accuracy is nominally that of the NIST primary frequency standard, that is,  $8 \times 10^{-14}$ . The accuracy level transferable to the oscillator depends upon the stability and noise properties of the oscillator.

### Characterization of Atomic Time and Frequency Standards (77110C)

An atomic standard is characterized by introducing it as a member of the NIST time scale system. The clock output is sampled every 2 hours in sequence with the other regular clocks in the time scale. The data are logged in the NIST time scale computer and the characteristics of the standard are readily determined in relation to the performance of the time scale ensemble of clocks. The standard test involves 30 days of data acquisition. The square root of the Allan variance,  $\sigma_y(\tau)$ , is measured to  $\pm 2 \times 10^{-12} \tau^{-1/2}$  for averaging times of about 7200 to  $10^6$  seconds. The time scale accuracy is about  $1 \times 10^{-13}$  and frequency drift is less than one part in  $10^{15}$  per day. The actual values transferable to the standard depend on its stability and noise properties.

### Characterization of Precision Oscillators: Time Domain (77120C)

For oscillator frequencies of 5, 10, and 100 MHz, the stability in terms of  $\sigma_y(\tau)$  is determined by repeated measurements. The square root of the Allan variance,  $\sigma_y(\tau)$ , is measured to  $\pm 2 \times 10^{-12} \tau^{-1/2}$  for averaging times of 1 to approximately 10,000 seconds, and frequency offset is measured to about  $1 \times 10^{-13}$ . As noted under the description of tests 77100C and 77110C, the transferable accuracy depends upon the stability and noise properties of the calibrated oscillator.

### Characterization of Precision Oscillators: Frequency Domain (77130C)

For oscillator frequencies of 5, 10, and 100 MHz, phase noise  $S_{\phi}(f)$  can be determined for Fourier frequency offsets from the carrier of 0.1 Hz to 300 kHz (higher by special request). The phase noise is measured for only a few user-specified frequency offsets.

For an offset of 1 Hz,  $S_{\phi}(f)$  can be measured to  $-115$  dB (relative to 1 radian<sup>2</sup>/Hertz) and for an offset of 10 kHz,  $S_{\phi}(f)$  is measured to  $-175$  dB.

**Characterization of Precision Oscillators: Frequency Domain, High-Accuracy Option (77131C)**

For a pair of identical oscillators within a limited range of Fourier offset frequencies, phase noise,  $S_{\phi}(f)$  can be measured with an error not exceeding  $\pm 0.6$  dB. For this accuracy, the frequency offset must lie between 20 Hz and 10 kHz. In other respects this service is the same as 77130C.

**Special Time/Frequency Measurements: Oscillators and Other Components (77140S)**

Frequency and time domain measurements can be made at frequencies

other than those cited in tests 77120C and 77130C, but the accuracy and cost are dependent upon the value of the frequency. Given two or more oscillators, synthesizers or amplifiers, relative phase noise can be measured to a very high precision and the frequency for the measurement is not as restrictive as above. Also, the one PPS (pulse per second) output of atomic frequency standards can be measured with an accuracy of 0.5 nanoseconds given an adequately defined, fast pulse.

**Reference – Oscillator Characterization**

Properties of Signal Sources and Measurement Methods, D. A. Howe, D. W. Allan, and J. A. Barnes, Proc. 35th Ann. Freq. Control Symp., A.1, Phil. (May 1981).



## ALPHABETICAL CROSS-INDEX

Item	Test	Number
Absolute pressure transducers .....	30010C	30011C
Accelerometers .....	24010C	24060S
Ac-dc thermal converters (100 Hz to 1 GHz) .....	53405S	53445S
Ac-dc thermal converters (to 1 MHz) .....	53310S	53341C
Ac-dc watt-hour or var-hour meters .....	56110S	56210M
Ac resistors .....	51410S	
Ac voltage, high-accuracy .....	53200S	53201S
Acoustic devices .....	25060S	
Acoustic emission transducers and sensors .....	26200C	26210S
Acoustic measurements .....	25010C	25070S
Activation detector dosimetry .....	44070C	44090C
A/D or D/A data converters .....	53500S	53540S
Air navigation aids .....	55210S	55230S
Airspeed measurements .....	19010C	19040S
Alpha-particle-emitting solid sources .....	43030C	43050C
Aluminum ultrasound reference blocks .....	26030S, 26050S,	26070S
American Petroleum Institute gages .....	12010C	
Analog-to-digital data converters .....	53500S	53540S
Anemometers .....	19010C	19040S
Angle gage blocks .....	14010C	
Angular measurements .....	14010C	14050S
Antenna parameter measurements, microwave .....	63100S	63400S
Attenuators, rf and microwave .....	61210S	61250S
Audiofrequency phase meter .....	55120C	55141C
Balls .....	11030S	
Barometers .....	29035C,	30010C-30011C
Bearing-angle indicators .....	55210C	55221C
Beckmann thermometers .....	31080C	
Beta particle applications .....	47030C	47040S
Beta-particle-emitting sources .....	43060S-43070S,	47030C-47040S
Bolometer units, rf and microwave .....	61110S	61129S
Calorimetric thermometers .....	31070C	
Capacitance and inductance measurements, high-frequency .....	52210S	52310S
Capacitance and inductance measurements, low-frequency .....	52110S	52181C
Capacitive voltage dividers .....	54310S	54311S
Capacitors, dielectric .....	52130C	
Capacitors, high-frequency .....	52210S	52221S
Capacitors, low-frequency .....	52110S	52171C
Capacitors, power-frequency .....	52400C	
Coaxial air line standards .....	61510S	
Coaxial attenuators .....	61210S	61211C

Coaxial terminations and reflection coefficients .....	61310S-61340S
Coaxial thermistor mounts .....	61110S-61129S
Color temperature .....	37140C-37160C
Complex dimensional standards .....	12010C-12040S
Converters, A/D and D/A .....	53500S-53540S
Cryogenic flow measurements .....	18800S
Current and voltage transformers .....	54510C-54600S
Data converters, A/D and D/A .....	53500S-53540S
Dc resistance measurements .....	51100S-51163C
Dc voltage measurements .....	53110S-53190S
Deadweight piston gages .....	29010C
Deadweight tester, ball-type .....	30025C
Density measurements, liquids .....	17040S
Detector standards, windowed photodiode .....	40560C-40561C
Detector standards, windowless photodiode .....	40510C-40540C
Detectors, near ultraviolet to soft x-ray region .....	40599S
Deuterium arc lamps .....	40030C
Deuterium lamps .....	39050C
Dew-point hygrometers .....	36010C-36020C
Diameter measurements .....	11010S-11070S
Dielectric materials .....	61620S
Differential pressure transducers .....	30020C-30021C
Digital multimeters, low-frequency .....	53200S
Digital-to-analog data converters .....	53500S-53540S
Dimensional metrology .....	10010C-14050S
Dividers, capacitive .....	54310S-54311S
Dividers, inductive .....	54110S-54131C
Dividers, mixed .....	54410S
Dividers, resistive .....	54210C-54214S
Dosimeters, electron-beam .....	48010M-48020S
Dosimeters, high-dose .....	49010C-49050S
Dosimeters, neutron .....	44100S
Dosimeters, radiochromic .....	49010C-49030C
Dosimeters, spectrophotometric reading .....	49040S-49041S
Dosimeters, x-ray, gamma-ray, and electron .....	46010C-48020S
Dosimetry, neutron .....	44010C-44100S
Earphones .....	25070S
Electromagnetic field strength parameter measurements .....	64100S-64300S
Electrometers .....	46030S
Electron beam dosimetry .....	48010M-48020S
Energy and power measurements, low frequency .....	56110S-56210M
Ferrous-ferric dosimeters .....	48010M-48011M
Field strength measurements, electromagnetic .....	64100S-64300S
Filament lamps, ribbon .....	35050C-35060C, 39010C-39020C
Filters, spectral transmittance .....	38010C-38040C
Fixed-point devices, thermometric .....	33360S
Flats, optical reference .....	13010S

Flow measurements, cryogenic.....	18800S
Flow rate meters, liquid and gas.....	18010C-18050S
Flux standards, luminous.....	37080S
Force transducers.....	23010C-23260S
Frequency and time measurement services.....	76100S-76110S
Frequency domain.....	77131C
Gage blocks.....	10010C
Gages, API.....	12010C
Gages, ionization.....	30034C-30038C
Gages, low-pressure.....	30040S
Gages, molecular drag.....	30029C-30031C
Gages, piston.....	29010C-29020C
Gages, plug.....	11010S
Gages, plug and ring.....	12020S
Gages, pressure.....	29010C-29040S
Gages, ring.....	11040S
Gages, step.....	11060S
Gages, two-dimensional.....	12030S
Gages, vacuum.....	30010C-30050S
Gamma-ray dosimeters.....	46010C-46021C
Gamma-ray-emitting sources.....	43010C-43020C, 47010C-47011C
Gas flow meters.....	18050S
Gear measuring wires.....	11020C
Germanium resistance thermometers.....	33140C
Global time service.....	76110S
Heat flux gauges.....	36510S
High-dose dosimetry.....	49010C-49050S
High-frequency standard capacitors and inductors.....	52210S-52221S
High-frequency standard resistors.....	51310S
High-vacuum gages.....	30029C-30038C
High-voltage resistors.....	51210C
Humidity measurements.....	36010C-36070S
Hydrometers.....	16010C
Hygrometers.....	36010C-36070S
Impedance measurements.....	52110S
Impulse generator spectrum amplitude.....	65100S
Impulse response of coaxial networks.....	65300S
Indexing tables.....	14030S
Inductance and capacitance measurements, low-frequency.....	52110S-52150C
Inductance and capacitance measurements, high-frequency.....	52210S-52310S
Inductive voltage dividers.....	54110S-54131C
Intensity standards, luminous.....	37015C-37035C
Internal diameter standards.....	11040S
Ionization chambers.....	47036C
Ionization gages.....	30034C-30038C
Irradiance sources.....	39040C-39050C, 40010C,40030C

Kerr cells .....	54410S
Laboratory thermometers .....	31010C-31160S
Lamps, deuterium arc .....	39050C, 40030C
Lamps, incandescent .....	37015C-37140C
Lamps, quartz-halogen .....	39040C-39045C
Lamps, ribbon filament .....	35050C-35060C, 39010C-39030C
Laser frequency/wavelength .....	14510S
Laser power and energy measurements .....	42110C-42170S
Leak artifacts .....	30060S
Length and diameter .....	11050S
Length measurements .....	10010C-10060S
Length standards .....	10050S
Line standards .....	10020C
Liquid flow meters .....	18010C-18050S
Liquid-in-glass thermometers .....	31010C-31160S
Load cells .....	23010C-23260S
Luminous directional transmittance standards .....	37170C
Luminous flux .....	37080S
Luminous intensity .....	37015C-37035C
Luminous intensity of retroreflectors .....	38070M
Luminous transmittance standards .....	37170C
Manometers .....	29035C
Mass measurements .....	22010C-22180M

#### MEASUREMENT ASSURANCE PROGRAMS

Dc resistance .....	51110M
Dc voltage .....	53120M
Dose interpretation of ferrous-ferric dosimeters .....	48010M-48011M
Laser power and energy .....	42120M, 42140M, 42150M
Mass .....	22180M
Platinum resistance thermometry .....	33370M-33390M
Retroreflectance .....	38070M-38074M
Transmittance .....	38080M
Watthour meters .....	56210M
Mercurial Barometer and Manometers .....	29035C
Meteorological airspeed instrumentation .....	19030S
Meters, flow rate .....	18030C
Meters, laser power and energy .....	42110C, 42170S
Meters, optical fiber power .....	42130C, 42140M, 42180S
Meters, phase .....	55110S-55141C
Meters, turbine .....	18010C-18020C
Microcopy resolution test charts .....	38100S
Microphones, pressure and free-field response .....	25010C-25050C
Micropotentiometers, low voltage .....	53201S

Micropotentiometers, rf.....	53440S-53445S
Microwave antenna parameter measurements.....	63100S-63400S
Mixed voltage dividers.....	54410S
Molecular drag gages.....	30029C-30031C
Neutron dosimeters.....	44100S
Neutron sources.....	44010C-44020C
Noise temperature measurements, coaxial and waveguide.....	62020S-62133S
Oil gaging and surveying tapes.....	10030C
Opal glass transmittance standard.....	37170C
Optical fiber power meters.....	42130C-42140M, 42180S
Optical flats.....	13010S
Optical polygons.....	14020S
Optical pyrometers.....	35010C-35040C
Optical reference planes.....	13010S
Oscillator characterization.....	77100C-77140S
Penetrimeters, x-ray.....	46040S
Personnel protection instrumentation.....	44060C
Phase measurements.....	55110S-55141S
Phase shifters, rf and microwave.....	61410S-61450S
Photodiode spectral response.....	39070C
Photodiodes, windowed and windowless.....	40510C-40560C
Photographic step tablets.....	38090S
Photometric tests.....	37180S
Photometry.....	37015C-37180S
Pickup sensitivity.....	24010C-24030C, 24050C
Piston gages, controlled clearance.....	29020C
Piston gages, deadweight.....	29010C
Pitot-static tubes.....	19010C
Platinum resistance thermometers.....	33010C-33310C
Plug and ring gages.....	12010C-12020C
Plug gages.....	11010S
Pneumatic bridge hygrometers.....	36060C
Polygons, optical.....	14020S
Power and energy measurements, low-frequency.....	56110S-56210M
Power meters, optical fiber.....	42130C-42140M, 42180S
Pressure gages and transducers.....	29030C
Pressure gages, low absolute.....	30010C-30011C
Pressure gages, low differential.....	30020C-30021C
Pressure gages, special tests.....	29040S
Pressure measurements.....	29010C-29040S, 30010C-30060S
Proving rings.....	23010C-23260S
Pulse voltage measuring systems.....	54410S
Pulse waveform measurements.....	65100S-65400S
Pyrometer indicators.....	32100C

Pyrometers, optical.....	35010C-35040C
Pyrometers, radiation.....	35070S
Q-standards.....	52710C-52711C
Quartz-halogen lamps.....	39040C-39045C
Radiance standard sources.....	39010C-39030C, 40020C
Radiant energy detectors.....	39070C
Radiation detectors.....	46010C-46011C
Radiation pyrometers.....	35070S
Radiation thermometry.....	35010C-35070S
Radioactive sources, alpha-emitting.....	43030C-43050C, 43090S
Radioactive sources, beta-emitting.....	43060S-43070S
Radioactive sources, gamma-emitting.....	43010C-43020C
Radioactive sources, neutron-emitting.....	44010C-44020C
Radiochrometric dosimeters.....	49020C-49030C
Radiometric detectors, special tests.....	39080S
Radiometric measurements.....	39010C-39080S, 40010C-40040S, 40510C-40599S
Radiometric sources.....	39060S
Radionuclides.....	43010C-43090S
Reference block measurements, ultrasonic.....	26030S-26070S
Reflection coefficients, coaxial and waveguide terminals.....	61310S-61340S
Resistance measurements, dc.....	51100S-51163C
Resistance thermometers.....	33010C-33310S
Resistive voltage dividers.....	54210C-54214S
Resistors, ac.....	51410S
Resistors, high-frequency.....	51310S
Resistors, high-precision standard, dc.....	51130C-51154C
Resistors, high-voltage.....	51210C
Resistors, megohm.....	51142C-51150C
Resistors for current measurements.....	51160C-51163C
Retroreflectors, coefficient of luminous intensity.....	38070M-38074M
Ribbon filament lamps.....	35050C-35060C
Ring gages.....	11040S
R-meters.....	46010C-46011C
Rods, surveying leveling.....	10040S
Rotary and indexing tables.....	14030S
Roughness specimens.....	15010C-15020C
Roundness measurements.....	13020S-13030S
Saturated standard cells.....	53130C-53131C
Shock measurements.....	24040S
Sieves.....	10060S
Spectral irradiance.....	39040C-39050C, 40010C,40030C
Spectral irradiance, lamps.....	39040C-39050C

Spectral radiance .....	39010C-39030C, 40020S
Spectral radiance, lamps .....	39010C-39030C
Spectral response, photodiode .....	39070C
Spectral transmittance filters .....	38010C-38040C,
Spectrophotometric measurements .....	38010C-38100S
Spherical diameter standards, balls .....	11030S
Standard voltage cells .....	53130C-53150C
Steel ultrasound reference blocks .....	26040S,26060S, 26070S
Step gages, length .....	11060S
Step height measurements .....	15030C
Step tablet density, photographic .....	38090S
Surface roughness standards .....	15020C
Surveying and oil gaging tapes .....	10030C
Surveying leveling rods .....	10040S
Thermal voltage and current converters (100 Hz-1 GHz) .....	53405S-53445S
Thermal voltage converters (to 1 MHz) .....	53310S-53341C
Thermocouples and thermocouple materials .....	32010C-32150S
Thermometers, Beckmann .....	31080C
Thermometers, calorimetric .....	31070C
Thermometers, cryogenic .....	33140S
Thermometers, germanium resistance .....	33140S
Thermometers, laboratory .....	31010C-31260S
Thermometers, platinum resistance .....	33010C-33310C
Thermometric fixed-point devices .....	33360S
Thermometry, radiation .....	35010C-35070S
Thread measuring wires .....	11020C
Threaded plug and ring gages .....	12020S
Time and frequency measurement services .....	76100S-76110S
Time domain .....	77120C
Titanium ultrasound reference blocks .....	26040S,26060S, 26070S
Transducer measurements, acoustic emission .....	26200C-26210S
Transducer measurements, ultrasonic .....	26100C-26120S
Transducers, low-pressure .....	30010C-30021C
Transformers, voltage and current .....	54510C-54600S
Transmittance, luminous directional .....	37170C
Transmittance, Measurement Assurance Program .....	38080M
Transmittance filters, spectral .....	38010C-38040C
Turbine flow meters .....	18010C-18020C
Ultrasonic reference block measurements .....	26030S-26080S
Ultrasonic system power, calorimetric .....	26110C
Ultrasonic transducer measurements .....	26100C-26120S
Ultrasonic transducer power, radiation pressure .....	26100C
Ultraviolet detectors .....	40510C-40599S
Ultraviolet sources .....	40010C-40040S
Unsaturated standard cells .....	53150C

Vacuum gages.....	30029C-30038C, 30050S
Vacuum measurements.....	30010C-30050S
Vacuum ultraviolet radiometric measurements.....	40010C-40040S
Var, varhour meters.....	56200C-56202C
Velocity reference blocks.....	26080S
Very-high-frequency omnidirectional range (VOR) measurements.....	55210C-55230S
Vibration and shock measurements.....	24010C-24060S
Voltage, ac.....	53201S
Voltage, dc.....	53110S-53190S
Voltage, rf-dc.....	53405S-53445S
Voltage and current transformers.....	54510C-54600S
Voltage dividers, capacitive.....	54310S-54311S
Voltage dividers, inductive.....	54110S-54131C
Voltage dividers, mixed.....	54410S
Voltage dividers, resistive.....	54210C-54214S
Voltage reference standards, solid state.....	53160C-53161C
Voltmeters, high-accuracy, ac.....	53200S
Volume standards.....	17010C-17020S
VOR measurements.....	55210C-55230S
Watt, watthour meters.....	56110S-56210M
Waveform measurements, pulse.....	65100S-65400S
Waveguide attenuators.....	61230S
Waveguide terminations and reflection coefficients.....	61320S-61340S
Waveguide thermistor mounts.....	61144S-61155S
Wavelength standards.....	38050C
Wedges.....	14040S
Weights (mass standards).....	22010C-22180M
Wires for thread and gear measurements.....	11020C
X-ray and photographic step tablets.....	38090S
X-ray dosimeters.....	46010C-46050S
X-ray penetrameters.....	46040S



# AT \$23.00 A YEAR , CAN YOU AFFORD NOT TO KNOW WHAT'S GOING ON AT THE NATION'S MEASUREMENT SCIENCE LABORATORY?

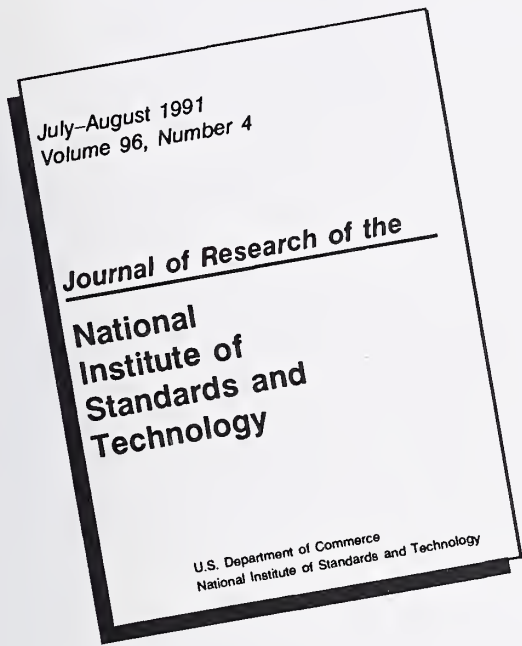

The *Journal of Research* Brings You Up-to-Date Scientific Articles and Information on:

- Measurement Science and Technology
- Calibration Services
- Standard Reference Materials
- Cooperative Research Opportunities and Grants
- Conference Reports

AND MUCH MORE!

It's All At Your Fingertips In the *Journal of Research of the NATIONAL INSTITUTE OF STANDARDS AND TECHNOLOGY*

## SUBSCRIBE TODAY !

**Journal of  
Research of the  
National  
Institute of  
Standards and  
Technology**

### Superintendent of Documents Subscription Order Form

**YES**, send me \_\_\_ subscriptions to the **JOURNAL OF RESEARCH OF THE NATIONAL INSTITUTE OF STANDARDS AND TECHNOLOGY** at \$23 per subscription (6 times a year) so I can stay up to date on the latest developments in measurement science and technology.

2. The total cost of my order is \$\_\_\_\_. All prices include domestic postage and handling. International customers please add 25 percent.

**3. PLEASE CHOOSE METHOD OF PAYMENT:**

- Check made out to the Superintendent of Documents
- GPO Deposit Account
- VISA, or MasterCard

\_\_\_\_\_ Thank you for your order!  
(Credit Card Expiration Date)

**1. Please Type or Print**

Order Processing Code  
**6596**

\_\_\_\_\_ (Company or personal name)  
 \_\_\_\_\_ (Additional address/attention line)  
 \_\_\_\_\_ (Street address)  
 \_\_\_\_\_ (City, State, ZIP Code)  
 \_\_\_\_\_ (Daytime phone including area code)

\_\_\_\_\_ (Signature) (2/89)

**4. MAIL TO:** Superintendent of Documents, Washington, DC 20402-9371. Kindly return this card even if you use your organization's purchase order. Thank you.





U.S. DEPARTMENT OF COMMERCE  
NATIONAL INSTITUTE OF STANDARDS  
AND TECHNOLOGY  
Physical Measurement Services Program  
Bldg. 411, Rm. A112  
Gaithersburg, MD 20899

Return Postage Guaranteed

Official Business

Penalty for Private Use, \$300

BULK RATE  
BOUND PRINTED MATTER  
POSTAGE & FEES PAID  
NIST  
PERMIT NO. G195