

**RECTANGULAR SUBSONIC JET FLOW  
FIELD MEASUREMENTS**

**Gerald L. Morrison  
and  
David H. Swan**

**Sponsored by NASA Langley Research Center  
Grant NAG-1-630**

**Turbomachinery Laboratory  
Mechanical Engineering Department**

(NASA-CR-185962) RECTANGULAR SUBSONIC JET  
FLOW FIELD MEASUREMENTS (Texas A&M Univ.)  
CSCL 20D  
164 p

N90-11255

Unclas  
G3/34 0235587

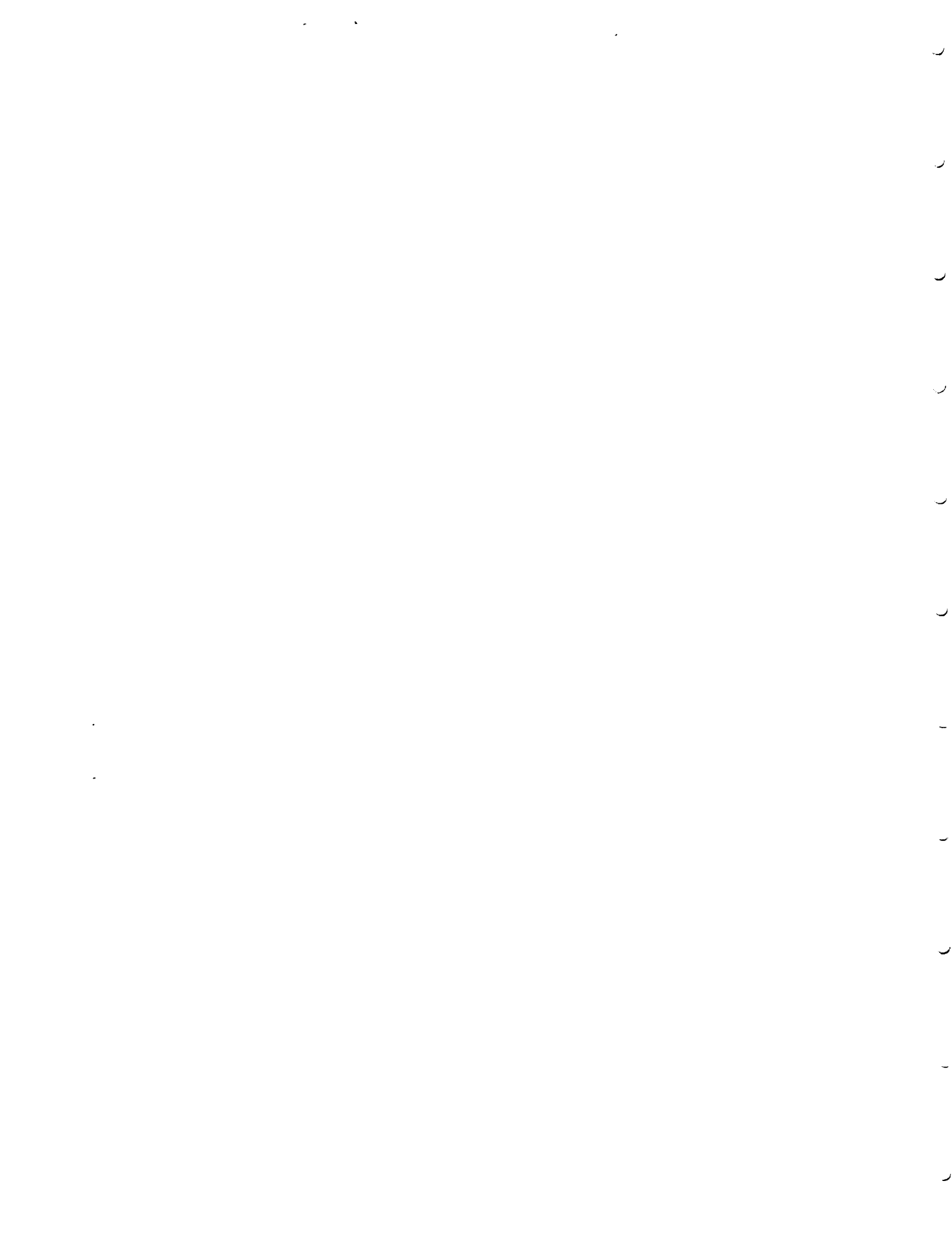

Rectangular Subsonic Jet Flow Field Measurements

by

G.L. Morrison

and

D.H. Swan

Turbomachinery Laboratories  
Mechanical Engineering Department  
Texas A&M University  
College Station, Texas 77843-3123  
(409) 845-5414

Prepared for

J. Seiner

NASA Langley Research Center

Hampton, Virginia

January 1989





Abstract

This report presents flow field measurements of three subsonic rectangular cold air jets. The three cases presented had aspect ratios of 1x2, 1x4 at a Mach number of 0.09 and an aspect ratio of 1x2 at a Mach number of 0.9. All measurements were made using a three dimensional laser Doppler anemometer system. The presented data includes the mean velocity vector, all Reynolds stress tensor components, turbulent kinetic energy and velocity correlation coefficients. The data is presented in tabular and graphical form. No analysis of the measured data or comparison to other published data is made in this report.

All tabular data are available in ASCII format on MS-DOS compatible disks.



Acknowledgment

This work was supported by a grant from NASA Langley Research Center (NAG-1-630) under the supervision of Dr. J. Seiner.



Table of Contents

	page
1. PRELIMINARY PAGES	
a) Title Page . . . . .	i
b) Abstract . . . . .	ii
c) Acknowledgments . . . . .	iii
d) Table of Contents . . . . .	iv
e) List of Tables . . . . .	v
f) List of Figures . . . . .	vi
g) Nomenclature . . . . .	viii
2. INTRODUCTION	
a) Rectangular Nozzles . . . . .	1
b) 3 Dimensional Laser Anemometer System . . . . .	2
c) Data Acquisition . . . . .	4
d) Error Analysis . . . . .	5
e) Data Processing . . . . .	7
3. RESULTS . . . . .	9
5. REFERENCES . . . . .	11
6. TABLES . . . . .	12
7. FIGURES . . . . .	68
8. APPENDICES . . . . .	138
A Nozzle dimensions and Plenum Drawing . . . . .	A1
B Vector Transformation of the Measured Data . . . . .	B1

List of Tables

Table #		page
1	Volume Continuity Error	12
2	Contour Plot Level Numbers	12
3	1x2 Ratio Nozzle M = 0.09 - WFv Flow Field Data	13
4	1x4 Ratio Nozzle M = 0.09 - WFv Flow Field Data	33
5	1x2 Ratio Nozzle M = 0.9 - WFv Flow Field Data	55
6	1x2 Ratio Nozzle M = 0.09 - WFv Initial Conditions Data	66
7	1x4 Ratio Nozzle M = 0.09 - WFv Initial Conditions Data	67

List of Figures

Figure #		page
1	Three Dimensional Laser Doppler Anemometer System	68
2	TiO <sub>2</sub> Measured Size Distribution	69
3	Rectangular Jet Coordinate System	70
4	Rectangular Jet File Coordinate System	71
5	Rectangular Jet Axial Momentum	72
6	Rectangular Jet Centerline Velocity	73
7	1x2 Nozzle M=0.09 Initial Conditions Mean Velocity	74
8	1x2 Nozzle M=0.09 Initial Conditions Velocity Variance	75
9	1x4 Nozzle M=0.09 Initial Conditions Mean Velocity	76
10	1x4 Nozzle M=0.09 Initial Conditions Velocity Variance	77
11	1x2 Nozzle M=0.09 Velocity Vectors (axial)	78
12	1x2 Nozzle M=0.09 Mean Velocity (axial)	79
13	1x2 Nozzle M=0.09 Velocity Variance (axial)	80
14	1x2 Nozzle M=0.09 Velocity Covariance (axial)	81
15	1x2 Nozzle M=0.09 Turbulent Kinetic Energy (axial)	82
16	1x2 Nozzle M=0.09 Velocity Correlation (axial)	83
17	1x2 Nozzle M=0.09 Velocity Vectors (cross section)	84
18	1x2 Nozzle M=0.09 U/Us (cross section)	85
19	1x2 Nozzle M=0.09 V/Us (cross section)	86
20	1x2 Nozzle M=0.09 W/Us (cross section)	87
21	1x2 Nozzle M=0.09 uu/(UsUs) x 100 (cross section)	88
22	1x2 Nozzle M=0.09 vv/(UsUs) x 100 (cross section)	89
23	1x2 Nozzle M=0.09 ww/(UsUs) x 100 (cross section)	90
24	1x2 Nozzle M=0.09 uv/(UsUs) x 100 (cross section)	91
25	1x2 Nozzle M=0.09 uw/(UsUs) x 100 (cross section)	92
26	1x2 Nozzle M=0.09 vw/(UsUs) x 100 (cross section)	93
27	1x2 Nozzle M=0.09 k/(UsUs) x 100 (cross section)	94
28	1x2 Nozzle M=0.09 C.C. (uv) (cross section)	95
29	1x2 Nozzle M=0.09 C.C. (uw) (cross section)	96
30	1x2 Nozzle M=0.09 C.C. (vw) (cross section)	97
31	1x4 Nozzle M=0.09 Velocity Vectors (axial)	98
32	1x4 Nozzle M=0.09 Mean Velocity (axial)	99
33	1x4 Nozzle M=0.09 Velocity Variance (axial)	100
34	1x4 Nozzle M=0.09 Velocity Covariance (axial)	101
35	1x4 Nozzle M=0.09 Turbulent Kinetic Energy (axial)	102
36	1x4 Nozzle M=0.09 Velocity Correlation (axial)	103
37	1x4 Nozzle M=0.09 Velocity Vectors (cross section)	104
38	1x4 Nozzle M=0.09 U/Us (cross section)	105
39	1x4 Nozzle M=0.09 V/Us (cross section)	106
40	1x4 Nozzle M=0.09 W/Us (cross section)	107
41	1x4 Nozzle M=0.09 uu/(UsUs) x 100 (cross section)	108

List of Figures Continued

Figure #		page
42	1x4 Nozzle M=0.09 $vv/(UeUe)$ x 100 (cross section)	109
43	1x4 Nozzle M=0.09 $ww/(UeUe)$ x 100 (cross section)	110
44	1x4 Nozzle M=0.09 $uv/(UeUe)$ x 100 (cross section)	111
45	1x4 Nozzle M=0.09 $uw/(UeUe)$ x 100 (cross section)	112
46	1x4 Nozzle M=0.09 $vw/(UeUe)$ x 100 (cross section)	113
47	1x4 Nozzle M=0.09 $k/(UeUe)$ x 100 (cross section)	114
48	1x4 Nozzle M=0.09 C.C. (uv) (cross section)	115
49	1x4 Nozzle M=0.09 C.C. (uw) (cross section)	116
50	1x4 Nozzle M=0.09 C.C. (vw) (cross section)	117
51	1x2 Nozzle M=0.9 Velocity Vectors (axial)	118
52	1x2 Nozzle M=0.9 Mean Velocity (axial)	119
53	1x2 Nozzle M=0.9 Velocity Variance (axial)	120
54	1x2 Nozzle M=0.9 Velocity Covariance (axial)	121
55	1x2 Nozzle M=0.9 Turbulent Kinetic Energy (axial)	122
56	1x2 Nozzle M=0.9 Velocity Correlation (axial)	123
57	1x2 Nozzle M=0.9 Velocity Vectors (cross section)	124
58	1x2 Nozzle M=0.9 $U/Ue$ (cross section)	125
59	1x2 Nozzle M=0.9 $V/Ue$ (cross section)	126
60	1x2 Nozzle M=0.9 $W/Ue$ (cross section)	127
61	1x2 Nozzle M=0.9 $uu/(UeUe)$ x 100 (cross section)	128
62	1x2 Nozzle M=0.9 $vv/(UeUe)$ x 100 (cross section)	129
63	1x2 Nozzle M=0.9 $ww/(UeUe)$ x 100 (cross section)	130
64	1x2 Nozzle M=0.9 $uv/(UeUe)$ x 100 (cross section)	131
65	1x2 Nozzle M=0.9 $uw/(UeUe)$ x 100 (cross section)	132
66	1x2 Nozzle M=0.9 $vw/(UeUe)$ x 100 (cross section)	133
67	1x2 Nozzle M=0.9 $k/(UeUe)$ x 100 (cross section)	134
68	1x2 Nozzle M=0.9 C.C. (uv) (cross section)	135
69	1x2 Nozzle M=0.9 C.C. (uw) (cross section)	136
70	1x2 Nozzle M=0.9 C.C. (vw) (cross section)	137



### Nomenclature

C.C.	correlation coefficient
C.C. (uv)	$U, V$ velocity correlation $[\overline{uv}/\sqrt{(\overline{uu}+\overline{vv})}]$
C.C. (uw)	$U, W$ velocity correlation $[\overline{uw}/\sqrt{(\overline{uu}+\overline{ww})}]$
C.C. (vw)	$V, W$ velocity correlation $[\overline{vw}/\sqrt{(\overline{vv}+\overline{ww})}]$
[C]	color to orthogonal coordinate transformation matrix
$D_h$	hydraulic diameter $(4 \cdot H_1 \cdot H_2)/(2 \cdot (H_1 + H_2))$
$H_1$	jet width on minor axis (Y) (see Figure 3.)
$H_2$	jet width on major axis (Z) (see Figure 3.)
$k$	turbulence kinetic energy $\frac{1}{2}(\overline{uu}+\overline{vv}+\overline{ww})$
[K]	orthogonal to color coordinate transformation matrix
$M_e$	momentum of Jet at nozzle exit (calculated)
$M_X$	total jet axial momentum at a given X location
$Re$	Reynolds number $(UeD_h\rho/\mu)$
$Ue$	nozzle exit velocity
$u, v, w$	cartesian fluctuating velocity ( $u = U - \bar{U}$ )
$U, V, W$	cartesian coordinate velocities
$V_g, V_b, V_v$	color coordinate velocities (green, blue, violet)
WF1	statistical weighting factor of 1
WFv	statistical weighting factor of $1/ \vec{v} $
X, Y, Z	cartesian coordinates (inches)
$ \vec{v} $	velocity vector magnitude

### Greek Letters

$\mu$	viscosity or micro ( $\times 10^{-6}$ )
$\rho$	density
$\theta_g, \theta_b, \theta_v$	color coordinate rotation angles (green, blue, violet)

### Mathematical Symbols

$\bar{H}$	time average (over bar)
-----------	-------------------------



## INTRODUCTION

The use of rectangular jets for thrust vectoring and enhanced mixing is now being used in the aerospace industry. The rectangular shape results in a three dimensional expansion and mixing pattern and hence, axisymmetric jet data is not applicable. The objective of this work was to measure and document these 3 dimensional effects.

This report presents flow field measurements of three subsonic rectangular cold air jets. The three cases presented had aspect ratios of 1x2 (25.4 x 50.8 mm) and 1x4 (12.7 x 50.8 mm) at a Mach number of 0.09 (30 m/s) and an aspect ratio of 1x2 (25.4 x 50.8 mm) at a Mach number of 0.9 (322.6 m/s). The Reynolds numbers based on the hydraulic diameter  $D_h$  for the low speed jets were 63,500 and 39,000 respectively, while the high speed case had a Reynolds number of 581,000. All measurements were made using a three dimensional laser Doppler anemometer system. The data is presented in tabular and graphical form. No analysis of the measured data or comparison to other published data is made in this report. Analysis and comparisons of the data are made in references 1, 2, 3 and 4.

### Rectangular Nozzles

The rectangular jets were produced by smoothly converging fiberglass nozzles that had exit dimensions of 25.4 x 50.8 mm and 12.7 x 50.8 mm for the 1x2 and 1x4 aspect ratio jets respectively. These rectangular exits are 2 to 8 times larger than the nozzle or orifice widths used in previous experimental studies, Hsia et.al.<sup>5</sup>, Krothapalli et.al.<sup>6</sup>, and Marsters<sup>7</sup>. Each nozzle converged from a circular cross section of approximately 300 mm to the rectangular cross section. The rectangular cross section was maintained approximately 50 mm before the nozzle exit. See Appendix A for nozzle coordinates and drawings. The nozzle was attached to a plenum that provided laminar flow. The plenum consisted of a 300 mm diameter pipe with internal perforated plates, honeycomb, and fine screens. See Appendix A for the Plenum drawing. Measurements with both a pitot probe and the laser anemometer system have shown that a uniform velocity distribution was obtained over the exit plane area.

Air to the plenum was supplied by a screw type compressor and controlled by an electro-pneumatic throttling valve. Control of the

valve was by computer which monitored the nozzle entrance pressure and temperature. Computer scanning and valve updating was performed approximately every 2 seconds. Control was based on a constant exit velocity and was  $\pm 1\%$  accurate. The air temperature entering the plenum was  $23^{\circ}\text{C}$  for the Mach number 0.09 case and  $46^{\circ}\text{C}$  for the Mach number 0.9 case. Assuming an isotropic acceleration of the jet, the nozzle exit temperatures were  $22.5^{\circ}\text{C}$  and  $1.5^{\circ}\text{C}$  respectively.

### Three Dimensional Anemometer System

The three dimensional laser anemometer system used to make the measurements is capable of measuring three non orthogonal velocity components simultaneously. Through vector transformations the three orthogonal components of the velocity vector can then be resolved. By repeatedly sampling the velocity at a given spatial location (2048 to 4096 times) the mean velocity of the three orthogonal components, their respective variance and covariance can be calculated (Reynolds stress tensor components).

The optical portion of the laser anemometer system (see Figure 1) consists of an argon-ion laser from which three different colors are utilized (green, blue, and violet). Each color is used to measure a velocity component by the dual beam method. Each color optical train is equipped with its own light polarization unit, Bragg cell (40 MHz frequency shift), and photo multiplier tube. In the configuration used there were two optical paths, one mounted above the other with their respective axes intersecting at a  $30^{\circ}$  angle. The lower optical path transmitted the blue and green laser light and collected violet light scattered from the flow field *seed* particles (the *seed* particles were micron size pieces of titanium dioxide that were put in the jet flow to make it visible to the anemometer system). The top optical path transmitted the violet light and collected blue and green scattered light. Different optical arrangements were used for each of the jets measured, different arrangements were selected to optimize the quality and data rate of the anemometer system. The maximum composite measurement volume used was approximately  $0.065 \times 0.065 \times 0.130$  mm in size.

The individual photo multiplier tubes used to measure the scattered light were equipped with color filters so that only the

specific color (blue, green, or violet) was sensed by the respective photo multiplier tube. Signals from the photo multiplier tubes were processed by individual counters (one for each velocity component). The counters were of the burst type and were interfaced together so that only data acquired at the same instant in time (within 10 to 50  $\mu$  second window) for all three velocity components was accepted as being valid (time coincident). The photo multiplier tubes and the counter systems had frequency responses of 200 MHz. Typical counter measured frequencies ranged between 40 and 65 MHz.

The titanium dioxide ( $\text{TiO}_2$ ) seed particles were injected into the jet air supply just upstream of the nozzle plenum. A fluidized bed was used to prepare and control the injection rate into the air supply. The titanium dioxide from the fluidized bed had a measured average aerodynamic diameter of approximately 0.8 microns and a physical diameter of approximately 0.4 microns. See Figure 2 for measured seed size distribution. This small size resulted in a 3 dB frequency response of 75 kHz (see reference 8 for the calculation method). This response was sufficient to assure that the seed particles were following the flow fluctuations.

In order to accurately place the measurement volume in space, the entire optical system was mounted on a three degree of freedom traversing system which could locate the measurement volume in space with a maximum resolution of 0.0025 mm and a repeatable accuracy of 0.0102 mm. With the high resolution of the traversing system and the small effective measurement volume, thin shear layers could be accurately measured.

The entire laser anemometer system was interfaced to a Digital PDP 11/23+ computer system which was programmed to control the traverse system and record data supplied by the counters. In a post data acquisition mode this computer was also used to statistically analyses the recorded data. A real-time display of the color frequency distributions was provided by specially equipped PC type computer.

#### Data Acquisition

The spatial coordinate system used in all data taking is shown in Figure 3 and is described as follows: the origin was located in the center of the nozzle exit, the X coordinate (zero value in the nozzle

exit plane) extends in the jet flow direction (axial direction), the Y coordinate extends in the *minor axis* direction while the Z coordinate extends in the *major axis* direction. The *minor axis* and *major axis* always refer to the narrow and long planes of the rectangular nozzle exit respectively.

The flow fields were measured by extensively mapping one quadrant of the expanding jets and checks were made to assure symmetry. The spatial pattern used expanded with the jet by taking data in axial lines. The first point on any line occurred at  $X = 0.2$  inches, the second point was at  $X = 1$  inches, then 2 inches, and so on until  $X = 19$  inches. The first point of 0.2 inches was used rather than  $X = 0$  due to the laser beams being physically clipped in this position by the nozzle, while the 19 inches was maximum motion of the traversing system. The Y and Z locations for each line were chosen such that an entire quadrant of the exit was mapped, see Figure 4. By choosing a slope for each line the cross sectional measurement plane expanded with the jet. A different rate of expansion was chosen for the Y and Z directions such that the pattern started at  $X = 0.2$  inches the same as the particular rectangular nozzle exit (1x2 or 0.5 x 2 inches) but, by  $X = 17$  inches was a square (5 x 5 inches). This pattern change allowed for the different rates of jet expansion in the Y and Z planes and thus gave a maximum spatial resolution.

Boundary conditions for the jets were taken by measuring lines of data outside the area directly affected by the jet. Boundary condition data was taken on the minor axis, major axis planes and in the corner region. The shear layer thickness and turbulence quantities at the beginning of the nozzle ( $X = 0.2$  inches) were measured in the minor and major axis planes by making small movements in the Y or Z direction only. This data may be used as an initial condition for computational comparison.

Approximately 1300 spatial locations were used in the mapping of each jet. At each spatial location 2048 to 4096 time coincidence velocity realizations were performed. The coincidence window used had a maximum time length of 10 or 50  $\mu$ s. Fifty  $\mu$ -seconds was used in the 1x2 aspect ratio nozzle, Mach number of 0.09, while 10- $\mu$  seconds was used in the other two cases. In all cases, the window of time was

significantly smaller than the average time between usable Doppler signals as indicated by the individual counter validation rates (100-1000 Hz). The time coincidence requirement ensured that the individual component velocity measurements were taken close enough together so as to accurately represent the velocity vector at that time.

All flow measurements were done with the nozzle positioned horizontally in an enclosed Turbomachinery Laboratory test cell. Outside air was piped into the nozzle plenum and a single exit from the test cell was used to exhaust the jet air. The test cell had internal measurements of 3.7 meters deep, 4.9 meters wide, and 3.7 meters high (67 m<sup>3</sup> volume). For the three flow case, 1x2, Mach 0.09, 1x4 Mach 0.09 and 1x2 Mach 0.9, the simple air exchange rate was 29, 58, and 2.7 minutes respectively.

The nozzle exit was placed in the test cell equidistant from the floor to the test cell ceiling. The nearest side wall was 1.4 meters from the nozzle exit, the wall behind the nozzle was 0.91 meters from the nozzle exit. The closest part of the anemometry system to the nozzle exit was 0.43 meters. Air for the jet was not recirculated but was exhausted outdoors through a 0.6 meter duct. The nozzle exit was 2.4 meters from the entrance to this exit. Considering the jet dimensions over which flow measurements were made was approximately 0.5 m long, 0.15 high and deep it is anticipated that the boundary effects were small.

All measured data was permanently recorded on 0.75 inch magnetic tape by the PDP computer.

#### Error Analysis

Errors and bias in the measurements can result from the laser Doppler anemometer system, flow field characteristics, and a combination of the anemometer system and flow field. Any error is then amplified by the transformation from the velocity component measurements to the orthogonal coordinate system of the velocity vector.

The laser Doppler anemometer system causes error through the superpositioning of high and low frequency noise on the Doppler signal and by counter clock resolution. The addition of high and low

frequency noise to the Doppler signal effects the location of the counter zero crossing which is used to time the Doppler burst. The error due to noise is unknown but appears to be small based on observation of the Doppler burst in laminar flow. The counter used in these measurements has a clock with a finite resolution of 1 nano second. In the presented flow field measurements this would attribute less than 1% error on any individual velocity validation.

Both of these system errors are small and random in character. As a result of being a random error they do not affect statistical mean quantities but do affect variance and covariance quantities.

Flow field characteristics that will cause measurement bias includes velocity bias, uneven seed distribution and insufficient data bias. Velocity bias is based on the idea that in a uniformly seeded flow, a greater number of fast moving particles will traverse the measurement volume than will slower moving particles in a given time interval. Thus, the measured mean velocity will be higher than the real velocity. This type of bias can not be corrected during data acquisition but can be identified and corrected by statistical processing, McLaughlin and Tiederman<sup>9</sup>. Further discussion on velocity biasing is covered in the data processing section of this report.

Uneven seed distribution will cause the same results as velocity bias. In free jet measurements there is a high degree of fluid entrainment into the jet. If the entrained air is not seeded or is low in seed density the entrained jet air cannot be seen by the anemometry system and biasing will occur. To minimize this problem, the data was taken in an enclosed test cell with a single exhaust to the outdoors. All air into the test cell came from the jet and thus very quickly the test cell air builds up in seed density to that of the jet. The exception to this was the high speed measurements in which some fresh air was allowed into the test cell due to pressure difference difficulties.

Insufficient data bias occurs when not enough data samples are taken to accurately describe the velocity population distribution of the turbulent flow. Reference 10 describes that the number of samples required to achieve a given confidence interval is a function of the velocity distribution shape. The higher the skewed distribution the



greater the number of samples required. In the measured low speed jet data 2048 samples per spatial location were taken while 4096 samples were taken for the high speed data.

The degree of flow field phenomena error is unknown. This type of error results in an error in the measured velocity mean value, variance and covariance.

Error due to the combination of the anemometer system and flow field is incomplete signal bias (fringe bias). The burst type counters are set to validate data only if a minimum number of Doppler cycles are counted (higher number of cycles reduces error due to noise and clock resolution). If a particle traverses the probe volume at an angle to the fringe plane, an insufficient number of fringes may be crossed. This problem was minimized through frequency shifting (fringe pattern motion) using a Bragg cell on each color. This was done for all the low speed data. For the high speed data a Bragg cell could not be used due to measurement problems. To overcome this, the fringe pattern of each color was rotated  $45^\circ$  to the axial direction of the jet. This approach works well as long as the measured frequency is higher than the Doppler pedestal frequency and there is no significant cross sectional velocity. As a result, the high speed data was limited to the high axial speed regions.

Any error in the measurement of the velocity components may be amplified by the transformation from the velocity component measurements to the orthogonal coordinate system of the velocity vector. The transformation matrices used in processing the data and the worst case amplification of errors are presented in appendix B.

#### Data Processing

Recorded data was in the form of X, Y, Z positions and the respective measured color frequencies. These frequencies were converted to velocity components and then transformed to the orthogonal coordinate system in Figure 3. Statistical analysis was then used to calculate velocity mean values, variance and covariance (Reynolds stress tensor components). This data was then used to compute the turbulent kinetic energy (k) and the respective correlation coefficients.

In the statistical processing of the data, two different weighting factors were used. The first weighting factor was 1 (WF1) resulting in a simple averaging of the data. The second weighting factor was the inverse of the velocity vector magnitude ( $1/|\vec{V}|$ ) (WFv), which resulted in a reduction in the velocity mean value and a change in the variance and covariance values. The WFv weighting factor was first proposed by McLaughlin and Tiederman<sup>9</sup> as a way to account for velocity bias (see velocity bias description in the error analysis section). The WFv has the effect of increasing the significance of measurements made when the velocity vector magnitude was small while reducing the significance of high speed measurements.

The accuracy of the processed data was checked by computing jet axial momentum and volume continuity. By conservation of momentum, the total axial momentum of a jet is predicted to remain constant. Axial momentum was calculated from data of both weighting factor methods and the results are shown in Figure 5. The WF1 data showed a constant rise in momentum for all three jet cases thus indicating an over estimation of the jet axial velocity. This is consistent with the velocity bias concept. The WFv data showed a near constant value approximately equal to the calculated jet exit momentum ( $M_e$ ).

Volume continuity of the jet as a whole does not remain constant due to entrainment into the jet. As a result the volume flow of the jet increases in the axial direction. Continuity calculations were therefore done on each individual spatial location. By considering a control volume around a given data point, the data points just outside the control volume were used to calculate the volume flux in and out. The difference in flux was then divided by the flux calculated from the given data point. The volume continuity was calculated at every measurement location, these results were then averaged and are given in Table 1. In comparison, the WF1 data was similar in magnitude to the WFv data for the low speed cases, but in the high speed case the WFv data appeared to be more accurate.

In summary, the momentum calculation indicated strongly that the WFv was more accurate and based on this result the WFv weighting factor was used in all statistical processing of the measured data.

## RESULTS

This report presents flow field measurements for three subsonic rectangular cold air jets. The three cases presented had aspect ratios of 1x2 (25.4 x 50.8 mm) and 1x4 (12.7 x 50.8 mm) at a Mach number of 0.09 (30 m/s) and an aspect ratio of 1x2 (12.7 x 50.8 mm) at a Mach number of 0.9 (322.6 m/s). The Reynolds numbers based on the hydraulic diameter  $D_h$  for the low speed jets were 63,500 and 39,000 respectively, while the high speed case had a Reynolds number of 581,000. All measurements were made using a three dimensional laser Doppler anemometer system. The data is presented in tabular and graphical form. No analysis of the measured data or comparison to other published data is made in this report. Analysis and comparisons of the data are made in references 1, 2, 3, and 4.

The table and figure sections contain all the results obtained from the flow field measurements. The tables contain data in dimensional form. The first three columns provide the spatial location of the measurement in inches. The following nine columns provide the mean velocity, the respective variance, and covariance measured at that location. These data are available on MS-DOS compatible disks.

Using the tabulated information, computer generated plots were created and are presented in the Figures section. Figure 6 shows the centerline velocity decay, while Figures 7 through 10 shown the mean velocity and variance of the initial shear layer at  $X = 0.2$  inches for the 1x2 and 1x4. Mach 0.09 cases. This initial shear layer information could not be measured for the Mach 0.9 case due to equipment limitations.

All graphical plots show views of the jet in an axial direction (X-Y minor axis or X-Z Major Axis) or in a cross sectional plane Y-Z ( $X = 1, 5, 9, 13, 17$  inches). All axes are in inches, all parameters are nondimensionalized by the exit velocity ( $U_e$ ) or the exit velocity squared ( $U_e U_e$ ). All variance, covariance and turbulent kinetic energy results are multiplied by one hundred to make the numbers more convenient.

The two types of graphical plots produced were vector plots and contour plots. The vector plots show the measured mean direction of flow and indicate the magnitude by length of the arrow (Figures 10, 16,

30, 36, 50, and 56). All contour plots were constructed using consistent contour values for ease of comparison. The contour values used are presented in Table 2. If a contour value falls outside the data range the contour is simply not plotted. The contours did not receive any smoothing. Note that only half the jet is shown in the axial contour plots (Figures 11 to 15, 31 to 35, and 51 to 55). The jet was checked for symmetry and it is anticipated that if full measurements had been made they would have shown symmetry about the center line in the respective minor and major axis planes.

REFERENCES

- <sup>1</sup> Morrison, G.L., Swan, D.H., and Tatterson, G.B., "Rectangular Subsonic Jet Flowfield Study", AIAA Paper No. 87-2732.
- <sup>2</sup> Swan, D.H., Morrison G.L., and Tatterson, G.B., "3-D LDA Study of a Rectangular Jet", AIAA Paper No. 88-0183.
- <sup>3</sup> Swan, D.H., and Morrison G.L. "Eddy Viscosity Measurements in a Rectangular Jet", 4th International Symposium on Applications of Laser Anemometry to Fluid Mechanics, July 11 to 14, 1988 Lisbon Portugal Instituto Superior Tecnico Mechanical Engineering Dept. 1096 Lisbon Codex Portugal.
- <sup>4</sup> Swan, D.H., "Flow Field Study of a Rectangular Jet", A Ph.D. dissertation, Mechanical Engineering, Texas A&M University, 1989.
- <sup>5</sup> Hsia, Y., Krothapalli, A., Baganoff, D., and Karamcheti, K., "Effects of Mach Number on the Development of a Subsonic Rectangular Jet," AIAA Journal, Vol. 21, No. 2, pp. 176-177.
- <sup>6</sup> Krothapalli, A., Baganoff, D., and Karamcheti, K., "Development and Structure of a Rectangular Jet in a Multiple Jet Configuration," AIAA Journal, Vol. 18, No. 8, pp. 945-950.
- <sup>7</sup> Marsters, G.F., "An Experimental Investigation of Spanwise Velocity Distributions in Jets from Rectangular Slots," AIAA Paper No. 80-0202.
- <sup>8</sup> "Laser Velocimetry Systems", A commercial laser velocimetry systems handbook, TSI St. Paul, MN, 55164, page 90, 1987.
- <sup>9</sup> McLaughlin, D.K., Tiederman, W.G., "Biasing Correction for Individual Realization of Laser Anemometer Measurements in Turbulent Flows", Physics of Fluids, Vol. 16, 1973, pp 2083.
- <sup>10</sup> Wiedner, B.G., "Experimental Investigation of Velocity Biasing In Laser Doppler Anemometry", A Masters of Science thesis, Mechanical Engineering, Texas A&M University, 1988.
- <sup>11</sup> Hinze, J.O., "Turbulence", McGraw-Hill, New York, 2 ed., 1975.

Table 1

## Volume Continuity Error

Nozzle	WF1	WFv
1x2 Nozzle M=0.09	-2%	3%
1x4 Nozzle M=0.09	-2%	4%
1x2 Nozzle M=0.9	-51%	-5%

Note Volume Continuity was calculated for each spatial location using the WF1 and WFv processed data. Table results are the simple average of all continuity calculations for each jet case.

Table 2

## Contour Level Values

## 1. Velocity Contours

$U/U_e$	.1, .3, .5, .7, .9, .95
$V/U_e$	-.06, -.05, -.04, -.03, -.02, -.01, .01, .02, .03,
$W/U_e$	

## 2. Reynolds Terms

$uu/(U_e U_e) \times 100$	.5, 1.0, 1.5, 2.0, 2.5, 3.0, 3.5, 4.0, 4.5
$vv/(U_e U_e) \times 100$	
$ww/(U_e U_e) \times 100$	
$uv/(U_e U_e) \times 100$	
$uv/(U_e U_e) \times 100$	-.7, -.5, -.3, -.1, .1, .3, .5, .7
$uv/(U_e U_e) \times 100$	

## 3. Turbulent Kinetic Energy (k)

$k/(U_e U_e) \times 100$	.5, 1.0, 1.5, 2.0, 2.5, 3.0, 3.5, 4.0, 4.5
--------------------------	--

## 4. Correlation Coefficients

$uv/\sqrt{(uu+vv)}$	-.8, -.7, -.6, -.5, -.4, -.3, -.2, -.1, .1, .2,
$uw/\sqrt{(uu+ww)}$	
$vw/\sqrt{(vv+ww)}$	

Note All plotted values are means ( $\bar{U}$ ,  $\overline{uu}$  etc.)

**TABLE 3**  
**1x2 Ratio Nozzle Mach# = .09 WFv Data**

X	Y	Z	$\bar{U}$	$\bar{V}$	$\bar{W}$	$\overline{uu}$	$\overline{vv}$	$\overline{ww}$	$\overline{uv}$	$\overline{uw}$	$\overline{vw}$	File Name
inch	inch	inch	m/s	m/s	m/s	m <sup>2</sup> /s <sup>2</sup>	m <sup>2</sup> /s <sup>2</sup>	m <sup>2</sup> /s <sup>2</sup>	m <sup>2</sup> /s <sup>2</sup>	m <sup>2</sup> /s <sup>2</sup>	m <sup>2</sup> /s <sup>2</sup>	
1.00	-0.595	0.002	.3320E+01	.6079E-01	-.4282E+00	.2080E+02	.3333E+02	.1370E+02	-.5196E+01	-.2723E+01	.1682E+01	D01064.BIS
5.00	-1.072	0.001	.2760E+01	.1260E-01	-.5960E+00	.1110E+02	.1099E+02	.7240E+01	-.3771E+01	-.5702E+00	-.3393E+00	D01064.BIS
9.00	-1.548	0.000	.1694E+01	.1943E+00	-.3160E+00	.7991E+01	.6759E+01	.5000E+01	-.2708E+01	-.6739E+00	-.1434E+00	D01064.BIS
13.00	-2.024	0.000	.1133E+01	.1949E+00	-.2620E+00	.5801E+01	.5947E+01	.3390E+01	-.2188E+01	-.4580E+00	-.3142E+00	D01064.BIS
17.00	-2.501	-0.001	.1373E+01	.1181E+00	-.2360E+00	.5780E+01	.4490E+01	.3210E+01	-.1758E+01	-.1802E-01	-.2902E+00	D01064.BIS
1.00	-0.476	0.002	.2105E+02	-.1920E+01	.9743E+00	.2400E+02	.3306E+02	.1440E+02	-.8635E+01	-.4823E+00	-.3511E+01	D02064.BIS
5.00	-0.857	0.001	.6606E+01	-.7232E-01	-.5233E+00	.2290E+02	.2080E+02	.1270E+02	-.6721E+01	-.1309E+01	-.2815E+00	D02064.BIS
9.00	-1.238	0.000	.4140E+01	.6285E-01	-.6157E+00	.1470E+02	.1102E+02	.8697E+01	-.4061E+01	-.1071E+01	-.4831E+00	D02064.BIS
13.00	-1.619	0.000	.3230E+01	-.5259E-01	-.3662E+00	.1090E+02	.9099E+01	.6200E+01	-.3521E+01	-.3662E+00	-.6614E+00	D02064.BIS
17.00	-2.000	-0.001	.3281E+01	-.7038E-01	-.3212E+00	.8840E+01	.7610E+01	.5420E+01	-.3259E+01	-.1969E+00	-.2733E+00	D02064.BIS
1.00	-0.357	0.002	.2958E+02	-.1320E+00	.1066E+01	.8650E+00	.8275E+00	.4840E+00	-.7626E-01	.1460E-01	.8019E-02	D03064.BIS
5.00	-0.642	0.001	.1284E+02	-.4428E+00	-.2978E+00	.2680E+02	.3096E+02	.1570E+02	-.7977E+01	-.5325E+00	-.8665E+00	D03064.BIS
9.00	-0.928	0.000	.8184E+01	-.1661E+00	-.5478E+00	.2440E+02	.1884E+02	.1390E+02	-.7506E+01	-.1332E+01	-.5059E-01	D03064.BIS
13.00	-1.215	0.000	.6375E+01	.9171E-02	-.4399E+00	.1780E+02	.1402E+02	.1120E+02	-.6236E+01	-.1919E+00	-.5998E+00	D03064.BIS
17.00	-1.501	-0.001	.5448E+01	-.1835E+00	-.3182E+00	.1280E+02	.1050E+02	.9100E+01	-.4410E+01	.3026E+00	-.8002E+00	D03064.BIS
1.00	-0.237	0.002	.3005E+02	-.3550E+00	-.9086E-01	.1380E+00	.1388E+00	.8121E-01	.3042E-01	.1621E-01	-.1209E-02	D04064.BIS
5.00	-0.428	0.001	.2057E+02	-.1010E+01	.4885E+00	.1730E+02	.3097E+02	.1140E+02	-.3817E+01	-.4198E+00	.1901E-01	D04064.BIS
9.00	-0.619	0.000	.1359E+02	-.2396E-01	-.2208E+00	.2880E+02	.2515E+02	.1630E+02	-.8788E+01	-.3966E+00	-.1170E+01	D04064.BIS
13.00	-0.810	0.000	.1037E+02	-.1488E+00	-.3382E+00	.2700E+02	.1914E+02	.1450E+02	-.9713E+01	.6736E+00	-.1233E+01	D04064.BIS
17.00	-1.000	-0.001	.9117E+01	-.1982E+00	-.4421E+00	.2170E+02	.1535E+02	.1190E+02	-.7764E+01	.5160E+00	-.5795E+00	D04064.BIS
0.20	-0.099	-0.200	.3004E+02	.1220E+00	-.4103E-01	.5030E-01	.6987E-01	.5070E-01	.6282E-03	.2430E-02	-.1192E-01	D05054.BIS
1.00	-0.119	-0.214	.2996E+02	.1570E+00	.3796E-01	.9090E-01	.8799E-01	.5640E-01	.5784E-04	.6360E-03	-.2702E-02	D05054.BIS
2.00	-0.143	-0.232	.2988E+02	.1691E+00	.9569E-01	.6560E+00	.4909E+00	.1810E+00	.3668E-01	.2743E-02	.1159E-01	D05054.BIS
3.00	-0.167	-0.250	.2933E+02	.1374E+00	.8702E-01	.1900E+01	.1774E+01	.7190E+00	-.4476E+00	-.4729E-01	-.6729E-01	D05054.BIS
4.00	-0.190	-0.268	.2823E+02	-.1629E+00	.9109E-01	.4640E+01	.4479E+01	.2211E+01	-.1006E+01	-.1671E+00	-.6351E-02	D05054.BIS
5.00	-0.214	-0.286	.2704E+02	-.3460E+00	-.1774E-01	.7030E+01	.1490E+02	.4021E+01	-.7656E+00	-.2900E+00	.1021E+01	D05054.BIS
6.00	-0.238	-0.304	.2502E+02	-.4238E+00	-.1182E+00	.1210E+02	.2076E+02	.6320E+01	-.2108E+01	-.1270E+00	.7053E+00	D05054.BIS
7.00	-0.262	-0.322	.2367E+02	-.5839E+00	-.2112E+00	.1470E+02	.2330E+02	.8059E+01	-.2619E+01	-.6124E+00	.8179E+00	D05054.BIS
8.00	-0.286	-0.339	.2210E+02	-.2920E+00	-.3801E+00	.1800E+02	.2415E+02	.9273E+01	-.4086E+01	-.7335E+00	.1023E+01	D05054.BIS
9.00	-0.309	-0.357	.2106E+02	-.6623E+00	-.4336E+00	.1920E+02	.2488E+02	.1060E+02	-.4325E+01	-.6922E+00	.1132E+00	D05054.BIS
10.00	-0.333	-0.375	.2000E+02	-.2731E+00	-.4158E+00	.2050E+02	.2463E+02	.1110E+02	-.5020E+01	-.1781E+01	.7550E+00	D05054.BIS
11.00	-0.358	-0.393	.1894E+02	-.4179E+00	-.5543E+00	.2240E+02	.2581E+02	.1050E+02	-.4054E+01	-.1176E+01	-.3475E+00	D05054.BIS
12.00	-0.381	-0.411	.1791E+02	-.2257E+00	-.6577E+00	.2250E+02	.2180E+02	.1110E+02	-.5095E+01	-.1031E+01	-.1444E+00	D05054.BIS
13.00	-0.405	-0.429	.1724E+02	-.2817E+00	-.6864E+00	.2340E+02	.2217E+02	.1220E+02	-.5213E+01	-.1134E+01	.8355E-01	D05054.BIS
14.00	-0.429	-0.447	.1638E+02	-.1763E+00	-.4715E+00	.2200E+02	.2030E+02	.1090E+02	-.5220E+01	-.1463E+01	-.1347E+00	D05054.BIS
15.00	-0.453	-0.465	.1529E+02	-.1217E-01	-.7876E+00	.2330E+02	.2038E+02	.1070E+02	-.5346E+01	-.1348E+01	-.5495E+00	D05054.BIS
16.00	-0.476	-0.482	.1487E+02	-.2799E+00	-.6696E+00	.2030E+02	.1893E+02	.1110E+02	-.4170E+01	-.1644E+01	-.2022E+00	D05054.BIS
17.00	-0.500	-0.500	.1430E+02	-.3922E-01	-.5991E+00	.1980E+02	.1846E+02	.1080E+02	-.4324E+01	-.1191E+01	-.6709E+00	D05054.BIS
18.00	-0.524	-0.518	.1339E+02	-.1795E+00	-.6169E+00	.2060E+02	.1629E+02	.9947E+01	-.3697E+01	-.1348E+01	-.5313E+00	D05054.BIS
19.00	-0.548	-0.536	.1289E+02	-.2474E+00	-.6460E+00	.1830E+02	.1444E+02	.9819E+01	-.3584E+01	-.1021E+01	-.4765E+00	D05054.BIS
0.20	-0.100	0.000	.3004E+02	.2509E-02	-.2681E-01	.5460E-01	.6797E-01	.5680E-01	.2343E-02	.2378E-02	-.5630E-02	D05064.BIS
1.00	-0.119	0.000	.2993E+02	-.6452E-01	.2767E-02	.9890E-01	.9413E-01	.6371E-01	.1008E-01	.3035E-02	-.8608E-03	D05064.BIS
2.00	-0.143	0.000	.2975E+02	-.5556E-01	.6853E-01	.6330E+00	.4633E+00	.1840E+00	.3973E-01	-.2060E-01	-.4023E-02	D05064.BIS
3.00	-0.167	-0.001	.2939E+02	-.6588E-01	.9349E-01	.1450E+01	.1283E+01	.7262E+00	-.1886E+00	-.1452E+00	-.5488E-01	D05064.BIS
4.00	-0.190	-0.001	.2863E+02	-.1986E+00	.1296E+00	.3480E+01	.2951E+01	.1860E+01	-.6567E+00	-.3080E+00	.1516E+00	D05064.BIS
5.00	-0.214	-0.001	.2727E+02	-.3622E+00	-.5563E-01	.7029E+01	.1279E+02	.3290E+01	-.9152E+00	-.5310E+00	.4949E+00	D05064.BIS
6.00	-0.238	-0.001	.2591E+02	-.6814E+00	.7873E-02	.1010E+02	.1590E+02	.5100E+01	-.1580E+01	-.6658E+00	.1140E+01	D05064.BIS
7.00	-0.262	-0.001	.2457E+02	-.6998E+00	.2858E-01	.1210E+02	.2137E+02	.7082E+01	-.2289E+01	-.5615E+00	.1577E+01	D05064.BIS
8.00	-0.286	-0.001	.2355E+02	-.7168E+00	-.1530E+00	.1480E+02	.2183E+02	.8390E+01	-.1987E+01	-.8451E+00	.1342E+01	D05064.BIS
9.00	-0.309	-0.001	.2232E+02	-.5218E+00	-.1691E+00	.1660E+02	.2246E+02	.8928E+01	-.4082E+01	-.1127E+00	.1260E+01	D05064.BIS
10.00	-0.334	-0.002	.2116E+02	-.5261E+00	-.1929E+00	.2010E+02	.2510E+02	.9819E+01	-.4704E+01	-.4907E-01	.1173E+01	D05064.BIS
11.00	-0.358	-0.002	.2059E+02	-.4177E+00	-.1871E+00	.1920E+02	.2392E+02	.1000E+02	-.4962E+01	.3470E+00	.8552E+00	D05064.BIS
12.00	-0.381	-0.002	.1942E+02	-.5986E+00	-.3032E+00	.2030E+02	.2309E+02	.1070E+02	-.4643E+01	.3329E+00	.4714E+00	D05064.BIS
13.00	-0.405	-0.002	.1828E+02	-.5220E+00	-.3059E+00	.2200E+02	.2237E+02	.1030E+02	-.4795E+01	.9068E+00	.4719E+00	D05064.BIS
14.00	-0.429	0.000	.1756E+02	-.4849E+00	-.2560E+00	.2150E+02	.2385E+02	.1150E+02	-.4762E+01	.7190E+00	.4857E+00	D05064.BIS
15.00	-0.453	0.000	.1663E+02	-.5212E+00	-.2608E+00	.2110E+02	.2012E+02	.1100E+02	-.4218E+01	.5429E+00	.9780E+00	D05064.BIS

TABLE 3  
Continued

X	Y	Z	$\bar{u}$	$\bar{v}$	$\bar{w}$	$\bar{u}^2$	$\bar{v}^2$	$\bar{w}^2$	$\bar{uv}$	$\bar{uv}$	$\bar{vw}$	File Name
inch	inch	inch	m/s	m/s	m/s	m <sup>2</sup> /s <sup>2</sup>	m <sup>2</sup> /s <sup>2</sup>	m <sup>2</sup> /s <sup>2</sup>	m <sup>2</sup> /s <sup>2</sup>	m <sup>2</sup> /s <sup>2</sup>	m <sup>2</sup> /s <sup>2</sup>	
17.00	-0.500	-0.001	.1546E+02	-.5841E+00	-.1779E+00	.1920E+02	.1713E+02	.1090E+02	-.4143E+01	.1061E+01	-.6332E-01	D05064.BIS
18.00	-0.524	-0.001	.1363E+02	-.4236E+00	-.3712E+00	.1940E+02	.1520E+02	.1070E+02	-.4995E+01	.1427E+01	.1084E+00	D05064.BIS
19.00	-0.549	0.000	.1364E+02	-.3470E+00	-.3244E+00	.1800E+02	.1521E+02	.9343E+01	-.4449E+01	.9526E+00	-.2341E-02	D05064.BIS
0.20	-0.099	0.200	.3009E+02	-.2548E+01	.8239E-02	.1360E+00	.7234E+00	.1360E+01	-.8647E-01	.2350E-01	.4193E-01	D05074.BIS
1.00	-0.118	0.214	.3005E+02	-.2571E+01	.5063E+00	.1510E+00	.7355E+00	.1570E+01	-.1011E+00	-.1149E-01	.1314E+00	D05074.BIS
2.00	-0.143	0.232	.3001E+02	-.2420E+01	.1211E+01	.4179E+00	.1031E+01	.1520E+01	-.2479E+00	-.4796E-01	-.5405E-01	D05074.BIS
3.00	-0.167	0.250	.2955E+02	-.1946E+01	.1670E+01	.1620E+01	.2806E+01	.1660E+01	-.6090E+00	-.2596E-02	-.4674E+00	D05074.BIS
4.00	-0.190	0.268	.2857E+02	-.1560E+01	.1702E+01	.4470E+01	.1420E+02	.2890E+01	-.9347E+00	.3596E+00	-.4804E-01	D05074.BIS
5.00	-0.214	0.286	.2652E+02	-.9750E+00	.1502E+01	.1020E+02	.1987E+02	.5430E+01	-.2899E+01	.7639E+00	.4407E+00	D05074.BIS
6.00	-0.238	0.303	.2420E+02	-.6252E+00	.1099E+01	.1630E+02	.2498E+02	.8850E+01	-.4347E+01	.1960E+01	-.1000E+00	D05074.BIS
7.00	-0.262	0.321	.2290E+02	-.1087E+01	.9485E+00	.1990E+02	.3071E+02	.9373E+01	-.4347E+01	.1419E+01	.6034E+00	D05074.BIS
8.00	-0.286	0.339	.2104E+02	-.7496E+00	.7113E+00	.2240E+02	.2837E+02	.1140E+02	-.6516E+01	.2049E+01	-.3002E-01	D05074.BIS
9.00	-0.309	0.357	.2054E+02	-.8644E+00	.5884E+00	.2150E+02	.2655E+02	.1190E+02	-.5870E+01	.7330E+00	.9314E+00	D05074.BIS
10.00	-0.333	0.375	.1837E+02	-.6843E+00	.4495E+00	.2580E+02	.2684E+02	.1340E+02	-.6620E+01	.2340E+01	.3464E+00	D05074.BIS
11.00	-0.358	0.393	.1733E+02	-.7342E+00	.3222E+00	.2750E+02	.2414E+02	.1340E+02	-.7563E+01	.2763E+01	.6791E+00	D05074.BIS
12.00	-0.381	0.410	.1633E+02	-.6513E+00	.1973E+00	.2640E+02	.2269E+02	.1320E+02	-.6529E+01	.3527E+01	.3574E+00	D05074.BIS
13.00	-0.405	0.429	.1660E+02	-.8568E+00	.3226E+00	.2170E+02	.2464E+02	.1210E+02	-.4279E+01	.2754E+01	.2119E+00	D05074.BIS
14.00	-0.429	0.446	.1589E+02	-.7289E+00	.3581E+00	.2270E+02	.2267E+02	.1100E+02	-.4982E+01	.2552E+01	.8934E+00	D05074.BIS
15.00	-0.453	0.464	.1426E+02	-.5312E+00	.2147E+00	.2360E+02	.1967E+02	.1250E+02	-.4942E+01	.3088E+01	-.3688E+00	D05074.BIS
16.00	-0.476	0.482	.1368E+02	-.8320E+00	.3422E+00	.2120E+02	.1929E+02	.1180E+02	-.4715E+01	.2666E+01	.1013E+01	D05074.BIS
17.00	-0.500	0.500	.1282E+02	-.5731E+00	.2229E+00	.2170E+02	.1612E+02	.1080E+02	-.5312E+01	.3251E+01	-.2004E+00	D05074.BIS
18.00	-0.524	0.518	.1222E+02	-.5323E+00	.1699E+00	.1890E+02	.1491E+02	.1020E+02	-.4043E+01	.2658E+01	-.2618E-02	D05074.BIS
19.00	-0.548	0.535	.1107E+02	-.3364E+00	.1012E+00	.1850E+02	.1354E+02	.9260E+01	-.4226E+01	.2987E+01	.1859E+00	D05074.BIS
0.20	-0.099	0.400	.3023E+02	-.1684E+01	.2204E+01	.8123E-01	.7746E+00	.6440E+00	-.5587E-01	-.9057E-02	-.3229E+00	D05084.BIS
1.00	-0.119	0.428	.3015E+02	-.1065E+01	.2262E+01	.1710E+00	.1072E+01	.9390E+00	.4007E-01	.3393E-01	-.4736E+00	D05084.BIS
2.00	-0.143	0.464	.3010E+02	-.3340E+00	.2226E+01	.3230E+00	.1155E+01	.1050E+01	.5217E-02	-.3230E-01	-.4645E+00	D05084.BIS
3.00	-0.167	0.500	.2957E+02	-.5102E-01	.2125E+01	.1670E+01	.5679E+01	.1740E+01	-.2347E+00	.4272E-01	-.4181E-01	D05084.BIS
4.00	-0.190	0.535	.2774E+02	-.1783E+00	.2001E+01	.7340E+01	.1449E+02	.3960E+01	-.9732E+00	.4299E+00	.3958E+00	D05084.BIS
5.00	-0.214	0.571	.2466E+02	-.1272E+00	.1713E+01	.1700E+02	.2595E+02	.8610E+01	-.2506E+01	.2056E+01	.1242E+01	D05084.BIS
6.00	-0.238	0.607	.2256E+02	-.3062E+00	.1350E+01	.2030E+02	.2987E+02	.1240E+02	-.3189E+01	.3061E+01	.1602E+01	D05084.BIS
7.00	-0.262	0.643	.2067E+02	-.4061E+00	.1334E+01	.2350E+02	.3088E+02	.1420E+02	-.5290E+01	.2497E+01	.2170E+01	D05084.BIS
8.00	-0.286	0.678	.1922E+02	-.6534E+00	.1135E+01	.2510E+02	.3112E+02	.1540E+02	-.6137E+01	.3793E+01	.1994E+01	D05084.BIS
9.00	-0.309	0.714	.1908E+02	-.8925E+00	.9516E+00	.2180E+02	.2918E+02	.1390E+02	-.5064E+01	.3471E+01	.1527E+01	D05084.BIS
10.00	-0.333	0.750	.1651E+02	-.6796E+00	.7216E+00	.2690E+02	.2929E+02	.1560E+02	-.6587E+01	.5297E+01	.1505E+01	D05084.BIS
11.00	-0.358	0.786	.1544E+02	-.6699E+00	.7538E+00	.2600E+02	.2946E+02	.1510E+02	-.6252E+01	.4441E+01	.1277E+01	D05084.BIS
12.00	-0.381	0.821	.1534E+02	-.9559E+00	.7406E+00	.2620E+02	.2568E+02	.1410E+02	-.6057E+01	.3964E+01	.1323E+01	D05084.BIS
13.00	-0.404	0.857	.1339E+02	-.4090E+00	.5349E+00	.2720E+02	.2288E+02	.1400E+02	-.6052E+01	.5548E+01	.8336E+00	D05084.BIS
14.00	-0.429	0.893	.1254E+02	-.7309E+00	.7191E+00	.2520E+02	.2183E+02	.1370E+02	-.4245E+01	.4920E+01	.1322E+01	D05084.BIS
15.00	-0.453	0.928	.1224E+02	-.7748E+00	.6276E+00	.2280E+02	.2289E+02	.1240E+02	-.5042E+01	.3881E+01	.6139E+00	D05084.BIS
16.00	-0.476	0.964	.1104E+02	-.4795E+00	.3866E+00	.2220E+02	.1878E+02	.1090E+02	-.4531E+01	.4997E+01	.4372E+00	D05084.BIS
17.00	-0.500	1.000	.1136E+02	-.5718E+00	.5740E+00	.1830E+02	.1720E+02	.1010E+02	-.3502E+01	.3313E+01	.5652E+00	D05084.BIS
18.00	-0.524	1.036	.1147E+02	-.6757E+00	.4840E+00	.1660E+02	.1514E+02	.9521E+01	-.2518E+01	.3671E+01	.6322E+00	D05084.BIS
19.00	-0.548	1.071	.9492E+01	-.3942E+00	.4322E+00	.1570E+02	.1365E+02	.9167E+01	-.3214E+01	.3168E+01	.4442E-01	D05084.BIS
0.20	-0.099	0.600	.3044E+02	.3491E-01	.1533E+01	.1010E+00	.3885E+00	.8241E+00	-.1415E-01	-.1318E-01	.7797E-01	D05094.BIS
1.00	-0.119	0.642	.3026E+02	.5946E-01	.1023E+01	.2060E+00	.4456E+00	.7590E+00	.2597E-01	.2860E-01	.1292E+00	D05094.BIS
2.00	-0.143	0.696	.3028E+02	.2617E-01	.1144E+01	.5489E+00	.9216E+00	.1090E+01	-.9915E-01	-.2068E-01	-.7423E-01	D05094.BIS
3.00	-0.167	0.750	.2923E+02	.1050E+00	.1240E+01	.3840E+01	.3945E+01	.2770E+01	-.3903E+00	.4148E+00	.4605E+00	D05094.BIS
4.00	-0.190	0.803	.2588E+02	-.1764E+00	.1515E+01	.1230E+02	.2988E+02	.7261E+01	-.1841E-01	.1431E+01	.2704E+01	D05094.BIS
5.00	-0.214	0.857	.2304E+02	-.4617E+00	.1303E+01	.1730E+02	.3250E+02	.1080E+02	-.1063E+01	.3690E+01	.3176E+01	D05094.BIS
6.00	-0.238	0.910	.2073E+02	-.6640E+00	.1433E+01	.1850E+02	.3366E+02	.1220E+02	-.3810E+00	.3732E+01	.3618E+01	D05094.BIS
7.00	-0.262	0.964	.1775E+02	-.6946E+00	.1441E+01	.2410E+02	.3192E+02	.1510E+02	-.3680E+01	.4450E+01	.3540E+01	D05094.BIS
8.00	-0.286	1.018	.1635E+02	-.5772E+00	.1491E+01	.2540E+02	.3367E+02	.1530E+02	-.4701E+01	.4969E+01	.2127E+01	D05094.BIS
9.00	-0.309	1.071	.1464E+02	-.3974E+00	.1201E+01	.2580E+02	.2837E+02	.1520E+02	-.3334E+01	.6179E+01	.2736E+01	D05094.BIS
10.00	-0.333	1.125	.1319E+02	-.3165E+00	.9643E+00	.2370E+02	.2497E+02	.1700E+02	-.4432E+01	.6159E+01	.2275E+01	D05094.BIS
11.00	-0.358	1.178	.1192E+02	-.4191E+00	.7190E+00	.2710E+02	.2464E+02	.1610E+02	-.4943E+01	.7151E+01	.1025E+01	D05094.BIS
12.00	-0.381	1.232	.1031E+02	-.7170E-01	.5569E+00	.2730E+02	.2122E+02	.1550E+02	-.5747E+01	.6972E+01	.3316E+00	D05094.BIS



TABLE 3  
Continued

X	Y	Z	$\bar{U}$	$\bar{V}$	$\bar{W}$	$\overline{uu}$	$\overline{vv}$	$\overline{ww}$	$\overline{uv}$	$\overline{uw}$	$\overline{vw}$	File Name
inch	inch	inch	m/s	m/s	m/s	m <sup>2</sup> /s <sup>2</sup>	m <sup>2</sup> /s <sup>2</sup>	m <sup>2</sup> /s <sup>2</sup>	m <sup>2</sup> /s <sup>2</sup>	m <sup>2</sup> /s <sup>2</sup>	m <sup>2</sup> /s <sup>2</sup>	
13.00	-0.404	1.285	.1005E+02	-.2447E+00	.5161E+00	.2750E+02	.1909E+02	.1420E+02	-.5400E+01	.6757E+01	.7692E+00	D05094.BIS
14.00	-0.429	1.339	.9565E+01	-.2276E+00	.5836E+00	.2150E+02	.1794E+02	.1290E+02	-.4323E+01	.6440E+01	.4923E-01	D05094.BIS
15.00	-0.453	1.393	.8304E+01	.5357E-01	.4535E+00	.2150E+02	.1571E+02	.1190E+02	-.3725E+01	.6450E+01	.1615E+00	D05094.BIS
16.00	-0.476	1.446	.8003E+01	-.1403E+00	.2887E+00	.1990E+02	.1503E+02	.1160E+02	-.4100E+01	.6452E+01	-.3790E+00	D05094.BIS
17.00	-0.500	1.500	.7568E+01	-.1233E+00	.2644E+00	.1730E+02	.1261E+02	.1040E+02	-.3342E+01	.4967E+01	-.1915E+00	D05094.BIS
18.00	-0.524	1.553	.7487E+01	-.2278E+00	.2847E+00	.1590E+02	.1293E+02	.9658E+01	-.2928E+01	.4628E+01	-.2082E+00	D05094.BIS
19.00	-0.548	1.607	.7288E+01	-.2125E+00	.2647E+00	.1450E+02	.1187E+02	.8669E+01	-.2956E+01	.4408E+01	-.5631E+00	D05094.BIS
0.20	-0.100	0.800	.3032E+02	.6152E+00	.3756E+00	.7533E-01	.2795E+00	.4419E+00	-.9429E-02	.1461E-02	-.3320E-01	D05104.BIS
1.00	-0.119	0.857	.3009E+02	.1483E+01	.5699E+00	.6840E+00	.9814E+00	.1050E+01	.2571E+00	.3882E-01	-.7780E-01	D05104.BIS
2.00	-0.143	0.928	.2527E+02	.1563E+01	.8463E+00	.1730E+02	.3984E+02	.6529E+01	.4680E+01	.4900E+01	.3827E+01	D05104.BIS
3.00	-0.167	1.000	.1968E+02	.5063E+00	.7180E+00	.2540E+02	.5434E+02	.1320E+02	.3048E+01	.8764E+01	.4698E+01	D05104.BIS
4.00	-0.190	1.071	.1668E+02	.1513E+00	.1374E+01	.2580E+02	.4064E+02	.1460E+02	.1570E+01	.8149E+01	.2690E+01	D05104.BIS
5.00	-0.214	1.143	.1446E+02	.3376E+00	.1460E+01	.2460E+02	.3622E+02	.1400E+02	.4729E+00	.6850E+01	.2429E+01	D05104.BIS
6.00	-0.238	1.214	.1321E+02	.8520E-01	.1806E+01	.2560E+02	.3069E+02	.1480E+02	-.2095E+01	.7318E+01	.1376E+01	D05104.BIS
7.00	-0.262	1.286	.1185E+02	.8457E-01	.1512E+01	.2640E+02	.2766E+02	.1500E+02	-.3443E+01	.7867E+01	.9062E+00	D05104.BIS
8.00	-0.286	1.357	.1049E+02	.9094E-01	.1287E+01	.2520E+02	.2249E+02	.1560E+02	-.3210E+01	.8525E+01	.3882E+00	D05104.BIS
9.00	-0.309	1.428	.9269E+01	-.1199E-01	.8575E+00	.2620E+02	.2149E+02	.1490E+02	-.3685E+01	.8498E+01	.4680E+00	D05104.BIS
10.00	-0.333	1.500	.8052E+01	.2626E+00	.9501E+00	.2290E+02	.2058E+02	.1390E+02	-.2406E+01	.7031E+01	.6299E+00	D05104.BIS
11.00	-0.358	1.571	.8243E+01	-.6110E-01	.8330E+00	.2200E+02	.2065E+02	.1360E+02	-.3774E+01	.7782E+01	.2066E+00	D05104.BIS
12.00	-0.381	1.643	.7894E+01	-.6376E-02	.7697E+00	.1980E+02	.1612E+02	.1260E+02	-.2811E+01	.6931E+01	.1200E+00	D05104.BIS
13.00	-0.405	1.714	.6722E+01	.5257E-02	.5320E+00	.1890E+02	.1470E+02	.1160E+02	-.2792E+01	.5810E+01	-.3568E+00	D05104.BIS
14.00	-0.429	1.785	.5538E+01	.2639E-01	.3741E+00	.1690E+02	.1328E+02	.1060E+02	-.3004E+01	.5872E+01	-.6334E-01	D05104.BIS
15.00	-0.453	1.857	.6012E+01	.3371E-01	.5094E+00	.1590E+02	.1343E+02	.9879E+01	-.1964E+01	.5500E+01	-.5401E-01	D05104.BIS
16.00	-0.476	1.928	.5776E+01	.7903E-02	.4591E+00	.1320E+02	.1239E+02	.8169E+01	-.2760E+01	.4220E+01	.7746E-01	D05104.BIS
17.00	-0.500	2.000	.5584E+01	-.7793E-03	.5670E+00	.1170E+02	.1185E+02	.7901E+01	-.1288E+01	.4052E+01	.5319E+00	D05104.BIS
18.00	-0.524	2.071	.5461E+01	-.5680E-01	.4630E+00	.1080E+02	.1052E+02	.7540E+01	-.1222E+01	.3520E+01	.6123E+00	D05104.BIS
19.00	-0.548	2.142	.5101E+01	-.1534E+00	.2996E+00	.1020E+02	.9761E+01	.6698E+01	-.1255E+01	.3829E+01	-.1995E+00	D05104.BIS
0.20	-0.098	1.000	.1112E+02	.2724E+01	-.9337E-01	.1760E+02	.1221E+02	.5856E+00	.5291E+01	.5979E+00	.1060E+01	D05114.BIS
1.00	-0.119	1.071	.1061E+02	.7644E+00	.9250E+00	.3180E+02	.8558E+02	.2000E+02	.6857E+01	.1220E+02	.4711E+01	D05114.BIS
2.00	-0.143	1.161	.8074E+01	.4399E+00	.7181E+00	.3170E+02	.4161E+02	.1640E+02	.1756E+01	.1130E+02	.2676E+01	D05114.BIS
3.00	-0.167	1.250	.5739E+01	.7000E+00	.2533E+00	.2190E+02	.2482E+02	.1240E+02	.6329E+00	.8848E+01	.1423E+01	D05114.BIS
4.00	-0.190	1.339	.5858E+01	.8995E+00	.6410E+00	.2010E+02	.1957E+02	.1260E+02	.1945E+01	.8409E+01	.9898E+00	D05114.BIS
5.00	-0.214	1.429	.5656E+01	.7607E+00	.5933E+00	.1890E+02	.1915E+02	.1220E+02	.1145E+01	.8060E+01	.5579E+00	D05114.BIS
6.00	-0.238	1.518	.6187E+01	.8082E+00	.8873E+00	.1930E+02	.1729E+02	.1280E+02	-.1078E+00	.8752E+01	.3343E+00	D05114.BIS
7.00	-0.262	1.607	.5609E+01	.7216E+00	.7324E+00	.1860E+02	.1523E+02	.1190E+02	-.1420E+01	.7460E+01	.2157E+00	D05114.BIS
8.00	-0.286	1.696	.5747E+01	.3651E+00	.9394E+00	.1580E+02	.1545E+02	.1090E+02	-.1030E+01	.6619E+01	.7120E+00	D05114.BIS
9.00	-0.309	1.785	.5449E+01	.1391E+00	.8386E+00	.1520E+02	.1420E+02	.1040E+02	-.7340E+00	.5659E+01	.9294E+00	D05114.BIS
10.00	-0.333	1.875	.5212E+01	.6301E-01	.7613E+00	.1390E+02	.1383E+02	.9852E+01	-.1437E+01	.5402E+01	.4544E+00	D05114.BIS
11.00	-0.358	1.964	.5196E+01	-.2476E+00	.6939E+00	.1400E+02	.1260E+02	.8821E+01	-.8779E+00	.5451E+01	-.1801E+00	D05114.BIS
12.00	-0.381	2.053	.4913E+01	.1646E-01	.5653E+00	.1170E+02	.1105E+02	.8468E+01	-.3916E+00	.4789E+01	-.1739E+00	D05114.BIS
13.00	-0.405	2.142	.4032E+01	.2014E+00	.4931E+00	.1110E+02	.1089E+02	.7470E+01	-.1630E+01	.3900E+01	-.2453E+00	D05114.BIS
14.00	-0.429	2.232	.4522E+01	-.1926E+00	.5664E+00	.1090E+02	.1217E+02	.7297E+01	-.1310E+01	.4078E+01	.4292E-01	D05114.BIS
15.00	-0.453	2.321	.4239E+01	-.2599E+00	.5913E+00	.9828E+01	.1456E+02	.6619E+01	-.5062E+00	.3628E+01	.5599E-01	D05114.BIS
16.00	-0.476	2.410	.4306E+01	-.2173E+00	.5337E+00	.1000E+02	.1307E+02	.6990E+01	-.8434E+00	.3800E+01	-.3258E+00	D05114.BIS
17.00	-0.500	2.500	.4133E+01	-.3147E+00	.5149E+00	.9168E+01	.1228E+02	.5898E+01	.1874E+00	.3168E+01	.3671E+00	D05114.BIS
18.00	-0.524	2.589	.3648E+01	-.2641E+00	.3577E+00	.8640E+01	.1052E+02	.5879E+01	-.5286E+00	.3389E+01	.2148E+00	D05114.BIS
19.00	-0.548	2.678	.3246E+01	-.1348E+00	.3568E+00	.8251E+01	.1041E+02	.5040E+01	-.3785E+00	.2570E+01	.1802E+00	D05114.BIS
1.00	0.002	-1.071	.7789E+01	.8597E+00	-.1011E+01	.2990E+02	.2120E+02	.2520E+02	.8208E+00	-.1210E+02	-.4728E+01	D06014.BIS
5.00	0.001	-1.429	.8323E+01	-.2612E-01	-.1328E+01	.2140E+02	.2312E+02	.1280E+02	-.1385E+01	-.7159E+01	.1086E+01	D06014.BIS
9.00	0.001	-1.786	.7246E+01	-.4001E-02	-.1195E+01	.1680E+02	.1569E+02	.1080E+02	.1712E+00	-.6389E+01	-.1800E+00	D06014.BIS
13.00	0.001	-2.143	.5523E+01	.1016E+00	-.8224E+00	.1350E+02	.1129E+02	.8981E+01	.2606E+00	-.5461E+01	-.5959E+00	D06014.BIS
17.00	0.001	-2.500	.5067E+01	.2164E+00	-.5860E+00	.9358E+01	.8649E+01	.6908E+01	.5640E+00	-.3958E+01	-.3834E+00	D06014.BIS
1.00	0.002	-0.857	.2965E+02	-.8845E+00	-.4850E+00	.1030E+01	.1084E+01	.1410E+01	.2235E-01	-.8518E-01	.1503E+00	D06024.BIS
5.00	0.001	-1.143	.1701E+02	-.4126E+00	-.1367E+01	.2340E+02	.3366E+02	.1360E+02	-.6352E+00	-.5796E+01	.1533E+01	D06024.BIS
9.00	0.001	-1.429	.1193E+02	.4879E-01	-.1433E+01	.2300E+02	.2611E+02	.1240E+02	-.7352E+00	-.5859E+01	.8623E+00	D06024.BIS
13.00	0.001	-1.715	.9565E+01	.2314E+00	-.1464E+01	.1920E+02	.1871E+02	.1140E+02	-.5784E+00	-.5869E+01	.5703E-01	D06024.BIS

TABLE 3  
Continued

X	Y	Z	$\bar{U}$	$\bar{V}$	$\bar{W}$	$\overline{uu}$	$\overline{vv}$	$\overline{ww}$	$\overline{uv}$	$\overline{uw}$	$\overline{vw}$	File Name
inch	inch	inch	m/s	m/s	m/s	m <sup>2</sup> /s <sup>2</sup>	m <sup>2</sup> /s <sup>2</sup>	m <sup>2</sup> /s <sup>2</sup>	m <sup>2</sup> /s <sup>2</sup>	m <sup>2</sup> /s <sup>2</sup>	m <sup>2</sup> /s <sup>2</sup>	
17.00	0.001	-2.000	.7718E+01	.9526E-01	-.9121E+00	.1390E+02	.1210E+02	.9029E+01	.2876E+00	-.4709E+01	-.5512E+00	D06024.BIS
1.00	0.002	-0.643	.3005E+02	-.6820E+00	-.6810E+00	.1010E+00	.1128E+00	.8571E-01	.1971E-01	.1891E-01	.1391E-01	D06034.BIS
5.00	0.002	-0.858	.2591E+02	-.7403E+00	-.9235E+00	.9841E+01	.6461E+01	.6032E+01	-.7003E+00	-.3201E+01	-.5515E+00	D06034.BIS
9.00	0.001	-1.072	.1822E+02	-.3696E+00	-.1272E+01	.2130E+02	.2776E+02	.1060E+02	.6432E+00	-.4169E+01	.9078E+00	D06034.BIS
13.00	0.001	-1.286	.1465E+02	-.1846E+00	-.1405E+01	.1970E+02	.2281E+02	.1120E+02	-.7599E-01	-.3352E+01	-.6252E+00	D06034.BIS
17.00	0.001	-1.500	.1138E+02	.1882E-01	-.1105E+01	.1680E+02	.1560E+02	.9909E+01	-.3612E+00	-.4069E+01	-.2754E+00	D06034.BIS
1.00	0.002	-0.428	.3002E+02	-.3709E+00	-.3465E+00	.9660E-01	.9908E-01	.7350E-01	.2634E-01	.1760E-01	.2466E-01	D06044.BIS
5.00	0.002	-0.572	.2877E+02	-.3645E+00	-.4121E+00	.3710E+01	.5435E+01	.2110E+01	-.3909E+00	-.4208E+00	.3973E+00	D06044.BIS
9.00	0.002	-0.715	.2194E+02	-.2031E+00	-.7056E+00	.1870E+02	.2419E+02	.8992E+01	-.1749E+01	-.2929E+01	.3008E+00	D06044.BIS
13.00	0.001	-0.858	.1749E+02	.1972E-01	-.1244E+01	.1900E+02	.2326E+02	.1010E+02	-.1500E+01	-.2991E+01	.1705E+00	D06044.BIS
17.00	0.001	-1.000	.1441E+02	.7146E-01	-.1098E+01	.1840E+02	.2006E+02	.9190E+01	-.6494E+00	-.2659E+01	.2365E+00	D06044.BIS
0.20	0.001	-0.200	.3019E+02	.9168E-01	-.1349E+00	.5020E-01	.8165E-01	.5100E-01	-.3565E-02	-.1377E-02	-.2188E-01	D06054.BIS
1.00	0.001	-0.214	.3005E+02	.1149E+00	-.1193E+00	.7500E-01	.9182E-01	.5330E-01	.4220E-04	-.9249E-03	-.1833E-01	D06054.BIS
2.00	0.001	-0.232	.3003E+02	.1229E-01	-.6228E-01	.4130E+00	.3208E+00	.1100E+00	.2698E-01	.1831E-03	-.1008E-01	D06054.BIS
3.00	0.001	-0.250	.2989E+02	.5046E-01	.3192E-02	.9680E+00	.1200E+01	.2930E+00	.1300E+00	-.1179E-01	.1000E+00	D06054.BIS
4.00	0.001	-0.268	.2965E+02	-.4202E-02	-.1578E-01	.1340E+01	.1838E+01	.5789E+00	.1985E+00	.3381E-01	.1837E+00	D06054.BIS
5.00	0.001	-0.286	.2928E+02	.6674E-01	-.7600E-01	.1930E+01	.3939E+01	.1200E+01	-.5478E-01	-.1354E+00	.2732E+00	D06054.BIS
6.00	0.001	-0.304	.2883E+02	.1834E+00	-.1994E+00	.3140E+01	.6057E+01	.1840E+01	-.1615E+00	-.2132E+00	.4505E+00	D06054.BIS
7.00	0.001	-0.322	.2787E+02	.6799E-01	-.2324E+00	.5590E+01	.1010E+02	.2920E+01	-.4317E+00	-.5387E+00	.3401E+00	D06054.BIS
8.00	0.001	-0.339	.2681E+02	-.1136E+00	-.3425E+00	.8581E+01	.1280E+02	.4140E+01	-.5712E+00	-.1250E+01	.6243E+00	D06054.BIS
9.00	0.001	-0.357	.2516E+02	-.8121E-01	-.4111E+00	.1250E+02	.1891E+02	.5741E+01	-.4685E+00	-.1731E+01	.6890E+00	D06054.BIS
10.00	0.000	-0.375	.2407E+02	-.1057E+00	-.4641E+00	.1350E+02	.2057E+02	.6502E+01	-.3420E+00	-.1582E+01	.4857E+00	D06054.BIS
11.00	0.000	-0.393	.2324E+02	-.1618E+00	-.4983E+00	.1450E+02	.2114E+02	.7050E+01	-.1458E+00	-.1690E+01	.5689E+00	D06054.BIS
12.00	0.000	-0.411	.2179E+02	.2326E+00	-.5121E+00	.1690E+02	.2298E+02	.8082E+01	-.1520E+01	-.1570E+01	.2132E+00	D06054.BIS
13.00	0.000	-0.429	.2065E+02	-.1580E+00	-.6001E+00	.1740E+02	.2389E+02	.8527E+01	.1575E+00	-.2030E+01	.8148E+00	D06054.BIS
14.00	0.000	-0.447	.1988E+02	-.2763E+00	-.7202E+00	.1640E+02	.2235E+02	.8854E+01	.5606E+00	-.9367E+00	.8667E+00	D06054.BIS
15.00	0.000	-0.465	.1895E+02	-.6457E-01	-.6824E+00	.1760E+02	.2171E+02	.8978E+01	-.1163E+01	-.1613E+01	.7346E+00	D06054.BIS
16.00	0.000	-0.482	.1799E+02	-.9208E-01	-.6159E+00	.1740E+02	.2168E+02	.8743E+01	-.8180E+00	-.1328E+01	.6954E+00	D06054.BIS
17.00	0.000	-0.500	.1724E+02	.1001E+00	-.5016E+00	.1670E+02	.1901E+02	.8837E+01	-.1626E+01	-.1450E+01	.2024E+00	D06054.BIS
18.00	0.000	-0.518	.1664E+02	-.6084E-01	-.5666E+00	.1630E+02	.1677E+02	.7889E+01	-.6477E+00	-.8153E+00	.3553E+00	D06054.BIS
19.00	0.000	-0.536	.1618E+02	-.2376E-01	-.6117E+00	.1330E+02	.1728E+02	.7491E+01	.2675E+00	-.6520E+00	-.1461E+00	D06054.BIS
0.20	0.001	-0.001	.2999E+02	-.6844E-04	-.1920E-01	.4980E-01	.6497E-01	.5040E-01	.1480E-02	.2511E-03	-.1059E-01	D06064.BIS
1.00	0.001	-0.001	.2987E+02	-.7450E-02	.3336E-02	.7980E-01	.8475E-01	.5090E-01	.1049E-01	-.1676E-03	-.1470E-01	D06064.BIS
2.00	0.001	-0.001	.2982E+02	.8887E-02	.4656E-01	.4020E+00	.2904E+00	.1050E+00	.3672E-01	-.1241E-01	-.7795E-02	D06064.BIS
3.00	0.001	-0.001	.2968E+02	-.1571E-01	.2659E-01	.8400E+00	.1091E+01	.2510E+00	.1401E+00	-.1247E-01	.1060E+00	D06064.BIS
4.00	0.001	-0.001	.2952E+02	-.2361E-01	.4955E-01	.1240E+01	.1561E+01	.5060E+00	.1411E+00	-.5189E-01	.9760E-01	D06064.BIS
5.00	0.001	-0.002	.2936E+02	.3413E-01	.4408E-01	.1470E+01	.2500E+01	.8476E+00	.7118E-01	-.8532E-01	.1734E+00	D06064.BIS
6.00	0.001	-0.002	.2900E+02	-.1025E-01	-.1627E-01	.2570E+01	.2450E+01	.1430E+01	-.4933E+00	-.1801E+00	-.3779E-01	D06064.BIS
7.00	0.000	-0.002	.2824E+02	.5793E-01	-.7968E-01	.4850E+01	.8625E+01	.2610E+01	-.1701E+00	-.2857E+00	.5976E+00	D06064.BIS
8.00	0.000	-0.002	.2721E+02	-.4253E-01	-.1688E+00	.7700E+01	.1360E+02	.3861E+01	.1380E+00	-.5788E-01	.7765E+00	D06064.BIS
9.00	0.000	-0.001	.2630E+02	-.3471E+00	-.3877E-01	.9800E+01	.1800E+02	.4720E+01	.5174E-01	-.4460E+00	.1070E+01	D06064.BIS
10.00	0.000	-0.001	.2507E+02	-.2571E+00	-.1969E+00	.1160E+02	.1970E+02	.5690E+01	-.7282E-01	-.4790E+00	.1159E+01	D06064.BIS
11.00	0.000	-0.001	.2399E+02	-.2802E+00	-.1504E+00	.1320E+02	.2146E+02	.6768E+01	-.2421E+00	-.4167E+00	.1410E+01	D06064.BIS
12.00	0.000	-0.001	.2299E+02	-.1493E+00	-.2398E+00	.1440E+02	.2225E+02	.7709E+01	-.9944E+00	-.2478E+00	.1168E+01	D06064.BIS
13.00	0.000	-0.001	.2193E+02	-.8162E-01	-.2078E+00	.1470E+02	.2174E+02	.7978E+01	-.1048E+01	.1670E+00	.1452E+01	D06064.BIS
14.00	0.000	-0.001	.2085E+02	-.1020E+00	-.2751E+00	.1560E+02	.2211E+02	.8517E+01	-.4909E+00	.4835E+00	.1021E+01	D06064.BIS
15.00	0.000	-0.001	.2010E+02	-.1080E+00	-.1750E+00	.1540E+02	.2071E+02	.7789E+01	.2271E+00	.2480E+00	.1874E+01	D06064.BIS
16.00	0.000	-0.001	.1899E+02	-.3381E+00	-.3202E+00	.1570E+02	.2013E+02	.8436E+01	.1367E+00	.8317E+00	.8817E+00	D06064.BIS
17.00	0.000	-0.001	.1855E+02	-.9807E-01	-.1594E+00	.1510E+02	.1748E+02	.7931E+01	-.4580E+00	.5626E+00	-.1625E+00	D06064.BIS
18.00	0.000	-0.001	.1739E+02	.7352E-01	-.2969E+00	.1520E+02	.1734E+02	.8560E+01	-.6878E+00	.1518E+01	.2998E+00	D06064.BIS
19.00	0.000	-0.002	.1681E+02	-.6089E-01	-.2484E+00	.1490E+02	.1575E+02	.8289E+01	-.4132E+00	.1343E+01	.5105E+00	D06064.BIS
0.20	0.002	0.200	.3064E+02	-.2256E+00	-.2248E+00	.5710E-01	.9013E-01	.5400E-01	.4805E-02	.1570E-01	-.1290E-01	D06074.BIS
1.00	0.002	0.214	.3044E+02	-.1952E+00	-.2370E+00	.1030E+00	.1216E+00	.8300E-01	.4635E-01	.2830E-01	.3292E-01	D06074.BIS
2.00	0.002	0.232	.3033E+02	-.2215E+00	-.2501E+00	.3659E+00	.2662E+00	.1180E+00	.5533E-01	.8093E-02	.2458E-01	D06074.BIS
3.00	0.002	0.250	.3012E+02	-.3087E+00	-.2552E+00	.7780E+00	.5252E+00	.2411E+00	.1118E+00	-.3269E-01	.2274E-01	D06074.BIS
4.00	0.002	0.268	.2995E+02	-.1900E+00	-.1681E+00	.1160E+01	.1650E+01	.4870E+00	.1459E+00	-.7918E-01	.1312E+00	D06074.BIS

TABLE 3  
Continued

X	Y	Z	$\bar{U}$	$\bar{V}$	$\bar{W}$	$\overline{uu}$	$\overline{vv}$	$\overline{ww}$	$\overline{uv}$	$\overline{uw}$	$\overline{vw}$	File Name
inch	inch	inch	m/s	m/s	m/s	m <sup>2</sup> /s <sup>2</sup>	m <sup>2</sup> /s <sup>2</sup>	m <sup>2</sup> /s <sup>2</sup>	m <sup>2</sup> /s <sup>2</sup>	m <sup>2</sup> /s <sup>2</sup>	m <sup>2</sup> /s <sup>2</sup>	
5.00	0.002	0.286	.2977E+02	-.1950E+00	-.5254E-01	.1850E+01	.1506E+01	.9661E+00	.3995E-01	-.1390E+00	-.4177E-01	D06074.BIS
6.00	0.002	0.303	.2924E+02	-.1635E+00	.2396E-01	.3120E+01	.2734E+01	.1710E+01	-.2168E+00	-.1768E+00	-.2537E-01	D06074.BIS
7.00	0.002	0.321	.2816E+02	-.3839E-01	.9180E-01	.6270E+01	.1010E+02	.3160E+01	-.1222E+00	.5152E+00	.3573E+00	D06074.BIS
8.00	0.002	0.339	.2687E+02	-.1146E+00	.1830E+00	.9370E+01	.1520E+02	.4510E+01	-.2215E+00	.1250E+01	.8241E+00	D06074.BIS
9.00	0.002	0.357	.2529E+02	-.3341E+00	.1919E+00	.1240E+02	.2062E+02	.6392E+01	.2017E+00	.1421E+01	.1643E+01	D06074.BIS
10.00	0.001	0.375	.2386E+02	-.2709E+00	.2277E+00	.1440E+02	.2266E+02	.7233E+01	-.6967E+00	.2573E+01	.1581E+01	D06074.BIS
11.00	0.001	0.393	.2313E+02	-.2486E+00	.4342E+00	.1560E+02	.2467E+02	.7941E+01	-.4277E+00	.2951E+01	.1926E+01	D06074.BIS
12.00	0.001	0.410	.2173E+02	-.1692E+00	.4128E+00	.1780E+02	.2483E+02	.8301E+01	-.7661E+00	.3142E+01	.1272E+01	D06074.BIS
13.00	0.001	0.429	.2053E+02	-.5653E-01	.3823E+00	.1840E+02	.2439E+02	.9130E+01	-.3792E+00	.3322E+01	.1512E+01	D06074.BIS
14.00	0.001	0.446	.1971E+02	-.1731E+00	.4617E+00	.1730E+02	.2416E+02	.9639E+01	-.8404E+00	.3083E+01	.1238E+01	D06074.BIS
15.00	0.001	0.464	.1880E+02	-.6401E-01	.3501E+00	.1730E+02	.2212E+02	.9961E+01	-.3835E+00	.3447E+01	.1282E+01	D06074.BIS
16.00	0.001	0.482	.1799E+02	-.1166E+00	.4080E+00	.1840E+02	.2213E+02	.9699E+01	-.3543E+00	.3708E+01	.1760E+01	D06074.BIS
17.00	0.001	0.500	.1698E+02	-.5343E-01	.3542E+00	.1870E+02	.1854E+02	.9471E+01	-.8692E+00	.3593E+01	.2741E+00	D06074.BIS
18.00	0.001	0.517	.1596E+02	-.5342E-01	.3504E+00	.1730E+02	.1836E+02	.8880E+01	-.9294E+00	.3111E+01	-.3755E+00	D06074.BIS
19.00	0.001	0.535	.1581E+02	-.1026E+00	.3874E+00	.1660E+02	.1684E+02	.8719E+01	.5158E+00	.3180E+01	.9319E+00	D06074.BIS
0.20	0.002	0.400	.3010E+02	-.3556E+00	-.1910E+00	.6540E-01	.8659E-01	.6230E-01	.1807E-01	.1800E-01	.2419E-02	D06084.BIS
1.00	0.002	0.428	.3001E+02	-.3666E+00	-.1545E+00	.1001E+00	.1045E+00	.6781E-01	.2343E-01	.1200E-01	-.2200E-03	D06084.BIS
2.00	0.002	0.464	.2991E+02	-.4085E+00	-.1108E+00	.5320E+00	.3496E+00	.1700E+00	.5434E-01	-.4013E-01	.1055E-01	D06084.BIS
3.00	0.002	0.500	.2964E+02	-.5922E+00	-.1863E+00	.1390E+01	.1600E+01	.5759E+00	.2471E+00	-.1689E+00	.1359E+00	D06084.BIS
4.00	0.002	0.535	.2936E+02	-.4146E+00	-.2119E+00	.2030E+01	.2162E+01	.1410E+01	.1045E+00	-.2688E+00	.5532E-01	D06084.BIS
5.00	0.002	0.571	.2844E+02	-.4376E+00	-.1599E+00	.4290E+01	.7405E+01	.2990E+01	.3974E+00	.3459E+00	.3194E+00	D06084.BIS
6.00	0.002	0.607	.2665E+02	-.5640E+00	-.7781E-01	.8860E+01	.1751E+02	.5341E+01	.1600E+00	.1980E+01	.1411E+01	D06084.BIS
7.00	0.002	0.643	.2433E+02	-.5098E+00	-.4009E-01	.1310E+02	.2285E+02	.7301E+01	.4250E+00	.3541E+01	.1119E+01	D06084.BIS
8.00	0.002	0.678	.2208E+02	-.4154E+00	.1675E+00	.1690E+02	.2758E+02	.8662E+01	-.7126E+00	.4102E+01	.1547E+01	D06084.BIS
9.00	0.002	0.714	.2075E+02	-.2154E+00	.3375E+00	.1830E+02	.2940E+02	.9538E+01	-.2954E+00	.4218E+01	.8552E+00	D06084.BIS
10.00	0.001	0.750	.1928E+02	-.2598E-01	.4376E+00	.2040E+02	.2810E+02	.1020E+02	-.1070E+01	.4743E+01	.1428E+01	D06084.BIS
11.00	0.001	0.785	.1817E+02	-.2362E-02	.5057E+00	.2000E+02	.2710E+02	.1060E+02	-.1661E+01	.4876E+01	.1057E+01	D06084.BIS
12.00	0.001	0.821	.1644E+02	-.1519E+00	.3242E+00	.2290E+02	.2617E+02	.1150E+02	-.2188E+01	.5866E+01	.3573E+00	D06084.BIS
13.00	0.001	0.857	.1556E+02	-.1392E-01	.4753E+00	.2380E+02	.2393E+02	.1080E+02	-.1896E+01	.5760E+01	-.4582E+00	D06084.BIS
14.00	0.001	0.893	.1561E+02	-.4563E-01	.6952E+00	.2080E+02	.2356E+02	.1100E+02	-.1849E+00	.4942E+01	.8232E+00	D06084.BIS
15.00	0.001	0.928	.1504E+02	-.8666E-01	.6156E+00	.1970E+02	.2469E+02	.1160E+02	-.5284E-01	.5199E+01	.5215E+00	D06084.BIS
16.00	0.001	0.964	.1349E+02	-.1019E-01	.4955E+00	.2190E+02	.2023E+02	.1140E+02	-.1228E+01	.6050E+01	.2884E+00	D06084.BIS
17.00	0.001	1.000	.1314E+02	-.1278E-01	.3682E+00	.2110E+02	.1910E+02	.1080E+02	-.7996E+00	.5991E+01	.7677E+00	D06084.BIS
18.00	0.001	1.036	.1268E+02	-.7325E-01	.6978E+00	.1880E+02	.1871E+02	.9978E+01	-.2046E+00	.4938E+01	.6939E+00	D06084.BIS
19.00	0.001	1.071	.1126E+02	-.1340E+00	.3268E+00	.1920E+02	.1691E+02	.1000E+02	-.9945E+00	.5180E+01	.1533E+00	D06084.BIS
0.20	0.002	0.600	.3013E+02	-.4707E+00	-.1912E+00	.6640E-01	.9051E-01	.6740E-01	.9008E-02	.1280E-01	-.5586E-02	D06094.BIS
1.00	0.002	0.642	.3000E+02	-.5281E+00	-.1970E+00	.1470E+00	.1454E+00	.1080E+00	.2978E-01	.1531E-01	.1525E-01	D06094.BIS
2.00	0.002	0.696	.2972E+02	-.5204E+00	-.1302E+00	.1200E+01	.1550E+01	.7648E+00	.1748E+00	-.1548E+00	.1501E+00	D06094.BIS
3.00	0.002	0.749	.2869E+02	-.6809E+00	.1006E+00	.3260E+01	.6818E+01	.2560E+01	.1030E+01	.3940E+00	.8121E+00	D06094.BIS
4.00	0.002	0.803	.2601E+02	-.6831E+00	.4334E+00	.9160E+01	.2310E+02	.5470E+01	.3010E+01	.2300E+01	.2149E+01	D06094.BIS
5.00	0.002	0.857	.2312E+02	-.6077E+00	.5836E+00	.1510E+02	.3227E+02	.9160E+01	.3388E+01	.4790E+01	.2778E+01	D06094.BIS
6.00	0.002	0.910	.2030E+02	-.2907E+00	.6975E+00	.1950E+02	.3335E+02	.1060E+02	.1223E+01	.5802E+01	.7234E+00	D06094.BIS
7.00	0.002	0.964	.1820E+02	-.3698E+00	.9107E+00	.2060E+02	.3357E+02	.1180E+02	-.2044E+00	.5837E+01	.2364E+01	D06094.BIS
8.00	0.002	1.018	.1597E+02	-.6293E-01	.9404E+00	.2380E+02	.3269E+02	.1270E+02	-.1518E+01	.6679E+01	.1231E+01	D06094.BIS
9.00	0.002	1.071	.1505E+02	-.1994E+00	.9376E+00	.2420E+02	.2817E+02	.1290E+02	-.2270E+01	.7708E+01	.1211E-01	D06094.BIS
10.00	0.001	1.125	.1340E+02	-.2753E+00	.4523E+00	.2590E+02	.2627E+02	.1340E+02	-.2150E+01	.7981E+01	-.2260E+00	D06094.BIS
11.00	0.001	1.178	.1282E+02	-.3248E+00	.7327E+00	.2300E+02	.2605E+02	.1290E+02	-.1935E+01	.6479E+01	.5354E+00	D06094.BIS
12.00	0.001	1.232	.1199E+02	-.8326E-01	.9814E+00	.2340E+02	.2316E+02	.1290E+02	-.1601E+01	.6460E+01	.9460E+00	D06094.BIS
13.00	0.001	1.285	.1108E+02	-.2128E+00	.6892E+00	.2500E+02	.2112E+02	.1240E+02	-.1258E+01	.7409E+01	.3592E+00	D06094.BIS
14.00	0.001	1.339	.9785E+01	.1380E+00	.4285E+00	.2330E+02	.1935E+02	.1200E+02	-.1422E+01	.6817E+01	.2888E+00	D06094.BIS
15.00	0.001	1.393	.9634E+01	.1289E+00	.5914E+00	.2070E+02	.1846E+02	.1220E+02	-.1140E+01	.6721E+01	.3587E+00	D06094.BIS
16.00	0.001	1.446	.1003E+02	-.1888E-01	.8242E+00	.1840E+02	.1782E+02	.1000E+02	.7117E+00	.5741E+01	.6773E+00	D06094.BIS
17.00	0.001	1.500	.9260E+01	-.3811E-01	.5042E+00	.1700E+02	.1575E+02	.1040E+02	-.3171E+00	.5580E+01	-.4215E-01	D06094.BIS
18.00	0.001	1.553	.8317E+01	.1952E+00	.4846E+00	.1900E+02	.1547E+02	.9518E+01	-.1391E+01	.5608E+01	.7006E+00	D06094.BIS
19.00	0.001	1.607	.8199E+01	.1428E+00	.5548E+00	.1520E+02	.1313E+02	.8350E+01	-.7648E+00	.4440E+01	.1256E+00	D06094.BIS
0.20	0.002	0.800	.3024E+02	-.5468E+00	-.1213E+00	.6312E-01	.1950E+00	.1200E+00	-.3238E-01	.1972E-01	-.4657E-01	D06104.BIS

TABLE 3  
Continued

X	Y	Z	$\bar{u}$	$\bar{v}$	$\bar{w}$	$\overline{uu}$	$\overline{vv}$	$\overline{ww}$	$\overline{uv}$	$\overline{uw}$	$\overline{vw}$	File Name
inch	inch	inch	m/s	m/s	m/s	m <sup>2</sup> /s <sup>2</sup>	m <sup>2</sup> /s <sup>2</sup>	m <sup>2</sup> /s <sup>2</sup>	m <sup>2</sup> /s <sup>2</sup>	m <sup>2</sup> /s <sup>2</sup>	m <sup>2</sup> /s <sup>2</sup>	
1.00	0.002	0.857	.2964E+02	-.7410E+00	-.3783E+00	.1600E+01	.2970E+01	.1830E+01	.3880E+00	-.9175E-02	.1011E+00	D06104.BIS
2.00	0.002	0.928	.2440E+02	-.1042E+01	.4214E+00	.1090E+02	.1539E+02	.7829E+01	-.5334E+00	.3619E+01	-.3321E+00	D06104.BIS
3.00	0.002	1.000	.1987E+02	-.4604E+00	.1086E+01	.1790E+02	.4736E+02	.1110E+02	.3068E+01	.4838E+01	.2958E+01	D06104.BIS
4.00	0.002	1.071	.1598E+02	-.2474E+00	.1019E+01	.2370E+02	.4192E+02	.1440E+02	-.1672E+00	.6438E+01	.1838E+01	D06104.BIS
5.00	0.002	1.143	.1354E+02	-.1381E+00	.9579E+00	.2500E+02	.3425E+02	.1450E+02	.7073E+00	.8051E+01	.5976E-01	D06104.BIS
6.00	0.002	1.214	.1139E+02	.2621E+00	.7848E+00	.2640E+02	.2893E+02	.1370E+02	-.1199E+01	.8489E+01	.2329E+00	D06104.BIS
7.00	0.002	1.285	.1035E+02	.4379E+00	.8963E+00	.2430E+02	.2624E+02	.1330E+02	-.3708E+01	.7821E+01	-.5130E+00	D06104.BIS
8.00	0.002	1.357	.9863E+01	.1595E+00	.8529E+00	.2290E+02	.2268E+02	.1340E+02	-.1097E+01	.7856E+01	-.4785E+00	D06104.BIS
9.00	0.002	1.428	.8552E+01	.2573E+00	.6017E+00	.2310E+02	.1858E+02	.1300E+02	-.1669E+01	.8008E+01	-.1075E+00	D06104.BIS
10.00	0.001	1.500	.8162E+01	-.1854E+00	.7165E+00	.2320E+02	.1797E+02	.1250E+02	.9942E-01	.7899E+01	-.1139E+01	D06104.BIS
11.00	0.001	1.571	.7686E+01	.2490E+00	.6439E+00	.1950E+02	.1755E+02	.1110E+02	-.1673E+01	.6451E+01	-.2584E+00	D06104.BIS
12.00	0.001	1.643	.7174E+01	.1598E+00	.6149E+00	.1790E+02	.1515E+02	.1090E+02	-.6385E+00	.6572E+01	-.5311E+00	D06104.BIS
13.00	0.001	1.714	.6829E+01	.2327E-01	.5644E+00	.1730E+02	.1460E+02	.1010E+02	-.6684E+00	.6211E+01	-.1832E+00	D06104.BIS
14.00	0.001	1.786	.6545E+01	.1440E+00	.4734E+00	.1590E+02	.1358E+02	.1020E+02	.5567E+00	.6022E+01	.1813E+00	D06104.BIS
15.00	0.001	1.857	.6113E+01	.1344E+00	.3270E+00	.1460E+02	.1299E+02	.9300E+01	-.2589E+00	.5410E+01	-.2206E-01	D06104.BIS
16.00	0.001	1.928	.5728E+01	.8753E-01	.3579E+00	.1410E+02	.1083E+02	.8578E+01	.5208E+00	.4948E+01	-.2123E+00	D06104.BIS
17.00	0.001	2.000	.5449E+01	.1772E+00	.3686E+00	.1290E+02	.1038E+02	.8542E+01	-.8856E+00	.5182E+01	-.1969E+00	D06104.BIS
18.00	0.001	2.071	.5303E+01	.9900E-01	.3438E+00	.1330E+02	.1014E+02	.8121E+01	-.3319E+00	.5081E+01	-.2873E+00	D06104.BIS
19.00	0.001	2.142	.5410E+01	.1867E-01	.5119E+00	.1050E+02	.1031E+02	.7221E+01	-.3043E+00	.4130E+01	-.3275E+00	D06104.BIS
0.20	0.002	1.000	.1660E+02	.1652E+01	-.8271E-01	.2570E+01	.1799E+01	.2674E+00	.3929E+00	.1617E+00	.8087E-01	D06114.BIS
1.00	0.002	1.071	.6770E+01	.6198E+00	.1298E+00	.2960E+02	.7089E+02	.2620E+02	.5436E+01	.1180E+02	.3674E+01	D06114.BIS
2.00	0.002	1.161	.9634E+01	-.3141E-01	.1324E+01	.2510E+02	.4152E+02	.1450E+02	.2186E+01	.8540E+01	.1138E+01	D06114.BIS
3.00	0.002	1.250	.8305E+01	.2634E+00	.1081E+01	.2620E+02	.2992E+02	.1510E+02	-.8674E-01	.9260E+01	.2638E+00	D06114.BIS
4.00	0.002	1.339	.6439E+01	.3527E+00	.6750E+00	.2130E+02	.2017E+02	.1300E+02	-.6702E+00	.8128E+01	-.2337E+00	D06114.BIS
5.00	0.002	1.429	.6004E+01	.2287E+00	.6282E+00	.1820E+02	.1779E+02	.1190E+02	-.1674E+00	.7358E+01	-.5958E+00	D06114.BIS
6.00	0.002	1.518	.5437E+01	.1426E+00	.5863E+00	.1610E+02	.1470E+02	.1060E+02	.8161E+00	.6159E+01	-.2325E+00	D06114.BIS
7.00	0.002	1.607	.4826E+01	.2994E+00	.4481E+00	.1570E+02	.1322E+02	.1020E+02	-.7366E+00	.6449E+01	-.7196E+00	D06114.BIS
8.00	0.002	1.696	.4997E+01	.2327E+00	.5068E+00	.1410E+02	.1232E+02	.8929E+01	-.1507E-01	.5129E+01	-.5536E+00	D06114.BIS
9.00	0.002	1.785	.4537E+01	.1967E+00	.3714E+00	.1360E+02	.1014E+02	.8603E+01	-.5192E+00	.5362E+01	-.5398E-01	D06114.BIS
10.00	0.001	1.875	.3710E+01	.3523E+00	.7407E-01	.1230E+02	.9089E+01	.7721E+01	-.9047E+00	.4620E+01	-.4631E+00	D06114.BIS
11.00	0.001	1.964	.3878E+01	.1078E+00	.3155E+00	.1230E+02	.9033E+01	.7781E+01	.1233E+00	.4381E+01	-.1878E+00	D06114.BIS
12.00	0.001	2.053	.4103E+01	.2457E-01	.3630E+00	.1140E+02	.9691E+01	.7582E+01	.1965E+00	.4351E+01	-.2916E+00	D06114.BIS
13.00	0.001	2.142	.3827E+01	-.6051E-01	.2649E+00	.9559E+01	.9657E+01	.6780E+01	.1699E+00	.3549E+01	-.1275E+00	D06114.BIS
14.00	0.001	2.232	.3546E+01	.2061E+00	.2208E+00	.9999E+01	.8427E+01	.5879E+01	-.2393E+00	.3189E+01	-.5620E-01	D06114.BIS
15.00	0.001	2.321	.3518E+01	.9418E-01	.2900E+00	.9358E+01	.8893E+01	.6149E+01	.7336E-03	.3178E+01	-.1747E+00	D06114.BIS
16.00	0.001	2.410	.3546E+01	.2652E+00	.3822E+00	.8768E+01	.8753E+01	.6299E+01	.4559E+00	.3009E+01	.1308E+00	D06114.BIS
17.00	0.001	2.500	.3462E+01	-.1117E+00	.3119E+00	.8050E+01	.8464E+01	.5540E+01	-.1456E+00	.2880E+01	-.1500E+00	D06114.BIS
18.00	0.001	2.589	.3206E+01	.9431E-01	.3309E+00	.8499E+01	.8510E+01	.5679E+01	-.3631E-01	.3039E+01	-.1126E+00	D06114.BIS
19.00	0.001	2.678	.3284E+01	.8153E-01	.2860E+00	.7150E+01	.8089E+01	.4960E+01	.2778E+00	.2690E+01	.3318E+00	D06114.BIS
0.20	0.101	-0.200	.3011E+02	-.7777E+00	-.6461E+00	.1220E+00	.4244E+00	.3619E+00	.4023E-02	.8230E-01	-.9458E-01	D07054.BIS
1.00	0.119	-0.214	.3009E+02	-.7747E+00	-.5535E+00	.9203E-01	.2513E+00	.3390E+00	.3344E-01	.3436E-01	.7430E-03	D07054.BIS
2.00	0.143	-0.233	.3004E+02	-.8818E+00	-.4818E+00	.3000E+00	.4717E+00	.4660E+00	.3172E-01	.2989E-01	-.4971E-01	D07054.BIS
3.00	0.167	-0.250	.2992E+02	-.1035E+01	-.4522E+00	.8970E+00	.1101E+01	.8670E+00	.1679E+00	.9047E-01	-.7687E-01	D07054.BIS
4.00	0.191	-0.268	.2927E+02	-.1206E+01	-.5879E+00	.2610E+01	.2290E+01	.1900E+01	.6839E+00	-.2202E+00	-.1974E+00	D07054.BIS
5.00	0.214	-0.286	.2764E+02	-.1132E+01	-.4931E+00	.7500E+01	.1320E+02	.4230E+01	.3271E+01	-.4161E-01	.8045E+00	D07054.BIS
6.00	0.238	-0.304	.2599E+02	-.1000E+01	-.5049E+00	.1030E+02	.1860E+02	.5840E+01	.4109E+01	.2509E+01	.1289E+01	D07054.BIS
7.00	0.262	-0.322	.2468E+02	-.6670E+00	-.6054E+00	.1250E+02	.1921E+02	.6300E+01	.4760E+01	.3348E+00	.5253E+00	D07054.BIS
8.00	0.286	-0.339	.2338E+02	-.6509E+00	-.4998E+00	.1450E+02	.2203E+02	.8075E+01	.5291E+01	.4851E+00	.1001E+01	D07054.BIS
9.00	0.309	-0.357	.2238E+02	-.4675E+00	-.6745E+00	.1550E+02	.2380E+02	.8322E+01	.6310E+01	.8876E+00	.1539E+01	D07054.BIS
10.00	0.333	-0.375	.2125E+02	-.5477E+00	-.5280E+00	.1690E+02	.2207E+02	.8901E+01	.5542E+01	.4541E+00	.6440E+00	D07054.BIS
11.00	0.357	-0.393	.2032E+02	-.2178E+00	-.6039E+00	.1750E+02	.2252E+02	.9517E+01	.4523E+01	.1110E+01	.1225E+01	D07054.BIS
12.00	0.381	-0.411	.1952E+02	-.1358E+00	-.5104E+00	.1800E+02	.2295E+02	.9721E+01	.5087E+01	.5613E+00	.2925E+00	D07054.BIS
13.00	0.404	-0.429	.1899E+02	.1555E+00	-.4339E+00	.1700E+02	.2243E+02	.1030E+02	.4166E+01	.1122E+00	.1106E+01	D07054.BIS
14.00	0.428	-0.447	.1804E+02	.8228E-01	-.4102E+00	.1690E+02	.2132E+02	.9379E+01	.3920E+01	-.2762E+00	.5208E+00	D07054.BIS
15.00	0.452	-0.465	.1716E+02	-.2829E-01	-.4581E+00	.1700E+02	.1969E+02	.1020E+02	.4252E+01	-.2339E+00	.6454E+00	D07054.BIS
16.00	0.477	-0.482	.1614E+02	-.6522E-01	-.2558E+00	.1770E+02	.1773E+02	.9802E+01	.3360E+01	-.8952E+00	-.1510E-02	D07054.BIS

TABLE 3  
Continued

X	Y	Z	$\bar{U}$	$\bar{V}$	$\bar{W}$	$\overline{uu}$	$\overline{vv}$	$\overline{ww}$	$\overline{uv}$	$\overline{uw}$	$\overline{vw}$	File Name
inch	inch	inch	m/s	m/s	m/s	m <sup>2</sup> /s <sup>2</sup>	m <sup>2</sup> /s <sup>2</sup>	m <sup>2</sup> /s <sup>2</sup>	m <sup>2</sup> /s <sup>2</sup>	m <sup>2</sup> /s <sup>2</sup>	m <sup>2</sup> /s <sup>2</sup>	
17.00	0.500	-0.500	.1560E+02	.2018E+00	-.3001E+00	.1620E+02	.1662E+02	.9081E+01	.3129E+01	-.2321E+00	.4455E+00	D07054.BIS
18.00	0.523	-0.518	.1465E+02	.5964E-01	-.3402E+00	.1540E+02	.1507E+02	.8453E+01	.3603E+01	-.3454E+00	-.2601E+00	D07054.BIS
19.00	0.548	-0.536	.1439E+02	.1396E+00	-.1172E+00	.1420E+02	.1288E+02	.7659E+01	.2744E+01	-.1001E+01	-.3024E+00	D07054.BIS
0.20	0.101	0.000	.3002E+02	.1088E-01	-.1617E+00	.6110E-01	.6914E-01	.6160E-01	.2242E-01	.9162E-02	.1548E-01	D07064.BIS
1.00	0.119	0.000	.2990E+02	-.1748E-01	-.1676E+00	.9571E-01	.9930E-01	.6340E-01	.1882E-01	.7480E-02	-.6063E-02	D07064.BIS
2.00	0.143	-0.001	.2987E+02	-.2572E-01	-.1388E+00	.5610E+00	.4337E+00	.1510E+00	.3533E-01	.5852E-02	-.3610E-02	D07064.BIS
3.00	0.167	-0.001	.2971E+02	.1622E-01	-.8745E-01	.1100E+01	.8220E+00	.4040E+00	.1965E+00	-.4581E-01	-.4287E-01	D07064.BIS
4.00	0.191	-0.001	.2932E+02	-.3640E-01	-.1191E+00	.2020E+01	.1603E+01	.1070E+01	.6901E+00	-.7764E-01	.7370E-02	D07064.BIS
5.00	0.214	-0.001	.2884E+02	-.2128E-01	-.8580E-01	.3400E+01	.2587E+01	.1910E+01	.9638E+00	-.3062E+00	-.8239E-01	D07064.BIS
6.00	0.238	-0.001	.2796E+02	.1771E-01	-.4839E-01	.5741E+01	.4345E+01	.2910E+01	.1649E+01	-.4453E+00	-.2162E+00	D07064.BIS
7.00	0.262	-0.001	.2712E+02	.7112E-01	-.6125E-01	.8510E+01	.1349E+02	.4080E+01	.3641E+01	-.5440E+00	.4019E+00	D07064.BIS
8.00	0.286	-0.001	.2644E+02	.8447E-01	-.1325E+00	.1020E+02	.1430E+02	.4910E+01	.4389E+01	.5797E-01	.1120E+01	D07064.BIS
9.00	0.309	-0.001	.2543E+02	.2447E+00	-.1572E-01	.1240E+02	.1699E+02	.5840E+01	.4639E+01	-.3110E+00	.5699E+00	D07064.BIS
10.00	0.333	-0.002	.2427E+02	.1801E+00	-.2386E+00	.1430E+02	.2057E+02	.7136E+01	.4395E+01	.1326E+00	.9178E+00	D07064.BIS
11.00	0.357	-0.002	.2312E+02	.4140E+00	-.1843E+00	.1600E+02	.2037E+02	.7690E+01	.4454E+01	.9161E+00	.8466E+00	D07064.BIS
12.00	0.381	-0.002	.2215E+02	.4546E+00	-.2597E+00	.1710E+02	.2264E+02	.8821E+01	.4923E+01	.9014E+00	.1723E+01	D07064.BIS
13.00	0.404	-0.002	.2122E+02	.4353E+00	-.2219E+00	.1770E+02	.2407E+02	.9269E+01	.4482E+01	.3648E+00	.7143E+00	D07064.BIS
14.00	0.428	0.000	.2046E+02	.4838E+00	-.2142E+00	.1610E+02	.2101E+02	.9922E+01	.3936E+01	.1343E+01	.1017E+01	D07064.BIS
15.00	0.452	0.000	.1922E+02	.3938E+00	-.2443E+00	.1760E+02	.2107E+02	.9617E+01	.4174E+01	.1060E+01	.2025E+00	D07064.BIS
16.00	0.477	0.000	.1894E+02	.4664E+00	-.9931E-01	.1670E+02	.1952E+02	.9260E+01	.3557E+01	.1055E+01	.1221E+01	D07064.BIS
17.00	0.500	-0.001	.1759E+02	.4324E+00	-.3345E+00	.1840E+02	.1870E+02	.9110E+01	.3114E+01	.1641E+01	.9103E+00	D07064.BIS
18.00	0.523	-0.001	.1695E+02	.5096E+00	-.1147E+00	.1700E+02	.1696E+02	.8791E+01	.3415E+01	.1047E+01	.3408E+00	D07064.BIS
19.00	0.548	-0.001	.1617E+02	.4011E+00	-.2703E+00	.1550E+02	.1529E+02	.8503E+01	.2318E+01	.1229E+01	.4927E+00	D07064.BIS
0.20	0.100	0.200	.3018E+02	-.3368E+00	-.2557E+00	.8530E-01	.1581E+00	.8950E-01	-.1389E-01	-.6349E-02	-.4623E-01	D07074.BIS
1.00	0.119	0.214	.3009E+02	-.4345E+00	-.2193E+00	.1410E+00	.2718E+00	.1150E+00	-.3093E-01	.7089E-02	-.7140E-01	D07074.BIS
2.00	0.143	0.232	.3007E+02	-.4386E+00	-.2049E+00	.6130E+00	.4294E+00	.1780E+00	.8405E-01	-.3816E-01	-.2423E-01	D07074.BIS
3.00	0.167	0.250	.2990E+02	-.4008E+00	-.1391E+00	.1240E+01	.8137E+00	.4450E+00	.1768E+00	-.1460E+00	-.3774E-01	D07074.BIS
4.00	0.191	0.268	.2953E+02	-.3843E+00	-.1070E+00	.2130E+01	.1543E+01	.1010E+01	.6720E+00	-.1204E+00	.1074E+00	D07074.BIS
5.00	0.214	0.285	.2894E+02	-.2689E+00	-.2274E-01	.3780E+01	.6603E+01	.2180E+01	.1491E+01	-.2358E+00	.4810E+00	D07074.BIS
6.00	0.238	0.303	.2808E+02	-.1718E+00	.1438E-01	.6290E+01	.9324E+01	.3770E+01	.2021E+01	.2099E-01	.4997E+00	D07074.BIS
7.00	0.262	0.321	.2684E+02	-.1581E+00	.2691E-01	.9270E+01	.1240E+02	.5180E+01	.3099E+01	.3677E+00	.1571E+00	D07074.BIS
8.00	0.286	0.339	.2620E+02	.1667E+00	.8316E-01	.1030E+02	.1789E+02	.6010E+01	.3869E+01	.4477E+00	.4226E+00	D07074.BIS
9.00	0.309	0.357	.2462E+02	.5952E-01	-.4270E-03	.1340E+02	.2319E+02	.7519E+01	.4513E+01	.1870E+01	.4660E+00	D07074.BIS
10.00	0.333	0.375	.2316E+02	.2639E+00	.1495E+00	.1720E+02	.2190E+02	.8478E+01	.4592E+01	.2848E+01	-.2045E+00	D07074.BIS
11.00	0.357	0.393	.2186E+02	.2380E+00	.1982E+00	.1920E+02	.2316E+02	.1010E+02	.4336E+01	.2859E+01	-.2911E+00	D07074.BIS
12.00	0.381	0.419	.2072E+02	.2826E+00	.1031E+00	.1960E+02	.2390E+02	.9838E+01	.4107E+01	.2922E+01	.4552E-01	D07074.BIS
13.00	0.404	0.429	.1965E+02	.5045E+00	.9967E-01	.2040E+02	.2223E+02	.1050E+02	.3787E+01	.3531E+01	-.3416E+00	D07074.BIS
14.00	0.428	0.446	.1856E+02	.3356E+00	.4672E-01	.2160E+02	.2182E+02	.1070E+02	.3296E+01	.4361E+01	.5537E-01	D07074.BIS
15.00	0.452	0.464	.1814E+02	.5710E+00	.3283E+00	.1960E+02	.2448E+02	.1040E+02	.4174E+01	.3398E+01	-.3115E+00	D07074.BIS
16.00	0.476	0.482	.1734E+02	.3703E+00	.4004E+00	.1870E+02	.2286E+02	.1070E+02	.3395E+01	.3150E+01	.1376E+00	D07074.BIS
17.00	0.500	0.500	.1606E+02	.4466E+00	.1858E+00	.1940E+02	.2229E+02	.1080E+02	.3360E+01	.3819E+01	.9169E-01	D07074.BIS
18.00	0.523	0.518	.1594E+02	.1347E+00	.2652E+00	.1790E+02	.1836E+02	.9621E+01	.2267E+01	.2782E+01	.7621E-01	D07074.BIS
19.00	0.548	0.535	.1516E+02	.4605E+00	.2091E+00	.1630E+02	.1713E+02	.9140E+01	.2196E+01	.3100E+01	-.1942E+00	D07074.BIS
0.20	0.100	0.400	.3012E+02	-.5426E+00	-.6605E+00	.1130E+00	.2200E+00	.1210E+00	.1169E+00	.2962E-01	.9343E-01	D07084.BIS
1.00	0.118	0.428	.3003E+02	-.7675E+00	-.5813E+00	.3150E+00	.2814E+00	.3070E+00	.1715E+00	-.6620E-01	.5148E-01	D07084.BIS
2.00	0.142	0.464	.3002E+02	-.9116E+00	-.3749E+00	.6989E+00	.4623E+00	.4560E+00	.2262E+00	-.1390E+00	.2821E-01	D07084.BIS
3.00	0.167	0.500	.2994E+02	-.8766E+00	-.2960E+00	.1430E+01	.8202E+00	.7781E+00	.2757E+00	-.2970E+00	.7981E-01	D07084.BIS
4.00	0.191	0.535	.2958E+02	-.6993E+00	-.1146E+00	.2900E+01	.2202E+01	.1730E+01	.9896E+00	-.3259E+00	-.9023E-01	D07084.BIS
5.00	0.214	0.571	.2858E+02	-.2333E+00	.4487E-01	.4870E+01	.1070E+02	.3550E+01	.2310E+01	.2367E+00	.8279E+00	D07084.BIS
6.00	0.238	0.607	.2648E+02	-.3851E+00	.2083E+00	.1020E+02	.1772E+02	.6401E+01	.3643E+01	.1781E+01	.1815E+01	D07084.BIS
7.00	0.262	0.643	.2407E+02	-.2719E+00	.4460E+00	.1460E+02	.2160E+02	.8161E+01	.3992E+01	.2781E+01	-.8433E-01	D07084.BIS
8.00	0.286	0.678	.2296E+02	.1568E+00	.5284E+00	.1510E+02	.2442E+02	.8399E+01	.3954E+01	.3349E+01	.6736E-01	D07084.BIS
9.00	0.309	0.714	.2069E+02	-.1265E+00	.7433E+00	.1970E+02	.2482E+02	.9697E+01	.4794E+01	.4090E+01	-.1999E+00	D07084.BIS
10.00	0.333	0.750	.1914E+02	.1651E+00	.6807E+00	.2130E+02	.2496E+02	.1130E+02	.5186E+01	.4290E+01	-.5070E+00	D07084.BIS
11.00	0.357	0.785	.1825E+02	.2537E+00	.7467E+00	.2120E+02	.2533E+02	.1140E+02	.4501E+01	.5022E+01	-.6137E+00	D07084.BIS
12.00	0.381	0.821	.1772E+02	.2881E+00	.7093E+00	.2040E+02	.2341E+02	.1120E+02	.3250E+01	.4808E+01	-.4617E+00	D07084.BIS

TABLE 3  
Continued

X	Y	Z	$\bar{U}$	$\bar{V}$	$\bar{W}$	$\overline{u^2}$	$\overline{v^2}$	$\overline{w^2}$	$\overline{uv}$	$\overline{uw}$	$\overline{vw}$	File Name
inch	inch	inch	m/s	m/s	m/s	m <sup>2</sup> /s <sup>2</sup>	m <sup>2</sup> /s <sup>2</sup>	m <sup>2</sup> /s <sup>2</sup>	m <sup>2</sup> /s <sup>2</sup>	m <sup>2</sup> /s <sup>2</sup>	m <sup>2</sup> /s <sup>2</sup>	
13.00	0.404	0.857	.1649E+02	.4260E+00	.5867E+00	.2280E+02	.2216E+02	.1110E+02	.4095E+01	.5638E+01	.2260E-01	D07084.BIS
14.00	0.428	0.893	.1557E+02	.3641E+00	.6742E+00	.2240E+02	.2001E+02	.1140E+02	.3031E+01	.4750E+01	-.3797E+00	D07084.BIS
15.00	0.453	0.928	.1524E+02	.5758E+00	.9406E+00	.2060E+02	.2155E+02	.1090E+02	.2459E+01	.3973E+01	-.5722E+00	D07084.BIS
16.00	0.477	0.964	.1444E+02	.4064E+00	.6914E+00	.2100E+02	.1727E+02	.1130E+02	.1709E+01	.5023E+01	-.2808E+00	D07084.BIS
17.00	0.500	1.000	.1239E+02	.2823E+00	.2471E+00	.2310E+02	.1672E+02	.1250E+02	.2487E+01	.6189E+01	-.9303E+00	D07084.BIS
18.00	0.523	1.036	.1200E+02	.3598E+00	.2980E+00	.2130E+02	.1551E+02	.1110E+02	.2883E+01	.5583E+01	-.8007E+00	D07084.BIS
19.00	0.548	1.071	.1145E+02	.2891E+00	.3569E+00	.1970E+02	.1350E+02	.1080E+02	.1717E+01	.5191E+01	-.6247E+00	D07084.BIS
0.20	0.101	0.600	.3018E+02	-.8161E+00	-.8174E+00	.1670E+00	.1795E+00	.2200E+00	.9182E-01	-.2557E-01	.3167E-01	D07094.BIS
1.00	0.118	0.643	.3002E+02	-.8961E+00	-.9509E+00	.6100E+00	.4512E+00	.8050E+00	.2408E+00	-.2740E+00	.1034E+00	D07094.BIS
2.00	0.142	0.697	.3005E+02	-.7703E+00	-.9868E+00	.9251E+00	.6409E+00	.7881E+00	.2161E+00	-.2521E+00	-.2801E-01	D07094.BIS
3.00	0.167	0.750	.2867E+02	-.6569E+00	-.6102E+00	.4590E+01	.4910E+01	.2760E+01	.4313E+00	.4331E+00	-.3516E+00	D07094.BIS
4.00	0.191	0.803	.2425E+02	-.1899E+00	.5311E-01	.1160E+02	.1428E+02	.6022E+01	-.3853E+00	.2722E+01	-.6159E+00	D07094.BIS
5.00	0.214	0.857	.2064E+02	.2174E-01	.1039E+00	.1760E+02	.2996E+02	.9362E+01	.2460E+01	.5272E+01	.1276E+00	D07094.BIS
6.00	0.238	0.910	.1802E+02	.3557E-01	.1731E+00	.2040E+02	.3045E+02	.1130E+02	.3099E+01	.6231E+01	-.6858E+00	D07094.BIS
7.00	0.262	0.964	.1636E+02	.1114E+00	.4672E+00	.2090E+02	.2786E+02	.1180E+02	.3011E+01	.6441E+01	-.1202E+01	D07094.BIS
8.00	0.286	1.018	.1443E+02	.1894E+00	.3289E+00	.2490E+02	.2589E+02	.1210E+02	.4046E+01	.7612E+01	-.3581E+00	D07094.BIS
9.00	0.309	1.071	.1340E+02	.2797E+00	.5092E+00	.2600E+02	.2456E+02	.1300E+02	.2843E+01	.8231E+01	-.9795E+00	D07094.BIS
10.00	0.333	1.125	.1280E+02	.4716E+00	.7336E+00	.2510E+02	.2316E+02	.1270E+02	.3166E+01	.7331E+01	-.1112E+01	D07094.BIS
11.00	0.357	1.178	.1246E+02	.3741E+00	.8444E+00	.2500E+02	.2481E+02	.1310E+02	.4600E+01	.7542E+01	-.9363E+00	D07094.BIS
12.00	0.381	1.232	.1181E+02	.3365E+00	.9057E+00	.2240E+02	.2230E+02	.1330E+02	.4189E+01	.7090E+01	-.5394E-01	D07094.BIS
13.00	0.404	1.285	.1085E+02	.1229E+00	.7064E+00	.2340E+02	.1899E+02	.1220E+02	.3181E+01	.6168E+01	-.8914E+00	D07094.BIS
14.00	0.428	1.339	.1110E+02	.5106E+00	.9513E+00	.2070E+02	.1892E+02	.1140E+02	.1997E+01	.5757E+01	-.8534E+00	D07094.BIS
15.00	0.453	1.393	.1061E+02	.4735E+00	.7771E+00	.2010E+02	.2036E+02	.1130E+02	.2424E+01	.6458E+01	.1937E+00	D07094.BIS
16.00	0.477	1.446	.9933E+01	.6327E+00	.7526E+00	.1770E+02	.1744E+02	.1060E+02	.1813E+01	.5521E+01	-.7790E+00	D07094.BIS
17.00	0.500	1.500	.9475E+01	.3792E+00	.6307E+00	.1750E+02	.1683E+02	.1090E+02	.1590E+01	.5180E+01	-.7882E+00	D07094.BIS
18.00	0.523	1.553	.8985E+01	.4239E+00	.6819E+00	.1730E+02	.1549E+02	.9569E+01	.1046E+01	.5399E+01	-.4588E+00	D07094.BIS
19.00	0.548	1.607	.8310E+01	.4017E+00	.6141E+00	.1620E+02	.1436E+02	.8839E+01	.1167E+01	.5489E+01	-.4169E+00	D07094.BIS
0.20	0.102	0.800	.3014E+02	.3034E+01	-.2310E+01	.1330E+00	.8989E+00	.5470E+00	-.5578E-02	.8406E-01	-.3758E+00	D07104.BIS
1.00	0.118	0.857	.2743E+02	.2186E+01	-.2780E+01	.7160E+01	.5539E+01	.2720E+01	.7172E-01	-.1800E+00	.1526E+00	D07104.BIS
2.00	0.142	0.928	.2066E+02	.5556E+00	-.7779E+00	.1880E+02	.2418E+02	.9769E+01	.1436E+01	.6229E+01	-.7752E+00	D07104.BIS
3.00	0.167	1.000	.1741E+02	.6510E+00	.1574E-01	.2210E+02	.5195E+02	.1060E+02	.6949E+01	.5760E+01	.3607E+01	D07104.BIS
4.00	0.190	1.071	.1452E+02	.7814E+00	.2796E+00	.2450E+02	.4064E+02	.1170E+02	.5660E+01	.6802E+01	.2458E+01	D07104.BIS
5.00	0.214	1.143	.1184E+02	.5995E+00	.1468E+00	.2600E+02	.3176E+02	.1250E+02	.4510E+01	.7570E+01	.4433E+00	D07104.BIS
6.00	0.238	1.214	.1064E+02	.6734E+00	.3182E+00	.2530E+02	.3001E+02	.1250E+02	.5359E+01	.7752E+01	.6310E+00	D07104.BIS
7.00	0.262	1.285	.9140E+01	.5827E+00	.2089E+00	.2610E+02	.2582E+02	.1220E+02	.4995E+01	.8071E+01	-.3580E+00	D07104.BIS
8.00	0.286	1.357	.1020E+02	.5042E+00	.7670E+00	.2420E+02	.2464E+02	.1370E+02	.5505E+01	.8661E+01	.8388E+00	D07104.BIS
9.00	0.309	1.428	.9059E+01	.7623E+00	.5887E+00	.2400E+02	.2196E+02	.1340E+02	.4123E+01	.8290E+01	-.9531E+00	D07104.BIS
10.00	0.333	1.500	.8457E+01	.5637E+00	.4206E+00	.2370E+02	.1969E+02	.1280E+02	.3683E+01	.7892E+01	.1898E+00	D07104.BIS
11.00	0.357	1.571	.9457E+01	.9847E+00	.9765E+00	.2120E+02	.2113E+02	.1180E+02	.2517E+01	.6499E+01	.2492E+00	D07104.BIS
12.00	0.381	1.643	.8736E+01	.7632E+00	.9489E+00	.2000E+02	.2080E+02	.1200E+02	.2498E+01	.6959E+01	.6542E+00	D07104.BIS
13.00	0.404	1.714	.8472E+01	.6567E+00	.8449E+00	.1900E+02	.1836E+02	.1170E+02	.1606E+01	.6270E+01	.1009E+01	D07104.BIS
14.00	0.428	1.785	.7828E+01	.6420E+00	.6787E+00	.1660E+02	.1656E+02	.1100E+02	.2161E+01	.6198E+01	.4624E+00	D07104.BIS
15.00	0.452	1.857	.7519E+01	.5724E+00	.6690E+00	.1740E+02	.1473E+02	.1020E+02	.7931E+00	.5871E+01	-.8838E-01	D07104.BIS
16.00	0.477	1.928	.6895E+01	.4719E+00	.6355E+00	.1390E+02	.1385E+02	.9119E+01	.1538E+01	.4789E+01	.4554E+00	D07104.BIS
17.00	0.500	2.000	.6432E+01	.2897E+00	.4752E+00	.1520E+02	.1153E+02	.9180E+01	.9008E+00	.5780E+01	-.3690E-01	D07104.BIS
18.00	0.523	2.071	.5993E+01	.4108E+00	.4299E+00	.1320E+02	.1103E+02	.7819E+01	.8837E+00	.4969E+01	.1489E+00	D07104.BIS
19.00	0.548	2.142	.6043E+01	.4232E+00	.5012E+00	.1140E+02	.1135E+02	.7239E+01	.5990E-01	.4130E+01	-.7936E-01	D07104.BIS
0.20	0.099	0.999	.1307E+02	.3831E+00	.1258E+00	.2550E+01	.2034E+01	.2657E+00	.8379E-01	.1479E+00	-.7417E-01	D07114.BIS
1.00	0.119	1.071	.7982E+01	.1809E+00	.8677E+00	.2530E+02	.7373E+02	.1890E+02	.3542E+01	.1130E+02	.4600E+01	D07114.BIS
2.00	0.143	1.161	.7850E+01	.1867E+00	.7695E+00	.2180E+02	.3832E+02	.1150E+02	.5824E-02	.6912E+01	.1817E+01	D07114.BIS
3.00	0.167	1.250	.6465E+01	-.4826E-01	.6328E+00	.1500E+02	.2130E+02	.9080E+01	.1466E+01	.5340E+01	-.1819E+00	D07114.BIS
4.00	0.191	1.339	.5620E+01	.2043E+00	.5055E+00	.1190E+02	.1704E+02	.7570E+01	.1443E+01	.4310E+01	.4749E+00	D07114.BIS
5.00	0.214	1.429	.4865E+01	.5142E+00	.2479E+00	.1040E+02	.1157E+02	.7012E+01	.3652E+00	.3882E+01	-.4361E+00	D07114.BIS
6.00	0.238	1.518	.4234E+01	.4259E+00	.2430E+00	.9600E+01	.1093E+02	.6530E+01	.1214E+01	.3459E+01	-.6954E+00	D07114.BIS
7.00	0.262	1.607	.4023E+01	.5403E+00	.1875E+00	.1080E+02	.1061E+02	.6941E+01	.1699E+01	.3731E+01	-.3764E-02	D07114.BIS
8.00	0.286	1.696	.4145E+01	.5568E+00	.2154E+00	.1020E+02	.1038E+02	.7689E+01	.1498E+01	.3959E+01	-.6125E+00	D07114.BIS

TABLE 3  
Continued

X	Y	Z	$\bar{U}$	$\bar{V}$	$\bar{W}$	$\overline{uu}$	$\overline{vv}$	$\overline{ww}$	$\overline{uv}$	$\overline{uw}$	$\overline{vw}$	File Name
inch	inch	inch	m/s	m/s	m/s	m <sup>2</sup> /s <sup>2</sup>	m <sup>2</sup> /s <sup>2</sup>	m <sup>2</sup> /s <sup>2</sup>	m <sup>2</sup> /s <sup>2</sup>	m <sup>2</sup> /s <sup>2</sup>	m <sup>2</sup> /s <sup>2</sup>	
9.00	0.309	1.785	.4245E+01	.6333E+00	.3282E+00	.1060E+02	.1058E+02	.6957E+01	.1079E+01	.3598E+01	-.2883E+00	D07114.BIS
10.00	0.333	1.875	.4940E+01	.9865E+00	.4626E+00	.1200E+02	.1231E+02	.7960E+01	.1871E+01	.4620E+01	.7112E+00	D07114.BIS
11.00	0.357	1.964	.4205E+01	.2786E+00	.3876E+00	.9501E+01	.1001E+02	.6362E+01	.2193E+01	.3312E+01	.4141E+00	D07114.BIS
12.00	0.381	2.053	.4003E+01	.3537E+00	.3804E+00	.9831E+01	.9507E+01	.6301E+01	.2034E+01	.3031E+01	.3733E+00	D07114.BIS
13.00	0.404	2.142	.4520E+01	.7511E+00	.3915E+00	.9359E+01	.9538E+01	.6600E+01	.1053E+01	.3540E+01	-.1584E+00	D07114.BIS
14.00	0.428	2.232	.4215E+01	.6077E+00	.3569E+00	.8910E+01	.8799E+01	.6270E+01	.7154E+00	.3010E+01	-.2149E+00	D07114.BIS
15.00	0.452	2.321	.3948E+01	.7443E+00	.1470E+00	.8879E+01	.8432E+01	.5998E+01	.2748E+00	.3238E+01	-.6355E-01	D07114.BIS
16.00	0.477	2.410	.3995E+01	.4929E+00	.4302E+00	.8620E+01	.8504E+01	.5670E+01	.1041E+01	.2850E+01	.1588E+00	D07114.BIS
17.00	0.500	2.500	.4056E+01	.4710E+00	.4175E+00	.8799E+01	.8443E+01	.6060E+01	.9944E+00	.3300E+01	.1424E+00	D07114.BIS
18.00	0.523	2.589	.3779E+01	.3641E+00	.4289E+00	.7650E+01	.7814E+01	.5570E+01	.6335E+00	.2830E+01	-.2343E+00	D07114.BIS
19.00	0.548	2.678	.3568E+01	.5575E+00	.2973E+00	.8650E+01	.7563E+01	.5351E+01	.8391E+00	.3020E+01	.3309E+00	D07114.BIS
0.20	0.200	-0.200	.3009E+02	-.8098E+00	-.2193E+00	.1060E+00	.3573E+00	.4370E+00	.6062E-01	.6217E-01	-.3406E-01	D08054.BIS
1.00	0.237	-0.214	.2999E+02	-.9265E+00	-.2183E+00	.1380E+00	.4390E+00	.5230E+00	-.1189E-01	.3871E-01	-.7497E-01	D08054.BIS
2.00	0.286	-0.232	.2974E+02	-.9874E+00	-.2157E+00	.1080E+01	.1205E+01	.1100E+01	.3067E+00	-.7882E-01	-.2228E+00	D08054.BIS
3.00	0.332	-0.250	.2755E+02	-.1027E+01	-.4426E-01	.7580E+01	.6355E+01	.4010E+01	.3218E+01	-.2877E+00	-.5417E+00	D08054.BIS
4.00	0.382	-0.268	.2460E+02	-.8430E+00	-.7842E-01	.1220E+02	.2299E+02	.7701E+01	.5708E+01	-.6105E-01	.2202E+01	D08054.BIS
5.00	0.428	-0.286	.2254E+02	-.4724E+00	-.2353E+00	.1490E+02	.2796E+02	.1000E+02	.6564E+01	.5906E+00	.1342E+01	D08054.BIS
6.00	0.477	-0.304	.2088E+02	-.3299E+00	-.3891E+00	.1490E+02	.2789E+02	.1160E+02	.6955E+01	.5167E+00	.8058E+00	D08054.BIS
7.00	0.523	-0.322	.1917E+02	-.3782E+00	-.5852E+00	.1660E+02	.2434E+02	.1230E+02	.6349E+01	.8967E+00	.1979E+01	D08054.BIS
8.00	0.572	-0.339	.1814E+02	-.1579E+00	-.5818E+00	.1850E+02	.2355E+02	.1280E+02	.6324E+01	.1673E+01	.6313E+00	D08054.BIS
9.00	0.618	-0.357	.1647E+02	-.5025E-01	-.7142E+00	.2160E+02	.2283E+02	.1350E+02	.7698E+01	.1708E+01	.8245E+00	D08054.BIS
10.00	0.667	-0.375	.1569E+02	.1051E-01	-.8556E+00	.2290E+02	.2034E+02	.1340E+02	.7648E+01	.1529E+01	.2173E+00	D08054.BIS
11.00	0.714	-0.393	.1519E+02	.1892E+00	-.5803E+00	.2310E+02	.2160E+02	.1380E+02	.7856E+01	.6460E+00	.5965E+00	D08054.BIS
12.00	0.762	-0.411	.1455E+02	.2443E+00	-.4886E+00	.2190E+02	.1927E+02	.1330E+02	.7465E+01	.2946E-02	.1838E+00	D08054.BIS
13.00	0.809	-0.429	.1371E+02	.5465E+00	-.5241E+00	.2390E+02	.1947E+02	.1300E+02	.8184E+01	.1947E+00	-.7139E+00	D08054.BIS
14.00	0.857	-0.447	.1337E+02	.3928E+00	-.4709E+00	.2170E+02	.1927E+02	.1300E+02	.6956E+01	.8197E-01	.6329E-01	D08054.BIS
15.00	0.905	-0.465	.1248E+02	.2126E+00	-.3930E+00	.2200E+02	.1709E+02	.1210E+02	.6427E+01	-.2703E+00	-.1170E+00	D08054.BIS
16.00	0.952	-0.482	.1219E+02	.2373E+00	-.5955E+00	.1910E+02	.1695E+02	.1180E+02	.5302E+01	-.4740E+00	-.4644E+00	D08054.BIS
17.00	1.000	-0.500	.1154E+02	.9442E-01	-.1865E+00	.1940E+02	.1560E+02	.1100E+02	.6265E+01	-.3601E+00	.2214E-01	D08054.BIS
18.00	1.047	-0.518	.1097E+02	.1917E+00	-.2234E+00	.1600E+02	.1404E+02	.9992E+01	.4707E+01	-.1171E+01	-.5544E+00	D08054.BIS
19.00	1.095	-0.536	.1105E+02	.2512E+00	-.3621E+00	.1641E+02	.1265E+02	.9004E+01	.4283E+01	-.9802E+00	-.1821E+00	D08054.BIS
0.20	0.199	-0.001	.3014E+02	-.4738E-01	-.1558E+00	.5850E-01	.7820E-01	.6180E-01	.5722E-02	.6890E-02	-.7105E-02	D08064.BIS
1.00	0.237	-0.001	.3000E+02	-.1035E+00	-.6200E-01	.2070E+00	.1860E+00	.7830E-01	.9967E-03	.4148E-02	-.9690E-02	D08064.BIS
2.00	0.286	-0.001	.2936E+02	-.8261E-01	-.5545E-01	.2040E+01	.1595E+01	.8204E+00	.6448E+00	-.9350E-02	-.4380E-01	D08064.BIS
3.00	0.333	-0.001	.2765E+02	-.1830E+00	.4005E-01	.6160E+01	.5203E+01	.3320E+01	.2839E+01	-.2643E+00	-.4476E+00	D08064.BIS
4.00	0.381	-0.001	.2578E+02	.9069E-01	.3055E-01	.1030E+02	.8801E+01	.5460E+01	.3909E+01	-.4051E-01	-.3700E+00	D08064.BIS
5.00	0.428	-0.002	.2451E+02	.3141E+00	.1493E-01	.1210E+02	.2279E+02	.7330E+01	.6399E+01	-.1663E+00	.1118E+01	D08064.BIS
6.00	0.477	-0.002	.2339E+02	.5990E+00	-.9295E-02	.1440E+02	.2393E+02	.9313E+01	.6165E+01	-.2266E+00	.1558E+01	D08064.BIS
7.00	0.523	-0.002	.2189E+02	.7637E+00	-.2968E-01	.1730E+02	.2327E+02	.9880E+01	.6797E+01	-.3452E+00	.1087E+01	D08064.BIS
8.00	0.572	-0.002	.2079E+02	.8585E+00	-.9670E-01	.1950E+02	.2489E+02	.1210E+02	.7196E+01	.2452E+00	.1037E+01	D08064.BIS
9.00	0.618	0.000	.1967E+02	.7917E+00	-.2062E+00	.2180E+02	.2441E+02	.1310E+02	.7724E+01	.1377E+01	.1044E+01	D08064.BIS
10.00	0.667	0.000	.1849E+02	.7808E+00	-.4147E+00	.2320E+02	.2343E+02	.1390E+02	.8557E+01	.1526E+01	.7645E+00	D08064.BIS
11.00	0.714	0.000	.1742E+02	.8610E+00	-.5319E+00	.2670E+02	.2339E+02	.1420E+02	.9437E+01	.2149E+01	.1129E+01	D08064.BIS
12.00	0.762	-0.001	.1718E+02	.7326E+00	-.4934E+00	.2410E+02	.2412E+02	.1350E+02	.8475E+01	.2628E+01	.1535E+01	D08064.BIS
13.00	0.809	-0.001	.1594E+02	.7673E+00	-.4529E+00	.2510E+02	.2257E+02	.1380E+02	.8494E+01	.2806E+01	.6865E+00	D08064.BIS
14.00	0.857	-0.001	.1500E+02	.8700E+00	-.5429E+00	.2550E+02	.2110E+02	.1370E+02	.8113E+01	.3081E+01	.7868E+00	D08064.BIS
15.00	0.905	-0.001	.1409E+02	.7862E+00	-.7086E+00	.2500E+02	.1886E+02	.1330E+02	.7737E+01	.3007E+01	.5114E+00	D08064.BIS
16.00	0.952	-0.001	.1391E+02	.8256E+00	-.5240E+00	.2280E+02	.1819E+02	.1230E+02	.7387E+01	.2279E+01	.4559E-01	D08064.BIS
17.00	1.000	-0.001	.1352E+02	.7839E+00	-.3040E+00	.2130E+02	.1759E+02	.1191E+02	.6024E+01	.1890E+01	.8249E+00	D08064.BIS
18.00	1.047	-0.001	.1314E+02	.7521E+00	-.4622E+00	.1910E+02	.1603E+02	.1120E+02	.6488E+01	.1060E+01	-.1611E+00	D08064.BIS
19.00	1.095	-0.002	.1211E+02	.7313E+00	-.2769E+00	.1910E+02	.1436E+02	.1120E+02	.5381E+01	.1460E+01	-.4257E-01	D08064.BIS
0.20	0.200	0.200	.3013E+02	-.3162E+00	-.5397E+00	.6190E-01	.8598E-01	.6390E-01	.3347E-01	.2160E-01	.1969E-01	D08074.BIS
1.00	0.237	0.213	.3001E+02	-.5874E+00	-.5029E+00	.2500E+00	.2017E+00	.1600E+00	.5567E-01	-.1261E-01	.9406E-02	D08074.BIS
2.00	0.286	0.232	.2966E+02	-.7296E+00	-.3145E+00	.1800E+01	.1360E+01	.8528E+00	.4391E+00	-.1431E+00	-.1057E+00	D08074.BIS
3.00	0.333	0.250	.2729E+02	-.6146E+00	-.2236E-01	.7950E+01	.6316E+01	.3680E+01	.2506E+01	-.2673E+00	-.4134E+00	D08074.BIS
4.00	0.381	0.268	.2536E+02	-.3312E+00	.1840E+00	.1110E+02	.9130E+01	.6080E+01	.3681E+01	-.3339E+00	-.2448E+00	D08074.BIS



TABLE 3  
Continued

X	Y	Z	$\bar{U}$	$\bar{V}$	$\bar{W}$	$\overline{uu}$	$\overline{vv}$	$\overline{ww}$	$\overline{uv}$	$\overline{uw}$	$\overline{vw}$	File Name
inch	inch	inch	m/s	m/s	m/s	m <sup>2</sup> /s <sup>2</sup>	m <sup>2</sup> /s <sup>2</sup>	m <sup>2</sup> /s <sup>2</sup>	m <sup>2</sup> /s <sup>2</sup>	m <sup>2</sup> /s <sup>2</sup>	m <sup>2</sup> /s <sup>2</sup>	
5.00	0.428	0.286	.2387E+02	-.4702E-01	.1494E+00	.1350E+02	2423E+02	.8342E+01	5987E+01	.3679E+00	.1946E+01	D08074.BIS
6.00	0.477	0.303	.2248E+02	.3584E+00	.3057E+00	.1590E+02	2583E+02	.1040E+02	6759E+01	.1744E+00	.9073E+00	D08074.BIS
7.00	0.523	0.321	.2116E+02	.2774E+00	.2408E+00	.1800E+02	2523E+02	.1130E+02	7420E+01	.1258E+01	.4017E+00	D08074.BIS
8.00	0.572	0.339	.2000E+02	.5396E+00	.8907E-01	.1960E+02	2349E+02	.1330E+02	6958E+01	.2292E+01	-.1981E+00	D08074.BIS
9.00	0.618	0.357	.1873E+02	.5359E+00	.5923E-01	.2230E+02	2417E+02	.1410E+02	8099E+01	.2923E+01	.4534E+00	D08074.BIS
10.00	0.667	0.375	.1816E+02	.7033E+00	.1646E+00	.2430E+02	2291E+02	.1410E+02	8248E+01	.1902E+01	.2056E-01	D08074.BIS
11.00	0.714	0.393	.1652E+02	.8073E+00	.4611E-01	.2540E+02	2377E+02	.1450E+02	8406E+01	.3791E+01	-.5172E+00	D08074.BIS
12.00	0.762	0.410	.1554E+02	.7340E+00	-.2427E+00	.2570E+02	2204E+02	.1470E+02	6448E+01	.4950E+01	.4238E+00	D08074.BIS
13.00	0.809	0.429	.1532E+02	.6838E+00	-.6975E-01	.2430E+02	2230E+02	.1360E+02	7420E+01	.3228E+01	-.1818E+00	D08074.BIS
14.00	0.857	0.446	.1422E+02	.7455E+00	-.5864E-01	.2490E+02	2051E+02	.1420E+02	6788E+01	.3728E+01	-.2033E+00	D08074.BIS
15.00	0.905	0.464	.1410E+02	.8639E+00	-.3180E-01	.2280E+02	2010E+02	.1380E+02	6874E+01	.3280E+01	-.1610E+00	D08074.BIS
16.00	0.952	0.482	.1327E+02	.6849E+00	-.1844E-01	.2180E+02	1699E+02	.1320E+02	6266E+01	.3059E+01	-.8080E+00	D08074.BIS
17.00	1.000	0.500	.1247E+02	.7140E+00	.3658E-01	.2400E+02	1718E+02	.1250E+02	7221E+01	.3520E+01	.3556E-01	D08074.BIS
18.00	1.047	0.518	.1220E+02	.6679E+00	.4785E-01	.2020E+02	1495E+02	.1130E+02	5217E+01	.2761E+01	-.6670E+00	D08074.BIS
19.00	1.095	0.535	.1184E+02	.7393E+00	-.5516E-01	.1920E+02	1539E+02	.9950E+01	5041E+01	.1922E+01	-.8415E+00	D08074.BIS
0.20	0.200	0.400	.3022E+02	-.5871E+00	-.1851E+00	.8230E-01	1556E+00	.8800E-01	-.2696E-01	-.9740E-02	-.3830E-01	D08084.BIS
1.00	0.237	0.428	.3007E+02	-.6297E+00	-.1408E+00	.2210E+00	2274E+00	.9029E-01	-.1991E-01	.5128E-02	-.2041E-01	D08084.BIS
2.00	0.286	0.464	.2962E+02	-.6313E+00	-.1505E+00	.1780E+01	1312E+01	.6800E+00	.2808E+00	-.6815E-01	-.1223E-01	D08084.BIS
3.00	0.332	0.500	.2748E+02	-.6575E+00	-.1289E+00	.7390E+01	6493E+01	.3960E+01	.2685E+01	.4049E+00	.4237E+00	D08084.BIS
4.00	0.382	0.535	.2465E+02	-.3155E+00	-.7117E-03	.1450E+02	2636E+02	.8618E+01	.6730E+01	.1021E+01	.1798E+01	D08084.BIS
5.00	0.428	0.571	.2195E+02	.1410E+00	-.7290E-01	.1950E+02	2794E+02	.1130E+02	.7640E+01	.2083E+01	.3329E+00	D08084.BIS
6.00	0.477	0.607	.1905E+02	.3922E+00	-.3639E-01	.2390E+02	2986E+02	.1510E+02	.7101E+01	.3987E+01	.6501E+00	D08084.BIS
7.00	0.523	0.643	.1771E+02	.6421E+00	.1620E+00	.2440E+02	3261E+02	.1510E+02	.7610E+01	.4347E+01	.3166E+00	D08084.BIS
8.00	0.572	0.678	.1590E+02	.6369E+00	.2230E+00	.2650E+02	2864E+02	.1630E+02	.7948E+01	.5263E+01	-.2021E+01	D08084.BIS
9.00	0.618	0.714	.1543E+02	.5288E+00	.2846E+00	.2580E+02	2551E+02	.1510E+02	.7700E+01	.4228E+01	-.1192E+01	D08084.BIS
10.00	0.667	0.750	.1384E+02	.6707E+00	-.1351E+00	.2810E+02	2675E+02	.1610E+02	.8751E+01	.5930E+01	.1717E+01	D08084.BIS
11.00	0.714	0.786	.1265E+02	.7564E+00	-.2034E+00	.2790E+02	2166E+02	.1560E+02	.6435E+01	.6222E+01	-.1554E+01	D08084.BIS
12.00	0.762	0.821	.1228E+02	.7248E+00	-.1855E+00	.2620E+02	2232E+02	.1630E+02	.7215E+01	.6151E+01	-.1471E+01	D08084.BIS
13.00	0.809	0.857	.1111E+02	.7209E+00	-.2113E+00	.2740E+02	2140E+02	.1480E+02	.7526E+01	.5279E+01	-.1412E+01	D08084.BIS
14.00	0.857	0.893	.1188E+02	.8415E+00	.1812E+00	.2410E+02	2202E+02	.1390E+02	.6996E+01	.4543E+01	-.1066E+01	D08084.BIS
15.00	0.905	0.928	.1113E+02	.8123E+00	.2713E+00	.2330E+02	2080E+02	.1260E+02	.6615E+01	.4218E+01	-.3535E+00	D08084.BIS
16.00	0.952	0.964	.1013E+02	.7021E+00	.1975E+00	.2160E+02	1764E+02	.1230E+02	.5472E+01	.4967E+01	-.5195E+00	D08084.BIS
17.00	1.000	1.000	.9287E+01	.5543E+00	.1292E+00	.2020E+02	1613E+02	.1080E+02	.5383E+01	.3726E+01	-.7590E+00	D08084.BIS
18.00	1.047	1.036	.9428E+01	.7089E+00	.1491E+00	.1890E+02	1453E+02	.1110E+02	.4367E+01	.4372E+01	-.9403E+00	D08084.BIS
19.00	1.095	1.071	.8416E+01	.4995E+00	.1615E+00	.1620E+02	1328E+02	.9612E+01	.3639E+01	.3762E+01	-.4627E+00	D08084.BIS
0.20	0.201	0.600	.3018E+02	-.4849E+00	-.5543E+00	.1490E+00	1539E+00	.1960E+00	.6562E-01	-.1918E-01	.5737E-01	D08094.BIS
1.00	0.237	0.642	.3002E+02	-.4528E+00	-.4674E+00	.4530E+00	2327E+00	.4210E+00	.1221E+00	-.2490E+00	-.8959E-01	D08094.BIS
2.00	0.286	0.697	.2980E+02	-.3993E+00	-.2519E+00	.1890E+01	1191E+01	.9810E+00	.2514E+00	-.2898E+00	.9097E-01	D08094.BIS
3.00	0.332	0.750	.2695E+02	-.7528E+00	.1964E+00	.9160E+01	2000E+02	.5330E+01	.4231E+01	.1380E+01	.1782E+01	D08094.BIS
4.00	0.382	0.803	.2131E+02	-.1060E+00	.2749E+00	.2030E+02	3458E+02	.1180E+02	.7537E+01	.4830E+01	.1248E+01	D08094.BIS
5.00	0.428	0.857	.1725E+02	.3751E+00	.3800E+00	.2420E+02	3387E+02	.1370E+02	.6468E+01	.5580E+01	-.9178E+00	D08094.BIS
6.00	0.477	0.910	.1512E+02	.4095E+00	.2877E+00	.2470E+02	2784E+02	.1300E+02	.5459E+01	.6228E+01	-.1393E+01	D08094.BIS
7.00	0.523	0.964	.1332E+02	.4081E+00	.4183E+00	.2340E+02	2507E+02	.1380E+02	.4910E+01	.6209E+01	-.2551E+01	D08094.BIS
8.00	0.572	1.018	.1062E+02	.4164E+00	.2238E+00	.2680E+02	2274E+02	.1450E+02	.5005E+01	.7312E+01	-.2035E+01	D08094.BIS
9.00	0.618	1.071	.1011E+02	.3967E+00	.3086E+00	.2230E+02	2033E+02	.1350E+02	.3736E+01	.5807E+01	-.2274E+01	D08094.BIS
10.00	0.667	1.125	.9300E+01	.4308E+00	.1376E+00	.2400E+02	1985E+02	.1380E+02	.5228E+01	.6914E+01	-.1532E+01	D08094.BIS
11.00	0.714	1.178	.8930E+01	.5229E+00	.1883E+00	.2050E+02	2197E+02	.1150E+02	.6164E+01	.5400E+01	-.1267E+01	D08094.BIS
12.00	0.762	1.232	.8147E+01	.5024E+00	-.3483E-01	.1910E+02	1685E+02	.1190E+02	.4059E+01	.5028E+01	-.1191E+01	D08094.BIS
13.00	0.809	1.285	.8315E+01	.7877E+00	.9785E-01	.1940E+02	1661E+02	.1120E+02	.4450E+01	.5287E+01	-.1094E+01	D08094.BIS
14.00	0.857	1.339	.8532E+01	.7931E+00	.2002E+00	.2020E+02	1779E+02	.1080E+02	.4609E+01	.4516E+01	-.7603E+00	D08094.BIS
15.00	0.905	1.393	.7657E+01	.7975E+00	.5046E-01	.1720E+02	1500E+02	.1040E+02	.3316E+01	.4358E+01	-.8361E+00	D08094.BIS
16.00	0.952	1.446	.7314E+01	.6853E+00	.7883E-01	.1540E+02	1378E+02	.9311E+01	.3593E+01	.4412E+01	-.1017E+01	D08094.BIS
17.00	1.000	1.500	.7260E+01	.6143E+00	.9359E-01	.1470E+02	1296E+02	.9231E+01	.3126E+01	.3691E+01	-.6110E+00	D08094.BIS
18.00	1.047	1.553	.7120E+01	.6438E+00	.2322E+00	.1420E+02	1246E+02	.8481E+01	.2307E+01	.3712E+01	-.9795E+00	D08094.BIS
19.00	1.095	1.607	.6833E+01	.6176E+00	.8796E-01	.1310E+02	1159E+02	.7812E+01	.2871E+01	.3682E+01	-.5061E+00	D08094.BIS
0.20	0.202	0.800	.2964E+02	.3141E+01	-.3336E+01	.2570E+00	1022E+01	.9370E+00	-.6224E+00	.5480E-01	.4475E-01	D08104.BIS



TABLE 3  
Continued

X	Y	Z	$\bar{u}$	$\bar{v}$	$\bar{w}$	$\overline{uu}$	$\overline{vv}$	$\overline{ww}$	$\overline{uv}$	$\overline{uw}$	$\overline{vw}$	File Name
inch	inch	inch	m/s	m/s	m/s	m <sup>2</sup> /s <sup>2</sup>	m <sup>2</sup> /s <sup>2</sup>	m <sup>2</sup> /s <sup>2</sup>	m <sup>2</sup> /s <sup>2</sup>	m <sup>2</sup> /s <sup>2</sup>	m <sup>2</sup> /s <sup>2</sup>	
1.00	0.237	0.857	.2900E+02	-.8127E+00	-.8695E+00	.2970E+01	.2493E+01	.2850E+01	-.1036E+01	-.2488E+00	.8615E+00	D08104.BIS
2.00	0.286	0.928	.2208E+02	-.7058E+00	-.1382E+00	.1640E+02	.2103E+02	.8001E+01	-.1496E+01	.4051E+01	-.1140E+01	D08104.BIS
3.00	0.333	1.000	.1523E+02	.7832E+00	-.1186E+00	.2490E+02	.4621E+02	.1110E+02	.3051E+01	.6427E+01	.2380E+00	D08104.BIS
4.00	0.381	1.071	.1106E+02	.9148E+00	-.4798E-01	.2490E+02	.2851E+02	.1230E+02	.3847E+01	.6929E+01	-.7640E+00	D08104.BIS
5.00	0.428	1.143	.8567E+01	.9155E+00	-.2808E+00	.2220E+02	.2434E+02	.1140E+02	.3121E+01	.6347E+01	-.9584E+00	D08104.BIS
6.00	0.477	1.214	.7308E+01	.8037E+00	-.1501E+00	.2050E+02	.1997E+02	.1090E+02	.4260E+01	.5449E+01	-.6438E+00	D08104.BIS
7.00	0.523	1.285	.6621E+01	.5733E+00	-.8196E-01	.1830E+02	.1775E+02	.1010E+02	.4492E+01	.4342E+01	-.1039E+01	D08104.BIS
8.00	0.572	1.357	.6710E+01	.8502E+00	-.2598E-01	.1750E+02	.1775E+02	.1010E+02	.4353E+01	.4739E+01	-.1406E+00	D08104.BIS
9.00	0.618	1.428	.6866E+01	.9194E+00	.9403E-01	.1770E+02	.1821E+02	.1060E+02	.5835E+01	.4321E+01	-.4047E+00	D08104.BIS
10.00	0.667	1.500	.6364E+01	.7628E+00	.1418E+00	.1630E+02	.1716E+02	.1030E+02	.4943E+01	.3979E+01	-.1500E+00	D08104.BIS
11.00	0.714	1.571	.6352E+01	.9386E+00	.1220E+00	.1560E+02	.1579E+02	.1020E+02	.3844E+01	.4199E+01	-.5491E+00	D08104.BIS
12.00	0.762	1.643	.6127E+01	.7820E+00	.9582E-01	.1630E+02	.1380E+02	.1010E+02	.3907E+01	.4178E+01	.3386E+00	D08104.BIS
13.00	0.809	1.714	.6344E+01	.8458E+00	.3204E+00	.1490E+02	.1443E+02	.9903E+01	.3730E+01	.4922E+01	.4384E+00	D08104.BIS
14.00	0.857	1.785	.6051E+01	.7951E+00	.3163E+00	.1370E+02	.1381E+02	.8661E+01	.3420E+01	.4132E+01	-.9986E-01	D08104.BIS
15.00	0.905	1.857	.6070E+01	.7280E+00	.3090E+00	.1350E+02	.1311E+02	.8832E+01	.2847E+01	.4382E+01	.2275E+00	D08104.BIS
16.00	0.952	1.928	.6024E+01	.6796E+00	.4403E+00	.1220E+02	.1217E+02	.7600E+01	.2746E+01	.3430E+01	-.1746E+00	D08104.BIS
17.00	1.000	2.000	.5777E+01	.6775E+00	.4499E+00	.1090E+02	.1209E+02	.7068E+01	.2731E+01	.2959E+01	.1896E+00	D08104.BIS
18.00	1.047	2.071	.5740E+01	.7036E+00	.5107E+00	.1100E+02	.1186E+02	.6959E+01	.2564E+01	.3259E+01	.3099E+00	D08104.BIS
19.00	1.095	2.142	.5408E+01	.6363E+00	.4401E+00	.1040E+02	.1012E+02	.6629E+01	.1982E+01	.3629E+01	.2178E-01	D08104.BIS
0.20	0.200	1.000	.1142E+02	.5873E+00	.1659E+00	.2050E+01	.1618E+01	.3061E+00	.2547E+00	.1599E+00	-.3893E-01	D08114.BIS
1.00	0.237	1.071	.1024E+02	-.1813E+00	.2009E+01	.2889E+02	.7100E+02	.1920E+02	.5387E+01	.1190E+02	.2939E+01	D08114.BIS
2.00	0.286	1.161	.7306E+01	.4230E+00	.7736E+00	.2220E+02	.3611E+02	.1240E+02	.5687E+01	.7491E+01	.1525E+01	D08114.BIS
3.00	0.332	1.250	.5319E+01	.5073E+00	.1218E+00	.1470E+02	.1707E+02	.9481E+01	.2751E+01	.5631E+01	-.8493E-01	D08114.BIS
4.00	0.381	1.339	.4065E+01	.4009E+00	.9821E-01	.1060E+02	.1326E+02	.6882E+01	.2067E+01	.3652E+01	-.2648E+00	D08114.BIS
5.00	0.428	1.429	.3581E+01	.3155E+00	-.2286E-01	.9260E+01	.9134E+01	.5939E+01	.1739E+01	.2820E+01	-.2680E+00	D08114.BIS
6.00	0.477	1.518	.3288E+01	.4631E+00	-.4821E-01	.8558E+01	.7763E+01	.5948E+01	.1181E+01	.3008E+01	-.1898E+00	D08114.BIS
7.00	0.523	1.607	.3164E+01	.6086E+00	-.5621E-01	.8339E+01	.8700E+01	.5020E+01	.2060E+01	.2360E+01	.7753E-01	D08114.BIS
8.00	0.572	1.696	.3137E+01	.2015E+00	.2235E+00	.8320E+01	.7314E+01	.5460E+01	.2189E+01	.2300E+01	-.1408E+00	D08114.BIS
9.00	0.618	1.785	.3417E+01	.5550E+00	.1659E+00	.9102E+01	.9840E+01	.5692E+01	.2777E+01	.2942E+01	.5281E+00	D08114.BIS
10.00	0.667	1.875	.3490E+01	.1011E+01	-.1320E+00	.9091E+01	.8214E+01	.5830E+01	.2172E+01	.2890E+01	.8271E-01	D08114.BIS
11.00	0.714	1.964	.2907E+01	.3029E+00	.2038E+00	.7620E+01	.8038E+01	.5230E+01	.1998E+01	.1980E+01	.2142E+00	D08114.BIS
12.00	0.762	2.053	.3548E+01	.7938E+00	-.3208E-02	.8400E+01	.8824E+01	.5510E+01	.2090E+01	.2650E+01	-.1603E-01	D08114.BIS
13.00	0.809	2.142	.3227E+01	.5469E+00	.8465E-01	.7861E+01	.7867E+01	.5300E+01	.1942E+01	.2240E+01	-.7380E-01	D08114.BIS
14.00	0.857	2.232	.3167E+01	.6792E+00	.5326E-01	.8767E+01	.7690E+01	.5788E+01	.1419E+01	.2728E+01	.1791E+00	D08114.BIS
15.00	0.905	2.321	.3409E+01	.6688E+00	.1198E+00	.8290E+01	.7144E+01	.5530E+01	.1421E+01	.2640E+01	.1022E+00	D08114.BIS
16.00	0.952	2.410	.3368E+01	.7108E+00	.7113E-01	.8290E+01	.7104E+01	.5721E+01	.1291E+01	.2770E+01	-.6054E-02	D08114.BIS
17.00	1.000	2.500	.3015E+01	.2729E+00	.1700E+00	.6960E+01	.7125E+01	.4960E+01	.1220E+01	.2290E+01	.2521E-01	D08114.BIS
18.00	1.047	2.589	.3010E+01	.4550E+00	.1693E+00	.7070E+01	.6413E+01	.4740E+01	.1691E+01	.2150E+01	.2868E+00	D08114.BIS
19.00	1.095	2.678	.3146E+01	.3047E+00	.1224E+00	.6180E+01	.6179E+01	.4350E+01	.1222E+01	.1830E+01	-.1878E+00	D08114.BIS
0.20	0.301	-0.200	.3011E+02	-.1065E+01	-.2338E+00	.7079E-01	.4913E+00	.5200E+00	-.4122E-01	.3180E-01	-.1529E+00	D09054.BIS
1.00	0.356	-0.214	.2991E+02	-.1034E+01	-.3526E+00	.7120E+00	.1085E+01	.8610E+00	-.6156E-02	-.8721E-01	-.3062E+00	D09054.BIS
2.00	0.428	-0.232	.2575E+02	-.4884E+00	-.6869E-01	.1130E+02	.9430E+01	.6940E+01	.4209E+01	-.6928E+00	-.5239E+00	D09054.BIS
3.00	0.500	-0.250	.2222E+02	.4469E+00	-.1254E+00	.1710E+02	.1504E+02	.1130E+02	.4679E+01	-.3938E+00	-.2884E+00	D09054.BIS
4.00	0.572	-0.268	.1967E+02	.5460E+00	-.5689E+00	.2040E+02	.3557E+02	.1420E+02	.8576E+01	.7324E+00	.1683E+01	D09054.BIS
5.00	0.642	-0.286	.1689E+02	.5000E+00	-.4980E+00	.2130E+02	.2898E+02	.1480E+02	.7865E+01	.1440E+01	.9845E+00	D09054.BIS
6.00	0.714	-0.304	.1470E+02	.3992E+00	-.6252E+00	.2260E+02	.2267E+02	.1540E+02	.7281E+01	.2308E+01	.1441E+01	D09054.BIS
7.00	0.786	-0.322	.1306E+02	.1084E+00	-.7259E+00	.2130E+02	.2102E+02	.1510E+02	.7347E+01	.2003E+01	.6984E+00	D09054.BIS
8.00	0.857	-0.339	.1165E+02	-.9841E-01	-.6633E+00	.2250E+02	.1871E+02	.1450E+02	.7662E+01	.8943E+00	.8996E+00	D09054.BIS
9.00	0.928	-0.357	.1057E+02	.2073E-01	-.5844E+00	.2150E+02	.1709E+02	.1420E+02	.7326E+01	.8513E+00	.8358E+00	D09054.BIS
10.00	1.000	-0.375	.1016E+02	.9243E-01	-.6837E+00	.2000E+02	.1587E+02	.1340E+02	.6543E+01	.1182E+00	-.1861E+00	D09054.BIS
11.00	1.071	-0.393	.9224E+01	.7052E-01	-.8342E+00	.2020E+02	.1622E+02	.1320E+02	.6983E+01	-.6010E+00	-.6334E+00	D09054.BIS
12.00	1.142	-0.411	.8789E+01	.1456E+00	-.7452E+00	.1950E+02	.1608E+02	.1250E+02	.7389E+01	-.8461E+00	-.8784E+00	D09054.BIS
13.00	1.214	-0.429	.8266E+01	.2214E+00	-.5679E+00	.1870E+02	.1396E+02	.1170E+02	.6814E+01	-.1001E+01	-.5688E+00	D09054.BIS
14.00	1.286	-0.447	.8274E+01	.1709E+00	-.3340E+00	.1630E+02	.1509E+02	.1140E+02	.6666E+01	-.7462E-01	.1347E+00	D09054.BIS
15.00	1.357	-0.465	.8088E+01	.1439E+00	-.4303E+00	.1600E+02	.1454E+02	.9998E+01	.6432E+01	-.8509E+00	-.4748E+00	D09054.BIS
16.00	1.428	-0.482	.7757E+01	.1354E+00	-.3899E+00	.1450E+02	.1176E+02	.9352E+01	.5358E+01	.1929E+00	-.1546E+00	D09054.BIS

TABLE 3  
Continued

X	Y	Z	$\bar{U}$	$\bar{V}$	$\bar{W}$	$\bar{u}$	$\bar{v}$	$\bar{w}$	$\bar{uv}$	$\bar{uv}$	$\bar{vw}$	File Name
inch	inch	inch	m/s	m/s	m/s	m <sup>2</sup> /s <sup>2</sup>	m <sup>2</sup> /s <sup>2</sup>	m <sup>2</sup> /s <sup>2</sup>	m <sup>2</sup> /s <sup>2</sup>	m <sup>2</sup> /s <sup>2</sup>	m <sup>2</sup> /s <sup>2</sup>	
17.00	1.500	-0.500	.7281E+01	.1993E+00	-.2621E+00	.1360E+02	.1031E+02	.9060E+01	.5094E+01	-.4411E+00	-.8246E+00	D09054.BIS
18.00	1.571	-0.518	.8043E+01	.1925E+00	-.5649E+00	.1290E+02	.1153E+02	.9034E+01	.5259E+01	-.8194E+00	-.2179E+00	D09054.BIS
19.00	1.642	-0.536	.7284E+01	.2847E+00	-.2991E+00	.1160E+02	.9987E+01	.8651E+01	.4308E+01	-.8886E+00	-.6875E+00	D09054.BIS
0.20	0.299	0.001	.2997E+02	.1014E+00	-.3078E-01	.8240E-01	.8715E-01	.8510E-01	.3273E-01	-.1278E-02	-.1019E-02	D09064.BIS
1.00	0.357	0.001	.2944E+02	-.8034E-01	.4322E-01	.1710E+01	.1264E+01	.3739E+00	.1371E+00	-.8640E-01	-.1033E+00	D09064.BIS
2.00	0.428	0.001	.2464E+02	.4218E+00	-.2554E+00	.1410E+02	.1298E+02	.8273E+01	.6195E+01	.4311E+00	-.2711E+00	D09064.BIS
3.00	0.500	0.001	.2142E+02	.1025E+01	-.2595E+00	.1780E+02	.1680E+02	.1210E+02	.7339E+01	.1823E+00	-.6270E+00	D09064.BIS
4.00	0.572	0.000	.1893E+02	.8931E+00	-.6135E-01	.1950E+02	.3474E+02	.1390E+02	.9174E+01	.3534E+00	.2491E+01	D09064.BIS
5.00	0.642	0.000	.1787E+02	.9982E+00	-.3871E+00	.2340E+02	.2771E+02	.1540E+02	.8896E+01	.1339E+01	.1878E+01	D09064.BIS
6.00	0.714	0.000	.1727E+02	.9351E+00	-.3881E+00	.2250E+02	.2943E+02	.1590E+02	.8061E+01	.8484E+00	.1523E+01	D09064.BIS
7.00	0.786	0.000	.1581E+02	.1033E+01	-.4800E+00	.2450E+02	.2714E+02	.1550E+02	.9811E+01	.1339E+01	.1123E+01	D09064.BIS
8.00	0.857	0.000	.1450E+02	.1188E+01	-.3743E+00	.2720E+02	.2471E+02	.1580E+02	.9796E+01	.1770E+01	.1252E+01	D09064.BIS
9.00	0.928	0.000	.1385E+02	.1131E+01	-.8370E+00	.2650E+02	.2373E+02	.1720E+02	.9999E+01	.2457E+01	.8724E+00	D09064.BIS
10.00	1.000	0.000	.1242E+02	.8577E+00	-.9192E+00	.2820E+02	.2387E+02	.1720E+02	.1120E+02	.2659E+01	.1418E+01	D09064.BIS
11.00	1.071	-0.001	.1197E+02	.1072E+01	-.7063E+00	.2540E+02	.2070E+02	.1610E+02	.8953E+01	.1796E+01	.1472E+00	D09064.BIS
12.00	1.142	-0.001	.1095E+02	.8956E+00	-.6896E+00	.2680E+02	.1954E+02	.1540E+02	.9068E+01	.1390E+01	.2240E+00	D09064.BIS
13.00	1.214	-0.001	.9939E+01	.9895E+00	-.4902E+00	.2750E+02	.1917E+02	.1440E+02	.9582E+01	.1268E+01	.1378E+00	D09064.BIS
14.00	1.286	-0.001	.9650E+01	.7450E+00	-.6594E+00	.2470E+02	.1720E+02	.1360E+02	.9259E+01	.1398E+01	.3390E+00	D09064.BIS
15.00	1.357	-0.001	.9521E+01	.7506E+00	-.6943E+00	.2240E+02	.1734E+02	.1220E+02	.8372E+01	.7520E+00	.8452E+00	D09064.BIS
16.00	1.428	-0.001	.9002E+01	.8002E+00	-.3812E+00	.2040E+02	.1586E+02	.1230E+02	.7695E+01	.1030E+00	.1675E-01	D09064.BIS
17.00	1.500	-0.001	.8787E+01	.7062E+00	-.4971E+00	.1830E+02	.1367E+02	.1150E+02	.6845E+01	.6763E+00	.1493E+00	D09064.BIS
18.00	1.571	-0.001	.8436E+01	.6403E+00	-.5319E+00	.1670E+02	.1314E+02	.1060E+02	.6371E+01	.2326E-01	-.4410E+00	D09064.BIS
19.00	1.642	-0.002	.8198E+01	.7880E+00	-.3958E+00	.1610E+02	.1175E+02	.9409E+01	.5772E+01	.6325E+00	-.4032E-01	D09064.BIS
0.20	0.301	0.200	.3019E+02	-.3585E+00	-.1776E+00	.6920E-01	.9922E-01	.8410E-01	-.5166E-02	.8888E-02	-.4760E-02	D09074.BIS
1.00	0.356	0.214	.2969E+02	-.8672E+00	-.1300E+00	.1910E+01	.1430E+01	.6718E+00	.2165E+00	-.1021E+00	-.8119E-01	D09074.BIS
2.00	0.428	0.232	.2473E+02	-.3101E+00	-.1905E+00	.1470E+02	.1314E+02	.8848E+01	.5309E+01	-.4215E-02	-.6254E+00	D09074.BIS
3.00	0.500	0.250	.2043E+02	.3363E-02	.1629E+00	.1990E+02	.3993E+02	.1440E+02	.9540E+01	.4344E+00	.3449E+01	D09074.BIS
4.00	0.572	0.268	.1895E+02	.1585E+00	.1779E+00	.1930E+02	.3495E+02	.1530E+02	.9335E+01	.7297E+00	.3116E+01	D09074.BIS
5.00	0.642	0.286	.1717E+02	.3776E+00	.1603E+00	.2190E+02	.3211E+02	.1640E+02	.8547E+01	.1060E+01	.1608E+01	D09074.BIS
6.00	0.714	0.303	.1543E+02	.7114E+00	.4286E-01	.2540E+02	.2859E+02	.1770E+02	.9566E+01	.2973E+01	.9016E+00	D09074.BIS
7.00	0.786	0.321	.1440E+02	.7165E+00	-.1066E-01	.2380E+02	.2595E+02	.1680E+02	.7923E+01	.2750E+01	.3197E+00	D09074.BIS
8.00	0.857	0.339	.1309E+02	.6931E+00	-.1787E+00	.2590E+02	.2311E+02	.1730E+02	.8007E+01	.3689E+01	-.1996E-01	D09074.BIS
9.00	0.928	0.357	.1183E+02	.5075E+00	-.1980E+00	.2600E+02	.2125E+02	.1760E+02	.9785E+01	.3351E+01	-.1013E+01	D09074.BIS
10.00	1.000	0.375	.1095E+02	.6115E+00	-.3320E+00	.2750E+02	.2128E+02	.1730E+02	.8486E+01	.4293E+01	-.2666E-02	D09074.BIS
11.00	1.071	0.393	.1047E+02	.5893E+00	-.4245E+00	.2480E+02	.1897E+02	.1630E+02	.8927E+01	.2950E+01	-.2061E+00	D09074.BIS
12.00	1.142	0.410	.9393E+01	.7170E+00	-.3596E+00	.2480E+02	.1809E+02	.1500E+02	.7877E+01	.2802E+01	-.1044E+01	D09074.BIS
13.00	1.214	0.429	.9174E+01	.7927E+00	-.4939E+00	.2330E+02	.1619E+02	.1440E+02	.7934E+01	.2671E+01	-.8593E-01	D09074.BIS
14.00	1.286	0.446	.8726E+01	.6102E+00	-.5071E+00	.2170E+02	.1659E+02	.1410E+02	.7591E+01	.3024E+01	-.1767E+00	D09074.BIS
15.00	1.357	0.464	.8041E+01	.6741E+00	-.3551E+00	.2110E+02	.1428E+02	.1290E+02	.7041E+01	.1913E+01	-.6753E+00	D09074.BIS
16.00	1.428	0.482	.8001E+01	.6784E+00	-.2680E+00	.1950E+02	.1533E+02	.1190E+02	.7201E+01	.2924E+01	-.3182E+00	D09074.BIS
17.00	1.500	0.500	.7998E+01	.7370E+00	-.2189E+00	.1820E+02	.1364E+02	.1110E+02	.5937E+01	.2259E+01	-.3636E+00	D09074.BIS
18.00	1.571	0.518	.7773E+01	.7237E+00	-.2515E+00	.1620E+02	.1213E+02	.1080E+02	.5295E+01	.2061E+01	-.6184E+00	D09074.BIS
19.00	1.642	0.535	.8049E+01	.6719E+00	-.2948E+00	.1450E+02	.1165E+02	.9569E+01	.4960E+01	.1000E+01	-.3595E+00	D09074.BIS
0.20	0.301	0.400	.3016E+02	-.4588E+00	.7862E-01	.7000E-01	.1050E+00	.7930E-01	.1391E-01	.6931E-02	-.2270E-01	D09084.BIS
1.00	0.356	0.428	.2969E+02	-.6360E+00	.3891E+00	.1520E+01	.1200E+01	.4009E+00	.1884E+00	-.1289E+00	-.2390E+00	D09084.BIS
2.00	0.428	0.464	.2603E+02	.5702E-02	.2413E+00	.1050E+02	.9142E+01	.7281E+01	.3198E+01	.6794E-01	.1087E+01	D09084.BIS
3.00	0.500	0.500	.2196E+02	.4410E+00	-.8991E-02	.1770E+02	.3689E+02	.1230E+02	.8831E+01	.7555E+00	.2288E+01	D09084.BIS
4.00	0.571	0.535	.1791E+02	.5365E+00	-.7469E-01	.2400E+02	.3723E+02	.1690E+02	.9096E+01	.2609E+01	.9076E+00	D09084.BIS
5.00	0.642	0.571	.1526E+02	.6048E+00	.1086E+00	.2560E+02	.3266E+02	.1800E+02	.8626E+01	.3554E+01	-.4865E+00	D09084.BIS
6.00	0.714	0.607	.1314E+02	.5548E+00	.1913E-01	.2520E+02	.2757E+02	.1790E+02	.8965E+01	.4047E+01	-.4513E+00	D09084.BIS
7.00	0.786	0.643	.1170E+02	.6311E+00	-.1277E+00	.2650E+02	.2403E+02	.1630E+02	.8932E+01	.3313E+01	-.2121E+01	D09084.BIS
8.00	0.857	0.678	.1018E+02	.4369E+00	-.2701E+00	.2620E+02	.2064E+02	.1650E+02	.8007E+01	.4133E+01	-.1162E+01	D09084.BIS
9.00	0.928	0.714	.9705E+01	.5984E+00	-.3898E+00	.2630E+02	.1947E+02	.1530E+02	.8562E+01	.4730E+01	-.5293E+00	D09084.BIS
10.00	1.000	0.750	.8329E+01	.6093E+00	-.2990E+00	.2190E+02	.1702E+02	.1410E+02	.6375E+01	.4602E+01	-.9749E+00	D09084.BIS
11.00	1.071	0.785	.8153E+01	.7175E+00	-.3101E+00	.2190E+02	.1865E+02	.1330E+02	.8360E+01	.3229E+01	-.8848E+00	D09084.BIS
12.00	1.142	0.821	.7666E+01	.3933E+00	-.3030E+00	.2080E+02	.1693E+02	.1250E+02	.7591E+01	.3172E+01	-.1137E+00	D09084.BIS

TABLE 3  
Continued

X	Y	Z	U	V	W	U	V	W	UV	UV	VW	File Name
inch	inch	inch	m/s	m/s	m/s	m <sup>2</sup> /s <sup>2</sup>	m <sup>2</sup> /s <sup>2</sup>	m <sup>2</sup> /s <sup>2</sup>	m <sup>2</sup> /s <sup>2</sup>	m <sup>2</sup> /s <sup>2</sup>	m <sup>2</sup> /s <sup>2</sup>	
13.00	1.214	0.857	.7703E+01	.7729E+00	-.3062E+00	.1860E+02	.1774E+02	.1220E+02	.6428E+01	.3451E+01	-.1253E+01	D09084.BIS
14.00	1.286	0.893	.7080E+01	.5482E+00	-.1214E+00	.1640E+02	.1535E+02	.1110E+02	.6092E+01	.2197E+01	-.7310E+00	D09084.BIS
15.00	1.357	0.928	.7746E+01	.8353E+00	-.3216E+00	.1820E+02	.1462E+02	.1090E+02	.6489E+01	.3267E+01	-.1200E+00	D09084.BIS
16.00	1.428	0.964	.7203E+01	.6190E+00	-.2372E+00	.1700E+02	.1393E+02	.9319E+01	.6113E+01	.1563E+01	-.4907E+00	D09084.BIS
17.00	1.500	1.000	.7015E+01	.8967E+00	-.7884E-01	.1300E+02	.1230E+02	.9809E+01	.4583E+01	.1708E+01	-.8291E+00	D09084.BIS
18.00	1.572	1.036	.7391E+01	.8613E+00	-.2611E+00	.1480E+02	.1178E+02	.9559E+01	.5025E+01	.2550E+01	-.4354E+00	D09084.BIS
19.00	1.642	1.071	.6940E+01	.8052E+00	-.9514E-01	.1270E+02	.1140E+02	.8497E+01	.4361E+01	.1708E+01	-.8191E+00	D09084.BIS
0.20	0.301	0.600	.3017E+02	-.6553E+00	-.1490E+00	.8270E-01	.2499E+00	.1050E+00	.3856E-01	-.1265E-02	-.7354E-01	D09094.BIS
1.00	0.356	0.643	.2974E+02	-.7479E+00	-.3804E-01	.1670E+01	.1294E+01	.5562E+00	.2871E+00	-.1381E+00	-.2306E+00	D09094.BIS
2.00	0.428	0.696	.2434E+02	-.6074E-01	-.2982E+00	.1730E+02	.1584E+02	.1060E+02	.6524E+01	.1037E+01	.1303E+01	D09094.BIS
3.00	0.500	0.749	.1735E+02	.6937E+00	-.1401E+00	.2970E+02	.4755E+02	.2080E+02	.1201E+02	.4121E+01	.2306E+01	D09094.BIS
4.00	0.571	0.803	.1306E+02	.4012E+00	-.3338E-01	.2900E+02	.3924E+02	.1990E+02	.1041E+02	.5259E+01	-.8242E-01	D09094.BIS
5.00	0.642	0.857	.9731E+01	.2583E+00	-.3808E+00	.2870E+02	.2728E+02	.1750E+02	.9353E+01	.5348E+01	-.1191E+01	D09094.BIS
6.00	0.714	0.910	.8418E+01	.3419E+00	-.3938E+00	.2470E+02	.2116E+02	.1500E+02	.7162E+01	.5363E+01	-.1308E+01	D09094.BIS
7.00	0.786	0.964	.6961E+01	.5249E+00	-.6030E+00	.2240E+02	.1738E+02	.1340E+02	.6952E+01	.4490E+01	-.1051E+01	D09094.BIS
8.00	0.857	1.018	.5904E+01	.2593E+00	-.5560E+00	.1980E+02	.1509E+02	.1140E+02	.5217E+01	.3971E+01	-.1366E+01	D09094.BIS
9.00	0.928	1.071	.5964E+01	.5147E+00	-.6626E+00	.2100E+02	.1605E+02	.1140E+02	.6964E+01	.3664E+01	-.1245E+01	D09094.BIS
10.00	1.000	1.125	.5279E+01	.4130E+00	-.5590E+00	.1779E+02	.1366E+02	.1030E+02	.4876E+01	.3210E+01	-.1221E+01	D09094.BIS
11.00	1.072	1.178	.4708E+01	.3964E+00	-.6122E+00	.1490E+02	.1145E+02	.9531E+01	.4580E+01	.2261E+01	-.1049E+01	D09094.BIS
12.00	1.142	1.232	.4872E+01	.3129E+00	-.2541E+00	.1580E+02	.1168E+02	.8723E+01	.4632E+01	.2149E+01	-.7559E+00	D09094.BIS
13.00	1.214	1.285	.5919E+01	.6440E+00	.3464E-01	.1570E+02	.1563E+02	.8877E+01	.5411E+01	.2798E+01	-.4083E-01	D09094.BIS
14.00	1.286	1.339	.5039E+01	.2346E+00	.2519E+00	.1270E+02	.1275E+02	.7770E+01	.4281E+01	.2650E+01	-.2978E+00	D09094.BIS
15.00	1.357	1.393	.5057E+01	.2783E+00	.2616E+00	.1370E+02	.1463E+02	.7760E+01	.5319E+01	.2680E+01	.1000E+01	D09094.BIS
16.00	1.428	1.446	.5348E+01	.4509E+00	.2217E+00	.1210E+02	.1375E+02	.7371E+01	.4030E+01	.2381E+01	.3473E+00	D09094.BIS
17.00	1.500	1.500	.5300E+01	.4686E+00	.1774E+00	.1110E+02	.1389E+02	.7221E+01	.3811E+01	.2640E+01	.4093E+00	D09094.BIS
18.00	1.571	1.554	.5583E+01	.6067E+00	.2407E+00	.1110E+02	.1239E+02	.7032E+01	.3695E+01	.2692E+01	.2765E+00	D09094.BIS
19.00	1.642	1.607	.4904E+01	.4729E+00	.2212E+00	.9360E+01	.1140E+02	.6060E+01	.3349E+01	.1990E+01	.8116E-01	D09094.BIS
0.20	0.299	0.799	.3008E+02	-.3372E+00	-.1193E+01	.9353E-01	.4848E+00	.5280E+00	-.1082E+00	.5321E-01	-.7735E-01	D09104.BIS
1.00	0.357	0.857	.2866E+02	-.1614E+01	.2980E-01	.5710E+01	.6681E+01	.1470E+01	.7145E+00	.6533E+00	.5706E+00	D09104.BIS
2.00	0.428	0.928	.1630E+02	-.2146E+00	.1834E+00	.3080E+02	.5799E+02	.1620E+02	.1018E+02	.6489E+01	.1377E+01	D09104.BIS
3.00	0.500	1.000	.9367E+01	.4966E+00	-.9696E-01	.2810E+02	.3579E+02	.1520E+02	.7590E+01	.5781E+01	-.1100E+01	D09104.BIS
4.00	0.572	1.071	.6880E+01	.7085E+00	-.2168E+00	.2040E+02	.2188E+02	.1110E+02	.6049E+01	.4517E+01	-.7515E+00	D09104.BIS
5.00	0.642	1.143	.5930E+01	.7503E+00	-.2229E+00	.1770E+02	.1579E+02	.9247E+01	.4953E+01	.4158E+01	-.6923E+00	D09104.BIS
6.00	0.714	1.214	.4622E+01	.6394E+00	-.2942E+00	.1380E+02	.1195E+02	.8547E+01	.3047E+01	.3528E+01	-.8013E+00	D09104.BIS
7.00	0.786	1.285	.4343E+01	.6162E+00	-.1684E+00	.1200E+02	.1169E+02	.7300E+01	.3414E+01	.2839E+01	-.4530E+00	D09104.BIS
8.00	0.857	1.357	.4109E+01	.6897E+00	-.4099E+00	.1080E+02	.1137E+02	.6018E+01	.4153E+01	.2308E+01	-.1760E+00	D09104.BIS
9.00	0.928	1.429	.4615E+01	.9260E+00	-.4740E+00	.1300E+02	.1276E+02	.6810E+01	.5062E+01	.2190E+01	-.1675E+00	D09104.BIS
10.00	1.000	1.500	.4219E+01	.6655E+00	-.2461E+00	.1170E+02	.1228E+02	.6548E+01	.4702E+01	.1918E+01	.5265E-01	D09104.BIS
11.00	1.071	1.571	.4062E+01	.7110E+00	-.2907E+00	.1130E+02	.1109E+02	.6430E+01	.4061E+01	.1750E+01	-.1349E+00	D09104.BIS
12.00	1.142	1.643	.4118E+01	.5512E+00	-.1810E+00	.1050E+02	.1060E+02	.6540E+01	.3620E+01	.1960E+01	.1360E+00	D09104.BIS
13.00	1.214	1.714	.3751E+01	.6458E+00	-.9769E-01	.1040E+02	.9748E+01	.5928E+01	.3745E+01	.1988E+01	.6875E-01	D09104.BIS
14.00	1.286	1.786	.4413E+01	.6200E+00	.6980E-01	.9560E+01	.9942E+01	.6360E+01	.3022E+01	.1780E+01	.4289E+00	D09104.BIS
15.00	1.357	1.857	.4142E+01	.4805E+00	.2510E+00	.9281E+01	.9733E+01	.5630E+01	.2980E+01	.1860E+01	.3965E+00	D09104.BIS
16.00	1.428	1.928	.4325E+01	.7631E+00	.5078E-01	.8050E+01	.8601E+01	.5080E+01	.2509E+01	.1460E+01	.1180E+00	D09104.BIS
17.00	1.500	2.000	.3932E+01	.5938E+00	.9600E-01	.7760E+01	.8715E+01	.4920E+01	.2852E+01	.1620E+01	.5789E+00	D09104.BIS
18.00	1.571	2.071	.4297E+01	.7634E+00	.3826E-01	.7170E+01	.8298E+01	.4839E+01	.1990E+01	.1590E+01	-.2497E+00	D09104.BIS
19.00	1.642	2.142	.3750E+01	.5892E+00	.2318E-01	.7080E+01	.7767E+01	.4850E+01	.2130E+01	.2140E+01	.1590E+00	D09104.BIS
0.20	0.302	1.000	.1040E+02	.1270E+01	.3265E-01	.1320E+01	.1065E+01	.3080E+00	.3898E+00	.1250E+00	-.9011E-02	D09114.BIS
1.00	0.356	1.071	.5919E+01	.4320E-02	.5601E+00	.2310E+02	.5090E+02	.1620E+02	.6343E+01	.9298E+01	.1873E+01	D09114.BIS
2.00	0.428	1.161	.3577E+01	.5414E+00	-.1329E+00	.1300E+02	.1791E+02	.8730E+01	.4655E+01	.3460E+01	.3629E+00	D09114.BIS
3.00	0.500	1.250	.3217E+01	.4104E+00	-.1079E+00	.1010E+02	.1134E+02	.6281E+01	.2523E+01	.3001E+01	.4618E+00	D09114.BIS
4.00	0.572	1.339	.3179E+01	.6255E+00	-.8551E-01	.7950E+01	.9283E+01	.5209E+01	.2010E+01	.2290E+01	.1707E+00	D09114.BIS
5.00	0.642	1.429	.2697E+01	.3867E+00	.5091E-01	.7130E+01	.6897E+01	.4060E+01	.2080E+01	.1750E+01	-.1652E+00	D09114.BIS
6.00	0.714	1.518	.2451E+01	.4416E+00	-.5112E-01	.7420E+01	.6687E+01	.4340E+01	.1872E+01	.2000E+01	.1692E+00	D09114.BIS
7.00	0.786	1.607	.2148E+01	.3300E+00	-.3384E-01	.6819E+01	.6334E+01	.3930E+01	.1339E+01	.1850E+01	-.1642E+00	D09114.BIS
8.00	0.857	1.696	.2045E+01	.2291E+00	-.6905E-01	.6630E+01	.5608E+01	.3630E+01	.1490E+01	.1500E+01	.1587E-01	D09114.BIS

TABLE 3  
Continued

X	Y	Z	$\bar{U}$	$\bar{V}$	$\bar{W}$	$\overline{uu}$	$\overline{vv}$	$\overline{ww}$	$\overline{uv}$	$\overline{vw}$	$\overline{wv}$	File Name
inch	inch	inch	m/s	m/s	m/s	m <sup>2</sup> /s <sup>2</sup>	m <sup>2</sup> /s <sup>2</sup>	m <sup>2</sup> /s <sup>2</sup>	m <sup>2</sup> /s <sup>2</sup>	m <sup>2</sup> /s <sup>2</sup>	m <sup>2</sup> /s <sup>2</sup>	
9.00	0.928	1.786	.2050E+01	.3910E+00	-.1423E+00	.7270E+01	.6337E+01	.4320E+01	.2289E+01	.1910E+01	.3487E+00	D09114.BIS
10.00	1.000	1.874	.2311E+01	.4655E+00	-.2147E+00	.6700E+01	.7119E+01	.4020E+01	.2159E+01	.1360E+01	.2653E+00	D09114.BIS
11.00	1.071	1.964	.2342E+01	.5379E+00	-.1936E+00	.7250E+01	.6522E+01	.4120E+01	.2132E+01	.1910E+01	.5044E+00	D09114.BIS
12.00	1.142	2.053	.2129E+01	.3583E+00	-.1574E+00	.6640E+01	.6633E+01	.3929E+01	.1981E+01	.1490E+01	.4122E+00	D09114.BIS
13.00	1.214	2.142	.2860E+01	.5439E+00	-.3109E-01	.6930E+01	.7693E+01	.4291E+01	.2548E+01	.1880E+01	.5633E+00	D09114.BIS
14.00	1.286	2.232	.2792E+01	.5411E+00	-.2671E-02	.6981E+01	.7280E+01	.4160E+01	.2201E+01	.1750E+01	.4258E+00	D09114.BIS
15.00	1.357	2.321	.2973E+01	.6857E+00	-.1801E-01	.7860E+01	.8017E+01	.4510E+01	.2510E+01	.2260E+01	.8976E+00	D09114.BIS
16.00	1.428	2.410	.2823E+01	.3883E+00	-.1741E+00	.6600E+01	.7118E+01	.4251E+01	.1890E+01	.1830E+01	.4391E+00	D09114.BIS
17.00	1.500	2.500	.2559E+01	.4417E+00	.4591E-01	.6630E+01	.6581E+01	.3710E+01	.1662E+01	.1630E+01	.2864E+00	D09114.BIS
18.00	1.048	2.589	.3535E+01	.3580E+00	.2451E+00	.7590E+01	.7545E+01	.4560E+01	.1390E+01	.2200E+01	.1698E+00	D09114.BIS
19.00	1.095	2.678	.3450E+01	.4178E+00	.2452E+00	.7820E+01	.7233E+01	.4679E+01	.1349E+01	.2740E+01	.4342E+00	D09114.BIS
0.20	0.402	-0.200	.3014E+02	-.8378E+00	-.5326E+00	.7201E-01	.3966E+00	.5050E+00	.8396E-02	.2874E-01	-.1049E+00	D10054.BIS
1.00	0.475	-0.214	.2303E+02	.3971E+00	-.1265E+00	.1990E+02	.1623E+02	.1200E+02	.6828E+01	-.2251E+01	-.2348E+00	D10054.BIS
2.00	0.571	-0.232	.1588E+02	.8223E+00	-.4451E+00	.2750E+02	.5046E+02	.1980E+02	.1349E+02	.3622E+00	.2781E+01	D10054.BIS
3.00	0.666	-0.250	.1448E+02	.1407E+01	-.5590E+00	.2620E+02	.3606E+02	.1810E+02	.1231E+02	.4331E+00	.1287E+01	D10054.BIS
4.00	0.762	-0.268	.1220E+02	.1029E+01	-.1077E+01	.2560E+02	.3191E+02	.1580E+02	.1040E+02	.2859E+00	.4414E+00	D10054.BIS
5.00	0.857	-0.286	.1009E+02	.5812E+00	-.7826E+00	.2221E+02	.2073E+02	.1480E+02	.8336E+01	-.7001E+00	.2275E+00	D10054.BIS
6.00	0.952	-0.304	.9144E+01	.3492E+00	-.1040E+01	.1880E+02	.1668E+02	.1240E+02	.7302E+01	.4024E-01	.3128E+00	D10054.BIS
7.00	1.048	-0.322	.7756E+01	.1492E+00	-.1126E+01	.1670E+02	.1442E+02	.1210E+02	.6361E+01	-.8818E+00	.2584E-01	D10054.BIS
8.00	1.143	-0.339	.7682E+01	.4324E+00	-.6821E+00	.1450E+02	.1216E+02	.1150E+02	.5138E+01	-.8606E+00	-.2334E+00	D10054.BIS
9.00	1.238	-0.357	.7003E+01	.3498E+00	-.3766E+00	.1480E+02	.1337E+02	.1030E+02	.5056E+01	-.7407E+00	-.4254E+00	D10054.BIS
10.00	1.333	-0.375	.6366E+01	.1884E+00	-.6489E+00	.1320E+02	.1090E+02	.9123E+01	.4852E+01	-.6265E+00	-.7566E+00	D10054.BIS
11.00	1.429	-0.393	.6024E+01	.1769E+00	-.4008E+00	.1140E+02	.1140E+02	.8613E+01	.4911E+01	-.9060E+00	-.4955E+00	D10054.BIS
12.00	1.524	-0.411	.6174E+01	.3104E+00	-.1798E+00	.1170E+02	.1070E+02	.8688E+01	.4829E+01	-.5611E+00	-.6412E+00	D10054.BIS
13.00	1.619	-0.429	.5706E+01	.2777E+00	-.1509E+00	.1210E+02	.1109E+02	.8199E+01	.4861E+01	-.4096E+00	-.6423E+00	D10054.BIS
14.00	1.714	-0.447	.6040E+01	.3525E+00	-.1074E+00	.1070E+02	.1010E+02	.7700E+01	.4411E+01	-.2409E+00	-.1125E+00	D10054.BIS
15.00	1.810	-0.465	.5589E+01	.3028E+00	-.2557E+00	.1030E+02	.1001E+02	.7090E+01	.4400E+01	-.1210E+01	.6708E-01	D10054.BIS
16.00	1.905	-0.482	.5513E+01	.4555E+00	.5510E-01	.9110E+01	.1039E+02	.6520E+01	.4119E+01	-.2113E+00	.1896E+00	D10054.BIS
17.00	2.000	-0.500	.5657E+01	.3761E+00	.2001E+00	.8740E+01	.1041E+02	.6000E+01	.3932E+01	.2927E-01	.2043E+00	D10054.BIS
18.00	2.095	-0.518	.5386E+01	.2072E+00	-.1263E+00	.8440E+01	.9227E+01	.5930E+01	.3949E+01	-.7061E+00	.1243E-01	D10054.BIS
19.00	2.191	-0.536	.5459E+01	.4673E+00	.1460E+00	.8110E+01	.9562E+01	.5470E+01	.3479E+01	-.2313E+00	.1375E+00	D10054.BIS
0.20	0.402	0.001	.3028E+02	-.3920E-02	.2125E+00	.6960E-01	.1036E+00	.7440E-01	.1142E-01	.9831E-02	-.1918E-01	D10064.BIS
1.00	0.476	0.001	.2268E+02	.9545E+00	-.6609E-01	.1900E+02	.1728E+02	.1010E+02	.8421E+01	-.3452E+00	-.3147E+01	D10064.BIS
2.00	0.571	0.001	.1364E+02	.5576E+00	-.5124E-02	.3360E+02	.6079E+02	.2140E+02	.1791E+02	.2102E+01	.4239E+01	D10064.BIS
3.00	0.666	0.001	.1278E+02	.9527E+00	-.2716E+00	.2730E+02	.4697E+02	.1970E+02	.1231E+02	.4932E+00	.2125E+01	D10064.BIS
4.00	0.762	0.000	.1273E+02	.9272E+00	-.5349E+00	.2580E+02	.3705E+02	.1990E+02	.1260E+02	.1011E+01	.2271E+01	D10064.BIS
5.00	0.857	0.000	.1185E+02	.9515E+00	-.6212E+00	.2710E+02	.2967E+02	.1750E+02	.1040E+02	.3979E+00	.1990E+01	D10064.BIS
6.00	0.952	0.000	.1031E+02	.7332E+00	-.6362E+00	.2500E+02	.2516E+02	.1650E+02	.8818E+01	.5891E+00	.1046E+01	D10064.BIS
7.00	1.047	0.000	.9348E+01	.7964E+00	-.8860E+00	.2500E+02	.2094E+02	.1530E+02	.9524E+01	.8270E+00	.8737E+00	D10064.BIS
8.00	1.143	0.000	.8570E+01	.8765E+00	-.5461E+00	.2340E+02	.1985E+02	.1540E+02	.9436E+01	.3041E+00	.2790E+00	D10064.BIS
9.00	1.238	0.000	.7788E+01	.7970E+00	-.8894E+00	.2370E+02	.1897E+02	.1330E+02	.9039E+01	.1240E+01	-.1039E+00	D10064.BIS
10.00	1.333	0.000	.6990E+01	.6611E+00	-.7284E+00	.2070E+02	.1710E+02	.1290E+02	.7659E+01	-.4041E+00	-.5274E-01	D10064.BIS
11.00	1.429	-0.001	.6565E+01	.7021E+00	-.5890E+00	.2140E+02	.1635E+02	.1240E+02	.8352E+01	.9893E-01	-.9770E-01	D10064.BIS
12.00	1.524	-0.001	.6259E+01	.6492E+00	-.6378E+00	.1890E+02	.1422E+02	.1190E+02	.7317E+01	.4146E-02	.1588E+00	D10064.BIS
13.00	1.619	-0.001	.5821E+01	.7058E+00	-.7109E+00	.1710E+02	.1354E+02	.1100E+02	.6750E+01	-.3718E+00	-.6208E+00	D10064.BIS
14.00	1.714	-0.001	.5608E+01	.4891E+00	-.4891E+00	.1530E+02	.1216E+02	.9690E+01	.6234E+01	-.1718E+00	-.2555E+00	D10064.BIS
15.00	1.809	-0.001	.5456E+01	.4995E+00	-.4171E+00	.1440E+02	.1122E+02	.8669E+01	.5595E+01	.2771E+00	.1401E+00	D10064.BIS
16.00	1.905	-0.001	.5347E+01	.5070E+00	-.5831E+00	.1260E+02	.1060E+02	.8347E+01	.5049E+01	-.6877E+00	-.4225E+00	D10064.BIS
17.00	2.000	-0.001	.4957E+01	.4713E+00	-.3118E+00	.1310E+02	.1020E+02	.7831E+01	.5440E+01	-.6195E+00	-.3687E+00	D10064.BIS
18.00	2.095	-0.002	.5287E+01	.5012E+00	-.6266E+00	.1060E+02	.8682E+01	.8000E+01	.3920E+01	-.7030E+00	-.4962E+00	D10064.BIS
19.00	2.190	-0.002	.4878E+01	.4374E+00	-.4212E+00	.1120E+02	.7915E+01	.7009E+01	.4552E+01	-.5691E+00	-.3059E+00	D10064.BIS
0.20	0.400	0.200	.3017E+02	-.6669E+00	.4127E+00	.8582E-01	.1293E+00	.1190E+00	.7306E-02	.1111E-01	-.1098E-01	D10074.BIS
1.00	0.475	0.214	.2249E+02	.9346E+00	.5189E+00	.1870E+02	.1708E+02	.1170E+02	.7358E+01	-.9911E+00	-.3068E+01	D10074.BIS
2.00	0.571	0.232	.1398E+02	.4379E+00	.1464E+00	.3210E+02	.5778E+02	.2100E+02	.1510E+02	.3177E+00	.2542E+01	D10074.BIS
3.00	0.666	0.250	.1230E+02	.2902E+00	-.7546E-01	.2650E+02	.3926E+02	.1950E+02	.1069E+02	.5943E+00	.1572E+01	D10074.BIS
4.00	0.762	0.268	.1156E+02	.7354E+00	-.3623E+00	.2370E+02	.2825E+02	.1760E+02	.9760E+01	.9585E+00	.1064E+01	D10074.BIS

TABLE 3  
Continued

X	Y	Z	U	V	W	UU	VV	WW	UV	UV	VW	File Name
inch	inch	inch	m/s	m/s	m/s	m <sup>2</sup> /s <sup>2</sup>	m <sup>2</sup> /s <sup>2</sup>	m <sup>2</sup> /s <sup>2</sup>	m <sup>2</sup> /s <sup>2</sup>	m <sup>2</sup> /s <sup>2</sup>	m <sup>2</sup> /s <sup>2</sup>	
5.00	0.857	0.285	.1019E+02	.8167E+00	.7815E-01	.2390E+02	.2590E+02	.1640E+02	.9432E+01	.1434E+01	.3604E+00	D10074.BIS
6.00	0.952	0.303	.8705E+01	.7809E+00	-.2389E+00	.2440E+02	.2100E+02	.1420E+02	.9070E+01	.2652E+01	.1824E+00	D10074.BIS
7.00	1.048	0.321	.8065E+01	.6593E+00	-.3113E+00	.2250E+02	.1826E+02	.1390E+02	.8143E+01	.1868E+01	.1146E-01	D10074.BIS
8.00	1.143	0.339	.7208E+01	.6243E+00	-.2664E+00	.2060E+02	.1655E+02	.1330E+02	.6669E+01	.1817E+01	-.6292E+00	D10074.BIS
9.00	1.238	0.357	.6685E+01	.5365E+00	-.2383E+00	.2040E+02	.1522E+02	.1240E+02	.7418E+01	.1559E+01	-.4463E-01	D10074.BIS
10.00	1.333	0.375	.6064E+01	.5077E+00	-.2078E+00	.1720E+02	.1380E+02	.1120E+02	.6754E+01	.1920E+01	-.2925E-01	D10074.BIS
11.00	1.428	0.393	.5610E+01	.4581E+00	-.2943E+00	.1560E+02	.1275E+02	.1030E+02	.5896E+01	.1357E+01	-.4550E+00	D10074.BIS
12.00	1.524	0.410	.5014E+01	.3926E+00	-.4112E+00	.1590E+02	.1201E+02	.9329E+01	.5924E+01	.9437E+00	-.3460E+00	D10074.BIS
13.00	1.619	0.429	.4969E+01	.5255E+00	-.4549E+00	.1470E+02	.1164E+02	.8858E+01	.5752E+01	.1491E+01	.8977E-01	D10074.BIS
14.00	1.714	0.446	.4761E+01	.5959E+00	-.3411E+00	.1300E+02	.1062E+02	.8161E+01	.4977E+01	.8537E+00	-.5035E+00	D10074.BIS
15.00	1.809	0.464	.4669E+01	.5260E+00	-.2691E+00	.1260E+02	.1021E+02	.7851E+01	.4683E+01	.1341E+01	-.2450E+00	D10074.BIS
16.00	1.905	0.482	.4479E+01	.6030E+00	-.1683E+00	.1210E+02	.1007E+02	.8228E+01	.4463E+01	.1168E+01	-.7548E-01	D10074.BIS
17.00	2.000	0.500	.4871E+01	.5852E+00	-.4546E+00	.1030E+02	.9159E+01	.7150E+01	.4020E+01	.2472E+00	.5124E-01	D10074.BIS
18.00	2.095	0.518	.4638E+01	.4730E+00	-.1003E+00	.9860E+01	.8256E+01	.6460E+01	.3819E+01	.8968E+00	-.1486E+00	D10074.BIS
19.00	2.190	0.535	.4563E+01	.4867E+00	.1425E-01	.9431E+01	.8093E+01	.5990E+01	.3892E+01	.8649E+00	.7746E-01	D10074.BIS
0.20	0.399	0.400	.3021E+02	-.5349E+00	.4257E-01	.7951E-01	.1180E+00	.9541E-01	.2783E-01	.3010E-01	.1458E-01	D10084.BIS
1.00	0.476	0.428	.2359E+02	.9557E+00	.7921E+00	.1520E+02	.1476E+02	.1080E+02	.8003E+01	.1405E+00	.1226E+00	D10084.BIS
2.00	0.571	0.464	.1618E+02	.9617E+00	-.3131E+00	.2640E+02	.2535E+02	.2130E+02	.1055E+02	-.2717E+00	.2518E+00	D10084.BIS
3.00	0.666	0.500	.1332E+02	.9815E+00	-.6588E-01	.2610E+02	.4072E+02	.2040E+02	.1120E+02	.2563E+01	.1114E+01	D10084.BIS
4.00	0.762	0.535	.1066E+02	.8627E+00	-.4037E-01	.2440E+02	.2728E+02	.1790E+02	.8320E+01	.2960E+01	.5124E-01	D10084.BIS
5.00	0.857	0.571	.8237E+01	.3737E+00	-.2128E+00	.2070E+02	.2371E+02	.1560E+02	.7443E+01	.1999E+01	-.7477E+00	D10084.BIS
6.00	0.952	0.607	.7276E+01	.5348E+00	-.5970E+00	.1830E+02	.1763E+02	.1270E+02	.6811E+01	.9836E+00	-.6913E+00	D10084.BIS
7.00	1.048	0.643	.6108E+01	.5193E+00	-.3000E+00	.1760E+02	.1531E+02	.1150E+02	.6201E+01	.2499E+01	-.1133E+00	D10084.BIS
8.00	1.143	0.678	.5645E+01	.4543E+00	-.5705E+00	.1660E+02	.1327E+02	.9839E+01	.6233E+01	.1787E+01	-.4111E+00	D10084.BIS
9.00	1.238	0.714	.5435E+01	.4657E+00	-.5769E+00	.1490E+02	.1229E+02	.1020E+02	.5295E+01	.1318E+01	-.3839E+00	D10084.BIS
10.00	1.333	0.750	.4732E+02	.6212E+00	-.4020E+00	.1360E+02	.1130E+02	.7982E+01	.4975E+01	.1532E+01	-.2562E+00	D10084.BIS
11.00	1.429	0.786	.4082E+01	.3466E+00	-.1736E+00	.1270E+02	.1036E+02	.8128E+01	.3957E+01	.2267E+01	-.7046E+00	D10084.BIS
12.00	1.524	0.821	.4324E+01	.6218E+00	-.5322E+00	.1190E+02	.1084E+02	.7992E+01	.4562E+01	.1362E+01	-.7982E+00	D10084.BIS
13.00	1.619	0.857	.3975E+01	.5640E+00	-.4711E+00	.1140E+02	.8816E+01	.7501E+01	.3452E+01	.1610E+01	-.7062E+00	D10084.BIS
14.00	1.714	0.893	.4299E+01	.5914E+00	-.5170E+00	.1120E+02	.9724E+01	.7171E+01	.4166E+01	.1091E+01	-.3093E+00	D10084.BIS
15.00	1.810	0.928	.4500E+01	.6999E+00	-.4437E+00	.9990E+01	.9171E+01	.6389E+01	.3891E+01	.1170E+01	.9582E-01	D10084.BIS
16.00	1.905	0.964	.4188E+01	.5638E+00	-.3176E+00	.9620E+01	.8928E+01	.6171E+01	.3359E+01	.1660E+01	.1590E+00	D10084.BIS
17.00	2.000	1.000	.4911E+01	.8832E+00	-.4657E+00	.1030E+02	.1039E+02	.6500E+01	.4288E+01	.1360E+01	.1199E+00	D10084.BIS
18.00	2.095	1.036	.3692E+01	.4196E+00	-.1689E+00	.8260E+01	.7445E+01	.5270E+01	.3009E+01	.1370E+01	-.3326E+00	D10084.BIS
19.00	2.191	1.071	.4636E+01	.7982E+00	-.3356E+00	.8250E+01	.8146E+01	.5440E+01	.3230E+01	.1290E+01	-.4502E-02	D10084.BIS
0.20	0.400	0.600	.3017E+02	-.4777E+00	.4300E-01	.2980E+00	.3609E+00	.3080E+00	.2321E+00	-.6397E-01	.9357E-01	D10094.BIS
1.00	0.475	0.642	.2384E+02	.7557E+00	.3772E+00	.1530E+02	.1546E+02	.1100E+02	.6612E+01	.7817E+00	-.5842E+00	D10094.BIS
2.00	0.571	0.696	.1407E+02	.7616E+00	-.1219E+00	.3020E+02	.5564E+02	.1890E+02	.1279E+02	.3847E+01	.1692E+01	D10094.BIS
3.00	0.666	0.750	.8379E+01	.1152E+00	.1718E+00	.2670E+02	.3029E+02	.1710E+02	.9019E+01	.6350E+01	.5014E+00	D10094.BIS
4.00	0.762	0.803	.7281E+01	.4749E+00	-.6098E+00	.1920E+02	.2318E+02	.1210E+02	.6381E+01	.2509E+01	-.5373E+00	D10094.BIS
5.00	0.857	0.857	.6059E+01	.6687E+00	-.4133E+00	.1770E+02	.1604E+02	.1060E+02	.6230E+01	.2069E+01	-.8532E+00	D10094.BIS
6.00	0.952	0.910	.4971E+01	.6436E+00	-.4641E+00	.1440E+02	.1288E+02	.9329E+01	.3970E+01	.2349E+01	-.7665E+00	D10094.BIS
7.00	1.047	0.964	.4339E+01	.4234E+00	-.3269E+00	.1300E+02	.1103E+02	.7988E+01	.3945E+01	.2249E+01	-.8526E+00	D10094.BIS
8.00	1.143	1.018	.4104E+01	.6078E+00	-.3750E+00	.1120E+02	.1024E+02	.7268E+01	.3462E+01	.2207E+01	-.6993E+00	D10094.BIS
9.00	1.238	1.071	.3927E+01	.7291E+00	-.6100E+00	.1090E+02	.9420E+01	.6851E+01	.3596E+01	.2022E+01	-.3584E+00	D10094.BIS
10.00	1.333	1.125	.3267E+01	.5997E+00	-.5094E+00	.1010E+02	.8354E+01	.6140E+01	.3450E+01	.1600E+01	-.5564E+00	D10094.BIS
11.00	1.428	1.178	.3253E+01	.5494E+00	-.5470E+00	.9689E+01	.8244E+01	.5720E+01	.2820E+01	.1310E+01	-.6838E+00	D10094.BIS
12.00	1.524	1.232	.3279E+01	.4683E+00	-.3062E+00	.8360E+01	.9107E+01	.5440E+01	.2950E+01	.1530E+01	.7345E-01	D10094.BIS
13.00	1.619	1.285	.3953E+01	.7504E+00	-.4986E+00	.9149E+01	.1100E+02	.5110E+01	.3549E+01	.1200E+01	.1528E-01	D10094.BIS
14.00	1.714	1.339	.3516E+01	.6830E+00	-.3122E+00	.8520E+01	.9200E+01	.4891E+01	.3230E+01	.1320E+01	.3205E+00	D10094.BIS
15.00	1.809	1.393	.3547E+01	.6442E+00	-.3068E+00	.8691E+01	.1071E+02	.5000E+01	.3382E+01	.1280E+01	.3371E-01	D10094.BIS
16.00	1.905	1.446	.3767E+01	.7684E+00	-.3097E+00	.7790E+01	.1109E+02	.4960E+01	.3220E+01	.1190E+01	.2615E+00	D10094.BIS
17.00	2.000	1.500	.4072E+01	.9505E+00	-.2481E+00	.8460E+01	.9898E+01	.4919E+01	.3379E+01	.1350E+01	.2660E+00	D10094.BIS
18.00	2.095	1.553	.3956E+01	.8455E+00	-.2896E+00	.7990E+01	.8806E+01	.4990E+01	.2910E+01	.1390E+01	-.1548E-01	D10094.BIS
19.00	2.190	1.607	.3929E+01	.8340E+00	-.2701E+00	.7939E+01	.8630E+01	.4580E+01	.3217E+01	.1540E+01	.3118E+00	D10094.BIS
0.20	0.399	0.800	.3043E+02	-.6917E+00	-.9398E-02	.6770E-01	.1494E+00	.1001E+00	-.1818E-01	.1150E-01	-.3252E-01	D10104.BIS

TABLE 3  
Continued

X	Y	Z	$\bar{u}$	$\bar{v}$	$\bar{w}$	$\overline{uu}$	$\overline{vv}$	$\overline{ww}$	$\overline{uv}$	$\overline{vw}$	$\overline{wv}$	File Name
inch	inch	inch	m/s	m/s	m/s	m <sup>2</sup> /s <sup>2</sup>	m <sup>2</sup> /s <sup>2</sup>	m <sup>2</sup> /s <sup>2</sup>	m <sup>2</sup> /s <sup>2</sup>	m <sup>2</sup> /s <sup>2</sup>	m <sup>2</sup> /s <sup>2</sup>	
1.00	0.476	0.857	.2050E+02	-.5747E-01	.1764E+00	.2630E+02	.3323E+02	.2270E+02	.9599E+01	.6360E+01	.9857E-01	D10104.BIS
2.00	0.571	0.928	.7007E+01	.1001E+01	-.1548E+00	.3020E+02	.4451E+02	.1860E+02	.1439E+02	.3549E+01	.2154E+01	D10104.BIS
3.00	0.666	1.000	.5501E+01	.1061E+01	-.3472E+00	.2050E+02	.2412E+02	.1290E+02	.6650E+01	.5445E+01	.9846E+00	D10104.BIS
4.00	0.762	1.071	.3783E+01	.5282E+00	-.1201E+00	.1510E+02	.1447E+02	.9260E+01	.4657E+01	.2930E+01	.1733E+00	D10104.BIS
5.00	0.857	1.143	.2884E+01	.6063E+00	-.5255E+00	.1190E+02	.9697E+01	.6990E+01	.4027E+01	.2310E+01	-.6460E-01	D10104.BIS
6.00	0.952	1.214	.2534E+01	.5007E+00	-.4793E+00	.9770E+01	.8136E+01	.5710E+01	.3290E+01	.1660E+01	-.3457E-01	D10104.BIS
7.00	1.048	1.285	.2029E+01	.2338E+00	-.2011E+00	.8290E+01	.7404E+01	.5159E+01	.2619E+01	.1280E+01	-.3929E+00	D10104.BIS
8.00	1.143	1.357	.1935E+01	.3168E+00	-.2535E+00	.7890E+01	.6627E+01	.4720E+01	.2698E+01	.1170E+01	.1093E+00	D10104.BIS
9.00	1.238	1.428	.2339E+01	.3942E+00	-.3728E+00	.8880E+01	.7423E+01	.4740E+01	.3420E+01	.9568E+00	.1716E-01	D10104.BIS
10.00	1.333	1.500	.2103E+01	.3993E+00	-.3057E+00	.7750E+01	.6813E+01	.4430E+01	.2809E+01	.1070E+01	.5686E-01	D10104.BIS
11.00	1.429	1.571	.2778E+01	.6153E+00	-.4057E+00	.9290E+01	.8389E+01	.4940E+01	.3650E+01	.1550E+01	.4395E+00	D10104.BIS
12.00	1.524	1.642	.2029E+01	.3688E+00	-.3647E+00	.8029E+01	.7799E+01	.4540E+01	.2748E+01	.1490E+01	.2656E+00	D10104.BIS
13.00	1.619	1.714	.2116E+01	.3435E+00	-.3122E+00	.7570E+01	.7739E+01	.4440E+01	.2411E+01	.1370E+01	.4363E-01	D10104.BIS
14.00	1.714	1.786	.2390E+01	.4979E+00	-.2560E+00	.8520E+01	.8708E+01	.4790E+01	.3079E+01	.1670E+01	.3031E+00	D10104.BIS
15.00	1.809	1.857	.2026E+01	.3019E+00	-.1343E+00	.6840E+01	.7401E+01	.4460E+01	.2419E+01	.1390E+01	.2910E+00	D10104.BIS
16.00	1.905	1.928	.2137E+01	.3958E+00	-.1254E+00	.6480E+01	.7786E+01	.4471E+01	.2500E+01	.1420E+01	.3797E+00	D10104.BIS
17.00	2.000	2.000	.2122E+01	.3744E+00	-.4921E-01	.7140E+01	.1190E+02	.3841E+01	.3380E+01	.1380E+01	.9537E+00	D10104.BIS
18.00	2.095	2.071	.2240E+01	.3215E+00	-.1059E-01	.7590E+01	.1761E+02	.4520E+01	.4801E+01	.2130E+01	.2991E+00	D10104.BIS
19.00	2.190	2.142	.2458E+01	.4893E+00	-.3555E-01	.7171E+01	.1690E+02	.4100E+01	.4460E+01	.1970E+01	.2310E+01	D10104.BIS
0.20	0.402	1.000	.9644E+01	.1054E+01	.2237E+00	.5609E+01	.6258E+01	.3619E+00	.1598E+01	.1249E+00	.7018E+00	D10114.BIS
1.00	0.475	1.071	.2196E+01	.6643E+00	-.4666E+00	.1090E+02	.1988E+02	.7358E+01	.4823E+01	.3098E+01	.2604E+01	D10114.BIS
2.00	0.571	1.161	.1324E+01	.5260E+00	-.6970E+00	.6950E+01	.8072E+01	.3989E+01	.2549E+01	.1350E+01	.1425E+00	D10114.BIS
3.00	0.666	1.250	.1561E+01	.6792E+00	-.4931E+00	.6709E+01	.7040E+01	.4000E+01	.2409E+01	.1640E+01	.7361E+00	D10114.BIS
4.00	0.762	1.339	.1429E+01	.5159E+00	-.3691E+00	.6060E+01	.5976E+01	.3539E+01	.1970E+01	.1630E+01	.5543E+00	D10114.BIS
5.00	0.857	1.429	.1236E+01	.3130E+00	-.1972E+00	.5450E+01	.5669E+01	.3350E+01	.1601E+01	.1260E+01	.6068E+00	D10114.BIS
6.00	0.952	1.518	.1201E+01	.3998E+00	-.3278E+00	.4920E+01	.5920E+01	.2970E+01	.1901E+01	.1190E+01	.6828E+00	D10114.BIS
7.00	1.048	1.607	.1137E+01	.2908E+00	-.3138E+00	.4610E+01	.6694E+01	.2800E+01	.1892E+01	.1200E+01	.6338E+00	D10114.BIS
8.00	1.143	1.696	.1220E+01	.2369E+00	-.1670E+00	.5309E+01	.1049E+02	.3050E+01	.3128E+01	.1310E+01	.1440E+01	D10114.BIS
9.00	1.238	1.785	.1451E+01	.3828E+00	-.2519E+00	.5750E+01	.1050E+02	.3330E+01	.3100E+01	.1430E+01	.1440E+01	D10114.BIS
10.00	1.333	1.875	.1385E+01	.4380E+00	-.2427E+00	.6100E+01	.1170E+02	.3290E+01	.3129E+01	.1170E+01	.1360E+01	D10114.BIS
11.00	1.429	1.964	.1591E+01	.4430E+00	-.2819E+00	.6819E+01	.1100E+02	.3280E+01	.3300E+01	.1330E+01	.1510E+01	D10114.BIS
12.00	1.524	2.053	.1655E+01	.4215E+00	-.1284E+00	.7050E+01	.1080E+02	.3379E+01	.3251E+01	.1360E+01	.1448E+01	D10114.BIS
13.00	1.619	2.142	.1692E+01	.4113E+00	-.1032E+00	.6070E+01	.1130E+02	.3520E+01	.3221E+01	.1210E+01	.1721E+01	D10114.BIS
14.00	1.714	2.232	.1808E+01	.4166E+00	-.7661E-01	.6780E+01	.1040E+02	.3470E+01	.3251E+01	.1600E+01	.1429E+01	D10114.BIS
15.00	1.810	2.321	.2203E+01	.6307E+00	-.1688E+00	.6600E+01	.1139E+02	.3760E+01	.3208E+01	.1760E+01	.1869E+01	D10114.BIS
16.00	1.905	2.410	.2064E+01	.5090E+00	-.9910E-01	.6301E+01	.1201E+02	.3750E+01	.3053E+01	.1610E+01	.1589E+01	D10114.BIS
17.00	2.000	2.500	.2298E+01	.4515E+00	.1623E-02	.6010E+01	.9806E+01	.3490E+01	.2662E+01	.1290E+01	.1101E+01	D10114.BIS
18.00	2.095	2.589	.1829E+01	.3474E+00	-.1280E+00	.5480E+01	.7649E+01	.3071E+01	.2050E+01	.1170E+01	.9229E+00	D10114.BIS
19.00	2.190	2.678	.1692E+01	.2077E+00	.3762E-01	.5530E+01	.1050E+02	.2990E+01	.2389E+01	.1230E+01	.1330E+01	D10114.BIS
0.20	0.500	-0.200	.1765E+01	-.1189E+00	.2594E+00	.2000E+00	.2243E+00	.1530E+00	.1285E-01	.7276E-02	-.2315E-01	D11054.BIS
1.00	0.595	-0.214	.5804E+01	.2700E+00	.4105E+00	.2450E+02	.2380E+02	.1490E+02	.1123E+02	.1433E+01	-.9557E+00	D11054.BIS
2.00	0.714	-0.232	.5817E+01	.8517E-01	.7834E-01	.1860E+02	.3083E+02	.1230E+02	.9245E+01	-.6879E-01	.2845E+01	D11054.BIS
3.00	0.833	-0.250	.5570E+01	-.7720E-02	-.1986E+00	.1680E+02	.1958E+02	.1020E+02	.8184E+01	-.1232E+01	.1385E+01	D11054.BIS
4.00	0.952	-0.268	.5334E+01	.1005E+00	-.2844E+00	.1480E+02	.1727E+02	.8777E+01	.7143E+01	-.1561E+01	.6982E+00	D11054.BIS
5.00	1.072	-0.286	.4989E+01	.1491E+00	-.6165E+00	.1300E+02	.1471E+02	.7279E+01	.5681E+01	-.1518E+01	.7596E+00	D11054.BIS
6.00	1.190	-0.304	.4510E+01	.3980E+00	-.2191E+00	.1310E+02	.1390E+02	.7318E+01	.5400E+01	-.9193E+00	.8480E+00	D11054.BIS
7.00	1.309	-0.322	.4199E+01	.1507E+00	-.2437E+00	.1210E+02	.1200E+02	.6989E+01	.4870E+01	-.1980E+01	-.3950E+00	D11054.BIS
8.00	1.428	-0.339	.3894E+01	.2204E+00	-.3907E+00	.1300E+02	.1261E+02	.6221E+01	.5351E+01	-.1721E+01	-.1888E+00	D11054.BIS
9.00	1.548	-0.357	.3555E+01	.1343E+00	-.2898E+00	.1110E+02	.1010E+02	.5982E+01	.4840E+01	-.1602E+01	-.5840E+00	D11054.BIS
10.00	1.667	-0.375	.3173E+01	.2278E+00	-.9895E-01	.1030E+02	.9992E+01	.5370E+01	.4240E+01	-.1020E+01	-.6408E-01	D11054.BIS
11.00	1.786	-0.393	.3384E+01	.2538E+00	-.3101E+00	.1140E+02	.1110E+02	.5740E+01	.5030E+01	-.8320E+00	-.4816E-01	D11054.BIS
12.00	1.904	-0.411	.3310E+01	.2282E+00	-.1579E+00	.1030E+02	.1191E+02	.4580E+01	.4561E+01	-.6981E+00	.2079E-01	D11054.BIS
13.00	2.023	-0.429	.3496E+01	.2845E+00	-.3233E+00	.1100E+02	.1220E+02	.5120E+01	.4870E+01	-.5176E+00	.2220E+00	D11054.BIS
14.00	2.143	-0.447	.3372E+01	.2548E+00	-.3349E+00	.9611E+01	.1011E+02	.4510E+01	.4343E+01	-.6808E+00	-.2819E+00	D11054.BIS
15.00	2.262	-0.465	.3117E+01	.2213E+00	-.2747E+00	.9440E+01	.9596E+01	.4440E+01	.3971E+01	-.1697E+00	.2066E+00	D11054.BIS
16.00	2.381	-0.482	.3201E+01	.2642E+00	-.1561E+00	.8340E+01	.9555E+01	.4349E+01	.3800E+01	-.5130E+00	.4429E-01	D11054.BIS

TABLE 3  
Continued

X	Y	Z	$\bar{u}$	$\bar{v}$	$\bar{w}$	$\overline{uu}$	$\overline{vv}$	$\overline{ww}$	$\overline{uv}$	$\overline{uw}$	$\overline{vw}$	File Name
inch	inch	inch	m/s	m/s	m/s	m <sup>2</sup> /s <sup>2</sup>	m <sup>2</sup> /s <sup>2</sup>	m <sup>2</sup> /s <sup>2</sup>	m <sup>2</sup> /s <sup>2</sup>	m <sup>2</sup> /s <sup>2</sup>	m <sup>2</sup> /s <sup>2</sup>	
17.00	2.500	-0.500	.3359E+01	.3560E+00	-.2629E+00	.7479E+01	.9650E+01	.4430E+01	.3719E+01	-.2634E+00	.2521E+00	D11054.BIS
18.00	2.619	-0.518	.3183E+01	.2870E+00	-.2078E+00	.7660E+01	.9315E+01	.4240E+01	.3350E+01	-.8814E-01	.1490E+00	D11054.BIS
19.00	2.738	-0.536	.3314E+01	.3422E+00	-.1629E+00	.6890E+01	.6849E+01	.3989E+01	.2789E+01	-.3029E+00	.2438E-01	D11054.BIS
0.20	0.501	-0.001	.1353E+01	-.1247E+00	.6864E-01	.6850E-01	.8758E-01	.7070E-01	.7741E-03	.1728E-02	-.1022E-01	D11064.BIS
1.00	0.595	-0.002	.5637E+01	.8056E+00	.1399E+00	.3020E+02	.2781E+02	.1560E+02	.1441E+02	.1893E+01	.3179E+00	D11064.BIS
2.00	0.713	-0.002	.6767E+01	.3782E+00	-.9197E-01	.2150E+02	.3902E+02	.1580E+02	.1229E+02	-.2178E+00	.2869E+01	D11064.BIS
3.00	0.833	-0.002	.7374E+01	.7235E+00	-.3683E+00	.2040E+02	.2825E+02	.1470E+02	.9996E+01	-.9879E+00	.1470E+01	D11064.BIS
4.00	0.952	0.000	.7050E+01	.7293E+00	-.6395E+00	.2330E+02	.2350E+02	.1250E+02	.9934E+01	-.1600E+01	.1014E+01	D11064.BIS
5.00	1.072	0.000	.6770E+01	.7963E+00	-.4119E+00	.2200E+02	.1953E+02	.1190E+02	.9833E+01	-.1088E+01	.5914E+00	D11064.BIS
6.00	1.190	-0.001	.5853E+01	.6412E+00	-.6750E+00	.2020E+02	.1732E+02	.1030E+02	.8881E+01	-.9554E+00	-.1942E+00	D11064.BIS
7.00	1.309	-0.001	.5196E+01	.5009E+00	-.6911E+00	.1720E+02	.1472E+02	.9809E+01	.7543E+01	-.2499E+00	.3094E+00	D11064.BIS
8.00	1.428	-0.002	.4651E+01	.3775E+00	-.4317E+00	.1630E+02	.1238E+02	.9151E+01	.5996E+01	-.7369E-02	.3533E+00	D11064.BIS
9.00	1.548	-0.001	.4245E+01	.4012E+00	-.5101E+00	.1450E+02	.1141E+02	.7562E+01	.5983E+01	-.7604E+00	.4441E-01	D11064.BIS
10.00	1.667	-0.001	.3957E+01	.2586E+00	-.3806E+00	.1370E+02	.1053E+02	.6722E+01	.5679E+01	.1094E+00	.5260E-01	D11064.BIS
11.00	1.786	-0.001	.3472E+01	.1155E+00	-.1105E+00	.1130E+02	.9553E+01	.6639E+01	.4630E+01	-.1452E+00	-.1431E-01	D11064.BIS
12.00	1.904	-0.001	.3427E+01	.1482E+00	-.9392E-02	.1140E+02	.9997E+01	.6130E+01	.4400E+01	-.6350E+00	.1125E-01	D11064.BIS
13.00	2.023	-0.001	.3301E+01	.1028E+00	-.4451E+00	.9959E+01	.1010E+02	.5890E+01	.4039E+01	-.4033E+00	.2331E-01	D11064.BIS
14.00	2.143	-0.002	.3205E+01	.2035E+00	-.3119E+00	.9430E+01	.7977E+01	.5790E+01	.3819E+01	-.3499E+00	-.4350E+00	D11064.BIS
15.00	2.262	-0.002	.3123E+01	.7967E-01	-.2222E+00	.9250E+01	.8968E+01	.4810E+01	.4270E+01	-.7796E-01	.2130E-01	D11064.BIS
16.00	2.381	-0.002	.3251E+01	.1076E+00	-.1623E+00	.9011E+01	.9913E+01	.4850E+01	.3912E+01	.1994E+00	.3915E+00	D11064.BIS
17.00	2.500	-0.002	.3166E+01	.1657E+00	-.2809E+00	.8460E+01	.9324E+01	.4590E+01	.3649E+01	-.2422E+00	.3339E+00	D11064.BIS
18.00	2.619	0.000	.3239E+01	.1661E+00	-.3527E+00	.7551E+01	.9675E+01	.4190E+01	.3281E+01	-.7953E-01	.1069E+00	D11064.BIS
19.00	2.738	0.000	.3061E+01	.2033E+00	-.3969E-02	.7540E+01	.7135E+01	.4380E+01	.2811E+01	.1070E+00	.1217E+00	D11064.BIS
0.20	0.500	0.200	.1529E+01	-.8190E-01	.3501E-01	.2890E+00	.6118E+00	.2480E+00	.3202E+00	.1230E+00	.2731E+00	D11074.BIS
1.00	0.594	0.214	.6395E+01	.1042E+01	-.5265E-01	.2620E+02	.2321E+02	.1390E+02	.1201E+02	-.5997E+00	-.3377E+01	D11074.BIS
2.00	0.714	0.232	.6856E+01	.3207E+00	-.9998E-01	.2070E+02	.3455E+02	.1270E+02	.1029E+02	.4642E+00	.2273E+01	D11074.BIS
3.00	0.833	0.250	.8232E+01	.8777E+00	-.3123E+00	.1800E+02	.2619E+02	.1170E+02	.8855E+01	-.5589E+00	.1345E+01	D11074.BIS
4.00	0.952	0.268	.6917E+01	.5554E+00	-.2051E+00	.1790E+02	.2122E+02	.9912E+01	.7850E+01	.1029E+01	.1069E+01	D11074.BIS
5.00	1.072	0.285	.6679E+01	.6960E+00	.2908E-01	.1280E+02	.1916E+02	.8907E+01	.6472E+01	.1107E+01	.1479E+01	D11074.BIS
6.00	1.191	0.303	.5764E+01	.5785E+00	.1820E+00	.1520E+02	.1781E+02	.8283E+01	.7402E+01	.6401E+00	.1053E+01	D11074.BIS
7.00	1.309	0.321	.4833E+01	.3531E+00	-.2750E+00	.1230E+02	.1218E+02	.7268E+01	.4776E+01	.1359E+01	.7044E+00	D11074.BIS
8.00	1.428	0.339	.4459E+01	.4308E+00	-.9989E-01	.1420E+02	.1382E+02	.7708E+01	.6316E+01	.1917E+01	.7000E+00	D11074.BIS
9.00	1.548	0.357	.4418E+01	.5239E+00	.8326E-01	.1140E+02	.1209E+02	.6201E+01	.5137E+01	.1050E+01	.3197E+00	D11074.BIS
10.00	1.667	0.375	.3721E+01	.2797E+00	.7609E-01	.1030E+02	.1039E+02	.5580E+01	.3891E+01	.6359E+00	.4096E+00	D11074.BIS
11.00	1.786	0.393	.3633E+01	.3787E+00	-.6522E-01	.1030E+02	.1210E+02	.5360E+01	.4520E+01	.1360E+01	.6662E+00	D11074.BIS
12.00	1.904	0.410	.3552E+01	.4387E+00	-.6581E+00	.8100E+01	.7902E+01	.4850E+01	.3060E+01	.8078E+00	.3258E+00	D11074.BIS
13.00	2.023	0.429	.3246E+01	.4150E+00	-.1260E+00	.9740E+01	.1010E+02	.5150E+01	.4081E+01	.1050E+01	.9260E+00	D11074.BIS
14.00	2.143	0.446	.3308E+01	.4130E+00	-.4181E+00	.8420E+01	.7638E+01	.4790E+01	.3021E+01	.6199E+00	.1017E+00	D11074.BIS
15.00	2.262	0.464	.3445E+01	.5205E+00	-.2076E+00	.7620E+01	.9146E+01	.4740E+01	.3281E+01	.4225E+00	.4625E+00	D11074.BIS
16.00	2.381	0.482	.3128E+01	.4700E+00	-.3488E+00	.8911E+01	.8731E+01	.4780E+01	.3691E+01	.7399E+00	.5008E+00	D11074.BIS
17.00	2.500	0.500	.2813E+01	.4335E+00	.8386E-01	.8311E+01	.8672E+01	.4620E+01	.3690E+01	.4458E+00	.3401E+00	D11074.BIS
18.00	2.619	0.517	.3256E+01	.5122E+00	-.3865E-01	.7199E+01	.7492E+01	.4100E+01	.2927E+01	.1182E+00	.7716E-01	D11074.BIS
19.00	2.738	0.535	.2837E+01	.4158E+00	.6514E-01	.6429E+01	.7071E+01	.4340E+01	.2429E+01	.6220E+00	.2483E+00	D11074.BIS
0.20	0.500	0.400	.1821E+01	-.6454E-01	-.3835E-01	.2510E+00	.3040E+00	.1650E+00	.1459E+00	.7690E-01	.9616E-01	D11084.BIS
1.00	0.595	0.428	.7410E+01	.1343E+01	-.1226E+00	.2640E+02	.2210E+02	.1680E+02	.1328E+02	-.2628E+01	-.1560E+01	D11084.BIS
2.00	0.714	0.464	.9346E+01	.1312E+01	-.2461E+00	.2320E+02	.2119E+02	.1530E+02	.1028E+02	-.5651E+00	-.1458E+01	D11084.BIS
3.00	0.833	0.500	.7494E+01	.7878E+00	-.5524E-01	.1880E+02	.2843E+02	.1170E+02	.8699E+01	.1869E+01	.1090E+01	D11084.BIS
4.00	0.952	0.535	.5871E+01	.3427E+00	.2029E+00	.1590E+02	.1897E+02	.9088E+01	.6523E+01	.2212E+01	.9920E+00	D11084.BIS
5.00	1.072	0.571	.4560E+01	.3555E+00	-.3337E-01	.1260E+02	.1229E+02	.7359E+01	.4479E+01	.1420E+01	.3254E+00	D11084.BIS
6.00	1.190	0.607	.4230E+01	.3422E+00	-.3606E+00	.1130E+02	.9810E+01	.6310E+01	.4370E+01	.9487E+00	-.1901E+00	D11084.BIS
7.00	1.309	0.643	.4127E+01	.3608E+00	.5862E-02	.1070E+02	.1027E+02	.6619E+01	.4325E+01	.1539E+01	.3977E+00	D11084.BIS
8.00	1.428	0.678	.3239E+01	.1258E+00	-.1770E+00	.9370E+01	.8963E+01	.5000E+01	.3699E+01	.9248E+00	-.1069E+00	D11084.BIS
9.00	1.548	0.714	.3272E+01	.3531E+00	-.1099E+00	.8490E+01	.8478E+01	.5280E+01	.2999E+01	.1230E+01	.6123E+00	D11084.BIS
10.00	1.667	0.750	.2730E+01	.2358E+00	-.9092E-01	.9341E+01	.7951E+01	.4560E+01	.3333E+01	.1330E+01	.6516E+00	D11084.BIS
11.00	1.786	0.785	.2476E+01	.2376E+00	-.7484E-01	.8910E+01	.8204E+01	.4910E+01	.3391E+01	.1270E+01	.4200E+00	D11084.BIS
12.00	1.904	0.821	.2391E+01	.1160E+00	-.1109E+00	.7740E+01	.8133E+01	.4570E+01	.2931E+01	.1400E+01	.5054E+00	D11084.BIS



TABLE 3  
Continued

X	Y	Z	$\bar{u}$	$\bar{v}$	$\bar{w}$	$\overline{uu}$	$\overline{vv}$	$\overline{ww}$	$\overline{uv}$	$\overline{uw}$	$\overline{vw}$	File Name
inch	inch	inch	m/s	m/s	m/s	m <sup>2</sup> /s <sup>2</sup>	m <sup>2</sup> /s <sup>2</sup>	m <sup>2</sup> /s <sup>2</sup>	m <sup>2</sup> /s <sup>2</sup>	m <sup>2</sup> /s <sup>2</sup>	m <sup>2</sup> /s <sup>2</sup>	
13.00	2.023	0.857	.2358E+01	.3376E+00	-.2933E+00	.8159E+01	.6440E+01	.4170E+01	.3118E+01	.1040E+01	.3700E+00	D11084.BIS
14.00	2.143	0.893	.2353E+01	.2005E+00	-.1532E+00	.6830E+01	.6932E+01	.4050E+01	.3120E+01	.7111E+00	.2638E+00	D11084.BIS
15.00	2.262	0.928	.2379E+01	.3087E+00	-.1364E+00	.7410E+01	.7190E+01	.4010E+01	.2789E+01	.7148E+00	-.2578E-01	D11084.BIS
16.00	2.381	0.964	.2229E+01	.2744E+00	-.2259E+00	.7161E+01	.6386E+01	.3920E+01	.2770E+01	.4498E+00	-.1009E+00	D11084.BIS
17.00	2.500	1.000	.2454E+01	.3576E+00	-.1955E+00	.7371E+01	.7623E+01	.3930E+01	.3291E+01	.8029E+00	.3492E+00	D11084.BIS
18.00	2.619	1.036	.2699E+01	.4621E+00	-.2726E+00	.6550E+01	.6621E+01	.3910E+01	.2661E+01	.7110E+00	.1513E+00	D11084.BIS
19.00	2.738	1.071	.2840E+01	.4705E+00	-.4020E+00	.6450E+01	.6073E+01	.3560E+01	.2700E+01	.4714E+00	-.2904E-01	D11084.BIS
0.20	0.499	0.600	.1792E+01	-.7809E-01	-.1049E+00	.3560E+00	.5452E+00	.2480E+00	.2720E+00	.1630E+00	.2459E+00	D11094.BIS
1.00	0.595	0.643	.7054E+01	.1450E+01	-.9566E+00	.2320E+02	.1964E+02	.1430E+02	.1179E+02	-.1991E+01	-.1613E+01	D11094.BIS
2.00	0.714	0.696	.5299E+01	.1273E+00	.1319E-01	.1890E+02	.2889E+02	.1090E+02	.8304E+01	.4640E+01	.2943E+01	D11094.BIS
3.00	0.833	0.750	.3941E+01	-.1476E+00	.1457E+00	.1380E+02	.1559E+02	.8862E+01	.4518E+01	.2932E+01	.4556E+00	D11094.BIS
4.00	0.953	0.803	.3246E+01	-.9272E-01	.1428E+00	.1170E+02	.1281E+02	.7350E+01	.3130E+01	.2649E+01	.9554E+00	D11094.BIS
5.00	1.072	0.857	.2844E+01	.1594E+00	-.2485E+00	.9389E+01	.9094E+01	.5610E+01	.2901E+01	.1450E+01	.2634E-01	D11094.BIS
6.00	1.190	0.910	.2938E+01	.3636E+00	-.5957E+00	.9080E+01	.8629E+01	.4810E+01	.3471E+01	.1160E+01	.6000E+00	D11094.BIS
7.00	1.309	0.964	.2434E+01	.1471E+00	-.8294E-01	.7900E+01	.8094E+01	.4590E+01	.2741E+01	.1430E+01	.2371E+00	D11094.BIS
8.00	1.428	1.018	.2150E+01	.4072E-01	-.1110E-01	.8579E+01	.7102E+01	.4790E+01	.2369E+01	.1510E+01	.2721E+00	D11094.BIS
9.00	1.548	1.071	.1926E+01	-.9760E-02	.1007E+00	.7230E+01	.6886E+01	.4181E+01	.2229E+01	.1340E+01	.4539E+00	D11094.BIS
10.00	1.667	1.125	.1840E+01	.2589E+00	-.2561E+00	.6670E+01	.6427E+01	.3739E+01	.2489E+01	.6660E+00	.1279E+00	D11094.BIS
11.00	1.786	1.178	.1719E+01	.8065E-01	-.8637E-01	.7240E+01	.7974E+01	.3850E+01	.2968E+01	.1210E+01	.6359E+00	D11094.BIS
12.00	1.904	1.232	.2113E+01	.4278E+00	-.5120E+00	.6920E+01	.7754E+01	.3490E+01	.2741E+01	.8330E+00	.3209E+00	D11094.BIS
13.00	2.023	1.285	.1558E+01	.1771E+00	-.2032E+00	.5520E+01	.5332E+01	.3370E+01	.1968E+01	.7619E+00	.6207E-01	D11094.BIS
14.00	2.143	1.339	.1883E+01	.2108E+00	-.2167E+00	.6271E+01	.6277E+01	.3250E+01	.2312E+01	.8101E+00	.5067E+00	D11094.BIS
15.00	2.262	1.393	.1816E+01	.2939E+00	-.4037E+00	.6190E+01	.7874E+01	.3280E+01	.2940E+01	.8703E+00	.6669E+00	D11094.BIS
16.00	2.381	1.446	.2123E+01	.5034E+00	-.5135E+00	.5980E+01	.6843E+01	.3150E+01	.2290E+01	.6900E+00	.4003E+00	D11094.BIS
17.00	2.500	1.500	.1436E+01	.9012E-01	-.8329E-01	.6700E+01	.6729E+01	.3440E+01	.2389E+01	.1310E+01	.5591E+00	D11094.BIS
18.00	2.619	1.553	.1659E+01	.5651E-01	.4009E-01	.6540E+01	.5999E+01	.2980E+01	.2240E+01	.8392E+00	.8172E-01	D11094.BIS
19.00	2.738	1.607	.1798E+01	.1539E+00	.5788E-01	.5890E+01	.5582E+01	.3470E+01	.2049E+01	.9057E+00	.2928E+00	D11094.BIS
0.20	0.499	0.800	.2010E+01	-.8047E-01	-.4736E-01	.6400E+00	.6042E+00	.2250E+00	.3181E+00	.1250E+00	.1912E+00	D11104.BIS
1.00	0.595	0.857	.3539E+01	.4642E-01	.2603E-01	.1630E+02	.3231E+02	.1180E+02	.8251E+01	.3580E+01	.4303E+01	D11104.BIS
2.00	0.714	0.928	.2283E+01	.2828E+00	-.4518E+00	.1280E+02	.1783E+02	.7101E+01	.5227E+01	.1741E+01	.1874E+01	D11104.BIS
3.00	0.833	1.000	.2193E+01	.2116E+00	-.1260E+00	.1120E+02	.1350E+02	.5979E+01	.5160E+01	.1570E+01	.1399E+01	D11104.BIS
4.00	0.952	1.071	.1776E+01	.3096E+00	-.2227E+00	.9281E+01	.1341E+02	.4290E+01	.4601E+01	.1440E+01	.1462E+01	D11104.BIS
5.00	1.072	1.143	.1464E+01	.1208E+00	-.1138E+00	.8150E+01	.1021E+02	.4010E+01	.3692E+01	.1500E+01	.1301E+01	D11104.BIS
6.00	1.190	1.214	.1135E+01	.9111E-01	-.9503E-01	.6229E+01	.6938E+01	.3340E+01	.2608E+01	.1150E+01	.7582E+00	D11104.BIS
7.00	1.309	1.286	.1039E+01	.6024E-02	-.1350E+00	.5640E+01	.6858E+01	.3190E+01	.2278E+01	.1190E+01	.7622E+00	D11104.BIS
8.00	1.428	1.357	.1056E+01	.7588E-01	-.2310E+00	.5050E+01	.9997E+01	.2989E+01	.2790E+01	.1070E+01	.1429E+01	D11104.BIS
9.00	1.548	1.429	.1185E+01	.2781E+00	-.3829E+00	.5630E+01	.5659E+01	.3110E+01	.2149E+01	.1070E+01	.7611E+00	D11104.BIS
10.00	1.667	1.500	.1263E+01	.2420E+00	-.3450E+00	.5450E+01	.1170E+02	.2940E+01	.3040E+01	.9413E+00	.1290E+01	D11104.BIS
11.00	1.786	1.571	.1295E+01	.3011E+00	-.4453E+00	.5200E+01	.1160E+02	.2840E+01	.3400E+01	.1050E+01	.1670E+01	D11104.BIS
12.00	1.904	1.643	.9170E+00	.1029E+00	-.2300E+00	.4380E+01	.4623E+01	.2880E+01	.1727E+01	.8160E+00	.5551E+00	D11104.BIS
13.00	2.023	1.714	.1292E+01	.3729E+00	-.3910E+00	.5120E+01	.1049E+02	.2700E+01	.3298E+01	.7767E+00	.1519E+01	D11104.BIS
14.00	2.143	1.785	.1202E+01	.2251E+00	-.2801E+00	.5210E+01	.5535E+01	.2860E+01	.2578E+01	.1190E+01	.1049E+01	D11104.BIS
15.00	2.262	1.857	.1154E+01	.1830E+00	-.2390E+00	.5240E+01	.1020E+02	.2929E+01	.2930E+01	.8118E+00	.1379E+01	D11104.BIS
16.00	2.381	1.928	.1393E+01	.2710E+00	-.2079E+00	.5250E+01	.9840E+01	.2801E+01	.2920E+01	.1080E+01	.1442E+01	D11104.BIS
17.00	2.500	2.000	.1164E+01	.3528E+00	-.4477E+00	.4430E+01	.4639E+01	.2560E+01	.1822E+01	.8973E+00	.4685E+00	D11104.BIS
18.00	2.619	2.071	.1269E+01	.1821E+00	-.2081E+00	.4500E+01	.4643E+01	.2740E+01	.1832E+01	.8379E+00	.6298E+00	D11104.BIS
19.00	2.738	2.142	.1179E+01	.2441E+00	-.2370E+00	.5030E+01	.1130E+02	.2500E+01	.2960E+01	.1040E+01	.1282E+01	D11104.BIS
0.20	0.499	1.000	.6030E+00	.3340E+00	-.5940E+00	.1040E+01	.1423E+01	.1010E+01	.5214E+00	.3999E+00	.4021E+00	D11114.BIS
1.00	0.595	1.071	.4542E+00	-.1591E+00	-.1001E+01	.7880E+00	.1022E+01	.8530E+00	-.1297E+00	.2231E-01	-.4717E-01	D11114.BIS
2.00	0.714	1.161	.8927E+00	.9787E-01	-.7316E+00	.1030E+02	.1601E+02	.5241E+01	.5035E+01	.3052E+01	.2914E+01	D11114.BIS
3.00	0.833	1.250	.7160E+00	.2798E-01	-.5650E+00	.6010E+01	.1351E+02	.3860E+01	.2700E+01	.1030E+01	.1462E+01	D11114.BIS
4.00	0.952	1.339	.6880E+00	.1359E+00	-.5450E+00	.5590E+01	.5710E+01	.3610E+01	.2145E+01	.9737E+00	.9339E+00	D11114.BIS
5.00	1.072	1.429	.5630E+00	.5200E-01	-.5420E+00	.3760E+01	.3905E+01	.2890E+01	.1180E+01	.5108E+00	.4666E+00	D11114.BIS
6.00	1.190	1.518	.6770E+00	.2060E+00	-.6640E+00	.3980E+01	.3937E+01	.2590E+01	.1927E+01	.3070E+00	.1738E+00	D11114.BIS
7.00	1.309	1.607	.5830E+00	.1140E+00	-.5890E+00	.4050E+01	.4188E+01	.2660E+01	.1951E+01	.6241E+00	.7978E+00	D11114.BIS
8.00	1.428	1.696	.6370E+00	.1380E+00	-.5720E+00	.4100E+01	.3903E+01	.2540E+01	.1627E+01	.3588E+00	.3131E+00	D11114.BIS



TABLE 3  
Continued

X	Y	Z	$\bar{U}$	$\bar{V}$	$\bar{W}$	$\bar{u}^2$	$\bar{v}^2$	$\bar{w}^2$	$\bar{uv}$	$\bar{vw}$	$\bar{uv}$	File Name
inch	inch	inch	m/s	m/s	m/s	m <sup>2</sup> /s <sup>2</sup>	m <sup>2</sup> /s <sup>2</sup>	m <sup>2</sup> /s <sup>2</sup>	m <sup>2</sup> /s <sup>2</sup>	m <sup>2</sup> /s <sup>2</sup>	m <sup>2</sup> /s <sup>2</sup>	
9.00	1.548	1.785	.6590E+00	.2060E+00	-.5990E+00	.4000E+01	.3957E+01	.2520E+01	.1848E+01	.5012E+00	.7243E+00	D11114.BIS
10.00	1.667	1.874	.6841E+00	.1151E+00	-.4680E+00	.3800E+01	.3731E+01	.2690E+01	.1434E+01	.3839E+00	.5181E+00	D11114.BIS
11.00	1.786	1.964	.6660E+00	.8493E-01	-.4630E+00	.3970E+01	.3968E+01	.2460E+01	.1669E+01	.3778E+00	-.4928E-01	D11114.BIS
12.00	1.904	2.053	.6860E+00	.1480E+00	-.4680E+00	.4090E+01	.4006E+01	.2440E+01	.1829E+01	.4939E+00	.4518E+00	D11114.BIS
13.00	2.024	2.142	.8600E+00	.1501E+00	-.4540E+00	.4480E+01	.4249E+01	.2730E+01	.1456E+01	.3869E+00	.1901E+00	D11114.BIS
14.00	2.143	2.232	.8130E+00	.8192E-01	-.3650E+00	.4190E+01	.4086E+01	.2540E+01	.1376E+01	.5519E+00	.3794E+00	D11114.BIS
15.00	2.262	2.321	.8080E+00	.1528E+00	-.4280E+00	.4040E+01	.4028E+01	.2720E+01	.1749E+01	.4198E+00	.3828E+00	D11114.BIS
16.00	2.381	2.410	.6539E+00	.6676E-01	-.3710E+00	.3860E+01	.3948E+01	.2620E+01	.1761E+01	.4611E+00	.3595E+00	D11114.BIS
17.00	2.500	2.500	.7510E+00	.6902E-01	-.3300E+00	.4180E+01	.4299E+01	.2670E+01	.1014E+01	.4138E+00	-.1800E+00	D11114.BIS
18.00	2.619	2.589	.8070E+00	.7989E-01	-.2560E+00	.4430E+01	.4679E+01	.2890E+01	.2365E+01	.6751E+00	.8176E+00	D11114.BIS
19.00	2.738	2.678	.7600E+00	.4600E-01	-.2510E+00	.4020E+01	.4040E+01	.2780E+01	.1591E+01	.5601E+00	.7456E+00	D11114.BIS
0.20	0.000	1.199	.9882E+00	-.1621E+01	-.3695E+00	.1293E+00	.1551E+01	.1133E+00	.2558E+00	-.3203E-01	-.2777E+00	D06128.BIS
1.00	0.000	1.286	.5641E+00	-.1669E+01	-.4789E+00	.2938E+00	.1383E+01	.3059E+00	.3199E+00	-.7097E-01	-.3221E+00	D06128.BIS
2.00	0.000	1.392	.6069E+00	-.1704E+01	-.3082E+00	.6491E+00	.1341E+01	.7395E+00	.4052E+00	.3896E-02	-.2377E+00	D06128.BIS
3.00	0.000	1.500	.6954E+00	-.1699E+01	-.2960E+00	.8246E+00	.1394E+01	.9541E+00	.3846E+00	.8568E-02	-.2142E+00	D06128.BIS
4.00	0.000	1.607	.8719E+00	-.1401E+01	-.2539E+00	.1388E+01	.1509E+01	.1197E+01	.3401E+00	.1792E+00	-.1686E+00	D06128.BIS
5.00	0.000	1.714	.1073E+01	-.1343E+01	-.2327E+00	.1875E+01	.1721E+01	.1388E+01	.3875E+00	.3530E+00	-.1705E+00	D06128.BIS
6.00	0.000	1.821	.1271E+01	-.1382E+01	-.2115E+00	.2445E+01	.1809E+01	.1646E+01	.4265E+00	.4717E+00	.1354E-01	D06128.BIS
7.00	0.000	1.928	.1682E+01	-.1222E+01	-.1218E+00	.3614E+01	.2221E+01	.1988E+01	.5030E+00	.7432E+00	.1518E+00	D06128.BIS
8.00	0.000	2.035	.2034E+01	-.1201E+01	-.1207E-01	.3979E+01	.2373E+01	.2353E+01	.4635E+00	.8882E+00	.1786E+00	D06128.BIS
9.00	0.000	2.143	.2063E+01	-.1131E+01	-.2241E-01	.4451E+01	.2713E+01	.2412E+01	.7232E+00	.1097E+01	.9739E-01	D06128.BIS
10.00	0.000	2.250	.2110E+01	-.1071E+01	-.2526E-01	.4337E+01	.2478E+01	.2326E+01	.5252E+00	.1057E+01	.1340E+00	D06128.BIS
11.00	0.000	2.357	.2267E+01	-.1048E+01	.4665E-01	.4264E+01	.2752E+01	.2512E+01	.7301E+00	.9277E+00	.1496E+00	D06128.BIS
12.00	0.000	2.464	.2713E+01	-.8234E+00	.8449E-01	.5181E+01	.2928E+01	.2791E+01	.6233E+00	.1175E+01	.2722E+00	D06128.BIS
13.00	0.000	2.571	.2540E+01	-.1063E+01	.1690E+00	.4633E+01	.2542E+01	.2561E+01	.6847E+00	.1201E+01	.2602E+00	D06128.BIS
14.00	0.000	2.678	.2460E+01	-.1055E+01	.7373E-01	.4265E+01	.2623E+01	.2423E+01	.5118E+00	.9623E+00	.8312E-01	D06128.BIS
15.00	0.000	2.785	.2216E+01	-.1091E+01	.1146E+00	.4176E+01	.2691E+01	.2176E+01	.5375E+00	.9116E+00	-.3531E-01	D06128.BIS
16.00	0.000	2.892	.2654E+01	-.8399E+00	.9382E-01	.4425E+01	.3003E+01	.2368E+01	.6749E+00	.8413E+00	.1943E-01	D06128.BIS
17.00	0.000	2.999	.2229E+01	-.9358E+00	.4123E-01	.3646E+01	.2531E+01	.2153E+01	.5382E+00	.7538E+00	.3022E-01	D06128.BIS
18.00	0.000	3.107	.2220E+01	-.9756E+00	.2879E-02	.3763E+01	.2521E+01	.2081E+01	.5884E+00	.8530E+00	-.3885E-01	D06128.BIS
19.00	0.000	3.214	.2288E+01	-.1090E+01	.4795E-01	.3738E+01	.2344E+01	.2153E+01	.6427E+00	.7684E+00	.2139E+00	D06128.BIS
20.00	0.000	3.321	.2636E+01	-.9222E+00	.1421E+00	.3977E+01	.2545E+01	.2443E+01	.6468E+00	.8236E+00	.2094E+00	D06128.BIS
0.20	0.600	-0.001	.1261E+01	-.1621E+01	.1530E+00	.9255E-01	.8627E+00	.1383E+00	.1725E+00	-.8804E-02	-.1755E+00	D12068.BIS
1.00	0.714	-0.001	.1005E+01	-.1882E+01	.5409E+00	.2536E+01	.2952E+01	.1209E+01	.6539E+00	.2922E-01	-.4126E+00	D12068.BIS
2.00	0.857	-0.001	.2259E+01	-.1391E+01	.4676E+00	.6409E+01	.7193E+01	.3945E+01	.1798E+01	.7645E+00	.9072E+00	D12068.BIS
3.00	1.000	-0.001	.2565E+01	-.1219E+01	.2359E+00	.7141E+01	.6144E+01	.3903E+01	.2061E+01	.5261E+00	.5678E+00	D12068.BIS
4.00	1.143	0.000	.2758E+01	-.1291E+01	.3516E+00	.7997E+01	.6606E+01	.3842E+01	.2480E+01	.3070E+00	.5817E+00	D12068.BIS
5.00	1.285	0.000	.2216E+01	-.1311E+01	.4268E-01	.5976E+01	.5707E+01	.2846E+01	.1788E+01	-.4367E-01	.3630E+00	D12068.BIS
6.00	1.428	-0.001	.1665E+01	-.1444E+01	.4788E-01	.4517E+01	.4975E+01	.2340E+01	.1024E+01	-.2951E-01	.3471E+00	D12068.BIS
7.00	1.572	-0.001	.1370E+01	-.1439E+01	.9658E-02	.3486E+01	.4297E+01	.1954E+01	.8869E+00	-.1067E+00	.2230E+00	D12068.BIS
8.00	1.714	-0.001	.1081E+01	-.1460E+01	.2293E-01	.2512E+01	.3633E+01	.1368E+01	.4867E+00	-.6002E-01	.2385E+00	D12068.BIS
9.00	1.858	0.000	.7953E+00	-.1548E+01	-.1548E-01	.1896E+01	.3758E+01	.1086E+01	.2436E+00	-.1136E+00	.1823E+00	D12068.BIS
10.00	2.000	0.000	.6823E+00	-.1467E+01	.4288E-01	.1634E+01	.3104E+01	.8664E+00	.2296E+00	-.1335E-01	.1379E+00	D12068.BIS
11.00	2.144	-0.001	.7686E+00	-.1484E+01	-.1127E+00	.1541E+01	.3036E+01	.8764E+00	.2609E+00	-.4291E-01	.1195E+00	D12068.BIS
12.00	2.285	-0.001	.6886E+00	-.1505E+01	-.1025E+00	.1303E+01	.2955E+01	.8315E+00	.1250E+00	-.1411E+00	.1298E+00	D12068.BIS
13.00	2.428	-0.001	.6802E+00	-.1544E+01	.2181E-01	.1262E+01	.2983E+01	.7082E+00	.1592E+00	-.8445E-01	.9462E-01	D12068.BIS
14.00	2.572	0.000	.6974E+00	-.1442E+01	-.1081E+00	.1365E+01	.3213E+01	.7858E+00	.1921E+00	-.1546E+00	.8735E-01	D12068.BIS
15.00	2.714	0.000	.8764E+00	-.1411E+01	-.2283E+00	.1537E+01	.3380E+01	.9489E+00	.2724E+00	-.1976E+00	.1871E+00	D12068.BIS
16.00	2.858	-0.001	.8804E+00	-.1291E+01	-.1965E+00	.1521E+01	.3051E+01	.8853E+00	.1844E+00	-.1678E+00	.8815E-01	D12068.BIS
17.00	3.000	-0.001	.8901E+00	-.1342E+01	-.2103E+00	.1651E+01	.3023E+01	.1016E+01	.1798E+00	-.1778E+00	.1233E+00	D12068.BIS
18.00	3.143	0.000	.9870E+00	-.1301E+01	-.2374E+00	.1699E+01	.3945E+01	.9604E+00	.2981E+00	-.1733E+00	.1375E+00	D12068.BIS
19.00	3.285	0.000	.8838E+00	-.1269E+01	-.1840E+00	.1486E+01	.2974E+01	.8312E+00	.1511E+00	-.2229E+00	.9473E-01	D12068.BIS
20.00	3.428	-0.001	.8704E+00	-.1306E+01	-.1611E+00	.1395E+01	.3194E+01	.8619E+00	.2180E+00	-.2209E+00	.1134E+00	D12068.BIS
0.20	0.599	1.199	.8466E+00	-.1687E+01	.1614E+00	.9515E-01	.1427E+01	.9136E-01	.2133E+00	-.1882E-01	-.2370E+00	D12128.BIS
1.00	0.713	1.285	.4896E+00	-.1666E+01	-.3809E-01	.1071E+00	.1186E+01	.9594E-01	.1922E+00	-.2271E-01	-.2237E+00	D12128.BIS
2.00	0.858	1.392	.3352E+00	-.1639E+01	-.1647E-01	.1165E+00	.1301E+01	.9271E-01	.2002E+00	-.2081E-01	-.2401E+00	D12128.BIS

**TABLE 3**  
Continued

X	Y	Z	$\bar{U}$	$\bar{V}$	$\bar{W}$	$\overline{uu}$	$\overline{vv}$	$\overline{ww}$	$\overline{uv}$	$\overline{uw}$	$\overline{vw}$	File Name
inch	inch	inch	m/s	m/s	m/s	m <sup>2</sup> /s <sup>2</sup>	m <sup>2</sup> /s <sup>2</sup>	m <sup>2</sup> /s <sup>2</sup>	m <sup>2</sup> /s <sup>2</sup>	m <sup>2</sup> /s <sup>2</sup>	m <sup>2</sup> /s <sup>2</sup>	
3.00	1.000	1.500	.3234E+00	-.1622E+01	.7321E-01	.1153E+00	.1126E+01	.9874E-01	.1971E+00	-.2528E-01	-.2147E+00	D12128.BIS
4.00	1.144	1.607	.2689E+00	-.1580E+01	.9495E-01	.1156E+00	.1072E+01	.1066E+00	.1860E+00	-.1404E-01	-.2061E+00	D12128.BIS
5.00	1.285	1.714	.3554E+00	-.1443E+01	-.4762E-02	.1102E+00	.8856E+00	.1037E+00	.1652E+00	-.2319E-01	-.1848E+00	D12128.BIS
6.00	1.428	1.821	.3277E+00	-.1509E+01	-.6525E-02	.1172E+00	.6982E+00	.9713E-01	.1388E+00	-.2220E-01	-.1549E+00	D12128.BIS
7.00	1.572	1.928	.4006E+00	-.1374E+01	-.2765E-01	.1142E+00	.7525E+00	.9934E-01	.1364E+00	-.2652E-01	-.1750E+00	D12128.BIS
8.00	1.714	2.035	.3365E+00	-.1383E+01	.2541E-01	.1180E+00	.8330E+00	.1043E+00	.1636E+00	-.3012E-01	-.1795E+00	D12128.BIS
9.00	1.858	2.142	.3878E+00	-.1295E+01	-.1530E-01	.1074E+00	.6019E+00	.1086E+00	.1269E+00	-.2100E-01	-.1388E+00	D12128.BIS
10.00	2.000	2.250	.4339E+00	-.1342E+01	-.9990E-02	.1085E+00	.6695E+00	.9927E-01	.1327E+00	-.1930E-01	-.1497E+00	D12128.BIS
11.00	2.143	2.357	.4172E+00	-.1400E+01	-.3705E-02	.1181E+00	.5927E+00	.9690E-01	.1112E+00	-.1190E-01	-.1417E+00	D12128.BIS
12.00	2.285	2.464	.4140E+00	-.1302E+01	-.1130E-01	.1265E+00	.7907E+00	.1086E+00	.1545E+00	-.2979E-01	-.1785E+00	D12128.BIS
13.00	2.428	2.571	.4001E+00	-.1190E+01	.1256E-02	.1267E+00	.6993E+00	.9783E-01	.1475E+00	-.2123E-01	-.1493E+00	D12128.BIS
14.00	2.572	2.678	.4071E+00	-.1285E+01	.2405E-01	.1289E+00	.8439E+00	.9770E-01	.1557E+00	-.1724E-01	-.1795E+00	D12128.BIS
15.00	2.714	2.785	.4217E+00	-.1245E+01	.1924E-01	.1255E+00	.8255E+00	.1039E+00	.1562E+00	-.2465E-01	-.1816E+00	D12128.BIS
16.00	2.858	2.892	.4070E+00	-.1214E+01	.2719E-01	.1241E+00	.8588E+00	.1069E+00	.1597E+00	-.1983E-01	-.1853E+00	D12128.BIS
17.00	3.000	2.999	.4307E+00	-.1286E+01	.3581E-01	.1293E+00	.9056E+00	.1015E+00	.1724E+00	-.1508E-01	-.1814E+00	D12128.BIS
18.00	3.143	3.107	.3975E+00	-.1160E+01	.1202E-01	.1143E+00	.9102E+00	.9817E-01	.1499E+00	-.1508E-01	-.1951E+00	D12128.BIS
19.00	3.285	3.214	.4096E+00	-.1241E+01	.5720E-01	.1326E+00	.8887E+00	.1110E+00	.1813E+00	-.2360E-01	-.1816E+00	D12128.BIS
20.00	3.428	3.321	.3808E+00	-.1258E+01	.6347E-01	.1348E+00	.7937E+00	.1020E+00	.1697E+00	-.2220E-01	-.1611E+00	D12128.BIS

TABLE 4  
1x4 Ratio Nozzle Mach# = .09 Wfv Data

X	Y	Z	U	V	W	U	V	W	UV	VW	File Name
inch	inch	inch	m/s	m/s	m/s	m <sup>2</sup> /s <sup>2</sup>	m <sup>2</sup> /s <sup>2</sup>	m <sup>2</sup> /s <sup>2</sup>	m <sup>2</sup> /s <sup>2</sup>	m <sup>2</sup> /s <sup>2</sup>	
1.00	-0.356	0.000	.4544E+01	-.7859E+00	.5408E-01	.1800E+02	.1837E+02	.1413E+02	-.6676E+01	.5273E+00	-.3703E+00 D0106B.BIS
5.00	-0.893	-0.001	.4712E+01	-.8041E+00	-.2420E+00	.9080E+01	.6214E+01	.6156E+01	-.2593E+01	.1486E+00	-.4995E+00 D0106B.BIS
9.00	-1.428	0.000	.3527E+01	-.6443E+00	-.2300E+00	.6360E+01	.4536E+01	.4479E+01	-.1730E+01	.1866E+00	-.1485E+00 D0106B.BIS
13.00	-1.964	-0.001	.3388E+01	-.6468E+00	-.3420E+00	.5020E+01	.3426E+01	.3518E+01	-.1390E+01	.1657E+00	-.1714E-02 D0106B.BIS
17.00	-2.499	0.000	.2893E+01	-.4821E+00	-.3962E+00	.3660E+01	.2576E+01	.2326E+01	-.1132E+01	.3248E+00	-.7943E-01 D0106B.BIS
1.00	-0.286	0.000	.1309E+02	-.1013E+01	.3057E+00	.3700E+02	.3762E+02	.2451E+02	-.1757E+02	.2229E+01	.1530E+01 D0206B.BIS
5.00	-0.713	-0.001	.9629E+01	-.1238E+01	-.3508E+00	.1720E+02	.9399E+01	.1141E+02	-.5262E+01	.2073E+00	-.5963E+00 D0206B.BIS
9.00	-1.143	0.000	.6599E+01	-.9020E+00	-.1775E+00	.1080E+02	.6468E+01	.7786E+01	-.3311E+01	.3357E+00	-.7872E-01 D0206B.BIS
13.00	-1.572	-0.001	.5496E+01	-.8793E+00	-.1855E+00	.7060E+01	.4829E+01	.5244E+01	-.2172E+01	.4687E+00	-.3116E+00 D0206B.BIS
17.00	-1.999	0.000	.4662E+01	-.7032E+00	-.1396E+00	.5210E+01	.3730E+01	.3855E+01	-.1526E+01	.2982E+00	-.7875E-01 D0206B.BIS
1.00	-0.214	0.000	.2686E+02	-.1103E+01	-.2509E+00	.1570E+02	.1425E+02	.7787E+01	-.6542E+01	.6104E+00	.9278E-01 D0306B.BIS
5.00	-0.536	-0.001	.1235E+02	-.1022E+01	.1656E-01	.2050E+02	.1076E+02	.1390E+02	-.6463E+01	.6359E-02	-.1091E+01 D0306B.BIS
9.00	-0.859	0.000	.9256E+01	-.9282E+00	.1167E+00	.1380E+02	.8134E+01	.9804E+01	-.4501E+01	.4966E+00	-.7945E+00 D0306B.BIS
13.00	-1.180	-0.001	.7674E+01	-.8625E+00	.6682E-01	.9880E+01	.6092E+01	.7179E+01	-.3010E+01	.3849E+00	-.1495E+00 D0306B.BIS
17.00	-1.500	0.000	.6648E+01	-.8418E+00	.1168E+00	.6580E+01	.4515E+01	.5248E+01	-.1944E+01	.1732E+00	-.4033E-01 D0306B.BIS
1.00	-0.143	0.000	.3003E+02	-.3865E+00	-.3103E+00	.2150E+01	.1873E+01	.7160E+00	-.6888E-02	-.1316E+00	-.5478E+00 D0406B.BIS
5.00	-0.358	-0.001	.1808E+02	-.9497E+00	.8997E-01	.2250E+02	.1163E+02	.1438E+02	-.7407E+01	-.2473E+00	-.4382E+00 D0406B.BIS
9.00	-0.572	0.000	.1375E+02	-.8017E+00	.2029E+00	.1990E+02	.1031E+02	.1078E+02	-.6276E+01	-.2728E+00	-.3018E+00 D0406B.BIS
13.00	-0.786	-0.001	.1095E+02	-.6445E+00	.1587E+00	.1290E+02	.7439E+01	.8063E+01	-.3810E+01	.3093E+00	-.3046E+00 D0406B.BIS
17.00	-1.000	0.000	.9093E+01	-.5734E+00	.1644E+00	.8370E+01	.5207E+01	.5671E+01	-.2186E+01	.6050E-01	-.1656E-01 D0406B.BIS
0.20	-0.050	-0.200	.3015E+02	-.3676E+00	-.3041E+00	.3700E+00	.1351E+00	.5634E-01	-.2642E-02	.1245E-01	-.3988E-01 D0505B.BIS
2.00	-0.098	-0.233	.2838E+02	-.5287E+00	-.3184E+00	.8970E+01	.8418E+01	.4825E+01	-.3976E+01	.3385E+00	-.6233E+00 D0505B.BIS
3.00	-0.124	-0.250	.2544E+02	-.7692E+00	.6828E-01	.2050E+02	.1134E+02	.1059E+02	-.6784E+01	.1728E+01	-.7069E+00 D0505B.BIS
4.00	-0.153	-0.268	.2391E+02	-.9530E+00	.9844E-01	.2230E+02	.1157E+02	.1235E+02	-.7197E+01	.1055E+01	-.1150E+00 D0505B.BIS
5.00	-0.179	-0.286	.2270E+02	-.1070E+01	.2021E-01	.2020E+02	.1128E+02	.1124E+02	-.5883E+01	.8587E+00	-.1592E+00 D0505B.BIS
6.00	-0.205	-0.304	.2138E+02	-.1013E+01	.2356E-01	.1950E+02	.1186E+02	.1079E+02	-.5479E+01	-.6237E-01	-.2885E+00 D0505B.BIS
7.00	-0.232	-0.322	.1987E+02	-.7314E+00	-.7199E-01	.1920E+02	.1059E+02	.1011E+02	-.4653E+01	-.1568E+01	-.2711E+00 D0505B.BIS
8.00	-0.259	-0.340	.1837E+02	-.6694E+00	-.1092E+00	.1730E+02	.1030E+02	.9254E+01	-.4509E+01	-.1689E+01	-.7368E+00 D0505B.BIS
9.00	-0.286	-0.358	.1685E+02	-.7317E+00	-.1153E+00	.1780E+02	.9914E+01	.8279E+01	-.4073E+01	-.1955E+01	-.6769E+00 D0505B.BIS
10.00	-0.312	-0.375	.1612E+02	-.7250E+00	-.1539E+00	.1600E+02	.9093E+01	.8189E+01	-.2817E+01	-.1973E+01	-.7604E+00 D0505B.BIS
11.00	-0.340	-0.394	.1519E+02	-.7198E+00	-.1901E+00	.1530E+02	.9057E+01	.7790E+01	-.3077E+01	-.2152E+01	-.4564E+00 D0505B.BIS
12.00	-0.367	-0.411	.1433E+02	-.7663E+00	-.1492E+00	.1350E+02	.8007E+01	.6969E+01	-.2516E+01	-.2000E+01	-.7659E+00 D0505B.BIS
13.00	-0.393	-0.429	.1346E+02	-.7035E+00	-.5733E-01	.1260E+02	.7573E+01	.6676E+01	-.2299E+01	-.1874E+01	-.7649E+00 D0505B.BIS
14.00	-0.419	-0.447	.1271E+02	-.6897E+00	-.1470E+00	.1170E+02	.7046E+01	.6303E+01	-.1902E+01	-.1928E+01	-.5935E+00 D0505B.BIS
15.00	-0.447	-0.465	.1203E+02	-.7462E+00	-.6462E-01	.1110E+02	.6424E+01	.6034E+01	-.1459E+01	-.1724E+01	-.7947E+00 D0505B.BIS
16.00	-0.474	-0.483	.1124E+02	-.7721E+00	-.6271E-01	.1020E+02	.6130E+01	.5482E+01	-.1493E+01	-.1578E+01	-.4708E+00 D0505B.BIS
17.00	-0.500	-0.501	.1095E+02	-.7362E+00	-.1029E+00	.9600E+01	.5502E+01	.4948E+01	-.1275E+01	-.1654E+01	-.2200E+00 D0505B.BIS
18.00	-0.526	-0.519	.1035E+02	-.7184E+00	-.1299E+00	.8490E+01	.4994E+01	.4640E+01	-.1380E+01	-.1454E+01	-.3453E+00 D0505B.BIS
19.00	-0.554	-0.537	.9753E+01	-.8341E+00	-.1719E+00	.7830E+01	.5266E+01	.4296E+01	-.1492E+01	-.1331E+01	-.1991E+00 D0505B.BIS
0.20	-0.050	0.000	.3022E+02	-.2488E+00	.1018E+00	.1900E+00	.8286E-01	.1133E+00	-.7927E-02	.6395E-02	.4967E-01 D0506B.BIS
2.00	-0.098	-0.001	.2917E+02	-.1583E+00	-.1145E-01	.7240E+01	.4212E+01	.3448E+01	-.2937E+01	-.3628E+00	-.5665E+00 D0506B.BIS
3.00	-0.124	-0.001	.2614E+02	-.2397E+00	-.8128E-01	.1540E+02	.1004E+02	.8739E+01	-.5855E+01	.6821E-01	-.2334E+00 D0506B.BIS
4.00	-0.153	-0.001	.2425E+02	-.2243E+00	.2449E-01	.1930E+02	.1041E+02	.1098E+02	-.5988E+01	-.1928E+00	-.9109E-01 D0506B.BIS
5.00	-0.179	0.000	.2348E+02	-.5474E+00	.1534E+00	.1810E+02	.9394E+01	.1045E+02	-.5142E+01	-.7670E+00	-.2948E+00 D0506B.BIS
6.00	-0.205	0.000	.2218E+02	-.4629E+00	.9217E-02	.1850E+02	.9786E+01	.1048E+02	-.4600E+01	-.3422E+00	-.5498E-01 D0506B.BIS
7.00	-0.232	-0.001	.2134E+02	-.5120E+00	.8942E-01	.1640E+02	.9395E+01	.9688E+01	-.4330E+01	-.5173E+00	.8636E-01 D0506B.BIS
8.00	-0.260	-0.001	.2005E+02	-.4149E+00	.9358E-01	.1790E+02	.1007E+02	.9521E+01	-.4952E+01	-.4352E+00	.4621E-01 D0506B.BIS
9.00	-0.286	-0.001	.1896E+02	-.3989E+00	.1404E-01	.1750E+02	.9691E+01	.9090E+01	-.4753E+01	.1113E+00	-.3578E+00 D0506B.BIS
10.00	-0.312	-0.001	.1771E+02	-.4298E+00	.1102E+00	.1700E+02	.9012E+01	.8697E+01	-.4170E+01	.5393E-01	-.2957E+00 D0506B.BIS
11.00	-0.340	0.000	.1669E+02	-.4373E+00	.4935E-01	.1640E+02	.8293E+01	.8097E+01	-.3979E+01	.5491E-01	-.8971E-01 D0506B.BIS
12.00	-0.367	0.000	.1564E+02	-.4021E+00	.1380E+00	.1530E+02	.8219E+01	.7698E+01	-.3383E+01	-.1145E+00	-.1039E+00 D0506B.BIS
13.00	-0.393	-0.001	.1473E+02	-.4076E+00	.1622E+00	.1390E+02	.7568E+01	.7331E+01	-.2988E+01	-.2650E+00	-.7250E-01 D0506B.BIS
14.00	-0.419	-0.001	.1383E+02	-.3740E+00	.1675E+00	.1260E+02	.6874E+01	.6653E+01	-.2657E+01	.3255E+00	-.4559E+00 D0506B.BIS
15.00	-0.447	-0.001	.1332E+02	-.4855E+00	.2196E+00	.1120E+02	.6648E+01	.6262E+01	-.2406E+01	-.8499E-01	.4324E-02 D0506B.BIS
16.00	-0.474	-0.001	.1244E+02	-.5057E+00	.2101E+00	.1070E+02	.5754E+01	.5918E+01	-.1869E+01	.2970E-01	.8818E-01 D0506B.BIS
17.00	-0.500	0.000	.1189E+02	-.4560E+00	.2152E+00	.9390E+01	.5728E+01	.5559E+01	-.1720E+01	.2372E-01	-.5227E-01 D0506B.BIS

TABLE 4  
Continued

X	Y	Z	$\bar{u}$	$\bar{v}$	$\bar{w}$	$\overline{uu}$	$\overline{vv}$	$\overline{ww}$	$\overline{uv}$	$\overline{uw}$	$\overline{vw}$	File Name
inch	inch	inch	m/s	m/s	m/s	m <sup>2</sup> /s <sup>2</sup>	m <sup>2</sup> /s <sup>2</sup>	m <sup>2</sup> /s <sup>2</sup>	m <sup>2</sup> /s <sup>2</sup>	m <sup>2</sup> /s <sup>2</sup>	m <sup>2</sup> /s <sup>2</sup>	
18.00	-0.526	0.000	.1138E+02	-.4488E+00	.2261E+00	.8950E+01	.5335E+01	.5410E+01	-.1681E+01	.5299E-01	-.5240E-01	D0506B.BIS
19.00	-0.554	-0.001	.1058E+02	-.3800E+00	.1813E+00	.8170E+01	.4867E+01	.4877E+01	-.1602E+01	.3713E+00	-.9474E-01	D0506B.BIS
0.20	-0.050	0.199	.3012E+02	.1264E+01	-.3249E+00	.2840E+00	.1103E+01	.8565E+00	-.1258E+00	.2264E-02	-.1945E+00	D0507B.BIS
2.00	-0.098	0.232	.2916E+02	.5963E+00	-.2061E+00	.4040E+01	.3788E+01	.3083E+01	-.1340E+01	.7600E-01	.2778E+00	D0507B.BIS
3.00	-0.124	0.250	.2655E+02	-.5031E-01	-.1917E+00	.1170E+02	.6617E+01	.6632E+01	-.3166E+01	-.8063E-01	.4655E+00	D0507B.BIS
4.00	-0.153	0.268	.2481E+02	-.4249E+00	-.7839E-01	.1400E+02	.8403E+01	.8734E+01	-.4351E+01	.1419E+00	.4062E+00	D0507B.BIS
5.00	-0.179	0.286	.2334E+02	-.6217E+00	.9492E-01	.1650E+02	.9377E+01	.9813E+01	-.4756E+01	.1426E+00	.4275E+00	D0507B.BIS
6.00	-0.205	0.303	.2210E+02	-.6813E+00	.2702E+00	.1690E+02	.9674E+01	.9870E+01	-.4296E+01	.6125E+00	-.4816E-01	D0507B.BIS
7.00	-0.232	0.322	.2069E+02	-.7914E+00	.4839E+00	.1750E+02	.1106E+02	.9926E+01	-.4747E+01	.4036E+00	-.3486E+00	D0507B.BIS
8.00	-0.259	0.339	.1899E+02	-.6616E+00	.8193E+00	.1820E+02	.1132E+02	.9442E+01	-.4590E+01	-.2706E-01	.5599E-01	D0507B.BIS
9.00	-0.286	0.357	.1739E+02	-.5999E+00	.4822E+00	.1770E+02	.1071E+02	.8713E+01	-.4517E+01	.5572E+00	.2208E+00	D0507B.BIS
10.00	-0.312	0.375	.1603E+02	-.4311E+00	.5038E+00	.1600E+02	.1004E+02	.8428E+01	-.3695E+01	.4428E+00	.1605E+00	D0507B.BIS
11.00	-0.340	0.393	.1528E+02	-.6519E+00	.5015E+00	.1420E+02	.9939E+01	.8115E+01	-.3071E+01	.5553E+00	.1713E-01	D0507B.BIS
12.00	-0.367	0.411	.1428E+02	-.5417E+00	.4676E+00	.1370E+02	.8139E+01	.7854E+01	-.2991E+01	.3352E+00	.1942E+00	D0507B.BIS
13.00	-0.393	0.429	.1321E+02	-.3949E+00	.3975E+00	.1230E+02	.7793E+01	.7181E+01	-.2485E+01	.8377E+00	.1162E+00	D0507B.BIS
14.00	-0.419	0.447	.1279E+02	-.7020E+00	.4129E+00	.1130E+02	.7990E+01	.6836E+01	-.1779E+01	.1117E+01	.1608E+00	D0507B.BIS
15.00	-0.447	0.465	.1188E+02	-.5151E+00	.3407E+00	.1020E+02	.6666E+01	.6160E+01	-.1695E+01	.1183E+01	.2225E-01	D0507B.BIS
16.00	-0.474	0.483	.1104E+02	-.5248E+00	.3265E+00	.9600E+01	.6355E+01	.5753E+01	-.1456E+01	.1038E+01	.2611E+00	D0507B.BIS
17.00	-0.500	0.500	.1064E+02	-.5593E+00	.4253E+00	.8040E+01	.6068E+01	.5292E+01	-.1583E+01	.6359E+00	.2890E+00	D0507B.BIS
18.00	-0.526	0.519	.1009E+02	-.4265E+00	.2958E+00	.7620E+01	.5722E+01	.4851E+01	-.1202E+01	.9978E+00	.2693E+00	D0507B.BIS
19.00	-0.554	0.536	.9529E+01	-.3391E+00	.2738E+00	.6930E+01	.4880E+01	.4536E+01	-.9679E+00	.8873E+00	.4424E+00	D0507B.BIS
0.20	-0.050	0.400	.3019E+02	-.3357E+00	-.9483E+00	.2800E+00	.4043E+00	.2599E+00	-.1080E-01	.1758E-01	-.9682E-01	D0508B.BIS
2.00	-0.098	0.464	.2925E+02	-.7960E-01	-.4742E+00	.4380E+01	.3865E+01	.2294E+01	-.1137E+01	-.7708E-01	-.1569E-02	D0508B.BIS
3.00	-0.124	0.500	.2555E+02	-.4416E-01	-.5050E+00	.1620E+02	.8162E+01	.8019E+01	-.4893E+01	.1020E+01	.8601E-01	D0508B.BIS
4.00	-0.153	0.535	.2357E+02	-.4828E+00	-.4468E+00	.2180E+02	.1071E+02	.9799E+01	-.7386E+01	.3212E+00	.4614E+00	D0508B.BIS
5.00	-0.179	0.571	.2167E+02	-.6018E+00	-.1017E+00	.2390E+02	.1138E+02	.9657E+01	-.6855E+01	.1629E+01	.1064E+00	D0508B.BIS
6.00	-0.205	0.607	.1970E+02	-.6661E+00	.2736E+00	.2340E+02	.1196E+02	.9978E+01	-.6083E+01	.2756E+01	.7166E+00	D0508B.BIS
7.00	-0.232	0.643	.1780E+02	-.7464E+00	.4606E+00	.2170E+02	.1182E+02	.9482E+01	-.5204E+01	.3391E+01	.2774E+00	D0508B.BIS
8.00	-0.260	0.678	.1659E+02	-.8804E+00	.5224E+00	.1870E+02	.1181E+02	.9613E+01	-.3556E+01	.3541E+01	.9817E+00	D0508B.BIS
9.00	-0.286	0.714	.1513E+02	-.8628E+00	.4900E+00	.1750E+02	.1099E+02	.9254E+01	-.3383E+01	.3549E+01	.7613E+00	D0508B.BIS
10.00	-0.313	0.749	.1384E+02	-.9126E+00	.3644E+00	.1450E+02	.1022E+02	.8826E+01	-.2149E+01	.3748E+01	.3219E+00	D0508B.BIS
11.00	-0.340	0.785	.1282E+02	-.7778E+00	.5191E+00	.1670E+02	.8922E+01	.8201E+01	-.1961E+01	.3474E+01	.2009E+00	D0508B.BIS
12.00	-0.367	0.821	.1194E+02	-.8274E+00	.4317E+00	.1400E+02	.8712E+01	.7884E+01	-.2152E+01	.3145E+01	.3678E+00	D0508B.BIS
13.00	-0.393	0.857	.1152E+02	-.7856E+00	.3989E+00	.1350E+02	.8006E+01	.6891E+01	-.1285E+01	.3472E+01	-.1505E+00	D0508B.BIS
14.00	-0.419	0.892	.1063E+02	-.7579E+00	.3413E+00	.1160E+02	.7604E+01	.6636E+01	-.2050E+01	.2801E+01	-.9196E-02	D0508B.BIS
15.00	-0.447	0.928	.1017E+02	-.7780E+00	.3748E+00	.1120E+02	.6989E+01	.6054E+01	-.1441E+01	.2960E+01	.9964E-01	D0508B.BIS
16.00	-0.474	0.964	.9687E+01	-.6307E+00	.3634E+00	.9590E+01	.6272E+01	.5628E+01	-.9760E+00	.2447E+01	.1166E+00	D0508B.BIS
17.00	-0.500	0.999	.9107E+01	-.6921E+00	.2512E+00	.9310E+01	.6058E+01	.4894E+01	-.1190E+01	.2379E+01	-.3093E-01	D0508B.BIS
18.00	-0.526	1.035	.8763E+01	-.6592E+00	.2403E+00	.8260E+01	.5822E+01	.4761E+01	-.7325E+00	.2131E+01	.1217E+00	D0508B.BIS
19.00	-0.554	1.071	.8545E+01	-.5371E+00	.2590E+00	.7610E+01	.4971E+01	.4433E+01	-.7687E+00	.1964E+01	.2323E+00	D0508B.BIS
0.20	-0.050	0.600	.3012E+02	-.3764E+00	-.7220E+00	.2980E+00	.1216E+00	.5636E-01	-.1976E-01	.8091E-02	-.3508E-01	D0509B.BIS
2.00	-0.098	0.696	.2864E+02	-.7410E-01	-.7716E+00	.1090E+02	.8046E+01	.4059E+01	-.5028E+01	.8283E+00	-.7751E+00	D0509B.BIS
3.00	-0.124	0.750	.2388E+02	-.8822E+00	-.7817E+00	.2590E+02	.1263E+02	.1310E+02	-.8119E+01	.3953E+01	.7990E+00	D0509B.BIS
4.00	-0.153	0.803	.2000E+02	-.1274E+01	.4682E-01	.2630E+02	.1489E+02	.1296E+02	-.5213E+01	.5014E+01	.1493E+01	D0509B.BIS
5.00	-0.179	0.857	.1598E+02	-.7556E+00	.4015E+00	.2440E+02	.1428E+02	.1150E+02	-.4299E+01	.5764E+01	.6108E+00	D0509B.BIS
6.00	-0.205	0.910	.1396E+02	-.8529E+00	.6215E+00	.2030E+02	.1348E+02	.1044E+02	-.3675E+01	.4704E+01	.8709E+00	D0509B.BIS
7.00	-0.232	0.964	.1169E+02	-.4796E+00	.6039E+00	.1640E+02	.1115E+02	.9330E+01	-.3289E+01	.4209E+01	.8683E+00	D0509B.BIS
8.00	-0.259	1.018	.1109E+02	-.4952E+00	.7430E+00	.1570E+02	.9981E+01	.8818E+01	-.1868E+01	.3991E+01	.5074E+00	D0509B.BIS
9.00	-0.286	1.071	.1022E+02	-.5944E+00	.7309E+00	.1400E+02	.9051E+01	.7839E+01	-.1640E+01	.3995E+01	.3349E+00	D0509B.BIS
10.00	-0.313	1.125	.9622E+01	-.5829E+00	.7152E+00	.1260E+02	.8662E+01	.7180E+01	-.1434E+01	.4198E+01	.1516E+00	D0509B.BIS
11.00	-0.340	1.179	.8620E+01	-.5732E+00	.6779E+00	.1220E+02	.8488E+01	.7450E+01	-.1397E+01	.3807E+01	.1483E+00	D0509B.BIS
12.00	-0.367	1.232	.8107E+01	-.6097E+00	.7705E+00	.1180E+02	.7514E+01	.6441E+01	-.6447E+00	.3656E+01	.8221E-01	D0509B.BIS
13.00	-0.393	1.286	.7670E+01	-.4628E+00	.7777E+00	.1090E+02	.6685E+01	.6213E+01	-.1202E+01	.2922E+01	.2400E-01	D0509B.BIS
14.00	-0.419	1.339	.7451E+01	-.4308E+00	.7706E+00	.9640E+01	.6277E+01	.5882E+01	-.1019E+01	.2898E+01	.4377E+00	D0509B.BIS
15.00	-0.447	1.393	.6906E+01	-.4015E+00	.7243E+00	.8980E+01	.6056E+01	.5359E+01	-.7640E+00	.2841E+01	-.7487E-01	D0509B.BIS
16.00	-0.474	1.447	.6910E+01	-.3444E+00	.6966E+00	.7960E+01	.5275E+01	.4741E+01	-.8128E+00	.2313E+01	.1407E+00	D0509B.BIS

TABLE 4  
Continued

X	Y	Z	$\bar{u}$	$\bar{v}$	$\bar{w}$	$\overline{uu}$	$\overline{vv}$	$\overline{ww}$	$\overline{uv}$	$\overline{uw}$	$\overline{vw}$	File Name
inch	inch	inch	m/s	m/s	m/s	m <sup>2</sup> /s <sup>2</sup>	m <sup>2</sup> /s <sup>2</sup>	m <sup>2</sup> /s <sup>2</sup>	m <sup>2</sup> /s <sup>2</sup>	m <sup>2</sup> /s <sup>2</sup>	m <sup>2</sup> /s <sup>2</sup>	
17.00	-0.500	1.500	.6958E+01	-.3936E+00	.6810E+00	.7360E+01	.5301E+01	.4875E+01	-.5097E+00	.2367E+01	.1914E+00	D0509B.BIS
18.00	-0.526	1.534	.6348E+01	-.3680E+00	.7349E+00	.7260E+01	.4673E+01	.3970E+01	-.5167E+00	.1734E+01	.3080E+00	D0509B.BIS
19.00	-0.554	1.607	.5935E+01	-.2196E+00	.6765E+00	.5720E+01	.4491E+01	.3753E+01	-.4825E+00	.1773E+01	.2251E+00	D0509B.BIS
1.00	0.001	-1.071	.9708E+01	.3214E+00	-.5844E+00	.2370E+02	.1387E+02	.1254E+02	-.5665E+00	-.8560E+01	-.3779E+00	D0601B.BIS
5.00	0.001	-1.429	.5801E+01	-.6291E-02	-.2452E+00	.9790E+01	.6259E+01	.6333E+01	-.6493E-01	-.3270E+01	-.1843E+00	D0601B.BIS
9.00	0.001	-1.786	.4392E+01	-.3857E-01	-.2048E+00	.6320E+01	.4435E+01	.4492E+01	.3327E-02	-.2182E+01	-.1544E+00	D0601B.BIS
13.00	0.001	-2.144	.3573E+01	-.3585E-01	-.1617E+00	.5010E+01	.3349E+01	.3425E+01	-.8144E-01	-.1577E+01	-.8398E-01	D0601B.BIS
17.00	0.000	-2.501	.3028E+01	.1882E-01	-.1871E+00	.4100E+01	.2601E+01	.2722E+01	.2013E-01	-.1261E+01	.4013E-01	D0601B.BIS
1.00	0.001	-0.857	.3029E+02	-.4903E+00	.3825E+00	.1530E+01	.8671E+00	.1025E+01	-.2731E-01	.9969E-01	.2292E+00	D0602B.BIS
5.00	0.001	-1.144	.1154E+02	-.2951E-01	-.6686E+00	.2010E+02	.1354E+02	.1039E+02	-.4709E+00	-.5625E+01	-.6069E+00	D0602B.BIS
9.00	0.001	-1.429	.7506E+01	-.4838E-01	-.2985E+00	.1060E+02	.7438E+01	.6276E+01	-.6764E-01	-.3198E+01	-.5104E+00	D0602B.BIS
13.00	0.001	-1.715	.5989E+01	-.5428E-01	-.2984E+00	.8140E+01	.5806E+01	.5221E+01	.1533E+00	-.2564E+01	-.2766E+00	D0602B.BIS
17.00	0.000	-2.001	.4889E+01	.4243E-02	-.2002E+00	.5940E+01	.4067E+01	.3751E+01	-.5137E-01	-.2012E+01	-.4058E-01	D0602B.BIS
1.00	0.001	-0.642	.3029E+02	-.4036E+00	.2082E+00	.7570E+00	.1538E+00	.2110E+00	.3143E-02	.8314E-01	.6003E-01	D0603B.BIS
5.00	0.001	-0.857	.1871E+02	.7865E-01	-.4672E+00	.2770E+02	.1736E+02	.1214E+02	-.2139E+01	-.6493E+01	-.7568E+00	D0603B.BIS
9.00	0.001	-1.072	.1129E+02	-.1430E+00	-.3313E+00	.1520E+02	.1071E+02	.8087E+01	-.2831E+00	-.4456E+01	-.5317E+00	D0603B.BIS
13.00	0.001	-1.287	.8679E+01	-.1628E+00	-.1648E+00	.1040E+02	.7580E+01	.6062E+01	.1475E+00	-.3083E+01	-.2496E+00	D0603B.BIS
17.00	0.000	-1.501	.7124E+01	-.4653E-01	-.1339E+00	.8340E+01	.5363E+01	.4476E+01	.1906E-01	-.2458E+01	-.1620E+00	D0603B.BIS
1.00	0.001	-0.429	.3022E+02	-.3091E+00	.3336E+00	.8470E+00	.1476E+00	.2032E+00	.2869E-02	.3018E-01	.6980E-01	D0604B.BIS
5.00	0.001	-0.572	.2423E+02	-.2136E+00	-.5717E-01	.2260E+02	.1298E+02	.1005E+02	-.2626E+01	-.2718E+01	-.1320E+00	D0604B.BIS
9.00	0.001	-0.715	.1564E+02	-.1830E-01	-.2701E+00	.1780E+02	.1125E+02	.8378E+01	-.8432E+00	-.4216E+01	-.3278E+00	D0604B.BIS
13.00	0.001	-0.858	.1200E+02	-.5866E-01	-.1230E+00	.1310E+02	.8516E+01	.6930E+01	-.3279E-01	-.3672E+01	-.2124E+00	D0604B.BIS
17.00	0.000	-1.001	.9417E+01	-.1994E+00	.1104E-01	.9840E+01	.6203E+01	.5191E+01	.2110E+00	-.2738E+01	-.1215E+00	D0604B.BIS
0.20	0.000	-0.200	.3013E+02	-.1938E+00	.1547E+00	.1770E+00	.1052E+00	.1361E+00	-.1286E-01	.2477E-02	.8021E-52	HD0605B
2.00	0.000	-0.233	.2997E+02	-.4092E+00	.8574E-01	.3290E+01	.8723E+00	.8182E+00	.6889E-02	-.1122E+00	-.5876E-52	HD0605B
3.00	0.000	-0.250	.2929E+02	-.3492E+00	.1004E+00	.5530E+01	.4786E+01	.2981E+01	-.1579E+00	-.3215E+00	-.1939E+52	HD0605B
4.00	0.000	-0.268	.2761E+02	-.1568E+00	.1369E+00	.9860E+01	.8091E+01	.5877E+01	-.1881E+00	-.5639E+00	.5632E-52	HD0605B
5.00	0.000	-0.286	.2575E+02	-.3922E-01	.1912E+00	.1400E+02	.9785E+01	.7449E+01	-.6831E+00	-.8665E+00	.2698E+52	HD0605B
6.00	0.000	-0.304	.2398E+02	-.3308E-01	.1291E+00	.1580E+02	.1011E+02	.8237E+01	-.4370E+00	-.1269E+01	.1158E+52	HD0605B
7.00	0.000	-0.322	.2230E+02	-.9553E-01	.5114E-01	.1630E+02	.1059E+02	.8373E+01	-.3830E+00	-.1895E+01	-.2549E-52	HD0605B
8.00	0.000	-0.339	.2070E+02	-.6171E-01	.4421E-01	.1650E+02	.1022E+02	.8390E+01	.2086E+00	-.2330E+01	-.2248E+52	HD0605B
9.00	0.000	-0.358	.1904E+02	-.6040E-01	.7577E-02	.1670E+02	.1004E+02	.8008E+01	.7358E-01	-.3115E+01	-.8830E-52	HD0605B
10.00	0.000	-0.375	.1824E+02	-.6632E-02	-.2915E+00	.1510E+02	.9353E+01	.7323E+01	.7430E-01	-.2648E+01	-.3762E+52	HD0605B
11.00	0.000	-0.393	.1692E+02	.4085E-01	-.2335E+00	.1490E+02	.9220E+01	.7255E+01	.2910E+00	-.2613E+01	-.2930E+52	HD0605B
12.00	-0.001	-0.411	.1584E+02	-.1991E-01	-.1859E+00	.1400E+02	.8622E+01	.6919E+01	.1676E+00	-.2727E+01	-.3844E+52	HD0605B
13.00	-0.001	-0.429	.1483E+02	.2491E-01	-.1537E+00	.1300E+02	.7774E+01	.6752E+01	.2650E+00	-.2684E+01	-.3586E+52	HD0605B
14.00	-0.001	-0.447	.1423E+02	.3702E-01	-.1482E+00	.1230E+02	.7503E+01	.6332E+01	.1369E+00	-.2132E+01	-.3216E+52	HD0605B
15.00	-0.001	-0.465	.1345E+02	.4368E-01	-.1954E+00	.1090E+02	.6798E+01	.5881E+01	.7410E-02	-.2170E+01	-.1239E+52	HD0605B
16.00	-0.001	-0.482	.1250E+02	.8942E-01	-.1172E+00	.1020E+02	.6299E+01	.5535E+01	.3951E+00	-.1898E+01	-.1673E+52	HD0605B
17.00	-0.001	-0.500	.1180E+02	-.3969E-01	-.6036E-01	.1000E+02	.5981E+01	.5394E+01	.2787E+00	-.2114E+01	-.2079E+52	HD0605B
18.00	-0.001	-0.518	.1111E+02	.4026E-01	-.4437E-01	.9240E+01	.5707E+01	.4783E+01	.1265E+00	-.1764E+01	-.5581E-52	HD0605B
19.00	-0.001	-0.536	.1060E+02	-.4140E-01	-.1328E-01	.8620E+01	.4998E+01	.4601E+01	.2744E+00	-.1800E+01	-.1429E+52	HD0605B
0.20	0.000	0.000	.3012E+02	.2625E+00	.2822E-01	.1710E+00	.9618E-01	.5859E-01	-.5662E-02	.7018E-02	-.2425E-01	D0606B.BIS
1.00	0.000	0.000	.2994E+02	.5345E+00	.2091E+00	.9540E+00	.1787E+00	.2115E+00	-.5125E-01	-.1793E-01	.3209E-01	D0606B.BIS
2.00	0.000	0.000	.2980E+02	.6882E+00	.2831E+00	.4290E+01	.1102E+01	.1205E+01	-.1936E+00	.1369E+00	.5433E-01	D0606B.BIS
3.00	0.000	-0.001	.2908E+02	.5184E+00	.9528E-01	.6170E+01	.5313E+01	.3696E+01	-.4853E+00	.1533E+00	.3160E+00	D0606B.BIS
4.00	0.000	-0.001	.2739E+02	.5041E+00	.1933E-01	.1050E+02	.7585E+01	.6486E+01	-.9680E+00	.1604E+00	.1569E+00	D0606B.BIS
5.00	0.000	-0.001	.2591E+02	.4635E+00	.1289E+00	.1220E+02	.9079E+01	.7473E+01	-.3293E+00	.1250E+00	.2308E+00	D0606B.BIS
6.00	0.000	-0.001	.2475E+02	.3754E+00	-.5699E-01	.1340E+02	.8761E+01	.7665E+01	-.3826E+00	.7380E+00	.1853E+00	D0606B.BIS
7.00	0.000	-0.001	.2355E+02	.1234E+00	-.1741E+00	.1360E+02	.8988E+01	.7784E+01	-.3417E+00	.9064E+00	.1109E+00	D0606B.BIS
8.00	0.000	-0.001	.2204E+02	.2839E+00	.6820E-01	.1440E+02	.8986E+01	.7692E+01	-.4635E+00	.5097E+00	.1416E-02	D0606B.BIS
9.00	0.000	-0.001	.2091E+02	.2727E+00	.3092E-01	.1480E+02	.8654E+01	.7614E+01	-.1425E+00	.5434E+00	.7074E-01	D0606B.BIS
10.00	0.000	-0.001	.1967E+02	.2256E+00	.1610E+00	.1410E+02	.8137E+01	.7340E+01	.6394E-02	.6607E+00	.7969E-01	D0606B.BIS
11.00	0.000	-0.001	.1830E+02	.1188E+00	.1622E+00	.1430E+02	.8471E+01	.7148E+01	.3064E+00	.6170E+00	.1260E+00	D0606B.BIS
12.00	0.000	-0.001	.1717E+02	.2462E+00	.1452E+00	.1300E+02	.7599E+01	.6998E+01	.2207E-01	.6063E+00	-.6239E-01	D0606B.BIS
13.00	0.000	-0.001	.1599E+02	.2187E+00	.1320E+00	.1200E+02	.7496E+01	.6713E+01	-.2791E+00	.4996E+00	-.9230E-01	D0606B.BIS

TABLE 4  
Continued

X	Y	Z	$\bar{u}$	$\bar{v}$	$\bar{w}$	$\overline{uu}$	$\overline{vv}$	$\overline{ww}$	$\overline{uv}$	$\overline{uw}$	$\overline{vw}$	File Name
inch	inch	inch	m/s	m/s	m/s	m <sup>2</sup> /s <sup>2</sup>	m <sup>2</sup> /s <sup>2</sup>	m <sup>2</sup> /s <sup>2</sup>	m <sup>2</sup> /s <sup>2</sup>	m <sup>2</sup> /s <sup>2</sup>	m <sup>2</sup> /s <sup>2</sup>	
14.00	0.000	-0.001	.1517E+02	.2087E+00	.1102E+00	.1100E+02	.6773E+01	.6010E+01	.3620E+00	.4459E+00	.1406E-01	D0606B.BIS
15.00	0.000	-0.001	.1421E+02	.1494E+00	.1805E+00	.1050E+02	.6413E+01	.5909E+01	.2315E+00	.2288E+00	.1223E+00	D0606B.BIS
16.00	0.000	-0.001	.1364E+02	.2510E+00	.1730E+00	.1000E+02	.6066E+01	.5306E+01	.1461E+00	.3591E+00	.2589E+00	D0606B.BIS
17.00	0.000	-0.001	.1290E+02	.2125E+00	.1322E+00	.8810E+01	.5692E+01	.5110E+01	.8652E-01	.4334E+00	.1672E+00	D0606B.BIS
18.00	0.000	-0.001	.1210E+02	.1575E+00	.1334E+00	.8250E+01	.5004E+01	.5020E+01	.8464E-01	.5975E+00	.1875E+00	D0606B.BIS
19.00	0.000	-0.001	.1163E+02	.1811E+00	.1367E+00	.7700E+01	.4686E+01	.4351E+01	-.1051E+00	.2451E+00	.2295E+00	D0606B.BIS
0.20	0.001	0.200	.3033E+02	-.3054E+00	-.9982E-02	.1830E+00	.1005E+00	.8530E-01	-.1793E-03	.6849E-02	-.1416E-01	D0607B.BIS
1.00	0.001	0.214	.3016E+02	-.2373E+00	-.8481E-01	.7180E+00	.1582E+00	.1834E+00	-.2829E-02	-.2294E-01	.2145E-01	D0607B.BIS
2.00	0.001	0.232	.3012E+02	-.2962E+00	-.3313E+00	.3340E+01	.8998E+00	.1041E+01	-.1131E+00	.4870E-01	.1082E+00	D0607B.BIS
3.00	0.001	0.250	.2933E+02	-.3668E+00	-.1860E+00	.6130E+01	.5445E+01	.3469E+01	.1778E+00	.2568E-01	.2573E+00	D0607B.BIS
4.00	0.001	0.268	.2752E+02	-.5893E-01	-.7883E-01	.1180E+02	.9879E+01	.6934E+01	-.1353E+01	.7013E+00	-.3452E+00	D0607B.BIS
5.00	0.001	0.285	.2560E+02	-.1571E-01	-.1710E+00	.1650E+02	.1139E+02	.8538E+01	-.1780E+01	.1006E+01	-.6508E+00	D0607B.BIS
6.00	0.001	0.303	.2346E+02	.4858E-01	-.9094E-01	.1810E+02	.1183E+02	.9180E+01	-.1973E+01	.1814E+01	-.5247E+00	D0607B.BIS
7.00	0.001	0.321	.2161E+02	-.4008E-01	.4211E-01	.1900E+02	.1162E+02	.9127E+01	-.1277E+01	.2328E+01	-.3622E+00	D0607B.BIS
8.00	0.001	0.339	.1981E+02	-.3186E-01	.1378E+00	.1800E+02	.1176E+02	.8808E+01	-.1191E+01	.2341E+01	-.1551E+00	D0607B.BIS
9.00	0.001	0.357	.1844E+02	-.1904E+00	.2675E+00	.1760E+02	.1038E+02	.8428E+01	-.9759E-01	.3081E+01	-.1200E+00	D0607B.BIS
10.00	0.001	0.375	.1699E+02	-.8495E-01	.1627E+00	.1610E+02	.1020E+02	.7898E+01	-.9121E+00	.3071E+01	-.1604E+00	D0607B.BIS
11.00	0.001	0.393	.1599E+02	-.6282E-01	.2968E+00	.1500E+02	.9481E+01	.7496E+01	-.8096E+00	.3032E+01	-.1098E+00	D0607B.BIS
12.00	0.001	0.410	.1481E+02	-.9178E-01	.2615E+00	.1430E+02	.8872E+01	.7088E+01	-.4464E+00	.2873E+01	-.1475E+00	D0607B.BIS
13.00	0.001	0.428	.1386E+02	-.2288E+00	.1693E+00	.1340E+02	.8111E+01	.6631E+01	-.1124E+00	.2919E+01	-.1976E+00	D0607B.BIS
14.00	0.001	0.446	.1336E+02	-.1733E+00	.2890E+00	.1190E+02	.7139E+01	.6131E+01	-.1241E+00	.2529E+01	-.9609E-01	D0607B.BIS
15.00	0.000	0.464	.1257E+02	-.2353E-01	.2134E+00	.1130E+02	.6835E+01	.5962E+01	-.3997E+00	.2353E+01	.5473E-02	D0607B.BIS
16.00	0.000	0.482	.1203E+02	-.2787E-01	.3172E+00	.1020E+02	.6405E+01	.5492E+01	-.4143E+00	.2153E+01	-.1653E+00	D0607B.BIS
17.00	0.000	0.500	.1145E+02	-.4024E-01	.2163E+00	.9800E+01	.5662E+01	.5054E+01	-.3248E+00	.2012E+01	.7763E-01	D0607B.BIS
18.00	0.000	0.518	.1083E+02	-.1837E+00	.1931E+00	.8830E+01	.5235E+01	.4665E+01	-.1292E+00	.1836E+01	.9043E-01	D0607B.BIS
19.00	0.000	0.535	.1038E+02	-.9742E-01	.1726E+00	.8280E+01	.5031E+01	.4350E+01	-.1879E+00	.1742E+01	.7506E-01	D0607B.BIS
0.20	0.001	0.399	.3038E+02	-.3850E+00	-.1899E+00	.2280E+00	.9869E-01	.1194E+00	-.6849E-02	.9161E-02	-.1974E-01	D0608B.BIS
1.00	0.001	0.428	.3022E+02	-.5026E+00	-.2192E+00	.4860E+00	.1319E+00	.1414E+00	.1416E-01	-.7526E-02	.4263E-02	D0608B.BIS
2.00	0.001	0.464	.3023E+02	-.5211E+00	-.1358E+00	.2670E+01	.9441E+00	.6663E+00	.1474E+00	-.2478E+00	-.1853E+00	D0608B.BIS
3.00	0.001	0.500	.2943E+02	-.1229E+00	-.1561E-01	.6390E+01	.5504E+01	.3242E+01	-.1055E+01	-.3045E+00	-.1274E+00	D0608B.BIS
4.00	0.001	0.535	.2762E+02	-.1566E+00	-.1016E+00	.1300E+02	.9708E+01	.7548E+01	-.2205E+01	.3212E-01	.2234E+00	D0608B.BIS
5.00	0.001	0.571	.2458E+02	-.2743E+00	.2590E-01	.2080E+02	.1279E+02	.1044E+02	-.1572E+01	.2786E+01	.2091E+00	D0608B.BIS
6.00	0.001	0.607	.2136E+02	-.3082E+00	.2181E+00	.2370E+02	.1385E+02	.1163E+02	-.9705E+00	.4404E+01	-.4069E+00	D0608B.BIS
7.00	0.001	0.643	.1848E+02	-.2337E+00	.4159E+00	.2170E+02	.1418E+02	.1091E+02	-.1227E+01	.4011E+01	.7164E-02	D0608B.BIS
8.00	0.001	0.678	.1663E+02	-.2245E+00	.5243E+00	.1890E+02	.1290E+02	.9908E+01	-.1018E+01	.4206E+01	-.5462E+00	D0608B.BIS
9.00	0.001	0.714	.1492E+02	-.1743E+00	.5202E+00	.1680E+02	.1131E+02	.8513E+01	-.1107E+01	.3720E+01	-.2044E+00	D0608B.BIS
10.00	0.001	0.750	.1376E+02	-.1236E+00	.5290E+00	.1550E+02	.1047E+02	.8060E+01	-.4024E+00	.3845E+01	-.2277E+00	D0608B.BIS
11.00	0.001	0.786	.1265E+02	-.2596E+00	.4829E+00	.1420E+02	.9528E+01	.7584E+01	-.1752E-01	.3540E+01	-.1630E+00	D0608B.BIS
12.00	0.001	0.821	.1162E+02	-.2225E+00	.4023E+00	.1270E+02	.8548E+01	.6933E+01	-.4003E+00	.3320E+01	-.1356E+00	D0608B.BIS
13.00	0.001	0.857	.1080E+02	-.1997E+00	.3480E+00	.1180E+02	.7921E+01	.6531E+01	-.7940E-01	.3266E+01	-.4388E+00	D0608B.BIS
14.00	0.000	0.893	.1033E+02	-.1349E+00	.3786E+00	.1090E+02	.7222E+01	.5858E+01	-.1995E+00	.2842E+01	-.2126E+00	D0608B.BIS
15.00	0.000	0.928	.9780E+01	-.6719E-01	.3644E+00	.1010E+02	.6619E+01	.5490E+01	-.3130E+00	.2681E+01	.6492E-02	D0608B.BIS
16.00	0.000	0.964	.9279E+01	-.1654E+00	.3525E+00	.9290E+01	.6127E+01	.5137E+01	-.2446E+00	.2439E+01	-.7243E-01	D0608B.BIS
17.00	0.000	1.000	.8856E+01	-.1529E+00	.4042E+00	.8450E+01	.5930E+01	.4716E+01	-.3432E+00	.2226E+01	-.7800E-01	D0608B.BIS
18.00	0.000	1.035	.8601E+01	-.1334E+00	.3931E+00	.8290E+01	.5629E+01	.4558E+01	-.3282E+00	.2262E+01	-.9606E-01	D0608B.BIS
19.00	0.000	1.071	.8236E+01	-.9871E-01	.3586E+00	.7340E+01	.4985E+01	.4093E+01	-.1238E+00	.1977E+01	-.4018E-01	D0608B.BIS
0.20	0.001	0.599	.3041E+02	-.4438E+00	-.3092E+00	.1820E+00	.1105E+00	.1342E+00	-.1423E-01	.4419E-02	.2135E-01	D0609B.BIS
1.00	0.001	0.642	.3028E+02	-.4908E+00	-.3887E+00	.3930E+00	.1301E+00	.1544E+00	-.2016E-01	.2692E-01	.2407E-01	D0609B.BIS
2.00	0.001	0.696	.3039E+02	-.4691E+00	-.3097E+00	.2100E+01	.9246E+00	.9225E+00	.7332E-01	-.3501E+00	-.4669E-02	D0609B.BIS
3.00	0.001	0.750	.2867E+02	-.4585E+00	-.2271E+00	.9510E+01	.6800E+01	.6357E+01	-.3767E+00	.1865E+01	.3295E+00	D0609B.BIS
4.00	0.001	0.803	.2300E+02	-.3187E+00	.2516E+00	.2710E+02	.1524E+02	.1286E+02	-.8958E+00	.6886E+01	-.4070E+00	D0609B.BIS
5.00	0.001	0.857	.1824E+02	-.3426E+00	.4711E+00	.2820E+02	.1674E+02	.1318E+02	-.7468E+00	.7256E+01	-.2958E+00	D0609B.BIS
6.00	0.001	0.910	.1510E+02	-.3579E+00	.6446E+00	.2440E+02	.1541E+02	.1223E+02	-.5975E+00	.6314E+01	-.7883E+00	D0609B.BIS
7.00	0.001	0.964	.1344E+02	-.3696E+00	.6822E+00	.2000E+02	.1312E+02	.1098E+02	-.6521E-01	.5456E+01	-.8767E+00	D0609B.BIS
8.00	0.001	1.018	.1198E+02	-.2643E+00	.6891E+00	.1670E+02	.1154E+02	.9569E+01	-.6452E+00	.4768E+01	-.3389E+00	D0609B.BIS
9.00	0.001	1.071	.1062E+02	-.3328E+00	.5189E+00	.1510E+02	.1019E+02	.8471E+01	-.1263E+00	.4425E+01	-.5642E+00	D0609B.BIS

TABLE 4  
Continued

X	Y	Z	$\bar{u}$	$\bar{v}$	$\bar{w}$	$\overline{uu}$	$\overline{vv}$	$\overline{ww}$	$\overline{uv}$	$\overline{uw}$	$\overline{vw}$	File Name
inch	inch	inch	m/s	m/s	m/s	m <sup>2</sup> /s <sup>2</sup>	m <sup>2</sup> /s <sup>2</sup>	m <sup>2</sup> /s <sup>2</sup>	m <sup>2</sup> /s <sup>2</sup>	m <sup>2</sup> /s <sup>2</sup>	m <sup>2</sup> /s <sup>2</sup>	
10.00	0.001	1.125	9804E+01	-3081E+00	5521E+00	.1290E+02	9822E+01	.7622E+01	.2333E+00	.3846E+01	-.5955E+00	D0609B.BIS
11.00	0.001	1.178	8752E+01	-.3517E+00	.3974E+00	.1170E+02	8505E+01	.7017E+01	-.1906E-01	.3574E+01	-.1144E+00	D0609B.BIS
12.00	0.001	1.232	8397E+01	-.3186E+00	.4100E+00	.1030E+02	7603E+01	.6263E+01	.2715E-01	.3106E+01	-.2615E+00	D0609B.BIS
13.00	0.001	1.286	7918E+01	-.2019E+00	.4520E+00	.9490E+01	6947E+01	.5651E+01	-.2073E+00	.2874E+01	-.1187E+00	D0609B.BIS
14.00	0.001	1.339	.7494E+01	-.2172E+00	.4323E+00	.8610E+01	.6518E+01	.5182E+01	-.1752E+00	.2701E+01	-.1489E+00	D0609B.BIS
15.00	0.001	1.393	.7020E+01	-.2621E+00	.4266E+00	.7930E+01	.5745E+01	.4924E+01	.7167E-02	.2543E+01	-.3159E-01	D0609B.BIS
16.00	0.000	1.446	.6689E+01	-.1766E+00	.2687E+00	.7290E+01	.5421E+01	.4360E+01	-.1453E+00	.2285E+01	.8895E-03	D0609B.BIS
17.00	0.000	1.500	.6219E+01	-.1368E+00	.2230E+00	.6820E+01	.4937E+01	.3982E+01	-.1334E+00	.2143E+01	-.1466E-01	D0609B.BIS
18.00	0.000	1.553	.6361E+01	-.2293E+00	.3643E+00	.6490E+01	.4932E+01	.4111E+01	-.1734E+00	.2104E+01	-.8968E-01	D0609B.BIS
19.00	0.000	1.607	.6163E+01	-.1594E+00	.3215E+00	.6120E+01	.4611E+01	.3690E+01	-.2317E+00	.1914E+01	-.9452E-01	D0609B.BIS
0.20	0.001	0.799	.3045E+02	-.3982E+00	.6915E-01	.2570E+00	.1014E+00	.1352E+00	-.1324E-01	.6297E-02	.4142E-01	D0610B.BIS
1.00	0.001	0.857	.3029E+02	-.4319E+00	-.2513E+00	.1640E+01	.9297E+00	.1136E+01	-.2036E-01	-.7124E-01	.1393E+00	D0610B.BIS
2.00	0.001	0.928	.2490E+02	-.1071E+01	.2373E+00	.2160E+02	.1259E+02	.1024E+02	.1515E+01	.5289E+01	.2706E+00	D0610B.BIS
3.00	0.001	1.000	.1466E+02	-.1002E+01	.4658E+00	.3360E+02	.1739E+02	.1429E+02	.1159E+01	.9410E+01	-.1187E+01	D0610B.BIS
4.00	0.001	1.071	.1312E+02	-.6124E+00	.1007E+01	.2410E+02	.1610E+02	.1318E+02	.1110E+00	.7336E+01	-.6802E+00	D0610B.BIS
5.00	0.001	1.143	.9811E+01	-.4045E+00	.8042E+00	.1870E+02	.1341E+02	.1080E+02	.3827E+00	.5791E+01	-.8444E+00	D0610B.BIS
6.00	0.001	1.214	.9408E+01	-.5076E+00	.8231E+00	.1540E+02	.1055E+02	.9042E+01	-.3684E+00	.4623E+01	-.6882E+00	D0610B.BIS
7.00	0.001	1.286	.7976E+01	-.4390E+00	.7767E+00	.1240E+02	.9036E+01	.7766E+01	-.3450E+00	.3742E+01	-.4278E+00	D0610B.BIS
8.00	0.001	1.357	.7476E+01	-.4303E+00	.7914E+00	.1130E+02	.8271E+01	.7230E+01	-.1671E+00	.3423E+01	-.4328E+00	D0610B.BIS
9.00	0.001	1.428	.6858E+01	-.4332E+00	.6761E+00	.9860E+01	.7441E+01	.6446E+01	-.2022E+00	.2964E+01	-.2540E+00	D0610B.BIS
10.00	0.001	1.500	.6333E+01	-.3991E+00	.6354E+00	.9070E+01	.6709E+01	.5848E+01	-.9863E-01	.2813E+01	-.3080E+00	D0610B.BIS
11.00	0.001	1.571	.5951E+01	-.4807E+00	.6111E+00	.8610E+01	.6000E+01	.5503E+01	-.2006E+00	.2721E+01	-.1963E+00	D0610B.BIS
12.00	0.001	1.643	.5690E+01	-.3775E+00	.6321E+00	.8150E+01	.5839E+01	.5245E+01	-.4038E+00	.2559E+01	-.4294E+00	D0610B.BIS
13.00	0.000	1.714	.5287E+01	-.5023E+00	.5784E+00	.7080E+01	.5157E+01	.4641E+01	-.7198E-01	.2110E+01	-.3694E+00	D0610B.BIS
14.00	0.000	1.786	.5007E+01	-.4233E+00	.5270E+00	.6440E+01	.4668E+01	.4111E+01	-.6315E-01	.1923E+01	-.2031E+00	D0610B.BIS
15.00	0.000	1.857	.4685E+01	-.3307E+00	.3891E+00	.5590E+01	.4088E+01	.3607E+01	.3485E-01	.1650E+01	-.9957E-01	D0610B.BIS
16.00	0.000	1.928	.4575E+01	-.3322E+00	.3961E+00	.5510E+01	.4179E+01	.3435E+01	-.3426E-01	.1618E+01	-.1453E-01	D0610B.BIS
17.00	0.000	2.000	.4408E+01	-.4321E+00	.4366E+00	.5020E+01	.3718E+01	.3147E+01	.6116E-01	.1465E+01	-.9175E-01	D0610B.BIS
18.00	0.000	2.071	.4302E+01	-.3811E+00	.3683E+00	.4950E+01	.3603E+01	.3046E+01	-.1100E-01	.1443E+01	-.5973E-02	D0610B.BIS
19.00	0.000	2.142	.4111E+01	-.3161E+00	.3750E+00	.4470E+01	.3325E+01	.2667E+01	-.5937E-01	.1280E+01	-.2241E-01	D0610B.BIS
0.20	0.001	1.000	.1221E+02	-.2784E-01	.1700E+00	.1960E+01	.1436E+00	.8522E-01	-.2384E-01	.5720E-01	-.3828E-01	D0611B.BIS
1.00	0.001	1.071	.1008E+02	-.6761E+00	.2150E+01	.2720E+02	.1598E+02	.1711E+02	-.9867E+00	.1153E+02	-.2521E+00	D0611B.BIS
2.00	0.001	1.160	.6767E+01	-.4840E+00	.8009E+00	.1490E+02	.9601E+01	.8797E+01	.4551E+00	.4890E+01	-.3260E+00	D0611B.BIS
3.00	0.001	1.250	.5055E+01	-.5077E+00	.6991E+00	.1080E+02	.6884E+01	.6659E+01	.1596E+00	.3230E+01	-.4871E+00	D0611B.BIS
4.00	0.001	1.339	.5282E+01	-.6027E+00	.1022E+01	.1030E+02	.6719E+01	.6443E+01	-.1330E+00	.3106E+01	-.4144E+00	D0611B.BIS
5.00	0.001	1.428	.4768E+01	-.5644E+00	.9103E+00	.9400E+01	.5833E+01	.5776E+01	-.4601E+00	.2782E+01	-.4175E+00	D0611B.BIS
6.00	0.001	1.518	.4961E+01	-.4878E+00	.8975E+00	.8410E+01	.5624E+01	.5668E+01	-.2092E+00	.2625E+01	-.2591E+00	D0611B.BIS
7.00	0.001	1.607	.4012E+01	-.5867E+00	.7736E+00	.7640E+01	.4883E+01	.5229E+01	-.2589E+00	.2075E+01	-.2911E+00	D0611B.BIS
8.00	0.001	1.696	.3920E+01	-.5530E+00	.7266E+00	.6770E+01	.4610E+01	.4732E+01	-.2379E+00	.1941E+01	-.2348E+00	D0611B.BIS
9.00	0.001	1.786	.3595E+01	-.6189E+00	.6410E+00	.6560E+01	.4385E+01	.4538E+01	-.3316E+00	.1866E+01	-.2237E+00	D0611B.BIS
10.00	0.001	1.875	.3341E+01	-.6285E+00	.5137E+00	.5890E+01	.3797E+01	.4013E+01	-.2458E+00	.1768E+01	-.2587E+00	D0611B.BIS
11.00	0.000	1.964	.3084E+01	-.5174E+00	.4223E+00	.5310E+01	.3595E+01	.3620E+01	-.2430E+00	.1522E+01	-.2682E+00	D0611B.BIS
12.00	0.000	2.053	.3194E+01	-.5093E+00	.4084E+00	.5040E+01	.3235E+01	.3328E+01	-.2025E+00	.1475E+01	-.3078E+00	D0611B.BIS
13.00	0.000	2.142	.3253E+01	-.4474E+00	.4741E+00	.4880E+01	.3285E+01	.3046E+01	-.1322E+00	.1261E+01	-.6546E-01	D0611B.BIS
14.00	0.000	2.232	.3151E+01	-.4758E+00	.4657E+00	.4390E+01	.3182E+01	.2883E+01	-.8300E-01	.1198E+01	-.7935E-01	D0611B.BIS
15.00	0.000	2.321	.3214E+01	-.4469E+00	.6634E+00	.4610E+01	.3297E+01	.2987E+01	-.1771E-01	.1274E+01	-.1671E+00	D0611B.BIS
16.00	0.000	2.410	.3038E+01	-.3767E+00	.5017E+00	.3930E+01	.2832E+01	.2567E+01	-.7657E-01	.1089E+01	-.5235E-01	D0611B.BIS
17.00	0.000	2.499	.3006E+01	-.3683E+00	.5691E+00	.4100E+01	.2831E+01	.2701E+01	-.8246E-01	.1160E+01	-.6986E-01	D0611B.BIS
18.00	0.000	2.589	.2901E+01	-.4657E+00	.5913E+00	.3670E+01	.2741E+01	.2412E+01	-.7459E-01	.9983E+00	-.8891E-02	D0611B.BIS
19.00	0.000	2.678	.2741E+01	-.3896E+00	.4439E+00	.3390E+01	.2456E+01	.2151E+01	-.7375E-01	.9659E+00	-.3811E-01	D0611B.BIS
0.20	0.000	1.200	.5303E+00	-.2878E+00	-.4623E+00	.2680E+00	.1465E+00	.4539E-01	-.3620E-01	.9360E-03	-.4343E-01	D0612B.BIS
1.00	0.000	1.285	.4542E+00	-.5391E+00	-.8451E+00	.3360E+00	.1813E+00	.8001E-01	-.2363E-01	.1762E-02	-.5249E-01	D0612B.BIS
2.00	-0.001	1.393	.2601E+00	-.5719E+00	-.6695E+00	.4670E+00	.3670E+00	.3441E+00	-.4414E-01	.4030E-02	-.2782E-01	D0612B.BIS
3.00	-0.001	1.499	.2402E+00	-.5057E+00	-.5586E+00	.6240E+00	.7442E+00	.5779E+00	-.7197E-01	.7309E-01	-.2578E-01	D0612B.BIS
4.00	-0.001	1.607	.2781E+00	-.5828E+00	-.4807E+00	.9540E+00	.8303E+00	.8664E+00	-.1123E+00	.1955E+00	.2079E-01	D0612B.BIS
5.00	-0.001	1.714	.3727E+00	-.5227E+00	-.3874E+00	.1080E+01	.9416E+00	.9858E+00	-.7724E-01	.2229E+00	.9128E-02	D0612B.BIS

TABLE 4  
Continued

X	Y	Z	$\bar{U}$	$\bar{V}$	$\bar{W}$	$\overline{uu}$	$\overline{vv}$	$\overline{ww}$	$\overline{uv}$	$\overline{uw}$	$\overline{vw}$	File Name
inch	inch	inch	m/s	m/s	m/s	m <sup>2</sup> /s <sup>2</sup>	m <sup>2</sup> /s <sup>2</sup>	m <sup>2</sup> /s <sup>2</sup>	m <sup>2</sup> /s <sup>2</sup>	m <sup>2</sup> /s <sup>2</sup>	m <sup>2</sup> /s <sup>2</sup>	
6.00	-0.001	1.821	.5258E+00	-.6358E+00	-.3065E+00	.1450E+01	.1230E+01	.1249E+01	-.1533E+00	.3618E+00	-.6647E-01	D0612B.BIS
7.00	-0.001	1.928	.5754E+00	-.3635E+00	-.1301E+00	.1480E+01	.1198E+01	.1259E+01	-.1472E+00	.3506E+00	-.8488E-02	D0612B.BIS
8.00	-0.001	2.035	.6072E+00	-.3186E+00	-.1307E+00	.1580E+01	.1414E+01	.1451E+01	-.1133E+00	.3923E+00	.8004E-01	D0612B.BIS
9.00	-0.001	2.142	.5318E+00	-.3315E+00	-.1293E+00	.1540E+01	.1260E+01	.1360E+01	-.1020E+00	.3773E+00	.4950E-02	D0612B.BIS
10.00	-0.001	2.250	.6670E+00	-.3752E+00	-.6725E-01	.1960E+01	.1369E+01	.1578E+01	-.1434E+00	.5305E+00	-.7783E-01	D0612B.BIS
11.00	-0.001	2.357	.7933E+00	-.3643E+00	-.2940E-02	.2030E+01	.1528E+01	.1673E+01	-.1116E+00	.4344E+00	.5984E-01	D0612B.BIS
12.00	-0.001	2.464	.8314E+00	-.3834E+00	.9465E-01	.2220E+01	.1622E+01	.1726E+01	-.1196E+00	.6745E+00	.2034E-01	D0612B.BIS
13.00	-0.001	2.571	.8854E+00	-.3798E+00	.3691E-01	.2060E+01	.1391E+01	.1510E+01	-.2305E+00	.5682E+00	-.1026E+00	D0612B.BIS
14.00	-0.001	2.678	.8258E+00	-.4015E+00	.3715E-01	.1910E+01	.1440E+01	.1510E+01	-.1274E+00	.5582E+00	.2048E-01	D0612B.BIS
15.00	-0.001	2.785	.9359E+00	-.4469E+00	.6698E-01	.1900E+01	.1325E+01	.1468E+01	-.1980E+00	.5239E+00	-.4951E-01	D0612B.BIS
16.00	-0.001	2.892	.9606E+00	-.3986E+00	.7871E-01	.1890E+01	.1299E+01	.1480E+01	-.1314E+00	.5677E+00	-.1196E-01	D0612B.BIS
17.00	-0.001	2.999	.1025E+01	-.4039E+00	.3045E-01	.1640E+01	.1245E+01	.1174E+01	-.1108E+00	.4509E+00	.4127E-01	D0612B.BIS
18.00	-0.001	3.106	.1053E+01	-.4120E+00	.8870E-01	.1750E+01	.1343E+01	.1233E+01	-.1289E+00	.4469E+00	.1688E-01	D0612B.BIS
19.00	-0.001	3.214	.9856E+00	-.5126E+00	.7802E-01	.1640E+01	.1223E+01	.1168E+01	-.1492E+00	.5270E+00	-.4792E-01	D0612B.BIS
0.20	0.000	-0.100	.3013E+02	-.5027E+00	.2816E+00	.2410E+00	.1171E+00	.5716E-01	.7535E-02	.5407E-02	.3315E-01	D0665B.BIS
2.00	0.000	-0.116	.2986E+02	-.7191E+00	.4030E+00	.2860E+01	.8591E+00	.6120E+00	.4690E-01	.8679E-01	-.1836E+00	D0665B.BIS
3.00	0.000	-0.125	.2924E+02	-.5316E+00	.1559E+00	.4860E+01	.2569E+01	.2452E+01	.1397E+00	.6229E-01	-.1778E+00	D0665B.BIS
4.00	0.000	-0.134	.2757E+02	-.4691E+00	-.4373E-02	.1020E+02	.7740E+01	.4812E+01	-.3066E+00	.1154E+00	.2459E-01	D0665B.BIS
5.00	0.000	-0.143	.2597E+02	-.4172E+00	-.1410E+00	.1220E+02	.8905E+01	.6339E+01	-.6843E+00	.5376E-01	-.7271E-01	D0665B.BIS
6.00	0.000	-0.152	.2438E+02	-.5669E+00	-.3390E+00	.1490E+02	.1034E+02	.6892E+01	-.8544E+00	-.2222E+00	-.1180E+00	D0665B.BIS
7.00	0.000	-0.161	.2309E+02	-.4019E+00	-.1812E+00	.1370E+02	.9737E+01	.7634E+01	-.1045E+01	-.2273E+00	.3376E+00	D0665B.BIS
8.00	0.000	-0.169	.2173E+02	-.3266E+00	-.2795E+00	.1470E+02	.1005E+02	.8090E+01	-.7734E+00	-.2936E+00	-.3587E-01	D0665B.BIS
9.00	0.000	-0.178	.2039E+02	-.4812E+00	-.8771E-01	.1510E+02	.9880E+01	.7102E+01	-.3469E-01	-.9772E+00	-.9579E-01	D0665B.BIS
10.00	0.000	-0.187	.1930E+02	-.4709E+00	-.2543E+00	.1530E+02	.9325E+01	.6986E+01	-.3210E+00	-.9018E+00	.8652E-01	D0665B.BIS
11.00	0.000	-0.196	.1789E+02	-.4574E+00	-.1607E+00	.1400E+02	.8953E+01	.7336E+01	-.2994E+00	-.9165E+00	-.8792E-01	D0665B.BIS
12.00	0.000	-0.205	.1710E+02	-.6029E+00	-.1493E+00	.1300E+02	.8107E+01	.6483E+01	-.2163E+00	-.1163E+01	-.1605E+00	D0665B.BIS
13.00	0.000	-0.214	.1566E+02	-.4182E+00	-.1391E+00	.1330E+02	.8031E+01	.6147E+01	-.2115E+00	-.1465E+01	.5494E-02	D0665B.BIS
14.00	0.000	-0.223	.1505E+02	-.5103E+00	-.1506E+00	.1130E+02	.7460E+01	.6164E+01	-.6843E-02	-.1169E+01	-.8143E-01	D0665B.BIS
15.00	0.000	-0.232	.1416E+02	-.4765E+00	-.1492E+00	.1040E+02	.6454E+01	.5872E+01	.4737E-02	-.1213E+01	-.1174E+00	D0665B.BIS
16.00	0.000	-0.241	.1352E+02	-.4201E+00	-.8474E-01	.9710E+01	.5947E+01	.5113E+01	.1017E+00	-.1201E+01	-.3373E+00	D0665B.BIS
17.00	0.000	-0.250	.1259E+02	-.4135E+00	-.1301E+00	.8900E+01	.5645E+01	.4951E+01	.3413E-01	-.8627E+00	-.2036E+00	D0665B.BIS
18.00	0.000	-0.259	.1201E+02	-.5277E+00	-.8836E-01	.8380E+01	.5397E+01	.4605E+01	-.3758E-01	-.9866E+00	-.1301E+00	D0665B.BIS
19.00	0.000	-0.268	.1127E+02	-.4121E+00	-.2390E-01	.8300E+01	.4634E+01	.4334E+01	-.8365E-01	-.1179E+01	-.1546E+00	D0665B.BIS
0.20	0.000	0.100	.3019E+02	-.5029E+00	-.1053E+00	.3090E+00	.1033E+00	.7438E-01	-.8931E-04	.6483E-02	-.2147E-01	D0666B.BIS
2.00	0.000	0.116	.2996E+02	-.3514E+00	-.7729E-01	.2510E+01	.7326E+00	.5436E+00	-.9370E-02	-.5700E-01	-.1379E+00	D0666B.BIS
3.00	0.000	0.125	.2938E+02	-.5023E+00	-.1238E+00	.4640E+01	.3997E+01	.2279E+01	-.3392E+00	-.3702E+00	.5062E-01	D0666B.BIS
4.00	0.000	0.133	.2821E+02	-.4960E+00	-.1007E+00	.7710E+01	.6360E+01	.4447E+01	-.1402E+00	-.5773E+00	.2606E+00	D0666B.BIS
5.00	0.000	0.142	.2665E+02	-.4961E+00	-.1556E+00	.1140E+02	.8363E+01	.5692E+01	.2383E-01	-.6664E-01	.5025E+00	D0666B.BIS
6.00	0.000	0.151	.2506E+02	-.4997E+00	.8314E-02	.1320E+02	.9500E+01	.7132E+01	-.2809E-01	-.4397E+00	.4438E+00	D0666B.BIS
7.00	0.000	0.160	.2340E+02	-.4581E+00	.2440E-01	.1510E+02	.9637E+01	.7491E+01	.3049E+00	-.4460E+00	.1776E+00	D0666B.BIS
8.00	0.000	0.169	.2177E+02	-.6250E+00	.1957E-01	.1640E+02	.1000E+02	.8110E+01	.1356E+00	-.1179E+00	-.6488E-01	D0666B.BIS
9.00	0.000	0.178	.2033E+02	-.4384E+00	.1288E+00	.1490E+02	.9701E+01	.7584E+01	-.1722E+00	.3612E+00	-.2984E+00	D0666B.BIS
10.00	0.000	0.187	.1905E+02	-.4963E+00	.5606E-01	.1450E+02	.9527E+01	.7003E+01	-.4172E+00	.9045E+00	.3938E-01	D0666B.BIS
11.00	0.000	0.196	.1776E+02	-.5219E+00	.1324E+00	.1480E+02	.9036E+01	.6941E+01	.5158E+00	.8785E+00	.4163E-01	D0666B.BIS
12.00	0.000	0.205	.1656E+02	-.3286E+00	.1028E+00	.1350E+02	.8278E+01	.6678E+01	-.3253E+00	.8117E+00	.9030E-01	D0666B.BIS
13.00	0.000	0.213	.1577E+02	-.4422E+00	.1770E+00	.1190E+02	.7893E+01	.6274E+01	.4416E-01	.1084E+01	-.7854E-01	D0666B.BIS
14.00	0.000	0.223	.1496E+02	-.5625E+00	.1772E+00	.1120E+02	.7516E+01	.6129E+01	.1312E+00	.7913E+00	-.2516E+00	D0666B.BIS
15.00	0.000	0.231	.1401E+02	-.3760E+00	.9541E-01	.1060E+02	.6753E+01	.5669E+01	-.7214E+00	.8033E+00	-.3919E+00	D0666B.BIS
16.00	0.000	0.240	.1339E+02	-.3782E+00	.9205E-01	.9340E+01	.5911E+01	.5475E+01	-.2371E+00	.8947E+00	-.2695E+00	D0666B.BIS
17.00	0.000	0.249	.1259E+02	-.3973E+00	.9899E-01	.8550E+01	.5742E+01	.4967E+01	-.9825E-01	.9326E+00	-.5062E-01	D0666B.BIS
18.00	0.000	0.258	.1201E+02	-.3058E+00	.1563E+00	.8030E+01	.5343E+01	.4727E+01	-.3827E+00	.3715E+00	-.1221E+00	D0666B.BIS
19.00	0.000	0.267	.1136E+02	-.2779E+00	.9435E-01	.7680E+01	.5115E+01	.4021E+01	-.1863E+00	.6243E+00	-.1528E+00	D0666B.BIS
0.20	0.000	0.300	.3015E+02	-.6898E+00	-.7212E+00	.2850E+00	.1549E+00	.7858E-01	-.2051E-01	.8063E-02	-.4329E-01	D0667B.BIS
2.00	0.000	0.348	.2998E+02	-.6101E+00	-.6568E+00	.2060E+01	.5755E+00	.4625E+00	.2104E+00	-.4401E-01	-.9345E-01	D0667B.BIS
3.00	0.000	0.375	.2944E+02	-.5868E+00	-.4991E+00	.3740E+01	.2625E+01	.1946E+01	.4225E+00	-.4183E+00	-.4905E+00	D0667B.BIS
4.00	0.000	0.402	.2787E+02	-.4620E+00	-.4070E+00	.8520E+01	.7783E+01	.4583E+01	.6481E-01	.4747E+00	-.7302E-01	D0667B.BIS



TABLE 4  
Continued

X	Y	Z	$\bar{U}$	$\bar{V}$	$\bar{W}$	$\overline{u^2}$	$\overline{v^2}$	$\overline{w^2}$	$\overline{uv}$	$\overline{uw}$	$\overline{vw}$	File Name
inch	inch	inch	m/s	m/s	m/s	m <sup>2</sup> /s <sup>2</sup>	m <sup>2</sup> /s <sup>2</sup>	m <sup>2</sup> /s <sup>2</sup>	m <sup>2</sup> /s <sup>2</sup>	m <sup>2</sup> /s <sup>2</sup>	m <sup>2</sup> /s <sup>2</sup>	
5.00	0.000	0.428	.2577E+02	-.4898E+00	-.2179E+00	.1490E+02	.1071E+02	.6906E+01	.6239E+00	.6000E+00	-.5407E+00	D06G7B.BIS
6.00	0.000	0.455	.2347E+02	-.1602E+00	.3860E+00	.1850E+02	.1245E+02	.8338E+01	.1555E+00	.1224E+01	-.5886E+00	D06G7B.BIS
7.00	0.000	0.482	.2126E+02	-.2630E+00	.4234E+00	.1930E+02	.1267E+02	.8579E+01	.5198E+00	.2366E+01	.1298E-01	D06G7B.BIS
8.00	0.000	0.508	.1943E+02	-.2756E+00	.6125E+00	.1780E+02	.1192E+02	.8361E+01	.4533E+00	.2946E+01	-.2844E+00	D06G7B.BIS
9.00	0.000	0.536	.1796E+02	-.2798E+00	.5037E+00	.1670E+02	.1130E+02	.8279E+01	.1070E+00	.3087E+01	-.2755E+00	D06G7B.BIS
10.00	0.000	0.562	.1671E+02	-.1176E+00	.6743E+00	.1560E+02	.1041E+02	.7956E+01	.6379E-02	.3208E+01	-.5753E+00	D06G7B.BIS
11.00	0.000	0.589	.1569E+02	-.1945E+00	.7048E+00	.1430E+02	.9870E+01	.7591E+01	.5166E-01	.2733E+01	.1140E+00	D06G7B.BIS
12.00	0.000	0.616	.1444E+02	-.3057E+00	.5362E+00	.1370E+02	.9314E+01	.6836E+01	-.3249E+00	.3007E+01	-.5803E+00	D06G7B.BIS
13.00	0.000	0.643	.1352E+02	-.1494E+00	.5602E+00	.1270E+02	.8188E+01	.6566E+01	.9726E-01	.2810E+01	-.5242E-01	D06G7B.BIS
14.00	0.000	0.670	.1298E+02	-.1964E+00	.5905E+00	.1180E+02	.8172E+01	.6123E+01	.2664E+00	.2576E+01	.1755E+00	D06G7B.BIS
15.00	0.000	0.696	.1216E+02	-.2262E+00	.5884E+00	.1110E+02	.7495E+01	.5626E+01	.3551E+00	.2247E+01	-.6215E-01	D06G7B.BIS
16.00	0.000	0.723	.1151E+02	-.1206E+00	.4838E+00	.9420E+01	.6651E+01	.5812E+01	-.4425E+00	.2342E+01	.3202E-02	D06G7B.BIS
17.00	0.000	0.750	.1071E+02	-.2029E+00	.3628E+00	.9310E+01	.6340E+01	.4876E+01	-.4006E+00	.2049E+01	-.4214E-01	D06G7B.BIS
18.00	0.000	0.776	.1046E+02	-.2752E+00	.3689E+00	.8580E+01	.5929E+01	.4488E+01	.1612E+00	.1900E+01	-.1610E-01	D06G7B.BIS
19.00	0.000	0.803	.9691E+01	-.1552E+00	.4539E+00	.7570E+01	.5556E+01	.4346E+01	-.2925E+00	.1463E+01	-.6118E-01	D06G7B.BIS
0.20	0.001	0.500	.3011E+02	-.2177E+00	-.2992E+00	.1940E+00	.1459E+00	.1732E+00	-.1234E-01	.3161E-02	.2273E-01	D06G8B.BIS
2.00	0.000	0.580	.3002E+02	-.3774E+00	.2331E+00	.1870E+01	.7220E+00	.6157E+00	.1021E+00	-.1941E+00	-.8511E-01	D06G8B.BIS
3.00	0.000	0.625	.2946E+02	-.4850E+00	.2990E+00	.4910E+01	.4675E+01	.2635E+01	.4867E+00	-.9993E+00	.1075E-01	D06G8B.BIS
4.00	0.000	0.669	.2738E+02	-.5263E+00	.3372E+00	.1330E+02	.9188E+01	.7499E+01	.5842E+00	.2502E+00	-.6748E+00	D06G8B.BIS
5.00	0.000	0.714	.2399E+02	-.4053E+00	.5937E+00	.2040E+02	.1284E+02	.9987E+01	.9846E+00	.2336E+01	-.4720E+00	D06G8B.BIS
6.00	0.000	0.758	.2042E+02	-.4018E+00	.6725E+00	.2100E+02	.1335E+02	.1069E+02	.7993E-01	.3692E+01	-.3338E+00	D06G8B.BIS
7.00	0.000	0.803	.1796E+02	-.3880E+00	.8887E+00	.1850E+02	.1342E+02	.1011E+02	.4760E+00	.3605E+01	-.5669E+00	D06G8B.BIS
8.00	0.000	0.847	.1541E+02	-.3956E+00	.7869E+00	.1780E+02	.1211E+02	.9815E+01	.1196E+01	.3757E+01	-.7133E+00	D06G8B.BIS
9.00	0.000	0.892	.1396E+02	-.3913E+00	.8459E+00	.1700E+02	.1183E+02	.8532E+01	.1294E+01	.4075E+01	-.2530E+00	D06G8B.BIS
10.00	0.000	0.937	.1293E+02	-.3020E+00	.6890E+00	.1490E+02	.1023E+02	.8694E+01	-.1393E+00	.3899E+01	-.8734E+00	D06G8B.BIS
11.00	0.000	0.981	.1188E+02	-.3230E+00	.6229E+00	.1420E+02	.9752E+01	.7847E+01	.8653E+00	.3961E+01	-.4204E+00	D06G8B.BIS
12.00	0.000	1.026	.1116E+02	-.2792E+00	.7808E+00	.1270E+02	.8970E+01	.7179E+01	-.1358E+00	.3230E+01	-.5330E+00	D06G8B.BIS
13.00	0.000	1.071	.1028E+02	-.1471E+00	.7186E+00	.1090E+02	.8196E+01	.6305E+01	.6851E-01	.2962E+01	-.3282E+00	D06G8B.BIS
14.00	0.000	1.115	.9523E+01	-.1759E+00	.4294E+00	.1030E+02	.7382E+01	.6028E+01	-.2916E+00	.3026E+01	-.3054E+00	D06G8B.BIS
15.00	0.000	1.160	.9053E+01	-.2546E+00	.5411E+00	.9480E+01	.6802E+01	.5860E+01	.2071E+00	.2674E+01	-.1396E+00	D06G8B.BIS
16.00	0.000	1.204	.8688E+01	-.1344E+00	.4383E+00	.9220E+01	.6044E+01	.5079E+01	.1637E-01	.2667E+01	-.9500E-01	D06G8B.BIS
17.00	0.000	1.249	.8457E+01	-.1935E+00	.4937E+00	.8550E+01	.5723E+01	.4682E+01	-.1873E+00	.2529E+01	-.3115E+00	D06G8B.BIS
18.00	0.000	1.293	.8136E+01	-.1948E+00	.4706E+00	.7540E+01	.5749E+01	.4438E+01	.1566E+00	.2252E+01	-.1313E+00	D06G8B.BIS
19.00	0.000	1.338	.7778E+01	-.1270E+00	.5980E+00	.7280E+01	.5098E+01	.3965E+01	-.3125E+00	.2015E+01	.8339E-02	D06G8B.BIS
0.20	0.001	0.700	.3014E+02	-.4213E+00	-.2006E-01	.2290E+00	.1497E+00	.1753E+00	-.8616E-02	.6481E-02	.1989E-01	D06G9B.BIS
2.00	0.000	0.812	.2965E+02	-.5643E+00	-.9127E-01	.3700E+01	.2698E+01	.2485E+01	-.6967E+00	.6810E+00	.6190E-01	D06G9B.BIS
3.00	0.000	0.875	.2474E+02	-.5975E+00	.3892E+00	.2010E+02	.1083E+02	.8734E+01	-.8027E+00	.6029E+01	-.2033E+00	D06G9B.BIS
4.00	0.000	0.937	.1854E+02	-.3417E+00	.6822E+00	.3040E+02	.1560E+02	.1270E+02	-.2872E+01	.9635E+01	-.1677E+01	D06G9B.BIS
5.00	0.000	1.000	.1543E+02	-.5894E+00	.9845E+00	.2490E+02	.1691E+02	.1197E+02	-.8461E+00	.7087E+01	-.1174E+01	D06G9B.BIS
6.00	0.000	1.062	.1341E+02	-.4511E+00	.8890E+00	.2100E+02	.1432E+02	.1104E+02	-.7280E+00	.6473E+01	-.8301E+00	D06G9B.BIS
7.00	0.000	1.125	.1226E+02	-.3569E+00	.9697E+00	.1860E+02	.1265E+02	.1064E+02	.7400E-01	.6429E+01	-.5816E+00	D06G9B.BIS
8.00	0.000	1.187	.1069E+02	-.3056E+00	.9042E+00	.1610E+02	.1141E+02	.8315E+01	.3051E-01	.4702E+01	-.8237E+00	D06G9B.BIS
9.00	0.000	1.250	.1006E+02	-.2579E+00	.9043E+00	.1460E+02	.1037E+02	.8112E+01	-.3565E+00	.4441E+01	-.6748E+00	D06G9B.BIS
10.00	0.000	1.312	.9095E+01	-.2206E+00	.6842E+00	.1240E+02	.8932E+01	.7627E+01	.3903E+00	.3762E+01	-.3712E+00	D06G9B.BIS
11.00	0.000	1.375	.8426E+01	-.2137E+00	.7002E+00	.1100E+02	.7882E+01	.6632E+01	.2390E+00	.3285E+01	-.3385E+00	D06G9B.BIS
12.00	0.000	1.437	.7871E+01	-.3929E+00	.6866E+00	.9800E+01	.7870E+01	.6148E+01	.2496E+00	.3003E+01	-.2428E+00	D06G9B.BIS
13.00	0.000	1.500	.7109E+01	-.3248E+00	.6351E+00	.9400E+01	.6915E+01	.5579E+01	.2844E+00	.2842E+01	-.3260E+00	D06G9B.BIS
14.00	0.000	1.562	.6775E+01	-.2985E+00	.5490E+00	.9170E+01	.6373E+01	.5150E+01	.2557E+00	.2676E+01	-.3681E+00	D06G9B.BIS
15.00	0.000	1.625	.6468E+01	-.2695E+00	.6310E+00	.7760E+01	.5989E+01	.4909E+01	.8575E-02	.2258E+01	-.4019E+00	D06G9B.BIS
16.00	0.000	1.687	.6368E+01	-.4724E+00	.7784E+00	.7370E+01	.5396E+01	.4406E+01	-.9284E-02	.2218E+01	-.4645E-01	D06G9B.BIS
17.00	0.000	1.750	.6111E+01	-.2503E+00	.7365E+00	.6990E+01	.5089E+01	.3980E+01	-.8874E-01	.2107E+01	-.1522E+00	D06G9B.BIS
18.00	0.000	1.812	.5952E+01	-.2717E+00	.6966E+00	.6300E+01	.4822E+01	.3941E+01	.1305E+00	.1739E+01	-.1083E+00	D06G9B.BIS
19.00	0.000	1.875	.5528E+01	-.3313E+00	.5096E+00	.6120E+01	.4288E+01	.3398E+01	.5033E-01	.1684E+01	-.2236E+00	D06G9B.BIS
0.20	0.050	-0.200	.3011E+02	-.5318E+00	.7717E-01	.2340E+00	.9491E-01	.7037E-01	-.2591E-01	.7199E-02	-.1852E-01	D0705B.BIS
2.00	0.098	-0.233	.2862E+02	-.3004E+00	.4199E+00	.6670E+01	.5629E+01	.3368E+01	.2399E+01	.9322E+00	-.6560E+00	D0705B.BIS
3.00	0.124	-0.250	.2618E+02	-.3095E+00	.2910E+00	.1500E+02	.9012E+01	.7737E+01	.5442E+01	-.2200E+01	-.8347E+00	D0705B.BIS

TABLE 4  
Continued

X	Y	Z	$\bar{U}$	$\bar{V}$	$\bar{W}$	$\bar{u}$	$\bar{v}$	$\bar{w}$	$\bar{uv}$	$\bar{uv}$	$\bar{vw}$	File Name
inch	inch	inch	m/s	m/s	m/s	m <sup>2</sup> /s <sup>2</sup>	m <sup>2</sup> /s <sup>2</sup>	m <sup>2</sup> /s <sup>2</sup>	m <sup>2</sup> /s <sup>2</sup>	m <sup>2</sup> /s <sup>2</sup>	m <sup>2</sup> /s <sup>2</sup>	
4.00	0.153	-0.268	.2437E+02	-.4848E-01	.4719E+00	.2050E+02	.1062E+02	.1010E+02	.6314E+01	-.1793E+01	-.3092E+00	D0705B.BIS
5.00	0.179	-0.286	.2308E+02	.9383E-01	.2737E+00	.2170E+02	.1074E+02	.1041E+02	.6315E+01	-.1481E+01	-.1397E+00	D0705B.BIS
6.00	0.205	-0.304	.2186E+02	.1025E+00	.7680E-01	.2230E+02	.9801E+01	.9882E+01	.5486E+01	-.2035E+01	.2937E+00	D0705B.BIS
7.00	0.232	-0.322	.2004E+02	-.4993E-01	.3059E-01	.2000E+02	.1079E+02	.9956E+01	.4494E+01	-.2567E+01	.6578E+00	D0705B.BIS
8.00	0.260	-0.340	.1861E+02	-.2518E+00	-.1639E+00	.2050E+02	.1061E+02	.9812E+01	.5645E+01	-.2434E+01	.5043E+00	D0705B.BIS
9.00	0.285	-0.358	.1759E+02	-.2188E+00	-.1859E+00	.1840E+02	.9405E+01	.8743E+01	.3976E+01	-.1879E+01	.4534E+00	D0705B.BIS
10.00	0.312	-0.375	.1642E+02	-.9992E-01	-.1221E+00	.1900E+02	.8954E+01	.8920E+01	.4091E+01	-.3044E+01	.3945E+00	D0705B.BIS
11.00	0.340	-0.394	.1498E+02	-.1407E+00	-.5065E-01	.1700E+02	.9293E+01	.8153E+01	.3580E+01	-.2267E+01	.6489E+00	D0705B.BIS
12.00	0.367	-0.411	.1386E+02	.3972E-01	.9820E-01	.1670E+02	.7887E+01	.7742E+01	.3513E+01	-.2655E+01	.5055E+00	D0705B.BIS
13.00	0.392	-0.429	.1302E+02	-.2543E-01	-.3347E-01	.1440E+02	.7862E+01	.7381E+01	.3042E+01	-.2516E+01	.2048E+00	D0705B.BIS
14.00	0.419	-0.447	.1238E+02	.2994E-01	-.2896E-01	.1280E+02	.6906E+01	.6786E+01	.2322E+01	-.2049E+01	.4141E+00	D0705B.BIS
15.00	0.447	-0.465	.1194E+02	-.7436E-01	-.1400E+00	.1240E+02	.6673E+01	.6434E+01	.2024E+01	-.2460E+01	.2691E+00	D0705B.BIS
16.00	0.474	-0.483	.1060E+02	-.2202E+00	-.1566E+00	.1080E+02	.6044E+01	.5577E+01	.1838E+01	-.2042E+01	.2240E+00	D0705B.BIS
17.00	0.499	-0.501	.1038E+02	-.2151E+00	-.1303E+00	.1010E+02	.5560E+01	.5226E+01	.1917E+01	-.1891E+01	.1166E+00	D0705B.BIS
18.00	0.526	-0.519	.9803E+01	-.2320E+00	-.1928E+00	.9660E+01	.5100E+01	.5243E+01	.1415E+01	-.1763E+01	.2757E+00	D0705B.BIS
19.00	0.555	-0.537	.9461E+01	-.1989E+00	-.2048E+00	.8660E+01	.4578E+01	.4375E+01	.1324E+01	-.1539E+01	.1005E+00	D0705B.BIS
0.20	0.050	0.000	.3021E+02	-.1518E+00	.1678E+00	.1850E+00	.1062E+00	.1443E+00	-.7993E-02	.5530E-02	.6940E-01	D0706B.BIS
2.00	0.098	0.000	.2930E+02	.2704E+00	.5384E-01	.4770E+01	.2718E+01	.2452E+01	.6042E+00	.6268E-01	-.2978E+00	D0706B.BIS
3.00	0.125	-0.001	.2726E+02	.4633E+00	-.4396E-01	.1140E+02	.7319E+01	.6534E+01	.2897E+01	-.4198E+00	.2014E-01	D0706B.BIS
4.00	0.153	-0.001	.2526E+02	.3112E+00	-.1645E+00	.1610E+02	.8296E+01	.9018E+01	.4024E+01	.4989E-01	.3654E-01	D0706B.BIS
5.00	0.179	-0.001	.2388E+02	.4434E+00	-.9843E-01	.1730E+02	.9383E+01	.1010E+02	.4461E+01	.1170E+00	.2769E+00	D0706B.BIS
6.00	0.205	-0.001	.2281E+02	.3974E+00	-.6609E-01	.1830E+02	.9524E+01	.9616E+01	.4514E+01	-.1404E+00	.1548E+00	D0706B.BIS
7.00	0.232	0.000	.2146E+02	.3395E+00	.9542E-01	.1860E+02	.9828E+01	.9897E+01	.4716E+01	-.4945E+00	-.8767E-01	D0706B.BIS
8.00	0.260	0.000	.2035E+02	.3443E+00	.1515E+00	.1810E+02	.9294E+01	.9092E+01	.4079E+01	-.9671E+00	-.3187E+00	D0706B.BIS
9.00	0.285	-0.001	.1916E+02	.3559E+00	.1044E+00	.1730E+02	.9378E+01	.8872E+01	.4155E+01	-.4182E+00	-.1699E+00	D0706B.BIS
10.00	0.312	-0.001	.1788E+02	.2120E+00	.4504E-02	.1790E+02	.9174E+01	.8602E+01	.4427E+01	-.2211E+00	-.1373E-01	D0706B.BIS
11.00	0.340	-0.001	.1659E+02	.2322E+00	-.2588E-03	.1700E+02	.8480E+01	.8351E+01	.3861E+01	-.2442E+00	-.4170E-01	D0706B.BIS
12.00	0.367	-0.001	.1581E+02	.1815E+00	-.1168E-02	.1490E+02	.8008E+01	.7826E+01	.3398E+01	.1979E+00	.2762E+00	D0706B.BIS
13.00	0.393	0.000	.1484E+02	.1928E+00	-.2288E-01	.1350E+02	.7509E+01	.7149E+01	.2879E+01	.6248E-01	.1658E+00	D0706B.BIS
14.00	0.420	0.000	.1400E+02	.2349E+00	.1151E-01	.1230E+02	.6913E+01	.6736E+01	.2476E+01	-.7588E-02	-.1137E+00	D0706B.BIS
15.00	0.447	-0.001	.1326E+02	.2483E+00	.1555E-01	.1140E+02	.6292E+01	.6280E+01	.2294E+01	.2603E+00	-.2603E-02	D0706B.BIS
16.00	0.474	-0.001	.1241E+02	.1180E+00	-.3146E-01	.1050E+02	.5941E+01	.6064E+01	.2268E+01	.1334E+00	.1690E-01	D0706B.BIS
17.00	0.499	-0.001	.1174E+02	.9453E-01	-.6546E-01	.9790E+01	.5687E+01	.5529E+01	.1909E+01	.4241E-01	-.6772E-01	D0706B.BIS
18.00	0.526	0.000	.1130E+02	.2300E+00	.1213E+00	.8900E+01	.5172E+01	.5256E+01	.1588E+01	-.2084E+00	.1890E-02	D0706B.BIS
19.00	0.555	0.000	.1083E+02	.1570E+00	.1211E+00	.8190E+01	.4611E+01	.4532E+01	.1700E+01	-.9636E-01	-.6369E-01	D0706B.BIS
0.20	0.050	0.200	.3029E+02	.2358E-01	-.3894E+00	.1890E+00	.6591E+00	.7010E+00	-.7673E-02	.1144E-01	.1448E-01	D0707B.BIS
2.00	0.098	0.232	.2959E+02	-.1742E+00	-.3971E+00	.3540E+01	.2683E+01	.2403E+01	.1244E+01	-.1245E+00	-.3071E+00	D0707B.BIS
3.00	0.125	0.250	.2697E+02	-.1333E+00	-.5201E+00	.1370E+02	.8470E+01	.7928E+01	.4027E+01	.4181E-01	.8766E-01	D0707B.BIS
4.00	0.152	0.268	.2444E+02	-.2384E-01	-.4386E+00	.1900E+02	.1021E+02	.1071E+02	.5206E+01	.3154E+00	-.4709E+00	D0707B.BIS
5.00	0.179	0.286	.2236E+02	-.6702E-02	-.1613E+00	.2310E+02	.1143E+02	.1123E+02	.6311E+01	.7098E+00	-.1057E+00	D0707B.BIS
6.00	0.205	0.303	.2063E+02	-.6607E-01	-.1988E-01	.2540E+02	.1158E+02	.1076E+02	.6698E+01	.1251E+01	-.3786E+00	D0707B.BIS
7.00	0.232	0.322	.1939E+02	-.8635E-01	.2048E+00	.2440E+02	.1157E+02	.1126E+02	.6096E+01	.1387E+01	-.6753E+00	D0707B.BIS
8.00	0.260	0.339	.1742E+02	-.1246E+00	.3262E+00	.2210E+02	.1164E+02	.1041E+02	.5978E+01	.2261E+01	-.5502E+00	D0707B.BIS
9.00	0.285	0.357	.1638E+02	-.7789E-01	.3512E+00	.2000E+02	.1141E+02	.9575E+01	.5191E+01	.1915E+01	-.1999E+00	D0707B.BIS
10.00	0.312	0.375	.1513E+02	-.5329E-01	.3883E+00	.1790E+02	.1045E+02	.9076E+01	.4223E+01	.1348E+01	-.6815E+00	D0707B.BIS
11.00	0.339	0.393	.1417E+02	-.8650E-01	.3886E+00	.1740E+02	.9148E+01	.8622E+01	.4335E+01	.1655E+01	-.3834E+00	D0707B.BIS
12.00	0.367	0.411	.1318E+02	-.1279E+00	.4221E+00	.1610E+02	.8655E+01	.8052E+01	.3264E+01	.1238E+01	-.6726E+00	D0707B.BIS
13.00	0.392	0.429	.1256E+02	-.1175E+00	.3574E+00	.1210E+02	.7809E+01	.7207E+01	.2650E+01	.1324E+01	-.4853E+00	D0707B.BIS
14.00	0.419	0.447	.1173E+02	-.1514E+00	.2156E+00	.1190E+02	.7341E+01	.6648E+01	.2690E+01	.1538E+01	-.5190E+00	D0707B.BIS
15.00	0.447	0.465	.1155E+02	-.9448E-02	.4086E+00	.1100E+02	.6857E+01	.6292E+01	.2056E+01	.1218E+01	-.5338E+00	D0707B.BIS
16.00	0.474	0.482	.1073E+02	-.2393E-01	.2872E+00	.9670E+01	.6408E+01	.5914E+01	.1796E+01	.1629E+01	-.4492E+00	D0707B.BIS
17.00	0.499	0.500	.1038E+02	.9587E-01	.3656E+00	.9270E+01	.5554E+01	.5346E+01	.1334E+01	.1468E+01	-.1452E+00	D0707B.BIS
18.00	0.526	0.518	.9933E+01	.1304E+00	.2531E+00	.8550E+01	.5428E+01	.4504E+01	.1269E+01	.1249E+01	-.1567E+00	D0707B.BIS
19.00	0.555	0.536	.9689E+01	.7392E-01	.3466E+00	.7890E+01	.5079E+01	.4384E+01	.1049E+01	.1053E+01	-.2066E+00	D0707B.BIS
0.20	0.100	0.400	.3016E+02	-.2753E+00	-.1313E+00	.2740E+00	.1079E+00	.1085E+00	-.1409E-01	.1079E-01	-.3188E-52	DD0708B
2.00	0.098	0.464	.2884E+02	-.5557E-01	-.2082E+00	.8310E+01	.3175E+01	.2636E+01	.2671E+01	.1926E+00	-.5246E+52	DD0708B

TABLE 4  
Continued

X	Y	Z	$\bar{u}$	$\bar{v}$	$\bar{w}$	$\overline{uu}$	$\overline{vv}$	$\overline{ww}$	$\overline{uv}$	$\overline{vw}$	$\overline{uv}$	File Name
inch	inch	inch	m/s	m/s	m/s	m <sup>2</sup> /s <sup>2</sup>	m <sup>2</sup> /s <sup>2</sup>	m <sup>2</sup> /s <sup>2</sup>	m <sup>2</sup> /s <sup>2</sup>	m <sup>2</sup> /s <sup>2</sup>	m <sup>2</sup> /s <sup>2</sup>	
3.00	0.124	0.500	.2599E+02	.7919E-01	-.3412E+00	.1800E+02	.1111E+02	.8978E+01	.6881E+01	.7963E-01	.8433E-52	D0708B
4.00	0.153	0.535	.2362E+02	.3094E-01	-.7386E-01	.2590E+02	.1363E+02	.1298E+02	.8176E+01	-.1835E+00	-.4452E+52	D0708B
5.00	0.179	0.571	.2055E+02	-.2285E-01	.2270E+00	.2850E+02	.1388E+02	.1220E+02	.6801E+01	.2082E+01	-.7196E+52	D0708B
6.00	0.205	0.607	.1817E+02	-.1151E+00	.4378E+00	.2710E+02	.1346E+02	.1189E+02	.5593E+01	.3755E+01	-.1307E+52	D0708B
7.00	0.232	0.642	.1594E+02	-.4602E+00	.3254E+00	.2120E+02	.1271E+02	.1088E+02	.4355E+01	.3577E+01	-.1410E+52	D0708B
8.00	0.260	0.678	.1491E+02	-.3602E+00	.4916E+00	.1860E+02	.1091E+02	.1051E+02	.2442E+01	.4098E+01	-.1696E+52	D0708B
9.00	0.285	0.714	.1349E+02	-.3582E+00	.4301E+00	.1770E+02	.1067E+02	.9075E+01	.2415E+01	.3774E+01	-.1484E+52	D0708B
10.00	0.312	0.750	.1264E+02	-.3068E+00	.4401E+00	.1550E+02	.9504E+01	.8471E+01	.1816E+01	.3485E+01	-.1773E+52	D0708B
11.00	0.340	0.785	.1205E+02	-.3921E+00	.4163E+00	.1360E+02	.8942E+01	.7778E+01	.1702E+01	.3594E+01	-.1293E+52	D0708B
12.00	0.367	0.821	.1118E+02	-.3543E+00	.5256E+00	.1390E+02	.8317E+01	.7003E+01	.1952E+01	.3152E+01	-.1309E+52	D0708B
13.00	0.392	0.857	.1074E+02	-.1456E+00	.3975E+00	.1160E+02	.7966E+01	.6822E+01	.1352E+01	.2731E+01	-.8480E+52	D0708B
14.00	0.419	0.892	.1006E+02	-.2711E+00	.4320E+00	.1130E+02	.7300E+01	.6059E+01	.9270E+00	.2853E+01	-.6568E+52	D0708B
15.00	0.447	0.928	.9412E+01	-.1920E+00	.3574E+00	.1210E+02	.6391E+01	.5649E+01	.1187E+01	.2694E+01	-.2178E+52	D0708B
16.00	0.474	0.964	.8987E+01	-.2910E+00	.2969E+00	.9080E+01	.5889E+01	.5254E+01	.8290E+00	.2563E+01	-.6588E+52	D0708B
17.00	0.499	0.999	.8865E+01	-.1939E+00	.2502E+00	.8840E+01	.5730E+01	.4821E+01	.8996E+00	.2327E+01	-.4554E+52	D0708B
18.00	0.526	1.035	.8337E+01	-.2746E+00	.3043E+00	.7900E+01	.5160E+01	.4586E+01	.8461E+00	.2032E+01	-.6882E+52	D0708B
19.00	0.555	1.071	.8011E+01	-.2406E+00	.2952E+00	.7650E+01	.4894E+01	.4010E+01	.8871E+00	.1735E+01	-.1855E+52	D0708B
0.20	0.049	0.600	.3020E+02	.3007E-01	-.2177E+00	.1910E+00	.1478E+00	.1963E+00	-.1130E-01	.6112E-02	.1071E+00	D0709B.BIS
2.00	0.098	0.696	.2887E+02	-.2419E+00	-.3283E+00	.8410E+01	.3652E+01	.4279E+01	.2543E+01	-.1425E+00	.3638E+00	D0709B.BIS
3.00	0.124	0.750	.2380E+02	.3018E+00	-.6128E+00	.2840E+02	.1538E+02	.1593E+02	.7959E+01	.6341E+01	-.2177E+00	D0709B.BIS
4.00	0.153	0.803	.1763E+02	.1511E+00	-.1138E-01	.3290E+02	.1762E+02	.1650E+02	.6370E+01	.7751E+01	-.2409E+01	D0709B.BIS
5.00	0.179	0.857	.1406E+02	.2922E-01	.3500E+00	.2630E+02	.1476E+02	.1283E+02	.4051E+01	.6294E+01	-.2257E+01	D0709B.BIS
6.00	0.205	0.910	.1244E+02	-.9057E-01	.6851E+00	.2180E+02	.1258E+02	.1125E+02	.3562E+01	.4874E+01	-.1619E+01	D0709B.BIS
7.00	0.232	0.964	.1060E+02	.1087E+00	.5881E+00	.1880E+02	.1105E+02	.9532E+01	.2616E+01	.4474E+01	-.1716E+01	D0709B.BIS
8.00	0.260	1.018	.9929E+01	-.8610E-01	.6972E+00	.1480E+02	.1019E+02	.8694E+01	.2186E+01	.3526E+01	-.1484E+01	D0709B.BIS
9.00	0.285	1.071	.9608E+01	.2261E-01	.8552E+00	.1310E+02	.8665E+01	.8372E+01	.1246E+01	.3481E+01	-.1103E+01	D0709B.BIS
10.00	0.312	1.125	.8461E+01	-.5629E-01	.7170E+00	.1300E+02	.8487E+01	.7497E+01	.1154E+01	.3388E+01	-.1088E+01	D0709B.BIS
11.00	0.340	1.179	.7738E+01	-.2724E+00	.1056E+01	.1230E+02	.7739E+01	.7113E+01	.1278E+01	.2929E+01	-.9118E+00	D0709B.BIS
12.00	0.367	1.232	.7530E+01	-.4835E-01	.8160E+00	.1060E+02	.7225E+01	.6414E+01	.9655E+00	.2934E+01	-.7936E+00	D0709B.BIS
13.00	0.392	1.286	.6976E+01	-.1081E+00	.7710E+00	.9270E+01	.6934E+01	.6059E+01	.9607E+00	.2648E+01	-.4930E+00	D0709B.BIS
14.00	0.419	1.339	.6913E+01	-.7869E-01	.9328E+00	.8870E+01	.6788E+01	.5914E+01	.1077E+01	.2558E+01	-.5094E+00	D0709B.BIS
15.00	0.447	1.393	.6619E+01	-.1307E+00	.8260E+00	.8710E+01	.5575E+01	.5176E+01	.9891E+00	.2603E+01	-.4546E+00	D0709B.BIS
16.00	0.474	1.447	.6282E+01	-.8003E-02	.6978E+00	.7320E+01	.5246E+01	.4789E+01	.5106E+00	.2076E+01	-.3928E+00	D0709B.BIS
17.00	0.499	1.500	.6072E+01	-.8595E-01	.7542E+00	.7570E+01	.4990E+01	.4352E+01	.5855E+00	.2143E+01	-.3146E+00	D0709B.BIS
18.00	0.526	1.554	.5937E+01	.7641E-01	.6950E+00	.6690E+01	.4718E+01	.3818E+01	.7590E+00	.1689E+01	-.3373E+00	D0709B.BIS
19.00	0.555	1.607	.5788E+01	-.5082E-01	.6505E+00	.6120E+01	.4499E+01	.3884E+01	.5239E+00	.1784E+01	-.3638E+00	D0709B.BIS
0.20	0.099	-0.199	.3013E+02	-.5072E+00	-.6664E-01	.1720E+00	.1767E+00	.4750E-01	-.5504E-02	.3494E-02	-.5151E-01	D0805B.BIS
2.00	0.197	-0.233	.2531E+02	.3335E+00	.5350E+00	.1860E+02	.1173E+02	.1163E+02	.7693E+01	-.3144E+01	-.1036E+01	D0805B.BIS
3.00	0.250	-0.250	.2061E+02	-.9749E-01	.8197E+00	.2920E+02	.1299E+02	.1691E+02	.9662E+01	-.5282E+01	-.5473E+00	D0805B.BIS
4.00	0.303	-0.268	.1837E+02	-.8532E-01	.4618E+00	.2880E+02	.1080E+02	.1586E+02	.8674E+01	-.4393E+01	-.7107E+00	D0805B.BIS
5.00	0.358	-0.286	.1666E+02	-.2646E+00	.1912E+00	.2440E+02	.1144E+02	.1434E+02	.7870E+01	-.2940E+01	-.1581E+00	D0805B.BIS
6.00	0.411	-0.304	.1507E+02	-.1879E+00	.2566E+00	.2370E+02	.1111E+02	.1329E+02	.6826E+01	-.1958E+01	-.6746E+00	D0805B.BIS
7.00	0.465	-0.322	.1411E+02	-.2295E+00	-.8261E-02	.2250E+02	.1042E+02	.1162E+02	.7080E+01	-.3220E+01	-.4500E-01	D0805B.BIS
8.00	0.518	-0.340	.1313E+02	.5745E-01	.4769E-01	.1980E+02	.9794E+01	.1068E+02	.5475E+01	-.2172E+01	.6064E-01	D0805B.BIS
9.00	0.572	-0.358	.1244E+02	.2227E-01	.1345E+00	.1890E+02	.9284E+01	.1034E+02	.5526E+01	-.2936E+01	.2935E-01	D0805B.BIS
10.00	0.625	-0.375	.1160E+02	.9145E-01	.1777E+00	.1630E+02	.7958E+01	.9330E+01	.4582E+01	-.2716E+01	.4787E-01	D0805B.BIS
11.00	0.680	-0.394	.1117E+02	.6768E-01	.1628E+00	.1500E+02	.7681E+01	.8125E+01	.4523E+01	-.2430E+01	.2029E+00	D0805B.BIS
12.00	0.732	-0.411	.1033E+02	.4697E-01	.1472E-01	.1330E+02	.7142E+01	.7499E+01	.3423E+01	-.1806E+01	.1266E+00	D0805B.BIS
13.00	0.787	-0.429	.1010E+02	.1528E-01	-.5255E-01	.1200E+02	.6744E+01	.6796E+01	.3518E+01	-.1870E+01	.3587E+00	D0805B.BIS
14.00	0.839	-0.447	.9470E+01	.1109E-01	-.7848E-01	.1130E+02	.6210E+01	.7209E+01	.2978E+01	-.2019E+01	.3160E+00	D0805B.BIS
15.00	0.893	-0.465	.9385E+01	.1252E+00	.2969E-01	.9780E+01	.5891E+01	.5755E+01	.2613E+01	-.1539E+01	.2599E+00	D0805B.BIS
16.00	0.947	-0.483	.9073E+01	.8233E-01	-.1882E+00	.9680E+01	.5618E+01	.5530E+01	.2661E+01	-.1262E+01	.2409E+00	D0805B.BIS
17.00	1.000	-0.501	.8496E+01	.1112E+00	-.2012E+00	.8230E+01	.4852E+01	.5429E+01	.2032E+01	-.1671E+01	-.1014E+00	D0805B.BIS
18.00	1.054	-0.519	.8360E+01	.1597E+00	-.1638E+00	.8530E+01	.4629E+01	.4802E+01	.1914E+01	-.1413E+01	.1788E+00	D0805B.BIS
19.00	1.108	-0.537	.7879E+01	.4443E-01	-.2647E+00	.7780E+01	.4324E+01	.4509E+01	.2133E+01	-.1103E+01	.6427E-01	D0805B.BIS
0.20	0.101	-0.001	.3024E+02	.3870E+00	.1544E+00	.2000E+00	.1248E+00	.1714E+00	.5798E-03	.8223E-02	.7827E-01	D0806B.BIS

TABLE 4  
Continued

X	Y	Z	$\bar{U}$	$\bar{V}$	$\bar{W}$	$\bar{U}^2$	$\bar{V}^2$	$\bar{W}^2$	$\bar{UV}$	$\bar{UV}$	$\bar{VW}$	File Name
inch	inch	inch	m/s	m/s	m/s	m <sup>2</sup> /s <sup>2</sup>	m <sup>2</sup> /s <sup>2</sup>	m <sup>2</sup> /s <sup>2</sup>	m <sup>2</sup> /s <sup>2</sup>	m <sup>2</sup> /s <sup>2</sup>	m <sup>2</sup> /s <sup>2</sup>	
2.00	0.196	0.000	.2530E+02	.9226E+00	-.3031E+00	.1860E+02	.1382E+02	.1099E+02	.7457E+01	.1827E+01	.1142E+01	D0806B.BIS
3.00	0.249	0.000	.2194E+02	.8628E+00	-.4016E+00	.2330E+02	.1324E+02	.1657E+02	.8168E+01	.1468E+01	-.2481E+00	D0806B.BIS
4.00	0.304	-0.001	.2029E+02	.8962E+00	-.2922E+00	.2500E+02	.1240E+02	.1597E+02	.8154E+01	.1494E+01	-.8637E-01	D0806B.BIS
5.00	0.357	-0.001	.1934E+02	.8040E+00	-.4963E-01	.2340E+02	.1196E+02	.1453E+02	.7701E+01	.7290E+00	-.4965E+00	D0806B.BIS
6.00	0.410	-0.001	.1804E+02	.7336E+00	-.1106E+00	.2390E+02	.1123E+02	.1375E+02	.7440E+01	.1146E+01	-.5030E+00	D0806B.BIS
7.00	0.465	-0.001	.1693E+02	.6586E+00	-.3638E-02	.2230E+02	.1057E+02	.1244E+02	.7105E+01	.8177E+00	-.5523E+00	D0806B.BIS
8.00	0.518	0.000	.1590E+02	.6725E+00	.1014E+00	.2030E+02	.1051E+02	.1204E+02	.6079E+01	.7663E+00	-.2718E+00	D0806B.BIS
9.00	0.572	0.000	.1461E+02	.5682E+00	.2011E+00	.1860E+02	.9165E+01	.1081E+02	.5336E+01	.3257E+00	-.3349E+00	D0806B.BIS
10.00	0.625	-0.001	.1374E+02	.4456E+00	.1425E+00	.1840E+02	.8911E+01	.9968E+01	.5773E+01	.6375E+00	-.1033E+00	D0806B.BIS
11.00	0.679	-0.001	.1290E+02	.5620E+00	.1977E+00	.1600E+02	.8277E+01	.8887E+01	.4792E+01	.5924E+00	-.3802E+00	D0806B.BIS
12.00	0.733	-0.001	.1212E+02	.4362E+00	.1289E+00	.1380E+02	.7496E+01	.8021E+01	.4186E+01	.1035E+00	-.2949E+00	D0806B.BIS
13.00	0.787	-0.001	.1152E+02	.4780E+00	.8722E-01	.1290E+02	.6784E+01	.7721E+01	.3411E+01	.2836E+00	-.3397E+00	D0806B.BIS
14.00	0.840	0.000	.1075E+02	.3559E+00	.1567E+00	.1160E+02	.6314E+01	.7059E+01	.3236E+01	.4092E+00	-.2967E-01	D0806B.BIS
15.00	0.894	0.000	.1038E+02	.4785E+00	.1235E+00	.1050E+02	.6076E+01	.6570E+01	.2904E+01	.2347E+00	-.2245E+00	D0806B.BIS
16.00	0.946	-0.001	.9905E+01	.4201E+00	.2119E+00	.9410E+01	.5591E+01	.6156E+01	.2428E+01	.1624E+00	-.1053E+00	D0806B.BIS
17.00	1.000	-0.001	.9343E+01	.3347E+00	.2487E-01	.8690E+01	.5075E+01	.5419E+01	.2261E+01	.2051E+00	-.7300E-01	D0806B.BIS
18.00	1.054	-0.001	.9119E+01	.4118E+00	.1845E+00	.8010E+01	.4903E+01	.5101E+01	.2127E+01	.4889E-01	.1183E-01	D0806B.BIS
19.00	1.107	0.000	.8610E+01	.3403E+00	.1111E+00	.7290E+01	.4513E+01	.4713E+01	.1893E+01	.2727E+00	-.6440E-01	D0806B.BIS
2.00	0.196	0.232	.2566E+02	.5553E+00	.2046E+00	.1650E+02	.1067E+02	.9672E+01	.5270E+01	-.5546E-01	.8375E+00	D0807B.BIS
3.00	0.250	0.250	.2063E+02	.4410E+00	-.1643E+00	.2940E+02	.1369E+02	.1571E+02	.9457E+01	.2156E+01	-.3910E+00	D0807B.BIS
4.00	0.303	0.268	.1788E+02	.2186E+00	.4652E-01	.2940E+02	.1524E+02	.1662E+02	.9580E+01	.4307E+01	-.4805E+00	D0807B.BIS
5.00	0.358	0.286	.1607E+02	.1224E+00	.2597E+00	.3000E+02	.1427E+02	.1550E+02	.8177E+01	.4022E+01	-.6116E+00	D0807B.BIS
6.00	0.411	0.303	.1510E+02	.2766E+00	.1132E+00	.2610E+02	.1325E+02	.1378E+02	.7018E+01	.3468E+01	-.5692E+00	D0807B.BIS
7.00	0.465	0.322	.1363E+02	-.2521E-01	.3821E+00	.2440E+02	.1364E+02	.1316E+02	.7040E+01	.3123E+01	-.1197E+01	D0807B.BIS
8.00	0.518	0.339	.1359E+02	.2258E+00	.2643E+00	.2090E+02	.1037E+02	.1265E+02	.4962E+01	.2899E+01	-.1514E+01	D0807B.BIS
9.00	0.572	0.357	.1297E+02	.3864E+00	.2904E+00	.1930E+02	.1058E+02	.1112E+02	.5224E+01	.2386E+01	-.5256E+00	D0807B.BIS
10.00	0.625	0.375	.1175E+02	.1779E+00	.1216E+00	.1900E+02	.9426E+01	.1053E+02	.5265E+01	.2638E+01	-.6929E+00	D0807B.BIS
11.00	0.680	0.393	.1142E+02	.3679E+00	.5914E-01	.1580E+02	.8785E+01	.9589E+01	.3977E+01	.2503E+01	-.4925E+00	D0807B.BIS
12.00	0.732	0.411	.1090E+02	.3854E+00	.2498E+00	.1390E+02	.8211E+01	.8222E+01	.3567E+01	.1612E+01	-.6585E+00	D0807B.BIS
13.00	0.787	0.429	.1036E+02	.2975E+00	.2755E+00	.1310E+02	.7429E+01	.7678E+01	.3501E+01	.1350E+01	-.8293E+00	D0807B.BIS
14.00	0.839	0.447	.9903E+01	.3184E+00	.2763E+00	.1140E+02	.6406E+01	.6925E+01	.2823E+01	.1084E+01	-.6803E+00	D0807B.BIS
15.00	0.894	0.465	.9479E+01	.2934E+00	.1625E+00	.1030E+02	.6548E+01	.6280E+01	.2685E+01	.1546E+01	-.4814E+00	D0807B.BIS
16.00	0.947	0.482	.9092E+01	.3463E+00	.1926E+00	.9370E+01	.5783E+01	.5732E+01	.2074E+01	.1208E+01	-.3237E+00	D0807B.BIS
17.00	1.000	0.500	.8657E+01	.3527E+00	.2443E+00	.8930E+01	.5013E+01	.5375E+01	.1937E+01	.1071E+01	-.3889E+00	D0807B.BIS
18.00	1.054	0.518	.8122E+01	.2730E+00	.1899E+00	.8070E+01	.5068E+01	.4777E+01	.2003E+01	.9198E+00	-.2638E+00	D0807B.BIS
19.00	1.107	0.536	.8029E+01	.2426E+00	.2623E+00	.6950E+01	.4573E+01	.4262E+01	.1464E+01	.6388E+00	-.1745E+00	D0807B.BIS
0.20	0.100	0.400	.3016E+02	-.2753E+00	-.1313E+00	.2740E+00	.1079E+00	.1085E+00	-.1409E-01	.1079E-01	-.3188E-02	D0808B.BIS
2.00	0.196	0.464	.2496E+02	.9246E+00	-.1416E+01	.1870E+02	.1642E+02	.1384E+02	.7108E+01	-.9811E+00	.1108E+01	D0808B.BIS
3.00	0.250	0.500	.2043E+02	.7785E+00	-.1464E+01	.2880E+02	.1803E+02	.2018E+02	.1049E+02	.1651E+01	-.9559E+00	D0808B.BIS
4.00	0.303	0.535	.1637E+02	.5118E+00	-.6081E+00	.3090E+02	.1753E+02	.1953E+02	.9424E+01	.2566E+01	-.2830E+01	D0808B.BIS
5.00	0.358	0.571	.1383E+02	.1679E+00	.7729E-01	.2740E+02	.1528E+02	.1624E+02	.6944E+01	.4633E+01	-.2459E+01	D0808B.BIS
6.00	0.411	0.607	.1281E+02	.1586E+00	.4840E+00	.2290E+02	.1357E+02	.1278E+02	.5480E+01	.3473E+01	-.2347E+01	D0808B.BIS
7.00	0.465	0.642	.1118E+02	-.7432E-01	.5474E+00	.1840E+02	.1170E+02	.1168E+02	.4059E+01	.3533E+01	-.2296E+01	D0808B.BIS
8.00	0.518	0.678	.1105E+02	.3063E-01	.5523E+00	.1580E+02	.1049E+02	.1005E+02	.3628E+01	.3223E+01	-.1402E+01	D0808B.BIS
9.00	0.572	0.714	.9954E+01	-.1366E-01	.3405E+00	.1480E+02	.9154E+01	.9281E+01	.3086E+01	.3276E+01	-.1212E+01	D0808B.BIS
10.00	0.625	0.749	.9614E+01	.6281E-01	.4878E+00	.1330E+02	.8255E+01	.8150E+01	.2858E+01	.2686E+01	-.9822E+00	D0808B.BIS
11.00	0.680	0.785	.9219E+01	.2444E-01	.6030E+00	.1230E+02	.7457E+01	.7691E+01	.2363E+01	.2319E+01	-.1085E+01	D0808B.BIS
12.00	0.732	0.821	.8504E+01	.1092E+00	.6313E+00	.1170E+02	.6965E+01	.7013E+01	.2052E+01	.2563E+01	-.7969E+00	D0808B.BIS
13.00	0.787	0.857	.8212E+01	.1151E+00	.5505E+00	.9610E+01	.6775E+01	.6851E+01	.1776E+01	.2117E+01	-.9727E+00	D0808B.BIS
14.00	0.839	0.892	.8121E+01	.9613E-01	.5260E+00	.9670E+01	.6072E+01	.5677E+01	.1980E+01	.2059E+01	-.5701E+00	D0808B.BIS
15.00	0.893	0.928	.7894E+01	.1707E+00	.6182E+00	.9000E+01	.6015E+01	.5874E+01	.1681E+01	.1981E+01	-.5297E+00	D0808B.BIS
16.00	0.947	0.964	.7578E+01	.2314E+00	.8277E+00	.8770E+01	.5515E+01	.5304E+01	.1717E+01	.1625E+01	-.5698E+00	D0808B.BIS
17.00	1.000	0.999	.7205E+01	.1898E+00	.6717E+00	.7440E+01	.5601E+01	.4940E+01	.1628E+01	.1339E+01	-.4273E+00	D0808B.BIS
18.00	1.054	1.035	.7177E+01	.2361E+00	.6265E+00	.7600E+01	.4858E+01	.4709E+01	.1382E+01	.1513E+01	-.3354E+00	D0808B.BIS
19.00	1.107	1.071	.6797E+01	.2665E+00	.4504E+00	.6660E+01	.4396E+01	.4028E+01	.1266E+01	.1318E+01	-.3323E+00	D0808B.BIS

TABLE 4  
Continued

X	Y	Z	$\bar{u}$	$\bar{v}$	$\bar{w}$	$\overline{uu}$	$\overline{vv}$	$\overline{ww}$	$\overline{uv}$	$\overline{uw}$	$\overline{vw}$	File Name
inch	inch	inch	m/s	m/s	m/s	m <sup>2</sup> /s <sup>2</sup>	m <sup>2</sup> /s <sup>2</sup>	m <sup>2</sup> /s <sup>2</sup>	m <sup>2</sup> /s <sup>2</sup>	m <sup>2</sup> /s <sup>2</sup>	m <sup>2</sup> /s <sup>2</sup>	
0.20	0.100	0.599	.3016E+02	-.1744E+00	-.2348E+00	.3070E+00	.1075E+00	.7044E-01	-.8410E-02	.7582E-02	-.2522E-01	D0809B.BIS
2.00	0.196	0.696	.2289E+02	.1317E+00	-.1088E+01	.3090E+02	.1521E+02	.1379E+02	.1166E+02	.1826E+01	-.2078E+00	D0809B.BIS
3.00	0.250	0.750	.1493E+02	-.2637E+00	-.2563E+00	.3300E+02	.1544E+02	.1721E+02	.9598E+01	.4223E+01	-.2437E+01	D0809B.BIS
4.00	0.303	0.803	.1183E+02	-.2634E+00	-.5365E-01	.2500E+02	.1416E+02	.1556E+02	.6568E+01	.4939E+01	-.2495E+01	D0809B.BIS
5.00	0.358	0.857	.1041E+02	-.1151E+00	.3366E+00	.2070E+02	.1165E+02	.1285E+02	.3957E+01	.4864E+01	-.1639E+01	D0809B.BIS
6.00	0.411	0.910	.8933E+01	-.1626E+00	.4505E+00	.1650E+02	.1053E+02	.1086E+02	.2882E+01	.3142E+01	-.2099E+01	D0809B.BIS
7.00	0.465	0.964	.8368E+01	-.2262E+00	.4640E+00	.1510E+02	.9187E+01	.1031E+02	.3004E+01	.4025E+01	-.1648E+01	D0809B.BIS
8.00	0.518	1.018	.8129E+01	-.6778E-01	.5163E+00	.1230E+02	.8841E+01	.9379E+01	.2343E+01	.3210E+01	-.1599E+01	D0809B.BIS
9.00	0.572	1.071	.7243E+01	-.1975E+00	.6155E+00	.1220E+02	.7777E+01	.7798E+01	.2080E+01	.2837E+01	-.1233E+01	D0809B.BIS
10.00	0.625	1.125	.6978E+01	-.2556E+00	.7048E+00	.1060E+02	.7254E+01	.7188E+01	.2102E+01	.2074E+01	-.1273E+01	D0809B.BIS
11.00	0.680	1.179	.6560E+01	-.2289E+00	.6867E+00	.9290E+01	.6956E+01	.6914E+01	.1452E+01	.2159E+01	-.1059E+01	D0809B.BIS
12.00	0.732	1.232	.6095E+01	-.2352E+00	.4885E+00	.8730E+01	.6070E+01	.6530E+01	.1300E+01	.2084E+01	-.9790E+00	D0809B.BIS
13.00	0.787	1.286	.6122E+01	-.2376E+00	.6332E+00	.8570E+01	.5681E+01	.5953E+01	.1621E+01	.2160E+01	-.7372E+00	D0809B.BIS
14.00	0.839	1.339	.5751E+01	-.2758E+00	.5784E+00	.7690E+01	.5196E+01	.5065E+01	.1317E+01	.1636E+01	-.6359E+00	D0809B.BIS
15.00	0.893	1.393	.5539E+01	-.3255E+00	.6285E+00	.7690E+01	.4652E+01	.4973E+01	.1149E+01	.1596E+01	-.6348E+00	D0809B.BIS
16.00	0.947	1.447	.5539E+01	-.3448E+00	.6955E+00	.6580E+01	.4559E+01	.4732E+01	.1078E+01	.1556E+01	-.7920E+00	D0809B.BIS
17.00	1.000	1.500	.5332E+01	-.1903E+00	.6386E+00	.5840E+01	.4233E+01	.4239E+01	.9700E+00	.1316E+01	-.3974E+00	D0809B.BIS
18.00	1.054	1.554	.5351E+01	-.2040E+00	.5394E+00	.5320E+01	.4123E+01	.3870E+01	.9167E+00	.1333E+01	-.3604E+00	D0809B.BIS
19.00	1.107	1.607	.5128E+01	-.1061E+00	.5191E+00	.5470E+01	.3544E+01	.3636E+01	.8240E+00	.1267E+01	-.3585E+00	D0809B.BIS
0.20	0.149	-0.199	.3013E+02	-.2130E+00	.6160E-01	.2800E+00	.9353E-01	.6898E-01	-.1597E-01	.8002E-02	-.1858E-01	D0905B.BIS
2.00	0.295	-0.233	.1856E+02	.9664E+00	.6104E+00	.3170E+02	.1684E+02	.1992E+02	.1180E+02	-.5085E+01	-.9018E+00	D0905B.BIS
3.00	0.375	-0.250	.1407E+02	.3419E+00	.4247E+00	.2680E+02	.1419E+02	.1729E+02	.8611E+01	-.3796E+01	-.5119E+00	D0905B.BIS
4.00	0.455	-0.268	.1226E+02	.5482E-01	.2380E+00	.2100E+02	.1209E+02	.1413E+02	.6830E+01	-.3170E+01	-.2734E+00	D0905B.BIS
5.00	0.535	-0.286	.1127E+02	.2179E-01	.1805E+00	.1900E+02	.1009E+02	.1308E+02	.6203E+01	-.2113E+01	-.2884E+00	D0905B.BIS
6.00	0.616	-0.304	.9847E+01	-.9849E-02	.1761E+00	.1820E+02	.9722E+01	.1129E+02	.5390E+01	-.2055E+01	-.2881E-01	D0905B.BIS
7.00	0.697	-0.322	.9457E+01	.1682E+00	.2181E+00	.1660E+02	.9241E+01	.1079E+02	.5381E+01	-.1997E+01	-.2585E+00	D0905B.BIS
8.00	0.778	-0.340	.9075E+01	.2352E+00	-.9303E-01	.1390E+02	.8322E+01	.9897E+01	.4533E+01	-.1679E+01	-.1305E+00	D0905B.BIS
9.00	0.857	-0.358	.8265E+01	.8087E-01	.2001E+00	.1340E+02	.7393E+01	.8526E+01	.4212E+01	-.9526E+00	-.6671E-01	D0905B.BIS
10.00	0.937	-0.375	.8230E+01	.2579E+00	-.2536E+00	.1190E+02	.6845E+01	.8358E+01	.3260E+01	-.1123E+01	-.1158E+00	D0905B.BIS
11.00	1.018	-0.394	.7621E+01	.3310E+00	-.3133E-01	.1090E+02	.6460E+01	.7676E+01	.3407E+01	-.1339E+01	-.5348E-01	D0905B.BIS
12.00	1.099	-0.411	.7350E+01	.2482E+00	-.9829E-01	.1040E+02	.6064E+01	.7004E+01	.2859E+01	-.1183E+01	.8615E-02	D0905B.BIS
13.00	1.180	-0.429	.7180E+01	.2157E+00	.6093E-01	.9700E+01	.5672E+01	.6406E+01	.3094E+01	-.1161E+01	-.2533E-01	D0905B.BIS
14.00	1.259	-0.447	.6931E+01	.3204E+00	-.1222E+00	.8210E+01	.5516E+01	.5907E+01	.2423E+01	-.9611E+00	.3256E+00	D0905B.BIS
15.00	1.339	-0.465	.7078E+01	.3388E+00	-.3754E+00	.7840E+01	.5353E+01	.5756E+01	.2359E+01	-.9810E+00	.2845E+00	D0905B.BIS
16.00	1.420	-0.483	.6634E+01	.3237E+00	-.2952E+00	.7790E+01	.4893E+01	.5211E+01	.2184E+01	-.1443E+01	-.2763E+00	D0905B.BIS
17.00	1.501	-0.501	.6198E+01	.2523E+00	-.1031E+00	.6720E+01	.4055E+01	.4756E+01	.1902E+01	-.1171E+01	-.1613E-01	D0905B.BIS
18.00	1.582	-0.519	.6442E+01	.2074E+00	-.3602E+00	.6150E+01	.3897E+01	.4472E+01	.1690E+01	-.1066E+01	.1120E+00	D0905B.BIS
19.00	1.661	-0.537	.6248E+01	.1191E+00	-.3114E+00	.6000E+01	.3590E+01	.4026E+01	.1724E+01	-.7991E+00	-.1338E-01	D0905B.BIS
0.20	0.150	0.000	.2966E+02	-.5137E+00	-.7429E-01	.1020E+00	.1069E+00	.9866E-01	.2249E-02	.4985E-02	-.9886E-02	D0906B.BIS
2.00	0.295	0.000	.1839E+02	.5503E+00	-.2289E-01	.3030E+02	.1926E+02	.1993E+02	.1144E+02	-.1131E+01	-.1002E+01	D0906B.BIS
3.00	0.375	0.000	.1654E+02	.8877E+00	.3013E+00	.2890E+02	.1469E+02	.1966E+02	.9439E+01	-.5486E+00	-.1197E+01	D0906B.BIS
4.00	0.454	-0.001	.1596E+02	.8390E+00	.2811E+00	.2450E+02	.1357E+02	.1786E+02	.8010E+01	-.7161E+00	-.9495E+00	D0906B.BIS
5.00	0.535	-0.001	.1534E+02	.8729E+00	.3208E+00	.2330E+02	.1309E+02	.1585E+02	.7075E+01	-.9082E+00	-.4304E+00	D0906B.BIS
6.00	0.616	-0.001	.1398E+02	.6003E+00	.3224E+00	.2300E+02	.1128E+02	.1396E+02	.7068E+01	-.6261E+00	-.5305E+00	D0906B.BIS
7.00	0.697	-0.001	.1304E+02	.6445E+00	.2749E+00	.1980E+02	.1026E+02	.1248E+02	.6088E+01	-.3505E+00	-.5665E+00	D0906B.BIS
8.00	0.778	0.000	.1191E+02	.4635E+00	.4342E+00	.1760E+02	.8874E+01	.1155E+02	.5170E+01	-.8004E+00	-.7352E+00	D0906B.BIS
9.00	0.857	0.000	.1107E+02	.3178E+00	.3591E+00	.1520E+02	.8758E+01	.9970E+01	.4792E+01	-.4853E+00	-.5687E+00	D0906B.BIS
10.00	0.937	-0.001	.1002E+02	.3381E+00	.4223E+00	.1340E+02	.7671E+01	.8839E+01	.4084E+01	-.7025E+00	-.6204E+00	D0906B.BIS
11.00	1.018	-0.001	.9444E+01	.2760E+00	.3885E+00	.1230E+02	.6843E+01	.8137E+01	.3767E+01	-.5568E+00	-.4442E+00	D0906B.BIS
12.00	1.099	-0.001	.8766E+01	.1993E+00	.3449E+00	.1100E+02	.6139E+01	.7121E+01	.3102E+01	-.4825E+00	-.4917E+00	D0906B.BIS
13.00	1.180	0.000	.8645E+01	.3836E+00	.1279E+00	.1000E+02	.5706E+01	.6861E+01	.2782E+01	-.4952E+00	-.2105E+00	D0906B.BIS
14.00	1.259	0.000	.7961E+01	.3109E+00	.2987E+00	.8920E+01	.5524E+01	.5971E+01	.2719E+01	-.1319E+00	-.2018E+00	D0906B.BIS
15.00	1.339	-0.001	.7448E+01	.2790E+00	.2330E+00	.8400E+01	.5078E+01	.5656E+01	.2387E+01	-.2328E+00	-.1841E+00	D0906B.BIS
16.00	1.420	-0.001	.7198E+01	.2296E+00	.3237E+00	.7920E+01	.4584E+01	.5146E+01	.2147E+01	-.2326E+00	-.2140E+00	D0906B.BIS
17.00	1.501	-0.001	.6908E+01	.2509E+00	.2514E+00	.7030E+01	.4516E+01	.4708E+01	.1952E+01	-.1914E+00	-.8308E-01	D0906B.BIS
18.00	1.582	0.000	.6347E+01	.1286E+00	.3085E+00	.6390E+01	.4020E+01	.4208E+01	.1652E+01	-.1985E+00	-.1772E+00	D0906B.BIS

TABLE 4  
Continued

X	Y	Z	$\bar{u}$	$\bar{v}$	$\bar{w}$	$\overline{uu}$	$\overline{vv}$	$\overline{ww}$	$\overline{uv}$	$\overline{vw}$	$\overline{wv}$	File Name
inch	inch	inch	m/s	m/s	m/s	m <sup>2</sup> /s <sup>2</sup>	m <sup>2</sup> /s <sup>2</sup>	m <sup>2</sup> /s <sup>2</sup>	m <sup>2</sup> /s <sup>2</sup>	m <sup>2</sup> /s <sup>2</sup>	m <sup>2</sup> /s <sup>2</sup>	
19.00	1.661	-0.001	.6118E+01	.1204E+00	.3037E+00	.5850E+01	.3757E+01	.3964E+01	.1680E+01	-.8083E-01	-.3381E-01	D0906B.BIS
0.20	0.150	0.199	.3017E+02	.4975E-01	-.7258E-01	.1800E+00	.9826E-01	.8295E-01	-.2428E-01	.2277E-02	-.1333E-01	D0907B.BIS
2.00	0.295	0.232	.1844E+02	.1337E+01	-.1013E+01	.3260E+02	.1807E+02	.2074E+02	.1205E+02	.2831E+01	.9143E+00	D0907B.BIS
3.00	0.375	0.250	.1460E+02	.4878E+00	-.1762E+00	.2610E+02	.1392E+02	.1768E+02	.7964E+01	.1587E+01	-.1508E+00	D0907B.BIS
4.00	0.455	0.268	.1346E+02	.4734E+00	.1810E+00	.2130E+02	.1160E+02	.1644E+02	.6521E+01	.9070E+00	-.1448E+01	D0907B.BIS
5.00	0.535	0.286	.1264E+02	.4612E+00	.4509E+00	.2170E+02	.1087E+02	.1454E+02	.6637E+01	.9007E+00	-.1334E+01	D0907B.BIS
6.00	0.616	0.303	.1196E+02	.5407E+00	.5352E+00	.1850E+02	.9951E+01	.1298E+02	.5202E+01	.1514E+01	-.7665E+00	D0907B.BIS
7.00	0.697	0.322	.1089E+02	.5461E+00	.5828E+00	.1740E+02	.9558E+01	.1157E+02	.5211E+01	.1340E+01	-.5845E+00	D0907B.BIS
8.00	0.778	0.339	.9831E+01	.6224E+00	.5100E+00	.1550E+02	.9002E+01	.1065E+02	.4674E+01	.1090E+01	-.8500E+00	D0907B.BIS
9.00	0.857	0.357	.9139E+01	.4457E+00	.3463E+00	.1400E+02	.8174E+01	.9924E+01	.4302E+01	.1058E+01	-.5837E+00	D0907B.BIS
10.00	0.937	0.375	.8536E+01	.5375E+00	.3140E+00	.1290E+02	.7796E+01	.9192E+01	.3674E+01	.1210E+01	-.3878E+00	D0907B.BIS
11.00	1.018	0.393	.7937E+01	.5375E+00	.3031E+00	.1220E+02	.7263E+01	.8524E+01	.3382E+01	.1426E+01	-.6216E+00	D0907B.BIS
12.00	1.099	0.411	.7624E+01	.5777E+00	.3700E+00	.1120E+02	.6812E+01	.7428E+01	.3172E+01	.9544E+00	-.3432E+00	D0907B.BIS
13.00	1.180	0.429	.7342E+01	.5366E+00	.3308E+00	.9760E+01	.6372E+01	.7040E+01	.2571E+01	.1155E+01	-.3804E+00	D0907B.BIS
14.00	1.259	0.447	.6850E+01	.5415E+00	.3796E+00	.9180E+01	.5815E+01	.6332E+01	.2620E+01	.8294E+00	-.3624E+00	D0907B.BIS
15.00	1.340	0.465	.6541E+01	.4386E+00	.3869E+00	.8000E+01	.5569E+01	.5797E+01	.2365E+01	.9059E+00	-.3279E+00	D0907B.BIS
16.00	1.420	0.482	.6221E+01	.4888E+00	.2367E+00	.7790E+01	.5164E+01	.5312E+01	.1933E+01	.1203E+01	-.2159E+00	D0907B.BIS
17.00	1.501	0.500	.6078E+01	.4754E+00	.3074E+00	.6680E+01	.4461E+01	.4904E+01	.1975E+01	.2795E+00	-.2457E+00	D0907B.BIS
18.00	1.582	0.518	.5882E+01	.4655E+00	.2785E+00	.5960E+01	.4138E+01	.4207E+01	.1689E+01	.5283E+00	-.2722E+00	D0907B.BIS
19.00	1.661	0.536	.5584E+01	.5167E+00	.3104E+00	.6250E+01	.3837E+01	.3893E+01	.1610E+01	.6561E+00	-.1124E+00	D0907B.BIS
0.20	0.149	0.400	.3016E+02	.8988E-01	.7031E-01	.2850E+00	.1047E+00	.1459E+00	.1511E-01	.1902E-01	.6688E-01	D0908B.BIS
2.00	0.295	0.464	.1699E+02	.1013E+01	-.7689E-01	.3320E+02	.1598E+02	.2105E+02	.1117E+02	-.6416E+01	.1411E+01	D0908B.BIS
3.00	0.375	0.500	.1510E+02	.1109E+01	-.9586E-01	.2570E+02	.1470E+02	.1740E+02	.8577E+01	-.1764E+01	-.7876E+00	D0908B.BIS
4.00	0.455	0.535	.1268E+02	.7077E+00	.3124E+00	.2270E+02	.1200E+02	.1517E+02	.6713E+01	.1466E+01	-.1312E+01	D0908B.BIS
5.00	0.535	0.571	.1110E+02	.5225E+00	.5631E+00	.2080E+02	.1117E+02	.1413E+02	.6025E+01	.2596E+01	-.1077E+01	D0908B.BIS
6.00	0.616	0.607	.9981E+01	.4939E+00	.7147E+00	.1760E+02	.9864E+01	.1310E+02	.5454E+01	.1941E+01	-.1404E+01	D0908B.BIS
7.00	0.697	0.643	.8729E+01	.4150E+00	.6160E+00	.1660E+02	.9441E+01	.1159E+02	.4276E+01	.1814E+01	-.1028E+01	D0908B.BIS
8.00	0.778	0.678	.8305E+01	.2188E+00	.6275E+00	.1470E+02	.8820E+01	.1089E+02	.4099E+01	.1783E+01	-.1245E+01	D0908B.BIS
9.00	0.857	0.714	.7405E+01	.4744E-01	.5321E+00	.1370E+02	.7971E+01	.8909E+01	.3364E+01	.1736E+01	-.1032E+01	D0908B.BIS
10.00	0.937	0.749	.7197E+01	.6223E-01	.5822E+00	.1150E+02	.7234E+01	.8304E+01	.3172E+01	.1049E+01	-.1101E+01	D0908B.BIS
11.00	1.018	0.785	.6829E+01	.7929E-01	.5219E+00	.1110E+02	.6891E+01	.7560E+01	.2968E+01	.1737E+01	-.8818E+00	D0908B.BIS
12.00	1.099	0.821	.6170E+01	-.1354E+00	.6111E+00	.9530E+01	.5616E+01	.6395E+01	.2301E+01	.1455E+01	-.5815E+00	D0908B.BIS
13.00	1.180	0.857	.6006E+01	-.1265E+00	.6263E+00	.8600E+01	.5194E+01	.5856E+01	.2057E+01	.1270E+01	-.6598E+00	D0908B.BIS
14.00	1.259	0.892	.5837E+01	-.1539E+00	.5627E+00	.7630E+01	.4729E+01	.5701E+01	.1875E+01	.9831E+00	-.6376E+00	D0908B.BIS
15.00	1.339	0.928	.5499E+01	-.2355E+00	.6903E+00	.6890E+01	.4305E+01	.4361E+01	.1753E+01	.9863E+00	-.4012E+00	D0908B.BIS
16.00	1.420	0.964	.5553E+01	-.2275E+00	.6503E+00	.6290E+01	.4116E+01	.4411E+01	.1572E+01	.6092E+00	-.4719E+00	D0908B.BIS
17.00	1.501	0.999	.5257E+01	-.2871E+00	.6462E+00	.5640E+01	.3727E+01	.4096E+01	.1367E+01	.6938E+00	-.3549E+00	D0908B.BIS
18.00	1.582	1.035	.4846E+01	-.2234E+00	.6539E+00	.5180E+01	.3134E+01	.3647E+01	.1091E+01	.8946E+00	-.2862E+00	D0908B.BIS
19.00	1.661	1.071	.5091E+01	-.1485E+00	.6930E+00	.5090E+01	.3448E+01	.3626E+01	.1222E+01	.7002E+00	-.3532E+00	D0908B.BIS
0.20	0.149	0.599	.3013E+02	-.2006E+00	.5183E-02	.1630E+00	.8017E-01	.1082E+00	-.8281E-02	.4294E-02	.5418E-01	D0909B.BIS
2.00	0.295	0.696	.1371E+02	.4363E+00	-.6270E+00	.3500E+02	.2468E+02	.2292E+02	.1198E+02	.6247E+01	.1655E+01	D0909B.BIS
3.00	0.375	0.750	.9760E+01	-.2259E+00	.7655E+00	.2580E+02	.1633E+02	.1917E+02	.7176E+01	.3360E+01	-.1814E+01	D0909B.BIS
4.00	0.455	0.803	.7540E+01	-.1850E+00	.8557E+00	.1890E+02	.1124E+02	.1316E+02	.4062E+01	.3036E+01	-.8785E+00	D0909B.BIS
5.00	0.535	0.857	.6529E+01	-.1919E+00	.6688E+00	.1440E+02	.9489E+01	.9892E+01	.3264E+01	.2345E+01	-.1312E+01	D0909B.BIS
6.00	0.616	0.910	.6135E+01	-.3375E-01	.7625E+00	.1150E+02	.7845E+01	.8869E+01	.2196E+01	.2258E+01	-.1125E+01	D0909B.BIS
7.00	0.697	0.964	.6104E+01	-.5563E-01	.7155E+00	.1070E+02	.7539E+01	.7516E+01	.2309E+01	.2036E+01	-.9746E+00	D0909B.BIS
8.00	0.777	1.018	.5654E+01	-.9355E-01	.7419E+00	.9050E+01	.6339E+01	.6970E+01	.1772E+01	.2282E+01	-.6285E+00	D0909B.BIS
9.00	0.857	1.071	.5387E+01	.4751E-01	.8453E+00	.8270E+01	.5759E+01	.6270E+01	.1571E+01	.1721E+01	-.5341E+00	D0909B.BIS
10.00	0.937	1.125	.5231E+01	-.4806E-01	.7709E+00	.7850E+01	.5162E+01	.5762E+01	.1398E+01	.1750E+01	-.6032E+00	D0909B.BIS
11.00	1.018	1.178	.5062E+01	.4993E-01	.6533E+00	.6860E+01	.4916E+01	.4914E+01	.1270E+01	.1594E+01	-.2357E+00	D0909B.BIS
12.00	1.099	1.232	.4737E+01	-.1285E+00	.8500E+00	.6520E+01	.4373E+01	.4538E+01	.1403E+01	.1485E+01	-.2290E+00	D0909B.BIS
13.00	1.180	1.286	.4496E+01	-.1120E+00	.8705E+00	.5980E+01	.4045E+01	.4233E+01	.1138E+01	.1390E+01	.7720E-02	D0909B.BIS
14.00	1.259	1.339	.4484E+01	-.1828E+00	.7735E+00	.5810E+01	.3992E+01	.4036E+01	.1031E+01	.1266E+01	-.3001E+00	D0909B.BIS
15.00	1.339	1.393	.4402E+01	-.4994E-01	.8129E+00	.5390E+01	.3953E+01	.3872E+01	.1011E+01	.1184E+01	-.2751E+00	D0909B.BIS
16.00	1.420	1.447	.4245E+01	-.1628E+00	.7737E+00	.5230E+01	.3688E+01	.3486E+01	.9409E+00	.1066E+01	-.9045E-01	D0909B.BIS
17.00	1.501	1.500	.4096E+01	-.1247E+00	.7607E+00	.5000E+01	.3474E+01	.3347E+01	.1143E+01	.1093E+01	-.6861E-01	D0909B.BIS

TABLE 4  
Continued

X	Y	Z	$\bar{U}$	$\bar{V}$	$\bar{W}$	$\overline{uu}$	$\overline{vv}$	$\overline{ww}$	$\overline{uv}$	$\overline{uw}$	$\overline{vw}$	File Name
inch	inch	inch	m/s	m/s	m/s	m <sup>2</sup> /s <sup>2</sup>	m <sup>2</sup> /s <sup>2</sup>	m <sup>2</sup> /s <sup>2</sup>	m <sup>2</sup> /s <sup>2</sup>	m <sup>2</sup> /s <sup>2</sup>	m <sup>2</sup> /s <sup>2</sup>	
18.00	1.582	1.554	.4127E+01	-.8703E-01	.7147E+00	.4660E+01	.3335E+01	.3101E+01	.8678E+00	.9678E+00	.3289E-01	D0909B.BIS
19.00	1.661	1.607	.4069E+01	-.5107E-01	.6952E+00	.4120E+01	.3059E+01	.2897E+01	.8021E+00	.9053E+00	-.1343E-01	D0909B.BIS
0.20	0.199	0.000	.3026E+02	.2868E+00	.7318E-01	.2190E+00	.1014E+00	.1163E+00	-.4677E-02	.6826E-02	.1048E-01	D1006B.BIS
2.00	0.393	-0.001	.1124E+02	.7711E+00	-.3709E+00	.2760E+02	.1863E+02	.2047E+02	.9429E+01	.3348E+01	-.1301E+01	D1006B.BIS
3.00	0.499	-0.001	.1091E+02	.9034E+00	.6782E-01	.2260E+02	.1312E+02	.1640E+02	.7127E+01	.1954E+01	-.6409E+00	D1006B.BIS
4.00	0.607	-0.001	.1059E+02	.7965E+00	.3412E+00	.1960E+02	.1108E+02	.1439E+02	.6176E+01	.1794E+01	-.9261E+00	D1006B.BIS
5.00	0.714	-0.001	.1000E+02	.8627E+00	.5199E+00	.1790E+02	.9806E+01	.1278E+02	.5530E+01	.1548E+01	-.5055E+00	D1006B.BIS
6.00	0.821	0.000	.9373E+01	.7616E+00	.3930E+00	.1640E+02	.9490E+01	.1195E+02	.5082E+01	.1033E+01	-.4852E+00	D1006B.BIS
7.00	0.928	0.000	.8682E+01	.7327E+00	.3533E+00	.1470E+02	.8956E+01	.1031E+02	.5018E+01	.3377E+00	-.7337E+00	D1006B.BIS
8.00	1.035	-0.001	.8010E+01	.7156E+00	.2377E+00	.1320E+02	.8045E+01	.9489E+01	.4354E+01	.3346E-01	-.4838E+00	D1006B.BIS
9.00	1.143	-0.001	.7570E+01	.7564E+00	.2874E+00	.1140E+02	.7194E+01	.8530E+01	.4049E+01	.3740E-01	-.3757E+00	D1006B.BIS
10.00	1.250	-0.001	.6956E+01	.6082E+00	.4640E+00	.9690E+01	.6483E+01	.7283E+01	.3057E+01	-.2934E+00	-.4813E+00	D1006B.BIS
11.00	1.357	-0.001	.6622E+01	.5685E+00	.4781E+00	.8990E+01	.5725E+01	.6475E+01	.2795E+01	.1231E+00	-.3608E+00	D1006B.BIS
12.00	1.464	0.000	.6382E+01	.6534E+00	.2006E+00	.8060E+01	.5404E+01	.6092E+01	.2487E+01	-.1218E+00	-.3416E+00	D1006B.BIS
13.00	1.571	0.000	.6131E+01	.5156E+00	.1913E+00	.7320E+01	.4834E+01	.5630E+01	.2208E+01	-.1566E+00	-.3048E+00	D1006B.BIS
14.00	1.678	-0.001	.5855E+01	.5151E+00	.5675E+00	.6860E+01	.4484E+01	.5098E+01	.2241E+01	-.2059E+00	-.1800E+00	D1006B.BIS
15.00	1.785	-0.001	.5604E+01	.5562E+00	.1843E+00	.6160E+01	.4227E+01	.4535E+01	.1852E+01	-.7055E-01	-.1827E+00	D1006B.BIS
16.00	1.891	-0.001	.5490E+01	.5343E+00	.4212E+00	.5510E+01	.4054E+01	.4473E+01	.1789E+01	-.1149E+00	-.6712E-01	D1006B.BIS
17.00	1.999	-0.001	.5289E+01	.4705E+00	.3780E+00	.5090E+01	.3656E+01	.4048E+01	.1519E+01	-.2010E-01	-.6255E-01	D1006B.BIS
18.00	2.106	0.000	.5020E+01	.4457E+00	.4526E+00	.4940E+01	.3461E+01	.3738E+01	.1479E+01	-.2172E+00	-.9606E-01	D1006B.BIS
19.00	2.213	0.000	.4915E+01	.4361E+00	.3377E+00	.4230E+01	.3205E+01	.3436E+01	.1306E+01	-.2581E+00	-.7921E-01	D1006B.BIS
0.20	0.200	0.799	.3025E+02	-.1341E+00	-.1033E+00	.2870E+00	.1073E+00	.1281E+00	-.2180E-01	.4745E-02	.1846E-01	D1010B.BIS
2.00	0.393	0.928	.5127E+01	.7187E+00	.1273E+00	.1580E+02	.1102E+02	.1073E+02	.4809E+01	.6161E+00	-.7358E+00	D1010B.BIS
3.00	0.499	0.999	.3482E+01	.3654E-01	.5347E+00	.1080E+02	.6750E+01	.7184E+01	.2182E+01	.1619E+01	.4172E-01	D1010B.BIS
4.00	0.607	1.071	.2291E+01	-.8602E-01	.4436E+00	.7060E+01	.4427E+01	.4641E+01	.1084E+01	.9949E+00	.2263E+00	D1010B.BIS
5.00	0.714	1.142	.1986E+01	-.1824E-01	.4104E+00	.6040E+01	.4115E+01	.4180E+01	.1163E+01	.9526E+00	.1925E+00	D1010B.BIS
6.00	0.821	1.214	.1822E+01	-.1393E+00	.3635E+00	.4960E+01	.3102E+01	.3070E+01	.9154E+00	.7707E+00	.2472E+00	D1010B.BIS
7.00	0.928	1.285	.2107E+01	.6117E-01	.4444E+00	.6090E+01	.3748E+01	.3979E+01	.8566E+00	.1138E+01	.3396E-01	D1010B.BIS
8.00	1.036	1.357	.1427E+01	-.4441E-01	.3723E+00	.4760E+01	.2793E+01	.3441E+01	.5997E+00	.1158E+01	.5029E-01	D1010B.BIS
9.00	1.143	1.428	.1738E+01	-.2495E+00	.3852E+00	.4670E+01	.2660E+01	.2887E+01	.5044E+00	.8960E+00	-.5787E-01	D1010B.BIS
10.00	1.250	1.499	.1541E+01	-.3297E+00	.2462E+00	.3970E+01	.2299E+01	.2359E+01	.5133E+00	.7523E+00	.1669E+00	D1010B.BIS
11.00	1.357	1.571	.1654E+01	-.4096E+00	.2827E+00	.3520E+01	.1952E+01	.2080E+01	.5027E+00	.7733E+00	.1807E+00	D1010B.BIS
12.00	1.464	1.642	.1708E+01	-.4537E+00	.3091E+00	.3390E+01	.2085E+01	.2076E+01	.3765E+00	.6908E+00	.1901E+00	D1010B.BIS
13.00	1.571	1.714	.1722E+01	-.3958E+00	.2954E+00	.3250E+01	.1794E+01	.1907E+01	.3918E+00	.7160E+00	.6515E-01	D1010B.BIS
14.00	1.678	1.785	.1665E+01	-.3954E+00	.2994E+00	.3310E+01	.1786E+01	.1820E+01	.2973E+00	.7707E+00	.2485E-01	D1010B.BIS
15.00	1.785	1.857	.1814E+01	-.4494E+00	.4744E+00	.3200E+01	.1834E+01	.1969E+01	.2953E+00	.7527E+00	.6507E-01	D1010B.BIS
16.00	1.892	1.928	.1703E+01	-.4065E+00	.3595E+00	.3090E+01	.1642E+01	.1758E+01	.2711E+00	.7358E+00	.8140E-01	D1010B.BIS
17.00	1.999	1.999	.1741E+01	-.4529E+00	.3614E+00	.2910E+01	.1697E+01	.1849E+01	.2682E+00	.7360E+00	.1170E+00	D1010B.BIS
18.00	2.106	2.070	.1886E+01	-.4087E+00	.3532E+00	.2980E+01	.1774E+01	.1664E+01	.2800E+00	.6548E+00	.1487E+00	D1010B.BIS
19.00	2.213	2.142	.2076E+01	-.3504E+00	.5166E+00	.2840E+01	.1707E+01	.1856E+01	.3325E+00	.6831E+00	.1774E-01	D1010B.BIS
0.20	0.249	0.000	.2045E+02	.4227E+00	.2290E+00	.4430E+01	.1239E+00	.1737E+00	-.4335E-01	.7011E-01	.6677E-01	D1106B.BIS
2.00	0.490	0.000	.6124E+01	.1238E+00	.1210E+00	.1490E+02	.1163E+02	.1347E+02	.4736E+01	.1282E+01	-.9086E+00	D1106B.BIS
3.00	0.625	0.000	.7145E+01	.5224E+00	.4651E+00	.1380E+02	.9272E+01	.1047E+02	.4081E+01	.1337E+01	-.5223E+00	D1106B.BIS
4.00	0.759	0.000	.6739E+01	.4259E+00	.5716E+00	.1330E+02	.8523E+01	.9514E+01	.3746E+01	.1259E+01	-.4534E+00	D1106B.BIS
5.00	0.893	0.000	.6523E+01	.4478E+00	.6711E+00	.1180E+02	.7838E+01	.8533E+01	.3718E+01	.1032E+01	-.2264E+00	D1106B.BIS
6.00	1.026	-0.001	.5942E+01	.3006E+00	.5077E+00	.1110E+02	.7163E+01	.7696E+01	.3538E+01	.7216E+00	-.3204E+00	D1106B.BIS
7.00	1.161	-0.001	.5483E+01	.3778E+00	.4556E+00	.8340E+01	.6273E+01	.6647E+01	.2676E+01	.3468E+00	-.5532E-01	D1106B.BIS
8.00	1.294	-0.001	.5177E+01	.3294E+00	.3266E+00	.7560E+01	.5646E+01	.5912E+01	.2381E+01	.2552E+00	-.2446E+00	D1106B.BIS
9.00	1.427	0.000	.4888E+01	.4131E+00	.3933E+00	.7210E+01	.4985E+01	.5471E+01	.2314E+01	.4953E-01	-.2838E+00	D1106B.BIS
10.00	1.563	0.000	.4575E+01	.3339E+00	.5563E+00	.6360E+01	.4346E+01	.4800E+01	.1964E+01	.2682E-01	-.2330E+00	D1106B.BIS
11.00	1.696	-0.001	.4539E+01	.3975E+00	.4036E+00	.5490E+01	.3926E+01	.4491E+01	.1533E+01	.3360E-01	-.1821E+00	D1106B.BIS
12.00	1.829	-0.001	.4348E+01	.3385E+00	.4644E+00	.5070E+01	.3725E+01	.3812E+01	.1526E+01	-.1257E+00	-.1569E+00	D1106B.BIS
13.00	1.965	-0.001	.4059E+01	.3515E+00	.3420E+00	.4690E+01	.3396E+01	.3546E+01	.1373E+01	-.6480E-01	-.9087E-01	D1106B.BIS
14.00	2.097	-0.001	.4259E+01	.5458E+00	.4825E+00	.4960E+01	.3672E+01	.3667E+01	.1510E+01	-.4758E-01	-.3975E-01	D1106B.BIS
15.00	2.232	0.000	.4021E+01	.4702E+00	.4800E+00	.4490E+01	.3364E+01	.3349E+01	.1468E+01	-.2116E-02	-.1694E-01	D1106B.BIS
16.00	2.366	0.000	.3783E+01	.4547E+00	.2812E+00	.4050E+01	.3194E+01	.3076E+01	.1233E+01	-.6989E-01	-.8605E-02	D1106B.BIS



TABLE 4  
Continued

X	Y	Z	U	V	W	U	V	W	UV	UV	VW	File Name
inch	inch	inch	m/s	m/s	m/s	m <sup>2</sup> /s <sup>2</sup>	m <sup>2</sup> /s <sup>2</sup>	m <sup>2</sup> /s <sup>2</sup>	m <sup>2</sup> /s <sup>2</sup>	m <sup>2</sup> /s <sup>2</sup>	m <sup>2</sup> /s <sup>2</sup>	
17.00	2.499	-0.001	.3567E+01	.3966E+00	.2672E+00	.3860E+01	.2845E+01	.2698E+01	.1189E+01	-.2795E-01	-.4938E-01	D1106B.BIS
18.00	2.632	-0.001	.3347E+01	.3327E+00	.3830E+00	.3910E+01	.2449E+01	.2364E+01	.1091E+01	-.8663E-01	-.1053E-02	D1106B.BIS
19.00	2.767	0.000	.3222E+01	.2467E+00	.2159E+00	.3440E+01	.2326E+01	.2351E+01	.9795E+00	-.1572E+00	.2078E-01	D1106B.BIS
0.20	0.300	0.000	.4625E+00	-.1264E+00	-.1583E+00	.2450E+00	.1524E+00	.1741E+00	-.1639E-01	.3303E-02	.1610E-01	D1206B.BIS
1.00	0.428	0.000	.1103E+01	-.1751E+00	.2548E-01	.4680E+01	.3975E+01	.2838E+01	.1211E+01	-.1205E-01	-.8380E+00	D1206B.BIS
2.00	0.590	0.000	.1313E+01	-.2188E-01	.6438E-01	.4890E+01	.4495E+01	.2513E+01	.1226E+01	-.1045E+00	-.1163E+00	D1206B.BIS
3.00	0.750	-0.001	.1237E+01	-.8665E-01	.1139E+00	.3720E+01	.3291E+01	.1895E+01	.8423E+00	-.7170E-01	-.6215E-01	D1206B.BIS
4.00	0.910	-0.001	.9993E+00	-.1168E+00	.1399E+00	.2560E+01	.2444E+01	.1485E+01	.4220E+00	-.7367E-01	-.2415E-01	D1206B.BIS
5.00	1.072	-0.001	.9194E+00	-.1019E+00	.5928E-01	.2170E+01	.2215E+01	.1309E+01	.3898E+00	.1240E-02	-.1971E-01	D1206B.BIS
6.00	1.232	-0.001	.7748E+00	-.1648E+00	.6629E-01	.1850E+01	.1873E+01	.1049E+01	.2993E+00	-.1421E-01	.2207E-01	D1206B.BIS
7.00	1.393	-0.001	.7574E+00	-.1678E+00	.7759E-01	.1790E+01	.1774E+01	.9724E+00	.2578E+00	-.6066E-03	.5088E-02	D1206B.BIS
8.00	1.553	-0.001	.7644E+00	-.1528E+00	.1723E+00	.1790E+01	.1040E+01	.9611E+00	.3195E+00	.8823E-01	-.1053E+00	D1206B.BIS
9.00	1.714	-0.001	.8396E+00	-.8246E-01	.1343E+00	.2030E+01	.1873E+01	.1107E+01	.3396E+00	.1367E+00	.4460E-02	D1206B.BIS
10.00	1.876	-0.001	.9842E+00	-.8288E-01	.1537E+00	.2040E+01	.1922E+01	.1143E+01	.4174E+00	.5955E-01	.3656E-01	D1206B.BIS
11.00	2.035	0.000	.1082E+01	.1606E-01	.1892E+00	.2420E+01	.1971E+01	.1325E+01	.5541E+00	.1173E+00	.3811E-01	D1206B.BIS
12.00	2.197	-0.001	.1338E+01	.5797E-01	.1848E+00	.2930E+01	.2258E+01	.1495E+01	.5824E+00	.1209E+00	.7357E-01	D1206B.BIS
13.00	2.357	-0.001	.1339E+01	.2931E-01	.1866E+00	.2430E+01	.1837E+01	.1241E+01	.5655E+00	.3069E-01	.3011E-02	D1206B.BIS
14.00	2.517	-0.001	.1338E+01	.5461E-01	.3241E+00	.2460E+01	.1992E+01	.1349E+01	.5417E+00	.1918E+00	.6979E-01	D1206B.BIS
15.00	2.679	-0.001	.1640E+01	.1679E+00	.2172E+00	.2510E+01	.1861E+01	.1363E+01	.5636E+00	.7965E-01	.8912E-01	D1206B.BIS
16.00	2.838	0.000	.1685E+01	.1490E+00	.2357E+00	.2460E+01	.1753E+01	.1244E+01	.5735E+00	.9222E-01	.8113E-01	D1206B.BIS
17.00	3.000	-0.001	.1636E+01	.9575E-01	.1809E+00	.2420E+01	.1795E+01	.1225E+01	.5765E+00	.1129E+00	.1679E+00	D1206B.BIS
18.00	3.161	-0.001	.1491E+01	.1374E+00	.2491E+00	.2120E+01	.1678E+01	.1193E+01	.5441E+00	.7293E-01	.1422E+00	D1206B.BIS
19.00	3.321	-0.001	.1451E+01	.7890E-01	.2536E+00	.2090E+01	.1705E+01	.1062E+01	.4651E+00	.5943E-01	.1035E+00	D1206B.BIS
0.20	0.299	1.200	.4578E+00	-.1159E+00	-.2963E+00	.2610E+00	.1151E+00	.1207E+00	-.1930E-01	-.4133E-02	.2333E-02	D1212B.BIS
1.00	0.428	1.285	.3721E+00	-.2810E+00	-.3715E+00	.3580E+00	.1214E+00	.1423E+00	-.2449E-01	.8502E-02	.1716E-01	D1212B.BIS
2.00	0.590	1.393	.2051E+00	-.2630E+00	-.2522E+00	.3300E+00	.1178E+00	.1302E+00	-.3583E-01	.5603E-02	.8719E-02	D1212B.BIS
3.00	0.749	1.500	.2262E+00	-.2552E+00	-.1744E+00	.3350E+00	.1053E+00	.1141E+00	-.3029E-01	.5146E-02	.5419E-02	D1212B.BIS
4.00	0.910	1.607	.2421E+00	-.2416E+00	-.1528E+00	.3840E+00	.1137E+00	.1044E+00	-.3144E-01	.1078E-01	-.1029E-01	D1212B.BIS
5.00	1.072	1.714	.2712E+00	-.2583E+00	-.1303E+00	.3280E+00	.1217E+00	.9947E-01	-.2696E-01	.6260E-02	-.1868E-01	D1212B.BIS
6.00	1.232	1.821	.2601E+00	-.2517E+00	-.1064E+00	.3760E+00	.1358E+00	.9908E-01	-.1818E-01	.1082E-01	-.2753E-01	D1212B.BIS
7.00	1.393	1.928	.2607E+00	-.2271E+00	-.9957E-01	.3370E+00	.1276E+00	.9166E-01	-.3089E-01	.2479E-02	-.2591E-01	D1212B.BIS
8.00	1.553	2.035	.2594E+00	-.2281E+00	-.8246E-01	.3550E+00	.1331E+00	.9324E-01	-.3768E-01	.8082E-02	-.2834E-01	D1212B.BIS
9.00	1.714	2.142	.2797E+00	-.2250E+00	-.5780E-01	.3170E+00	.1282E+00	.9263E-01	-.2274E-01	.9178E-02	-.2627E-01	D1212B.BIS
10.00	1.876	2.249	.2746E+00	-.2298E+00	-.4253E-01	.3560E+00	.1315E+00	.1084E+00	-.2651E-01	.1072E-01	-.1998E-01	D1212B.BIS
11.00	2.036	2.357	.2621E+00	-.2324E+00	-.5461E-01	.3220E+00	.1418E+00	.9347E-01	-.2012E-01	.6240E-02	-.3280E-01	D1212B.BIS
12.00	2.196	2.464	.2367E+00	-.2263E+00	-.4318E-01	.3100E+00	.1300E+00	.1045E+00	-.2144E-01	.1142E-01	-.2142E-01	D1212B.BIS
13.00	2.357	2.570	.2371E+00	-.2239E+00	-.4450E-01	.3310E+00	.1420E+00	.1154E+00	-.2738E-01	.1061E-01	-.2251E-01	D1212B.BIS
14.00	2.517	2.678	.2284E+00	-.2753E+00	-.6704E-01	.3070E+00	.1601E+00	.1250E+00	-.3971E-01	.3358E-02	-.2750E-01	D1212B.BIS
15.00	2.679	2.784	.1962E+00	-.1798E+00	.1818E-01	.3130E+00	.1444E+00	.1313E+00	-.1557E-01	.7388E-02	-.1425E-01	D1212B.BIS
16.00	2.839	2.892	.1908E+00	-.1513E+00	.1523E-01	.3260E+00	.1680E+00	.1652E+00	-.2141E-01	.6437E-02	-.7123E-02	D1212B.BIS
17.00	3.000	2.999	.1272E-01	-.1908E+00	.4611E-01	.5740E+00	.3095E+00	.3251E+00	.1938E-01	.2475E-01	.8170E-03	D1212B.BIS
18.00	3.161	3.105	.9493E-01	-.9051E-01	-.6883E-01	.4970E+00	.2563E+00	.2083E+00	-.2135E-01	.2808E-01	-.4178E-01	D1212B.BIS
1.00	-0.072	-0.214	.3058E+02	-.3202E+00	-.1538E+00	.8700E+00	.3036E+00	.1250E+00	-.3258E-02	.1099E-01	-.8907E-52	MD01GC
1.00	0.000	-0.214	.3051E+02	-.3279E+00	-.1998E+00	.6550E+00	.2465E+00	.1049E+00	-.2199E-01	.5662E-02	-.7178E-52	MD01GC
1.00	0.072	-0.214	.3055E+02	-.4268E+00	-.8509E-01	.1160E+01	.4360E+00	.1878E+00	-.9138E-01	.2836E-01	-.1278E+52	MD01GC
1.00	0.143	-0.214	.3015E+02	-.7587E+00	.2816E+00	.3920E+01	.2418E+01	.9906E+00	.3746E+00	-.2192E-01	-.7060E+52	MD01GC
1.00	0.214	-0.214	.2632E+02	.6183E+00	-.2610E-01	.1500E+02	.9239E+01	.8959E+01	.7293E+01	-.2985E+00	-.6917E+52	MD01GC
1.00	0.286	-0.214	.1352E+02	.1844E+01	-.4614E+00	.4180E+02	.3024E+02	.2105E+02	.1766E+02	-.5777E+00	-.7228E+52	MD01GC
1.00	0.357	-0.214	.4777E+01	.9472E+00	-.1429E-01	.1830E+02	.1912E+02	.1235E+02	.6982E+01	-.8357E+00	-.1493E+52	MD01GC
1.00	-0.071	-0.001	.3062E+02	-.2854E+00	-.3427E-02	.8840E+00	.3683E+00	.1254E+00	-.4371E-02	-.1843E-01	-.1081E+52	MD01GC
1.00	0.072	-0.001	.3055E+02	-.2942E+00	.3469E+00	.9630E+00	.4446E+00	.1809E+00	-.4831E-01	-.9751E-02	-.1298E+52	MD01GC
1.00	0.214	-0.001	.2626E+02	.1105E+01	-.4286E-01	.1720E+02	.1306E+02	.1188E+02	.9362E+01	-.2047E+01	-.1348E+52	MD01GC
1.00	0.144	-0.001	.3039E+02	-.6420E-01	.2932E+00	.3120E+01	.2121E+01	.1203E+01	.3486E+00	-.2751E+00	-.5425E+52	MD01GC
1.00	0.286	-0.001	.1173E+02	.6234E+00	.6789E+00	.3990E+02	.3133E+02	.2876E+02	.1865E+02	-.4141E+01	.2917E+52	MD01GC
1.00	0.357	-0.001	.4734E+01	.1821E+00	-.1590E+00	.1730E+02	.1611E+02	.1537E+02	.5625E+01	-.4165E+01	-.1267E+52	MD01GC
1.00	-0.072	0.214	.3057E+02	-.5116E+00	-.9954E-01	.7650E+00	.3813E+00	.1276E+00	.4954E-01	-.1581E-01	-.1118E+52	MD01GC



TABLE 4  
Continued

X	Y	Z	$\bar{U}$	$\bar{V}$	$\bar{W}$	$\overline{uu}$	$\overline{vv}$	$\overline{ww}$	$\overline{uv}$	$\overline{uw}$	$\overline{vw}$	File Name
inch	inch	inch	m/s	m/s	m/s	m <sup>2</sup> /s <sup>2</sup>	m <sup>2</sup> /s <sup>2</sup>	m <sup>2</sup> /s <sup>2</sup>	m <sup>2</sup> /s <sup>2</sup>	m <sup>2</sup> /s <sup>2</sup>	m <sup>2</sup> /s <sup>2</sup>	
1.00	0.072	0.214	.3049E+02	-.4513E+00	-.5575E+00	.9090E+00	.3134E+00	.2113E+00	-.5397E-02	.1526E-01	-.7092E-52	ND01GC
1.00	0.143	0.214	.3015E+02	-.7438E+00	-.5709E+00	.3610E+01	.2054E+01	.1612E+01	.9910E+00	.4227E+00	-.3971E+52	ND01GC
1.00	0.214	0.214	.2470E+02	.4485E+00	.3076E-01	.2660E+02	.2135E+02	.1561E+02	.1349E+02	-.1457E+01	-.1570E+52	ND01GC
1.00	0.287	0.214	.9565E+01	.1928E+00	-.1823E+00	.3530E+02	.2784E+02	.2567E+02	.1548E+02	-.4769E+00	-.4835E+52	ND01GC
1.00	0.357	0.214	.3148E+01	-.4123E+00	-.1548E+00	.1360E+02	.1490E+02	.1298E+02	.3644E+01	.1456E+01	-.1610E+52	ND01GC
1.00	-0.072	0.428	.3051E+02	-.5483E+00	-.4819E+00	.7650E+00	.2918E+00	.1448E+00	.5031E-02	.5295E-02	-.8163E-52	ND01GC
1.00	0.072	0.428	.3051E+02	-.3835E+00	-.1441E+00	.8500E+00	.3570E+00	.1941E+00	-.2924E-01	-.2487E-01	-.9422E-52	ND01GC
1.00	0.143	0.428	.3027E+02	-.4078E+00	-.2705E+00	.3470E+01	.1889E+01	.1249E+01	.5658E+00	-.1614E+00	-.4291E+52	ND01GC
1.00	0.214	0.428	.2503E+02	.8654E+00	-.4000E+00	.2630E+02	.2094E+02	.1368E+02	.1140E+02	-.1909E+00	.1867E+52	ND01GC
1.00	0.287	0.428	.1079E+02	.7020E+00	-.6662E-01	.4340E+02	.3048E+02	.2412E+02	.1888E+02	.5539E+00	.4652E+52	ND01GC
1.00	0.357	0.428	.4775E+01	.4836E+00	.1997E-01	.1800E+02	.1727E+02	.1429E+02	.7092E+01	-.1858E+00	.1764E+52	ND01GC
1.00	-0.072	0.643	.3058E+02	.9874E-01	-.4840E+00	.7790E+00	.3390E+00	.1929E+00	-.3617E-02	.2457E-01	-.8971E-52	ND01GC
1.00	0.072	0.643	.3045E+02	-.1896E+00	-.3425E+00	.9990E+00	.3710E+00	.1652E+00	-.5979E-01	-.3856E-02	-.1067E+52	ND01GC
1.00	0.143	0.643	.3029E+02	-.3702E+00	-.1819E+00	.3970E+01	.2154E+01	.1296E+01	.5634E+00	-.4455E-01	-.5416E+52	ND01GC
1.00	0.214	0.643	.2512E+02	.1013E+01	-.2424E+00	.2560E+02	.1895E+02	.1098E+02	.1099E+02	-.2292E+00	.3208E+52	ND01GC
1.00	0.287	0.643	.1227E+02	.1362E+01	-.7680E+00	.3940E+02	.2490E+02	.2076E+02	.1712E+02	-.2275E+01	-.1824E+52	ND01GC
1.00	0.357	0.643	.5572E+01	.1304E+01	-.1369E+01	.1710E+02	.1679E+02	.1325E+02	.6863E+01	-.9289E+00	-.1737E+52	ND01GC
1.00	-0.072	0.857	.3050E+02	-.1050E+01	-.8774E+00	.2000E+01	.1133E+01	.9739E+00	.9302E-01	.3076E-01	.1841E+52	ND01GC
1.00	0.072	0.857	.3046E+02	-.2529E+00	.2362E+00	.1650E+01	.6732E+00	.6508E+00	-.1032E+00	-.6253E-01	-.2960E-52	ND01GC
1.00	0.143	0.857	.3039E+02	-.3844E+00	.4611E+00	.3080E+01	.1539E+01	.1491E+01	-.2116E-01	-.5033E+00	-.4380E-52	ND01GC
1.00	0.214	0.857	.2454E+02	.5218E-01	-.5446E+00	.2770E+02	.1628E+02	.1585E+02	.1141E+02	.2945E+01	.1213E+52	ND01GC
1.00	0.287	0.857	.8423E+01	.3203E+00	-.1312E+01	.2930E+02	.1709E+02	.1858E+02	.9461E+01	.3379E+01	.1019E+52	ND01GC
1.00	0.357	0.857	.3099E+01	.1827E+00	.3406E+00	.1190E+02	.8600E+01	.9071E+01	.3311E+01	.7864E+00	.4068E+52	ND01GC
1.00	-0.072	1.071	.7774E+01	-.1286E+01	.1079E+01	.2220E+02	.1551E+02	.1710E+02	-.2942E+01	.9056E+01	-.2063E+52	ND01GC
1.00	0.072	1.071	.6142E+01	-.8971E-02	.3267E+00	.1730E+02	.1360E+02	.1480E+02	.1187E+01	.7350E+01	-.9607E-52	ND01GC
1.00	0.143	1.071	.3362E+01	.2914E+00	-.3812E-01	.1140E+02	.9896E+01	.8847E+01	.1459E+01	.3426E+01	.3159E+52	ND01GC
1.00	0.214	1.071	.1394E+01	-.2328E+00	.1866E+00	.6070E+01	.5057E+01	.4805E+01	-.3513E-02	.1568E+01	-.1217E+52	ND01GC
1.00	0.287	1.071	.5885E+00	-.2600E+00	-.1482E+00	.2230E+01	.2237E+01	.2075E+01	.2107E+00	.4487E+00	.6610E+52	ND01GC
1.00	0.357	1.071	.3633E+00	-.3118E+00	-.5097E+00	.4020E+00	.2333E+00	.2536E+00	-.3207E-01	.1317E-01	.1096E-52	ND01GC
1.00	0.000	-0.106	.3045E+02	-.2197E+00	.8392E-01	.4890E+00	.3478E+00	.3506E+00	.2152E-01	.1325E-01	-.1029E-52	ND01GC
1.00	0.000	0.106	.3052E+02	-.1535E+00	-.1321E+00	.5160E+00	.5378E+00	.5383E+00	.1145E-01	.2411E-01	-.1865E-52	ND01GC
1.00	0.000	0.322	.3047E+02	.4256E+00	-.2730E+00	.5640E+00	.6601E+00	.4393E+00	-.5518E-01	.7394E-02	-.1507E+52	ND01GC
1.00	0.000	0.535	.3056E+02	.7552E+00	.3158E+00	.4980E+00	.1211E+01	.7769E+00	-.6152E-01	.3024E-01	-.2894E+52	ND01GC
1.00	0.000	0.750	.3053E+02	-.1030E+00	.3787E+00	.5770E+00	.4425E+00	.4810E+00	-.3906E-01	.8097E-03	.2177E-52	ND01GC
1.00	0.000	0.964	.2683E+02	-.9680E+00	.7276E+00	.1550E+02	.9932E+01	.8657E+01	.4729E+00	.6930E+01	.1466E+52	ND01GC
0.20	-0.050	0.799	.3062E+02	-.4394E-01	-.7320E+00	.4310E+00	.1242E+00	.1002E+00	.2606E-02	.6646E-02	-.2033E-01	D0510C.BIS
2.00	-0.098	0.928	.2349E+02	-.1596E+01	.1277E+00	.2720E+02	.1578E+02	.1418E+02	-.2012E+01	.8833E+01	-.4118E-01	D0510C.BIS
3.00	-0.124	0.999	.1333E+02	-.1303E+01	.2735E+00	.3040E+02	.1817E+02	.1445E+02	-.1250E+01	.1018E+02	-.9222E+00	D0510C.BIS
4.00	-0.153	1.071	.9887E+01	-.9742E+00	.3776E+00	.2330E+02	.1364E+02	.1167E+02	-.6951E-01	.6885E+01	-.4941E+00	D0510C.BIS
5.00	-0.179	1.142	.8793E+01	-.9243E+00	.4772E+00	.1740E+02	.1119E+02	.9877E+01	-.7698E+00	.5682E+01	-.2691E+00	D0510C.BIS
6.00	-0.205	1.214	.7870E+01	-.1118E+01	.6568E+00	.1560E+02	.1055E+02	.8742E+01	-.7075E+00	.4312E+01	-.6735E+00	D0510C.BIS
7.00	-0.232	1.285	.7253E+01	-.1285E+01	.7243E+00	.1310E+02	.9584E+01	.7798E+01	-.4630E+00	.4203E+01	-.4122E+50	D0510C.BIS
8.00	-0.259	1.357	.6964E+01	-.1155E+01	.5786E+00	.1100E+02	.7737E+01	.7202E+01	-.8007E+00	.3535E+01	-.4883E+00	D0510C.BIS
9.00	-0.286	1.428	.6175E+01	-.1011E+01	.6244E+00	.1120E+02	.7348E+01	.6296E+01	-.7618E+00	.3070E+01	-.4530E+00	D0510C.BIS
10.00	-0.313	1.499	.6126E+01	-.1110E+01	.7394E+00	.9810E+01	.6500E+01	.6211E+01	-.3649E+00	.2792E+01	-.3140E+00	D0510C.BIS
11.00	-0.340	1.571	.5559E+01	-.9701E+00	.5843E+00	.8650E+01	.5894E+01	.5988E+01	-.5136E+00	.2730E+01	-.4781E+00	D0510C.BIS
12.00	-0.367	1.642	.5306E+01	-.1035E+01	.6140E+00	.8060E+01	.5593E+01	.5249E+01	-.5833E+00	.2013E+01	-.3855E+00	D0510C.BIS
13.00	-0.393	1.714	.4925E+01	-.1014E+01	.6605E+00	.7800E+01	.5353E+01	.5166E+01	-.7203E+00	.1956E+01	-.5060E+00	D0510C.BIS
14.00	-0.419	1.785	.4861E+01	-.8332E+00	.6000E+00	.7590E+01	.4839E+01	.4778E+01	-.4540E+00	.2180E+01	-.2795E+00	D0510C.BIS
15.00	-0.447	1.857	.4562E+01	-.8833E+00	.5566E+00	.6940E+01	.4702E+01	.4471E+01	-.6492E+00	.1862E+01	-.1755E+00	D0510C.BIS
16.00	-0.474	1.928	.4466E+01	-.8969E+00	.5316E+00	.7150E+01	.4200E+01	.3973E+01	-.6679E+00	.1908E+01	-.1431E+00	D0510C.BIS
17.00	-0.500	1.999	.4351E+01	-.8799E+00	.5088E+00	.5730E+01	.4084E+01	.3799E+01	-.3669E+00	.1469E+01	-.2196E+00	D0510C.BIS
18.00	-0.526	2.070	.4145E+01	-.7543E+00	.4304E+00	.5440E+01	.3819E+01	.3241E+01	-.3157E+00	.1310E+01	-.2442E-01	D0510C.BIS
19.00	-0.554	2.142	.4005E+01	-.8811E+00	.5289E+00	.5120E+01	.3475E+01	.3301E+01	-.2347E+00	.1492E+01	-.2713E-02	D0510C.BIS
0.20	-0.050	0.999	.1050E+02	-.2506E+00	-.1789E-01	.9710E+00	.1517E+00	.4162E-01	-.5550E-02	.4939E-01	-.4524E-01	D0511C.BIS
2.00	-0.098	1.160	.8190E+01	-.1271E+01	.1304E+01	.1700E+02	.1037E+02	.1120E+02	-.4623E+00	.5551E+01	-.9546E+00	D0511C.BIS

TABLE 4  
Continued

X	Y	Z	$\bar{u}$	$\bar{v}$	$\bar{w}$	$\overline{u^2}$	$\overline{v^2}$	$\overline{w^2}$	$\overline{uv}$	$\overline{uw}$	$\overline{vw}$	File Name
inch	inch	inch	m/s	m/s	m/s	m <sup>2</sup> /s <sup>2</sup>	m <sup>2</sup> /s <sup>2</sup>	m <sup>2</sup> /s <sup>2</sup>	m <sup>2</sup> /s <sup>2</sup>	m <sup>2</sup> /s <sup>2</sup>	m <sup>2</sup> /s <sup>2</sup>	
3.00	-0.124	1.250	.5595E+01	-.9641E+00	.9761E+00	.1330E+02	.7800E+01	.7846E+01	.5909E-02	.3628E+01	-.6394E+00	D0511C.BIS
4.00	-0.153	1.339	.4632E+01	-.7294E+00	.8781E+00	.1150E+02	.6544E+01	.7069E+01	.2586E-01	.3308E+01	-.4242E+00	D0511C.BIS
5.00	-0.179	1.428	.4547E+01	-.8887E+00	.1000E+01	.9860E+01	.5813E+01	.6415E+01	-.4973E+00	.2683E+01	-.6104E+00	D0511C.BIS
6.00	-0.205	1.518	.3901E+01	-.6230E+00	.9479E+00	.8510E+01	.5085E+01	.5734E+01	-.5411E+00	.2476E+01	-.3448E+00	D0511C.BIS
7.00	-0.232	1.607	.3576E+01	-.7847E+00	.7410E+00	.7190E+01	.4664E+01	.5493E+01	-.4665E+00	.1899E+01	-.4862E+00	D0511C.BIS
8.00	-0.259	1.696	.3483E+01	-.9234E+00	.6411E+00	.7040E+01	.4348E+01	.5018E+01	-.6252E+00	.1985E+01	-.5650E+00	D0511C.BIS
9.00	-0.286	1.786	.3476E+01	-.8708E+00	.6637E+00	.6520E+01	.4403E+01	.4685E+01	-.5181E+00	.1570E+01	-.3235E+00	D0511C.BIS
10.00	-0.312	1.875	.3221E+01	-.6426E+00	.6778E+00	.6440E+01	.4027E+01	.4872E+01	-.4958E+00	.1868E+01	-.4800E+00	D0511C.BIS
11.00	-0.340	1.964	.3119E+01	-.6516E+00	.7114E+00	.6570E+01	.3971E+01	.4681E+01	-.5237E+00	.2032E+01	-.3528E+00	D0511C.BIS
12.00	-0.367	2.054	.2898E+01	-.7405E+00	.4997E+00	.5500E+01	.3620E+01	.4235E+01	-.5654E+00	.1562E+01	-.3646E+00	D0511C.BIS
13.00	-0.393	2.142	.2898E+01	-.7873E+00	.5976E+00	.5670E+01	.3382E+01	.3897E+01	-.5514E+00	.1417E+01	-.4700E+00	D0511C.BIS
14.00	-0.419	2.232	.3089E+01	-.8470E+00	.5931E+00	.5550E+01	.3351E+01	.3778E+01	-.4005E+00	.1614E+01	-.4183E+00	D0511C.BIS
15.00	-0.447	2.321	.2875E+01	-.8901E+00	.5666E+00	.5150E+01	.3467E+01	.3412E+01	-.4414E+00	.1513E+01	-.2791E+00	D0511C.BIS
16.00	-0.474	2.410	.2848E+01	-.7633E+00	.5252E+00	.4990E+01	.3098E+01	.3260E+01	-.5675E+00	.1478E+01	-.3011E+00	D0511C.BIS
17.00	-0.500	2.500	.2864E+01	-.8902E+00	.4645E+00	.4580E+01	.3105E+01	.3103E+01	-.4171E+00	.1337E+01	-.2317E+00	D0511C.BIS
18.00	-0.526	2.589	.2994E+01	-.8175E+00	.5058E+00	.4360E+01	.2740E+01	.2737E+01	-.3646E+00	.1241E+01	-.2501E+00	D0511C.BIS
19.00	-0.554	2.678	.3072E+01	-.9652E+00	.4792E+00	.3890E+01	.2762E+01	.2513E+01	-.3306E+00	.9806E+00	-.1834E+00	D0511C.BIS
0.20	0.000	0.900	.3091E+02	-.2530E+00	-.3054E-01	.2450E+00	.1576E+00	.5404E-01	-.1023E-01	.3387E-02	-.4680E-01	D06G1C.BIS
2.00	0.000	1.044	.1335E+02	-.1614E+01	.4366E+00	.2990E+02	.1617E+02	.1516E+02	-.9286E+00	.8598E+01	-.1888E+01	D06G1C.BIS
3.00	0.000	1.125	.8926E+01	-.1028E+01	.6730E+00	.2400E+02	.1806E+02	.1154E+02	-.9597E+00	.6404E+01	-.1598E+00	D06G1C.BIS
4.00	0.000	1.205	.7724E+01	-.4023E+00	.6845E+00	.1760E+02	.1248E+02	.1050E+02	-.2547E+00	.5497E+01	-.1144E+01	D06G1C.BIS
5.00	0.000	1.286	.6825E+01	-.4588E+00	.7489E+00	.1420E+02	.9255E+01	.8536E+01	-.7583E+00	.3633E+01	-.1064E+01	D06G1C.BIS
6.00	0.000	1.366	.5761E+01	-.4605E+00	.5628E+00	.1210E+02	.7479E+01	.7184E+01	-.6024E+00	.3405E+01	-.6812E+00	D06G1C.BIS
7.00	0.000	1.446	.5230E+01	-.6089E+00	.6282E+00	.9970E+01	.6670E+01	.6318E+01	-.5028E+00	.2376E+01	-.7299E+00	D06G1C.BIS
8.00	0.000	1.527	.4947E+01	-.6602E+00	.7055E+00	.9530E+01	.6359E+01	.6142E+01	-.2803E+00	.2434E+01	-.5500E+00	D06G1C.BIS
9.00	0.000	1.607	.4799E+01	-.7829E+00	.7278E+00	.8520E+01	.5591E+01	.5683E+01	-.1356E+00	.2266E+01	-.5278E+00	D06G1C.BIS
10.00	0.000	1.688	.4514E+01	-.7332E+00	.7377E+00	.7710E+01	.5107E+01	.5494E+01	-.1941E+00	.2093E+01	-.6029E+00	D06G1C.BIS
11.00	0.000	1.768	.4390E+01	-.7705E+00	.6202E+00	.6830E+01	.4976E+01	.5089E+01	-.1454E-01	.1820E+01	-.4636E+00	D06G1C.BIS
12.00	-0.001	1.849	.4139E+01	-.8485E+00	.7754E+00	.7350E+01	.4876E+01	.5142E+01	-.1641E+00	.1873E+01	-.6429E+00	D06G1C.BIS
13.00	-0.001	1.929	.4210E+01	-.8471E+00	.6439E+00	.6570E+01	.4521E+01	.4861E+01	-.1950E+00	.1852E+01	-.3881E+00	D06G1C.BIS
14.00	-0.001	2.009	.4111E+01	-.7353E+00	.6107E+00	.6440E+01	.4149E+01	.4226E+01	-.8852E-01	.1768E+01	-.5130E+00	D06G1C.BIS
15.00	-0.001	2.089	.3968E+01	-.8325E+00	.6551E+00	.5820E+01	.4170E+01	.4319E+01	-.1445E+00	.1641E+01	-.2809E+00	D06G1C.BIS
16.00	-0.001	2.170	.3813E+01	-.6947E+00	.6024E+00	.5560E+01	.3743E+01	.4056E+01	-.8989E-01	.1574E+01	-.3234E+00	D06G1C.BIS
17.00	-0.001	2.250	.3752E+01	-.8631E+00	.5595E+00	.5380E+01	.3480E+01	.3499E+01	-.9358E-01	.1459E+01	-.3515E+00	D06G1C.BIS
18.00	-0.001	2.331	.3621E+01	-.8214E+00	.6566E+00	.4710E+01	.3182E+01	.2952E+01	-.1366E+00	.1150E+01	-.3794E+00	D06G1C.BIS
19.00	-0.001	2.411	.3739E+01	-.8745E+00	.5839E+00	.4740E+01	.3217E+01	.3058E+01	-.8961E-01	.1251E+01	-.2637E+00	D06G1C.BIS
0.20	0.050	0.799	.3093E+02	-.8598E+00	.7825E-02	.1460E+00	.1565E+00	.7296E-01	-.9998E-02	.5688E-02	-.4499E-01	D0710C.BIS
2.00	0.097	0.928	.2210E+02	-.2396E+00	.2663E+00	.3120E+02	.1747E+02	.1933E+02	-.6029E+01	.9824E+01	-.1826E+01	D0710C.BIS
3.00	0.124	0.999	.1363E+02	-.5968E+00	.5250E+00	.3190E+02	.1776E+02	.1663E+02	-.5737E+01	.8003E+01	-.2667E+01	D0710C.BIS
4.00	0.153	1.071	.1011E+02	-.3427E+00	.5115E+00	.2210E+02	.1291E+02	.1358E+02	-.3702E+01	.5201E+01	-.1848E+01	D0710C.BIS
5.00	0.179	1.142	.8212E+01	-.3324E+00	.5839E+00	.1710E+02	.1008E+02	.1011E+02	-.2365E+01	.4333E+01	-.1157E+01	D0710C.BIS
6.00	0.205	1.214	.7290E+01	-.1408E+00	.3808E+00	.1410E+02	.8526E+01	.8962E+01	-.2079E+01	.3200E+01	-.1093E+01	D0710C.BIS
7.00	0.232	1.285	.6235E+01	-.2930E+00	.5749E+00	.1090E+02	.7087E+01	.7550E+01	-.1658E+01	.2592E+01	-.9134E+00	D0710C.BIS
8.00	0.260	1.357	.6206E+01	-.2929E+00	.4763E+00	.9900E+01	.7191E+01	.6720E+01	-.1058E+01	.2404E+01	-.1144E+01	D0710C.BIS
9.00	0.285	1.428	.5322E+01	-.4182E+00	.5399E+00	.8850E+01	.6502E+01	.6275E+01	-.7784E+00	.2295E+01	-.8098E+00	D0710C.BIS
10.00	0.312	1.499	.5307E+01	-.5440E+00	.5821E+00	.9030E+01	.6001E+01	.5903E+01	-.1037E+01	.2280E+01	-.6022E+00	D0710C.BIS
11.00	0.339	1.571	.5088E+01	-.5624E+00	.6758E+00	.8080E+01	.5818E+01	.5824E+01	-.7245E+00	.2284E+01	-.8107E+00	D0710C.BIS
12.00	0.367	1.642	.4689E+01	-.4203E+00	.4890E+00	.7970E+01	.5417E+01	.5494E+01	-.8661E+00	.2291E+01	-.5581E+00	D0710C.BIS
13.00	0.392	1.714	.4956E+01	-.6254E+00	.6853E+00	.6950E+01	.5198E+01	.5245E+01	-.4041E+00	.2112E+01	-.5807E+00	D0710C.BIS
14.00	0.419	1.785	.4791E+01	-.6666E+00	.6626E+00	.7230E+01	.5097E+01	.4846E+01	-.4394E+00	.1950E+01	-.4884E+00	D0710C.BIS
15.00	0.447	1.856	.4580E+01	-.6344E+00	.6318E+00	.6620E+01	.4754E+01	.4553E+01	-.5704E+00	.1903E+01	-.3455E+00	D0710C.BIS
16.00	0.474	1.928	.4360E+01	-.7282E+00	.7997E+00	.6250E+01	.4197E+01	.4274E+01	-.5387E+00	.1363E+01	-.2192E+00	D0710C.BIS
17.00	0.499	1.999	.4126E+01	-.6499E+00	.7455E+00	.5740E+01	.3827E+01	.3699E+01	-.2693E+00	.1469E+01	-.3954E+00	D0710C.BIS
18.00	0.526	2.070	.4154E+01	-.6140E+00	.6834E+00	.5200E+01	.3586E+01	.3282E+01	-.2764E+00	.1324E+01	-.2599E+00	D0710C.BIS
19.00	0.555	2.142	.4158E+01	-.7318E+00	.5888E+00	.5130E+01	.3643E+01	.3256E+01	-.3770E+00	.1412E+01	-.1523E+00	D0710C.BIS
0.20	0.050	0.999	.1303E+02	-.2181E+00	.3639E-01	.2330E+01	.1137E+00	.1174E+00	-.3131E-01	.7343E-01	-.6508E-02	D0711C.BIS

TABLE 4  
Continued

X	Y	Z	$\bar{U}$	$\bar{V}$	$\bar{W}$	$\overline{uu}$	$\overline{vv}$	$\overline{ww}$	$\overline{uv}$	$\overline{uw}$	$\overline{vw}$	File Name
inch	inch	inch	m/s	m/s	m/s	m <sup>2</sup> /s <sup>2</sup>	m <sup>2</sup> /s <sup>2</sup>	m <sup>2</sup> /s <sup>2</sup>	m <sup>2</sup> /s <sup>2</sup>	m <sup>2</sup> /s <sup>2</sup>	m <sup>2</sup> /s <sup>2</sup>	
2.00	0.098	1.160	.2803E+01	-.3575E-01	.9542E-01	.1030E+02	.6741E+01	.6684E+01	.6237E+00	.2485E+01	-.4067E+00	D0711C.BIS
3.00	0.124	1.250	.3329E+01	-.1476E+00	.7172E+00	.9580E+01	.5530E+01	.6294E+01	.4930E+00	.1935E+01	-.4537E+00	D0711C.BIS
4.00	0.153	1.339	.3104E+01	.2121E-01	.6507E+00	.9160E+01	.5403E+01	.5541E+01	.6228E+00	.2243E+01	-.2148E+00	D0711C.BIS
5.00	0.179	1.428	.3077E+01	-.9827E-01	.6105E+00	.7720E+01	.4956E+01	.5085E+01	.4808E+00	.2114E+01	-.1943E+00	D0711C.BIS
6.00	0.205	1.518	.3153E+01	-.1346E+00	.8101E+00	.7560E+01	.4510E+01	.4934E+01	.4019E+00	.1569E+01	-.6387E-01	D0711C.BIS
7.00	0.232	1.607	.2766E+01	-.3525E+00	.6719E+00	.6930E+01	.3870E+01	.4376E+01	.3736E+00	.1782E+01	.8018E-01	D0711C.BIS
8.00	0.260	1.696	.2651E+01	-.2196E+00	.7014E+00	.6610E+01	.3898E+01	.4326E+01	.1965E+00	.1583E+01	-.8705E-01	D0711C.BIS
9.00	0.285	1.786	.2683E+01	-.2369E+00	.7085E+00	.6330E+01	.3983E+01	.4426E+01	.3624E+00	.1585E+01	-.3501E+00	D0711C.BIS
10.00	0.312	1.875	.2872E+01	-.2592E+00	.6748E+00	.6270E+01	.4184E+01	.4612E+01	.3034E+00	.1513E+01	-.2200E+00	D0711C.BIS
11.00	0.340	1.964	.2840E+01	-.3566E+00	.7936E+00	.6050E+01	.3880E+01	.4113E+01	.9447E-01	.1347E+01	-.2280E+00	D0711C.BIS
12.00	0.367	2.054	.2854E+01	-.6384E+00	.9415E+00	.5780E+01	.3759E+01	.4203E+01	.1622E+00	.1520E+01	-.1749E+00	D0711C.BIS
13.00	0.392	2.143	.2730E+01	-.3406E+00	.7701E+00	.5160E+01	.3371E+01	.3880E+01	.3588E+00	.1283E+01	-.9726E-01	D0711C.BIS
14.00	0.419	2.232	.2557E+01	-.3966E+00	.8771E+00	.5240E+01	.3235E+01	.3447E+01	.1860E+00	.1425E+01	-.6892E-01	D0711C.BIS
15.00	0.447	2.321	.2861E+01	-.4304E+00	.7812E+00	.4850E+01	.3012E+01	.3548E+01	.3097E+00	.1254E+01	-.4907E-01	D0711C.BIS
16.00	0.474	2.411	.2785E+01	-.5603E+00	.8218E+00	.4580E+01	.3214E+01	.3205E+01	.2565E+00	.1207E+01	.2437E-02	D0711C.BIS
17.00	0.499	2.500	.2985E+01	-.7663E+00	.7609E+00	.4290E+01	.3109E+01	.3107E+01	.7913E-01	.1229E+01	-.2170E+00	D0711C.BIS
18.00	0.526	2.589	.2707E+01	-.6484E+00	.6413E+00	.4190E+01	.2627E+01	.2843E+01	-.1071E-02	.1166E+01	-.1670E+00	D0711C.BIS
19.00	0.555	2.678	.2447E+01	-.6073E+00	.4956E+00	.3750E+01	.2114E+01	.2303E+01	.9557E-01	.9898E+00	-.1156E+00	D0711C.BIS
0.20	0.099	0.799	.3099E+02	-.2127E+00	-.6695E-01	.3040E+00	.1023E+00	.8701E-01	-.1716E-01	.6855E-02	-.1389E-01	D0810C.BIS
2.00	0.197	0.928	.1685E+02	.5139E+00	.4889E+00	.3500E+02	.2230E+02	.2232E+02	.9661E+01	.7858E+01	-.1882E+01	D0810C.BIS
3.00	0.250	0.999	.9273E+01	-.2299E+00	.4011E+00	.2370E+02	.1315E+02	.1569E+02	.3458E+01	.5335E+01	-.1823E+01	D0810C.BIS
4.00	0.303	1.071	.6446E+01	-.2419E+00	.5780E+00	.1600E+02	.1005E+02	.1058E+02	.3010E+01	.3312E+01	-.7616E+00	D0810C.BIS
5.00	0.358	1.142	.5163E+01	-.4716E+00	.6991E+00	.1240E+02	.7334E+01	.8699E+01	.2122E+01	.2203E+01	-.8991E+00	D0810C.BIS
6.00	0.411	1.214	.4858E+01	-.3273E+00	.6716E+00	.1050E+02	.7595E+01	.7498E+01	.1542E+01	.2190E+01	-.1154E+01	D0810C.BIS
7.00	0.465	1.285	.4820E+01	-.2284E+00	.6787E+00	.1010E+02	.6474E+01	.6668E+01	.1398E+01	.2009E+01	-.6508E+00	D0810C.BIS
8.00	0.518	1.357	.4364E+01	-.3247E+00	.7438E+00	.8200E+01	.5465E+01	.5504E+01	.1104E+01	.1567E+01	-.3574E+00	D0810C.BIS
9.00	0.572	1.428	.6028E+01	-.1711E+00	.6844E+00	.8620E+01	.5163E+01	.5525E+01	.5382E+00	.1948E+01	-.5671E+00	D0810C.BIS
10.00	0.625	1.499	.3357E+01	-.2427E+00	.7410E+00	.7710E+01	.4605E+01	.4345E+01	.3608E+00	.1593E+01	-.3074E+00	D0810C.BIS
11.00	0.680	1.571	.3583E+01	-.1952E+00	.5883E+00	.6960E+01	.4497E+01	.4583E+01	.5407E+00	.1723E+01	-.3099E+00	D0810C.BIS
12.00	0.732	1.642	.3499E+01	-.2595E+00	.6885E+00	.7130E+01	.3983E+01	.4364E+01	.7383E+00	.1557E+01	-.1615E+00	D0810C.BIS
13.00	0.787	1.714	.3783E+01	-.3084E+00	.6378E+00	.6740E+01	.4599E+01	.4362E+01	.7867E+00	.1346E+01	-.3356E+00	D0810C.BIS
14.00	0.839	1.785	.3320E+01	-.3683E+00	.5274E+00	.6390E+01	.3896E+01	.4050E+01	.8271E+00	.1667E+01	-.1178E+00	D0810C.BIS
15.00	0.893	1.857	.3384E+01	-.5023E+00	.6755E+00	.6550E+01	.3373E+01	.3661E+01	.3993E+00	.1691E+01	-.1655E+00	D0810C.BIS
16.00	0.947	1.928	.3376E+01	-.4482E+00	.6695E+00	.5220E+01	.3606E+01	.3720E+01	.6397E+00	.1474E+01	-.2511E+00	D0810C.BIS
17.00	1.000	1.999	.3554E+01	-.4528E+00	.5871E+00	.5370E+01	.3487E+01	.3315E+01	.5326E+00	.1209E+01	-.1790E+00	D0810C.BIS
18.00	1.054	2.070	.3316E+01	-.4701E+00	.6028E+00	.4640E+01	.3049E+01	.2851E+01	.4905E+00	.1126E+01	-.1141E+00	D0810C.BIS
19.00	1.107	2.142	.3323E+01	-.5289E+00	.6463E+00	.4480E+01	.2825E+01	.2854E+01	.3757E+00	.1184E+01	-.5951E-01	D0810C.BIS
0.20	0.100	0.999	.1230E+02	-.4670E+00	-.1586E-01	.7570E+00	.1651E+00	.2532E-01	.2363E-02	.2682E-01	-.4227E-01	D0811C.BIS
2.00	0.197	1.160	.3064E+01	-.9995E+00	.7260E+00	.1080E+02	.5814E+01	.8113E+01	-.3555E+00	.3539E+01	-.6612E+00	D0811C.BIS
3.00	0.250	1.250	.2498E+01	-.5999E+00	.4970E+00	.7520E+01	.4310E+01	.5708E+01	.3863E+00	.2338E+01	-.1895E+00	D0811C.BIS
4.00	0.303	1.339	.2174E+01	-.4269E+00	.4096E+00	.6630E+01	.3967E+01	.4822E+01	.6005E+00	.1693E+01	-.3171E-01	D0811C.BIS
5.00	0.358	1.428	.2115E+01	-.2725E+00	.4822E+00	.6110E+01	.3597E+01	.4797E+01	.5757E+00	.1769E+01	.2126E+00	D0811C.BIS
6.00	0.411	1.518	.2308E+01	-.3728E+00	.7851E+00	.6790E+01	.4060E+01	.4432E+01	.6269E+00	.1518E+01	-.2040E-02	D0811C.BIS
7.00	0.465	1.607	.2028E+01	-.4624E+00	.6383E+00	.5780E+01	.3562E+01	.4319E+01	.3917E+00	.1270E+01	.6607E-02	D0811C.BIS
8.00	0.518	1.696	.1758E+01	-.3521E+00	.3418E+00	.5020E+01	.2778E+01	.3918E+01	.4130E+00	.1439E+01	.1705E+00	D0811C.BIS
9.00	0.572	1.786	.1835E+01	-.2568E+00	.5973E+00	.5150E+01	.3020E+01	.3484E+01	.2012E+00	.1192E+01	.1069E+00	D0811C.BIS
10.00	0.625	1.875	.1781E+01	-.4159E+00	.6211E+00	.4930E+01	.2771E+01	.3491E+01	.1268E+00	.1121E+01	-.1557E-01	D0811C.BIS
11.00	0.680	1.964	.1905E+01	-.5385E+00	.6037E+00	.4710E+01	.2612E+01	.3452E+01	.1163E+00	.1140E+01	-.8613E-01	D0811C.BIS
12.00	0.732	2.054	.1974E+01	-.5998E+00	.7033E+00	.4390E+01	.2670E+01	.3025E+01	.2990E+00	.1010E+01	-.3547E-02	D0811C.BIS
13.00	0.787	2.143	.1996E+01	-.5206E+00	.6923E+00	.4620E+01	.2772E+01	.3284E+01	.4216E+00	.9978E+00	.1308E+00	D0811C.BIS
14.00	0.839	2.232	.1928E+01	-.6073E+00	.6368E+00	.4540E+01	.2424E+01	.2967E+01	.7189E-01	.1057E+01	-.3528E-01	D0811C.BIS
15.00	0.893	2.321	.2139E+01	-.5107E+00	.6878E+00	.4340E+01	.2580E+01	.3040E+01	.1548E+00	.1113E+01	.2594E-01	D0811C.BIS
16.00	0.947	2.411	.1983E+01	-.5008E+00	.6170E+00	.4380E+01	.2150E+01	.2550E+01	.1554E+00	.1121E+01	-.2601E-02	D0811C.BIS
17.00	1.000	2.500	.2037E+01	-.5795E+00	.5838E+00	.3830E+01	.2273E+01	.2410E+01	.3827E-01	.9260E+00	-.4420E-01	D0811C.BIS
18.00	1.055	2.589	.1977E+01	-.5058E+00	.5353E+00	.3560E+01	.2178E+01	.2261E+01	.1325E+00	.9405E+00	-.8214E-01	D0811C.BIS
19.00	1.107	2.678	.2074E+01	-.5878E+00	.4981E+00	.3400E+01	.1986E+01	.2212E+01	.8257E-01	.9581E+00	-.1081E-01	D0811C.BIS

TABLE 4  
Continued

X	Y	Z	$\bar{U}$	$\bar{V}$	$\bar{W}$	$\overline{u^2}$	$\overline{v^2}$	$\overline{w^2}$	$\overline{uv}$	$\overline{uw}$	$\overline{vw}$	File Name
inch	inch	inch	m/s	m/s	m/s	m <sup>2</sup> /s <sup>2</sup>	m <sup>2</sup> /s <sup>2</sup>	m <sup>2</sup> /s <sup>2</sup>	m <sup>2</sup> /s <sup>2</sup>	m <sup>2</sup> /s <sup>2</sup>	m <sup>2</sup> /s <sup>2</sup>	
0.20	0.150	0.799	.3064E+02	-.1874E+00	.9029E-02	.3460E+00	.1332E+00	.8069E-01	-.1588E-01	.8856E-02	-.3360E-01	D0910C.BIS
2.00	0.295	0.928	.8979E+01	-.5241E+00	.1790E+00	.2560E+02	.1530E+02	.1597E+02	.7321E+01	.3267E+01	-.1744E+01	D0910C.BIS
3.00	0.375	0.999	.5564E+01	-.8654E-01	.6658E+00	.1440E+02	.9475E+01	.9505E+01	.2762E+01	.2888E+01	-.9121E+00	D0910C.BIS
4.00	0.455	1.071	.4981E+01	-.3622E+00	.1267E+01	.1240E+02	.7570E+01	.8318E+01	.1733E+01	.2553E+01	-.4348E+00	D0910C.BIS
5.00	0.535	1.142	.4460E+01	-.2244E+00	.1296E+01	.1030E+02	.6725E+01	.7351E+01	.1563E+01	.1875E+01	-.1058E+00	D0910C.BIS
6.00	0.616	1.214	.3851E+01	-.4033E-01	.1059E+01	.9130E+01	.5916E+01	.6807E+01	.1517E+01	.2153E+01	-.1682E+00	D0910C.BIS
7.00	0.697	1.285	.3763E+01	-.1085E+00	.1199E+01	.8350E+01	.5663E+01	.6114E+01	.9708E+00	.1911E+01	-.1321E+00	D0910C.BIS
8.00	0.778	1.357	.3270E+01	-.9565E-01	.9758E+00	.7230E+01	.4346E+01	.5215E+01	.9897E+00	.1750E+01	.1329E+00	D0910C.BIS
9.00	0.857	1.428	.3289E+01	-.1160E+00	.1146E+01	.7080E+01	.4232E+01	.4841E+01	.1129E+01	.1496E+01	.1629E+00	D0910C.BIS
10.00	0.937	1.499	.3279E+01	-.6545E-02	.1016E+01	.6270E+01	.4324E+01	.4663E+01	.9637E+00	.1343E+01	.1889E+00	D0910C.BIS
11.00	1.018	1.571	.3010E+01	-.1619E+00	.9238E+00	.5720E+01	.3801E+01	.4277E+01	.7126E+00	.1408E+01	.1238E+00	D0910C.BIS
12.00	1.099	1.642	.3020E+01	-.1375E+00	.1011E+01	.5670E+01	.4012E+01	.4101E+01	.7970E+00	.9437E+00	-.1640E-01	D0910C.BIS
13.00	1.180	1.714	.3307E+01	-.7591E-01	.1004E+01	.5720E+01	.3738E+01	.4015E+01	.7270E+00	.1027E+01	.6290E-01	D0910C.BIS
14.00	1.259	1.785	.2892E+01	-.1802E+00	.9030E+00	.4680E+01	.3040E+01	.3471E+01	.5160E+00	.1116E+01	.4052E-01	D0910C.BIS
15.00	1.339	1.856	.2865E+01	-.1431E+00	.8780E+00	.4810E+01	.3303E+01	.3208E+01	.6191E+00	.8900E+00	.1210E+00	D0910C.BIS
16.00	1.420	1.928	.2768E+01	-.3375E+00	.7923E+00	.4330E+01	.2769E+01	.2828E+01	.5795E+00	.8897E+00	-.4033E-01	D0910C.BIS
17.00	1.501	1.999	.2750E+01	-.4359E+00	.6371E+00	.4210E+01	.2644E+01	.2711E+01	.5796E+00	.7614E+00	-.8614E-01	D0910C.BIS
18.00	1.582	2.070	.2742E+01	-.5088E+00	.7429E+00	.3730E+01	.2524E+01	.2529E+01	.5101E+00	.9022E+00	.1740E-01	D0910C.BIS
19.00	1.661	2.142	.2543E+01	-.4443E+00	.6795E+00	.3680E+01	.2198E+01	.2279E+01	.4325E+00	.7347E+00	-.7411E-01	D0910C.BIS
0.20	0.150	0.999	.2792E+01	-.4187E+00	-.1947E+00	.8870E+00	.2213E+00	.4574E-01	-.3967E-01	.2688E-01	-.6198E-01	D0911C.BIS
2.00	0.295	1.160	.2395E+01	-.3224E+00	.5270E+00	.1000E+02	.5031E+01	.6621E+01	.9887E+00	.2427E+01	.5826E+00	D0911C.BIS
3.00	0.375	1.250	.1573E+01	-.9734E-01	.1587E+00	.5630E+01	.3669E+01	.4180E+01	.8503E+00	.1286E+01	.2965E+00	D0911C.BIS
4.00	0.455	1.339	.1099E+01	-.6422E-01	-.1556E+00	.4150E+01	.2664E+01	.2804E+01	.5379E+00	.8187E+00	.1666E+00	D0911C.BIS
5.00	0.535	1.428	.1284E+01	-.7866E-02	.1598E+00	.5080E+01	.3027E+01	.2697E+01	.5309E+00	.6963E+00	.1789E+00	D0911C.BIS
6.00	0.616	1.518	.9602E+00	-.7500E-01	.1014E+00	.4040E+01	.2324E+01	.2347E+01	.5075E+00	.6987E+00	.2713E+00	D0911C.BIS
7.00	0.697	1.607	.9576E+00	-.1965E+00	.9570E-01	.3230E+01	.2146E+01	.2272E+01	.2894E+00	.7814E+00	.2629E+00	D0911C.BIS
8.00	0.778	1.696	.9807E+00	-.3081E+00	.3724E-01	.3400E+01	.1954E+01	.2107E+01	.3418E+00	.6940E+00	.1907E+00	D0911C.BIS
9.00	0.857	1.786	.9387E+00	-.3153E+00	.6123E-01	.2860E+01	.1757E+01	.2073E+01	.2674E+00	.7852E+00	.1954E+00	D0911C.BIS
10.00	0.937	1.875	.1021E+01	-.2653E+00	.1069E+00	.2930E+01	.1791E+01	.2349E+01	.2388E+00	.8911E+00	.3183E+00	D0911C.BIS
11.00	1.018	1.964	.1033E+01	-.2742E+00	.2775E+00	.3090E+01	.1865E+01	.2116E+01	.2305E+00	.6584E+00	.1459E+00	D0911C.BIS
12.00	1.099	2.054	.1070E+01	-.2838E+00	.6506E-01	.2880E+01	.1712E+01	.2052E+01	.2190E+00	.7767E+00	.1397E+00	D0911C.BIS
13.00	1.180	2.142	.6332E+00	-.3616E+00	-.1337E+00	.1820E+01	.1376E+01	.1210E+01	.1140E+00	.3703E+00	.1734E+00	D0911C.BIS
14.00	1.259	2.232	.5556E+00	-.4084E+00	-.1092E+00	.1650E+01	.1271E+01	.1111E+01	.7053E-01	.3796E+00	.8850E-01	D0911C.BIS
15.00	1.339	2.321	.6380E+00	-.4244E+00	-.1015E+00	.1750E+01	.1341E+01	.1163E+01	-.1493E-02	.4204E+00	.3158E-01	D0911C.BIS
16.00	1.420	2.410	.6359E+00	-.2421E+00	.1474E+00	.2890E+01	.1659E+01	.1267E+01	.1076E+00	.5129E+00	.1556E+00	D0911C.BIS
17.00	1.501	2.500	.6573E+00	-.3473E+00	.1693E+00	.2360E+01	.1586E+01	.1278E+01	.1141E+00	.5253E+00	.4992E-01	D0911C.BIS
18.00	1.582	2.589	.7584E+00	-.3761E+00	.1154E+00	.2380E+01	.1699E+01	.1488E+01	-.1566E-01	.5218E+00	.5003E-01	D0911C.BIS
19.00	1.661	2.678	.7884E+00	-.4053E+00	.1544E+00	.2170E+01	.1666E+01	.1499E+01	.9453E-01	.5300E+00	-.5027E-01	D0911C.BIS
0.20	0.200	-0.200	.3101E+02	-.1011E+00	-.3471E+00	.3960E+00	.1611E+00	.5947E-01	.2565E-02	.1494E-01	-.4807E-01	D1005C.BIS
2.00	0.393	-0.233	.9006E+01	-.1224E+00	.1728E+00	.2180E+02	.1496E+02	.1746E+02	.8491E+01	.2520E+01	.2190E+00	D1005C.BIS
3.00	0.500	-0.250	.8866E+01	.2217E+00	-.3301E+00	.1940E+02	.1174E+02	.1494E+02	.5732E+01	-.2786E+01	-.5784E+00	D1005C.BIS
4.00	0.607	-0.268	.8570E+01	.2034E+00	-.2380E+00	.1610E+02	.9055E+01	.1251E+02	.4608E+01	-.1587E+01	-.3853E+00	D1005C.BIS
5.00	0.714	-0.286	.7708E+01	.1965E+00	-.1934E+00	.1540E+02	.8366E+01	.1022E+02	.4273E+01	-.1306E+01	-.4074E+00	D1005C.BIS
6.00	0.821	-0.304	.7102E+01	.2380E+00	-.7581E-01	.1360E+02	.8207E+01	.9920E+01	.4294E+01	-.1406E+01	-.3642E+00	D1005C.BIS
7.00	0.928	-0.322	.6501E+01	.2368E+00	.3556E-01	.1210E+02	.7015E+01	.8622E+01	.3628E+01	-.6386E+00	-.4526E+00	D1005C.BIS
8.00	1.036	-0.340	.6095E+01	.6923E-01	.7358E-02	.1090E+02	.7028E+01	.8224E+01	.3451E+01	-.7998E+00	-.2476E+00	D1005C.BIS
9.00	1.143	-0.358	.5745E+01	.1432E+00	-.2701E-01	.9960E+01	.6332E+01	.7521E+01	.3119E+01	-.6676E+00	-.6122E+00	D1005C.BIS
10.00	1.250	-0.375	.5422E+01	.1166E+00	.4412E-01	.8910E+01	.5488E+01	.6426E+01	.2597E+01	-.4085E+00	-.2585E+00	D1005C.BIS
11.00	1.357	-0.394	.5472E+01	.1871E+00	.1860E+00	.8510E+01	.5206E+01	.6094E+01	.2784E+01	-.6206E+00	-.2998E+00	D1005C.BIS
12.00	1.464	-0.411	.5448E+01	.2268E+00	.1846E+00	.7540E+01	.5101E+01	.5700E+01	.2542E+01	-.6924E+00	-.3200E+00	D1005C.BIS
13.00	1.571	-0.429	.5326E+01	.2665E+00	.2457E+00	.7430E+01	.4683E+01	.5064E+01	.2151E+01	-.4383E+00	-.1654E+00	D1005C.BIS
14.00	1.678	-0.447	.4984E+01	.1516E+00	.2410E+00	.6540E+01	.4350E+01	.4690E+01	.2160E+01	-.5229E+00	-.1634E+00	D1005C.BIS
15.00	1.785	-0.465	.5054E+01	.2891E+00	.2989E+00	.6150E+01	.4159E+01	.4251E+01	.1742E+01	-.4946E+00	-.2983E+00	D1005C.BIS
16.00	1.892	-0.483	.4924E+01	.2239E+00	.1798E+00	.5340E+01	.3849E+01	.4000E+01	.1633E+01	-.7130E+00	-.1893E+00	D1005C.BIS
17.00	1.999	-0.501	.4739E+01	.2301E+00	.5931E-01	.5510E+01	.3301E+01	.3947E+01	.1533E+01	-.5773E+00	-.2008E+00	D1005C.BIS
18.00	2.106	-0.519	.4797E+01	.1685E+00	.6735E-01	.5170E+01	.3262E+01	.3536E+01	.1482E+01	-.6007E+00	-.8792E-02	D1005C.BIS

TABLE 4  
Continued

X	Y	Z	$\bar{U}$	$\bar{V}$	$\bar{W}$	$\overline{uu}$	$\overline{vv}$	$\overline{ww}$	$\overline{uv}$	$\overline{uw}$	$\overline{vw}$	File Name
inch	inch	inch	m/s	m/s	m/s	m <sup>2</sup> /s <sup>2</sup>	m <sup>2</sup> /s <sup>2</sup>	m <sup>2</sup> /s <sup>2</sup>	m <sup>2</sup> /s <sup>2</sup>	m <sup>2</sup> /s <sup>2</sup>	m <sup>2</sup> /s <sup>2</sup>	
19.00	2.213	-0.537	.4593E+01	.1985E+00	.9775E-01	.5260E+01	.3364E+01	.3518E+01	.1539E+01	-.5632E+00	-.1858E+00	D1005C.BIS
0.20	0.199	0.199	.3067E+02	-.1139E+00	.1789E+00	.3570E+00	.1017E+00	.8109E-01	-.1656E-01	.1270E-01	-.1735E-01	D1007C.BIS
2.00	0.393	0.232	.9546E+01	.2505E+00	-.1735E+00	.2460E+02	.1539E+02	.1638E+02	.9054E+01	.1572E+01	-.1368E+01	D1007C.BIS
3.00	0.500	0.250	.8446E+01	.2298E+00	.6710E-01	.1760E+02	.1059E+02	.1263E+02	.5503E+01	.6565E+00	-.4430E+00	D1007C.BIS
4.00	0.607	0.268	.7405E+01	.1556E+00	.3962E+00	.1440E+02	.8481E+01	.1084E+02	.3661E+01	.7763E+00	-.3976E+00	D1007C.BIS
5.00	0.714	0.286	.6909E+01	.2630E+00	.2482E+00	.1250E+02	.7522E+01	.9941E+01	.3579E+01	.6009E+00	-.6362E+00	D1007C.BIS
6.00	0.821	0.303	.6370E+01	.3899E+00	.6912E+00	.1150E+02	.7271E+01	.8778E+01	.3257E+01	-.3916E-02	-.4795E+00	D1007C.BIS
7.00	0.928	0.322	.5939E+01	.2250E+00	.2644E+00	.1020E+02	.6473E+01	.7758E+01	.2739E+01	-.8762E-02	-.6609E+00	D1007C.BIS
8.00	1.035	0.339	.5636E+01	.1452E+00	.3514E+00	.1010E+02	.6299E+01	.7063E+01	.2729E+01	.2810E+00	-.4009E+00	D1007C.BIS
9.00	1.143	0.357	.5572E+01	.1532E+00	.2799E+00	.8550E+01	.5901E+01	.6254E+01	.2501E+01	.2927E+00	-.4916E+00	D1007C.BIS
10.00	1.250	0.375	.5084E+01	.2101E+00	.3787E+00	.9240E+01	.5843E+01	.6008E+01	.2690E+01	.3779E+00	-.3014E+00	D1007C.BIS
11.00	1.357	0.393	.5258E+01	.2600E+00	.4189E+00	.8440E+01	.5232E+01	.5754E+01	.2469E+01	.2923E+00	-.5181E+00	D1007C.BIS
12.00	1.464	0.411	.5109E+01	.1875E+00	.4683E+00	.7510E+01	.5053E+01	.5608E+01	.2335E+01	.1803E+00	-.2206E+00	D1007C.BIS
13.00	1.571	0.429	.5001E+01	.1743E+00	.4973E+00	.7080E+01	.4698E+01	.4924E+01	.1859E+01	.2776E+00	-.3124E+00	D1007C.BIS
14.00	1.678	0.447	.4997E+01	.1793E+00	.5238E+00	.6280E+01	.4253E+01	.4564E+01	.1771E+01	.2763E+00	-.3188E+00	D1007C.BIS
15.00	1.785	0.465	.4888E+01	.1599E+00	.4896E+00	.5820E+01	.4215E+01	.4127E+01	.1711E+01	.3356E+00	-.1847E+00	D1007C.BIS
16.00	1.892	0.483	.4813E+01	.1549E+00	.3757E+00	.5480E+01	.3860E+01	.3874E+01	.1671E+01	.2752E+00	-.3769E+00	D1007C.BIS
17.00	1.999	0.500	.4698E+01	.1316E+00	.4673E+00	.5400E+01	.3486E+01	.3682E+01	.1283E+01	.4171E+00	-.1389E+00	D1007C.BIS
18.00	2.106	0.518	.4739E+01	.2069E+00	.4810E+00	.4920E+01	.3380E+01	.3449E+01	.1226E+01	.1816E+00	-.1931E+00	D1007C.BIS
19.00	2.213	0.536	.4635E+01	.1444E+00	.5020E+00	.4870E+01	.3327E+01	.3236E+01	.1303E+01	.1323E+00	-.7253E-01	D1007C.BIS
0.20	0.200	0.399	.3109E+02	-.3255E+00	-.3999E+00	.4360E+00	.1412E+00	.1271E+00	-.7561E-02	.2483E-01	-.1615E-01	D1008C.BIS
2.00	0.393	0.464	.1150E+02	.8680E+00	-.1191E+00	.2530E+02	.1596E+02	.1845E+02	.8232E+01	-.2693E+01	-.2475E+00	D1008C.BIS
3.00	0.500	0.500	.9701E+01	.6425E+00	-.2178E+00	.2110E+02	.1133E+02	.1395E+02	.6539E+01	-.7685E+00	-.1335E+01	D1008C.BIS
4.00	0.607	0.535	.7877E+01	.3409E+00	.1046E+00	.1620E+02	.9136E+01	.1052E+02	.4763E+01	.4036E+00	-.1092E+01	D1008C.BIS
5.00	0.714	0.571	.6453E+01	.1034E+00	.4504E-01	.1290E+02	.8089E+01	.8745E+01	.3932E+01	.6859E+00	-.8269E+00	D1008C.BIS
6.00	0.821	0.607	.5664E+01	.7482E-01	.3277E+00	.1170E+02	.6959E+01	.7910E+01	.2911E+01	.1148E+01	-.8223E+00	D1008C.BIS
7.00	0.928	0.642	.5237E+01	.1464E+00	.4661E+00	.1070E+02	.6492E+01	.6885E+01	.2910E+01	.6923E+00	-.3969E+00	D1008C.BIS
8.00	1.036	0.678	.5068E+01	.1835E+00	.3763E+00	.9260E+01	.6427E+01	.7154E+01	.2501E+01	.1196E+01	-.3530E+00	D1008C.BIS
9.00	1.142	0.714	.4828E+01	.1142E+00	.6453E+00	.8610E+01	.5703E+01	.6375E+01	.2329E+01	.6637E+00	-.3568E+00	D1008C.BIS
10.00	1.250	0.750	.4476E+01	.6991E-01	.6477E+00	.7350E+01	.5425E+01	.5461E+01	.1889E+01	.5799E+00	-.4826E+00	D1008C.BIS
11.00	1.357	0.785	.4238E+01	-.1719E-01	.5486E+00	.7270E+01	.4737E+01	.5159E+01	.2048E+01	.5497E+00	-.2963E+00	D1008C.BIS
12.00	1.464	0.821	.4262E+01	-.1169E+00	.6174E+00	.6420E+01	.4250E+01	.4620E+01	.1720E+01	.5682E+00	-.1014E+00	D1008C.BIS
13.00	1.571	0.857	.4012E+01	-.6173E-01	.6449E+00	.6410E+01	.4287E+01	.4423E+01	.1548E+01	.6280E+00	-.2749E+00	D1008C.BIS
14.00	1.678	0.892	.4075E+01	-.3425E-01	.6458E+00	.6040E+01	.3872E+01	.4041E+01	.1559E+01	.5838E+00	-.2711E+00	D1008C.BIS
15.00	1.785	0.928	.4080E+01	-.1398E+00	.6609E+00	.5500E+01	.3790E+01	.3766E+01	.1620E+01	.6849E+00	-.2385E+00	D1008C.BIS
16.00	1.892	0.964	.3926E+01	-.1522E+00	.6657E+00	.5180E+01	.3459E+01	.3370E+01	.1279E+01	.5610E+00	-.1987E+00	D1008C.BIS
17.00	1.999	0.999	.3823E+01	-.1302E+00	.6092E+00	.4500E+01	.3159E+01	.3135E+01	.1050E+01	.4773E+00	-.1006E+00	D1008C.BIS
18.00	2.106	1.035	.3916E+01	-.1525E+00	.6215E+00	.4200E+01	.2990E+01	.2953E+01	.1033E+01	.4370E+00	-.1315E+00	D1008C.BIS
19.00	2.213	1.071	.3657E+01	-.1344E+00	.6465E+00	.4240E+01	.2917E+01	.3041E+01	.9521E+00	.5861E+00	-.3010E+00	D1008C.BIS
0.20	0.199	0.599	.3097E+02	-.2222E+00	-.4432E+00	.2720E+00	.1370E+00	.1013E+00	-.9073E-02	.8047E-02	-.2713E-01	D1009C.BIS
2.00	0.393	0.696	.8543E+01	.2967E+00	-.1100E+00	.2160E+02	.1468E+02	.1391E+02	.5874E+01	.2096E+01	-.1607E+01	D1009C.BIS
3.00	0.500	0.750	.5912E+01	.1135E+00	.2010E+00	.1500E+02	.9111E+01	.9472E+01	.3848E+01	.1388E+01	-.9790E+00	D1009C.BIS
4.00	0.607	0.803	.4872E+01	.5722E-01	.4103E+00	.1170E+02	.7159E+01	.7451E+01	.2873E+01	.1343E+01	-.4638E+00	D1009C.BIS
5.00	0.714	0.857	.3881E+01	-.2011E-01	.5189E+00	.9380E+01	.5783E+01	.6416E+01	.2164E+01	.1053E+01	-.2804E+00	D1009C.BIS
6.00	0.821	0.910	.3381E+01	-.2175E-01	.4409E+00	.8210E+01	.4941E+01	.5407E+01	.1387E+01	.1257E+01	-.1362E+00	D1009C.BIS
7.00	0.928	0.964	.3248E+01	-.8842E-01	.6381E+00	.7710E+01	.4836E+01	.4954E+01	.1331E+01	.1204E+01	-.9527E-01	D1009C.BIS
8.00	1.036	1.018	.3046E+01	-.1280E+00	.4751E+00	.7050E+01	.4484E+01	.4922E+01	.1368E+01	.1155E+01	-.1153E+00	D1009C.BIS
9.00	1.143	1.071	.2853E+01	-.3372E-01	.4938E+00	.6590E+01	.4096E+01	.4665E+01	.1118E+01	.1212E+01	-.1447E+00	D1009C.BIS
10.00	1.250	1.125	.2901E+01	-.5547E-01	.6384E+00	.6300E+01	.4028E+01	.4343E+01	.1118E+01	.8110E+00	-.1110E+00	D1009C.BIS
11.00	1.357	1.179	.2519E+01	-.3311E-01	.5034E+00	.6110E+01	.3560E+01	.3801E+01	.9786E+00	.7708E+00	-.4654E-01	D1009C.BIS
12.00	1.464	1.232	.2403E+01	.1147E+00	.5423E+00	.5610E+01	.3633E+01	.3330E+01	.8027E+00	.9440E+00	-.2931E-01	D1009C.BIS
13.00	1.571	1.286	.2355E+01	-.1474E-01	.4624E+00	.5610E+01	.3606E+01	.3522E+01	.8158E+00	.9771E+00	-.8133E-01	D1009C.BIS
14.00	1.678	1.339	.2758E+01	.9680E-01	.5572E+00	.5590E+01	.3434E+01	.3416E+01	.8806E+00	.8645E+00	-.4843E-01	D1009C.BIS
15.00	1.785	1.393	.2902E+01	-.1815E+00	.4945E+00	.5010E+01	.2954E+01	.3053E+01	.8120E+00	.8014E+00	.8302E-02	D1009C.BIS
16.00	1.892	1.447	.2786E+01	-.1639E+00	.5319E+00	.4640E+01	.2906E+01	.2634E+01	.7010E+00	.8202E+00	.1709E-01	D1009C.BIS
17.00	1.999	1.500	.2970E+01	-.2107E+00	.6555E+00	.4270E+01	.2865E+01	.2498E+01	.5949E+00	.7200E+00	.5253E-01	D1009C.BIS

TABLE 4  
Continued

X	Y	Z	$\bar{U}$	$\bar{V}$	$\bar{W}$	$\bar{u}$	$\bar{v}$	$\bar{w}$	$\bar{uv}$	$\bar{uw}$	$\bar{vw}$	File Name
inch	inch	inch	m/s	m/s	m/s	m <sup>2</sup> /s <sup>2</sup>	m <sup>2</sup> /s <sup>2</sup>	m <sup>2</sup> /s <sup>2</sup>	m <sup>2</sup> /s <sup>2</sup>	m <sup>2</sup> /s <sup>2</sup>	m <sup>2</sup> /s <sup>2</sup>	
18.00	2.106	1.554	.2671E+01	-.1916E+00	.5226E+00	.4100E+01	.2768E+01	.2276E+01	.6983E+00	.6693E+00	-.4387E-01	D1009C.BIS
19.00	2.213	1.607	.2664E+01	-.2056E+00	.4827E+00	.3680E+01	.2426E+01	.2351E+01	.6320E+00	.7598E+00	-.8290E-02	D1009C.BIS
0.20	0.200	1.000	.1531E+01	-.2517E+00	-.2182E+00	.8580E+00	.2473E+00	.3891E-01	-.1086E+00	.3143E-01	-.6541E-01	D1011C.BIS
2.00	0.393	1.160	.4155E+00	-.6113E+00	-.3419E+00	.1540E+01	.1550E+01	.1510E+01	-.3095E-03	.3576E+00	.3280E+00	D1011C.BIS
3.00	0.499	1.250	.4143E+00	-.5868E+00	-.4092E+00	.1040E+01	.1157E+01	.8568E+00	.1450E-01	.1797E+00	.2213E+00	D1011C.BIS
4.00	0.607	1.339	.2994E+00	-.5936E+00	-.4235E+00	.8510E+00	.5780E+00	.6189E+00	-.5335E-01	.7429E-01	.1317E-01	D1011C.BIS
5.00	0.714	1.428	.3133E+00	-.4177E+00	-.1956E+00	.1570E+01	.1335E+01	.9539E+00	.3110E-01	.1884E+00	.2019E+00	D1011C.BIS
6.00	0.821	1.518	.2997E+00	-.4147E+00	-.1472E+00	.1750E+01	.8905E+00	.9672E+00	.4085E-02	.1593E+00	.2533E-01	D1011C.BIS
7.00	0.928	1.607	.2689E+00	-.5513E+00	-.2776E+00	.7350E+00	.4292E+00	.4366E+00	-.3162E-01	.5189E-01	-.1025E-01	D1011C.BIS
8.00	1.035	1.696	.3015E+00	-.4452E+00	-.1911E+00	.1090E+01	.1039E+01	.7201E+00	-.6116E-03	.1165E+00	.1269E+00	D1011C.BIS
9.00	1.143	1.786	.2551E+00	-.3960E+00	-.7159E-01	.1230E+01	.1070E+01	.9173E+00	.1410E-01	.2270E+00	.2021E+00	D1011C.BIS
10.00	1.250	1.875	.3215E+00	-.4940E+00	-.1660E+00	.7350E+00	.4364E+00	.4661E+00	-.2376E-01	.6059E-01	.7787E-02	D1011C.BIS
11.00	1.357	1.964	.3288E+00	-.4248E+00	-.5343E-01	.9820E+00	.9816E+00	.7222E+00	-.4129E-01	.1153E+00	.1112E+00	D1011C.BIS
12.00	1.464	2.054	.3281E+00	-.4669E+00	-.1410E+00	.8270E+00	.5293E+00	.5688E+00	-.4094E-01	.1082E+00	.1003E-01	D1011C.BIS
13.00	1.571	2.142	.3871E+00	-.4629E+00	-.9436E-01	.8690E+00	.9893E+00	.6805E+00	-.2165E-02	.1380E+00	.8284E-01	D1011C.BIS
14.00	1.678	2.232	.4414E+00	-.3542E+00	.7542E-01	.1360E+01	.1256E+01	.1034E+01	.1787E-01	.2506E+00	.1805E+00	D1011C.BIS
15.00	1.785	2.321	.5386E+00	-.3839E+00	.8110E-01	.1460E+01	.1261E+01	.1009E+01	.3353E-01	.2854E+00	.1647E+00	D1011C.BIS
16.00	1.892	2.410	.5976E+00	-.3479E+00	.1358E+00	.1720E+01	.1251E+01	.1113E+01	.1417E+00	.4346E+00	.1666E+00	D1011C.BIS
17.00	1.999	2.500	.6590E+00	-.3937E+00	.1329E+00	.1540E+01	.1214E+01	.1049E+01	-.4276E-03	.3506E+00	.1217E+00	D1011C.BIS
18.00	2.106	2.589	.6990E+00	-.4732E+00	.1451E+00	.1500E+01	.1171E+01	.1046E+01	.3069E-01	.2915E+00	.6665E-01	D1011C.BIS
19.00	2.213	2.678	.5793E+00	-.4464E+00	.9961E-01	.1350E+01	.1140E+01	.8961E+00	.5621E-01	.2803E+00	.5967E-01	D1011C.BIS
0.20	0.250	-0.199	.6526E+01	-.3131E+00	-.2751E+00	.5660E+01	.2448E+00	.3532E-01	.3729E-01	.9430E-01	-.5965E-01	D1105C.BIS
2.00	0.491	-0.233	.4063E+01	-.1410E+00	-.5129E+00	.1150E+02	.8716E+01	.1002E+02	.3080E+01	-.1423E+01	-.8867E+00	D1105C.BIS
3.00	0.625	-0.250	.5382E+01	.1170E+00	.2235E+00	.1140E+02	.7427E+01	.9582E+01	.3296E+01	-.1137E+00	-.4321E+00	D1105C.BIS
4.00	0.760	-0.268	.5192E+01	.1118E+00	.1690E+00	.1120E+02	.7391E+01	.8226E+01	.3415E+01	-.5744E+00	-.5544E+00	D1105C.BIS
5.00	0.892	-0.286	.4811E+01	.2238E+00	-.4076E-01	.9970E+01	.6623E+01	.6963E+01	.3052E+01	-.6253E+00	-.1044E+00	D1105C.BIS
6.00	1.027	-0.304	.4385E+01	.2511E+00	-.1719E+00	.8560E+01	.6148E+01	.6085E+01	.2481E+01	-.6082E+00	-.5262E+00	D1105C.BIS
7.00	1.161	-0.322	.3863E+01	.1174E+00	-.1219E+00	.7930E+01	.5343E+01	.5719E+01	.2183E+01	-.5336E+00	-.4382E+00	D1105C.BIS
8.00	1.294	-0.340	.3646E+01	.1369E+00	-.2378E-01	.7040E+01	.4804E+01	.4942E+01	.2007E+01	-.4711E+00	-.3565E+00	D1105C.BIS
9.00	1.427	-0.358	.3271E+01	.1186E+00	-.6123E-01	.6910E+01	.4502E+01	.4181E+01	.1835E+01	-.4847E+00	-.4166E+00	D1105C.BIS
10.00	1.563	-0.375	.3413E+01	.1780E+00	.2892E-01	.6620E+01	.4564E+01	.4220E+01	.1828E+01	-.1445E+00	-.1749E+00	D1105C.BIS
11.00	1.695	-0.394	.3421E+01	.7342E-01	.2015E+00	.5230E+01	.3663E+01	.3790E+01	.1494E+01	-.1629E+00	-.1893E+00	D1105C.BIS
12.00	1.829	-0.411	.3259E+01	.2263E+00	.2630E-02	.5240E+01	.4101E+01	.3573E+01	.1607E+01	-.1086E+00	-.1690E+00	D1105C.BIS
13.00	1.965	-0.430	.2274E+01	.2022E+00	-.1929E+00	.4840E+01	.3221E+01	.2903E+01	.1049E+01	-.1076E+00	.5559E-01	D1105C.BIS
14.00	2.097	-0.447	.2684E+01	.2696E+00	-.3971E-01	.4530E+01	.2938E+01	.2916E+01	.8886E+00	-.5112E-01	-.7411E-01	D1105C.BIS
15.00	2.231	-0.465	.2649E+01	.9034E-01	-.1136E+00	.4410E+01	.2777E+01	.2588E+01	.1140E+01	-.1965E+00	-.2761E+00	D1105C.BIS
16.00	2.366	-0.483	.2907E+01	.1141E+00	-.1429E+00	.4940E+01	.3213E+01	.2736E+01	.1339E+01	-.2319E+00	-.3091E+00	D1105C.BIS
17.00	2.499	-0.501	.2989E+01	.1670E+00	.2954E-01	.4180E+01	.2669E+01	.2389E+01	.1047E+01	.1026E-01	.3023E-01	D1105C.BIS
18.00	2.633	-0.519	.3034E+01	.4535E-01	.1651E+00	.3880E+01	.2727E+01	.2189E+01	.9622E+00	-.1851E+00	-.3411E-01	D1105C.BIS
19.00	2.768	-0.537	.2859E+01	.2720E-01	.1181E+00	.3740E+01	.2528E+01	.2011E+01	.1024E+01	-.1309E+00	.5393E-01	D1105C.BIS
0.20	0.250	0.199	.3291E+01	-.3644E+00	-.2273E+00	.3360E+01	.2415E+00	.6120E-01	-.1639E+00	.8363E-01	-.7169E-01	D1107C.BIS
2.00	0.491	0.232	.5269E+01	.4354E+00	.1221E+00	.1530E+02	.1150E+02	.1061E+02	.4564E+01	.1979E+00	-.5565E+00	D1107C.BIS
3.00	0.625	0.250	.4970E+01	.1726E+00	-.6369E-01	.1190E+02	.6805E+01	.8863E+01	.2667E+01	-.8192E-01	-.3765E+00	D1107C.BIS
4.00	0.760	0.268	.4825E+01	.2689E+00	-.1845E+00	.1060E+02	.6602E+01	.7175E+01	.2726E+01	-.2158E+00	-.2193E+00	D1107C.BIS
5.00	0.892	0.286	.4552E+01	.2523E+00	.7102E-01	.8760E+01	.6264E+01	.6044E+01	.2649E+01	-.7349E-01	-.6226E+00	D1107C.BIS
6.00	1.026	0.303	.3497E+01	.5968E-01	-.7121E-01	.7400E+01	.4924E+01	.4746E+01	.1717E+01	.1418E+00	-.4654E+00	D1107C.BIS
7.00	1.161	0.322	.3419E+01	.4871E-01	.2011E+00	.6890E+01	.4609E+01	.4515E+01	.1742E+01	.1311E+00	-.2227E+00	D1107C.BIS
8.00	1.294	0.339	.3142E+01	.2547E-01	.2057E+00	.6710E+01	.4713E+01	.4276E+01	.1672E+01	.1481E+00	-.3010E+00	D1107C.BIS
9.00	1.428	0.357	.2922E+01	.2039E-01	.2190E+00	.5920E+01	.3973E+01	.3791E+01	.1516E+01	.2279E+00	-.3701E-01	D1107C.BIS
10.00	1.563	0.375	.2854E+01	.3416E-02	.3920E+00	.5760E+01	.3937E+01	.3610E+01	.1489E+01	.3683E-01	-.8513E-01	D1107C.BIS
11.00	1.695	0.393	.2919E+01	.1699E-01	.3053E+00	.5680E+01	.3778E+01	.3333E+01	.1482E+01	.2697E+00	-.5608E-01	D1107C.BIS
12.00	1.829	0.411	.2862E+01	.1637E-01	.4100E+00	.5160E+01	.3629E+01	.3215E+01	.1436E+01	.3054E+00	.9324E-01	D1107C.BIS
13.00	1.965	0.429	.2906E+01	.4507E-01	.3117E+00	.5140E+01	.3294E+01	.3232E+01	.1189E+01	.2448E+00	-.7693E-01	D1107C.BIS
14.00	2.097	0.447	.3093E+01	.7627E-01	.3959E+00	.4690E+01	.3204E+01	.3060E+01	.1065E+01	.2063E+00	-.9370E-01	D1107C.BIS
15.00	2.231	0.465	.2602E+01	.2342E+00	.2249E+00	.5010E+01	.3329E+01	.2816E+01	.1052E+01	.1382E+00	-.6662E-01	D1107C.BIS
16.00	2.366	0.482	.2338E+01	.2291E+00	.2604E+00	.4220E+01	.2559E+01	.2074E+01	.8258E+00	.2915E+00	-.7775E-01	D1107C.BIS

TABLE 4  
Continued

X	Y	Z	$\bar{u}$	$\bar{v}$	$\bar{w}$	$\overline{uu}$	$\overline{vv}$	$\overline{ww}$	$\overline{uv}$	$\overline{uw}$	$\overline{vw}$	File Name
inch	inch	inch	m/s	m/s	m/s	m <sup>2</sup> /s <sup>2</sup>	m <sup>2</sup> /s <sup>2</sup>	m <sup>2</sup> /s <sup>2</sup>	m <sup>2</sup> /s <sup>2</sup>	m <sup>2</sup> /s <sup>2</sup>	m <sup>2</sup> /s <sup>2</sup>	
17.00	2.499	0.500	.2796E+01	.9787E-01	.3309E+00	.4010E+01	.2673E+01	.2265E+01	.9572E+00	.1201E+00	-.1017E+00	D1107C.BIS
18.00	2.633	0.518	.2810E+01	.7685E-01	.2401E+00	.3760E+01	.2646E+01	.2308E+01	.9228E+00	.1711E+00	-.3555E-01	D1107C.BIS
19.00	2.767	0.536	.2740E+01	-.2393E-02	.2042E+00	.4090E+01	.2657E+01	.2187E+01	.1087E+01	.3379E+00	-.8200E-01	D1107C.BIS
0.20	0.250	0.399	.2887E+01	-.3825E+00	-.3282E+00	.2520E+01	.2905E+00	.5267E-01	-.7200E-02	.9522E-01	-.7846E-01	D1108C.BIS
2.00	0.491	0.464	.6725E+01	.5306E+00	-.1138E+01	.1610E+02	.1030E+02	.1050E+02	.4387E+01	-.1807E+01	-.6057E+00	D1108C.BIS
3.00	0.625	0.500	.5922E+01	.3339E+00	-.2977E+00	.1300E+02	.9056E+01	.8302E+01	.4087E+01	-.8659E-01	-.3254E+00	D1108C.BIS
4.00	0.760	0.535	.4645E+01	.3684E+00	-.2373E+00	.1130E+02	.7290E+01	.6935E+01	.3221E+01	-.3444E-01	-.4848E+00	D1108C.BIS
5.00	0.892	0.571	.3756E+01	.1663E+00	-.7306E-01	.9120E+01	.5740E+01	.5495E+01	.2632E+01	.5007E+00	-.1877E+00	D1108C.BIS
6.00	1.026	0.607	.3130E+01	.3231E-01	.2653E-02	.7560E+01	.5177E+01	.4702E+01	.2016E+01	.2643E+00	-.1477E+00	D1108C.BIS
7.00	1.161	0.642	.2535E+01	.7715E-04	.2035E-01	.6770E+01	.4289E+01	.4306E+01	.1686E+01	.3158E+00	.2823E-01	D1108C.BIS
8.00	1.294	0.678	.2141E+01	-.4139E-01	-.1067E+00	.5970E+01	.3709E+01	.3443E+01	.1306E+01	.4478E+00	.1461E+00	D1108C.BIS
9.00	1.428	0.714	.2084E+01	-.4439E-01	-.1569E+00	.5870E+01	.3668E+01	.3684E+01	.1295E+01	.4600E+00	.4056E-01	D1108C.BIS
10.00	1.563	0.750	.1722E+01	.3081E+00	-.1290E+00	.5940E+01	.4116E+01	.3826E+01	.1040E+01	.6870E+00	.3014E-01	D1108C.BIS
11.00	1.695	0.785	.1691E+01	.2368E+00	-.1076E+00	.5670E+01	.3677E+01	.3265E+01	.1118E+01	.6746E+00	.2433E+00	D1108C.BIS
12.00	1.829	0.821	.1776E+01	.1407E+00	-.4577E-01	.5390E+01	.3442E+01	.2942E+01	.1456E+01	.4308E+00	.2451E-01	D1108C.BIS
13.00	1.965	0.857	.1815E+01	-.1567E-01	.1457E+00	.4710E+01	.3141E+01	.2813E+01	.1032E+01	.4380E+00	.1269E+00	D1108C.BIS
14.00	2.097	0.892	.2026E+01	-.1054E+00	.1331E+00	.4320E+01	.2879E+01	.2610E+01	.9203E+00	.5763E+00	.5466E-01	D1108C.BIS
15.00	2.231	0.928	.1691E+01	-.1226E+00	.1585E+00	.4300E+01	.2509E+01	.2271E+01	.8551E+00	.5828E+00	.1241E+00	D1108C.BIS
16.00	2.366	0.964	.2104E+01	-.9941E-01	.3460E+00	.4040E+01	.2407E+01	.2611E+01	.7649E+00	.3965E+00	.8794E-01	D1108C.BIS
17.00	2.499	0.999	.2213E+01	-.1232E+00	.2832E+00	.3990E+01	.2416E+01	.2142E+01	.8074E+00	.6042E+00	.9659E-01	D1108C.BIS
18.00	2.633	1.035	.2193E+01	-.1589E+00	.3303E+00	.3800E+01	.2355E+01	.2128E+01	.8396E+00	.5400E+00	.6233E-01	D1108C.BIS
19.00	2.768	1.071	.2311E+01	-.1384E+00	.3898E+00	.3560E+01	.2103E+01	.2037E+01	.7619E+00	.5114E+00	.1053E+00	D1108C.BIS
0.20	0.250	0.599	.2576E+01	-.3642E+00	-.3045E+00	.1310E+01	.2041E+00	.6319E-01	-.4648E-01	.5334E-01	-.6166E-01	D1109C.BIS
2.00	0.491	0.696	.5573E+01	.4711E+00	.1547E+00	.1550E+02	.1057E+02	.1052E+02	.3903E+01	.2298E+01	.1616E+00	D1109C.BIS
3.00	0.625	0.750	.3598E+01	.1332E+00	.3839E+00	.1070E+02	.6694E+01	.6955E+01	.2221E+01	.1586E+01	.3863E+00	D1109C.BIS
4.00	0.760	0.803	.2860E+01	-.5980E-01	.2878E+00	.8130E+01	.5112E+01	.5373E+01	.1520E+01	.1365E+01	.5432E-01	D1109C.BIS
5.00	0.892	0.857	.2140E+01	-.1806E+00	.1517E+00	.6630E+01	.3964E+01	.3978E+01	.1255E+01	.9132E+00	.1108E+00	D1109C.BIS
6.00	1.026	0.910	.1816E+01	-.1981E+00	.1428E+00	.5260E+01	.3380E+01	.3454E+01	.9490E+00	.8253E+00	.2642E+00	D1109C.BIS
7.00	1.161	0.964	.1718E+01	.5452E-01	.8985E-01	.4910E+01	.3398E+01	.3148E+01	.8985E+00	.7056E+00	.2075E+00	D1109C.BIS
8.00	1.294	1.018	.1289E+01	-.1613E+00	.1249E-01	.4090E+01	.2620E+01	.2687E+01	.6276E+00	.6930E+00	.1833E+00	D1109C.BIS
9.00	1.428	1.071	.6822E+00	-.3744E+00	-.2072E+00	.1940E+01	.1590E+01	.1254E+01	.2313E+00	.2676E+00	.1612E+00	D1109C.BIS
10.00	1.563	1.125	.7956E+00	-.3104E+00	-.5613E-01	.2040E+01	.1702E+01	.1408E+01	.2397E+00	.3384E+00	.1826E+00	D1109C.BIS
11.00	1.696	1.179	.7333E+00	-.3238E+00	-.1254E+00	.1960E+01	.1755E+01	.1358E+01	.2612E+00	.3352E+00	.2367E+00	D1109C.BIS
12.00	1.829	1.232	.1072E+01	-.2334E-01	.1628E+00	.3690E+01	.2424E+01	.2206E+01	.5149E+00	.4989E+00	.3336E+00	D1109C.BIS
13.00	1.964	1.286	.1009E+01	-.1158E+00	.5904E-01	.3110E+01	.1963E+01	.1623E+01	.3909E+00	.4329E+00	.1678E+00	D1109C.BIS
14.00	2.098	1.339	.1135E+01	-.2596E+00	.1984E+00	.3010E+01	.2019E+01	.1821E+01	.3677E+00	.5742E+00	.1106E+00	D1109C.BIS
15.00	2.231	1.393	.9944E+00	-.2336E+00	.1369E+00	.2460E+01	.1824E+01	.1543E+01	.2318E+00	.4340E+00	.8413E-01	D1109C.BIS
16.00	2.366	1.447	.9551E+00	-.2529E+00	.8049E-03	.2190E+01	.1435E+01	.1250E+01	.2232E+00	.3695E+00	.1040E+00	D1109C.BIS
17.00	2.499	1.500	.1055E+01	-.2240E+00	.1130E+00	.2370E+01	.1583E+01	.1304E+01	.2902E+00	.4575E+00	.1093E+00	D1109C.BIS
18.00	2.633	1.554	.1001E+01	-.2622E+00	.1283E+00	.2420E+01	.1539E+01	.1194E+01	.2710E+00	.4489E+00	.1628E+00	D1109C.BIS
19.00	2.768	1.607	.1031E+01	-.2481E+00	.1450E+00	.2270E+01	.1444E+01	.1386E+01	.2034E+00	.4788E+00	.1045E+00	D1109C.BIS
0.20	0.249	0.799	.2386E+01	-.4025E+00	-.3404E+00	.1310E+01	.2139E+00	.8492E-01	-.1769E-01	.6434E-01	-.6497E-01	D1110C.BIS
2.00	0.491	0.928	.1444E+01	-.1206E-01	.1818E-01	.7170E+01	.5477E+01	.4721E+01	.1281E+01	.7850E+00	-.4500E-01	D1110C.BIS
3.00	0.625	0.999	.1010E+01	-.2764E+00	.5399E-01	.4430E+01	.3060E+01	.3433E+01	.6977E+00	.9675E+00	.4394E+00	D1110C.BIS
4.00	0.760	1.071	.8081E+00	-.1260E+00	.1521E+00	.4300E+01	.2843E+01	.2871E+01	.6599E+00	.7579E+00	.3338E+00	D1110C.BIS
5.00	0.892	1.142	.4919E+00	-.2669E+00	-.1632E+00	.2950E+01	.2196E+01	.2076E+01	.2375E+00	.4845E+00	.3608E+00	D1110C.BIS
6.00	1.027	1.214	.4896E+00	-.3036E+00	-.1589E+00	.2190E+01	.1749E+01	.1516E+01	.2069E+00	.3035E+00	.2336E+00	D1110C.BIS
7.00	1.161	1.285	.3455E+00	-.4145E+00	-.2862E+00	.1390E+01	.1264E+01	.9945E+00	.7501E-01	.2134E+00	.1594E+00	D1110C.BIS
8.00	1.294	1.357	.4484E+00	-.2787E+00	-.2145E+00	.2030E+01	.1766E+01	.1303E+01	.2112E+00	.2371E+00	.2325E+00	D1110C.BIS
9.00	1.427	1.428	.3883E+00	-.2754E+00	-.1432E+00	.1750E+01	.1599E+01	.1123E+01	.1770E+00	.2533E+00	.2571E+00	D1110C.BIS
10.00	1.563	1.499	.3386E+00	-.3925E+00	-.1332E+00	.1210E+01	.1110E+01	.8978E+00	.1300E-01	.2184E+00	.1514E+00	D1110C.BIS
11.00	1.695	1.571	.2828E+00	-.3436E+00	-.2660E+00	.1070E+01	.6745E+00	.7656E+00	.5651E-01	.1416E+00	.4671E-01	D1110C.BIS
12.00	1.829	1.642	.3096E+00	-.3757E+00	-.2374E+00	.1190E+01	.7289E+00	.7583E+00	.8121E-01	.1569E+00	-.1428E-01	D1110C.BIS
13.00	1.965	1.714	.2532E+00	-.2555E+00	-.1691E+00	.1940E+01	.8716E+00	.9269E+00	.2031E+00	.2846E+00	-.1201E-01	D1110C.BIS
14.00	2.097	1.785	.3110E+00	-.2381E+00	-.2678E-01	.1930E+01	.9682E+00	.1057E+01	.1777E+00	.3293E+00	.1166E-01	D1110C.BIS
15.00	2.231	1.857	.2282E+00	-.3535E+00	-.7718E-01	.1380E+01	.1147E+01	.8712E+00	.9369E-01	.2642E+00	.1279E+00	D1110C.BIS

TABLE 4  
Continued

X	Y	Z	$\bar{U}$	$\bar{V}$	$\bar{W}$	$\overline{uu}$	$\overline{vv}$	$\overline{ww}$	$\overline{uv}$	$\overline{uw}$	$\overline{vw}$	File Name
inch	inch	inch	m/s	m/s	m/s	m <sup>2</sup> /s <sup>2</sup>	m <sup>2</sup> /s <sup>2</sup>	m <sup>2</sup> /s <sup>2</sup>	m <sup>2</sup> /s <sup>2</sup>	m <sup>2</sup> /s <sup>2</sup>	m <sup>2</sup> /s <sup>2</sup>	
16.00	2.367	1.928	.2219E+00	-.2908E+00	-.2221E+00	.1340E+01	.6970E+00	.7169E+00	.1223E+00	.2070E+00	-.2656E-01	D1110C.BIS
17.00	2.499	1.999	.3119E+00	-.3147E+00	-.2313E+00	.1560E+01	.1106E+01	.7908E+00	.1647E+00	.3151E+00	.1304E+00	D1110C.BIS
18.00	2.633	2.070	.4766E+00	-.3629E+00	-.9439E-01	.1510E+01	.1128E+01	.8126E+00	.1001E+00	.2377E+00	.1125E+00	D1110C.BIS
19.00	2.768	2.142	.4644E+00	-.3182E+00	-.2306E+00	.1390E+01	.1102E+01	.7857E+00	.1075E+00	.2394E+00	.8973E-01	D1110C.BIS
0.20	0.249	0.999	.4733E+00	-.1632E+00	-.6301E+00	.2910E+00	.3061E+00	.1227E+00	-.2677E-01	.1458E-01	-.9067E-01	D1111C.BIS
2.00	0.491	1.160	.2180E+00	-.4769E+00	-.7064E+00	.1200E+01	.7099E+00	.8081E+00	.1242E+00	.1702E+00	.4630E-01	D1111C.BIS
3.00	0.625	1.250	.1239E+00	-.5117E+00	-.5905E+00	.6260E+00	.3770E+00	.3478E+00	-.3246E-02	.3617E-01	-.3611E-01	D1111C.BIS
4.00	0.760	1.339	.9472E-01	-.4463E+00	-.5713E+00	.4740E+00	.2712E+00	.2354E+00	.5982E-02	.2918E-01	-.3599E-01	D1111C.BIS
5.00	0.892	1.428	.9305E-01	-.4592E+00	-.5328E+00	.4570E+00	.2485E+00	.2105E+00	.7929E-02	.3091E-01	-.3644E-01	D1111C.BIS
6.00	1.026	1.518	.8469E-01	-.4893E+00	-.4886E+00	.4930E+00	.2030E+00	.1714E+00	-.3055E-01	.2950E-01	-.2962E-01	D1111C.BIS
7.00	1.161	1.607	.7275E-01	-.4538E+00	-.4815E+00	.4900E+00	.2242E+00	.1815E+00	-.2266E-01	.1291E-01	-.3610E-01	D1111C.BIS
8.00	1.294	1.696	.1261E-01	-.4525E+00	-.4885E+00	.5150E+00	.2382E+00	.1804E+00	-.1082E-01	.1256E-01	-.4503E-01	D1111C.BIS
9.00	1.428	1.786	-.2560E-01	-.4849E+00	-.4864E+00	.5030E+00	.2500E+00	.1888E+00	-.1529E-01	.1894E-01	-.4789E-01	D1111C.BIS
10.00	1.563	1.875	-.1232E-01	-.4365E+00	-.5118E+00	.5270E+00	.2346E+00	.1927E+00	-.6666E-02	.1812E-01	-.3680E-01	D1111C.BIS
11.00	1.696	1.964	-.3600E-01	-.4263E+00	-.4585E+00	.5470E+00	.2253E+00	.1922E+00	-.1172E-01	.2739E-01	-.3169E-01	D1111C.BIS
12.00	1.829	2.054	-.2068E-01	-.3918E+00	-.5251E+00	.5590E+00	.2634E+00	.2165E+00	.5442E-03	.3143E-01	-.4220E-01	D1111C.BIS
13.00	1.965	2.142	.1080E-01	-.4101E+00	-.4249E+00	.6120E+00	.2835E+00	.2801E+00	.1182E-01	.4319E-01	-.1517E-01	D1111C.BIS
14.00	2.097	2.232	-.4686E-01	-.4420E+00	-.4083E+00	.5380E+00	.2693E+00	.2231E+00	-.6541E-02	.2416E-01	-.4148E-01	D1111C.BIS
15.00	2.231	2.321	.5949E-01	-.4323E+00	-.3220E+00	.5810E+00	.3362E+00	.3261E+00	-.6240E-02	.7815E-01	-.2420E-01	D1111C.BIS
16.00	2.366	2.410	-.2289E-02	-.4051E+00	-.3610E+00	.5490E+00	.2948E+00	.3042E+00	-.4354E-02	.6206E-01	-.6287E-02	D1111C.BIS
17.00	2.499	2.500	.7838E-01	-.4030E+00	-.2648E+00	.7040E+00	.3477E+00	.3705E+00	-.1040E-01	.6724E-01	.3437E-02	D1111C.BIS
18.00	2.633	2.589	.3368E-01	-.3922E+00	-.2645E+00	.6520E+00	.3577E+00	.3638E+00	.1805E-02	.7381E-01	-.1217E-01	D1111C.BIS
19.00	2.768	2.678	.1120E+00	-.3965E+00	-.2160E+00	.7090E+00	.3705E+00	.3987E+00	.9661E-02	.1082E+00	.3111E-02	D1111C.BIS



**TABLE 5**  
**1x2 Ratio Nozzle Mach# = 0.9 Wfv Data**

X	Y	Z	$\bar{U}$	$\bar{V}$	$\bar{W}$	$\bar{u}$	$\bar{v}$	$\bar{w}$	$\bar{uv}$	$\bar{uw}$	$\bar{vw}$	File Name
inch	inch	inch	m/s	m/s	m/s	m <sup>2</sup> /s <sup>2</sup>	m <sup>2</sup> /s <sup>2</sup>	m <sup>2</sup> /s <sup>2</sup>	m <sup>2</sup> /s <sup>2</sup>	m <sup>2</sup> /s <sup>2</sup>	m <sup>2</sup> /s <sup>2</sup>	
1.00	-0.476	0.001	.2386E+03	-.5021E+01	.4009E+01	.1760E+04	.1626E+04	.7740E+03	-.5313E+03	-.2540E+02	.3561E+02	D02065.BIS
1.00	-0.357	0.000	.3214E+03	-.9400E+00	.2571E+01	.1790E+02	.2259E+02	.1080E+02	-.2356E+01	-.6693E+00	-.5044E+01	D03065.BIS
5.00	-0.643	-0.001	.1521E+03	-.1273E+02	.7941E+01	.2060E+04	.3225E+04	.5800E+03	-.4349E+03	-.7082E+01	.2874E+03	D03065.BIS
9.00	-0.929	-0.002	.1019E+03	-.7339E+01	.4811E+01	.1740E+04	.1689E+04	.3410E+03	-.4669E+03	-.1963E+02	.1322E+03	D03065.BIS
13.00	-1.214	0.000	.8853E+02	-.6453E+01	.5110E+01	.1290E+04	.1263E+04	.2740E+03	-.3550E+03	-.1839E+02	.9991E+02	D03065.BIS
17.00	-1.500	-0.001	.8648E+02	-.9743E+01	.5340E+01	.1090E+04	.1100E+04	.2270E+03	-.3410E+03	.3508E+02	.4947E+02	D03065.BIS
1.00	-0.238	0.000	.3217E+03	-.8459E+00	.3432E+00	.5330E+01	.1256E+02	.3950E+01	-.2083E+01	-.9059E+00	-.3438E+01	D04065.BIS
5.00	-0.429	-0.001	.2380E+03	-.1239E+02	.9023E+01	.1800E+04	.1342E+04	.7731E+03	-.3953E+03	-.7928E+02	.1445E+03	D04065.BIS
9.00	-0.619	-0.002	.1698E+03	-.1314E+02	.7973E+01	.2100E+04	.3152E+04	.6584E+03	-.3671E+03	-.8426E+02	.3097E+03	D04065.BIS
13.00	-0.810	0.000	.1394E+03	-.1194E+02	.7094E+01	.2110E+04	.2335E+04	.5167E+03	-.5804E+03	-.3918E+02	.2135E+03	D04065.BIS
17.00	-1.000	-0.001	.1221E+03	-.1036E+02	.6905E+01	.1870E+04	.1778E+04	.4008E+03	-.5336E+03	-.9623E+01	.1345E+03	D04065.BIS
0.20	-0.099	-0.200	.3229E+03	-.1475E+01	-.1255E+01	.4380E+01	.1803E+02	.3320E+01	-.3172E+01	-.5744E+00	-.4203E+01	D05055.BIS
1.00	-0.119	-0.214	.3229E+03	-.1899E+01	-.7672E+00	.5350E+01	.1584E+02	.3380E+01	-.2289E+01	-.6441E+00	-.4311E+01	D05055.BIS
2.00	-0.143	-0.232	.3224E+03	-.1092E+01	.2759E+00	.1150E+02	.1858E+02	.6210E+01	-.3962E+01	.1490E+00	-.3723E+01	D05055.BIS
3.00	-0.167	-0.250	.3218E+03	-.1326E+01	.1040E+01	.3680E+02	.3835E+02	.1920E+02	-.8043E+01	.2371E+01	-.1275E+01	D05055.BIS
4.00	-0.190	-0.268	.3192E+03	-.2432E+00	.9609E+00	.1200E+03	.1333E+03	.7301E+02	-.5087E+02	.4679E+01	.3433E+01	D05055.BIS
5.00	-0.214	-0.286	.3076E+03	-.8080E+00	.9882E+00	.4969E+03	.8871E+03	.2320E+03	-.1383E+03	-.4240E+02	.7896E+02	D05055.BIS
6.00	-0.238	-0.304	.2879E+03	-.2318E+01	-.2684E+00	.1090E+04	.1509E+04	.4099E+03	-.2181E+03	-.9000E+02	.1068E+03	D05055.BIS
7.00	-0.262	-0.322	.2672E+03	-.7454E+00	.3524E+00	.1600E+04	.1969E+04	.5819E+03	-.3822E+03	-.1709E+03	.1541E+03	D05055.BIS
8.00	-0.286	-0.339	.2528E+03	-.2839E+01	.5784E+00	.1820E+04	.2030E+04	.6399E+03	-.4313E+03	-.1818E+03	.1459E+03	D05055.BIS
9.00	-0.309	-0.357	.2374E+03	-.3090E+01	.1735E+00	.2060E+04	.2339E+04	.6701E+03	-.4790E+03	-.1960E+03	.1610E+03	D05055.BIS
10.00	-0.333	-0.375	.2280E+03	-.2201E+01	.2087E+00	.2120E+04	.2511E+04	.7000E+03	-.5435E+03	-.2134E+03	.2086E+03	D05055.BIS
11.00	-0.357	-0.393	.2006E+03	-.1761E+01	.2686E+01	.2150E+04	.2644E+04	.6911E+03	-.4539E+03	-.1862E+03	.2200E+03	D05055.BIS
12.00	-0.381	-0.411	.1935E+03	-.6389E+00	.1127E+01	.2050E+04	.2406E+04	.6487E+03	-.4524E+03	-.2120E+03	.2274E+03	D05055.BIS
13.00	-0.405	-0.429	.1865E+03	-.1421E+01	.1728E+01	.2110E+04	.2356E+04	.6398E+03	-.4345E+03	-.2172E+03	.2076E+03	D05055.BIS
14.00	-0.429	-0.447	.1813E+03	-.7006E+00	.8736E+00	.1900E+04	.2466E+04	.6377E+03	-.3605E+03	-.1670E+03	.2168E+03	D05055.BIS
15.00	-0.453	-0.464	.1754E+03	-.7164E+00	.1409E+01	.1850E+04	.2255E+04	.5521E+03	-.3086E+03	-.1548E+03	.2031E+03	D05055.BIS
16.00	-0.476	-0.483	.1695E+03	-.1977E+01	.2363E+01	.1750E+04	.2009E+04	.5340E+03	-.2976E+03	-.1350E+03	.1443E+03	D05055.BIS
17.00	-0.500	-0.500	.1650E+03	-.3346E+01	.2834E+01	.1590E+04	.1982E+04	.4891E+03	-.3052E+03	-.1131E+03	.1519E+03	D05055.BIS
18.00	-0.524	-0.518	.1597E+03	-.3627E+01	.2397E+01	.1620E+04	.1741E+04	.4772E+03	-.2939E+03	-.9446E+02	.1459E+03	D05055.BIS
19.00	-0.548	-0.536	.1541E+03	-.5277E+01	.1819E+01	.1550E+04	.1528E+04	.4279E+03	-.2480E+03	-.1200E+03	.1038E+03	D05055.BIS
20.00	-0.571	-0.554	.1501E+03	-.4707E+01	.2431E+01	.1460E+04	.1430E+04	.4300E+03	-.2509E+03	-.1219E+03	.7831E+02	D05055.BIS
0.20	-0.101	0.000	.3227E+03	-.5389E+00	-.6284E+00	.5020E+01	.1183E+02	.4210E+01	-.1560E+01	-.1620E+01	-.3542E+01	D05065.BIS
1.00	-0.119	0.000	.3229E+03	-.4171E+00	-.7056E-01	.5610E+01	.1211E+02	.4340E+01	-.1596E+01	-.1810E+01	-.3592E+01	D05065.BIS
2.00	-0.143	0.000	.3226E+03	-.1208E+00	-.1410E+00	.1060E+02	.1454E+02	.6050E+01	-.2152E+01	-.1370E+01	-.3600E+01	D05065.BIS
3.00	-0.167	0.000	.3226E+03	.9759E-01	.6772E-01	.3150E+02	.2965E+02	.1500E+02	-.5060E+01	-.1690E+01	-.2805E+01	D05065.BIS
4.00	-0.191	-0.001	.3208E+03	.5509E-01	.1037E+01	.8260E+02	.8358E+02	.4700E+02	-.2867E+02	.7008E+00	.2068E+01	D05065.BIS
5.00	-0.214	-0.001	.3147E+03	-.1656E+01	.2547E+01	.2700E+03	.2247E+03	.1470E+03	-.9290E+02	-.2511E+02	.1959E+02	D05065.BIS
6.00	-0.238	-0.001	.3010E+03	-.5503E+01	.4029E+01	.6920E+03	.1140E+04	.3200E+03	-.8319E+02	-.5952E+02	.1390E+03	D05065.BIS
7.00	-0.262	-0.001	.2830E+03	-.6946E+01	.6540E+01	.1230E+04	.1581E+04	.4871E+03	-.2160E+03	-.9207E+02	.1442E+03	D05065.BIS
8.00	-0.286	-0.001	.2644E+03	-.7028E+01	.6263E+01	.1690E+04	.1987E+04	.5799E+03	-.3201E+03	-.1419E+03	.1951E+03	D05065.BIS
9.00	-0.309	-0.002	.2489E+03	-.6783E+01	.7042E+01	.1870E+04	.2286E+04	.6771E+03	-.3915E+03	-.1642E+03	.2065E+03	D05065.BIS
10.00	-0.333	-0.002	.2115E+03	-.2403E+01	.5234E+01	.1910E+04	.2530E+04	.6723E+03	-.4327E+03	-.2521E+03	.2554E+03	D05065.BIS
11.00	-0.357	0.000	.2011E+03	-.2426E+01	.5265E+01	.1950E+04	.2476E+04	.6241E+03	-.4175E+03	-.2543E+03	.2485E+03	D05065.BIS
12.00	-0.381	0.000	.1941E+03	-.1944E+01	.5379E+01	.1910E+04	.2353E+04	.6210E+03	-.4058E+03	-.2304E+03	.2311E+03	D05065.BIS
13.00	-0.405	0.000	.1913E+03	-.3949E+01	.8991E+01	.1860E+04	.2395E+04	.5991E+03	-.4160E+03	-.1710E+03	.2309E+03	D05065.BIS
14.00	-0.429	-0.001	.1814E+03	-.3956E+01	.9163E+01	.1830E+04	.2071E+04	.5553E+03	-.4222E+03	-.1529E+03	.1975E+03	D05065.BIS
15.00	-0.453	-0.001	.1764E+03	-.5454E+01	.9076E+01	.1780E+04	.2126E+04	.5442E+03	-.3928E+03	-.1150E+03	.1889E+03	D05065.BIS
17.00	-0.500	-0.001	.1701E+03	-.5713E+01	.7520E+01	.1750E+04	.2104E+04	.5113E+03	-.2649E+03	-.7650E+02	.1621E+03	D05065.BIS
18.00	-0.524	-0.002	.1660E+03	-.6828E+01	.7157E+01	.1620E+04	.1857E+04	.4728E+03	-.2441E+03	-.2996E+02	.1431E+03	D05065.BIS
20.00	-0.571	0.000	.1508E+03	-.5281E+01	.4454E+01	.1660E+04	.1499E+04	.4138E+03	-.3202E+03	-.4956E+02	.1111E+03	D05065.BIS
0.20	-0.100	0.200	.3224E+03	-.3576E+01	-.8387E+00	.3870E+01	.1383E+02	.3190E+01	-.2638E+01	-.3112E+00	-.3403E+01	D05075.BIS
1.00	-0.119	0.214	.3227E+03	-.3669E+01	-.4890E+00	.4160E+01	.1485E+02	.3230E+01	-.2573E+01	-.3878E+00	-.3772E+01	D05075.BIS
2.00	-0.143	0.232	.3224E+03	-.3276E+01	.6718E-01	.9860E+01	.1392E+02	.5050E+01	-.1983E+01	-.3676E+00	-.3261E+01	D05075.BIS
3.00	-0.167	0.250	.3218E+03	-.2550E+01	.4131E+00	.2890E+02	.3176E+02	.1300E+02	-.3434E+01	-.5270E+00	-.5730E+01	D05075.BIS
4.00	-0.190	0.268	.3204E+03	-.1600E+01	.8957E+00	.6809E+02	.8720E+02	.3900E+02	-.2066E+02	.1416E+00	-.1177E+02	D05075.BIS

TABLE 5  
Continued

X	Y	Z	$\bar{u}$	$\bar{v}$	$\bar{w}$	$\overline{uu}$	$\overline{vv}$	$\overline{ww}$	$\overline{uv}$	$\overline{uw}$	$\overline{vw}$	File Name
inch	inch	inch	m/s	m/s	m/s	m <sup>2</sup> /s <sup>2</sup>	m <sup>2</sup> /s <sup>2</sup>	m <sup>2</sup> /s <sup>2</sup>	m <sup>2</sup> /s <sup>2</sup>	m <sup>2</sup> /s <sup>2</sup>	m <sup>2</sup> /s <sup>2</sup>	
5.00	-0.214	0.285	.3145E+03	-.1696E+01	.1710E+01	.2430E+03	.2978E+03	.1290E+03	-.1244E+03	-.5135E+01	-.6352E+01	D05075.BIS
6.00	-0.238	0.303	.3009E+03	-.2613E+01	.2775E+01	.6710E+03	.1300E+04	.2941E+03	-.1751E+03	-.1373E+02	.8434E+02	D05075.BIS
7.00	-0.262	0.321	.2837E+03	-.3150E+01	.4175E+01	.1170E+04	.2023E+04	.4570E+03	-.2719E+03	-.3541E+02	.1670E+03	D05075.BIS
8.00	-0.286	0.339	.2677E+03	-.4902E+01	.5022E+01	.1510E+04	.2341E+04	.5718E+03	-.3001E+03	-.5004E+02	.2032E+03	D05075.BIS
9.00	-0.309	0.357	.2529E+03	-.2478E+01	.7057E+01	.1780E+04	.2584E+04	.6551E+03	-.3505E+03	-.3840E+02	.2326E+03	D05075.BIS
10.00	-0.333	0.375	.2419E+03	-.3073E+01	.8201E+01	.1910E+04	.2605E+04	.6688E+03	-.4243E+03	-.2997E+02	.2420E+03	D05075.BIS
11.00	-0.357	0.393	.2313E+03	-.4115E+01	.7048E+01	.1980E+04	.2894E+04	.6950E+03	-.3799E+03	-.2330E+02	.2071E+03	D05075.BIS
12.00	-0.381	0.410	.2210E+03	-.2450E+01	.9169E+01	.2010E+04	.2946E+04	.6453E+03	-.4202E+03	.3602E+02	.2030E+03	D05075.BIS
13.00	-0.405	0.428	.2112E+03	-.1587E+01	.8298E+01	.1930E+04	.2911E+04	.6490E+03	-.4017E+03	-.2308E+01	.2234E+03	D05075.BIS
14.00	-0.429	0.446	.1875E+03	-.1671E+00	.6121E+01	.1760E+04	.2536E+04	.5710E+03	-.3693E+03	-.1145E+01	.2184E+03	D05075.BIS
15.00	-0.453	0.464	.1798E+03	-.1573E+01	.5675E+01	.1800E+04	.2250E+04	.5559E+03	-.2966E+03	.6561E+01	.1752E+03	D05075.BIS
16.00	-0.476	0.482	.1734E+03	-.8188E+00	.6417E+01	.1730E+04	.2076E+04	.5164E+03	-.3031E+03	.1245E+02	.1547E+03	D05075.BIS
17.00	-0.500	0.500	.1669E+03	-.1990E+01	.6045E+01	.1670E+04	.2041E+04	.4752E+03	-.2890E+03	.2889E+02	.1670E+03	D05075.BIS
18.00	-0.524	0.517	.1639E+03	-.2680E+01	.6243E+01	.1590E+04	.1882E+04	.4559E+03	-.1968E+03	.3347E+02	.1120E+03	D05075.BIS
19.00	-0.548	0.535	.1576E+03	-.3105E+01	.6220E+01	.1540E+04	.1664E+04	.4290E+03	-.3107E+03	-.4982E+01	.9635E+02	D05075.BIS
20.00	-0.571	0.553	.1508E+03	-.4161E+01	.5429E+01	.1480E+04	.1449E+04	.4181E+03	-.2820E+03	.2110E+02	.8562E+02	D05075.BIS
0.20	-0.100	0.399	.3224E+03	-.3339E+01	.2759E+00	.4240E+01	.9517E+01	.3270E+01	-.1524E+01	-.5792E+00	-.2680E+01	D05085.BIS
1.00	-0.119	0.428	.3225E+03	-.3454E+01	-.2809E+00	.4400E+01	.1357E+02	.3240E+01	-.2759E+01	-.2734E+00	-.3254E+01	D05085.BIS
2.00	-0.143	0.464	.3224E+03	-.2456E+01	.1366E+00	.1200E+02	.1738E+02	.5890E+01	-.2022E+01	-.3613E-01	-.4308E+01	D05085.BIS
3.00	-0.167	0.500	.3218E+03	-.2871E+01	.5524E+00	.3810E+02	.3803E+02	.1980E+02	-.4473E+01	-.3059E+01	-.6122E+01	D05085.BIS
4.00	-0.190	0.535	.3200E+03	-.3176E+01	.1451E+01	.1070E+03	.1296E+03	.7070E+02	-.3352E+02	.1330E+00	-.1221E+02	D05085.BIS
5.00	-0.214	0.571	.3115E+03	-.5180E+01	.2814E+01	.3540E+03	.7959E+03	.1960E+03	-.6343E+02	.9283E+01	.6123E+02	D05085.BIS
6.00	-0.238	0.607	.2958E+03	-.5331E+01	.6866E+01	.8350E+03	.7771E+03	.3930E+03	-.3049E+03	.1993E+02	.6832E+02	D05085.BIS
7.00	-0.262	0.642	.2762E+03	-.6944E+01	.7909E+01	.1260E+04	.2463E+04	.5820E+03	-.2650E+03	.8162E+02	.2660E+03	D05085.BIS
8.00	-0.286	0.678	.2574E+03	-.6896E+01	.9094E+01	.1540E+04	.3207E+04	.6572E+03	-.1900E+03	.1371E+03	.3311E+03	D05085.BIS
9.00	-0.309	0.714	.2399E+03	-.6056E+01	.1056E+02	.1690E+04	.3194E+04	.6789E+03	-.2091E+03	.1898E+03	.3370E+03	D05085.BIS
10.00	-0.333	0.750	.2231E+03	-.5893E+01	.9595E+01	.1690E+04	.3239E+04	.6432E+03	-.2179E+03	.1942E+03	.3040E+03	D05085.BIS
11.00	-0.357	0.785	.2132E+03	-.5480E+01	.1026E+02	.1560E+04	.3172E+04	.6258E+03	-.2494E+03	.1729E+03	.2834E+03	D05085.BIS
12.00	-0.381	0.821	.2040E+03	-.5711E+01	.1029E+02	.1660E+04	.3133E+04	.5961E+03	-.2269E+03	.1841E+03	.2621E+03	D05085.BIS
13.00	-0.405	0.857	.1966E+03	-.6783E+01	.1047E+02	.1590E+04	.2803E+04	.5598E+03	-.1485E+03	.1728E+03	.2296E+03	D05085.BIS
14.00	-0.428	0.893	.1874E+03	-.4624E+01	.1002E+02	.1600E+04	.2358E+04	.5361E+03	-.1985E+03	.1821E+03	.2084E+03	D05085.BIS
15.00	-0.453	0.928	.1676E+03	-.5469E+01	.7441E+01	.1510E+04	.2108E+04	.5048E+03	-.1998E+03	.1057E+03	.1661E+03	D05085.BIS
16.00	-0.476	0.964	.1602E+03	-.4095E+01	.7902E+01	.1610E+04	.2034E+04	.4770E+03	-.2241E+03	.1130E+03	.1590E+03	D05085.BIS
17.00	-0.500	1.000	.1572E+03	-.5808E+01	.7751E+01	.1470E+04	.1826E+04	.4341E+03	-.1957E+03	.9544E+02	.1181E+03	D05085.BIS
18.00	-0.524	1.035	.1488E+03	-.5854E+01	.8187E+01	.1490E+04	.1813E+04	.4241E+03	-.2314E+03	.1111E+03	.1129E+03	D05085.BIS
19.00	-0.548	1.071	.1415E+03	-.5897E+01	.7735E+01	.1500E+04	.1598E+04	.3951E+03	-.2293E+03	.9930E+02	.1070E+03	D05085.BIS
20.00	-0.571	1.107	.1379E+03	-.5090E+01	.8530E+01	.1420E+04	.1465E+04	.3818E+03	-.2172E+03	.1418E+03	.1098E+03	D05085.BIS
0.20	-0.100	0.599	.3224E+03	-.3139E+01	.5545E+00	.4280E+01	.2855E+02	.3290E+01	-.4280E+01	-.4796E+00	-.5889E+01	D05095.BIS
1.00	-0.119	0.642	.3226E+03	-.2970E+01	-.1686E-02	.5780E+01	.1850E+02	.4010E+01	-.3007E+01	-.3332E+00	-.4908E+01	D05095.BIS
2.00	-0.143	0.696	.3222E+03	-.3061E+01	.2754E+00	.2710E+02	.3720E+02	.2000E+02	-.4511E+01	.4362E+00	-.7603E+01	D05095.BIS
3.00	-0.167	0.750	.3204E+03	-.4571E+01	.1453E+01	.1140E+03	.2963E+03	.1110E+03	.3336E+02	.1798E+02	.2676E+02	D05095.BIS
4.00	-0.190	0.803	.3057E+03	-.7364E+01	.5022E+01	.5140E+03	.5775E+03	.3200E+03	-.4676E+02	.1160E+03	.9438E+01	D05095.BIS
5.00	-0.214	0.857	.2718E+03	-.7710E+01	.9216E+01	.1340E+04	.1310E+04	.5342E+03	-.1508E+03	.2602E+03	.6059E+02	D05095.BIS
6.00	-0.238	0.910	.2396E+03	-.5826E+01	.1168E+02	.1660E+04	.3549E+04	.6100E+03	.6019E+02	.3340E+03	.3174E+03	D05095.BIS
7.00	-0.262	0.964	.2145E+03	-.5216E+01	.1235E+02	.1740E+04	.3714E+04	.6400E+03	.6430E+02	.3660E+03	.3022E+03	D05095.BIS
8.00	-0.286	1.018	.1985E+03	-.2833E+01	.1250E+02	.1700E+04	.3499E+04	.6210E+03	.1834E+03	.3710E+03	.3312E+03	D05095.BIS
9.00	-0.309	1.071	.1849E+03	-.4227E+01	.1231E+02	.1680E+04	.3040E+04	.5852E+03	.9171E+02	.3522E+03	.2628E+03	D05095.BIS
10.00	-0.333	1.125	.1619E+03	-.3737E+01	.8744E+01	.1620E+04	.2738E+04	.5298E+03	.9806E+02	.2649E+03	.3016E+03	D05095.BIS
11.00	-0.357	1.178	.1574E+03	-.4404E+01	.9703E+01	.1640E+04	.2655E+04	.5181E+03	.3723E+02	.2382E+03	.2227E+03	D05095.BIS
12.00	-0.381	1.232	.1499E+03	-.5116E+01	.8637E+01	.1650E+04	.2461E+04	.4932E+03	.8247E+02	.2673E+03	.2260E+03	D05095.BIS
13.00	-0.405	1.285	.1428E+03	-.5581E+01	.8688E+01	.1610E+04	.2358E+04	.4591E+03	.1318E+02	.2302E+03	.1981E+03	D05095.BIS
14.00	-0.429	1.339	.1364E+03	-.5662E+01	.8441E+01	.1640E+04	.2190E+04	.4392E+03	.3575E+01	.2492E+03	.1895E+03	D05095.BIS
15.00	-0.453	1.393	.1341E+03	-.5846E+01	.8691E+01	.1540E+04	.2122E+04	.4412E+03	.9782E+01	.2102E+03	.1711E+03	D05095.BIS
16.00	-0.476	1.446	.1295E+03	-.5677E+01	.8890E+01	.1500E+04	.1862E+04	.3841E+03	-.7197E+02	.1931E+03	.1452E+03	D05095.BIS
17.00	-0.500	1.500	.1243E+03	-.7094E+01	.9567E+01	.1520E+04	.1727E+04	.3759E+03	-.8824E+02	.2178E+03	.1066E+03	D05095.BIS
18.00	-0.524	1.553	.1202E+03	-.7035E+01	.9127E+01	.1350E+04	.1648E+04	.3428E+03	-.7534E+02	.1868E+03	.1052E+03	D05095.BIS

TABLE 5  
Continued

X	Y	Z	$\bar{U}$	$\bar{V}$	$\bar{W}$	$\bar{u}$	$\bar{v}$	$\bar{w}$	$\bar{uv}$	$\bar{uv}$	$\bar{vw}$	File Name
inch	inch	inch	m/s	m/s	m/s	m <sup>2</sup> /s <sup>2</sup>	m <sup>2</sup> /s <sup>2</sup>	m <sup>2</sup> /s <sup>2</sup>	m <sup>2</sup> /s <sup>2</sup>	m <sup>2</sup> /s <sup>2</sup>	m <sup>2</sup> /s <sup>2</sup>	
19.00	-0.548	1.607	.1182E+03	-.8102E+01	.8577E+01	.1290E+04	.1431E+04	.3670E+03	-.7375E+02	.2000E+03	.9105E+02	D05095.BIS
20.00	-0.571	1.660	.1149E+03	-.7864E+01	.8258E+01	.1300E+04	.1359E+04	.3591E+03	-.1689E+02	.1982E+03	.1206E+03	D05095.BIS
0.20	-0.100	0.799	.3226E+03	-.3236E+01	.9036E+00	.3990E+01	.1059E+02	.3330E+01	-.1573E+01	-.3628E+00	-.3101E+01	D05105.BIS
1.00	-0.119	0.857	.3220E+03	-.3168E+01	.6229E+00	.2370E+02	.3199E+02	.1900E+02	.2982E+01	.2608E+01	-.7736E+01	D05105.BIS
2.00	-0.143	0.928	.2994E+03	-.3311E+01	.3117E+01	.6180E+03	.8251E+03	.3280E+03	-.1222E+03	.1690E+03	-.6099E+02	D05105.BIS
3.00	-0.167	1.000	.2284E+03	-.2349E+01	.1136E+02	.1630E+04	.1766E+04	.5853E+03	-.1828E+03	.3782E+03	-.3875E+02	D05105.BIS
4.00	-0.190	1.071	.1741E+03	-.1168E+01	.7674E+01	.1760E+04	.1631E+04	.5691E+03	.8400E+02	.3611E+03	.2870E+02	D05105.BIS
5.00	-0.214	1.143	.1496E+03	-.6733E+00	.8789E+01	.1890E+04	.3622E+04	.4898E+03	.5235E+03	.3458E+03	.3023E+03	D05105.BIS
6.00	-0.238	1.214	.1341E+03	-.1069E+01	.8781E+01	.1900E+04	.2903E+04	.4530E+03	.4985E+03	.3450E+03	.2673E+03	D05105.BIS
7.00	-0.262	1.285	.1226E+03	-.1043E+01	.8426E+01	.1720E+04	.2329E+04	.3901E+03	.3504E+03	.2901E+03	.2043E+03	D05105.BIS
8.00	-0.286	1.357	.1172E+03	-.4546E+00	.7890E+01	.1650E+04	.2119E+04	.3801E+03	.3480E+03	.2960E+03	.2142E+03	D05105.BIS
9.00	-0.309	1.428	.1091E+03	-.2185E+01	.6997E+01	.1610E+04	.2036E+04	.3492E+03	.3084E+03	.2902E+03	.1683E+03	D05105.BIS
0.20	-0.100	1.000	.3212E+03	-.1314E+01	-.9822E+00	.3500E+02	.1117E+03	.3560E+02	-.2191E+02	-.4354E+01	-.2931E+02	D05115.BIS
1.00	-0.119	1.071	.1363E+03	-.1298E-01	.1411E+02	.1930E+04	.1782E+04	.5878E+03	.3735E+03	.5348E+03	.1464E+03	D05115.BIS
1.00	0.001	-0.857	.3173E+03	.2364E+01	.5361E+00	.1450E+03	.1388E+03	.2610E+03	-.2533E+02	-.3539E+02	.3309E+02	D06025.BIS
5.00	0.001	-1.144	.1657E+03	.4841E+00	.2279E+01	.1940E+04	.1046E+04	.6348E+03	-.1973E+03	-.4749E+03	-.9747E+01	D06025.BIS
9.00	0.001	-1.429	.1313E+03	-.5465E+01	.2139E+01	.1890E+04	.2000E+04	.4451E+03	.1161E+03	-.3441E+03	.1419E+03	D06025.BIS
13.00	0.001	-1.715	.1126E+03	-.7939E+01	.2252E+01	.1680E+04	.1479E+04	.3602E+03	.7605E+02	-.2411E+03	.1080E+03	D06025.BIS
17.00	0.001	-2.001	.9910E+02	-.8417E+01	.2690E+01	.1330E+04	.1190E+04	.2860E+03	.2433E+02	-.1910E+03	.1058E+03	D06025.BIS
1.00	0.001	-0.643	.3214E+03	-.3349E+01	-.3629E+01	.8210E+01	.2153E+02	.8210E+01	-.5120E+01	-.1660E+01	-.5100E+01	D06035.BIS
5.00	0.001	-0.858	.2567E+03	.2068E+01	-.5219E+00	.1960E+04	.9238E+03	.6819E+03	-.1918E+03	-.5169E+03	.6113E+02	D06035.BIS
9.00	0.001	-1.073	.1966E+03	.2565E+01	-.1369E+01	.1820E+04	.9019E+03	.6769E+03	-.4154E+02	-.4739E+03	-.2929E+02	D06035.BIS
13.00	0.001	-1.286	.1692E+03	-.2152E+01	-.1888E+01	.1730E+04	.8946E+03	.5658E+03	-.6888E+01	-.3528E+03	-.1079E+02	D06035.BIS
17.00	0.001	-1.501	.1407E+03	-.5169E+01	-.7103E+00	.1630E+04	.1721E+04	.4220E+03	.1130E+03	-.2630E+03	.1150E+03	D06035.BIS
1.00	0.002	-0.429	.3228E+03	-.1956E+01	-.2509E+01	.6450E+01	.9324E+01	.4790E+01	-.5687E+00	-.1820E+01	-.3199E+01	D06045.BIS
5.00	0.001	-0.572	.3215E+03	-.2303E+01	-.3350E+01	.1280E+03	.2762E+03	.1240E+03	.9227E+01	-.4037E+01	.8114E+01	D06045.BIS
9.00	0.001	-0.715	.2648E+03	-.5798E+01	.1110E+01	.1670E+04	.9027E+03	.7228E+03	-.1145E+03	-.4148E+03	-.3861E+01	D06045.BIS
13.00	0.001	-0.858	.2004E+03	-.9138E+01	.2476E+01	.1590E+04	.8728E+03	.6249E+03	.6602E+02	-.2899E+03	-.1342E+02	D06045.BIS
17.00	0.002	-1.001	.1713E+03	-.9469E+01	.5086E+01	.1390E+04	.1720E+04	.4770E+03	.1648E+03	-.2071E+03	.1450E+03	D06045.BIS
0.20	-0.001	-0.200	.3230E+03	-.1412E+01	-.1463E+01	.4300E+01	.1325E+02	.3260E+01	-.2477E+01	-.4759E+00	-.3322E+01	D06055.BIS
1.00	-0.001	-0.214	.3228E+03	-.1519E+01	-.1116E+01	.4830E+01	.2175E+02	.3190E+01	-.3259E+01	-.6398E+00	-.5095E+01	D06055.BIS
2.00	-0.001	-0.232	.3230E+03	-.1054E+01	-.7666E+00	.7990E+01	.1476E+02	.4660E+01	-.2263E+01	-.3455E+00	-.3909E+01	D06055.BIS
3.00	-0.001	-0.250	.3226E+03	-.8011E+00	-.6983E+00	.1820E+02	.2190E+02	.9162E+01	-.3555E+01	.5784E+00	-.3321E+01	D06055.BIS
4.00	-0.001	-0.268	.3223E+03	-.1867E+00	-.9086E+00	.3800E+02	.4085E+02	.1800E+02	-.6453E+01	.2950E+01	-.3242E+01	D06055.BIS
5.00	-0.001	-0.286	.3221E+03	.4530E+00	-.1188E+01	.6900E+02	.7817E+02	.3910E+02	-.2140E+02	.6148E+01	-.1611E+01	D06055.BIS
6.00	-0.001	-0.304	.3210E+03	.2677E+00	-.1610E+01	.1330E+03	.1529E+03	.8089E+02	-.4304E+02	.4943E+01	-.7265E+01	D06055.BIS
7.00	-0.001	-0.322	.3162E+03	-.2992E+00	-.2951E+01	.3110E+03	.6499E+03	.1630E+03	-.4314E+02	-.3009E+01	.2696E+02	D06055.BIS
8.00	-0.001	-0.340	.3072E+03	.1999E+00	-.3472E+01	.6290E+03	.1110E+04	.2750E+03	-.8455E+02	-.2441E+02	.7862E+02	D06055.BIS
9.00	-0.001	-0.357	.2958E+03	.8025E+00	-.3583E+01	.1010E+04	.1500E+04	.3870E+03	-.1069E+03	-.7010E+02	.8565E+02	D06055.BIS
10.00	-0.001	-0.375	.2804E+03	.9732E+00	-.3500E+01	.1440E+04	.2033E+04	.5000E+03	-.7024E+02	-.1099E+03	.1471E+03	D06055.BIS
11.00	-0.001	-0.393	.2663E+03	.2434E+01	-.2925E+01	.1680E+04	.2381E+04	.6228E+03	-.8687E+02	-.1729E+03	.2040E+03	D06055.BIS
12.00	-0.001	-0.411	.2514E+03	.5860E+00	-.1656E+01	.1820E+04	.2546E+04	.6391E+03	-.4180E+02	-.2231E+03	.2340E+03	D06055.BIS
13.00	-0.001	-0.429	.2381E+03	.9057E+00	-.1914E+01	.1830E+04	.1173E+04	.6642E+03	-.1454E+03	-.2073E+03	.3347E+02	D06055.BIS
14.00	-0.001	-0.447	.2120E+03	.6278E+00	-.1174E+01	.1610E+04	.1023E+04	.6202E+03	-.9334E+02	-.1992E+03	.1718E+02	D06055.BIS
15.00	-0.001	-0.464	.2029E+03	.1379E+01	.3258E+00	.1580E+04	.2210E+04	.5731E+03	.9940E+02	-.2041E+03	.1501E+03	D06055.BIS
16.00	-0.001	-0.483	.1953E+03	-.9633E+00	.9945E+00	.1440E+04	.2100E+04	.5402E+03	.6557E+02	-.1672E+03	.1570E+03	D06055.BIS
17.00	-0.001	-0.500	.1891E+03	-.6860E+00	.1459E+01	.1440E+04	.1939E+04	.5170E+03	.6507E+02	-.1401E+03	.1268E+03	D06055.BIS
18.00	-0.001	-0.518	.1814E+03	-.1968E+01	.2337E+01	.1400E+04	.1810E+04	.4830E+03	.6155E+02	-.1411E+03	.1449E+03	D06055.BIS
19.00	-0.001	-0.536	.1766E+03	-.2819E+01	.1971E+01	.1310E+04	.1631E+04	.4659E+03	.1150E+03	-.1279E+03	.9880E+02	D06055.BIS
20.00	-0.001	-0.554	.1714E+03	-.3180E+01	.2788E+01	.1260E+04	.1530E+04	.4340E+03	.9575E+02	-.1070E+03	.8779E+02	D06055.BIS
0.20	0.000	-0.001	.3226E+03	.1905E+01	-.3503E+00	.4490E+01	.5344E+01	.3220E+01	.5852E+00	.5169E+00	-.9436E+00	D06065.BIS
1.00	0.000	-0.001	.3229E+03	.2414E+01	-.1400E+00	.4740E+01	.5281E+01	.3500E+01	.7348E+00	.5338E+00	-.6426E+00	D06065.BIS
2.00	0.000	-0.001	.3224E+03	.2600E+01	.1366E+00	.7330E+01	.6731E+01	.4300E+01	.1213E+01	.3783E+00	-.5215E+00	D06065.BIS
3.00	0.000	-0.001	.3223E+03	.3059E+01	.4846E+00	.1580E+02	.1307E+02	.7659E+01	.1046E+00	.6051E+00	.1799E+00	D06065.BIS
4.00	0.000	-0.001	.3220E+03	.3814E+01	.7622E+00	.3400E+02	.2830E+02	.1490E+02	-.4534E+00	.1321E+01	-.1686E+00	D06065.BIS
5.00	0.000	-0.002	.3224E+03	.5107E+01	.1182E+01	.5690E+02	.4778E+02	.2769E+02	-.3746E+01	.1343E+01	.6744E+00	D06065.BIS

TABLE 5  
Continued

X	Y	Z	$\bar{u}$	$\bar{v}$	$\bar{w}$	$\overline{uu}$	$\overline{vv}$	$\overline{ww}$	$\overline{uv}$	$\overline{uw}$	$\overline{vw}$	File Name
inch	inch	inch	m/s	m/s	m/s	m <sup>2</sup> /s <sup>2</sup>	m <sup>2</sup> /s <sup>2</sup>	m <sup>2</sup> /s <sup>2</sup>	m <sup>2</sup> /s <sup>2</sup>	m <sup>2</sup> /s <sup>2</sup>	m <sup>2</sup> /s <sup>2</sup>	
6.00	0.000	-0.002	.3214E+03	.4962E+01	.1596E+01	.8850E+02	.8278E+02	.5101E+02	-.2078E+02	-.2589E+01	-.5558E+00	D06065.BIS
7.00	0.000	0.000	.3189E+03	.3037E+01	.2214E+01	.1700E+03	.1613E+03	.9982E+02	-.3505E+02	-.1100E+02	-.9296E+01	D06065.BIS
8.00	0.000	0.000	.3133E+03	.1741E+01	.3308E+01	.3210E+03	.2850E+03	.1780E+03	-.6456E+02	-.2129E+02	-.7108E+01	D06065.BIS
9.00	0.000	0.000	.3049E+03	-.5211E+00	.4601E+01	.6049E+03	.4378E+03	.2530E+03	-.3474E+02	-.4418E+02	-.4199E+01	D06065.BIS
10.00	0.000	-0.001	.2898E+03	.3333E+00	.6217E+01	.1320E+04	.1770E+04	.4320E+03	.3726E+02	-.9259E+02	.1580E+03	D06065.BIS
11.00	0.000	-0.001	.2773E+03	-.2398E+01	.5893E+01	.1630E+04	.2222E+04	.5321E+03	.1710E+03	-.8562E+02	.2070E+03	D06065.BIS
12.00	0.000	-0.001	.2610E+03	-.3640E+01	.7853E+01	.1890E+04	.2706E+04	.5991E+03	.2399E+03	-.8031E+02	.2189E+03	D06065.BIS
13.00	0.000	-0.001	.2488E+03	-.2788E+01	.5858E+01	.1940E+04	.2558E+04	.5899E+03	.1681E+03	-.4257E+02	.2600E+03	D06065.BIS
14.00	0.000	-0.002	.2350E+03	-.3427E+01	.6922E+01	.1910E+04	.2778E+04	.5994E+03	.1701E+03	-.4022E+02	.2618E+03	D06065.BIS
15.00	0.000	-0.002	.2240E+03	-.4581E+01	.7091E+01	.1780E+04	.2462E+04	.5669E+03	.1887E+03	-.5758E+02	.2298E+03	D06065.BIS
16.00	0.000	0.000	.2136E+03	-.4639E+01	.7401E+01	.1680E+04	.2430E+04	.5314E+03	.1878E+03	-.4131E+02	.1956E+03	D06065.BIS
17.00	0.000	0.000	.2057E+03	-.4380E+01	.7790E+01	.1590E+04	.2163E+04	.5202E+03	.1860E+03	-.4710E+02	.1711E+03	D06065.BIS
18.00	0.000	0.000	.1882E+03	-.3852E+01	.6472E+01	.1380E+04	.2051E+04	.4700E+03	.1580E+03	-.5939E+02	.1721E+03	D06065.BIS
19.00	0.000	-0.001	.1818E+03	-.3615E+01	.6100E+01	.1280E+04	.1930E+04	.4570E+03	.1580E+03	-.2720E+02	.1770E+03	D06065.BIS
20.00	0.000	-0.001	.1781E+03	-.5186E+01	.6365E+01	.1250E+04	.1720E+04	.4310E+03	.1851E+03	-.1301E+02	.1510E+03	D06065.BIS
0.20	-0.001	0.199	.3231E+03	-.1534E+01	-.6950E-01	.4690E+01	.1414E+02	.3670E+01	-.2360E+01	-.9322E+00	-.3701E+01	D06075.BIS
1.00	-0.001	0.214	.3229E+03	-.1300E+01	-.6876E-01	.5110E+01	.1099E+02	.3770E+01	-.1593E+01	-.1000E+01	-.3188E+01	D06075.BIS
2.00	-0.001	0.232	.3229E+03	-.1060E+01	.2081E+00	.7680E+01	.1163E+02	.4981E+01	-.2220E+01	-.1140E+01	-.2744E+01	D06075.BIS
3.00	-0.001	0.250	.3231E+03	-.2920E+00	.4878E+00	.1740E+02	.1791E+02	.7997E+01	-.1264E+01	-.2012E+01	-.4104E+01	D06075.BIS
4.00	-0.001	0.268	.3232E+03	-.6727E+00	.8363E+00	.3160E+02	.2726E+02	.1650E+02	-.4210E+01	-.3912E+01	-.2805E+01	D06075.BIS
5.00	-0.001	0.285	.3231E+03	-.7977E+00	.1254E+01	.5450E+02	.4977E+02	.3010E+02	-.7665E+01	-.6724E+01	-.6168E+01	D06075.BIS
6.00	-0.001	0.303	.3220E+03	-.3245E+00	.2434E+01	.8730E+02	.8784E+02	.5490E+02	-.1300E+02	-.4133E+01	-.9067E+01	D06075.BIS
7.00	-0.001	0.321	.3211E+03	-.1477E+00	.3685E+01	.1510E+03	.1608E+03	.1020E+03	-.4586E+02	-.6123E+01	-.7129E+01	D06075.BIS
8.00	-0.001	0.339	.3169E+03	-.1292E+01	.5341E+01	.3060E+03	.2867E+03	.1850E+03	-.5890E+02	-.1962E+02	-.1504E+02	D06075.BIS
9.00	-0.001	0.357	.3087E+03	-.1266E+01	.7471E+01	.6299E+03	.1170E+04	.3030E+03	.1665E+02	-.1471E+02	.9103E+02	D06075.BIS
10.00	-0.001	0.375	.2977E+03	-.2867E+01	.9172E+01	.9391E+03	.7690E+03	.4040E+03	-.7517E+02	.6964E+01	.8255E+00	D06075.BIS
11.00	-0.001	0.393	.2837E+03	-.3612E+01	.1058E+02	.1370E+04	.2260E+04	.5180E+03	.9577E+02	.4029E+02	.1910E+03	D06075.BIS
12.00	-0.001	0.410	.2690E+03	-.4614E+01	.1185E+02	.1600E+04	.2609E+04	.6179E+03	.1611E+03	.3261E+02	.2279E+03	D06075.BIS
13.00	-0.001	0.428	.2544E+03	-.4405E+01	.1187E+02	.1700E+04	.2583E+04	.6623E+03	.9310E+02	.5333E+02	.1757E+03	D06075.BIS
14.00	-0.001	0.446	.2412E+03	-.5793E+01	.1266E+02	.1730E+04	.2827E+04	.6460E+03	.1673E+03	.3249E+02	.2125E+03	D06075.BIS
15.00	-0.001	0.464	.2139E+03	-.3678E+01	.9910E+01	.1510E+04	.2508E+04	.6259E+03	.1461E+03	.3976E+02	.2658E+03	D06075.BIS
16.00	-0.001	0.482	.2051E+03	-.5223E+01	.9668E+01	.1540E+04	.2305E+04	.5850E+03	.1763E+03	.2151E+02	.2193E+03	D06075.BIS
17.00	-0.001	0.500	.1973E+03	-.4598E+01	.9779E+01	.1410E+04	.2101E+04	.5150E+03	.1330E+03	.3520E+02	.1759E+03	D06075.BIS
18.00	-0.001	0.517	.1896E+03	-.4310E+01	.9124E+01	.1360E+04	.1860E+04	.5040E+03	.1428E+03	.2165E+02	.1692E+03	D06075.BIS
19.00	-0.001	0.535	.1842E+03	-.3348E+01	.8268E+01	.1280E+04	.1660E+04	.4800E+03	.1219E+03	.2039E+02	.1301E+03	D06075.BIS
20.00	-0.001	0.553	.1764E+03	-.3322E+01	.7543E+01	.1250E+04	.1590E+04	.4431E+03	.1180E+03	.3572E+02	.1162E+03	D06075.BIS
0.20	-0.001	0.399	.3225E+03	-.2171E+01	.1371E+00	.4280E+01	.1924E+02	.3210E+01	-.3244E+01	-.5283E+00	-.4434E+01	D06085.BIS
1.00	-0.001	0.428	.3229E+03	-.1962E+01	.4173E+00	.4630E+01	.1218E+02	.3100E+01	-.1787E+01	-.3331E+00	-.3443E+01	D06085.BIS
2.00	-0.001	0.464	.3228E+03	-.2287E+01	.5561E+00	.8461E+01	.1768E+02	.4800E+01	-.3400E+01	-.6759E+00	-.4301E+01	D06085.BIS
3.00	-0.001	0.500	.3227E+03	-.1909E+01	.1183E+01	.2120E+02	.2339E+02	.1150E+02	-.2327E+01	-.1290E+01	-.4608E+01	D06085.BIS
4.00	-0.001	0.535	.3224E+03	-.2159E+01	.2018E+01	.4630E+02	.4468E+02	.3130E+02	-.4374E+01	-.2701E+01	-.4464E+01	D06085.BIS
5.00	-0.001	0.571	.3221E+03	-.1766E+01	.2574E+01	.8970E+02	.2100E+03	.7740E+02	.1050E+02	.3072E+01	.6287E+01	D06085.BIS
6.00	-0.001	0.607	.3188E+03	-.1726E+01	.4094E+01	.2050E+03	.5192E+03	.1710E+03	.3615E+02	.2949E+02	.3266E+02	D06085.BIS
7.00	-0.001	0.642	.3096E+03	-.1661E+01	.6011E+01	.5170E+03	.1151E+04	.3180E+03	.3132E+02	.1190E+03	.7384E+02	D06085.BIS
8.00	-0.001	0.678	.2914E+03	-.1197E+01	.6780E+01	.9991E+03	.1913E+04	.4870E+03	.3923E+02	.2230E+03	.1289E+03	D06085.BIS
9.00	-0.001	0.714	.2726E+03	.7113E-01	.9568E+01	.1480E+04	.2495E+04	.5979E+03	.1357E+03	.2799E+03	.1839E+03	D06085.BIS
10.00	-0.001	0.750	.2554E+03	-.2066E+00	.1104E+02	.1680E+04	.2997E+04	.6431E+03	.1740E+03	.3222E+03	.2680E+03	D06085.BIS
11.00	-0.001	0.785	.2391E+03	.2846E+00	.1091E+02	.1730E+04	.3098E+04	.6681E+03	.1694E+03	.3161E+03	.2795E+03	D06085.BIS
12.00	-0.001	0.821	.2282E+03	.1599E+01	.1129E+02	.1660E+04	.3144E+04	.6752E+03	.2052E+03	.2871E+03	.2293E+03	D06085.BIS
13.00	-0.001	0.857	.2185E+03	.3365E+01	.1118E+02	.1650E+04	.3125E+04	.6441E+03	.1672E+03	.2751E+03	.2622E+03	D06085.BIS
14.00	-0.001	0.893	.2091E+03	.2749E+01	.1156E+02	.1580E+04	.2762E+04	.6228E+03	.1761E+03	.2519E+03	.2252E+03	D06085.BIS
15.00	-0.001	0.928	.1883E+03	.2224E+01	.7795E+01	.1490E+04	.2535E+04	.5539E+03	.2532E+03	.1989E+03	.2372E+03	D06085.BIS
16.00	-0.001	0.964	.1833E+03	.4838E+00	.8544E+01	.1350E+04	.2391E+04	.5613E+03	.1420E+03	.1812E+03	.2279E+03	D06085.BIS
17.00	-0.001	1.000	.1778E+03	.9991E+00	.9220E+01	.1320E+04	.2260E+04	.4990E+03	.1591E+03	.1370E+03	.1642E+03	D06085.BIS
18.00	-0.001	1.035	.1702E+03	-.5460E-01	.8356E+01	.1380E+04	.2198E+04	.4721E+03	.1962E+03	.1701E+03	.1974E+03	D06085.BIS
19.00	-0.001	1.071	.1639E+03	-.1366E+01	.9448E+01	.1340E+04	.1916E+04	.4658E+03	.1351E+03	.1598E+03	.1534E+03	D06085.BIS

TABLE 5  
Continued

X	Y	Z	$\bar{U}$	$\bar{V}$	$\bar{W}$	$\overline{u^2}$	$\overline{v^2}$	$\overline{w^2}$	$\overline{uv}$	$\overline{uw}$	$\overline{vw}$	File Name
inch	inch	inch	m/s	m/s	m/s	m <sup>2</sup> /s <sup>2</sup>	m <sup>2</sup> /s <sup>2</sup>	m <sup>2</sup> /s <sup>2</sup>	m <sup>2</sup> /s <sup>2</sup>	m <sup>2</sup> /s <sup>2</sup>	m <sup>2</sup> /s <sup>2</sup>	
20.00	-0.001	1.107	.1569E+03	-.1143E+01	.9074E+01	.1320E+04	.1641E+04	.4160E+03	.7908E+02	.1541E+03	.1433E+03	D06085.BIS
0.20	-0.001	0.600	.3226E+03	-.1850E+01	.9736E+00	.4110E+01	.1759E+02	.3260E+01	-.2768E+01	-.8118E+00	-.4200E+01	D06095.BIS
1.00	-0.001	0.642	.3229E+03	-.1503E+01	.7654E+00	.4910E+01	.1190E+02	.3550E+01	-.1923E+01	-.8229E+00	-.3266E+01	D06095.BIS
2.00	-0.001	0.696	.3231E+03	-.1537E+01	.9057E+00	.1820E+02	.2677E+02	.1470E+02	-.3284E+01	-.7726E+00	-.6499E+01	D06095.BIS
3.00	-0.001	0.750	.3224E+03	-.1835E+01	.9031E+00	.8558E+02	.1717E+03	.8278E+02	.2203E+02	.1678E+02	.3621E+01	D06095.BIS
4.00	-0.001	0.803	.3109E+03	-.2047E+01	.3577E+01	.4510E+03	.1200E+04	.2820E+03	.9075E+02	.1270E+03	.8866E+02	D06095.BIS
5.00	-0.001	0.857	.2781E+03	-.5341E+01	.9309E+01	.1320E+04	.2456E+04	.4701E+03	.2435E+03	.2821E+03	.1832E+03	D06095.BIS
6.00	-0.001	0.910	.2465E+03	-.7738E+01	.1302E+02	.1740E+04	.3122E+04	.5709E+03	.3311E+03	.3789E+03	.3078E+03	D06095.BIS
7.00	-0.001	0.964	.2234E+03	-.5947E+01	.1559E+02	.1890E+04	.3428E+04	.6050E+03	.3704E+03	.4300E+03	.2971E+03	D06095.BIS
8.00	-0.001	1.018	.2038E+03	-.5050E+01	.1572E+02	.1920E+04	.3292E+04	.6152E+03	.3306E+03	.4652E+03	.3086E+03	D06095.BIS
9.00	-0.001	1.071	.1761E+03	-.4580E+01	.9910E+01	.1760E+04	.2940E+04	.5322E+03	.3774E+03	.3442E+03	.3033E+03	D06095.BIS
10.00	-0.001	1.124	.1704E+03	-.5694E+01	.1038E+02	.1820E+04	.2829E+04	.5548E+03	.3705E+03	.3988E+03	.2752E+03	D06095.BIS
11.00	-0.001	1.178	.1624E+03	-.5675E+01	.9651E+01	.1850E+04	.2886E+04	.5308E+03	.3188E+03	.3758E+03	.3789E+03	D06095.BIS
12.00	-0.001	1.232	.1577E+03	-.4984E+01	.1075E+02	.1830E+04	.2642E+04	.5081E+03	.3875E+03	.3631E+03	.2505E+03	D06095.BIS
13.00	-0.001	1.285	.1520E+03	-.5077E+01	.9641E+01	.1810E+04	.2318E+04	.4829E+03	.2493E+03	.3209E+03	.2025E+03	D06095.BIS
14.00	-0.001	1.339	.1459E+03	-.5958E+01	.1024E+02	.1810E+04	.2303E+04	.4769E+03	.2919E+03	.3630E+03	.2070E+03	D06095.BIS
15.00	-0.001	1.393	.1442E+03	-.4998E+01	.1066E+02	.1750E+04	.2222E+04	.4598E+03	.2567E+03	.3288E+03	.1948E+03	D06095.BIS
16.00	-0.001	1.446	.1408E+03	-.4810E+01	.1070E+02	.1690E+04	.1982E+04	.4292E+03	.2830E+03	.3092E+03	.1937E+03	D06095.BIS
17.00	-0.001	1.500	.1345E+03	-.6173E+01	.1004E+02	.1660E+04	.1797E+04	.4039E+03	.1859E+03	.3039E+03	.1548E+03	D06095.BIS
18.00	-0.001	1.553	.1298E+03	-.6434E+01	.1007E+02	.1630E+04	.1619E+04	.3989E+03	.1658E+03	.2990E+03	.1217E+03	D06095.BIS
19.00	-0.001	1.607	.1252E+03	-.6005E+01	.9376E+01	.1580E+04	.1501E+04	.3660E+03	.1544E+03	.2890E+03	.1241E+03	D06095.BIS
20.00	-0.001	1.660	.1208E+03	-.5153E+01	.9561E+01	.1510E+04	.1444E+04	.3500E+03	.1689E+03	.2760E+03	.1166E+03	D06095.BIS
0.20	-0.001	0.799	.3226E+03	-.2596E+01	.1600E+01	.3980E+01	.1512E+02	.3360E+01	-.3182E+01	-.3699E+00	-.3423E+01	D06105.BIS
1.00	-0.001	0.857	.3227E+03	-.1791E+01	.1740E+01	.1270E+02	.2186E+02	.1110E+02	-.1308E+01	.8813E+00	-.6173E+01	D06105.BIS
2.00	-0.001	0.928	.3098E+03	-.4146E+01	.5872E+01	.4050E+03	.5030E+03	.2760E+03	.3300E+02	.1460E+03	.1077E+02	D06105.BIS
3.00	-0.001	1.000	.2363E+03	-.5764E+01	.1313E+02	.1740E+04	.1736E+04	.5861E+03	-.3370E+02	.4591E+03	.6863E+02	D06105.BIS
4.00	-0.001	1.071	.1880E+03	-.3272E+01	.1218E+02	.1920E+04	.1848E+04	.5942E+03	.1498E+03	.4951E+03	.4948E+02	D06105.BIS
5.00	-0.001	1.142	.1600E+03	-.2019E+01	.1041E+02	.2040E+04	.3949E+04	.5752E+03	.5919E+03	.4802E+03	.4419E+03	D06105.BIS
6.00	-0.001	1.214	.1362E+03	-.2791E+01	.8211E+01	.2080E+04	.3207E+04	.4651E+03	.5829E+03	.3981E+03	.3330E+03	D06105.BIS
7.00	-0.001	1.285	.1166E+03	-.3829E+01	.6119E+01	.1740E+04	.2309E+04	.3878E+03	.4567E+03	.2998E+03	.2215E+03	D06105.BIS
8.00	-0.001	1.357	.1123E+03	-.1731E+01	.6180E+01	.1720E+04	.2288E+04	.3651E+03	.4733E+03	.2831E+03	.2081E+03	D06105.BIS
9.00	-0.001	1.428	.1082E+03	-.3272E+01	.6506E+01	.1560E+04	.2046E+04	.3369E+03	.3417E+03	.2639E+03	.1689E+03	D06105.BIS
10.00	-0.001	1.500	.1057E+03	-.3574E+01	.6469E+01	.1490E+04	.1940E+04	.3439E+03	.3784E+03	.2549E+03	.1976E+03	D06105.BIS
11.00	-0.001	1.571	.1051E+03	-.2777E+01	.7156E+01	.1440E+04	.1824E+04	.3280E+03	.3134E+03	.2350E+03	.1452E+03	D06105.BIS
12.00	-0.001	1.642	.1032E+03	-.4320E+01	.7477E+01	.1350E+04	.1727E+04	.3178E+03	.3093E+03	.2328E+03	.1452E+03	D06105.BIS
13.00	-0.001	1.714	.1009E+03	-.3793E+01	.7120E+01	.1330E+04	.1731E+04	.3030E+03	.3050E+03	.2250E+03	.1602E+03	D06105.BIS
14.00	-0.001	1.785	.9957E+02	-.4453E+01	.7638E+01	.1330E+04	.1610E+04	.3089E+03	.3040E+03	.2410E+03	.1518E+03	D06105.BIS
15.00	-0.001	1.857	.9851E+02	-.3375E+01	.7801E+01	.1200E+04	.1490E+04	.3070E+03	.2841E+03	.2130E+03	.1438E+03	D06105.BIS
16.00	-0.001	1.928	.9796E+02	-.3240E+01	.8064E+01	.1220E+04	.1470E+04	.2920E+03	.2991E+03	.1980E+03	.1170E+03	D06105.BIS
17.00	-0.001	2.000	.9513E+02	-.3748E+01	.7649E+01	.1140E+04	.1361E+04	.2640E+03	.2373E+03	.1920E+03	.1110E+03	D06105.BIS
18.00	-0.001	2.071	.9337E+02	-.4712E+01	.7726E+01	.1110E+04	.1240E+04	.2560E+03	.2120E+03	.2120E+03	.9989E+02	D06105.BIS
19.00	-0.001	2.142	.9294E+02	-.4084E+01	.7948E+01	.1030E+04	.1220E+04	.2680E+03	.2160E+03	.1960E+03	.9836E+02	D06105.BIS
20.00	-0.001	2.214	.8892E+02	-.4906E+01	.6679E+01	.9370E+03	.1080E+04	.2470E+03	.1711E+03	.1730E+03	.1020E+03	D06105.BIS
0.20	0.000	1.000	.3204E+03	-.2801E+01	.1991E+00	.6120E+02	.1079E+03	.5830E+02	-.8495E+01	.5198E+01	-.2881E+02	D06115.BIS
1.00	0.000	1.071	.1386E+03	-.1209E+01	.1493E+02	.2790E+04	.5254E+04	.5993E+03	.7934E+03	.7012E+03	.6303E+03	D06115.BIS
0.20	0.100	-0.200	.3224E+03	-.1585E+01	-.1883E+01	.4130E+01	.1637E+02	.3280E+01	-.2239E+01	-.6992E+00	-.4367E+01	D07055.BIS
1.00	0.119	-0.215	.3226E+03	-.1703E+01	-.1465E+01	.5040E+01	.2296E+02	.3980E+01	-.3507E+01	-.1270E+01	-.5204E+01	D07055.BIS
2.00	0.143	-0.232	.3229E+03	-.1235E+01	-.1115E+01	.9040E+01	.2388E+02	.4620E+01	-.4069E+01	-.4270E+00	-.6025E+01	D07055.BIS
3.00	0.167	-0.250	.3225E+03	-.2327E+01	-.1256E+01	.2540E+02	.3590E+02	.1060E+02	-.5492E+01	.6796E+00	-.7659E+01	D07055.BIS
4.00	0.190	-0.268	.3221E+03	-.2877E+01	-.1327E+01	.5829E+02	.6332E+02	.2980E+02	-.2078E+01	.2961E+01	-.1014E+02	D07055.BIS
5.00	0.214	-0.286	.3192E+03	-.2281E+01	-.1686E+01	.1520E+03	.1419E+03	.9118E+02	.4034E+02	.3675E+01	-.2166E+02	D07055.BIS
6.00	0.238	-0.304	.3092E+03	-.1889E+01	-.9565E+00	.5050E+03	.3722E+03	.2340E+03	.1663E+03	-.2582E+02	-.4067E+02	D07055.BIS
7.00	0.262	-0.322	.2936E+03	-.8418E+00	-.1014E+01	.1110E+04	.1251E+04	.3900E+03	.4561E+03	-.6840E+02	.5065E+02	D07055.BIS
8.00	0.285	-0.340	.2750E+03	-.4500E+00	.9381E+00	.1680E+04	.1709E+04	.5731E+03	.6409E+03	-.1442E+03	.2698E+02	D07055.BIS
9.00	0.309	-0.357	.2607E+03	-.2209E+01	.2209E+01	.2040E+04	.2151E+04	.6712E+03	.7463E+03	-.1831E+03	.1132E+03	D07055.BIS
10.00	0.333	-0.375	.2303E+03	-.4231E+00	.7781E-01	.2410E+04	.2774E+04	.7329E+03	.1090E+04	-.1349E+03	.1727E+03	D07055.BIS

TABLE 5  
Continued

X	Y	Z	$\bar{u}$	$\bar{v}$	$\bar{w}$	$\overline{uu}$	$\overline{vv}$	$\overline{ww}$	$\overline{uv}$	$\overline{uw}$	$\overline{vw}$	File Name
inch	inch	inch	m/s	m/s	m/s	m <sup>2</sup> /s <sup>2</sup>	m <sup>2</sup> /s <sup>2</sup>	m <sup>2</sup> /s <sup>2</sup>	m <sup>2</sup> /s <sup>2</sup>	m <sup>2</sup> /s <sup>2</sup>	m <sup>2</sup> /s <sup>2</sup>	
11.00	0.357	-0.393	.2191E+03	-.6380E+00	-.1026E+00	.2440E+04	.2750E+04	.7068E+03	.1100E+04	-.1727E+03	.1498E+03	D07055.BIS
12.00	0.381	-0.411	.2098E+03	.6502E+00	.1466E+01	.2310E+04	.2661E+04	.7181E+03	.9388E+03	-.1983E+03	.1326E+03	D07055.BIS
13.00	0.405	-0.429	.1996E+03	-.3471E+00	.2125E+01	.2220E+04	.2561E+04	.6853E+03	.9074E+03	-.2010E+03	.1336E+03	D07055.BIS
14.00	0.428	-0.447	.1900E+03	-.8588E-01	.2368E+01	.2190E+04	.2501E+04	.6420E+03	.9461E+03	-.1699E+03	.1302E+03	D07055.BIS
15.00	0.452	-0.464	.1848E+03	.1038E+01	.2907E+01	.2000E+04	.2331E+04	.6141E+03	.7961E+03	-.1300E+03	.1322E+03	D07055.BIS
16.00	0.476	-0.483	.1750E+03	-.2114E+00	.3497E+01	.1990E+04	.2352E+04	.5572E+03	.8217E+03	-.1558E+03	.1406E+03	D07055.BIS
17.00	0.500	-0.500	.1695E+03	-.1122E+01	.4243E+01	.1820E+04	.1993E+04	.4971E+03	.7487E+03	-.1197E+03	.9904E+02	D07055.BIS
18.00	0.524	-0.518	.1667E+03	.1746E+01	.3816E+01	.1760E+04	.1820E+04	.4899E+03	.6459E+03	-.1058E+03	.1140E+03	D07055.BIS
19.00	0.548	-0.536	.1631E+03	.1402E+01	.3732E+01	.1620E+04	.1780E+04	.4701E+03	.5640E+03	-.1071E+03	.9990E+02	D07055.BIS
20.00	0.572	-0.554	.1576E+03	.2120E+01	.3712E+01	.1580E+04	.1651E+04	.4502E+03	.4953E+03	-.9681E+02	.9925E+02	D07055.BIS
0.20	0.099	-0.001	.3236E+03	.3850E+01	.7680E+00	.5170E+01	.6038E+01	.4310E+01	.3016E+00	.1912E+00	-.1021E+01	D07065.BIS
1.00	0.118	-0.001	.3239E+03	.4038E+01	.1118E+01	.5130E+01	.6551E+01	.4030E+01	-.6311E-01	.3972E+00	-.1216E+01	D07065.BIS
2.00	0.142	-0.001	.3234E+03	.1319E+01	.7675E+00	.8659E+01	.1157E+02	.4980E+01	-.8103E+00	-.6088E+00	-.3186E+01	D07065.BIS
3.00	0.167	-0.002	.3229E+03	.5255E+00	.5566E+00	.2500E+02	.2268E+02	.1100E+02	-.2026E+00	-.4539E+00	-.3122E+01	D07065.BIS
4.00	0.190	-0.002	.3233E+03	.1513E+00	.9063E+00	.5760E+02	.5792E+02	.2900E+02	-.1860E+01	-.1101E+01	-.9902E+01	D07065.BIS
5.00	0.214	-0.002	.3198E+03	-.8511E+00	.1172E+01	.1730E+03	.1429E+03	.8459E+02	.6016E+02	-.2262E+00	-.2006E+02	D07065.BIS
6.00	0.238	0.000	.3116E+03	-.1506E+01	.2744E+01	.4590E+03	.3353E+03	.2100E+03	.1799E+03	-.2030E+02	-.2232E+02	D07065.BIS
7.00	0.262	0.000	.2966E+03	-.1114E+01	.4988E+01	.9990E+03	.1200E+04	.3740E+03	.4640E+03	-.7260E+02	.4115E+02	D07065.BIS
8.00	0.286	0.000	.2764E+03	-.1067E+01	.3173E+01	.1600E+04	.1610E+04	.4740E+03	.6670E+03	-.3804E+02	.9599E+02	D07065.BIS
9.00	0.309	-0.001	.2599E+03	-.2654E+01	.5341E+01	.1980E+04	.1947E+04	.5718E+03	.7873E+03	-.7538E+02	.1033E+03	D07065.BIS
10.00	0.333	-0.001	.2268E+03	-.6257E+01	.5359E+01	.2290E+04	.2543E+04	.6455E+03	.9772E+03	-.5300E+02	.1812E+03	D07065.BIS
11.00	0.357	-0.001	.2196E+03	-.3319E+01	.7214E+01	.2430E+04	.2776E+04	.6781E+03	.1079E+04	-.8112E+02	.1774E+03	D07065.BIS
12.00	0.381	-0.001	.2078E+03	-.4271E+01	.7588E+01	.2360E+04	.2885E+04	.6539E+03	.1020E+04	-.3777E+02	.1935E+03	D07065.BIS
13.00	0.405	-0.002	.2025E+03	-.2348E+01	.8266E+01	.2140E+04	.2770E+04	.6058E+03	.9128E+03	-.2089E+02	.2001E+03	D07065.BIS
14.00	0.428	-0.002	.1938E+03	-.1883E+01	.7885E+01	.2120E+04	.2688E+04	.6159E+03	.9237E+03	-.1350E+02	.2039E+03	D07065.BIS
15.00	0.452	0.000	.1878E+03	-.5943E+00	.7794E+01	.1990E+04	.2450E+04	.5710E+03	.7454E+03	-.4382E+02	.1872E+03	D07065.BIS
16.00	0.476	0.000	.1803E+03	-.1108E+01	.7975E+01	.1890E+04	.2090E+04	.4991E+03	.6712E+03	-.3542E+02	.1480E+03	D07065.BIS
17.00	0.500	0.000	.1730E+03	-.1803E+01	.9760E+01	.1900E+04	.1868E+04	.5268E+03	.7224E+03	-.7474E+01	.1234E+03	D07065.BIS
18.00	0.524	-0.001	.1693E+03	-.1900E+01	.7865E+01	.1780E+04	.1681E+04	.4442E+03	.5865E+03	-.1911E+02	.1152E+03	D07065.BIS
19.00	0.548	-0.001	.1645E+03	.3794E+00	.7360E+01	.1680E+04	.1579E+04	.4328E+03	.5830E+03	-.3400E+02	.1167E+03	D07065.BIS
20.00	0.572	-0.001	.1577E+03	-.7390E+00	.7753E+01	.1670E+04	.1539E+04	.4209E+03	.5159E+03	-.9929E+01	.1157E+03	D07065.BIS
0.20	0.099	0.200	.3228E+03	-.3326E+01	-.6978E+00	.4820E+01	.2108E+02	.3890E+01	-.3174E+01	-.1290E+01	-.4899E+01	D07075.BIS
1.00	0.119	0.214	.3235E+03	-.2907E+01	-.1113E+01	.5950E+01	.2532E+02	.3980E+01	-.3726E+01	-.1190E+01	-.5881E+01	D07075.BIS
2.00	0.143	0.232	.3231E+03	-.2455E+01	-.7661E+00	.1040E+02	.2309E+02	.5610E+01	-.3960E+01	-.1290E+01	-.5877E+01	D07075.BIS
3.00	0.167	0.250	.3228E+03	-.2644E+01	-.1405E+00	.2460E+02	.2992E+02	.1000E+02	-.4601E+01	-.1227E+01	-.6033E+01	D07075.BIS
4.00	0.190	0.268	.3228E+03	-.2084E+01	-.1405E+00	.5510E+02	.5983E+02	.2590E+02	-.6506E+01	-.4400E+01	-.1226E+02	D07075.BIS
5.00	0.214	0.285	.3209E+03	-.2048E+01	.5493E+00	.1300E+03	.1225E+03	.7460E+02	.2351E+02	.1454E+01	-.2054E+02	D07075.BIS
6.00	0.238	0.303	.3136E+03	-.1417E+01	.1637E+01	.3660E+03	.2852E+03	.1760E+03	.9208E+02	-.7207E+01	-.2728E+02	D07075.BIS
7.00	0.262	0.321	.2950E+03	.3391E+00	.3728E+01	.1030E+04	.1219E+04	.3830E+03	.4039E+03	-.4040E+02	-.6275E+01	D07075.BIS
8.00	0.286	0.339	.2819E+03	.3209E+01	.4377E+01	.1460E+04	.1640E+04	.4928E+03	.5280E+03	-.3883E+02	.3383E+02	D07075.BIS
9.00	0.309	0.357	.2725E+03	.4690E+01	.7199E+01	.1600E+04	.1869E+04	.5819E+03	.5688E+03	-.5180E+02	.1375E+02	D07075.BIS
10.00	0.333	0.375	.2567E+03	.4726E+01	.8673E+01	.1910E+04	.2232E+04	.6398E+03	.6900E+03	-.1686E+02	.7096E+02	D07075.BIS
11.00	0.357	0.393	.2456E+03	.5114E+01	.9329E+01	.1920E+04	.2399E+04	.6823E+03	.6979E+03	.2705E+02	.9064E+02	D07075.BIS
12.00	0.381	0.410	.2343E+03	.4889E+01	.1110E+02	.2100E+04	.2468E+04	.6692E+03	.7357E+03	.4426E+02	.1007E+03	D07075.BIS
13.00	0.404	0.428	.2231E+03	.3089E+01	.1155E+02	.2030E+04	.2517E+04	.6441E+03	.7178E+03	.8812E+02	.1552E+03	D07075.BIS
14.00	0.428	0.446	.2142E+03	.2380E+01	.1228E+02	.1920E+04	.2572E+04	.6059E+03	.6515E+03	.4584E+02	.1684E+03	D07075.BIS
15.00	0.452	0.464	.2054E+03	.1581E+01	.1141E+02	.1900E+04	.2322E+04	.5781E+03	.6287E+03	.1049E+03	.1399E+03	D07075.BIS
16.00	0.476	0.482	.1984E+03	.2684E+01	.1187E+02	.1730E+04	.2163E+04	.5391E+03	.5841E+03	.1049E+03	.1411E+03	D07075.BIS
17.00	0.500	0.500	.1904E+03	.2176E+01	.1296E+02	.1650E+04	.2080E+04	.5160E+03	.5709E+03	.8144E+02	.1449E+03	D07075.BIS
18.00	0.524	0.517	.1744E+03	-.1367E+01	.9347E+01	.1590E+04	.1921E+04	.4872E+03	.5193E+03	.6722E+02	.1745E+03	D07075.BIS
19.00	0.548	0.535	.1670E+03	-.6762E+00	.1023E+02	.1520E+04	.1752E+04	.4521E+03	.4893E+03	.6504E+02	.1446E+03	D07075.BIS
20.00	0.571	0.553	.1633E+03	.4653E+00	.9864E+01	.1450E+04	.1550E+04	.4330E+03	.4370E+03	.6831E+02	.1138E+03	D07075.BIS
0.20	0.099	0.399	.3221E+03	-.4004E+01	-.3518E+00	.4020E+01	.9659E+01	.3040E+01	-.1214E+01	-.4291E+00	-.2948E+01	D07085.BIS
1.00	0.119	0.429	.3224E+03	-.4219E+01	-.5600E+00	.4210E+01	.8501E+01	.3170E+01	-.9141E+00	-.2848E+00	-.2642E+01	D07085.BIS
2.00	0.143	0.464	.3226E+03	-.3610E+01	-.6983E+00	.9130E+01	.1173E+02	.4990E+01	-.1258E+01	-.2159E+00	-.2656E+01	D07085.BIS
3.00	0.167	0.500	.3215E+03	-.3799E+01	-.1452E+00	.2830E+02	.2449E+02	.1350E+02	-.1628E+01	-.1101E+01	-.2120E+01	D07085.BIS

TABLE 5  
Continued

X	Y	Z	$\bar{u}$	$\bar{v}$	$\bar{w}$	$\overline{uu}$	$\overline{vv}$	$\overline{ww}$	$\overline{uv}$	$\overline{uw}$	$\overline{vw}$	File Name
inch	inch	inch	m/s	m/s	m/s	m <sup>2</sup> /s <sup>2</sup>	m <sup>2</sup> /s <sup>2</sup>	m <sup>2</sup> /s <sup>2</sup>	m <sup>2</sup> /s <sup>2</sup>	m <sup>2</sup> /s <sup>2</sup>	m <sup>2</sup> /s <sup>2</sup>	
4.00	0.190	0.535	.3215E+03	-.4042E+01	.6907E+00	.6870E+02	.5956E+02	.4440E+02	.3811E+00	-.4398E+01	-.4953E+01	D07085.BIS
5.00	0.214	0.571	.3183E+03	-.2254E+01	.2002E+01	.1730E+03	.1608E+03	.1170E+03	.2889E+02	.1956E+01	-.1568E+02	D07085.BIS
6.00	0.238	0.607	.3075E+03	-.1885E-01	.4053E+01	.4830E+03	.9547E+03	.2780E+03	.1801E+03	.3522E+02	.2069E+02	D07085.BIS
7.00	0.262	0.642	.2897E+03	.1694E+01	.6356E+01	.1000E+04	.1790E+04	.4580E+03	.3942E+03	.1230E+03	.6771E+02	D07085.BIS
8.00	0.285	0.678	.2698E+03	.4244E+01	.8512E+01	.1490E+04	.2460E+04	.6421E+03	.4992E+03	.1880E+03	.1022E+03	D07085.BIS
9.00	0.309	0.714	.2504E+03	.5103E+01	.8789E+01	.1710E+04	.3035E+04	.6883E+03	.6090E+03	.2802E+03	.1632E+03	D07085.BIS
10.00	0.333	0.750	.2333E+03	.6074E+01	.9841E+01	.1650E+04	.3225E+04	.6480E+03	.5942E+03	.2450E+03	.1930E+03	D07085.BIS
11.00	0.357	0.785	.2205E+03	.7867E+01	.1035E+02	.1760E+04	.3299E+04	.6599E+03	.6898E+03	.2910E+03	.2207E+03	D07085.BIS
12.00	0.381	0.821	.2116E+03	.9871E+01	.1046E+02	.1680E+04	.3208E+04	.6399E+03	.6522E+03	.2749E+03	.2963E+03	D07085.BIS
13.00	0.405	0.857	.2030E+03	.7390E+01	.9591E+01	.1690E+04	.2852E+04	.6301E+03	.6549E+03	.2741E+03	.2306E+03	D07085.BIS
14.00	0.428	0.893	.1943E+03	.7811E+01	.1033E+02	.1630E+04	.2873E+04	.5601E+03	.5864E+03	.2372E+03	.2393E+03	D07085.BIS
15.00	0.452	0.928	.1870E+03	.7082E+01	.1030E+02	.1660E+04	.2583E+04	.5251E+03	.6373E+03	.2370E+03	.2324E+03	D07085.BIS
16.00	0.476	0.964	.1779E+03	.5272E+01	.9987E+01	.1610E+04	.2504E+04	.4822E+03	.6407E+03	.2162E+03	.2037E+03	D07085.BIS
17.00	0.500	1.000	.1718E+03	.4391E+01	.9616E+01	.1520E+04	.2151E+04	.4581E+03	.5554E+03	.2031E+03	.1694E+03	D07085.BIS
18.00	0.524	1.035	.1680E+03	.5327E+01	.9950E+01	.1540E+04	.2077E+04	.4558E+03	.4792E+03	.1968E+03	.1651E+03	D07085.BIS
19.00	0.548	1.071	.1606E+03	.4660E+01	.8739E+01	.1520E+04	.1718E+04	.4298E+03	.4674E+03	.2048E+03	.1484E+03	D07085.BIS
20.00	0.571	1.107	.1485E+03	.1447E+01	.8172E+01	.1480E+04	.1548E+04	.3839E+03	.4604E+03	.1719E+03	.1296E+03	D07085.BIS
0.20	0.099	0.599	.3221E+03	-.4647E+01	-.7319E-01	.4140E+01	.1618E+02	.3070E+01	-.2733E+01	-.3392E+00	-.4008E+01	D07095.BIS
1.00	0.119	0.642	.3229E+03	-.4730E+01	.2780E+00	.4960E+01	.1611E+02	.3430E+01	-.2453E+01	-.2420E+00	-.4394E+01	D07095.BIS
2.00	0.143	0.696	.3221E+03	-.4029E+01	.6928E+00	.2060E+02	.3007E+02	.1530E+02	-.3400E+01	.7598E+00	-.6666E+01	D07095.BIS
3.00	0.167	0.750	.3211E+03	-.3128E+01	.4105E+00	.9141E+02	.2198E+03	.8331E+02	.1573E+02	.1751E+02	.2268E+01	D07095.BIS
4.00	0.190	0.803	.3090E+03	-.8848E+00	.3292E+01	.4680E+03	.5950E+03	.2800E+03	-.3290E+02	.1220E+03	-.4594E+02	D07095.BIS
5.00	0.214	0.857	.2750E+03	.2639E+01	.7695E+01	.1290E+04	.1325E+04	.5139E+03	-.4964E+02	.2759E+03	-.1355E+02	D07095.BIS
6.00	0.238	0.910	.2381E+03	.7047E+01	.9789E+01	.1810E+04	.3869E+04	.6028E+03	.3796E+03	.3637E+03	.2846E+03	D07095.BIS
7.00	0.262	0.964	.2137E+03	.8793E+01	.1144E+02	.1700E+04	.3757E+04	.6270E+03	.3910E+03	.4060E+03	.2843E+03	D07095.BIS
8.00	0.285	1.018	.1846E+03	.6655E+01	.7712E+01	.1610E+04	.1443E+04	.5659E+03	.2318E+03	.3139E+03	.4278E+02	D07095.BIS
9.00	0.309	1.071	.1731E+03	.6312E+01	.7949E+01	.1640E+04	.3326E+04	.5452E+03	.5177E+03	.3152E+03	.2588E+03	D07095.BIS
10.00	0.333	1.125	.1638E+03	.3006E+01	.8890E+01	.1640E+04	.2849E+04	.5142E+03	.4903E+03	.2862E+03	.2003E+03	D07095.BIS
11.00	0.357	1.178	.1561E+03	.3213E+01	.8513E+01	.1710E+04	.2667E+04	.5000E+03	.5298E+03	.3000E+03	.2190E+03	D07095.BIS
12.00	0.381	1.232	.1474E+03	.3197E+01	.8823E+01	.1770E+04	.2531E+04	.4559E+03	.5508E+03	.3110E+03	.1907E+03	D07095.BIS
13.00	0.405	1.285	.1427E+03	.3423E+01	.8625E+01	.1750E+04	.2351E+04	.4320E+03	.5823E+03	.2740E+03	.1802E+03	D07095.BIS
14.00	0.428	1.339	.1386E+03	.2814E+01	.8449E+01	.1710E+04	.2243E+04	.4250E+03	.5716E+03	.2549E+03	.1888E+03	D07095.BIS
15.00	0.452	1.393	.1328E+03	.1121E+01	.8003E+01	.1700E+04	.2007E+04	.3860E+03	.5361E+03	.2360E+03	.1493E+03	D07095.BIS
16.00	0.476	1.446	.1298E+03	.1124E+01	.8807E+01	.1630E+04	.1842E+04	.3791E+03	.4322E+03	.2611E+03	.1419E+03	D07095.BIS
17.00	0.500	1.500	.1230E+03	-.7256E+00	.8525E+01	.1580E+04	.1749E+04	.3561E+03	.4583E+03	.2451E+03	.1303E+03	D07095.BIS
18.00	0.524	1.553	.1197E+03	-.1388E+01	.8791E+01	.1600E+04	.1609E+04	.3380E+03	.4657E+03	.2360E+03	.1157E+03	D07095.BIS
19.00	0.548	1.607	.1176E+03	-.1304E+00	.9703E+01	.1510E+04	.1540E+04	.3420E+03	.4664E+03	.2181E+03	.1121E+03	D07095.BIS
20.00	0.572	1.660	.1157E+03	-.6984E+00	.1063E+02	.1410E+04	.1433E+04	.3151E+03	.3976E+03	.1942E+03	.9599E+02	D07095.BIS
0.20	0.099	0.799	.3229E+03	-.2405E+01	.9746E+00	.4600E+01	.2824E+02	.3680E+01	-.3857E+01	-.9901E+00	-.6041E+01	D07105.BIS
1.00	0.119	0.857	.3227E+03	-.2190E+01	.1183E+01	.1400E+02	.3369E+02	.1360E+02	-.6448E+01	.1057E+01	-.8670E+01	D07105.BIS
2.00	0.143	0.928	.3039E+03	-.1181E+01	.2925E+01	.5130E+03	.6402E+03	.2840E+03	-.3172E+02	.1400E+03	-.4361E+02	D07105.BIS
3.00	0.167	1.000	.2292E+03	.7199E+01	.1143E+02	.1640E+04	.1590E+04	.5578E+03	.1622E+03	.3919E+03	.5269E+01	D07105.BIS
4.00	0.190	1.071	.1862E+03	.7858E+01	.1336E+02	.1820E+04	.1643E+04	.5580E+03	.1678E+03	.3950E+03	.6589E+02	D07105.BIS
5.00	0.214	1.142	.1611E+03	.3116E+01	.1215E+02	.1950E+04	.3810E+04	.5531E+03	.5295E+03	.4461E+03	.3786E+03	D07105.BIS
6.00	0.238	1.214	.1346E+03	-.1394E+01	.8588E+01	.1880E+04	.2796E+04	.4620E+03	.3347E+03	.3270E+03	.2590E+03	D07105.BIS
7.00	0.262	1.285	.1210E+03	-.3291E+01	.7716E+01	.1790E+04	.2398E+04	.3938E+03	.2858E+03	.2898E+03	.1891E+03	D07105.BIS
8.00	0.285	1.357	.1129E+03	-.3410E+01	.7464E+01	.1640E+04	.2184E+04	.3728E+03	.2964E+03	.2838E+03	.1675E+03	D07105.BIS
9.00	0.309	1.428	.1077E+03	-.4982E+01	.6838E+01	.1550E+04	.2054E+04	.3531E+03	.2973E+03	.2751E+03	.1492E+03	D07105.BIS
0.20	0.100	1.000	.3202E+03	.4697E+00	-.1404E+01	.8500E+02	.1632E+03	.6980E+02	-.3161E+02	.1030E+02	-.3542E+02	D07115.BIS
1.00	0.119	1.071	.1228E+03	-.2889E+01	.1217E+02	.1940E+04	.1732E+04	.4977E+03	.3230E+03	.5028E+03	.1230E+03	D07115.BIS
0.20	0.200	-0.200	.3219E+03	-.1224E-01	-.1537E+01	.5970E+01	.2144E+03	.4840E+01	-.1611E+02	-.1850E+01	-.1787E+02	D08055.BIS
1.00	0.238	-0.214	.3223E+03	-.2150E+01	-.1884E+01	.7100E+01	.7016E+02	.5020E+01	-.7957E+01	-.1670E+01	-.1170E+02	D08055.BIS
2.00	0.286	-0.232	.3224E+03	-.2172E+01	-.8387E+00	.2940E+02	.6616E+02	.1310E+02	-.1047E+02	.2048E+00	-.1721E+02	D08055.BIS
3.00	0.333	-0.250	.3184E+03	-.2004E+00	.7490E+00	.1830E+03	.1858E+03	.1190E+03	.4200E+02	.1346E+00	-.4166E+02	D08055.BIS
4.00	0.381	-0.268	.2936E+03	.3986E+01	.1703E+01	.9420E+03	.1349E+04	.4590E+03	.4099E+03	-.4320E+02	.2615E+02	D08055.BIS
5.00	0.428	-0.286	.2601E+03	.6853E+01	.1650E+01	.1760E+04	.2213E+04	.7725E+03	.7589E+03	-.5791E+02	.1318E+03	D08055.BIS



TABLE 5  
Continued

X	Y	Z	$\bar{u}$	$\bar{v}$	$\bar{w}$	$\overline{uu}$	$\overline{vv}$	$\overline{ww}$	$\overline{uv}$	$\overline{uw}$	$\overline{vw}$	File Name
inch	inch	inch	m/s	m/s	m/s	m <sup>2</sup> /s <sup>2</sup>	m <sup>2</sup> /s <sup>2</sup>	m <sup>2</sup> /s <sup>2</sup>	m <sup>2</sup> /s <sup>2</sup>	m <sup>2</sup> /s <sup>2</sup>	m <sup>2</sup> /s <sup>2</sup>	
6.00	0.476	-0.304	.2293E+03	.5624E+01	.3348E+01	.2280E+04	.2580E+04	.8433E+03	.1082E+04	-.1198E+03	.1098E+03	D08055.BIS
7.00	0.524	-0.322	.2091E+03	.4357E+01	.4110E+01	.2340E+04	.2430E+04	.8259E+03	.1120E+04	-.6148E+02	.1309E+03	D08055.BIS
8.00	0.572	-0.339	.1842E+03	.1621E+01	.4716E+01	.2400E+04	.2560E+04	.7569E+03	.1170E+04	-.8752E+02	.1382E+03	D08055.BIS
9.00	0.618	-0.357	.1758E+03	.1452E+00	.4267E+01	.2460E+04	.2394E+04	.7149E+03	.1209E+04	-.8265E+02	.9372E+02	D08055.BIS
10.00	0.667	-0.375	.1666E+03	.6939E+00	.5487E+01	.2510E+04	.2528E+04	.6640E+03	.1280E+04	-.9428E+02	.1340E+03	D08055.BIS
11.00	0.714	-0.393	.1605E+03	.1783E+01	.4141E+01	.2560E+04	.2492E+04	.6662E+03	.1310E+04	-.5359E+02	.1305E+03	D08055.BIS
12.00	0.762	-0.411	.1518E+03	.1480E+01	.5433E+01	.2470E+04	.2381E+04	.6181E+03	.1190E+04	-.1122E+02	.1575E+03	D08055.BIS
13.00	0.809	-0.429	.1452E+03	.8624E-01	.5819E+01	.2480E+04	.2157E+04	.5951E+03	.1161E+04	-.4011E+02	.1483E+03	D08055.BIS
14.00	0.857	-0.447	.1424E+03	.1018E+01	.5287E+01	.2370E+04	.2063E+04	.5531E+03	.1089E+04	-.6237E+02	.9279E+02	D08055.BIS
15.00	0.904	-0.464	.1350E+03	-.1164E+01	.5322E+01	.2260E+04	.1795E+04	.5190E+03	.1001E+04	-.3464E+02	.1158E+03	D08055.BIS
16.00	0.952	-0.483	.1308E+03	-.1340E+01	.6066E+01	.2130E+04	.1687E+04	.4958E+03	.9111E+03	-.1502E+02	.1143E+03	D08055.BIS
17.00	1.000	-0.500	.1287E+03	-.1070E+01	.6797E+01	.2060E+04	.1528E+04	.4726E+03	.8533E+03	.1382E+02	.1124E+03	D08055.BIS
18.00	1.047	-0.518	.1254E+03	.1190E+01	.7544E+01	.1880E+04	.1477E+04	.4428E+03	.7542E+03	-.1824E+02	.1321E+03	D08055.BIS
19.00	1.095	-0.536	.1213E+03	-.3794E+00	.7292E+01	.1700E+04	.1357E+04	.4160E+03	.6652E+03	.1221E+02	.1325E+03	D08055.BIS
20.00	1.143	-0.554	.1170E+03	-.6729E+00	.6984E+01	.1600E+04	.1332E+04	.4121E+03	.6124E+03	.1831E+02	.1405E+03	D08055.BIS
0.20	0.199	0.000	.3237E+03	.2571E+01	.3506E+00	.6660E+01	.7425E+01	.4750E+01	.2087E+00	-.1801E+00	-.1589E+01	D08065.BIS
1.00	0.238	0.000	.3234E+03	.2420E+01	.8369E+00	.6200E+01	.6472E+01	.4480E+01	.5373E+00	.1909E+00	-.8771E+00	D08065.BIS
2.00	0.286	0.000	.3238E+03	.2989E+01	.1814E+01	.2430E+02	.2438E+02	.1170E+02	-.1058E+01	-.2990E+00	-.3996E+01	D08065.BIS
3.00	0.333	0.000	.3204E+03	.3450E+01	.2846E+01	.1490E+03	.1279E+03	.8670E+02	.4775E+02	-.8722E+00	-.1572E+02	D08065.BIS
4.00	0.381	-0.001	.2968E+03	.4089E+01	.4501E+01	.8740E+03	.6322E+03	.3780E+03	.3715E+03	-.2530E+02	-.1086E+00	D08065.BIS
5.00	0.428	-0.001	.2630E+03	.4149E+01	.8278E+01	.1670E+04	.2172E+04	.6461E+03	.8055E+03	-.5378E+02	.1747E+03	D08065.BIS
6.00	0.477	-0.001	.2366E+03	.2860E+01	.9575E+01	.2020E+04	.2426E+04	.7153E+03	.9824E+03	.9786E+01	.2115E+03	D08065.BIS
7.00	0.523	-0.001	.2164E+03	.2336E+01	.1069E+02	.2240E+04	.2365E+04	.7107E+03	.1040E+04	-.7402E+01	.2134E+03	D08065.BIS
8.00	0.572	-0.002	.2005E+03	.3414E+01	.1146E+02	.2330E+04	.2383E+04	.6629E+03	.1050E+04	.1411E+02	.1912E+03	D08065.BIS
9.00	0.618	-0.002	.1835E+03	.7771E+00	.1238E+02	.2490E+04	.2379E+04	.6243E+03	.1221E+04	.6587E+02	.2037E+03	D08065.BIS
10.00	0.667	-0.002	.1614E+03	-.5978E+00	.8533E+01	.2470E+04	.2161E+04	.6358E+03	.1131E+04	-.7132E+02	.1737E+03	D08065.BIS
11.00	0.714	0.000	.1553E+03	.6193E+00	.4819E+01	.2490E+04	.2314E+04	.5401E+03	.1190E+04	.6443E+00	.1889E+03	D08065.BIS
12.00	0.762	0.000	.1467E+03	-.1896E+01	.5999E+01	.2631E+04	.2383E+04	.5118E+03	.1261E+04	.4378E+02	.2026E+03	D08065.BIS
13.00	0.809	0.000	.1394E+03	-.2189E+01	.6404E+01	.2610E+04	.2155E+04	.4790E+03	.1190E+04	.7884E+02	.2014E+03	D08065.BIS
14.00	0.857	-0.001	.1358E+03	-.3532E+01	.6962E+01	.2580E+04	.2113E+04	.4591E+03	.1151E+04	.8131E+02	.2196E+03	D08065.BIS
15.00	0.904	-0.001	.1332E+03	-.2257E+01	.8060E+01	.2420E+04	.1943E+04	.4470E+03	.1000E+04	.1018E+03	.2034E+03	D08065.BIS
16.00	0.952	-0.001	.1281E+03	-.2786E+01	.7819E+01	.2310E+04	.1866E+04	.4054E+03	.9843E+03	.1040E+03	.1771E+03	D08065.BIS
17.00	1.000	-0.001	.1260E+03	-.1582E+01	.7950E+01	.2150E+04	.1583E+04	.4100E+03	.8496E+03	.7291E+02	.1656E+03	D08065.BIS
18.00	1.047	-0.002	.1237E+03	-.1635E+01	.8040E+01	.2050E+04	.1439E+04	.3848E+03	.7635E+03	.6413E+02	.1505E+03	D08065.BIS
19.00	1.095	0.000	.1194E+03	-.1872E+01	.7536E+01	.1920E+04	.1409E+04	.3568E+03	.7266E+03	.4425E+02	.1300E+03	D08065.BIS
19.00	1.143	0.000	.1151E+03	-.1906E+01	.8168E+01	.1800E+04	.1360E+04	.3382E+03	.6640E+03	.4238E+02	.1299E+03	D08065.BIS
20.00	1.143	0.000	.1180E+03	.1466E+01	.5413E+01	.1770E+04	.1303E+04	.3673E+03	.6930E+03	.3642E+01	.7887E+02	D08065.BIS
0.20	0.200	0.200	.3225E+03	-.1809E+01	-.1415E+00	.5940E+01	.6362E+02	.4630E+01	-.8376E+01	-.2613E+00	-.1136E+02	D08075.BIS
1.00	0.238	0.214	.3233E+03	-.1612E+01	.2097E+00	.6610E+01	.4561E+02	.5050E+01	-.7664E+01	.2588E+00	-.9462E+01	D08075.BIS
2.00	0.286	0.232	.3231E+03	-.7133E+00	-.1070E-03	.2370E+02	.5176E+02	.1060E+02	-.9876E+01	.1281E+00	-.1222E+02	D08075.BIS
3.00	0.333	0.250	.3218E+03	.7770E+00	.1528E+01	.1140E+03	.1074E+03	.7040E+02	.1001E+02	-.1291E+01	-.1492E+02	D08075.BIS
4.00	0.381	0.268	.3013E+03	.3014E+01	.2776E+01	.7470E+03	.5494E+03	.3390E+03	.2530E+03	-.1321E+02	-.1554E+02	D08075.BIS
5.00	0.428	0.285	.2693E+03	.5386E+01	.5515E+01	.1600E+04	.2043E+04	.6322E+03	.6709E+03	.9541E+00	.1810E+03	D08075.BIS
6.00	0.476	0.303	.2418E+03	.5993E+01	.7922E+01	.2030E+04	.2305E+04	.7879E+03	.8392E+03	-.7454E+01	.1263E+03	D08075.BIS
7.00	0.524	0.321	.2166E+03	.4209E+01	.1006E+02	.2360E+04	.2432E+04	.8317E+03	.1020E+04	.4612E+02	.1746E+03	D08075.BIS
8.00	0.572	0.339	.2013E+03	.4232E+01	.1258E+02	.2500E+04	.2725E+04	.7900E+03	.1181E+04	.7530E+02	.2193E+03	D08075.BIS
9.00	0.618	0.357	.1891E+03	.3470E+01	.1323E+02	.2490E+04	.2376E+04	.7809E+03	.1090E+04	.1038E+03	.2317E+03	D08075.BIS
10.00	0.667	0.375	.1686E+03	.1070E+01	.9186E+01	.2500E+04	.2453E+04	.7142E+03	.1220E+04	.4957E+02	.2258E+03	D08075.BIS
11.00	0.714	0.393	.1620E+03	.1764E-01	.8396E+01	.2610E+04	.2329E+04	.6927E+03	.1199E+04	.1071E+03	.2515E+03	D08075.BIS
12.00	0.762	0.410	.1542E+03	-.2047E+01	.9064E+01	.2630E+04	.2432E+04	.6541E+03	.1251E+04	.1263E+03	.2626E+03	D08075.BIS
13.00	0.809	0.428	.1504E+03	-.1388E+01	.1035E+02	.2380E+04	.2279E+04	.6400E+03	.1109E+04	.1359E+03	.2709E+03	D08075.BIS
14.00	0.857	0.446	.1483E+03	.4560E+00	.9627E+01	.2370E+04	.2081E+04	.6186E+03	.1058E+04	.1370E+03	.2316E+03	D08075.BIS
15.00	0.904	0.464	.1383E+03	-.8377E+00	.8427E+01	.2360E+04	.2046E+04	.5579E+03	.1040E+04	.1462E+03	.2451E+03	D08075.BIS
16.00	0.952	0.482	.1376E+03	-.9748E+00	.7874E+01	.2220E+04	.1755E+04	.5218E+03	.9417E+03	.1343E+03	.1861E+03	D08075.BIS
17.00	1.000	0.500	.1317E+03	-.1233E+01	.7895E+01	.2030E+04	.1694E+04	.4909E+03	.8410E+03	.1537E+03	.1931E+03	D08075.BIS
18.00	1.047	0.517	.1282E+03	.9406E-01	.7004E+01	.1960E+04	.1536E+04	.4470E+03	.7598E+03	.1131E+03	.1369E+03	D08075.BIS



TABLE 5  
Continued

X	Y	Z	$\bar{U}$	$\bar{V}$	$\bar{W}$	$\overline{uu}$	$\overline{vv}$	$\overline{ww}$	$\overline{uv}$	$\overline{uw}$	$\overline{vw}$	File Name
inch	inch	inch	m/s	m/s	m/s	m <sup>2</sup> /s <sup>2</sup>	m <sup>2</sup> /s <sup>2</sup>	m <sup>2</sup> /s <sup>2</sup>	m <sup>2</sup> /s <sup>2</sup>	m <sup>2</sup> /s <sup>2</sup>	m <sup>2</sup> /s <sup>2</sup>	
19.00	1.095	0.536	.1248E+03	.4771E+00	.6664E+01	.1810E+04	.1463E+04	.4570E+03	.7737E+03	.9600E+02	.1238E+03	D08075.BIS
20.00	1.143	0.553	.1208E+03	.1476E+00	.6503E+01	.1680E+04	.1416E+04	.4188E+03	.7291E+03	.5550E+02	.1093E+03	D08075.BIS
0.20	0.199	0.399	.3226E+03	-.2284E+01	-.1395E+01	.4300E+01	.1033E+02	.3350E+01	-.1761E+01	-.5523E+00	-.2830E+01	D08085.BIS
1.00	0.238	0.429	.3231E+03	-.2314E+01	-.1254E+01	.5820E+01	.1112E+02	.3520E+01	-.1521E+01	-.3908E+00	-.3130E+01	D08085.BIS
2.00	0.286	0.464	.3226E+03	-.2727E+01	-.8376E+00	.2330E+02	.2006E+02	.9519E+01	-.3842E-02	-.1140E+01	-.2952E+01	D08085.BIS
3.00	0.333	0.500	.3198E+03	-.2596E+01	.4058E+00	.1510E+03	.1215E+03	.8338E+02	.4591E+02	-.2504E+01	-.9517E+01	D08085.BIS
4.00	0.381	0.535	.2965E+03	-.9733E+00	.4500E+01	.8570E+03	.6330E+03	.3650E+03	.3171E+03	-.3049E+01	-.1215E+02	D08085.BIS
5.00	0.428	0.571	.2636E+03	.1691E+01	.1002E+02	.1590E+04	.2378E+04	.6108E+03	.7236E+03	-.2793E+02	.1556E+03	D08085.BIS
6.00	0.476	0.607	.2368E+03	.3815E+01	.1403E+02	.2010E+04	.2942E+04	.7462E+03	.9236E+03	.3565E+02	.2523E+03	D08085.BIS
7.00	0.523	0.642	.2176E+03	.3654E+02	.1494E+02	.2150E+04	.2797E+04	.7138E+03	.1001E+04	.1073E+03	.2151E+03	D08085.BIS
8.00	0.572	0.678	.2023E+03	.4567E+01	.1537E+02	.2230E+04	.2687E+04	.6791E+03	.1041E+04	.1928E+03	.2527E+03	D08085.BIS
9.00	0.619	0.714	.1912E+03	.3135E+01	.1359E+02	.2160E+04	.2648E+04	.6312E+03	.9702E+03	.1982E+03	.2260E+03	D08085.BIS
10.00	0.667	0.750	.1691E+03	-.4525E+00	.1156E+02	.2090E+04	.2337E+04	.5638E+03	.9447E+03	.1982E+03	.2530E+03	D08085.BIS
11.00	0.714	0.785	.1595E+03	.2686E+01	.9641E+01	.2110E+04	.2221E+04	.5434E+03	.9071E+03	.1958E+03	.2222E+03	D08085.BIS
12.00	0.762	0.821	.1527E+03	.1666E+01	.9692E+01	.2060E+04	.2088E+04	.4997E+03	.8749E+03	.1848E+03	.2090E+03	D08085.BIS
13.00	0.809	0.857	.1460E+03	.1658E+01	.9173E+01	.2010E+04	.1901E+04	.4861E+03	.8210E+03	.2157E+03	.2169E+03	D08085.BIS
14.00	0.857	0.893	.1380E+03	.1236E+01	.8998E+01	.2080E+04	.1824E+04	.4473E+03	.8430E+03	.2121E+03	.1939E+03	D08085.BIS
15.00	0.904	0.928	.1332E+03	.1754E+01	.8562E+01	.2000E+04	.1913E+04	.4278E+03	.8272E+03	.2109E+03	.1782E+03	D08085.BIS
16.00	0.952	0.964	.1270E+03	.1178E+01	.8393E+01	.1940E+04	.1785E+04	.3922E+03	.8318E+03	.1992E+03	.1740E+03	D08085.BIS
17.00	1.000	1.000	.1221E+03	.1048E+01	.8243E+01	.1810E+04	.1497E+04	.3729E+03	.7012E+03	.1648E+03	.1505E+03	D08085.BIS
18.00	1.047	1.035	.1174E+03	.1669E+01	.7174E+01	.1700E+04	.1477E+04	.3478E+03	.6333E+03	.1458E+03	.1211E+03	D08085.BIS
19.00	1.095	1.071	.1130E+03	.1615E+01	.6997E+01	.1640E+04	.1330E+04	.3279E+03	.6627E+03	.1349E+03	.1078E+03	D08085.BIS
20.00	1.143	1.107	.1080E+03	.9191E+00	.5795E+01	.1510E+04	.1218E+04	.3039E+03	.5906E+03	.1269E+03	.9203E+02	D08085.BIS
0.20	0.200	0.599	.3221E+03	-.3760E+01	-.1188E+01	.4410E+01	.2090E+02	.3550E+01	-.3262E+01	-.6562E+00	-.4960E+01	D08095.BIS
1.00	0.238	0.642	.3225E+03	-.4777E+01	-.5595E+00	.6210E+01	.1402E+02	.5100E+01	-.2017E+01	-.1220E+01	-.4163E+01	D08095.BIS
2.00	0.286	0.696	.3224E+03	-.5586E+01	.2759E+00	.3770E+02	.3290E+02	.2140E+02	-.2663E+01	-.1831E+01	-.2125E+01	D08095.BIS
3.00	0.333	0.750	.3150E+03	-.1952E+01	.3593E+01	.2890E+03	.2544E+03	.1810E+03	.7819E+02	-.1001E+02	-.4163E+02	D08095.BIS
4.00	0.381	0.803	.2783E+03	-.2288E+00	.1203E+02	.1310E+04	.2040E+04	.5649E+03	.5260E+03	.2059E+02	.9668E+02	D08095.BIS
5.00	0.428	0.856	.2421E+03	.4991E+01	.1621E+02	.1680E+04	.3000E+04	.6812E+03	.7478E+03	.2133E+03	.2197E+03	D08095.BIS
6.00	0.476	0.910	.2119E+03	.1027E+02	.1394E+02	.1800E+04	.3011E+04	.6591E+03	.7395E+03	.2431E+03	.1356E+03	D08095.BIS
7.00	0.524	0.964	.1904E+03	.1169E+02	.1310E+02	.1920E+04	.2605E+04	.6278E+03	.7129E+03	.2998E+03	.1468E+03	D08095.BIS
8.00	0.572	1.017	.1755E+03	.1047E+02	.1221E+02	.1760E+04	.2645E+04	.5731E+03	.7025E+03	.2570E+03	.1918E+03	D08095.BIS
9.00	0.618	1.071	.1648E+03	.1078E+02	.1314E+02	.1770E+04	.2573E+04	.5541E+03	.8102E+03	.2790E+03	.2325E+03	D08095.BIS
10.00	0.667	1.124	.1437E+03	.5254E+01	.1014E+02	.1750E+04	.2202E+04	.5031E+03	.6821E+03	.2481E+03	.1481E+03	D08095.BIS
11.00	0.714	1.178	.1347E+03	.5126E+01	.9647E+01	.1730E+04	.1985E+04	.4600E+03	.6364E+03	.2491E+03	.1572E+03	D08095.BIS
12.00	0.762	1.232	.1282E+03	.3689E+01	.8934E+01	.1800E+04	.1921E+04	.4471E+03	.6632E+03	.2381E+03	.1083E+03	D08095.BIS
13.00	0.809	1.285	.1187E+03	.3367E+01	.8585E+01	.1760E+04	.1648E+04	.3900E+03	.6892E+03	.2130E+03	.1133E+03	D08095.BIS
14.00	0.857	1.339	.1158E+03	.2177E+01	.7614E+01	.1620E+04	.1829E+04	.3850E+03	.7168E+03	.2460E+03	.1740E+03	D08095.BIS
15.00	0.905	1.392	.1136E+03	.2048E+01	.7780E+01	.1590E+04	.1727E+04	.3938E+03	.6995E+03	.2318E+03	.1473E+03	D08095.BIS
16.00	0.952	1.446	.1075E+03	.5177E+00	.7904E+01	.1490E+04	.1557E+04	.3518E+03	.6532E+03	.1918E+03	.1212E+03	D08095.BIS
17.00	1.000	1.500	.1048E+03	.7477E+00	.7086E+01	.1400E+04	.1437E+04	.3428E+03	.5922E+03	.1938E+03	.1332E+03	D08095.BIS
18.00	1.047	1.553	.1004E+03	.1255E+01	.7104E+01	.1370E+04	.1358E+04	.3220E+03	.6056E+03	.1949E+03	.1378E+03	D08095.BIS
19.00	1.095	1.607	.9842E+02	.4119E+00	.6944E+01	.1230E+04	.1310E+04	.2960E+03	.5261E+03	.1610E+03	.1261E+03	D08095.BIS
20.00	1.143	1.660	.9658E+02	.7114E+00	.6826E+01	.1180E+04	.1160E+04	.2790E+03	.4862E+03	.1440E+03	.1170E+03	D08095.BIS
0.20	0.199	0.799	.3224E+03	-.2755E+01	.2065E+00	.3960E+01	.1513E+02	.3600E+01	-.2612E+01	-.6340E+00	-.3852E+01	D08105.BIS
1.00	0.238	0.857	.3224E+03	-.2474E+01	.2065E+00	.1700E+02	.2208E+02	.1480E+02	-.8224E+00	-.1429E+01	-.3510E+01	D08105.BIS
2.00	0.285	0.928	.3015E+03	-.8244E+00	.6330E+01	.5890E+03	.6291E+03	.3150E+03	.2088E+02	.1490E+03	.1470E+02	D08105.BIS
3.00	0.333	1.000	.2271E+03	.9369E+01	.1442E+02	.1730E+04	.1720E+04	.5880E+03	.5691E+02	.4149E+03	-.1678E+01	D08105.BIS
4.00	0.381	1.071	.1746E+03	-.4748E+00	.1401E+02	.1780E+04	.1617E+04	.5450E+03	.1900E+03	.3910E+03	.5110E+02	D08105.BIS
5.00	0.428	1.143	.1498E+03	.3631E+01	.1235E+02	.1810E+04	.3208E+04	.4908E+03	.5951E+03	.3428E+03	.3140E+03	D08105.BIS
6.00	0.476	1.214	.1284E+03	.2917E+01	.1035E+02	.1830E+04	.2640E+04	.4489E+03	.5543E+03	.3499E+03	.2354E+03	D08105.BIS
7.00	0.523	1.285	.1196E+03	.1844E+01	.9550E+01	.1680E+04	.2229E+04	.3878E+03	.5012E+03	.2628E+03	.1984E+03	D08105.BIS
8.00	0.572	1.357	.1079E+03	.9518E-01	.8616E+01	.1560E+04	.1974E+04	.3512E+03	.5350E+03	.2872E+03	.2237E+03	D08105.BIS
9.00	0.619	1.428	.1003E+03	-.8920E+00	.7717E+01	.1440E+04	.1681E+04	.3241E+03	.4063E+03	.2691E+03	.1554E+03	D08105.BIS
0.20	0.200	0.999	.3204E+03	-.2760E+01	.5982E-01	.3380E+02	.1093E+03	.3200E+02	-.2631E+02	.3838E+01	-.2518E+02	D08115.BIS
1.00	0.238	1.071	.1294E+03	-.1626E+01	.1330E+02	.1810E+04	.1634E+04	.5469E+03	.3770E+03	.4938E+03	.1763E+03	D08115.BIS

TABLE 5  
Continued

X	Y	Z	$\bar{U}$	$\bar{V}$	$\bar{W}$	$\bar{u}^2$	$\bar{v}^2$	$\bar{w}^2$	$\bar{uv}$	$\bar{uw}$	$\bar{vw}$	File Name
inch	inch	inch	m/s	m/s	m/s	m <sup>2</sup> /s <sup>2</sup>	m <sup>2</sup> /s <sup>2</sup>	m <sup>2</sup> /s <sup>2</sup>	m <sup>2</sup> /s <sup>2</sup>	m <sup>2</sup> /s <sup>2</sup>	m <sup>2</sup> /s <sup>2</sup>	
0.20	0.299	-0.200	.3225E+03	-.4456E+01	-.6988E+00	4.110E+01	.1713E+02	3.730E+01	-.2954E+01	-.8860E+00	-.4102E+01	D09055.BIS
1.00	0.357	-0.215	.3229E+03	-.4652E+01	-.9746E+00	.1060E+02	.2876E+02	.6569E+01	-.5125E+01	-.5990E+00	-.7329E+01	D09055.BIS
2.00	0.428	-0.232	.3022E+03	-.3063E+00	.2501E+01	.6350E+03	.4658E+03	3.000E+03	.2023E+03	-.1608E+02	-.1274E+02	D09055.BIS
3.00	0.500	-0.250	.2334E+03	.9121E+01	.5174E+01	.1800E+04	.1255E+04	7.081E+03	.6621E+03	-.3051E+02	.2649E+02	D09055.BIS
4.00	0.572	-0.268	.1832E+03	.6670E+01	.5617E+01	.1980E+04	.2787E+04	.6458E+03	.1039E+04	-.2262E+02	.1835E+03	D09055.BIS
5.00	0.642	-0.286	.1552E+03	.4043E+01	.6560E+01	.2330E+04	.2606E+04	5.727E+03	.1159E+04	.9942E+01	.1952E+03	D09055.BIS
6.00	0.714	-0.304	.1352E+03	.2204E+01	.6312E+01	.2400E+04	.2284E+04	4.762E+03	.1181E+04	.1406E+02	.1757E+03	D09055.BIS
7.00	0.786	-0.322	.1243E+03	.2015E+00	.4580E+01	.2320E+04	.2298E+04	4.578E+03	.1169E+04	-.7683E+01	.1635E+03	D09055.BIS
8.00	0.857	-0.339	.1143E+03	-.1603E+01	.3881E+01	.2260E+04	.2279E+04	4.377E+03	.1139E+04	-.1326E+01	.1702E+03	D09055.BIS
9.00	0.928	-0.357	.1067E+03	-.3271E+01	.4355E+01	.2070E+04	.1999E+04	3.850E+03	.1040E+04	.3419E+02	.1598E+03	D09055.BIS
0.20	0.298	0.000	.3222E+03	-.4959E+00	.1111E+01	.5540E+01	.7366E+02	5.120E+01	-.7906E+01	-.2230E+01	-.9918E+01	D09065.BIS
1.00	0.357	0.000	.3228E+03	-.1126E+01	.1392E+01	.1170E+02	.3090E+02	6.600E+01	-.6357E+01	-.1349E+01	-.6961E+01	D09065.BIS
2.00	0.428	0.000	.3035E+03	.1175E+01	.3481E+01	.6310E+03	.4551E+03	2.920E+03	.2368E+03	-.2072E+02	-.1207E+01	D09065.BIS
3.00	0.500	-0.001	.2321E+03	.3080E+01	.9419E+01	.1880E+04	.2470E+04	6.783E+03	.8830E+03	-.1660E+02	.2260E+03	D09065.BIS
4.00	0.572	-0.001	.1910E+03	.4187E+01	.9965E+01	.2190E+04	.2560E+04	6.173E+03	.1062E+04	.5479E+02	.2614E+03	D09065.BIS
5.00	0.642	-0.001	.1550E+03	-.8450E+00	.8858E+01	.2399E+04	.2423E+04	5.216E+03	.1108E+04	.5791E+02	.2287E+03	D09065.BIS
6.00	0.714	-0.001	.1378E+03	-.1022E+01	.8056E+01	.2570E+04	.2301E+04	4.970E+03	.1160E+04	.1357E+03	.2718E+03	D09065.BIS
7.00	0.786	-0.001	.1237E+03	-.3566E+01	.7726E+01	.2450E+04	.2122E+04	4.410E+03	.1071E+04	.1234E+03	.2411E+03	D09065.BIS
8.00	0.857	-0.002	.1103E+03	-.4641E+01	.7231E+01	.2380E+04	.1903E+04	3.739E+03	.1039E+04	.1359E+03	.2321E+03	D09065.BIS
9.00	0.928	-0.002	.1011E+03	-.6012E+01	.6459E+01	.2280E+04	.1522E+04	3.410E+03	.8974E+03	.1232E+03	.1882E+03	D09065.BIS
10.00	1.000	-0.002	.9484E+02	-.7352E+01	.5628E+01	.2030E+04	.1397E+04	3.077E+03	.8050E+03	.1259E+03	.1752E+03	D09065.BIS
11.00	1.071	0.000	.9006E+02	-.7825E+01	.5318E+01	.1830E+04	.1239E+04	2.869E+03	.7293E+03	.1098E+03	.1546E+03	D09065.BIS
12.00	1.143	0.000	.8851E+02	-.6166E+01	.5570E+01	.1670E+04	.1257E+04	2.637E+03	.7343E+03	.1288E+03	.1632E+03	D09065.BIS
13.00	1.214	0.000	.8551E+02	-.7928E+01	.5587E+01	.1580E+04	.1160E+04	2.580E+03	.6730E+03	.1220E+03	.1600E+03	D09065.BIS
14.00	1.286	-0.001	.8608E+02	-.5572E+01	.5261E+01	.1530E+04	.1181E+04	2.431E+03	.6750E+03	.7980E+02	.1292E+03	D09065.BIS
15.00	1.357	-0.001	.8682E+02	-.2871E+01	.4533E+01	.1450E+04	.1130E+04	2.471E+03	.6549E+03	.4248E+02	.1200E+03	D09065.BIS
16.00	1.428	-0.001	.8937E+02	-.7719E+00	.5733E+01	.1400E+04	.1210E+04	2.791E+03	.6860E+03	.2072E+02	.1191E+03	D09065.BIS
17.00	1.500	-0.002	.8812E+02	-.5734E+00	.5046E+01	.1330E+04	.1080E+04	2.460E+03	.6098E+03	.3119E+02	.9172E+02	D09065.BIS
18.00	1.572	-0.002	.8717E+02	-.1878E+00	.4283E+01	.1300E+04	.1141E+04	2.430E+03	.6641E+03	.3124E+02	.1122E+03	D09065.BIS
19.00	1.642	0.000	.8524E+02	-.5390E+00	.4269E+01	.1130E+04	.1000E+04	2.250E+03	.5640E+03	.2278E+02	.9316E+02	D09065.BIS
20.00	1.714	0.000	.8360E+02	-.4419E+00	.4416E+01	.1040E+04	.9011E+03	2.090E+03	.4999E+03	.2641E+02	.9534E+02	D09065.BIS
0.20	0.299	0.200	.3216E+03	-.1655E+01	.1179E+01	.9298E+01	4.507E+02	7.998E+01	-.4734E+01	-.5138E+01	-.9078E+01	D09075.BIS
1.00	0.357	0.214	.3212E+03	-.2772E+01	.3058E+01	.7241E+02	.1495E+03	.2190E+02	-.1869E+02	-.1080E+02	-.3897E+02	D09075.BIS
2.00	0.428	0.232	.2724E+03	-.1246E+01	.5387E+01	.1650E+04	.1982E+04	.5251E+03	.7625E+03	-.1138E+02	.1516E+03	D09075.BIS
3.00	0.500	0.250	.2219E+03	.4985E+01	.5899E+01	.1970E+04	.2378E+04	.7830E+03	.8864E+03	-.2002E+03	.1935E+03	D09075.BIS
4.00	0.572	0.268	.1959E+03	.6215E+01	.6291E+01	.2100E+04	.2222E+04	.7790E+03	.9295E+03	-.2038E+03	.1906E+03	D09075.BIS
5.00	0.642	0.285	.1756E+03	.5369E+01	.6565E+01	.2150E+04	.2163E+04	.6881E+03	.9788E+03	-.1377E+03	.1678E+03	D09075.BIS
6.00	0.714	0.303	.1578E+03	.3618E+01	.7266E+01	.2340E+04	.2061E+04	.6290E+03	.1100E+04	-.6226E+02	.1570E+03	D09075.BIS
7.00	0.786	0.321	.1404E+03	.2075E+00	.5976E+01	.2430E+04	.1996E+04	.5732E+03	.1131E+04	.8307E+01	.1706E+03	D09075.BIS
8.00	0.857	0.339	.1285E+03	-.7688E+00	.5459E+01	.2220E+04	.1892E+04	.5243E+03	.1021E+04	.1714E+01	.1747E+03	D09075.BIS
9.00	0.928	0.357	.1186E+03	-.2861E+01	.6335E+01	.2130E+04	.1668E+04	.4569E+03	.9677E+03	.1113E+02	.1635E+03	D09075.BIS
0.20	0.299	0.399	.3217E+03	-.1124E+01	-.6321E+00	.3730E+01	.1185E+02	.3450E+01	-.2341E+01	-.6933E+00	-.2959E+01	D09085.BIS
1.00	0.357	0.429	.3214E+03	.1899E+00	.6208E+00	.2020E+02	.3069E+02	.1380E+02	-.3841E+01	-.1032E+01	-.7938E+01	D09085.BIS
2.00	0.428	0.464	.3083E+03	.1062E+01	.4265E+01	.4810E+03	.4011E+03	.2690E+03	.2005E+03	.7530E+01	-.1198E+02	D09085.BIS
3.00	0.500	0.500	.2501E+03	-.8767E+00	.7117E+01	.1820E+04	.1417E+04	.7537E+03	.7867E+03	.9245E+02	.9590E+02	D09085.BIS
4.00	0.572	0.535	.2063E+03	-.8430E+00	.1016E+02	.1990E+04	.1529E+04	.7238E+03	.8321E+03	.1572E+03	.1756E+03	D09085.BIS
5.00	0.642	0.571	.1766E+03	-.2507E+01	.1151E+02	.2090E+04	.3308E+04	.6440E+03	.1160E+04	.2584E+03	.4354E+03	D09085.BIS
6.00	0.714	0.607	.1577E+03	-.2272E+01	.1012E+02	.2250E+04	.2737E+04	.5642E+03	.1080E+04	.2408E+03	.3497E+03	D09085.BIS
7.00	0.786	0.642	.1464E+03	-.1231E+01	.9481E+01	.2270E+04	.2356E+04	.5049E+03	.9563E+03	.1751E+03	.2964E+03	D09085.BIS
8.00	0.857	0.678	.1342E+03	-.3873E+00	.7799E+01	.2350E+04	.2310E+04	.4804E+03	.1031E+04	.1729E+03	.3045E+03	D09085.BIS
9.00	0.928	0.714	.1282E+03	.3102E+01	.6224E+01	.2240E+04	.2300E+04	.4561E+03	.1110E+04	.1826E+03	.2769E+03	D09085.BIS
0.20	0.299	0.599	.3224E+03	-.3513E+01	-.1047E+01	.4220E+01	.1644E+02	.3820E+01	-.2930E+01	-.7299E+00	-.4054E+01	D09095.BIS
1.00	0.357	0.642	.3227E+03	-.3828E+01	-.9070E+00	.1240E+02	.1682E+02	.8637E+01	-.2872E+01	-.3625E-01	-.3093E+01	D09095.BIS
2.00	0.428	0.696	.3011E+03	-.3718E+00	-.8065E-01	.6671E+03	.5095E+03	.3080E+03	.2078E+03	.2218E+02	.2020E+02	D09095.BIS
3.00	0.500	0.750	.2210E+03	.6464E+01	.7498E+01	.2110E+04	.1457E+04	.6960E+03	.7493E+03	.1969E+02	.3635E+02	D09095.BIS
4.00	0.572	0.803	.1875E+03	.1196E+02	.8071E+01	.2230E+04	.2975E+04	.6190E+03	.1131E+04	.3792E+02	.2851E+03	D09095.BIS

TABLE 5  
Continued

X	Y	Z	$\bar{U}$	$\bar{V}$	$\bar{W}$	$\overline{uu}$	$\overline{vv}$	$\overline{ww}$	$\overline{uv}$	$\overline{uw}$	$\overline{vw}$	File Name
inch	inch	inch	m/s	m/s	m/s	m <sup>2</sup> /s <sup>2</sup>	m <sup>2</sup> /s <sup>2</sup>	m <sup>2</sup> /s <sup>2</sup>	m <sup>2</sup> /s <sup>2</sup>	m <sup>2</sup> /s <sup>2</sup>	m <sup>2</sup> /s <sup>2</sup>	
5.00	0.642	0.856	.1585E+03	.1026E+02	.6711E+01	.2150E+04	.2887E+04	.5148E+03	.1199E+04	.6252E+02	.2223E+03	D09095.BIS
6.00	0.714	0.910	.1425E+03	.8613E+01	.7182E+01	.2180E+04	.2584E+04	.4661E+03	.1140E+04	.9933E+02	.1946E+03	D09095.BIS
7.00	0.786	0.964	.1307E+03	.6689E+01	.6749E+01	.2150E+04	.2318E+04	.4218E+03	.1049E+04	.1249E+03	.1906E+03	D09095.BIS
8.00	0.857	1.018	.1183E+03	.4835E+01	.7177E+01	.2000E+04	.2032E+04	.3962E+03	.9696E+03	.1802E+03	.1985E+03	D09095.BIS
9.00	0.928	1.071	.1084E+03	.2285E+01	.6925E+01	.1740E+04	.1757E+04	.3358E+03	.8461E+03	.1438E+03	.1543E+03	D09095.BIS
10.00	1.000	1.124	.1017E+03	.2283E+01	.6670E+01	.1620E+04	.1613E+04	.3131E+03	.7335E+03	.1551E+03	.1455E+03	D09095.BIS
11.00	1.071	1.178	.9599E+02	.2042E+01	.6837E+01	.1370E+04	.1409E+04	.2780E+03	.6481E+03	.1490E+03	.1457E+03	D09095.BIS
12.00	1.143	1.232	.9488E+02	.2963E+01	.7251E+01	.1260E+04	.1410E+04	.2550E+03	.5880E+03	.1050E+03	.1079E+03	D09095.BIS
13.00	1.214	1.285	.9304E+02	.3147E+01	.7237E+01	.1200E+04	.1190E+04	.2480E+03	.5441E+03	.1180E+03	.1081E+03	D09095.BIS
14.00	1.286	1.339	.8924E+02	.2561E+01	.7105E+01	.1130E+04	.1220E+04	.2300E+03	.5761E+03	.1160E+03	.1080E+03	D09095.BIS
15.00	1.357	1.392	.8613E+02	.2400E+01	.7017E+01	.1030E+04	.1100E+04	.2120E+03	.5030E+03	.8849E+02	.8429E+02	D09095.BIS
16.00	1.428	1.446	.8376E+02	.1744E+01	.7245E+01	.9451E+03	.1031E+04	.2040E+03	.4853E+03	.9791E+02	.9188E+02	D09095.BIS
17.00	1.500	1.500	.8184E+02	.1602E+01	.7189E+01	.9120E+03	.9524E+03	.1920E+03	.4291E+03	.1010E+03	.9525E+02	D09095.BIS
18.00	1.572	1.553	.8556E+02	.3422E+00	.6611E+01	.8790E+03	.1100E+04	.2080E+03	.4448E+03	.7589E+02	.1111E+03	D09095.BIS
19.00	1.642	1.607	.8365E+02	.4635E+00	.6520E+01	.8140E+03	.9790E+03	.2010E+03	.4359E+03	.7018E+02	.1011E+03	D09095.BIS
20.00	1.714	1.660	.8331E+02	.1155E+01	.6916E+01	.7789E+03	.9667E+03	.1980E+03	.4319E+03	.7962E+02	.1049E+03	D09095.BIS
0.20	0.299	0.799	.3224E+03	-.2555E+01	.4851E+00	.4080E+01	.4238E+02	.4420E+01	-.6040E+01	-.3889E+00	-.8093E+01	D09105.BIS
1.00	0.357	0.857	.3225E+03	-.3136E+01	.5551E+00	.4130E+02	.4675E+02	.3260E+02	-.3225E+01	-.9086E+00	-.7174E+01	D09105.BIS
2.00	0.428	0.928	.2806E+03	.1131E+02	.1022E+02	.1070E+04	.1085E+04	.5480E+03	.1291E+03	.1430E+03	-.1046E+03	D09105.BIS
3.00	0.500	1.000	.2002E+03	.1667E+02	.1320E+02	.1690E+04	.1468E+04	.5939E+03	.5258E+03	.2969E+03	.3715E+02	D09105.BIS
4.00	0.572	1.071	.1516E+03	.1139E+02	.1188E+02	.1790E+04	.2991E+04	.4851E+03	.8577E+03	.2431E+03	.2867E+03	D09105.BIS
5.00	0.642	1.143	.1280E+03	.7229E+01	.1036E+02	.1760E+04	.2264E+04	.4289E+03	.8096E+03	.2729E+03	.2397E+03	D09105.BIS
6.00	0.714	1.214	.1131E+03	.5233E+01	.1069E+02	.1610E+04	.1967E+04	.3638E+03	.6812E+03	.2468E+03	.2205E+03	D09105.BIS
7.00	0.786	1.285	.1014E+03	.2749E+01	.1016E+02	.1430E+04	.1620E+04	.3010E+03	.5989E+03	.2179E+03	.1639E+03	D09105.BIS
8.00	0.857	1.357	.9367E+02	.8588E+00	.8974E+01	.1230E+04	.1409E+04	.2799E+03	.5929E+03	.2170E+03	.1788E+03	D09105.BIS
9.00	0.928	1.428	.8822E+02	.3649E+00	.8488E+01	.1090E+04	.1250E+04	.2440E+03	.4650E+03	.1690E+03	.1398E+03	D09105.BIS
0.20	0.300	1.000	.3872E+03	.1112E+02	-.1028E+02	.3060E+03	.5296E+03	.2800E+03	-.6405E+02	.4202E+02	-.1176E+03	D09115.BIS
1.00	0.357	1.071	.1349E+02	.4894E+01	.1362E+02	.7720E+04	.6964E+04	.2190E+04	.1220E+04	.2080E+04	.6504E+03	D09115.BIS
0.20	0.401	-0.200	.3223E+03	-.2063E+01	.2644E+01	.5080E+01	.7142E+02	.6270E+01	-.1158E+02	.1477E+00	-.1159E+02	D10055.BIS
1.00	0.476	-0.214	.2655E+03	.2614E+01	.4108E+01	.1620E+04	.1179E+04	.6552E+03	.6362E+03	.2555E+02	.8559E+02	D10055.BIS
2.00	0.571	-0.232	.1457E+03	.4688E+01	.6455E+01	.2350E+04	.3213E+04	.5562E+03	.1281E+04	.5760E+02	.3591E+03	D10055.BIS
3.00	0.666	-0.250	.1107E+03	.1073E+01	.5874E+01	.2280E+04	.2329E+04	.4109E+03	.1230E+04	.1199E+03	.2737E+03	D10055.BIS
0.20	0.401	0.000	.3220E+03	.3430E-01	.3131E+01	.5200E+01	.1688E+03	.5630E+01	-.1742E+02	-.5260E-01	-.1895E+02	D10065.BIS
1.00	0.476	0.000	.2807E+03	.7509E+01	.1232E+00	.1260E+04	.1004E+04	.6280E+03	.4701E+03	.6760E+02	.8766E+02	D10065.BIS
2.00	0.571	0.000	.1498E+03	.3890E+01	.7606E+01	.2780E+04	.3420E+04	.5675E+03	.1659E+04	.1062E+03	.3169E+03	D10065.BIS
3.00	0.666	0.000	.1087E+03	-.1285E+01	.5609E+01	.2200E+04	.2331E+04	.4200E+03	.1158E+04	.1216E+03	.2984E+03	D10065.BIS
0.20	0.401	0.200	.3215E+03	-.8652E+00	.5219E+01	.5450E+01	.1528E+03	.5180E+01	-.1443E+02	-.1130E+01	-.1623E+02	D10075.BIS
1.00	0.476	0.214	.2588E+03	.1686E+01	.8681E+01	.1630E+04	.1187E+04	.6041E+03	.7209E+03	.3227E+02	.1246E+03	D10075.BIS
2.00	0.571	0.232	.1767E+03	.1089E+02	.6987E+01	.2200E+04	.1404E+04	.6033E+03	.9179E+03	-.6668E+02	.7562E+02	D10075.BIS
3.00	0.666	0.250	.1407E+03	.4112E+01	.6096E+01	.2350E+04	.2540E+04	.4907E+03	.1160E+04	-.1820E+02	.2528E+03	D10075.BIS
0.20	0.401	0.600	.3220E+03	.1292E-01	-.2581E+01	.9448E+01	.2756E+02	.1290E+02	-.4081E+01	-.5959E+01	-.8094E+01	D10095.BIS
1.00	0.476	0.642	.2948E+03	.2895E+01	-.2431E+00	.8240E+03	.7574E+03	.4660E+03	.3530E+03	.9921E+02	.3481E+02	D10095.BIS
2.00	0.571	0.696	.1694E+03	.1564E+01	.1044E+02	.2430E+04	.3385E+04	.6289E+03	.1279E+04	.2227E+03	.4088E+03	D10095.BIS
3.00	0.666	0.750	.1198E+03	-.3469E+01	.8520E+01	.2260E+04	.2358E+04	.4589E+03	.1079E+04	.2357E+03	.2849E+03	D10095.BIS
0.20	0.400	1.000	.3156E+03	.6095E+01	.1087E+01	.2970E+03	.4286E+03	.2050E+03	-.7498E+02	.7447E+02	-.3854E+02	D10115.BIS
1.00	0.476	1.071	.1289E+03	.6441E+00	.1443E+02	.2170E+04	.1957E+04	.6277E+03	.7485E+03	.6228E+03	.3064E+03	D10115.BIS

**TABLE 6**  
**1x2 Ratio Nozzle Mach# = 0.09 Initial Conditions WfV Data**

X	Y	Z	$\bar{u}$	$\bar{v}$	$\bar{w}$	$\overline{u^2}$	$\overline{v^2}$	$\overline{w^2}$	$\overline{uv}$	$\overline{uw}$	$\overline{vw}$	File Name
inch	inch	inch	m/s	m/s	m/s	m <sup>2</sup> /s <sup>2</sup>	m <sup>2</sup> /s <sup>2</sup>	m <sup>2</sup> /s <sup>2</sup>	m <sup>2</sup> /s <sup>2</sup>	m <sup>2</sup> /s <sup>2</sup>	m <sup>2</sup> /s <sup>2</sup>	
0.20	0.480	0.970	.5841E+01	.1406E+00	.1330E+00	.1632E+01	.1195E+01	.4409E+00	-.4954E+00	-.5422E-01	-.1979E+00	C11118.BIS
0.20	0.470	0.950	.1196E+02	.1201E+01	-.3439E+00	.4103E+01	.2291E+01	.6962E+00	-.5790E+00	.6016E-01	.1110E+00	C11118.BIS
0.20	0.460	0.930	.2352E+02	-.3613E+01	.7490E+00	.5287E+01	.2471E+01	.6639E+00	-.1148E+01	.4050E+00	.1272E+00	C11118.BIS
0.20	0.450	0.910	.2047E+02	-.3235E+01	.7483E+00	.6536E+01	.3301E+01	.9794E+00	-.5027E+00	-.1924E-01	.8849E+00	C11118.BIS
0.20	0.440	0.890	.2167E+02	-.3287E+00	.1504E+00	.4079E+01	.3600E+01	.2028E+00	.2106E-01	.2032E+00	.1599E+00	C11118.BIS
0.20	0.430	0.870	.2979E+02	.4731E+00	-.4511E+00	.3125E+00	.3125E+00	.1468E+00	-.4500E-01	-.1023E-01	-.7928E-01	C11118.BIS
0.20	0.420	0.850	.3020E+02	.3399E+00	-.3621E+00	.9865E-01	.3823E+00	.1222E+00	.8197E-01	-.3921E-01	-.9897E-01	C11118.BIS
0.20	0.410	0.830	.3003E+02	.4317E+00	-.2916E+00	.1394E+00	.5131E+00	.1372E+00	.1306E+00	-.4178E-01	-.1146E+00	C11118.BIS
0.20	0.000	0.999	.6825E+01	-.5110E-01	.5768E+00	.2070E+01	.1597E+01	.1502E+01	.4800E+00	.8488E+00	-.2159E+00	E06118.BIS
0.20	0.000	1.010	.1591E+01	-.1367E+01	-.2369E-01	.8478E+00	.1300E+01	.1226E+01	.1140E+00	.6968E-01	-.2880E+00	E06118.BIS
0.20	0.000	1.020	.1346E+01	-.1506E+01	.6829E-02	.4699E+00	.1301E+01	.4808E+00	.2503E+00	-.6455E-02	-.3567E+00	E06118.BIS
0.20	0.000	1.030	.1265E+01	-.1593E+01	-.1052E-02	.2189E+00	.8572E+00	.1860E+00	.1659E+00	-.1415E-01	-.2179E+00	E06118.BIS
0.20	0.400	0.999	.6146E+01	.9342E+00	.1589E+00	.1309E+01	.2113E+01	.3228E+00	.5066E+00	.1898E+00	-.3823E+00	E10118.BIS
0.20	0.400	1.010	.1845E+01	-.1692E+01	.8270E-01	.3693E+00	.8279E+00	.2450E+00	.1892E+00	-.1031E+00	-.1709E+00	E10118.BIS
0.20	0.400	1.020	.1412E+01	-.2095E+01	.1994E-01	.3740E+00	.1052E+01	.1880E+00	.2151E+00	-.1314E+00	-.2518E+00	E10118.BIS
0.20	0.470	-0.001	.2993E+02	.7423E+00	.2029E-02	.2051E+00	.3482E+00	.9383E-01	.5952E-01	-.3250E-01	-.7739E-01	E11068.BIS
0.20	0.479	-0.001	.2844E+02	.1738E+01	-.5290E+00	.5628E+00	.3361E+00	.4267E+00	-.8803E-01	.9844E-01	.9387E-01	E11068.BIS
0.20	0.489	-0.001	.2171E+02	.5026E+01	-.2238E+01	.4278E+01	.4951E+01	.4038E+01	-.2446E+01	.7142E+00	.2783E+01	E11068.BIS
0.20	0.500	-0.001	.9920E+01	.3693E+01	-.1343E+01	.3692E+01	.4999E+01	.3513E+01	-.6577E+00	-.1208E+00	-.1540E+01	E11068.BIS
0.20	0.509	-0.001	.3496E+01	-.5551E+00	.9852E-01	.9282E+00	.2014E+01	.3558E+00	.2271E+00	.4702E-01	-.6025E+00	E11068.BIS
0.20	0.520	-0.001	.1340E+01	-.1081E+01	.1907E+00	.3095E+00	.8556E+00	.1692E+00	.2164E+00	-.3913E-01	-.1763E+00	E11068.BIS
0.20	0.530	-0.001	.1264E+01	-.1234E+01	.1827E+00	.1976E+00	.1301E+01	.1672E+00	.2528E+00	-.1114E-01	-.2627E+00	E11068.BIS
0.20	0.490	0.800	.2523E+02	.4069E+01	-.9896E+00	.2944E+01	.3950E+01	.2478E+01	-.1939E+01	.3931E+00	.2073E+01	E11108.BIS
0.20	0.500	0.800	.1456E+02	.7441E+01	-.1705E+01	.6020E+01	.6512E+01	.5894E+01	-.2613E+01	-.9959E+00	.3583E+01	E11108.BIS
0.20	0.509	0.800	.5839E+01	.1210E+01	-.1127E+00	.2560E+01	.3733E+01	.1780E+01	-.8909E+00	.4768E+00	-.2044E+01	E11108.BIS
0.20	0.520	0.800	.1479E+01	-.1021E+01	.1979E+00	.3349E+00	.8263E+00	.1597E+00	.1406E+00	-.5078E-01	-.2187E+00	E11108.BIS
0.20	0.530	0.800	.1141E+01	-.1194E+01	.2282E+00	.2569E+00	.8087E+00	.1596E+00	.1569E+00	-.2143E-01	-.2033E+00	E11108.BIS
0.20	0.500	0.999	.9305E+00	-.1645E+01	.7848E+00	.8803E-01	.1454E+01	.1503E+00	.2130E+00	-.8732E-02	-.2746E+00	E11118.BIS
0.20	0.489	0.990	.1112E+01	-.1440E+01	.8579E+00	.1265E+00	.1399E+01	.1538E+00	.1962E+00	.6622E-02	-.2811E+00	E11118.BIS
0.20	0.471	0.990	.4698E+01	-.4935E+00	.8569E+00	.1247E+01	.1052E+01	.2926E+00	-.2050E+00	.1314E+00	-.3958E+00	E11118.BIS
0.20	0.450	0.990	.5737E+01	-.1280E+01	.8761E+00	.1785E+01	.1082E+01	.2086E+00	.1780E+00	.3768E+00	-.1222E+00	E11118.BIS
0.20	0.429	0.990	.8632E+01	.2568E+01	-.2764E+00	.3033E+01	.5701E+01	.6012E+00	.1027E+01	-.2257E+00	-.1333E+01	E11118.BIS
0.20	0.410	0.990	.1564E+02	.2399E+01	-.2567E+00	.3934E+01	.3264E+01	.9050E+00	-.1080E+00	.1368E+00	-.6998E+00	E11118.BIS
0.20	0.490	0.970	.3216E+01	-.6114E+00	.4229E+00	.1293E+01	.1524E+01	.3412E+00	.1535E+00	-.1837E+00	-.2713E+00	E11118.BIS
0.20	0.490	0.950	.6830E+01	-.2432E+00	.5475E+00	.3893E+01	.2036E+01	.6223E+00	.1533E+00	.7110E+00	-.1341E+00	E11118.BIS
0.20	0.490	0.930	.1633E+02	.6717E+01	-.1042E+01	.1088E+02	.8000E+01	.5652E+01	-.4467E+01	-.4284E-01	.1931E+01	E11118.BIS
0.20	0.490	0.910	.2213E+02	.6120E+01	-.9133E+00	.5160E+01	.6147E+01	.4127E+01	-.3886E+01	.2156E+00	.2241E+01	E11118.BIS
0.20	0.490	0.890	.2620E+02	.3774E+01	-.1772E+00	.2161E+01	.1976E+01	.1818E+01	-.1153E+01	.2336E+00	.8325E+00	E11118.BIS
0.20	0.490	0.870	.2609E+02	.3896E+01	-.4279E+00	.2565E+01	.2332E+01	.2126E+01	-.1353E+01	.3382E+00	.1043E+01	E11118.BIS
0.20	0.490	0.850	.2660E+02	.3556E+01	-.3953E+00	.2608E+01	.2073E+01	.1871E+01	-.1407E+01	.4570E+00	.6120E+00	E11118.BIS
0.20	0.490	0.830	.2701E+02	.3171E+01	-.4040E+00	.2338E+01	.1883E+01	.1601E+01	-.1228E+01	.3069E+00	.6267E+00	E11118.BIS
0.20	0.490	0.810	.2716E+02	.3133E+01	-.4675E+00	.1779E+01	.1898E+01	.1255E+01	-.1086E+01	.1478E+00	.9136E+00	E11118.BIS

**TABLE 7**  
**1x4 Ratio Nozzle Mach# = 0.09 Initial Conditions WFv Data**

X	Y	Z	$\bar{U}$	$\bar{V}$	$\bar{W}$	$\overline{uu}$	$\overline{vv}$	$\overline{ww}$	$\overline{uv}$	$\overline{vw}$	File Name
inch	inch	inch	m/s	m/s	m/s	m <sup>2</sup> /s <sup>2</sup>	m <sup>2</sup> /s <sup>2</sup>	m <sup>2</sup> /s <sup>2</sup>	m <sup>2</sup> /s <sup>2</sup>	m <sup>2</sup> /s <sup>2</sup>	
0.20	0.000	1.020	.5652E+00	-.3204E+00	-.2000E+00	.3520E+00	.1591E+00	.4945E-01	-.5747E-01	-.5797E-02	I0612C.BIS
0.20	0.000	1.010	.2473E+01	-.3810E+00	-.1578E+00	.6520E+00	.1965E+00	.7370E-01	-.3844E-01	.2249E-01	I0612C.BIS
0.20	0.000	1.000	.1298E+02	-.3296E+00	.1730E-01	.1290E+01	.2332E+00	.3662E-01	-.1385E-01	.4849E-01	I0612C.BIS
0.20	0.000	0.990	.2580E+02	-.3200E+00	.1490E+00	.1510E+01	.1532E+00	.6568E-01	-.3293E-01	.7216E-01	I0612C.BIS
0.20	0.000	0.980	.3037E+02	-.4719E+00	.1730E+00	.3240E+00	.1769E+00	.7227E-01	-.1719E-01	.2474E-01	I0612C.BIS
0.20	0.200	1.020	.4863E+00	-.2177E+00	-.2980E+00	.3600E+00	.2482E+00	.5640E-01	-.4775E-01	.1511E-01	I1012C.BIS
0.20	0.200	1.010	.1812E+01	-.2779E+00	-.1704E+00	.3510E+01	.2962E+00	.5025E-01	-.3726E+00	.1865E+00	I1012C.BIS
0.20	0.200	1.000	.1009E+02	-.6891E+00	.4513E-01	.1140E+02	.4880E+00	.3675E-01	-.4983E+00	.3862E+00	I1012C.BIS
0.20	0.200	0.989	.1823E+02	-.8944E+00	.7378E-01	.1960E+02	.3506E+00	.7372E-01	-.6239E+00	.6887E+00	I1012C.BIS
0.20	0.200	0.980	.2419E+02	-.1005E+01	.9632E-01	.1500E+02	.2721E+00	.9263E-01	-.3287E+00	.5418E+00	I1012C.BIS
0.20	0.200	0.970	.2577E+02	-.5239E+00	.1455E+00	.2140E+01	.2841E+00	.9151E-01	-.9948E-01	.9744E-01	I1012C.BIS
0.20	0.200	0.960	.2241E+02	-.8137E-01	.6463E-01	.3360E+01	.3252E+00	.6511E-01	-.2824E+00	.8548E-01	I1012C.BIS
0.20	0.200	0.950	.1997E+02	.1228E+00	-.6190E-01	.4670E+01	.3483E+00	.5390E-01	-.1219E+00	.1797E+00	I1012C.BIS
0.20	0.200	0.940	.2370E+02	.3757E-01	-.1078E+00	.1470E+02	.3480E+00	.6866E-01	-.3103E+00	.4315E+00	I1012C.BIS
0.20	0.200	0.930	.2893E+02	-.9436E-01	-.7685E-01	.6540E+01	.3725E+00	.8341E-01	-.8806E-01	.3124E+00	I1012C.BIS
0.20	0.200	0.930	.2865E+02	-.1110E+00	-.8638E-01	.7390E+01	.1439E+00	.7699E-01	-.9086E-01	.3329E+00	I1012C.BIS
0.20	0.200	0.920	.3046E+02	-.1782E+00	-.1414E-01	.1590E+01	.1623E+00	.9297E-01	-.6637E-01	.1325E+00	I1012C.BIS
0.20	0.200	0.910	.3099E+02	-.2382E+00	.8591E-01	.3120E+00	.1492E+00	.1058E+00	-.1192E-01	.1751E-01	I1012C.BIS
0.20	0.260	0.000	.1036E+01	-.3383E+00	-.3857E+00	.7810E+00	.2091E+00	.8607E-01	-.5117E-01	.1634E-01	I1206C.BIS
0.20	0.250	0.000	.1051E+02	-.2586E+00	-.1748E+00	.2690E+02	.7012E+00	.7900E-01	-.1608E+00	.3408E+00	I1206C.BIS
0.20	0.240	0.000	.1422E+02	-.1715E+00	-.5084E-01	.2490E+02	.4698E+00	.1133E+00	.4071E+00	-.8847E-01	I1206C.BIS
0.20	0.229	0.000	.2613E+02	-.1101E+00	-.1313E+00	.1420E+02	.4534E+00	.3060E+00	.4259E+00	-.4076E+00	I1206C.BIS
0.20	0.220	0.000	.2866E+02	-.2591E+00	.1930E+00	.1120E+02	.7498E+00	.6622E+00	.5852E+00	-.4864E+00	I1206C.BIS
0.20	0.210	0.000	.3054E+02	-.2457E+00	-.2494E-01	.1970E+01	.7502E+00	.5071E+00	.1968E+00	-.1777E+00	I1206C.BIS
0.20	0.201	0.000	.3089E+02	-.1887E+00	.3049E+00	.1060E+01	.9689E+00	.1012E+01	.1635E+00	-.1458E+00	I1206C.BIS
0.20	0.249	0.000	.8039E+01	-.2660E+00	-.2308E+00	.2150E+02	.2145E+00	.1085E+00	.2301E+00	.3760E+00	I1206C.BIS
0.20	0.260	0.000	.9918E+00	-.3525E+00	-.3815E+00	.8690E+00	.1963E+00	.1255E+00	.2884E-01	.1161E-02	I1206C.BIS
0.20	0.260	0.800	.6665E+00	-.3408E+00	-.4686E+00	.6080E+00	.1945E+00	.1198E+00	-.5075E-01	.3365E-02	I1210C.BIS
0.20	0.250	0.800	.2140E+01	-.3976E+00	-.2976E+00	.2040E+01	.1766E+00	.9153E-01	-.1026E+00	.8908E-01	I1210C.BIS
0.20	0.240	0.800	.1044E+02	-.3038E+00	.4451E+00	.7830E+01	.2809E+00	.4951E-01	-.1051E+00	.3270E+00	I1210C.BIS
0.20	0.230	0.800	.2321E+02	-.1922E+00	.1014E+01	.8000E+01	.1651E+00	.7869E-01	-.2468E-01	.2234E+00	I1210C.BIS
0.20	0.220	0.800	.2927E+02	-.2078E+00	.8861E+00	.1340E+01	.1632E+00	.1121E+00	.8384E-02	.3668E-01	I1210C.BIS
0.20	0.210	0.800	.3083E+02	-.2765E+00	.7243E+00	.2830E+00	.1538E+00	.1393E+00	-.3712E-02	.2611E-01	I1210C.BIS
0.20	0.250	0.990	.5791E+00	-.1238E+00	-.6402E+00	.3530E+00	.4372E+00	.2714E+00	-.2654E-01	-.2708E-01	I1212C.BIS
0.20	0.240	0.990	.1582E+01	-.1431E+00	-.5311E+00	.1550E+01	.3564E+00	.1482E+00	.7560E-01	-.1043E+00	I1212C.BIS
0.20	0.230	0.990	.8087E+01	-.5311E+00	.8361E-01	.7390E+01	.6150E+00	.5685E-01	-.2418E+00	.1891E+00	I1212C.BIS
0.20	0.220	0.990	.1459E+02	-.8745E+00	.5672E+00	.1010E+02	.5434E+00	.8060E-01	-.2625E+00	.5627E+00	I1212C.BIS
0.20	0.210	0.990	.2242E+02	-.1166E+01	.8869E+00	.1030E+02	.7145E+00	.8604E-01	-.1121E+00	.5842E+00	I1212C.BIS
0.20	0.240	0.980	.3684E+01	-.2858E+00	-.3938E+00	.4420E+01	.2530E+00	.1179E+00	-.1687E+00	.2209E+00	I1212C.BIS
0.20	0.240	0.960	.9119E+01	-.3177E+00	.2439E+00	.4890E+01	.3794E+00	.5471E-01	-.7779E-01	.2337E+00	I1212C.BIS
0.20	0.240	0.940	.1070E+02	-.2480E+00	.5365E+00	.6420E+01	.4095E+00	.5822E-01	.3587E-01	.3131E+00	I1212C.BIS
0.20	0.240	0.920	.1019E+02	-.2691E+00	.6123E+00	.6130E+01	.4975E+00	.4982E-01	-.1183E+00	.2891E+00	I1212C.BIS
0.20	0.240	0.880	.9379E+01	-.3376E+00	.5228E+00	.5320E+01	.3926E+00	.4547E-01	-.4010E-01	.2427E+00	I1212C.BIS
0.20	0.240	0.840	.9490E+01	-.3550E+00	.5552E+00	.5780E+01	.4414E+00	.4357E-01	-.8620E-01	.2347E+00	I1212C.BIS
0.20	0.230	0.980	.1206E+02	-.5599E+00	.4575E+00	.9350E+01	.1939E+00	.7323E-01	-.1477E+00	.4950E+00	I1212C.BIS
0.20	0.220	0.960	.2813E+02	-.1760E+00	.1168E+01	.1240E+01	.1984E+00	.8726E-01	.2953E-01	-.1752E-01	I1212C.BIS
0.20	0.210	0.940	.2909E+02	-.5159E-01	.5329E+00	.4310E+01	.2819E+00	.1240E+00	-.1493E+00	.3120E+00	I1212C.BIS
0.20	0.210	0.930	.3006E+02	-.9081E-01	.4848E+00	.1420E+01	.1758E+00	.1426E+00	-.9601E-01	.1381E+00	I1212C.BIS
0.20	0.210	0.920	.3046E+02	-.1634E+00	.5128E+00	.6460E+00	.2226E+00	.1512E+00	-.2966E-01	.4633E-01	I1212C.BIS
0.20	0.210	0.910	.3052E+02	-.1650E+00	.5888E+00	.4190E+00	.2018E+00	.1598E+00	-.1985E-01	.1530E-03	I1212C.BIS

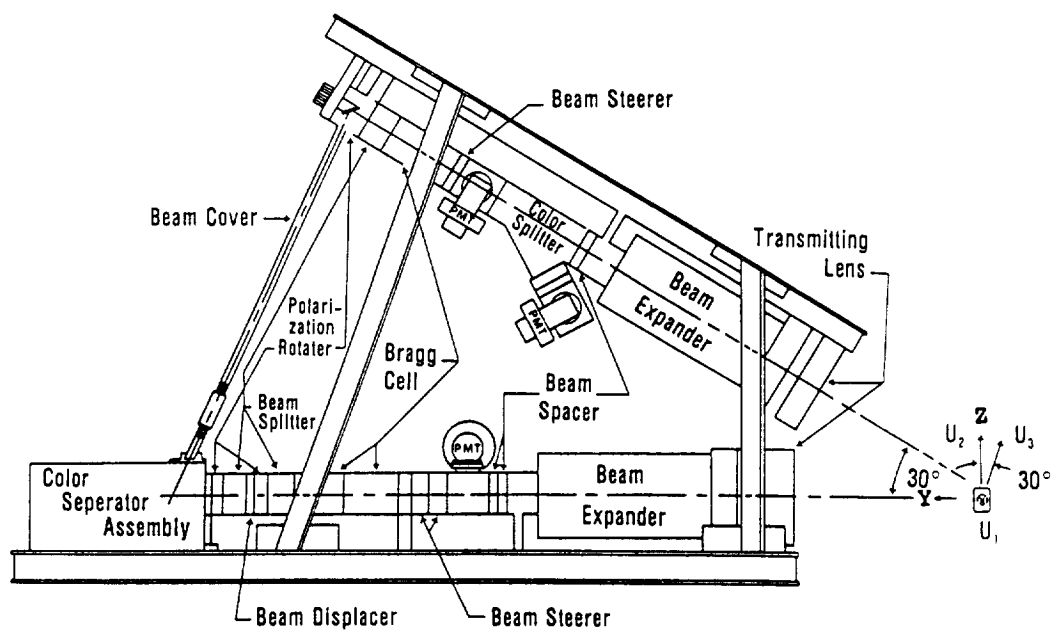

**Figure 1**  
**Three Dimensional Laser Doppler Anemometer System**

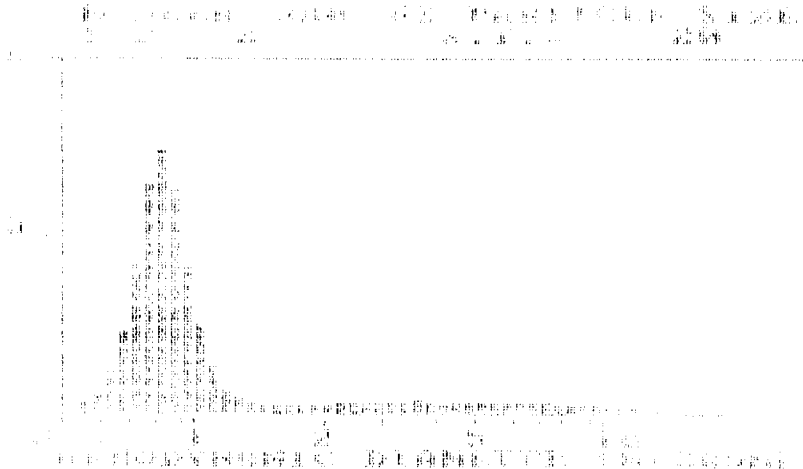

TiO<sub>2</sub> Measured Size Distribution (Aerodynamic Size)  
Measurement made at the 1x2 nozzle exit, U<sub>e</sub> = 30 m/s

Frequency Response Calculation for TiO<sub>2</sub>

The following text and equations are from reference 8.  
The particle velocity at any time t, after a step change in fluid velocity is given by the following equation where  $\rho_g \ll \rho_p$  :

$$\frac{V_g - V_p}{V_{gi} - V_{pi}} = e^{-t/\tau}$$

Where:

V<sub>g</sub> = gas velocity after the step change

V<sub>p</sub> = particle velocity at time t

V<sub>gi</sub> and V<sub>pi</sub> = gas and particle velocity before the step change

and

$$\tau = \frac{\rho_p d_p^2}{18\mu} = \text{relaxation time of the particle}$$

The particle physical diameter (d<sub>p</sub>) is related to the aerodynamic diameter (d<sub>pa</sub>) and specific gravity (SG) by  $d_p = d_{pa}/(SG)^{1/2}$ . The frequency response can be calculated from  $\tau$  as follows:

$$f = \frac{1}{2\pi\tau} \left[ \frac{1}{A_r^2} - 1 \right]^{1/2}$$

Where A<sub>r</sub> = particle oscillation amplitude divided by fluid oscillation amplitude. For A<sub>r</sub> = 0.707 (3 db point)

$$f = \frac{1}{2\pi\tau}$$

The frequency response of TiO<sub>2</sub> SG = 41, with a d<sub>pa</sub> of 0.8 μm is 81 kHz.

Figure 2

TiO<sub>2</sub> Measured Size Distribution

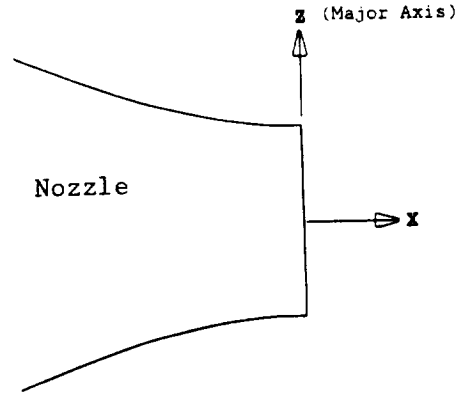

Side View

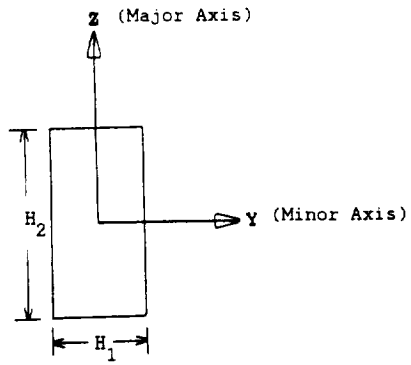

End View

Figure 3  
Rectangular Jet Coordinate System



The outline below represents a cross section of the jet. Each file name represents a string of data in the axial direction. The file name is made up of a letter, four numbers and a three letter extension. The first letter is a D or M. The following two numbers represent the horizontal position of the string, the next two the vertical position. The file extension is used for identification in data processing.  
**Example** - File D0810B is marked with a \*.

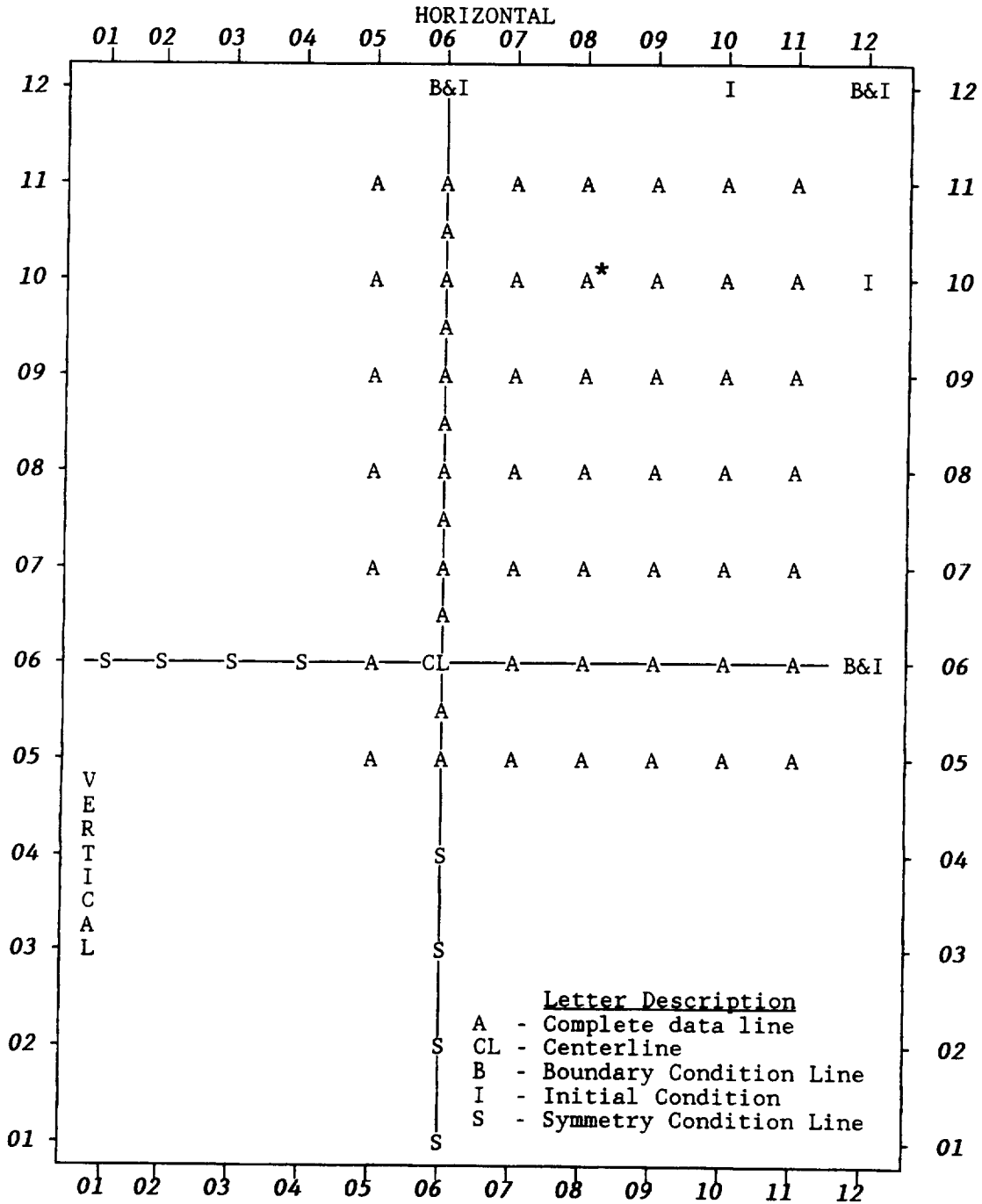

**Figure 4**  
 Rectangular Jet File Coordinate System

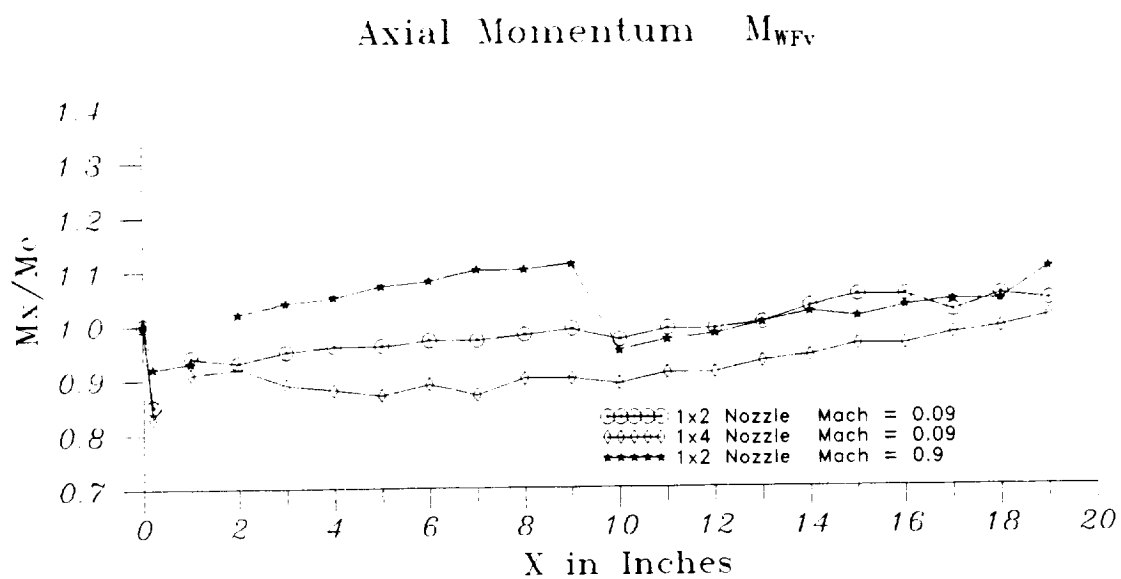
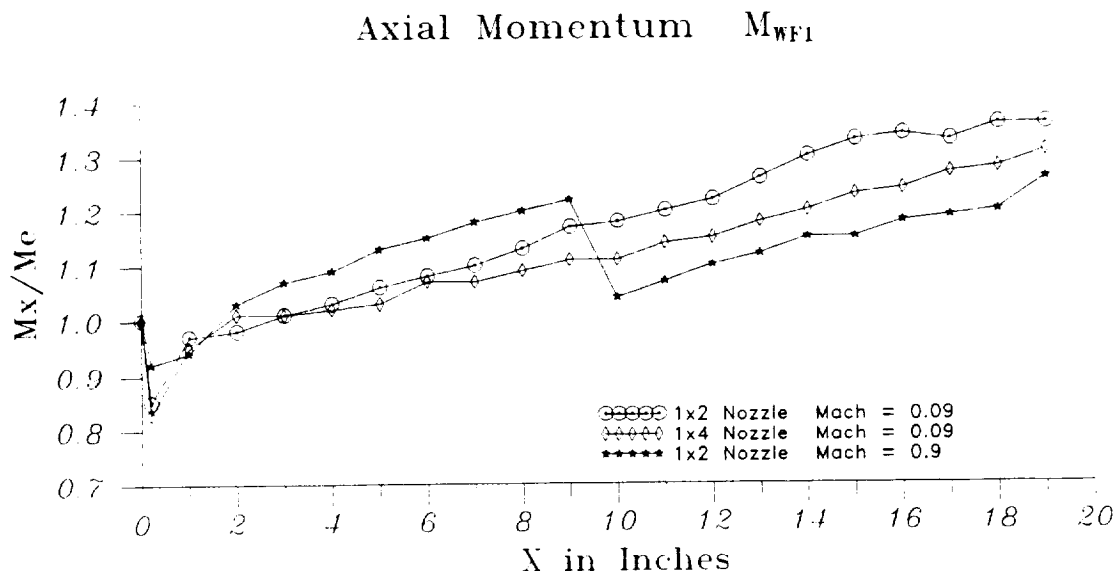

Fig. 5 Rectangular Jet Axial Momentum

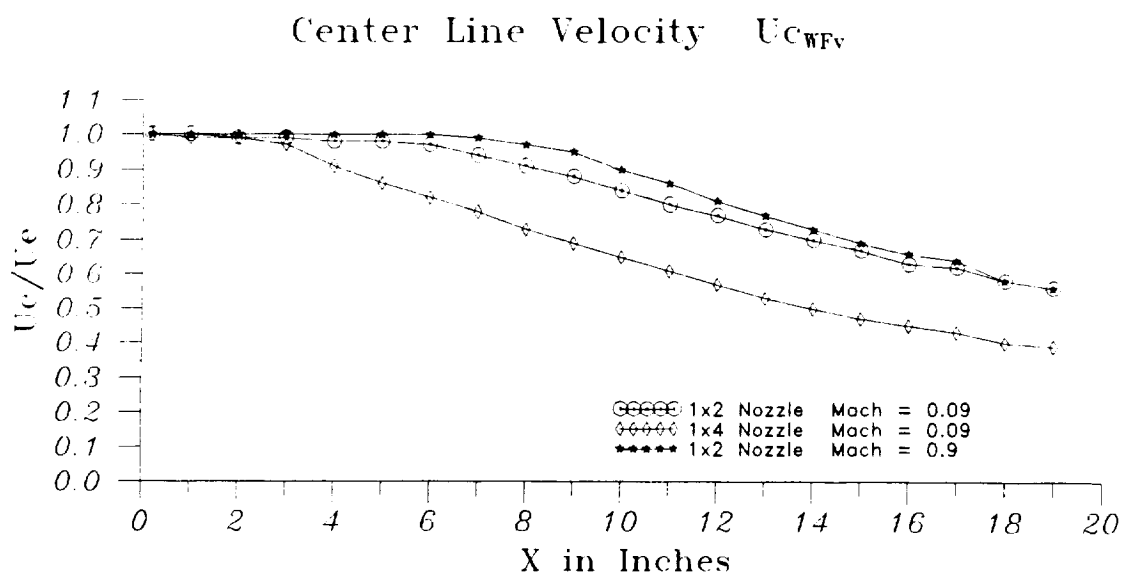
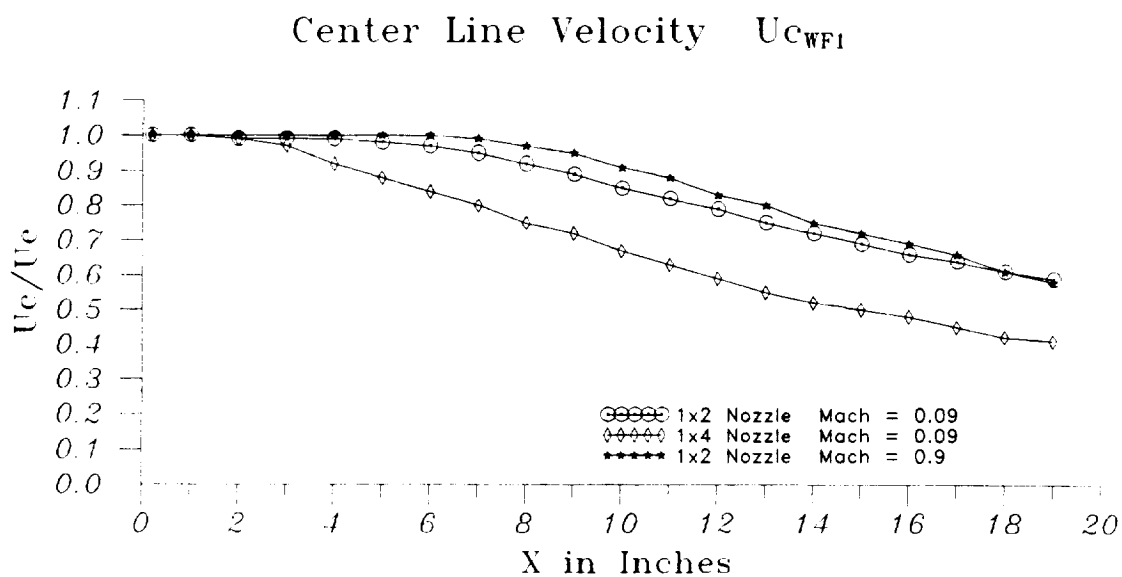

Fig. 6 Rectangular Jet Centerline Velocity

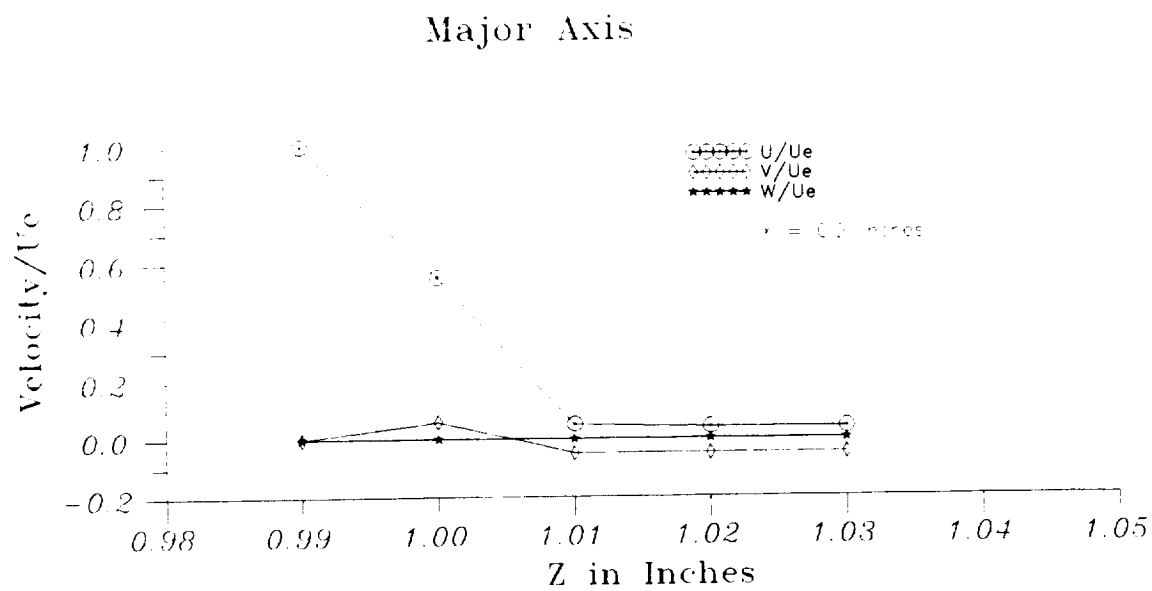
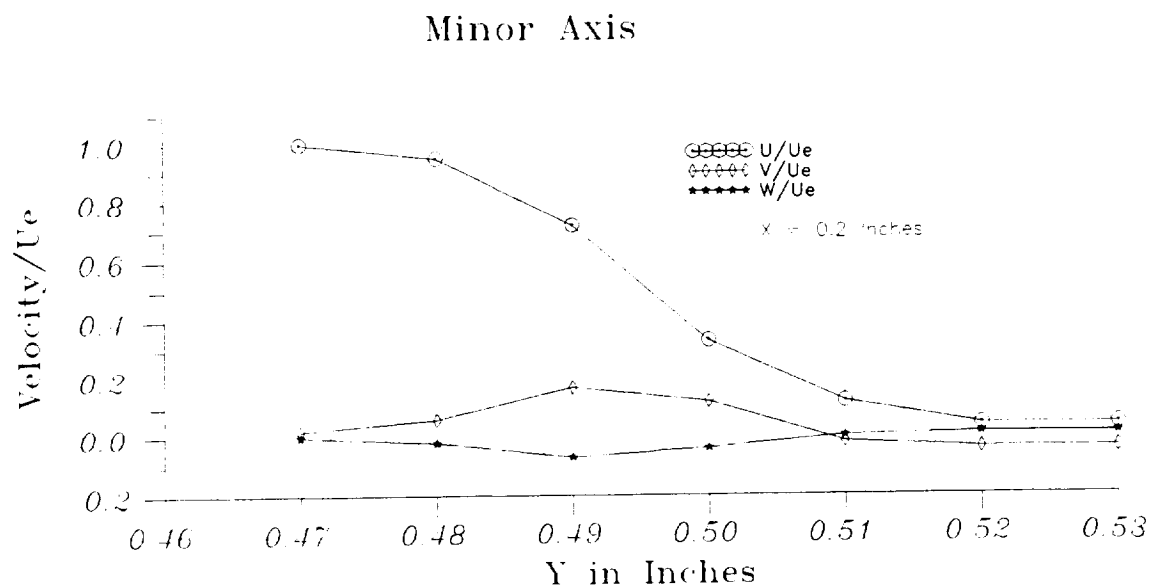
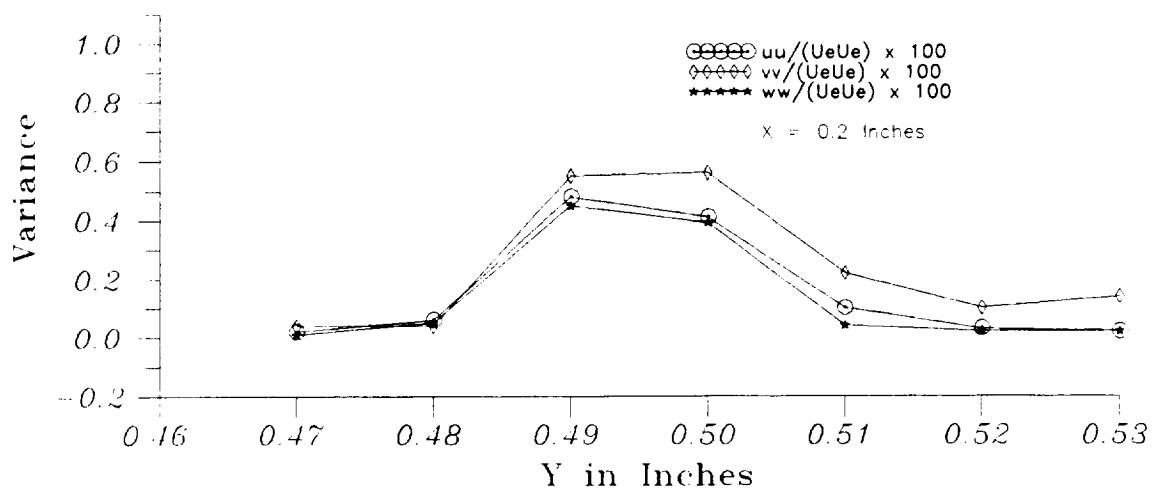

Fig. 7 1x2 Nozzle M=0.09 Initial Conditions  
Mean Velocity

## Minor Axis



## Major Axis

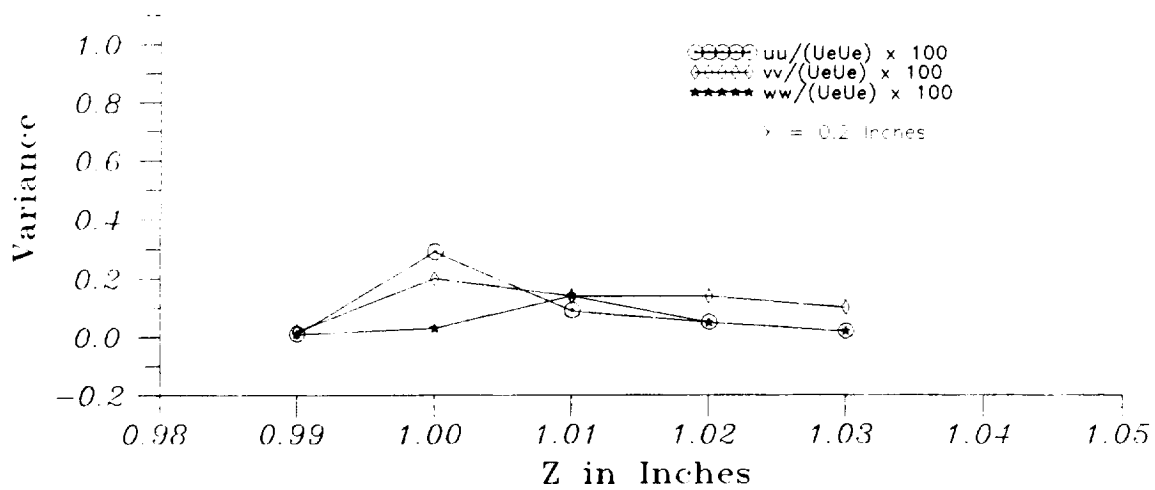

Fig. 10 1x2 Nozzle  $M=0.09$  Initial Conditions  
Velocity Variance

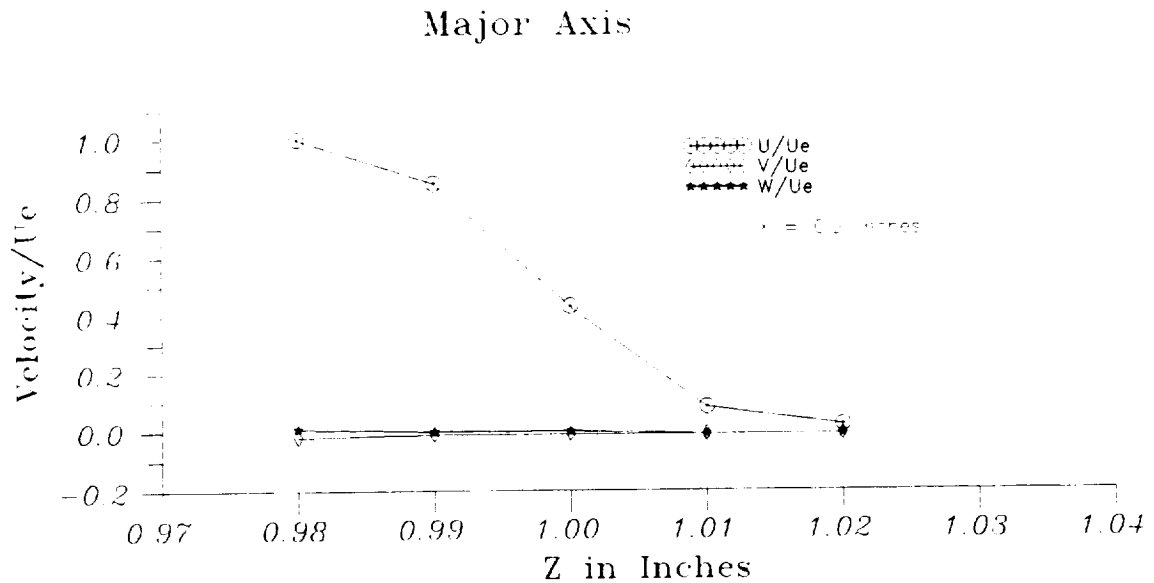
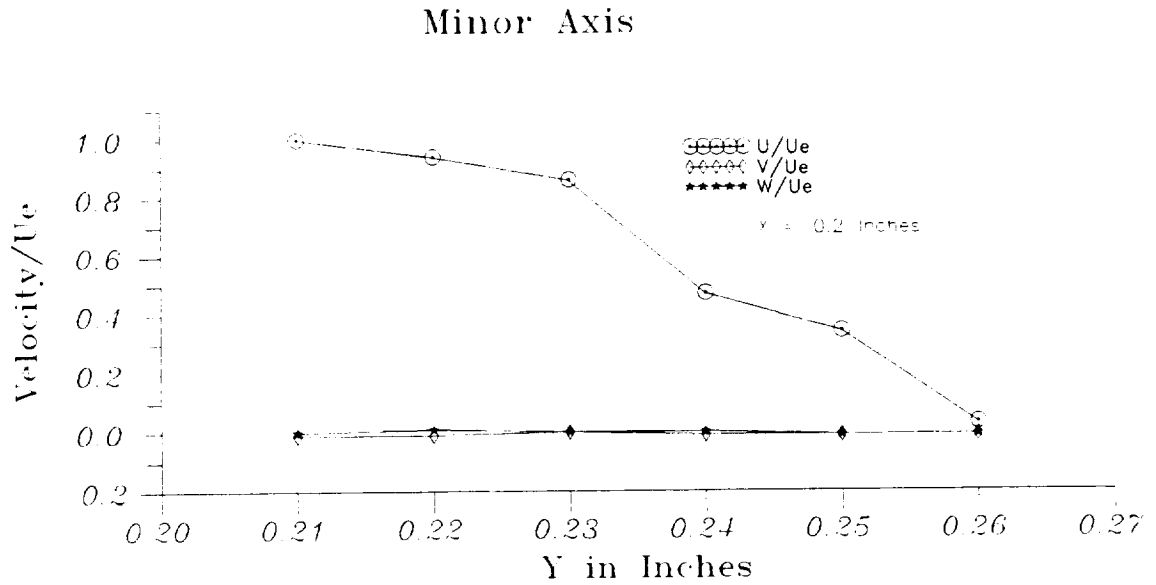

Fig. 9 1x4 Nozzle  $M=0.09$  Initial Conditions  
Mean Velocity

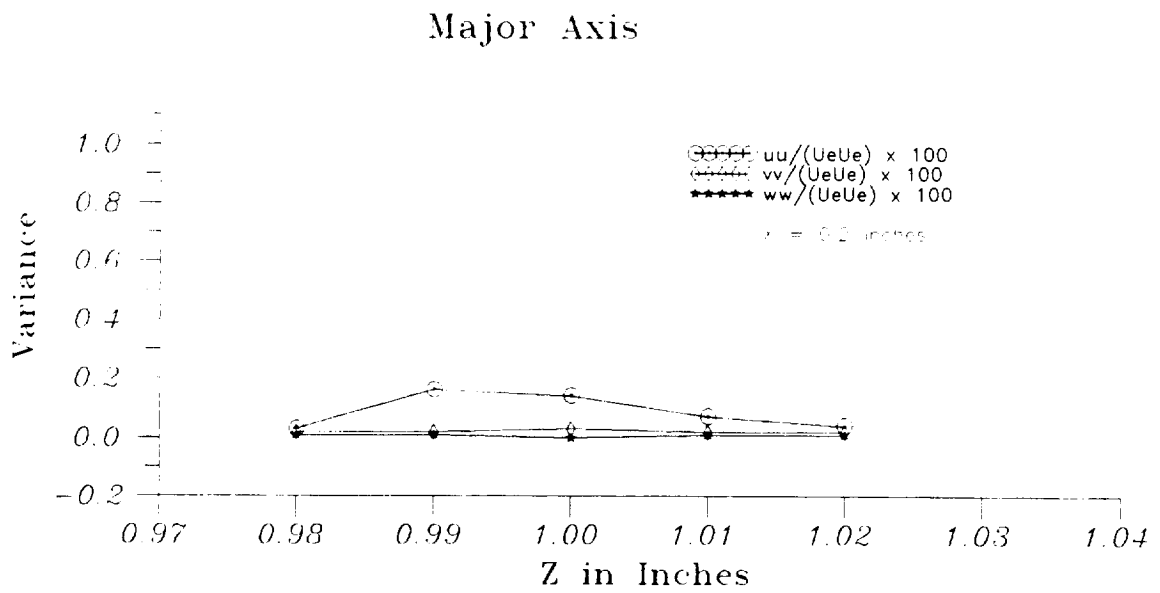
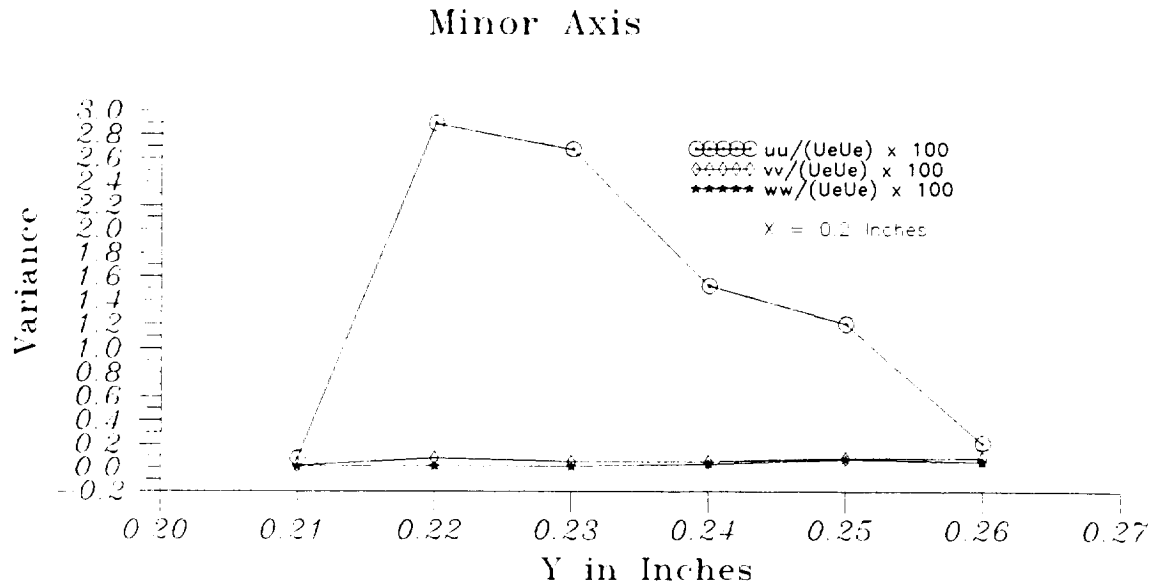
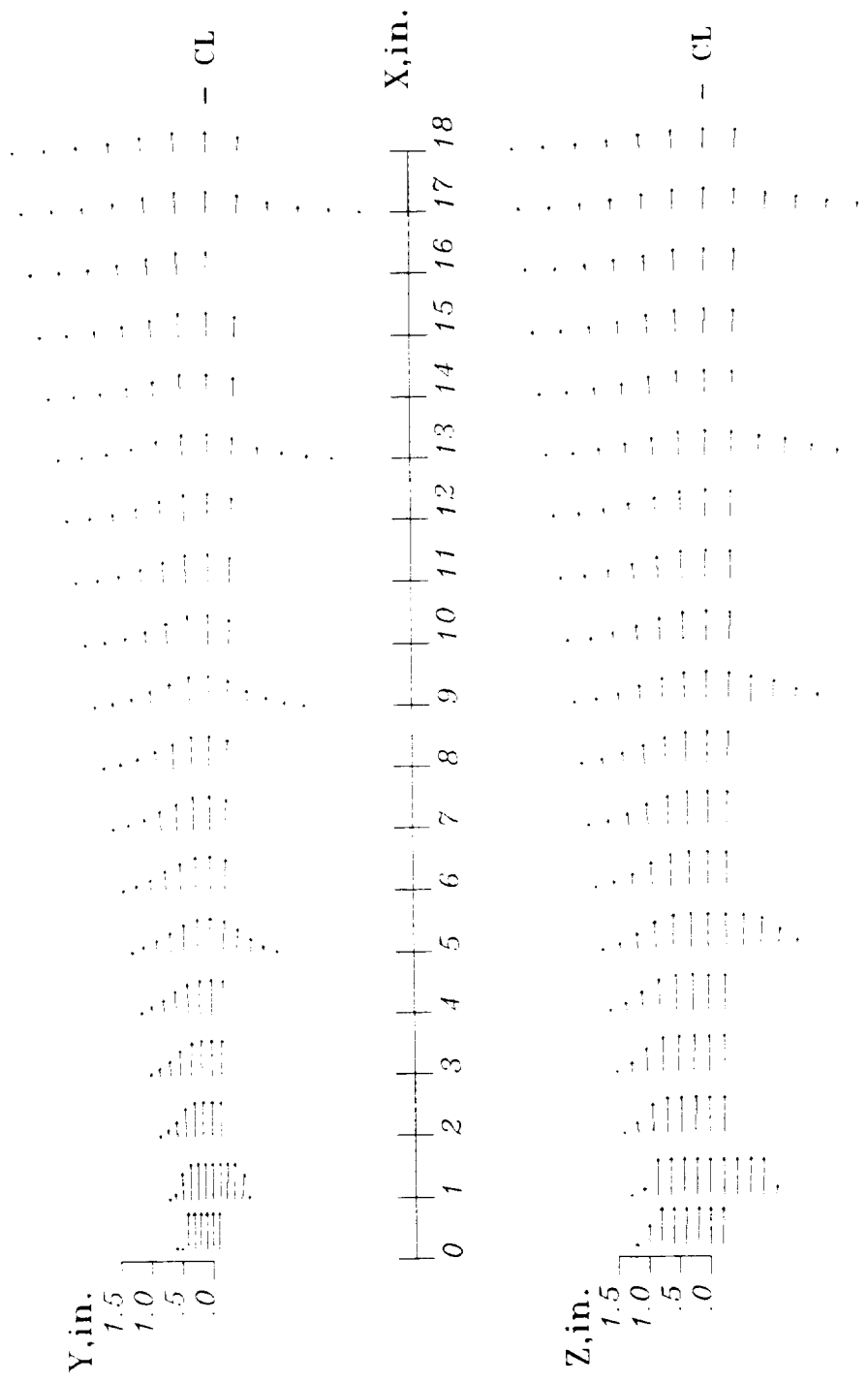

Fig. 10 1x4 Nozzle  $M=0.09$  Initial Conditions  
Velocity Variance



Spatial Scale 1 to 3 Vector Scale  $U_e = \dots$   
 Fig. 11 1x2 Nozzle  $M=0.09$  Velocity Vectors



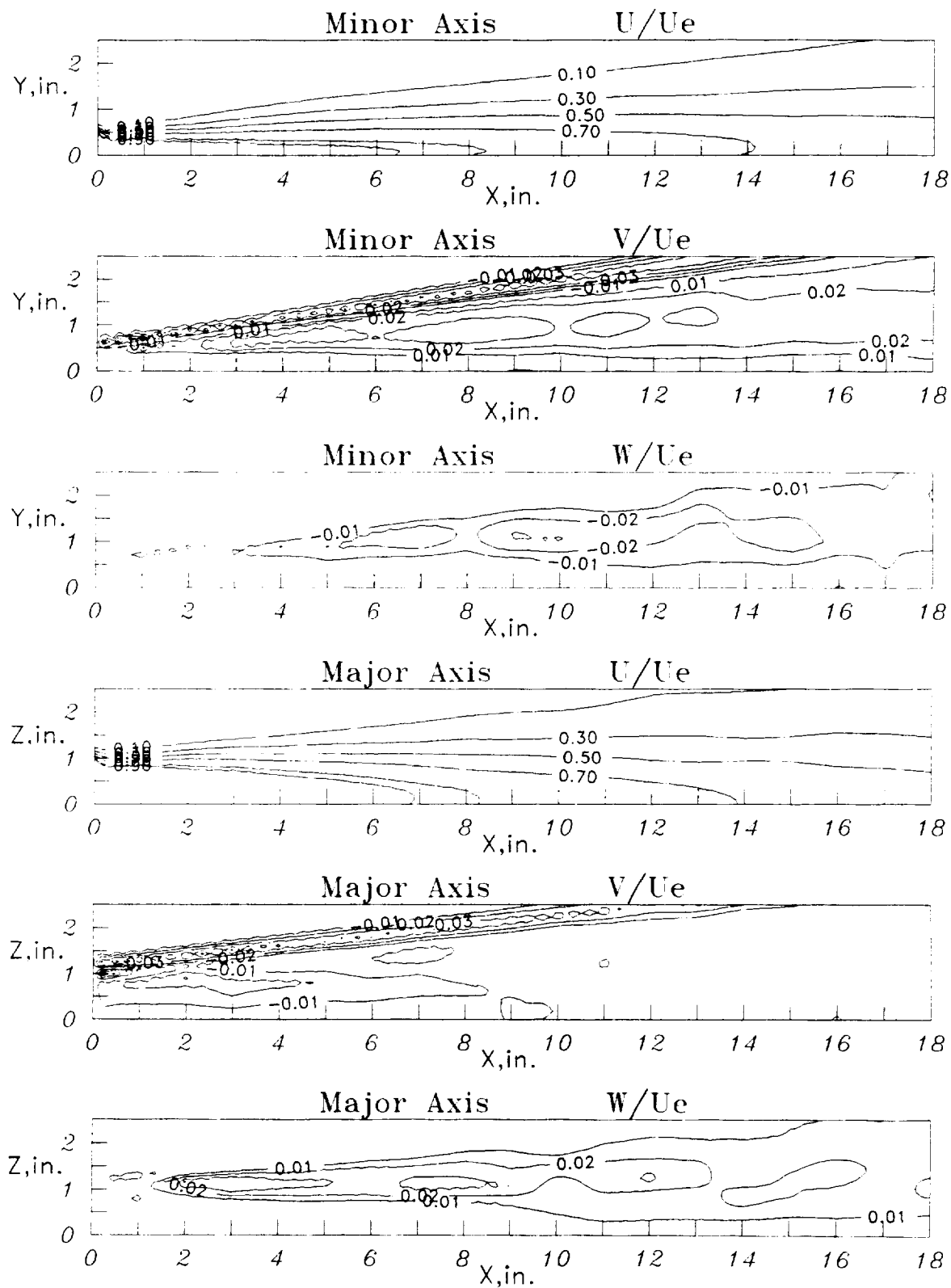

Fig. 12 1x2 Nozzle  $M=0.09$  Mean Velocity

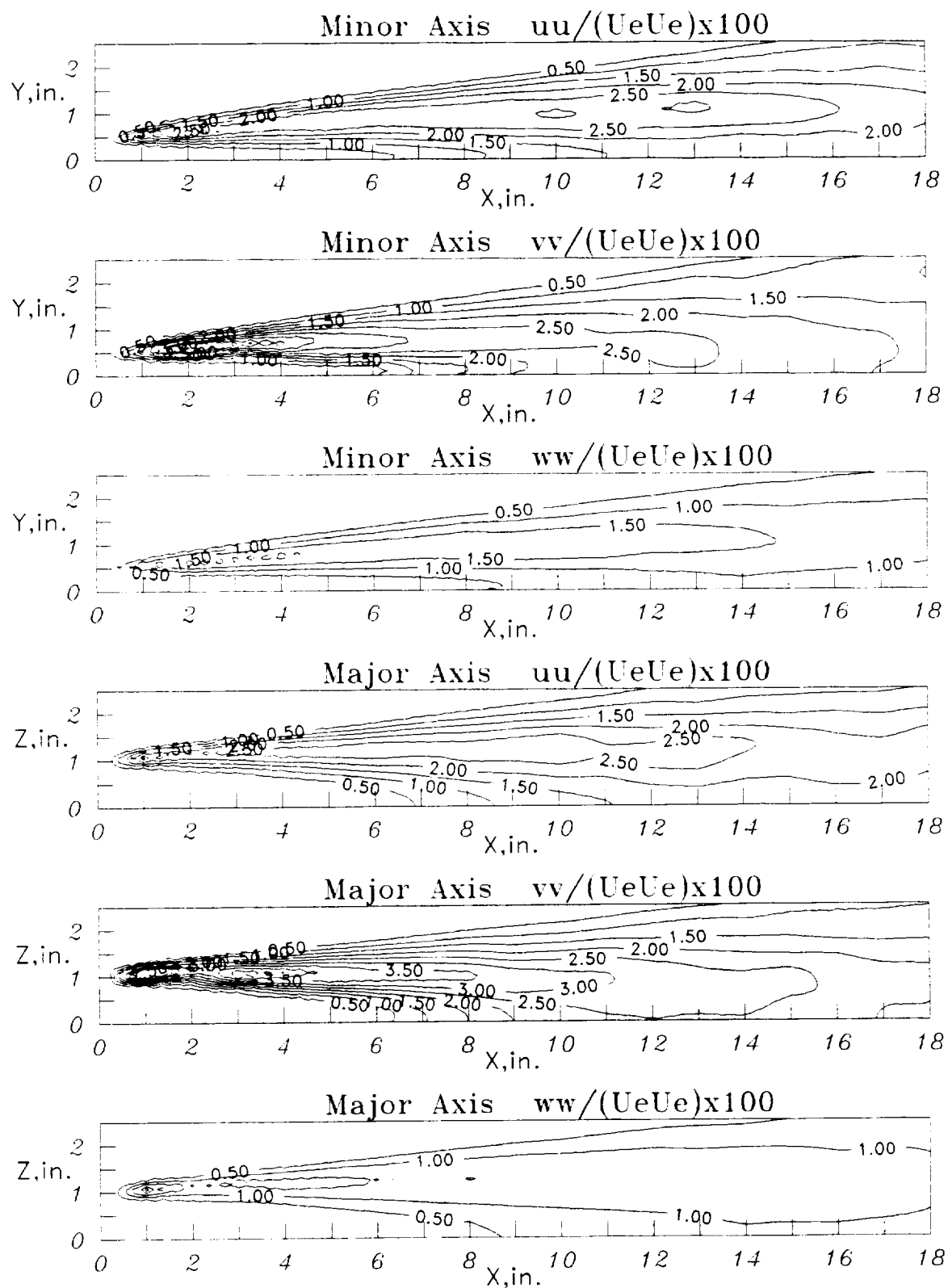

Fig. 13 1x2 Nozzle  $M=0.09$  Velocity Variance

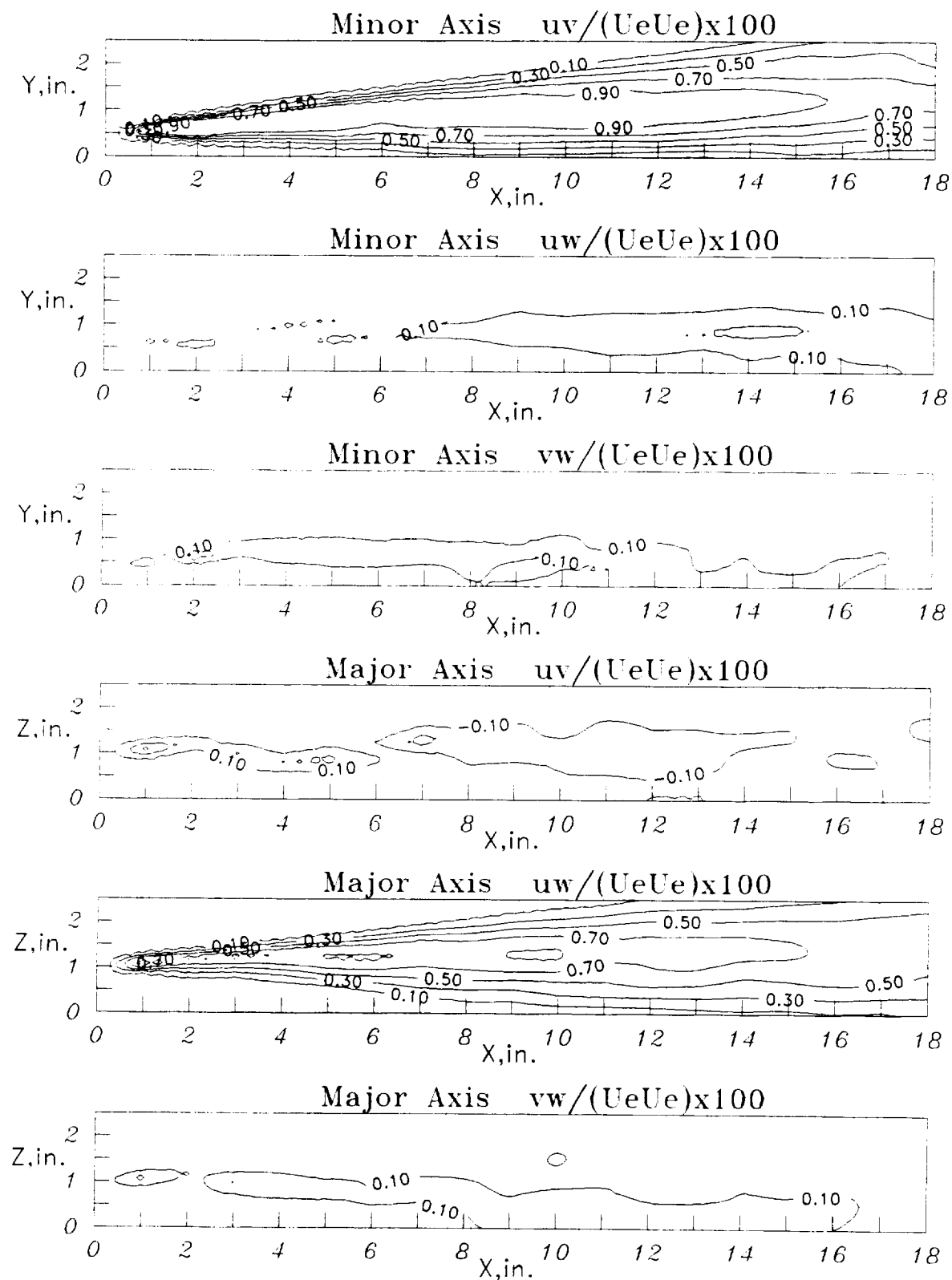

Fig. 14 1x2 Nozzle  $M=0.09$  Velocity Covariance

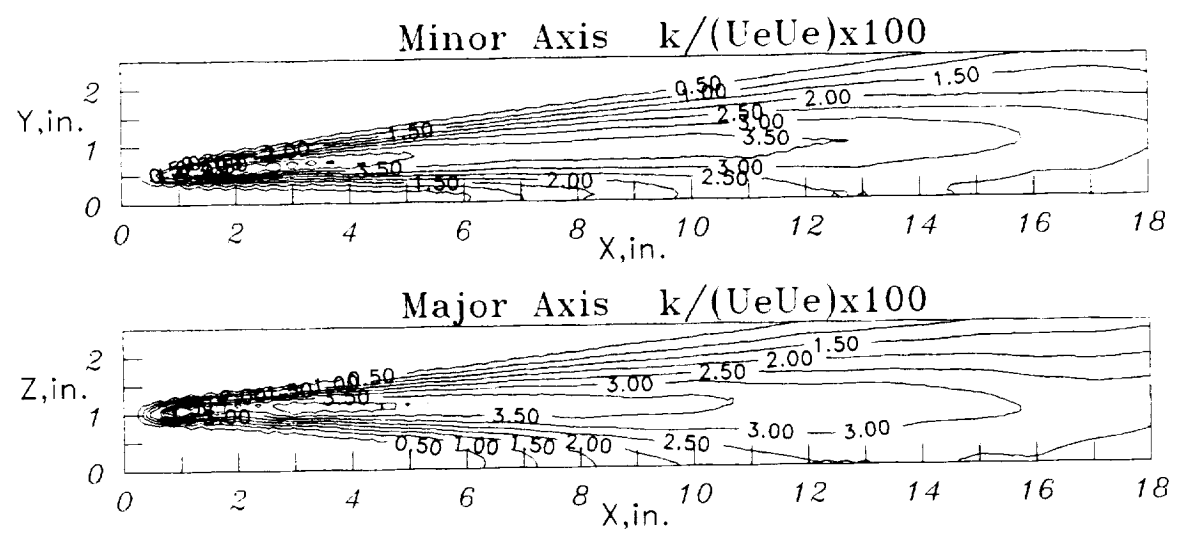

Fig. 15 1x2 Nozzle M=0.09 Turbulent K.E. (k)

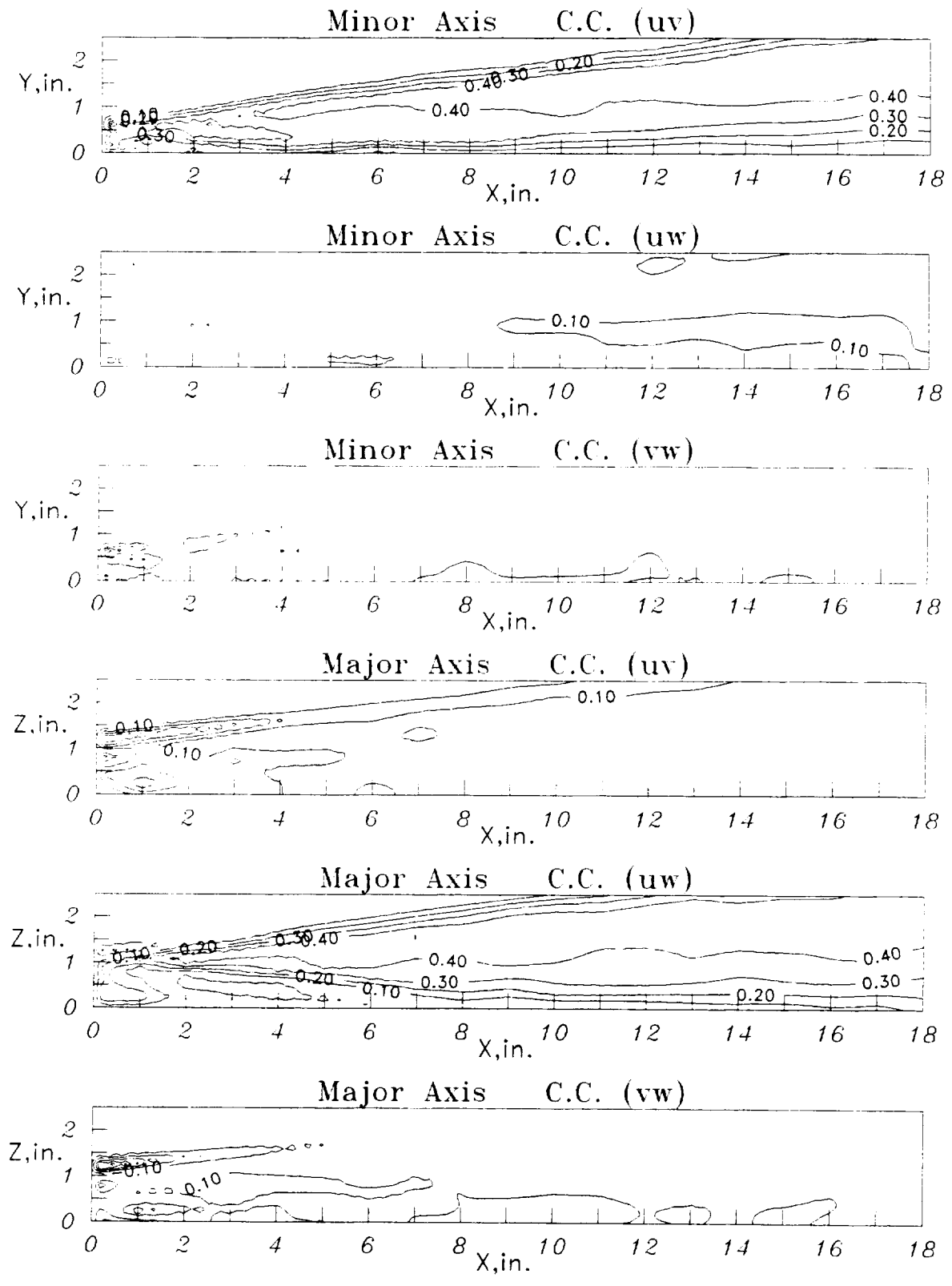

Fig. 16 1x2 Nozzle  $M=0.09$  Velocity Correlation

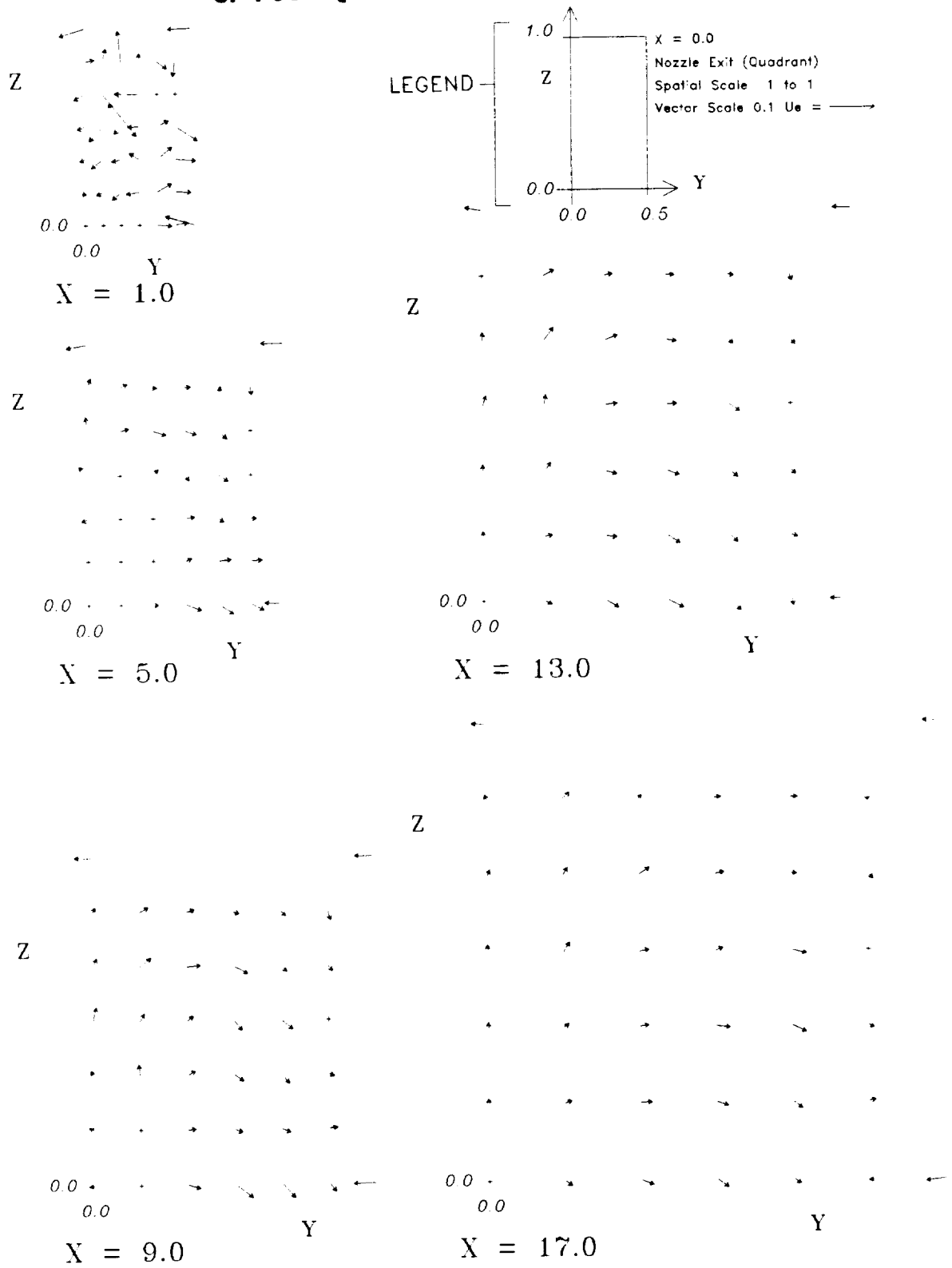

Fig. 17 1x2 Nozzle  $M=0.09$  Velocity Vectors

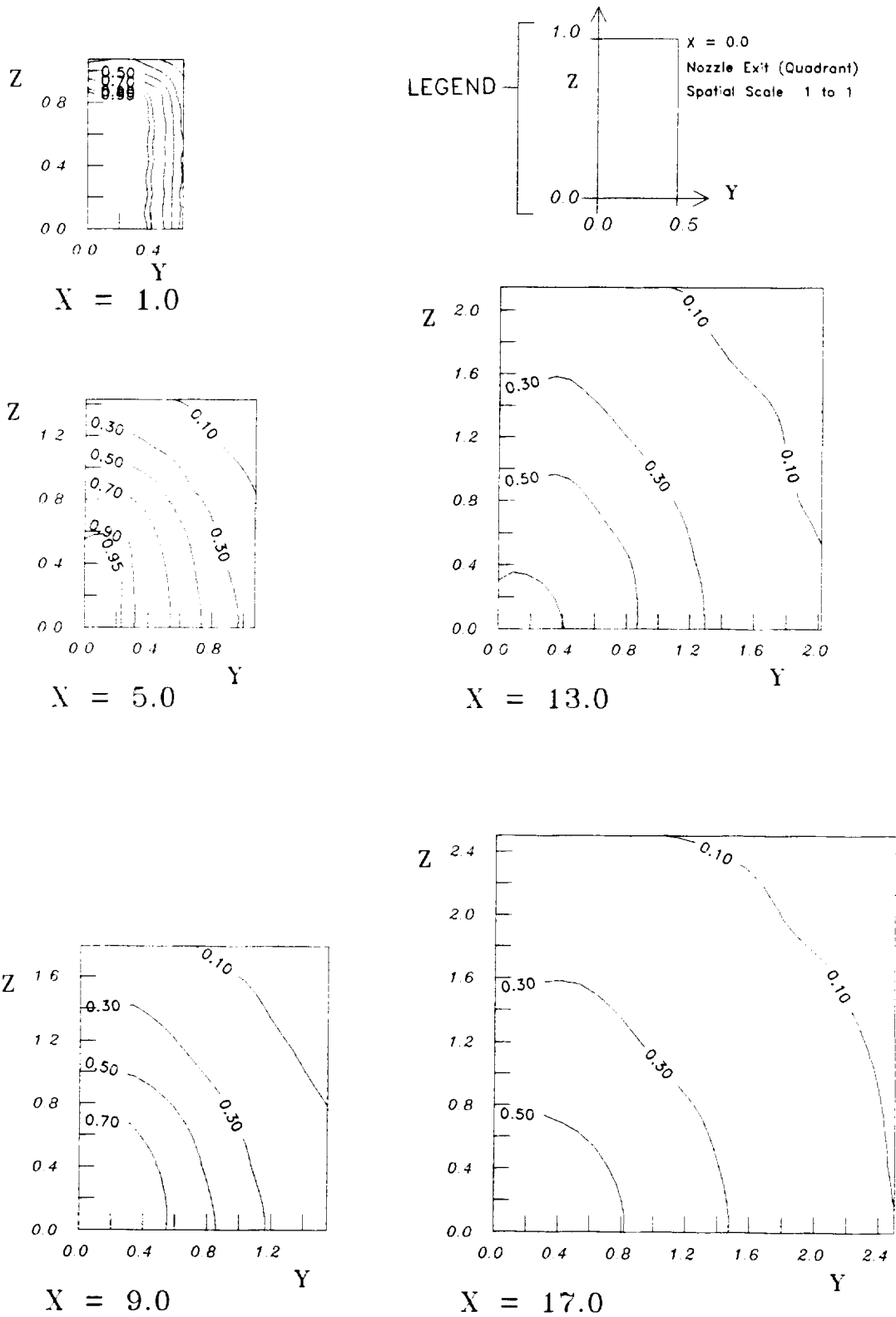

Fig. 18 1x2 Nozzle  $M=0.09$   $U/U_e$

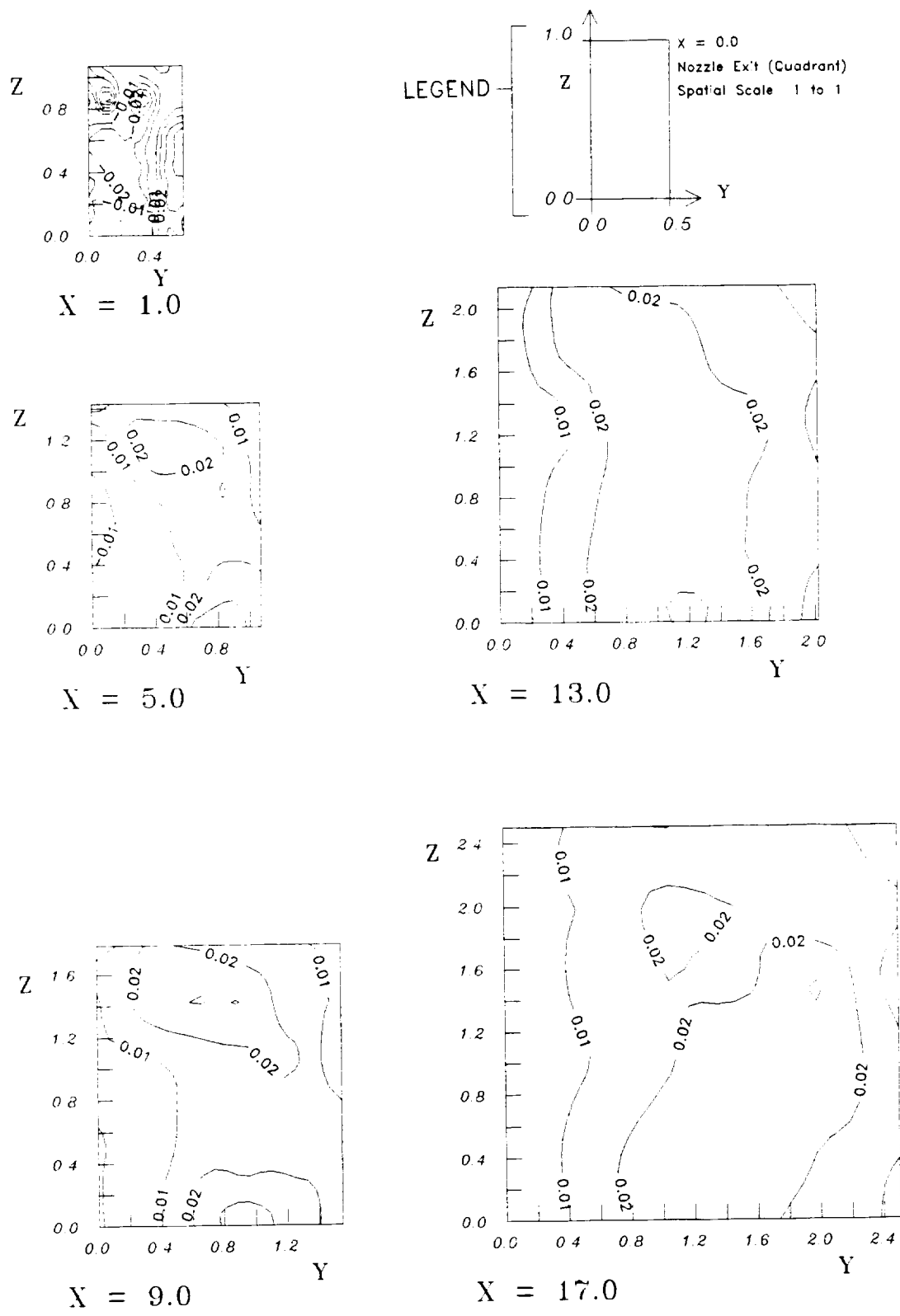

Fig. 19 1x2 Nozzle  $M=0.09$   $V/U_e$



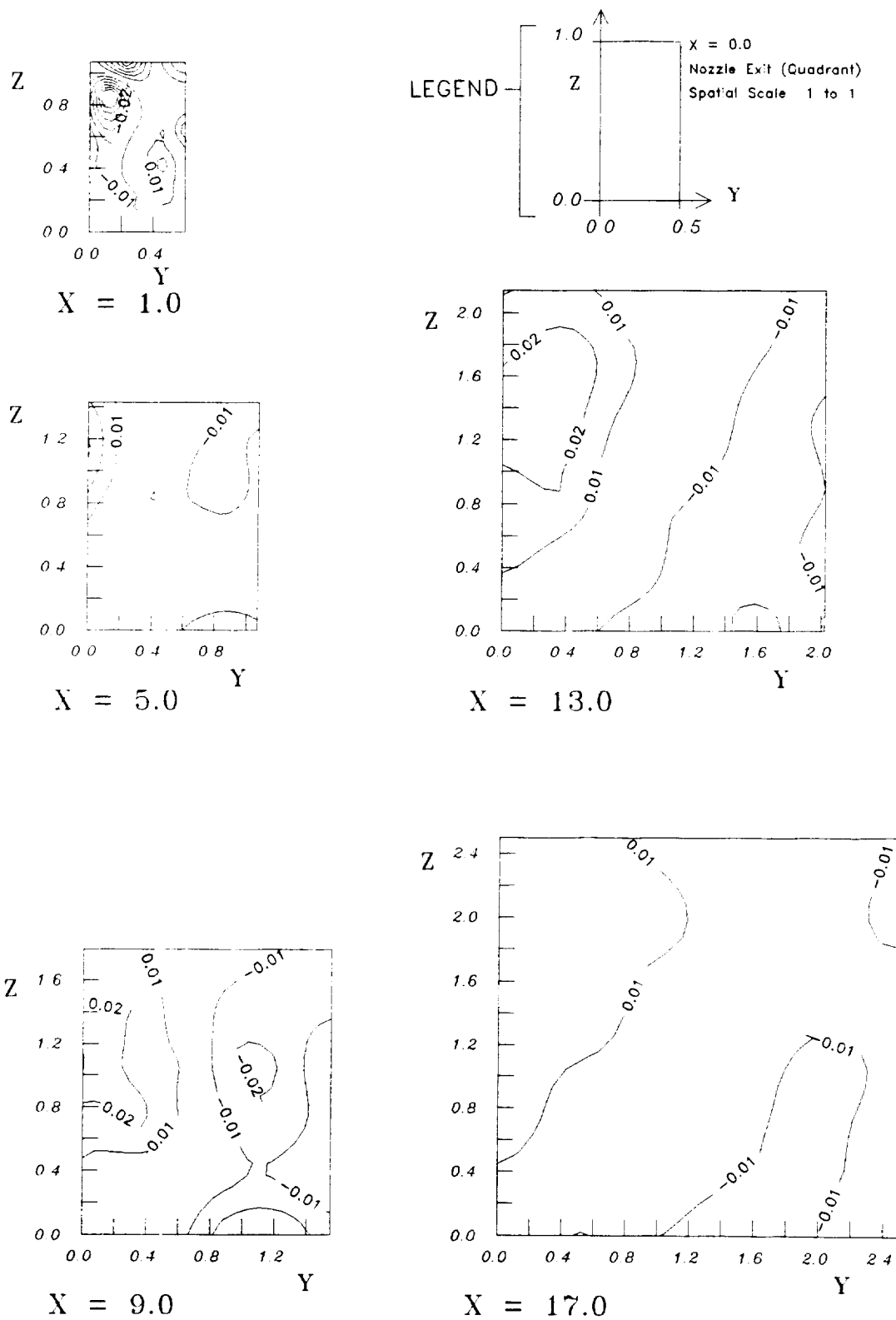

Fig. 20 1x2 Nozzle  $M=0.09$   $W/U_e$

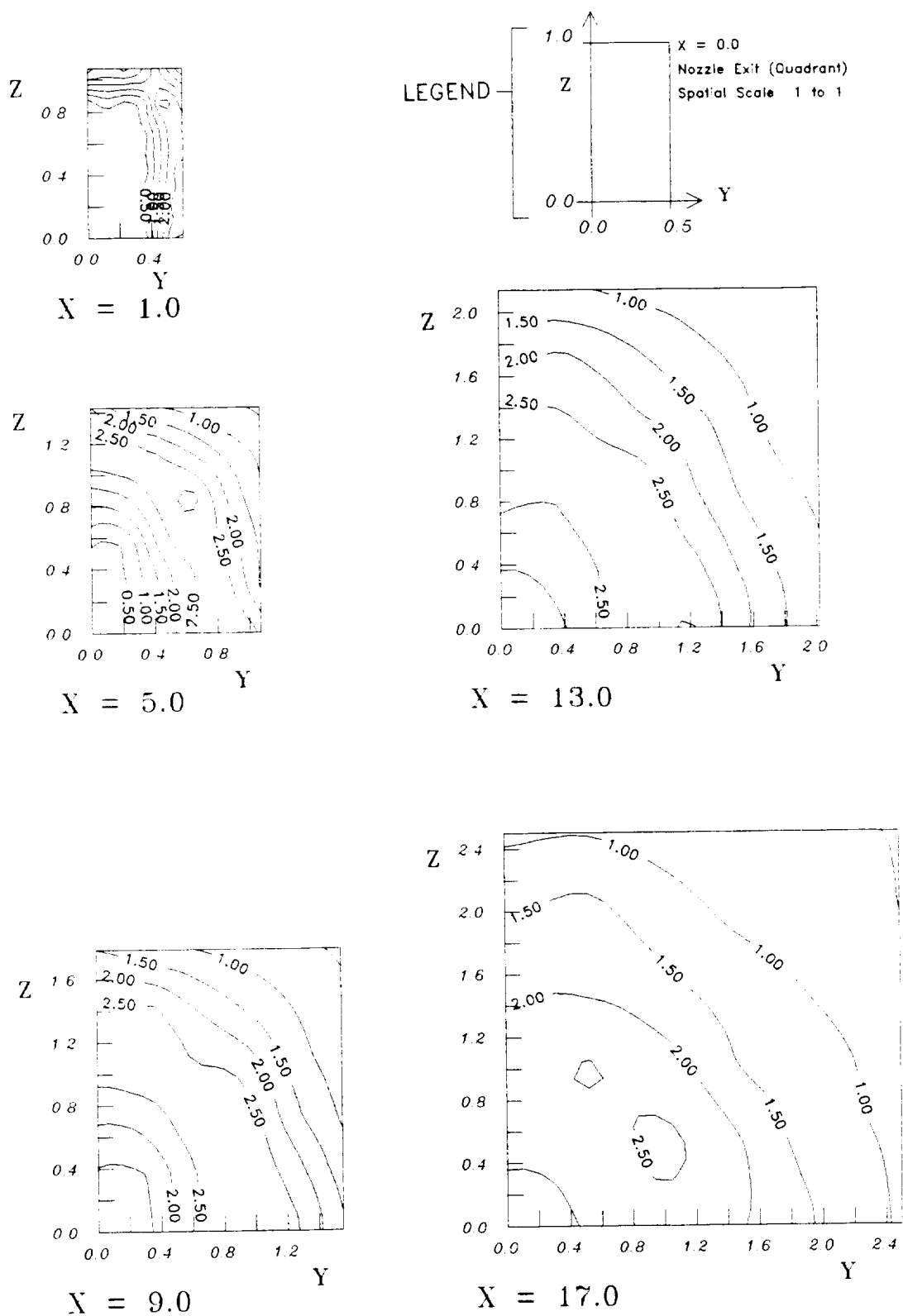

Fig. 21  $1 \times 2$  Nozzle  $M=0.09$   $uu/(UeUe) \times 100$

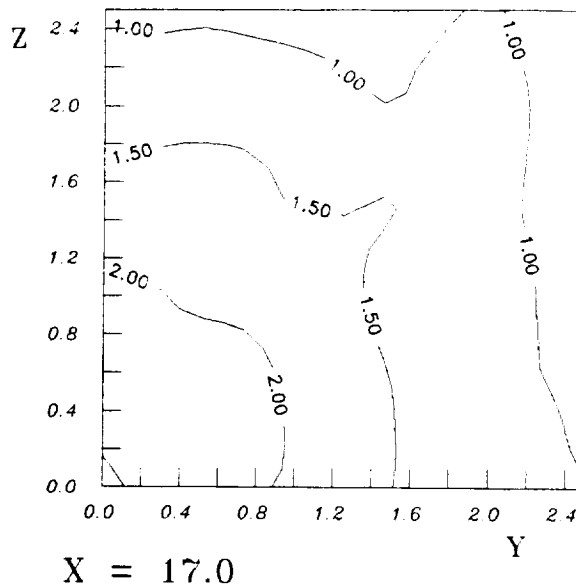
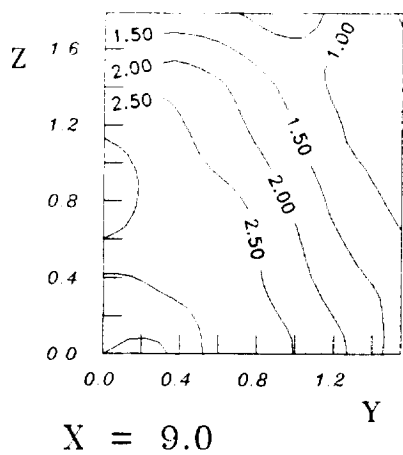
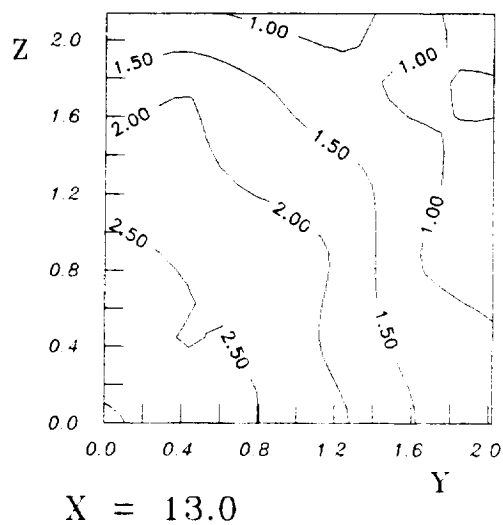
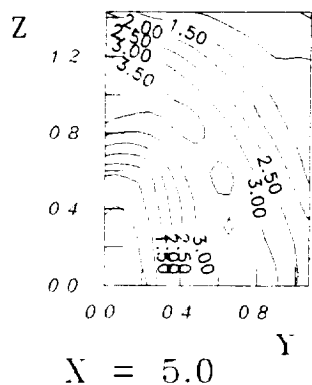
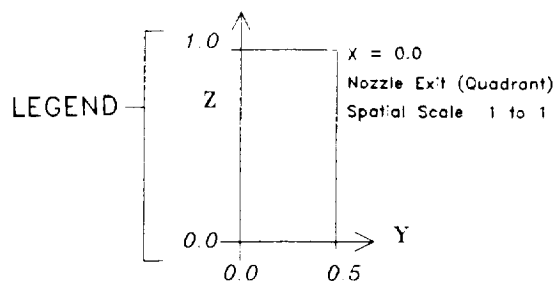
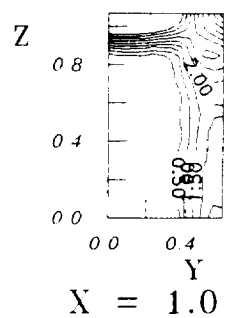

Fig. 22 1x2 Nozzle  $M=0.09$   $vv/(UeUe)x100$

C-2

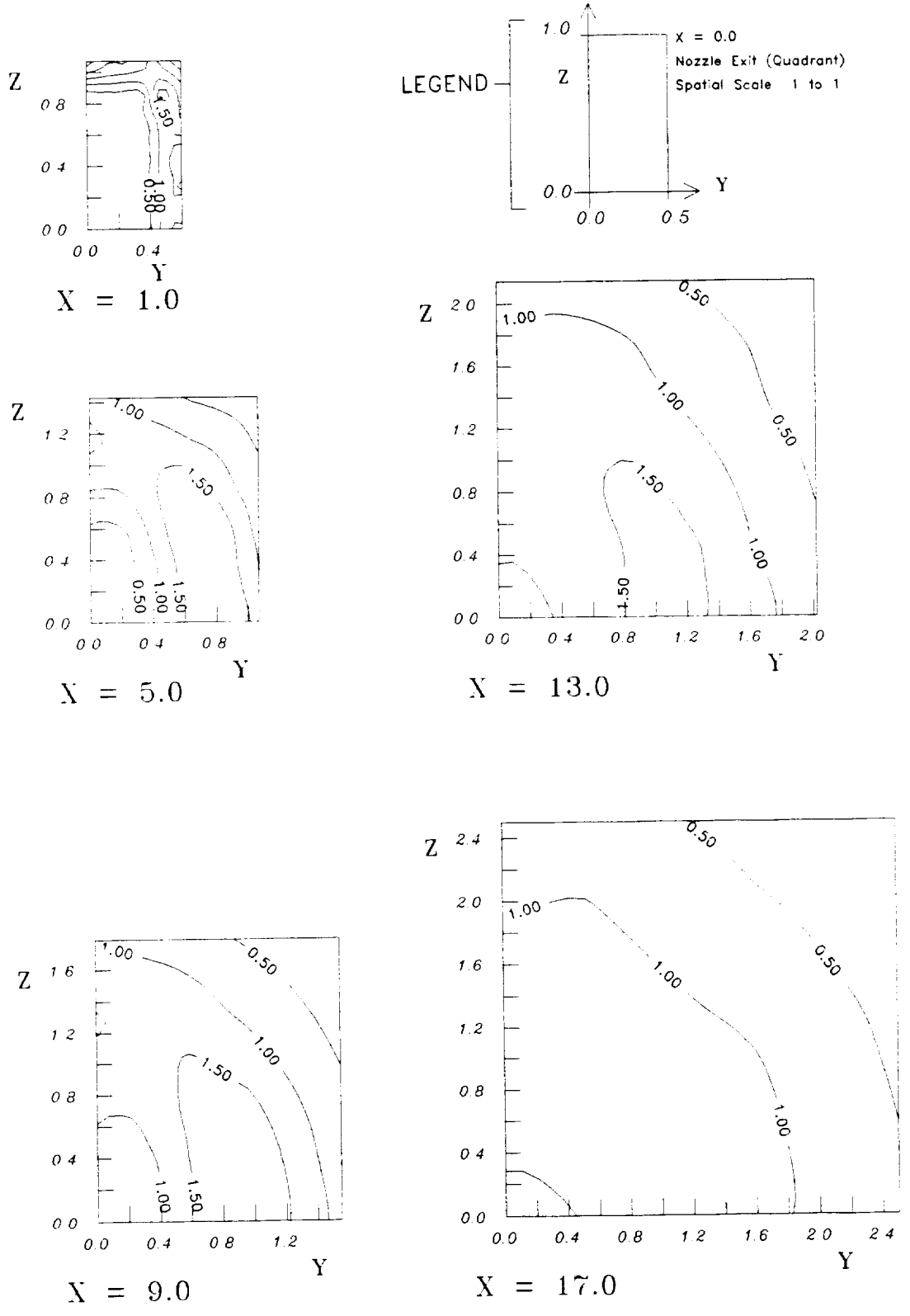

Fig. 23 1x2 Nozzle  $M=0.09$   $wv/(UeUe)x100$

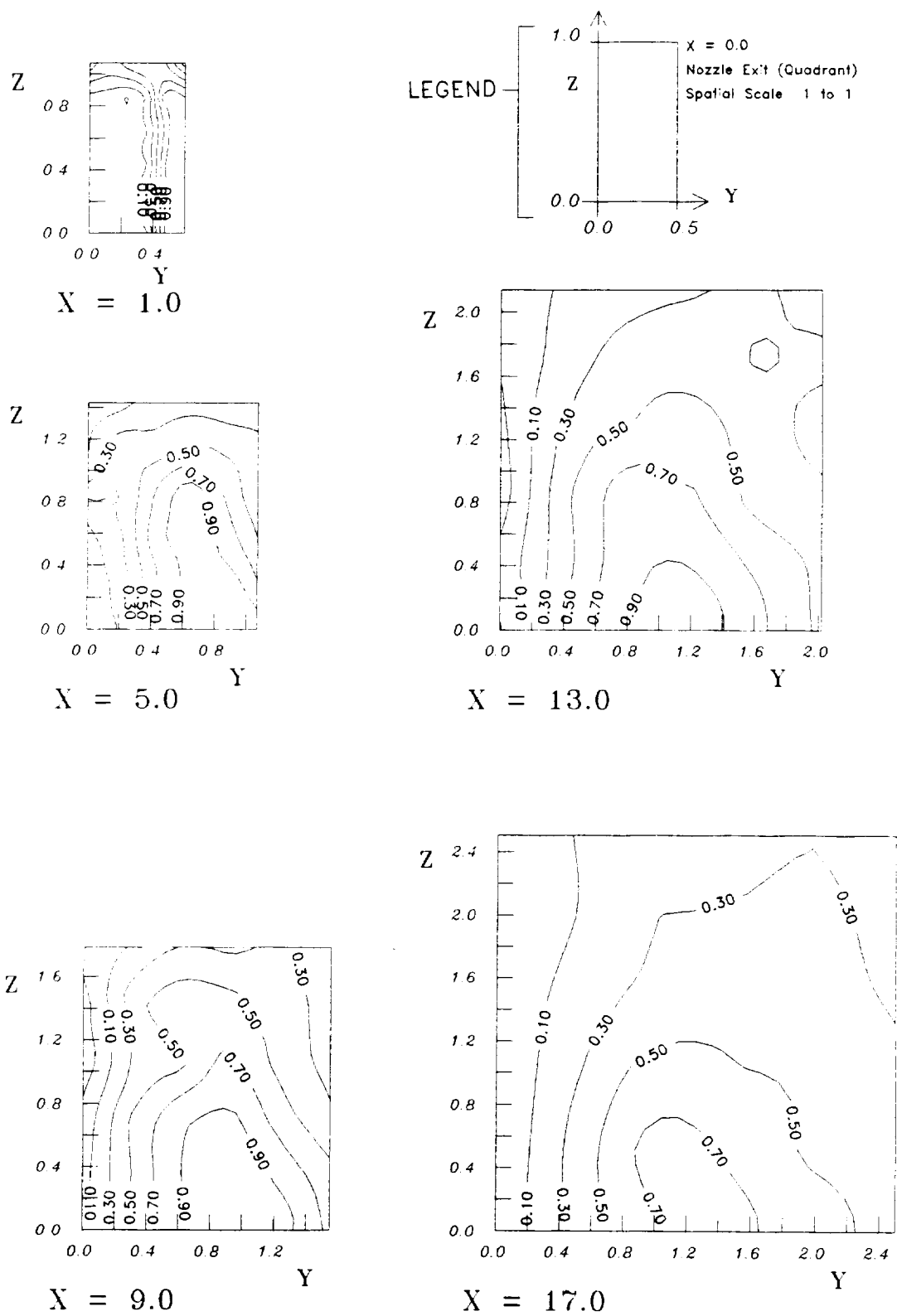

Fig. 24 1x2 Nozzle  $M=0.09$   $uv/(UeUe)x100$

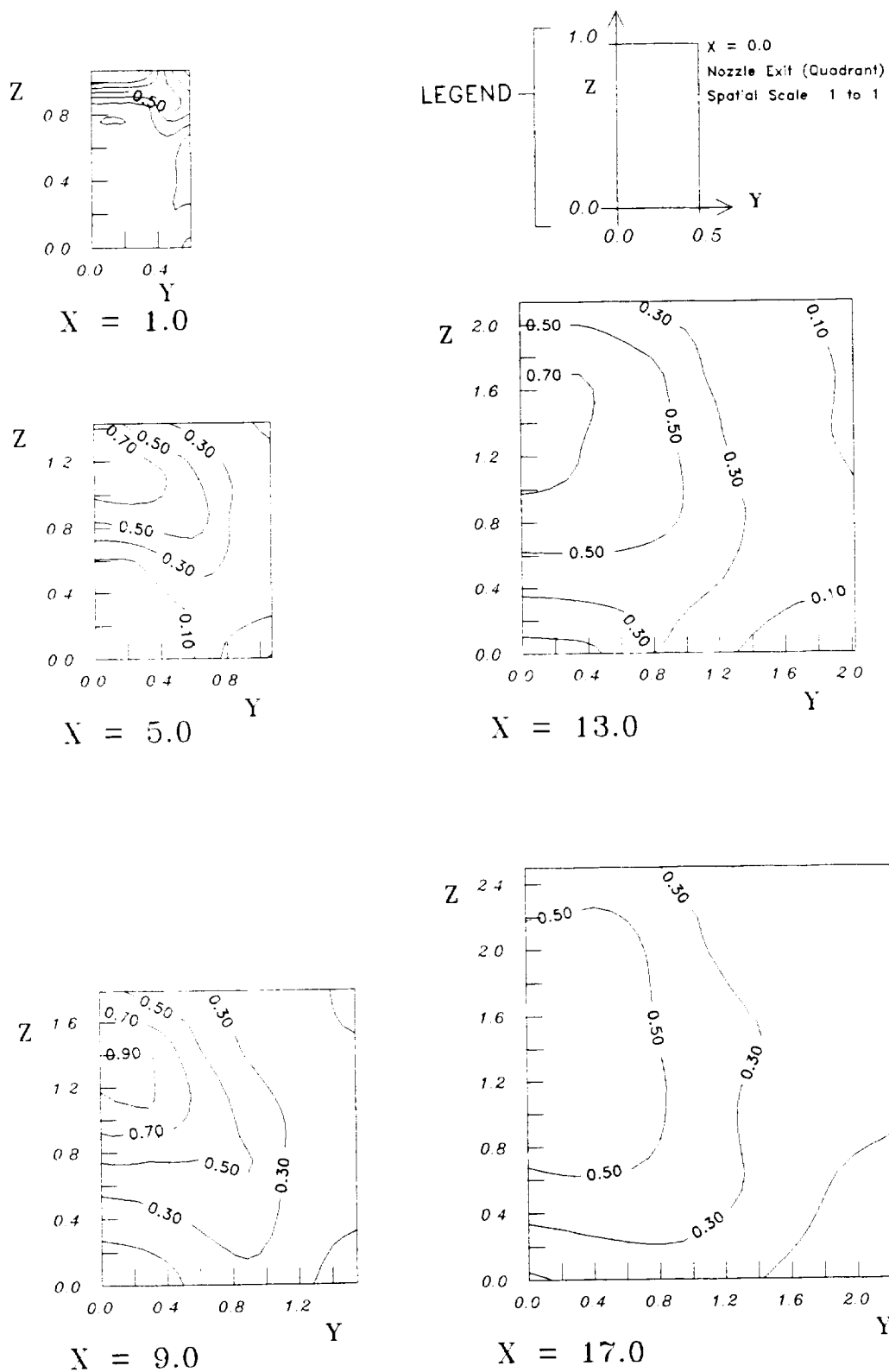

Fig. 25 1x2 Nozzle  $M=0.09$   $uw/(UeUe) \times 100$

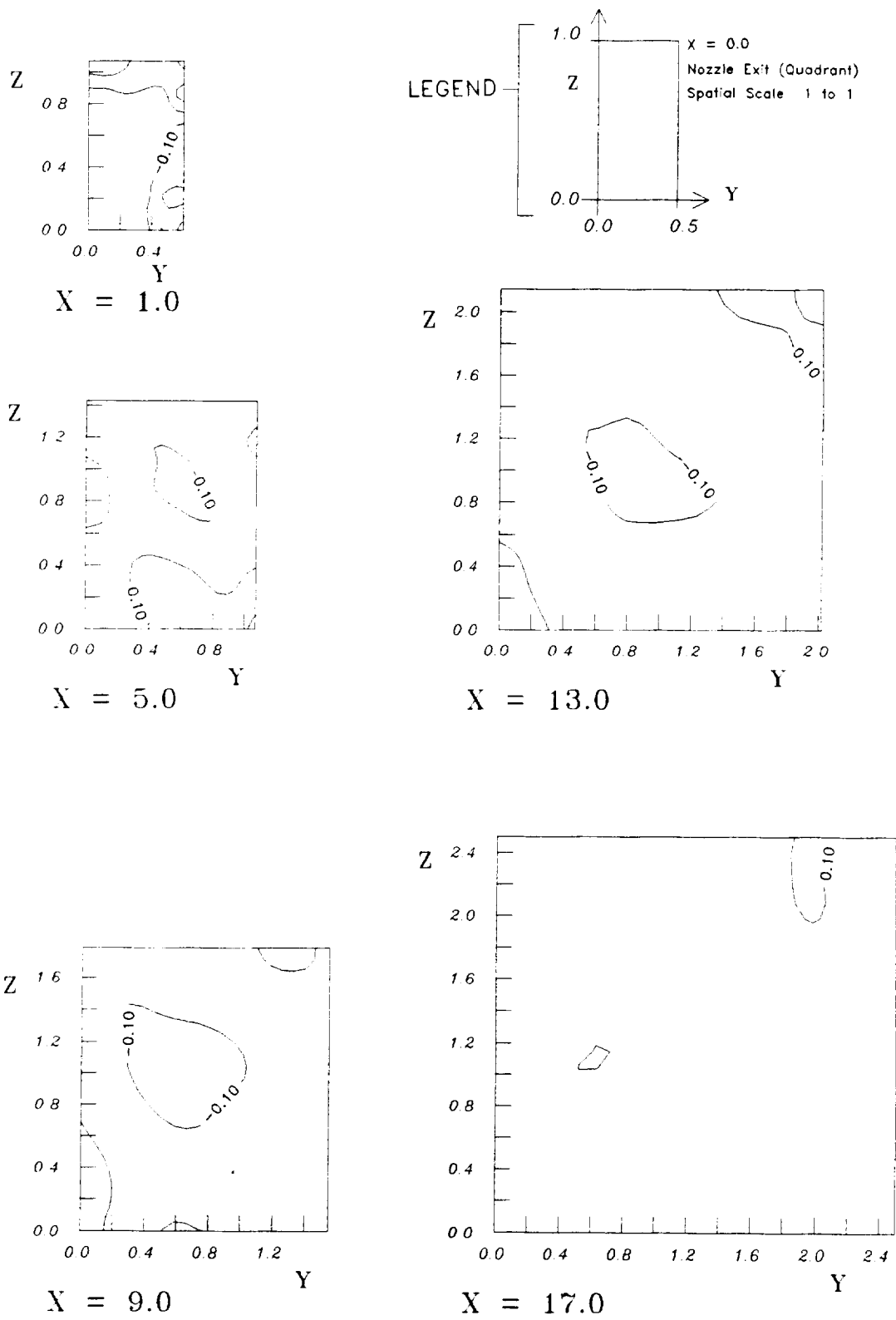

Fig. 26 1x2 Nozzle  $M=0.09$   $vw/(UeUe) \times 100$

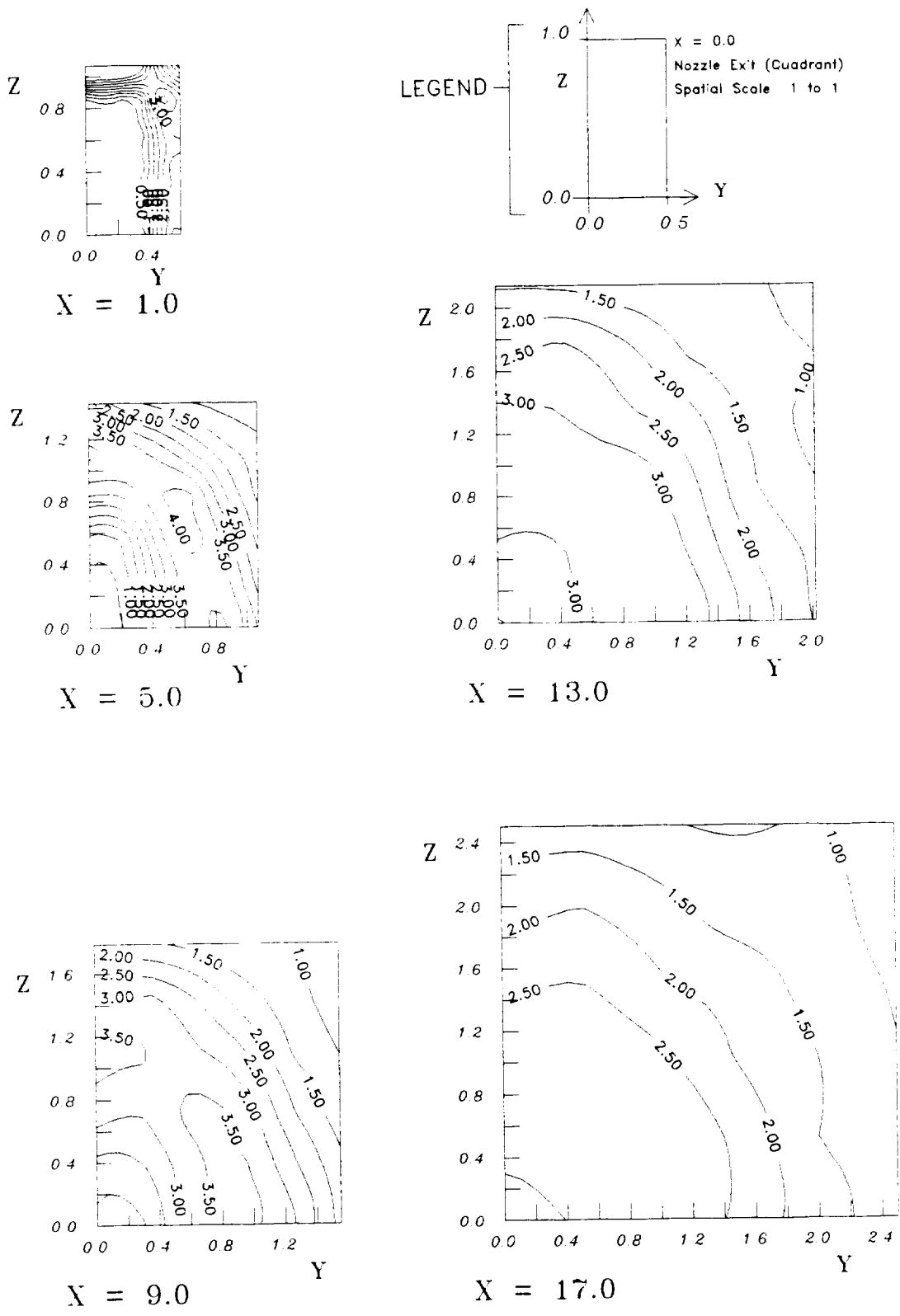

Fig. 27 1x2 Nozzle  $M=0.09$   $k/(UeUe) \times 100$



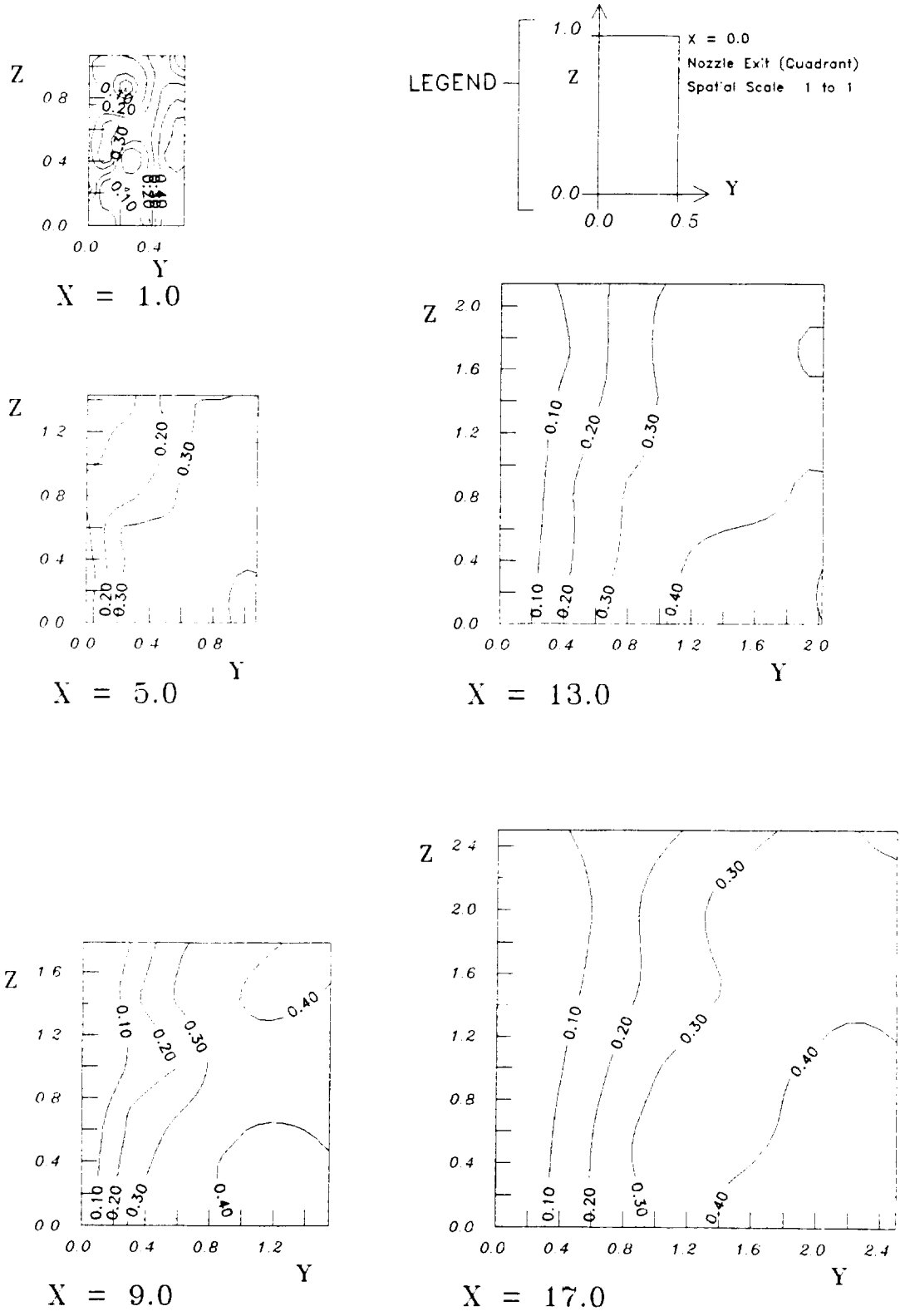

Fig. 28 1x2 Nozzle  $M=0.09$  C.C.(uv)

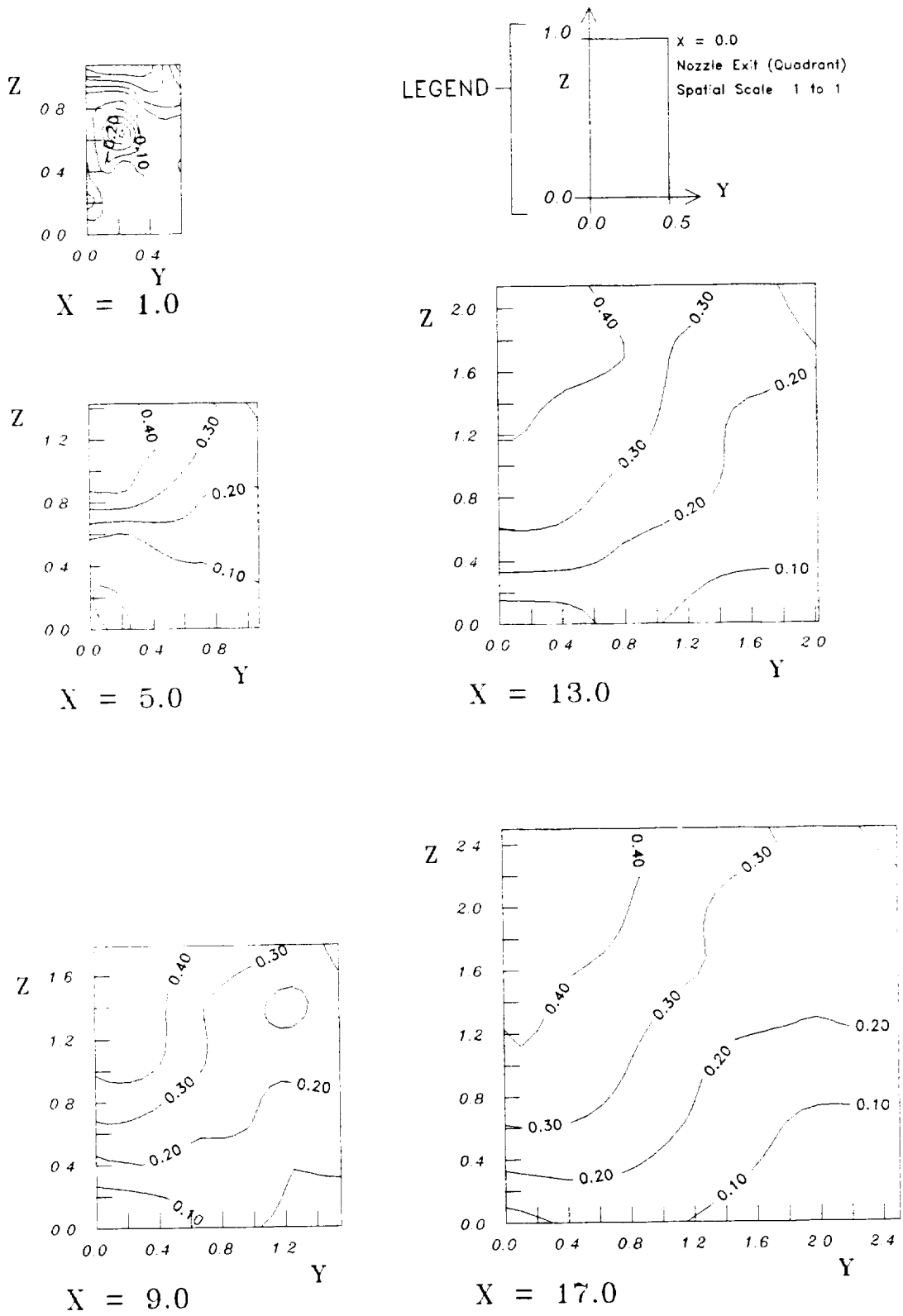

Fig. 29 1x2 Nozzle  $M=0.09$  C.C.(uw)

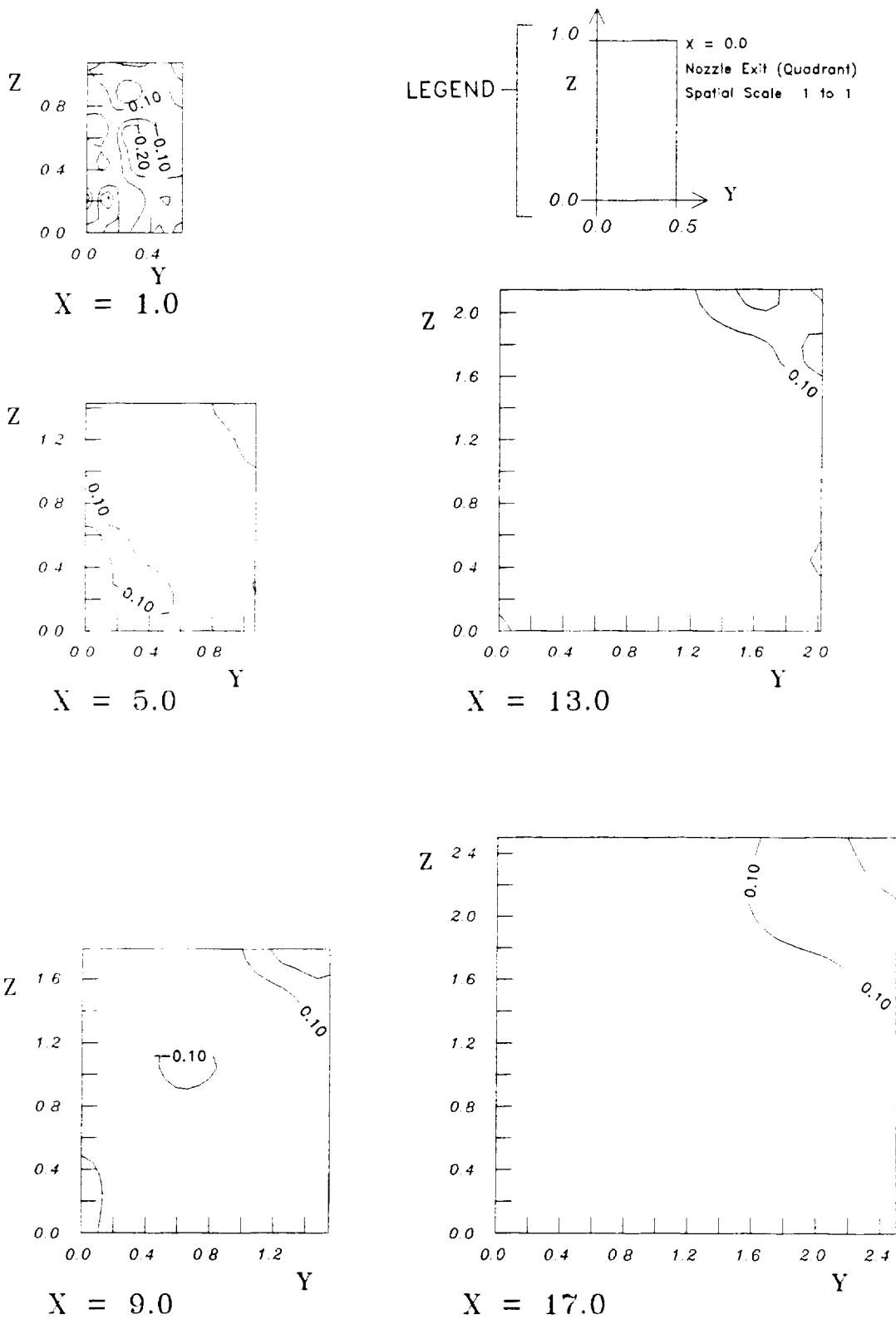
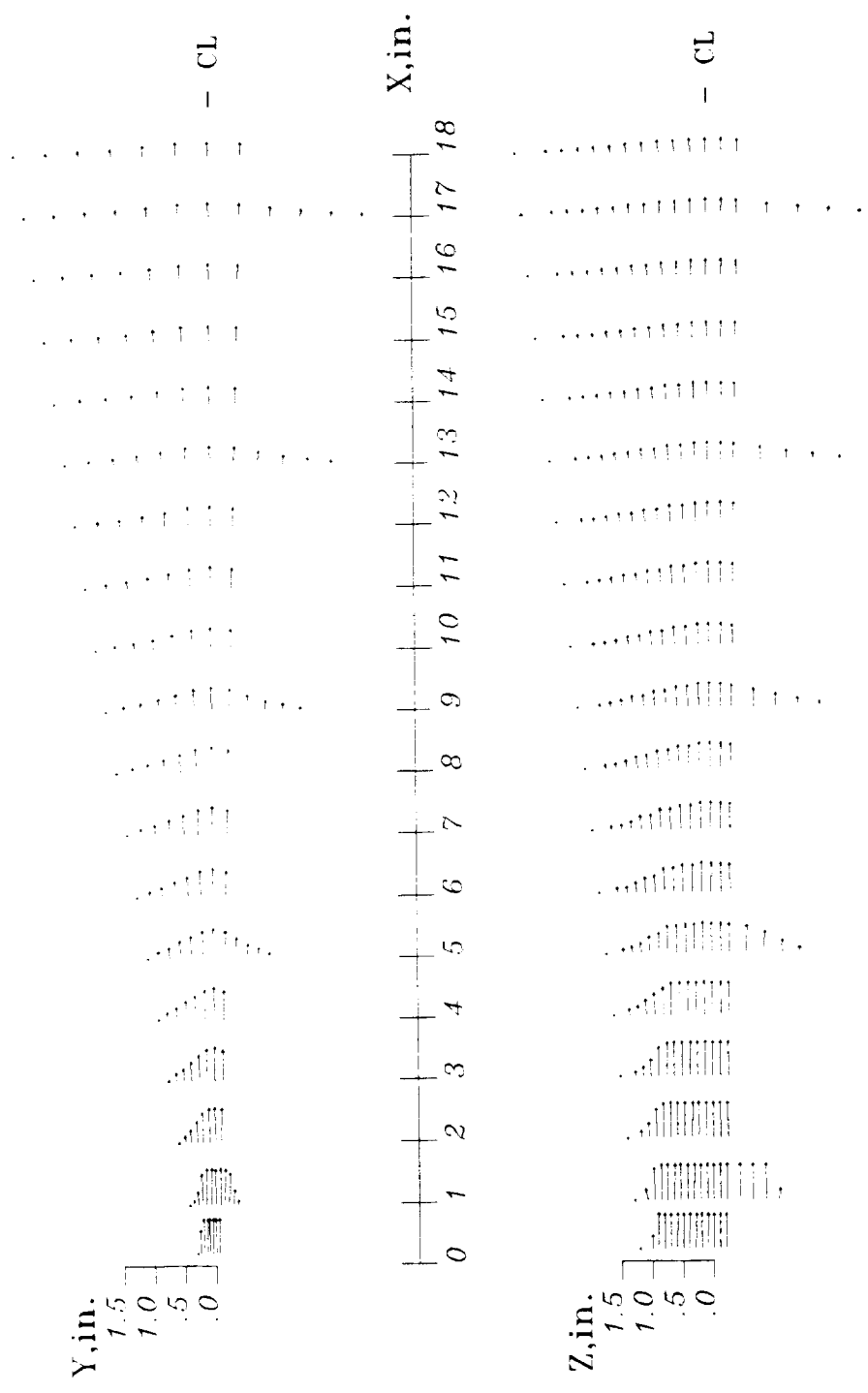

Fig. 30 1x2 Nozzle  $M=0.09$  C.C.(vw)



Spatial Scale 1 to 3 Vector Scale  $U_e = \rightarrow$   
 Fig. 31 1x4 Nozzle  $M=0.09$  Velocity Vectors

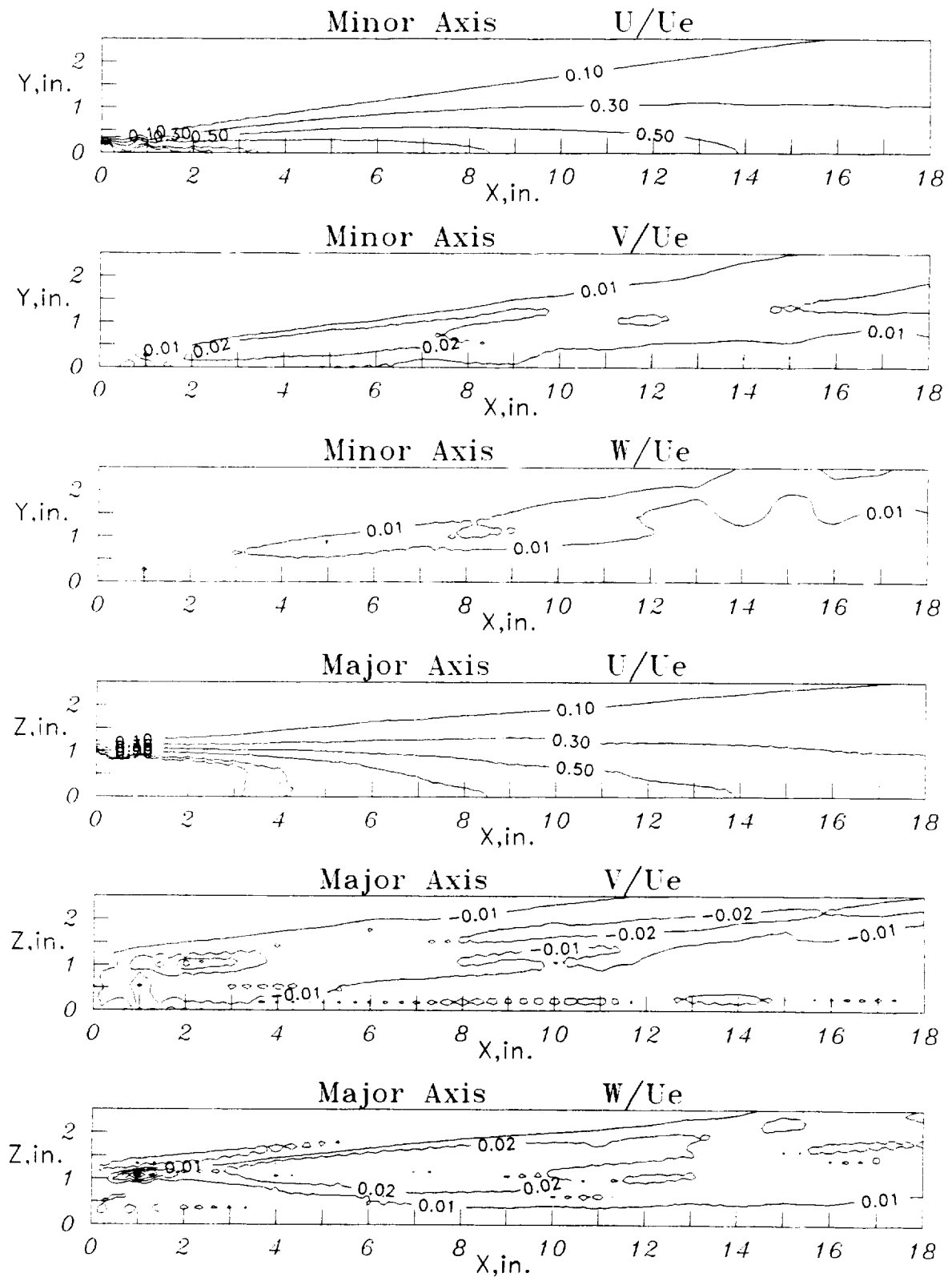

Fig. 32 1x4 Nozzle M=0.09 Mean Velocity

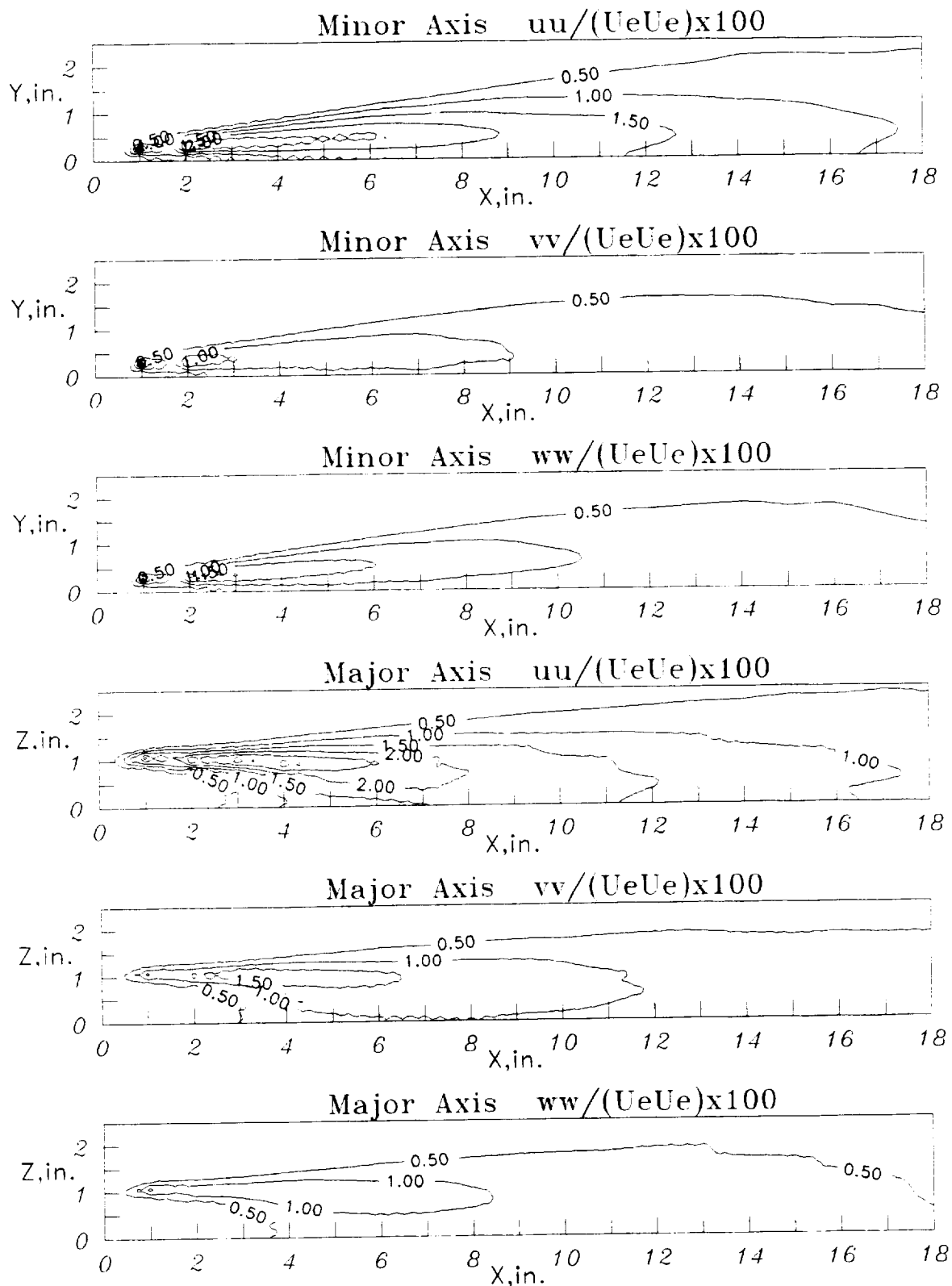

Fig. 33  $M=0.09$  1x4 Nozzle Velocity Variance

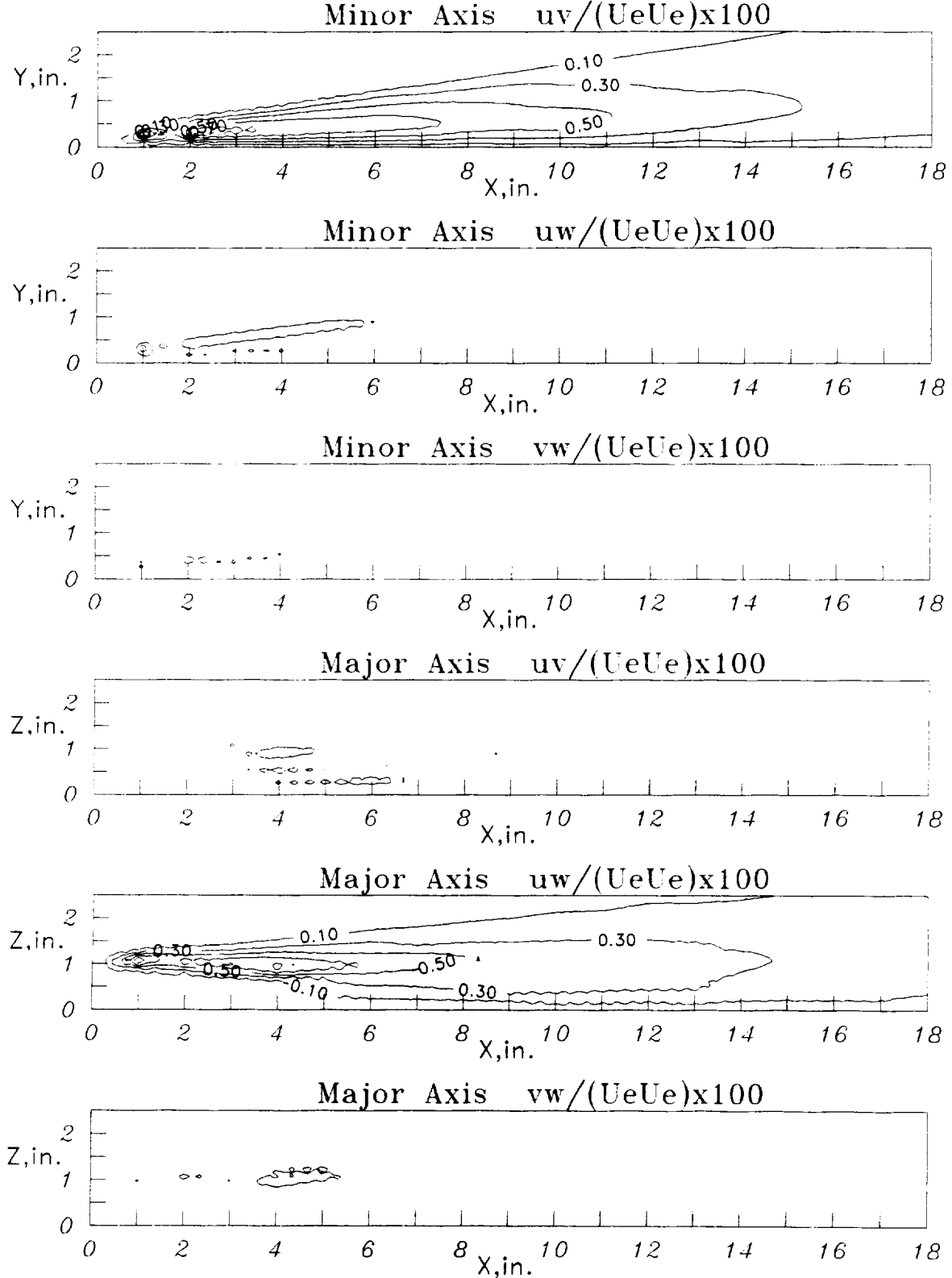

Fig. 34 M=0.09 1x4 Nozzle Velocity Covariance

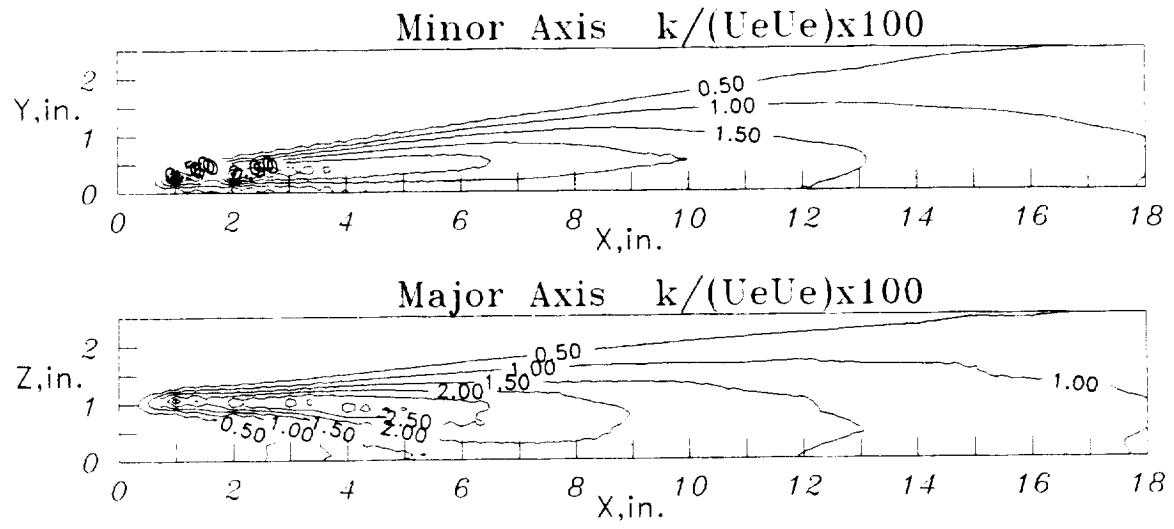

Fig. 35 1x4 Nozzle M=0.09 Turbulent K.E. (k)



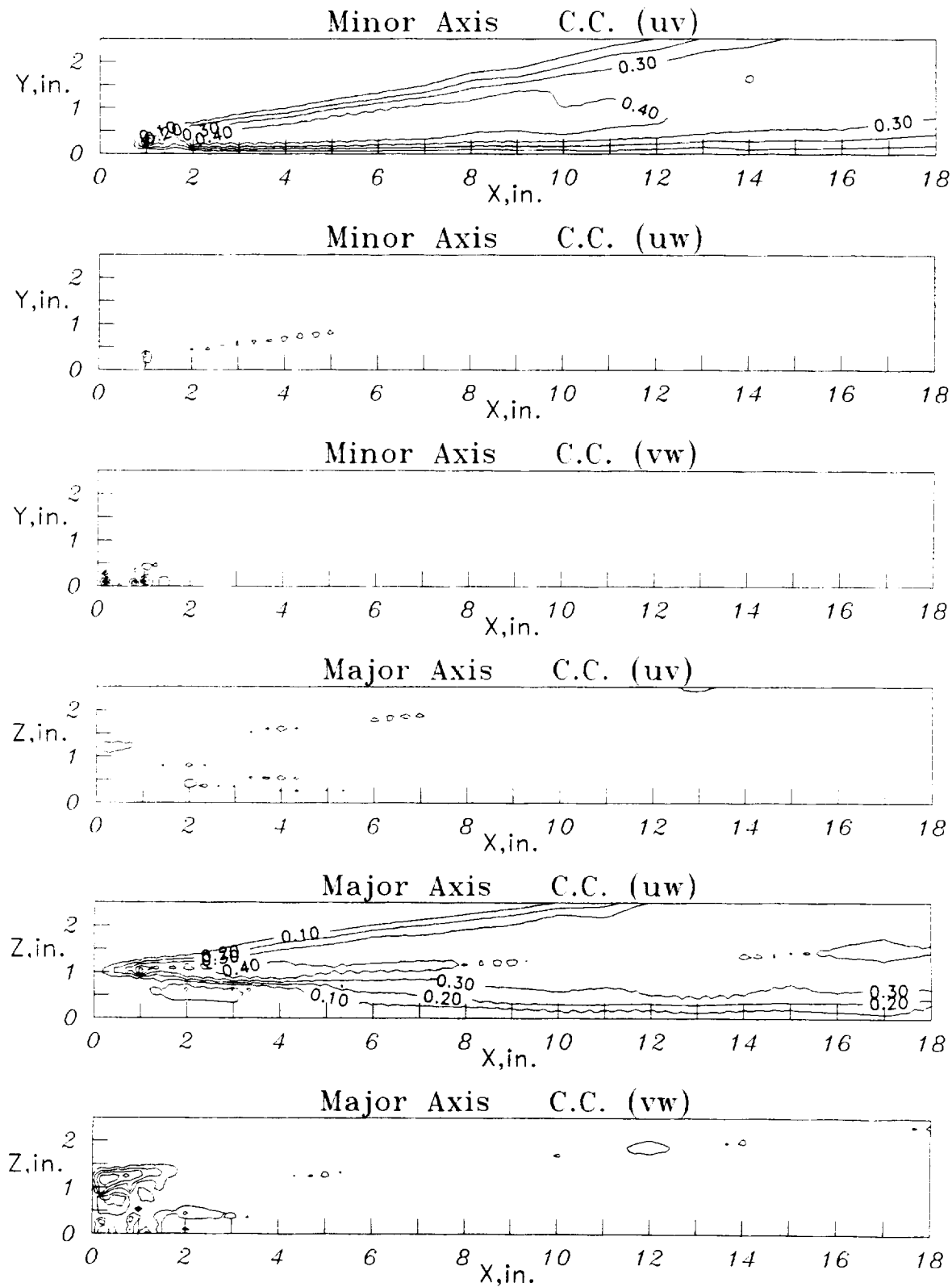

Fig. 36 1x4 Nozzle M=0.09 Velocity Correlation

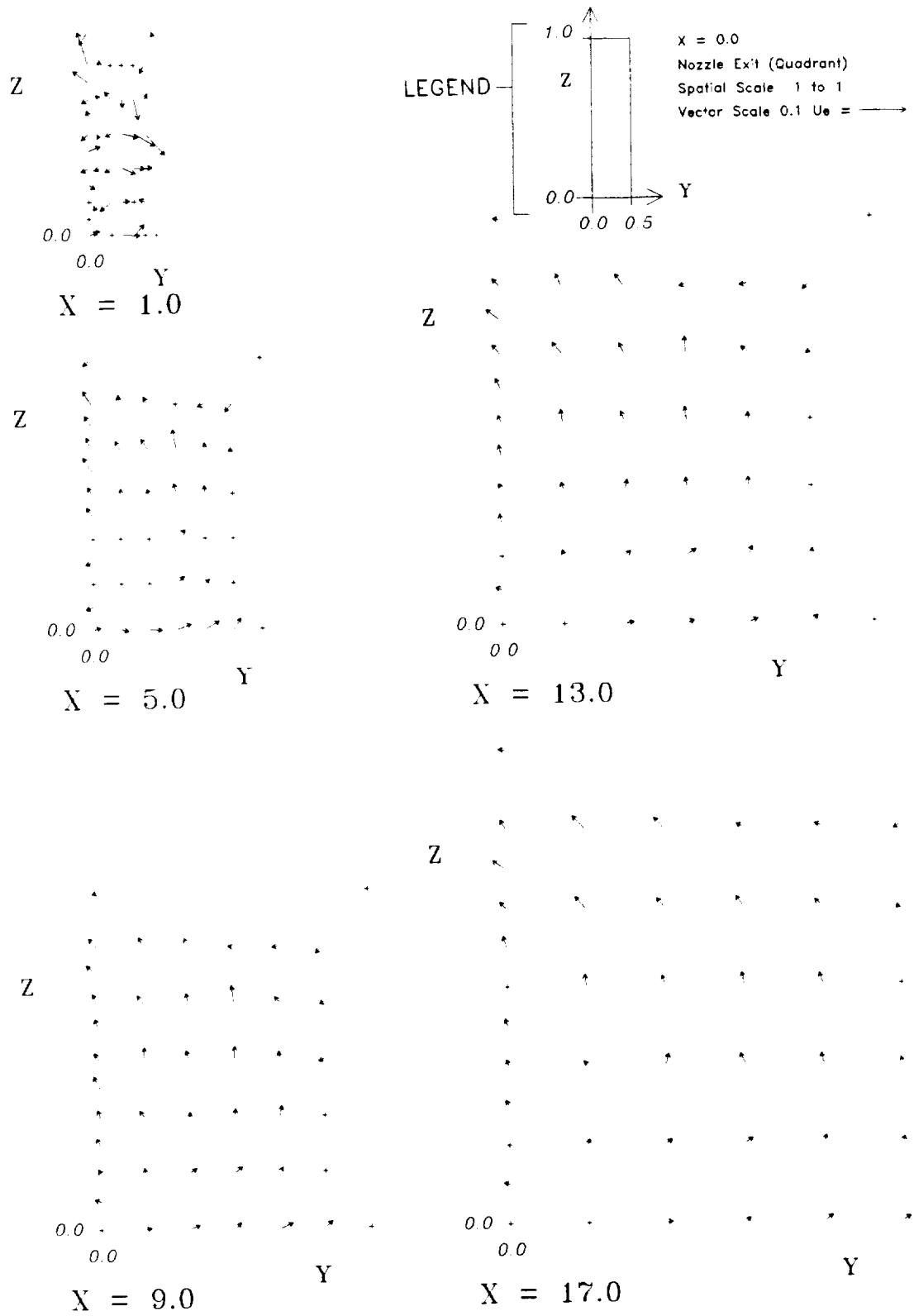

Fig. 37 1x4 Nozzle  $M=0.09$  Velocity Vectors

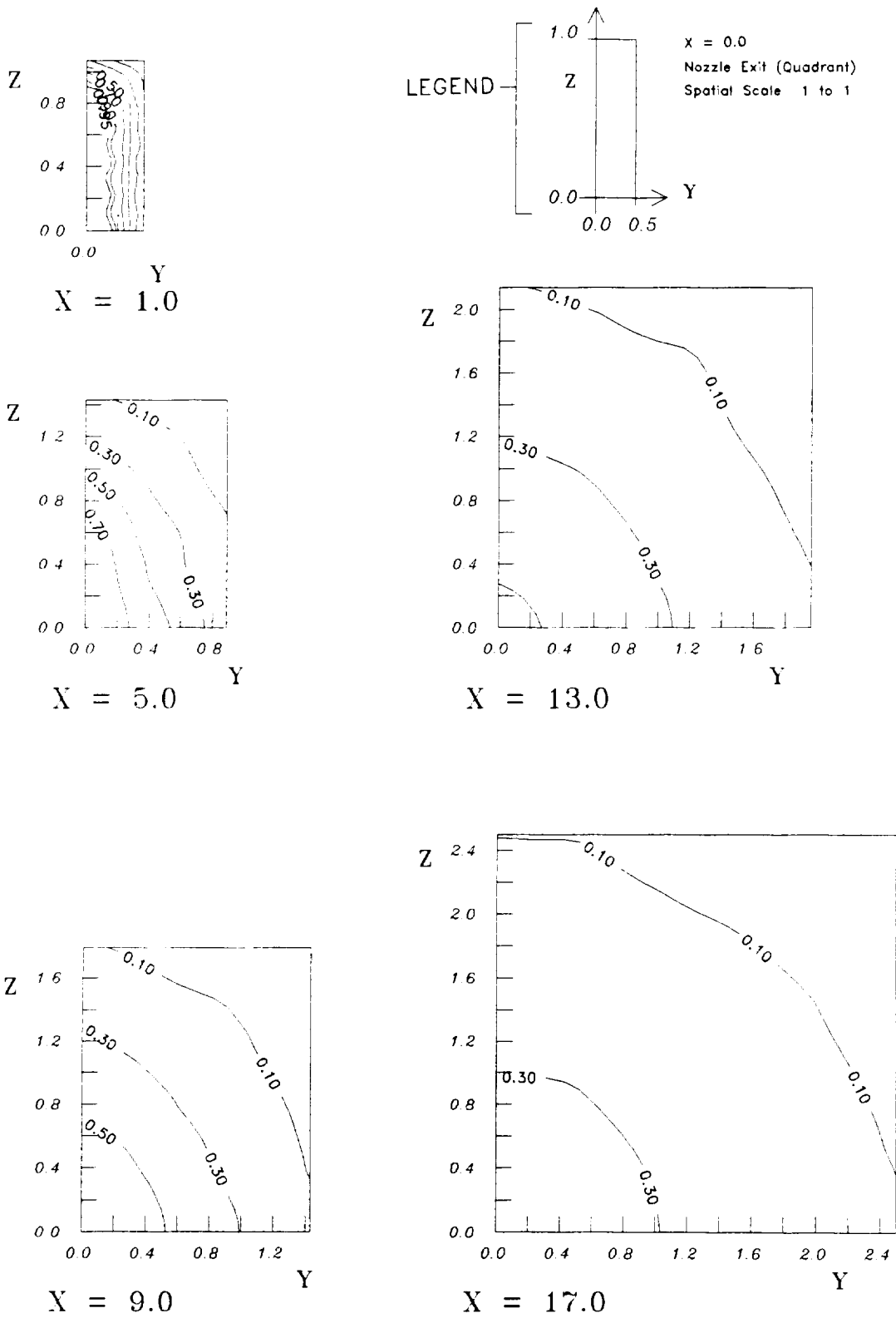

Fig. 38 1x4 Nozzle  $M=0.09$   $U/U_e$

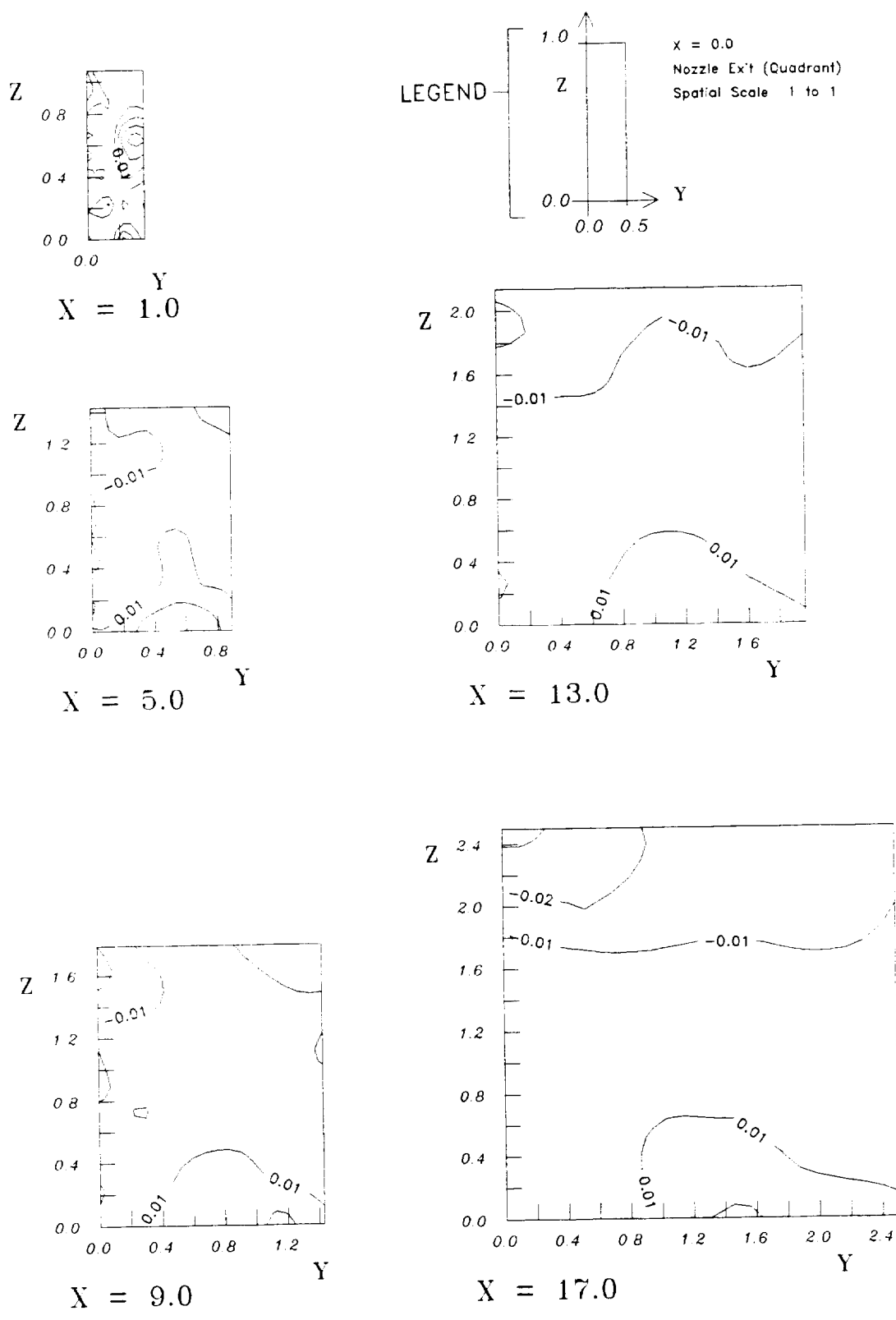

Fig. 39 1x4 Nozzle  $M=0.09$   $v/U_e$

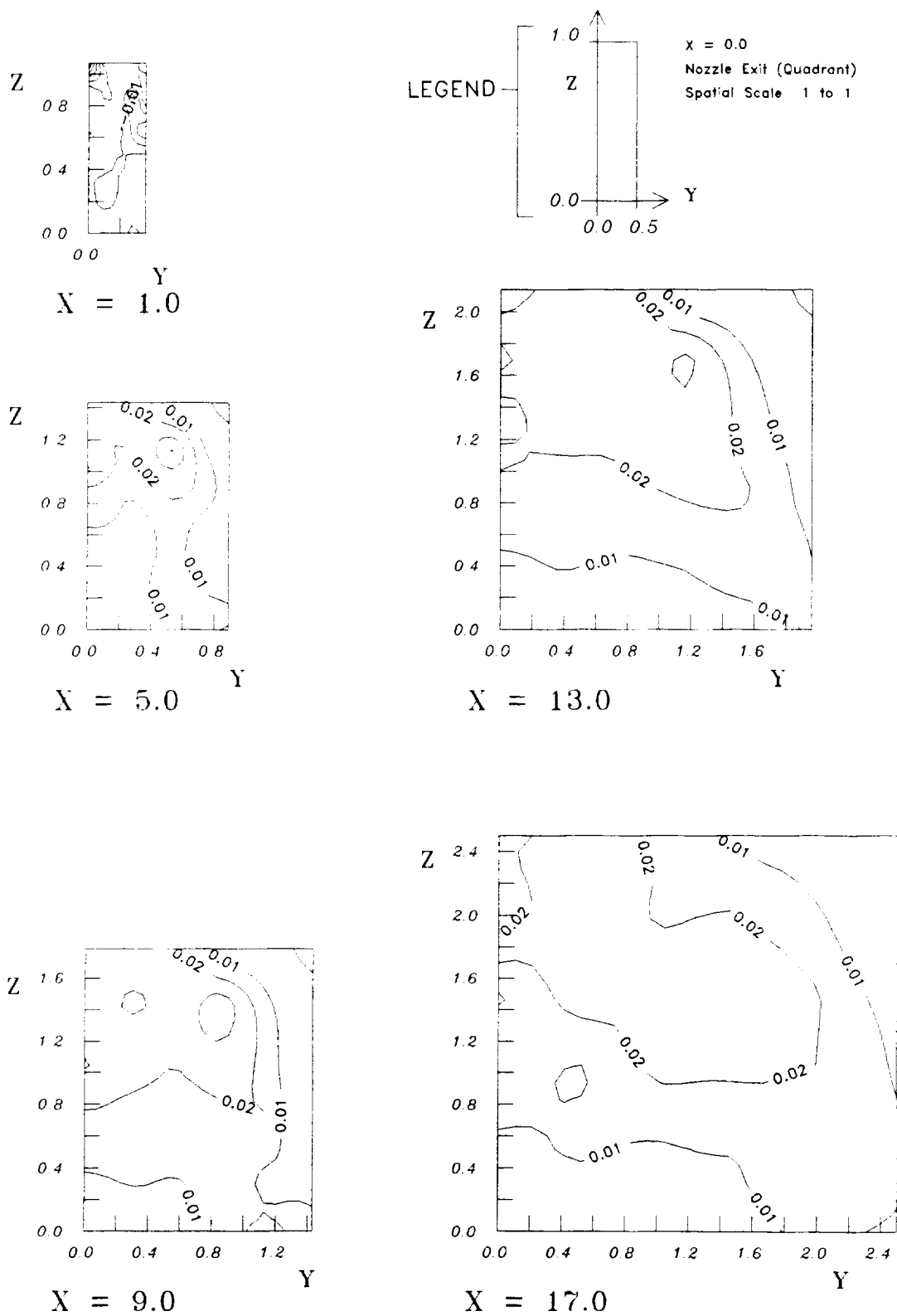

Fig. 40 1x4 Nozzle  $M=0.09$   $W/U_e$

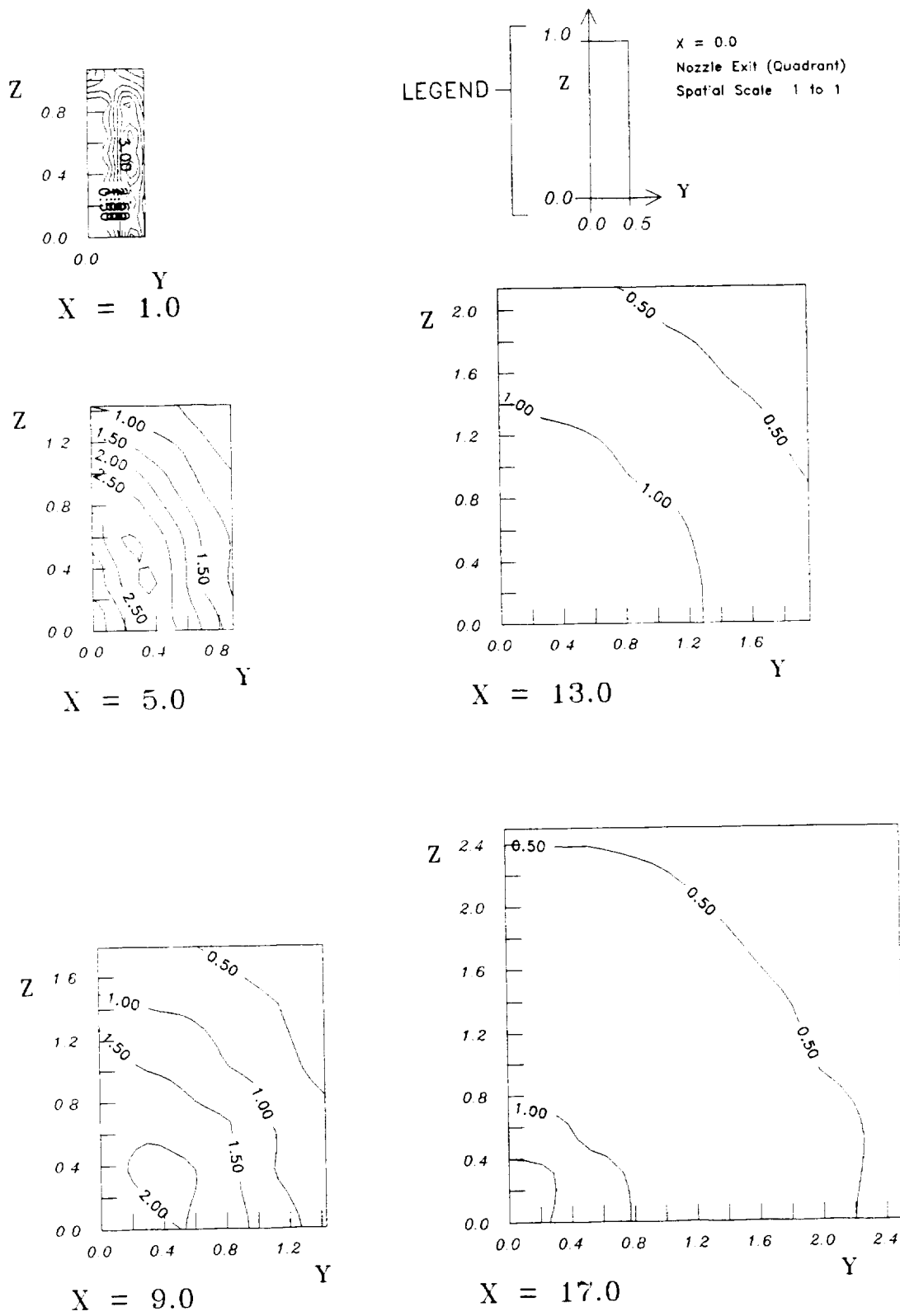

Fig. 41 1x4 Nozzle  $M=0.09$   $uu/(UeUe) \times 100$

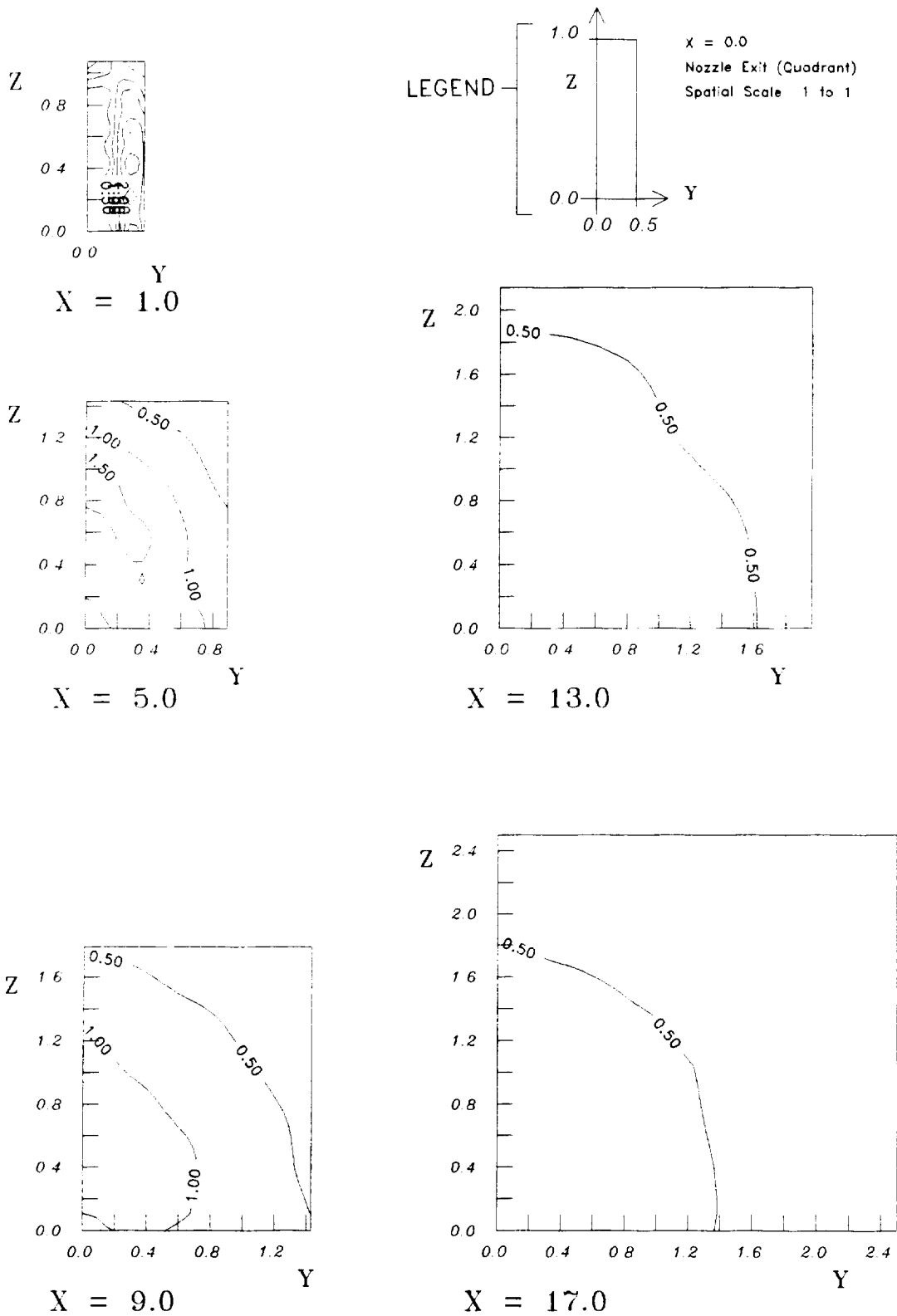

Fig. 42 1x4 Nozzle  $M=0.09$   $v_v/(U_e U_e) \times 100$

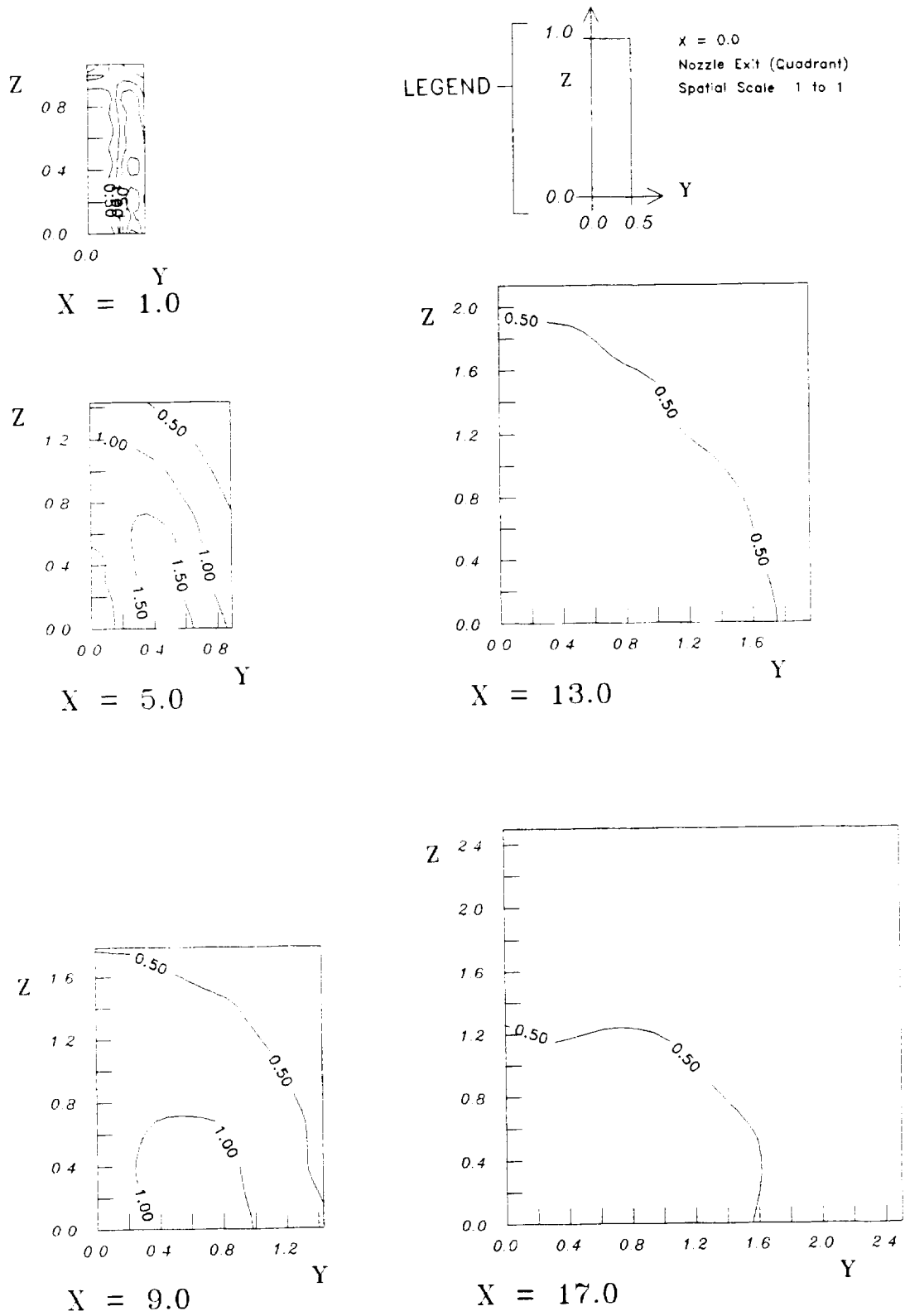

Fig. 43 1x4 Nozzle  $M=0.09$   $w_w/(U_e U_e) \times 100$



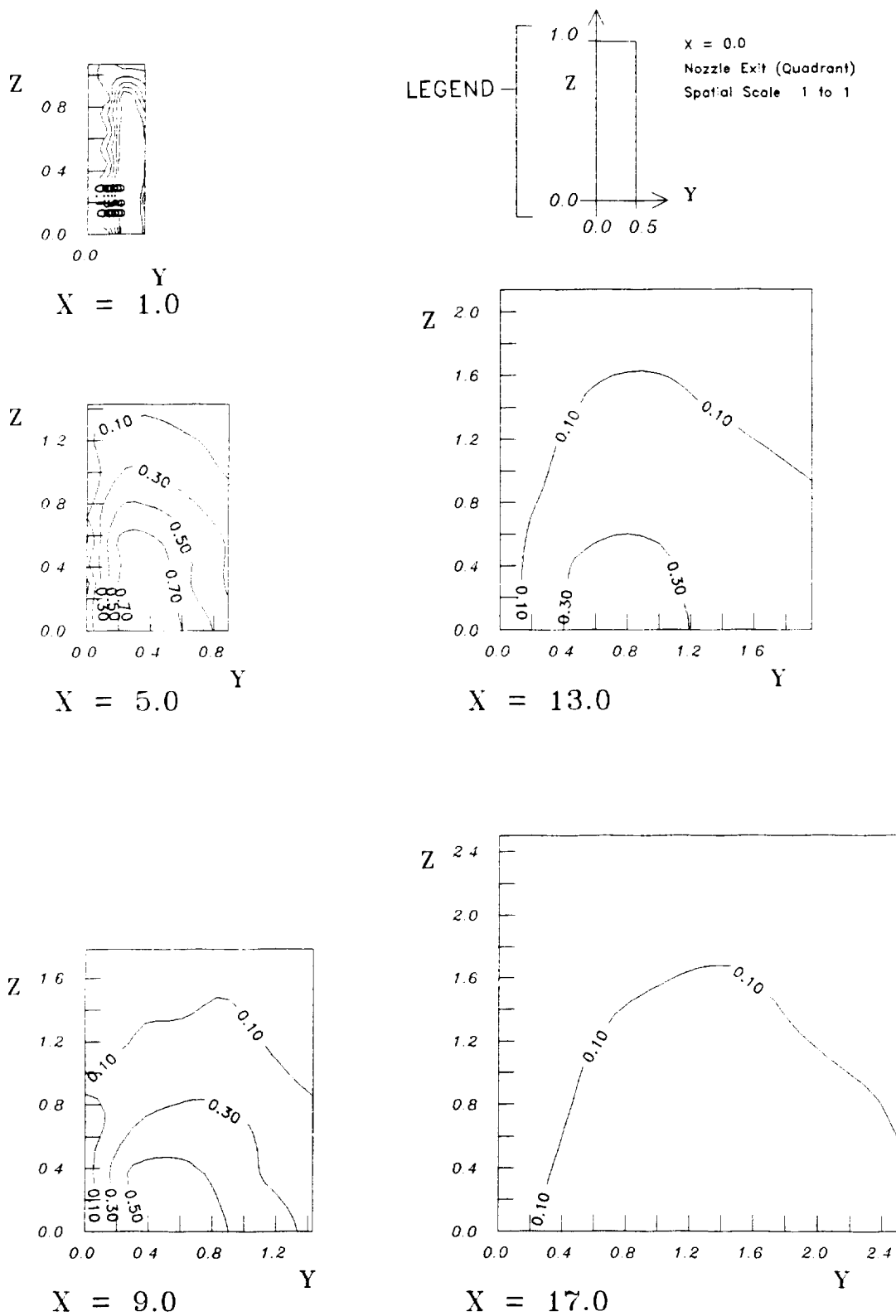

Fig. 44 1x4 Nozzle  $M=0.09$   $uv/(UeUe)x100$

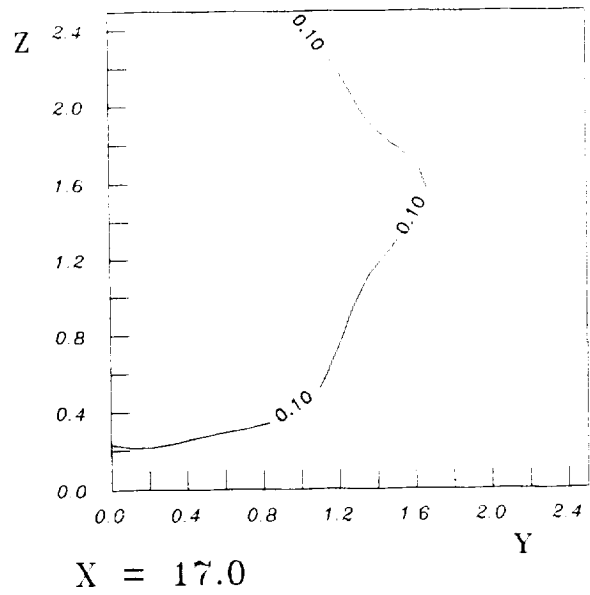
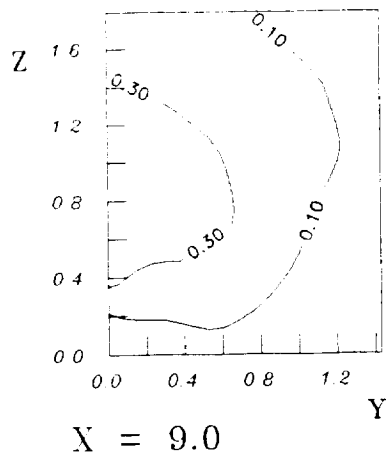
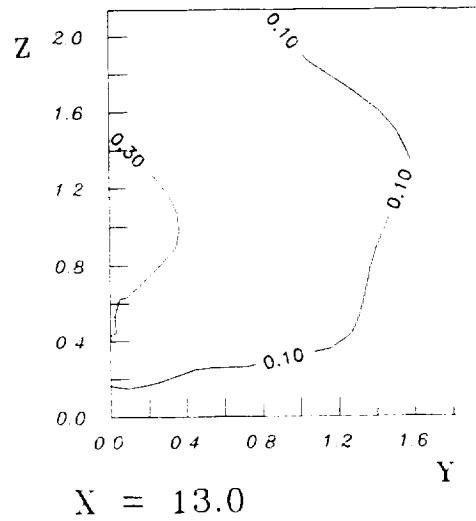
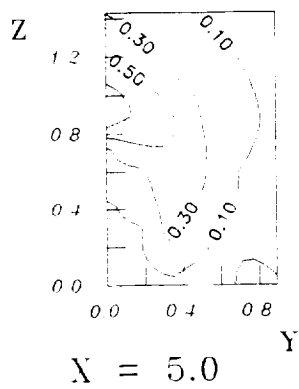
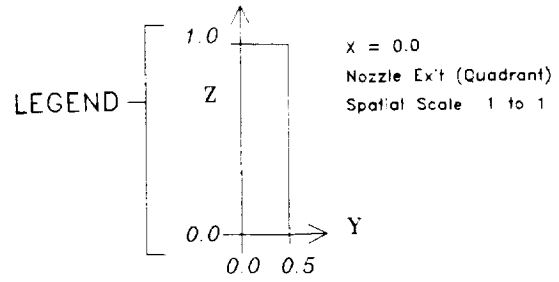
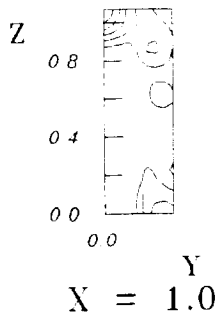

Fig. 45 1x4 Nozzle  $M=0.09$   $uw/(UeUe) \times 100$

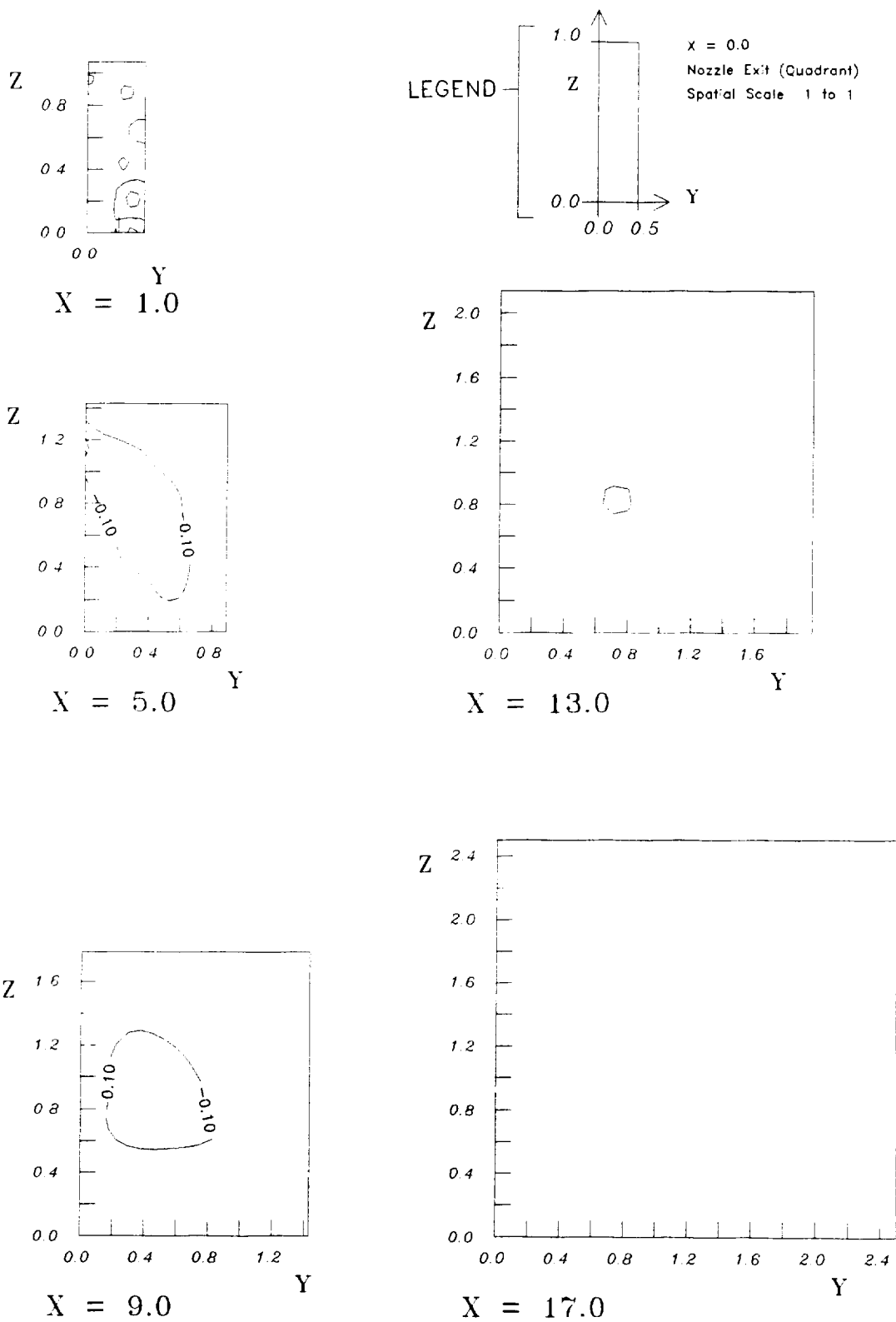

Fig. 46 1x4 Nozzle  $M=0.09$   $vw/(UeUe)x100$

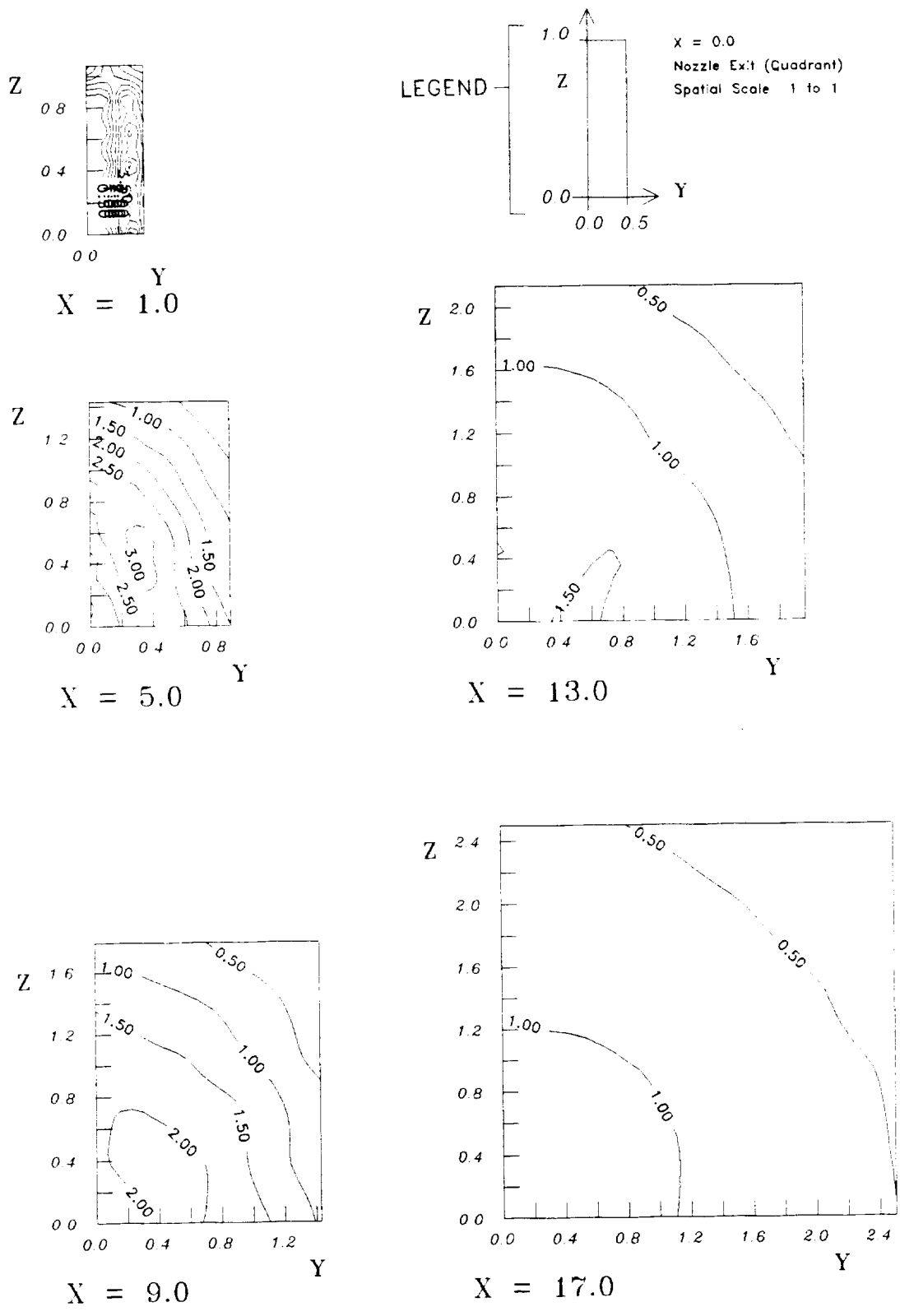

Fig. 47 1x4 Nozzle  $M=0.09$   $k/(UeUe)x100$

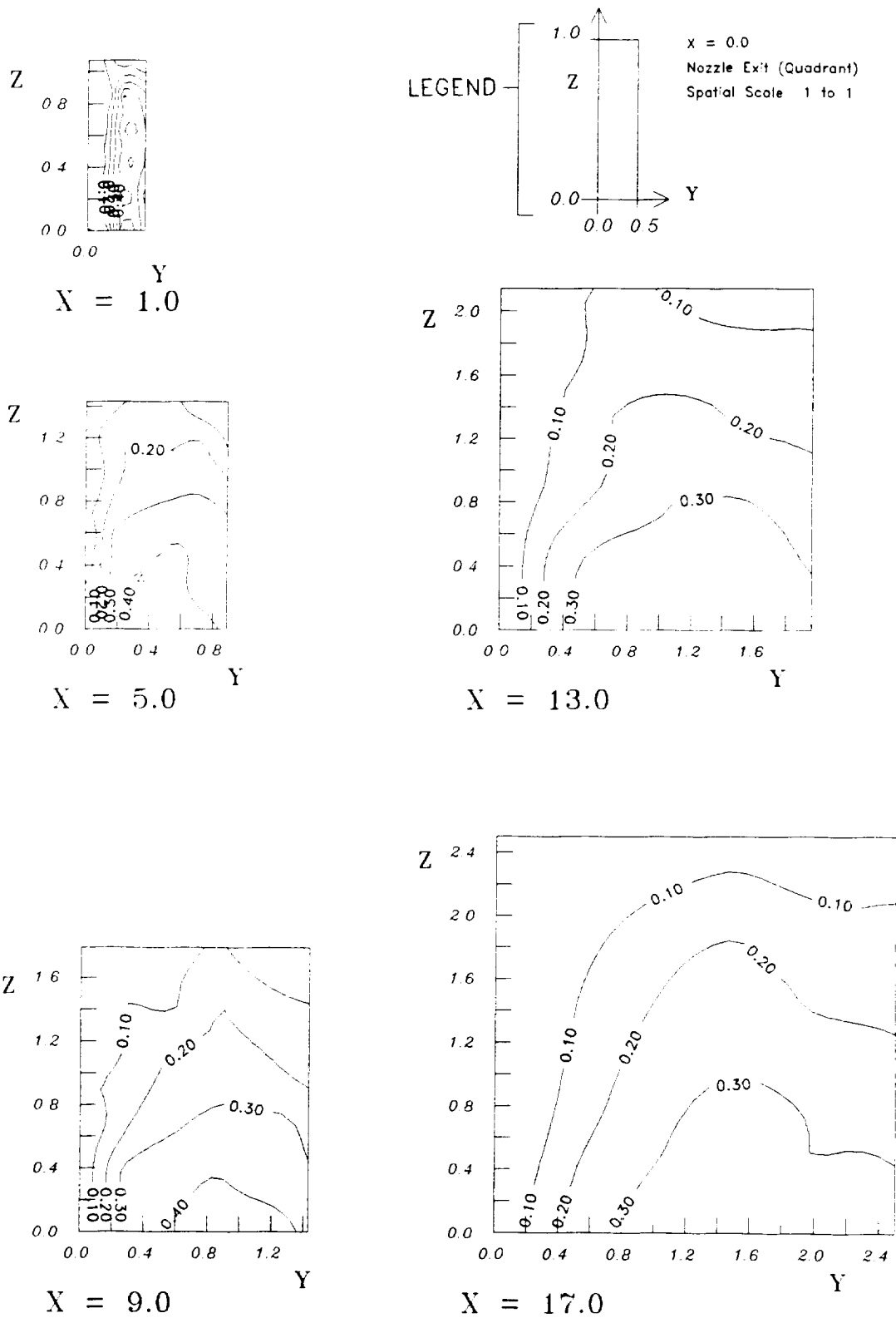

Fig. 48 1x4 Nozzle  $M=0.09$  C.C.(uv)

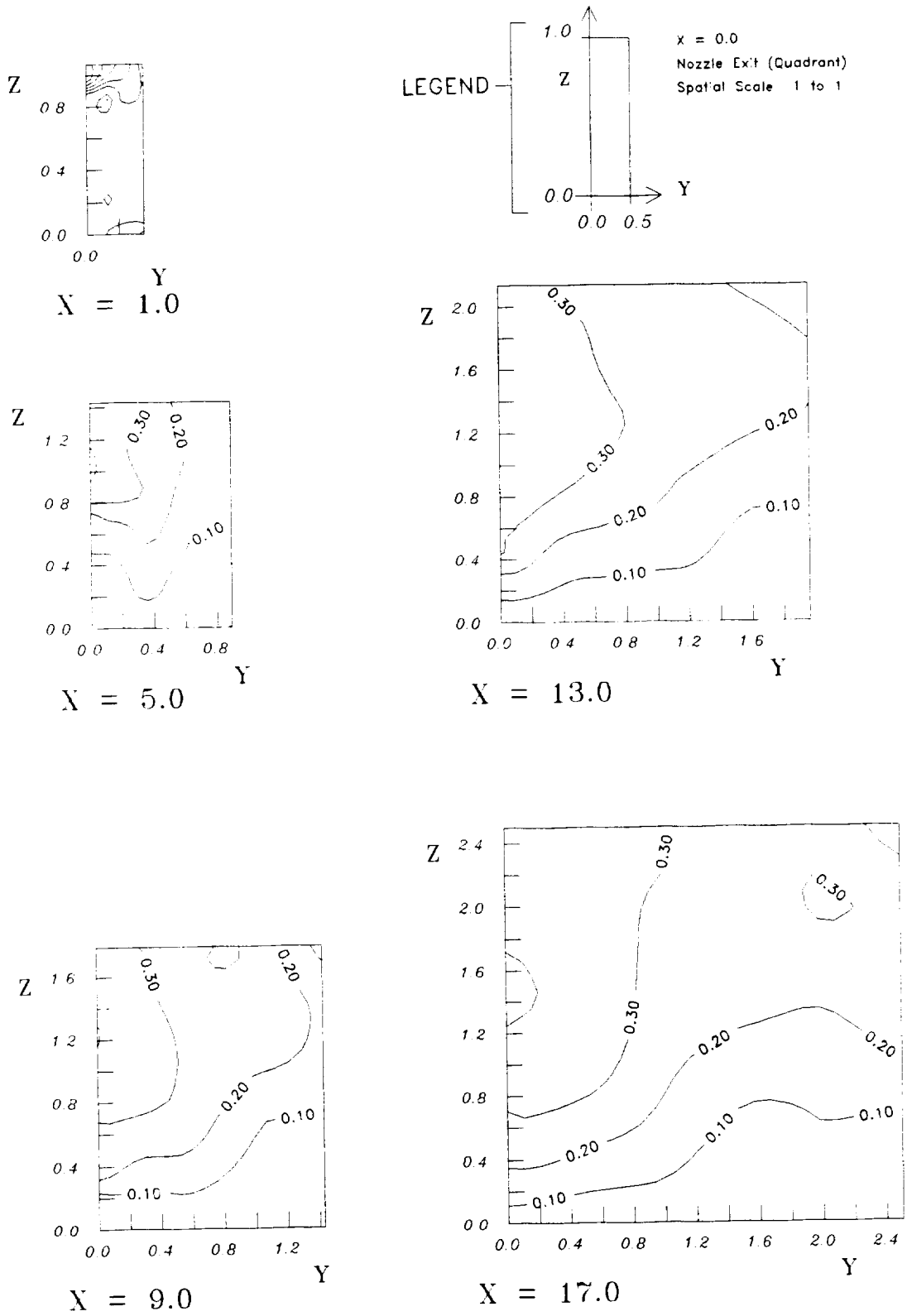

Fig. 49 1x4 Nozzle  $M=0.09$  C.C.(uw)

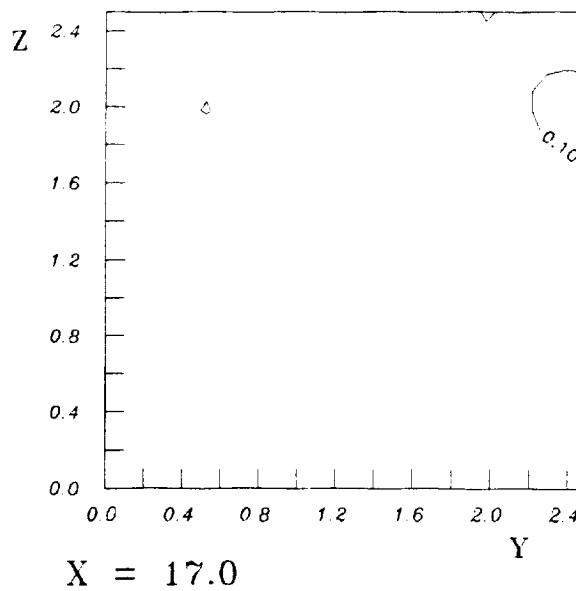
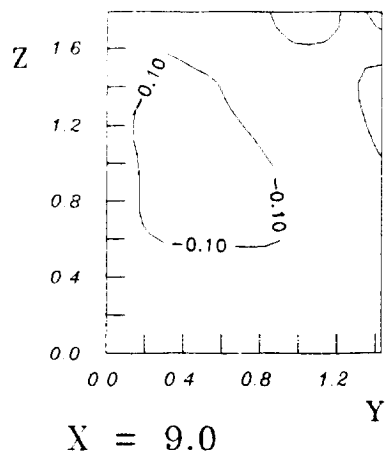
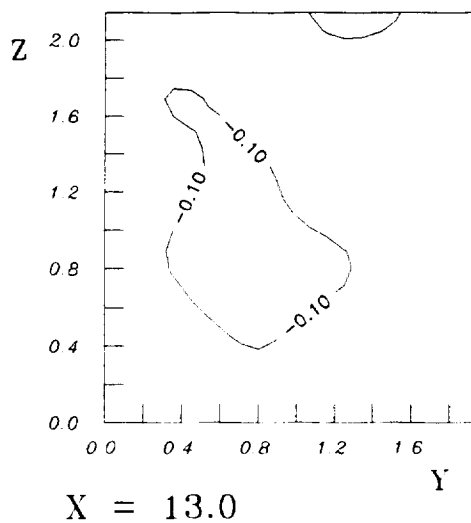
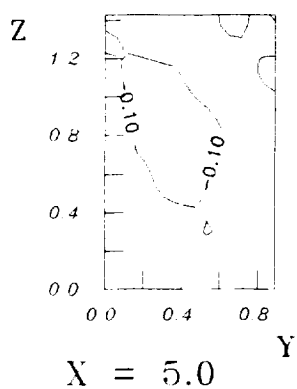
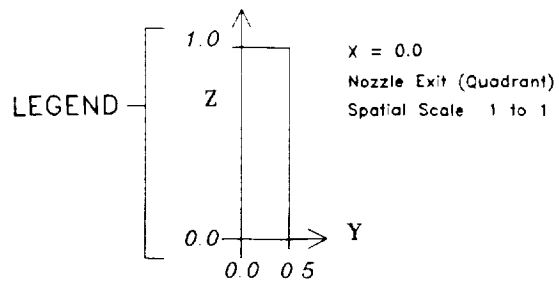
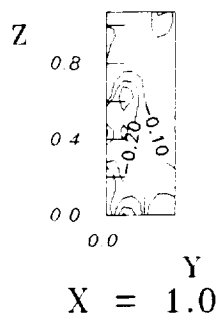
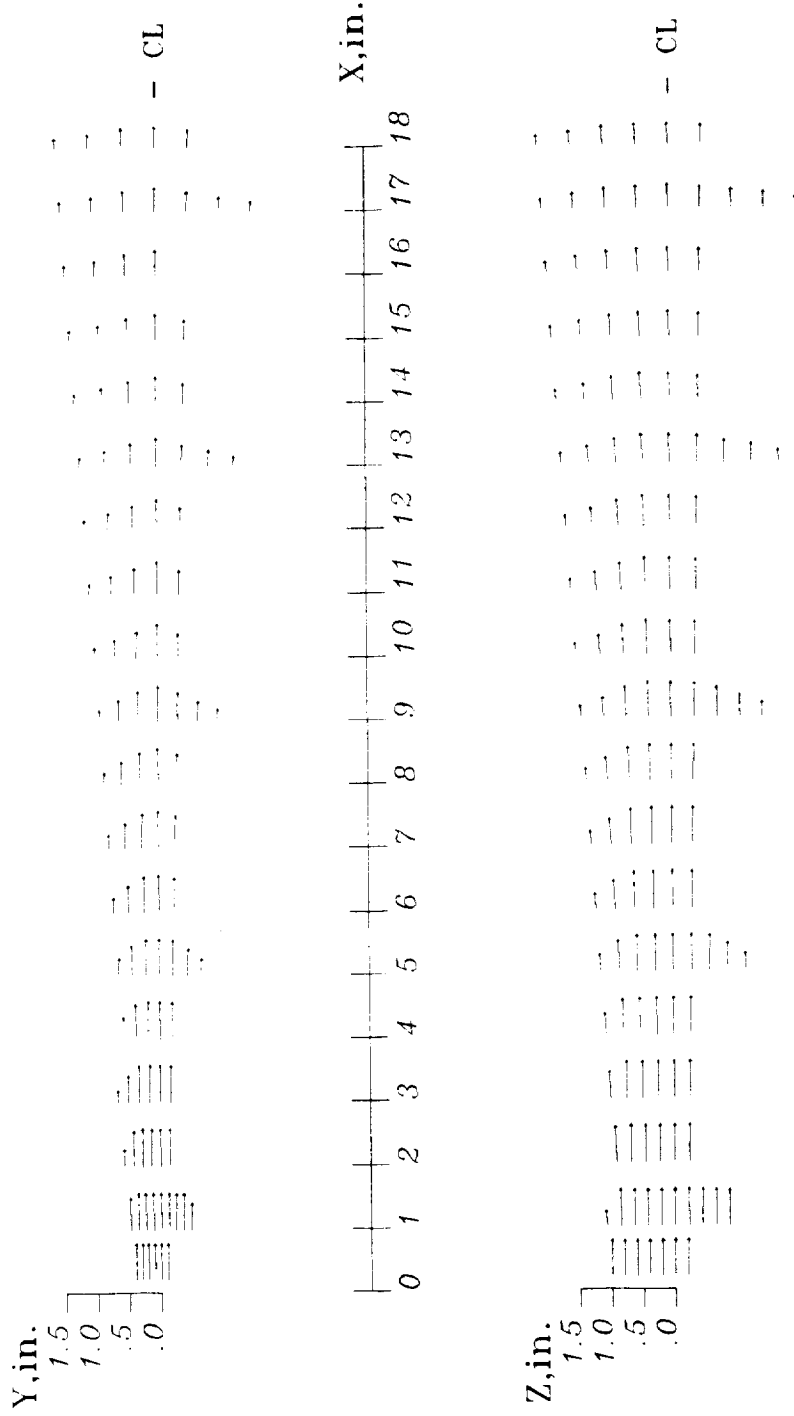

Fig. 50 1x4 Nozzle  $M=0.09$  C.C.(vw)



Spatial Scale 1 to 3 Vector Scale  $U_e = \dots$   
Fig. 51 1x2 Nozzle  $M=0.9$  Velocity Vectors



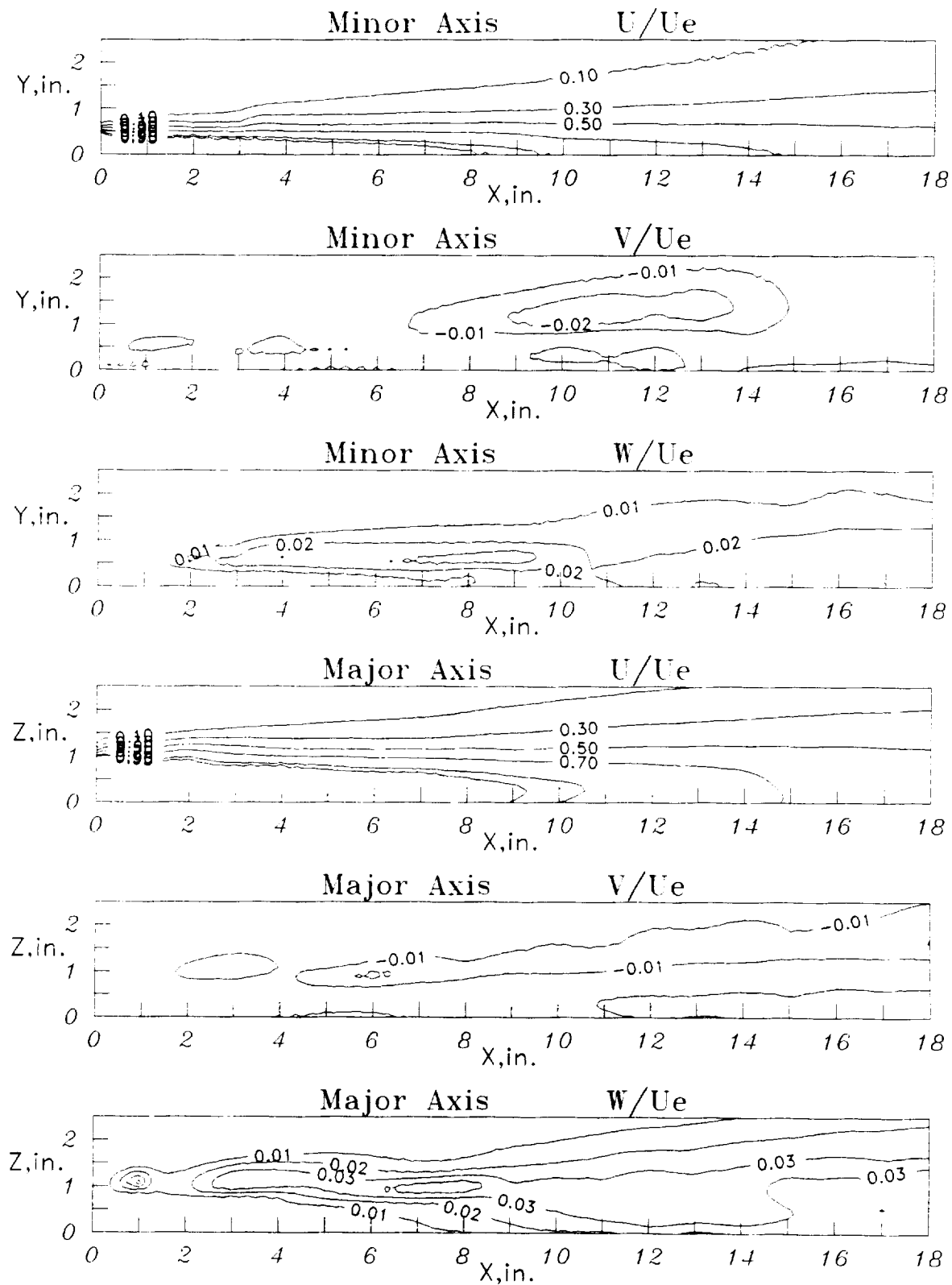

Fig. 52 1x2 Nozzle M=0.9 Mean Velocity

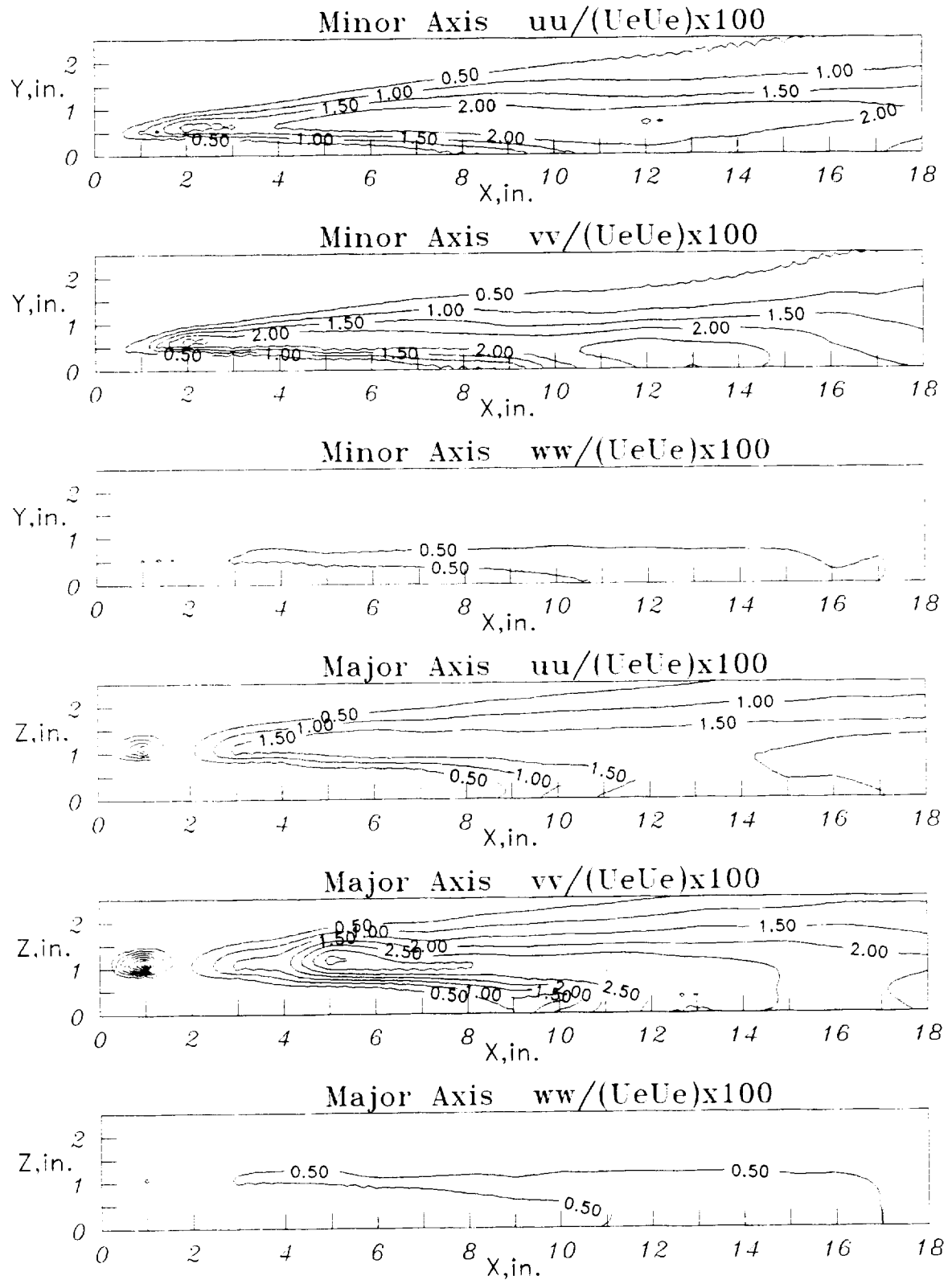

Fig. 53 1x2 Nozzle  $M=0.9$  Velocity Variance

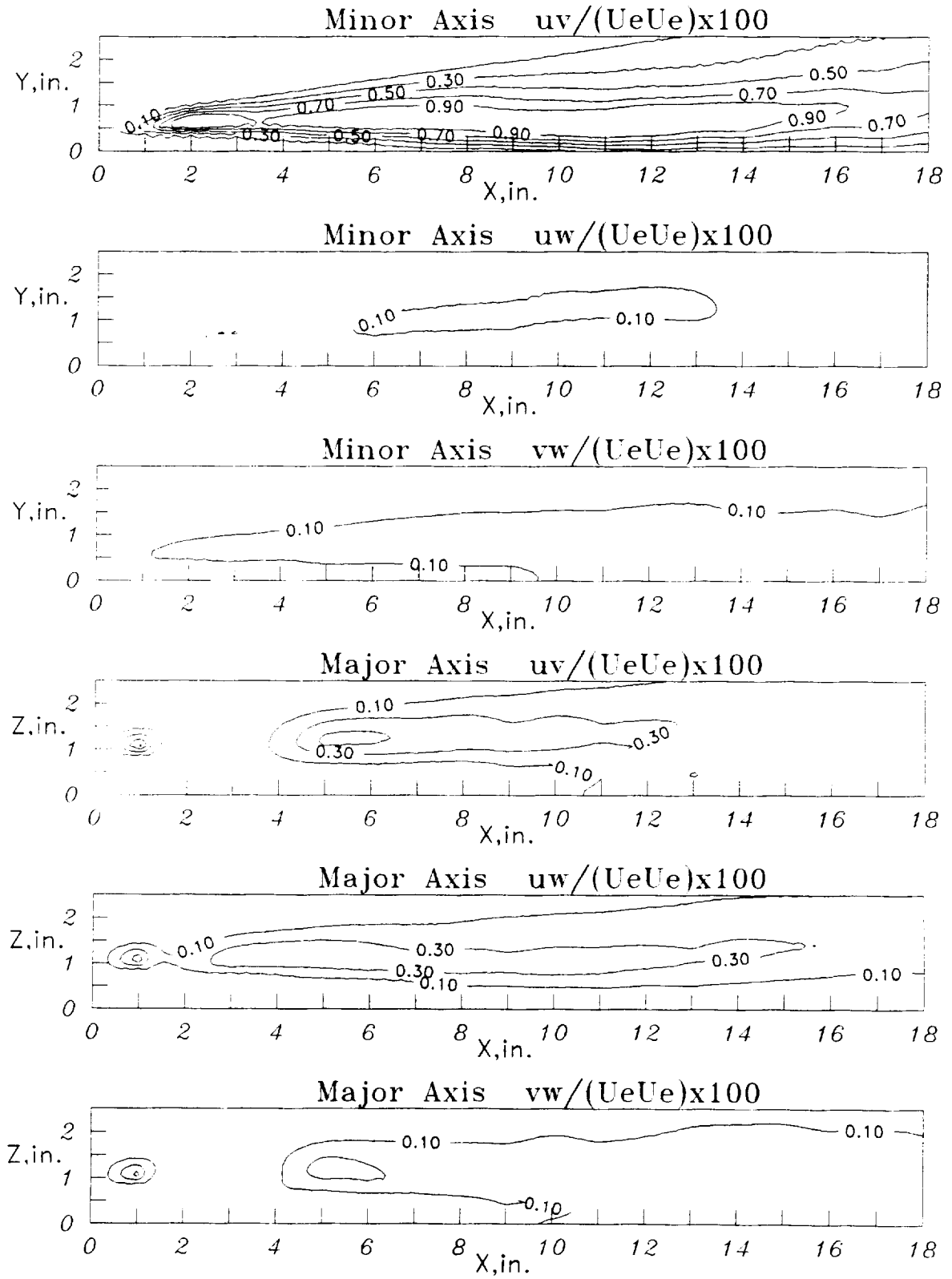

Fig. 54 1x2 Nozzle  $M=0.9$  Velocity Covariance

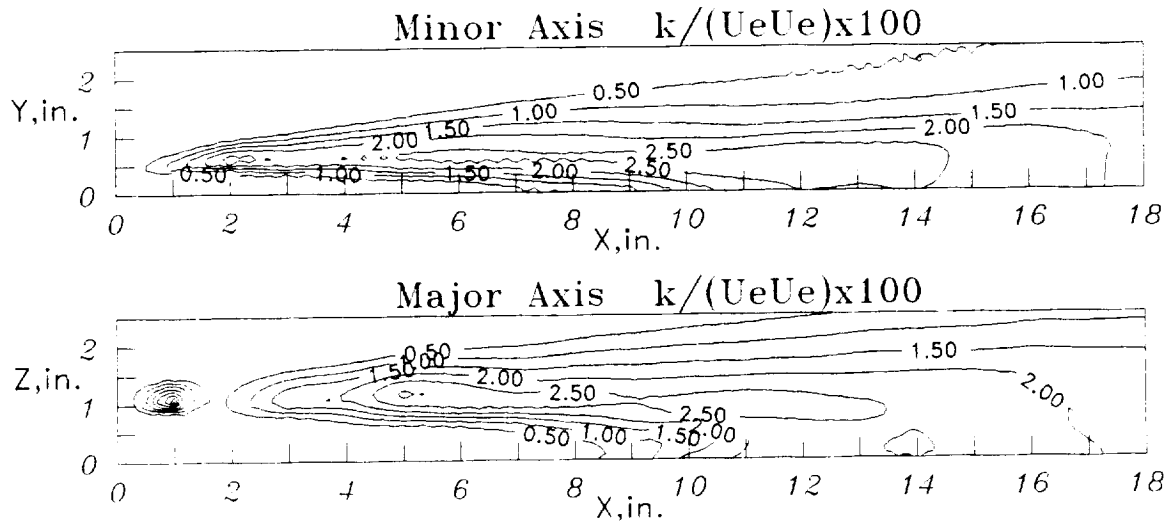

Fig. 55 1x2 Nozzle  $M=0.9$  Turbulent K.E. (k)

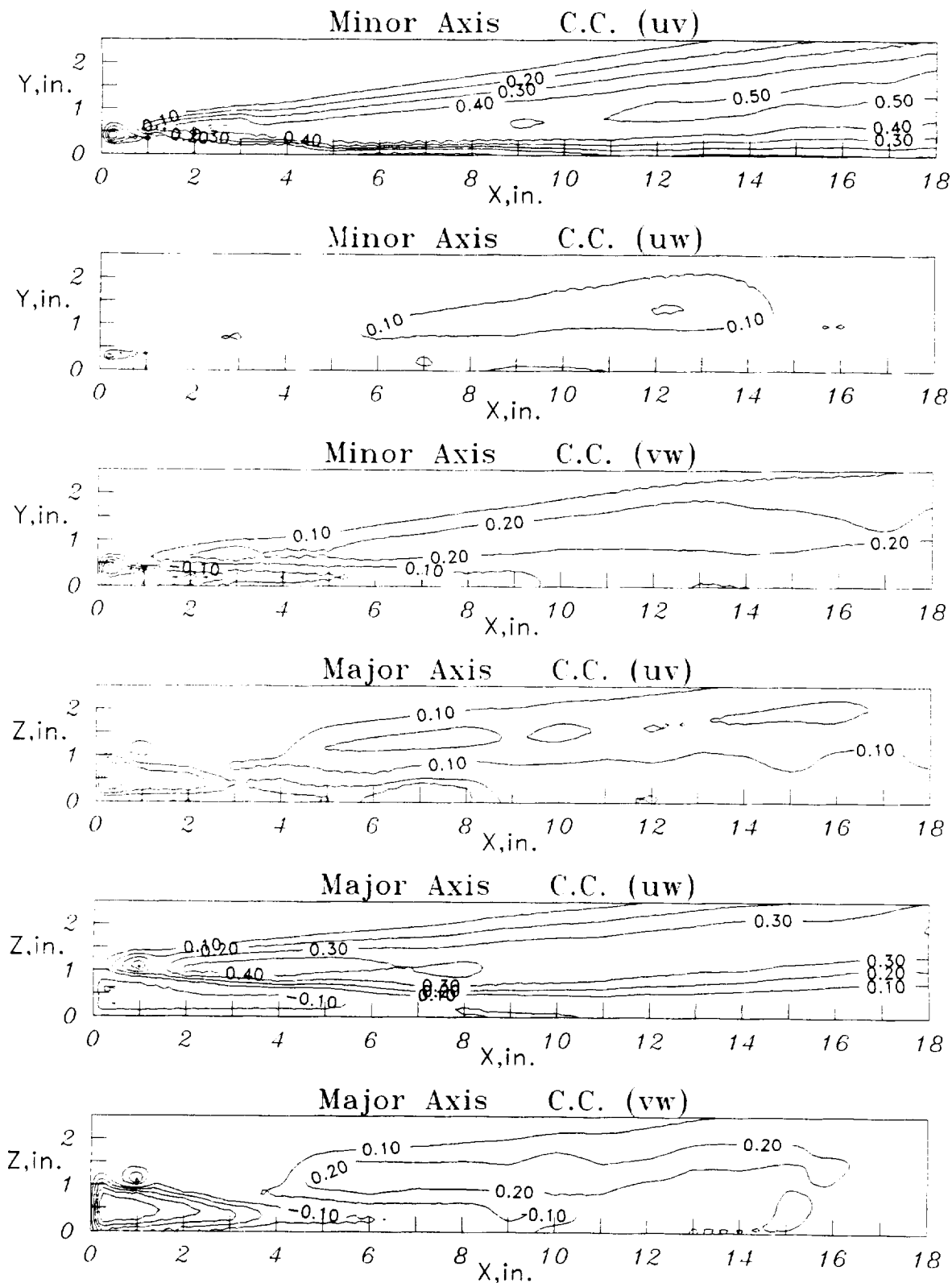

Fig. 56 1x2 Nozzle  $M=0.9$  Velocity Correlation

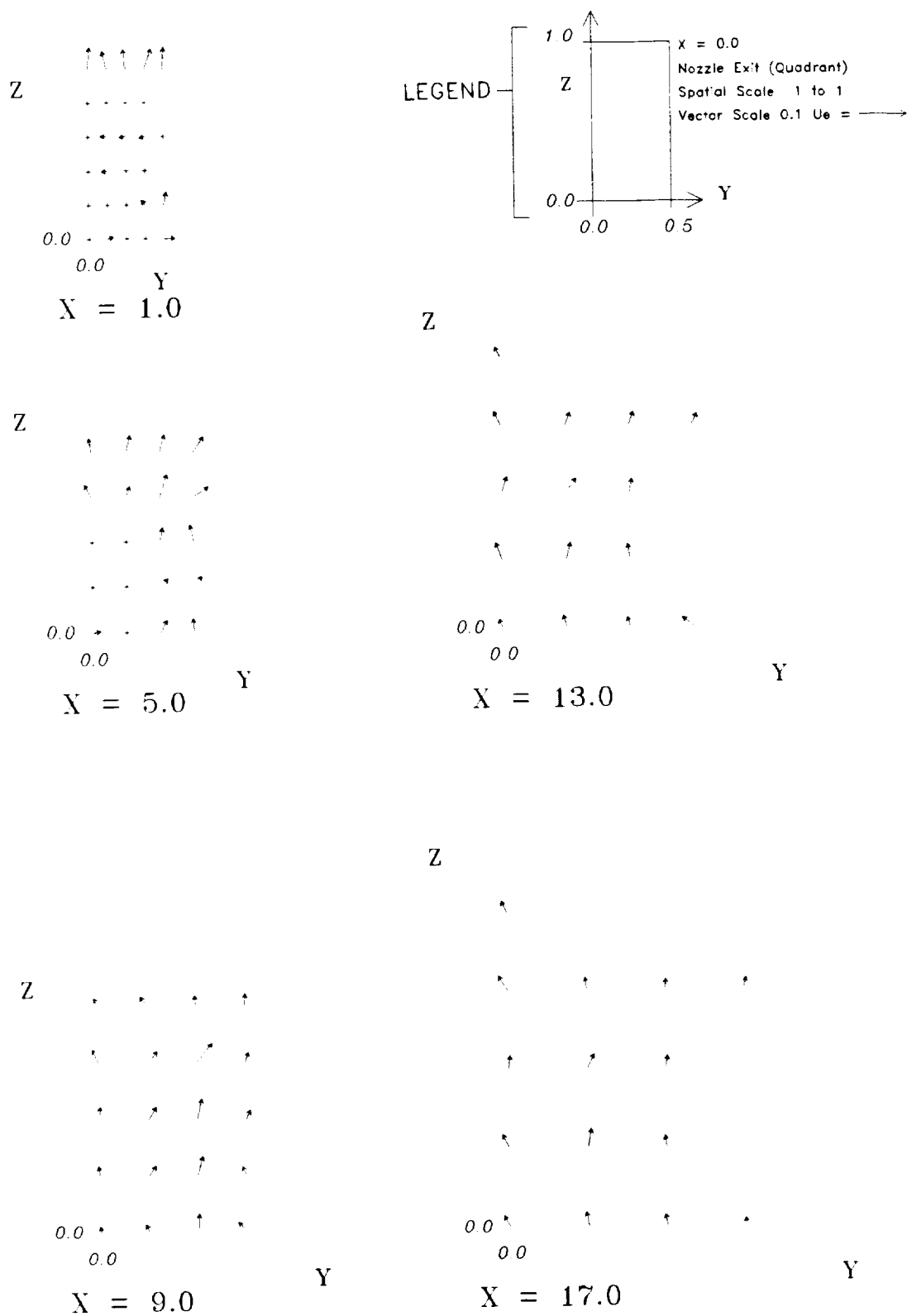
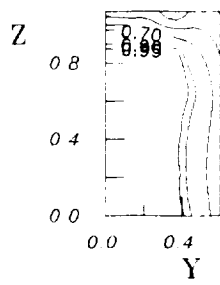
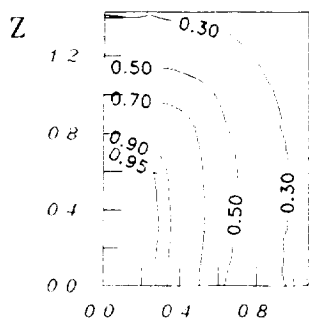
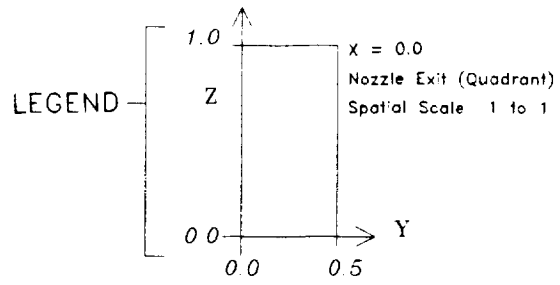

Fig. 57 1x2 Nozzle M=0.9 Velocity Vectors



X = 1.0



X = 5.0

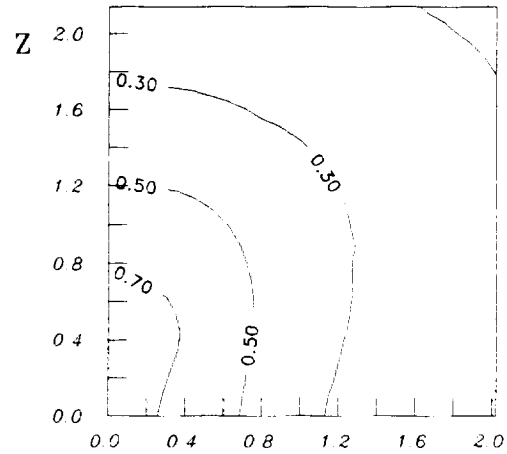

X = 13.0

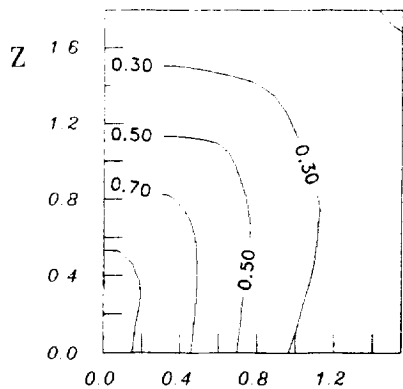

X = 9.0

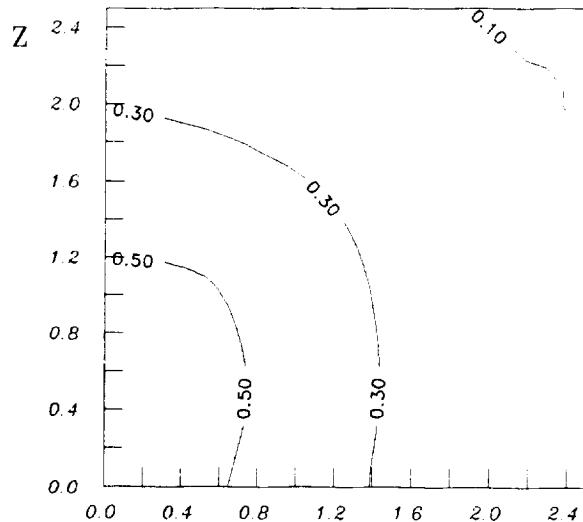

X = 17.0

Fig. 58 M=0.9 1x2 Nozzle U/Ue

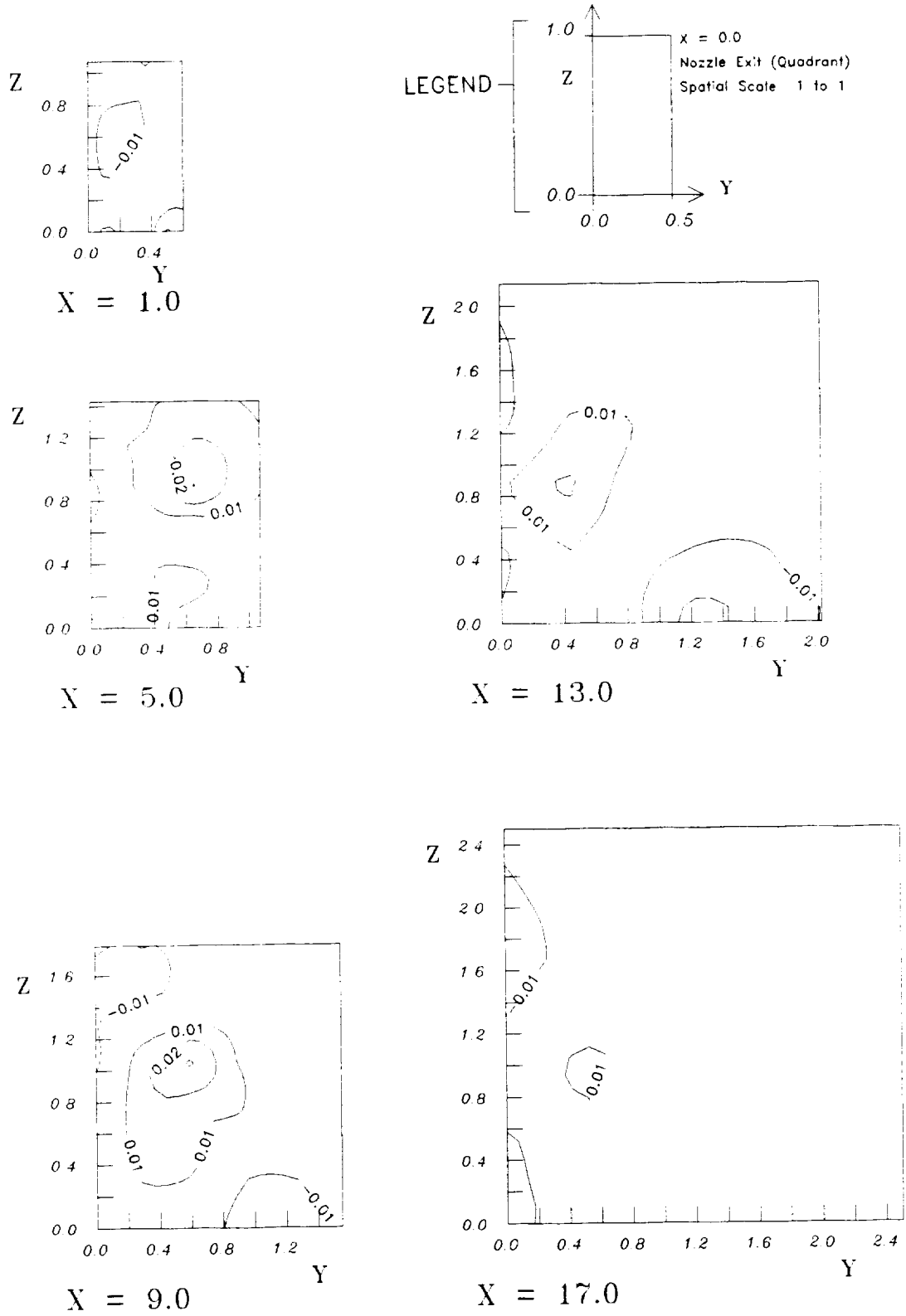

Fig. 59 1x2 Nozzle  $M=0.9$   $V/U_e$



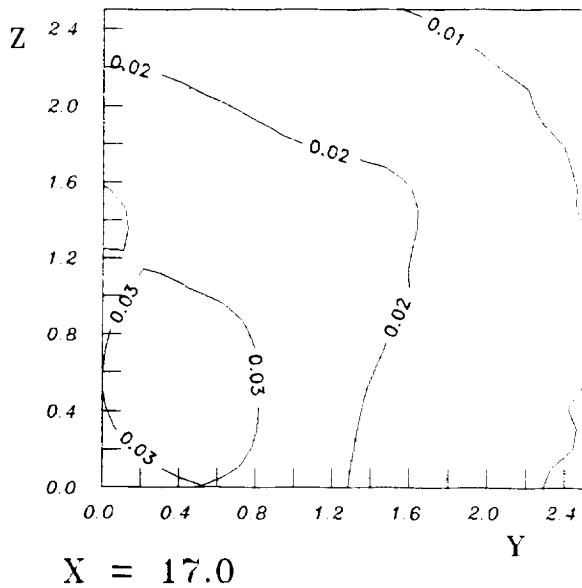
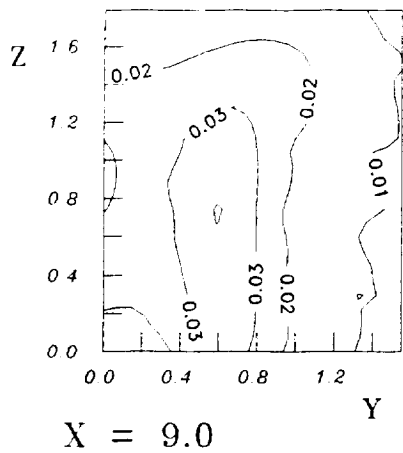
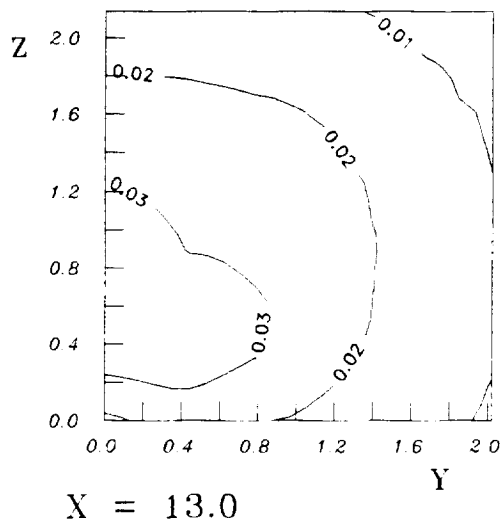
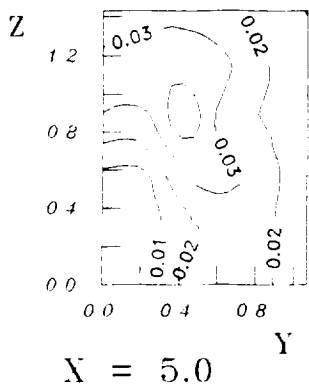
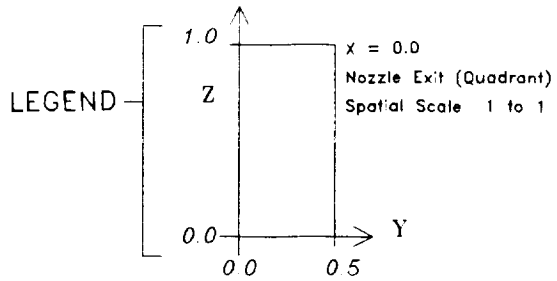
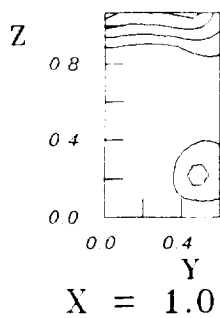

Fig. 60 1x2 Nozzle M=0.9 W/Ue

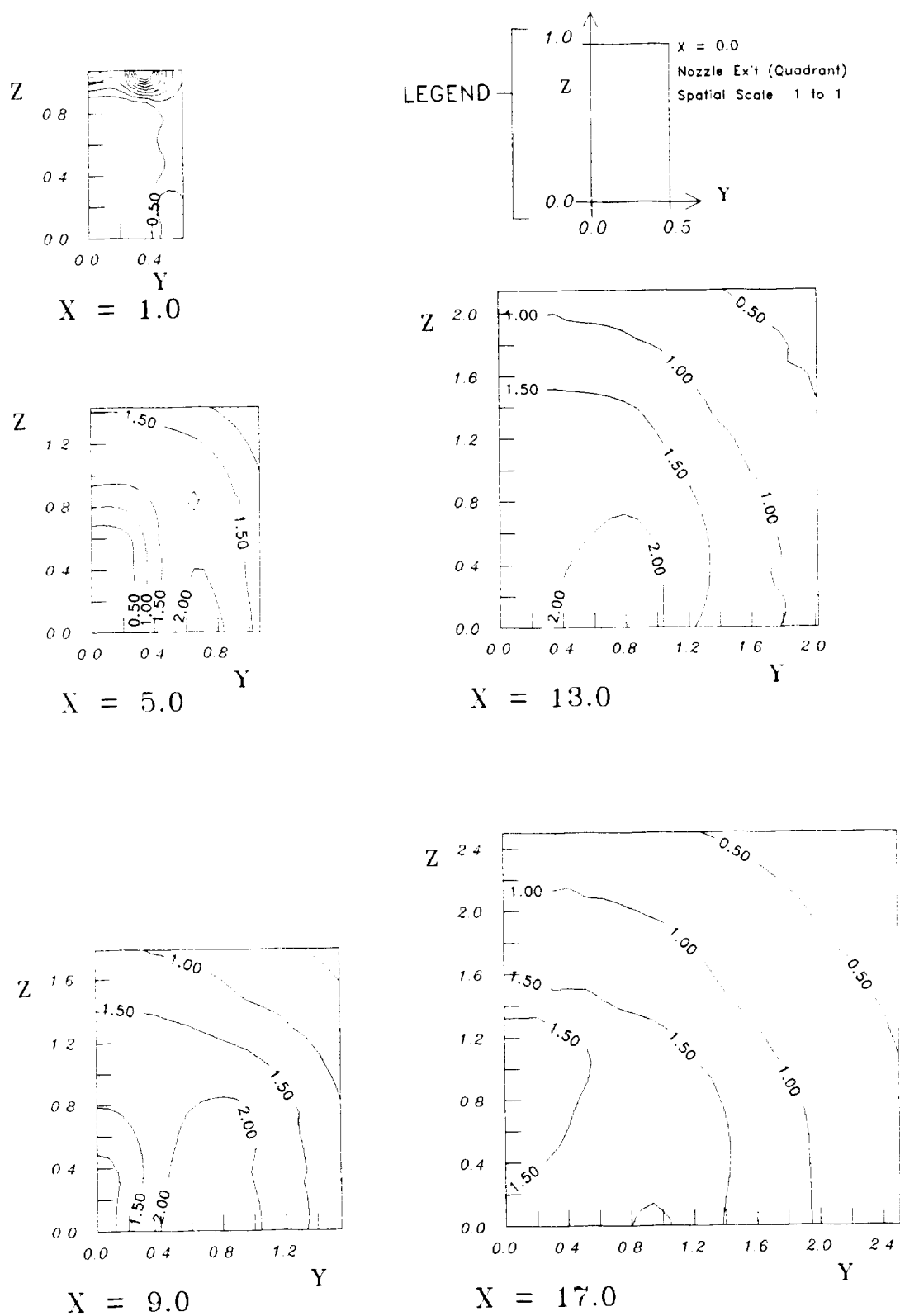

Fig. 61 1x2 Nozzle  $M=0.9$   $uu/(UeUe)x100$

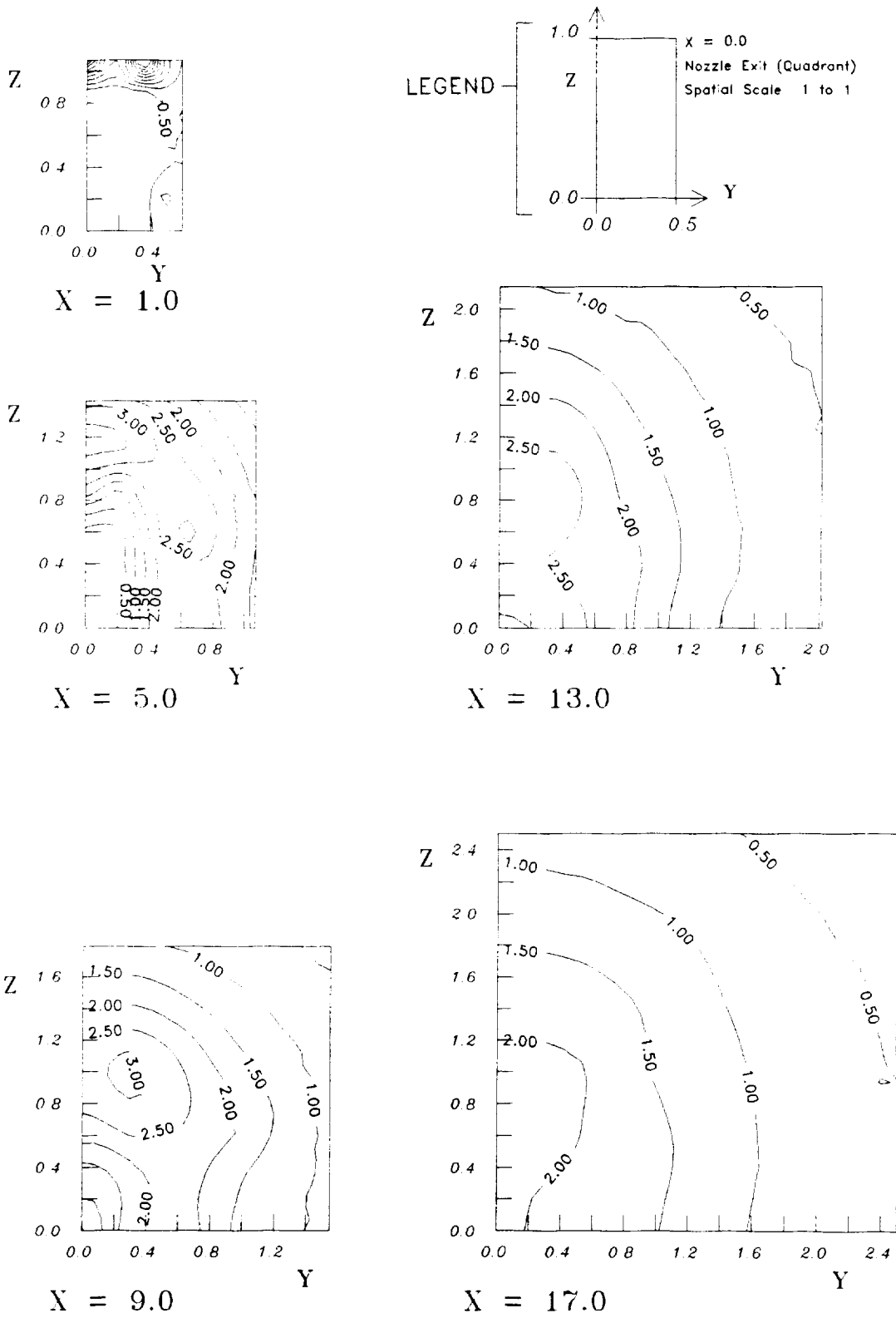

Fig. 62 1x2 Nozzle M=0.9  $v_v / (U_e U_e) \times 100$

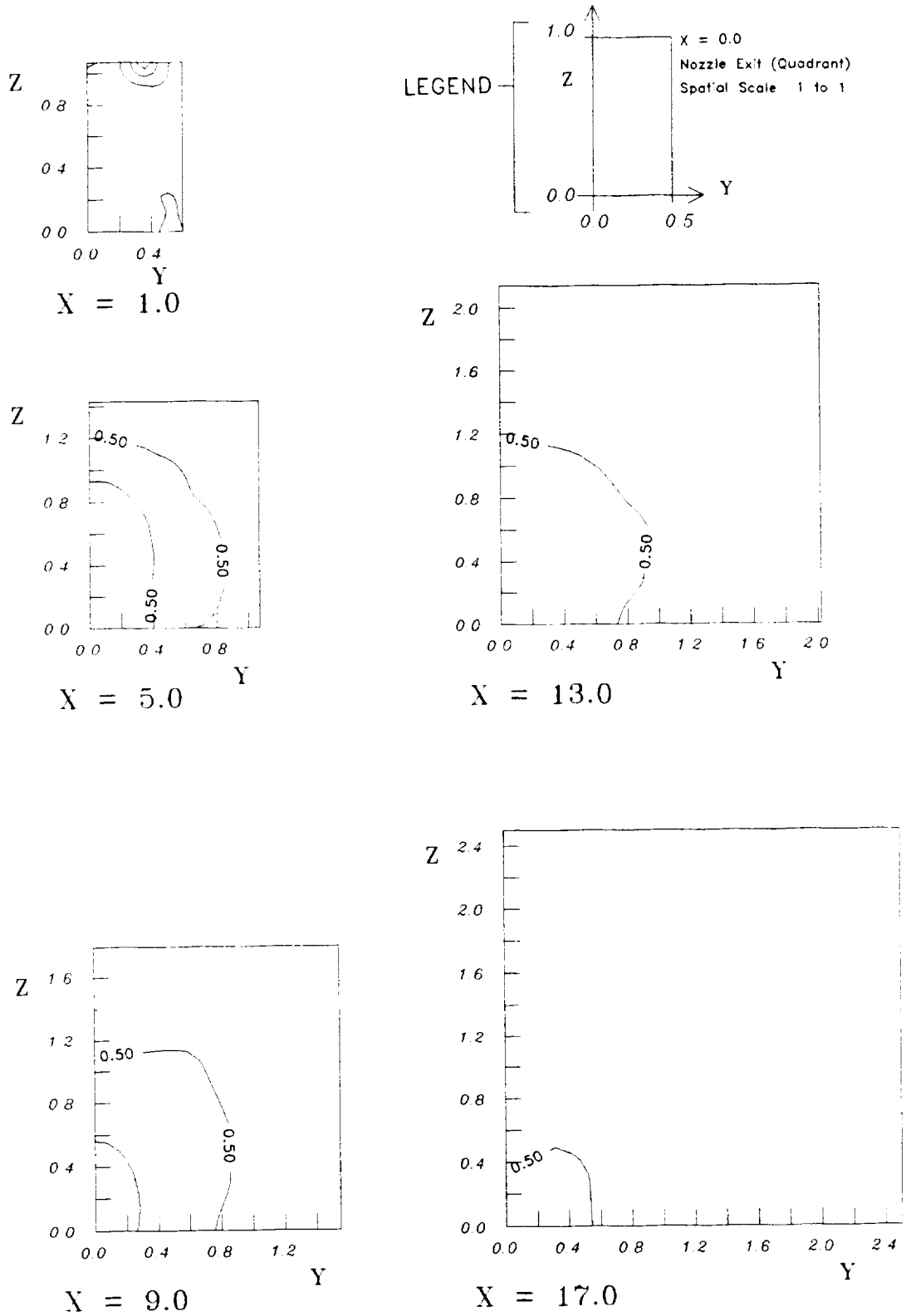

Fig. 63 1x2 Nozzle  $M=0.9$   $w_w/(U_e U_e) \times 100$

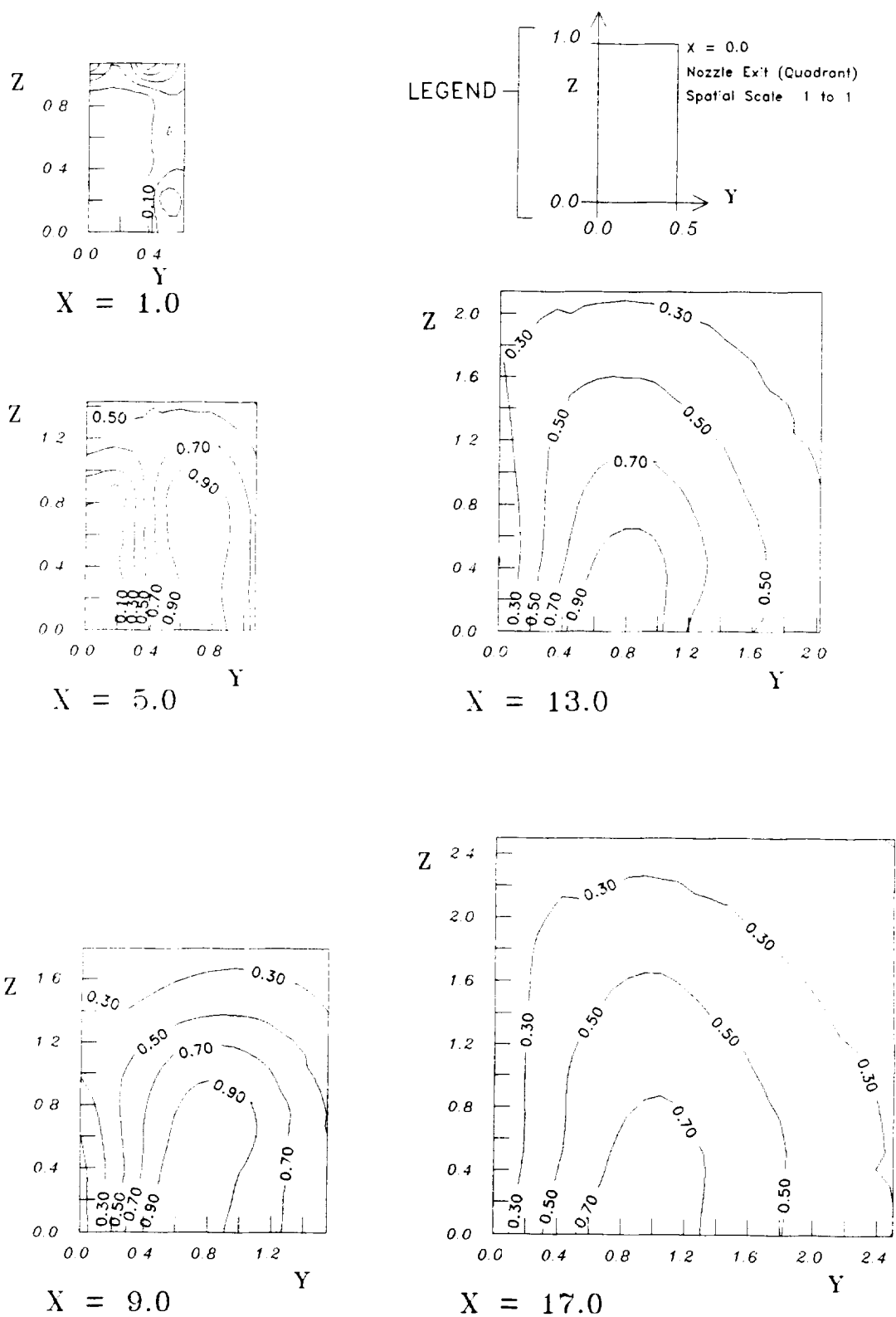
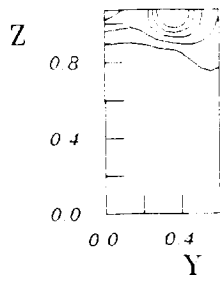
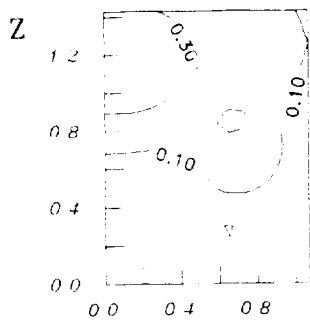
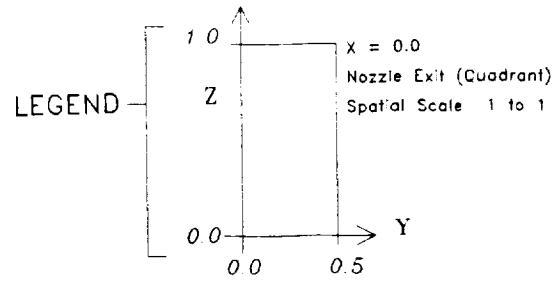

Fig. 64 1x2 Nozzle M=0.9  $uv/(UeUe) \times 100$



X = 1.0



X = 5.0

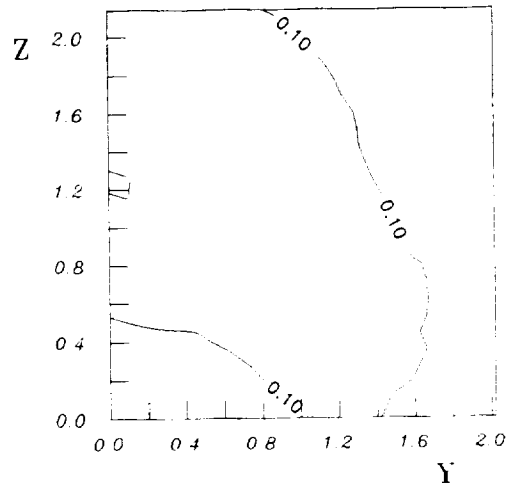

X = 13.0

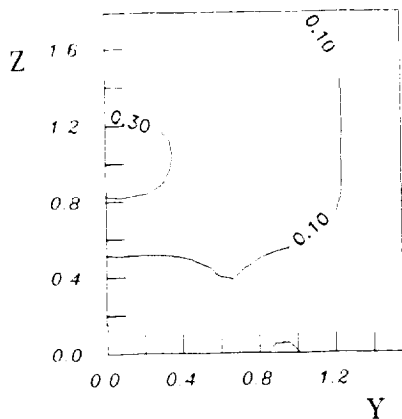

X = 9.0

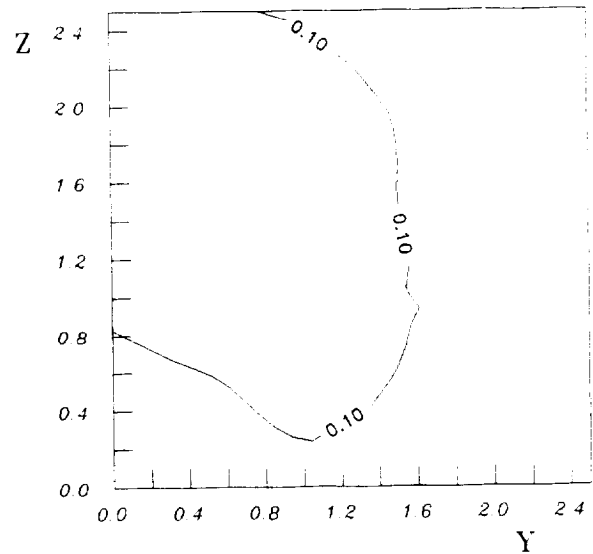

X = 17.0

Fig. 65 1x2 Nozzle M=0.9  $uw/(UeUe) \times 100$

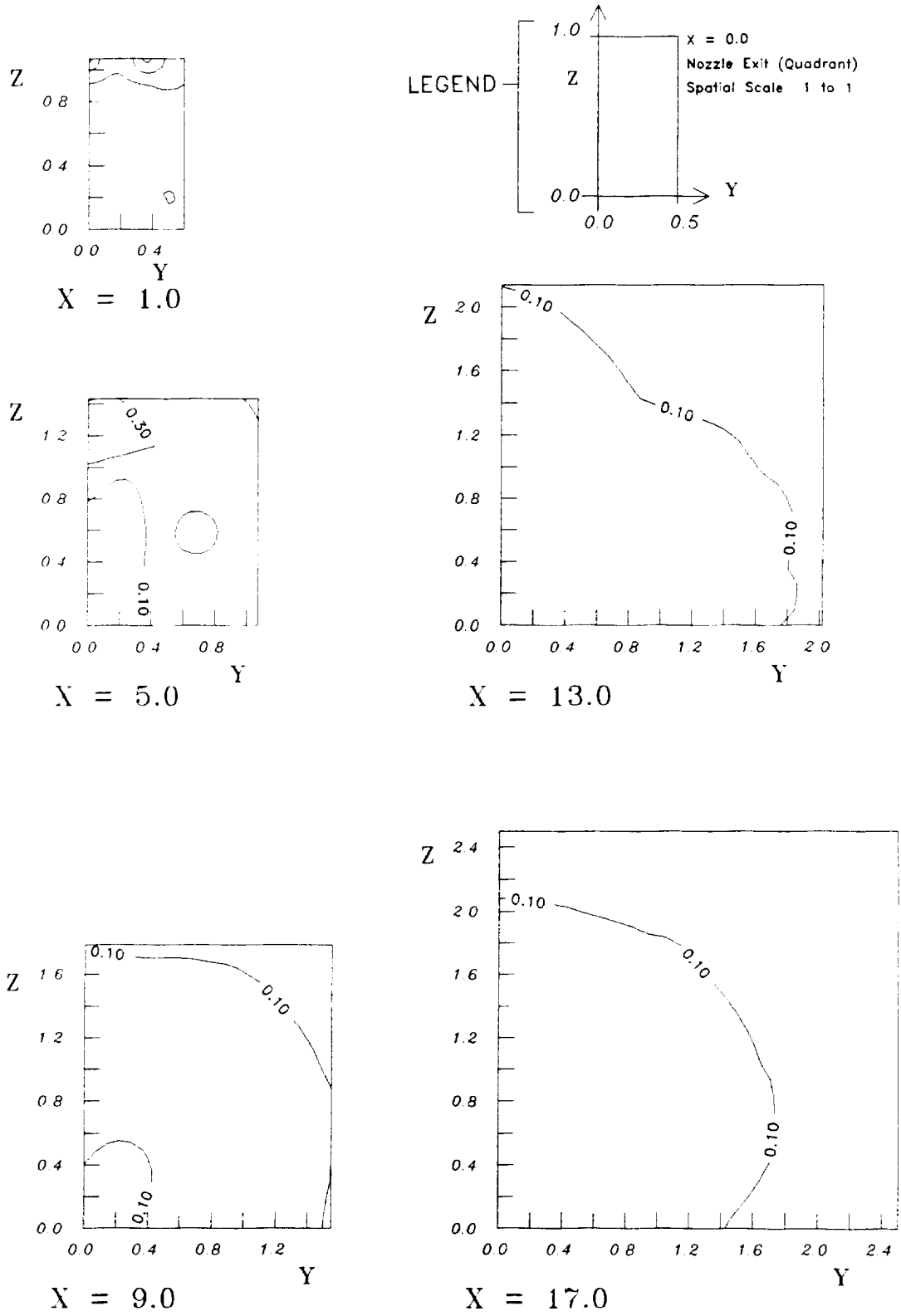

Fig. 66 1x2 Nozzle  $M=0.9$   $vw/(UeUe)x100$

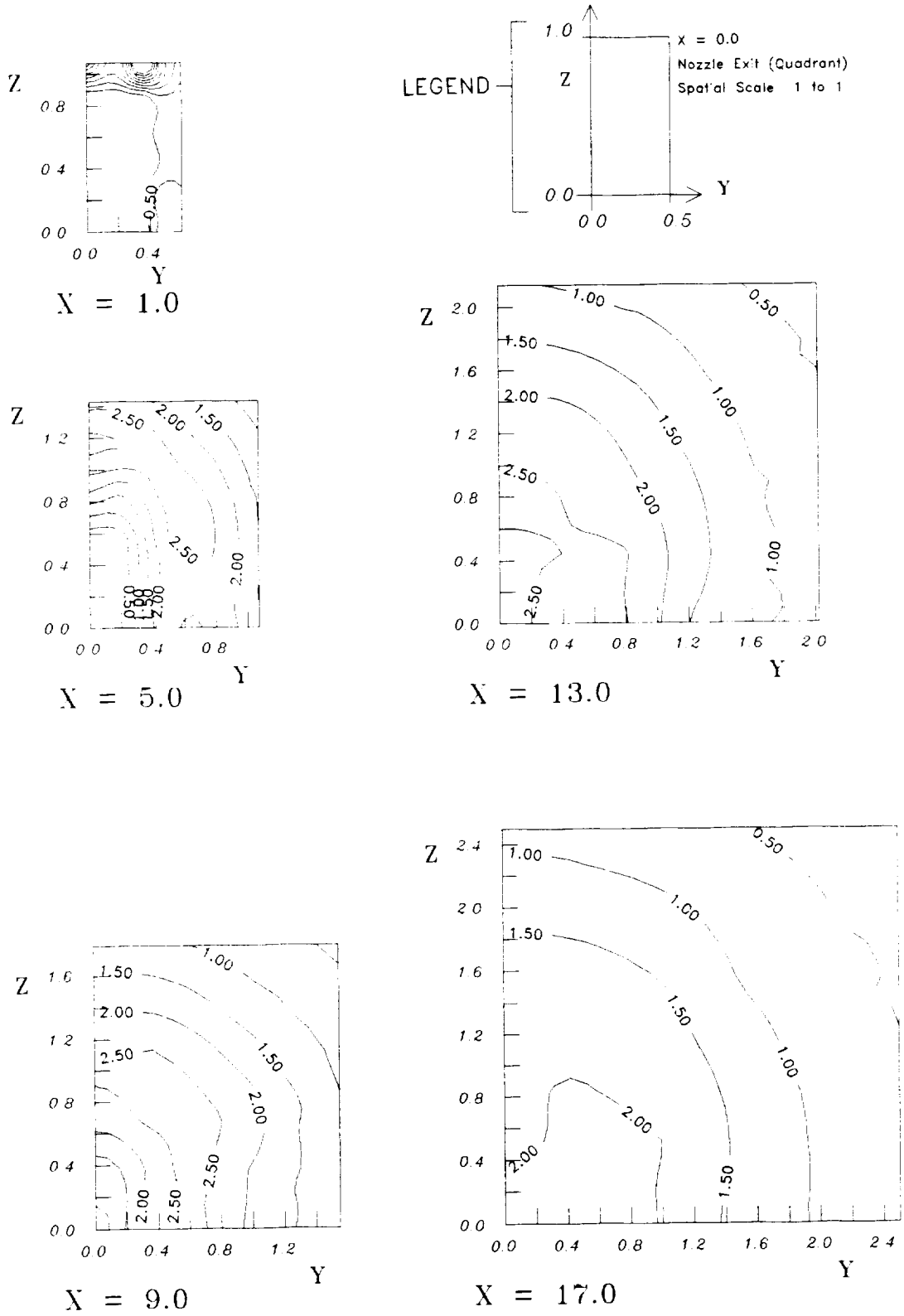

Fig. 67 1x2 Nozzle  $M=0.9$   $k/(UeUe)x100$



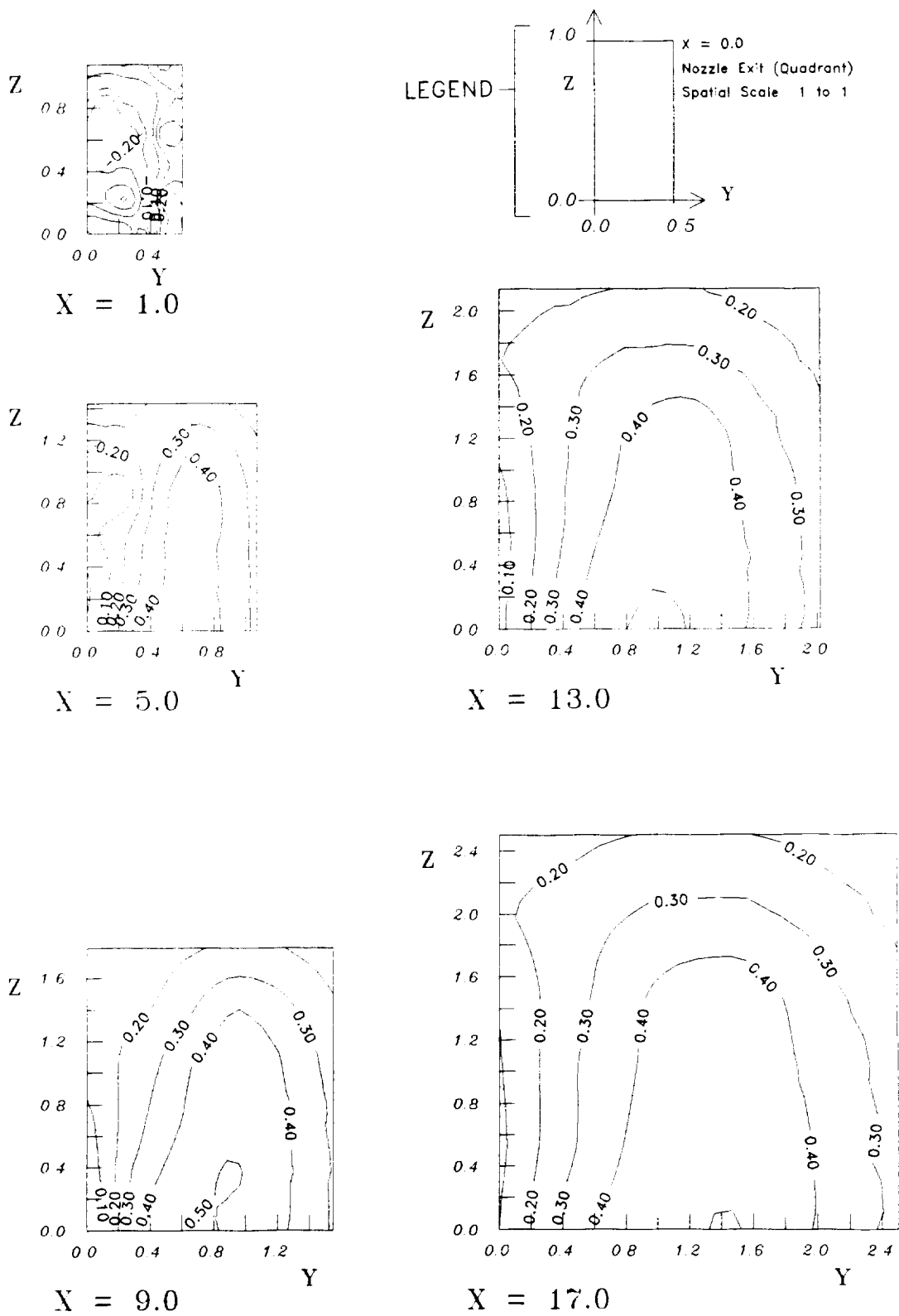

Fig. 68 1x2 Nozzle  $M=0.9$  C.C.(uv)

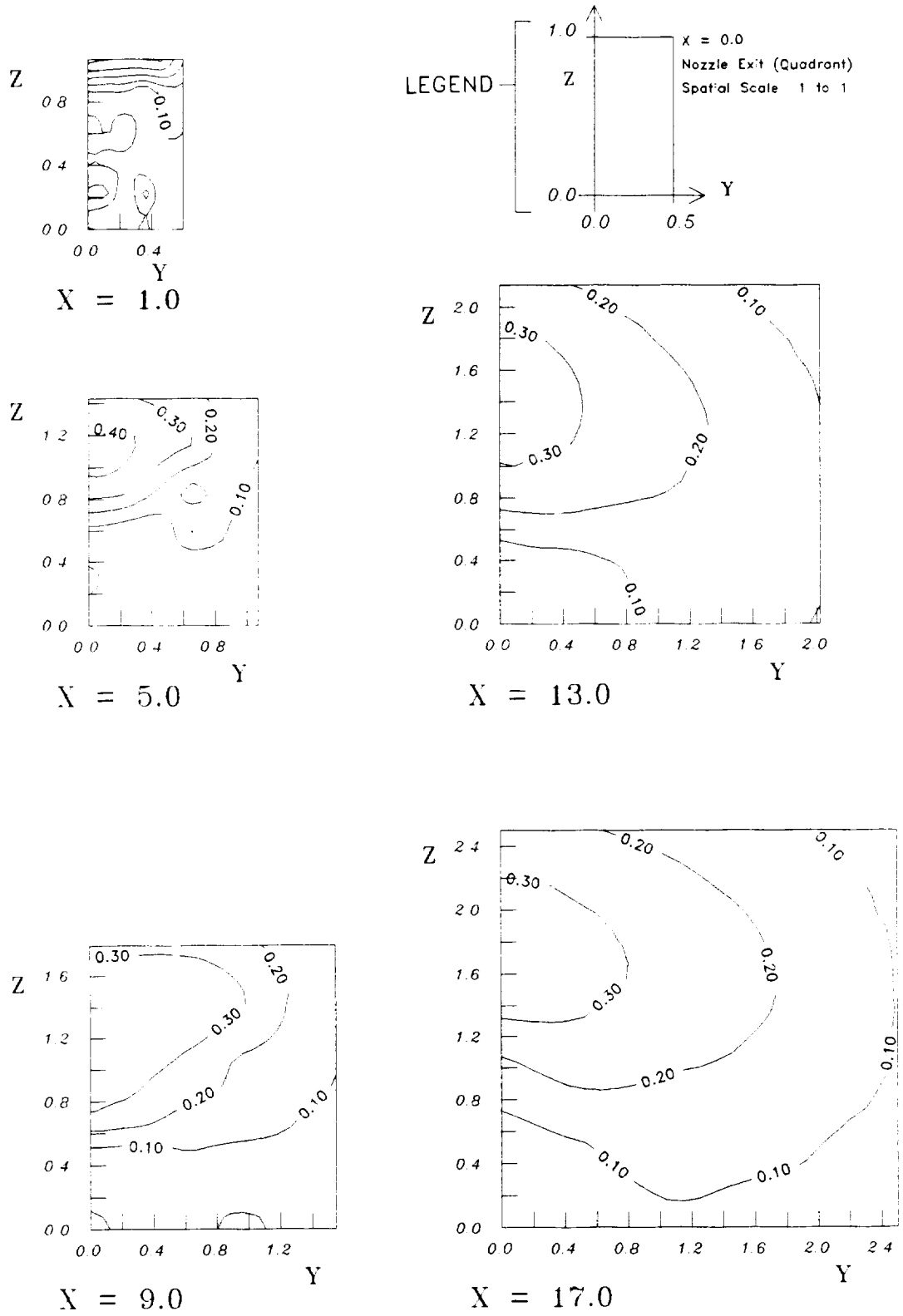

Fig. 69 1x2 Nozzle  $M=0.9$  C.C.(uw)

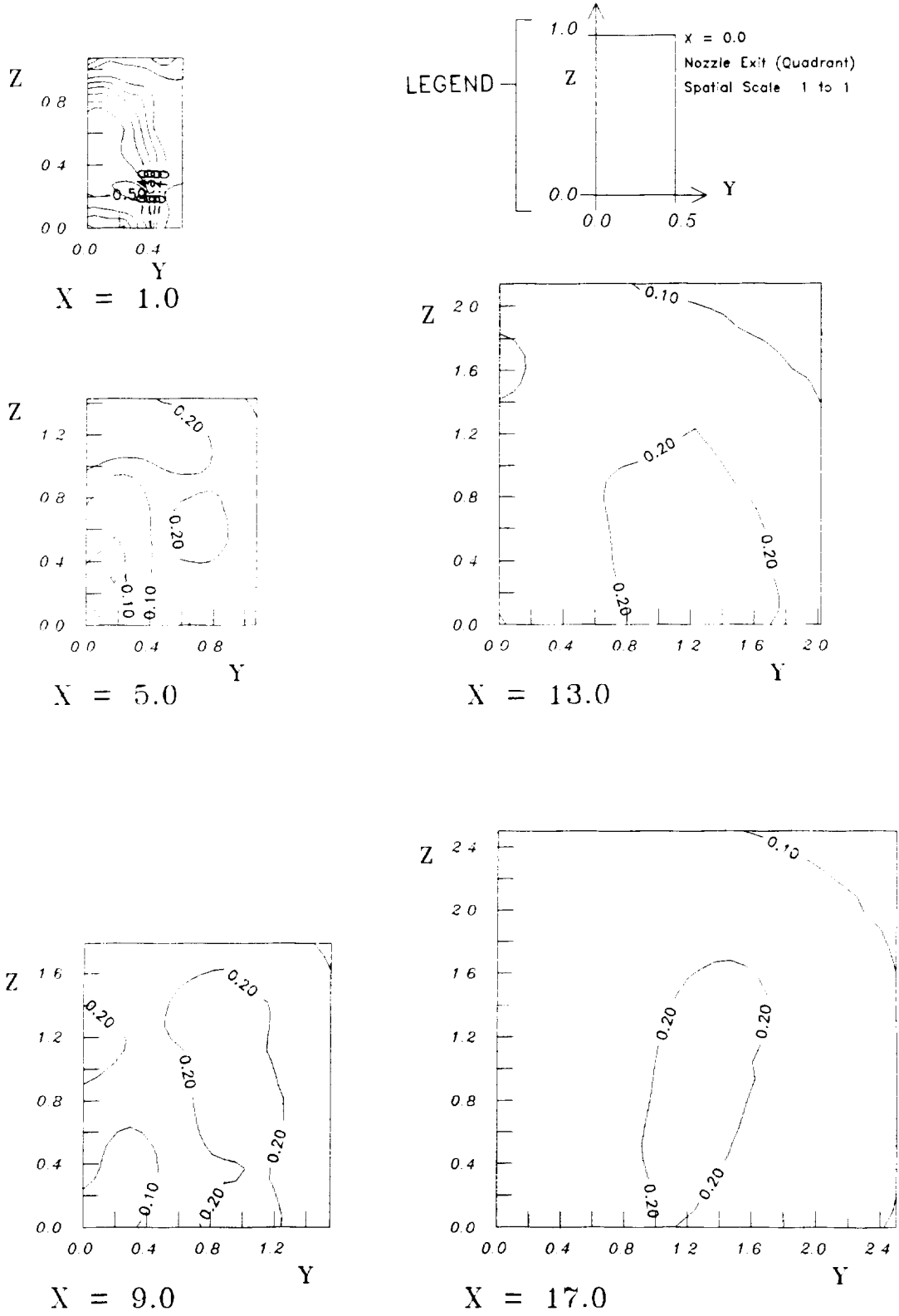

Fig. 70 1x2 Nozzle  $M=0.9$  C.C.(vw)

## APPENDICES

- A) Nozzle Dimensions and Plenum Drawing
- B) Vector Transformation of the Measured Data

## Appendix A

### **Nozzle Dimensions and Plenum Drawing**

The rectangular jets were produced by smoothly converging nozzles that had exit dimensions of 25.4 x 50.8 mm and 12.7 x 50.8 mm for the 1x2 and 1x4 aspect ratio jets respectively. Each nozzle converged from a circular cross section of approximately 300 mm to the rectangular cross section. The rectangular cross section was maintained approximately 50 mm before the nozzle exit.

The nozzles were constructed by layering fiber glass on a metal mandrel. Before the fiberglass was laid a *gel coat* was sprayed on the mandrel, thus giving the inside of the finished nozzle a smooth surface. Dimensions of the mandrels used to construct the two nozzles are given in Table A-1, A-2 and Figure A-1, a drawing of the mandrel is provided in Figure A-2. The mandrel dimensions were scaled from a NASA rectangular nozzle construction drawing, (drawing # LD-204685, Langley Research Center Hampton Virginia 23665). The X dimension is length, the R dimension is radius, the Y and Z dimensions are minor and major axis respectively. The circular to rectangular profile was constructed in the following manner: a) the material was placed in a numerical lathe and turned to the given X-R profile. The material was then placed in a numerical mill where the X-Y and X-Z profiles were cut at a 90° angle to each other. The dimensions were held to a 5/1000 inch tolerance, and the finish was sanded smooth.

The flow straighting plenum consisted of a 300 mm diameter schedule 40 PVC pipe with internal perforated plates, honeycomb, and fine screens. Dimensions and a cross-sectional view are provided in Figure 3A.

Table 1A  
1x2 Nozzle Mandrel Coordinates  
Note Dimensions in Inches

X	R	Z	Y
.00	1.200	1.000	.500
.10	1.200	1.000	.500
.20	1.200	1.000	.500
.30	1.200	1.000	.500
.40	1.200	1.000	.500
.50	1.200	1.000	.500
.60	1.200	1.000	.500
.70	1.200	1.000	.500
.80	1.200	1.000	.500
.90	1.200	1.000	.500
1.00	1.200	1.000	.500
1.10	1.201	1.000	.500
1.20	1.203	1.000	.500
1.30	1.204	1.001	.501
1.40	1.206	1.002	.502
1.50	1.208	1.004	.504
1.60	1.211	1.006	.507
1.70	1.215	1.010	.511
1.80	1.221	1.015	.517
1.90	1.227	1.021	.523
2.00	1.235	1.029	.532
2.10	1.245	1.039	.543
2.20	1.257	1.050	.555
2.30	1.271	1.063	.569
2.40	1.287	1.078	.586
2.50	1.306	1.096	.605
2.60	1.327	1.116	.627
2.70	1.350	1.138	.651
2.80	1.376	1.162	.678
2.90	1.405	1.189	.708
3.00	1.436	1.219	.741
3.10	1.470	1.251	.776
3.20	1.507	1.286	.814
3.30	1.547	1.323	.856
3.40	1.589	1.364	.900
3.50	1.635	1.407	.947
3.60	1.683	1.453	.998
3.70	1.733	1.501	1.051
3.80	1.787	1.552	1.107
3.90	1.843	1.606	1.166
4.00	1.901	1.662	1.228
4.10	1.962	1.721	1.293
4.20	2.025	1.782	1.361
4.30	2.090	1.846	1.431
4.40	2.157	1.912	1.503
4.50	2.226	1.980	1.578
4.60	2.297	2.050	1.655

Table 1A Continued

X	R	Z	Y
4.70	2.370	2.122	1.734
4.80	2.444	2.196	1.816
4.90	2.519	2.271	1.899
5.00	2.592	2.346	1.981
5.10	2.666	2.421	2.065
5.20	2.741	2.498	2.150
5.30	2.817	2.575	2.236
5.40	2.892	2.654	2.322
5.50	2.968	2.732	2.410
5.60	3.044	2.811	2.497
5.70	3.119	2.890	2.585
5.80	3.194	2.970	2.673
5.90	3.269	3.049	2.760
6.00	3.346	3.131	2.851
6.10	3.423	3.213	2.941
6.20	3.500	3.295	3.031
6.30	3.576	3.377	3.121
6.40	3.651	3.458	3.210
6.50	3.726	3.539	3.299
6.60	3.800	3.619	3.387
6.70	3.873	3.698	3.475
6.80	3.945	3.777	3.562
6.90	4.016	3.855	3.648
7.00	4.086	3.933	3.733
7.10	4.156	4.009	3.817
7.20	4.224	4.084	3.900
7.30	4.292	4.159	3.981
7.40	4.358	4.232	4.062
7.50	4.423	4.304	4.141
7.60	4.487	4.375	4.219
7.70	4.550	4.445	4.296
7.80	4.612	4.513	4.371
7.90	4.673	4.580	4.445
8.00	4.732	4.646	4.517
8.10	4.790	4.710	4.587
8.20	4.847	4.772	4.656
8.30	4.902	4.833	4.723
8.40	4.956	4.893	4.789
8.50	5.009	4.950	4.852
8.60	5.061	5.006	4.914
8.70	5.111	5.061	4.974
8.80	5.160	5.114	5.032
8.90	5.207	5.165	5.088
9.00	5.253	5.214	5.162
9.10	5.298	5.261	5.194
9.20	5.341	5.307	5.244
9.30	5.382	5.351	5.293
9.40	5.423	5.393	5.339
9.50	5.462	5.433	5.383

Table 1A Continued

X	R	Z	Y
9.60	5.499	5.472	5.426
9.70	5.535	5.509	5.466
9.80	5.569	5.544	5.505
9.90	5.602	5.577	5.541
10.00	5.633	5.608	5.576
10.10	5.663	5.638	5.608
10.20	5.692	5.666	5.639
10.30	5.719	5.692	5.668
10.40	5.744	5.717	5.695
10.50	5.768	5.740	5.720
10.60	5.791	5.761	5.744
10.70	5.812	5.781	5.766
10.80	5.832	5.799	5.786
10.90	5.850	5.816	5.805
11.00	5.867	5.832	5.822
11.10	5.882	5.846	5.837
11.20	5.896	5.858	5.851
11.30	5.909	5.870	5.864
11.40	5.920	5.880	5.875
11.50	5.930	5.889	5.885
11.60	5.933	5.897	5.894
11.70	5.933	5.904	5.901
11.80	5.933	5.910	5.908
11.90	5.933	5.915	5.914
12.00	5.933	5.920	5.918
12.10	5.933	5.923	5.922
12.20	5.933	5.926	5.925
12.30	5.933	5.928	5.928
12.40	5.933	5.930	5.929
12.50	5.933	5.931	5.931
12.60	5.933	5.932	5.932
12.70	5.933	5.932	5.932
12.80	5.933	5.932	5.932
12.90	5.933	5.932	5.932
13.00	5.933	5.933	5.933



Table 2A  
 1x4 Nozzle Mandrel Coordinates  
Note Dimensions in Inches

X	R	Z	Y
.00	1.200	1.000	.250
.10	1.200	1.000	.250
.20	1.200	1.000	.250
.30	1.200	1.000	.250
.40	1.200	1.000	.250
.50	1.200	1.000	.250
.60	1.200	1.000	.250
.70	1.200	1.000	.250
.80	1.200	1.000	.250
.90	1.200	1.000	.250
1.00	1.200	1.000	.250
1.10	1.201	1.000	.250
1.20	1.203	1.000	.250
1.30	1.204	1.001	.251
1.40	1.206	1.002	.251
1.50	1.208	1.004	.253
1.60	1.211	1.006	.254
1.70	1.215	1.010	.257
1.80	1.221	1.015	.261
1.90	1.227	1.021	.265
2.00	1.235	1.029	.271
2.10	1.245	1.039	.277
2.20	1.257	1.050	.286
2.30	1.271	1.063	.295
2.40	1.287	1.078	.306
2.50	1.306	1.096	.319
2.60	1.327	1.116	.334
2.70	1.350	1.138	.351
2.80	1.376	1.162	.370
2.90	1.405	1.189	.391
3.00	1.436	1.219	.415
3.10	1.470	1.251	.441
3.20	1.507	1.286	.470
3.30	1.547	1.323	.501
3.40	1.589	1.364	.536
3.50	1.635	1.407	.573
3.60	1.683	1.453	.614
3.70	1.733	1.501	.657
3.80	1.787	1.552	.704
3.90	1.843	1.606	.754
4.00	1.901	1.662	.807
4.10	1.962	1.721	.864
4.20	2.025	1.782	.924
4.30	2.090	1.846	.987
4.40	2.157	1.912	1.053
4.50	2.226	1.980	1.122
4.60	2.297	2.050	1.195

Table 2A Continued

X	R	Z	Y
4.70	2.370	2.122	1.270
4.80	2.444	2.196	1.348
4.90	2.519	2.271	1.429
5.00	2.595	2.348	1.513
5.10	2.673	2.427	1.599
5.20	2.751	2.506	1.687
5.30	2.830	2.587	1.777
5.40	2.909	2.669	1.869
5.50	2.988	2.751	1.962
5.60	3.068	2.834	2.057
5.70	3.148	2.917	2.153
5.80	3.227	3.000	2.250
5.90	3.306	3.083	2.348
6.00	3.384	3.167	2.446
6.10	3.461	3.249	2.543
6.20	3.538	3.331	2.641
6.30	3.614	3.412	2.739
6.40	3.689	3.493	2.837
6.50	3.763	3.574	2.935
6.60	3.836	3.654	3.032
6.70	3.909	3.733	3.129
6.80	3.981	3.812	3.226
6.90	4.052	3.889	3.322
7.00	4.121	3.966	3.417
7.10	4.190	4.042	3.511
7.20	4.258	4.117	3.604
7.30	4.325	4.191	3.697
7.40	4.390	4.263	3.788
7.50	4.455	4.335	3.877
7.60	4.518	4.405	3.966
7.70	4.580	4.474	4.053
7.80	4.641	4.541	4.138
7.90	4.700	4.607	4.222
8.00	4.759	4.672	4.304
8.10	4.816	4.735	4.384
8.20	4.872	4.797	4.463
8.30	4.926	4.857	4.540
8.40	4.979	4.915	4.614
8.50	5.031	4.971	4.687
8.60	5.081	5.026	4.757
8.70	5.130	5.080	4.826
8.80	5.177	5.131	4.892
8.90	5.223	5.181	4.956
9.00	5.268	5.229	5.018
9.10	5.311	5.275	5.078
9.20	5.353	5.319	5.135
9.30	5.393	5.362	5.190
9.40	5.432	5.402	5.243
9.50	5.469	5.441	5.294

Table 2A Continued

X	R	Z	Y
9.60	5.505	5.478	5.342
9.70	5.539	5.513	5.388
9.80	5.572	5.547	5.432
9.90	5.604	5.578	5.473
10.00	5.633	5.608	5.512
10.10	5.663	5.638	5.550
10.20	5.692	5.666	5.587
10.30	5.719	5.692	5.621
10.40	5.744	5.717	5.653
10.50	5.768	5.740	5.682
10.60	5.791	5.761	5.710
10.70	5.812	5.781	5.736
10.80	5.832	5.799	5.760
10.90	5.850	5.816	5.781
11.00	5.867	5.832	5.801
11.10	5.882	5.846	5.820
11.20	5.896	5.858	5.836
11.30	5.909	5.870	5.851
11.40	5.920	5.880	5.864
11.50	5.930	5.889	5.876
11.60	5.933	5.897	5.887
11.70	5.933	5.904	5.896
11.80	5.933	5.910	5.903
11.90	5.933	5.915	5.910
12.00	5.933	5.920	5.916
12.10	5.933	5.923	5.920
12.20	5.933	5.926	5.924
12.30	5.933	5.928	5.927
12.40	5.933	5.930	5.929
12.50	5.933	5.931	5.930
12.60	5.933	5.932	5.931
12.70	5.933	5.932	5.932
12.80	5.933	5.932	5.932
12.90	5.933	5.932	5.932
13.00	5.933	5.933	5.933

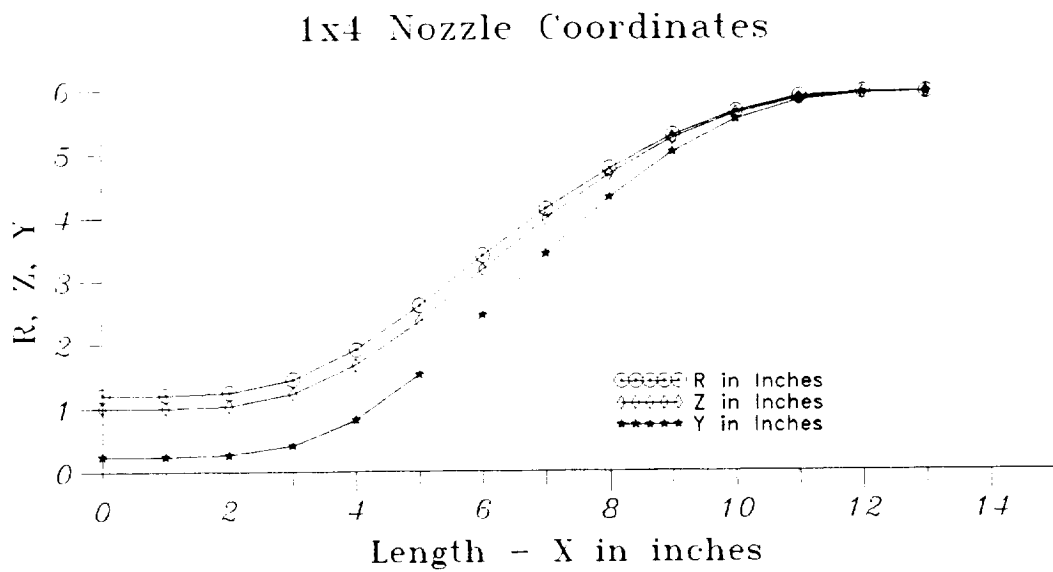
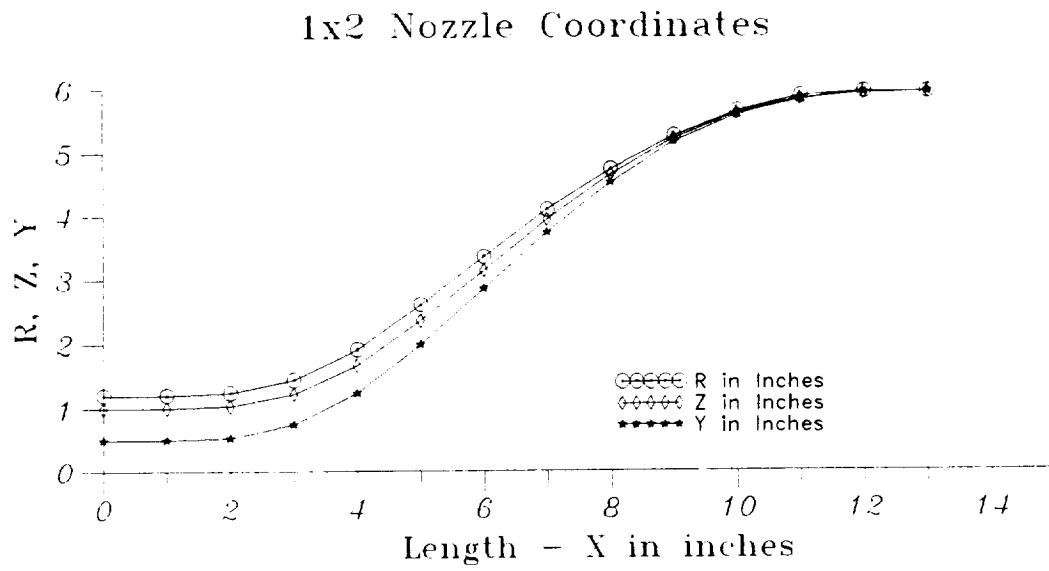
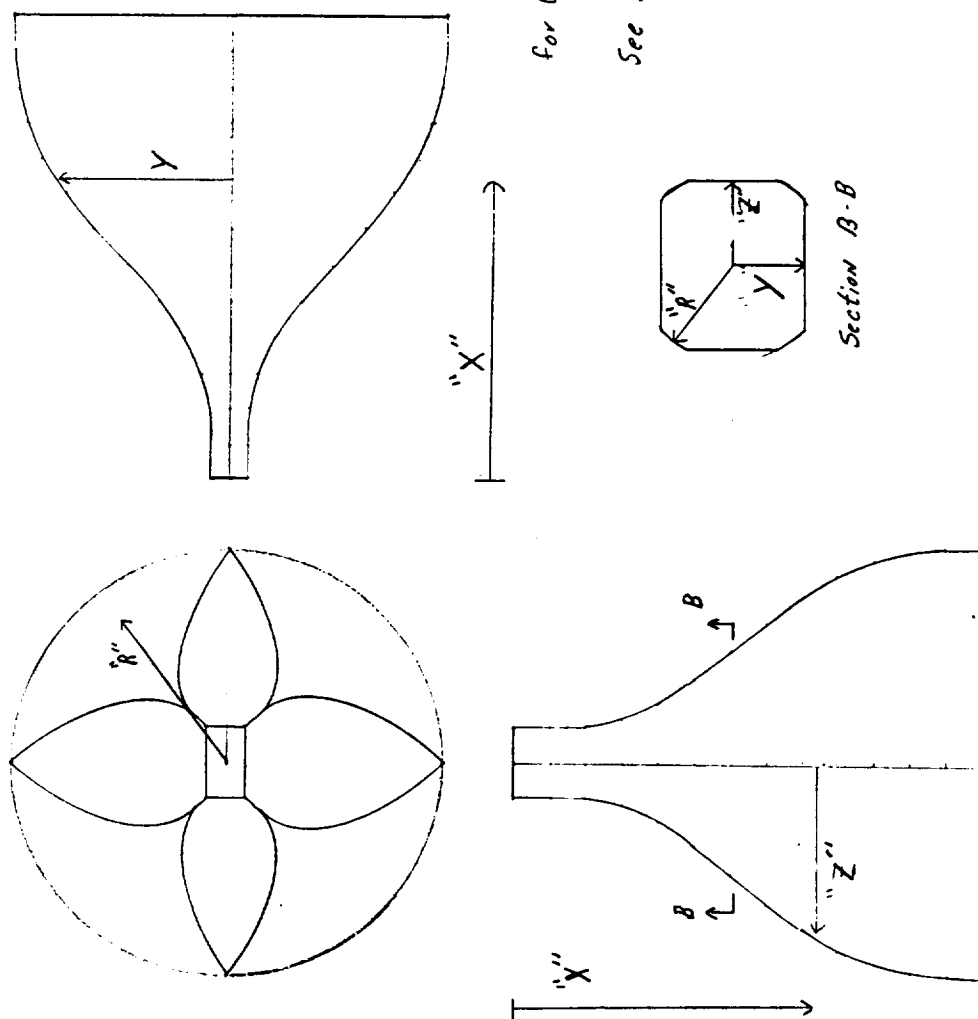

Fig. A1 Internal Nozzle Coordinates



for Coordinates  
See Separate Table

Texas A&M Mech. Eng.  
Mandrel for 2" by 1" Nozzle  
March 15, 1988 D. Swan

**Figure A2**  
Nozzle Construction Mandrel

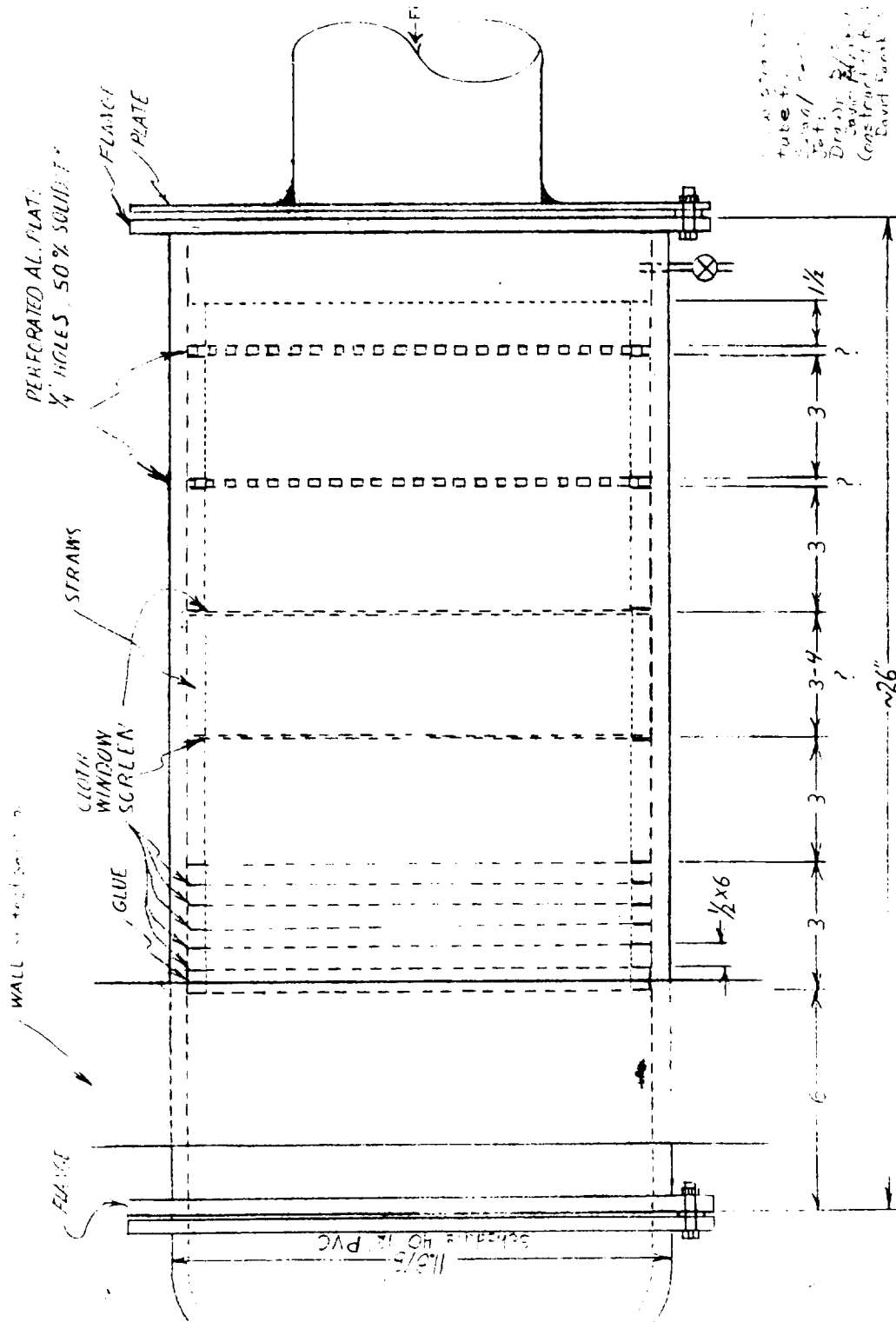

Figure A3

Nozzle Flow Straightening Plenum

ORIGINAL PAGE IS  
OF POOR QUALITY

## APPENDIX B

### Vector Transformation of the Measured Data

The LDV system measures the flow velocity in a non-orthogonal coordinate system. This non-orthogonal coordinate system is referred to as the color coordinates, in reference to the laser beam colors that measure each component (green, blue, violet). Each color measures a component of the velocity vector. The particular component is dependent on the LDV system configuration and alignment. These vector component values are transformed to an orthogonal coordinate system by the following vector transformation.

#### Vector Algebra for 3-D LDV

Referring to the Nozzle Coordinate System of X, Y, and Z (Figure B-1), the non orthogonal color coordinate system is as follows:

- The green color measurement is always made in the XZ plane, and can be rotated by  $\theta_g$  in that plane. The green color can measure components of  $U^g$  and  $W$ .
- The blue color measurement is always made in the XZ plane, and can be rotated by  $\theta_b$  in that plane. The blue color can measure components of  $U$  and  $W$ .
- The violet color measurement is always made in the plane that is parallel to the XZ plane but at an angle  $\alpha$  to it. The violet measurement direction can be rotated by  $\theta_v$  in that plane. The blue color can measure components of  $U$ ,  $V$ , and  $W$ .

The cartesian coordinate system unit vectors in the color directions are as follows:

$$\hat{e}_g = \hat{i} \cos \theta_g + \hat{j} 0 + \hat{k} \sin \theta_g \rightarrow \text{Unit vector - green direction}$$

$$\hat{e}_b = \hat{i} \cos \theta_b + \hat{j} 0 + \hat{k} \sin \theta_b \rightarrow \text{Unit vector - blue direction}$$

$$\hat{e}_v = \hat{i} \cos \theta_v + \hat{j} \sin \alpha \cos \theta_v + \hat{k} \sin \alpha \sin \theta_v \rightarrow \text{Unit vector - violet direction.}$$

The unit vectors can be used to derive the following equation where the color velocities ( $V_c$ ) can be calculated given the orthogonal values of velocity ( $U_i$ )

$$[K] [U_i] = [V_c]$$

The terms  $[K]$ ,  $(U_i)$ , and  $(V_c)$  are as follows

$$\begin{bmatrix} \cos \theta_g & 0 & \sin \theta_g \\ \cos \theta_v & \sin \alpha \cos \theta_v & \sin \alpha \sin \theta_v \\ \cos \theta_b & 0 & \sin \theta_b \end{bmatrix}_K \begin{bmatrix} U \\ V \\ W \end{bmatrix}_{U_i} = \begin{bmatrix} V_g \\ V_b \\ V_v \end{bmatrix}_{V_c}$$

By inverting the [K] matrix,  $\{U_i\}$  can be solved for given the  $\{V_c\}$  matrix.

$$\begin{bmatrix} U_i \end{bmatrix} = \begin{bmatrix} K \end{bmatrix}^{-1} \begin{bmatrix} V_c \end{bmatrix}$$

Let

$$\begin{bmatrix} C \end{bmatrix} = \begin{bmatrix} K \end{bmatrix}^{-1} = \begin{bmatrix} C1 & C2 & C3 \\ C4 & C5 & C6 \\ C7 & C8 & C9 \end{bmatrix}$$

The determinant of the [C] matrix (D) is as follows:

$$D = -\cos(\theta_g) * \sin(\theta_b) * \cos(\theta_v) * \sin(\alpha) - \cos(\theta_b) * \sin(\theta_g) * \cos(\theta_v) * \sin(\alpha)$$

The individual terms in the matrix [C] are as follows:

$$\begin{aligned} C1 &= -\sin(\theta_b) * \cos(\theta_v) * \sin(\alpha) / D \\ C2 &= -\sin(\theta_g) * \cos(\theta_v) * \sin(\alpha) / D \\ C3 &= 0 \\ C4 &= (-\sin(\theta_b) * \sin(\theta_v) - \cos(\theta_b) * \cos(\theta_v) * \cos(\alpha)) / D \\ C5 &= (\cos(\theta_g) * \cos(\theta_v) * \cos(\alpha) - \sin(\theta_g) * \sin(\theta_v)) / D \\ C6 &= (\sin(\theta_g) * \cos(\theta_b) + \cos(\theta_g) * \sin(\theta_b)) / D \\ C7 &= -\cos(\theta_b) * \cos(\theta_v) * \sin(\alpha) / D \\ C8 &= \cos(\theta_g) * \cos(\theta_v) * \sin(\alpha) / D \\ C9 &= 0 \end{aligned}$$

Thus to transform the measured color velocities to orthogonal velocities:

$$\begin{bmatrix} U \\ V \\ W \end{bmatrix} = \begin{bmatrix} C1 & C2 & C3 \\ C4 & C5 & C6 \\ C7 & C8 & C9 \end{bmatrix} \begin{bmatrix} V_g \\ V_b \\ V_v \end{bmatrix}$$

Using the velocity transformation the Reynolds terms (variance and covariance of velocity) may be calculated in terms of the [C] matrix terms.

$$\begin{bmatrix} Re_i \end{bmatrix} = \begin{bmatrix} C_{Re} \end{bmatrix} \begin{bmatrix} Re_c \end{bmatrix}$$

This results in the following matrices.



$$\begin{bmatrix} \overline{uu} \\ \overline{vv} \\ \overline{ww} \\ \overline{uv} \\ \overline{uw} \\ \overline{vw} \end{bmatrix} = \begin{bmatrix} C1^2 & C2^2 & C3^2 & 2C1 \cdot C2 & 2C1 \cdot C3 & 2C2 \cdot C3 \\ C4^2 & C5^2 & C6^2 & 2C4 \cdot C5 & 2C4 \cdot C6 & 2C5 \cdot C6 \\ C7^2 & C8^2 & C9^2 & 2C7 \cdot C8 & 2C7 \cdot C9 & 2C8 \cdot C9 \\ C1 \cdot C4 & C2 \cdot C5 & C3 \cdot C6 & C1 \cdot C5+ & C1 \cdot C6+ & C2 \cdot C6+ \\ & & & C2 \cdot C4 & C3 \cdot C4 & C3 \cdot C5 \\ C1 \cdot C7 & C2 \cdot C8 & C3 \cdot C9 & C1 \cdot C8+ & C1 \cdot C9+ & C2 \cdot C9+ \\ & & & C2 \cdot C7 & C3 \cdot C7 & C3 \cdot C8 \\ C4 \cdot C7 & C5 \cdot C8 & C6 \cdot C9 & C4 \cdot C8+ & C6 \cdot C7+ & C6 \cdot C8+ \\ & & & C5 \cdot C7 & C4 \cdot C9 & C5 \cdot C9 \end{bmatrix} \begin{bmatrix} \overline{gg} \\ \overline{bb} \\ \overline{vv} \\ \overline{gb} \\ \overline{gv} \\ \overline{bv} \end{bmatrix}$$

Note  $\overline{uu}$ ,  $\overline{vv}$ ,  $\overline{ww}$ ,  $\overline{uv}$ ,  $\overline{uw}$ ,  $\overline{vw}$  are the cartesian coordinate system Reynolds terms.

and  $\overline{gg}$ ,  $\overline{bb}$ ,  $\overline{vv}$ ,  $\overline{gb}$ ,  $\overline{gv}$ ,  $\overline{bv}$  are the color coordinate system Reynolds terms (green, blue, violet).

### Error Amplification Due To Vector Transformation

The LDV system makes measurements in a color coordinate system and these measurements are then transformed to an orthogonal coordinate system. Any errors that occur in the color measurements may be amplified by the coordinate transformation. The measured data was taken using 3 different laser system alignments and, as a result, was transformed using 3 different [C] and [C<sub>Re</sub>] matrices, see Table B-1. Each of the three data types (the mean, variance and covariance of the orthogonal velocity components) will be analyzed for a worst case amplification of error.

#### Mean Velocity Transformation

The  $\bar{U}_i$  values are calculated by multiplying the constants in the [C] matrix by the  $\bar{V}_c$  terms. Examination the [C] matrix terms in Table B-1 shows that they are in some cases much larger than 1 thus amplifying any error in a color measurement.

The worst case for amplified error is for the 1x2 nozzle Mach 0.09, V velocity calculation. In this case, the color velocities of  $\bar{V}_g$ ,  $\bar{V}_b$ , and  $\bar{V}_v$  are multiplied by 2.7, 0.21 and -2.89 respectively. Assuming that the maximum error in any mean velocity measurement was 0.1 m/s (0.5% of measured color velocity), a worst case error would be where the  $\bar{V}_g$  and  $\bar{V}_b$  values increased by 0.1 and the  $\bar{V}_v$  value decreased by 0.1 m/s. This worst case would accumulate a total error of  $0.27+0.021+0.289 = 0.58$  m/s on  $\bar{V}$ . This worst case error could represent up to 100% of the  $\bar{V}$  value.

#### Velocity Variance Transformation

The first three rows of the [C<sub>Re</sub>] matrix calculate the velocity variance terms ( $\overline{uu}$ ,  $\overline{vv}$ ,  $\overline{ww}$ ). In calculating the term,  $\overline{vv}$ , the largest coefficients in the C<sub>Re</sub> matrix are used and, thus,  $\overline{vv}$  is most susceptible to amplification of errors. The calculation of  $\overline{vv}$  involves color variance and color covariance terms. Random errors will tend to increase the color variance while random errors will tend to decrease the color covariance.

The worst case for amplified variance error is for the 1x2 nozzle Mach 0.09,  $\overline{vv}$  calculation. In this case, the C<sub>Re</sub> coefficients are 7.28, 0.04, 8.34, 1.11, -15.6, and -1.19 respectively. Choosing an absolute color variance error of  $0.1 \text{ m}^2/\text{s}^2$  (1% of high turbulence

measurements) and a covariance error of  $0.2 \text{ m}^2/\text{s}^2$ , a worst case amplification of error would be  $0.728+0.004+0.834+0.222+3.12+0.238 = 5.15 \text{ m}^2/\text{s}^2$ . This worst case error would represent 50% to 100% of most calculated values of  $\overline{v'v'}$ .

#### Velocity Covariance Transformation

The last three rows of the  $[C_{Re}]$  matrix calculate the covariance terms ( $\overline{uv}$ ,  $\overline{uw}$ ,  $\overline{vw}$ ). In calculating the  $\overline{uv}$  term the largest coefficients in the  $C_{Re}$  matrix are used and, thus,  $\overline{uv}$  is most susceptible to amplification of errors.

Once again the worst case for amplified variance error is for the 1x2 nozzle Mach 0.09,  $\overline{uv}$  calculation. In this case, the  $C_{Re}$  coefficients are 1.92, 0.14, 0.0, 2.02, -2.05, and -2.01 respectively. Choosing an absolute color variance error of  $0.1 \text{ m}^2/\text{s}^2$  (1% of high turbulence measurements) and a covariance error of  $0.2 \text{ m}^2/\text{s}^2$ , a worst case amplification of error would be  $0.192+0.014+0.0+0.202+0.205+0.201 = 0.814 \text{ m}^2/\text{s}^2$ . This worst case error would represent 15% to 25% of most calculated values of  $\overline{uv}$ .

Table B-1  
Transformation Matrices

Case	A	B	C
Mach #	0.09	0.09	0.9
A.R.	1x2	1x4	1x2
$\alpha$	30.0	30.0	30.0
$\theta^g$	44.1	91.5	46.1
$\theta^b$	45.3	.0	45.7
$\theta^v$	46.2	177.6	44.6
D	-.35	.50	-.36

Case A (1x2 Nozzle, Mach # =0.09)

$$\begin{bmatrix} C \end{bmatrix}_A = \begin{bmatrix} .71 & .70 & .00 \\ 2.70 & .21 & -2.89 \\ .70 & -.72 & .00 \end{bmatrix}_A$$

$$\begin{bmatrix} C_{Re} \end{bmatrix}_A = \begin{bmatrix} .50 & .48 & .00 & .99 & .00 & .00 \\ 7.28 & .04 & 8.34 & 1.11 & -15.6 & -1.19 \\ .50 & .52 & .00 & -1.01 & .00 & .00 \\ 1.92 & .14 & .00 & 2.02 & -2.05 & -2.01 \\ .50 & -.50 & .00 & -.02 & .00 & .00 \\ 1.90 & -.15 & 0 & -1.79 & -2.03 & 2.07 \end{bmatrix}_A$$

Case B (1x4 Nozzle, Mach # =0.09)

$$\begin{bmatrix} C \end{bmatrix}_B = \begin{bmatrix} .00 & 1.00 & .00 \\ 1.73 & -.04 & 2.00 \\ 1.00 & .03 & .00 \end{bmatrix}_B$$

$$\begin{bmatrix} C_{Re} \end{bmatrix}_B = \begin{bmatrix} .00 & 1.00 & .00 & .00 & .00 & .00 \\ 3.00 & .00 & 4.01 & -.13 & 6.9 & -.14 \\ 1.00 & .00 & .00 & .05 & .00 & .00 \\ .00 & -.04 & .00 & 1.73 & .00 & 2.00 \\ .00 & .03 & .00 & 1.00 & .00 & .00 \\ 1.73 & -.00 & 0 & .01 & 2.00 & .05 \end{bmatrix}_B$$

Table B-1 Continued

Case C (1x2 Nozzle, Mach # -0.9)

$$\begin{aligned}
 [c]_C &= \begin{bmatrix} .72 & .72 & .00 \\ 2.62 & .22 & -2.81 \\ .70 & -.69 & .00 \end{bmatrix}_C \\
 [c_{Re}]_C &= \begin{bmatrix} .51 & .52 & .00 & 1.03 & .00 & .00 \\ 6.88 & .05 & 7.89 & 1.15 & -14.7 & -1.23 \\ .49 & .48 & .00 & -.97 & .00 & .00 \\ 1.88 & .16 & .00 & 2.05 & -2.01 & -2.02 \\ .50 & -.50 & .00 & .01 & .00 & .00 \\ 1.83 & -.15 & 0 & -1.67 & -1.96 & 1.95 \end{bmatrix}_C
 \end{aligned}$$

