

NASA CR-166,081

NASA Contractor Report 166081

NASA-CR-166081
19850002610

FORCE AND MOMENT MEASUREMENTS ON A 74°
DELTA WING WITH AN APEX FLAP
(Data Report)

Thomas A. Buter and Dhanvada M. Rao

NORTH CAROLINA STATE UNIVERSITY
Raleigh, North Carolina

Cooperative Agreement NCC1-46
October 1984



NF02245



National Aeronautics and
Space Administration

Langley Research Center
Hampton, Virginia 23665

LIBRARY COPY

NOV 14 1984

LANGLEY RESEARCH CENTER
LIBRARY, NASA
HAMPTON, VIRGINIA

ABSTRACT

Results are presented of a subsonic experimental investigation of an apex flap concept on a 74° swept delta wing with trailing-edge flaps. The apex flap comprised approximately 6 percent of the wing area forward of a transverse hinge, allowing for both upward and downward deflection angles from $+40^\circ$ to -20° . Upward deflection forces leading-edge vortex formation on the apex flap, resulting in an increased lift component on the apex area. The associated nose-up moment balances the nose-down moment due to trailing-edge flaps, resulting in sizeable increase in the trimmed lift coefficient particularly at low angles of attack. Nose-down apex deflection may be used to augment the pitch control for rapid recovery from high-alpha maneuvers. Balance measurements were obtained in the NASA Langley 7- by 10-Foot High-Speed Tunnel at $M_\infty = 0.2$ and $R_{\frac{c}{c}} = 4 \times 10^6$. This report presents the balance data without analysis.

LIST OF SYMBOLS

α , ALPHA	angle of attack, deg
b	wing span, cm
β , BETA	sideslip angle, deg
\bar{c}	mean geometric chord, cm
CA	axial-force coefficient, Axial force/ $q_\infty S$
CD	drag coefficient, Drag/ $q_\infty S$
CL	lift coefficient, Lift/ $q_\infty S$
CMS	pitching-moment coefficient, Pitching moment/ $q_\infty S \bar{c}$
CN	normal-force coefficient, Normal force/ $q_\infty S$
C_{pu}	upper surface pressure coefficient, $(P_u - P_\infty)/q_\infty$
C_r	wing root chord, cm
CRMS	rolling-moment coefficient, Rolling moment/ $q_\infty S b$
CYS	side-force coefficient, Side force/ $q_\infty S$
CYMS	yawing-moment coefficient, Yawing moment/ $q_\infty S b$
D	drag, N
δ_a	apex flap deflection, deg
δ_{TE}	trailing-edge flap deflection, deg
L	lift, N
LE	leading edge
M_∞	free-stream Mach number
P_u	upper surface static pressure, Pa
P_∞	free-stream static pressure, Pa
Q, q_∞	free-stream dynamic pressure, Pa
$R_{\bar{c}}$	free-stream Reynolds number based on \bar{c}

S wing planform area, cm^2
X/C_r x-location in fraction of root chord

INTRODUCTION

Supersonic aircraft configurations generally utilize thin, highly swept wings of delta or related planform primarily for their supersonic and high subsonic aerodynamic qualities. In the supersonic regime, wave drag is reduced due to the small thickness ratio and high sweep angle. High drag-divergence Mach number is another advantage of the delta wing in high subsonic and transonic flight. However, the highly swept delta wing has certain deficiencies such as poor lift at low angles of attack and excessive drag at high lift coefficients.

Recent studies at NASA Langley Research Center and elsewhere have attempted to correct these disadvantages through vortical flow manipulation. This approach consists of devising means of reordering or relocating the leading-edge vortex system inherent to highly swept wings. References 1 and 2 report extensive studies of leading-edge devices used to enhance the low speed characteristics of a 60° delta wing by such vortex flow manipulation. However, those studies were directed toward improving the high-alpha characteristics of the delta; comparatively little has been done to improve its low-alpha lift capability which is important during take-off, landing and other low-speed, low-alpha maneuvers. One of the previous devices, the leading-edge vortex flap, has been tested in the up-deflected sense (ref. 3) to force an earlier formation and strengthening of the leading-edge vortex system to increase the lift at low-alpha. However, a large portion of the wing (e.g., 20 to 30 percent of the total area) had to be deflected to obtain even modest lift gains (i.e., $\Delta C_L = 0.50$) on a 74° delta wing. Flaps of this size will pose actuation problems and severely reduce the usable volume in the wing.

In this investigation, the apex portion of the delta wing is hinged transversely and deflected upwards to induce vortex formation from its leading edges (fig. 1). With the vortex lift primarily concentrated in the apex region, a relatively small percentage of the wing area occupied by the apex flap should generate a substantial positive pitching moment. This moment may be used to trim out flow-augmented trailing-edge flaps to yield relatively high increments of usable lift. If the apex vortices persist in strength downstream on the main wing surface, an additional lift due to the induced suction effect may be obtained.

This report documents the force and moment data acquired in the NASA Langley 7- by 10-Foot High Speed Tunnel on a 74° planar delta wing incorporating an apex flap and trailing-edge flaps. The test model configurations included apex flap deflected upward, apex flap up plus trailing-edge flaps down, and differential trailing-edge flaps as elevons. Some configurations were also tested in sideslip. The tabulated force data are presented without analysis.

RESEARCH MODEL

The model used in this study is constructed from aluminum and has a root chord length of 40 inches. The leading edges as well as the trailing edge are symmetrically bevelled. The apex flap was obtained by incorporating a transverse hinge at $X/C_r = 0.25$. The force model was also fitted with hinged trailing-edge flaps (see fig. 2 for dimensions) capable of independent deflection in both the upward and downward direction. The hinge lines were taped to prevent leakage. A six-component sting-type balance (NASA Model 738) was housed in a streamlined fuselage provided for this purpose. See figure 2 for model dimensions and planform characteristics.

WIND TUNNEL FACILITY

NASA Langley Research Center's 7- by 10-Foot High-Speed Tunnel is a continuous-flow, closed circuit, subsonic-transonic tunnel which operates at ambient atmospheric conditions. The test section of the tunnel is 6.59 feet high and 9.58 feet wide, with a usable length of 10.28 feet.

The model support system used in this test is referred to as the standard angle-of-attack sting. It consists of a vertical strut with a variable pitch angle sting support system with a range of approximately -4° to 20° . In addition to the pitch mode, the standard sting has a vertical translation mode which allows the model to be kept near the center of the test section throughout the angle-of-attack range. Reference 4 contains a detailed description of the tunnel facility.

The data acquisition, display, and control system for the 7- by 10-Foot High-Speed Tunnel is controlled by a dedicated on-site computer. The system includes a Xerox Sigma-3 computer, a data acquisition unit, a line printer, and a Tektronix 4014 graphics terminal. Reference 5 contains a detailed description of the data reduction capabilities of the system.

DATA REDUCTION

Forces and moments as sensed by a wind tunnel balance must be corrected for external interferences unrealistic of actual flight. Jet boundary corrections were applied to the angle of attack to account for the vertical flow component induced by the walls at the model (ref. 6).

To account for initial balance loads due to model weight, "wind-off" weight tare measurements were taken at various balance attitudes and used in the reduction of balance data (ref. 7). Balance axial force measurements were corrected for housing pressure drag by using chamber (base) pressure measurements. The method of reference 7 was used to

calculate and correct for the solid and wake blockage effects. Since the angle of attack was measured by means of an accelerometer located inside the model, no correction for sting bending due to aerodynamic loading was necessary. Once all necessary corrections were applied to the force and moment data, the final results were presented in coefficient form. C_L and C_D are oriented along the conventional wind axis, with C_A and C_N (axial and normal force coefficients, respectively) along the body axis. Moments are calculated about the reference center shown in figure 2.

DATA PRESENTATION

The tests were conducted at $M_\infty = 0.2$ and $R_c = 4 \times 10^6$. Apex up deflections ranged from 0° to 40° in 5° increments. Angle-of-attack range was -4° to 19.5° . Apex down deflections of -5° , -10° , and -20° were also tested.

Several "tandem" configurations, i.e., up-deflected apex together with down trailing-edge flaps, were also tested. Roll control effectiveness with the trailing-edge flaps deflected as elevons for positive rolling moment (fig. 3), as well as lateral/directional characteristics at $\pm 5^\circ$ sideslip were also investigated.

The test data are presented without analysis. Table I provides a configuration summary for all force runs, and provides a key to the tabulated data listed by run number in Table II.

REFERENCES

1. Tingas, S. A.; and Rao, D. M.: Subsonic Balance and Pressure Investigation of a 60-deg. Delta Wing with Leading-Edge Devices. NASA CR-165923, May 1982.
2. Johnson, T. D., Jr.; and Rao, D. M.: Experimental Study of Delta Wing Leading-Edge Devices for Drag Reduction at High Lfit. NASA CR-165846, February 1982.
3. Marchman, J. F.: The Aerodynamics of Inverted Leading Edge Flaps on Delta Wings. AIAA Paper No. 81-0356, 1981.
4. Fox, C. H., Jr.; and Huffman, J. K.: Calibration and Test Capabilities of the Langley 7- by 10-Foot High-Speed Tunnel. NASA TM X-74027, 1977.
5. Fox, C. H., Jr.: Real-Time Data Reduction Capabilities of the Langley 7- by 10-Foot High-Speed Tunnel. NASA TM 78801, 1980.
6. Gillis, C. L.; Polhamus, E. C.; and Gray, J. L., Jr.: Charts for Determining Jet-Boundary Corrections for Complete Models in 7- by 10-Foot Closed Rectangular Wind Tunnels. NACA NR L-123, 1945.
7. Herriot, J. G.: Blockage Corrections for Three-Dimensional-Flow Closed-Throat Wind Tunnels, with Consideration of the Effect of Compressibility. NACA Rep. 995, 1950.

TABLE I. RUN SUMMARY

Description	Run #	δ_a	δ_{TE} (L/R)	β (deg)
planar delta	1	0°	0/0	0

Apex	30	5°	0/0	0
	2,3	10°	0/0	0
flap	31	15°	0/0	0
	4	20°	0/0	0
deflection	51	25°	0/0	0
	5	30°	0/0	0
only	52	35°	0/0	0
	6	40°	0/0	0

Apex/T.E.	7	0°	10/10	0
	8	0°	15/15	0
Flap	9	0°	20/20	0
	10	0°	25/25	0
Series	11	0°	30/30	0
	30	5°	10/10	0
	22	10°	10/10	0
	12	10°	15/15	0
	29	10°	20/20	0
	21	10°	25/25	0
	32	15°	10/10	0
	33	15°	15/15	0
	23	20°	10/10	0
	13	20°	15/15	0
	28	20°	20/20	0
	18	20°	25/25	0
	24	30°	10/10	0
	14,17	30°	15/15	0
	27	30°	20/20	0
	19	30°	25/25	0
	25	40°	10/10	0
	15,16	40°	15/15	0
	26	40°	20/20	0
	20	40°	25/25	0

TABLE I. Concluded

Description	Run #	δ_a	δ_{TE} (L/R)	β (deg)
Sideslip	36	0°	0/0	+5
	37	0°	0/0	-5
Tail-On	35	20°	0/0	+5

Sideslip	59	0°	0/0	+5
	56	0°	0/0	-5
Tail-Off	58	20°	0/0	+5
	57	20°	0/0	-5

Negative apex flap deflection	55	-5°	0/0	0
	53	-10°	0/0	0
	54	-20°	0/0	0

Elevon configurations	49	0°	+15/-15	0
	50	20°	+15/-15	0

TABLE II. TEST RESULTS

NASA LANGLEY			7 X 10 HIGH SPEED TUNNEL								
TEST 106			RUN 1								
MACH	α	ALPHA	BETA	CL	CD	CMS	CRMS	CYMS	CYS	CN	CA
NUMB	PA	DEG	DEG								
.200	2741.6	.01	-.00	.0095	.0073	.0037	-.0002	.0009	-.0015	.0035	.0073
.200	2739.0	-1.93	.01	-.0432	.0088	-.0020	-.0001	.0008	-.0020	-.0435	.0073
.200	2745.4	-4.16	.02	-.1084	.0150	-.0088	-.0003	.0008	-.0025	-.1092	.0073
.200	2742.6	.03	-.00	.0047	.0073	.0037	-.0005	.0007	-.0018	.0047	.0073
.200	2736.7	1.91	-.01	.0537	.0092	.0091	-.0004	.0008	-.0019	.0539	.0074
.200	2753.3	3.92	-.02	.1120	.0147	.0163	-.0001	.0008	-.0018	.1128	.0070
.200	2743.8	5.62	-.03	.1770	.0245	.0248	.0000	.0007	-.0024	.1786	.0064
.200	2742.2	7.80	-.04	.2504	.0405	.0364	.0000	.0006	-.0025	.2536	.0061
.200	2750.7	9.91	-.05	.3343	.0642	.0507	.0004	.0006	-.0021	.3404	.0057
.200	2752.8	11.81	-.05	.4092	.0908	.0841	.0004	.0008	-.0024	.4191	.0051
.200	2762.8	13.87	-.06	.4991	.1280	.0818	.0009	.0007	-.0030	.5152	.0047
.201	2787.5	16.13	-.07	.6024	.1784	.1027	.0012	.0006	-.0016	.6283	.0040
.200	2754.7	17.94	-.08	.6834	.2245	.1196	.0012	.0001	-.0029	.7193	.0032
.201	2766.0	19.26	-.09	.7454	.2632	.1334	.0011	-.0001	-.0024	.7905	.0026
.201	2770.2	.03	.00	.0036	.0074	.0035	-.0005	.0003	-.0031	.0036	.0074
TEST 106			RUN 2								
MACH	α	ALPHA	BETA	CL	CD	CMS	CRMS	CYMS	CYS	CN	CA
NUMB	PA	DEG	DEG								
.200	2741.6	.03	-.00	.0094	.0097	.0094	-.0005	.0008	-.0012	.0094	.0097
.200	2750.3	-1.99	.01	-.0406	.0110	.0027	-.0006	.0009	-.0005	-.0409	.0095
.201	2760.6	-4.36	.02	-.1128	.0164	-.0063	-.0008	.0008	-.0021	-.1137	.0085
.201	2771.9	.01	-.00	.0080	.0104	.0090	-.0004	.0008	-.0014	.0080	.0104
.201	2762.2	1.94	-.01	.0598	.0130	.0172	-.0001	.0012	-.0014	.0602	.0110
.201	2764.7	3.89	-.02	.1170	.0198	.0260	.0001	.0010	-.0013	.1181	.0118
.200	2757.1	5.81	-.03	.1822	.0311	.0364	.0002	.0008	-.0002	.1844	.0125
.200	2747.0	7.80	-.04	.2625	.0498	.0487	.0001	.0008	-.0016	.2669	.0137
.200	2748.6	9.84	-.05	.3421	.0743	.0633	.0001	.0010	-.0024	.3498	.0147
.200	2745.5	11.87	-.06	.4261	.1060	.0803	.0008	.0008	-.0012	.4387	.0161
.201	2762.0	13.87	-.06	.5087	.1432	.0968	.0009	.0004	-.0030	.5282	.0171
.200	2757.1	15.82	-.07	.5966	.1880	.1153	.0013	.0002	-.0013	.6252	.0182
.201	2762.9	17.84	-.08	.6866	.2411	.1342	.0014	-.0002	-.0026	.7274	.0192
.200	2741.4	19.33	-.09	.7574	.2871	.1506	.0014	-.0002	-.0028	.8098	.0202
.201	2766.6	.01	-.00	.0102	.0098	.0096	-.0004	.0006	-.0018	.0102	.0098
TEST 106			RUN 3								
MACH	α	ALPHA	BETA	CL	CD	CMS	CRMS	CYMS	CYS	CN	CA
NUMB	PA	DEG	DEG								
.201	2780.7	.03	-.00	.0084	.0103	.0091	-.0004	.0010	-.0006	.0084	.0103
.200	2764.7	-4.32	.02	-.1142	.0167	-.0061	-.0010	.0006	-.0018	-.1152	.0081
.200	2764.5	.01	-.00	.0075	.0105	.0092	-.0005	.0010	-.0017	.0075	.0104
.201	2779.4	3.88	-.02	.1150	.0199	.0236	-.0001	.0012	-.0014	.1160	.0121
.199	2748.6	7.78	-.04	.2596	.0502	.0484	.0004	.0008	-.0026	.2640	.0146
.200	2770.5	11.82	-.05	.4182	.1045	.0789	.0007	.0006	-.0029	.4307	.0166
.201	2783.5	15.79	-.07	.5928	.1874	.1151	.0012	.0006	-.0014	.6215	.0190
.200	2774.2	19.49	-.09	.7642	.2927	.1523	.0013	-.0002	-.0026	.8180	.0210
.201	2782.9	.01	-.00	.0072	.0103	.0094	-.0005	.0011	-.0012	.0072	.0103
TEST 106			RUN 4								
MACH	α	ALPHA	BETA	CL	CD	CMS	CRMS	CYMS	CYS	CN	CA
NUMB	PA	DEG	DEG								
.200	2769.6	.08	-.00	.0275	.0207	.0293	-.0008	.0006	-.0016	.0276	.0236
.200	2766.5	-1.93	.01	-.0488	.0196	.0115	-.0005	.0006	-.0019	-.0494	.0179
.201	2785.9	-4.12	.02	-.1083	.0232	-.0009	-.0007	.0003	-.0021	-.1097	.0154
.201	2795.2	.00	-.00	.0265	.0207	.0297	-.0007	.0007	-.0013	.0266	.0207
.201	2786.8	1.96	-.01	.0714	.0263	.0382	-.0005	.0006	-.0021	.0723	.0218
.201	2782.5	4.13	-.02	.1304	.0361	.0479	-.0003	.0005	-.0029	.1326	.0266
.200	2762.4	5.99	-.03	.1859	.0484	.0572	-.0003	.0006	-.0039	.1899	.0291
.200	2767.8	7.88	-.04	.2632	.0698	.0701	-.0002	.0003	-.0012	.2703	.0331
.200	2770.4	9.92	-.04	.3536	.0986	.0838	.0005	.0000	-.0032	.3653	.0362
.200	2795.3	11.88	-.05	.4337	.1318	.1001	.0007	.0000	-.0034	.4516	.0397
.200	2780.9	.08	-.00	.0258	.0207	.0294	-.0008	.0008	-.0011	.0258	.0206
.200	2780.4	9.91	-.04	.3548	.0989	.0845	.0007	.0001	-.0022	.3666	.0363
.200	2780.3	11.88	-.05	.4316	.1311	.0996	.0008	.0000	-.0025	.4494	.0394
.199	2754.2	13.95	-.06	.5194	.1733	.1188	.0010	-.0003	-.0025	.5459	.0430
.201	2785.5	15.93	-.07	.6020	.2201	.1370	.0015	-.0010	-.0026	.6393	.0464
.200	2765.0	17.95	-.08	.6962	.2786	.1578	.0014	-.0014	-.0031	.7482	.0505
.200	2776.3	19.36	-.08	.7603	.3234	.1725	.0014	-.0012	-.0032	.8245	.0531
.200	2772.9	.08	-.00	.0271	.0208	.0304	-.0005	.0006	-.0008	.0271	.0207
TEST 106			RUN 5								
MACH	α	ALPHA	BETA	CL	CD	CMS	CRMS	CYMS	CYS	CN	CA
NUMB	PA	DEG	DEG								
.200	2778.1	.12	.00	.0352	.0400	.0425	-.0014	.0000	-.0036	.0353	.0399
.200	2765.4	-1.84	.01	-.0395	.0360	.0263	-.0004	.0005	-.0028	-.0406	.0347
.200	2767.7	-4.07	.02	-.1067	.0381	.0102	-.0008	.0003	-.0032	-.1092	.0304
.200	2775.8	.14	.00	.0356	.0400	.0425	-.0012	-.0001	-.0046	.0357	.0399
.201	2784.3	2.15	-.01	.0942	.0498	.0589	-.0004	.0002	-.0030	.0960	.0463
.201	2781.5	4.07	-.02	.1476	.0613	.0707	-.0002	.0002	-.0050	.1516	.0507
.200	2773.4	5.97	-.03	.1992	.0755	.0795	.0004	-.0002	-.0048	.2059	.0543
.201	2782.2	7.93	-.03	.2574	.0945	.0886	.0003	-.0022	-.0048	.2680	.0581
.200	2773.7	9.97	-.04	.3373	.1233	.1000	.0006	-.0015	-.0066	.3536	.0631
.201	2785.1	11.92	-.05	.4164	.1573	.1126	.0005	-.0018	-.0059	.4399	.0678
.200	2768.3	13.94	-.06	.5011	.2001	.1283	.0006	-.0018	-.0063	.5346	.0731
.201	2801.7	15.99	-.07	.5800	.2464	.1440	.0010	-.0022	-.0068	.6253	.0781
.201	2790.2	18.00	-.07	.6664	.3042	.1629	.0016	-.0030	-.0089	.7278	.0839
.202	2810.5	19.38	-.08	.7243	.3473	.1766	.0012	-.0026	-.0082	.7985	.0873
.200	2772.7	.11	.00	.0369	.0406	.0422	-.0005	-.0001	-.0049	.0370	.0406

TABLE II. continued

MACH		Q	ALPHA		BETA		CL	CD	CMS	CRMS	CYMS	CYS	CM	CA
NUMB	PA	DEG	DEG	DEG	DEG	DEG								
.200	2786.5	.12	.00	.0271	.0524	.0476	.0476	.0329	-.0005	-.0001	-.0042	-.0273	.0523	
.200	2767.6	-1.86	.01	-.0302	.0496	.0329	.0329	.0209	-.0000	-.0003	-.0039	-.0318	.0486	
.200	2769.4	-4.01	.02	-.0883	.0511	.0209	.0209	.0469	-.0008	.0001	-.0037	-.0917	.0448	
.200	2763.5	.11	.00	.0262	.0322	.0469	.0322	.0594	-.0002	-.0000	-.0037	-.0263	.0522	
.201	2784.9	2.03	-.01	.0912	.0594	.0594	.0594	.0716	-.0004	-.0000	-.0038	.0932	.0561	
.200	2770.9	4.06	-.02	.1476	.0718	.0716	.0716	.0865	-.0001	-.0002	-.0038	.1523	.0612	
.200	2759.1	5.93	-.02	.2004	.0865	.0796	.0796	.0893	.0002	-.0007	-.0034	.2083	.0654	
.200	2775.4	7.91	-.03	.2645	.1078	.0893	.0893	.1011	.0006	-.0007	-.0037	.2768	.0704	
.200	2778.2	9.97	-.04	.3371	.1368	.1011	.1011	.1253	.0005	-.0010	-.0040	.3557	.0764	
.200	2770.2	11.92	-.05	.4083	.1696	.1253	.1253	.1488	.0009	-.0013	-.0052	.4345	.0816	
.201	2787.7	13.95	-.06	.4853	.2104	.1488	.1488	.1787	.0008	-.0016	-.0058	.5217	.0871	
.201	2785.7	15.87	-.07	.5658	.2573	.1787	.1787	.2104	.0013	-.0021	-.0051	.6147	.0930	
.200	2777.2	17.92	-.07	.6519	.3152	.2104	.2104	.2535	.0015	-.0019	-.0072	.7172	.0994	
.201	2780.0	19.36	-.08	.7071	.3578	.2535	.2535	.2924	.0013	-.0025	-.0060	.7857	.1032	
.200	2773.3	.13	.00	.0320	.0327	.0472	.0472	.0601	.0001	.0000	-.0038	.0329	.0526	

MACH		Q	ALPHA		BETA		CL	CD	CMS	CRMS	CYMS	CYS	CM	CA
NUMB	PA	DEG	DEG	DEG	DEG	DEG								
.200	2777.1	.01	-.00	.0493	.0099	-.0090	-.0090	-.0148	-.0011	.0005	-.0002	.0493	.0099	
.200	2776.8	-1.95	.01	-.0001	.0098	-.0148	-.0148	-.0235	-.0014	.0006	-.0002	-.0004	.0098	
.199	2755.2	-4.30	.02	-.0642	.0145	-.0235	-.0235	-.0391	-.0014	.0004	-.0012	-.0631	.0097	
.200	2771.0	.02	-.00	.0451	.0099	-.0091	-.0091	-.0138	-.0011	.0006	-.0010	.0451	.0099	
.201	2789.3	1.98	-.01	.1024	.0138	-.0138	-.0138	-.0208	-.0012	.0006	-.0008	.1028	.0102	
.200	2779.4	3.91	-.02	.1621	.0212	-.0208	-.0208	-.0302	-.0010	.0006	-.0010	.1631	.0101	
.200	2768.4	5.95	-.03	.2382	.0391	-.0302	-.0302	-.0421	-.0001	.0006	-.0013	.2405	.0103	
.200	2759.6	7.78	-.04	.3055	.0521	-.0421	-.0421	-.0521	.0001	.0005	-.0017	.3097	.0102	
.200	2775.0	9.84	-.05	.3899	.0779	-.0521	-.0521	-.0666	.0010	.0005	-.0023	.3975	.0101	
.200	2770.7	11.87	-.05	.4802	.1108	-.0666	-.0666	-.0800	.0009	.0005	-.0031	.4928	.0096	
.200	2775.7	13.86	-.06	.5666	.1488	-.0800	-.0800	-.0997	.0003	.0003	-.0021	.5857	.0087	
.200	2780.7	15.79	-.07	.6554	.1934	-.0997	-.0997	-.1188	.0003	.0001	-.0020	.6833	.0078	
.200	2775.0	17.95	-.08	.7609	.2535	-.1188	-.1188	-.1488	.0002	-.0001	-.0009	.8020	.0067	
.201	2789.5	19.23	-.08	.8211	.2924	-.1488	-.1488	-.1800	.0012	-.0004	-.0020	.8716	.0058	
.200	2772.7	.03	-.00	.0409	.0105	-.0083	-.0083	-.0105	-.0003	.0005	-.0025	.0409	.0105	

MACH		Q	ALPHA		BETA		CL	CD	CMS	CRMS	CYMS	CYS	CM	CA
NUMB	PA	DEG	DEG	DEG	DEG	DEG								
.200	2778.1	.01	-.00	.0828	.0113	-.0192	-.0192	-.0251	-.0002	.0008	-.0014	.0928	.0112	
.200	2778.9	-1.93	.01	.0402	.0099	-.0251	-.0251	-.0346	-.0008	.0007	-.0011	.0399	.0112	
.200	2771.7	-4.34	.02	-.0254	.0128	-.0346	-.0346	-.0469	-.0003	.0009	-.0013	-.0263	.0109	
.201	2786.7	.01	-.00	.0846	.0132	-.0469	-.0469	-.0601	-.0003	.0008	-.0016	.0846	.0112	
.201	2784.1	1.91	-.01	.1396	.0162	-.0601	-.0601	-.0753	-.0002	.0007	-.0017	.1401	.0116	
.200	2773.7	4.00	-.02	.2119	.0262	-.0753	-.0753	-.0924	.0001	.0007	-.0013	.2132	.0113	
.200	2776.5	5.82	-.03	.2771	.0394	-.0924	-.0924	-.1108	.0003	.0006	-.0015	.2797	.0113	
.200	2772.2	7.76	-.04	.3517	.0592	-.1108	-.1108	-.1396	.0005	.0009	-.0017	.3565	.0111	
.200	2772.5	9.61	-.05	.4340	.0862	-.1396	-.1396	-.1720	.0009	.0007	-.0022	.4424	.0109	
.201	2794.5	11.78	-.05	.5196	.1190	-.1720	-.1720	-.2104	.0010	.0009	-.0016	.5329	.0104	
.200	2767.6	13.91	-.06	.6137	.1620	-.2104	-.2104	-.2535	.0010	.0006	-.0016	.6347	.0097	
.200	2781.0	15.78	-.07	.6978	.2065	-.2535	-.2535	-.3000	.0010	.0003	-.0014	.7277	.0090	
.200	2764.5	17.84	-.08	.7946	.2643	-.3000	-.3000	-.3578	.0013	-.0001	-.0008	.8374	.0082	
.200	2778.0	19.28	-.09	.8649	.3105	-.3578	-.3578	-.4211	.0021	-.0004	-.0007	.9190	.0075	
.200	2780.4	.01	-.00	.0855	.0111	-.0193	-.0193	-.0251	-.0003	.0007	-.0015	.0855	.0111	

MACH		Q	ALPHA		BETA		CL	CD	CMS	CRMS	CYMS	CYS	CM	CA
NUMB	PA	DEG	DEG	DEG	DEG	DEG								
.200	2781.0	.01	-.00	.0903	.0147	-.0202	-.0202	-.0261	-.0001	.0011	-.0010	.0903	.0147	
.200	2765.9	-1.93	.01	.0468	.0131	-.0261	-.0261	-.0346	-.0002	.0010	-.0004	.0463	.0147	
.200	2774.6	-4.51	.02	-.0214	.0161	-.0346	-.0346	-.0469	-.0001	.0011	-.0014	-.0263	.0144	
.201	2782.8	.06	-.00	.0930	.0166	-.0469	-.0469	-.0601	.0004	.0011	-.0006	.0930	.0145	
.201	2789.4	1.92	-.01	.1460	.0198	-.0601	-.0601	-.0753	.0004	.0011	-.0007	.1466	.0149	
.200	2777.6	3.86	-.02	.2144	.0288	-.0753	-.0753	-.0924	.0015	.0009	-.0009	.2163	.0143	
.200	2767.7	5.85	-.03	.2858	.0436	-.0924	-.0924	-.1108	.0021	.0006	-.0014	.2888	.0143	
.201	2788.5	7.77	-.04	.3595	.0638	-.1108	-.1108	-.1396	.0021	.0010	-.0004	.3648	.0146	
.200	2766.9	9.82	-.05	.4439	.0919	-.1396	-.1396	-.1720	.0023	.0008	-.0015	.4531	.0149	
.200	2764.3	11.92	-.05	.5402	.1293	-.1720	-.1720	-.2104	.0030	.0007	-.0011	.5553	.0149	
.201	2789.7	13.90	-.06	.6338	.1720	-.2104	-.2104	-.2535	.0025	.0004	-.0016	.6565	.0147	
.201	2788.7	15.78	-.07	.7239	.2195	-.2535	-.2535	-.3000	.0019	.0001	-.0006	.7563	.0144	
.200	2776.5	17.92	-.08	.8325	.2833	-.3000	-.3000	-.3578	.0022	-.0000	-.0002	.8793	.0134	
.200	2778.7	19.22	-.09	.8979	.3265	-.3578	-.3578	-.4211	.0019	.0003	-.0003	.9553	.0127	
.200	2779.8	.02	-.00	.0910	.0143	-.0204	-.0204	-.0261	.0002	.0010	-.0001	.0910	.0142	

MACH		Q	ALPHA		BETA		CL	CD	CMS	CRMS	CYMS	CYS	CM	CA
NUMB	PA	DEG	DEG	DEG	DEG	DEG								
.200	2774.4	.01	-.00	.1026	.0178	-.0237	-.0237	-.0296	.0001	.0008	-.0003	.1026	.0178	
.201	2783.7	-1.90	.01	.0594	.0160	-.0296	-.0296	-.0391	.0001	.0007	-.0010	.0589	.0179	
.200	2757.9	-4.20	.02	-.0002	.0179	-.0391	-.0391	-.0500	.0001	.0008	-.0012	-.0015	.0178	
.201	2790.1	.03	-.00	.1040	.0179	-.0500	-.0500	-.0601	.0006	.0010	-.0006	.1040	.0179	
.201	2787.2	1.91	-.01	.1546	.0232	-.0601	-.0601	-.0753	.0005	.0007	-.0010	.1553	.0181	
.200	2776.1	3.89	-.02	.2185	.0332	-.0753	-.0753	-.0924	.0009	.0007	-.0015	.2203	.0183	
.200	2761.4	5.82	-.03	.2894	.0486	-.0924	-.0924	-.1108	.0013	.0005	-.0021	.2928	.0191	
.200	2774.3	7.80	-.04	.3755	.0710	-.1108	-.1108	-.1396	.0031	.0004	-.0017	.3817	.0193	
.200	2769.8	9.85	-.05	.4593	.0996	-.1396	-.1396	-.1720	.0027	.0006	-.0011	.4696	.0195	
.200	2772.7	11.81	-.05	.5457	.1340	-.1720	-.1720	-.2104	.0021	.0006	-.0015	.5616	.0195	
.200	2778.0	13.90	-.06	.6465	.1796	-.2104	-.2104	-.2535	.0005	.0004	-.0012	.6707	.0191	
.199	2751.2	15.82	-.07	.7371	.2287	-.2535	-.2535	-.3000	.0004	.0003	-.0004	.7716	.0191	
.200	2775.6	17.94	-.08	.8414	.2920	-.3000	-.3000	-.3578	.0008	.0003	-.0009	.8904	.0186	
.201	2779.6	19.31	-.09	.9194	.3452	-.3578	-.3578	-.4211	.0018	.0002	-.0021	.9819	.0183	
.200	2772.1	.03	-.00	.1047	.0179	-.0240	-.0240	-.0296	.0008	.0007	-.0015	.1047	.0178	

TABLE II. continued

NASA LANGLEY
7 x 10 HIGH SPEED TUNNEL

		TEST 106			RUN 11						
MACH	Q NUMB PA	ALPHA DEG	BETA DEG	CL	CD	CMS	CRMS	CYMS	CYS	CN	CA
.200	2776.4	.01	-.00	.1150	.0208	-.0266	.0002	.0009	-.0010	.1150	.0267
.200	2761.8	-1.92	.01	.0689	.0183	-.0319	.0002	.0008	-.0013	.0682	.0266
.200	2769.7	-4.39	.02	.0034	.0205	-.0412	-.0002	.0006	-.0012	.0038	.0209
.201	2779.2	.01	-.00	.1150	.0207	-.0268	.0003	.0008	-.0013	.1150	.0207
.201	2787.1	1.89	-.01	.1076	.0267	-.0220	.0007	.0007	-.0015	.1684	.0211
.200	2774.5	3.87	-.02	.2340	.0379	-.0137	.0010	.0007	-.0013	.2361	.0221
.202	2805.5	5.81	-.03	.3040	.0341	-.0087	.0012	.0009	-.0015	.3079	.0231
.200	2772.1	7.78	-.04	.3794	.0755	.0016	.0011	.0007	-.0013	.3861	.0235
.201	2770.7	9.85	-.05	.4683	.1056	.0140	.0013	.0006	-.0020	.4795	.0239
.200	2769.2	11.81	-.05	.5525	.1401	.0272	.0013	.0008	-.0012	.5694	.0241
.200	2756.5	13.87	-.06	.6475	.1845	.0434	.0012	.0002	-.0014	.6728	.0240
.201	2789.6	15.81	-.07	.7438	.2362	.0575	.0008	-.0002	-.0003	.7800	.0246
.200	2768.3	17.86	-.08	.8485	.2991	.0755	.0012	-.0000	-.0006	.8994	.0244
.201	2781.4	19.21	-.09	.9209	.3469	.0874	.0018	.0000	-.0005	.9838	.0245
.200	2772.9	.02	-.00	.1156	.0205	-.0263	.0005	.0007	-.0011	.1156	.0205

		TEST 106			RUN 12						
MACH	Q NUMB PA	ALPHA DEG	BETA DEG	CL	CD	CMS	CRMS	CYMS	CYS	CN	CA
.200	2765.1	.03	-.00	.0919	.0144	-.0132	-.0001	.0009	-.0019	.0919	.0143
.200	2759.0	-1.92	.01	.0495	.0120	-.0206	-.0007	.0010	-.0012	.0491	.0136
.201	2782.2	-4.21	.02	-.0168	.0129	-.0311	-.0004	.0007	-.0018	-.0177	.0117
.200	2769.3	.03	-.00	.0923	.0144	-.0133	-.0002	.0013	-.0002	.0923	.0144
.200	2767.3	1.94	-.01	.1479	.0205	-.0056	.0001	.0010	-.0012	.1485	.0154
.200	2767.8	3.88	-.02	.2064	.0303	.0020	.0004	.0013	-.0004	.2080	.0162
.200	2767.9	5.90	-.03	.2866	.0479	.0106	.0003	.0008	-.0013	.2900	.0182
.201	2778.4	7.83	-.04	.3685	.0706	.0219	.0004	.0008	-.0015	.3746	.0197
.200	2763.5	9.88	-.05	.4529	.1001	.0358	.0005	.0011	-.0018	.4634	.0208
.201	2787.6	11.85	-.06	.5341	.1347	.0515	.0005	.0008	-.0018	.5503	.0221
.201	2780.1	13.92	-.06	.6250	.1793	.0694	.0011	.0002	-.0008	.6498	.0236
.201	2780.8	15.85	-.07	.7130	.2284	.0866	.0011	-.0000	-.0003	.7482	.0250
.200	2755.4	18.03	-.08	.8135	.2929	.1084	.0014	-.0000	-.0025	.8641	.0265
.201	2786.1	19.27	-.08	.8722	.3341	.1215	.0020	-.0005	-.0018	.9336	.0276
.200	2773.9	.04	-.00	.0915	.0145	-.0129	-.0004	.0009	-.0008	.0915	.0144

		TEST 106			RUN 13						
MACH	Q NUMB PA	ALPHA DEG	BETA DEG	CL	CD	CMS	CRMS	CYMS	CYS	CN	CA
.200	2772.9	.08	-.00	.0866	.0266	.0132	-.0002	.0009	-.0022	.0867	.0264
.201	2778.9	-1.91	.01	.0154	.0233	-.0039	-.0004	.0007	-.0022	.0146	.0238
.200	2759.9	-4.22	.02	-.0424	.0242	-.0185	-.0004	.0004	-.0028	-.0441	.0210
.200	2765.1	.07	.00	.0880	.0267	.0122	-.0008	.0006	-.0035	.0880	.0266
.200	2776.7	2.01	-.01	.1411	.0347	.0178	-.0002	.0008	-.0034	.1423	.0298
.200	2761.1	3.92	-.02	.2017	.0468	.0255	-.0002	.0004	-.0041	.2044	.0329
.200	2776.0	5.91	-.03	.2733	.0548	.0350	.0002	.0005	-.0046	.2785	.0363
.200	2759.2	7.86	-.04	.3689	.0926	.0438	-.0002	.0004	-.0044	.3781	.0413
.200	2776.3	9.92	-.04	.4814	.1266	.0560	.0012	.0002	-.0046	.4763	.0452
.200	2757.7	11.99	-.05	.5900	.1668	.0732	-.0014	-.0007	-.0046	.5727	.0489
.200	2758.4	13.95	-.06	.6326	.2111	.0907	.0020	-.0014	-.0053	.6644	.0523
.200	2766.1	15.89	-.07	.7200	.2634	.1084	.0020	-.0015	-.0054	.7646	.0561
.201	2784.1	17.99	-.08	.8126	.3272	.1287	.0019	-.0015	-.0057	.8739	.0602
.200	2775.8	19.38	-.08	.8789	.3759	.1430	.0025	-.0021	-.0059	.9539	.0630
.200	2754.9	.07	.00	.0862	.0273	.0126	-.0003	.0004	-.0031	.0862	.0272

		TEST 106			RUN 14						
MACH	Q NUMB PA	ALPHA DEG	BETA DEG	CL	CD	CMS	CRMS	CYMS	CYS	CN	CA
.201	2779.2	.12	.00	.0971	.0458	.0264	.0002	.0004	-.0034	.0972	.0456
.200	2760.7	-1.87	.01	-.0175	.0395	-.0093	-.0000	.0006	-.0027	.0162	.0400
.200	2755.8	-4.11	.02	-.0470	.0389	-.0261	-.0006	.0005	-.0027	-.0496	.0354
.200	2767.4	.10	.00	.0959	.0453	.0262	-.0002	.0003	-.0033	.0960	.0452
.200	2769.3	2.03	-.01	.1507	.0565	.0413	.0001	.0002	-.0032	.1526	.0511
.200	2754.3	4.00	-.02	.2208	.0719	.0494	.0001	.0003	-.0039	.2252	.0563
.201	2781.4	5.94	-.03	.2860	.0905	.0579	.0004	.0002	-.0041	.2938	.0605
.200	2765.2	7.92	-.03	.3543	.1148	.0661	.0014	-.0013	-.0032	.3668	.0649
.200	2767.1	9.98	-.04	.4450	.1498	.0751	.0012	-.0013	-.0059	.4643	.0704
.200	2770.6	11.92	-.05	.5314	.1901	.0882	.0013	-.0017	-.0058	.5592	.0762
.200	2773.7	13.98	-.06	.6164	.2375	.1025	.0015	-.0017	-.0055	.6555	.0816
.200	2768.4	15.90	-.07	.7005	.2898	.1192	.0018	-.0021	-.0063	.7530	.0868
.201	2783.8	17.97	-.07	.7853	.3516	.1379	.0021	-.0025	-.0063	.8554	.0922
.201	2780.4	19.61	-.08	.8464	.4038	.1524	.0021	-.0030	-.0059	.9328	.0963
.200	2762.3	.12	.00	.0982	.0463	.0261	.0004	.0004	-.0033	.0983	.0461

		TEST 106			RUN 15						
MACH	Q NUMB PA	ALPHA DEG	BETA DEG	CL	CD	CMS	CRMS	CYMS	CYS	CN	CA
.200	2763.6	-1.12	.00	.0994	.0579	.0278	.0011	.0006	-.0046	.0995	.0576
.200	2759.6	-1.85	.01	-.0397	.0527	.0151	.0009	.0008	-.0045	.0379	.0530
.199	2743.8	-4.15	.02	-.0250	.0515	-.0068	.0010	.0009	-.0039	-.0286	.0495
.201	2782.5	.15	.00	.1057	.0580	.0279	.0012	.0007	-.0053	.1058	.0577
.200	2774.1	2.07	-.01	.1749	.0680	.0388	.0007	.0004	-.0051	.1772	.0617
.201	2781.0	4.00	-.02	.2369	.0836	.0486	.0005	.0002	-.0046	.2422	.0669
.200	2768.2	5.94	-.03	.2982	.1033	.0566	.0005	.0002	-.0040	.3072	.0719
.201	2776.8	7.94	-.03	.3650	.1293	.0661	.0007	-.0016	-.0033	.3794	.0777
.200	2774.4	9.97	-.04	.4422	.1636	.0777	.0007	-.0009	-.0039	.4639	.0845
.201	2781.8	11.99	-.05	.5223	.2041	.0896	.0008	-.0014	-.0048	.5533	.0911
.201	2785.4	13.94	-.06	.6043	.2518	.1030	.0008	-.0014	-.0052	.6472	.0983
.201	2790.1	15.94	-.07	.6834	.3038	.1176	.0017	-.0019	-.0055	.7405	.1045
.201	2777.0	17.94	-.07	.7687	.3647	.1338	.0013	-.0025	-.0076	.8437	.1102
.201	2792.5	19.54	-.08	.8326	.4175	.1468	.0016	-.0032	-.0080	.9243	.1150
.201	2776.3	.14	.00	.1142	.0581	.0250	.0003	-.0002	-.0037	.1143	.0576

NASA LANGLEY 7 X 10 HIGH SPEED TUNNEL											
TEST 106				RUN 16							
MACH NUMB	Q PA	ALPHA DEG	BETA DEG	CL	CD	CMS	CRMS	CYMS	CYS	CM	CA
.201	2791.7	.12	.00	.1126	.0582	.0255	-.0012	-.0005	-.0036	.1127	.0379
.200	2774.3	-1.83	.01	.0491	.0526	.0124	-.0010	-.0004	-.0036	.0474	.0341
.200	2773.7	-4.18	.02	-.0175	.0510	-.0026	-.0017	-.0006	-.0032	-.0212	.0496
.201	2784.6	.13	.00	.1153	.0579	.0247	-.0007	-.0006	-.0049	.1154	.0376
.201	2784.9	2.04	-.01	.1835	.0679	.0358	-.0004	-.0004	-.0034	.1858	.0614
.200	2773.3	4.07	-.02	.2450	.0846	.0474	.0000	-.0008	-.0064	.2504	.0670
.200	2782.9	5.95	-.02	.3031	.1091	.0556	.0004	-.0009	-.0064	.3122	.0721
.201	2786.2	7.92	-.03	.3686	.1297	.0655	.0004	-.0012	-.0055	.3830	.0777
.201	2785.2	10.01	-.04	.4484	.1651	.0773	.0004	-.0018	-.0049	.4701	.0847
.200	2770.9	11.91	-.05	.5233	.2032	.0886	.0006	-.0020	-.0065	.5539	.0908
.200	2760.8	13.97	-.06	.6083	.2521	.1024	.0008	-.0022	-.0073	.6512	.0978
.202	2821.7	15.90	-.06	.6855	.3029	.1163	.0013	-.0027	-.0082	.7422	.1036
.201	2794.9	17.94	-.07	.7720	.3664	.1332	.0009	-.0028	-.0091	.8473	.1108
.201	2803.1	19.46	-.08	.8281	.4143	.1452	.0011	-.0034	-.0087	.9186	.1146
.200	2783.4	.14	.00	.1169	.0578	.0237	-.0004	-.0006	-.0036	.1191	.0376

TEST 106 RUN 17											
MACH NUMB	Q PA	ALPHA DEG	BETA DEG	CL	CD	CMS	CRMS	CYMS	CYS	CM	CA
.201	2794.9	.12	.00	.1257	.0451	.0177	.0013	.0004	-.0028	.1258	.0448
.200	2776.9	-1.96	.01	.0461	.0381	.0013	-.0002	.0006	-.0025	.0447	.0396
.200	2782.6	-4.10	.02	-.0213	.0361	-.0165	.0000	.0005	-.0023	-.0238	.0345
.201	2803.0	.11	.00	.1257	.0455	.0177	.0020	.0003	-.0030	.1257	.0452
.201	2786.3	2.03	-.01	.1781	.0571	.0340	.0003	.0007	-.0033	.1860	.0507
.200	2771.2	4.01	-.02	.2390	.0724	.0457	.0008	-.0015	-.0013	.2435	.0553
.200	2770.9	5.92	-.03	.2933	.0902	.0559	.0008	-.0002	-.0016	.3011	.0595
.200	2776.4	7.98	-.03	.3587	.1156	.0730	.0010	-.0003	-.0021	.3732	.0643
.201	2785.4	9.94	-.04	.4272	.1492	.0875	.0013	-.0010	-.0039	.4662	.0698
.200	2777.9	11.96	-.05	.5352	.1905	.0878	.0015	-.0015	-.0050	.5630	.0754
.200	2775.2	13.96	-.06	.6178	.2364	.1024	.0020	-.0019	-.0055	.6566	.0804
.200	2774.3	15.96	-.07	.7059	.2918	.1201	.0018	-.0016	-.0059	.7590	.0863
.200	2774.7	18.01	-.07	.7877	.3525	.1389	.0023	-.0025	-.0061	.8581	.0916
.201	2804.9	19.54	-.08	.8501	.4034	.1533	.0021	-.0024	-.0053	.9361	.0958
.201	2788.3	.12	-.00	.1297	.0462	.0183	.0017	.0006	-.0019	.1298	.0459

TEST 106 RUN 18											
MACH NUMB	Q PA	ALPHA DEG	BETA DEG	CL	CD	CMS	CRMS	CYMS	CYS	CM	CA
.200	2780.1	.08	-.00	.1234	.0318	-.0001	.0001	.0006	-.0018	.1235	.0317
.200	2776.1	-1.88	.01	.0347	.0273	-.0137	.0004	.0005	-.0018	.0338	.0291
.200	2772.3	-4.09	.02	-.0088	.0267	-.0242	-.0004	.0000	-.0025	-.0107	.0260
.201	2784.1	.09	.00	.1262	.0324	.0008	-.0001	.0005	-.0022	.1263	.0322
.200	2759.0	2.00	-.01	.1728	.0409	.0084	.0004	.0004	-.0026	.1742	.0348
.200	2776.3	3.94	-.02	.2284	.0528	.0160	.0005	.0002	-.0033	.2315	.0370
.200	2772.5	5.90	-.03	.3083	.0730	.0235	.0005	-.0001	-.0021	.3142	.0409
.200	2766.6	7.84	-.04	.4186	.1065	.0300	-.0014	-.0001	-.0024	.4292	.0481
.200	2774.3	9.93	-.04	.5042	.1409	.0439	-.0007	-.0003	-.0037	.5210	.0518
.200	2769.4	11.91	-.05	.5893	.1812	.0592	-.0002	-.0005	-.0024	.6141	.0557
.200	2775.3	14.03	-.06	.6777	.2307	.0780	.0007	-.0011	-.0038	.7134	.0593
.200	2764.7	15.91	-.07	.7645	.2840	.0952	.0015	-.0004	-.0056	.8131	.0636
.199	2741.9	17.96	-.08	.8592	.3496	.1141	.0020	-.0011	-.0056	.9251	.0676
.200	2763.9	19.65	-.08	.9408	.4119	.1313	.0029	-.0019	-.0055	1.0245	.0716
.200	2760.5	.10	.00	.1265	.0325	.0008	.0003	.0003	-.0026	.1265	.0323

TEST 106 RUN 19											
MACH NUMB	Q PA	ALPHA DEG	BETA DEG	CL	CD	CMS	CRMS	CYMS	CYS	CM	CA
.201	2781.4	.12	.00	.1365	.0525	.0152	.0020	-.0000	-.0026	.1366	.0522
.200	2772.5	-1.95	.01	.0541	.0446	-.0014	.0004	.0003	-.0020	.0526	.0464
.200	2777.5	-4.22	.02	-.0121	.0430	-.0153	.0005	-.0001	-.0022	-.0132	.0420
.201	2787.9	.09	.00	.1352	.0523	.0152	.0016	.0003	-.0021	.1353	.0521
.201	2784.4	2.01	-.01	.1892	.0641	.0303	.0003	.0000	-.0031	.1914	.0574
.200	2766.2	4.06	-.02	.2624	.0818	.0399	.0003	-.0003	-.0029	.2679	.0630
.200	2776.4	5.92	-.02	.3248	.1016	.0465	.0004	-.0016	-.0015	.3335	.0675
.200	2779.1	7.90	-.03	.4046	.1302	.0526	.0002	-.0016	-.0032	.4187	.0734
.200	2772.2	9.96	-.04	.4994	.1683	.0617	.0001	-.0015	-.0039	.5209	.0794
.200	2779.4	11.97	-.05	.5884	.2125	.0747	.0009	-.0016	-.0032	.6197	.0859
.200	2772.0	13.98	-.06	.6718	.2616	.0889	.0014	-.0021	-.0046	.7151	.0915
.201	2780.0	15.90	-.07	.7524	.3152	.1058	.0011	-.0015	-.0053	.8100	.0970
.200	2773.6	17.95	-.07	.8317	.3769	.1236	.0021	-.0028	-.0061	.9073	.1022
.201	2790.8	19.41	-.08	.8927	.4277	.1374	.0024	-.0034	-.0054	.9841	.1066
.201	2790.8	.11	.00	.1407	.0526	.0156	.0016	-.0002	-.0026	.1408	.0524

TEST 106 RUN 20											
MACH NUMB	Q PA	ALPHA DEG	BETA DEG	CL	CD	CMS	CRMS	CYMS	CYS	CM	CA
.200	2781.5	.13	.00	.1278	.0634	.0214	.0001	-.0004	-.0042	.1280	.0631
.201	2785.1	-1.83	.01	.0623	.0573	.0091	.0003	-.0003	-.0041	.0605	.0593
.200	2769.3	-4.13	.02	-.0047	.0591	-.0042	.0004	-.0005	-.0038	-.0087	.0546
.200	2786.4	.14	.00	.1306	.0638	.0216	.0002	-.0004	-.0042	.1307	.0635
.200	2780.4	2.13	-.01	.1884	.0756	.0335	-.0000	-.0004	-.0043	.2011	.0682
.201	2785.6	4.03	-.02	.2573	.0924	.0436	.0003	-.0007	-.0049	.2632	.0741
.200	2782.5	5.95	-.02	.3205	.1136	.0500	.0002	-.0026	-.0035	.3306	.0798
.200	2781.1	7.91	-.03	.3974	.1432	.0583	-.0002	-.0022	-.0040	.4133	.0871
.200	2770.7	10.06	-.04	.4789	.1819	.0699	-.0007	-.0016	-.0056	.5034	.0952
.200	2767.9	11.92	-.05	.5543	.2210	.0811	-.0004	-.0019	-.0069	.5880	.1018
.200	2780.3	14.05	-.06	.6421	.2735	.0941	-.0005	-.0021	-.0078	.6893	.1095
.200	2774.3	15.89	-.07	.7224	.3268	.1062	-.0006	-.0019	-.0087	.7843	.1165
.200	2767.3	18.11	-.07	.8148	.3967	.1226	-.0004	-.0026	-.0090	.8977	.1238
.201	2786.6	19.38	-.08	.8626	.4382	.1319	.0003	-.0037	-.0098	.9591	.1271
.201	2786.3	.14	.00	.1320	.0642	.0206	-.0001	-.0006	-.0062	.1321	.0639

TABLE II. continued

NASA LANGLEY 7 X 10 HIGH SPEED TUNNEL											
TEST 106					RUN 21						
MACH NUMB	0 PA	ALPHA DEG	BETA DEG	CL	CD	CMS	CRMS	CYMS	CYS	CM CA	
.200	2780.3	.03	-0.00	.1055	.0208	-.0156	.0009	.0005	-.0012	.1055	.0207
.200	2780.8	-1.99	-.01	.0508	.0178	-.0236	.0003	.0007	-.0006	.0581	.0198
.200	2780.9	-4.36	.02	-.0056	.0193	-.0343	.0004	.0005	-.0009	-.0070	.0188
.201	2797.8	.08	-0.00	.1046	.0205	-.0164	.0006	.0005	-.0012	.1047	.0203
.201	2787.6	1.92	-0.01	.1576	.0271	-.0092	.0004	.0003	-.0016	.1584	.0218
.200	2777.8	3.69	-0.02	.2231	.0385	-.0014	.0010	.0004	-.0007	.2252	.0232
.200	2783.8	5.84	-0.03	.3033	.0576	.0058	.0005	.0001	.0002	.3076	.0265
.200	2767.3	7.81	-0.04	.3866	.0826	.0176	-.0003	.0005	-.0010	.3943	.0293
.200	2784.6	9.88	-0.05	.4747	.1143	.0312	-.0011	.0008	-.0012	.4873	.0311
.200	2770.2	11.86	-0.06	.5681	.1533	.0442	-.0011	.0008	-.0004	.5874	.0333
.201	2785.5	13.93	-0.06	.6668	.2021	.0590	-.0010	.0003	-.0008	.6958	.0356
.200	2772.4	15.86	-0.07	.7593	.2548	.0754	-.0009	.0001	-.0005	.8000	.0375
.200	2782.5	17.91	-0.08	.8639	.3207	.0943	-.0005	.0009	-.0020	.9207	.0395
.200	2776.8	19.41	-0.09	.9356	.3730	.1095	.0002	.0002	-.0019	1.0064	.0410
.200	2776.7	.03	-0.00	.1062	.0207	-.0162	.0002	.0006	-.0000	.1062	.0206
TEST 106					RUN 22						
MACH NUMB	0 PA	ALPHA DEG	BETA DEG	CL	CD	CMS	CRMS	CYMS	CYS	CM CA	
.200	2781.7	.03	-0.00	.0648	.0118	-.0056	-.0004	.0009	-.0006	.0648	.0117
.200	2781.8	-2.05	-0.01	.0160	.0101	-.0150	-.0003	.0010	-.0007	.0156	.0107
.200	2787.4	-4.15	-.02	-.0410	.0125	-.0226	-.0003	.0008	-.0009	-.0418	.0099
.201	2785.1	.33	-0.00	.0655	.0116	-.0057	-.0003	.0009	-.0010	.0655	.0116
.201	2791.9	1.93	-0.01	.1209	.0169	.0019	-.0002	.0009	-.0006	.1214	.0128
.200	2775.0	3.69	-0.02	.1794	.0259	.0095	.0001	.0008	-.0011	.1807	.0136
.200	2775.6	5.91	-0.03	.2540	.0417	.0196	.0009	.0006	-.0009	.2570	.0153
.200	2764.2	7.80	-0.04	.3361	.0634	.0307	.0007	.0009	-.0012	.3416	.0172
.201	2790.3	9.93	-0.05	.4230	.0927	.0458	.0009	.0009	-.0009	.4326	.0184
.200	2763.5	11.87	-0.06	.5013	.1252	.0607	.0007	.0008	-.0011	.5164	.0194
.200	2780.2	13.90	-0.06	.5881	.1668	.0781	.0010	-.0007	.0014	.6109	.0206
.200	2758.8	15.86	-0.07	.6757	.2147	.0963	.0017	-.0005	-.0009	.7087	.0219
.200	2772.9	17.88	-0.08	.7686	.2723	.1162	.0016	-.0005	-.0001	.8131	.0232
.201	2794.4	19.35	-0.09	.8391	.3205	.1314	.0018	-.0001	-.0013	.8979	.0243
.201	2790.6	.05	-0.00	.0659	.0120	-.0041	-.0009	.0007	-.0001	.0659	.0119
TEST 106					RUN 23						
MACH NUMB	0 PA	ALPHA DEG	BETA DEG	CL	CD	CMS	CRMS	CYMS	CYS	CM CA	
.200	2758.7	.07	-0.00	.0661	.0236	.0155	-.0007	.0011	-.0011	.0661	.0235
.200	2768.8	-1.90	-.01	-.0070	.0210	.0016	-.0005	.0007	-.0019	-.0077	.0207
.200	2763.3	-4.13	.02	-.0655	.0232	-.0119	-.0011	.0004	-.0013	-.0670	.0184
.200	2768.9	.08	-0.00	.0681	.0236	.0155	-.0011	.0007	-.0017	.0681	.0235
.200	2762.3	2.03	-0.01	.1242	.0308	.0229	-.0009	.0007	-.0019	.1252	.0246
.200	2769.2	3.99	-0.02	.1803	.0413	.0309	-.0005	.0007	-.0020	.1825	.0287
.201	2772.3	5.88	-0.03	.2528	.0578	.0399	.0002	.0006	-.0026	.2574	.0316
.201	2779.6	7.86	-0.04	.3385	.0821	.0489	.0006	.0003	-.0042	.3465	.0351
.200	2761.1	9.91	-0.04	.4285	.1140	.0635	.0008	-.0006	-.0035	.4418	.0385
.200	2768.0	11.89	-0.05	.5082	.1497	.0795	.0012	-.0018	-.0017	.5281	.0419
.201	2771.8	13.94	-0.06	.5950	.1945	.0984	.0010	-.0010	-.0033	.6243	.0454
.200	2763.5	15.86	-0.07	.6785	.2435	.1157	.0020	-.0013	-.0029	.7193	.0488
.200	2750.7	17.93	-0.08	.7725	.3052	.1360	.0024	-.0012	-.0050	.8289	.0526
.200	2766.4	19.64	-0.08	.8536	.3642	.1541	.0025	-.0016	-.0045	.9263	.0561
.200	2763.4	.12	-0.00	.0731	.0234	.0134	-.0018	.0003	-.0021	.0731	.0233
TEST 106					RUN 24						
MACH NUMB	0 PA	ALPHA DEG	BETA DEG	CL	CD	CMS	CRMS	CYMS	CYS	CM CA	
.201	2771.2	.12	.00	.0898	.0424	.0286	-.0008	-.0002	-.0024	.0899	.0422
.200	2756.9	-1.93	.01	.0099	.0368	.0119	-.0016	-.0001	-.0015	-.0086	.0371
.200	2768.3	-4.13	.02	-.0545	.0366	-.0043	-.0017	-.0002	-.0016	-.0570	.0326
.201	2771.2	.11	.00	.0901	.0425	.0290	-.0003	-.0002	-.0017	.0902	.0423
.201	2781.0	1.98	-0.01	.1423	.0522	.0430	-.0010	.0002	-.0020	.1440	.0473
.200	2767.0	3.95	-0.02	.2093	.0666	.0530	-.0003	.0004	-.0032	.2134	.0521
.201	2776.7	5.88	-0.03	.2625	.0831	.0623	.0002	-.0001	-.0034	.2697	.0557
.201	2776.4	7.85	-0.03	.3268	.1058	.0717	.0009	-.0024	-.0013	.3382	.0601
.200	2765.9	9.92	-0.04	.4144	.1391	.0828	.0011	-.0015	-.0043	.4322	.0656
.201	2772.9	11.88	-0.05	.4980	.1771	.0956	.0015	-.0020	-.0038	.5238	.0707
.200	2759.1	13.92	-0.06	.5834	.2231	.1113	.0014	-.0021	-.0044	.6200	.0762
.201	2771.6	15.86	-0.07	.6641	.2731	.1276	.0018	-.0024	-.0055	.7134	.0812
.201	2775.9	17.92	-0.07	.7490	.3337	.1469	.0019	-.0028	-.0061	.8154	.0870
.201	2780.5	19.36	-0.08	.8083	.3801	.1602	.0015	-.0025	-.0053	.8887	.0906
.201	2774.5	.09	.00	.0902	.0423	.0278	-.0011	-.0002	-.0021	.0903	.0422
TEST 106					RUN 25						
MACH NUMB	0 PA	ALPHA DEG	BETA DEG	CL	CD	CMS	CRMS	CYMS	CYS	CM CA	
.201	2777.1	.12	.00	.0859	.0545	.0327	-.0007	-.0002	-.0035	.0860	.0543
.200	2768.0	-1.86	.01	.0240	.0503	.0199	-.0004	-.0000	-.0031	.0224	.0511
.201	2770.1	-4.10	.02	-.0357	.0499	.0067	-.0009	-.0001	-.0027	-.0392	.0472
.200	2765.2	.11	.00	.0854	.0545	.0325	-.0003	.0000	-.0029	.0855	.0544
.201	2775.8	2.02	-0.01	.1529	.0636	.0448	-.0005	.0000	-.0035	.1551	.0581
.200	2762.2	4.03	-0.02	.2093	.0779	.0553	-.0002	.0000	-.0033	.2144	.0630
.201	2774.4	5.92	-0.02	.2686	.0961	.0638	.0006	-.0008	-.0029	.2771	.0679
.201	2776.0	7.89	-0.03	.3324	.1200	.0731	.0007	-.0010	-.0026	.3457	.0732
.201	2778.1	9.95	-0.04	.4089	.1525	.0847	.0007	-.0009	-.0031	.4291	.0795
.200	2753.8	11.90	-0.05	.4842	.1894	.0962	.0009	-.0010	-.0038	.5128	.0855
.200	2768.2	13.97	-0.06	.5699	.2366	.1102	-.0012	-.0020	-.0055	.6101	.0921
.201	2791.3	15.88	-0.07	.6461	.2855	.1238	.0011	-.0021	-.0057	.6996	.0977
.201	2788.2	17.94	-0.07	.7301	.3481	.1406	.0012	-.0022	-.0062	.8012	.1046
.201	2782.9	19.55	-0.08	.7945	.3978	.1540	.0018	-.0029	-.0064	.8818	.1090
.200	2767.3	.15	.00	.0883	.0549	.0325	-.0003	.0000	-.0032	.0884	.0547

TABLE II. continued

NASA LANGLEY				7 X 10 HIGH SPEED TUNNEL							
TEST 106				RUN 26							
MACH	Q	ALPHA	BETA	CL	CD	CMS	CRMS	CYMS	CYS	CN	CA
NUMB	PA	DEG	DEG								
.201	2767.0	.13	.00	.1358	.0604	.0204	.0001	.0001	-.0036	.1399	.0601
.200	2762.1	-1.83	.01	.0660	.0541	.0074	.0003	.0002	-.0038	.0642	.0562
.200	2742.2	-4.30	.02	-.0035	.0523	-.0064	.0003	-.0001	-.0036	-.0075	.0521
.200	2760.6	.14	.00	.1366	.0604	.0204	.0001	.0001	-.0036	.1367	.0600
.201	2778.0	2.06	-.01	.2032	.0713	.0314	-.0001	.0000	-.0036	.2056	.0639
.200	2753.8	4.02	-.02	.2645	.0882	.0417	.0004	-.0003	-.0043	.2700	.0694
.201	2774.1	5.95	-.02	.3275	.1092	.0492	.0006	-.0008	-.0032	.3370	.0747
.201	2773.2	7.97	-.03	.3968	.1374	.0591	.0007	-.0012	-.0029	.4120	.0810
.200	2766.6	9.97	-.04	.4752	.1732	.0703	.0010	-.0012	-.0048	.4980	.0883
.201	2773.1	11.94	-.05	.5512	.2138	.0817	.0011	-.0013	-.0052	.5836	.0952
.200	2750.6	14.01	-.06	.6365	.2640	.0952	.0014	-.0020	-.0052	.6814	.1021
.200	2786.4	15.90	-.07	.7157	.3172	.1100	.0011	-.0015	-.0071	.7752	.1089
.200	2752.5	17.99	-.07	.8005	.3815	.1266	.0018	-.0027	-.0069	.8792	.1157
.201	2783.6	19.35	-.08	.8510	.4258	.1373	.0018	-.0032	-.0070	.9440	.1198
.201	2780.1	.16	.00	.1351	.0603	.0202	.0002	-.0001	-.0048	.1393	.0602
TEST 106				RUN 27							
MACH	Q	ALPHA	BETA	CL	CD	CMS	CRMS	CYMS	CYS	CN	CA
NUMB	PA	DEG	DEG								
.200	2760.7	.12	.00	.1369	.0492	.0179	.0022	.0001	-.0035	.1370	.0489
.200	2761.3	-1.94	.01	.0549	.0413	.0003	.0008	.0006	-.0027	.0535	.0431
.200	2743.0	-4.32	.02	-.0195	.0396	-.0171	.0011	.0002	-.0034	-.0224	.0380
.201	2768.0	.11	.00	.1361	.0492	.0182	.0019	-.0001	-.0044	.1361	.0490
.200	2761.5	2.02	-.01	.1869	.0609	.0325	.0008	.0002	-.0031	.1889	.0543
.200	2758.3	4.01	-.02	.2593	.0770	.0412	.0006	-.0000	-.0049	.2640	.0586
.200	2758.4	5.92	-.02	.3149	.0937	.0499	.0009	-.0021	-.0024	.3231	.0627
.201	2768.0	7.89	-.03	.3862	.1221	.0577	.0012	-.0027	-.0027	.3993	.0679
.200	2765.7	9.95	-.04	.4798	.1596	.0673	.0012	-.0018	-.0045	.5001	.0743
.201	2773.1	11.91	-.05	.5651	.2008	.0792	.0012	-.0023	-.0056	.5944	.0798
.200	2758.2	14.00	-.06	.6510	.2505	.0950	.0015	-.0025	-.0061	.6923	.0856
.200	2751.8	15.94	-.07	.7290	.3031	.1126	.0016	-.0020	-.0080	.7842	.0912
.201	2770.0	17.95	-.07	.8126	.3655	.1313	.0020	-.0026	-.0069	.8857	.0972
.201	2789.1	19.38	-.08	.8687	.4126	.1441	.0025	-.0037	-.0076	.9584	.1008
.201	2773.0	.11	.00	.1377	.0492	.0177	.0018	-.0000	-.0042	.1377	.0490
TEST 106				RUN 28							
MACH	Q	ALPHA	BETA	CL	CD	CMS	CRMS	CYMS	CYS	CN	CA
NUMB	PA	DEG	DEG								
.201	2774.7	.06	-.00	.1222	.0288	.0024	-.0005	.0010	-.0009	.1222	.0287
.200	2757.6	-1.91	.01	.0459	.0243	-.0124	.0008	.0010	-.0011	.0451	.0258
.200	2759.4	-4.15	.02	-.0108	.0239	-.0253	.0005	.0008	-.0009	-.0125	.0231
.200	2759.8	.07	-.00	.1194	.0286	.0020	-.0004	.0010	-.0005	.1195	.0285
.201	2766.1	1.97	-.01	.1716	.0370	.0093	.0001	.0006	-.0019	.1727	.0311
.200	2762.6	3.99	-.02	.2340	.0500	.0176	.0003	.0006	-.0024	.2369	.0336
.200	2757.2	5.93	-.03	.3169	.0708	.0256	.0002	.0005	-.0008	.3226	.0377
.200	2749.9	7.88	-.04	.4041	.0980	.0342	.0007	.0004	-.0027	.4137	.0417
.201	2770.9	9.93	-.04	.4936	.1324	.0483	.0013	-.0013	.0006	.5090	.0453
.201	2765.1	11.90	-.05	.5721	.1707	.0643	.0014	-.0004	-.0009	.5950	.0491
.200	2757.7	13.99	-.06	.6579	.2184	.0834	.0012	-.0009	-.0017	.6911	.0529
.200	2739.6	15.99	-.07	.7477	.2734	.1022	.0015	-.0002	-.0032	.7941	.0569
.200	2740.9	17.94	-.08	.8362	.3357	.1210	.0021	-.0006	-.0030	.9009	.0611
.201	2772.8	19.57	-.08	.9149	.3940	.1371	.0024	-.0014	-.0032	.9940	.0648
.200	2751.3	.07	-.00	.1217	.0286	.0023	-.0005	.0031	.0002	.1218	.0287
TEST 106				RUN 29							
MACH	Q	ALPHA	BETA	CL	CD	CMS	CRMS	CYMS	CYS	CN	CA
NUMB	PA	DEG	DEG								
.200	2753.8	.03	-.00	.0984	.0176	-.0154	.0006	.0011	-.0008	.0984	.0176
.200	2744.6	-1.93	.01	.0538	.0151	-.0229	-.0003	.0008	-.0017	.0533	.0169
.200	2741.9	-4.26	.02	-.0108	.0162	-.0324	.0005	.0008	-.0014	-.0120	.0154
.200	2761.9	.03	-.00	.0997	.0175	-.0151	.0007	.0010	-.0013	.0997	.0174
.201	2771.5	1.93	-.01	.1543	.0239	-.0078	.0011	.0010	-.0012	.1550	.0187
.200	2750.9	3.98	-.02	.2185	.0349	-.0006	.0015	.0009	-.0017	.2204	.0196
.200	2759.6	5.95	-.03	.3031	.0531	.0057	.0014	.0009	-.0015	.3070	.0219
.201	2776.4	7.84	-.04	.3862	.0773	.0163	.0019	.0009	-.0018	.3931	.0239
.201	2762.6	9.99	-.05	.4760	.1098	.0326	.0013	.0009	-.0016	.4878	.0256
.200	2759.2	11.89	-.05	.5576	.1449	.0458	.0013	.0007	-.0007	.5755	.0269
.200	2757.2	13.92	-.06	.6483	.1901	.0621	.0019	-.0001	-.0009	.6750	.0285
.200	2752.4	15.87	-.07	.7383	.2413	.0801	.0020	-.0008	-.0006	.7761	.0301
.201	2775.6	17.92	-.08	.8305	.3017	.0995	.0020	.0000	-.0028	.8830	.0316
.200	2748.2	19.53	-.09	.9069	.3568	.1159	.0023	-.0003	-.0022	.9739	.0330
.200	2739.0	.06	-.00	.1032	.0177	-.0136	.0006	.0011	-.0011	.1032	.0176
TEST 106				RUN 30							
MACH	Q	ALPHA	BETA	CL	CD	CMS	CRMS	CYMS	CYS	CN	CA
NUMB	PA	DEG	DEG								
.201	2804.0	.02	-.00	.0074	.0083	.0060	-.0007	.0008	-.0010	.0074	.0083
.200	2778.0	-1.96	.01	-.0433	.0094	-.0006	-.0007	.0008	-.0010	-.0436	.0079
.200	2772.3	-4.35	.02	-.1141	.0138	-.0076	-.0011	.0006	-.0013	-.1150	.0071
.200	2777.3	.03	-.00	.0059	.0084	.0055	-.0007	.0005	-.0008	.0059	.0084
.201	2793.3	1.91	-.01	.0543	.0106	.0117	-.0004	.0005	-.0006	.0546	.0088
.200	2768.1	3.93	-.02	.1163	.0170	.0201	-.0004	.0005	-.0012	.1172	.0090
.200	2780.7	5.81	-.03	.1818	.0279	.0301	-.0002	.0004	-.0007	.1837	.0094
.200	2781.3	7.79	-.04	.2532	.0444	.0419	.0002	.0005	-.0010	.2549	.0097
.201	2793.0	9.86	-.05	.3356	.0682	.0561	.0005	.0003	-.0023	.3423	.0098
.200	2782.1	11.81	-.05	.4160	.0972	.0715	.0005	.0004	-.0017	.4271	.0100
.199	2754.5	13.92	-.06	.5039	.1333	.0891	.0009	.0001	-.0021	.5216	.0102
.201	2801.3	15.81	-.07	.5881	.1772	.1064	.0011	-.0001	-.0017	.6142	.0103
.201	2811.0	17.87	-.08	.6847	.2316	.1269	.0015	-.0008	-.0017	.7228	.0103
.202	2820.0	19.40	-.08	.7940	.2764	.1426	.0013	-.0011	-.0006	.8030	.0103
.201	2785.3	.03	-.00	.0093	.0086	.0068	-.0005	.0004	-.0011	.0093	.0086

NASA LANGLEY 7 X 10 HIGH SPEED TUNNEL

TEST 106		RUN 31									
MACH	Q	ALPHA	BETA	CL	CD	CMS	CRMS	CYMS	CYS	CN	CA
NUMB	PA	DEG	DEG								
.200	2775.1	.05	-.00	-.0152	.0143	.0182	-.0010	.0011	-.0004	.0152	.0143
.200	2781.3	-1.92	.01	-.0458	.0138	.0060	-.0007	.0010	-.0006	-.0463	.0123
.200	2788.0	-4.17	.02	-.1097	.0184	-.0045	-.0005	.0005	-.0006	-.1108	.0104
.200	2778.1	.05	-.00	-.0159	.0142	.0186	-.0011	.0012	-.0006	.0159	.0142
.201	2788.9	1.92	-.01	.0636	.0180	.0260	-.0004	.0008	-.0014	.0642	.0178
.201	2792.3	3.92	-.02	.1211	.0259	.0332	-.0002	.0010	-.0006	.1226	.0175
.200	2765.0	5.87	-.03	.1850	.0385	.0453	-.0001	.0007	-.0014	.1879	.0193
.201	2789.2	7.82	-.04	.2644	.0583	.0573	.0004	.0004	-.0024	.2698	.0218
.200	2760.7	9.87	-.05	.3477	.0848	.0721	.0004	.0009	-.0007	.3371	.0240
.199	2753.0	11.85	-.05	.4280	.1164	.0890	.0005	.0004	-.0014	.4428	.0260
.201	2790.9	13.99	-.06	.5183	.1584	.1079	.0010	.0000	-.0024	.5412	.0283
.200	2775.0	15.85	-.07	.6009	.2024	.1236	.0014	-.0006	-.0022	.6333	.0306
.201	2804.0	17.92	-.08	.6926	.2589	.1461	.0011	-.0006	-.0001	.7387	.0333
.201	2795.7	19.38	-.09	.7596	.3043	.1615	.0015	-.0005	-.0022	.8176	.0351
.201	2784.9	.06	-.00	.0171	.0143	.0189	-.0010	.0011	.0006	.0171	.0143

TEST 106		RUN 32									
MACH	Q	ALPHA	BETA	CL	CD	CMS	CRMS	CYMS	CYS	CN	CA
NUMB	PA	DEG	DEG								
.201	2786.0	.05	-.00	-.0751	.0173	.0017	-.0009	.0006	-.0012	.0751	.0172
.200	2782.5	-1.91	.01	-.0077	.0153	-.0086	-.0009	-.0002	-.0002	.0072	.0156
.200	2770.1	-3.82	.02	-.0457	.0175	-.0178	-.0014	-.0008	-.0008	-.0467	.0144
.201	2803.5	.06	.00	-.0665	.0179	.0030	-.0017	-.0001	-.0011	.0665	.0179
.201	2785.8	1.95	-.01	.1239	.0237	.0093	-.0005	.0003	-.0018	.1246	.0195
.201	2788.8	3.91	-.02	.1817	.0337	.0183	-.0004	.0000	-.0024	.1836	.0212
.201	2795.0	5.86	-.03	.2452	.0486	.0296	.0001	-.0003	-.0027	.2489	.0233
.201	2786.8	7.84	-.04	.3307	.0721	.0390	.0003	-.0001	-.0025	.3374	.0264
.200	2757.9	9.90	-.04	.4069	.1007	.0576	-.0012	-.0004	-.0018	.4182	.0292
.200	2772.1	11.87	-.05	.4951	.1359	.0709	.0010	-.0004	-.0004	.5125	.0311
.200	2778.1	13.94	-.06	.5817	.1789	.0893	.0008	-.0010	-.0034	.6077	.0335
.200	2758.0	15.87	-.07	.6641	.2262	.1070	.0006	-.0016	-.0034	.7006	.0360
.200	2781.4	17.94	-.08	.7586	.2866	.1285	.0010	-.0011	-.0041	.8100	.0389
.201	2785.4	19.55	-.08	.8322	.3390	.1461	.0010	-.0014	-.0037	.8977	.0409
.200	2781.2	.06	.00	.0665	.0183	.0027	-.0016	-.0002	-.0009	.0665	.0183

TEST 106		RUN 33									
MACH	Q	ALPHA	BETA	CL	CD	CMS	CRMS	CYMS	CYS	CN	CA
NUMB	PA	DEG	DEG								
.200	2771.6	.05	-.00	-.0847	.0196	-.0015	-.0006	.0005	-.0006	.0847	.0196
.200	2765.9	-1.94	.01	-.0226	.0167	-.0116	.0000	.0004	-.0002	.0221	.0175
.200	2763.2	-4.28	.02	-.0401	.0189	-.0235	-.0005	.0002	-.0002	-.0414	.0159
.201	2807.2	.04	-.00	-.0880	.0200	-.0029	-.0005	.0006	-.0009	.0880	.0199
.201	2800.9	1.93	-.01	.1337	.0267	.0056	-.0014	.0002	-.0002	.1345	.0222
.201	2795.3	3.89	-.02	.1910	.0369	.0149	-.0013	.0000	-.0018	.1930	.0239
.200	2775.9	5.85	-.03	.2707	.0541	.0235	-.0007	.0001	-.0014	.2746	.0263
.201	2787.0	7.83	-.04	.3671	.0801	.0306	.0006	-.0003	-.0003	.3745	.0293
.200	2778.5	9.89	-.04	.4414	.1099	.0471	.0000	-.0000	-.0018	.4537	.0325
.200	2776.8	11.86	-.05	.5244	.1454	.0637	.0015	-.0003	-.0003	.5431	.0346
.201	2784.2	13.93	-.06	.6088	.1893	.0811	.0009	-.0008	-.0013	.6365	.0372
.201	2800.2	15.86	-.07	.6924	.2379	.1011	.0000	-.0011	-.0005	.7311	.0396
.200	2769.8	17.92	-.08	.7842	.2982	.1219	.0002	-.0003	-.0017	.8379	.0424
.201	2805.2	19.50	-.09	.8560	.3507	.1387	.0008	-.0007	-.0015	.9240	.0449
.201	2786.0	.05	.00	.0720	.0212	.0030	-.0031	-.0002	.0005	.0720	.0211

TEST 106		RUN 34									
MACH	Q	ALPHA	BETA	CL	CD	CMS	CRMS	CYMS	CYS	CN	CA
NUMB	PA	DEG	DEG								
.200	2770.4	.02	-.00	-.0456	.0113	-.0057	-.0006	.0004	-.0010	.0456	.0115
.200	2775.4	-1.94	.01	-.0004	.0114	-.0124	-.0003	.0005	-.0009	-.0008	.0114
.200	2753.0	-4.20	.02	-.0654	.0158	-.0196	.0000	.0005	-.0017	-.0664	.0110
.201	2786.8	.05	-.00	-.0441	.0117	-.0050	.0004	.0004	.0027	.0441	.0117
.201	2792.2	1.92	-.01	.0897	.0159	.0026	-.0007	.0001	-.0028	.0902	.0129
.200	2782.0	3.90	-.02	.1628	.0243	.0081	.0004	.0006	-.0029	.1640	.0132
.200	2779.7	5.85	-.03	.2314	.0371	.0177	.0022	.0005	-.0034	.2339	.0134
.200	2782.9	7.80	-.03	.3027	.0558	.0292	.0031	.0004	-.0046	.3075	.0141
.200	2773.1	9.95	-.04	.3932	.0839	.0436	.0030	.0004	-.0040	.4018	.0147
.200	2771.6	11.83	-.05	.4724	.1144	.0569	.0033	.0003	-.0045	.4859	.0151
.200	2779.3	13.98	-.06	.5673	.1573	.0739	.0037	-.0002	-.0047	.5885	.0156
.200	2773.8	15.82	-.07	.6540	.2019	.0907	.0035	-.0008	-.0031	.6843	.0160
.201	2804.4	17.90	-.08	.7537	.2606	.1097	.0032	-.0013	-.0033	.7974	.0163
.200	2768.8	19.17	-.08	.8127	.2999	.1222	.0031	-.0007	-.0040	.8661	.0165
.200	2775.4	.05	.00	.0335	.0126	-.0029	.0010	.0006	-.0050	.0336	.0126

TEST 106		RUN 35									
MACH	Q	ALPHA	BETA	CL	CD	CMS	CRMS	CYMS	CYS	CN	CA
NUMB	PA	DEG	DEG								
.200	2760.4	.03	-.00	-.0112	.0190	.0209	.0039	-.0076	.0199	.0112	.0190
.200	2781.5	-1.91	.01	-.0463	.0176	.0082	.0018	-.0082	.0208	-.0468	.0161
.200	2777.3	-4.18	.02	-.1096	.0202	-.0047	-.0001	-.0086	.0227	-.1110	.0121
.200	2784.0	.06	-.00	-.0115	.0191	.0211	.0039	-.0080	.0194	.0115	.0190
.200	2780.9	1.95	-.00	.0656	.0240	.0337	.0052	-.0073	.0156	.0663	.0218
.201	2786.3	3.92	-.00	.1234	.0332	.0441	.0062	-.0086	.0130	.1233	.0247
.200	2767.4	5.91	-.04	.1867	.0474	.0559	.0114	-.0102	.0089	.1906	.0280
.200	2779.5	7.87	-.04	.2532	.0667	.0698	.0121	-.0122	.0079	.2399	.0314
.200	2782.8	10.00	-.05	.3437	.0967	.0852	.0147	-.0173	.0110	.3353	.0355
.200	2773.9	11.91	-.04	.4187	.1285	.1008	.0167	-.0211	.0138	.4362	.0393
.200	2776.1	14.00	-.04	.5071	.1710	.1188	.0186	-.0233	.0120	.5334	.0432
.201	2793.8	15.92	-.04	.5875	.2160	.1358	.0205	-.0245	.0064	.6242	.0466
.201	2789.1	18.12	-.04	.6810	.2766	.1572	.0218	-.0269	.0066	.7332	.0511
.200	2782.7	19.43	-.04	.7364	.3165	.1702	.0221	-.0280	-.0038	.7987	.0535
.200	2783.2	.06	-.00	.0096	.0199	.0214	.0035	-.0083	.0187	.0096	.0199

TABLE II. continued

NASA LANGLEY											
7 X 10 HIGH SPEED TUNNEL											
TEST 106						RUN 36					
MACH	Q	ALPHA	BETA	CL	CD	CHS	CRMS	CYMS	CYS	CN	CA
NUMB	PA	DEG	DEG								
.200	2774.0	-0.02	-4.99	-.0029	.0063	.0008	.0027	-.0075	.0266	-.0029	.0063
.200	2766.5	-1.97	-4.98	-.0493	.0082	-.0059	.0016	-.0075	.0259	-.0495	.0065
.200	2762.9	-4.11	-4.96	-.1101	.0142	-.0139	-.0003	-.0074	.0262	-.1109	.0063
.200	2780.6	-.02	-4.99	-.0037	.0063	.0009	.0024	-.0077	.0257	-.0037	.0063
.201	2790.0	1.88	-5.00	.0443	.0078	.0073	.0044	-.0075	.0265	.0445	.0063
.201	2785.9	3.86	-5.00	.1052	.0132	.0153	.0067	-.0079	.0252	.1059	.0061
.200	2775.0	5.79	-4.99	.1707	.0232	.0245	.0091	-.0088	.0253	.1721	.0059
.200	2776.8	7.78	-4.98	.2427	.0387	.0356	.0112	-.0095	.0266	.2457	.0055
.200	2776.7	9.84	-4.96	.3241	.0612	.0490	.0135	-.0106	.0264	.3297	.0050
.200	2770.4	11.81	-4.94	.4070	.0899	.0640	.0155	-.0120	.0272	.4168	.0047
.201	2804.6	13.90	-4.91	.4989	.1274	.0818	.0176	-.0136	.0256	.5149	.0038
.201	2798.9	15.82	-4.87	.5805	.1677	.0980	.0192	-.0144	.0229	.6042	.0031
.200	2768.1	17.93	-4.83	.6804	.2225	.1187	.0213	-.0160	.0189	.7159	.0022
.201	2786.9	19.29	-4.79	.7413	.2607	.1318	.0225	-.0164	.0141	.7858	.0013
.201	2785.1	.00	-4.99	-.0037	.0066	.0013	.0025	-.0078	.0252	-.0037	.0066
TEST 106						RUN 37					
MACH	Q	ALPHA	BETA	CL	CD	CHS	CRMS	CYMS	CYS	CN	CA
NUMB	PA	DEG	DEG								
.200	2768.2	.03	5.00	.0034	.0064	.0022	-.0024	.0065	-.0241	.0035	.0064
.201	2779.5	-1.93	5.00	-.0422	.0077	-.0045	-.0019	.0066	-.0244	-.0424	.0063
.200	2764.4	-4.24	5.00	-.1142	.0143	-.0150	.0005	.0062	-.0232	-.1150	.0058
.200	2767.4	.04	5.00	.0020	.0063	.0019	-.0026	.0066	-.0244	.0020	.0063
.201	2791.9	1.93	4.98	.0507	.0079	.0082	-.0040	.0068	-.0244	.0310	.0062
.201	2800.7	3.90	4.96	.1102	.0134	.0163	-.0062	.0072	-.0236	.1109	.0059
.200	2775.4	5.85	4.94	.1765	.0235	.0260	-.0085	.0079	-.0244	.1780	.0054
.200	2769.8	7.83	4.91	.2525	.0398	.0384	-.0102	.0085	-.0248	.2556	.0050
.200	2778.3	9.89	4.87	.3319	.0626	.0518	-.0121	.0085	-.0231	.3377	.0047
.201	2781.3	11.87	4.83	.4168	.0919	.0680	-.0138	.0099	-.0233	.4268	.0042
.200	2758.6	14.03	4.78	.5084	.1307	.0853	-.0155	.0109	-.0225	.5250	.0035
.200	2778.1	15.86	4.73	.5904	.1707	.1016	-.0171	.0125	-.0200	.6146	.0029
.201	2785.5	17.95	4.67	.6879	.2248	.1219	-.0187	.0145	-.0174	.7237	.0018
.200	2773.8	19.30	4.62	.7471	.2628	.1348	-.0197	.0157	-.0152	.7919	.0011
.200	2771.8	.06	5.00	.0025	.0064	.0020	-.0027	.0063	-.0237	.0025	.0064
TEST 106						RUN 49					
MACH	Q	ALPHA	BETA	CL	CD	CHS	CRMS	CYMS	CYS	CN	CA
NUMB	PA	DEG	DEG								
.201	2795.5	.01	-.00	.0081	.0119	.0019	.0123	.0018	-.0056	.0081	.0119
.201	2795.2	-1.94	.01	-.0389	.0132	-.0039	.0137	.0018	-.0043	-.0393	.0119
.200	2777.1	-3.80	.01	-.0963	.0190	-.0077	.0136	.0021	-.0041	-.0973	.0126
.200	2785.8	-.00	.00	-.0136	.0134	.0063	.0105	.0003	-.0022	-.0136	.0134
.200	2776.3	1.87	-.01	.0690	.0158	.0041	.0133	.0008	-.0060	.0695	.0136
.201	2793.4	3.83	-.02	.1283	.0217	.0146	.0146	.0007	-.0071	.1295	.0131
.201	2804.0	5.79	-.02	.1912	.0323	.0194	.0155	.0005	-.0100	.1935	.0129
.201	2792.7	7.74	-.03	.2547	.0477	.0317	.0166	-.0007	-.0087	.2588	.0130
.201	2791.9	9.79	-.04	.3242	.0695	.0474	.0143	-.0006	-.0096	.3313	.0134
.200	2785.0	11.75	-.04	.4091	.0986	.0612	.0164	-.0012	-.0104	.4206	.0132
.200	2782.0	13.82	-.05	.5108	.1396	.0764	.0160	-.0012	-.0118	.5291	.0126
.200	2779.5	15.74	-.06	.5868	.1781	.0950	.0147	-.0030	-.0091	.6131	.0123
.200	2787.9	17.80	-.07	.6753	.2288	.1173	.0148	-.0038	-.0089	.7129	.0114
.200	2777.1	19.37	-.07	.7471	.2738	.1325	.0149	-.0041	-.0103	.7956	.0106
.200	2780.6	-.01	.00	.0096	.0139	.0005	.0109	.0009	-.0075	.0096	.0139
TEST 106						RUN 50					
MACH	Q	ALPHA	BETA	CL	CD	CHS	CRMS	CYMS	CYS	CN	CA
NUMB	PA	DEG	DEG								
.200	2786.2	.08	-.00	.0443	.0259	.0227	.0123	.0029	-.0053	.0443	.0259
.200	2780.0	-1.90	.00	-.0230	.0241	.0059	.0121	.0031	-.0057	-.0238	.0233
.201	2791.3	-3.76	.01	-.0732	.0262	-.0067	.0115	.0035	-.0056	-.0745	.0214
.200	2790.0	.07	-.00	.0540	.0261	.0205	.0114	.0029	-.0052	.0540	.0260
.200	2787.1	1.96	-.01	.0995	.0330	.0295	.0117	.0027	-.0052	.1006	.0296
.201	2793.5	3.93	-.02	.1559	.0427	.0395	.0118	.0021	-.0069	.1585	.0319
.201	2790.5	5.87	-.03	.2220	.0583	.0509	.0124	.0018	-.0051	.2268	.0353
.200	2781.2	7.84	-.03	.2899	.0797	.0630	.0122	.0011	-.0074	.2980	.0394
.200	2787.7	9.91	-.04	.3853	.1117	.0769	.0135	.0008	-.0086	.3987	.0437
.200	2784.8	11.87	-.05	.4576	.1441	.0942	.0119	-.0020	-.0052	.4775	.0468
.200	2782.9	13.94	-.05	.5437	.1874	.1130	.0120	-.0021	-.0052	.5728	.0509
.201	2807.1	15.87	-.06	.6284	.2352	.1308	.0126	-.0021	-.0052	.6688	.0544
.200	2783.3	17.93	-.07	.7207	.2950	.1512	.0124	-.0016	-.0074	.7765	.0588
.201	2791.3	19.48	-.07	.7871	.3437	.1681	.0142	-.0027	-.0105	.8567	.0616
.201	2803.5	.08	-.00	.0429	.0272	.0244	.0100	.0016	-.0025	.0429	.0272
TEST 106						RUN 51					
MACH	Q	ALPHA	BETA	CL	CD	CHS	CRMS	CYMS	CYS	CN	CA
NUMB	PA	DEG	DEG								
.201	2790.8	.10	.00	.0379	.0311	.0356	.0018	-.0001	-.0013	.0380	.0310
.200	2771.9	-1.89	.01	-.0378	.0283	.0152	.0002	-.0004	-.0020	-.0387	.0271
.200	2779.9	-4.14	.02	-.1021	.0307	.0003	.0001	-.0001	-.0016	-.1040	.0233
.201	2791.7	.11	.00	.0446	.0310	.0330	.0010	-.0004	-.0020	.0446	.0309
.200	2781.3	2.02	-.01	.0998	.0390	.0485	.0001	.0003	-.0013	.1011	.0344
.201	2790.3	3.96	-.02	.1463	.0489	.0567	.0003	-.0002	-.0031	.1493	.0387
.201	2792.3	5.90	-.02	.2013	.0636	.0661	.0009	-.0011	-.0029	.2067	.0426
.200	2783.6	7.88	-.03	.2668	.0847	.0779	.0009	-.0019	-.0022	.2759	.0473
.200	2774.3	9.93	-.04	.3495	.1142	.0910	.0007	-.0004	-.0054	.3640	.0522
.200	2780.7	11.91	-.05	.4317	.1495	.1087	.0017	.0001	-.0047	.4532	.0573
.201	2798.6	13.97	-.06	.5080	.1902	.1264	.0024	-.0005	-.0064	.5389	.0619
.201	2803.5	15.89	-.07	.5889	.2361	.1440	.0023	-.0013	-.0058	.6310	.0659
.201	2804.5	17.95	-.08	.6790	.2946	.1629	.0019	-.0010	-.0056	.7368	.0710
.200	2787.1	19.29	-.08	.7363	.3366	.1759	.0019	-.0018	-.0061	.8061	.0744
.201	2794.0	.11	.00	.0394	.0317	.0335	.0018	-.0008	-.0036	.0395	.0316

TABLE II. Concluded.

NASA LANGLEY											
7 X 10 HIGH SPEED TUNNEL											
TEST 106				RUN 57							
RACH	Q	ALPHA	BETA	CL	CO	CMS	CRMS	CYMS	CYS	CN	CA
NUMB	PA	DEG	DEG								
.200	2786.7	.04	-5.00	.0178	.0178	.0214	.0024	.0009	.0021	.0178	.0178
.200	2778.6	-1.95	-4.99	-.0392	.0162	.0079	.0001	.0010	.0030	-.0398	.0149
.199	2757.4	-4.17	-4.97	-.1039	.0188	-.0050	-.0026	.0008	.0035	-.1050	.0112
.201	2791.9	.03	-5.00	.0203	.0178	.0214	.0028	.0008	.0019	.0203	.0178
.201	2796.6	1.91	-5.01	.0762	.0230	.0337	.0050	.0003	.0002	.0769	.0205
.200	2788.5	3.88	-5.01	.1316	.0323	.0441	.0081	-.0006	-.0032	.1339	.0233
.200	2780.1	5.87	-5.00	.1944	.0466	.0553	.0117	-.0021	-.0056	.1981	.0265
.200	2787.3	7.87	-4.98	.2669	.0682	.0701	.0115	-.0048	-.0053	.2737	.0310
.200	2786.6	9.94	-4.96	.3555	.0979	.0866	.0150	-.0073	-.0035	.3671	.0351
.200	2770.8	11.90	-4.93	.4289	.1294	.1015	.0167	-.0092	-.0066	.4464	.0382
.200	2773.0	13.94	-4.90	.5129	.1707	.1262	.0183	-.0110	-.0087	.5369	.0422
.200	2775.6	15.87	-4.86	.5950	.2167	.1377	.0205	-.0132	-.0120	.6316	.0457
.201	2799.6	17.95	-4.82	.6853	.2740	.1374	.0227	-.0162	-.0167	.7364	.0495
.201	2789.8	19.32	-4.78	.7393	.3143	.1703	.0230	-.0180	-.0200	.8017	.0520
.201	2797.9	.03	-5.00	.0188	.0182	.0218	.0027	.0006	.0019	.0188	.0182
TEST 106				RUN 58							
RACH	Q	ALPHA	BETA	CL	CO	CMS	CRMS	CYMS	CYS	CN	CA
NUMB	PA	DEG	DEG								
.201	2798.0	.08	5.00	.0210	.0181	.0228	-.0020	-.0008	-.0031	.0210	.0181
.200	2781.6	-1.92	5.01	-.0346	.0166	.0102	-.0001	-.0007	-.0025	-.0352	.0154
.201	2797.1	-4.30	5.01	-.1078	.0189	-.0046	.0030	-.0007	-.0030	-.1090	.0107
.200	2787.9	.09	5.00	.0227	.0181	.0227	-.0020	-.0006	-.0022	.0227	.0181
.201	2802.3	1.95	4.99	.0765	.0236	.0351	-.0037	-.0002	-.0018	.0773	.0210
.201	2800.4	4.00	4.97	.1348	.0332	.0455	-.0072	.0010	.0024	.1368	.0237
.201	2792.4	5.92	4.94	.1992	.0480	.0577	-.0103	.0025	.0045	.2031	.0272
.200	2786.6	7.90	4.91	.2745	.0700	.0720	-.0107	.0050	.0021	.2816	.0317
.201	2797.9	9.96	4.87	.3561	.0986	.0877	-.0134	.0067	.0017	.3678	.0355
.201	2790.6	11.97	4.83	.4365	.1325	.1044	-.0150	.0083	.0038	.4545	.0390
.200	2774.7	14.01	4.78	.5253	.1750	.1220	-.0177	.0103	.0058	.5521	.0425
.200	2766.2	15.98	4.72	.6071	.2217	.1402	-.0192	.0122	.0082	.6447	.0460
.200	2770.4	17.99	4.66	.6917	.2768	.1595	-.0207	.0147	.0132	.7433	.0496
.201	2790.2	19.30	4.61	.7532	.3225	.1740	-.0212	.0164	.0165	.8176	.0526
.201	2806.5	.10	5.00	.0239	.0186	.0234	-.0022	-.0006	-.0023	.0239	.0186
TEST 106				RUN 59							
RACH	Q	ALPHA	BETA	CL	CO	CMS	CRMS	CYMS	CYS	CN	CA
NUMB	PA	DEG	DEG								
.201	2788.7	.03	5.00	.0072	.0057	.0015	-.0008	-.0018	-.0048	.0073	.0037
.201	2788.6	-1.89	5.01	-.0363	.0067	-.0056	-.0002	-.0020	-.0055	-.0365	.0055
.200	2778.8	-4.45	5.01	-.1175	.0141	-.0173	.0031	-.0016	-.0045	-.1182	.0049
.200	2775.5	.03	5.00	.0060	.0055	.0009	-.0010	-.0019	-.0057	.0060	.0055
.201	2787.8	1.94	4.99	.0581	.0076	.0070	-.0034	-.0016	-.0045	.0583	.0057
.201	2794.3	3.94	4.97	.1215	.0137	.0162	-.0053	-.0011	-.0045	.1221	.0053
.201	2792.8	5.90	4.95	.1856	.0241	.0249	-.0083	-.0006	-.0052	.1871	.0049
.201	2785.9	7.82	4.92	.2600	.0404	.0374	-.0102	.0004	-.0045	.2631	.0047
.201	2797.0	9.88	4.88	.3372	.0629	.0501	-.0128	.0012	-.0058	.3430	.0041
.201	2786.7	11.86	4.84	.4204	.0920	.0652	-.0150	.0023	-.0064	.4303	.0036
.200	2769.2	13.99	4.79	.5138	.1311	.0841	-.0165	.0038	-.0056	.5303	.0030
.200	2770.6	15.90	4.74	.5993	.1730	.1008	-.0186	.0057	-.0037	.6237	.0022
.200	2771.8	17.94	4.68	.6915	.2252	.1205	-.0204	.0080	-.0009	.7273	.0013
.200	2777.8	19.80	4.62	.7866	.2740	.1375	-.0218	.0095	.0008	.8159	.0002
.200	2772.5	.09	5.00	.0078	.0056	.0014	-.0010	-.0019	-.0053	.0078	.0056

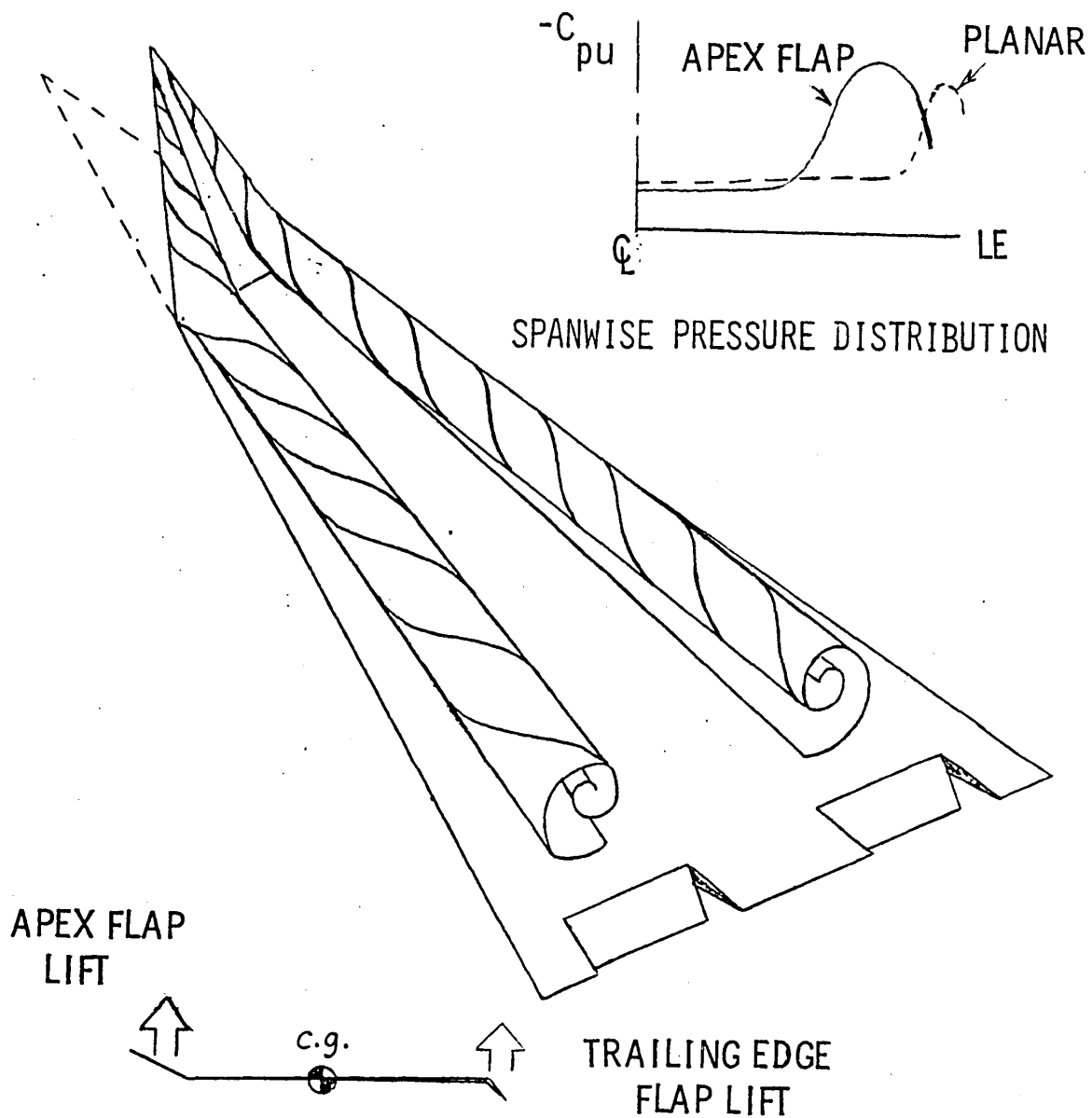

Figure 1.- Apex Flap Concept.

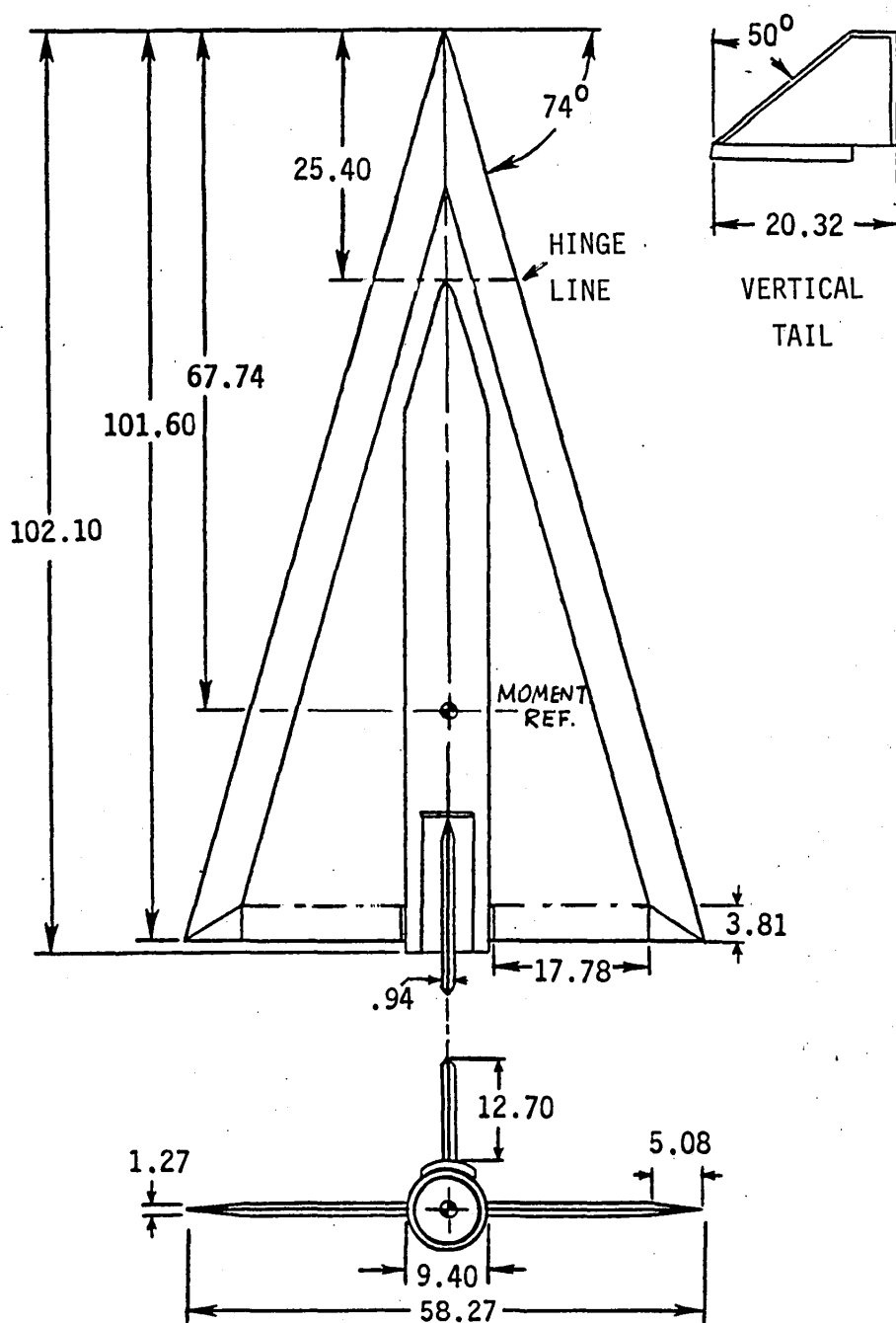

Figure 2.- 74° Delta Model. Dimensions in centimeters.

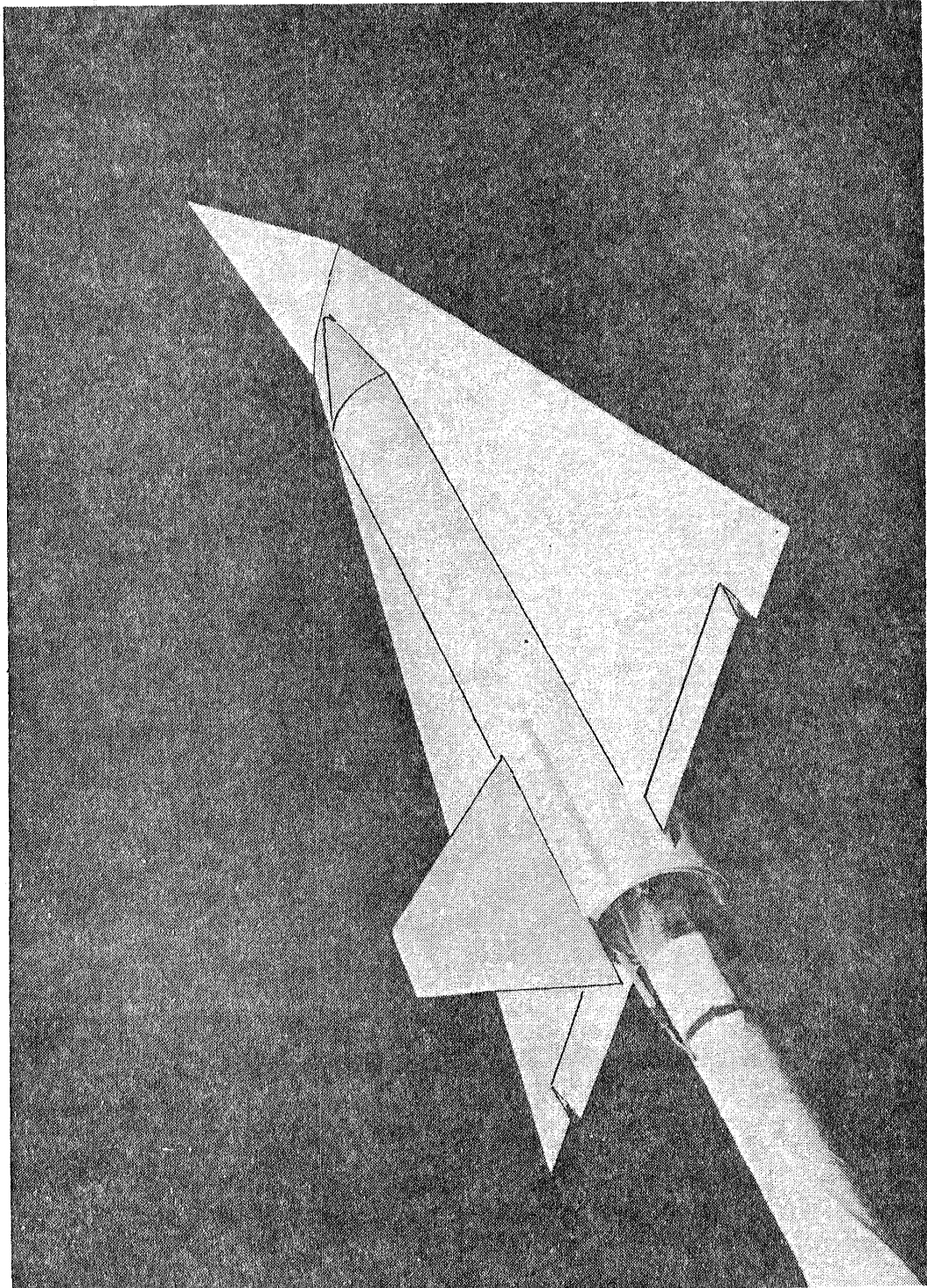

Figure 3.- NASA 74° Delta Wing.

1. Report No. NASA CR-166081		2. Government Accession No.		3. Recipient's Catalog No.	
4. Title and Subtitle Force and Moment Measurements on a 74° Delta Wing With an Apex Flap (Data Report)				5. Report Date October 1984	
				6. Performing Organization Code 505-31-43-03	
7. Author(s) Thomas A. Buter* and Dhanvada M. Rao**				8. Performing Organization Report No.	
9. Performing Organization Name and Address North Carolina State University Mechanical and Aero. Eng. Dept. Raleigh, NC 27650				10. Work Unit No.	
				11. Contract or Grant No. NCC1-46	
12. Sponsoring Agency Name and Address National Aeronautics and Space Administration Washington, DC 20546				13. Type of Report and Period Covered Contractor Report	
				14. Sponsoring Agency Code 505-31-43-03	
15. Supplementary Notes *North Carolina State University, Raleigh, NC 27650 **Vigyan Research Associates, Inc., 28 Research Drive, Hampton, VA 23666 Langley Technical Monitor: W. E. Schoonover, Jr.					
16. Abstract Results are presented of a subsonic experimental investigation of an apex flap concept on a 74° swept delta wing with trailing-edge flaps. The apex flap comprised approximately 6 percent of the wing area forward of a transverse hinge, allowing for both upward and downward deflection angles from +40° to -20°. Upward deflection forces leading-edge vortex formation on the apex flap, resulting in an increased lift component on the apex area. The associated nose-up moment balances the nose-down moment due to trailing-edge flaps, resulting in sizeable increase in the trimmed lift coefficient particularly at low angles of attack. Nose-down apex deflection may be used to augment the pitch control for rapid recovery from high-alpha maneuvers. Balance measurements were obtained in the NASA Langley 7- by 10-Foot High-Speed Tunnel at $M_\infty = 0.2$ and $R_c = 4 \times 10^6$. This report presents the balance data without analysis.					
17. Key Words (Suggested by Author(s)) Apex flap Balance measurements Trimmed lift Vortex lift			18. Distribution Statement Unclassified - Unlimited Subject Category 02		
19. Security Classif. (of this report) Unclassified		20. Security Classif. (of this page) Unclassified		21. No. of Pages 22	22. Price A02

End of Document