

TOPICAL REPORT

ACOUSTIC ATTENUATION ANALYSIS PROGRAM  
FOR DUCTS WITH MEAN FLOW

by

R. K. Kunze, Jr.

(NASA-CR-120985) ACOUSTIC ATTENUATION N75-11211  
ANALYSIS PROGRAM FOR DUCTS WITH MEAN  
FLOW (Boeing Co., Wichita, Kans.) 95 p  
CSCL 20D Unclass  
63/34 02767

THE BOEING COMPANY  
3801 SOUTH OLIVER  
WICHITA, KANSAS 67210

Prepared For  
NATIONAL AERONAUTICS AND SPACE ADMINISTRATION  
August 17, 1972

CONTRACT NASA 3-14321

NASA-LEWIS RESEARCH CENTER  
CLEVELAND, OHIO  
H. BLOOMER, PROJECT MANAGER  
V/STOL AND NOISE DIVISION



Reproduced by  
NATIONAL TECHNICAL  
INFORMATION SERVICE  
US Department of Commerce  
Springfield, VA. 22151

PRICES SUBJECT TO CHANGE

## FOREWORD

The work described herein was done by The Boeing Company, Wichita Division, under NASA contract NAS 3-14321 with Mr. H. Bloomer, V/STOL and Noise Division, NASA - Lewis Research Center, as Project Manager.

## ABSTRACT

A computerized acoustic attenuation prediction procedure has been developed to evaluate acoustically lined ducts for various geometric and environmental parameters. The analysis procedure is based on solutions to the acoustic wave equation, assuming uniform airflow on a duct cross section, combined with appropriate mathematical lining impedance models. The impedance models included in the analysis procedure are representative of either perforated sheet or porous polyimide impregnated fiberglass facing sheet coupled with a cellular backing space. Advantages and limitations of the analysis procedure are reviewed.

# TABLE OF CONTENTS

	PAGE
ABSTRACT . . . . .	iii
NOMENCLATURE . . . . .	v
INDEX OF FIGURES . . . . .	vi
SUMMARY . . . . .	vii
1.0 INTRODUCTION . . . . .	1
1.1 Background . . . . .	1
1.2 Technical Approach . . . . .	1
2.0 ANALYTICAL MODEL . . . . .	3
3.0 METHOD OF APPLICATION . . . . .	9
3.1 General Description . . . . .	9
3.2 Impedance Models . . . . .	9
3.3 Modal Pressure Subdivision and Recombination . . . . .	13
3.4 Boundary Value Solution Application . . . . .	13
3.5 Modal Ordering . . . . .	14
3.6 Lining Length Incrementation . . . . .	14
4.0 PROGRAM APPLICATION AND LIMITATION . . . . .	17
4.1 Modal Content . . . . .	17
4.2 Duct Length Incrementation . . . . .	17
4.3 Multiple Lining Analysis . . . . .	17
4.4 Application to Annular Geometry Ducts . . . . .	17
4.5 Application to Ducts with Sheared Flow . . . . .	17
5.0 CONCLUDING REMARKS . . . . .	19
APPENDIX I, ANNULAR GEOMETRY ANALYTICAL MODEL, APPROXIMATION BY RECTANGULAR GEOMETRY. . . . .	27
APPENDIX II, PROGRAM DESCRIPTION . . . . .	31
APPENDIX III, PROGRAM LISTING AND SAMPLE PROGRAM OUTPUT . . . . .	41
APPENDIX IV, PROGRAM FLOW CHART . . . . .	69
6.0 REFERENCES . . . . .	93

## NOMENCLATURE

c	Velocity of sound, cm/sec
d	Acoustic lining backing depth, cm
f	Frequency, Hz
$h_x, h_y$	Rectangular duct cross section dimension, cm
k	$k = \omega/c$ 1/cm
$k_x, k_y, k_z$	Rectangular duct wave numbers
$k_r, m, k_z$	Annular duct wave numbers
n	Hard wall mode number
p	Acoustic pressure, dynes/cm <sup>2</sup>
t	Time, sec
r, $\theta$ , z	Cylindrical coordinates
x, y, z	Rectangular coordinates
p, q, r, s	Cross products of Bessel functions
$J_\nu, Y_\nu$	Bessel functions, first and second kind, respectively, of order $\nu$
$H_\nu^{(1)}, H_\nu^{(2)}$	Hankel functions of order $\nu$ , Type 1 and Type 2.
L	Lining treatment length, cm
$\bar{L}$	$\bar{L} = 1/Z$
M	Mach number
R	Attenuation rate, db/cm, db/inch
U	Duct mean airflow velocity, cm/sec
V	Acoustic particle velocity, cm/sec
Z	Specific acoustic impedance c.g.s. rayls
$\xi$	Particle displacement, cm
$\nu$	Bessel and Hankel function order
$\rho$	Density, gm/cm <sup>3</sup>
$\omega$	Angular frequency, radians/sec
$\mu$	Viscosity (poise)

## INDEX OF FIGURES

<u>FIGURE</u>		<u>PAGE</u>
1	Analysis Procedure Flow Chart . . . . .	21
2	Rectangular Duct Geometry . . . . .	22
3	Acoustic Lining Panel . . . . .	23
4	Annular Duct Geometry . . . . .	24
5	Input Format . . . . .	25

## SUMMARY

A systematic acoustic lining design procedure was developed for the NASA Fan Noise Suppression Program. This design procedure consists of several computerized modules, including the Acoustic Attenuation Analysis Program. The analysis procedure is based on solutions to the acoustic wave equation, combined with appropriate mathematical lining impedance models, when all the modes that can propagate are considered at the duct entrance with equal amplitude.

The analytical model is that of a semi-infinite duct with airflow. The airflow is assumed inviscid and nonturbulent, with a uniform velocity on a duct cross section. For the rectangular duct case, one wall or two opposing walls may be acoustically treated. The two-wall lined case is restricted to the walls having the same impedance. The environmental parameters considered are temperature, pressure, Mach number, and the acoustic spectrum within the duct.

The impedance models included in the analysis procedure are representative of either perforated sheet or porous polyimide impregnated fiberglass facing sheet coupled with a cellular backing space. These models consist of a mathematical description of the porous facing sheet acoustic impedance dependence on material porosity characteristics, temperature, pressure, and particle velocity effects.

The basic analysis determines the modal propagation constants within a given duct increment as a function of duct geometry, environment, and lining impedance. The overall analysis procedure involves applying the basic analysis to sequential lining increments to establish the acoustic performance of the total duct. Variations in Mach number, lining impedance, and geometry are permissible on an incremental basis. However, the analytical procedure does neglect the effects of wave reflection resulting from geometric changes and/or lining impedance discontinuities.

A detailed description of the derivation and corresponding application of this technology are presented in this report.

## 1.0 INTRODUCTION

### 1.1 Background

A systems acoustic lining design procedure was developed for the NASA Fan Noise Suppression Program. This design procedure consists of several computerized modules, including the Acoustic Attenuation Analysis Program. The program combines the basics of two technologies, acoustic propagated wave analysis and material acoustic impedance modeling, into an acoustic lined duct performance simulation.

The zero airflow work of Cremer (Reference 1) and the mean flow results of Eversman (Reference 2) were incorporated into an early version of this program, using a rudimentary impedance model for perforated sheet impedance (Reference 3). This version was utilized in the NASA Langley Treated Tailpipe Program (Reference 4). More recent studies at Boeing-Wichita (Reference 5) have led to improvements in the impedance model for perforated sheet and development of an impedance model for polyimide liners. A portion of the experimental impedance data for these models was included in work reported by Rice (Reference 6). These models have been incorporated along with expanded wave analysis applications, into the current version of the program. A detailed description of the analytical techniques is presented in the following sections.

### 1.2 Technical Approach

The technical approach used in the development of this analytical program is the solution of the mean flow acoustic duct wave equation. The duct is assumed to be infinite in length with one or two walls lined. A rectangular duct is assumed for computational purposes, and annular geometry applications are treated by approximating a sector of the annulus by a rectangle. Normally reacting duct walls are assumed for lined surfaces. Variations in Mach number, wall impedance, and duct dimensions in the direction of airflow are treated approximately, and acoustic wave reflections due to these variations are neglected. Wall impedances are provided by semiempirical impedance models for perforated plate and polyimide facing sheets with cellular air backing cavities.

The computer application of the acoustic wave equation solution to the acoustic lined duct performance simulation is shown in the block diagram of Figure (1). The major components of this program will be discussed in detail in the following sections.



## 2.0 ANALYTICAL MODEL

The analytical model for this study is that of a semi-infinite duct with airflow. The airflow is assumed inviscid and nonturbulent, with a uniform axial velocity  $U$  on a duct cross section. The acoustic pressure is assumed to be small in magnitude in comparison with the uniform pressure.

For a duct with the flow axis in the  $Z$  coordinate direction, the acoustic wave equation is

$$c^2 \nabla^2 p = \left( \frac{\partial}{\partial t} + U \frac{\partial}{\partial z} \right)^2 p \quad (1)$$

where

$c$  = velocity of sound

$p$  = acoustic pressure

$U$  = uniform airflow velocity

The solution and boundary condition analysis for a rectangular duct, as depicted in Figure 2, follows.

An assumed solution to (1) is

$$p = e^{i\omega t} e^{-ik_z z} \left[ A e^{ik_x x} + B e^{-ik_x x} \right] \left[ C e^{ik_y y} + D e^{-ik_y y} \right] \quad (2)$$

Substitution of this solution into (1) results in the following relationship between the wave numbers  $k$ ,  $k_x$ ,  $k_y$  and  $k_z$ :

$$k_z = \left( \frac{1}{1-M^2} \right) \left( -kM \pm \sqrt{k^2 - (1-M^2)(k_x^2 + k_y^2)} \right) \quad (3)$$

where

$\omega$  = angular frequency - radians/sec

$k = \omega/c$

$M = U/c$

The expressions for  $k_x$  and  $k_y$  are determined from boundary conditions at the duct walls. These conditions are obtained from the assumption of continuity of particle displacement at the walls. Let  $\xi_1$  be the particle displacement normal to the wall at  $X = h_x$ . The equation of motion for fluid flow at  $X = h_x$  in this direction is

$$\rho_1 \left( \frac{D}{Dt} (\xi_1) \right)^2 = - \left( \frac{\partial p}{\partial x} \right)_{x=h_x} \quad (4)$$

where

$\rho$  = air density gm/cm<sup>3</sup> and (D/Dt) is the total derivative with respect to time (t)

$$\frac{D}{Dt} = \frac{\partial}{\partial t} + \frac{\partial x}{\partial t} \frac{\partial}{\partial x} + \frac{\partial y}{\partial t} \frac{\partial}{\partial y} + \frac{\partial z}{\partial t} \frac{\partial}{\partial z}$$

For the wall at  $x = 0$ , (4) becomes

$$\rho \left( \frac{D}{Dt} (\xi_2) \right)^2 = \left( \frac{\partial P}{\partial X} \right)_{x=0} \quad (5)$$

where  $\xi_2$  is the particle displacement normal to the wall at  $x = 0$ . The difference in sign between (4) and (5) is due to the change in direction of the normal to the wall with respect to the x coordinate axis.

The mean velocity components in the x and y direction are zero, thus (4) and (5) become, respectively

$$\left[ \rho \left( \frac{\partial}{\partial t} + U \frac{\partial}{\partial z} \right)^2 \xi_1 = - \frac{\partial P}{\partial X} \right]_{x=h_x} \quad (6)$$

$$\left[ \rho \left( \frac{\partial}{\partial t} + U \frac{\partial}{\partial z} \right)^2 \xi_2 = \frac{\partial P}{\partial X} \right]_{x=0} \quad (7)$$

The acoustic impedance ( $Z/\rho c$ ) and admittance ( $\bar{L}$ ) may be defined by

$$\left[ \frac{1}{\rho c} \frac{P}{\frac{\partial \xi}{\partial t}} = \frac{Z}{\rho c} = \frac{1}{\bar{L}} \right]_{x=x_n} \quad (8)$$

$$\left[ \frac{1}{\rho c} \frac{P}{\frac{\partial \xi}{\partial t}} = - \frac{Z}{\rho c} = - \frac{1}{\bar{L}} \right]_{x=0} \quad (9)$$

For harmonic motion

$$\frac{\partial}{\partial t} (\xi) = i\omega \xi$$

and from (2)

$$\frac{\partial}{\partial z} P = -ik_z P$$

applying these relations to (6), (7), (8) and (9) we obtain the boundary value equations

$$\left[ i\omega \bar{L} (1 - Mk_z/k)^2 P = -\frac{\partial P}{\partial X} \right]_{X=h_x} \quad (10)$$

$$\left[ i\omega \bar{L} (1 - Mk_z/k)^2 P = \frac{\partial P}{\partial X} \right]_{X=0} \quad (11)$$

application of the boundary condition (10) and (11) to a duct with one lined wall at  $X = h_x$  leads to

$$\text{at } y = 0: \bar{L} = 0 \text{ and } \frac{\partial P}{\partial y} = 0$$

$$y = h_y: \bar{L} = 0 \text{ and } \frac{\partial P}{\partial y} = 0$$

$$x = 0: \bar{L} = 0 \text{ and } \frac{\partial P}{\partial x} = 0$$

$$\text{at } x = h_x: \bar{L} = \bar{L}_1$$

and

$$i\bar{L}_1 k \left( 1 - \frac{Mk_z}{k} \right)^2 P = -\frac{\partial P}{\partial X}$$

for the  $y$  direction we obtain

$$\text{SIN}(k_y h_y) = 0$$

or

$$k_y = \frac{n\pi}{h_y}; \quad n = 0, 1, 2, \dots \quad (12)$$

for the x direction

$$\text{or } iL_1 k \left(1 - \frac{Mk_z}{k}\right)^2 \cos(k_x h_x) = -k_x \sin(k_x h_x)$$

$$iL_1 k h_x = h_x k_x \tan(h_x k_x) / \left(1 - \frac{Mk_z}{k}\right)^2$$

In the case of a duct with equal admittance walls at both  $x = 0$  and  $x = h_x$ , we obtain x boundary equations in the following manner from (2), (10), and (11),

$$iL_1 k \left(1 - \frac{Mk_z}{k}\right)^2 \left[ A e^{ik_x h_x} + B e^{-ik_x h_x} \right]$$

$$= -ik_x \left[ A e^{ik_x h_x} - B e^{-ik_x h_x} \right]$$

$$iL_1 k \left(1 - \frac{Mk_z}{k}\right)^2 \left[ A + B \right]$$

$$= ik_x \left[ A - B \right]$$

where  $L_1$  is the admittance at  $x = 0$  and  $x = h_x$

These two relations may be combined to eliminate A and B, resulting in a quadratic equation in  $(iL_1 k h_x)$ :

$$h_x^2 (iL_1 k)^2 \left(1 - \frac{Mk_z}{k}\right)^4 \sin(h_x k_x)$$

$$+ 2iL_1 h_x k \left(1 - \frac{Mk_z}{k}\right)^2 h_x k_x \cos k_x h_x - h_x^2 k_x^2 \sin k_x h_x$$

$$= 0$$

or

$$iL_1 h_x k = \frac{-h_x k_x (\cos(h_x k_x) \pm 1) / \sin(k_x h_x)}{(1 - Mk_z/k)^2}$$

using half angle trigonometric identities (17) becomes

for the "+" sign

$$iL_1 k h_x / 2 = \frac{-(h_x k_x / 2) \cot (h_x k_x / 2)}{(1 - M k_z / k)^2} \quad (18)$$

for the "-" sign

$$iL_1 k h_x / 2 = \frac{(h_x k_x / 2) \tan (h_x k_x / 2)}{(1 - M k_z / k)^2} \quad (19)$$

### 3.0 METHOD OF APPLICATION

The acoustic attenuation prediction program provides an analytical evaluation of the attenuation characteristics of an acoustically treated rectangular duct. Lining configurations may be either a single treated wall or two opposite walls with identical treatment. In addition, propagation of the acoustic pressure wave may be in opposition to the flow or in the same direction as the flow.

#### 3.1 General Description

The analytical acoustic attenuation prediction program evaluates the attenuation characteristics of rectangular ducts with mean airflow and acoustically lined walls, having either one or two walls treated.

The basic analysis consists of determining the acoustic modal propagation constants for a given duct geometry, environment, and lined wall impedance. The environmental parameters considered are temperature, pressure, Mach number, and duct acoustic source spectrum. The lined wall impedance is obtained from acoustic impedance mathematical models, which is discussed in Section 3.2

Initially, the input acoustic source spectrum is subdivided at each frequency into modal pressures. The wall impedance at each frequency is then determined for the first lining increment, and the boundary value problem solutions are obtained. The resulting modal attenuations are now applied to the modal pressures, and the corresponding attenuated acoustic spectrum is calculated.

This process is repeated for each lining increment until the entire lined length has been analyzed. However, the source spectrum is subdivided into modal pressures for the first increment only, with each succeeding incremental treatment utilizing the attenuated modal pressure spectrum resulting from the preceding increment. Also, the resultant acoustic spectrum at each increment is used for impedance determination in the next increment.

#### 3.2 Impedance Models

The impedance models in the present program include mathematical representations for both perforated plate and porous polyimide facing sheets with cellular air backings terminated by an impervious sheet (Figure 3).

These models consist of a mathematical description of the impedance of the porous face sheet dependence on material porosity characteristics, temperature, pressure, and total particle velocity. The total particle velocity  $V_T$  is a combination of particle velocities resulting from both grazing airflow,  $V_{gf}$ , at the face sheet, and acoustic pressure excitation  $V_a$ :

$$V_T = (V_{gf}^2 + V_a^2)^{1/2}$$

PRECEDING PAGE BLANK NOT FILMED

(20)

The explicit expression for the complex acoustic face sheet impedance of polyimide and perforated sheet, including expressions for the respective grazing flow particle velocities, are as follows:

Polyimide

$$Z = Q + .305 \mu N^2 f + 2.86 \rho N^2 V_p + i \left\{ .549 \rho N^{3/2} f - 5.12 \cdot 10^{-5} \rho N^3 f V_p \right\} \quad (21)$$

$$V_{gf} = \frac{.05 c M^2}{\left[ Q / \rho c + \sqrt{(Q / \rho c)^2 + .71 N^2 M^2} \right]} \quad (22)$$

where  $Q = 4640. \mu N^{4/3}$

$\mu$  = viscosity (Poise)

$$i = \sqrt{-1}$$

$c$  = velocity of sound in air (cm/SEC)

$N$  = number of plies of polyimide

$\rho$  = density of air (gm/cm<sup>3</sup>)

$V_p$  = particle velocity

$f$  = frequency

Perforated Sheet

$$Z / \rho c = Q + \frac{3.83 \cdot 10^{-5} \theta \quad .75 \sqrt{f}}{P_{OA} \sqrt{\delta(\theta + .416)}} \left[ T/D + 1 - P_{OA} \right] + \pi/2 \sqrt{2} V_p / c E e^{-1.8 S \eta}$$

$$+ i \left\{ \frac{4.69 \cdot 10^{-4} f}{P_{OA} \sqrt{\theta}} (T + \Delta) \right\}$$

$$V_{gf} = \frac{.25 K c M^2}{Q/2 + \sqrt{(Q/2)^2 + K/2 E M^2}}$$

where  $\Delta = \begin{cases} \Delta_1; \Delta_1 > 0 \\ 0; \Delta_1 \leq 0 \end{cases}$

$$\Delta_1 = .85D (1 - .7\sqrt{P_{OA}}) - \frac{1.2 \cdot 10^{-5}}{P_{OA}} V_p$$

f = frequency (Hz)

$$S_\eta = \frac{2.54 D f P_{OA}}{V_p}$$

T = sheet thickness (inches) (cm.)

D = perforate hole diameter (inches) (cm.)

$\theta = T_T$  (total temperature  $^{\circ}R$ )/519 (=  $T_T$  ( $^{\circ}K$ )/288.33)

$$\delta = \frac{\text{static pressure (PSIA)}}{14.7} = \left( \frac{\text{static pressure (dynes/cm}^2)}{(1.013 \times 10^6)} \right)$$

$$Q = \frac{.077 T}{\delta P_{OA}} \left( \frac{\theta^2}{\theta + .416} \right)$$

$$E = 1.0251 (1/P_{OA}^2 - 1) (1/P_{OA})^{.1} e^{-.5072 T/D}$$

$$K = .05 + .11 D/\theta\eta$$

$\theta\eta$  = boundary layer momentum thickness (inches) (cm.)

$V_p$  = particle velocity

These face sheet impedance models are described in greater detail in Reference (5).



The face sheet impedance  $Z_F$  is modeled as a function of total particle velocity, and the wall impedance,  $Z_w$ , is given by

$$Z_w = Z_F - i \cot(kd)$$

where  $d$  is the depth of the air backing cavity.

The acoustic pressure particle velocity due to the acoustic pressure at a single frequency  $P_i$  is given by

$$V_{ai} = P_i / Z_w \quad (25)$$

Particle velocities and impedances are calculated assuming that the acoustic pressure particle velocity impedance dependence is based on either the acoustic pressure at single frequencies or the combined effects of the acoustic pressure at all frequencies.

In the first case, the expression for total particle velocity calculation is

$$V_T(f) = \left( v_{gf}^2 + \left( \frac{P(f)}{|Z_w(f, V_T(f))|} \right)^2 \right)^{1/2} \quad (26)$$

where

$f$  = frequency

$V_T(f)$  = total particle velocity at frequency  $f$

$P(f)$  = acoustic pressure at frequency  $f$

$Z_w(f, V_T(f))$  = wall impedance at frequency  $f$  and particle velocity  $V_T(f)$

In the second case, the total particle velocity is denoted  $V_{T_{rms}}$  to indicate the dependence on acoustic pressure at all frequencies, and the expression becomes

$$V_{T_{rms}} = \left( v_{gf}^2 + \sum_f v_{af}^2 \right) \quad (27)$$

$$\text{where } v_{af} = \frac{P_f}{|Z_{wf}(V_{T_{rms}})|}$$

These expressions are solved by iteration techniques based on the Newton Raphson method to obtain  $V_T(f)$  or  $V_{T_{rms}}$  and the wall impedances.

### 3.3 Modal Pressure Subdivision and Recombination

The acoustic pressure at a given frequency is subdivided according to the number of modes which can propagate at that frequency. The cutoff frequency for any given mode number  $n$  is given by  $f = \frac{nc \sqrt{1 - M^2}}{2hy}$  for unlined ducts. The cutoff frequency is decreased for lined ducts, and a factor of 1.1 has been arbitrarily introduced in the denominator of the above equation to account for this effect.

The subdivision of acoustic pressure into modal pressure amplitudes is accomplished assuming the acoustic modes are uncorrelated and initially have equal modal pressure amplitudes. The total sound pressure level at any frequency ( $SPL_{total}$ ) is given in terms of the total acoustic pressure ( $P_{total}$ ) by

$$SPL_{total} = 10 \log_{10} (P_{total}/.00022)^2 \quad (28)$$

where  $P_{total}$  is in dynes/cm<sup>2</sup>

Defining  $SPL_{i_{modal}}$  as the sound pressure level of the  $i$ th modal pressure amplitude, for  $n$  propagating modes the expression for modal amplitude subdivision is

$$SPL_{i_{modal}} = SPL_{total} - 10 \log_{10} n \quad (29)$$

The recombination of attenuated modal sound pressure levels to obtain a total attenuated SPL is given by

$$SPL_{total} = 10 \log_{10} \left[ \sum_{i=1}^n 10^{(SPL_{i_{modal}}/10)} \right] \quad (30)$$

where all SPL's in this expression have been attenuated. The attenuation for any frequency is then the difference between the initial and attenuated values of  $SPL_{total}$ .

### 3.4 Boundary Value Solution Application

The boundary value problem solutions are obtained for each frequency of interest and for each increment of wall lining analyzed. These solutions are obtained by iterative procedures based on the Newton Raphson method. Rewriting the boundary value equation for the symmetric modes of a duct with two walls lined, equation (19) becomes

$$iL_1 kh_x/2 = (h_x/2)k_x \tan (h_x/2)k_x / (1 - Mk_z/k)^2 \quad (31)$$

It is noted that the required solutions for physical wall impedances lie in the first quadrant of the complex plane  $(h_x/2)k_x$ . (The third quadrant is a mirror image of the first, while the second and fourth quadrant corresponds to wall impedances whose real part is negative.)

The solution to (31) for zero Mach number and unlined walls are easily obtained real quantities.

The starting points for the iterative solutions for no-flow, lined ducts are chosen near the unlined wall solutions. Similarly, the lined wall duct with flow is solved using the lined wall no-flow solutions as starting points. However, the iterative solution for the flow case must be accomplished in incremental Mach number steps to obtain all solutions of interest. The incrementation of Mach number by .05 steps appears to be sufficient for most applications.

In some cases, the iterative procedure crosses into the second or fourth quadrant of the complex plane. This effect is checked in the solution procedure, and countered by returning the iteration to a new starting point. This point is specified by selecting the point on a line segment connecting the non-first quadrant point to the last iteration point in the first quadrant.

### 3.5 Modal Ordering

The eigenvalue solutions are ordered according to increasing modal attenuation rate. This ordering scheme assures that the least attenuated mode is always considered. Under the above stated assumption of initially equal modal pressure amplitude, it can be seen that the least attenuated mode is the most significant contributor to the resultant sound pressure level after some length  $L$  of treatment. Consider the simplified case of two modes with attenuation rates  $R_1$  and  $R_2$ . If the final total sound pressure level is

$$SPL_T = 10 \log_{10} (10^{SPL_1/10} + 10^{SPL_2/10}) \quad (32)$$

where  $SPL_1$  and  $SPL_2$  are the sound pressure levels of modes 1 and 2, respectively, after length  $L$ . The difference,  $\Delta$ , between  $SPL_T$  and  $SPL_1$  can be expressed as:

$$\Delta = 10 \log_{10} (1 + 10^{-(R_2 - R_1)L/10}) \quad (33)$$

From this representation, it can be seen that the maximum difference is 3 dB, which results if  $R_1 = R_2$  and that for  $R_2 = R_1 + .58$ , the difference becomes 1 dB.

### 3.6 Lining Length Incrementation

The analysis of a duct by incremental lengths is incorporated to account for effects of

changes in Mach number, duct, height, and lining characteristics with progressive position in the direction of acoustic propagation. These effects are treated by specification of the varying parameters for each increment analyzed. Acoustic wave reflection is not considered, and thus the analysis is applicable for small parameter variations.

## 4.0 PROGRAM APPLICATION AND LIMITATION

The assumptions of acoustic modal content, mean airflow, and neglect of acoustic wave reflections are the major limiting factors in the application of this program. Some of the pertinent characteristics of these assumptions as related to program application are as follows:

### 4.1 Modal Content

The equal modal pressure amplitude assumption is incorporated since experimental modal pressure amplitude definition is unavailable, and for ease of application. As definitive modal content information becomes available, it can be incorporated in this program.

### 4.2 Duct Length Incrementation

The sensitivity of the impedance models to sound pressure level spectrum variation requires the analysis of an acoustic liner in several incremental lengths. A check on the validity of any increment length utilized may be accomplished by comparison of the attenuation rates of each lining segment; gross differences indicate the need for further subdivision of the increment length used.

A further consideration for increment selection is the degree of variation of the other environmental parameters with length, e.g., Mach number, geometry, etc. Variations in these parameters may require a further reduction in the increment length than for fixed parameters.

### 4.3 Multiple Lining Analysis

The treatment of cases having sequential segments of differing acoustic liners should be accomplished with one program execution in preference to an execution for each lining type. This approach maintains the continuity of modal pressure contributions for the entire lining treatment, conversely, an execution for each lining type would redistribute the modal pressures, and the final duct attenuations would be overestimated.

### 4.4 Application to Annular Geometry Ducts

The subject program can be utilized in the performance prediction of annular geometry ducts by approximating a section of the duct annulus with a rectangle. Details of this type of application are treated in Appendix I.

### 4.5 Application to Ducts with a Sheared Flow

The applicability of the subject program to ducts with a sheared flow (nonuniform

velocity profile on a duct cross section) depends upon the relative direction of the acoustic wave propagation and the airflow, and upon the magnitude of the boundary layer thickness and Mach number. Using the nomenclature "inlet mode" and "exhaust mode" to denote cases in which the acoustic flow and airflow are in the opposing and identical direction, respectively, the work of Eversman (Reference 7) and Munger and Plumblee (Reference 8) indicate that the shear flow effects are generally small for the exhaust mode, but can be very significant in the inlet mode. Analytical methods have been developed to correct for the sheared flow effect, but have not been included in this document.

## 5.0 CONCLUDING REMARKS

The acoustic attenuation analysis program provides an analytical capability to evaluate lined duct configurations having uniform flow on a duct cross section. Variations in duct geometry, Mach number, and lining impedance are permissible within the duct. However, variations in these parameters are treated approximately in that acoustic wave reflection effects are neglected. Initial modal pressure amplitudes are assumed equal, modal interaction effects are neglected and modes are assumed to be in phase. Acoustic wall impedances are obtained from semiempirical impedance models.

The acoustic attenuation analysis program was developed primarily for application to aircraft fan jet engines. The major limitation is considered to be the assumption of mean airflow within the inlets of these engines. For this case, the program results should be corrected to account for the sheared flow effects to obtain a more accurate estimate of the acoustic attenuation.

Further analysis and subsequent program improvements are indicated in the following areas:

- Sheared flow effects
- Modal pressure amplitude definition
- Modal phasing and interaction
- Acoustic wave reflection effects

The first item requires a reformulation of the analytical procedure so that the sheared flow effects can be evaluated as an integral part of the analysis program. This modification would provide a more detailed and rigorous analysis than correcting the mean flow results.

The second and third items are contingent on having adequate space-time data from which modal amplitude and phase information can be extracted. These data are necessary to compute the initial modal energies and to track these energies down the treated duct.

The fourth item deals with the reflection of acoustic modes in the treated duct. These reflections can result from changes in the wall impedance and/or geometry. This problem can be approached using either assumed modal amplitudes and phase or when available the results of items two and three.

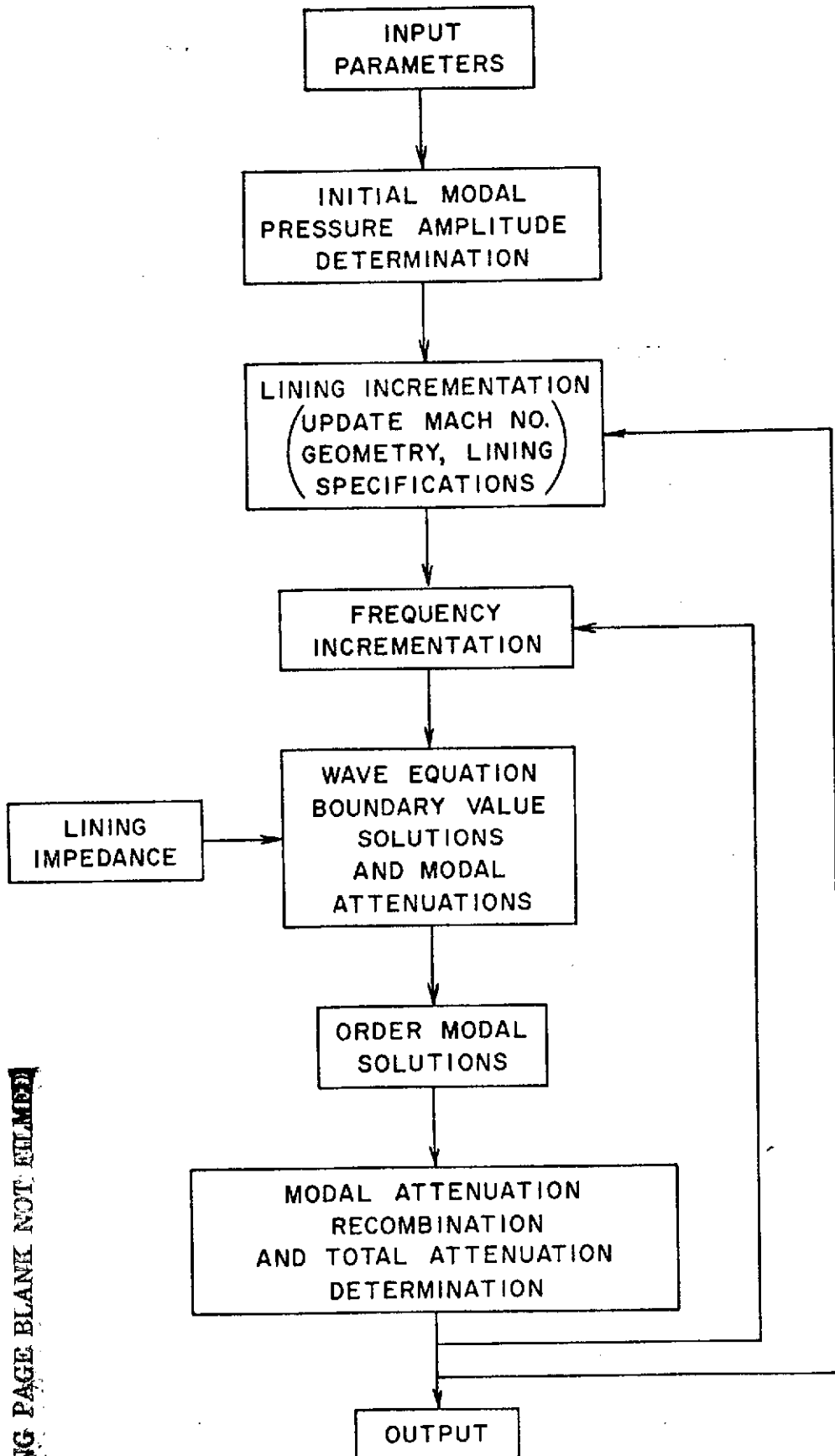

PRECEDING PAGE BLANK NOT FILMED

ANALYSIS PROCEDURE FLOW CHART  
FIGURE 1



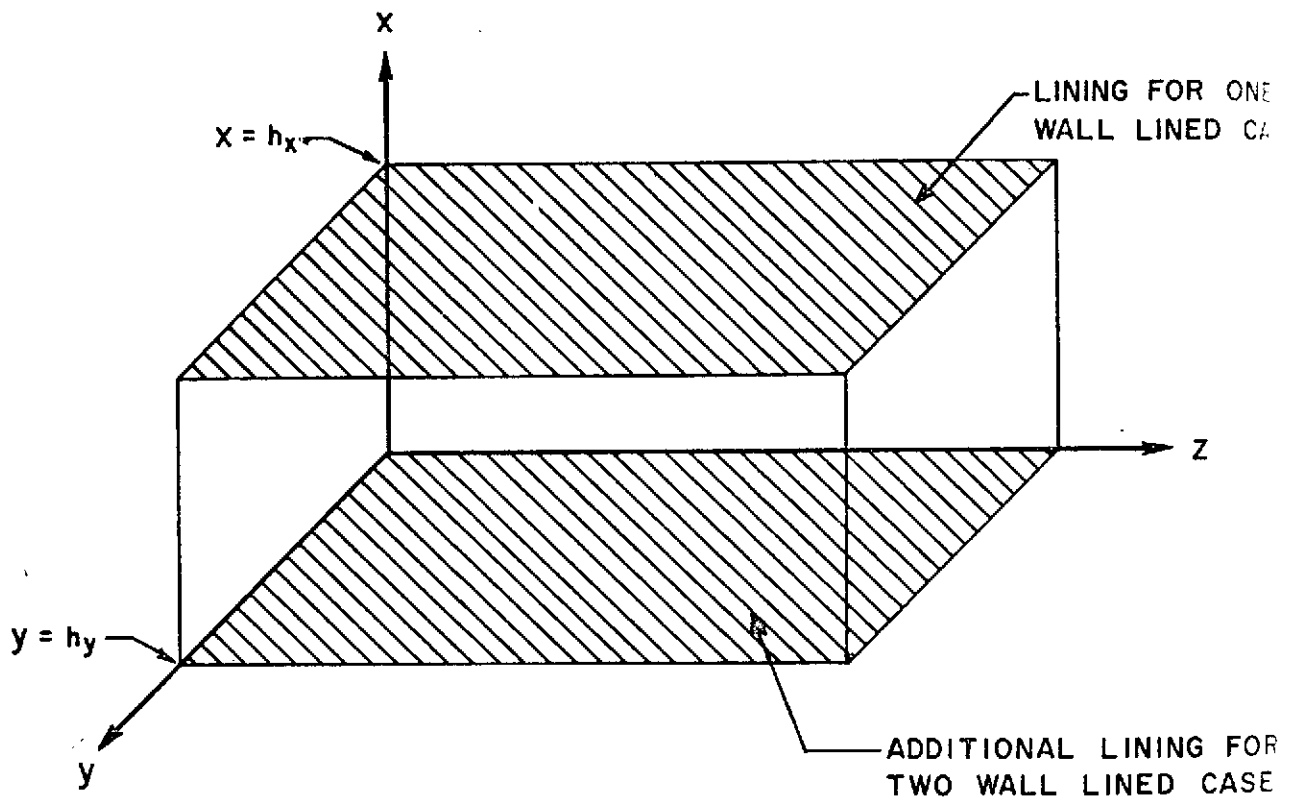

RECTANGULAR DUCT GEOMETRY  
 FIGURE 2

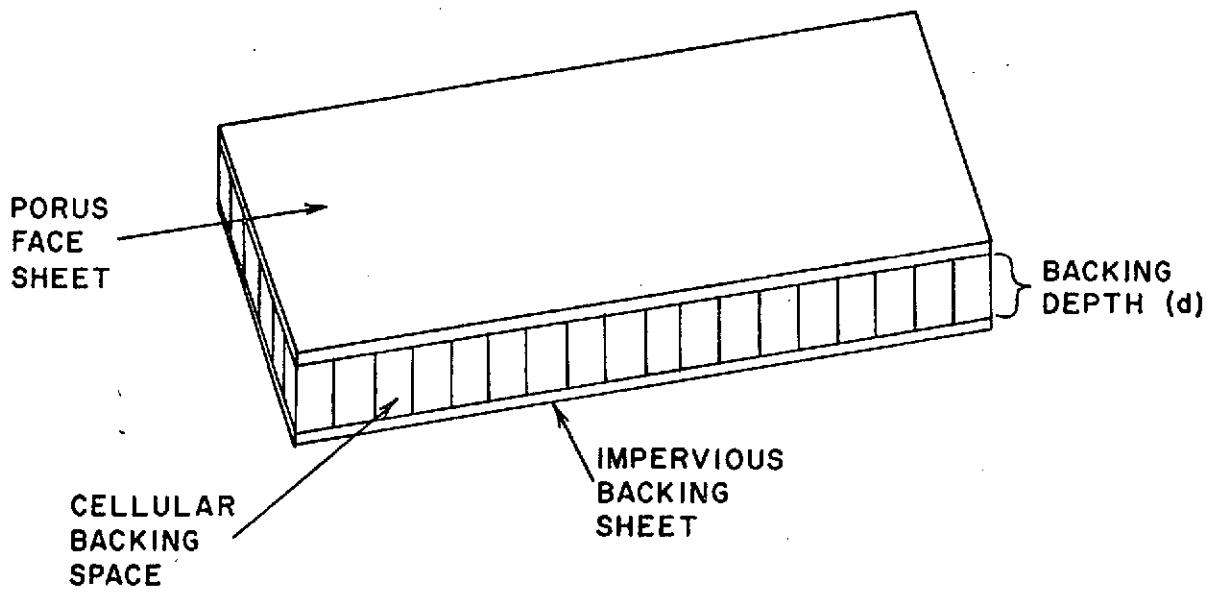

ACOUSTIC LINING PANEL  
FIGURE 3

REPRODUCIBILITY OF THE  
ORIGINAL PAGE IS POOR

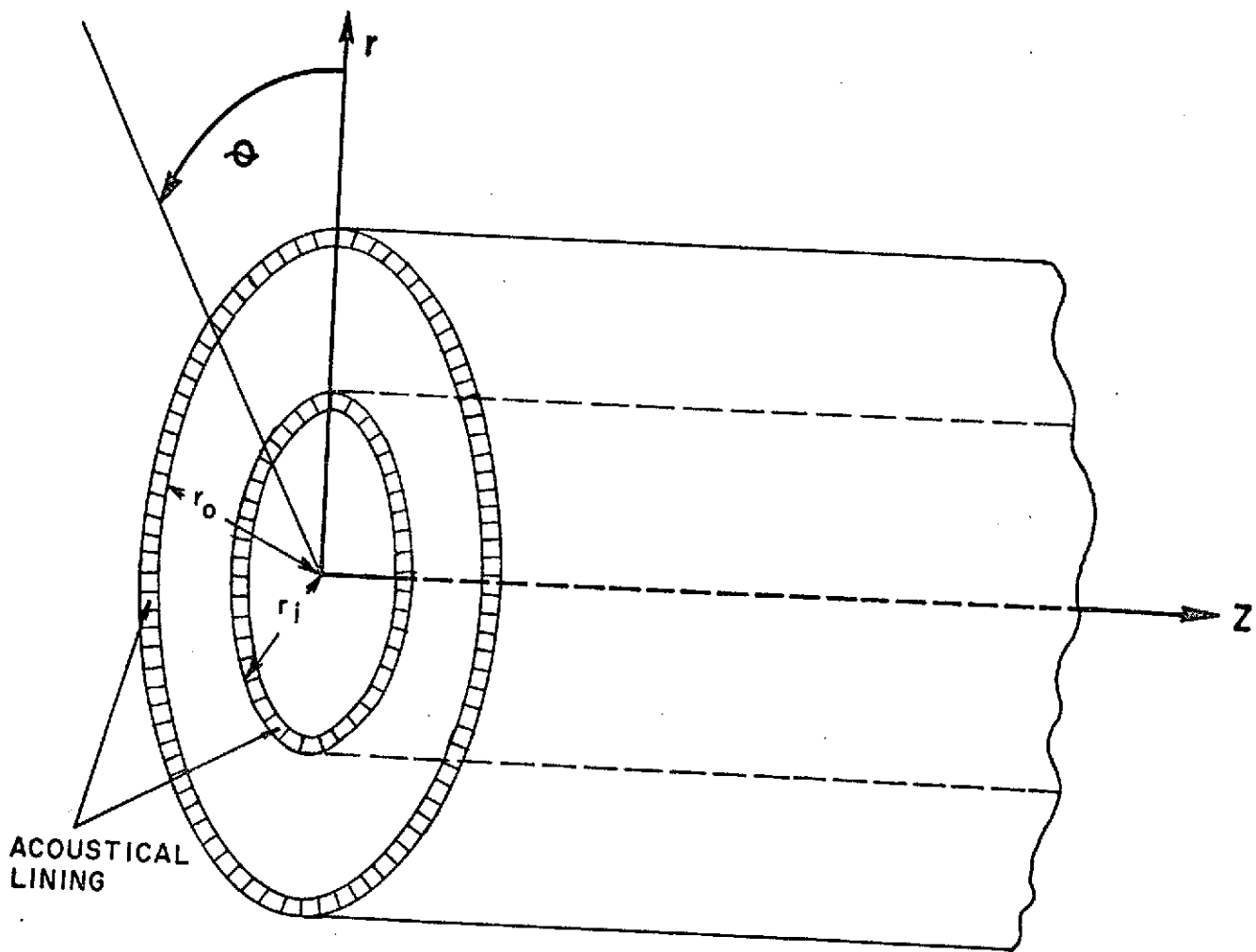

$r, \theta, z$ : CYLINDRICAL COORDINATES  
 $r_i$ : INNER RADIUS  
 $r_o$ : OUTER RADIUS

ANNULAR DUCT GEOMETRY  
 FIGURE 4

REPRODUCIBILITY OF THE  
 ORIGINAL PAGE IS POOR



## APPENDIX I

### ANNULAR GEOMETRY ANALYTICAL MODEL, APPROXIMATION BY RECTANGULAR GEOMETRY

The annular geometry analysis follows that of the rectangular duct solution, using cylindrical coordinates in the wave equation solution. The duct geometry and coordinate system is shown in Figure 4. The acoustic wave equation is again

$$c^2 \nabla^2 P = \left( \frac{\partial}{\partial t} + U \frac{\partial}{\partial z} \right)^2 P \quad (\text{A-1})$$

Separation of variables leads to the solution:

$$P = (A J_m(r k_r) + B Y_m(r k_r)) \cos(m\theta) e^{j(\omega t - k_z Z)} \quad (\text{A-2})$$

and

$$k_z = \left( \frac{1}{1-M^2} \right) \left( -Mk \pm \sqrt{k^2 - (1-M^2)k_r^2} \right) \quad (\text{A-3})$$

where  $r, \theta, z$  are the system cylindrical coordinates

$$k = \omega/c$$

$$M = U/c$$

$$m = \text{angular wave number} = 0, 1, 2, \dots$$

$$J_m(r k_r) = \text{Bessel function, first kind, order } m$$

$$Y_m(r k_r) = \text{Bessel function, second kind, order } m$$

Both walls are assumed lined with identical wall admittance  $\bar{\Gamma}$ . The boundary condition at  $r_0$ , the outer annular wall, and  $r_i$ , the inner annular wall for this assumption become

$$\text{at } r_i: ik\bar{\Gamma} \left( 1 - M \frac{k_z}{k} \right)^2 P = \frac{\partial P}{\partial r} \quad (\text{A-4})$$

$$\text{at } r_0: ik\bar{\Gamma} \left( 1 - M \frac{k_z}{k} \right)^2 P = - \frac{\partial P}{\partial r} \quad (\text{A-5})$$

Substitution of A-2 into A-4 and A-5 and solving, the following eigenvalue equation is obtained:

$$\left[ (ikL) \left( 1 - M \frac{k_z}{k} \right)^2 \right]^2 P_m - (ikL) \left( 1 - M \frac{k_z}{k} \right)^2 (q_m - r_m) - S_m = 0 \quad (\text{A-6})$$

where

$$a = r_o k_r$$

$$b = r_i k_r$$

and

$$P_y = J_y(a) Y_y(b) - J_y(b) Y_y(a) \quad (\text{A-7})$$

$$q_y = (J_y(a) Y_y'(b) - J_y'(b) Y_y(a)) k_r \quad (\text{A-8})$$

$$r_y = (J_y'(a) Y_y(b) - J_y(b) Y_y'(a)) k_r \quad (\text{A-9})$$

$$S_y = (J_y'(a) Y_y'(b) - J_y'(b) Y_y'(a)) k_r^2 \quad (\text{A-10})$$

(Primes denote differentiation of the Bessel function with respect to the particular function argument.)

As in the rectangular case, A-6 may be written as the quadratic solution

$$ikL = \frac{1}{2P_m} \left\{ (q_m - r_m) \pm \sqrt{(q_m - r_m)^2 + 4P_m S_m} \right\} / \left( 1 - M \frac{k_z}{k} \right)^2 \quad (\text{A-11})$$

The approximation of an annulus by a rectangle might be presumed, by inspection, to be valid whenever the radius ratio,  $r_i/r_o$ , is close to unity. This presumption may be mathematically verified in part by applying large argument Bessel function approximations to A-6. Taking the definition for Hankel functions in terms of Bessel functions:

$$H_y^{(1)}(Z) = J_y(Z) + iY_y(Z)$$

$$H_y^{(2)}(Z) = J_y(Z) - iY_y(Z)$$

where  $H_y^{(1)}(Z)$  and  $H_y^{(2)}(Z)$  are Hankel functions, type 1 and type 2, respectively. The large argument approximations for  $H_y^{(1)}(Z)$  and  $H_y^{(2)}(Z)$  are (Reference 9):

$$H_y^{(1)}(Z) \sim \sqrt{2/\pi Z} e^{i\left(Z - \frac{Y\pi}{2} - \frac{\pi}{4}\right)} \quad (\text{A-12})$$

$$H_Y^{(2)}(Z) \sim \sqrt{2/\pi Z} e^{-i\left(Z - \frac{\gamma\pi}{2} - \frac{\pi}{4}\right)} \quad (\text{A-13})$$

The Bessel cross products  $P_Y$ ,  $q_Y$ ,  $r_Y$ ,  $S_Y$ , A-7, A-8, A-9 and A-10 may be written in terms of Hankel function cross product

$$P_Y = -\frac{1}{2i} (H_Y^{(1)}(a) H_Y^{(2)}(b) - H_Y^{(1)}(b) H_Y^{(2)}(a)) \quad (\text{A-14})$$

$$q_Y = -\frac{k_r}{2i} (H_Y^{(1)}(a) H_Y^{(2)'}(b) - H_Y^{(1)'}(b) H_Y^{(2)}(a)) \quad (\text{A-15})$$

$$r_Y = -\frac{k_r}{2i} (H_Y^{(1)'}(a) H_Y^{(2)}(b) - H_Y^{(1)}(b) H_Y^{(2)'}(a)) \quad (\text{A-16})$$

$$S_Y = -\frac{k_r^2}{2i} (H_Y^{(1)'}(a) H_Y^{(2)'}(b) - H_Y^{(1)'}(b) H_Y^{(2)'}(a)) \quad (\text{A-17})$$

Applying A-12 and A-13 to the above yields:

$$P_Y \approx \frac{-2}{\pi\sqrt{ab}} \text{SIN}(a-b) \quad (\text{A-18})$$

$$q_Y \approx k_r \left( \frac{2}{\pi\sqrt{ab}} \text{COS}(a-b) + \frac{\gamma}{b} P_Y \right) \quad (\text{A-19})$$

$$r_Y \approx k_r \left( \frac{-2}{\pi ab} \text{COS}(a-b) + \frac{\gamma}{b} P_Y \right) \quad (\text{A-20})$$

$$S_Y \approx -k_r^2 \left( \left( \frac{\gamma^2}{ab} + 1 \right) \left( \frac{2}{\pi\sqrt{ab}} \right) \text{SIN}(a-b) + \left( \frac{\gamma}{b} - \frac{\gamma}{a} \right) \frac{2}{\pi\sqrt{ab}} \text{COS}(a-b) \right) \quad (\text{A-21})$$

Using the above relations in A-11 results in

$$iL_{jk} \approx \frac{k_r}{2\text{SIN}(a-b)} \left\{ -2\text{COS}(a-b) - \left( \frac{\gamma}{a} - \frac{\gamma}{b} \right) \text{SIN}(a-b) \pm \left[ 4 + \left( \frac{\gamma}{a} + \frac{\gamma}{b} \right) \text{SIN}^2(a-b) + 8 \left( \frac{\gamma}{a} - \frac{\gamma}{b} \right) \text{COS}(a-b) \text{SIN}(a-b) \right]^{1/2} \right\} \quad (\text{A-22})$$

noting  $(a-b) = h k_r$ , where  $h$  is the distance between lined walls for the annular duct. For the case where  $r = a$  (radial modes only), A-22 becomes

$$iL_{jkh} = hkr \frac{(\cos(hkr) \pm 1)}{\sin(hkr)} \left/ \left( 1 - M \frac{k_z}{k} \right)^2 \right. \quad (\text{A-23})$$

which is identically the rectangular solution (Equation 17).

The use of the large argument approximation has two implications: first, for large radii and/or  $k_j$ , the rectangular approximation appears valid, and second, a further limitation on the relative magnitudes of  $r_o$  and  $r_j$  is implied. This limitation is that if  $r_o k_r$  satisfies the large argument approximation, then  $r_j/r_o$  should not be nearly zero, since the approximation is applied to both  $r_o k_r$  and  $r_j k_r$ .



## APPENDIX II

### PROGRAM DESCRIPTION

This program consists of a mainline control program and subroutines. The mainline program calls subroutine "input" to obtain all input data and obtain preliminary processed data. The incrementation loop is then set up and the subroutine "ATNSPL" is called for each lining increment. "ATNSPL" serves as overall control for all calculations for each increment except for the calculation of an attenuation spectra at the current increment. A maximum of 50 increments may be treated.

#### Subroutine "INPUT"

This subroutine reads all input data, calculates speed of sound, density, and the numbers of propagating modes for all frequencies, and model pressure spectra based on these data. The input format is shown in Figure 5. The variable name definitions and the input options are as follows:

TITLE	Identification only
A	Number of 100 Hz bandwidth SPL values to be input (beginning with frequency of 200 Hz, maximum value 99)
SWM	Maximum number of soft wall modes treated
HWM	Maximum number of hard wall modes treated
H	Number of walls lined (1 of 2)
PSPL	Flat SPL spectrum value; if zero, will read "A" values of SPL, if nonzero, sets up flat spectrum array of "A" values of SPL equal to "PSPL"
RMS	0. Impedance programs calculate particle velocity and impedance as function of SPL at one frequency 1. Impedance programs calculate an "RMS" particle velocity based on entire SPL spectrum
REORD	0. Modal ordering by least attenuated mode 1. Modal ordering by largest real part of downstream wave numbers
OVRMOD	0. Treats number of modes propagating to limits of "SWM", "HWM" 1. Treats "SWM", "HWM" modes, cutoff conditions not applied
SPL NAM	SPL spectrum identification title

SPL	Array of up to "A" sound pressure levels
TL	Total duct lined length (inches)
DL	Increment length (inches)
DHH	Hard wall duct height (inches)
G	Ratio of specific heats for duct environment
TT	Total temperature ( $^{\circ}$ R)
PT	Total pressure (PSIA)
"A", "B"	Frequency limits for calculation of attenuation ( $H_z$ )
ANPLY	Impedance model selection
	0. Perforated sheet
	1. Polyimide
AM	Mach number
DHS	Lined wall duct height (inches)
OPA NP	Perforated sheet fractional open area or polyimide number of plies
D	Backing depth (inches)
DIA	Hole diameter (inches)
R	Material thickness (inches)
MTHK	Boundary layer momentum thickness (inches)
	("DIA", "R", and "MTHK" are required for perforated sheet impedance model only.)

The following data arrays are required when the corresponding variables above are zero. The number of values per array is equal to the number of increments as determined from the total length and incremental length:

AAM(I)	Mach number
ADHS(I)	Lined wall duct height (inches)

POAC(I) Perforated sheet fractional open area or number of polyimide plies  
DCON(I) Liner backing depth (inches)  
DIAS(I) Perforated sheet hole diameter (inches)  
THKC(I) Perforated sheet thickness (inches)  
MTHKC(I) Boundary layer momentum thickness (inches)

### Subroutine "ATNSPL"

Subroutine "ATNSPL" is the control routine for the calculations pertaining to one duct increment. Initially, if RMS impedance treatment has been selected, the RMS particle velocity for the desired lining type is obtained by a call sequence to the "ENTRY" section of the appropriate impedance subroutine. If the discrete frequency impedance treatment option has been selected, the above call sequence is skipped over, and the frequency increment "do loop" is entered.

The frequency increment "do loop" controls calculation of impedance, eigenvalue equation solutions, modal attenuation ordering, and attenuated SPL spectra for each frequency in the range specified.

The impedance is obtained by standard calls to one of the impedance routines "IMPQD" or "IMPPD". A parameter "TSP" in the impedance routine call sequence specifies whether the routine is to calculate discrete or RMS particle velocity impedance. The impedance and other required data are then entered to the subroutine "UX" which determines eigenvalue solutions for the lined walls.

This subroutine returns the solutions ordered in terms of increasing attenuation. The subroutine "RORDER" is then called if ordering is desired according to decreasing real part of the down stream propagation constant.

The (n,o) modal attenuations are next applied to the appropriate modal spectra. If more than one hard wall mode is specified, the remaining eigenvalue solutions are obtained from subroutine "HWDBS" and the resultant attenuations applied to the modal spectra. Finally, the attenuated SPL spectra are synthesized from the modal spectra, and control returned to the "Mainline" program.

### Impedance Subroutines "IMPQD" and "IMPPD"

These subroutines are the impedance models of the program. The models are semiempirical models for perforated sheet and polyimide, respectively, with cellular air backing.

Each routine is set up in two parts — the first accessed by a standard subroutine call, and the second accessed by an "entry" call. The second part is used to determine an "RMS" particle velocity for the lining, while the first part calculates either an impedance from an input "RMS" particle velocity or an impedance based on a discrete frequency particle velocity.

### Subroutine "UX"

This subroutine controls the calculation of lined wall eigenvalue solutions for one frequency. The zero Mach number solutions are obtained from subroutine "RTZ" and are filtered for duplicate and invalid solutions. The filtered set of solutions are then input to subroutine "MRT" from which solutions for the required Mach number are obtained. Control is then returned to subroutine "ATNSPL".

### Subroutines "RTZ" and "NRAPH"

"RTZ" controls the calculation of zero Mach number solutions accomplished in "NRAPH". The maximum number of modes possible is limited only by the size of the array "ALZRT" in "RTZ" and "UX", and array "A" in "ANTSPL". Presently, these arrays are dimensioned at 42, which gives a maximum of twenty modes. If N is the required number of modes,  $2(N + 1)$  is the array size required. "NRAPH" calculates eigenvalue solutions by the Newton Raphson method. The forms of equations solved are:

$$0 = F - Z \tan (Z)$$

$$0 = F + Z \cot (Z)$$

where F is some complex constant and Z is the required solution.

### Subroutine "MRT"

This routine accepts a filtered set of zero Mach number eigenvalue solutions and obtains solutions for the required Mach number. These solutions are then ordered according to least attenuated mode. For Mach number specified zero, the Mach  $\neq 0$  calculation section is skipped, and the only function of this routine is the ordering process.

The Mach = 0 solutions are accomplished in incremental Mach number steps. The number of increments is based on a Mach number increment nearest .05 which subdivides the specified Mach number an integer number of times. The eigenvalue equations appropriate to the duct geometry and number of lined walls are solved for each incremental Mach number. The Newton Raphson method is employed with modifications necessary to restrain the solutions to the first quadrant of the complex plane.

### Subroutine "HWDBS"

This routine calculates the eigenvalue solutions for lined wall-hard wall combination modes having hard wall mode numbers greater than zero. The soft wall solutions for zero hard wall mode number are used as starting points. The Newton Raphson method is employed for the solution.

## Subroutine "RORDER"

This routine accepts lined wall eigenvalue solutions in any order and orders them according to the largest real part of the downstream propagation constants. These constants are calculated in "RORDER".

## Naming Conventions for Transfer Variables

Variables are transferred between routines through "common" statements and through the "call" statements. The naming conventions for these variables are given here for program reference.

An unnamed common statement is used for the "mainline" routines and subroutines "INPUT", "ATNSPL", "IMPOD", and "IMPPD". In the "mainline" and "input" routines, all names are identical and are as follows:

AAM, ADHS, POAC, DCON, DIAC, THKC, MTHKC	Arrays of input variables of which each array member corresponds to a particular duct increment; the array names correspond to Mach number, lined wall duct height, perforated sheet fractional open area or polyimide number of plies, lining backing depth, hole diameter, material thickness, and boundary layer momentum thickness, respectively. The last three arrays pertain to perforated sheet linings only.
OSPL	Input sound pressure level spectrum. This array remains unchanged throughout the program.
CFRO	Standard, 100Hz bandwidth center frequency array (200 Hz to 10 KHz).
SPL	Attenuated sound pressure level spectrum.
TSPL	Three-dimensional array of modal sound pressure level spectra; the first index refers to the hard wall mode number, the second to the lined wall mode number, and the third to the frequency at which these modes are calculated.
NSPL	Number of input sound pressure levels.
H	Number of lined walls.
RMS	Impedance option; RMS or discrete particle velocity treatment.
REORD	Modal ordering option.

OVERMOD	Option to treat fixed number of modes irrespective of cut-off considerations.
TL	Total lined duct length (inches)
DL	Duct incremental lined length (inches)
DHH	Hard wall duct height (inches)
G	Thermodynamic ratio of specific heats.
TT	Total temperature, degrees Rankine.
PT	Total pressure, psia
ANPLY	Number of polyimide plies or perforated sheet fractional open area if these parameters are constants, otherwise zero.
J	Number of lined increments.
LOW, IUP	Index constants for the array "CFRQ" indicating the lowest and highest frequencies for which eigenvalue solutions will be obtained.
PS	Static pressure, psia
C	Velocity of sound, cm/sec
RO	Density of air, gm/cm <sup>2</sup>
PC	Characteristic impedance of duct environment (cgs rayls).
NSWM	Maximum number of lined wall acoustic modes to be treated.
NHWM	Maximum number of hard wall acoustic modes to be treated.
X	Lined length of treatment completed at any point in the program
DHSI	Soft wall duct height of first increment.
TSR	Static temperature, degrees Rankine.

The only differences in naming the common statement for routine "ATNSPL" are for variable names "AK" and "J" which are renamed "AKDUM" and "JDUM", respectively. In "ATNSPL" variable names "AK" and "J" are used for other purposes and have no relationship to the variables used in the "MAINLINE" and "INPUT" routines.

The "commons" occurring in "IMPQD" and "IMPPD" differ from the above representation in that only the following variables are required, and all other variables are unused:

"CFRQ" (renamed "FQ")

"SPL"

"NSPL"

Variable transfer through the "call" statements occur between the following routines:

From "ATNSPL" to "GETV", "GETVPP", "IMPPD", "IMPQD", "UX",  
"RORDER", "HWDBS".

From "UX" to "RTZ" and "MRT".

From "RTZ" to "NRAPH"

The variable names and meanings for these transfers are as follows (names in parentheses indicate name conventions in the called routine where differences exist).

Calls from "ATNSPL"

"GETV" and "IMPPD"

POA (PLY) Number of polyimide plies

V(VP) Particle velocity (cm/sec)

AM Mach number

RO Density (gm/cm/cm)

TSR(TSDR) Static temperature (degrees R)

D(BSP) Lined wall backing depth

C Speed of sound

PC(ROC) Environmental characteristic impedance (cgs Rayls)

FTPI Logical variable indicating first frequency pass through IMPPD

FRQ(F) Frequency

TSP(TSPL) Real variable indicating method of particle velocity treatment

ZZ Calculated impedance

"GETVPP" and "IMPOD"

The variable names and meanings are the same as for "GETV" and "IMPPD" with the following exceptions:

POA	Perforated sheet fractional open area
TT	Total temperature (degrees Rankine)
PS	Static pressure (psia)
THK, DIA	Perforated sheet thickness and hole diameter, respectively
MTHK	Boundary layer momentum thickness

"UX"

FRQ(F)	Frequency
AM	Mach number
H	Number of lined walls
C	Velocity of sound
DBN	Modal attenuation rates
MCUX	Number of lined wall eigenvalue solutions required
Z(ZS)	Modal lined wall eigenvalue solutions
NN(NS)	Variable indicating sequence of symmetric and antisymmetric modes
DHS(S)	Lined wall duct height
FSMAL	Combined admittance, frequency and geometry parameter
ZZ(Z)	Lined wall impedance

"RORDER"

The variables are identical with those of "UX" immediately above except for the following:

AK	$\omega/c$
G	Duct height parameter
Z	Modal lined wall eigenvalue solutions



"HWDBS"

Z(R)	Lined wall eigenvalue solution
DB	Model attenuation rate
N	Variable indicating symmetric or antisymmetric mode
AM	Mach number
FRQ	Frequency
C	Velocity of sound
K(M)	Hard wall mode number
DHS	Lined wall duct height
DHH	Hard wall duct height
FSMAL	Combined admittance frequency and geometry parameter
H	Number of walls lined

Calls from "UX"

"RTZ"

ALZRT Zero Mach number eigenvalue solutions

MCUX(NALZ) Input is number of modes requested, output is number of eigenvalue solutions supplied

(Variables "FSMAL" and "H" are identical with those of "HWDBS" above.)

"MRT"

ALZRT(ZRT) Zero Mach number eigenvalue solutions input as starting points for nonzero Mach number eigenvalue problem

RK  $\omega/c$

All other parameters are as defined for inputs to "UX" and retain the same names except "MCUX" which is named "NROOT" in "MRT".

Calls from "RTZ" to "NRAPH"

FSMAL As defined for "HWDBS"

Z(ZS) Starting point for eigenvalue solution

ALZRT(ZF) Eigenvalue solution

The variable "N" in routine "NRAPH" indicates that the solution is required for a symmetric or antisymmetric mode.

**APPENDIX III**

**PROGRAM LISTING AND SAMPLE PROGRAM OUTPUT**

C \*\*\*\* NOISE SUPPRESSION - MULTIMODE ANALYSIS - Z(PPM) \*\*\*\*  
 C SINGLE LINING POLYIMID OF PERF SHEET ZDM917 30 6-28-7  
 C VARIABLE CHARACTERISTICS ALONG DUCT LENGTH  
 C

DIMENSION DBD(999)

REAL MTHK, MTHKC

INTEGER FIRST F

COMMON AAM(50), ADHS(50), POAC(50), DCON(50), DIA

1 THKC(50), MTHKC(50)

2 , NSPL(99), CFRO(99), SPL(99), TSPL(4,20,99)

3 NSPL, H, RMS, REORD, OVRMOD, TL, DL, DHH, G

4 TT, PT, ANPLY, J, LOW, IUP, PS, C, RD, PC

5 NSWM, NHWM, X, DHS1, TSR

DIMENSION PLY(50)

EQUIVALENCE (OPA NP, POA, POAC(1), PLY(1)), (AM, AAM(1)),

1 (DHS, ADHS(1)), (DCON(1)), (DIA, DIAC(1)),

2 (THK, R, THKC(1)), (MTHK, MTHKC(1))

EQUIVALENCE (VMACH, AAM(2)), (VDHS, ADHS(2)), (VOPA NP, PO

1 (VD , DCN(2)), (VDIA, DIAC(2)), (VTHK , TH

2 (VMTHK, MTHKC(2))

CALL INPUT

X = DL

IDL = 1

DHS1 = DHS

GO TO 40

38 X = X + IDL

IDL = IDL + 1

IF (VMACH .NE. 0.0) AM = AAM (IDL)

IF (VDHS .NE. 0.0) DHS = ADHS (IDL)

IF (VOPA NP .NE. 0.0) POA = POAC (IDL)

IF (VD .NE. 0.0) ) = DCON (IDL)

IF (VDIA .NE. 0.0) DIA = DIAC (IDL)

IF (VTHK .NE. 0.0) THK = THKC (IDL)

IF (VMTHK .NE. 0.0) MTHK = MTHKC (IDL)

IF (VMACH .EQ. 0.0) GO TO 40

PS = PT / (1.0 + (G - 1.0) \* AM \* AM / 2.0) \*\* (G / (G - 1.0))

TSR = TT / (1.0 + (G - 1.0) \* AM \* AM / 2.0)

TS = 273.16 + 5.0 / 9.0 \* (TSR - 491.69)

C = 33145.0 \* SORT(TS / 273.16)

RD = 273.16 / TS \* PS / 1.01325E6 \* 1.293E-3 \* 6R047.

PC = RD \* C

40 CALL ATNSPL

DO 50 I = LOW, IUP

50 DBD(I) = OSPL(I) - SPL(I)

WRITE (6, 5) X

WRITE (6, 7) (CFRO(I), DBD(I), I = LOW, IUP)

WRITE (1, 5) X

WRITE (1, 7) (CFRO(I), DBD(I), I = LOW, IUP)

REPRODUCIBILITY OF THE ORIGINAL PAGE IS POOR

```

IF (ABS(X-TL) .GT. 0.1) GO TO 38
WRITE (6,13)
WRITE (1,13)
FIRST F = 100*LOW + 100
IFIRST = LOW
80 LAST F = MIN0(FIRST F + 300, 100*IUP + 100)
   ILAST = MIN0(IFIRST + 3, IUP)
   WRITE (6,81) FIRST F, LAST F, (SPL(I),I = IFIRST, ILAST)
   WRITE (1,81) FIRST F, LAST F, (SPL(I),I = IFIRST, ILAST)
   IF (ILAST .EQ. IUP) GO TO 90
   FIRST F = LAST F + 100
   IFIRST = ILAST + 1
   GO TO 80
90 IM1 = IUP - 1
   DO 70 I = LOW, IM1
   DRD(I) = (DRD(I) + DRD(I+1))/2.
70 CERQ(I) = (CERQ(I) + CERQ(I+1))/2.
   WRITE (1, 15) X
   WRITE (1, 17)      (DRD(I),I=LOW,IM1)
   STOP
5  FORMAT ('1 DR DIFFERENCE AFTER',F6.2,' INCHES OF LINING',//)
7  FORMAT (' ',F8.0,F10.2)
13 FORMAT ('1 FREQUENCIES      FINAL SPECTRUM')
15 FORMAT ('0 DR DIFFERENCES (SMOOTHED) AFTER',F6.2,' INCHES OF',
1     ' LINING',//)
17 FORMAT (' ',5F10.2)
81 FORMAT ('0', I4, ' TO', I6, 4F11.2)
END

```

REPRODUCIBILITY OF THE  
ORIGINAL PAGE IS POOR

SUBROUTINE INPUT

REAL MTHK, MTHKC

INTEGER FIRST F

COMMON AAM(50), ADHS(50), POAC(50), DCON(50), DIAC(

1 THKC(50), MTHKC(50)

2 , OSPL(99), CFRO(99), SPL(99), TSPL(6,20,99),

3 NSPL, H, RMS, REORD, OVRMOD, TL, DL, DHH, G,

4 TT, PT, ANPLY, J, LOW, IHP, PS, C, RO, PC,

5 NSWM, NHWM, X, DHS1, TSR

DIMENSION PLY(50), SPL NAM(18)

EQUIVALENCE (OPA NP, PJAC(1), PLY(1)), (AM, AAM(1)),

1 (DHS, ADHS(1)), (D,DCON(1)), (DIA, DIAC(1)),

2 (THK, R, THKC(1)), (MTHK, MTHKC(1))

COMMON /NJN/ NJN(2,99)

EQUIVALENCE (VMACH, AAM(21)), (VDHS, ADHS(2)), (VOPA NP, POAC(

1 (VD ,DCON(2)), (VDIA, DIAC(2)), (VTHK , THKC(

2 (VMTHK, MTHKC(2))

SET CONSTANT VALUE FLAGS(VARIATION ALONG DUCT LENGTH IF NON

VMACH = 0.0

VDHS = 0.0

VOPA NP = 0.0

VD = 0.0

VDIA = 0.0

VTHK = 0.0

VMTHK = 0.0

DIMENSION TITLE (18)

READ (5, 4) TITLE

READ (5,23) A, SWM, HWM, H, PSPL, RMS, REORD, OVRMOD

NSPL = A

IF (PSPL .EQ. 0.0) GO TO 44

DO 43 I = 1, NSPL

43 SPL(I) = PSPL

GO TO 45

44 READ (5, 4) SPL NAM

READ (5, 23) (SPL(I), I = 1, NSPL)

45 IF (HWM .EQ. 0.0) HWM = 1.0

HWM = AMIN1(6.0, HWM)

NHWM = HWM

IF (SWM .EQ. 0.0) SWM = 1.0

SWM = AMIN1(20.0, SWM)

NSWM = SWM

K = 1

DO 46 J = 1, 20

DO 46 I = 1, NSPL

46 TSPL(K, J, I) = 0.0

CFRO(I) = 200.

DO 56 I = 2, NSPL

56 CFRO(I) = CFRO(I-1) + 100.

READ (5,23) TL, DL, DHH, G, TT, PT, A, R

REPRODUCIBILITY OF THE ORIGINAL PAGE IS POOR

```

J = (TL + 0.11)/DL
READ (5,23) ANPLY, AM, DHS, OPA NP, D, DIA, R, MTHK
WRITE (6, 1) TITLE
WRITE (1, 6) TITLE
IF (ANPLY .EQ. 0.0) WRITE (6, 2)
IF (ANPLY .NE. 0.0) WRITE (6, 3)
WRITE (6,5)
LOW = A/100. -.9
IF (LOW .EQ. 0) LOW = 1
IUP = B/100. -.9
IF (IUP .EQ. 0) IUP = NSPL
WRITE (6, 9) NSPL, NSWM, NHWM, H, PSPL, RMS, REORD, OVRMOD
WRITE (1, 9) NSPL, NSWM, NHWM, H, PSPL, RMS, REORD, OVRMOD
WRITE (6, 8) TL, DL, JHH, G, TT, PT, CERQ(LOW), CERQ(IUP)
WRITE (1, 8) TL, DL, JHH, G, TT, PT, CERQ(LOW), CERQ(IUP)
WRITE (6,10) ANPLY, AM, DHS
WRITE (1,10) ANPLY, AM, DHS
IF (ANPLY .NE. 0.0) GO TO 68
WRITE (6, 11) OPA NP
WRITE (1, 11) OPA NP
WRITE (6, 14) D, DIA, R, MTHK
WRITE (1, 14) D, DIA, R, MTHK
GO TO 69
68 WRITE (6, 12) OPA NP, D
WRITE (1, 12) OPA NP, D
69 FJFCT = AMIN1 (ABS(AM), DHS, OPA NP, D, DIA, R, MTHK)
IF (AM .NE. 0.0) GO TO 70
READ (5, 23) (AAM (I), I = 1, J)
WRITE (6, 30) (AAM (I), I = 1, J)
WRITE (1, 30) (AAM (I), I = 1, J)
70 IF (DHS.NE. 0.0) GO TO 71
READ (5, 23) (ADHS (I), I = 1, J)
WRITE (6, 31) (ADHS (I), I = 1, J)
WRITE (1, 31) (ADHS (I), I = 1, J)
71 IF (OPA NP .NE. 0.0) GO TO 72
READ (5, 23) (POAC (I), I = 1, J)
IF (ANPLY .NE. 0.0) GO TO 77
C PERFORATED SHEET 'PER CENT' OPEN AREAS
C INTERNALLY, FRACTIONAL
C EXTERNALLY, PER CENT
WRITE (6, 32) (POAC (I), I = 1, J)
WRITE (1, 32) (POAC (I), I = 1, J)
GO TO 72
C POLYIMID - NUMBER OF PLYS
77 WRITE (6, 37) (PLY (I), I = 1, J)
WRITE (1, 37) (PLY (I), I = 1, J)
72 IF (D .NE. 0.0) GO TO 73
READ (5, 23) (DCON (I), I = 1, J)
WRITE (6, 33) (DCON (I), I = 1, J)
WRITE (1, 33) (DCON (I), I = 1, J)
73 IF (DIA .NE. 0.0 .OR. ANPLY .NE. 0.0) GO TO 74

```

REPRODUCIBILITY OF THE ORIGINAL PAGE IS POOR

```

      READ (5, 23) (DIAC (I), I = 1, J)
      WRITE (6, 34) (DIAC (I), I = 1, J)
      WRITE (1, 34) (DIAC (I), I = 1, J)
74  IF (R .NE. 0.0 .OR. ANPLY .NE. 0.0) GO TO 75
      READ (5, 23) (THKC (I), I = 1, J)
      WRITE (6, 35) (THKC (I), I = 1, J)
      WRITE (1, 35) (THKC (I), I = 1, J)
75  IF (MTHK .NE. 0.0 .OR. ANPLY .NE. 0.0) GO TO 76
      READ (5, 23) (MTHKC(I), I = 1, J)
      WRITE (6, 36) (MTHKC(I), I = 1, J)
      WRITE (1, 36) (MTHKC(I), I = 1, J)
76  IF (PSPL .NE. 0.0) GO TO 130
      IF (EJECT .NE. 0.0) GO TO 79
      WRITE (6, 6)
      WRITE (1, 6)
79  WRITE (6, 13) SPL NAM
      WRITE (1, 13) SPL NAM
      FIRST F = 200
      IFIRST = 1
80  LAST F = MIN0(FIRST F + 300, 100*NSPL + 100)
      ILAST = MIN0(IFIRST + 3, NSPL)
      WRITE (6, 81) FIRST F, LAST F, (SPL(I), I = IFIRST, ILAST)
      IF (LOW .LF. IFIRST .AND. IFIRST .LF. IUP .OR.
1    LOW .LF. ILAST .AND. ILAST .LF. IUP)
2    WRITE (1, 81) FIRST F, LAST F, (SPL(I), I = IFIRST, ILAST)
      IF (ILAST .EQ. NSPL) GO TO 120
      FIRST F = LAST F + 100
      IFIRST = ILAST + 1
      GO TO 80
120 WRITE (6, 6)
      WRITE (1, 6)
130 CONTINUE

C
PS = PT / (1.0 + (G - 1.0)*AM*AM/2.0)**(G / (G - 1.0))
TSR = TT / (1.0 + (G - 1.0)*AM*AM/2.0)
TS = 273.16 + 5.0/9.0*(TSR - 491.69)
C = 33145.0*SQRT(TS/273.16)
R0 = 273.16/TS*PS/1.01325E6*1.293E-03* 68947.
PC = R0*C
WRITE (6, 19)
DO 50 I = LOW, IUP
SW = (2.2*CFRQ(I)*DHS*2.54/C + 1.0) / SQRT(1.0 - AM*AM)
HW = (2.2*CFRQ(I)*DHH*2.54/C + 1.0) / SQRT(1.0 - AM*AM)
IF (SW .GT. SWM .OR. OVRMOD .GT. 0.0) SW = SWM
IF (HW .GT. HWM .OR. OVRMOD .GT. 0.0) HW = HWM
IH = HW
IS = SW
IF (IH .LT. 1) IH = 1
IF (IS .LT. 1) IS = 1
A = IS
A = SPL(I) - 10.*ALOG10(A*IH)

```



```

NJN(1,I) = IS
NJN(2,I) = IH
DO 22 L = 1,IS
DO 22 K = 1,IH
22 TSPL(K,L,I) = A
WRITE (6,21) CFREQ(I), NJN(1,I), NJN(2,I), TSPL(1,1,I)
50 OSPL(I) = SPL(I)
RETURN
1 FORMAT ('1*$*F',18A4)
2 FORMAT ('0 RECTANGULAR ANALYSIS - PERFORATED SHEET MODEL')
3 FORMAT ('0 RECTANGULAR ANALYSIS - POLYIMIDE MODEL')
4 FORMAT (18A4)
5 FORMAT ('0 INPUT PARAMETERS')
6 FORMAT ('1',18A4)
8 FORMAT ('0', F13.6, 6X, 'TOTAL DUCT LENGTH'//
5F14.6, 6X, 'INCREMENT LENGTH'//
FF14.6, 6X, 'HARD WALL DUCT HEIGHT'//
8F14.6, 6X, 'GAS CONSTANT'//
9F14.6, 6X, 'TOTAL TEMPERATURE'//
7F14.6, 6X, 'TOTAL PRESSURE'//
CF14.6, 6X, 'LOWEST FREQUENCY CONSIDERED'//
DF14.6, 6X, 'HIGHEST FREQUENCY CONSIDERED'//
9 FORMAT ('0', I13, 6X, 'NUMBER OF SPL'S'//
6 I14, 6X, 'MAXIMUM NUMBER OF SOFT WALL MODES CONSIDERED'//
HI14, 6X, 'MAXIMUM NUMBER OF HARD WALL MODES CONSIDERED'//
3 F14.6, 6X, 'NUMBER OF WALLS LINED'//
JF14.6, 6X, 'UNIFORM SPL'//
KF14.6, 6X, 'RMS PARTICLE VELOCITY'//
LF14.6, 6X, 'REFORDER OPTION'//
MF14.6, 6X, 'OVERRIDE MODE OPTION'//
10 FORMAT ('0', F13.6, 6X, 'MODEL SELECTOR'//
1F14.6, 6X, 'MACH NUMBER'//
FF14.6, 6X, 'SOFT WALL DUCT HEIGHT'//
11 FORMAT (2PF14.6, 6X, 'PERCENT OPEN AREA'//
12 FORMAT (F14.6, 6X, 'NUMBER OF POLYIMIDE PLYS'//
1F14.6, 6X, 'BACKING SPACE'//'1')
13 FORMAT (1X, 18A4/ '0 FREQUENCIES SOUND PRESSURE LEVELS')
14 FORMAT (F14.6, 6X, 'BACKING SPACE'//
YF14.6, 6X, 'HOLE DIAMETER'//
AF14.6, 6X, 'MATERIAL THICKNESS'//
ZF14.6, 6X, 'MOMENTUM THICKNESS'//'1')
19 FORMAT ('0 EQUAL PRESSURE MODAL SPL'//
1 '0 FREQ NUMBER OF NUMBER OF SPL FOR'//
2 ' SOFT WALL HARD WALL EACH MODE'//4X,2(6X, 'MODES')//)
21 FORMAT (1X, F6.0, 16, I11, F13.1)
23 FORMAT (9F,2)
30 FORMAT ('0 MACH NUMBERS //(9F12.6))
31 FORMAT ('0 SOFT WALL DUCT HEIGHTS //(9F12.6))
32 FORMAT ('0 PERCENT OPEN AREA //(2PF12.6))
33 FORMAT ('0 BACKING SPACES //(9F12.6))
34 FORMAT ('0 DIAMETERS //(9F12.6))

```

```
25 FORMAT ('O THICKNESSES', '(9F12.6)')
26 FORMAT ('O MOMENTUM THICKNESSES', '(9F12.6)')
27 FORMAT ('O NUMBER OF POLYIMID PLYS', '(9F12.6)')
R1 FORMAT ('O', I4, ' TO', I6, '4F11.2)')
END
```

SUBROUTINE ATNSPL

REAL MTHK, MTHKC, PI/3.14159/

INTEGER FIRST F

COMMON AAM(50), ADHS(50), POAC(50), DCON(50), DIA(50),

1 THKC(50), MTHKC(50)

2 , NSPL(99), CFRO(99), SPL(99), TSPL(6,20,99),

3 NSPL, H, RMS, REORD, OVRMOD, TL, DL, DHH, AKDUM,

4 TT, PT, ANPLY, JOUM, LOW, IUP, PS, C, RO, PC,

5 NSWM, NHWM, X, DHS1, TSR

DIMENSION PLY(50)

EQUIVALENCE (POA NP, POA, POAC(1), PLY(1)), (AM, AAM(1)),

1 (DHS, ADHS(1)), (DCON(1)), (DIA, DIA(1)),

2 (THK, R, THKC(1)), (MTHK, MTHKC(1))

EQUIVALENCE (VMACH, AAM(2)), (VDHS, ADHS(2)), (VOPA NP, POAC(2)),

1 (VD ,DCON(2)), (VDIA, DIA(2)), (VTHK , THKC(2)),

2 (VMTHK, MTHKC(2))

COMMON /NJN/ NJN(2,99)

COMPLEX Z(42),FSMAL,FS,ZZ, SAVE Z7

DIMENSION DBN(42),NN(42)

V = 40.

FTPI = .TRUE.

IF (RMS .LE. 0.) GO TO 50

WRITE (6, 19)

19 FORMAT ('1')

IF (ANPLY.NF.0.0)CALL GETV(POA,V,AM,RO,TSP,D,C,PC, +50)

CALL GETVPP (POA, V, AM, TT, PS, THK, DIA, MTHK, D, C, PC)

50 DO 70 I = LOW,IUP

TSP = SPL(I)

IF (RMS .IF. 0.) TSP = -TSP

FRQ = CFRO(I)

IF (ANPLY .NF. 0.0) CALL IMPPD (FTPI, FRQ , POA, V, AM, RO,

TSP, D, C, PC, TSP, ZZ, +55)

CALL IMPQD (FTPI, FRQ , POA, V, AM,

TT, PS, THK, DIA, MTHK, D, C, PC, TSP, ZZ)

55 WRITE(6,9) FRQ, ZZ, V

A = 0.0

NS = (2.2\*FRQ\*DHS1\*2.54/C + 1.0) / SQRT(1.0 - AM\*AM)

NH = (2.\*FRQ\*DHH\*2.54/C + 1.0) / SQRT(1.0 - AM\*AM)

IF (NS .GT. NSWM .OR. OVRMOD .GT. 0.0) NS = NSWM

IF (NH .GT. NHWM .OR. OVRMOD .GT. 0.0) NH = NHWM

IF (NS .LT. 1) NS = 1

IF (NH .LT. 1) NH = 1

MCUX = NS

CALL UX (FRQ, AM, H, C, DBN, MCUX, Z, NN, DHS, FSMAL, Z7)

WRITE (6,5) (Z(J),DBN(J),NN(J),J=1,MCUX)

AK = 2.\*PI\*CFRO(I)/C

REPRODUCIBILITY OF THE  
ORIGINAL PAGE IS POOR

```

G = DHS*2.54/H
IF (REORD .GT. 0.) CALL RORDER (AM,AK,G,MCUX,7,NN,DBN)
M = MINO(MCUX,NS, NJN(1,I))
NH = MINO(NH, NJN(2,I))
WRITE (6,2)
IF (DBN(1) .NE. DBN(2)) GO TO 21
IF (RFAL(Z(1)) .NE. REAL(Z(2)) .AND. AIMAG(Z(1)) .NE. AIMAG(Z(2))
1 GO TO 21
WRITE (6, 22) CERQ(I)
DBN(I) = 0.0
22 FORMAT (' FOR FREQUENCY =', F10.1, ', ERROR. DUPLICATE SOLUTION'
1 ', NO ATTENUATION APPLIED FOR ONE OR TWO MODES')
21 WRITE (6,6)
DO 20 J = 1,M
TSPL(1,J,I) = TSPL(1,J,I) - DBN(J)*DL
IF (NH .EQ. 1) GO TO 20
N = NN(J)
IF (DBN(J) .EQ. 0.) GO TO 20
DO 10 K = 2,NH
CALL HWDBS (Z(J),DB,N,AM,FRQ,C,K,DHS,OH,FSMAL,H,FS)
WRITE (6,7) J,K,Z(J),DB,N
10 TSPL(K,J,I) = TSPL(K,J,I) - DB*DL
20 CONTINUE
NS = MINO(NS, NJN(1,I))
DO 30 J = 1,NS
DO 30 K = 1,NH
30 A = A + 10.**(TSPL(K,J,I)/10.)
SPL(I) = 10.*ALOG10(A)
IF (MOD(I-LW, 2) .EQ. 1) WRITE (6, 2)
70 CONTINUE

WRITE (6,1) X
FIRST F = 200
IFIRST = 1
80 LAST F = MINO(FIRST F + 300, 100*NSPL + 100)
ILAST = MINO(IFIRST + 3, NSPL)
WRITE (6,81) FIRST F, LAST F, (SPL(I), I = IFIRST, ILAST)
IF (ILAST .EQ. NSPL) RETURN
FIRST F = LAST F + 100
IFIRST = ILAST + 1
GO TO 80
81 FORMAT ('0', I4, ' TO', I6, 4F11.2)
1 FORMAT ('1 FREQUENCIES NEW SPECTRUM AFTER', F4.0,
1 ' INCHES OF LINING')
2 FORMAT ('8')
3 FORMAT ('0', 1PBE12.3)
5 FORMAT ('0 ROOTS AND 03/IN'//
1 2(' 7PFAL ZIMAG DBN NN')/
2 2(1PF14.5, F13.5, 0PF8.4, I3))
6 FORMAT (' SWM HWM ZREAL ZIMAG DBN NN')
7 FORMAT (I5, I4, 1PF14.5, F13.5, 0PF8.4, I3)

```

```
9 FORMAT ('C'/' FREQUENCY ', F6.0, ' H7'/' ' ZR,ZI' , 1P2E14.5,  
1      ' V', F14.5)  
END
```

```

SUBROUTINE IMPDD(FTP1,F,PLY,VP,AM,R0,TSDR,BSP,C,ROC,TSPL,ZZ, *1
IMPEDANCE - POLYIMIDE
7DM91)
COMPLEX CMPLX,ZZ
LOGICAL*4 FTP1
DATA PI/3.14159/
COMMON BUNCH(449), FQ(99), SPL(99),MORF(11880), NSPL, THE,RFST(
DIMENSION PSPL(99)
COT(X)=COS(X)/SIN(X)
D=BSP
P=2.2E-4*PI**2*(ABS(TSPL)/20.)
TKD=2.*PI*F/C*D*2.54
ITN=0
IN=0
IF(.NOT.FTP1) GO TO 50
U=3.17E-8/2.089*TSDR**1.5*734.7/(TSDR+216.)
RVDC=4640.*U*PLY**1.333
VPGF=.05*C*AM*AM/(RVDC/ROC+SQRT((RVDC/ROC)**2+.71*PLY*PLY*AM**2))
IF (TSPL .LT. 0.0) WRITE (6,1) VPGF
1 FORMAT ('0 GRAZING FLOW PARTICLE VELOCITY =', F11.4,' FROM SURF
1 'ROUTINE IMPDD')
FTP1 = .FALSE.
50 CONTINUE
RIAC=2.06*R0*PLY*PLY*VP
RVAC=U*.305*PI*PLY*F
R7=R[AC+RVAC+RVDC
RX=R0*F*(.549*PLY**1.5-5.12E-5*PLY**3*VP)
IF(TSPL.GE.0.) GO TO 80
RZPV=RIAC/VP
RXPV=-5.12E-5*R0*PLY**3*F
ZZ=CMPLX(RZ,RX-ROC*COT(TKD))
QAB = CABS(ZZ)
SQRTV = SQRT(VPGF**2 + (P/QAB)**2)
FNR = VP - SQRTV
PPDZ = -2./QAB**4*(RZ*RZPV + RX*RXPV)*P*P
FNRP = 1.0 - PPDZ*.5/SQRTV
VPN=VP-FNR/FNRP
IF(VPN.LT.0.) GO TO 4)
IF((ABS(VPN-VP)-.0001*VP).LT.0.) GO TO 60
ITN=ITN+1
IF(ITN.GT.50) GO TO 70
VP=VPN
GO TO 50
4) VP=1.0
IN=IN+1
IF(IN.GT.3) GO TO 70
GO TO 50
70 CONTINUE
ZZ = ZZ/ROC
RETURN 1
60 CONTINUE
ZZ = ZZ/ROC

```

```

VP=VPN
RETURN 1
80 TKD=2.*PI*F/C*BSP*2.54
ZZ=CMPLX(RZ/ROC,RX/ROC-COT(TKD))
RETURN 1
ENTRY GETV (PLY, VP, AM, RD, TSDR, BSP, C, ROC, *)
DO 5 I = 1, NSPL
5 PSPL(I) = 2.2E-4*10.**((SPL(I)/20.)
U=3.17E-8/2.*R9*TSDR**1.5*734.7/(TSDR+216.)
DCM = BSP * 2.54
RVDC=4640.*U*PLY**1.333
VPGF=.05*C*AM*AM/(RVDC/ROC+SQRT((RVDC/ROC)**2+.71*PLY*PLY*AM*AM))
WRITE (6, 1) VPGF
TK = 2.0*PI/C
VP = 100.0
17 RIAC=2.86*RD*PLY*PLY*VP
PPOZ=0.
POZ=0.
DO 15 I = 1, NSPL
TKD=TK*FQ(I)*DCM
RVAC=U*.305*PLY*PLY*FQ(I)
RZ=R IAC+RVAC+RVDC
RX=RQ*FQ(I)*( .540*PLY**1.5-5.12E-5*PLY**3*VP)
ZZ=CMPLX(RZ,RX-ROC*COT(TKD))
QAB=CABS(ZZ)
POZF=(PSPL(I)/QAB)**2
POZ=POZ+POZF
PZI=-5.12E-5*RD*PLY**3*FQ(I)
PZR=2.86*RD*PLY*PLY
15 PPOZ=PPOZ-2./QAB**4*(RZ*PZR+RX*PZI)*PSPL(I)*PSPL(I)
SORTV=SQRT(VPGF*VPGF+POZ)
FA1=VP -SORTV
FA1P=1.- PPOZ*.5/SORTV
VP1 =VP -FA1/FA1P
IF(ABS(VP1 -VP ).LT..0001*VP ) RETURN 1
VP = VP1
GO TO 17
END

```

REPRODUCIBILITY OF THE  
ORIGINAL PAGE IS POOR

```

SUBROUTINE IMPQD(FTPI,F,POA,VP,AM,TT,PS,THK,DIA,MTHK,RSP,C,
1RDC,TSPL,Z7)
C
IMPEDANCE - PERFORATED SHEET
COMMON BUNCH(449),FO(99),SPL(99),MORF(11880),NSPL,THF,RFST(22)
DIMENSION PSPL(99)
COMPLEX CMPLX,Z7
LOGICAL*4 FTPI
REAL MTHK
DATA PI/3.14159/
COT(X)=COS(X)/SIN(X)
P=2.2E-4*10.** (ABS(TSPL)/20.)
TKD=2.*PI*F/C*RSP*2.54
ITN=0
IN=0
IF(.NOT.FTPI) GO TO 50
TH=TT/519.
PP2=PI/2./SQRT(2.)
DEL=PS/14.7
F=1.0251*(1./POA**2-1)/POA**.1/EXP(.5072*THK/DIA)
RVDC=.077*THK/DEL/POA*TH*TH/(TH+.416)
RV2=RVDC/2.
VPGF=(.025+.055*DIA/MTHK)*C*AM*AM/(RV2+SQRT(RV2**2+(.025+.055*DIA/
1MTHK)*E**AM*AM))
2 * 0.5
IF (TSPL .LT. 0.0) WRITE (6,1) VPGF
1 FORMAT ('0 GRAZING FLOW PARTICLE VELOCITY =',F11.4,' FROM SUPR',
1 'ROUTINE IMPQD')
FTPI = .FALSE.
50 CONTINUE
SN = 2.54 * DIA * F * POA/VP
RIAC=PP2*VP/C*E*EXP(-1.8*SN*SN)
RVAC=3.83E-5*TH**.75*SQRT(F)*(THK/DIA+1.-POA)/(POA*SQRT(DEL*(TH
1+.416)))
R7=(RIAC+RVAC+RVDC)*RDC
DLT=.85*DIA*(1.-.7*SQRT(POA))-1.2E-5/POA*VP
IF(DLT.LT.0.) DLT=0.
RX=4.69E-4/POA*F/SQRT(TH)*(THK+DLT)*RDC
IF(TSPL.GE.0.) GO TO R0
RZPV = RIAC/VP*(1.+3.6*SN*SN)*RDC
RXPV=-RX/(THK+DLT)*1.2E-5/POA
IF (DLT .EQ. 0.0) RXPV = 0.0
ZZ=CMPLX(RZ,RX-RDC*COT(TKD))
QAB = CABS(ZZ)
SQRTV = SQRT(VPGF**2 + (P/QAB)**2)
FNR=VP-SQRTV
PPNZ = -2./QAB**4*(RZ*RZPV+RX*RXPV)*P*P
FNRD = 1.0 - PPNZ*.5/SQRTV
VPN=VP-FNR/FNRD
IF(VPN.LT.0.) GO TO 41
IF((ABS(VPN-VP)-.0001*VP).LT.0.) GO TO 60
ITN=ITN+1

```

7DM917 31



```

IF (ITN.GT.50) GO TO 70
VP=VPN
GO TO 50
41 VP=1.0
IN=IN+1
IF (AM.NE.0.0) VP = VPGF + 1.0
IF (IN.GT.3) GO TO 70
GO TO 50
70 CONTINUE
WRITE (6, 71) IN, ITN
71 FORMAT (' RETURNED VIA 70 FROM IMPQD IN =', I3, ' ITN =', I3)
ZZ = ZZ/ROC
RETURN
60 CONTINUE
ZZ = ZZ/ROC
VP=VPN
RETURN
80 TKD=2.*PI*F/C*BSP*2.54
ZZ=CMPLX(RZ/ROC,RX/ROC-COT(TKD))
RETURN
ENTRY GETVPP (POA, VP, AM, TT, PS, THK, DIA, MTHK, BSP, C, ROC)
DO 5 I = 1, NSPL
5 PSPL(I) = 2.2E-4*10.**((SPL(I)/20.)
REAL K = .05 + .11*DIA/MTHK
TH=TT/519.
PP2=PI/SQRT(9.0)
DEL=PS/14.7
E=1.0251*(1./POA**2-1)/POA**.1/EXP(.5072*THK/DIA)
RVDC = RVDC/(2*POC)
RVDC=.077*THK/DEL*TH*TH/(TH+.416)/POA/2.0
VPGF=0.5*REAL K*C*AM*AM/(RVDC+SQRT(RVDC**2+.5*REAL K*E*AM*AM))
2 * 0.5
WRITE (6, 1) VPGF
VP = 100.0
IN = 0
17 POZ=0.
POZ=0.
IN = IN + 1
DO 15 I = 1, NSPL
TKD=2.*PI*FQ(I)/C*BSP*2.54
RVAC=.0000383*TH**.75*SQRT(FQ(I))/POA/SQRT(DEL*(TH+.416))
1 * (THK/DIA+1.0-POA)
SN = 2.54*DIA*FQ(I)*POA/VP
RIAC=PP2*VP/C*E*EXP(-1.8*SN*SN)
RZ=R IAC+RVAC+RVDC+RVDC
DLT = AMAX1(.95*DIA*(1.0-.7*SQRT(POA))-0.00012*VP/POA, 0.0)
RX = .000469*FQ(I)*(THK+DLT)
RX = .000469*FQ(I)*(THK+DLT)/POA/SQRT(TH)
ZZ=CMPLX(RZ,RX-COT(TKD))*ROC
QAR=CABS(ZZ)
POZF=(PSPL(I)/QAR)**2

```

```

PQZ=PQZ+PQZF
RXPV=-RX/(THK+DLT)*.000012/POA
RZPV=RIAC/VP*(1.0+3.6*SN*SN)
RX = RX - COT(TKD)
15 PPOZ=PPDZ-2./OAP**4*(R7*RZPV+RX*RXPV)*PSPL(I)*PSPL(I)*RDC**2
SQRTV=SQRT(VPGF*VPGF+PQZ)
FA1=VP - SQRTV
FA1P=1.- PPOZ*.5/SQRTV
VP1 =VP -FA1/FA1P
IF (VP1 .LT. 0.01) GO TO 20
IF (ABS(VP1 -VP ) .LT. .0001*VP ) RETURN
VP = VP1
GO TO 17
20 IF (IN .EQ. 3) GO TO 21
VP = 1.0
IF (AM .NE. 0.0) VP = VPGF + 1.0
GO TO 17
21 WRITE (6,22)
22 FORMAT (' RETURNED VIA 21 FROM GETVPP IN = ', I3)
RETURN
END

```

```

SUBROUTINE UX(F, AM, H, C, DBN, MCUX, ZS, NS, S, FSMAL, Z)
COMPLEX*8 AD, Z, AI, FSMAL, ALZRT(42), ZS(42)
REAL*4 DBN(42)
DIMENSION NS(42)
C
**** RK IS K=W/C
PI=3.14159
AI = CMPLX(0.0, 1.0)
RK=2.*PI*F/C
DHS = S
AD=1./Z
IF (REAL(AD).LT.0.0) GO TO 50
FSMAL = AI*AD*RK*DHS*2.54/H
CALL RTZ(FSMAL, AI, ZRT, MCUX, H)
WRITE (6, 1) FSMAL, (ALZRT(J), J=1, MCUX)
IF (REAL(FSMAL) .GE. 0.0) GO TO 64
N = MCUX - 1
DO 3 J=1, N
L=J+1
DO 4 K=L, MCUX
ABSRF = ABS(REAL(ALZRT(J))-REAL(ALZRT(K)))
ABSIM = ABS(AIMAG(ALZRT(J))-AIMAG(ALZRT(K)))
IF(ABSRF .GT. 1.E-5) GO TO 4
IF(ABSIM .GT. 1.E-5) GO TO 4
ALZRT(J) = CMPLX(1.E20, 0.0)
GO TO 3
4 CONTINUE
3 CONTINUE
64 CALL MRT(FSMAL, ALZRT, RK, H, MCUX, DBN, AM, DHS, ZS, NS)
RETURN
50 WRITE (6, 101) AD
101 FORMAT (1X, 25(' * '))//0 SINCE THE REAL PART OF THE ABOVE '
1 'IMPEDANCE (' , 2F11.4, ') IS//' NEGATIVE, SOME CALC'
2 'ULATIONS ARE BYPASSED FOR THIS FREQUENCY AND PRINTED'
3 ' RESULTS ARE INVALID. '//25(' * ')
WRITE (1, 102) AD
102 FORMAT (1X, 25(' * '))//0 SINCE THE REAL PART OF THE '
1 'IMPEDANCE (' , 2F11.4, ') IS//' NEGATIVE, SOME CALC'
2 'ULATIONS ARE BYPASSED FOR THIS FREQUENCY AND PRINTED'
3 ' RESULTS ARE INVALID. '//25(' * ')
MCUX = 0
RETURN
1 FORMAT ('0 ADMITTANCE PARAMETER = ', 1PF11.4, E12.4/
1 '0 PRELIMINARY MACH = 0 SOLUTIONS', //3(E13.4, E12.4))
END

```

REPRODUCIBILITY OF THE  
ORIGINAL PAGE IS POOR

```

SUBROUTINE RTZ(FSMAL,ALZRT,NALZ,H)
COMPLEX FSMAL,ALZRT(42),Z
P=3.14159
IF (REAL(FSMAL).GE.0.0) GO TO 21
Z = CMPLX(AIMAG(FSMAL),-REAL(FSMAL))
CALL NRAPH (FSMAL,Z,ALZRT(1),1)
N = NALZ
IF (H .EQ. 2.0) N = (N+1)/2
IF (H .EQ. 1.0) GO TO 10
Z = CMPLX(AIMAG(FSMAL),-REAL(FSMAL))
CALL NRAPH (FSMAL,Z,ALZRT(2*N+2),-1)
10 DO 3 J=1,N
Z = CMPLX(P*(J-.5) + .05,.05)
CALL NRAPH (FSMAL,Z,ALZRT(J+1),1)
Z = CMPLX(P*J -.05,.05)
CALL NRAPH (FSMAL,Z,ALZRT(J+N+1),1)
IF (H .EQ. 1.0) GO TO 3
Z = CMPLX(P*(J-.5)-.05,.05)
CALL NRAPH (FSMAL,Z,ALZRT(J+2*N+2),-1)
Z = CMPLX(P*J+.05,.05)
CALL NRAPH (FSMAL,Z,ALZRT(J+3*N+2),-1)
3 CONTINUE
NALZ = 2*N + 1
IF (H .EQ. 2.0) NALZ = 4*N + 2
RETURN
21 IF (H .EQ. 1.0) NALZ = NALZ*2
DO 7 J = 1,NALZ
IF (H .EQ. 1.0) GO TO 20
Z = CMPLX(P*J-.05,.02)
CALL NRAPH (FSMAL,Z,ALZRT(J+NALZ),-1)
20 Z = CMPLX(P*(J-.5)-.05,.02)
7 CALL NRAPH (FSMAL,Z,ALZRT(J),1)
IF (H .EQ. 2.0) NALZ = NALZ*2
RETURN
END

```

```

SUBROUTINE MRT (FSMAL, ZRT, RK, H, NRROOT, DBN, AM, DHS, ZS, NS)
COMPLEX FSMAL, ZRT(42), ZS(42)
COMPLEX*16 Z, F, P, CTANZ, CSECZ, RR, DFS
REAL*4 DBN(42), DB(42)
DIMENSION NN(42), NS(42)
REAL*8 ZR, ZI, S(2), DMACH, DAM, A, RD, TMM, AL, R
EQUIVALENCE (Z, S(1))
DHS = 100.
A = DHS*2.54/H
RD = RK
DFS = FSMAL
LH = H
NMACH = ABS(AM)/.05 + 1.0
DAM = AM/NMACH
NR = 0
DO 100 I = 1, NRROOT
DB (I) = 0.0
Z = ZRT(I)
SIC = S(I)
IF (SIC .GE. 1.E20) GO TO 180
TMM = 1.00
ZRT(I) = CMPLX(1.E20, 0.0)
DMACH = 0.00
N = 1
IF (L*LH .GT. NRROOT) N = -1
IF (AM .EQ. 0.0) GO TO 100
DO 90 J=1, NMACH
DMACH = DMACH + DAM
I = 0
TMM = 1.00 - DMACH*DMACH
DO 91 K=1, 100
ZR = S(1)
ZI = S(2)
IF (DABS(ZR) .GT. 3.4010 .OR. DABS(ZI) .GT. 174.00) GO TO 180
IF (N .GT. 0) CTANZ = -CDSIN(ZI)/CDCOS(ZI)
IF (N .LT. 0) CTANZ = CDCOS(ZI)/CDSIN(ZI)
IF (N .GT. 0) CSECZ = 1./CDCOS(ZI)
IF (N .LT. 0) CSECZ = 1./CDSIN(ZI)
RR = CDSQRT(1.00-TMM*Z*Z/(RD*RD*A*A))
F = DFS/TMM/TMM*(1.-DMACH*RR)**2 + Z*CTANZ
P = RD*RD*A*A*TMM
P = 2.00*DFS*(1.00-DMACH*RR)*DMACH/RR*Z/P
P = P + CTANZ - Z*CSECZ*CSECZ
CARP = CCABS(P)
IF (CARP .LT. 1.E-40) GO TO 180
Z = Z - F/P*.700
IF (S(1) .GE. 0.00 .AND. S(2) .GE. 0.00) GO TO 16
I = I + 1
IF (I .GT. 5) GO TO 180
Z = Z + F/P*.500
IF (S(1) .LT. 0.00 .OR. S(2) .LT. 0.00) GO TO 180

```

```

16 IF (DABS(7R-S(1)) .LT. 1.D-6 .AND. DABS(ZI-S(2)) .LT. 1.D-6)G
91 CONTINUE
GO TO 180
99 CONTINUE
100 7R = S(1)/A
ZI = S(2)/A
AL = RD*RD - TMM*(7R*7R - ZI*ZI)
R = TMM*(2.*7R*ZI)
NR = NR + 1
DB(NR) = R.6RDC* DSORT(.5DC*DABS(DSQRT(AL*AL+R*R)-AL))/TMM*2.5
ZRT(NR) = Z
NN(NR) = N
180 CONTINUE
DO 50 J = 1,NP
DO 40 I = 1,NR
IF (DB(I) .LT. DBS) IS = I
40 IF (DB(I) .LT. DBS) DBS = DB(I)
DBN(J) = DBS
DBS = 1.E10
ZS(J) = ZRT(IS)
NS(J) = NN(IS)
50 DB(IS) = 1.E20
NR00T = NR
RETURN
END

```

```

SUBROUTINE NRAPH (FSMAL,7S,ZF,N)
COMPLEX*8 FSMAL,7S,7F
COMPLEX*16 Z,F,P,CTANZ,CSECZ
REAL*8 RZ,7I,H(2)
EQUIVALENCE (Z,H(1))
Z = ZS
J = 0
DO 30 I=1,100
RZ = H(1)
ZI = H(2)
IF (DABS(RZ) .GT. 3.5371D+15 .OR. DABS(ZI) .GT. 174.67D0) GO TO 22
IF (N .GT. 0) CTANZ = - CDSIN(Z)/CDCOS(Z)
IF (N .LT. 0) CTANZ = CDCOS(Z)/CDSIN(Z)
IF (N .GT. 0) CSECZ = 1./CDCOS(Z)
IF (N .LT. 0) CSECZ = 1./CDSIN(Z)
F = FSMAL + Z*CTANZ
P = CTANZ - Z*CSECZ*CSECZ
IF (CDABS(P) .LT. 1.0-40) GO TO 22
Z = Z - F/P
IF (H(1) .GE. 0.000 .AND. H(2) .GE. 0.000) GO TO 16
J = J + 1
IF (J .GT. 6) GO TO 22
Z = Z + F/P*.500
IF (H(1) .LT. 0.000 .OR. H(2) .LT. 0.000) GO TO 22
16 IF(DABS(RZ-H(1)).LT.1.0-6.AND.DABS(ZI-H(2)).LT.1.0-6) GO TO 21
30 CONTINUE
C
22 ZF = CMPLX(1.F20,0.0)
RETURN
21 ZF = Z
IF (H(1) .LT. 1.0-9 .AND. H(2) .LT. 1.0-9) ZF = CMPLX(1.F20,0.0)
RETURN
END

```

REPRODUCIBILITY OF THE  
ORIGINAL PAGE IS POOR

```

SUBROUTINE HWDBS (R,DR,N,AM,FRQ,C,M,DHS,DHH,FSMAL,H,FS)
COMPLEX FSMAL,R,FS
COMPLEX*16 Z,F,P,CTANZ,CSECZ,BR,DFS
REAL*9 RZ,ZI,S(2),A,RK,PI,YK,TMM,DAM,AL,B
EQUIVALENCE (Z,S(1))
A = DHS*2.54/H
PI = 3.1415926536
RK = 2.00*PI*FRQ/C
DAM = AM
YK = PI*(M-1)/DHH/2.54
DFS = FSMAL
DR = 0.0
Z = R
IF ( S(1) .GE. 1.020) RETURN
R = CMPIX(1.F20,0.0)
TMM = 1.00 - DAM*DAM
IF (AM .EQ. 0.0) GO TO 100
J = 0
DO 91 K = 1,100
RZ = S(1)
ZI = S(2)
IF (DABS(RZ) .GT. 3.F371015 .OR. DABS(ZI) .GT. 174.6700) RETURN
IF (N .GT. 0) CTANZ = -CDSIN(Z)/CDCOS(Z)
IF (N .LT. 0) CTANZ = CDCOS(Z)/CDSIN(Z)
IF (N .GT. 0) CSECZ = 1./CDCOS(Z)
IF (N .LT. 0) CSECZ = 1./CDSIN(Z)
BR = CDSQRT(1.00-TMM/RK/RK*(Z*Z/A/A + YK*YK))
F = DFS/TMM/TMM*(1.00 - DAM*BR)**2
FS = F
F = F + Z*CTANZ
P = RK*RK*A*A*TMM
P = 2.00*DFS*(1.00-DAM*BR)*DAM/BR*7/P
P = P + CTANZ - Z*CSECZ*CSECZ
IF (CDABS(P) .LT. 1.0-40) RETURN
Z = Z - F/P
IF (S(1) .GE. 0.00 .AND. S(2) .GE. 0.00) GO TO 16
J = J + 1
IF (J .GT. 6) RETURN
Z = Z + F/P*.500
IF (S(1) .LT. 0.00 .OR. S(2) .LT. 0.00) RETURN
16 IF (DABS(RZ-S(1)).LT.1.0-6 .AND. DABS(ZI-S(2)).LT.1.0-6) GO TO 91
91 CONTINUE
RETURN
100 ZR = S(1)/A
ZI = S(2)/A
R = Z
AL = RK*RK - TMM*(7P*7P - ZI*ZI + YK*YK)
R = -TMM*(2.*7P*ZI)
DR = 8.6800*DSQRT(.500*DABS(DSQRT(AL*AL+R*R)-AL))/TMM*2.54
RETURN
END

```



```

SUBROUTINE RORDER (AM,AK,G,MCUX,Z,NN,DP)
COMPLEX*8 Z(21),ZK(21),ZNR(21),ZKNR(21),Z1
DIMENSION NN(14),NNR(14),DB(14)
WRITE (6,1)
DO 10 I = 1,MCUX
Z1 = AK*AK - (1.-AM*AM)*Z(I)*Z(I)/G/G
10 ZK(I) = -AM*AK + CSORT(Z1)
DO 30 J = 1,MCUX
BIG = -1.E20
DO 20 K = 1,MCUX
IF (REAL(ZK(K)) .LT. BIG) GO TO 20
BIG = REAL(ZK(K))
KS = K
20 CONTINUE
ZNR(J) = Z(KS)
ZKNR(J) = ZK(KS)
DB(J) = -2.54*8.68*AIMAG(ZK(KS))
NNR(J) = NN(KS)
30 ZK(KS) = CMPLX(-1.E25,0.0)
DO 40 L = 1,MCUX
Z(L) = ZNR(L)
ZK(L) = ZKNR(L)
NN(L) = NNR(L)
40 WRITE (6,2) Z(L),ZK(L),DB(L)
RETURN
1 FORMAT ('1 Z,KZ,DB FROM SUBROUTINE RORDER')
3 FORMAT ('0',1P5F14.5)
END

```

```

SUBROUTINE PORDER (AM,AK,G,MCUX,Z,NN,DB)
COMPLEX*8 Z(21),ZK(21),ZNR(21),ZKNR(21),Z1
DIMENSION NN(14),NNR(14),DB(14)
WRITE (6,1)
DO 10 I = 1,MCUX
Z1 = AK*AK -(1.-AM*AM)*Z(I)*Z(I)/G/G
10 ZK(I) = (-AM*AK + CSQRT(Z1))/(1.0 - AM*AM)
DO 20 J = 1,MCUX
BIG = -1.E20
DO 20 K = 1,MCUX
IF (REAL(ZK(K)) .LT. BIG) GO TO 20
BIG = REAL(ZK(K))
KS = K
20 CONTINUE
ZNR(J) = Z(KS)
ZKNR(J) = ZK(KS)
DB(J) = -2.54*8.68*AIMAG(ZK(KS))
NNR(J) = NN(KS)
30 ZK(KS) = CMPLX(-1.E25,0.0)
DO 40 L = 1,MCUX
Z(L) = ZNR(L)
ZK(L) = ZKNR(L)
NN(L) = NNR(L)
40 WRITE (6,3) Z(L),ZK(L),DB(L)
RETURN
1 FORMAT ('1 Z,KZ,DB FROM SUBROUTINE PORDER')
3 FORMAT ('0',1P5E14.5)
END

```

TWO WALLS LINED POLYIMIDE

99	NUMBER OF SPLIS
8	MAXIMUM NUMBER OF SOFT WALL MODES CONSIDERED
3	MAXIMUM NUMBER OF HARD WALL MODES CONSIDERED
2.000000	NUMBER OF WALLS LINED
135.000000	UNIFORM SPL
1.000000	RMS PARTICLE VELOCITY
0.0	REORDER OPTION
0.0	OVERRIDE MODE OPTION
12.000000	TOTAL DUCT LENGTH
4.000000	INCREMENT LENGTH
12.000000	HARD WALL DUCT HEIGHT
1.400000	GAS CONSTANT
520.000000	TOTAL TEMPERATURE
15.000000	TOTAL PRESSURE
2000.000000	LOWEST FREQUENCY CONSIDERED
4000.000000	HIGHEST FREQUENCY CONSIDERED
1.000000	MODEL SELECTOR
0.0	MACH NUMBER
0.0	SOFT WALL DUCT HEIGHT
6.000000	NUMBER OF POLYIMID PLYS
0.500000	BACKING SPACE

REPRODUCIBILITY OF THE  
ORIGINAL PAGE IS POOR

MACH NUMBERS

0.190000      0.200000      0.220000

SOFT WALL DUCT HEIGHTS

5.759999      6.000000      6.200000

DB DIFFERENCE AFTER 4.00 INCHES OF LINING

2000.	2.60
2100.	4.09
2200.	4.30
2300.	4.60
2400.	4.98
2500.	5.43
2600.	5.92
2700.	6.46
2800.	7.04
2900.	7.63
3000.	8.15
3100.	8.91
3200.	8.53
3300.	8.21
3400.	7.93
3500.	7.65
3600.	7.33
3700.	6.98
3800.	6.62
3900.	6.28
4000.	5.97

DB DIFFERENCE AFTER 8.00 INCHES OF LINING

2000.	4.93
2100.	7.10
2200.	7.78
2300.	8.55
2400.	9.44
2500.	10.41
2600.	11.46
2700.	12.54
2800.	13.64
2900.	14.72
3000.	14.88
3100.	14.02
3200.	12.60
3300.	11.59
3400.	10.82
3500.	10.21
3600.	9.68
3700.	9.20
3800.	8.76
3900.	8.36
4000.	7.99

DB DIFFERENCE AFTER 12.00 INCHES OF LINING

2000.	7.03
2100.	9.68
2200.	10.80
2300.	12.05
2400.	13.43
2500.	14.94
2600.	16.52
2700.	18.04
2800.	19.53
2900.	20.79
3000.	19.89
3100.	17.62
3200.	15.48
3300.	14.01
3400.	12.91
3500.	12.05
3600.	11.35
3700.	10.76
3800.	10.24
3900.	9.78
4000.	9.36

FREQUENCIES	FINAL SPECTRUM			
2000 TO 2300	127.97	125.32	124.20	122.95
2400 TO 2700	121.57	120.06	118.48	116.96
2800 TO 3100	115.47	114.21	115.11	117.38
3200 TO 3500	119.52	120.99	122.09	122.95
3600 TO 3900	123.65	124.24	124.76	125.22
4000 TO 4000	125.64			

DB DIFFERENCES (SMOOTHED) AFTER 12.00 INCHES OF LINING

8.35	10.24	11.42	12.74	14.18
15.73	17.28	18.79	20.16	20.34
18.75	16.55	14.75	13.46	12.48
11.70	11.05	10.50	10.01	9.57

**APPENDIX IV**  
**PROGRAM FLOW CHART**

**MAIN PROGRAM**

\*\*\*\*\* NOISE SUPPRESSION - MULTIMODE ANALYSIS - 2 PPM \*\*\*\*\*  
 SINGLE LINEAR POLYNOMIAL BY PEAF SHEET 2081730 8-28-71  
 VARIABLE CHARACTERISTICS ALONG DUCT LENGTH

CALL INPUT  
 I = 0  
 JOL = 1  
 RMS = RMS  
 GO TO 40

C GO TO 40

SS X = X + BL  
 JOL = JOL + 1

IF WASH .NE. 0.0  
 WH = WH (JOL)

IF WMS .NE. 0.0  
 WS = WS (JOL)

IF WPA .NE. 0.0  
 PA = PA (JOL)

IF WD .NE. 0.0  
 D = WD (JOL)

IF WDR .NE. 0.0  
 DR = DR (JOL)

IF TH .NE. 0.0  
 TH = TH (JOL)

IF THK .NE. 0.0  
 THK = THK (JOL)

IF WASH .EQ. 0.0  
 GO TO 40

PS = PT / 11.0 + 15 - 1.01 \* WASH / 2.01 \* WIG / 16 - 1.01  
 TSP = TT / 11.0 + 15 - 1.01 \* WASH / 2.01  
 IS = 273.15 \* C / 2.73 + 1.69  
 C = 33145.0 \* IS / 273.15  
 RB = 273.15 / TSP \* 1.0132566 \* 1.289E-36 \* 60M7.  
 PC = RB \* C

40 CALL ATNSPL

50 50 J = LON, JUP

50 000 (J) = 0 SPL (J) - SPL (J)

WRITE (6, 5) X  
 WRITE (6, 7) (CFM (J), 000 (J), J=LON, JUP)  
 WRITE (6, 5) Y  
 WRITE (6, 7) (CFM (J), 000 (J), J=LON, JUP)

IF RMS .GT. 0.1  
 GO TO 38

(1A)



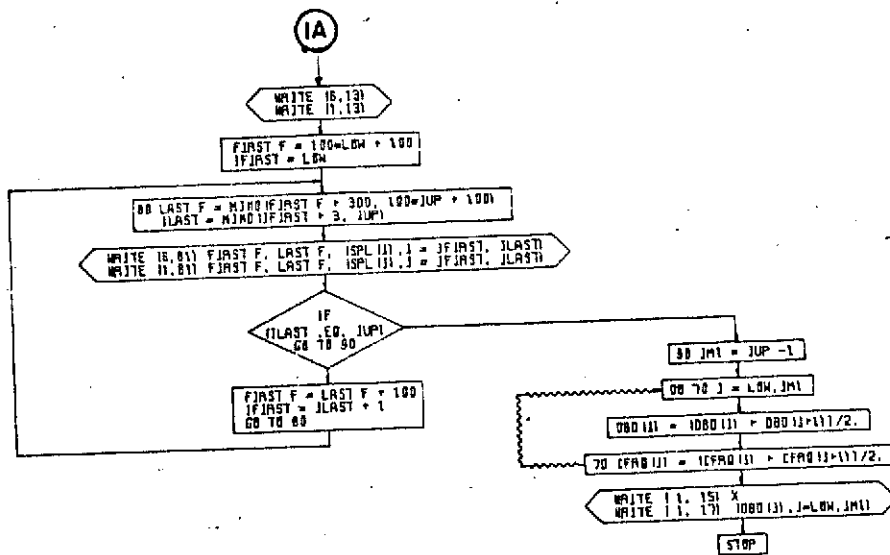

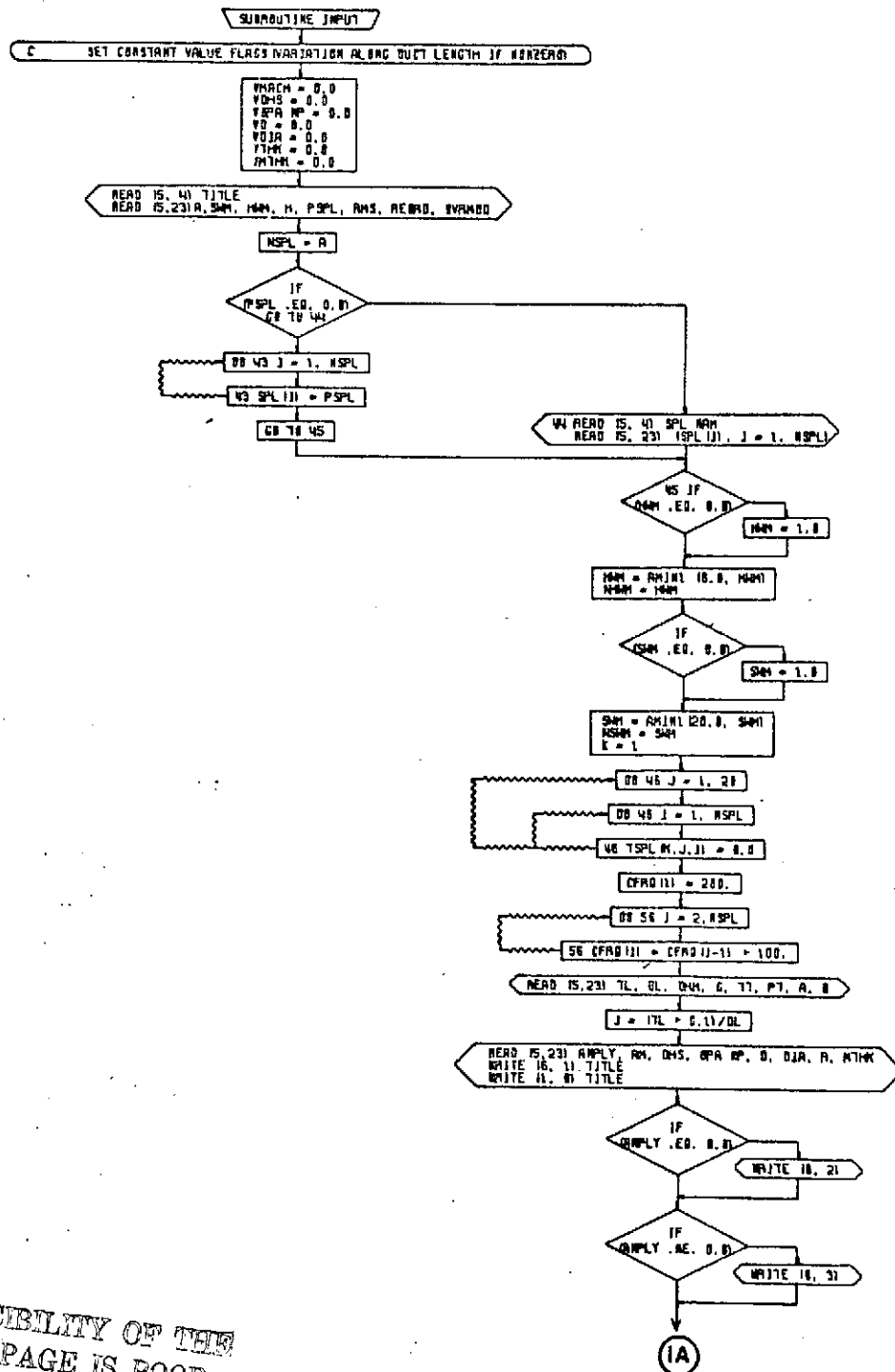

REPRODUCIBILITY OF THE ORIGINAL PAGE IS POOR.

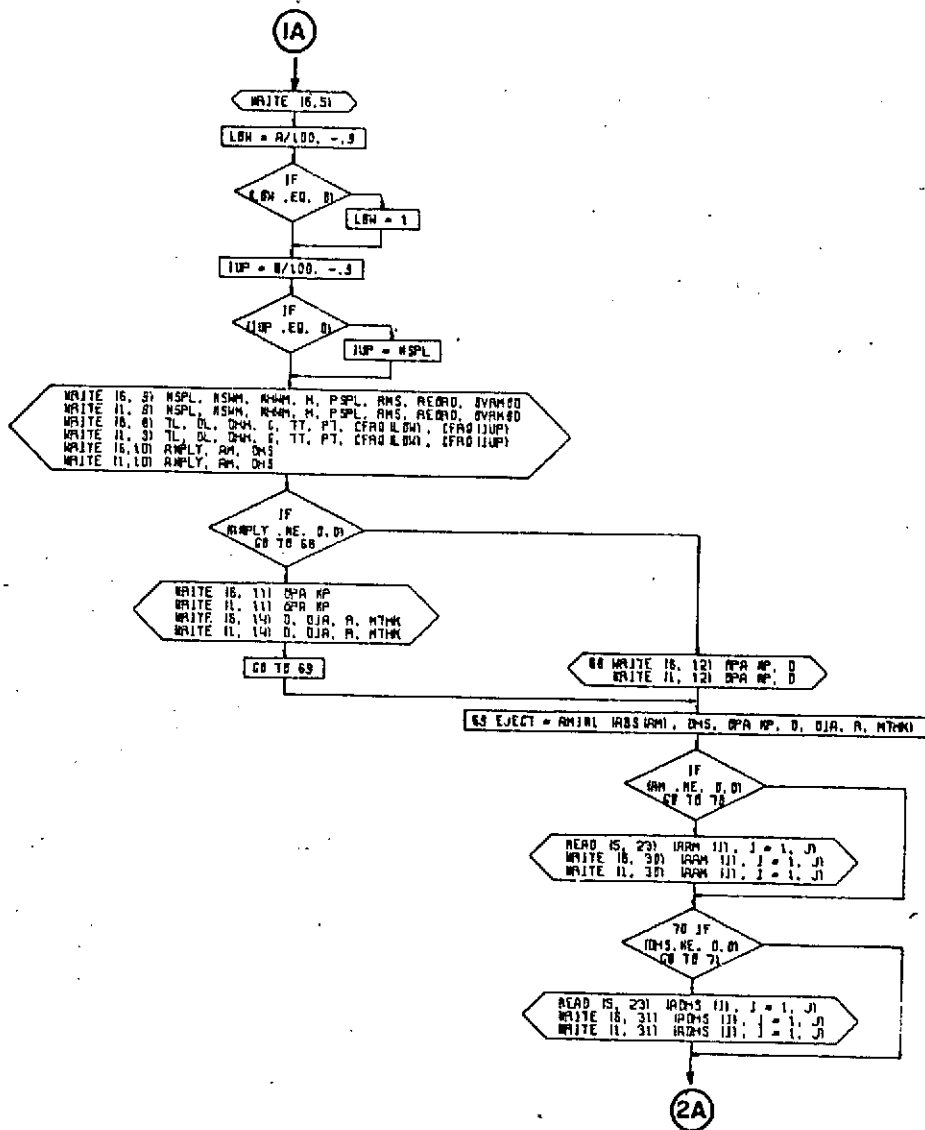

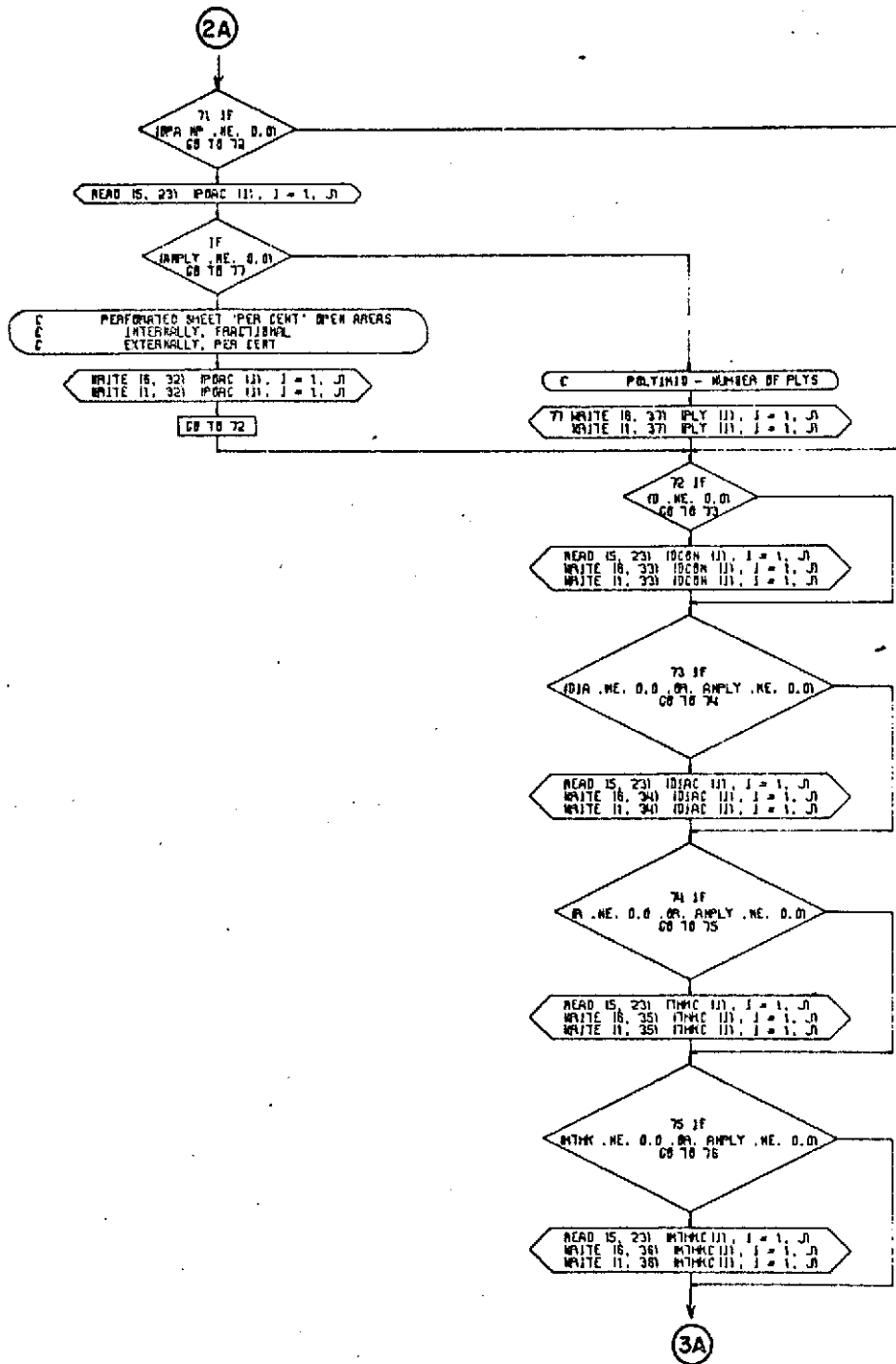

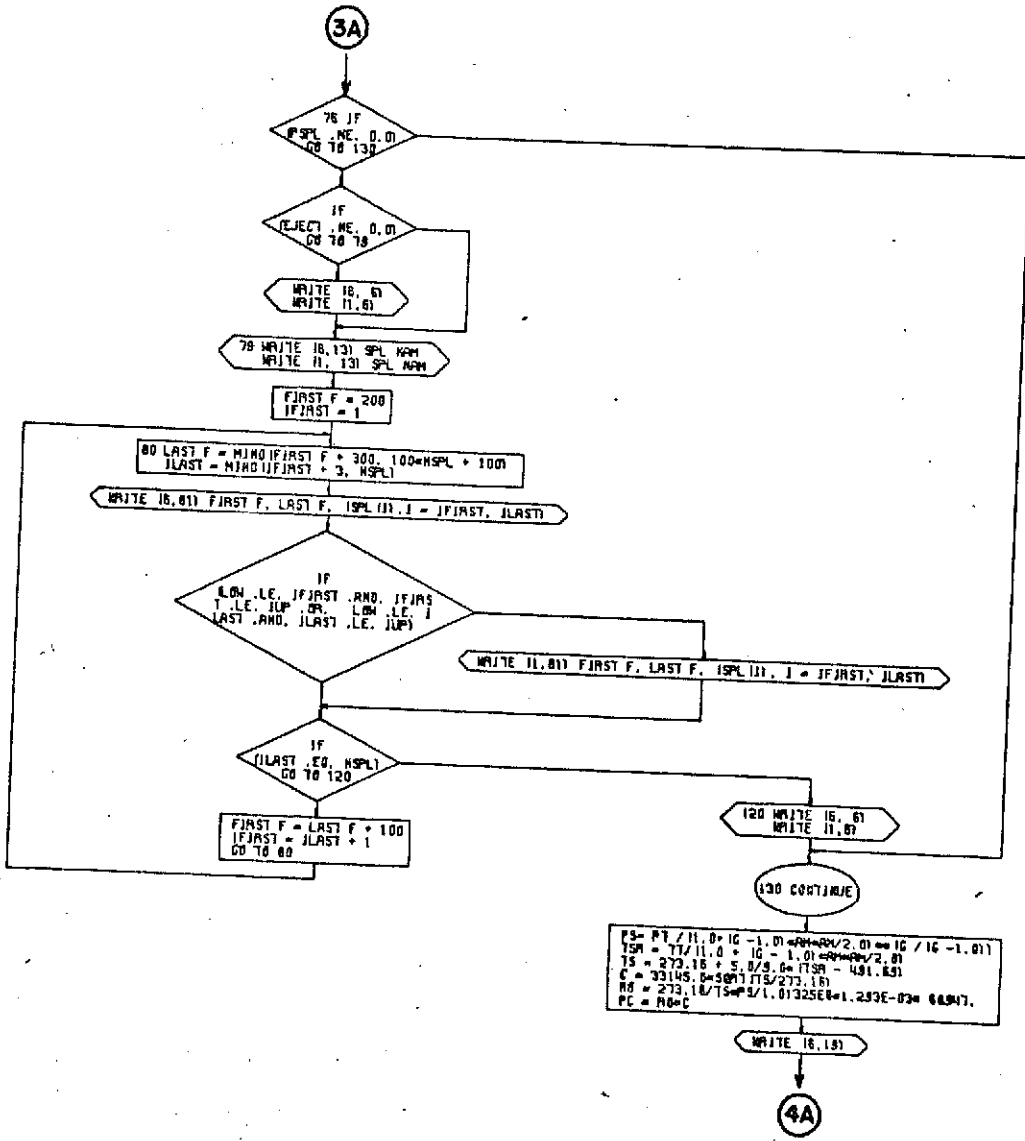

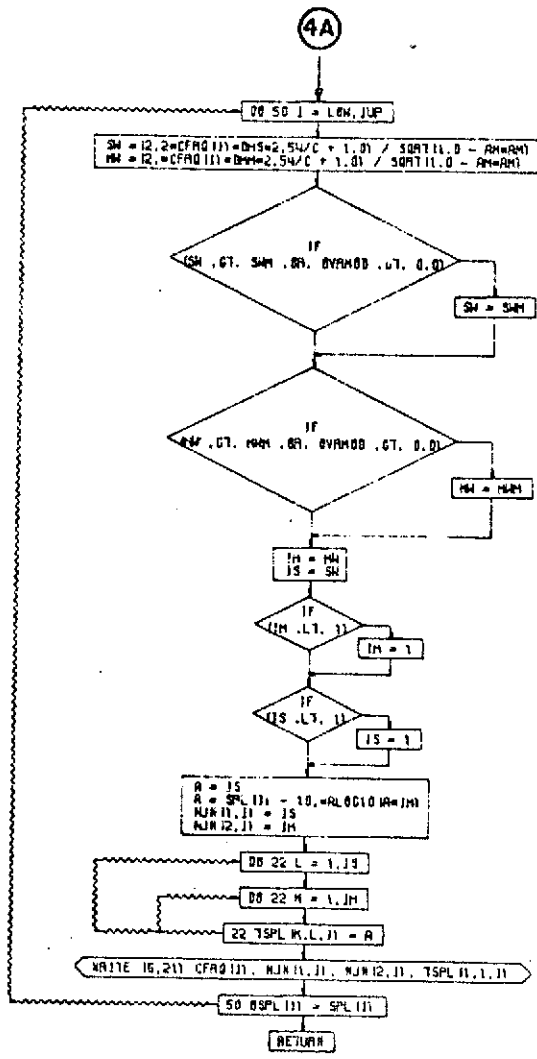

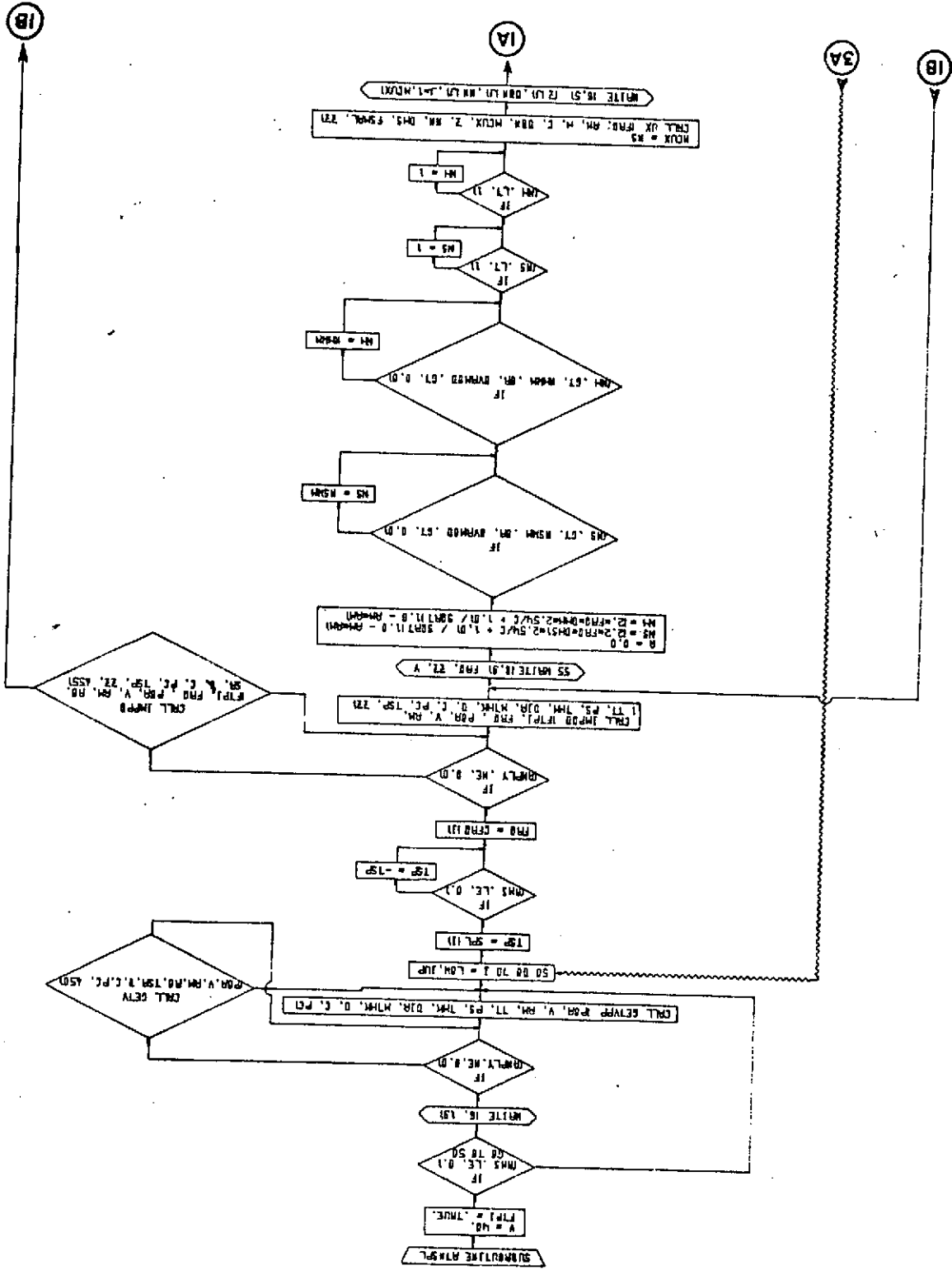

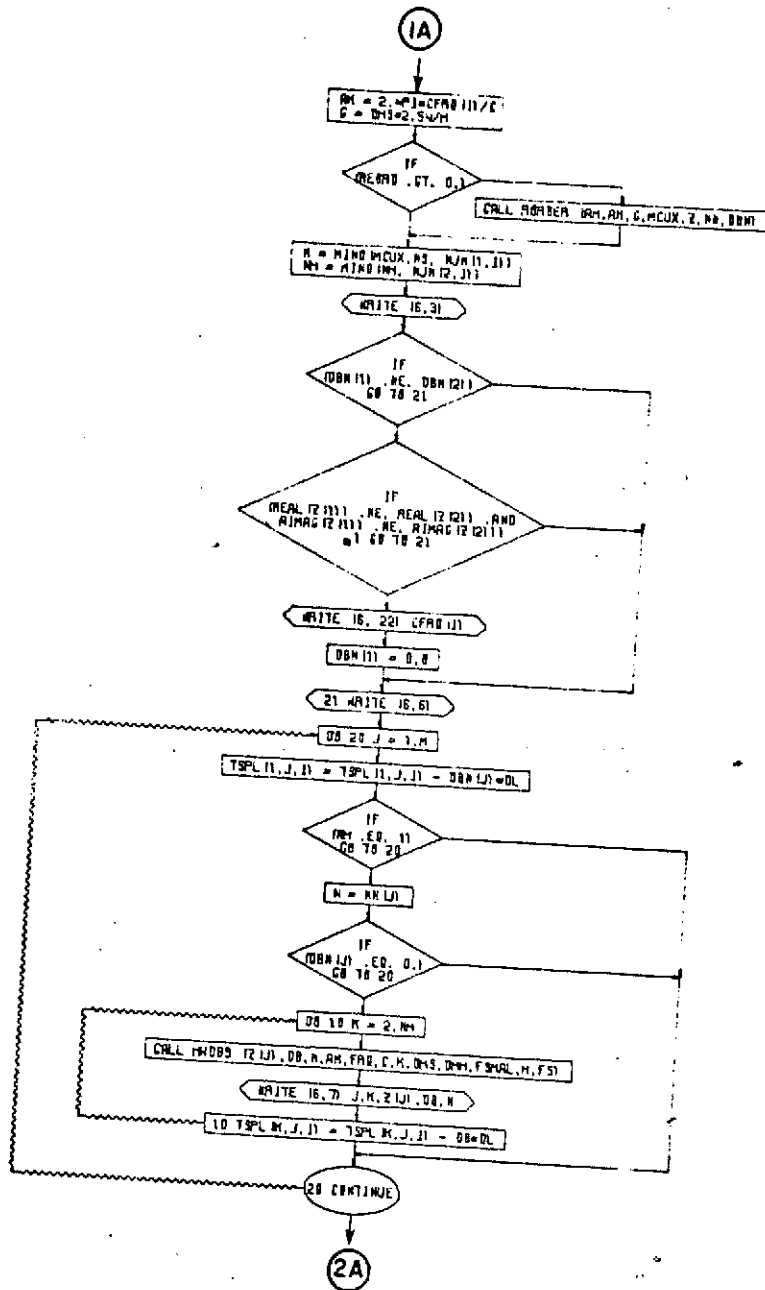

REPRODUCIBILITY OF THE ORIGINAL PAGE IS POOR



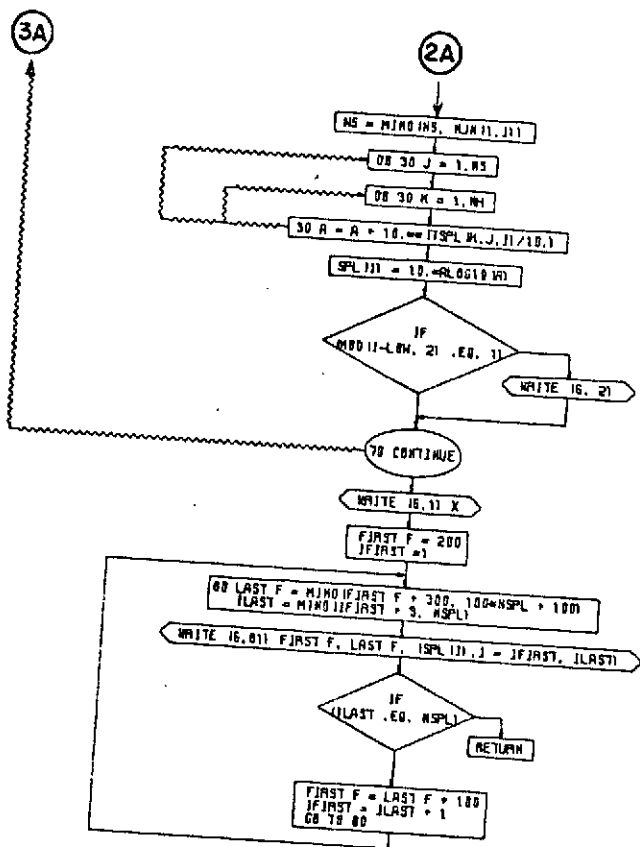

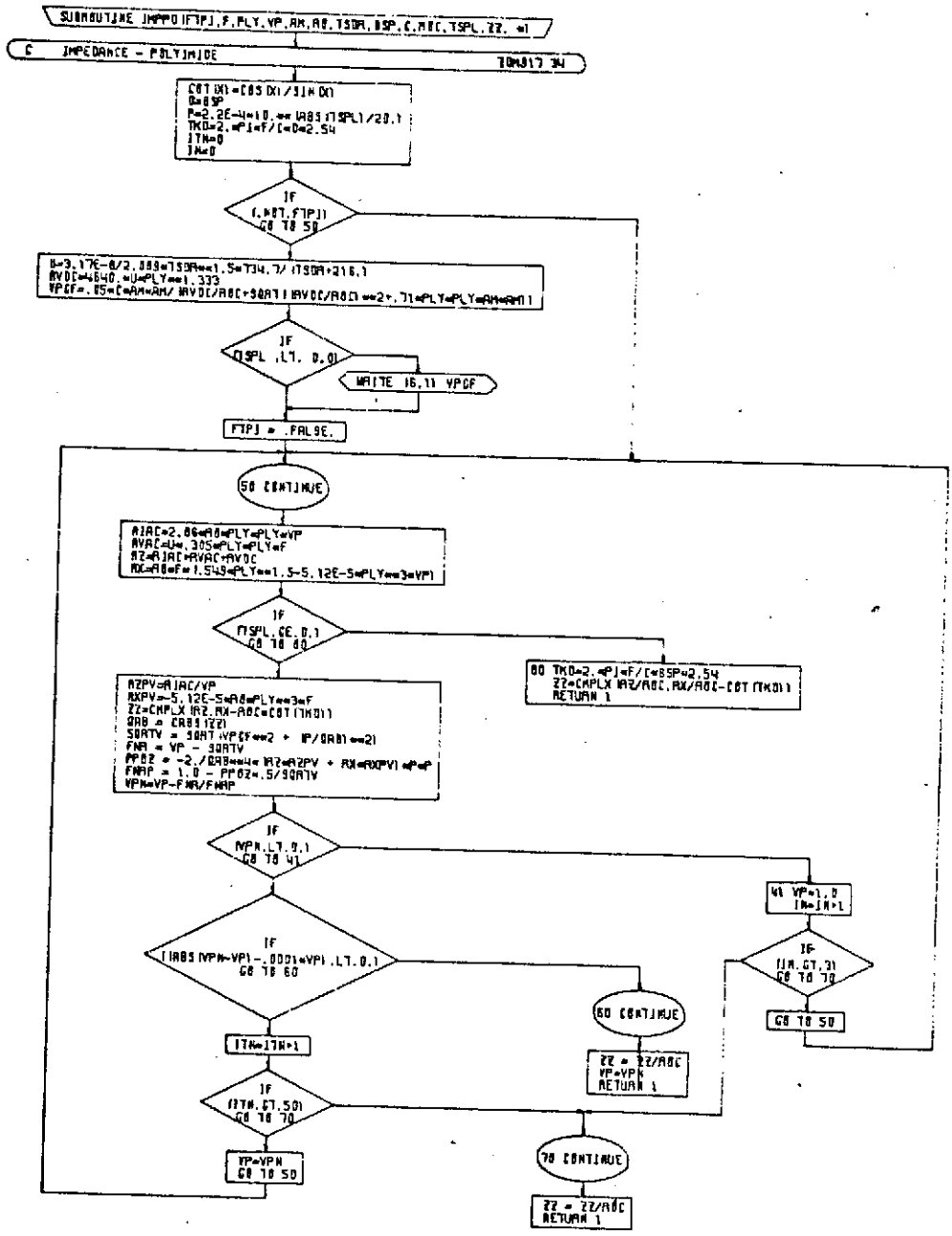

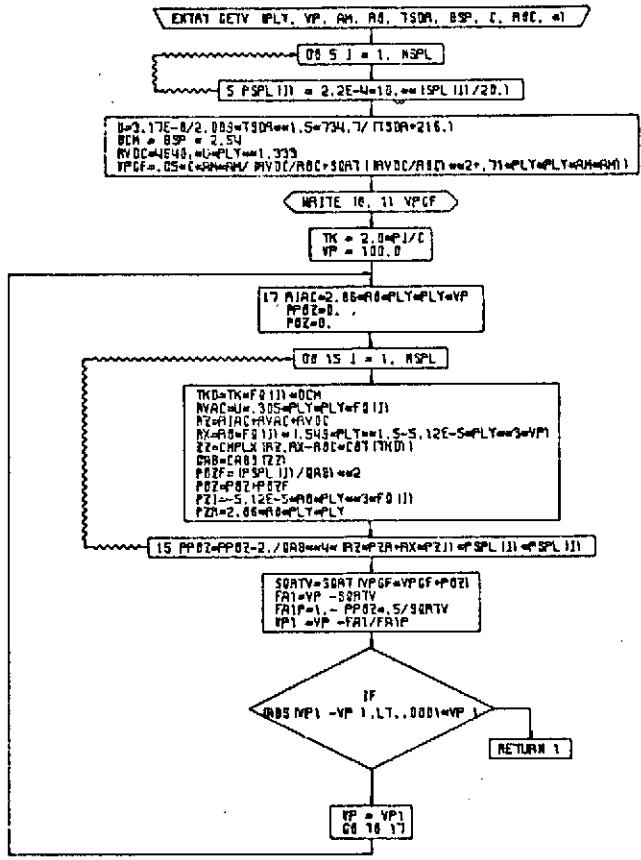

SUBROUTINE IMP00 IFTPI, F, PBA, VP, AM, TT, PS, TH, DJA, HTH, BSP, C,  
 IASC, ISPL, ZI

C IMPERANCE - PERFORATED SHEET 20M917 33

COT (X) = (C85 (X)) / SJM (X)  
 P = 2.2E-4 \* 10.0 \* IRB5 IT SPLI / 20.1  
 TH = 2. \* F / C \* BSP = 2.54  
 IASC = 0

IF (.NOT. IFTPI)  
 GO TO 50

TH = TT / 513  
 PP2 = (1/2) / SORT 2.1  
 DEL = P / 14.1  
 E = 1.025 \* (1. / PBA - 2 - 1) / PBA \* 1 / EXP 1.5072 \* TH / DJA  
 NYDC = (0.7) \* TH / DEL / PBA \* TH \* TH \* 1.416  
 NY2 = NYDC / 2.  
 VP = 1.025 \* .855 \* DJA / HTH \* (C \* AM \* VP / NY2 + SORT NY2 \* 2 + 1.025 \* .855 \* DJA /  
 IHTH) \* C \* AM \* HTH  
 Z = 0.5

IF (ISPL .LT. 0.0)  
 WRITE 16, 11 VPCF

IFTPI = .FALSE.

50 CONTINUE

SN = 2.54 \* DJA \* F \* PBA / VP  
 A JAC = PP2 \* VP / C \* E \* EXP - 1.6 \* SN \* SN  
 NYAC = 3.83E-5 \* TH \* 75 \* SORT IFTPI \* TH \* DJA \* 1. - PBA / PBA \* SORT IDEL = TH  
 \* 1.416  
 NZ = NYAC \* NYDC \* NYDC \* AOC  
 DLT = .85 \* DJA \* 1. - 7 \* SORT PBA \* 1 - 1.2E-5 / PBA \* VP

IF (DLT .LT. 0.)  
 DLT = 0.

RX = 4.83E-4 / PBA \* F / SORT IHTH \* TH \* DLT \* AOC

IF (ISPL .GE. 0.)  
 GO TO 60

RZPV = NYAC / VP \* 11. \* 3.6 \* SN \* SN \* AOC  
 RXPV = RX / TH \* DLT \* 1.2E-5 / PBA

60 THD = 2. \* F / C \* BSP = 2.54  
 ZZ = CMPLX NY2 / AOC, RX / AOC - COT THD  
 RETURN

IF (DLT .EQ. 0.0)  
 RXPV = 0.0

ZZ = CMPLX NY2, RX - AOC \* COT THD  
 ORB = CABS ZZ  
 SORTV = SORT (VPCF \* 2 + IP / ORB) \* 2  
 FNA = VP - SORTV  
 PPBT = -2. / ORB \* NY2 \* RZPV \* RX \* RXPV \* F \* P  
 FNP = 1.0 - PPBT \* 5 / SORTV  
 VPA = VP - FNP / FNP

IF (VPA .LT. 0.1)  
 GO TO 41

IF (IRB5 VPA - VPI - 0.001 \* VPI) .LT. 0.1  
 GO TO 60

JTH = JTH + 1

IF (JTH .GT. 50)  
 GO TO 70

VP = VPA  
 GO TO 50

41 VP = 1.0  
 JH = JH + 1

IF (AM .NE. 0.0)  
 VP = VPCF + 1.0

IF (JH .GT. 3)  
 GO TO 50

50 CONTINUE

ZZ = ZZ / AOC  
 RETURN

70 CONTINUE

WRITE 16, 11 JH, JTH

ZZ = ZZ / AOC  
 RETURN

QUALITY OF THE  
 ORIGINAL PAGE IS POOR

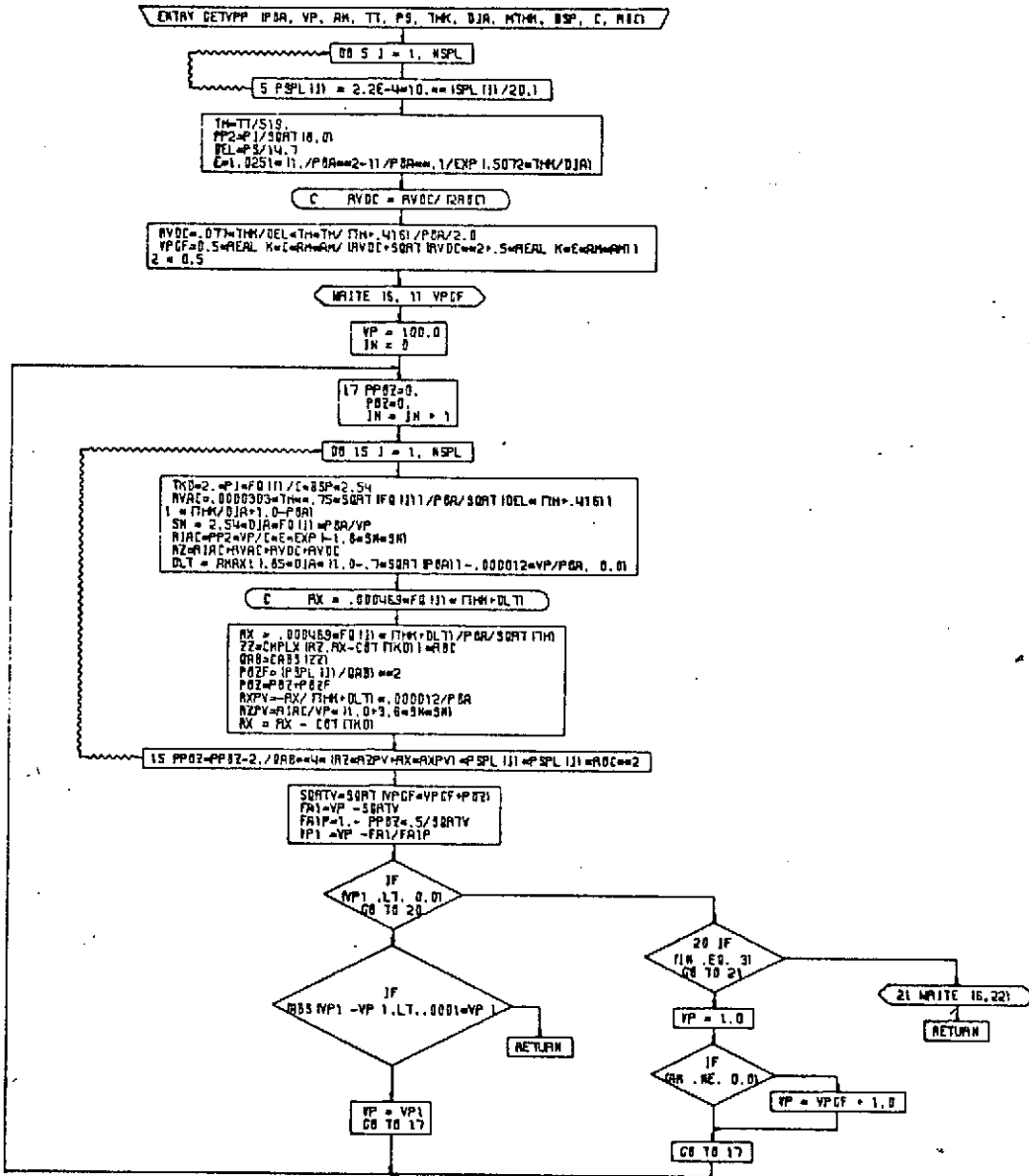

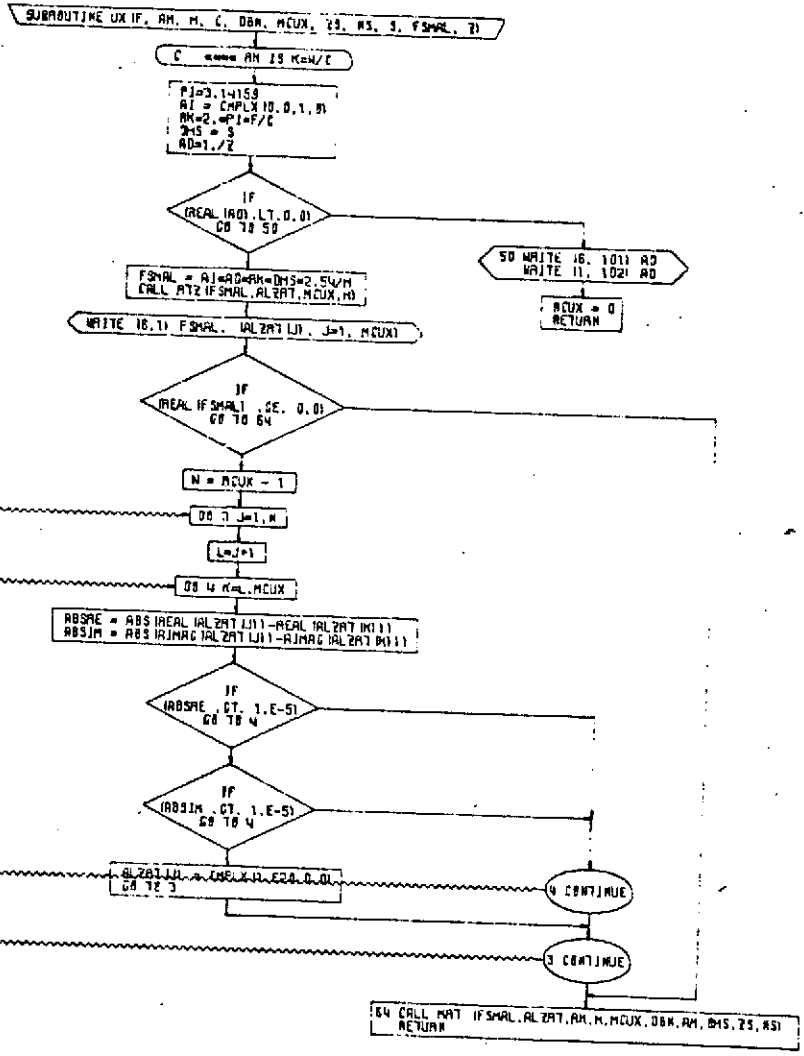

REPRODUCIBILITY OF THIS ORIGINAL PAGE IS POOR

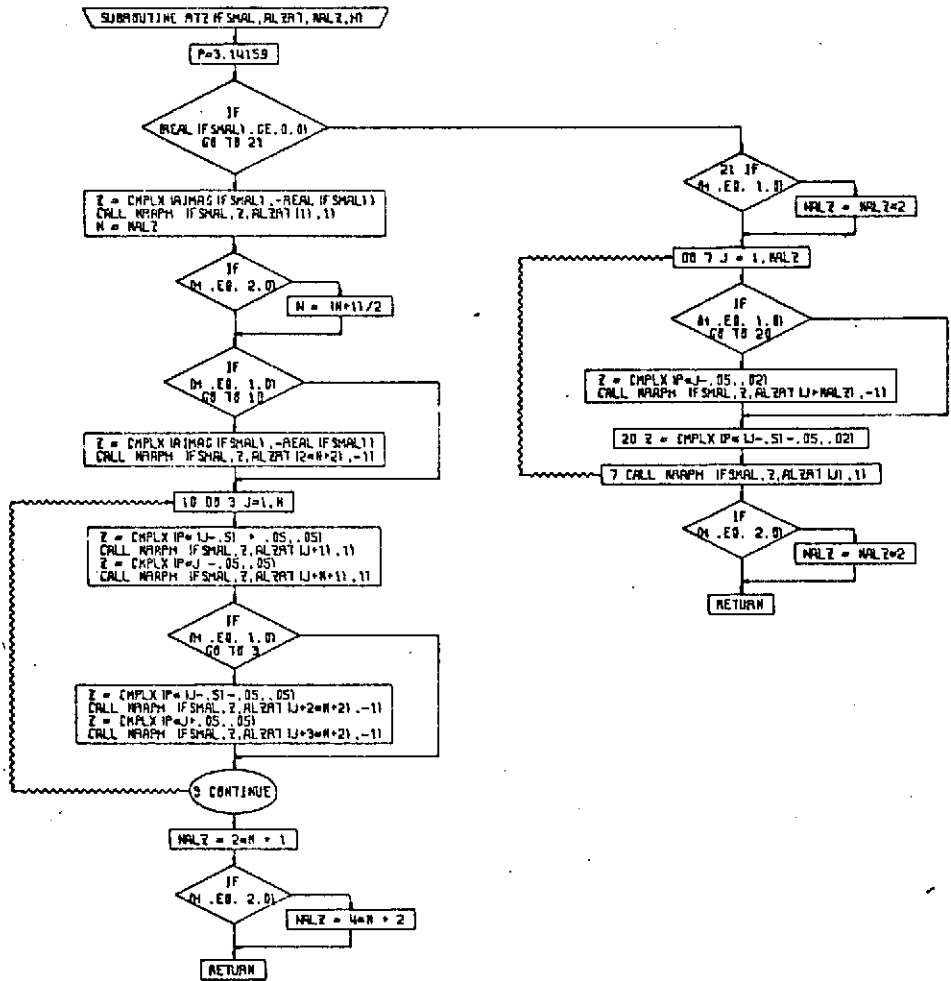

SUBROUTINE PART1 IF SPAL, TAT, AM, M, WABST, DAM, AM, DMS, ES, NSI

$ZBS = 1.00$   
 $A = DMS * 2.54 / M$   
 $AD = AM$   
 $DF3 = 7 * SPAL$   
 $LM = M$   
 $MARCH = ABS(IAM) / .05 * 1.0$   
 $DAM = AM / MARCH$   
 $NA = 0$

DO 100 L = 1, WABST

$CB(L) = 0.0$   
 $Z = ZAT(L)$   
 $SLC = S(L)$

IF (SLC .GE. 1.E20)  
GO TO 100

$TAN = 1.00$   
 $ZPT(L) = COMPLX(1.E20, 0.0)$   
 $DMARCH = 0.00$   
 $N = 1$

IF (LM .GT. WABST)  
N = -1

IF (IAM .EQ. 0.0)  
GO TO 100

DO 90 J = 1, MARCH

$DMARCH = DMARCH + DAM$   
 $I = 0$   
 $TAN = 1.00 - DMARCH * DMARCH$

DO 91 K = 1, 100

$ZK = S(K)$   
 $ZJ = S(J)$

IF (ABS(ZK) .GT. 3.4010 .OR.  
ABS(ZJ) .GT. 174.00)  
GO TO 100

IF (M .GT. 0)  
CTANZ = -EDSIN(Z) / CDCOS(Z)

IF (M .LT. 0)  
CTANZ = CDCOS(Z) / CBSIN(Z)

IF (M .GT. 0)  
CSECEZ = 1. / CDCOS(Z)

IF (M .LT. 0)  
CSECEZ = 1. / EDSIN(Z)

$BA = EDSIN(Z) * DO - TAN * Z / (RD * D * DAM)$   
 $F = DF3 * TAN / (TAN * (1. - DMARCH * BA) + 2 * CTANZ$   
 $P = RD * DAM * BA * TAN$   
 $P = 2.00 * DF3 * (1.00 - DMARCH * BA) * DMARCH * BA * Z / P$   
 $P = P * CTANZ - 2 * CSECEZ * CSECEZ$   
 $CRAP = CDABS(P)$

IF (CRAP .LT. 1.E-40)  
GO TO 100

2A

2B

2C

1A

1B

REPRODUCIBILITY OF THE ORIGINAL PAGE IS POOR



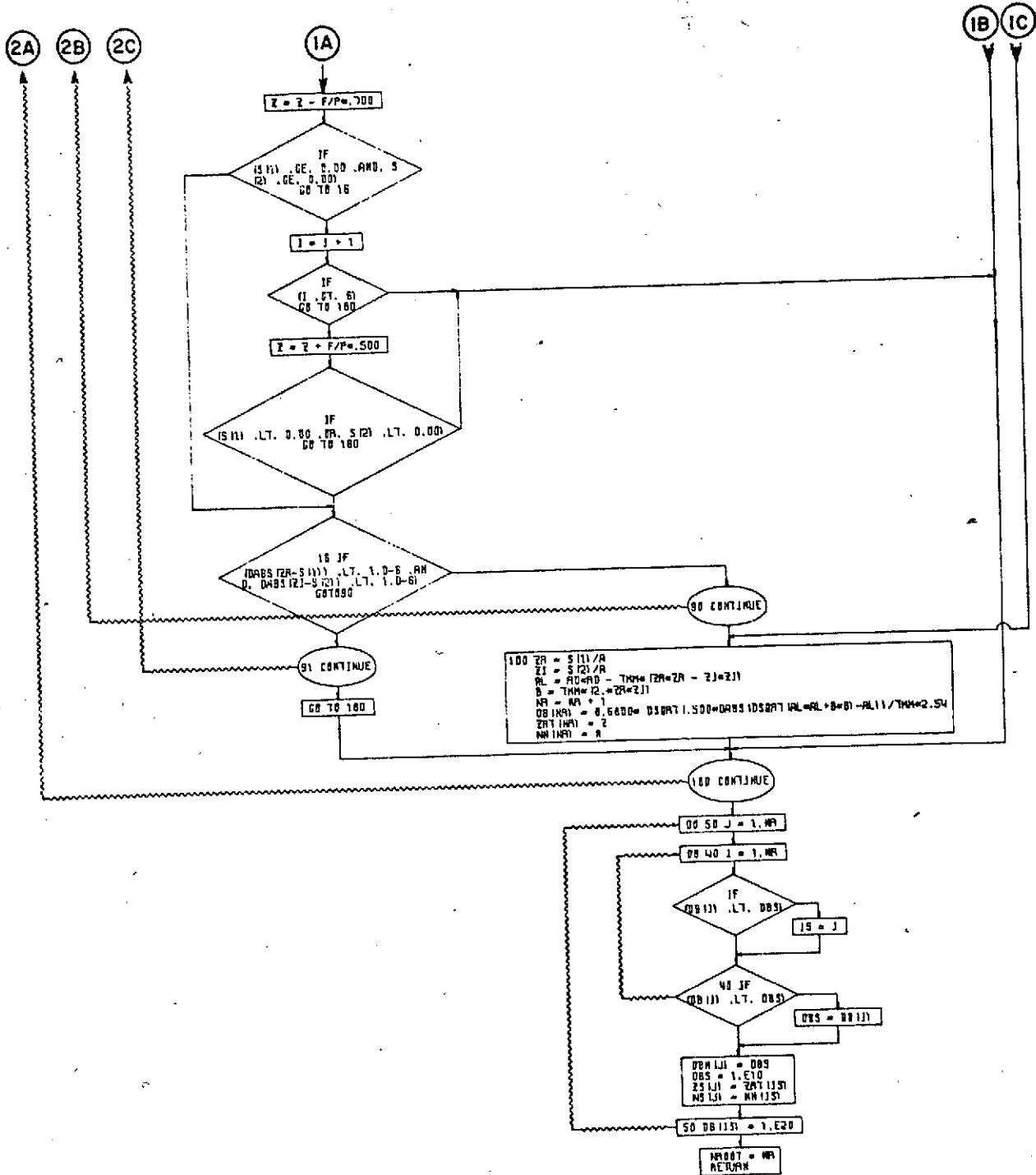

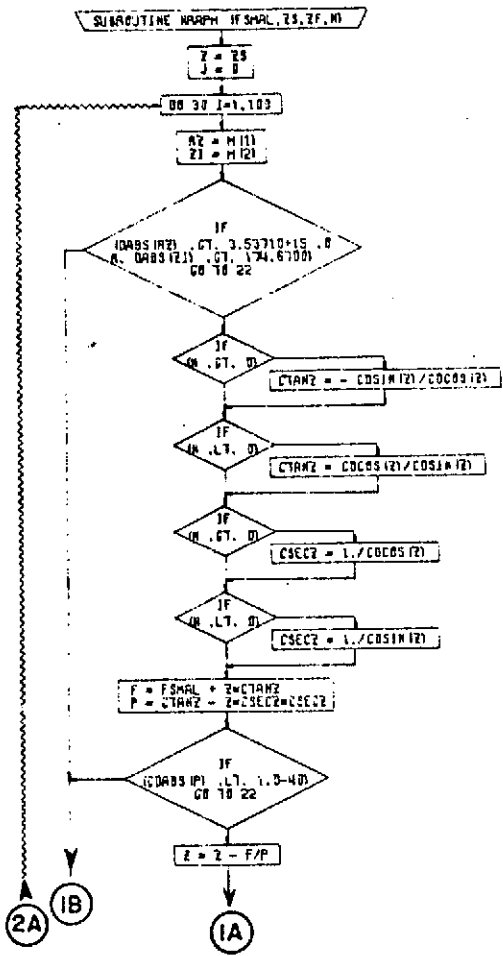

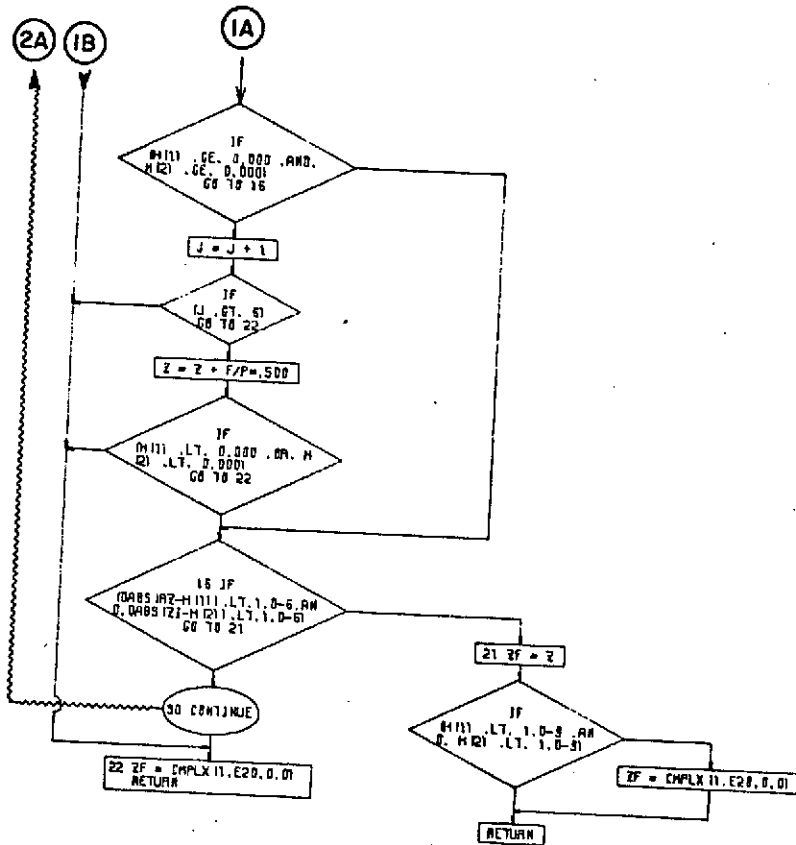

SUBROUTINE F4083 (R, DR, A, AM, FAZ, C, M, DMS, DM1, FSHAL, H, F3)

R = DMS/2.54/M  
 PI = 3.1415926536  
 MK = 2.00\*PI/FAZ/C  
 DRM = AM  
 TS = PI\*(M-1)/DM/2.54  
 F3 = FSHAL  
 DS = D.0  
 Z = R

IF (.S11) .GE. 1.0Z0  
 RETURN

Q = CMPLX(1.E20,0.0)  
 THN = 1.00 - DRM\*DM1

IF DRM .EQ. 0.0  
 GO TO 100

J = 0

DO 91 K = 1,100

RZ = S11  
 ZI = S12

IF (DABS(RZ) .GT. 3.5371015 .OR.  
 DABS(ZI) .GT. 174.6700)  
 RETURN

IF (M .GT. 0)  
 CTANZ = -CDOSIN(FZ)/CDCOS(FZ)

IF (M .LT. 0)  
 CTANZ = CDCOS(FZ)/COSIN(FZ)

IF (M .GT. 0)  
 CSECF = 1./CDCOS(FZ)

IF (M .LT. 0)  
 CSECF = 1./COSIN(FZ)

DR = CDOSRT(1.00-THN/AM/AM\*(Z+Z/A/R + YN\*YH))
 F = DS/THN/THN\*(1.00 - DRM\*DR) \*\*2  
 FS = F  
 F = F + Z\*CTANZ  
 P = AM\*AM\*AM\*AM\*THN  
 P = 2.00\*DS\*(1.00 - DRM\*DR) + DRM/AM\*Z/P  
 P = P \* CTANZ - Z\*CSECF\*CSECF

IF (DABS(P) .LT. 1.0-40)  
 RETURN

R = Z - F/P

2A

1A

1B

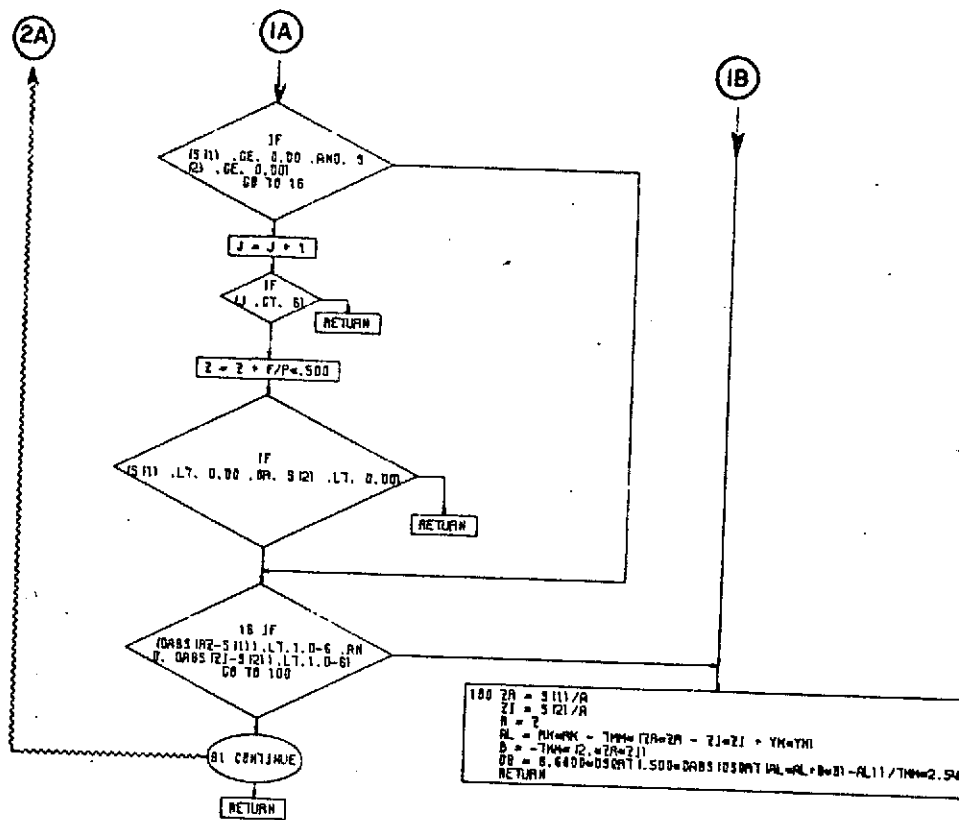

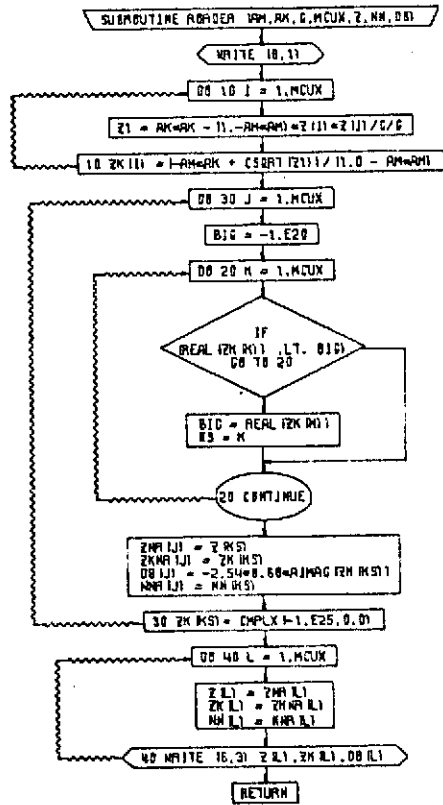

## 6.0 REFERENCES

1. Cremer, L., "Theorie der Luftschall - Dämpfung in Rechteckkanal mit Schluckender Wand und das sich Dabei Ergebende Höchste Dämpfungsmass," *Acustica* 3, 249-263 (1953)
2. Eversman, W., "The Effect of Mach Number on the Tuning of an Acoustic Lining in a Flow Duct," *J. Acoust. Soc. Am.* 48, 425-428 (1970)
3. Eversman, W., Nelsen, M. D., Armstrong, D., and Hall, O., "Theoretical and Experimental Analysis of Acoustic Linings for Ducts with Flow," AIAA Paper No. 71-731
4. Nelsen, M. D., Linscheid, L., Dinwiddie, B., and Hall, O., "Study and Development of Acoustic Treatment for Jet Engine Tailpipes," NASA CR-1853, November 1971
5. Armstrong, D., "Acoustic Grazing Flow Impedance Using Waveguide Principles." NASA CR-120848, December 1971
6. Rice, E., "A Model for the Acoustic Impedance of a Perforated Plate Liner with Multiple Frequency Excitation," NASA TM X-67950, October 1971
7. Eversman, W., "Effect of Boundary Layer on the Transmission and Attenuation of Sound in an Acoustically Treated Circular Duct," *J. Acoust. Soc. Am.* 49, 1372-1380 (1971)
8. Munger, P., and Plumblee, H.E., "Propagation and Attenuation of Sound in a Soft Walled Annular Duct Containing a Sheared Flow," NASA SP-207, 305-327 (1969)
9. "Handbook of Mathematical Functions," Applied Mathematics Series 55, June 1954