

COMMISSIONER'S COURT AGENDA

November 8, 2022

Invocation

Pledge of Allegiance to the Flag.

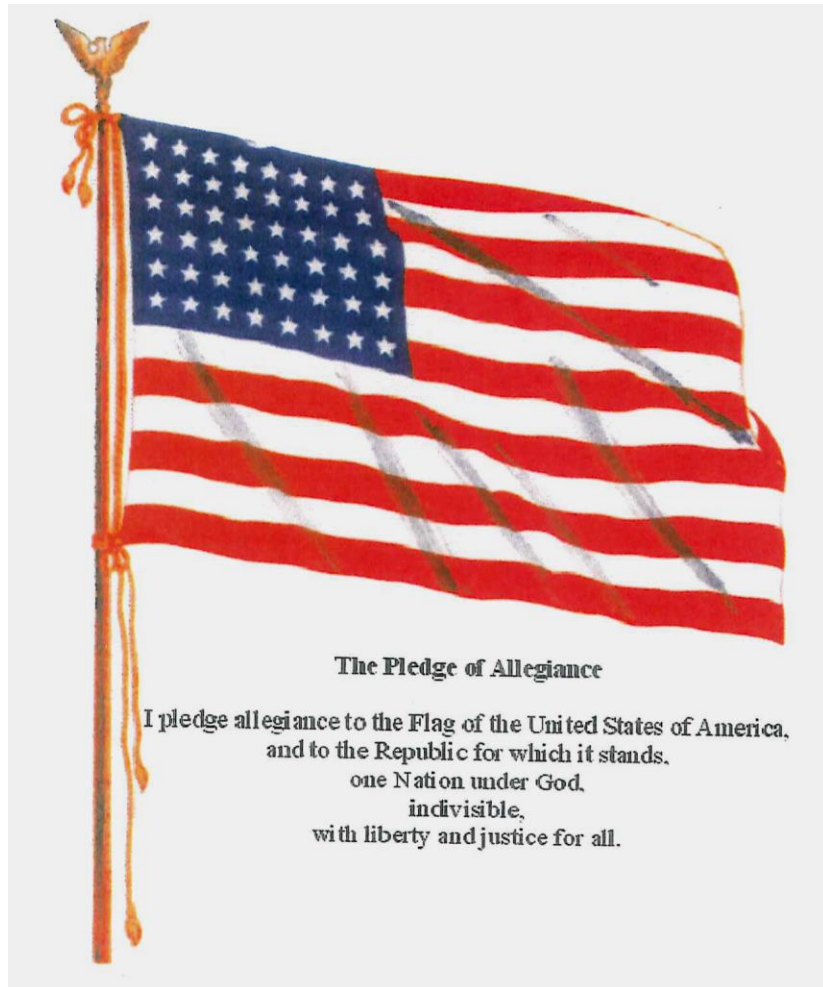

**(Texas Pledge: Honor the Texas flag;
I pledge allegiance to thee, Texas, one
state under God, one and indivisible).**

Pledge to the Texas Flag



Honor the Texas
Flag; I pledge
allegiance to thee,
Texas, one state
under God, one and
indivisible

Announcements:

**Items or comments from Court
Members or Staff.**

Citizens' Comments:

At this time any person may speak to Commissioners Court if they have filled out a Caldwell County Commissioners Court Participation Form. Comments will be limited to four (4) minutes per person. No action will be taken on these items and no discussion will be had between the speaker(s) and members of the Court. The Court does retain the right to correct factual inaccuracies made by the speakers. (If longer than 30 minutes, then the balance of comment will continue as the last agenda item of the day).

CONSENT AGENDA (The following consent items may be acted upon in one motion).

- 1. Approve payment of County invoices and County Purchase Orders: \$977,892.13**

Caldwell County Agenda Item Request Form

To: All Elected Officials and Department Heads – Hand deliver or scan & email to hopyy.haden@co.caldwell.tx.us and ezzy.chan@co.caldwell.tx.us . Deadline is 5:00 pm Tuesday before the Regular meetings, however, please submit this completed form ASAP. “Anything missing will cause the Agenda Item to be held over to the next Regular meeting,” according to our Rules & Procedures.

AGENDA DATE: 11.08.2022

Type of Agenda Item

- Consent Discussion/Action Executive Session Workshop
 Public Hearing

What will be discussed? What is the proposed motion?

Approve payment of County invoices and County Purchase Orders:
\$977,892.13

1. Costs:

Actual Cost or Estimated Cost \$ _____

Is this cost included in the County Budget? _____

Is a Budget Amendment being proposed? _____

2. Agenda Speakers:

	Name	Representing	Title
--	------	--------------	-------

(1)	Judge Haden		
-----	-------------	--	--

(2)			
-----	--	--	--

(3)			
-----	--	--	--

3. Backup Materials: None To Be Distributed 34 total # of backup pages
(including this page)

4.  _____
Signature of Court Member

Date 11/1/2022



Caldwell County, TX

Payment Register

APPKT09955 - 11/08/22 A/P Run & P.O.'s

01 - Vendor Set 01

Bank: 2022 AP BNK - POOLED CASH-OPERATION-2022

Vendor Number AISWHI	Vendor Name AISHA WHITE-THOMPSON, CSR, RPR					Total Vendor Amount 1,789.05
Payment Type Check	Payment Number	Remittance Address		Payment Date 11/01/2022	Payment Amount 1,789.05	

Payable Number 14-813	Description SOT V. RUDY	Payable Date 10/18/2022	Due Date 11/08/2022	Discount Amount 0.00	Payable Amount 1,789.05
---	-----------------------------------	-----------------------------------	-------------------------------	--------------------------------	-----------------------------------

Vendor Number ALLBAS	Vendor Name ALLISON, BASS & MAGEE, LLP					Total Vendor Amount 10,000.00
Payment Type Check	Payment Number	Remittance Address ATTN: ACCOUNTS RECEIVABLE 402 WEST 12TH STREET AUSTIN, Texas 78701		Payment Date 11/01/2022	Payment Amount 10,000.00	

Payable Number 6672	Description 2020 Redistricting Invoice	Payable Date 10/21/2022	Due Date 11/08/2022	Discount Amount 0.00	Payable Amount 10,000.00
---	--	-----------------------------------	-------------------------------	--------------------------------	------------------------------------

Vendor Number AMESTR	Vendor Name AMERICAN STRUCTUREPOINT, INC					Total Vendor Amount 23,512.50
Payment Type Check	Payment Number	Remittance Address 9025 N. RIVER ROAD, SUITE 200 INDIANAPOLIS, Indiana 46240-		Payment Date 11/01/2022	Payment Amount 23,512.50	

Payable Number 155696	Description Project 0002020.01861.0001 Caldwell Co, SH 142	Payable Date 10/25/2022	Due Date 11/08/2022	Discount Amount 0.00	Payable Amount 23,512.50
---	--	-----------------------------------	-------------------------------	--------------------------------	------------------------------------

Vendor Number ESQTOW	Vendor Name ANGEL D ESQUIVEL					Total Vendor Amount 120.00
Payment Type Check	Payment Number	Remittance Address		Payment Date 11/01/2022	Payment Amount 120.00	

Payable Number 1709	Description LIC PLATE: HYG 1888 2002 DODGE 1500 BLUE	Payable Date 10/20/2022	Due Date 11/08/2022	Discount Amount 0.00	Payable Amount 120.00
---	--	-----------------------------------	-------------------------------	--------------------------------	---------------------------------

Vendor Number ANIDEL	Vendor Name ANITA DELEON					Total Vendor Amount 46.50
Payment Type Check	Payment Number	Remittance Address		Payment Date 11/01/2022	Payment Amount 46.50	

Payable Number 92822	Description INQUESTS 9/10 - 18/22	Payable Date 09/28/2022	Due Date 11/08/2022	Discount Amount 0.00	Payable Amount 46.50
--	---	-----------------------------------	-------------------------------	--------------------------------	--------------------------------

Vendor Number ASCO	Vendor Name ASSOCIATED SUPPLY COMPANY, INC					Total Vendor Amount 507.25
Payment Type Check	Payment Number	Remittance Address P.O. BOX 3888 LUBBOCK, Texas 79452		Payment Date 11/01/2022	Payment Amount 507.25	

Payable Number 346871-1	Description BP0068193	Payable Date 08/29/2022	Due Date 11/08/2022	Discount Amount 0.00	Payable Amount 507.25
---	---------------------------------	-----------------------------------	-------------------------------	--------------------------------	---------------------------------

Payment Register

APPKT09955 - 11/08/22 A/P Run & P.O.'s

Vendor Number	Vendor Name					Total Vendor Amount
AT0189	AT&T					48,024.60
Payment Type	Payment Number	Remittance Address	Payment Date	Payment Amount		
Check		P.O. BOX 5001 CAROL STREAM, Illinois 60197-5001	11/01/2022	48,024.60		
Payable Number	Description	Payable Date	Due Date	Discount Amount	Payable Amount	
Service 10/05/2022 - 11/04/21	512 A13-0189 725 3	10/05/2022	11/08/2022	0.00	48,024.60	
AWMOIL	AWM OIL TOOLS, INC.					182.90
Payment Type	Payment Number	Remittance Address	Payment Date	Payment Amount		
Check		P.O. BOX 1133 LULING, Texas 78648	11/01/2022	182.90		
Payable Number	Description	Payable Date	Due Date	Discount Amount	Payable Amount	
86574	TEFLON TAPE 1"	10/11/2022	11/08/2022	0.00	182.90	
BEACOM	BEARCOM OPERATING, LLC					600.00
Payment Type	Payment Number	Remittance Address	Payment Date	Payment Amount		
Check		4009 DISTRIBUTION DRIVE, SUITE 200 GARLAND, Texas 75041-	11/01/2022	600.00		
Payable Number	Description	Payable Date	Due Date	Discount Amount	Payable Amount	
5296171	acct # 1626576	11/30/2021	11/08/2022	0.00	600.00	
BILSOU	BILLBOARD SOURCE, INC.					1,920.00
Payment Type	Payment Number	Remittance Address	Payment Date	Payment Amount		
Check		6125 LUTHER LANE, #384 DALLAS, Texas 75225-	11/01/2022	1,920.00		
Payable Number	Description	Payable Date	Due Date	Discount Amount	Payable Amount	
572681	environmental billboard	09/01/2022	11/08/2022	0.00	960.00	
572682	Billboard	09/01/2022	11/08/2022	0.00	960.00	
BOETRA	BOEHRM TRACTOR SALES, INC.					94.64
Payment Type	Payment Number	Remittance Address	Payment Date	Payment Amount		
Check		P.O. BOX 1102 SHINER, Texas 77984	11/01/2022	94.64		
Payable Number	Description	Payable Date	Due Date	Discount Amount	Payable Amount	
CT209498	ACCT # C03021 BELT 'V'	10/12/2022	11/08/2022	0.00	94.64	
BRAMAT	BRAUNTEX MATERIALS, INC.					91,351.70
Payment Type	Payment Number	Remittance Address	Payment Date	Payment Amount		
Check		PO BOX 312622 NEW BRAUNFELS, Texas 78131-2622	11/01/2022	91,351.70		
Payable Number	Description	Payable Date	Due Date	Discount Amount	Payable Amount	
140430	1600	10/13/2022	11/08/2022	0.00	4,318.50	
140630	1600	10/17/2022	11/08/2022	0.00	26,597.92	
140631	1600	10/17/2022	11/08/2022	0.00	30,556.50	
140798	1600	10/25/2022	11/08/2022	0.00	16,425.28	
140799	1600	10/25/2022	11/08/2022	0.00	13,453.50	
CALTAX	CALDWELL COUNTY TAX ASSESSOR					30.00
Payment Type	Payment Number	Remittance Address	Payment Date	Payment Amount		
Check		110 S. MAIN, RM 101 LOCKHART, Texas 78644-2747	11/01/2022	7.50		
Payable Number	Description	Payable Date	Due Date	Discount Amount	Payable Amount	
1263147_2022	LICENSE # 1263147 VIN # ENDS W/1422	10/19/2022	11/08/2022	0.00	7.50	

Payment Register

APPKT09955 - 11/08/22 A/P Run & P.O.'s

Check		110 S. MAIN, RM 101 LOCKHART, Texas 78644-2747			11/01/2022		7.50
Payable Number	Description		Payable Date	Due Date	Discount Amount	Payable Amount	
9021461_2022	PLATE # 9021461 VIN # ENDS W/4944 BLDG MAINT		10/28/2022	11/08/2022	0.00	7.50	
Check		110 S. MAIN, RM 101 LOCKHART, Texas 78644-2747			11/01/2022		7.50
Payable Number	Description		Payable Date	Due Date	Discount Amount	Payable Amount	
9021466_2022	PLATE # 9021466 VIN # ENDS W/6262 CODE ENFORCEMEN		10/24/2022	11/08/2022	0.00	7.50	
Check		110 S. MAIN, RM 101 LOCKHART, Texas 78644-2747			11/01/2022		7.50
Payable Number	Description		Payable Date	Due Date	Discount Amount	Payable Amount	
KYM 6308	PLATE # KYM 6308 VIN # ENDS W/1085 (LANE)		10/20/2022	11/08/2022	0.00	7.50	
Vendor Number	Vendor Name						Total Vendor Amount
CALTRA	CALDWELL-TRAVIS SWCD						900.00
Payment Type	Payment Number	Remittance Address			Payment Date	Payment Amount	
Check		111 E. MLK JR INDUSTRIAL BLVD LOCKHART, Texas 78644-			11/01/2022	900.00	
Payable Number	Description		Payable Date	Due Date	Discount Amount	Payable Amount	
469	FY 2023 donation		10/26/2022	11/08/2022	0.00	900.00	
Vendor Number	Vendor Name						Total Vendor Amount
CAPCOG	CAPITAL AREA COUNCIL OF GOVERNMENTS						2,339.55
Payment Type	Payment Number	Remittance Address			Payment Date	Payment Amount	
Check		6800 BURLESON RD. BUILDING 310, SUITE 165 AUSTIN, Texas 78744			11/01/2022	2,339.55	
Payable Number	Description		Payable Date	Due Date	Discount Amount	Payable Amount	
2023M 169	CAPCOG 2023 Annual membership dues		10/13/2022	11/08/2022	0.00	2,339.55	
Vendor Number	Vendor Name						Total Vendor Amount
CARSER	CARD SERVICE CENTER						1,043.36
Payment Type	Payment Number	Remittance Address			Payment Date	Payment Amount	
Check		PO BOX 569100 DALLAS, Texas 75356-9100			11/01/2022	1,043.36	
Payable Number	Description		Payable Date	Due Date	Discount Amount	Payable Amount	
1022	ACCT # ENDS W/1237		10/28/2022	11/08/2022	0.00	1,043.36	
Vendor Number	Vendor Name						Total Vendor Amount
CASDAR	CASE J. DARWIN						1,800.00
Payment Type	Payment Number	Remittance Address			Payment Date	Payment Amount	
Check		604 W. HOPKINS SAN MARCOS, Texas 78666-			11/01/2022	1,800.00	
Payable Number	Description		Payable Date	Due Date	Discount Amount	Payable Amount	
21-059	CAUSE # 21-059 EDWING		10/17/2022	11/08/2022	0.00	1,800.00	
Vendor Number	Vendor Name						Total Vendor Amount
CENREF	CENTRAL TEXAS REFUSE, INC						1,947.46
Payment Type	Payment Number	Remittance Address			Payment Date	Payment Amount	
Check		P.O. BOX 18685 AUSTIN, Texas 78760-8685			11/01/2022	581.55	
Payable Number	Description		Payable Date	Due Date	Discount Amount	Payable Amount	
0000430466	Dumpster rental		07/31/2022	11/08/2022	0.00	581.55	
Check		P.O. BOX 18685 AUSTIN, Texas 78760-8685			11/01/2022	561.72	
Payable Number	Description		Payable Date	Due Date	Discount Amount	Payable Amount	
0000437868	Dumpster rental		09/15/2022	11/08/2022	0.00	561.72	
Check		P.O. BOX 18685 AUSTIN, Texas 78760-8685			11/01/2022	554.45	
Payable Number	Description		Payable Date	Due Date	Discount Amount	Payable Amount	
0000444422	Dumpster Rental		10/15/2022	11/08/2022	0.00	554.45	

Payment Register

APPKT09955 - 11/08/22 A/P Run & P.O.'s

Check	P.O. BOX 18685 AUSTIN, Texas 78760-8685	11/01/2022	249.74				
Payable Number	Description	Payable Date	Due Date	Discount Amount	Payable Amount		
439038	ACCT # 020545 SITE: 9675 HWY 142 OCT. 2022	10/01/2022	11/08/2022	0.00	249.74		
Vendor Number	Vendor Name					Total Vendor Amount	
CENAIR	CENTURY HVAC DISTRIBUTING, L.P.					598.21	
Payment Type	Payment Number	Remittance Address	Payment Date	Payment Amount			
Check		P.O. BOX 735878 DALLAS, Texas 75373-5878	11/01/2022	598.21			
Payable Number	Description	Payable Date	Due Date	Discount Amount	Payable Amount		
111264745	SERVICE CHARGE	07/29/2022	11/08/2022	0.00	1.47		
111286727	SERVICE CHARGE	08/31/2022	11/08/2022	0.00	1.64		
111303429	SERVICE CHARGE	09/30/2022	11/08/2022	0.00	3.08		
111306351	PICK TICKET # 8591377 NASHUA 2IN BLACK UL181 CLOT	10/06/2022	11/08/2022	0.00	494.42		
111307609	PICK TICKET # 8592413 2X2 PERF TBAR LAY IN DIFF R	10/10/2022	11/08/2022	0.00	97.60		
Vendor Number	Vendor Name					Total Vendor Amount	
CHALAU	CHARLES E. LAURENCE, M.D.					3,000.00	
Payment Type	Payment Number	Remittance Address	Payment Date	Payment Amount			
Check			11/01/2022	3,000.00			
Payable Number	Description	Payable Date	Due Date	Discount Amount	Payable Amount		
74507	Medical Director July	07/01/2022	11/08/2022	0.00	1,000.00		
74508	Medical Director August	08/01/2022	11/08/2022	0.00	1,000.00		
74509	Medical Director September	09/01/2022	11/08/2022	0.00	1,000.00		
Vendor Number	Vendor Name					Total Vendor Amount	
SPEBUS	CHARTER COMMUNICATIONS HOLDINGS, LLC					11,519.36	
Payment Type	Payment Number	Remittance Address	Payment Date	Payment Amount			
Check		P.O. BOX 60074 CITY OF INDUSTRY, California 91716-0074	11/01/2022	11,290.19			
Payable Number	Description	Payable Date	Due Date	Discount Amount	Payable Amount		
0000426100822	acct # 8260163000000426	10/08/2022	11/08/2022	0.00	11,290.19		
Check		P.O. BOX 60074 CITY OF INDUSTRY, California 91716-0074	11/01/2022	229.17			
Payable Number	Description	Payable Date	Due Date	Discount Amount	Payable Amount		
0226726100422	8260 16 115 0226726	10/04/2022	11/08/2022	0.00	229.17		
Vendor Number	Vendor Name					Total Vendor Amount	
CINTAS	CINTAS CORPORATION #86					2,505.13	
Payment Type	Payment Number	Remittance Address	Payment Date	Payment Amount			
Check		PO BOX 650838 DALLAS, Texas 75265-0838	11/01/2022	2,505.13			
Payable Number	Description	Payable Date	Due Date	Discount Amount	Payable Amount		
4133506491	SOLD TO # 13228085 PAYER # 13242165	10/06/2022	11/08/2022	0.00	49.88		
4133506854	SOLD TO # 13228013 PAYER # 13242157	10/06/2022	11/08/2022	0.00	55.14		
4133506917	SOLD TO # 13232687 PAYER # 13243034	10/06/2022	11/08/2022	0.00	280.44		
4133506989	SOLD TO # 13232664 PAYER # 13243034	10/06/2022	11/08/2022	0.00	204.78		
4133507003	SOLD TO # 13228849 PAYER # 13243034	10/06/2022	11/08/2022	0.00	220.26		
4134207617	SOLD TO # 13228085 PAYER # 13242165	10/13/2022	11/08/2022	0.00	49.88		
4134207789	SOLD TO # 13228013 PAYER # 13242157	10/13/2022	11/08/2022	0.00	55.14		
4134207925	SOLD TO # 13232687 PAYER # 13243034	10/13/2022	11/08/2022	0.00	280.44		
4134207951	SOLD TO # 13232664 PAYER # 13243034	10/13/2022	11/08/2022	0.00	204.78		
4134207964	SOLD TO # 13228849 PAYER # 13243034	10/13/2022	11/08/2022	0.00	220.26		
4134882711	SOLD TO # 13228085 PAYER # 13242165	10/20/2022	11/08/2022	0.00	51.88		
4134883084	SOLD TO # 13232687 PAYER # 13243034	10/20/2022	11/08/2022	0.00	280.44		
4134883202	SOLD TO # 13228849 PAYER # 13243034	10/20/2022	11/08/2022	0.00	220.26		
4134883267	SOLD TO # 13232664 PAYER # 13243034	10/20/2022	11/08/2022	0.00	331.55		

Payment Register

APPKT09955 - 11/08/22 A/P Run & P.O.'s

Vendor Number	Vendor Name	Payment Type	Payment Number	Remittance Address	Payment Date	Payment Amount	Total Vendor Amount
CITLOC	CITY OF LOCKHART	Check		P.O. BOX 239 LOCKHART, Texas 78644	11/01/2022	24,133.85	24,133.85
			ASV 22-Q4	acct # 100-4300	10/01/2022	24,133.85	
						0.00	24,133.85
CLIMCC	CLIFFORD W. MCCORMACK	Check		ATTORNEY AT LAW 174 S. GUADALUPE, SUITE 106 SAN MARCOS, Texas 78666	11/01/2022	1,515.00	1,515.00
			48,759	CAUSE # 48,759 ELTON	10/05/2022	555.00	
			49,119	CAUSE # 49,119 OSCAR	10/05/2022	405.00	
			49,194	CAUSE # 49,194 FREDRICK	10/05/2022	555.00	
COLWIS	COLIN WISE	Check		1921 CORPORATE DR., SUITE 102 SAN MARCOS, Texas 78666	11/01/2022	655.00	655.00
			49,173	CAUSE # 49,173 TERRANCE	10/04/2022	250.00	
			49,321	CAUSE # 49,321 NAZARIO	10/05/2022	405.00	
COMTRE	COMAL COUNTY TREASURER'S OFFICE	Check		150 NORTH SEGUIN STREET, SUITE 2037 NEW BRAUNFELS, Texas 78130-5122	11/01/2022	3,618.63	3,618.63
			2022C	COURT ADMIN - JULY, AUGUST & SEPTEMBER 2022	10/05/2022	3,618.63	
CDCAT	COUNTY & DISTRICT CLERKS' ASSOCIATION OF TEXAS	Check		P.O. BOX 2711 SAN ANTONIO, Texas 78299-	11/01/2022	200.00	200.00
			330958	MEMBER ID: 253064 JUANITA ALLEN 1/23 - 26/23	10/25/2022	200.00	
DAWMER	DAWN T. MEREDITH	Check		P.O BOX 150129 AUSTIN, Texas 78715-	11/01/2022	665.00	665.00
			21-FL-273	CAUSE # 21-FL-273 ANGELICA	10/20/2022	665.00	
DELCOM	DELL MARKETING L.P.	Check		P.O. BOX 676021 C/O DELL USA L.P. DALLAS, Texas 75267-6021	11/01/2022	19.80	19.80
			10617530376	CUST # 2120993 KIT- DELL HDMI TO VGA ADAPTER	09/26/2022	19.80	

Payment Register

APPKT09955 - 11/08/22 A/P Run & P.O.'s

Vendor Number	Vendor Name				Total Vendor Amount
DENENG	DENNIS ENGELKE				50.69
Payment Type	Payment Number	Remittance Address	Payment Date	Payment Amount	
Check			11/01/2022	50.69	
Payable Number	Description	Payable Date	Due Date	Discount Amount	Payable Amount
10242022	TRAVEL 10/08 - 20/22	10/24/2022	11/08/2022	0.00	50.69

Vendor Number	Vendor Name				Total Vendor Amount
DEWPOT	DEWITT POTTH & SON				1,064.40
Payment Type	Payment Number	Remittance Address	Payment Date	Payment Amount	
Check		PO BOX 487 YOAKUM, Texas 77995	11/01/2022	1,064.40	
Payable Number	Description	Payable Date	Due Date	Discount Amount	Payable Amount
693540-0	ACCT # 12430 ENVELOPE, CLASP, HVYDTY, 10X13	09/12/2022	11/08/2022	0.00	17.95
697365-0	ACCT # 12430 SPOTPAPER - LETTER	10/17/2022	11/08/2022	0.00	249.35
697365-1	ACCT # 12430 CUP, HOT, 12 OZ, 50/PK	10/18/2022	11/08/2022	0.00	46.44
697636-0	ACCT # 12430 PEN, BALLPNT, F-301, RT, 0.7, BE	10/18/2022	11/08/2022	0.00	38.79
697655-0	ACCT # 12430 DESPAD	10/18/2022	11/08/2022	0.00	203.07
698167-0	Paper	10/21/2022	11/08/2022	0.00	508.80

Vendor Number	Vendor Name				Total Vendor Amount
DOJASS	DOUCET & ASSOCIATES, INC				14,812.50
Payment Type	Payment Number	Remittance Address	Payment Date	Payment Amount	
Check		7401B HIGHWAY 71 WEST, SUITE 160 AUSTIN, Texas 78735-	11/01/2022	7,985.00	
Payable Number	Description	Payable Date	Due Date	Discount Amount	Payable Amount
2209031	Doucet & Assoc. Blanket PO FY 21-22	09/29/2022	11/08/2022	0.00	7,985.00
Check		7401B HIGHWAY 71 WEST, SUITE 160 AUSTIN, Texas 78735-	11/01/2022	412.50	
Payable Number	Description	Payable Date	Due Date	Discount Amount	Payable Amount
2209032	ARWA segment D	09/29/2022	11/08/2022	0.00	412.50
Check		7401B HIGHWAY 71 WEST, SUITE 160 AUSTIN, Texas 78735-	11/01/2022	275.00	
Payable Number	Description	Payable Date	Due Date	Discount Amount	Payable Amount
2209033	sagada dos phase 2	09/29/2022	11/08/2022	0.00	275.00
Check		7401B HIGHWAY 71 WEST, SUITE 160 AUSTIN, Texas 78735-	11/01/2022	137.50	
Payable Number	Description	Payable Date	Due Date	Discount Amount	Payable Amount
2209034	clearwater ranch	09/29/2022	11/08/2022	0.00	137.50
Check		7401B HIGHWAY 71 WEST, SUITE 160 AUSTIN, Texas 78735-	11/01/2022	550.00	
Payable Number	Description	Payable Date	Due Date	Discount Amount	Payable Amount
2209035	bollinger prelim plat	09/29/2022	11/08/2022	0.00	550.00
Check		7401B HIGHWAY 71 WEST, SUITE 160 AUSTIN, Texas 78735-	11/01/2022	68.75	
Payable Number	Description	Payable Date	Due Date	Discount Amount	Payable Amount
2209036	lockhart acres	09/29/2022	11/08/2022	0.00	68.75
Check		7401B HIGHWAY 71 WEST, SUITE 160 AUSTIN, Texas 78735-	11/01/2022	690.00	
Payable Number	Description	Payable Date	Due Date	Discount Amount	Payable Amount
2209037	exodus solar	09/29/2022	11/08/2022	0.00	690.00
Check		7401B HIGHWAY 71 WEST, SUITE 160 AUSTIN, Texas 78735-	11/01/2022	68.75	
Payable Number	Description	Payable Date	Due Date	Discount Amount	Payable Amount
2209038	JK ranch	09/29/2022	11/08/2022	0.00	68.75
Check		7401B HIGHWAY 71 WEST, SUITE 160 AUSTIN, Texas 78735-	11/01/2022	140.00	
Payable Number	Description	Payable Date	Due Date	Discount Amount	Payable Amount
2209040	el destino	09/29/2022	11/08/2022	0.00	140.00

Payment Register

APPKT09955 - 11/08/22 A/P Run & P.O.'s

Check		7401B HIGHWAY 71 WEST, SUITE 160 AUSTIN, Texas 78735-		11/01/2022		550.00
Payable Number	Description		Payable Date	Due Date	Discount Amount	Payable Amount
2209041	lake longhorn		09/29/2022	11/08/2022	0.00	550.00
Check		7401B HIGHWAY 71 WEST, SUITE 160 AUSTIN, Texas 78735-		11/01/2022		137.50
Payable Number	Description		Payable Date	Due Date	Discount Amount	Payable Amount
2209042	cotton gateway		09/29/2022	11/08/2022	0.00	137.50
Check		7401B HIGHWAY 71 WEST, SUITE 160 AUSTIN, Texas 78735-		11/01/2022		137.50
Payable Number	Description		Payable Date	Due Date	Discount Amount	Payable Amount
2209046	cotton gateway		09/29/2022	11/08/2022	0.00	137.50
Check		7401B HIGHWAY 71 WEST, SUITE 160 AUSTIN, Texas 78735-		11/01/2022		137.50
Payable Number	Description		Payable Date	Due Date	Discount Amount	Payable Amount
2209049	Project R1911-252-01 Urbana Sunset Prelim		09/29/2022	11/08/2022	0.00	137.50
Check		7401B HIGHWAY 71 WEST, SUITE 160 AUSTIN, Texas 78735-		11/01/2022		766.25
Payable Number	Description		Payable Date	Due Date	Discount Amount	Payable Amount
2209051	Project R1911-253-01 7539 N Hwy 183		09/29/2022	11/08/2022	0.00	766.25
Check		7401B HIGHWAY 71 WEST, SUITE 160 AUSTIN, Texas 78735-		11/01/2022		137.50
Payable Number	Description		Payable Date	Due Date	Discount Amount	Payable Amount
2209052	Project R1911-254-01 Greenhouse Rd		09/29/2022	11/08/2022	0.00	137.50
Check		7401B HIGHWAY 71 WEST, SUITE 160 AUSTIN, Texas 78735-		11/01/2022		412.50
Payable Number	Description		Payable Date	Due Date	Discount Amount	Payable Amount
2209056	Project R1911-255-01 RYTY Site		09/29/2022	11/08/2022	0.00	412.50
Check		7401B HIGHWAY 71 WEST, SUITE 160 AUSTIN, Texas 78735-		11/01/2022		575.00
Payable Number	Description		Payable Date	Due Date	Discount Amount	Payable Amount
2209060	Project R1911-256-01 Ridge Estates Short		09/30/2022	11/08/2022	0.00	575.00
Check		7401B HIGHWAY 71 WEST, SUITE 160 AUSTIN, Texas 78735-		11/01/2022		506.25
Payable Number	Description		Payable Date	Due Date	Discount Amount	Payable Amount
2209062	Project R1911-257-01 Fox Tail Farms		09/30/2022	11/08/2022	0.00	506.25
Check		7401B HIGHWAY 71 WEST, SUITE 160 AUSTIN, Texas 78735-		11/01/2022		1,125.00
Payable Number	Description		Payable Date	Due Date	Discount Amount	Payable Amount
2209065	Project R1911-225-01 Sunset Oaks		09/30/2022	11/08/2022	0.00	1,125.00
Vendor Number	Vendor Name					Total Vendor Amount
E&RSUP	E & R SUPPLY CO., INC					3,669.88
Payment Type	Payment Number	Remittance Address		Payment Date		Payment Amount
Check		1717 S. CHADBOURNE SAN ANGELO, Texas 76903-		11/01/2022		3,669.88
Payable Number	Description		Payable Date	Due Date	Discount Amount	Payable Amount
226243	ACCT # 0023750 ALUM KAMLOCK		10/10/2022	11/08/2022	0.00	34.88
226307	0023750		10/17/2022	11/08/2022	0.00	3,635.00
Vendor Number	Vendor Name					Total Vendor Amount
EDOTEC	EDOC TECHNOLOGIES, INC.					8,650.00
Payment Type	Payment Number	Remittance Address		Payment Date		Payment Amount
Check		ACCOUNTING OFFICE 301 S. MAIN ST. MCGREGOR, Texas 76657		11/01/2022		8,650.00
Payable Number	Description		Payable Date	Due Date	Discount Amount	Payable Amount
19747	EDOC		10/01/2022	11/08/2022	0.00	8,250.00
19748	ANNUAL MAINT. - 10/2022 TO 9/2023		10/01/2022	11/08/2022	0.00	400.00

Payment Register

APPKT09955 - 11/08/22 A/P Run & P.O.'s

Vendor Number ELESYS	Vendor Name ELECTION SYSTEMS & SOFTWARE INC.					Total Vendor Amount 10,124.54
Payment Type Check	Payment Number	Remittance Address 6055 PAYSHERE CIRCLE CHICAGO, Illinois 60674	Payment Date 11/01/2022	Payment Amount 10,124.54		
Payable Number CD2043706	Description Thermal Ballots	Payable Date 10/04/2022	Due Date 11/08/2022	Discount Amount 0.00	Payable Amount 1,573.68	
CD2044669	Media Burn/Equipment	10/07/2022	11/08/2022	0.00	6,621.23	
CD2045369	ES&S Software Training	10/14/2022	11/08/2022	0.00	1,929.63	

Vendor Number ELILAR	Vendor Name ELIZABETH LARIVEE					Total Vendor Amount 132.50
Payment Type Check	Payment Number	Remittance Address	Payment Date 11/01/2022	Payment Amount 132.50		
Payable Number 101722	Description COLLEGE STATION - 10/17 - 20/22	Payable Date 10/24/2022	Due Date 11/08/2022	Discount Amount 0.00	Payable Amount 132.50	

Vendor Number ERGASP	Vendor Name ERGON ASPHALT AND EMULSIONS, INC.					Total Vendor Amount 24,525.54
Payment Type Check	Payment Number	Remittance Address DEPT #2135 P O BOX 11407 BIRMINGHAM, Alabama 35246-2135	Payment Date 11/01/2022	Payment Amount 24,525.54		
Payable Number 9402813544	Description 912994	Payable Date 10/13/2022	Due Date 11/08/2022	Discount Amount 0.00	Payable Amount 6,088.56	
9402813545	912994	10/13/2022	11/08/2022	0.00	6,051.87	
9402814563	DEMURRAGE .84 HOURS	10/14/2022	11/08/2022	0.00	75.60	
9402814564	DEMURRAGE 1.33 HOURS	10/14/2022	11/08/2022	0.00	119.70	
9402814729	912994	10/14/2022	11/08/2022	0.00	6,039.64	
9402814730	912994	10/14/2022	11/08/2022	0.00	6,015.17	
9402816937	DEMURRAGE 1 HOUR	10/18/2022	11/08/2022	0.00	90.00	
9402816938	DEMURRAGE .5 HOURS	10/18/2022	11/08/2022	0.00	45.00	

Vendor Number FERJOS	Vendor Name FERRIS JOSEPH PRODUCE, INC.					Total Vendor Amount 1,274.75
Payment Type Check	Payment Number	Remittance Address 113 BUFKIN LN LOCKHART, Texas 78644	Payment Date 11/01/2022	Payment Amount 1,274.75		
Payable Number 122808	Description Ferris Joseph Blanket PO FY 22-23	Payable Date 10/13/2022	Due Date 11/08/2022	Discount Amount 0.00	Payable Amount 124.25	
122816	Ferris Joseph Blanket PO FY 22-23	10/14/2022	11/08/2022	0.00	816.00	
122854	Ferris Joseph Blanket PO FY 22-23	10/15/2022	11/08/2022	0.00	200.50	
122856	Ferris Joseph Blanket PO FY 22-23	10/17/2022	11/08/2022	0.00	134.00	

Vendor Number FIRTRO	Vendor Name FIRETROL PROTECTION SYSTEMS, INC.					Total Vendor Amount 801.70
Payment Type Check	Payment Number	Remittance Address 4616 W. HOWARD LANE #7-700 AUSTIN, Texas 78728-	Payment Date 11/01/2022	Payment Amount 801.70		
Payable Number 100812015	Description cust # 4700021	Payable Date 09/29/2022	Due Date 11/08/2022	Discount Amount 0.00	Payable Amount 801.70	

Vendor Number FUEMAN	Vendor Name FLETCOR TECHNOLOGIES, INC					Total Vendor Amount 29,067.99
Payment Type Check	Payment Number	Remittance Address P.O. BOX 70887 CHARLOTTE, North Carolina 28272-0887	Payment Date 11/01/2022	Payment Amount 29,067.99		
Payable Number NP63152536	Description ACCT # BG114286 BILL PERIOD: 9/26 - 10/30/22	Payable Date 10/31/2022	Due Date 11/08/2022	Discount Amount 0.00	Payable Amount 29,067.99	

Payment Register

APPKT09955 - 11/08/22 A/P Run & P.O.'s

Vendor Number	Vendor Name						Total Vendor Amount
BUTBAK	FLOWERS BAKING CO. OF SAN ANTONIO						603.78
Payment Type	Payment Number	Remittance Address	Payment Date	Payment Amount			
Check		P.O. BOX 841940 DALLAS, Texas 75284	11/01/2022	603.78			
Payable Number	Description	Payable Date	Due Date	Discount Amount	Payable Amount		
4038382500	0040078309	10/18/2022	11/08/2022	0.00	603.78		
GAPOWE	GA POWERS						184.41
Payment Type	Payment Number	Remittance Address	Payment Date	Payment Amount			
Check		2640 FM 1979 SAN MARCOS, Texas 78666	11/01/2022	184.41			
Payable Number	Description	Payable Date	Due Date	Discount Amount	Payable Amount		
58855	3/8" X 75' FLEXICORE STEEL CABLE	10/14/2022	11/08/2022	0.00	184.41		
CAROHL	GERMER INSURANCE, INC						60.00
Payment Type	Payment Number	Remittance Address	Payment Date	Payment Amount			
Check		115 S. MAIN LOCKHART, Texas 78644	11/01/2022	60.00			
Payable Number	Description	Payable Date	Due Date	Discount Amount	Payable Amount		
65655919	REBECCA DIAZ - DEPUTY COUNTY TREASURER	10/04/2022	11/08/2022	0.00	60.00		
GRAING	GRAINGER						173.38
Payment Type	Payment Number	Remittance Address	Payment Date	Payment Amount			
Check		DEPT-841505548 PO BOX 419267 KANSAS CITY, Missouri 64141-6267	11/01/2022	173.38			
Payable Number	Description	Payable Date	Due Date	Discount Amount	Payable Amount		
9477210968	ACC # 841505548 HI-VIS BOMBER JACKEET, INSLTD, LI	10/13/2022	11/08/2022	0.00	173.38		
GTDIST	GT DISTRIBUTORS, INC.						35.98
Payment Type	Payment Number	Remittance Address	Payment Date	Payment Amount			
Check		1124 NEW MEISTER LN., STE 100 PFLUGERVILLE, Texas 78660-	11/01/2022	35.98			
Payable Number	Description	Payable Date	Due Date	Discount Amount	Payable Amount		
INV0924609	CUST ID: 006679 STRONG RECESSED BADGE	10/06/2022	11/08/2022	0.00	35.98		
HANEQU	HANSON EQUIPMENT						1,921.32
Payment Type	Payment Number	Remittance Address	Payment Date	Payment Amount			
Check		DOUGLAS D. SPILLMANN 1412 S. COLORADO LOCKHART, Texas 78644	11/01/2022	1,921.32			
Payable Number	Description	Payable Date	Due Date	Discount Amount	Payable Amount		
295254	FLATWASHER 5/8 (65/5LB)	10/04/2022	11/08/2022	0.00	298.56		
295316	BLADE-RHINO TS12 WINGS	10/06/2022	11/08/2022	0.00	334.82		
295317	FACING 5.5" X 3.0" (STEALTH)	10/06/2022	11/08/2022	0.00	270.04		
295323	12.4-28/8 CROPMASTER REAR R MOUNT TIRE	10/06/2022	11/08/2022	0.00	440.60		
295375	MOUNT TIRE 19.5	10/10/2022	11/08/2022	0.00	145.00		
295421	O-RING 7"	10/12/2022	11/08/2022	0.00	91.23		
295456	# CAL001 11.2/12.4-28 TUBE TR218	10/13/2022	11/08/2022	0.00	93.80		
295537	# CAL001 FLAT TIRE REPAIR	10/18/2022	11/08/2022	0.00	19.83		
295542	# CAL001 BLADE-RHION TS12 WINGS	10/19/2022	11/08/2022	0.00	227.44		

Payment Register

APPKT09955 - 11/08/22 A/P Run & P.O.'s

Vendor Number JAMUND	Vendor Name HERBERT L. JAMISON & CO., LLC					Total Vendor Amount 2,212.87
Payment Type Check	Payment Number	Remittance Address 20 COMMERCE DRIVE, SUITE 200 CRANFORD, New Jersey 07016-	Payment Date 11/01/2022	Payment Amount 2,212.87		
Payable Number 10.13.2022	Description acct # SCH0362	Payable Date 10/13/2022	Due Date 11/08/2022	Discount Amount 0.00	Payable Amount 2,212.87	

Vendor Number HOLBUR	Vendor Name HOLLIS WILBURN BURKLUND					Total Vendor Amount 900.00
Payment Type Check	Payment Number	Remittance Address 403 W. SAN ANTONIO LOCKHART, Texas 78644	Payment Date 11/01/2022	Payment Amount 900.00		
Payable Number 2835-20CC 2	Description CAUSE # 2835-20CC P.G.	Payable Date 10/20/2022	Due Date 11/08/2022	Discount Amount 0.00	Payable Amount 200.00	
2895-22 CC	CAUSE # 2895-22 CC C.E.M.	10/20/2022	11/08/2022	0.00	400.00	
2901-22CC 1	CAUSE # 2901-22CC & 2922-22CC M.J.E.	10/20/2022	11/08/2022	0.00	300.00	

Vendor Number I-CON	Vendor Name I-CON SYSTEMS, INC					Total Vendor Amount 327.09
Payment Type Check	Payment Number	Remittance Address P.O. BOX 748371 ATLANTA, Georgia 30374-8371	Payment Date 11/01/2022	Payment Amount 327.09		
Payable Number SI001804	Description CUST ID: CS000835 CHECKSTOP: NO FITTING: 1/2" : 62	Payable Date 10/06/2022	Due Date 11/08/2022	Discount Amount 0.00	Payable Amount 327.09	

Vendor Number INLTRU	Vendor Name INLAND TRUCK PARTS COMPANY					Total Vendor Amount 137.54
Payment Type Check	Payment Number	Remittance Address 9000 E. HWY 290 AUSTIN, Texas 78724-	Payment Date 11/01/2022	Payment Amount 137.54		
Payable Number CM-096218	Description CUST # 020818 PUMP (AIR, DIRECT MOUNT)	Payable Date 10/19/2022	Due Date 10/19/2022	Discount Amount 0.00	Payable Amount -782.15	
IN-1173377	020818	07/12/2022	11/08/2022	0.00	919.69	

Vendor Number FARPLA	Vendor Name JOHN DEERE FINANCIAL					Total Vendor Amount 307.49
Payment Type Check	Payment Number	Remittance Address P.O. BOX 650215 DALLAS, Texas 75265-0215	Payment Date 11/01/2022	Payment Amount 307.49		
Payable Number 2210-051177	Description ACCT # 1-99 LED SMRT CYL E26 300W	Payable Date 10/11/2022	Due Date 11/08/2022	Discount Amount 0.00	Payable Amount 26.24	
2210-053212	ACCT # 1-99 ACE BOTTLE WATER	10/13/2022	11/08/2022	0.00	101.70	
2210-053684	CUST # 1-99 STIHL - 16" 3/8 .043 PICCO	10/14/2022	11/08/2022	0.00	72.00	
2210-060499	ACCT # 1-99 NAIL EXTRACTOR	10/24/2022	11/08/2022	0.00	107.55	

Vendor Number JUAALL	Vendor Name JUANITA ALLEN					Total Vendor Amount 131.25
Payment Type Check	Payment Number	Remittance Address	Payment Date 11/01/2022	Payment Amount 131.25		
Payable Number 10212022	Description TRAVEL 10/18 - 20/22	Payable Date 10/21/2022	Due Date 11/08/2022	Discount Amount 0.00	Payable Amount 131.25	

Vendor Number KJSAUT	Vendor Name KJ'S AUTO ACCESSORIES					Total Vendor Amount 475.00
Payment Type Check	Payment Number	Remittance Address P.O. BOX 266 LOCKHART, Texas 78644-0266	Payment Date 11/01/2022	Payment Amount 475.00		
Payable Number 27755	Description STEPS 4" F-250 17-21	Payable Date 10/13/2022	Due Date 11/08/2022	Discount Amount 0.00	Payable Amount 475.00	

Payment Register

APPKT09955 - 11/08/22 A/P Run & P.O.'s

Vendor Number	Vendor Name					Total Vendor Amount
LAWENF	LAW ENFORCEMENT SYSTEMS, INC.					252.00
Payment Type	Payment Number	Remittance Address	Payment Date	Payment Amount		
Check		PO BOX 1835 CORSICANA, Texas 75151-1835	11/01/2022	252.00		
Payable Number	Description	Payable Date	Due Date	Discount Amount	Payable Amount	
217688	ACCT # 78644 TEXAS TRAFFIC TICKETS W/WARNINGS	10/04/2022	11/08/2022	0.00	252.00	
THOLEO	LEON TRANSLATIONS					230.00
Payment Type	Payment Number	Remittance Address	Payment Date	Payment Amount		
Check		THOMAS LEON 7200 ANAQUA DR. AUSTIN, Texas 78750	11/01/2022	230.00		
Payable Number	Description	Payable Date	Due Date	Discount Amount	Payable Amount	
22443	SERVICES PERFORMED BY SOFIA LEON	09/29/2022	11/08/2022	0.00	230.00	
BLULAY	LOCAL LINUX, INC					21,868.64
Payment Type	Payment Number	Remittance Address	Payment Date	Payment Amount		
Check		6119 79TH LUBBOCK, Texas 79424-	11/01/2022	21,868.64		
Payable Number	Description	Payable Date	Due Date	Discount Amount	Payable Amount	
74919	Blue Layer Invoices	10/23/2022	11/08/2022	0.00	17,825.00	
74946	Blue Layer Invoices	10/23/2022	11/08/2022	0.00	3,858.00	
IN2204099918	ACCT # B100105039874 CIVIL PROCESS FOR TX / BOOK	05/31/2022	11/08/2022	0.00	185.64	
LOCTRU	LOCKHART HARDWARE					1,627.37
Payment Type	Payment Number	Remittance Address	Payment Date	Payment Amount		
Check		518 W SAN ANTONIO LOCKHART, Texas 78644-	11/01/2022	1,627.37		
Payable Number	Description	Payable Date	Due Date	Discount Amount	Payable Amount	
43379 /1	CUST # 11239 SCREW, NUTS & BOLTS	10/04/2022	11/08/2022	0.00	10.58	
43417 /1	CUST # 11239 2 X 4 X 08 #1 TREATED SYP	10/06/2022	11/08/2022	0.00	56.92	
43418 /1	CUST # 11239 2X608 #1 TREATED SYP	10/06/2022	11/08/2022	0.00	39.45	
43431 /1	CUST # 11239 SM STORAGE BOX 10 COMPT	10/07/2022	11/08/2022	0.00	61.97	
43442 /1	CUST # 11239 STEP LADDER 2' ALUM TYPE 1A	10/07/2022	11/08/2022	0.00	328.14	
43460 /1	CUST #11239 TUBE COPPER M 1/2"X2'	10/10/2022	11/08/2022	0.00	129.66	
43465 /1	CUST # 11239 CONTRACTOR BAG	10/10/2022	11/08/2022	0.00	53.97	
43482 /1	CUST # 11239 COM SWVL MNT LGHT CONTRL	10/11/2022	11/08/2022	0.00	35.98	
43498 /1	CUST # 11239 SPACKLING LIGHT 32 OZ	10/12/2022	11/08/2022	0.00	218.36	
43525 /1	CUST # 11239 RECIP SAW BLD 6" 8TPI	10/13/2022	11/08/2022	0.00	93.52	
43557 /1	CUST # 11239 BIT DRIL PERCUSN 3/16X4"	10/17/2022	11/08/2022	0.00	43.96	
43558 /1	CUST # 11239 WHLBRW INNR TUBE 8" RM	10/17/2022	11/08/2022	0.00	14.99	
43560 /1	CUST # 11239 2 X 6 X 12 # 1 TREATED	10/17/2022	11/08/2022	0.00	50.76	
43565 /1	CUST # 11239 ELBOW PVC 90 HUB 3"	10/17/2022	11/08/2022	0.00	63.96	
43580 /1	CUST # 11239 TEE SAN PVC 3"	10/18/2022	11/08/2022	0.00	35.97	
43596 /1	CUST # 11239 MTL CUT WHEEL 4X1/16X5/8	10/19/2022	11/08/2022	0.00	14.95	
43600 /1	CUST # 11239 SCREWS, NUTS & BOLTS	10/19/2022	11/08/2022	0.00	13.80	
43602 /1	CUST # 11239 LEVEL 3" LINE ALUM ACE	10/19/2022	11/08/2022	0.00	5.99	
43605 /1	CUST # 11239 STEP LADDER 2' ALUM TUYPE 1A	10/19/2022	11/08/2022	0.00	105.33	
43609 /1	CUST # 11239 FACE MOUNT HANGER LU26	10/19/2022	11/08/2022	0.00	23.85	
43623 /1	CUST # 11239 CAP PVC S&D 3" SOLV WELD	10/20/2022	11/08/2022	0.00	33.16	
43624 /1	CUST # 11239 FILTER AIR PLEAT 16X25X1	10/20/2022	11/08/2022	0.00	16.77	
43630 /1	CUST # 11239 2 X 6 X 08 #1 TREATED SYP	10/20/2022	11/08/2022	0.00	51.07	
43643 /1	CUST # 11239 8-18 X 1" SLF DRILL MTL SC	10/21/2022	11/08/2022	0.00	65.72	
43649 /1	CUST # 11239 BOX OUTLET PVC F5E 1/2"	10/21/2022	11/08/2022	0.00	30.57	
43671 /1	CUST # 11239 MOP PAD WETJET 15PK	10/24/2022	11/08/2022	0.00	27.97	

Payment Register

APPKT09955 - 11/08/22 A/P Run & P.O.'s

Vendor Number	Vendor Name					Total Vendor Amount
LOCPOS	LOCKHART POST REGISTER					1,189.35
Payment Type	Payment Number	Remittance Address	Payment Date	Payment Amount		
Check		111 S CHURCH LOCKHART, Texas 78644	11/01/2022	9.00		
Payable Number	Description	Payable Date	Due Date	Discount Amount	Payable Amount	
00093968	8/11/22 COUNTY RFB 22CF01B	08/11/2022	11/08/2022	0.00	9.00	
Check		111 S CHURCH LOCKHART, Texas 78644	11/01/2022	93.75		
Payable Number	Description	Payable Date	Due Date	Discount Amount	Payable Amount	
00094014	8/18/22 HIRING ELECTION WORKERS	08/18/2022	11/08/2022	0.00	93.75	
Check		111 S CHURCH LOCKHART, Texas 78644	11/01/2022	798.00		
Payable Number	Description	Payable Date	Due Date	Discount Amount	Payable Amount	
00094065	Lockhart Post Register Blanket PO FY 22-23	09/01/2022	11/08/2022	0.00	798.00	
Check		111 S CHURCH LOCKHART, Texas 78644	11/01/2022	129.00		
Payable Number	Description	Payable Date	Due Date	Discount Amount	Payable Amount	
00094119	9/22 CAREER IN LAW ENFORCEMENT	09/22/2022	11/08/2022	0.00	129.00	
Check		111 S CHURCH LOCKHART, Texas 78644	11/01/2022	129.00		
Payable Number	Description	Payable Date	Due Date	Discount Amount	Payable Amount	
00094133	9/29 CAREERS IN LAW ENFORCEMENT	09/29/2022	11/08/2022	0.00	129.00	
Check		111 S CHURCH LOCKHART, Texas 78644	11/01/2022	30.60		
Payable Number	Description	Payable Date	Due Date	Discount Amount	Payable Amount	
00094143	Lockhart Post Register Blanket PO FY 22-23	09/01/2022	11/08/2022	0.00	30.60	
LONLIV	LONGHORN S LIVESTOCK FEED					147.50
Payment Type	Payment Number	Remittance Address	Payment Date	Payment Amount		
Check		1501 E. PIERCE ST. LULING, Texas 78648-	11/01/2022	147.50		
Payable Number	Description	Payable Date	Due Date	Discount Amount	Payable Amount	
10800	SHERIFF'S OFFICE - COASTAL BALE TWO STRAND	10/21/2022	11/08/2022	0.00	147.50	
JCOJAN	M.B. HAMMO ENTERPRISES, LLC					1,785.81
Payment Type	Payment Number	Remittance Address	Payment Date	Payment Amount		
Check		101 UHLAND RD. BLDG. C SAN MARCOS, Texas 78666	11/01/2022	1,785.81		
Payable Number	Description	Payable Date	Due Date	Discount Amount	Payable Amount	
92528	J-COJAN Janitorial Supply	08/10/2022	11/08/2022	0.00	972.89	
92711	JCO Janitorial Supply Blanket PO FY 22-23	10/12/2022	11/08/2022	0.00	812.92	
DEPMOR	MIRANDA LEE GONZALES					310.00
Payment Type	Payment Number	Remittance Address	Payment Date	Payment Amount		
Check			11/01/2022	310.00		
Payable Number	Description	Payable Date	Due Date	Discount Amount	Payable Amount	
4083	. BODY REMOVAL	10/17/2022	11/08/2022	0.00	310.00	
NETDAT	NET DATA					8,980.00
Payment Type	Payment Number	Remittance Address	Payment Date	Payment Amount		
Check		1110 ENTERPRISE DRIVE SULPHUR SPRINGS, Texas 75482-	11/01/2022	8,980.00		
Payable Number	Description	Payable Date	Due Date	Discount Amount	Payable Amount	
ND-004220	SOFTWARE MAINT - RVI IMAGE 10/01/2022-9/30/23	09/01/2022	11/08/2022	0.00	8,980.00	

Payment Register

APPKT09955 - 11/08/22 A/P Run & P.O.'s

Vendor Number <u>OFFIDE</u>	Vendor Name ODP BUSINESS SOLUTIONS					Total Vendor Amount 1,041.60
Payment Type Check	Payment Number	Remittance Address PO BOX 660113 DALLAS, Texas 75266-0113	Payment Date 11/01/2022	Payment Amount 1,041.60		
Payable Number	Description	Payable Date	Due Date	Discount Amount	Payable Amount	
266543140001	ACCT # 43682634 TOTE, FLATLID, 4PK, 23 GAL, Y	10/17/2022	11/08/2022	0.00	97.98	
269372293001	ACCT # 43682634 FOLDER, 1/5 ET LTR BOT KF	10/08/2022	11/08/2022	0.00	312.95	
269373760001	ACCT # 43682634 STAPLER, DESK, STD, FULL, BL	10/10/2022	11/08/2022	0.00	25.78	
272421432001	ACCT # 43682634 TONER HP 55A LJ P3015 BI	10/12/2022	11/08/2022	0.00	276.34	
272896627001	ACCT # 43682634 SURGE, 12OUT, TEL, DSS	10/12/2022	11/08/2022	0.00	47.09	
272896858001	ACCT # 43682634 TRIPP LITE SMARTRACK SRW	10/12/2022	11/08/2022	0.00	221.79	
272973537001	ACCT # 43682634 PAPER, BOND 24X100	10/12/2022	11/08/2022	0.00	59.67	

Vendor Number <u>O'REIL</u>	Vendor Name O'REILLY AUTOMOTIVE, INC.					Total Vendor Amount 504.52
Payment Type Check	Payment Number	Remittance Address PO BOX 9464 SPRINGFIELD, Missouri 65801-9464	Payment Date 11/01/2022	Payment Amount 504.52		
Payable Number	Description	Payable Date	Due Date	Discount Amount	Payable Amount	
0642-117512	CUST # 188092 BATTERY	10/10/2022	11/08/2022	0.00	206.54	
0642-119064	CUST # 188092 AIR REEL	10/17/2022	11/08/2022	0.00	286.99	
0642-119554	CUST # 188092 TOGGLE SWITCH	10/19/2022	11/08/2022	0.00	10.99	

Vendor Number <u>ORKIN</u>	Vendor Name ORKIN - AUSTIN COMMERCIAL					Total Vendor Amount 320.00
Payment Type Check	Payment Number	Remittance Address 5810 TRADE CENTER DR, STE 300 BLDG 1 AUSTIN, Texas 78744-1365	Payment Date 11/01/2022	Payment Amount 320.00		
Payable Number	Description	Payable Date	Due Date	Discount Amount	Payable Amount	
233042299	ACCT # 29121597 PC STANDARD - MONTHLY	09/09/2022	11/08/2022	0.00	320.00	

Vendor Number <u>PAUEVA</u>	Vendor Name PAUL MATTHEW EVANS					Total Vendor Amount 1,214.04
Payment Type Check	Payment Number	Remittance Address P.O. BOX 660 LOCKHART, Texas 78644-	Payment Date 11/01/2022	Payment Amount 1,214.04		
Payable Number	Description	Payable Date	Due Date	Discount Amount	Payable Amount	
101422	CAUSE # NI JOE	10/14/2022	11/08/2022	0.00	400.00	
49,475	CAUSE # 49.475 STEPHEN	10/05/2022	11/08/2022	0.00	814.04	

Vendor Number <u>PFGTEM</u>	Vendor Name PERFORMANCE FOODSERVICE - TEMPLE					Total Vendor Amount 8,552.13
Payment Type Check	Payment Number	Remittance Address P.O. BOX 208391 DALLAS, Texas 75320-8391	Payment Date 11/01/2022	Payment Amount 8,552.13		
Payable Number	Description	Payable Date	Due Date	Discount Amount	Payable Amount	
1726819	435577	10/03/2022	11/08/2022	0.00	1,689.40	
1730718	435577	10/06/2022	11/08/2022	0.00	1,726.69	
1733402	435577	10/10/2022	11/08/2022	0.00	1,679.31	
1737378	cust # 435577	10/13/2022	11/08/2022	0.00	1,879.10	
1740045	cust # 435577	10/17/2022	11/08/2022	0.00	1,577.63	

Vendor Number <u>PETTRA</u>	Vendor Name PETROLEUM TRADERS CORPORATION					Total Vendor Amount 11,535.12
Payment Type Check	Payment Number	Remittance Address P.O. Box 2357 FORT WAYNE, Indiana 46801-2357	Payment Date 11/01/2022	Payment Amount 11,535.12		
Payable Number	Description	Payable Date	Due Date	Discount Amount	Payable Amount	
148285	Petroleum Traders Blanket PO FY 22-23	10/17/2022	11/08/2022	0.00	659.22	
1817121	990644/1	10/12/2022	11/08/2022	0.00	10,875.90	

Payment Register

APPKT09955 - 11/08/22 A/P Run & P.O.'s

Vendor Number	Vendor Name					Total Vendor Amount
PRISOL	PRINTING SOLUTIONS					416.82
Payment Type	Payment Number	Remittance Address	Payment Date	Payment Amount		
Check		113 E. SAN ANTONIO ST LOCKHART, Texas 78644	11/01/2022	416.82		
Payable Number	Description	Payable Date	Due Date	Discount Amount	Payable Amount	
2797 POS	SIGNS BANNERS 3X6 VOTES HERE BANNER	10/06/2022	11/08/2022	0.00	198.00	
2889 POS	ENVELOPE 2 10 # 10 REGULAR ENVELOPES	10/25/2022	11/08/2022	0.00	218.82	
Vendor Number	Vendor Name					Total Vendor Amount
PROMIC	PROGRESSIVE MICROTECHNOLOGY, INC.					217.21
Payment Type	Payment Number	Remittance Address	Payment Date	Payment Amount		
Check		4475 US 1 SOUTH, UNIT 501 SAINT AUGUSTINE, Florida 32086-	11/01/2022	217.21		
Payable Number	Description	Payable Date	Due Date	Discount Amount	Payable Amount	
221029	EVIDENCE LABEL KIT	10/18/2022	11/08/2022	0.00	217.21	
Vendor Number	Vendor Name					Total Vendor Amount
QUAFIN	QUADIENT FINANCE USA, INC					5,017.47
Payment Type	Payment Number	Remittance Address	Payment Date	Payment Amount		
Check		PO BOX 6813 CAROL STREAM, Illinois 60197-6813	11/01/2022	308.57		
Payable Number	Description	Payable Date	Due Date	Discount Amount	Payable Amount	
101222	ACCT # 7900 0440 8052 6951 POSTAGE 9/16 & 10/06	10/12/2022	11/08/2022	0.00	308.57	
Check		PO BOX 6813 CAROL STREAM, Illinois 60197-6813		11/01/2022	1,660.19	
Payable Number	Description	Payable Date	Due Date	Discount Amount	Payable Amount	
101620200	ACCT # 7900 0440 8010 9295 9/22 & 10/04	10/16/2022	11/08/2022	0.00	1,660.19	
Check		PO BOX 6813 CAROL STREAM, Illinois 60197-6813		11/01/2022	3,048.71	
Payable Number	Description	Payable Date	Due Date	Discount Amount	Payable Amount	
101622	ACCT # 7900 0440 8038 5499 9/19/22	10/16/2022	11/08/2022	0.00	3,048.71	
Vendor Number	Vendor Name					Total Vendor Amount
QUALEA	QUADIENT LEASING USA, INC					345.11
Payment Type	Payment Number	Remittance Address	Payment Date	Payment Amount		
Check		PO BOX 123682, DEPT 3682 DALLAS, Texas 75312-3682	11/01/2022	345.11		
Payable Number	Description	Payable Date	Due Date	Discount Amount	Payable Amount	
N9624094	cust # 01054254	10/09/2022	11/08/2022	0.00	345.11	
Vendor Number	Vendor Name					Total Vendor Amount
QUELTD	QUESTICA LTD					19,500.00
Payment Type	Payment Number	Remittance Address	Payment Date	Payment Amount		
Check		FILE 2321 1801 W. OLYMPIC BLVD PASADENA, California 91199-2321	11/01/2022	19,500.00		
Payable Number	Description	Payable Date	Due Date	Discount Amount	Payable Amount	
INV113198-REV	Qustica Software: Year 2	10/01/2022	11/08/2022	0.00	19,500.00	
Vendor Number	Vendor Name					Total Vendor Amount
QUICOR	QUILL CORPORATION					62.06
Payment Type	Payment Number	Remittance Address	Payment Date	Payment Amount		
Check		P.O. BOX 37600 PHILADELPHIA, Pennsylvania 19101-0600	11/01/2022	62.06		
Payable Number	Description	Payable Date	Due Date	Discount Amount	Payable Amount	
28180325	ACCT # 4881802 6FT VGA M M HI RES COAX HD15	10/06/2022	11/08/2022	0.00	10.49	
28188218	ACCT # 4881802 6FT VGA M M HI RES COAX HD 15	10/06/2022	11/08/2022	0.00	25.58	
28233666	ACCT # 4881802 QSI P50 1.06 X 2.63	10/10/2022	11/08/2022	0.00	25.99	

Payment Register

APPKT09955 - 11/08/22 A/P Run & P.O.'s

Vendor Number ROBHAE	Vendor Name ROBERT A HAEDGE					Total Vendor Amount 2,210.00
Payment Type Check	Payment Number	Remittance Address 1987 TUMBLEWEED TRAIL DALE, Texas 78616-	Payment Date 11/01/2022	Payment Amount 2,210.00		
Payable Number 21-108	Description CAUSE # 21-108 AARON GLEN	Payable Date 10/21/2022	Due Date 11/08/2022	Discount Amount 0.00	Payable Amount 1,205.00	
21-241	CAUSE # 21-241 RUDY YANEZ	10/20/2022	11/08/2022	0.00	1,005.00	

Vendor Number SALMER	Vendor Name SALT FLAT MERCANTILE, LLC					Total Vendor Amount 166.45
Payment Type Check	Payment Number	Remittance Address 898 N. MAGNOLIA AVE P.O. BOX 1281 LULING, Texas 78648-	Payment Date 11/01/2022	Payment Amount 166.45		
Payable Number 15583-43809	Description CUST # 27269 HOSE	Payable Date 10/18/2022	Due Date 11/08/2022	Discount Amount 0.00	Payable Amount 64.19	
15583-43896	CUST # 27269 STRIKER LIGHTER	10/19/2022	11/08/2022	0.00	102.26	

Vendor Number SAMROS	Vendor Name SAMUEL ROSEN					Total Vendor Amount 700.00
Payment Type Check	Payment Number	Remittance Address 2424 WOOLDRIDGE DR AUSTIN, Texas 78703-	Payment Date 11/01/2022	Payment Amount 700.00		
Payable Number 49,169	Description CAUSE # 49,169 JOSE	Payable Date 10/07/2022	Due Date 11/08/2022	Discount Amount 0.00	Payable Amount 700.00	

Vendor Number SCHSON	Vendor Name SCHMIDT & SONS, INC					Total Vendor Amount 13,636.51
Payment Type Check	Payment Number	Remittance Address PO BOX 232 GONZALES, Texas 78629-	Payment Date 11/01/2022	Payment Amount 13,636.51		
Payable Number 0501228-IN	Description Cust # 05-Caldco	Payable Date 08/22/2022	Due Date 11/08/2022	Discount Amount 0.00	Payable Amount 10,832.61	
0504048-IN	05-CALDCO	10/17/2022	11/08/2022	0.00	2,803.90	

Vendor Number REDAUT	Vendor Name SEAN MATTHEW MANN					Total Vendor Amount 2,942.09
Payment Type Check	Payment Number	Remittance Address 204 NORTH COMMERCE LOCKHART, Texas 78644-	Payment Date 11/01/2022	Payment Amount 2,942.09		
Payable Number 146702	Description ACCT # 2010 CORE DEPOSIT	Payable Date 10/19/2022	Due Date 10/19/2022	Discount Amount 0.00	Payable Amount -18.00	
146905	ACCT # 2010 LUCAS HUB OIL	10/19/2022	11/08/2022	0.00	71.22	
146906	ACCT # 2010 BRAKE PARTS CLEANER	10/19/2022	11/08/2022	0.00	148.44	
147774	ACCT # 2010 NAPA GOLD AIR FILTER	10/06/2022	11/08/2022	0.00	51.52	
147882	ACCT # 2010 2 YR WTY BAT	10/10/2022	11/08/2022	0.00	169.99	
147920	ACCT # 2010 OIL DRY	10/10/2022	11/08/2022	0.00	39.40	
147955	CUST # 2010 NAPA HYDRAULIC FILTER	10/11/2022	11/08/2022	0.00	92.62	
148023	ACCT # 2010 NAPA 10W30 5 QUART	10/12/2022	11/08/2022	0.00	53.97	
148031	ACCT # 2010 18 MO WTY BAT	10/12/2022	11/08/2022	0.00	184.97	
148118	ACCT # 2010 BRAKE PARTS CLEANER	10/13/2022	11/08/2022	0.00	280.32	
148141	ACCT # 2010 BLUE DEF 2.5 GAL	10/14/2022	11/08/2022	0.00	465.11	
148296	2010	10/18/2022	11/08/2022	0.00	569.38	
148301	ACCT # 2010 CORE DEPOSIT	10/18/2022	10/18/2022	0.00	-108.00	
148392	Redhead Auto Parts Blanket PO FY 22-23	10/19/2022	11/08/2022	0.00	669.98	
148403	ACCT # 2010 SWITCH - TOOGLE	10/19/2022	11/08/2022	0.00	18.78	
148418	ACCT # 2010 NAPA GOLD OIL FILTER	10/19/2022	11/08/2022	0.00	205.97	
148439	ACCT # 2010 NAPAGOLD FUEL FILER	10/20/2022	11/08/2022	0.00	7.88	
148467	ACCT # 2010 SPLASH GUARD - NAPA L	10/20/2022	11/08/2022	0.00	38.54	

Payment Register

APPKT09955 - 11/08/22 A/P Run & P.O.'s

Vendor Number	Vendor Name						Total Vendor Amount
SECONE	SECURITY ONE, INC						50.00
Payment Type	Payment Number	Remittance Address	Payment Date	Payment Amount			
Check		716 W. BYRD BLVD UNIVERSAL CITY, Texas 78148-	11/01/2022	25.00			
Payable Number	Description	Payable Date	Due Date	Discount Amount	Payable Amount		
1071706	CUST # 805335 OCT 2022	10/01/2022	11/08/2022	0.00	25.00		
Check		716 W. BYRD BLVD UNIVERSAL CITY, Texas 78148-	11/01/2022	25.00			
Payable Number	Description	Payable Date	Due Date	Discount Amount	Payable Amount		
1076089	CUST # 805335 NOVEMBER 2022	11/01/2022	11/08/2022	0.00	25.00		
Vendor Number	Vendor Name						Total Vendor Amount
SHIGOV	SHI GOVERNMENT SOLUTIONS, INC.						1,695.31
Payment Type	Payment Number	Remittance Address	Payment Date	Payment Amount			
Check		P.O. BOX 847434 DALLAS, Texas 75284-7434	11/01/2022	1,695.31			
Payable Number	Description	Payable Date	Due Date	Discount Amount	Payable Amount		
GB00412105	CUST # 3000529 ACROBAT PROFESSIONAL	05/14/2022	11/08/2022	0.00	423.49		
GB00432228	CUST # 3000529 SALES ORDER GS00697134	10/22/2022	11/08/2022	0.00	423.94		
GB00439874	CUST # 3000529 ACROBAT PROFESSIONAL, LICENSE NEW	12/29/2021	11/08/2022	0.00	847.88		
Vendor Number	Vendor Name						Total Vendor Amount
SMISUP	SMITH SUPPLY CO.- LOCKHART						202.20
Payment Type	Payment Number	Remittance Address	Payment Date	Payment Amount			
Check		1830 S. COLORADO LOCKHART, Texas 78644	11/01/2022	202.20			
Payable Number	Description	Payable Date	Due Date	Discount Amount	Payable Amount		
949580	RECIP BLADE 18TX6 5PK	10/13/2022	11/08/2022	0.00	26.90		
949685	AXE CAMP HICKORY 1-1/4 # 33160	10/14/2022	11/08/2022	0.00	44.90		
950137	SAFETY CONE CRANCK 28"	10/19/2022	11/08/2022	0.00	33.85		
950264	ANGLE METAL 3"X2" X 3/16"	10/20/2022	11/08/2022	0.00	68.95		
950584	WEATHER PROOF REC BX 30215-5	10/24/2022	11/08/2022	0.00	17.65		
950593	WP POWER RNCPT COVER	10/24/2022	11/08/2022	0.00	9.95		
Vendor Number	Vendor Name						Total Vendor Amount
SMILLUL	SMITH SUPPLY CO.-LULING						262.95
Payment Type	Payment Number	Remittance Address	Payment Date	Payment Amount			
Check		1150 N. MAGNOLIA-N. 183 LULING, Texas 78648	11/01/2022	262.95			
Payable Number	Description	Payable Date	Due Date	Discount Amount	Payable Amount		
103810	RED HI-LIFT JACK HL -485	10/21/2022	11/08/2022	0.00	112.95		
103880	CAR SCREW 5/16 X 2-1/2	10/24/2022	11/08/2022	0.00	150.00		
Vendor Number	Vendor Name						Total Vendor Amount
SOUHEA	SOUTHERN HEALTH PARTNERS, INC.						48,322.45
Payment Type	Payment Number	Remittance Address	Payment Date	Payment Amount			
Check		2030 HAMILTON PLACE BLVD., STE 140 CHATTANOOGA, Tennessee 37421-	11/01/2022	48,322.45			
Payable Number	Description	Payable Date	Due Date	Discount Amount	Payable Amount		
BASE45569	CAL-7388	10/02/2022	11/08/2022	0.00	48,322.45		
Vendor Number	Vendor Name						Total Vendor Amount
SOUTIR	SOUTHERN TIRE MART, LLC						2,442.01
Payment Type	Payment Number	Remittance Address	Payment Date	Payment Amount			
Check		DEPT.143 P.O. BOX 1000 MEMPHIS, Tennessee 38148-0143	11/01/2022	2,442.01			
Payable Number	Description	Payable Date	Due Date	Discount Amount	Payable Amount		
4650129535	0280894	10/07/2022	11/08/2022	0.00	319.50		
4650130776	0142726	10/20/2022	11/08/2022	0.00	1,708.56		

Payment Register

APPKT09955 - 11/08/22 A/P Run & P.O.'s

[4650130859](#) CUST # 0142726 SOTERA STH1+ AP 10/19/2022 11/08/2022 0.00 413.95

Vendor Number **Vendor Name** **Total Vendor Amount**
[SUPEDI](#) SUPERIOR DISPOSAL, LLC 3,525.00

Payment Type **Payment Number** **Remittance Address** **Payment Date** **Payment Amount**
 Check PO BOX 2120 11/01/2022 3,525.00
 SAN MARCOS, Texas 78667-

Payable Number	Description	Payable Date	Due Date	Discount Amount	Payable Amount
35957	Dumpster rental for clean up day	08/09/2022	11/08/2022	0.00	575.00
38989	01-3472 7	10/10/2022	11/08/2022	0.00	2,950.00

Vendor Number **Vendor Name** **Total Vendor Amount**
[SYSCO](#) SYSCO CENTRAL TEXAS, INC 6,363.81

Payment Type **Payment Number** **Remittance Address** **Payment Date** **Payment Amount**
 Check 1260 SCHWAB ROAD 11/01/2022 6,363.81
 NEW BRAUNFELS, Texas 78132-5155

Payable Number	Description	Payable Date	Due Date	Discount Amount	Payable Amount
613904419	043430	10/05/2022	11/08/2022	0.00	106.49
613904420	043430	10/05/2022	11/08/2022	0.00	1,744.90
613912357	043430	10/07/2022	11/08/2022	0.00	71.00
613912358	043430	10/07/2022	11/08/2022	0.00	1,740.43
613927874	043430	10/12/2022	11/08/2022	0.00	67.78
613927875	043430	10/12/2022	11/08/2022	0.00	157.90
613927876	cust # 043430	10/12/2022	11/08/2022	0.00	862.68
613935884	043430	10/14/2022	11/08/2022	0.00	77.04
613935885	cust # 043430	10/14/2022	11/08/2022	0.00	1,535.59

Vendor Number **Vendor Name** **Total Vendor Amount**
[T7ENTE](#) T7 ENTERPRISES, LLC 1,456.00

Payment Type **Payment Number** **Remittance Address** **Payment Date** **Payment Amount**
 Check P.O. BOX 1418 11/01/2022 1,456.00
 3345 E. STATE HWY 29
 BURNET, Texas 78611

Payable Number	Description	Payable Date	Due Date	Discount Amount	Payable Amount
16003	T7 Enterprises, LLC - Tire Disposal	10/01/2022	11/08/2022	0.00	1,456.00

Vendor Number **Vendor Name** **Total Vendor Amount**
[TACRIS](#) TEXAS ASSOCIATION OF COUNTIES 198,587.00

Payment Type **Payment Number** **Remittance Address** **Payment Date** **Payment Amount**
 Check RISK MANAGEMENT POOL 11/01/2022 198,587.00
 P.O. BOX 2426
 San Antonio, Texas 78298-9900

Payable Number	Description	Payable Date	Due Date	Discount Amount	Payable Amount
37215	0280	10/01/2022	11/08/2022	0.00	198,587.00

Vendor Number **Vendor Name** **Total Vendor Amount**
[DEPPUB](#) TEXAS DEPT. OF PUBLIC SAFETY 3.00

Payment Type **Payment Number** **Remittance Address** **Payment Date** **Payment Amount**
 Check PO BOX 15999 11/01/2022 3.00
 AUSTIN, Texas 78761-5999

Payable Number	Description	Payable Date	Due Date	Discount Amount	Payable Amount
CRS-202209-248007	9/01 - 20/2022 SECURE SITE CCH 3 NAME SEARCHES	09/30/2022	11/08/2022	0.00	3.00

Vendor Number **Vendor Name** **Total Vendor Amount**
[TEXVITST](#) TEXAS DEPT.OF STATE HEALTH SERVICES 75.03

Payment Type **Payment Number** **Remittance Address** **Payment Date** **Payment Amount**
 Check VITAL STATISTICS UNIT-MC 1966 11/01/2022 75.03
 P.O.BOX 149347
 AUSTIN, Texas 78714-9347

Payable Number	Description	Payable Date	Due Date	Discount Amount	Payable Amount
2017430	ACCT # 17460016318 007 SEPTEMBER 2022	10/03/2022	11/08/2022	0.00	75.03

Payment Register

APPKT09955 - 11/08/22 A/P Run & P.O.'s

Vendor Number	Vendor Name					Total Vendor Amount
TDCA	TEXAS DISTRICT COURT ALLIANCE					150.00
Payment Type	Payment Number	Remittance Address	Payment Date	Payment Amount		
Check		c/o SHERRY GRIFFIS, TREASURER 200 W. HOUSTON ST., STE 234 MARSHALL, Texas 75670-	11/01/2022	100.00		
Payable Number	Description	Payable Date	Due Date	Discount Amount	Payable Amount	
8152022	REBECCA	10/18 - 20/22	08/15/2022	11/08/2022	0.00	100.00
Check		c/o SHERRY GRIFFIS, TREASURER 200 W. HOUSTON ST., STE 234 MARSHALL, Texas 75670-			11/01/2022	50.00
Payable Number	Description	Payable Date	Due Date	Discount Amount	Payable Amount	
81522	JUANITA	10/18 - 20/22	08/15/2022	11/08/2022	0.00	50.00
Vendor Number	Vendor Name					Total Vendor Amount
SWTSU	TEXAS JUSTICE COURT TRAINING CENTER					545.00
Payment Type	Payment Number	Remittance Address	Payment Date	Payment Amount		
Check		1701 DIRECTORS BLVD., SUITE 530 AUSTIN, Texas 78744-	11/01/2022	185.00		
Payable Number	Description	Payable Date	Due Date	Discount Amount	Payable Amount	
63366	SHANNA	2/05/23 FY_23 JUSTICE OF THE PEA	09/16/2022	11/08/2022	0.00	185.00
Check		1701 DIRECTORS BLVD., SUITE 530 AUSTIN, Texas 78744-			11/01/2022	310.00
Payable Number	Description	Payable Date	Due Date	Discount Amount	Payable Amount	
63755	AMY	4/25/23 FY_23 VIRTUAL	09/14/2022	11/08/2022	0.00	50.00
Check		1701 DIRECTORS BLVD., SUITE 530 AUSTIN, Texas 78744-			11/01/2022	50.00
Payable Number	Description	Payable Date	Due Date	Discount Amount	Payable Amount	
63771	LAURA	1/10/22 FY_23 VIRTUAL NEW COURT PER	09/14/2022	11/08/2022	0.00	50.00
Check		1701 DIRECTORS BLVD., SUITE 530 AUSTIN, Texas 78744-			11/01/2022	310.00
Payable Number	Description	Payable Date	Due Date	Discount Amount	Payable Amount	
64216	JAMIE	5/16/23 / CORPUS CHRISTI	10/19/2022	11/08/2022	0.00	260.00
Vendor Number	Vendor Name					Total Vendor Amount
GONINQ	THE GONZALES INQUIRER					63.00
Payment Type	Payment Number	Remittance Address	Payment Date	Payment Amount		
Check		P.O. BOX 1777 CEDAR PARK, Texas 78630-	11/01/2022	63.00		
Payable Number	Description	Payable Date	Due Date	Discount Amount	Payable Amount	
33347	3X3 - CORRECTIONAL OFFICER & COOK	09/29/2022	11/08/2022	0.00	63.00	
Vendor Number	Vendor Name					Total Vendor Amount
LULNEW	THE LULING NEWSBOY & SIGNAL					862.13
Payment Type	Payment Number	Remittance Address	Payment Date	Payment Amount		
Check		LULING PUBLISHING CO., INC. P.O. BOX 352 LULING, Texas 78648-	11/01/2022	862.13		
Payable Number	Description	Payable Date	Due Date	Discount Amount	Payable Amount	
90122	9/01 NOTICE OF HEARING ON TAX RATE	09/01/2022	11/08/2022	0.00	244.13	
9302022	9/29 HELP WANTED - CAREER IN LAW ENFORCEMENT	09/29/2022	11/08/2022	0.00	49.00	
93022	9/22 HELP WANTED - CAREER IN LAW ENFORCEMENT	09/22/2022	11/08/2022	0.00	49.00	
Luling Newsboy	Community collections event Newsboy	09/30/2022	11/08/2022	0.00	520.00	
Vendor Number	Vendor Name					Total Vendor Amount
THEPOL	THE POLICE AND SHERIFFS PRESS					17.58
Payment Type	Payment Number	Remittance Address	Payment Date	Payment Amount		
Check		P.O. BOX 1489 LYONS, Georgia 30436-	11/01/2022	17.58		
Payable Number	Description	Payable Date	Due Date	Discount Amount	Payable Amount	
168706	ID CARDS	10/07/2022	11/08/2022	0.00	17.58	

Payment Register

APPKT09955 - 11/08/22 A/P Run & P.O.'s

Vendor Number	Vendor Name					Total Vendor Amount
WESGRO	THOMSON REUTERS - WEST PUBLISHING CORP					360.00
Payment Type	Payment Number	Remittance Address	Payment Date	Payment Amount		
Check		THOMSON REUTERS - WEST PAYMENT CENTER P.O. BOX 6292 CAROL STREAM, Illinois 60197-6292	11/01/2022	360.00		
Payable Number	Description	Payable Date	Due Date	Discount Amount	Payable Amount	
847093677-1	ACCT # 1000732986 ONLINE/SOFTWARE SUBSCRIPTION	10/01/2022	11/08/2022	0.00	360.00	
Vendor Number	Vendor Name					Total Vendor Amount
TOSBLA	TOSA BLANKS & MORE, INC.					1,400.00
Payment Type	Payment Number	Remittance Address	Payment Date	Payment Amount		
Check		5423 JACKWOOD DRIVE SAN ANTONIO, Texas 78238-	11/01/2022	1,400.00		
Payable Number	Description	Payable Date	Due Date	Discount Amount	Payable Amount	
71397	cust # 2118	07/21/2022	11/08/2022	0.00	1,400.00	
Vendor Number	Vendor Name					Total Vendor Amount
TRARIS	TRANSUNION RISK AND ALTERNATIVE DATA SOLUTIONS, I					1,200.00
Payment Type	Payment Number	Remittance Address	Payment Date	Payment Amount		
Check		P.O. BOX 209047 DALLAS, Texas 75320-9047	11/01/2022	1,200.00		
Payable Number	Description	Payable Date	Due Date	Discount Amount	Payable Amount	
81179110212022	TLO Services Constable 1	10/21/2022	11/08/2022	0.00	1,200.00	
Vendor Number	Vendor Name					Total Vendor Amount
TYLBEL	TYLER MICHAEL BELL					240.00
Payment Type	Payment Number	Remittance Address	Payment Date	Payment Amount		
Check			11/01/2022	240.00		
Payable Number	Description	Payable Date	Due Date	Discount Amount	Payable Amount	
10252022	12 ATTEMPTS	10/25/2022	11/08/2022	0.00	240.00	
Vendor Number	Vendor Name					Total Vendor Amount
TYLTEC	TYLER TECHNOLOGIES, INC.					128,484.38
Payment Type	Payment Number	Remittance Address	Payment Date	Payment Amount		
Check		P.O. BOX 203556 DALLAS, Texas 75320-3556	11/01/2022	128,484.38		
Payable Number	Description	Payable Date	Due Date	Discount Amount	Payable Amount	
020-137741	47804	09/16/2022	11/08/2022	0.00	26,598.00	
025-390085	cust # 47804	08/10/2022	11/08/2022	0.00	48,572.00	
025-390157	cust # 47804	09/01/2022	11/08/2022	0.00	12,147.38	
130 131321	47804	10/01/2022	11/08/2022	0.00	41,167.00	
Vendor Number	Vendor Name					Total Vendor Amount
UNIFIR	UNIFIRST CORPORATION					141.04
Payment Type	Payment Number	Remittance Address	Payment Date	Payment Amount		
Check		PO BOX 650481 DALLAS, Texas 75265-0481	11/01/2022	141.04		
Payable Number	Description	Payable Date	Due Date	Discount Amount	Payable Amount	
8222532316	cust # 222727	08/12/2022	11/08/2022	0.00	66.78	
8222548288	cust # 222727	10/14/2022	11/08/2022	0.00	74.26	
Vendor Number	Vendor Name					Total Vendor Amount
UNRENT	UNITED RENTALS (NORTH AMERICA), INC.					256.45
Payment Type	Payment Number	Remittance Address	Payment Date	Payment Amount		
Check		P.O. BOX 840514 DALLAS, Texas 75284-0514	11/01/2022	256.45		
Payable Number	Description	Payable Date	Due Date	Discount Amount	Payable Amount	
211784019-001	CUST # 1331322 DEMO HAMMER 27 - 34 # ELECTRIC	10/17/2022	11/08/2022	0.00	256.45	

Payment Register

APBKT09955 - 11/08/22 A/P Run & P.O.'s

Vendor Number UNIENV	Vendor Name UNIVERSAL ENVIRONMENTAL SERVICES, LLC					Total Vendor Amount 38.85
Payment Type Check	Payment Number	Remittance Address 411 DIVIDEND DRIVE PEACHTREE CITY, Georgia 30269-	Payment Date 11/01/2022			Payment Amount 38.85
Payable Number IN0485298	Description CUST # CAL171 OILY WATER	Payable Date 10/17/2022	Due Date 11/08/2022	Discount Amount 0.00	Payable Amount 12.25	
IN0485364	CUST # CAL171 OILY WATER	10/17/2022	11/08/2022	0.00	13.65	
IN0485371	CUST # CAL171 OILY WATER	10/17/2022	11/08/2022	0.00	12.95	

Vendor Number VICBRO	Vendor Name VICTOREA D. BROWN					Total Vendor Amount 355.00
Payment Type Check	Payment Number	Remittance Address 1920-A CORPRATE DRIVE SUITE 203 SAN MARCOS, Texas 78666	Payment Date 11/01/2022			Payment Amount 355.00
Payable Number 10172022	Description CAUSE # UI ERICA ANN	Payable Date 10/17/2022	Due Date 11/08/2022	Discount Amount 0.00	Payable Amount 355.00	

Vendor Number VISTA	Vendor Name VISTA SOLUTIONS, LP					Total Vendor Amount 7,122.50
Payment Type Check	Payment Number	Remittance Address 9020 N. CAPITAL OF TEXAS HWY BLDG 1, SUITE 210 AUSTIN, Texas 78759-	Payment Date 11/01/2022			Payment Amount 7,122.50
Payable Number 11352	Description Licenses/Support	Payable Date 10/14/2022	Due Date 11/08/2022	Discount Amount 0.00	Payable Amount 7,122.50	

Vendor Number CNASUR	Vendor Name WESTERN SURETY COMPANY					Total Vendor Amount 277.50
Payment Type Check	Payment Number	Remittance Address P.O. BOX 957312 ST LOUIS, Missouri 63195-7312	Payment Date 11/01/2022			Payment Amount 227.50
Payable Number 64441385	Description BARBARA	Payable Date 10/27/2022	Due Date 11/08/2022	Discount Amount 0.00	Payable Amount 177.50	
72501923	BOND #	09/19/2022	11/08/2022	0.00	50.00	
Check		P.O. BOX 957312 ST LOUIS, Missouri 63195-7312		11/01/2022	50.00	
Payable Number 72501925	Description BOND #	Payable Date 09/19/2022	Due Date 11/08/2022	Discount Amount 0.00	Payable Amount 50.00	

Vendor Number WJCCON	Vendor Name WJC CONSTRUCTORS SERVICES, LLC					Total Vendor Amount 120,396.05
Payment Type Check	Payment Number	Remittance Address PO BOX 104 SMITHVILLE, Texas 78957-	Payment Date 11/01/2022			Payment Amount 120,396.05
Payable Number App. No. 3 Black Ankle	Description Black Ankle Rd at Dry Branch	Payable Date 10/21/2022	Due Date 11/08/2022	Discount Amount 0.00	Payable Amount 45,861.99	
App. No. 3 Witter Rd	Witter Rd at Jerry Creek	10/21/2022	11/08/2022	0.00	37,151.12	
App. No. 4 Political Rd	Political Rd at Dickerson Creek	10/21/2022	11/08/2022	0.00	37,382.94	

Vendor Number WOLENT	Vendor Name WOLFCOM ENTERPRISES					Total Vendor Amount 1,826.40
Payment Type Check	Payment Number	Remittance Address 1700 LINCOLN AVE PASADENA, California 91103-	Payment Date 11/01/2022			Payment Amount 1,826.40
Payable Number SI-00011202	Description Wolfcom Halo Body Worn Camera	Payable Date 10/21/2022	Due Date 11/08/2022	Discount Amount 0.00	Payable Amount 1,826.40	

Payment Register

APPKT09955 - 11/08/22 A/P Run & P.O.'s

Vendor Number XERCOR	Vendor Name XEROX CORPORATION					Total Vendor Amount 9,421.86
Payment Type Check	Payment Number	Remittance Address P.O. BOX 202882 DALLAS, Texas 75320-2882	Payment Date 11/01/2022	Payment Amount 4,710.93		
Payable Number 3474714	Description 001-0063777-002		Payable Date 09/10/2022	Due Date 11/08/2022	Discount Amount 0.00	Payable Amount 4,710.93
Check		P.O. BOX 202882 DALLAS, Texas 75320-2882			11/01/2022	4,710.93
Payable Number 3530777	Description Xerox Lease Blanket PO FY 22-23		Payable Date 10/10/2022	Due Date 11/08/2022	Discount Amount 0.00	Payable Amount 4,710.93
Vendor Number XLPART	Vendor Name XL PARTS, LLC					Total Vendor Amount 693.74
Payment Type Check	Payment Number	Remittance Address PO BOX 736201 DALLAS, Texas 75373-6201	Payment Date 11/01/2022	Payment Amount 693.74		
Payable Number 0416PU5934	Description CUST # 490536 9/30/22 SERVICE CHR		Payable Date 10/19/2022	Due Date 11/08/2022	Discount Amount 0.00	Payable Amount 0.30
0416PX6463	CUST # 490093 AIR FITLER		10/05/2022	11/08/2022	0.00	240.32
0416PY6800	CUST # 490093 AIR FILTER		10/06/2022	11/08/2022	0.00	98.20
0416PZ2266	CUST # 490093 AIR FITLER		10/06/2022	11/08/2022	0.00	24.96
0416QF0072	CUST #490093 AIR FILTER		10/13/2022	11/08/2022	0.00	329.96

Payment Summary

Bank Code	Type	Payable Count	Payment Count	Discount	Payment
2022 AP BNK	Check	310	149	0.00	977,892.13
Packet Totals:		310	149	0.00	977,892.13

Cash Fund Summary

Fund	Name	Amount
999	POOLED CASH	-977,892.13
Packet Totals:		-977,892.13



Vendor Name	Payable Number	Description (Item)	Account Name	Account Number	Amount
Fund: 001 - GENERAL FUND					
QUADIENT FINANCE USA, INC	101620200	ACCT # 7900 0440 8010 9295 ...	POSTAGE INVENTORY	001-1370	1,660.19
QUADIENT FINANCE USA, INC	101622	ACCT # 7900 0440 8038 5499 ...	POSTAGE INVENTORY	001-1370	3,048.71
FLEETCOR TECHNOLOGIES, INC	NP63152536	ACCT # BG114286 BILL PERIOD..	DUE FROM C C A D	001-1260	424.78
					5,133.68
Department : 2120 - COUNTY TREASURER					
GERMER INSURANCE, INC	6S655919	REBECCA DIAZ - DEPUTY COU...	EMPLOYEE BONDING	001-2120-2070	60.00
					Department 2120 - COUNTY TREASURER Total: 60.00
Department : 2150 - COUNTY CLERK					
DEWITT POTH & SON	698167--0	Paper	OFFICE SUPPLIES	001-2150-3110	508.80
TEXAS DEPT.OF STATE HEALTH...	2017430	ACCT # 17460016318 007 SEP...	Remote Site Trans Fees	001-2150-3145	75.03
SHI GOVERNMENT SOLUTIONS,..	GB00412105	CUST # 3000529 ACROBAT PR...	MACHINERY AND EQUIPMENT	001-2150-5310	423.49
					Department 2150 - COUNTY CLERK Total: 1,007.32
Department : 3200 - DISTRICT ATTORNEY					
EDOC TECHNOLOGIES, INC.	19747	annual maintenance	REPAIRS & MAINTENANCE	001-3200-4510	8,250.00
THOMSON REUTERS - WEST P...	847093677-1	ACCT # 1000732986 ONLINE/...	PUBLICATIONS	001-3200-4315	360.00
DEWITT POTH & SON	697365-0	ACCT # 12430 SPOTPAPER - L...	OFFICE SUPPLIES	001-3200-3110	249.35
DEWITT POTH & SON	697365-1	ACCT # 12430 CUP, HOT, 12 O...	OFFICE SUPPLIES	001-3200-3110	46.44
FLEETCOR TECHNOLOGIES, INC	NP63152536	ACCT # BG114286 BILL PERIOD..	TRANSPORTATION	001-3200-4260	142.71
DEWITT POTH & SON	693540-0	ACCT # 12430 ENVELOPE, CLA...	OFFICE SUPPLIES	001-3200-3110	17.95
					Department 3200 - DISTRICT ATTORNEY Total: 9,066.45
Department : 3201 - ENVIRONMENTAL TASK FORCE					
T7 ENTERPRISES, LLC	16003	Tire Disposal	DISPOSAL FEES	001-3201-3151	1,456.00
CENTRAL TEXAS REFUSE, INC	0000444422	Dumpster Rental	RENTALS	001-3201-4610	554.45
CENTRAL TEXAS REFUSE, INC	0000430466	Dumpster rental	RENTALS	001-3201-4610	581.55
SUPERIOR DISPOSAL, LLC	35957	Dumpster Rental	PUBLIC OUTREACH	001-3201-4300	575.00
BILLBOARD SOURCE, INC.	572681	Billboard Rental	PUBLIC OUTREACH	001-3201-4300	960.00
BILLBOARD SOURCE, INC.	572682	Billboard Inv# 572682	PUBLIC OUTREACH	001-3201-4300	960.00
CENTRAL TEXAS REFUSE, INC	0000437868	Dumpster rental	RENTALS	001-3201-4610	561.72
					Department 3201 - ENVIRONMENTAL TASK FORCE Total: 5,648.72
Department : 3220 - DISTRICT CLERK					
QUILL CORPORATION	28233666	ACCT # 4881802 QSI P50 1.06 ...	OFFICE SUPPLIES	001-3220-3110	25.99
JUANITA ALLEN	10212022	TRAVEL 10/18 - 20/22	TRANSPORTATION	001-3220-4260	131.25
COUNTY & DISTRICT CLERKS' A...	330958	MEMBER ID: 253064 JUANITA ...	TRAINING	001-3220-4810	200.00
QUILL CORPORATION	28180325	ACCT # 4881802 6FT VGA M M...	OFFICE SUPPLIES	001-3220-3110	10.49
QUILL CORPORATION	28188218	ACCT # 4881802 6FT VGA M M...	OFFICE SUPPLIES	001-3220-3110	25.58
TEXAS DISTRICT COURT ALLIA...	8152022	REBECCA CATCHING - 10/18 - ...	TRAINING	001-3220-4810	100.00
TEXAS DISTRICT COURT ALLIA...	81522	JUANITA ALLEN - 10/18 - 20/22	TRAINING	001-3220-4810	50.00
					Department 3220 - DISTRICT CLERK Total: 543.31
Department : 3230 - DISTRICT JUDGE					
HERBERT L. JAMISON & CO., L...	10.13.2022	State Judges Professional Liab...	OTHER INSURANCE	001-3230-2090	2,212.87
PAUL MATTHEW EVANS	101422	CAUSE # NI JOE THORNBURG	ADULT - INDIGENT ATTORNEY ...	001-3230-4160	400.00
VICTOREA D. BROWN	10172022	CAUSE # UI ERICA ANN MEND...	ADULT - ATTY LITIGATION EXP...	001-3230-4080	5.00
VICTOREA D. BROWN	10172022	CAUSE # UI ERICA ANN MEND...	ADULT - INDIGENT ATTORNEY ...	001-3230-4160	350.00
CASE J. DARWIN	21-059	CAUSE # 21-059 EDWING GO...	ADULT - INDIGENT ATTORNEY ...	001-3230-4160	1,800.00
AISHA WHITE-THOMPSON, CSR..	14-813	SOT V. RUDY HERRERA / CAUS...	ADMINISTRATIVE EXPENDITUR...	001-3230-4011	1,789.05
DEWITT POTH & SON	697655-0	ACCT # 12430 DESPAD	OFFICE SUPPLIES	001-3230-3110	203.07
ROBERT A HAEDGE	21-241	CAUSE # 21-241 RUDY YANEZ ...	ADULT - ATTY LITIGATION EXP...	001-3230-4080	5.00
ROBERT A HAEDGE	21-241	CAUSE # 21-241 RUDY YANEZ ...	ADULT - INDIGENT ATTORNEY ...	001-3230-4160	1,000.00
DAWN T. MEREDITH	21-FL-273	CAUSE # 21-FL-273 ANGELICA ...	ADULT - INDIGENT ATTORNEY ...	001-3230-4160	665.00
ROBERT A HAEDGE	21-108	CAUSE # 21-108 AARON GLEN ...	ADULT - ATTY LITIGATION EXP...	001-3230-4080	5.00
ROBERT A HAEDGE	21-108	CAUSE # 21-108 AARON GLEN ...	ADULT - INDIGENT ATTORNEY ...	001-3230-4160	1,200.00

Expense Approval Register

Packet: APPKT09955 - 11/08/22 A/P Run & P.O.'s

Vendor Name	Payable Number	Description (Item)	Account Name	Account Number	Amount
COMAL COUNTY TREASURER'S...	2022C	COURT ADMIN - JULY, AUGUST..	ADMINISTRATIVE EXPENDITUR...	001-3230-4011	3,618.63
LEON TRANSLATIONS	22443	SERVICES PERFORMED BY SOF...	ADMINISTRATIVE EXPENDITUR...	001-3230-4011	230.00
				Department 3230 - DISTRICT JUDGE Total:	13,483.62

Department : 3240 - COUNTY COURT LAW

EDOC TECHNOLOGIES, INC.	19748	ANNUAL MAINT. - 10/2022 TO...	REPAIRS & MAINTENANCE	001-3240-4510	400.00
HOLLIS WILBURN BURKLUND	2835-20CC 2	CAUSE # 2835-20CC P.G.	ADULT - INDIGENT ATTORNEY ...	001-3240-4160	200.00
HOLLIS WILBURN BURKLUND	2895-22 CC	CAUSE # 2895-22 CC C.E.M.	ADULT - INDIGENT ATTORNEY ...	001-3240-4160	400.00
HOLLIS WILBURN BURKLUND	2901-22CC 1	CAUSE # 2901-22CC & 2922-2...	ADULT - INDIGENT ATTORNEY ...	001-3240-4160	300.00
WESTERN SURETY COMPANY	64441385	BARBARA MOLINA - BOND # 6...	OTHER INSURANCE	001-3240-2090	177.50
COLIN WISE	49,173	CAUSE # 49,173 TERRANCE R...	ADULT - ATTY LITIGATION EXP...	001-3240-4080	5.00
COLIN WISE	49,173	CAUSE # 49,173 TERRANCE R...	ADULT - INDIGENT ATTORNEY ...	001-3240-4160	245.00
CLIFFORD W. MCCORMACK	48,759	CAUSE # 48,759 ELTON THO...	ADULT - ATTY LITIGATION EXP...	001-3240-4080	5.00
CLIFFORD W. MCCORMACK	48,759	CAUSE # 48,759 ELTON THO...	ADULT - INDIGENT ATTORNEY ...	001-3240-4160	550.00
CLIFFORD W. MCCORMACK	49,119	CAUSE # 49,119 OSCAR PEREZ	ADULT - ATTY LITIGATION EXP...	001-3240-4080	5.00
CLIFFORD W. MCCORMACK	49,119	CAUSE # 49,119 OSCAR PEREZ	ADULT - INDIGENT ATTORNEY ...	001-3240-4160	400.00
CLIFFORD W. MCCORMACK	49,194	CAUSE # 49,194 FREDRICK WH..	ADULT - ATTY LITIGATION EXP...	001-3240-4080	5.00
CLIFFORD W. MCCORMACK	49,194	CAUSE # 49,194 FREDRICK WH..	ADULT - INDIGENT ATTORNEY ...	001-3240-4160	550.00
COLIN WISE	49,321	CAUSE # 49,321 NAZARIO RE...	ADULT - ATTY LITIGATION EXP...	001-3240-4080	5.00
COLIN WISE	49,321	CAUSE # 49,321 NAZARIO RE...	ADULT - INDIGENT ATTORNEY ...	001-3240-4160	400.00
PAUL MATTHEW EVANS	49,475	CAUSE # 49.475 STEPHEN ME...	ADULT - ATTY LITIGATION EXP...	001-3240-4080	14.04
PAUL MATTHEW EVANS	49,475	CAUSE # 49.475 STEPHEN ME...	ADULT - INDIGENT ATTORNEY ...	001-3240-4160	800.00
SAMUEL ROSEN	49,169	CAUSE # 49,169 JOSE ELIZON...	ADULT - INDIGENT ATTORNEY ...	001-3240-4160	700.00
				Department 3240 - COUNTY COURT LAW Total:	5,161.54

Department : 3251 - JUSTICE OF THE PEACE - PRCT. 1

CARD SERVICE CENTER	1022	ACCT # ENDS W/1237	TRANSPORTATION	001-3251-4260	51.20
FLEETCOR TECHNOLOGIES, INC	NP63152536	ACCT # BG114286 BILL PERIOD..	TRANSPORTATION	001-3251-4260	98.76
				Department 3251 - JUSTICE OF THE PEACE - PRCT. 1 Total:	149.96

Department : 3252 - JUSTICE OF THE PEACE - PRCT. 2

DEWITT POTH & SON	697636-0	ACCT # 12430 PEN, BALLPNT, ...	OFFICE SUPPLIES	001-3252-3110	38.79
FLEETCOR TECHNOLOGIES, INC	NP63152536	ACCT # BG114286 BILL PERIOD..	TRANSPORTATION	001-3252-4260	39.47
TEXAS JUSTICE COURT TRAINI...	63755	AMY HORNE - 4/25/23 FY_23 V..	TRAINING	001-3252-4810	50.00
TEXAS JUSTICE COURT TRAINI...	63771	LAURA MURRAY - 1/10/22 FY_...	TRAINING	001-3252-4810	50.00
TEXAS JUSTICE COURT TRAINI...	63366	SHANNA CONLEY - 2/05/23 FY...	TRAINING	001-3252-4810	185.00
				Department 3252 - JUSTICE OF THE PEACE - PRCT. 2 Total:	363.26

Department : 3253 - JUSTICE OF THE PEACE - PRCT. 3

TEXAS JUSTICE COURT TRAINI...	64216	JAMIE HERRERA - 5/16/23 / C...	TRAINING	001-3253-4810	260.00
LOCAL LINUX, INC	IN2204099918	ACCT # B100105039874 CIVIL ...	OFFICE SUPPLIES	001-3253-3110	185.64
ANITA DELEON	92822	INQUESTS 9/10 - 18/22	TRANSPORTATION	001-3253-4260	46.50
				Department 3253 - JUSTICE OF THE PEACE - PRCT. 3 Total:	492.14

Department : 4300 - COUNTY SHERIFF

QUADIENT FINANCE USA, INC	101222	ACCT # 7900 0440 8052 6951 ...	POSTAGE	001-4300-3120	308.57
ODP BUSINESS SOLUTIONS	272896627001	ACCT # 43682634 SURGE, 12...	OPERATING SUPPLIES	001-4300-3130	47.09
ODP BUSINESS SOLUTIONS	272896858001	ACCT # 43682634 TRIPP LITE ...	OPERATING SUPPLIES	001-4300-3130	221.79
PROGRESSIVE MICROTECHNO...	221029	EVIDENCE LABEL KIT	OPERATING SUPPLIES	001-4300-3130	217.21
LONGHORN S LIVESTOCK FEED	10800	SHERIFF'S OFFICE - COASTAL B...	OPERATING SUPPLIES	001-4300-3130	147.50
ELIZABETH LARIVÉE	101722	COLLEGE STATION - 10/17 - 2...	TRANSPORTATION	001-4300-4260	132.50
PRINTING SOLUTIONS	2889 POS	ENVELOPE 2 10 # 10 REGULAR...	OPERATING SUPPLIES	001-4300-3130	218.82
FLEETCOR TECHNOLOGIES, INC	NP63152536	ACCT # BG114286 BILL PERIOD..	TRANSPORTATION	001-4300-4260	18,264.59
LAW ENFORCEMENT SYSTEMS,...	217688	ACCT # 78644 TEXAS TRAFFIC T...	OPERATING SUPPLIES	001-4300-3130	252.00
BEARCOM OPERATING, LLC	5296171	Service Call from 11/30/21 for...	REPAIRS & MAINTENANCE	001-4300-4510	600.00
				Department 4300 - COUNTY SHERIFF Total:	20,410.07

Department : 4310 - COUNTY JAIL

PERFORMANCE FOODSERVICE ...	1733402	Performance Food Blanket PO ...	FOOD SUPPLIES	001-4310-3100	1,679.31
ODP BUSINESS SOLUTIONS	269373760001	ACCT # 43682634 STAPLER, D...	OPERATING SUPPLIES	001-4310-3130	25.78
ODP BUSINESS SOLUTIONS	272421432001	ACCT # 43682634 TONER HP ...	OPERATING SUPPLIES	001-4310-3130	276.34
SYSCO CENTRAL TEXAS, INC	613927874	Sysco Operating Supplies FY 22...	OPERATING SUPPLIES	001-4310-3130	67.78
SYSCO CENTRAL TEXAS, INC	613927875	Sysco Operating Supplies FY 22..	OPERATING SUPPLIES	001-4310-3130	157.90
SYSCO CENTRAL TEXAS, INC	613927876	Sysco Food Supplies FY 22-23	FOOD SUPPLIES	001-4310-3100	862.68

Expense Approval Register

Packet: AppxT09955 - 11/08/22 A/P Run & P.O.'s

Vendor Name	Payable Number	Description (Item)	Account Name	Account Number	Amount
M.B. HAMMO ENTERPRISES, L...	92711	JCO Janitorial Supply	OPERATING SUPPLIES	001-4310-3130	812.92
FERRIS JOSEPH PRODUCE, INC.	122808	Ferris Joseph	FOOD SUPPLIES	001-4310-3100	124.25
PERFORMANCE FOODSERVICE ...	1737378	Performance Food Blanket PO ...	FOOD SUPPLIES	001-4310-3100	1,879.10
FERRIS JOSEPH PRODUCE, INC.	122816	Ferris Joseph	FOOD SUPPLIES	001-4310-3100	816.00
SYSCO CENTRAL TEXAS, INC	613935884	Sysco Operating Supplies FY 22...	OPERATING SUPPLIES	001-4310-3130	77.04
SYSCO CENTRAL TEXAS, INC	613935885	Sysco Food Supplies FY 22-23	FOOD SUPPLIES	001-4310-3100	1,535.59
UNIFIRST CORPORATION	8222548288	Unifirst	OPERATING SUPPLIES	001-4310-3130	74.26
FERRIS JOSEPH PRODUCE, INC.	122854	Ferris Joseph	FOOD SUPPLIES	001-4310-3100	200.50
FERRIS JOSEPH PRODUCE, INC.	122856	Ferris Joseph	FOOD SUPPLIES	001-4310-3100	134.00
PERFORMANCE FOODSERVICE ...	1740045	Performance Food Blanket PO ...	FOOD SUPPLIES	001-4310-3100	1,577.63
FLOWERS BAKING CO. OF SAN...	4038382500	Flowers Baking	FOOD SUPPLIES	001-4310-3100	603.78
SOUTHERN HEALTH PARTNERS,..	BASE45569	Southern Health Professionals-...	PROFESSIONAL SERVICES	001-4310-4110	48,322.45
PERFORMANCE FOODSERVICE ...	1726819	Performance Food Blanket PO ...	FOOD SUPPLIES	001-4310-3100	1,689.40
FLEETCOR TECHNOLOGIES, INC	NP63152536	ACCT # BG114286 BILL PERIOD..	TRANSPORTATION	001-4310-4260	1,958.45
SYSCO CENTRAL TEXAS, INC	613904419	Sysco Operating Supplies FY 22...	OPERATING SUPPLIES	001-4310-3130	106.49
SYSCO CENTRAL TEXAS, INC	613904420	Sysco Food Supplies FY 22-23	FOOD SUPPLIES	001-4310-3100	1,744.90
PERFORMANCE FOODSERVICE ...	1730718	Performance Food Blanket PO ...	FOOD SUPPLIES	001-4310-3100	1,726.69
I-CON SYSTEMS, INC	SI001804	CUST ID: CS000835 CHECKSTO...	REPAIRS & MAINTENANCE	001-4310-4510	327.09
SYSCO CENTRAL TEXAS, INC	613912357	Sysco Operating Supplies FY 22...	OPERATING SUPPLIES	001-4310-3130	71.00
SYSCO CENTRAL TEXAS, INC	613912358	Sysco Food Supplies FY 22-23	FOOD SUPPLIES	001-4310-3100	1,740.43
ODP BUSINESS SOLUTIONS	269372293001	ACCT # 43682634 FOLDER, 1/5..	OPERATING SUPPLIES	001-4310-3130	312.95
M.B. HAMMO ENTERPRISES, L...	92528	JCO Janitorial Supply	OPERATING SUPPLIES	001-4310-3130	972.89
UNIFIRST CORPORATION	8222532316	UNIFIRST Blanket PO FY 21-22	OPERATING SUPPLIES	001-4310-3130	66.78
LOCKHART POST REGISTER	00094119	9/22 CAREER IN LAW ENFORC...	OPERATING SUPPLIES	001-4310-3130	129.00
THE LULING NEWSBOY & SIGN...	93022	9/22 HELP WANTED - CAREER ...	OPERATING SUPPLIES	001-4310-3130	49.00
LOCKHART POST REGISTER	00094133	9/29 CAREERS IN LAW ENFOR...	OPERATING SUPPLIES	001-4310-3130	129.00
FIRETROL PROTECTION SYSTE...	100812015	Ansul Replacement - Labor	REPAIRS & MAINTENANCE	001-4310-4510	250.00
FIRETROL PROTECTION SYSTE...	100812015	Ansul Replacement	REPAIRS & MAINTENANCE	001-4310-4510	551.70
THE GONZALES INQUIRER	33347	3X3 - CORRECTIONAL OFFICER...	OPERATING SUPPLIES	001-4310-3130	63.00
THE LULING NEWSBOY & SIGN...	9302022	9/29 HELP WANTED - CAREER ...	OPERATING SUPPLIES	001-4310-3130	49.00
ORKIN - AUSTIN COMMERCIAL	233042299	ACCT # 29121597 PC STANDA...	REPAIRS & MAINTENANCE	001-4310-4510	320.00
				Department 4310 - COUNTY JAIL Total:	71,485.08
Department : 4321 - CONSTABLES - PCT 1					
TRANSUNION RISK AND ALTE...	81179110212022	Online Investigative Services 1...	DUES & SUBSCRIPTIONS	001-4321-3050	1,200.00
WOLFCOM ENTERPRISES	SI-00011202	Wolfcom Halo Body Worn Ca...	MACHINERY AND EQUIPMENT	001-4321-5310	1,826.40
FLEETCOR TECHNOLOGIES, INC	NP63152536	ACCT # BG114286 BILL PERIOD..	TRANSPORTATION	001-4321-4260	1,101.11
THE POLICE AND SHERIFFS PRE...	168706	ID CARDS	OFFICE SUPPLIES	001-4321-3110	17.58
				Department 4321 - CONSTABLES - PCT 1 Total:	4,145.09
Department : 4322 - CONSTABLES - PCT 2					
FLEETCOR TECHNOLOGIES, INC	NP63152536	ACCT # BG114286 BILL PERIOD..	TRANSPORTATION	001-4322-4260	546.73
				Department 4322 - CONSTABLES - PCT 2 Total:	546.73
Department : 4323 - CONSTABLES - PCT 3					
KJ'S AUTO ACCESSORIES	27755	STEPS 4" F-250 17-21	MACHINERY AND EQUIPMENT	001-4323-5310	475.00
FLEETCOR TECHNOLOGIES, INC	NP63152536	ACCT # BG114286 BILL PERIOD..	TRANSPORTATION	001-4323-4260	2,115.76
				Department 4323 - CONSTABLES - PCT 3 Total:	2,590.76
Department : 4324 - CONSTABLES - PCT 4					
FLEETCOR TECHNOLOGIES, INC	NP63152536	ACCT # BG114286 BILL PERIOD..	TRANSPORTATION	001-4324-4260	931.58
				Department 4324 - CONSTABLES - PCT 4 Total:	931.58
Department : 6510 - NON-DEPARTMENTAL					
TEXAS ASSOCIATION OF COUN...	37215	TAC Liability 10.01.22 thru 10....	INSURANCE	001-6510-4845	198,587.00
XEROX CORPORATION	530777	Lease Blanket PO FY 22-23	RENTALS	001-6510-4610	4,710.93
CAPITAL AREA COUNCIL OF G...	2023M 169	2023 CAPCOG Annual Member...	DUES & SUBSCRIPTIONS	001-6510-3050	2,339.55
MIRANDA LEE GONZALES	4083	RILEY, RANDALL H. - BODY RE...	AUTOPSY	001-6510-4123	310.00
CALDWELL COUNTY TAX ASSE...	1263147 2022	LICENSE # 1263147 VIN # END...	County Fleet-Tags-Titles	001-6510-4853	7.50
CALDWELL COUNTY TAX ASSE...	KYM 6308	PLATE # KYM 6308 VIN # ENDS..	County Fleet-Tags-Titles	001-6510-4853	7.50
ALLISON, BASS & MAGEE, LLP	6672	2020 Redistricting - 3rd Invoice	PROFESSIONAL SERVICES	001-6510-4110	10,000.00
CALDWELL COUNTY TAX ASSE...	9021466 2022	PLATE # 9021466 VIN # ENDS...	County Fleet-Tags-Titles	001-6510-4853	7.50
CALDWELL-TRAVIS SWCD	469	Inv. #469	DONATIONS	001-6510-3200	900.00
CARD SERVICE CENTER	1022	ACCT # ENDS W/1237	DUES & SUBSCRIPTIONS	001-6510-3050	239.88

Expense Approval Register

Vendor Name	Payable Number	Description (Item)	Account Name	Account Number	Amount
CALDWELL COUNTY TAX ASSE...	9021461 2022	PLATE # 9021461 VIN # ENDS ...	County Fleet-Tags-Titles	001-6510-4853	7.50
CHARTER COMMUNICATIONS ...	0226726100422	Spectrum Blanket PO FY 22-23	FAX & INTERNET	001-6510-4425	229.17
AT&T	Service 10/05/2022 - 11/04/2...	Fiber Line Blanket PO FY 22-23	FAX & INTERNET	001-6510-4425	48,024.60
CHARTER COMMUNICATIONS ...	0000426100822	Spectrum Blanket PO FY 22-23	FAX & INTERNET	001-6510-4425	11,290.19
QUADIENT LEASING USA, INC	N9624094	Equipment Lease Blanket PO F...	RENTALS	001-6510-4610	345.11
CHARLES E. LAURENCE, M.D.	74507	Medical Director	MEDICAL DIRECTOR	001-6510-4100	1,000.00
CHARLES E. LAURENCE, M.D.	74508	Medical Director	MEDICAL DIRECTOR	001-6510-4100	1,000.00
CHARLES E. LAURENCE, M.D.	74509	Medical Director	MEDICAL DIRECTOR	001-6510-4100	1,000.00
XEROX CORPORATION	3474714	Lease Blanket PO FY 22-23	RENTALS	001-6510-4610	4,710.93
DOUCET & ASSOCIATES, INC	2209031	Doucet & Assoc. Blanket PO FY...	PROFESSIONAL SERVICES	001-6510-4110	7,985.00
DOUCET & ASSOCIATES, INC	2209032	Doucet & Assoc. Blanket PO FY...	PROFESSIONAL SERVICES	001-6510-4110	412.50
DOUCET & ASSOCIATES, INC	2209033	Doucet & Assoc. Blanket PO FY...	PROFESSIONAL SERVICES	001-6510-4110	275.00
DOUCET & ASSOCIATES, INC	2209034	Doucet & Assoc. Blanket PO FY...	PROFESSIONAL SERVICES	001-6510-4110	137.50
DOUCET & ASSOCIATES, INC	2209035	Doucet & Assoc. Blanket PO FY...	PROFESSIONAL SERVICES	001-6510-4110	550.00
DOUCET & ASSOCIATES, INC	2209036	Doucet & Assoc. Blanket PO FY...	PROFESSIONAL SERVICES	001-6510-4110	68.75
DOUCET & ASSOCIATES, INC	2209037	Doucet & Assoc. Blanket PO FY...	PROFESSIONAL SERVICES	001-6510-4110	690.00
DOUCET & ASSOCIATES, INC	2209038	Doucet & Assoc. Blanket PO FY...	PROFESSIONAL SERVICES	001-6510-4110	68.75
DOUCET & ASSOCIATES, INC	2209040	Doucet & Assoc. Blanket PO FY...	PROFESSIONAL SERVICES	001-6510-4110	140.00
DOUCET & ASSOCIATES, INC	2209041	Doucet & Assoc. Blanket PO FY...	PROFESSIONAL SERVICES	001-6510-4110	550.00
DOUCET & ASSOCIATES, INC	2209042	Doucet & Assoc. Blanket PO FY...	PROFESSIONAL SERVICES	001-6510-4110	137.50
DOUCET & ASSOCIATES, INC	2209046	Doucet & Assoc. Blanket PO FY...	PROFESSIONAL SERVICES	001-6510-4110	137.50
DOUCET & ASSOCIATES, INC	2209049	Doucet & Assoc. Blanket PO FY...	PROFESSIONAL SERVICES	001-6510-4110	137.50
DOUCET & ASSOCIATES, INC	2209051	Doucet & Assoc. Blanket PO FY...	PROFESSIONAL SERVICES	001-6510-4110	766.25
DOUCET & ASSOCIATES, INC	2209052	Doucet & Assoc. Blanket PO FY...	PROFESSIONAL SERVICES	001-6510-4110	137.50
DOUCET & ASSOCIATES, INC	2209056	Doucet & Assoc. Blanket PO FY...	PROFESSIONAL SERVICES	001-6510-4110	412.50
DOUCET & ASSOCIATES, INC	2209060	Doucet & Assoc. Blanket PO FY...	PROFESSIONAL SERVICES	001-6510-4110	575.00
DOUCET & ASSOCIATES, INC	2209062	Doucet & Assoc. Blanket PO FY...	PROFESSIONAL SERVICES	001-6510-4110	506.25
DOUCET & ASSOCIATES, INC	2209065	Doucet & Assoc. Blanket PO FY...	PROFESSIONAL SERVICES	001-6510-4110	1,125.00
				Department 6510 - NON-DEPARTMENTAL Total:	299,529.86

Department : 6520 - BUILDING MAINTENANCE

SECURITY ONE, INC	1071706	CUST # 805335 OCT 2022	JP3 SIMON BUILDING-MAXWE...	001-6520-3500	25.00
CENTRAL TEXAS REFUSE, INC	439038	ACCT # 020545 SITE: 9675 H...	RENTALS	001-6520-4610	249.74
O'REILLY AUTOMOTIVE, INC.	0642-117512	CUST # 188092 BATTERY	JUDICIAL CENTER-LOCKHART	001-6520-3550	206.54
CENTURY HVAC DISTRIBUTING,...	111307609	PICK TICKET # 8592413 2X2 P...	LULING ANNEX	001-6520-3510	97.60
LOCKHART HARDWARE	43460 /1	CUST #11239 TUBE COPPER M...	REPAIRS & MAINTENANCE	001-6520-4510	129.66
LOCKHART HARDWARE	43465 /1	CUST # 11239 CONTRACTOR ...	JUDICIAL CENTER-LOCKHART	001-6520-3550	53.97
JOHN DEERE FINANCIAL	2210-051177	ACCT # 1-99 LED SMRT CYL E2...	REPAIRS & MAINTENANCE	001-6520-4510	26.24
LOCKHART HARDWARE	43482 /1	CUST # 11239 COM SWVL MN...	L.W.SCOTT ANNEX-LOCKHART	001-6520-3540	35.98
LOCKHART HARDWARE	43498 /1	CUST # 11239 SPACKLING LIG...	REPAIRS & MAINTENANCE	001-6520-4510	218.36
CINTAS CORPORATION #86	4134207789	SOLD TO # 13228013 PAYER # ...	UNIFORMS	001-6520-3140	55.14
LOCKHART HARDWARE	43525 /1	CUST # 11239 RECIP SAW BLD...	JUDICIAL CENTER-LOCKHART	001-6520-3550	93.52
SMITH SUPPLY CO.- LOCKHART	949580	RECIP BLADE 18TX6 5PK	JUDICIAL CENTER-LOCKHART	001-6520-3550	26.90
GA POWERS	58855	3/8" X 75' FLEXICORE STEEL C...	REPAIRS & MAINTENANCE	001-6520-4510	184.41
SMITH SUPPLY CO.- LOCKHART	949685	AXE CAMP HICKORY 1-1/4 # 3...	JUDICIAL CENTER-LOCKHART	001-6520-3550	44.90
UNITED RENTALS (NORTH AM...	211784019-001	CUST # 1331322 DEMO HAM...	JUDICIAL CENTER-LOCKHART	001-6520-3550	256.45
LOCKHART HARDWARE	43557 /1	CUST # 11239 BIT DRIL PERCU...	JUDICIAL CENTER-LOCKHART	001-6520-3550	43.96
LOCKHART HARDWARE	43558 /1	CUST # 11239 WHLBRW INNR...	REPAIRS & MAINTENANCE	001-6520-4510	14.99
LOCKHART HARDWARE	43560 /1	CUST # 11239 2 X 6 X 12 # 1 T...	JUDICIAL CENTER-LOCKHART	001-6520-3550	50.76
LOCKHART HARDWARE	43565 /1	CUST # 11239 ELBOW PVC 90...	JUDICIAL CENTER-LOCKHART	001-6520-3550	63.96
LOCKHART HARDWARE	43580 /1	CUST # 11239 TEE SAN PVC 3"	JUDICIAL CENTER-LOCKHART	001-6520-3550	35.97
LOCKHART HARDWARE	43596 /1	CUST # 11239 MTL CUT WHEE...	REPAIRS & MAINTENANCE	001-6520-4510	14.95
LOCKHART HARDWARE	43600 /1	CUST # 11239 SCREWS, NUTS...	REPAIRS & MAINTENANCE	001-6520-4510	13.80
LOCKHART HARDWARE	43602 /1	CUST # 11239 LEVEL 3" LINE A...	JUDICIAL CENTER-LOCKHART	001-6520-3550	5.99
LOCKHART HARDWARE	43609 /1	CUST # 11239 FACE MOUNT ...	JUDICIAL CENTER-LOCKHART	001-6520-3550	23.85
SMITH SUPPLY CO.- LOCKHART	950137	SAFETY CONE CRANCK 28"	JUDICIAL CENTER-LOCKHART	001-6520-3550	33.85
LOCKHART HARDWARE	43623 /1	CUST # 11239 CAP PVC S&D 3"...	JUDICIAL CENTER-LOCKHART	001-6520-3550	33.16
LOCKHART HARDWARE	43624 /1	CUST # 11239 FILTER AIR PLE...	REPAIRS & MAINTENANCE	001-6520-4510	16.77
LOCKHART HARDWARE	43630 /1	CUST # 11239 2 X 6 X 08 #1 T...	JUDICIAL CENTER-LOCKHART	001-6520-3550	51.07
LOCKHART HARDWARE	43643 /1	CUST # 11239 8-18 X 1" SLF DR...	UNIT ROAD/SANITION	001-6520-3620	65.72
LOCKHART HARDWARE	43649 /1	CUST # 11239 BOX OUTLET P...	UNIT ROAD/SANITION	001-6520-3620	30.57

Expense Approval Register

Packet: APPKT09955 - 11/08/22 A/P Run & P.O.'s

Vendor Name	Payable Number	Description (Item)	Account Name	Account Number	Amount
JOHN DEERE FINANCIAL	2210-060499	ACCT # 1-99 NAIL EXTRACTOR	REPAIRS & MAINTENANCE	001-6520-4510	107.55
LOCKHART HARDWARE	43671 /1	CUST # 11239 MOP PAD WETJ...	REPAIRS & MAINTENANCE	001-6520-4510	27.97
SMITH SUPPLY CO.- LOCKHART	950584	WEATHER PROOF REC BX 302...	UNIT ROAD/SANITION	001-6520-3620	17.65
SMITH SUPPLY CO.- LOCKHART	950593	WP POWER RNCPT COVER	UNIT ROAD/SANITION	001-6520-3620	9.95
FLEETCOR TECHNOLOGIES, INC	NP63152536	ACCT # BG114286 BILL PERIOD..	TRANSPORTATION	001-6520-4260	1,316.42
LOCKHART HARDWARE	43379 /1	CUST # 11239 SCREW, NUTS &..	L.W.SCOTT ANNEX-LOCKHART	001-6520-3540	10.58
CENTURY HVAC DISTRIBUTING,..	111306351	PICK TICKET # 8591377 NASH...	OPERATING SUPPLIES	001-6520-3130	494.42
CINTAS CORPORATION #86	4133506854	SOLD TO # 13228013 PAYER # ...	UNIFORMS	001-6520-3140	55.14
LOCKHART HARDWARE	43417 /1	CUST # 11239 2 X 4 X 08 #1 T...	MARKET ST. ANNEX-LOCKHART	001-6520-3530	56.92
LOCKHART HARDWARE	43418 /1	CUST # 11239 2X608 #1 TREAT...	MARKET ST. ANNEX-LOCKHART	001-6520-3530	39.45
GT DISTRIBUTORS, INC.	INV0924609	CUST ID: 006679 STRONG REC...	UNIFORMS	001-6520-3140	35.98
LOCKHART HARDWARE	43431 /1	CUST # 11239 SM STORAGE B...	REPAIRS & MAINTENANCE	001-6520-4510	61.97
SECURITY ONE, INC	1076089	CUST # 805335 NOVEMBER 2...	JP3 SIMON BUILDING-MAXWE...	001-6520-3500	25.00
CENTURY HVAC DISTRIBUTING,..	111264745	SERVICE CHARGE	OPERATING SUPPLIES	001-6520-3130	1.47
CENTURY HVAC DISTRIBUTING,..	111286727	SERVICE CHARGE	OPERATING SUPPLIES	001-6520-3130	1.64
CENTURY HVAC DISTRIBUTING,..	111303429	SERVICE CHARGE	OPERATING SUPPLIES	001-6520-3130	3.08
Department 6520 - BUILDING MAINTENANCE Total:					4,468.97

Department : 6550 - ELECTIONS

VISTA SOLUTIONS, LP	11352	Licenses/Support	DUES & SUBSCRIPTIONS	001-6550-3050	7,122.50
ELECTION SYSTEMS & SOFTW...	CD2045369	ES&S Software Training	TRAINING	001-6550-4810	1,929.63
CARD SERVICE CENTER	1022	ACCT # ENDS W/1237	Ballot Supplies	001-6550-3115	254.67
CARD SERVICE CENTER	1022	ACCT # ENDS W/1237	Ballot Supplies	001-6550-3115	142.67
FLEETCOR TECHNOLOGIES, INC	NP63152536	ACCT # BG114286 BILL PERIOD..	TRANSPORTATION	001-6550-4260	66.09
ELECTION SYSTEMS & SOFTW...	CD2043706	Thermal Ballots	Ballot Supplies	001-6550-3115	1,573.68
PRINTING SOLUTIONS	2797 POS	SIGNS BANNERS 3X6 VOTES H...	OFFICE SUPPLIES	001-6550-3110	198.00
ELECTION SYSTEMS & SOFTW...	CD2044669	Media Burn/Equipment	MACHINERY AND EQUIPMENT	001-6550-5310	6,621.23
LOCKHART POST REGISTER	00094014	8/18/22 HIRING ELECTION W...	ADVERTISING AND LEGAL NOT...	001-6550-4310	93.75
WESTERN SURETY COMPANY	72501923	BOND # 72501923 DEVANTE ...	EMPLOYEE BONDING	001-6550-2070	50.00
WESTERN SURETY COMPANY	72501925	BOND # 72501925 MAYRA OR...	EMPLOYEE BONDING	001-6550-2070	50.00
Department 6550 - ELECTIONS Total:					18,102.22

Department : 6560 - COMMISSIONERS COURT

CARD SERVICE CENTER	1022	ACCT # ENDS W/1237	OFFICE SUPPLIES	001-6560-3110	284.94
CARD SERVICE CENTER	1022	ACCT # ENDS W/1237	TRAINING	001-6560-4810	70.00
LOCKHART POST REGISTER	00094065	Post Register Blanket PO	ADVERTISING AND LEGAL NOT...	001-6560-4310	798.00
LOCKHART POST REGISTER	00094143	Post Register Blanket PO	ADVERTISING AND LEGAL NOT...	001-6560-4310	30.60
THE LULUNG NEWSBOY & SIGN...	90122	9/01 NOTICE OF HEARING ON ...	ADVERTISING AND LEGAL NOT...	001-6560-4310	244.13
Department 6560 - COMMISSIONERS COURT Total:					1,427.67

Department : 6580 - HUMAN RESOURCES

TEXAS DEPT. OF PUBLIC SAFETY	CRS-202209-248007	9/01 - 20/2022 SECURE SITE C...	OFFICE SUPPLIES	001-6580-3110	3.00
------------------------------	-------------------	---------------------------------	-----------------	---------------	------

Department 6580 - HUMAN RESOURCES Total: 3.00

Department : 6590 - PURCHASING

SHI GOVERNMENT SOLUTIONS,..	GB00432228	CUST # 3000529 SALES ORDER...	MACHINERY AND EQUIPMENT	001-6590-5310	423.94
SHI GOVERNMENT SOLUTIONS,..	GB00439874	CUST # 3000529 ACROBAT PR...	MACHINERY AND EQUIPMENT	001-6590-5310	847.88
LOCKHART POST REGISTER	00093968	8/11/22 COUNTY RFB 22CF01B	ADVERTISING	001-6590-4310	9.00
DELL MARKETING L.P.	10617530376	CUST # 2120993 KIT- DELL H...	MACHINERY AND EQUIPMENT	001-6590-5310	19.80
Department 6590 - PURCHASING Total:					1,300.62

Department : 6600 - ENG. & SUBDIVISION

AMERICAN STRUCTUREPOINT, ...	155696	American Structurepoint Blan...	Professional Services	001-6600-4110	23,512.50
------------------------------	--------	---------------------------------	-----------------------	---------------	-----------

Department 6600 - ENG. & SUBDIVISION Total: 23,512.50

Department : 6610 - IT-TECHNOLOGY

QUESTICA LTD	INV113198-REV	Software as a Service: Year 2	COMPUTER SUPPORT	001-6610-4185	19,500.00
ODP BUSINESS SOLUTIONS	266543140001	ACCT # 43682634 TOTE, FLATL...	MACHINERY AND EQUIPMENT	001-6610-5310	97.98
LOCAL LINUX, INC	74919	Inv. 74919 - labor fees	Outside Services	001-6610-4840	17,825.00
LOCAL LINUX, INC	74946	Inv 74946 - Dato	Outside Services	001-6610-4840	3,858.00
TYLER TECHNOLOGIES, INC.	025-390085	INCODE - Personnel Mgmt- An...	COMPUTER SUPPORT	001-6610-4185	13,471.00
TYLER TECHNOLOGIES, INC.	025-390085	INCODE - Cashiering- Annual S...	COMPUTER SUPPORT	001-6610-4185	2,194.00
TYLER TECHNOLOGIES, INC.	025-390085	INCODE - ESS Time & Attendan...	COMPUTER SUPPORT	001-6610-4185	3,759.00
TYLER TECHNOLOGIES, INC.	025-390085	INCODE - Project Accounting- ...	COMPUTER SUPPORT	001-6610-4185	2,983.00

Expense Approval Register

Packet: APPKT09955 - 11/08/22 A/P Run & P.O.'s

Vendor Name	Payable Number	Description (Item)	Account Name	Account Number	Amount
TYLER TECHNOLOGIES, INC.	025-390085	INCODE - Tyler Content Mana...	COMPUTER SUPPORT	001-6610-4185	6,867.00
TYLER TECHNOLOGIES, INC.	025-390085	INCODE - Core Financials- Ann...	COMPUTER SUPPORT	001-6610-4185	19,298.00
Department 6610 - IT-TECHNOLOGY Total:					89,852.98
Department : 6630 - GRANT WRITING/ADMIN					
DENNIS ENGELKE	10242022	TRAVEL 10/08 - 20/22	TRANSPORTATION	001-6630-4260	50.69
Department 6630 - GRANT WRITING/ADMIN Total:					50.69
Department : 6640 - CODE INVESTIGATOR					
FLEETCOR TECHNOLOGIES, INC	NP63152536	ACCT # BG114286 BILL PERIOD..	TRANSPORTATION	001-6640-4260	1,112.14
Department 6640 - CODE INVESTIGATOR Total:					1,112.14
Department : 6650 - EMERG MGNT / HOMELAND SEC					
FLEETCOR TECHNOLOGIES, INC	NP63152536	ACCT # BG114286 BILL PERIOD..	TRANSPORTATION	001-6650-4260	799.59
TOSA BLANKS & MORE, INC.	71397	Vehicle Reflective Wrap	REPAIRS & MAINTENANCE	001-6650-4510	1,400.00
Department 6650 - EMERG MGNT / HOMELAND SEC Total:					2,199.59
Department : 7600 - ANIMAL CONTROL					
CITY OF LOCKHART	ASV 22-Q4	Animal Shelter Lease and Dogs...	ANIMAL CONTROL EXPENSES	001-7600-4114	24,133.85
Department 7600 - ANIMAL CONTROL Total:					24,133.85
Department : 7610 - SANITATION DEPARTMENT					
FLEETCOR TECHNOLOGIES, INC	NP63152536	ACCT # BG114286 BILL PERIOD..	TRANSPORTATION	001-7610-4260	55.34
Department 7610 - SANITATION DEPARTMENT Total:					55.34
Department : 8700 - COUNTY AGENT					
FLEETCOR TECHNOLOGIES, INC	NP63152536	ACCT # BG114286 BILL PERIOD..	TRANSPORTATION-AG/4H/NR	001-8700-4260	94.47
Department 8700 - COUNTY AGENT Total:					94.47
Fund 001 - GENERAL FUND Total:					607,063.21
Fund: 002 - UNIT ROAD FUND					
Department : 1101 - ADMINISTRATION					
HANSON EQUIPMENT	295375	MOUNT TIRE 19.5	TIRES	002-1101-3190	145.00
PETROLEUM TRADERS CORPO...	1817121	Fuel	FUEL	002-1101-3163	10,875.90
HANSON EQUIPMENT	295421	O-	OPERATING SUPPLIES	002-1101-3130	91.23
BRAUNTEX MATERIALS, INC.	140430	Aggregate	AGGREGATE / GRAVEL	002-1101-3153	4,318.50
JOHN DEERE FINANCIAL	2210-053212	ACCT # 1-99 ACE BOTTLE WAT...	OPERATING SUPPLIES	002-1101-3130	101.70
HANSON EQUIPMENT	295456	# CAL001 11.2/12.4-28 TUBE ...	TIRES	002-1101-3190	93.80
CINTAS CORPORATION #86	4134207925	Uniforms	UNIFORMS	002-1101-3140	280.44
CINTAS CORPORATION #86	4134207951	Uniforms	UNIFORMS	002-1101-3140	204.78
CINTAS CORPORATION #86	4134207964	Uniforms	UNIFORMS	002-1101-3140	220.26
ERGON ASPHALT AND EMULSI...	9402813544	Dust Control	DUST CONTROL	002-1101-4620	6,088.56
ERGON ASPHALT AND EMULSI...	9402813545	Dust Control	DUST CONTROL	002-1101-4620	6,051.87
GRAINGER	9477210968	ACC # 841505548 HI-VIS BOM...	OPERATING SUPPLIES	002-1101-3130	173.38
JOHN DEERE FINANCIAL	2210-053684	CUST # 1-99 STIHL - 16" 3/8 .0...	OPERATING SUPPLIES	002-1101-3130	72.00
ERGON ASPHALT AND EMULSI...	9402814563	DEMURRAGE .84 HOURS	DUST CONTROL	002-1101-4620	75.60
ERGON ASPHALT AND EMULSI...	9402814564	DEMURRAGE 1.33 HOURS	DUST CONTROL	002-1101-4620	119.70
ERGON ASPHALT AND EMULSI...	9402814729	Dust Control	DUST CONTROL	002-1101-4620	6,039.64
ERGON ASPHALT AND EMULSI...	9402814730	Dust Control	DUST CONTROL	002-1101-4620	6,015.17
SCHMIDT & SONS, INC	0504048-IN	Oil & Lubricants	LUBRICANTS	002-1101-3170	2,803.90
BRAUNTEX MATERIALS, INC.	140630	Aggregate	AGGREGATE / GRAVEL	002-1101-3153	26,597.92
BRAUNTEX MATERIALS, INC.	140631	Flex Base	FLEX BASE MATERIALS	002-1101-3143	30,556.50
PETROLEUM TRADERS CORPO...	148285	Fuel	FUEL	002-1101-3163	659.22
UNIVERSAL ENVIRONMENTAL ...	IN0485298	CUST # CAL171 OILY WATER	OPERATING SUPPLIES	002-1101-3130	12.25
UNIVERSAL ENVIRONMENTAL ...	IN0485364	CUST # CAL171 OILY WATER	OPERATING SUPPLIES	002-1101-3130	13.65
UNIVERSAL ENVIRONMENTAL ...	IN0485371	CUST # CAL171 OILY WATER	OPERATING SUPPLIES	002-1101-3130	12.95
HANSON EQUIPMENT	295537	# CAL001 FLAT TIRE REPAIR	TIRES	002-1101-3190	19.83
ERGON ASPHALT AND EMULSI...	9402816937	DEMURRAGE 1 HOUR	DUST CONTROL	002-1101-4620	90.00
ERGON ASPHALT AND EMULSI...	9402816938	DEMURRAGE .5 HOURS	DUST CONTROL	002-1101-4620	45.00
HANSON EQUIPMENT	295542	# CAL001 BLADE-RHION TS12...	OPERATING SUPPLIES	002-1101-3130	227.44
LOCKHART HARDWARE	43605 /1	CUST # 11239 STEP LADDER 2'...	OPERATING SUPPLIES	002-1101-3130	105.33
SOUTHERN TIRE MART, LLC	4650130859	CUST # 0142726 SOTERA STH...	TIRES	002-1101-3190	413.95
CINTAS CORPORATION #86	4134883084	Uniforms	UNIFORMS	002-1101-3140	280.44
CINTAS CORPORATION #86	4134883202	Uniforms	UNIFORMS	002-1101-3140	220.26
CINTAS CORPORATION #86	4134883267	Uniforms	UNIFORMS	002-1101-3140	331.55

Expense Approval Register

Packet: APPKT09955 - 11/08/22 A/P Run & P.O.'s

Vendor Name	Payable Number	Description (Item)	Account Name	Account Number	Amount
SOUTHERN TIRE MART, LLC	4650130776	Tires	TIRES	002-1101-3190	1,708.56
SMITH SUPPLY CO.- LOCKHART	950264	ANGLE METAL 3"X2" X 3/16"	OPERATING SUPPLIES	002-1101-3130	68.95
SMITH SUPPLY CO.-LULING	103810	RED HI-LIFT JACK HL -485	OPERATING SUPPLIES	002-1101-3130	112.95
SMITH SUPPLY CO.-LULING	103880	CAR SCREW 5/16 X 2-1/2	OPERATING SUPPLIES	002-1101-3130	150.00
BRAUNTEX MATERIALS, INC.	140798	Aggregate	AGGREGATE / GRAVEL	002-1101-3153	16,425.28
BRAUNTEX MATERIALS, INC.	140799	Flex Base	FLEX BASE MATERIALS	002-1101-3143	13,453.50
HANSON EQUIPMENT	295254	FLATWASHER 5/8 (65/5LB)	OPERATING SUPPLIES	002-1101-3130	298.56
HANSON EQUIPMENT	295316	BLADE-RHINO TS12 WINGS	OPERATING SUPPLIES	002-1101-3130	334.82
HANSON EQUIPMENT	295317	FACING 5.5" X 3.0" (STEALTH)	OPERATING SUPPLIES	002-1101-3130	270.04
HANSON EQUIPMENT	295323	12.4-28/8 CROPMASTER REAR...	TIRES	002-1101-3190	440.60
CINTAS CORPORATION #86	4133506917	Uniforms	UNIFORMS	002-1101-3140	280.44
CINTAS CORPORATION #86	4133506989	Uniforms	UNIFORMS	002-1101-3140	204.78
CINTAS CORPORATION #86	4133507003	Uniforms	UNIFORMS	002-1101-3140	220.26
LOCKHART HARDWARE	43442 /1	CUST # 11239 STEP LADDER 2'...	OPERATING SUPPLIES	002-1101-3130	328.14
SCHMIDT & SONS, INC	0501228-IN	Schmidt & Sons blaket PO fuel	FUEL	002-1101-3163	10,832.61

Department 1101 - ADMINISTRATION Total: 148,487.21

Department : 1102 - VEHICLE MAINTENANCE

SEAN MATTHEW MANN	147882	ACCT # 2010 2 YR WTY BAT	REPAIRS & MAINTENANCE	002-1102-4510	169.99
SEAN MATTHEW MANN	147920	ACCT # 2010 OIL DRY	SUPPLIES & SMALL TOOLS	002-1102-3136	39.40
E & R SUPPLY CO., INC	226243	ACCT # 0023750 ALUM KAML...	REPAIRS & MAINTENANCE	002-1102-4510	34.88
SEAN MATTHEW MANN	147955	CUST # 2010 NAPA HYDRAULI...	REPAIRS & MAINTENANCE	002-1102-4510	92.62
AWM OIL TOOLS, INC.	86574	TEFLON TAPE 1"	REPAIRS & MAINTENANCE	002-1102-4510	182.90
SEAN MATTHEW MANN	148023	ACCT # 2010 NAPA 10W30 5 ...	SUPPLIES & SMALL TOOLS	002-1102-3136	53.97
SEAN MATTHEW MANN	148031	ACCT # 2010 18 MO WTY BAT	REPAIRS & MAINTENANCE	002-1102-4510	184.97
BOEHM TRACTOR SALES, INC.	CT209498	ACCT # C03021 BELT 'V'	REPAIRS & MAINTENANCE	002-1102-4510	94.64
SEAN MATTHEW MANN	148118	ACCT # 2010 BRAKE PARTS CL...	SUPPLIES & SMALL TOOLS	002-1102-3136	280.32
SEAN MATTHEW MANN	148141	ACCT # 2010 BLUE DEF 2.5 GAL	SUPPLIES & SMALL TOOLS	002-1102-3136	465.11
O'REILLY AUTOMOTIVE, INC.	0642-119064	CUST # 188092 AIR REEL	SUPPLIES & SMALL TOOLS	002-1102-3136	286.99
E & R SUPPLY CO., INC	226307	E&R Supply Co. Gas Honda	REPAIRS & MAINTENANCE	002-1102-4510	3,485.00
E & R SUPPLY CO., INC	226307	E&R Supply Co. Air Operated G...	REPAIRS & MAINTENANCE	002-1102-4510	150.00
SEAN MATTHEW MANN	148296	Repair/Maintenance	REPAIRS & MAINTENANCE	002-1102-4510	569.38
SEAN MATTHEW MANN	148301	ACCT # 2010 CORE DEPOSIT	REPAIRS & MAINTENANCE	002-1102-4510	-108.00
SALT FLAT MERCANTILE, LLC	15583-43809	CUST # 27269 HOSE	REPAIRS & MAINTENANCE	002-1102-4510	64.19
O'REILLY AUTOMOTIVE, INC.	0642-119554	CUST # 188092 TOGGLE SWT...	REPAIRS & MAINTENANCE	002-1102-4510	10.99
SEAN MATTHEW MANN	146702	ACCT # 2010 CORE DEPOSIT	SUPPLIES & SMALL TOOLS	002-1102-3136	-18.00
SEAN MATTHEW MANN	146905	ACCT # 2010 LUCAS HUB OIL	SUPPLIES & SMALL TOOLS	002-1102-3136	71.22
SEAN MATTHEW MANN	146906	ACCT # 2010 BRAKE PARTS CL...	SUPPLIES & SMALL TOOLS	002-1102-3136	148.44
SEAN MATTHEW MANN	148392	Repair/Maintenance	REPAIRS & MAINTENANCE	002-1102-4510	669.98
SEAN MATTHEW MANN	148403	ACCT # 2010 SWITCH - TOOGLE	REPAIRS & MAINTENANCE	002-1102-4510	18.78
SEAN MATTHEW MANN	148418	ACCT # 2010 NAPA GOLD OIL F...	REPAIRS & MAINTENANCE	002-1102-4510	205.97
SALT FLAT MERCANTILE, LLC	15583-43896	CUST # 27269 STRIKER LIGHT...	SUPPLIES & SMALL TOOLS	002-1102-3136	102.26
INLAND TRUCK PARTS COMPA...	CM-096218	CUST # 020818 PUMP (AIR, DI...	REPAIRS & MAINTENANCE	002-1102-4510	-782.15
SEAN MATTHEW MANN	148439	ACCT # 2010 NAPAGOLD FUEL...	REPAIRS & MAINTENANCE	002-1102-4510	7.88
SEAN MATTHEW MANN	148467	ACCT # 2010 SPLASH GUARD -...	REPAIRS & MAINTENANCE	002-1102-4510	38.54
SEAN MATTHEW MANN	147774	ACCT # 2010 NAPA GOLD AIR F...	REPAIRS & MAINTENANCE	002-1102-4510	51.52
INLAND TRUCK PARTS COMPA...	IN-1173377	Dump Pump; Air Shift	SUPPLIES & SMALL TOOLS	002-1102-3136	919.69
ASSOCIATED SUPPLY COMPAN...	346871-1	Cap Fuel	REPAIRS & MAINTENANCE	002-1102-4510	179.30
ASSOCIATED SUPPLY COMPAN...	346871-1	Key	REPAIRS & MAINTENANCE	002-1102-4510	193.60
ASSOCIATED SUPPLY COMPAN...	346871-1	Freigt Out	REPAIRS & MAINTENANCE	002-1102-4510	27.25
ASSOCIATED SUPPLY COMPAN...	346871-1	Key Ignition	REPAIRS & MAINTENANCE	002-1102-4510	107.10

Department 1102 - VEHICLE MAINTENANCE Total: 7,998.73

Department : 1103 - FLEET MAINTENANCE

XL PARTS, LLC	0416QF0072	CUST #490093 AIR FILTER	OPERATING SUPPLIES	002-1103-3135	329.96
CINTAS CORPORATION #86	4134207617	Uniforms	UNIFORMS	002-1103-3140	49.88
XL PARTS, LLC	0416PU5934	CUST # 490536 9/30/22 SERVI...	OPERATING SUPPLIES	002-1103-3135	0.30
ANGEL D ESQUIVEL	1709	LIC PLATE: HYG 1888 2002 D...	REPAIRS & MAINTENANCE	002-1103-4510	120.00
CINTAS CORPORATION #86	4134882711	Uniforms	UNIFORMS	002-1103-3140	51.88
XL PARTS, LLC	0416PX6463	CUST # 490093 AIR FITLER	OPERATING SUPPLIES	002-1103-3135	240.32
XL PARTS, LLC	0416PY6800	CUST # 490093 AIR FILTER	OPERATING SUPPLIES	002-1103-3135	98.20
XL PARTS, LLC	0416PZ2266	CUST # 490093 AIR FITLER	OPERATING SUPPLIES	002-1103-3135	24.96

Expense Approval Register

Packet: APPKT09955 - 11/08/22 A/P Run & P.O.'s

Vendor Name	Payable Number	Description (Item)	Account Name	Account Number	Amount
CINTAS CORPORATION #86	4133506491	Uniforms	UNIFORMS	002-1103-3140	49.88
SOUTHERN TIRE MART, LLC	4650129535	Tires	TIRES	002-1103-3190	319.50
				Department 1103 - FLEET MAINTENANCE Total:	1,284.88
				Fund 002 - UNIT ROAD FUND Total:	157,770.82
Fund: 003 - RECORDS PRESERVATION FUND					
Department : 3000 - COUNTY CLERK EXP					
TYLER TECHNOLOGIES, INC.	025-390157	Maintenance 01/oct/2022-30/...	SOFTWARE MAINTENANCE	003-3000-4520	5,371.38
TYLER TECHNOLOGIES, INC.	025-390157	Web Hosting - Redording	SOFTWARE MAINTENANCE	003-3000-4520	6,776.00
				Department 3000 - COUNTY CLERK EXP Total:	12,147.38
				Fund 003 - RECORDS PRESERVATION FUND Total:	12,147.38
Fund: 010 - GRANT FUND - GENERAL					
Department : 2000 - DIST CLERK EXPENSES					
WJC CONSTRUCTORS SERVICES..	App. No. 3	Black Ankle Rd at Dry Branch	BLACK ANKLE ROAD	010-2000-4073	45,861.99
WJC CONSTRUCTORS SERVICES..	App. No. 3	Witter Rd at Jerry Creek	WITTER ROAD	010-2000-4072	37,151.12
WJC CONSTRUCTORS SERVICES..	App. No. 4	Political Rd at Dickerson Creek	POLITICAL ROAD	010-2000-4071	37,382.94
				Department 2000 - DIST CLERK EXPENSES Total:	120,396.05
Department : 4323 - CONSTABLES - PCT 3					
TYLER MICHAEL BELL	10252022	12 ATTEMPTS	Operating Exp-PCT 3	010-4323-4515	240.00
				Department 4323 - CONSTABLES - PCT 3 Total:	240.00
Department : 6640 - CODE INVESTIGATOR					
SUPERIOR DISPOSAL, LLC	38989	comm collection dumpsters	COMMUNITY COLLECTION EV...	010-6640-3162	2,950.00
THE LULING NEWSBOY & SIGN...	Luling Newsboy	Luling Newsboy Community col..	COMMUNITY COLLECTION EV...	010-6640-3162	520.00
				Department 6640 - CODE INVESTIGATOR Total:	3,470.00
				Fund 010 - GRANT FUND - GENERAL Total:	124,106.05
Fund: 011 - 911 FUND					
Department : 3000 - COUNTY CLERK EXP					
ODP BUSINESS SOLUTIONS	272973537001	ACCT # 43682634 PAPER, BO...	OFFICE SUPPLIES	011-3000-3110	59.67
				Department 3000 - COUNTY CLERK EXP Total:	59.67
				Fund 011 - 911 FUND Total:	59.67
Fund: 016 - JUSTICE COURT TECHNOLOGY FUND					
Department : 3251 - JUSTICE OF THE PEACE - PRCT. 1					
NET DATA	ND-004220	ANNUAL SOFTWARE MAINT - ...	SOFTWARE MAINTENANCE	016-3251-4520	2,245.00
				Department 3251 - JUSTICE OF THE PEACE - PRCT. 1 Total:	2,245.00
Department : 3252 - JUSTICE OF THE PEACE - PRCT. 2					
NET DATA	ND-004220	ANNUAL SOFTWARE MAINT - ...	SOFTWARE MAINTENANCE	016-3252-4520	2,245.00
				Department 3252 - JUSTICE OF THE PEACE - PRCT. 2 Total:	2,245.00
Department : 3253 - JUSTICE OF THE PEACE - PRCT. 3					
NET DATA	ND-004220	ANNUAL SOFTWARE MAINT - ...	SOFTWARE MAINTENANCE	016-3253-4520	2,245.00
				Department 3253 - JUSTICE OF THE PEACE - PRCT. 3 Total:	2,245.00
Department : 3254 - JUSTICE OF THE PEACE - PRCT. 4					
NET DATA	ND-004220	ANNUAL SOFTWARE MAINT - ...	SOFTWARE MAINTENANCE	016-3254-4520	2,245.00
				Department 3254 - JUSTICE OF THE PEACE - PRCT. 4 Total:	2,245.00
				Fund 016 - JUSTICE COURT TECHNOLOGY FUND Total:	8,980.00
Fund: 019 - American Rescue Plan Fund					
Department : 1000 - DEPARTMENTS - Header					
TYLER TECHNOLOGIES, INC.	130 131321	Tyler Technology Blanket PO F...	ODYSSEY	019-1000-5166	41,167.00
TYLER TECHNOLOGIES, INC.	020-137741	Tyler Technology Blanket PO F...	ODYSSEY	019-1000-5166	26,598.00
				Department 1000 - DEPARTMENTS - Header Total:	67,765.00
				Fund 019 - American Rescue Plan Fund Total:	67,765.00
				Grand Total:	977,892.13

Fund Summary

Fund	Expense Amount
001 - GENERAL FUND	607,063.21
002 - UNIT ROAD FUND	157,770.82
003 - RECORDS PRESERVATION FUND	12,147.38
010 - GRANT FUND - GENERAL	124,106.05
011 - 911 FUND	59.67
016 - JUSTICE COURT TECHNOLOGY FUND	8,980.00
019 - American Rescue Plan Fund	67,765.00
Grand Total:	977,892.13

Account Summary

Account Number	Account Name	Expense Amount
001-1260	DUE FROM C C A D	424.78
001-1370	POSTAGE INVENTORY	4,708.90
001-2120-2070	EMPLOYEE BONDING	60.00
001-2150-3110	OFFICE SUPPLIES	508.80
001-2150-3145	Remote Site Trans Fees	75.03
001-2150-5310	MACHINERY AND EQUIP...	423.49
001-3200-3110	OFFICE SUPPLIES	313.74
001-3200-4260	TRANSPORTATION	142.71
001-3200-4315	PUBLICATIONS	360.00
001-3200-4510	REPAIRS & MAINTENANCE	8,250.00
001-3201-3151	DISPOSAL FEES	1,456.00
001-3201-4300	PUBLIC OUTREACH	2,495.00
001-3201-4610	RENTALS	1,697.72
001-3220-3110	OFFICE SUPPLIES	62.06
001-3220-4260	TRANSPORTATION	131.25
001-3220-4810	TRAINING	350.00
001-3230-2090	OTHER INSURANCE	2,212.87
001-3230-3110	OFFICE SUPPLIES	203.07
001-3230-4011	ADMINISTRATIVE EXPEND...	5,637.68
001-3230-4080	ADULT - ATTY LITIGATION...	15.00
001-3230-4160	ADULT - INDIGENT ATTO...	5,415.00
001-3240-2090	OTHER INSURANCE	177.50
001-3240-4080	ADULT - ATTY LITIGATION...	39.04
001-3240-4160	ADULT - INDIGENT ATTO...	4,545.00
001-3240-4510	REPAIRS & MAINTENANCE	400.00
001-3251-4260	TRANSPORTATION	149.96
001-3252-3110	OFFICE SUPPLIES	38.79
001-3252-4260	TRANSPORTATION	39.47
001-3252-4810	TRAINING	285.00
001-3253-3110	OFFICE SUPPLIES	185.64
001-3253-4260	TRANSPORTATION	46.50
001-3253-4810	TRAINING	260.00
001-4300-3120	POSTAGE	308.57
001-4300-3130	OPERATING SUPPLIES	1,104.41
001-4300-4260	TRANSPORTATION	18,397.09
001-4300-4510	REPAIRS & MAINTENANCE	600.00
001-4310-3100	FOOD SUPPLIES	16,314.26
001-4310-3130	OPERATING SUPPLIES	3,441.13
001-4310-4110	PROFESSIONAL SERVICES	48,322.45
001-4310-4260	TRANSPORTATION	1,958.45
001-4310-4510	REPAIRS & MAINTENANCE	1,448.79
001-4321-3050	DUES & SUBSCRIPTIONS	1,200.00
001-4321-3110	OFFICE SUPPLIES	17.58
001-4321-4260	TRANSPORTATION	1,101.11
001-4321-5310	MACHINERY AND EQUIP...	1,826.40
001-4322-4260	TRANSPORTATION	546.73
001-4323-4260	TRANSPORTATION	2,115.76
001-4323-5310	MACHINERY AND EQUIP...	475.00

Account Summary

Account Number	Account Name	Expense Amount
001-4324-4260	TRANSPORTATION	931.58
001-6510-3050	DUES & SUBSCRIPTIONS	2,579.43
001-6510-3200	DONATIONS	900.00
001-6510-4100	MEDICAL DIRECTOR	3,000.00
001-6510-4110	PROFESSIONAL SERVICES	24,812.50
001-6510-4123	AUTOPSY	310.00
001-6510-4425	FAX & INTERNET	59,543.96
001-6510-4610	RENTALS	9,766.97
001-6510-4845	INSURANCE	198,587.00
001-6510-4853	County Fleet-Tags-Titles	30.00
001-6520-3130	OPERATING SUPPLIES	500.61
001-6520-3140	UNIFORMS	146.26
001-6520-3500	JP3 SIMON BUILDING-MA...	50.00
001-6520-3510	LULING ANNEX	97.60
001-6520-3530	MARKET ST. ANNEX-LOCK...	96.37
001-6520-3540	L.W.SCOTT ANNEX-LOCK...	46.56
001-6520-3550	JUDICIAL CENTER-LOCKH...	1,024.85
001-6520-3620	UNIT ROAD/SANITION	123.89
001-6520-4260	TRANSPORTATION	1,316.42
001-6520-4510	REPAIRS & MAINTENANCE	816.67
001-6520-4610	RENTALS	249.74
001-6550-2070	EMPLOYEE BONDING	100.00
001-6550-3050	DUES & SUBSCRIPTIONS	7,122.50
001-6550-3110	OFFICE SUPPLIES	198.00
001-6550-3115	Ballot Supplies	1,971.02
001-6550-4260	TRANSPORTATION	66.09
001-6550-4310	ADVERTISING AND LEGAL...	93.75
001-6550-4810	TRAINING	1,929.63
001-6550-5310	MACHINERY AND EQUIP...	6,621.23
001-6560-3110	OFFICE SUPPLIES	284.94
001-6560-4310	ADVERTISING AND LEGAL...	1,072.73
001-6560-4810	TRAINING	70.00
001-6580-3110	OFFICE SUPPLIES	3.00
001-6590-4310	ADVERTISING	9.00
001-6590-5310	MACHINERY AND EQUIP...	1,291.62
001-6600-4110	Professional Services	23,512.50
001-6610-4185	COMPUTER SUPPORT	68,072.00
001-6610-4840	Outside Services	21,683.00
001-6610-5310	MACHINERY AND EQUIP...	97.98
001-6630-4260	TRANSPORTATION	50.69
001-6640-4260	TRANSPORTATION	1,112.14
001-6650-4260	TRANSPORTATION	799.59
001-6650-4510	REPAIRS & MAINTENANCE	1,400.00
001-7600-4114	ANIMAL CONTROL EXPEN...	24,133.85
001-7610-4260	TRANSPORTATION	55.34
001-8700-4260	TRANSPORTATION-AG/4H...	94.47
002-1101-3130	OPERATING SUPPLIES	2,373.39
002-1101-3140	UNIFORMS	2,243.21
002-1101-3143	FLEX BASE MATERIALS	44,010.00
002-1101-3153	AGGREGATE / GRAVEL	47,341.70
002-1101-3163	FUEL	22,367.73
002-1101-3170	LUBRICANTS	2,803.90
002-1101-3190	TIRES	2,821.74
002-1101-4620	DUST CONTROL	24,525.54
002-1102-3136	SUPPLIES & SMALL TOOLS	2,349.40
002-1102-4510	REPAIRS & MAINTENANCE	5,649.33
002-1103-3135	OPERATING SUPPLIES	693.74
002-1103-3140	UNIFORMS	151.64

Account Summary

Account Number	Account Name	Expense Amount
002-1103-3190	TIRES	319.50
002-1103-4510	REPAIRS & MAINTENANCE	120.00
003-3000-4520	SOFTWARE MAINTENANCE	12,147.38
010-2000-4071	POLITICAL ROAD	37,382.94
010-2000-4072	WITTER ROAD	37,151.12
010-2000-4073	BLACK ANKLE ROAD	45,861.99
010-4323-4515	Operating Exp-PCT 3	240.00
010-6640-3162	COMMUNITY COLLECTION..	3,470.00
011-3000-3110	OFFICE SUPPLIES	59.67
016-3251-4520	SOFTWARE MAINTENANCE	2,245.00
016-3252-4520	SOFTWARE MAINTENANCE	2,245.00
016-3253-4520	SOFTWARE MAINTENANCE	2,245.00
016-3254-4520	SOFTWARE MAINTENANCE	2,245.00
019-1000-5166	ODYSSEY	67,765.00
	Grand Total:	977,892.13

Project Account Summary

Project Account Key	Expense Amount
None	977,892.13
	Grand Total:
	977,892.13

- 2. Ratify re-occurring County Payments:**
 - A. \$373,572.57 Payroll (10/09/2022 – 10/22/2022)**

Caldwell County Agenda Item Request Form

To: All Elected Officials and Department Heads – Hand deliver or scan & email to hopyy.haden@co.caldwell.tx.us and ezzy.chan@co.caldwell.tx.us . Deadline is 5:00 pm Tuesday before the Regular meetings, however, please submit this completed form ASAP. “Anything missing will cause the Agenda Item to be held over to the next Regular meeting,” according to our Rules & Procedures.

AGENDA DATE: 11.08.2022

Type of Agenda Item

- Consent Discussion/Action Executive Session Workshop
 Public Hearing

What will be discussed? What is the proposed motion?

\$373,572.57 Payroll (10/09/2022 – 10/22/2022)

1. Costs:

Actual Cost or **Estimated Cost** \$ _____

Is this cost included in the County Budget? _____

Is a Budget Amendment being proposed? _____

2. Agenda Speakers:

	Name	Representing	Title
--	------	--------------	-------

(1) Judge Haden

(2) _____

(3) _____

3. Backup Materials:

None To Be Distributed 21 total # of backup pages
(including this page)

4. 
Signature of Court Member

Date 10/26/2022



Packet: PYPKT02559 - Payroll 100922 thru 102222
Payroll Set: 01 - Payroll Set 01

Pay Period: 10/09/2022 - 10/22/2022

Department: 0000 - 911-GIS

Total Direct Deposits: 1,643.54
Total Check Amounts: 0.00

EARNINGS

Pay Code	Units	Pay Amount
165 Stipend w/RET	0.00	34.62
S	8.00	207.98
SAL	-7.00	1,871.83
Total:	1.00	2,114.43

TAXES

Code	Subject To	Employee	Employer
Federal W/H	1,790.10	0.00	0.00
MC	1,895.82	27.49	27.49
SS	1,895.82	117.54	117.54
Unemployment	2,083.85	0.00	0.00
Total:		145.03	145.03

DEDUCTIONS

Code	Subject To	Employee	Employer
400	2,114.43	105.72	127.29
550	0.00	30.58	0.00
580	0.00	1.53	0.00
590	0.00	159.39	411.01
595	0.00	5.74	0.00
615	0.00	22.90	0.00
Total:		325.86	538.30

RECAP 0000 - 911-GIS

Earnings: 2,114.43 Benefits: 0.00 Deductions: 325.86 Taxes: 145.03 Net Pay: 1,643.54

Department: 1000 - Courthouse Security

Total Direct Deposits: 11,293.96
Total Check Amounts: 0.00

EARNINGS

Pay Code	Units	Pay Amount
165 Stipend w/RET	0.00	16.15
Hourly	496.00	12,862.03
S	36.00	918.68
Uniform	0.00	175.00
Vacation	28.00	714.53
Total:	560.00	14,686.39

TAXES

Code	Subject To	Employee	Employer
Federal W/H	13,669.94	1,266.39	0.00
MC	14,404.28	208.87	208.87
SS	14,404.28	893.07	893.07
Unemployment	14,630.42	0.00	0.00
Total:		2,368.33	1,101.94

DEDUCTIONS

Code	Subject To	Employee	Employer
400	14,686.39	734.34	884.13
550	0.00	55.97	0.00
551	0.00	20.00	0.00
580	0.00	7.65	0.00
590	0.00	159.39	1,885.57
595	0.00	5.72	0.00
615	0.00	41.03	0.00
Total:		1,024.10	2,769.70

RECAP 1000 - Courthouse Security

Earnings: 14,686.39 Benefits: 0.00 Deductions: 1,024.10 Taxes: 2,368.33 Net Pay: 11,293.96

Department: 1101 - Unit Road

Total Direct Deposits: 32,914.86
 Total Check Amounts: 1,293.49

EARNINGS

Pay Code	Units	Pay Amount
165 Stipend w/RET	0.00	66.92
BEREAVEMENT	24.00	728.43
FLOAT	3.00	58.96
Hourly	1,948.50	39,653.20
JURY DUTY	8.00	164.80
S	38.08	762.38
SAL	-23.00	1,699.66
Vacation	82.42	1,686.89
Total:	2,081.00	44,821.24

TAXES

Code	Subject To	Employee	Employer
Federal W/H	40,637.03	3,121.20	0.00
MC	42,878.10	621.75	621.75
SS	42,878.10	2,658.46	2,658.46
Unemployment	38,370.09	0.00	0.00
Total:		6,401.41	3,280.21

DEDUCTIONS

Code	Subject To	Employee	Employer
400	44,821.24	2,241.07	2,698.30
550	0.00	177.47	0.00
551	0.00	38.46	0.00
580	0.00	13.77	0.00
590	0.00	1,445.53	9,016.84
595	0.00	47.94	0.00
610	0.00	13.50	0.00
615	0.00	233.74	0.00
Total:		4,211.48	11,715.14

RECAP 1101 - Unit Road

Earnings: 44,821.24 Benefits: 0.00 Deductions: 4,211.48 Taxes: 6,401.41 Net Pay: 34,208.35

Department: 1102 - Vehicle Maintenance

Total Direct Deposits: 1,243.13
 Total Check Amounts: 2,818.40

EARNINGS

Pay Code	Units	Pay Amount
Hourly	224.00	4,748.50
Vacation	16.00	337.52
Total:	240.00	5,086.02

TAXES

Code	Subject To	Employee	Employer
Federal W/H	4,793.42	344.21	0.00
MC	5,047.72	73.19	73.19
SS	5,047.72	312.96	312.96
Unemployment	3,498.70	0.00	0.00
Total:		730.36	386.15

DEDUCTIONS

Code	Subject To	Employee	Employer
400	5,086.02	254.30	306.18
550	0.00	30.24	0.00
580	0.00	1.53	0.00
590	0.00	0.00	1,105.92
615	0.00	8.06	0.00
Total:		294.13	1,412.10

RECAP 1102 - Vehicle Maintenance

Earnings: 5,086.02 Benefits: 0.00 Deductions: 294.13 Taxes: 730.36 Net Pay: 4,061.53

Department: 1103 - Fleet Maintenance

Total Direct Deposits: 1,316.83
Total Check Amounts: 1,411.58

EARNINGS

Pay Code	Units	Pay Amount
Hourly	152.00	3,166.19
S	8.00	176.08
Total:	160.00	3,342.27

TAXES

Code	Subject To	Employee	Employer
Federal W/H	3,160.03	174.03	0.00
MC	3,327.15	48.24	48.24
SS	3,327.15	206.29	206.29
Unemployment	3,327.15	0.00	0.00
Total:		428.56	254.53

DEDUCTIONS

Code	Subject To	Employee	Employer
400	3,342.27	167.12	201.21
550	0.00	15.12	0.00
580	0.00	3.06	0.00
590	0.00	0.00	368.64
Total:		185.30	569.85

RECAP 1103 - Fleet Maintenance

Earnings	3,342.27	Benefits	0.00	Deductions	185.30	Taxes	428.56	Net Pay	2,728.41
----------	----------	----------	------	------------	--------	-------	--------	---------	----------

Department: 2120 - County Treasurer

Total Direct Deposits: 4,503.26
Total Check Amounts: 0.00

EARNINGS

Pay Code	Units	Pay Amount
Hourly	148.00	3,193.72
S	12.00	274.02
SAL	1.00	2,324.78
Total:	161.00	5,792.52

TAXES

Code	Subject To	Employee	Employer
Federal W/H	5,326.93	387.12	0.00
MC	5,666.56	82.16	82.16
SS	5,666.56	351.33	351.33
Unemployment	5,777.40	0.00	0.00
Total:		820.61	433.49

DEDUCTIONS

Code	Subject To	Employee	Employer
400	5,792.52	289.63	348.71
520	0.00	50.00	0.00
550	0.00	15.12	0.00
551	0.00	63.46	0.00
580	0.00	3.06	0.00
590	0.00	0.00	1,105.92
595	0.00	5.72	0.00
615	0.00	41.66	0.00
Total:		468.65	1,454.63

RECAP 2120 - County Treasurer

Earnings	5,792.52	Benefits	0.00	Deductions	468.65	Taxes	820.61	Net Pay	4,503.26
----------	----------	----------	------	------------	--------	-------	--------	---------	----------

Department: 2130 - County Auditor

Total Direct Deposits: 7,584.09
 Total Check Amounts: 0.00

EARNINGS

Pay Code	Units	Pay Amount
165 Stipend w/RET	0.00	34.62
Hourly	223.50	5,187.16
S	14.50	336.53
SAL	-10.00	5,417.30
Vacation	14.00	513.73
Total:	242.00	11,489.34

TAXES

Code	Subject To	Employee	Employer
Federal W/H	9,723.25	1,315.71	0.00
MC	10,547.73	152.94	152.94
SS	10,547.73	653.95	653.95
Unemployment	7,740.97	0.00	0.00
Total:	36,560.68	2,122.60	806.89

DEDUCTIONS

Code	Subject To	Employee	Employer
400	11,489.34	574.48	691.65
520	0.00	250.00	0.00
550	0.00	34.97	0.00
551	0.00	119.92	0.00
580	0.00	3.06	0.00
590	0.00	680.22	1,970.31
595	0.00	14.05	0.00
610	0.00	13.50	0.00
615	0.00	92.45	0.00
Total:	11,489.34	1,782.65	2,661.96

RECAP 2130 - County Auditor

Earnings: 11,489.34 Benefits: 0.00 Deductions: 1,782.65 Taxes: 2,122.60 Net Pay: 7,584.09

Department: 2140 - Tax Assessor-Collector

Total Direct Deposits: 8,791.55
 Total Check Amounts: 0.00

EARNINGS

Pay Code	Units	Pay Amount
165 Stipend w/RET	0.00	50.77
Hourly	458.00	8,583.18
LWOP	1.84	0.00
S	14.08	254.39
SAL	1.00	2,320.52
Vacation	6.08	107.76
Total:	481.00	11,316.62

TAXES

Code	Subject To	Employee	Employer
Federal W/H	10,483.58	834.50	0.00
MC	11,169.41	161.96	161.96
SS	11,169.41	692.51	692.51
Unemployment	7,528.49	0.00	0.00
Total:	39,351.89	1,688.97	854.47

DEDUCTIONS

Code	Subject To	Employee	Employer
400	11,316.62	565.83	681.27
520	0.00	120.00	0.00
550	0.00	30.24	0.00
551	0.00	41.65	0.00
580	0.00	3.06	0.00
590	0.00	0.00	2,211.84
595	0.00	11.44	0.00
615	0.00	63.88	0.00
Total:	11,316.62	836.10	2,893.11

RECAP 2140 - Tax Assessor-Collector

Earnings: 11,316.62 Benefits: 0.00 Deductions: 836.10 Taxes: 1,688.97 Net Pay: 8,791.55

Department: 2150 - County Clerk

Total Direct Deposits: 9,955.72
 Total Check Amounts: 0.00

EARNINGS

Pay Code	Units	Pay Amount
Hourly	529.75	9,624.86
S	30.25	540.05
SAL	1.00	2,329.39
VAC-PAYOU'	15.04	255.25
Total:	576.04	12,749.55

TAXES

Code	Subject To	Employee	Employer
Federal W/H	11,593.87	675.18	0.00
MC	12,291.36	178.22	178.22
SS	12,291.36	762.07	762.07
Unemployment	8,297.69	0.00	0.00
Total:	1,615.47	940.29	

DEDUCTIONS

Code	Subject To	Employee	Employer
400	12,749.55	637.49	767.54
520	0.00	60.00	0.00
550	0.00	84.94	0.00
551	0.00	81.76	0.00
580	0.00	9.18	0.00
590	0.00	159.39	2,622.85
595	0.00	25.49	0.00
610	0.00	13.50	0.00
615	0.00	106.61	0.00
Total:	1,178.36	3,390.39	

RECAP 2150 - County Clerk

Earnings	12,749.55	Benefits	0.00	Deductions	1,178.36	Taxes	1,615.47	Net Pay	9,955.72
----------	-----------	----------	------	------------	----------	-------	----------	---------	----------

Department: 3000 - County Clerk

Total Direct Deposits: 1,108.19
 Total Check Amounts: 0.00

EARNINGS

Pay Code	Units	Pay Amount
Hourly	80.00	1,386.00
Total:	80.00	1,386.00

TAXES

Code	Subject To	Employee	Employer
Federal W/H	1,301.58	88.52	0.00
MC	1,370.88	19.88	19.88
SS	1,370.88	84.99	84.99
Unemployment	1,370.88	0.00	0.00
Total:	193.39	104.87	

DEDUCTIONS

Code	Subject To	Employee	Employer
400	1,386.00	69.30	83.44
550	0.00	15.12	0.00
590	0.00	0.00	368.64
Total:	84.42	452.08	

RECAP 3000 - County Clerk

Earnings	1,386.00	Benefits	0.00	Deductions	84.42	Taxes	193.39	Net Pay	1,108.19
----------	----------	----------	------	------------	-------	-------	--------	---------	----------

Department: 3200 - District Attorney

Total Direct Deposits: 26,354.01
Total Check Amounts: 31.97

EARNINGS

Pay Code	Units	Pay Amount
165 Stipend w/RET	0.00	50.77
ADA Supplement	0.00	692.31
ADA/ETF Stipend	0.00	723.07
BEREAVEMENT	48.00	945.66
DA Staff Supplement	0.00	1,228.17
Hourly	439.50	9,746.20
S	91.00	2,842.51
SAL	-87.00	17,910.19
Vacation	75.50	2,232.96
Total:	567.00	36,371.84

TAXES

Code	Subject To	Employee	Employer
Federal W/H	32,748.52	3,709.22	0.00
MC	34,563.98	501.18	501.18
SS	34,563.98	2,142.96	2,142.96
Unemployment	28,771.72	0.00	0.00
Total:	6,353.36	2,644.14	

DEDUCTIONS

Code	Subject To	Employee	Employer
400	35,109.05	1,755.46	2,113.57
520	0.00	60.00	0.00
550	0.00	121.30	0.00
551	0.00	296.16	0.00
552	0.00	192.30	0.00
580	0.00	9.18	0.00
590	0.00	1,084.09	5,288.07
595	0.00	31.32	0.00
615	0.00	82.69	0.00
Total:	3,632.50	7,401.64	

RECAP 3200 - District Attorney

Earnings: 36,371.84 Benefits: 0.00 Deductions: 3,632.50 Taxes: 6,353.36 Net Pay: 26,385.98

Department: 3201 - Environmental Task Force

Total Direct Deposits: 6,058.44
Total Check Amounts: 0.00

EARNINGS

Pay Code	Units	Pay Amount
165 Stipend w/RET	0.00	85.39
Hourly	304.00	7,520.80
S	8.00	262.50
Uniform	0.00	75.00
Vacation	8.00	178.28
Total:	320.00	8,121.97

TAXES

Code	Subject To	Employee	Employer
Federal W/H	7,369.47	711.61	0.00
MC	7,775.57	112.74	112.74
SS	7,775.57	482.09	482.09
Unemployment	2,667.77	0.00	0.00
Total:	1,306.44	594.83	

DEDUCTIONS

Code	Subject To	Employee	Employer
400	8,121.97	406.10	488.94
550	0.00	77.67	0.00
551	0.00	50.00	0.00
580	0.00	4.59	0.00
590	0.00	159.39	1,148.29
595	0.00	8.60	0.00
615	0.00	50.74	0.00
Total:	757.09	1,637.23	

RECAP 3201 - Environmental Task Force

Earnings: 8,121.97 Benefits: 0.00 Deductions: 757.09 Taxes: 1,306.44 Net Pay: 6,058.44

Department: 3220 - District Clerk

Total Direct Deposits: 9,694.64
 Total Check Amounts: 0.00

EARNINGS

Pay Code	Units	Pay Amount
FLOAT	8.00	146.89
Hourly	549.00	10,130.44
SAL	1.00	2,330.67
Vacation	3.00	63.01
Total:	561.00	12,671.01

TAXES

Code	Subject To	Employee	Employer
Federal W/H	11,673.44	1,031.19	0.00
MC	12,306.99	178.45	178.45
SS	12,306.99	763.04	763.04
Unemployment	7,087.54	0.00	0.00
Total:	1,972.68	941.49	

DEDUCTIONS

Code	Subject To	Employee	Employer
400	12,671.01	633.55	762.80
550	0.00	58.98	0.00
551	0.00	28.84	0.00
580	0.00	6.12	0.00
590	0.00	159.39	2,622.85
595	0.00	8.58	0.00
615	0.00	108.23	0.00
Total:	1,003.69	3,385.65	

RECAP 3220 - District Clerk

Earnings	12,671.01	Benefits	0.00	Deductions	1,003.69	Taxes	1,972.68	Net Pay	9,694.64
----------	-----------	----------	------	------------	----------	-------	----------	---------	----------

Department: 3230 - District Judge

Total Direct Deposits: 5,561.05
 Total Check Amounts: 979.07

EARNINGS

Pay Code	Units	Pay Amount
Hourly	80.00	1,923.08
SAL	1.00	6,463.40
Vacation	8.00	369.30
Total:	87.00	8,755.78

TAXES

Code	Subject To	Employee	Employer
Federal W/H	7,701.06	529.14	0.00
MC	8,238.84	119.46	119.46
SS	8,238.84	510.81	510.81
Unemployment	8,679.04	0.00	0.01
Total:	1,159.41	630.28	

DEDUCTIONS

Code	Subject To	Employee	Employer
400	8,755.78	437.78	527.10
520	0.00	100.00	0.00
550	0.00	30.58	0.00
551	0.00	76.92	0.00
580	0.00	1.53	0.00
590	0.00	318.78	822.02
595	0.00	5.74	0.00
615	0.00	84.92	0.00
Total:	1,056.25	1,349.12	

RECAP 3230 - District Judge

Earnings	8,755.78	Benefits	0.00	Deductions	1,056.25	Taxes	1,159.41	Net Pay	6,540.12
----------	----------	----------	------	------------	----------	-------	----------	---------	----------

Department: 3240 - County Court Law

Total Direct Deposits: 8,588.59
 Total Check Amounts: 0.00

EARNINGS

Pay Code	Units	Pay Amount
165 Stipend w/RET	0.00	34.62
Jud Stip	0.00	3,230.77
S	8.00	330.00
SAL	-5.00	8,319.40
Total:	3.00	11,914.79

TAXES

Code	Subject To	Employee	Employer
Federal W/H	11,013.72	1,516.35	0.00
MC	11,859.46	171.96	171.96
SS	11,859.46	735.29	735.29
Unemployment	9,558.18	0.00	0.00
Total:	2,423.60	907.25	

DEDUCTIONS

Code	Subject To	Employee	Employer
400	11,914.79	595.74	717.27
520	0.00	250.00	0.00
550	0.00	27.23	0.00
580	0.00	1.53	0.00
590	0.00	0.00	737.28
595	0.00	11.30	0.00
615	0.00	16.80	0.00
Total:	902.60	1,454.55	

RECAP 3240 - County Court Law

Earnings: 11,914.79 Benefits: 0.00 Deductions: 902.60 Taxes: 2,423.60 Net Pay: 8,588.59

Department: 3251 - JP Prect. 1

Total Direct Deposits: 3,544.75
 Total Check Amounts: 0.00

EARNINGS

Pay Code	Units	Pay Amount
Hourly	148.00	2,580.50
Misc	0.69	12.87
S	4.00	74.59
SAL	1.00	2,059.29
Vacation	8.00	149.18
Total:	161.69	4,876.43

TAXES

Code	Subject To	Employee	Employer
Federal W/H	4,177.35	217.86	0.00
MC	4,421.17	64.10	64.10
SS	4,421.17	274.11	274.11
Unemployment	1,504.64	0.00	0.00
Total:	556.07	338.21	

DEDUCTIONS

Code	Subject To	Employee	Employer
400	4,876.43	243.82	293.56
550	0.00	31.15	0.00
551	0.00	188.45	0.00
560	0.00	75.00	0.00
580	0.00	1.53	0.00
590	0.00	159.39	1,148.29
595	0.00	8.44	0.00
615	0.00	67.83	0.00
Total:	775.61	1,441.85	

RECAP 3251 - JP Prect. 1

Earnings: 4,876.43 Benefits: 0.00 Deductions: 775.61 Taxes: 556.07 Net Pay: 3,544.75

Department: 3252 - JP Prec. 2

Total Direct Deposits: 3,811.81
 Total Check Amounts: 0.00

EARNINGS

Pay Code	Units	Pay Amount
Hourly	148.00	2,711.84
S	12.00	219.12
SAL	1.00	2,059.29
Total:	161.00	4,990.25

TAXES

Code	Subject To	Employee	Employer
Federal W/H	4,583.72	384.08	0.00
MC	4,833.23	70.08	70.08
SS	4,833.23	299.66	299.66
Unemployment	3,477.71	0.00	0.00
Total:	753.82	753.82	369.74

DEDUCTIONS

Code	Subject To	Employee	Employer
400	4,990.25	249.51	300.41
550	0.00	91.74	0.00
580	0.00	4.59	0.00
590	0.00	0.00	1,105.92
595	0.00	8.44	0.00
610	0.00	13.50	0.00
615	0.00	56.84	0.00
Total:	424.62	424.62	1,406.33

RECAP 3252 - JP Prec. 2

Earnings: 4,990.25 Benefits: 0.00 Deductions: 424.62 Taxes: 753.82 Net Pay: 3,811.81

Department: 3253 - JP Prec. 3

Total Direct Deposits: 3,509.17
 Total Check Amounts: 0.00

EARNINGS

Pay Code	Units	Pay Amount
165 Stipend w/RET	0.00	34.62
Hourly	142.00	2,600.87
S	8.00	145.14
SAL	1.00	2,059.29
Vacation	10.00	184.95
Total:	161.00	5,024.87

TAXES

Code	Subject To	Employee	Employer
Federal W/H	4,505.43	629.31	0.00
MC	4,756.68	68.97	68.97
SS	4,756.68	294.92	294.92
Unemployment	4,994.63	0.00	0.00
Total:	993.20	993.20	363.89

DEDUCTIONS

Code	Subject To	Employee	Employer
400	5,024.87	251.25	302.49
550	0.00	30.24	0.00
580	0.00	3.06	0.00
590	0.00	159.39	1,148.29
595	0.00	11.46	0.00
615	0.00	67.10	0.00
Total:	522.50	522.50	1,450.78

RECAP 3253 - JP Prec. 3

Earnings: 5,024.87 Benefits: 0.00 Deductions: 522.50 Taxes: 993.20 Net Pay: 3,509.17

Department: 3254 - JP Prect. 4

Total Direct Deposits: 2,342.88
 Total Check Amounts: 0.00

EARNINGS

Pay Code	Units	Pay Amount
Hourly	72.00	1,331.62
S	4.00	73.98
SAL	1.00	2,059.29
Vacation	4.00	73.98
Total:	81.00	3,538.87

TAXES

Code	Subject To	Employee	Employer
Federal W/H	3,141.98	311.38	0.00
MC	3,318.92	48.12	48.12
SS	3,318.92	205.77	205.77
Total:		565.27	253.89

DEDUCTIONS

Code	Subject To	Employee	Employer
400	3,538.87	176.94	213.04
530	0.00	230.77	0.00
550	0.00	15.12	0.00
580	0.00	3.06	0.00
590	0.00	159.39	779.65
595	0.00	5.74	0.00
615	0.00	39.70	0.00
Total:		630.72	992.69

RECAP 3254 - JP Prect. 4

Earnings: 3,538.87 Benefits: 0.00 Deductions: 630.72 Taxes: 565.27 Net Pay: 2,342.88

Department: 4300 - County Sheriff

Total Direct Deposits: 75,981.58
 Total Check Amounts: 0.00

EARNINGS

Pay Code	Units	Pay Amount
165	0.00	16.15
165 Stipend w/RET	0.00	537.73
FLOAT	8.00	204.15
Hourly	2,888.00	70,253.95
OT	212.00	7,503.70
S	16.00	348.41
SAL	-11.00	13,723.63
Uniform	0.00	925.00
Vacation	88.00	2,284.36
VAC-PAYOUT	219.38	5,598.39
Total:	3,420.38	101,395.47

TAXES

Code	Subject To	Employee	Employer
Federal W/H	94,479.45	10,117.15	0.00
MC	99,548.42	1,443.47	1,443.47
SS	99,548.42	6,172.02	6,172.02
Unemployment	78,953.35	0.00	0.00
Total:		17,732.64	7,615.49

DEDUCTIONS

Code	Subject To	Employee	Employer
400	101,379.32	5,068.97	6,103.03
530	0.00	709.16	0.00
550	0.00	482.75	0.00
551	0.00	309.23	0.00
580	0.00	29.07	0.00
590	0.00	637.56	13,071.88
595	0.00	53.95	0.00
610	0.00	27.00	0.00
615	0.00	363.56	0.00
Total:		7,681.25	19,174.91

RECAP 4300 - County Sheriff

Earnings: 101,395.47 Benefits: 0.00 Deductions: 7,681.25 Taxes: 17,732.64 Net Pay: 75,981.58

Department: 4310 - County Jail

Total Direct Deposits: 66,451.78
 Total Check Amounts: 0.00

EARNINGS

Pay Code	Units	Pay Amount
165 Stipend w/RET	0.00	233.06
FH - LAW	8.50	227.93
FLOAT	24.00	658.01
Hourly	2,852.75	66,459.49
OT	253.50	8,812.42
S	28.00	610.56
SAL	-5.00	7,361.92
Uniform	0.00	775.00
Vacation	93.00	2,205.08
Total:	3,254.75	87,343.47

TAXES

Code	Subject To	Employee	Employer
Federal W/H	80,384.08	7,124.70	0.00
MC	84,751.28	1,228.89	1,228.89
SS	84,751.28	5,254.58	5,254.58
Unemployment	62,661.02	0.00	0.00
Total:		13,608.17	6,483.47

DEDUCTIONS

Code	Subject To	Employee	Employer
400	87,343.47	4,367.20	5,258.05
530	0.00	286.15	0.00
550	0.00	470.76	0.00
551	0.00	115.36	0.00
580	0.00	24.48	0.00
590	0.00	1,275.12	13,978.64
595	0.00	90.33	0.00
610	0.00	13.50	0.00
615	0.00	640.62	0.00
Total:		7,283.52	19,236.69

RECAP 4310 - County Jail

Earnings: 87,343.47 Benefits: 0.00 Deductions: 7,283.52 Taxes: 13,608.17 Net Pay: 66,451.78

Department: 4321 - Constables-Pct. 1

Total Direct Deposits: 1,615.16
 Total Check Amounts: 0.00

EARNINGS

Pay Code	Units	Pay Amount
Hourly	126.00	1,950.90
Total:	126.00	1,950.90

TAXES

Code	Subject To	Employee	Employer
Federal W/H	1,853.35	88.95	0.00
MC	1,950.90	28.28	28.28
SS	1,950.90	120.96	120.96
Unemployment	1,245.30	0.00	0.01
Total:		238.19	149.25

DEDUCTIONS

Code	Subject To	Employee	Employer
400	1,950.90	97.55	117.45
Total:		97.55	117.45

RECAP 4321 - Constables-Pct. 1

Earnings: 1,950.90 Benefits: 0.00 Deductions: 97.55 Taxes: 238.19 Net Pay: 1,615.16

Department: 4322 - Constables-Pct. 2

Total Direct Deposits: 1,584.76
Total Check Amounts: 0.00

EARNINGS

Pay Code	Units	Pay Amount
165 Stipend w/RET	0.00	34.62
Hourly	56.00	834.96
SAL	1.00	1,448.45
Uniform	0.00	50.00
Total:	57.00	2,368.03

TAXES

Code	Subject To	Employee	Employer
Federal W/H	2,115.37	359.72	0.00
MC	2,233.77	32.39	32.39
SS	2,233.77	138.50	138.50
Unemployment	1,494.45	0.00	0.00
Total:	530.61	530.61	170.89

DEDUCTIONS

Code	Subject To	Employee	Employer
400	2,368.03	118.40	142.56
550	0.00	13.62	0.00
551	0.00	103.84	0.00
590	0.00	0.00	368.64
615	0.00	16.80	0.00
Total:	252.66	252.66	511.20

RECAP 4322 - Constables-Pct. 2

Earnings: 2,368.03 Benefits: 0.00 Deductions: 252.66 Taxes: 530.61 Net Pay: 1,584.76

Department: 4323 - Constables-Pct. 3

Total Direct Deposits: 3,331.20
Total Check Amounts: 0.00

EARNINGS

Pay Code	Units	Pay Amount
165 Stipend w/RET	0.00	50.77
Hourly	152.00	2,470.05
S	8.00	144.75
SAL	1.00	1,448.45
Uniform	0.00	25.00
Vacation	8.00	144.75
Total:	169.00	4,283.77

TAXES

Code	Subject To	Employee	Employer
Federal W/H	3,797.89	156.70	0.00
MC	4,012.08	58.18	58.18
SS	4,012.08	248.75	248.75
Unemployment	1,805.51	0.00	0.00
Total:	463.63	463.63	306.93

DEDUCTIONS

Code	Subject To	Employee	Employer
400	4,283.77	214.19	257.89
550	0.00	30.58	0.00
580	0.00	3.06	0.00
590	0.00	159.39	779.65
595	0.00	13.89	0.00
615	0.00	67.83	0.00
Total:	488.94	488.94	1,037.54

RECAP 4323 - Constables-Pct. 3

Earnings: 4,283.77 Benefits: 0.00 Deductions: 488.94 Taxes: 463.63 Net Pay: 3,331.20

Department: 4324 - Constables-Pct. 4

Total Direct Deposits: 2,449.25
 Total Check Amounts: 859.58

EARNINGS

Pay Code	Units	Pay Amount
Hourly	186.00	2,913.16
SAL	1.00	1,448.45
Total:	187.00	4,361.61

TAXES

Code	Subject To	Employee	Employer
Federal W/H	3,809.49	187.97	0.00
MC	4,067.57	58.96	58.96
SS	4,067.57	252.20	252.20
Unemployment	596.40	0.00	0.00
Total:	12,541.03	499.13	311.16

DEDUCTIONS

Code	Subject To	Employee	Employer
400	4,361.61	218.08	262.57
520	0.00	40.00	0.00
550	0.00	36.35	0.00
551	0.00	50.00	0.00
580	0.00	1.53	0.00
590	0.00	159.39	779.65
595	0.00	8.60	0.00
615	0.00	39.70	0.00
Total:	4,361.61	553.65	1,042.22

RECAP 4324 - Constables-Pct. 4

Earnings	4,361.61	Benefits	0.00	Deductions	553.65	Taxes	499.13	Net Pay	3,308.83
----------	----------	----------	------	------------	--------	-------	--------	---------	----------

Department: 4330 - Driver's License

Total Direct Deposits: 596.50
 Total Check Amounts: 0.00

EARNINGS

Pay Code	Units	Pay Amount
Hourly	48.00	702.24
Total:	48.00	702.24

TAXES

Code	Subject To	Employee	Employer
Federal W/H	667.13	16.91	0.00
MC	702.24	10.18	10.18
SS	702.24	43.54	43.54
Total:	2,071.61	70.63	53.72

DEDUCTIONS

Code	Subject To	Employee	Employer
400	702.24	35.11	42.27
Total:	702.24	35.11	42.27

RECAP 4330 - Driver's License

Earnings	702.24	Benefits	0.00	Deductions	35.11	Taxes	70.63	Net Pay	596.50
----------	--------	----------	------	------------	-------	-------	-------	---------	--------

Department: 5401 - Juvenile Probation

Total Direct Deposits: 14,496.17
 Total Check Amounts: 0.00

EARNINGS

Pay Code	Units	Pay Amount
165 Stipend w/RET	0.00	147.67
Hourly	440.75	12,480.07
JP COMP TAKEN	1.50	40.36
PER DIEM ALLOWANCE	0.00	15.00
S	5.50	143.39
SAL	-6.00	6,396.81
Vacation	40.25	1,313.65
Total:	482.00	20,536.95

BENEFITS

Pay Code	Units	Pay Amount
JP COMP EARNED	13.50	392.40
Total:	13.50	392.40

TAXES

Code	Subject To	Employee	Employer
Federal W/H	17,532.20	1,589.48	0.00
MC	18,809.04	272.74	272.74
SS	18,809.04	1,166.16	1,166.16
Unemployment	20,536.95	0.00	0.00
Total:	3,028.38	1,438.90	

DEDUCTIONS

Code	Subject To	Employee	Employer
400	20,536.95	1,026.84	1,236.31
520	0.00	250.00	0.00
551	0.00	588.44	0.00
552	0.00	192.30	0.00
580	0.00	7.65	0.00
590	0.00	839.61	2,749.96
595	0.00	5.74	0.00
615	0.00	101.82	0.00
Total:	3,012.40	3,986.27	

RECAP 5401 - Juvenile Probation

Earnings: 20,536.95 Benefits: 392.40 Deductions: 3,012.40 Taxes: 3,028.38 Net Pay: 14,496.17

Department: 6520 - Building Maintenance

Total Direct Deposits: 8,634.60
 Total Check Amounts: 0.00

EARNINGS

Pay Code	Units	Pay Amount
165 Stipend w/RET	0.00	131.52
Hourly	460.00	8,629.52
S	8.00	147.32
SAL	-39.00	972.98
Vacation	52.00	1,213.84
Total:	481.00	11,095.18

TAXES

Code	Subject To	Employee	Employer
Federal W/H	10,331.78	842.86	0.00
MC	10,886.54	157.86	157.86
SS	10,886.54	674.97	674.97
Unemployment	9,527.14	0.00	0.00
Total:	1,675.69	832.83	

DEDUCTIONS

Code	Subject To	Employee	Employer
400	11,095.18	554.76	667.94
550	0.00	78.70	0.00
551	0.00	88.44	0.00
580	0.00	7.65	0.00
590	0.00	0.00	2,580.48
595	0.00	8.58	0.00
610	0.00	13.84	0.00
615	0.00	32.92	0.00
Total:	784.89	3,248.42	

RECAP 6520 - Building Maintenance

Earnings: 11,095.18 Benefits: 0.00 Deductions: 784.89 Taxes: 1,675.69 Net Pay: 8,634.60

Department: 6550 - Elections

Total Direct Deposits: 4,318.84
 Total Check Amounts: 647.34

EARNINGS

Pay Code	Units	Pay Amount
Hourly	303.00	4,942.89
OT	42.50	1,150.78
Vacation	5.00	88.62
Total:	350.50	6,182.29

TAXES

Code	Subject To	Employee	Employer
Federal W/H	5,839.34	405.45	0.00
MC	6,113.41	88.67	88.67
SS	6,113.41	379.04	379.04
Unemployment	1,713.60	0.00	0.00
Total:		873.16	467.71

DEDUCTIONS

Code	Subject To	Employee	Employer
400	5,481.29	274.07	329.97
550	0.00	30.24	0.00
590	0.00	0.00	737.28
595	0.00	5.72	0.00
615	0.00	32.92	0.00
Total:		342.95	1,067.25

RECAP 6550 - Elections

Earnings:	6,182.29	Benefits:	0.00	Deductions:	342.95	Taxes:	873.16	Net Pay:	4,966.18
-----------	----------	-----------	------	-------------	--------	--------	--------	----------	----------

Department: 6560 - Commissioners Court

Total Direct Deposits: 11,910.75
 Total Check Amounts: 1,247.61

EARNINGS

Pay Code	Units	Pay Amount
165 Stipend w/RET	0.00	228.66
Hourly	80.00	1,730.77
S	8.00	205.89
SAL	-25.00	15,113.18
Vacation	24.00	617.67
Total:	87.00	17,896.17

TAXES

Code	Subject To	Employee	Employer
Federal W/H	15,692.34	1,253.20	0.00
MC	16,662.16	241.61	241.61
SS	16,662.16	1,033.05	1,033.05
Unemployment	13,705.32	0.00	0.00
Total:		2,527.86	1,274.66

DEDUCTIONS

Code	Subject To	Employee	Employer
400	17,896.17	894.82	1,077.33
520	0.00	75.00	0.00
550	0.00	72.94	0.00
551	0.00	180.84	0.00
580	0.00	6.12	0.00
590	0.00	882.27	3,076.23
595	0.00	22.36	0.00
615	0.00	75.60	0.00
Total:		2,209.95	4,153.56

RECAP 6560 - Commissioners Court

Earnings:	17,896.17	Benefits:	0.00	Deductions:	2,209.95	Taxes:	2,527.86	Net Pay:	13,158.36
-----------	-----------	-----------	------	-------------	----------	--------	----------	----------	-----------

Department: 6570 - Veteran Service Officer

Total Direct Deposits: 1,633.23
Total Check Amounts: 0.00

EARNINGS

Pay Code	Units	Pay Amount
165 Stipend w/RET	0.00	34.62
Hourly	14.00	264.60
S	6.00	132.78
SAL	-5.00	1,637.68
Total:	15.00	2,069.68

TAXES

Code	Subject To	Employee	Employer
Federal W/H	1,966.20	173.11	0.00
MC	2,069.68	30.01	30.01
SS	2,069.68	128.32	128.32
Unemployment	1,805.08	0.00	0.00
Total:	7,850.64	331.44	158.33

DEDUCTIONS

Code	Subject To	Employee	Employer
400	2,069.68	103.48	124.60
580	0.00	1.53	0.00
Total:	2,069.68	105.01	124.60

RECAP 6570 - Veteran Service Officer

Earnings: 2,069.68 Benefits: 0.00 Deductions: 105.01 Taxes: 331.44 Net Pay: 1,633.23

Department: 6580 - Human Resources

Total Direct Deposits: 1,329.42
Total Check Amounts: 0.00

EARNINGS

Pay Code	Units	Pay Amount
SAL	1.00	2,102.67
Total:	1.00	2,102.67

TAXES

Code	Subject To	Employee	Employer
Federal W/H	1,983.92	494.69	0.00
MC	2,089.05	30.29	30.29
SS	2,089.05	129.52	129.52
Unemployment	2,089.05	0.00	0.00
Total:	8,251.07	654.50	159.81

DEDUCTIONS

Code	Subject To	Employee	Employer
400	2,102.67	105.13	126.58
550	0.00	13.62	0.00
Total:	2,102.67	118.75	126.58

RECAP 6580 - Human Resources

Earnings: 2,102.67 Benefits: 0.00 Deductions: 118.75 Taxes: 654.50 Net Pay: 1,329.42

Department: 6590 - Purchasing Department

Total Direct Deposits: 4,471.89
 Total Check Amounts: 0.00

EARNINGS

Pay Code	Units	Pay Amount
165 Stipend w/RET	0.00	66.92
Hourly	152.00	3,049.04
S	14.00	363.46
SAL	-12.00	2,029.32
Vacation	7.00	212.02
Total:	161.00	5,720.76

TAXES

Code	Subject To	Employee	Employer
Federal W/H	5,368.17	460.68	0.00
MC	5,654.20	81.98	81.98
SS	5,654.20	350.56	350.56
Total:		893.22	432.54

DEDUCTIONS

Code	Subject To	Employee	Employer
400	5,720.76	286.03	344.38
550	0.00	30.24	0.00
580	0.00	3.06	0.00
590	0.00	0.00	1,105.92
595	0.00	11.46	0.00
615	0.00	24.86	0.00
Total:		355.65	1,450.30

RECAP 6590 - Purchasing Department

Earnings: 5,720.76 Benefits: 0.00 Deductions: 355.65 Taxes: 893.22 Net Pay: 4,471.89

Department: 6630 - Grants Department

Total Direct Deposits: 3,618.96
 Total Check Amounts: 0.00

EARNINGS

Pay Code	Units	Pay Amount
165 Stipend w/RET	0.00	50.77
Hourly	80.00	1,672.17
SAL	1.00	2,756.25
Total:	81.00	4,479.19

TAXES

Code	Subject To	Employee	Employer
Federal W/H	4,220.45	259.96	0.00
MC	4,444.41	64.45	64.45
SS	4,444.41	275.55	275.55
Unemployment	4,464.07	0.00	0.00
Total:		599.96	340.00

DEDUCTIONS

Code	Subject To	Employee	Employer
400	4,479.19	223.96	269.65
550	0.00	15.12	0.00
580	0.00	1.53	0.00
590	0.00	0.00	368.64
595	0.00	2.86	0.00
615	0.00	16.80	0.00
Total:		260.27	638.29

RECAP 6630 - Grants Department

Earnings: 4,479.19 Benefits: 0.00 Deductions: 260.27 Taxes: 599.96 Net Pay: 3,618.96

Department: 6650 - Emerg Mgnt/Homeland Sec

Total Direct Deposits: 3,595.55
 Total Check Amounts: 0.00

EARNINGS

Pay Code	Units	Pay Amount
Hourly	80.00	1,904.98
SAL	1.00	2,633.88
Total:	81.00	4,538.86

TAXES

Code	Subject To	Employee	Employer
Federal W/H	4,235.64	297.18	0.00
MC	4,462.58	64.70	64.70
SS	4,462.58	276.68	276.68
Unemployment	4,493.16	0.00	0.00
Total:		638.56	341.38

DEDUCTIONS

Code	Subject To	Employee	Employer
400	4,538.86	226.94	273.24
550	0.00	45.70	0.00
580	0.00	1.53	0.00
590	0.00	0.00	737.28
595	0.00	5.72	0.00
615	0.00	24.86	0.00
Total:		304.75	1,010.52

RECAP 6650 - Emerg Mgnt/Homeland Sec

Earnings: 4,538.86 Benefits: 0.00 Deductions: 304.75 Taxes: 638.56 Net Pay: 3,595.55

Department: 7610 - Sanitation Department

Total Direct Deposits: 4,233.63
 Total Check Amounts: 0.00

EARNINGS

Pay Code	Units	Pay Amount
165 Stipend w/RET	0.00	34.62
Hourly	112.00	1,767.49
S	24.00	484.62
SAL	1.00	2,907.69
Uniform	0.00	25.00
Total:	137.00	5,219.42

TAXES

Code	Subject To	Employee	Employer
Federal W/H	4,901.82	271.70	0.00
MC	5,162.80	74.86	74.86
SS	5,162.80	320.10	320.10
Unemployment	3,573.45	0.00	0.00
Total:		666.66	394.96

DEDUCTIONS

Code	Subject To	Employee	Employer
400	5,219.42	260.98	314.21
550	0.00	45.70	0.00
580	0.00	1.53	0.00
590	0.00	0.00	737.28
595	0.00	2.86	0.00
615	0.00	8.06	0.00
Total:		319.13	1,051.49

RECAP 7610 - Sanitation Department

Earnings: 5,219.42 Benefits: 0.00 Deductions: 319.13 Taxes: 666.66 Net Pay: 4,233.63

Department: 8700 - County Agent

Total Direct Deposits: 4,209.79
 Total Check Amounts: 0.00

EARNINGS

Pay Code	Units	Pay Amount
Hourly	48.00	919.03
SAL	3.00	2,915.11
Vacation	32.00	612.68
VAC-PAYOU	36.36	814.35
Total:	119.36	5,261.17

TAXES

Code	Subject To	Employee	Employer
Federa W/H	5,099.07	486.79	0.00
MC	5,261.17	76.29	76.29
SS	5,261.17	326.20	326.20
Unemployment	3,550.95	0.00	0.00
Total:	19,162.36	889.28	402.49

DEDUCTIONS

Code	Subject To	Employee	Employer
400	3,241.93	162.10	195.17
590	0.00	0.00	368.64
595	0.00	0.00	0.00
615	0.00	0.00	0.00
Total:	3,241.93	162.10	563.81

RECAP 8700 - County Agent

Earnings	5,261.17	Benefits	0.00	Deduct ons	162.10	Taxes	889.28	Net Pay	4,209.79
----------	----------	----------	------	------------	--------	-------	--------	---------	----------



Caldwell County, TX

Detail Register

Payroll Summary

Packet: PYPKT02559 - Payroll 100922 thru 102222
 Payroll Set: 01 - Payroll Set 01

Pay Period: 10/09/2022 - 10/22/2022

Males Paid: 152
 Females Paid: 139
 Total Employees: 291

Total Direct Deposits: 364,283.53
 Total Check Amounts: 9,289.04

EARNINGS	Pay Code	Units	Pay Amount
165		0.00	16.15
165 Stipend w/RET		0.00	1,959.44
ADA Supplement		0.00	692.31
ADA/ETF Stipend		0.00	723.07
BEREAVEMENT		72.00	1,674.09
DA Staff Supplement		0.00	1,228.17
FH - LAW		8.50	227.93
FLOAT		43.00	1,068.01
Hourly		14,220.75	309,895.50
JP COMP TAKEN		1.50	40.36
Jud Stip		0.00	3,230.77
JURY DUTY		8.00	164.80
LWOP		1.84	0.00
Misc		0.69	12.87
OT		508.00	17,466.90
PER DIEM ALLOWANCE		0.00	15.00
S		413.41	9,999.13
SAL		-218.00	124,120.77
Uniform		0.00	2,050.00
Vacation		612.25	15,304.76
VAC-PAYOUT		270.78	6,667.99
Total:		15,942.72	496,558.02

BENEFITS	Pay Code	Units	Pay Amount
JP COMP EARNED		13.50	392.40
Total:		13.50	392.40

TAXES	Code	Subject To	Employee	Employer
Federal W/H		453,672.11	41,834.20	0.00
MC		479,555.15	6,953.57	6,953.57
SS		479,555.15	29,732.52	29,732.52
Unemployment		371,581.67	0.00	0.02
Total:			78,520.29	36,686.11

Fed W/H - 41,834.20
MC - 13,907.14
SS - 29,732.52

102,689.38

DEDUCTIONS	Code	Subject To	Employee	Employer
400		492,558.84	24,628.04	29,652.10
520		0.00	1,255.00	0.00
530		0.00	1,226.08	0.00
550		0.00	2,340.10	0.00
551		0.00	2,441.77	0.00
552		0.00	384.60	0.00
560		0.00	75.00	0.00
580		0.00	169.83	0.00
590		0.00	8,757.08	77,308.37
595		0.00	447.79	0.00
610		0.00	108.34	0.00
615		0.00	2,631.53	0.00
Total:			44,465.16	106,960.47

RECAP 01 - Payroll Set 01

Earnings: 496,558.02 Benefits: 392.40 Deductions: 44,465.16 Taxes: 78,520.29 Net Pay: 373,572.57

B. \$102,689.38 Payroll Tax (10/09/2022 – 10/22/2022)

Caldwell County Agenda Item Request Form

To: All Elected Officials and Department Heads – Hand deliver or scan & email to hopy.haden@co.caldwell.tx.us and ezzy.chan@co.caldwell.tx.us . Deadline is 5:00 pm Tuesday before the Regular meetings, however, please submit this completed form ASAP. “Anything missing will cause the Agenda Item to be held over to the next Regular meeting,” according to our Rules & Procedures.

AGENDA DATE: 11.08.2022

Type of Agenda Item

- Consent Discussion/Action Executive Session Workshop
 Public Hearing

What will be discussed? What is the proposed motion?

\$102,689.38 Payroll Tax (10/09/2022 – 10/22/2022)

1. Costs:

Actual Cost or **Estimated Cost** \$ _____

Is this cost included in the County Budget? _____

Is a Budget Amendment being proposed? _____

2. Agenda Speakers:

	Name	Representing	Title
--	------	--------------	-------

(1) Judge Haden _____

(2) _____

(3) _____

3. Backup Materials: None To Be Distributed 2 total # of backup pages
(including this page)

4.  _____
Signature of Court Member

10/26/2022 _____
Date

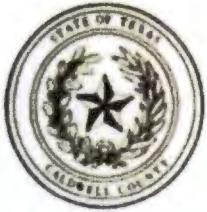

Packet: PYPKT02559 - Payroll 100922 thru 102222
Payroll Set: 01 - Payroll Set 01

Pay Period: 10/09/2022 - 10/22/2022

Total Direct Deposits: 364,283.53
Total Check Amounts: 9,289.04

Males Paid: 152
Females Paid: 139
Total Employees: 291

EARNINGS

Pay Code	Units	Pay Amount
165	0.00	16.15
165 Stipend w/RET	0.00	1,959.44
ADA Supplement	0.00	692.31
ADA/ETF Stipend	0.00	723.07
BEREAVEMENT	72.00	1,674.09
DA Staff Supplement	0.00	1,228.17
FH - LAW	8.50	227.93
FLOAT	43.00	1,068.01
Hourly	14,220.75	309,895.50
JP COMP TAKEN	1.50	40.36
Jud Stip	0.00	3,230.77
JURY DUTY	8.00	164.80
LWOP	1.84	0.00
Misc	0.69	12.87
OT	508.00	17,466.90
PER DIEM ALLOWANCE	0.00	15.00
S	413.41	9,999.13
SAL	-218.00	124,120.77
Uniform	0.00	2,050.00
Vacation	612.25	15,304.76
VAC-PAYOUT	270.78	6,667.99
Total:	15,942.72	496,558.02

BENEFITS

Pay Code	Units	Pay Amount
JP COMP EARNED	13.50	392.40
Total:	13.50	392.40

TAXES

Code	Subject To	Employee	Employer
Federal W/H	453,672.11	41,834.20	0.00
MC	479,555.15	6,953.57	6,953.57
SS	479,555.15	29,732.52	29,732.52
Unemployment	371,581.67	0.00	0.02
Total:	78,520.29	36,686.11	

Fed W/H - 41,834.20
 MC - 13,907.14
 SS - 29,732.52

 \$ 102,689.38

DEDUCTIONS

Code	Subject To	Employee	Employer
400	492,558.84	24,628.04	29,652.10
520	0.00	1,255.00	0.00
530	0.00	1,226.08	0.00
550	0.00	2,340.10	0.00
551	0.00	2,441.77	0.00
552	0.00	384.60	0.00
560	0.00	75.00	0.00
580	0.00	169.83	0.00
590	0.00	8,757.08	77,308.37
595	0.00	447.79	0.00
610	0.00	108.34	0.00
615	0.00	2,631.53	0.00
Total:	44,465.16	106,960.47	

RECAP 01 - Payroll Set 01

Earnings: 496,558.02 Benefits: 392.40 Deductions: 44,465.16 Taxes: 78,520.29 Net Pay: 373,572.57

**3. To approve the Bond for Callie Hoehne,
Purchasing Assistant.**

Caldwell County Agenda Item Request Form

To: All Elected Officials and Department Heads – Hand deliver or scan & email to hobby.haden@co.caldwell.tx.us and ezzy.chan@co.caldwell.tx.us . Deadline is 5:00 pm Tuesday before the Regular meetings, however, please submit this completed form ASAP. "Anything missing will cause the Agenda Item to be held over to the next Regular meeting," according to our Rules & Procedures.

AGENDA DATE: 11.08.2022

Type of Agenda Item

- Consent Discussion/Action Executive Session Workshop
 Public Hearing

What will be discussed? What is the proposed motion?

to approve the Bond for Callie Hoehne, Purchasing Assistant

1. Costs:

Actual Cost or **Estimated Cost** \$ _____

Is this cost included in the County Budget? _____

Is a Budget Amendment being proposed? _____

2. Agenda Speakers:

	Name	Representing	Title
--	------	--------------	-------

(1) Judge Haden _____

(2) _____

(3) _____

3. Backup Materials: None To Be Distributed 1 total # of backup pages
(including this page)

4.  _____
Signature of Court Member

_____ 10/26/2022 _____
Date

Texas



Western Surety Company

OFFICIAL BOND AND OATH

THE STATE OF TEXAS }
County of CALDWELL } ss

KNOW ALL PERSONS BY THESE PRESENTS: BOND No. _____

That we, Callie Hoehne Espinosa, as Principal, and WESTERN SURETY COMPANY, a corporation duly licensed to do business in the State of Texas, as Surety, are held and bound unto County of Caldwell, his successors in office, in the sum of Fifty Thousand and 00/100 DOLLARS (\$50,000.00), for the payment of which we hereby bind ourselves and our heirs, executors and administrators, jointly and severally, by these presents.

Dated this 7th day of September, 2022.

THE CONDITION OF THE ABOVE OBLIGATION IS SUCH, That whereas, the above bounden Principal was on the _____ day of _____, _____, duly appointed (Elected—Appointed) to the office of Purchasing Assistant in and for CALDWELL County, State of Texas, for a term of one year commencing on the 29th day of August, 2022.

NOW THEREFORE, if the said Principal shall well and faithfully perform and discharge all the duties required of him by law as the aforesaid officer, ~~and shall~~ ⁴

then this obligation to be void, otherwise to remain in full force and effect.

PROVIDED, HOWEVER, that regardless of the number of years this bond may remain in force and the number of claims which may be made against this bond, the liability of the Surety shall not be cumulative and the aggregate liability of the Surety for any and all claims, suits, or actions under this bond shall not exceed the amount stated above. Any revision of the bond amount shall not be cumulative.

PROVIDED, FURTHER, that this bond may be cancelled by the Surety by sending written notice to the party to whom this bond is payable stating that, not less than thirty (30) days thereafter, the Surety's liability hereunder shall terminate as to subsequent acts of the Principal.

Callie Hoehne Espinosa Principal
WESTERN SURETY COMPANY
By Paul T. Bruffat
Paul T. Bruffat, Vice President

4. To ratify the Interlocal Agreement between the Capital Area Council of Governments and Caldwell County for use by Caldwell County of the CAPCOG Regional Notification System.

Caldwell County Agenda Item Request Form

To: All Elected Officials and Department Heads – Hand deliver or scan & email to hoppy.haden@co.caldwell.tx.us and ezzy.chan@co.caldwell.tx.us . Deadline is 5:00 pm Tuesday before the Regular meetings, however, please submit this completed form ASAP. “Anything missing will cause the Agenda Item to be held over to the next Regular meeting,” according to our Rules & Procedures.

AGENDA DATE: 11.08.2022

Type of Agenda Item

- Consent Discussion/Action Executive Session Workshop
 Public Hearing

What will be discussed? What is the proposed motion?

to ratify the Interlocal Agreement Between the Capital Area Council of Governments and Caldwell County for Use by Caldwell County of the CAPCOG Regional Notification System

1. Costs:

Actual Cost or Estimated Cost \$ None

Is this cost included in the County Budget? _____

Is a Budget Amendment being proposed? _____

2. Agenda Speakers:

	Name	Representing	Title
--	------	--------------	-------

(1) Judge Haden

(2) _____

(3) _____

3. Backup Materials: None To Be Distributed 5 total # of backup pages
(including this page)

4. 
Signature of Court Member

10/26/2022
Date

**INTERLOCAL AGREEMENT
BETWEEN THE CAPITAL AREA COUNCIL OF GOVERNMENTS
AND CALDWELL COUNTY
FOR USE BY CALDWELL COUNTY OF THE CAPCOG REGIONAL NOTIFICATION
SYSTEM**

This Agreement is by and among Caldwell County and the Capital Area Council of Governments (CAPCOG) (also referred to as the "Parties" or a "Party").

RECITALS

Whereas, the Regional Notification System (RNS), an automated phone-dialing, texting and emailing system, used by authorized public safety personnel in the 10-county CAPCOG region alert residents, response groups, disaster recovery planners and other selected contacts during emergencies and for other governmental activities.

Whereas, the RNS is a computer-based system that uses phone numbers and addresses maintained by the 9-1-1 system, as well as a cell phone registration system, to warn people in a given area of threats posed by wildfires, floods, chemical releases, criminal activity and other emergency incidents.

Whereas, the RNS also uses other databases, provided by both the vendor and the jurisdiction using the system to provide notification of people within a specified area or contained on a notification list of information that may impact them.

Whereas, this Agreement is authorized by the Interlocal Cooperation Act, Chapter 791 of the Texas Government Code. Each party's monetary obligations, if any, are for the performance of governmental functions or services and are payable only from the current revenues appropriated and available for the performance of those functions or services.

AGREEMENT

Section 1. Purpose

This Agreement authorizes Caldwell County to use the RNS provided by CAPCOG. This Agreement supersedes any previous Agreement between the Parties.

Section 2. CAPCOG's Duties and Rights.

CAPCOG agrees to perform the duties assigned to it in the latest revision of the CAPCOG *Regional Notification System (RNS) Policies and Procedures* as approved by the CAPCOG Executive Committee, which is attached hereto as Exhibit A and incorporated into this Agreement.

At its sole discretion, CAPCOG may immediately disable Caldwell County user account while

an investigation into a possible violation by Caldwell County of the CAPCOG *Regional Notification System (RNS) Policies and Procedures* is being conducted or while the agreement is being terminated pursuant to section 5, below.

CAPCOG agrees to maintain current *Regional Notification System (RNS) Policies and Procedures* as approved by the CAPCOG Executive Committee, and to distribute all updates to Caldwell County within five (5) working days of approval.

CAPCOG agrees to maintain and make available all training materials related to the Regional Notification System on a dedicated website.

CAPCOG agrees to provide written materials to each participating jurisdiction that clearly identify the telephone contact information to be used to contact the RNS vendor when assistance is needed in making a notification using the system.

Section 3. Caldwell County Duties and Rights.

Caldwell County agrees to use the RNS solely in accordance with the latest revision of the CAPCOG *Regional Notification System (RNS) Policies and Procedures* as approved by the CAPCOG Executive Committee, which is attached hereto as Exhibit A and incorporated into this Agreement.

Caldwell County agrees to contact the RNS vendor at the telephone numbers provided by CAPCOG in accordance with Section 2, for guidance on operational issues or when Caldwell County needs assistance in making a notification using the system.

If Caldwell County receives a request under the Texas Public Information Act for disclosure of any of the 9-1-1 database information, including names addresses and telephone numbers of persons who have been notified using that portion of the RNS that derives its call list from the 9-1-1 database, Caldwell County agrees not to disclose the information prior to notification of CAPCOG's Director of Emergency Communications Division in writing within two business days of the receipt of the request.

Section 4. Agreement Term

The term of this Agreement commences on the date the signed agreement is returned to CAPCOG and continuing until this agreement is superseded by another agreement related to use of the RNS or cancelled in writing by either party.

Section 5. Termination

Either Party may terminate this Agreement at any time upon thirty calendar (30) days' prior written notice to the other Party. However, if Caldwell County violates the CAPCOG *Regional Notification System (RNS) Policies and Procedures* and does not correct the violation within five (5) business days after CAPCOG gives Caldwell County written notice of the violation, this constitutes grounds for termination of this Agreement. If Caldwell County fails to timely correct the violation after notice from CAPCOG, CAPCOG may terminate this Agreement by notifying Caldwell County, in writing, of its intent to terminate, and the Agreement terminates fifteen (15) calendar days after the date on the notice.

Section 6. Limitation of Liability and Governmental Immunity

Each party to this Agreement agrees that it shall have no liability whatsoever for the actions and/or omissions of the other party's employees, officers, or agents, regardless of where the individual's actions and/or omissions occurred. Each party is solely responsible for the actions and/or omissions of its employees, officers, and agents; however, such responsibility is only to the extent required by Texas law. Where injury or property damage results from the joint or concurring acts and/or omissions of the parties, any liability shall be shared by each party in accordance with the applicable Texas law, subject to all defenses, including governmental immunity. These provisions are solely for the benefit of the parties hereto and not for the benefit of any person or entity not a party hereto; nor shall any provision hereof be deemed a waiver of any defenses available by law.

Section 7. Fees.

There is no cost to Caldwell County for use of the RNS.

Section 8. Notice.

All notices sent pursuant to this Agreement shall be in writing and may be hand delivered, or sent by registered or certified mail, postage prepaid, return receipt requested.

When notices sent are hand delivered, notice shall be deemed effective upon delivery. When notices are mailed by registered or certified mail, notice shall be deemed effective three days after deposit in a U.S. mailbox or at a U.S. post office.

Either Party may change its address for notice under this Agreement by providing a notice of the change in compliance with this paragraph to the other Party.

Notice will be provided to the following persons or their successors:

Caldwell County

Hoppy Haden
County Judge
110 S. Main St., Room 101
Lockhart, Texas 78644

CAPCOG

Betty Voights
Executive Director
6800 Burluson Road, Building 310, Suite 165
Austin, Texas 78744

Section 9. Miscellaneous

Each individual signing this agreement on behalf of a Party warrants that he or she is legally authorized to do so and that the Party is legally authorized to perform the obligations undertaken. The individuals legally authorized to execute this document will have the authority to negotiate and execute amendments to this agreement without further action by each party's governing body in such a way that would not constitute a substantive modification of the agreement's terms and conditions or otherwise violate Chapter 791 of the Texas Government Code. Any amendments that would constitute a substantive modification to the agreement must be approved by each Party's governing body.

This Agreement states the entire agreement of the Parties, and an amendment to it is not effective unless in writing and signed by both Parties.

This Agreement is executed in duplicate originals.

Capital Area Council of Governments

By:

Betty Voights
Executive Director

Caldwell County

By: 

Hoppy Haden
County Judge

5. To approve the 2023 Appraisal District and Collection Budgets.

Caldwell County Agenda Item Request Form

To: All Elected Officials and Department Heads – Hand deliver or scan & email to hopyy.haden@co.caldwell.tx.us and ezzy.chan@co.caldwell.tx.us . Deadline is 5:00 pm Tuesday before the Regular meetings, however, please submit this completed form ASAP. "Anything missing will cause the Agenda Item to be held over to the next Regular meeting," according to our Rules & Procedures.

AGENDA DATE: 11.08.2022

Type of Agenda Item

- Consent Discussion/Action Executive Session Workshop
 Public Hearing

What will be discussed? What is the proposed motion?

to approve the 2023 Appraisal District and Collection Budgets

1. Costs:

Actual Cost or Estimated Cost \$ None

Is this cost included in the County Budget? _____

Is a Budget Amendment being proposed? _____

2. Agenda Speakers:

	Name	Representing	Title
--	------	--------------	-------

(1)	<u>Judge Haden</u>		
-----	--------------------	--	--

(2)			
-----	--	--	--

(3)			
-----	--	--	--

3. Backup Materials: None To Be Distributed 6 total # of backup pages
(including this page)

4. 
Signature of Court Member

10/26/2022
Date

Caldwell County Appraisal District

Date: October 19, 2022

To: Presiding Officers/Chief Administrators of all taxing units

From: Shanna Ramzinski, Chief Appraiser

Re: Cost Allocation for 2022 Appraisal District and Collection Budgets

Enclosed you will find a copy of the 2023 Caldwell County Appraisal District's budget cost allocation for each taxing entity. The cost allocations have been adjusted to reflect the 2022 tax levies.

Please contact me if you have any questions.

Sincerely,

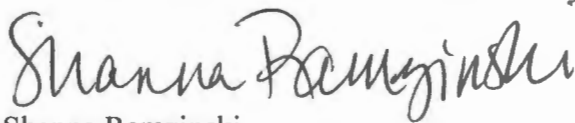

Shanna Ramzinski
Chief Appraiser

Encl. Cost Allocation



211 Bufkin Ln
P.O. Box 900
Lockhart, Texas 78644
United States

PHONE (512) 398-5550
FAX (512) 398-5551
E-MAIL general@caldwellcad.org
WEB SITE www.caldwellcad.org

2023 APPRAISAL BUDGET ALLOCATION

Caldwell County Appraisal District ADOPTED Budget

ENTITIES	2022 TAX LEVY	RATIO %	2023 BUDGET	ASSESSMENT
CITY OF LOCKHART	\$7,059,211.33	8.759%	\$1,743,770.50	\$152,741.29
CITY OF LULING	\$1,628,544.83	2.021%	\$1,743,770.50	\$35,237.09
CITY OF MARTINDALE	\$370,640.43	0.460%	\$1,743,770.50	\$8,019.61
CITY OF MUSTANG RIDGE	\$117,700.29	0.146%	\$1,743,770.50	\$2,546.70
CITY OF NIEDERWALD	\$53,784.92	0.067%	\$1,743,770.50	\$1,163.75
CITY OF UHLAND	\$29,998.60	0.037%	\$1,743,770.50	\$649.08
CALDWELL-HAYS ESD1	\$820,422.09	1.018%	\$1,743,770.50	\$17,751.61
CALDWELL ESD #2	\$266,840.43	0.331%	\$1,743,770.50	\$5,773.67
CALDWELL ESD #3	\$208,104.13	0.258%	\$1,743,770.50	\$4,502.78
CALDWELL ESD #4	\$228,238.39	0.283%	\$1,743,770.50	\$4,938.43
MCC2	\$13,314.64	0.017%	\$1,743,770.50	\$288.09
CALDWELL COUNTY	\$24,032,242.99	29.820%	\$1,743,770.50	\$519,989.52
LOCKHART ISD	\$31,092,500.44	38.580%	\$1,743,770.50	\$672,753.45
LULING ISD	\$6,949,838.72	8.623%	\$1,743,770.50	\$150,370.45
PRAIRIE LEA ISD	\$1,881,412.44	2.335%	\$1,743,770.50	\$40,708.42
GONZALES COUNTY UWD	\$9,197.17	0.011%	\$1,743,770.50	\$199.00
PLUM CREEK CONS DIST	\$403,916.81	0.501%	\$1,743,770.50	\$8,739.61
PLUM CREEK UNDERGROUND	\$396,292.18	0.492%	\$1,743,770.50	\$8,574.64
CITY OF SAN MARCOS	\$201,971.53	0.251%	\$1,743,770.50	\$4,370.09
GONZALES ISD	\$510,092.08	0.633%	\$1,743,770.50	\$11,036.94
HAYS ISD	\$1,068,659.36	1.323%	\$1,743,770.50	\$23,122.75
SAN MARCOS ISD	\$2,752,511.70	3.415%	\$1,743,770.50	\$59,556.54
WAELDER ISD	\$417,721.54	0.518%	\$1,743,770.50	\$9,038.31
AUSTIN COMMUNITY COLLEGE	\$78,506.68	0.097%	\$1,743,770.50	\$1,698.66
TOTALS	\$80,591,483.72	100.00%	\$1,743,770.50	\$1,743,770.50

2023 APPRAISAL BUDGET ALLOCATION
Caldwell County Appraisal District ADOPTED Budget

ENTITIES	2022 TAX LEVY	RATIO %	2023 BUDGET	ASSESSMENT	JANUARY 1 PAYMENT	APRIL 1 PAYMENT	JULY 1 PAYMENT	OCTOBER 1 PAYMENT	TOTAL COLLECTED
CITY OF LOCKHART	\$7,059,211.33	8.759%	\$1,743,770.50	\$152,741.29	\$38,185.32	\$38,185.32	\$38,185.32	\$38,185.32	\$152,741.29
CITY OF LULING	\$1,628,544.83	2.021%	\$1,743,770.50	\$35,237.09	\$8,809.27	\$8,809.27	\$8,809.27	\$8,809.27	\$35,237.09
CITY OF MARTINDALE	\$370,640.43	0.460%	\$1,743,770.50	\$8,019.61	\$2,004.90	\$2,004.90	\$2,004.90	\$2,004.90	\$8,019.61
CITY OF MUSTANG RIDGE	\$117,700.29	0.146%	\$1,743,770.50	\$2,546.70	\$636.68	\$636.68	\$636.68	\$636.68	\$2,546.70
CITY OF NIEDERWALD	\$53,784.92	0.067%	\$1,743,770.50	\$1,163.75	\$290.94	\$290.94	\$290.94	\$290.94	\$1,163.75
CITY OF UHLAND	\$29,998.60	0.037%	\$1,743,770.50	\$649.08	\$162.27	\$162.27	\$162.27	\$162.27	\$649.08
CALDWELL-HAYS ESD1	\$820,422.09	1.018%	\$1,743,770.50	\$17,751.61	\$4,437.90	\$4,437.90	\$4,437.90	\$4,437.90	\$17,751.61
CALDWELL ESD #2	\$266,840.43	0.331%	\$1,743,770.50	\$5,773.67	\$1,443.42	\$1,443.42	\$1,443.42	\$1,443.42	\$5,773.67
CALDWELL ESD #3	\$208,104.13	0.258%	\$1,743,770.50	\$4,502.78	\$1,125.70	\$1,125.70	\$1,125.70	\$1,125.70	\$4,502.78
CALDWELL ESD #4	\$228,238.39	0.283%	\$1,743,770.50	\$4,938.43	\$1,234.61	\$1,234.61	\$1,234.61	\$1,234.61	\$4,938.43
MCC2	\$13,314.64	0.017%	\$1,743,770.50	\$288.09	\$72.02	\$72.02	\$72.02	\$72.02	\$288.09
CALDWELL COUNTY	\$24,032,242.99	29.820%	\$1,743,770.50	\$519,989.52	\$129,997.38	\$129,997.38	\$129,997.38	\$129,997.38	\$519,989.52
LOCKHART ISD	\$31,092,500.44	38.580%	\$1,743,770.50	\$672,753.45	\$168,188.36	\$168,188.36	\$168,188.36	\$168,188.36	\$672,753.45
LULING ISD	\$6,949,638.72	8.623%	\$1,743,770.50	\$150,370.45	\$37,592.61	\$37,592.61	\$37,592.61	\$37,592.61	\$150,370.45
PRAIRIE LEA ISD	\$1,881,412.44	2.335%	\$1,743,770.50	\$40,708.42	\$10,177.11	\$10,177.11	\$10,177.11	\$10,177.11	\$40,708.42
GONZALES COUNTY UWD	\$9,197.17	0.011%	\$1,743,770.50	\$199.00	\$49.75	\$49.75	\$49.75	\$49.75	\$199.00
PLUM CREEK CONS.DIST.	\$403,916.81	0.501%	\$1,743,770.50	\$8,739.61	\$2,184.90	\$2,184.90	\$2,184.90	\$2,184.90	\$8,739.61
PLUM CREEK UNDERGRND	\$396,292.18	0.492%	\$1,743,770.50	\$8,574.64	\$2,143.66	\$2,143.66	\$2,143.66	\$2,143.66	\$8,574.64
CITY OF SAN MARCOS	\$201,971.53	0.251%	\$1,743,770.50	\$4,370.09	\$1,092.52	\$1,092.52	\$1,092.52	\$1,092.52	\$4,370.09
GONZALES ISD	\$510,092.08	0.633%	\$1,743,770.50	\$11,036.94	\$2,759.24	\$2,759.24	\$2,759.24	\$2,759.24	\$11,036.94
HAYS ISD	\$1,068,659.36	1.326%	\$1,743,770.50	\$23,122.75	\$5,780.69	\$5,780.69	\$5,780.69	\$5,780.69	\$23,122.75
SAN MARCOS ISD	\$2,752,511.70	3.415%	\$1,743,770.50	\$59,556.54	\$14,889.13	\$14,889.13	\$14,889.13	\$14,889.13	\$59,556.54
WAELEDER ISD	\$417,721.54	0.518%	\$1,743,770.50	\$9,038.31	\$2,259.58	\$2,259.58	\$2,259.58	\$2,259.58	\$9,038.31
AUSTIN COMMUNITY COLLEGE	\$78,506.68	0.097%	\$1,743,770.50	\$1,698.66	\$424.67	\$424.67	\$424.67	\$424.67	\$1,698.66
TOTALS	\$80,591,463.72	100.00%	\$1,743,770.50	\$1,743,770.50	\$435,942.63	\$435,942.63	\$435,942.63	\$435,942.63	\$1,743,770.50

2023 COLLECTION BUDGET ALLOCATION

Caldwell County Appraisal District ADOPTED Budget

ENTITIES	2022 TAX LEVY	RATIO %	2023 BUDGET	ASSESSMENT
CITY OF LOCKHART	\$7,059,211.33	9.141%	\$523,168.12	\$47,823.30
CITY OF LULING	\$1,661,853.97	2.152%	\$523,168.12	\$11,258.39
CITY OF MARTINDALE	\$370,640.43	0.480%	\$523,168.12	\$2,510.94
CITY OF MUSTANG RIDGE	\$117,700.29	0.152%	\$523,168.12	\$797.37
CITY OF NIEDERWALD	\$53,784.92	0.070%	\$523,168.12	\$364.37
CITY OF UHLAND	\$29,998.60	0.039%	\$523,168.12	\$203.23
CALDWELL-HAYS ESD1	\$820,422.09	1.062%	\$523,168.12	\$5,558.03
CALDWELL ESD #2	\$266,840.43	0.346%	\$523,168.12	\$1,807.74
CALDWELL ESD #3	\$208,104.13	0.269%	\$523,168.12	\$1,409.82
CALDWELL ESD #4	\$228,238.39	0.296%	\$523,168.12	\$1,546.22
MCC2	\$13,314.64	0.017%	\$523,168.12	\$90.20
CALDWELL COUNTY	\$24,032,242.99	31.120%	\$523,168.12	\$162,808.73
LOCKHART ISD	\$31,092,500.44	40.262%	\$523,168.12	\$210,639.12
LULING ISD	\$8,007,843.69	10.369%	\$523,168.12	\$54,249.90
PRAIRIE LEA ISD	\$2,452,894.38	3.176%	\$523,168.12	\$16,617.37
GONZALES COUNTY UWD	\$9,197.17	0.012%	\$523,168.12	\$62.31
PLUM CREEK CONS DIST	\$403,916.81	0.523%	\$523,168.12	\$2,736.37
PLUM CREEK UWD	\$396,292.18	0.513%	\$523,168.12	\$2,684.72
TOTALS	\$77,224,996.88	100.00%	\$523,168.12	\$523,168.12

2023 COLLECTION BUDGET ALLOCATION

Caldwell County Appraisal District ADOPTED Budget

ENTITIES	2022 TAX LEVY	RATIO %	2023 BUDGET	ASSESSMENT	JANUARY 1 PAYMENT	APRIL 1 PAYMENT	JULY 1 PAYMENT	OCTOBER 1 PAYMENT	TOTAL COLLECTED
CITY OF LOCKHART	\$7,059,211.33	9.141%	\$523,168.12	\$47,823.30	\$11,955.83	\$11,955.83	\$11,955.83	\$11,955.83	\$47,823.30
CITY OF LULING	\$1,661,853.97	2.152%	\$523,168.12	\$11,258.39	\$2,814.60	\$2,814.60	\$2,814.60	\$2,814.60	\$11,258.39
CITY OF MARTINDALE	\$370,640.43	0.480%	\$523,168.12	\$2,510.94	\$627.73	\$627.73	\$627.73	\$627.73	\$2,510.94
CITY OF MUSTANG RIDGE	\$117,700.29	0.152%	\$523,168.12	\$797.37	\$199.34	\$199.34	\$199.34	\$199.34	\$797.37
CITY OF NIEDERWALD	\$53,784.92	0.070%	\$523,168.12	\$364.37	\$91.09	\$91.09	\$91.09	\$91.09	\$364.37
CITY OF UHLAND	\$29,998.60	0.039%	\$523,168.12	\$203.23	\$50.81	\$50.81	\$50.81	\$50.81	\$203.23
CALDWELL-HAYS ESD1	\$820,422.09	1.062%	\$523,168.12	\$5,558.03	\$1,389.51	\$1,389.51	\$1,389.51	\$1,389.51	\$5,558.03
CALDWELL ESD #2	\$266,840.43	0.346%	\$523,168.12	\$1,807.74	\$451.93	\$451.93	\$451.93	\$451.93	\$1,807.74
CALDWELL ESD #3	\$208,104.13	0.269%	\$523,168.12	\$1,409.82	\$352.46	\$352.46	\$352.46	\$352.46	\$1,409.82
CALDWELL ESD #4	\$228,238.39	0.296%	\$523,168.12	\$1,546.22	\$386.56	\$386.56	\$386.56	\$386.56	\$1,546.22
MCC2	\$13,314.64	0.017%	\$523,168.12	\$90.20	\$22.55	\$22.55	\$22.55	\$22.55	\$90.20
CALDWELL COUNTY	\$24,032,242.99	31.120%	\$523,168.12	\$162,808.73	\$40,702.18	\$40,702.18	\$40,702.18	\$40,702.18	\$162,808.73
LOCKHART ISD	\$31,092,500.44	40.262%	\$523,168.12	\$210,639.12	\$52,659.78	\$52,659.78	\$52,659.78	\$52,659.78	\$210,639.12
LULING ISD	\$8,007,843.69	10.369%	\$523,168.12	\$54,249.90	\$13,562.48	\$13,562.48	\$13,562.48	\$13,562.48	\$54,249.90
PRAIRIE LEA ISD	\$2,452,894.38	3.176%	\$523,168.12	\$16,617.37	\$4,154.34	\$4,154.34	\$4,154.34	\$4,154.34	\$16,617.37
GONZALES COUNTY UWD	\$9,197.17	0.012%	\$523,168.12	\$62.31	\$15.58	\$15.58	\$15.58	\$15.58	\$62.31
PLUM CREEK CONS. DIST.	\$403,916.81	0.523%	\$523,168.12	\$2,736.37	\$684.09	\$684.09	\$684.09	\$684.09	\$2,736.37
PLUM CREEK UNDERGRND	\$396,292.18	0.513%	\$523,168.12	\$2,684.72	\$671.18	\$671.18	\$671.18	\$671.18	\$2,684.72
TOTALS	\$77,224,996.88	100.00%	\$523,168.12	\$523,168.12	\$130,792.03	\$130,792.03	\$130,792.03	\$130,792.03	\$523,168.12

6. To approve Constable Pct. 1 September Monthly Report.

Caldwell County Agenda Item Request Form

To: All Elected Officials and Department Heads – Hand deliver or scan & email to hoppy.haden@co.caldwell.tx.us and ezzy.chan@co.caldwell.tx.us . Deadline is 5:00 pm Tuesday before the Regular meetings, however, please submit this completed form ASAP. "Anything missing will cause the Agenda Item to be held over to the next Regular meeting," according to our Rules & Procedures.

AGENDA DATE: 11.08.2022

Type of Agenda Item

- Consent Discussion/Action Executive Session Workshop
- Public Hearing

What will be discussed? What is the proposed motion?
to approve Constable Pct. 1 September Monthly Report

1. Costs:

Actual Cost or Estimated Cost \$ None

Is this cost included in the County Budget? _____

Is a Budget Amendment being proposed? _____

2. Agenda Speakers:

	Name	Representing	Title
(1)	Judge Haden		
(2)			
(3)			

3. Backup Materials: None To Be Distributed 3 total # of backup pages (including this page)

4. 
Signature of Court Member

10/26/2022
Date



Caldwell County Constable Precinct One

405 E. Market St.
Lockhart Tx, 78644

To: Judge Haden

From: Chief Deputy Sanders

Re: September Monthly Report

Sir, here is the monthly report for the month of September

There was a total of 120 citizen contacts for the month. We continue to interact with the public in different ways.

There was a total of 57 traffic stops with 44 citations written and 22 warnings issued.

There were 33 attempts to serve civil citations with 14 served for the month. Two of these were writs of possession with one of the Writs taking 2 days to complete. The writ that took 2 days was at 596 Boulder Ln. and due to the number of threats that the current resident was making we used 6 deputies for the writ. I also had EMS on standby and the resident was transported to Luling hospital due to medical condition and was evaluated and released from the hospital after receiving a criminal trespass warning for the Boulder Ln. address.

We also had 2 civil standby calls while subjects retrieved their clothing and other items needed.



Caldwell County Constable Precinct One

405 E. Market St.
Lockhart Tx, 78644

We had 7 agency assist between the Fire Dept., EMS and Police.

We assisted the public 2 times with various information.

We served 1 warrant and arrested the subject.

We assisted Lockhart PD with a major accident.

We provided bailiff duties to the JP-1 court 5 times this month and are continuing to work with that office to provide quality service.

Overall, this month was consistent but could have been better. I will make the effort to continue to keep morale up for the deputies after he passing of our Constable.

Respectfully Submitted

A handwritten signature in black ink, appearing to read "Richard Sanders".

Richard Sanders-Chief Deputy

7. To approve Treasurer's Filed/Paid Q3 State Report.

Caldwell County Agenda Item Request Form

To: All Elected Officials and Department Heads – Hand deliver or scan & email to hoppy.haden@co.caldwell.tx.us and ezzy.chan@co.caldwell.tx.us . Deadline is 5:00 pm Tuesday before the Regular meetings, however, please submit this completed form ASAP. "Anything missing will cause the Agenda Item to be held over to the next Regular meeting," according to our Rules & Procedures.

AGENDA DATE: Next Available 11/08/2023

Type of Agenda Item

- Consent Discussion/Action Executive Session Workshop
 Public Hearing

What will be discussed? What is the proposed motion?

Filed/Paid Q3 State Reporting

1. Costs:

Actual Cost or **Estimated Cost** \$ _____

Is this cost included in the County Budget? _____

Is a Budget Amendment being proposed? _____

2. Agenda Speakers:

	Name	Representing	Title
(1)	Judge Haden		
(2)	Angela Rawlinson		
(3)			

3. Backup Materials: None To Be Distributed 7 total # of backup pages
(including this page)

4. 
Signature of Court Member

10/26/2022
Date

Specialty Court Program Account

Original Return for period ending 09/30/2022

Confirmation: You Have Filed Successfully

Please do NOT send a paper return.

If you need to enroll or make changes to an existing TEXNET account click the following link:

[TEXNET](#)

Call 1-800-442-3453 for questions about TEXNET Payments.

Print this page for your records.**Reference Number:** [REDACTED]**Date and Time of Filing:** 10/20/2022 11:13:05 AM**Taxpayer ID:** [REDACTED]**Taxpayer Name:** CALDWELL COUNTY**Taxpayer Address:** 110 S MAIN ST STE 103 LOCKHART , TX 78644 - 2705**Entered by:** Angela Rawlinson**Email Address:** angela.rawlinson@co.caldwell.tx.us**Telephone Number:** (512) 398-1800
[REDACTED]

Description	Amount
Total Amount of Specialty Court Program Fees Collected	495.63
Amount Retained (50%) for Established Specialty Court Programs	- 247.82
Service Fee	- 49.56
Subtotal	198.25

Total Fee Due = 198.25**Balance Due = 198.25****Pending Payments - 0.00****Total Amount Due and Payable = 198.25****Payment Summary****Amount to Pay:** \$198.25**Total TEXNET Payment:** \$198.25**TEXNET:****Identification** [REDACTED] **Location #:** [REDACTED]**Trace Number:** [REDACTED]**Settlement Date:** 10/21/2022

texas.gov
[Texas Records and Information Locator \(TRAIL\)](#)
[State Link Policy](#)
[Texas Homeland Security](#)
[Texas Veterans Portal](#)
[Glenn Hegar, Texas Comptroller](#)
[Home](#)
[Contact Us](#)
[Privacy and Security Policy](#)
[Accessibility Policy](#)
[Link Policy](#)
[Public Information Act](#)
[Compact with Texans](#)

Child Safety Seat and Seat Belt Violation Fines

Original Return for period 2022 (Fiscal Year End 9/30)

Confirmation: You Have Filed Successfully

Please do NOT send a paper return.

Print this page for your records.

Reference Number: [REDACTED]
Date and Time of Filing: 10/20/2022 11:07:45 AM

Taxpayer ID: [REDACTED]
Taxpayer Name: CALDWELL COUNTY
Taxpayer Address: 110 S MAIN ST STE 103 LOCKHART , TX 78644 - 2705

Entered by: Angela Rawlinson
Email Address: angela.rawlinson@co.caldwell.tx.us
Telephone Number: (512) 398-1800
[REDACTED]

Total Amount of Fines Collected	Fee Rate	Amount Due
3,101.92	.50	1,550.96
Subtotal		1,550.96

Total Fines Due = 1,550.96
Balance Due = 1,550.96
Pending Payments - 0.00
Total Amount Due and Payable = 1,550.96

Payment Summary

Amount to Pay: \$1,550.96
Electronic Check: \$1,550.96

Payment Reference Number: [REDACTED]
Trace Number: [REDACTED]
Type of Bank Account: [REDACTED]
Accountholder Name: [REDACTED]
Bank Routing Number: [REDACTED]
Bank Account Number: [REDACTED]
Payment Effective Date: 10/20/2022

[Print](#) [Return to Menu](#) [File for Another Taxpayer](#)

[texas.gov](https://www.texas.gov) [Texas Records and Information Locator \(TRAIL\)](#) [State Link Policy](#) [Texas Homeland Security](#) [Texas Veterans Portal](#)
 Glenn Hegar, Texas Comptroller • [Home](#) • [Contact Us](#)
[Privacy and Security Policy](#) [Accessibility Policy](#) [Link Policy](#) [Public Information Act](#) [Compact with Texans](#)

County Criminal Costs and Fees

Original Return for period ending 09/30/2022

Confirmation: You Have Filed Successfully

Please do NOT send a paper return.

If you need to enroll or make changes to an existing TEXNET account click the following link:

[TEXNET](#)
Call 1-800-442-3453 for questions about TEXNET Payments.

Print this page for your records.

Reference Number: [REDACTED]

Date and Time of Filing: 10/20/2022 12:41:15 PM

Taxpayer ID: [REDACTED]

Taxpayer Name: CALDWELL COUNTY

Taxpayer Address: 110 S MAIN ST STE 103 LOCKHART , TX 78644 - 2705

Entered by: Angela Rawlinson

Email Address: angela.rawlinson@co.caldwell.tx.us

Telephone Number: (512) 398-1800

[REDACTED]

Costs and Fees		Service Fee	Amount Due
01-01-2020 foward	73,393.24	-7,339.33	66,053.91
01-01-2004 --- 12-31-2019	5,500.88	-550.09	4,950.79
09-01-1991 - 12-31-2003	70.16	-7.02	63.14
Bail Bond Fee (BB)	2,940.00	-294.00	2,646.00
DNA Testing Fee - Juvenile (DNA JV)	0.00	n/a	0.00
EMS Trauma Fund (EMS)	2,051.22	-205.13	1,846.09
Prior Mandatory Costs (JRF, IDF & JS)	1,328.05	-132.81	1,195.24
Juvenile Probation Diversion Fee (JPD)	0.00	n/a	0.00
State Traffic Fine (STF2) 9-1-19 fwd	37,851.97	-1,514.08	36,337.89
State Traffic Fine (STF) Prior to 9-1-19	1,564.84	-78.25	1,486.59
Intoxicated Driver Fine	0.00	n/a	0.00
Moving Violation Fees (MVF)	6.32	-0.64	5.68
DNA Testing Fee-Felony Conviction (DNA)	50.00	-5.00	45.00
DNA Testing Fee - MSDM & CS (DNA & CS)	34.00	-3.40	30.60
Truancy Prevention/Diversion Fnd (TPD)	178.27	n/a	178.27
Failure Appear/Pay (rpt 2/3 fee) (FTA)	1,725.03	n/a	1,725.03
Time Payment Fees (rpt 50% of fees) (TP)	427.75	n/a	427.75
Judicial Fund - Statutory County Court	85.50	n/a	85.50
Peace Officer Fees (Report 20% of fees)	700.15	n/a	700.15
Motor Carrier Wght Fines (rpt 50%) (MCW)	0.00	n/a	0.00
Driving Records Fee (100% of fees) (DRF)	0.00	n/a	0.00
Subtotal		-10,129.75	117,777.63

Total Fee Due = 117,777.63

Balance Due = 117,777.63

Pending Payments - 0.00

Total Amount Due and Payable = 117,777.63

Payment Summary

Amount to Pay: \$117,777.63

Total TEXNET Payment: \$117,777.63

TEXNET:

Identification [REDACTED] Location [REDACTED]

Trace Number: [REDACTED]

Settlement Date: 10/21/2022

[Print] [Return to Menu] [File for Another Taxpayer]

Civil Fees

Original Return for period ending 09/30/2022

Confirmation: You Have Filed Successfully

Please do NOT send a paper return.

If you need to enroll or make changes to an existing TEXNET account click the following link.

[TEXNET](#)

Call 1-800-442-3453 for questions about TEXNET Payments.

Print this page for your records.

Reference Number: [REDACTED]

Date and Time of Filing: 10/20/2022 12:20:40 PM

Taxpayer ID: [REDACTED]

Taxpayer Name: CALDWELL COUNTY

Taxpayer Address: 110 S MAIN ST STE 103 LOCKHART , TX 78644 - 2705

Entered by: Angela Rawlinson

Email Address: angela.rawlinson@co.caldwell.tx.us

Telephone Number: (512) 398-1800

[REDACTED]

Description	Issued / Filed	Total Collected	Service Fee	Amount Due
Birth Certificate Fees	275	495.00		495.00
Marriage License Fees	54	1,620.00		1,620.00
Declaration of Informal Marriage	5	62.50		62.50
Juror Donations	10	64.00		64.00
JP Cons Civil Fee \$21	178	3,738.00		3,738.00
Stat Probate Civil \$137	0	0.00		0.00
Stat County Civil \$137	0	0.00		0.00
Stat County Other \$45	0	0.00		0.00
County Court Civil \$137	0	0.00		0.00
Dist Court Civil \$137	20	2,740.00		2,740.00
Dist Court Other \$45	1	45.00		45.00
County Alternate Dispute Resolution Fund	0	0.00		0.00
Repealed Nondisclosure Fees	0	0.00		0.00
REPEALED Justice Courts ILS (6)	1	573.00	-28.65	544.35
REPEALED Stat Probate ILS(7a)	0	0.00	-0.00	0.00
REPEALED Stat Cnty ILS (8a)	80	111.22	-5.56	105.66
REPEALED Stat Cnty JF (8b)	80	444.88		444.88
REPEALED CCC ILS (9a)	0	0.00	-0.00	0.00
REPEALED Dist Court Divorce (10a)	0	0.00	-0.00	0.00
REPEALED Dist Crt Oth Than Divorce (10b)	26	1,300.00	-13.00	1,287.00
REPEALED Dist Court ILS (10C)	100	310.00	-15.50	294.50
REPEALED Judicial Support (11)	180	1,559.11		1,559.11
REPEALED Judicial Court Training (12)	28	140.62		140.62
Subtotal		13,203.33	-62.71	13,140.62

Total Fee Due = 13,140.62**Balance Due = 13,140.62****Pending Payments - 0.00****Total Amount Due and Payable = 13,140.62****Payment Summary****Amount to Pay: \$13,140.62****Total TEXNET Payment: \$13,140.62****TEXNET:****Identification [REDACTED] Location [REDACTED]****Trace Number: [REDACTED]****Settlement Date: 10/21/2022**

Electronic Filing System Fund

Original Return for period ending 09/30/2022

Confirmation You Have Filed Successfully

Please do NOT send a paper return.**Print this page for your records.**

Reference Number: [REDACTED]

Date and Time of Filing: 10/20/2022 11:15:59 AM

Taxpayer ID: [REDACTED]

Taxpayer Name: CALDWELL COUNTY

Taxpayer Address: 110 S MAIN ST STE 103 LOCKHART, TX 78644 - 2705

Entered by: Angela Rawlinson

Email Address: angela.rawlinson@co.caldwell.tx.us

Telephone Number: (512) 398-1800
[REDACTED]

Filing Fees (Civil Cases)		Amount Due
	District Court Filing Fees (@ \$30)	680.00
	County Courts Filing Fees (@ \$30)	333.66
	Justice Courts Filing Fees (@ \$10)	0.00
Criminal Costs on Convictions		Amount Due
	District Court Convictions (@ \$5)	10.00
	County Courts Convictions (@ \$5)	224.09
Subtotal		1,247.75

Total Fee Due = 1,247.75**Balance Due = 1,247.75****Pending Payments - 0.00****Total Amount Due and Payable = 1,247.75****Payment Summary****Amount to Pay:** \$1,247.75**Electronic Check:** \$1,247.75**Payment Reference Number:** [REDACTED]**Trace Number:** [REDACTED]**Type of Bank Account:** [REDACTED]**Accountholder Name:** [REDACTED]**Bank Routing Number:** [REDACTED]**Bank Account Number:** [REDACTED]**Payment Effective Date:** 10/20/2022

texas.gov
[Texas Records and Information Locator \(TRAIL\)](#)
[State Link Policy](#)
[Texas Homeland Security](#)
[Texas Veterans Portal](#)
[Glenn Hegar, Texas Comptroller](#) • [Home](#) • [Contact Us](#)
[Privacy and Security Policy](#)
[Accessibility Policy](#)
[Link Policy](#)
[Public Information Act](#)
[Compact with Texans](#)

Sexual Assault/Substance Abuse Felony Programs

Original Return for period ending 09/30/2022

Confirmation: You Have Filed Successfully

Please do NOT send a paper return.

If you need to enroll or make changes to an existing TEXNET account click the following link:

[TEXNET](#)

Call 1-800-442-3453 for questions about TEXNET Payments.

Print this page for your records.

Reference Number: [REDACTED]

Date and Time of Filing: 10/20/2022 11:11:23 AM

Taxpayer ID: [REDACTED]

Taxpayer Name: CALDWELL COUNTY

Taxpayer Address: 110 S MAIN ST STE 103 LOCKHART , TX 78644 - 2705

Entered by: Angela Rawlinson

Email Address: angela.rawlinson@co.caldwell.tx.us

Telephone Number: (512) 398-1800

[REDACTED]

	Total for Sexual Assault Program	Total for Substance Abuse Felony Program	Amount Due
	100.00	0.00	100.00
Subtotal			100.00

Total Fee Due = 100.00

Balance Due = 100.00

Pending Payments - 0.00

Total Amount Due and Payable = 100.00

Uploaded Supplement Files
No files uploaded

Payment Summary

Amount to Pay: \$100.00

Total TEXNET Payment: \$100.00

TEXNET:

Identification [REDACTED] Location [REDACTED]

Trace Number: [REDACTED]

Settlement Date: 10/21/2022

[Print](#) [Return to Menu](#) [File for Another Taxpayer](#)

texas.gov [Texas Records and Information Locator \(TRAIL\)](#) [State Link Policy](#) [Texas Homeland Security](#) [Texas Veterans Portal](#)

Glenn Hegar, Texas Comptroller • [Home](#) • [Contact Us](#)

[Privacy and Security Policy](#) [Accessibility Policy](#) [Link Policy](#) [Public Information Act](#) [Compact with Texans](#)

8. To approve October 2022 Indigent Burial Report.

Caldwell County Agenda Item Request Form

To: All Elected Officials and Department Heads – Hand deliver or scan & email to hoppy.haden@co.caldwell.tx.us and ezzy.chan@co.caldwell.tx.us . Deadline is 5:00 pm Tuesday before the Regular meetings, however, please submit this completed form ASAP. "Anything missing will cause the Agenda Item to be held over to the next Regular meeting," according to our Rules & Procedures.

AGENDA DATE: 11.08.2022

Type of Agenda Item

- Consent Discussion/Action Executive Session Workshop
 Public Hearing

What will be discussed? What is the proposed motion?

To approve October 2022 Indigent Burial Report

1. Costs:

Actual Cost or Estimated Cost \$ None

Is this cost included in the County Budget? _____

Is a Budget Amendment being proposed? _____

2. Agenda Speakers:

	Name	Representing	Title
<hr/>			

(1) Judge Haden

(2) _____

(3) _____

3. Backup Materials: None To Be Distributed 2 total # of backup pages
(including this page)

4. 
Signature of Court Member

11/1/2022
Date



Caldwell County Indigent Burial Report
Monthly Financial Report

Month: October 2022

Date	City FY 2022 Budget	Deceased	Fiscal Budget \$21,000	Amount Paid	Budget Remaining
Blanket PO	Luling-OBAFUN		\$7,200		remaining in PO
Blanket PO	Lockhart-MCCFUN		\$7,800		remaining in PO
Other					
				YTD	<u>\$0.00</u> <u>\$21,000.00</u>

Report Submitted by: Judge Haden
11.01.2022

9. To approve the SO Forfeiture Audit 21-22.

Caldwell County Agenda Item Request Form

To: All Elected Officials and Department Heads – Hand deliver or scan & email to hoppy.haden@co.caldwell.tx.us and ezzy.chan@co.caldwell.tx.us . Deadline is 5:00 pm Tuesday before the Regular meetings, however, please submit this completed form ASAP. "Anything missing will cause the Agenda Item to be held over to the next Regular meeting," according to our Rules & Procedures.

AGENDA DATE: 11.08.2022

Type of Agenda Item

- Consent Discussion/Action Executive Session Workshop
 Public Hearing

What will be discussed? What is the proposed motion?

to approve the SO Forfeiture Audit 21-22

1. **Costs:**

Actual Cost or Estimated Cost \$ None

Is this cost included in the County Budget? _____

Is a Budget Amendment being proposed? _____

2. **Agenda Speakers:**

Name	Representing	Title
------	--------------	-------

(1) Judge Haden

(2) _____

(3) _____

3. **Backup Materials:** None To Be Distributed 2 total # of backup pages
(including this page)

4. 
Signature of Court Member

Date 11/11/2022

Hoppy Haden
County Judge
512 398-1808

Angela Rawlinson
County Treasurer
512 398-1800

Danie Teltow
County Auditor
512 398-1801

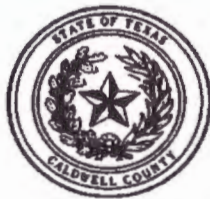

Caldwell County Courthouse
110 South Main Street
Lockhart, TX 78644
Fax: 512 398-1828

B.J. Westmoreland
Commissioner Precinct 1

Barbara Shelton
Commissioner Precinct 2

Edward "Ed" Theriot
Commissioner Precinct 3

Joelvan Roland
Commissioner Precinct 4

October 18, 2022

Caldwell County, Texas
110 South Main Street
Lockhart, TX 78644

Honorable Commissioners' Court:

Re: Chapter 59 Asset Forfeiture Report by Law Enforcement Agency

The Auditor's office conducted an audit on the Caldwell County Sheriff's Office Chapter 59 Asset Forfeiture account. This written review coincides with filing of the 2022 Chapter 59 Asset Forfeiture Report by Law Enforcement Agency to the Attorney General of Texas

Bank statements were reconciled for October 01, 2021, to September 30, 2022, on the Caldwell County Sheriff Forfeiture Account without exception.

The Caldwell County Sheriff Forfeiture Account's beginning balance was \$48,789.19 as of October 1, 2021. During the FY 2021-2022 the Caldwell County Sheriff Forfeiture did not receive any awards from Caldwell County District Attorney. Expenditures totaled \$25,449.43 which included:

\$ 2,075.00 Falling Skies – Griffin Armament GP5
\$ 2,623.00 BP Firearms Company – Rifles
\$ 7,788.93 Unmanned Vehicle Technologies- Drone
\$12,962.00 AGM Global Vision – Night vision goggles

With the addition of \$369.30 from earned interest, final balance as of September 30, 2022 is \$23,709.06

The expenditures from the Caldwell County Sheriff Office were in compliance with Article 59.06(d-3) of the Texas Code of Criminal Procedure. As stated in Article 59.06(d), whereas the Law Enforcement agency should present Caldwell County Commissioner's Court a budget with detailed and clearly list of define categories of expenditures prior to forfeiture money being spend. Before each fiscal year, the Caldwell County Sheriff Office should submit such budget to the Commissioner's Court. As of this date, this budget has not been presented to the Caldwell County Commissioner's Court.

We wish to thank the Caldwell County Sheriff's Office for their input and help with this audit.

Respectfully submitted,

Danie Teltow
Caldwell County Auditor

CC: Mike Lane, Sheriff
Jon Craigmile, Chief Deputy

SPECIAL PRESENTATION

- **Odyssey Implementation Update**

Caldwell County Agenda Item Request Form

To: All Elected Officials and Department Heads – Hand deliver or scan & email to hoppy.haden@co.caldwell.tx.us and ezzy.chan@co.caldwell.tx.us . Deadline is 5:00 pm Tuesday before the Regular meetings, however, please submit this completed form ASAP. "Anything missing will cause the Agenda Item to be held over to the next Regular meeting," according to our Rules & Procedures.

AGENDA DATE: 11.08.2022

Type of Agenda Item

- Consent Discussion/Action Executive Session Workshop
- Public Hearing

What will be discussed? What is the proposed motion?

SPECIAL PRESENTATION

Odyssey Implementation Update

1. Costs:

Actual Cost or Estimated Cost \$ None

Is this cost included in the County Budget? _____

Is a Budget Amendment being proposed? _____

2. Agenda Speakers:

	Name	Representing	Title
(1)	Judge Haden		
(2)	Roland Sequeira		
(3)	Greg Wallace		

3. Backup Materials: None To Be Distributed _____ total # of backup pages (including this page)

4. 
Signature of Court Member

10/28/2022
Date



Caldwell County Texas Governance and Executive Team Status Update

November 2022

Agenda

- Introductions
- Tyler-Wide Project Status
- Project Status by Team



Roland Sequeira

Project Manager, Enterprise Justice *powered by Odyssey*

Ben Furth

Project Manager, Enterprise Corrections

Joanna Bailey

Project Manager, Enterprise Jury Manager

Governance is required to manage the varied goals of project stakeholders

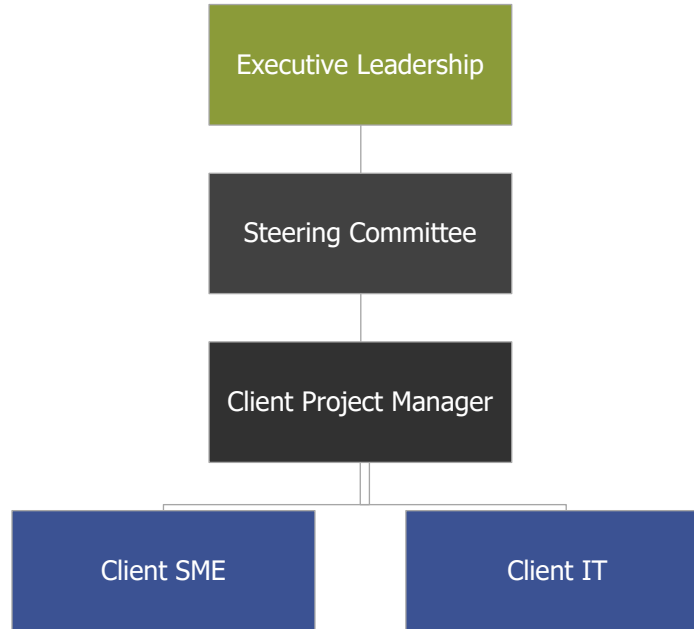

Profiles for **successful governance**

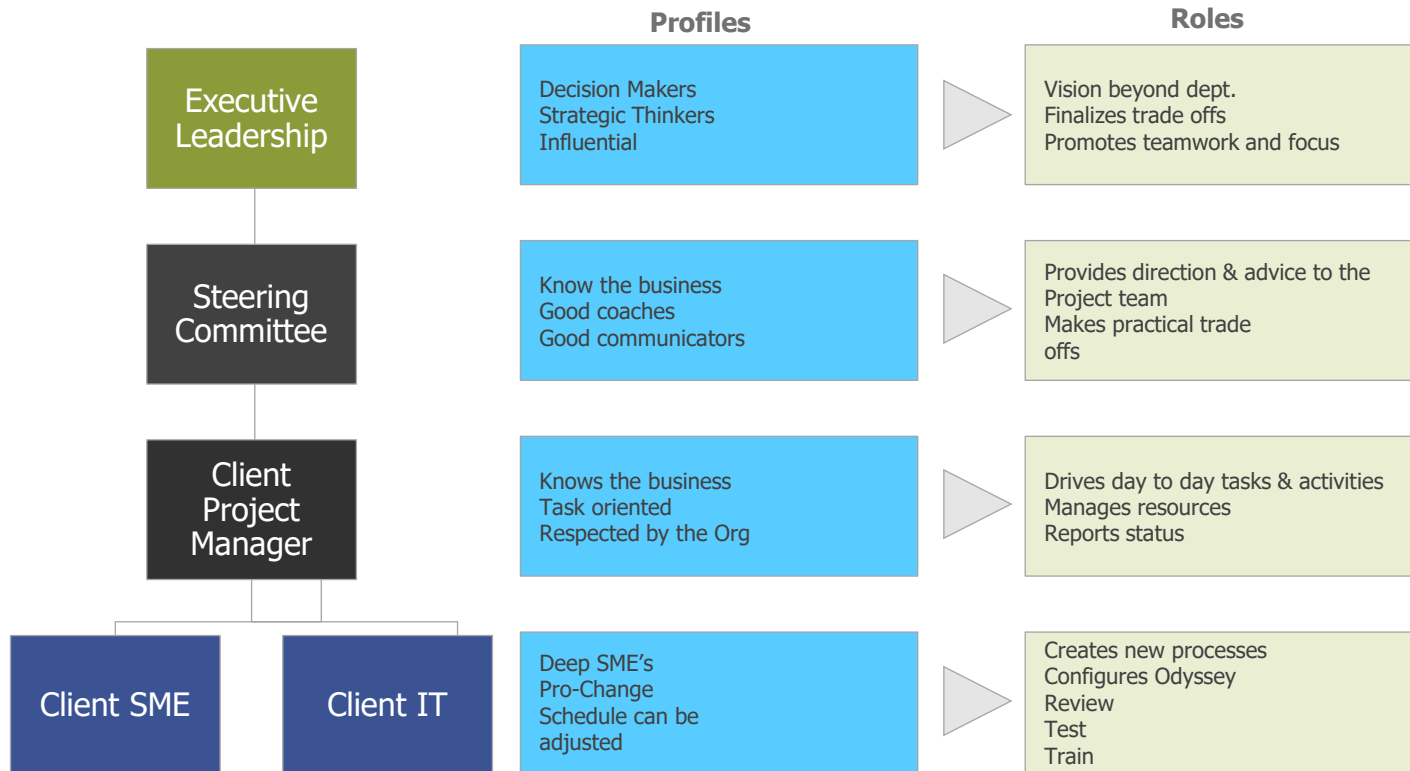

Guiding Principles

Utilize configuration 'out of the box', **adjust business processes** to gain efficiencies

Focus on **workable solutions**, don't dwell on perfection

Consider **advice and perspectives** from Tyler and other Agencies implementing applications

Think holistically, beyond one's department or physical work location

Make **quick and informed decisions**, then move forward

Be **flexible with time and act with a high sense of urgency** related to the implementation project

Drive **standardization** throughout all locations

Streamline and simplify, do not be constrained by the present

Make **comments and suggestions** in a constructive manner, criticize the process, not the person

Communicate effectively with all of our Partners

Be respectful, as we are all working on the same team and toward the same goal

Seek **good solutions**, not perfect solutions

Be aware that **incremental review and improvement continues after go-live**

Tyler-wide Project Status



Criteria For Project Status

● Green

- There is enough budget to successfully complete the project
- The relationship with the business unit for the project is positive
- The current resources, development schedule, and project plan are on track to complete the project by the scheduled date
- Agreement on key success factors with stakeholders – what is the definition of success?



● Yellow

- Not green, but a plan has been agreed to with the client to mitigate

● Red

- If any of the above categories are not true and no plan has been agreed to with the client to address

Tyler-wide Project Status

Product Group	Status	Next Milestone Date	Next Milestone	Plan to Mitigate
Enterprise Justice		Nov 2022	Configuration Sprints in progress	
Enterprise Corrections		Nov 2022	Integrations/JDE Activities (client facing calls/emails)	
Enterprise Jury Manager		Nov 2022	Load SOS list into Production.	

Project Completion Timeline – Caldwell County, TX

Enterprise Jury Manager

January 2023

Enterprise Justice

July 2023

Enterprise Corrections

July 2023

Communication Cadence

Project Team –

Enterprise Justice: **Weekly calls Thursday, 1:00 PM**

Enterprise Corrections: **Weekly calls Wednesday 10:00 AM**

Enterprise Jury Manager: **Weekly calls Wednesday, 9:00 AM**

Executive Status Updates – Every month commencing Nov 2022

Enterprise Justice Project Status

powered by Odyssey

Nov 2022

- Completed CFSA
- Completed SME Training
- Config Sprints in progress



Enterprise Justice Project Risks Requiring Mitigation



As of 11/08/2022

Risk 1

Project Go-Live Q3- 2023

Mitigation:

- *In the forthcoming weeks, Tyler will require greater stakeholders' participation and resource commitment*

Enterprise Justice GL Delivery

- Go-Live date July 24th, 2023
 - District Clerk, County Clerk, District Attorney and County Court at Law

Enterprise Justice 90-Day Look Ahead

Nov 2022	Estimated Completion
Configuration Sprints (in progress)	11/1-12/9
Conversion Activities	On-going
Tyler U (Ongoing)	On-going
Enterprise Justice Odyssey environment upgrade	11/30
Dec 2022	Estimated Completion
Configuration Sprints (in progress)	11/1-12/9
Conversion Activities	On-going
Tyler U (Ongoing)	On-going
Jan 2023	Estimated Completion
1 st Data Conversion Push and internal Review	1/9 – 1/27
Portal & OCR Deployment	1/30
Tyler U (Ongoing)	On-going

Enterprise Justice Overall Health

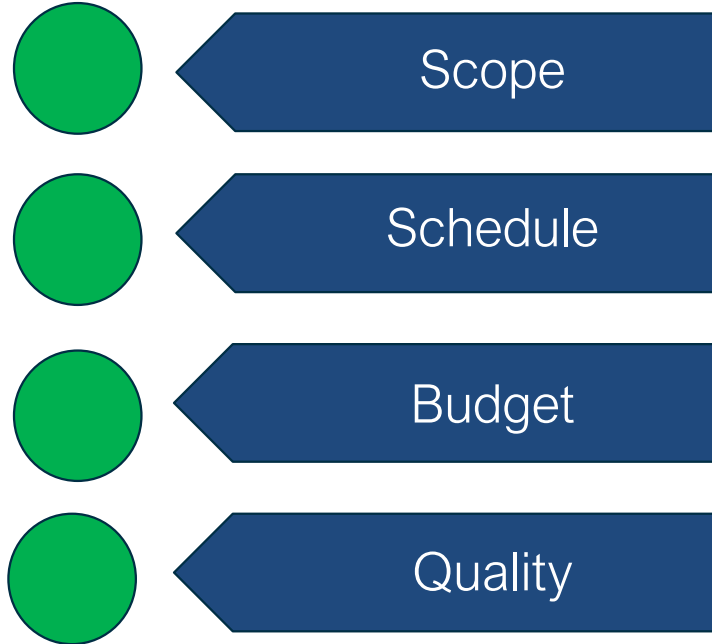

Enterprise Justice Schedule

CALDWELL TX Timeline

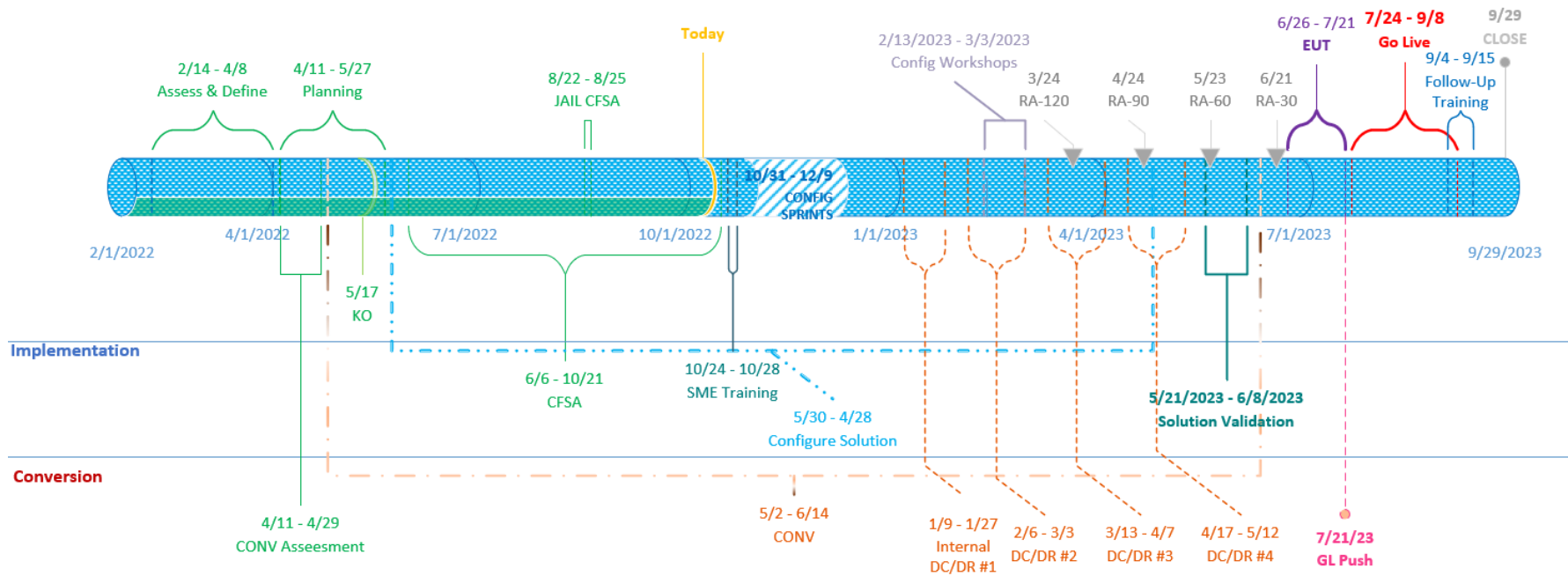

Rev RS Q4 2022

Enterprise Justice Accomplishments

As of 11/08/2022

Task/Activity Name	Completion Date
Project Kick Off	May 17, 2022
Current & Future State Analysis	July 07- Oct 21, 2022
Tyler U Registration & Demo	September 08, 2022
Subject Matter Expert (SME) Training	October 10/24 – 10/28/2022

Enterprise Corrections Project Status

Nov 2022

- Completed CFSA and readout
- Initial configuration complete
- JDE work planned for this month



Enterprise Corrections Overall **Health**

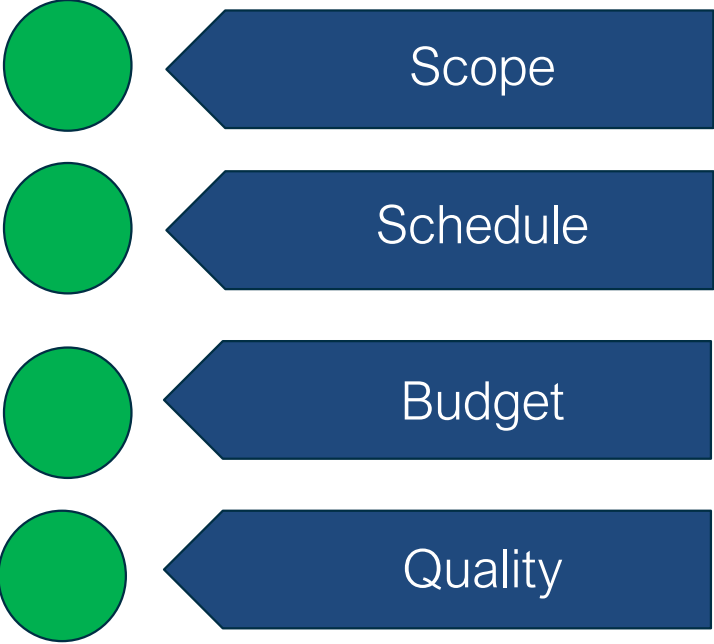

Enterprise Corrections Accomplishments

As of 11/08/2022

Task/Activity Name	Completion Date
Project Kick Off	May 17, 2022
Current & Future State Analysis	August 8, 2022 – October 19, 2022
Initial Configuration	October 24, 2022 – October 28, 2022
Code Mapping	October 31, 2022 – November 4, 2022

Enterprise Corrections Risks

As of Nov 2022

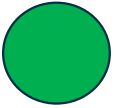

Risk 1

Staffing levels at the jail mean that the project team does not always have the time or availability to participate in project tasks.

Enterprise Corrections 90-Day Look Ahead

Nov 2022	Estimated Completion
Integrations / JDE Activities (client facing calls/emails)	11/14/22-11/18/22
Dec 2022	Estimated Completion
None	
Jan 2023	Estimated Completion
SME Training	1/9/23-1/20/23
Internal Data Review #1	1/16/23-1/20/23
JDE Follow-up	1/23/23-1/27/23

Enterprise Jury Manager Project Status

Nov 2022

- Full system and user training completed.
- System configuration completed in TEST.
- First pool to be created on December 5, 2022.
- Jurors first reporting date identified as January 4, 2023



Enterprise Jury Manager Overall Health

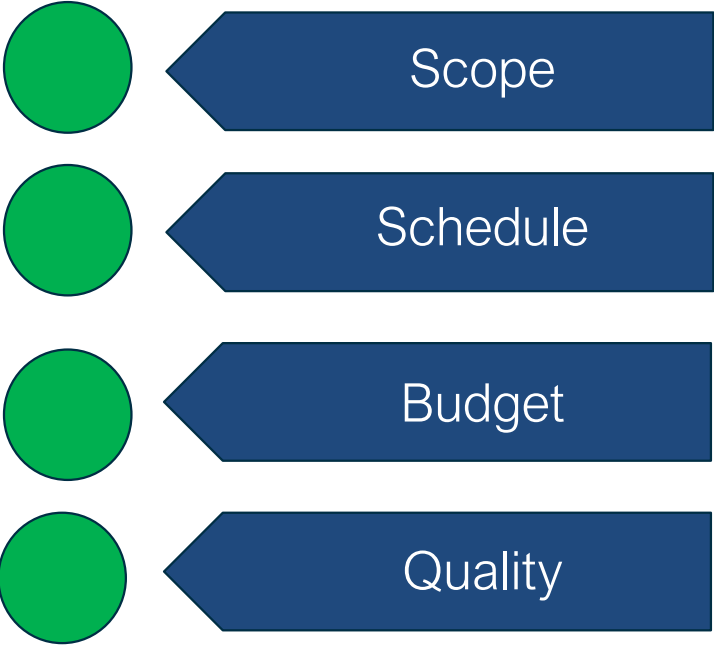

Enterprise Jury Manager Accomplishments

As of 11/08/2022

Task/Activity Name	Completion Date
Project kick off	6/3/2022
System Administrative training	8/30/2022
Full system/user training	10/12/2022
Configuration completed in TEST	10/31/2022
Source list update scheduled	11/18/2022

Enterprise Jury Manager Risks

As of Nov 2022

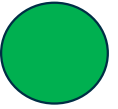

Risk 1

Receipt of the Secretary of State list requested for the first week of November; if there is a delay of more than 2 weeks, it may impact the go-live date.

Enterprise Jury Manager 90-Day Look Ahead

Nov 2022	Estimated Completion
Source list loaded into production	11/18/2022
Copy of configuration into production.	11/18/2022
Dec 2022	Estimated Completion
First pool created in EJM production	12/5/2022
Jan 2023	Estimated Completion
First reporting date for newly created pool	01/04/2023

Questions

Empowering people who serve the public[®]



tyler
technologies

PUBLIC HEARING

- **Re-Plat of Austin, Skyline, Section 5, Lot 20, Property ID 12699-120222
Located off Skyline Rd. on Prairie Hill Drive.**
- **Re-Plat of Wild Plum Estates, Lot #3 and 4, Property ID 121662-121663
Located on Wild Plum Rd. (CR 163).**

Caldwell County Agenda Item Request Form

To: All Elected Officials and Department Heads – Hand deliver or scan & email to hopy.haden@co.caldwell.tx.us and ezzy.chan@co.caldwell.tx.us . Deadline is 5:00 pm Tuesday before the Regular meetings, however, please submit this completed form ASAP. "Anything missing will cause the Agenda Item to be held over to the next Regular meeting," according to our Rules & Procedures.

AGENDA.DATE: 11.08.2022

Type of Agenda Item

- Consent Discussion/Action Executive Session Workshop
- Public Hearing

What will be discussed? What is the proposed motion?

Re-plat of Austin Skyline, Section 5, Lot 20, Property ID 12699-120222 located off Skyline Road on Prairie Hill Drive.

1. Costs:

Actual Cost or Estimated Cost \$ None

Is this cost included in the County Budget? _____

Is a Budget Amendment being proposed? _____

2. Agenda Speakers:

Name	Representing	Title
(1) <u>Judge Haden</u>		
(2) _____		
(3) _____		

3. Backup Materials:

None To Be Distributed _____ total # of backup pages (including this page)

4. 
Signature of Court Member

10/28/2022
Date

Caldwell County Agenda Item Request Form

To: All Elected Officials and Department Heads – Hand deliver or scan & email to hoppy.haden@co.caldwell.tx.us and ezzy.chan@co.caldwell.tx.us . Deadline is 5:00 pm Tuesday before the Regular meetings, however, please submit this completed form ASAP. "Anything missing will cause the Agenda Item to be held over to the next Regular meeting," according to our Rules & Procedures.

AGENDA DATE: 11.08.2022

Type of Agenda Item

- Consent Discussion/Action Executive Session Workshop
 Public Hearing

What will be discussed? What is the proposed motion?

Re-plat of Wild Plum Estates, Lot #3 & 4, Property ID 121662-121663 located on Wild Plum Road (CR 163).

1. Costs:

Actual Cost or Estimated Cost \$ None

Is this cost included in the County Budget? _____

Is a Budget Amendment being proposed? _____

2. Agenda Speakers:

	Name	Representing	Title
--	------	--------------	-------

(1) Judge Haden

(2) _____

(3) _____

3. Backup Materials: None To Be Distributed _____ total # of backup pages
(including this page)

4.  _____
Signature of Court Member

10/28/2022
Date

DISCUSSION/ACTION ITEMS:

10. Discussion/Action to consider the approval of the Replat for Austin Skyline Subdivision of Section 5, Replat of Lot 20 in Block B located at Skyline Road and Prairie Hill Dr. **Speaker: Commissioner Theriot/ Kasi Miles; Backup: 18; Cost: None.**

Caldwell County Agenda Item Request Form

To: All Elected Officials and Department Heads – Hand deliver or scan & email to hopyy.haden@co.caldwell.tx.us and ezzy.chan@co.caldwell.tx.us . Deadline is 5:00 pm Tuesday before the Regular meetings, however, please submit this completed form ASAP. "Anything missing will cause the Agenda Item to be held over to the next Regular meeting," according to our Rules & Procedures.

AGENDA DATE: 11.08.2022

Type of Agenda Item

- Consent Discussion/Action Executive Session Workshop
 Public Hearing

What will be discussed? What is the proposed motion?

to consider the approval of the Replat for Austin Skyline Subdivision of Section 5, Replat of Lot 20 in Block B located at Skyline Road and Prairie Hill Drive.

1. Costs:

Actual Cost or Estimated Cost \$ _____

Is this cost included in the County Budget? _____

Is a Budget Amendment being proposed? _____

2. Agenda Speakers:

	Name	Representing	Title
--	------	--------------	-------

(1)	Commissioner Theriot		
-----	----------------------	--	--

(2)	Kasi Miles		
-----	------------	--	--

(3)			
-----	--	--	--

3. Backup Materials: None To Be Distributed 18 total # of backup pages
(including this page)

4. Ed Theriot
Signature of Court Member

11/1/2022
Date



7401B Highway 71 West, Suite 160
Austin, TX 78735
Office: 512.583.2600
Fax: 800.587.2817

Doucetengineers.com

October 19, 2022

Kasi Miles
Caldwell County
1700 FM 2720
Lockhart, Texas 78644

Re: Austin Skyline Subdivision Replat
Project No. 1911-259-01

Dear Ms. Miles,

Doucet has completed our review of the replat application for Austin Skyline Lot 20, a 4-lot subdivision of a 4.33-acres located at Skyline Road and Prairie Hill Drive. The subdivision will be served by OSSF and Maha Water Supply Company.

The plat appears to be in general conformance with the rules and regulations of Caldwell County. Therefore, we recommend placing the plat on the Commissioners Court agenda for consideration. Please note that state law and the subdivision rules of Caldwell County call for a 30-day notice and public hearing to be held prior to approval of a replat.

Per Texas Local Government Code §232.009(d):

(d) During a regular term of the commissioners court, the court shall adopt an order to permit the revision of the subdivision plat if it is shown to the court that:

- (1) the revision will not interfere with the established rights of any owner of a part of the subdivided land; or*
- (2) each owner whose rights may be interfered with has agreed to the revision.*

It is our pleasure to be of assistance to the County on this project.

Kimberly Johnson-Hopkins

Kimberly Johnson-Hopkins
Planner, Land Development

TBPE Firm # 3937
State of Texas Surveying Firm Certification # 10105800

COMMITMENT YOU EXPECT.
EXPERIENCE YOU NEED.
PEOPLE YOU TRUST.

STATE OF TEXAS
COUNTY OF TRAVIS

We, RAMON SILVA HERNANDEZ, EFRAIN ALVAREZ MEDINA and ANA M. SALINAS JAIMES, the undersigned owners of the land shown on this plat and described as Lot 20 (4.33 acres) in Block B of Austin Skyline Subdivision Section 5 according to the map or plat thereof recorded in Volume 332 Page 389 of the Deed Records of Caldwell County, Texas and being described as a part of Lot 20 in Block B called 3.036 acres and conveyed to Ramon Silva Hernandez and Efrain Alvarez Medina by deed recorded in Instrument # 2021-003619 of the Official Public Records of Caldwell County, Texas and also being described as part of Lot 20 in Block B called 1.300 acres and conveyed to Ana M. Salinas Jaimes by deed recorded in Instrument #2020-006277 of the said Official Public Records, and designated as AUSTIN SKYLINE SUBDIVISION SECTION FIVE REPLAT OF LOT 20 IN BLOCK B, CALDWELL COUNTY, TEXAS and partially located in the Extra Territorial Jurisdiction (ETJ) of the City of Mustang Ridge. We do hereby dedicate to the use of the public forever, the streets and alleys shown hereon, and further reserves to the public all easements for the mutual use of all public utilities desiring to use the same; that any public utility shall have the right to remove and keep removed all or any part of any growth or construction for maintenance or efficient use of its respective system in such easements, and further shall have full and uninterrupted access along such easements.

DATE _____
RAMON SILVA HERNANDEZ
222 COUNTRY LANE
KYLE, TX 78640

DATE _____
EFRAIN ALVAREZ MEDINA
9301 BRENTS ELM DRIVE
AUSTIN, TX 78744

DATE _____
ANA M. SALINAS JAIMES
113 PRAIRIE HILL ROAD
DALE, TX 78616

STATE OF TEXAS
COUNTY OF CALDWELL

Before me, the undersigned authority, personally appeared RAMON SILVA HERNANDEZ, known to me to be the person whose name is subscribed to the foregoing instrument, and acknowledged to me that he executed the same for the purpose and considerations stated hereon.

Notary Public in and for the State of Texas

STATE OF TEXAS
COUNTY OF CALDWELL

Before me, the undersigned authority, personally appeared EFRAIN ALVAREZ MEDINA, known to me to be the person whose name is subscribed to the foregoing instrument, and acknowledged to me that he executed the same for the purpose and considerations stated hereon.

Notary Public in and for the State of Texas

STATE OF TEXAS
COUNTY OF CALDWELL

Before me, the undersigned authority, personally appeared ANA M. SALINAS JAIMES, known to me to be the person whose name is subscribed to the foregoing instrument, and acknowledged to me that he executed the same for the purpose and considerations stated hereon.

Notary Public in and for the State of Texas

LEGAL DESCRIPTION

All of a certain tract or parcel of land situated in Caldwell County, Texas and being also all of Lot 20 in Block B of Austin Skyline Subdivision Section 5 as recorded in Volume 332 Page 389 of the Deed Records of Caldwell County, Texas and being also all of two tracts of land described in Instrument #2021-003619 and #2020-006277 of the Official Public Records of Caldwell County, Texas and being more particularly described as follows:

BEGINNING at a 1/2" iron pin found used for basis of bearing in the intersection of the NE line of Skyline Road and the NW line of Prairie Hill Drive and the South corner of the said Lot 20 for the South corner this tract.

THENCE N 46°44'24" W with the SW line of the said Lot 20 and the NE line of Skyline Road 280.09 feet to a capped 1/2" iron pin set stamped HINKLE SURVEYORS in the West corner of the said Lot 20 and the South corner of Lot 21 in the said Block B for the West corner this tract.

THENCE N 43°08'13" E with the NW line of the said Lot 20 and the SE line of the said Lot 21 669.80 feet to a capped 1/2" iron pin set stamped HINKLE SURVEYORS in the North corner of the said Lot 20 and the East corner of Lot 21 and the South corner of Lot 18 and the West corner of the said Lot 19 in the said Block B for the North corner this tract.

THENCE S 46°46'43" E with the NE line of the said Lot 20 and the SW line of the said Lot 19 283.88 feet to a 1/2" iron pin found used for basis of bearing in the East corner of the said Lot 20 and the South corner of Lot 19 and the NW line of Prairie Hill Road for the East corner this tract.

THENCE S 43°27'41" W with the SE line of the said Lot 20 and the NW line of Prairie Hill Road 669.99 feet to the place of beginning containing 4.337 acres of land more or less.

SURVEYORS NOTES:

- The Lots shown lie in flood zone areas approximate as shown and create no liability on the part of the surveyor and are based on from a flood insurance rate map according to FEMA Panel #48055C0025E effective date June 19, 2012. Flood Zone "X" is areas determined to be outside the 0.2% annual chance floodplain. WARNING: This Flood Statement, as Determined by a H.U.D. - F.I.A. FLOOD HAZARD BOUNDARY MAP, DOES NOT IMPLY that the Property or the improvements thereon will be Free from Flooding or Flood Damage. On rare occasions, Greater Floods Can and Will Occur, and Flood Heights may be increased by Man-Made or Natural Causes.
- This Subdivision is located within the boundaries of the Lockhart Independent School District.
- This Subdivision is located within Caldwell County Precinct #3.
- This Subdivision is serviced by Chisolm Trail Fire & Rescue.
- The original deeded calls of record are in parentheses shown on this plat.
- In order to promote safe use of roadways and preserve the conditions of public roadways, no driveway constructed on any lot within this subdivision shall be permitted access onto a publicly dedicated county roadway and or State highway unless a DRIVEWAY PERMIT has been issued by the appropriate County Road and Bridge Department and or TXDOT.
- No Lots are to be occupied until OSSF Permitted or public sewer, public water distribution system or an approved onsite water well with a copy of the water availability study prepared in accordance with TCEQ guidelines (3.6.3.D), and electric utility availability/intent to serve letters for electricity (3.6.3.G) is completed and approved by Caldwell County Sanitation Department.
- Utilities Provided by:
ELECTRICITY: Bluebonnet Electric Cooperative, Inc.
WATER: Creedmoor-Maha Water Supply
- RECORD OWNERS OF LAND: Ramon Silva Hernandez, Efrain Alvarez Medina and Ana M. Salinas Jaimes
DESIGNER OF PLAT: Hinkle Surveyors, PO Box 1027, Lockhart TX 78644
(512) 398-2000
DATE OF PREPARATION: September 2022
SURVEYOR: Jerry L. Hinkle, R.P.L.S. #5459 PO Box 1027, Lockhart TX 78644
(512) 398-2000
- Lot Closures-- Lot 20-A: 1 in 301203', Lot 20-B: 1 in 214389', Lot 20-C: 1 in 227516', Lot 20-D: 1 in 195409'
- Boundary Closure: 1 in 1367596'

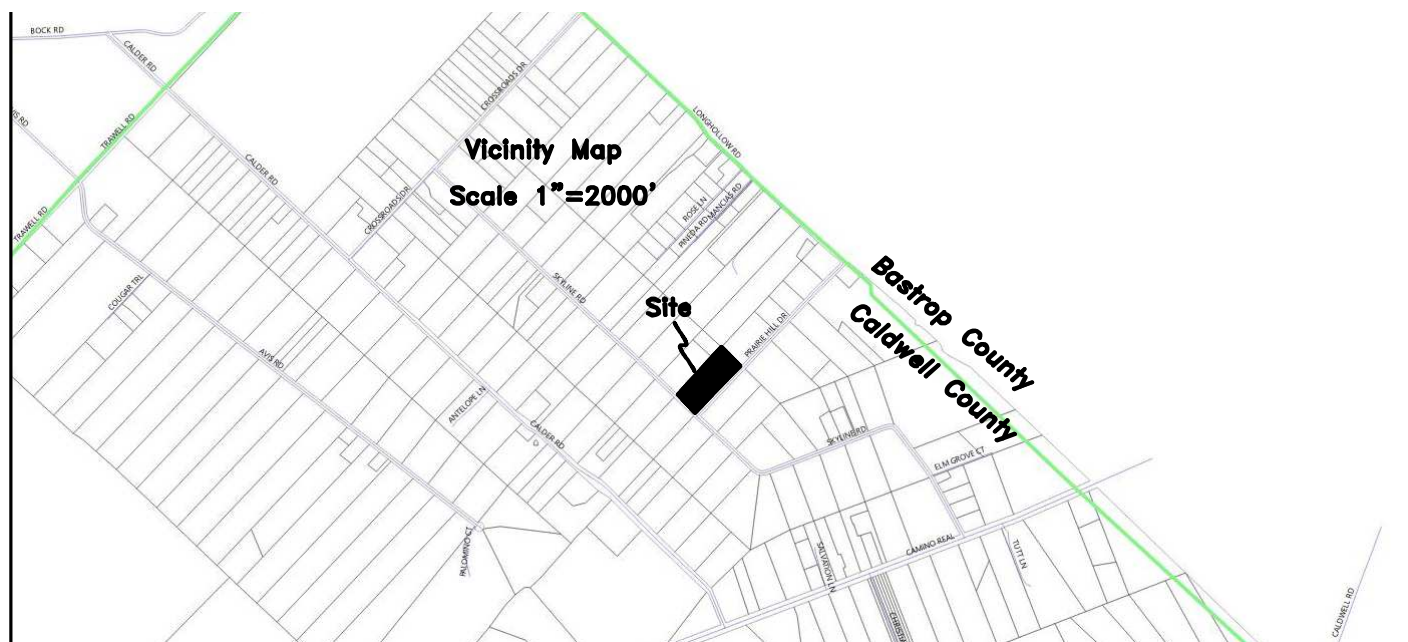

Austin Skyline Subdivision Section 5 Replat of Lot 20 in Block B

STATE OF TEXAS
COUNTY OF CALDWELL

I, Jerry L. Hinkle, registered professional land surveyor, State of Texas, hereby certify that this plat is a true and correct representation of a survey made on the ground under my direct supervision and is true and correct to the best of my knowledge.

IN WITNESS THEREOF, my hand and seal, this the _____ day of _____, 20____.

NOT FOR PUBLIC RELEASE

Jerry L. Hinkle
Registered Professional
Land Surveyor #5459

STATE OF TEXAS
COUNTY OF CALDWELL

I, Teresa Rodriguez, County Clerk in and for Caldwell County, Texas do hereby certify that this map or plat, with field notes shown hereon, has been fully presented and approved by the Commissioners Court of Caldwell County, Texas on the ____ day of _____, 20____, to be recorded in the Plat Records of Caldwell County, Texas.

Teresa Rodriguez
Caldwell County Clerk

STATE OF TEXAS
COUNTY OF CALDWELL

I, Teresa Rodriguez, Clerk of Caldwell County, Texas do hereby certify that the foregoing instrument of writing and its certificate of authentication was filed for record in my office on the ____ day of _____, 20____, A.D. at ____ o'clock ____ M., duly recorded on the ____ day of _____, 20____, A.D., at ____ o'clock ____ M., of said County and State in Plat Cabinet _____ Slide _____, Plat Records of Caldwell County.

Witness my hand and seal of office of the County Clerk, this _____ day of _____, 20____, A.D.

Teresa Rodriguez, County Clerk
CALDWELL COUNTY, TEXAS

Deputy

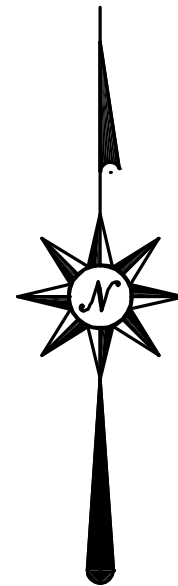

Scale 1"=100'



LEGEND

- CAPPED 1/2" IRON PIN SET STAMPED "HINKLE SURVEYORS"
- 1/2" IRON PIN FOUND
- ⊕ 4" CEDAR FENCE POST
- ⊕ 2" IRON PIPE FCP
- △ EL POLE
- ⊗ WATER METER
- E- OVERHEAD ELECTRIC LINE
- X- FENCE
- (.....) ORIGINAL DEEDED CALLS
- 5' PUBLIC UTILITY/DRAINAGE EASEMENT
- ▨ GRAVEL
- UNLESS OTHERWISE NOTED

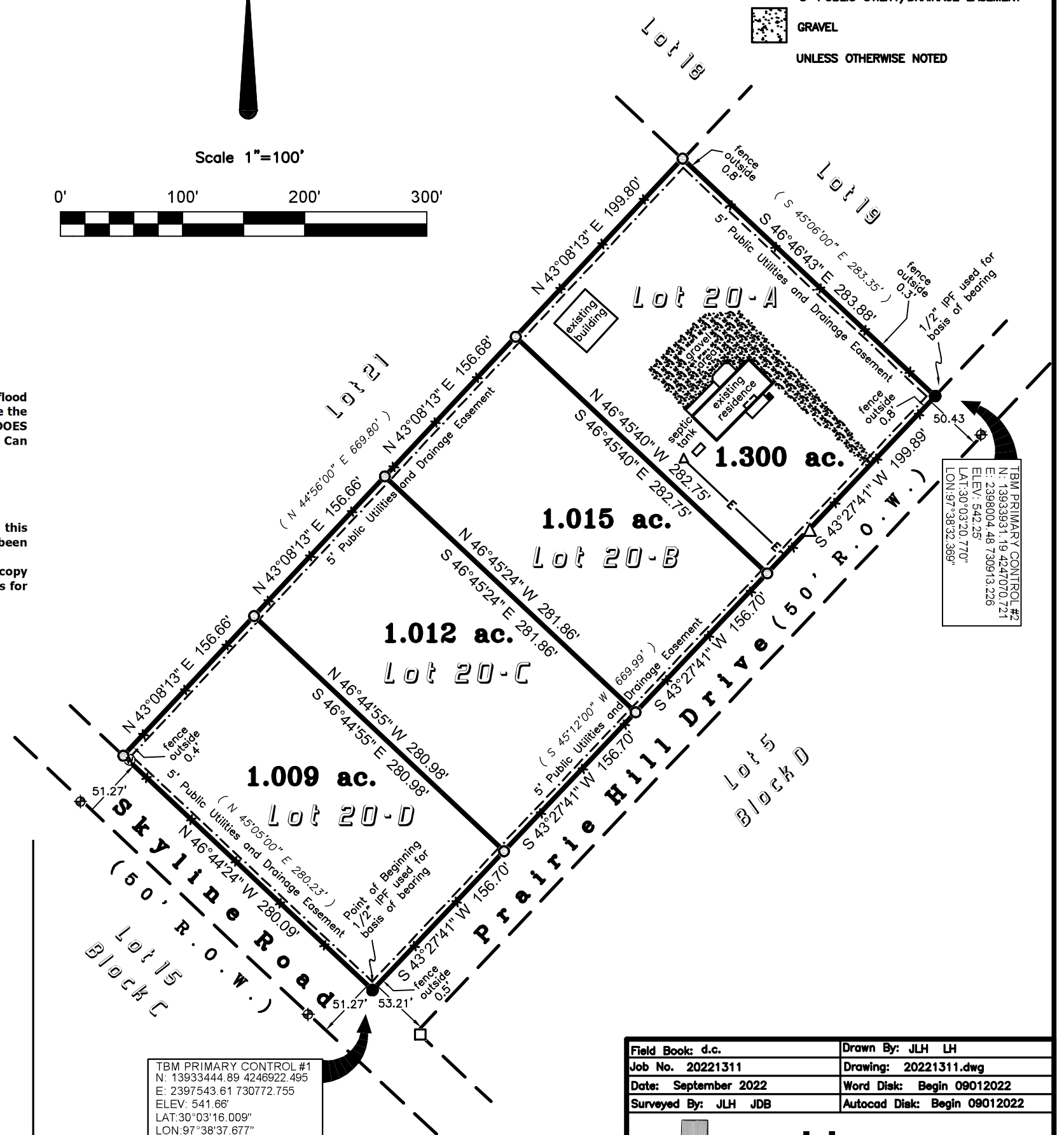

TBM PRIMARY CONTROL #1
N: 13933444.89 4246922.495
E: 2397543.81 730772.755
ELEV: 541.98
LAT: 30°03'18.009"
LON: 97°38'37.677"

Field Book: d.c.	Drawn By: JLH LH
Job No. 20221311	Drawing: 20221311.dwg
Date: September 2022	Word Disk: Begin 09012022
Surveyed By: JLH JDB	Autocad Disk: Begin 09012022

HINKLE SURVEYORS

P.O. Box 1027 1109 S. Main Street Lockhart, TX 78644
Ph: (512) 398-2000 Fax: (512) 398-7683 Email: contact@hinklesurveyors.com Firm Registration No. 100886-00

512-897-6981



August 4, 2020

Maria Aguilera

113 Prairie Hill Rd Dale TX 78616

Re: Service availability letter

To Whom It May Concern:

We have determined that the location of your inquiry in Caldwell County is in the certificated service territory of Bluebonnet Electric Cooperative, Inc. and we are therefore willing to provide electric service. Bluebonnet's promise to provide service is contingent upon the applicant fulfilling all the requirements of our Tariff including our Line Extension Policy.

If you have any questions regarding this request, please contact a new service coordinator at 800-842-7708, option 3 or email newservice@bluebonnet.coop.

Sincerely,

Barbara Seilheimer

Manager, Member Services

Creedmoor- Maha Water Supply Corp
12100 Laws Rd. Buda, Texas 78610
(512) 243-2113 | FAX: (512) 354-1444
creedmoormahawsc.com



Maria Aguilera
113 Prairie Hill Road
Dale, TX 78616

May 18, 2020

RE: Account #505

Creedmoor Maha Water Supply Corporation has provided the above-mentioned address with Water Service as follows, November 5, 2009 to September 2018. We can continue to provide services in the future when they decide to place a new water meter.

Please do not hesitate to contact me if you have any questions or concerns regarding this account.

Sincerely,

A handwritten signature in black ink that reads "Maria Perez". The signature is fluid and cursive.

Maria Perez
Creedmoor Maha WSC
512.243.2113

City of Mustang Ridge
12800 U.S. Highway 183 South
Mustang Ridge, Texas 78610

Telephone (512) 243-1775
Facsimile (512) 243-1048

July 12, 2021

To Whom It May Concern:

On July 12, 2021, the City Council of Mustang Ridge approved a proposed re-subdivision of 3.02 acres of land, more or less, owned by Maria Aguilera, said land having a physical address of 113 Prairie Hill, Lockhart, Texas 78644. The legal description of this land is 3.02 acres out of Lot 20, Block B, Section 5, Austin Skyline subdivision, a subdivision of record in the Plat Records of Caldwell County, Texas. This tract of land is further identified by the Caldwell County Central Appraisal District as parcel number 12699.

The proposed re-subdivision would see the 3.02 acres divided into three (3) lots, with each lot being at least one (1) acre in size.

This property lies within the ETJ of the City of Mustang Ridge; therefore, this approval is by consensus only.



David Bunn, Mayor

CLAUDE HINKLE SURVEYORS
PO BOX 1122
LOCKHART, TX 78644

9-26-22

3002

Caldwell County
Five hundred ~~100~~/100

\$ 500 ~~00~~

* FirstLockhart

MEMBER NATIONAL

Replat of Austin Skyline

Kasi S Miles



CALDWELL COUNTY SANITATION DEPT.

1700 FM 2720
LOCKHART, TEXAS 78644
(512) 398-1803

8872

DATE 10 27 22

RECEIVED FROM Claude Hinkle Surveyors \$ 500 ⁰⁰
Five hundred dollars of m/k/s
FOR Replat of Austin Skyline Lot # 20

AMOUNT OF RECEIPT	
TWO PAID TO	500.00
BALANCE DUE	0.

CASH
 CHECK
 CREDIT CARD BY Kasi S Miles
 MONEY ORDER

Thank You

Caldwell County Development Application



Date Submitted

9-26-2022

Type of Application

- Preliminary Plat
- Final Plat (New)
- Short Form Final Plat
- Replat
- Subdivision Construction Plans
- Floodplain
- Commercial Development

Application Contacts

1. Owner Information (i.e. Land owner name, address, contact name, phone, email)

Ramon Silva Hernandez
222 Country Lane
Kyle TX
Efrain Alvarex Medina
9301 Brents Elm Drive
Austin TX 78744
Ana M Salinas Jaimes
113 Prairie Hill Rd Dale TX 78616

2. Applicant Information (i.e. Developer name, address, contact name, phone, email)

Maria Aguilera
113 Prairie Hill Rd
Dale TX 78616
512-897-6981
lenya_1185@yahoo.com

3. Designated Contact (i.e. Person County will coordinate with in regards to comments/approvals. Include name, address, contact name, phone, email)

Maria Aguilera
113 Prairie Hill Road
Dale TX 78616
jenya_1185@yahoo.com or
Linda Hinkle
Hinkle Surveyors
512-398-2000
Contact@hinklesurveyors.com

4. Consultants (*If applicable)

none

Licensed Professional Engineer*:

none

Registered Professional Land Surveyor*:

Jerry L Hinkle
1109 S Main Street
Lockhart TX 78644
contact@hinklesurveyors.com
512-398-2000

Registered Sanitarian*:

none

Geoscientists*:

none

Application Questionnaire

Property Address (or approximate location)

113 Prairie Hill Drive

Survey Information (Survey/Abstract, Acreage, Recorded Vol/Pg/Instrument):

Austin Skyline Subdivision Section 5 Lot 20

Parcel Tax ID Number

12699 / 120222

Caldwell County Precinct Number

- Precinct 1
- Precinct 2
- Precinct 3
- Precinct 4

Located in City ETJ:

- Yes, City Name: 1/2 + 1/2
- No, Mustang Rupp + Caldwell Co.

Anticipated source of water in the development

- Individual Wells
- Rainwater Collection System(s)
- From Groundwater
- From Surface Water
- Water Provider: Maha Water

Anticipated wastewater system in the development

- Standard/Conventional On-Site Sewage Facility
- Advanced On-Site Sewage Facility
- Sewer Provider: _____

Project Description

Residential Lots fixing problem with selling lots and not replatting.

Subdivision Plat Application Questionnaire

Proposed Name of Subdivision:

Austin Skyline Subdivision Section 5

If application is for a replat (list reason(s) for the replat)

Replat because lots were sold without platting, fixing the issue

Total Acreage of Subject Property

4.336

Total Proposed Residential Lots

4

Total Proposed Commercial Lots

none

Type of Construction

Residential

Has Appropriate Application Checklist been attached?

- Yes
- No

Owner's Certification

I hereby certify that I have given permission for the below applicant to submit this Application and to represent me in all matters affecting said Application. The below individual will be known as the "Applicant"

- Owner Name: Maera Aguilera Phone Number: 512-897-6981
- Applicant Name: same as listed Phone Number: _____
- Owner Email: lenya - 1185 @ yahoo.com
- Owner Signature: Maera Aguilera By Linda Hinkle

NOTICE OF CONFIDENTIALITY RIGHTS: IF YOU ARE A NATURAL PERSON, YOU MAY REMOVE OR STRIKE ANY OR ALL OF THE FOLLOWING INFORMATION FROM ANY INSTRUMENT THAT TRANSFERS AN INTEREST IN REAL PROPERTY BEFORE IT IS FILED FOR RECORD IN THE PUBLIC RECORDS: YOUR SOCIAL SECURITY NUMBER OR YOUR DRIVER'S LICENSE NUMBER.

SPECIAL WARRANTY DEED WITH VENDOR'S LIEN

Date: May 10, 2021

Grantor: Maria Aguilera

Grantor's Mailing Address:
11908 Walton Hill Pass
Coupland, Texas 78615

Grantee: Ramon Silva Hernandez and Efrain Alvarez Medina

Grantee's Mailing Address:
9301 Brentx Elm Drive,
Austin, Texas 78744

Consideration:

WITNESSETH, For and in consideration of the sum of TEN AND NO/100 DOLLARS (\$10.00) and other good and valuable consideration, the receipt and adequacy of which are hereby acknowledged.

Property (including any improvements):

BEING 3.036 ACRES OUT OF LOT 20, BLOCK B, AUSTIN SKYLINE SECTION FIVE, RECORDED IN VOLUME 322, PAGE 389 MAP RECORDS, CALDWELL COUNTY, TEXAS. SAME BEING OUT OF THE SAID LOT 20, BLOCK B, DESCRIBED IN A GENERAL WARRANTY DEED WITH VENDOR'S, CONVEYED TO MARIA AGUILERA, DATED APRIL 29, 2020, RECORDED IN DOCUMENT No. 2020-002188, OFFICIAL PUBLIC RECORDS CALDWELL COUNTY, TEXAS, SAID 3.036 ACRES TRACT OF LAND BEING PARTICULARLY DESCRIBED BY METES AND BOUNDS AS DESCRIBED IN EXHIBIT A (THE "PROPERTY")

*for
3.036 ac
tract*

Reservations from Conveyance: None

Exceptions to Conveyance and Warranty:

It is hereby expressly agreed and acknowledged that that a certain Deed of Trust to be recorded contemporaneously with this deed, is retained in favor of the Lender who is also the Grantor of those certain obligations against the Property, the premises and improvements, until the obligation and all interest on the obligation are fully paid according to the terms of said note, and at that time this Deed shall become absolute.

Validly existing easements, rights of way, and prescriptive rights, whether of record or not; all presently recorded and validly existing restrictions, reservations, covenants, conditions, oil and gas leases, mineral interests, and water interests outstanding in persons other than Grantor, and other instruments other than conveyances of the surface fee estate, that affect the Property; validly existing rights of adjoining owners in any walls and fences situated on a common boundary; any discrepancies, conflicts, or shortages in area or boundary lines; any encroachments or overlapping of improvements, all rights, obligations, and other matters arising from and existing by reason of the Caldwell County Tax Assessor; and any due for the property including taxes for 2021, which Grantee assumes and agrees to pay their proportionate share, and subsequent assessments for that and

*Ramon
222 Country Lane
Kyle TX
78640*

prior years due to change in land usage, ownership or both, the payment of which Grantee assumes

AS IS CONVEYANCE: THIS CONVEYANCE CONVEYS THE PROPERTY IN ITS "AS IS" CONDITION. THE PARTIES HAVE BARGAINED FOR AND HEREBY AGREE THAT THERE ARE NO WARRANTIES EITHER EXPRESS OR IMPLIED OTHER THAN ANY REPRESENTATIONS EXPRESSLY CONTAINED IN THE PURCHASE CONTRACT, THIS INSTRUMENT, OR THE CLOSING DOCUMENTS.

Conveyance: Grantor, for the Consideration and subject to the Reservations from Conveyance and the Exceptions to Conveyance and Warranty, grants, sells, and conveys to Grantee the Property, together with all and singular the rights and appurtenances thereto in any way belonging, to have and to hold it to Grantee and Grantee's heirs, successors, and assigns forever.

Warranty: Except for Reservations and Exceptions stated above, Grantor binds Grantor and Grantor's heirs, executors, successors and administrators to warrant and forever defend all and singular the Property to Grantee and Grantee's heirs, successors, and assigns against every person whomsoever lawfully claiming or to claim the same or any part thereof but this warranty is made only when such claims are by, through or under Grantors'. When the context requires, singular nouns and pronouns include the plural.

By: *Maria Aguilera*
Maria Aguilera

STATE OF TEXAS §
 §
COUNTY OF TRAVIS §

Before me, Mario J. Flores, on this day personally appeared Maria Aguilera, known to me to be the person whose name is subscribed to the foregoing instrument and acknowledged to me that he/she, Maria Aguilera, executed the same for the purposes and consideration therein expressed.

Given under my hand and seal of office this 10th day of May, 2021.

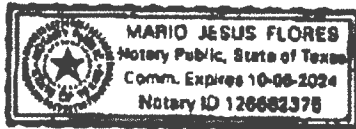

Mario J. Flores
Notary Public, State of Texas

AFTER RECORDING RETURN TO
Ramon Silva Hernandez and Efrain Alvarez Medina
9301 Brents Elm Drive
Austin, Texas 78744

EXHIBIT A
METES AND BOUNDS
3.036 ACRE TRACT

BEING 3.036 ACRES OUT OF LOT 20, BLOCK B, AUSTIN SKYLINE SECTION FIVE, RECORDED IN VOLUME 322 PAGE 389, MAP RECORDS, CALDWELL COUNTY, TEXAS SAME BEING OUT OF THE SAID LOT 20, BLOCK B, DESCRIBED IN A GENERAL WARRANTY DEED WITH VENDOR'S, CONVEYED TO MARIA AGUILERA, DATED APRIL 29, 2020, RECORDED IN DOCUMENT No. 2020-002188, OFFICIAL PUBLIC RECORDS CALDWELL COUNTY, TEXAS, SAID 3.036 ACRES TRACT OF LAND BEING PARTICULARLY DESCRIBED BY METES AND BOUNDS AS FOLLOWS:

COMMENCING, AT A 1/2 INCH IRON ROD FOUND, THE SOUTH CORNER LOT 19, BLOCK B, AUSTIN SKYLINE SECTION FIVE, SAME BEING THE SOUTHEAST CORNER OF A CALLED 1.300 ACRES OUT OF LOT 20, DESCRIBED IN SPECIAL WARRANTY DEED CONVEYED TO ANA M. SALINAS JAIMES DATED OCTOBER 26, 2020, RECORDED IN DOCUMENT No. 2020-006277, OFFICIAL PUBLIC RECORDS CALDWELL COUNTY TEXAS, SAID BEING A POINT ON THE WEST RIGHT-OF-WAY LINE OF PRAIRIE HILL ROAD.

THENCE, S43°22'41"W, ALONG THE NORTHERLY RIGHT OF WAY OF PRAIRIE HILL ROAD, SAME BEING THE SOUTHERLY LINE OF THE SAID 1.300 ACRES A DISTANCE OF 199.89 FEET TO A 1/2 INCH IRON ROD FOUND WITH PINK CAP, THE SOUTH CORNER OF THE SAID JAIMES TRACT, FOR THE EAST CORNER OF THE HEREIN DESCRIBED TRACT AND THE POINT OF BEGINNING;

THENCE, S43°22'41"W, CONTINUE ALONG THE NORTHERLY RIGHT-OF-WAY OF PRAIRIE HILL ROAD, SAME BEING THE SOUTHERLY LINE OF THE SAID LOT 20, A DISTANCE OF 470.00 FEET TO A 1/2 INCH IRON ROD SET WITH PINK CAP, ON THE EAST RIGHT-OF-WAY LINE OF SKYLINE ROAD, FOR THE SOUTH CORNER OF THE HEREIN DESCRIBED TRACT,

THENCE, N46°50'40"W, ALONG THE EASTERLY RIGHT-OF-WAY LINE OF SKYLINE ROAD, SAME BEING THE WESTERLY LINE OF THE SAID LOT 20, A DISTANCE OF 280.39 FEET TO A 1/2 INCH IRON ROD SET WITH PINK CAP, ON THE WESTERLY RIGHT-OF-WAY LINE OF SKYLINE ROAD, SAME BEING THE SOUTH CORNER OF THE SAID LOT 21, BLOCK B, AUSTIN SKYLINE SECTION FIVE, FOR THE WEST CORNER OF THE HEREIN DESCRIBED TRACT;

THENCE, N43°03'13"E, ALONG THE SOUTHERLY LINE OF THE SAID LOT 21, SAME BEING THE NORTHERLY LINE OF THE SAID LOT 20, A DISTANCE OF 470.00 FEET TO A 1/2 INCH IRON ROD FOUND WITH PINK CAP, THE WEST CORNER OF THE SAID 1.300 ACRES, A POINT ON THE SOUTHERLY LINE OF THE SAID LOT 21, SAME BEING THE NORTHERLY LINE OF THE SAID LOT 20, FOR THE NORTH CORNER OF THE HEREIN DESCRIBED TRACT;

THENCE, S46°50'40"E, ALONG THE WESTERLY LINE OF THE SAID 1.300 ACRES A DISTANCE OF 282.75 FEET TO THE POINT OF BEGINNING, AND CONTAINING 3.036 ACRES OF LAND, MORE OR LESS.

A SURVEY PLAT OF EVEN DATE HEREBY ACCOMPANIES THESE METES AND BOUNDS DESCRIPTION

EXHIBIT B
THREE 3.000 ACRES OUT OF LOT 28, BLOCK B, ANSTON SKYLINE
SECTION FIVE, RECORDED IN VOLUME 228, PAGE 288, CALDWELL
COUNTY DEED RECORDS, CALDWELL COUNTY, TEXAS

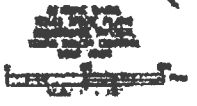
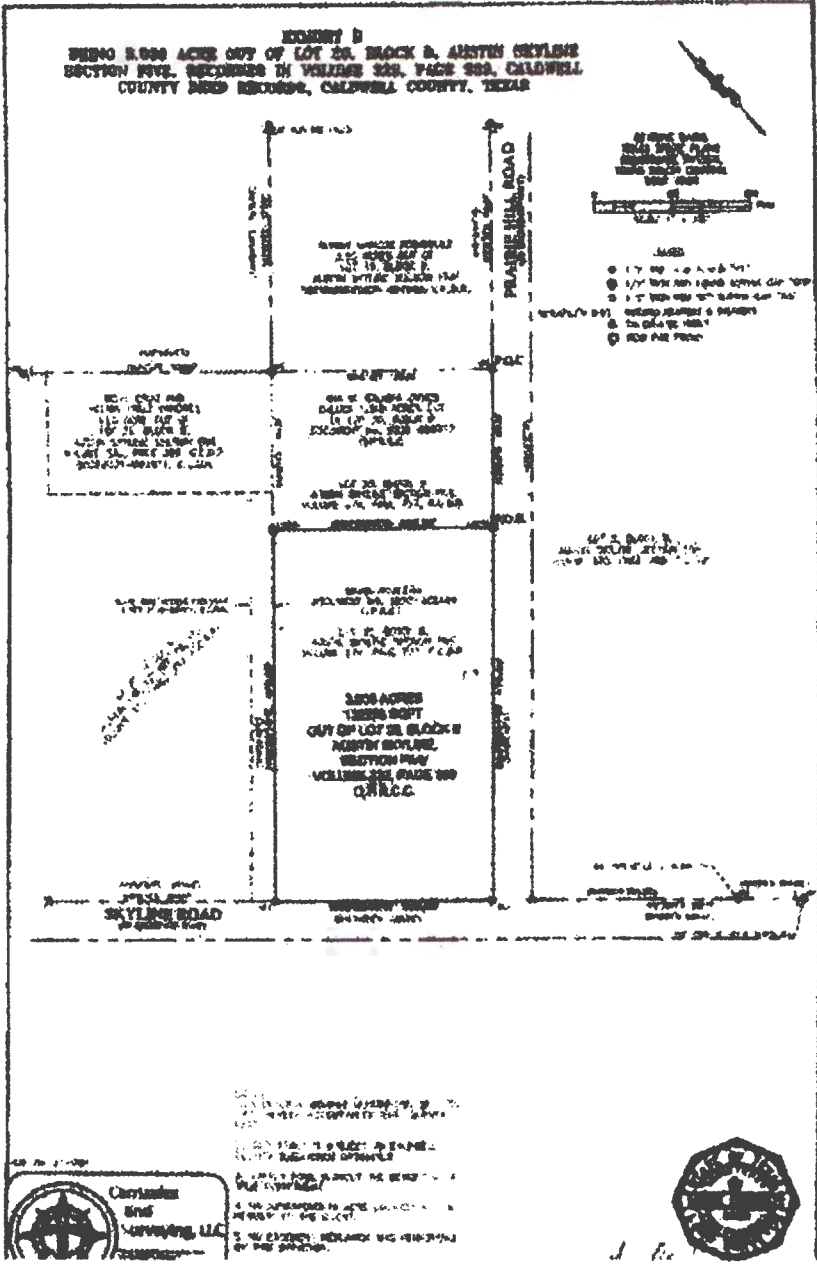

- LEGEND**
- ① 1/4" = 10' SCALE
 - ② 1/4" = 10' SCALE
 - ③ 1/4" = 10' SCALE
 - ④ 1/4" = 10' SCALE
 - ⑤ 1/4" = 10' SCALE
 - ⑥ 1/4" = 10' SCALE
 - ⑦ 1/4" = 10' SCALE
 - ⑧ 1/4" = 10' SCALE
 - ⑨ 1/4" = 10' SCALE
 - ⑩ 1/4" = 10' SCALE

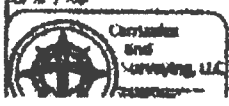

1. THIS SURVEY WAS MADE IN ACCORDANCE WITH THE SURVEYING ACT OF 1909 AND THE SURVEYING ACT OF 1924.

2. THE SURVEY WAS MADE BY ME OR UNDER MY CLOSE PERSONAL SUPERVISION AND TO THE BEST OF MY KNOWLEDGE AND BELIEF IT COMES IN ACCORDANCE WITH THE ACTS AND REGULATIONS OF THE BOARD OF SURVEYING ENGINEERS AND LAND SURVEYORS OF THE STATE OF TEXAS.

3. I HEREBY CERTIFY THAT I AM A LICENSED SURVEYOR IN THE STATE OF TEXAS.

4. I HAVE NOT BEEN CONVICTED OF A CRIME INVOLVING MORAL TURPITUDE.

5. I HAVE NOT BEEN DEBARRED OR RESTRICTED BY THE BOARD OF SURVEYING ENGINEERS AND LAND SURVEYORS OF THE STATE OF TEXAS.

FILED AND RECORDED

Instrument Number: 2021-083818 WARRANTY DEED

Filing and Recording Date: 05/20/2021 10:53:02 AM Pages: 5 Recording Fee: \$38.00

I hereby certify that this instrument was FILED on the date and time stamped hereon and RECORDED in the OFFICIAL PUBLIC RECORDS of Caldwell County, Texas.



Teresa Rodriguez

Teresa Rodriguez County Clerk
Caldwell County, Texas

ANY PROVISION CONTAINED IN ANY DOCUMENT WHICH RESTRICTS THE SALE, RENTAL, OR USE OF THE REAL PROPERTY IS SUBJECT TO THE PROVISIONS OF THE FEDERAL HOUSING AND URGENCY ACT OF 1961 AND IS UNENFORCEABLE.

DO NOT REMOVE. THIS PAGE IS PART OF THE OFFICIAL PUBLIC RECORD.

Untitled Map

Write a description for your map.

Legend

- Feature 1
- Feature 2
- 📍 Skyline Rd



Google Earth

© 2021 Google

300 ft

Issued By:
Caldwell County Appraisal District
211 Bufkin Ln.
P.O. Box 900
Lockhart, TX 78644

Property Information

Property ID: 120222 Geo ID: 0100810-002-020-10
Legal Acres: 1.3000
Legal Desc: AUSTIN SKYLINE SEC 5, BLOCK B, LOT PT 20,
ACRES 1 3, LABEL1 PFS0453113 / PFS0453114, SN1
PH0513248A, SN2 PH0513248B
Situs: 113 PRAIRIE HILL DR DALE, TX 78616
DBA:
Exemptions:

Owner ID: 230509 100.00%
JAIMES ANA M SALINAS
113 PRAIRIE HILL DR
DALE, TX 78616-3620

For Entities

Value Information

Caldwell County	Improvement HS:	0
Caldwell-Hays ESD 1	Improvement NHS:	103,810
Farm to Market Road	Land HS:	0
Lockhart ISD	Land NHS:	80,210
	Productivity Market:	0
	Productivity Use:	0
	Assessed Value	184,020

Current/Delinquent Taxes

This is to certify that, after a careful check of the tax records of this office, the following delinquent taxes, penalties, interest and any known costs and expenses as provided by Tax Code §33.48, are due on the described property for the following taxing unit(s):

Year	Entity	Taxable	Tax Due	Disc./P&I	Attorney Fee	Total Due
Totals:			0.00	0.00	0.00	0.00

Effective Date: 09/21/2022

Total Due if paid by: 09/30/2022

0.00



Tax Certificate Issued for:	Taxes Paid in 2021
Lockhart ISD	2,078.87
Farm to Market Road	0.18
Caldwell County	1,236.25
Caldwell-Hays ESD 1	184.02

If applicable, the above-described property has/is receiving special appraisal based on its use, and additional rollback taxes may become due based on the provisions of the special appraisal (Comptroller Rule 9.3040) or property omitted from the appraisal roll as described under Tax Code Section 25.21 is not included in this certificate [Tax Code Section 31.08(b)].

Pursuant to Tax Code Section 31.08, if a person transfers property accompanied by a tax certificate that erroneously indicates that no delinquent taxes, penalties or interest are due a taxing unit on the property or that fails to include property because of its omission from an appraisal roll, the unit's tax lien on the property is extinguished and the purchaser of the property is absolved of liability to the unit for delinquent taxes, penalties or interest on the property or for taxes based on omitted property. The person who was liable for the tax for the year the tax was imposed or the property was omitted remains personally liable for the tax and for any penalties or interest.

A tax certificate issued through fraud or collusion is void.

This certificate does not clear abuse of granted exemptions as defined in Section 11.43 Paragraph(1) of the Texas Property Tax Code.

May Be Subject to Court Costs if Suit is Pending

Date of Issue: 09/21/2022
Requested By: HINKLE SURVEYING
Fee Amount: 10.00
Reference #:

Brittani Medina

Signature of Authorized Officer of Collecting Office

11. Discussion/Action to consider the approval of the Replat for Wild Plum Estates located at Wild Plum Road and Old Colony Line Road.
Speaker: Commissioner Shelton/ Kasi Miles; Backup: 17; Cost: None.

Caldwell County Agenda Item Request Form

To: All Elected Officials and Department Heads – Hand deliver or scan & email to hobby.haden@co.caldwell.tx.us and ezzy.chan@co.caldwell.tx.us . Deadline is 5:00 pm Tuesday before the Regular meetings, however, please submit this completed form ASAP. "Anything missing will cause the Agenda Item to be held over to the next Regular meeting," according to our Rules & Procedures.

AGENDA DATE: 11.08.2022

Type of Agenda Item

- Consent Discussion/Action Executive Session Workshop
 Public Hearing

What will be discussed? What is the proposed motion?

to concenter the approval of the Replat of Wild Plum Estates located at Wild Plum Road and Old Colony Line Road.

1. Costs:

Actual Cost or Estimated Cost \$ _____

Is this cost included in the County Budget? _____

Is a Budget Amendment being proposed? _____

2. Agenda Speakers:

Name	Representing	Title
------	--------------	-------

(1) Commissioner Shelton

(2) Kasi Miles

(3) _____

3. Backup Materials: None To Be Distributed 17 total # of backup pages
(including this page)

4. Barbara Shelton
Signature of Court Member

11/11/2022
Date



7401B Highway 71 West, Suite 160
Austin, TX 78735
Office: 512.583.2600
Fax: 800.587.2817

Doucetengineers.com

October 19, 2022

Kasi Miles
Caldwell County
1700 FM 2720
Lockhart, Texas 78644

Re: Wild Plum Estates Replat of Lots 3 and 4
Project No. 1911-258-01

Dear Ms. Miles,

Doucet has completed our review of the replat application for Wild Plum Estates Lots 3 and 4, a 2-lot subdivision of a 22.014-acres located at Wild Plum Road and Old Colony Line Road. The subdivision will be served by OSSF and Individual Wells.

The plat appears to be in general conformance with the rules and regulations of Caldwell County. Therefore, we recommend placing the plat on the Commissioners Court agenda for consideration. Please note that state law and the subdivision rules of Caldwell County call for a 30-day notice and public hearing to be held prior to approval of a replat.

Per Texas Local Government Code §232.009(d):

(d) During a regular term of the commissioners court, the court shall adopt an order to permit the revision of the subdivision plat if it is shown to the court that:

- (1) the revision will not interfere with the established rights of any owner of a part of the subdivided land; or*
- (2) each owner whose rights may be interfered with has agreed to the revision.*

It is our pleasure to be of assistance to the County on this project.

Kimberly Johnson-Hopkins

Kimberly Johnson-Hopkins
Planner, Land Development

TBPE Firm # 3937
State of Texas Surveying Firm Certification # 10105800

COMMITMENT YOU EXPECT.
EXPERIENCE YOU NEED.
PEOPLE YOU TRUST.



7401B Highway 71 West, Suite 160
Austin, TX 78735
Office: 512.583.2600
Fax: 800.587.2817

Doucetengineers.com

October 19, 2022

Kasi Miles
Caldwell County
1700 FM 2720
Lockhart, Texas 78644

Re: Wild Plum Estates Replat of Lots 3 and 4
Project No. 1911-258-01

Dear Ms. Miles,

Doucet has completed our review of the replat application for Wild Plum Estates Lots 3 and 4, a 2-lot subdivision of a 22.014-acres located at Wild Plum Road and Old Colony Line Road. The subdivision will be served by OSSF and Individual Wells.

The plat appears to be in general conformance with the rules and regulations of Caldwell County. Therefore, we recommend placing the plat on the Commissioners Court agenda for consideration. Please note that state law and the subdivision rules of Caldwell County call for a 30-day notice and public hearing to be held prior to approval of a replat.

Per Texas Local Government Code §232.009(d):

(d) During a regular term of the commissioners court, the court shall adopt an order to permit the revision of the subdivision plat if it is shown to the court that:

- (1) the revision will not interfere with the established rights of any owner of a part of the subdivided land; or*
- (2) each owner whose rights may be interfered with has agreed to the revision.*

It is our pleasure to be of assistance to the County on this project.

Kimberly Johnson-Hopkins

Kimberly Johnson-Hopkins
Planner, Land Development

TBPE Firm # 3937
State of Texas Surveying Firm Certification # 10105800

COMMITMENT YOU EXPECT.
EXPERIENCE YOU NEED.
PEOPLE YOU TRUST.

WILD PLUM ESTATES REPLAT OF LOTS 3 AND 4

LEGAL DESCRIPTION

All of a certain tract or parcel of land situated in Caldwell County, Texas and being a part of the Arthur Swift Survey A-273 and also being also all of Lots 3 and 4 of WILD PLUM ESTATES according to the map or plat thereof recorded in Plat Cabinet D Slide 23 of the Plat Records of Caldwell County, Texas and being more particularly described as follows:

BEGINNING at a capped 1/2" iron pin set (stamped "HINKLE SURVEYORS") in the South corner of Lot 4 and in the newly dedicated NW line of Wild Plum Road and in the NE line of a tract of land called 51.38 acres and conveyed to William Bellamy et ux by deed recorded in Volume 399 Page 1 of the Official Public Records of Caldwell County, Texas for the South corner this tract and from which point a 8" fence corner post found marking the East corner of the said 51.38 acre tract bears S 53°55'13" E 8.12 feet.

THENCE N 53°55'13" W with the SW line of the said Lot 4 and the NE line of the said Bellamy tract **1002.66 feet** to a 1/2" iron pin found used for basis of bearing (SPC 4204 N: 13876896.31 E: 2420940.44) in the South corner of a tract of land called 40,000 acres and conveyed to David Travis et ux by deed recorded in Volume 642 Page 365 of the said Official Public Records and in the West corner of the said Lot 4 for the West corner this tract.

THENCE N 63°35'10" E with the NW lines of the said Lots 3 and 4 and with the SE line of the above mentioned 40,000 acre tract and partially along the SE line of a tract of land called 30,000 acres and conveyed to Robert Riendeau et ux by deed recorded in Inst. #2018001764 of the said Official Public Records **1195.83 feet** to a capped iron pin found stamped HINKLE SURVEYORS in the North corner of the said Lot 3 and the West corner of Lot 2 of the said Wild Plum Estates for the North corner this tract.

THENCE S 46°18'34" E with the NE line of the said Lot 3 and the SW line of the said Lot 2 **861.57 feet** to a capped iron pin found stamped HINKLE SURVEYORS in the East corner of the said Lot 3 and the South corner of the said Lot 2 and the NW line of the newly dedicated NW line of Wild Plum Road for the East corner this tract.

THENCE S 59°10'24" W with the newly dedicated NW line of Wild Plum Road and the SE line of the said Lots 3 and 4 **1029.00 feet** to the place of beginning containing **22.014 acres** of land more or less.

SURVEYORS NOTES:

- The Lots shown lie in flood zone areas approximate as shown and create no liability on the part of the surveyor and are based on from a flood insurance rate map according to FEMA Panel #48055C0150E effective date June 19, 2012. Flood Zone "X" (AREA NOT SHADED) is areas determined to be outside the 0.2% annual chance floodplain. Flood Zone "A" (SHADED AREA) is a special flood hazard areas subject to inundation by the 1% annual chance flood. No Base Flood Elevations determined. The 1% annual chance flood (100-year flood), also known as the base flood, is the flood that has a 1% chance of being equaled or exceeded in any given year. The Special Flood Hazard Area is the area subject to flooding by the 1% annual chance flood. The Base Flood Elevation is the water-surface elevation of the 1% annual chance flood. **WARNING:** This Flood Statement, as Determined by a H.U.D. - F.I.A. FLOOD HAZARD BOUNDARY MAP, DOES NOT IMPLY that the Property or the improvements thereon will be Free from Flooding or Flood Damage. On rare occasions, Greater Floods Can and Will Occur, and Flood Heights may be increased by Man-Made or Natural Causes.
- According to Section 3.6.1 (J) any lot shown containing or within three hundred (300') feet of a floodplain shall have the finished floor of any habitable structure on said lot shall be built at least 2 feet above the 100 year flood level as determined by a Professional Engineer or RPLS or as shown on FEMA FIRM maps. Any structure built within this zone shall have an elevation certificate prepared by a Professional Engineer or an RPLS.
- Within the shaded areas shown as FEMA floodplain hereon or as amended by issuance of new FEMA Flood Insurance Rate Maps no new structures will be constructed and any new fencing installed shall be of split rail or wire design that permits free flow of water within the floodplain.
- Prior to installation of any new residential structures on these lots the owner shall engage a RPLS or Professional Engineer to 1) accurately determine the location of FEMA floodplain on the property and 2) determine the base flood elevation. All new residential construction shall comply with Caldwell County regulations for construction within or near floodplains.
- This Subdivision is located within the boundaries of the Lockhart Independent School District.
- This Subdivision is located within Caldwell County Precinct #2.
- This Subdivision is serviced by Dale Volunteer Fire Department.
- In order to promote safe use of roadways and preserve the conditions of public roadways, no driveway constructed on any lot within this subdivision shall be permitted access onto a publicly dedicated county roadway and or State highway unless a DRIVEWAY PERMIT has been issued by the appropriate County Road and Bridge Department and or TXDOT.
- No Lots are to be occupied until OSSF Permitted or public sewer, water and electricity and roads have been provided and construction is completed and approved by Caldwell County Sanitation Department.
- Utilities Provided by:
ELECTRICITY: Bluebonnet Electric Cooperative, Inc.
WATER: Aqua Water Supply Corp.
- According to Section 3.7 (A)(4)(a) of the Caldwell County Development Ordinance Plats of 4 lots or less that are a minimum of one-acre in size are restricted to one single family residence. Such lots shall be restricted from installation of greater than 20% impervious cover and from further subdivision platting.
- RECORD OWNERS OF LAND: GH Wild Plum Forest Lakes LLC
DESIGNER OF PLAT: Hinkle Surveyors, PO Box 1027, Lockhart TX 78644 (512) 398-2000
DATE OF PREPARATION: September 2022
SURVEYOR: Jerry L. Hinkle, R.P.L.S. #5459 PO Box 1027, Lockhart TX 78644 (512) 398-2000
- Lot Closures-- Lot 3-A: 1 in 614578'; Lot 4-A: 1 in 1102557'
- Boundary Closure: 1 in 1685764'

STATE OF TEXAS
COUNTY OF CALDWELL

KNOW ALL MEN BY THESE PRESENTS: THAT WE THE UNDERSIGNED, BEING THE OWNERS OF THE TRACT OF LAND CALLED LOTS 3 and 4 of WILD PLUM ESTATES OUT OF THE ARTHUR SWIFT SURVEY A-273 IN CALDWELL COUNTY, TEXAS RECORDED IN PLAT CABINET D SLIDE 23 OF THE PLAT RECORDED OF CALDWELL COUNTY, TEXAS AND CONVEYED TO GH WILD PLUM FOREST LAKES LLC BY DEED RECORDED IN INSTRUMENT #2021-007539 OF THE OFFICIAL PUBLIC RECORDS OF CALDWELL COUNTY, TEXAS AND IN ACCORDANCE WITH TEXAS LOCAL GOVERNMENT CODE AND THE MAP OR PLAT SHOWN HEREON, TO BE KNOWN AS

WILD PLUM ESTATES REPLAT OF LOTS 3 AND 4

SUBJECT TO THE COVENANTS AND RESTRICTIONS SHOWN HEREON, AND SUBJECT TO ANY EASEMENTS AND/OR RESTRICTIONS HERETOFORE GRANTED AND NOT RELEASED.

DATE _____ GH WILD PLUM FOREST LAKES LLC (REP.)
3005 STRATFORD DRIVE
AUSTIN, TEXAS 78746

STATE OF TEXAS
COUNTY OF _____

This instrument was acknowledged before me on _____, 20____ by _____
REPRESENTATIVE for GH WILD PLUM FOREST LAKES LLC.

Notary Public in and for the State of Texas

STATE OF TEXAS
COUNTY OF CALDWELL

I, Jerry L. Hinkle, registered professional land surveyor, State of Texas, hereby certify that this plat is a true and correct representation of a survey made on the ground under my direct supervision and that all necessary monuments are correctly shown and complies with all survey requirements of the Caldwell County Subdivision Ordinance and is true and correct to the best of my knowledge.

IN WITNESS THEREOF, my hand and seal, this the _____ day of _____, 20____.

NOT FOR PUBLIC RELEASE

Jerry L. Hinkle
Registered Professional
Land Surveyor #5459

STATE OF TEXAS
COUNTY OF CALDWELL

I, Teresa Rodriguez, County Clerk in and for Caldwell County, Texas do hereby certify that this map or plat, with field notes shown hereon, has been fully presented and approved by the Commissioners Court of Caldwell County, Texas on the _____ day of _____, 20____, to be recorded in the Plat Records of Caldwell County, Texas.

Teresa Rodriguez
Caldwell County Clerk

STATE OF TEXAS
COUNTY OF CALDWELL

I, Teresa Rodriguez, County Clerk in and for Caldwell County, Texas do hereby certify that the foregoing instrument with its certificates of authentication was filed for record in my office the _____ day of _____, 20____, at _____ o'clock _____ M. and duly recorded on the _____ day of _____, 20____, in the Plat Records of Caldwell County, Texas in Plat Cabinet _____ at Slide _____.

Teresa Rodriguez
Caldwell County Clerk

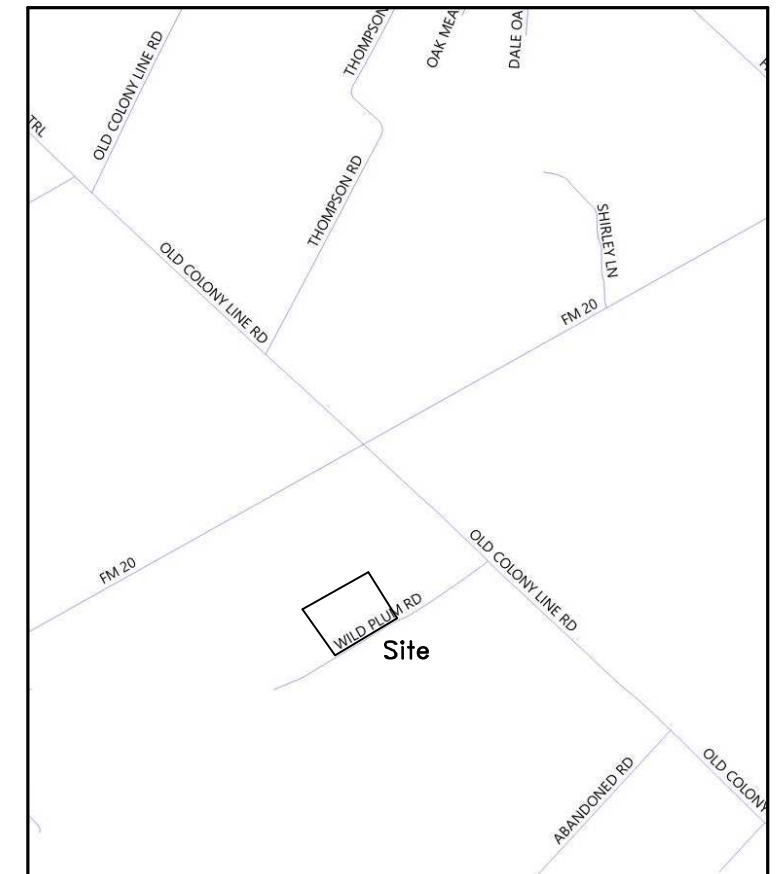

Vicinity Map
Not to Scale



Scale 1"=200'



Field Book: d.c.	Drawn By: JLH LH
Job No. 20211991-sub-replat	Drawing: 20211991-sub-replat.dwg
Date: September 2022	Word Date: Begin 9/2022
Surveyed By: JLH JDB	Autocad Date: Begin 9/2022

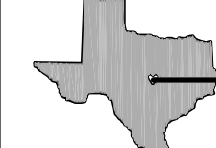

**HINKLE
SURVEYORS**

P.O. Box 1027 1109 S. Main Street Lockhart, TX 78644
Ph: (512) 398-2000 Fax: (512) 398-7683 Email: contact@hinklesurveyors.com Firm Registration No. 100886-00

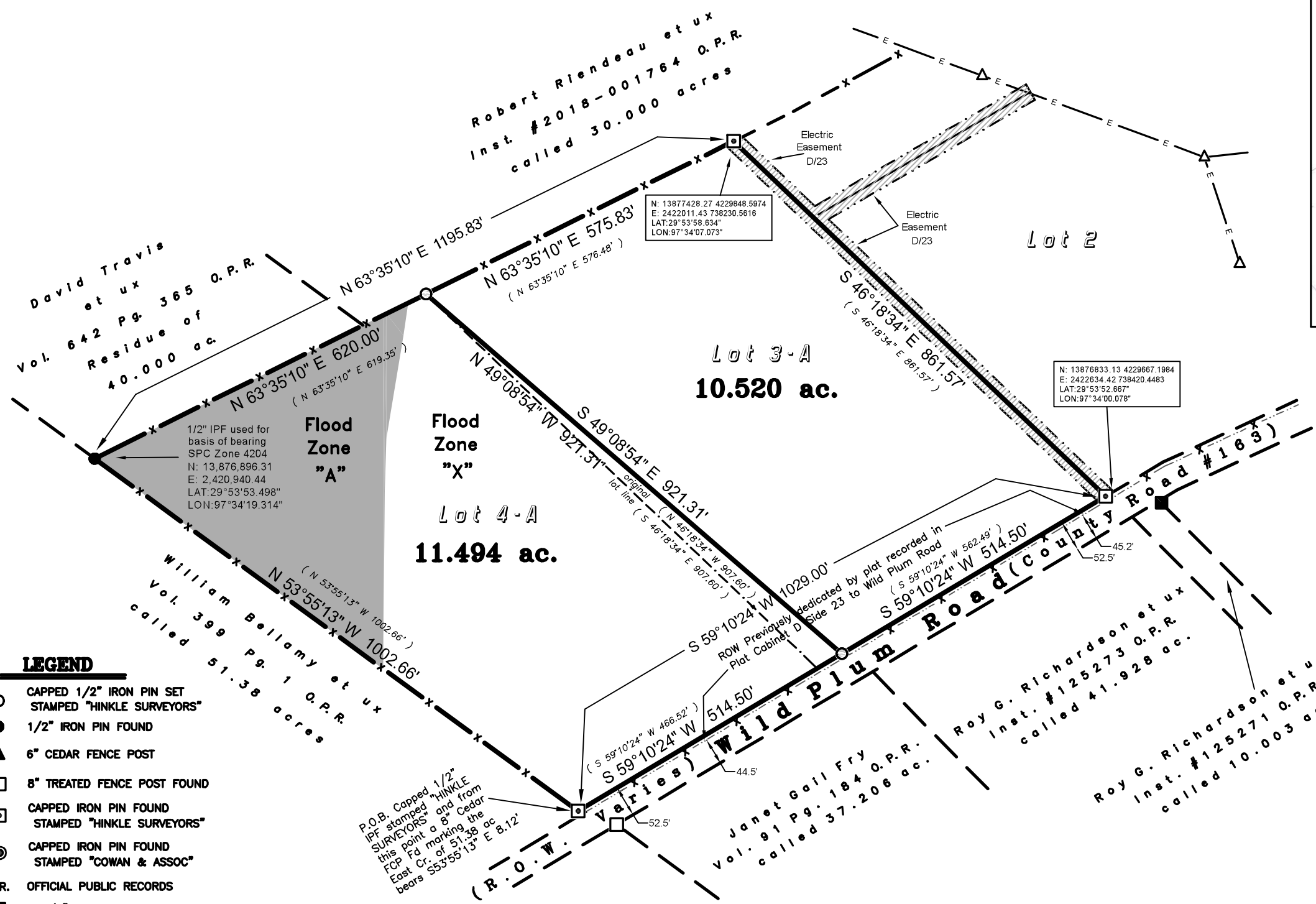

LEGEND

- CAPPED 1/2" IRON PIN SET STAMPED "HINKLE SURVEYORS"
- 1/2" IRON PIN FOUND
- ▲ 6" CEDAR FENCE POST
- 8" TREATED FENCE POST FOUND
- ▣ CAPPED IRON PIN FOUND STAMPED "HINKLE SURVEYORS"
- ⊙ CAPPED IRON PIN FOUND STAMPED "COWAN & ASSOC"
- O.P.R. OFFICIAL PUBLIC RECORDS
- 2 1/2" IRON PIPE FENCE POST
- (.....) ORIGINAL DEEDED CALLS
- X- FENCES MEANDER
- - - ORIGINAL LOT LINE
- EASEMENT
- UNLESS OTHERWISE NOTED

WILD PLUM ESTATES REPLAT OF LOTS 3 AND 4

LEGAL DESCRIPTION

All of a certain tract or parcel of land situated in Caldwell County, Texas and being a part of the Arthur Swift Survey A-273 and also being also all of Lots 3 and 4 of WILD PLUM ESTATES according to the map or plat thereof recorded in Plat Cabinet D Slide 23 of the Plat Records of Caldwell County, Texas and being more particularly described as follows:

BEGINNING at a capped 1/2" iron pin set (stamped "HINKLE SURVEYORS") in the South corner of Lot 4 and in the newly dedicated NW line of Wild Plum Road and in the NE line of a tract of land called 51.38 acres and conveyed to William Bellamy et ux by deed recorded in Volume 399 Page 1 of the Official Public Records of Caldwell County, Texas for the South corner this tract and from which point a 8" fence corner post found marking the East corner of the said 51.38 acre tract bears S 53°55'13" E 8.12 feet.

THENCE N 53°55'13" W with the SW line of the said Lot 4 and the NE line of the said Bellamy tract **1002.66 feet** to a 1/2" iron pin found used for basis of bearing (SPC 4204 N: 13876896.31 E: 2420940.44) in the South corner of a tract of land called 40,000 acres and conveyed to David Travis et ux by deed recorded in Volume 642 Page 365 of the said Official Public Records and in the West corner of the said Lot 4 for the West corner this tract.

THENCE N 63°35'10" E with the NW lines of the said Lots 3 and 4 and with the SE line of the above mentioned 40,000 acre tract and partially along the SE line of a tract of land called 30,000 acres and conveyed to Robert Riendeau et ux by deed recorded in Inst. #2018001764 of the said Official Public Records **1195.83 feet** to a capped iron pin found stamped HINKLE SURVEYORS in the North corner of the said Lot 3 and the West corner of Lot 2 of the said Wild Plum Estates for the North corner this tract.

THENCE S 46°18'34" E with the NE line of the said Lot 3 and the SW line of the said Lot 2 **861.57 feet** to a capped iron pin found stamped HINKLE SURVEYORS in the East corner of the said Lot 3 and the South corner of the said Lot 2 and the NW line of the newly dedicated NW line of Wild Plum Road for the East corner this tract.

THENCE S 59°10'24" W with the newly dedicated NW line of Wild Plum Road and the SE line of the said Lots 3 and 4 **1029.00 feet** to the place of beginning containing **22.014 acres** of land more or less.

SURVEYORS NOTES:

- The Lots shown lie in flood zone areas approximate as shown and create no liability on the part of the surveyor and are based on from a flood insurance rate map according to FEMA Panel #48055C0150E effective date June 19, 2012. Flood Zone "X" (AREA NOT SHADED) is areas determined to be outside the 0.2% annual chance floodplain. Flood Zone "A" (SHADED AREA) is a special flood hazard areas subject to inundation by the 1% annual chance flood. No Base Flood Elevations determined. The 1% annual chance flood (100-year flood), also known as the base flood, is the flood that has a 1% chance of being equaled or exceeded in any given year. The Special Flood Hazard Area is the area subject to flooding by the 1% annual chance flood. The Base Flood Elevation is the water-surface elevation of the 1% annual chance flood. **WARNING:** This Flood Statement, as Determined by a H.U.D. - F.I.A. FLOOD HAZARD BOUNDARY MAP, DOES NOT IMPLY that the Property or the improvements thereon will be Free from Flooding or Flood Damage. On rare occasions, Greater Floods Can and Will Occur, and Flood Heights may be increased by Man-Made or Natural Causes.
- According to Section 3.6.1 (J) any lot shown containing or within three hundred (300') feet of a floodplain shall have the finished floor of any habitable structure on said lot shall be built at least 2 feet above the 100 year flood level as determined by a Professional Engineer or RPLS or as shown on FEMA FIRM maps. Any structure built within this zone shall have an elevation certificate prepared by a Professional Engineer or an RPLS.
- Within the shaded areas shown as FEMA floodplain hereon or as amended by issuance of new FEMA Flood Insurance Rate Maps no new structures will be constructed and any new fencing installed shall be of split rail or wire design that permits free flow of water within the floodplain.
- Prior to installation of any new residential structures on these lots the owner shall engage a RPLS or Professional Engineer to 1) accurately determine the location of FEMA floodplain on the property and 2) determine the base flood elevation. All new residential construction shall comply with Caldwell County regulations for construction within or near floodplains.
- This Subdivision is located within the boundaries of the Lockhart Independent School District.
- This Subdivision is located within Caldwell County Precinct #2.
- This Subdivision is serviced by Dale Volunteer Fire Department.
- In order to promote safe use of roadways and preserve the conditions of public roadways, no driveway constructed on any lot within this subdivision shall be permitted access onto a publicly dedicated county roadway and or State highway unless a DRIVEWAY PERMIT has been issued by the appropriate County Road and Bridge Department and or TXDOT.
- No Lots are to be occupied until OSSF Permitted or public sewer, water and electricity and roads have been provided and construction is completed and approved by Caldwell County Sanitation Department.
- Utilities Provided by:
ELECTRICITY: Bluebonnet Electric Cooperative, Inc.
WATER: Aqua Water Supply Corp.
- According to Section 3.7 (A)(4)(a) of the Caldwell County Development Ordinance Plats of 4 lots or less that are a minimum of one-acre in size are restricted to one single family residence. Such lots shall be restricted from installation of greater than 20% impervious cover and from further subdivision platting.
- RECORD OWNERS OF LAND: GH Wild Plum Forest Lakes LLC
DESIGNER OF PLAT: Hinkle Surveyors, PO Box 1027, Lockhart TX 78644 (512) 398-2000
DATE OF PREPARATION: September 2022
SURVEYOR: Jerry L. Hinkle, R.P.L.S. #5459 PO Box 1027, Lockhart TX 78644 (512) 398-2000
- Lot Closures-- Lot 3-A: 1 in 614578'; Lot 4-A: 1 in 1102557'
- Boundary Closure: 1 in 1685764'

STATE OF TEXAS
COUNTY OF CALDWELL

KNOW ALL MEN BY THESE PRESENTS: THAT WE THE UNDERSIGNED, BEING THE OWNERS OF THE TRACT OF LAND CALLED LOTS 3 and 4 of WILD PLUM ESTATES OUT OF THE ARTHUR SWIFT SURVEY A-273 IN CALDWELL COUNTY, TEXAS RECORDED IN PLAT CABINET D SLIDE 23 OF THE PLAT RECORDED OF CALDWELL COUNTY, TEXAS AND CONVEYED TO GH WILD PLUM FOREST LAKES LLC BY DEED RECORDED IN INSTRUMENT #2021-007539 OF THE OFFICIAL PUBLIC RECORDS OF CALDWELL COUNTY, TEXAS AND IN ACCORDANCE WITH TEXAS LOCAL GOVERNMENT CODE AND THE MAP OR PLAT SHOWN HEREON, TO BE KNOWN AS

WILD PLUM ESTATES REPLAT OF LOTS 3 AND 4

SUBJECT TO THE COVENANTS AND RESTRICTIONS SHOWN HEREON, AND SUBJECT TO ANY EASEMENTS AND/OR RESTRICTIONS HERETOFORE GRANTED AND NOT RELEASED.

DATE _____ GH WILD PLUM FOREST LAKES LLC (REP.)
3005 STRATFORD DRIVE
AUSTIN, TEXAS 78746

STATE OF TEXAS
COUNTY OF _____

This instrument was acknowledged before me on _____, 20____ by _____
REPRESENTATIVE for GH WILD PLUM FOREST LAKES LLC.

Notary Public in and for the State of Texas

STATE OF TEXAS
COUNTY OF CALDWELL

I, Jerry L. Hinkle, registered professional land surveyor, State of Texas, hereby certify that this plat is a true and correct representation of a survey made on the ground under my direct supervision and that all necessary monuments are correctly shown and complies with all survey requirements of the Caldwell County Subdivision Ordinance and is true and correct to the best of my knowledge.

IN WITNESS THEREOF, my hand and seal, this the _____ day of _____, 20____.

NOT FOR PUBLIC RELEASE

Jerry L. Hinkle
Registered Professional
Land Surveyor #5459

STATE OF TEXAS
COUNTY OF CALDWELL

I, Teresa Rodriguez, County Clerk in and for Caldwell County, Texas do hereby certify that this map or plat, with field notes shown hereon, has been fully presented and approved by the Commissioners Court of Caldwell County, Texas on the _____ day of _____, 20____, to be recorded in the Plat Records of Caldwell County, Texas.

Teresa Rodriguez
Caldwell County Clerk

STATE OF TEXAS
COUNTY OF CALDWELL

I, Teresa Rodriguez, County Clerk in and for Caldwell County, Texas do hereby certify that the foregoing instrument with its certificates of authentication was filed for record in my office the _____ day of _____, 20____, at _____ o'clock _____ M. and duly recorded on the _____ day of _____, 20____, in the Plat Records of Caldwell County, Texas in Plat Cabinet _____ at Slide _____.

Teresa Rodriguez
Caldwell County Clerk

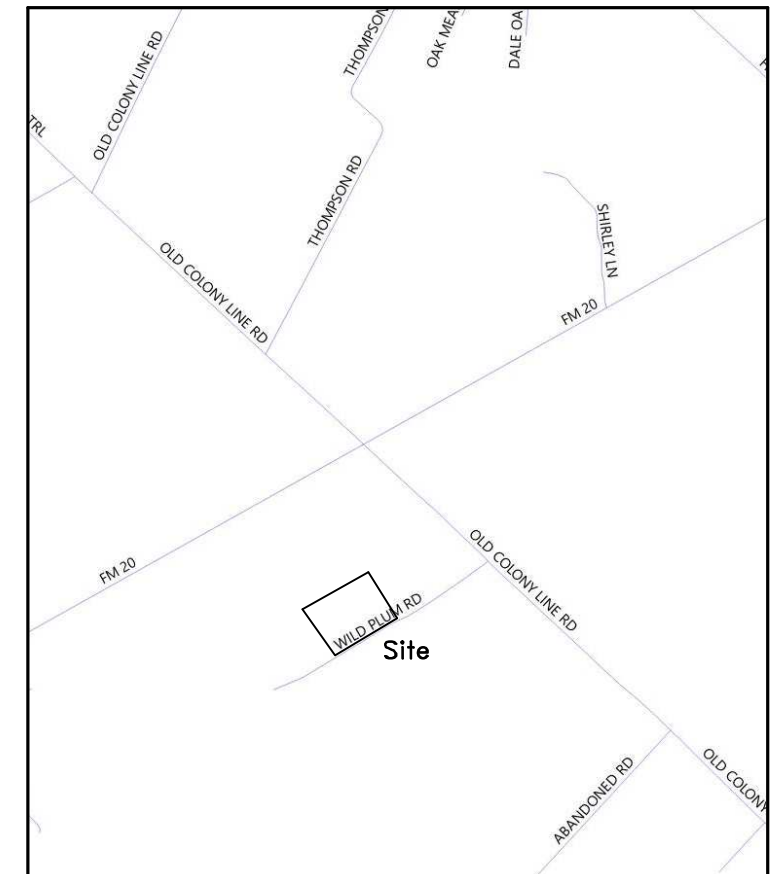

Vicinity Map
Not to Scale



Scale 1"=200'



Field Book: d.c.	Drawn By: J.LH LH
Job No. 20211991-sub-replat	Drawing: 20211991-sub-replat.dwg
Date: September 2022	Word Disk: Begin 9/2022
Surveyed By: J.LH JDB	Autocad Disk: Begin 9/2022

HINKLE SURVEYORS
P.O. Box 1027 1109 S. Main Street Lockhart, TX 78644
Ph: (512) 398-2000 Fax: (512) 398-7683 Email: contact@hinklesurveyors.com Firm Registration No. 100886-00

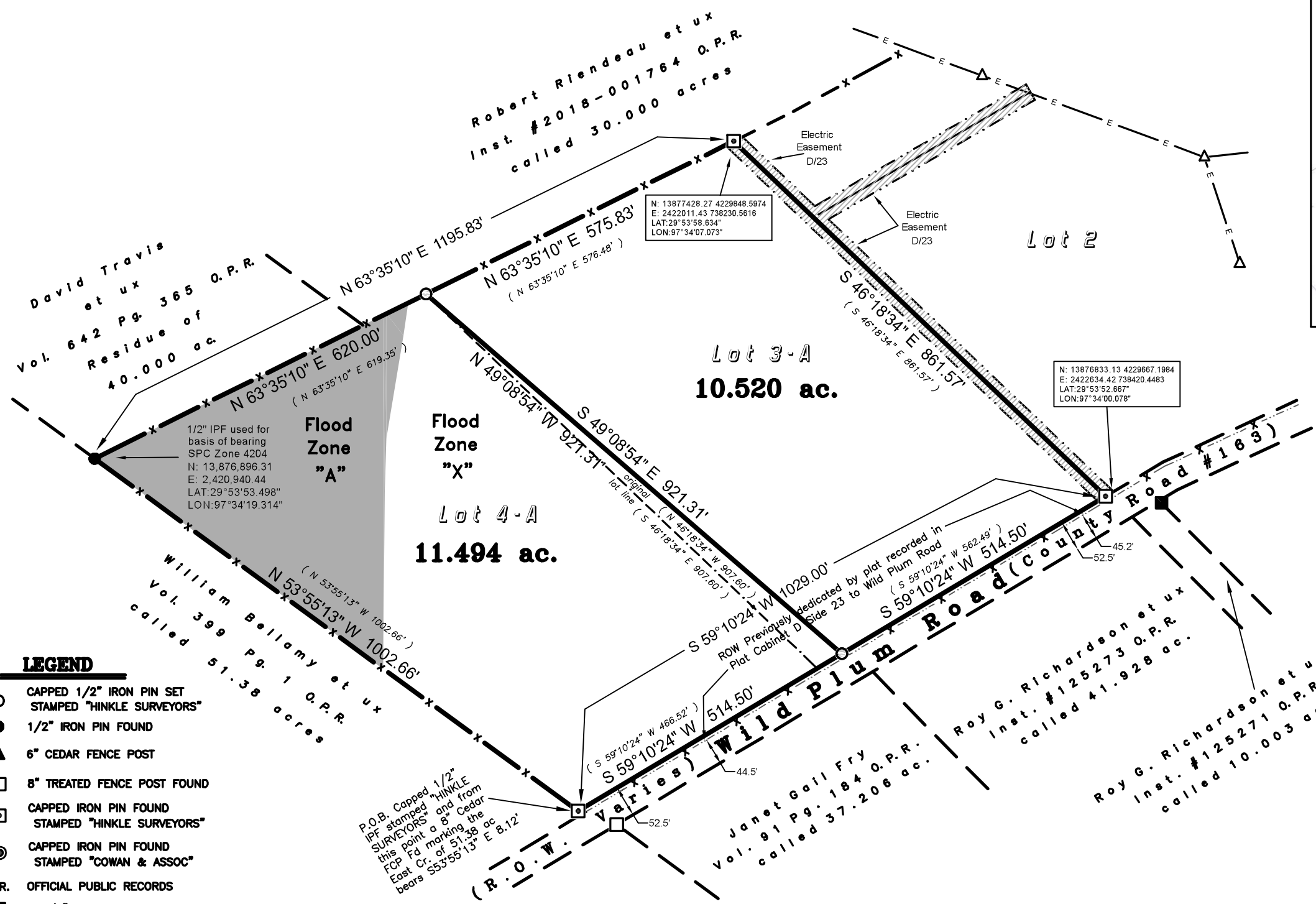

LEGEND

- CAPPED 1/2" IRON PIN SET STAMPED "HINKLE SURVEYORS"
- 1/2" IRON PIN FOUND
- ▲ 6" CEDAR FENCE POST
- 8" TREATED FENCE POST FOUND
- ◻ CAPPED IRON PIN FOUND STAMPED "HINKLE SURVEYORS"
- ⊙ CAPPED IRON PIN FOUND STAMPED "COWAN & ASSOC"
- O.P.R. OFFICIAL PUBLIC RECORDS
- 2 1/2" IRON PIPE FENCE POST
- (.....) ORIGINAL DEEDED CALLS
- X- FENCES MEANDER
- - - ORIGINAL LOT LINE
- EASEMENT
- UNLESS OTHERWISE NOTED



7401B Highway 71 West, Suite 160
Austin, TX 78735
Office: 512.583.2600
Fax: 800.587.2817

Doucetengineers.com

October 19, 2022

Kasi Miles
Caldwell County
1700 FM 2720
Lockhart, Texas 78644

Re: Wild Plum Estates Replat of Lots 3 and 4
Project No. 1911-258-01

Dear Ms. Miles,

Doucet has completed our review of the replat application for Wild Plum Estates Lots 3 and 4, a 2-lot subdivision of a 22.014-acres located at Wild Plum Road and Old Colony Line Road. The subdivision will be served by OSSF and Individual Wells.

The plat appears to be in general conformance with the rules and regulations of Caldwell County. Therefore, we recommend placing the plat on the Commissioners Court agenda for consideration. Please note that state law and the subdivision rules of Caldwell County call for a 30-day notice and public hearing to be held prior to approval of a replat.

Per Texas Local Government Code §232.009(d):

(d) During a regular term of the commissioners court, the court shall adopt an order to permit the revision of the subdivision plat if it is shown to the court that:

- (1) the revision will not interfere with the established rights of any owner of a part of the subdivided land; or*
- (2) each owner whose rights may be interfered with has agreed to the revision.*

It is our pleasure to be of assistance to the County on this project.

Kimberly Johnson-Hopkins

Kimberly Johnson-Hopkins
Planner, Land Development

TBPE Firm # 3937
State of Texas Surveying Firm Certification # 10105800

COMMITMENT YOU EXPECT.
EXPERIENCE YOU NEED.
PEOPLE YOU TRUST.

WILD PLUM ESTATES REPLAT OF LOTS 3 AND 4

LEGAL DESCRIPTION

All of a certain tract or parcel of land situated in Caldwell County, Texas and being a part of the Arthur Swift Survey A-273 and also being also all of Lots 3 and 4 of WILD PLUM ESTATES according to the map or plat thereof recorded in Plat Cabinet D Slide 23 of the Plat Records of Caldwell County, Texas and being more particularly described as follows:

BEGINNING at a capped 1/2" iron pin set (stamped "HINKLE SURVEYORS") in the South corner of Lot 4 and in the newly dedicated NW line of Wild Plum Road and in the NE line of a tract of land called 51.38 acres and conveyed to William Bellamy et ux by deed recorded in Volume 399 Page 1 of the Official Public Records of Caldwell County, Texas for the South corner this tract and from which point a 8" fence corner post found marking the East corner of the said 51.38 acre tract bears S 53°55'13" E 8.12 feet.

THENCE N 53°55'13" W with the SW line of the said Lot 4 and the NE line of the said Bellamy tract **1002.66 feet** to a 1/2" iron pin found used for basis of bearing (SPC 4204 N: 13876896.31 E: 2420940.44) in the South corner of a tract of land called 40,000 acres and conveyed to David Travis et ux by deed recorded in Volume 642 Page 365 of the said Official Public Records and in the West corner of the said Lot 4 for the West corner this tract.

THENCE N 63°35'10" E with the NW lines of the said Lots 3 and 4 and with the SE line of the above mentioned 40,000 acre tract and partially along the SE line of a tract of land called 30,000 acres and conveyed to Robert Riendeau et ux by deed recorded in Inst. #2018001764 of the said Official Public Records **1195.83 feet** to a capped iron pin found stamped HINKLE SURVEYORS in the North corner of the said Lot 3 and the West corner of Lot 2 of the said Wild Plum Estates for the North corner this tract.

THENCE S 46°18'34" E with the NE line of the said Lot 3 and the SW line of the said Lot 2 **861.57 feet** to a capped iron pin found stamped HINKLE SURVEYORS in the East corner of the said Lot 3 and the South corner of the said Lot 2 and the NW line of the newly dedicated NW line of Wild Plum Road for the East corner this tract.

THENCE S 59°10'24" W with the newly dedicated NW line of Wild Plum Road and the SE line of the said Lots 3 and 4 **1029.00 feet** to the place of beginning containing **22.014 acres** of land more or less.

SURVEYORS NOTES:

- The Lots shown lie in flood zone areas approximate as shown and create no liability on the part of the surveyor and are based on from a flood insurance rate map according to FEMA Panel #48055C0150E effective date June 19, 2012. Flood Zone "X" (AREA NOT SHADED) is areas determined to be outside the 0.2% annual chance floodplain. Flood Zone "A" (SHADED AREA) is a special flood hazard areas subject to inundation by the 1% annual chance flood. No Base Flood Elevations determined. The 1% annual chance flood (100-year flood), also known as the base flood, is the flood that has a 1% chance of being equaled or exceeded in any given year. The Special Flood Hazard Area is the area subject to flooding by the 1% annual chance flood. The Base Flood Elevation is the water-surface elevation of the 1% annual chance flood. WARNING: This Flood Statement, as Determined by a H.U.D. - F.I.A. FLOOD HAZARD BOUNDARY MAP, DOES NOT IMPLY that the Property or the improvements thereon will be Free from Flooding or Flood Damage. On rare occasions, Greater Floods Can and Will Occur, and Flood Heights may be increased by Man-Made or Natural Causes.
- According to Section 3.6.1 (J) any lot shown containing or within three hundred (300') feet of a floodplain shall have the finished floor of any habitable structure on said lot shall be built at least 2 feet above the 100 year flood level as determined by a Professional Engineer or RPLS or as shown on FEMA FIRM maps. Any structure built within this zone shall have an elevation certificate prepared by a Professional Engineer or an RPLS.
- Within the shaded areas shown as FEMA floodplain hereon or as amended by issuance of new FEMA Flood Insurance Rate Maps no new structures will be constructed and any new fencing installed shall be of split rail or wire design that permits free flow of water within the floodplain.
- Prior to installation of any new residential structures on these lots the owner shall engage a RPLS or Professional Engineer to 1) accurately determine the location of FEMA floodplain on the property and 2) determine the base flood elevation. All new residential construction shall comply with Caldwell County regulations for construction within or near floodplains.
- This Subdivision is located within the boundaries of the Lockhart Independent School District.
- This Subdivision is located within Caldwell County Precinct #2.
- This Subdivision is serviced by Dale Volunteer Fire Department.
- In order to promote safe use of roadways and preserve the conditions of public roadways, no driveway constructed on any lot within this subdivision shall be permitted access onto a publicly dedicated county roadway and or State highway unless a DRIVEWAY PERMIT has been issued by the appropriate County Road and Bridge Department and or TXDOT.
- No Lots are to be occupied until OSSF Permitted or public sewer, water and electricity and roads have been provided and construction is completed and approved by Caldwell County Sanitation Department.
- Utilities Provided by:
ELECTRICITY: Bluebonnet Electric Cooperative, Inc.
WATER: Aqua Water Supply Corp.
- According to Section 3.7 (A)(4)(a) of the Caldwell County Development Ordinance Plats of 4 lots or less that are a minimum of one-acre in size are restricted to one single family residence. Such lots shall be restricted from installation of greater than 20% impervious cover and from further subdivision platting.
- RECORD OWNERS OF LAND: GH Wild Plum Forest Lakes LLC
DESIGNER OF PLAT: Hinkle Surveyors, PO Box 1027, Lockhart TX 78644
(512) 398-2000
DATE OF PREPARATION: September 2022
SURVEYOR: Jerry L. Hinkle, R.P.L.S. #5459 PO Box 1027, Lockhart TX 78644
(512) 398-2000
- Lot Closures-- Lot 3-A: 1 in 614578'; Lot 4-A: 1 in 1102557'
- Boundary Closure: 1 in 1685764'

STATE OF TEXAS
COUNTY OF CALDWELL

KNOW ALL MEN BY THESE PRESENTS: THAT WE THE UNDERSIGNED, BEING THE OWNERS OF THE TRACT OF LAND CALLED LOTS 3 and 4 of WILD PLUM ESTATES OUT OF THE ARTHUR SWIFT SURVEY A-273 IN CALDWELL COUNTY, TEXAS RECORDED IN PLAT CABINET D SLIDE 23 OF THE PLAT RECORDED OF CALDWELL COUNTY, TEXAS AND CONVEYED TO GH WILD PLUM FOREST LAKES LLC BY DEED RECORDED IN INSTRUMENT #2021-007539 OF THE OFFICIAL PUBLIC RECORDS OF CALDWELL COUNTY, TEXAS AND IN ACCORDANCE WITH TEXAS LOCAL GOVERNMENT CODE AND THE MAP OR PLAT SHOWN HEREON, TO BE KNOWN AS

WILD PLUM ESTATES REPLAT OF LOTS 3 AND 4

SUBJECT TO THE COVENANTS AND RESTRICTIONS SHOWN HEREON, AND SUBJECT TO ANY EASEMENTS AND/OR RESTRICTIONS HERETOFORE GRANTED AND NOT RELEASED.

DATE _____ GH WILD PLUM FOREST LAKES LLC (REP.)
3005 STRATFORD DRIVE
AUSTIN, TEXAS 78746

STATE OF TEXAS
COUNTY OF _____

This instrument was acknowledged before me on _____, 20____ by _____
REPRESENTATIVE for GH WILD PLUM FOREST LAKES LLC.

Notary Public in and for the State of Texas

STATE OF TEXAS
COUNTY OF CALDWELL

I, Jerry L. Hinkle, registered professional land surveyor, State of Texas, hereby certify that this plat is a true and correct representation of a survey made on the ground under my direct supervision and that all necessary monuments are correctly shown and complies with all survey requirements of the Caldwell County Subdivision Ordinance and is true and correct to the best of my knowledge.

IN WITNESS THEREOF, my hand and seal, this the _____ day of _____, 20____.

NOT FOR PUBLIC RELEASE

Jerry L. Hinkle
Registered Professional
Land Surveyor #5459

STATE OF TEXAS
COUNTY OF CALDWELL

I, Teresa Rodriguez, County Clerk in and for Caldwell County, Texas do hereby certify that this map or plat, with field notes shown hereon, has been fully presented and approved by the Commissioners Court of Caldwell County, Texas on the _____ day of _____, 20____, to be recorded in the Plat Records of Caldwell County, Texas.

Teresa Rodriguez
Caldwell County Clerk

STATE OF TEXAS
COUNTY OF CALDWELL

I, Teresa Rodriguez, County Clerk in and for Caldwell County, Texas do hereby certify that the foregoing instrument with its certificates of authentication was filed for record in my office the _____ day of _____, 20____, at _____ o'clock _____ M. and duly recorded on the _____ day of _____, 20____, in the Plat Records of Caldwell County, Texas in Plat Cabinet _____ at Slide _____.

Teresa Rodriguez
Caldwell County Clerk

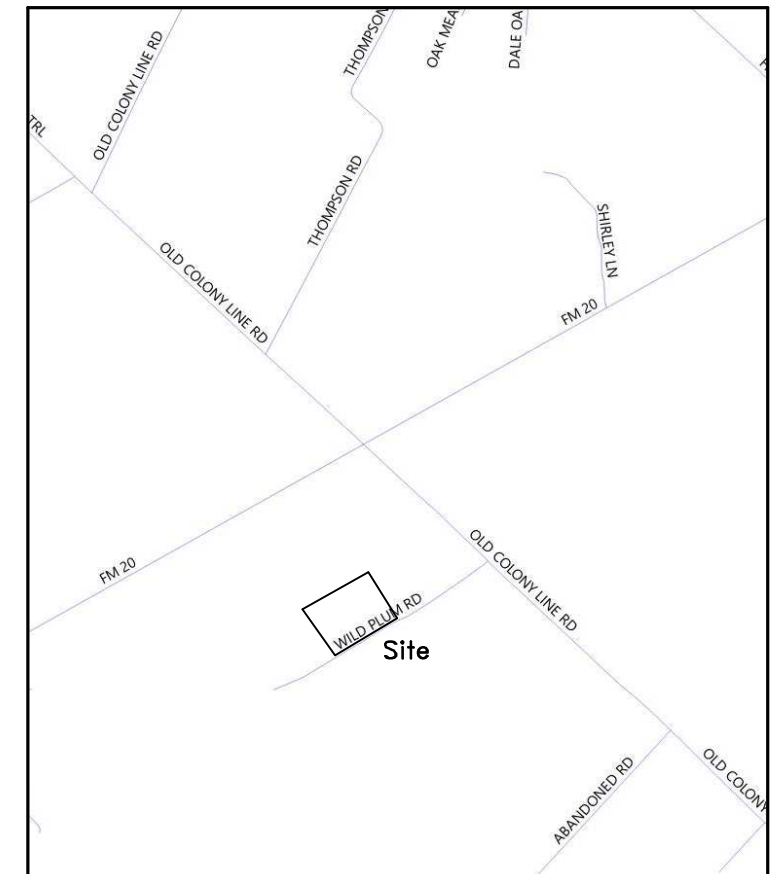

Vicinity Map
Not to Scale



Scale 1"=200'



Field Book: d.c.	Drawn By: JLH LH
Job No. 20211991-sub-replat	Drawing: 20211991-sub-replat.dwg
Date: September 2022	Word Disk: Begin 9/2022
Surveyed By: JLH JDB	Autocad Disk: Begin 9/2022



**HINKLE
SURVEYORS**

P.O. Box 1027 1109 S. Main Street Lockhart, TX 78644
Ph: (512) 398-2000 Fax: (512) 398-7683 Email: contact@hinklesurveyors.com Firm Registration No. 100886-00

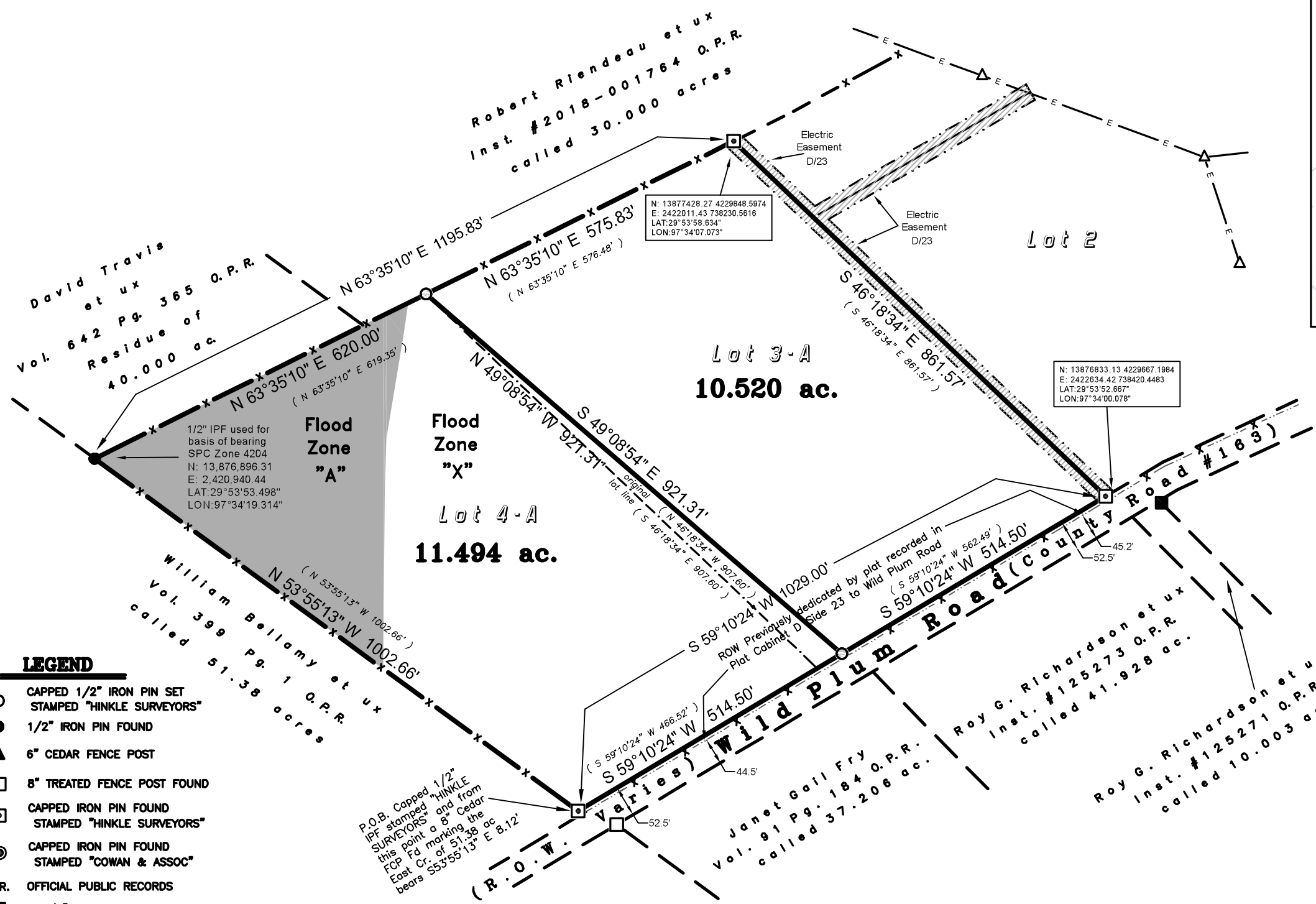

LEGEND

- CAPPED 1/2" IRON PIN SET STAMPED "HINKLE SURVEYORS"
- 1/2" IRON PIN FOUND
- ▲ 6" CEDAR FENCE POST
- 8" TREATED FENCE POST FOUND
- ◻ CAPPED IRON PIN FOUND STAMPED "HINKLE SURVEYORS"
- ⊙ CAPPED IRON PIN FOUND STAMPED "COWAN & ASSOC"
- O.P.R. OFFICIAL PUBLIC RECORDS
- 2 1/2" IRON PIPE FENCE POST
- (.....) ORIGINAL DEEDED CALLS
- X- FENCES MEANDER
- - - ORIGINAL LOT LINE
- EASEMENT
- UNLESS OTHERWISE NOTED



September 23, 2021

Trevor Dallas

Re: Letter of availability Wild Plum Road lot 3 and 4, Wild Plum Estates, Dale Tx

To Whom It May Concern:

We have determined that the location of your inquiry in Caldwell County is in the certificated service territory of Bluebonnet Electric Cooperative, Inc. and we are therefore willing to provide electric service. Bluebonnet's promise to provide service is contingent upon the applicant fulfilling all the requirements of our Tariff including our Line Extension Policy.

If you have any questions regarding this request, please contact a new service coordinator at 800-842-7708, option 3 or email newservice@bluebonnet.coop.

Sincerely,

Barbara Scilheimer

Manager, Member Services

Charles Royall

Sent from my iPhone

On Sep 20, 2021, at 10:12 AM, Trevor Dallas <dallasts@yahoo.com> wrote:

Hello Charlie, it was a pleasure talking with you just now. I'm just forwarding you the email I sent you last week so that you didn't need to hunt it down.

Thank you!

Regards,

Trevor Dallas
(512) 825-6140

----- Forwarded Message -----

From: Trevor Dallas <dallasts@yahoo.com>
To: royallswindmill@yahoo.com <royallswindmill@yahoo.com>
Sent: Monday, September 13, 2021, 11:14:12 AM CDT
Subject: Fw: 102 Wild Plum - Water Availability Letter

Hello Charles, I left you a Voice Mail regarding this email. We are purchasing lots 3 & 4 (see attached plat) of the 102 Wild Plum Subdivision and are evaluating subdividing further. Since these two lots are a subset of the land for which you wrote the email below to Kenny Meurchison, would you mind sending the same email to us for Lots 3 & 4?

Regards,

Trevor Dallas
(512) 825-6140

----- Forwarded message -----

From: Kenny Murchison <kmurx@nisc.com>
Date: Mon, Sep 13, 2021 at 9:32 AM
Subject: Fwd: 102 Wild Plum
To: <zroesinger@gmail.com>

When I had the property subdivided I had to provide proof to the commissioner's court that utilities were available.

This is the letter I used for the water.

I will need to scan the letter I used for power and send it.

Fwd: Wild Plum Lots 3 & 4 - Water Availability Letter

From: Trevor Dallas (dallasts@yahoo.com)
To: contact@hinklesurveyors.com
Date: Thursday, April 21, 2022 at 10:06 AM CDT

Resending water availability for wild plum lots from October

Regards,

Trevor Dallas

Sent from my iPhone. Please forgive any spelling errors.

Begin forwarded message:

From: Trevor Dallas <dallasts@yahoo.com>
Date: October 21, 2021 at 11:45:09 AM CDT
To: Jerry Hinkle <contact@hinklesurveyors.com>
Subject: Fw: Wild Plum Lots 3 & 4 - Water Availability Letter

Linda, please see the email from Charles Royall regarding water availability at Wild Plum lots attached. Will this email suffice? (this is the same guy who wrote the email of water availability for Kenny Murchison, the Seller of the Wild Plum lots)

Regards,

Trevor Dallas
(512) 825-6140

----- Forwarded Message -----

From: charles royall <royallswindmill@yahoo.com>
To: Trevor Dallas <dallasts@yahoo.com>
Sent: Tuesday, September 21, 2021, 08:48:09 AM CDT
Subject: Re: Wild Plum - Water Availability Letter

Trevor Dallas, located at 102 Wild Plum Lots 3 and 4, contacted me and asked me to verify if ground water is available. Based on my research and knowledge of the area ground water should be available. Listed are the basis of my information

1. He stated the adjacent property had a functioning well at one time
2. According to the state well report database there are wells in the vicinity of the area that produce adequate water.
3. I have serviced wells on Wild Plum that service residences.

Thank you,

GH WILD PLUM FOREST LAKES LLC
3005 STRATFORD DR
AUSTIN, TX 78746-0000

9/20/22

1011

Pay to the
Order of

Caldwell County
Sanitation

\$ 400



or NP Replate Fee

[Handwritten signature]



CALDWELL COUNTY SANITATION DEPT.
1700 FM 2720
LOCKHART, TEXAS 78644
(512) 398-1803

8871

DATE 10-27-22

RECEIVED FROM

GH Wild Plum Lakes, LLC

\$ 400.00

Four hundred dollars + no/xx

DOLLARS

FOR

Replate fees Wild Plum Estates

Thank You

AMOUNT OF ACCOUNT

PAYMENT 400.00

CASH

CHECK

CREDIT CARD

MONEY ORDER

BY Kase L Miles

Caldwell County Development Application



Date Submitted

9-26-2022

Type of Application

- Preliminary Plat
- Final Plat (New)
- Short Form Final Plat
- Replat
- Subdivision Construction Plans
- Floodplain
- Commercial Development

Application Contacts

1. Owner Information (i.e. Land owner name, address, contact name, phone, email)

GH Wild Plum Forest Lakes LLC
Trevor Dallas (Rep)
3005 Stratford Dr
Austin TX 78746-4650
512-825-6140
dallacts@tpeco.com

2. Applicant Information (i.e. Developer name, address, contact name, phone, email)

same as above

3. Designated Contact (i.e. Person County will coordinate with in regards to comments/approvals. Include name, address, contact name, phone, email)

Trevor Dallas 512-825-6140
dallasts@yahoo.com
Linda Hinkle
512-398-2000
contact@hinklesurveyors.com

4. Consultants (*If applicable)

none

Licensed Professional Engineer*:

none

Registered Professional Land Surveyor*:

Jerry L Hinkle
1109 S Main St
Lockhart TX 78644
512-398-2000
contact@hinklesurveyors.com

Registered Sanitarian*:

none

Geoscientists*:

none

Application Questionnaire

Property Address (or approximate location)

none

Survey Information (Survey/Abstract, Acreage, Recorded Vol/Pg/Instrument):

Wild Plum Estates Lot 3 and 4

Parcel Tax ID Number

Lot 3 (11.008 ac) Lot 4 (11.006 ac)

121662 - 121663
Caldwell County Precinct Number

- Precinct 1
- Precinct 2
- Precinct 3
- Precinct 4

Located in City ETJ:

- Yes, City Name: _____
- No

Anticipated source of water in the development

- Individual Wells
- Rainwater Collection System(s)
- From Groundwater
- From Surface Water
- Water Provider: _____

Anticipated wastewater system in the development

- Standard/Conventional On-Site Sewage Facility
- Advanced On-Site Sewage Facility
- Sewer Provider: _____

Project Description

Subdivision Plat Application Questionnaire

Proposed Name of Subdivision:

Wild Plum Estates replat

If application is for a replat (list reason(s) for the replat)

Redesign lot frontage distances.

Total Acreage of Subject Property

22.014 (11.494 ac - 10.520 ac.)

Total Proposed Residential Lots

2

Total Proposed Commercial Lots

none

Type of Construction

residential

Has Appropriate Application Checklist been attached?

Yes

No

Owner's Certification

I hereby certify that I have given permission for the below applicant to submit this Application and to represent me in all matters affecting said Application. The below individual will be known as the "Applicant"

- Owner Name: GH Wild Plum Forest Lake Phone Number: 512.825.6140
- Applicant Name: Innovor Pallas LLC Phone Number: same
- Owner Email: challengest@yahoo.com
- Owner Signature: Innovor Pallas by [Signature]

Wild Plum
Closure sheet

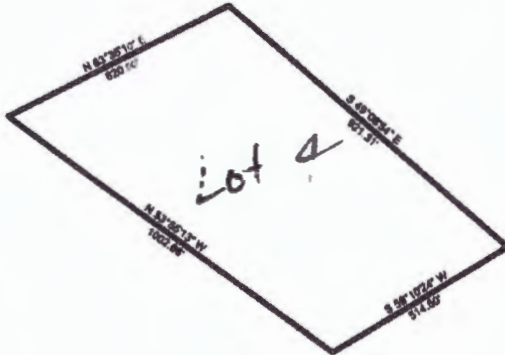

Command:
 Pick point or point number: 2426162.28,13876878.11
 Exit/Curve/Select/<Bearing (Qdd.mmss)>: 453.6513
 Undo/Select/Varas/Meters/Rods/Chains/<Distance(ft)>: 1002.66
 Undo/Exit/Curve/Select/Bearing (Qdd.mmss)<453.5513>: 163.3510
 Undo/Select/Varas/Meters/Rods/Chains/<Distance(ft)>: 620.00
 Undo/Exit/Curve/Select/Bearing (Qdd.mmss)<163.3510>: 249.0854
 Undo/Select/Varas/Meters/Rods/Chains/<Distance(ft)>: 821.31
 Undo/Exit/Curve/Select/Bearing (Qdd.mmss)<249.0854>: 359.1024
 Undo/Select/Varas/Meters/Rods/Chains/<Distance(ft)>: 514.50
 Undo/Exit/Curve/Select/Bearing (Qdd.mmss)<359.1024>: e
 SQ. FEET: 500681 SQ. YARDS: 55631 SQ. MILES: 0
 ACRES: 11.494
 Closure error distance> 0.0028 Error Bearing> N 44°37'36" W
 Closure Precision> 1 in 1102556.8 Total Distance Traversed> 3058.470



Command:
 Pick point or point number: 2428645.38,13872365.75
 Exit/Curve/Select/<Bearing (Qdd.mmss)>: 449.0854
 Undo/Select/Varas/Meters/Rods/Chains/<Distance(ft)>: 821.31
 Undo/Exit/Curve/Select/Bearing (Qdd.mmss)<449.0854>: 163.3510
 Undo/Select/Varas/Meters/Rods/Chains/<Distance(ft)>: 575.83
 Undo/Exit/Curve/Select/Bearing (Qdd.mmss)<163.3510>: 246.1834
 Undo/Select/Varas/Meters/Rods/Chains/<Distance(ft)>: 861.57
 Undo/Exit/Curve/Select/Bearing (Qdd.mmss)<246.1834>: 359.1024
 Undo/Select/Varas/Meters/Rods/Chains/<Distance(ft)>: 514.50
 Undo/Exit/Curve/Select/Bearing (Qdd.mmss)<359.1024>: e
 SQ. FEET: 458247 SQ. YARDS: 50916 SQ. MILES: 0
 ACRES: 10.520
 Closure error distance> 0.0047 Error Bearing> S 68°46'25" E
 Closure Precision> 1 in 614578.1 Total Distance Traversed> 2873.210

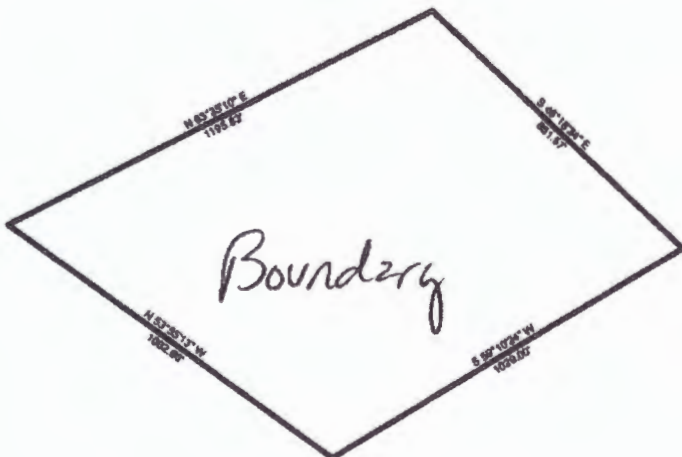

Command: pdd
 Pick point or point number: 2428161.72,13871087.22
 Exit/Curve/Select/<Bearing (Qdd.mmss)>: 453.5513
 Undo/Select/Varas/Meters/Rods/Chains/<Distance(ft)>: 1002.66
 Undo/Exit/Curve/Select/Bearing (Qdd.mmss)<453.5513>: 163.3510
 Undo/Select/Varas/Meters/Rods/Chains/<Distance(ft)>: 1195.83
 Undo/Exit/Curve/Select/Bearing (Qdd.mmss)<163.3510>: 246.1834
 Undo/Select/Varas/Meters/Rods/Chains/<Distance(ft)>: 861.57
 Undo/Exit/Curve/Select/Bearing (Qdd.mmss)<246.1834>: 359.1024
 Undo/Select/Varas/Meters/Rods/Chains/<Distance(ft)>: 1029
 Undo/Exit/Curve/Select/Bearing (Qdd.mmss)<359.1024>: e
 SQ. FEET: 958930 SQ. YARDS: 106548 SQ. MILES: 0
 ACRES: 22.014
 Closure error distance> 0.0024 Error Bearing> N 83°20'0" E
 Closure Precision> 1 in 1685763.9 Total Distance Traversed> 4089.060

Independence Title/GFN 2159717-LKH/LWK

NOTICE OF CONFIDENTIALITY RIGHTS: IF YOU ARE A NATURAL PERSON, YOU MAY REMOVE OR STRIKE ANY OR ALL OF THE FOLLOWING INFORMATION FROM ANY INSTRUMENT THAT TRANSFERS AN INTEREST IN REAL PROPERTY BEFORE IT IS FILED FOR RECORD IN THE PUBLIC RECORDS: YOUR SOCIAL SECURITY NUMBER OR YOUR DRIVER'S LICENSE NUMBER.

GENERAL WARRANTY DEED

Date: October 13, 2021

Grantor: KENNETH D. MURCHISON and LEZLI S. MURCHISON, a married couple

Grantor's Mailing Address:

P. O. Box 66
Giddings, Texas 78942

Grantee: OH WILD PLUM FOREST LAKES LLC

Grantee's Mailing Address:

3005 Stratford Drive
Austin, Texas 78746

Consideration: Cash and other good and valuable consideration, the receipt and sufficiency of which are hereby acknowledged.

Property (including any improvements):

Lots 3 and 4, WILD PLUM ESTATES, according to the map or plat thereof, recorded in Cabinet D, Slide 23, Plat Records, Caldwell County, Texas.

Reservations from Conveyance: For Grantor, and Grantor's successors, a reservation of all of the oil, gas and other minerals owned by Grantor that are in and under the Property or that may be produced from it. The mineral estate does NOT include water, sand, gravel, limestone, building stone, caliche, surface shale, near-surface lignite, and iron, but DOES include the reasonable use of these surface materials for mining, drilling, exploring, operating, developing or removing the oil, gas and other minerals. Grantor does not reserve the implied rights of ingress and egress and the reasonable use of the Property (including surface materials) for mining, drilling, exploring, operating, developing or removing the oil, gas and other minerals.

Exceptions to Conveyance and Warranty: All presently recorded and validly existing instruments, other than conveyances of the surface fee estate, that affect the Property; and taxes for 2021, which Grantee assumes and agrees to pay, and subsequent assessments for that and prior years due to change in land usage, ownership, or both, the payment of which Grantee assumes.

FILED AND RECORDED

Instrument Number: 2021-007539 WARRANTY DEED

Filing and Recording Date: 10/15/2021 11:39:19 AM Pages: 3 Recording Fee: \$30.00

I hereby certify that this instrument was FILED on the date and time stamped hereon and RECORDED in the OFFICIAL PUBLIC RECORDS of Caldwell County, Texas.



Teresa Rodriguez

Teresa Rodriguez, County Clerk
Caldwell County, Texas

ANY PROVISION CONTAINED IN ANY DOCUMENT WHICH RESTRICTS THE SALE, RENTAL, OR USE OF THE REAL PROPERTY DESCRIBED THEREIN BECAUSE OF RACE OR COLOR IS INVALID UNDER FEDERAL LAW AND IS UNENFORCEABLE.

DO NOT REMOVE. THIS PAGE IS PART OF THE OFFICIAL PUBLIC RECORD.

Caldwell CAD

Property Search Results > 121662 GH WILD PLUM FOREST LAKES LLC for Year 2023

Tax Year: 2023 - Values not available

Property

Account

Property ID: 121662 Legal Description: WILD PLUM ESTATES, LOT 3, ACRES 11.008
 Geographic ID: 0201050-000-300-00 Zoning:
 Type: Real Agent Code: 1144
 Property Use Code:
 Property Use Description:

Location

Address: WILD PLUM RD Mapsco: 01-322
 LOCKHART, TX 78644
 Neighborhood: RURAL DALE-LYTTON-NE OF LOCKHART AREA Map ID: 01-322
 Neighborhood CD: 4210

Owner

Name: GH WILD PLUM FOREST LAKES LLC Owner ID: 233926
 Mailing Address: 3005 STRATFORD DR % Ownership: 100.0000000000%
 AUSTIN, TX 78746-4650
 Exemptions:

Values

(+) Improvement Homesite Value:	+	N/A	
(+) Improvement Non-Homesite Value:	+	N/A	
(+) Land Homesite Value:	+	N/A	
(+) Land Non-Homesite Value:	+	N/A	Ag / Timber Use Value
(+) Agricultural Market Valuation:	+	N/A	N/A
(+) Timber Market Valuation:	+	N/A	N/A

(=) Market Value:	=	N/A	
(-) Ag or Timber Use Value Reduction:	-	N/A	

(=) Appraised Value:	=	N/A	
(-) HS Cap:	-	N/A	

(=) Assessed Value:	=	N/A	

Taxing Jurisdiction

Owner: GH WILD PLUM FOREST LAKES LLC
 % Ownership: 100.0000000000%
 Total Value: N/A

Entity	Description	Tax Rate	Appraised Value	Taxable Value	Estimated Tax
CAD	Caldwell Appraisal District	N/A	N/A	N/A	N/A

Issued By:

Caldwell County Appraisal District
211 Bufkin Ln.
P.O. Box 900
Lockhart, TX 78644

Property Information

Property ID: 37016 Geo ID: 0201050-000-200-00
Legal Acres: 38.6650
Legal Desc: A273 SWIFT, ARTHUR, BLOCK A273, ACRES 38 665
Situs: 102 WILD PLUM RD LOCKHART, TX 78644
DBA:
Exemptions:

Owner ID: 45920 100.00%
MURCHISON KENNETH D & LEZLI
PO BOX 66
GIDDINGS, TX 78942-0066

For Entities

Value Information

Caldwell County	Improvement HS	0
Farm to Market Road	Improvement NHS	19,700
Lockhart ISD	Land HS	0
Plum Creek Conservation District	Land NHS	26,870
Plum Creek Underground Water	Productivity Market:	408,120
	Productivity Use	3,280
	Assessed Value	49,830

Property is receiving Ag Use

Current/Delinquent Taxes

This is to certify that, after a careful check of the tax records of this office, the following delinquent taxes, penalties, interest and any known costs and expenses as provided by Tax Code §33.48, are due on the described property for the following taxing unit(s):

Year Entity	Taxable	Tax Due	Disc./P&I	Attorney Fee	Total Due
Totals:		0.00	0.00	0.00	0.00

Effective Date: 09/28/2022

Total Due if paid by: 09/30/2022

0 00



Tax Certificate Issued for:	Taxes Paid in 2021	POSSIBLE ROLLBACK
Lockhart ISD	562 93	
Plum Creek Underground Water	10 38	
Plum Creek Conservation District	10 22	
Farm to Market Road	0 05	
Caldwell County	334 76	

If applicable, the above-described property has/is receiving special appraisal based on its use, and additional rollback taxes may become due based on the provisions of the special appraisal (Comptroller Rule 9.3040) or property omitted from the appraisal roll as described under Tax Code Section 25.21 is not included in this certificate [Tax Code Section 31.08(b)].

Pursuant to Tax Code Section 31.06, if a person transfers property accompanied by a tax certificate that erroneously indicates that no delinquent taxes, penalties or interest are due a taxing unit on the property or that fails to include property because of its omission from an appraisal roll, the unit's tax lien on the property is extinguished and the purchaser of the property is absolved of liability to the unit for delinquent taxes, penalties or interest on the property or for taxes based on omitted property. The person who was liable for the tax for the year the tax was imposed or the property was omitted remains personally liable for the tax and for any penalties or interest.

A tax certificate issued through fraud or collusion is void.

This certificate does not clear abuse of granted exemptions as defined in Section 11.43 Paragraph(1) of the Texas Property Tax Code.

May Be Subject to Court Costs if Suit is Pending

Date of Issue 09/28/2022
Requested By HINKLE SURVEYING
Fee Amount 10 00
Reference #

Signature of Authorized Officer of Collecting Office

12. Discussion/Action regarding the Burn Ban.
Speaker: Judge Haden/ Hector Rangel:
Backup: 3; Cost: None.

Caldwell County Agenda Item Request Form

To: All Elected Officials and Department Heads – Hand deliver or scan & email to hoppy.haden@co.caldwell.tx.us and ezzy.chan@co.caldwell.tx.us . Deadline is 5:00 pm Tuesday before the Regular meetings, however, please submit this completed form ASAP. "Anything missing will cause the Agenda Item to be held over to the next Regular meeting," according to our Rules & Procedures.

AGENDA DATE: 11.08.2022

Type of Agenda Item

Consent Discussion/Action Executive Session Workshop
 Public Hearing

What will be discussed? What is the proposed motion?
regarding the burn ban

1. Costs:

Actual Cost or Estimated Cost \$ None

Is this cost included in the County Budget? _____

Is a Budget Amendment being proposed? _____

2. Agenda Speakers:

	Name	Representing	Title
--	------	--------------	-------

(1) Judge Haden

(2) _____

(3) _____

3. Backup Materials: None To Be Distributed _____ total # of backup pages
(including this page)

4. 
Signature of Court Member

Date 10/28/2022

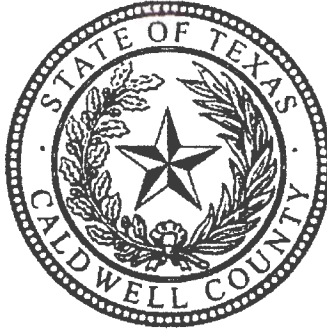

**CALDWELL COUNTY, TEXAS
DECLARATION OF LOCAL DISASTER
PROHIBITION OF OUTDOOR BURNING**

WHEREAS, Section §418.108 of the Local Government Code provides that the County Judge can declare a slate of Local Disaster within the county) and order, may prohibit outdoor burning in the unincorporated area of the county when he finds that circumstances present in all or part of the unincorporated area of the county create a public safety hazard that would be exacerbated by outdoor burning and,

WHEREAS, the County Judge does find that circumstances present in all of the unincorporated area of the county create a public safety hazard that could be exacerbated by outdoor burning;

BE IT THEREFORE ORDERED, that the following emergency regulations are hereby established for all unincorporated areas of Caldwell County, Texas that are not subject to public ownership or stewardship for the duration of the above mentioned declaration:

- I. Action Prohibited:
 - (a) A person violates this order if he/she burns a combustible material outside of an enclosure, which serves to contain all flame and/or sparks, or orders such burning by others.
 - (b) A person violates this order if he /she engages in any activity outdoors which could allow flames or sparks that could result in a fire, unless done in an enclosure designed to protect the spread of fire, or orders such activities by others.

2. Enforcement:
 - (a) Upon notification of suspected outdoor burning the fire department assigned shall respond to the scene and take immediate measures to contain or extinguish the fire.
 - (b) If requested by a fire official, a duly commissioned peace officer, when available, shall be notified and sent to the scene to investigate the nature of the fire.
 - (c) If, in the opinion of the officer investigating and the fire official, the goal of this order can be obtained by informing the responsible party about the prohibitions established by this order the officer may at his discretion notify the party about the provisions of this order and request compliance with it, or issue a citation for: **Violation of Bum Ban Order.**
Therefore it is in accordance with Local Government Code 352.08 I, a violation of this order is a class C Misdemeanor, punishable by a fine not to exceed \$500.00.

3. This Order does not prohibit prescribed fire(s) conducted in compliance with guidelines set forth by federal or state natural resource agencies and conducted by a prescribed burn manager certified under Section 153.048 Natural Resources Code, and meets the standards of Section 153.047, Natural Resources Code, burned under a burn plan approved by such agencies, or outdoor burning activities related to public health and safety that are authorized by the Texas Commission on Environmental Quality for:
- (a) Firefighter training
 - (b) Public utility, natural gas pipeline or mining operations
 - (c) Planting or harvesting of agricultural crops

IT IS FURTHER ORDERED that an exemption be hereby granted for a bona fide commercial land clearing business, allowing said business to burn as long as all other provisions of the Order and applicable laws and ordinances are adhered to as set forth herein, and contact is made and the burning approved by the Caldwell County Emergency Management Coordinator at 1403 Blackjack St. Lockhart, TX at phone Number 512-398-1822, and receiving permission, prior to any outdoor burning.

IT IS FURTHER ORDERED that an exemption be hereby granted to those businesses where welding is an essential function of the business, allowing welding operations to proceed as long as the area of welding operations has been cleared of vegetation for a distance of no less than ten (10) feet in all directions, that there be a second capable person acting as a fire spotter with a sufficient water source available to extinguish fires which may be ignited from stray sparks, and only when all other provisions of the Order and applicable laws and ordinances are adhered to as set forth herein.

BE IT ALSO ORDERED, that the purpose of this order is the mitigation of the hazard posed by wildfire during the term of the dry, weather by curtailing outdoor burning; which purpose is to be taken into account in any enforcement action based upon this order.

This order will remain in effect for a period of 14 days, and shall expire at the end of said period.

IN WITNESS WHEREOF, I AFFIX MY SIGNATURE this, the 8th day of November 2022.

Hoppy Haden, County Judge

ATTEST:

Teresa Rodriguez
County Clerk

13. Discussion/Action to consider the approval of Resolution 1-2023, for Caldwell County Appraisal Roll with tax amounts entered by the assessor due totaling \$4,299.43 for the Farm to Market Road 2022 Tax Roll. **Speaker: Judge Haden; Backup: 9; Cost: None.**

Caldwell County Agenda Item Request Form

To: All Elected Officials and Department Heads – Hand deliver or scan & email to hopy.haden@co.caldwell.tx.us and ezzy.chan@co.caldwell.tx.us . Deadline is 5:00 pm Tuesday before the Regular meetings, however, please submit this completed form ASAP. “Anything missing will cause the Agenda Item to be held over to the next Regular meeting,” according to our Rules & Procedures.

AGENDA DATE: 11.08.2022

Type of Agenda Item

- Consent Discussion/Action Executive Session Workshop
 Public Hearing

What will be discussed? What is the proposed motion?

to consider Resolution 1-2023, for Farm to Market Road Appraisal roll with tax amounts entered by the assessor due totaling \$4,299.43 for the Farm to Market Road 2022 Tax Roll.

1. Costs:

Actual Cost or **Estimated Cost** \$ _____

Is this cost included in the County Budget? _____

Is a Budget Amendment being proposed? _____

2. Agenda Speakers:

	Name	Representing	Title
--	------	--------------	-------

(1) Judge Haden _____

(2) _____

(3) _____

3. Backup Materials: None To Be Distributed 9 total # of backup pages
(including this page)

4.  _____
Signature of Court Member

10/26/2022 _____
Date



**Resolution
01-2023**

**RESOLUTION APPROVING FARM TO MARKET ROAD APPRAISAL
ROLL**

WHEREAS, Section 26.09 of the Property Tax Code requires approval by the Commissioners Court of the Farm to Market Road appraisal roll with tax amounts entered by the assessor, for the tax year 2022; and

WHEREAS, such roll was presented to the Caldwell County Commissioners Court on the **8th day of November, 2022** and appears in all things correct as under the applicable laws of Texas; and

WHEREAS, said Commissioners Court voted in open session to approve said roll.

IT IS HEREBY RESOLVED by the Caldwell County Commissioners Court that the appraisal roll with amounts due totaling \$4,299.43 for the year 2022 is approved and is the tax roll for the Farm to Market Road for the year 2022.

Hoppy Haden
Caldwell County Judge

B.J. Westmoreland
Commissioner, Precinct 1

Barbara Shelton
Commissioner, Precinct 2

Ed Theriot
Commissioner, Precinct 3

Joe Ivan Roland
Commissioner, Precinct 4

ATTEST:

Teresa Rodriguez
Caldwell County Clerk

Caldwell County Appraisal District

10/14/22

Farm to Market Road
County Judge
110 S. Main, Room 201
Lockhart TX 78644

RE: Resolution for 2022 tax roll

I have enclosed for your use a resolution to be used for approval of the 2022 tax roll, along with a copy of the totals from the tax roll. The resolution should be adopted at the next meeting of your governing body as formal approval of the 2022 tax roll.

If you have any questions, please feel free to contact me at (512) 398-5550 ext #207.

Thank you,



Shanna Ramzinski
Chief Appraiser

Encl: Resolution
Levy Totals



211 Bufkin Ln
P.O. Box 900
Lockhart, Texas 78644
United States

PHONE (512) 398-5550
FAX (512) 398-5551
E-MAIL general@caldwellcad.org
WEB SITE www.caldwellcad.org

2022 LEVY TOTALS

FTM - Farm to Market Road

Property Count: 45,696

10/11/2022 12:37:32PM

Land		Value			
Homesite:		548,641,283			
Non Homesite:		1,193,007,322			
Ag Market:		2,519,725,760			
Timber Market:		1,152,330	Total Land	(+) 4,262,526,695	
Improvement		Value			
Homesite:		1,559,137,388			
Non Homesite:		1,474,549,909	Total Improvements	(+) 3,033,687,297	
Non Real		Count	Value		
Personal Property:	2,294		434,303,520		
Mineral Property:	17,595		122,353,211		
Autos:	0		0	Total Non Real	(+) 556,656,731
				Market Value	= 7,852,870,723
Ag		Non Exempt	Exempt		
Total Productivity Market:	2,498,078,730		22,799,360	Productivity Loss	(-) 2,473,907,334
Ag Use:	24,154,246		150,580	Appraised Value	= 5,378,963,389
Timber Use:	17,150		0	Homestead Cap	(-) 462,425,671
Productivity Loss:	2,473,907,334		22,648,780	Assessed Value	= 4,916,537,718
				Total Exemptions Amount (Breakdown on Next Page)	(-) 479,429,551
				Net Taxable	= 4,437,108,167

Freeze	Assessed	Taxable	Actual Tax	Celling	Count			
DP	48,807,148	43,618,599	33.51	52.81	381			
DPS	427,353	421,353	0.28	0.50	3			
OV65	578,851,644	529,411,163	403.35	657.99	3,312			
Total	628,086,145	573,451,115	437.14	711.30	3,696	Freeze Taxable	(-) 573,451,115	
Tax Rate	0.0001000							
						Freeze Adjusted Taxable	= 3,863,657,052	

Levy Info				
M&O Rate:	0.0001000	M&O Tax:	4,297.33	
I&S Rate:	0.0000000	I&S Tax:	0.00	
Protected I&S Rate:	0.0000000	Protected I&S Tax:	0.00	
		Ag Penalty:	2.10	
		PP Late Penalty:	0.00	
		Late Correction Penalty:	0.01	
			Total Levy	4,299.43
Tax Increment Finance Value:				0
Tax Increment Finance Levy:				0.00

2022 LEVY TOTALS

FTM - Farm to Market Road

Property Count: 45,696

10/11/2022

12:37:48PM

Exemption Breakdown

Exemption	Count	Local	State	Total
DP	402	0	0	0
DPS	3	0	0	0
DV1	70	0	617,583	617,583
DV1S	3	0	15,000	15,000
DV2	59	0	506,420	506,420
DV2S	1	0	7,500	7,500
DV3	67	0	627,200	627,200
DV3S	1	0	0	0
DV4	251	0	2,028,854	2,028,854
DV4S	10	0	103,029	103,029
DVHS	214	0	55,182,552	55,182,552
DVHSS	1	0	182,790	182,790
EX	25	0	6,181,890	6,181,890
EX-XF	6	0	5,006,380	5,006,380
EX-XG	6	0	3,909,620	3,909,620
EX-XL	13	0	2,534,650	2,534,650
EX-XN	1	0	1,082,400	1,082,400
EX-XR	59	0	10,907,800	10,907,800
EX-XU	4	0	1,709,660	1,709,660
EX-XU (Prorated)	1	0	58,231	58,231
EX-XV	648	0	339,916,602	339,916,602
EX-XV (Prorated)	1	0	42,220	42,220
EX366	5,024	0	552,515	552,515
FR	2	616,010	0	616,010
HS	8,171	0	12,889,331	12,889,331
HT	2	0	0	0
OV65	3,556	33,216,194	0	33,216,194
OV65S	19	169,667	0	169,667
PC	3	344,852	0	344,852
SO	71	1,020,601	0	1,020,601
Totals		35,367,324	444,062,227	479,429,551

2022 LEVY TOTALS

FTM - Farm to Market Road
Under ARB Review Totals

Property Count: 13

10/11/2022 12:37:32PM

Land		Value			
Homesite:		403,530			
Non Homesite:		867,130			
Ag Market:		0			
Timber Market:		0	Total Land	(+) 1,270,660	
Improvement		Value			
Homesite:		907,820			
Non Homesite:		797,960	Total Improvements	(+) 1,705,780	
Non Real		Count	Value		
Personal Property:	0		0		
Mineral Property:	0		0		
Autos:	0		0	Total Non Real	(+) 0
			Market Value	= 2,976,440	
Ag		Non Exempt	Exempt		
Total Productivity Market:	0		0		
Ag Use:	0		0	Productivity Loss	(-) 0
Timber Use:	0		0	Appraised Value	= 2,976,440
Productivity Loss:	0		0	Homestead Cap	(-) 320,480
			Assessed Value	= 2,655,960	
			Total Exemptions Amount (Breakdown on Next Page)	(-) 9,000	
			Net Taxable	= 2,646,960	

Freeze	Assessed	Taxable	Actual Tax	Ceiling	Count			
DP	117,099	114,099	0.10	0.10	1			
Total	117,099	114,099	0.10	0.10	1	Freeze Taxable	(-) 114,099	
Tax Rate	0.0001000							
						Freeze Adjusted Taxable	= 2,532,861	

Tax Increment Finance Value: 0
Tax Increment Finance Levy: 0.00

2022 LEVY TOTALS

FTM - Farm to Market Road
Under ARB Review Totals

Property Count: 13

10/11/2022

12:37:48PM

Exemption Breakdown

Exemption	Count	Local	State	Total
DP	1	0	0	0
HS	3	0	9,000	9,000
	Totals	0	9,000	9,000

2022 LEVY TOTALS

FTM - Farm to Market Road
Grand Totals

Property Count: 45,709

10/11/2022 12:37:32PM

Land		Value			
Homesite:		549,044,813			
Non Homesite:		1,193,874,452			
Ag Market:		2,519,725,760			
Timber Market:		1,152,330	Total Land	(+) 4,263,797,355	
Improvement		Value			
Homesite:		1,560,045,208			
Non Homesite:		1,475,347,869	Total Improvements	(+) 3,035,393,077	
Non Real		Count	Value		
Personal Property:	2,294		434,303,520		
Mineral Property:	17,595		122,353,211		
Autos:	0		0	Total Non Real	(+) 556,656,731
				Market Value	= 7,855,847,163
Ag		Non Exempt	Exempt		
Total Productivity Market:	2,498,078,730		22,799,360	Productivity Loss	(-) 2,473,907,334
Ag Use:	24,154,246		150,580	Appraised Value	= 5,381,939,829
Timber Use:	17,150		0	Homestead Cap	(-) 462,746,151
Productivity Loss:	2,473,907,334		22,648,780	Assessed Value	= 4,919,193,678
				Total Exemptions Amount (Breakdown on Next Page)	(-) 479,438,551
				Net Taxable	= 4,439,755,127

Freeze	Assessed	Taxable	Actual Tax	Celling	Count		
DP	48,924,247	43,732,698	33.61	52.91	382		
DPS	427,353	421,353	0.28	0.50	3		
OV65	578,851,644	529,411,163	403.35	657.99	3,312		
Total	628,203,244	573,565,214	437.24	711.40	3,697	Freeze Taxable	(-) 573,565,214
Tax Rate	0.0001000						
						Freeze Adjusted Taxable	= 3,866,189,913

Levy Info				
M&O Rate:	0.0001000	M&O Tax:	4,297.33	
I&S Rate:	0.0000000	I&S Tax:	0.00	
Protected I&S Rate:	0.0000000	Protected I&S Tax:	0.00	
		Ag Penalty:	2.10	
		PP Late Penalty:	0.00	
		Late Correction Penalty:	0.01	
			Total Levy	4,299.43
Tax Increment Finance Value:	0			
Tax Increment Finance Levy:	0.00			

2022 LEVY TOTALSFTM - Farm to Market Road
Grand Totals

Property Count: 45,709

10/11/2022

12:37:48PM

Exemption Breakdown

Exemption	Count	Local	State	Total
DP	403	0	0	0
DPS	3	0	0	0
DV1	70	0	617,583	617,583
DV1S	3	0	15,000	15,000
DV2	59	0	506,420	506,420
DV2S	1	0	7,500	7,500
DV3	67	0	627,200	627,200
DV3S	1	0	0	0
DV4	251	0	2,028,854	2,028,854
DV4S	10	0	103,029	103,029
DVHS	214	0	55,182,552	55,182,552
DVHSS	1	0	182,790	182,790
EX	25	0	6,181,890	6,181,890
EX-XF	6	0	5,006,380	5,006,380
EX-XG	6	0	3,909,620	3,909,620
EX-XL	13	0	2,534,650	2,534,650
EX-XN	1	0	1,082,400	1,082,400
EX-XR	59	0	10,907,800	10,907,800
EX-XU	4	0	1,709,660	1,709,660
EX-XU (Prorated)	1	0	58,231	58,231
EX-XV	648	0	339,916,602	339,916,602
EX-XV (Prorated)	1	0	42,220	42,220
EX366	5,024	0	552,515	552,515
FR	2	616,010	0	616,010
HS	8,174	0	12,898,331	12,898,331
HT	2	0	0	0
OV65	3,556	33,216,194	0	33,216,194
OV65S	19	169,667	0	169,667
PC	3	344,852	0	344,852
SO	71	1,020,601	0	1,020,601
Totals		35,367,324	444,071,227	479,438,551

14. Discussion/Action to consider the approval of Resolution 2-2023, for Caldwell County Appraisal Roll with tax amounts entered by the assessor due totaling \$4,027,943.56 for the 2022 Tax Roll. **Speaker: Judge Haden; Backup: 9; Cost: None.**

Caldwell County Agenda Item Request Form

To: All Elected Officials and Department Heads – Hand deliver or scan & email to hoppy.haden@co.caldwell.tx.us and ezzy.chan@co.caldwell.tx.us . Deadline is 5:00 pm Tuesday before the Regular meetings, however, please submit this completed form ASAP. "Anything missing will cause the Agenda Item to be held over to the next Regular meeting," according to our Rules & Procedures.

AGENDA DATE: 11.08.2022

Type of Agenda Item

- Consent Discussion/Action Executive Session Workshop
 Public Hearing

What will be discussed? What is the proposed motion?

to consider Resolution 2-2023, for Caldwell County Appraisal roll. with tax amounts entered by the assessor due totaling \$4,027,943.56 for the 2022 Tax Roll.

1. Costs:

Actual Cost or Estimated Cost \$ None

Is this cost included in the County Budget? _____

Is a Budget Amendment being proposed? _____

2. Agenda Speakers:

	Name	Representing	Title
--	------	--------------	-------

(1) Judge Haden

(2) _____

(3) _____

3. Backup Materials: None To Be Distributed 9 total # of backup pages
(including this page)

4. 
Signature of Court Member

10/26/2022
Date



RESOLUTION 2-2023

RESOLUTION OF CALDWELL COUNTY COMMISSIONERS COURT

WHEREAS, Section 26.09 of the Property Tax Code requires approval by the Commissioners Court of the Caldwell County appraisal roll with tax amounts entered by the assessor, for the tax year 2022, and,

WHEREAS, such roll was presented to the Caldwell County on the **8th day of November 2022**, and appears in all things correct as under the applicable laws of Texas, and

WHEREAS, said Commissioners Court voted in open session to approve said roll.

IT IS HEREBY RESOLVED by the Caldwell County that the appraisal roll with amounts due totaling \$4,027,943.56 for the year 2022 is approved and is the tax roll for the Caldwell County for the year 2022.

Hoppy Haden
Caldwell County Judge

B.J. Westmoreland
Commissioner, Precinct 1

Barbara Shelton
Commissioner, Precinct 2

Ed Theriot
Commissioner, Precinct 3

Joe Ivan Roland
Commissioner, Precinct 4

ATTEST:

Teresa Rodriguez
Caldwell County Clerk

Caldwell County Appraisal District

10/14/22

Caldwell County
County Judge
110 S. Main, Room 201
Lockhart TX 78644

RE: Resolution for 2022 tax roll

I have enclosed for your use a resolution to be used for approval of the 2022 tax roll, along with a copy of the totals from the tax roll. The resolution should be adopted at the next meeting of your governing body as formal approval of the 2022 tax roll.

If you have any questions, please feel free to contact me at (512) 398-5550 ext #207.

Thank you,

Shanna Ramzinski
Chief Appraiser

Encl: Resolution
Levy Totals



211 Bufkin Ln
P.O. Box 900
Lockhart, Texas 78644
United States

PHONE (512) 398-5550
FAX (512) 398-5551
E-MAIL general@caldwellcad.org
WEB SITE www.caldwellcad.org

2022 LEVY TOTALS

GCA - Caldwell County

Property Count: 45,696

10/11/2022 12:37:32PM

Land		Value			
Homesite:		548,641,283			
Non Homesite:		1,193,007,322			
Ag Market:		2,519,725,760			
Timber Market:		1,152,330	Total Land	(+)	
				4,262,526,695	
Improvement		Value			
Homesite:		1,559,137,388			
Non Homesite:		1,474,419,681	Total Improvements	(+)	
				3,033,557,069	
Non Real		Count	Value		
Personal Property:	2,295		440,104,220		
Mineral Property:	17,595		122,353,211		
Autos:	0		0	Total Non Real	(+)
				Market Value	=
					562,457,431
					7,858,541,195
Ag		Non Exempt	Exempt		
Total Productivity Market:	2,498,078,730		22,799,360	Productivity Loss	(-)
Ag Use:	24,154,246		150,580	Appraised Value	=
Timber Use:	17,150		0		5,384,633,861
Productivity Loss:	2,473,907,334		22,648,780	Homestead Cap	(-)
				Assessed Value	=
					4,922,208,190
				Total Exemptions Amount	(-)
				(Breakdown on Next Page)	466,737,225
				Net Taxable	=
					4,455,470,965

Freeze	Assessed	Taxable	Actual Tax	Ceiling	Count			
DP	48,807,148	44,599,630	205,196.55	218,005.38	381			
DPS	427,353	427,353	1,846.92	1,846.92	3			
OV65	578,851,644	529,400,318	2,328,516.46	2,397,773.97	3,312			
Total	628,086,145	574,427,301	2,535,559.93	2,617,626.27	3,696	Freeze Taxable	(-)	
Tax Rate	0.5531000							574,427,301
						Freeze Adjusted Taxable	=	
							3,881,043,664	

Levy Info				
M&O Rate:	0.5176000	M&O Tax:	22,474,877.15	
I&S Rate:	0.0355000	I&S Tax:	1,541,456.30	
Protected I&S Rate:	0.0000000	Protected I&S Tax:	0.00	
		Ag Penalty:	11,610.11	
		PP Late Penalty:	0.00	
		Late Correction Penalty:	28.20	
			Total Levy	24,027,943.56
Tax Increment Finance Value:			0	
Tax Increment Finance Levy:			0.00	

2022 LEVY TOTALS

GCA - Caldwell County

Property Count: 45,696

10/11/2022

12:37:48PM

Exemption Breakdown

Exemption	Count	Local	State	Total
DP	402	0	0	0
DPS	3	0	0	0
DV1	70	0	621,728	621,728
DV1S	3	0	15,000	15,000
DV2	59	0	506,420	506,420
DV2S	1	0	7,500	7,500
DV3	67	0	627,200	627,200
DV3S	1	0	0	0
DV4	251	0	2,034,285	2,034,285
DV4S	10	0	103,029	103,029
DVHS	214	0	56,120,100	56,120,100
DVHSS	1	0	185,790	185,790
EX	25	0	6,181,890	6,181,890
EX-XF	6	0	5,006,380	5,006,380
EX-XG	6	0	3,909,620	3,909,620
EX-XL	13	0	2,534,650	2,534,650
EX-XN	1	0	1,082,400	1,082,400
EX-XR	59	0	10,907,800	10,907,800
EX-XU	4	0	1,709,660	1,709,660
EX-XU (Prorated)	1	0	58,231	58,231
EX-XV	648	0	339,916,602	339,916,602
EX-XV (Prorated)	1	0	42,220	42,220
EX366	5,024	0	552,515	552,515
FR	2	616,010	0	616,010
HT	2	0	0	0
OV65	3,556	32,463,075	0	32,463,075
OV65S	19	169,667	0	169,667
PC	3	344,852	0	344,852
SO	71	1,020,601	0	1,020,601
Totals		34,614,205	432,123,020	466,737,225

2022 LEVY TOTALS

GCA - Caldwell County
Under ARB Review Totals

Property Count: 13

10/11/2022 12:37:32PM

Land	Value			
Homesite:	403,530			
Non Homesite:	867,130			
Ag Market:	0			
Timber Market:	0	Total Land	(+)	1,270,660

Improvement	Value			
Homesite:	907,820			
Non Homesite:	797,960	Total Improvements	(+)	1,705,780

Non Real	Count	Value		
Personal Property:	0	0		
Mineral Property:	0	0		
Autos:	0	0	Total Non Real	(+)
			Market Value	=
				0
				2,976,440

Ag	Non Exempt	Exempt		
Total Productivity Market:	0	0		
Ag Use:	0	0	Productivity Loss	(-)
Timber Use:	0	0	Appraised Value	=
Productivity Loss:	0	0		0
			Homestead Cap	(-)
				320,480
			Assessed Value	=
				2,655,960
			Total Exemptions Amount (Breakdown on Next Page)	(-)
				0
			Net Taxable	=
				2,655,960

Freeze	Assessed	Taxable	Actual Tax	Ceiling	Count		
DP	117,099	117,099	647.67	647.67	1		
Total	117,099	117,099	647.67	647.67	1	Freeze Taxable	(-)
Tax Rate	0.5531000						

Freeze Adjusted Taxable = 2,538,861

Tax Increment Finance Value: 0
 Tax Increment Finance Levy: 0.00

2022 LEVY TOTALS

Exemption Breakdown

Exemption	Count	Local	State	Total
DP	1	0	0	0
Totals		0	0	0

2022 LEVY TOTALS

GCA - Caldwell County
Grand Totals

Property Count: 45,709

10/11/2022 12:37:32PM

Land		Value			
Homesite:		549,044,813			
Non Homesite:		1,193,874,452			
Ag Market:		2,519,725,760			
Timber Market:		1,152,330	Total Land	(+) 4,263,797,355	
Improvement		Value			
Homesite:		1,560,045,208			
Non Homesite:		1,475,217,641	Total Improvements	(+) 3,035,262,849	
Non Real		Count	Value		
Personal Property:	2,295		440,104,220		
Mineral Property:	17,595		122,353,211		
Autos:	0		0	Total Non Real	(+) 562,457,431
				Market Value	= 7,861,517,635
Ag		Non Exempt	Exempt		
Total Productivity Market:	2,498,078,730		22,799,360	Productivity Loss	(-) 2,473,907,334
Ag Use:	24,154,246		150,580	Appraised Value	= 5,387,610,301
Timber Use:	17,150		0	Homestead Cap	(-) 462,746,151
Productivity Loss:	2,473,907,334		22,648,780	Assessed Value	= 4,924,864,150
				Total Exemptions Amount (Breakdown on Next Page)	(-) 466,737,225
				Net Taxable	= 4,458,126,925

Freeze	Assessed	Taxable	Actual Tax	Celling	Count		
DP	48,924,247	44,716,729	205,844.22	218,653.05	382		
DPS	427,353	427,353	1,846.92	1,846.92	3		
OV65	578,851,644	529,400,318	2,328,516.46	2,397,773.97	3,312		
Total	628,203,244	574,544,400	2,536,207.60	2,618,273.94	3,697	Freeze Taxable	(-) 574,544,400
Tax Rate	0.5531000						
						Freeze Adjusted Taxable	= 3,883,582,525

Levy Info				
M&O Rate:	0.5176000	M&O Tax:	22,474,877.15	
I&S Rate:	0.0355000	I&S Tax:	1,541,456.30	
Protected I&S Rate:	0.0000000	Protected I&S Tax:	0.00	
		Ag Penalty:	11,610.11	
		PP Late Penalty:	0.00	
		Late Correction Penalty:	28.20	
			Total Levy	24,027,943.56
Tax Increment Finance Value:				0
Tax Increment Finance Levy:				0.00

2022 LEVY TOTALS**Exemption Breakdown**

Exemption	Count	Local	State	Total
DP	403	0	0	0
DPS	3	0	0	0
DV1	70	0	621,728	621,728
DV1S	3	0	15,000	15,000
DV2	59	0	506,420	506,420
DV2S	1	0	7,500	7,500
DV3	67	0	627,200	627,200
DV3S	1	0	0	0
DV4	251	0	2,034,285	2,034,285
DV4S	10	0	103,029	103,029
DVHS	214	0	56,120,100	56,120,100
DVHSS	1	0	185,790	185,790
EX	25	0	6,181,890	6,181,890
EX-XF	6	0	5,006,380	5,006,380
EX-XG	6	0	3,909,620	3,909,620
EX-XL	13	0	2,534,650	2,534,650
EX-XN	1	0	1,082,400	1,082,400
EX-XR	59	0	10,907,800	10,907,800
EX-XU	4	0	1,709,660	1,709,660
EX-XU (Prorated)	1	0	58,231	58,231
EX-XV	648	0	339,916,602	339,916,602
EX-XV (Prorated)	1	0	42,220	42,220
EX366	5,024	0	552,515	552,515
FR	2	616,010	0	616,010
HT	2	0	0	0
OV65	3,556	32,463,075	0	32,463,075
OV65S	19	169,667	0	169,667
PC	3	344,852	0	344,852
SO	71	1,020,601	0	1,020,601
Totals		34,614,205	432,123,202	466,737,225

15. Discussion/Action to consider the approval to reappoint Will Conley and Commissioner Ed Theriot to the 2023 CAMPO Technical Advisory Committee (TAC). **Speaker: Judge Haden; Backup: 4; Cost: None.**

Caldwell County Agenda Item Request Form

To: All Elected Officials and Department Heads – Hand deliver or scan & email to hoppy.haden@co.caldwell.tx.us and ezzy.chan@co.caldwell.tx.us . Deadline is 5:00 pm Tuesday before the Regular meetings, however, please submit this completed form ASAP. "Anything missing will cause the Agenda Item to be held over to the next Regular meeting," according to our Rules & Procedures.

AGENDA DATE: 11.08.2022

Type of Agenda Item

- Consent Discussion/Action Executive Session Workshop
 Public Hearing

What will be discussed? What is the proposed motion?

to consider the approval to reappointment Will Conley and Commissioner Theriot to the 2023 CAMPO Technical Advisory Committee (TAC)

1. Costs:

Actual Cost or **Estimated Cost** \$ None

Is this cost included in the County Budget? _____

Is a Budget Amendment being proposed? _____

2. Agenda Speakers:

	Name	Representing	Title

(1) Judge Haden _____

(2) _____

(3) _____

3. Backup Materials: None To Be Distributed 4 total # of backup pages
(including this page)

4.  _____
Signature of Court Member

Date 11/1/2022



2022 TECHNICAL ADVISORY COMMITTEE

City of Austin

Richard Mendoza - *Primary Member*
Eric Bollich, P.E., PTOE - *Alternate*

Cole Kitten - *Primary Member*
Kelsey Vizzard - *Alternate*

Stevie Greathouse - *Primary Member*
Erica Leak - *Alternate*

City of Cedar Park

Tom Gdala - *Primary Member*
Randall Lueders - *Alternate*

City of Georgetown

Nick Woolery - *Primary Member*
(Vacant) - *Alternate*

City of Kyle

Jeff Prato - *Primary Member*
Leon Barba - *Alternate*

City of Leander

Ross Blackketter - *Primary Member*
Sarvesh Dhakal - *Alternate*

City of Pflugerville

Emily Barron - *Primary Member*
(Vacant) - *Alternate*

City of Round Rock

Gary Hudder - *Vice Chair*
Gerald Pohlmeier - *Alternate*

City of San Marcos

Laurie Moyer, P.E. - *Chair*
Rohit Vij - *Alternate*

Capital Metro

Sharmila Mukherjee - *Primary Member*
Nadia Barrera-Ramirez - *Alternate*

Capital Area Rural Transportation System

David Marsh - *Primary Member*
Ed Collins - *Alternate*

Central Texas Regional Mobility Authority

Mike Sexton, P.E. - *Primary Member*
Oscar Solis, P.E. - *Alternate*

Texas Department of Transportation

Heather Ashley-Nguyen, P.E. - *Primary Member*
Akila Thamizharasan - *Alternate*

Bastrop County

Aimee Robertson - *Primary Member*
Robert Pugh, P.E. - *Alternate*

Bastrop County (Smaller Cities)

David Harrell - *Primary Member*
Trey Job - *Alternate*

Burnet County

Greg Haley, P.E. - *Primary Member*
Herb Darling - *Alternate*

Burnet County (Smaller Cities)

Mike Hodge, P.E. - *Primary Member*
Caleb Kraenzel - *Alternate*

Caldwell County

Will Conley - *Primary Member*
Commissioner Ed Theriot - *Alternate*

Caldwell County (Smaller Cities)

David Fowler, AICP - *Primary Member*

John Westbrook - *Alternate*

Hays County

Jerry Borcharding - *Primary Member*

Winton Porterfield - *Alternate*

Hays County (Smaller Cities)

John Nett - *Primary Member*

Chad Gilpin - *Alternate*

Travis County

Charlie Watts - *Primary Member*

Scheleen Walker - *Alternate*

Travis County (Smaller Cities)

Cathy Stephens - *Primary Member*

Melissa Zone - *Alternate*

Williamson County

Bob Daigh, P.E. - *Primary Member*

Terron Evertson - *Alternate*

Williamson County (Smaller Cities)

Tom Yantis - *Primary Member*

(Vacant) - *Alternate*



**2023 APPOINTMENT TO THE
TECHNICAL ADVISORY COMMITTEE**

PRIMARY VOTING MEMBER:

*Name: _____

*Title: _____

*Organization: _____

*Representing: _____

*Address: _____

*Phone: _____

*Email: _____

*Term Expiration: January 31, 2024 _____

ALTERNATE VOTING MEMBER:

*Name: _____

*Title: _____

*Organization: _____

*Representing: _____

*Address: _____

*Phone: _____

*Email: _____

*Term Expiration: January 31, 2024 _____

Return to: Kimberly Petty, Executive Assistant
CAMPO
3300 N. IH-35, Suite 630
Austin, Texas 78705
kimberly.petty@campotexas.org

Signature of Appointing Official

***DEADLINE FOR COMPLETED FORM - DECEMBER 16, 2022**

16. Discussion/Action to consider the approval to authorize the County Judge to enter into lease negotiations with Aqua Water Supply Corporation for office space located at 2990 FM 1185, Lockhart, TX. **Speaker: Judge Haden; Backup: 1; Cost: TBD.**

Caldwell County Agenda Item Request Form

To: All Elected Officials and Department Heads – Hand deliver or scan & email to hoppy.haden@co.caldwell.tx.us and ezzy.chan@co.caldwell.tx.us . Deadline is 5:00 pm Tuesday before the Regular meetings, however, please submit this completed form ASAP. "Anything missing will cause the Agenda Item to be held over to the next Regular meeting," according to our Rules & Procedures.

AGENDA DATE: 11.08.2022

Type of Agenda Item

- Consent Discussion/Action Executive Session Workshop
 Public Hearing

What will be discussed? What is the proposed motion?

to consider the approval to authorize the County Judge to enter into lease negotiations with Aqua Water Supply Corporation for office space located at 2990 FM 1185, Lockhart, Texas

1. Costs:

Actual Cost or **Estimated Cost** \$ None

Is this cost included in the County Budget? _____

Is a Budget Amendment being proposed? _____

2. Agenda Speakers:

	Name	Representing	Title
--	------	--------------	-------

(1) Judge Haden

(2) _____

(3) _____

3. Backup Materials: None To Be Distributed _____ total # of backup pages
(including this page)

4. 
Signature of Court Member

10/28/2022
Date

17. Discussion/Action to consider the approval on implementing an inspection fee for mass gathering permits as permitted under Texas Health and Safety Code 751.013. **Speaker: Judge Haden; Backup: 8; Cost: None.**

Caldwell County Agenda Item Request Form

To: All Elected Officials and Department Heads – Hand deliver or scan & email to hopy.haden@co.caldwell.tx.us and ezzy.chan@co.caldwell.tx.us . Deadline is 5:00 pm Tuesday before the Regular meetings, however, please submit this completed form ASAP. “Anything missing will cause the Agenda Item to be held over to the next Regular meeting,” according to our Rules & Procedures.

AGENDA DATE: 11/8/2022

Type of Agenda Item

- Consent Discussion/Action Executive Session Workshop
 Public Hearing

What will be discussed? What is the proposed motion?

Implementing an inspection fee for mass gathering permits as permitted under Texas Health and Safety Code 751.013.

1. Costs:

Actual Cost or **Estimated Cost** \$ 0.00

Is this cost included in the County Budget? _____

Is a Budget Amendment being proposed? _____

2. Agenda Speakers:

	Name	Representing	Title
--	------	--------------	-------

(1) Judge Haden _____

(2) _____

(3) _____

3. Backup Materials: None To Be Distributed 8 total # of backup pages
(including this page)

4. 

Signature of Court Member

Date 11/28/2022

HEALTH AND SAFETY CODE

TITLE 9. SAFETY

SUBTITLE A. PUBLIC SAFETY

CHAPTER 751. MASS GATHERINGS

Sec. 751.001. SHORT TITLE. This chapter may be cited as the Texas Mass Gatherings Act.

Acts 1989, 71st Leg., ch. 678, Sec. 1, eff. Sept. 1, 1989.

Sec. 751.002. DEFINITIONS. In this chapter:

(1) "Mass gathering" means a gathering:

(A) that is held outside the limits of a municipality;

(B) that attracts or is expected to attract:

(i) more than 2,500 persons; or

(ii) more than 500 persons, if 51 percent or more of

those persons may reasonably be expected to be younger than 21 years of age and it is planned or may reasonably be expected that alcoholic beverages will be sold, served, or consumed at or around the gathering; and

(C) at which the persons will remain:

(i) for more than five continuous hours; or

(ii) for any amount of time during the period beginning at 10 p.m. and ending at 4 a.m.

(2) "Person" means an individual, group of individuals, firm, corporation, partnership, or association.

(3) "Promote" includes organize, manage, finance, or hold.

(4) "Promoter" means a person who promotes a mass gathering.

Acts 1989, 71st Leg., ch. 678, Sec. 1, eff. Sept. 1, 1989. Amended by Acts 1999, 76th Leg., ch. 553, Sec. 1, eff. June 18, 1999.

Amended by:

Acts 2005, 79th Leg., Ch. 692 (S.B. 270), Sec. 1, eff. June 17, 2005.

Sec. 751.0021. APPLICABILITY TO CERTAIN HORSE AND GREYHOUND RACES.

(a) This chapter applies to a horse or greyhound race that attracts or is expected to attract at least 100 persons, except that this chapter does not apply if the race is held at a location at which pari-mutuel

wagering is authorized under Subtitle A-1, Title 13, Occupations Code (Texas Racing Act).

(b) This section does not legalize any activity prohibited under the Penal Code or other state law.

Added by Acts 2015, 84th Leg., R.S., Ch. 1274 (S.B. 917), Sec. 1, eff. September 1, 2015.

Amended by:

Acts 2017, 85th Leg., R.S., Ch. 963 (S.B. 1969), Sec. 2.05, eff. April 1, 2019.

Sec. 751.003. PERMIT REQUIREMENT. A person may not promote a mass gathering without a permit issued under this chapter.

Acts 1989, 71st Leg., ch. 678, Sec. 1, eff. Sept. 1, 1989.

Sec. 751.004. APPLICATION PROCEDURE. (a) At least 45 days before the date on which a mass gathering will be held, the promoter shall file a permit application with the county judge of the county in which the mass gathering will be held.

(b) The application must include:

- (1) the promoter's name and address;
- (2) a financial statement that reflects the funds being supplied to finance the mass gathering and each person supplying the funds;
- (3) the name and address of the owner of the property on which the mass gathering will be held;
- (4) a certified copy of the agreement between the promoter and the property owner;
- (5) the location and a description of the property on which the mass gathering will be held;
- (6) the dates and times that the mass gathering will be held;
- (7) the maximum number of persons the promoter will allow to attend the mass gathering and the plan the promoter intends to use to limit attendance to that number;
- (8) the name and address of each performer who has agreed to appear at the mass gathering and the name and address of each performer's agent;
- (9) a description of each agreement between the promoter and a performer;
- (10) a description of each step the promoter has taken to ensure that minimum standards of sanitation and health will be maintained during

the mass gathering;

(11) a description of all preparations being made to provide traffic control, to ensure that the mass gathering will be conducted in an orderly manner, and to protect the physical safety of the persons who attend the mass gathering;

(12) a description of the preparations made to provide adequate medical and nursing care; and

(13) a description of the preparations made to supervise minors who may attend the mass gathering.

Acts 1989, 71st Leg., ch. 678, Sec. 1, eff. Sept. 1, 1989.

Sec. 751.005. INVESTIGATION. (a) After a permit application is filed with the county judge, the county judge shall send a copy of the application to the county health authority, the county fire marshal or the person designated under Subsection (c), and the sheriff.

(b) The county health authority shall inquire into preparations for the mass gathering. At least five days before the date on which the hearing prescribed by Section 751.006 is held, the county health authority shall submit to the county judge a report stating whether the health authority believes that the minimum standards of health and sanitation prescribed by state and local laws, rules, and orders will be maintained.

(c) The county fire marshal shall investigate preparations for the mass gathering. If there is no county fire marshal in that county, the commissioners court shall designate a person to act under this section. At least five days before the date on which the hearing prescribed by Section 751.006 is held, the county fire marshal or the commissioners court designee shall submit to the county judge a report stating whether the fire marshal or designee believes that the minimum standards for ensuring public fire safety and order as prescribed by state and local laws, rules, and orders will be maintained.

(d) The sheriff shall investigate preparations for the mass gathering. At least five days before the date on which the hearing prescribed by Section 751.006 is held, the sheriff shall submit to the county judge a report stating whether the sheriff believes that the minimum standards for ensuring public safety and order that are prescribed by state and local laws, rules, and orders will be maintained.

(e) The county judge may conduct any additional investigation that the judge considers necessary.

(f) The county health authority, county fire marshal or commissioners court designee, and sheriff shall be available at the hearing prescribed by Section 751.006 to give testimony relating to their reports.

Acts 1989, 71st Leg., ch. 678, Sec. 1, eff. Sept. 1, 1989. Amended by Acts 1999, 76th Leg., ch. 553, Sec. 2, eff. June 18, 1999.

Sec. 751.0055. DELEGATION OF DUTIES OF COUNTY JUDGE. (a) The county judge of a county may file an order with the commissioners court of the county delegating to another county officer the duty to hear applications for a permit under this chapter. The order may provide for allowing the county officer to revoke a permit under Section 751.008.

(b) An order of a county officer acting under the delegated authority of the county judge in regard to a permit has the same effect as an order of the county judge.

(c) During the period in which the order is in effect, the county judge may withdraw the authority delegated in relation to an application and the county judge may hear the application.

(d) The county judge may at any time revoke an order delegating duties under this section.

Added by Acts 2001, 77th Leg., ch. 1, Sec. 1, effective March 26, 2001.

Sec. 751.006. HEARING. (a) Not later than the 10th day before the date on which a mass gathering will begin, the county judge shall hold a hearing on the application. The county judge shall set the date and time of the hearing.

(b) Notice of the time and place of the hearing shall be given to the promoter and to each person who has an interest in whether the permit is granted or denied.

(c) At the hearing, any person may appear and testify for or against granting the permit.

Acts 1989, 71st Leg., ch. 678, Sec. 1, eff. Sept. 1, 1989.

Sec. 751.007. FINDINGS AND DECISION OF COUNTY JUDGE. (a) After the completion of the hearing prescribed by Section 751.006, the county judge shall enter his findings in the record and shall either grant or deny the permit.

(b) The county judge may deny the permit if he finds that:

- (1) the application contains false or misleading information or omits required information;
- (2) the promoter's financial backing is insufficient to ensure that the mass gathering will be conducted in the manner stated in the application;
- (3) the location selected for the mass gathering is inadequate for the purpose for which it will be used;
- (4) the promoter has not made adequate preparations to limit the number of persons attending the mass gathering or to provide adequate supervision for minors attending the mass gathering;
- (5) the promoter does not have assurance that scheduled performers will appear;
- (6) the preparations for the mass gathering do not ensure that minimum standards of sanitation and health will be maintained;
- (7) the preparations for the mass gathering do not ensure that the mass gathering will be conducted in an orderly manner and that the physical safety of persons attending will be protected;
- (8) adequate arrangements for traffic control have not been provided; or
- (9) adequate medical and nursing care will not be available.

Acts 1989, 71st Leg., ch. 678, Sec. 1, eff. Sept. 1, 1989.

Sec. 751.008. PERMIT REVOCATION. (a) The county judge may revoke a permit issued under this chapter if the county judge finds that preparations for the mass gathering will not be completed by the time the mass gathering will begin or that the permit was obtained by fraud or misrepresentation.

(b) The county judge must give notice to the promoter that the permit will be revoked at least 24 hours before the revocation. If requested by the promoter, the county judge shall hold a hearing on the revocation.

Acts 1989, 71st Leg., ch. 678, Sec. 1, eff. Sept. 1, 1989.

Sec. 751.009. APPEAL. A promoter or a person affected by the granting, denying, or revoking of a permit may appeal that action to a district court having jurisdiction in the county in which the mass gathering will be held.

Acts 1989, 71st Leg., ch. 678, Sec. 1, eff. Sept. 1, 1989. Amended by Acts 2001, 77th Leg., ch. 1, Sec. 2, eff. March 26, 2001.

Sec. 751.010. RULES. (a) After notice and a public hearing, the executive commissioner of the Health and Human Services Commission shall adopt rules relating to minimum standards of health and sanitation to be maintained at mass gatherings.

(b) After notice and a public hearing, the Department of Public Safety shall adopt rules relating to minimum standards that must be maintained at a mass gathering to protect public safety and maintain order.

Acts 1989, 71st Leg., ch. 678, Sec. 1, eff. Sept. 1, 1989.

Amended by:

Acts 2015, 84th Leg., R.S., Ch. 1 (S.B. 219), Sec. 3.1507, eff. April 2, 2015.

Sec. 751.011. CRIMINAL PENALTY. (a) A person commits an offense if the person violates Section 751.003.

(b) An offense under this section is a misdemeanor punishable by a fine of not more than \$1,000, confinement in the county jail for not more than 90 days, or both.

Acts 1989, 71st Leg., ch. 678, Sec. 1, eff. Sept. 1, 1989.

Sec. 751.012. INSPECTIONS. (a) The county health authority may inspect a mass gathering during the mass gathering to ensure that the minimum standards of health and sanitation prescribed by state and local laws, rules, and orders are being maintained. If the county health authority determines a violation of the minimum standards is occurring, the health authority may order the promoter of the mass gathering to correct the violation.

(b) The county fire marshal or the person designated under Section 751.005(c) may inspect a mass gathering during the mass gathering to ensure that the minimum standards for ensuring public fire safety and order as prescribed by state and local laws, rules, and orders are being maintained. If the marshal or commissioners court designee determines a violation of the minimum standards is occurring, the marshal or designee may order the promoter of the mass gathering to correct the violation.

(c) The sheriff may inspect a mass gathering during the mass gathering to ensure that the minimum standards for ensuring public safety and order prescribed by state and local laws, rules, and orders are being maintained. If the sheriff determines a violation of the minimum standards

is occurring, the sheriff may order the promoter of the mass gathering to correct the violation.

(d) A promoter who fails to comply with an order issued under this section commits an offense. An offense under this section is a Class C misdemeanor.

Added by Acts 1999, 76th Leg., ch. 553, Sec. 3, eff. June 18, 1999.

Sec. 751.013. INSPECTION FEES. (a) A commissioners court may establish and collect a fee for an inspection performed under Section 751.012. The fee may not exceed the amount necessary to defray the costs of performing the inspections. The fee shall be deposited into the general fund of the county.

(b) A commissioners court may use money collected under this section to reimburse the county department or, if a state agency performs the inspection on behalf of the county, the state agency, the cost of performing the inspection.

Added by Acts 1999, 76th Leg., ch. 553, Sec. 3, eff. June 18, 1999.

18. Discussion/Action to consider the approval of Budget Amendment #1 to transfer money from 001-6510-4860 Contingency to Elections 001-6550-4810 to increase training line item.
Speaker: Judge Haden/ Danie Teltow;
Backup: 2; Cost: \$7,500.00.

Caldwell County Agenda Item Request Form

To: All Elected Officials and Department Heads – Hand deliver or scan & email to hobby.haden@co.caldwell.tx.us and ezzy.chan@co.caldwell.tx.us . Deadline is 5:00 pm Tuesday before the Regular meetings, however, please submit this completed form ASAP. "Anything missing will cause the Agenda Item to be held over to the next Regular meeting," according to our Rules & Procedures.

AGENDA DATE: November 8, 2022

Type of Agenda Item

- Consent Discussion/Action Executive Session Workshop
 Public Hearing

What will be discussed? What is the proposed motion?

To consider Budget Amendment approval to transfer contingency funds to Elections funds in order to increase the training line item.

BA#1

1. **Costs:**

Actual Cost or Estimated Cost \$ 7,500.00

Is this cost included in the County Budget? YES

Is a Budget Amendment being proposed? YES

2. **Agenda Speakers:**

	Name	Representing	Title
(1)	<u>Danie Teltow</u>		<u>County Auditor</u>
(2)			
(3)			

3. **Backup Materials:** None To Be Distributed 2 total # of backup pages
(including this page)

4. 
Signature of Court Member

10/27/2022
Date

Exhibit A

19. Discussion/Action to consider the approval of Budget Amendment #2 to transfer money from 001-6510-4825 Tax Abatement to 001-6510-4845 Insurance to pay invoice coverage.
Speaker: Judge Haden/ Danie Teltow;
Backup: 3; Cost: \$10,115.00.

Caldwell County Agenda Item Request Form

To: All Elected Officials and Department Heads – Hand deliver or scan & email to hoppy.haden@co.caldwell.tx.us and ezzy.chan@co.caldwell.tx.us . Deadline is 5:00 pm Tuesday before the Regular meetings, however, please submit this completed form ASAP. "Anything missing will cause the Agenda Item to be held over to the next Regular meeting," according to our Rules & Procedures.

AGENDA DATE: November 8, 2022

Type of Agenda Item

- Consent Discussion/Action Executive Session Workshop
 Public Hearing

What will be discussed? What is the proposed motion?

To consider Budget Amendment approval to transfer Tax Abatement funds to Insurance funds in order to pay invoice coverage.

BA #2

1. Costs:

Actual Cost or **Estimated Cost** \$ 10,115.00

Is this cost included in the County Budget? YES

Is a Budget Amendment being proposed? YES

2. Agenda Speakers:

	Name	Representing	Title
--	------	--------------	-------

(1)	Danie Teltow	County Auditor	
-----	--------------	----------------	--

(2)			
-----	--	--	--

(3)			
-----	--	--	--

3. Backup Materials: None To Be Distributed 73 total # of backup pages (including this page)

4. 
Signature of Court Member

10/28/2022
Date



TEXAS ASSOCIATION *of* COUNTIES RISK MANAGEMENT POOL

TACRIS
001-6510-4845

INVOICE

Caldwell County
Attn: Hoppy Haden
110 S Main St Rm 101
Lockhart, TX 78644-2701

Invoice Due Date: July 1, 2022

Invoice #: 36281

Coverage #: PR-0280-20220701-1

Coverage Period: July 1, 2022 - July 1, 2023

Member Number: 0280

Contribution for the coverage below is now due.

Coverage	Contribution Due
Property	\$111,524
Total Due:	\$111,524

Caldwell County
Attn: Hoppy Haden
110 S Main St Rm 101
Lockhart, TX 78644-2701

Invoice Due Date: July 1, 2022

Invoice #: NRCN-36281-PC

Contribution Due: \$111,524

Amount Enclosed: _____

If the total amount enclosed is not \$111,524,
please use the notes section below to explain:

Please make checks payable to:

Texas Association of Counties Risk Management Pool

Box # 2426

San Antonio, TX 78298-9900

05/02/2022

20. Discussion/Action to consider the approval of REQ02027 and payment of invoice #36281 in the amount of \$111,524.00 for Texas Association of Counties Risk Management Pool Property Coverage. **Speaker: Judge Haden/ Carolyn Caro; Backup: 3; Cost: \$111,524.00.**

Caldwell County Agenda Item Request Form

To: All Elected Officials and Department Heads – Hand deliver or scan & email to hopy.haden@co.caldwell.tx.us and ezzy.chan@co.caldwell.tx.us . Deadline is 5:00 pm Tuesday before the Regular meetings, however, please submit this completed form ASAP. "Anything missing will cause the Agenda Item to be held over to the next Regular meeting," according to our Rules & Procedures.

AGENDA DATE: 11.08.2022

Type of Agenda Item

- Consent Discussion/Action Executive Session Workshop
 Public Hearing

What will be discussed? What is the proposed motion?

Request to approve REQ02027 and payment of invoice # 36281 in the amount of \$111,524.00 for Texas Association of Counties Risk Management Pool Property Coverage.

1. Costs:

Actual Cost or Estimated Cost \$ 111,524.00

Is this cost included in the County Budget? Yes

Is a Budget Amendment being proposed? Yes

2. Agenda Speakers:

	Name	Representing	Title
(1)	Carolyn Caro		Purchasing Agent
(2)	Hopy Haden		County Judge
(3)			

3. Backup Materials: None To Be Distributed 3 total # of backup pages (including this page)

4. 
Signature of Court Member

10/27/2022
Date

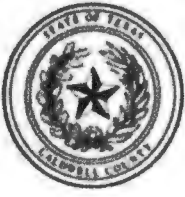

REQUISITION

Requisition #: REQ02027

Date: 10/27/2022

Vendor #: TACRIS

ISSUED TO: TEXAS ASSOCIATION OF COUNTIES
Attn: RISK MANAGEMENT POOL
P.O. BOX 2426
San Antonio, TX 78298-9900

SHIP TO: County Judge
110 S. Main St., RM 201
Lockhart, TX 78644

ITEM	UNITS DESCRIPTION	PROJECT #	PRICE GL ACCOUNT NUMBER	AMOUNT
1	1 Invoice #36281		111,524.00 001-6510-4845	111,524.00

PO Description: Property Ins Renewal
Detailed Description:
Insurance Property Renewal coverage: July 1, 2022 - July 1, 2023

Authorized By: _____

SUBTOTAL:	111,524.00
TOTAL TAX:	0.00
SHIPPING:	0.00
TOTAL	111,524.00



TEXAS ASSOCIATION of COUNTIES
RISK MANAGEMENT POOL

INVOICE

Caldwell County
Attn: Hoppy Haden
110 S Main St Rm 101
Lockhart, TX 78644-2701

Invoice Due Date: July 1, 2022
Invoice #: 36281
Coverage #: PR-0280-20220701-1
Coverage Period: July 1, 2022 - July 1, 2023
Member Number: 0280

Contribution for the coverage below is now due.

Coverage	Contribution Due
Property	\$111,524
Total Due:	\$111,524

Invoice Due Date: July 1, 2022
Invoice #: NRCN-36281-PC
Contribution Due:\$111,524
Amount Enclosed: _____

Caldwell County
Attn: Hoppy Haden
110 S Main St Rm 101
Lockhart, TX 78644-2701

If the total amount enclosed is not \$111,524,
please use the notes section below to explain:

Please make checks payable to:
Texas Association of Counties Risk Management Pool
Box # 2426
San Antonio, TX 78298-9900

05/02/2022

21. Discussion/Action to discuss the non-compliant credit card charges from the Tax Assessor's Office. **Speaker: Judge Haden/Carolyn Caro; Backup: 4; Cost: None**

Hoppy Haden
County Judge
512 398-1808

Angela Rawlinson
County Treasurer
512 398-1800

Danie Teltow
County Auditor
512 398-1801

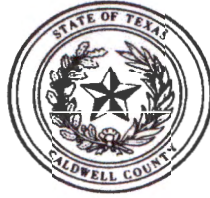

Caldwell County Courthouse
Purchasing Department
631 S. Colorado St
Lockhart, TX 78644
Fax: 512 398-1828

B.J. Westmoreland
Commissioner Precinct 1

Barbara Shelton
Commissioner Precinct 2

Edward "Ed" Theriot
Commissioner Precinct 3

Joe Ivan Roland
Commissioner Precinct 4

MEMORANDUM

October 27, 2022

To: Caldwell County Tax Assessor
From: Carolyn Caro, Caldwell County Purchasing Department
Re: Non-Compliance with County Credit Card Policy

The credit card charges for AGEX Agrilife Learn totaling in the amount of \$150.00 were found by the Purchasing Department to be in non-compliance after repeated attempts to obtain itemized receipts from the responsible department.

In accordance with the Caldwell County Credit Card Policy, all county-obtained credit card purchases must be documented with itemized receipts. All receipts must be turned in to the auditor's office within three business days of the date of the charge. In order to finalize and close out this non-compliance issue, this must be made aware to Commissioner's Court and acknowledged if any further actions are required upon Commissioner Court request.

Please contact Carolyn Caro or the Purchasing Department if you have any questions regarding our purchasing policies and procedures.

•
Thank you,

I acknowledge receipt of this notice on _____ [date]
(Department Head acknowledgement)

Authorized Signature of County Judge: _____

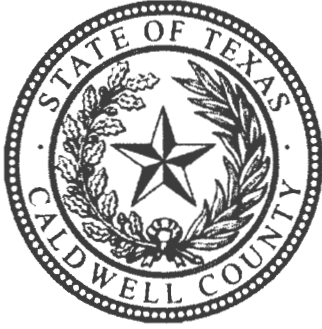

Caldwell County Credit Card Policy

The Caldwell County Commissioners Court recognizes that using county-obtained credit cards to obtain certain goods and services to conduct the business of Caldwell County fulfills a public purpose. In order to safeguard the taxpayers' money and ensure financial accountability and transparency regarding county-obtained credit card transactions, the Caldwell County Commissioners Court finds it is in the public interest to adopt this Caldwell County Credit Card Policy.

OBTAINING AND ADMINISTERING COUNTY CREDIT CARDS

1. Subject to the approval of the Caldwell County Commissioners Court, the Caldwell County Purchasing Department will obtain and administer credit cards in the name of Caldwell County to conduct the business of Caldwell County.
2. No other Caldwell County elected official or employee may obtain or administer a credit card in the name of Caldwell County.
3. The Caldwell County Purchasing Department will keep under lock and key all county-obtained credit cards that are not issued to a specific individual. These cards may be checked out to transact county business upon request to the purchasing department, who will keep records of all requests.
4. The Caldwell County Commissioners Court must vote in open session to authorize the Caldwell County Purchasing department to issue a county-obtained credit card to a specific county elected official, county employee or county office.
5. Only Caldwell County elected officials and employees may use county-obtained credit cards, and only for the business of Caldwell County.
6. Before being allowed to use a county-obtained credit card, Caldwell County elected officials and employees must acknowledge in writing that they have read and understand this policy. This acknowledgment will be kept in their personnel file.
7. This policy does not affect the Caldwell County Fuel Card Policy.

USING COUNTY CREDIT CARDS

1. All county-obtained credit card purchases must comply with all federal, state, and county purchasing statutes, rules, policies, and procedures.
2. All county-obtained credit card purchases must be documented with itemized receipts. All receipts must be turned in to the auditor's office within three business days of the date of the charge.
3. The following constitute unauthorized uses of county-obtained credit cards:
 - a. Personal expenditures;
 - b. Cash advances;
 - c. Sales tax (except in cases where state law does not exempt local governments);
 - d. Entertainment of any kind, including the purchase of alcohol;
 - e. Purchases under contracts, unless an emergency or necessity is deemed by the Caldwell County Auditor;
 - f. Separate, sequential and component purchases or transactions made with the intent to circumvent state law or county policy;
 - g. Purchases that are split to stay within card transaction limits;
 - h. Amounts greater than a county-obtained credit card's transaction limits;
 - i. Expenditures made without department head approval.
4. An individual who makes an unauthorized use of a county-obtained credit card or who does not document a purchase with an itemized receipt may be held responsible for such expenditures. An individual whose failure to turn in receipts results in a late charge or fee from the credit card company may be held responsible for such late charge or fee.
5. Failure to comply with this policy will result in suspension of the privileges to use the credit card.
6. Unauthorized use of a county-obtained credit card may be considered misappropriation of county funds and may result in disciplinary action, up to and including termination, and could result in criminal prosecution.

ELECTED OFFICIAL/EMPLOYEE ACKNOWLEDGEMENT:

I acknowledge that I have read and understand the above Caldwell County Credit Card Policy

Signature _____

Date _____

Transactions

Card Service Center

09-13-2022	PACKTRACK 9549143675 FL	Return	-\$140.00	
09-13-2022	ZOOM.US 888-799-9666 SAN JOSE CA	Sale	\$239.88	... Actions
09-14-2022	BT ARCIT 5082324600 MA	Sale	\$514.79	... Actions
09-16-2022	SPLASHTOP.COM 408-861-1088 CA	Sale	\$4,677.75	... Actions
09-16-2022	AGEX AGRILIFE LEARN 979-803-1372 TX	Sale	\$75.00	... Actions
09-19-2022	PAYMENT - THANK YOU	Payment	-\$2,882.96	
09-20-2022	GOOGLE *PLAY G.CO/HELPPAY#CA	Sale	\$25.00	... Actions
09-21-2022	AGEX AGRILIFE LEARN 979-803-1372 TX	Sale	\$30.00	... Actions
09-20-2022	WM SUPERCENTER #292 LOCKHART TX	Sale	\$29.88	... Actions
09-22-2022	AGEX AGRILIFE LEARN 979-803-1372 TX	Sale	\$45.00	... Actions

22. Discussion/Action to consider the approval to accept a \$17,000.00 Proposal from Cobb, Fendley & Associates, Inc., for professional engineering services related to GIS Review and Map Creation related to Broadband Accessibility as well as Creation and Maintenance of Speed Test and Survey.
Speaker: Judge Haden; Backup: 9; Cost: None

Caldwell County Agenda Item Request Form

To: All Elected Officials and Department Heads – Hand deliver or scan & email to hopy.haden@co.caldwell.tx.us and ezzy.chan@co.caldwell.tx.us . Deadline is 5:00 pm Tuesday before the Regular meetings, however, please submit this completed form ASAP. "Anything missing will cause the Agenda Item to be held over to the next Regular meeting," according to our Rules & Procedures.

AGENDA DATE: 11.08.2022

Type of Agenda Item

Consent Discussion/Action Executive Session Workshop
 Public Hearing

What will be discussed? What is the proposed motion?

to consider the approval to accept a \$17,000.00 Proposal from Cobb, Fendley & Associates, Inc. for professional engineering services related to GIS Review and Map Creation related to Broadband Accessibility as well as Creation and Maintenance of Speed Test and Survey.

1. Costs:

Actual Cost or Estimated Cost \$ None

Is this cost included in the County Budget? _____

Is a Budget Amendment being proposed? _____

2. Agenda Speakers:

Name	Representing	Title
------	--------------	-------

(1) Judge Haden

(2) _____

(3) _____

3. Backup Materials: None To Be Distributed 9 total # of backup pages
(including this page)

4. 
Signature of Court Member

11/1/2022
Date

To: Caldwell County Commissioners Court
Judge Hoppy Haden
110 S Main
Lockhart, TX 78644

From: Jarod Branstetter, P.E.
Broadband Group Lead

Lacey Hazel
Data Utilization & GIS Group Lead

Date: October 12, 2022

Re: Proposal for Professional Engineering Services:

1 INTRODUCTION/BACKGROUND

Dear Judge Haden,

Cobb, Fendley & Associates, Inc. ("CobbFendley") is pleased to submit this proposal for professional engineering services to assist Caldwell County ("Client") with GIS Review and Map Creation related to Broadband Accessibility, Creation and Maintenance of Speed Test, Survey and related geospatial data detailed in the scope of work outlined below (see Exhibit A). The proposed scope of services, basis of compensation, and schedule are outlined below for your review.

CobbFendley's services are to be performed for the sole benefit of Caldwell County, who shall be responsible for payment of those services. When accepted by the signature of Client's authorized representative, the authorization and the documents referenced herein shall constitute the entire agreement between Client and CobbFendley with respect to this project.

2 SCOPE OF SERVICES

2.1 Phasing and Unit Line Items

The specific tasks to be performed by CobbFendley in conjunction with this project are limited to the following:

- Initial Setup:
 - Acquire data layers
 - Initial Setup of ArcGIS Layers
 - Maintenance
- Creation of PDF Map Exhibits Including:
 - Unserved
 - Underserved
 - Number of Broadband Providers
 - Population
 - Households with Internet Access without Subscription
 - Household Median Income & Size
 - Households without Smart Device
 - Median Age
 - Urban and Rural
 - Households without Internet
 - Right of Ways/ Jurisdictions

- Fiber Locator - Metro Networks
- Fiber Locator - Long Haul Networks
- Fiber Locator - Connected Buildings
- Asset Inventory
- Targeted Areas of Need
- Speed Test and Survey:
 - Creation of Speed Test and Survey
 - Creation and Maintenance of Survey Dashboard
 - Data Analysis and Creation of Map Exhibits based upon Survey Data
- Funding Analysis
 - Provide an overview of Federal Infrastructure Bill Funding and Texas Broadband Development Office Programs.
 - Evaluate all data sources to determine a level of eligibility for applicable funding programs with timeline for implementation.

2.2 Basis of Compensation

CobbFendley proposes to perform the described Scope of Services for the following lump sum fees:

Initial Setup	\$2,880.00
Create Exhibits.....	\$6,120.00
Speed Test & Survey	\$6,240.00
<u>Funding Analysis.....</u>	<u>\$1,760.00</u>
<i>Scope of Services to Completed for a Total Fee.....</i>	<i>\$17,000.00</i>

2.3 Schedule of Services

As shown in Exhibit B.

3 ASSUMPTIONS, EXCLUSIONS, AND ADDITIONAL SERVICES

3.1 Assumptions

The following assumptions were made in the development of this Scope of Work:

- All Data tabular and spatial will be stored and maintained by CobbFendley as related to this Scope of Work.
- Data will be delivered in static .pdf or Microsoft Excel file for Survey response data.

3.2 Exclusions

The following exclusions will apply to this Scope of Work:

- Survey outreach – no door-to-door surveys will be conducted; Survey will provided as a hyperlink to post to the County website or distribute as needed.
- Data Ownership – GIS (.gdb/shapefile/kmz) data will not be delivered as part of this scope of work.
- ArcGIS Licensing – The County will be granted access to the Survey dashboard and ArcGIS server for the duration of the contract. Static exports of Dashboard data (.xlsx) and .jpg/.pdf maps will be provided at project conclusion.

- Broadband Feasibility Study

3.3 Additional Services

Any services not included in the scope shall be considered Additional Services. Additional Services are provided on a negotiated lump sum basis, if requested, and after Client authorization with the execution of a Supplement to the Original Agreement.

- GIS Asset Management
- ArcGIS Licensing, Training and General GIS Support
- Broadband Feasibility Study
- Broadband High-Level Design

4 PROPOSAL ACCEPTANCE

If this proposal is acceptable to you, please provide an authorization to begin work or indicate your acceptance by signing in the space provided below and return one original to us for our file. This proposal is void if not accepted within thirty days of the date hereon. The opportunity to propose professional engineering services to your firm is appreciated and we look forward to serving you on this project. A copy of CobbFendley's General Terms and Conditions is attached and constitutes a part of this agreement.

Sincerely,

Cobb, Fendley & Associates, Inc.

Lacey Hazel

PM/SIGNATURE AUTHORITY
CC: GL/DM OR OTHER REQUIRED FROM
SIGNATURE AUTHORITY

This Proposal Accepted By:

CLIENT

Signature

Print Name

Title

Date of Authorization

5 LIST OF EXHIBITS

1. Exhibit A

Task Name	Hours	Duration	Start	Finish	Rate
Acquire data layers	12	1.5d	10/24/22	10/25/22	\$1,440.00
Initial Setup of ArcGIS Layers	6	0.75d	10/25/22	10/26/22	\$720.00
Maintenance	6	0.75d	10/26/22	10/26/22	\$720.00
Creation of PDF Map Exhibits	51	6.376d	10/25/22	11/02/22	\$6,120.00
Unserviced	15	0.188d	10/25/22	10/25/22	\$180.00
Underserved	15	0.188d	10/25/22	10/25/22	\$180.00
Number of Broadband Providers	2	0.25d	10/25/22	10/26/22	\$240.00
Population	2	0.25d	10/26/22	10/26/22	\$240.00
Households with Internet Access without Subscription	2	0.25d	10/26/22	10/26/22	\$240.00
Household Median Income & Size	2	0.25d	10/26/22	10/26/22	\$240.00
Households without Smart Device	2	0.25d	10/26/22	10/27/22	\$240.00
Median Age	2	0.25d	10/27/22	10/27/22	\$240.00
Urban and Rural	2	0.25d	10/27/22	10/27/22	\$240.00
Households without Internet	2	0.25d	10/27/22	10/27/22	\$240.00
Right of Ways/ Jurisdictions	10	1.25d	10/27/22	10/31/22	\$1,200.00
Fiber Locator - Metro Networks	2	0.25d	10/31/22	10/31/22	\$240.00
Fiber Locator - Long Haul Networks	2	0.25d	10/31/22	10/31/22	\$240.00
Fiber Locator - Connected Buildings	2	0.25d	10/31/22	10/31/22	\$240.00
Asset Inventory	8	1d	10/31/22	11/01/22	\$960.00
Targeted Areas of Need	8	1d	11/01/22	11/02/22	\$960.00
Speed Test & Survey	52	6.5d	11/02/22	11/11/22	\$6,240.00
Creation of Speed Test and Survey	16	2d	11/02/22	11/04/22	\$1,920.00
Creation and Maintenance of Survey Dashboard	20	2.5d	11/04/22	11/09/22	\$2,400.00
Data Analysis and Creation of Map Exhibits based up	16	2d	11/09/22	11/11/22	\$1,920.00

2. Exhibit B

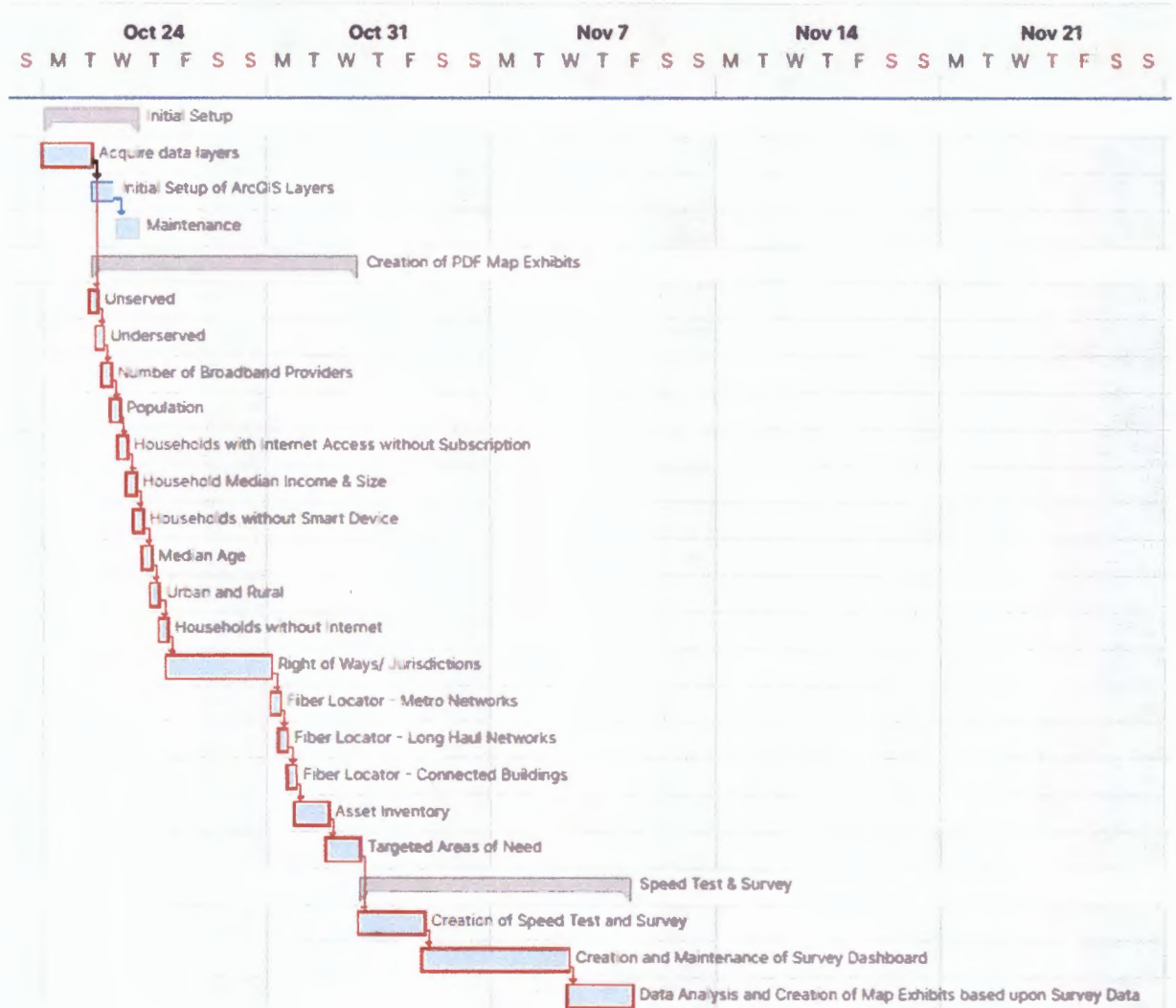

6 GENERAL TERMS AND CONDITIONS OF THE AUTHORIZATION FOR PROFESSIONAL SERVICES

6.1 REIMBURSABLE EXPENSES

CobbFendley's direct expenses shall be those costs incurred on or directly for the CLIENT'S project, including but not limited to necessary transportation costs including mileage at the current IRS rate, meals and lodging, laboratory tests and analyses, and printing and binding charges. These direct expenses shall be billed in accordance with the attached rate schedule.

6.2 OUTSIDE SERVICES

When technical or professional services are furnished by an outside source, when approved by the CLIENT, an additional amount shall be added to the cost of these services by CobbFendley to cover CobbFendley's administrative costs, as provided in the attached CobbFendley rate schedule.

6.3 COST PROJECTIONS

If included in CobbFendley's scope of services, opinions or estimates of probable construction costs are prepared on the basis of CobbFendley's experience and qualifications and represent CobbFendley's judgment as a professional generally familiar with the industry. However, since CobbFendley has no control over the cost of labor, materials, equipment or services furnished by others, over contractor's methods of determining prices, or over competitive bidding or market conditions, CobbFendley cannot and does not guarantee, represent or warrant that proposals, bids, or the actual construction cost will not vary from CobbFendley's opinions or estimates of probable construction cost.

6.4 PROFESSIONAL STANDARDS

CobbFendley agrees to perform its services in accordance with the standard of professional care used by other practicing professional engineers of ordinary prudence in the same field of engineering and performing the same type of work in CLIENT'S community under the same or similar circumstances. CobbFendley makes no other warranty, expressed or implied.

6.5 TERMINATION

Either CLIENT or CobbFendley may terminate this authorization by giving 30 days written notice to the other party. In such event, CLIENT shall forthwith pay CobbFendley in full for all work previously authorized and performed prior to effective date of termination. If no notice of termination is given, the relationships and obligations created by this Authorization shall be terminated upon completion of all applicable requirements of this Authorization. Failure by Client to make payments when due shall be cause for suspension of services or, ultimately, termination, unless and until CobbFendley has been paid in full all amounts due for services, expenses and other related charges, including interest on past due amounts.

6.6 OWNERSHIP OF DOCUMENTS

All documents prepared or furnished by CobbFendley pursuant to this Agreement are instruments of CobbFendley's professional service, and CobbFendley shall retain an ownership and property interest therein, including all copyrights. CobbFendley grants Client a license to use instruments of CobbFendley's professional service for the purpose of constructing, occupying or maintaining the project. Reuse or modification of any such documents by Client, without CobbFendley's written permission, shall be at Client's sole risk, and Client agrees to indemnify and hold CobbFendley harmless from all claims, damages and expenses, including attorneys' fees, arising out of such reuse by Client or by others acting through Client.

6.7 USE OF ELECTRONIC DOCUMENTS

Copies of documents that may be relied upon by Client are limited to the printed copies (also known as hard copies) or fully-scaled PDF files that are signed and sealed by CobbFendley's authorized design professionals. Files in

electronic formats, or other types of information furnished by CobbFendley to Client such as text, data or graphics, are only for convenience of Client. Any conclusion or information obtained or derived from such electronic files will be at the user's sole risk. When transferring documents in electronic formats, CobbFendley makes no representations as to long-term compatibility, usability, or readability of documents resulting from the use of software application packages, operating systems or computer hardware differing from those in use by CobbFendley at the beginning of this project.

6.8 HAZARDOUS ENVIRONMENTAL CONDITIONS

CobbFendley shall have no liability or responsibility for the discovery, presence, handling, removal, disposal, cleanup, or exposure of persons or other property to underground substances, hazards, or conditions or other latent substances, hazards or conditions (including but not limited to contaminants, pollutants, chemicals or other hazardous or toxic solids, liquids or gases of any kind), Client acknowledges that CobbFendley is performing professional services for Client and CobbFendley is not and shall not be required to become an "arranger," "operator," "generator" or "transporter" of hazardous substances, as defined in the Comprehensive Environmental Response, Compensation, and Liability Act of 1990 (CERCLA).

6.9 FORCE MAJEURE

Neither party shall be deemed in default of this agreement to the extent that any delay or failure in the performance of its obligations results from any cause beyond its reasonable control and without its negligence.

6.10 CONSTRUCTION PHASE SERVICES

If this Agreement provides for any construction phase services by CobbFendley, it is agreed that the Contractor, not CobbFendley, is responsible for the construction of the project, and that CobbFendley is not responsible for the acts or omissions of any contractor, subcontractor or material supplier; for time of performance; for safety precautions, programs or enforcement; or for construction means, methods, techniques, sequences and procedures employed by the Contractor. CobbFendley shall not be obligated to make exhaustive or continuous on-site inspections to check the quality or adequacy of construction or to verify that the work or materials of any contractor, subcontractor or materials supplier is in compliance with the plans and specifications. CobbFendley shall not be responsible for the Contractor's failure to execute the work in accordance with the Construction contract.

6.11 LIMITATION OF LIABILITY FOR DAMAGES

IN THE EVENT THAT CLIENT SHALL MAKE ANY CLAIM OR FILE ANY SUIT FOR DAMAGES AGAINST COBBFENDLEY ARISING OUT OF OR RELATED TO COBBFENDLEY'S PERFORMANCE OR NON-PERFORMANCE OF THE SERVICES TO BE PROVIDED UNDER THIS AGREEMENT, COBBFENDLEY'S LIABILITY TO CLIENT FOR ANY SUCH DAMAGES SHALL BE LIMITED TO ACTUAL AND DIRECT DAMAGES TO AN AMOUNT NOT TO EXCEED THE AMOUNT FEES CHARGED BY COBBFENDLEY TO CLIENT HEREUNDER. COBBFENDLEY SHALL HAVE NO LIABILITY FOR ANY CONSEQUENTIAL OR INDIRECT DAMAGES, INCLUDING BUT NOT LIMITED TO LOST PROFITS, LOST BUSINESS OPPORTUNITIES, ADDITIONAL OVERHEAD, OR DAMAGES FOR LOSS OF USE OR LOSS OF PRODUCTION.

6.12 ALTERNATIVE DISPUTE RESOLUTION

In the event that any dispute shall arise between Client and CobbFendley regarding the parties rights or obligations under this Agreement, the parties shall, as a condition precedent to taking any action against one another make a good faith effort to resolve such disagreements by negotiation and/or non-binding mediation.

6.13 LEGAL EXPENSES

In the event that legal action is brought by CLIENT or CobbFendley against the other party to enforce any of the obligations hereunder or arising out of any dispute concerning the terms and conditions hereby created, the losing party shall pay the prevailing party such reasonable amounts for fees, costs and expenses as may be set by the court.

6.14 PAYMENT TO COBBFENDLEY

Monthly invoices will be issued by CobbFendley for all work performed under the terms of this agreement. Invoices are due and payable within ten (10) business days of receipt. Unless noted otherwise, tasks stated in the Scope of Services will be invoiced on a lump sum basis. If CLIENT is not the OWNER, CLIENT agrees to pay CobbFendley within ten (10) business days of receipt of payment from OWNER. Pending resolution of any dispute concerning any portion of any invoice submitted by CobbFendley, all undisputed portions shall be paid in accordance with this paragraph. Progress payments on CobbFendley fees for percentage of project completion and reimbursable expenses incurred will be due and payable upon receipt of invoice at the end of each month. If payment is not received within 60 days from date of invoice, CobbFendley retains the right to cease further work on the project until such time that the overdue invoices are paid. CobbFendley also retains the right to withhold final approved plans and other deliverables until all overdue invoices are paid.

6.15 AUTHORIZATION OF OWNER

Client hereby authorizes CobbFendley to enter upon the property for the purpose of conducting CobbFendley services thereon. If Client is not the Owner of the property, Client agrees to obtain such authorization from the Owner and provide same in writing to CobbFendley.

6.16 CONTRACT DOCUMENTS

This signed Authorization, together with the attached General Terms and Conditions of the Authorization for Professional Services and CobbFendley Rate Schedule contains the entire and integrated agreement between Client and CobbFendley and supersedes all prior negotiations, representations or agreements, either written or oral. This agreement may only be amended by written instrument signed by both parties.

6.17 SALES TAX

To the extent that state sales taxes apply to any of the services or materials to be provided hereunder, such taxes are in addition to and are not included in the proposed fees of this Authorization.

6.18 BENEFICIARIES AND ASSIGNMENT

This agreement is made for the sole benefit of Client and CobbFendley and nothing in this agreement shall create a contractual relationship or cause of action in favor of any third party against either Client or CobbFendley. This agreement may not be assigned without the written consent of both Client and CobbFendley.

23. Discussion on update on GLO
Infrastructure Grant Roads. **Speaker:**
Commissioner Westmoreland/ Dennis
Engelke; Backup: 1; Cost: None

24. EXECUTIVE SESSION Pursuant to Texas Government Code Section 551.087, the discussion of deliberation regarding economic development negotiations associated with Project Exodus. **Speaker: Judge Haden; Backup: 1; Cost: None**

Caldwell County Agenda Item Request Form

To: All Elected Officials and Department Heads – Hand deliver or scan & email to hopyy.haden@co.caldwell.tx.us and ezzy.chan@co.caldwell.tx.us . Deadline is 5:00 pm Tuesday before the Regular meetings, however, please submit this completed form ASAP. “Anything missing will cause the Agenda Item to be held over to the next Regular meeting,” according to our Rules & Procedures.

AGENDA DATE: 11.08.2022

Type of Agenda Item

- Consent Discussion/Action Executive Session Workshop
 Public Hearing

What will be discussed? What is the proposed motion?

EXECUTIVE SESSION Pursuant to Texas Government Code Section 551.087, the discussion of deliberation regarding economic development negotiations associated with Project Exodus

1. Costs:

Actual Cost or Estimated Cost \$ None

Is this cost included in the County Budget? _____

Is a Budget Amendment being proposed? _____

2. Agenda Speakers:

	Name	Representing	Title
<hr/>			

(1) Judge Haden _____

(2) _____

(3) _____

3. Backup Materials: None To Be Distributed 1 total # of backup pages
(including this page)

4. 
Signature of Court Member

10/28/2022
Date

25. Discussion/Action to consider taking action on Executive Session. **Speaker: Judge Haden; Backup:1; Cost: None**

26. Adjournment.

As authorized by Chapter 551 of the Texas Government Code, the Commissioners Court of Caldwell County, Texas reserves the right to adjourn into Executive Session at any time during the course of this meeting to discuss any of the matters listed above. The Court may adjourn for matters that may relate to Texas Government Code Section 551.071(1) (Consultation with Attorney about pending or contemplated litigation or settlement offers); Texas Government Code Section 551.071(2) (Consultation with Attorney when the attorney's obligations under the Texas Disciplinary Rules of Professional Conduct of the State Bar of Texas conflicts with Chapter 551 of the Texas Government Code); Texas Government Code Section 551.072 (Deliberations about Real Property); Texas Government Code Section 551.073 (Deliberations about Gifts and Donations); Texas Government Code Section 551.074 (Personnel Matters); Texas Government Code Section 551.0745 (Deliberations about a County Advisory Body); Texas Government Code Section 551.076 (Deliberations about Security Devices); and Texas Government Code Section 551.087 (Economic Development Negotiations). In the event that the Court adjourns into Executive Session, the Court will announce under what section of the Texas Government Code the Commissioners Court is using as its authority to enter into an Executive Session. The meeting facility is wheelchair accessible and accessible parking spaces are available. Request for accommodations or interpretive services must be made 48 hours prior to this meeting. Please contact the County Judge's office at 512-398-1808 for further information.