



FEATURES

- Four models covering a range of nominal heating capacities
 - 28,000 to 101,000 BTU/hour
- Multi-position (upflow, downflow, horizontal left, horizontal right) without modifications *
 - Modifiable for side-entry return air
- Low-flow, high-head pump custom designed to work with Rinnai's tankless water heaters
- Integrated control board with learning algorithm
- No combustion air infiltration losses when used with a Rinnai tankless water heater
- Four selectable heat blower off delay times
- Multi-speed motors
- Strong 20-gauge steel cabinet
 - Galvanized, painted
 - Fully insulated cabinet
 - Complies with air leakage standard _____
 - Low 34 inch profile
- Multi-position control box
- Designed for serviceability
- Schrader valves to purge air from the system
- Integral filter rack with filter

* NOTE: The unit is not designed to be installed on its back or face down.

The optimum in hydronic technology, the newly designed Rinnai® multi-position hydronic air handlers offer a unique solution for a wide variety of small- and medium-sized residential and light commercial applications. They are compact and ready to fit in tight spaces which may include, but not limited to, attics, basements, closets, crawlspaces, and utility rooms.

Intelligent Microprocessor Controller

The 37AHA units are equipped with an intelligent microprocessor control that allows for domestic hot water priority and adapts to available hot water flow for space heating by automatically regulating the pump and fan sequence to maximize comfort.

Fine Tuned to Work with Rinnai Tankless Water Heaters

These unique hydronic air handlers are designed to work in combination with our line of Rinnai® tankless water heaters to deliver heating capacities that cover a wide spectrum of residential and light commercial heating applications. When combined, the units form the Rinnai Tankless Heating System, the only matched, tankless hydronic heating solution in the industry!



This product is manufactured in a facility registered by UL to ISO 9001. File No. A6887.

Equipment



- ← **CABINET** 20 gauge
pre-painted
galvanized steel
fully insulated
- ← **HEAT EXCHANGER** copper tube
aluminum fin
- ← **PUMP** high-head
low-flow
integrated check valve
- ← **BLOWER ASSEMBLY** multi-speed motor (PSC)
- ← **CONTROL BOARD** integrated
microprocessor based
- ← **FILTER**

Accessories



THERMOSTATS

Programmable, 5-2 days;
both A/C and heat pump
versions



FLOW SENSOR *

For domestic hot water priority
* Supplied with the unit



ANTI-SCALD MIXING VALVE

To maintain safe domestic
hot water temperature



FILTER RACKS and BOTTOM FILL PLATES

For modification to allow side-entry
return airflow.
Factory available from Rinnai.

Optional Equipment

FIELD-SUPPLIED ACCESSORIES capable of interfacing with the Rinnai Hydronic Air Handler:

- Humidifier (HUM)** Connect an auxiliary 2.5 FLA, 2.5 LRA @ 115 VAC max Humidifier. Connections are made via the "HUM" quick connects. The humidifier output is on whenever a heating demand is being satisfied. The contacts of this output are isolated to allow application of 24 VAC or 115 VAC to one terminal and the humidifier load to the other.
- Electronic Air Cleaner (EAC)** Connect an auxiliary Electronic Air Cleaner; rating shall be max 1.0 Amp @ 115 VAC. This output is energized whenever any of the four blower speeds are energized. Connections are made via 0.250 x 0.032" male quick connect terminals labeled "EAC" and "N3".
- UV Lamp** Connect an auxiliary UV lamp (if required); rating shall be max 1.0 Amp @ 115 VAC. This output is energized whenever any of the four blower speeds are energized. Connections are made via 0.250 x 0.032" male quick connect terminals labeled "UV" and "N2".
- Cooling Coil** Can accommodate most brands of evaporator A-coil for cooling applications.

Nomenclature

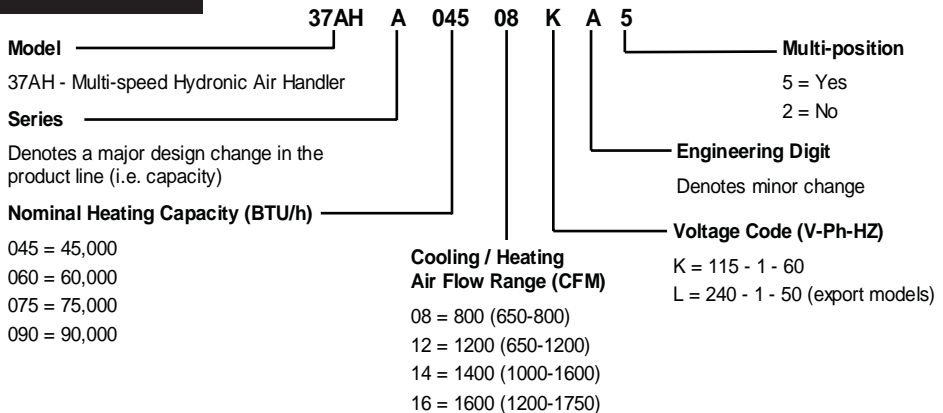

Heating Capacities

Nominal heating capacities as tested with Rinnai tankless water heaters. For final rated capacities refer to the Performance Table in the Operation and Installation Manual

	AH45 (BTU)	AH60 (BTU)	AH75 (BTU)	AH90 (BTU)
120° F	28,000	37,500	46,000	55,000
130° F	33,750	45,000	55,500	66,250
140° F	39,500	52,500	65,000	77,500
150° F	45,000	60,000	75,000	90,000
160° F	51,000	68,000	84,500	101,000

Dimensions

UNIT SIZE	A		B		C		D		E	
	in.	mm	in.	mm	in.	mm	in.	mm	in.	mm
37AHA04508KA5 (AH45)	14	355.6	18	457.2	12	304.8	10 - 1/2	266.7	19	482.6
37AHA06012KA5 (AH60)	17 - 1/2	444.5	18	457.2	16	406.4	16 - 11/16	423.9	19 - 1/4	489.0
37AHA07514KA5 (AH75)	21	533.4	18	457.2	20	508	18 - 11/16	474.7	19 - 1/2	495.3
37AHA09016KA5 (AH90)	24 - 1/2	622.3	18	457.2	24	609.6	21 - 1/8	536.6	19	482.6

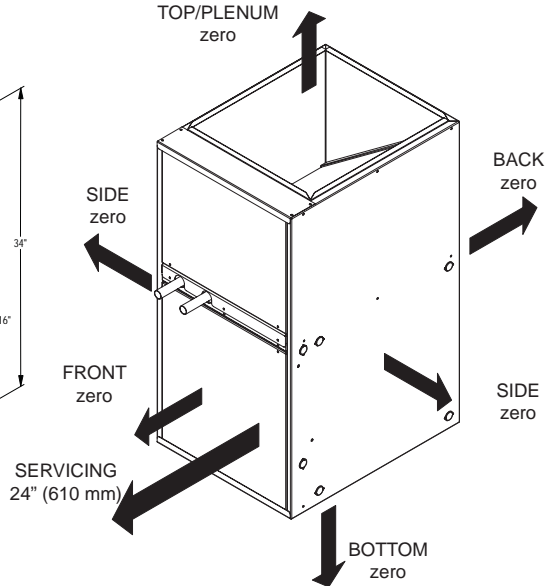
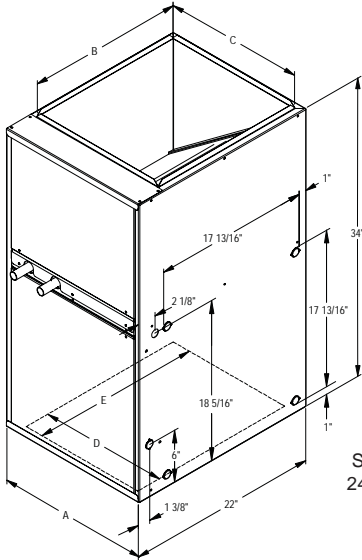

**Minimum Clearance to
Combustible Construction**

Warranty

Parts: 5 years * / Labor: 1 year *

* Parts and Labor will only be covered when the air handler is connected to a Rinnai tankless water heater. Parts and Labor are not covered if connected to any other type or brand of unit.

Rinnai will repair or replace the covered product or any part or component that is defective in materials or workmanship as set forth.

Rinnai will pay reasonable labor charges associated with the repair or replacement of any such part or component.

All repair parts must be genuine Rinnai parts. All repairs or replacements must be performed by an individual or servicing company that is properly trained, state qualified or licensed to do the type of repair.

Specifications

UNIT MODELS		37AHA04508KA5	37AHA06012KA5	37AHA07514KA5	37AHA09016KA5
Trade Name		AH45	AH60	AH75	AH90
RATING AND PERFORMANCE		Descriptor (Typ.)			
Nominal Output Capacity (BTU/h) †		45,000	60,000	75,000	90,000
Air Side Temperature Rise Rate in °F (68°F Entering Air @ 150°F Entering Water)	Heat Speed	50	50	50	50
External Static Pressure	(in. W.C.)	0.5	0.5	0.5	0.5
Nominal Airflow (CFM)	Heating	800 ±	1200 ±	1400 ±	1600 ±
	Cooling Range	650 - 800	650 - 1200	1000 - 1600	1200 - 1750
ELECTRICAL					
Power Supply	V - HZ - PH	115-60-1			
Minimum Circuit Ampacity	MCA	6.3	8.7	13.7	14.3
Max. Rating of Overcurrent Protective Device	MOP (Calculated)	9.9	14.2	23.2	24.3
Maximum Fuse or CKT BKR Size	Amps	15	15	20	20
Transformer (24V)		40 VA (Primary: 120 VAC / Secondary: 24 VAC)			
Printed Circuit Board	PCB	INTEGRAL (with connections for A/C system, UV lamp, Humidifier, and electronic air cleaner)			
CONTROLS					
Available Unit Configurations	A/C or HP	Dip Switch Selectable (SW1)			
	Single or Two Stage FS or WH	Dip Switch Selectable (SW1) Shunt Selectable (P-7)			
Safety Door Switch	Rated Voltage	125 VAC			
	Resistive Load	21 Amp			
Blower Off Delay	HTG/CLG	Dip-switch Selectable/Fixed 30 Sec			
Cool / Heat Blower On Delay	Varies	Cool: 1 second / Heat: 25 seconds (see Sequence of Operations)			
INDOOR BLOWER MOTOR					
Type		DIRECT DRIVE MOTOR (PSC)			
Motor HP		1/3	1/2	3/4	1
Motor (Rated Load Amps/Locked Rotor Amps)	RLA/LRA	3.6 / 11.0	5.5 / 18.2	9.5 / 21.5	10.0 / 22.2
Run Capacitor	mfd/volts	10/370			25/370
Volts-PH-HZ		115-1-60			
CIRCULATING PUMP					
Type		Wet Rotor			
Volts-PH-HZ		115-1-60			
Motor (Full Load Amps/Locked Rotor Amps)	FLA/LRA	1.8 / 2.6			
Pump Motor HP		1/8			
Run Capacitor	mfd/volts	14/250			
Maximum Working Pressure	PSI	125			
Min/Max Fluid Temperature	°F (°C)	120 (49) / 160 (71)			
HYDRONIC HEATING COIL					
Coil Construction		3/8" OD copper tubes, aluminum fins, galvanized steel frame			
Rows...Fins/In		2...16	2...16	3...14	3...15
Total Face Area	Sq. Ft.	2.3	2.6	2.8	3.3
Approximate Internal Volume	Gallons	0.47	0.53	0.86	1.02
PIPING CONNECTIONS - (QT Y)					
Type		Copper Stubs			
Supply Diameter	Inches	(1) 3/4			
Return Diameter	Inches	(1) 3/4			
RETURN-AIR FILTERS					
Filter Type (Throwaway)	Inches ††	12 X 20 X 1	16 X 20 X 1	20 X 20 X 1	(2) 12 X 20 X 1
UNIT WEIGHT					
Shipping	lbs	92	109	118	136
Installed (with water)	lbs	107	127	138	159

† Tested in accordance with ANSI/ASHRAE Standard 37-1988

‡ Airflow shown is for bottom only return-air (fan speed factory set). For air delivery other than stated, refer to Fan Performance table

†† Required filter sizes shown are based on the larger of the ARI (Air Conditioning & Refrigeration Institute) rated cooling airflow or the heating airflow velocity of 300 ft/min for throwaway type or 450 ft/min for high-capacity type.

‡‡ Side intake filter to be (1) 20"x20"x1" typical for all models.

Air filter pressure drop for non-standard filters must not exceed 0.08 in. WC.

1 MBH = 1000 BTU/h

Dry Coil Air Delivery

UNIT SIZE	OPERATING MODE	BLOWER SPEED	ESP (in. w.c.)								
			0.00	0.10	0.20	0.30	0.40	0.50	0.60	0.70	0.80
37AHA04508KA5 (AH45) (Bottom or Right Side Return w/ Optional Side Filter Rack)			AIRFLOW (CFM)								
	1-1/2 Ton A/C or HP	Low	800	780	760	730	700	670	610	540	470
	2 Ton A/C or HP	Medium	920	900	870	830	780	740	680	610	540
	Hydronic Heat	High	1090	1050	1000	950	900	830 ‡	760	680	590
37AHA04508KA5 (AH45) (Left Side Return w/ Optional Side Filter Rack)			AIRFLOW (CFM)								
	1-1/2 Ton A/C or HP	Low	800	800	790	780	750	730	670	610	550
	2 Ton A/C or HP	Medium	980	970	950	910	860	810	750	680	610
	Hydronic Heat	High	1190	1140	1090	1040	980	920	840	770	690
37AHA06012KA5 (AH60) (Bottom or Right Side Return w/ Optional Side Filter Rack)			AIRFLOW (CFM)								
	1-1/2 Ton A/C or HP	Low	710	710	700	690	680	670	630	590	520
	2 Ton A/C or HP	Medium-Low	860	850	840	830	820	810	790	750	690
	2-1/2 Ton A/C or HP	Medium-High	1150	1140	1130	1110	1050	1020	950	920	820
	Hydronic Heat / 3 Ton A/C or HP	High	1460	1440	1410	1350	1300	1240 ‡	1170	1080	1000
37AHA06012KA5 (AH60) (Left Side Return w/ Optional Side Filter Rack)			AIRFLOW (CFM)								
	1-1/2 Ton A/C or HP	Low	720	720	710	700	690	680	640	600	530
	2 Ton A/C or HP	Medium-Low	870	860	850	840	830	820	800	760	700
	2-1/2 Ton A/C or HP	Medium-High	1210	1200	1180	1160	1100	1070	1000	960	860
	Hydronic Heat / 3 Ton A/C or HP	High	1570	1550	1520	1460	1400	1340	1260	1160	1080
37AHA07514KA5 (AH75) (Bottom or Right Side Return w/ Optional Side Filter Rack)			AIRFLOW (CFM)								
	2-1/2 Ton A/C or HP	Low	1130	1120	1100	1080	1050	1020	990	910	860
	3 Ton A/C or HP	Medium-Low	1340	1320	1300	1270	1240	1200	1160	1130	1030
	Hydronic Heat / 3-1/2 Ton A/C or HP	Medium-High	1570	1550	1510	1480	1440	1400 ‡	1330	1260	1210
	4 Ton A/C or HP	High	1860	1810	1760	1710	1650	1600	1530	1460	1370
37AHA07514KA5 (AH75) (Left Side Return w/ Optional Side Filter Rack)			AIRFLOW (CFM)								
	2-1/2 Ton A/C or HP	Low	1140	1130	1110	1090	1060	1030	1000	920	870
	3 Ton A/C or HP	Medium-Low	1380	1360	1350	1310	1280	1240	1200	1170	1060
	Hydronic Heat / 3-1/2 Ton A/C or HP	Medium-High	1670	1650	1600	1570	1530	1490	1410	1340	1280
	4 Ton A/C or HP	High	2010	1960	1910	1850	1790	1730	1660	1580	1480
37AHA09016KA5 (AH90) (Bottom or Right Side Return w/ Optional Side Filter Rack)			AIRFLOW (CFM)								
	3 Ton A/C or HP	Low	1370	1360	1340	1290	1260	1230	1180	1130	1080
	3-1/2 Ton A/C or HP	Medium-Low	1620	1600	1530	1480	1450	1400	1330	1250	1150
	Hydronic Heat / 4 Ton A/C or HP	Medium-High	1760	1730	1710	1680	1650	1590 ‡	1500	1400	1290
	5 Ton A/C or HP	High	2050	2000	1940	1890	1820	1730	1630	1540	1400
37AHA09016KA5 (AH90) (Left Side Return w/ Optional Side Filter Rack)			AIRFLOW (CFM)								
	3 Ton A/C or HP	Low	1350	1340	1340	1330	1330	1320	1300	1240	1170
	3-1/2 Ton A/C or HP	Medium-Low	1620	1610	1600	1570	1500	1480	1460	1380	1310
	Hydronic Heat / 4 Ton A/C or HP	Medium-High	1800	1790	1780	1770	1720	1660	1600	1510	1400
	5 Ton A/C or HP	High	2180	2140	2070	1990	1920	1850	1760	1680	1570

CFM Cubic Feet per Minute (with filter installed)

ESP External Static Pressure

‡ Factory Setting