

# ergotron<sup>®</sup>

*moving you forward*

## **LX** **Desk Monitor Arm**

- Increases viewing comfort by helping reduce eye, back and neck strain
- 13" (33 cm) height range meets the ergonomic needs of more than nine out of ten adults
- Patented Constant Force™ motion technology positions displays with a light touch
- Folding arm frees up space in constrained areas
- Passes Ergotron's 10,000-cycle motion test
- 10-year warranty
- Multiple desk attachment options included with LX arms and as accessory kits



UNPARALLELED RANGE OF MOTION ENHANCES  
ERGONOMIC COMFORT AND PRODUCTIVITY!



Outfit your desk with an accessory that makes an impact. The LX Desk Monitor Arm adds flexibility and ergonomics backed by research for your monitor or TV. Sleek and streamlined, it frees up space and allows you to easily position your display for greater productivity. Ideal for home and office use, the LX Desk Monitor Arm is the go-to solution for areas where several people use the same display.

# LX Desk Monitor Arm

## AVAILABLE DESK ATTACHMENT OPTIONS

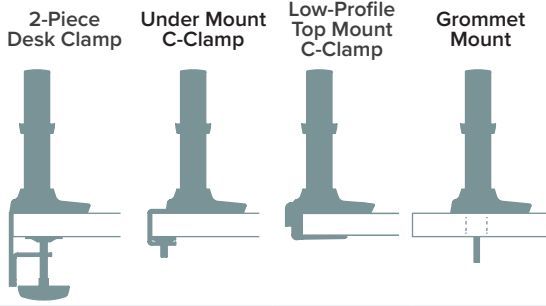

	2-Piece Desk Clamp	Under Mount C-Clamp	Low-Profile Top Mount C-Clamp	Grommet Mount
Height-adjustable tables	Compatible	Compatible	Recommended	Compatible
Sliding desks	—	—	Recommended	—
Panel systems	Recommended	—	—	Compatible
Benching systems	—	Recommended	—	Compatible
Other	Recommended	—	—	Compatible

Included with some monitor arms or as accessories



	LX Desk Monitor Arm	LX Desk Monitor Arm, Tall Pole	LX Desk Monitor Arm, Under Mount C-Clamp	LX Desk Monitor Arm, Low-Profile Top Mount C-Clamp
Part # (color)	45-241-026 (polished aluminum/black) 45-490-216 (white) 45-241-224 (matte black)	45-295-026 (polished aluminum/black) 45-537-216 (white)	45-503-216 (white)	Americas: 45-626-216 (white) 45-626-224 (matte black)
Includes	45-241-026/ 45-241-224: Monitor arm, extension, 7" pole and base, standard 2-piece desk clamp, grommet mount and monitor mounting hardware 45-490-216: Monitor arm, extension, 7" pole and base, standard 2-piece desk clamp and monitor mounting hardware	45-295-026: Monitor arm, extension, tall 12" pole and base, standard 2-piece desk clamp, grommet mount and monitor mounting hardware 45-537-216: Monitor arm, extension, tall 12" pole and base, standard 2-piece desk clamp and monitor mounting hardware	Monitor arm, extension, 7" pole and base, under mount c-clamp and monitor mounting hardware	Monitor arm, extension, 7" pole and base, low-profile top mount c-clamp and monitor mounting hardware. Compatible with 0.98–1.38" (25–35 mm) thick worksurfaces. Clamp kits available for thinner worksurfaces.
Typical LCD Size	≤ 34"			
<small>LCD SIZE IS APPROXIMATION. DIMENSION IS DIAGONAL MEASUREMENT OF SCREEN. LCD SIZE MAY BE EXCEEDED AS LONG AS SCREEN WEIGHT DOES NOT EXCEED MAXIMUM WEIGHT CAPACITY OF THE MOUNT.</small>				
Weight Capacity	7–25 lbs (3,2–11,3 kg)			
Lift	13" (33 cm)			
Tilt	75° ↑ 70° / ↓ 5°			
Pan	360°			
Rotation	360°			
VESA	VESA FDMI MIS-D, 100/75, C (100 x 100 mm & 75 x 75 mm hole pattern)			
Extension	≤ 25" (64 cm)			
Shipping Weight	9.75 lbs (4,4 kg)	11.2 lbs (5,2 kg)	8.55 lbs (3,8 kg)	8.8 lbs (4 kg)
Shipping Dimensions	22.2" x 9.9" x 5.6" (56 x 25 x 14 cm)	22.8" x 11.4" x 7.1" (58 x 29 x 18 cm)	18.1" x 10.8" x 7.2" (46 x 27,4 x 18,2 cm)	16.7" x 13.2" x 6.2" (42,4 x 33,5 x 15,7 cm)
Warranty	10 years			



# ergotron®

*moving you forward*

## LX Dual Stacking Arm

- Positions monitors for maximum comfort with unparalleled range of motion
- Helps reduce eye, back and neck strain with 13" (33 cm) of height adjustment
- Allows you to easily position displays thanks to patented Constant Force™ technology
- Frees up space in tight areas with the foldable arms
- Passes Ergotron's 10,000-cycle motion test with a 10-year warranty
- Multiple desk attachment options are available included with LX arms and as accessory kits

## TALL POLE DIFFERENTIATORS

- 22" (55,9 cm) pole lets you mount 1–2 additional displays (requires an LX Arm, Extension and Collar Kit for each)
- Supports larger displays and positions monitors higher for a better view when standing

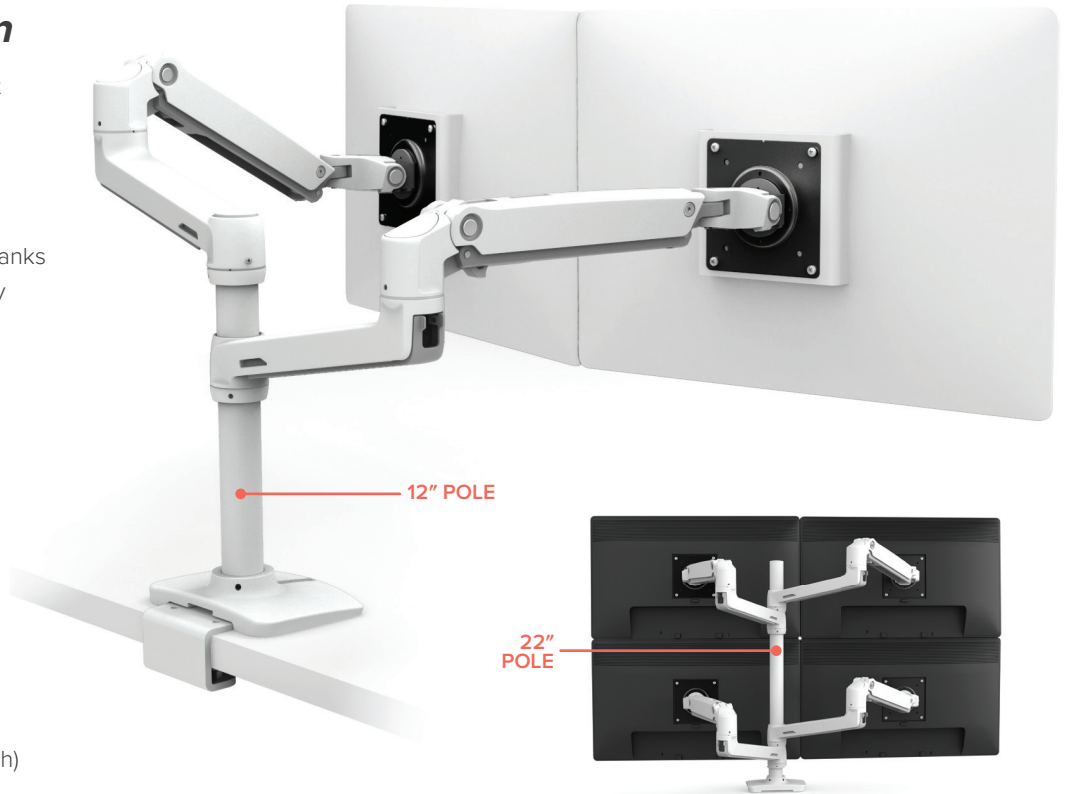

22"  
POLE

TALL POLE VERSION ALLOWS YOU TO MOUNT UP TO TWO ADDITIONAL DISPLAYS (REQUIRES AN LX ARM, EXTENSION AND COLLAR KIT FOR EACH)

UNPARALLELED RANGE OF MOTION WITH  
MULTIPLE MONITORS ENHANCES PRODUCTIVITY

Outfit your desk with an accessory that makes an impact. The LX Monitor Arm adds flexibility and ergonomics backed by research for your monitor or TV. Sleek and streamlined, it frees up space and allows you to easily position multiple displays for greater productivity. Ideal for home and office use, the LX Monitor Arm is the go-to solution for areas where several people use the same system.

The Tall Pole version supports additional and larger displays, often used in security, air traffic and emergency control centers. It makes monitor viewing easy on trading floors/finance, call centers, medical departments, and positions multiple displays used for software development, gaming and more.



# LX Dual Stacking Arm



NOTEBOOK TRAY KIT SHOWN ABOVE IS INCLUDED WITH THE POLISHED ALUMINUM LX DUAL STACKING ARM #45-248-026

FOR ALL OTHER LX DUAL STACKING ARMS, THE NOTEBOOK TRAY KIT CAN BE ORDERED SEPARATELY #50-193-200 (AVAILABLE IN BLACK ONLY)

## SEVERAL DESK ATTACHMENT OPTIONS ARE AVAILABLE

### 2-Piece Desk Clamp



Most common attachment  
Slides on from back or side of desk  
Works with a wide variety of desk sizes and shapes

### Under Mount C-Clamp



Use when the space for clamp under desk is very limited  
Presents a cleaner look  
Requires minimum space under desk for attachment

### Top Mount C-Clamp



Attaches above the desk surface for an easier and more ergonomic installation  
Requires minimum space under desk for attachment

### Grommet Mount



Use when mounting to edge of desk is not available or not preferred

Included with some products and also available as accessory kits

### LX Dual Stacking Arm

### LX Dual Stacking Arm, Under Mount C-Clamp

### LX Dual Stacking Arm, Top Mount C-Clamp

Part # (color)	45-248-026 (polished aluminum/black) 45-492-216 (white) North America/APAC: 45-492-224 (matte black)	45-502-216 (white)	45-525-216 (white) EMEA
Includes	45-248-026: Two (2) monitor arms and extensions, 12" pole, standard 2-piece desk clamp and grommet mount, one (1) notebook tray* and fastening kit (Velcro, non-slip pad or clips) 45-492-216/45-492-224: Two (2) monitor arms and extensions, pole and standard 2-piece desk clamp; <i>notebook tray not included</i>	Two monitor arms and extensions, 12" pole and Under Mount C-Clamp <i>(notebook tray not included)</i>	Two monitor arms and extensions, 12" pole and Top Mount C-Clamp <i>(notebook tray not included)</i>
Typical LCD Size	≤ 24"		
<small>LCD SIZE IS APPROXIMATION. DIMENSION IS DIAGONAL MEASUREMENT OF SCREEN. LCD SIZE MAY BE EXCEEDED AS LONG AS SCREEN WEIGHT DOES NOT EXCEED MAXIMUM WEIGHT CAPACITY OF THE MOUNT.</small>			
Weight Capacity	7–20 lbs (3,2–9,1 kg) each *Notebook 2.5–12 lbs (1,1–5,4 kg) Maximum combined 40 lbs (18,1 kg)	7–20 lbs (3,2–9,1 kg) Maximum combined 40 lbs (18,1 kg)	
Lift	13" (33 cm)		
Tilt	75° ↑ 70° / ↓ 5°		
Pan	360°		
Rotation	360°		
VESA	VESA FDMI MIS-D, 100/75, C (100 x 100 mm & 75 x 75 mm hole pattern)		
Extension	≤ 25" (64 cm)		
Shipping Weight	15.75 lbs (7,18 kg)	16 lbs (7,2 kg)	
Shipping Dimensions	19.25"H x 15.25"W x 9"D (48,7 x 38,7 x 22,9 cm)	19.6" x 15.7" x 10.7" (50 x 39,8 x 27,1 cm)	15.75" x 9.5" x 10.5" (40,1 x 24,1 x 26,7 cm)
Warranty	10 years		

# LX Dual Stacking Arm, Tall Pole



STANDARD CONFIGURATION SUPPORTS TWO DISPLAYS

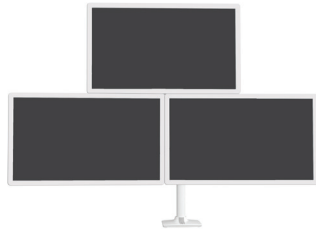

ONE LX ARM, EXTENSION AND COLLAR KIT SUPPORTS THREE DISPLAYS

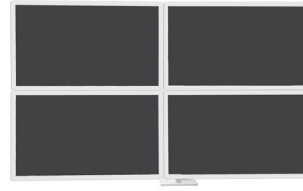

TWO LX ARM, EXTENSION AND COLLAR KITS SUPPORT FOUR DISPLAYS



## LX Dual Stacking Arm, Tall Pole

Part # (color)	45-549-026 (polished aluminum/black accents) 45-509-216 (white/grey accents)
Includes	Two (2) LX arms and extensions, 22" pole, heavy-duty 2-piece mounting clamp desk bracket with dual mounting clamps, pole collar, cap, grommet mount plate and hardware, and monitor mounting hardware
Typical LCD Size	≤ 40"
<small>LCD SIZE IS APPROXIMATION. DIMENSION IS DIAGONAL MEASUREMENT OF SCREEN. LCD SIZE MAY BE EXCEEDED AS LONG AS SCREEN WEIGHT DOES NOT EXCEED MAXIMUM WEIGHT CAPACITY OF THE MOUNT.</small>	
Weight Capacity	Two arms: 7–20 lbs (3,2–9,1 kg) each Three or four arms: 7–11 lbs (3,2–5 kg) each
Lift	13" (33 cm)
Tilt	75° ↑ 70° / ↓ 5°
Pan	360°
Rotation	360°
VESA	VESA FDMI MIS-D, 100/75, C (100 x 100 mm & 75 x 75 mm hole pattern)
Extension	≤ 25" (64 cm)
Shipping Weight	24 lbs (10,9 kg)
Shipping Dimensions	29.9"H x 17.7"W x 7.1"D (76 x 45 x 18 cm)
Warranty	10 years



LX ARM, EXTENSION AND COLLAR KIT REQUIRED TO ADD A THIRD AND FOURTH ARM TO THE TALL POLE VERSION



POLISHED ALUMINUM WITH BLACK ACCENTS  
#97-940-026



WHITE WITH GREY ACCENTS  
#98-130-216



A NOTEBOOK TRAY KIT CAN BE ORDERED SEPARATELY #50-193-200 (AVAILABLE IN BLACK ONLY)

Download additional resources at [ergotron.com](http://ergotron.com).

For more information:

Americas: 800.888.8458 / +1.651.681.7600 / [insidesales@ergotron.com](mailto:insidesales@ergotron.com)

EMEA: +31.33.45.45.600 / [info.eu@ergotron.com](mailto:info.eu@ergotron.com)

APAC: [apaccustomerservice@ergotron.com](mailto:apaccustomerservice@ergotron.com)

Custom: [custom@ergotron.com](mailto:custom@ergotron.com)

© Ergotron, Inc. 03.26.2020

Literature made in the U.S.A. Content subject to change.

Ergotron devices are not intended to cure, treat, mitigate or prevent any disease.

Patent information available at [www.ergotron.com/patents](http://www.ergotron.com/patents).

WorkFit, StyleView, LearnFit, Neo-Flex, PowerShuttle, LiFeKinnex, CareFit and eKinnex are trademarks of Ergotron.



# ergotron®

*moving you forward*

## **LX Dual Side-by-Side Arm**

- Position monitors for maximum ergonomic comfort with unparalleled range of motion
- Increases viewing comfort and helps reduce eye, back and neck strain
- Provides 13" (33 cm) height adjustment
- Allows you to easily position displays with patented Constant Force™ technology
- Folding arms free up space in tight spaces
- Passes Ergotron's 10,000-cycle motion test with a 10-year warranty
- Multiple desk attachment options are available with LX arms and as accessory kits



UNPARALLELED RANGE OF MOTION ENHANCES  
ERGONOMIC COMFORT AND PRODUCTIVITY!



An LX Dual Side-by-Side Arm is the perfect desk accessory to add flexibility and superior ergonomics to your monitors. Sleek and streamlined, it frees up space and allows you to easily position your displays for greater productivity. It's ideal for home and office use, especially in areas where several people use the same system.

# LX Dual Side-by-Side Arm

SEVERAL DESK ATTACHMENT OPTIONS ARE AVAILABLE

## 2-Piece Desk Clamp



Most common attachment  
Slides on from back or side of desk  
Works with a wide variety of desk sizes and shapes

## Under Mount C-Clamp



Use when the space for clamp under desk is very limited  
Presents a cleaner look  
Requires minimum space under desk for attachment

## Top Mount C-Clamp

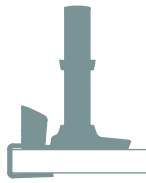

Attaches above the desk surface for an easier and more ergonomic installation  
Requires minimum space under desk for attachment

## Grommet Mount



Use when mounting to edge of desk is not available or not preferred

Included with some products and also available as accessory kits

## LX Dual Side-by-Side Arm

Part # (Color)	45-245-026 (polished aluminum) 45-491-216 (white) 45-245-224 (matte black)
Includes	45-245-026: Two monitor arms, extensions, pole, standard 2-piece desk clamp and grommet mount 45-491-216/45-245-224: Two monitor arms, extensions, pole and standard 2-piece desk clamp
Typical LCD Size	≤ 27"
<small>LCD SIZE IS APPROXIMATION. DIMENSION IS DIAGONAL MEASUREMENT OF SCREEN. LCD SIZE MAY BE EXCEEDED AS LONG AS SCREEN WEIGHT DOES NOT EXCEED MAXIMUM WEIGHT CAPACITY OF THE MOUNT.</small>	
Weight Capacity	7–20 lbs (3,2–9,1 kg) Maximum combined 40 lbs (18,1 kg)
Lift	13" (33 cm)
Tilt	75° ↑ 70° / ↓ 5°
Pan	360°
Rotation	360°
VESA	VESA FDMI MIS-D, 100/75, C (100 x 100 mm & 75 x 75 mm hole pattern)
Extension	≤ 25" (64 cm)
Shipping Weight	17.25 lbs (7,85 kg)
Shipping Dimensions	19.3"H x 17.8"W x 6.3"D (49 x 45 x 16 cm)
Warranty	10 years



CABLES ROUTE BENEATH THE ARM, OUT OF THE WAY

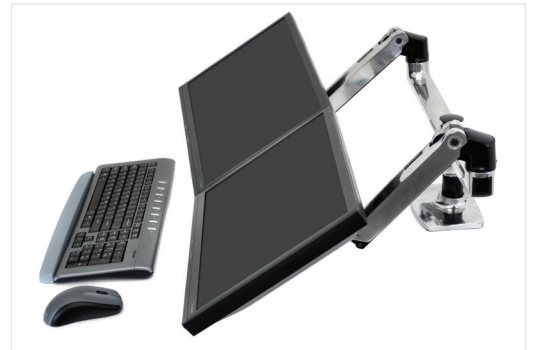

Download additional resources at [ergotron.com](http://ergotron.com).

For more information:

Americas: 800.888.8458 / +1.651.681.7600 / [insidesales@ergotron.com](mailto:insidesales@ergotron.com)

EMEA: +31.33.45.45.600 / [info.eu@ergotron.com](mailto:info.eu@ergotron.com)

APAC: [apaccustomerservice@ergotron.com](mailto:apaccustomerservice@ergotron.com)

Custom: [custom@ergotron.com](mailto:custom@ergotron.com)

© Ergotron, Inc. 03.26.2020

Literature made in the U.S.A. Content subject to change.

Ergotron devices are not intended to cure, treat, mitigate or prevent any disease.

Patent information available at [www.ergotron.com/patents](http://www.ergotron.com/patents).

WorkFit, StyleView, LearnFit, Neo-Flex, PowerShuttle, LiFeKinnex, CareFit and eKinnex are trademarks of Ergotron.



# ergotron®

*moving you forward*

## **LX Desk Dual Direct Arm**

- Easily move two monitors simultaneously to the best ergonomic position
- Allows you to work comfortably and helps reduce eye, back and neck strain
- Frees up your desktop to increase valuable workspace
- Offers an easy to use experience — simple installation to effortless operation
- Provides easy display adjustment with patented Constant Force™ technology
- Passes Ergotron's 10,000-cycle motion test ensuring years of trouble-free height adjustment
- 10-year warranty
- Multiple desk attachment options included with LX arms and as accessory kits

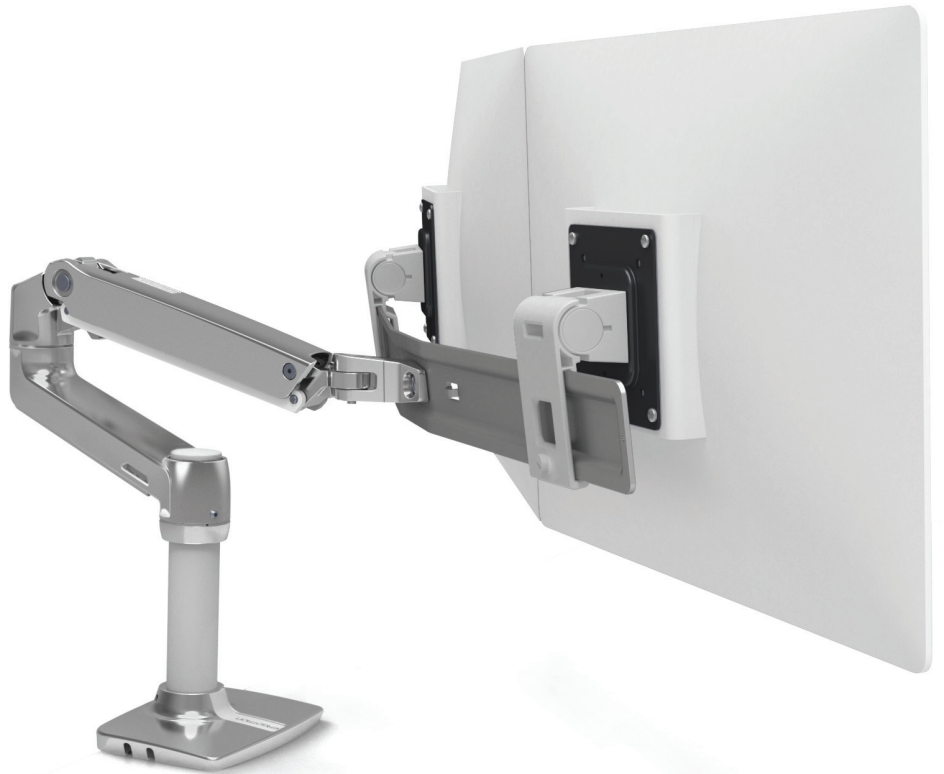

### COMPACT DUAL MONITOR ARM INCREASES YOUR WORKSPACE WITH FLEXIBLE, EASY-TO-USE ADJUSTMENT

Create a fully adjustable side-by-side monitor set-up that lifts both LCD screens simultaneously with the LX Desk Dual Direct Arm. The monitor arm makes it easier to see your screens while letting you make the most of valuable workspace.

Repositioning your LCDs is easy. With a simple touch, you can move the screens up, down, forward or back. Customize your view further with individual up and down tilt for each monitor. The low-profile monitor cross-bar provides a compact range of motion that is suitable for most desks.





# LX Desk Dual Direct Arm

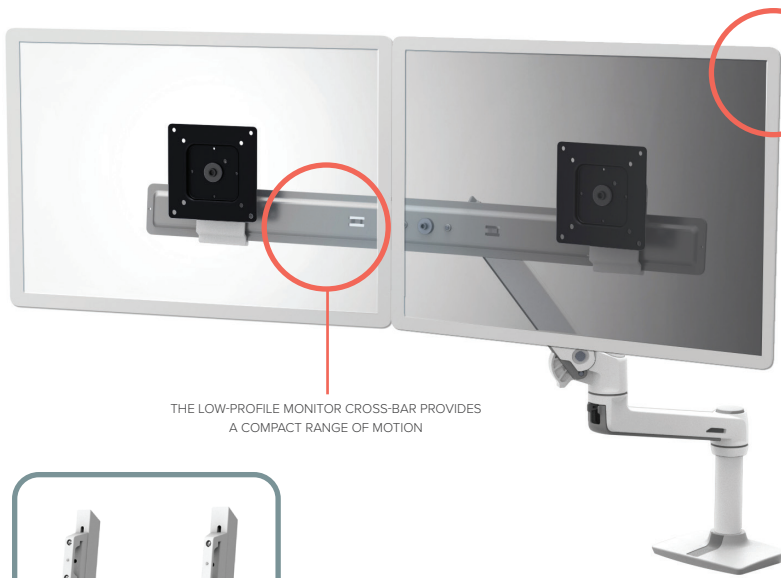

EACH MONITOR HAS INDIVIDUAL UP/DOWN TILT

THE LOW-PROFILE MONITOR CROSS-BAR PROVIDES A COMPACT RANGE OF MOTION

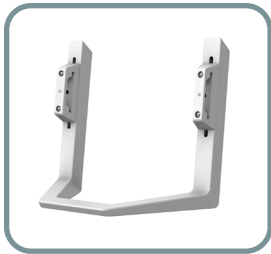

RECOMMENDED ACCESSORY:  
LX DUAL DIRECT HANDLE KIT  
98-037-062 WHITE  
98-037-224 MATTE BLACK

## AVAILABLE DESK ATTACHMENT OPTIONS

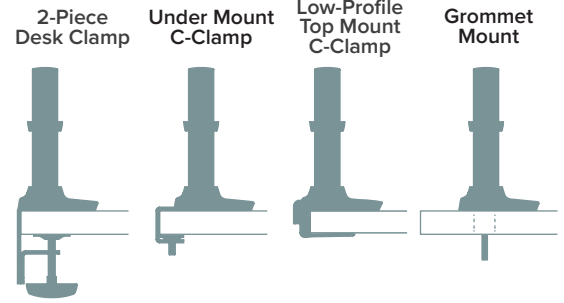

	2-Piece Desk Clamp	Under Mount C-Clamp	Low-Profile Top Mount C-Clamp	Grommet Mount
Height-adjustable tables	Compatible	Compatible	Recommended	Compatible
Sliding desks	—	—	Recommended	—
Panel systems	Recommended	—	—	Compatible
Benching systems	—	Recommended	—	Compatible
Other	Recommended	—	—	Compatible

Included with some monitor arms or as accessories

	LX Desk Dual Direct Arm	LX Desk Dual Direct Arm, Under Mount C-Clamp	LX Desk Dual Direct Arm, Low-Profile Top Mount C-Clamp	LX Desk Dual Direct Handle Kit
Part # (color)	Americas, APAC: 45-489-026 (polished aluminum) 45-489-216 (white) 45-489-224 (matte black)	45-522-216 (white)	Americas: 45-627-216 (white) 45-627-224 (matte black)	98-037-062
Includes	Monitor arm, extension, standard 2-piece desk clamp, dual bow, 2 monitor pivots, 7" pole and monitor mounting hardware	Monitor arm, extension, dual bow, 2 monitor pivots, 7" pole, under mount c-clamp and monitor mounting hardware	LX Arm, extension, low-profile top mount c-clamp, dual bow, (2) monitor pivots, 7" pole and monitor mounting hardware. Compatible with 0.98–1.38" (25–35 mm) thick worksurfaces. Clamp kits available for thinner worksurfaces.	Handle and handle mounting hardware
Typical LCD Size	≤ 25"			—
LCD SIZE IS APPROXIMATION. DIMENSION IS DIAGONAL MEASUREMENT OF SCREEN. LCD SIZE MAY BE EXCEEDED AS LONG AS SCREEN WEIGHT DOES NOT EXCEED MAXIMUM WEIGHT CAPACITY OF THE MOUNT.				
Weight Capacity	Maximum individual LCD weight 2–11 lbs (1–5 kg) per monitor. Total weight capacity 4–22 lbs (1,8–10 kg)			—
Lift	13" (33 cm)			5.7–10" (14,5–25,4 cm) Adjustable vertical height from center of monitor pivot to top of handle
Tilt	↑ 15° / ↓ 15°			—
Pan	360°			—
Rotation	360°			—
VESA	VESA FDMI MIS-D, 100/75, C (100 x 100 mm & 75 x 75 mm hole pattern)			—
Extension	≤ 24.3" (61,7 cm)			—
Shipping Weight	15.5 lbs (6,6 kg)	13.6 lbs (6,2 kg)	13.2 lbs (6 kg)	13.3 lbs (1,5 kg)
Shipping Dimensions	32.8" x 13" x 7" (83 x 33 x 18 cm)	32.9" x 12.8" x 6.9" (83 x 32 x 17,5 cm)	30.6" x 12.2" x 7.6" (77,7 x 31 x 19,2 cm)	14.6" x 13" x 8.4" (37 x 33 x 21 cm)
Warranty	10 years			

