

Operation Manual

Network Management Card 2 for Modular PDU, RPP, and RDP

PDPM138H-5U

PDPM138H-R

PDPM144F

PDPM277H

PDPM72F-5U

990-9931-001

Publication Date: June 2016

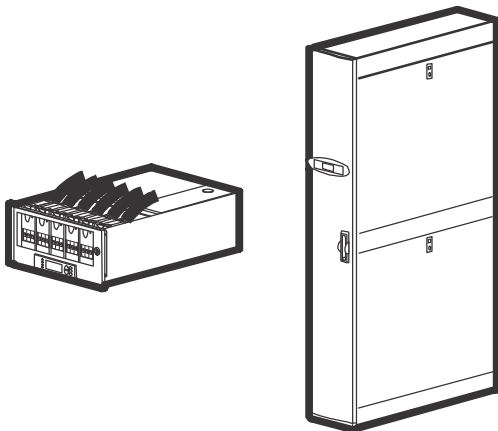

Schneider Electric Legal Disclaimer

The information presented in this manual is not warranted by Schneider Electric to be authoritative, error free, or complete. This publication is not meant to be a substitute for a detailed operational and site specific development plan. Therefore, Schneider Electric assumes no liability for damages, violations of codes, improper installation, system failures, or any other problems that could arise based on the use of this Publication.

The information contained in this Publication is provided as is and has been prepared solely for the purpose of evaluating data center design and construction. This Publication has been compiled in good faith by Schneider Electric. However, no representation is made or warranty given, either express or implied, as to the completeness or accuracy of the information this Publication contains.

IN NO EVENT SHALL SCHNEIDER ELECTRIC, OR ANY PARENT, AFFILIATE OR SUBSIDIARY COMPANY OF SCHNEIDER ELECTRIC OR THEIR RESPECTIVE OFFICERS, DIRECTORS, OR EMPLOYEES BE LIABLE FOR ANY DIRECT, INDIRECT, CONSEQUENTIAL, PUNITIVE, SPECIAL, OR INCIDENTAL DAMAGES (INCLUDING, WITHOUT LIMITATION, DAMAGES FOR LOSS OF BUSINESS, CONTRACT, REVENUE, DATA, INFORMATION, OR BUSINESS INTERRUPTION) RESULTING FROM, ARISING OUT, OR IN CONNECTION WITH THE USE OF, OR INABILITY TO USE THIS PUBLICATION OR THE CONTENT, EVEN IF SCHNEIDER ELECTRIC HAS BEEN EXPRESSLY ADVISED OF THE POSSIBILITY OF SUCH DAMAGES. SCHNEIDER ELECTRIC RESERVES THE RIGHT TO MAKE CHANGES OR UPDATES WITH RESPECT TO OR IN THE CONTENT OF THE PUBLICATION OR THE FORMAT THEREOF AT ANY TIME WITHOUT NOTICE.

Copyright, intellectual, and all other proprietary rights in the content (including but not limited to software, audio, video, text, and photographs) rests with Schneider Electric or its licensors. All rights in the content not expressly granted herein are reserved. No rights of any kind are licensed or assigned or shall otherwise pass to persons accessing this information.

This Publication shall not be for resale in whole or in part.

Table of Contents

Overview	1
Important Information	1
About This Manual	2
Related Documents	2
User Comments	2
Safety	3
IMPORTANT SAFETY INSTRUCTIONS	3
Regulatory Agency Approval	4
Waste Electrical and Electronic Equipment (WEEE) disposal	4
Additional Safety Information	5
Before you begin	5
Operation and Adjustments	5
Commissioning	6
Pre-Start Checklists	6
Initial Inspection Checklist	6
Electrical Inspection Checklist	6
User Interface Inspection Checklist	6
Final Inspection Checklist	6
Start-up Inspection Checklist	7
Operation	8
Display Interface	8
Navigate the display interface	8
Top dynamic display	9
Main Menu Screen	9
Password protection	9
Menu tree	10
Modules Submenu	11
View Module status	11
View Power Distribution Module information	12
View circuit status information	13
View load status	13
View total load by phase	14
View output voltages	14
View the log	15
Clear the log	15
View the list of active alarms	16

Configuration.....	17
Settings	17
Set up the network	17
Set the name and location of the circuits	17
Set individual alarm thresholds	18
Set alarm thresholds for all Modules in the PDU	19
Set and change the password settings	19
Change the display settings	20
Change date and time	20
Modbus Configuration.....	21
Modbus Serial Configuration	21
Modbus TCP Configuration	22
Network Management Configuration	23
Overview	23
Connections	23
Initial setup	23
Device IP Configuration Wizard	24
Supported Web browsers	24
Network management features	24
Log On	25
Overview	25
URL address formats	25
User Account Overview	26
Watchdog Features	27
Network interface watchdog mechanism	27
Resetting the network timer	27
Recover from a Lost Password	28
Maintenance	29
Parts Replacement.	29
Determine if you need a replacement part	29
Return parts	29
Power Distribution Modules	30
Component identification	30
Module Types	31
Installation	33
Remove a PDM	39
Troubleshooting	40
LED Indicators on PDMs	40
Status and Alarm Messages	40

Overview

Important Information

Read the instructions carefully to become familiar with this product before trying to install, operate, service or maintain it. The following messages may appear throughout this manual or on the equipment to warn of potential hazards or to call attention to information that clarifies or simplifies a procedure.



The addition of this symbol to a Danger or Warning safety label indicates that an electrical hazard exists which will result in personal injury if the instructions are not followed.



This is the safety alert symbol. It is used to alert you to potential personal injury hazards. Obey all safety messages that follow this symbol to avoid possible injury or death.

DANGER

DANGER indicates an imminently hazardous situation which, if not avoided, **will result in** death or serious injury.

WARNING

WARNING indicates a potentially hazardous situation which, if not avoided, **can result in** death or serious injury.

CAUTION

CAUTION indicates a potentially hazardous situation which, if not avoided, **can result in** minor or moderate injury.

CAUTION

CAUTION, used without the safety alert symbol, indicates a potentially hazardous situation which, if not avoided, **can result in** equipment damage.

NOTICE

NOTICE addresses practices not related to physical injury including certain environmental hazards, potential damage or loss of data.

About This Manual

This manual contains important safety warnings and instructions, gives an introduction to the display interface and provides detailed information for proper use of the equipment.

Related Documents

Download technical publications or look for updates to your manual at www.apc.com.

User Comments

Contact www.apc.com. We welcome your comments about this document.

Safety

IMPORTANT SAFETY INSTRUCTIONS

This manual contains important instructions that must be followed during installation, operation, and maintenance of the PDU. For safety reasons, only trained users are allowed to operate the display interface and replace the Power Distribution Modules (PDMs).

DANGER

HAZARD OF ELECTRIC SHOCK, EXPLOSION, OR ARC FLASH

- Electrical equipment must be installed, operated, serviced, and maintained only by qualified personnel.
- To remove a Power Distribution Module:
 1. Turn off all power supplying the equipment and perform appropriate lockout/tagout procedures before installing or removing the Power Distribution Module.
OR
 2. If a Symmetra PX UPS is providing power to the Modular PDU, place the UPS into battery operation (to reduce fault current) before removing the Power Distribution Module. To place the UPS into battery operation, see the UPS Operation Manual.
- The PDU must be installed in accordance with the National Electrical Code or the Canadian Electrical Code and all applicable local codes.
- Service access areas are locked with a Red Key. The Red Keys must remain under the control of qualified service personnel.
- Wear appropriate personal protection equipment (PPE) when performing maintenance on this PDU.

Failure to follow these instructions will result in death or serious injury.

WARNING

UNEXPECTED BEHAVIOR OF APPLICATION

Only trained users should operate the display or replace the Power Distribution Modules.

Failure to follow these instructions can result in death, serious injury, or equipment damage.

CAUTION

HAZARD OF EQUIPMENT DAMAGE

- For PDMs with Residual Current Devices (RCDs) installed, the occurrence of a ground fault will automatically open the adjacent circuit-breaker.
- PDMs with RCDs are equipped with a test button. Periodic testing of the RCD may be required. Check local codes for your region.

Failure to follow these instructions can result in equipment damage.

Regulatory Agency Approval

This equipment has been tested and found to comply with the limits for a class A digital device, pursuant to part 15 of the FCC Rules. These limits are designed to provide reasonable protection against harmful interference, when the equipment is operated in a commercial environment. This equipment generates, uses, and can radiate radio frequency energy and, if not installed and used in accordance with the installation guide, may cause harmful interference to radio communications. Operation of this equipment in a residential area is likely to cause harmful interference in which case the user will be required to correct the interference at his own expense.

This class A digital apparatus complies with Canadian ICES-003.

Cet appareil numérique de la classe A est conforme à la norme NMB-003 du Canada.

This is a class A product. In a domestic environment this product may cause interference in which case the user may be required to take adequate measures.

Waste Electrical and Electronic Equipment (WEEE) disposal



Schneider Electric products comply with international directives on the Restriction of Hazardous Substances (RoHS) in electronic and electrical equipment and the disposal of Waste Electrical and Electronic Equipment (WEEE). Dispose of any waste electronic or electrical equipment with the appropriate recycling center. Contact Schneider Electric for assistance.

Additional Safety Information

Before you begin

Verify that the system is free from all short circuits and grounds, except those grounds installed according to local regulations (according to the National Electrical Code in the U.S.A., for instance). If high-potential voltage testing is necessary, follow recommendations in equipment documentation to prevent accidental equipment damage.

Before energizing equipment:

- Remove tools, meters, and debris from equipment.
- Close the equipment enclosure door.
- Perform all start-up tests recommended by the manufacturer.

Operation and Adjustments

The following precautions are from the NEMA Standards Publication ICS 7.1-195 (English version prevails):

- Regardless of the care exercised in the design and manufacture of equipment or in the selection and ratings of components, there are hazards that can be encountered if such equipment is improperly operated.
- It is possible to misadjust the equipment and thus produce unsatisfactory or unsafe operation. Always use the manufacturer's instructions as a guide for functional adjustments. Personnel who have access to these adjustments should be familiar with the equipment manufacturer's instructions and other equipment used with this product.
- Only those operational adjustments actually required by the operator should be accessible to the operator. Access to other controls should be restricted to prevent unauthorized changes in operating characteristics.

⚠ WARNING
UNGUARDED MACHINERY HAZARD <ul style="list-style-type: none">• Do not use this product with equipment which does not have point-of-operation protection.• Do not reach into equipment during operation. Failure to follow these instructions can result in death, serious injury, or equipment damage.

Commissioning

Pre-Start Checklists

⚠ ⚠ DANGER
HAZARD OF ELECTRIC SHOCK, EXPLOSION, OR ARC FLASH
<ul style="list-style-type: none">• Procedures in this section should be performed by qualified personnel only.• Equipment must be properly de-energized and locked-out prior to performing service.
Failure to follow these instructions will result in death or serious injury.

After installation, verify that all components are working properly and that the equipment is ready to begin operation.

Initial Inspection Checklist

Ensure the:

<input type="checkbox"/>	Installation procedure is complete according to the installation manual.
<input type="checkbox"/>	Equipment shows no signs of damage.
<input type="checkbox"/>	Clearance around the equipment is in accordance with local and national codes and regulations as well as the installation manual.
<input type="checkbox"/>	Equipment is leveled and joined to the adjacent racks as specified in the installation manual.

Electrical Inspection Checklist

Ensure the:

<input type="checkbox"/>	Incoming voltages match the phase and voltage listing on the nameplate.
<input type="checkbox"/>	Electrical wiring complies with local and national codes and regulations.
<input type="checkbox"/>	Equipment is properly grounded.
<input type="checkbox"/>	All field electrical connections are tight.
<input type="checkbox"/>	Circuit breakers are correct.

User Interface Inspection Checklist

Ensure the:

<input type="checkbox"/>	The building management system is connected correctly.
<input type="checkbox"/>	The network port is connected correctly and an IP address has been assigned to the equipment.

Final Inspection Checklist

Ensure the:

<input type="checkbox"/>	System is clean and free from debris.
<input type="checkbox"/>	Packaging materials are disposed of properly.

Start-up Inspection Checklist

DANGER

HAZARD OF ELECTRIC SHOCK, EXPLOSION, OR ARC FLASH

Wear appropriate personal protective equipment (PPE) when checking hazardous voltages.

Failure to follow these instructions will result in death or serious injury.

<input type="checkbox"/>	Verify that the PDU is in Total Power OFF mode. All circuit breakers and modules are OFF.
<input type="checkbox"/>	Set all modules that will be used to ON
<input type="checkbox"/>	1. Power Up the PDU. 2. Make sure the incoming power circuit breaker is set to ON. 3. If applicable, set the Subfeed circuit breaker to ON.
<input type="checkbox"/>	Verify that the display interface is working properly.
<input type="checkbox"/>	Verify through the display interface that the PDU sees the correct number of power modules.
<input type="checkbox"/>	Using a phase rotation meter, verify phase rotation.
<input type="checkbox"/>	Resolve any unexpected alarms.
<input type="checkbox"/>	Configure the date and time through the display interface.
<input type="checkbox"/>	Review the Event Log. Check for abnormalities in the log. Resolve any abnormalities in the log. Clear the Event Log when you are finished.

Operation

Display Interface

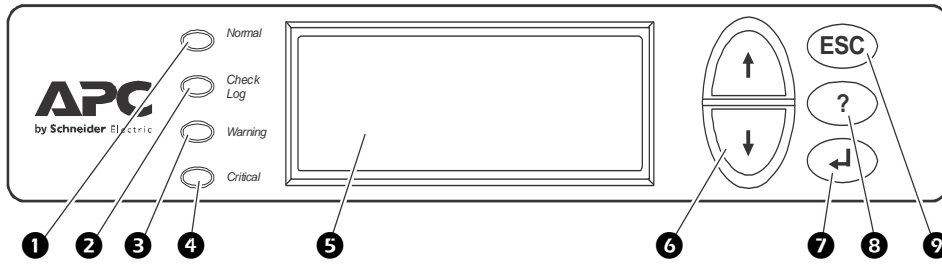

1	NORMAL LED	When green, no alarms are present.
2	CHECK LOG LED	When green, a new event has been added to the log.
3	WARNING LED	When yellow, a warning alarm exists.
4	CRITICAL LED	When red, there are one or more critical alarms in the system.
5	LCD SCREEN	Displays alarms, status data, instructional help, and configuration items.
6	UP AND DOWN KEYS	Scrolls through menu items.
7	ENTER	Opens menu items and confirms changes to system parameters.
8	HELP	Opens context-sensitive help.
9	ESC	Returns to previous screen.

Navigate the display interface

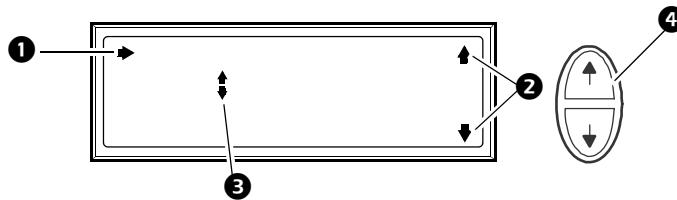

- 1 Selector arrow. Press the UP or DOWN arrow key to move the selector arrow to a menu option or setting. Press the ENTER key to view the selected screen or modify the setting.
- 2 Continue arrows. Indicate that additional screens are available on a menu or status screen. Press the UP or DOWN arrow key to view the additional items.
- 3 Input arrows. Input arrows next to a selected setting indicate that the setting can be modified by pressing the UP or DOWN arrow key. Press the ENTER key to save the change or the ESC key to cancel.
- 4 Press the UP or DOWN arrow key to:
 - a. navigate the selector arrow through the menu prompts
 - b. change target item
 - c. edit a text string. Press the UP or DOWN arrow key to change the character in the text string. Press ENTER to confirm and advance to the next character.

Top dynamic display

Overview Screens When the system is running, the display will scroll through screens showing status information of the PDU and any active alarms.

Overview Screens (No active alarms)

```
No Active Alarms

System Date/Time:
01/09/2012 10:37:01
```

```
Out   Amps   kW
L1:   0.0   0.00
L2:   0.0   0.00
L3:   0.0   0.00
```

```
Output Voltage
L1: 00V L1-2: 0V
L2: 00V L2-3: 0V
L3: 00V L3-1: 0V
```

Overview screen Alarm Shown

```
Active Alarms: 1 of 15
Communication Lost
With Metering Board
[1.6]
```

Press the **ENTER** key to move from the Overview Screens to the Main Menu Screen.

Main Menu Screen

Use the Main Menu Screen to operate, configure, and monitor the system through the sub menu screens: Modules, Totals, Alarms, Log, Admin, and Help.

Main Menu Screen

◆Modules	Admin
Totals	Help
Alarms	
Log	



- NOTE:**
1. If the display interface is inactive for the time configured for the screen timeout, the display will return to the scrolling status screens.
 2. Pressing the **UP** arrow key when the selector arrow is at the first item of the main menu will take you to the last item on the menu.

Password protection

Certain screens can be configured to require a predefined password to allow access to those screens. Pressing the **ENTER** key after selecting a protected screen will result in the user being prompted for the password.

```
Enter Password:
*****
```

```
Incorrect Password:
Press any key to
Try again...
```

Menu tree

The menu tree provides a quick overview of the functions and views you can access.

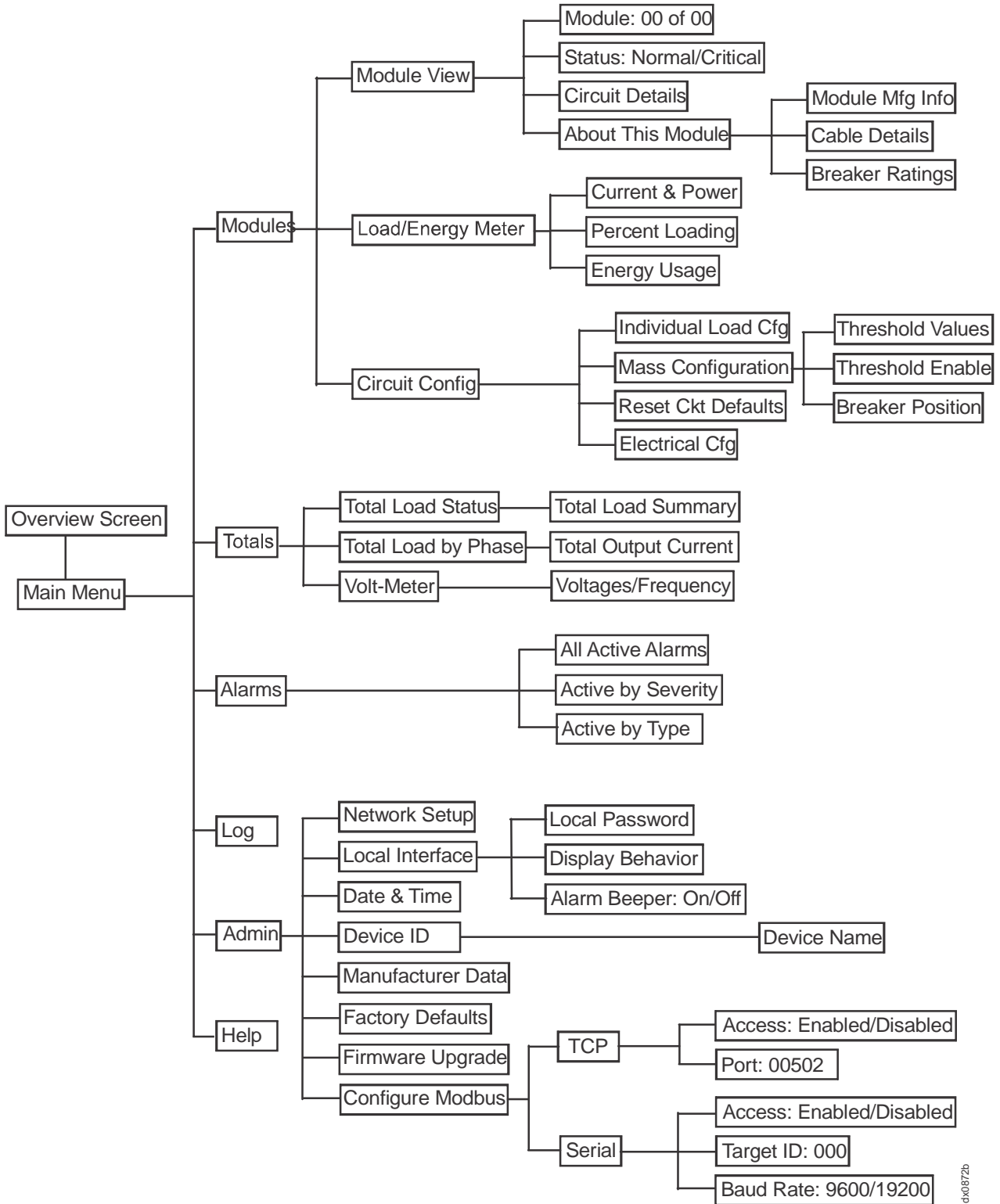

pd00872b

Modules Submenu

View Module status

- 1 Select Modules on the Main Menu Screen and press ENTER. At the next screen, select Module View and press ENTER.
- 2 Press ENTER at the Module number. Scroll through the module list to the specific module and press ENTER.
- 3 To view more information about the module, select Circuit Details and press ENTER.
- 4 For 3-cord modules, select the relevant cable and press ENTER.
- 5 Scroll through the three status screens for information on the specific Power Distribution Module.

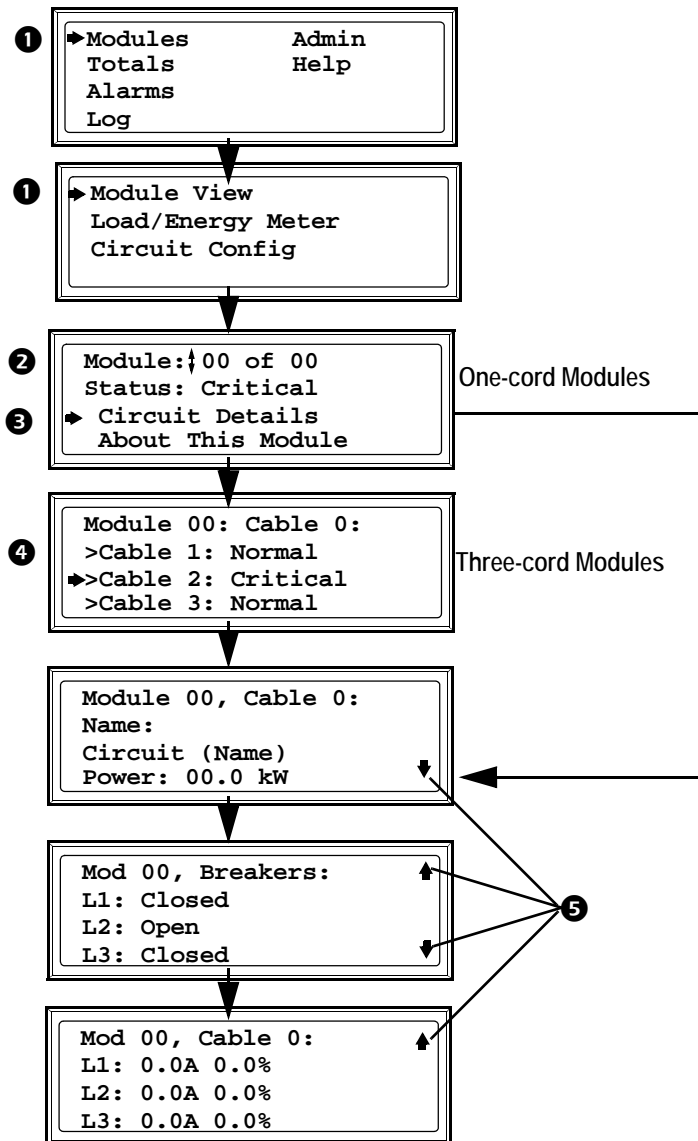

View Power Distribution Module information

- 1 Select Modules on the Main Menu Screen and press ENTER. On the next screen, select Module View and press ENTER.
- 2 Press ENTER at the Module number. Scroll through the list of modules to the specific module and press ENTER.
- 3 Select About This Module and press ENTER.
- 4 The module you chose is shown in this submenu. Select and press ENTER to view:
 - A Module Mfg Info
 - B Cable Details
 - C Breaker Ratings

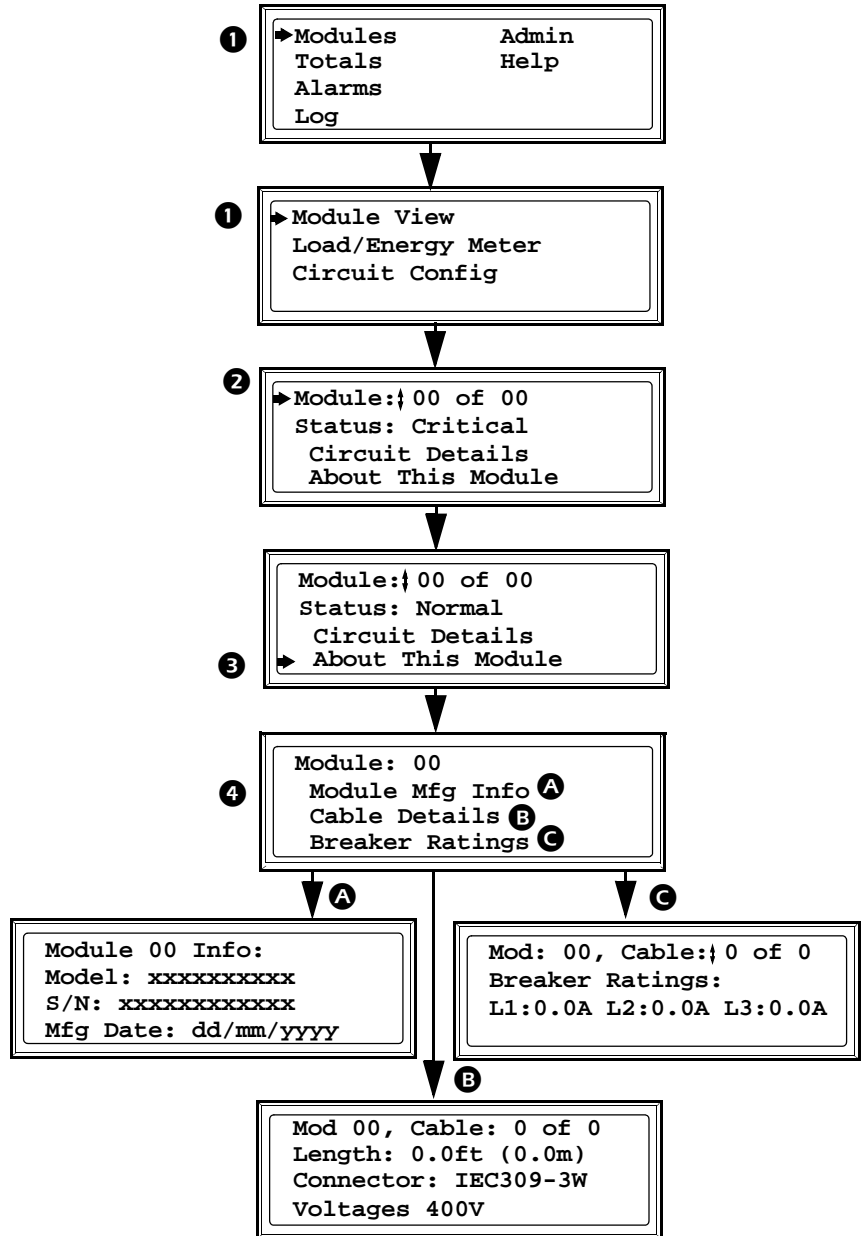

View circuit status information

Use the Load/Energy screens to view status information on a circuit level and the data is grouped by output cable. Scroll through the list to the specific circuit. The circuit names are listed for identification.

Refer to “Set the name and location of the circuits” on page 17 for information on how to set the circuit name.

- 1 Select Modules on the Main Menu Screen and press ENTER.
- 2 Select Load/Energy Meter on the submenu screen and press ENTER.
- 3 Select from the Circuit Loading submenu:
 - A Current & Power
 - B Percent Loading
 - C Energy Usage (kWh)
 Press ENTER at the Reset prompt to reset the kWh registration to zero and change the reset date to the current date.

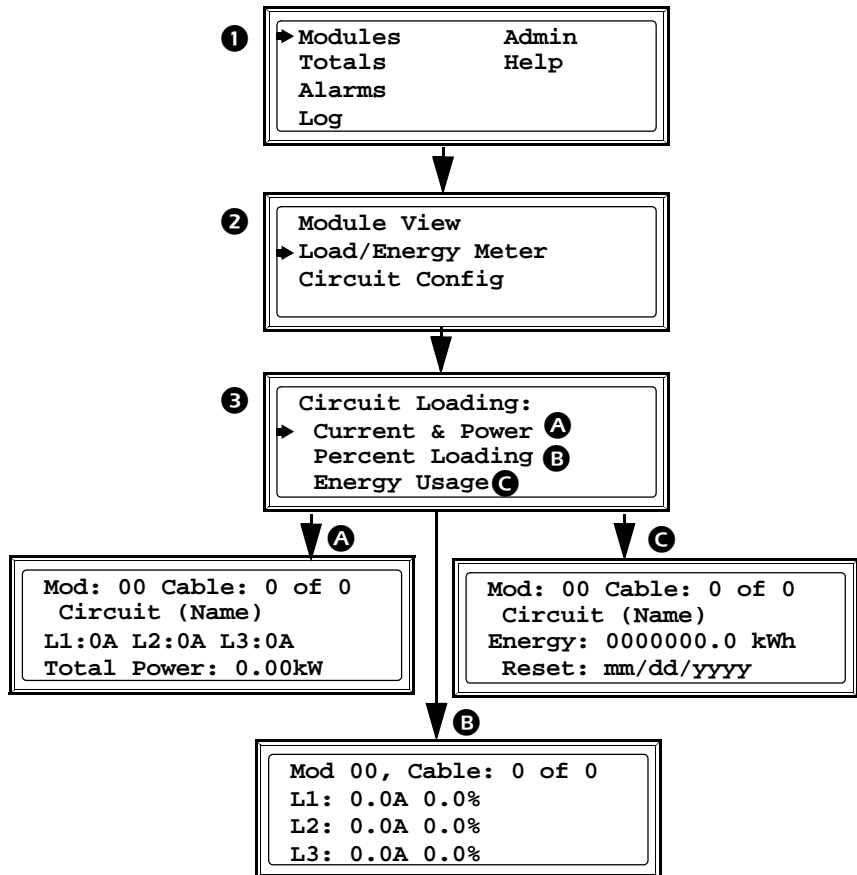

View load status

- 1 Select Totals on the Main Menu Screen and press ENTER.
- 2 Select Total Load Status on the submenu and press ENTER.
- 3 Status can be Normal, Warning, or Critical. The total power factor and total load is shown in kW and kVA.

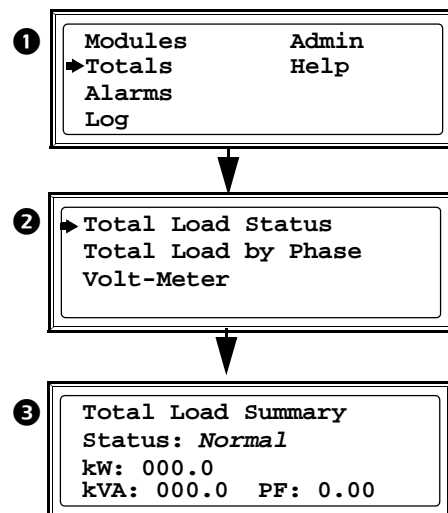

View total load by phase

- 1 Select Totals on the Main Menu Screen and press ENTER.
- 2 Select Total Load by Phase on the submenu and press ENTER.
- 3 View total output current and power for each phase. High!, Low!, Min!, or Max! indicates a reading above or below the threshold level.

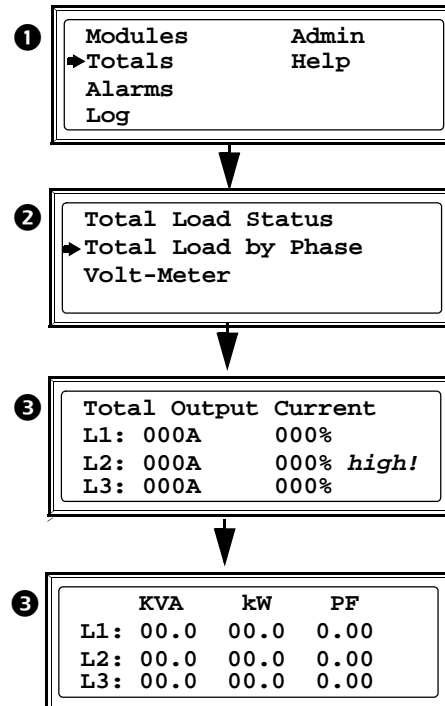

View output voltages

- 1 Select Totals on the Main Menu Screen and press ENTER.
- 2 Select Volt-Meter on the submenu and press ENTER.
- 3 The Voltage Screen shows the output voltages for the three phases and the phase-to-phase voltages.

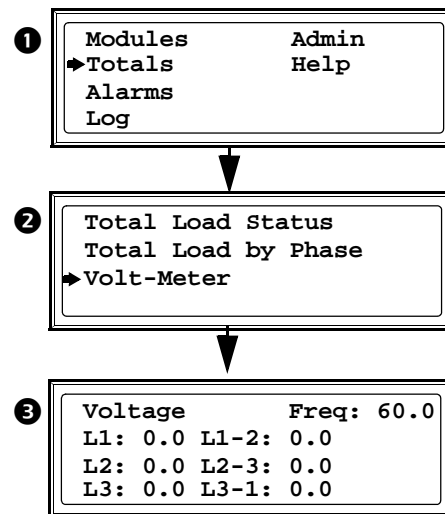

View the log

The log saves information every time a change in the PDU is detected. Alarms and events are recorded in the log and displayed as an active alarm. Status changes are only displayed in the log, and will not display as an active alarm. Viewing the log will clear the Check Log LED.

- 1 Select Log on the Main Menu Screen, and press ENTER.
- 2 Choose to view recently logged items or the entire log.
- 3 Use the arrow keys to scroll through the list of events. Press the ENTER key to view the date and time of a specific event.

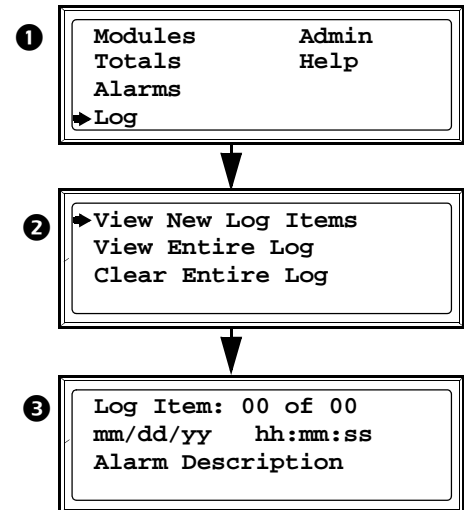

Clear the log

- 1 Select Log on the Main Menu Screen, and press ENTER.
- 2 Select Clear Entire Log and press ENTER.
- 3 Select Yes and press ENTER to clear the entire log, or No to return to the Main Menu Screen.

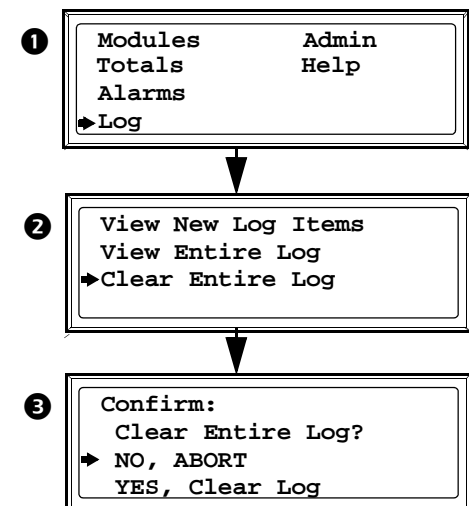

View the list of active alarms

The alarm menu lists all active alarms in the PDU. When an alarm is triggered, the PDU will create an alarm and the LEDs on the front panel will illuminate to signify that an alarm has been set.

- 1 From the Main Menu Screen, select Alarms.
- 2 View all alarms, or alarms by severity or type.
Use the UP and DOWN arrow keys to scroll through the list.
- 3
 - A All Active Alarms
 - B Active by Severity
 - C Active by type

Press the ENTER key at the selected alarm to view the date and time of a specific alarm.

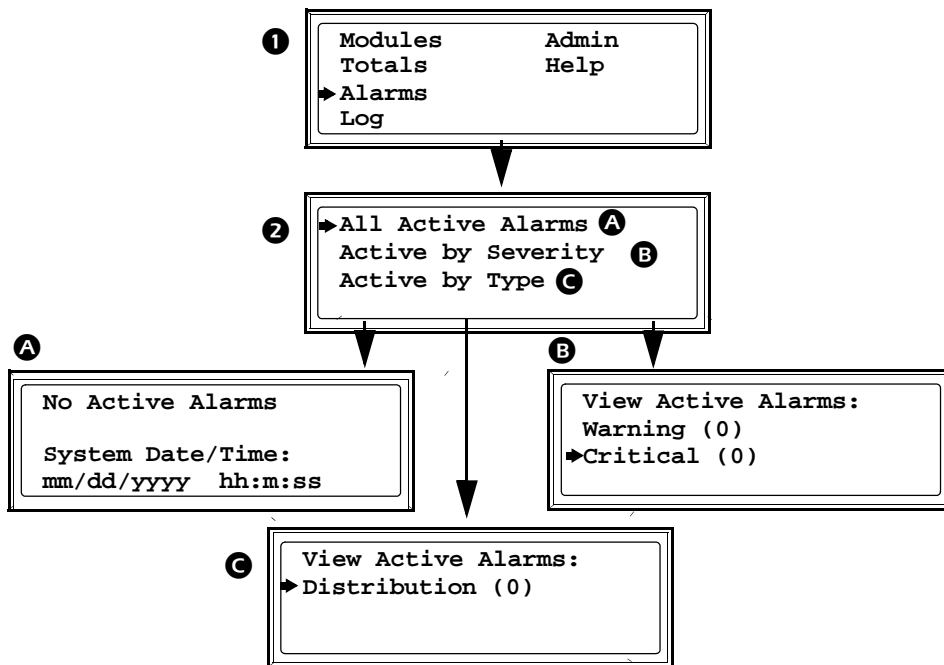

Configuration

Settings

Set up the network

- 1 Select Admin on the Main Menu Screen, and press ENTER.
- 2 Select Network Setup and press ENTER.
- 3 Mode choices are DHCP Only or BOOTP Only to set the IP-address and subnet mask for the system) or Fixed IP Address.
- 4 Press the continue arrow to set the Gateway address. The MAC address can be viewed on this screen.

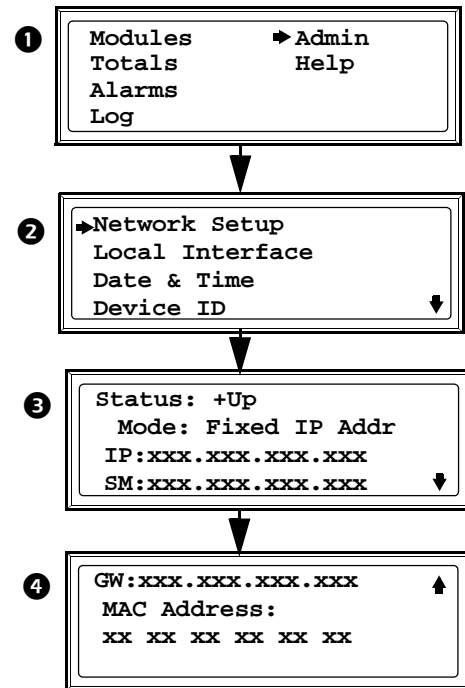

Set the name and location of the circuits

- 1 Select Modules on the Main Menu Screen, and press ENTER.
- 2 Select Circuit Config on the submenu, and press ENTER.
- 3 Select Individual Load Cfg and press ENTER.
- 4 Select Name/Location and press ENTER.
- 5 Change the settings for circuit name and circuit location. Use the UP and DOWN arrow keys to select a character, press ENTER to confirm, and go to the next character.

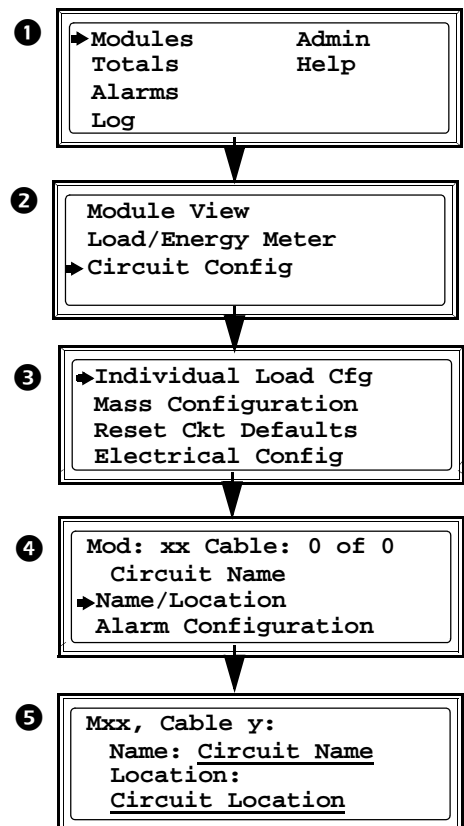

Set individual alarm thresholds

The Individual Load Cfg screens are used to set the alarm thresholds for a single Power Distribution Module.

- 1 Select Modules on the Main Menu Screen, and press ENTER.
- 2 Select Circuit Config on the submenu screen, and press ENTER.
- 3 Select Individual Load Cfg and press ENTER.
- 4 In the next submenu, scroll to the desired module. Press ENTER to select a module.
- 5 After the module has been selected, scroll to Alarm Configuration and press ENTER.

- 6 The selections for Alarm Configuration are:
 - A Alarms: Enable or disable.
 - B Alarm Thresholds: Change the settings.
 - C Reset to defaults: Reset to factory defaults.

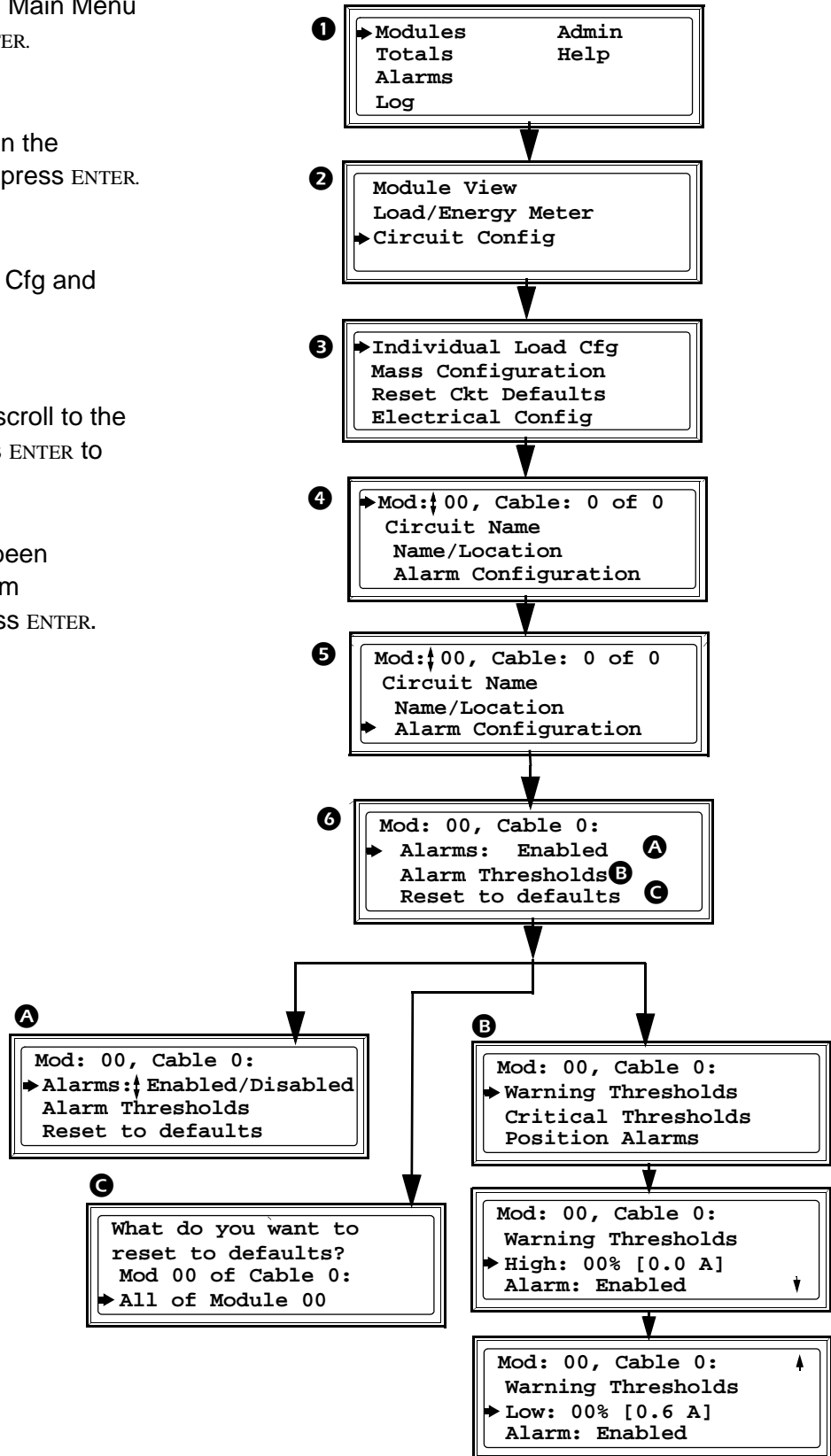

Set alarm thresholds for all Modules in the PDU

- 1 Select Modules on the Main Menu Screen, and press ENTER.
- 2 Select Circuit Config on the submenu screen, and press ENTER.
- 3 Select Mass Configuration and press ENTER.
- 4 Change the settings for
 - A Threshold Values: Select the maximum and minimum values that should generate an alarm.
 - B Threshold Enable: Enable or disable the alarms for the different settings.
 - C Breaker Position: Enable or disable alarms when a breaker is opened.
- 5 Select Apply to All and press ENTER to confirm your changes.

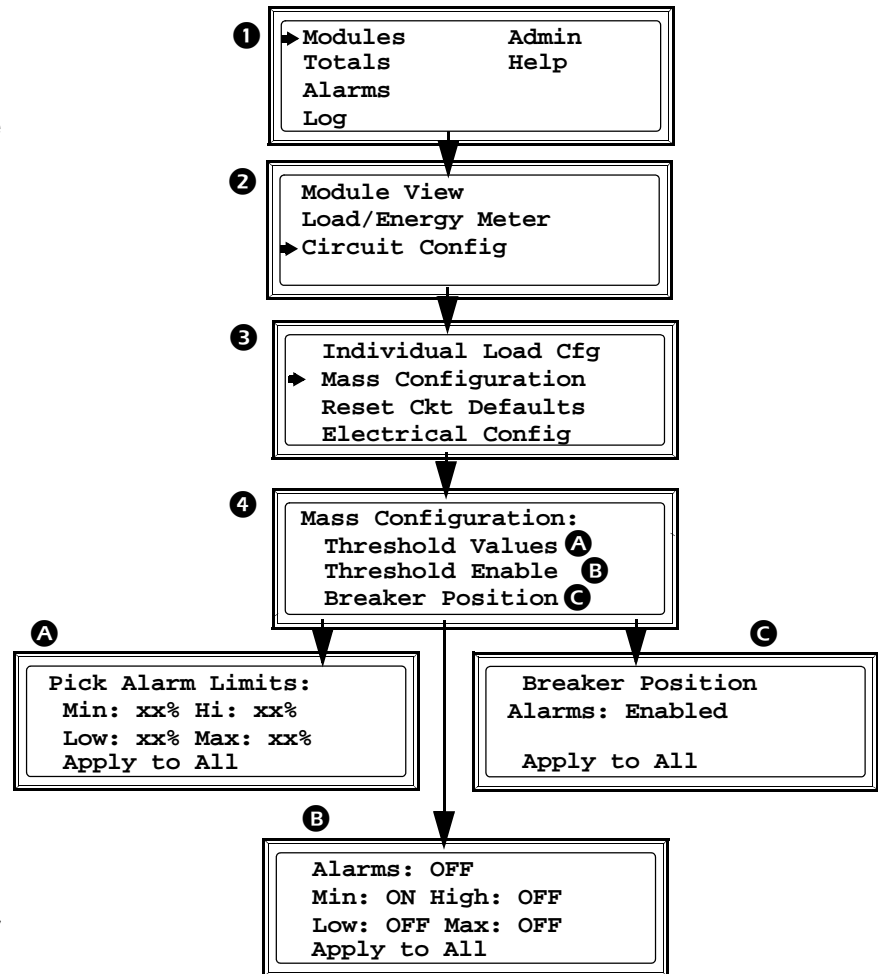

Set and change the password settings

Set, change or set the time lock on password-protected screens. Set the time limit before the display will lock, and a password will be required to make any changes.

- 1 Select Admin on the Main Menu screen and press ENTER.
- 2 Select Local Interface and press ENTER.
- 3 Select Local Password and press ENTER.
- 4 Select Password and enter the new password. Use the UP and DOWN arrow keys to select a character and press ENTER to confirm and go to the next character.

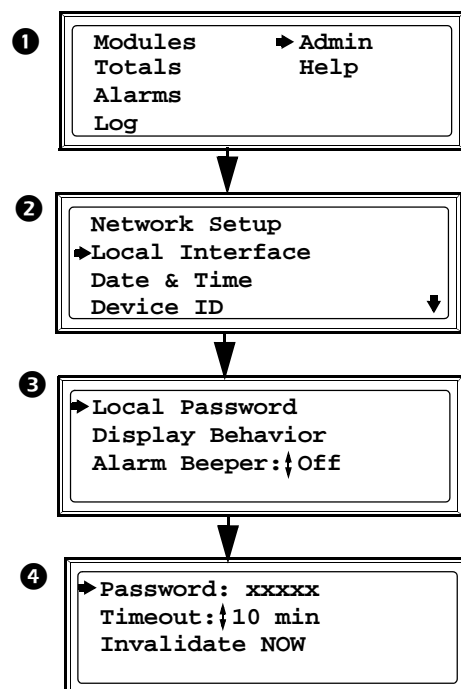

Change the display settings

- 1 Select Admin on the Main Menu screen and press ENTER.
- 2 Select Local Interface and press ENTER.
- 3 Select Display Behavior and press ENTER.
- 4 From this screen, change the settings for:
 - a. Contrast - setting from 00 to 07
 - b. Key Click - Off/On
 - c. Beeper Volume - Off/Low/Med/High
 - d. Check Log Light - Info/Warning/Critical/Disable

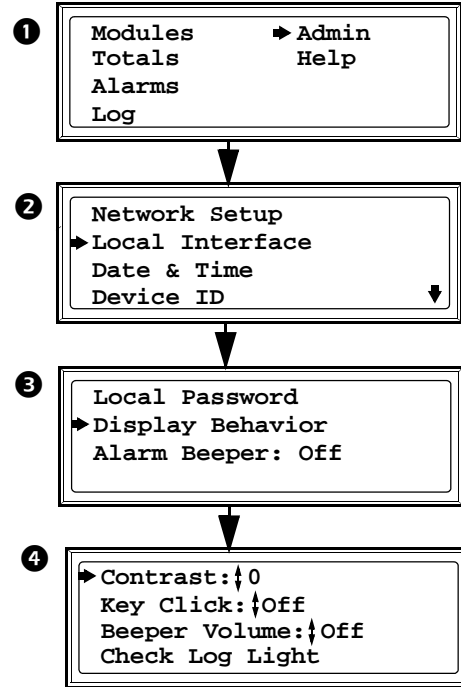

Change date and time

- 1 Select Admin on the Main Menu screen and press ENTER.
- 2 Select Date & Time and press ENTER.
- 3 The date format, date, and time can be changed from this screen.

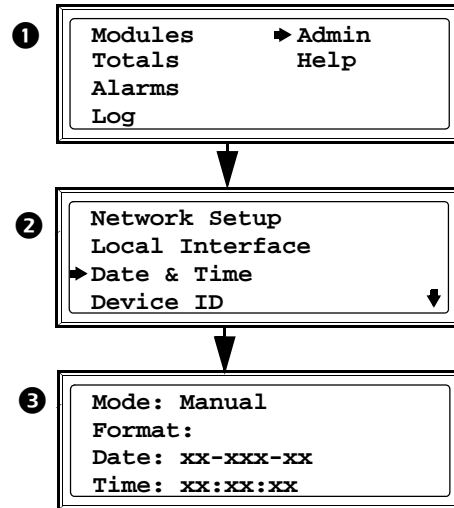

Modbus Configuration

Modbus Serial Configuration

Configure Modbus Serial through the Display Interface.

Path: Main > Admin > Configure Modbus > Serial

Use the Serial menu to set up communications between the equipment and the building management system.

Access: Enable or disable Modbus Serial

Target ID: Each Modbus device must have a unique target identification number. Enter a unique number, ranging from 1 to 247, for this unit.

Baud Rate: Choose either 9600 bps or 19200 bps.

Modbus communication is available at the console port (RS232 DB-9 connector).

Note: An RS232 to RS485 converter (not provided) must be used to connect to a building management system.

To communicate RS-232 to the RPP/RDP through the console port, the RS232 to RS485 converter must be configured as a DTE device with Send Data Control rather than RTS control (most converters are DCE - some can be ordered as DTE). Some devices like the Omega Model 285 Superverter support DCE/DTE selection with a switch. Other devices such as those produced by B&B Electronics require a zero ohm resistor re-position to configure as a DCE device - see the device data sheet for details. RTS or SD selection is generally accomplished with a jumper. An appropriate RS-232 cable like the APC 940-0024D is also required.

The console port can be configured to run at either 9600 or 19200 baud. This must match the Building Management System or Modbus network transfer rate.

Most serial converters are capable of either 4-wire or 2-wire modbus connections. The unit is designed to handle 2-wire, half-duplex communication. For a 2-wire, half-duplex connection, jumper connectors should be placed between R+ & T+, and R- & T-. Then the modbus + wire is connected to R+/T+ and the - wire is connected to R-/T-. Some converters like the B&B Electronics 4850T9L offer dip switches to accomplish the jumper connections.

Note: All RS232 to RS485 converters tested relied on a power supply that plugs into 110V AC wall receptacle.

Note: There is a known modbus polarity labeling ambiguity between converters, so if the modbus communication isn't successful, try reversing the 2-wire connection.

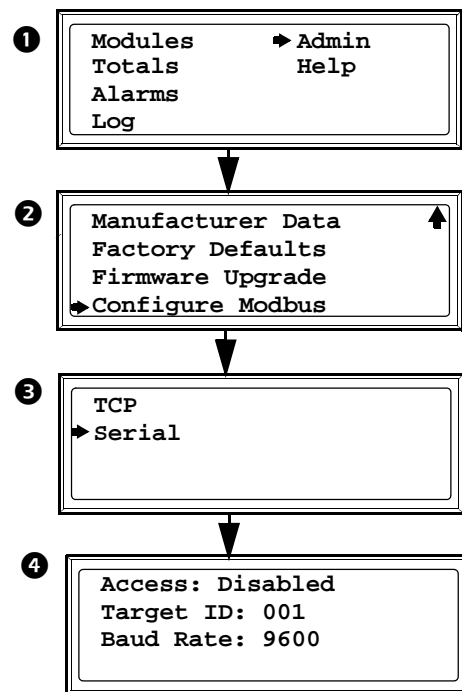

Modbus TCP Configuration

Configure Modbus TCP through the Display Interface.

Path: Main > Admin > Configure Modbus > TCP

Use the TCP menu to set up communications between the equipment and the building management system through TCP.

Status: Enable or disable Modbus TCP to view the device through your building management service's interface.

Port: Each Modbus TCP must have a unique target TCP port number. Enter a unique number, ranging from 502, 5000 to 32768.

Press ENTER, the display interface will navigate to the reboot page to save your settings.

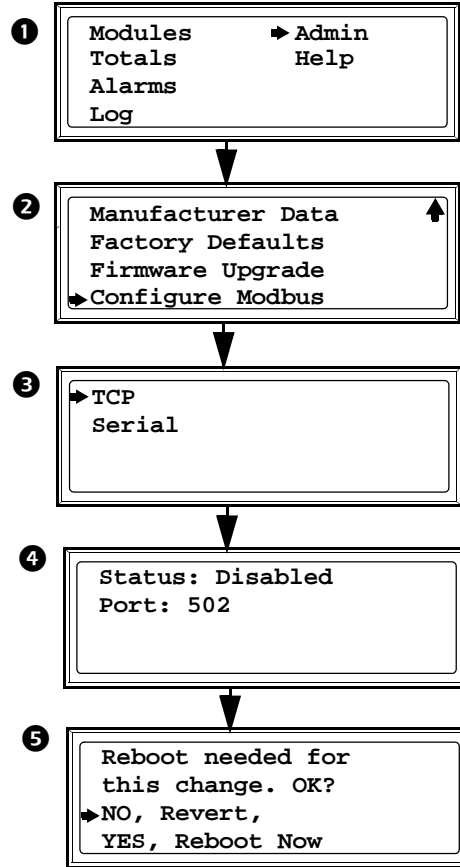

Network Management Configuration

Overview

NOTE: For complete Network Management Card setup instructions, see the online User Guide at www.apc.com.

Connections

Make the connection to the PDU: A Cat-5 cable is plugged into the bottom RJ-45 connector **C** on the back of the unit. Connect the other end of the cable to a local computer or a network hub. Do not use the top RJ-45 connector **A** above the serial port **B**.

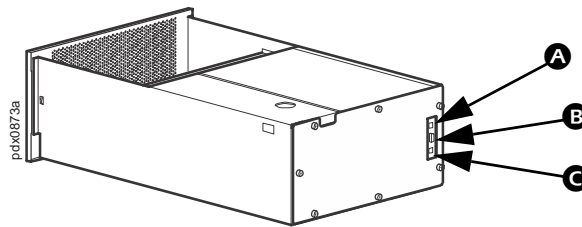

A serial cable can be connected at the serial port **B**. Connect the other end to a local computer.

Initial setup

You must configure the following three TCP/IP settings before the Modular PDU can operate on a network:

- IP address of the Modular PDU
- Subnet mask
- Default gateway
If a default gateway is unavailable, use the IP address of a computer (that is usually running) located on the same subnet as the NMC. The NMC uses the default gateway to test the network when traffic is light.

NOTE: Do not use the loopback address as the default gateway address for the Network Management Card. You will lose communication with the equipment. Doing so will disable the card and require you to reset TCP/IP settings to their defaults using a local serial login.

TCP/IP configuration methods

Use one of the following methods to define the basic TCP/IP settings needed by the Network Management Card.

- APC Device IP Configuration Wizard
- BOOTP or DHCP server
- Networked computer

Device IP Configuration Wizard

The Wizard runs on Microsoft Windows 2000, Windows 2003, and Windows XP operating systems. The Device IP Configuration Wizard configures the IP address, subnet mask, and default gateway of one or more NMCs.

You can use the Wizard in either of the following ways:

- Remotely over your TCP/IP network to discover and configure unconfigured NMCs on the same network segment as the computer running the Wizard.
- Through a direct connection from a serial port of your computer to the PDU to configure or reconfigure it.

Installation

Install the Wizard from a downloaded executable file:

1. Go to www.apc.com/tools/download.
2. Download the Device IP Configuration Wizard.
3. Run the executable file in the folder in which it was downloaded.

Launch the Wizard

The installation creates a shortcut link in the Start menu to launch the Wizard. Most software firewalls must be temporarily disabled for the Wizard to discover unconfigured NMCs.

Supported Web browsers

Use Microsoft® Internet Explorer (IE) 7.x and higher (Windows operating systems) or Mozilla Firefox 3.0.6 or higher (all operating systems) to access the NMC through its Web interface. Other commonly available browsers may work but have not been fully tested by Schneider Electric. The NMC cannot work with a proxy server. Before using a Web browser to access its Web interface, do one of the following:

- Configure the Web browser to disable the use of a proxy server for the NMC.
- Configure the proxy server so that it does not proxy the specific IP address of the NMC.

Network management features

These applications and utilities work with a Modular PDU that connects to the network through its Network Management Card:

- StruxureWare—Provide enterprise-level power management and management of agents, PDUs, information controllers, and environmental monitors
- PowerNet® Management Information Base (MIB) with a standard MIB browser—Perform SNMP SETs and GETs and to use SNMP traps
- Device IP Configuration Wizard—Configure the basic settings of one or more NMCs over the network
- Security Wizard—Create the components needed for high security for the NMC when using Secure Sockets Layer (SSL) and related protocols and encryption routines

Log On

Overview

Use the DNS name or System IP address of the unit for the URL address of the Web interface. Use your case-sensitive user name and password to log on.

The default user password for three account types is **apc**. The default user name differs by account type:

- **apc** for the Super User
- **device** for a Device User
- **readonly** for a Read-Only User

The Super User or an Administrator created by the Super User should define the user names, passwords, and other account characteristics for the lower tier users.

If you are using HTTPS (SSL/TSL) as your access protocol, your logon credentials are compared with information in a server certificate. If the certificate was created with the APC Security Wizard, and an IP address was specified as the common name in the certificate, you must use an IP address to log on to the unit. If a DNS name was specified as the common name on the certificate, you must use a DNS name to log on.

URL address formats

Type the DNS name or IP address of the unit in the URL address field of the Web browser and press ENTER. When you specify a non-default Web server port in Internet Explorer, you must include `http://` or `https://` in the URL.

Common browser error messages at log-on

Error Message	Browser	Cause of the Error
"This page cannot be displayed."	Internet Explorer	Web access is disabled, or the URL was not correct
"Unable to connect."	Firefox	

URL format examples

- For a DNS name of Web1:
 - `http://Web1` if HTTP is your access mode
 - `https://Web1` if HTTPS (HTTP with SSL) is your access mode
- For a System IP address of 139.225.6.133 and the default Web server port (80):
 - `http://139.225.6.133` if HTTP is your access mode
 - `https://139.225.6.133` if HTTPS (HTTP with SSL) is your access mode
- For a System IP address of 139.225.6.133 and a non-default Web server port (5000):
 - `http://139.225.6.133:5000` if HTTP is your access mode
 - `https://139.225.6.133:5000` if HTTPS (HTTP with SSL) is your access mode

For a System IPv6 address of 2001:db8:1::2c0:b7ff:fe00:1100 and a non-default Web server port (5000):

`http://[2001:db8:1::2c0:b7ff:fe00:1100]:5000` if HTTP is your access mode

User Account Overview

The Modular Power Distribution Unit arrives configured with three User Types, as well as associated User Names:

- *Super User* (User Name: *apc*)
- *Device* (User Name: *device*)
- *Read-Only* (User Name: *readonly*).

The initial default password for each of these is *apc*. All levels of access require user name and password permissions.

Both user name and password are case-sensitive, and have a 64 byte maximum, supporting up to 64 ASCII characters; less for multi-byte languages.

The *Super User* can define additional user accounts, as well as set other variables for the additional users. It is generally recommended that non-default user name and passwords be set.

NOTE: The Super User cannot be renamed or deleted, but it can be disabled. It is recommended that the Super User account is disabled once any additional Administrator accounts are created. Make sure that there is at least one Administrator account enabled before the Super User account is disabled.

In order to manage User settings from the web browser (accessed by entering the NMC IP address into the address bar), navigate to **Configuration > Security > Local Users > Management**.

- Click on Add User

The User types which can be added are:

- **Administrator:** The Administrator user has full access just as the Super User does, but this user type can be deleted.
NOTE: A Super User account must be enabled before all administrator accounts are deleted or disabled.
- **Device:** The Device user has read-write access to the device-related menus only. The Administrator can enable or disable the Device user account.
- **Read-Only:** The Read-Only User account has read-only access, through the Web interface, to view status but not to control a device or change any configured value. The Administrator can enable or disable the Read-Only user account.
- **Network-Only:** The Network-Only user has read-write access to the network-related menus only. The Administrator can enable or disable the Network-Only user account.

Watchdog Features

Watchdog mechanisms detect internal problems. After a restart, a System: Warmstart event is recorded in the event log.

Network interface watchdog mechanism

Watchdog mechanisms protect the NMC from becoming inaccessible over the network. If it does not receive any network traffic for 9.5 minutes, it assumes there is a problem with its interface and restarts.

Resetting the network timer

To ensure the NMC does not restart if the network is quiet for 9.5 minutes, it attempts to contact the default gateway every 4.5 minutes. The gateway response resets the 9.5-minute timer. If your application does not require or have a gateway, specify the IP address of a computer that is running on the network most of the time and is on the same subnet. The network traffic of that computer will restart the 9.5-minute timer frequently enough to prevent the NMC from restarting.

Recover from a Lost Password

You can use a local computer (a computer connected to your power distribution unit through the serial port) to access the command line interface.

1. At the local computer, select a serial port, and disable any service that uses it.
2. Connect the provided serial cable to the selected serial port on the local computer and the other end of the cable to the serial port on the power distribution unit.
3. Open a terminal program (such as HyperTerminal[®]) and configure the port for:
 - 9600 bps,
 - 8 data bits,
 - no parity,
 - 1 stop bit, and
 - no flow control.
4. Press `ENTER`, repeatedly if necessary, to display the User Name prompt. If you are unable to display the User Name prompt, verify the following:
 - The serial port is not in use by another application.
 - The terminal settings are correct as specified in step 3.
 - The correct cable is being used as specified in step 2.
 - `SCROLL LOCK` is not turned on.
5. Press the Reset button on the back of the unit. The Status LED will flash. Press the Reset button a second time while the LED is flashing to reset the user name and password to the default temporarily.
6. Press `ENTER` as many times as necessary to redisplay the User Name prompt, then use the default, **apc**, user name and password. (If you take longer than 30 seconds to log on after the User Name prompt is redisplayed, you must repeat step 5 and log on again.)
7. At the Command Console, use the following commands to change the password setting for the Super User account, for which the user name is always `apc`, and the password is now temporarily `apc`:

```
user -n apc -pw yourNewSuperUserPassword
```

Example: to change the Super User's password to `p@ssword` type:

```
user -n apc -pw p@ssword
```

NOTE: Because the *Super User* can also reset the password for any account, you can reset other user's passwords as well.

Example: to change the password for user `bmadmin` to `p@ssword` type:

```
user -n bmadmin -pw p@ssword
```

NOTE: Changing user name information is no longer supported via the Command Console. If a user's user name needs to be changed, it must be deleted and re-created. The Super User will also have access now to log in and adjust any other user's password.

8. Type `QUIT`, `EXIT`, or `BYE` to log off. Remember to reconnect any serial cable you may have disconnected, and to restart any service you may have disabled. Return the local computer to its original configuration.

NOTE: Modbus and the Command Console share a common serial port. In some instances, the baud rate may be set to different speeds for other services, i.e. Modbus (19200 bps).

Maintenance

Parts Replacement

Determine if you need a replacement part

To determine if you need a replacement part, contact Schneider Electric Customer Support and follow the procedure below so that a representative can assist you promptly:

1. The display interface may show additional screens if module replacement is necessary. Press any key to scroll through these lists, record the information, and provide it to the representative.
2. Write down the serial number of the unit so that you will have it easily accessible when you contact Customer Support.
3. If possible, call Customer Support from a telephone that is within reach of the unit so that you can gather and report additional information to the representative.
4. Be prepared to provide a detailed description of the problem. A representative will attempt to help you over the telephone, if possible, or will assign a Return Material Authorization (RMA) number to you. If a module is returned, this RMA number must be clearly printed on the outside of the package.
5. If the unit is within the warranty period, repairs or replacements will be performed free of charge. If it is not within the warranty period, there will be a charge.
6. If the unit is covered by a service contract, have the contract available to provide information to the representative.

Return parts

Contact Customer Support to obtain an (Returned Materials Authorization (RMA) number.

To return a module, pack the module in the original shipping materials, and return it by insured, prepaid carrier. The Customer Support representative will provide the destination address. If you no longer have the original shipping materials, ask the representative about obtaining a new set. Pack the module properly to avoid damage in transit. Never use Styrofoam beads or other loose packaging materials when shipping a module, as the module may settle in transit and become damaged. Enclose a letter in the package with your name, RMA number, address, a copy of the sales receipt, description of the problem, a phone number, and a check as payment (if necessary).

NOTE: Damages sustained in transit are not covered under warranty.

Power Distribution Modules

⚠ ⚠ DANGER

HAZARD OF ELECTRIC SHOCK, EXPLOSION, OR ARC FLASH

- Electrical equipment must be installed, operated, serviced, and maintained only by qualified personnel.
- To remove a Power Distribution Module:
 1. Turn off all power supplying the equipment and perform appropriate lockout/tagout procedures before installing or removing the Power Distribution Module.
 - OR
 2. If a Symmetra PX UPS is providing power to the Modular PDU, place the UPS into battery operation (to reduce fault current) before removing the Power Distribution Module. To place the UPS into battery operation, see the UPS Operation Manual.

Failure to follow these instructions will result in death or serious injury.

NOTICE

- Install only Schneider Electric PDMs with matching output voltage.
- Install PDMs starting from the bottom of the panel to avoid cable congestion.
- Save filler plates for future re-use. If a module is removed, a filler plate must be installed to cover the open space.

Factory installed filler plates and slot locks cover each module position.

Before putting the unit into service, the backplane of each module position must be covered with a filler plate or a Power Distribution Module (PDM). All positions must be secured with a slot lock.

Component identification

- ❶ Slot lock key
- ❷ Slots (hold modules in place)
- ❸ Backplane
- ❹ Filler plate
- ❺ Module slot lock
- ❻ Power distribution module

NOTE: Two slot locks are attached together as a pair. The illustration shows the top lock removed from its slot but still attached to the installed lock below it.

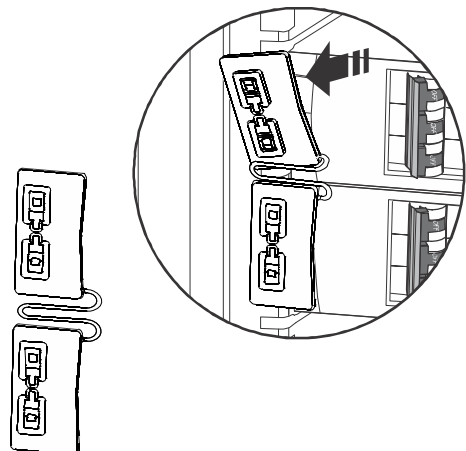
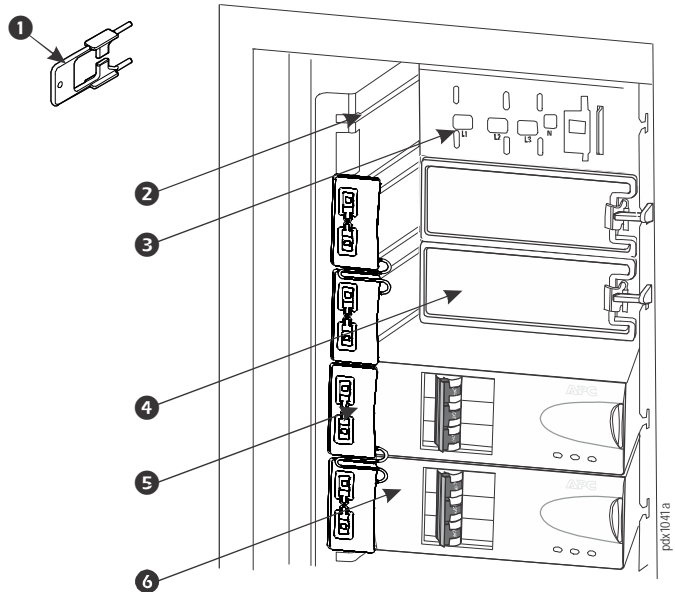

Module Types

NOTICE

- A ground fault will automatically open the adjacent circuit breaker on PDMs with Residual Current Devices (RCDs) installed.
- PDMs with RCDs are equipped with a test button. Periodic testing of the RCD may be required. Check local codes for your region.

PDM – Single and Three phase

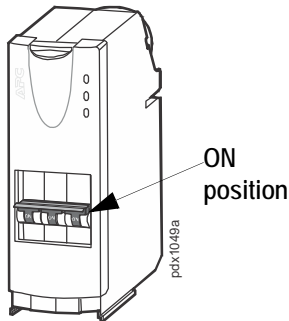

PDM with RCD (Residual Current Devices) - Three phase

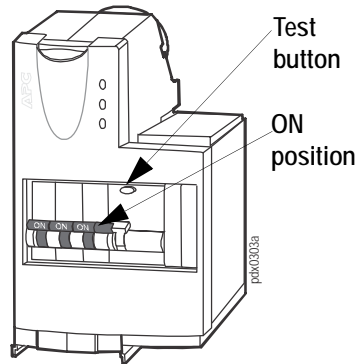

PDM with RCD – Single phase

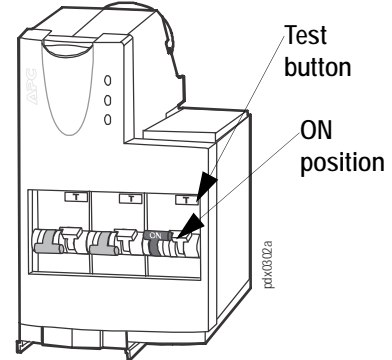

PDMs with RCDs

- A** A ground fault will open the adjacent circuit breaker to the OFF position. The fault is indicated by a red strip on the RCD toggle.
- B** The circuit breaker has been closed manually by pushing the toggle to the ON position.

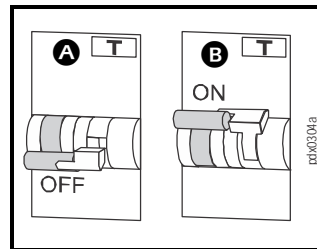

Test the Residual Current Device

NOTE: Pushing the test button will open circuit breakers, distributing power to the equipment.

- 1 Press the test button and confirm that the Residual Current Device (RCD) and adjacent circuit breaker trip to the OFF position.
- 2 Reset the RCD and circuit breaker to normal by pushing the toggle to the ON position.

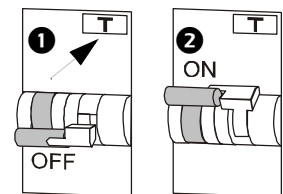

NOTE: Some module circuit breaker styles have circuit breaker handles that will pull all the breakers to the OFF position but can be flipped up to access the individual breakers separately.

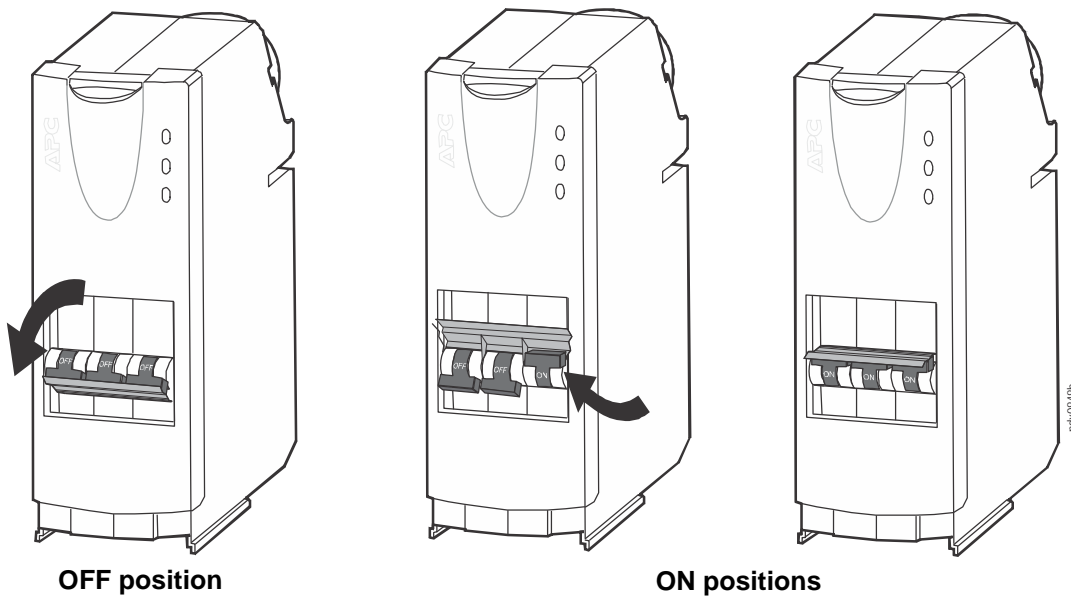

Installation

⚠ ⚠ DANGER

HAZARD OF ELECTRIC SHOCK, EXPLOSION, OR ARC FLASH

- Electrical equipment must be installed, operated, serviced, and maintained only by qualified personnel.
- To remove a Power Distribution Module:
 1. Turn off all power supplying the equipment and perform appropriate lockout/tagout procedures before installing or removing the Power Distribution Module.
OR
 2. If a Symmetra PX UPS is providing power to the Modular PDU, place the UPS into battery operation (to reduce fault current) before removing the Power Distribution Module. To place the UPS into battery operation, see the UPS Operation Manual.

Failure to follow these instructions will result in death or serious injury.

Open the front door of the unit.

Remove the slot lock

Use the key (provided) to remove the slot lock.

- ❶ Insert the key in the slot lock as shown in the illustration.
- ❷ Squeeze the sides of the key inward to grasp the slot lock firmly.
- ❸ Pull the slot lock key out, while squeezing, to extract the lock from the slot.

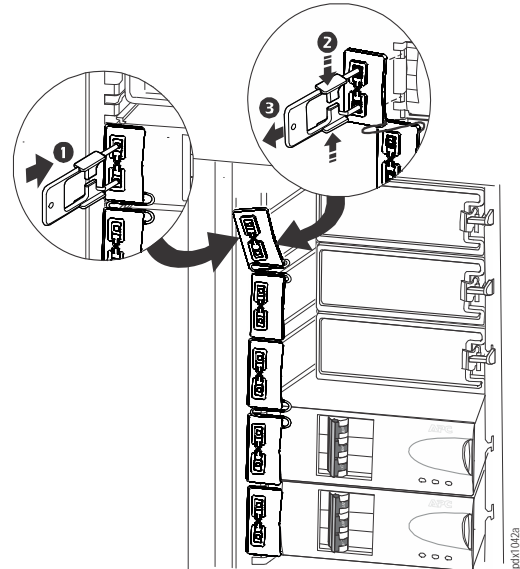

Remove the filler plates

- 1 Press down on the filler plate clip to release its locking mechanism.
- 2 Pull the filler plate along the slot until it is free.

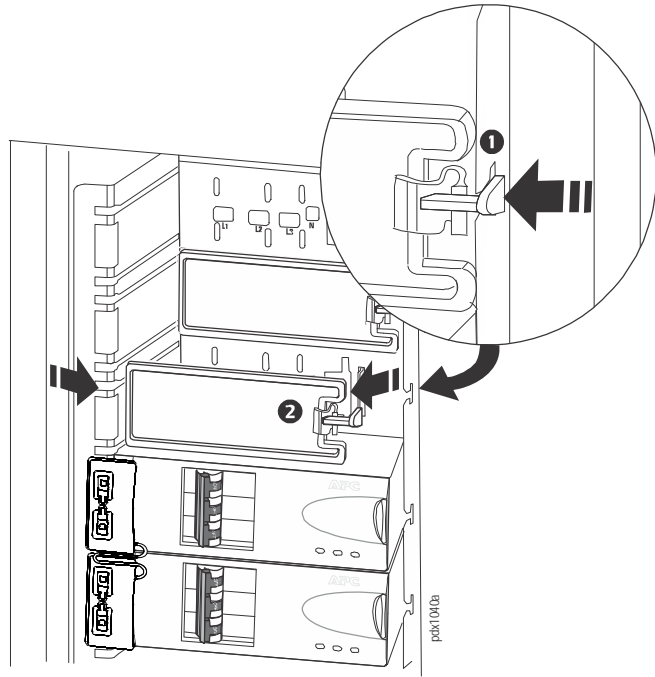

Install a module

- 1 Make sure all circuit breakers on the PDM being installed are in the OFF (open) position.

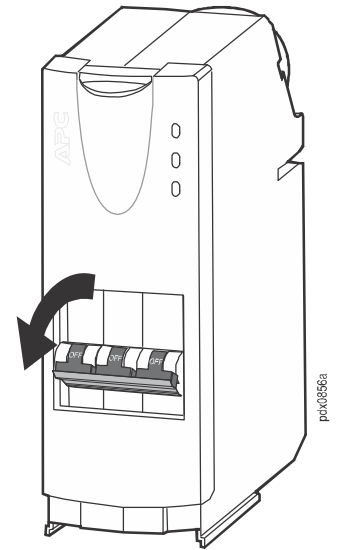

- 2 Press the red button to release the latch on the PDM.
- 3 Pull open the latch.

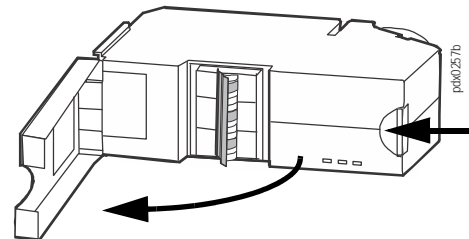

- Slide the PDM into the panel using the top and bottom guide tracks (slots) for that position. Slide the PDM all the way into position. Close the latch to tighten the electrical contacts in the PDM against the backplane.

Horizontal Rack Distribution Panel

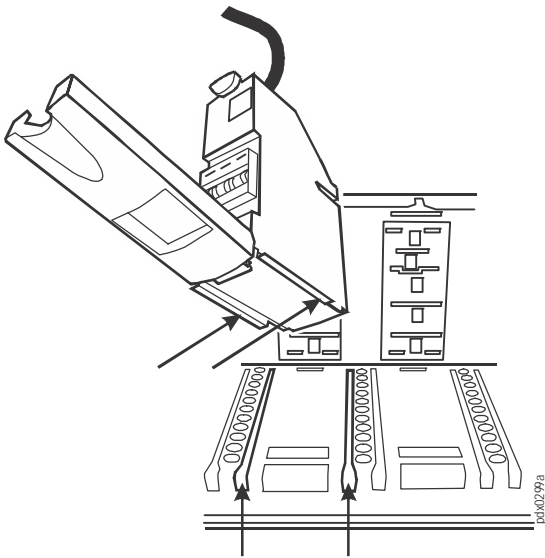

Vertical Rack Distribution Panel

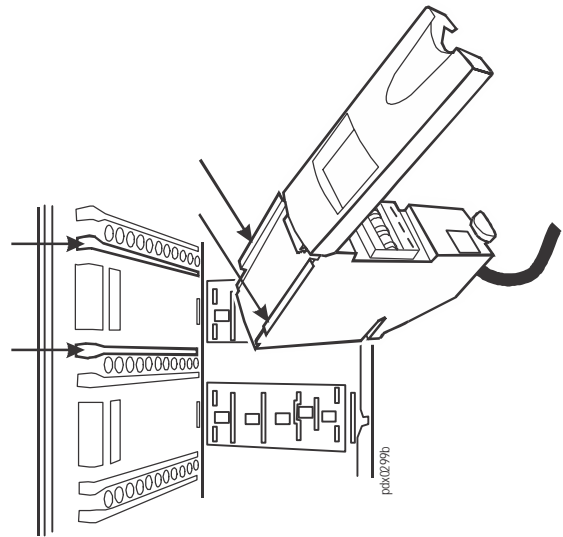

- Feed cable from the PDM through the slot in the roof.

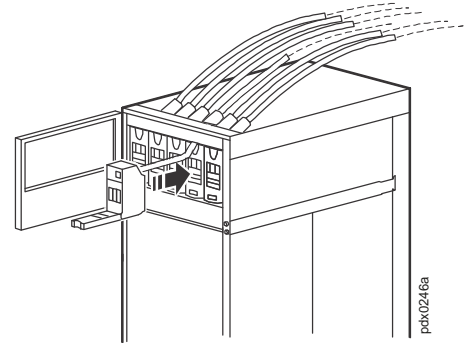

- 6 Vertical Rack Distribution Panel Only: Leave a minimum of 7 inches (178 mm) of slack in the cable behind the module. The slack is useful in case the module is ever removed or replaced. 10 to 20 inches (254 to 508 mm) is recommended but space restrictions in the PDU and cable diameter size will cause the amount of slack to necessarily vary.

When installing PDMs near the top of the panel, feed the cable first, pulling up the slack, and then secure the module to the backplane to avoid cable congestion between the panel and the slot.

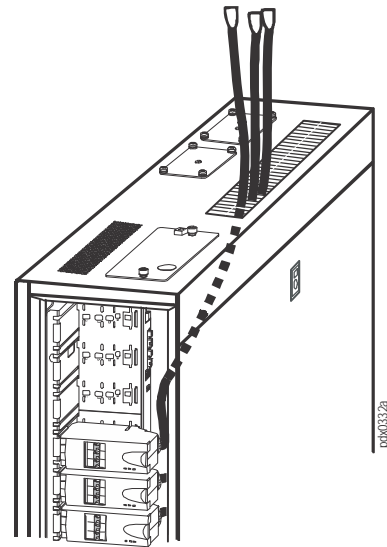

Use plastic ties to secure loose cable(s) to the enclosure

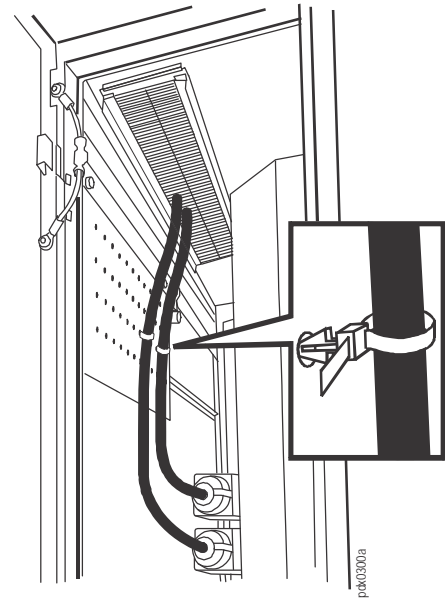

- 7 Set the required breakers on the newly installed PDM to the ON (closed) position.

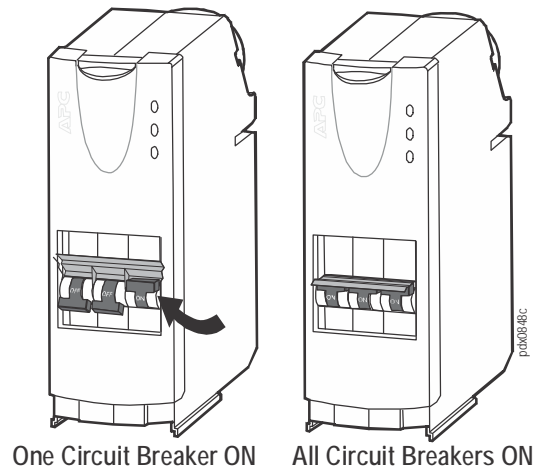

Install filler plates

Install filler plates to properly cover 3-pole panel positions not occupied by a PDM.

- 1 Position the filler plate in front of an open PDM location and insert the bottom tab of the filler plate into the slot.
- 2 Snap the filler plate into position. Check that the latch is secure.

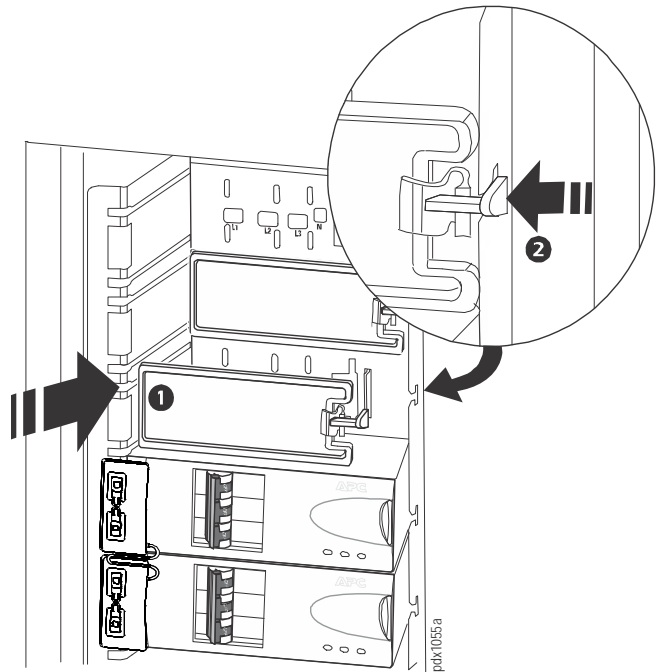

Install a slot lock

NOTE: A slot lock must be installed in each module space whether filled by a module or filler plate.

Press the slot lock into the slots as shown in the illustration.

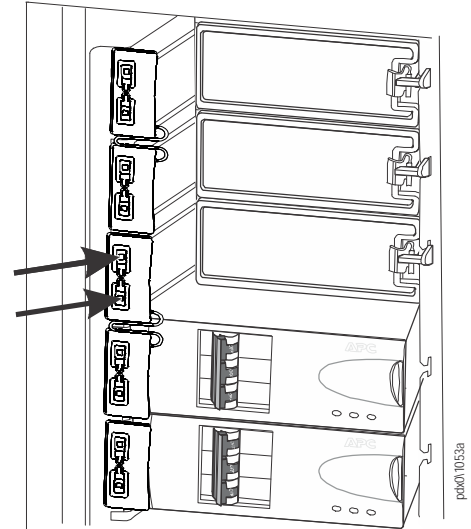

NOTE: Upon completion of PDM installation, close the door to the PDU.

Connect Module cables

Connect the PDM cable to the appropriate Rack PDU or other equipment.

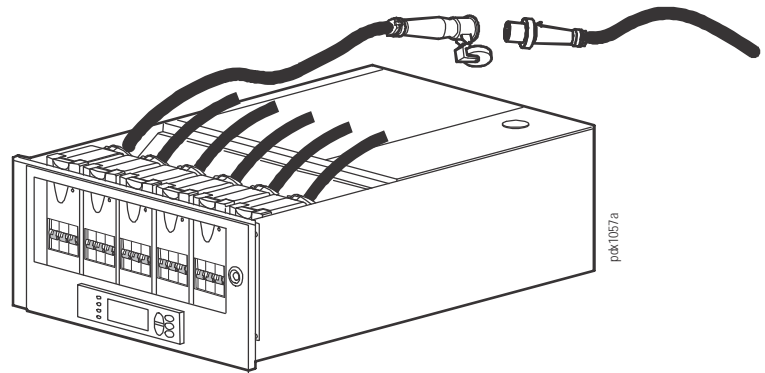

NOTE: Power can be restored to the PDU following connection of the PDM cables to the load.

Remove a PDM

⚠ ⚠ DANGER

HAZARD OF ELECTRIC SHOCK, EXPLOSION, OR ARC FLASH

- Electrical equipment must be installed, operated, serviced, and maintained only by qualified personnel.
- To remove a Power Distribution Module:
 1. Turn off all power supplying the equipment and perform appropriate lockout/tagout procedures before installing or removing the Power Distribution Module.
OR
 2. If a Symmetra PX UPS is providing power to the Modular PDU, place the UPS into battery operation (to reduce fault current) before removing the Power Distribution Module. To place the UPS into battery operation, see the UPS Operation Manual.

Failure to follow these instructions will result in death or serious injury.

Reverse the module installation procedure to remove a PDM.

Troubleshooting

LED Indicators on PDMs

There are three LEDs on each Power Distribution Module. The LEDs indicate the following conditions:

- Red: A critical alarm.
- Yellow: A warning alarm
- Green: No alarm.
- Flashing green: The module is being identified by the system.

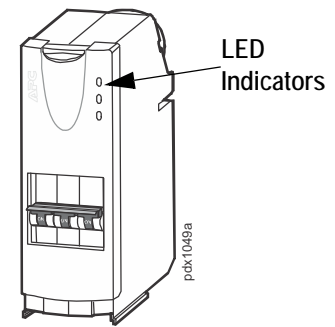

Status and Alarm Messages

Display Message	Detailed Description	Corrective Action
High Module Current.	The high module current threshold has been exceeded.	Evaluate the threshold setting. Adjust for your situation.
High Subfeed Current.	The high subfeed current threshold has been exceeded.	Evaluate the threshold setting. Adjust for your situation.
High Total Output Current	The total output current exceeded the high threshold.	Evaluate the threshold setting. Adjust for your situation.
High Output Voltage	The output voltage exceeded the high threshold.	Evaluate the threshold setting. Adjust for your situation.
Low Module Current.	The low module current threshold has been exceeded.	Evaluate the threshold setting. Adjust for your situation.
Low Subfeed Current.	The low subfeed current threshold has been exceeded.	Evaluate the threshold setting. Adjust for your situation.
Low Total Output Current	The total output current dropped below the low threshold.	Evaluate the threshold setting. Adjust for your situation.
Low Output Voltage	The output voltage dropped below the low threshold.	Evaluate the threshold setting. Adjust for your situation.
Maximum Module Current.	The maximum module current threshold has been exceeded.	Evaluate the threshold setting. Adjust for your situation.
Maximum Subfeed Current.	The maximum subfeed current threshold has been exceeded.	Evaluate the threshold setting. Adjust for your situation.
Max Total Output Current	The total output current exceeded the maximum threshold.	Evaluate the threshold setting. Adjust for your situation.
Max Output Voltage	The output voltage exceeded the maximum threshold.	Evaluate the threshold setting. Adjust for your situation.
Minimum Module Current.	The minimum module current threshold has been exceeded.	Evaluate the threshold setting. Adjust for your situation.
Minimum Subfeed Current.	The minimum subfeed current threshold has been exceeded.	Evaluate the threshold setting. Adjust for your situation.

Display Message	Detailed Description	Corrective Action
Modular Distribution Communication.	Communication has been lost with the modular distribution breakers.	Check the communication cables to ensure they are properly connected. Contact Customer Support.
Module Breaker Open.	A modular circuit breaker is open.	Check the modular circuit breakers to see if one has overloaded. Replace if necessary.
Output Frequency	The output frequency is exceeding the frequency deviation threshold.	Evaluate the threshold setting and the power quality. Adjust the threshold setting to accommodate your situation. Note: Some backup generators do not tightly regulate their output during normal operation and can trigger this alarm.
Subfeed Breaker Open.	A subfeed circuit breaker is open.	Check the subfeed circuit breakers to see if one has been over-loaded.

Worldwide Customer Support

Customer support for this product is available at www.apc.com.