

**BRISTOL HISTORIC DISTRICT COMMISSION**  
**APPLICATION FOR REVIEW OF PROPOSED WORK**

1. Property Address (Street & No.) 31 Constitution Street

2. Plat # 14 Lot # 103 Contributing \_\_\_\_\_ Non-Contributing \_\_\_\_\_

3. a. Applicant: Brendan Maguire

Mailing Address: 31 Constitution Street, Bristol, RI

Phone: Day 857-261-4193 Evening \_\_\_\_\_

b. Owner (if different from applicant written authorization of owner required): \_\_\_\_\_

Mailing Address: \_\_\_\_\_

Phone: Day \_\_\_\_\_ Evening \_\_\_\_\_

4. a. Architect/Draftsman: William Connolly

Address: \_\_\_\_\_

Phone: Day \_\_\_\_\_ Evening \_\_\_\_\_

b. Contractor: \_\_\_\_\_

Address: \_\_\_\_\_

Phone: Day \_\_\_\_\_ Evening \_\_\_\_\_

5. Work Category:  Replacing in-kind\* *authorization required* \_\_\_\_\_

\_\_\_\_\_ New Structure(s) \_\_\_\_\_ Partial Demolition of Structure(s)

Addition to Structure(s) \_\_\_\_\_ Total Demolition of Structure(s)

\_\_\_\_\_ Remodeling of Structure \_\_\_\_\_ Sign(s) / Landscaping Features

6. Description of proposed work: Windows, fascia board, gutters. Replacing windows in-kind, with fully wood window - Auralust Pine Wood double hung, primed wood SDL. Repairing fascia board

\*All changes must match the existing in materials, design and configuration.

(Continued): Around most of the property, replacing (in-kind)  
portion along Hope Street, which is missing. Installation of aluminum  
gutters - there are no existing gutters to replace   Check here if  
in-kind, or any knowledge of previous gutters.  
continued on additional sheets.

7. Included with the application (check those applicable):

PHOTOGRAPHS: Please label all photographs submitted.

Overall view of property from street(s)  Overall views of building  
 Existing details to be altered by work  
 Other (Identify) \_\_\_\_\_

Drawings: Maximum size accepted: 11" x 17"

Site Plan(s) (drawn to scale)  Floor plan(s) (drawn to scale)  
 Exterior Elevations  Details

OTHER:  Renderings  Catalogue Cuts  Specifications  
 Other (Identify) \_\_\_\_\_

Brendan Maguire  
Applicant's Name - Printed

Brendan Maguire  
Applicant's Signature

Date: 9/19/2023

Contact Person if other than Applicant:

Name (Printed): \_\_\_\_\_

Phone: Day \_\_\_\_\_ Evening \_\_\_\_\_

---

A Certificate of Appropriateness (Green Sheet) is valid for one year from the date of issuance.

Note: If work on a project has started within twelve months of its approval date, you have as long as is necessary to finish the job (in other words, longer than a year).

**sill and trim  
rot, broken  
glass/  
boarded  
window**





**sill and  
trim rot**



**sill and  
trim rot**



**sill and  
trim rot**



**missing fascia board and lack of existing gutters**

**aluminum gutters (shown on neighboring house)**



**9 windows to be replaced  
on south side of house**





**6 windows to be replaced  
on east side of house**

**12  
windows  
to be  
replaced  
on west  
side of  
house**

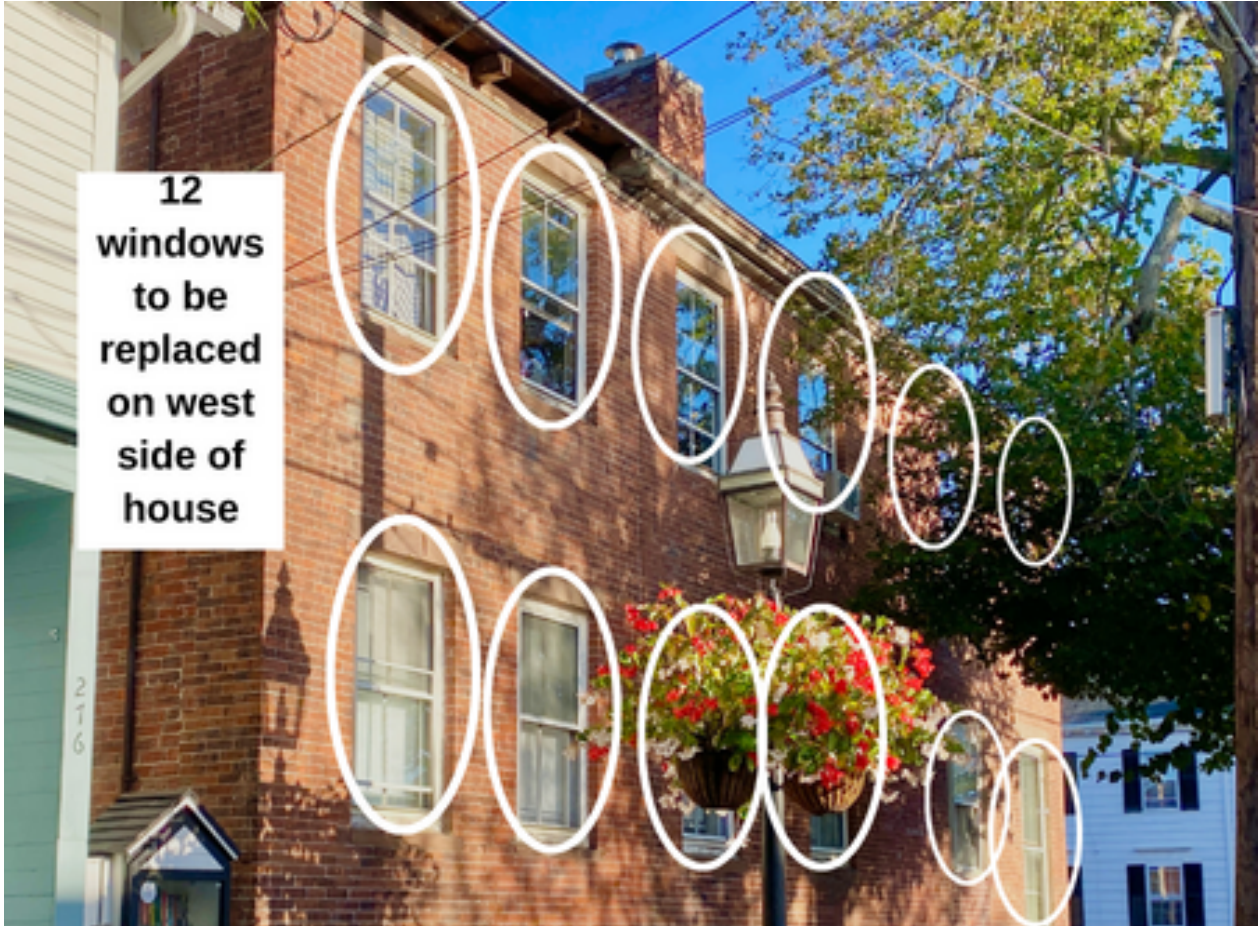

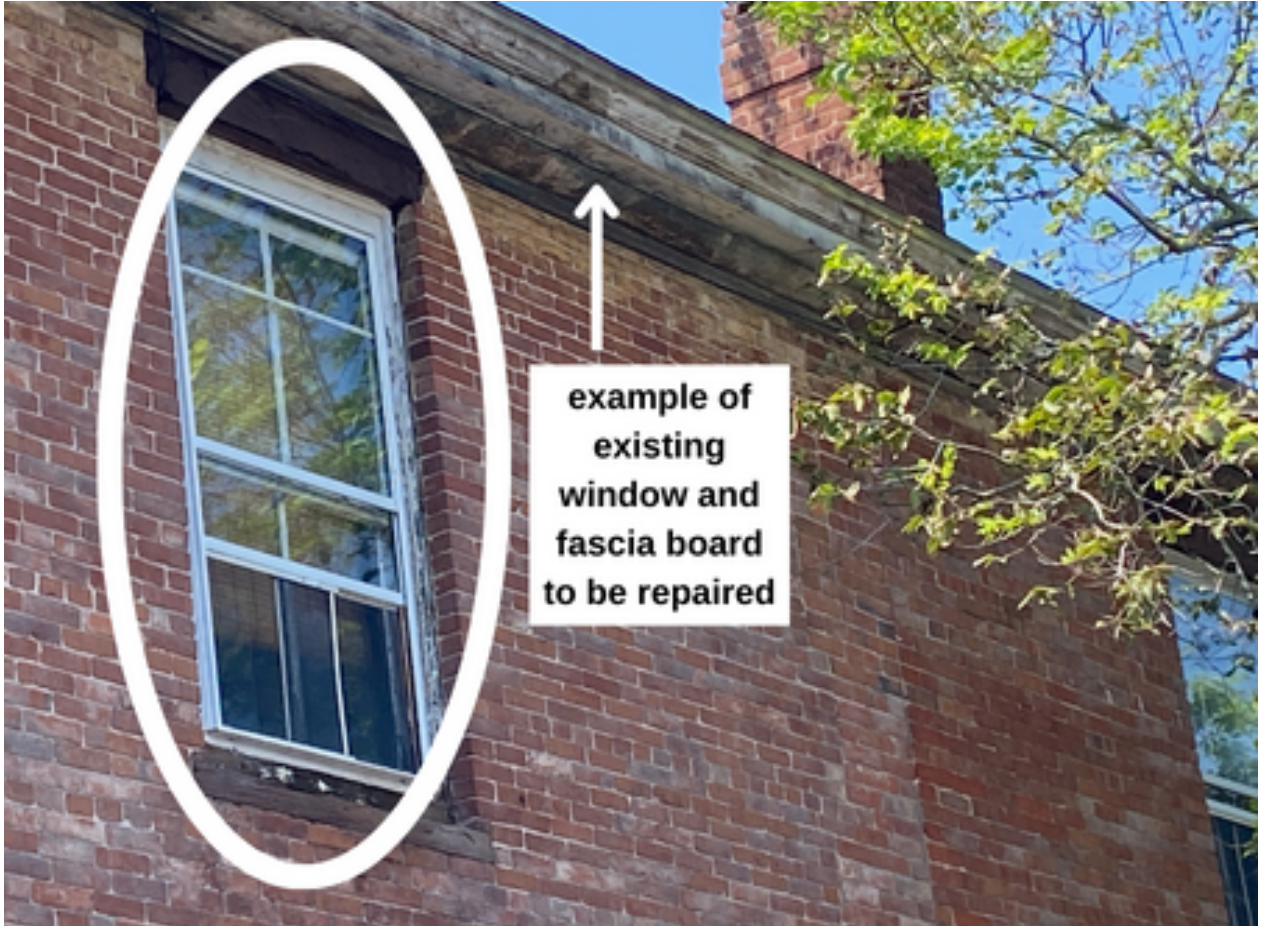

**example of  
existing  
window and  
fascia board  
to be repaired**

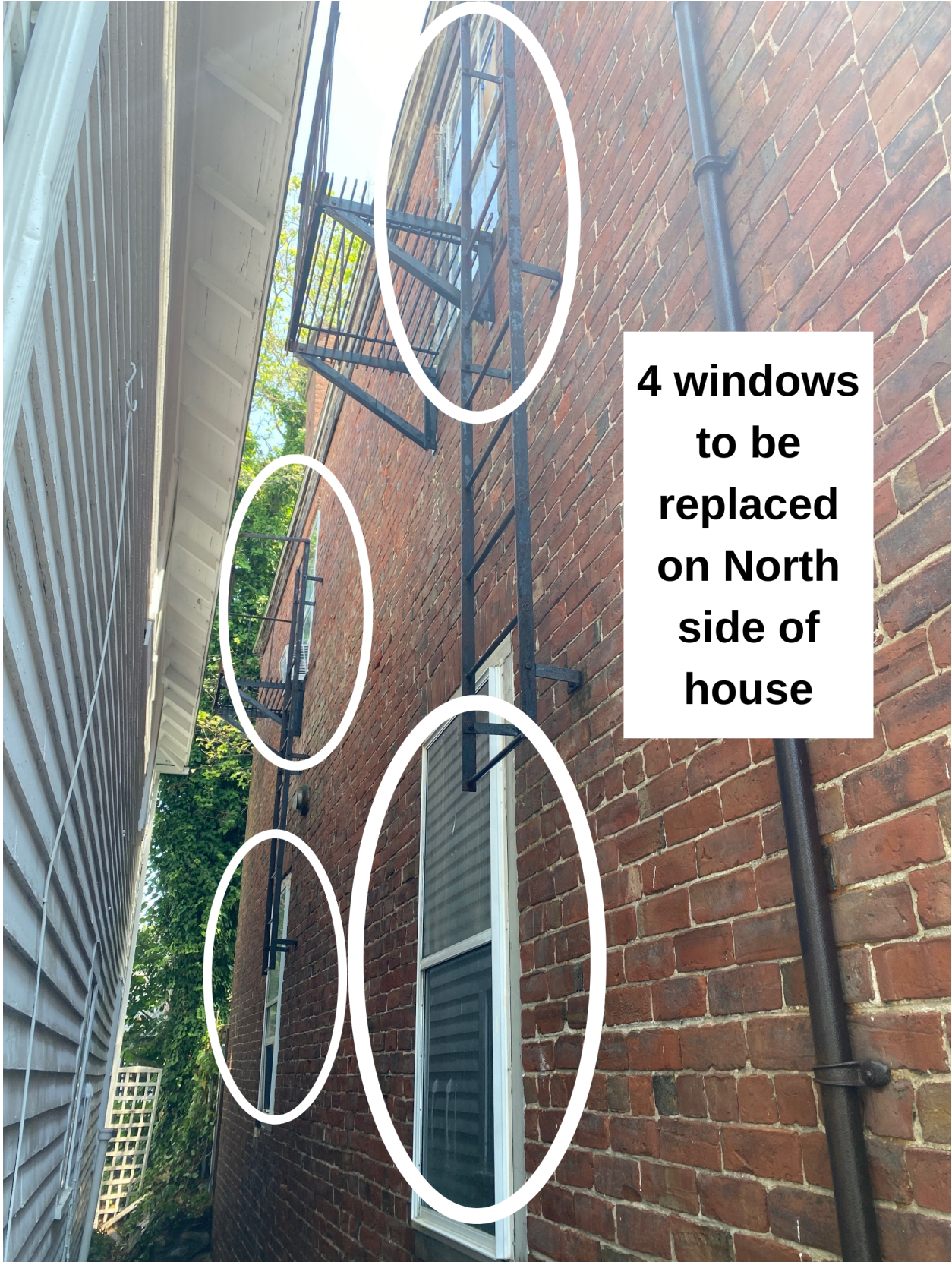

**4 windows  
to be  
replaced  
on North  
side of  
house**

**example of existing window**





**example of existing window**

Eric MacIver

**QUOTE BY :** Jack Haines  
**SOLD TO :** Brendan Maguire  
 Brendan  
**Phone :** (857) 261-4193  
**PO# :**  
**Ship Via :** Ground

**QUOTE # :** JW23080138N - Version 0  
**SHIP TO :**

**PROJECT NAME :**  
**REFERENCE :** ALL WOOD OPTION

**U-Factor Weighted Average:** 0.26

**SHGC Weighted Average:** 0.18

LINE	LOCATION SIZE INFO	BOOK CODE DESCRIPTION	NET UNIT PRICE	QTY	EXTENDED PRICE
Line 1	Pocket Opening : 32 1/2 X 59 1/4	Sitrine Wood Double Hung, Auralast Pine, Pocket Unit, Pocket Opening = 32 1/2 X 59 1/4 Primed Exterior, Natural Interior, 3 1/4 Jamb, 14 Deg Sill, White Jambliner, Concealed Jambliner White Hardware, US National-WDMA/ASTM, PG 35, Insulated SunResist with HeatSave Annealed Glass, Protective Film, Black Spacer, Argon Filled, Traditional Glz Bd, Primed Wood SDL, 7/8" Putty SDL w/Perm Wood Putty Int BAR, Light Bronze Shadow Bar, Colonial All Lite(s) 2 Wide 1 High Top, 2 Wide 1 High Btm, BetterVue Mesh Brilliant White Screen, IGThick=0.698(3/32 / 3/32), Clear Opening:28.2w, 26.3h, 5.1 sf U-Factor: 0.26, SHGC: 0.18, VLT: 0.41, CR: 48.00, CPD: JEL-N-908- 01177-00001 PEV 2023.3.0.4399/PDV 7.119 (09/06/23)NW	\$993.72	30	\$29,811.60

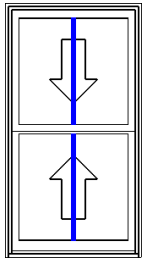

Viewed from Exterior. Scale: 1/2" = 1'

Line 2	Pocket Opening : 36 1/2 X 88 1/4	Sitrine Wood Double Hung, Auralast Pine, Pocket Unit, Pocket Opening = 36 1/2 X 88 1/4 Primed Exterior, Natural Interior, 3 1/4 Jamb, 14 Deg Sill, White Jambliner, Concealed Jambliner White Hardware, US National-WDMA/ASTM, PG 35, Insulated SunResist with HeatSave Annealed Glass, Protective Film, Black Spacer, Argon Filled, Traditional Glz Bd, Primed Wood SDL, 7/8" Putty SDL w/Perm Wood Putty Int BAR, Light Bronze Shadow Bar, Colonial All Lite(s) 2 Wide 1 High Top, 2 Wide 1 High Btm, BetterVue Mesh Brilliant White Screen, IGThick=0.698(3/32 / 3/32), Clear Opening:32.2w, 40.8h, 9.1 sf U-Factor: 0.26, SHGC: 0.18, VLT: 0.41, CR: 48.00, CPD: JEL-N-908- 01177-00001 PEV 2023.3.0.4399/PDV 7.119 (09/06/23)NW	\$1,360.33	1	\$1,360.33
--------	----------------------------------	---	------------	---	------------

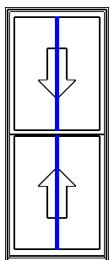

Viewed from Exterior. Scale: 1/2" = 1'

LINE	LOCATION SIZE INFO	BOOK CODE DESCRIPTION	NET UNIT PRICE	QTY	EXTENDED PRICE
<b>Total:</b>					\$31,171.93
<b>MA Tax (6.2500%):</b>					\$1,948.25
<b>Net Total:</b>					\$33,120.18
<b>Total Units:</b>					31

 Protect yourself when you choose JELD-WEN AuraLast pine products backed by a limited lifetime warranty against wood rot and termite damage.





## **SITELINE® | POCKET DOUBLE-HUNG**

WOOD WINDOWS

ARCHITECTURAL DESIGN MANUAL | July 2023

## TABLE OF CONTENTS

---

### PRODUCT INFORMATION

GENERAL INFORMATION & POCKET SIZING	3
GRID PATTERNS	4
GRID, BOTTOM RAIL & GLASS STOP OPTIONS	5
CLEAR OPENING FORMULAS	6
FRAME SIZE FORMULAS	7

### SECTION DETAILS

OPERATOR SECTIONS	8
STATIONARY SECTIONS	9
TRANSOM SECTIONS	10

## GENERAL INFORMATION & POCKET SIZING

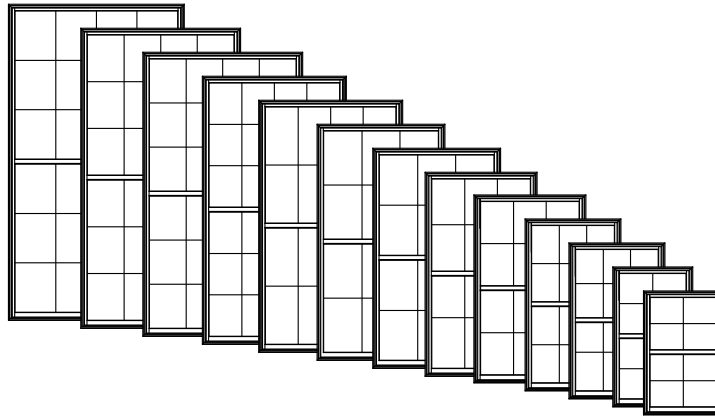

### Dimensional Windows

Siteline® Wood Pocket Double-Hung windows may be specified as "dimensional" by adjusting the desired pocket opening width or height. Siteline® Wood Pocket Double-Hung windows feature fully operating upper and lower sash which can be tilted or removed for easy cleaning.

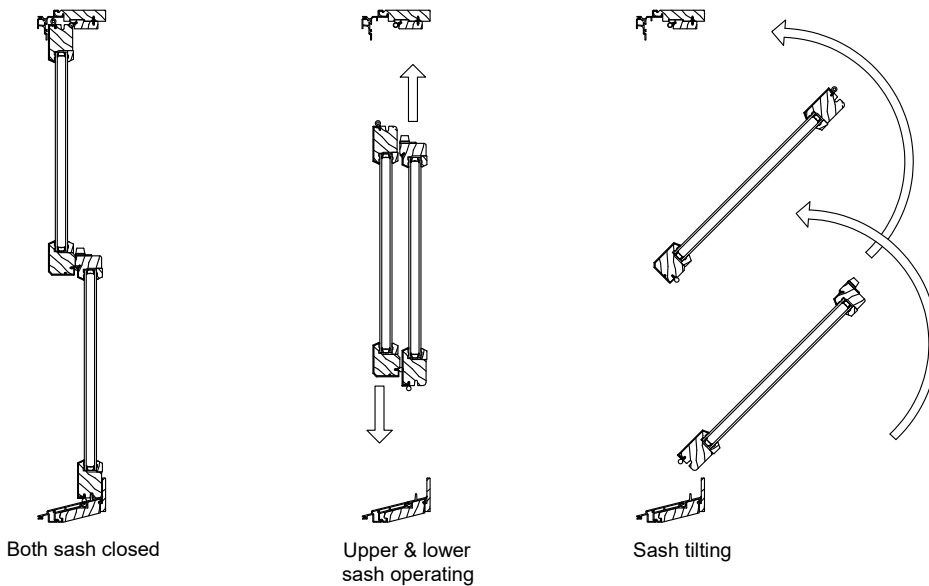

Wood Pocket Double-Hung Min/Max Sizing		
Min/Max	Rating	Width x Height
<b>Minimum Size</b>		
Operating	PG35/PG50	21 3/8" x 31 7/32"
Stationary & Transom	PG35/PG50	21 3/8" x 15"
<b>Maximum Size</b>		
Operating	PG35	45 3/8" x 91 7/32"
Operating	PG50	45 3/8" x 71 7/32"
Stationary	PG35	66 3/8" x 91 7/32"
Stationary	PG50	66 3/8" x 71 7/32"
Transom	PG50	74 3/4" x 35 7/32"

Standard sizes are shown. Smaller or larger sizes may be available as custom orders. Contact JELD-WEN Customer Service for more information.

## GRID PATTERNS

---

Siteline® Wood Pocket Double-Hung Windows are available with Grilles Between Glass (GBG), or Simulated Divided Lites (SDL) in various widths and styles. The standard grid patterns are shown below.

Special grid patterns can include a wide variety of straight line and radius patterns. Non-standard patterns are subject to factory approval.

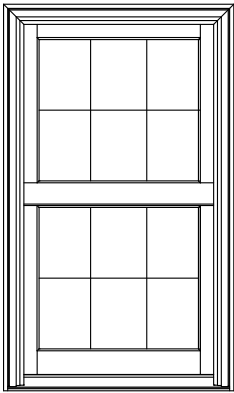

Colonial

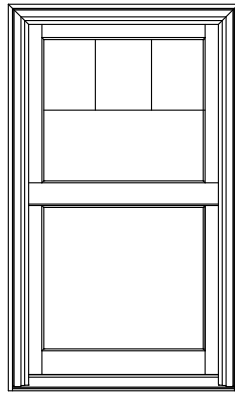

Colonial From  
Top Down

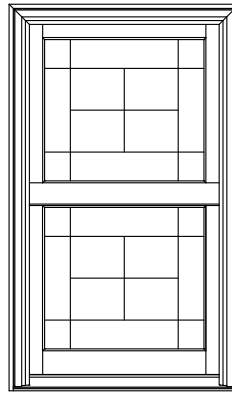

Uneven

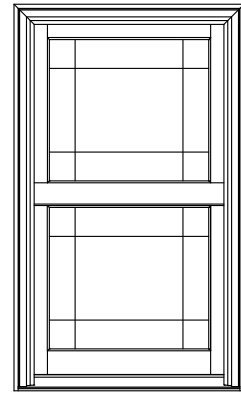

Prairie

### Bar Alignment

Alignment of bars from product to product is often required. SDL, GBG, and wood grilles may be specified with bars aligned.

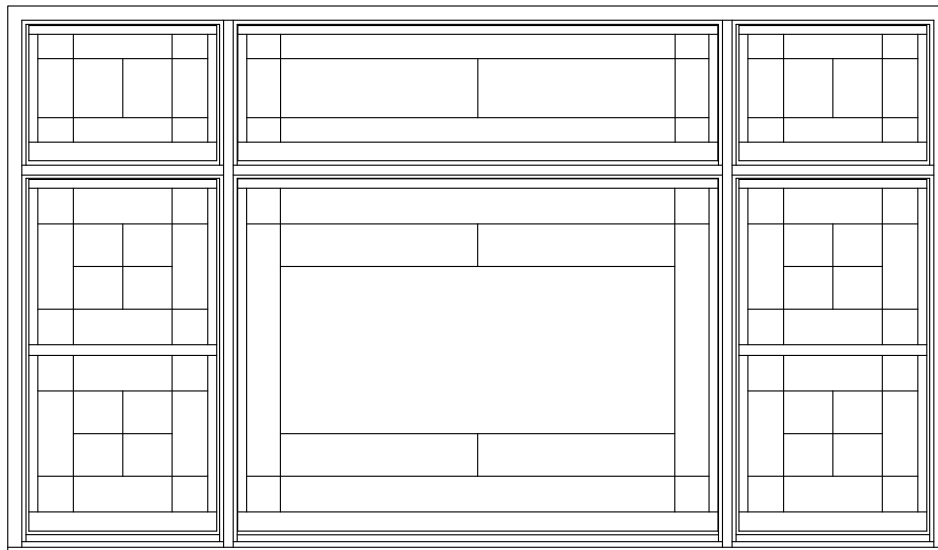

## GRID, BOTTOM RAIL & GLASS STOP OPTIONS

Exterior ← → Interior

### SDL Options

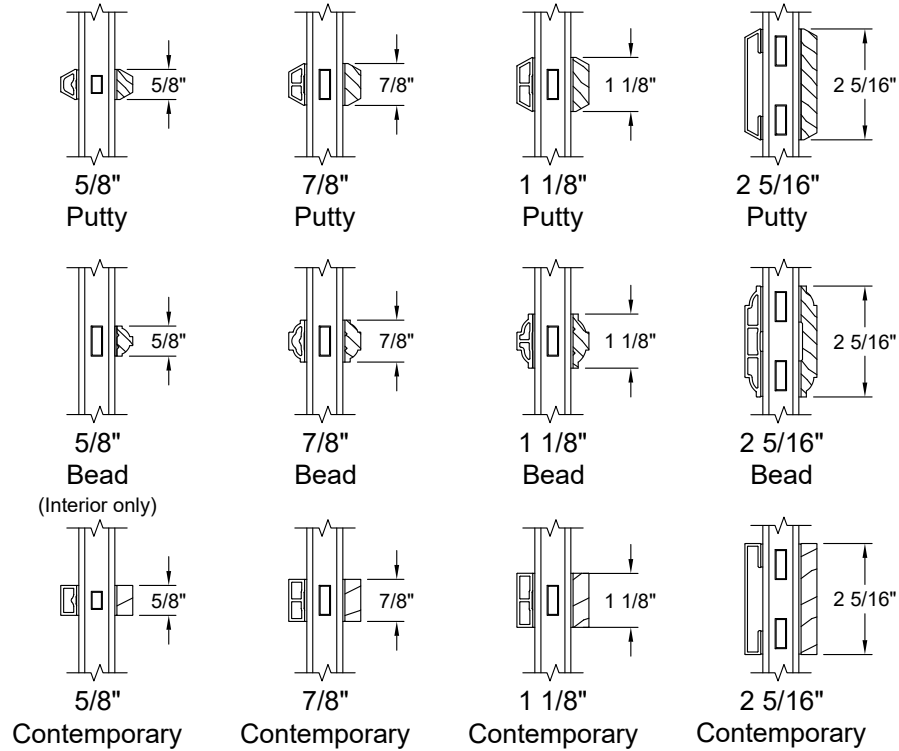

Various Combinations of the SDL Bars Shown are Available

### GBG Options

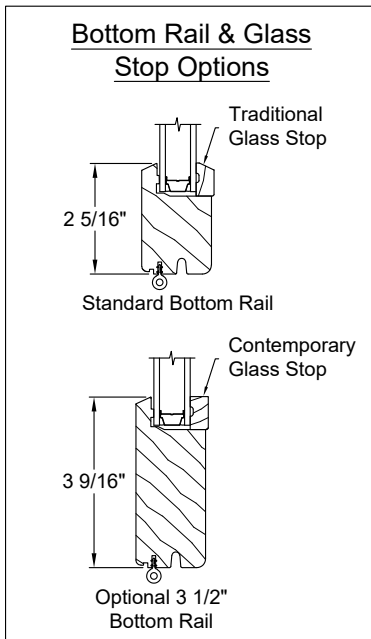
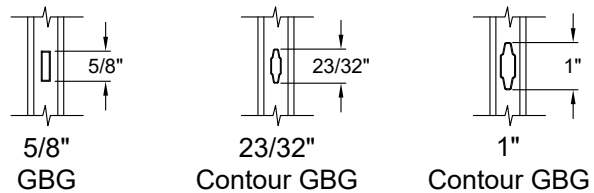

## CLEAR OPENING FORMULAS

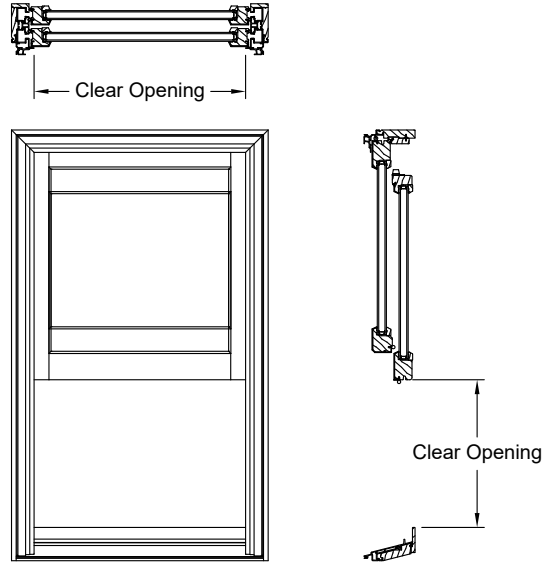

### Double-Hung (Even Divide)

Width = Frame Width - 3 3/4"

Height = (Frame Height / 2) - 3 1/8"

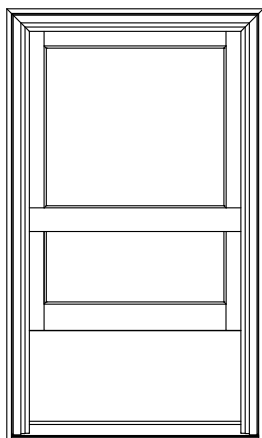
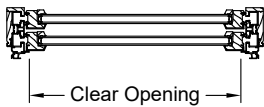

### Cottage Double-Hung

Width = Frame Width - 3 3/4"

Height = (Frame Height / 2) - 5 25/32"

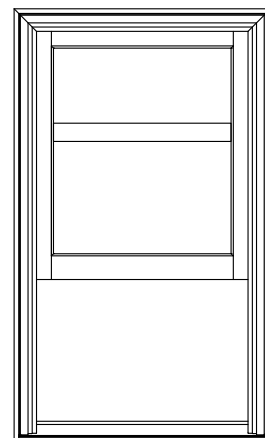
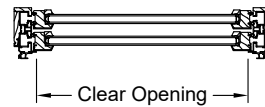
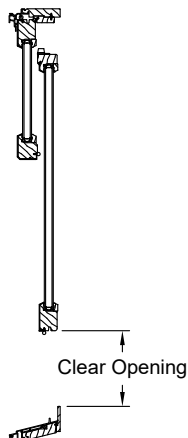

### Reverse Cottage Double-Hung

Width = Frame Width - 3 3/4"

Height = (Frame Height / 2) - 5 5/8"

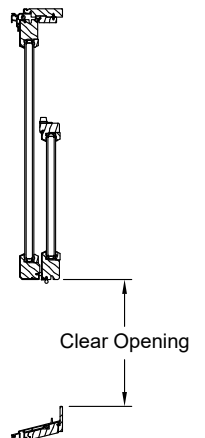

## FRAME SIZE FORMULAS

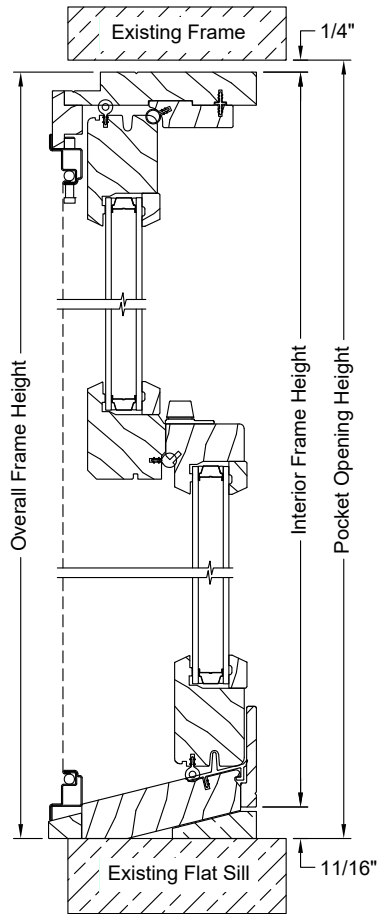

Interior Frame Size =  
Pocket Opening Height - 15/16"

Overall Frame Height =  
Pocket Opening Height - 1/4"

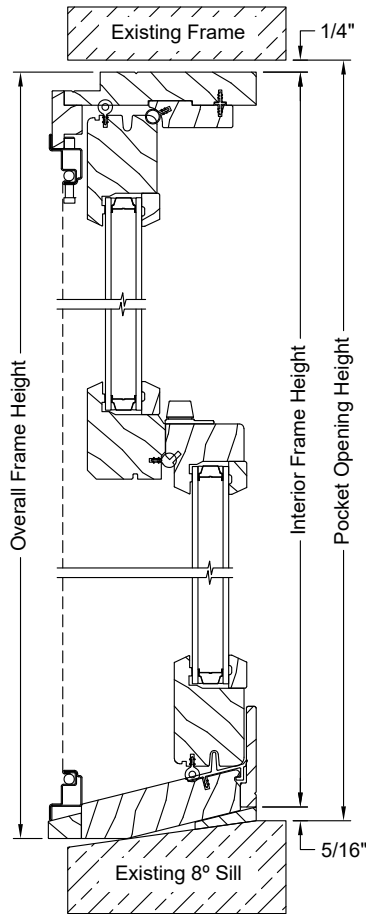

Interior Frame Size =  
Pocket Opening Height - 9/16"

Overall Frame Height =  
Pocket Opening Height + 1/8"

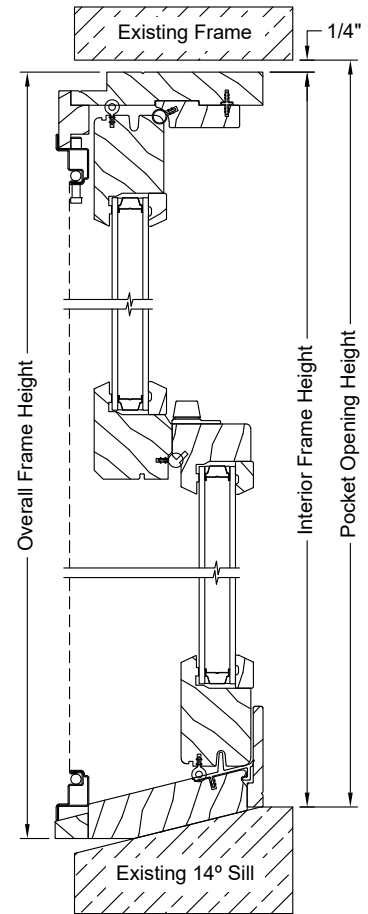

Interior Frame Size =  
Pocket Opening Height - 1/4"

Overall Frame Height =  
Pocket Opening Height + 7/16"

### OPERATOR SECTIONS

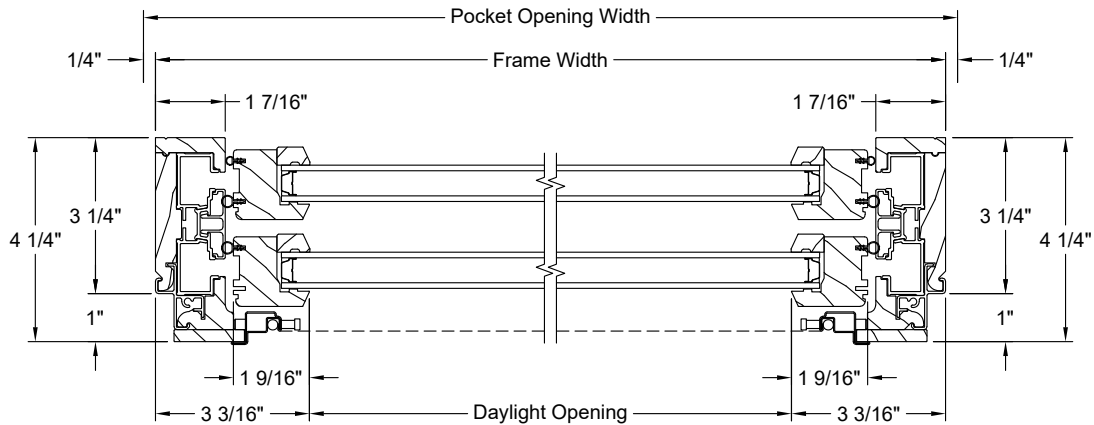
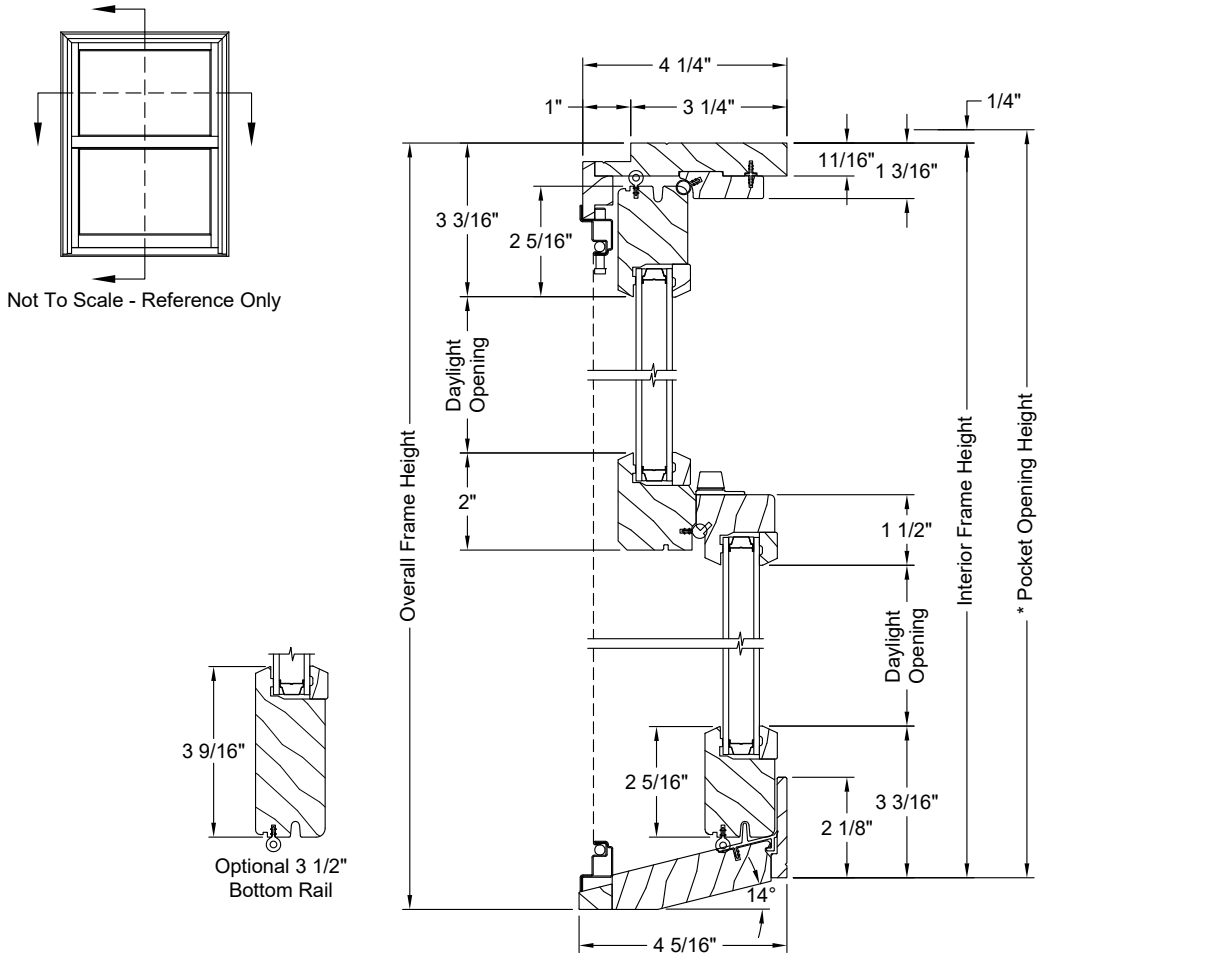

\* Pocket Opening height varies by existing sill slope. 14° sill is shown in this example. See page 6 for all variations.



### STATIONARY SECTIONS

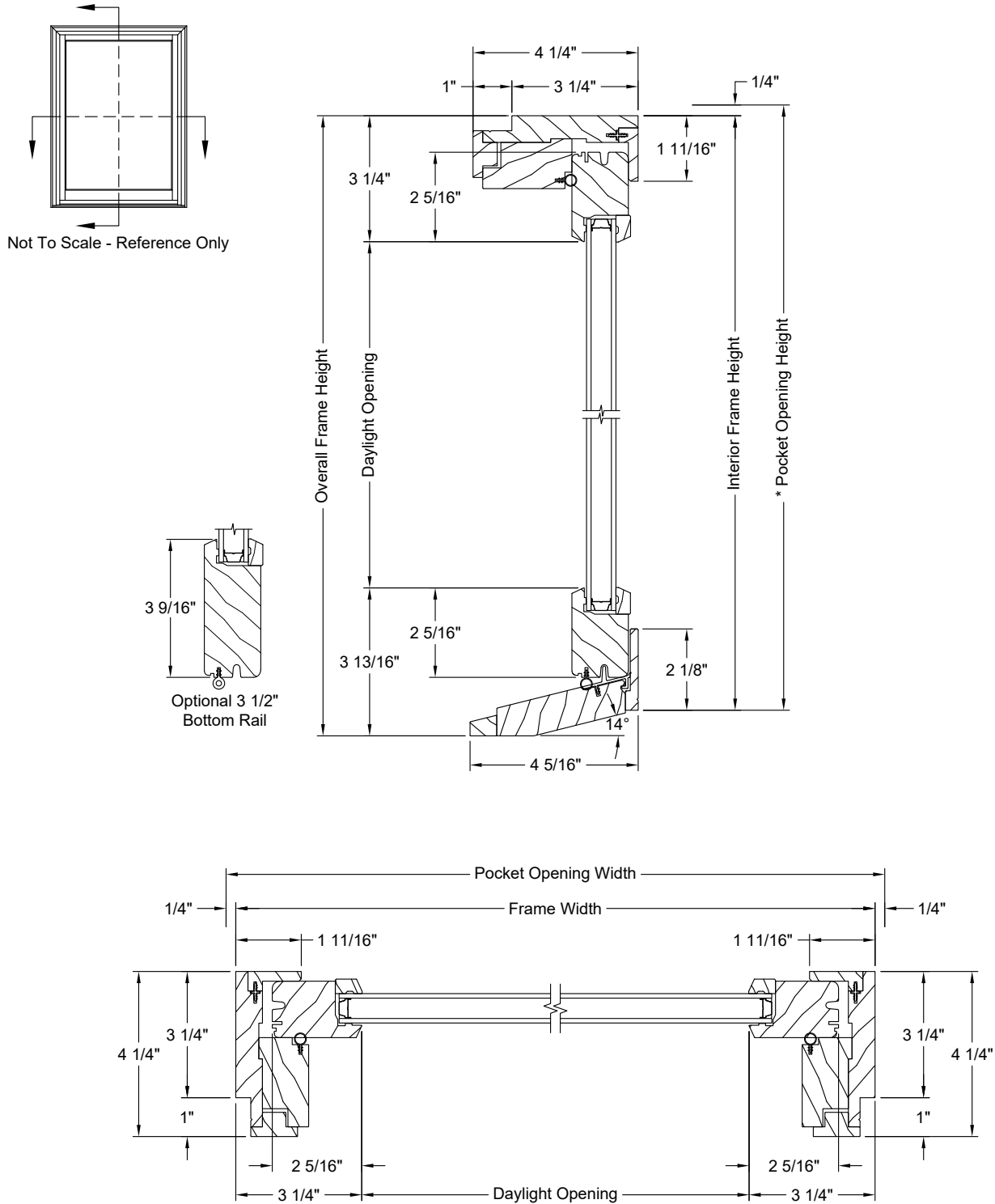

\* Pocket Opening height varies by existing sill slope. 14° sill is shown in this example. See page 6 for all variations.

## TRANSOM SECTIONS

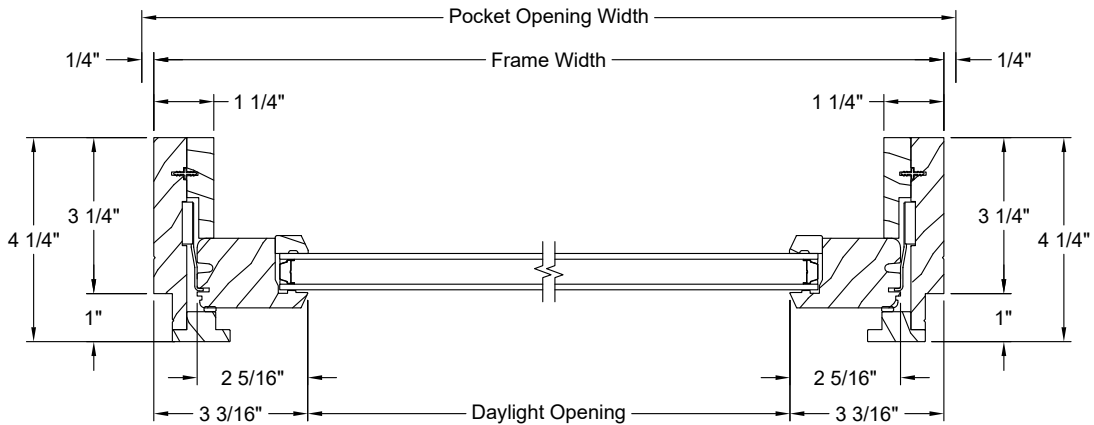
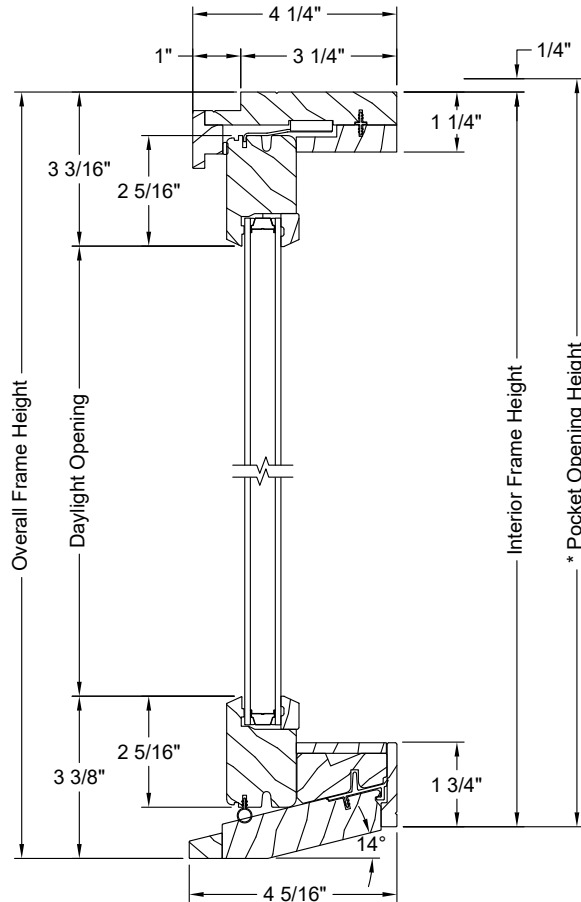
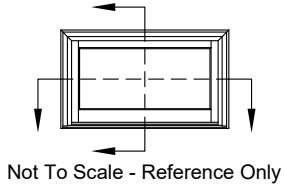

\* Pocket Opening height varies by existing sill slope. 14° sill is shown in this example. See page 6 for all variations.