



CATALOGUE

— 2021



simple. gripping. future.

Contents

Preface	3
New products	4
About LANG	6
Philosophy	8
All from one source	10
Quick•Point® Zero-Point Clamping System	12
Makro•Grip® Stamping Technology	66
Makro•Grip® 5-Axis Vices	84
Makro•Grip® Ultra	114
Conventional Workholding	140
RoboTrex Automation system	172
HAUBEX Automation system	202
Clean•Tec Chip Fan	214
“Heart for children” campaign	221
Product finder	224
Legal notice	228



Dear customer,

After a challenging few months for all of us, we are now looking ahead again and are full of optimism. As a company, we have also been able to find positive aspects in the difficult economic situation, because a lot has happened at LANG Technik. Among other things, we focused on optimising our own production as well as internal structures and processes in order to position ourselves ideally for future tasks. From a sales point of view, we have achieved this with the foundation of our second foreign subsidiary – LANG Technik France. In what is probably the most interesting area for you, namely product developments, we were also able to present some innovations in the past 18 months.

With the product group Makro-Grip® Ultra we are now clamping large components and flat material in completely new dimensions. Of course, as you know it from us, with the stamping technology. The Night King, a pure raw part vice from the Makro-Grip® range, provides enormous cost advantages in automated manufacturing. In addition, we expanded our range of products for round part clamping with the flexible Vasto-Clamp 6-jaw chuck and the Makro-4Grip technology, which can now be used to pre-stamp cylindrical shapes and clamp them by form-fit.

All these innovations, which have been available for a few months now and have been very well received by the market, are now included in this complete catalogue, as well as the automation chapter which was previously shown in a separate brochure. So you will find our complete product range on 228 pages, clearly sorted according to product groups.

Among them – brand new – the HAUBEX automation system. A patented solution with a workholding hood as a carrier system for the vice and workpiece blank, which is automatically loaded into the machine from the tool magazine. This makes automated production possible for practically every machining centre.

You can already look forward to further innovations in the coming months. We invite you to visit our completely revised website regularly to discover what we have in store for you. It will be worth it, we can promise you that much.

Discover LANG Technik – the „Original“!

Philipp Lang, CEO

LANG Technik

New products 2020/2021

The size of our general catalogue has increased noticeably and, with more than 200 pages, is considerably larger than the previous version. This is due to the fact that the density of new developments at LANG in the past two years is higher than ever before. Contrary to the last edition, all automation products have also been integrated

again. This means that you really do have „All from one source“ in one hand again, or rather you have our entire product range at a glance! On this double page you will find an overview of the most important innovations in this catalogue, which we have been producing for you for some time or offer as of now.



HAUBEX Automation System

HAUBEX is a flexible and cost-effective automation solution for small batches that transforms the tool magazine into an automation system. The heart of HAUBEX is a workholding hood, which serves as a carrier system for the newly developed Makro-Grip® 5-Axis Vice with clamped workpiece blank and is exchanged from the tool magazine like an ordinary tool. By automatically changing the clamping device from the tool magazine, HAUBEX uses the existing capacities of the milling machine and manages completely without a feed unit or robot. The vice and zero-point clamping system are operated purely mechanically, which in the case of the zero-point clamping system is done automatically by the workholding hood. With HAUBEX, LANG Technik offers all machining companies a simple, flexible and inexpensive entry into the world of automation.

Makro-Grip® Contour Jaws

LANG Technik is expanding its clamping jaw range for the Makro-Grip® 5-Axis Vice with a new variant of its popular contour jaws for clamping profile and pre-machined parts. The special feature is the attachment of the contour jaws to the clamping jaws of the 5-Axis Vice without jaw exchange or the use of tools, which guarantees a very simple and fast set-up process. When it comes to positioning the contour jaws, LANG relies on proven technology and uses the form-fit between the serration of the clamping jaws and a matching contour in the soft jaws, which ensures the positioning accuracy of the contour jaws. Magnets finally pull them towards the clamping jaws and provide a firm and secure fit. The contour jaws are available in two versions per base body width so that they can be used for both sides of the clamping jaws.

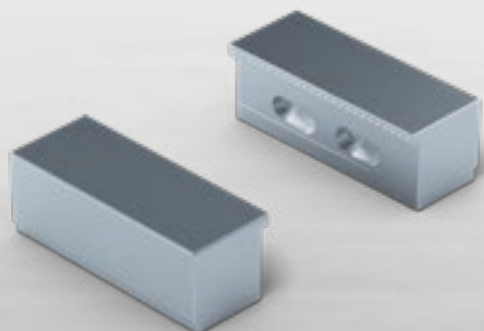



Preci-Point for ER 32 collets

In addition to the Preci-Point collet chuck for ER 50, LANG now also offers a version for collets of type ER 32, which can be used to clamp round parts with $\varnothing 3 - \varnothing 20$ mm. Equipped with clamping studs for a quick set-up process in the Quick-Point® 52 zero-point clamping system, it offers excellent handling characteristics and ideal accessibility during machining thanks to its slim design.



Makro-Grip® Ultra

Incredible modularity meets enormous application variety! The Makro-Grip® Ultra product line offers countless clamping possibilities and can be changed quickly and easily at the same time. Thanks to the expandability of its modules Makro-Grip® Ultra is capable of clamping parts of 810 mm length and beyond safely. With its size it pushes the LANG workholding to new heights and is suitable for mould making and clamping applications of flat and large parts. Different system

heights, individually expandable clamping ranges, interchangeable clamping jaw types and useful accessories – Makro-Grip® Ultra is extremely flexible and equally applicable for single part or multiple clamping, prismatic, round or asymmetrical workpieces. Through its wide range of possible configurations the modular system practically covers any imaginable clamping application.



LANG Technik
simple. gripping. future.

**Subsidiary
France:**

LANG Technik France SAS
Behren Les Forbach

Headquarters:

Holzmaden –
GERMANY

**Subsidiary
USA:**

LANG Technovation Co.
Hartland, Wisconsin

**Training and
Technology Centres:**

Neuhausen auf den Fildern
– Germany
Seelze near Hanover
Germany

140
EMPLOYEES AT FIVE
LOCATIONS

40
EXCLUSIVE
DISTRIBUTORS
WORLDWIDE

450
PRODUCTS

> 1.000

WORKHOLDING SYSTEMS ARE
DISPATCHED EVERY MONTH

TRADITION AND INNOVATION

LANG Technik is looking back on almost 40 years of experience in the machining industry. Starting as a sub-contractor, we have been developing own products since 1997, always true to the motto "Made in Germany". Since then, numerous patents and pioneering innovations have followed. Today our family business is one of the world's market leaders in workholding and automation.



EXPERTISE

Workholding and automation for the machining industry.

MAIN PRODUCT GROUPS



Zero-Point
Clamping



Workholding



Automation

Regionally rooted – globally active

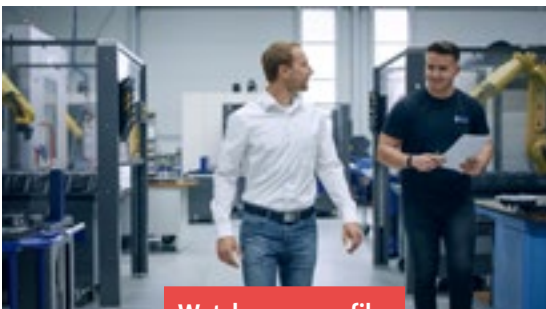

[Watch company film](#)

SIMPLE USABILITY – ATTRACTIVELY PRICED

SOLUTIONS FOR ANY APPLICATION

Companies of all sizes, from 1-man-operation to global players, from various industries trust our vast experience and innovative strength.



→ Engineering



→ Medical



→ Aerospace



→ Automotive / Racing

- Power Generation → Defense → Food Industry
- Precision Engineering → Schools → Universities
- Research Institutes → and many more



ESSENTIAL

LANG Technik Philosophy

Our name stands for Swabian ingenuity, innovation and decisive solutions in the field of workholding, optimisation of set-up time and automation. Learn more about what drives us, what we stand for and what our customers can expect from us.

Our Vision

Giving every machining company worldwide access to innovative and flexible workholding solutions, simplifying their processes, reducing costs and guaranteeing consistent quality.



ANG ECHNIK

Our Mission

As a pioneer in this industry, we develop and produce integrated solutions in the field of automation, zero-point clamping and workholding for both ourselves and for all machining industry sectors.

Our Values

SECURITY – PROXIMITY – SUSTAINABILITY –
SIMPLICITY – INNOVATION

Learn the meaning of each of these values on our website.

Workholding and Automation – from one source

A proven and perfectly combined package of workholding, zero-point clamping and automation, along with our unrivaled stamping technology, provides our customers with the necessary requirements to stay efficient and competitive.

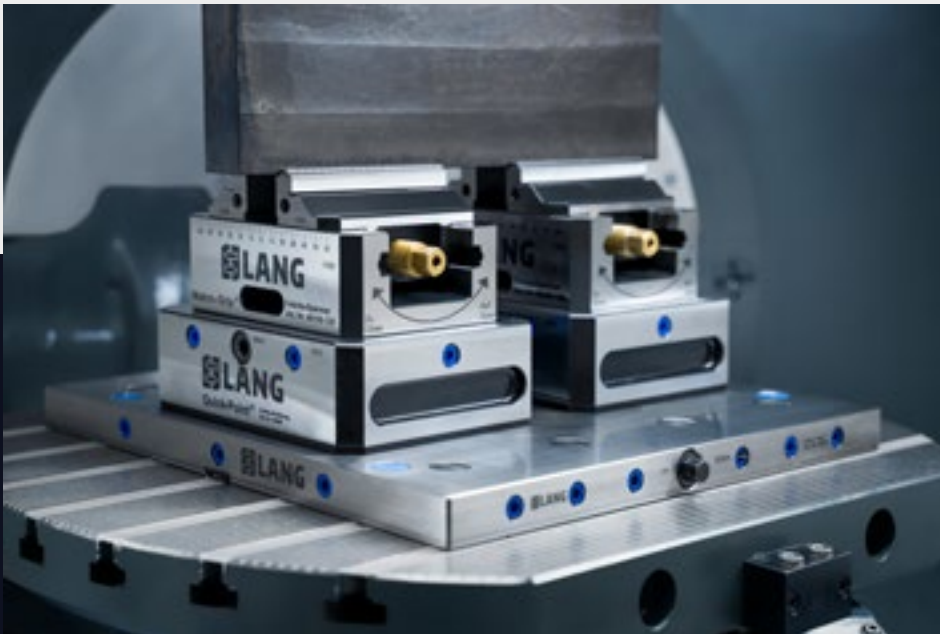
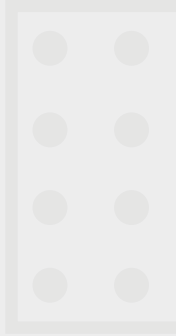

Zero-Point Clamping

Quick-Point® fits anywhere

- Fits any machine table
- Versatile application possibilities for 3-/5-axis machines and rotary tables
- Modular design
- Enormous set-up time savings
- Wide range of customisation options
- Highly precise positioning
- Direct clamping of workpieces
- Simple operation, easy maintenance and cleaning



Workholding

A suitable clamping solution for all

- For raw, round, pre-machined, (semi) finished workpieces
- Highest holding forces and process reliability
- Ideal accessibility for 5-sided machining
- Wear and distortion-free clamping
- Fully compatible centring vices and chucks
- Compact design, low weights, ergonomic
- Integrated zero-point adaptation
- For automated or manual production systems

Learn more about
our solutions:

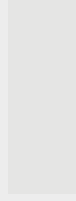
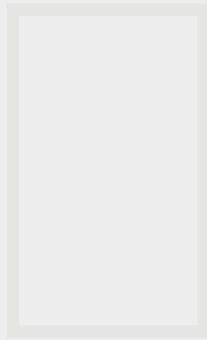
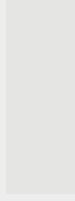

any machining task

(re-) finished and large parts
reliability

ing

clamping jaws
omnic handling

n, can be used with competing

Automation

Flexible single part or large scale production

- Retrofittable to any machining centre
- (Re-)equipping of automation system within a few seconds
- Highly flexible single-part or batch production
- Simple operation, no knowledge about robots required
- Quick installation, minimum training expenses
- No skilled labour required
- Automation trolleys as a flexible storage
- High storage capacity on small footprint



ZERO-POINT CLAMPING

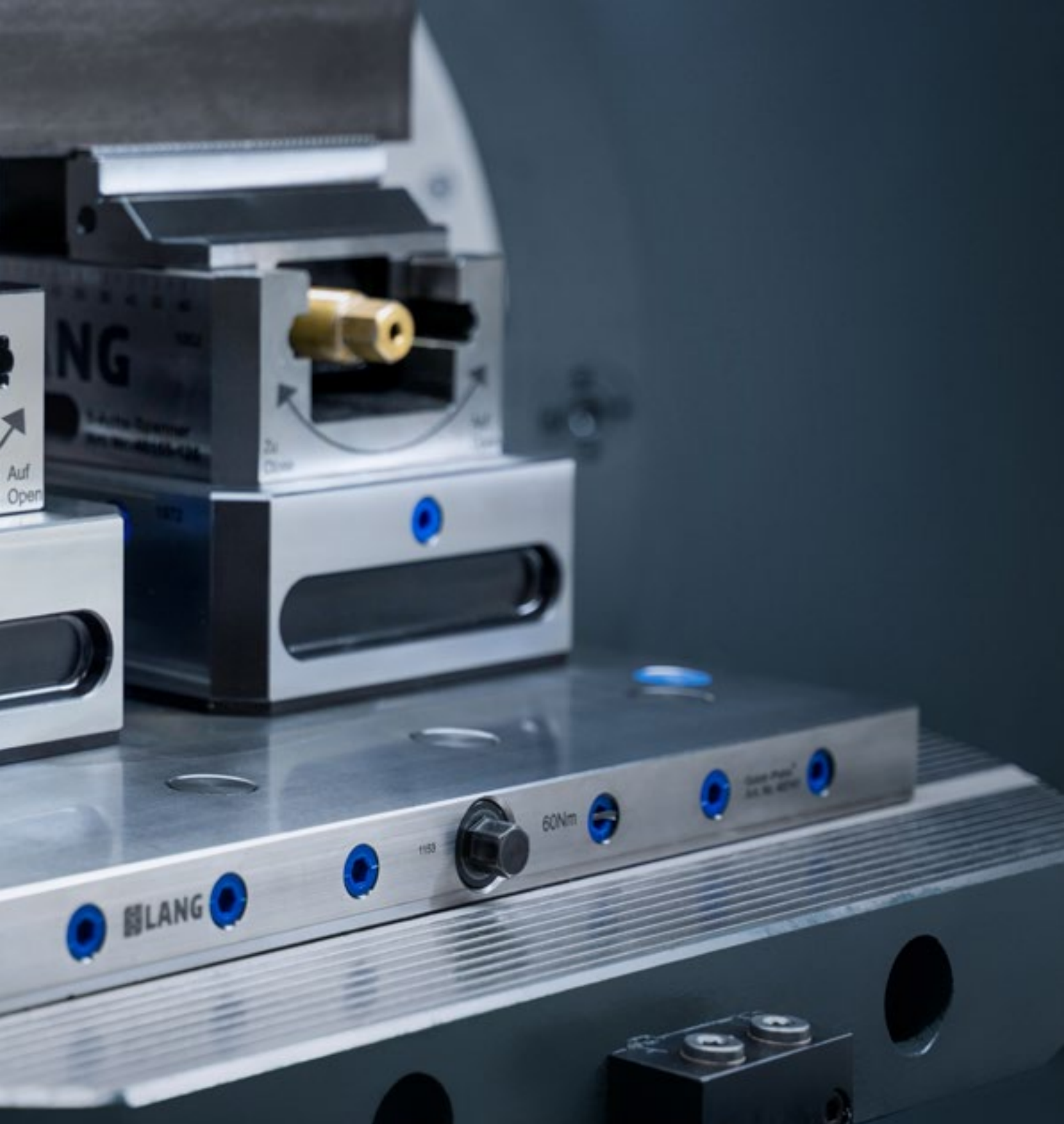

20 Quick·Point® **Single Plates**
32 Quick·Point® **Multi Plates**
38 Quick·Point® **Adaptor Plates**
40 Quick·Point® **Risers**
44 Quick·Point® **Clamping Towers for Vertical Machining Centres**

48 Quick·Tower **Clamping Tower for Horizontal Machining Centres**
54 Quick·Point® **Accessories**
62 **Alignment and Mounting Options**
64 Quick·Point® **Service**

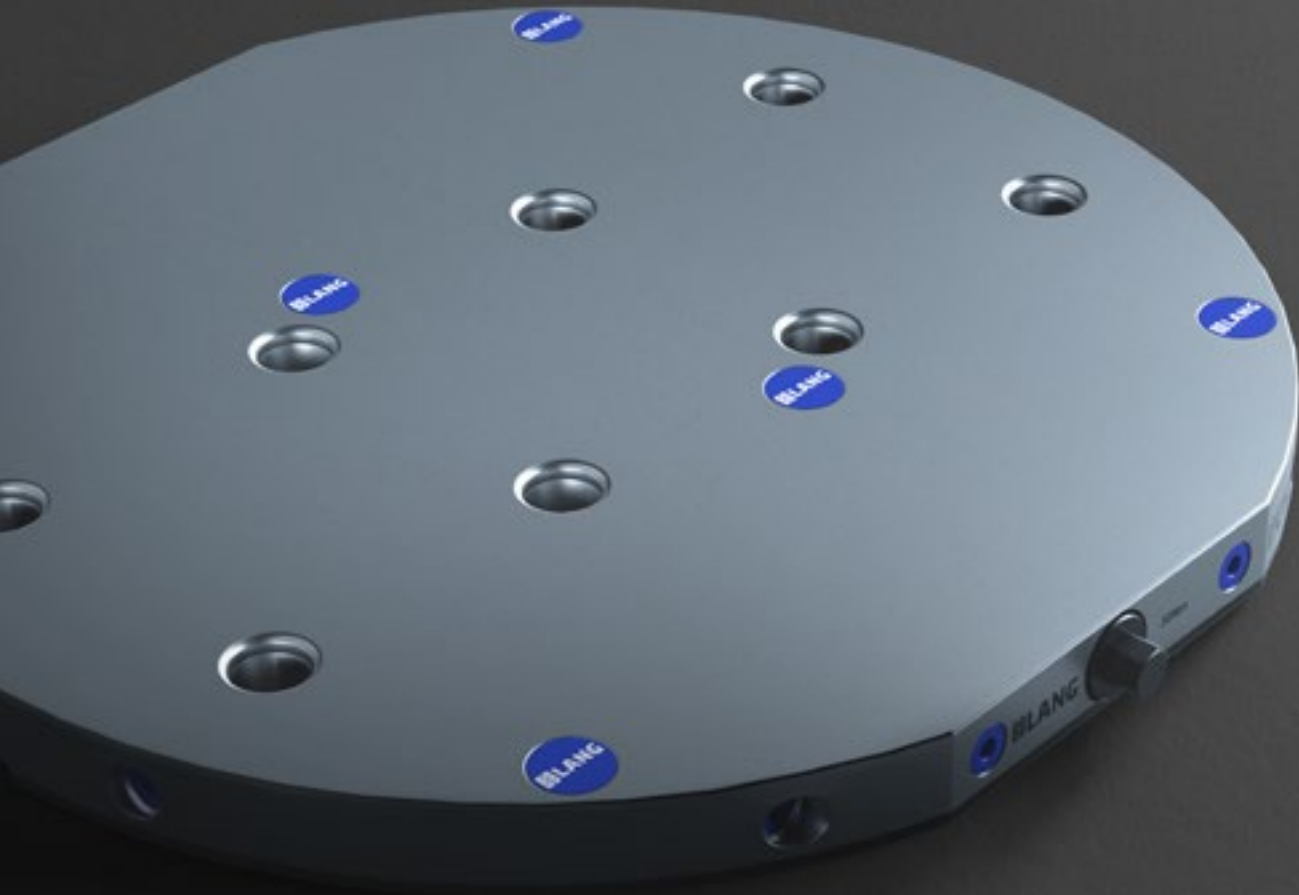

**simple.
quick.
clamping.**

Flexible, precise and extremely durable.

The Quick·Point® Zero-Point Clamping System combines:

SET-UP TIME SAVINGS

MODULARITY

SIMPLE, MECHANICAL OPERATION

As an interface between the machine table and clamping device, Quick·Point® is characterised by an enormous range of variations and high repeatability. Round, rectangular or square in shape, for single or multiple clamping, two different stud sizes and spacings (52 mm and 96 mm), Quick·Point® provides a solution for every application. It can be used universally in vertical and horizontal machining centres, on 3- and 5-axis tables and 4th axis rotary or trunnion systems. Due to its modularity the system can be expanded precisely at any time.

Benefits of the Quick·Point® Zero-Point Clamping System



Minimum setup time required



Direct clamping of workpieces



Wide range of customisation options



Highly precise positioning



Maintenance-free and durable components



Automated, pneumatic actuation possible

Quick-Point® Technology

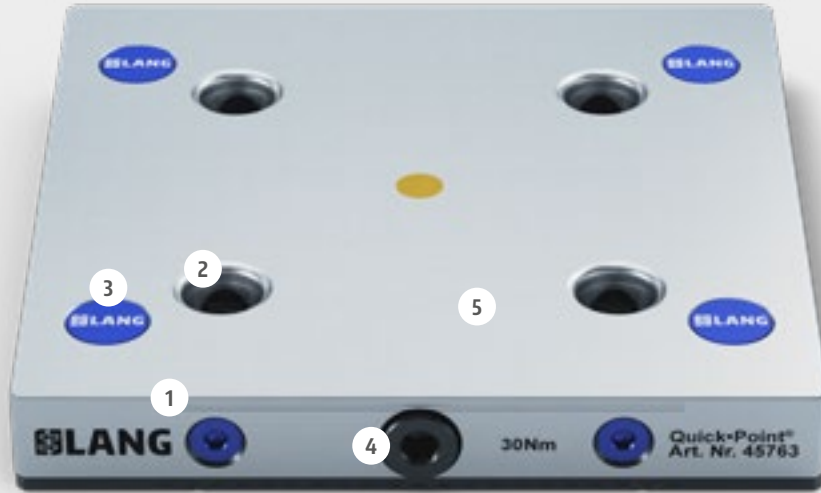

- 1 With only 27 mm one of the lowest zero-point systems on the market
- 2 Highly precise with < 0.005 mm repeat accuracy
- 3 Cover discs for mounting bores
- 4 Robust mechanical clamping with one actuation screw or Quick-Lock fastener
- 5 Rigid, compact base plate made of case-hardened and ground steel

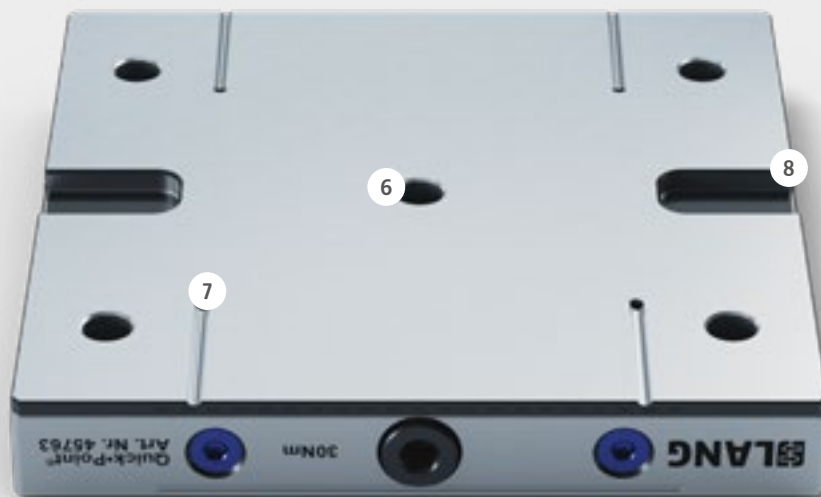

- 6 Ø12F5 fitting for concentric alignment, centring studs are also available (page 61)
- 7 Coolant drainage
- 8 20H7 keyways for axial alignment

Functional principle of Quick-Point® Zero-Point Plates

By design Quick-Point® is a purely mechanical zero-point system. A patented rod system inside the plate guarantees a repeatability of less than 0.005 mm. Quick-Point® plates are actuated by one screw or the Quick-Lock device to ensure simple and easy operation. With an actuation torque of 30 Nm (60 Nm for 4-fold grid plates) holding forces of up to 6.000 kg are realised. Due to a very small number of wear-free parts the system is reliable and virtually maintenance free.

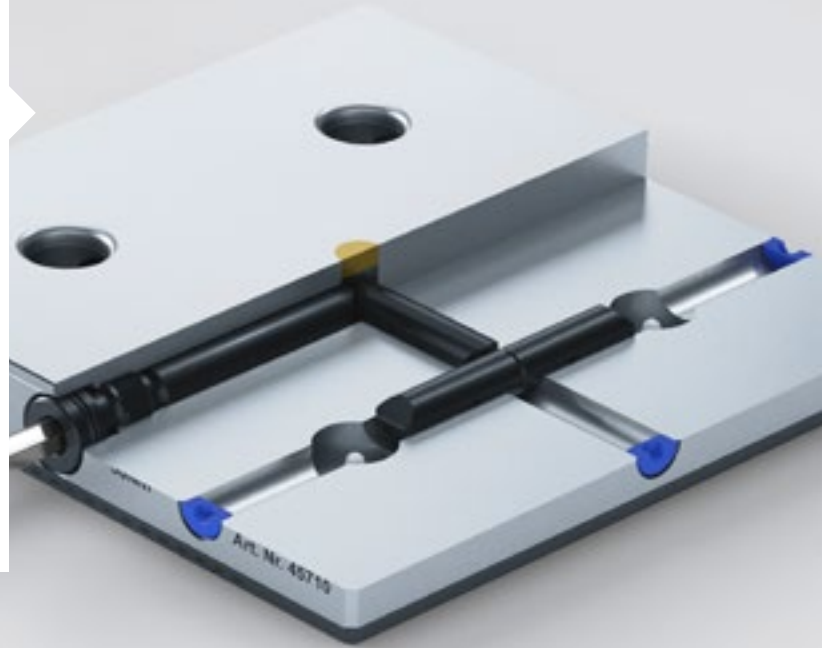

Modular, flexible and always a good fit.

With nearly 50 different types of zero-point plates and diverse customisation possibilities Quick-Point® provides a suitable solution for every type of machine table. On large machine tables a continuous grid can be realised using (multi) grid plates in order to make best use of the available space. Quick-Point® unfolds its enormous modularity through complementary items, such as risers, tombstones and, in particular, adaptor plates with which the zero-point grid size can be reduced from 96 mm to 52 in order to use all sizes of LANG vices flexibly.



Recommendation:

If the size of the machine table allows it, we recommend, the larger Quick-Point® 96 zero point clamping system as the basis on the machine table. This ensures the greatest possible flexibility with regard to future system expansions. In this way, you remain flex-

ible and can use both larger vices or clamping systems such as Makro-Grip® Ultra, as well as smaller vices by adapting them to the Quick-Point® 52 zero-point clamping system.

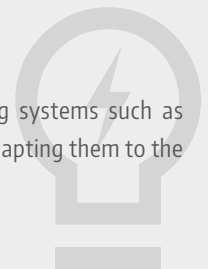



Direct clamping of workpieces and fixtures

Quick-Point® clamping studs connect the zero-point system and LANG workholding devices. They can be also mounted directly to a workpiece in order to clamp it directly without a workholding device. Even the mounting to customers' own fixtures or conventional vices is possible to benefit from all the advantages of the Quick-Point® zero-point clamping system. The connection between clamping studs and zero-point plate is extremely robust, very precise and can undoubtedly resist even the strongest machining forces.

Image: Poseidon Propulsion B.V.

High degree of customisation possibilities

All of our Quick-Point® plates with prefabricated mounting bores are also available without such, in order to be individually adapted to any kind of machine table. If the zero-point plate protrudes the machine table, cutting off the plate's corners provides a nice and clean customisation.

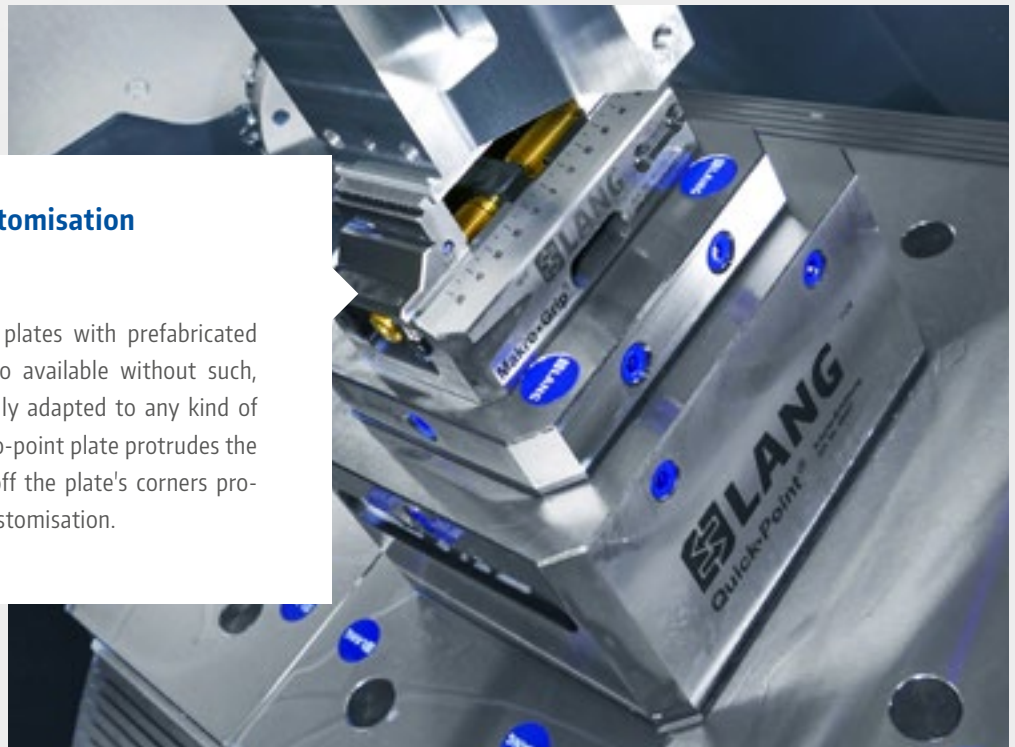

Image: Donner GmbH The Qualifactory



A great fit for rotary tables

The low overall height, the wide range of customisation options and the mechanical functional principle make the Quick-Point® zero-point clamping system a great choice for rotary tables, e.g. from Kitagawa, Lehmann, Nikken or Haas, just to name a few. Rotary tables and trunnions can be retrofitted easily with Quick-Point® plates which provide added value in terms of flexibility and set-up times.

Automated manufacturing

The Quick-Point® zero-point clamping system is used not only in manual but also in automated, lights-out manufacturing. The zero-point clamping system can be actuated either by the machine tool (pneumatically) or the robot gripper (mechanically or pneumatically). A media interface within the machine is not required.



Quick-Point® Single Plates

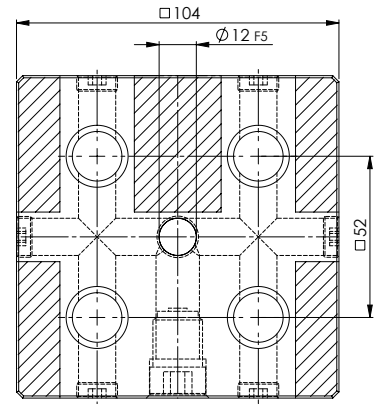

QUICK-POINT® 52, GRID PLATE 104 × 104 × 27 MM, WITHOUT MOUNTING BORES



ITEM NO.	DIMENSIONS	WEIGHT
45600	104 × 104 × 27 mm	2.0 kg
45004	Set mounting bores according to customer's request	
45002	Set keyways according to customer's request	

Suitable Quick-Lock: Item No. 44552 (page 58)

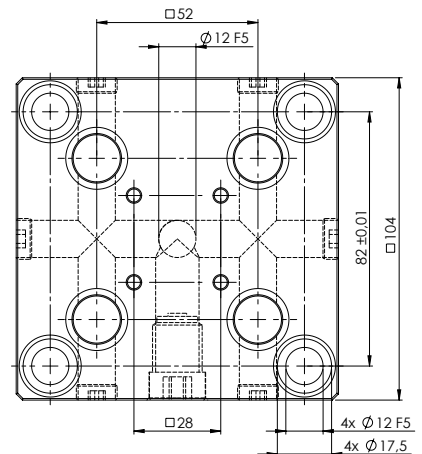

QUICK-POINT® 52, GRID PLATE 104 × 104 × 27 MM, WITH MOUNTING BORES FOR QUICK-TOWER

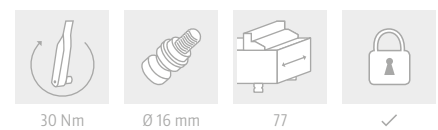

ITEM NO.	DIMENSIONS	MOUNTING BORES	WEIGHT
75600	104 × 104 × 27 mm	82 × 82 mm	1.8 kg

This Grid Plate can also be found on page 46 & 52.
Suitable Quick-Lock: Item No. 44552 (page 58)

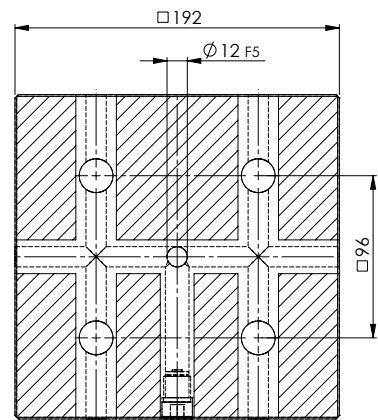

QUICK-POINT® 96, GRID PLATE
192 × 192 × 27 MM, WITHOUT MOUNTING BORES

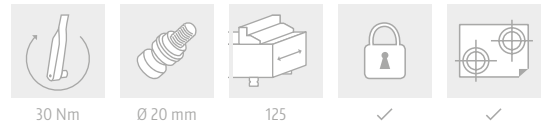

ITEM NO.	DIMENSIONS	WEIGHT
45710	192 × 192 × 27 mm	7.2 kg
45004	Set mounting bores according to customer's request	
45002	Set keyways according to customer's request	

Suitable Quick-Lock: Item No. 44596 (page 58)

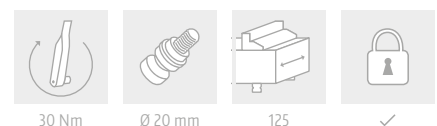
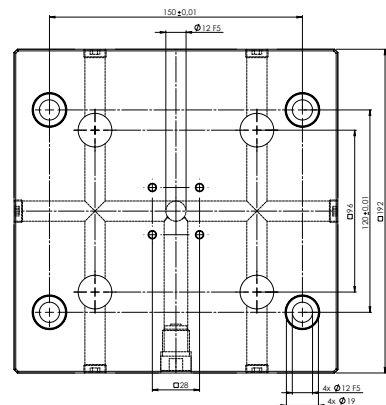

QUICK-POINT® 96, GRID PLATE
192 × 192 × 27 MM, WITH MOUNTING BORES FOR QUICK-TOWER

ITEM NO.	DIMENSIONS	MOUNTING BORES	WEIGHT
75710	192 × 192 × 27 mm	150 × 120 mm	7.0 kg

This Grid Plate can also be found on page 53.
 Suitable Quick-Lock: Item No. 44596 (page 58)

Quick-Point® Single Plates

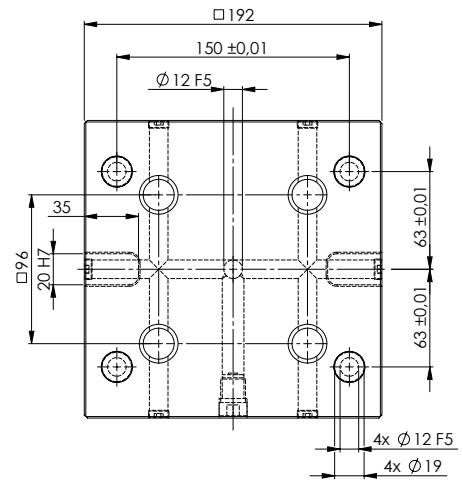

QUICK-POINT® 96, GRID PLATE 192 × 192 × 27 MM, WITH MOUNTING BORES FOR 63 MM T-SLOT DISTANCE

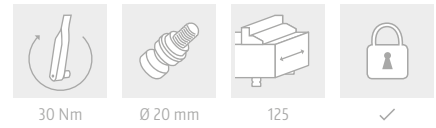

ITEM NO.	DIMENSIONS	MOUNTING BORES	WEIGHT
45763	192 × 192 × 27 mm	for 63 mm t-slot distance	7.0 kg

Suitable Quick-Lock: Item No. 44596 (page 58)

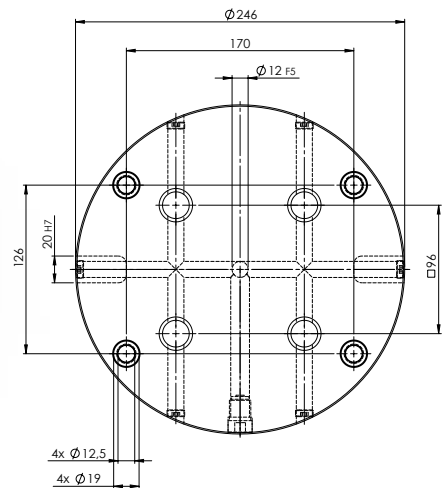
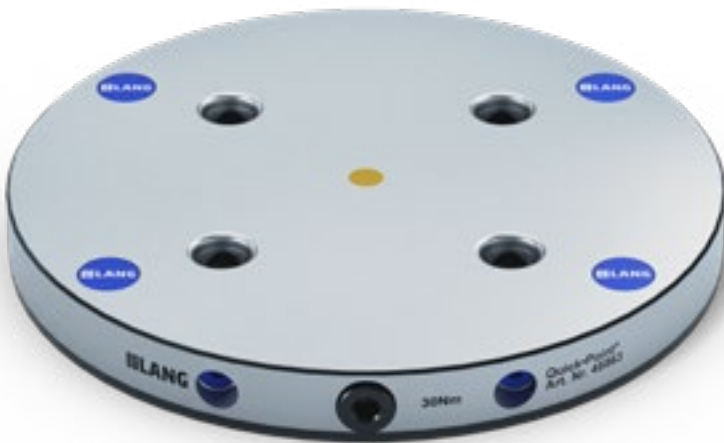

QUICK-POINT® 96, ROUND PLATE Ø 246 × 27 MM, WITH MOUNTING BORES FOR 63 MM T-SLOT DISTANCE

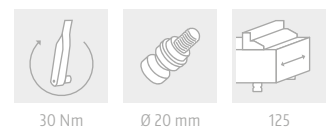

ITEM NO.	DIMENSIONS	MOUNTING BORES	WEIGHT
45863	Ø 246 × 27 mm	for 63 mm t-slot distance	9.3 kg

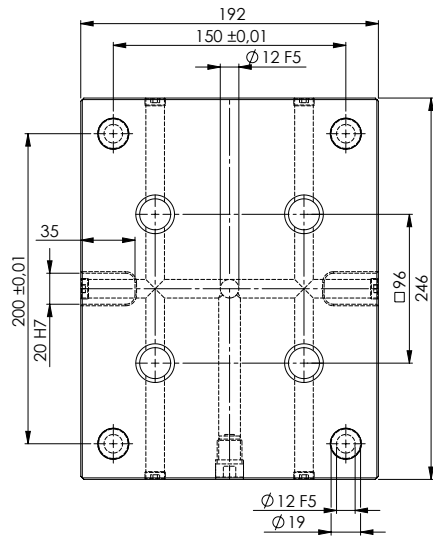

QUICK-POINT® 96, EXTENDED GRID PLATE
246 × 192 × 27 MM, WITH MOUNTING BORES FOR 100 MM T-SLOT DISTANCE

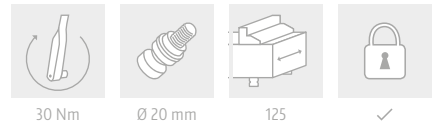

ITEM NO.	DIMENSIONS	MOUNTING BORES	WEIGHT
45715	246 × 192 × 27 mm	for 100 mm t-slot distance	9.2 kg

Suitable Quick-Lock: Item No. 44596 (page 58)

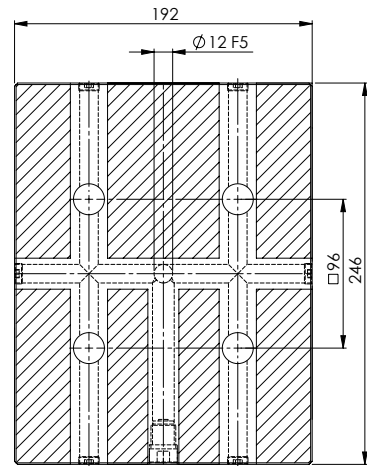

QUICK-POINT® 96, EXTENDED GRID PLATE
246 × 192 × 27 MM, WITHOUT MOUNTING BORES

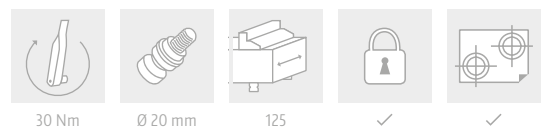

ITEM NO.	DIMENSIONS	WEIGHT
45716	246 × 192 × 27 mm	9.4 kg
45004	Set mounting bores according to customer's request	
45002	Set keyways according to customer's request	

Suitable Quick-Lock: Item No. 44596 (page 58)

Quick-Point® Single Plates

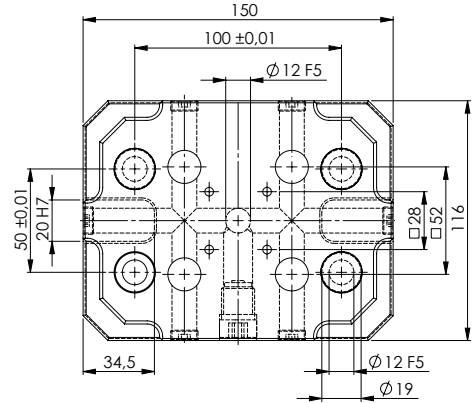

QUICK-POINT® 52, RECTANGULAR PLATE 150 × 116 × 27 MM, WITH CLAMPING EDGE & MOUNTING BORES

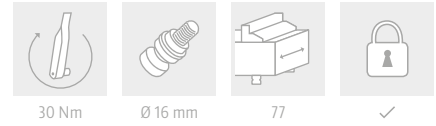

ITEM NO.	DIMENSIONS	MOUNTING BORES	WEIGHT
45150	150 × 116 × 27 mm	100 × 50 mm	2.9 kg

Suitable Quick-Lock: Item No. 44552 (page 58)

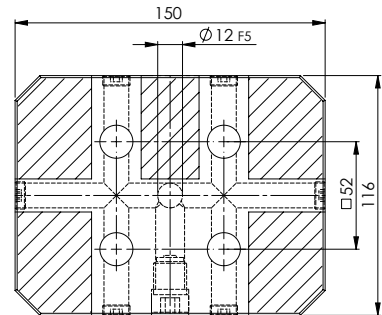

QUICK-POINT® 52, RECTANGULAR PLATE 150 × 116 × 27 MM, WITHOUT CLAMPING EDGE & MOUNTING BORES

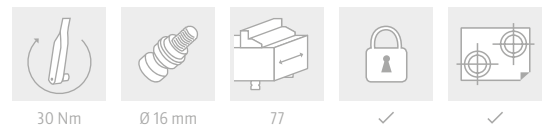

ITEM NO.	DIMENSIONS	WEIGHT
45151	150 × 116 × 27 mm	3.4 kg
45004	Set mounting bores according to customer's request	
45002	Set keyways according to customer's request	

Suitable Quick-Lock: Item No. 44552 (page 58)

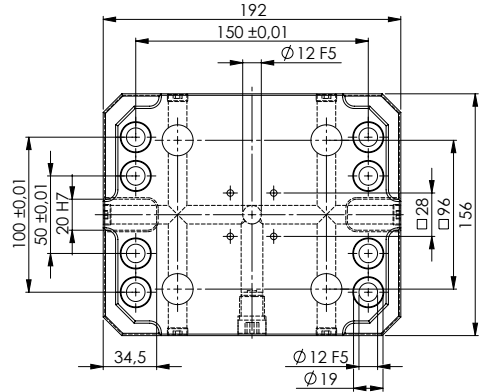

QUICK-POINT® 96, RECTANGULAR PLATE
192 × 156 × 27 MM, WITH CLAMPING EDGE & MOUNTING BORES

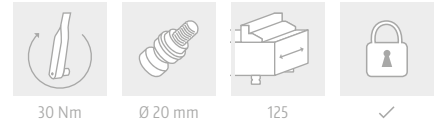

ITEM NO.	DIMENSIONS	MOUNTING BORES	WEIGHT
45400	192 × 156 × 27 mm	150 × 100 / 50 mm	5.5 kg

Suitable Quick-Lock: Item No. 44596 (page 58)

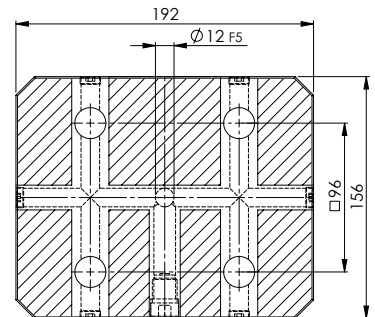

QUICK-POINT® 96, RECTANGULAR PLATE
192 × 156 × 27 MM, WITHOUT CLAMPING EDGE & MOUNTING BORES

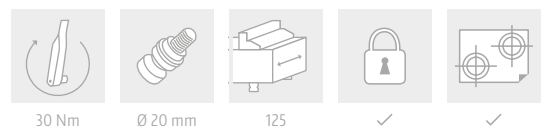

ITEM NO.	DIMENSIONS	WEIGHT
45401	192 × 156 × 27 mm	6.0 kg
45004	Set mounting bores according to customer's request	
45002	Set keyways according to customer's request	

Suitable Quick-Lock: Item No. 44596 (page 58)

Quick-Point® Single Plates

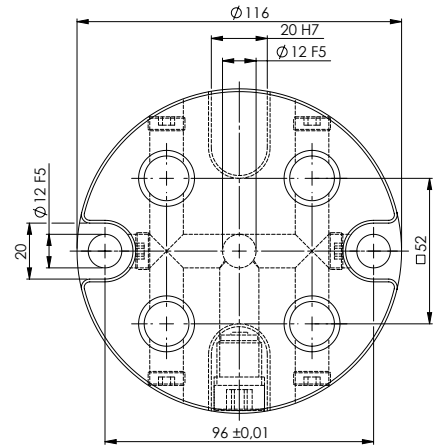

QUICK-POINT® 52, ROUND PLATE
Ø 116 × 27 MM

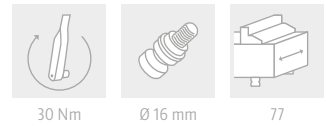

ITEM NO.	DIMENSIONS	MOUNTING BORES	WEIGHT
45750	Ø 116 × 27 mm	96 mm distance	1.9 kg

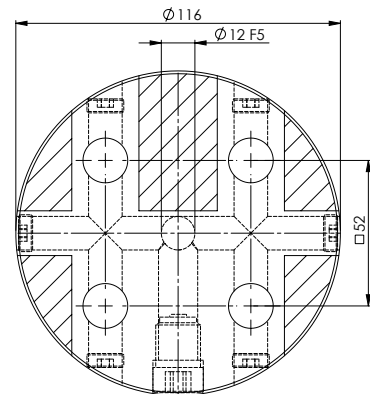

QUICK-POINT® 52, ROUND PLATE
Ø 116 × 27 MM, WITHOUT MOUNTING BORES

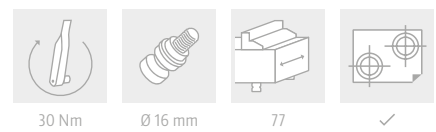

ITEM NO.	DIMENSIONS	WEIGHT
45751	Ø 116 × 27 mm	2.1 kg
45004	Set mounting bores according to customer's request	
45002	Set keyways according to customer's request	

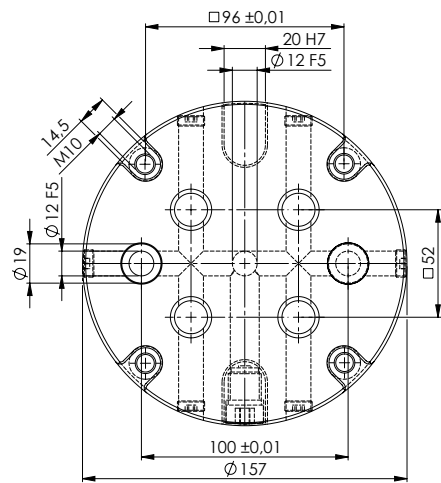

QUICK-POINT® 52, ROUND PLATE
Ø 157 × 27 MM

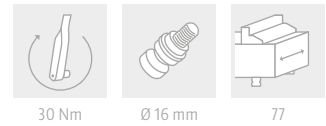

ITEM NO.	DIMENSIONS	MOUNTING BORES	WEIGHT
45900	Ø 157 × 27 mm	100 mm distance	3.5 kg

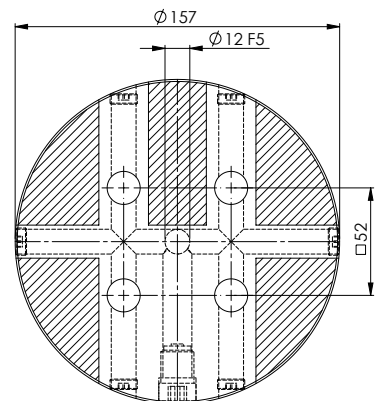

QUICK-POINT® 52, ROUND PLATE
Ø 157 × 27 MM, WITHOUT MOUNTING BORES

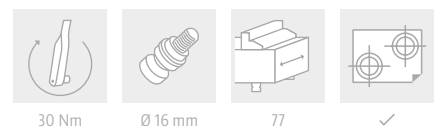

ITEM NO.	DIMENSIONS	WEIGHT
45901	Ø 157 × 27 mm	3.8 kg
45004	Set mounting bores according to customer's request	
45002	Set keyways according to customer's request	

Quick-Point® Single Plates

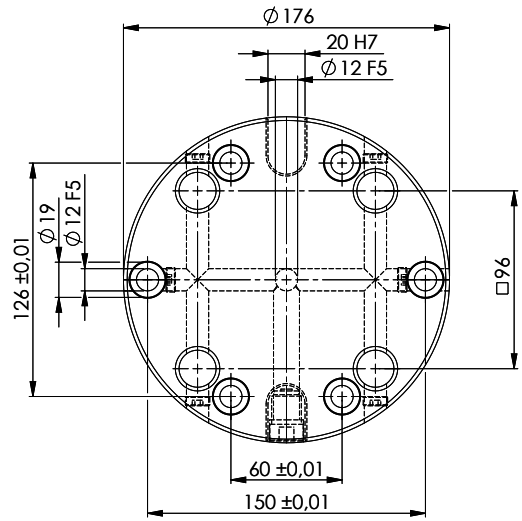

QUICK-POINT® 96, ROUND PLATE
Ø 176 × 27 MM

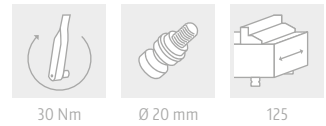

ITEM NO.	DIMENSIONS	MOUNTING BORES	WEIGHT
45800	Ø 176 × 27 mm	for 63 mm t-slot distance & 150 mm distance	4.7 kg

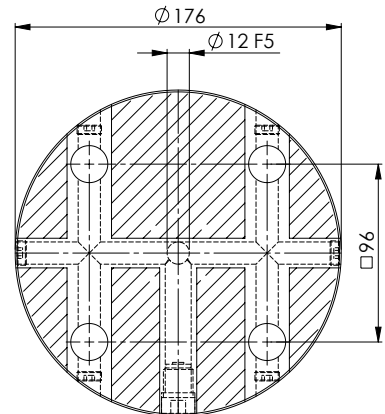

QUICK-POINT® 96, ROUND PLATE
Ø 176 × 27 MM, WITHOUT MOUNTING BORES

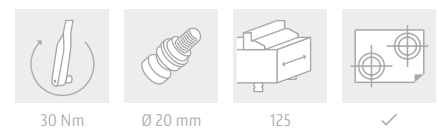

ITEM NO.	DIMENSIONS	WEIGHT
45801	Ø 176 × 27 mm	4.8 kg
45004	Set mounting bores according to customer's request	
45002	Set keyways according to customer's request	

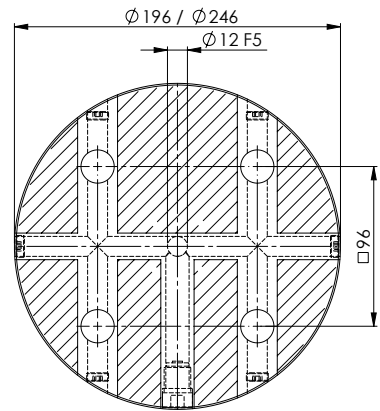

QUICK-POINT® 96, ROUND PLATES
Ø 196 / 246 × 27 MM, WITHOUT MOUNTING BORES

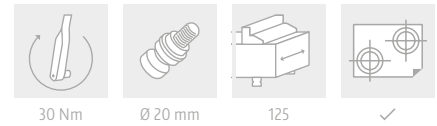

ITEM NO.	DIMENSIONS	WEIGHT
45820	Ø 196 × 27 mm	6.0 kg
45840	Ø 246 × 27 mm	9.5 kg
45004	Set mounting bores according to customer's request	
45002	Set keyways according to customer's request	

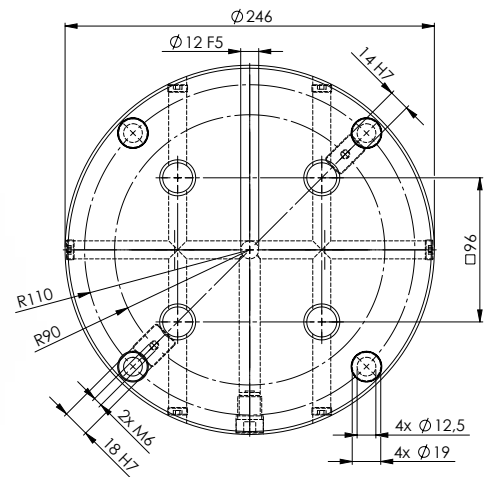
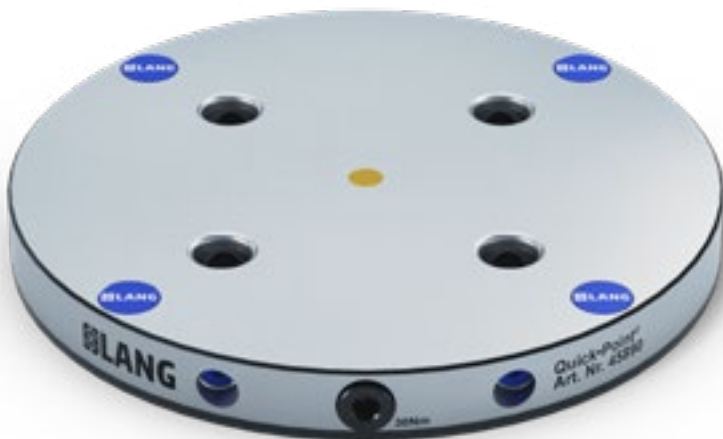

QUICK-POINT® 96, ROUND PLATE
Ø 246 × 27 MM, WITH MOUNTING BORES FOR TABLES WITH 90° GROOVES

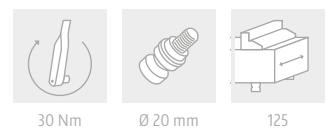

ITEM NO.	DIMENSIONS	MOUNTING BORES	WEIGHT
45890	Ø 246 × 27 mm	4 × 90° / Radius 110 mm	9.3 kg

Suitable slot keys: Item No. 452214 / 442218 (page 61)

Quick-Point® Single Plates for individual centre bore

A centre bore with individually selectable diameter and tolerance provides the option for access to rotary joints.

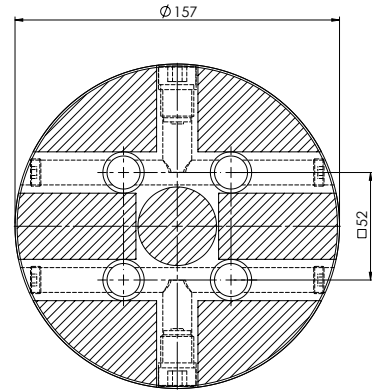

QUICK-POINT® 52, ROUND PLATE Ø 157 × 27 MM, FOR INDIVIDUAL CENTRE BORE

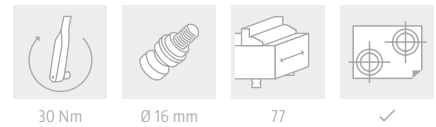

ITEM NO.	DIMENSIONS	MAX. Ø CENTRE BORE	WEIGHT
45903	Ø 157 × 27 mm	38 mm	3.7 kg
45004		Set mounting bores according to customer's request	
45002		Set keyways according to customer's request	
45009		Set centre bore according to customer's request	

Possible Modification of Quick-Point® Plate 45903

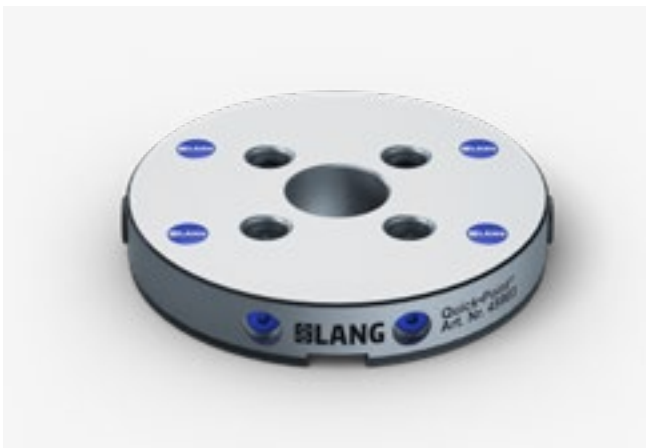

- 1 × Centre bore Ø 38 mm
- 1 × Keyway 20H7
- 4 × Mounting bores for M8 screws, incl. step for Ø 15 mm cover discs, for machine tables with 6 × 60° grooves

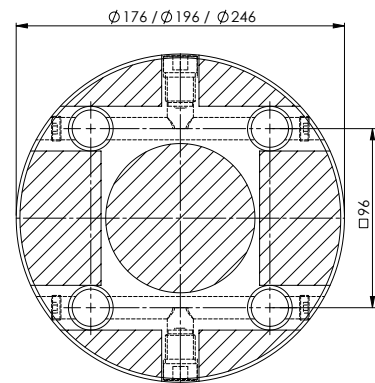

QUICK-POINT® 96, ROUND PLATES
Ø 176 / 196 / 246 × 27 MM, FOR INDIVIDUAL CENTRE BORE

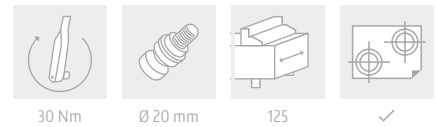

ITEM NO.	DIMENSIONS	MAX. Ø CENTRE BORE	WEIGHT
45803	Ø 176 × 27 mm	80 mm	4.8 kg
45823	Ø 196 × 27 mm	80 mm	6.0 kg
45843	Ø 246 × 27 mm	80 mm	9.5 kg
45004	Set mounting bores according to customer's request		
45002	Set keyways according to customer's request		
45009	Set centre bore according to customer's request		

Possible Modification of Quick-Point® Plate 45823



- 1 × Centre bore Ø 80 mm
- 1 × 130H6 tapered fitting
- 4 × Mounting bores for M12 screws, incl. step for Ø 20 mm cover discs, for machine tables with 6 × 60° grooves

Quick-Point® Multi Plates

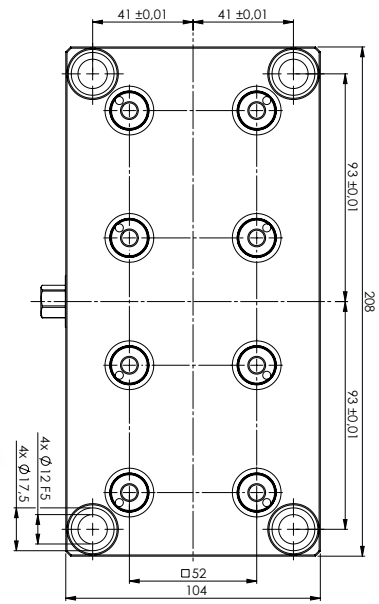

QUICK-POINT® 52, 2-FOLD GRID PLATE 208 × 104 × 27 MM

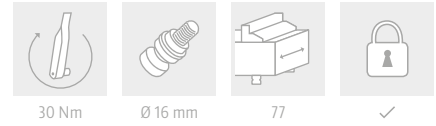

ITEM NO.	DIMENSIONS	MOUNTING BORES	WEIGHT
45621	208 × 104 × 27 mm	186 × 82 mm	4.0 kg

Suitable Quick-Lock: Item No. 45252 (page 58)

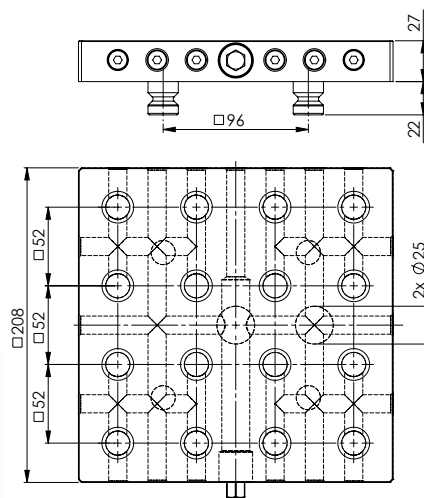

QUICK-POINT® 52, 4-FOLD GRID PLATE
208 × 208 × 27 MM, WITHOUT MOUNTING BORES

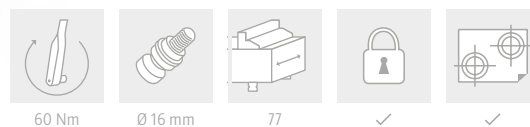

ITEM NO.	DIMENSIONS	WEIGHT
45640	208 × 208 × 27 mm	8.2 kg
45644	Set mounting bores according to customer's request	
45642	Set keyways according to customer's request	

Included in delivery: 4 × Quick-Point® clamping studs Ø 20 mm, for adapting the plate to the Quick-Point® 96 system
 Suitable Quick-Lock: Item No. 45452 (page 58)

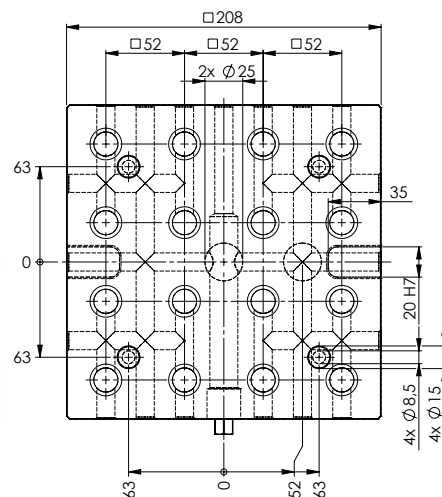

QUICK-POINT® 52, 4-FOLD GRID PLATE
208 × 208 × 27 MM, WITH MOUNTING BORES FOR 63 MM T-SLOT DISTANCE

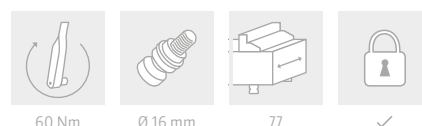

ITEM NO.	DIMENSIONS	MOUNTING BORES	WEIGHT
45641	208 × 208 × 27 mm	for 63 mm t-slot distance	8.0 kg

Suitable Quick-Lock: Item No. 45452 (page 58)

Quick-Point® Multi Plates

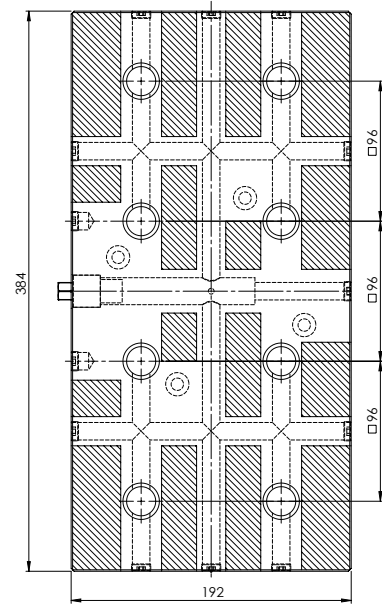

QUICK-POINT® 96, 2-FOLD GRID PLATE 384 × 192 × 27 MM, WITHOUT MOUNTING BORES



ITEM NO.	DIMENSIONS	WEIGHT
45720	384 × 192 × 27 mm	14.7 kg
45024	Set mounting bores according to customer's request	
45022	Set keyways according to customer's request	

Suitable Quick-Lock: Item No. 45296 (page 58)

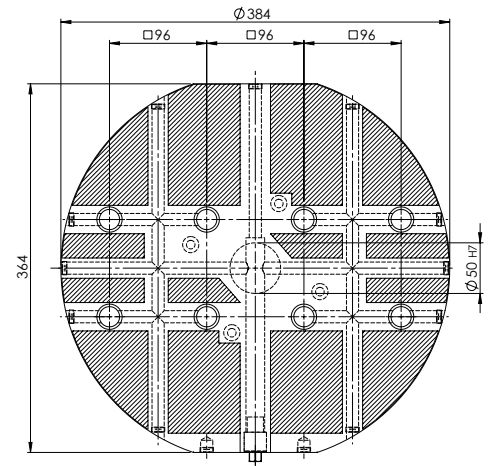

QUICK-POINT® 96, 2-FOLD GRID PLATE, ROUND Ø 384 × 27 MM, WITHOUT MOUNTING BORES

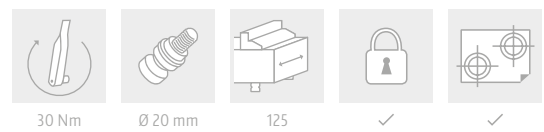

ITEM NO.	DIMENSIONS	WEIGHT
45962	Ø 384 × 27 mm	22.8 kg
45044	Set mounting bores according to customer's request	
45042	Set keyways according to customer's request	

Suitable Quick-Lock: Item No. 45996 (page 58)

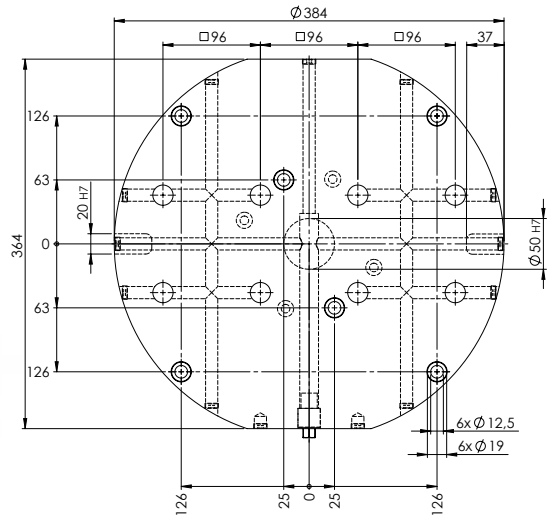

**QUICK-POINT® 96, 2-FOLD GRID PLATE, ROUND
Ø 384 x 27 mm, WITH MOUNTING BORES FOR 63 mm T-SLOT DISTANCE**

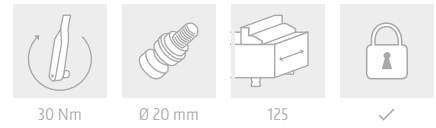

ITEM NO.	DIMENSIONS	MOUNTING BORES	WEIGHT
45963	Ø 384 x 27 mm	for 63 mm t-slot distance	22.4 kg

Suitable Quick-Lock: Item No. 45996 (page 58)

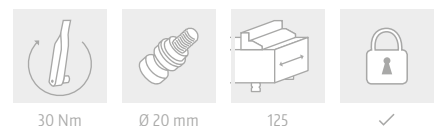
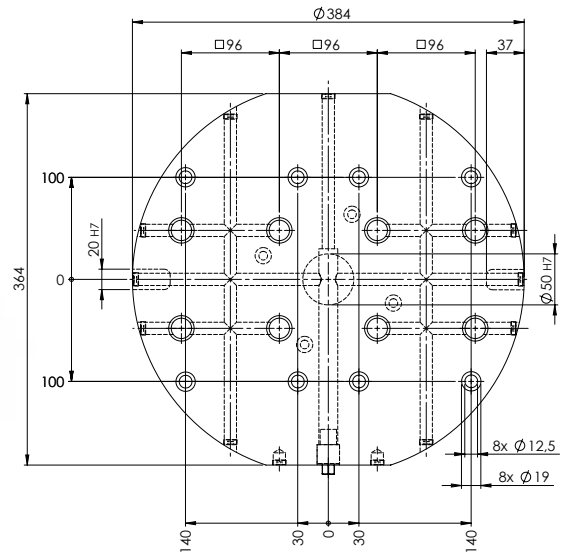

**QUICK-POINT® 96, 2-FOLD GRID PLATE, ROUND
Ø 384 x 27 mm, WITH MOUNTING BORES FOR 100 mm T-SLOT DISTANCE**

ITEM NO.	DIMENSIONS	MOUNTING BORES	WEIGHT
45964	Ø 384 x 27 mm	for 100 mm t-slot distance	22.4 kg

Suitable Quick-Lock: Item No. 45996 (page 58)

Quick-Point® Multi Plates

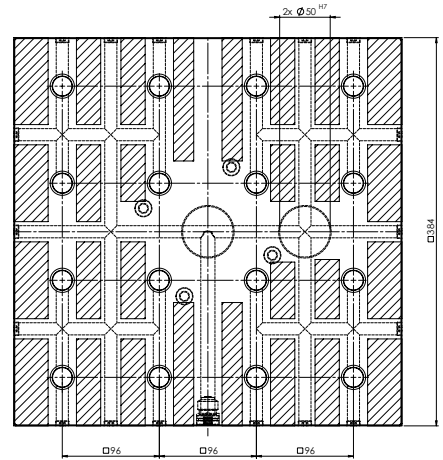

QUICK-POINT® 96, 4-FOLD GRID PLATE 384 × 384 × 27 MM, WITHOUT MOUNTING BORES

60 Nm	Ø 20 mm	125	✓	✓

ITEM NO.	DIMENSIONS	WEIGHT
45740	384 × 384 × 27 mm	29.7 kg
45044	Set mounting bores according to customer's request	
45042	Set keyways according to customer's request	

Suitable Quick-Lock: Item No. 45496 (page 58)

Applications

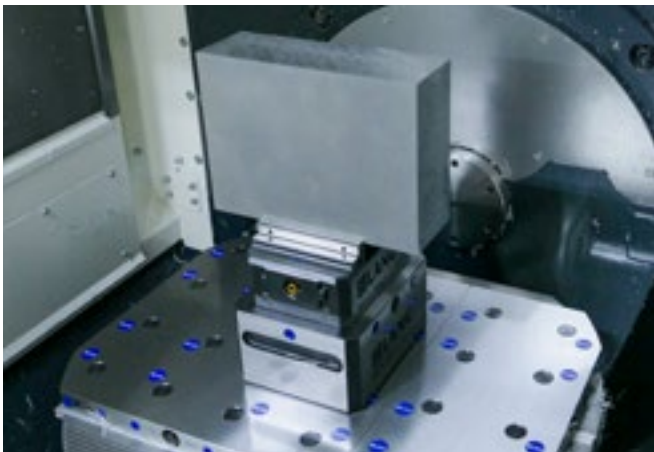
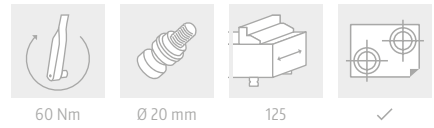
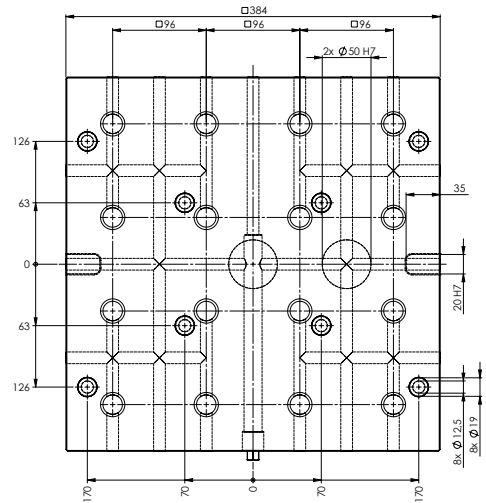

Image: Donner GmbH The Qualifactory



Image: Orrhaga WaterJet AB



QUICK-POINT® 96 4-FOLD GRID PLATE
384 × 384 × 27 MM, WITH MOUNTING BORES FOR 63 MM T-SLOT DISTANCE

ITEM NO.	DIMENSIONS	MOUNTING BORES	WEIGHT
45741	384 × 384 × 27 mm	for 63 mm t-slot distance	29.2 kg

Suitable Quick-Lock: Item No. 45496 (page 58)

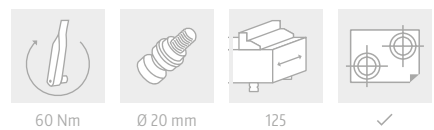
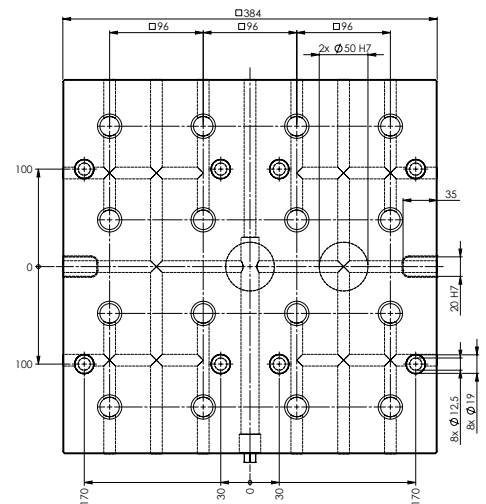

QUICK-POINT® 96, 4-FOLD GRID PLATE
384 × 384 × 27 MM, WITH MOUNTING BORES FOR 100 MM T-SLOT DISTANCE

ITEM NO.	DIMENSIONS	MOUNTING BORES	WEIGHT
45742	384 × 384 × 27 mm	for 100 mm t-slot distance	29.2 kg

Suitable Quick-Lock: Item No. 45496 (page 58)

Quick-Point® Adaptor Plates

The adaptor plate emphasizes the modularity and versatility of the zero-point clamping system. This facilitates the change from the large 96 mm grid size to the small 52 mm grid size if the user has not only large but also small clamping devices in use. Here, and thanks to the raised position of the clamping device, the adaptor plate improves accessibility when machining small components.



Applications

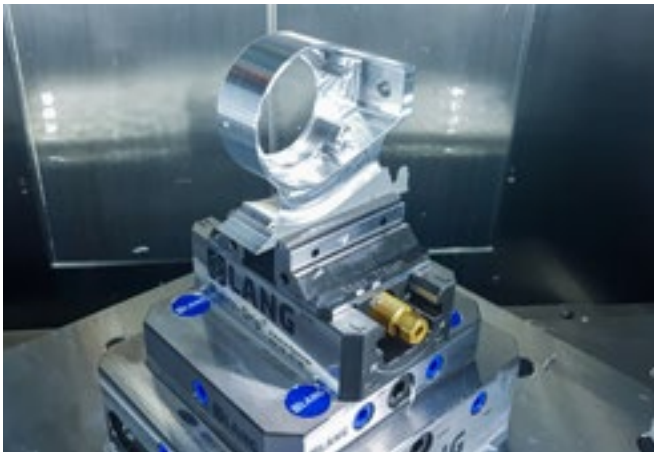

Image: Thoma Tec



Image: Ratiotechnik Milde GmbH



Image: Campagno Engineering

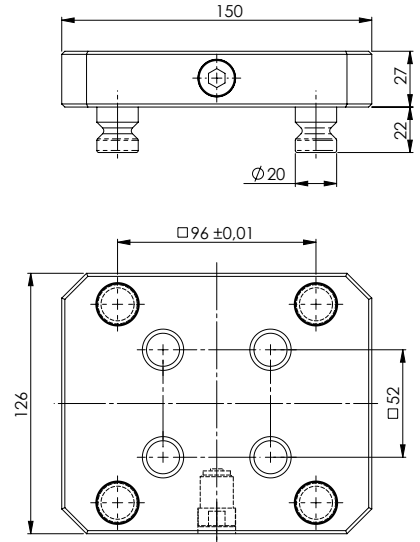

QUICK-POINT® ADAPTOR PLATE
150 × 126 × 27 MM

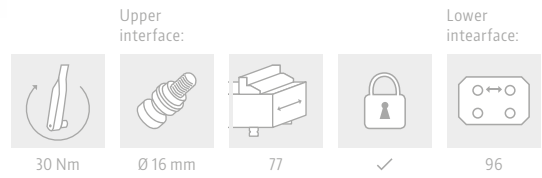

ITEM NO.	DIMENSIONS	WEIGHT
45160	150 × 126 × 27 mm	3.4 kg

Suitable Quick-Lock: Item No. 44552 (page 58)

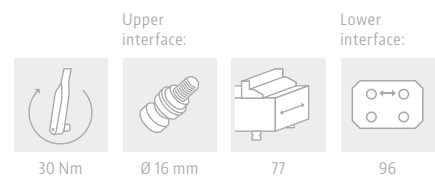
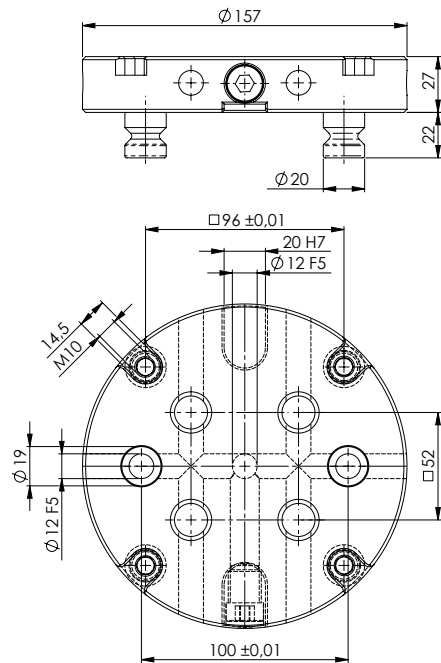

QUICK-POINT® ADAPTOR PLATE, ROUND
Ø 157 × 27 MM

ITEM NO.	DIMENSIONS	WEIGHT
45910	Ø 157 × 27 mm	3.7 kg

Quick-Point® 5-Axis Risers

5-axis risers improve accessibility in 5-sided machining and extend, thanks to the integrated Quick-Point® mounting bolts on their underside the zero-point clamping system on the machine table quickly and precisely. In the robust, yet handy steel base body, vices, fixtures or workpieces are clamped directly.



This riser also features bores for $\varnothing 20$ mm clamping studs to use it as an adaptor for the 96 mm grid system.

Applications



Image: CNC-Manufaktur Brüssow GmbH & Co. KG

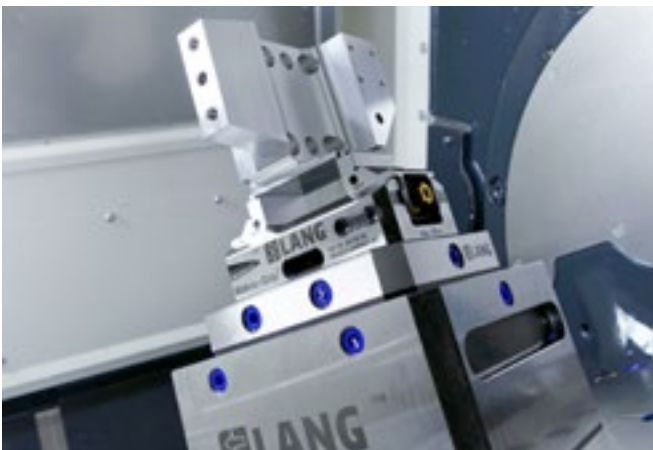
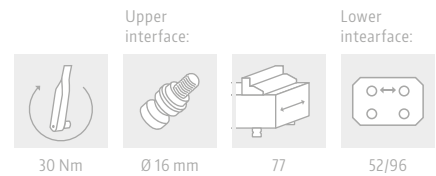
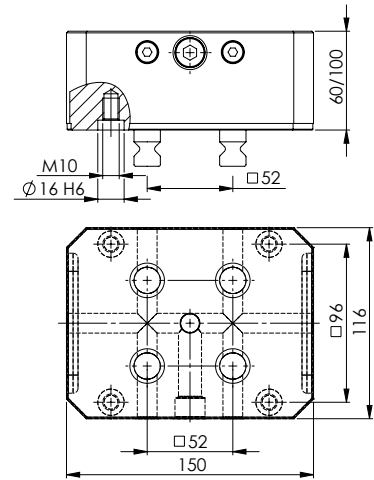

Image: Donner GmbH The Qualifactory
40



Image: Campagno Engineering



QUICK-POINT® 52, 5-AXIS RISER

ITEM NO.	DIMENSIONS	WEIGHT
45156	150 × 116 × 60 mm	6.1 kg
45157	150 × 116 × 100 mm	10.0 kg

Included: 4 × Quick-Point® clamping studs Ø 16 mm.
 Suitable Quick-Lock: Item No. 44552 (page 58).

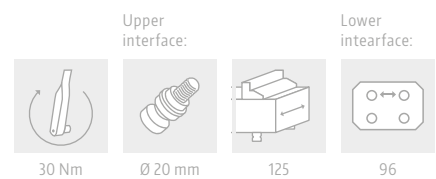
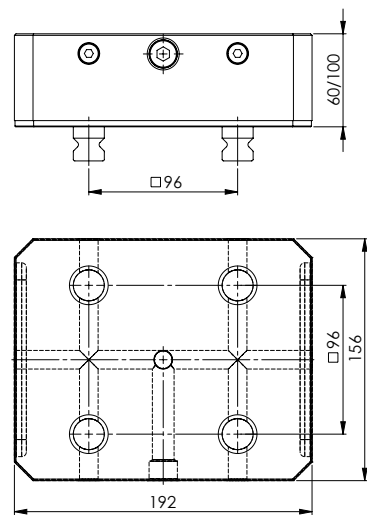

QUICK-POINT® 96, 5-AXIS RISER

ITEM NO.	DIMENSIONS	WEIGHT
45406	192 × 156 × 60 mm	11.2 kg
45407	192 × 156 × 100 mm	18.1 kg

Included: 4 × Quick-Point® clamping studs Ø 20 mm.
 Suitable Quick-Lock: Item No. 44596 (page 58).

Quick-Point® Risers

A riser improves accessibility in 5-sided machining and can either be mounted directly and firmly on the machine table or set up and removed on a zero-point plate. It is available in round and rectangular versions in heights of 60 and 100 mm. The zero-point plates are pinned, aligned and mounted to the riser via bushings.

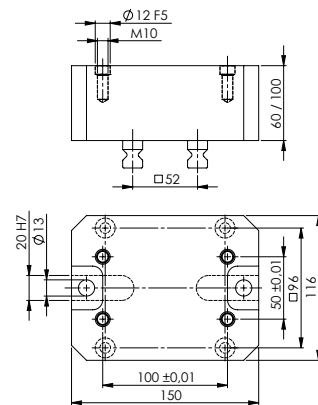

Upper interface

Lower interface:



Ø 16 mm



77



52/96

QUICK-POINT® 52, RISER

ITEM NO.	DIMENSIONS	WEIGHT
43060	150 × 116 × 60 mm	2.5 kg
43100	150 × 116 × 100 mm	4.2 kg

Suitable for Quick-Point® Plate, Item No. 45150.

Included: 4 × Quick-Point® clamping studs Ø 16 mm, 4 screws M 10 + 2 bushings Ø 12 × 12 mm (Item No. 45000-09).

This riser also features bores for Ø 20 mm clamping studs to use it as an adaptor for the 96 mm grid system.

Applications

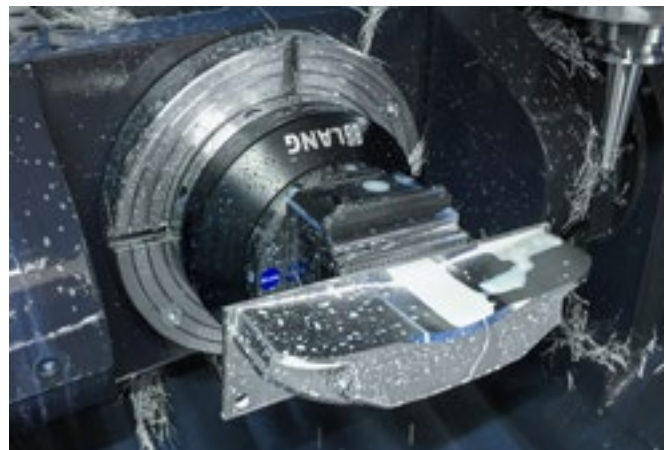
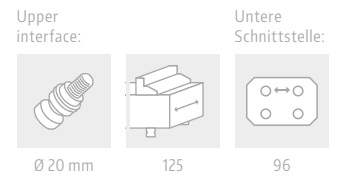
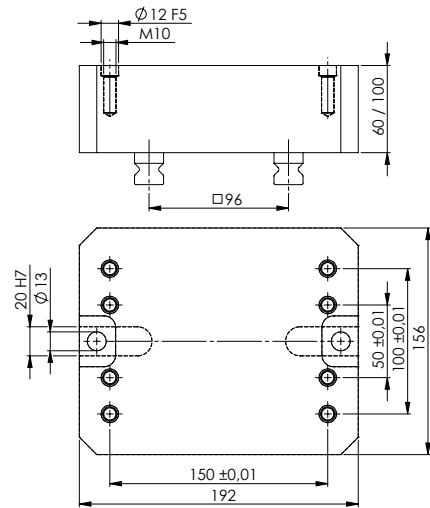

Image: Powerbrake SA



QUICK-POINT® 96, RISER

ITEM NO.	DIMENSIONS	WEIGHT
44060	192 × 156 × 60 mm	4.7 kg
44100	192 × 156 × 100 mm	7.9 kg

Suitable for Quick-Point® Plate, Item No. 45400.

Included: 4 × Quick-Point® clamping studs Ø 20 mm, 4 screws M 10 + 2 bushings Ø 12 × 12 mm (Item No. 45000-09).

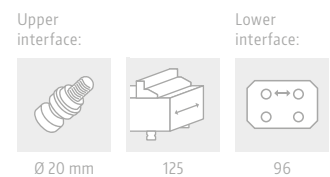
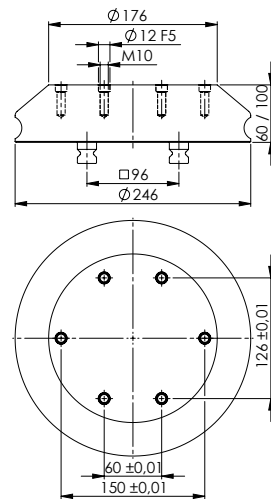

QUICK-POINT® 96, RISER, ROUND

ITEM NO.	HEIGHT	DIAMETER	WEIGHT
44006	60 mm	bottom: 246 mm, top: 176 mm	6.6 kg
44010	100 mm	bottom: 246 mm, top: 176 mm	11.8 kg

Suitable for Quick-Point® plate Item No. 45800.

Included: 4 × Quick-Point® clamping studs Ø 20 mm, 6 screws M 10 + 2 bushings Ø 12 × 12 mm (Item No. 45000-09).

Individual mounting bores in the area of the flange possible.

Quick-Point® 3-face Pyramid

The high-strength, aluminium 3-face Pyramid with integrated Quick-Point® round plates is designed for increasing the run time of 5-axis machine tools.

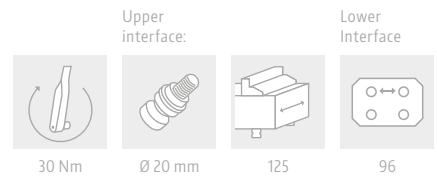
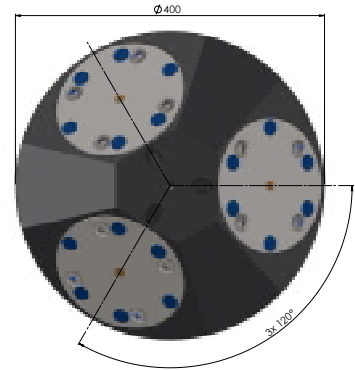
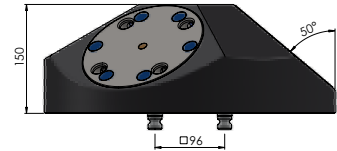

QUICK-POINT® 96, 3-FACE PYRAMID

ITEM NO.	DIMENSIONS	WEIGHT
43400	Ø 400 × 150 mm	43.0 kg

Included: 4 × Quick-Point® clamping studs Ø 20 mm

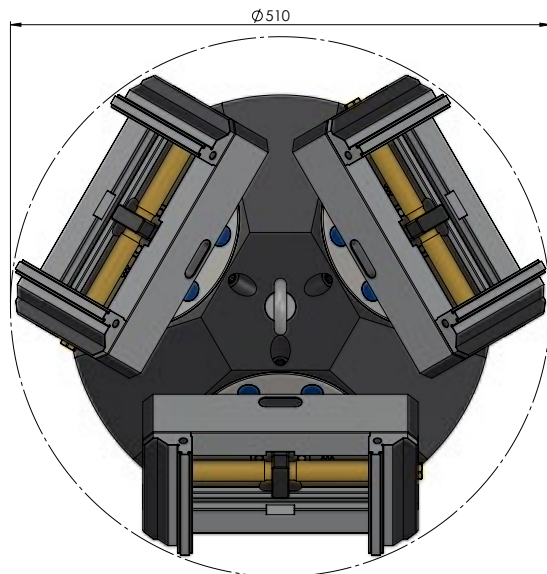
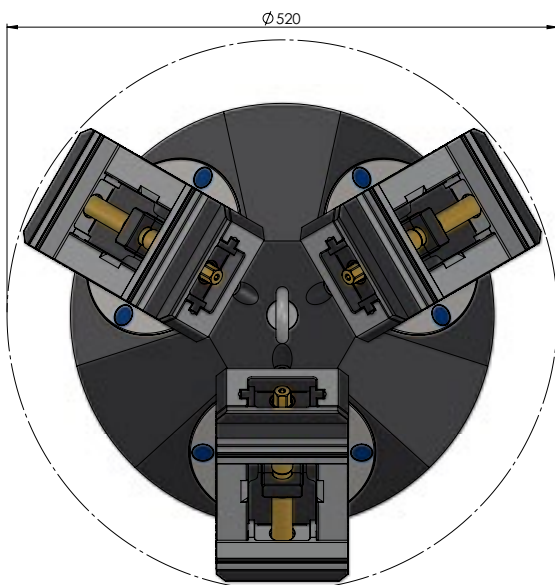

The 3-face Pyramid can accept Makro-Grip® 5-Axis Vices 125 with a maximum length of 210 mm when mounted vertically (left), whereas the maximum length is 260 mm when mounted horizontally (right).

Quick·Point® Twin Base

The hardened and ground Twin Base is ideal for manufacturing 5-axis parts with a 3-axis machine tool. Workpieces can be positioned $4 \times 90^\circ$ safely and with a high repeat accuracy.

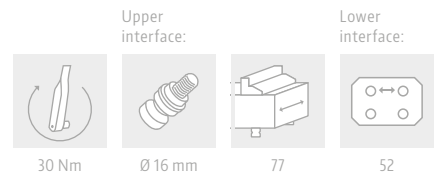
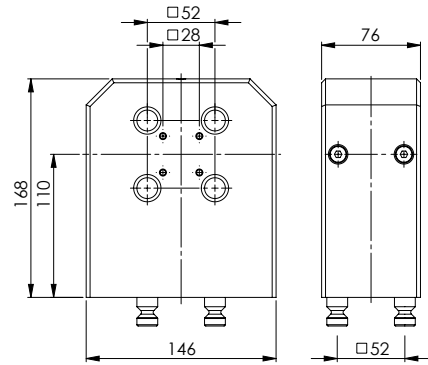

QUICK·POINT® 52, TWIN BASE

ITEM NO.	DIMENSIONS	WEIGHT
47220	146 × 76 × 168 mm	13.9 kg

Suitable Quick-Lock: Item No. 44552 (page 58)

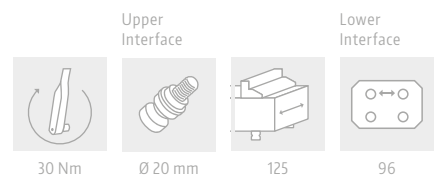
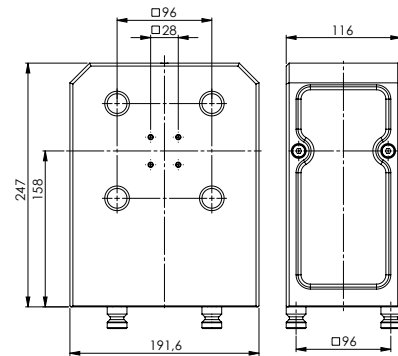

QUICK·POINT® 96, TWIN BASE

ITEM NO.	DIMENSIONS	WEIGHT
47520	192 × 116 × 247 mm	27.8 kg

Suitable Quick-Lock: Item No. 44596 (page 58)

Quick-Point® MT3 3-face Tombstone

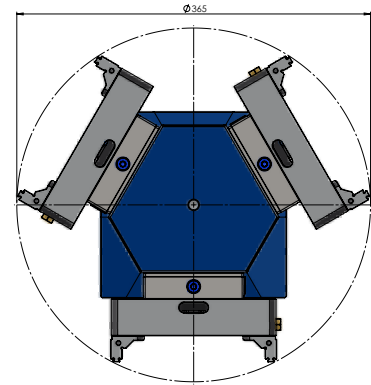
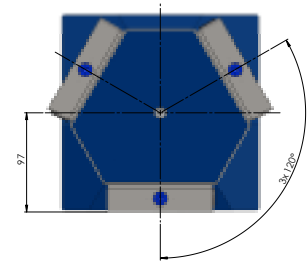
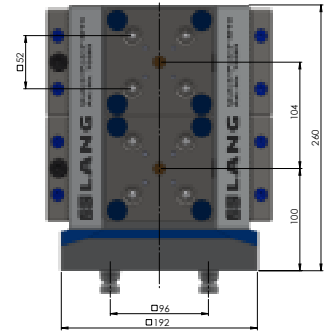
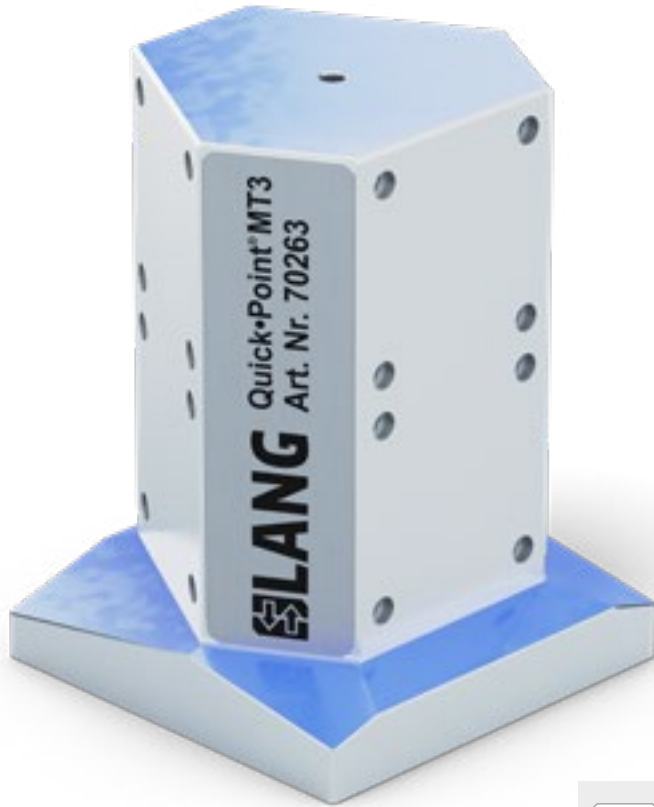

96

The 3-face Tombstone can accept all vices with a jaw width of 46 and 77 mm when mounted horizontally.

QUICK-POINT® MT3, 3-FACE TOMBSTONE

ITEM NO.	DIMENSIONS	MAX. QTY OF GRID PLATES	WEIGHT
70263	192 × 192 × 260 mm	6 × 75600 or 3 × 45621	44.8 kg

Included: 4 × Quick-Point® clamping studs Ø 20 mm

Suitable Quick-Point® Plate for both Tombstones:



QUICK-POINT® 52 GRID PLATE, 104 × 104 × 27 MM

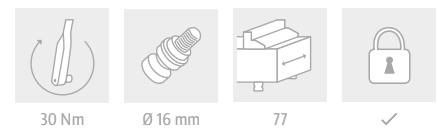

ITEM NO.	DIMENSIONS	MOUNTING BORES	WEIGHT
75600	104 × 104 × 27 mm	82 × 82 mm	1.8 kg

Drawing on page 20.

Quick-Point® MT4 4-face Tombstone

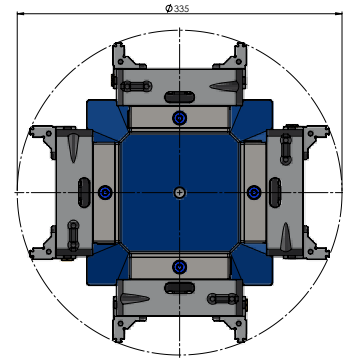
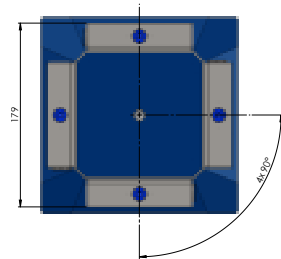
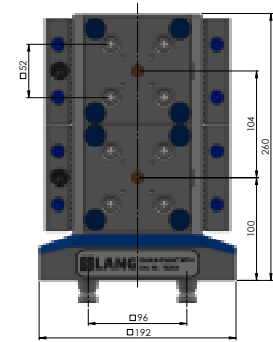

96

The 4-face Tombstone can accept vices (jaw width 46 / 77) with a max. base length of 130 mm when mounted horizontally.

QUICK-POINT® MT4, 4-FACE TOMBSTONE

ITEM NO.	DIMENSIONS	MAX. QTY OF GRID PLATES	WEIGHT
70264	192 × 192 × 260 mm	8 × 75600 or 4 × 45621	37.7 kg

Included: 4 × Quick-Point® clamping studs Ø 20 mm

Suitable Quick-Point® Plate for both Tombstones:



QUICK-POINT® 52 2-FOLD GRID PLATE, 208 × 104 × 27 MM

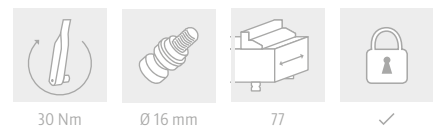

ITEM NO.	DIMENSIONS	MOUNTING BORES	WEIGHT
45621	208 × 104 × 27 mm	186 × 82 mm	4.0 kg

Drawing on page 32.

Quick·Tower – The zero-point clamping system for horizontal machining centres

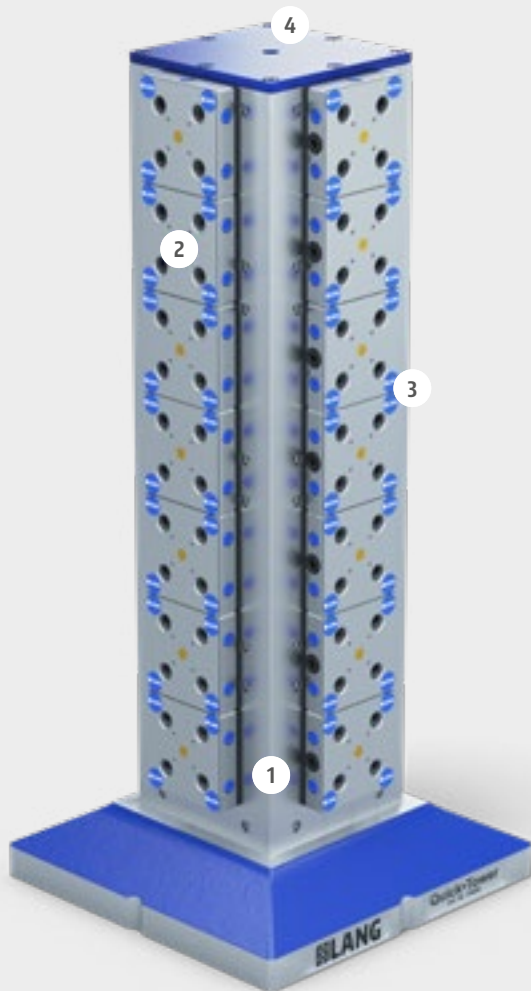

- 1 Stable and sturdy cast body with a plane parallelism of ± 0.02 mm
- 2 Up to 28 \times Quick·Point® Grid Plates 52 and 16 \times Quick·Point® Grid Plates 96 can be mounted depending on the size of the Quick·Tower
- 3 Continuous zero-point grid on all four faces
- 4 Included in delivery: Eye bolt for transport via crane
- 5 Equipped with 12 \times Quick·Point® clamping studs $\varnothing 20$ mm



Mounting options

For mounting the Quick·Tower onto the machine tool table there are three options:

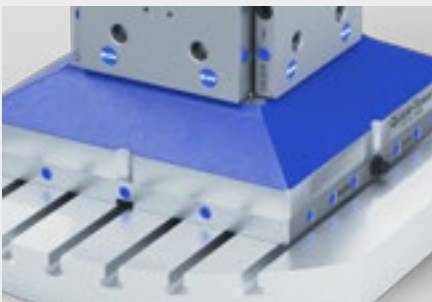

Mounted to the Quick·Point® system (e.g. 4-fold Grid Plate 96)

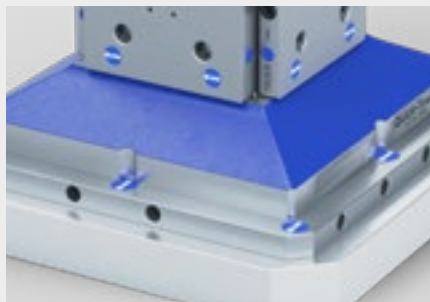

Mounted to the Quick·Tower Universal Base Plate (see page 51)

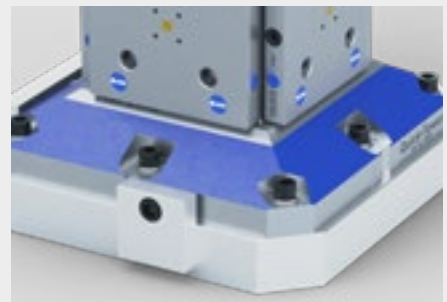

Mounted directly to the machine table with custom bores (price upon request!)

Applications

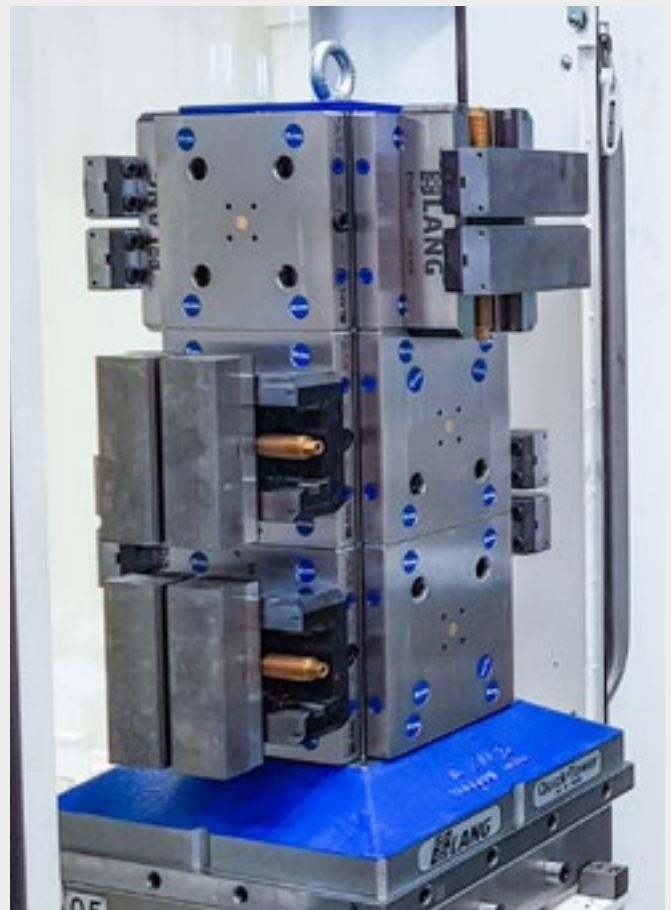
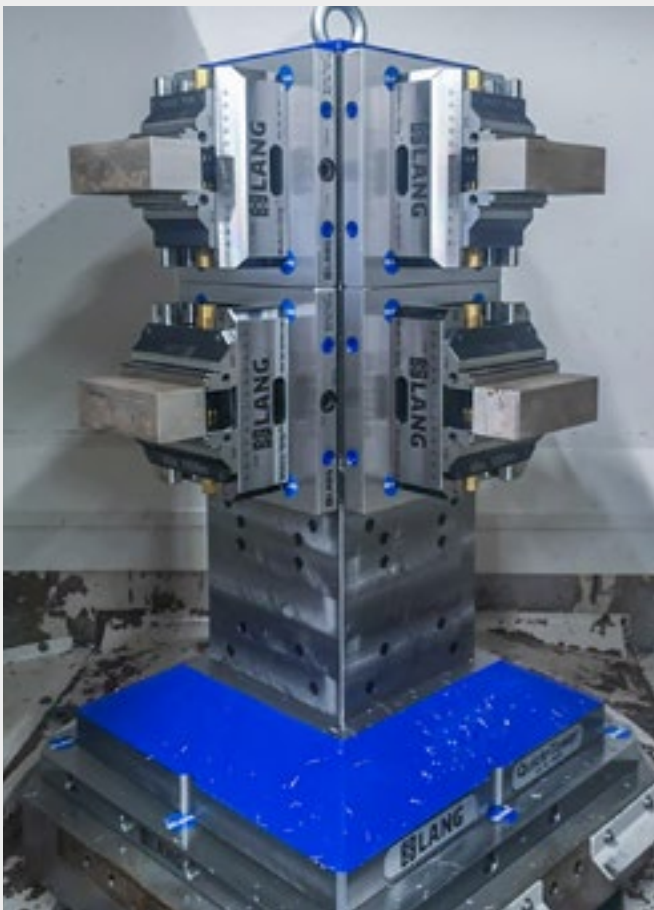
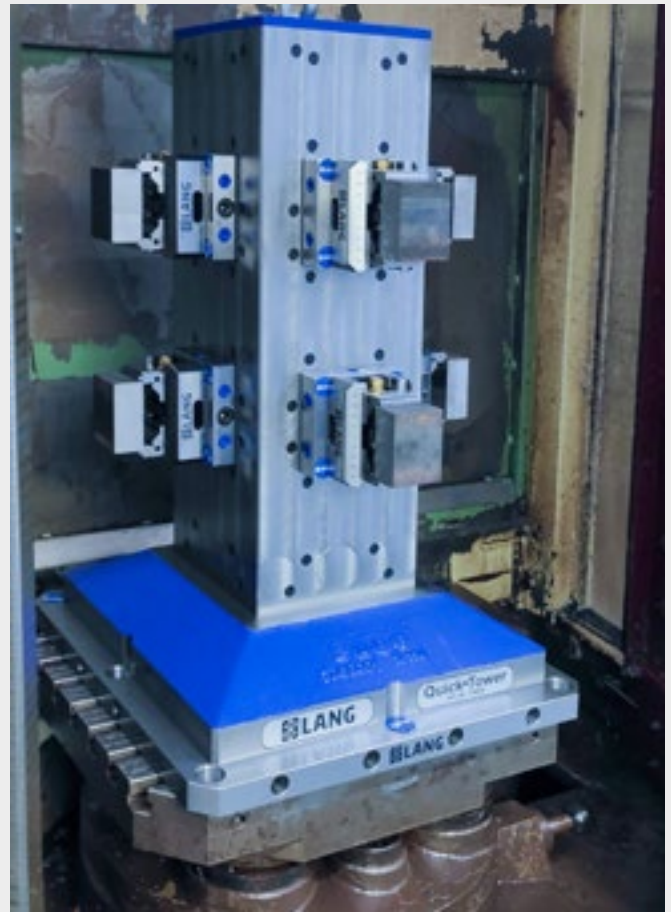
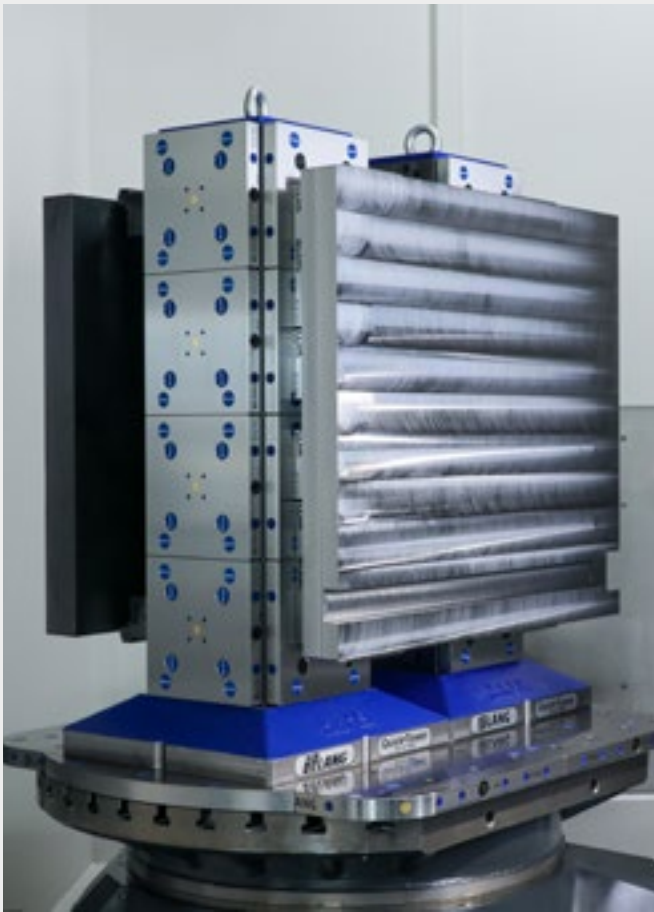

Quick-Tower Base Body

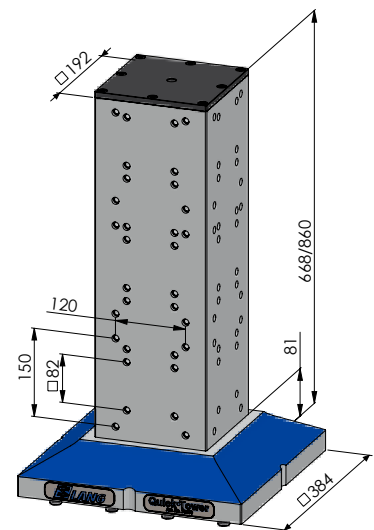
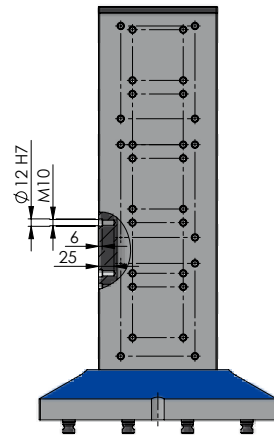
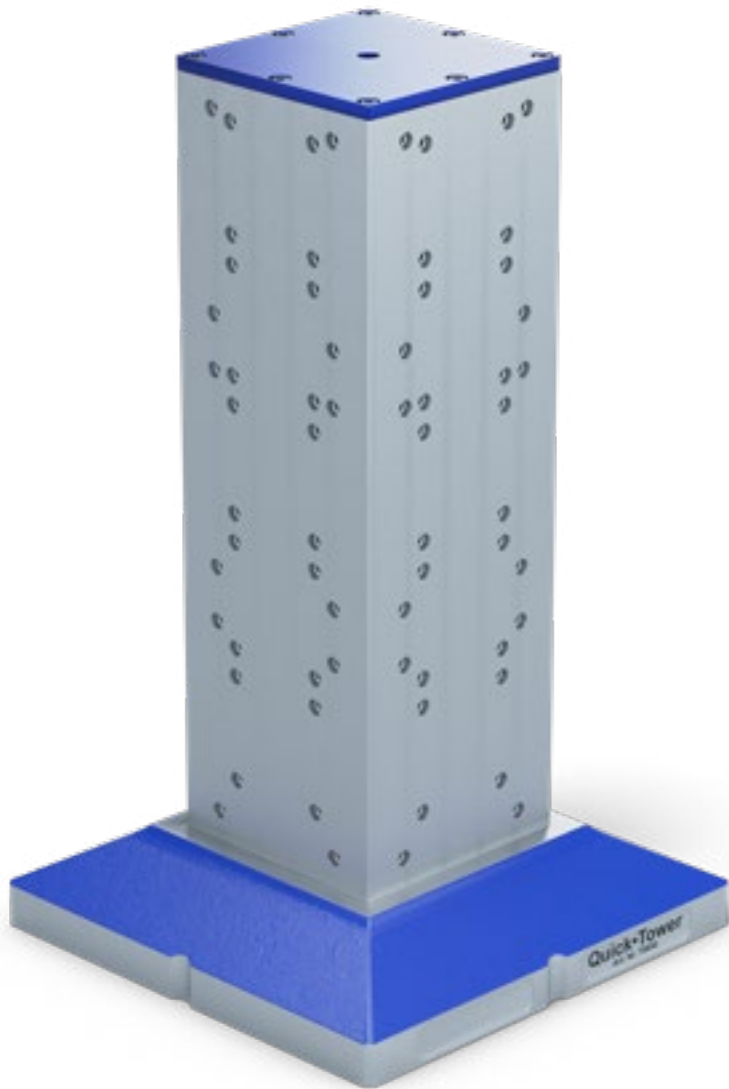

Grid of $150 \times 120\text{ mm}$ is designed to mount Quick-Point® plates 75710.

Grid of $82 \times 82\text{ mm}$ is designed to mount Quick-Point® plates 75600.

QUICK-TOWER BASE BODY

ITEM NO.	BODY DIMENSIONS	BASE DIMENSIONS	TOTAL HEIGHT	WEIGHT
70650	192 × 192 mm	384 × 384 mm	668 mm	160 kg
70850	192 × 192 mm	384 × 384 mm	860 mm	200 kg

If you prefer to fix the tombstone directly onto the machine tool table/pallet using its threads or slots just ask for an individual quotation.

Quick-Tower **Universal Base Plate**



QUICK-TOWER UNIVERSAL BASE PLATE, THROUGH BORE Ø 50H7, WITHOUT MOUNTING BORES

ITEM NO.	DIMENSIONS	MOUNTING BORES	WEIGHT
70005	396 × 396 × 27 mm	-	32.5 kg
70006	Set mounting bores according to customer's request		

Drawing to be found on our website www.lang-technik.de

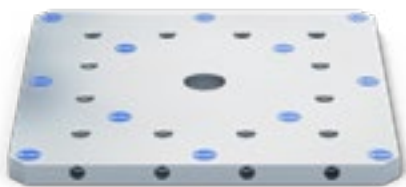

QUICK-TOWER UNIVERSAL BASE PLATE, THROUGH BORE Ø 50H7, WITH MOUNTING BORES

ITEM NO.	DIMENSIONS	MOUNTING BORES	WEIGHT
70008	446 × 446 × 27 mm	12 × M16 at 200 mm distance	39.5 kg

Drawing to be found on our website www.lang-technik.de

Utilisation and mounting:

These sub-plates act as an interface between the machine table and the Quick-Tower. This allows the utilisation of one standard Quick-Tower in different machine tools and/or on different pallets.

The sub-plate can be aligned concentrically using the plate's Ø 50H7 through bore and the table's/pallet's centre bore accordingly. The axial alignment can be done by probing the outer faces or adding keyways for T-slot keys. The base plate is mounted to the table/pallet with DIN EN ISO 4762 cylinder screws. The fixation of the Quick-Tower is done with 12 × M16 threaded pins that are located in the four lateral faces of the base plate. These pins fix the Quick-Tower into position strongly with Quick-Point® clamping studs.

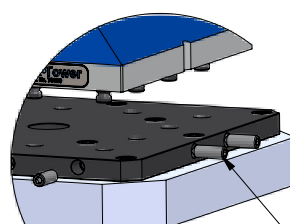

Threaded pin
12 × M16

Quick-Tower Grid Plates

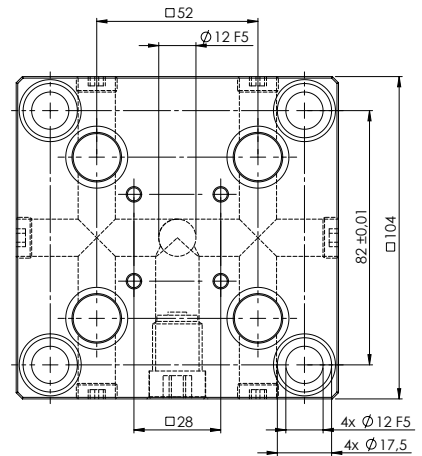

QUICK-TOWER 52, GRID PLATE 104 × 104 × 27 MM

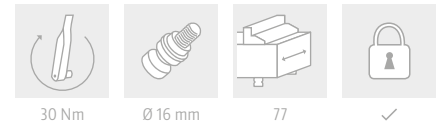

ITEM NO.	DIMENSIONS	MOUNTING BORES	WEIGHT	QUANTITY
75600	104 × 104 × 27 mm	82 × 82 mm	1.8 kg	1 - 10
				11 - 25
				26 - 49
				from 50

*Block pricing only applies for a purchase of a Quick-Tower.
Included: 4 screws M 10 × 35, 2 bushings Ø 12 × 12 mm (Item No. 45000-09).

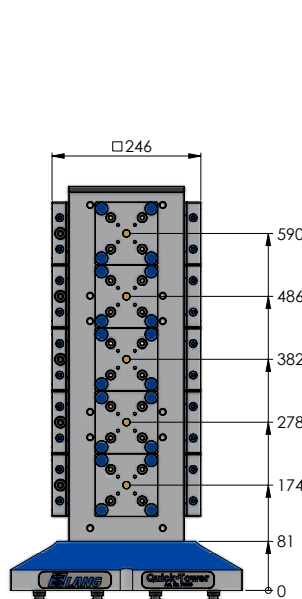

Tower 70650, height 668 mm,
max. 5 pallets on each face.

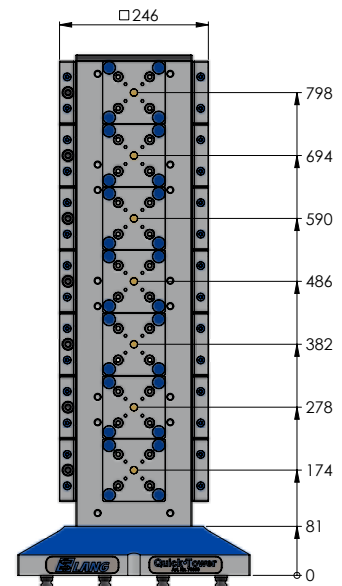

Tower 70850, height 860 mm,
max. 7 pallets on each face.

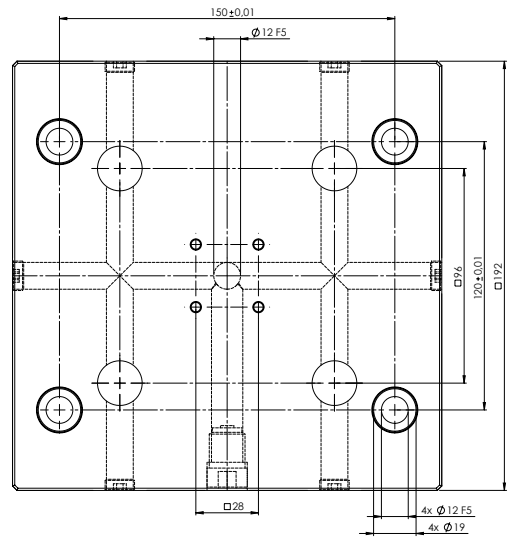

QUICK-TOWER 96, GRID PLATE
192 × 192 × 27 MM

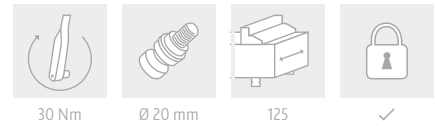

ITEM NO.	DIMENSIONS	MOUNTING BORES	WEIGHT	QUANTITY
75710	192 × 192 × 27 mm	150 × 120 mm	7.0 kg	1 – 6
				7 – 11
				12 – 29
				from 30

*Block pricing only applies for a purchase of a Quick-Tower.
 Included: 4 screws M 10 × 35, 2 bushings Ø 12 × 12 mm (Item No. 45000-09).

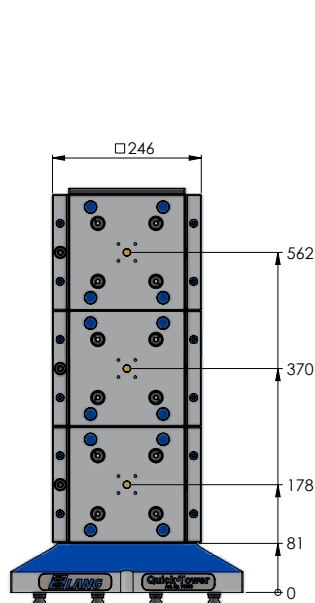
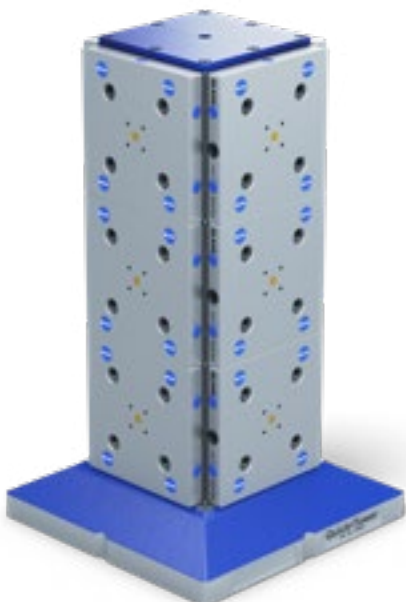

Tower 70650, height 668 mm,
 max. 3 pallets on each face.

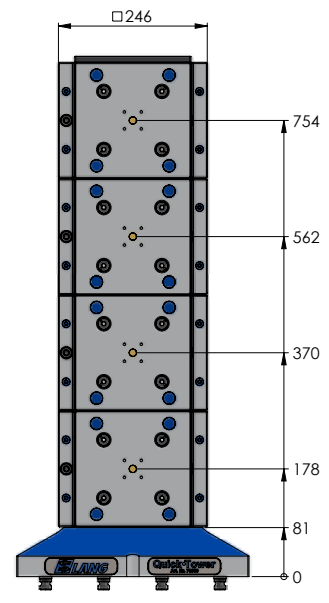

Tower 70850, height 860 mm,
 max. 4 pallets on each face.

Quick-Point® Clamping Studs

For individual adaptation of fixtures, workpieces or existing vices onto our Quick-Point® zero-point clamping system.



QUICK-POINT® CLAMPING STUDS FOR INDIVIDUAL ADAPTATION

ITEM NO.	DESCRIPTION	UNIT
45270	Ø 16 mm for 52 mm spacing, incl. M 8 threaded pin	1 pc.
45570	Ø 20 mm for 96 mm spacing, incl. M 10 threaded pin	1 pc.

Please note: 4 Clamping Studs are required for one Quick-Point® plate!

How it works:

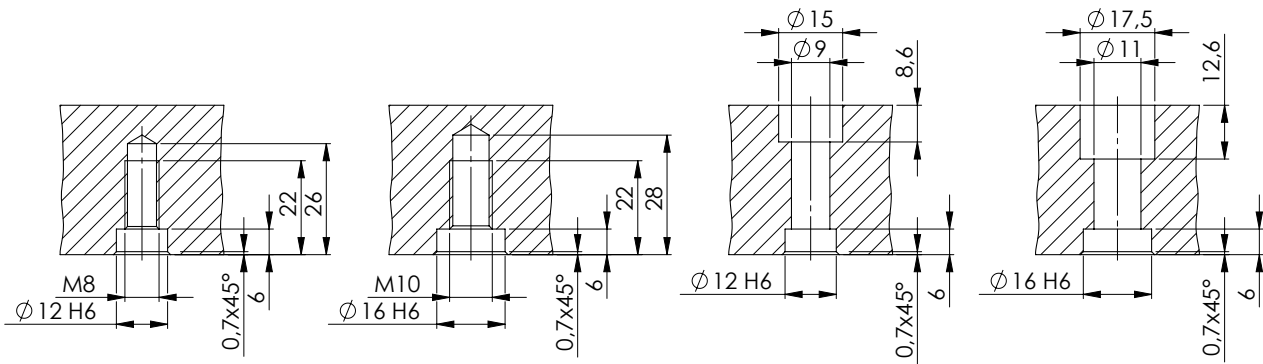

with threaded pins

with screws

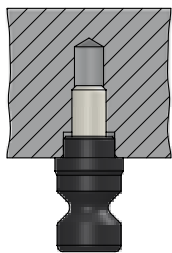

52

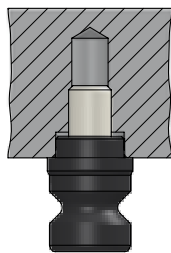

96

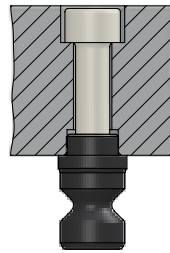

52

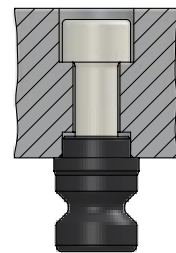

96

Applications:

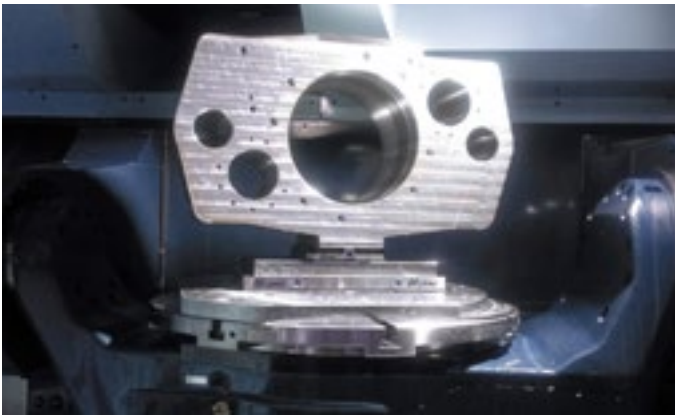

The studs need to be positioned in a 52 mm / 96 mm (± 0.01 mm) spacing for clamping workpieces straight onto the Quick-Point® plates.



The workpiece is clamped securely, without a vice, directly into the zero-point system.



Aluminium part (weight: 1.315 kg, dimensions: 1.067 × 406 × 1.016 mm) clamped with 16 clamping studs.

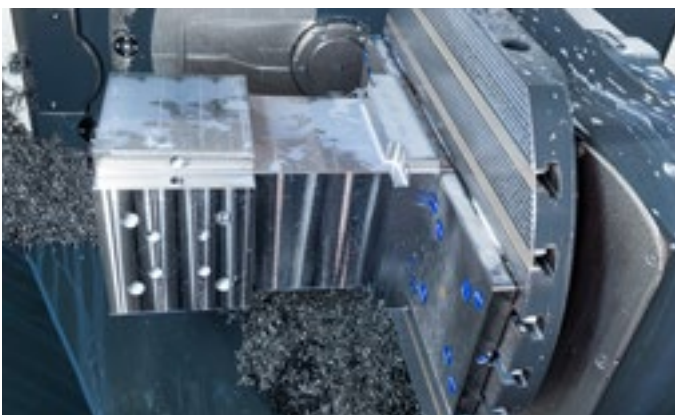

Not only highly precise but also extremely rigid: Workpiece with 200 kg weight, 500 mm height. Clamped with just 4 studs in a single Quick-Point® plate.

Quick-Point® Support Plates

Support plates made of non-hardened steel – for individual adaptation of fixtures and other devices.

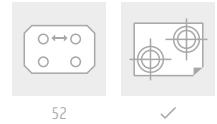

QUICK-POINT® 52, SUPPORT PLATES

ITEM NO.	DIMENSIONS	WEIGHT
45275	96 × 96 × 27 mm	2.0 kg
45277	156 × 156 × 27 mm	5.2 kg

Included: 4 × Quick-Point® clamping studs Ø 16 mm



QUICK-POINT® 96, SUPPORT PLATES

ITEM NO.	DIMENSIONS	WEIGHT
45575	156 × 156 × 27 mm	5.3 kg
45577	192 × 192 × 27 mm	8.3 kg

Included: 4 × Quick-Point® clamping studs Ø 20 mm

Quick·Point® Spacer Studs

Spacer studs allow for through holes in material which is clamped directly in the zero-point system. It also improves accessibility when machining edges and angles.



QUICK·POINT® SPACER STUDS

ITEM NO.	DIAMETER	SPACER HEIGHT	UNIT
45270-10	Ø 16 mm for 52 mm spacing	10 mm (Ø 24 mm)	1 Set (4 pcs.)
45570-10	Ø 20 mm for 96 mm spacing	10 mm (Ø 28 mm)	1 Set (4 pcs.)

Applications

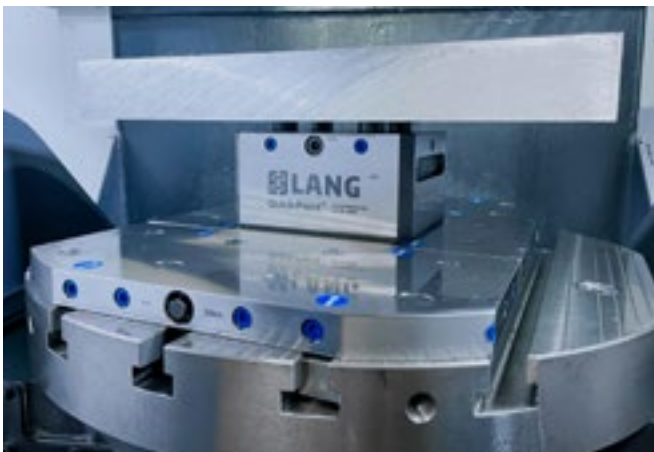

Quick-Point® Quick-Lock Fast Actuation System

Mechanical and quick fastener, compatible with all rectangular and squared Quick-Point® plates. Also compatible with the Quick-Point® 96, 2-fold Grid Plate, round. With the Quick-Lock, we provide a clamping lever and washers to adjust clamping force as needed.



QUICK-POINT® QUICK-LOCK 52

ITEM NO.	DESCRIPTION	FOR ITEM NO.	WEIGHT
44552	Quick-Lock for Quick-Point® 52 Single-Plates, Twin Base 52, Adaptor Plate, 5-Axis Riser 52	45600 / 75600 / 45150 / 45151 / 47220 / 45160 / 45156 / 45157	0.3 kg
45252	Quick-Lock for Quick-Point® 52, 2-fold Grid Plate	45621	0.8 kg
45452	Quick-Lock for Quick-Point® 52, 4-fold Grid Plate	45640 / 45641	0.9 kg

QUICK-POINT® QUICK-LOCK 96

ITEM NO.	DESCRIPTION	FOR ITEM NO.	WEIGHT
44596	Quick-Lock for Quick-Point® 96 Single-Plates, Twin Base 96, Adaptor Plate, 5-Axis Riser 96	45710 / 45763 / 45715 / 45716 / 45400 / 45401 / 47520 / 45406 / 45407	0.4 kg
45296	Quick-Lock for Quick-Point® 96, 2-fold Grid Plate	45720	0.9 kg
45996	Quick-Lock for Quick-Point® 96, 2-fold Grid Plates, round	45962 / 45963 / 45964	0.9 kg
45496	Quick-Lock for Quick-Point® 96, 4-fold Grid Plates	45740 / 45741 / 45742	1.0 kg

Easy assembly in a few steps

Within just a few seconds the Quick-Lock fast actuation system is mounted to a Quick-Point® Plate. With a 180° motion of the lever the Quick-Lock clamps and releases the vice.



Removal of the Quick-Point® actuation screw:

Remove actuation screw and the two plastic covers and keep them safe. With multi fold plates you also have to remove the actuation bolt. During the whole installation process the Quick-Point® plate does not have to be removed from the machine table if already mounted.



Installation of the Quick-Lock fastener:

Insert the Quick-Lock pressure bolt into the actuation screw channel and tighten the two screws.



Checking the clamping forces:

Insert the clamping lever into the clamping element of the Quick-Lock fastener. Move the clamping lever in a 180° motion from right to left until you feel resistance. If the remaining angle is more/less than 70°, the clamping force needs to be adjusted by adding/removing washers. Detailed instructions and videos can be found on our website www.lang-technik.de.

Quick-Lock utilisation

The clamping lever equipped with a rotation lock can be used both horizontally and vertically. For vices and fixtures protruding from the Quick-Point® plate, the lever is used horizontally (right picture).

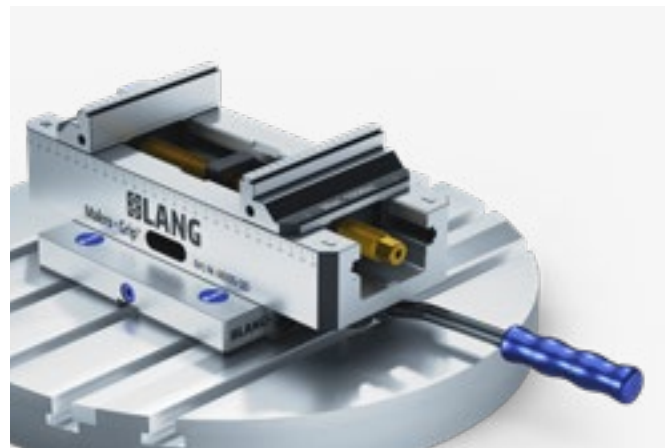
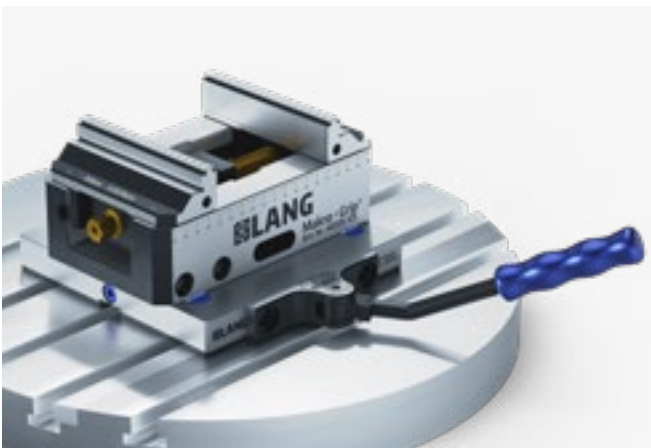

Quick-Point® Accessories



QUICK-POINT® COVER DISCS, PLASTIC

ITEM NO.	DIAMETER	UNIT
45008-15	Ø 15 mm	1 set (20 pcs.)
45008-20	Ø 20 mm	1 set (20 pcs.)
45008-27	Ø 27 mm	1 set (20 pcs.)

Heat-resistant, fibreglass reinforced cover discs for protecting the mounting screws against material pollution.



QUICK-POINT® COVER PLUGS, PLASTIC

ITEM NO.	DIAMETER	UNIT
45052-20	Ø 16 mm for 52 mm spacing	1 set (4 pcs.)
45096-20	Ø 20 mm for 96 mm spacing	1 set (4 pcs.)

Cover plugs made of plastic for the protection of the stud holes when not in use. For multi fold plates steel plugs (see below) are necessary.



QUICK-POINT® COVER PLUGS, STEEL

ITEM NO.	DIAMETER	UNIT
45052-30	Ø 16 mm for 52 mm spacing	1 set (4 pcs.)
45096-30	Ø 20 mm for 96 mm spacing	1 set (4 pcs.)

Cover plugs made of steel spread the increased clamping force of multi grid plates evenly and protect stud holes not in use. They can be removed from plates with the Cover Plug Remover.



QUICK-POINT® COVER PLUG REMOVER

ITEM NO.	DESCRIPTION
45000-30	Cover Plug Remover

Comfortable grip with magnet for removing steel plugs from the Quick-Point® plates.



QUICK-POINT® HANDLE BAR, ALUMINIUM

ITEM NO.	DESCRIPTION
66605	Quick-Point® 52
46081	Quick-Point® 96

This handle bar facilitates the handling of Quick-Point® devices when setting up and dismantling. As with usual LANG clamping devices, the handle bar is clamped with two Quick-Point® 96 clamping studs in the zero-point system and is thereby especially suited for the transportation of heavier Quick-Point® products.

Quick-Point® Alignment



SLOT KEYS, LOOSE, DIN 6323, FOR AXIAL ALIGNMENT OF QUICK-POINT® PLATES

ITEM NO.	SIZE	UNIT
452014	20 to 14 mm	1 pc.
452018	20 to 18 mm	1 pc.

To make the assembly and alignment of the Quick-Point® plates as easy as possible, we offer slot keys for the plates' 20H7 keyways matching your table's t-slots (14 or 18 mm).

Attention: Keys not suitable for Item No. 45800 and 45890!



SLOT KEYS FOR AXIAL ALIGNMENT OF QUICK-POINT® ROUND PLATE, ITEM NO. 45890 (PAGE 29)

ITEM NO.	DIMENSIONS	UNIT
452214	14 × 22 mm	1 pc.
452218	18 × 22 mm	1 pc.

For the alignment of Quick-Point® plate, Item No. 45890, which has 14 & 18 H7 grooves in the bottom, we offer these keys. Grooves and keys are equipped with a M6 thread, suitable for screws DIN 84 or DIN 912, M6 × 16.



CENTRING STUDS FOR CONCENTRIC ALIGNMENT OF QUICK-POINT® PLATES

ITEM NO.	SIZE	UNIT
451230	12 to 30 mm	1 pc.
451232	12 to 32 mm	1 pc.
451250	12 to 50 mm	1 pc.
452530	25 to 30 mm	1 pc.
452532	25 to 32 mm	1 pc.
452550	25 to 50 mm	1 pc.
455030	50 to 30 mm	1 pc.
455032	50 to 32 mm	1 pc.
455050	50 to 50 mm	1 pc.

For the concentric alignment of Quick-Point® plates via fitting bores in the bottom (12, 25, 50 mm) we offer centring studs for the most common machine table holes (30, 32, 50 mm).



BUSHINGS FOR THE ALIGNMENT OF VICES AND ZERO-POINT PLATES

ITEM NO.	DIMENSIONS	FOR SCREW SIZE	UNIT
45000-09	Ø 12 × 12 mm	M 10	1 pc.
65191-04	Ø 12 × 12 mm	M 8	1 pc.
65191-05	Ø 16 × 15 mm	M 10	1 pc.

Item No. 45000-09 is suitable for aligning Quick-Point® plates on aluminum risers, Quick-Tower tombstones and other, select applications. Bushings 65191-04 and 65191-05 are used for the alignment and mounting of Makro-Grip® 5-Axis Vices on (old) LANG automation support pallets Item No. 65190 and 65197.

Quick·Point® Gauging Pallet

Jig-ground gauging pallet for a quick and precise alignment of Quick·Point® plates. Recommended especially for rotary tables or chucks.

NEW VERSION

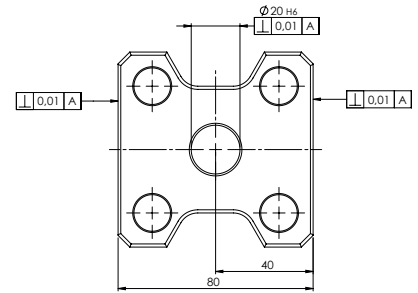
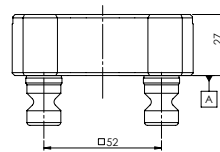

QUICK·POINT® 52 GAUGING PALLET

ITEM NO.	FOR	DIMENSIONS	MEASURING LENGTH	WEIGHT
44522	Quick·Point® 52	80 × 80 × 27 mm	70 mm per side	1.2 kg

NEW VERSION

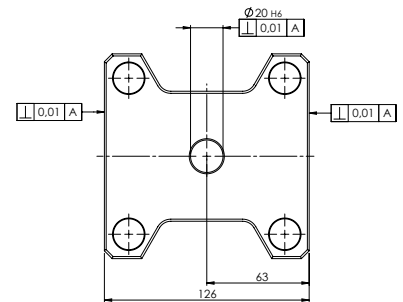
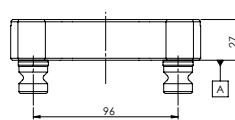

QUICK·POINT® 96 GAUGING PALLET

ITEM NO.	FOR	DIMENSIONS	MEASURING LENGTH	WEIGHT
44962	Quick·Point® 96	126 × 126 × 27 mm	116 mm per side	2.8 kg

How it works:

After clamping the gauging pallet in a Quick·Point® plate is done by probing the jig-ground sides of the gauging pallet. For concentric alignment the inner diameter of the gauging pallet can be used.



Quick·Point® Alignment Gauge

For easy and quick assembly of the Quick·Point® Grid Plates we recommend using the alignment gauge. The precise alignment and dimensional accuracy of the plates is guaranteed.

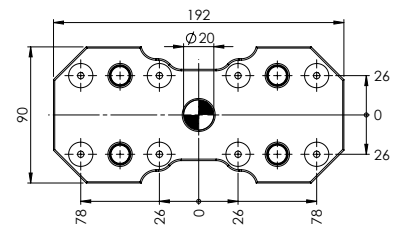

ALIGNMENT GAUGE 52 FOR QUICK·POINT® GRID PLATES

ITEM NO.	DESCRIPTION	WEIGHT
44152	Ausrichtlehre 52	3.4 kg
44152-10	Alignment gauge 52 for rent	-

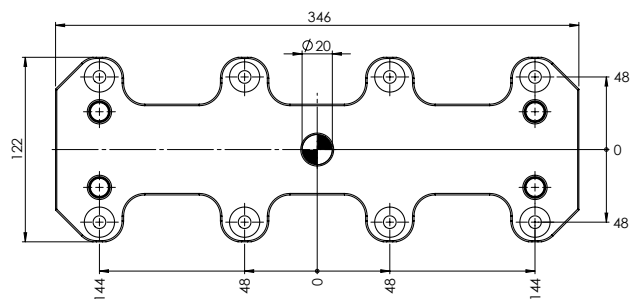

ALIGNMENT GAUGE 96 FOR QUICK·POINT® GRID PLATES

ITEM NO.	DESCRIPTION	WEIGHT
44196	Alignment gauge 96	6.5 kg
44196-10	Alignment gauge 96 for rent	-

How it works:

The Quick·Point® Alignment Gauge guarantees an accurate alignment of two or more Grid Plates positioned next to each other. This ensures that vices and fixtures can be clamped across two different plates. After the first plate is placed on the table, aligned with a probe and the screws fixed, the alignment gauge is applied on the neighboring plates and the outer accessible fixing screws can be tightened.



Quick·Point® Service

Set mounting bores

All of our Quick·Point® plates with prefabricated mounting bores are also available without such. The case-hardened zero-point plates (57 HRC, 0.7 mm deep) can be drilled according to the t-slots of the machine table. We offer this as a service.

The drawings of the Quick·Point® plates without mounting bores in this catalogue show hatched areas. These areas can be

used for mounting bores. On rare occasions mounting bores can even be set through rod channels. If this might be required for your application please ask your local LANG contact person.

All drawings and models, as well as video that explain the Quick·Point® plates are mounted to the machine table are available on our website www.lang-technik.de



Quick·Point® plate with prefabricated mounting bores.



Same Quick·Point® plate without mounting bores. These can be installed by LANG or the customer.

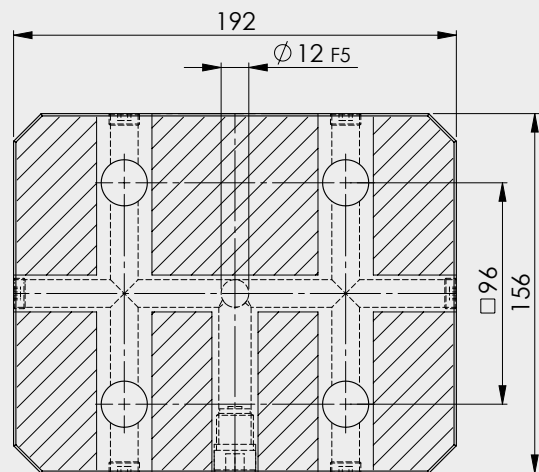

M5 Index bores

Inserting a threaded pin or screw ensures that LANG clamping devices (with an equivalent recess on the bottom) are always positioned in the correct way on the zero-point plate.

By default index bores are included in following plates: Item No. 45150, 45400, 75600, 75710, 47220 and 47520.

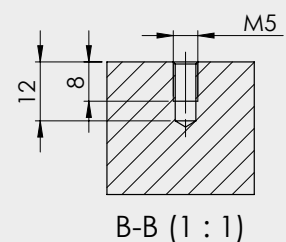
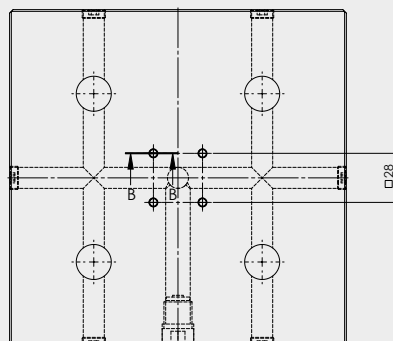

Covering mounting bores



Quick-Point® plate with plastic cover discs.

Mounting bores in Quick-Point® plates, either prefabricated or customised by LANG, have a 2.1 mm step. Plastic discs can be inserted and act as covers to prevent swarf or chips from clogging these bores. Plastic discs are available in three different diameters \varnothing 15 mm, \varnothing 20 mm and \varnothing 27 mm (see page 56).

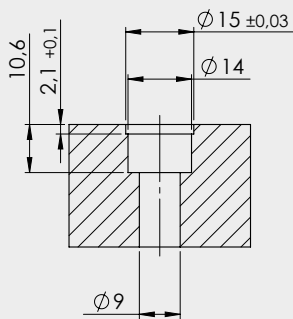

M8

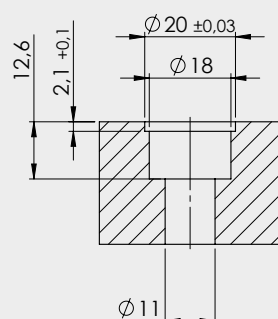

M10

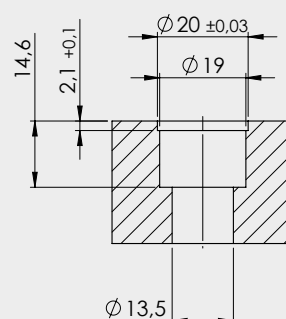

M12

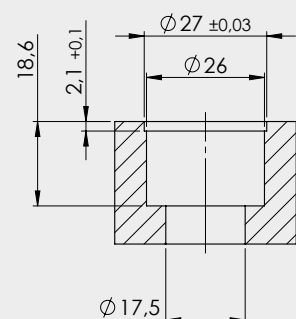

M16

Custom corner radius for Quick-Point® grid / multi-fold plates

Upon request, we can adjust the zero-point system (multi grid or individual grid plates in a row) to round tables of the machine tool

by cutting off the corners. A clean solution that avoids in most cases a protrusion of the zero-point plates to the machine table.

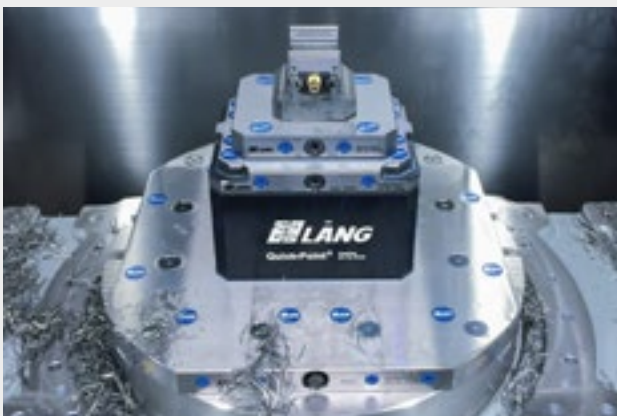

CUSTOM CORNER RADIUS FOR QUICK-POINT® GRID / MULTI-FOLD PLATES

ITEM NO.	QUANTITY
45043-01	Cut off 1 corner
45043-02	Cut off 2 corners
45043-04	Cut off 4 corners



MAKRO·GRIP® STAMPING TECHNOLOGY

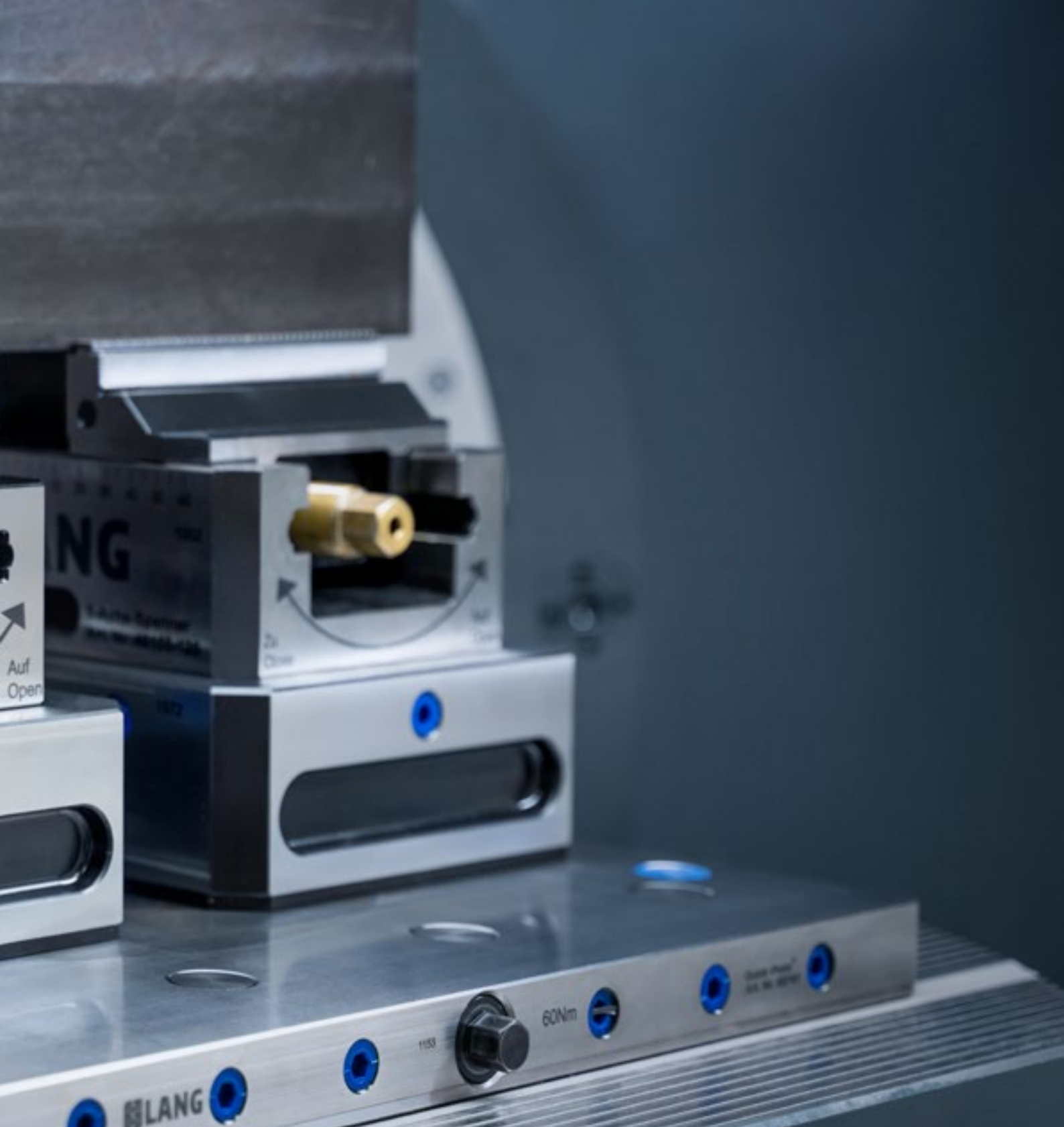

- 69 Makro-Grip® **Stamping Technology**
- 76 Stamping Unit for the workbench
- 77 Stamping Unit on trolley
- 80 Centre Marking Tool and Gauging Blocks
- 81 Stamping Jaws
- 82 Makro-4Grip **Round Part Clamping**

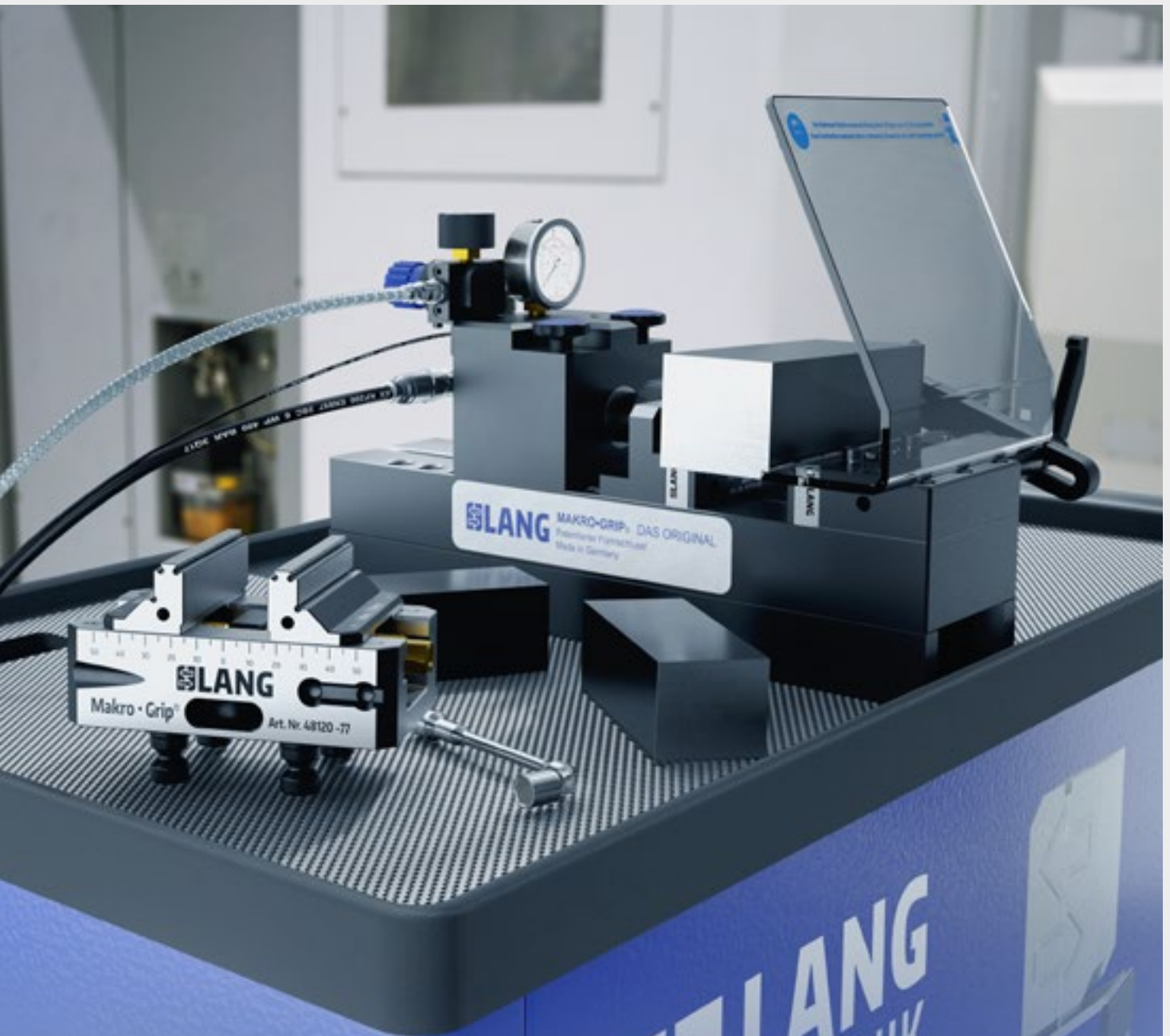

**simple.
reliable.
gripping.**

„The Original“ – Stamping Technology

The Makro·Grip® Stamping Technology allows:

SECURE AND RELIABLE CLAMPING PROCESSES

WEAR- AND DISTORTION-FREE CLAMPING

ENORMOUS MATERIAL SAVINGS

The stamping technology was invented by LANG nearly 20 years ago and can be regarded as the heart of the Makro·Grip® workholding system. It guarantees highest holding forces and ideal accessibility in 5-axis machining of blanks. The pre-stamping of workpiece blanks favors a variety of factors that have a positive effect on process reliability and cost-efficient production, which is why the Makro·Grip® technology is considered the benchmark in today's workholding. During the pre-stamping process workpieces are prepared with a defined contour at an external stamping unit under high pressure, which generates a form-fit between serrated jaws of the Makro·Grip® 5-Axis Vice and the stamping contour when clamping the workpiece. As pre-stamping is conducted externally, no additional machine capacities have to be spent in order to prepare the workpiece. The process only takes about 5 seconds – but these 5 seconds will forever change your manufacturing processes and the way you clamp your workpieces.

Benefits of the Makro·Grip® Stamping Technology:



Highest holding forces
due to form-fit clamping



Maximum
process reliability



Increased
milling quality



Minimum wear on
the clamping device



Effortless pre-stamping
of high-tensile material



High repeatability
thanks to defined
stamping contour

Different types of Stamping Units

Stamping Units are available in a stationary version for workbenches as well as mobile on a trolley. The actual stamping base is available in two different lengths with either Standard Stamping Jaws for materials up to 35 HRC or with High-End Stamping Jaws for materials up to 45 HRC.

The Dual Stamping Unit is suitable for extremely long workpieces. The mobile Stamping Unit offers great flexibility, allowing workpieces to be pre-stamped wherever they are needed. Pre-stamping is conducted conveniently via foot pedal, so both hands remain free to hold and insert heavy workpieces.



Makro-Grip® Stamping Unit for workbenches



Makro-Grip® Stamping Unit for workbenches



Trolley with Makro-Grip® Stamping Unit, extended version, on T-slot plate

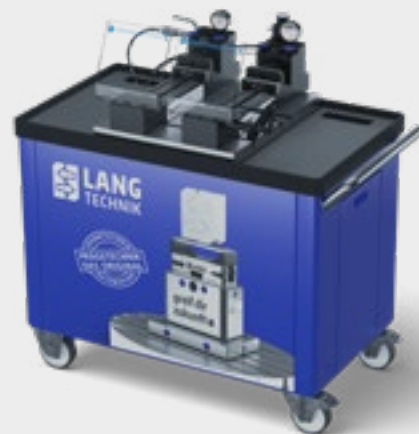

Trolley with Makro-Grip® Dual Stamping Unit, extended version, on T-slot plate



Makro-4Grip Stamping Technology for round parts

With the Makro-4Grip clamping system there are completely new possibilities and applications for the stamping technology. By retrofitting the Makro-Grip® stamping unit and a LANG centring vice the form-fit clamping principle can be applied for round parts now easily and cost-efficiently. Makro-4Grip jaw are available for all LANG vice sizes and cover a clamping range of Ø 36 to Ø 300 depending on their type and the vice's base length.

Makro-Grip® Ultra Stamping Technology for flat and large components

The Stamping Technology is now available for large parts. The form-fit effect which is made possible by pre-stamping guarantees highest holding forces at low tightening torque. Especially with large or deformation-sensitive components, holding forces and process reliability are without question among the most important attributes when clamping large components – two factors that are clearly associated with the Stamping Technology. Pre-stamped plate material on the other hand can be held extremely gently, but yet securely. The low actuation torque virtually eliminates distortion and deformation on the material.



Functional principle of the Stamping Technology



1 – Sawing

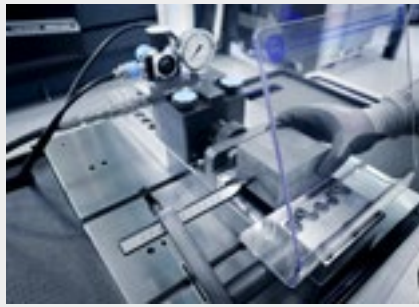

2 – Stamping

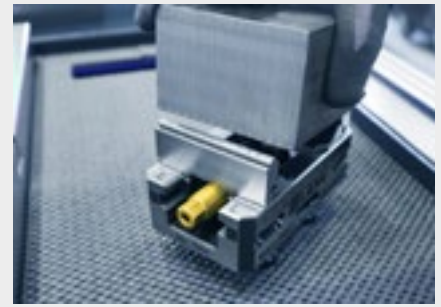

3 – Clamping

5 seconds that revolutionise your machining processes!

The workpiece is stamped directly on the saw cut or cinder layer of the blank. Additional preparatory work is generally not necessary. Stamping is realised within less than 5 seconds. The form-closure

effect between the stamping contour in the workpiece (truncated pyramid indents) and the holding teeth of the 5-Axis Vice allows for an accurate repeatability even without endstops.

A reliable wear-free clamping process for high-tensile materials

The stamping unit adds the form-closure contour to the workpiece with up to 20 tons of pressure. This allows you to clamp even high-tensile materials up to 1.500 N/mm² tensile strength reliably and virtually wear-free. Different material hardness requires

different stamping jaws to extend longevity and guarantee safe clamping. Our standard jaws allow you to stamp workpieces up to 35 HRC, whereas high-tensile materials up to 45 HRC require High-End stamping jaws.

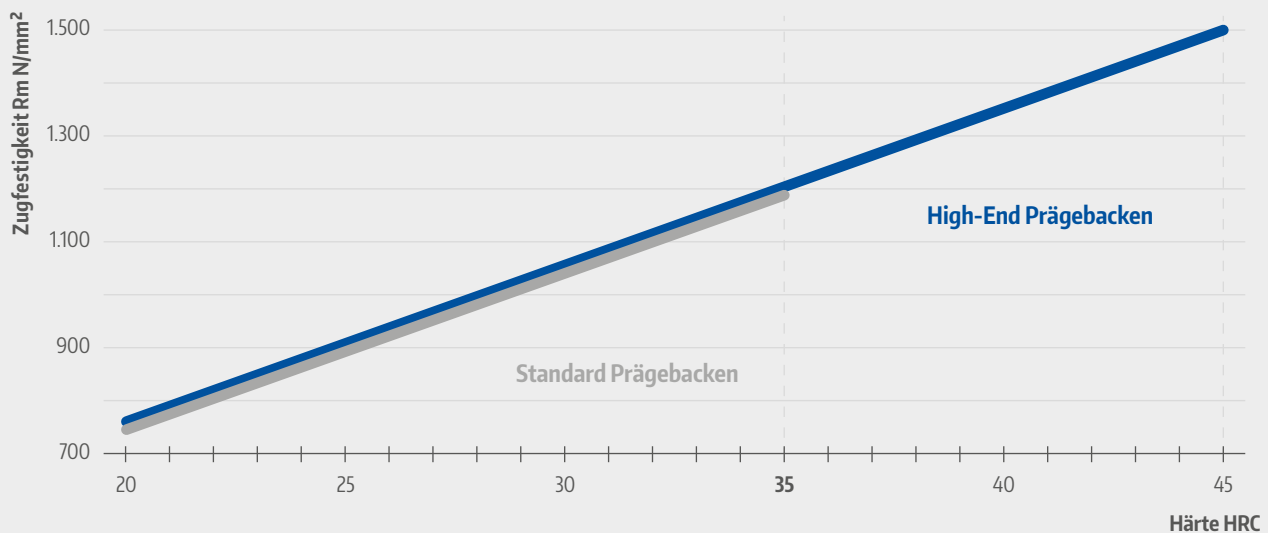

Setting the stamping depth and pressure correctly

The large number of alloys makes it difficult to make an exact statement about the stamping pressure to be set. The two main parameters are workpiece width and material. In general, we recommend always starting with a low stamping pressure and slowly increasing it until the desired stamping depth in the workpiece is achieved.

For the material type 1.7131 (16MnCr5) we have made a measurement in this regard and set rough guide values for setting the stamping pressure.

Material type 1.7131 (16MnCr5)

MATERIAL WIDTH	STAMPING PRESSURE
76 mm	100 bar
126 mm	140 bar

Please note: Depending on the surface quality, the required inlet pressure may deviate from these values. Therefore, carry out a test stamping and check the stamping contour with a visual inspection before each stamping series.

Stamping tooth imprint with correct stamping

The visual inspection gives the user reliable feedback as to whether the inlet pressure has been selected correctly or whether readjustment is required. Depending on the material hardness, there are two different stamping tooth imprints. Soft material needs a bit

more “holding surface” due to the higher toughness. Therefore, it must be stamped in such a way that control marks between the stamping tooth imprints are visible. With harder materials, it is not necessary to stamp as deeply because of the higher resistance.

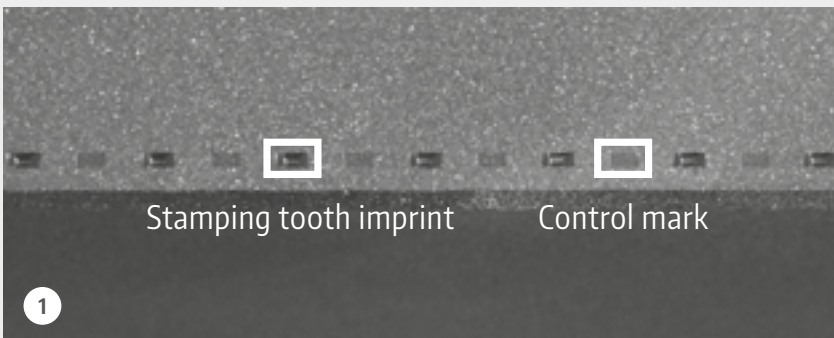

1 Material < 35 HRC with Standard stamping jaws

The stamping contour with alternating stamping tooth imprints and control marks is clearly visible. The depth of the control marks should be about 0.1 mm. The depth of the imprints should be about 0.25 mm.

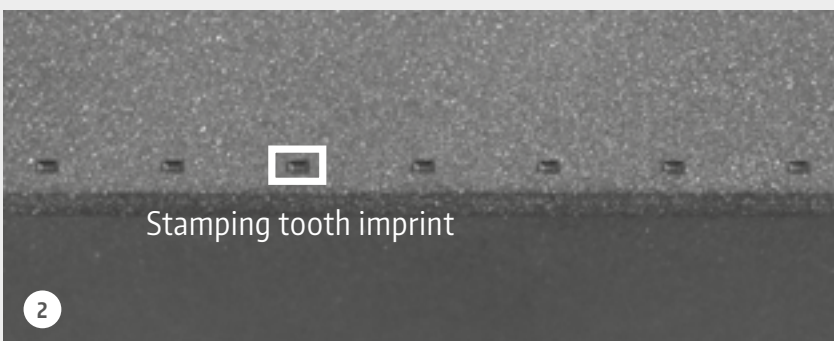

2 Materials > 35 HRC with High-End stamping jaws

For material with a hardness between 35 and 45 HRC, the control marks should not be visible. The depth of the imprints is about 0.15 mm.

Highest holding forces and process reliability thanks to clamping by form-fit

Conventional vices penetrate the workpiece blank with high forces exposing both, the vice and the workpiece to high strains. The Makro-Grip® technology however uses a different approach. By pre-stamping the workpiece blank with up to 20 tons of pressure and preparing it with a defined contour, the forces are already applied before the actual clamping process. Once it is prepared with the contour (pyramid-shaped truncated indents), the Makro-Grip® 5-Axis Vice can hold the workpiece by

form-fit, absolutely gently and securely with low clamping pressure – always with the same clamping jaws, regardless of the material and the hardness. Due to the low clamping pressure, distortion on the workpiece as well as wear on the vice can virtually be ruled out. Even with high-tensile material an always consistent clamping quality is guaranteed, which is crucial to achieving the desired quality of the machined workpiece.

The benefits of the stamping technology:

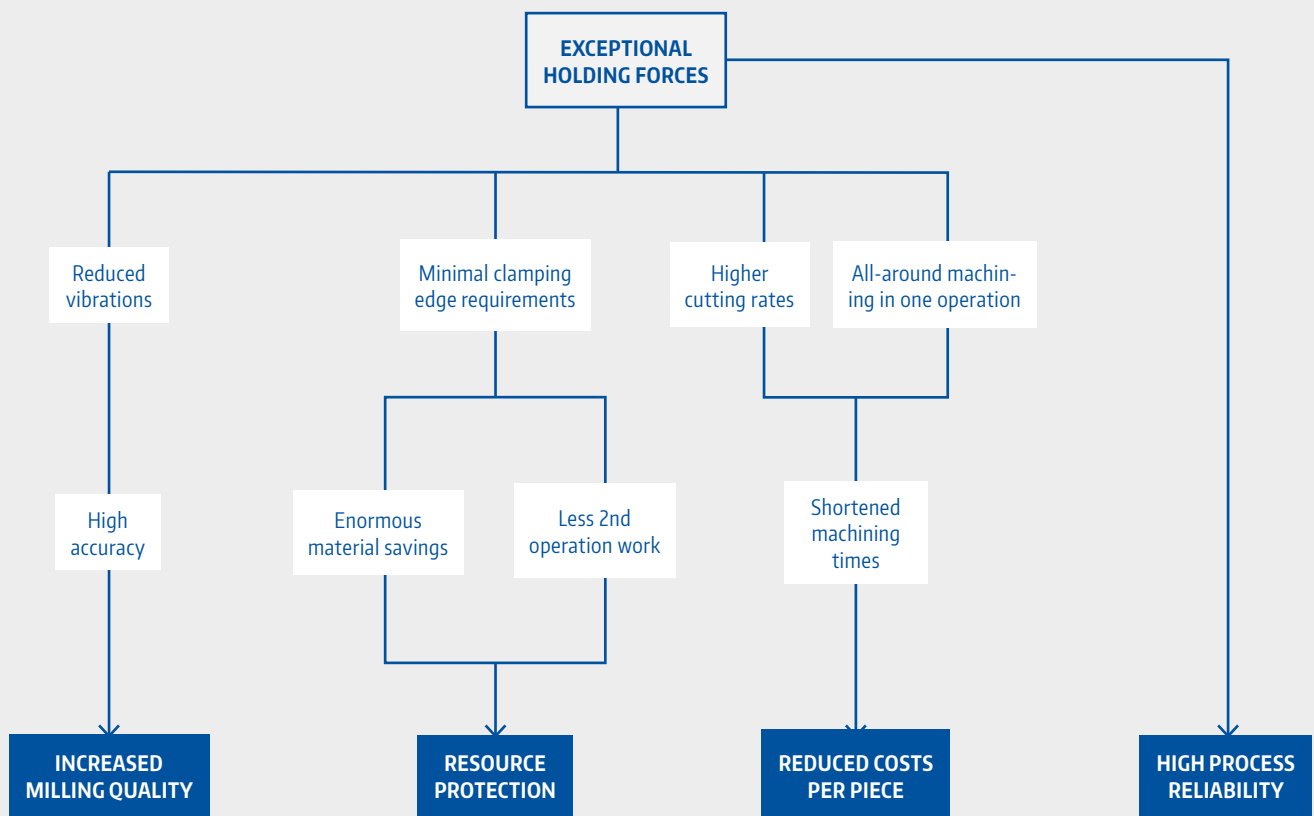



Clamping large workpieces with compact vices

Stamping Technology allows the Makro-Grip® 5-Axis Vice to clamp workpieces which substantially exceed its volume. Despite a clamping depth of only 3 mm the Makro-Grip® Stamping Technology guarantees highest process reliability. The compact design in relation to the maximum allowed workpiece size ensures ideal accessibility and thus allows for short tools which results in reduced vibrations and higher cutting rates.

As a guideline, the Makro-Grip® 5-Axis Vice is able to clamp parts of following size:

Width of workpiece:
3 × jaw width of vice
Height of workpiece:
2 × jaw width of vice

Finishing parts in one operation

The form-fit between clamping jaw serration and stamping contour makes it possible to safely pick up the workpiece at its smallest cross-section and clamp it edgewise with ideal accessibility. This strategy allows a lot of parts to be finished in one operation. For automated, lights-out machining it means that complete batches can be produced without the presence of an operator.



Makro-Grip® Stamping Unit



Side view

- 1 Operated pneumatically by hand or foot
- 2 Pneumatic-hydraulic power multiplier with visible oil-level display
- 3 Makrolon protection shield
- 4 Easily readable hydraulic pressure gauge
- 5 Quick adjustment of stamping with for different part sizes
- 6 Robust steel hydraulic housing with integrated T-slot key
- 7 Scaled endstop for quick positioning of blanks
- 8 Stamping jaws for all materials up to 35 HRC / 45 HRC
- 9 Convenient adjustment of the stamping pressure
- 10 Quick connection system consisting of quick connector and quick connector socket

MAKRO-GRIP® STAMPING UNIT FOR WORKBENCHES

ITEM NO.	TYPE	MAX. STAMPING RANGE	TYPE OF STAMPING JAWS	WEIGHT
41200	Standard	245 mm	Standard stamping jaws for materials up to 35 HRC	76 kg
41350	Extended	355 mm	Standard stamping jaws for materials up to 35 HRC	84 kg
41200-HE	Standard	245 mm	High-End stamping jaws for materials up to 45 HRC	76 kg
41350-HE	Extended	355 mm	High-End stamping jaws for materials up to 45 HRC	84 kg

- Scope of delivery:
- Stamping vice
 - Stamping jaws with parallels, 3 mm
 - Pneumatic-hydraulic power multiplier (1 – 360 bar)
 - Gauging blocks for measuring wear of stamping teeth
 - Scaled workpiece endstop
 - Protection shield

Stamping trolley with Makro·Grip® Stamping Unit, Standard



- 1 Makro·Grip® Standard Stamping Unit with a stamping range up to 245 mm
- 2 T-slot plate can be retrofitted
- 3 Practical, rigid trolley for a flexible and mobile use
- 4 Broad space on the plastic tray that can be used for preparing vices or for depositing tools, etc.

STAMPING TROLLEY WITH MAKRO·GRIP® STAMPING UNIT, STANDARD

ITEM NO.	TYPE	MAX. STAMPING RANGE	TYPE OF STAMPING JAWS	WEIGHT
41521	Standard	245 mm	Standard stamping jaws for material up to 35 HRC	210 kg
41521-HE	Standard	245 mm	High-End stamping jaws for material up to 45 HRC	210 kg

- Scope of delivery:
- Stamping vice
 - Stamping jaws with parallels, 3 mm
 - Workshop trolley
 - Protection shield
 - Pneumatic-hydraulic power multiplier (1-360 bar)
 - Gauging blocks for measuring wear of stamping teeth
 - Scaled workpiece endstop

Stamping trolley with Makro-Grip® Stamping Unit, extended, on T-slot plate



- 1 Large stamping range up to 355 mm
- 2 Practical, rigid trolley for a flexible and mobile use
- 3 T-slot plate included allowing a second stamping unit to be retrofitted easily with marking bores or T-slot

STAMPING TROLLEY WITH MAKRO-GRIP® STAMPING UNIT, EXTENDED, ON T-SLOT PLATE

ITEM NO.	TYPE	MAX. STAMPING RANGE	TYPE OF STAMPING JAWS	WEIGHT
41400	Extended	355 mm	Standard stamping jaws for material up to 35 HRC	300 kg
41400-HE	Extended	355 mm	High-End stamping jaws for material up to 45 HRC	300 kg
41140	Additional extended stamping vice for dual stamping	355 mm	Standard stamping jaws for material up to 35 HRC	50 kg
41140-HE	Additional extended stamping vice for dual stamping	355 mm	High-End stamping jaws for material up to 45 HRC	50 kg

Scope of delivery Item No. 41400 und 41400-HE:

- Stamping vice
- T-slot plate 596 × 496 mm
- Stamping jaws with parallels, 3mm
- Pneumatic-hydraulic power multiplier (1-360 bar)
- Workshop trolley
- Gauging blocks for measuring wear of stamping teeth
- Scaled workpiece endstop
- Protection shield

Stamping trolley with Makro·Grip® Dual Stamping Unit, extended, on T-slot plate



STAMPING TROLLEY WITH MAKRO·GRIP® DUAL STAMPING UNIT, EXTENDED, ON T-SLOT PLATE

ITEM NO.	TYPE	MAX. STAMPING RANGE	TYPE OF STAMPING JAWS	WEIGHT
41402	Extended	2 × 355 mm	Standard stamping jaws for material up to 35 HRC	350 kg
41402-HE	Extended	2 × 355 mm	High-End stamping jaws for material up to 45 HRC	350 kg

Scope of delivery:

- 2 stamping vices
- T-slot plate 596 × 496 mm
- 2 pairs of stamping jaws with parallels, 3 mm
- Pneumatic-hydraulic power multiplier (1-360 bar)
- Workshop trolley
- Gauging blocks for measuring wear of stamping teeth
- 2 scaled workpiece endstop
- 2 protection shield



The dual stamping unit is ideal for preparing long parts with two stamping vices simultaneously and clamping these stamped parts accordingly in two 5-Axis Vices on the machine table.

The distance of the two units can be adjusted individually using the T-slots or marking bores, in order to match the distance of Quick·Point® pitch and thus the position of the Makro·Grip®s' holding teeth.

Centre Marking Tool for Stamping Unit

The centre marking tool plunges a notch above the stamping contour at the centre of the part.
This marking allows the exact and centric positioning of parts in Makro-Grip® 5-Axis Vices without any endstops.



CENTRE MARKING TOOL

ITEM NO.	DESCRIPTION
41010	Centre marking tool
41010-01	Spare marking stud

The centre marking tool will be mounted to the moveable jaw of the stamping unit with two M 6 × 14 screws (included).

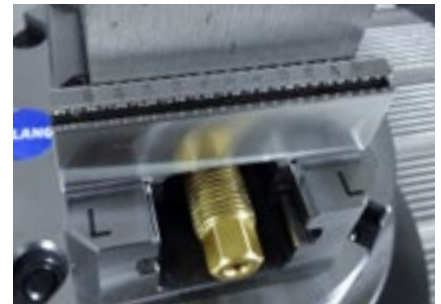

Gauging Blocks for measuring wear of Stamping Jaws



GAUGING BLOCKS FOR MEASURING WEAR OF STAMPING JAWS

ITEM NO.	UNIT
41020	1 set (3 pcs.)

Creating trust! Always the same clamping quality. To ensure consistent holding power in the clamping device, it is necessary to check the wear of the stamping teeth regularly.



Position one gauging block with slots on each side of the stamping jaws. Tighten the jaws by hand only, do not actuate the switch!



Make sure that the stamping teeth are placed in the grooves of the gauging blocks.



When the indicator block fits between the stamping contour, the jaws need to be sent in for reconditioning.

Stamping Jaws – Standard and High-End version



STANDARD STAMPING JAWS WITH 3 MM PARALLELS

ITEM NO.	FOR MATERIALS	UNIT
41111	up to 35 HRC	1 pair

Standard stamping jaws for all materials up to 35 HRC.



HIGH-END STAMPING JAWS WITH 3 MM PARALLELS

ITEM NO.	FOR MATERIALS	UNIT
41112	up to 45 HRC	1 pair

Standard stamping jaws for all materials up to 45 HRC.

Reconditioning Stamping Jaws



RECONDITIONING STAMPING JAWS

ITEM NO.	VERSION
41111-01	Standard stamping jaws
41112-01	High-End stamping jaws

When the stamping teeth are worn out the jaws can be reconditioned up to 6 times per pair. The original thickness of a stamping jaw is 18 mm. With every reconditioning process the thickness is reduced by 0.5 mm until it has reached 15 mm (measured at the highest stamping tooth tip). If a stamping tooth is broken off more than the regular 0.5 mm per reconditioning is required. The total amount of possible reconditioning processes is reduced accordingly.

Note for dual stamping: With every reconditioning process we generally supply shims. The thickness of these shims is determined by the remaining thickness of the stamping jaw. Thickness of stamping jaw and shim will always amount to 18 mm. This guarantees that stamping jaws which have been reconditioned at different intervals can be used together, applying the same pressure on the workpiece.

Tip for your benefit:

In order to bridge the time of the reconditioning process we suggest keeping a second pair of stamping jaws in reserve!



Makro·4Grip Round Part Clamping

PATENT PENDING

Stamping Technology for round parts

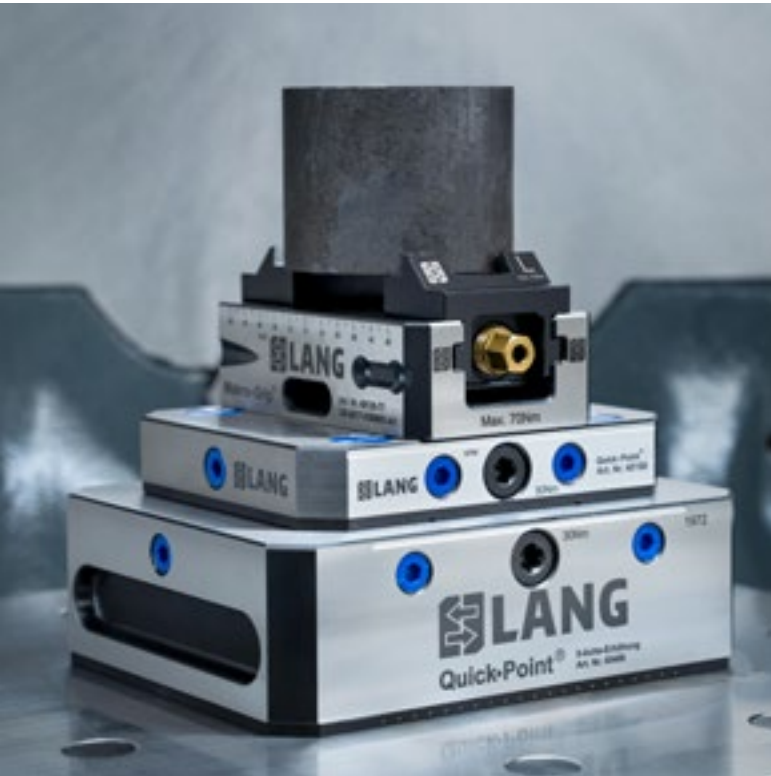

Due to its efficiency and the beneficial characteristics for work-holding the LANG stamping technology still is the benchmark when it comes to processing raw parts in 5-axis machining. With the Makro·4Grip Clamping System there are completely new possibilities and applications for the stamping technology. **By retrofitting the Makro·Grip® stamping unit and LANG centring vices the form-fit clamping technology can be applied for round parts now easily and cost efficiently.**

The jaws grip the pre-stamped part in four indentations at a clamping depth of 6.5 mm with up to 20 kN and therefore realise the same form-fit effect as for the well-proven system for prismatic parts. Makro·4Grip covers a clamping range of Ø 36 mm to Ø 300 mm and thus provides a seamless transition from the maximum range of the Preci·Point Collet Chuck.

The Makro·4Grip system consists of universal stamping jaws including stamping inserts for individual positioning as well as matching clamping jaws for all sizes of LANG centring vices. The clamping jaws are available as a separate set of jaws for all 77 and 125 vices.

Stamping imprint

Opposed to stamping prismatic parts where control marks give an indication about the correct stamping depth, the Makro·4Grip technology relies on a visual examination. Stamping round material, the correct imprint is consistently thick and deep.

The required stamping pressure and depth depends on material and its diameter. In general, we recommend always starting with a low stamping pressure and slowly increasing it until the desired stamping depth in the workpiece is achieved.



Makro·4Grip Stamping Technology – The right setup

According to the vice and clamping jaw size used in the machining process the four stamping inserts (2 inserts per stamping jaw) are placed differently in the respective seats.

The scheme below shows how the stamping inserts need to be positioned for each clamping setup.

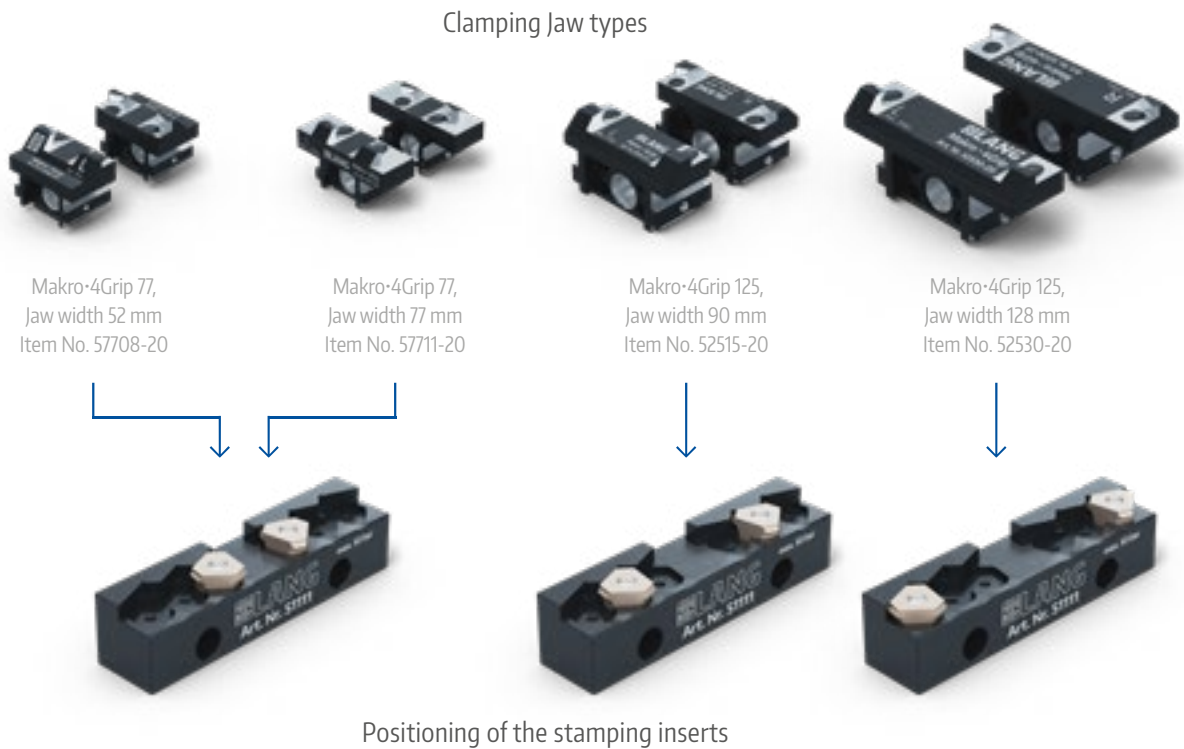

Makro·4Grip Stamping Jaws and Inserts



MAKRO·4GRIP STAMPING JAWS

ITEM NO.	QUANTITY
51111	1 pair

4 stamping jaw inserts are included.
Suitable for all Makro·Grip® stamping unit versions!

MAKRO·4GRIP STAMPING JAW INSERTS

ITEM NO.	QUANTITY
51111-40	4 pcs.

Each stamping jaw insert has a total of three cutting edges. If a cutting edge is worn, the stamping jaw insert can be turned two more times. For an even stamping and clamping quality, make sure that all four stamping inserts are turned / exchanged at the same time.



MAKRO-GRIP® 5-AXIS VICES / RAW PART CLAMPING



- 88** Makro·Grip® **5-Axis Vices**
 - 96** 5-Axis Vices 77
 - 102** 5-Axis Vices 125
- 110** Makro·Grip® **Dual-Clamping Vice**
- 112** Retrofitting kit for 5-Axis Vice



**simple.
reliable.
gripping.**

Unbeatable combination of compactness and holding power

3 reasons why the Makro·Grip® is perfectly fitted for 5-sided machining

ACCESSIBILITY

HOLDING POWER

GREAT HANDLING CHARACTERISTICS

External pre-stamping enables a workpiece to be held reliably in the Makro·Grip® 5-Axis Vice with low clamping pressure. Deformation and distortion of the material during clamping are therefore excluded and wear on the clamping device is reduced to a minimum. Its compact design and the use of the form-fit technology make the 5-Axis Vice ideal for 5-sided machining.

Benefits of the Makro·Grip® 5-Axis Vice:

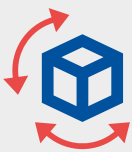

Ideal accessibility in 5-sided machining



Highest holding forces at low clamping pressure



Distortion-free and wear-free clamping



High material savings due to minimal clamping edge requirements



Process reliability and consistent clamping quality



Ergonomic handling thanks to low weight vices

Makro·Grip® Technology

PATENTED

Compact and unmatched holding power for the 5-sided machining of blanks and unfinished parts

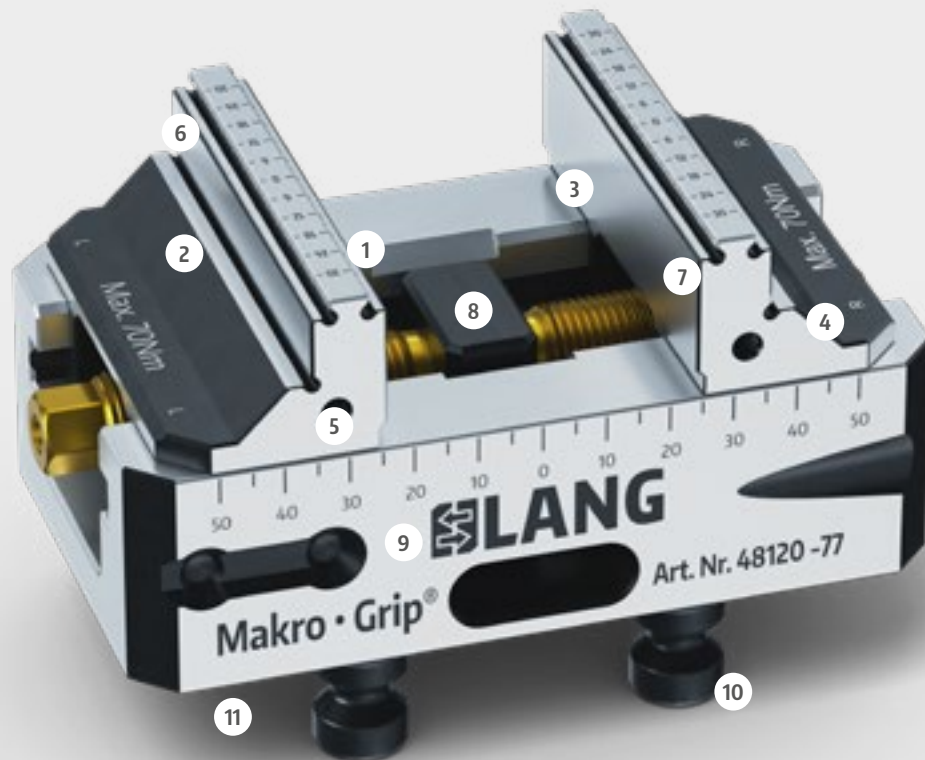

- 1 Makro·Grip® jaws with double-sided serration (same serration for all types of vices)
- 2 Additional clamping support for non-stamped parts
- 3 Special Tungsten-Carbide Coating can be applied on the plain clamping surfaces in order to increase friction when clamping non-stamped parts
- 4 Clamping jaws milled from solid case-hardened steel for maximum stability
- 5 Thread for mounting an endstop
- 6 The reversible jaws are changed over within one minute. A larger clamping range is achieved and interferences are eliminated
- 7 Clamping edge requirement of 3 mm guarantees ideal accessibility for tools and enormous material savings
- 8 Centring accuracy ± 0.02 mm
- 9 Rigid and sturdy base for great longevity. All LANG jaw types within the size group can be mounted to this base
- 10 Integrated with clamping studs for precise clamping in the Quick·Point® zero-point clamping system
- 11 Additional bores/threads can be drilled in the bottom of the base body to adapt the Makro·Grip® 5-Axis Vice to other zero-point systems

Makro-Grip® serration

All Makro-Grip® clamping jaw sizes use the double-sided serration. The minimum clamping depth of only 3 mm (other depths are available on request) guarantees ideal accessibility and enormous material savings. The Makro-Grip® serration offers very good reproducibility, which is particularly advantageous when workpieces have to be clamped again for reworking tasks.



Reversible clamping jaws

The reversible clamping jaws of the Makro-Grip® 5-Axis Vice are changed over within one minute. Thus, a larger clamping range is achieved and interferences are eliminated. Opposed to conventional vice whose top jaws are often mounted to the jaw guide, the Makro-Grip® jaws are milled from solid, which results in enormous stability advantages.





Robust and automation-ready

The tapered grooves on the side surface of the Makro-Grip® 77 (length 130 mm), as well as the front-end bores in the base body of the Makro-Grip® 125 (length 210 mm) are used to hold and store the 5-Axis Vise on the RoboTrex automation trolleys. Due to the upright mounting of the vices, the RoboTrex storage medium offers an excellent ratio of space requirement and storage capacity. The 5-Axis Vices are also equipped with grooves for the RoboTrex gripper.

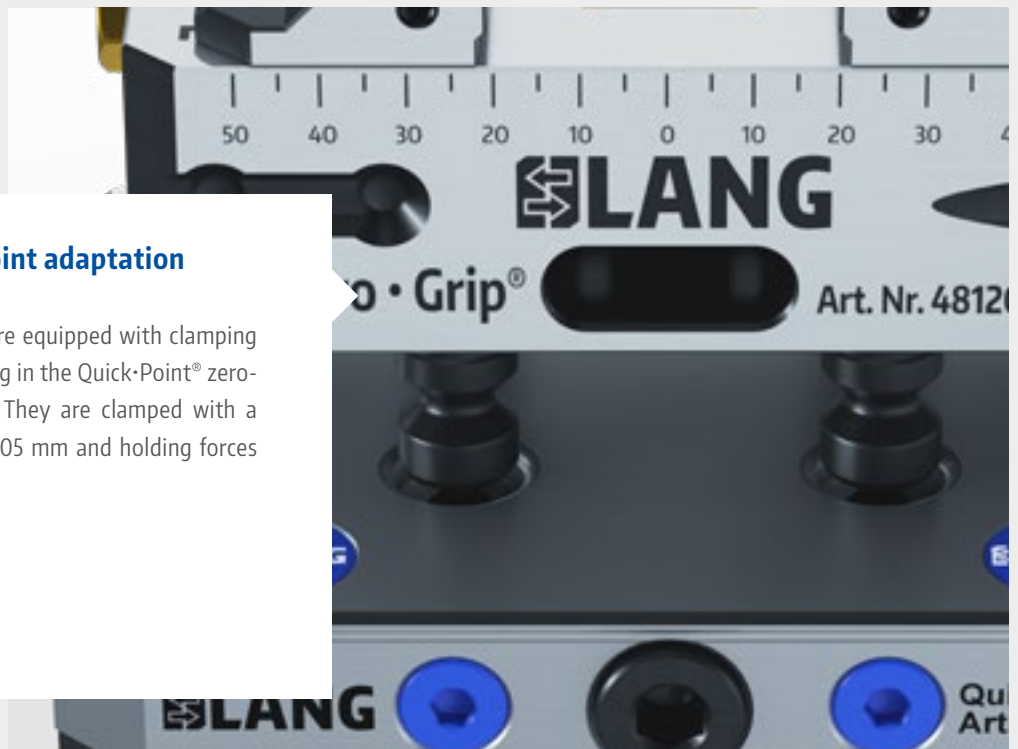

Integrated zero-point adaptation

All LANG vice versions are equipped with clamping studs for precise clamping in the Quick-Point® zero-point clamping system. They are clamped with a repeat accuracy of < 0.005 mm and holding forces of up to up to 6.000 kg.



Single or multiple clamping

Due to the encapsulated centre piece, the guide of the TIN-coated threaded spindle is protected against dirt and chips. Replacing the centre piece / spindle set with a centre jaw conversion kit, the Makro-Grip® is transformed into a multiple clamping vice, in which several workpieces can be clamped simultaneously.

Additional clamping possibilities

With their plain surfaces and clamping steps, Makro-Grip® jaws also offer various clamping options for 2nd operations or for workpieces that are not to be pre-stamped. Makro-Grip® clamping jaws are available with or without serration and are equipped with threaded holes on their side face to attach endstops. Besides, a special Tungsten-Carbide coating can be applied on the plain clamping surfaces in order to double the friction force when clamping non-stamped parts.



Different versions of the 5-Axis Vice

Makro·Grip® 5-Axis Vice 77

Base width:
77 mm



Jaw width: 46 mm
Base lengths: 102 / 130 mm



Jaw width: 77 mm
Base lengths:
102 / 130 / 170 / 210 mm



Jaw width: 77 mm
Base length: 130 mm

Makro·Grip® Night King:
A pure 5-Axis Vice for automated
manufacturing with RoboTrex.

Makro·Grip® 5-Axis Vice 125

Base width:
125 mm



Jaw width: 77 mm
Base lengths: 160 / 210 mm

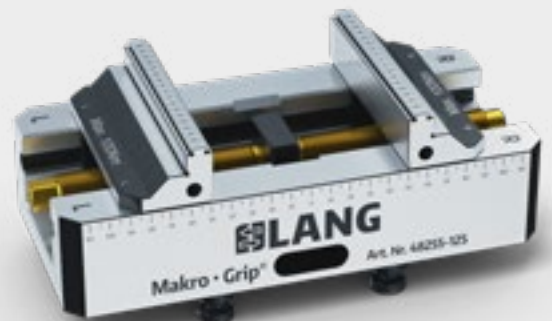

Jaw width: 125 mm
Base lengths:
160 / 210 / 260 / 310 / 360 mm

The benefits of pre-stamping on the clamping process

The external pre-stamping of the workpiece relieves the 5-Axis Vice. While conventional machining vices with serrated teeth have to work double duty (1. indent the material, 2. hold the workpiece), the Makro-Grip® 5-Axis Vice's function is limited to

only holding the workpiece. The compact build of the Makro-Grip® 5-Axis Vice is possible due to the requirement of much lower clamping forces. The resulting advantages are shown below.

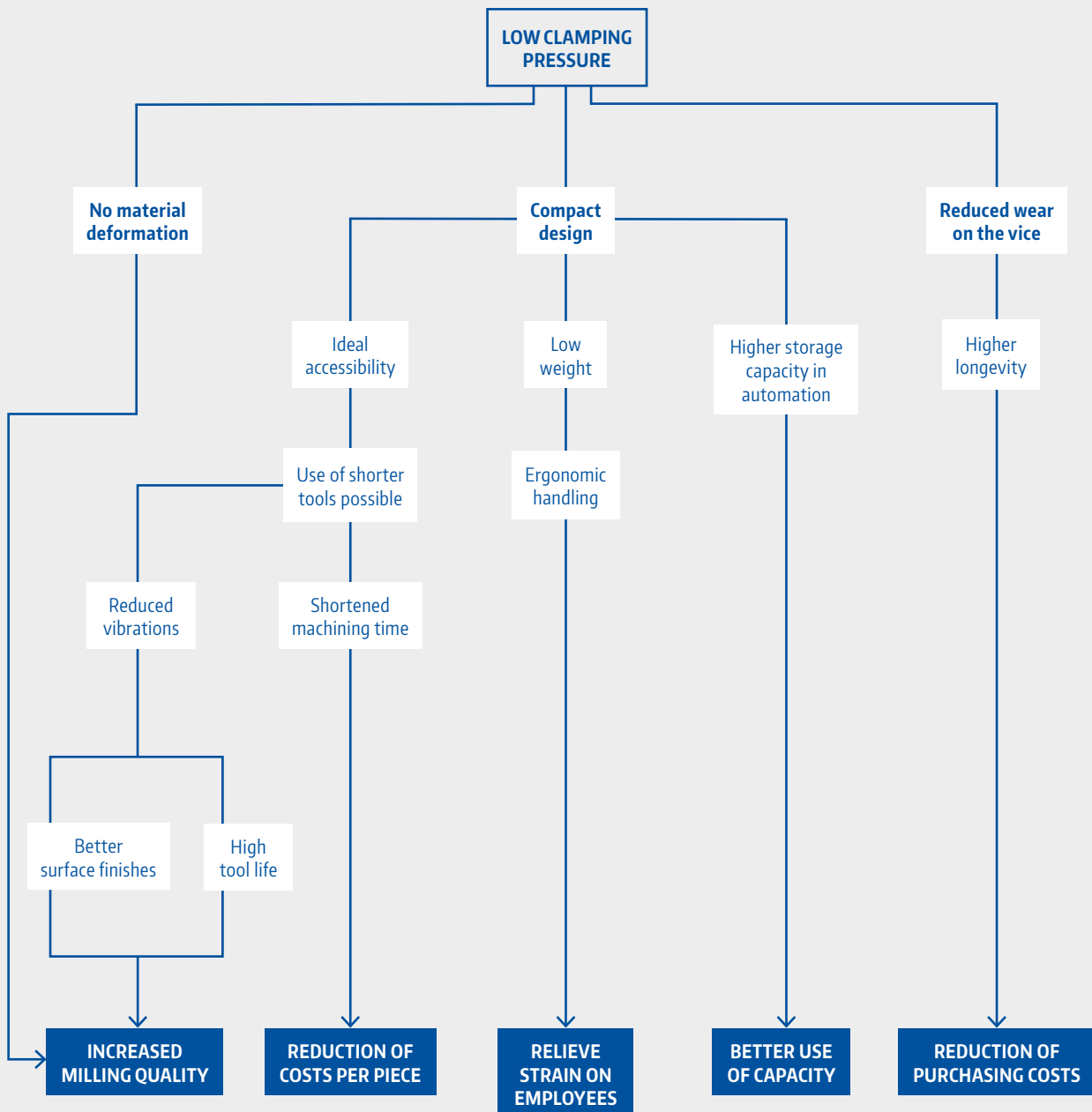

Clamping pressure – holding force ratio

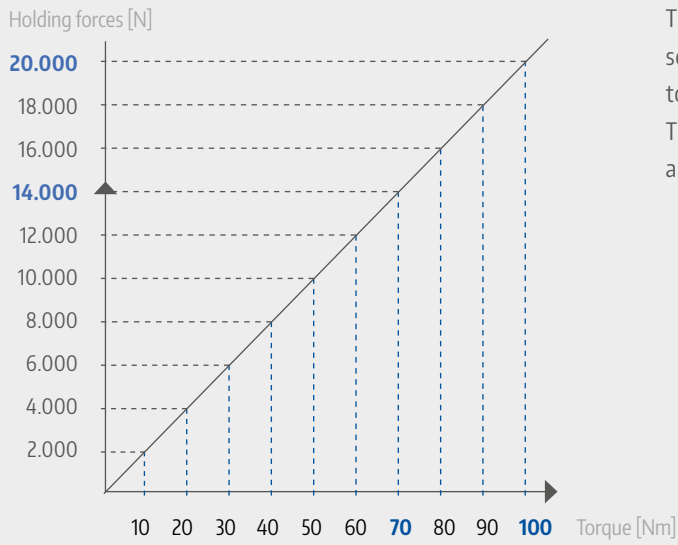

Thanks to the form-fit clamping technology, workpieces can be securely clamped with low clamping pressure. Deformation and distortion of the material while clamping and releasing is impossible! This diagram highlights the relation between the actuation torque and the resulting holding forces.

Applications

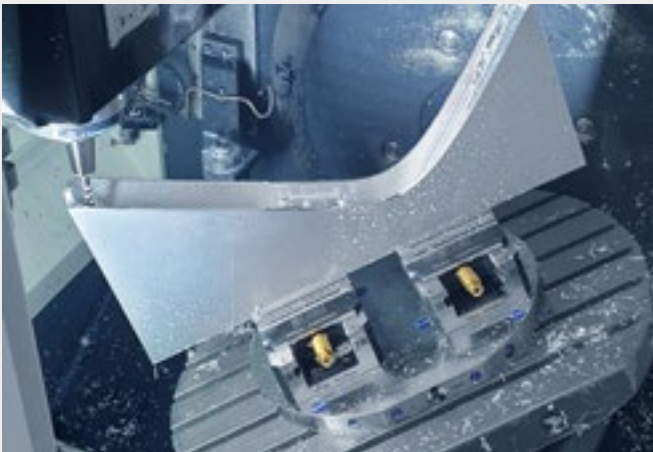

Image: Aximech AB

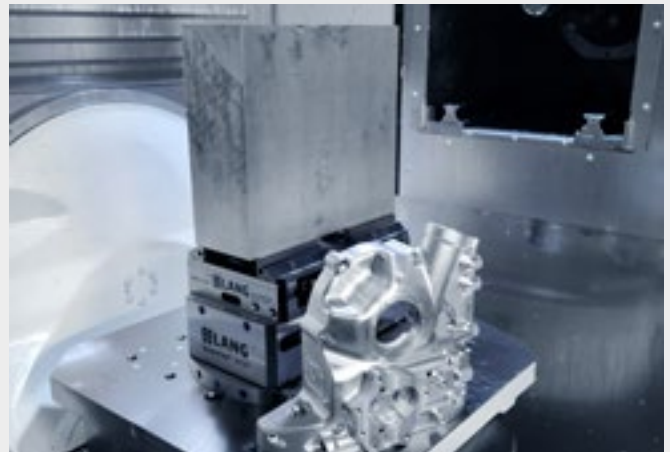

Image: Chips Motorsports LLC



Image: Donner GmbH The Qualifactory
94



Image: Nueva Precision



One base, many clamping jaw options

A fitting solution for any challenging clamping task – with only one vice base! All LANG vices use the same base in different lengths and widths. This guarantees that all jaw types are interchangeable and compatible to each other. It also means that you do not necessar-

ily have to invest in two vices. The interchangeability of the jaws allows you to build a flexible "vice fleet" regardless of the vice type you start with. Additional jaws can be added at a later time according to demand and application.

Makro·Grip® 5-Axis Vice 77



MAKRO·GRIP® 5-AXIS VICE 77, JAW WIDTH 46 MM



ITEM NO.	BASE LENGTH	CLAMPING RANGE	WEIGHT
48085-46	102 mm	0 - 85 mm	2.1 kg
48120-46	130 mm	0 - 120 mm	2.5 kg

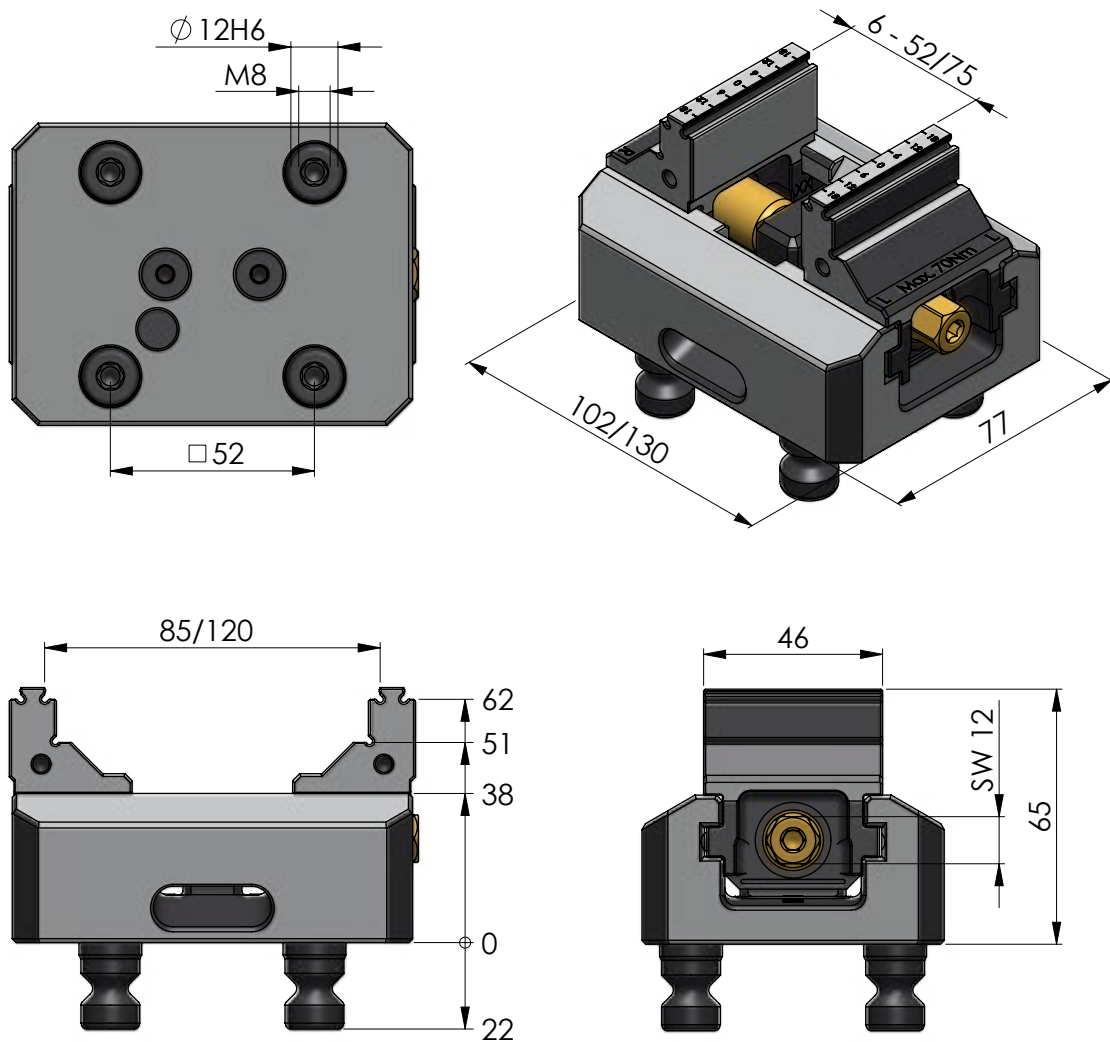

Spare parts and accessories



Spare jaws and compatible jaw types can be found on pages 100 / 101.

Spindles and other accessories such as wrenches can be found on pages 108 / 109.

Makro·Grip® 5-Axis Vice 77



**MAKRO·GRIP® 5-AXIS VICE 77,
JAW WIDTH 77 MM**



ITEM NO.	BASE LENGTH	CLAMPING RANGE	WEIGHT	COMPARABLE PREVIOUS VERSION
48085-77	102 mm	0 – 85 mm	2.3 kg	47085
48120-77	130 mm	0 – 120 mm	2.9 kg	47120
48160-77	170 mm	0 – 160 mm	3.5 kg	47160
48200-77	210 mm	0 – 200 mm	4.2 kg	47200

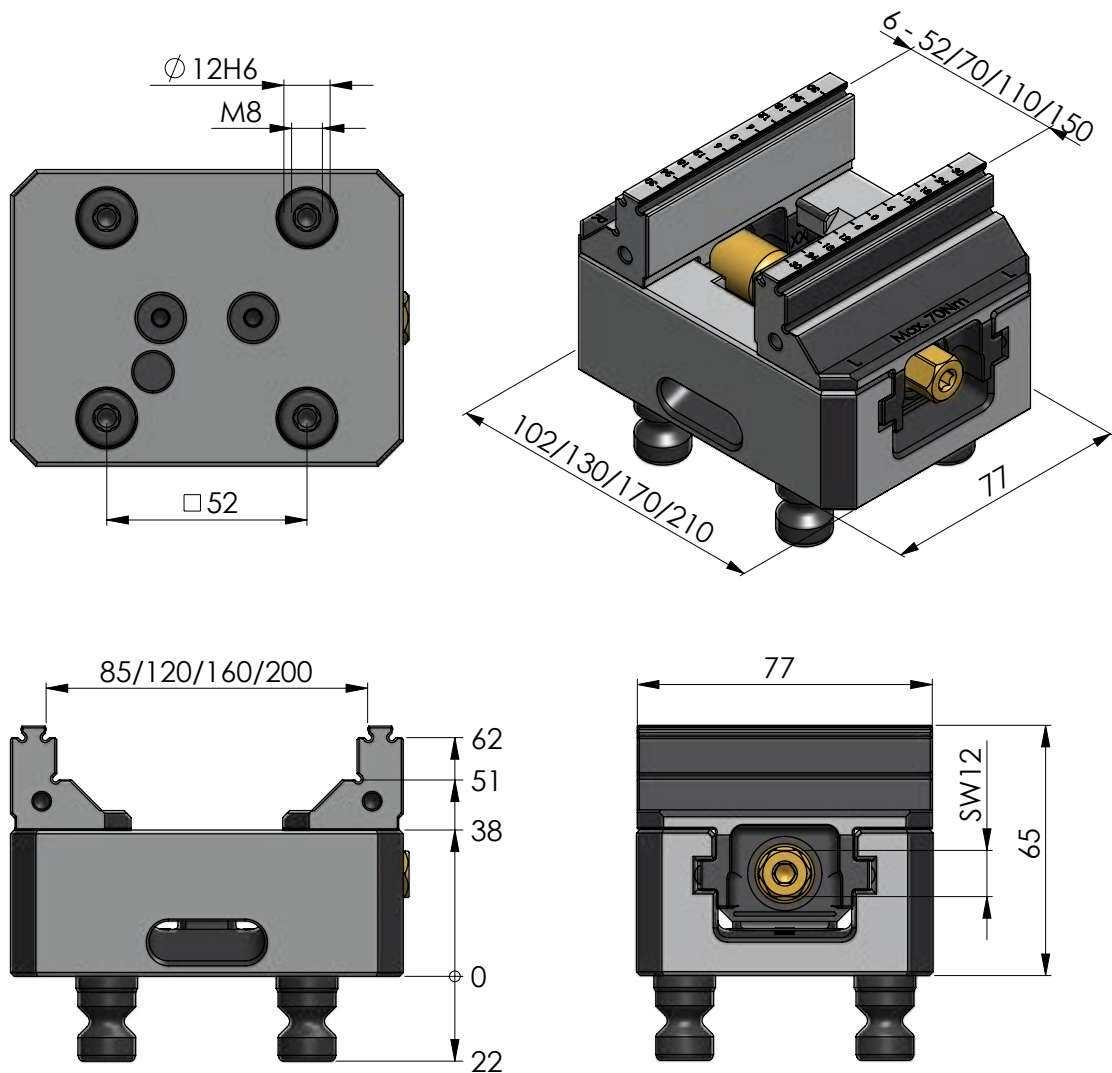

Spare parts and accessories



Spare jaws and compatible jaw types can be found on pages 100 / 101.



Spindles and other accessories such as wrenches can be found on pages 108 / 109.

Makro-Grip® 5-Axis Vice 77

Available Clamping Jaws



SPARE JAWS FOR MAKRO-GRIP® 5-AXIS VICE 77

ITEM NO.	FOR	WEIGHT	UNIT
48085-4620	48085-46	0.5 kg	1 pair
48077-4620	48120-46	0.5 kg	1 pair
48085-7720	48085-77	0.7 kg	1 pair
48077-7720	48120-77 48160-77 48200-77	0.7 kg	1 pair



SPARE JAWS WITHOUT SERRATION, FOR MAKRO-GRIP® 5-AXIS VICE 77

ITEM NO.	FOR	WEIGHT	UNIT
48085-4622	48085-46	0.5 kg	1 pair
48077-4622	48120-46	0.5 kg	1 pair
48085-7722	48085-77	0.7 kg	1 pair
48077-7722	48120-77 48160-77 48200-77	0.7 kg	1 pair



AVANTI BASE JAWS FOR MAKRO-GRIP® 5-AXIS VICE 77

ITEM NO.	FOR	WEIGHT	UNIT
44771-46	48085-46 48120-46	0.6 kg	1 pair
44771-77	48120-77 48160-77 48200-77	1.4 kg	1 pair



PROFILO BASE JAWS FOR MAKRO-GRIP® 5-AXIS VICE 77

ITEM NO.	FOR	WEIGHT	UNIT
49077	all Makro-Grip® 77, jaw width 77 mm	1.6 kg	1 pair



VARIO-TEC JAWS FOR MAKRO-GRIP® 5-AXIS VICE 77

ITEM NO.	FOR	WEIGHT	UNIT
42018-77	48120-77 48160-77 48200-77	1.2 kg	1 Set (2 pin jaws + 2 carrier jaws)

NEW



MAKRO-4GRIP 77 CLAMPING JAWS

ITEM NO.	JAW WIDTH	CLAMPING RANGE	WEIGHT	UNIT
57708-20	52 mm	Ø 36 – 115 mm	0.6 kg	1 pair
57711-20	77 mm	Ø 54 – 115 mm	0.7 kg	1 pair

Makro-4Grip clamping jaws are compatible with all LANG vices. The clamping range depends on the length of the vice base. The maximum possible clamping ranges can be taken from the data sheet in the download area of our website.

NEW

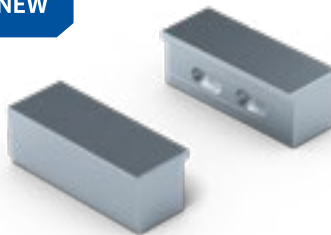

CONTOUR JAWS, ALUMINIUM FOR MAKRO-GRIP® 5-AXIS VICES 77

ITEM NO.	JAW WIDTH	FOR	WEIGHT	UNIT
48409-77	77 mm	inside	0.3 kg	1 pair
48419-77	77 mm	outside	0.3 kg	1 pair

The matching magnets are available separately, as is the assembly tool. Contour jaws can also be used for jaw width 46 mm by mill them off. Exact details on compatibility and clamping ranges for the individual base body lengths can be found on our website.

ACCESSORIES FOR CONTOUR JAWS

ITEM NO.	DESCRIPTION	WEIGHT	UNIT
48410	Magnet Set for Contour Jaws	0.02 kg	Set of 10
48420	Assembly Tool for Magnets	0.01 kg	1 pc.



Makro·Grip® 5-Axis Vice 125



MAKRO·GRIP® 5-AXIS VICE 125, JAW WIDTH 77 MM



ITEM NO.	BASE LENGTH	CLAMPING RANGE	WEIGHT
48155-77	160 mm	0 – 155 mm	7.4 kg
48205-77	210 mm	0 – 205 mm	9.1 kg

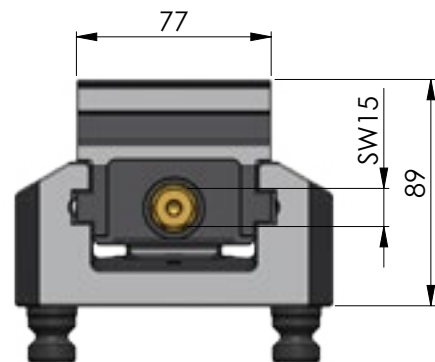
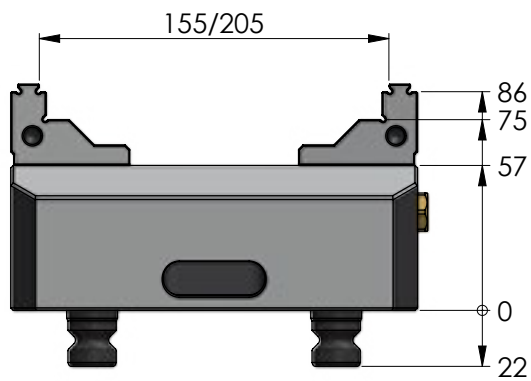
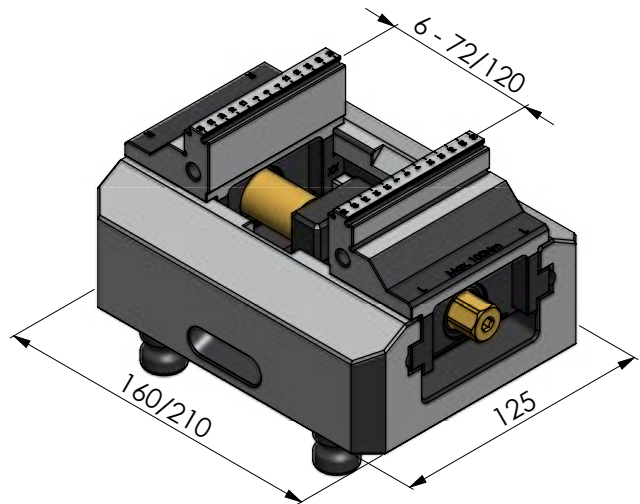
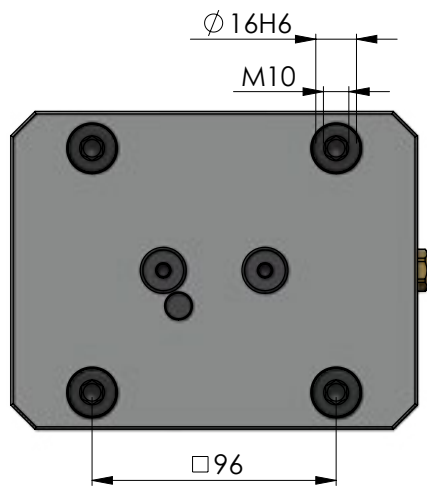

Spare parts and accessories



Spare jaws and compatible jaw types can be found on pages 106/107.

Spindles and other accessories such as wrenches can be found on pages 108 / 109.

Makro·Grip® 5-Axis Vice 125



**MAKRO·GRIP® 5-AXIS VICE 125,
JAW WIDTH 125 MM**

96	Ø 20 mm	max. 100 Nm	max. 20.000 N	± 0,02 mm

ITEM NO.	BASE LENGTH	CLAMPING RANGE	WEIGHT	COMPARABLE PREVIOUS VERSION
48155-125	160 mm	0 - 155 mm	8.4 kg	47155
48205-125	210 mm	0 - 205 mm	10.2 kg	47205
48255-125	260 mm	0 - 255 mm	12.1 kg	47255
48305-125	310 mm	0 - 305 mm	14.0 kg	47305
48355-125	360 mm	0 - 355 mm	15.9 kg	47355

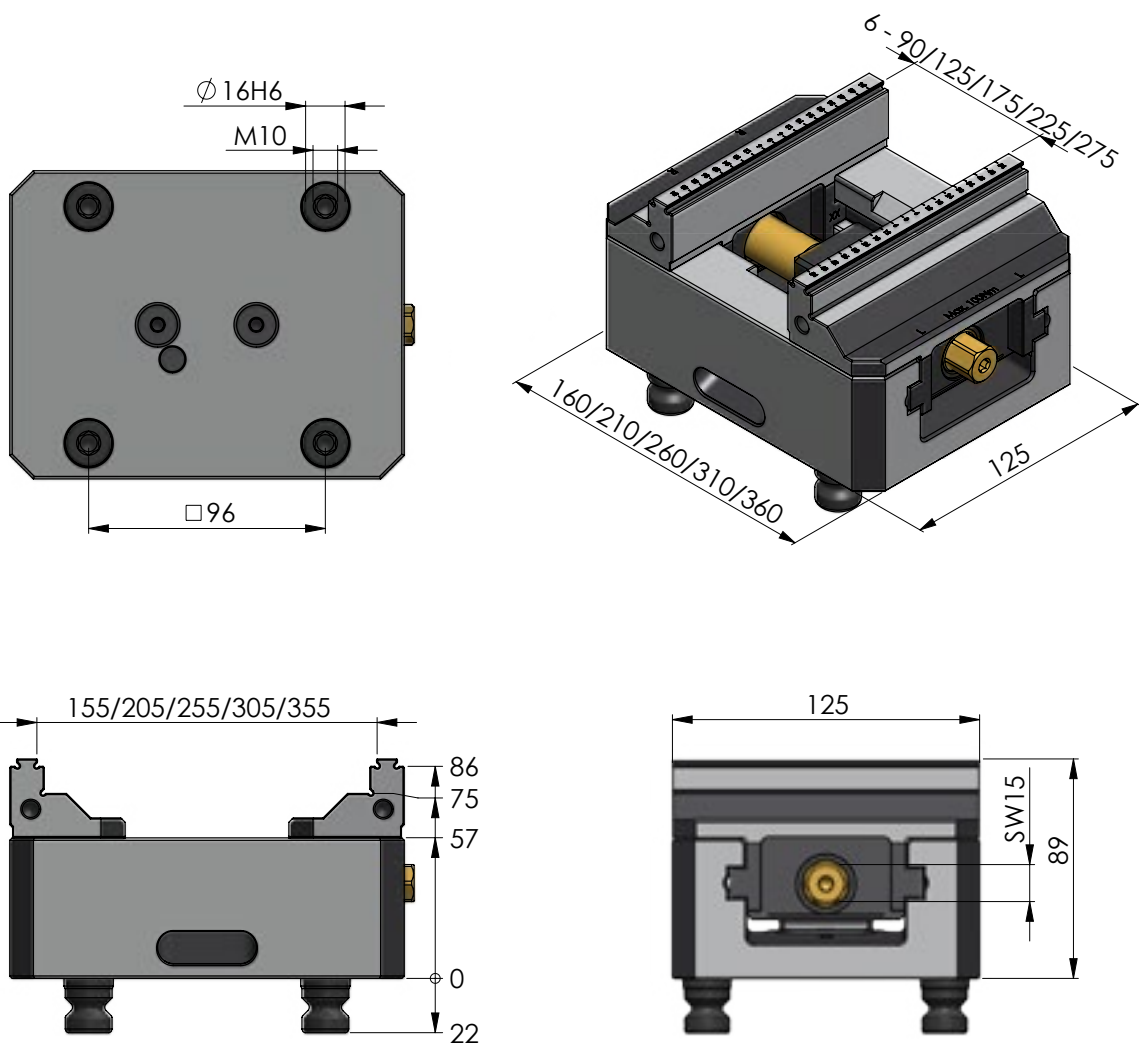

Spare parts and accessories



Spare jaws and compatible jaw types can be found on pages 106/107.



Spindles and other accessories such as wrenches can be found on pages 108 / 109.

Makro-Grip® 5-Axis Vice 125

Available Clamping Jaws



SPARE JAWS FOR MAKRO-GRIP® 5-AXIS VICE 125

ITEM NO.	FOR	WEIGHT	UNIT
48125-7720	all Makro-Grip® 125, jaw width 77 mm	2.0 kg	1 pair
48125-2520	all Makro-Grip® 125, jaw width 125 mm	2.6 kg	1 pair



SPARE JAWS WITHOUT SERRATION, FOR MAKRO-GRIP® 5-AXIS VICE 125

ITEM NO.	FOR	WEIGHT	UNIT
48125-7722	all Makro-Grip® 125, jaw width 77 mm	2.0 kg	1 pair
48125-2522	all Makro-Grip® 125, jaw width 125 mm	2.6 kg	1 pair



AVANTI BASE JAWS FOR MAKRO-GRIP® 5-AXIS VICE 125

ITEM NO.	FOR	WEIGHT	UNIT
44251-125	all Makro-Grip® 125, jaw width 125 mm	3.7 kg	1 pair



PROFILO BASE JAWS FOR MAKRO-GRIP® 5-AXIS VICE 125

ITEM NO.	FOR	WEIGHT	UNIT
49125	all Makro-Grip® 125, jaw width 125 mm	4.3 kg	1 pair



VARIO-TEC JAWS FOR MAKRO-GRIP® 5-AXIS VICE 125

ITEM NO.	FOR	WEIGHT	UNIT
42018-125	all Makro-Grip® 125 with jaw width 125 mm	4.7 kg	1 Set (2 pin jaws + 2 carrier jaws)

NEW



MAKRO-4GRIP 125 CLAMPING JAWS

ITEM NO.	JAW WIDTH	CLAMPING RANGE	WEIGHT	UNIT
52515-20	90 mm	Ø 115 – 180 mm	1.6 kg	1 pair
52530-20	128 mm	Ø 180 – 300 mm	1.9 kg	1 pair

Makro-4Grip clamping jaws are compatible with all LANG vices. The clamping range depends on the length of the vice base. The maximum possible clamping ranges can be taken from the data sheet in the download area of our website.

NEW



CONTOUR JAWS, ALUMINIUM FOR MAKRO-GRIP® 5-AXIS VICES 125

ITEM NO.	JAW WIDTH	FOR	WEIGHT	UNIT
48409-77	77 mm	inside	0.3 kg	1 pair
48419-77	77 mm	outside	0.3 kg	1 pair
48409-125	125 mm	inside	0.6 kg	1 pair
48419-125	125 mm	outside	0.6 kg	1 pair

The matching magnets are available separately, as is the assembly tool. Exact details on compatibility and clamping ranges for the individual base body lengths can be found on our website.

ACCESSORIES FOR CONTOUR JAWS

ITEM NO.	DESCRIPTION	WEIGHT	UNIT
48410	Magnet Set for Contour Jaws	0.02 kg	Set of 10
48420	Assembly Tool for Magnets	0.01 kg	1 pc.



Makro·Grip® Spare Parts



SPARE SPINDLE + CENTRE PIECE FOR MAKRO·GRIP® 5-AXIS VICE 77

ITEM NO.	FOR	SPINDLE LENGTH	WEIGHT
4877100	48085-46 / 48085-77	100 mm	0.2 kg
4877135	48120-46 / 48120-77	135 mm	0.3 kg
4877175	48160-77	175 mm	0.4 kg
4877215	48200-77	215 mm	0.4 kg

Threaded spindle with low-wear TIN coating with internal hexagon (size 5) and external hexagon (size 12).

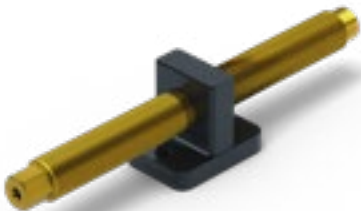

SPARE SPINDLE + CENTRE PIECE FOR MAKRO·GRIP® 5-AXIS VICE 125

ITEM NO.	FOR	SPINDLE LENGTH	WEIGHT
4825164	48155-77 / 48155-125	164 mm	0.7 kg
4825214	48205-77 / 48205-125	214 mm	0.7 kg
4825264	48255-125	264 mm	0.9 kg
4825314	48305-125	314 mm	1.0 kg
4825364	48355-125	364 mm	1.1 kg

Threaded spindle with low-wear TIN coating with internal hexagon (size 5) and external hexagon (size 15)



Practical hint

Replacing the centre piece (+ threaded spindle) with a centre jaw (+ threaded spindle) transforms your 5-Axis Vice into a multiple clamping vice, allowing several workpieces to be clamped simultaneously. For more information, see pages 110 – 113.

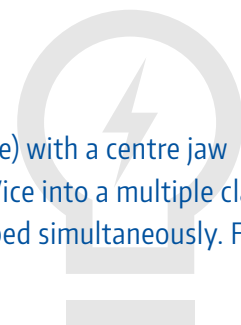

Makro·Grip® Accessories



WRENCH FOR MAKRO·GRIP® 5-AXIS VICE

ITEM NO.	FOR	VICE SIZE	WRENCH SIZE
45500	External Hexagon	77	SW 12
45501	External Hexagon	125	SW 15
45505	Internal Hexagon	77 / 125	SW 5

Wrenches for pre-adjusting the clamping range, initial clamping setting (external hexagon) and reversing the clamping jaws (internal hexagon).



HEXAGON SOCKET

ITEM NO.	SQUARE DRIVE	VICE SIZE	WRENCH SIZE
45508	3/8"	77	SW 12
45509	3/8"	125	SW 15

Hexagon Socket (DIN 3120) for a consistent and safe clamping process.



CORDLESS DRILL ATTACHMENT

ITEM NO.	FOR	SIZE
47005	Internal Hexagon	5 mm

The cordless drill attachment is used to achieve centring accuracy of the jaws easier when exchanging them, especially with longer vice bases. You will also speed-up the exchange or reversal of jaws by using the cordless drill attachment.

Service



TUNGSTEN-CARBIDE-COATING FOR MAKRO·GRIP® JAWS

ITEM NO.	JAW WIDTH	QUANTITY
45046-17	46 mm	per pair
45077-17	77 mm	per pair
45125-17	125 mm	per pair

A special Tungsten-Carbide-Coating can be applied on the jaws' planar surfaces in order to intensify the friction when clamping non-stamped workpieces.

(Attention: Included in price is only the coating, not the jaws.)

Makro·Grip® Dual Clamping Vice – Retrofitting Kit for 5-Axis Vices

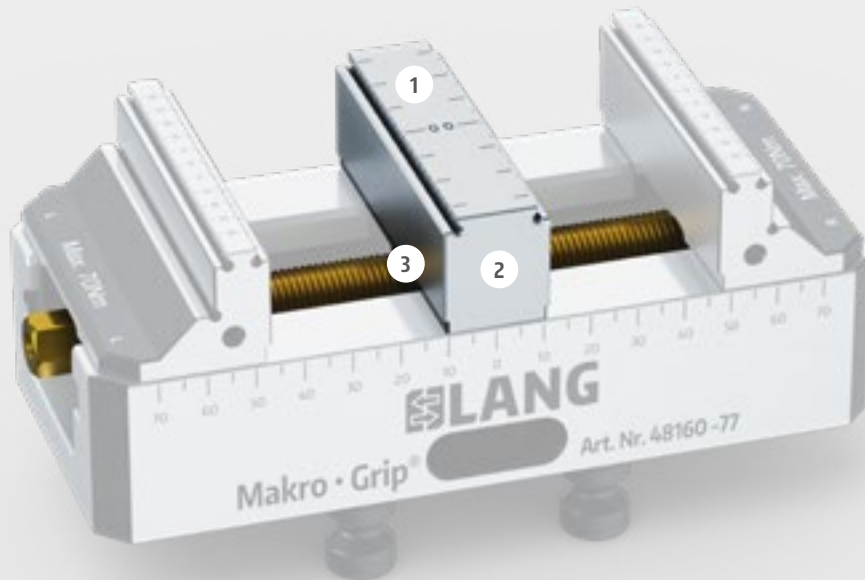

Please read all about the Makro·Grip® 5-Axis Vice's features on page 88.

- 1 Scope of delivery: Centre jaw with double-sided serration and threaded spindle
- 2 In the jaw widths 46 and 77 mm we offer a narrow (17 mm) and a wider (27 mm) version in order to increase the machining area of the tool between the workpieces and thus to be able to use larger tool diameters.
- 3 Conception of the centre piece allows to clamp workpieces with 2 mm variance in length (cutting tolerance)

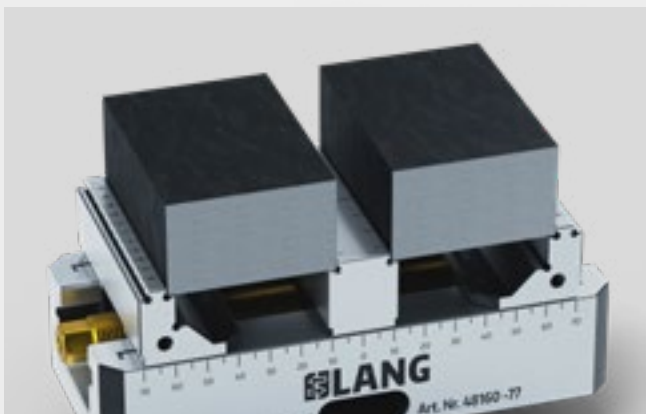

The multiple clamping in the 5-Axis Vice increases the spindle running times of the machine tool.



The centre jaw can now also be mounted to the Makro·Grip® 5-Axis Vice for RoboTrex automation. This increases the capacity of the automation system significantly.

Transform your Makro-Grip® 5-Axis Vice into a Dual Clamping Vice



Unscrew the Makro-Grip® jaws from the base using a hexagon wrench (internal 5 mm).



Flip base and remove the two screws.

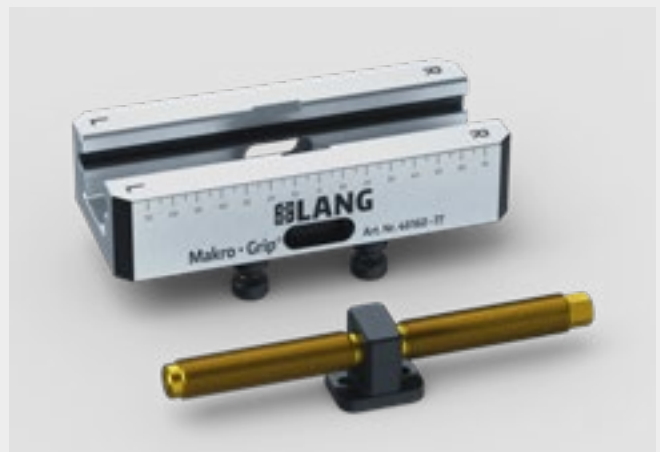

Remove spindle and centre piece.

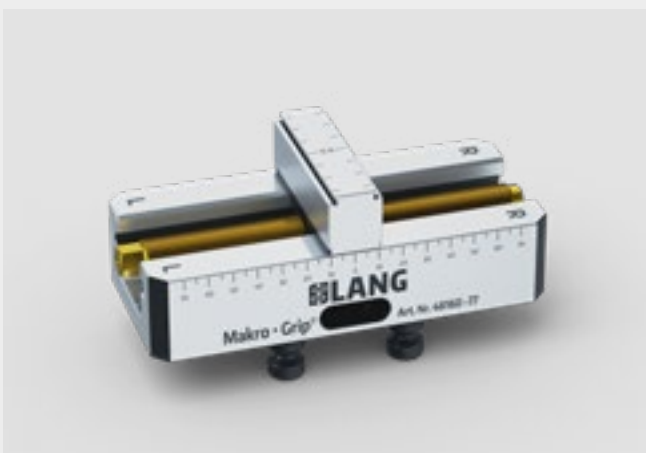

Insert centre jaw and spindle and tighten the screws on the bottom side.



Assemble the Makro-Grip® jaws back onto the base. You are now able to use your Makro-Grip® 5-Axis Vice as a dual vice.

Makro-Grip® 5-Axis Vice 77 Centre Jaw and Spindle

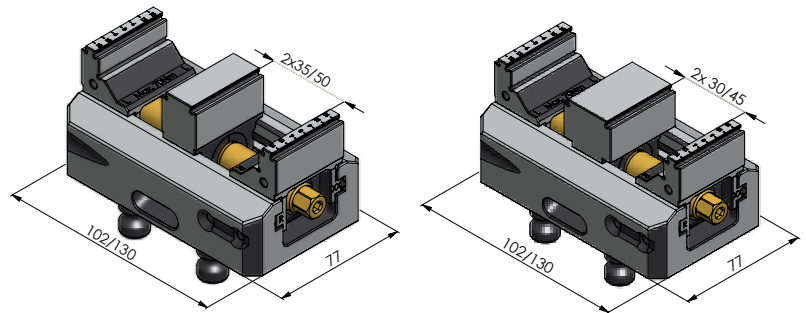

CENTRE JAW AND SPINDLE FOR MAKRO-GRIP® 5-AXIS VICE 77, JAW WIDTH 46 MM

ITEM NO.	FOR MAKRO-GRIP®	CENTRE JAW WIDTH	SPINDLE LENGTH	CLAMPING RANGE
48085-TG4617	48085-46	17 mm	100 mm	2 × 35 mm
48085-TG4627	48085-46	27 mm	100 mm	2 × 30 mm
48120-TG4617	48120-46	17 mm	135 mm	2 × 50 mm
48120-TG4627	48120-46	27 mm	135 mm	2 × 45 mm

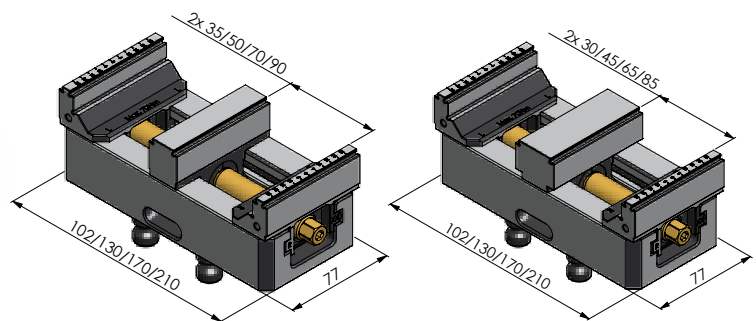

CENTRE JAW AND SPINDLE FOR MAKRO-GRIP® 5-AXIS VICE 77, JAW WIDTH 77 MM

ITEM NO.	FOR MAKRO-GRIP®	CENTRE JAW WIDTH	SPINDLE LENGTH	CLAMPING RANGE
48085-TG7717	48085-77	17 mm	100 mm	2 × 35 mm
48085-TG7727	48085-77	27 mm	100 mm	2 × 30 mm
48120-TG7717	48120-77	17 mm	135 mm	2 × 50 mm
48120-TG7727	48120-77	27 mm	135 mm	2 × 45 mm
48160-TG7717	48160-77	17 mm	175 mm	2 × 70 mm
48160-TG7727	48160-77	27 mm	175 mm	2 × 65 mm
48200-TG7717	48200-77	17 mm	215 mm	2 × 90 mm
48200-TG7727	48200-77	27 mm	215 mm	2 × 85 mm

Makro·Grip® 5-Axis Vice 125

Centre Jaw and Spindle

NEW

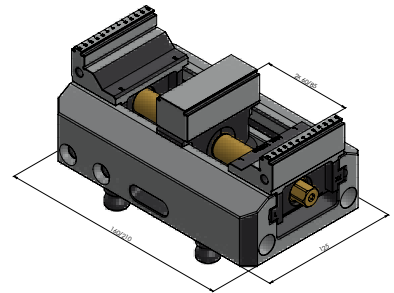

CENTRE JAW AND SPINDLE FOR MAKRO·GRIP® 5-AXIS VICE 125, JAW WIDTH 77 MM

ITEM NO.	FOR MAKRO·GRIP®	CENTRE JAW WIDTH	SPINDLE LENGTH	CLAMPING RANGE
48155-TG7727	48155-125	27 mm	164 mm	2 × 60 mm
48205-TG7727	48205-125	27 mm	214 mm	2 × 85 mm

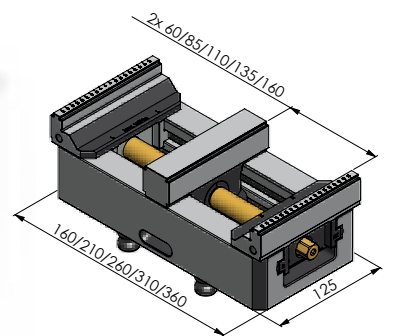

CENTRE JAW AND SPINDLE FOR MAKRO·GRIP® 5-AXIS VICE 125, JAW WIDTH 125 MM

ITEM NO.	FOR MAKRO·GRIP®	CENTRE JAW WIDTH	SPINDLE LENGTH	CLAMPING RANGE
48155-TG2527	48155-125	27 mm	164 mm	2 × 60 mm
48205-TG2527	48205-125	27 mm	214 mm	2 × 85 mm
48255-TG2527	48255-125	27 mm	264 mm	2 × 110 mm
48305-TG2527	48305-125	27 mm	314 mm	2 × 135 mm
48355-TG2527	48355-125	27 mm	364 mm	2 × 160 mm



MAKRO·GRIP® ULTRA



- 124 Makro-Grip® Ultra **Clamping System**
- 134 Makro-Grip® Ultra **Single Components**
- 138 Makro-Grip® Ultra **Stamping Units**



**simple.
gripping.
bigger.**

Workholding in new dimensions

Makro-Grip® Ultra convinces with:

MODULARITY

PRECISION

SIMPLE OPERATION

The completely new product line Makro-Grip® Ultra offers various clamping possibilities and can be changed quickly and easily at the same time. Thanks to the expandability of its modules Makro-Grip® Ultra is capable of clamping parts of 810 mm length and beyond safely.

With its size it pushes the LANG workholding to new heights. Different system heights, individually expandable clamping ranges, interchangeable clamping jaw types and useful accessories – Through its wide range of possible configurations Makro-Grip® Ultra covers any imaginable clamping application and is particularly suited for mould making and clamping flat and large components.

Benefits of Makro-Grip® Ultra:



Changeover of clamping situation within seconds



Low-vibration and distortion-low clamping



Clamping of asymmetrical parts



All-around machining without changing over the clamping system



Integration of automated machining processes without removing the clamping system



Simple cleaning and maintenance

The clamping system at a glance

1 Makro-Grip® Ultra Clamping Jaw

The Makro-Grip® Ultra clamping jaw which is made from solid is available in two different types (jaw width 125 mm), either with a clamping depth of 3 mm or 5 mm. The clamping jaw has the same serration as regular Makro-Grip® 5-Axis Vices and grips the workpiece by form-fit effect. This way highest holding forces can be accomplished, gently and virtually wear-free. Additionally LANG offers a hardened jaw without serration but with a plain clamping step (clamping depth 16 mm) which is making use of the Avanti dovetail technology. This means that also regular Avanti top jaws can be mounted, in order to clamp parts that are not prismatic. More information about the different jaw types can be found on pages 19 and 23.



2 Base Body

The case-hardened, robust base body with integrated zero-point interface impresses with its simplicity, however it offers some technical refinements. Available are two different lengths, each in three different heights. Clamping ranges of 410, 610 and 810 mm are realised when putting them together in different compositions. The base bodies are positioned so accurately that you almost do not notice the transition from one base to the other when sliding the clamping jaws over the rails. Thanks to the exact spindle seat an exceptionally high centring accuracy is achieved. Different centring plates mounted to the inner ends of the base bodies allow for clamping parts either centrally or in combination with a centre jaw multiple parts can be clamped. The base bodies also have a practical snap-in function which makes it easier to locate the jaws.



5



3 Threaded Cap

Each clamping jaw is individually secured by a threaded cap and thus can be moved independently from other clamping jaws. Removing the threaded cap with a magnet allows the clamping jaw's position to be shifted quickly without actuating the spindle.

4 Spindle

The spindle (M 26×2) comes in three different lengths and is equally used for single-part and multiple clamping. For clamping ranges beyond 800 mm the spindle can be ordered as a customised solution in a longer version. The actuation torque is 170 Nm.

5 Quick-Point® Zero-Point Clamping System

The interface between Makro-Grip® Ultra and the machine table is the ultra-precise Quick-Point® zero-point clamping system. Depending on requirements and workpiece size, its 96 mm grid allows supplementary base bodies to be placed next to each other and connected with each other.





Raw Part Clamping with serrated Makro-Grip® Ultra jaws

The Makro-Grip® stamping and workholding technology, which has been tried and tested for years, now also shows its unique advantages in the clamping of large parts. Moulds, plates and all kinds of components from 40 to 810 mm in length and beyond are pre-stamped and then held by form-fit in the Makro-Grip® clamping jaws at only 3 or 5 mm clamping depth. The workpiece is held reliably with the highest holding forces at relatively low actuation torque, which leads to precise results, especially for deformation-sensitive and flat material.



Clamping long components across several Makro-Grip® Ultra units

Not only nearly unlimited in clamping range, but also highly adaptable and modular. Makro-Grip® Ultra can be assembled flexibly using a variety of clamping jaws, base bodies and spindles. The modularity and high centring accuracy of the Makro-Grip® Ultra clamping elements, coupled with the precision and flexibility of the Quick-Point® zero-point clamping system, guarantee ideal clamping of long parts.

Image: ifm electronic gmbh



2nd operation / rear-face machining using contour jaws

Even with geometrically unshaped components, Makro-Grip® Ultra offers a simple but efficient solution: Since the jaws are independently adjustable towards the centre, asymmetrical clamping configurations can be realised quickly and easily. This reduces set-up for the second operation to a minimum. The quick and precise adjustment of the jaws is ensured by a removable threaded cap and a scale on the base body.

Large plate clamping on the Quick-Tower tombstone

Makro-Grip® Ultra is not only a highly efficient clamping option for 3- and 5-axis machines, but also offers a low-build clamping system when used on horizontal machines and thus optimised accessibility when machining plates and large components. Thanks to the integrated Quick-Point® clamping studs, the vices can be quickly mounted with high repeatability or removed from tombstones which are equipped with zero-point plates.





Modularity

The modularity and small number of components, as well as the consistent Quick·Point® 96 zero-point grid allow to change the clamping setup immediately. Adding base bodies to increase the clamping range, a complete exchange of base bodies to alter the system height and changing jaw types can be done in a few simple steps without special tools.



Easy setting and cleaning

Just as quickly as it is set up, Makro·Grip® Ultra can be disassembled. Clamping jaws and spindles are removed easily which simplifies cleaning and maintenance after and in between machining processes. Clamping tasks that are performed with other fixtures are possible even without having to remove the Makro·Grip® Ultra system. Accessibility still remains and the risk of swarf clogging is low.



Quick jaw adjustment

By removing the threaded cap with a magnetic handle the position of the clamping jaws can be changed in no time without actuating the spindle. Despite their high accuracy of fit the clamping jaws glide smoothly over the guide surface. The threaded cap is kept in place by two extremely resilient hexagon screws (5 mm) which are opened/locked with half a turn.



Scale and snap-in function

For a quick adjustment into the desired position the clamping jaws feature an integrated snap-in function as an orientation aid where the operator feel resistance every 48 mm. Each base body also has a scale which provides a visual aid when positioning the clamping jaws.

Makro-Grip® Ultra Base Set



The two base body lengths 192 mm and 96 mm (in each case in the system heights S / M / L) result in different compositions of certain clamping ranges. The combination of one long and one short base body – each on the left and right of the system centre – results in

a clamping unit with a maximum clamping range of 610 mm. With two long base bodies per side, a maximum clamping range of 810 mm is realised.

BASE SET

ITEM NO.	DESCRIPTION	HEIGHT	SPINDLE LENGTH	CLAMPING RANGE	WEIGHT
81400	Base Set 410 S	45 mm	441 mm	40 – 410 mm	12.8 kg
81415	Base Set 410 M	109 mm	441 mm	40 – 410 mm	26.0 kg
81423	Base Set 410 L	189 mm	441 mm	40 – 410 mm	43.2 kg
81600	Base Set 610 S	45 mm	617 mm	40 – 610 mm	19.1 kg
81615	Base Set 610 M	109 mm	617 mm	40 – 610 mm	40.1 kg
81623	Base Set 610 L	189 mm	617 mm	40 – 610 mm	66.9 kg
81800	Base Set 810 S	45 mm	825 mm	40 – 810 mm	25.3 kg
81815	Base Set 810 M	109 mm	825 mm	40 – 810 mm	51.7 kg
81823	Base Set 810 L	189 mm	825 mm	40 – 810 mm	85.7 kg

Note: Included in delivery of Base Sets 610 and 810 are two connection plates as well.

Clamping range up to 810 mm



A Base Set consists of the base body and the following components:



1x Spindle Unit
Item No. 81004 / 81006 / 81008



2x Centring Plates
Item No. 81010



Quick-Point® Clamping Studs
Item No. 45570



1x Quick-Point® Cover Plug Remover
Item No. 45000-30



1x Wrench
Internal Hexagon size 5 mm
Item No. 45505



1x Wrench
External Hexagon size 19 mm
Item No. 45519

Additionally included in the Base Sets 610 and 810:



2 × Connection Plates
Item No. 81015

Overview of the Base Set system heights with mounted clamping jaws

Basis-Set

System height „S“



+ Clamping Jaw type
81483



+ Clamping Jaw type
81485



+ Clamping Jaw type
81440 + 81450



+ Clamping Jaw type
81440 + 44259-46

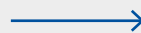

+ Clamping Jaw type
81440 + 44259-76



System height „M“

System height „L“

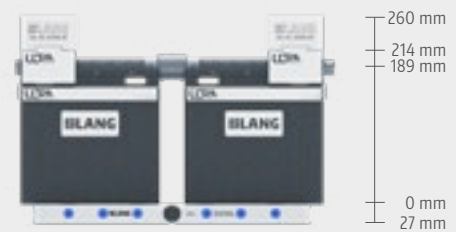
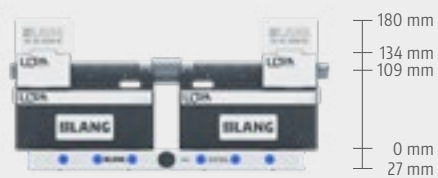
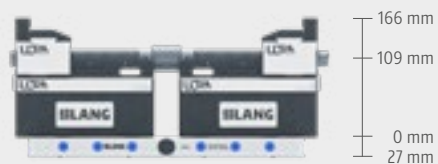
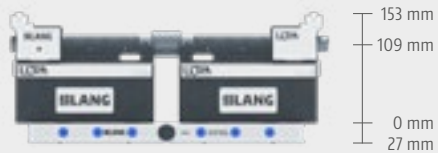

Makro·Grip® Ultra Base Body

An individual base body is needed especially when an existing base set is to be expanded. For instance, if you want to go from a clamping range of 410 mm to 610 mm / 810 mm or beyond. With an individual base body Quick·Point® clamping studs are included (4 pcs. for long base bodies, 2 pcs. for short base bodies). Also included are a slot nut and the respective scaling. For stringing together individual base bodies, connection plates are required which can be found on page 134.



SHORT BASE, HEIGHT "S"

ITEM NO.	HEIGHT	LENGTH	WEIGHT
81011	45 mm	96 mm	2.8 kg



SHORT BASE, HEIGHT "M"

ITEM NO.	HEIGHT	LENGTH	WEIGHT
81012	109 mm	96 mm	6.7 kg



SHORT BASE, HEIGHT "L"

ITEM NO.	HEIGHT	LENGTH	WEIGHT
81013	189 mm	96 mm	11.7 kg



LONG BASE, HEIGHT "S"

ITEM NO.	HEIGHT	LENGTH	WEIGHT
81021	45 mm	192 mm	5.5 kg



LONG BASE, HEIGHT "M"

ITEM NO.	HEIGHT	LENGTH	WEIGHT
81022	109 mm	192 mm	12.1 kg



LONG BASE, HEIGHT "L"

ITEM NO.	HEIGHT	LENGTH	WEIGHT
81023	189 mm	192 mm	20.7 kg

Makro·Grip® Ultra Clamping Jaws

The Makro·Grip® Ultra 125 clamping jaw with the Makro·Grip® serration guarantees highest holding forces despite a clamping depth of only 3 or 5 mm. Each jaw is individually secured by a threaded cap and can be moved independently of other clamping jaws. The centre jaw with a double-sided serration enables multiple clamping in the Makro·Grip® Ultra system. It is mounted directly on the two middle base bodies of the system and used in combination with the Makro·Grip® clamping jaws.

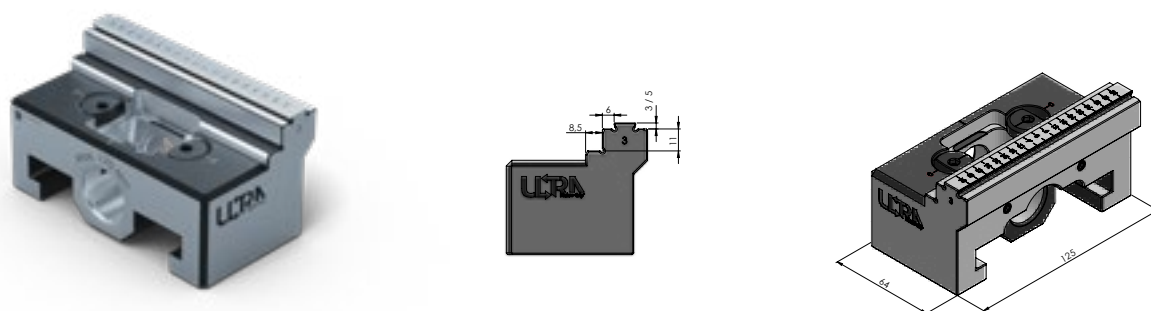

MAKRO·GRIP® ULTRA 125, SERRATED CLAMPING JAW, STEEL (HARDENED)

ITEM NO.	CLAMPING DEPTH	CLAMPING BY	WEIGHT
81483	3 mm	form-fit	2.2 kg
81485	5 mm	form-fit	2.2 kg

Selling unit: 1 piece. For each clamping unit 2 pieces are required.
The specified weight relates to 1 piece.

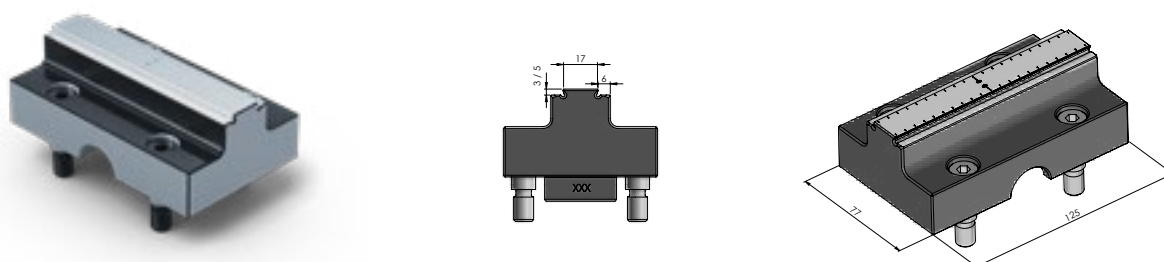

MAKRO·GRIP® ULTRA 125 SERRATED CENTRE JAW, STEEL (HARDENED)

ITEM NO.	CLAMPING DEPTH	APPLICATION	WEIGHT
81483-TG	3 mm	Multiple clamping by form-fit	2.2 kg
81485-TG	5 mm	Multiple clamping by form-fit	2.2 kg

Selling unit: 1 piece. The specified weight relates to 1 piece.

Makro·Grip® Ultra Base Jaws

The Makro·Grip® Ultra Base Jaw can be used in conjunction with various Avanti top jaws to clamp round components or contours. In addition to the hardened Avanti top jaw with plain clamping step, the adaptation of standardised Avanti 125 top jaws made of aluminium and steel in heights of 46 and 76 mm is possible.

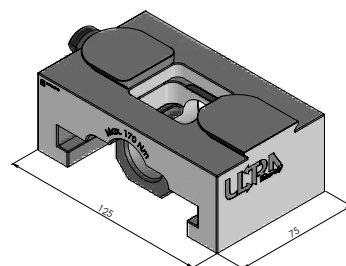

BASE JAW AVANTI 125, STEEL (HARDENED)

ITEM NO.	APPLICATION	WEIGHT
81440	As a base for Avanti top jaws	2.2 kg

Selling unit: 1 piece. For each clamping unit 2 pieces are required.
The specified weight relates to 1 piece.

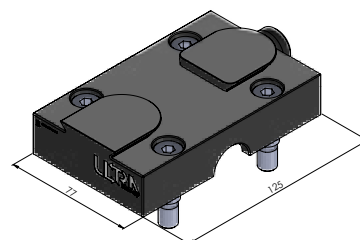

CENTRE BASE JAW AVANTI 125, STEEL (HARDENED)

ITEM NO.	APPLICATION	WEIGHT
81440-TG	As a base for support or Avanti top jaws	1.8 kg

Selling unit: 1 piece. The specified weight relates to 1 piece.

Makro·Grip® Ultra Top and Support Jaws

The top or support jaws shown are used in combination with the base jaws on p.131. They are used for smooth clamping of cubic components, profiles and shapes (single or multiple in each case) or as an additional support surface for centric clamping.

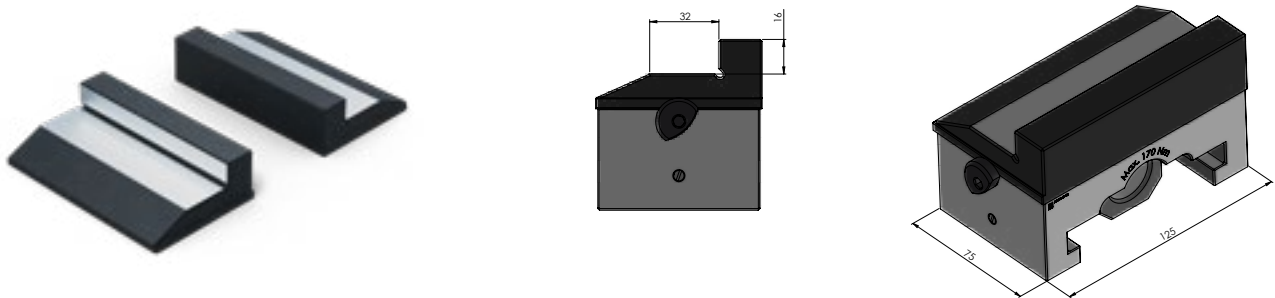

AVANTI 125 TOP JAW WITH PLAIN CLAMPING STEP, STEEL (HARDENED)

ITEM NO.	CLAMPING DEPTH	CLAMPING BY	WEIGHT
81450	16 mm	friction	2.6 kg

Selling unit: 1 pair. The specified weight relates to 1 pair.

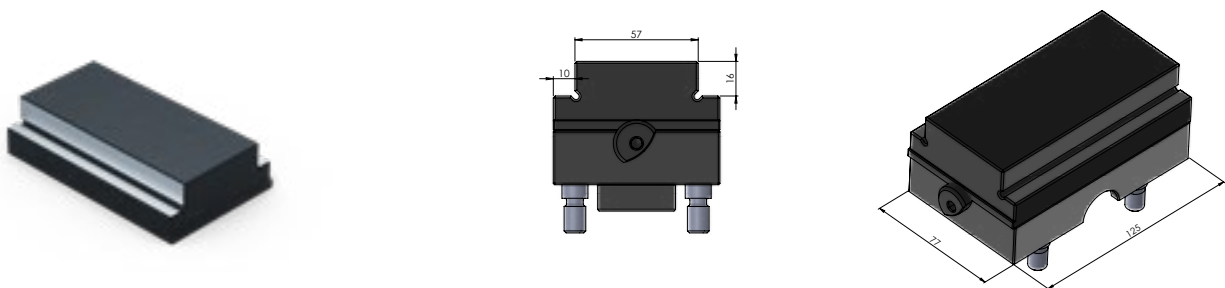

CENTRE TOP JAW AVANTI 125 WITH PLAIN CLAMPING STEP, STEEL (HARDENED)

ITEM NO.	CLAMPING DEPTH	APPLICATION	WEIGHT
81450-TG	16 mm	Multiple clamping by friction	2.0 kg

Selling unit: 1 piece. The specified weight relates to 1 piece.

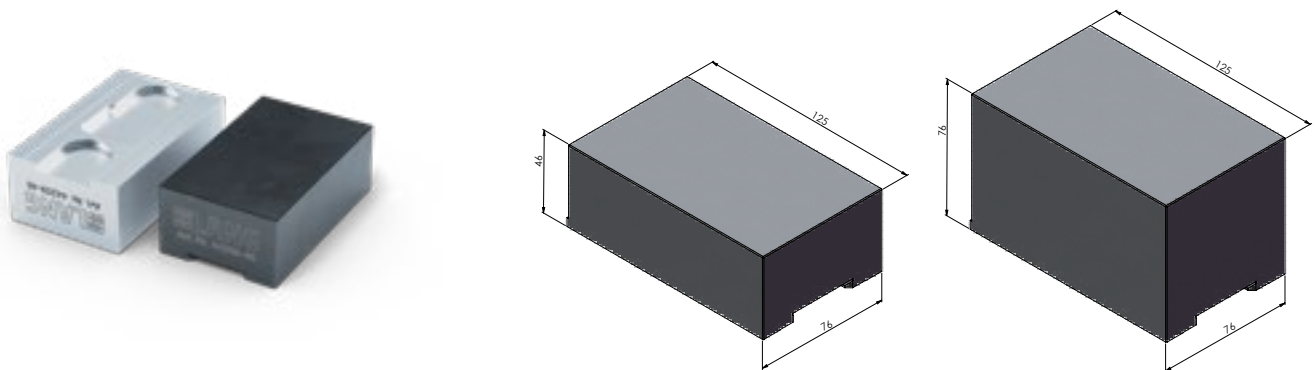

AVANTI 125 TOP JAW (SOFT)

ITEM NO.	MATERIAL	HEIGHT	WEIGHT
44258-46	Steel (16 MnCr 5)	46 mm	3.3 kg
44258-76	Steel (16 MnCr 5)	76 mm	5.5 kg
44259-46	Aluminium (F50)	46 mm	1.1 kg
44259-76	Aluminium (F50)	76 mm	1.8 kg

Selling unit: 1 piece. The specified weight relates to 1 piece.

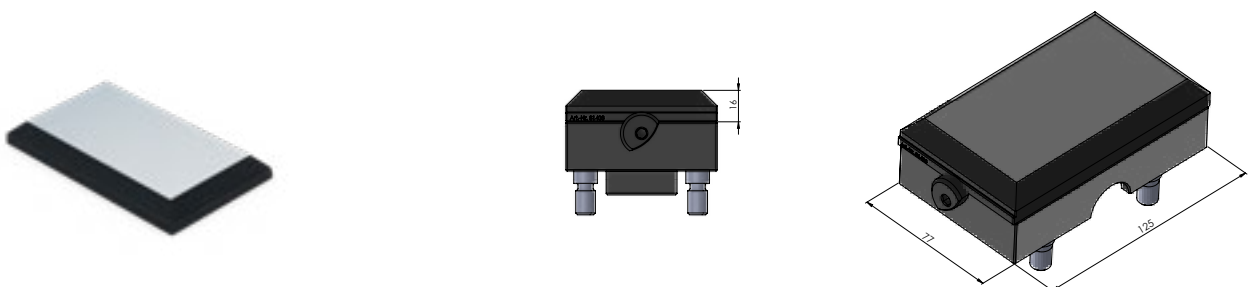

SUPPORT JAW, STEEL (SOFT)

ITEM NO.	FOR	APPLICATION	WEIGHT
81403	81483 / 81450	Single-part clamping by form-fit / friction	1.0 kg
81405	81485	Single-part clamping by form-fit / friction	0.9 kg

Selling unit: 1 piece. The specified weight relates to 1 piece.

Makro·Grip® Ultra individual components



SPINDLE

ITEM NO.	DESCRIPTION	LENGTH	WEIGHT
81004	Spindle unit 410	441 mm	1.8 kg
81006	Spindle unit 610	617 mm	2.5 kg
81008	Spindle unit 810	825 mm	3.3 kg

The spindle (M 26 × 2) comes in three different lengths and is equally used for single-part and multiple clamping. For clamping ranges beyond 800 mm the spindle can be ordered as a customised solution in a longer version. The actuation torque is 170 Nm.



CENTRING PLATE

ITEM NO.	APPLICATION	QUANTITY
81010	Single-part clamping, concentric	1 pc
81040	Multiple clamping, compensating	1 pc

For each clamping unit 2 centring plates of the same kind are required. They are mounted to the inner ends of the base bodies and ensure the accurate positioning of the spindle. Two different versions are available for single-part and multiple clamping. The centring plate for multiple clamping has a recess which allows to clamp workpieces with a 4 mm variance in length.



CONNECTION PLATE

ITEM NO.	DESCRIPTION	QUANTITY
81015	Connection plate	1 pc

Connection plates are already included in delivery of Base Sets. They are used for stringing together base bodies.



PLASTIC COVERS

ITEM NO.	DESCRIPTION	EQUANTITY
81500	Plastic covers for base bodies	20 pcs.

To cover the bores on the upper guide surface of the base body, if centre jaws are not mounted.



WRENCHES

ITEM NO.	FOR	WRENCH SIZE
45505	Internal hexagon	SW 5
45519	External hexagon	SW 19

Wrenches for the initial clamping setting (external hexagon) and actuation of the threaded caps' screws (internal hexagon).



HEXAGON SOCKET

ITEM NO.	SQUARE DRIVE	WRENCH SIZE
45511	1/2"	SW 19

Hexagon socket for commercial torque wrenches.



QUICK-POINT® COVER PLUG REMOVER

ITEM NO.	DESCRIPTION
45000-30	Cover Plug Remover

Comfortable magnetic handle for removing threaded caps from the clamping jaws and steel plugs from the Quick-Point® plates.



THREADED CAP

ITEM NO.	DESCRIPTION	WEIGHT	QUANTITY
81080	Threaded cap, right	0.2 kg	1 piece
81090	Threaded cap, left	0.2 kg	1 piece

For each clamping unit 1 left and 1 right threaded cap is required.

Makro·Grip® Ultra Hydro·Sup screw jack



A specific hydraulic screw jack and spacers to match the respective height of the base bodies have a supporting effect on the clamping process which is particularly important with flat and wide material.

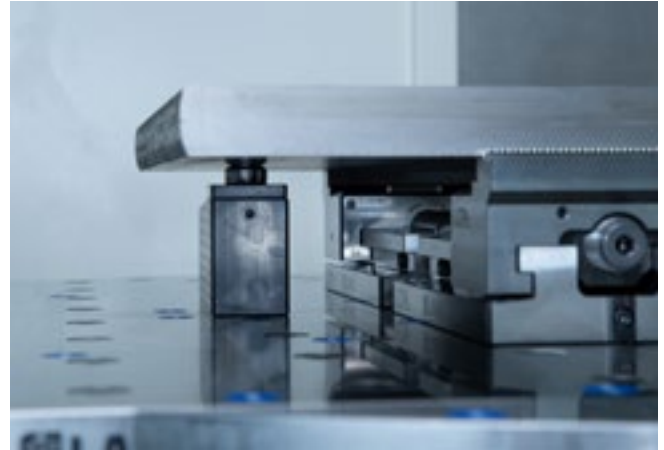

The screw jack which is actuated by a socket wrench adapts to the workpiece with its self-aligning support and reduces vibrations, which contributes to an increased surface quality.



Hydro-Sup is mounted and fixed like any other LANS workholding device with its clamping stud to the Quick·Point® zero-point clamping system.

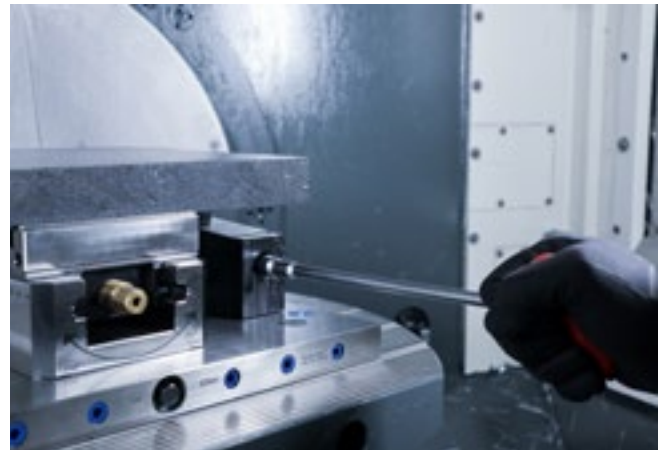

Due to its height of 86 mm the Hydro-Sup screw jack can also be used – without spacers – when clamping overhanging parts in a regular Makro·Grip® 5-Axis Vice 125.



HYDRO-SUP SCREW JACK

ITEM NO.	DESCRIPTION	RESTING HEIGHT	WEIGHT
81586	Hydro-Sup hydraulic screw jack	85 – 89 mm	3.0 kg
81515	Spacer for system height "M"	148 – 152 mm	2.9 kg
81523	Spacer for system height "L"	228 – 232 mm	6.7 kg

The hydraulic screw jack Hydro-Sup helps to minimise vibrations during the machining process of overhanging workpieces. The height of 86 mm is identical to Makro-Grip® Ultra system height "S". With the addition of spacers system heights "M" and "L" can be matched.

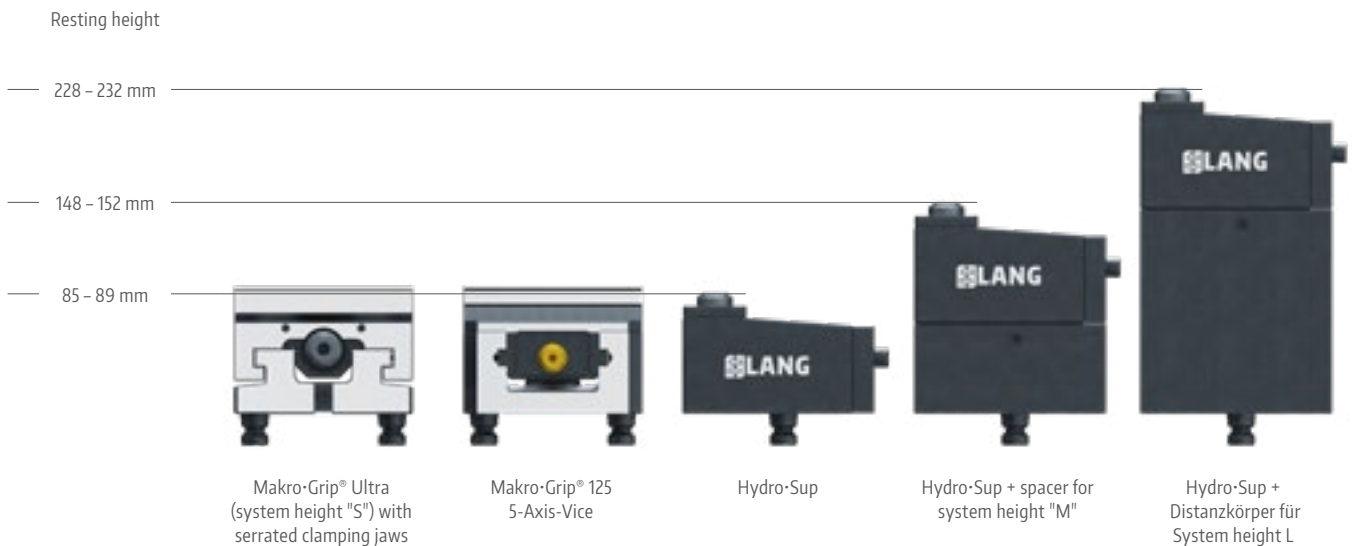

The hydraulic screw jack with its spacers is suitable for all Makro-Grip® Ultra system heights. It can also be used with regular Makro-Grip® 5-Axis-Vices 125 in order to support overhanging workpieces.



HYDRO-SUP HEXAGON WRENCH

ITEM NO.	LENGTH	WRENCH SIZE
45512	230 mm	SW 12

For actuation of the Hydro-Sup screw jack.

Makro·Grip® Ultra Stamping Unit

ORIGINAL
MAKRO·GRIP

The Stamping Technology

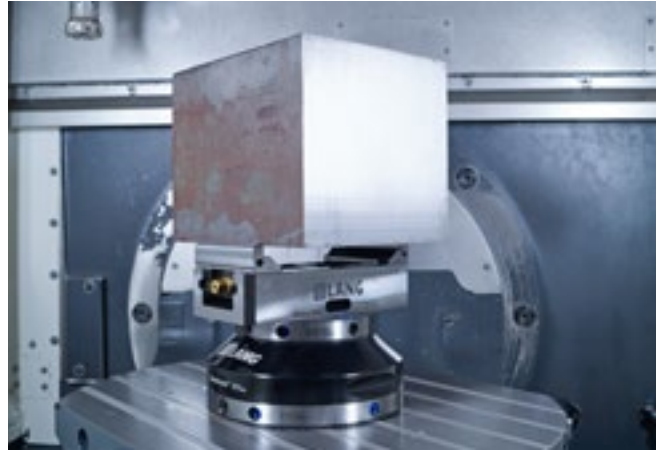

Form-Closure Technology refers to a technology in which the workpiece to be clamped is "pre-stamped" with a defined contour under high stamping pressure (up to 20 t) outside of the machine tool, before it is clamped in the clamping device. Due to the great

amount of advantages for the actual clamping process through "pre-stamping", the Makro·Grip® technology is considered a benchmark in the 5-sided machining of blanks and absolutely beneficial to automated manufacturing.

Why pre-stamp a workpiece?

The form-fit effect between the gripping serration of the clamping jaws and stamping indentation guarantees highest holding forces and maximum process reliability at a very low clamping pressure. This practically eliminates any material deformation which is crucial to clamping flat and deformation-sensitive material and a key factor in achieving the desired milling quality. The stamping technology completes the Makro·Grip® Ultra system and raises the quality of plate and large part clamping to a new level.



Makro-Grip® Ultra stamping system

The Makro-Grip® Ultra stamping unit is available in two different sizes for the market launch. Fundamentally they are identical, but differ in their base plate's size and number of grooves and locking holes.

The system is designed as a dual-stamping unit which can be placed flexibly in the 96 mm grid of the base plate. The stamping unit is operated conveniently via push button. Included in delivery are two different sets of parallels which match the clamping depth of the serrated Makro-Grip® Ultra clamping jaws (3 mm and 5 mm).



MAKRO-GRIP® ULTRA STAMPING UNIT

ITEM NO.	TYPE	BASE PLATE	MAX. STAMPING RANGE
83420-HE	High-End	680 × 612 mm	420 mm
83810-HE	High-End	1080 × 996 mm	810 mm

- Scope of delivery:
- Frame with base plate
 - 2 stamping units
 - 2 pairs of stamping jaws
 - 2 pairs of each parallel type (3 mm + 5 mm)
 - Pneumatic-hydraulic power multiplier (1 – 360 bar)
 - Scaled endstops and protection shields
 - Push button for operation by hand
 - Gauging blocks for measuring the wear of the serration



MAKRO-GRIP® STAMPING JAWS

ITEM NO.	TYPE	FOR MATERIALS	QUANTITY
41112-06	High-End	up to 45 HRC	1 pair

Note: Stamping jaws are sold without parallels. These must be ordered separately.



MAKRO-GRIP® STAMPING JAW PARALLELS

ITEM NO.	CLAMPING DEPTH	QUANTITY
41111-0308	3 mm	1 pair
41111-0508	5 mm	1 pair

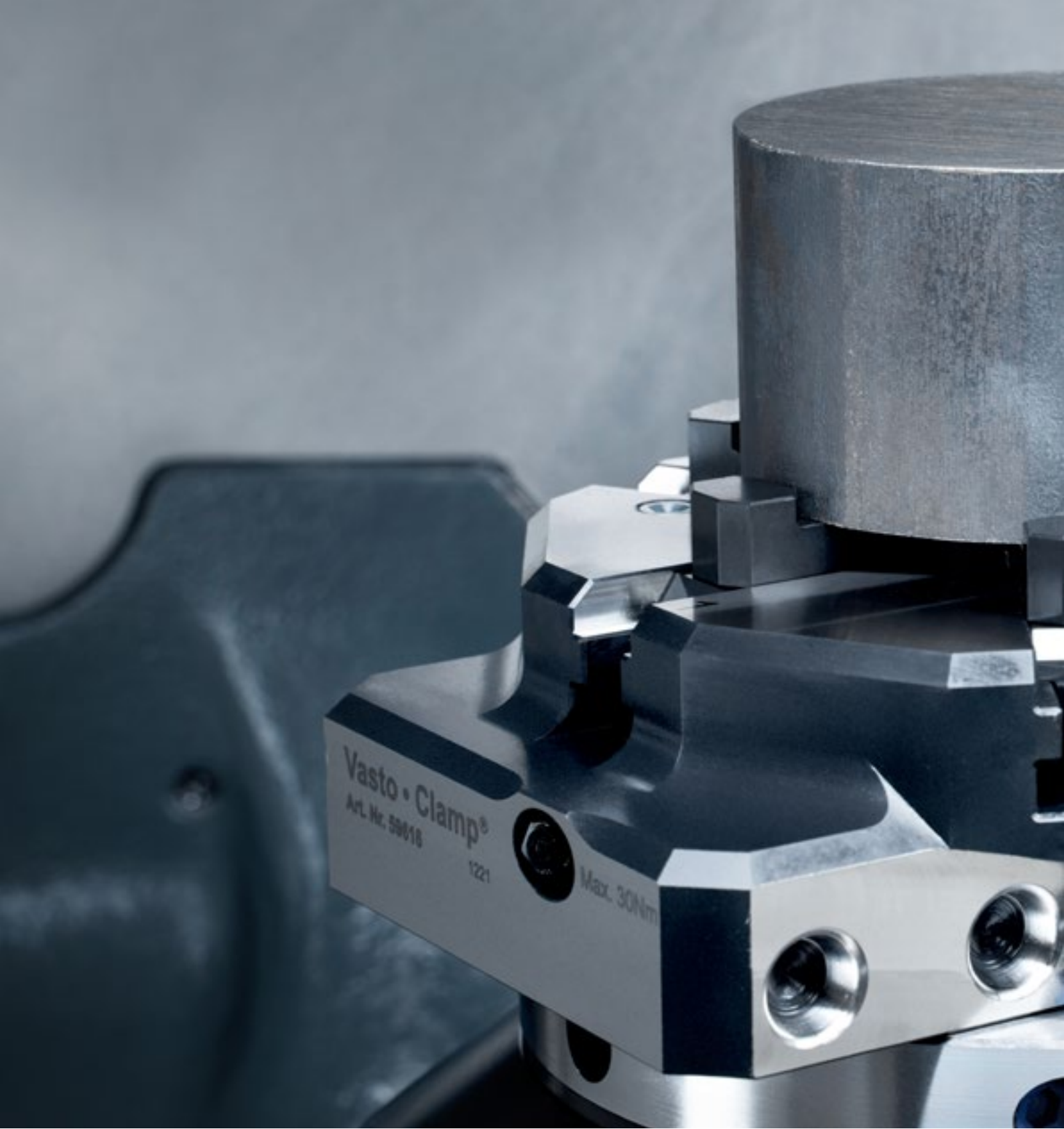

Vasto-Clamp®
Art. Nr. 59018
1221

Max. 30Nm

CONVENTIONAL WORKHOLDING

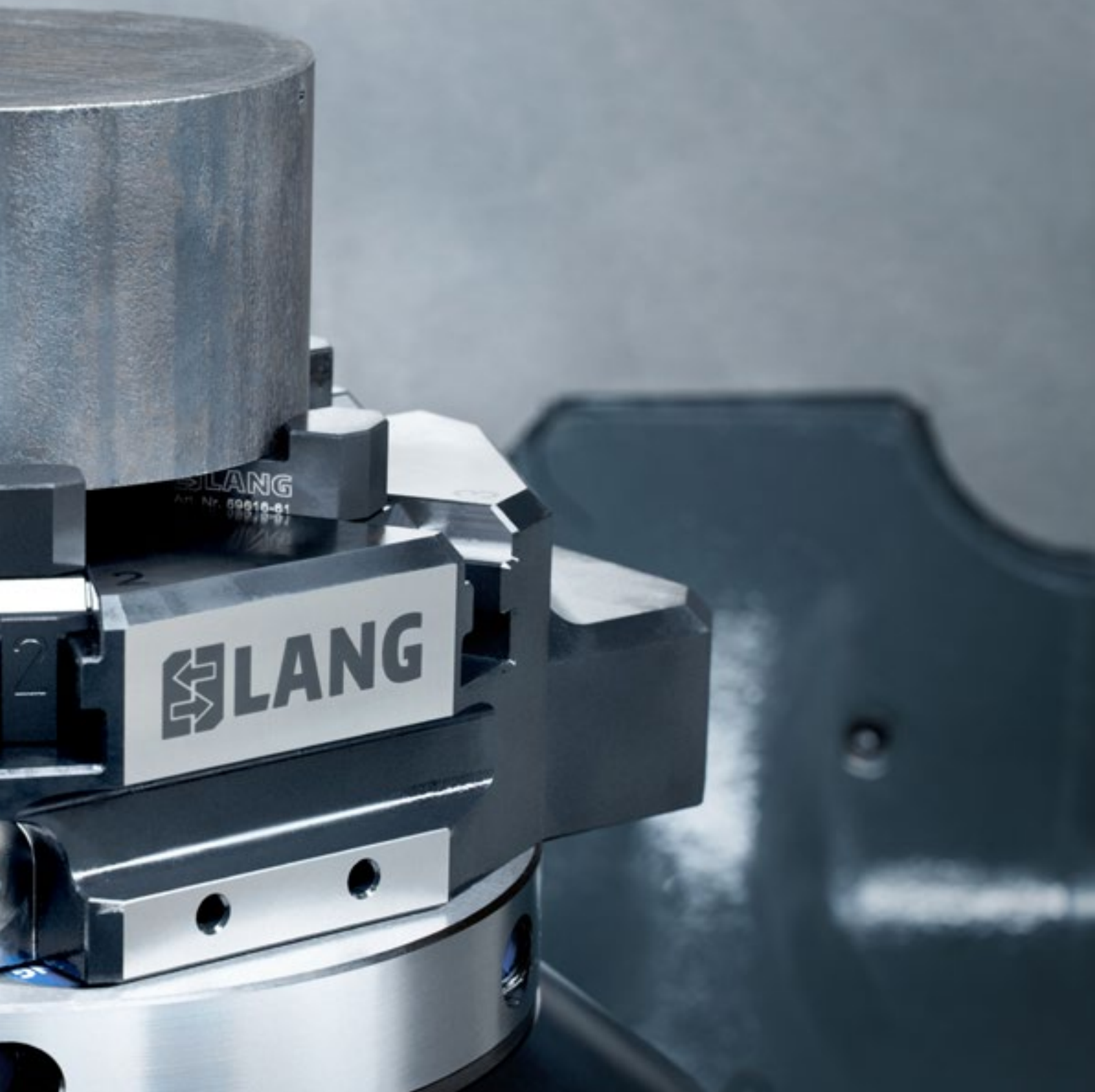

144 Vasto·Clamp **6-jaw Chuck**

148 Avanti / Profilo comparison

150 Avanti **Profile Clamping**

152 Avanti 77

156 Avanti 125

158 Profilo **Profile Clamping**

160 Profilo 77

162 Profilo 125

164 Vario·Tec **Support and Resting System**

166 Vario·Tec 77

168 Vario·Tec 125

170 Preci·Point **Collet Chuck**



**simple.
versatile.
clamping.**

Diverse clamping solutions for milling round or pre-machined components

Conventional Workholding solutions by LANG are characterised by:

FLEXIBILITY

VERSATILITY

SET-UP TIME SAVINGS

While the strengths of Makro-Grip® stamping technology and the 5-Axis Vices are mainly seen in the processing of unmachined parts, workholding devices of the „Conventional Workholding“ category offer various options for smooth clamping of round or pre-machined components. To solve the respective clamping task, a 6-jaw chuck, two collet chucks and a total of three different types of centring vices are available to the operator.

The vices differ only in the type of their clamping jaws. They use the same base body as the Makro-Grip® 5-Axis Vice, which ensures consistent compatibility and interchangeability. The different types of jaws of the „Conventional Workholding“ are ideally suited for demanding rear-face machining tasks and perfectly complement the 5-Axis Vice in order to machine all faces of a workpiece.

Benefits of Conventional Workholding solutions:



Minimal time required for set-up



Simple and user-friendly operation



Enormous flexibility due to the possibility of using different top jaws



Diverse clamping solutions for differently shaped parts



All centring vice jaw types compatible with the Makro-Grip® 5-Axis Vice



Precise and robust mounting between base and top jaws

Vasto-Clamp Technology

The versatile 6-jaw chuck with quick exchange system



- 1 Innovative click mechanism ensures quick jaw exchange
- 2 Different jaw types offer various application possibilities
- 3 Gripper interface allows utilisation in the RoboTrex 96 automation system
- 4 Integrated Quick-Point® zero-point interface
- 5 Robust steel base for maximum durability
- 6 Recess for an ergonomic handling
- 7 Swarf and coolant drain



Vasto-Clamp 6-jaw chuck with 6 soft top jaws



Vasto-Clamp 6-jaw chuck with 3 hardened gripping jaws

Innovative jaw exchange without tools



Without the use of any tools, the top jaws are locked into the base jaws (directional movement from the inside to the outside).

The Vasto-Clamp 6-jaw chuck with quick-jaw exchange system is equally suited for machining blanks as well as for contour clamping of deformation-sensitive components. Depending on the application, the user can choose between hardened gripping jaws and soft top jaws. In both cases the hand-operated spiral chuck uses a clamping principle by friction. The top jaws are fastened completely



A spring-loaded ball bearing ensures a firm fit of the top jaw.

without additional tools via an innovative click mechanism, which ensures an extremely robust and resilient jaw fit. The jaw chuck is equipped with an integrated zero-point mounting and automation interface for RoboTrex and can be used for both outer diameter and, with special jaws, for inner diameter clamping.

Variety of applications due to different types of top jaws:



59616-60 Gripping Jaws (hardened)
Clamping Range 30 – 120 mm



59616-61 Gripping Jaws (hardened)
Clamping Range 75 – 160 mm



59616-62 Top Jaws (soft)
Clamping Range 10 – 160 mm



59616-63 Top Jaws (soft)
Clamping Range 10 – 160 mm

Applications



Image: CNC-Technik Ortlieb GmbH & Co. KG

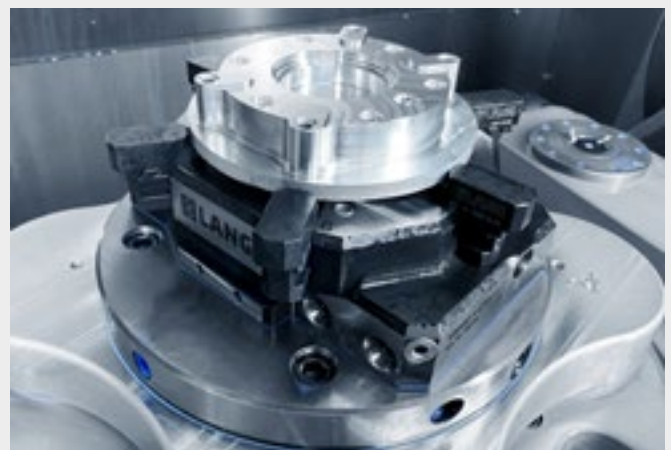

Image: Dengler CNC-Technik

Vasto-Clamp 6-Jaw Chuck



VASTO-CLAMP 6-JAW CHUCK

ITEM NO.	DIMENSIONS	CLAMPING RANGE
59616	210 × 155 × 57 mm	10 – 160 mm

Included in delivery: Hexagon socket square drive 1/4", size 8 mm

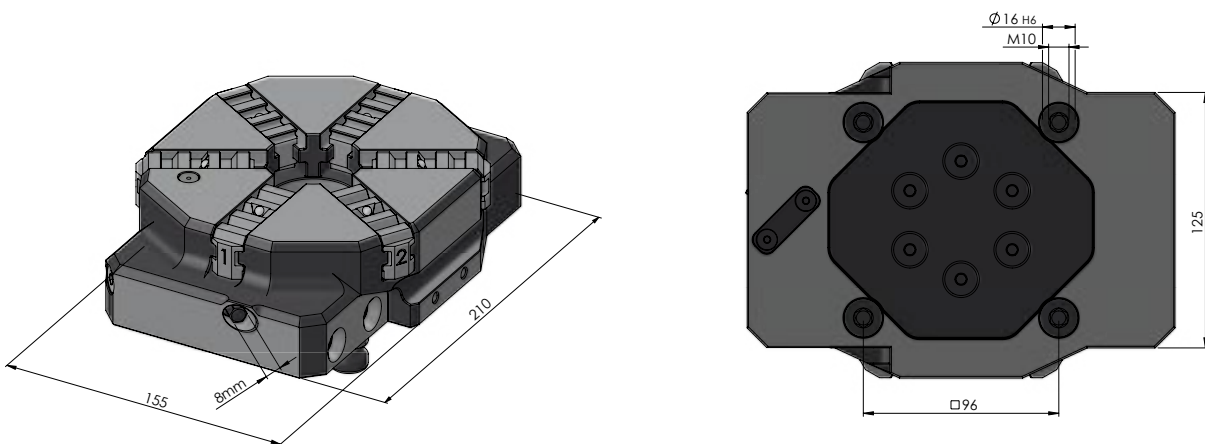



59616-60

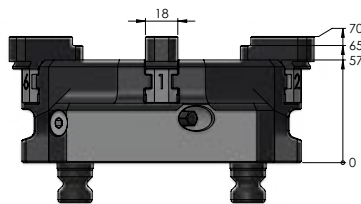

- min. Ø = 30 mm
- max. Ø = 120 mm

VASTO-CLAMP GRIPPING JAWS (HARDENED)

ITEM NO.	MATERIAL	CLAMPING RANGE	QUANTITY
59616-60	Steel (16 MnCr 5)	30 - 120 mm	6 pcs.



59616-61

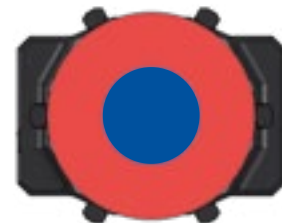
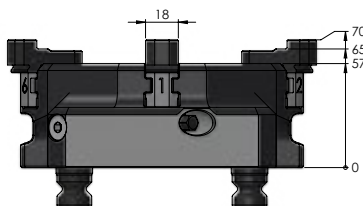

- min. Ø = 75 mm
- max. Ø = 160 mm

VASTO-CLAMP GRIPPING JAWS (HARDENED)

ITEM NO.	MATERIAL	CLAMPING RANGE	QUANTITY
59616-61	Steel (16 MnCr 5)	75 - 160 mm	6 pcs.



59616-62 / 59616-63

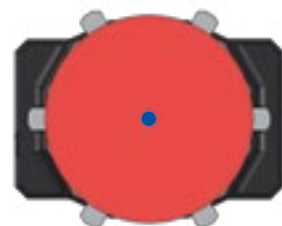
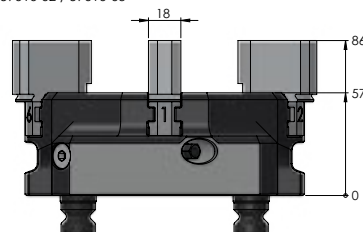

- min. Ø = 10 mm
- max. Ø = 160 mm

VASTO-CLAMP TOP JAWS, SOFT

ITEM NO.	MATERIAL	CLAMPING RANGE	QUANTITY
59616-62	Steel (16 MnCr 5)	10 - 160 mm	6 pcs.
59616-63	Aluminium (F 50)	10 - 160 mm	6 pcs.

Avanti and Profilo – Different strengths, different purposes

The two vice types Profilo and Avanti serve a similar purpose – namely the clamping of round and pre-machined parts – but have different strengths.

If setup times are important and operators have to change between different jaw types consistently, the Avanti is clearly the right choice. Thanks to extremely low purchasing costs, there is no need to manufacture Avanti top jaws in-house or spend additional

machine capacities for their preparation.

The Profilo, on the other hand, impresses with its flexibility and the possibility of using self-made top jaws or fixtures on the vice.

Both vice types use an interchangeable jaw system and can be converted into multiple clamping vices by adding centre jaws. By default, the top jaws are available in aluminum and steel, but are mounted differently, which is described below.

Profilo and Avanti – a head-to-head comparison:

PROFILO	VS.	AVANTI
Highly flexible due to self-made top jaws	SPECIALTY	Quick changeover
no / yes / yes	FOR JAW WIDTH 46 / 77 / 125	yes / yes / yes
Yes	IN-HOUSE MANUFACTURING OF TOP JAWS POSSIBLE	No
No	TOP JAWS AVAILABLE IN DIFFERENT HEIGHTS	Yes
Yes	CUSTOMISED TOP JAWS UPON REQUEST	Yes
No	QUICK RELEASE FASTENER	Yes
Feather keys	POSITIONING	Dovetail
4 cylinder head screws per jaw, mounted from the top or bottom	MOUNTING	Lateral force by tightening one screw and pull-down effect by dovetail

Avanti Profile Clamping Vice

The universal vice with great handling characteristics and extremely fast jaw exchange.

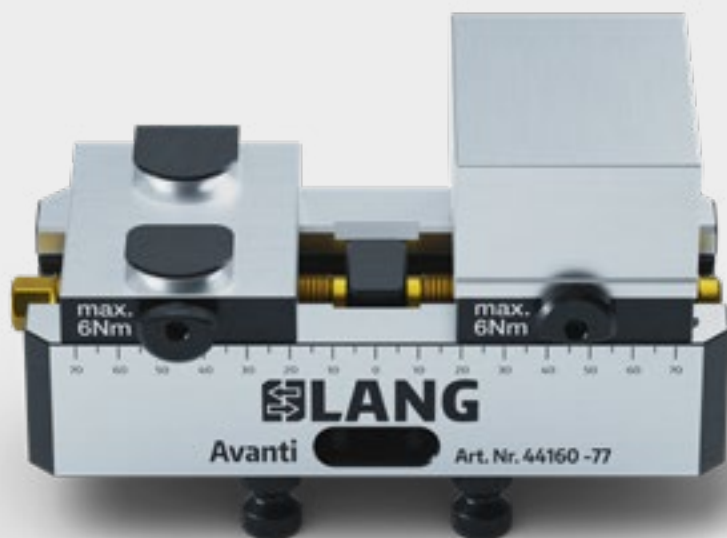

Large-volume steel or aluminium top jaws are available in different heights. They are clamped from the outside with just one screw allowing the complete block to be used for contours.

Profilo Profile Clamping Vice

The versatile clamping system for all round or pre-machined parts.

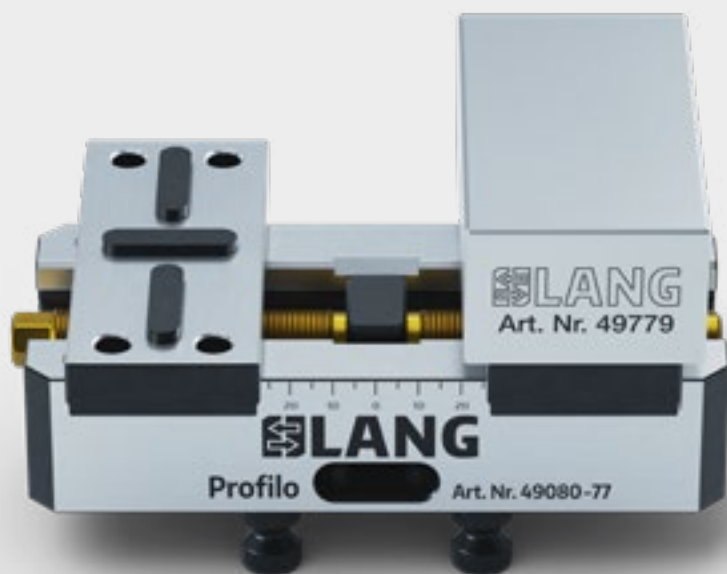

Just like the Avanti, the Profilo top jaws are available in aluminium and steel. The large-volume blocks allow contours to be added on both sides of the jaws.

Avanti Technology

PATENTED

The universal vice with great handling characteristics and unbeatable quick set-up time.

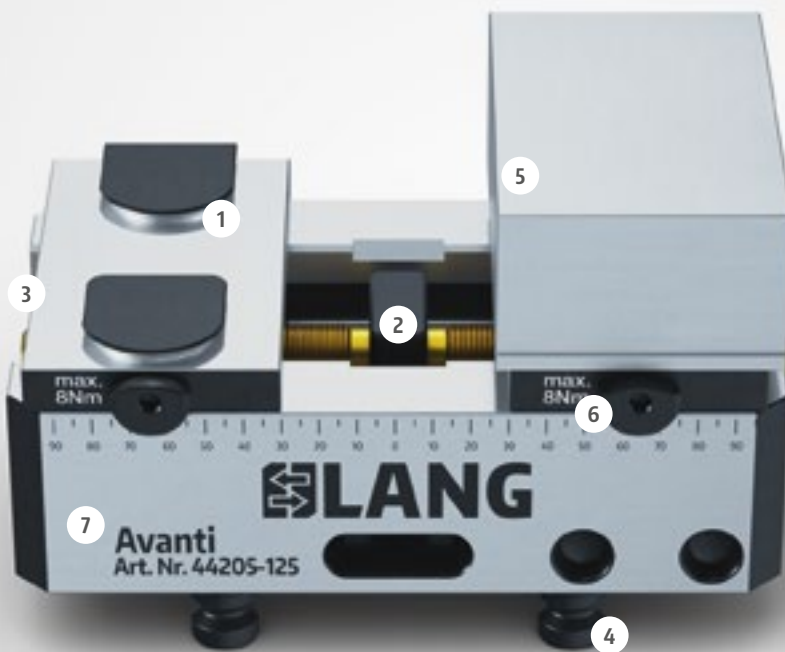

Large-volume steel or aluminium top jaws are available in different heights. They are clamped from the outside with just one screw allowing the complete block to be used for contours.

- 1 Precise positioning of jaws thanks to patented clamping interface
- 2 Centring accuracy ± 0.02 mm
- 3 Double guided jaws
- 4 Integrated with clamping studs for precise clamping in the Quick-Point® zero-point clamping system
- 5 Add-on jaws available in steel or aluminium
- 6 Changing the jaws rapidly with only one screw (internal hexagon 5 mm)
- 7 Rigid and sturdy base – but still lightweight and handy

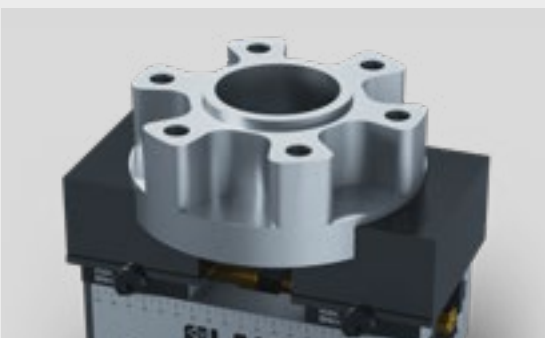

If the maximum clamping diameter ($\varnothing 34$ mm) of the Preci-Point Collet Chuck is not enough, the Avanti vice is a great choice to clamp round stock with a larger diameter.

Avanti Quick Jaw Exchange System applications



Independent from the alignment of the workpiece a great variety of profiles can be clamped for best accessibility with the patented quick jaw exchange system. By adding contours on both sides of the jaws and through their maximum usable volume top jaws can be used twice.



How to prepare top jaws:

In order to get the best results when machining with the Avanti we recommend you simulate the future clamping setup as accurately as possible.

We suggest clamping a precision block at maximum torque between the top jaws while machining the workpiece contour into the add-on jaws.



Tip for your benefit:

Avanti adaptor jaw to use own clamping fixtures

As an interface for customised clamping fixtures such as prisms, a special Avanti adaptor jaw can be offered and manufactured upon request, making the system even more versatile.

An individual borehole pattern (e.g. tapped holes or fittings) enables the simple assembly of your clamping fixture. Combine the benefits of the Avanti quick jaw exchange system with your own fixtures!

Avanti 77



AVANTI 77, JAW WIDTH 46 MM

ITEM NO.	BASE LENGTH	MAX. CLAMPING RANGE	WEIGHT	COMPARABLE PREVIOUS VERSION
44085-46	102 mm	97 mm	2.2 kg	44065
44120-46*	130 mm	125 mm	2.6 kg	44105

*automatable

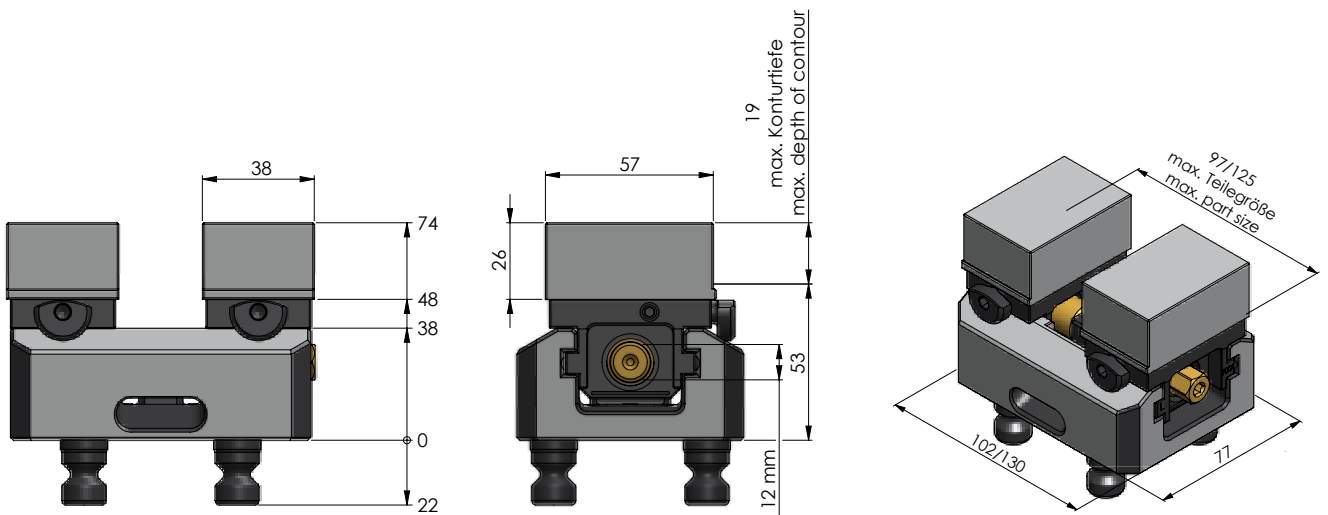



AVANTI 77 BASE JAWS, JAW WIDTH 46 MM

ITEM NO.	DIMENSIONS	WEIGHT	UNIT	COMPARABLE PREVIOUS VERSION
44771-46	55 × 36 mm	0.6 kg	1 pair	44461

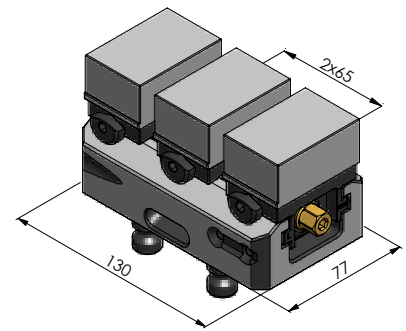
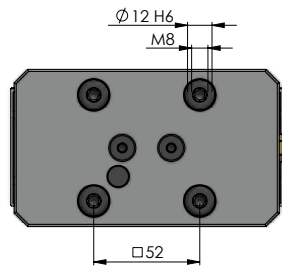

CENTRE BASE JAW + SPINDLE FOR AVANTI 77, JAW WIDTH 46 MM

ITEM NO.	SPINDLE LENGTH (+Ø)	FOR AVANTI	WEIGHT
44120-TG46	135 mm (Ø 16 mm)	44120-46	0.5 kg



AVANTI 46 TOP JAWS, SOFT

ITEM NO.	MATERIAL	DIMENSIONS	WEIGHT
44468-26	Steel (16MnCr5)	57 × 38 × 26 mm	0.6 kg
44469-26	Aluminium (F50)	57 × 38 × 26 mm	0.2 kg

Top jaws fit the new base jaw version and also the previous one.

Avanti 77



AVANTI 77, JAW WIDTH 77 MM

ITEM NO.	BASE LENGTH	MAX. CLAMPING RANGE	WEIGHT	COMPARABLE PREVIOUS VERSION
44120-77*	130 mm	125 mm	3.5 kg	44120
44160-77	170 mm	165 mm	4.2 kg	44160
44200-77	210 mm	205 mm	4.8 kg	44200

*automatable

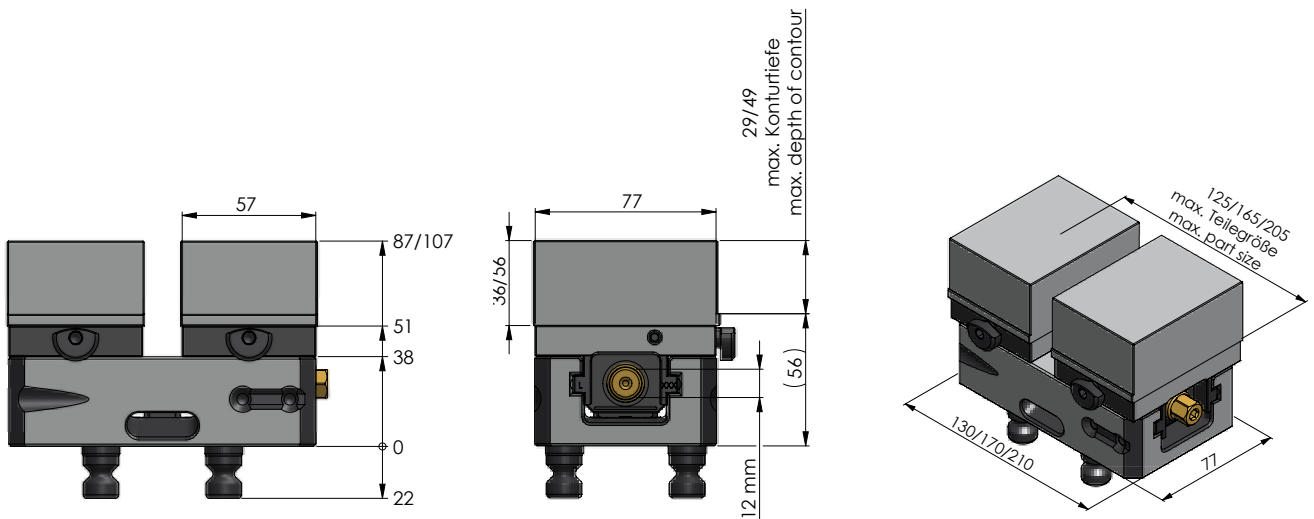



AVANTI 77 BASE JAWS, JAW WIDTH 77 MM

ITEM NO.	DIMENSIONS	WEIGHT	UNIT	COMPARABLE PREVIOUS VERSION
44771-77	77 × 57 mm	1.4 kg	1 pair	44771

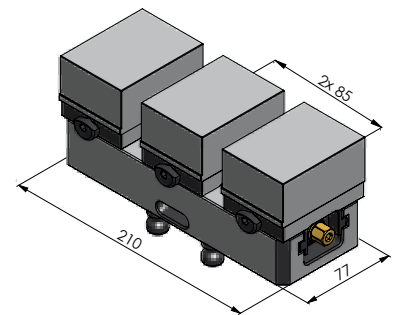
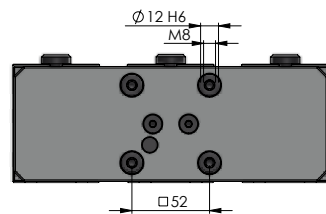

CENTRE BASE JAW + SPINDLE FOR AVANTI 77, JAW WIDTH 77 MM

ITEM NO.	SPINDLE LENGTH (+ \varnothing)	FOR AVANTI	WEIGHT
44200-TG77	215 mm ($\varnothing 16$ mm)	44200-77	0.9 kg



AVANTI 77 TOP JAWS, SOFT

ITEM NO.	MATERIAL	DIMENSIONS	WEIGHT	UNIT
44778-36	Steel (16MnCr5)	78 × 58 × 36 mm	0.6 kg	1 pc.
44779-36	Aluminium (F50)	78 × 58 × 36 mm	0.2 kg	1 pc.
44778-56	Steel (16MnCr5)	78 × 58 × 56 mm	0.9 kg	1 pc.
44779-56	Aluminium (F50)	78 × 58 × 56 mm	0.3 kg	1 pc.

Top jaws fit the new base jaw version and also the previous one.

Avanti 125



AVANTI 125, JAW WIDTH 125 MM

ITEM NO.	BASE LENGTH	MAX. CLAMPING RANGE	WEIGHT	COMPARABLE PREVIOUS VERSION
44205-125*	210 mm	210 mm	11.3 kg	44205
44255-125	260 mm	260 mm	13.2 kg	44255
44305-125	310 mm	310 mm	15.1 kg	44305
44355-125	360 mm	360 mm	16.9 kg	44355

*automatable

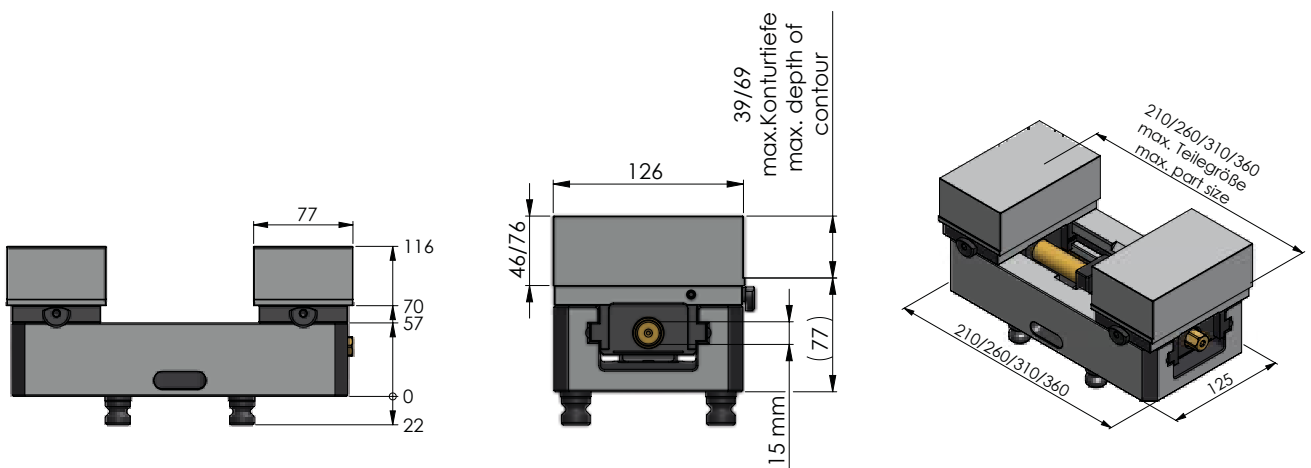



AVANTI 125 BASE JAWS, WIDTH 125 MM

ITEM NO.	DIMENSIONS	WEIGHT	UNIT	COMPARABLE PREVIOUS VERSION
44251-125	125 × 69 mm	3.7 kg	1 pair	44251

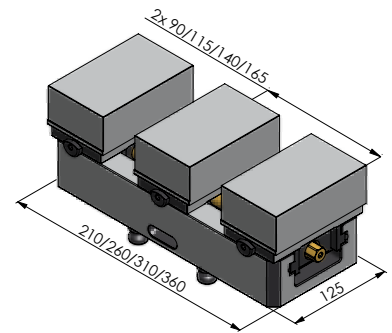
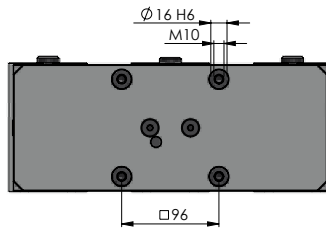
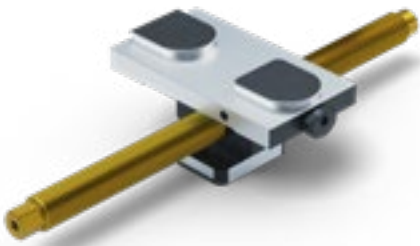

CENTRE BASE JAW + SPINDLE FOR AVANTI 125

ITEM NO.	SPINDLE LENGTH (+ \varnothing)	FOR AVANTI	WEIGHT
44255-TG125	264 mm (\varnothing 20 mm)	44255-125	2.1 kg
44305-TG125	314 mm (\varnothing 20 mm)	44305-125	2.2 kg
44355-TG125	364 mm (\varnothing 20 mm)	44355-125	2.3 kg



AVANTI 125 TOP JAWS, SOFT

ITEM NO.	MATERIAL	DIMENSIONS	WEIGHT	UNIT
44258-46	Steel (16MnCr5)	126 × 77 × 46 mm	3.3 kg	1 pc.
44259-46	Aluminium (F50)	126 × 77 × 46 mm	1.1 kg	1 pc.
44258-76	Steel (16MnCr5)	126 × 77 × 76 mm	5.5 kg	1 pc.
44259-76	Aluminium (F50)	126 × 77 × 76 mm	1.8 kg	1 pc.

Top jaws fit the new base jaw version and also the previous one.

Profilo Technology

Your clamping system for all shaped parts

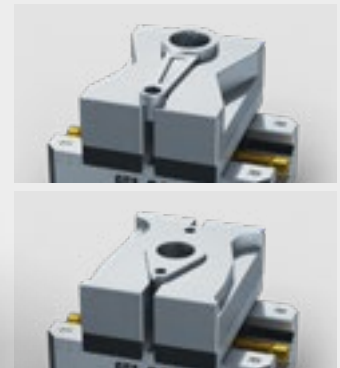
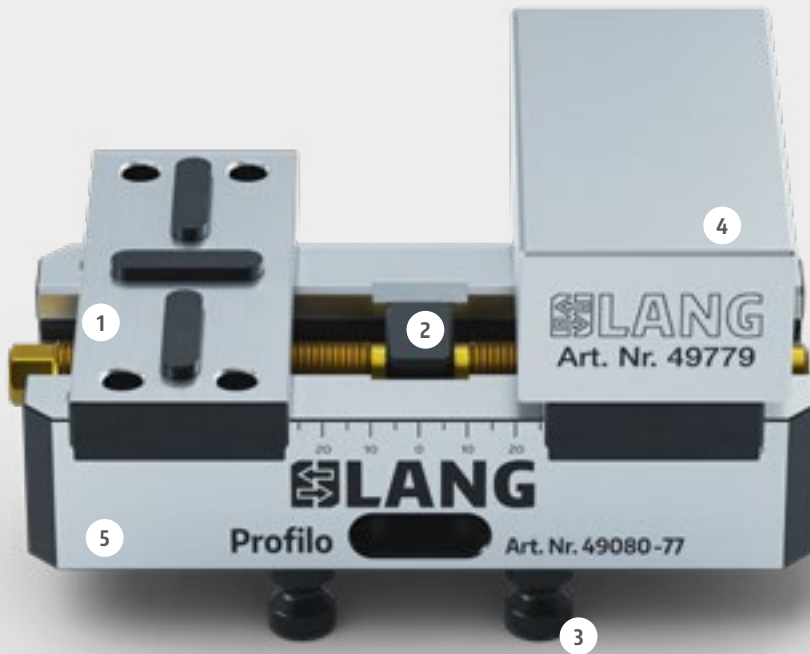

Large-volume steel or aluminium add-on jaw allows contours to be added on both sides of the jaws to use it for two different clamping applications.

- 1 Case-hardened, double guided base jaws with keyways
- 2 Centring accuracy ± 0.02 mm
- 3 Integrated with clamping studs for precise clamping in the Quick-Point® zero-point clamping system
- 4 top jaws available in steel or aluminium
- 5 Rigid and sturdy base – but still lightweight and handy

Mounting options



Softtop jaws mounted from beneath with 4 screws.

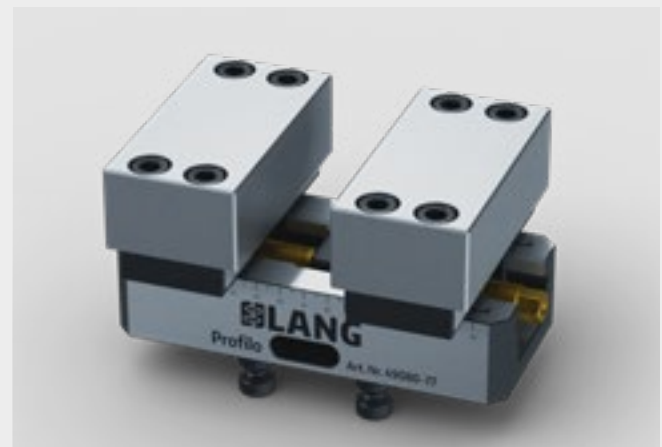

Thanks to threads in the base jaws, top jaws can also be mounted from the top for better accessibility towards the screws.

Self-made Profilo top jaws

The versatile Profilo system allows you to manufacture your own, customised top jaws for your LANG vice. The drawings below show you how to machine your jaws. The drawings and 3D models can also be downloaded from our website.

Profilo 77:

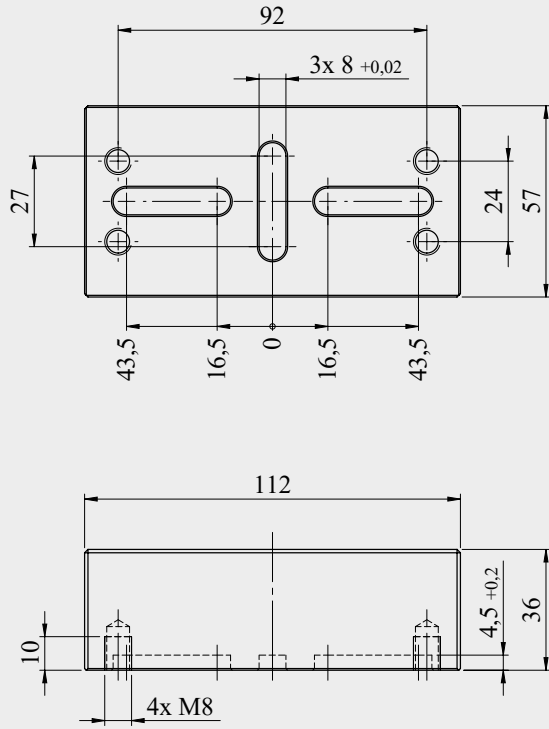

Profilo 125:

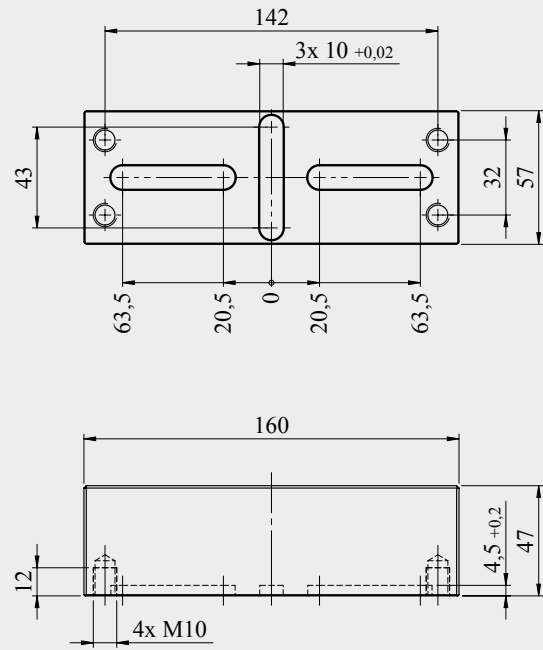

Applications

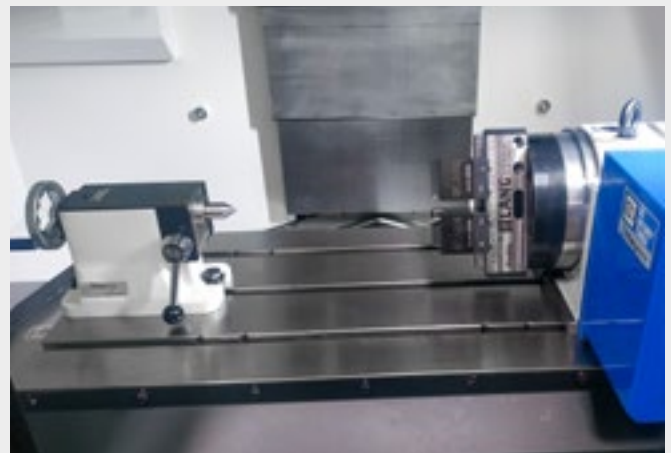
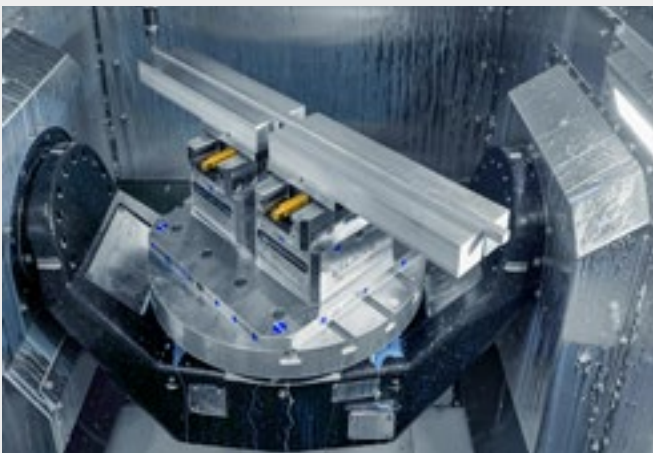
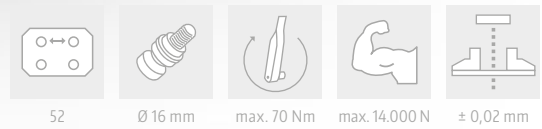

Image: CNC-Manufaktur Brüssow GmbH & Co. KG

Profilo 77



PROFILO 77

ITEM NO.	BASE LENGTH	MAX. CLAMPING RANGE	WEIGHT	COMPARABLE PREVIOUS VERSION
49010-77	102 mm	100 mm	3.2 kg	49010
49040-77	130 mm	130 mm	3.6 kg	49040
49080-77	170 mm	170 mm	4.3 kg	49080
49120-77	210 mm	210 mm	5.0 kg	49120

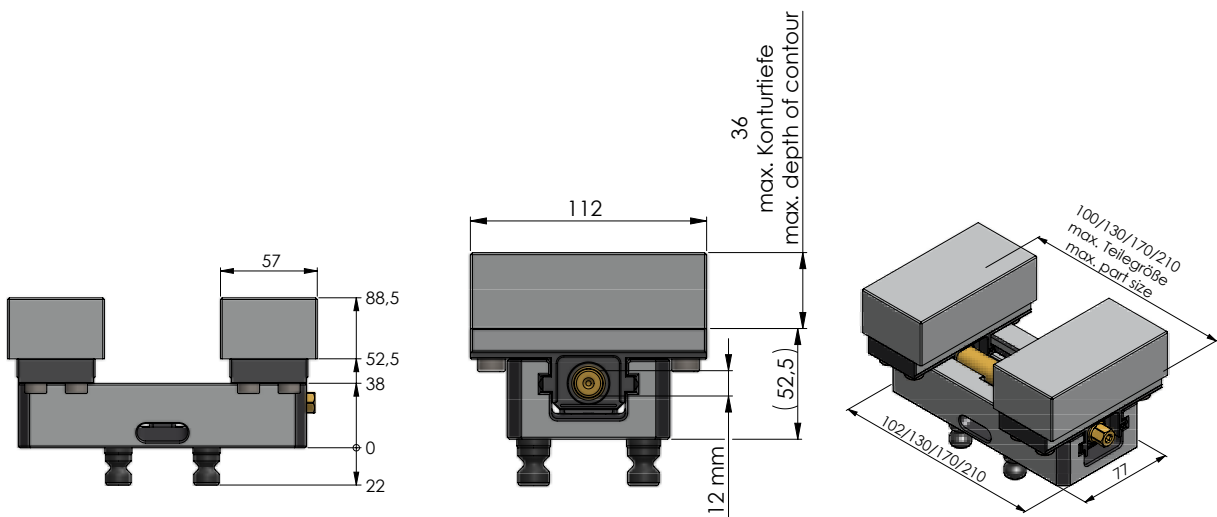



PROFILO 77 BASE JAWS

ITEM NO.	DIMENSIONS	WEIGHT	UNIT	COMPARABLE PREVIOUS VERSION
49077	112 × 46 mm	1.6 kg	1 pair	49771

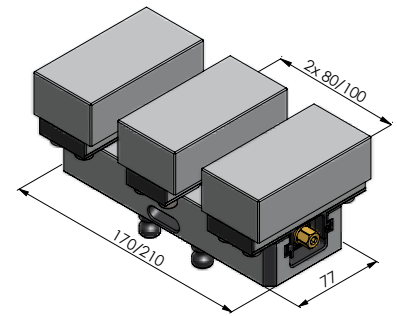
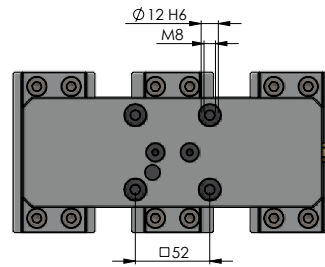

CENTRE BASE JAW 112 × 46 MM + SPINDLE FOR PROFILO 77

ITEM NO.	SPINDLE LENGTH (+Ø)	FOR PROFILO	WEIGHT	COMPARABLE PREVIOUS VERSION
49080-TG77	175 mm (Ø 16 mm)	49080-77	0.9 kg	49080-TG
49120-TG77	215 mm (Ø 16 mm)	49120-77	1.0 kg	49120-TG



PROFILO 77 TOP JAWS, SOFT

ITEM NO.	MATERIAL	DIMENSIONS	WEIGHT	UNIT
49778	Steel (16MnCr5)	112 × 57 × 36 mm	1.8 kg	1 pc.
49779	Aluminium (F50)	112 × 57 × 36 mm	0.7 kg	1 pc.

Topjaws fit the new base jaw version and also the previous one.

Profilo 125



PROFILO 125

ITEM NO.	BASE LENGTH	MAX. CLAMPING RANGE	WEIGHT	COMPARABLE PREVIOUS VERSION
49050-125	160 mm	155 mm	10.1 kg	49050
49100-125	210 mm	205 mm	11.9 kg	49100
49150-125	260 mm	255 mm	13.8 kg	49150
49200-125	310 mm	305 mm	15.7 kg	49200
49250-125	360 mm	355 mm	17.5 kg	49250

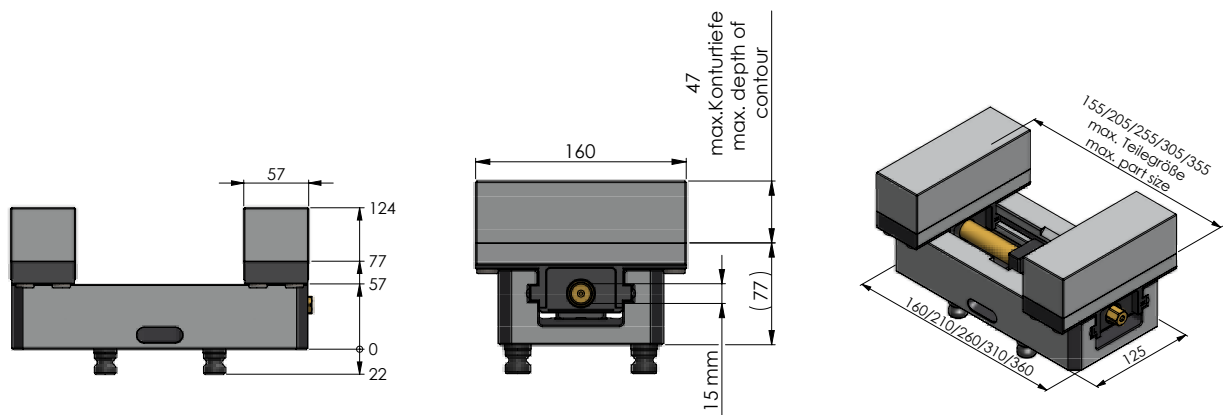



PROFILO 125 BASE JAWS

ITEM NO.	DIMENSIONS	WEIGHT	UNIT	COMPARABLE PREVIOUS VERSION
49125	160 × 57 mm	4.3 kg	1 pair	49251

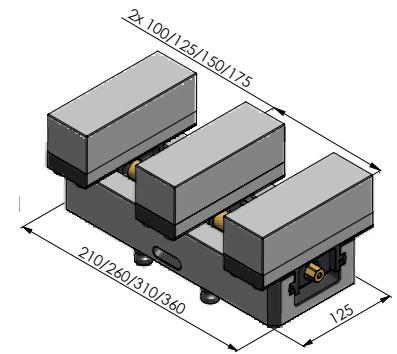
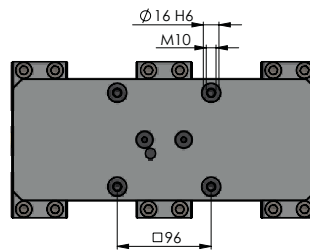

CENTRE BASE JAW 160 × 57 MM + SPINDLE FOR PROFILO 125

ITEM NO.	SPINDLE LENGTH (+ \varnothing)	FOR PROFILO	WEIGHT	COMPARABLE PREVIOUS VERSION
49100-TG125	214 mm ($\varnothing 20$ mm)	49100-125	2.5 kg	49100-TG
49150-TG125	264 mm ($\varnothing 20$ mm)	49150-125	2.6 kg	49150-TG
49200-TG125	314 mm ($\varnothing 20$ mm)	49200-125	2.7 kg	49200-TG
49250-TG125	364 mm ($\varnothing 20$ mm)	49250-125	2.9 kg	49250-TG



PROFILO 125 TOP JAWS, SOFT

ITEM NO.	MATERIAL	DIMENSIONS	WEIGHT	UNIT
49258	Steel (16MnCr5)	160 × 57 × 47 mm	3.3 kg	1 pc.
49259	Aluminium (F50)	160 × 57 × 47 mm	1.2 kg	1 pc.

Top jaws fit the new base jaw version and also the previous one.

Vario-Tec Technology

The convenient and versatile clamping solution for (semi-)finished parts.



- 1 Centring accuracy ± 0.02 mm
- 2 Channels for blowing out pins
- 3 Rigid and sturdy base for great longevity
- 4 Lateral swarf/coolant drain in the base body
- 5 Integrated with clamping studs for precise clamping in the Quick-Point® zero-point clamping system

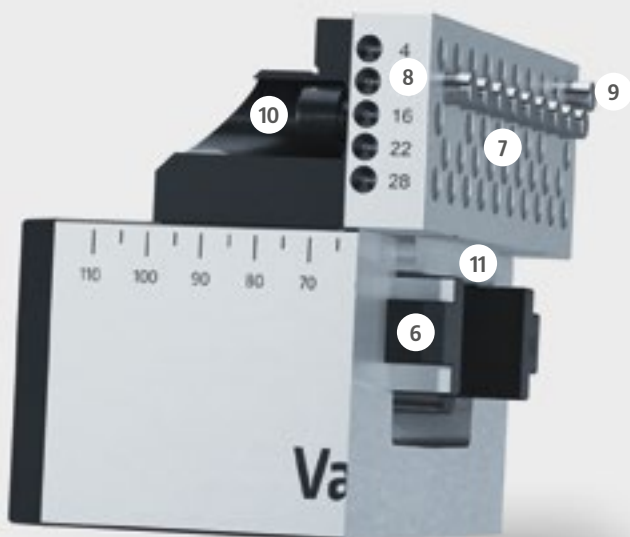

- 6 Double guided jaws
- 7 Positioning accuracy of pins ± 0.01 mm
- 8 Pins are blown out row by row with compressed air
- 9 Support and resting possibilities. Parallels are not needed
- 10 Jaws are sealed up front and mounted from behind through the carrier jaw. No swarf clogging possible!
- 11 Pin jaws are guided in the base for a highly accurate location to one another.

Applications



Pins not needed are simply pushed back by hand. The remaining pins act as a support and resting system. Parallels and additional endstops which affect accessibility in a negative way are not needed.



Resting a workpiece on only two pins ensures great freedom to machine until close to the edge of the workpiece and inner surfaces of the clamping pin jaws.

Maintenance recommendation



In order to keep up the proper function of the system the pins should be blown out when not needed to prevent jamming caused by the coolant. Furthermore we recommend applying a multi-purpose oil on the pins occasionally.

Vario-Tec 77

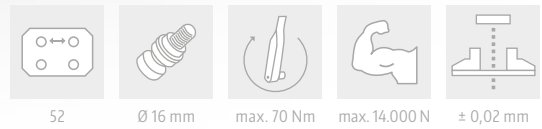

VARIO-TEC 77

ITEM NO.	BASE LENGTH	MAX. CLAMPING RANGE	WEIGHT	COMPARABLE PREVIOUS VERSION
42057-77*	130 mm	57 mm	3.3 kg	42057
42097-77	170 mm	97 mm	4.0 kg	42097
42137-77	210 mm	137 mm	4.6 kg	42137

*automatable

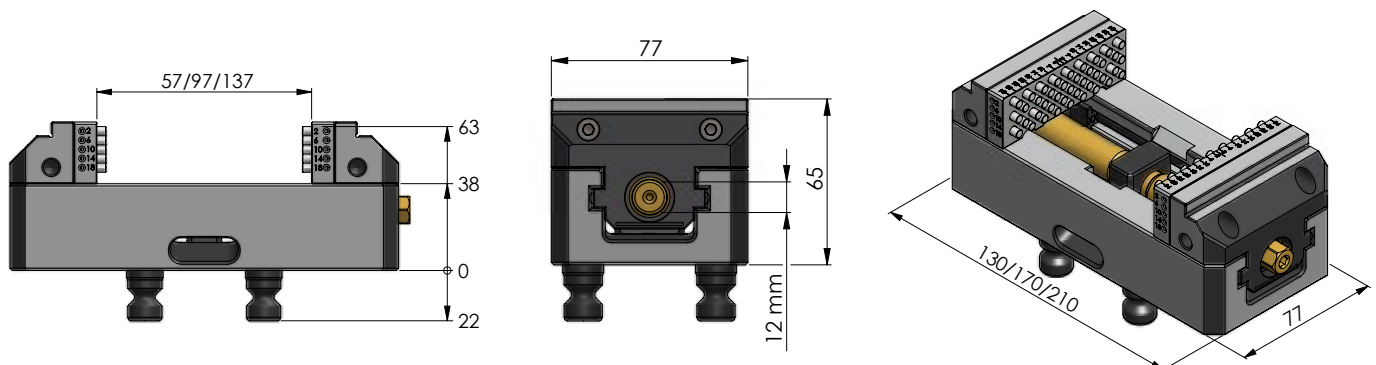

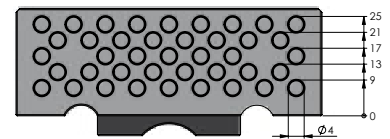
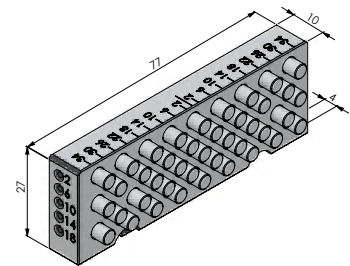

The jaws are fixed with screws from behind ($2 \times M6$, distance of 48 mm), so they are sealed up front. Hence swarf clogging has no chance!

VARIO-TEC 77 SPARE JAWS

ITEM NO.	DESCRIPTION	UNIT	WEIGHT	COMPARABLE PREVIOUS VERSION
42018-77	Spare Jaws	1 set (2 pin jaws + 2 carrier jaws)	1.2 kg	42077

ACCESSORIES VARIO-TEC 77



ITEM NO.	DESCRIPTION	UNIT
20000	Spare pins \varnothing 4 mm	5 pcs.
200009	O-Rings \varnothing 2 \times 1.5 mm for spare pins \varnothing 4 mm	100 pcs.
20004	Compressed Air Gun	1 pc.

Vario-Tec 125

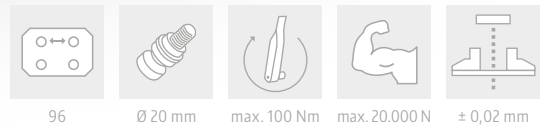

VARIO-TEC 125

ITEM NO.	BASE LENGTH	MAX. CLAMPING RANGE	WEIGHT	COMPARABLE PREVIOUS VERSION
42102-125*	210 mm	100 mm	12.3 kg	42102
42152-125	260 mm	150 mm	14.2 kg	42152
42202-125	310 mm	200 mm	16.0 kg	42202
42252-125	360 mm	250 mm	17.9 kg	42252

*automatable

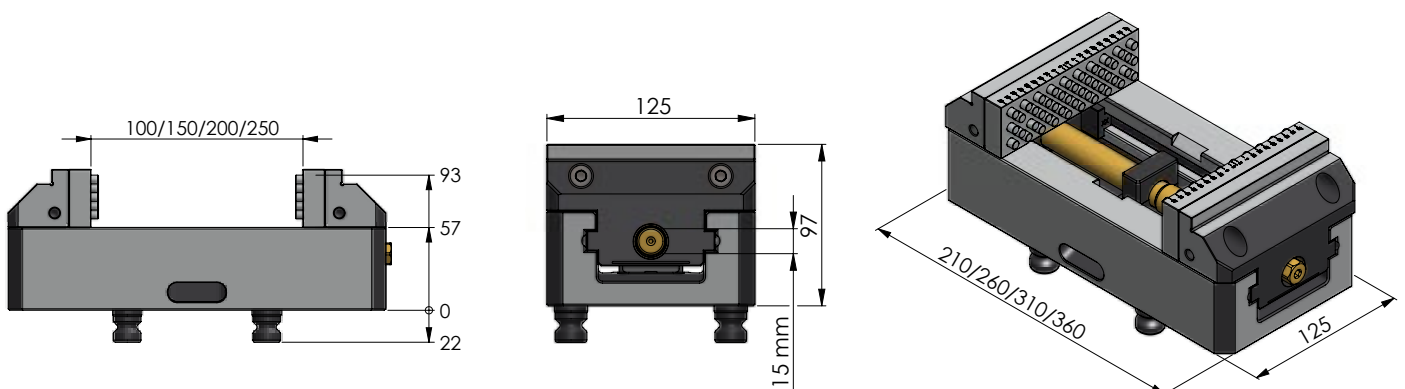

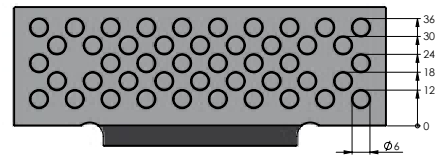
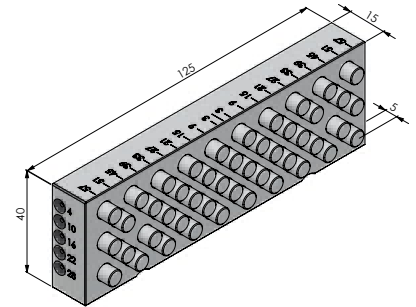
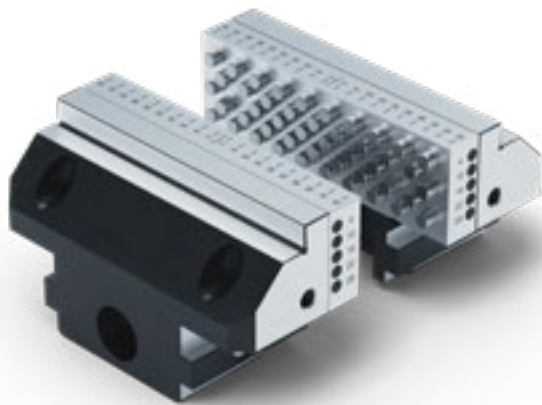

The jaws are fixed with screws from behind ($2 \times M 8$, distance of 84 mm), so they are sealed up front. Hence swarf clogging has no chance!

VARIO-TEC 125 SPARE JAWS

ITEM NO.	DESCRIPTION	UNIT	WEIGHT	COMPARABLE PREVIOUS VERSION
42018-125	Spare Jaws	1 set (2 pin jaws + 2 carrier jaws)	4.7 kg	42125

ACCESSORIES VARIO-TEC 125



ITEM NO.	DESCRIPTION	UNIT
20001	Spare pins $\varnothing 6$ mm	5 pcs.
200010	O-Rings $\varnothing 3.5 \times 2$ mm for spare pins $\varnothing 6$ mm	100 pcs.
20004	Compressed Air Gun	1 pc.

Preci-Point Collet Chuck

The collet chuck with ideal accessibility for milling round parts



- 1 Suitable for commercially available collets type ER 32 (clamping range \varnothing 3 – 20 mm) and ER 50 (clamping range \varnothing 6 – 34 mm)
- 2 M6 tapped hole to use an endstop
- 3 Robust, case-hardened and coated base body
- 4 Equipped with clamping studs for precise clamping in the Quick-Point® zero-point clamping system
- 5 Recess as a coolant drainage

NEW

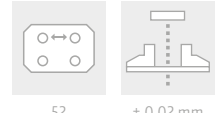
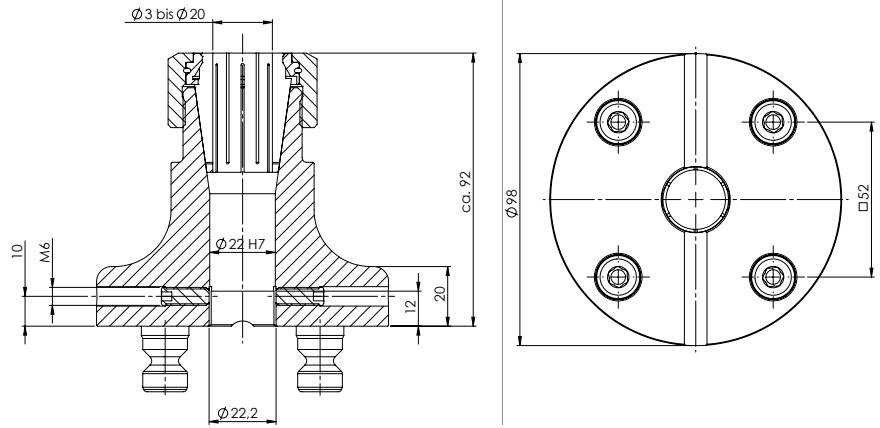

PRECI-POINT COLLET CHUCK FOR ER 32

ITEM NO.	DIMENSIONS	WEIGHT
41032	Ø 98 × 92 mm	2.0 kg

Included: 4 × Quick-Point® clamping studs Ø 16 mm and screwcap.

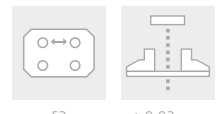
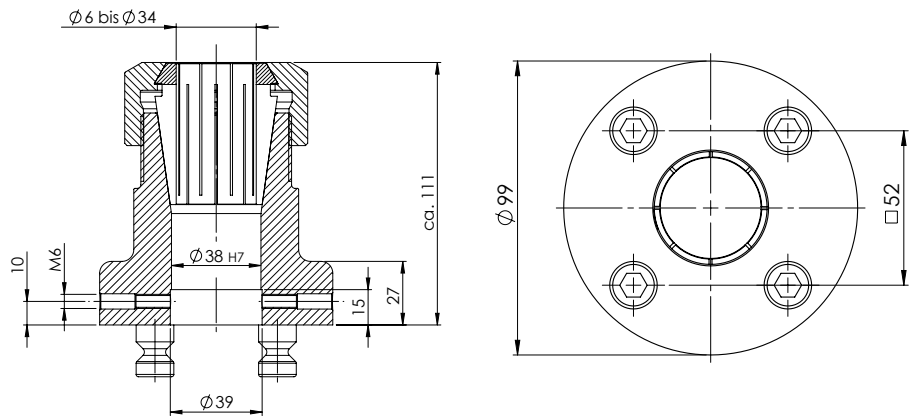

PRECI-POINT COLLET CHUCK FOR ER 50

ITEM NO.	DIMENSIONS	WEIGHT
41052	Ø 99 × 111 mm	3.0 kg

Included: 4 × Quick-Point® clamping studs Ø 16 mm and screwcap.



PRECI-POINT CLAMPING WRENCH

ITEM NO.	FOR PRECI-POINT
41032-03	ER 32
41052-03	ER 50



ROBOTREX AUTOMATION



182 RoboTrex 52 **Automation System**

192 RoboTrex 96 **Automation System**

200 Individual automation solutions

201 Makro-Grip® **Mobile Storage Unit**



**simple. flexible.
automation.**

More efficiency, automatically!

Automation systems by LANG Technik are characterised by:

SIMPLE OPERATION

SET-UP TIME SAVINGS

FLEXIBILITY

Efficiency, speed and flexibility – RoboTrex combines all these attributes and prepares your manufacturing for the future! Automation systems by LANG cover every need from single part to large-scale production. They are flexible, easy to use and offer best value for money. This makes them appealing for SME's and for those just starting out.

Benefits of the RoboTrex Automation System:



(Re-) equipping of automation within just a few seconds



Simple operation, no knowledge about robots required



Minimum training expenses



No skilled labour required



Works with almost every machine tool



Single part or large-scale production

The RoboTrex Automation System



Machine tools we have already equipped with an automation:

- | | | | |
|--------------|-----------------|----------------|-----------|
| → Alzmetall | → Fehlmann | → Kern | → Müga |
| → Awea | → Grob | → Leadwell | → OKK |
| → Bridgeport | → GMC | → Litz | → Okuma |
| → Brother | → Haas | → Makino | → Quaser |
| → Chiron | → Hedelius | → Matec | → Spinner |
| → DMG Mori | → Hermle | → Matsuura | → Stama |
| → Doosan | → Hitachi Seiki | → Mazak | → Victor |
| → Emco | → Hurco | → Mikron | → YCM |
| → Fanuc | → Huron | → Mitsui Seiki | |
| → Feeler | → Hyundai | → MT Cut | |

Faster set-up, more flexible automation

The innovative and patented automation trolley as the storage of the automation system ensures highest flexibility and machine tool utilisation, even in a mostly unmanned shift. By preparing the trolleys offline, the RoboTrex automation system can be re-equipped within a few moments without any machine downtime. Thank to the special, angled mounting of the vices, the trolley has a high storage capacity on a relatively small footprint, which is why RoboTrex can be integrated in nearly any machine shop. RoboTrex is not only suitable for batch production of homogeneous parts but can also

process single parts flexibly, by assigning a NC program to every vice position. It is also possible to deselect certain vice positions or entire rows to handle parts with excess width or height. Whether a completely new machine tool or as a retrofit to an existing one, due to the simple communication, RoboTrex fits almost every machine tool. The simple and uncomplicated operation provides an easy start in automated manufacturing. In economic terms, it offers a great value-for-money ratio and guarantees a quick return on investment.

RoboTrex 52 and 96 – head-to-head comparison



**RoboTrex 52
Automation System**



**RoboTrex 96
Automation System**

30 / 42 Vices	STORAGE CAPACITY OF TROLLEY	15 / 16 Vices
max. 4 pcs.	QTY OF TROLLEYS	max. 4 pcs.
max. 120 / 168 Vices	TOTAL STORAGE CAPACITY	60 / 64 Vices
max. 120 × 120 × 100 / max. 120 × 100 × 70 mm	WORKPIECE DIMENSIONS WITH FULLY EQUIPPED TROLLEY	max. 205 × 205 × 90 / max. 205 × 150 × 150 mm
max. 12 kg	WORKPIECE WEIGHT	max. 25 kg, optional: max. 45 kg
no	GRIPPER EXCHANGE INTERFACE	yes
mechanical or pneumatical	ACTUATION OF ZERO-POINT SYSTEM	pneumatical
from 1.70 × 2.20 m	FOOTPRINT	from 2.00 × 2.70 m
through machine door or side window	LOADING	through machine door or side window

Well thought-out and excellently proven in practice

RoboTrex offers elementary advantages with each of its components, which have an immediate and extremely profitable effect on machining processes and production sequences.



THE AUTOMATION SYSTEM

- Simple retrofitting as front or side loading on existing or new machine
- Communication with the machine via M-function
- Minimal training required, fast commissioning
- Delivery in ready-to-use, pre-programmed state
- No robot knowledge required, also suitable for unskilled personnel
- Simple, intuitive operation via touch pad

THE ROBOT / GRIPPER

- Proven Fanuc robot quality
- One gripper for all types of workpieces
- No adjustments necessary for different types of workpieces
- Automatic loading/unloading takes place independently of the milled contour
- No additional programming effort for different components
- With gripper exchange interface for RoboTrex 96



THE AUTOMATION TROLLEY

- Flexible, offline preparation of the storage medium
- Direct set-up, retooling on the automation trolley
- No machine downtimes during trolley exchange
- Flexible order management, from single-part to large-scale production
- High storage capacity on a small footprint
- Immediate access to entire storage medium
- Interchangeable and therefore usable in other RoboTrex systems at any time



The Vice

- Vice and pallet in one
- No additional interfaces for highest stability and manufacturing accuracy
- High space saving in the automation system and machine tool due to compact design
- Highest process reliability thanks to stamping technology
- Vices can be used in other machines at any time
- High repeat accuracy and reproducibility of the clamping situation thanks to defined clamping

THE ZERO-POINT CLAMPING SYSTEM

- Mechanical or pneumatic operation
- No additional utilities required within the machine
- Low-maintenance, wear-free components
- Repeat accuracy < 0.005 mm
- Can also be used without automation system for manual production



New categorisation: Grippers and automation zero-point devices



RoboTrex 96 – the flexible 2-in-1 solution



The gripper exchange interface, a new standard feature of RoboTrex 96, is a zero-point adaptation on the robot arm which ensures even more options and flexibility when it comes to the variety of processable part sizes. The new interface allows switching between different gripper sizes and thus using both, RoboTrex 96 and 52 trolleys

(and all associated components) in the same system. This makes RoboTrex 96 a flexible 2-in-1 solution that can not only handle bigger and heavier parts up to 25 kg (or 45 kg), but also smaller parts in larger lot sizes efficiently.

RoboTrex 52 Automation System



ROBOTREX 52 AUTOMATION SYSTEM

ITEM NO.	BASIC EQUIPMENT
66000	Complete robotic automation system incl. enclosure, trolley entry system and 1 automation trolley

Applications



Image: JH Maschinenbau



Image: PJK Feinmechanik GmbH



Image: Vedos Verspanende Techniek B.V.



Image: Qualiturn Products Ltd.



Image: HEL Performance Products Ltd.



Image: ASEDO GmbH & Co.KG

RoboTrex 52 Automation Trolley



ROBOTREX 52, AUTOMATION TROLLEY

ITEM NO.	STORAGE CAPACITY	MAX. PART SIZE (WHEN FULLY LOADED)	WEIGHT
66030	30	120 × 120 × 100 mm	167 kg
66042	42	120 × 100 × 70 mm	170 kg

Maximum load capacity of trolley: 500 kg

Batch production or individual program assignment for single parts

Flexible job management

Besides the rather conventional processing of identical parts per trolley, the RoboTrex automation system offers further possibilities, which enables a flexible job management for a diverse range of parts. From the deselection of certain vice positions or rows – in order to process parts with excess width or height – to a very individual single part production by assigning a NC program to each vice position – everything is imaginable.



Start and stop mark



Deselection of vice positions



Individual program assignment

RoboTrex 52 Grippers and Zero-Point Devices

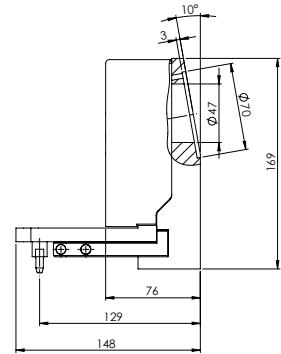
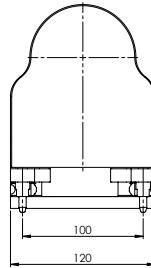

GRIPPER 52, MECHANICAL

ITEM NO.	ACTUATION	FITS ITEM NO.
66930	mechanical	66500

Max. workpiece weight: 12 kg.

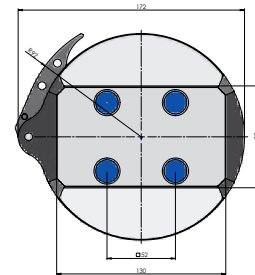
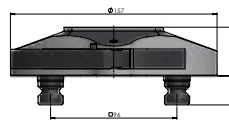

ZERO-POINT DEVICE 52, MECHANICAL

ITEM NO.	ACTUATION	FITS ITEM NO.
66500	mechanical	66930

Included in delivery: Zero-point device, clamping lever for manual operation, aluminium handle bar

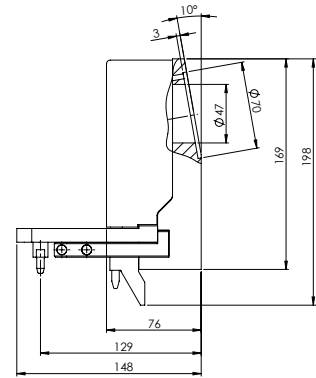
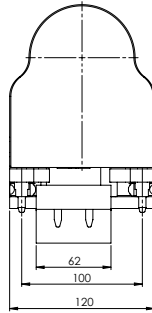

GRIPPER 52, PNEUMATIC

ITEM NO.	ACTUATION	FITS ITEM NO.
66900	pneumatic	66600

Max. workpiece weight: 12 kg.

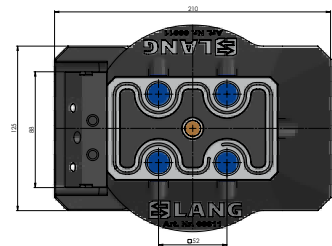
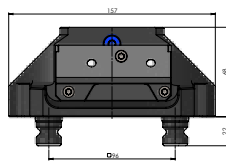

ZERO-POINT DEVICE 52, PNEUMATIC

ITEM NO.	ACTUATION	FITS ITEM NO.
66600	pneumatic	66900 / 66950

Included in delivery: Zero-point device, adapter for manual operation + bracket, aluminium handle bar

Makro·Grip® Night King



MAKRO·GRIP® NIGHT KING, JAW WIDTH 77 MM

ITEM NO.	BASE LENGTH	JAW WIDTH	CLAMPING RANGE	WEIGHT
68120-77	130 mm	77 mm	0 - 120 mm	2.9 kg

*sold as a set of 10

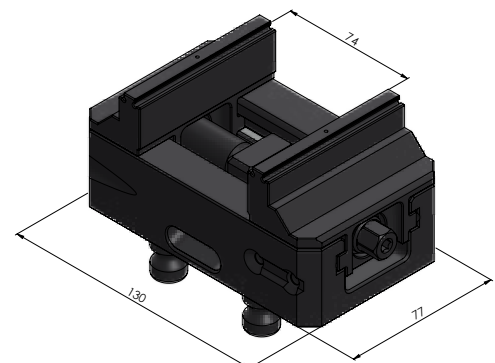
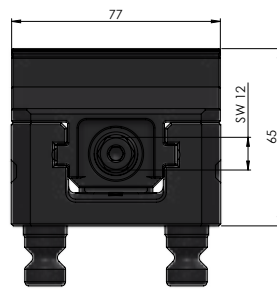
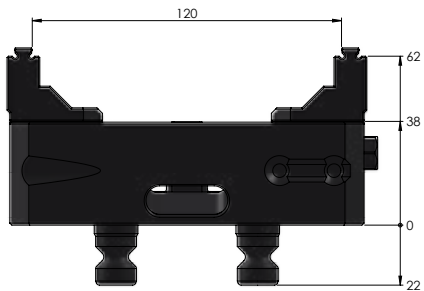

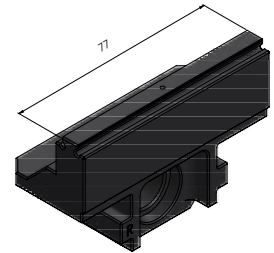
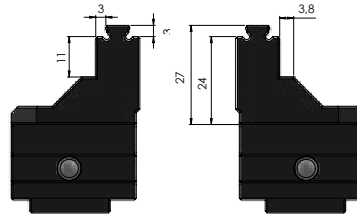

SPARE JAWS FOR MAKRO-GRIP® NIGHT KING

ITEM NO.	FOR	WEIGHT	QTY
68077-7720	68120-77	1.1 kg	1 pair

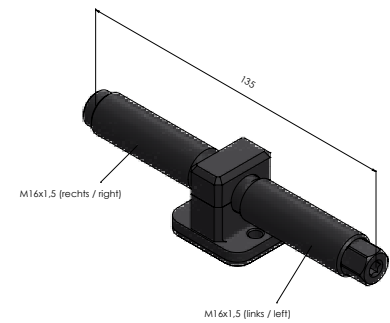

SPINDLE + CENTRE PIECE FOR MAKRO-GRIP® NIGHT KING

ITEM NO.	FOR	SPINDLE LENGTH (+Ø)	WEIGHT
6877135	68120-77	135 mm / Ø 16 mm	0.3 kg

Applications



Makro·Grip® 5-Axis Vice 77



MAKRO·GRIP® 5-AXIS VICE 77, JAW WIDTH 46 MM



ITEM NO.	BASE LENGTH	CLAMPING RANGE	WEIGHT
48120-46	130 mm	0 - 120 mm	2.5 kg

Spare Jaws and accessories can be found on p. 101/102 and p. 108/109.

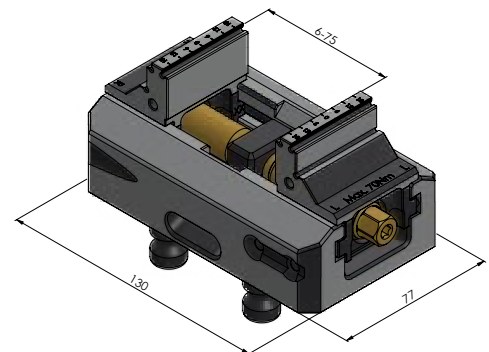
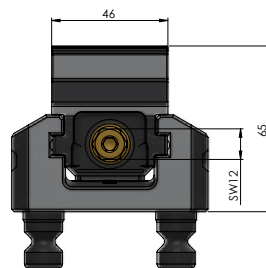
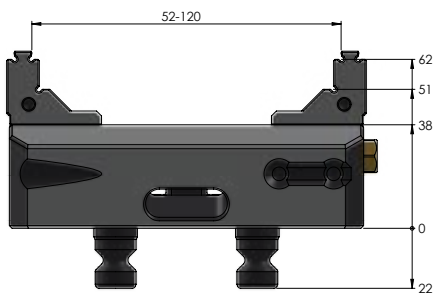

Makro·Grip® 5-Axis Vice 77



MAKRO·GRIP® 5-AXIS VICE 77, JAW WIDTH 77 MM



ITEM NO.	BASE LENGTH	CLAMPING RANGE	WEIGHT
48120-77	130 mm	0 - 120 mm	2.9 kg

Spare Jaws and accessories can be found on p. 101/102 and p. 108/109.

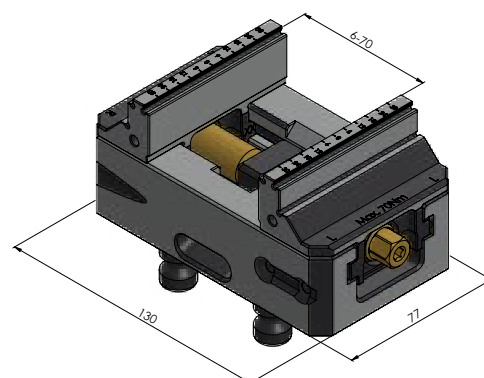
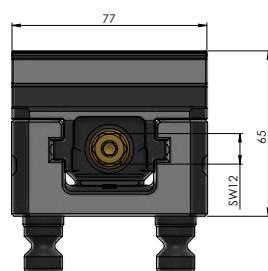
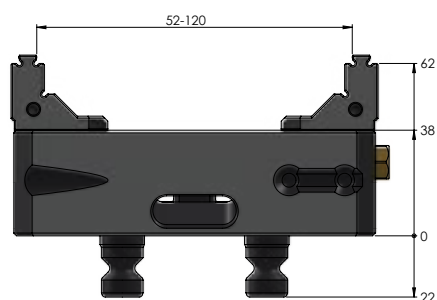

RoboTrex 96 Automation System



ROBOTREX 96 AUTOMATION SYSTEM

ITEM NO.	BASIC EQUIPMENT
64000	Complete robotic automation system incl. enclosure, trolley entry system and 1 automation trolley

Applications



Image: Somic-Haag



Image: Lindauer DORNIER GmbH



Image: Waibel GmbH



Image: Schleipfner & Stocker GmbH



Image: Beer Zerspanungstechnik GmbH

RoboTrex 96 Automation Trolley



ROBOTREX 96, AUTOMATION TROLLEY

ITEM NO.	STORAGE CAPACITY	MAX. PART SIZE (WHEN FULLY LOADED)	WEIGHT
64015	15	205 × 205 × 90 mm	178 kg
64016	16	205 × 150 × 150 mm	174 kg

Maximum load capacity of trolley: 500 kg

RoboTrex 96 Gripper Exchange Interface

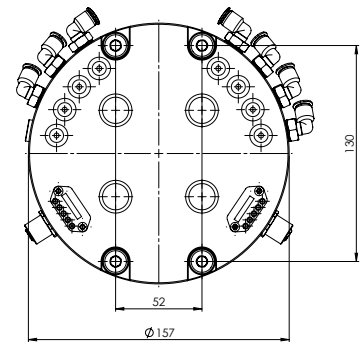
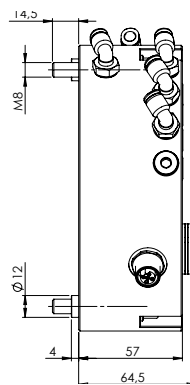

GRIPPER EXCHANGE INTERFACE

ITEM NO.	FITS ITEM NO.
64266	66950 / 64850

Applications

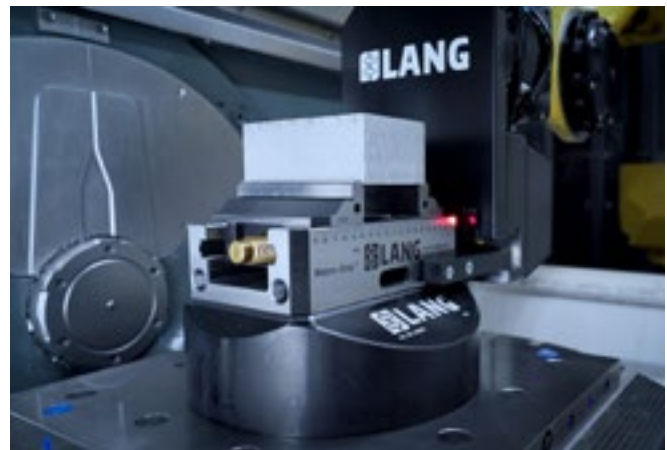

The gripper exchange interface, which is standard on RoboTrex 96, allows you to change between different gripper sizes and thus use different vice sizes in the same automation system. As a single component, the gripper exchange interface can also be used in third-party automation systems to take advantage of the benefits of LANG workholding technology and to switch flexibly between different system sizes.

RoboTrex 96 Grippers and Zero-Point Devices

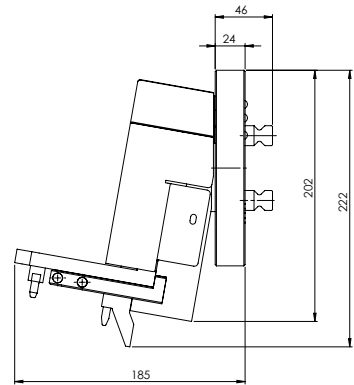
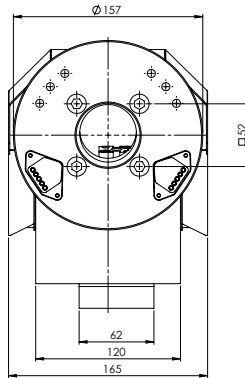

GRIPPER 52, PNEUMATIC

ITEM NO.	ACTUATION	FITS ITEM NO.
66950	pneumatic	66600

Max. workpiece weight: 15 kg.
 This gripper type allows using RoboTrex 52 components in the RoboTrex 96 automation system.

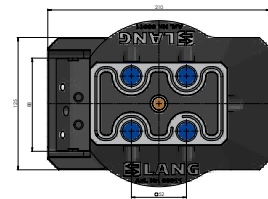
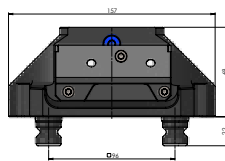

ZERO-POINT DEVICE 52, PNEUMATIC

ITEM NO.	ACTUATION	FITS ITEM NO.
66600	pneumatic	66900 / 66950

Included in delivery: zero-point device, adapter for manual operation + bracket, aluminium handle.
 Also suitable for RoboTrex 96!

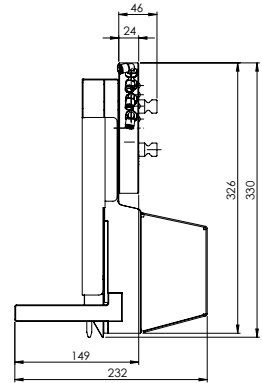
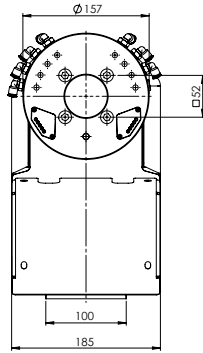

GRIPPER 96, PNEUMATIC

ITEM NO.	ACTUATION	FITS ITEM NO.
64850	pneumatic	64500

Max. workpiece weight: 25 kg.

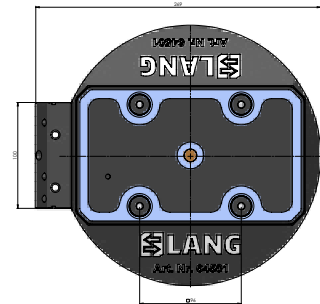
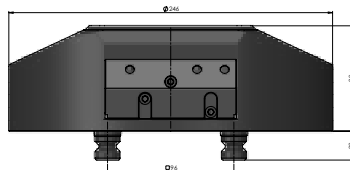

ZERO-POINT DEVICE 96, PNEUMATIC

ITEM NO.	ACTUATION	FITS ITEM NO.
64500	pneumatic	64850

Included in delivery: zero-point device, adapter for manual operation + bracket, aluminium handle.

Makro·Grip® 5-Axis Vice 125



MAKRO·GRIP® 5-AXIS VICE 125, JAW WIDTH 77 MM



ITEM NO.	BASE LENGTH	CLAMPING RANGE	WEIGHT
48205-77	210 mm	0 – 205 mm	9.1 kg

Spare Jaws and accessories can be found on p. 106 – 109.

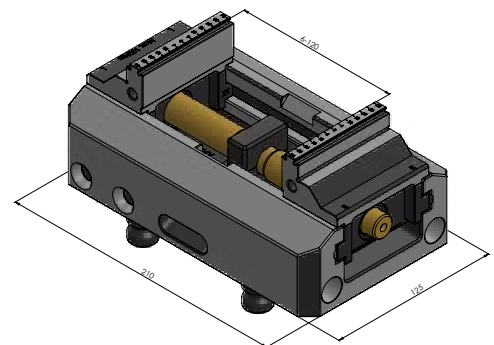
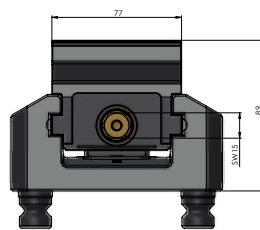
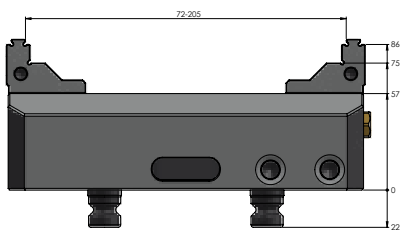

Makro·Grip® 5-Axis Vice 125

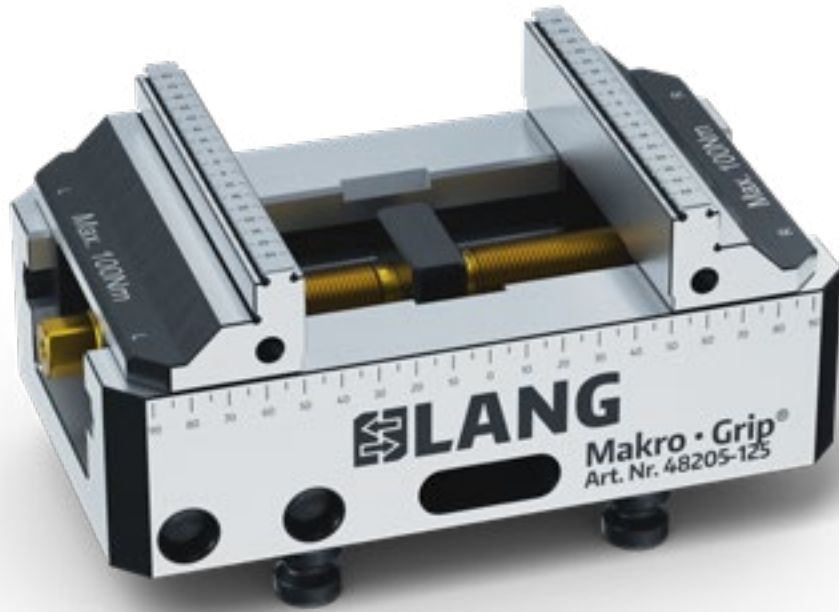

MAKRO·GRIP® 5-AXIS VICE 125, JAW WIDTH 125 MM



ITEM NO.	BASE LENGTH	CLAMPING RANGE	WEIGHT
48205-125	210 mm	0 - 205 mm	10.2 kg

Spare Jaws and accessories can be found on p. 106 - 109.

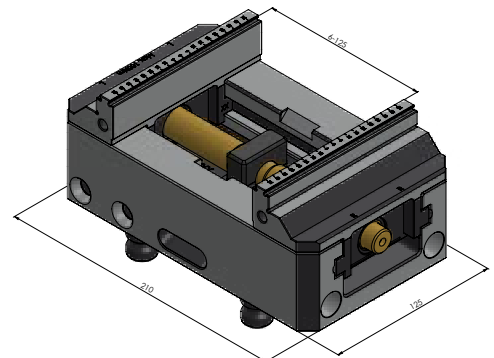
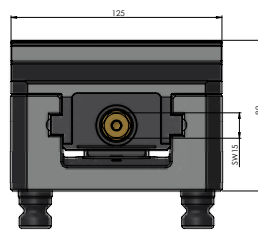
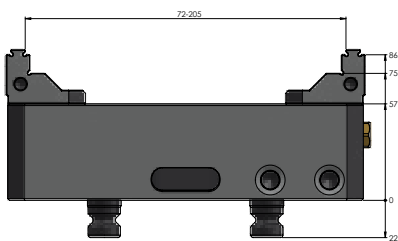

Other components for individual automation solutions



All essential RoboTrex components are also available as individual components in order to be used with conventional automation systems. Whether it's a connection to an existing robotic system, an integration in robot cells or shelf systems or a flexible in-house solution, LANG clamping systems make every automated manufacturing process more efficient.

From the various vice versions and automation trolleys to the automation window, all of these components are listed in the table below. Grippers and zero-point devices can be found on the previous pages and are not listed hereafter.

CENTRING VICES:	ITEM NO.
Makro-Grip® 5-Axis-Vice 77, jaw width 46 mm	48120-46
Makro-Grip® 5-Axis-Vice 77, jaw width 77 mm	48120-77
Makro-Grip® 77 Night King, Quantity 10 – 30	68120-77
Makro-Grip® 77 Night King, Quantity 40 – 60	68120-77
Makro-Grip® 77 Night King, Quantity 70 – 90	68120-77
Makro-Grip® 77 Night King, Quantity from 100	68120-77
Makro-Grip® 5-Axis-Vice 125, jaw width 77 mm	48205-77
Makro-Grip® 5-Axis-Vice 125, jaw width 125 mm	48205-125
AUTOMATION TROLLEYS AND POSITIONING BOLTS:	ITEM NO.
RoboTrex 52 Automation Trolley, 30 parts	66030
RoboTrex 52 Automation Trolley, 42 parts	66042
Positioning Bolt for RoboTrex 52 Automation Trolley	66087
RoboTrex 96 Automation Trolley, 15 parts	64015
RoboTrex 96 Automation Trolley, 16 parts	64016
Positioning Bolt for RoboTrex 96 Automation Trolley	64086
Automation Trolley with special alignment	99996
MISCELLANEOUS:	ITEM NO.
RoboTrex 52 Gripper, old version, for mechanical actuation	66801
RoboTrex 96 Gripper, no gripper exchange option	64801
Trolley Entry System for RoboTrex 52 and 96	66120
Automation Window for RoboTrex 52 and 96	66750

Makro·Grip® Mobile Storage Unit

Space saving stocking solution for vices and fixtures



- 1 Space to hold up to 60 devices (30 devices on each side)
- 2 Convenient handle for pushing and pulling the unit
- 3 Non-corrosive galvanised sheet steel
- 4 Powder coated coolant collecting tray with integrated drain screw
- 5 Both Quick·Point® spacings 52 and 96 mm integrated

MAKRO·GRIP® MOBILE STORAGE UNIT

ITEM NO.	STORAGE CAPACITY	DIMENSIONS	WEIGHT
61060	max. 60 clamping devices	1.200 × 800 × 1.500 mm	160 kg



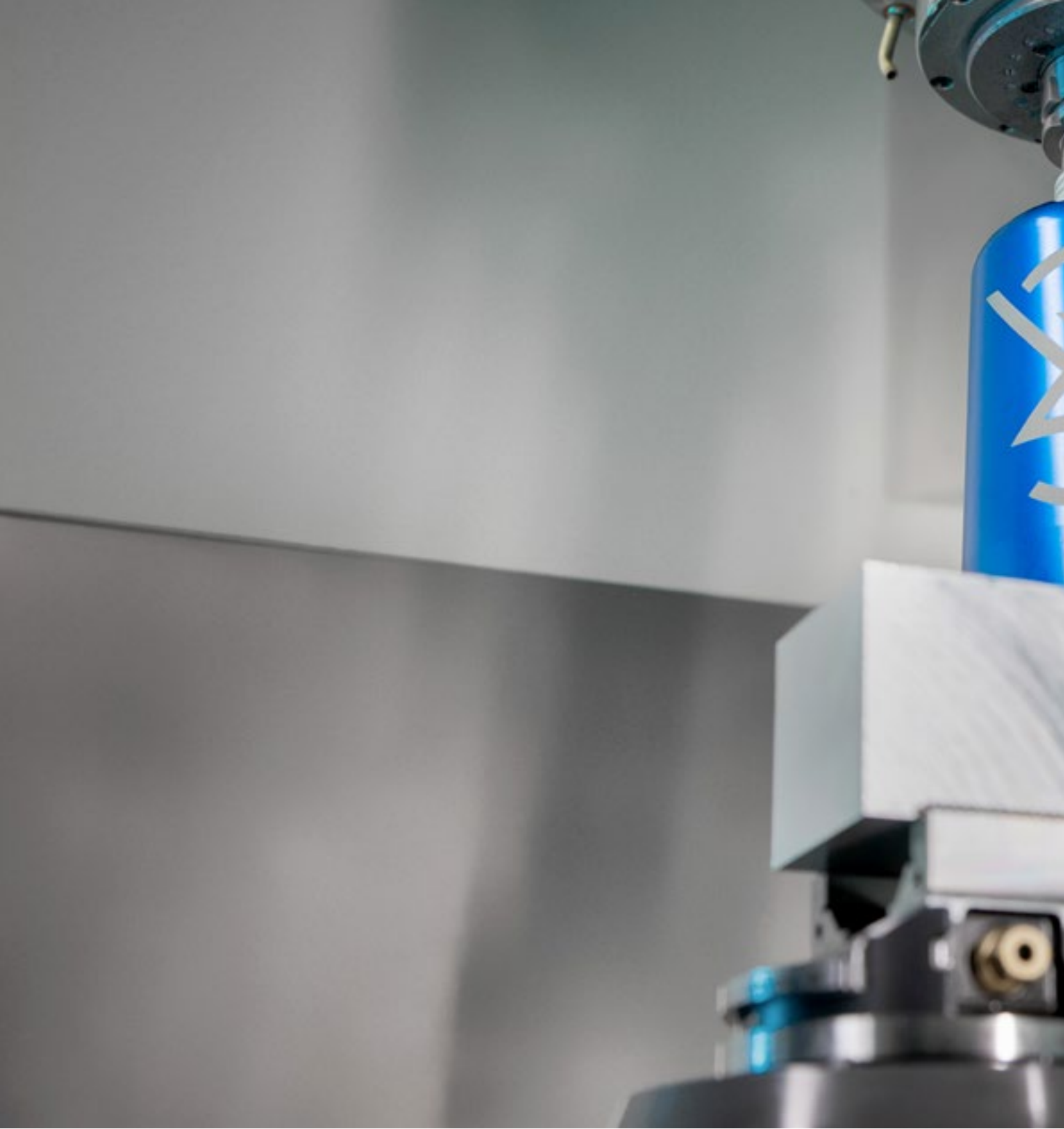

HAUBEX AUTOMATION



204 HAUBEX Automation

210 HAUBEX Components



**simple.
automatic.
change.**

The automatic vice change from the tool magazine

UNIVERSAL

FLEXIBLE

COST-EFFICIENT

Automated manufacturing without any pallet changer, feeding unit or robot? In cooperation with Erst Maschinenbau, LANG Technik presents a new, patented system that transforms the tool magazine of a machine tool into an automation system. The world's probably most simple automation solution enables automated production with any machine tool.

Benefits of the HAUBEX Automation System:



Can be used in almost any machine tool



Flexible use throughout the entire production



Cost-efficient automation solution for beginners



No knowledge about automation and robotic systems required



Can be ideally integrated into existing production environment



No time-consuming installation or machine downtimes



The automatic vice change by Erst Maschinenbau and LANG Technik



In joint cooperation, Erst Maschinenbau and LANG Technik present a patented system with which every machine tool can manufacture automatically without an additional feeding unit or robot – innovative. patented. unique.

HAUBEX Technology



1 HAUBEX tool holders

Tool holders of type HSK-A63, SK-40 and BT-40 specially adapted to HAUBEX guarantee an exactly defined positioning of the workholding hood in the machine spindle.

2 HAUBEX workholding hood

The aluminium workholding hood is the carrier system which transfers vice and workpiece blank from the tool magazine into the zero-point clamping system on the machine table. By means of a 90° closing movement, it opens and locks the zero-point system mechanically, which means that the system does not require any additional utilities on the machine side. A safety element between the workholding hood and the tool holder acts as a buffer and protects the machine spindle in the event of unexpected collisions. An integrated guide and fixation secures the vice against unintentional release from the workholding hood and ensures a secure fit.

3 Makro·Grip® HAUBEX 5-Axis Vice

HAUBEX uses a modified version of the Makro·Grip® as the workholding device. The slim design of the 5-Axis Vice and the narrow jaw width of 46 mm ensure ideal accessibility in 5-sided machining of blanks. The maximum workpiece size of approx. 80 × 75 × 70 mm is given by the height and diameter of the workholding hood. Examples of maximum possible workpiece dimensions and a formula for their calculation are available on the website.

4 Quick·Point® HAUBEX zero-point clamping system

The patented clamping mechanism of the zero-point device is actuated by the HAUBEX workholding hood in automated production or manually via a clamping lever, in each case by a 90° closing movement. The zero-point device is equipped with clamping studs which guarantees a fast set-up process in the Quick·Point® 96 system.





Workpiece clamping

Workpiece blanks with dimensions of approx. 80 × 75 × 70 mm can be clamped in the Makro-Grip® HAUBEX 5-Axis Vice by form-fit. With a maximum tightening torque of 70 Nm, the 5-Axis Vice achieves holding forces of up to 14.000 N. Thanks to the defined form-fit between the pre-stamped workpiece and the jaw serration, the Makro-Grip® technology guarantees absolute process reliability and repeatability.



Equipping the workholding hood

The workholding hood can be equipped in several ways. If the workholding hood is placed in a tool setting device, the 5-Axis Vice with the workpiece blank can be inserted overhead. Alternatively, the workholding hood can be slipped over the 5-Axis Vice at a set-up station, in each case by a 45° snap-in function.



Measuring and program sequence

Measuring the z-height on the tool setting device and entering it in the program. Sample specifications for NC programs for setting up the automatic vice change can be downloaded from our website.

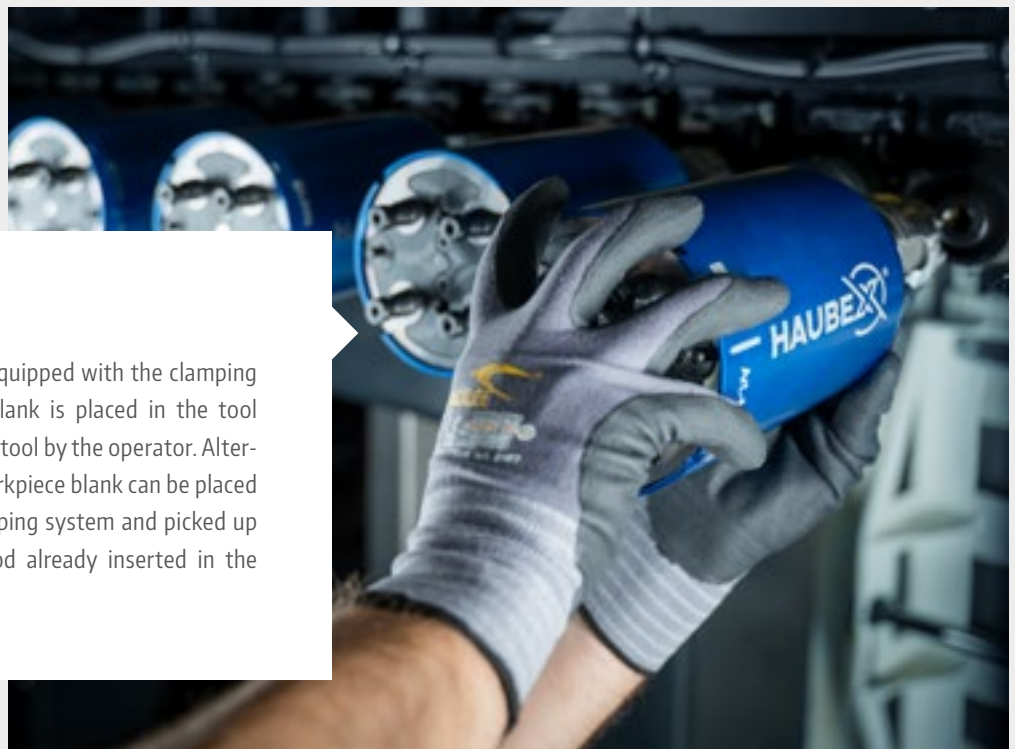

Vice storage

The workholding hood equipped with the clamping device and workpiece blank is placed in the tool magazine like a common tool by the operator. Alternatively, the vice and workpiece blank can be placed into the zero-point clamping system and picked up by the workholding hood already inserted in the tool magazine.



Clamping mechanism

The workholding hood places the 5-Axis Vice into the zero-point clamping system and locks it by a 90° closing movement. Alternatively, the zeropoint device can be actuated via a clamping lever during manual operation without HAUBEX.



Cleaning

After the machining process and prior to the automatic removal through the workholding hood, we recommend cleaning the machine interior and all relevant interfaces with the Clean·Tec chip fan.

HAUBEX Components



HAUBEX TOOL HOLDER

ITEM NO.	TYPE	STANDARD	WEIGHT	TOOL LENGTH*
61500-HSK63	HSK-A63 (Hollow taper shank)	DIN 69893-1	1.0 kg	approx. 247 mm
61500-SK40	SK-40 (Steep taper)	DIN ISO 7388-1	1.1 kg	approx. 240 mm
61500-BT40	BT-40 (Steep taper)	JIS B6339	1.3 kg	approx. 250 mm

* including workholding hood and Makro-Grip®. Measured to the lower edge of the clamping studs of the 5-Axis Vice.

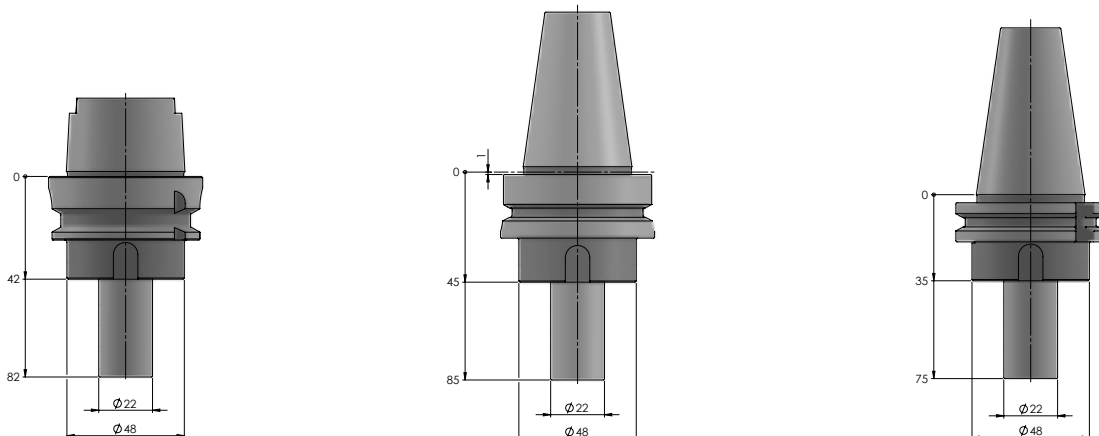



HAUBEX WORKHOLDING HOOD

ITEM NO.	LOWER DIAMETER	MAX. WORKPIECE SIZE	WEIGHT	TOTAL HEIGHT
61125	Ø 125 mm	approx. 80 × 75 × 70 mm	0.9 kg	185 mm

* including safety element

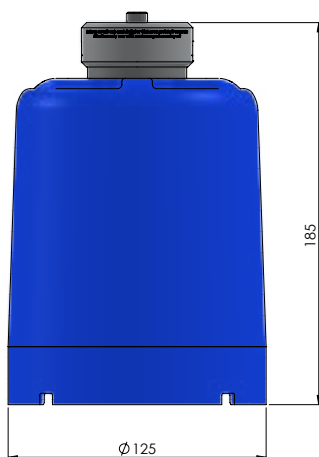

HAUBEX Workholding



MAKRO-GRIP® HAUBEX 5-AXIS VICE

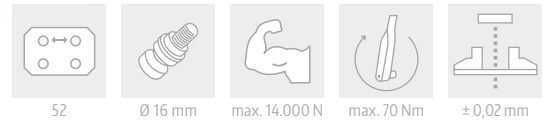

ITEM NO.	DIMENSIONS	CLAMPING RANGE	WEIGHT
61085-46	Ø 120 × 65 mm	0 – 80 mm	2.6 kg

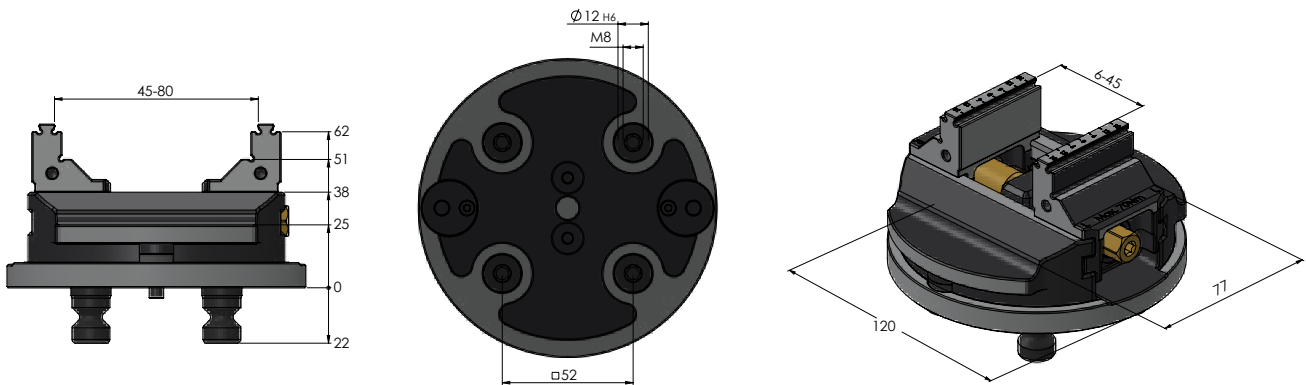



QUICK-POINT® HAUBEX ZERO-POINT CLAMPING SYSTEM

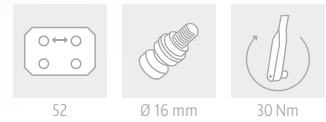

ITEM NO.	DIMENSIONS	GRID SIZE	WEIGHT
61110	Ø 211 × 74 mm	52	8.6 kg

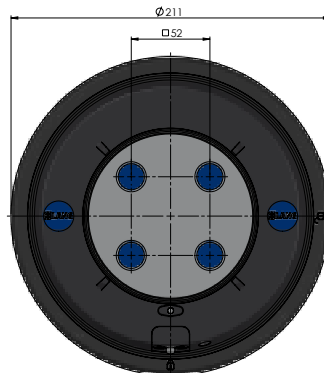
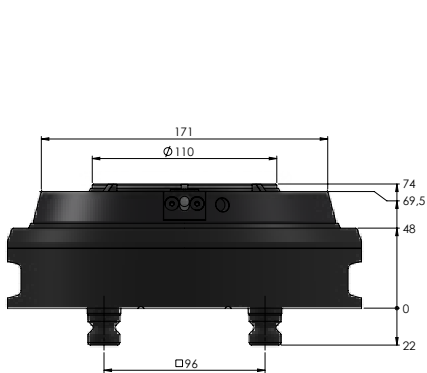



CHIP FAN

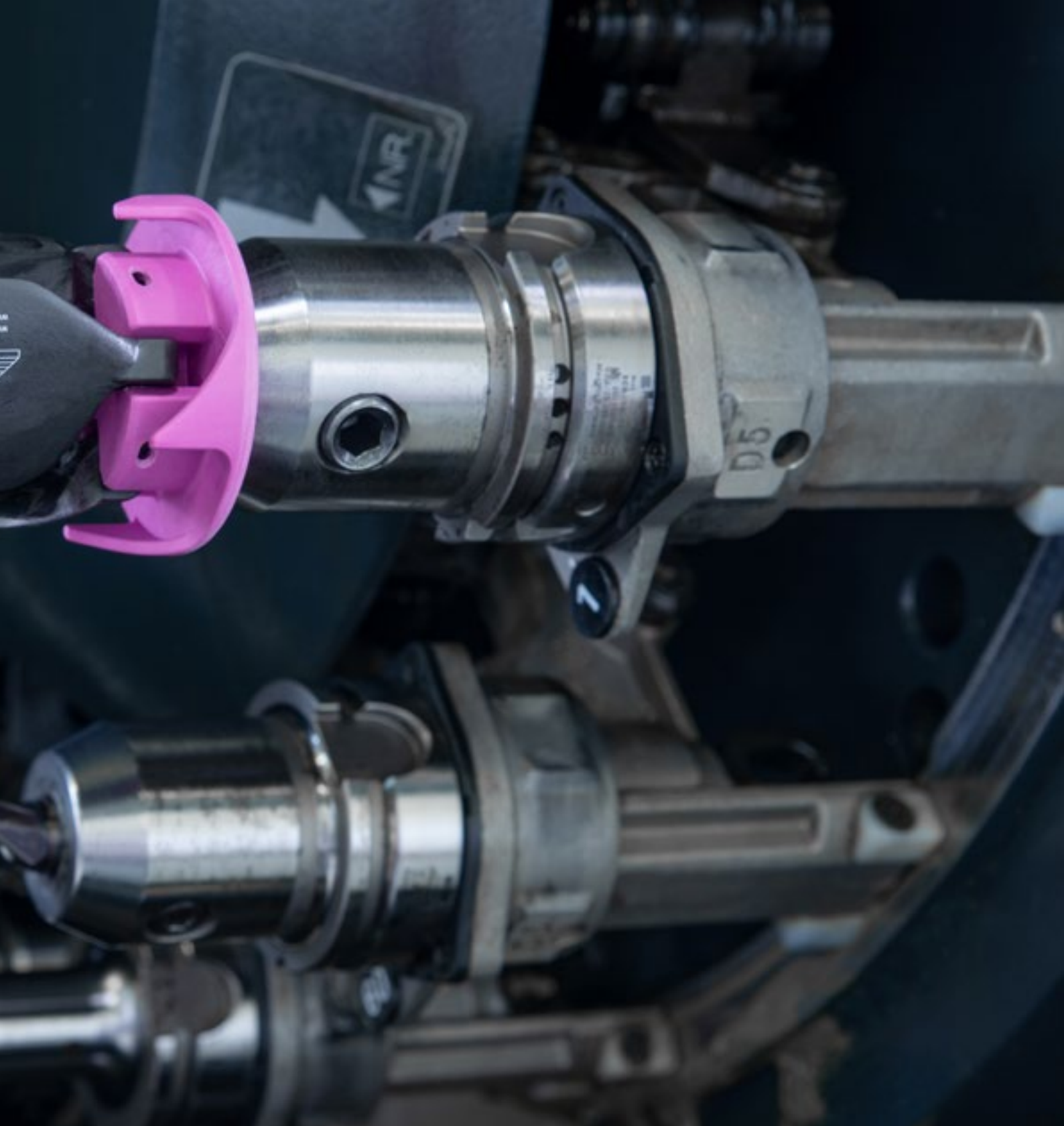

218 Clean·Tec Chip Fan



**simple.
automatic.
cleaning.**



Automatic cleaning of workpieces and fixtures after the machining process

The Clean·Tec chip fan ensures and enables:

CLEANLINESS

ENERGY SAVINGS

UNMANNED CLEANING

The Clean·Tec, “The Original” Chip Fan cleans the machine interior after machining processes, removing chips and coolant without the operator having to open the machine tool door. As a final step in the machining process, the Chip Fan is called up via the machine program and selected from the tool magazine. Its blades are opened and closed by controlling the speed of the machine tool spindle. Especially in automated manufacturing the Clean·Tec is a must-have. Prior to the automatic unloading, the Chip Fan cleans all relevant interfaces between workholding fixtures and thus ensures a clean and reliable process.

Benefits of the Clean·Tec chip fan:



Clean machining environment thanks to in-process cleaning



Energy savings and no need for expensive compressed air



Ideal for unmanned, automated manufacturing



Flexible application possibilities due to different sizes



Suitable for every standard tool holder

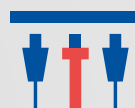

Space savings in the tool magazine thanks to the slim design

Clean·Tec Technology



Save expensive compressed air – use Clean·Tec



- 1 Fibreglass compound body with steel centre core. Can be clamped in every common shank Ø 20 mm
- 2 Rigid retaining spring for the secure folding of blades after the cleaning process
- 3 Strong and wear-resistant carbon fibre blades for best durability – even with tough chipping
- 4 Slim design for space-saving storage in the tool magazine



**WITH EVERY CLEAN·TEC
FAN SOLD, 2 EUROS WILL
BE DONATED TO THE
“HERZ FÜR KINDER”-
FOUNDATION.**

Learn more on page 221



The Clean·Tec blades open and close automatically by switching the machine tool spindle on and off.

Use recommendations

Acceleration

Turn clockwise to clean the parts. By rotating the spindle the blades will open. We recommend to accelerate in 2 stages:

1. Accelerate to 2.000 RPM

2. Accelerate to the operating RPM

(Clean·Tec works efficiently at 4.000 RPM already!)



Motion

Move the rotating fan with a distance of **100 – 150 mm** above the workpiece and apply a feed rate of **3 – 10 m/min**. Then return to the tool change position.



The design of Clean·Tec allows you to wash workpieces and fixtures using coolant – **with the machine spindle turned off and the Clean·Tec blades folded!** – This enhances the cleaning effect and makes perfect sense if pockets and bores are commonly packed with swarf and chips.



For smooth processes in automated, unmanned production Clean·Tec is a must-have! It is ideal for cleaning workpieces, fixtures and the machine table prior to an automatic unloading.

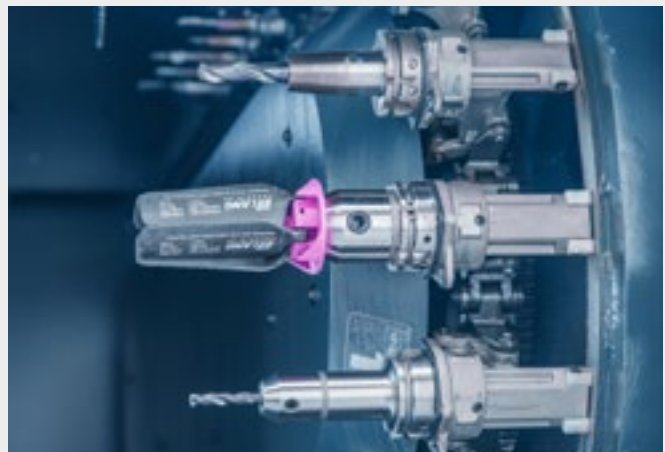

The Clean·Tec Chip Fan is stored just like a common tool in the tool magazine and selected automatically via a CNC program. Thanks to its compact design (only \varnothing 68 mm) tool pockets neighboring the Clean·Tec's storage place can be equipped with other tools and don't have to be left empty.

Clean·Tec Chip Fan



CLEAN·TEC 160

ITEM NO.	Ø WITH OPEN BLADES	RPM RANGE
30160	160 mm	6.000 – 12.000 RPM

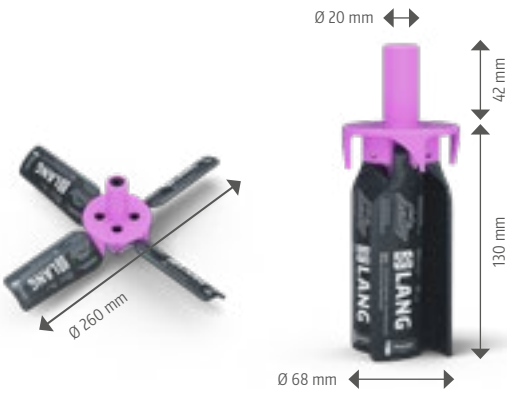

CLEAN·TEC 260

ITEM NO.	Ø WITH OPEN BLADES	RPM RANGE
30260	260 mm	5.000 – 8.000 RPM

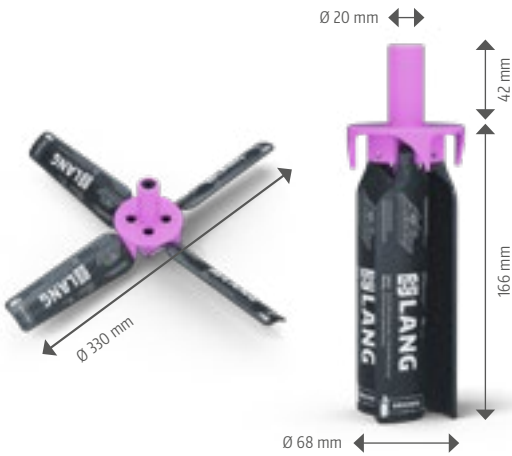

CLEAN·TEC 330

ITEM NO.	Ø WITH OPEN BLADES	RPM RANGE
30330	330 mm	3.000 – 8.000 RPM



SPARE PART KIT, 4 PCS. BLADES AND SPRINGS

ITEM NO.	FOR
30164	30160
30264	30260
30334	30330

LANG Technik supports **Bild hilft e.V. “Ein Herz für Kinder”**



As a family owned company, we think in generations. For this reason, we have for years supported different projects that sponsor and strengthen our next generations. One of those is the Bild hilft e.V. “Ein Herz für Kinder” campaign founded by the Axel Springer Verlag in 1978. For the last four years we've donated 2 € with every Clean·Tec fan sold. Up to this date, we've collected more than 85.000 € for children in need.

Bild hilft e.V. “Ein Herz für Kinder” is an internationally active aid organisation founded in 1978 by Axel Springer. Since its foundation it has raised more than 315 million Euro. Funding priority is Germany, but projects all over the world are supported. For example, “Ein Herz für Kinder” supports children's hospitals, kindergartens, soup kitchens, schools and families. The aid organization also ensures life-saving surgeries and therapies for children who are seriously ill and cannot be treated sufficiently in their home country. Additionally, Bild hilft e.V. “Ein Herz für Kinder” provides immediate help in war and disaster zones.

- Find out more about the aid organisation and its current projects:
www.ehfk.de.



With every Clean·Tec fan sold,
2 Euros will be donated to the
BILD hilft e.V. “Ein Herz für
Kinder” foundation.

Further organisation and associations which are regularly supported by LANG Technik are for example:

- Madeleine-Schickedanz-Kinderkrebs-Stiftung
- Zukunft für Kinder – Förderverein Kinder- u. Jugendheim Neuhausen e.V.
- Helfer vor Ort – First Responder – DRK Weilheim

Spare Parts for former vice versions

On this double page you find all spare parts for your existing vices (versions until September 2018)



5-AXIS VICE

SPARE JAWS

Makro-Grip® 46	47046-20	Spare Jaws Makro-Grip® 46
Makro-Grip® 77	47077-20	Spare Jaws Makro-Grip® 77
	47085-20	Spare Jaws Makro-Grip® 77, for Item No. 47085
Makro-Grip® 125	47125-20	Spare Jaws Makro-Grip® 125



AVANTI

BASE JAWS

44461	Avanti Base Jaws 46
44771	Avanti Base Jaws 77
44251	Avanti Base Jaws 125



PROFILO

BASE JAWS

49771	Profilo Base Jaws 77
49251	Profilo Base Jaws 125



CENTRE BASE JAW + SPINDLE

49080-TG	Centre Base Jaw 77 + Spindle Ø 16 mm, length 175 mm
49120-TG	Centre Base Jaw 77 + Spindle Ø 16 mm, length 215 mm
49100-TG	Centre Base Jaw 125 + Spindle Ø 20 mm, length 215 mm
49150-TG	Centre Base Jaw 125 + Spindle Ø 20 mm, length 265 mm
49200-TG	Centre Base Jaw 125 + Spindle Ø 20 mm, length 315 mm
49250-TG	Centre Base Jaw 125 + Spindle Ø 20 mm, length 365 mm



VARIO-TEC

SPARE JAW SET

42077	Spare Jaw Set 77 (2 pin jaws + 2 carrier jaws)
42125	Spare Jaw Set 125 (2 pin jaws + 2 carrier jaws)

5-AXIS VICE



CENTRE PIECE + SPINDLE

Makro-Grip® 46	4046082	Centre Piece + Spindle Ø 12 mm, length 82 mm
	4046122	Centre Piece + Spindle Ø 12 mm, length 122 mm
	4046162	Centre Piece + Spindle Ø 12 mm, length 162 mm
Makro-Grip® 77	4077102	Centre Piece + Spindle Ø 16 mm, length 102.5 mm
	4077135	Centre Piece + Spindle Ø 16 mm, length 135 mm
	4077175	Centre Piece + Spindle Ø 16 mm, length 175 mm
	4077215	Centre Piece + Spindle Ø 16 mm, length 215 mm
Makro-Grip® 125	4025165	Centre Piece + Spindle Ø 20 mm, length 165 mm
	4025215	Centre Piece + Spindle Ø 20 mm, length 215 mm
	4025265	Centre Piece + Spindle Ø 20 mm, length 265 mm
	4025315	Centre Piece + Spindle Ø 20 mm, length 315 mm
	4025365	Centre Piece + Spindle Ø 20 mm, length 365 mm



CENTRE JAW + SPINDLE FOR DUAL CLAMPING

Makro-Grip® 46	47065-TG	Centre Jaw + Spindle Ø 12 mm, length 82 mm
	47105-TG	Centre Jaw + Spindle Ø 12 mm, length 122 mm
	47145-TG	Centre Jaw + Spindle Ø 12 mm, length 162 mm
Makro-Grip® 77	47085-TG17	Centre Jaw 17 mm + Spindle Ø 16 mm, length 102.5 mm
	47085-TG27	Centre Jaw 27 mm + Spindle Ø 16 mm, length 102.5 mm
	47120-TG17	Centre Jaw 17 mm + Spindle Ø 16 mm, length 135 mm
	47120-TG27	Centre Jaw 27 mm + Spindle Ø 16 mm, length 135 mm
	47160-TG17	Centre Jaw 17 mm + Spindle Ø 16 mm, length 175 mm
	47160-TG27	Centre Jaw 27 mm + Spindle Ø 16 mm, length 175 mm
	47200-TG17	Centre Jaw 17 mm + Spindle Ø 16 mm, length 215 mm
	47200-TG27	Centre Jaw 27 mm + Spindle Ø 16 mm, length 215 mm
Makro-Grip® 125	47155-TG17	Centre Jaw 17 mm + Spindle Ø 20 mm, length 165 mm
	47155-TG27	Centre Jaw 27 mm + Spindle Ø 20 mm, length 165 mm
	47205-TG17	Centre Jaw 17 mm + Spindle Ø 20 mm, length 215 mm
	47205-TG27	Centre Jaw 27 mm + Spindle Ø 20 mm, length 215 mm
	47255-TG17	Centre Jaw 17 mm + Spindle Ø 20 mm, length 265 mm
	47255-TG27	Centre Jaw 27 mm + Spindle Ø 20 mm, length 265 mm
	47305-TG17	Centre Jaw 17 mm + Spindle Ø 20 mm, length 315 mm
	47305-TG27	Centre Jaw 27 mm + Spindle Ø 20 mm, length 315 mm
	47355-TG17	Centre Jaw 17 mm + Spindle Ø 20 mm, length 365 mm
	47355-TG27	Centre Jaw 27 mm + Spindle Ø 20 mm, length 365 mm

SPINDLE COVERS

Makro-Grip® 46	47046-80	Spindle Covers Foam, 10 pcs.
Makro-Grip® 77	47077-70	Spindle Covers Plastic, 10 pcs.
	47077-80	Spindle Covers Foam, 10 pcs.
Makro-Grip® 125	47125-70	Spindle Covers Plastic, 10 pcs.
	47125-80	Spindle Covers Foam, 10 pcs.



Product Finder

ITEM NO.	DESCRIPTION	PAGE	ITEM NO.	DESCRIPTION	PAGE
misc.	Centring studs for alignment of Quick-Point® plates	61	44160-77	Avanti 77, Profile Clamping Vice, Jaw width 77 mm, max. clamping range 165 mm	154
20000	Vario-Tec 77, O-Rings, Ø 2 x 1,5 mm, for spare pins Ø 4 mm	167	44196	Quick-Point® 96, Alignment Gauge, Purchase	63
200009	Vario-Tec 77, O-Rings, Ø 2 x 1,5 mm, for spare pins Ø 4 mm	167	44196-10	Quick-Point® 96, Alignment Gauge, for rent	63
200010	Vario-Tec 125, O-Rings, Ø 3,5 x 2 mm, for spare pins Ø 6 mm	169	44200-77	Avanti 77, Profile Clamping Vice, Jaw width 77 mm, max. clamping range 205 mm	154
20001	Vario-Tec 125, Spare Pins, Ø 6 mm	169	44200-TG77	Avanti 77, Centre Base Jaw + Spindle, Jaw width 77 mm, Spindle length 215 mm	155
20004	Vario-Tec, Compressed Air Gun	167	44205-125	Avanti 125, Profile Clamping Vice, Jaw width 125 mm, max. clamping range 205 mm	156
30160	Clean-Tec 160, Chip Fan, Shaft-Ø 20 mm	220	44251-125	Avanti 125, Base Jaws, Jaw width 125 mm	157
30164	Clean-Tec 160, Spare Part Kit	220	44522	Quick-Point® 52, Gauging Pallet	62
30260	Clean-Tec 260, Chip Fan, Shaft-Ø 20 mm	220	44255-125	Avanti 125, Profile Clamping Vice, Jaw width 125 mm, max. clamping range 255 mm	156
30264	Clean-Tec 260, Spare Part Kit	220	44255-TG125	Avanti 125, Centre Base Jaw + Spindle, Jaw width 125 mm, Spindle length 264 mm	157
30330	Clean-Tec 330, Chip Fan, Shaft-Ø 20 mm	220	44258-46	Avanti 125, Top Jaw, Jaw width 125 mm, Steel, height 46 mm	157
30334	Clean-Tec 330, Spare Part Kit	220	44258-76	Avanti 125, Top Jaw, Jaw width 125 mm, Steel, height 76 mm	157
41010	Makro-Grip®, Centre Marking Tool	80	44259-46	Avanti 125, Top Jaw, Jaw width 125 mm, Aluminium, height 46 mm	157
41010-01	Makro-Grip®, Spare Stud, for centre marking tool	80	44259-76	Avanti 125, Top Jaw, Jaw width 125 mm, Aluminium, height 76 mm	157
41020	Makro-Grip®, Gauging Blocks, for measuring wear of Stamping Jaws	80	44962	Quick-Point® 96, Gauging Pallet	62
41032	Preci-Point 52, Collet Chuck, for ER 32 collets, Clamping range Ø 3 - 20 mm	171	44305-125	Avanti 125, Profile Clamping Vice, Jaw width 125 mm, max. clamping range 305 mm	156
41032-03	Preci-Point, Clamping Wrench, for ER 32	171	44305-TG125	Avanti 125, Centre Base Jaw + Spindle, Jaw width 125 mm, Spindle length 314 mm	157
41052	Preci-Point 52, Collet Chuck, for ER 50 collets, Clamping range Ø 6 - 34 mm	171	44355-125	Avanti 125, Profile Clamping Vice, Jaw width 125 mm, max. clamping range 355 mm	156
41052-03	Preci-Point, Clamping Wrench, for ER 50	171	44355-TG125	Avanti 125, Centre Base Jaw + Spindle, Jaw width 125 mm, Spindle length 364 mm	157
41111	Makro-Grip®, Stamping Jaws, Standard, for materials up to 35 HRC	81	44468-26	Avanti 46, Top Jaw, Jaw width 46 mm, Steel, height 26 mm	153
41111-01	Reconditioning, Standard Stamping Jaws	81	44469-26	Avanti 46, Top Jaw, Jaw width 46 mm, Aluminium, height 26 mm	153
41111-0308	Makro-Grip® Ultra, Parallels, Thickness 8 mm, Support height 3 mm	139	44552	Quick-Point® 52, Quick-Lock, for single plates 52 (a.o.)	58
41111-0508	Makro-Grip® Ultra, Parallels, Thickness 8 mm, Support height 5 mm	139	44596	Quick-Point® 96, Quick-Lock, for single plates 96 (a.o.)	58
41112	Makro-Grip®, Stamping Jaws, High-End, for materials up to 45 HRC	81	44771-46	Avanti 77, Base Jaws, Jaw width 46 mm	153
41112-01	Reconditioning, High-End Stamping Jaws	81	44771-77	Avanti 77, Base Jaws, Jaw width 77 mm	155
41112-06	Makro-Grip®, Stamping Jaws, High-End, without parallels	139	44778-36	Avanti 77, Top Jaw, Jaw width 77 mm, Steel, height 36 mm	155
41140	Makro-Grip®, Stamping Unit, Additional stamping unit, extended, with standard stamping jaws	78	44778-56	Avanti 77, Top Jaw, Jaw width 77 mm, Steel, height 56 mm	155
41140-HE	Makro-Grip®, Stamping Unit, Additional stamping unit, extended, with High-End jaws	78	44779-36	Avanti 77, Top Jaw, Jaw width 77 mm, Aluminium, height 36 mm	155
41200	Makro-Grip®, Stamping Unit, Standard, with standard stamping jaws	76	44779-56	Avanti 77, Top Jaw, Jaw width 77 mm, Aluminium, height 56 mm	155
41200-HE	Makro-Grip®, Stamping Unit, Standard, with High-End stamping jaws	76	45000-09	Quick-Point®, Bushings, ø 12 x 12 mm, for screw size M 10	61
41350	Makro-Grip®, Stamping Unit, Extended, with standard stamping jaws	76	45000-30	Quick-Point®, Cover Plug Remover	60
41350-HE	Makro-Grip®, Stamping Unit, Extended, with High-End stamping jaws	76	45002	Set keyways according to customer's request	div.
41400	Makro-Grip®, Stamping Trolley, extended stamping unit, on t-slot plate, with standard stamping jaws	78	45004	Set mounting bores according to customer's request	div.
41400-HE	Makro-Grip®, Stamping Trolley, extended stamping unit, on t-slot plate, with High-End stamping jaws	78	45008-15	Quick-Point®, Cover Discs, 20 pcs., ø 15 mm	60
41402	Makro-Grip®, Stamping Trolley, extended dual stamping unit, on t-slot plate, with standard stamping jaws	79	45008-20	Quick-Point®, Cover Discs, 20 pcs., ø 20 mm	60
41402-HE	Makro-Grip®, Stamping Trolley, extended dual stamping unit, on t-slot plate, with High-End stamping jaws	79	45008-27	Quick-Point®, Cover Discs, 20 pcs., ø 27 mm	60
41521	Makro-Grip®, Stamping Trolley, Standard stamping unit, without t-slot plate, with standard stamping jaws	77	45009	Set centre bore according to customer's request	30, 31
41521-HE	Makro-Grip®, Stamping Trolley, Standard stamping unit, without t-slot plate, with High-End stamping jaws	77	45022	Set keyways in double grid plate 96 according to customer's request	34
42018-77	Vario-Tec 77, Pair Of Jaws, Jaw width 77 mm	167	45024	Set mounting bores in double grid plate 96 according to customer's request	34
42018-125	Vario-Tec 125, Pair Of Jaws, Jaw width 125 mm	169	45042	Set keyways in 4-fold (6 double, round) grid plate 96 according to customer's request	34, 36
42057-77	Vario-Tec 77, Centring Vice, Jaw width 77 mm, max. clamping range 57 mm	166	45043-01	Custom corner radius for Quick-Point® (Multi-) Grid Plates, cut off 1 corner	65
42097-77	Vario-Tec 77, Centring Vice, Jaw width 77 mm, max. clamping range 97 mm	166	45043-02	Custom corner radius for Quick-Point® (Multi-) Grid Plates, cut off 2 corners	65
42102-125	Vario-Tec 125, Centring Vice, Jaw width 125 mm, max. clamping range 100 mm	168	45043-04	Custom corner radius for Quick-Point® (Multi-) Grid Plates, cut off 3 corners	65
42137-77	Vario-Tec 77, Centring Vice, Jaw width 77 mm, max. clamping range 137 mm	166	45044	Set mounting bores in 4-fold (6 double, round) grid plate 96 according to customer's request	34, 36
42152-125	Vario-Tec 125, Centring Vice, Jaw width 125 mm, max. clamping range 150 mm	168	45052-20	Quick-Point® 52, Cover Plugs, ø 16 mm, for 52 mm spacing, Plastic	60
42202-125	Vario-Tec 125, Centring Vice, Jaw width 125 mm, max. clamping range 200 mm	168	45052-30	Quick-Point® 52, Cover Plugs, ø 16 mm, for 52 mm spacing, Steel	60
42252-125	Vario-Tec 125, Centring Vice, Jaw width 125 mm, max. clamping range 250 mm	168	45096-20	Quick-Point® 96, Cover Plugs, ø 20 mm, for 96 mm spacing, Plastic	60
43060	Quick-Point® 52, Riser, 150 x 116 mm, Height 60 mm	42	45096-30	Quick-Point® 96, Cover Plugs, ø 20 mm, for 96 mm spacing, Steel	60
43100	Quick-Point® 52, Riser, 150 x 116 mm, Height 100 mm	42	45150	Quick-Point® 52, Single Plate, 150 x 116 x 27 mm, with bores 100 x 50 mm and clamping edge	24
43400	Quick-Point® 96, 3-face Pyramid, ø 400 x 150 mm	44	45151	Quick-Point® 52, Single Plate, 150 x 116 x 27 mm, without mounting bores	24
44006	Quick-Point® 96, Riser, round, ø 246 / 176 mm, Height 60 mm	43	45156	Quick-Point® 52, 5-Axis Riser, 150 x 116 mm, Height 60 mm	41
44010	Quick-Point® 96, Riser, round, ø 246 / 176 mm, Height 100 mm	43	45157	Quick-Point® 52, 5-Axis Riser, 150 x 116 mm, Height 100 mm	41
44060	Quick-Point® 96, Riser, 192 x 156 mm, Height 60 mm	43	45160	Quick-Point®, Adaptor Plate, rectangular, 150 x 126 x 27 mm	39
44085-46	Avanti 77, Profile Clamping Vice, Jaw width 46 mm, max. clamping range 97 mm	152	452014	Quick-Point®, Slot Key, DIN 6323, 20 x 14 mm	61
44100	Quick-Point® 96, Riser, 192 x 156 mm, Height 100 mm	43	452018	Quick-Point®, Slot Key, DIN 6323, 20 x 18 mm	61
44120-46	Avanti 77, Profile Clamping Vice, Jaw width 46 mm, max. clamping range 125 mm	152	452214	Quick-Point®, Slot Key, for Quick-Point® Round plate item no. 45890, 14 x 22 mm	61
44120-77	Avanti 77, Profile Clamping Vice, Jaw width 77 mm, max. clamping range 125 mm	154	452218	Quick-Point®, Slot Key, for Quick-Point® Round plate item no. 45890, 18 x 22 mm	61
44120-TG46	Avanti 77, Centre Base Jaw + Spindle, Jaw width 46 mm, Spindle length 135 mm	153	45252	Quick-Point® 52, Quick-Lock, for 2-fold grid plate 52	58
44152	Quick-Point® 52, Alignment Gauge	63	45270	Quick-Point® 52, Clamping Studs, ø 16 mm, for 52 mm bolt distance	54
44152-10	Quick-Point® 52, Alignment Gauge, for rent	63	45270-10	Quick-Point® 52, Spacer Studs, ø 16 mm, distance height 10 mm, for 52 mm spacing	57
			45275	Quick-Point® 52, Support Plate, 96 x 96 x 27 mm	56
			45277	Quick-Point® 52, Support Plate, 156 x 156 x 27 mm	56
			45296	Quick-Point® 96, Quick-Lock, for 2-fold grid plate 96	58

ITEM NO.	DESCRIPTION	PAGE
45400	Quick-Point® 96, Single Plate, 192 x 156 x 27 mm, with bores 150 x 100 / 50 mm and clamping edge	25
45401	Quick-Point® 96, Single Plate, 192 x 156 x 27 mm, without mounting bores	25
45406	Quick-Point® 96, 5-Axis Riser, 192 x 156 mm, Height 60 mm	41
45407	Quick-Point® 96, 5-Axis Riser, 192 x 156 mm, Height 100 mm	41
45452	Quick-Point® 52, Quick-Lock, for 4-fold grid plate 52	58
45496	Quick-Point® 96, Quick-Lock, for 4-fold grid plate 96	58
45500	Makro-Grip®, Wrench, for external hexagon, wrench size 12 mm	109
45501	Makro-Grip®, Wrench, for external hexagon, wrench size 15 mm	109
45505	Makro-Grip®, Wrench, for hexagon socket, wrench size 5 mm	109
45508	Makro-Grip®, Hexagon Socket, with hexagon, for external hexagon, wrench size 12 mm	109
45509	Makro-Grip®, Hexagon Socket, with hexagon, for external hexagon, wrench size 15 mm	109
45511	Makro-Grip® Ultra, Hexagon Socket, with hexagon, for external hexagon, wrench size 19 mm	135
45512	Hydro-Sup, Hexagon Socket Wrench, for external hexagon, wrench size 12 mm	137
45519	Makro-Grip® Ultra, Wrench, for external hexagon, wrench size 19 mm	135
45570	Quick-Point® 96, Clamping Studs, ø 20 mm, for 96 mm bolt distance	54
45570-10	Quick-Point® 96, Spacer Studs, ø 20 mm, distance height 10 mm, for 96 mm spacing	57
45575	Quick-Point® 96, Support Plate, 156 x 156 x 27 mm	56
45577	Quick-Point® 96, Support Plate, 192 x 192 x 27 mm	56
45600	Quick-Point® 52, Single Plate, 104 x 104 x 27 mm, without mounting bores	20
45621	Quick-Point® 52, Grid Plate, 2-fold, 208 x 104 x 27 mm, with mounting bores 186 x 82 mm	32
45640	Quick-Point® 52, Grid Plate, 4-fold, 208 x 208 x 27 mm, without mounting bores	33
45641	Quick-Point® 52, Grid Plate, 4-fold, 208 x 208 x 27 mm, with mounting bores for 63 mm slot distance	33
45642	Set keyways in 4-fold grid plate 52 according to customer's request	33
45644	Set mounting bores in 4-fold grid plate 52 according to customer's request	33
45710	Quick-Point® 96, Single Plate, 192 x 192 x 27 mm, without mounting bores	21
45715	Quick-Point® 96, Grid Plate, extended, 246 x 192 x 27 mm, with mounting bores for 100 mm slot distance	23
45716	Quick-Point® 96, Grid Plate, extended, 246 x 192 x 27 mm, without mounting bores	23
45720	Quick-Point® 96, Grid Plate, 2-fold, 384 x 192 x 27 mm, without mounting bores	34
45740	Quick-Point® 96, Grid Plate, 4-fold, 384 x 384 x 27 mm, without mounting bores	36
45741	Quick-Point® 96, Grid Plate, 4-fold, 384 x 384 x 27 mm, with mounting bores for 63 mm slot distance	36
45742	Quick-Point® 96, Grid Plate, 4-fold, 384 x 384 x 27 mm, with mounting bores for 100 mm slot distance	36
45750	Quick-Point® 52, Round Plate, ø 116 x 27 mm, with mounting bores at a distance of 96 mm	26
45751	Quick-Point® 52, Round Plate, ø 116 x 27 mm, without mounting bores	26
45763	Quick-Point® 96, Grid Plate, 192 x 192 x 27 mm, with mounting bores for 63 mm slot distance	22
45800	Quick-Point® 96, Round Plate, ø 176 x 27 mm, with mounting bores for 63 mm slot distance and 150 mm distance	28
45801	Quick-Point® 96, Round Plate, ø 176 x 27 mm, without mounting bores	28
45803	Quick-Point® 96, Round Plate, ø 176 x 27 mm, without mounting bores, for individual centre hole	31
45820	Quick-Point® 96, Round Plate, ø 196 x 27 mm, without mounting bores	29
45823	Quick-Point® 96, Round Plate, ø 196 x 27 mm, without mounting bores, for individual centre hole	31
45840	Quick-Point® 96, Round Plate, ø 246 x 27 mm, without mounting bores	29
45843	Quick-Point® 96, Round Plate, ø 246 x 27 mm, without mounting bores, for individual centre hole	31
45863	Quick-Point® 96, Round Plate, ø 246 x 27 mm, with mounting bores for 63 mm slot distance	22
45890	Quick-Point® 96, Round Plate, ø 246 x 27 mm, with mounting bores for machine tables with cross slot	29
45900	Quick-Point® 52, Round Plate, ø 157 x 27 mm, with mounting bores at a distance of 100 mm	27
45901	Quick-Point® 52, Round Plate, ø 157 x 27 mm, without mounting bores	27
45903	Quick-Point® 52, Round Plate, ø 157 x 27 mm, without mounting bores, for individual centre hole	30
45910	Quick-Point®, Adaptor Plate, round, Ø 157 x 27 mm	39
45962	Quick-Point® 96, Grid Plate, 2-fold, round, ø 384 x 27 mm, without mounting bores	34
45963	Quick-Point® 96, Grid Plate, 2-fold, round, ø 384 x 27 mm, with mounting bores for 63 mm slot distance	35
45964	Quick-Point® 96, Grid Plate, 2-fold, round, ø 384 x 27 mm, with mounting bores for 100 mm slot distance	35
45996	Quick-Point® 96, Quick-Lock, for round 2-fold grid plate 96	58
46081	Quick-Point® 96, Handle Bar, Aluminium	60
47005	Makro-Grip®, Cordless Drill Attachment, Wrench size 5 mm, for hexagon socket	109
47220	Quick-Point® 52, Twin Base, 146 x 76 x 168 mm	45

ITEM NO.	DESCRIPTION	PAGE
47520	Quick-Point® 96, Twin Base, 192 x 116 x 247 mm	45
48077-4620	Makro-Grip® 77, Spare Jaws, Jaw width 46 mm, with Makro-Grip® serration	100
48077-4622	Makro-Grip® 77, Spare Jaws, Jaw width 46 mm, with plain clamping step	100
48077-7720	Makro-Grip® 77, Spare Jaws, Jaw width 77 mm, with Makro-Grip® serration	100
48077-7722	Makro-Grip® 77, Spare Jaws, Jaw width 77 mm, with plain clamping step	100
48085-46	Makro-Grip® 77, 5-Axis Vice, Jaw width 46 mm, Clamping range 0 - 85 mm	96
48085-4620	Makro-Grip® 77, Spare Jaws, Jaw width 46 mm, with Makro-Grip® serration, for item no. 48085-46	100
48085-4622	Makro-Grip® 77, Spare Jaws, Jaw width 46 mm, with plain clamping step, for item no. 48085-46	100
48085-77	Makro-Grip® 77, 5-Axis Vice, Jaw width 77 mm, Clamping range 0 - 85 mm	98
48085-7720	Makro-Grip® 77, Spare Jaws, Jaw width 77 mm, with Makro-Grip® serration, for item no. 48085-77	100
48085-7722	Makro-Grip® 77, Spare Jaws, Jaw width 77 mm, with plain clamping step, for item no. 48085-77	100
48085-TG4617	Makro-Grip® 77, Centre Jaw + Spindle, Jaw width 46 mm, Jaw thickness 17 mm, spindle length 100 mm	112
48085-TG4627	Makro-Grip® 77, Centre Jaw + Spindle, Jaw width 46 mm, Jaw thickness 27 mm, spindle length 100 mm	112
48085-TG7717	Makro-Grip® 77, Centre Jaw + Spindle, Jaw width 77 mm, Jaw thickness 17 mm, spindle length 100 mm	112
48085-TG7727	Makro-Grip® 77, Centre Jaw + Spindle, Jaw width 77 mm, Jaw thickness 27 mm, spindle length 100 mm	112
48120-46	Makro-Grip® 77, 5-Axis Vice, Jaw width 46 mm, Clamping range 0 - 120 mm	96
48120-77	Makro-Grip® 77, 5-Axis Vice, Jaw width 77 mm, Clamping range 0 - 120 mm	98
48120-TG4617	Makro-Grip® 77, Centre Jaw + Spindle, Jaw width 46 mm, Jaw thickness 17 mm, spindle length 135 mm	112
48120-TG4627	Makro-Grip® 77, Centre Jaw + Spindle, Jaw width 46 mm, Jaw thickness 27 mm, spindle length 135 mm	112
48120-TG7717	Makro-Grip® 77, Centre Jaw + Spindle, Jaw width 77 mm, Jaw thickness 17 mm, spindle length 135 mm	112
48120-TG7727	Makro-Grip® 77, Centre Jaw + Spindle, Jaw width 77 mm, Jaw thickness 27 mm, spindle length 135 mm	112
48125-2520	Makro-Grip® 125, Spare Jaws, Jaw width 125 mm, with Makro-Grip® serration	106
48125-2522	Makro-Grip® 125, Spare Jaws, Jaw width 125 mm, with plain clamping step	106
48125-7720	Makro-Grip® 125, Spare Jaws, Jaw width 77 mm, with Makro-Grip® serration	106
48125-7722	Makro-Grip® 125, Spare Jaws, Jaw width 77 mm, with plain clamping step	106
48155-77	Makro-Grip® 125, 5-Axis Vice, Jaw width 77 mm, Clamping range 0 - 155 mm	102
48155-125	Makro-Grip® 125, 5-Axis Vice, Jaw width 125 mm, Clamping range 0 - 155 mm	104
48155-TG7727	Makro-Grip® 125, Centre Jaw + Spindle, Jaw width 77 mm, Jaw thickness 27 mm, spindle length 164 mm	113
48155-TG2527	Makro-Grip® 125, Centre Jaw + Spindle, Jaw width 125 mm, Jaw thickness 27 mm, spindle length 164 mm	113
48160-77	Makro-Grip® 77, 5-Axis Vice, Jaw width 77 mm, Clamping range 0 - 160 mm	98
48160-TG7717	Makro-Grip® 77, Centre Jaw + Spindle, Jaw width 77 mm, Jaw thickness 17 mm, spindle length 175 mm	112
48160-TG7727	Makro-Grip® 77, Centre Jaw + Spindle, Jaw width 77 mm, Jaw thickness 27 mm, spindle length 175 mm	112
48200-77	Makro-Grip® 77, 5-Axis Vice, Jaw width 77 mm, Clamping range 0 - 200 mm	98
48200-TG7717	Makro-Grip® 77, Centre Jaw + Spindle, Jaw width 77 mm, Jaw thickness 17 mm, spindle length 215 mm	112
48200-TG7727	Makro-Grip® 77, Centre Jaw + Spindle, Jaw width 77 mm, Jaw thickness 27 mm, spindle length 215 mm	112
48205-77	Makro-Grip® 125, 5-Axis Vice, Jaw width 77 mm, Clamping range 0 - 205 mm	102
48205-125	Makro-Grip® 125, 5-Axis Vice, Jaw width 125 mm, Clamping range 0 - 205 mm	104
48205-TG7727	Makro-Grip® 125, Centre Jaw + Spindle, Jaw width 77 mm, Jaw thickness 27 mm, spindle length 214 mm	113
48205-TG2527	Makro-Grip® 125, Centre Jaw + Spindle, Jaw width 125 mm, Jaw thickness 27 mm, spindle length 214 mm	113
4825164	Makro-Grip® 125, Set Spindle + Centre Piece, Spindle length 164 mm	108
4825214	Makro-Grip® 125, Set Spindle + Centre Piece, Spindle length 214 mm	108
4825264	Makro-Grip® 125, Set Spindle + Centre Piece, Spindle length 264 mm	108
4825314	Makro-Grip® 125, Set Spindle + Centre Piece, Spindle length 314 mm	108
4825364	Makro-Grip® 125, Set Spindle + Centre Piece, Spindle length 364 mm	108
48255-125	Makro-Grip® 125, 5-Axis Vice, Jaw width 125 mm, Clamping range 0 - 255 mm	104
48255-TG2527	Makro-Grip® 125, Centre Jaw + Spindle, Jaw width 125 mm, Jaw thickness 27 mm, spindle length 264 mm	113
48305-125	Makro-Grip® 125, 5-Axis Vice, Jaw width 125 mm, Clamping range 0 - 305 mm	104
48305-TG2527	Makro-Grip® 125, Centre Jaw + Spindle, Jaw width 125 mm, Jaw thickness 27 mm, spindle length 314 mm	113
48355-125	Makro-Grip® 125, 5-Axis Vice, Jaw width 125 mm, Clamping range 0 - 355 mm	104

ITEM NO.	DESCRIPTION	PAGE
48355-TG2527	Makro-Grip® 125, Centre Jaw + Spindle, Jaw width 125 mm, Jaw thickness 27 mm, spindle length 364 mm	113
4877100	Makro-Grip® 77, Set Spindle + Centre Piece, Spindle length 100 mm	108
4877135	Makro-Grip® 77, Set Spindle + Centre Piece, Spindle length 135 mm	108
4877175	Makro-Grip® 77, Set Spindle + Centre Piece, Spindle length 175 mm	108
4877215	Makro-Grip® 77, Set Spindle + Centre Piece, Spindle length 215 mm	108
48409-125	Makro-Grip® 125, Contour Jaws, Jaw width 125 mm, for the inner side	107
48409-77	Makro-Grip® 77, Contour Jaws, Jaw width 77 mm, for the inner side	101, 107
48410	Makro-Grip®, Magnet-set for contour jaws	101, 107
48420	Makro-Grip®, Assembly Tool for magnets	101, 107
48419-125	Makro-Grip® 125, Contour Jaws, Jaw width 125 mm, for the outside	107
48419-77	Makro-Grip® 77, Contour Jaws, Jaw width 77 mm, for the outside	101, 107
49010-77	Profilo 77, Profilo Clamping Vice, Jaw width 112 mm, max. clamping range 97 mm	160
49040-77	Profilo 77, Profilo Clamping Vice, Jaw width 112 mm, max. clamping range 125 mm	160
49050-125	Profilo 125, Profilo Clamping Vice, Jaw with 160 mm, max. clamping range 155 mm	162
49077	Profilo 77, Base Jaws, Jaw width 112 mm	161
49080-77	Profilo 77, Profilo Clamping Vice, Jaw width 112 mm, max. clamping range 165 mm	160
49080-TG77	Profilo 77, Centre Jaw + Spindle, Jaw width 112 mm, Spindle length 175 mm	161
49100-125	Profilo 125, Profilo Clamping Vice, Jaw width 160 mm, max. clamping range 205 mm	162
49100-TG125	Profilo 125, Centre Jaw + Spindle, Jaw width 160 mm, Spindle length 214 mm	163
49120-77	Profilo 77, Profilo Clamping Vice, Jaw width 112 mm, max. clamping range 205 mm	160
49120-TG77	Profilo 77, Centre Jaw + Spindle, Jaw width 112 mm, Spindle length 215 mm	161
49125	Profilo 125, Base Jaws, Jaw width 160 mm	163
49150-125	Profilo 125, Profilo Clamping Vice, Jaw width 160 mm, max. clamping range 255 mm	162
49150-TG125	Profilo 125, Centre Jaw + Spindle, Jaw width 160 mm, Spindle length 264 mm	163
49200-125	Profilo 125, Profilo Clamping Vice, Jaw width 160 mm, max. clamping range 305 mm	162
49200-TG125	Profilo 125, Centre Jaw + Spindle, Jaw width 160 mm, Spindle length 314 mm	163
49250-125	Profilo 125, Profilo Clamping Vice, Jaw width 160 mm, max. clamping range 355 mm	162
49250-TG125	Profilo 125, Centre Jaw + Spindle, Jaw width 160 mm, Spindle length 364 mm	163
49258	Profilo 125, Top Jaw, Jaw width 160 mm, Steel	163
49259	Profilo 125, Top Jaw, Jaw width 160 mm, Aluminium	163
49778	Profilo 77, Top Jaw, Jaw width 112 mm, Steel	161
49779	Profilo 77, Top Jaw, Jaw width 112 mm, Aluminium	161
51111	Makro-4Grip, Stamping Jaws, incl. 4 stamping inserts	83
51111-40	Makro-4Grip, Stamping Inserts, 4 pieces	83
52515-20	Makro-4Grip 125, Clamping Jaws, Jaw width 90 mm, clamping range Ø 115 - 180 mm	107
52530-20	Makro-4Grip 125, Clamping Jaws, Jaw width 128 mm, clamping range Ø 180 - 300 mm	107
57708-20	Makro-4Grip 77, Clamping Jaws, Jaw width 52 mm, clamping range Ø 36 - 115 mm	101
57711-20	Makro-4Grip 77, Clamping Jaws, Jaw width 77 mm, clamping range Ø 54 - 115 mm	101
59616	Vasto-Clamp 96, 6-Jaw Chuck, Clamping range 10 - 160 mm	146
59616-60	Vasto-Clamp 96, Top Jaws, Steel, hardened, clamping range Ø 30 - 120 mm	147
59616-61	Vasto-Clamp 96, Top Jaws, Steel, hardened, clamping range Ø 75 - 160 mm	147
59616-62	Vasto-Clamp 96, Top Jaws, Steel, soft, clamping range Ø 10 - 160 mm	147
59616-63	Vasto-Clamp 96, Top Jaws, Aluminum, soft, clamping range Ø 10 - 160 mm	147
61060	Makro-Grip®, Mobile Storage Unit, Storage capacity 60 vices	201
61085-46	Makro-Grip® 77, Haubex 5-Axis Vice, Jaw width 46 mm, Clamping range 0 - 80 mm	212
61110	Quick-Point®, Haubex Zero-Point Clamping System, Ø 211 x 74 mm	213
61125	Haubex, Workholding Hood, Ø 125 x 185 mm	211
61500-BT40	Haubex, Tool Holder, BT-40	210
61500-HSK63	Haubex, Tool Holder, HSK-A63	210
61500-SK40	Haubex, Tool Holder, SK-40	210
64000	RoboTrex 96, Automation System	192
64015	RoboTrex 96, Automation Trolley, Storage capacity 15 vices	194
64016	RoboTrex 96, Automation Trolley, Storage capacity 16 vices	194
64086	RoboTrex 96, Positioning Bolt, for automation trolley	200
64266	RoboTrex, Gripper Exchange Interface	195
64500	RoboTrex 96, Automation Zero-Point Clamping System, pneumatic	197
64801	RoboTrex 96, Gripper, old, without gripper exchange option	200
64850	RoboTrex 96, Gripper, pneumatic	197
65191-04	Quick-Point®, Bushings, Ø 12 x 12 mm, for screw size M 8	61
65191-05	Quick-Point®, Bushings, Ø 16 x 15 mm, for screw size M 10	61
66000	RoboTrex 52, Automation System	182
66030	RoboTrex 52, Automation Trolley, Storage capacity 30 vices	184
66042	RoboTrex 52, Automation Trolley, Storage capacity 42 spots	184
66087	RoboTrex 52, Positioning Bolt, for automation trolley	200

ITEM NO.	DESCRIPTION	PAGE
66120	RoboTrex, Trolley Entry System, universal	200
66500	RoboTrex 52, Automation Zero-Point Clamping System, mechanical	186
66600	RoboTrex 52, Automation Zero-Point Clamping System, pneumatic	187
66750	RoboTrex, Automation Window, universal	200
66801	RoboTrex 52, Gripper, mechanical (old version)	186
66900	RoboTrex 52, Gripper, pneumatic	187
66930	RoboTrex 52, Gripper, mechanical	186
66950	RoboTrex 52, Gripper, pneumatic, for RoboTrex 96	196
68077-7720	Makro-Grip® 77, Spare Jaws, Jaw width 77 mm, with Makro-Grip® serration, for Night King	189
68120-77	Makro-Grip® 77, Night King, Jaw width 77 mm, Clamping range 0 - 120 mm	188
6877135	Makro-Grip® 77, Set Spindle + Centre Piece, Spindle length 135 mm	189
70005	Quick-Point®, Quick-Tower Base Plate, 396 x 396 x 27 mm, without mounting bores	51
70006	Set mounting bores in Quick-Tower Base Plate	51
70008	Quick-Point®, Quick-Tower Base Plate, 446 x 446 x 27 mm, with mounting bores	51
70263	Quick-Point® 52, 3-face Tombstone, 192 x 192 x 260 mm	46
70264	Quick-Point® 52, 4-face Tombstone, 192 x 192 x 260 mm	47
70650	Quick-Point®, Quick-Tower, Tombstone, Height 668 mm	50
70850	Quick-Point®, Quick-Tower, Tombstone, Height 860 mm	50
75600	Quick-Point® 52, Grid Plate, 104 x 104 x 27 mm, with bores for Quick-Tower tombstone	20
75710	Quick-Point® 96, Grid Plate, 192 x 192 x 27 mm, with mounting bores for Quick-Tower tombstone	21
81004	Makro-Grip® Ultra, Spindle Unit, Spindle length 441 mm, for clamping range 40 - 410 mm	134
81006	Makro-Grip® Ultra, Spindle Unit, Spindle length 617 mm, for clamping range 40 - 610 mm	134
81008	Makro-Grip® Ultra, Spindle Unit, Spindle length 825 mm, for clamping range 40 - 810 mm	134
81010	Makro-Grip® Ultra, Centring Plate, for centric single part clamping	134
81011	Makro-Grip® Ultra, Base Body, Height 45 mm, length 96 mm	128
81012	Makro-Grip® Ultra, Base Body, Height 109 mm, length 96 mm	128
81013	Makro-Grip® Ultra, Base Body, Height 189 mm, length 96 mm	128
81015	Makro-Grip® Ultra, Connection Plate, for base body	134
81021	Makro-Grip® Ultra, Base Body, Height 45 mm, length 192 mm	129
81022	Makro-Grip® Ultra, Base Body, Height 109 mm, length 192 mm	129
81023	Makro-Grip® Ultra, Base Body, Height 189 mm, length 192 mm	129
81040	Makro-Grip® Ultra, Centring Plate, for the compensating multiple clamping	134
81080	Makro-Grip® Ultra, Threaded Cap, right side	135
81090	Makro-Grip® Ultra, Threaded Cap, left side	135
81400	Makro-Grip® Ultra, Base Set, Height 45 mm, clamping range 40 - 410 mm	124
81403	Makro-Grip® Ultra 125, Support Jaw, for 81483 / 81450	133
81405	Makro-Grip® Ultra 125, Support Jaw, for 81485 / 81450	133
81415	Makro-Grip® Ultra, Base Set, Height 109 mm, clamping range 40 - 410 mm	124
81423	Makro-Grip® Ultra, Base Set, Height 189 mm, clamping range 40 - 410 mm	124
81440	Makro-Grip® Ultra 125, Base Jaw, Avanti	131
81440-TG	Makro-Grip® Ultra 125, Centre Base Jaw, Avanti	131
81450	Makro-Grip® Ultra 125, Top Jaw, Avanti, with plain clamping step, Clamping depth 16 mm	132
81450-TG	Makro-Grip® Ultra 125, Centre Top Jaw, Avanti, with plain clamping step, Clamping depth 16 mm	132
81483	Makro-Grip® Ultra 125, Clamping Jaw, with Makro-Grip® serration, Clamping depth 3 mm	130
81483-TG	Makro-Grip® Ultra 125, Centre Jaw, with Makro-Grip® serration, Clamping depth 3 mm	130
81485	Makro-Grip® Ultra 125, Clamping Jaw, with Makro-Grip® serration, Clamping depth 5 mm	130
81485-TG	Makro-Grip® Ultra 125, Centre Jaw, with Makro-Grip® serration, Clamping depth 5 mm	130
81500	Makro-Grip® Ultra, Cover Discs, for base body	134
81515	Hydro-Sup, Spacer, System height "M", for support height 148 - 152 mm	137
81523	Hydro-Sup, Spacer, System height "L", for support height 228 - 232 mm	137
81586	Hydro-Sup, Hydraulic Screw Jack, for support height 85 - 89 mm	137
81600	Makro-Grip® Ultra, Base Set, Height 45 mm, clamping range 40 - 610 mm	124
81615	Makro-Grip® Ultra, Base Set, Height 109 mm, clamping range 40 - 610 mm	124
81623	Makro-Grip® Ultra, Base Set, Height 189 mm, clamping range 40 - 610 mm	124
81800	Makro-Grip® Ultra, Base Set, Height 45 mm, clamping range 40 - 810 mm	124
81815	Makro-Grip® Ultra, Base Set, Height 109 mm, clamping range 40 - 810 mm	124
81823	Makro-Grip® Ultra, Base Set, Height 189 mm, clamping range 40 - 810 mm	124
83420-HE	Makro-Grip® Ultra, Stamping Unit, with High-End stamping jaws, max. stamping range 420 mm	139
83810-HE	Makro-Grip® Ultra, Stamping Unit, with High-End stamping jaws, max. stamping range 810 mm	139

Icon Description

To simplify specifications we use these icons to highlight technical information and the compatibility of the products:



Grid system:

Zero-point pitch



Clamping stud size:

Diameter of the clamping studs



Quick-Lock:

The fast actuation system can be attached



Vice size:

Width of vice



Torque:

Maximum allowed torque



Clamping force:

Clamping force at maximum torque



Centring accuracy:

Centring tolerance of vices



Mounting bores:

Individual mounting bores and keyways are possible



Automatable:

Automation interface included

Terms & Conditions

Offer validity

Our offers are valid for 60 days and may be revoked by us at any time thereafter.

Prices

Prices are ex works, excluding packaging, transport, customs and plus the statutory value added tax. This shall also apply in the case of agreed partial deliveries and express deliveries.

Minimum order value

The minimum order value is € 30.00 net. In the case of a lower order value, the minimum amount of 30.00 € plus statutory value added tax will be charged.

Reservation of ownership

The delivered goods remain our property until full payment of the purchase price and can be reclaimed at any time, in which case the costs for this will be invoiced.

Incorrect order / return

Returns are possible up to a maximum of four weeks after receipt of the goods. The returned goods must not show any signs of use. If goods are returned with visual damage, restocking costs amounting to 20% of the value of the goods will be charged.

You can find the complete Terms & Conditions on our website www.lang-technik.de.

Imprint

Title:

LANG catalogue 2021
Date of Printing 10/2021

Editor:

LANG Technik GmbH
Albstraße 1-6
D-73271 Holzmaden
Phone: +49 7023 9585-0
Fax: +49 7023 9585-100
www.lang-technik.de
info@lang-technik.de

Legal provisions:

Copyright © 2021
LANG Technik GmbH
All rights reserved. Reprint, recording in online-services, internet and duplication on data carrier as CD ROM, DVD, etc. or in extracts are prohibited. Misprints, errors and changes are subject to modifications. All indications of weight are approximate values. Illustrations can vary from articles.



→ facebook.com/langtechnik
→ instagram.com/langtechnik

→ twitter.com/langtechnik
→ youtube.com/langtechnik

→ linkedin.com/company/lang-technik
→ www.lang-technik.de