

# Keysight 6610xA Power Modules

Service Guide

NOTICE: This document contains references to Agilent Technologies. Agilent's former Test and Measurement business has become Keysight Technologies. For more information, go to [www.keysight.com](http://www.keysight.com).



## **CERTIFICATION**

*Keysight Technologies certifies that this product met its published specifications at time of shipment from the factory. Keysight Technologies further certifies that its calibration measurements are traceable to the United States National Bureau of Standards, to the extent allowed by the Bureau's calibration facility, and to the calibration facilities of other International Standards Organization members.*

## **WARRANTY**

This Keysight Technologies hardware product is warranted against defects in material and workmanship for a period of three years from date of delivery. Keysight software and firmware products, which are designated by Keysight Technologies for use with a hardware product and when properly installed on that hardware product, are warranted not to fail to execute their programming instructions due to defects in material and workmanship for a period of 90 days from date of delivery. During the warranty period Keysight Technologies will, at its option, either repair or replace products which prove to be defective. Keysight Technologies does not warrant that the operation of the software, firmware, or hardware shall be uninterrupted or error free.

For warranty service, with the exception of warranty options, this product must be returned to a service facility designated by Keysight Technologies. Customer shall prepay shipping charges (and shall pay all duty and taxes) for products returned to Keysight Technologies for warranty service. Except for products returned to Customer from another country, Keysight Technologies shall pay for return of products to Customer.

Warranty services outside the country of initial purchase are included in Keysight Technologies' product price, only if Customer pays Keysight Technologies international prices (defined as destination local currency price, or U.S. or Geneva Export price).

If Keysight Technologies is unable, within a reasonable time to repair or replace any product to condition as warranted, the Customer shall be entitled to a refund of the purchase price upon return of the product to Keysight Technologies.

## **LIMITATION OF WARRANTY**

The foregoing warranty shall not apply to defects resulting from improper or inadequate maintenance by the Customer, Customer-supplied software or interfacing, unauthorized modification or misuse, operation outside of the environmental specifications for the product, or improper site preparation and maintenance. **NO OTHER WARRANTY IS EXPRESSED OR IMPLIED. KEYSIGHT TECHNOLOGIES SPECIFICALLY DISCLAIMS THE IMPLIED WARRANTIES OF MERCHANTABILITY AND FITNESS FOR A PARTICULAR PURPOSE.**

## **EXCLUSIVE REMEDIES**

**THE REMEDIES PROVIDED HEREIN ARE THE CUSTOMER'S SOLE AND EXCLUSIVE REMEDIES. KEYSIGHT TECHNOLOGIES SHALL NOT BE LIABLE FOR ANY DIRECT, INDIRECT, SPECIAL, INCIDENTAL, OR CONSEQUENTIAL DAMAGES, WHETHER BASED ON CONTRACT, TORT, OR ANY OTHER LEGAL THEORY.**

## **ASSISTANCE**

*The above statements apply only to the standard product warranty. Warranty options, extended support contracts, product maintenance agreements and customer assistance agreements are also available. Contact your nearest Keysight Technologies Sales and Service office for further information on Keysight Technologies' full line of Support Programs.*

## SAFETY SUMMARY

*The following general safety precautions must be observed during all phases of operation of this power module. Failure to comply with these precautions or with specific warnings elsewhere in this guide violates safety standards of design, manufacture, and intended use of the power module. Keysight Technologies assumes no liability for the user's failure to comply with these requirements.*

### GROUND THE POWER MODULE.

When installed in a properly wired mainframe, this product is a Safety Class 1 instrument (provided with a protective earth terminal). To minimize shock hazard, the mainframe must be connected to an electrical ground. The mainframe must be connected to the ac power supply mains through a three-conductor power cable, with the third wire firmly connected to an electrical ground (safety ground) at the power outlet. Any interruption of the protective (grounding) conductor or disconnection of the protective earth terminal will cause a potential shock hazard that could result in personal injury.

### DO NOT EXCEED INPUT RATINGS.

The mainframe is equipped with a power line filter to reduce electromagnetic interference and must be connected to a properly grounded receptacle to minimize electric shock hazard. Operation at line voltages or frequencies in excess of those stated on the line rating label may cause leakage currents in excess of 5.0 mA peak.

### DO NOT OPERATE IN AN EXPLOSIVE ATMOSPHERE.

Do not operate the power module in the presence of flammable gases or fumes.

### BEFORE APPLYING POWER.

Verify that the power module line voltage switch is set to match the available line voltage.

### SAFETY SYMBOLS.



Instruction manual symbol: the product will be marked with this symbol when it is necessary for the user to refer to the instruction manual (refer to Table of Contents) .



Indicates hazardous voltages.

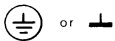

Indicate earth (ground) terminal.

#### WARNING

The WARNING sign denotes a hazard. It calls attention to a procedure, practice, or the like, which, if not correctly performed or adhered to, could result in personal injury. Do not proceed beyond a WARNING sign until the indicated conditions are fully understood and met.

#### CAUTION

The CAUTION sign denotes a hazard. It calls attention to an operating procedure, or the like, which, if not correctly performed or adhered to, could result in damage to or destruction of part or all of the product. Do not proceed beyond a CAUTION sign until the indicated conditions are fully understood and met.

Power modules that appear damaged or defective should be made inoperative and secured against unintended operation until they can be repaired by qualified service personnel.

## Printing History

The current edition of this guide is indicated below. Reprints of this guide containing minor corrections and updates may have the same printing date. New editions are identified by a new printing date and, in some cases, by a new part number. A new edition incorporates all new or corrected material since the previous edition. Changes to the guide occurring between editions are covered by change sheets shipped with this guide.

Edition 1 . . . . October, 1993 (Keysight Model 6610xA)

Updated . . . . June 2000, December 2002

Edition 2 . . . . December, 2014

© Copyright 1993, 2000, 2014 Keysight Technologies

This document contains proprietary information protected by copyright. All rights are reserved. No part of this document may be photocopied, reproduced, or translated into another language without prior consent of Keysight Technologies. The information contained in this document is subject to change without notice.

# Table of Contents

<b>Overview.....</b>	<b>7</b>
About This Manual .....	7
Related Documents .....	8
Revisions and Updates.....	8
Manual .....	8
Firmware.....	8
Safety Considerations .....	9
Electrostatic Discharge .....	9
Service Tools and Equipment .....	9
<b>Verification and Performance Tests.....</b>	<b>11</b>
Operation Verification Tests.....	11
Performance Tests .....	11
Measurement Techniques .....	12
Setup for Most Tests.....	12
Current-Monitoring Resistor.....	12
Programming .....	12
Constant Voltage (CV) Tests .....	13
CV Setup.....	13
Voltage Programming/Readback Accuracy .....	13
CV Load Effect.....	13
CV Source Effect.....	14
CV Noise (PARD) .....	14
Transient Recovery Time.....	14
Constant Current (CC) Tests.....	15
CC Setup.....	15
Current Programming/Readback Accuracy.....	15
CC Load and Line Regulation .....	15
CC Load Effect .....	16
CC Source Effect .....	16
CC Noise (PARD) .....	17
<b>Troubleshooting.....</b>	<b>25</b>
Troubleshooting Sequence.....	25
Accessing the Flowcharts.....	25
If You Experienced a Selftest Failure or RunTime Error Message.....	26
If You Experienced Other Problems With the Module.....	26
Test Points .....	48
Built-In Test Functions .....	48
EEPROM Troubleshooting and Initialization.....	51
Troubleshooting.....	51
Initialization.....	51
Disassembly Procedures .....	56
Removing the Module and Module Connector .....	56
Removing the Cover .....	56
Removing the Fan .....	56
Removing the Front Panel Assembly.....	57
Removing the Power Board.....	57
Removing the Bias Board .....	57
Removing the Front Panel Board.....	57

Installing the Power Board .....	58
Installing the Bias Board .....	58
Installing the Front Panel Board and Front Panel Assembly .....	59
Installing the Fan .....	59
Installing the Cover.....	59
<b>Theory of Operation.....</b>	<b>61</b>
AC Input and Bias Supplies .....	61
Microprocessor Circuits.....	61
CV/CC DACs .....	61
CV Amplifier.....	63
CC Amplifier .....	63
OR Gates .....	63
Pulse-Width Modulator, FETS, and Isolation Transformer.....	64
Downprogrammer Circuit.....	64
Readback Multiplexer.....	64
OV Circuit .....	65
<b>Replacement Parts.....</b>	<b>67</b>
<b>Diagrams .....</b>	<b>83</b>
Schematic Sheets .....	83
Component Location Diagrams .....	83
Schematic Notes .....	84
<b>Manual Backdating .....</b>	<b>97</b>
<b>Index .....</b>	<b>99</b>

# Overview

---

## About This Manual

This manual is a complete guide for servicing the Keysight 6610xA Power Modules. Troubleshooting information for the Keysight 66000A MPS Mainframe is provided in the mainframe service manual (see "Related Documents"), which should be used with this manual.

---

**Note** Troubleshooting the Keysight 6610xA Power Modules requires the use of one working Keysight 66000A MPS Mainframe.

---

This manual is organized into the following major sections:

**Overview** discusses safety and equipment considerations to be aware of when troubleshooting. It also lists the tools and equipment required for troubleshooting.

**Verification and Performance** consists of a series of tests that are used to verify....

**Troubleshooting** procedures systematically verify selected circuits to isolate the cause of a problem. Suggestions for remedying the problem are also provided. The following troubleshooting procedures are provided:

- Overall
- Microprocessor
- Error Messages
- Overvoltage Circuit
- Output Circuit
- CV and CC Circuits
- Downprogrammer Circuits
- DAC Circuit
- Readback Circuit

Disassembly procedures are provided at the end of the chapter.

**Theory of Operation** provides a brief description of the overall operation of the power module.

**Replacement Parts** lists part numbers for electrical components and miscellaneous chassis parts.

**Schematics** and component location diagrams are provided as an aid in troubleshooting and repair.



## Related Documents

The following documents are related to this manual:

Manual	Part Number	Description
Keysight 66000A MPS Mainframe Installation Guide	66000-90001	Provides product specifications, installation, and connection information.
Keysight Series 6610xA MPS Power Modules User's Guide	5959-3386	Describes the operation of the MPS Power Modules.
Keysight Series 6610xA MPS Power Modules Programming Guide	5959-3362	Describes SCPI programming commands, status reporting.
Keysight Series 66000A MPS Mainframe Service Manual	66000-90003	Provides replaceable-parts lists, circuit diagrams, and verification procedures for the Keysight Series 66000A MPS Mainframe.

---

## Revisions and Updates

### Manual

Keysight Technologies instruments are identified by a 10-digit serial number. The format is described as follows: first two letters indicate the country of manufacture. The next four digits are a code that identify either the date of manufacture or of a significant design change. The last four digits are a sequential number assigned to each instrument.

Item	Description
------	-------------

<b>US</b>	The first two letters indicates the country of manufacture, where US = USA; MY = Malaysia; SG = Singapore.
-----------	------------------------------------------------------------------------------------------------------------

<b>3648</b>	This is a code that identifies either the date of manufacture or the date of a significant design change.
-------------	-----------------------------------------------------------------------------------------------------------

<b>0101</b>	The last four digits are a unique number assigned to each power module.
-------------	-------------------------------------------------------------------------

If changes have been made to your unit since the publication of this manual, a yellow Manual Change sheet may be supplied with the manual. It defines the differences between your unit and the unit described in this manual. The yellow change sheet may also contain information for correcting errors in the manual. Note that because not all changes to the product require changes to the manual, there may be no update information required for your unit.

Older serial number formats used with these instruments had a two-part serial number, i.e. 2701A-00101. This manual also applies to instruments with these older serial number formats. Refer to Manual Backdating for backdating information.

### Firmware

This manual applies to power modules that run on software revision A.00.01 through A.00.04. Firmware revision A.00.04 is backward compatible with all previous revisions. The ROM chip (U2) has a label that specifies the firmware revision.

---

## Safety Considerations

The Keysight 6610xA Power Modules are Safety Class 1 instruments that connect to a protective earth terminal when properly installed in a Keysight 66000A MPS Mainframe. Refer to the Safety Summary page at the beginning of this manual for general safety procedures and the meaning of safety symbols appearing in the manual and on the module.

---

## Electrostatic Discharge

---

**CAUTION**

The Modular Power System has components that can be damaged by ESD (electrostatic discharge). Failure to observe standard anti-static practices can result in serious degradation of performance even when complete failure does not occur.

---

When working on the Modular Power System, observe all anti-static work practices. This includes, but is not limited to:

- Working at a static-free station, such as a table covered with static-dissipative laminate or with a conductive table mat (Keysight p/n 9300-0797).
- Using a conductive wrist strap (Keysight p/n 9300-0969 or 9300-0970).
- Grounding all metal equipment at the station to a single, common ground.
- Connecting low-impedance test equipment to static sensitive components only when those components have power applied to them.
- Removing power from the Modular Power System before removing or installing printed circuit boards.

---

## Service Tools and Equipment

The following tools are required to repair the Keysight 6610xA MPS Modules:

- T10 TORX driver
- 7mm HEX NUT drivers
- #2 POZI driver
- Slot-head screwdriver - medium
- DIP component removal tool
- Soldering iron and solder
- De-solder removal tool
- Needle-nose pliers
- Anti-static work mat and wrist strap

The following equipment is required to verify and troubleshoot the Keysight 6610xA Power Modules:

**Table 1-1. Service Test Equipment**

Equipment Required	Critical Specifications	Recommended Model	Use <sup>1</sup>
GPIB Controller	Full GPIB capabilities	HP Series 200/300 computer	T
Oscilloscope	Sensitivity: 1mV Bandwidth Limit: 20MHz Probe: 1:1 with RF tip	Keysight 54504A	T
Rms Voltmeter	True RMS Bandwidth: 20MHz Sensitivity: 100µV	Keysight 3400B	T
Digital Voltmeter	Resolution: 10nV @ 1V (8 1/2 digit)	Keysight 3458A Accuracy: 20 ppm	V,T
Variable Voltage Transformer	Adjustable from- 13% to + 6% of input range. 1KVA min.		T
CC RMS Noise Resistor (R <sub>M</sub> )	Keysight 66101A,102A - 100A (.01 Ω) ± 0.04% <sup>2</sup> Keysight 66103A,106A - 15A (.01 Ω) ± 0.04% <sup>3</sup>	Guildline 9230/100 Guildline 9230/15	V,T
Electronic Load	Voltage and current range must exceed range of module under test. Power Range: 600W minimum	Keysight 6050A Load mainframe and Keysight 60503A module (240V) or Keysight 60507A module (120V).	V,T
Load Resistor (R <sub>L</sub> )	Keysight 66101A- 0.1 Ω ± 5% 300W Keysight 66102A-106A- 1.0 Ω ± 5% 300W	Ohmite C300KR10 Ohmite C300KIR0	T
MPS Mainframe		Keysight 66000A	V,T
MPS Keyboard <sup>4</sup>		Keysight 66001A	V,T

1 V = Verification; T = Troubleshooting.

2 Guildline Shunt Accuracy determined by Power Coefficient ( ± 0.01% + (0.0004%/watt))

3 Guildline Shunt Accuracy determined by Power Coefficient ( ± 0.01% + (0.002%/watt))

4 Use of the keyboard is recommended for displaying selftest error messages.

## Verification and Performance Tests

This chapter contains test procedures to check the operation of the Keysight 6610xA Power Modules. The required test equipment is specified in Chapter 1. Sample performance test record sheets are included at the end of the chapter. Instructions are given for performing the tests either from a GPIB controller or the MPS keyboard. Two types of procedures are provided: Operation Verification tests and Performance tests.

**Operation Verification**      These tests do not check all parameters, but comprise a short procedure to verify that the power module is performing properly.

**Performance**                These test all the Performance Specifications (not Supplementary Characteristics) listed in Table 1-1 of the Power Module User's Guide.

If you encounter failures or out-of-specification test results, see "Troubleshooting Procedures" in Chapter 3 of this manual. Those procedures will determine if repair and/or calibration is required.

---

**Note**                        The power module must pass the selftest at power-on before the following tests can be performed. If the module fails selftest, refer to the overall troubleshooting procedures in Chapter 3.

---

**WARNING**

**SHOCK HAZARD** The tests should only be performed by qualified personnel. During the performance of these tests, hazardous voltages may be present at the output of the module.

---



---

### Operation Verification Tests

To assure that the module is operating properly, without testing all specified parameters, perform the following test procedures:

1. Perform the turn-on and checkout procedures given in Chapter 3 of the *Power Module User's Guide*.
2. Perform the Voltage Programming/Readback Accuracy and the Current Programming/Readback Accuracy Performance Tests in this chapter.

---

### Performance Tests

The following paragraphs provide test procedures for verifying the module's compliance with the specifications listed in Table 1-1 of the Power Module User's Guide. All of the performance test specifications are listed in the Performance Test Records at the end of this chapter. You can record the actual measured values in the column provided.

## Measurement Techniques

### Setup for Most Tests

Most tests are performed at the rear terminals as shown in the following figure. Measure the dc voltage directly at the + S and - S terminals. Set the connector sense switch for local sensing and use adequate wire gauge for load leads as described in Chapter 2 of the *Power Module User's Guide*.

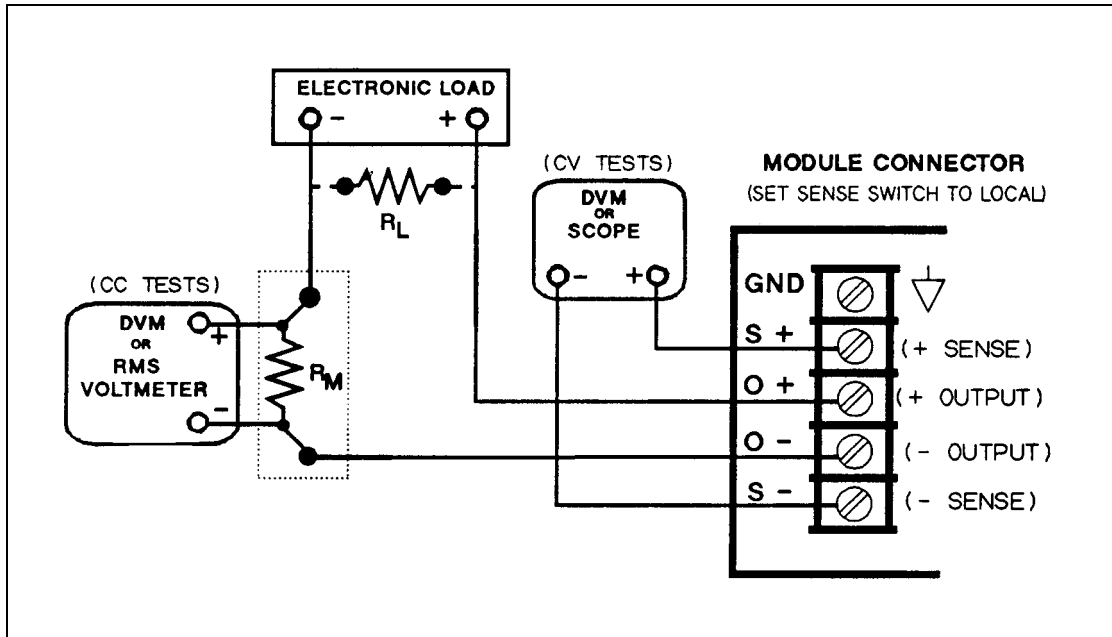

Figure 2-1. Performance Test Setup

Many of the test procedures require the use of a variable load capable of dissipating the required power (see Table 1-1). If a variable resistor is used, switches must be used to connect, disconnect, and short the load resistor. For most tests, an electronic load can be used. The electronic load is considerably easier to use than load resistors but some may not be fast enough to test transient recovery time and may be too noisy for the noise (PARD) tests. Fixed load resistors may be used in place of a variable load, with minor changes to the test procedures in this chapter. Also, if computer controlled test setups are used, the relatively slow (compared to computers and system voltmeters) settling time and slew rates of the power module may have to be taken into account. **WAIT** statements can be used in the test program if the test system is faster than the module.

### Current-Monitoring Resistor

To eliminate output current measurement error caused by voltage drops in the leads and connections, connect the current monitoring resistor between the output and the load as a four-terminal device (see  $R_M$  in Figure 2-1). Connect the current monitoring leads inside the load lead connections directly at the monitoring points on the resistor element.

## Programming

Table 2-1 lists the programming and current values for each module. You may program the module from the MPS Keyboard or from a GPIB controller when performing the tests. The test procedures are written assuming that you know how to do either or both. Complete instructions for remote and local programming are given in the module *Power Module Programming Guide* and *Power Module User's Guide*.

**Table 2-1. Power Module Voltage and Current Values**

<b>Keysight Model</b>	<b>Full-Scale Voltage</b>	<b>Max. Prog. Voltage</b>	<b>Full-Scale Current</b>	<b>Max. Prog. Current</b>	<b>Max. Prog. Overvoltage</b>
66101A	8V	8.190V	16A	16.380A	10V
66102A	20V	20.475V	7.5A	7.678A	24V
66103A	35V	35.831V	4.5A	4.607A	42V
66104A	60V	61.425V	2.5A	2.559A	72V
66105A	120V	122.85V	1.25A	1.280A	144V
66106A	200V	204.75V	0.75A	0.768A	240V

## Constant Voltage (CV) Tests

### CV Setup

If more than one meter or a meter and an oscilloscope are used, connect each to the terminals by a separate pair of leads to avoid mutual coupling effects. For constant voltage dc tests, connect only to + **S** and - **S** because the module regulates the output voltage that appears between those terminals, not between the + and - output terminals. Use coaxial cable or shielded 2-wire cable to avoid noise pickup on the test leads.

### Voltage Programming/Readback Accuracy

This test verifies that the voltage programming, readback, and front panel display functions are within specifications. Note that the values read back over the GPIB should be identical to those displayed on the keyboard display.

1. Turn off the power module and connect a digital voltmeter between the + **S** and -**S** terminals (see Figure 2-1).
2. Turn on the module and program it for zero volts and the maximum programmable current (see Table 2-1) with the load off.
3. Record the output voltage readings on the DVM and the keyboard display. The readings should be within the limits specified in the Performance Test Record Tables under CV PROGRAMMING @ 0 VOLTS, for the particular model being tested. The **CV** annunciator should be on and the output current reading should be approximately zero.
4. Program the output voltage to full scale (see Table 2-1).
5. Record the output voltage readings on the DVM and the keyboard display. The readings should be within the limits specified in the Performance Test Record Tables under CV PROGRAMMING @ FULL SCALE, for the particular model being tested.

### CV Load Effect

This test measures the change in output voltage resulting from a change in output current from full-load to no-load.

1. Turn off the module and connect the output as shown in Figure 2-1 with the DVM connected between the + **S** and - **S** terminals.
2. Turn on the module and program the current to the maximum programmable value and the voltage to the full-scale value (see Table 2-1).
3. Adjust the load for the full-scale current (see Table 2-1) as indicated on the keyboard display. The front panel **CV** annunciator must be on. If it is not, adjust the load so that the output current drops slightly until the annunciator comes on.
4. Record the output voltage reading on the DVM connected to + **S** and - **S**.
5. Open the load and again record the DVM voltage reading.
6. The difference between the DVM readings in steps (4) and (5) is the load effect voltage and should not exceed the value listed in the Performance Test Record Tables under CV LOAD EFFECT, for the model being tested.

## CV Source Effect

This test measures the change in output voltage that results from a change in ac line voltage from the minimum to maximum value within the line voltage specifications.

1. Turn off the module and connect the ac power line through a variable-voltage transformer.
2. Connect the output as shown in Figure 2-1 with the DVM connected between the + S and - S terminals. Set the transformer to nominal line voltage (either 115Vac or 230Vac).
3. Turn on the module and program the current to the maximum programmable value and the output voltage to the full-scale value (see Table 2-1).
4. Adjust the load for the full-scale current value (see Table 2-1) as indicated on the keyboard display. The front panel **CV** annunciator must be on. If it is not, adjust the load so that the output current drops slightly until the annunciator comes on.
5. Adjust the transformer to the **LOW** line voltage (e.g., 87Vac for a 115Vac nominal input, or 174Vac for a 230Vac nominal input).
6. Record the output voltage reading on the DVM.
7. Adjust the transformer to the **HIGH** line voltage (e.g., 132Vac for a 115Vac nominal input, or 250Vac for a 230Vac nominal input).
8. Record the output voltage reading on the DVM.
9. The difference between the DVM readings in steps (6) and (8) is the source effect voltage and should not exceed the value listed in the Performance Test Record Tables under CV SOURCE EFFECT, for the model being tested.

## CV Noise (PARD)

Periodic and random deviations (PARD) in the output (ripple and noise) combine to produce a residual ac voltage superimposed on the dc output voltage. This test measures CV PARD, specified as the rms or peak-to-peak output voltage over the frequency range of 20Hz to 20MHz.

1. Turn off the module and connect the output as shown in Figure 2-1 to an oscilloscope (ac coupled) between the + and-- terminals. Set the oscilloscope's bandwidth limit to 20MHz (30MHz on the Keysight 54504A) and use an RF tip on the oscilloscope probe.
2. Turn on the module and program the current to the maximum programmable value and the output voltage to the full-scale value (see Table 2-1).
3. Adjust the load for the full-scale current value (see Table 2-1) as indicated on the keyboard display.
4. The waveform on the oscilloscope should not exceed the peak-to-peak limits in the Performance Test Record Tables under CV NOISE (PARD), for the model being tested.
5. Disconnect the oscilloscope and connect an ac rms voltmeter in its place. The rms voltage reading should not exceed the rms limits in the Performance Test Record Tables under CV NOISE (PARD) for the model being tested.

## Transient Recovery Time

This test measures the time for the output voltage to recover to within the specified value following a 10% change in the load current.

1. Turn off the module and connect the output as shown in Figure 2-1 with the oscilloscope across the + S and -S terminals.
2. Turn on the module and program the output voltage to the full-scale value and the current to the maximum programmable value (see Table 2-1).
3. Set the load to the Constant Current mode and program the load current to 90% of the power module full-scale rated current.
4. Set the electronic load's transient generator frequency to 100Hz and its duty cycle to 50%.
5. Program the load's transient level to the module's full-scale current value and turn the transient on.
6. Adjust the oscilloscope for a waveform similar to that in Figure 2-2.
7. The output voltage should return to within 100mV of the nominal value in less than 1ms. Check both loading and

unloading transients by triggering on the positive and negative slope.

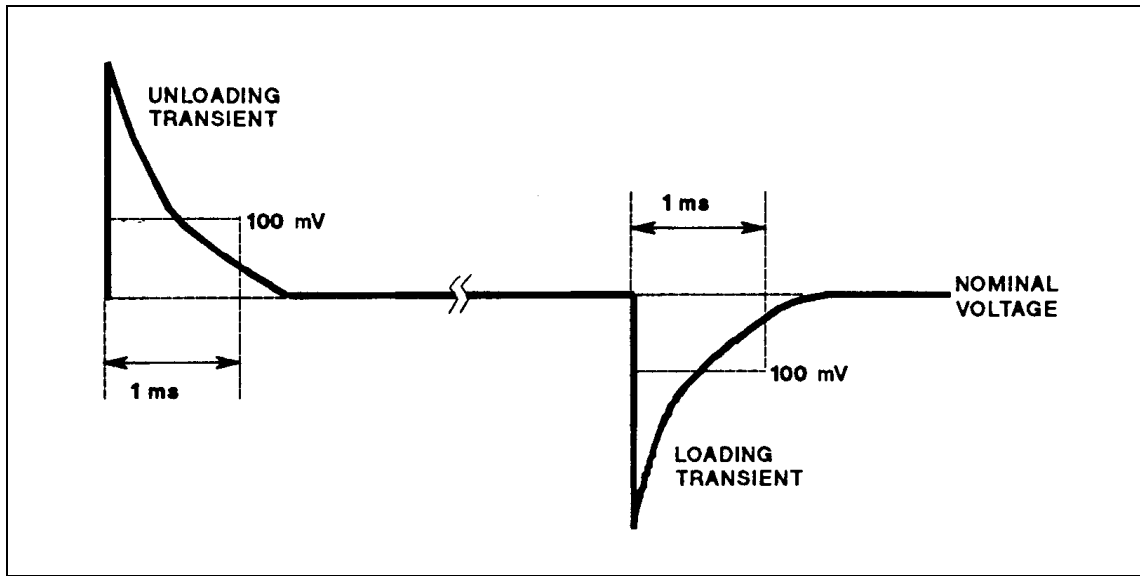

Figure 2-2. Transient Response Waveform

## Constant Current (CC) Tests

### CC Setup

Follow the general setup instructions in the Measurement Techniques paragraph and the specific instructions given in the following paragraphs.

### Current Programming/Readback Accuracy

This test verifies that the current programming and readback are within specification. The accuracy of the current monitoring resistor is determined by the power coefficient (see Table 1-1).











1. Turn off the module and connect the current monitoring resistor directly across the output and a DVM across the resistor. Refer to the "Current Monitoring Resistor" paragraph.
2. Turn on the module and program the output voltage to 5V and the current to zero.
3. Divide the voltage drop (DVM reading) across the current monitoring resistor by its resistance to convert to amps and record this value as ( $I_o$ ). The actual current ( $I_o$ ) and the reading on the keyboard display should be within the limits specified in the Performance Test Record Tables under CC PROGRAMMING @ 0 AMPS, for the particular model being tested.
4. Program the output voltage to 5V and the current to full-scale (see Table 2-1).
5. Divide the voltage drop (DVM reading) across the current monitoring resistor by its resistance to convert to amps and record this value as ( $I_o$ ). The actual current ( $I_o$ ) and the reading on the keyboard display should be within the limits specified in the Performance Test Record Tables under CC PROGRAMMING @ FULL SCALE, for the particular model being tested.

### CC Load and Line Regulation

These tests (CC Load Effect and CC Source Effect given below) are tests of the dc regulation of the power module's output current. To insure that the values read are not the instantaneous measurement of the ac peaks of the output current ripple, several dc measurements should be made and the average of these readings calculated.



The following steps show how to set up a Keysight 3458A System Voltmeter from its front panel to take a statistical average of 100 readings.  represents the unlabeled shift key in the FUNCTION/RANGE group.

1. Program 10 power line cycles per sample by pressing **NPLC** **1** **0** **Enter**.
2. Program 100 samples per trigger by pressing **N Rds/Trig** **1** **0** **0** **Enter**.
3. Set up the voltmeter to take measurements in the statistical mode as follows:
4. a. Press  **f0**  **N**.
- b. Press  until the MATH function is selected; then press .
- c. Press  until the STAT function is selected; then press **Enter**.
5. Now set up the voltmeter to read the average value of the measurements as follows:
6. a. Press  **f1**  **N**.
- b. Press  until the RMATH function is selected; then press .
- c. Press  until the MEAN function is selected; then press **Enter**.
7. Execute the average reading program by pressing **f0** **Enter** **TRIG** **Enter**.
8. Wait for 100 readings and then read the average measurement by pressing **f1** **Enter**. Record this as your result.

To repeat the measurement, perform steps (7) and (8).

### CC Load Effect

This test measures the change in output current for a change in the load from full-scale output voltage to short circuit.

1. Turn off the module and connect the output to be tested as shown in Figure 2-1 with the voltmeter connected across the current monitoring resistor.
2. Turn on the module and program the current to the full-scale current value and the output voltage to the maximum programmable voltage value (see Table 2-1).
3. Adjust the load in the CV mode for full-scale voltage as indicated on the keyboard display. Check that the **CC** annunciator is on. If it is not, adjust the load to drop the output voltage slightly until the annunciator comes on.
4. Record the output current reading (DVM reading ÷ current monitor resistance value in ohms).

---

### Note

You may want to use the average reading program described previously.

---

5. Short the load switch and record the output current reading.
6. The difference in the current readings in steps (4) and (5) is the load effect and should not exceed the limit specified in the Performance Test Record Tables under CC LOAD EFFECT, for the particular model being tested.

### CC Source Effect

This test measures the change in output current that results when the ac line voltage changes from the minimum to the maximum value within the specifications.

1. Turn off the module and connect the ac power line through a variable-voltage transformer.
2. Connect the output terminals as shown in Figure 2-1 with the voltmeter connected across the current monitoring resistor. Set the transformer to the nominal line voltage.
3. Turn on the module and program the current to the full-scale value and the output voltage to the maximum programmable value (see Table 2-1).
4. Adjust the load in the CV mode for full-scale voltage as indicated on the front panel display. Check that the **CC** annunciator is on. If it is not, adjust the load to drop the output voltage slightly until the annunciator comes on.
5. Adjust the transformer to the LOW line voltage (e.g., 87Vac for a 115Vac nominal input, or 174Vac for a 230Vac nominal input).
6. Record the output current reading (DVM reading ÷ current monitoring resistor in ohms).

---

**Note** You may want to use the average reading program described previously.

---

7. Adjust the transformer to the **HIGH** line voltage (e.g., 132Vac for a 115Vac nominal input, or 250Vac for a 230Vac nominal input), and record the output current reading.
8. The difference in the current readings in steps (6) and (7) is the CC source effect and should not exceed the values listed in the Performance Test Record Tables under CC SOURCE EFFECT, for the particular model being tested.

### **CC Noise (PARD)**

Periodic and random deviations (PARD) in the output (ripple and noise) combine to produce a residual ac current as well as an ac voltage superimposed on the dc output. Constant current (CC) PARD is specified as the rms output current in a frequency range 20Hz to 20MHz with the module in CC operation.

1. Turn off the module and connect the load resistor ( $R_L$ ) and rms voltmeter as shown in Figure 2-1. Use only a **resistive load** for this test. Keep leads as short as possible to reduce noise pickup.
2. Check the test setup for noise with the module turned off. Other equipment (e.g. computers, DMM, etc.) may affect the reading.
3. Turn on the module and program the current to full-scale and the output voltage to the maximum programmable value (see Table 2-1).
4. The output current should be at the full-scale rating with the CC Mode on.
5. Divide the reading on the rms voltmeter by the shunt resistance to obtain rms current. It should not exceed the values listed in the Performance Test Record Tables under CC NOISE (Rms) for the particular unit being tested.

**Table 2-2. Performance Test Record for Model Keysight 66101A (8V, 16A)**

	Pre Cal _____	Post Cal _____
<b>Model Keysight 66101A</b>	<b>Temperature</b> _____	<b>Test Performed</b>
<b>By</b> _____		
<b>Serial Number</b> _____	<b>Humidity</b> _____	<b>Date</b> _____

Test Description	Specification	Actual
CV PROGRAMMING @ 0 volts Output Accuracy (DVM Reading) Display and Readback Accuracy	0 ± 3mV DVM ± 2mV	_____ _____
CV PROGRAMMING @ full-scale Output Accuracy (DVM Reading) Display and Readback Accuracy	8V ± 5.4mV DVM ± 3.6mV	_____ _____
CV LOAD EFFECT	1mV	_____
CV SOURCE EFFECT	0.5mV	_____
CV NOISE (PARD) Peak to Peak Rms	5mV 2mV	_____ _____
TRANSIENT RECOVERY in 1 ms	100mV	_____
CC PROGRAMMING @ 0 amps Output Accuracy (Io) Display and Readback Accuracy	0 ± 6mA Io ± 6mA	_____ _____
CC PROGRAMMING @ full-scale Output Accuracy (Io) Display and Readback Accuracy	16A ± 10.8mA Io ± 9.2mA	_____ _____
CC LOAD EFFECT	0.5mA	_____
CC SOURCE EFFECT	0.75mA	_____
CC NOISE (RMS)	8mA	_____

**Table 2-3. Performance Test Record for Model Keysight 66102A (20V, 7.5A)**

	Pre Cal _____	Post Cal _____
<b>Model Keysight 66102A</b>	<b>Temperature</b> _____	<b>Test Performed</b>
<b>By</b> _____		
<b>Serial Number</b> _____	<b>Humidity</b> _____	<b>Date</b> _____

Test Description	Specification	Actual
CV PROGRAMMING @ 0 volts Output Accuracy (DVM Reading) Display and Readback Accuracy	0 ± 8mV DVM ± 5mV	_____ _____
CV PROGRAMMING @ full-scale Output Accuracy (DVM Reading) Display and Readback Accuracy	20V ± 14mV DVM ± 9mV	_____ _____
CV LOAD EFFECT	1mV	_____
CV SOURCE EFFECT	0.5mV	_____
CV NOISE (PARD) Peak to Peak Rms	7mV 3mV	_____ _____
TRANSIENT RECOVERY in 1 ms	100mV	_____
CC PROGRAMMING @ 0 amps Output Accuracy (Io) Display and Readback Accuracy	0 ± 3mA Io ± 3mA	_____ _____
CC PROGRAMMING @ full-scale Output Accuracy (Io) Display and Readback Accuracy	7.5A ± 5.3mA Io ± 4.5mA	_____ _____
CC LOAD EFFECT	0.2mA	_____
CC SOURCE EFFECT	0.5mA	_____
CC NOISE (RMS)	4mA	_____

**Table 2-4. Performance Test Record for Model Keysight 66103A (35V, 4.5A)**

	Pre Cal _____	Post Cal _____
<b>Model Keysight 66103A</b>	Temperature _____	Test Performed _____
By _____		
Serial Number _____	Humidity _____	Date _____

Test Description	Specification	Actual
CV PROGRAMMING @ 0 volts Output Accuracy (DVM Reading) Display and Readback Accuracy	0 ± 13mV DVM ± 8mV	_____ _____
CV PROGRAMMING @ full-scale Output Accuracy (DVM Reading) Display and Readback Accuracy	35V ± 23.5mV DVM ± 15mV	_____ _____
CV LOAD EFFECT	1mV	_____
CV SOURCE EFFECT	1mV	_____
CV NOISE (PARD) Peak to Peak Rms	10mV 5mV	_____ _____
TRANSIENT RECOVERY in 1 ms	100mV	_____
CC PROGRAMMING @ 0 amps Output Accuracy (Io) Display and Readback Accuracy	0 ± 2mA Io ± 2mA	_____ _____
CC PROGRAMMING @ full-scale Output Accuracy (Io) Display and Readback Accuracy	4.5A ± 3.4mA Io ± 2.9mA	_____ _____
CC LOAD EFFECT	0.2mA	_____
CC SOURCE EFFECT	0.3mA	_____
CC NOISE (RMS)	2mA	_____

**Table 2-5. Performance Test Record for Model Keysight 66104A (60V, 2.5A)**

	Pre Cal _____	Post Cal _____
<b>Model Keysight 66104A</b>	<b>Temperature</b> _____	<b>Test Performed</b>
<b>By</b> _____		
<b>Serial Number</b> _____	<b>Humidity</b> _____	<b>Date</b> _____

Test Description	Specification	Actual
CV PROGRAMMING @ 0 volts Output Accuracy (DVM Reading) Display and Readback Accuracy	0 ± 27mV DVM ± 16mV	_____ _____
CV PROGRAMMING @ full-scale Output Accuracy (DVM Reading) Display and Readback Accuracy	60V ± 45mV DVM ± 28mV	_____ _____
CV LOAD EFFECT	2mV	_____
CV SOURCE EFFECT	2mV	_____
CV NOISE (PARD) Peak to Peak Rms	15mV 9mV (1)	_____ _____
TRANSIENT RECOVERY in 1 ms	100mV	_____
CC PROGRAMMING @ 0 amps Output Accuracy (Io) Display and Readback Accuracy	0 ± 1.2mA Io ± 1.0mA	_____ _____
CC PROGRAMMING @ full-scale Output Accuracy (Io) Display and Readback Accuracy	2.5A ± 1.95mA Io ± 1.5mA	_____ _____
CC LOAD EFFECT	0.1mA	_____
CC SOURCE EFFECT	0.1mA	_____
CC NOISE (RMS)	1mA	_____

(1) 18mV Rms when the ac input is between 87 and 104Vac.

**Table 2-6. Performance Test Record for Model Keysight 66105A (120V, 1.25 A)**

	Pre Cal _____	Post Cal _____
<b>Model Keysight 66105A</b>	<b>Temperature</b> _____	<b>Test Performed</b>
<b>By</b> _____		
<b>Serial Number</b> _____	<b>Humidity</b> _____	<b>Date</b> _____

Test Description	Specification	Actual
CV PROGRAMMING @ 0 volts Output Accuracy (DVM Reading) Display and Readback Accuracy	0 ± 54mV DVM ± 32mV	_____ _____
CV PROGRAMMING @ full-scale Output Accuracy (DVM Reading) Display and Readback Accuracy	120V ± 90mV DVM ± 56mV	_____ _____
CV LOAD EFFECT	4mV	_____
CV SOURCE EFFECT	3mV	_____
CV NOISE (PARD) Peak to Peak Rms	25mV 18mV	_____ _____
TRANSIENT RECOVERY in 1 ms	100mV	_____
CC PROGRAMMING @ 0 amps Output Accuracy (Io) Display and Readback Accuracy	0 ± 0.6mA Io ± 0.6mA	_____ _____
CC PROGRAMMING @ full-scale Output Accuracy (Io) Display and Readback Accuracy	1.25A ± 975µA Io ± 850µA	_____ _____
CC LOAD EFFECT	50µA	_____
CC SOURCE EFFECT	50µA	_____
CC NOISE (RMS)	1mA	_____

**Table 2-7. Performance Test Record for Model Keysight 66106A (200V, 0.75A)**

	Pre Cal _____	Post Cal _____
<b>Model Keysight 66106A</b>	<b>Temperature</b> _____	<b>Test Performed</b>
<b>By</b> _____		
<b>Serial Number</b> _____	<b>Humidity</b> _____	<b>Date</b> _____

Test Description	Specification	Actual
CV PROGRAMMING @ 0 volts Output Accuracy (DVM Reading) Display and Readback Accuracy	0 ± 90mV DVM ± 54mV	_____ _____
CV PROGRAMMING @ full-scale Output Accuracy (DVM Reading) Display and Readback Accuracy	200V ± 150mV DVM ± 94mV	_____ _____
CV LOAD EFFECT	7mV	_____
CV SOURCE EFFECT	5mV	_____
CV NOISE (PARD) Peak to Peak Rms	50mV 30mV	_____ _____
TRANSIENT RECOVERY in 1 ms	100mV	_____
CC PROGRAMMING @ 0 amps Output Accuracy (Io) Display and Readback Accuracy	0 ± 0.4mA Io ± 0.3mA	_____ _____
CC PROGRAMMING @ full-scale Output Accuracy (Io) Display and Readback Accuracy	0.75A ± 625µA Io ± 450µA	_____ _____
CC LOAD EFFECT	30µA	_____
CC SOURCE EFFECT	30µA	_____
CC NOISE (RMS)	1mA	_____





# Troubleshooting

This chapter provides troubleshooting and repair information for the Keysight 6610xA Power Modules. Before attempting to troubleshoot the modules, ensure that the problem is not with an external circuit or application, the mainframe, the GPIB controller, the application program, or the input power line.

**WARNING**

**SHOCK HAZARD** Most of the troubleshooting procedures given in this chapter are performed with power applied and protective covers removed. Such maintenance should be performed only by trained service personnel who are aware of the hazards (for example, fire and electrical shock).

Hazardous voltages are present throughout the Power and Bias board assemblies. Ac line voltage is present on some connectors even when the module is not turned on. The dc rail voltage to the module is 310 volts when the unit is turned on.

---

## Troubleshooting Sequence

1. Verify that the module is at fault.
2. Use the flowcharts to locate the functional block at fault.
3. Troubleshoot the functional block per flowchart instructions.

Selftest routines built into firmware are provided to help isolate a problem to a particular circuit on the board. Once a problem has been isolated to a circuit, suggestions are given in the appropriate flowchart as to what component may be at fault.

**CAUTION**

This instrument uses components that can be damaged or suffer serious performance degradation as a result of ESD (electrostatic discharge). Observe the standard anti-static precautions discussed in Chapter 1 to avoid damage to components.

---

## Accessing the Flowcharts

The following troubleshooting flowcharts are provided to help you identify and isolate a problem to a specific circuit. Once a problem has been narrowed down, suggestions are provided as to the components that may be responsible for the problem. Refer to the schematic diagrams for detailed information on circuit wiring and component function.

- Figure 3-1 - Overall Troubleshooting
- Figure 3-2 - Troubleshooting Microprocessor Circuits
- Figure 3-3 - Troubleshooting Error Messages
- Figure 3-4 - Troubleshooting Overvoltage at Turn-on

- Figure 3-5 - Troubleshooting No Output
- Figure 3-6 - Troubleshooting High Output
- Figure 3-7 - Troubleshooting Will Not Overvoltage
- Figure 3-8 - Troubleshooting CV Accuracy
- Figure 3-9 - Troubleshooting CC Accuracy
- Figure 3-10 - Troubleshooting Downprogrammer
- Figure 3-11 - Troubleshooting DAC Circuit
- Figure 3-12 - Troubleshooting Readback Circuits

Oscilloscope waveforms are provided on some flowcharts along with the settings required to generate the waveforms.

---

**WARNING**

Connect the module to ac mains through an isolation transformer when making measurements with an oscilloscope or any equipment that has the measuring input grounded.

---

### **If You Experienced a Selftest Failure or RunTime Error Message**

If you experienced a selftest failure or runtime error message as described in Chapter 3 of the *Power Module User's Guide*, disassemble the module and proceed directly to the flowchart in Figure 3-3 "Troubleshooting Error Messages".

### **If You Experienced Other Problems With the Module**

If you experienced problems other than a selftest failure or a runtime error message, disassemble the module and proceed directly to Figure 3-1 "Overall Troubleshooting".

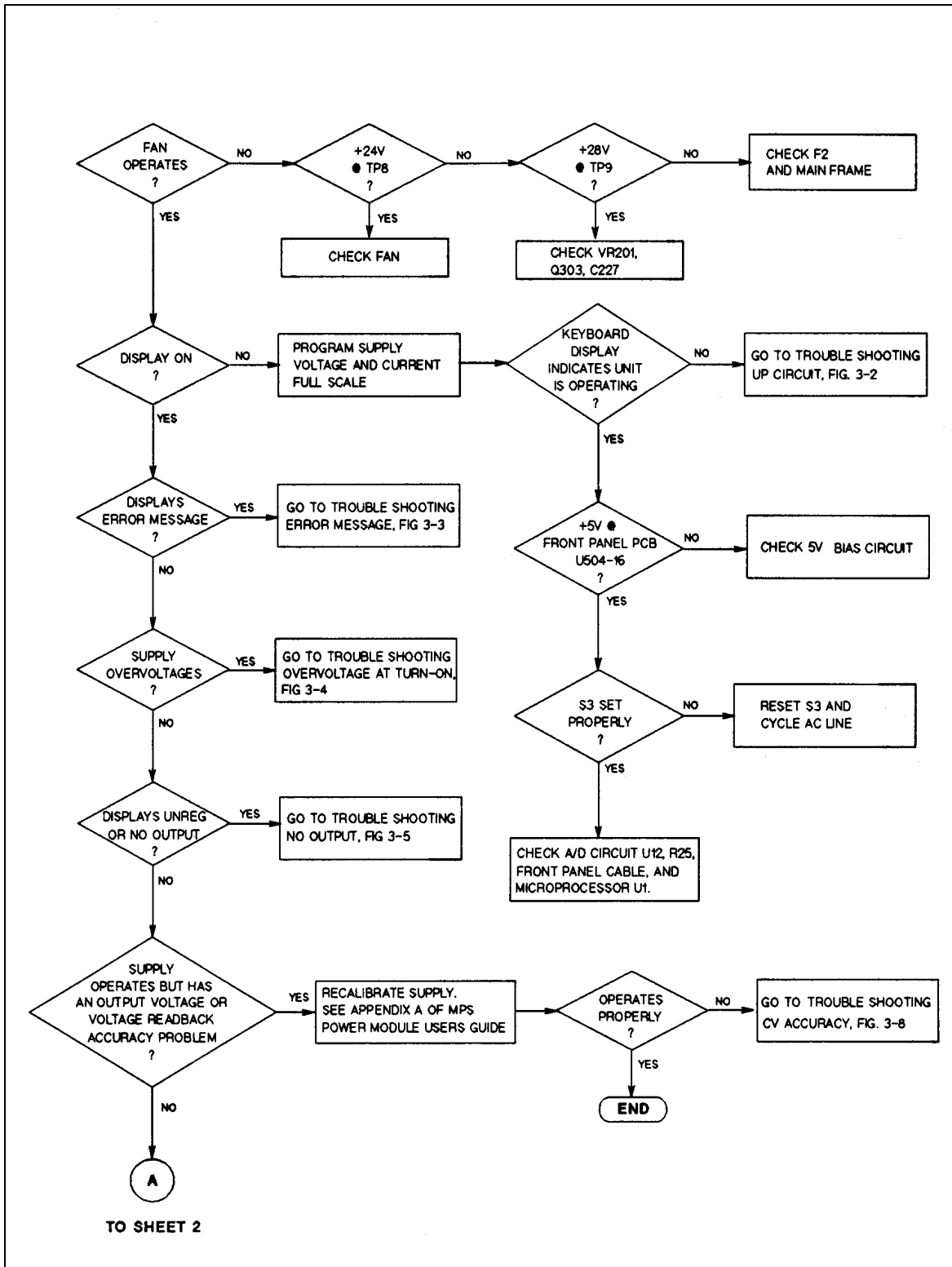

Figure 3-1. Overall Troubleshooting (Sheet 1 of 3)

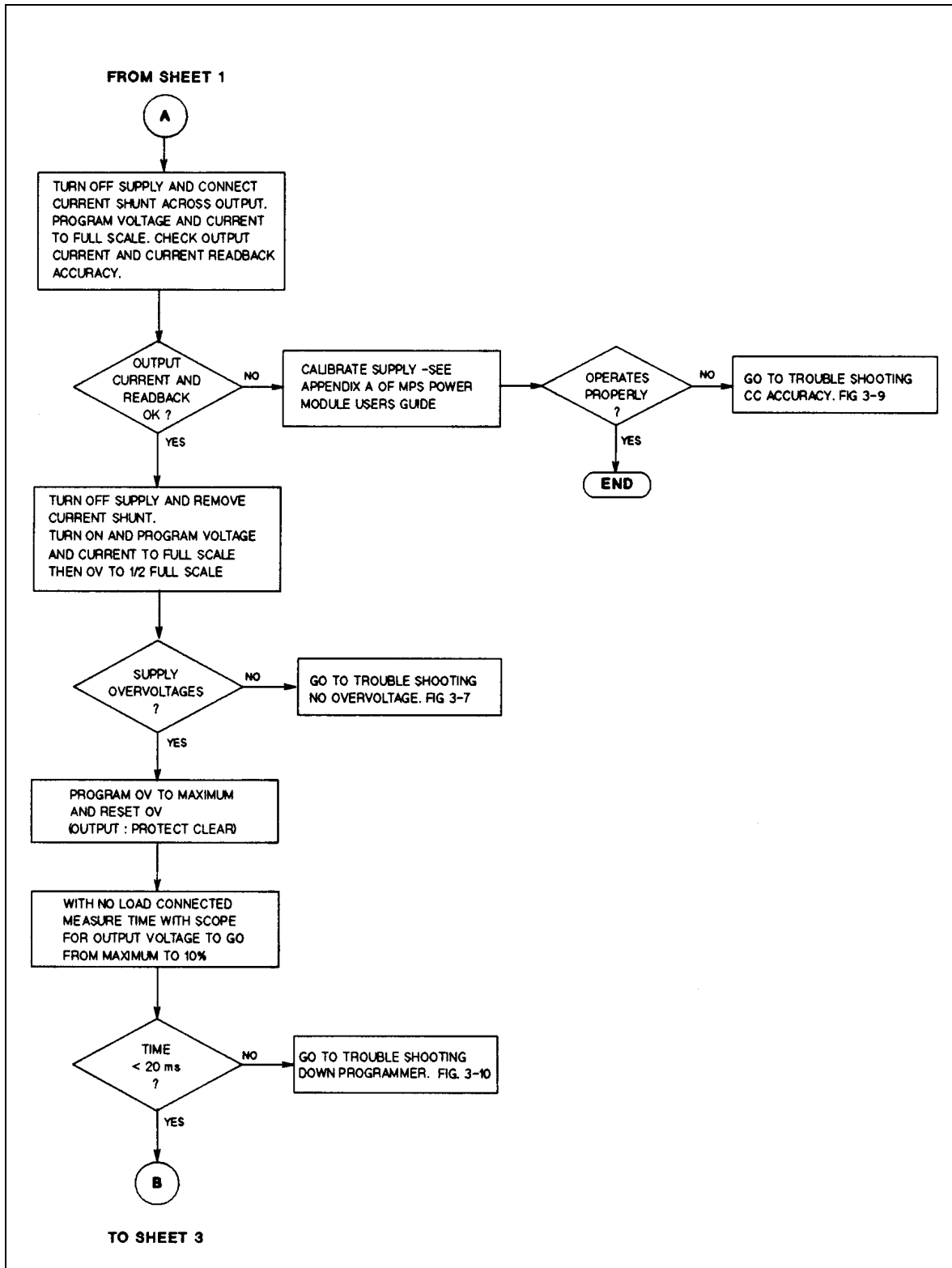

Figure 3-1. Overall Troubleshooting (Sheet 2 of 3)

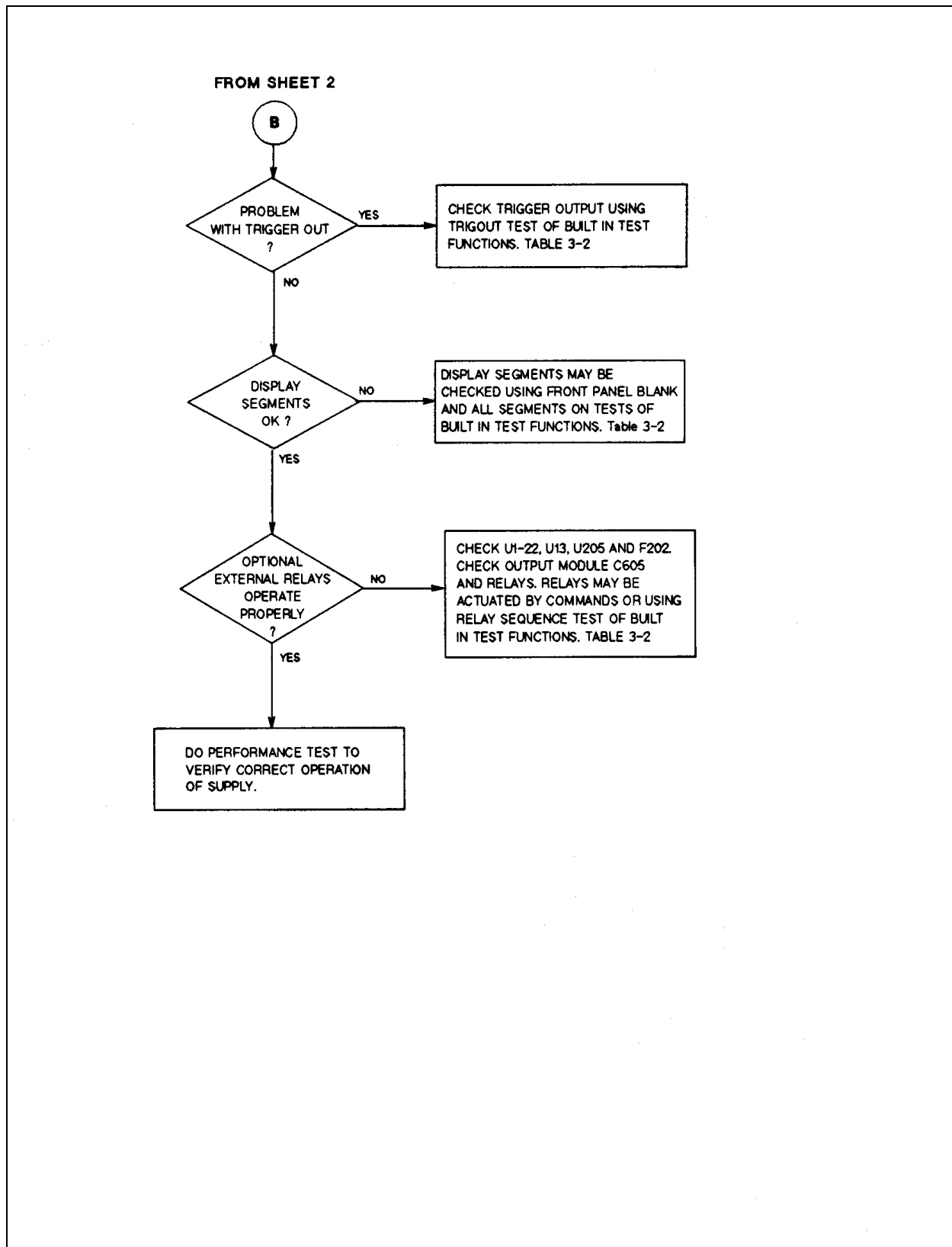

Figure 3-1. Overall Troubleshooting (Sheet 3 of 3)

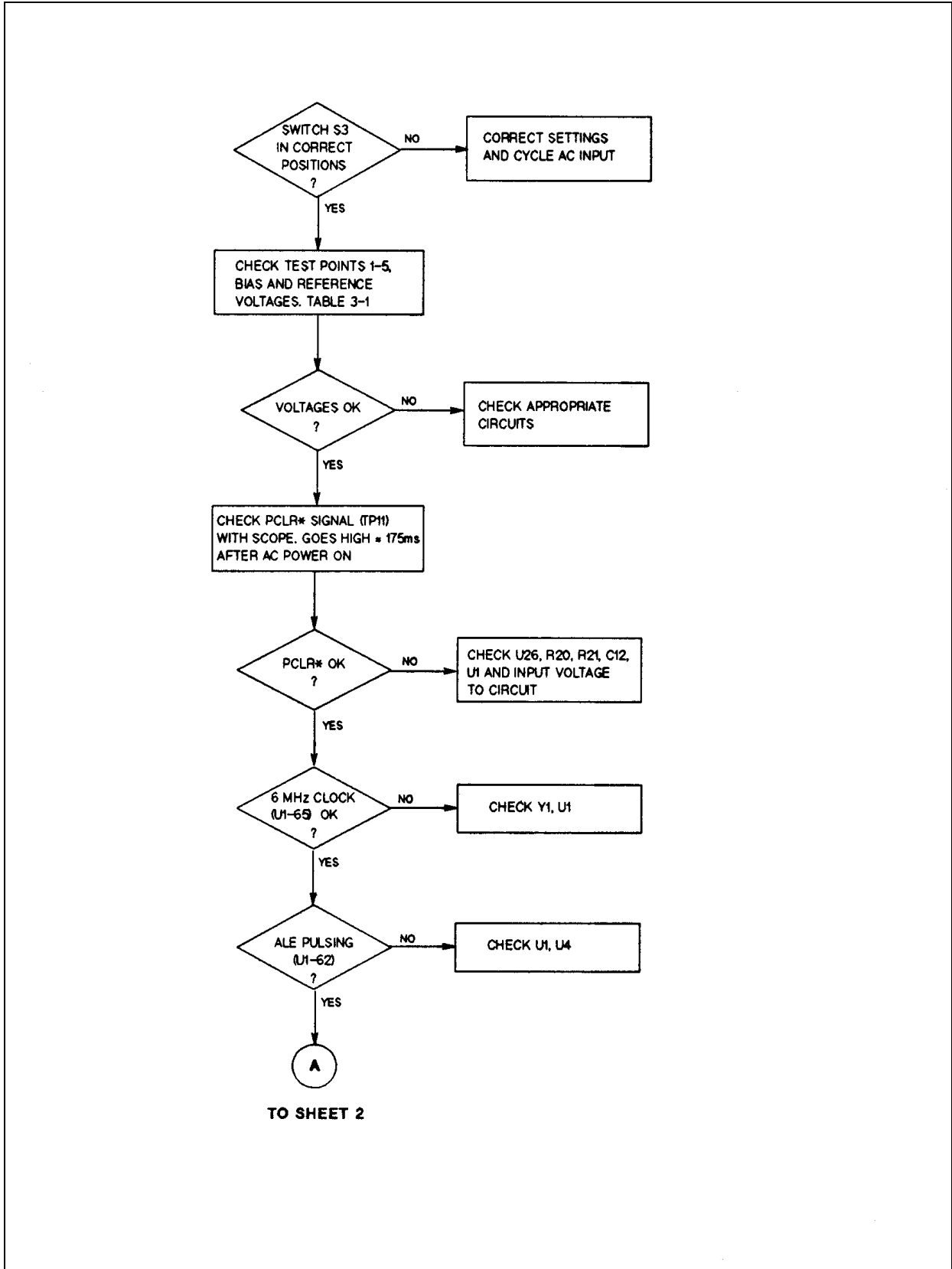

Figure 3-2. Troubleshooting Microprocessor Circuits (Sheet 1 of 2)

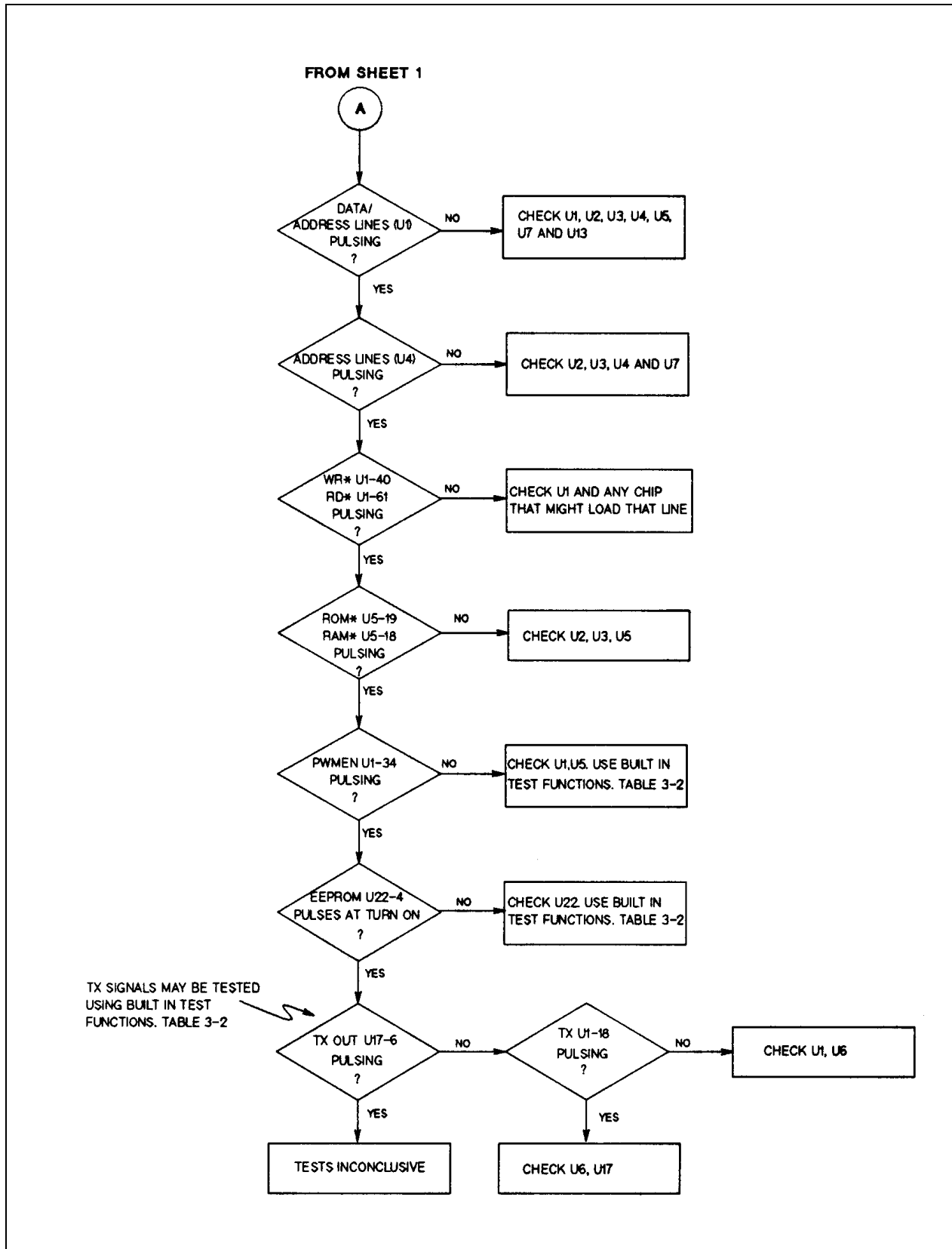

Figure 3-2. Troubleshooting Microprocessor Circuits (Sheet 2 of 2)



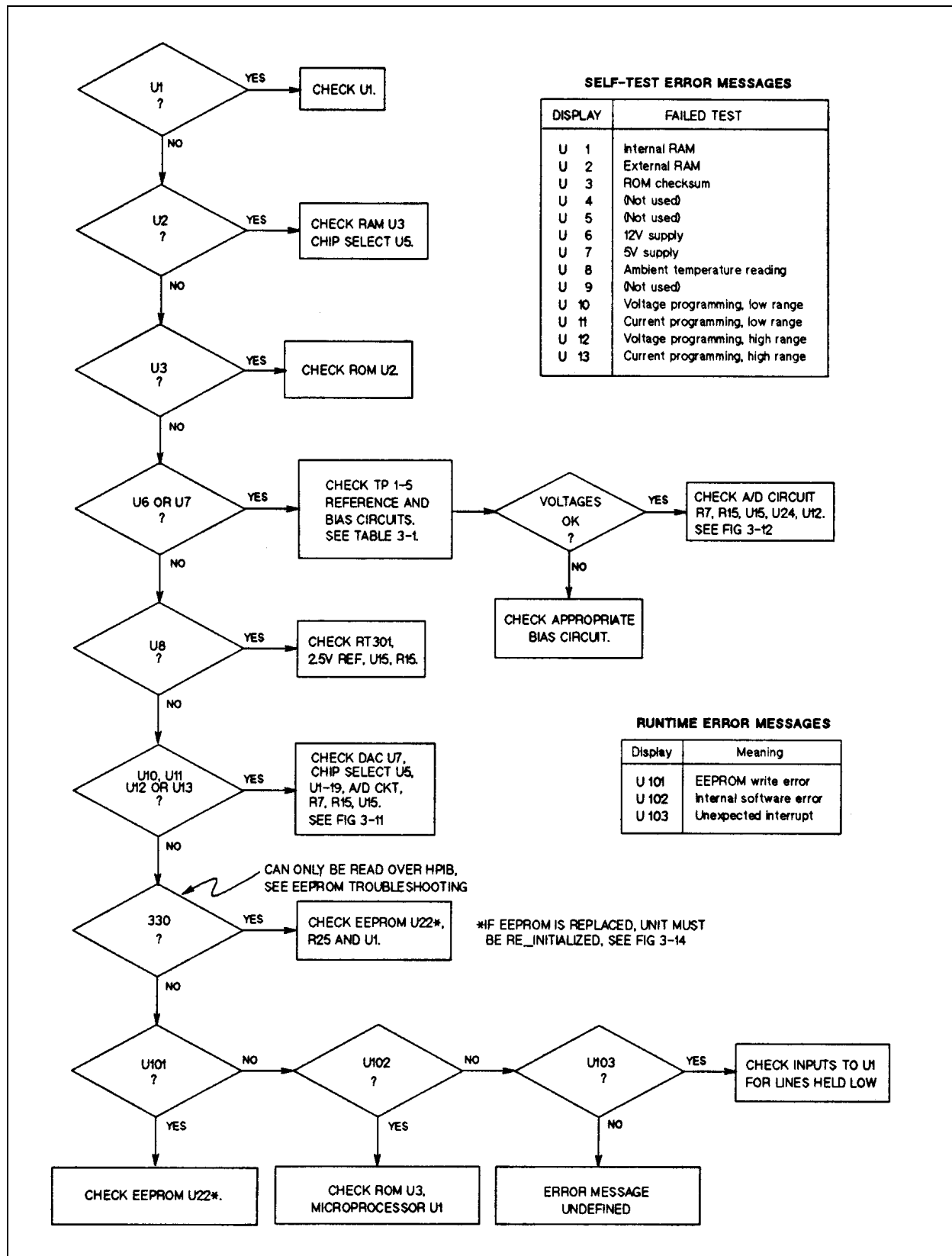

Figure 3-3. Troubleshooting Error Messages

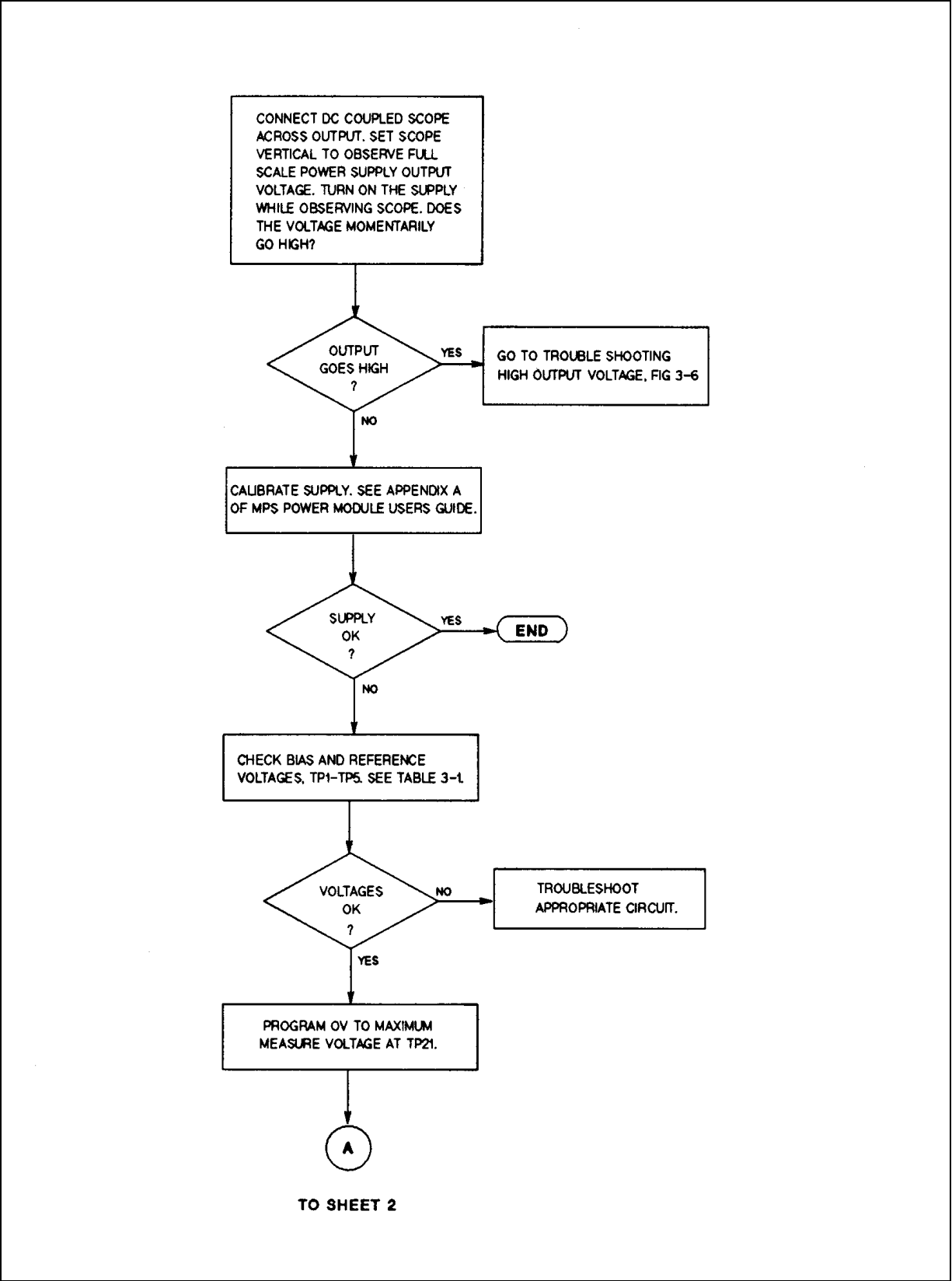

Figure 3-4. Troubleshooting Overvoltage at Turn-On (Sheet 1 of 2)

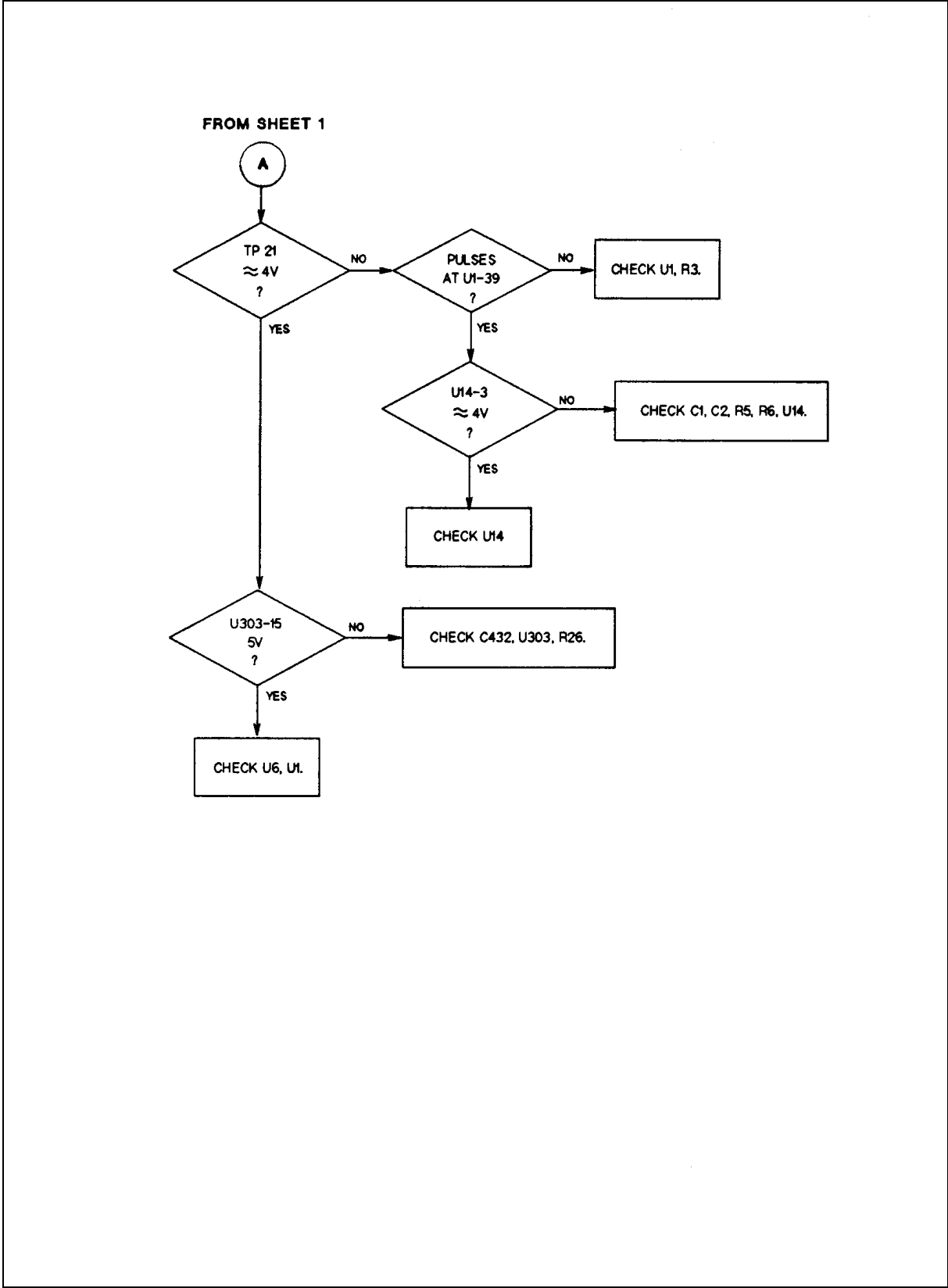

Figure 3-4. Troubleshooting Overvoltage at Turn-On (Sheet 2 of 2)

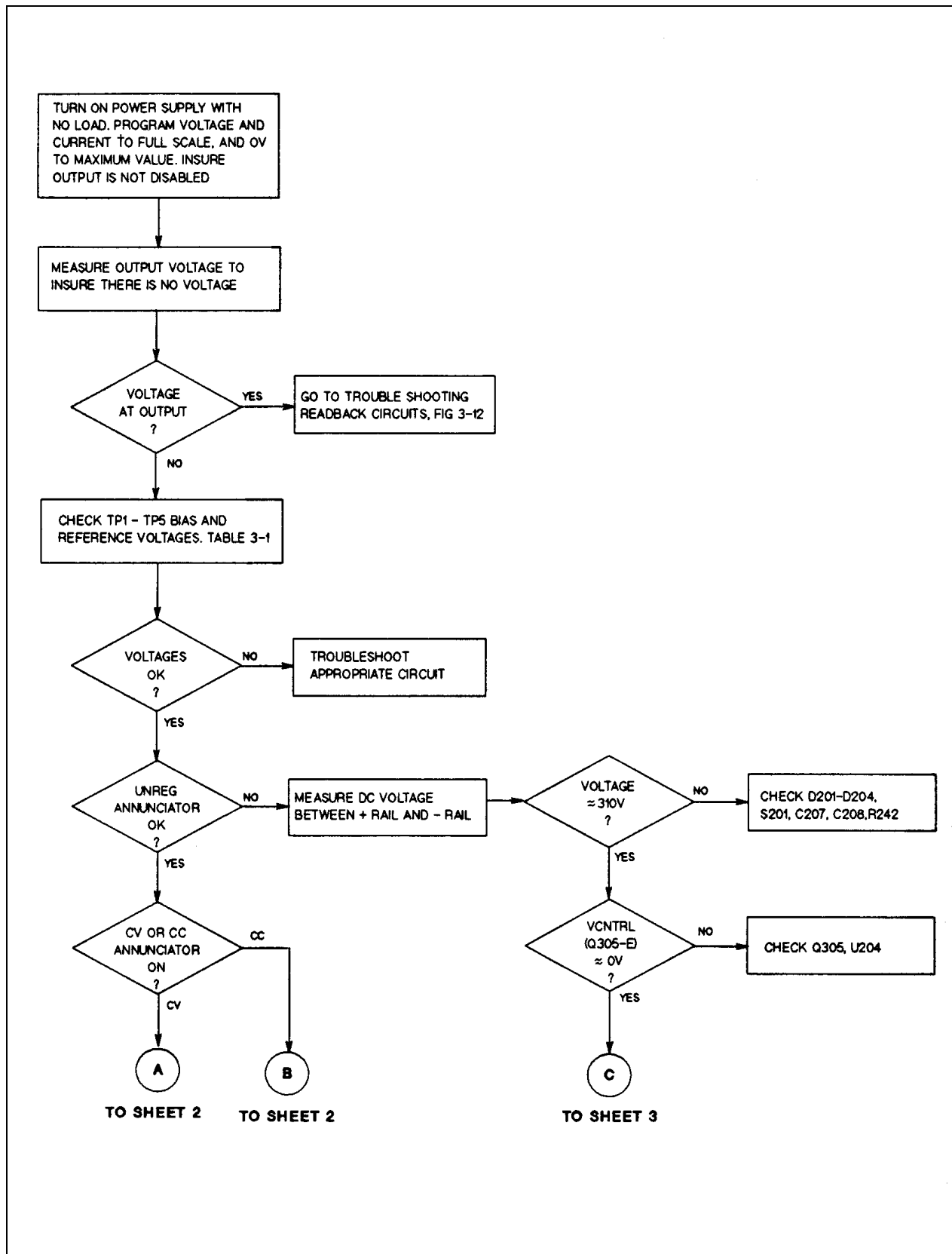

Figure 3-5. Troubleshooting No Output (Sheet 1 of 5)

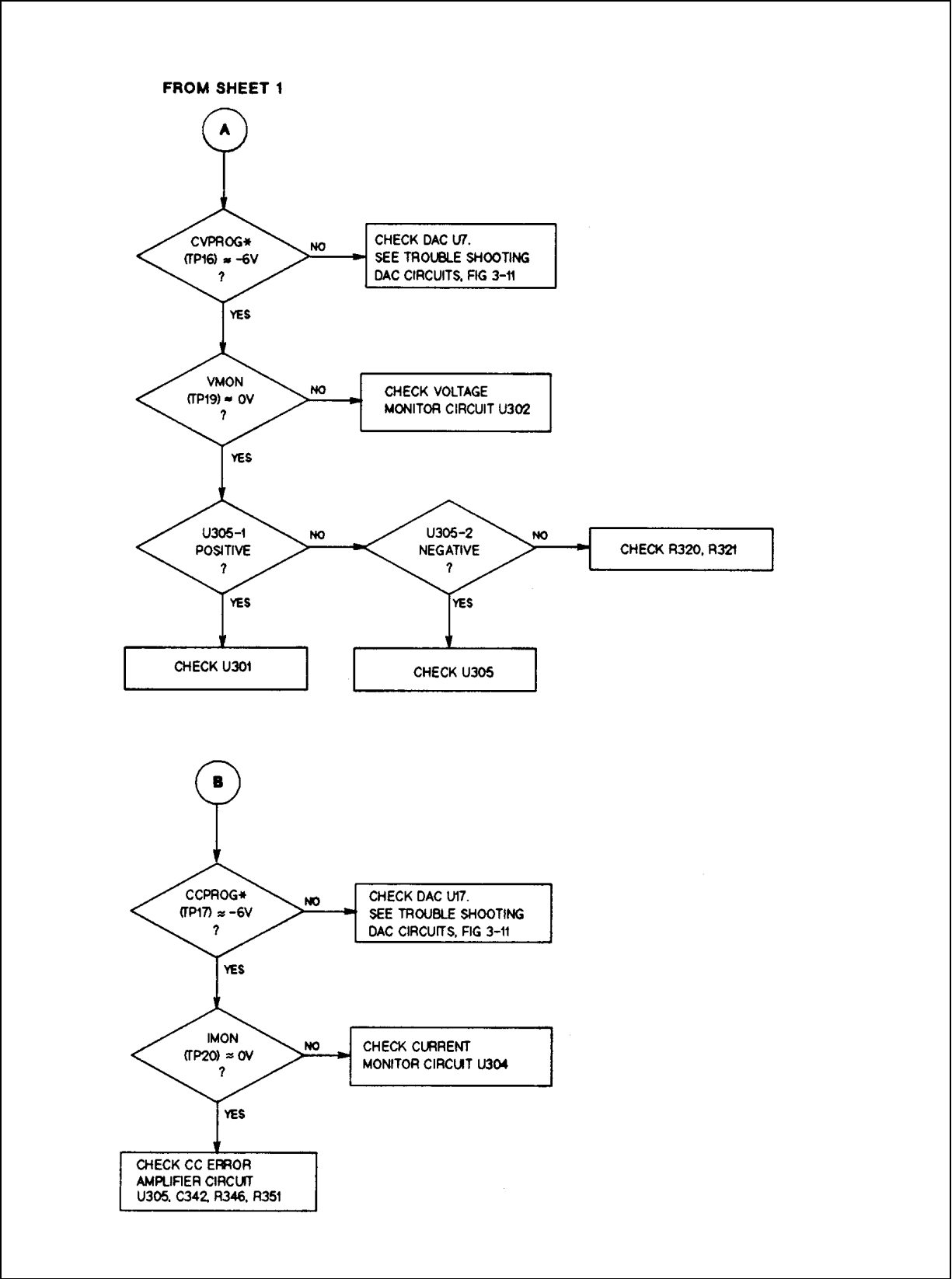

Figure 3-5. Troubleshooting No Output (Sheet 2 of 5)

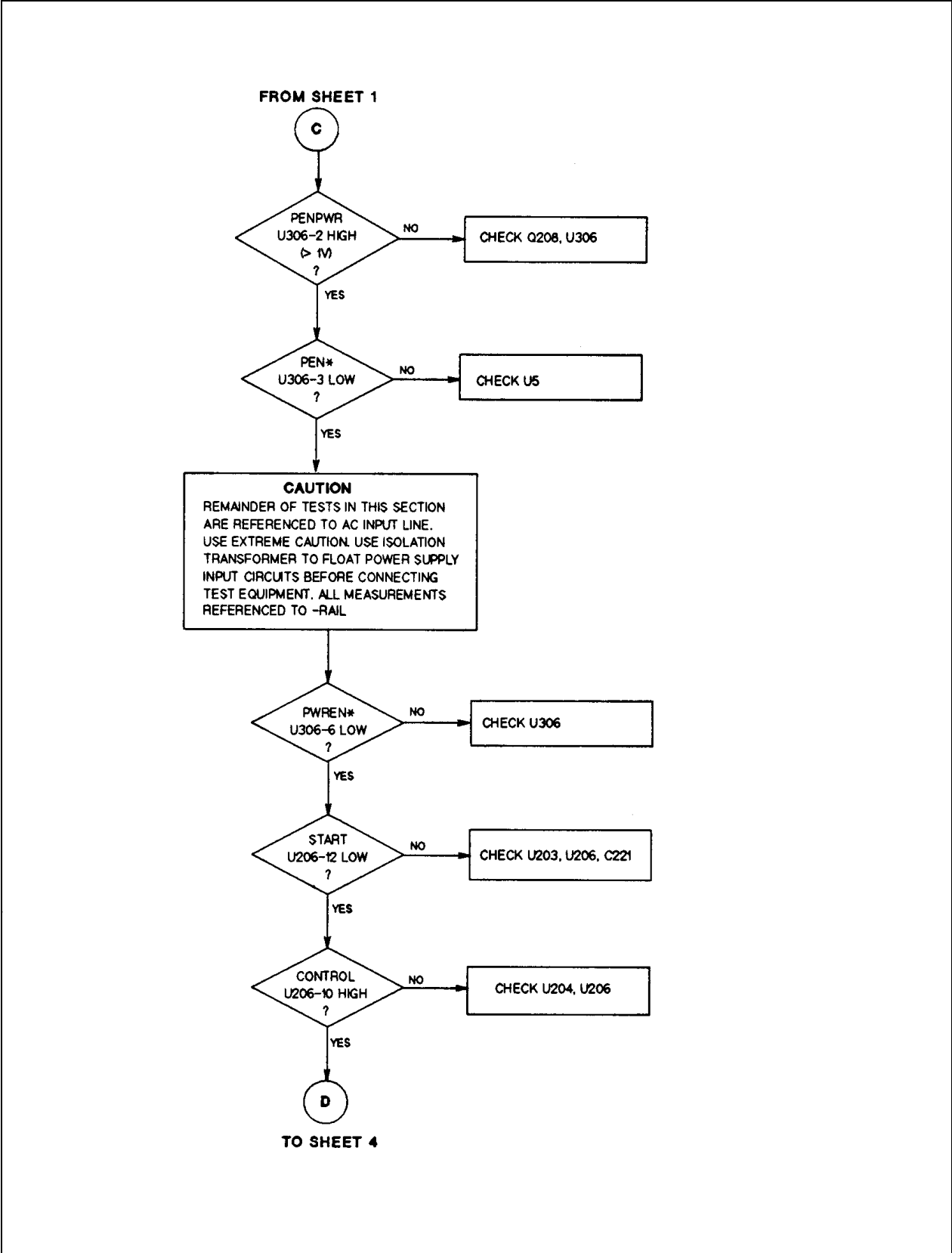

Figure 3-5. Troubleshooting No Output (Sheet 3 of 5)

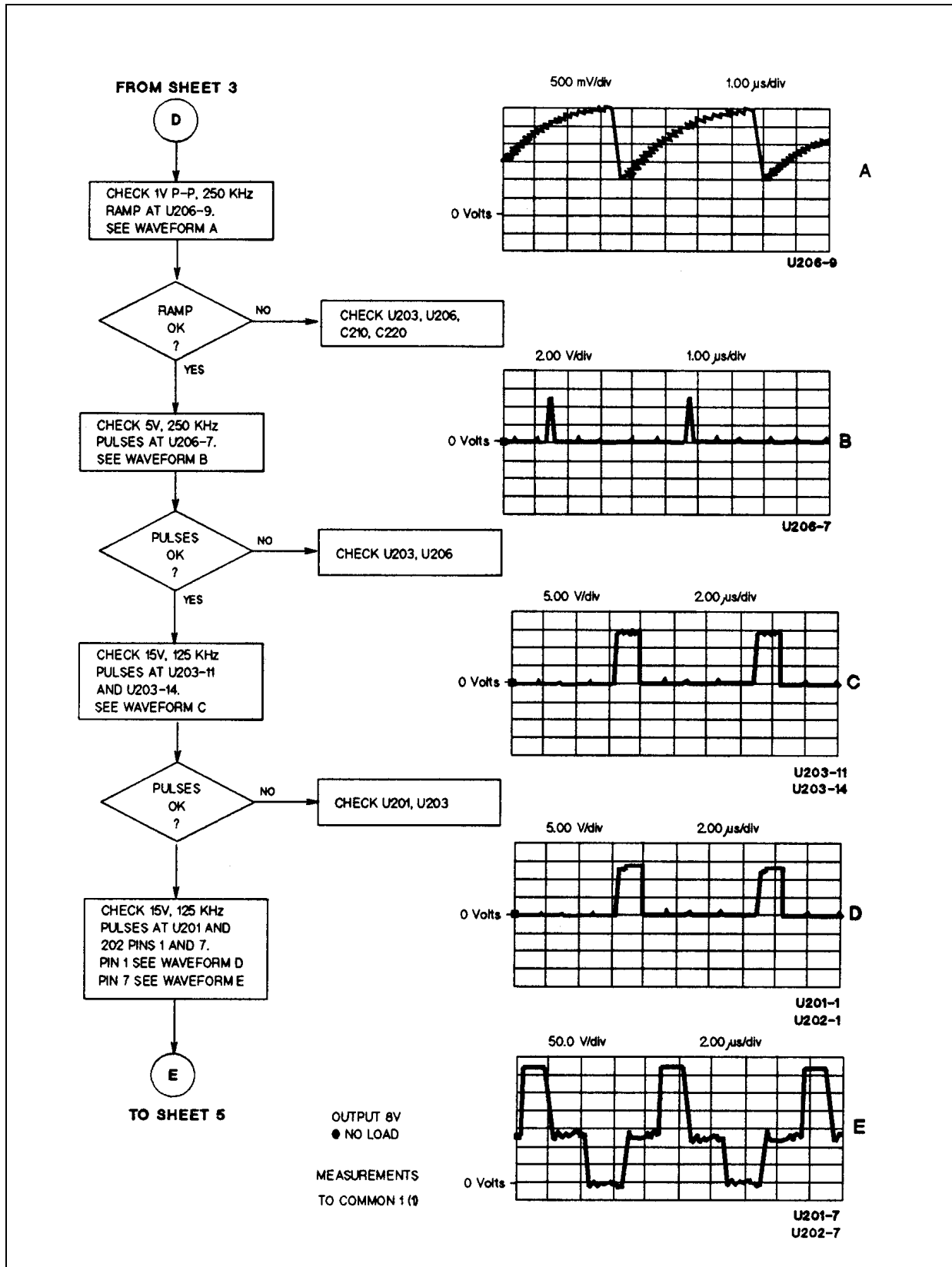

Figure 3-5. Troubleshooting No Output (Sheet 4 of 5)

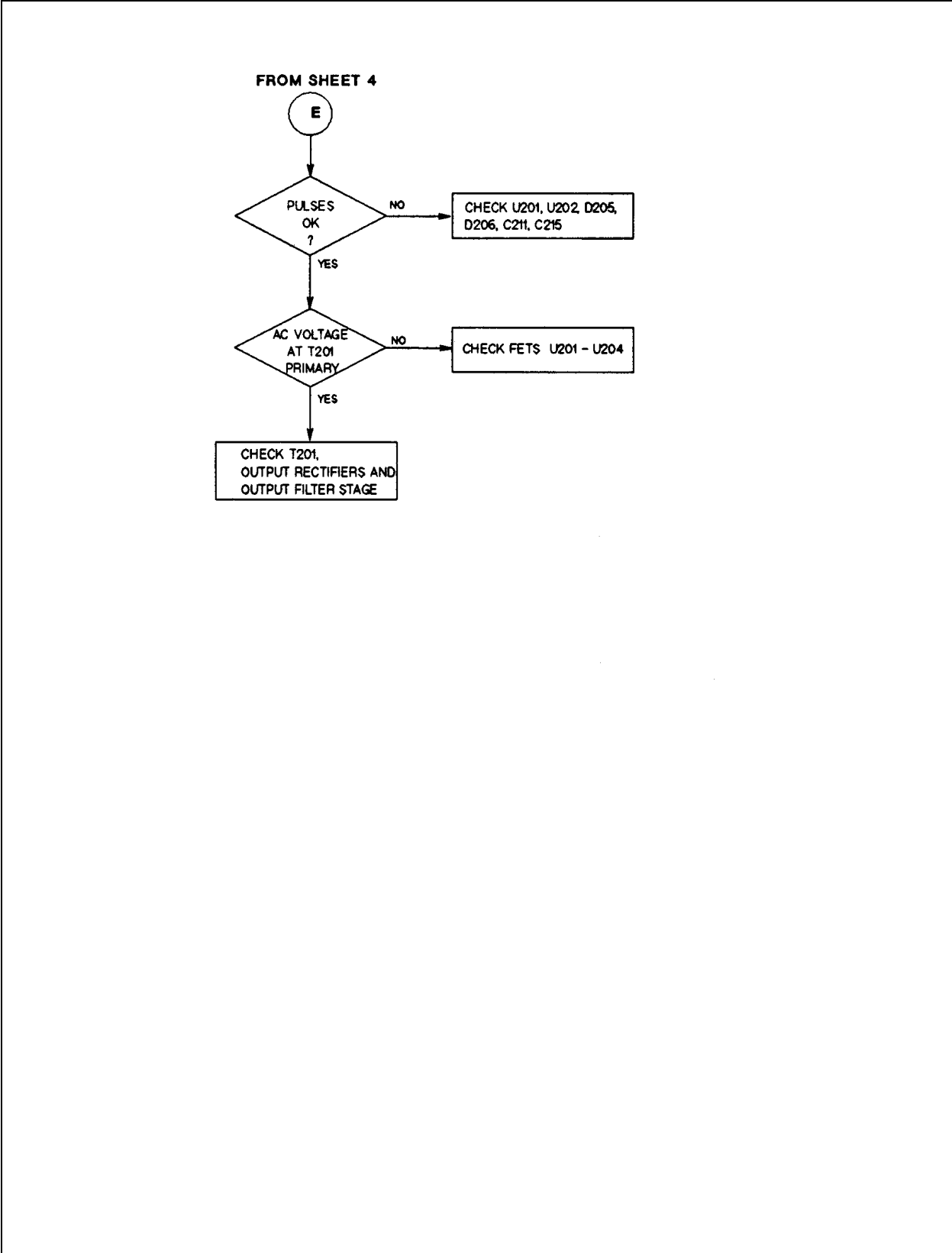

Figure 3-5. Troubleshooting No Output (Sheet 5 of 5)



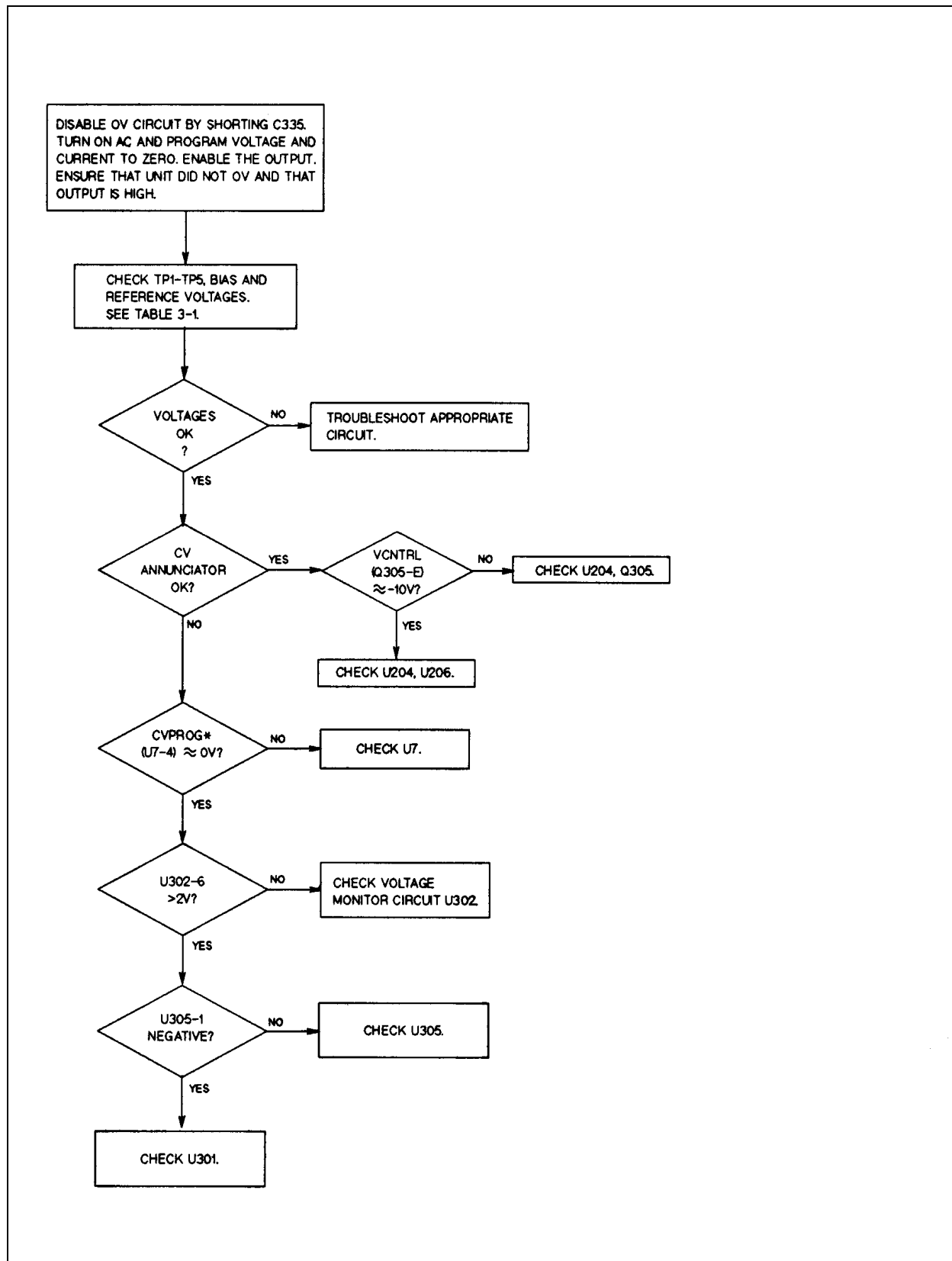

Figure 3-6. Troubleshooting High Output

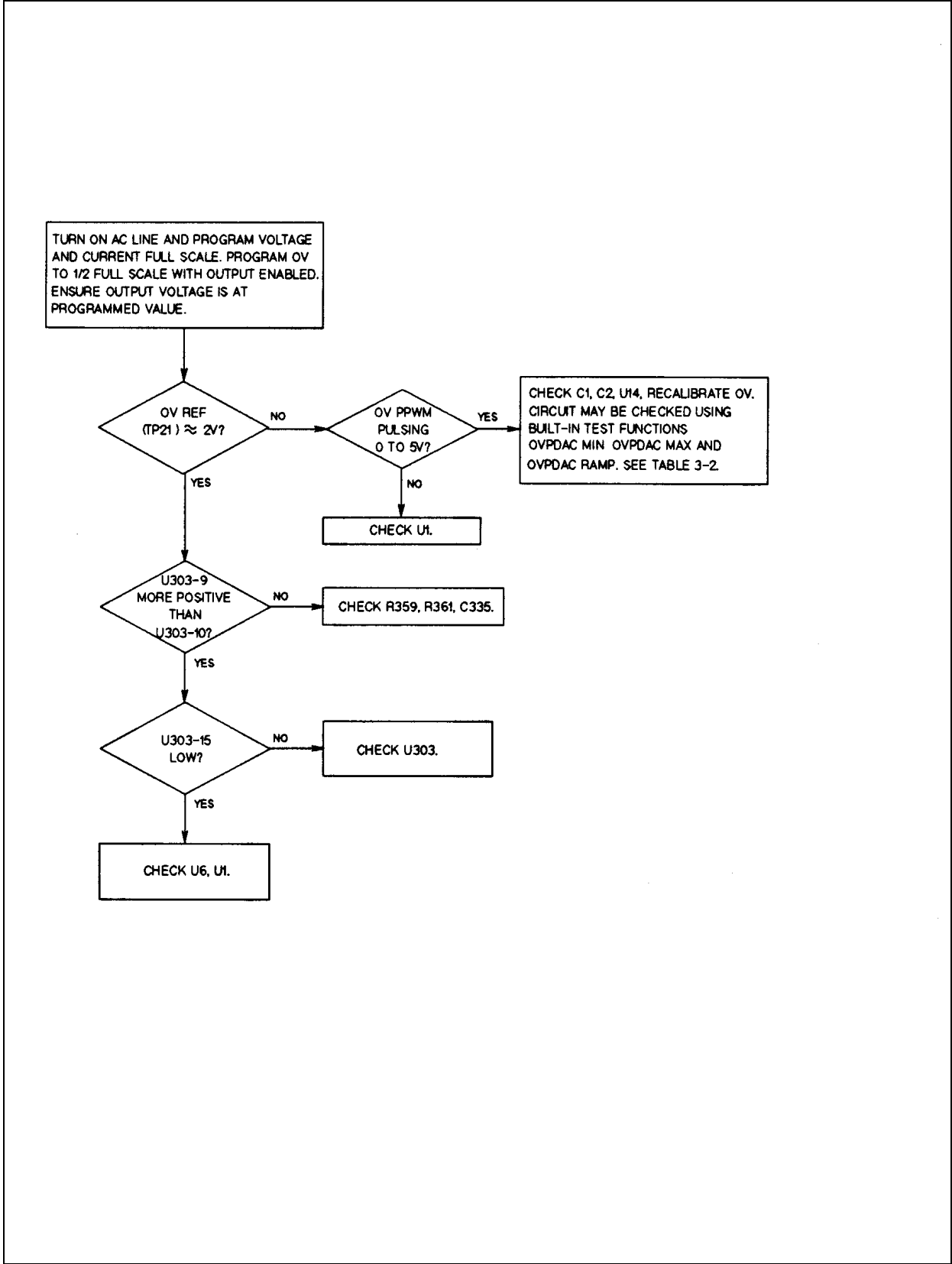

Figure 3-7. Troubleshooting Will Not Overvoltage

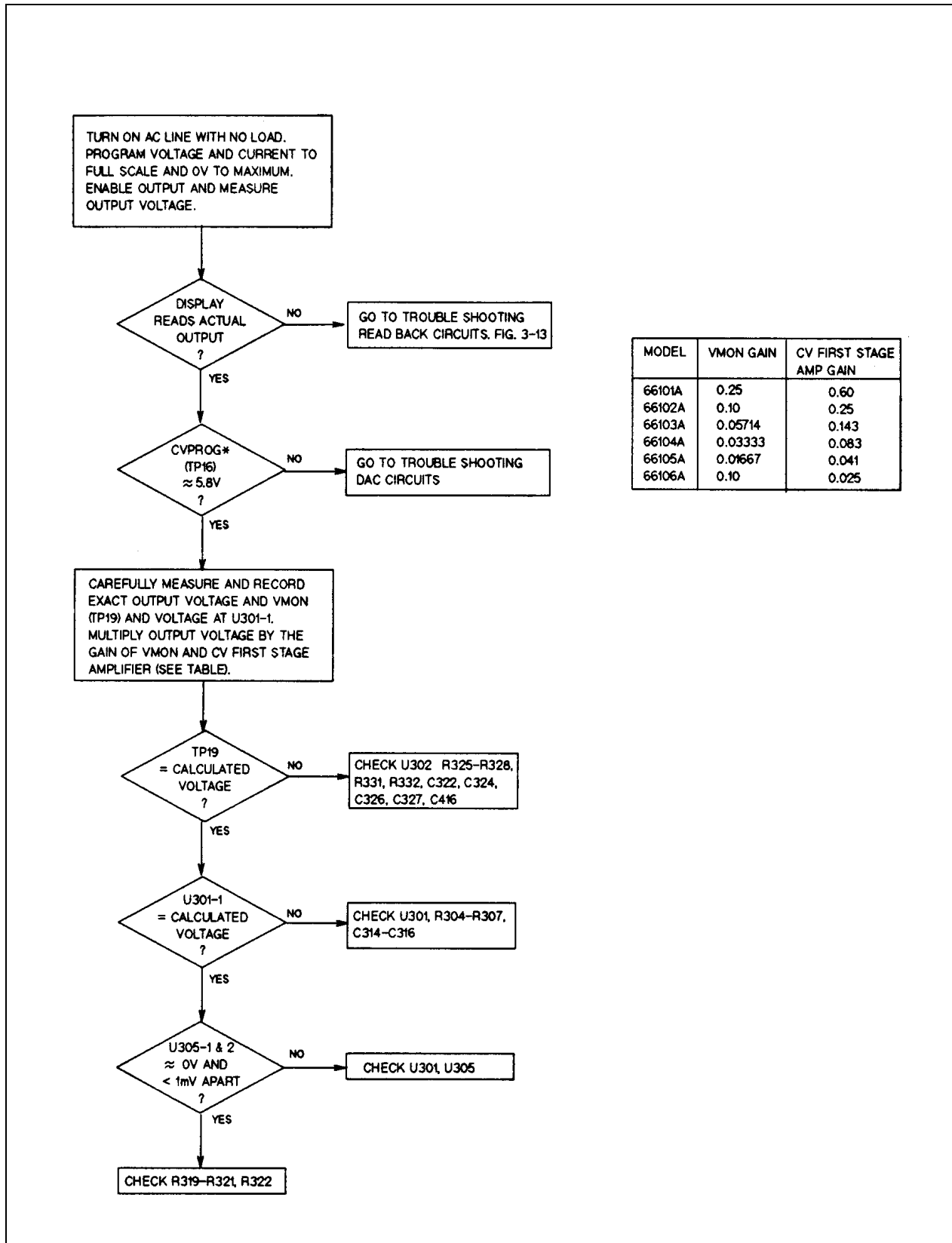
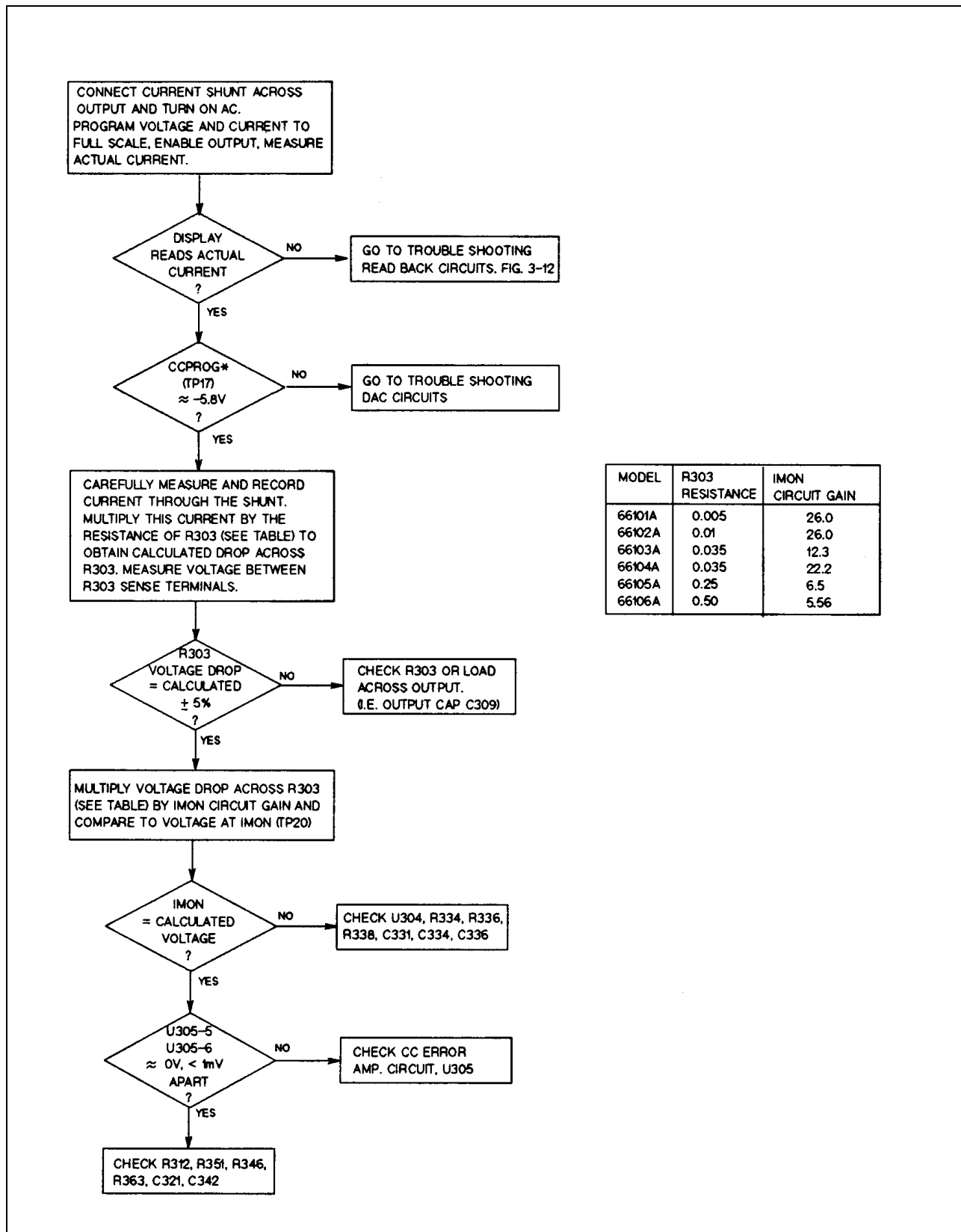

Figure 3-8. Troubleshooting CV Accuracy



MODEL	R303 RESISTANCE	IMON CIRCUIT GAIN
66101A	0.005	26.0
66102A	0.01	26.0
66103A	0.035	12.3
66104A	0.035	22.2
66105A	0.25	6.5
66106A	0.50	5.56

Figure 3-9. Troubleshooting CC Accuracy

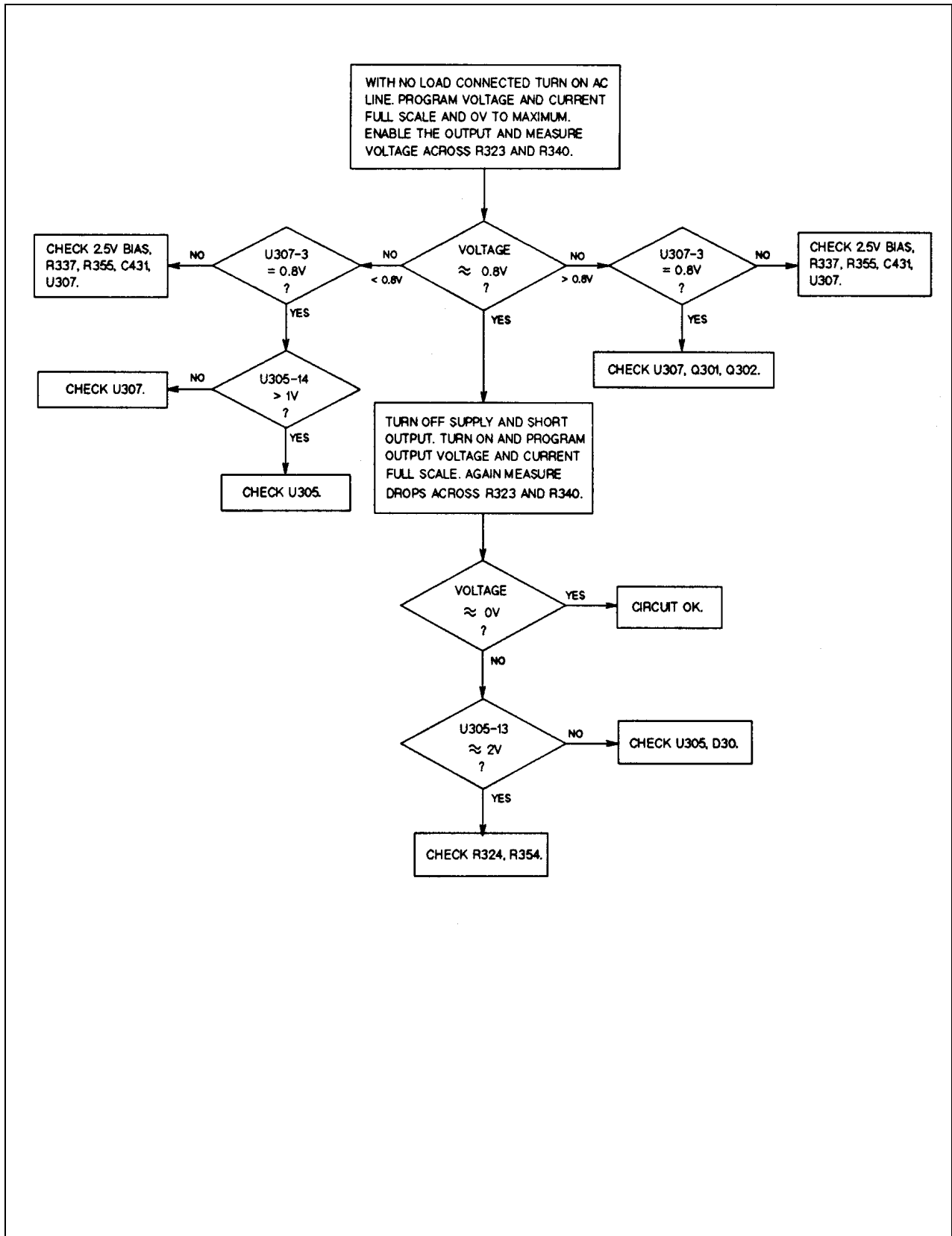

Figure 3-10. Troubleshooting Downprogrammer

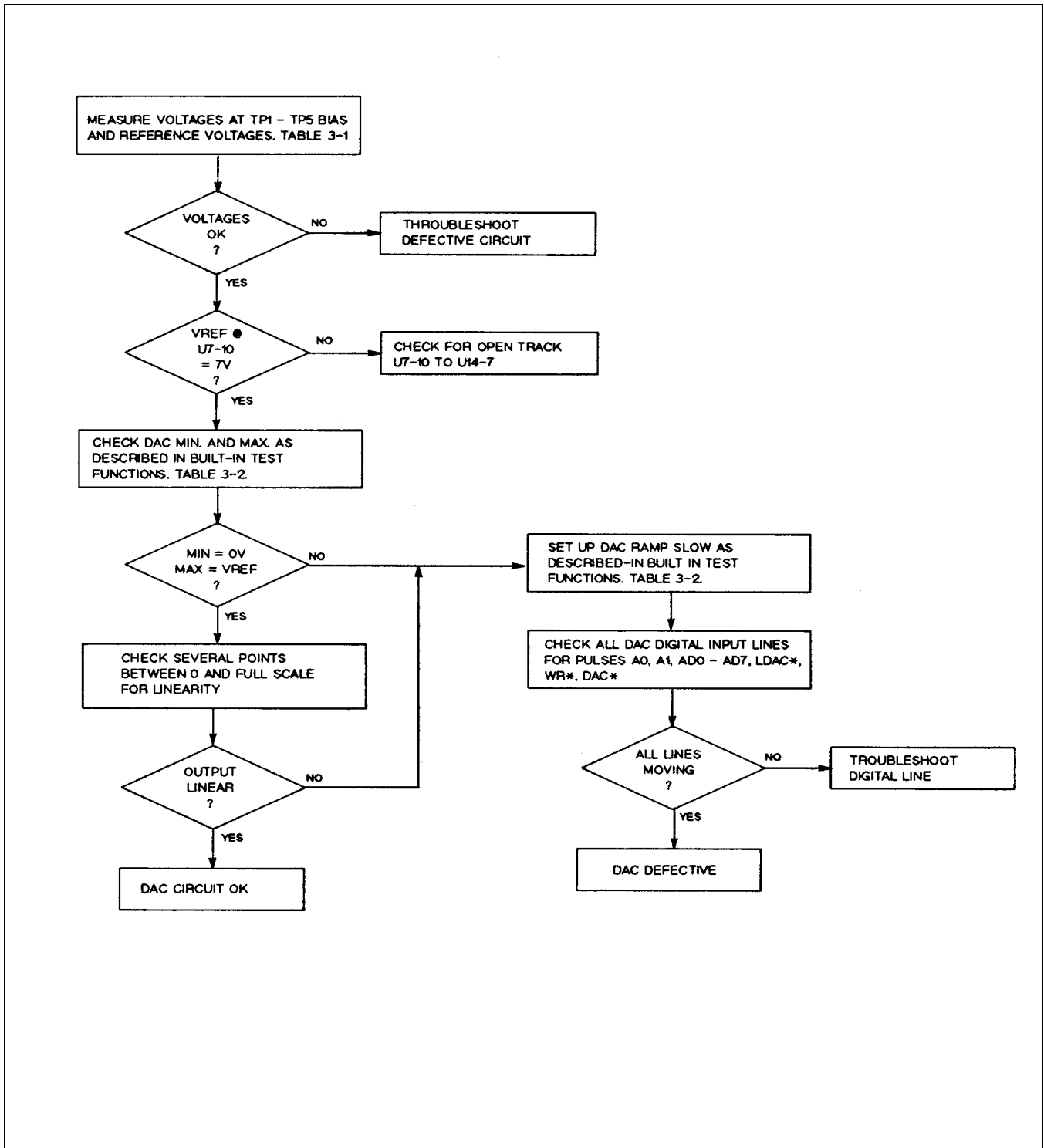

Figure 3-11. Troubleshooting DAC Circuit

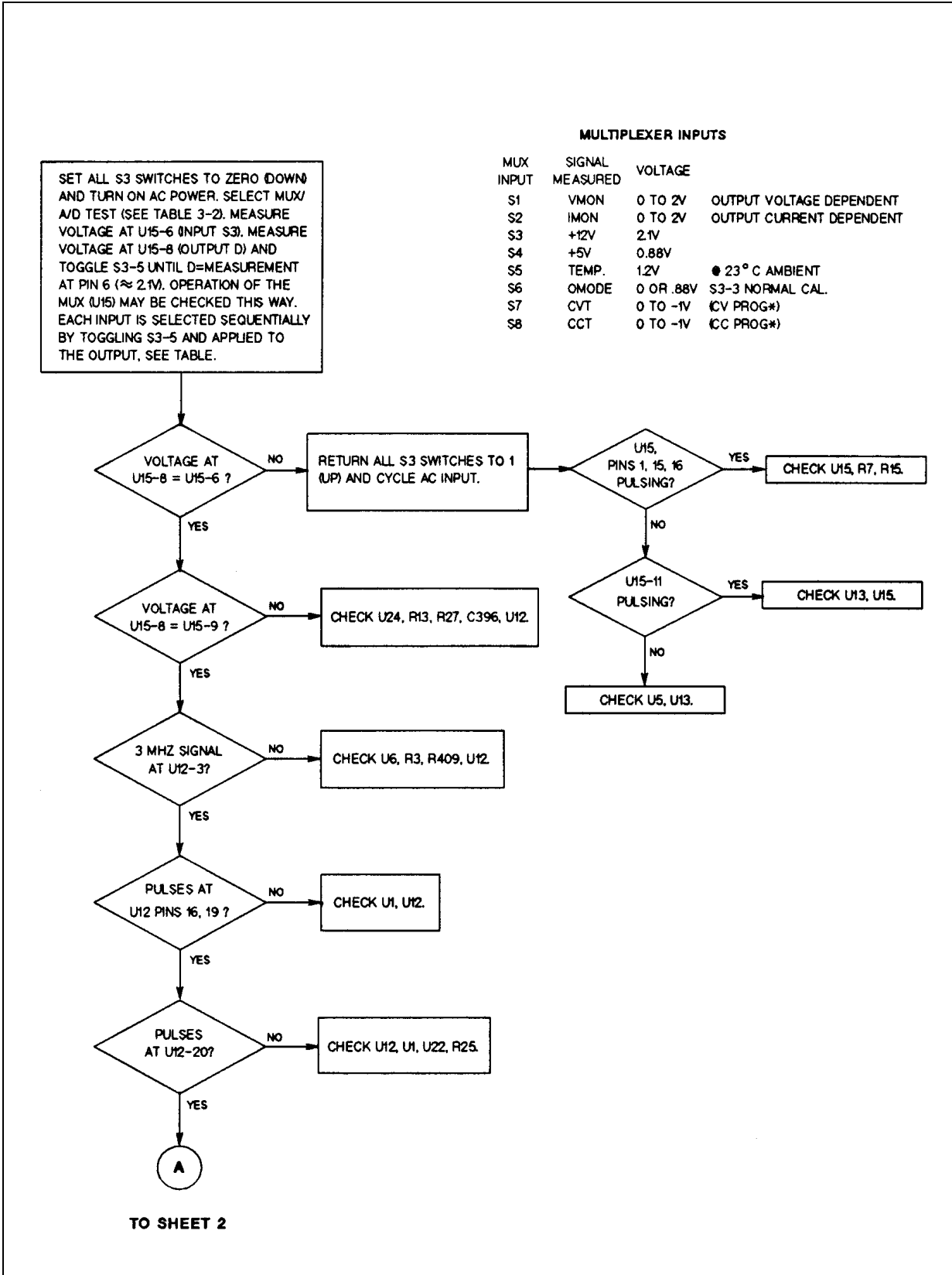

Figure 3-12. Troubleshooting Readback Circuits (Sheet 1 of 2)

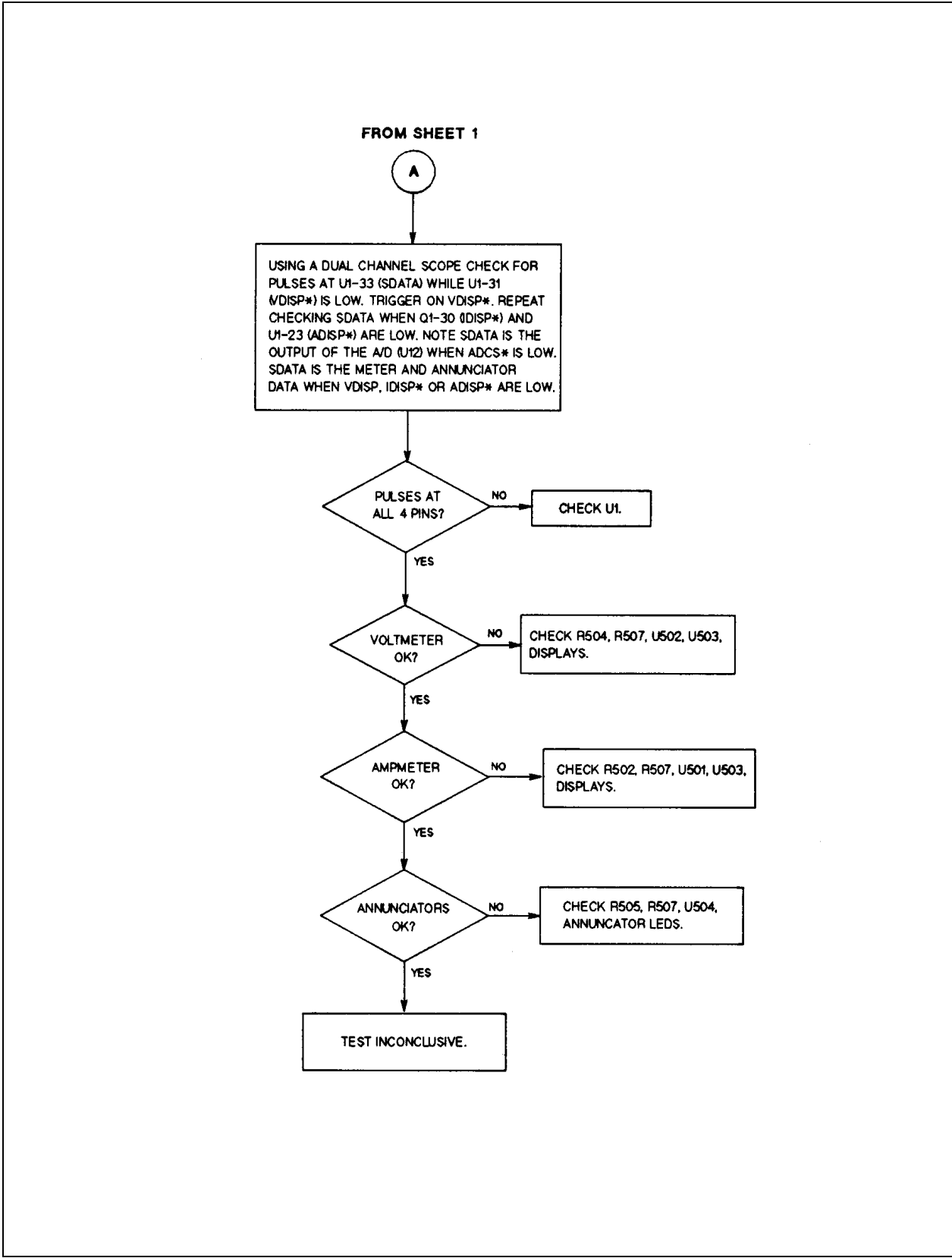

Figure 3-12. Troubleshooting Readback Circuits (Sheet 2 of 2)



---

## Test Points

The following test points are referenced in the troubleshooting flowcharts. Refer to the component locations diagram in Chapter 6 for the actual location of the test points on the pc board.

**Table 3-1. Test Points**

Test Point	Description
TP 0	Output circuit common (located on inboard side of R303)
TP 1	+5V (4.8 to 5.2 volts)
TP 2	+12V (11.4 to 12.6 volts)
TP 3	+7V (6.7 to 7.3 volts)
TP 4	+2.5V (2.4 to 2.6 volts)
TP 5	-12V (-11.4 to -12.6 volts)
TP 6	+15V (14.25 to 15.75 volts, referenced to the-rail) <sup>1</sup>
TP 7	+5V (4.75 to 5.25 volts, referenced to frame common)
TP 8	+24V (24.3 to 27.3 volts, referenced to frame common)
TP 9	+28V (unregulated, referenced to frame common)
TP 10	Frame common $\overline{F}$
TP 11	PCLR* (goes low for 175ms at turn-on)
TP 12	6MHz (microprocessor clock out)
TP 13	3MHz (A/D clock in)
TP 14	+ output
TP 15	-output
TP 16	0 to -6V (CVPROG)
TP 17	0 to -6V (CCPROG)
TP 18	0 to 2V (A/D INPUT)
TP 19	0 to 2V (VMON)
TP 20	0 to 2V (IMON)
TP 21	0 to 4V (OVREF)
TP 22	-3.4 to -4V (OR GATE, output dependent)

<sup>1</sup> Test Equipment must be isolated from ground.

---

## Built-In Test Functions

To aid in troubleshooting, the module configuration switch (S3) can be set to run various test routines as described in the Overall Troubleshooting flowchart. To start the test, set all switches to 0 (down) and turn on ac power. Then set the switch to perform the selected test as shown in the following table.

**Table 3-2. S3 Test Settings**

<b>S3 Setting</b>	<b>Test Description</b>
<b>8 7 6 5 4 3 2 1</b>	
0 0 0 0 0 0 0 0	Start with blank front panel
0 0 0 1 0 0 0 0	Front panel with all segments on
0 0 0 0 0 0 0 1	VDAC minimum (TP16 = 0V)
0 0 0 1 0 0 0 1	VDAC maximum (TP16 = -VREF)
0 0 0 0 0 0 1 0	IDAC minimum (TP17 = 0V)
0 0 0 1 0 0 1 0	IDAC maximum (TP17 = -VREF)
0 0 0 0 0 0 1 1	OVPDAC minimum (TP21 = 0V)
0 0 0 1 0 0 1 1	OVPDAC maximum (TP21 = 4V)
0 0 0 0 0 1 0 0	VDAC ramp slow (TP16, see waveform B)
0 0 0 1 0 1 0 0	VDAC ramp fast (TP16, see waveform C)
0 0 0 0 0 1 0 1	IDAC ramp slow (TP17, see waveform B)
0 0 0 1 0 1 0 1	IDAC ramp fast (TP17, see waveform C)
0 0 0 0 0 1 1 0	OVPDAC ramp (TP21, see waveform A)
0 0 0 1 0 1 1 1	MUX/AD (Toggle S3 switch 5 to select input)
0 0 0 0 1 0 0 0	SRST* and OVRST\$ pulse
0 0 0 0 1 0 0 1	PWMENhigh
0 0 0 1 1 0 0 1	PWMEN low
0 0 0 0 1 0 1 0	DOCAL pulse
0 0 0 0 1 0 1 1	TRIGOUT (TOUT) pulse
0 0 0 0 1 1 0 0	EEPROM read (U22 pin 4) <sup>2</sup>
0 0 0 0 1 1 0 1	Relay sequence (toggle S3 switch 5 to select relay) <sup>3</sup>
0 0 0 0 1 1 1 0	Tx pulses

- 1 Tests multiplexer inputs. First measure voltage at U15 pin 4. Toggle S3 switch 5 until voltage at U15 pin 8 equals the voltage at U15 pin 4. Now each time S3 switch 5 is toggled, the multiplexer will sequence through its inputs. The input of the A/D (U12-9) will be equal to the output of the multiplexer. Because the A/D is continually reading, its output (U12-20) should pulse.
- 2 Continuously reads the contents of location 0 of EEPROM. Check pulses at U22 pin 4.
- 3 Tests relays K601-K606. Toggling S3 switch 5 sequences through the relays. A relay is off when both ends of the coil are at +12V. A relay is on when one end is pulled low. A particular relay will energize every 5th toggle on S3 switch 5. Note that K607 is not tested.

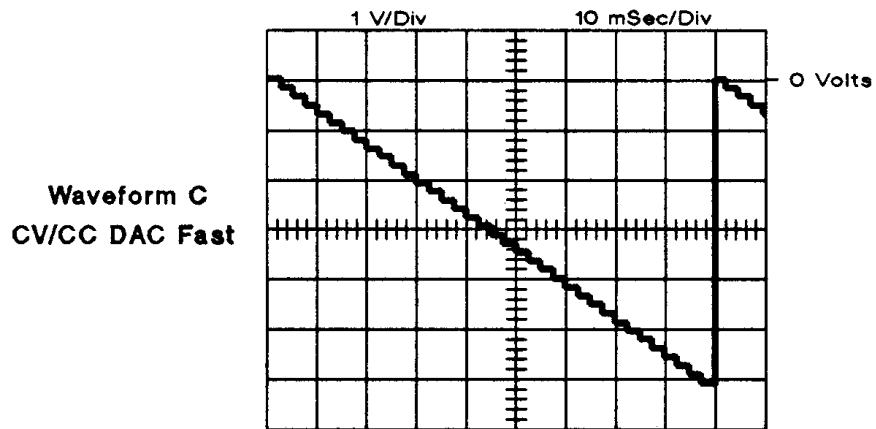
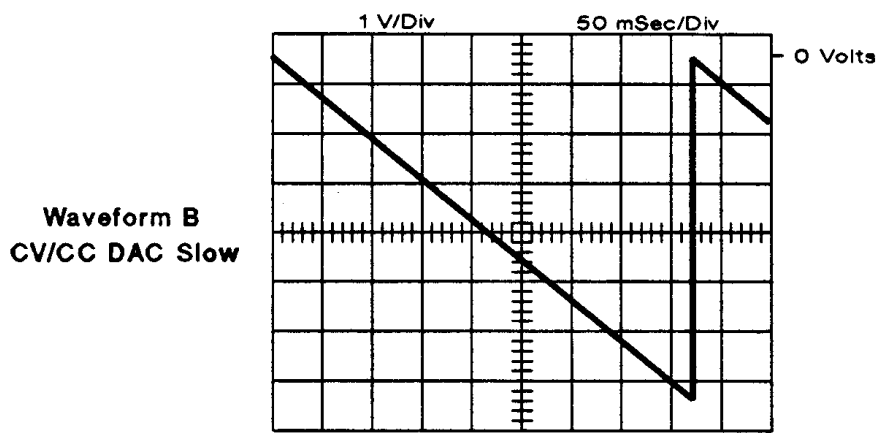
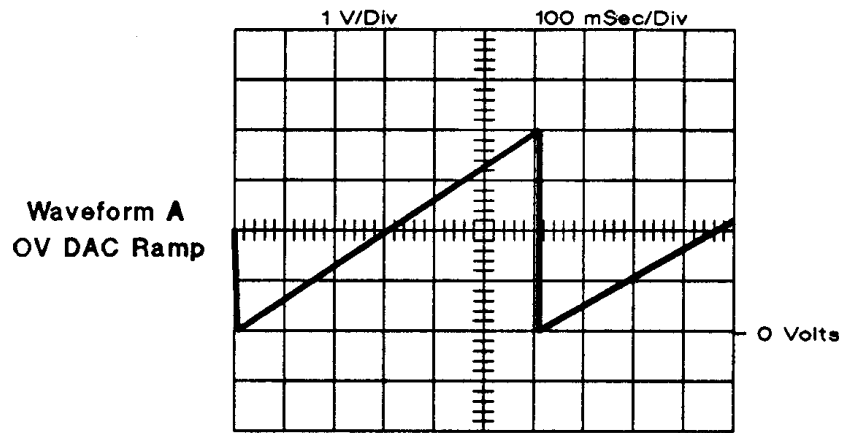

Figure 3-13. S3 Switch Setting Waveforms

---

## EEPROM Troubleshooting and Initialization

### Troubleshooting

The power module can detect an EEPROM checksum error. This error is not identified by number, but causes the following symptoms:

- The power module starts up with both the VOLTS and AMPS full-scale programming and metering ranges accepting values up to 1000.
- Selftest error code 330 is stored in the SCPI error queue where it can be read by the controller (see Chapter 5 in the Power Module Programming Guide).
- The \*IDN? query returns 0A in the model field.
- The calibration password is set to 0.

An EEPROM checksum error can occur if there has been an excessive number of write cycles to an EEPROM. This condition is not recoverable and requires a new EEPROM.

An EEPROM checksum error can also occur due to loss of ac power during a checksum calculation. This condition is very unlikely, but may be recoverable by performing the following steps from the controller:

- Enable calibration mode (CAL:STAT ON,0)
- Save an operating state to EEPROM. (for example, \*SAV 2)

### Initialization

EEPROM U22 on the power board stores the module's GPIB address, model number, and other operating and calibration constants. The EEPROM was initialized with the proper constants at the factory. If you need to re-initialize the module with the proper operating constants, run the following program.

After you have initialized the module by running the initialization program, you must calibrate the module as described in Appendix A of the Power Module User's Guide.

```

10 ! Program to initialize EEPROM or move factory preset data in 66101A,
20 ! 66102A, 66103A, 66104A, 66105A and 66106A power supply modules.
30 ! Rev A.00.00 dated May 27, 1993
40 !
50 DIM Init_data(1:39),Model$(6),Idn$(21),Cal_data$(40)
60 INTEGER Addr(1:39),Length(1:39)
70 ASSIGN @Ps TO 70500 ! Supply must be at address 70500
80 CLEAR SCREEN
90 !
100 Eprom_data_addr: ! Data address
110 DATA 2,6,10,14,18,19,20,24,28,32
120 DATA 36,37,38,42,46,50,55,56,57,58
130 DATA 62,66,70,74,,110,111,112,114,118,119
140 DATA 120,121,122,124,125,126,127,128,130
150 !
160 Eprom_data_len: ! Data for word length
170 DATA 4,4,4,4,1,1,4,4,4,4
180 DATA 1,1,4,4,4,4,1,1,1,4
190 DATA 4,4,4,4,1,1,2,4,1,1
200 DATA 1,1,2,1,1,1,1,1,2
210 !
220 Eprom_data_101a: ! EEPROM data for 66101A
230 DATA 409.668,32.2818,8.19,0,66,0,221.586,33.0533,16.38,0
240 DATA 66,4,23.5,19,10,0,255,100,20,66101
250 DATA 3277.35,-1.74536,1772.04,-1.50366,0,0,4,66101,20,150
260 DATA 20,150,28321,40,20,10,83,83,0
270 !
280 Eprom_data_102a: ! EEPROM data for 66102A
290 DATA 164.035,32.3969,20.475,0,66,0,440.367,30.0918,7.678,0
300 DATA 66,4,9,5.25,24,0,0,255,100,20,66102
310 DATA 1311.8,,248047,3523.12,-28.4202,0,0,4,66102,20,150
320 DATA 20,150,28321,40,20,10,83,83,0
330 !
340 Eprom_data_103a: ! EEPROM data for 66103A
350 DATA 93.7474,32.2944,35.831,0,66,0,735.971,26.127,4.607,0
360 DATA 66,4,4,,93986,5.50002,42,0,255,100,20,66103
370 DATA 749.745,-.725342,5885.92,-54.0496,0,0,4,66103,20,150
380 DATA 20,150,28321,40,20,10,83,83,0
390 !
400 Eprom_data_104a: ! EEPROM data for 66104A
410 DATA 54,32.3969,61.425,0,66,0,1320,30.0918,2.559,0
420 DATA 66,4,3,5.25,72,0,0,255,100,20,66104
430 DATA 437,,248047,10569,-28.4202,0,0,4,66104,20,150
440 DATA 20,150,28321,40,20,10,83,83,0
450 !
460 Eprom_data_105a: ! EEPROM data for 66105A
470 DATA 27,32.3969,122.85,0,65,0,2640,30.0918,1.28,0
480 DATA 66,4,1.5,5,5.25,144,0,255,100,20,66105
490 DATA 219,,248047,21000,-28.4202,0,0,4,66105,20,150
500 DATA 20,150,28321,40,20,10,82,83,0

```

Figure 3-14. EEPROM Initialization Program (Sheet 1 of 5)

```

510      !
520 Eprom_data_106a: !                               ! EEPROM data for 66106A
530      DATA 16.4035,32.3969,204.75,0,65,0,4403.67,30.0918,0.768,0
540      DATA 67,4,0.9,5.25,240,0,255,100,20,66106
550      DATA 131.18,.248047,35231.2,-28.4202,0,0,4,66106,20,150
560      DATA 20,150,28321,40,20,10,82,84,0
570      !
580      INPUT "Input Power Supply model number. Example: ""66101A""",Model$
590      Model$=TRIM$(UPC$(MODEL$))
600      CLEAR SCREEN
610      !
620      PRINT "The Power Supply Module must be in slot 0. Press ""Continue""
630      PRINT "to resume program."
640      PAUSE
650      CLEAR SCREEN
660      !
670      RESTORE Eprom_data_addr
680      !
690      FOR I=1 TO 39
700          READ Addr(I)
710      NEXT I
720      !
730      RESTORE Eprom_data_len
740      !
750      FOR I=1 TO 39
760          READ Length(I)
770      NEXT I
780      !
790      SELECT Model$
800      !
810      CASE "66101A"
820          RESTORE Eprom_data_101a
830      CASE "66102A"
840          RESTORE Eprom_data_102a
850      CASE "66103A"
860          RESTORE Eprom_data_103a
870      CASE "66104A"
880          RESTORE Eprom_data_104a
890      CASE "66105A"
900          RESTORE Eprom_data_105a
910      CASE "66106A"
920          RESTORE Eprom_data_106a
930      CASE ELSE
940          PRINT "Model number not found. Program is for Keysight models"
950          PRINT "66101A through 66106A ONLY"
960          STOP
970      END SELECT
980      !
990      FOR I=1 TO 39                               ! Read model dependent data
1000     READ Init_data(I)

```

Figure 3-14. EEPROM Initialization Program (Sheet 2 of 5)

```

1010 NEXT I
1020 !
1030 OUTPUT @Ps;"*CLS" ! Clears power supply registers
1040 !
1050 OUTPUT @Ps;"CAL;STATE ON," ! Turn on cal mode, "0" passcode
1060 !
1070 GOSUB Ps_error ! Error if passcode is not "0"!
1080 IF Err THEN
1090 OUTPUT @Ps;"*IDN?" ! Get data from model # location
1100 ENTER @Ps;Idn$
1110 Model=VAL(Idn$[POS(Idn$,"")+1])
1120 ELSE
1130 GOTO Start
1140 END IF
1150 !
1160 OUTPUT @Ps;"CAL:STATE ON,";Model ! Turn on cal mode, passcode =
1170 ! data at model number location
1180 !
1190 GOSUB Ps_error ! Error if passcode is not same as
1200 ! data at model # location
1210 IF Err THEN
1220 OUTPUT @Ps;"CAL:STATE ON,";Model$[1,4] ! Turn on cal mode, passcode =
1230 ! model #
1240 GOSUB Ps_error
1250 IF Err THEN
1260 PRINT "Change pass code to the power supply model # or zero. Restart program."
1270 STOP
1280 ELSE
1290 GOTO Start
1300 END IF
1310 END IF
1320 !
1330 Start: !
1340 !
1350 INPUT "Select Initialization (I) or Factory preset replacement (F).",Sel$
1360 CLEAR SCREEN
1370 SELECT (UPC$(Sel$))
1380 CASE "I" ! Select Initialization
1390 GOTO Init_eeprom
1400 CASE "F" ! Select install new factory data
1410 GOTO Fact_preset
1420 CASE ELSE
1430 BEEP
1440 GOTO Start
1450 END SELECT
1460 !
1470 Init_eeprom: !
1480 PRINT "Initializing EEPROM"
1490 !
1500 FOR I=1 TO 39

```

Figure 3-14. EEPROM Initialization Program (Sheet 3 of 5)

```

1510     OUTPUT @Ps;"DIAG:EEPR ";Addr(I);";Length(I);";Init_data(I)
1520     NEXT I
1530     GOTO Cal_off
1540     !
1550 Fact_preset:      !
1560     CLEAR SCREEN
1570     PRINT "This program should ONLY be completed if your power supply"
1580     PRINT "EEPROM has been replaced or a component that will effect"
1590     PRINT "the calibration AND the alignment of voltage, overvoltage"
1600     PRINT "and current is complete AND unit has passed the performance"
1610     PRINT "test.           Enter C to continue, any other key to abort."
1620     INPUT Cont_prog$
1630     IF (UPC$(Cont_prog$))<>"C" THEN GOTO Cal_off
1640     !
1650     CLEAR SCREEN
1660     PRINT "Transferring calibration data to factory preset locations."
1670     !
1680 Fact_cal_sour:    ! Address of factory calibration data source
1690     DATA 2,6,62,66,20,24,70,74
1700     !
1710 Fact_cal_dest    :  ! Address of factory calibration data destination
1720     DATA 78,82,86,90,94,98,102,106
1730     !
1740 Fact_cal_len:    ! Length of factory calibration data
1750     DATA 4,4,4,4,4,4,4,4,
1760     !
1770     RESTORE Fact_cal_sour
1780     FOR I=1 TO 8
1790         READ Cal_sour_addr(I)
1800     NEXT I
1810     !
1820     RESTORE Fact_cal_dest
1830     FOR I=1 TO 8
1840         READ Cal_dest_addr(I)
1850     NEXT I
1860     !
1870     FOR I=1 TO 8                                ! Locations of good data
1880         OUTPUT @Ps;"DIAG:EEPR? ";Cal_sour_addr(I);";4    ! Read good data
1890         ENTER @Ps;Cal_data$                          ! Enter good data
1900         OUTPUT @Ps;"DIAG:EEPR";Cal_dest_addr(I);";4;";";Cal_data$    ! Write data
1910     NEXT I
1920     !
1930 Cal_off      !
1940     CLEAR SCREEN
1950     OUTPUT @Ps;"CaL:STATE OFF"                      ! Turn off cal mode
1960     !
1970     GOSUB Ps_error                                  ! Check for errors
1980     IF Err THEN
1990         PRINT "An error occurred during the EEPROM read/write, Check for"
2000         PRINT "programming errors. Initialization data may be incorrect."

```

**Figure 3-14. EEPROM Initialization Program (Sheet 4 of 5)**



```

2010    STOP
2020    END IF
2030    !
2040    PRINT "Operation complete. Program stopped."
2050    STOP
2060    !
2070 Ps_error:                ! Error handling subroutine
2080    OUTPUT @Ps;"SYST:ERR?" ! Check for errors
2090    ENTER @Ps;Err
2100    RETURN
2110    !
2120    END

```

**Figure 3-14. EEPROM Initialization Program (Sheet 5 of 5)**

---

## Disassembly Procedures

This section describes how to disassemble and reassemble the Keysight 6610xA Power Modules. Refer to Chapter 5 for the component descriptions. Refer to Chapter 1 for the tools required to disassemble and reassemble the unit.

### CAUTION

Most of the attaching hardware is metric. Using the wrong fasteners will damage threaded inserts. Observe all standard anti-static procedures when removing the pc boards from the chassis (see Chapter 1).

---

## Removing the Module and Module Connector

Before you can disassemble the module, you must first remove the power modules from the mainframe.

1. Use the slot-head screwdriver and release the pull tab at the front of each module.
2. Pull the power module out of the mainframe.
3. To remove the module connector, use the Pozi driver and disconnect the module connectors from the back of the mainframe.

## Removing the Cover

1. Use the T10 driver and remove the seven screws that connect the chassis cover to the chassis.
2. Lift the cover off.

## Removing the Fan

1. Carefully unplug the fan cable from the J102 connector on the Power board.
2. Use the T10 driver and 7mm nut driver and remove the two screws that connect the fan to the fan bracket.
3. Remove the fan.

## Removing the Front Panel Assembly

1. Carefully unplug the front panel cable from the J3 connector on the Power board.
2. Spread the bottom of the chassis away from the front panel assembly and lift the assembly out of the chassis.

## Removing the Power Board

1. Carefully unplug the front panel cable from the J3 connector, the bias board cables from the J301 and J302 connectors, and the fan cable from the J102 connector on the Power board.
2. Use the T10 driver and remove the four screws (two toward the back and two near the center) that attach the Power board to the chassis.
3. Lift up on the top edge of the Power board and carefully remove the board from the chassis.

## Removing the Bias Board

Removing the Front Panel assembly first makes it easier to remove the Bias board.

1. Carefully unplug the bias board cables from the J401 and J402 connectors on the Bias board. If you have not already done so, carefully unplug the front panel cable from the J3 connector on the Power board.
2. Use the T10 driver and remove the two screws at the front that attach the Bias board to the chassis.
3. Lift up on the front edge of the Bias board and carefully remove the board from the chassis.

## Removing the Front Panel Board

You must first remove the Front Panel assembly before you can remove the Front Panel board.

1. Separate the two halves of the front panel assembly by releasing the four locking tabs with the flat-bladed screwdriver (see figure 3-15).
2. Insert the screwdriver into the areas indicated on the figure and press against the tabs to release them.
3. Once separated, you can easily remove the front panel board from the front panel assembly.
4. You can also easily remove the latching mechanism once the front panel assembly is separated.

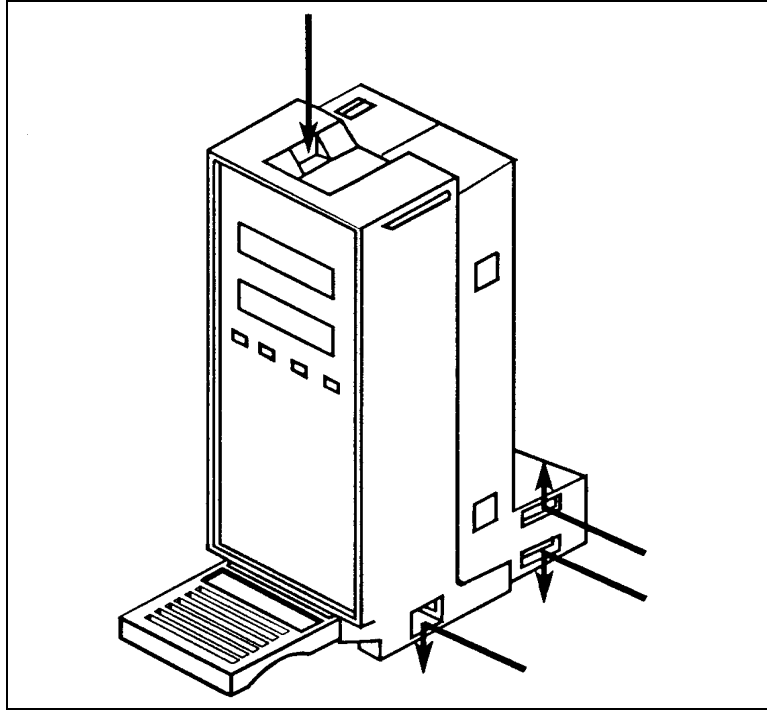

**Figure 3-15. Front Panel Assembly Locking Tabs**

## **Installing the Power Board**

1. Insert the tabs along the bottom edge of the board in the corresponding slots on the bottom of the chassis and carefully install the board in the chassis.
2. Use the T10 driver and insert the four screws (two toward the back and two near the center) that attach the Power board to the chassis.
3. Connect the front panel cable into the J3 connector, the bias board cables into the J301 and J302 connectors, and the fan cable into the J102 connector on the Power board.
4. Insert the front panel cable and the bias board cables into the appropriate cable cutout on the fan bracket.
5. To prevent the cover from pinching the cables, route the front panel cable, the longer bias board cable, and the fan cable between T201 and L201.

## **Installing the Bias Board**

1. Carefully install the Bias board so that T401 is positioned up against the fan bracket.
2. Use the T10 driver and insert the two screws at the front that attach the Bias board to the chassis.
3. Connect the bias board cables into the J401 and J402 connectors on the Bias board.
4. Insert the bias board cables into the appropriate cable cutout on the fan bracket. Route the longer bias cable in between T201 and L201.

## Installing the Front Panel Board and Front Panel Assembly

1. Install the front panel, the front panel board, and the latch assembly in one of the front assembly halves.
2. Make sure that the front panel board is positioned in the slot closest to the front panel.
3. Carefully snap the other half of the front panel assembly together.
4. Insert the tab on the top of the front panel assembly in the corresponding notch on the chassis and position the front panel assembly into the chassis. The two tabs on the side of the assembly should be positioned in the corresponding notches on the side of the chassis.
5. Connect the front panel cable into the J3 connector on the Power board. Route the cable through the cutout on the fan bracket and in between T201 and L201.

## Installing the Fan

1. Position the fan up against the fan bracket.

---

**CAUTION**

Make sure that the arrow on the fan is pointing to the **BACK** of the module. The airflow must be from the front of the module to the back of the module.

---

2. Use the T10 driver and 7mm nut driver and insert the two screws and nuts that connect the fan to the fan bracket. Place the locking nuts against the fan bracket.
3. Connect the fan cable into the J102 connector on the Power board. Route the cable in between T201 and L201.

## Installing the Cover

1. Position the cover over the chassis so that the screw holes and the notches on the front panel assembly notches line up with the corresponding openings in the cover. Make sure that no cables are being pinched by the cover.
2. Use the T10 driver and insert the seven screws that connect the chassis cover to the chassis



## Theory of Operation

This chapter provides a brief theory of operation for the Keysight 6610xA Power Modules. Figure 4-1 is a block diagram of the primary circuit functions of the power modules. The diagram references the schematic sheets where the circuits are located.

---

### AC Input and Bias Supplies

AC input power is distributed to each module through the backplane connector board on the mainframe. A turn-on relay inside the module applies ac power from the mainframe to the power module. This relay receives its bias power from the mainframe and is opened and closed by a control signal from the mainframe.

The ac input is rectified and filtered in the power module, producing the + and - dc rail. In addition to the dc rail, the ac input is also applied to a bias transformer, which provides the following bias voltages:

- + 15V (primary)
- + 5V (secondary)
- ± 12V (secondary)

---

### Microprocessor Circuits

All communication between the modules and the controller or keyboard except for the trigger signals is processed by U44 on the mainframe. The primary function of this microprocessor is to distribute the digital signals from controller or keyboard to the correct module slot in the mainframe.

Microprocessor U1 on the modules communicates with U44 through two data lines -a transmit and a receive line (Tx and Rx). Associated with U1 is ROM chip U2, RAM chip U3, and EEPROM chip U22.

At turn-on, microprocessor U1 first transfers the calibration constants that are stored in the EEPROM chip of each module into RAM. It then applies the calibration correction factors in RAM to the voltage or current setting information and calculates a bit count that it sends to the DACs. The microprocessor directs the data either to the CV or the CC DAC. It is able to send sixteen data bits to each DAC by first strobing in the upper byte, and then strobing in the lower byte.

---

### CV/CC DACs

Upon receiving data from the microprocessor, the CC and CV DACS output the correct analog output voltage. Both the CC and the CV DACs output an analog signal in the range of 0 to minus 6 volts (calibrated), which corresponds to the zero to full-scale output range of the power module's voltage and current. The DACs are referenced to a regulated 7V bias.

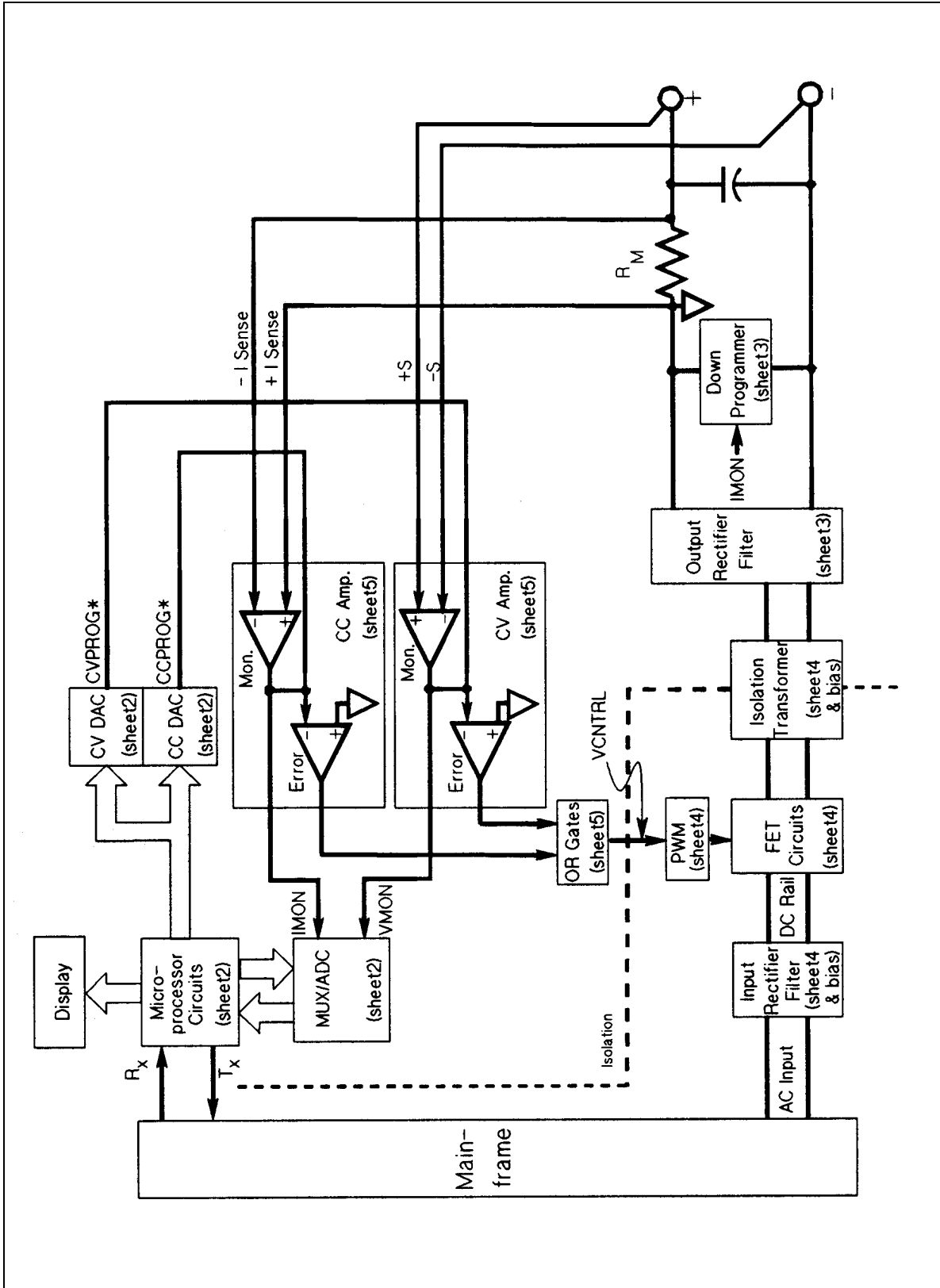

Figure 4-1. Block Diagram

---

## CV Amplifier

The CV amplifier controls the output of the power module when the module is operating in constant voltage mode. The CV amplifier consists of two stages: an error amplifier stage and a voltage monitor stage. The calibrated CVPROG\* signal from the CV DAC pulls current out of the negative input of the error amplifier at a rate determined by the DAC's programmed value. The error amplifier in turn, controls the output of the module.

The output of the module is monitored by the voltage monitor stage. It reduces the module's output voltage so that the 0 to full-scale output voltage of the module is represented by a range of 0 to 2 volts at the output of the voltage monitor amplifier. The voltage monitor amplifier's output (VMON) is fed through a resistor to develop a current. This current is fed **into** the negative input of the error amplifier stage at the same time that current is being pulled **out** of this input by the CVPROG\* signal from the CV DAC.

When the current pulled out of the error amplifier input by the CV DAC exceeds the current fed into the input by the voltage monitor, the error amplifier turns on, which turns the output of the module on. When the current pulled out of the error amplifier input by the CV DAC is less than the current fed into the input by the voltage monitor, the error amplifier turns off, which turns off the output of the module. When the current pulled out of the error amplifier input by the CV DAC is equal to the current fed into the input by the voltage monitor, the net current into the error amplifier is zero. At this point, there is no change on the output voltage of the power module because the output voltage equals the programmed voltage value.

---

## CC Amplifier

The CC amplifier controls the output of the power module when the module is operating in constant current mode. The CC amplifier also consists of two stages: an error amplifier stage, and a current monitor stage. The calibrated CCPROG\* signal from the CC DAC pulls current out of the negative input of the error amplifier at a rate determined by the DAC's programmed value. The error amplifier in turn, controls the output of the module.

The current monitor stage monitors the current at the output of the module by sensing the voltage drop across current monitor resistor (RM). The current monitor amplifies this voltage (which is typically in the range of 0 to 50mV) so that the 0 to full-scale current output of the module is represented by a range of 0 to 2 volts at the output of the current monitor amplifier. The current monitor amplifier's output (IMON) is fed through a resistor to develop a current. This current is fed **into** the negative input of the error amplifier stage at the same time that current is being pulled out of this input by the CCPROG\* signal from the CC DAC.

When the current pulled out of the error amplifier input by the CC DAC exceeds the current fed into the input by the current monitor, the error amplifier turns on, which turns on the output of the module. When the current pulled out of the error amplifier input by the CC DAC is less than the current fed into the input by the current monitor, the error amplifier turns off, which turns off the output of the module. When the current pulled out of the error amplifier input by the CC DAC is equal to the current fed into the input by the current monitor, the net current into the error amplifier is zero. At this point, there is no change on the output current of the power module because the output current equals the programmed current value.

---

## OR Gates

The outputs of the CV and CC amplifiers are "or"ed through two diodes, producing a single pulse-width modulator control signal (VCNTRL). Whichever of the two signals (CC or CV) is the most negative, with respect to the output of the module, controls the pulse-width modulator. The pulse-width modulator in turn controls the FETS. The more negative that the controlling signal is with respect to the output, the harder it causes the pulse-width modulators to turn on the FETS.



---

## Pulse-Width Modulator, FETS, and Isolation Transformer

The pulse-width modulator controls the FETS. The FETS are arranged in an "H" bridge configuration with the + and - dc rail at the top and bottom of the H. The 4 FETS are located on each leg of the "H", and the isolation transformer is located on the horizontal bar of the H. The FETS located diagonally across from each other are alternately turned on and off (Q201 and Q204 are turned on, then off; followed by Q202 and Q203 being turned on, then off).

In this way current flows from the + dc rail through the primary of T201 to the - dc rail. When Q201 and Q204 are on, current flows through the primary of T201 in one direction. When Q202 and Q203 are on, current flows through the primary of T201 in the opposite direction. This generates the positive and negative pulses on the secondary winding of T201. The output of T201 is then rectified and filtered to produce the dc output.

T202, located in series with T201, is part of the peak current limit circuit, which limits the amount of current that can flow through the FETs. This protects the internal and external circuits from excessive currents that may result when the output of the module is shorted.

---

## Downprogrammer Circuit

The downprogrammer circuit internally draws current through the output rectifier and filter to keep the FET circuits turned on when the module is programmed to a low or zero output. The maximum current that flows through the downprogrammer is 10% of the total output current .

The downprogrammer circuit monitors the current at the output of the module and turns off when the output current reaches 1/2 of its full-scale rating.

Additionally, when voltage is programmed to a low value or programmed off, the downprogrammer helps to pull down the output of the supply to speed up downprogramming time.

---

## Readback Multiplexer

The readback multiplexer and the readback A to D are used to read back information from the module during normal operation and during selftest. The microprocessor selects an input on the readback multiplexer and reads back data on that input. The following signals comprise the inputs to the multiplexer:

- IMON
- VMON
- +12V reference
- +5V reference
- temperature reference
- power turn-on switch setting
- CV DAC output
- CC DAC output

The multiplexer inputs are between 2.5 volts and -2.5 volts, which is the voltage range of the 16-bit readback A to D converter. The IMON and VMON signals are in the range of 0 to 2 volts, which represents the 0 to full-scale output of the supply. The readback A to D converter converts the analog signal from the multiplexer to a digital signal, which is returned to the microprocessor. The microprocessor in turn sends the corrected (calibrated) data to the display.

---

## OV Circuit

The OV circuit consists of a comparator that compares the output voltage of the module with an overvoltage reference signal and shuts down the output when the output of the supply exceeds the overvoltage reference level.

The microprocessor generates the overvoltage reference by putting out a pulse-width modulated signal that is filtered to produce a 0 to 4 volts reference (OVREF). This reference is proportional to an overvoltage setting of about 0 to 110% of full scale output and is applied to the + input of the overvoltage comparator.

The output of the supply goes to a voltage divider which steps down the output to a proportional voltage that also ranges from 0 to 4 volts. This signal is applied to the negative input of the overvoltage comparator. When the voltage at the negative input exceeds the voltage at the positive input, the output of the comparator changes state, informing the microprocessor that an overvoltage condition has occurred. The microprocessor then turns off the pulse-width modulators, which turns off the FETs.



## Replacement Parts

Table 5-1 lists the electrical components of the Keysight 6610xA Power Modules' main, bias, and front panel boards. Table 5-2 lists the mechanical components of the module. Table 5-3 lists all of the components of the connector assembly. These tables provide the following information:

- Reference designation
- Keysight Technologies part number
- Description of part

You can order parts from your local Keysight Technologies sales office. A list of the regional sales offices is given at the back of this manual. When ordering parts, include the following information:

- Keysight Technologies part number
- Description of the part
- Quantity desired
- MPS model number (e.g. Keysight 66101A)

---

**Note** The test point and locations diagrams in Chapter 6 identify the location of the electrical components on the circuit boards.

---

**Table 5-1. Keysight 6610xA Power Modules Parts List - Electrical**

Reference Designators	Model	Part Number	Description
	66101A	66101-61022	ASSEMBLY-POWER BOARD
	66102A	66102-61022	ASSEMBLY-POWER BOARD
	66103A	66103-61022	ASSEMBLY-POWER BOARD
	66104A	66104-61022	ASSEMBLY-POWER BOARD
	66105A	66105-61022	ASSEMBLY-POWER BOARD
	66106A	66106-61022	ASSEMBLY-POWER BOARD
	All Models	5060-3358	ASSEMBLY-FAN (REF J102)
C1, C2	All Models	0160-5422	CAP .047uF 20%
C3	All Models	0180-4136	CAP 10uF 20V
C4-C10	All Models	0160-5422	CAP .047uF 20%
C11, C12	All Models	0180-4136	CAP 10uF 20V
C13, C14	All Models	0160-4807	CAP 33pF 5% 100V
C15-C17	All Models	0160-4822	CAP 1000pF 5%
C18	All Models	0180-4136	CAP 10uF 20V
C20-C24	All Models	0160-5422	CAP .047uF 20%
C27	All Models	0160-5422	CAP .047uF 20%
C28	All Models	0160-4281	CAP 2200pF 20%
C192	All Models	0160-5422	CAP .047uF 20%
C201	All Models	0160-4830	CAP 2200pF 10%
C202	All Models	0160-4808	CAP 470pF 5%
C203, C204	All Models	0160-4183	CAP 1000pF 20%
C206	All Models	0160-4259	CAP .22uF 10%
C207, C208	All Models	0180-4393	CAP 560uF 250V
C209	All Models	0160-7578	CAP 330pF 630VDC
C210	All Models	0160-4814	CAP 150pF 5%
C211, C212	All Models	0160-5422	CAP .047uF 20%
C213	All Models	0180-4136	CAP 10uF 20V
C214	All Models	0160-7578	CAP 330pF 630VDC
C215	All Models	0160-5422	CAP .047uF 20%
C217-C221	All Models	0160-5422	CAP .047uF 20%
C222	All Models	0160-4803	CAP 68pF 5% 100V
C223	All Models	0160-5422	CAP .047uF 20%
C224	All Models	0160-4801	CAP 100pF 5%
C225, C226	All Models	0160-7578	CAP 330pF 630VDC
C227	All Models	0180-3680	CAP 10uF 50V
C228	All Models	0160-4830	CAP 2200pF 10%
C229	All Models	0160-4833	CAP .022uF 10%
C230	All Models	0160-5098	CAP .22uF 10%
C232	All Models	0160-4439	CAP 4700pF 20%
C301	66101A	0160-7568	CAP 4700pF 250V 5%
	66102A	0160-7522	CAP 1000pF 630V
	66103A	0160-7639	CAP 470pF 1600V
	66104A	0160-6838	CAP 2200pF
	66105A	0160-7639	CAP 470pF 1600V
	66106A	0160-7640	CAP 330pF 1600V

**Table 5-1. Keysight 6610xA Power Modules Parts List - Electrical (continued)**

Reference Designators	Model	Part Number	Description
C303	66101A	0180-4398	CAP 470uF 63V
	66102A	0180-4400	CAP 220uF 63V
	66103A	0180-4397	CAP 100uF 63V
	66104A	0180-3649	CAP 47uF 100VDC
	66105A	0180-3648	CAP 10uF 250V
	66106A	0180-3169	CAP 4.7uF 250VDC
C304	66101A	0180-4398	CAP 470uF 63V
	66102A	0180-4400	CAP 220uF 63V
	66103A	0180-4397	CAP 100uF 63V
	66104A	0180-3649	CAP 47uF 100V
	66105A	0180 3696	CAP 22uF 250V
	66106A	0180-3648	CAP 10uF 250V
C305	All Models	0160-4323	CAP .047uF 20%
C306, C307	All Models	0160-4259	CAP .22uF 10%
C307	All Models	0160-4259	CAP .22uF 10%
C308	All Models	0160-4323	CAP .047uF 20%
C309A	66101A-66103A	0160-7562	CAP 6.8uF 63V
	66104A-66106A	Not Used	
C309B	66101A	0160-7562	CAP 6.8uF 63V
	66102A, 66103A	Not Used	
	66104A-66106A	0160-5050	CAP 1.0uF 250V
C310	All Models	0160-4808	CAP 470pF 5%
C311	66101A, 66104A	0160-4831	CAP 4700pF 10%
	66102A, 66103A	0160-7001	CAP 3300pF 100V
	66105A	0160-4830	CAP 2200pF 10%
	66106A	0160-7001	CAP 3300pF 100V
	All Models	0160-4281	CAP 2200pF 20%
C312, C313	All Models	0160-4808	CAP 470pF 5%
C314, C315	All Models	0160-4795	CAP 4.7pF
C316	All Models	0160-4795	CAP 4.7pF
C317	66101A, 66102A	0160-4831	CAP 4700pF 10%
	66103A, 66104A	0160-6616	CAP 6800pF 100V
	66105A	0160-4832	CAP .01uF 10%
	66106A	0160-5166	CAP .015uF 20%
	All Models	0160-4795	CAP 4.7pF
C318	All Models	0160-4795	CAP 4.7pF
C319	All Models	0160-5467	CAP 0.01uF 63V
C320	All Models	0160-4791	CAP 10pF 5% 100V
C321	66101A	0160-5892	CAP .22uF 10%
	66102A-66106A	0160-5468	CAP 0.47uF 50V
C322	All Models	0160-4807	CAP 33pF 5% 100V
C323	All Models	0160-5892	CAP .22uF 10%
C324, C325	All Models	0160-4808	CAP 470pF 5%
C326, C327	All Models	0160-5422	CAP .047uF 20%
C328	All Models	0160-4822	CAP 1000pF 5%
C329	All Models	0160 5422	CAP .047uF 20%
C330	All Models	0160-4832	CAP .01uF 10%
C331	66101A, 66102A	0160-4787	CAP 22pF 5% 100V
	66103A-66106A	0160-4805	CAP 47pF 5% 100V

**Table 5-1. Keysight 6610xA Power Modules Parts List - Electrical (continued)**

Reference Designators	Model	Part Number	Description
C332, C333	All Models	0160-5422	CAP .047uF 20%
C334	All Models	0160-4807	CAP 33pF 5% 100V
C335	66101A	0160-4831	CAP 4700pF 10%
	66102A-66106A	0160-4830	CAP 2200pF 10%
C336	66101A, 66102A	0160-4787	CAP 22pF 5% 100V
	66103A-66106A	0160-4805	CAP 47pF 5% 100V
C337	All Models	0160-4830	CAP 2200pF 10%
C338-C341	All Models	0160-5422	CAP .047uF 20%
C342	All Models	0160-5892	CAP .22uF 10%
C343	66101A-66104A	0160-4831	CAP 4700pF 10%
	66105A	0160-4833	CAP .022uF 10%
	66106A	0160-7001	CAP 3300pF 100V
C346	66101A	0160-4832	CAP .01uF 10%
	66102A	0160-6616	CAP 6800pF 100V
	66103A, 66104A	0160-4832	CAP .01uF 10%
	66105A	0160-4833	CAP .022uF 10%
	66106A	0160-4832	CAP .01uF 10%
C347	66101A	0160-4801	CAP 100pF 5%
	66102A-66104A	0160-4803	CAP 68pF 5% 100V
	66105A	0160-4813	CAP 180pF 5%
	66106A	0160-4803	CAP 68pF 5% 100V
C349	66101A-66105A	0160-4812	CAP 220pF 5%
	66106A	0160-4808	CAP 470pF 5%
C358	All Models	0160-4830	CAP 2200pF 10%
C395	All Models	0180-4129	CAP 1uF 35V
C396	All Models	0160-7578	CAP 330pF 630VDC
C397	All Models	0160-4835	CAP .1uF 10% 50V
C403	All Models	0160-4183	CAP 1000pF 20%
C404	All Models	0160-5422	CAP .047uF 20%
C407	All Models	0180-4136	CAP 10uF 20V
C408-C410	All Models	0180-4129	CAP 1uF 35V
C411-C413	All Models	0160-4835	CAP .1uF 10% 50V
C414, C415	All Models	0160-4822	CAP 1000pF 5%
C416	All Models	0160-4808	CAP 470pF 5%
C418	All Models	0160-5422	CAP .047uF 20%
C420-C425	All Models	0160-5422	CAP .047uF 20%
C427A	66101A-66103A	0160-4835	CAP .1uF 10% 50V
	66104A	0160-4834	CAP .047uF 10%
	66105A, 66106A	Not Used	
C427B	66101A-66103A	Not Used	
	66104A	0160-4834	CAP .047uF 10%
C427B	66105A, 66106A	0160-0269	CAP .1uF 20%
C428, C429	66101A-66104A	Not Used	
	66105A, 66106A	0160-0269	CAP .1uF 20%
C430	66101A-66106A	Not Used	
C431, C432	All Models	0160-5422	CAP .047uF 20%

**Table 5-1. Keysight 6610xA Power Modules Parts List - Electrical (continued)**

Reference Designators	Model	Part Number	Description
C433	All Models	0160-4791	CAP 10pF 5% 100V
C434, C435	All Models	0160-5422	CAP .047uF 20%
D201-D204	All Models	1901-1087	DIODE-PWR RECT
D205, D206	All Models	1901-1214	DIODE-PWR RECT
D207, D208	All Models	1901-1098	DIODE-IN4150
D210-D212	All Models	1901-1098	DIODE-IN4150
D215	All Models	1901-1098	DIODE-IN4150
D216, D217	66101A-66103A	1901-1098	DIODE-IN4150
	66104A-66106A	1901-1214	DIODE-PWR RECT
D301	66101A-66103A	Not Used	
	66104A	1901-1383	DIODE-PWR RECT
	66105A-66106A	1901-1199	DIODE-PWR RECT
D301A	66101A-66105A	Not Used	
	66106A	1901-1199	DIODE-PWR RECT
D302	All Models	1901-1098	DIODE-IN4150
D303, D304	66101A-66103A	5060-3378	ASSY-HS, DIODE (1901-1383)
	66104A	1901-1383	DIODE-PWR RECT
	66105A-66106A	1901-1199	DIODE-PWR RECT
D303A, D304A	66101A-66105A	Not Used	
	66106A	1901-1199	DIODE-PWR RECT
D314-D316	All Models	1901-1098	DIODE-IN4150
D317, D318	All Models	1901-0880	DIODE GEN PRP
D324, D325	All Models	1901-0880	DIODE GEN PRP
D326	66101A-66103A	Not Used	
	66104A	1901-1383	DIODE-PWR RECT
	66105A-66106A	1901-1199	DIODE-PWR RECT
D326A	66101A-66105A	Not Used	
	66106A	1901-1199	DIODE-PWR RECT
F1	All Models	2110-0671	FUSE .125A 125V
F2	All Models	2110-0716	FUSE-SUBMIN .5A
F201	All Models	2110-0056	FUSE 6A 250V, CLIPS (2110-0726)
F202	All Models	2110-0716	FUSE-SUBMIN .5A
J3	All Models	1252-1152	CONNECTOR, To FRONT PANEL
J102	All Models	1252-0063	CONNECTOR, To FAN
J103	All Models	1251-8410	CONNECTOR, To MAINFRAME AC
J301	All Models	1252-0056	CONNECTOR, To BIAS BOARD
J302	All Models	1251-8676	CONNECTOR, To BIAS BOARD
K201	All Models	0490-1781	RELAY 2C 24VDC
L1	All Models	9100-1610	COIL 150nH 20%
L201	All Models	5080-2179	CHOKE-LINE
L202	All Models	5080-2180	CHOKE-INPUT
L203	All Models	9140-0137	COIL 1mH 5%
L204-L211	All Models	5080-2251	BEAD-FERRITE
L301	66101A	66101-80001	CHOKE-OUTPUT
L301	66102A	66102-80001	CHOKE-OUTPUT
	66103A	66103-80001	CHOKE-OUTPUT
	66104A	66104-80001	CHOKE-OUTPUT
	66105A	66105-80001	CHOKE-OUTPUT
	66106A	66106-80001	CHOKE-OUTPUT



**Table 5-1. Keysight 6610xA Power Modules Parts List - Electrical (continued)**

Reference Designators	Model	Part Number	Description
L302, L303	All Models	5080-2219	CHOKE-OUTPUT
L304	66101A-66103A	9140-1064	CHOKE-OUTPUT
	66104A-66106A	5080-2252	CHOKE-OUTPUT
L305, L306	66101A	5080-2251	BEAD-FERRITE
	66102A-66106A	Not Used	
L307	66101A	5080-2251	BEAD-FERRITE
	66102A-66105A	Not Used	
	66106A	5080-2251	BEAD-FERRITE
L308	66101A	5080-2251	BEAD-FERRITE
	66102A-66106A	Not Used	
P301	All Models	1252-0167	CONNECTOR, HOOD
Q201-Q204	All Models	5060-3457	ASSY-FET, HS (1855-0510)
Q208	All Models	1854-0087	TRANSISTOR NPN SI
Q301, Q302	66101A-66104A	5060-3382	ASSY-FET, HS (1866-0670)
	66105A, 66106A	5060-3466	ASSY-FET, HS (1855-0631)
Q303	All Models	1854-0828	TRANSISTOR NPN SI
Q305	All Models	1853-0086	TRANSISTOR PNP SI
Q401	All Models	5060-2942	ASSY-REGULATOR, HS (1826-0393)
Q403	All Models	5060-2948	ASSY-REGULATOR, HS (1826-0122)
Q404	All Models	5060-2942	ASSY-REGULATOR, HS (1826-0393)
R1	All Models	0757-0447	RES 16.2K 1%
R2	All Models	0699-2246	RES 25K .05%
R3	All Models	1810-0483	NETWORK-RES SIP
R4	All Models	0699-3414	RES 45K .1W .05%
R5, R6	All Models	0698-3155	RES 4.64K 1%
R7	All Models	1810-0355	NETWORK-RES SIP
R8	All Models	0757-0346	RES 10 1% .125W
R9	66101A-66106A	0757-0346	RES 10 1% .125W
R10	All Models	0698-4123	RES 499 1% .125W
R11	All Models	0698-6619	RES 15K .1%
R12	All Models	0757-0346	RES 10 1% .125W
R13	All Models	0757-0442	RES 10K 1% .125W
R15	All Models	1810-0206	NETWORK-RES SIP
R16	All Models	0757-0280	RES 1K 1% .125W
R18, R19	All Models	0698-0082	RES 464 1% .125W
R20	All Models	0698-4202	RES 8.87K 1%
R21	All Models	0698-3155	RES 4.64K 1%
R22	66101A-66103A	0757-0346	RES 10 1% .125W
	66104A-66106A	8159-0005	RES-ZERO OHMS
R23	All Models	0698-3155	RES 4.64K 1%
R24	All Models	0757-0430	RES 2.21K 1%
R25	All Models	1810-0279	NETWORK-RES SIP
R26	All Models	1810-0280	NETWORK-RES SIP
R27	All Models	0699-0486	RES 2K .1% .1W F
R28	All Models	0698-3445	RES 348 1% .125W

**Table 5-1. Keysight 6610xA Power Modules Parts List - Electrical (continued)**

Reference Designators	Model	Part Number	Description
R29	All Models	0698-0082	RES 464 1% .125W
R201, R202	All Models	0764-0045	RES 22K 5% 2W Mo
R203	All Models	0698-3430	RES 21.5 1% .125W
R204	All Models	0757-0403	RES 121 1% .125W
R205	All Models	0683-0335	RES 3.3 5% .25W
R206, R208	66101A-66103A	0698-3445	RES 348 1% .125W
	66104A-66106A	0757-0407	RES 200 1% .125W
R210, R211	All Models	0698-3631	RES 330 5% 2W Mo
R212	All Models	0698-3430	RES 21.5 1%
R213	All Models	0683-0335	RES 3.3 5% .25W
R214	All Models	0757-0403	RES 121 1% .125W
R215-R217	All Models	0757-0442	RES 10K 1% .125W
R218, R219	All Models	0698-3432	RES 26.1 1%
R220	All Models	1810-0203	NETWORK-RES SIP
R221	66101A-66103A	0698-4470	RES 6.98K 1%
	66104A-66106A	0757-0290	RES 6.19K 1%
R222	All Models	0757-0449	RES 20K 1% .125W
R223	All Models	0698-3446	RES 383 1% .125W
R224	All Models	0757-0442	RES 10K 1% .125W
R225	All Models	0757-0279	RES 3.16K 1%
R228, R229	All Models	0757-0442	RES 10K 1% .125W
R232	All Models	0757-0442	RES 10K 1% .125W
R234	All Models	0757-0401	RES 100 1% .125W
R235	All Models	0698-3279	RES 4.99K 1%
R236	All Models	0757-0430	RES 2.21K 1%
R237, R238	All Models	0698-3631	RES 330 5% 2W Mo
R239	All Models	0757-0442	RES 10K 1% .125W
R240	All Models	0698-4406	RES 115 1% .125W
R241	All Models	0757-0283	RES 2K 1% .125W
R244	All Models	0698-3159	RES 26.1K 1%
R245, R246	All Models	0698-8827	RES 1M 1% .125W
R247	All Models	0757-0280	RES 1K 1% .125W
R249	All Models	0757-0462	RES 75K 1% .125W
R250	All Models	0698-4099	RES 139 1% .125W
R301, R302	66101A, 66102A	0811-3896	RES 20 5% 10W
	66103A	0811-3897	RES 62 5% 10W
	66104A	0811-3896	RES 20 5% 10W
	66105A	0811-3891	RES 75 5% 10W
	66106A	0811-3892	RES 300 5% 10W
R303	66101A	5080-2217	SHUNT .005 OHMS
	66102A	5080-2218	SHUNT .01 OHMS
	66103A, 66104A	5080-2224	SHUNT .035 OHMS
	66105A	0811-3771	RES .25 OHM 1%
	66106A	0811-3772	RES .50 OHM 1%
R304	All Models	0698-3279	RES 4.99K 1%

**Table 5-1. Keysight 6610xA Power Modules Parts List - Electrical (continued)**

Reference Designators	Model	Part Number	Description
R305	66101A	0757-0441	RES 8.25K 1%
	66102A	0757-0449	RES 20K 1% .125W
	66103A	0757-0123	RES 34.8K 1%
	66104A	0698-3572	RES 60.4K 1%
	66105A	0757-0467	RES 121K 1%
	66106A	0757-0472	RES 200K 1%
R306	66101A	0757-0441	RES 8.25K 1%
	66102A	0757-0449	RES 20K 1% .125W
	66103A	0757-0123	RES 34.8K 1%
	66104A	0698-3572	RES 60.4K 1%
	66105A	0757-0467	RES 121K 1%
	66106A	0698-6358	RES 100K .1%
R307	All Models	0698-3279	RES 4.99K 1%
R308	66101A-66104A	0757-0472	RES 200K 1%
	66105A	0757-0270	RES 249K 1%
	66106A	0757-0472	RES 200K 1%
R309	66101A-66104A	Not Used	
	66105A	0811-1732	RES 1 3W 5%
	66106A	Not Used	
R310	66101A	0757-0441	RES 8.25K 1%
	66102A	0757-0446	RES 15K 1% .125W
	66103A	0757-0444	RES 12.1K 1%
	66104A	0757-0946	RES 8.2K 2%
	66105A	0698-4444	RES 4.87K 1%
	66106A	0698-3498	RES 8.66K 1%
R311	66101A	0757-0458	RES 51.1K 1%
	66102A	0757-0462	RES 75K 1% .125W
	66103A	0757-0458	RES 51.1K 1%
	66104A	0757-0349	RES 22.6K 1%
	66105A	0698-4486	RES 24.9K 1%
	66106A	0757-0449	RES 20K 1% .125W
R312	All Models	0699-0070	RES 3.16M 1%
R313	66101A	0698-0085	RES 2.61K 1%
	66102A	0698-0084	RES 2.15K 1%
	66103A	0757-0279	RES 3.16K 1%
	66104A, 66105A	0757-0427	RES 1.5K 1%
R314	66106A	0757-0279	RES 3.16K 1%
	66101A	0757-0442	RES 10K 1% .125W
	66102A	0698-3162	RES 46.4K 1%
	66103A	0757-0458	RES 51.1K 1%
	66104A	0757-0449	RES 20K 1% .125W
	66105A	0757-0461	RES 68.1K 1%
R315	66106A	0757-0469	RES 150K 1%
	66101A	0698-4435	RES 2.49K 1%
	66102A	0757-0439	RES 6.81K 1%
	66103A	0698-3153	RES 3.83K 1%
	66104A, 66105A	0698-4435	RES 2.49K 1%
	66106A	0757-0440	RES 7.5K 1%

**Table 5-1. Keysight 6610xA Power Modules Parts List - Electrical (continued)**

Reference Designators	Model	Part Number	Description
R316	All Models	0698-8827	RES 1M 1% .125W
R317	All Models	0757-0472	RES 200K 1%
R318	All Models	0757-0349	RES 22.6K 1%
R319, R320	All Models	0699-2246	RES 25K .05%
R321	All Models	0699-2248	RES 47.5K .05%
R322	All Models	0699-0070	RES 3.16M 1%
R323	66101A	0811-2568	RES 1 1% 3W
	66102A	0811-2455	RES 2 1% 3W
	66103A-66105A	Not Used	
	66106A	0698-3433	RES 28.7 1%
R323A	66101A,66102A	Not Used	
	66103A	0698-8822	RES 6.81 1%
	66104A	0698-4356	RES 12.7 1%
	66105A	0757-0382	RES 16.2 1%
	66106A	Not Used	
R323B	66101A,66102A	Not Used	
	66103A	0698-8822	RES 6.81 1%
	66104A	0698-4356	RES 12.7 1%
	66105A,66106A	Not Used	
R324	All Models	0757-0283	RES 2K 1% .125W
R325	66101A-66105A	0699-3415	RES 5K .1W .05%
	66106A	0699-3417	RES 3.85K .1W
R326	All Models	0699-3415	RES 5K .1W .05%
R327, R328	66101A	0699-3103	RES 19K .05%
	66102A	0699-2248	RES 47.5K .05%
	66103A	0699-2879	RES 80K .05% 5PPM .1W
	66104A	0699-3446	RES 125K .05%
	66105A	0699-3104	RES 250K .125W
	66106A	0699-3448	RES 300K .05%
R329, R330	All Models	0757-0280	RES 1K 1% .125W
R331	66101A	0698-6362	RES 1K .1% .125W
	66102A	0698-6631	RES 2.5K .1%
	66103A	0698-8184	RES 7.5K 1%
	66104A	0699-2246	RES 25K .05%
	66105A	0698-6353	RES 50K .1%
	66106A	0699-3447	RES 85K .1%
R332	66101A	0698-6362	RES 1K .1% .125W
	66102A	0698-6631	RES 2.5K .1%
	66103A	0698-8184	RES 7.5K 1%
	66104A	0699-2246	RES 25K .05%
	66105A	0698-6353	RES 50K .1%
	66106A	0698-6358	RES 100K .1%
R333	66101A	0698-3159	RES 26.1K 1%
	66102A, 66103A	0757-0442	RES 10K 1% .125W
	66104A	0757-0443	RES 11K 1% .125W
	66105A	0757-0441	RES 8.25K 1%
	66106A	0757-0447	RES 16.2K 1%

**Table 5-1. Keysight 6610xA Power Modules Parts List - Electrical (continued)**

Reference Designators	Model	Part Number	Description
R334	66101A-66103A	0698-7933	RES 3.83K .1%
	66104A	0698-8607	RES 4.5K .1%
	66105A	0698-7933	RES 3.83K .1%
	66106A	0698-8607	RES 4.5K .1%
R336	66101A-66103A	0699-3417	RES 3.85K .1W
	66104A	0699-3449	RES 4.5K .05%
	66105A	0699-3417	RES 3.85K .1W
	66106A	0699-3449	RES 4.5K .05%
R337	All Models	1810-0483	NETWORK-RES SIP
R338	66101A, 66102A	0699-3416	RES 100K .1W
	66103A	0699-2248	RES 47.5K .05%
	66104A	0699-3416	RES 100K .1W
	66105A, 66106A	0699-2246	RES 25K .05%
R339	All Models	0698-3430	RES 21.5 1%
R340	66101A	0811-2568	RES 1 1% 3W
	66102A	0811-2455	RES 2 1% 3W
	66103A-66105A	Not Used	
	66106A	0698-3433	RES 28.7 1%
R340A	66101A, 66102A	Not Used	
	66103A	0698-8822	RES 6.81 1%
	66104A	0698-4356	RES 12.7 1%
	66105A	0757-0382	RES 16.2 1%
	66106A	Not Used	
R340B	66101A, 66102A	Not Used	
	66103A	0698-8822	RES 6.81 1%
	66104A	0698-4356	RES 12.71%
	66105A, 66106A	Not Used	
R341	All Models	0698-3430	RES 21.5 1%
R342	66101A	0757-0462	RES 75K 1% .125W
	66102A	0698-3450	RES 42.2K 1%
	66103A, 66104A	0757-0470	RES 162K 1%
	66105A	0757-0463	RES 82.5K 1%
R343	66106A	0757-0470	RES 162K 1%
	66101A	0757-0441	RES 8.25K 1%
	66102A	0757-0288	RES 9.09K 1%
	66103A	0757-0441	RES 8.25K 1%
	66104A	0757-0447	RES 16.2K 1%
	66105A	0757-0446	RES 15K 1% .125W
	66106A	0757-0447	RES 16.2K 1%
R344	66101A	0698-3450	RES 42.2K 1%
	66102A-66106A	0698-4509	RES 80.6K 1%
R345	All Models	0757-0280	RES 1K 1% .125W
R346	All Models	0699-2248	RES 47.5K .05%
R347	66101A-66105A	8159-0005	RES-ZERO OHMS
	66106A	0699-3416	RES 100K .1W

**Table 5-1. Keysight 6610xA Power Modules Parts List - Electrical (continued)**

Reference Designators	Model	Part Number	Description
R348	66101A, 66102A	0757-0441	RES 8.25K 1%
	66103A, 66104A	0757-0444	RES 12.1K 1%
R349	66105A	0698-3136	RES 17.8K 1%
	66106A	0698-3159	RES 26.1K 1%
R350	All Models	0757-0472	RES 200K 1%
R351	66101A-66105A	8159-0005	RES-ZERO OHMS
	66106A	0698-6358	RES 100K .1%
R352	All Models	0699-2246	RES 25K .05%
R353	All Models	0683-2255	RES 2.2M 5% .25W
R354	66101A	0698-4443	RES 4.53K 1%
	66102A	0757-0349	RES 22.6K 1%
R355	66103A	0757-0467	RES 121K 1%
	66104A	0698-6376	RES 200K .1%
R359	66105A, 66106A	Not Used	
R359	All Models	0757-0283	RES 2K 1% .125W
R359	All Models	0757-0442	RES 10K 1% .125W
R360	66101A-66103A	0698-6360	RES 10K .1%
	66104A	0698-6320	RES 5K .1% .125W
R361	66105A	0698-6360	RES 10K .1%
	66106A	0698-8061	RES 8.25K .1%
R362	66101A	0698-4196	RES 1.07K 1%
	66102A	8159-0005	RES-ZERO OHMS
R363	66103A	0698-0064	RES 9.31K 1%
	66104A	8159-0005	RES-ZERO OHMS
R364	66105A	0698-7841	RES 164K .1%
	66106A	0698-6376	RES 200K .1%
R365	66101A	0698-6619	RES 15K .1%
	66102A	0699-2248	RES 47.5K .05%
R366	66103A, 66104A	0698-6359	RES 80K 0.1%
	66105A	0698-7841	RES 164K .1%
R367	66106A	0698-8050	RES 256K .1%
R368	All Models	0757-0465	RES 100K 1%
R369	All Models	0699-2246	RES 25K .05%
R370	All Models	0698-3279	RES 4.99K 1%
R371	All Models	0698-6358	RES 100K .1%
R372	66101A, 66102A	0698-8812	RES 1 1% .125W
R373	66103A-66105A	Not Used	
	66106A	0757-0346	RES 10 1% .125W
R374	66101A, 66102A	0698-8812	RES 1 1% .125W
R375	66103A-66106A	Not Used	
R401	All Models	0699-1069	RES 229 .1%
R402	AU Models	0699-0486	RES 2K .1% .1W F
R406	All Models	0757-0437	RES 4.75K 1%
R407, R408	All Models	0757-0407	RES 200 1% .125W
R409-R411	All Models	0757-0280	RES 1K 1% .125W
R416	All Models	8159-0005	RES-ZERO OHMS
R419	All Models	0757-0449	RES 20K 1% .125W

**Table 5-1. Keysight 6610xA Power Modules Parts List - Electrical (continued)**

Reference Designators	Model	Part Number	Description
R420	66101A, 66102A	0698-6358	RES 100K .1%
	66103A	0699-2248	RES 47.5K .05%
	66104A	0698-6358	RES 100K .1%
	66105A, 66106A	0699-2246	RES 25K .05%
R421	All Models	0698-3155	RES 4.64K 1%
R422	All Models	0757-0346	RES 10 1% .125W
R423	All Models	0698-8812	RES 1 1% .125W
R424	All Models	0757-0280	RES 1K 1% .125W
R427	66101A-66103A	0698-8812	RES 1 1% .125W
	66104A-66106A	Not Used	
R428	66101A-66105A	0698-8812	RES 1 1% .125W
	66106A	Not Used	
R429	66101A-66103A	0698-8812	RES 1 1% .125W
	66104A, 66105A	Not Used	
	66106A	0757-0346	RES 10 1% .125W
R430	All Models	0757-0280	RES 1K 1% .125W
RT301	All Models	0837-0397	THERMISTOR
S3	All Models	3101-2243	SWITCH 8-1A
S201	All Models	3101-2966	SWITCH DPDT
T201	66101A	9100-5020	TRANSFORMER-POWER
	66102A	9100-5021	TRANSFORMER-POWER
	66103A	9100-5022	TRANSFORMER-POWER
	66104A	9100-5001	TRANSFORMER-POWER
	66105A	9100-5002	TRANSFORMER-POWER
	66106A	9100-5003	TRANSFORMER-POWER
T202	All Models	9140-0974	INDUCTOR-FIXED
U1	All Models	1821-1479	MICROPROCESSOR, SOCKET (1200-1274)
U2	All Models	5080-2529	PROGRAMMED-ROM, SOCKET (1200-0567)
U3	All Models	1818-4134	IC-MEMORY, 64K
U4	All Models	1820-2724	IC SN74ALS573BN
U5	AU Models	5080-2236	PROGRAMMED-GAL, SOCKET (1200-0639)
U6	All Models	5080-2530	PROGRAMMED-GAL, SOCKET (1200-0639)
U7	All Models	1826-2402	IC-CONVERTOR AD7837BN
U11	All Models	1826-2284	IC
U12	All Models	1826-2484	IC-CONVERTOR
U13	All Models	1820-3399	IC MC74HC273N
U14	All Models	1826-1409	IC 1013
U15	All Models	1826-1021	ANALOG MULTIPLEXER
U17-U20	All Models	1990-1502	OPTO ISOLATOR
U21	All Models	1820-2110	IC-INTERFACE
U22	All Models	1818-4792	IC-EEPROM
U23	All Models	1820-2110	IC-INTERFACE
U24	All Models	1826-1896	IC-LINEAR
U25	All Models	1990-1502	OPTO ISOLATOR
U26	All Models	1826-2341	IC-VOLTAGE SENSE
U201, U202	All Models	1820-8433	IC PULSE WIDTH MODULATOR

**Table 5-1. Keysight 6610xA Power Modules Parts List - Electrical (continued)**

Reference Designators	Model	Part Number	Description
U203	All Models	1826-2075	IC UC3825N
U204	All Models	1990-1502	OPTO ISOLATOR
U205	All Models	1858-0069	TRANSISTOR ARRAY 18P-DIP
U206	All Models	1826-0175	IC 319
U301	66101A-66103A	1826-0346	IC OP-AMP
	66104A-66106A	1826-0962	IC OP-AMP
U302	All Models	1826-1896	IC-LINEAR
U303	All Models	1826-1370	IC 365
U304	All Models	1826-1895	PRECISION OP-AMP
U305	All Models	1826-1553	IC-LINEAR
U306	All Models	1990-1502	OPTO ISOLATOR
U307	All Models	1826-0346	IC OP-AMP
VR201	All Models	1902-0968	DIODE-ZENER 27V 5%
VR302	All Models	1902-0951	DIODE-ZENER
VR304, VR305	All Models	1902-0018	DIODE-ZENER IN941 11.7V
Y1	All Models	0410-2109	CRYSTAL 12.000 MHZ
	All Models	5060-3455	ASSEMBLY-BIAS BOARD
C401	All Models	0180-3587	CAP 1000uF 50V
C402	All Models	0180-4273	CAP 1000uF
C404	All Models	0160-5422	CAP .047uF 20%
C405	All Models	0180-3587	CAP 1000uF 50V
C406	All Models	0180-4389	CAP 6800uF 25V
C408, C410	All Models	0180-4129	CAP 1uF 35V
C411	All Models	0160-4835	CAP .1uF 10% 50V
D401, D402	All Models	1901-0731	DIODE-PWR RECT
D402	All Models	1901-0731	DIODE-PWR RECT
F401	All Models	2110-0820	FUSE .5A 250V, HOLDER (2110-0714)
J401	All Models	1252-0056	CONNECTOR, TO POWER BOARD
J402	All Models	1251-8676	CONNECTOR, TO POWER BOARD
Q402	All Models	1826-0527	IC LM337T
Q404	All Models	5060-2942	ASSY-HS, TO-220
R403	All Models	0699-0486	RES 2K .1% .1W F
R404	All Models	0699-1069	RES 229 .1%
R405	All Models	0698-3447	RES 422 1% .125W
R406	All Models	0757-0437	RES 4.75K 1%
S402	All Models	3101-2966	SWITCH DPDT
T401	All Models	9100-4932	TRANSFORMER-BIAS
U401, U402	All Models	1906-0006	DIODE BRIDGE 400V
	All Models	5060-3454	ASSEMBLY-FRONT PANEL BOARD
C501, C502	All Models	0160-5422	CAP .047uF 20%
C503, C504	All Models	0160-4833	CAP .022uF 10%
CR501-CR503	All Models	1990-1554	LED GREEN
CR504-CR506	All Models	1990-1553	LED YELLOW
D501-D508	All Models	1990-1492	DISPLAY, LED
D509	All Models	1902-3110	DIODE-ZENER 5.9V 2%
J501	All Models	1252-3844	CONNECTOR, TO POWER BOARD



**Table 5-1. Keysight 6610xA Power Modules Parts List - Electrical (continued)**

Reference Designators	Model	Part Number	Description
R501	All Models	1810-0405	NETWORK RES SIP
R502	All Models	1810-0405	NETWORK RES SIP
R503	All Models	1810-0405	NETWORK RES SIP
R504	All Models	1810-0405	NETWORK RES SIP
R505	All Models	1810-0636	NETWORK RES SIP
R506	All Models	1810-0636	NETWORK RES SIP
R507	All Models	1810-0483	NETWORK RES SIP
U501	All Models	1821-0045	IC DISPLAY DRIVE
U502	All Models	1821-0045	IC DISPLAY DRIVE
U503	All Models	1858-0069	TRANSISTOR ARRAY 18P-DIP
U504	All Models	1820-3344	IC MC74HC595N

**Table 5-2. Keysight 6610xA Power Modules Parts List - Mechanical**

Model	Part Number	Description
All Models	0403-0086	BUMPER FOOT PRESS-IN
All Models	0515-1946	SCREW-MACH, M3 X 0.5 6MM LG, TORX T10 FLT, (REF COVER)
All Models	0515-0430	SCREW-MACH, M3 X 0.5 6MM LG, TORX T10 PAN, (REF PC BD)
All Models	0515-1038	SCREW-MACH, M3 X 0.5 35MM LG, TORX T10 PAN, (REF FAN)
All Models	0535-0031	NUT-HEX W/LKWR, M3 X 0.5, (REF FAN)
All Models	1460-2307	SPRING (REF LATCH)
All Models	5001-6759	CHASSIS
All Models	5001-6760	COVER
All Models	5001-6761	BRACKET-FAN
All Models	5001-6762	INSULATOR
All Models	5040-1677	BEZEL-LEFT
All Models	5040-1678	BEZEL-RIGHT
All Models	5040-1680	LATCH-PLASTIC
All Models	5040-1681	PULLER
All Models	5080-2193	ASSEMBLY-FRONT PANEL CABLE (REF J501/J3)
All Models	5080-2194	ASSEMBLY-BIAS BOARD CABLE (REF J402/J302)
All Models	5080-2195	ASSEMBLY-BIAS BOARD CABLE (REF J401/J301)
All Models	5080-2223	LABEL, AC/S3 SWITCH CONFIG
66101A	66101-40001	PANEL-FRONT
66102A	66102-40001	PANEL-FRONT
66103A	66103-40001	PANEL-FRONT
66104A	66104-40001	PANEL-FRONT
66105A	66105-40001	PANEL-FRONT
66106A	66106-40001	PANEL-FRONT

**Table 5-3. Output Connector Assembly Parts List**

<b>Reference Designators</b>	<b>Part Number</b>	<b>Description</b>
	5060-3470	ASSEMBLY-OUTPUT CONNECTOR BOARD
C602, C603	0160-5422	CAP .047uF 20%
C604	0160-4281	CAP 2200pF 20%
C605	1810-1379	NETWORK-CAP SIP
J601	1251-8410	CONNECTOR, TO POWER BOARD
J602, J603	1252-4311	CONNECTOR, TO CONNECTOR BOARD
R601	0757-0442	RES 10K 1% .125W
SW1	3101-3133	SWITCH, SLIDE
TB601	0360-2423	TERMINAL BLOCK
VR601-VR603	1902-0968	DIODE-ZENER 27V 5%
	5060-3351	ASSEMBLY-OUTPUT RELAY BOARD
C601	0180-4136	CAP 10uF 20V
F601, F602	2110-0757	FUSE .062A
K601-K604	0490-1670	PWR RELAY
K605-K607	0490-1405	RELAY 2C 12 VDC
P602, P603	1252-4310	CONNECTOR, TO CONNECTOR BOARD
R601-R603	0686-3305	RES 33 5% .5W CC
	5060-3386	OUTPUT ASSEMBLY-without relays
	5060-3387	OUTPUT ASSEMBLY-with relays
	1400-0307	Cable Tie
	5040-1682	Hood Base
	5040-1683	Hood Cover
	5080-2220	Hood Label



## Diagrams

This chapter contains test point and component location diagrams and schematics for troubleshooting the Keysight 6610xA Power Modules.

---

**SHOCK HAZARD** Hazardous voltages are present throughout the Power and Bias board assemblies. Ac line voltage is present on some connectors even when the module is not turned on. The dc rail voltage to the module is 310 volts when the unit is turned on.

---



---

### Schematic Sheets

Foldout #1	front--Power board sheet 1 of 5 back--Power board sheet 2 of 5
Foldout #2	front--Power board sheet 3 of 5 back--Power board sheet 4 of 5
Foldout #3	front--Power board sheet 5 of 5 back--Front panel schematic and component locations
Foldout #4	front--Output connector board schematic and component locations back--Relay board schematic and component locations
Foldout #5	front--Bias board schematic and component locations back--Power board component locations and test points
Foldout #6	front--Main board Component coordinates back--blank

---

### Component Location Diagrams

Component location diagrams are provided for all of the module circuit boards.

The component location diagram for the power board is located on the back of the last foldout sheet (the bias board schematic) foldout sheet. The diagram is divided into columns and rows designated "x coordinates" and "y coordinates". The table on the facing page lists all of the components on the Power board and gives the coordinate location of each component. For example, resistor R201 is located at x coordinate 3.9 and y coordinate 1.4. Refer to Chapter 5 for the part number and description of each electrical part.

The test points shown on the component location diagram for the power board correspond with the test points that are used in the troubleshooting procedures of Chapter 3.

The component location diagrams for the bias, front panel, connector, and relay boards are located on the same sheets as their schematic diagrams.

---

## Schematic Notes

Notes that apply to all schematic sheets are as follows:

- All resistors are in ohms +/-1%, 1/8 W, unless otherwise specified.
- All capacitors are in microfarads unless otherwise specified.
- Refer to the parts list (Table 5-1) for the values of the resistors and capacitors that are enclosed by a heavy rectangle on the schematic. Their values differ from model to model. The schematic shows only the values used by Model 66105A.
- An asterisk negates a signal name. For example,  $\overline{WR}$  appears on the schematic as **WR\***.
- Signal line destinations are given inside the parentheses at the end of the signal lines. For example, PCLR\* (S02C5) on Power board schematic sheet 1 of 5, indicates that the **PCLR\*** signal continues on schematic sheet 2 of 5 at grid coordinates C, 5. Coordinates are labeled on the schematic border.
- Signal lines that are terminated by flags  continue onto other sheets. Note that flags do **NOT** indicate signal flow direction.
- Signal lines without flags go to another location of the same schematic sheet.
- Test points on the schematic sheets (e.g. **TP22**) identify the location of the test points used in the troubleshooting procedures in Chapter 3.
- Voltages and waveforms shown on the schematics are obtained when following the troubleshooting procedures in Chapter 3.

NOTES:  
 1. UNLESS OTHERWISE SPECIFIED:  
 ALL RESISTOR VALUES ARE IN OHMS, +/-1%, 1/10W.  
 ALL CAPACITOR VALUES ARE IN MICROFARADS.

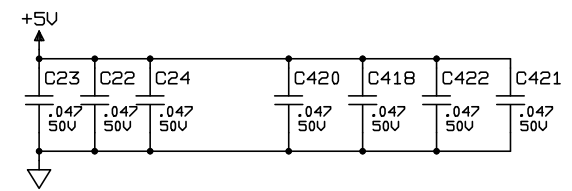
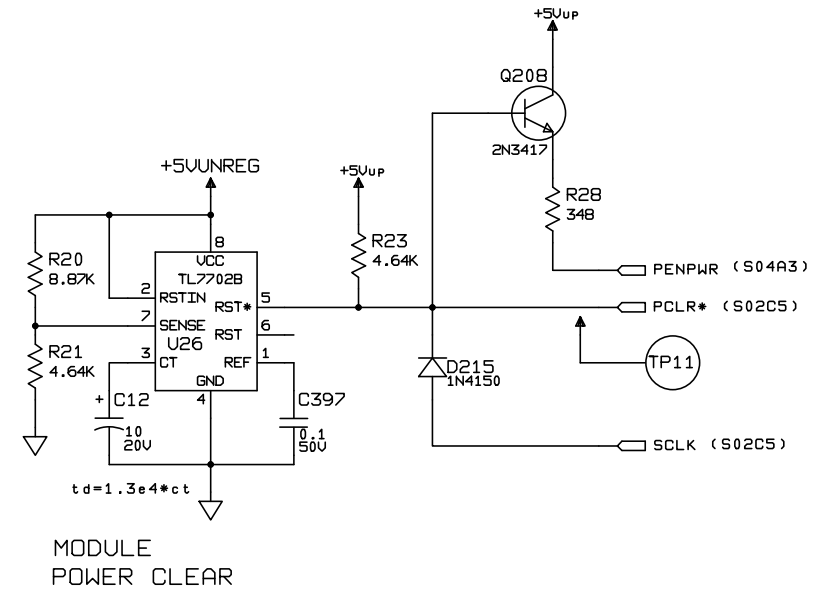
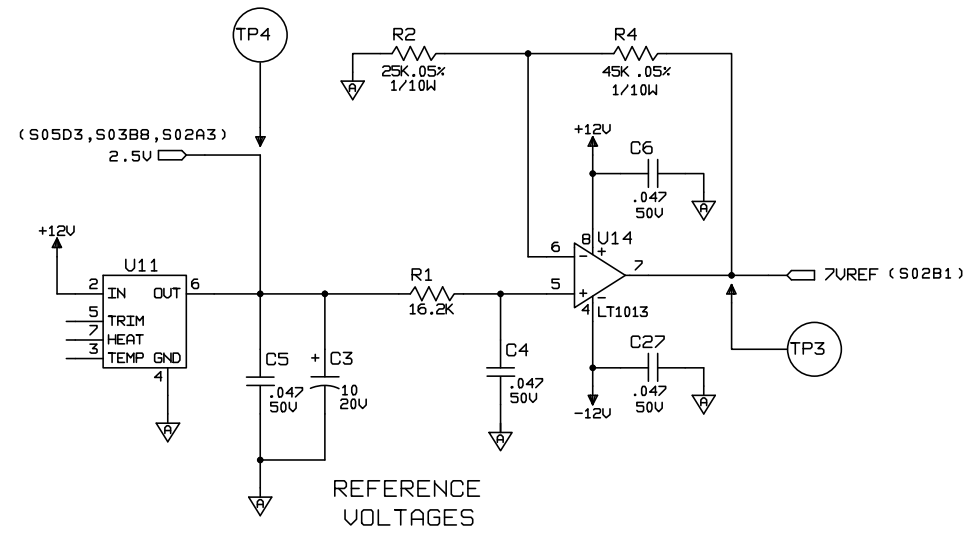
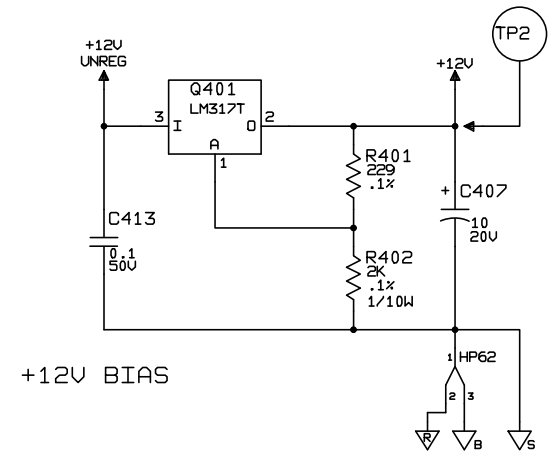
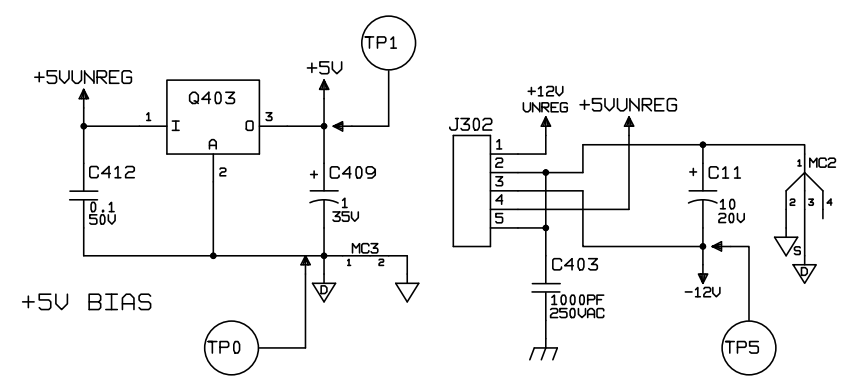

POWER BOARD		
D	66105A	B1
06/10/95	SHT 1 OF 5	

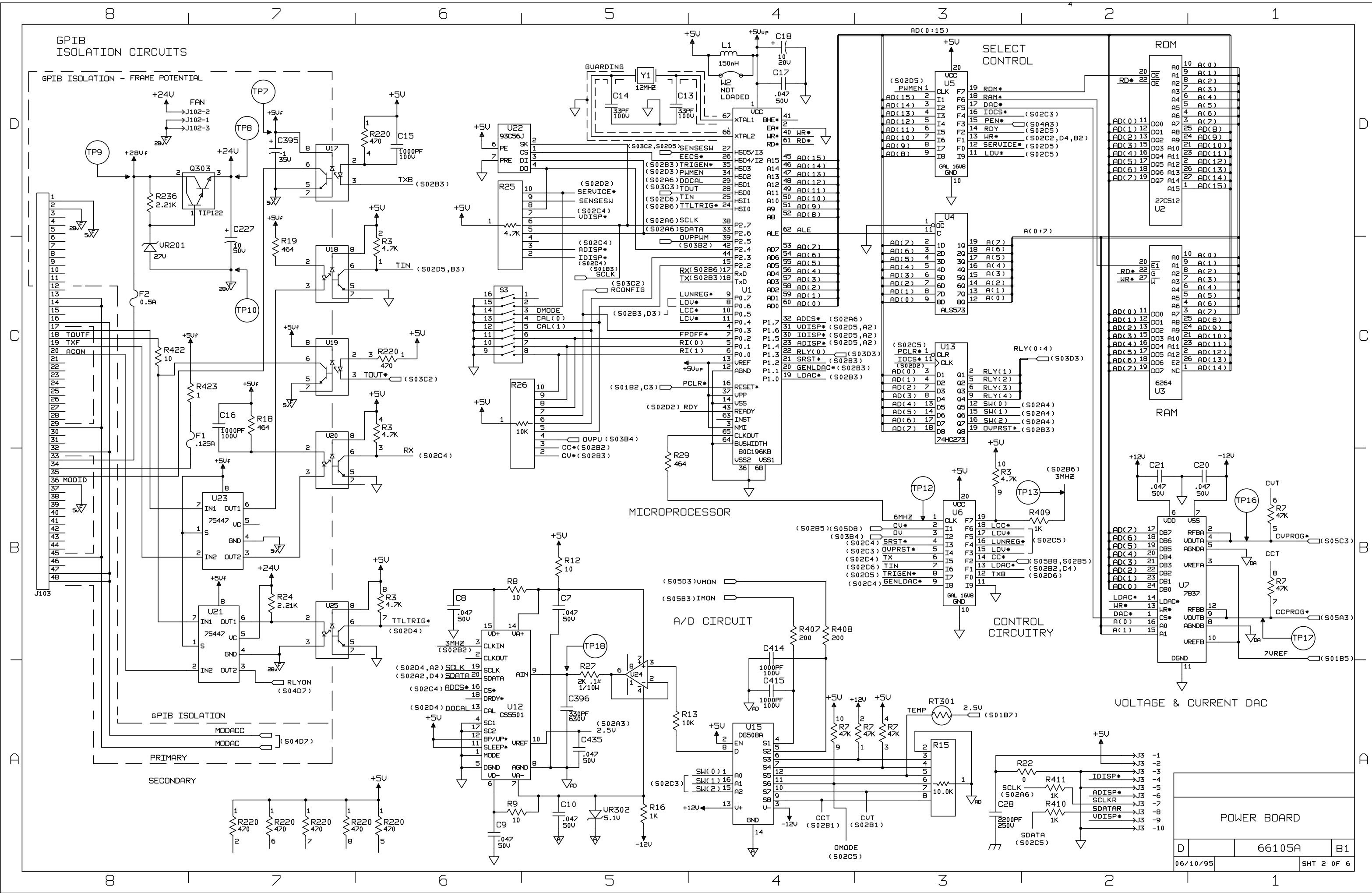

D	66105A	B1
06/10/95		SHT 2 OF 6

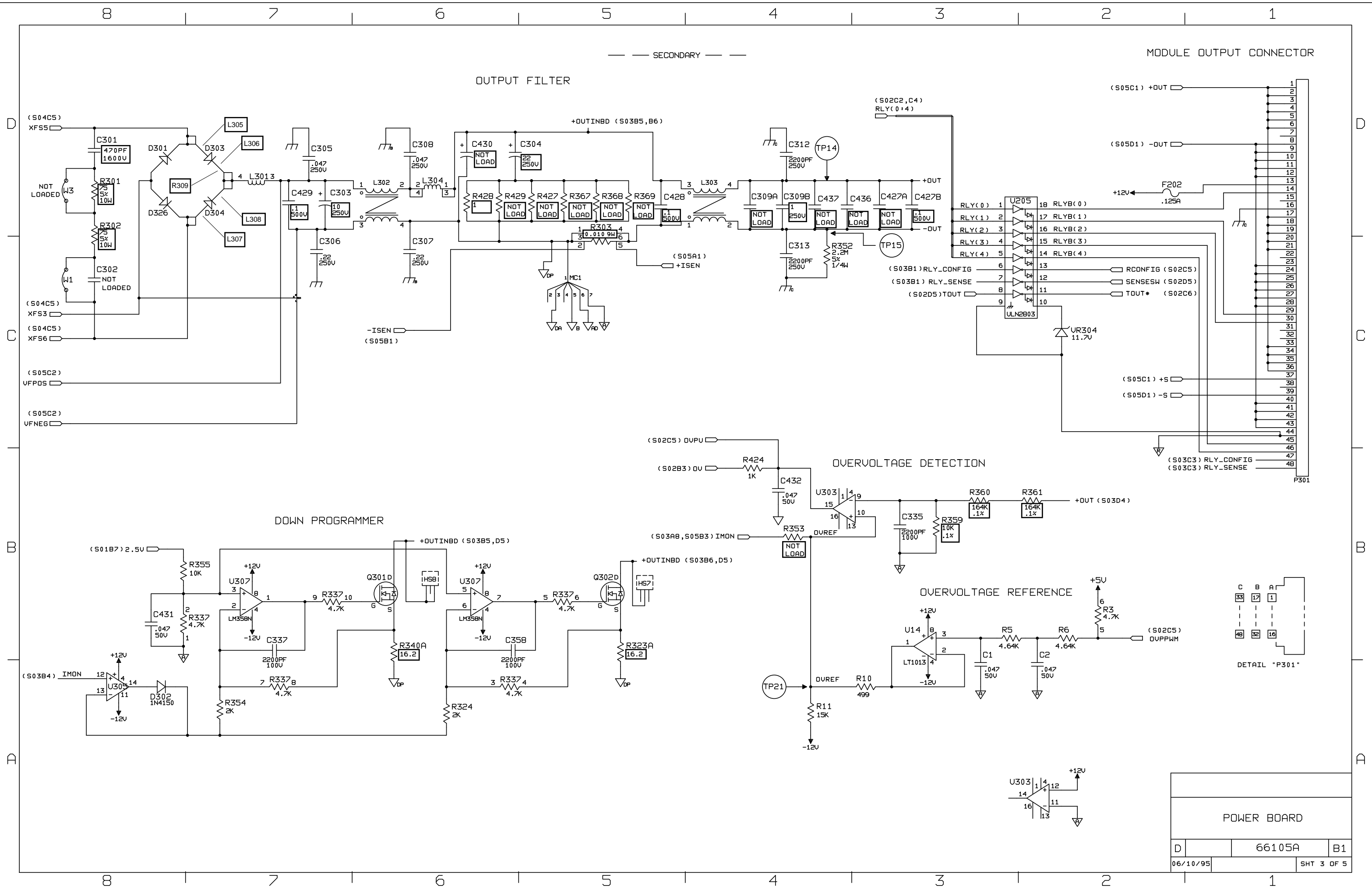

MODULE OUTPUT CONNECTOR

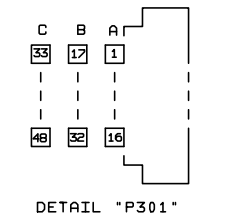
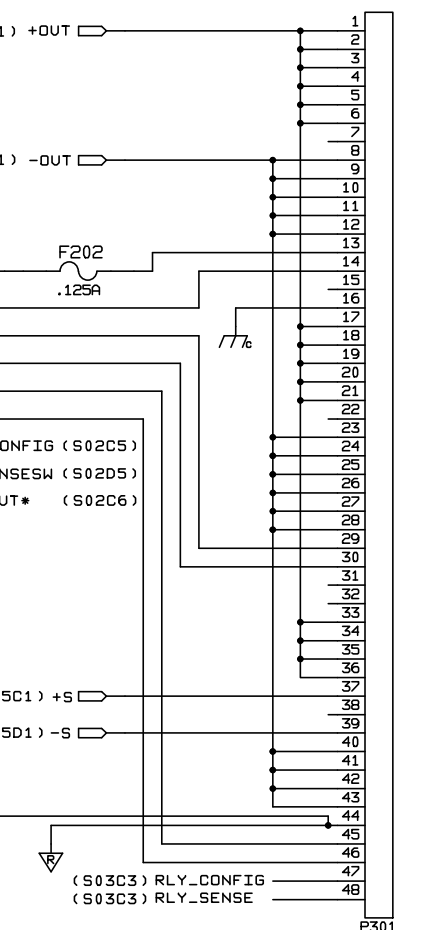

POWER BOARD		
D	66105A	B1
06/10/95		SHT 3 OF 5



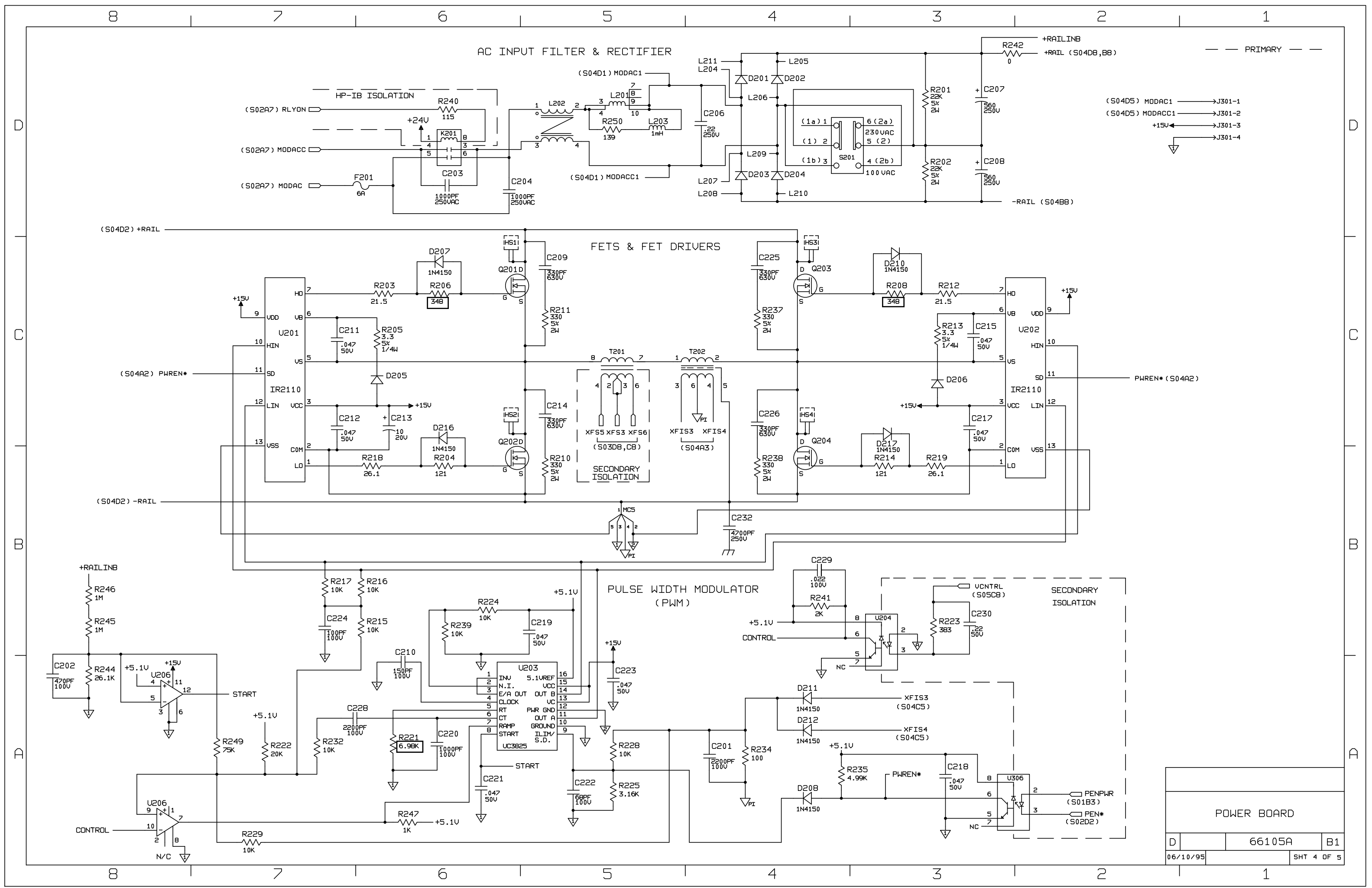

POWER BOARD		
D	66105A	B1
06/10/95		SHT 4 OF 5

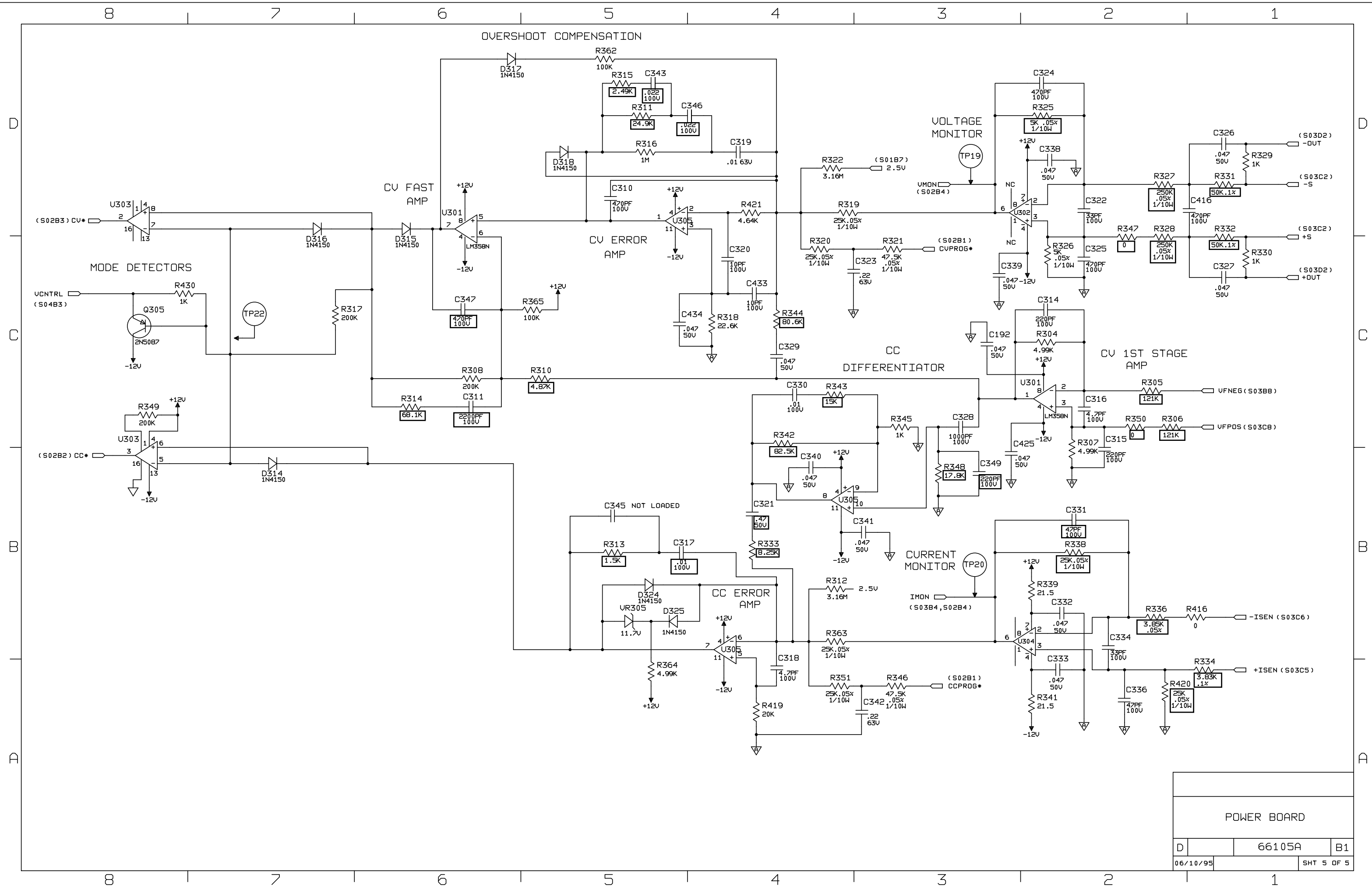

POWER BOARD		
D	66105A	B1
06/10/95		SHT 5 OF 5

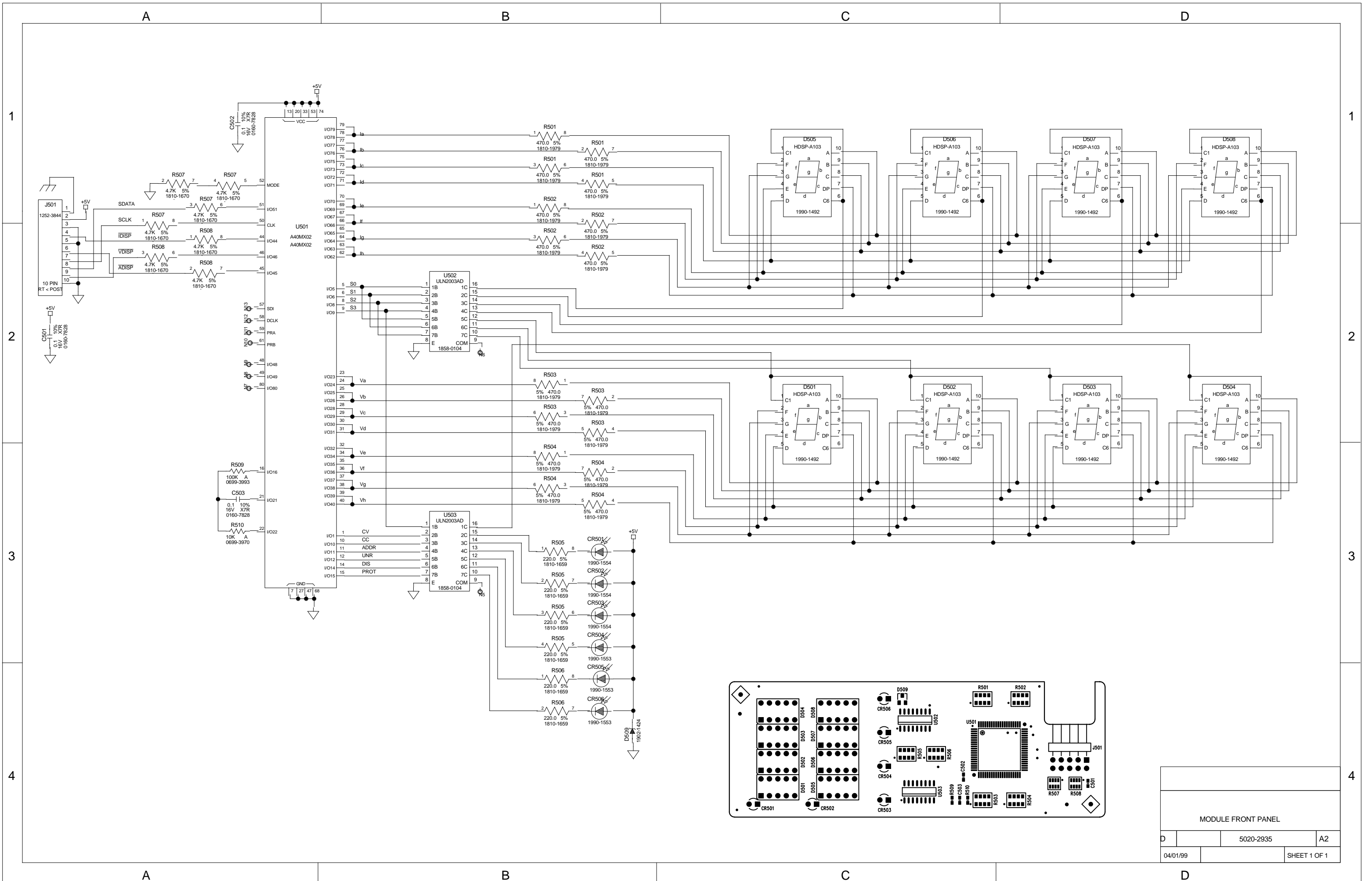

MODULE FRONT PANEL		
D	5020-2935	A2
04/01/99	SHEET 1 OF 1	

8 7 6 5 4 3 2 1

D

D

C

C

B

B

A

A

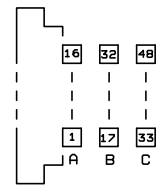
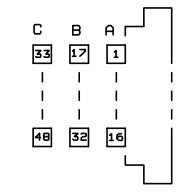
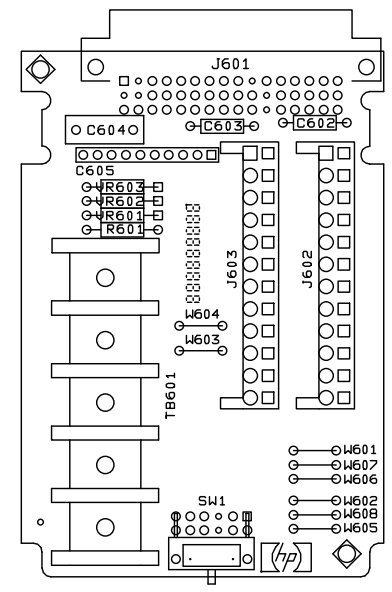
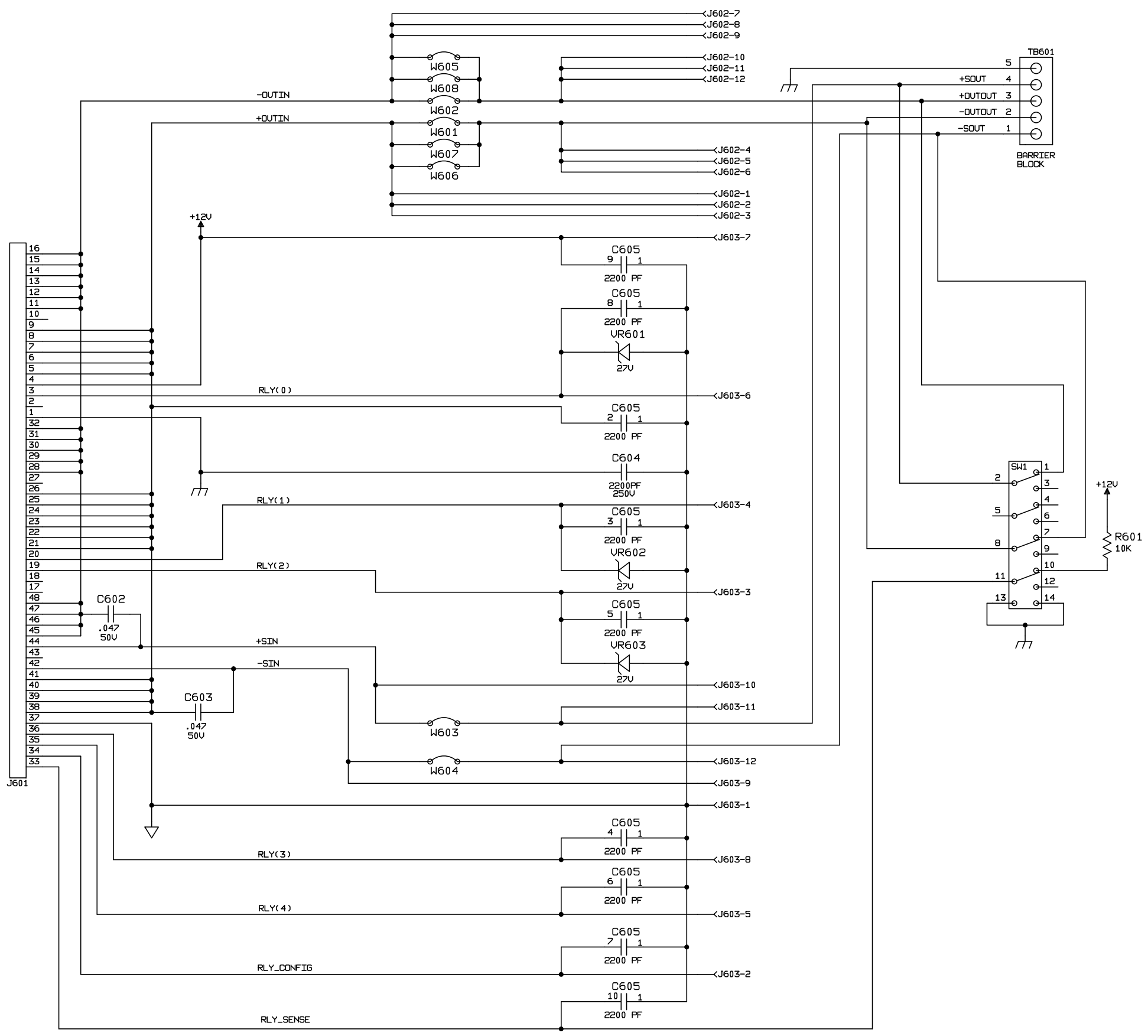

HOOD OUTPUT BD		
D	5020-2798	A1
02/05/92		SHT 1 OF 1

8 7 6 5 4 3 2 1

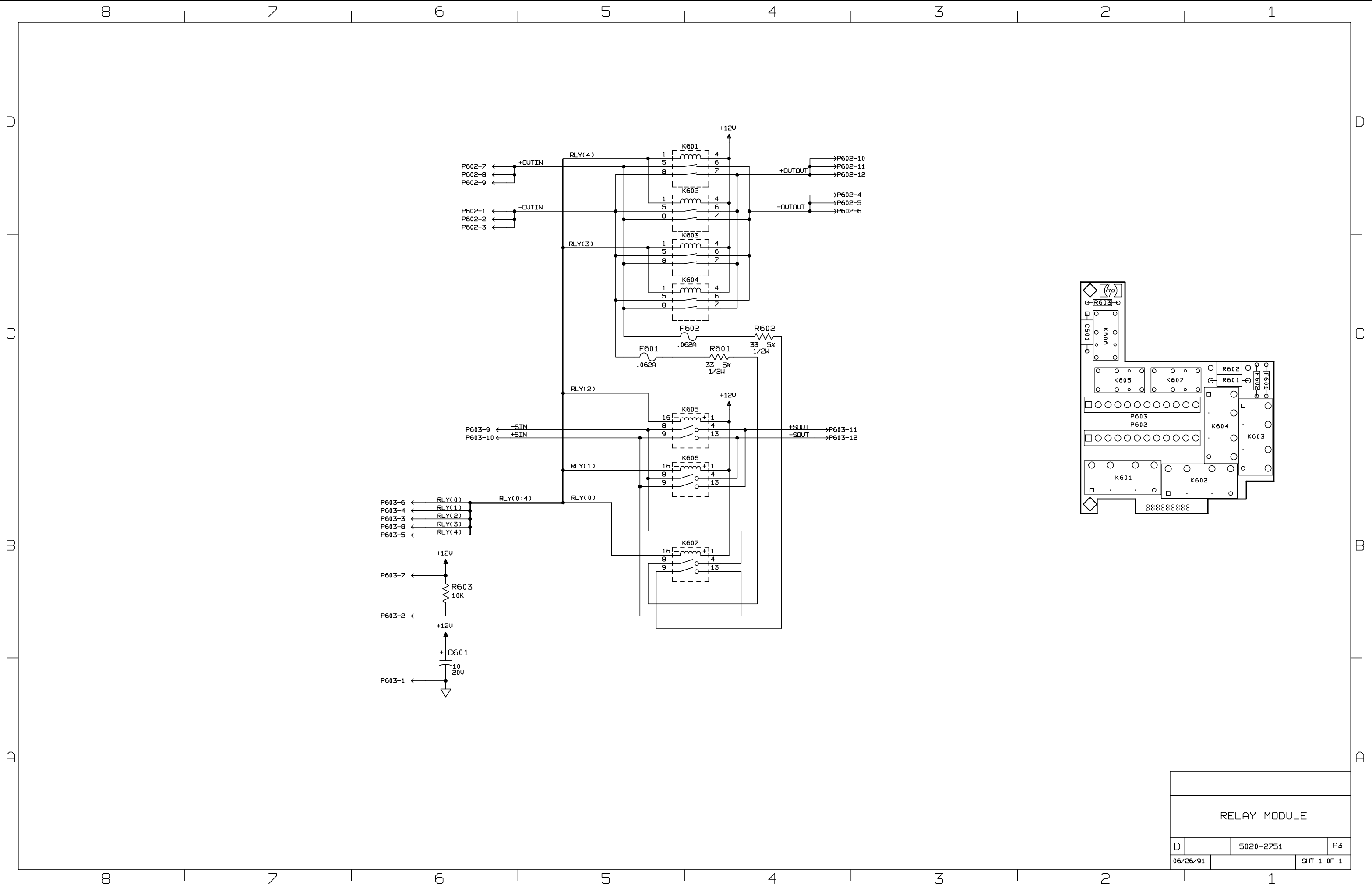

RELAY MODULE		
D	5020-2751	A3
06/26/91		SHT 1 OF 1

8 7 6 5 4 3 2 1

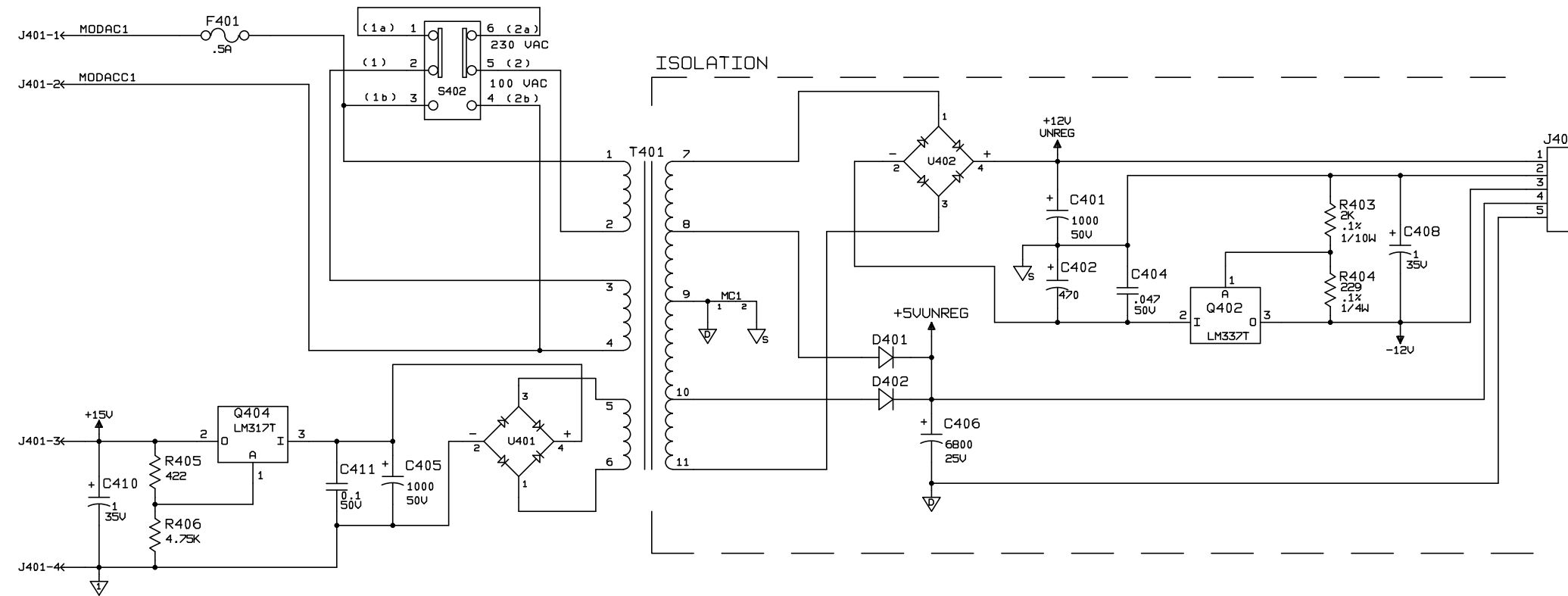
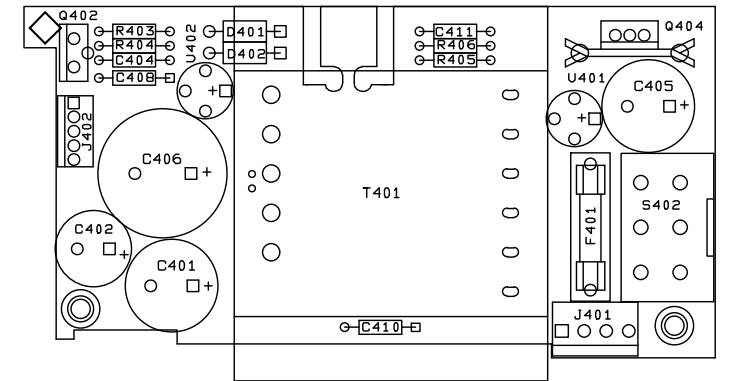

BIAS BOARD

D	5020-2801	B1
06/14/95		SHT 1 OF 1

8 7 6 5 4 3 2 1

5 11 0 4 17 18 10 22 -1 20 15 14 19

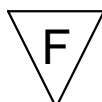
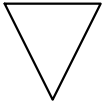

SENSE

- OUT

+ OUT

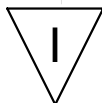
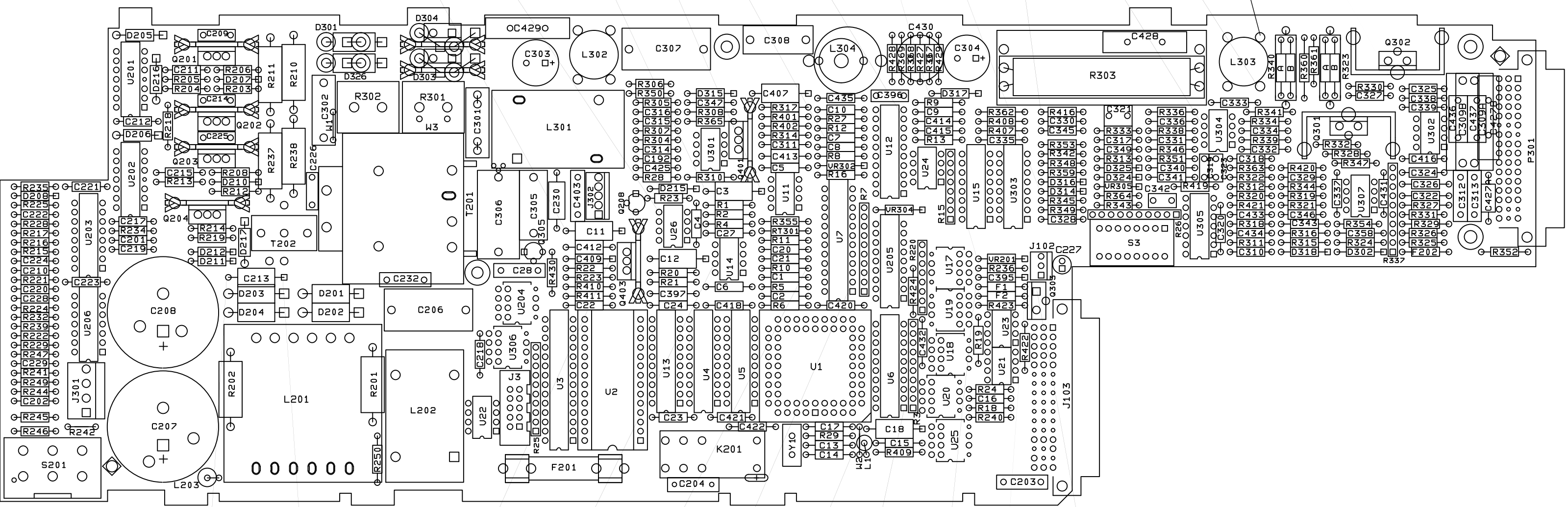

6 1 3 21 16 13 12 9 7 8

Main Board Component Coordinates

	X	Y		X	Y		X	Y		X	Y		X	Y		X	Y		X	Y		X	Y			
C1	8.1	2.2	C220	0.5	2.1	C331	12.7	3.7	C435	9.1	4.1	L301	5.4	3.5	R201	3.9	1.4	R303	10.6	4.6	R348	11.5	3.4	U3	6.0	0.4
C2	8.1	2.0	C221	1.0	3.2	C332	13.7	3.6	C436	15.5	4.1	L302	6.3	4.3	R202	2.3	0.6	R304	7.1	3.7	R349	11.5	2.9	U4	7.6	0.8
C3	8.1	3.1	C222	0.0	2.9	C333	13.4	4.1	C437	15.7	4.1	L303	13.4	4.2	R203	2.6	4.2	R305	6.7	4.1	R350	6.6	4.2	U5	8.0	0.8
C4	7.3	3.0	C223	1.0	2.1	C334	13.2	3.8	D201	3.7	2.0	L304	8.9	4.5	R204	2.1	4.2	R306	6.4	4.3	R351	12.7	3.5	U6	9.6	0.8
C5	8.5	3.4	C224	0.0	2.4	C335	10.9	3.7	D202	3.7	1.8	P301	16.2	4.5	R205	1.6	4.3	R307	6.7	3.8	R352	16.3	2.5	U7	9.0	2.0
C6	7.9	2.1	C225	2.3	3.7	C336	12.2	3.9	D203	2.9	2.0	Q201	2.2	4.6	R206	2.2	4.4	R308	7.2	4.0	R353	11.0	3.6	U11	8.4	2.9
C7	9.1	3.7	C226	3.2	3.3	C337	14.2	3.3	D204	2.9	1.8	Q202	2.2	3.9	R208	2.6	3.3	R310	7.7	3.3	R354	14.7	2.8	U12	9.6	3.1
C8	9.1	3.6	C227	11.3	2.3	C338	14.9	4.1	D205	1.6	4.8	Q203	2.2	3.5	R210	3.0	4.8	R311	13.5	2.6	R355	8.0	2.8	U13	7.2	0.8
C9	9.7	4.0	C228	0.5	2.0	C339	15.4	4.0	D206	1.6	3.7	Q204	2.1	2.9	R211	2.8	4.8	R312	13.5	3.2	R359	11.0	3.3	U14	7.8	2.2
C10	9.1	4.0	C229	0.0	1.3	C340	12.2	3.4	D207	2.6	4.3	Q208	6.7	3.1	R212	2.1	3.1	R313	12.1	3.5	R360	13.9	4.8	U15	10.5	2.8
C11	6.5	2.7	C230	5.8	3.3	C341	12.7	3.3	D208	0.5	3.1	Q301	14.3	3.7	R213	1.5	3.2	R314	8.0	3.7	R361	14.0	4.3	U17	9.9	2.4
C12	7.4	2.4	C232	4.0	2.2	C342	12.2	3.0	D210	2.6	3.2	Q302	14.9	4.6	R214	1.9	2.7	R315	14.1	2.6	R362	10.9	4.0	U18	10.3	1.2
C13	8.5	0.4	C301	5.0	3.5	C343	13.6	2.8	D211	2.4	2.4	Q303	11.1	1.9	R215	0.0	2.5	R316	14.1	2.7	R363	13.5	3.4	U19	9.9	2.0
C14	8.5	0.3	C302	3.3	4.3	C345	11.0	3.8	D212	2.4	2.5	Q305	5.5	2.5	R216	0.5	2.6	R317	8.5	4.0	R364	12.1	3.1	U20	10.2	0.8
C15	9.3	0.4	C303	5.7	4.5	C346	14.1	2.9	D215	7.3	3.1	Q401	7.9	3.7	R217	0.5	2.7	R318	13.5	2.8	R365	7.7	3.9	U21	10.8	1.1
C16	10.7	0.9	C304	10.3	4.5	C347	7.2	4.1	D216	1.5	4.5	Q403	6.7	2.4	R218	1.7	4.0	R319	14.1	3.1	R367	9.8	4.8	U22	5.2	0.5
C17	8.5	0.6	C305	5.6	3.3	C349	11.6	3.6	D217	2.5	2.8	R1	7.4	3.0	R219	1.9	2.6	R320	13.5	3.1	R368	9.6	4.8	U23	10.8	1.5
C18	9.8	0.6	C306	5.2	3.3	C358	14.7	2.7	D301	3.4	4.7	R2	7.4	2.9	R220	9.8	1.8	R321	13.6	3.0	R369	9.5	4.8	U24	10.0	3.2
C20	8.0	2.5	C307	6.6	4.6	C395	10.9	2.2	D302	14.7	2.5	R3	9.7	0.8	R221	0.5	2.2	R322	13.5	3.3	R401	8.5	3.9	U25	10.3	0.3
C21	8.0	2.4	C308	8.5	4.7	C396	9.6	4.1	D303	4.6	4.4	R4	7.9	2.8	R222	0.5	1.6	R323	14.1	4.0	R402	8.0	3.8	U26	7.2	2.6
C22	5.9	1.9	C309A	15.7	3.4	C397	7.3	2.0	D304	4.6	4.7	R5	8.5	2.1	R223	6.4	2.2	R324	14.7	2.6	R407	10.9	3.8	U201	1.4	4.0
C23	6.9	0.7	C309B	15.6	3.4	C403	6.1	3.3	D314	11.5	3.1	R6	8.0	1.9	R224	0.5	1.9	R325	15.4	2.6	R408	10.9	3.9	U202	1.4	2.9
C24	7.3	1.9	C310	13.5	2.5	C407	8.5	4.2	D315	7.7	4.2	R7	9.1	2.0	R225	0.0	3.0	R326	15.4	2.7	R409	9.8	0.3	U203	1.0	2.3
C27	7.4	2.7	C311	8.5	3.6	C409	6.4	2.4	D316	11.5	3.2	R8	8.6	3.5	R228	0.5	2.8	R327	14.9	3.0	R410	5.9	2.1	U204	5.6	1.8
C28	5.6	2.3	C312	15.5	2.9	C412	6.4	2.5	D317	10.4	4.2	R9	9.7	4.1	R229	0.5	1.5	R328	14.5	3.5	R411	5.9	2.0	U205	9.6	2.0
C192	6.7	3.5	C313	15.7	3.3	C413	8.0	3.5	D318	14.1	2.5	R10	8.0	2.3	R232	0.5	1.8	R329	15.4	2.8	R416	11.0	4.0	U206	1.0	1.4
C201	1.1	2.6	C314	7.1	3.6	C414	10.2	3.9	D324	12.1	3.3	R11	8.5	2.6	R234	1.1	2.7	R330	14.8	4.2	R419	12.9	3.2	U301	7.6	3.4
C202	0.5	0.9	C315	6.7	3.9	C415	10.2	3.8	D325	12.1	3.4	R12	9.1	3.8	R235	0.0	3.2	R331	15.4	2.9	R420	14.1	3.4	U302	15.4	3.6
C203	10.6	0.0	C316	7.1	4.0	C416	15.4	3.5	D326	3.4	4.5	R13	9.7	3.7	R236	10.4	2.3	R332	14.0	3.6	R421	13.5	3.0	U303	10.9	2.8
C204	7.1	0.0	C317	12.1	3.7	C418	7.9	1.9	F1	10.4	2.1	R15	10.1	2.8	R237	2.8	3.8	R333	12.1	3.8	R422	10.9	1.7	U304	13.1	3.6
C206	4.1	1.8	C318	13.5	3.5	C420	9.1	1.9	F2	10.4	2.0	R16	8.6	3.3	R238	3.0	3.1	R334	13.7	3.9	R423	10.9	1.9	U305	12.9	2.4
C207	1.6	0.6	C319	12.8	3.5	C421	7.5	0.7	F201	5.3	0.1	R18	10.7	0.8	R239	0.5	1.7	R336	12.2	4.0	R424	9.7	2.3	U306	5.5	1.3
C208	1.6	1.8	C320	13.0	2.5	C422	8.2	0.6	F202	15.4	2.5	R19	10.4	1.8	R240	10.3	0.7	R337	14.8	2.5	R427	9.7	4.8	U307	14.6	2.9
C209	2.3	4.8	C321	12.0	3.9	C425	7.1	3.4	J3	5.4	0.6	R20	7.3	2.2	R241	0.0	1.2	R338	12.7	3.8	R428	9.4	4.8	VR201	10.9	2.4
C210	0.5	2.3	C322	15.4	3.1	C427A	15.8	3.3	J102	11.0	2.2	R21	6.8	2.1	R242	0.6	0.6	R339	13.7	3.7	R429	9.9	4.8	VR302	9.1	3.4
C211	1.6	4.4	C323	12.9	3.3	C427B	15.8	4.1	J103	11.3	0.0	R22	6.4	2.3	R244	0.5	1.0	R340	13.7	4.0	R430	5.8	2.5	VR304	9.8	2.9
C212	1.1	3.9	C324	15.4	3.3	C428	12.0	4.7	J301	0.8	0.7	R23	6.8	3.0	R245	0.0	0.7	R341	13.2	4.0	RT301	8.0	2.7	VR305	12.1	3.2
C213	2.9	2.2	C325	15.4	4.2	C429	5.7	4.9	J302	6.3	2.9	R24	10.7	1.0	R246	0.5	0.5	R342	11.0	3.5	S3	12.4	2.7	W1	3.4	3.7
C214	2.3	4.1	C326	15.4	3.2	C430	9.8	4.5	K201	8.0	0.4	R25	5.6	0.5	R247	0.5	1.4	R343	12.1	3.0	S201	0.1	0.0	W2	9.1	0.3
C215	1.5	3.3	C327	14.3	4.1	C431	14.7	3.3	L1	9.1	0.4	R26	12.5	2.9	R249	0.5	1.1	R344	13.6	3.2	T201	4.7	2.5	W3	4.4	3.9
C217	1.5	2.8	C328	11.0	2.8	C432	9.8	1.7	L201	2.6	0.1	R27	8.6	3.9	R250	3.9	0.5	R345	11.0	3.0	T202	3.2	2.7	Y1	8.4	0.3
C218	5.0	1.1	C329	14.1	3.3	C433	13.5	2.9	L202	4.7	0.3	R28	7.1	4.4	R301	4.4	4.0	R346	12.2	3.6	U1	8.6	0.7			
C219	1.1	2.5	C330	11.0	3.9	C434	13.1	2.7	L203	2.1	0.0	R29	8.5	0.5	R302	3.7	4.0	R347	14.2	3.4	U2	6.7	0.4			





# Manual Backdating

This section describes changes that must be made to the manual so that it applies to power modules with older serial number formats. Look for the serial number of your module on the table and make only those changes listed for that serial number.

Keysight Model	Prefix Number	Serial Number	Make Changes	Keysight Model	Prefix Number	Serial Number	Make Changes
66101A	3444A	03900-03271	1	66103A	3151A	00155-00149	1,5-7
	3444A	03270-01394	1,4		3147A	00148-00141	1,5-8
	3421A	01393-01354	1,4		3139A	00140-00101	1,5-8,10
	3231A	00516-00360	1,4,5	66104A	3445A	02435-01778	1
	3151A	00359-00151	1,4-6		3445A	01777-00840	1,2
	3147A	00150-00141	1,4-9		3421A	00839-00795	1-3
	3139A	00140-00101	1,4-10		3306A	00421-00395	1-3,5
66102A	3421A	05364-04131	1	3207A	00394-00101	1-3,5,11	
	3226A	00597-00420	1,5	66105A	3421A	01030-00811	1
	3204A	00419-00195	1,5,6		3421A	00810-00403	1,2
	3151A	00194-00153	1,5-7		3218A	00215-00126	1,2,5,12
	3147A	00152-00141	1,5-9	3207A	00126-00101	1,2,5,12,13	
	3139A	00140-00101	1,5-10	66106A	3421A	00927-00761	1
66103A	3421A	04175-03501	1		3421A	00760-00369	1,2
	3226A	00444-00273	1,5		3207A	00222-00101	1,2,5
	3204A	00272-00156	1,5,6				

- CHANGE 1:** In the parts list on page 78 and in the table on schematic sheet 3 of 5, change the part number of U2 to 5080-2235 and U6 to 5080-2237.
- CHANGE 2:** In the parts list on page 79, change the part number of U301 to 1826-0346.
- CHANGE 3:** In the parts list on page 73 and in the table on schematic sheet 3 of 5, change R301 and R302 to 25 ohms , part number 0811-3890.  
In the parts list on page 68 and in the table on schematic sheet 3 of 5, change C301 to 1500pF, part number 0160-7638.  
In the parts list on page 71, change the part number of D301, 303, 304 and 326 to 1901-1199.
- CHANGE 4:** In the parts list on page 77 and in the table on schematic sheet 3 of 5, change R360 to zero ohms, part number 8159-0005.  
In the parts list on page 70 and in the table on schematic sheet 3 of 5, change C335 to 2200pF, part number 0160-4830.  
In Table 2-1 on page 13, change the maximum programmable overvoltage to 9.6V.  
In the program listing on page 52, change line 240 to read:  
DATA 66,4,25,9.25002,9.6,0,255,100,20,66101
- CHANGE 5:** In the parts list on page 62, change the part number of the power boards from 6610xA-61022 to 6610xA-61020.
- CHANGE 6:** In the parts list on page 75, change the part number of the output connector board from 5060-3470 to 5060-3350.
- CHANGE 7:** In the parts list on page 74, delete bumper foot, part number 0403-0086. Indicate that software revision A.00.02 applies to these and earlier models.
- CHANGE 8:** In the parts list on page 65, change L204 through L211 from part number 5080-2251 to 9170-0442.

- CHANGE 9:** On page 67, change R204, R214 to 61.8 ohms, part number 0757-0397. On page 65, delete D216, D217, part number 1901-1214.
- CHANGE 10:** Indicate that software revision A.00.01 applies to these and earlier models.
- CHANGE 11:** In the parts list on page 63, change C311 from 0160-4831 to 2200pF, part number 0160-4830. On page 68, change R311 from 0757-0349 to 51.1K part number 0757-0458.
- CHANGE 12:** In the parts list on page 68, change R308 from 249K to 200K part number 0757-0472. Delete R309.
- CHANGE 13:** In the parts list on page 63, change C303 from 0180-3648 to 0180-4497. On page 71, change R348 from 17.8K to 12.1K part number 0757-0444. Delete R333.

# Index

## B

backdating ..... 89

## C

component locator ..... 83  
constant current (cc) tests ..... 15  
constant voltage tests ..... 13  
current monitoring ..... 12

## D

disassembly  
    bias board ..... 57  
    cover ..... 56  
    fan ..... 56  
    front panel ..... 57  
    front panel board ..... 57  
    modules ..... 56  
    power board ..... 57  
documents - related ..... 8

## E

electrostatic discharge ..... 9  
equipment ..... 9

## I

initialization ..... 51  
installing  
    bias board ..... 59  
    cover ..... 59  
    fan ..... 59  
    front panel board ..... 59  
    power board ..... 58

## M

mainframe ..... 7

## P

parts  
    Bias board - electrical ..... 79  
    Front Panel board - electrical ..... 79  
    mechanical ..... 80  
    output connector ..... 81  
Power board - electrical ..... 68

performance tests.....	11
programming values - modules.....	12

**R**

revision number.....	8
run-time error message.....	26

**S**

S3 switch settings.....	49
schematic	
notes.....	84
schematics.....	83
bias board.....	83
connector board.....	83
front panel board.....	83
power board.....	83
relay board.....	83
selftest failure.....	26
serial number.....	8
service manual.....	8
shock hazard.....	25
switch setting waveforms.....	50

**T**

test points.....	48
test record - 66101A.....	18
test record - 66102A.....	19
test record - 66103A.....	20
test record - 66104A.....	21
test record - 66105A.....	22
test record - 66106A.....	23
theory.....	61
ac input.....	61
bias supplies.....	61
CC DAC.....	61
CCPROG*.....	62
CV DAC.....	61
CVPROG*.....	62
downprogrammer.....	64
FETS.....	64
IMON.....	63, 64
isolation transformer.....	64
microprocessor.....	61
OR Gates.....	63
OV comparator.....	65
readback multiplexer.....	64
turn-on.....	61
VCNTRL.....	63
VMON.....	63, 64
tools.....	9
troubleshooting.....	25
cc accuracy.....	43

cv accuracy.....	42
DAC .....	45
downprogrammer .....	44
error messages.....	32
flowcharts.....	25
high output .....	40
microprocessor.....	30
no output .....	35
no overvoltage.....	27
overall.....	27
overvoltage.....	33
readback .....	46
Troubleshooting	
EEPROM .....	51
<b>V</b>	
verification tests .....	11



This information is subject to change without notice.  
© Keysight Technologies 1993, 2000, 2014  
Edition 2, December 2014



5959-3364

[www.keysight.com](http://www.keysight.com)