

Spares

FORT VALE

UK Tel : +44 (0)1282 687100
UK Fax : +44 (0)1282 687110
sales@fortvale.com

NL Tel : +31 180 483333
NL Fax : +31 180 410797
bvsales@fortvale.com

FOR SPARES



www.fortvale.com

**Worldwide Aftermarket
Care and Support**

INDEX

	Page No.	Ref.
ANCILLARIES		
BLANK CAPS & COUPLINGS		
Express Couplings – Stainless Steel	22	SPA043
Threaded Blank Caps	1	SPA032
TW Couplings	2	SPA048
BURSTING DISCS	3	SPA033
CABLE	4	SPA047
CATWALKS	4	SPA047
DATA PLATES	4	SPA047
DOCUMENT HOLDERS	5	SPA041
FLAMEPROOF GAUZES	5	SPA041
FLANGES		
Adaptor flanges	6	SPA037
Blind flanges	7	SPA036
Outlet flanges	6	SPA037
Weld-in flanges	7	SPA036
GASKETS & SEALS		
Manlid Packing and Seals	8	SPA038
Valve Gaskets	9	SPA006
Valve Main Seals & O Rings	8	SPA038
Valve Seal Kits	10	SPA039
GAUGES		
Pressure Gauges	11	SPA046
Temperature Gauges	11	SPA046
SWINGBOLT ASSEMBLIES	12	SPA034
TEST RIG, TOOL KITS & MAINTENANCE MANUALS	13	SPA035
BALL VALVES		
BSP Female Socket Ball Valves	14	SPA040
1½" Airline Ball valve Installation Details	15	SPA042
1½" BSP to DIN flange Airline Ball valve conversion kits	15	SPA042
1½" BSP Blacko Airline Ball valve	16	SPA005
1½" Dual Fitting Blacko Airline Ball valve	16	SPA005
1½" Flanged Blacko Airline Ball valve	17	SPA014
2" Blacko Ball valve – 2" BSP Outlet	18	SPA017
2" Blacko Ball valve – Slotted 4 hole Outlet	19	SPA049
3" Blacko Ball valve – 3" BSP Outlet	20	SPA015
3" Blacko Ball valve – Slotted 4 hole Outlet	21	SPA016



INDEX

	Page No.	Ref.
BUTTERFLY VALVES		
2" Airline Butterfly valve Installation Details	22	SPA043
2" BSP Airline Butterfly valve	23	SPA009
2" Clamped Butterfly valve	24	SPA012
2" Flanged Airline Butterfly valve	25	SPA010
3" Clamped Butterfly valve	26	SPA003
3" Flanged Butterfly valve	27	SPA004
3" Flanged Butterfly valve – Top Discharge Installation Details	28	SPA044
3" Tankpro Butterfly valve	29	SPA011
4" Clamped Butterfly valve	30	SPA013
TW80 Butterfly valve	31	SPA007
TW100 Butterfly valve	32	SPA008
FOOTVALVES		
3" 30° & 45° Cleanflow Footvalve	33	SPA001
3" 30° & 45° MKII Highlift Footvalve	34	SPA002
3" 45° MKIII Highlift Footvalve	35	SPA053
3" 45° Pneumatic Cleanflow Footvalve	36	SPA018
3" 30° & 45° Uniflow Discharge Assembly	37	SPA051
3" 30° & 45° Univalve Discharge Assembly	38	SPA050
4" 90° Pneumatic Cleanflow Footvalve	39	SPA052
GAS		
2" Short Profile Footvalve for compressed liquefied gas	40	SPA029
3" to 2" Liquid Phase Short Profile Footvalve	41	SPA030
80mm Internal Gas Relief Valve	42	SPA028
80mm Internal Gas Relief Valve & Bursting Disc Holder	43	SPA027
ACME Outlet Assemblies – 1.75" & 3.25"	44	SPA031
RELIEF VALVES		
Minnow Relief Valve – 1" BSP Pressure Only	45	SPA026
Steam Valves - 3/4" BSPT Tell Tale & 3/4" BSPT Relief Valve	46	SPA025
Super Maxi Relief Valve - 2 1/2" BSP	47	SPA019
Super Maxi Relief Valve – 80mm Flanged Pressure Only	48	SPA021
Super Maxi Relief Valve – 80mm Flanged Pressure/Vacuum	49	SPA020
Twinact Relief Valve – 2 1/2" BSP Pressure Only	50	SPA023
Twinact Relief Valve – 2 1/2" BSP Pressure/Vacuum	51	SPA022
Uniact Relief Valve – 1 1/2" BSP Vacuum Only/1 1/2" Pressure Only	52	SPA024



Threaded Blank Caps

A range of stainless steel check caps is also available. The part numbers have a **'CK'** suffix instead of the 'PS'.

Please contact our Sales team if the size or material you require is not listed below.

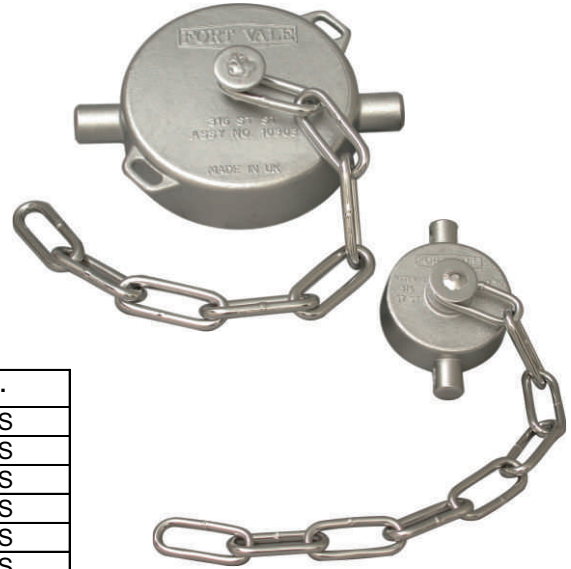

BSP - Stainless Steel

Description	Part No.
½" BSP stainless steel cap with wire & PTFE washer	10316PS
¾" BSP stainless steel cap with chain & PTFE washer	10306PS
1" BSP stainless steel cap with chain & PTFE washer	10305PS
1½" BSP stainless steel cap with chain & PTFE washer	10300PS
2" BSP stainless steel cap with chain & PTFE washer	10301PS
2½" BSP stainless steel cap with wire & PTFE washer	10302PS
3" BSP stainless steel cap with chain & PTFE washer	10303PS
4" BSP stainless steel cap with wire & PTFE washer	10304PSC

BSP - Aluminium

Description	Part No.
¾" BSP aluminium cap with chain & leather washer	10706AL
1" BSP aluminium cap with chain & leather washer	10707AL
1½" BSP aluminium cap with chain & leather washer	10708AL
2" BSP aluminium cap with chain & leather washer	10709AL
2½" BSP aluminium cap with chain & leather washer	10710AL
3" BSP aluminium cap with chain & leather washer	10711AL

NPT

Description	Part No.
1½" NPT stainless steel cap with chain and Teflon washer	10300NPTP
2" NPT stainless steel cap with chain and Teflon washer	10301NPTP
3" NPSL stainless steel cap with chain and Teflon washer	425/3240
3" NPT aluminium cap with brass chain and leather washer	10711NPT

Washers

Description	Part No. LEATHER	Part No. PTFE
½" washer	-	10335P
¾" washer	10331L	10331P
1" washer	10319L	10319P
1½" washer	10326L	10326P
2" washer	10327L	10327P
2½" washer	10328L	10328P
3" washer	10329L	10329P

TW Couplings

TW Couplings are produced to EN 14420-6:2004 and are available in 50mm (2"), 80mm (3") and 100mm (4").



Male Connection

Description	Part No.
VK50 coupler in stainless steel	90/TWVK50SS
VK80 coupler in stainless steel	90/TWVK80SS
VK100 coupler in stainless steel	90/TWVK100SS

Caps

Description	Part No.
MB50 cap in stainless steel	90/TWMB50SS
MB80 cap in stainless steel	90/TWMB80SS
MB100 cap in stainless steel	90/TWMB100SS

Associated Parts

Main gasket to suit female coupler.

Description	Part No.
50mm CSM gasket	5005-TWMK50HYP
80mm CSM gasket	5005-TWMK80HYP
100mm CSM gasket	5005-TWMK100HYP
50mm natural black rubber gasket	5005-TWMK50NBR
80mm natural black rubber gasket	5005-TWMK80NBR
100mm natural black rubber gasket	5005-TWMK100NBR

Thread seal.

Description	Part No.
50mm PTFE seal	5005-TW50PTFE
80mm PTFE seal	5005-TW80PTFE
100mm PTFE seal	5005-TW100PTFE

Female Connection

Description	Part No.
MK50 coupler in stainless steel	90/TWMK50SS
MK80 coupler in stainless steel	90/TWMK80SS
MK100 coupler in stainless steel	90/TWMK100SS

Plugs

Description	Part No.
VB50 plug in stainless steel	90/TWVB50SS
VB80 plug in stainless steel	90/TWVB80SS
VB100 plug in stainless steel	90/TWVB100SS

Bursting Discs

Our range includes stocks of standard 65mm, 65mm XL and 80mm discs as well as more specialised discs for Gas Relief Valves (89mm) and Hydrogen Peroxide applications (250mm).

We can offer the following types:

- Forward Acting - cross scored solid metal disc
- Forward Composite - multi-layered (composite) disc, for settings of less than 3.67 Bar
- Reverse Acting disc
- Standard 250mm disc

NOTE: Fitting a bursting disc derates the flow capacity of the valve. For deration factors, please contact Fort Vale.



Part Number	Type	Set to burst at
General Purpose Tank Containers / Road Tankers		
862/X0228	65mm XL	2.28 Bar @ 20°C
862/X0241	65mm XL	2.41 Bar @ 20°C
862/X0269	65mm XL	2.69 Bar @ 20°C
862/X0310	65mm XL	3.10 Bar @ 20°C
862/X0367	65mm XL	3.67 Bar @ 20°C
862/X0410	65mm XL	4.10 Bar @ 20°C
862/X0440	65mm XL	4.40 Bar @ 20°C
862/X0484	65mm XL	4.84 Bar @ 20°C
Compressed Liquefied Gas Tanks		
864/X1210	89mm Reverse Acting	12.10 Bar @ 55°C
864/X1500	89mm Reverse Acting	15.00 Bar @ 55°C
864/X2200	89mm Reverse Acting	22.00 Bar @ 55°C
864/X2750	89mm Reverse Acting	27.50 Bar @ 55°C
864/X3450	89mm Reverse Acting	34.50 Bar @ 55°C
Hydrogen Peroxide		
865/1200	250mm Std	4.50 Bar @ 20°C
865/1250	250mm Std	4.50 Bar @ 60°C
865/1400	250mm Std	6.00 Bar @ 20°C

"X" in the above part numbers indicates a variable.
Please contact our Sales Team for more information.

Catwalks

Non-slip design to allow safe working in almost all environmental conditions. Profiled surface promotes efficient drainage of liquids such as oil or grease. Easy and quick to assemble. Manufactured in ALMG3 aluminium.

Dimensions "A" x "B" x "C" x Length	Part No.
240 x 40 x 2.5 x 5800mm	BV24040
300 x 40 x 2.5 x 5800mm	BV30040
400 x 40 x 2.5 x 5800mm	BV40040
400 x 50 x 2.5 x 5800mm	BV40050
400 x 75 x 2.5 x 5800mm	BV40075
480 x 40 x 2.5 x 5800mm	BV48040
480 x 50 x 2.5 x 5800mm	BV48050
480 x 65 x 2.5 x 5800mm	BV48065
480 x 75 x 2.5 x 5800mm	BV48075

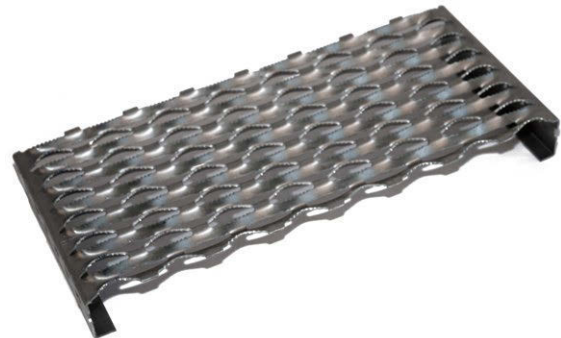
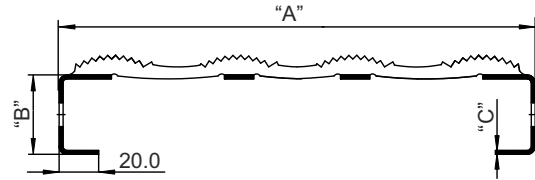

Other types available on request.

Associated Parts

Description	Part No.
Catwalk olives (pack of 50)	BV5020

Data Plates

Description	Part No.
Manufacturer Combined APP/CSC	324/0000
Approved Under Customs Seal	324/0001
CSC Safety Approval	324/0002
Manufacturer	324/0003

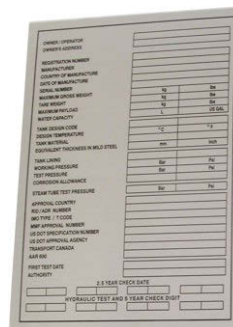

Stainless Steel Cable

Suitable for remote control assemblies and securing dust caps, blank caps, plugs etc. Supplied in rolls of 100 metres.

Description	Part No.
2mm x 100m roll	6110-110
3mm x 100m roll	6110-111
4mm x 100m roll	6110-112

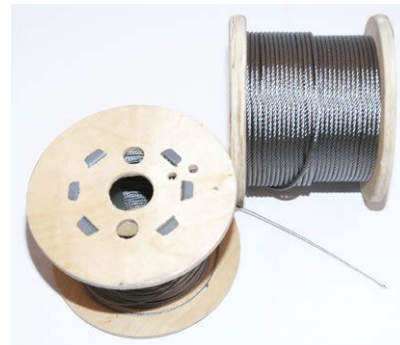

Document Holders

Description	Part No.
75mm plastic document holder with st.st. cap retaining wire, plastic brackets	360/1101
75mm clear plastic document holder with st.st. cap retaining wire, plastic brackets	360/1101T
75mm plastic document holder with st.st. cap retaining wire and brackets	360/1101ABSS
75mm clear plastic document holder with st.st. cap retaining wire and brackets	360/1101TBSS
110mm plastic document holder with st.st. cap retaining wire, plastic brackets	460/1101
110mm clear plastic document holder, st.st. cap retaining wire, plastic brackets	460/1101T
110mm plastic document holder with st.st. cap retaining wire and brackets	460/1101ABSS
110mm clear plastic document holder with st.st. cap retaining wire and brackets	460/1101TBSS



Associated Parts

Description	Part No.
75mm PVC cap with stainless steel cable	360/1010
110mm PVC cap with stainless steel cable	460/1010
75mm fixing bracket – plastic	360/1007
75mm fixing bracket – stainless steel	360/1007SS
110mm fixing bracket – plastic	460/1007
110mm fixing bracket – stainless steel	460/1007SS

Clamped Gauze Rings

Clamped gauze rings are available for our 1", 1½", 2½", 65mm and 80mm relief valves. A clamped gauze fits around the valve body ports and offers flame protection to valves with a vacuum setting of 0.21 Bar (6"Hg) and above. For valves with a vacuum setting of less than 0.21 Bar, a clamped gauze is often fitted to provide dust protection.

Description	Part No.
Clamped gauze – 1" Minnow valves	179/0300
Clamped gauze – 1½" Twinact valves	200/5000
Clamped gauze – 2½" Twinact valves	130/5000
Clamped gauze – 2½"/65mm Super Maxi valves *	176/2900
Clamped gauze – 80mm Hyper Maxi 043/series & 049/series only *	176/2920



Fitting a clamped gauze to a Minnow or a Twinact relief valve reduces the valve flow rate.

Fitting clamped gauze 176/2900 to a 65mm Super Maxi relief valve reduces the valve flow rate by 1%.

Fitting clamped gauze 176/2920 to an 043/series or 049/series 80mm Hyper Maxi relief valve reduces the valve flow rate by 5.4%.

* Please note that the 176/2900 and 176/2920 are NOT interchangeable. For further advice, please contact our Sales Department.

Flanges



Adaptor Flanges



Adaptor Flange to suit :	No. holes	Hole Ø (mm)	PCD (mm)	Drilling Spec.	Part No.
Top discharge butterfly valve	8	18 & M16	160	DIN80	S0404
2½" BSP Relief valve	4	14	130	DIN65 PN6	176/3000
2½" BSP Relief valve	4	18	145	DIN65 PN10	176/3091
2½" BSP Relief valve	6	11	105	-	176/7001
2½" BSP Relief valve/burst disc	6	M10	105	-	176/7002
1½" BSP Relief valve/burst disc	6	11	105	-	176/7085
3" bottom discharge mating flange	4	18	160	DIN80	294/0081
Top discharge syphon tube	6	14	168	-	368/0810
1½" BSP airline ball valve	4	18	110	DIN40	530/ADAP40
1½" BSP airline ball valve	4	18	125	DIN50	530/ADAP50
4" bottom discharge mating flange	8	18	180	DIN100 PN10	875/4150



S0404



176/3000



176/3091



176/7001



176/7002



176/7085



294/0081



368/0810



875/4150



530/ADAP40 & 530/ADAP50
 (For kit including adaptor flange, bent handle, gasket, blind flange & bolting kit, see SPA042)

Outlet Flanges



Outlet Flange description	No. holes	Hole Ø (mm)	PCD (mm)	Drilling Spec.	Part No.
¾" ACME extended thread, gauge tap	4	18	125	DIN50 PN10	252/2058EX
3" BSPM thread	4	19 (slots)	146 to 160	-	368/8010
3" BSPM eccentric spigot	4	18	160	DIN80	368/8047
3" Camlock	4	17 (slots)	146 to 160	3" BSTD	368/8058



252/2058EX



368/8010



368/8047



368/8058

Flanges

Blind Flanges

Blind Flange to suit :	No. holes	Hole Ø (mm)	PCD (mm)	Drilling Spec.	Part No.
Top discharge tank pad (368/0800)	6	14	168	-	S0206CM
Relief valve tank pad (176/3150)	6	11	105	-	176/3160CM
Top/bottom discharge	4	18	160	DIN80	312/0022CM
Top/bottom discharge	4	18 SLOT	146 to 160	DIN80/3"ASA	360/8066
Airline connection	4	18	125	DIN50 PN10	370/4239CM
Flanged airline ball valve e.g. 530/1200	4	18	110	DIN40 PN10	530/8053CM



S0206CM



176/3160CM



312/0022CM



360/8066



370/4239CM



530/8053CM

Weld-in Flanges

Weld-in Flange to suit :	No. holes	Hole Ø (mm)	PCD (mm)	Drilling Spec.	Part No.
Flanged Maxi relief valve – 3" ASA 150	4	M16	152	3"ASA 150	S0604
2½" BSP Threaded Maxi relief valve	6	M10	105	-	176/3166
45° Footvalve	8	M12	178	3½"ASA 150	324/9000



S0604



176/3166



324/9000

LASER Etching

Please note that Fort Vale are happy to customise flanges by laser etching with **your company logo**. Please contact us for further details.

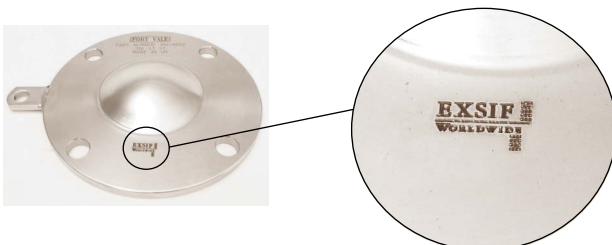

Valve Main Seals and O Rings



Please contact our Sales team if the size or material you require is not listed below.

Valve Main Seals



Description	Part No.
1½" Blacko airline ball valve PTFE front seal	5005-006
1½" Blacko airline ball valve PTFE rear seal	5005-007
2" Blacko ball valve PTFE front/rear seal	370/0102
2" Widdop airline butterfly valve PTFE main seal	355/0202
2½" BSP Maxi Highflow relief valve Tytan seal – Fortyt/EPDM (00/6XXXX series)	176/0052
3" Blacko ball valve PTFE front seal	20399
3" Blacko ball valve PTFE rear seal	11470
3" Widdop butterfly valve PTFE main seal	368/0002
3½" Emmott Screwdown valve PTFE main seal disc	269/1003



Valve O Rings



Description	Part No.
EPDM O ring – 3" Butterfly valve clamping plate	5005-476
Fortyt 3" footvalve main O ring / 80mm Flgd Super Maxi	5005-104
Fortyt 2½"/65mm relief valve pressure O ring	5005-101
Fortyt Super Maxi relief valve vacuum O ring	5005-108H
EPDM O ring – 2" Butterfly valve clamping plate	5005-664
PFA spindle O ring – Cleanflow footvalve	5005-384
PTFE spindle O ring – Butterfly valve / Highlift footvalve	20363
PTFE spindle O ring – Cleanflow footvalve	5005-008
Viton 3" footvalve main O ring	5005-105
Viton 2½" relief valve pressure O ring	5005-102
Viton spindle O ring – Butterfly valve / Highlift footvalve	20361
Viton spindle O ring – Cleanflow footvalve	5005-336

Manlid Packing & Seals



Manlid Packing & Ancillaries



Description	Part No.
14x10x1650mm - silicone core - Non gas tight	5005-1410S165
15x10x1650mm - silicone core - Non gas tight	5005-1510S165
14x14x1650mm - without silicone core - Non gas tight	5005-1414D165
14x14x1650mm - silicone core - Non gas tight	5005-1414S165
14x14mm x 50 metre - silicone core - Non gas tight	5005-1414SR50
15x15x1650mm - silicone core - Non gas tight	5005-1515S165
16x16x1750mm - silicone core - Non gas tight	5005-1616S175
16x16mm x 30 metre - silicone core - Non gas tight	5005-1616SR30
14x14x500mm braided PTFE impregnated fibre with silicone core - Non gas tight – Jointed	5005-50P/A
Ancillaries	
Mitre seal cutter – ideal for braided PTFE packing	400/3100



Manlid Seals



Description	Part No.
300mm Sweet white rubber seal – FDA compliant	5005-30SWR
500mm Sweet white rubber seal – FDA compliant	5005-50SWR
300mm Super Tanktyt - PTFE outer/Nitrile inner	5005-890
- PTFE outer/EPDM inner	5005-890EP
500mm Super Tanktyt - PTFE outer/Nitrile inner	5005-860
- PTFE outer/EPDM inner	5005-860EP

Valve Gaskets

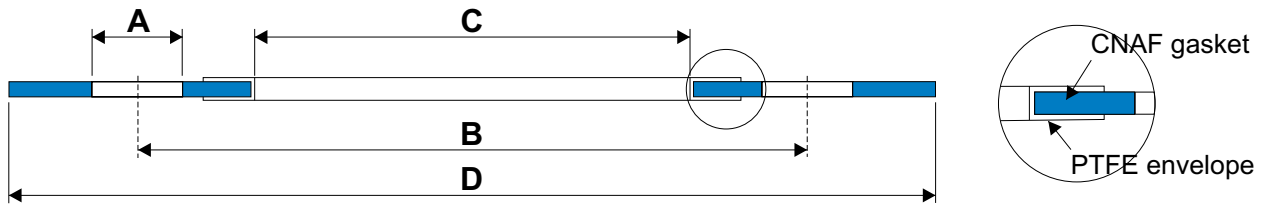

Part No.	Material	No. of holes	A Hole Ø	B PCD	C Internal Ø	D External Ø	To fit
5005-015	CNAF/PTFE	8	14mm	178mm	114mm	203mm	45°/90° Cleanflow/Highlift footvalve inlet
5005-016	CNAF/PTFE	6	14mm	159mm	127mm	184mm	Parkfield footvalve inlet
5005-023	CNAF/PTFE	4	18mm	172mm	127mm	203mm	3" top discharge valve/30° footvalve inlet
5005-032	CNAF/PTFE	4	19mm	178mm	114mm	216mm	30° footvalve inlet
5005-036	SOLID PTFE	4	18mm	146mm	80mm	184mm	3" BSTD
5005-046	Black rubber /PTFE	-	-	-	75mm	90mm	2½" BSP relief valve tank seal
5005-049	CNAF/PTFE	-	-	-	78mm	112mm	3" clamped butterfly valve inlet
5005-052	CNAF/PTFE	-	-	-	78mm	142mm	3" clamped butterfly valve inlet
5005-055	CNAF/PTFE	4	17mm	114mm	55mm	152mm	2" BSTE
5005-169	CNAF/PTFE	6	13mm Not equi-spaced	168mm	78mm	197mm	3" flanged butterfly/3" ball valve inlet
5005-177	CNAF/PTFE	4	18mm	172mm	136mm	203mm	3" top discharge ball valve inlet
5005-191	CNAF/PTFE	-	-	-	75mm	90mm	2½" BSP relief valve tank seal
5005-193	SOLID PTFE	4	14mm	98mm	50mm	127mm	1.5"ASA 150 / 1.5" BSTD
5005-195	CNAF/PTFE	4	18mm	160mm	89mm	144mm SQUARE	3" clamped butterfly valve outlet
5005-222	CNAF/PTFE	6	14mm Not equi-spaced	168mm	102mm	203mm	3" top discharge butterfly valve inlet
5005-288	SOLID PTFE	4	18mm	152mm	78mm	184mm	3" ASA 150
5005-345	SOLID PTFE	6	11mm	119mm	89mm	140mm	3" composite butterfly valve outlet
5005-348	SOLID PTFE	4	18mm	110mm	37mm	152mm	1½" flanged airline ball valve outlet
5005-360	SOLID PTFE	4	18mm	125mm	49mm	165mm	2" flanged airline butterfly valve inlet
5005-361	SOLID PTFE	4	18mm SLOTS	114mm MINIMUM	50mm	165mm	2" flanged airline butterfly valve outlet
5005-398	CNAF/PTFE	6	11mm	105mm	75mm	127mm	2½" flanged relief valve tank pad
5005-417	SOLID PTFE	4	18mm SLOTS	146mm MINIMUM	83mm	190mm	3" flanged butterfly/ball valve outlet - 3"ASA/BSTD/DIN 80
5005-427	CNAF/PTFE	4	18mm SLOTS	146mm MINIMUM	83mm	190mm	3" flanged butterfly/ball valve outlet - 3"ASA/BSTD/DIN 80
5005-490	CNAF/PTFE	-	-	-	89mm	142mm	3" clamped butterfly valve outlet
5005-500	SOLID PTFE	4	11mm	100mm	50mm	95mm SQUARE	2"BSP butterfly valve inlet
5005-875	CNAF/PTFE	4	18mm	146mm	89mm	184mm	3" clamped butterfly valve outlet – 3" BSTD

NOTE : ALL DIAMETERS ARE NOMINAL

Valve Seal Kits

Please contact our Sales team if the size or material you require is not listed below.

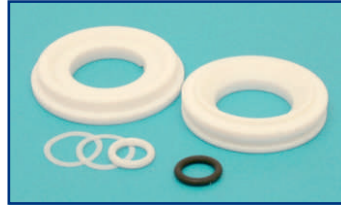
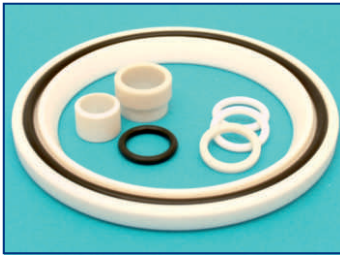

Seal Kit to suit :	Part No.
BALL VALVES	
1½" Blacko airline ball valve (350/ series)	350/00SK
1½" Blacko airline ball valve (530/ series)	530/00SK
1½" Blacko airline ball valve front & rear seal kit	350/0BSK
2" Blacko ball valve	370/015SK
3" Blacko ball valve – (360/ series and 362/ series)	360/00SK
3" Blacko ball valve – (360/5 series)	360/50SK
BUTTERFLY VALVES	
2" Widdop airline butterfly valve (535/ series)	535/00SK
2" Widdop clamped butterfly valve (355/ series)	355/70SK
3" & TW80 Widdop clamped & flanged butterfly valve	368/00SK
3" Tankpro Road Tanker butterfly valve	368/94SK
4" & TW100 Widdop clamped butterfly valve	468/00SK
FOOTVALVES	
3" 30°, 45° & 90° Cleanflow footvalve	845/00SK
3" 45° Pneumatic Cleanflow cylinder – ref. 844/2190 *	844/21SK
ref. 844/2110	844/2110SK
ref. 844/2210 **	
3" 30° & 45° Highlift footvalve	826/00SK
GAS EQUIPMENT	
2" gas ball valve	370/33SK
2" excess flow valve (252/XXXX , 888/252XXX early models)	252/35SK
2" excess flow valve (888/252XXX later models, 802/XXXX)	252/50SK
3" excess flow valve (253/XXXX , 888/252XXX early models)	253/35SK
3" excess flow valve (888/252XXX later models, 803/XXXX)	253/50SK
80mm internal gas relief valve	006/00SK
80mm internal gas relief valve & burst disc holder	005/00SK
RELIEF VALVES	
2½" BSP Super Maxi relief valve – pressure/vacuum	000/1PVSK
2½" BSP Super Maxi relief valve – pressure only	000/1PSK
2½" BSP Twinact relief valve – pressure/vacuum/Fortyt	20/1PVSK
2½" BSP Twinact relief valve – pressure/vacuum/Viton	20/0PVSK
2½" BSP Twinact relief valve – pressure only/Fortyt	20/1PSK
2½" BSP Twinact relief valve – pressure only/Viton	20/0PSK
80mm flanged Super Maxi relief valve – pressure/vacuum	000/1PVSK80
80mm flanged Super Maxi relief valve – pressure only	000/1PSK80



844/2190 *

844/2110
844/2210 **

Gauges



Pressure Gauges



Description	Part No.
0-6 Bar (0-90 PSI) Pressure Gauge, 1/4" BSP connection, brass internals, glycerine filled.	921/06BBSP
0-6 Bar (0-90 PSI) Pressure Gauge, 1/4" BSP connection, st.st. internals, glycerine filled.	920/06BBSP
0-10 Bar (0-150 PSI) Pressure Gauge, 1/4" BSP connection, brass internals, glycerine filled.	921/10BBSP
0-10 Bar (0-150 PSI) Pressure Gauge, 1/4" BSP connection, st.st. internals, glycerine filled.	920/10BBSP



Tell-Tale Pressure Gauges



Description	Part No.
Pressure gauge with Tell-Tale Pointer 0-6 Bar (0-90 PSI), 1/4" BSP connection, brass internals, glycerine filled.	921/06TTBBSP
Pressure gauge with Tell-Tale Pointer 0-6 Bar (0-90 PSI), 1/4" BSP connection, st.st. internals, glycerine filled.	920/06TTBBSP
Pressure gauge with Tell-Tale Pointer 0-10 Bar (0-150 PSI), 1/4" BSP connection, brass internals, glycerine filled.	921/10TTBBSP
Pressure gauge with Tell-Tale Pointer 0-10 Bar (0-150 PSI), 1/4" BSP connection, st.st. internals, glycerine filled.	920/10TTBBSP
Pressure gauge with Tell-Tale Pointer 0-16 Bar (0-230 PSI), 1/4" BSP connection, st.st. internals, glycerine filled.	920/16TTBBSP



Temperature Gauge



Description	Part No.
Analogue Temperature Gauge with 2500mm capillary. Silicone oil filled. Range : -20°C to 200°C / -4°F to 392°F	922/TEMP200
Analogue Temperature Gauge with 2500mm capillary. Silicone oil filled. Range : -20°C to 160°C / -4°F to 320°F	922/TEMP160
Analogue Temperature Gauge with 250mm st/st tube & brass thermo well probe. Range : -20°C to 200°C / -4°F to 392°F	922/TEMPT200
Analogue Temperature Gauge with 250mm st/st tube & brass thermo well probe. Range : -20°C to 160°C / -4°F to 320°F	922/TEMPT160
Digital Temperature Gauge with 2500mm capillary. Range : -50°C to 200°C / -58°F to 392°F	922/TEMPDIGI

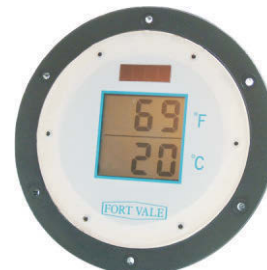

Please note that the temperature ranges apply to the capillary/probe only.

Swingbolt Assemblies



Eyebolt with 16mm or 3/4" eye (Dimension A) x 3/4" BSW (Dimension B) x length from centre of eye to end of bolt (Dimension C). Manufactured in Stainless Steel. Fitted with M8 grubscrew. Supplied with swingbolt hinge pin and captivated handnut (see below for options)

Standard handnuts :

- low profile stainless steel
- low profile naval brass with stainless steel thrust washer
- stainless steel "Anti-Galling" handnut (brass thread)

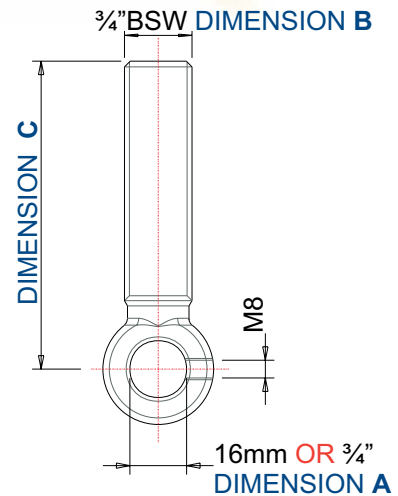

16mm eye Swingbolt Assemblies

Part Number : 496/XXXX

Eyebolt Length (mm/") Dimension "C"	Swingbolt Assy. St.St. handnut	Swingbolt Assy. N. Brass handnut	Swingbolt Assy. Anti-Galling handnut
66mm (2.60")	496/5260	496/1260	496/C260
87mm (3.42")	496/5342	496/1342	496/C342
95mm (3.75")	496/5375	496/1375	496/C375

3/4" eye Swingbolt Assemblies

Part Number : 495/XXXX

Eyebolt Length (mm/") Dimension "C"	Swingbolt Assy St. St. handnut	Swingbolt Assy N. Brass handnut
66mm (2.60")	495/1005	495/1081
87mm (3.42")	495/1015	495/1060
95mm (3.75")	495/1059	495/1055

Hinge Pins

Description	Part Number
16mm Ø eyebolt pivot pin	10913SS
3/4" Ø eyebolt pivot pin	10911SS
Manlid/neck hinge pin assembly	600/1060
16mm Ø locking manway hinge pin	600/1060/3



Repair & Maintenance Equipment



Fort Vale offer a full range of instruction manuals and proprietary tools for the repair, maintenance and testing of our valves.

Maintenance manuals may be provided electronically and in printed format. Training courses in valve refurbishment and testing are available on application.

Fort Vale highly recommend the use of proprietary tools to ensure the quick and efficient refurbishment of valves without damaging the seals, and more importantly, to guarantee that the valve passes its pressure test once re-assembled.

Test Rig



Pressure / Vacuum Test Rig - is used for the testing of any pressure or vacuum Super Maxi, Twinact, Uniact, Minnow and Steam Relief Valve. Connection is by a 2½" BSP socket mounted on top of the rig with adaptors available upon request. The rig comprises of a digital pressure and vacuum gauge and two control valves.

The testing range of the rig is -10 PSI to 100 PSI (-0.7 Bar to 6.9 Bar).

Supply connection to the test rig is via a 1/4" BSP female socket on the back of the rig.



Part No. 400/8000

Tool Kits



Description	Part No.
Relief Valve Test Rig – digital gauges	400/8000
Test rig adaptor flange, adapts 2½" BSP to 3" ASA150, DIN65 PN10 & DIN80 PN6	425/1000
C Spanner – to fit/remove Twinact relief valves	400/3000
C Spanner – to fit/remove Super Maxi relief valve	400/3001
Tightening tool for MKIII Super Maxi relief valve	400/8380
1½" & 2½" Twinact relief valve Tool Kit	400/2000
2½" BSP Maxi & Highflow relief valve Tool Kit	400/8100
65mm & 80mm Super Maxi Relief Valve Tool Kit	400/8300
Footvalve & Relief Valve Seat Repair Kit	400/2600
Box of 100 x 60 grit grinding discs	400/2610
Box of 100 x 80 grit grinding discs	400/2620
Box of 100 x 180 grit polishing discs	400/2630
Box of 100 x 600 grit polishing discs	400/2640
3" Cleanflow Footvalve Tool Kit	400/2150
3" Highlift Footvalve Tool Kit	400/2450
2" Butterfly Valve Tool Kit	400/2300
3" Butterfly Valve Tool Kit	400/2700
1½" Ball Valve Tool Kit	400/2500
3" Ball Valve Tool Kit	400/2200



Part No. 400/2600



Part No. 400/2000



Part No. 400/8300

Female Socket Ball Valves - Stainless Steel

One Piece Ball Valve

Description	Part No.
1/4" BSP one piece ball valve	410/104025
3/8" BSP one piece ball valve	410/104037
1/2" BSP one piece ball valve	410/104050
3/4" BSP one piece ball valve	410/104075
1" BSP one piece ball valve	410/104100
1 1/4" BSP one piece ball valve	410/104125
1 1/2" BSP one piece ball valve	410/104150
2" BSP one piece ball valve	410/104200

Two Piece Ball Valve

Description	Part No.
1/4" BSP two piece ball valve	410/204025
3/8" BSP two piece ball valve	410/204037
1/2" BSP two piece ball valve	410/204050
3/4" BSP two piece ball valve	410/204075
1" BSP two piece ball valve	410/204100
1 1/4" BSP two piece ball valve	410/204125
1 1/2" BSP two piece ball valve	410/204150
2" BSP two piece ball valve	410/204200
2 1/2" BSP two piece ball valve	410/204250
3" BSP two piece ball valve	410/204300

Three Piece Ball Valve

Description	Part No. BSP	Part No. WELD PREP
1/4" BSP three piece ball valve	410/304025B	410/304025W
3/8" BSP three piece ball valve	410/304037B	410/304037W
1/2" BSP three piece ball valve	410/304050B	410/304050W
3/4" BSP three piece ball valve	410/304075B	410/304075W
1" BSP three piece ball valve	410/304100B	410/304100W
1 1/4" BSP three piece ball valve	410/304125B	410/304125W
1 1/2" BSP three piece ball valve	410/304150B	410/304150W
2" BSP three piece ball valve	410/304200B	410/304200W
2 1/2" BSP three piece ball valve	410/304250B	410/304250W
3" BSP three piece ball valve	410/304300B	410/304300W
4" BSP three piece ball valve	410/304400B	410/304400W

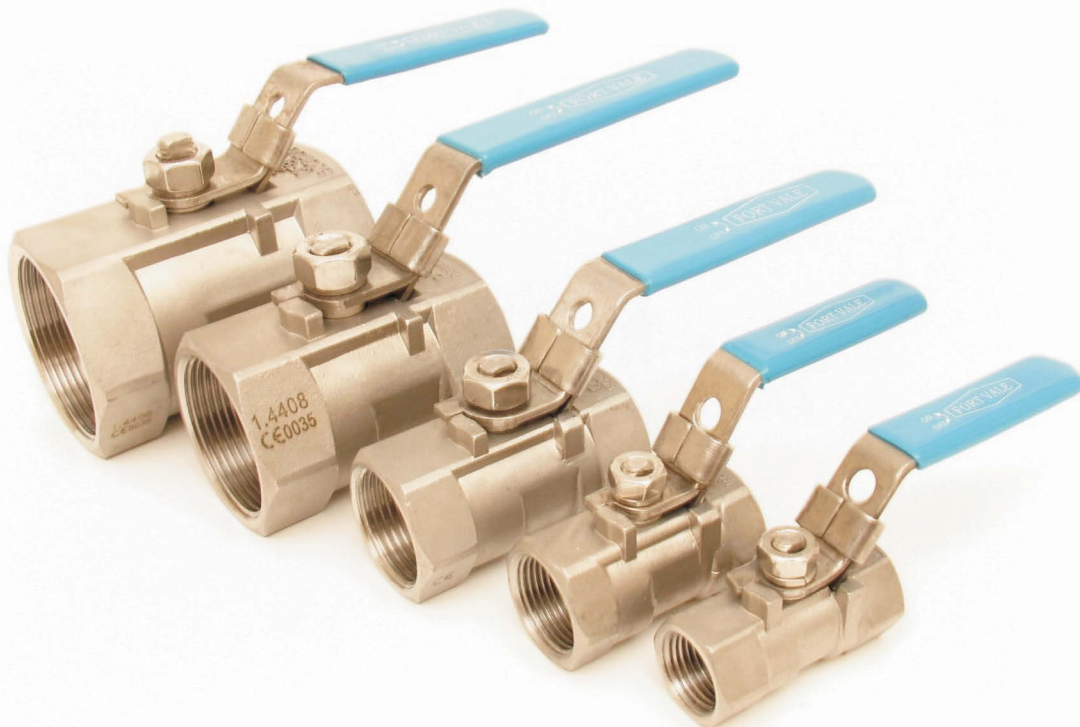

CAUTION: Do not overtighten these ball valves.

Airline Valve Installation

1½" Airline Ball Valves

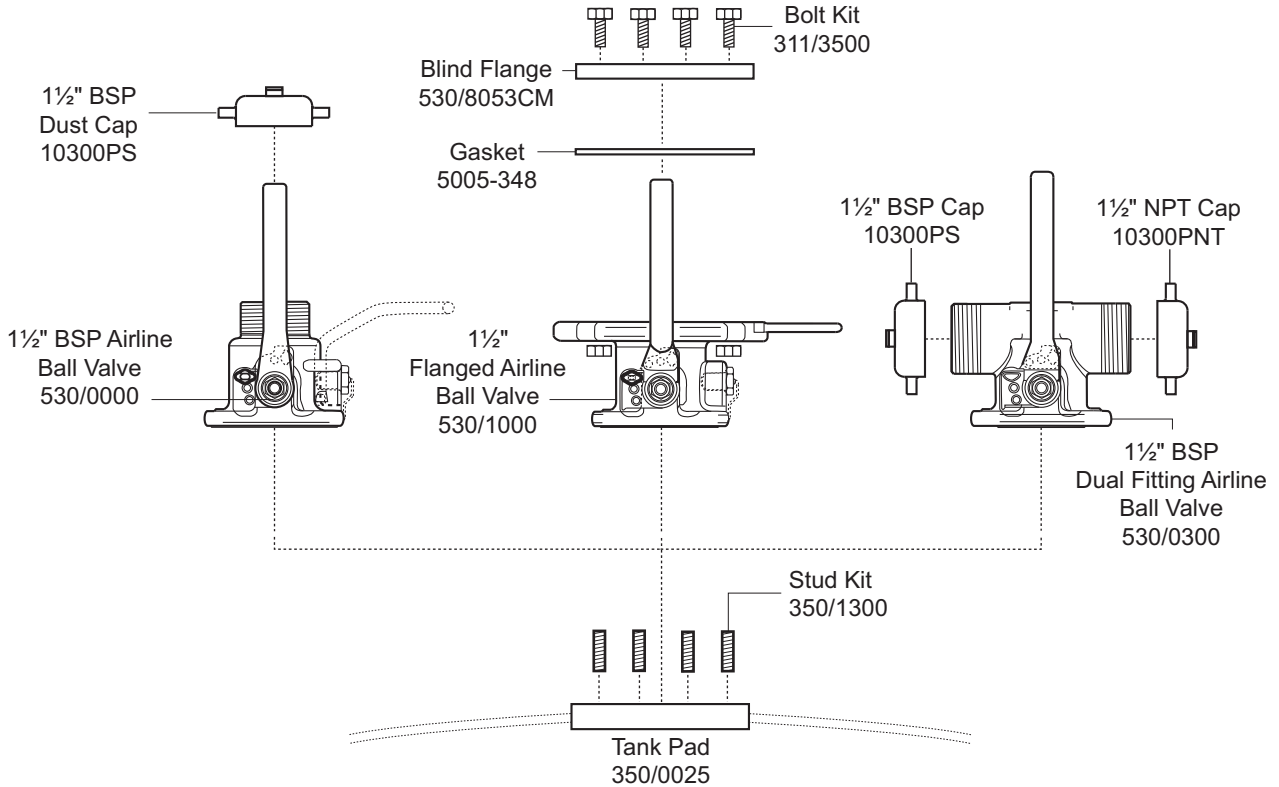

1½" BSP to DIN Adaptor Flange Conversion Kits

To convert a 1½" BSP Blacko airline ball valve to a DIN40 or a DIN50 flanged connection. Kit includes BSP to DIN adaptor flange, bent handle, envelope gasket, blind flange and bolting kit. Adaptor flange available separately.
Note : Airline ball valve not included.

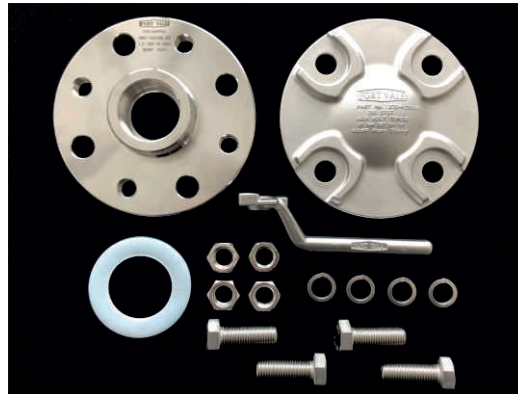

Description	Part No.
1½" BSP to DIN 40 conversion kit	530/ADAP40KIT
1½" BSP to DIN 40 adaptor flange only	530/ADAP40
1½" BSP to DIN 50 conversion kit	530/ADAP50KIT
1½" BSP to DIN 50 adaptor flange only	530/ADAP50

1½" Blacko Airline Ball Valve

Part Number : 530/0000

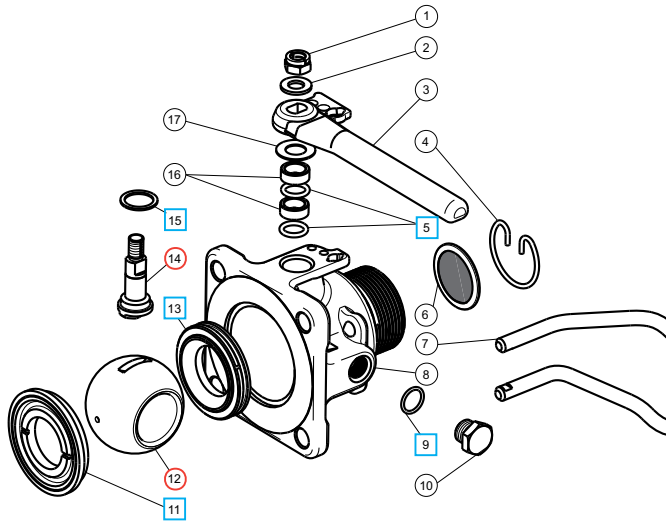

Spare Parts

Item	Description	Part No.
1	Self-locking nut	5112-031
2	ø8 washer	5113-005
3	Handle	531/0025
4	Snap ring (optional suffix 'F')	5120-017
5	PTFE O ring (2)	5005-008 <input type="checkbox"/> <input type="radio"/>
6	Gauze filter (optional suffix 'F')	353/0010
7	Gauge guard (optional suffix 'G')	530/0040
8	Valve body	530/0100
9	PTFE O ring	5005-048 <input type="checkbox"/> <input type="radio"/>
10	¼" BSP plug	5128-005
11	Rear ball seal	5005-007 <input type="checkbox"/> <input type="radio"/>
12	Ball	350/0002 <input type="radio"/>
13	Front ball seal	5005-006 <input type="checkbox"/> <input type="radio"/>
14	Spindle	530/0001 <input type="radio"/>
15	PTFE washer	5003-002 <input type="checkbox"/> <input type="radio"/>
16	Stuffing boss (2)	530/0003
17	Disc spring	5113-036

SEAL KIT - 530/00SK contains parts marked

REPAIR KIT - 530/00RK contains parts marked

1½" Dual Fitting Blacko Airline Ball Valve

Part Number : 530/0300XX

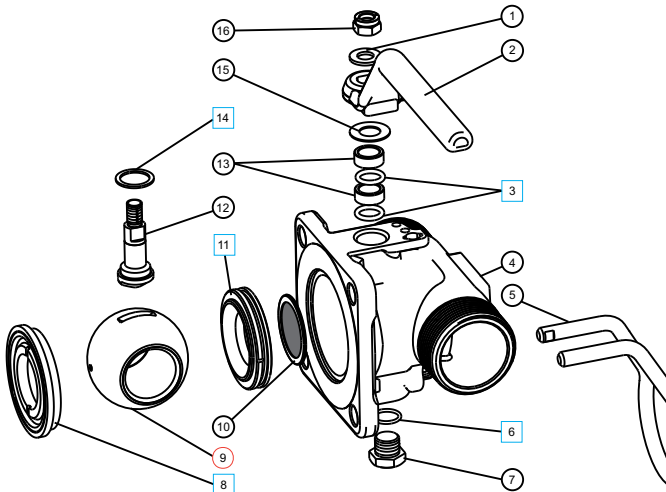

Spare Parts

Item	Description	Part No.
1	ø8 washer	5113-005
2	Handle	530/0020
3	PTFE O ring (2)	5005-008 <input type="checkbox"/> <input type="radio"/>
4	Valve body	530/0301
5	Gauge guard (optional suffix 'G')	530/0040
6	PTFE O ring	5005-048 <input type="checkbox"/> <input type="radio"/>
7	¼" BSP plug	5128-005
8	Rear ball seal	5005-007 <input type="checkbox"/> <input type="radio"/>
9	Ball	350/0002 <input type="radio"/>
10	Gauze filter (optional suffix 'F')	353/0010
11	Front ball seal	5005-006 <input type="checkbox"/> <input type="radio"/>
12	Spindle	530/0001
13	Stuffing boss (2)	530/0003
14	PTFE washer	5003-002 <input type="checkbox"/> <input type="radio"/>
15	Disc spring	5113-036
16	Self-locking nut	5112-031

SEAL KIT - 530/00SK contains parts marked

REPAIR KIT - 530/00RK contains parts marked

Associated Parts

Associated Parts	Part No.
Gauge	920/07BBSP
Gauge Adaptor	352/4004
BSP Cap	10300PS
NPT Cap	10300PNT
Stud Kit	350/1300
Tank Pad	350/0025

1½" Flanged Blacko Airline Ball Valve

Part Number : 530/1000X

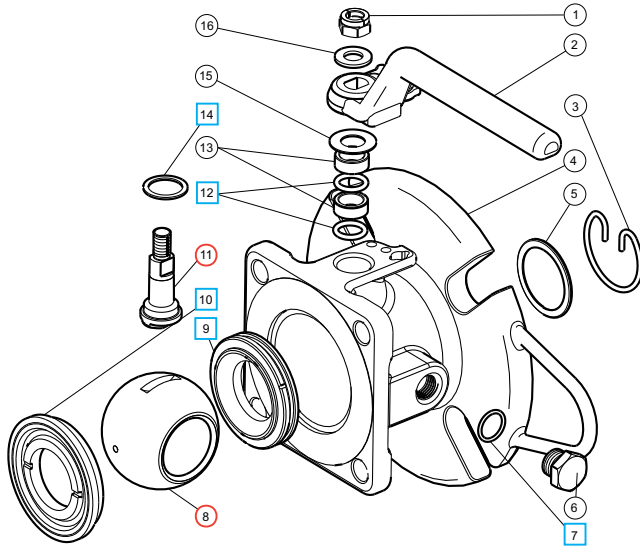

Spare Parts

Item	Description	Part No.
1	Self locking nut	5112-031
2	Handle	530/0020
3	Snap ring (optional suffix 'F')	5120-017
4	Valve body	530/1100
5	Gauge filter (optional suffix 'F')	353/0010
6	¼" BSP plug	5128-005
7	PTFE O ring	5005-048 <input type="checkbox"/> <input type="radio"/>
8	Ball	350/0002 <input type="radio"/>
9	Front ball seal	5005-006 <input type="checkbox"/> <input type="radio"/>
10	Rear ball seal	5005-007 <input type="checkbox"/> <input type="radio"/>
11	Spindle	530/0001 <input type="radio"/>
12	PTFE O ring (2)	5005-008 <input type="checkbox"/> <input type="radio"/>
13	Stuffing boss (2)	530/0003
14	PTFE washer	5003-002 <input type="checkbox"/> <input type="radio"/>
15	Disc spring	5113-036
16	ø8 washer	5113-005

SEAL KIT - 530/00SK contains parts marked

REPAIR KIT - 530/00RK contains parts marked

Associated Parts

Associated Parts	Part No.
Blind Flange	530/8053
Bolting Kit	311/3500
Gasket	5005-348
Stud Kit	350/1300
Tank Pad	350/0025

2" Blacko Ball Valve - 2" BSP Outlet

Part Number : 370/0150

Spare Parts

Item	Description	Part No.
1	M10 self lock nut	5112-008
2	M10 plain washer	5113-009
3	Handle	370/0125
4	16mm Belleville washer (3)	5113-038
5	Stuffing collar	370/0103
6	Bottom bearing bush	370/0104
7	PTFE O ring	5005-688
8	Spindle	370/0120
9	Stop bolt	370/0107
10	2" ballvalve body	370/0110
11	PTFE seal (2)	370/0102
12	50mm ball	370/3301
13	Body seal	370/0106
14	Outlet flange	370/0130
15	M16 full nut (4)	5112-003
16	M16 spring washer (4)	5113-012
17	M16 hexhead setscrew (4)	5111-036

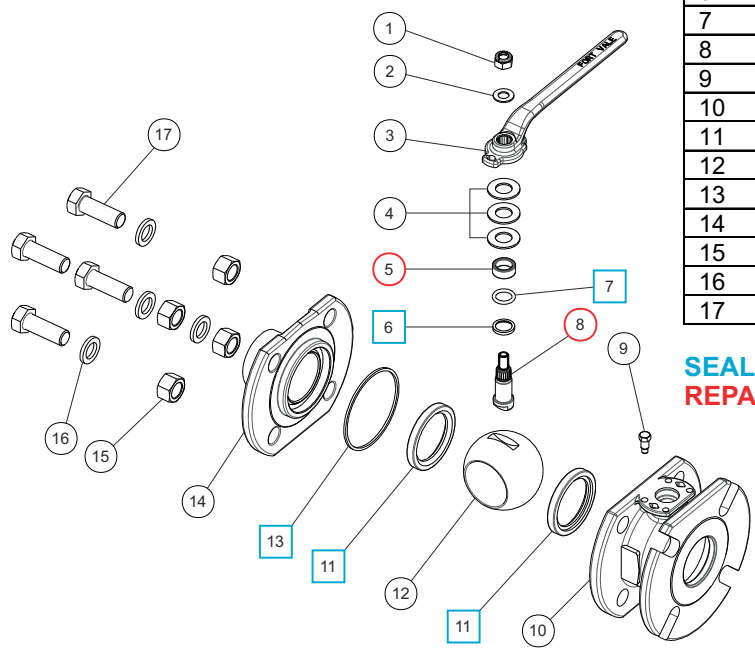

SEAL KIT - 370/015SK contains parts marked □
REPAIR KIT - 370/015RK contains parts marked ○

Associated Parts

Part No.	Description
355/3100	Tank weld-in flange
311/3700	Stud kit
10301PS	2" BSP blank cap with chain & PTFE seal
10301NPTP	2" NPTP blank cap with captivation wire & PTFE seal

2" Blacko Ball Valve - Slotted 4 Hole Outlet

Part Number : 370/0100

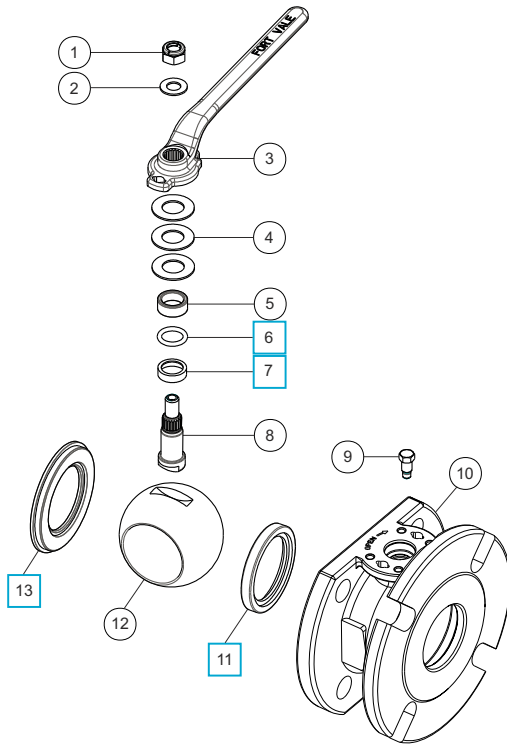

Spare Parts

Item	Description	Part No.
1	M10 self lock nut	5112-008
2	M10 plain washer	5113-009
3	Handle	370/0125
4	16mm Belleville washer (3)	5113-038
5	Stuffing collar	370/0103
6	PTFE O ring	5005-688 <input type="checkbox"/>
7	Bottom bearing	370/0104 <input type="checkbox"/>
8	Spindle	370/0120
9	Stop bolt	370/0107
10	2" ballvalve body	370/0110
11	PTFE seal	370/0102 <input type="checkbox"/>
12	50mm ball	370/3301
13	PTFE seal	370/0105 <input type="checkbox"/>

SEAL KIT - 370/01SK contains parts marked

Associated Parts

Associated Parts	Part No.
Tank weld-in pad	355/3100
Stud kit	311/3700
Outlet gasket	5005-361
Blind flange	370/4239CM
Bolting kit	311/3500

3" Blacko Ball Valve - 3" BSP Outlet

Part Number : 360/5000X

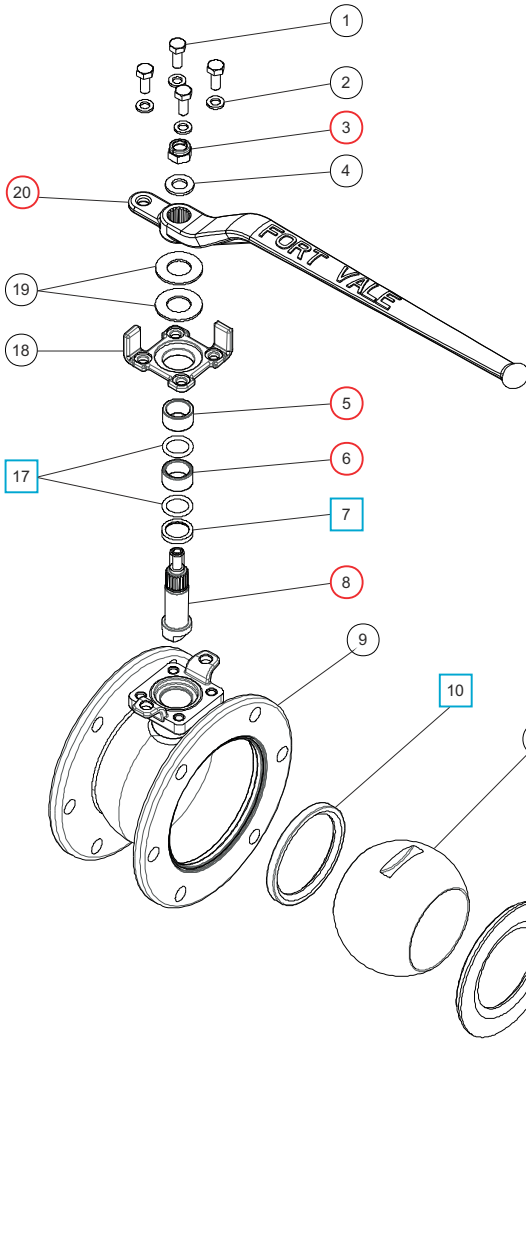

Spare Parts

Item	Description	Part No.
1	M8 hex head bolt (4)	5111-822
2	M8 flat section spring washer (4)	5113-003
3	M12 self locking nut	5112-007
4	M12 washer	5123-003
5	Top stuffing collar	360/3412
6	Bottom stuffing collar	360/3413
7	Bottom bearing	360/3421
8	Spindle	360/3422
9	3" flanged ball valve body	360/5014
10	Back seal	360/3402

Item	Description	Part No.
11	Solid ball plug	360/3401
12	Front seal	360/3405
13	3" BSP male outlet flange	20409/14
14	M12 full nut (6)	5112-006
15	M12 flat section spring washer (6)	5113-010
16	M12 hex head bolt (6)	5111-023
17	PTFE O ring (2)	5005-113
18	Clamp plate	360/5005
19	20mm Belleville washer (2)	5113-041
20	Handle weld assembly	360/3416

SEAL KIT - 360/50SK contains parts marked □
REPAIR KIT - 360/50RK contains parts marked ○

Associated Parts

Part No.	Description
20378	Mating flange
360/0300	Inlet bolting kit
20406	Bobbin adaptor for 3" table D outlet
5005-036	Outlet gasket 3" Table D
360/8070	Blind flange
311/3000	Outlet bolting kit
10303PS	3" BSP dust cap with PTFE washer
10329P	3" dust cap washer

3" Blacko Ball Valve - Slotted 4 Hole Outlet

Part Number : 360/5050X

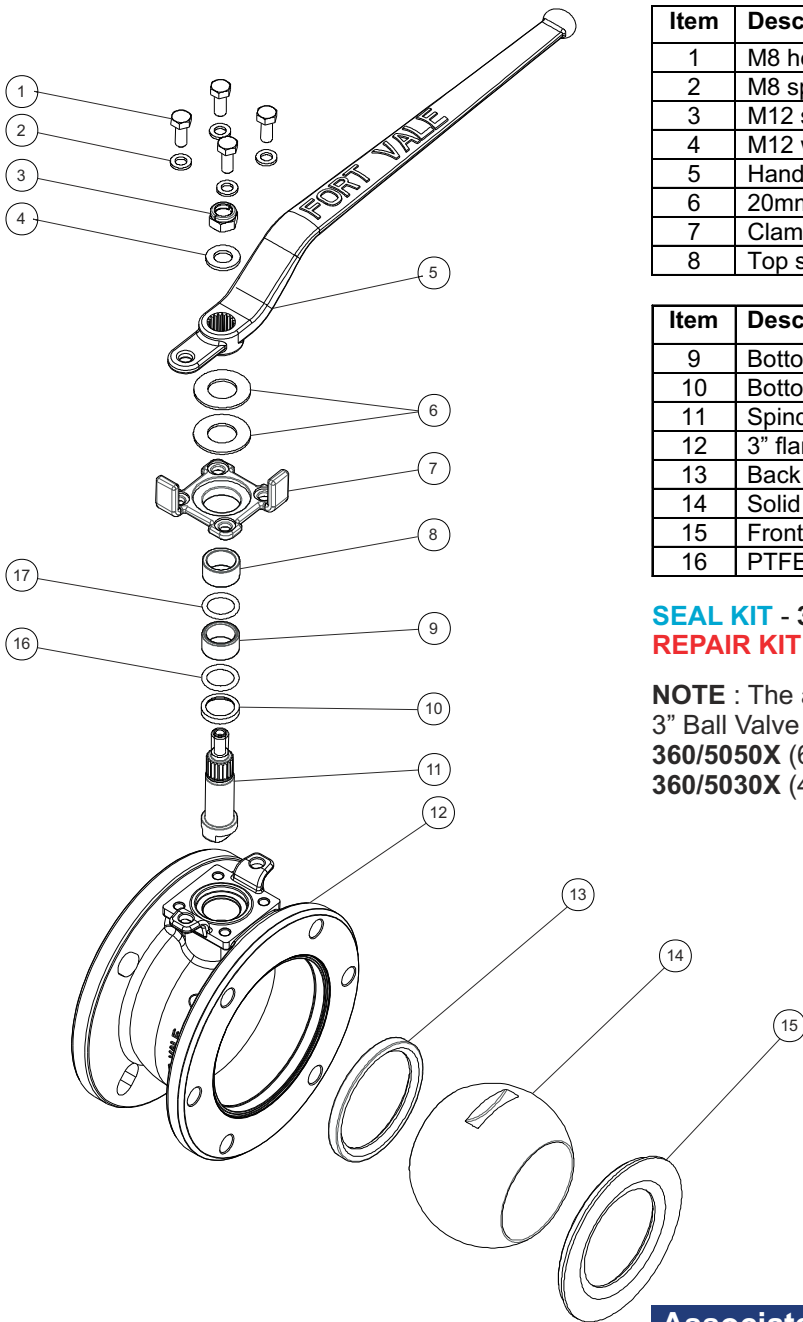

Spare Parts

Item	Description	Part No.
1	M8 hex head bolt (4)	5111-822
2	M8 spring washer (4)	5113-003
3	M12 self locking nut	5112-007
4	M12 washer	5123-003
5	Handle	360/3416
6	20mm Belleville washer (2)	5113-041
7	Clamp plate	360/5005
8	Top stuffing collar	360/3412

Item	Description	Part No.
9	Bottom stuffing collar	360/3413
10	Bottom bearing	360/3421
11	Spindle	360/3422
12	3" flanged ball valve body	360/5015
13	Back seal	360/3402
14	Solid ball plug	360/3401
15	Front seal	360/3405
16	PTFE O ring (2)	5005-113

SEAL KIT - 360/50SK contains parts marked □

REPAIR KIT - 360/50RK contains parts marked ○

NOTE : The above seal kit and repair kit is suitable for 3" Ball Valve part nos :

360/5050X (6 hole inlet/4 hole outlet)

360/5030X (4 hole inlet/4 hole slotted outlet)

Associated Parts

Associated Parts	Part No.
Outlet flange	368/0500
Outlet gasket	5005-417
Blind flange	360/8095
Bolting kit (outlet)	311/3500
Mating flange	20378
Inlet gasket to suit 20378 mating flange	5005-169
Bolting kit (inlet)	360/0300

Airline Valve Installation

2" Airline Butterfly Valves

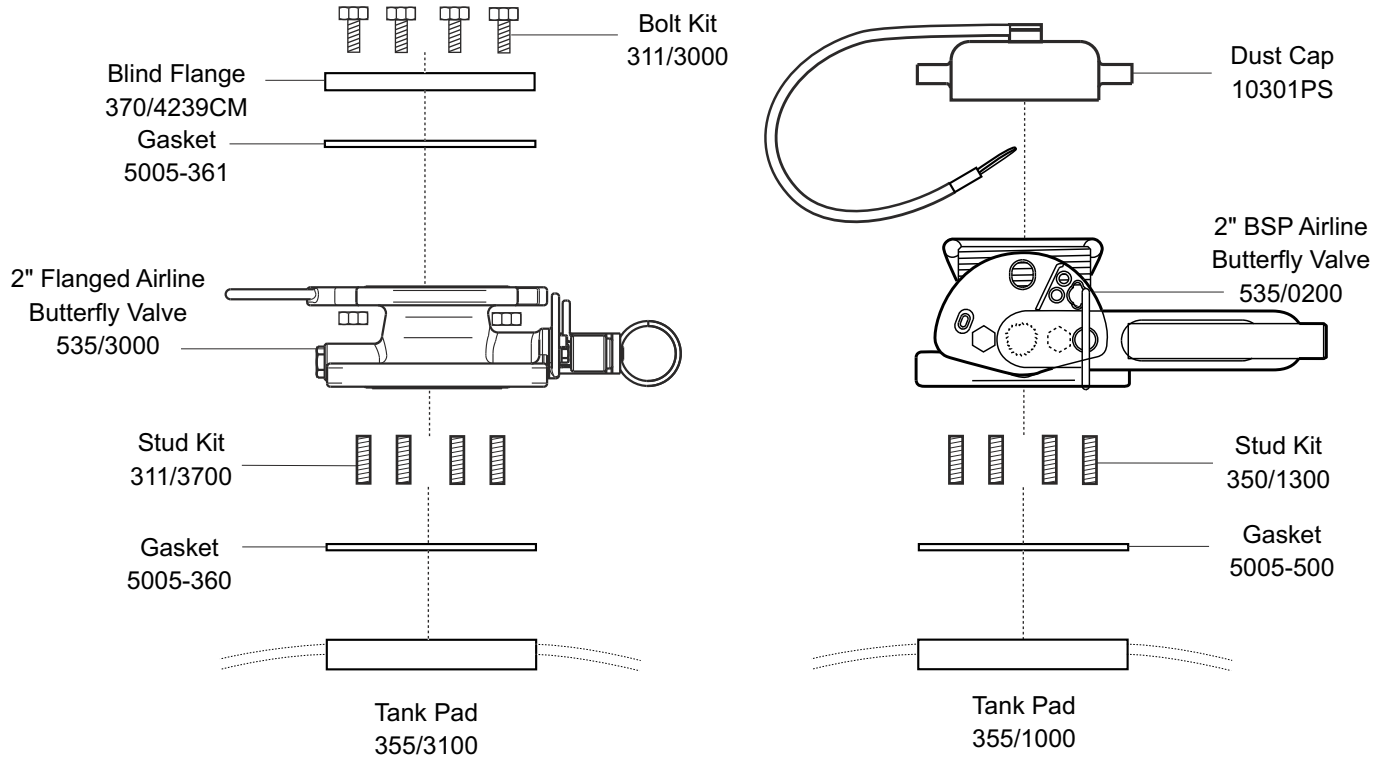

Express Couplings - Stainless Steel

Description	Part No.
3/4" BSPM Express Coupling with Viton seal	425/8000
3/4" BSPF Express Coupling with Viton seal	425/8030
1" BSPM Express Coupling with Viton seal	425/8010
1" BSPF Express Coupling with Viton seal	425/8013
Standard blanking cap with Viton seal	425/8020
Low profile blanking cap with Viton seal	425/8022
Viton seal - suits coupling and blanking cap	425/0001



2" BSP Airline Butterfly Valve

Part Number : 535/0200X

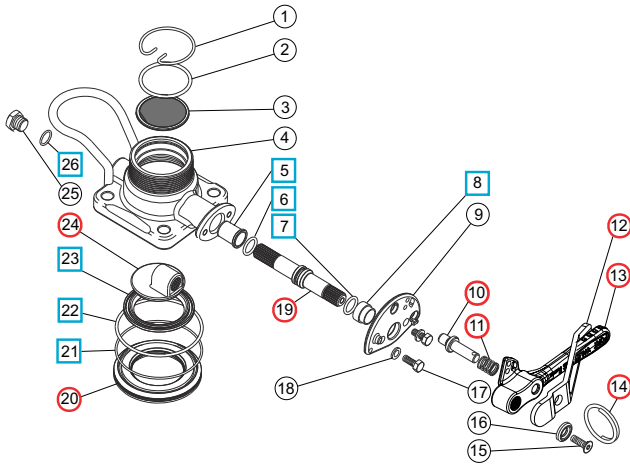

Item	Description	Part No.
1	Snap ring (Optional F,S)	5120-005
2	Spacer (Optional F,S)	355/0295
3	Gauze filter (Optional F)	355/0010
4	Sintered filter (2) (Optional S)	355/0206
5	PTFE bearing	535/0009 <input type="checkbox"/> <input type="radio"/>

Spare Parts

Item	Description	Part No.
6	Viton O ring	20361 <input type="checkbox"/> <input type="radio"/>
7	PTFE O ring	20363 <input type="checkbox"/> <input type="radio"/>
8	Stuffing bush	368/0301 <input type="checkbox"/> <input type="radio"/>
9	Stuffing clamp	535/0204
10	Location pin	368/0010 <input type="radio"/>
11	Location pin spring	368/0012 <input type="radio"/>
12	Operating lever	368/9838 <input type="radio"/>
13	Handle	535/0050 <input type="radio"/>
14	Split ring	368/0011 <input type="radio"/>
15	M6 x 30 screw	5111-030
16	Retaining washer	20370
17	M6 x 16mm hex screw (2)	5111-022
18	Spring washer (2)	5113-008
19	Spindle	535/0203 <input type="radio"/>
20	Seal plate	535/0201 <input type="radio"/>
21	O ring	5005-664 <input type="checkbox"/> <input type="radio"/>
22	PTFE O ring	5005-659 <input type="checkbox"/> <input type="radio"/>
23	Seal	355/0202 <input type="checkbox"/> <input type="radio"/>
24	Closure plate	535/0225 <input type="radio"/>
25	1/4" BSP plug	5128-005
26	PTFE O ring	5005-048 <input type="checkbox"/> <input type="radio"/>

SEAL KIT - 535/00SK contains parts marked

REPAIR KIT - 535/00RK contains parts marked

Associated Parts

Associated Parts	Part No.
Dust Cap	10301PS
Gauge	920/07BBSP
Gauge Adaptor	352/4004
Stud Kit	350/1300
Gasket	5005-500
Tank Pad	355/1000

2" Clamped Widdop Butterfly Valve

Part Number : 355/7000

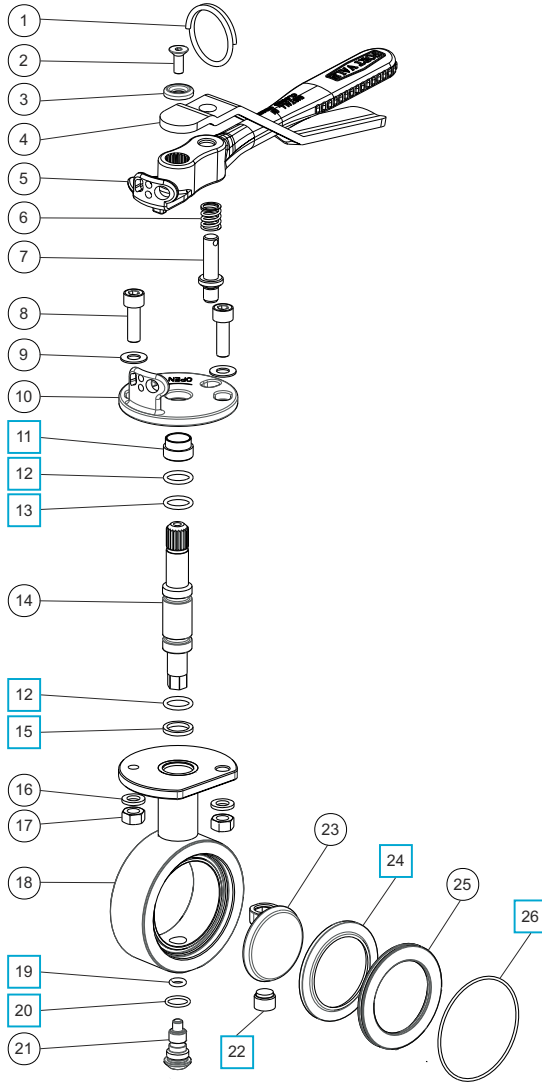

Spare Parts

Item	Description	Part No.
1	Split ring	368/0011
2	M6 countersunk bolt	5111-030
3	Washer	20370
4	Operating lever	368/9837
5	Handle	368/0050
6	Handle location spring	368/0012
7	Handle location pin	368/0010
8	Sockethead capscrew (2)	5111-148
9	Plain washer (2)	5113-005
10	Stuffing clamp	368/0040
11	PTFE stuffing clamp bush	368/0301
12	PTFE O ring (2)	20363
13	Viton O ring	20361
14	Spindle	355/5020
15	PTFE spindle seat	355/5009
16	Spring washer (2)	5113-003
17	Full nut (2)	5112-001
18	Body	355/7010
19	PTFE O ring	5005-541
20	PTFE O ring	5005-048
21	Bottom spindle	355/5005
22	PTFE lower bush	355/5007
23	Closure plate	355/5030
24	PTFE main seal	355/0202
25	Seal clamp plate	355/0201
26	EPDM O ring	5005-476

SEAL KIT - 355/70SK contains parts marked

Associated Parts

Associated Parts	Part No.
CNAF/PTFE inlet gasket *Note	5005-724
CNAF/PTFE outlet gasket *Note	6005-610

Note: Gasket drilling 4 x 18mm holes on a 125mm PCD.

2" Flanged Airline Butterfly Valve

Part Number : 535/3000X

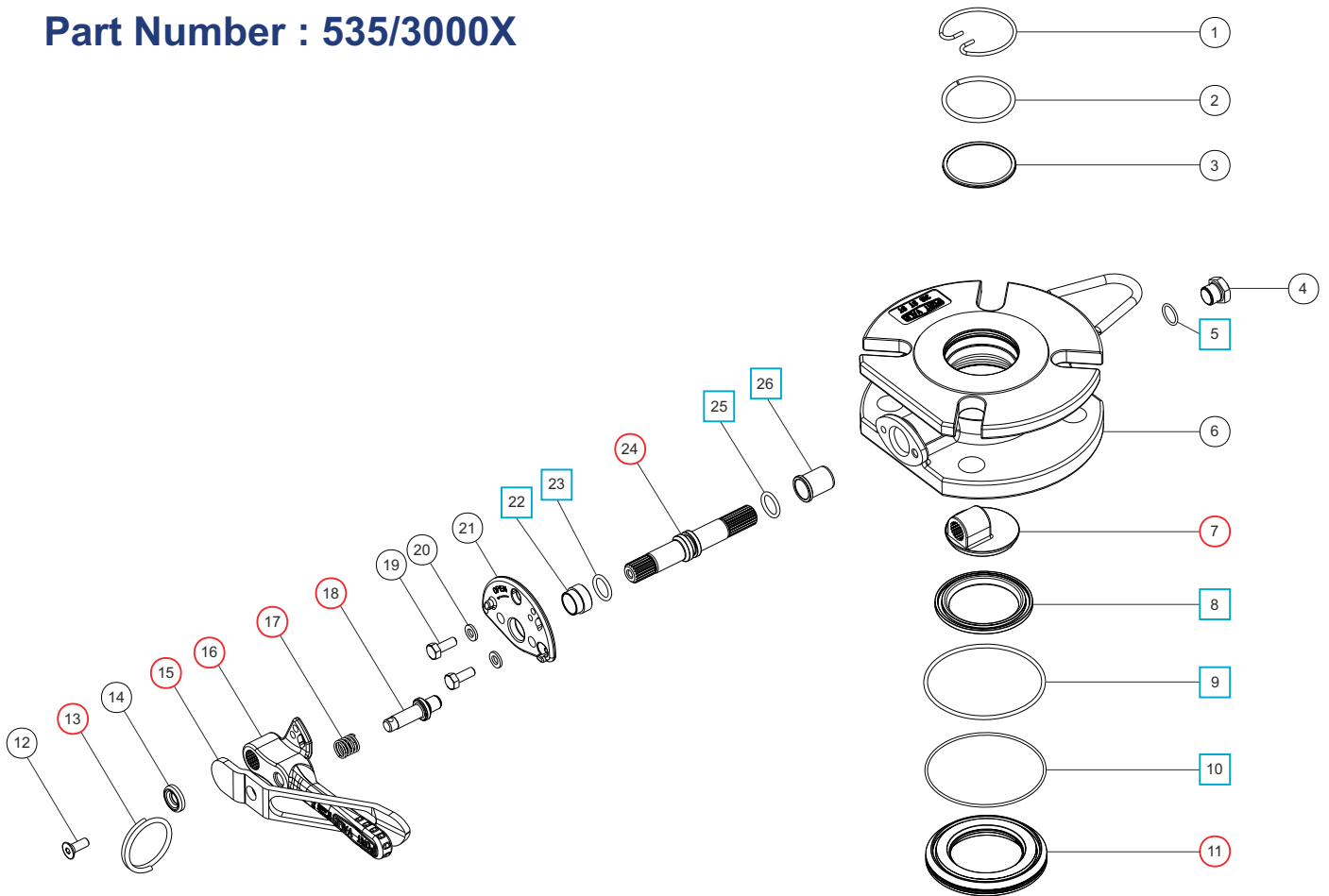

Associated Parts

Associated Parts	Part No.
Blind Flange	370/4239
Inlet Gasket	5005-360
Bolting Kit	311/3000
Gauge	920/07BBSP
Gauge Adaptor	352/4004
Stud Kit	311/3700
Outlet Gasket	5005-361
Tank Pad	355/3100

SEAL KIT - 535/00SK contains parts marked □

REPAIR KIT - 535/00RK contains parts marked ○

Spare Parts

Item	Description	Part No.
1	Snap ring (Optional F,S)	5120-005
2	Spacer (Optional F, S)	355/0295
3	Gauze filter (Optional F) Sintered filter (2) (Optional S)	355/0010 355/0206
4	1/4" BSP plug	5128-005
5	PTFE O ring	5005-048 □ ○
6	Body	535/3015
7	Closure plate	535/0225 ○
8	Seal	355/0202 □ ○
9	PTFE O ring	5005-659 □ ○
10	O ring	5005-664 □ ○
11	Seal plate	535/0201 ○
12	M6 screw	5111-030
13	Split ring	368/0011 ○
14	Retaining washer	20370
15	Operating lever	368/9838 ○
16	Handle	535/0050 ○
17	Location pin spring	368/0012 ○
18	Location pin	368/0010 ○
19	M6 x 16mm hex bolt (2)	5111-022
20	Spring washer (2)	5113-008
21	Stuffing clamp	535/0204C
22	Stuffing bush	368/0301 □ ○
23	PTFE O ring	20363 □ ○
24	Spindle	535/0203 ○
25	Viton O ring	20361 □ ○
26	PTFE bearing	535/0009 □ ○

3" Clamped Widdop Butterfly Valve

Part Number : 368/7000B

Spare Parts

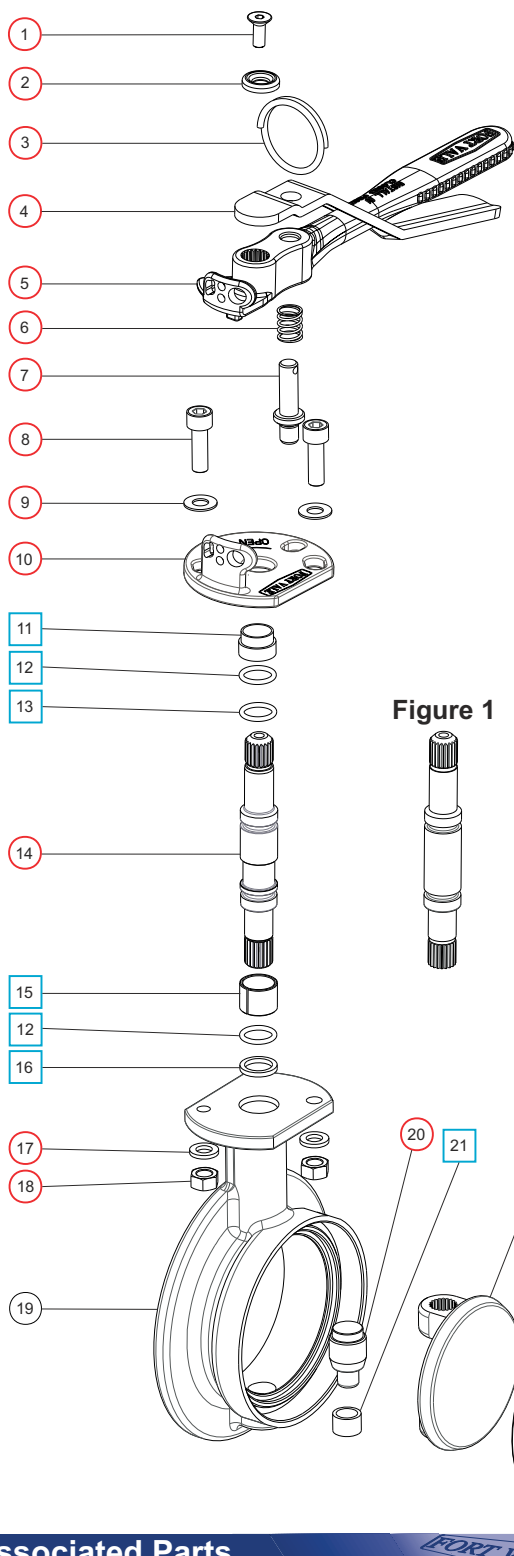

Item	Description	Part No.	
1	Sockethead setscrew	5111-030	○
2	Washer	20370	○
3	Split ring	368/0011	○
4	Operating lever	368/9837	○
5	Handle	368/0050	○
6	Handle location spring	368/0012	○
7	Handle location pin	368/0010	○
8	Sockethead capscrew (2)	5111-148	○
9	Plain washer (2)	5113-005	○
10	Stuffing clamp	368/0040	○
11	PTFE stuffing clamp bush	368/0301	□○
12	PTFE O ring (2)	20363	□○
13	Viton O ring	20361	□○
14	Spindle	368/0200	○
15	Split bearing *See note	252/0517	□○
16	PTFE spindle seat	368/0009	□○
17	Spring washer (2)	5113-003	○
18	Full nut (2)	5112-001	○
19	Body	368/0150	
20	Bottom spindle	368/0036	○
21	PTFE bottom bush	368/0035	□○
22	Closure plate	368/0400	
23	PTFE main seal	368/0002	□○
24	Seal clamp plate	368/0045	
25	Nitrile O ring	5005-342	□○

SEAL KIT - 368/00SK contains parts marked □
REPAIR KIT - 368/00RKA contains parts marked ○

NOTE: Modified spindle (14) & split bearing (15) are used in valves manufactured from November 2011. (See main exploded view)
 Prior to this date, no bearing was used and the spindle design was as in **Figure 1**.
368/00SK is compatible with both spindle types.

Associated Parts

CNAF/PTFE inlet gasket	5005-049
CNAF/PTFE outlet gasket	5005-490
Bolting kit	368/1100
3" BSP outlet flange	368/8047
3" BSP blank cap with PTFE washer	10303PS
3" Camlock outlet flange	368/8058
3" Camlock blank cap	90/DC300
3" NPT outlet flange	368/8049
3" NPT blank cap with PTFE washer	425/3250



SELF ADHESIVE DECAL
PART NO. 368/0300
 Text in English, German & French.

3" Flanged Widdop Butterfly Valve

Part Number : 368/3160A

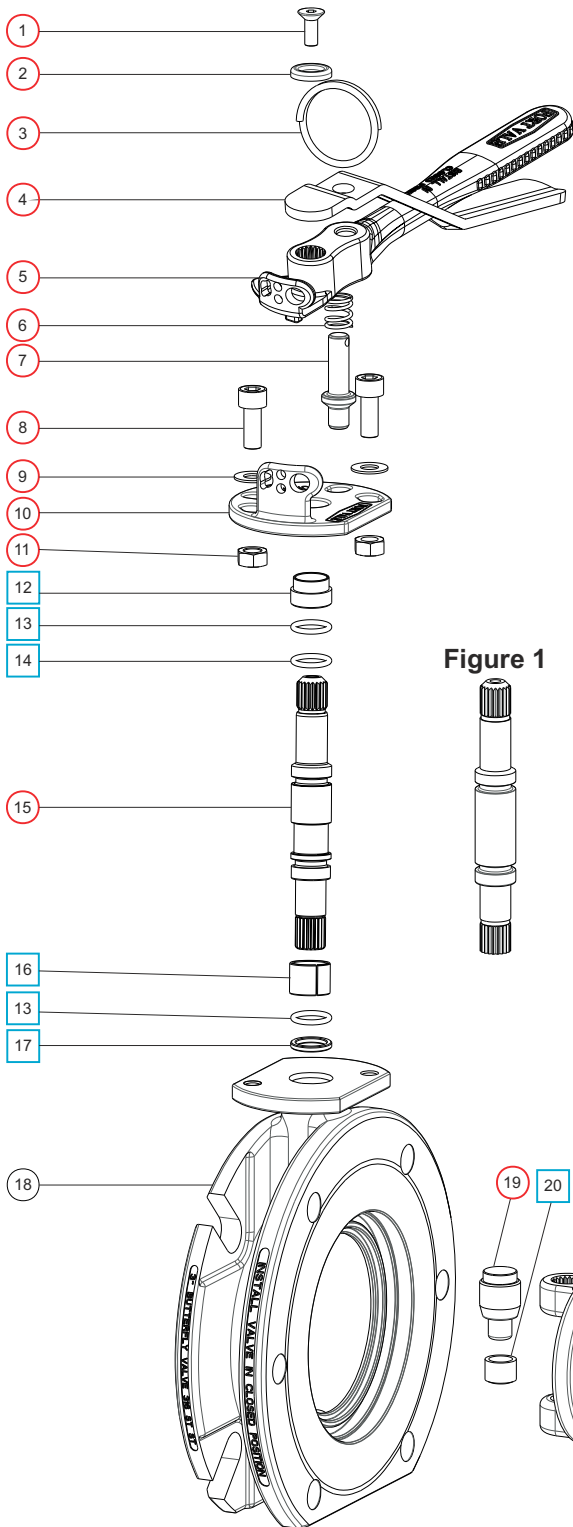

Spare Parts

Item	Description	Part No.
1	Countersunk setscrew	5111-030
2	Washer	20370
3	Split ring	368/0011
4	Operating lever	368/9837
5	Handle	368/0050
6	Handle location spring	368/0012
7	Handle location pin	368/0010
8	Sockethead capscrew (2)	5111-010
9	Plain washer (2)	5113-005
10	Stuffing clamp	368/0040
11	Full nut (2)	5112-001
12	PTFE stuffing clamp bush	368/0301
13	PTFE O ring (2)	20363
14	Viton O ring	20361
15	Spindle	368/0200
16	Split bearing *See note	252/0517
17	PTFE spindle seat	368/0009
18	Body	368/9141
19	Bottom spindle	368/0036
20	PTFE bottom bush	368/0035
21	Closure plate	368/0400
22	PTFE main seal	368/0002
23	Nitrile O ring	5005-342
24	Seal clamp plate	368/9148

SEAL KIT - 368/00SK contains parts marked

REPAIR KIT - 368/316RKA contains parts marked

NOTE: Modified spindle 15 & split bearing 16 are used in valves manufactured since November 2011. (See main exploded view)

Prior to this date, no bearing was used and the spindle design was as in **Figure 1**.

368/00SK is compatible with both spindle types.



**SELF ADHESIVE DECAL
 PART NO. 368/0300**

Text in English, German & French.

Associated Parts

Associated Parts	Part No.
CNAF/PTFE inlet gasket	5005-169
Solid PTFE outlet gasket	5005-417
Dished blind flange	312/0022CM
Bolting kit	311/3500
Pivot pin	368/7506

Top Discharge Installation

3" Flanged Butterfly Valve

Example Assembly

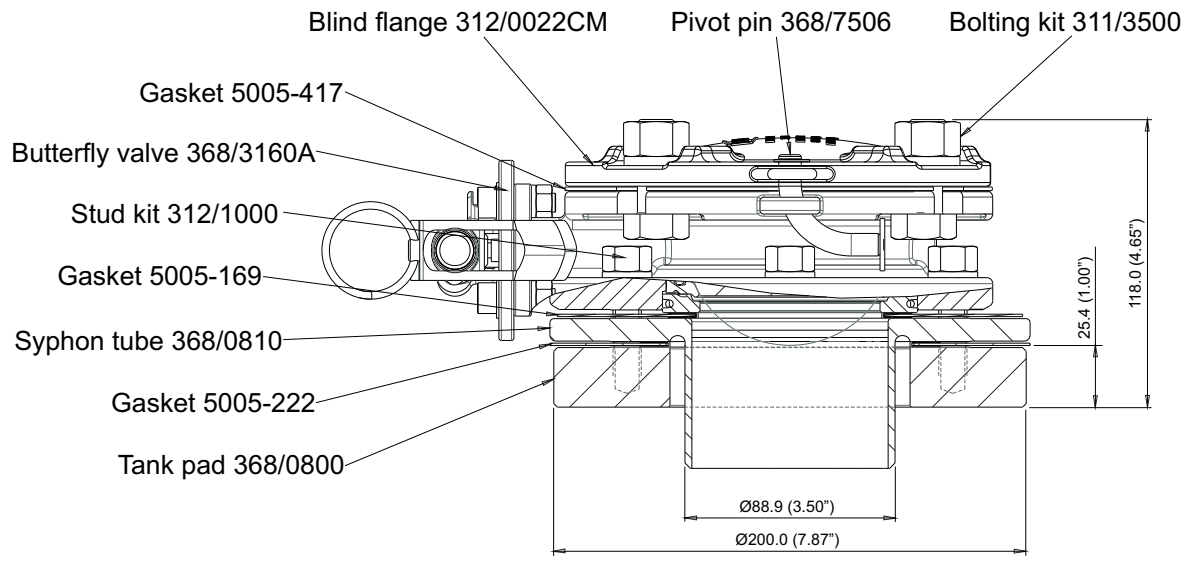

3" Tank-Pro Road Tanker Butterfly Valve

Part Number : 368/9400XXXX

Associated Parts

Associated Parts	Part No.
3" BSP blank cap with PTFE seal	10303PS
Conversion mounting kit	368/9401KIT

NOTE A: Modified spindle (11) & split bearing (12) are used in valves manufactured since November 2011. (See main exploded view)
 Prior to this date, no bearing was used and the spindle design was as in **Figure 1**.
368/94SK is compatible with both spindle types.

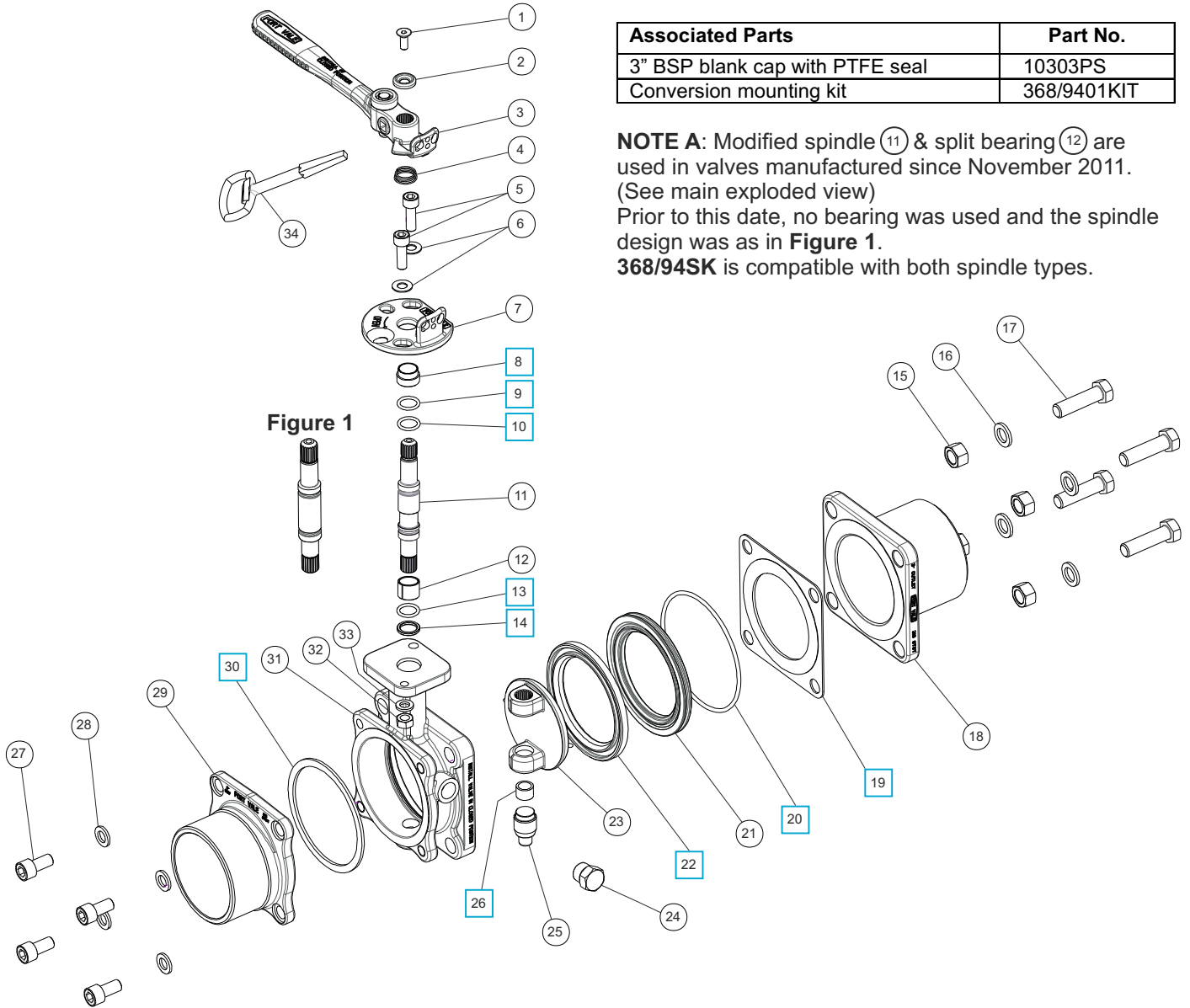

Spare Parts

Item	Description	Part No.
1	M6 socket head set screw	5111-030
2	Washer	20370
3	Handle assembly	368/0075
4	Electrical continuity spring	368/0014
5	M8 socket head cap screw (2)	5111-148
6	M8 plain washer (2)	5113-005
7	Stuffing plate	368/0041
8	Stuffing clamp bush	368/0301 <input type="checkbox"/>
9	PTFE O Ring	20363 <input type="checkbox"/>
10	Viton O ring	20361 <input type="checkbox"/>
11	Spindle	368/0200
12	Split bearing *See Note A	252/0517
13	Perfluoroelastomer O Ring	5005-586 <input type="checkbox"/>
14	PTFE spindle seat	368/0009 <input type="checkbox"/>
15	M12 full nut (4)	5112-006
16	M12 spring washer (4)	5113-010
17	M12 hex head set screw (4)	5111-023

Spare Parts

Item	Description	Part No.
18	Inlet adaptor *See Note B	368/9410
19	CNAF/PTFE inlet gasket	5005-707 <input type="checkbox"/>
20	Nitrile O ring	5005-342 <input type="checkbox"/>
21	Seal clamp	368/9148
22	PTFE main seal	368/0002 <input type="checkbox"/>
23	Closure plate	368/0400
24	3/8 Taper plug *See Note B	5128-0XX
25	Bottom spindle	368/0036
26	Bottom spindle bush	368/0035 <input type="checkbox"/>
27	M10 socket head cap screw (4)	5111-053
28	M10 spring washer (4)	5113-002
29	3" BSP outlet *See Note B	368/9430
30	PTFE outlet seal	5005-706 <input type="checkbox"/>
31	Body (non-vented) *See Note B	368/9420A
32	M8 full nut (2)	5112-001
33	M8 spring washer (2)	5113-003
34	Key	368/4625

SEAL KIT - 368/94SK contains parts marked

Note B : Part number varies according to specification
 Page 29

4" Clamped Widdop Butterfly Valve

Part Number : 468/7000B

Spare Parts

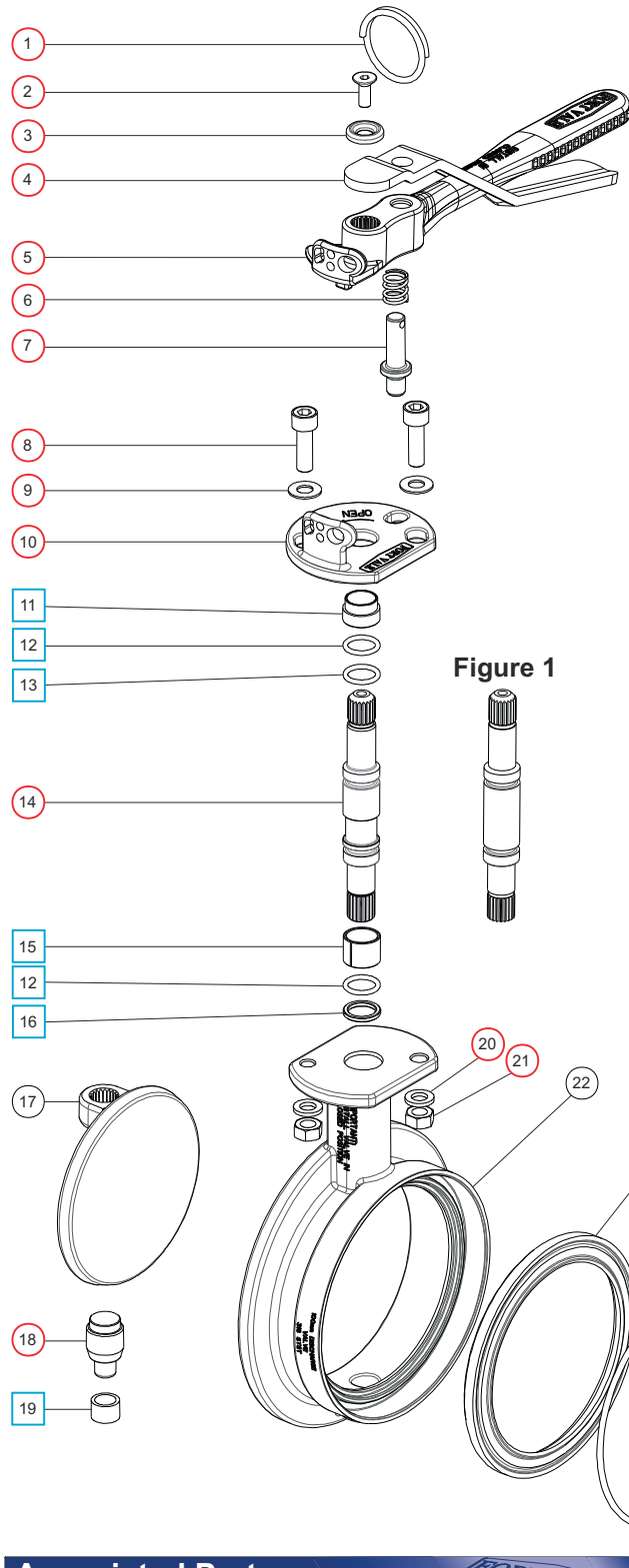

Item	Description	Part No.	
1	Split ring	368/0011	○
2	Sockethead setscrew	5111-030	○
3	Washer	20370	○
4	Operating lever	368/9837	○
5	Handle	368/0050	○
6	Handle location spring	368/0012	○
7	Handle location pin	368/0010	○
8	Sockethead capscrew (2)	5111-148	○
9	Plain washer (2)	5113-005	○
10	Stuffing clamp	368/0040	○
11	PTFE stuffing clamp bush	368/0301	□ ○
12	PTFE O ring (2)	20363	□ ○
13	Viton O ring	20361	□ ○
14	Spindle	368/0200	○
15	Split bearing *See note	252/0517	□ ○
16	PTFE spindle seat	368/0009	□ ○
17	Closure plate	468/0400	
18	Lower spindle	368/0036	○
19	PTFE lower spindle bush	368/0035	□ ○
20	Spring washer (2)	5113-003	○
21	Full nut (2)	5112-001	○
22	Body	468/0150	
23	PTFE main seal	468/0002	□ ○
24	Nitrile O ring	5005-357	□ ○
25	Seal clamp plate	468/5505	

SEAL KIT - 468/00SKB contains parts marked □

REPAIR KIT - 468/00RKB contains parts marked ○

NOTE: Modified spindle (14) & split bearing (15) are used in valves manufactured since November 2011. (See main exploded view)

Prior to this date, no bearing was used and the spindle design was as in **Figure 1**.

468/00SKB is compatible with both spindle types.

Associated Parts	
CNAF/PTFE inlet gasket	5005-468
CNAF/PTFE outlet gasket	5005-469
Bolting kit (8 x bolts, nuts, washers)	468/1100
4" BSP outlet flange	468/8047
4" BSP blank cap with PTFE washer	10304PSC
4" NPT outlet flange	468/8049
4" NPT blank cap with PTFE washer	425/4000

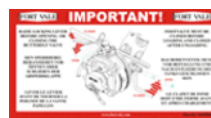

SELF ADHESIVE DECAL
PART NO. 326/0300

Text in English, German & French

TW80 Clamped Butterfly Valve

Part Number : 368/5500B

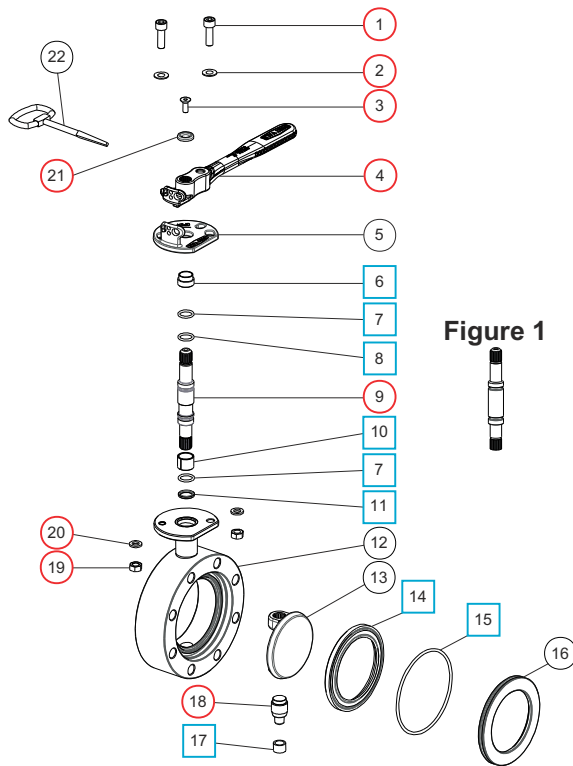

Spare Parts

Item	Description	Part No.	
1	M8 socket capscrew (2)	5111-148	○
2	M8 plain washer (2)	5113-005	○
3	M6 countersunk setscrew	5111-030	○
4	Barrel lock handle	368/0075	○
5	Stuffing clamp	368/0041	
6	Stuffing clamp bush	368/0301	□ ○
7	PTFE O ring (2)	20363	□ ○
8	Viton O ring	20361	□ ○
9	Butterfly valve spindle	368/0200	○
10	Split bearing *See note	252/0517	□ ○
11	PTFE spindle seat	368/0009	□ ○
12	Body	368/5510	
13	Closure plate	368/0400	
14	Main seal	368/0002	□ ○
15	Nitrile O ring	5005-342	□ ○
16	Seal clamp	368/9148	
17	Bottom bush	368/0035	□ ○
18	Bottom spindle	368/0036	○
19	M8 full nut (2)	5112-001	○
20	M8 flat section spring washer (2)	5113-003	○
21	Washer	20370	○
22	Operating key (sold separately)	368/4625	

SEAL KIT - 368/00SK contains parts marked □

REPAIR KIT - 368/50RKB contains parts marked ○

NOTE: Modified spindle (9) & split bearing (10) are used in valves manufactured from November 2011. (See main exploded view)

Prior to this date, no bearing was used and the spindle design was as in **Figure 1**.

368/00SK is compatible with both spindle types.

Associated Parts

Part No.	Associated Parts
5005-715	PTFE/CNAF TW80 envelope gasket
845/8001	TW80 mating flange
368/5513	3" BSP eccentric TW80 outlet flange

TW100 Clamped Butterfly Valve

Part Number : 468/5500B

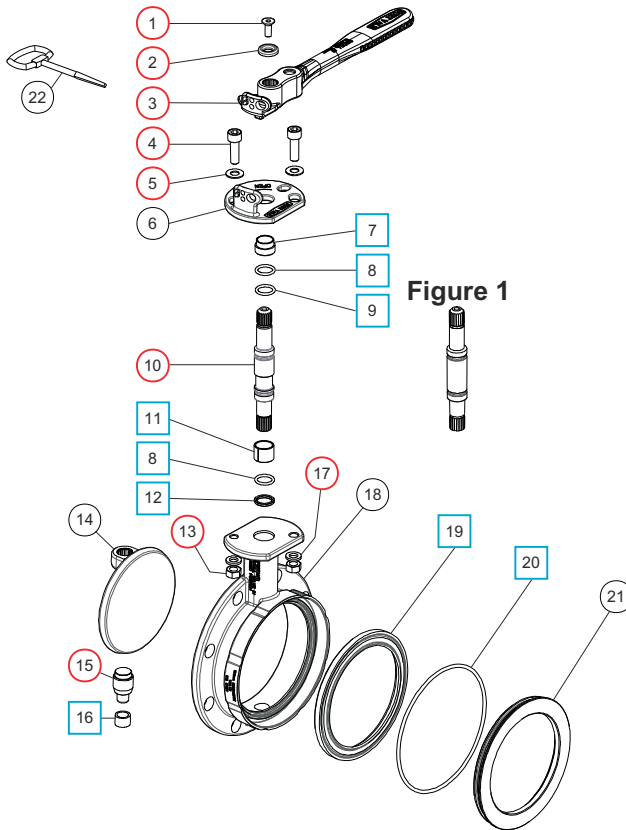

Spare Parts

Item	Description	Part No.	
1	M6 countersunk setscrew	5111-030	○
2	Washer	20370	○
3	Barrel lock handle	368/0075	○
4	M8 socket capscrew (2)	5111-148	○
5	M8 plain washer (2)	5113-005	○
6	Stuffing clamp	368/0041	
7	Stuffing clamp bush	368/0301	○
8	PTFE O ring (2)	20363	□ ○
9	Viton O ring	20361	□ ○
10	Spindle	368/0200	○
11	Split bearing *See note	252/0517	□ ○
12	PTFE spindle seat	368/0009	□ ○
13	M8 full nut (2)	5112-001	○
14	Closure plate	468/0400	
15	Bottom spindle	368/0036	○
16	Bottom bush	368/0035	□ ○
17	M8 flat section spring washer (2)	5113-003	○
18	4" Butterfly valve body	468/0160	
19	PTFE seal	468/0002	□ ○
20	Nitrile O ring	5005-357	□ ○
21	Seal clamp plate	468/5505	
22	Operating key (sold separately)	368/4625	

SEAL KIT - 468/00SKB contains parts marked □

REPAIR KIT - 468/50RKB contains parts marked ○

NOTE: Modified spindle (10) & split bearing (11) are used in valves manufactured from November 2011. (See main exploded view)

Prior to this date, no bearing was used and the spindle design was as in **Figure 1**.

468/00SKB is compatible with both spindle types.

Associated Parts

Part No.	Associated Parts
5005-832	PTFE/CNAF TW100 envelope gasket
875/8001	TW100 mating flange
468/5175	4" BSP eccentric TW100 outlet flange

3" 30° & 45° Cleanflow Footvalve

**Part Number : 845/1200A - 45° (Illustrated)
848/1000A - 30°**

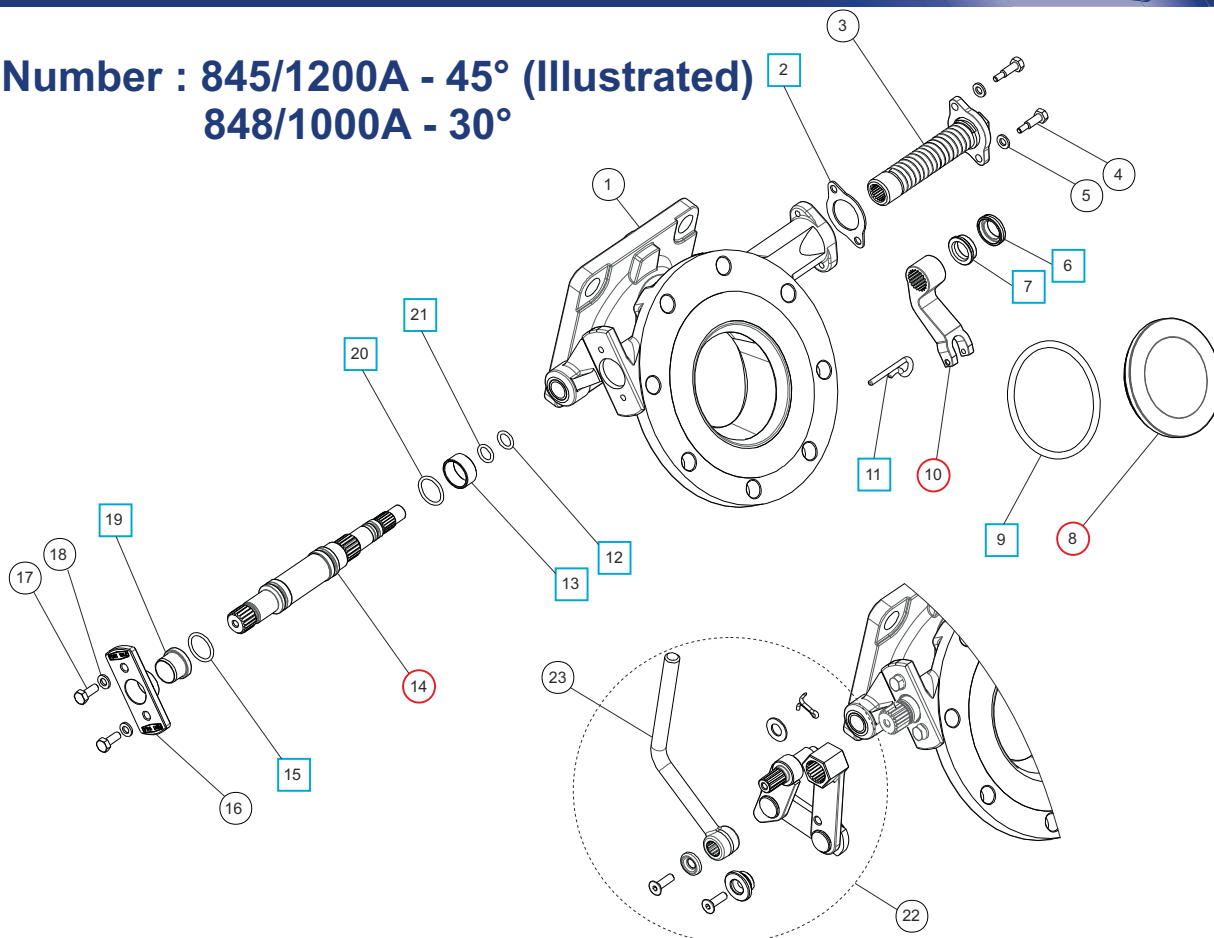

Spare Parts - 30° & 45°

Item	Description	Part No.
1	Body	Variable
2	Spring boss gasket	5005-845 <input type="checkbox"/>
3	Spring assembly	845/0050
4	Clamp screw (2)	845/0017
5	Spring washer (2)	5113-008
6	Bush seal	845/0064 <input type="checkbox"/>
7	Seal energizer	845/0063 <input type="checkbox"/>
8	Poppet	845/0040 <input type="checkbox"/>
9	Fortyt O ring	5005-104 <input type="checkbox"/>
10	Lifting fork	845/0010 <input type="checkbox"/>
11	Retaining pin	845/0015 <input type="checkbox"/>
12	Perfluoroelastomer O ring	10133PHT <input type="checkbox"/>

Spare Parts - 30° & 45°

Item	Description	Part No.
13	Spindle bearing	845/0062 <input type="checkbox"/>
14	Spindle	845/0200 <input type="checkbox"/>
15	Viton O ring	5005-336 <input type="checkbox"/>
16	Stuffing clamp	845/0016
17	Clamp bolt (2)	5111-022
18	Spring washer (2)	5113-008
19	Stuffing seal	845/0061 <input type="checkbox"/>
20	Perlast O ring	5005-384 <input type="checkbox"/>
21	PTFE O ring	5005-008 <input type="checkbox"/>
22	Handle linkage assembly	324/8910
23	Handle	T.B.A. *See note

SEAL KIT - 845/00SK contains parts marked

REPAIR KIT - 845/00RK contains parts marked

Associated Parts - 45°

Associated Parts	Part No.
Tank pad	324/9000
Stud kit	845/2040
Bolting kit – 4 hole outlet	311/3500
Bolting kit – 6 hole outlet	360/0300
Inlet gasket – 8 hole	5005-015
Outlet gasket	5005-049
Outlet gasket – 6 hole	5005-169

Associated Parts - 30°

Associated Parts	Part No.
Tank pad	324/9030

NOTE: All other 30° Associated Parts are identical to 45°

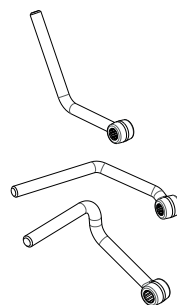

NOTE: Please select handle type.

STANDARD CLEANFLOW HANDLE
Part No. 324/8670

STANDARD HIGHLIFT HANDLES
Part No. 330/5010

Part No. 324/8671



SELF ADHESIVE DECAL
Part No. 845/0320
Text in English, German & French

3" 30° & 45° MKII Highlift Footvalve

Part Number : 826/0000 - 45° (Illustrated)
 830/3200 - 30°

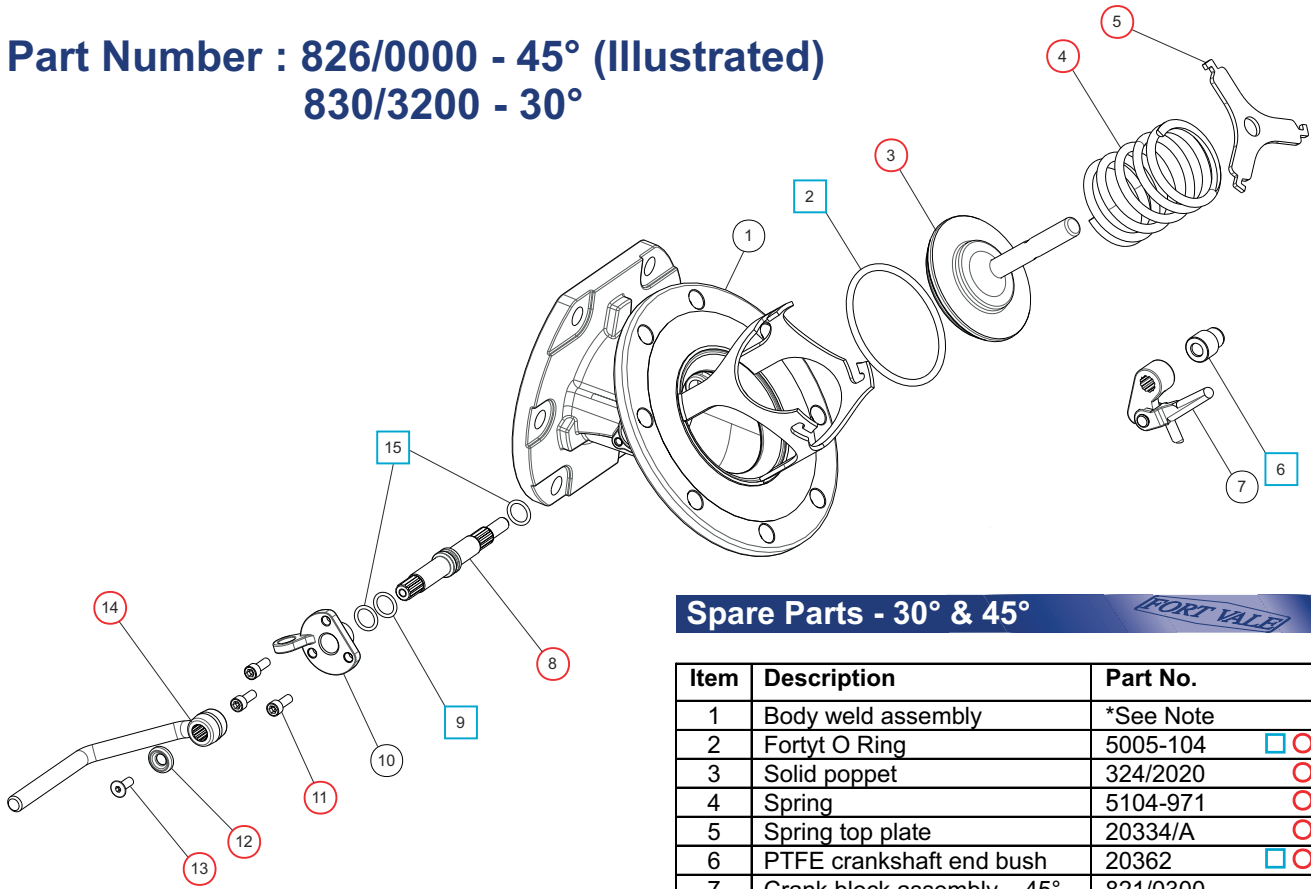

Spare Parts - 30° & 45°

Item	Description	Part No.
1	Body weld assembly	*See Note
2	Fortyt O Ring	5005-104 <input type="checkbox"/> <input type="radio"/>
3	Solid poppet	324/2020 <input type="radio"/>
4	Spring	5104-971 <input type="radio"/>
5	Spring top plate	20334/A <input type="radio"/>
6	PTFE crankshaft end bush	20362 <input type="checkbox"/> <input type="radio"/>
7	Crank block assembly – 45° Crank block assembly – 30°	821/0300 821/0303
8	Spindle	821/0010 <input type="radio"/>
9	Viton O ring	20361 <input type="checkbox"/> <input type="radio"/>
10	Stuffing clamp	324/1001
11	M6 socket head capscrew (3)	5111-017 <input type="radio"/>
12	Handle retaining washer	20370 <input type="radio"/>
13	Handle retaining screw	5111-030 <input type="radio"/>
14	Handle	330/5010 <input type="radio"/>
15	PTFE O ring (2)	20363 <input type="checkbox"/> <input type="radio"/>

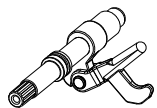

SPINDLE & CRANK BLOCK ASSEMBLY
 Part No. 821/0200 - 45°
 821/0203 - 30°

Includes spindle, crank block assembly,
 O rings and end bush
 (Item nos. 6 7 8 9 & 15)

* Note Part number varies according to valve specification, eg. 30°, 45°, body drilling.

SEAL KIT - 826/00SK contains parts marked

REPAIR KIT - 826/00RK contains parts marked

Associated Parts - 30°

Associated Parts	Part No.
Tank pad	341/001L
Stud kit	311/3700
Bolting kit – 4 hole outlet	368/1100
Bolting kit – 6 hole outlet	360/0300
Inlet gasket – 4 hole	5005-032
Outlet gasket	5005-049
Outlet gasket – 6 hole	5005-169

Associated Parts - 45°

Associated Parts	Part No.
Tank pad	324/9000
Stud kit	324/2060
Inlet gasket – 8 hole	5005-015
Outlet gasket – 6 hole	5005-169
Ring gasket - suits 4 hole outlet	5005-049



SELF ADHESIVE DECAL
 Part No. 326/0300
 Text in English, German & French

3" 45° MKIII Highlift Footvalve

Part Number : 826/1200A

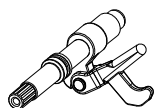
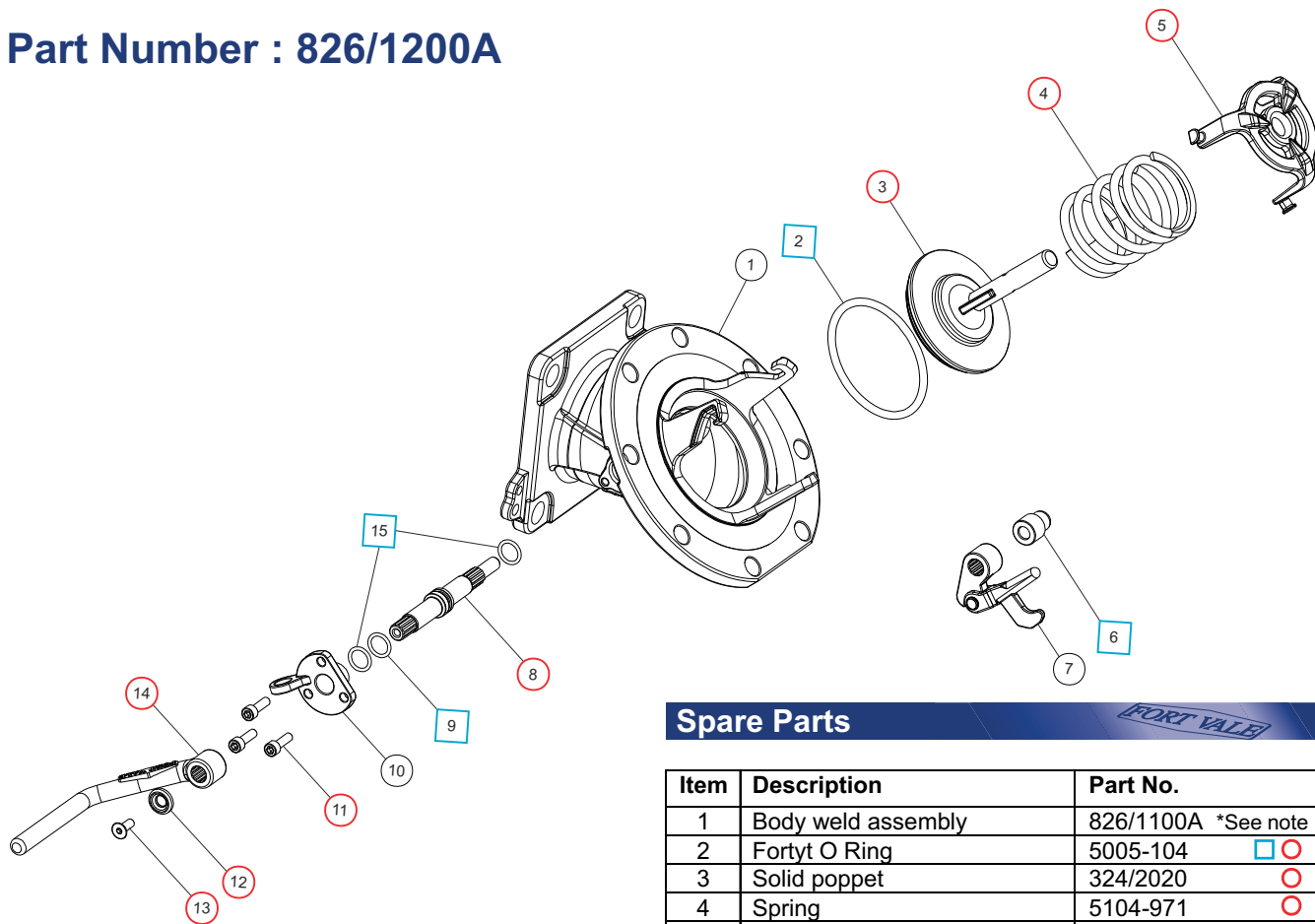

SPINDLE & CRANK BLOCK ASSEMBLY PART NO. 821/0200

Includes spindle, crank block assembly,
 O rings and end bush
 (Item nos. 6 7 8 9 & 15)

Spare Parts

Item	Description	Part No.
1	Body weld assembly	826/1100A *See note
2	Fortyt O Ring	5005-104 <input type="checkbox"/> <input type="radio"/>
3	Solid poppet	324/2020 <input type="radio"/>
4	Spring	5104-971 <input type="radio"/>
5	Spring top plate	290/6104 <input type="radio"/>
6	PTFE crankshaft end bush	20362 <input type="checkbox"/> <input type="radio"/>
7	Crank block assembly	821/0300
8	Spindle	821/0010 <input type="radio"/>
9	Viton O ring	20361 <input type="checkbox"/> <input type="radio"/>
10	Stuffing clamp	324/1001
11	M6 capscrew (3)	5111-017 <input type="radio"/>
12	Handle retaining washer	20370 <input type="radio"/>
13	Handle retaining screw	5111-030 <input type="radio"/>
14	Handle	330/5010 <input type="radio"/>
15	PTFE O ring (2)	20363 <input type="checkbox"/> <input type="radio"/>

*NB Part number varies according to valve specification

SEAL KIT - 826/00SK contains parts marked

REPAIR KIT - 826/00RKA contains parts marked

Associated Parts

Associated Parts	Part No.
Tank pad	324/9000
Stud kit	324/2070
Standard bolting kit – 4 hole outlet	311/3500
8 hole inlet gasket – CNAF/PTFE	5005-015
Standard outlet gasket – CNAF/PTFE	5005-049



SELF ADHESIVE DECAL Part No. 326/0300

Text in English, German & French

3" 45° Pneumatic Cleanflow Footvalve

Part Number : 845/820ASSRX

PNEUMATIC CYLINDER SEAL KITS

Seal kit **844/21SK** - Pneumatic Cylinder ref. **844/2190** (new style as illustrated)

Seal kit **844/2110SK** - Pneumatic Cylinder ref. **844/2210** (old style)

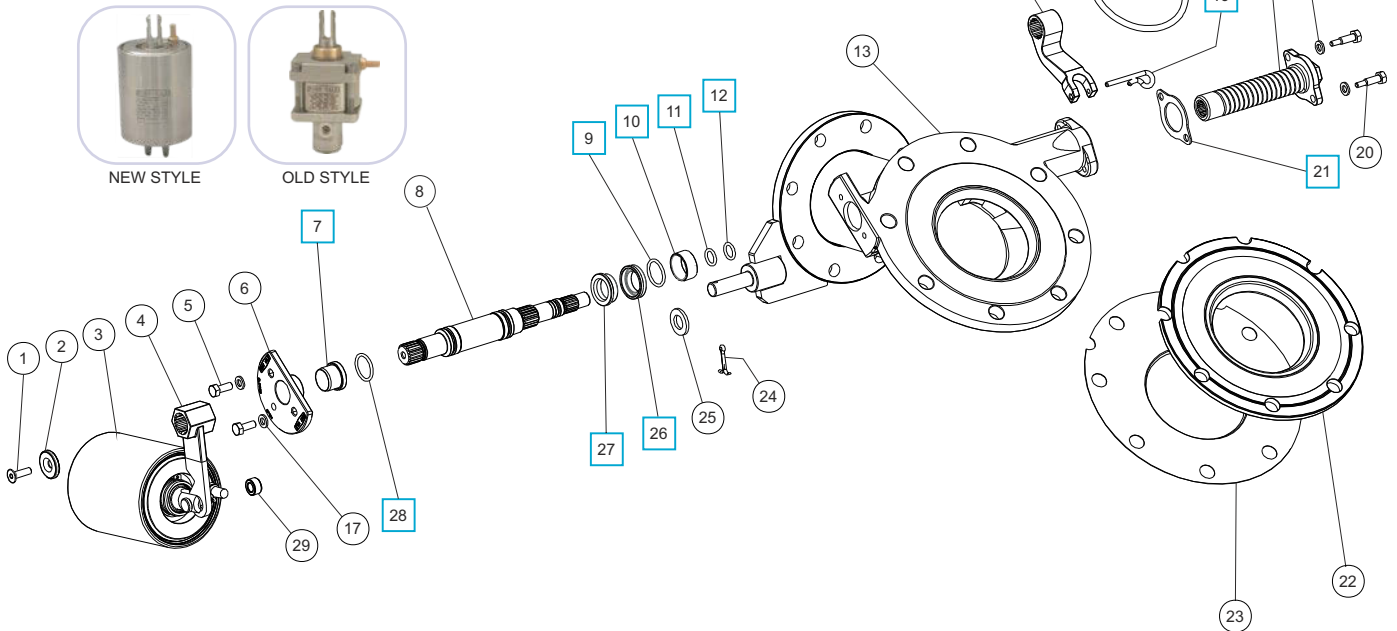

Spare Parts

Item	Description	Part No.
1	6mm countersunk bolt	5111-019
2	M12 plain washer	20370/2
3	Pneumatic cylinder	844/2190
4	Extended crank arm assembly	844/2041
5	M6 hex head bolt (2)	5111-022
6	Stuffing clamp flange	845/0060
7	Spindle stuffing seal	845/0061 <input type="checkbox"/>
8	Main spindle	845/0200
9	Perfluoroelastomer O ring	5005-384 <input type="checkbox"/>
10	Spindle bearing	845/0062 <input type="checkbox"/>
11	PTFE O ring	5005-008 <input type="checkbox"/>
12	Perfluoroelastomer O ring	10133PHT <input type="checkbox"/>
13	3" Cleanflow footvalve body	845/8210
14	Lifting fork <i>*see note</i>	845/X010X
15	Fortyt O ring	5005-104 <input type="checkbox"/>

NB Part number varies according to specification

Spare Parts

Item	Description	Part No.
16	Extended seal clamp poppet	845/0042
17	M6 spring washer (4)	5113-008
18	Spring assembly	845/0050
19	Retaining pin	845/0015 <input type="checkbox"/>
20	M6 special hex screw (2)	845/0017
21	Spring housing gasket	5005-845 <input type="checkbox"/>
22	Replaceable seal face <i>*see note</i>	845/0090X
23	Wafer seal	5005-829
24	1/8" split pin	5118-010
25	M12 plain washer	5113-006
26	Bottom bush seal	845/0064 <input type="checkbox"/>
27	Bottom seal energiser	845/0063 <input type="checkbox"/>
28	Viton O ring	5005-336 <input type="checkbox"/>
29	Pneumatic cleanflow bush	844/2011

SEAL KIT - 845/00SK contains parts marked

Associated Parts

Associated Parts	Part No.
Tank pad	324/9000
Stud kit	845/2055
Bolting kit – 8 hole outlet	845/0013
Inlet gasket – 8 hole	5005-015
Outlet gasket	5005-715



SELF ADHESIVE DECAL

Part No. 845/0320

Text in English, German & French

3" 30° & 45° Uniflow

Part Number :
806/4000 - 45° (Illustrated)
807/4000 - 30°

SEAL KIT - 806/40SK contains parts marked



SELF ADHESIVE DECAL
PART NO. 326/0303
Text in English, German & French

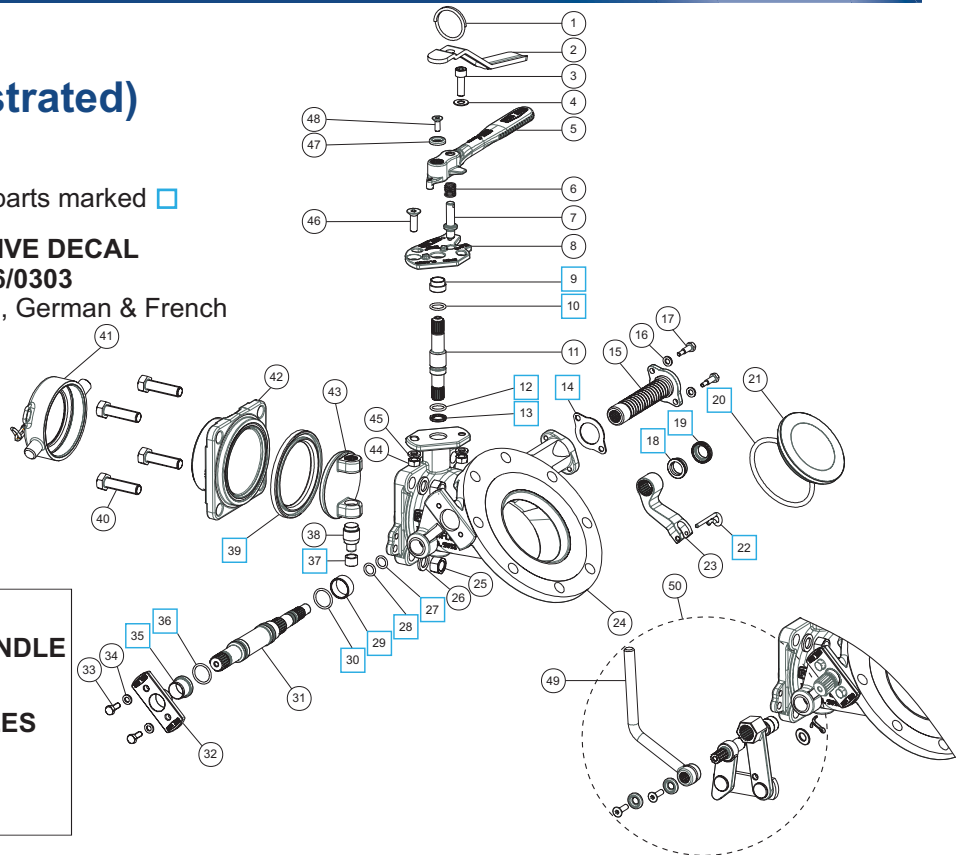

***See Part No. 49**

STD CLEANFLOW HANDLE
Part No. 324/8670

STD HIGHLIFT HANDLES
Part No. 330/5010

Part No. 324/8671

Spare Parts - 30° & 45°

Item	Description	Part No.
1	Split ring	368/0011
2	Handle lever	368/9837
3	M8 cap screw	5111-148
4	M8 plain washer	5113-005
5	Butterfly valve handle	368/0057
6	Handle location spring	368/0012
7	Handle locator pin	368/0010
8	Stuffing clamp	368/0047
9	Stuffing clamp bush	368/0301 <input type="checkbox"/>
10	PTFE O ring	20363 <input type="checkbox"/>
11	Spindle	368/0201
12	Viton O ring	20361 <input type="checkbox"/>
13	PTFE spindle seat	368/0009 <input type="checkbox"/>
14	Spring boss gasket	5005-845 <input type="checkbox"/>
15	Spring assembly	845/0050
16	Spring washer (2)	5113-008
17	Clamp screw (2)	845/0017
18	Seal energizer	845/0063 <input type="checkbox"/>
19	Bush seal	845/0064 <input type="checkbox"/>
20	Fortyt O ring	5005-104 <input type="checkbox"/>
21	Poppet	845/0040
22	Retaining pin	845/0015 <input type="checkbox"/>
23	Lifting fork	845/0010
24	Body	See Table 1
25	M12 full nut (4)	5112-006

Table 1

Item	Description	Part No.
24	Body assembly – 45° Uniflow	845/1107
	Body assembly – 30° Uniflow	848/1107

Spare Parts - 30° & 45°

Item	Description	Part No.
26	M12 spring washer (4)	5113-010
27	Perfluoroelastomer O ring	10133PHT <input type="checkbox"/>
28	PTFE O ring	5005-008 <input type="checkbox"/>
29	Spindle bearing	845/0062 <input type="checkbox"/>
30	Perlast O ring	5005-384 <input type="checkbox"/>
31	Spindle	845/0200
32	Stuffing clamp	845/0016
33	Clamp bolt (2)	5111-022
34	Spring washer (2)	5113-008
35	Stuffing seal	845/0061 <input type="checkbox"/>
36	Viton O ring	5005-336 <input type="checkbox"/>
37	PTFE bottom bush	368/0035 <input type="checkbox"/>
38	Bottom spindle	368/0036
39	PTFE butterfly valve main seal	368/0002 <input type="checkbox"/>
40	M12 hex bolt (4)	5111-023
41	3" BSP cap with chain & washer	10303PS
42	Outlet flange	368/5129
43	Closure plate	368/0400
44	M8 full nut (2)	5112-001
45	M8 spring washer (2)	5113-003
46	M8 countersunk bolt	5111-085
47	Retaining washer	20370
48	M6 setscrew	5111-030
49	Handle – See illustrations above	TBA-see note*
50	Handle linkage assembly	324/8910

Associated Parts

Associated Parts	Part No.
Stud kit	845/2040
Inlet gasket – 8 hole	5005-015
3" BSP Blank cap with PTFE washer	10303PS
Slotted adaptor flange	368/5219/3

3" 30° & 45° Univalve

Part Number :
804/4000A - 45° (Illustrated)
805/4000A - 30°

SEAL KIT - 804/40SK contains parts marked



SELF ADHESIVE DECAL
PART NO. 326/0302
 Text in English, German & French

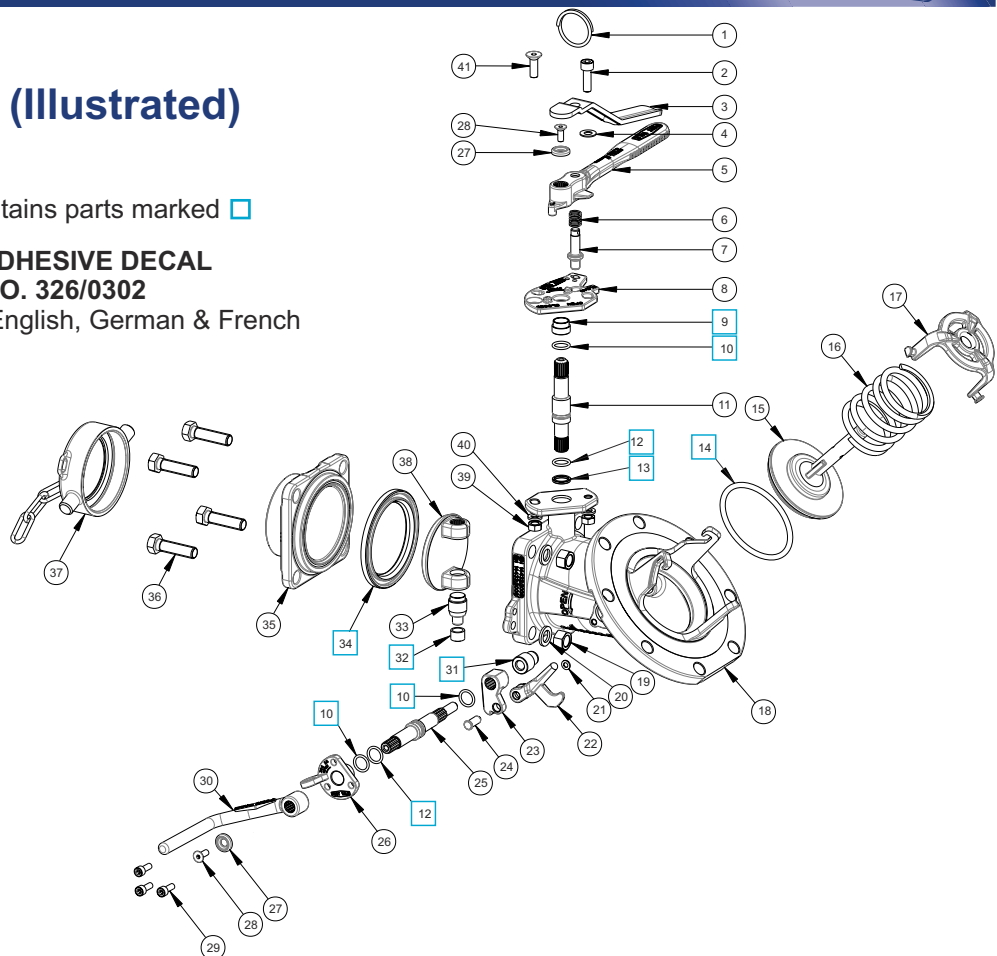

Spare Parts - 30° & 45°

Item	Description	Part No.
1	Split ring	368/0011
2	M8 cap screw	5111-148
3	Handle lever	368/9837
4	M8 plain washer	5113-005
5	Butterfly valve handle	368/0057
6	Handle location spring	368/0012
7	Handle locator pin	368/0010
8	Stuffing clamp	368/0047
9	Stuffing clamp bush	368/0301 <input type="checkbox"/>
10	PTFE O ring (3)	20363 <input type="checkbox"/>
11	Spindle	368/0201
12	Viton O ring (2)	20361 <input type="checkbox"/>
13	PTFE spindle seat	368/0009 <input type="checkbox"/>
14	Fortyt footvalve main O ring	5005-104 <input type="checkbox"/>
15	Poppet	324/2020
16	Closure spring	5104-971
17	Spring top plate	290/6104
18	Body assembly	See Table 1
19	M12 full nut (4)	5112-006
20	M12 spring washer (4)	5113-010
21	5mm plain washer	5113-015

Spare Parts - 30° & 45°

Item	Description	Part No.
22	Lifting finger	See Table 1
23	Crank block	821/0025
24	Pivot pin	821/0034
25	Spindle	821/0010
26	Stuffing clamp	324/1001
27	Retaining washer (2)	20370
28	M6 bolt (2)	5111-030
29	M6 cap screw (3)	5111-017
30	Footvalve handle	330/5010
31	PTFE crankshaft end bush	20362 <input type="checkbox"/>
32	PTFE bottom bush	368/0035 <input type="checkbox"/>
33	Bottom spindle	368/0036
34	PTFE Butterfly valve main seal	368/0002 <input type="checkbox"/>
35	Outlet flange	368/5129
36	M12 hex bolt (4)	5111-023
37	3" BSP cap with chain & washer	10303PS1
38	Closure plate	368/0400
39	M8 full nut (2)	5112-001
40	M8 spring washer (2)	5113-003
41	M8 countersunk bolt	5111-085

Table 1

Item	Description	Part No.
18	Body assembly – 45° Univalve	826/1252A
	Body assembly – 30° Univalve	830/1252A
22	Lifting finger – 45° Univalve	821/0033
	Lifting finger – 30° Univalve	821/0052

Associated Parts

Associated Parts	Part No.
Stud kit	324/2070
Inlet gasket – 8 hole	5005-015
3" BSP Blank cap with PTFE washer	10303PS
Slotted adaptor flange	368/5219/3

4" 90° Pneumatic Cleanflow Footvalve

Part Number : 875/4000SS

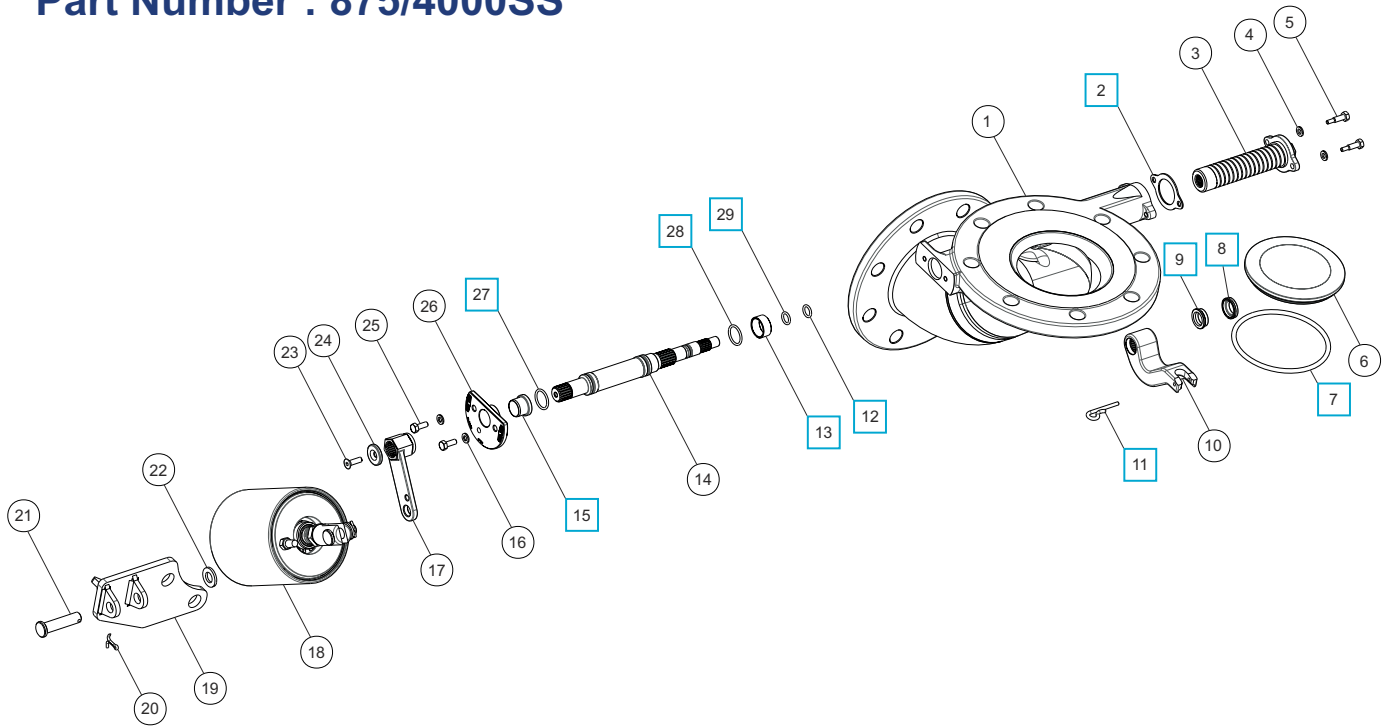

Spare Parts

Item	Description	Part No.
1	Body	875/4110
2	Spring boss gasket	5005-846 <input type="checkbox"/>
3	Spring assembly	875/0050
4	Spring washer (2)	5113-008
5	Clamp screw (2)	845/0017
6	Poppet	875/0040
7	Fortyt O ring	5005-349 <input type="checkbox"/>
8	PTFE bottom bush seal	845/0064 <input type="checkbox"/>
9	Bottom seal energizer	845/0063 <input type="checkbox"/>
10	Lifting fork	875/0010
11	Retaining pin	845/0015 <input type="checkbox"/>
12	Perfluoroelastomer O ring	10133PHT <input type="checkbox"/>
13	PTFE spindle bearing	845/0062 <input type="checkbox"/>
14	Main spindle	875/0200
15	PTFE spindle stuffing seal	845/0061 <input type="checkbox"/>

Spare Parts

Item	Description	Part No.
16	Spring washer (2)	5113-008
17	Crank arm weld assembly	324/8105
18	Pneumatic cylinder assembly	875/2110
19	Bracket	875/4115
20	Split pin	5220-008
21	Clevis pin	875/2122
22	Plain washer	5113-006
23	Countersunk screw	5111-019
24	Retaining washer	20370
25	Hex head bolt (2)	5111-022
26	Stuffing clamp flange	845/0060
27	Viton O ring	5005-336 <input type="checkbox"/>
28	Perfluoroelastomer O ring	5005-384 <input type="checkbox"/>
29	PTFE O ring	5005-008 <input type="checkbox"/>

SEAL KIT - 875/00SK contains parts marked

Associated Parts

Associated Parts	Part No.
Tank pad	854/9000
Stud kit	875/2040
Bolting kit – 8 hole outlet	468/1100
Inlet gasket – 8 hole	5005-467
Outlet gasket	5005-468



SELF ADHESIVE DECAL

Part No. 845/0320
 Text in English, German & French

2" Short Profile Footvalve for compressed liquefied gas

**Part Number :
802/0010X**

SEAL KITS

252/50SK : parts marked □
370/33SK : parts marked ■

REPAIR KITS

252/50RK : parts marked ○
370/33RK : parts marked ●

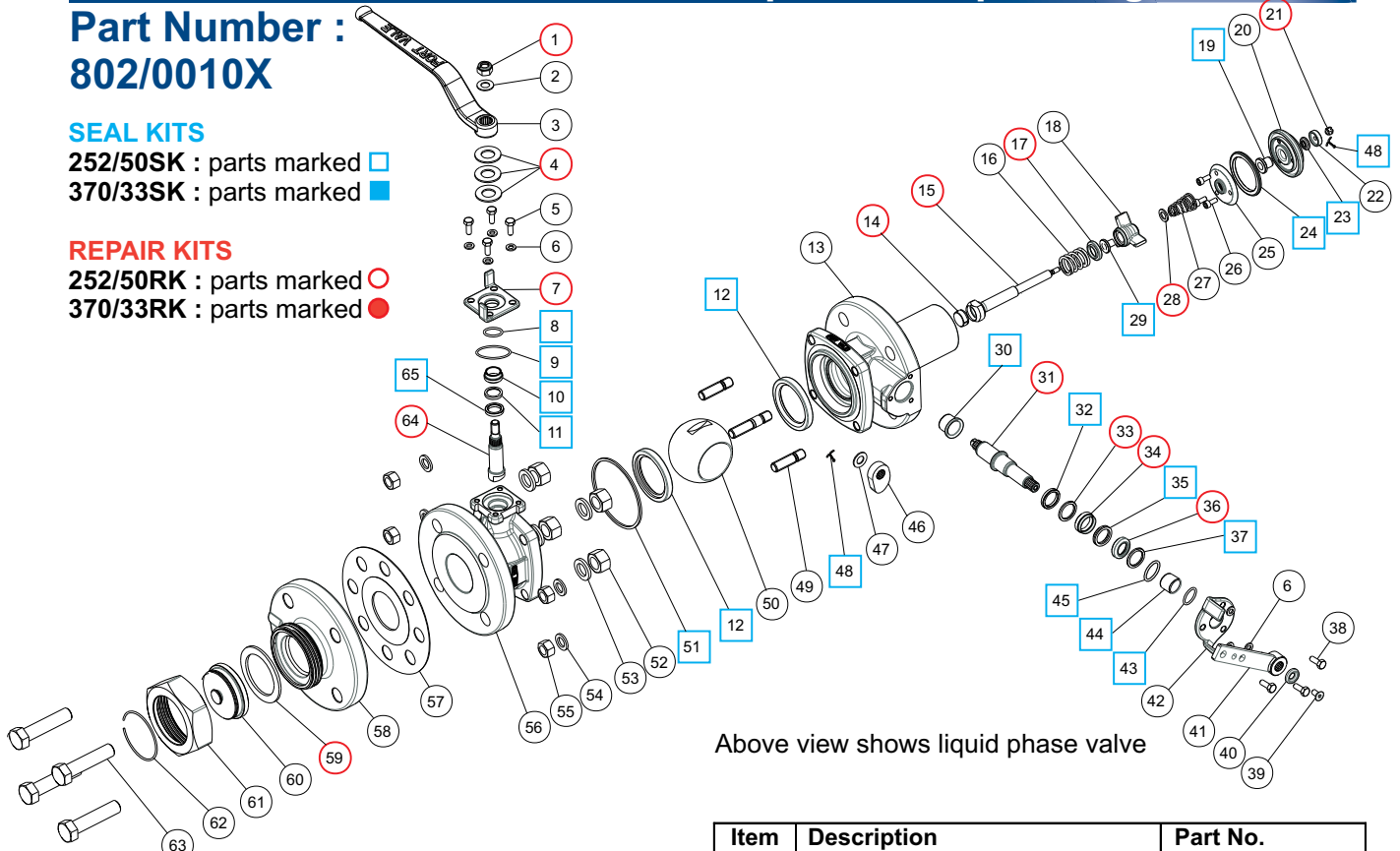

Above view shows liquid phase valve

Spare Parts

Item	Description	Part No.
1	M10 self locking nut	5112-008 ●
2	M10 washer	5113-009
3	Handle	370/3306
4	Disc spring (3)	5113-038 ●
5	M6 hex head bolt (4)	5111-022
6	M6 spring washer (7)	5113-008
7	Clamp plate	370/3305B ●
8	Neoprene O ring	5005-216 ■ ●
9	Neoprene O ring	5005-866N ■ ●
10	Spindle bush	370/3307B ■ ●
11	Spindle seal	359/2007 ■ ●
12	PTFE ball seal (2)	370/3302 ■ ●
13	2" Footvalve body	252/5065X
14	Fluorosint bearing pad	252/0580 ○
15	Push stem	252/0525 ○
16	Poppet spring	5104-826
17	Bottom spring pad	252/0526 ○
18	Spider stem guide	252/3165
19	Spindle guide bush	252/0589 □ ○
20	Poppet head	252/0586
21	M5 castle nut	5112-020 ○
22	Pilot seal retainer	252/0579
23	Pilot seal	252/0583 □ ○
24	PTFE main seal	252/0563 □ ○
25	Seal clamp	252/0588
26	M5 sockethead capscrew (3)	5111-118
27	Liquid phase spring	5104-824L
	Gas phase spring	5104-821G
28	Spring location washer	252/0511
29	Push stem guide bush	252/0565 □ ○
30	Bottom guide bush	252/0506B □ ○
31	Spindle	252/0504 ○
32	Bottom stem seal	359/4007 □ ●
33	Spacer ring	359/4012 ○

Item	Description	Part No.
34	Spacer ring	252/0512 ○
35	Top gland seal	359/4013 □ ○
36	Top seal bush	252/0507 ○
37	Top guide bush	252/0502B □ ○
38	M6 hex head bolt (3)	5111-022
39	M6 countersunk screw	5111-018
40	Retaining washer	20370
41	Handle weld assembly	252/3520
42	Stuffing plate	252/5058B
43	Neoprene O ring	5005-216 □ ○
44	Split bearing	252/0517 □ ○
45	Neoprene O ring	5005-217 □ ○
46	Operating cam	252/0527
47	M10 washer	5113-009
48	Split pin (2)	5118-011 □ ○
49	M12 stud (4)	370/3314
50	50mm ball	370/3301
51	Body seal	370/3303 ■ ●
52	M16 full nut (4)	5112-003
53	M16 spring washer (4)	5113-012
54	M12 spring washer (4)	5113-010
55	M12 full nut (4)	5112-006
56	2" gas ball valve body	370/3368
57	CNAF/PTFE envelope gasket	5005-726
58	3.25" ACME outlet	252/2069
	1.75" ACME outlet	252/2084
59	PTFE seal (3.25" ACME)	5005-877 ●
	PTFE seal (1.75" ACME)	5005-878 ●
60	3.25" ACME cap plug	252/2076
	1.75" ACME cap plug	252/2086
61	3.25" ACME dust cap	252/2075
	1.75" ACME dust cap	252/2085
62	Retaining ring clip (3.25" ACME)	5120-027
	Retaining ring clip (1.75" ACME)	5120-028
63	M16 hex head bolt (4)	5111-090
64	Spindle	370/3320 ●
65	Bottom bush	370/3321 ■ ●

3" to 2" Liquid Phase Short Profile Footvalve

Part Number : 803/0020X

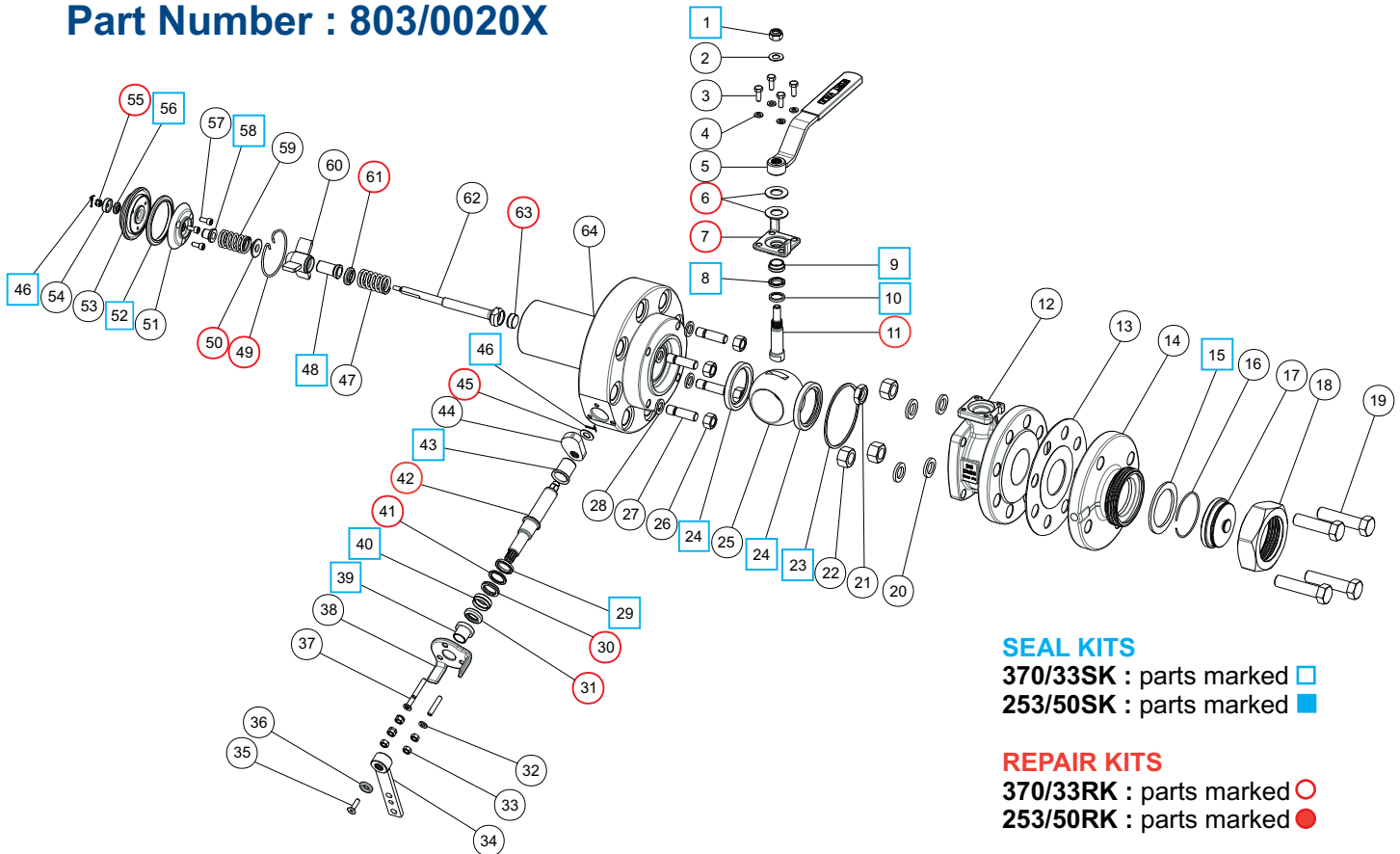

SEAL KITS

370/33SK : parts marked
253/50SK : parts marked

REPAIR KITS

370/33RK : parts marked
253/50RK : parts marked

Spare Parts

Item	Description	Part No.	
1	M10 self locking nut	5112-008	<input type="checkbox"/> <input type="checkbox"/>
2	M10 washer	5113-009	
3	M6 hex head bolt (4)	5111-022	
4	M6 spring washer (4)	5113-008	
5	Handle	370/3306	
6	M16 belleville Washer (2)	5113-038	<input type="checkbox"/>
7	Clamp plate	370/3305	<input type="checkbox"/>
8	Spindle seal	359/2007	<input type="checkbox"/> <input type="checkbox"/>
9	Spindle bush	370/3307	<input type="checkbox"/> <input type="checkbox"/>
10	Bottom bush	370/3321	<input type="checkbox"/> <input type="checkbox"/>
11	Spindle	370/3320	<input type="checkbox"/>
12	2" gas ballvalve body	370/3365	
13	PTFE envelope gasket	5005-726	
14	3.25" ACME outlet	252/2070	
15	PTFE seal	5005-877	<input type="checkbox"/> <input type="checkbox"/>
16	Retaining ring clip	5120-027	
17	3.25" ACME cap plug	252/2076	
18	3.25" ACME dust cap	252/2075	
19	M16 hex head bolt (4)	5111-090	
20	M16 spring washer (4)	5113-012	
21	M16 half nut	5112-021	
22	M16 full nut (3)	5112-003	
23	Body seal	370/3303	<input type="checkbox"/> <input type="checkbox"/>
24	PTFE ball seal (2)	370/3302	<input type="checkbox"/> <input type="checkbox"/>
25	50mm ball	370/3301	
26	M12 full nut (4)	5112-006	
27	M12 stud (4)	324/2041	
28	M12 spring washer (4)	5113-010	
29	Bottom stem seal	359/4007	<input type="checkbox"/> <input type="checkbox"/>
30	Spacer ring	252/0512	<input type="checkbox"/>
31	Top seal bush	252/0507	<input type="checkbox"/>
32	M6 spring washer (3)	5113-008	

Spare Parts

Item	Description	Part No.	
33	M6 full nut (6)	5112-012	
34	Handle weld assembly	252/3520	
35	M6 countersunk socket screw	5111-019	
36	Retaining washer	20370	
37	M6 stud (3)	252/0594	
38	Stuffing plate	252/5052	
39	Top guide bush	252/0502	<input type="checkbox"/> <input checked="" type="checkbox"/>
40	Top gland seal	359/4013	<input type="checkbox"/> <input checked="" type="checkbox"/>
41	Spacer ring	359/4012	<input checked="" type="checkbox"/>
42	Spindle	253/0504	<input checked="" type="checkbox"/>
43	Bottom spindle guide	253/0506	<input type="checkbox"/> <input checked="" type="checkbox"/>
44	Operating cam	253/0527	
45	M10 washer	5113-009	<input checked="" type="checkbox"/>
46	Split pin (2)	5118-011	<input type="checkbox"/> <input checked="" type="checkbox"/>
47	Pilot spring	5104-815	
48	Push stem guide bush	253/0565	<input type="checkbox"/> <input checked="" type="checkbox"/>
49	Snap ring	5120-006	<input checked="" type="checkbox"/>
50	Spring location washer	252/0584	<input checked="" type="checkbox"/>
51	Poppet clamp	253/0588	
52	PTFE main seal	253/0563	<input type="checkbox"/> <input checked="" type="checkbox"/>
53	Poppet head	253/0586	
54	Pilot seal retainer	252/0579	
55	M5 castle nut	5112-020	<input checked="" type="checkbox"/>
56	Pilot seal	252/0583	<input type="checkbox"/> <input checked="" type="checkbox"/>
57	M5 sockethead capscrew (3)	5111-118	
58	Poppet guide bush	252/0589	<input type="checkbox"/> <input checked="" type="checkbox"/>
59	Excess flow spring	5104-816	
60	Spider stem guide	253/3155	
61	Bottom spring pad	252/0526	<input checked="" type="checkbox"/>
62	Push rod	253/0525	<input checked="" type="checkbox"/>
63	Fluorosint bearing pad	252/0580	<input checked="" type="checkbox"/>
64	3" gas footvalve body	253/5075L	

80mm Internal Gas Relief Valve

Part Number : 006/2XXX5

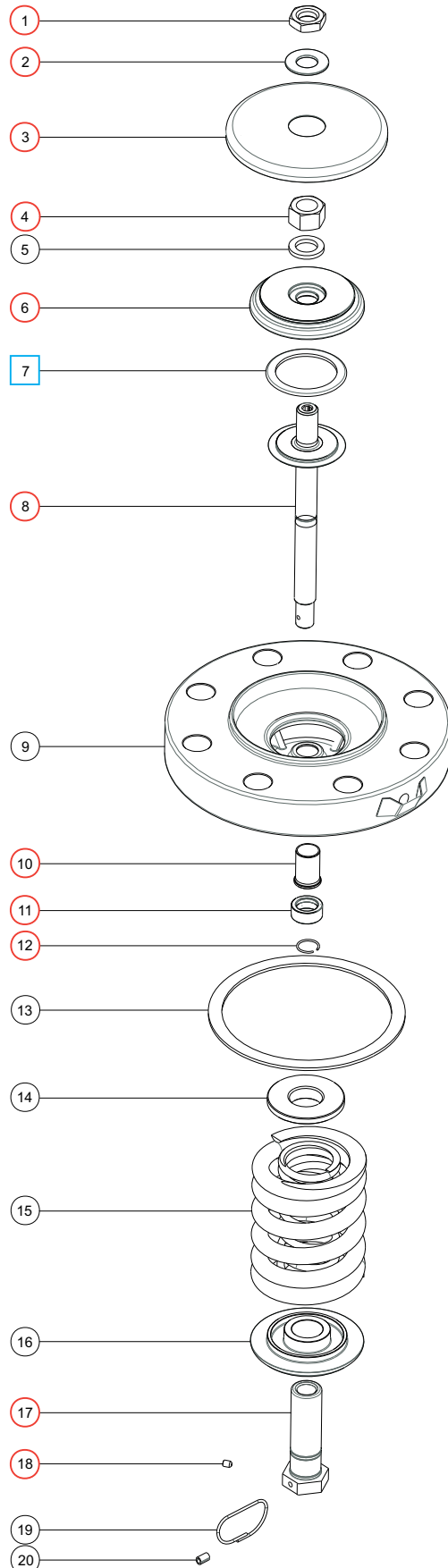

Spare Parts

Item	Description	Part No.
1	M20 x 1.5mm lock nut	5112-036 ○
2	Cowl retaining washer	055/0135 ○
3	Cowl	055/0130 ○
4	M20 x 1.5mm full nut	5112-033 ○
5	M20 spring washer	5113-016
6	Poppet head	055/0117 ○
7	Main seal	5005-825 □ ○
8	Poppet stem assembly	055/0120 ○
9	Body weld assembly (006/2XXX5)	055/0250
10	Spindle guide bush	055/0115 □ ○
11	Stop collar	055/0113 ○
12	Retaining ring clip	055/0114 ○
13	PTFE gasket (supplied separate)	5005-81X
14	Top spring locator (see below)	055/0116X
15	Spring pair (see below)	8104-XXXX
16	Bottom spring locator (see below)	055/0110X
17	Spring nut	055/0020 ○
18	M6 x 8mm grub screw	5111-133 ○
19	Tamper wire	055/0060
20	Stainless ferrule	SF2.5

SEAL KIT - 006/00SK contains parts marked □
REPAIR KIT - 006/00RK contains parts marked ○

Springs and Spring Locators

Please note that the top and bottom spring locators are manufactured to suit the dimensions of the spring pair. We advise that you contact our Sales department for spring information.

Associated Parts

Associated Parts	Part No.
Pressure gauges to suit various valve pressures	Various – please contact our Sales team
PTFE gasket (006/2XXX0)	5005-818
PTFE gasket (006/2XXX5)	5005-812



SELF ADHESIVE DECAL
 Part No. 005/DECAL
 Text in English, German & French

80mm Internal Gas Relief Valve & Bursting Disc Holder
Part Number : 005/2XXX5

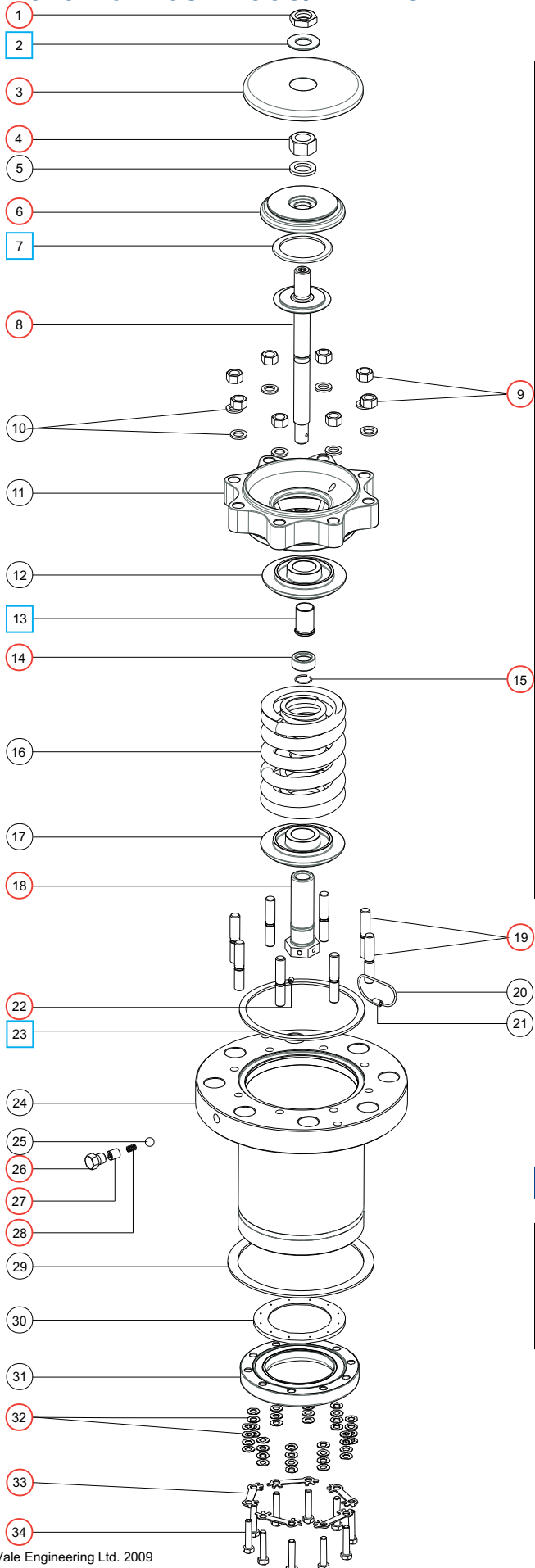

Spare Parts

Item	Description	Part No.
1	M20 x 1.5mm lock nut	5112-036 ○
2	Cowl retaining washer	055/0135 □○
3	Cowl	055/0130 ○
4	M20 x 1.5mm full nut	5112-033 ○
5	M20 spring washer	5113-016
6	Poppet head	055/0117 ○
7	Main seal	5005-825 □○
8	Poppet stem assembly	055/0120 ○
9	M12 full nut (8)	5112-006 ○
10	M12 spring washer (8)	5113-010
11	Body weld assembly	055/0100
12	Top spring locator <i>see note</i>	055/0116X
13	Spindle guide bush	055/0115 □○
14	Stop collar	055/0113 ○
15	Retaining ring clip	055/0114 ○
16	Spring pair <i>see note</i>	8104-XXXX
17	Bottom spring locator <i>see note</i>	055/0110X
18	Spring nut	055/0020 ○
19	M12 stud (8)	055/0050 ○
20	Retaining wire	055/0060
21	Stainless ferrule	SF2.5
22	M6 x 8mm grub screw	5111-133 ○
23	PTFE gasket	5005-826 □○
24	Burst disc holder	055/0150
25	11mm ball	055/0031
26	¼" BSP taper plug	5128-009 ○
27	Ball seal	055/0030 ○
28	Spring	5104-115 ○
29	PTFE tank seal (sold separately)	5005-812
30	Burst disc (sold separately)	various
31	Bursting disc support flange	044/1034
32	8mm Belleville washer (40)	5113-020 ○
33	Anti rotation tab (5)	055/0025 ○
34	Hex bolt (10)	5111-011 ○

SEAL KIT - 005/00SK contains parts marked □
REPAIR KIT - 005/00RK contains parts marked ○

Springs and Spring Locators

Please note that the top and bottom spring locators are manufactured to suit the dimensions of the spring pair. We advise that you contact our Sales department for spring information.

Associated Parts

Associated Parts	Part No.
Pressure Gauges to suit various valve pressures	Various – please contact our Sales team
CNAF/PTFE gasket (005/2XXX0)	5005-815
PTFE gasket (005/2XXX5XX)	5005-812



SELF ADHESIVE DECAL
Part No. 005/DECAL
Text in English, German & French

ACME Outlet Assemblies - 1.75" & 3.25"

Part Number : 252/2087



1.75" ACME outlet spigot complete with cap and PTFE seal. Drilled 4 x 18mm holes on a 127mm PCD. Manufactured in 316 stainless steel.

This assembly is suitable for gas phase applications.

Spare Parts

Description	Part No.
1.75" ACME outlet	252/2080
1.75" ACME dust cap	252/2085
1.75" ACME cap plug	252/2086
PTFE seal for 1.75" ACME dust cap	5005-878
Retaining ring clip for 1.75" ACME	5120-028
Captivating wire	425/0004

Part Number : 252/2077



3.25" ACME outlet spigot complete with cap and PTFE seal. Drilled 4 x 18mm holes on a 127mm PCD. Manufactured in 316 stainless steel.

This assembly is suitable for liquid phase applications.

Spare Parts

Description	Part No.
3.25" ACME outlet	252/2070
3.25" ACME dust cap	252/2075
3.25" ACME cap plug	252/2076
PTFE seal for 3.25" ACME dust cap	5005-877
Retaining ring clip for 3.25" ACME	5120-027
Captivating wire	425/0004

1" BSP Minnow Relief Valve - Pressure Only

Part Number : 65/XXX00

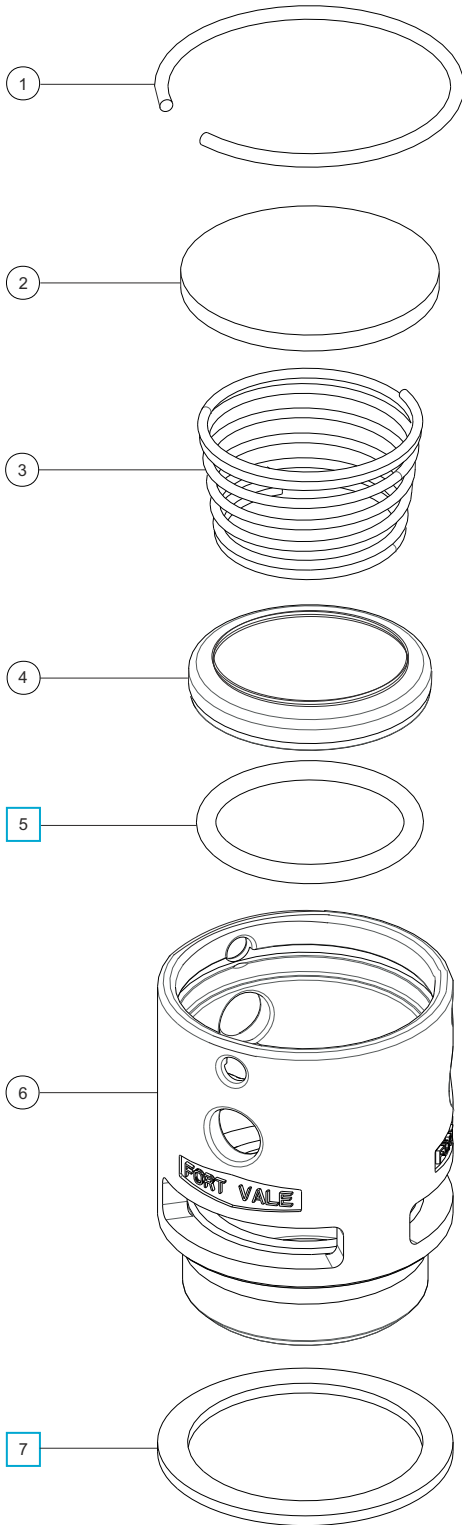

Spare Parts

Item	Description	Part No.
1	Retaining clip (below 10 PSI/0.69 Bar)	5120-015
	Retaining clip (above 10 PSI/0.69 Bar)	5120-021
2	Top cap	179/0010
3	Pressure spring See Table 1	5104-XXX
4	Pressure plate See NOTE	179/0050XX
5	Pressure o ring See Table 2 & NOTE	5005-XXX <input type="checkbox"/>
6	Body	179/0100
7	PTFE gasket	5005-553 <input type="checkbox"/>

SEAL KIT - 65/XPSK contains parts marked
 (Part number varies according to seal material)

NOTE

Please note that additional tooling is required to peen the pressure o ring into the pressure plate.
 When a pressure o ring requires replacing, Fort Vale strongly recommends the purchase of a pressure plate with a factory-fit pressure o ring. (See Table 2)

TABLE 1

Common Pressure Settings	Pressure Spring Part No.
3 PSI (0.21 Bar)	5104-653
6 PSI (0.41 Bar)	5104-656
9 PSI (0.62 Bar)	5104-659
30 PSI (2 Bar)	5104-695

Pressure springs are available from 1 PSI (0.07 Bar) to 45 PSI (3.10 Bar)

TABLE 2 - See NOTE

Seal Material	Pressure o ring	Pressure plate with o ring
Viton	5005-552	179/0050VS
EPDM	5005-651	179/0050ES
Perfluoroelastomer	5005-585	179/0050PERS
Silicone	5005-615	179/0050SS

Associated Parts

Part No.	Description
600/1025	1" tank weld-in socket
600/1026	1" tank weld-in nipple
179/0300	1" Clamped type gauze ring

3/4" BSPT Steam Tell-Tale Valve

Part Number : 56/0XXX0

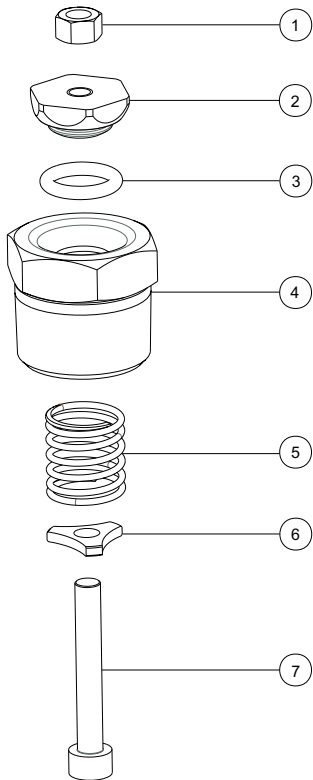

Spare Parts

Item	Description	Part No.
1	M5 nut	5112-010
2	Poppet head	54/00003
3	Viton O ring	5005-650
4	Body	54/00001
5	Spring <i>Part no. varies</i>	5104-XXXXA
6	Spring locator	54/00002
7	M5 cap screw	5111-128

3/4" BSPT Steam Relief Valve

Part Number : 53/0XX00

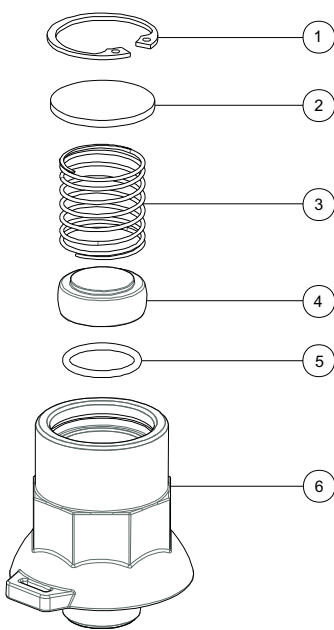

Spare Parts

Item	Description	Part No.
1	Cap	58/03650
2	Setscrew	5121-001
3	Inner spring <i>* See note</i>	5104-90XX
4	Outer spring <i>* See note</i>	5104-9XXX
5	Poppet assembly with Viton GF seal <i>* See note</i>	58/0362X
6	Body	58/03640

2 1/2" BSP Super Maxi Relief Valve

Part Number : 010/1XXXX
(pressure/vacuum - Illustrated)
Part Number : 010/1XX00
(pressure only - not shown)

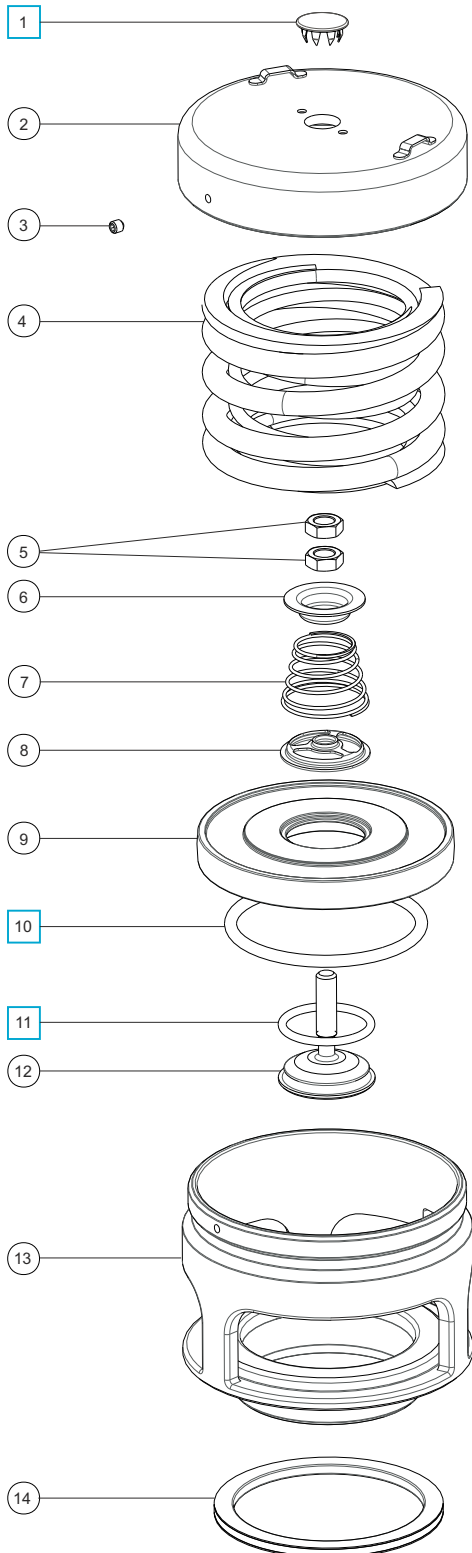

Spare Parts - Pressure/Vacuum version

Item	Description	Part No.
1	Stainless steel plug	10978 <input type="checkbox"/>
2	Cap	1760/0005
3	Setting locking grub screw	5121-001
4	Pressure springs *See Table 1	6104-XXXX
5	M8 half nut (2)	5112-004
6	Vacuum spring pad	1860/0005
7	Vacuum spring *See Table 2	7104-XXX
8	Spring pad	10986/3
9	Pressure plate *See Note	1860/005X
10	Fortyt pressure O ring *See Note	5005-101 <input type="checkbox"/>
11	Fortyt vacuum O ring *See Note	5005-108H <input type="checkbox"/>
12	Vacuum poppet	10983V/3
13	Body	1860/0100
14	Rubber/PTFE envelope seal	5005-046

*Note: Part no. varies according to valve specification.
SEAL KIT - 000/1PVSK contains parts marked

Spare Parts - Pressure Only version

Item	Description	Part No.
1	Stainless steel plug	10978 <input type="checkbox"/>
2	Cap	1760/0005
3	Setting locking grub screw	5121-001
4	Pressure spring *See Table 1	6104-XXXX
9	Fortyt pressure plate *See Note	1860/0058
10	Fortyt pressure O ring *See Note	5005-101 <input type="checkbox"/>
13	Body assembly	1860/0100
14	Rubber/PTFE envelope seal	5005-046

*Note: Part no. varies according to valve specification.
SEAL KIT - 000/1PSK contains parts marked

TABLE 1

Common Pressure Settings	Pressure Spring Part No.
31.8 PSI (2.19 Bar)	6104-0252
48 PSI (3.31 Bar)	6104-0112 & 6104-0252
53.8 PSI (3.71 Bar)	6104-0422 (Pair)
63.8 PSI (4.40 Bar)	6104-0485 (Pair)

TABLE 2

Common Vacuum Setting	Vacuum Spring Part No.
6.2"Hg (0.21 Bar)	7104-012

Pressure springs are available from 2 PSI to 75 PSI (0.14 Bar to 5.17 Bar).

Vacuum springs are available from 0.5"Hg to 26"Hg (0.02 Bar to 0.88 Bar)

Associated Parts

Part No.	Associated Parts
600/1000	2 1/2" BSP weld-in socket
176/7020	Adaptor assembly for bursting disc
176/3150	Tank weld-in pad
176/7001	Adaptor flange for bursting disc
862/XXXX	65mm bursting disc – full range available
5005-398	CNAF/PTFE gasket to suit weld-in pad/adaptor flange
92X/07XXXX	0-100 PSI pressure gauge – contact Sales for details of full range
176/2900	Removable flameproof gauze
176/6000	Gauzed cowl

80mm Flanged Super Maxi Relief Valve - Pressure Only

Part Number : 013/1XX0080X

Spare Parts

Item	Description	Part No.
1	Plastic plug	10978 <input type="checkbox"/>
2	Top cap <i>see below</i>	1760/000X
3	Setting locking grub screw	5121-001
4	Spring pair <i>see below</i>	6104-0XXX
5	Pressure plate <i>see below</i>	1860/006X
6	Fortyt O Ring	5005-104 <input type="checkbox"/>
7	Body <i>see below</i>	1860/080X

SEAL KIT - 000/1PSK80 contains parts marked

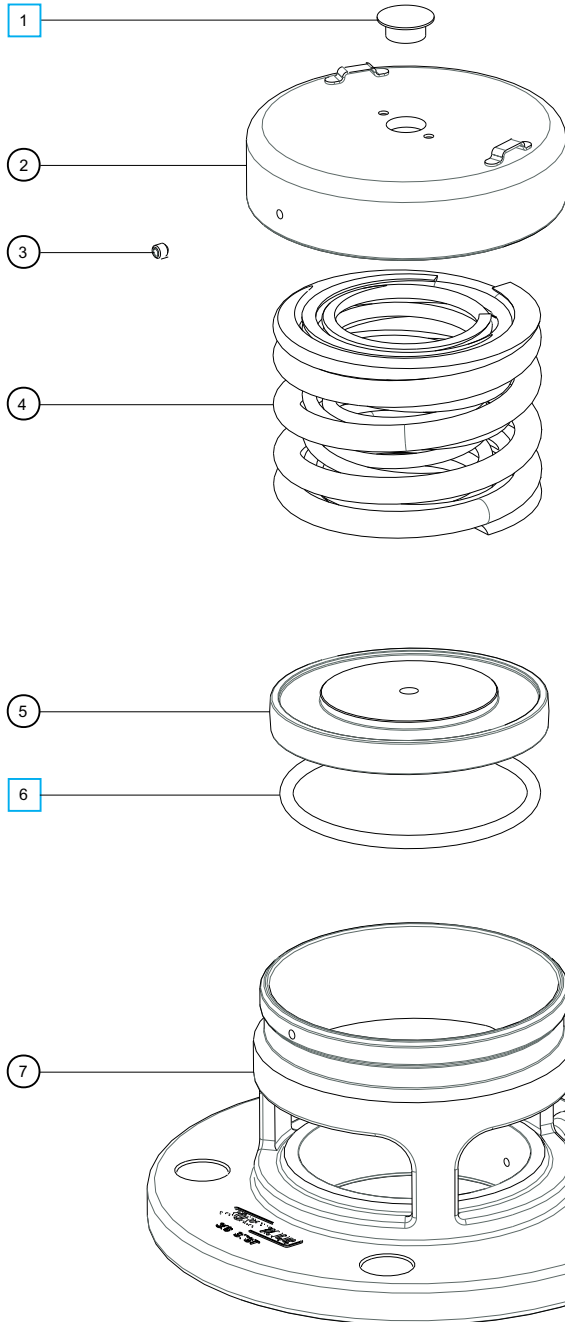

Pressure Setting	Pressure Springs	Top Cap	Pressure Plate
31.8 PSI	6104-0310	1760/0005	1860/0060
48 PSI	6104-0485	1760/0005	1860/0060
53.8 PSI	6104-0570	1760/0005	1860/0060
63.8 PSI	6104-0665	1760/0007	1860/0062

Flange Drilling	Body
013/1XXXX800	1860/0800
013/1XXXX801	1860/0801
013/1XXXX805	1860/0805
013/1XXXX807	1860/0807
013/1XXXX808	1860/0808

Associated Parts

Part No.	Flange Drilling	Weld-in Flange	Gasket
013/1XXXX800	DIN 65 PN 10	176/3250	5005-332
013/1XXXX801	DIN 80 PN 6	176/3158	5005-334
013/1XXXX805	3" ASA 150	176/3125	5005-204

Part No.	Associated Parts
921/07BBSP	0-100 PSI pressure gauge, bottom entry, brass internal parts
921/07RBSP	0-100 PSI pressure gauge, rear entry, brass internal parts
920/07BBSP	0-100 PSI pressure gauge, bottom entry, stainless steel internal parts
176/2900	Removeable clamped gauze
864/XXXX	80mm bursting disc
311/3700	Stud kit (4 x M16)

80mm Flanged Super Maxi Relief Valve - Pressure/Vacuum

Part Number : 013/1XXXX80X

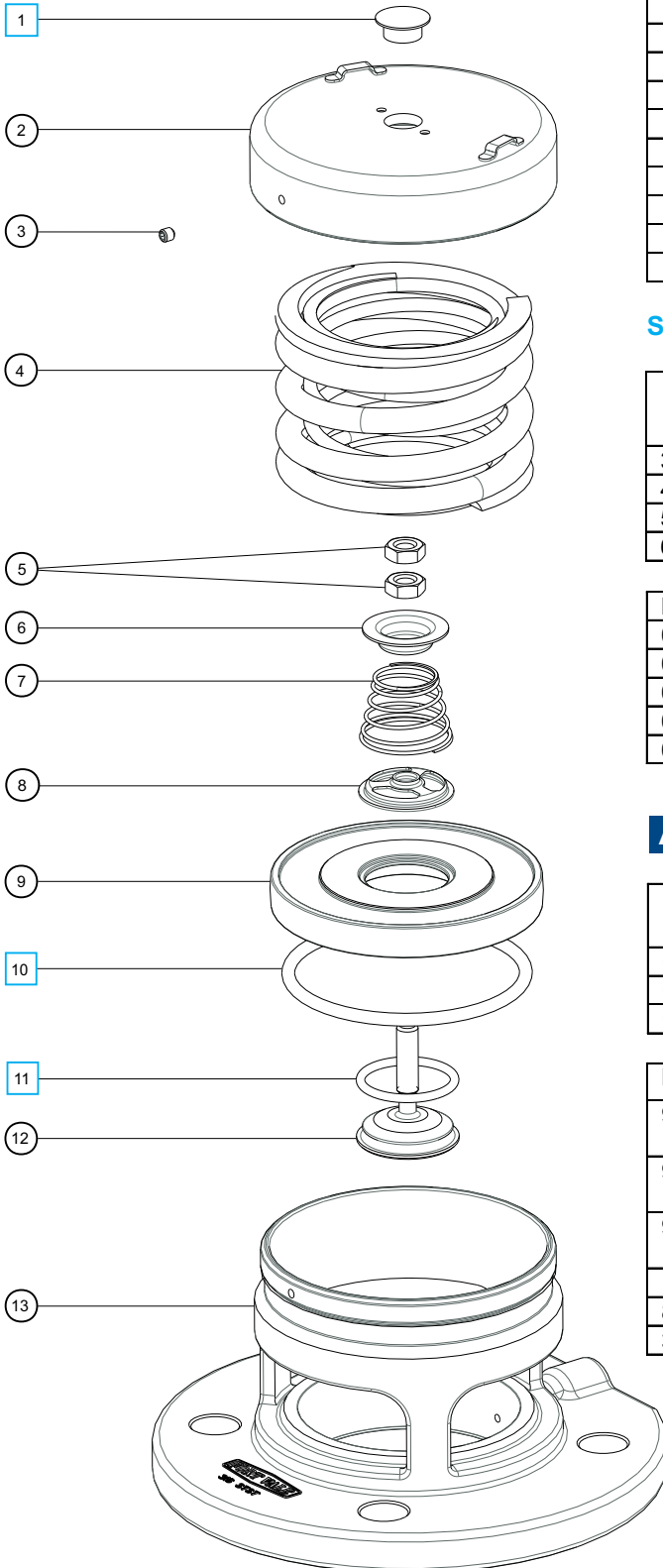

Spare Parts

Item	Description	Part No.
1	Plastic plug	10978 <input type="checkbox"/>
2	Cap <i>see below</i>	1760/000X
3	Setting locking grub screw	5121-001
4	Pressure spring pair <i>see below</i>	6104-XXXX
5	M8 lock nut (2)	5112-004
6	Vacuum spring pad	1860/0005
7	Vacuum spring	7104-012
8	Spring pad	10986/3
9	Pressure plate <i>see below</i>	1860/006X
10	Fortyt pressure O ring	5005-104 <input type="checkbox"/>
11	Fortyt vacuum O ring	5005-108H <input type="checkbox"/>
12	Vacuum poppet	10983V/3
13	Body assembly <i>see below</i>	1860/080X

SEAL KIT - 000/1PVSK80 contains parts marked

Pressure Setting	Pressure Springs	Top Cap	Pressure Plate
31.8 PSI	6104-0310	1760/0005	1860/0061
48 PSI	6104-0485	1760/0005	1860/0061
53.8 PSI	6104-0570	1760/0005	1860/0061
63.8 PSI	6104-0665	1760/0007	1860/0066

Flange Drilling	Body
013/1XXXX800	1860/0800
013/1XXXX801	1860/0801
013/1XXXX805	1860/0805
013/1XXXX807	1860/0807
013/1XXXX808	1860/0808

Associated Parts

Part No.	Flange Drilling	Weld-in Flange	Gasket
013/1XXXX800	DIN 65 PN 10	176/3250	5005-332
013/1XXXX801	DIN 80 PN 6	176/3158	5005-334
013/1XXXX805	3" ASA 150	176/3125	5005-204

Part No.	Associated Parts
921/07BBSP	0-100 PSI pressure gauge, bottom entry, brass internal parts
921/07RBSP	0-100 PSI pressure gauge, rear entry, brass internal parts
920/07BBSP	0-100 PSI pressure gauge, bottom entry, stainless steel internal parts
176/2900	Removeable clamped gauze
864/XXXX	80mm bursting disc
311/3700	Stud kit (4 x M16)

2 1/2" BSP Twinact Relief Valve - Pressure Only

Part Number : 20/XXX00

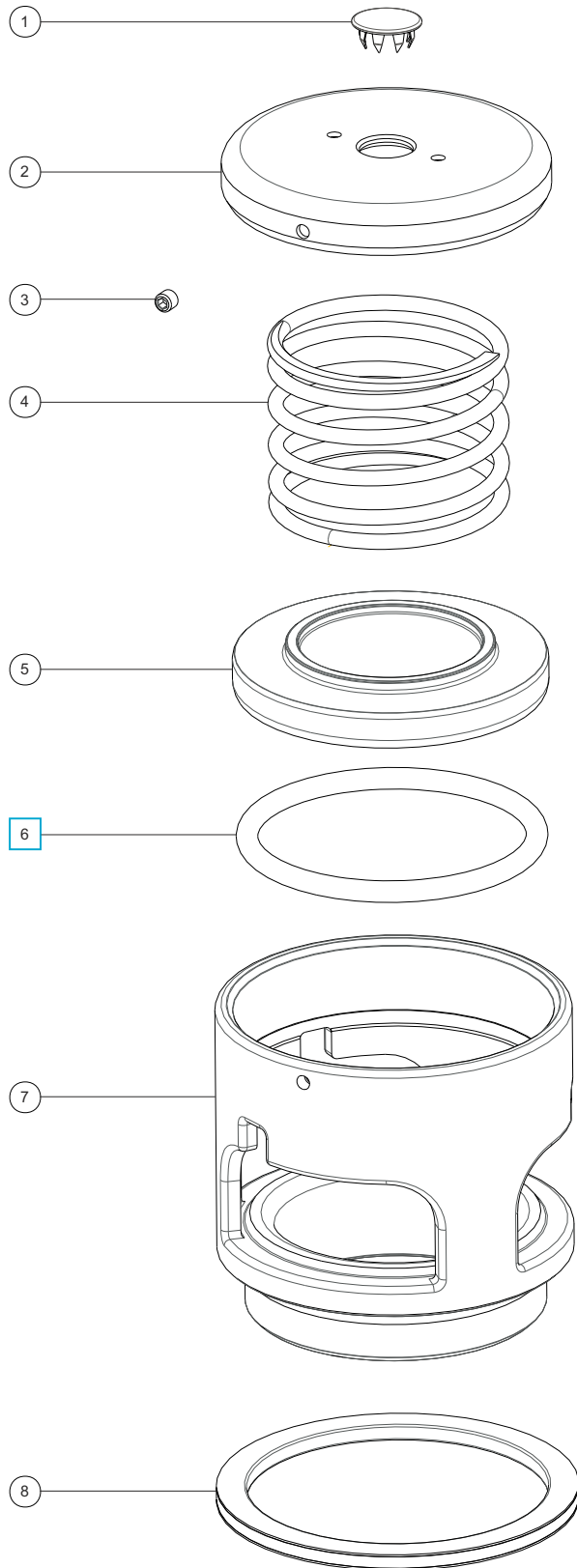

Spare Parts

Item	Description	Part No.
1	Stainless steel plug	10978
2	Top cap	10967/1
3	Grub screw	5121-001
4	Pressure spring See Table 1	5104-XXX
5	Pressure plate See NOTE	175/XXXX
6	Pressure o ring See Table 2 & NOTE	5005-XXX <input type="checkbox"/>
7	Body assembly	10951
8	Rubber/PTFE envelope gasket	5005-046

SEAL KIT - contains all parts marked

Part number **20/1PSK** contains Fortyt O ring
 Part number **20/0PSK** contains Viton O ring

NOTE

Please note that additional tooling is required to peen the pressure o ring into the pressure plate. When a pressure plate needs replacing, Fort Vale strongly recommends the purchase of a pressure plate with a factory-fit pressure o ring. (See Table 3)

TABLE 1

Common Pressure Settings	Pressure Springs
28 to 30 PSI (1.93 Bar to 2.07 Bar)	5104-529

Pressure springs are available from 1 PSI (0.07 Bar) to 63 PSI (4.34 Bar)

TABLE 2 - See NOTE

Seal Material	Pressure o ring
Fortyt	5005-101
Viton	5005-102

TABLE 3

Seal Material	Pressure Plate	Pressure plate with o ring
Fortyt	175/0111	175/0111F
Viton	175/0121	175/0121V

Associated Parts

Part No.	Description
600/1000	2 1/2" Tank weld in socket
176/3150	2 1/2" Tank weld in flange
130/5000	2 1/2" Clamped type gauze ring
5005-027	PTFE tank seal
5005-026	CNAF tank seal



C SPANNER : 400/3000

For fitting & removal of relief valves, size range 1 1/4" to 3".

2 1/2" BSP Twinact Relief Valve - Pressure/Vacuum

Part Number : 20/XXXXX

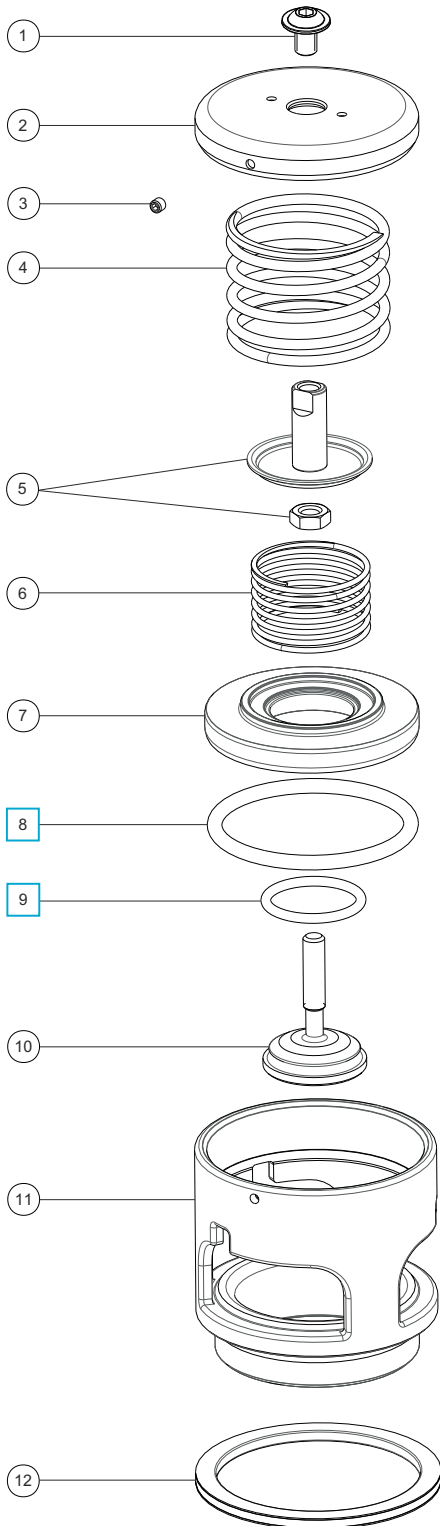

C SPANNER : 400/3000
 For fitting & removal of relief valves, size range 1 1/4" to 3".

Spare Parts

Item	Description	Part No.
1	Flanged button screw	5111-9812
2	Top cap	10967/1
3	Grub screw	5121-001
4	Pressure spring See Table 1	5104-XXX
5	Spring pad assembly	130/0010
6	Vacuum spring See Table 2	5104-XXX
7	Pressure plate See NOTE	175/00XXX
8	Pressure o ring see Table 3 & NOTE	5005-XXX <input type="checkbox"/>
9	Vacuum o ring see Table 3	5005-XXX <input type="checkbox"/>
10	Vacuum poppet	10983V
11	Body	10951
12	Rubber/PTFE envelope gasket	5005-046

SEAL KIT - contains all parts marked

Part no. **20/1PVSK** contains Fortyt O rings
 Part no. **20/0PVSK** contains Viton O rings

NOTE

Please note that additional tooling is required to peen the pressure o ring into the pressure plate. When a pressure plate needs replacing, Fort Vale strongly recommends the purchase of a pressure plate with a factory-fit pressure o ring. (See Table 4)

TABLE 1

Common Pressure Settings	Pressure Springs
28 to 30 PSI (1.93 Bar to 2.07 Bar)	5104-529

Pressure springs are available from 1 PSI (0.07 Bar) to 63 PSI (4.34 Bar)

TABLE 2

Common Vacuum Settings	Vacuum Springs
0.5" Hg (0.02 Bar)	5104-560
1" Hg (0.03 Bar)	5104-561
3" Hg (0.10 Bar)	5104-563

Vacuum springs are available from 0.5"Hg (0.02 Bar) to 28"Hg (0.94 Bar)

TABLE 3 - See NOTE

Seal Material	Pressure o ring	Vacuum o ring
Fortyt	5005-101	5005-108H
Viton	5005-102	5005-107

TABLE 4

Seal Material	Pressure plate	Pressure plate with o ring
Fortyt	175/0061	175/0061F
Viton	175/0031	175/0031V

Associated Parts

Part No.	Description
600/1000	2 1/2" Tank weld-in socket
176/3150	2 1/2" Tank weld-in flange
130/5000	2 1/2" Clamped type gauze ring
5005-046	Rubber/PTFE tank seal
5005-026	CNAF tank seal (high temp. application)

1½" BSP Uniact Relief Valve - Vacuum Only

Part Number : 47/XXXXXA

Part No. 47/XXXXXAGZ illustrated

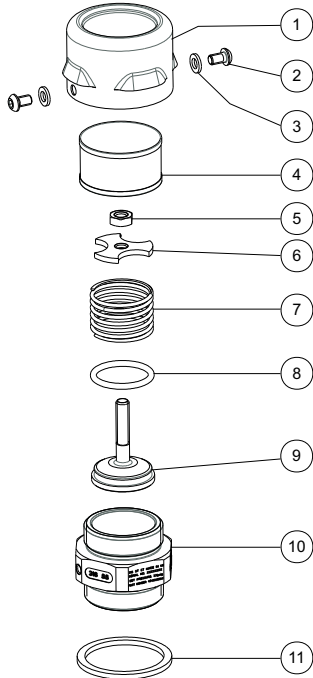

Spare Parts - Vacuum Only

Item	Description	Part No.
1	Cap	10217/1
2	M6 button screw (2)	5111-611
3	M6 spring washer (2)	5113-008
4	Gauze ring	10204
5	M8 half nut	5112-004
6	Spring pad	10215
7	Spring (see table 1)	5104-XXX
8	O ring (see table 2)	5005-XXX
9	Poppet	10983V
10	Body	10213
11	CNAF gasket	5005-011

TABLE 1

Vacuum Setting	Vacuum Spring
1" Hg	5104-601

Associated Parts

Part No.	Associated Parts
600/1010	1½" tank weld-in socket
176/2660	50mm DIN 11851 milk fitting socket
176/2670	50mm DIN 11851 milk fitting nut
10217/1	Pressed stainless steel cap
10217/1GZ	Pressed stainless steel cap with gauze

1½" BSP Uniact Relief Valve - Pressure Only

Part Number : 47/XXX00A

Part No. 47/XXX00AGZ illustrated

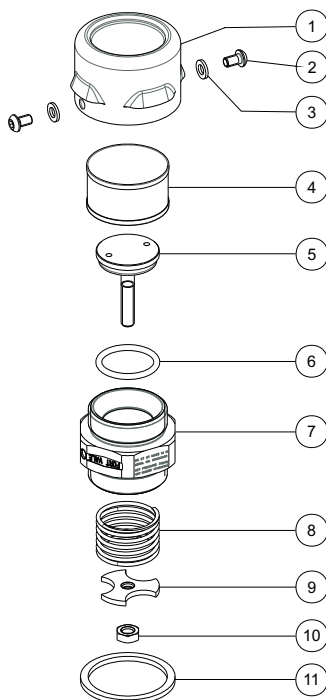

Spare Parts - Pressure Only

Item	Description	Part No.
1	Cap	10217/1
2	M6 button screw (2)	5111-611
3	M6 spring washer (2)	5113-008
4	Gauze ring	10204
5	Poppet	10983V
6	O ring (see table 2)	5005-XXX
7	Body	10213
8	Spring (see table 1)	5104-XXX
9	Spring pad	10215
10	M8 half nut	5112-004
11	CNAF gasket tank seal	5005-011

TABLE 1

Pressure Setting	Pressure Spring
30 PSI	5104-630

TABLE 2

O ring Material	Temp. Range	Vacuum Seal
Viton	-20°C to +200°C	5005-107
Fortyt	-55°C to +200°C	5005-108H
Perfluoroelastomer	-15°C to +260°C	5005-764
EPDM	-20°C to +150°C	5005-255
High Temp. Fortyt	-55°C to +260°C	5005-108HPFA



C SPANNER : 400/3000

For fitting & removal of relief valves, size range 1¼" to 3".



Fort Vale UK
Head Office & Manufacturing Plant

Tel : +44 (0)1282 687120
Fax : +44 (0)1282 687110
Email : sales@fortvale.com

Fort Vale USA

Tel : +1 281 471 8100
Fax : +1 281 471 8116
Email : ussales@fortvale.com

Fort Vale Netherlands

Tel : +31 (0)180 483333
Fax : +31 (0)180 410797
Email : bvsales@fortvale.com

Fort Vale Russian Federation

Tel : +7 916 682 0947
Email : rw@fortvale.ru

Fort Vale P.R. China

Tel : +86 21 6442 1367
Fax : +86 21 6442 1376
Email : cnsales@fortvale.com

Fort Vale Singapore

Tel : +65 6515 9950
Fax : +65 6515 3034
Email : sgsales@fortvale.com

Fort Vale Australia

Tel : +61 7 3310 4854
Email : ausales@fortvale.com

www.fortvale.com

All goods supplied will be subject to Fort Vale Engineering Ltd Terms and Conditions of Sale (Ref. FV4) which are available upon request, or may be viewed at www.fortvale.com.

Please note that this brochure and the contents herein remain the property of Fort Vale Engineering Limited.

This brochure may not be copied or reproduced, or the information contained herein divulged to any third party without the prior written permission of Fort Vale Engineering Limited.

Repair/refurbishment/resetting of Fort Vale valves may be carried out only by trained and authorised personnel. Fort Vale Engineering Limited shall not, in any circumstances, be liable for injuries, losses, expenses or damage, direct or consequential, sustained by the buyer or any person which may in any degree be attributable to the adoption, either by the buyer or any third party, of technical or other information, data or advice given on behalf of Fort Vale Engineering Limited or however otherwise caused in relation to the use of its products in accordance with Fort Vale Engineering Limited's recommendation.

The specifications included in this catalogue are intended to be generic and must be interpreted as equivalent or functionally equivalent. The identification of many items is facilitated by illustrations (photographs and line drawings). The mention of, or reference to specific companies, national standards, or trade names, including those that might appear on the photographs, is intended for illustration purposes only. It does not imply an endorsement, preference or availability of any specific standard, brand or supplier.

The data and information contained herein is being provided for information only and without responsibility, and Fort Vale Engineering Limited makes no representations or warranties, either expressed or implied, as to the accuracy, completeness, or fitness for a particular purpose. Fort Vale Engineering Limited does not accept any responsibility or liability with regard to the reliance on, or use of this data and information.

