

Flex System CN4022 2-port 10Gb Converged Adapter and EN4172 2-port 10Gb Ethernet Adapter

Product Guide

The Flex System™ CN4022 2-port 10Gb Converged Adapter is a dual-port 10 Gigabit Ethernet network adapter that supports Ethernet, FCoE, and iSCSI protocols as standard. The EN4172 2-port 10Gb Ethernet Adapter is a similar adapter that supports Ethernet protocols. Both adapters also support virtual network interface controller (vNIC) capability, which helps clients to reduce cost and complexity. These adapters are based on the Broadcom BCM57840 controller.

The CN4022 and EN4172 are shown in the following figure. The adapters are physically identical.



Figure 1. Flex System CN4022 2-port 10Gb Converged Adapter and EN4172 2-port 10Gb Ethernet Adapter

Did you know?

The CN4022 is based on the industry-standard PCIe architecture and is ideal for clients who use 10 GbE in their network infrastructure and who are looking for an entry price point for FCoE or iSCSI capabilities. The adapter ships standard with support for FCoE and iSCSI and with vNIC features that allow each physical port of the adapter to be virtualized into four vNICs.

Part number information

The following table shows the ordering part numbers and feature codes.

Table 1. Ordering part numbers and feature codes

Part number	Feature code	Description
88Y5920	A4K3	Flex System CN4022 2-port 10Gb Converged Adapter
00AG530	A5RN	Flex System EN4172 2-port 10Gb Ethernet Adapter

The part numbers listed in Table 1 include the following items:

- One adapter
- Documentation CD
- Important Notices flyer

Features

The CN4022 and EN4172 adapters have these features:

- One Broadcom BCM57840 ASIC
- Connection to either 1 Gb or 10 Gb data center infrastructure (1 Gb and 10 Gb auto-negotiation).
- PCIe 2.0 x8 (CN4022) or PCIe 3.0 x8 (EN4172) host interface
- Full line-rate performance
- Support 10 Gb Ethernet (CN4022 and EN4172)
- Support FCoE, and iSCSI (CN4022 only)
- IBM Flex System Manager™ support (Tier 2 support only, no alerting)

Ethernet features

- Ethernet frame: 1500 byte or 9600 byte (jumbo frame)
- Virtual LAN (VLAN) support with VLAN tagging
- vNIC support:
 - Supports Switch Independent Mode (vNIC2 mode)
 - Four vNIC/NPAR Ethernet devices per 10Gb physical port
 - Support either for two iSCSI ports or for one iSCSI port and one FCoE port, per 10Gb physical port (CN4022 only)
- UFP support
 - UFP mode available on all supported compute nodes
 - Stacked switch support (EN4093R and CN4093) planned for 2Q/2016
 - Supports Flex System Interconnect Fabric
- Stateless offload:
 - IP, TCP, and UDP checksum offloads
 - IPv4 and IPv6 offloads
 - Large send offload (LSO)
- Performance optimization:
 - Receive Side Scaling (RSS)
 - Transmit Side Scaling (TSS)
 - MSI and MSI-X support
 - RX/TX multiqueue
 - TCP Offload Engine (TOE) support

- SR-IOV-ready
- Wake on LAN
- Preboot eXecution Environment (PXE) support
- Network teaming, failover, and load balancing:
 - Smart Load Balancing (SLB)
 - Link Aggregation Control Protocol (LACP) and generic trunking
- Management using the Broadcom Advanced Control Suite management application
- Compliance:
 - IEEE 802.3ae (10 Gb Ethernet)
 - IEEE 802.3ad (Link aggregation)
 - IEEE 802.3ap Clause73 1G/10G Autonegotiation for 10GBase-KR channels
 - IEEE 802.1q (VLAN)
 - IEEE 802.1p (Priority Encoding)
 - IEEE 802.3x (Flow Control)
 - IEEE 802.1au (Congestion Notification)
 - IPv4 (RFQ 791)
 - IPv6 (RFC 2460)
 - IEEE 1588/802.1as (Precision Time Protocol (PTP))
 - IEEE 802.1Qbb Priority Flow Control (PFC)
 - IEEE 802.1Qaz Enhanced Transmission Selection (ETS)
 - IEEE 802.1Qaz Data Center Exchange Protocol (DCBX)

iSCSI Specifications (CN4022 only)

- iSCSI initiator hardware offload and boot support
- Protocols:
 - RFC 3347 (iSCSI Requirements and Design Considerations)
 - Challenge Handshake Authentication Protocol (CHAP)
 - iSNS
 - Service Location Protocol (SLP)

FCoE features (CN4022 only)

- 3,500 N_Port ID Virtualization (NPIV) interfaces (total for adapter)
- Support for FIP and FCoE EtherTypes
- Fabric Provided Media Access Control (MAC) Addressing (FPMA) support
- 2,048 concurrent port logins (RPIs) per port
- 1,024 active exchanges (XRIs) per port

Notes:

- FCoE support for VLAN discovery only with the port set to PVID = 1, but if VLAN discovery fails, it defaults to VLAN 1002
- SAN boot of the VMware hypervisor over iSCSI or FCoE is supported.

Supported servers

The following table lists the Flex System compute nodes that support the adapters.

Table 2. Support for Flex System servers

Part number	Description	x220 (7906)	x222 (7916)	x240 (8737, E5-2600)	x240 (8737, E5-2600 v2)	x240 (7162)	x240 M5 (9532)	x440 (7917)	x440 (7167)	x880/x480/x280 X6 (7903)	x280/x480/x880 X6 (7196)
88Y5920	Flex System CN4022 2-port 10Gb Converged Adapter	Y	N	Y	Y*	Y	Y	Y	N	Y	Y
00AG530	Flex System EN4172 2-port 10Gb Ethernet Adapter	N	N	N	N	Y	Y	N	Y	Y	Y

* Certain models of the x240 -- those with a model of the form 8737-xMx -- have one CN4022 2-port 10Gb Converged Adapter installed as standard.

See ServerProven® at the following web address for the latest information about the expansion cards that are supported by each blade server type:

<http://www.lenovo.com/us/en/serverproven/flexsystem.shtml>

I/O adapter cards are installed in the slot in supported servers, such as the x240, as highlighted in the following figure.

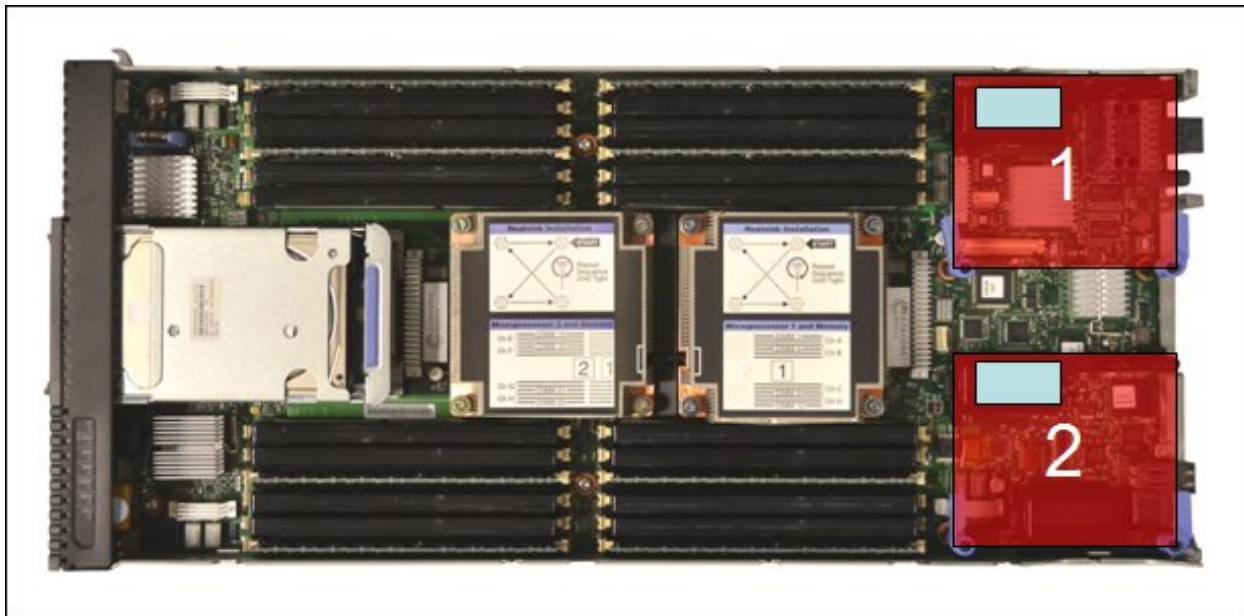

Figure 2. Location of the I/O adapter slots in the Flex System x240 Compute Node

Supported I/O modules

These adapters can be installed in any I/O adapter slot of a supported Flex System compute node. Two compatible I/O modules must be installed in the chassis to enable both ports of the adapter. The following table lists the switches that are supported.

When connected to the EN2092 1Gb Ethernet Scalable Switch, the internal switch ports will operate at 1 Gb speeds.

Table 3. I/O modules and upgrades for use with the CN4022 and EN4172 adapters

Description	Part number	Feature code (x-config)
10 Gb Ethernet connectivity		
Lenovo Flex System Fabric EN4093R 10Gb Scalable Switch	00FM514	ASUU
Lenovo Flex System Fabric CN4093 10Gb Converged Scalable Switch	00FM510	ASUT
Lenovo Flex System SI4091 10Gb System Interconnect Module	00FE327	ARZM
Lenovo Flex System Fabric SI4093 System Interconnect Module	00FM518	ASUV
Flex System Fabric CN4093 10Gb Converged Scalable Switch	00D5823	A3HH
Flex System Fabric EN4093R 10Gb Scalable Switch	95Y3309	A3J6
Flex System Fabric EN4093 10Gb Scalable Switch	49Y4270	A0TB
Flex System EN4091 10Gb Ethernet Pass-thru	88Y6043	A1QV
Flex System Fabric SI4093 System Interconnect Module	95Y3313	A45T
Flex System EN6131 40Gb Ethernet Switch	90Y9346	A3HJ
Cisco Nexus B22 Fabric Extender for Flex System	94Y5350	ESWB
Flex System EN4023 10Gb Scalable Switch	94Y5212	ESWD
1 Gb Ethernet connectivity		
Flex System EN2092 1Gb Ethernet Scalable Switch*	49Y4294	A0TF

* CN4022 supports 1 Gbps links with the EN2092 with firmware 2.4.1D1 and driver nx2-2.2.5f-1.710.11 or later levels. For additional information, refer to <http://ibm.com/support/entry/portal/docdisplay?Indocid=migr-5094970>

The following table shows the connections between adapters installed in the compute nodes to the switch bays in the chassis.

Table 4. Adapter to I/O bay correspondence

I/O adapter slot in the server	Port on the adapter	Corresponding I/O module bay in the chassis
Slot 1	Port 1	Module bay 1
	Port 2	Module bay 2
Slot 2	Port 1	Module bay 3
	Port 2	Module bay 4
Slot 3 (x440 only)	Port 1	Module bay 1
	Port 2	Module bay 2
Slot 4 (x440 only)	Port 1	Module bay 3
	Port 2	Module bay 4

The connections between the adapters installed in the compute nodes to the switch bays in the chassis are shown diagrammatically in the following figure. The figure shows both standard nodes, such as the x240 with two adapters, and double-wide nodes, such as the x440 with four adapters.

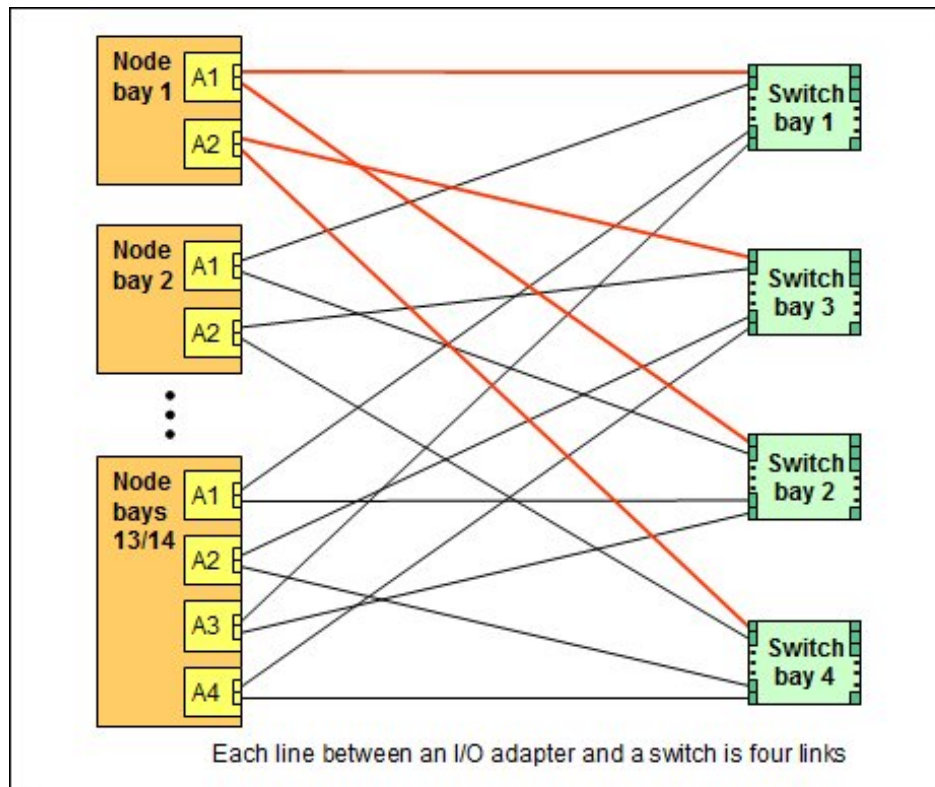

Figure 3. Logical layout of the interconnects between I/O adapters and I/O modules

Operating system support

The adapters support the following operating systems:

- Microsoft Windows Server 2008 R2
- Microsoft Windows Server 2008, Datacenter x64 Edition
- Microsoft Windows Server 2012
- Microsoft Windows Server 2012 R2
- Red Hat Enterprise Linux 5 Server x64 Edition
- Red Hat Enterprise Linux 6 Server x64 Edition
- Red Hat Enterprise Linux 7
- SUSE LINUX Enterprise Server 10 for AMD64/EM64T
- SUSE LINUX Enterprise Server 11 for AMD64/EM64T
- SUSE LINUX Enterprise Server 11 with Xen for AMD64/EM64T
- SUSE LINUX Enterprise Server 12
- VMware vSphere 5.0 (ESXi)
- VMware vSphere 5.1 (ESXi)
- VMware vSphere 5.5 (ESXi)
- VMware vSphere 6.0 (ESXi)

Support for operating systems is based on the combination of the expansion card and the blade server on which it is installed. See the ServerProven® website for the latest information about the specific versions and service packs supported. Select the blade server, and then select the expansion card to see the supported operating systems: <http://www.lenovo.com/us/en/serverproven/flexsystem.shtml>

Warranty

There is a 1-year, customer-replaceable unit (CRU) limited warranty. When installed in a server, these adapters assume your system's base warranty and any Lenovo Services warranty upgrade.

Physical specifications

The dimensions and weight of the adapter are specified:

- Width: 100 mm (3.9 inches)
- Depth: 80 mm (3.1 inches)
- Weight: 136 g (0.3 lb)

Shipping dimensions and weight (approximate):

- Height: 58 mm (2.3 in)
- Width: 229 mm (9.0 in)
- Depth: 208 mm (8.2 in)
- Weight: 400 g (0.89 lb)

Regulatory compliance

The adapters conform to the following standards:

- United States FCC 47 CFR Part 15, Subpart B, ANSI C63.4 (2003), Class A
- United States UL 60950-1, Second Edition
- IEC/EN 60950-1, Second Edition
- FCC - Verified to comply with Part 15 of the FCC Rules, Class A
- Canada ICES-003, issue 4, Class A
- UL/IEC 60950-1
- CSA C22.2 No. 60950-1-03
- Japan VCCI, Class A
- Australia/New Zealand AS/NZS CISPR 22:2006, Class A
- IEC 60950-1(CB Certificate and CB Test Report)
- Taiwan BSMI CNS13438, Class A
- Korea KN22, Class A; KN24
- Russia/GOST ME01, IEC-60950-1, GOST R 51318.22-99, GOST R 51318.24-99, GOST R 51317.3.2-2006, GOST R 51317.3.3-99
- IEC 60950-1 (CB Certificate and CB Test Report)
- CE Mark (EN55022 Class A, EN60950-1, EN55024, EN61000-3-2, EN61000-3-3)
- CISPR 22, Class A

Popular configurations

The adapter can be used in various configurations. The following figure shows two CN4022 2-port 10Gb Converged Adapters installed in both slots of the x240, which in turn is installed in the chassis. The chassis also has four Flex System Fabric EN4093R 10Gb Scalable Switches installed.

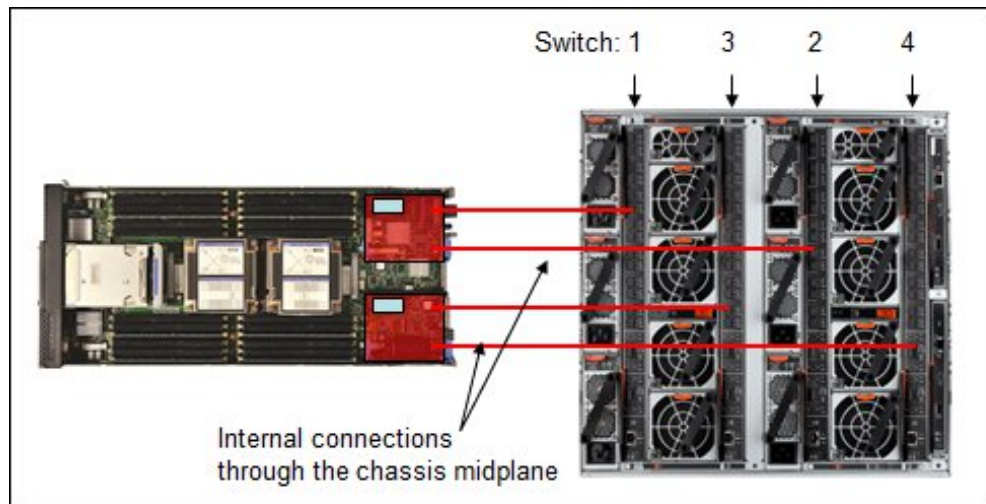

Figure 4. Example configuration

The following table lists the parts that are used in the configuration.

Table 5. Components used when connecting the adapter to the 10 GbE switches

Part number	Description	Quantity
8737-x1x or x2x	Flex System x240 Compute Node (without Embedded 10Gb Virtual Fabric Adapter) or other supported server	1 to 14
90Y3554	Flex System CN4022 2-port 10Gb Converged Adapter	2 per server
8721-A1x	Flex System Enterprise Chassis	1
95Y3309	Flex System Fabric EN4093R 10Gb Scalable Switch	4

Related publications

For more information, see the following resources:

- U.S. Announcement Letter for the CN4022 2-port 10Gb Converged Adapter
<http://ibm.com/common/ssi/cgi-bin/ssialias?infotype=dd&subtype=ca&&htmlfid=897/ENUS113-198>
- U.S. Announcement Letter for the EN4172 2-port 10Gb Ethernet Adapter
<http://ibm.com/common/ssi/cgi-bin/ssialias?infotype=dd&subtype=ca&&htmlfid=897/ENUS114-140>
- Lenovo Press Product Guides for switches and pass-thru modules
<http://lenovopress.com/flexsystem/iomodels>
- Lenovo Press Product Guides for compute nodes
<http://lenovopress.com/flexsystem/nodes>
- Flex System Information Center (User's Guides for servers and options)
<http://publib.boulder.ibm.com/infocenter/flexsys/information>
- *Flex System Interoperability Guide*
<http://lenovopress.com/fsig>
- *Flex System Products and Technology for x86 Systems*
<http://lenovopress.com/sg248255>
- *System x® and Cluster Solutions configurator (x-config)*
<http://ibm.com/products/hardware/configurator/americas/bhui/asit/>
- *System x Configuration and Options Guide*
<http://ibm.com/systems/xbc/cog/>
- *ServerProven: Compatibility for Flex System*
<http://www.lenovo.com/us/en/serverproven/flexsystem.shtml>

Related product families

Product families related to this document are the following:

- [Blade Network Adapters](#)

Notices

Lenovo may not offer the products, services, or features discussed in this document in all countries. Consult your local Lenovo representative for information on the products and services currently available in your area. Any reference to a Lenovo product, program, or service is not intended to state or imply that only that Lenovo product, program, or service may be used. Any functionally equivalent product, program, or service that does not infringe any Lenovo intellectual property right may be used instead. However, it is the user's responsibility to evaluate and verify the operation of any other product, program, or service. Lenovo may have patents or pending patent applications covering subject matter described in this document. The furnishing of this document does not give you any license to these patents. You can send license inquiries, in writing, to:

Lenovo (United States), Inc.
1009 Think Place - Building One
Morrisville, NC 27560
U.S.A.
Attention: Lenovo Director of Licensing

LENOVO PROVIDES THIS PUBLICATION "AS IS" WITHOUT WARRANTY OF ANY KIND, EITHER EXPRESS OR IMPLIED, INCLUDING, BUT NOT LIMITED TO, THE IMPLIED WARRANTIES OF NON-INFRINGEMENT, MERCHANTABILITY OR FITNESS FOR A PARTICULAR PURPOSE. Some jurisdictions do not allow disclaimer of express or implied warranties in certain transactions, therefore, this statement may not apply to you.

This information could include technical inaccuracies or typographical errors. Changes are periodically made to the information herein; these changes will be incorporated in new editions of the publication. Lenovo may make improvements and/or changes in the product(s) and/or the program(s) described in this publication at any time without notice.

The products described in this document are not intended for use in implantation or other life support applications where malfunction may result in injury or death to persons. The information contained in this document does not affect or change Lenovo product specifications or warranties. Nothing in this document shall operate as an express or implied license or indemnity under the intellectual property rights of Lenovo or third parties. All information contained in this document was obtained in specific environments and is presented as an illustration. The result obtained in other operating environments may vary. Lenovo may use or distribute any of the information you supply in any way it believes appropriate without incurring any obligation to you.

Any references in this publication to non-Lenovo Web sites are provided for convenience only and do not in any manner serve as an endorsement of those Web sites. The materials at those Web sites are not part of the materials for this Lenovo product, and use of those Web sites is at your own risk. Any performance data contained herein was determined in a controlled environment. Therefore, the result obtained in other operating environments may vary significantly. Some measurements may have been made on development-level systems and there is no guarantee that these measurements will be the same on generally available systems. Furthermore, some measurements may have been estimated through extrapolation. Actual results may vary. Users of this document should verify the applicable data for their specific environment.

© Copyright Lenovo 2017. All rights reserved.

This document, TIPS1087, was created or updated on August 9, 2016.

Send us your comments in one of the following ways:

- Use the online Contact us review form found at:
<http://lenovopress.com/TIPS1087>
- Send your comments in an e-mail to:
comments@lenovopress.com

This document is available online at <http://lenovopress.com/TIPS1087>.

Trademarks

Lenovo, the Lenovo logo, and For Those Who Do are trademarks or registered trademarks of Lenovo in the United States, other countries, or both. A current list of Lenovo trademarks is available on the Web at <http://www3.lenovo.com/us/en/legal/copytrade/>.

The following terms are trademarks of Lenovo in the United States, other countries, or both:

Flex System
Lenovo Services
Lenovo®
ServerProven®
System x®
vNIC

The following terms are trademarks of other companies:

Linux® is a trademark of Linus Torvalds in the United States, other countries, or both.

Access®, Microsoft®, Windows Server®, and Windows® are trademarks of Microsoft Corporation in the United States, other countries, or both.

Other company, product, or service names may be trademarks or service marks of others.