

AIR AND HYDRAULIC CYLINDERS NFPA INDUSTRIAL TYPE

Pneumatics
It's that easy

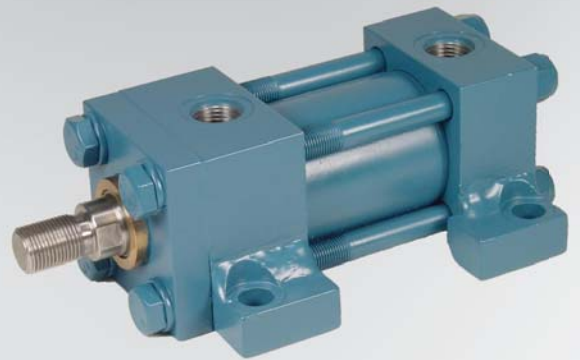

NFPA Industrial Type Cylinders

TaskMaster® Pneumatic Cylinders (to 200 psi)



1 1/2" - 4" Bores
Profile Design



5" & 6" Bores
External Tie Rods

PowerMaster® NFPA PPT Pneumatic & PHT Hydraulic Cylinders



PPT Pneumatic (to 250 psi, 1 1/2" - 14" Bores standard)
PHT Hydraulic (to 1500 psi, 1 1/2" - 14" Bores standard)

PressureMaster® NFPA HHT Hydraulic Cylinders & AccuMaster™ Linear Positioner



HHT Hydraulic (to 3000 psi nominal, 5000 psi non-shock; 1 1/2" - 14" Bores standard)



AccuMaster™ Hydraulic
Linear Positioner

How to Order NFPA Cylinders:

Our on-line configurator allows you to design custom cylinders while preventing the selection of impossible configurations. Provides part number, model number and CAD drawing (2D/3D). Go to: www.aventics.com/us

Custom Cylinders!

Custom materials, porting, rod ends, mounts, corrosion protection, etc.

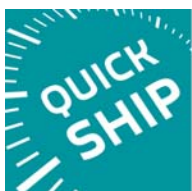

Focused
Delivery
Program

Many versions of NFPA cylinders are available on our Quick Ship Focused delivery program, visit: www.aventics.com/us/QuickShipNFPA



GENERAL INDEX

TASKMASTER® PNEUMATIC CYLINDERS INDEX - AIR TO 200 PSI - 1 1/2" THRU 6"		Page No.
BORE		
Aluminum Construction, Pre-Lubricated Design, NFPA Dimensions, Detachable Mounting Kits		2
1-1/2" thru 4" Bore (profile version)	Features & Specifications.....	2
	Model Codes.....	3
	Common Cylinder Model Numbers to Part Numbers.....	4 - 5
	MS4 Basic Cylinder Specifications.....	6
	Rod Size/Thread Options.....	7
	Mounting Styles & Dimensions.....	8 - 15
	Accessories.....	16 - 18
	Proximity Switch Options.....	19 - 20
	Integral Position Sensor (Smart Cylinder).....	21
	E/P Positioner.....	21 - 22
	Taskmaster Cylinder/Series 740™ Valve Combination.....	23 - 24
5" thru 6" Bore (tie rod version)	Features & Specifications.....	25
	How to Order.....	26
	Mounting Styles & Dimensions.....	27 - 32
	Accessories.....	33 - 35
Service Information		36 - 44
Pneumatic Timing Volumes		45
POWERMASTER® NFPA PPT AIR & PHT HYDRAULIC CYLINDER - AIR TO 250 PSI - HYDRAULIC TO 1500 PSI		
Machine Tool Grade, Steel Head & Tube/Tie Rod Construction, Quick Change Rod Cartridge, 21 Standard Mountings, Cushioning, Wide Selection of Options, Modifications & Accessories		
	Features & Specifications.....	48 - 49
	Options & Modifications.....	50 - 52
	Rod End Options & Standard Porting (Fold-out page*).....	52a*
	Mounting Style Index.....	53
	Mounting Style & Dimensional Data—1 1/2" thru 14" Bore.....	54 - 67
	How To Order.....	68
	Service Information (Pneumatic & Hydraulic).....	70 - 75
	Accessories (Fold-out page*).....	99a* - 100a
PRESSUREMASTER® NFPA HHT HIGH PRESSURE HYDRAULIC CYLINDERS— 3000 PSI NOMINAL/5000 PSI NON-SHOCK		
Machine Tool Grade, Steel Head & Tube/Tie Rod Construction, Quick Change Rod Cartridge, 22 Standard Mountings, Cushioning, Wide Selection of Options, Modifications & Accessories		
	Features & Specifications.....	78 - 79
	Options & Modifications.....	80 - 83
	Integral Position Feedback Opt. - ACCUMASTER™ Hyd. Linear Position.....	84
	Rod End Options & Standard Porting (Fold-out page*).....	52a*
	Mounting Style Index.....	85
	Mounting Style & Dimensional Data.....	86-99
	Accessories (Fold-out page*).....	99a* - 100a
	How To Order.....	100
	Service Information (Pneumatic & Hydraulic).....	101 - 105
APPLICATION DATA - ALL CYLINDERS		
	Metric Conversion Chart/Fluid Power "SI" Units.....	46
	Sizing - Force & Displacement Tables.....	105 - 108
	Mounting Considerations.....	109 - 111
	Stop Tube Calculations & Column Strength/Oversize Rod Selection.....	112 - 114
	Cylinder Specifications Sheet.....	115
	AVENTICS Cylinders & Actuators Overview.....	116
	Notice to Product users & Warranty Information.....	Inside Back Cover

TaskMaster® Pneumatic Cylinder

Design Features, 1-1/2" - 4" Bores

Technical Data, 1-1/2" - 4" bore sizes

Standard Features include:

Pressure rating: 200 psi air

Temperature range: 0° F to 160° F ambient (for other temperature ranges, contact factory).

Three integral mounts (head, cap and MS4), plus ten additional NFPA mountings available.

Piston Rod: Case hardened to 50-55 Rockwell "C" chrome-plated and finished to 15 micro-inches or better (5/8" not case hardened).

Tube: Hard anodized alloy aluminum for light weight, high strength, & maximum corrosion resistance.

Pre-Lubricated Design: Teflon-coated piston and polyurethane rod seals plus factory pre-lubrication eliminates the need for air line lubrication.

Two versions available: TM-1 series is NFPA compliant including rod threads and ports, TM-8 series replaces the original TaskMaster design.

Magnetic piston standard in all cylinders for sensor applications.

Oversize rods available as a standard option.

Stop tubes are available for long stroke, heavy side load applications.

Viton seals available for all seals except piston and cushion seals

Ports and cushions can be placed in any quadrant for maximum design flexibility.

Smooth head and cap design eliminates gathering of foreign material.

Ports: NPTF dryseal tapered threads, oversize ports available.

Rod End Threads: KK1 male, KK2 male, KK1 female or KK1 studded male threads.

Ports at quadrant 1, cushions at quadrant 2 (both can be ordered in different locations).

Teflon Coated Cup Buna "N" Type, low-friction piston seals are wear-compensating for extended service life.

Non-metallic wear strip provides extended service even under harsh side loads.

Positive rod seal. Pressure energized, polyurethane cup seal is wear compensating for longer life.

Needle valve provides accurate external cushion adjustment.

Long-life rod bearing is corrosion resistant graphite. Operates efficiently even under conditions of marginal lubrication. Rod cartridge can be replaced without cylinder disassembly.

Magnetic piston standard for sensors.

Protective rod wiper increases cylinder life preventing dirt from entering rod gland.

Rugged, non-corroding aluminum tubing is hard anodized for longer cylinder life, and features smooth profile.

Strong, fatigue-resistant rod threads.

High strength steel piston rod. Hard chromium plated for maximum durability. Stainless

Self aligning cushions. Teflon coated floating check valve allows greater cylinder speed.

Smooth, anodized aluminum head and cap design eliminates gathering of foreign material.

(1-1/2" to 4" bore version shown above.)

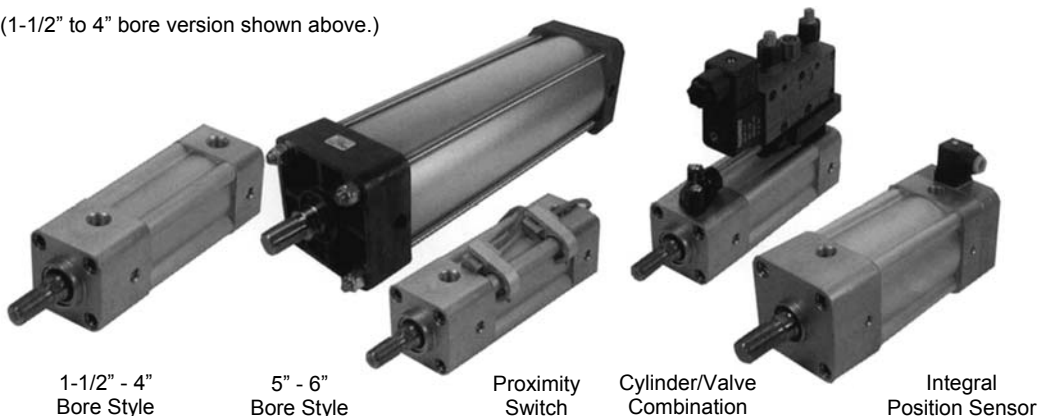

1-1/2" - 4" Bore Style

5" - 6" Bore Style

Proximity Switch

Cylinder/Valve Combination

Integral Position Sensor

TaskMaster® Pneumatic Cylinder

Design Features, 1-1/2" - 4" Bores

Model Code - Taskmaster Cylinders up to 4" Bore

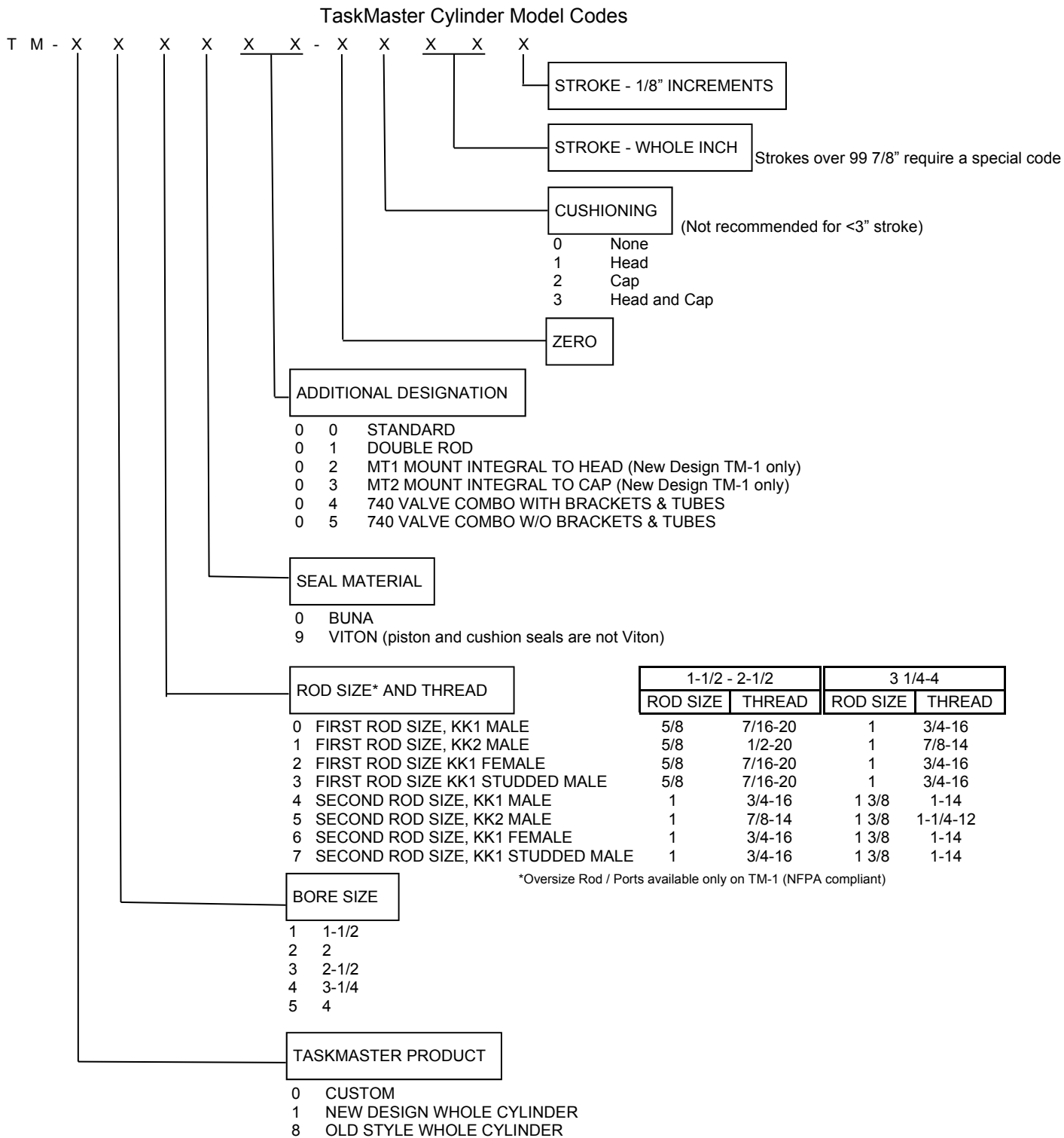

Old custom cylinders converted to new format will be the old part number with the "P" replaced by "TM"
 Example: P- 0 2 6 4 6 5 - 0 0 0 0 0 will become TM- 0 2 6 4 6 5 - 0 0 0 0 0

Custom cylinders begin with T M - 0 3 1 0 0 0 - X X X X X and proceed sequentially from there
 X X X X X is standard suffix format
 Customer cylinder are assigned by factory only!

Model code example: T M - 1 2 0 0 0 0 - 0 3 1 2 5 New design cylinder, 2" bore, first rod size, buna seals, cushions both ends, 12-5/8" stroke

TaskMaster® Pneumatic Cylinder

Design Features, 1-1/2" - 4" Bores

Common MS4 (Basic) Cylinder Part Numbers

Common cylinder model numbers with integral MS4 mount are listed here. For other cylinders, see How To Order section.

The basic TASKMASTER Cylinder is furnished with 3 possible means of mounting: side tapped (MS4) cap flush, head male rabbet.

Twelve popular mounting kits can be assembled to the basic cylinder and are shown on the following pages.

Mounting kits should be ordered separately from the cylinder.

Mounting kit part numbers and accessory part numbers follow.

For part numbers listed here, rod threads are KK2 male for the TM-8 series. For TM-1 series listed, rod threads are KK1 male. See "How To Order" section for complete breakdown



1.5"
Bore

(Original replacement TM-8) Rod thread KK2 = 1/2-20 Port size EE = 1/4" NPTF		(NFPA Compliant TM-1) Rod thread KK1 = 7/16-20 Port size EE = 3/8" NPTF		Description
Part Number	Model No.	Part Number	Model No.	
R432021805	TM-811000-00010	R432020388	TM-110000-00010	1.5 X 1 (non-cush)
R432021812	TM-811000-00020	R432020390	TM-110000-00020	1.5 X 2 (non-cush)
R432021815	TM-811000-00030	R432020394	TM-110000-00030	1.5 X 3 (non-cush)
R432021892	TM-811000-03040	R432020418	TM-110000-03040	1.5 X 4 (cushioned)
R432021895	TM-811000-03050	R432020419	TM-110000-03050	1.5 X 5 (cushioned)
R432021901	TM-811000-03060	R432020422	TM-110000-03060	1.5 X 6 (cushioned)
R432021903	TM-811000-03070	R432020424	TM-110000-03070	1.5 X 7 (cushioned)
R432021906	TM-811000-03080	R432020425	TM-110000-03080	1.5 X 8 (cushioned)
R432021908	TM-811000-03090	R432020427	TM-110000-03090	1.5 X 9 (cushioned)
R432021911	TM-811000-03100	R432020429	TM-110000-03100	1.5 X 10 (cushioned)
R432021917	TM-811000-03120	R432020433	TM-110000-03120	1.5 X 12 (cushioned)

2"
Bore

(Original replacement TM-8) Rod thread KK2 = 1/2-20 Port size EE = 1/4" NPTF		(NFPA Compliant TM-1) Rod thread KK1 = 7/16-20 Port size EE = 3/8" NPTF		Description
Part Number	Model No.	Part Number	Model No.	
R432022232	TM-821000-00010	R432020604	TM-120000-00010	2 X 1 (non-cush)
R432022237	TM-821000-00020	R432020606	TM-120000-00020	2 X 2 (non-cush)
R432022240	TM-821000-00030	R432020610	TM-120000-00030	2 X 3 (non-cush)
R432022318	TM-821000-03040	R432020636	TM-120000-03040	2 X 4 (cushioned)
R432022323	TM-821000-03050	R432020638	TM-120000-03050	2 X 5 (cushioned)
R432022327	TM-821000-03060	R432020640	TM-120000-03060	2 X 6 (cushioned)
R432022331	TM-821000-03070	R432020641	TM-120000-03070	2 X 7 (cushioned)
R432022332	TM-821000-03080	R432020643	TM-120000-03080	2 X 8 (cushioned)
R432022335	TM-821000-30390	R432020644	TM-120000-03090	2 X 9 (cushioned)
R432022337	TM-821000-03100	R432020645	TM-120000-03100	2 X 10 (cushioned)
R432022341	TM-821000-03120	R432020647	TM-120000-03120	2 X 12 (cushioned)

TaskMaster® Pneumatic Cylinder
Design Features, 1-1/2" - 4" Bores

2.5" Bore	(Original replacement TM-8) Rod thread KK2 = 1/2-20 Port size EE = 1/4" NPTF		(NFPA Compliant TM-1) Rod thread KK1 = 7/16-20 Port size EE = 3/8" NPTF		Description
	Part Number	Model No.	Part Number	Model No.	
	R432022613	TM-831000-00010	R432020859	TM-130000-00010	2.5 X 1 (non-cush)
	R432022619	TM-831000-00020	R432020861	TM-130000-00020	2.5 X 2 (non-cush)
	R432022625	TM-831000-00030	R432020863	TM-130000-00030	2.5 X 3 (non-cush)
	R432022686	TM-831000-03040	R432020890	TM-130000-03040	2.5 X 4 (cushioned)
	R432022689	TM-831000-03050	R432020892	TM-130000-03050	2.5 X 5 (cushioned)
	R432022691	TM-831000-03060	R432020893	TM-130000-03060	2.5 X 6 (cushioned)
	R432022696	TM-831000-03070	R432020894	TM-130000-03070	2.5 X 7 (cushioned)
	R432022699	TM-831000-03080	R432020895	TM-130000-03080	2.5 X 8 (cushioned)
	R432022702	TM-831000-30390	R432020897	TM-130000-03090	2.5 X 9 (cushioned)
	R432022703	TM-831000-03100	R432020898	TM-130000-03100	2.5 X 10 (cushioned)
	R432022708	TM-831000-03120	R432020900	TM-130000-03120	2.5 X 12 (cushioned)
3.25" Bore	(Original replacement TM-8) Rod thread KK2 = 7/8-14 Port size EE = 3/8" NPTF		(NFPA Compliant TM-1) Rod thread KK1 = 3/4-16 Port size EE = 1/2" NPTF		Description
	Part Number	Model No.	Part Number	Model No.	
	R432022902	TM-841000-00010	R432021102	TM-140000-00010	3.25 X 1 (non-cush)
	R432022906	TM-841000-00020	R432021104	TM-140000-00020	3.25 X 2 (non-cush)
	R432022910	TM-841000-00030	R432021106	TM-140000-00030	3.25 X 3 (non-cush)
	R432022973	TM-841000-03040	R432021143	TM-140000-03040	3.25 X 4 (cushioned)
	R432022978	TM-841000-03050	R432021145	TM-140000-03050	3.25 X 5 (cushioned)
	R432022981	TM-841000-03060	R432021148	TM-140000-03060	3.25 X 6 (cushioned)
	R432022985	TM-841000-03070	R432021149	TM-140000-03070	3.25 X 7 (cushioned)
	R432022989	TM-841000-03080	R432021150	TM-140000-03080	3.25 X 8 (cushioned)
	R432022992	TM-841000-30390	R432021151	TM-140000-03090	3.25 X 9 (cushioned)
	R432022994	TM-841000-03100	R432021153	TM-140000-03100	3.25 X 10 (cushioned)
	R432023002	TM-841000-03120	R432021155	TM-140000-03120	3.25 X 12 (cushioned)
4" Bore	(Original replacement TM-8) Rod thread KK2 = 7/8-14 Port size EE = 3/8" NPTF		(NFPA Compliant TM-1) Rod thread KK1 = 3/4-16 Port size EE = 1/2" NPTF		Description
	Part Number	Model No.	Part Number	Model No.	
	R432023256	TM-851000-00010	R432021306	TM-150000-00010	4 X 1 (non-cush)
	R432023258	TM-851000-00020	R432021308	TM-150000-00020	4 X 2 (non-cush)
	R432023260	TM-851000-00030	R432021312	TM-150000-00030	4 X 3 (non-cush)
	R432023314	TM-851000-03040	R432021339	TM-150000-03040	4 X 4 (cushioned)
	R432023317	TM-851000-03050	R432021340	TM-150000-03050	4 X 5 (cushioned)
	R432023320	TM-851000-03060	R432021341	TM-150000-03060	4 X 6 (cushioned)
	R432023322	TM-851000-03070	R432021342	TM-150000-03070	4 X 7 (cushioned)
	R432023325	TM-851000-03080	R432021343	TM-150000-03080	4 X 8 (cushioned)
	R432023328	TM-851000-30390	R432021344	TM-150000-03090	4 X 9 (cushioned)
	R432023331	TM-851000-03100	R432021346	TM-150000-03100	4 X 10 (cushioned)
	R432023336	TM-851000-03120	R432021347	TM-150000-03120	4 X 12 (cushioned)

MODEL NUMBER CONVERSION					
Bore	1960's	1970's	1980's-90's	Current Versions	
				TM-8-Series	TM-1-Series
1 1/2"	P -057270-	P -060162-	P -068174-	TM-811000-	TM-110000-
2"	P -057196-	P -060170-	P -068177-	TM-821000-	TM-120000-
2 1/2"	P -057284-	P -060179-	P -068180-	TM-831000-	TM-130000-
3 1/4"	P -057297-	P -060188-	P -068183-	TM-841000-	TM-140000-
4"	P -057527-	P -060197-	P -068186-	TM-841000-	TM-150000-

TaskMaster® Pneumatic Cylinder MS4 Basic Cylinder Specifications

MS4 (Basic Cylinder) / Side Tapped Mounting

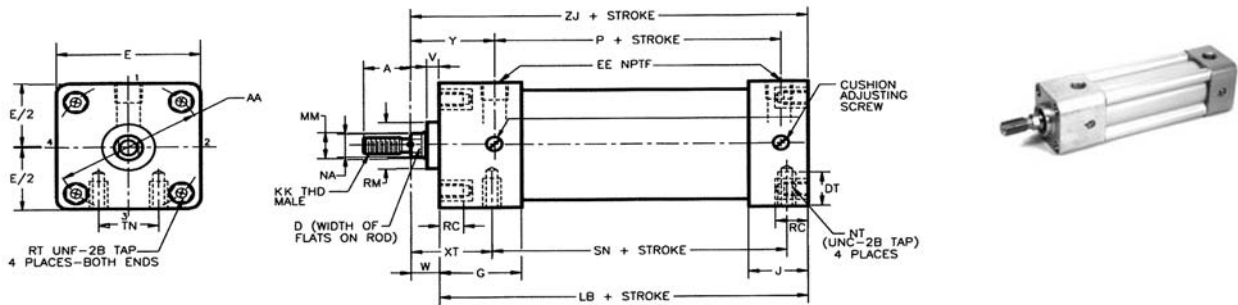

BASIC CYLINDER - MODULAR DESIGN. Refer to these tables for dimensions not shown on other mounts, or those affected by rod size. All dimensions are in inches unless otherwise indicated.

TaskMaster basic cylinder is furnished with 3 possible mounts: MS4 side-tapped mount, cap flush, or head male rabbit.

Twelve popular mounting kits can be assembled to the basic cylinder and are detailed in the following sections.

Mounting kits should be ordered separately from the cylinder; for basic cylinder part numbers, see "How to Order" section or Common Cylinder Part Numbers section.

MS4 Table 1. Dimensions affected by rod diameter. (Dimensions in inches)

Bore Size	MM ROD	W [TM-8]	W [TM-1]	EE [TM-8]	EE [TM-1]	RM	DT (cap)	DT (Head)	ZJ [TM-8]	ZJ [TM-1]	A [TM-8]	A [TM-1]	D	NA
1.50	0.625	0.59	0.62	1/4	3/8	1.12	0.38	0.38	4.63	4.66	1.00	0.75	0.50	0.56
1.50	1.000	-	1.00	-	3/8	1.50	0.38	0.25	-	5.04	-	1.12	0.88	0.94
2.00	0.625	0.59	0.62	1/4	3/8	1.12	0.50	0.50	4.63	4.66	1.00	0.75	0.50	0.56
2.00	1.000	-	1.00	-	3/8	1.50	0.50	0.38	-	5.04	-	1.12	0.88	0.94
2.50	0.625	0.59	0.62	1/4	3/8	1.12	0.69	0.69	4.75	4.78	1.00	0.75	0.50	0.56
2.50	1.000	-	1.00	-	3/8	1.50	0.69	0.50	-	5.16	-	1.12	0.88	0.94
3.25	1.000	0.75	0.75	3/8	1/2	1.50	0.75	0.75	5.63	5.63	1.50	1.12	0.88	0.94
3.25	1.375	-	1.00	-	1/2	2.38	0.75	0.75	-	5.88	-	1.63	1.12	1.31
4.00	1.000	0.75	0.75	3/8	1/2	1.50	0.75	0.75	5.63	5.63	1.50	1.12	0.88	0.94
4.00	1.375	-	1.00	-	1/2	2.38	0.75	0.75	-	5.88	-	1.63	1.12	1.31

Oversized rods and ports are not available for TM-8 series

MS4 Table 1. (cont.) Dimensions affected by rod diameter

BORE SIZE	MM ROD	Y [TM-8]	Y [TM-1]	XT [TM-8]	XT [TM-1]
1.50	0.625	1.75	1.79	1.94	1.98
1.50	1.000	-	2.16	-	2.35
2.00	0.625	1.75	1.79	1.94	1.98
2.00	1.000	-	2.16	-	2.35
2.50	0.625	1.75	1.79	1.94	1.98
2.50	1.000	-	2.16	-	2.35
3.25	1.000	2.34	2.39	2.44	2.45
3.25	1.375	-	2.64	-	2.70
4.00	1.000	2.34	2.39	2.44	2.45
4.00	1.375	-	2.64	-	2.70

MS4 Table 2. Dimensions not affected by rod diameter

BORE SIZE	E	G	J	P	V	AA	LB	NT	RC	RT	SN	TN
1.50	2.00	1.72	1.12	2.31	0.25	2.02	4.03	1/4-20	0.47	1/4-28	2.25	0.62
2.00	2.50	1.72	1.12	2.31	0.25	2.60	4.03	5/16-18	0.50	5/16-24	2.25	0.88
2.50	3.00	1.72	1.25	2.44	0.25	3.10	4.16	3/8-16	0.50	5/16-24	2.38	1.25
3.25	3.75	2.25	1.12	2.75*	0.25	3.90	4.88	1/2-13	0.53	3/8-24	2.62	1.50
4.00	4.50	2.25	1.12	2.69	0.25	4.70	4.88	1/2-13	0.53	3/8-24	2.62	2.06

*For 1.375" rod, P= 2.84

TaskMaster[®] Pneumatic Cylinder
MS4 Basic Cylinder Specifications

Rod Size/Thread Options

TASKMASTER ROD THREAD OPTIONS

Male Rod

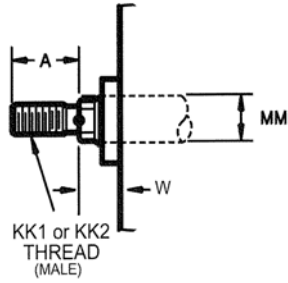

Female Rod

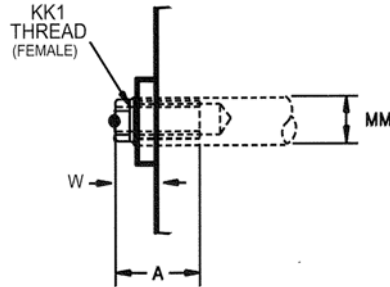

Studded Rod

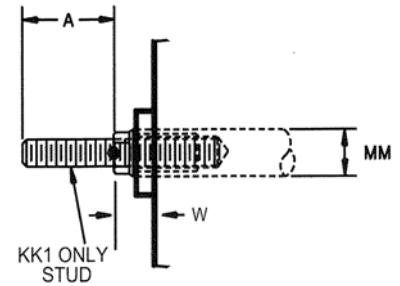

Bore Size	MM Rod	Rod thread options				TM-8		TM-1	
		Male	Female KK1	Male	Stud	A	W	A	W
1-1/2, 2, 2-1/2"	0.625	1/2-20	7/16-20	7/16-20	7/16-20	1.00	0.59	0.75	0.62
1-1/2, 2, 2-1/2"	1.000	7/8-14	3/4-16	3/4-16	3/4-16	-	-	1.12	1.00
3-1/4, 4"	1.000	7/8-14	3/4-16	3/4-16	3/4-16	1.50	0.75	1.12	0.75
3-1/4, 4"	1.380	1-1/4-12	1-14	1-14	1-14	-	-	1.63	1.00

Male threads available in KK1 and KK2 thread sizes.
 Female threads available in KK1 thread only. KK1 studded male rod end available.
 Note: Oversize rods were not available on earlier models, therefore not available on TM-8 series.

TaskMaster® Pneumatic Cylinder MF1 Flange Mounting Kits - 1.5" thru 4" bore

MF1 Flange Mounting Kit (Aluminum)

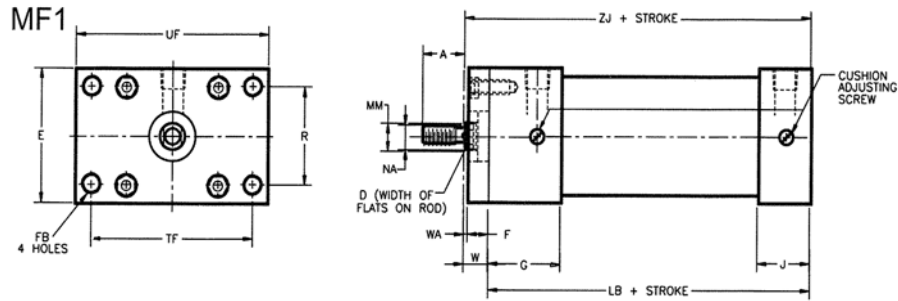

Part Number	MF1												
Kit Part Number	BORE SIZE	MM ROD	E	F	R	W*	FB	LB	TF	UF	WA*	ZJ*	WEIGHT
R432013373	1.500	0.625	2.00	0.38	1.43	0.59	0.34	4.03	2.75	3.38	0.22	4.63	0 lb. 4 oz.
R432012520	2.000	0.625	2.50	0.50	1.84	0.59	0.41	4.03	3.38	4.13	0.09	4.63	0 lb. 8 oz.
R432013382	2.500	0.625	3.00	0.50	2.19	0.59	0.41	4.16	3.88	4.63	0.09	4.75	0 lb. 12 oz.
R432013388	3.250	1.000	3.50**	0.63	2.76	0.75	0.47	4.88	4.69	5.50	0.13	5.63	1 lb. 4 oz.
R432013396	4.000	1.000	4.50	0.63	3.32	0.75	0.47	4.88	5.44	6.25	0.13	5.63	1 lb. 12 oz.

Mounting kit only, order cylinder separately. These kits fit first and second rod sizes. Dimensions in inches, for those not shown see MS4 basic cylinder drawing.

*Dimensions are for TM-8 series, for TM-1 series see MS4 basic cylinder drawing.

**Dimensions not NFPA standard, and differs from E dimension on cylinder, see basic MS4 cylinder drawing.

MF2 Flange Mounting Kit (Aluminum)

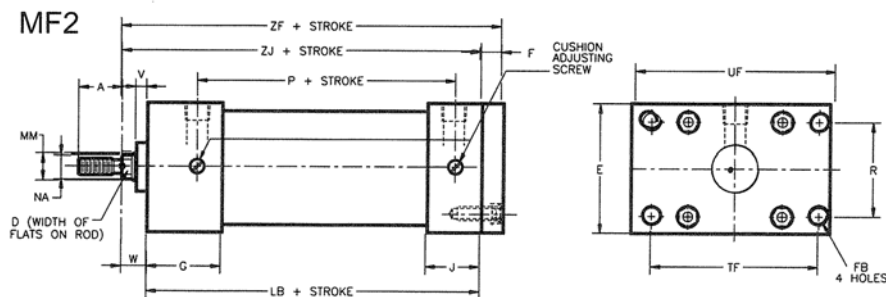

Model	MF2												
Kit Part Number	BORE SIZE	MM ROD	E	F	R	W*	FB	LB	TF	UF	WA*	ZJ*	WEIGHT
R432013373	1.500	0.625	2.00	0.38	1.43	0.59	0.34	4.03	2.75	3.38	0.22	4.63	0 lb. 4 oz.
R432012520	2.000	0.625	2.50	0.50	1.84	0.59	0.41	4.03	3.38	4.13	0.09	4.63	0 lb. 8 oz.
R432013382	2.500	0.625	3.00	0.50	2.19	0.59	0.41	4.16	3.88	4.63	0.09	4.75	0 lb. 12 oz.
R432013388	3.250	1.000	3.50**	0.63	2.76	0.75	0.47	4.88	4.69	5.50	0.13	5.63	1 lb. 4 oz.
R432013396	4.000	1.000	4.50	0.63	3.32	0.75	0.47	4.88	5.44	6.25	0.13	5.63	1 lb. 12 oz.

Mounting kit only, order cylinder separately. These kits fit first and second rod sizes. Dimensions in inches, for those not shown see MS4 basic cylinder drawing.

*Dimensions are for TM-8 series, for TM-1 series see MS4 basic cylinder drawing.

**Dimensions not NFPA standard, and differs from E dimension on cylinder, see basic MS4 cylinder drawing.

TaskMaster® Pneumatic Cylinder
MP1 Clevis Mounting Kits - 1.5" thru 4" bore

MP1 Clevis Mounting Kit (Cast Iron), includes pivot pin

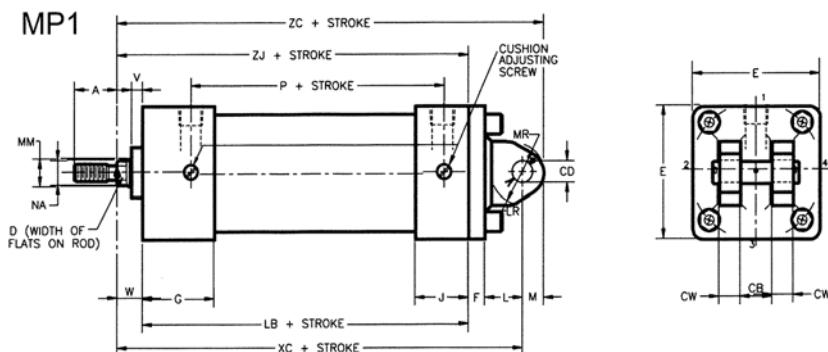

Model	MP1															
Kit Part Number	BORE SIZE	MM ROD	E	F	L	W*	CB	CD	CW	LB	LR	MR	XC*	ZC*	ZJ*	WEIGHT
R432015731	1.500	0.625	2.00	0.38	0.38	0.59	0.34	4.03	0.500	4.03	0.75	0.63	5.38	5.88	4.63	0 lb. 6 oz.
R432015733	2.000	0.625	2.50	0.38	0.38	0.59	0.41	4.03	0.500	4.03	0.75	0.63	5.38	5.88	4.63	1 lb. 0 oz.
R432015735	2.500	0.625	3.00	0.38	0.38	0.59	0.41	4.16	0.500	4.16	0.75	0.63	5.50	6.00	4.75	1 lb. 4 oz.
R432015737	3.250	1.000	3.75	0.63	0.63	0.75	0.47	4.88	0.750	4.88	1.25	0.88	6.88	7.63	5.63	2 lb. 8 oz.
R432015739	4.000	1.000	4.50	0.63	0.63	0.75	0.47	4.88	0.750	4.88	1.25	0.88	6.88	7.63	5.63	3 lb. 8 oz.

Mounting kit only, order cylinder separately. These kits fit first and second rod sizes. Dimensions in inches, for those not shown see MS4 basic cylinder drawing.

*Dimensions are for TM-8 series, for TM-1 series see MS4 basic cylinder drawing.

MP2 Clevis Mounting Kit (Aluminum and Steel), includes pivot pin

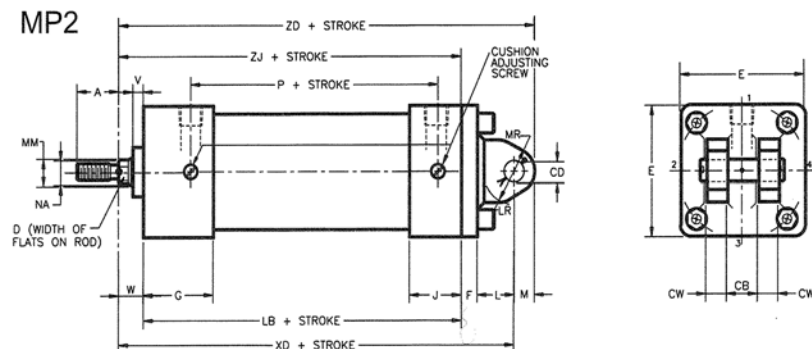

Model	MP2																
Bore Size/ (Kit Material)	Kit Part Number	Weight	MM Rod	E	F	L	M	W*	CB	CD	CW	LB	LR	MR	XD*	ZD*	ZJ*
1.5 (Alum.)	R432013371	0 lb. 8 oz.	0.625	2.00	0.38	0.75	0.50	0.59	0.75	0.500	0.50	4.03	0.63	0.53	5.75	6.25	4.63
1.5 (Steel)	R432008309	0 lb. 14 oz.	0.625	2.00	0.38	0.75	0.50	0.59	0.75	0.500	0.50	4.03	0.59	0.69	5.75	6.25	4.63
2.0 (Alum.)	R432012512	0 lb. 8 oz.	0.625	2.50	0.38	0.75	0.50	0.59	0.75	0.500	0.50	4.03	0.63	0.53	5.75	6.25	4.63
2.0 (Steel)	R432008305	1 lb. 4 oz.	0.625	2.50	0.38	0.75	0.50	0.59	0.75	0.500	0.50	4.03	0.59	0.69	5.75	6.25	4.63
2.5 (Alum.)	R432013379	0 lb. 12 oz.	0.625	3.00	0.38	0.75	0.50	0.59	0.75	0.500	0.50	4.16	0.63	0.53	5.88	6.38	4.75
2.5 (Steel)	R432008306	1 lb. 8 oz.	0.625	3.00	0.38	0.75	0.50	0.59	0.75	0.500	0.50	4.16	0.59	0.69	5.88	6.38	4.75
3.25 (Alum.)	R432013394	1 lb. 12 oz.	1.000	3.75	0.56	1.31	0.75	0.75	1.25	0.750	0.63	4.88	0.88	0.88	7.50	8.25	5.63
3.25 (Steel)	R432008307	3 lb. 12 oz.	1.000	3.75	0.63	1.25	0.75	0.75	1.25	0.750	0.63	4.88	0.88	1.00	7.50	8.25	5.63
4.0 (Alum.)	R432013402	2 lb. 4 oz.	1.000	4.50	0.63	1.25	0.75	0.75	1.25	0.750	0.63	4.88	0.88	0.78	7.50	8.25	5.63
4.0 (Steel)	R432008308	4 lb. 12 oz.	1.000	4.50	0.63	1.25	0.75	0.75	1.25	0.750	0.63	4.88	0.88	1.00	7.50	8.25	5.63

Mounting kit only, order cylinder separately. These kits are not affected by rod size. Dimensions in inches, for those not shown see MS4 basic cylinder drawing.

*Dimensions are for TM-8 series, for TM-1 series see MS4 basic cylinder drawing.

TaskMaster® Pneumatic Cylinder MP4 Mounting Kits - 1.5" thru 4" bore

MP4 Eye Bracket Mounting Kit (Aluminum)

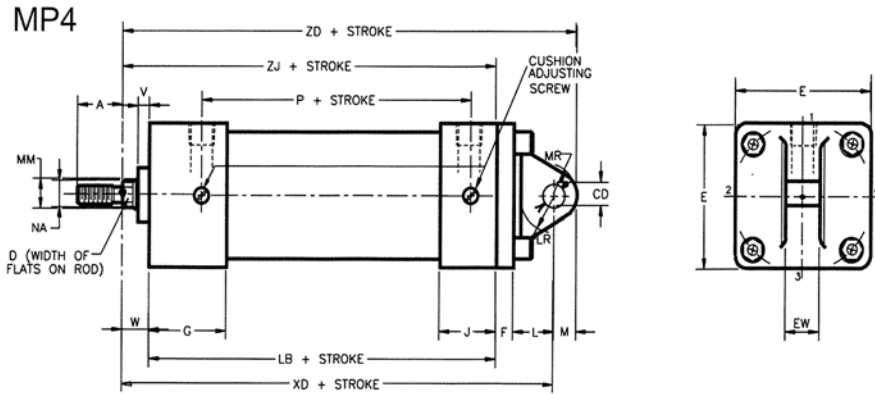

Model	MP4															
Kit Part Number	BORE SIZE	MM ROD	E	F	L	M	W*	CD	EW	LB	LR	MR	XD*	ZD*	ZJ*	WEIGHT
R432013369	1.500	0.625	2.00	0.38	0.75	0.50	0.59	0.500	0.75	4.03	0.63	0.53	5.75	6.25	4.63	0 lb. 8 oz.
R432012549	2.000	0.625	2.50	0.38	0.75	0.50	0.59	0.500	0.75	4.03	0.63	0.53	5.75	6.25	4.63	0 lb. 8 oz.
R432013377	2.500	0.625	3.00	0.38	0.75	0.50	0.59	0.500	0.75	4.16	0.63	0.53	5.88	6.38	4.75	0 lb. 9 oz.
R432013392	3.250	1.000	3.75	0.63	1.25	0.75	0.75	0.750	1.25	4.88	0.88	0.78	7.50	8.25	5.63	1 lb. 7 oz.
R432013400	4.000	1.000	4.50	0.63	1.25	0.75	0.75	0.750	1.25	4.88	0.88	0.78	7.50	8.25	5.63	1 lb. 12 oz.

Mounting kit only, order cylinder separately. These kits fit first and second rod sizes. Dimensions in inches, for those not shown see MS4 basic cylinder drawing.

*Dimensions are for TM-8 series, for TM-1 series see MS4 basic cylinder drawing.

MS1 Mounting Kit (Steel)

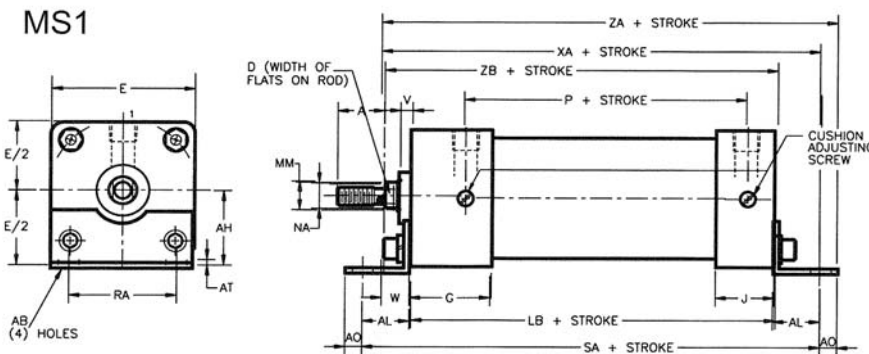

Model	MS1																
Bore Size	Kit Part Number	Weight	MM Rod	E	W*	AB	AH	AL	AO	AT	DD	LB	RA	SA	XA*	ZA*	ZB*
1.500	R432013623	0 lb. 6 oz.	0.625	2.00	0.59	0.44	1.19	1.00	0.37	0.12	1/4-28	4.03	1.25	6.03	5.63	6.00	4.63
2.000	R432013625	0 lb. 8 oz.	0.625	2.50	0.59	0.44	1.44	1.00	0.37	0.12	5/16-24	4.03	1.75	6.03	5.63	6.00	4.63
2.500	R432013628	0 lb. 9 oz.	0.625	3.00	0.59	0.44	1.62	1.00	0.37	0.12	5/16-24	4.16	2.25	6.16	5.75	6.13	4.75
3.250	R432013631	0 lb. 14	1.000	3.75	0.75	0.56	1.94	1.25	0.50	0.12	3/8-24	4.88	2.75	7.38	6.88	7.38	5.63
4.000	R432013634	1 lb. 0 oz.	1.000	4.50	0.75	0.56	2.25	1.25	0.50	0.12	3/8-24	4.88	3.50	7.38	6.88	7.38	5.63

Mounting kit only, order cylinder separately. These kits fit first and second rod sizes. Dimensions in inches, for those not shown see MS4 basic cylinder drawing.

*Dimensions are for TM-8 series, for TM-1 series see MS4 basic cylinder drawing.

TaskMaster® Pneumatic Cylinder
MS2 Mounting Kits - 1.5" thru 4" bore

MS2 Mounting Kit (Steel) 1 1/2" - 2 1/2" Bore

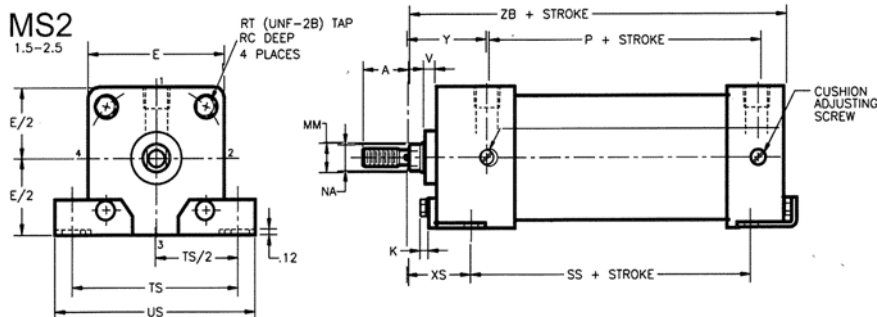

Model	MS2																	
Kit Part Number	Weight	Bore Size	MM Rod	C	F	K	W*	SB	SS	ST	SU	SW	SY	SZ	TS	US	XS*	ZB*
R432013616	0 lb. 6 oz.	1.500	0.625	0.75	2.00	0.23	0.59	0.44	2.88	0.12	0.48	0.88	0.90	0.50	2.75	3.43	1.38	4.62
R432013641	0 lb. 6 oz.	2.000	0.625	0.75	2.50	0.28	0.59	0.44	2.88	0.12	0.48	0.88	0.90	0.50	3.32	4.08	1.38	4.62
R432013641	0 lb. 6 oz.	2.500	0.625	0.75	3.00	0.28	0.59	0.44	3.00	0.12	0.48	0.88	0.90	0.50	3.67	4.43	1.38	4.75

Mounting kit only, order cylinder separately. These kits fit first and second rod sizes. Dimensions in inches, for those not shown see MS4 basic cylinder drawing.

*Dimensions are for TM-8 series, for TM-1 series see MS4 basic cylinder drawing.

MS2 Mounting Kit (Steel) 3 1/4" - 4" Bore

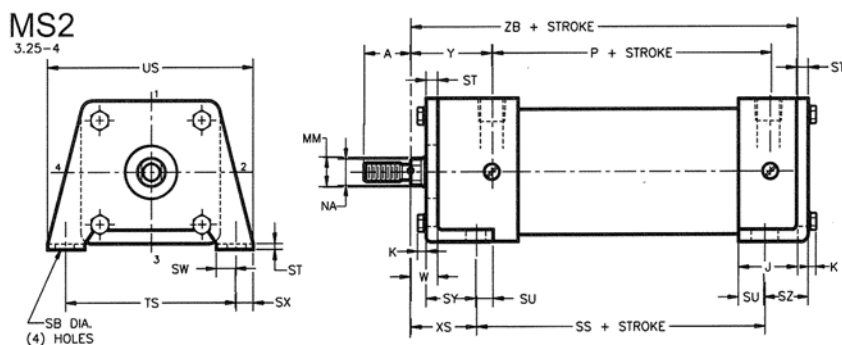

Model	MS2																	
Kit Part Number	Weight	Bore Size	MM Rod	E	K	W*	SB	SS	ST	SU	SW	SX	SY	SZ	TS	US	XS*	ZB*
R432013648	2 lb. 12 oz.	3.250	1.000	3.75	0.34	0.75	0.56	3.25	0.25	0.62	0.50	0.50	1.38	0.75	4.75	5.75	1.88	5.62
R432013651	4 lb. 4 oz.	4.000	1.000	4.50	0.34	0.75	0.56	3.25	0.31	0.62	0.50	0.50	1.44	0.81	5.50	6.50	1.88	5.62

Mounting kit only, order cylinder separately. These kits fit first and second rod sizes. Dimensions in inches, for those not shown see MS4 basic cylinder drawing.

*Dimensions are for TM-8 series, for TM-1 series see MS4 basic cylinder drawing.

TaskMaster® Pneumatic Cylinder MT1 Mounts - 1.5" thru 4" bore

MT1 Front Trunnion¹ Mount - TM-1 Series [NFPA compliant] Complete Cylinder Dimensions

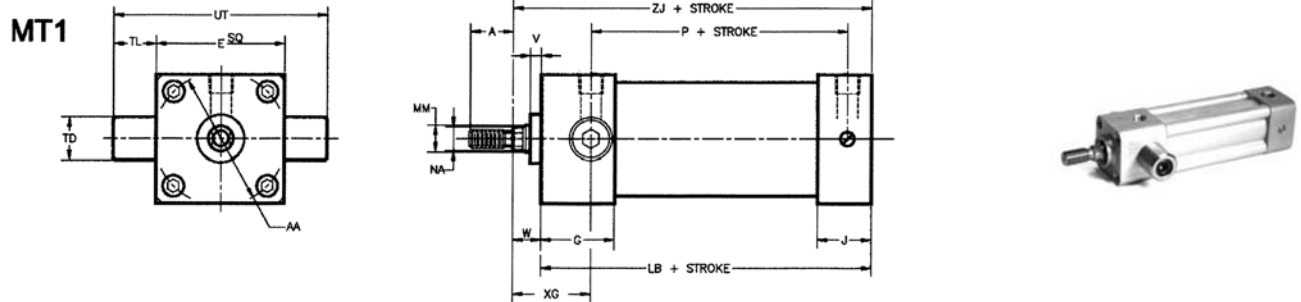

MT1 [TM-1 Series Complete Cylinder Dimensions]											
BORE SIZE	MM ROD	E	W	AA	LB	TD	TL	UT	XG	ZJ	WEIGHT
1.500	0.625	2.00	0.63	2.02	4.03	1.00	1.00	4.00	1.75	4.66	2 lb. 2 oz.
1.500	1.000	2.00	1.00	2.02	4.03	1.00	1.00	4.00	2.12	5.04	2 lb. 12 oz.
2.000	0.625	2.50	0.63	2.60	4.03	1.00	1.00	4.50	1.75	4.66	2 lb. 15 oz.
2.000	1.000	2.50	1.00	2.60	4.03	1.00	1.00	4.50	2.12	5.04	3 lb. 9 oz.
2.500	0.625	3.00	0.63	3.10	4.16	1.00	1.00	5.00	1.75	4.78	3 lb. 0 oz.
2.500	1.000	3.00	1.00	3.10	4.16	1.00	1.00	5.00	2.12	5.16	3 lb. 10 oz.
3.250	1.000	3.75	0.75	3.90	4.88	1.00	1.00	5.75	2.25	5.63	7 lb. 7 oz.
3.250	1.375	3.75	1.00	3.90	4.88	1.00	1.00	5.75	2.50	5.88	8 lb. 9 oz.
4.000	1.000	4.50	0.75	4.70	4.88	1.00	1.00	6.50	2.25	5.63	10 lb. 5 oz.
4.000	1.375	4.50	1.00	4.70	4.88	1.00	1.00	6.50	2.50	5.88	11 lb. 7 oz.

¹These are complete cylinders, not bolt-on kits.
Dimensions in inches, for those not shown see MS4 basic cylinder drawing

MT1 Front Trunnion² Mounting Kit - TM-8 Series Only (Aluminum block with steel trunnion pins)

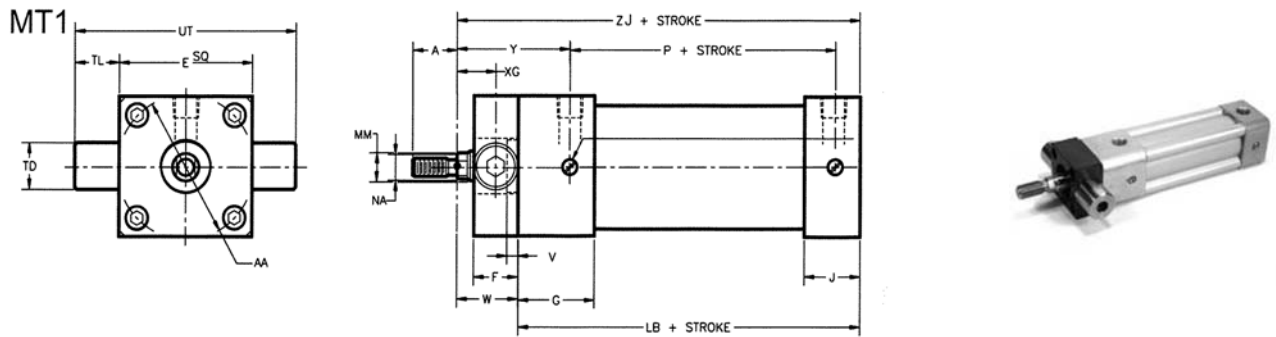

Model	MT1 [TM-8 Series]												
KIT PART NUMBER	BORE SIZE	MM ROD	E	F	W	AA	LB	TD	TL	UT	XG	ZJ	WEIGHT
R432013510	1.500	0.625	2.00	1.00	1.38	2.02	4.03	1.00	1.00	4.00	0.88	5.41	0 lb. 12 oz.
R432013507	2.000	0.625	2.50	1.00	1.38	2.60	4.03	1.00	1.00	4.50	0.88	5.41	1 lb. 0 oz.
R432013513	2.500	0.625	3.00	1.00	1.38	3.10	4.16	1.00	1.00	5.00	0.88	5.53	1 lb. 4 oz.
R432013489	3.250	1.000	3.75	1.00	1.50	3.90	4.88	1.00	1.00	5.75	1.00	6.38	1 lb. 12 oz.
R432013516	4.000	1.000	4.50	1.00	1.50	4.70	4.88	1.00	1.00	6.50	1.00	6.38	2 lb. 8 oz.

²These kits are for replacement only. For new cylinder, MT1 must be specified with cylinder due to rod extension being required.
Dimensions in inches, for those not shown see MS4 basic cylinder drawing.

TaskMaster® Pneumatic Cylinder
 MT2 Mounts - 1.5" thru 4" bore

MT2 Trunnion¹ Mount - TM-1 Series [NFPA compliant] Complete Cylinder Dimensions

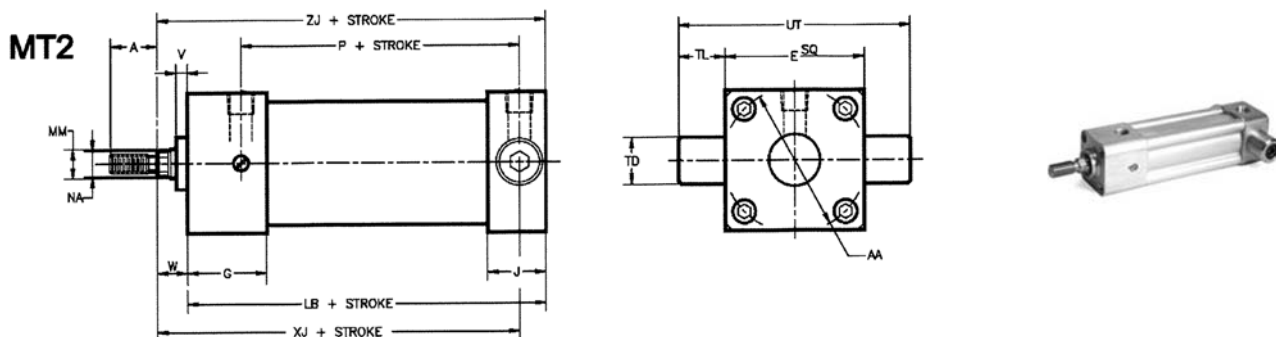

MT2 [TM-1 Series Complete Cylinder Dimensions]											
WEIGHT	BORE SIZE	MM ROD	E	W	AA	LB	TD	TL	UT	XJ	ZJ
2 lb. 2 oz.	1.500	0.625	2.00	0.63	2.02	4.03	1.00	1.00	4.00	4.12	4.66
2 lb. 12 oz.	1.500	1.000	2.00	1.00	2.02	4.03	1.00	1.00	4.00	4.50	5.04
2 lb. 15 oz.	2.000	0.625	2.50	0.63	2.60	4.03	1.00	1.00	4.50	4.12	4.66
3 lb. 9 oz.	2.000	1.000	2.50	1.00	2.60	4.03	1.00	1.00	4.50	4.50	5.04
3 lb. 0 oz.	2.500	0.625	3.00	0.63	3.10	4.16	1.00	1.00	5.00	4.25	4.78
3 lb. 10 oz.	2.500	1.000	3.00	1.00	3.10	4.16	1.00	1.00	5.00	4.61	5.16
7 lb. 7 oz.	3.250	1.000	3.75	0.75	3.90	4.88	1.00	1.00	5.75	5.00	5.63
8 lb. 9 oz.	3.250	1.375	3.75	1.00	3.90	4.88	1.00	1.00	5.75	5.25	5.88
10 lb. 5 oz.	4.000	1.000	4.50	0.75	4.70	4.88	1.00	1.00	6.50	5.00	5.63
11 lb. 7 oz.	4.000	1.375	4.50	1.00	4.70	4.88	1.00	1.00	6.50	5.25	5.88

Dimensions in inches, for those not shown see MS4 basic cylinder drawing.

¹These are complete cylinders, not bolt-on kits.

MT2 Trunnion Mounting Kit - TM-8 Series only (Aluminum block with steel trunnion pins)

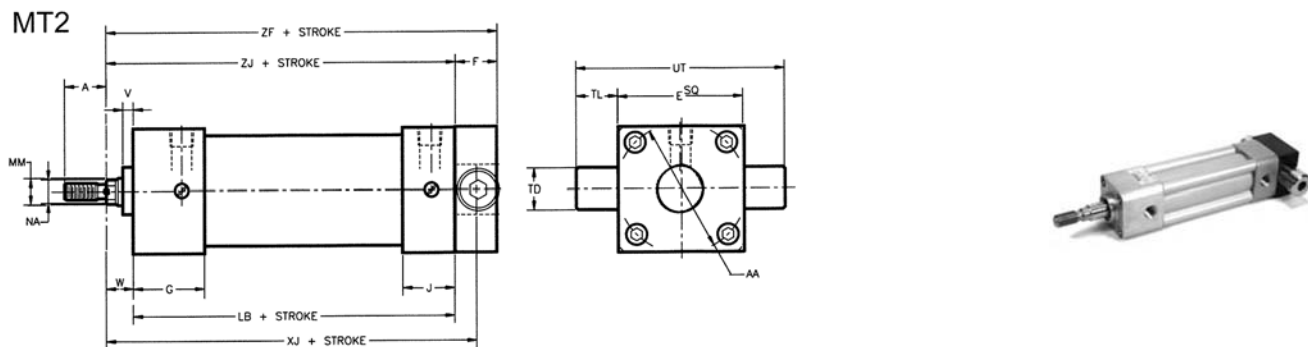

Model	MT2 [TM-8 Series]													
	WEIGHT	KIT PART NUMBER	BORE SIZE	MM ROD	E	F	W	AA	LB	TD	TL	UT	XJ	ZF
0 lb. 12 oz.	R432013510	1.500	0.625	2.00	1.00	0.59	2.02	4.03	1.00	1.00	4.00	5.13	5.63	4.63
1 lb. 0 oz.	R432013507	2.000	0.625	2.50	1.00	0.59	2.60	4.03	1.00	1.00	4.50	5.13	5.63	4.63
1 lb. 4 oz.	R432013513	2.500	0.625	3.00	1.00	0.59	3.10	4.16	1.00	1.00	5.00	5.25	5.75	4.75
1 lb. 12 oz.	R432013489	3.250	1.000	3.75	1.00	0.75	3.90	4.88	1.00	1.00	5.75	6.13	6.63	5.63
2 lb. 8 oz.	R432013516	4.000	1.000	4.50	1.00	0.75	4.70	4.88	1.00	1.00	6.50	6.13	6.63	5.63

Part number is for mounting kit only. Dimensions in inches, for those not shown see MS4 basic cylinder drawing.

TaskMaster® Pneumatic Cylinder MX1, 2, 3, 4 - (Extended Tie Rods) Mounting Kit

MX1, 2, 3, 4 Kits (Extended Tie Rods) Mounting Kit

MX1, 2, 3, 4

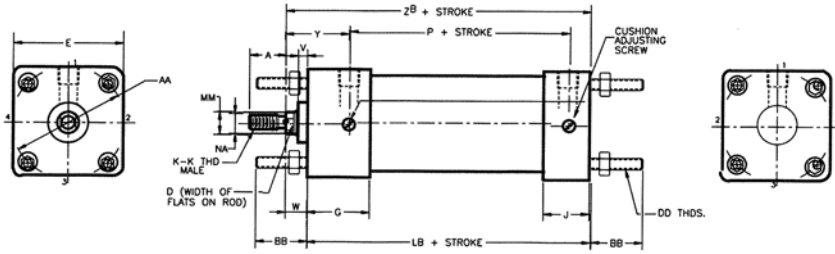

- NOTE:
 MX1 - Tie rods extended both ends: Order (2) MX kits.
 MX2 - Tie rods extended cap end: Order (1) MX kit.
 MX3 - Tie rods extended head end: Order (1) MX kit.
 MX4 - Two tie rods extended both ends: Order (1) MX kit.

Model	MX1, 2, 3, 4													
KIT PART NUMBER	BORE SIZE	MM ROD	E	G	J	V	W*	AA	BB	DD	LB	RM	ZB*	WEIGHT
R432013684	1.500	0.625	2.00	1.72	1.13	0.25	0.59	2.02	1.31	1/4-28	4.03	1.13	4.62	0 lb. 2 oz.
R432013686	2.000	0.625	2.50	1.72	1.13	0.25	0.59	2.60	1.53	5/16-24	4.03	1.13	4.62	0 lb. 4 oz.
R432013686	2.500	0.625	3.00	1.72	1.25	0.25	0.59	3.10	1.53	5/16-24	4.16	1.13	4.75	0 lb. 4 oz.
R432013688	3.250	1.000	3.75	2.25	1.13	0.25	0.75	3.90	2.13	3/8-24	4.88	1.50	5.62	0 lb. 6 oz.
R432013688	4.000	1.000	4.50	2.25	1.13	0.25	0.75	4.70	2.13	3/8-24	4.88	1.50	5.62	0 lb. 6 oz.

Mounting kit only, order cylinder separately. These kits are not affected by rod size. Dimensions in inches, for those not shown see MS4 basic cylinder drawing.

*Dimensions are for TM-8 series, for TM-1 series see MS4 basic cylinder drawing.

D Double Rod

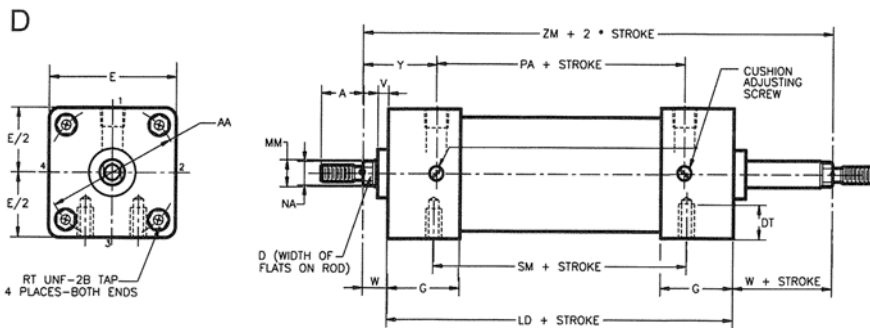

Model	D Double Rod															
Bore Size	MM ROD	E	G	V	W*	AA	DT	LD	NT	PA	RC	RT	SM	TN	XT	ZM*
1.500	0.625	2.00	1.72	0.25	0.59	2.02	0.38	4.63	1/4-20	2.31	0.47	1/4-28	1.94	0.63	1.94	5.81
2.000	0.625	2.50	1.72	0.25	0.59	2.60	0.50	4.63	5/16-18	2.31	0.50	5/16-24	1.94	0.88	1.94	5.81
2.500	0.625	3.00	1.72	0.25	0.59	3.10	0.69	4.63	3/8-16	2.31	0.50	5/16-24	1.94	1.25	1.94	5.81
3.250	1.000	3.75	2.25	0.25	0.75	3.90	0.75	6.00	1/2-13	2.81	0.53	3/8-24	2.62	1.50	2.44	7.50
4.000	1.000	4.50	2.25	0.25	0.75	4.70	0.75	6.00	1/2-13	2.81	0.53	3/8-24	2.62	2.06	2.44	7.50

Dimensions in inches, for those not shown see MS4 basic cylinder drawing.

*Dimensions are for TM-8 series, for TM-1 series see MS4 basic cylinder drawing.

TaskMaster® Pneumatic Cylinder
MR3 - 1.5" thru 4" bore Nose Mounting Kit

MR3 Nose Mounting Kit (TM-8 Series Only)

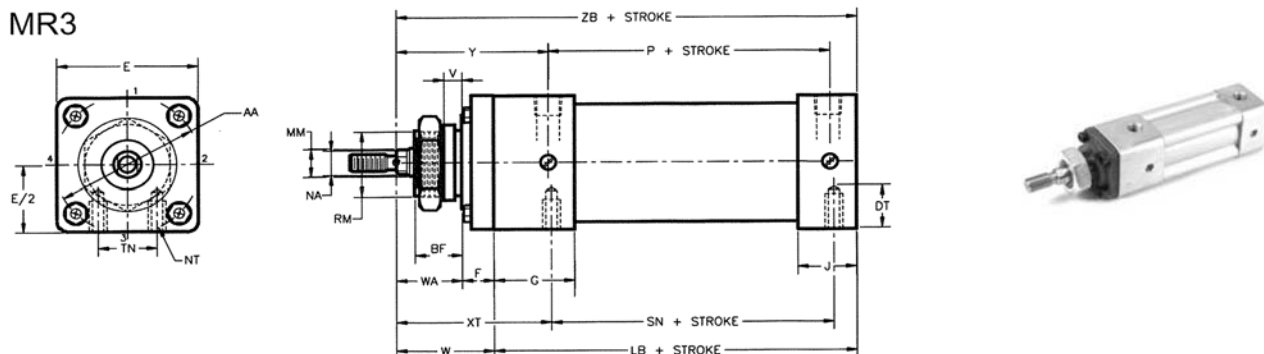

MR3 Nose Mount Kit*				
BORE SIZE	MM ROD	STANDARD CYLINDER PREFIX (TM-8 Series)	KIT PART NO.*	WEIGHT
1.50	0.625	TM-068204-	R432013497	0 lb. 9 oz.
2.00	0.625	TM-068207-	R432013499	0 lb. 12 oz.
2.50	0.625	TM-068210-	R432013501	0 lb. 13 oz.
3.25	1.000	TM-068213-	R432013503	1 lb. 4 oz.
4.00	1.000	TM-068216-	R432013505	4 lb. 4 oz.

These kits are for replacement only. For complete cylinders, order by description, using prefixes for cylinder shown.
*TM-8 series only, not available for TM-1 series.

Dimensions												
E	F	V	W	Y	AA	BF	LB	RM	WA	XT	ZB	BK - THD
2.00	0.56	0.25	1.78	2.94	2.02	0.88	4.03	1.061	1.22	3.13	5.81	1.00 - 14
2.50	0.68	0.25	1.78	3.06	2.60	0.88	4.03	1.061	1.22	3.25	5.94	1.00 - 14
3.00	0.68	0.31	2.03	3.19	3.10	1.00	4.16	1.374	1.34	3.38	6.19	1.38 - 12
3.75	0.93	0.31	2.43	4.03	3.90	1.00	4.88	1.499	1.50	4.13	7.31	1.50 - 12
4.50	0.93	0.38	2.56	4.22	4.70	1.13	4.88	1.749	1.63	4.25	7.44	1.75 - 12

These dimensions are not affected by rod size. Dimensions in inches, for those not shown see MS4 basic cylinder drawing.

TaskMaster® Pneumatic Cylinder Accessories - 1.5" thru 4" bore

Female Rod Clevis (Aluminum)

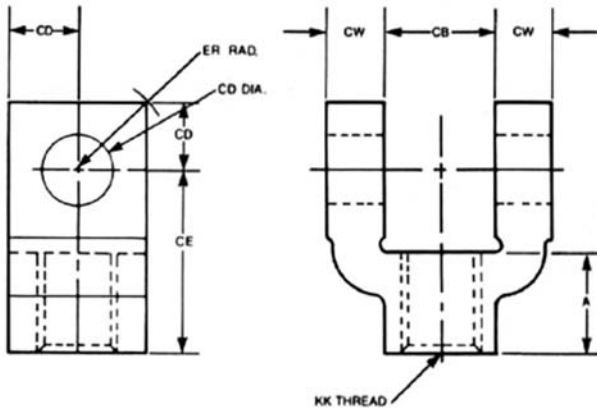

PART NO.	BORE	ROD	THREAD KK	A	CB	CD	CE	CW	ER	WEIGHT
R432012516	1.5, 2 & 2.5	0.625	1/2-20	0.75	0.75	0.50	1.50	0.50	0.72	0 lb. 9 oz.
R432013386	3.25 & 4	1.000	7/8-14	1.13	1.25	0.75	2.06	0.63	1.06	1 lb. 0 oz.

Includes pivot pin, retaining rings and jam nut. For sizes not shown, see NFPA cylinder accessories

Eye Bracket (Aluminum)

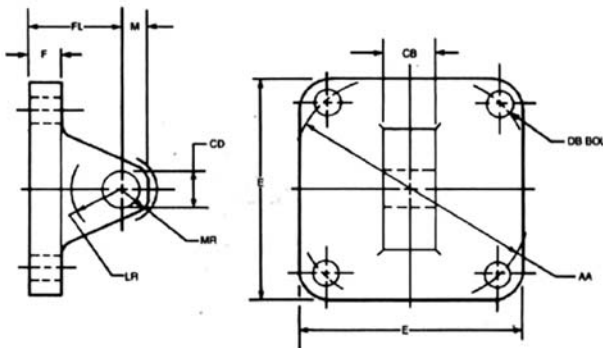

PART NO.	WEIGHT	BORE	E	F	M	AA	CB	CD	DB	FL	LR	MR
R432013368	0 lb. 4 oz.	1.50	2.00	0.38	0.50	2.02	0.75	0.50	0.25	1.13	0.63	0.53
R432012551	0 lb. 4 oz.	2.00	2.50	0.38	0.50	2.60	0.75	0.50	0.31	1.13	0.63	0.53
R432013376	0 lb. 8 oz.	2.50	3.00	0.38	0.50	3.10	0.75	0.50	0.31	1.13	0.63	0.53
R432008890	1 lb. 4 oz.	3.25	3.75	0.63	0.75	3.90	1.25	0.75	0.38	1.88	0.88	0.78
R432008892	1 lb. 8 oz.	4.00	4.50	0.63	0.75	4.70	1.25	0.75	0.38	1.88	0.88	0.78

Eye bracket mates with female rod clevis or MP1, MP2 mounts

TaskMaster® Pneumatic Cylinder
Accessories - 1.5" thru 4" bore

Female Rod Eye (Steel)

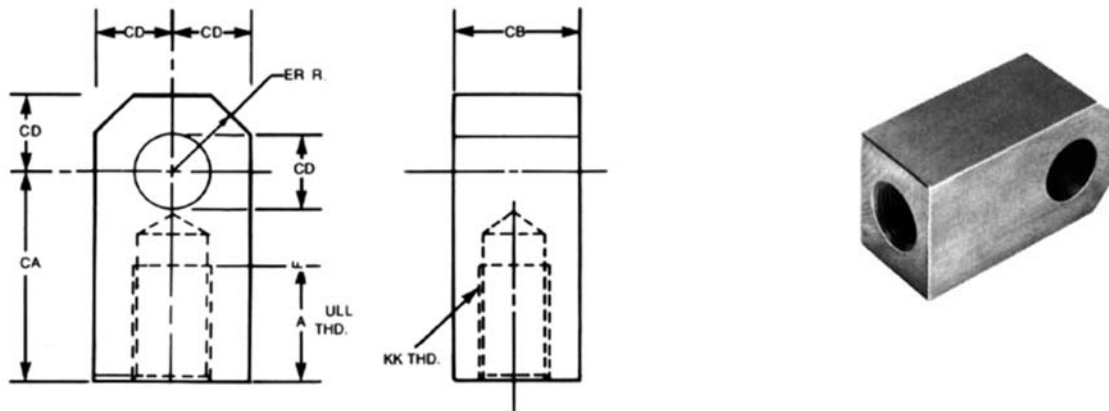

PART NO.	BORE	THREAD KK	A	CA	CB	CD	ER	WEIGHT
R432006533	1.5, 2 & 2.5	1/2-20	0.88	1.50	0.75	0.50	0.56	0 lb. 5 oz.
R432013437	3.25 & 4	7/8-14	1.13	2.06	1.25	0.75	0.84	1 lb. 0 oz.

For sizes not shown, see NFPA cylinder accessories .

Clevis Bracket (Aluminum)

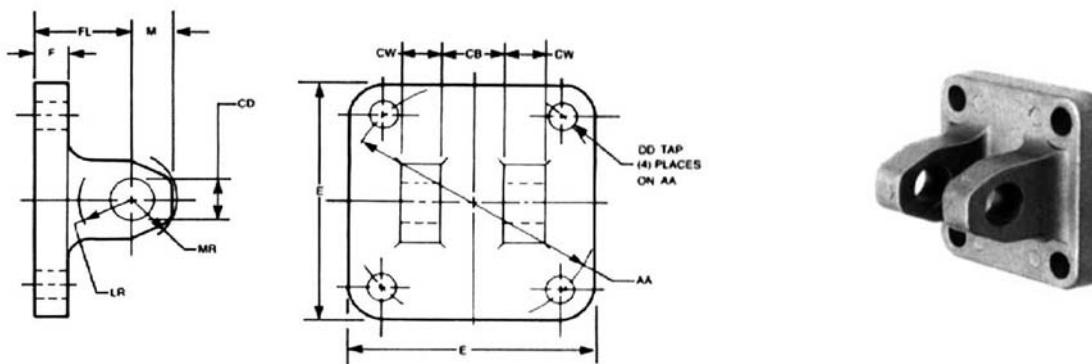

PART NO.	WEIGHT	BORE	E	F	M	AA	CB	CD	CW	DD	FL	LR	MR
R432013366	0 lb. 4 oz.	1.50	2.00	0.38	0.50	2.02	0.75	0.50	0.50	0.25	1.13	0.63	0.53
R432012511	0 lb. 4 oz.	2.00	2.50	0.38	0.50	2.60	0.75	0.50	0.50	0.31	1.13	0.63	0.53
R432013381	0 lb. 8 oz.	2.50	3.00	0.38	0.50	3.10	0.75	0.50	0.50	0.31	1.13	0.63	0.53
R432008891	1 lb. 2 oz.	3.25	3.75	0.63	0.75	3.90	1.25	0.75	0.63	0.38	1.88	0.88	0.78
R432008893	1 lb. 8 oz.	4.00	4.50	0.63	0.75	4.70	1.25	0.75	0.63	0.38	1.88	0.88	0.78

Clevis bracket mates with female rod eye or MP4 mount. For sizes not shown see NFPA cylinder accessories.

TaskMaster® Pneumatic Cylinder

Accessories - 1.5" thru 4" bore

Pivot Pin (Steel), includes retaining rings

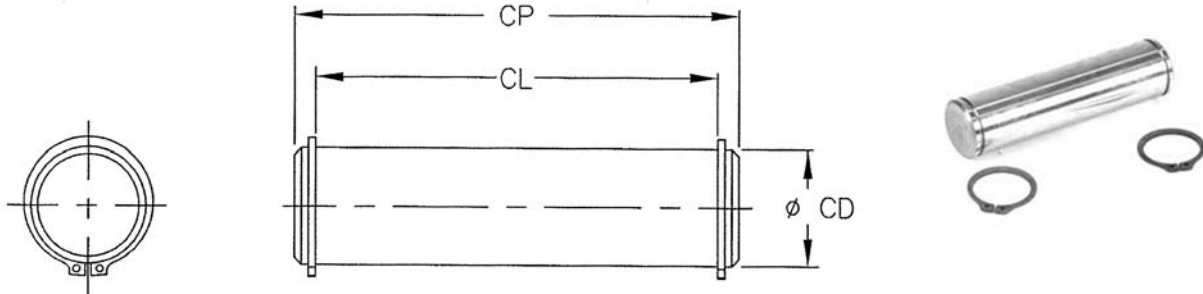

PART NO.	WEIGHT	BORE	CD	CL	CP
R433012619	0 lb. 4 oz.	1.5, 2 & 2.5	0.50	1.88	2.09
R433012621	0 lb. 8 oz.	3.25, 4 & 5	0.75	2.62	2.88
R433012623	0 lb. 13 oz.	6	1.00	3.12	3.38

For sizes not shown, see NFPA cylinder accessories .

Right Angle Flow Controls - 540 Series NPTF ports

Mounting directly on cylinder, thread sealant on male threads.
360° swivel compact body.
See SC-400 for additional details

HOW TO ORDER:	Part Number	Description
	R432027182	Threaded inlet, 1/4" NPTF with screwdriver slot
	R432027183	Threaded inlet, 3/8" NPTF with screwdriver slot
	R432027184	Threaded inlet, 1/2" NPTF with screwdriver slot
	R432027186	Threaded inlet, 1/4" NPTF with knob adjustment
	R432027187	Threaded inlet, 3/8" NPTF with knob adjustment
	R432027188	Threaded inlet, 1/2" NPTF with knob adjustment
	R432027191	Push-in fitting, 1/4" NPTF x 1/4" tube, with slot
	R432027192	Push-in fitting, 3/8" NPTF x 3/8" tube, with slot
	R432027194	Push-in fitting, 1/4" NPTF x 1/4" tube, with knob
	R432027195	Push-in fitting, 3/8" NPTF x 3/8" tube, with knob



TaskMaster® Pneumatic Cylinder

Optional Configurations

Proximity Switches for 1 1/2" - 4" bore Taskmaster Cylinders

- Features** **For all bore sizes of Taskmaster Cylinders**
- New, low profile designs
 - Meets NEMA 1, 4, and 13
 - Easy to adjust
 - Handles from 6 VDC to 120 VAC (unless otherwise indicated)
 - LED indicators
 - Built-in surge suppression
- Switch specifications**
- Single pole, normally open
 - 0°F to 160°F



Operation

AVENTICS magnetically operated Proximity Switches are the normally open, single pole, and single throw style. The switch is designed to close in the presence of a magnetic field, produced by the magnetic piston of the cylinder.

Signals, useful for operating lights, valves, or other devices, are possible anywhere along the stroke of the cylinder.

Multiple switches may be spaced as close as 0.62 inches by using more than one rib of the cylinder for mounting.

Part No. (all included clamp)						
Symbol	Type	Bore Size	Fig.	mA Rating	Part No.	Desc. & Cable Length L
	Reed	1.5" - 6"	2 & 5	500	R432008720	Surge suppression, LED, 3' leads
	Reed	1.5" - 6"	2 & 5	500	R432008721	Surge suppression, LED, 12' leads
	Reed	1.5" - 6"	2 & 3	500	R432008722	Surg. supp., LED, Brad Harrison®, 1' leads
	Reed	1.5" - 6"	2 & 4	500	P-026966-00003	Surg. supp., LED, Molex/GM, 4" leads
	Reed	1.5" - 2.5"	1	25	R432008731	3-pin quick disconnect (8mm), 6" leads
	Reed	1.5" - 2.5"	1 & 5	25	R432008724	Pigtail, two 3' leads
	Reed	1.5" - 2.5"	1 & 5	25	R432008725	Pigtail, two 9' leads
	Reed	1.5" - 2.5"	1 & 3	25	R432008726	Brad Harrison 1' leads
	Reed	1.5" - 2.5"	1 & 4	25	P-026966-00007	Molex/GM
		NPN	1.5" - 2.5"	1 & 5	300/6-24VDC	R432008730
NPN		1.5" - 2.5"	1	300/6-24VDC	R432008733	3-pin quick disconnect (8mm), 6" leads
	PNP	1.5" - 2.5"	1 & 5	300/6-24VDC	R432008729	9' pigtail
	PNP	1.5" - 2.5"	1	300/6-24VDC	R432008732	3-pin quick disconnect (8mm), 6" leads

Note: See following page for 3-pin connector cables with female connector

Proximity Switch & Clamp - Figure 1

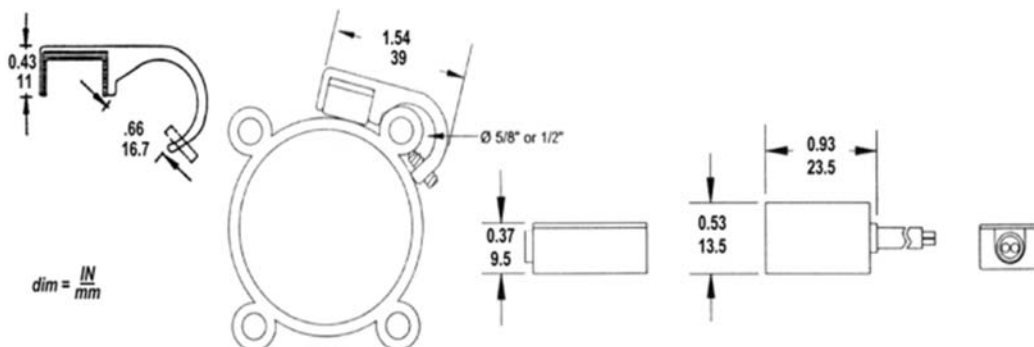

TaskMaster® Pneumatic Cylinder Optional Configurations

Proximity Reed Switch & Clamp - Figure 2

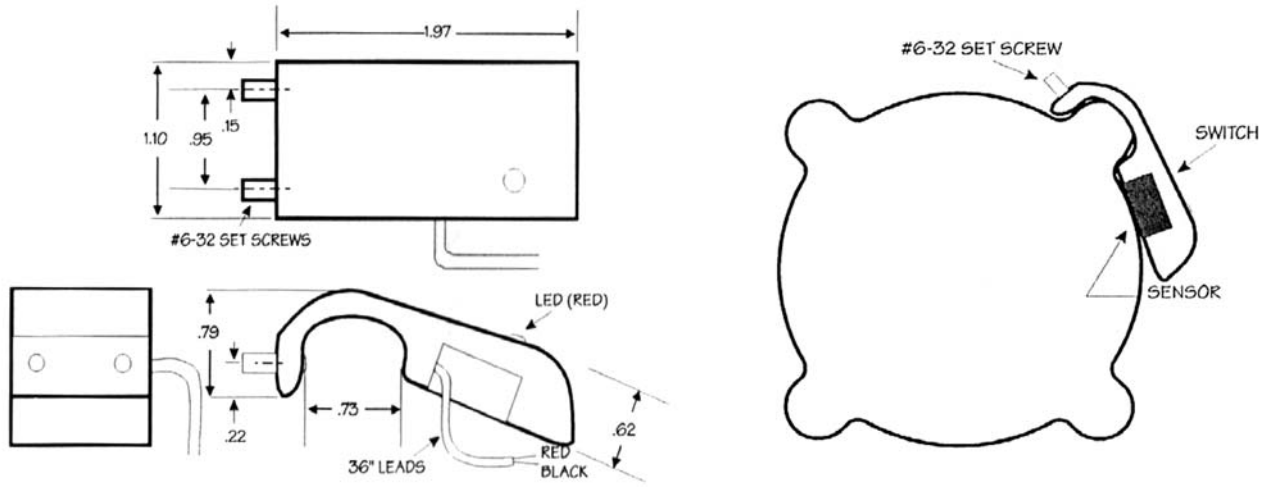

Connector Styles

Schematic	Figure No.	Description
<p>BRAD HARRISON CONNECTOR</p> <p>12MM MALE PLUG WITH EXTERNAL THREADS CATALOG #604006A09M020. ONE FOOT LONG CABLE.</p>	3	Brad Harrison® Style
<p>MOLEX/GM CONNECTOR</p> <p>MOLEX MICRO-C: 12MM INVERTED MALE PLUG GM WINDSOR STANDARD APPROVED MICRO CORDS.</p>	4	Molex/GM Style
<p>PIGTAIL</p> <p>CABLE SPECIFICATIONS: 22 AWG, 300V, 80', 2 LEADS.</p> <p>BROWN (POS.) WHITE (NEG.)</p>	5	Pigtail

TaskMaster® Pneumatic Cylinder

Optional Configurations

Integral Position Sensor

The TASKMASTER Cylinder with Integral Position Sensor includes an internal position sensor (potentiometer) for infinite rod position indication.

Application

Used where knowledge of cylinder position is needed through entire stroke, at a point remote from the cylinder. A voltmeter graduated in inches or percent may be used as a position read-out device.

Integral Position Sensor

Sensor Features

- Integrated into cylinder, hence protected from external damage
- Conductive plastic construction
- Resistance approximately 1500 ohms per inch
- Linearity 1 percent of stroke
- Temperature range 0 to 160°F (-40°F optional)
- Maximum power rating 0.1 watts per inch
- Electrical connection: DIN connector (same as Series 740 Valve)
- Can be checked with simple voltmeters
- Does not require non-rotating rod
- Position sensing is absolute (not incremental);
- Position indication is not lost after power failure

Cylinder Specifications

- 1.5" thru 4" bore Taskmaster cylinders
- All standard mounts applicable
- Cushioning available
- Strokes: 4, 6, 8, 10, 12 inches.
- Additional strokes available in 2" increments, 18" maximum.



Part Number and Stroke (KK2 Male rod thread)					
Bore	4" Stroke	6" Stroke	8" Stroke	10" Stroke	12" Stroke
1.50	R432034030	R432020385	TM-069860-03080	R432020386	TM-069860-03120
2.00	R432030503	R434002679	R434004036	TM-069862-03100	R434002690
2.50	TM-069866-03040	TM-069866-03060	TM-069866-03080	TM-069866-03100	TM-069866-03120
3.25	TM-069868-03040	TM-069868-03060	TM-069868-03080	TM-069868-03100	TM-069868-03120
4.00	R434002676	R432030521	TM-069870-03080	TM-069870-03100	R434002675

Other rod end thread options are available on request.

Electro-Pneumatic Positioner Specifications

- Stroke: Any length in 1" increments, to 10"
2" increments between 10" and 16" strokes
- Accuracy: +/- .050" or 1 percent full stroke, whichever is greater
- Repeatability: +/- .050
- Stroking Speed: Approximately: Fast 2"/sec., slow .5"/sec.
- Operating Temp.: 41°F to 122°F
- Power Requirements: 24vdc, 600ma
- Signal Options: 0Ö10vdc, 0Ö20ma, 5k ohm pot.
- Feedback Device: Linear potentiometer, internally mounted
- Supply Pressure: 100 psi nominal, 125 psi max. at 3 micron filtration recommended
- Optional Meter Drive: 0-20ma



Application

Wherever infinite positioning requirements allow electrical analog control signals. Interfaces with computer, PLC or simple potentiometer. Consists of cylinder with integral sensor, optimized valving, and an electronic controller. Available in bore sizes 1-1/2 thru 4" and strokes up to 16"; single or dual stroking speed control available.

Load Capacities per Bore Size					
Bore Size (inches)	1.5	2	2.5	3.25	4
Load rating (lbs.)	35	63	98	166	250

At 100 psi supply pressure, 1 percent positioning accuracy.

TaskMaster® Pneumatic Cylinder Optional Configurations

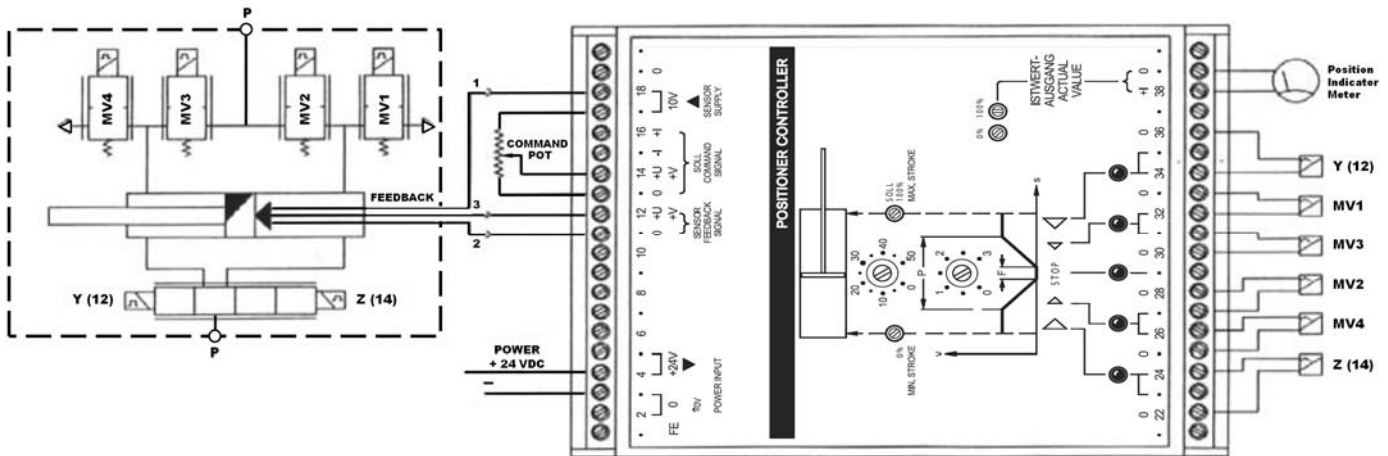

The basic concept involves a cylinder with integral feedback potentiometer in conjunction with a controller and matched solenoid valves.

Figure 1 represents the system layout. The figure represents a 2 speed system utilizing (4) 2-way solenoid valves (energized in pairs) for slow speed and a double solenoid, 4-way, closed center for fast speed.

The two speed feature offers the fastest response without sacrificing accuracy.

The single speed positioners are applied in areas that require accuracy and only slow speed, or fast speeds that do not require 1% accuracy.

For single speed applications, only one set of valves is necessary.

For the slow retract, (mv1) and (mv3) solenoid valves are energized simultaneously.

Valves (mv2) and (mv4) are energized for the slow extend command.

The double solenoid valve is energized for either the fast retract or for fast extend.

The controller constantly monitors the command signal and compares the feedback signal the position sensor located in the cylinder.

If the command signal is greater than the feedback, the controller will energize the solenoid valves associated with extension.

The retract solenoid valves are energized when the command signal is less than the feedback signal.

If the command equals the feedback signal, all of the solenoid valves are De-energized and position is maintained.

The two speed controller consists of a narrow window and a wide window comparator.

A large difference between the command and feedback results in energization of both sets of solenoid valves.

When the position approaches the set-point command, only the slow speed valves are energized.

A unique feature is that each set of solenoids is pulsed before complete shut-off to provide a stepped, gradual deceleration of the load.

The width of sensitivity and the width of the deceleration is adjustable on the controller to allow tailoring of the positioner for each application.

E-P Positioner Selection

HOW TO SELECT:

1. Determine the amount of force required for the application.
2. Determine the available supply pressure.
3. Not length of stroke required.
4. Check and note accuracy and speed requirements.
5. Determine if meter drive output is desired.
6. Contact sales representative or factory for component selection.

TaskMaster® Pneumatic Cylinder Optional Configurations

Taskmaster® Cylinder/Series 740™ Valve Combination Specifications

1-1/2", 2" 2-1/2", 3-1/4", & 4" Bore
 100" stroke maximum, 1/4" minimum stroke
 Male or female rod thread
 Pressure: 20 to 150 psi (2 position valves)
 50 to 150 psi (3 position valves)
 Temperature: 5°F to 140°F
 Standard Voltages: 6-24 VDC
 110-220 VAC
 Non-lube cylinder
 Positive air cushions at both ends (optional)
 Most NFPA mounts



Features

Air pilot or solenoid operated, single or double
 2 position spring returned valve or 3 position closed center valve
 Indicator light optionally available
 Valve has built in flow controls and integrated fittings
 Manual override
 Valve mounts at head or cap
 Valve has polyacetal body
 Corrosion resistant package, pre-lubricated
 Reduced air consumption
 Simplified customer plumbing
 Easy valve interchange (no screws to remove)
 Reduce labor cost

Valves are not factory assembled to cylinders. Valve mounting bracket and piping are factory assembled.
 Additional Series 740 valve features and specifications may be found in the valve catalog pages.
 Select Series 740 valve from the following pages.

Taskmaster® Cylinders with Mounting Bracket and Piping - For TM-8 Series Only*

Base Model Number	Bore	Rod Size	KK2 Male Thread
TM-027924-...	1-1/2	5/8	1/2-20
TM-026049-...	2	5/8	1/2-20
TM-026050-...	2-1/2	5/8	1/2-20
TM-026433-...	3-1/4	1	7/8-14
TM-026481-...	4	1	7/8-14

*TM-1 compliant cylinders are available; see order code.
 These TM-8 compliant cylinders include valve mounting bracket complete with tubing.
 Above cylinders are modified to accept mounting bracket.
 Standard Taskmaster cylinders may be modified by ordering field mounting kit,
 Part Number R432008535 (does not contain piping from head to cap).
 Estimated operating speeds in inches per second at 100 psi are: 1-1/2" bore, 50; 2", 28; 2-1/2", 18; 3-1/4", 9; and 4", 7.

How to Order Series 740™ Combinations

Select the appropriate part number from the list and add the 4-digit suffix which describes cushioning and stroke. Order mounting kits separately.
4-DIGIT SUFFIX EXPLANATION
 The first digit indicates the degree of cushioning...
 0-Noncushioned
 1-Cushioned in head end only
 2-Cushioned in cap ends only
 3-Cushioned in both ends
 Second and third digits are used to indicate the stroke in inches.
 Fourth digit is used to indicate additional eighths of an inch of stroke,

TaskMaster® Pneumatic Cylinder

Optional Configurations

Series 740 Valve Options

Type		Diaphragm poppet valve
Pressure range	Minimum	20 psi
	Maximum	150 psi
Flow		$C_v = 0.7$ to 0.95
Temperature range	Solenoid	5°F to 122°F
	Air Pilot	5°F to 140°F
Medium		Compressed air, lubricated or non-lubricated
Port sizes		3/8", 5/16" and 8mm also available [not shown]
<hr/>		
Materials	Body / Seals	Polyacetal plastic w/ Buna N seals
<hr/>		
Operating voltages		DC $\pm 10\%$
	50 Hz	AC - 20% + 10%
	60 Hz	AC - 10% + 20%
Power Consumption	DC 24 V	2, 14 W
Inrush power	AC 220/230 V 50/60 Hz	6,60 / 5,50 VA
Holding power	AC 220/230 V 50/60 HZ	4, 18 / 3,30 VA
<hr/>		
Protection with el. Connector		NEMA 4 [IP 65 to DIN VDE 0470]
Duty cycle	ED	100%
Switching times	t_{on}	18 ms
	t_{off}	32 ms
<hr/>		



Note

Electrical connectors must be ordered separately; one per solenoid required.
For entire line of Series 740 Valve options and accessories, see SC-300 catalog.

Series 740 Valve - Air Pilot		
Part Number	Description	
R432013808	Single Air Pilot, spring return	
R432013810	Double Air Pilot, 2 position	
Series 740 Valve - 2 Position, Solenoid Operated		
Single Solenoid, Air Spring Return	Description	Double Solenoid
5727495270	110V-50Hz/120V-60Hz	R432016659
R432016655	220V-50Hz/240V-60Hz	R432016660
R432016656	6 VDC	R432016661
R432016657	12 VDC	R432016662
5727490220	24VDC	R432016663
R432016658	24 VAC-50/60Hz	R432016664
Series 740 Valve - 3 Position, Double Solenoid Operated		
Closed Center	Description	Exhaust Open Center
R432016670	110V-50Hz/120V-60Hz	R432016665
R432016671	220V-50Hz/240V-60Hz	R432016666
R432016672	6 VDC	—
R432016673	12 VDC	R432016667
R432016674	24 VDC	R432016668
R432016675	24 VAC-50/60Hz	R432016669

Caution: Simultaneous activation of both solenoids will provide full supply pressure to both delivery and exhaust ports. Care should be taken to avoid applications where a back pressure spike can occur from heavy inertia loads.

Solenoid Connectors - Order One per Solenoid		
Strain Relief Connectors	Description	1/2" Conduit Connectors*
8941000302	Non-lighted	—
R432013747	Non-lighted for Wireways	—
—	Metallic Non-lighted	R432015781
—	Non-lighted Molded Plastic	R432015626
R432013726 (110 VAC)	Lighted	R432008421 (110V AC/DC)
R432013728 (230 VAC)	Lighted	R432008422 (230V AC/DC)
R432013729 (12 VDC)	Lighted	R432008423 (12V AC/DC)
R432013730 (24 VDC)	Lighted	R432008424 (24V AC/DC)
R432015629 (24 VAC)	Lighted	—

*CSA approved

TaskMaster® Pneumatic Cylinder

Technical Data and Design Features, 5" and 6" bores

Technical Data, 5"- 6" bore sizes

Pressure Rating	200 psi maximum
Temperature Range	0° to 160°F ambient, 200°F intermittent
Medium	Compressed air, non-lubricated or lubricated
Strokes	Furnished to nearest 1/8"
Pneumatic Cushioning	Optional on both ends
Mountings	One integral, plus ten NFPA mountings
Ports	NPTF dryseal tapered
Materials	
Tube	Hard anodized aluminum
Tie Rods	303 Stainless Steel
Head and Cap	Die cast aluminum
Piston Rod	Steel, hard chrome plated, oversize available

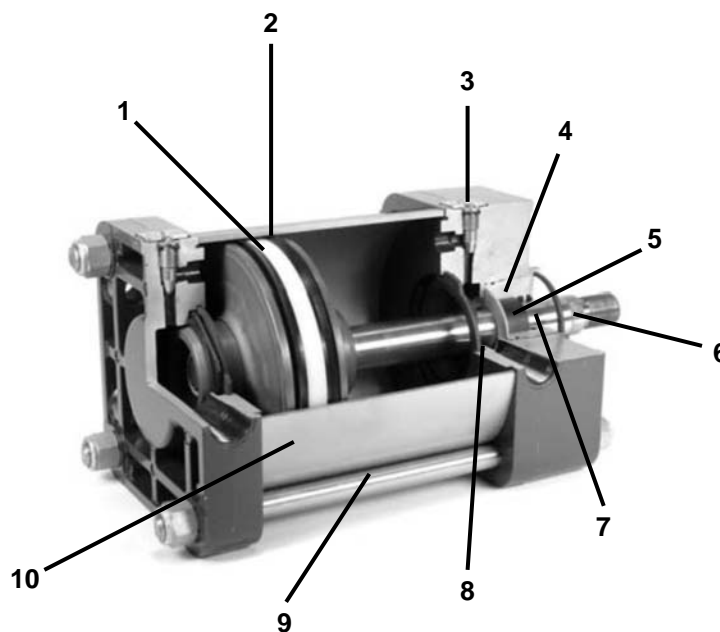
**TaskMaster Design Features, 5" - 6"**

Design Features

1. Non-metallic wear strip provides extended service even under harsh side loads.
2. Pressure energized Teflon coated cup-type piston seals provide positive, low friction sealing. They are self-regulating and wear compensating for extended service life.
3. Highly accurate external cushion adjustment
4. Durable rod bearing. Dependable non-scoring, corrosion-resistant graphite material. Cartridge can be removed without cylinder disassembly.
5. Positive rod seal. Pressure energized polyurethane cup seal is wear compensating for longer life.
6. High strength steel piston rod. Hard chrome plated for maximum durability with a 100,000 psi minimum yield. Oversize rod available. Case hardened to 50-55 Rockwell "C", finished to 15 microinches or better.
7. Protective rod wiper. Polyurethane lip-type wiper increases cylinder life by preventing damaging dirt from entering the cylinder gland
8. Self-aligning cushions. Teflon-coated, floating check valve allows greater cylinder speed.
9. 303 stainless steel tie rods for maximum corrosion resistance.
10. Rugged, non-corrosive tubing. Reinforced, hard anodized aluminum.

Magnetic piston (for use with sensors) available as an option. Select appropriate sensor from proximity switch section.

TaskMaster® Pneumatic Cylinder

How To Order Cylinders - 5" and 6" bore

Basic Ordering Code 5" - 6" Cylinders

EXAMPLE:

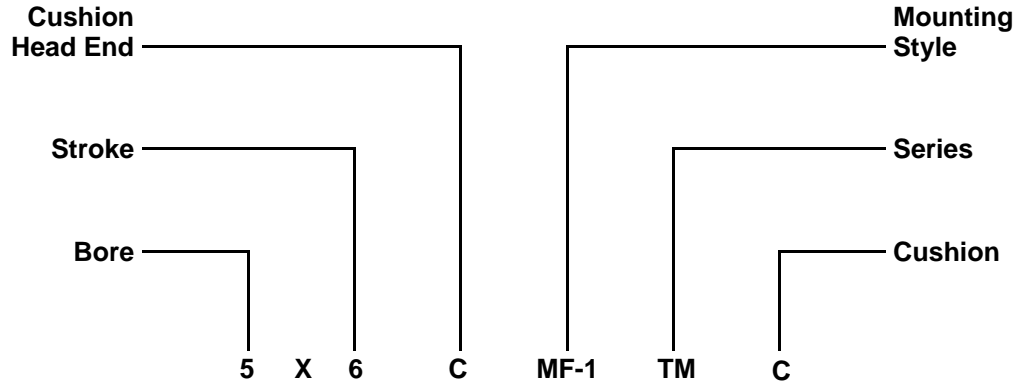

Part Number Listing:

A current part number with description listing is available at www.aventics.com/us

Notes:

- The basic ordering code must accompany the part number when ordering.
- If the magnetic piston (for use with sensors) is desired, it must also be specified when ordering. Select sensor from proximity switch section.
- Normal stroke tolerance +/- 1/16"
- Cushioning not recommended for under 3" stroke.

Old Part Numbers Reference for 5" and 6" bores

5" BORE PART NUMBER	5" BORE ROD DIA.	5" BORE ROD THREAD	5" & 6" MOUNT	6" BORE PART NUMBER	6" BORE ROD DIA.	6" BORE ROD THREAD
P -067997-00000	1.00	3/4-16	MF-1	P -068003-00000	1.38	1-14
P -068000-00000	1.38	1-14	MF-1	P -068006-00000	1.75	1 1/4-12
P -068009-00000	1.00	3/4-16	MF-2	P -068015-00000	1.38	1-14
P -068012-00000	1.38	1-14	MF-2	P -068018-00000	1.75	1 1/4-12
P -068021-00000	1.00	3/4-16	MF-5	P -068027-00000	1.38	1-14
P -068024-00000	1.38	1-14	MF-5	P -068030-00000	1.75	1 1/4-12
P -068033-00000	1.00	3/4-16	MF-6	P -068039-00000	1.38	1-14
P -068036-00000	1.38	1-14	MF-6	P -068042-00000	1.75	1 1/4-12
P -068045-00000	1.00	3/4-16	MP-2	P -068051-00000	1.38	1-14
P -068048-00000	1.38	1-14	MP-2	P -068054-00000	1.75	1 1/4-12
P -068057-00000	1.00	3/4-16	MS-1	P -068063-00000	1.38	1-14
P -068060-00000	1.38	1-14	MS-1	P -068066-00000	1.75	1 1/4-12
P -067985-00000	1.00	3/4-16	MS-4	P -067991-00000	1.38	1-14
P -067988-00000	1.38	1-14	MS-4	P -067994-00000	1.75	1 1/4-12

MP1 mount available, contact factory

5 DIGIT SUFFIX EXPLANATION

The first digit will always be zero. The second digit indicates the degree of cushioning:

- 0 - Non-cushioned
- 1 - Cushioned in head end only
- 2 - Cushioned in cap ends only
- 3 - Cushioned in both ends

Third and fourth digits are used to indicate the stroke in inches.

Fifth digit is used to indicate additional eighths of an inch of stroke.

EXAMPLE: Both ends cushioned, 10-1/2" stroke, 1-1/2" bore, KK2 THD = P -068174-03104

TaskMaster® Pneumatic Cylinder
 MS4- 5" and 6" bore
 Basic Cylinder

MS4 [Basic Cylinder]

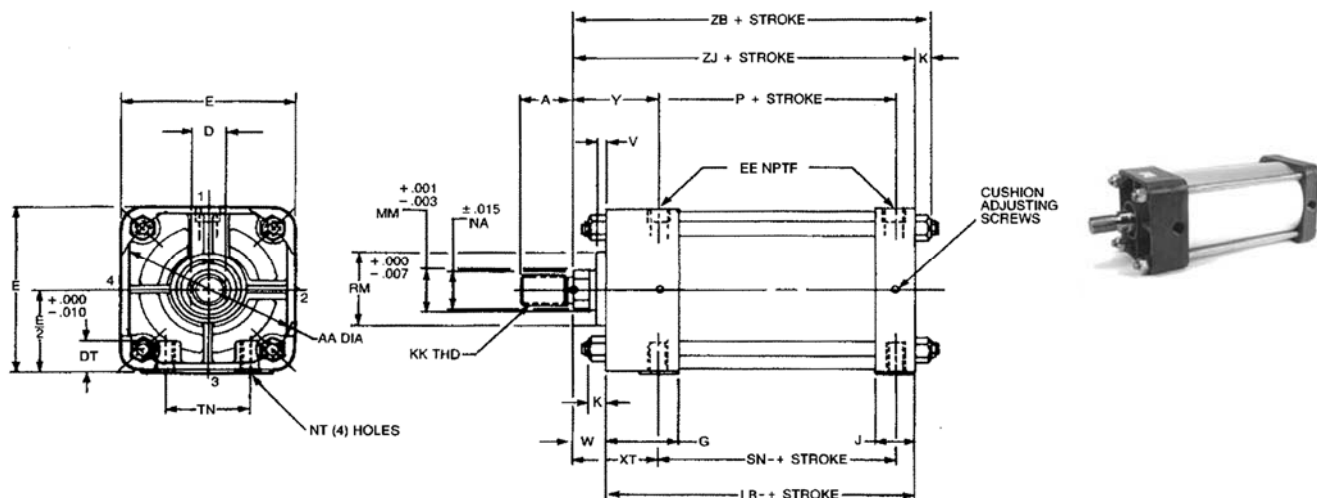

EE = 5" bore 1/2-14 NPTF, 6" bore 3/4-14 NPTF

MS4 Mount																				
Bore Size	MM Rod	E	G	J	K	P	V	W	Y	AA	DT	NA	LB	NT TAP	RM	SN	TN	XT	ZB	ZJ
5.00	1.00	5.50	2.31	1.19	0.61	2.88	0.25	0.75	2.44	5.80	1.06	0.94	5.13	5/8-11	2.374	2.88	2.69	2.44	6.49	5.88
5.00	1.38	5.50	2.31	1.19	0.61	2.88	0.25	1.00	2.69	5.80	1.06	1.31	5.13	5/8-11	2.374	2.88	2.69	2.69	6.74	6.13
6.00	1.38	6.50	2.69	1.44	0.61	3.13	0.25	0.88	2.81	6.90	1.19	1.31	5.75	3/4-10	2.624	3.13	3.25	2.81	7.23	6.63
6.00	1.75	6.50	2.69	1.44	0.61	3.13	0.25	1.13	3.06	6.90	1.19	1.69	5.75	3/4-10	2.624	3.13	3.25	3.06	7.49	6.88

5" and 6" bore Taskmaster pre-lubricated cylinders are versatile, durable, yet economical. The basic cylinder is furnished with MS4, side tapped mount with ten additional NFPA mountings available. Corrosion resistant aluminum head, cap and tube plus stainless steel tie rods make the Taskmaster Cylinder excellent where corrosion is a problem. These cylinders can be applied with medium-heavy loadings where large masses are to be moved or where frequency is high. The optional pneumatic cushioning is adjustable and gives quick acceleration. Each bore size offers the advantage of an oversize rod that can be used for larger loads and longer strokes. Dimensions in inches.

TaskMaster® Pneumatic Cylinder Rod Thread Options

Rod Size / Thread Options

TASKMASTER ROD THREAD OPTIONS

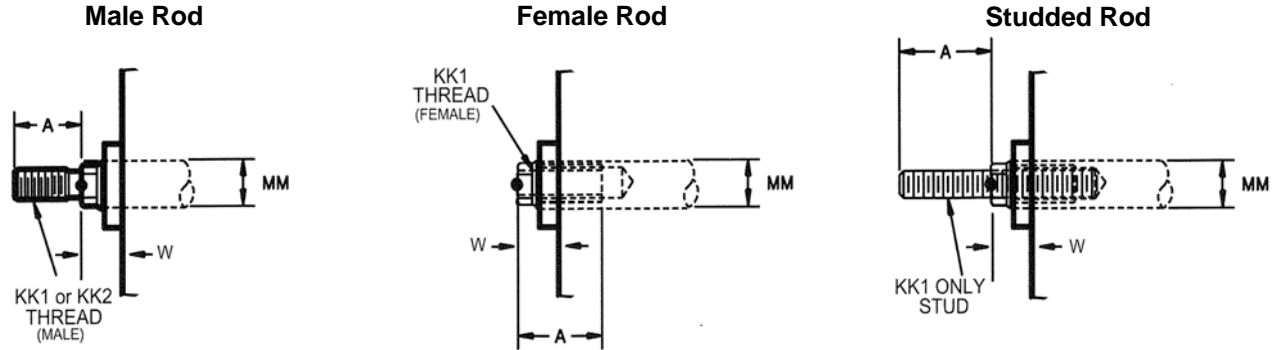

Rod Thread Options						
BORE SIZE	MM ROD	KK1 THD	KK2 THD	A	D*	W
5.000	1.000	3/4-16	7/8-14	1.13	0.88	0.75
5.000	1.375	1-14	1 1/4-12	1.63	1.13	1.00
6.000	1.375	1-14	1 1/4-12	1.63	1.13	0.88
6.000	1.750	1 1/4-12	1 1/2-12	2.00	1.50	1.13

NOTE

Male thread available in KK1 and KK2 thread sizes. KK1 male furnished when thread not specified. Female thread available in KK1 thread only. KK1 studded male rod end available on request.

*D = width across rod flats

TaskMaster® Pneumatic Cylinder

MF1 - 5" and 6" bore

MF2

MF1 Head Rectangular Flange

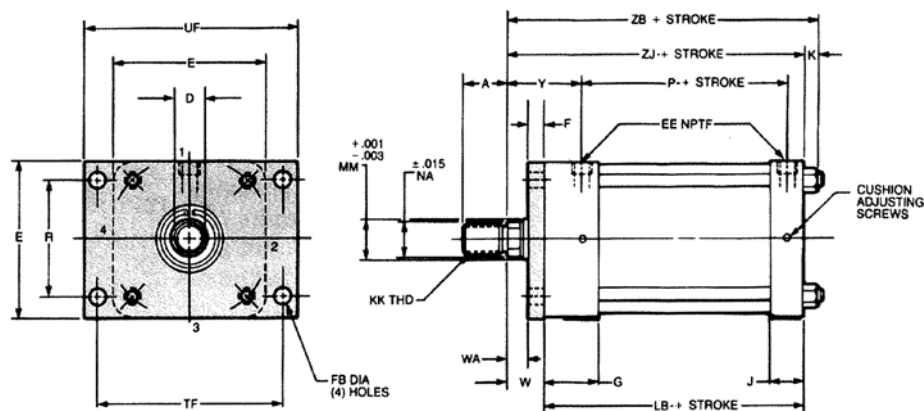

Model	MF1 Head Rectangular Flange												
BORE SIZE	MM ROD	E	F	K	R	W	FB	LB	TF	UF	WA	ZB	ZJ
5.000	1.000	5.50	0.63	0.61	4.10	0.75	0.53	5.13	6.63	7.63	0.13	6.49	5.88
5.000	1.375	5.50	0.63	0.61	4.10	1.00	0.53	5.13	6.63	7.63	0.38	6.74	6.13
6.000	1.375	6.50	0.75	0.61	4.88	0.88	0.53	5.75	7.62	8.62	0.12	7.23	6.63
6.000	1.750	6.50	0.75	0.61	4.88	1.12	0.53	5.75	7.62	8.62	0.38	7.49	6.88

Dimensions in inches, for those not shown see MS4 basic cylinder drawing.

MF2 Cap Rectangular Flange

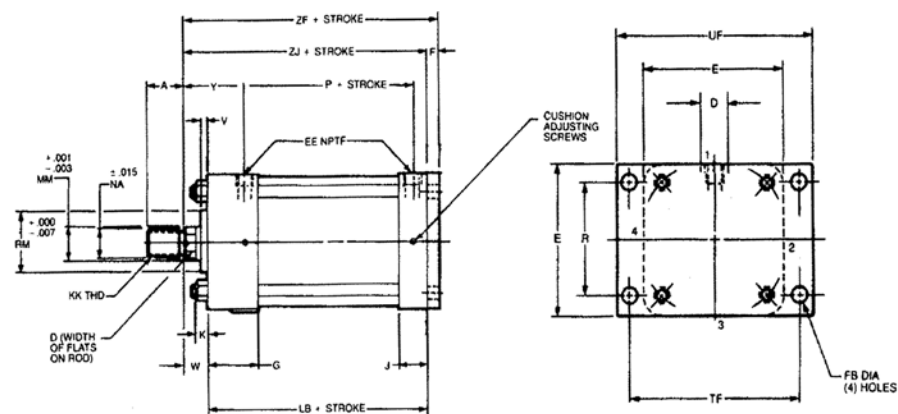

Model	MF2 Cap Rectangular Flange											
BORE SIZE	MM ROD	E	F	K	R	W	FB	LB	TF	UF	ZF	ZJ
5.000	1.000	5.50	0.63	0.61	4.10	0.75	0.53	5.13	6.63	7.63	6.50	5.88
5.000	1.375	5.50	0.63	0.61	4.10	1.00	0.53	5.13	6.63	7.63	6.75	6.13
6.000	1.375	6.50	0.75	0.61	4.88	0.88	0.53	5.75	7.63	8.63	7.38	6.63
6.000	1.750	6.50	0.75	0.61	4.88	1.13	0.53	5.75	7.63	8.63	7.63	6.88

Dimensions in inches, for those not shown see MS4 basic cylinder drawing.

TaskMaster® Pneumatic Cylinder

MF5 - 5" and 6" bore

MF6

MF5 Head Square Flange

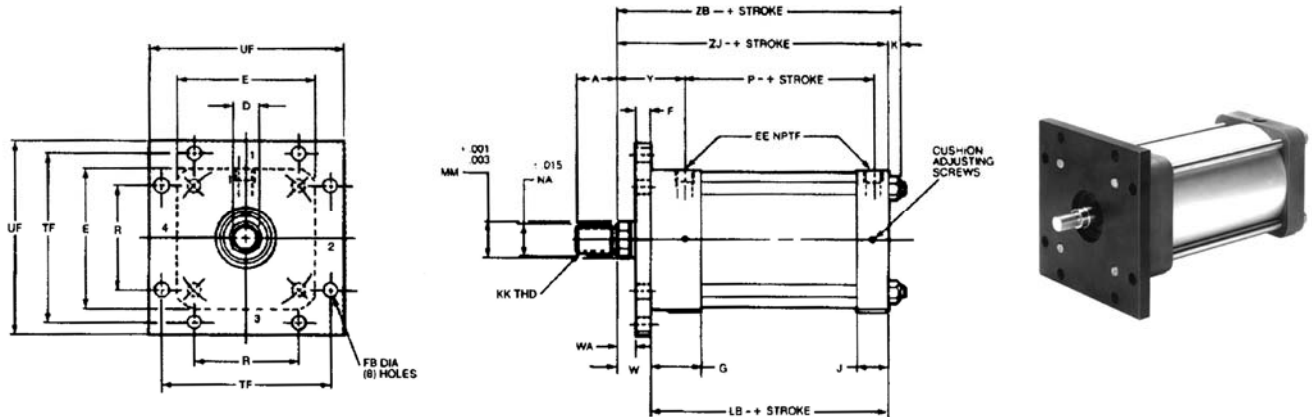

Model	MF5 Head Square Flange												
BORE SIZE	MM ROD	E	F	K	R	W	FB	LB	TF	UF	WA	ZB	ZJ
5.000	1.000	5.50	0.63	0.61	4.10	0.75	0.53	5.13	6.63	7.63	0.13	6.49	5.88
5.000	1.375	5.50	0.63	0.61	4.10	1.00	0.53	5.13	6.63	7.63	0.38	6.74	6.13
6.000	1.375	6.50	0.75	0.61	4.88	0.88	0.53	5.75	7.62	8.62	0.12	7.23	6.63
6.000	1.750	6.50	0.75	0.61	4.88	1.12	0.53	5.75	7.62	8.62	0.37	7.49	6.88

Dimensions in inches, for those not shown see MS4 basic cylinder drawing.

MF6 Cap Square Flange (Steel)

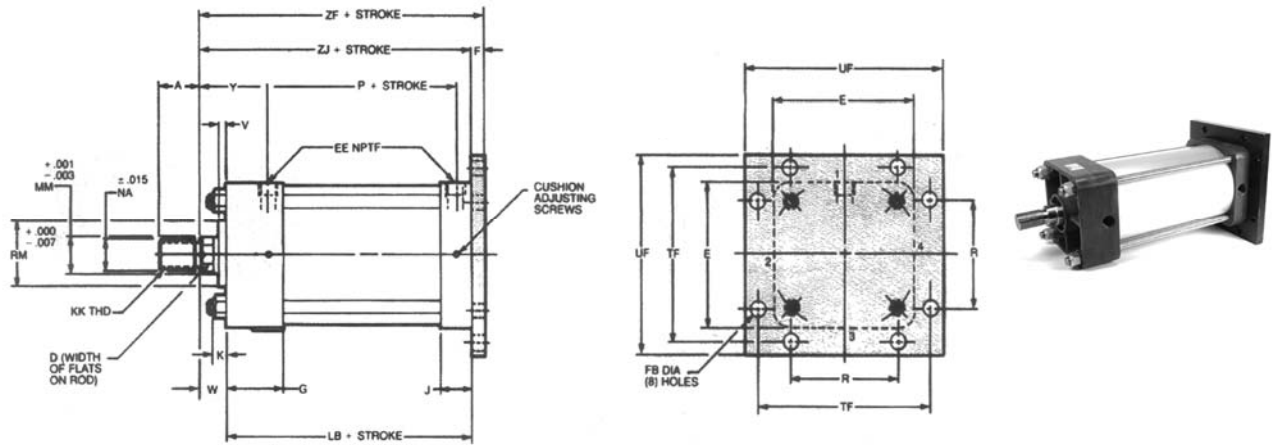

Model	MF6 Cap Square Flange												
BORE SIZE	MM ROD	E	F	K	R	W	FB	LB	TF	UF	ZF	ZJ	
5.000	1.000	5.50	0.63	0.61	4.10	0.75	0.53	5.13	6.63	7.63	6.50	5.88	
5.000	1.375	5.50	0.63	0.61	4.10	1.00	0.53	5.13	6.63	7.63	6.75	6.13	
6.000	1.375	6.50	0.75	0.61	4.88	0.88	0.53	5.75	7.63	8.63	7.38	6.63	
6.000	1.750	6.50	0.75	0.61	4.88	1.12	0.53	5.75	7.63	8.63	7.63	6.88	

Dimensions in inches, for those not shown see MS4 basic cylinder drawing.

TaskMaster® Pneumatic Cylinder
 MP2 - 5" and 6" bore
 MS1

MP2 Detachable Clevis (Aluminum)

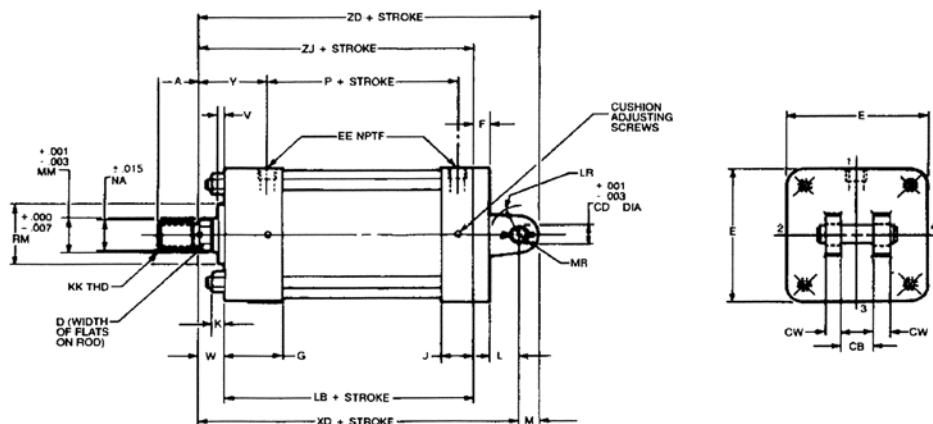

Model	MP2 Detachable Clevis														
BORE SIZE	MM ROD	E	F	K	L	M	CB	CD	CW	LB	LR	MR	XD	ZD	ZJ
5.000	1.000	5.50	0.63	0.61	1.25	0.75	1.25	0.750	0.63	5.13	0.88	0.75	7.75	8.50	5.88
5.000	1.375	5.50	0.63	0.61	1.25	0.75	1.25	0.750	0.63	5.13	0.88	0.75	8.00	8.75	6.13
6.000	1.375	6.50	0.75	0.61	1.50	1.00	1.50	1.000	0.75	5.75	1.19	1.00	8.88	9.88	6.63
6.000	1.750	6.50	0.75	0.61	1.50	1.00	1.50	1.000	0.75	5.75	1.19	1.00	9.13	10.13	6.88

Dimensions in inches, for those not shown see MS4 basic cylinder drawing.

MS1 Side End Angles (Steel)

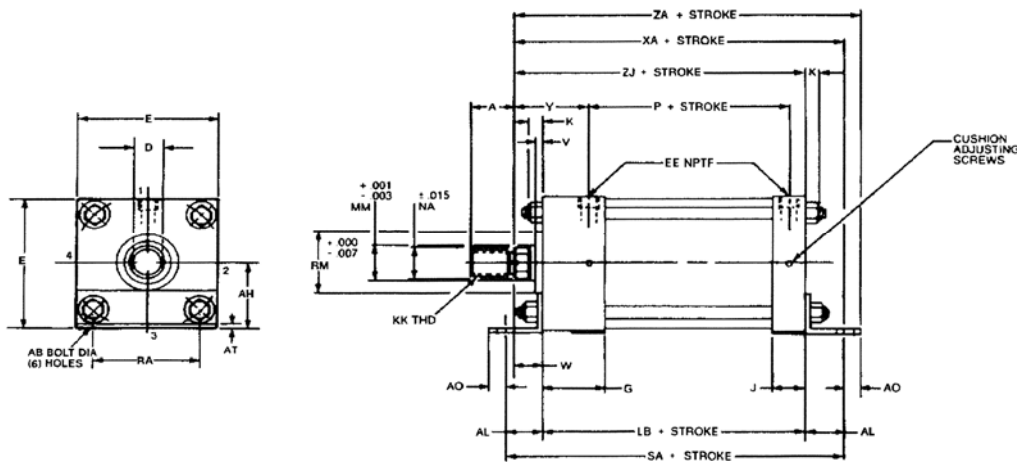

Model	MF1 Head Rectangular Flange														
BORE SIZE	MM ROD	E	K	AB	AH	AL	AO	AT	LB	RA	SA	XA	ZA	ZJ	
5.000	1.000	5.50	0.61	0.69	2.75	1.38	0.63	0.19	5.13	4.25	7.88	7.25	7.88	5.88	
5.000	1.375	5.50	0.61	0.69	2.75	1.38	0.63	0.19	5.13	4.25	7.88	7.50	8.13	6.13	
6.000	1.375	6.50	0.61	0.81	3.25	1.38	0.63	0.19	5.75	5.25	8.50	8.25	8.63	6.63	
6.000	1.750	6.50	0.61	0.81	3.25	1.38	0.63	0.19	5.75	5.25	8.50	8.25	8.88	6.88	

Dimensions in inches, for those not shown see MS4 basic cylinder drawing.

TaskMaster® Pneumatic Cylinder MX1, MX2, MX3, MX4—5" and 6" bore D Double Rod

MX1, MX2, MX3, MX4 Tie Rods Extended

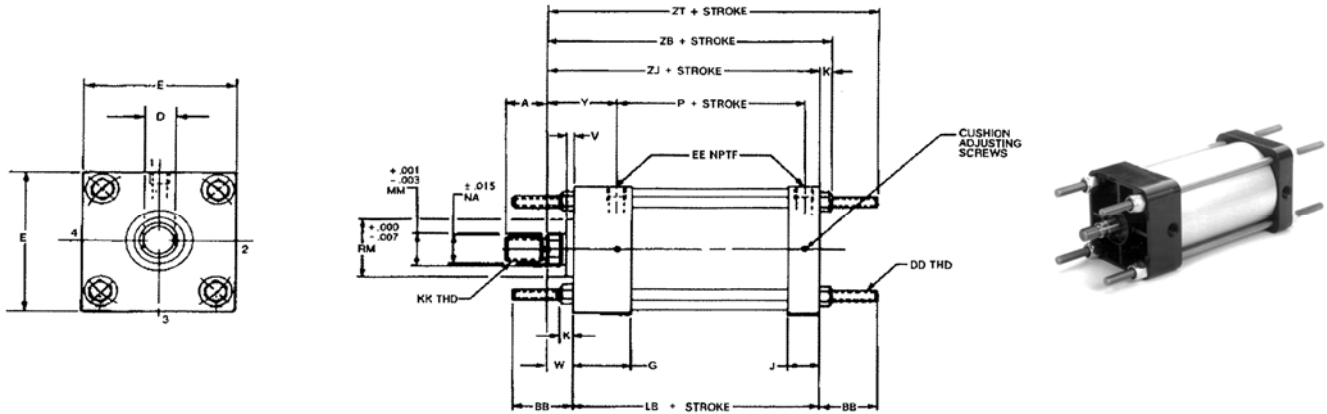

MX1—Tie rods extended both ends
MX2—Tie rods extended cap end

MX3—Tie rods extended head end
MX4—Two tie rods extended both ends

Model	MX1, MX2, MX3, MX4										
BORE SIZE	MM Rod	E	K	W	AA	BB	DD	LB	ZB	ZJ	ZT
5.000	1.000	5.50	0.61	0.75	5.80	1.81	1/2-20	5.13	6.49	5.88	7.69
5.000	1.375	5.50	0.61	1.00	5.80	1.81	1/2-20	5.13	6.74	6.13	7.94
6.000	1.375	6.50	0.61	0.88	6.90	1.81	1/2-20	5.75	7.23	6.63	8.84
6.000	1.750	6.50	0.61	1.12	6.90	1.81	1/2-20	5.75	7.49	6.88	8.69

Dimensions in inches, for those not shown see MS4 basic cylinder drawing.

D Double Rod

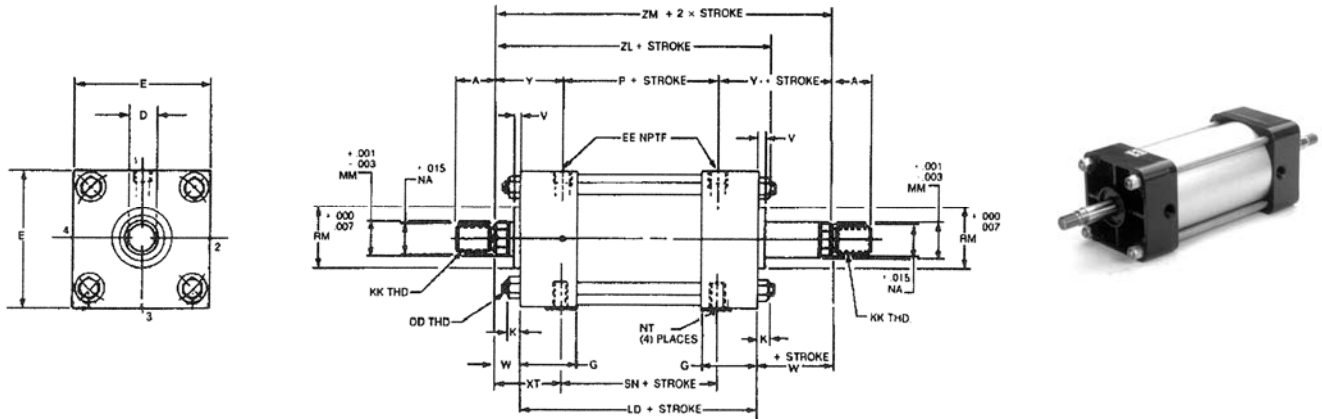

Technical Data																				
BORE SIZE	MM ROD	E	G	K	P	V	W	Y	AA	DD	DT	EE	LD	NT	RM	SN	TN	XT	ZL	ZM
5.000	1.000	5.50	2.31	0.61	2.88	0.25	0.75	2.44	5.80	1/2-20	1.06	1/2-14	6.25	5/8-11	2.374	2.88	2.69	2.44	7.61	7.75
5.000	1.375	5.50	2.31	0.61	2.88	0.25	1.00	2.69	5.80	1/2-20	1.06	1/2-14	6.25	5/8-11	2.374	2.88	2.69	2.69	7.86	8.25
6.000	1.375	6.50	2.69	0.61	3.13	0.25	0.88	2.81	6.90	1/2-20	1.19	3/4-14	7.00	3/4-10	2.624	3.13	3.25	2.81	8.49	8.75
6.000	1.750	6.50	2.69	0.61	3.13	0.25	1.13	3.06	6.90	1/2-20	1.19	3/4-14	7.00	3/4-10	2.624	3.13	3.25	3.06	8.74	9.25

Dimensions in inches, for those not shown see MS4 basic cylinder drawing.

TaskMaster® Pneumatic Cylinder
Accessories—5" and 6" bore

Female Rod Clevis (Steel)

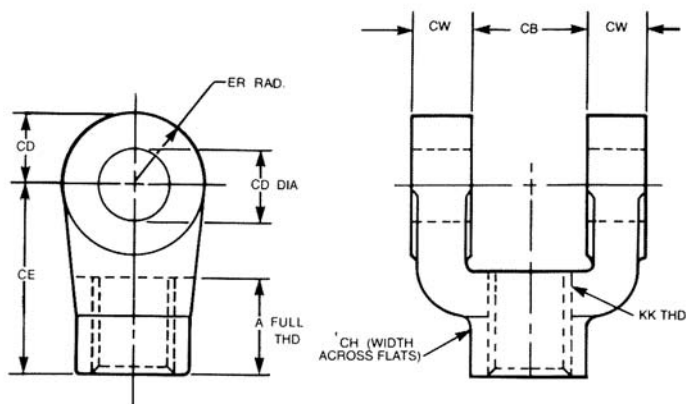

PART NO.	BORE SIZE	ROD SIZE	A	CB	CD	CE	CH	CW	ER	KK	WGT.
R433012603	5"	1.000	1.13	1.25	0.750	2.38	1.25	0.63	0.75	3/4-16	1 lbs. 4 oz.
R432012515*	5"	1.000	1.13	1.25	0.750	2.06	—	0.63	1.06	7/8-14	0 lbs. 7 oz.
R433012604	5" & 6"	1.375	1.63	1.50	1.000	3.13	1.63	0.75	1.00	1-14	2 lbs. 8 oz.
R433012606	6"	1.750	2.00	2.00	1.375	4.13	2.00	1.00	1.38	1-1/4-12	6 lbs. 6 oz.
R433012607	6"	1.750	2.25	2.50	1.750	4.50	2.38	1.25	1.75	1-1/2-12	11 lbs. 8 oz.

* Aluminum. Dimensions in inches.

Eye Bracket (Steel)

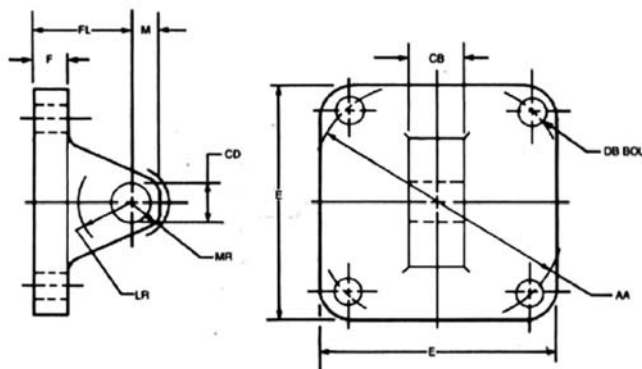

PART NO.	WEIGHT	BORE SIZE	E	F	M	AA	CB	CD	DB	FL	LR	MR
R433012640	3 lbs. 4 oz.	5"	3.50	0.63	0.75	3.60	1.25	0.750	0.50	1.88	1.00	0.75
R433012641	6 lbs. 4 oz.	5" & 6"	4.50	0.75	1.00	4.60	1.50	1.000	0.63	2.25	1.38	1.00
R433012642	10 lbs. 4 oz.	6"	5.00	0.88	1.38	5.40	2.00	1.375	0.63	3.00	2.00	1.38
R433012643	16 lbs. 12 oz.	6"	6.50	0.88	1.75	7.00	2.50	1.750	0.88	3.13	2.25	1.75

Dimensions in inches. This part mates with female rod clevis, or MP1, MP2 mounts

TaskMaster® Pneumatic Cylinder Accessories -- 5" and 6" bore

Female Rod Eye (Steel)

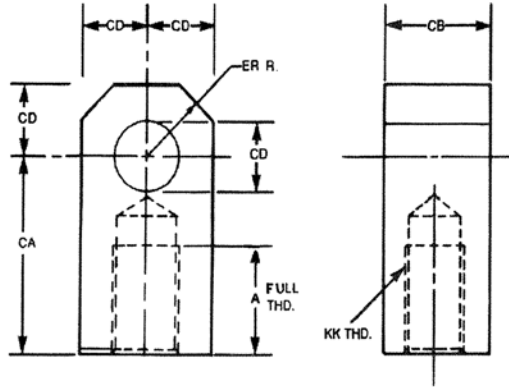

PART NO.	BORE SIZE	ROD SIZE	A	CA	CB	CD	ER	KK	WEIGHT
R433012611	5"	1.000	1.13	2.06	1.25	0.750	0.81	3/4-16	1 lb. 4 oz.
R433012612	5"	1.000	1.13	2.38	1.50	1.000	1.13	7/8-14	2 lb. 3 oz.
R433012613	5" & 6"	1.375	1.63	2.81	1.50	1.000	1.13	1-14	2 lb. 8 oz.
R433012614	5" & 6"	1.375	2.00	3.44	2.00	1.375	1.69	1-1/4-12	6 lb. 6 oz.
R433012614	6"	1.750	2.00	3.44	2.00	1.375	1.69	1-1/4-12	6 lb. 6oz.
R433012615	6"	1.750	2.25	4.00	2.50	1.750	2.06	1-1/2-12	11 lb. 8 oz.

Dimension in inches.

Clevis Bracket (Steel)

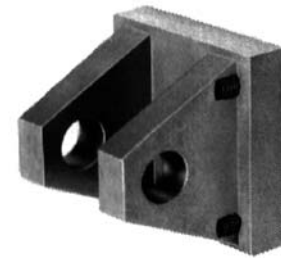
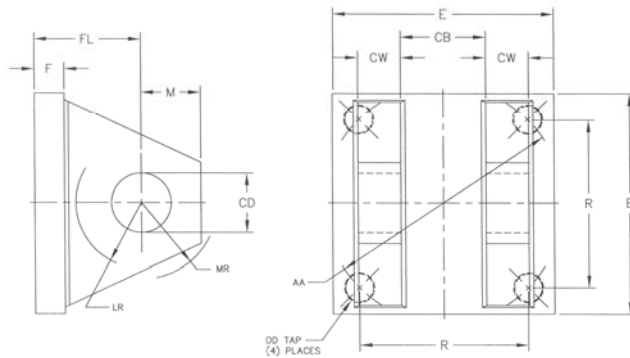

PART NO.	WEIGHT	BORE SIZE	E	F	M	AA	CB	CD	CW	DB	FL	LR	MR
R433012633	3 lb. 4 oz.	5"	3.50	0.63	0.75	3.60	1.25	0.750	0.63	1/2-20	1.88	0.88	1.25
R433012634	6 lb. 2 oz.	5" & 6"	4.50	0.75	1.00	4.60	1.50	1.000	0.75	5/8-18	2.25	1.19	1.13
R433012635	11 lb. 8 oz.	6"	5.00	0.88	1.38	5.40	2.00	1.375	1.00	5/8-18	3.00	1.75	1.63
R433012636	20 lb. 0 oz.	6"	6.50	0.88	1.75	7.00	2.50	1.750	1.25	7/8-14	3.13	2.13	2.13

Dimensions in inches. This part mates with female rod eye or MP4 mount.

TaskMaster[®] Pneumatic Cylinder
 Accessories -- 5" and 6" bore

Pivot Pin (Steel), including retaining rings

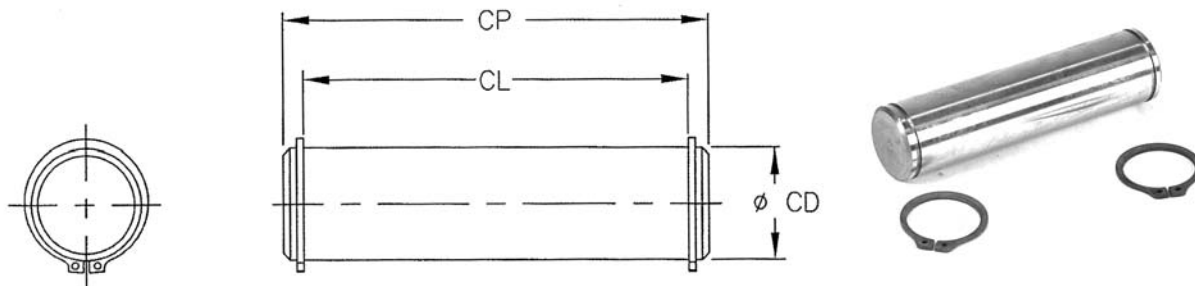

PART NO.	BORE SIZE	CD	CL	CP	WEIGHT
R433012621	5"	0.750	2.62	2.88	0 lb. 8 oz.
R433012623	5" & 6"	1.000	3.12	3.38	0 lb. 13 oz.
R433012625	6"	1.375	4.19	4.48	2 lb. 0 oz.
R433012627*	6"	1.750	5.19	5.54	3 lb. 14 oz.

Dimensions in inches.

*Has Cotter pins instead of retaining rings.

MP1 Bracket—Cast Iron (for mating with clevis bracket)

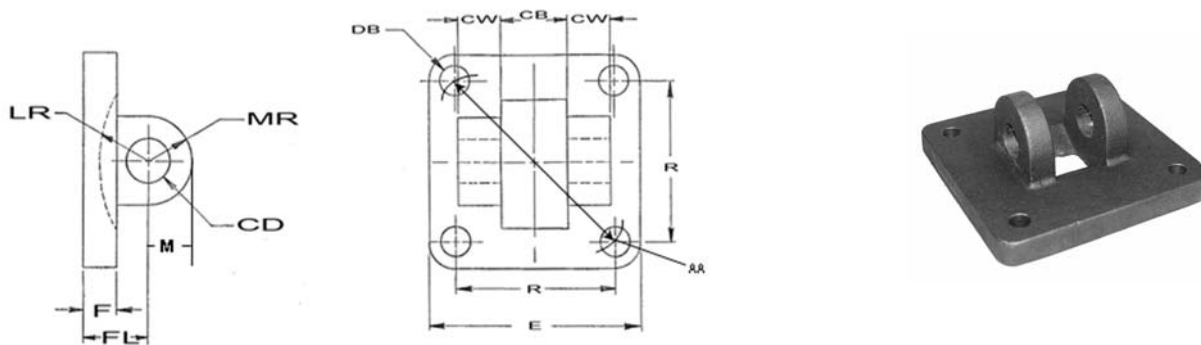

Part Number	Bore	E	F	R	AA	CW	CB	CD	DB	FL	LR	MR	M
R432015746	5"	5.50	0.62	4.10	5.80	0.63	1.26	0.75	0.53	1.25	0.88	0.88	0.75
R432015747	6"	6.50	0.75	4.88	6.90	0.75	1.51	1.00	0.53	1.50	1.13	1.25	1.00

Dimensions in inches.

TaskMaster® Pneumatic Cylinder

Installation and Service Information

INSTALLATION AND SERVICE INFORMATION

TABLE OF CONTENTS	PAGE NO.
Description, Warning	36
Installation	36
Standard & Special Repair Kits (1-1/2" - 6" Bore)	37
Operation	38
Standard Specifications	38
Adjustments	38
General Maintenance & Repair Recommendations	38
Parts List & Assembly Drawing (1-1/2" - 4" Bore)*	39
Parts List & Assembly Drawing (1-1/2" - 4" Bore)**	40
Major Repair, Maintenance and Testing (1-1/2" - 4" Bore)	41
Basic Cylinder Parts List & Assembly Drawing (5" & 6" Bore)	42
Major Repair, Maintenance & Testing (5" & 6" Bore)	43
Double Rod Cylinder Assembly Drawings (All Bores)	44

GENERAL INFORMATION

DESCRIPTION

Taskmaster Pre-Lubricated Pneumatic cylinders are available in 1-1/2" - 6" bores. The basic cylinder is furnished with an MS4 side tapped mount, with up to 12 additional NFPA mountings available. The popular mounting kits can be assembled to the basic cylinder on the 1-1/2" - 4" bore. Most mounting kits should be ordered separately from the cylinder. Basic cylinder part numbers, mounting kit and accessory part numbers for 1-1/2" - 4" bore cylinders are listed on the catalog pages. The available mounting kits for 1-1/2" - 4" bore are MS4 (basic), MF1, MF2, MP1, MP2, MP4, MS1, MS2, MT1, M1, 2, 3, & 4. The current generation of 1-1/2" - 4" bore cylinders begin with "TM" model codes. Model codes beginning "TM-8" are replacement for the original "P" number cylinders. Model codes beginning with "TM-1" match MFPA standards for rod and port dimensions.

The 5" and 6" bore cylinders are ordered with the desired mount. Part numbers for cylinders and accessories are listed on the catalog pages. The available mounts are: MS4, MF1, MF2, MF5, MF6, MP2, MS1, MX1, 2, 3, & 4.

Double rod models are available in all bore sizes.

WARNINGS— INSTALLATION AND MOUNTING

The user of these devices must conform to all applicable electrical, mechanical, piping and other codes in the installation, operations or repair of these devices.

INSTALLATION! Do not attempt to install, operate or repair these devices without proper training in the technique of working with pneumatic systems and devices, unless under trained supervision. Compressed air systems contain high levels of stored energy. Do not attempt to connect, disconnect or repair these products when a system is under pressure. Always exhaust the pressure from an air system before performing any service work. Failure to do so can result in serious personal injury. Disconnect the electrical power supply before connecting or servicing a solenoid operated valve.

MOUNTING! Devices should be mounted and positioned in such a manner that they cannot be accidentally operated.

INSTALLATION

Outline dimensions for installation of basic cylinders, mounting kits, and cylinder accessories are shown on the catalog pages. Port sizes are shown on standard specification chart on page 38. Before mounting the cylinder, all air lines in the system should be blown clean to remove any harmful dirt or moisture. To prevent corrosion and an accumulation of foreign matter in the cylinder, a 10 MICRON or better AVENTICS filter should be installed in the supply line to the cylinder control valve.

Teflon-coated piston and rod seals plus factory pre-lubrication, eliminates the need for air line lubrications. (However, lubricators can be used if desired). A complete selection of air line lubricators are available from AVENTICS.

A very important consideration in mounting the Taskmaster cylinder is keeping the cylinder thrust as close as possible to the centerline of the piston rod and free of misalignment or side loading. Off-center thrust or side loads decrease the normal life of the rod bearing and seals, and can cause binding in the cylinder or linkage. Forcing rod, clevis pins, or mounting bolts into position indicates that the cylinder is not properly aligned, and permanent damage may result from such installation.

*For model codes beginning in "TM" and date code of L 10-00 or later.

**For part numbers beginning with "P"

Note: For "TM" part numbers with date code prior to L 10-00 contact factory.

TaskMaster® Pneumatic Cylinder
Installation and Service Information

Repair Kits and Parts

ROD CARTRIDGE KIT (See Note 1)

Bore	Rode Size	Part Number	
1-1/2, 2 & 2 1/2"	5/8	R432015242 R432013557	(Std.) (Viton)
3-1/4 & 4	1	R432015245 R432015482	(Std.) (Viton)
5	1 1-3/8	R432014626 R432014630	(Std*) (Std*)
6	1-3/8 1-3/4	R432014637 R432014641	(Std*) (Std*)

PISTON & TUBE SEAL KITS
Standard Cylinders (repairs all versions)

Bore	Part No. (std.)Tube seals	Part No. Viton Tube seals
1-1/2"	R432015250	R432008802
2"	R432015256	R432008753
2-1/2"	R432015263	R432008550
3-1/4"	R432015269	R432015270
4"	R432015279	R432015280
5"	R432014614	
6"	R432014620	

ROD CARTRIDGE KIT (see Note 2)

Description	Part Number
1 1/2" bore, 5/8" rod, cushion @2	R434001403
1 1/2" bore, 5/8" rod, non-cushioned	R434001375
2" bore, 5/8" rod, cushion @2	R434001396
2" bore, 5/8" rod, non-cushioned	R434001394
2 1/2" bore, 5/8" rod, cushioned @2	R434001366
2 1/2" bore, 5/8" rod, non-cushioned	R434004054
3 1/4" bore, 1" rod, cushioned @2	R434001367
3 1/4" bore, 1" rod, non-cushioned	R434001368
4" bore, 1" rod, cushioned @2	R434001370
4" bore, 1" rod	R434001371

PISTON & LUBE SEAL KITS
Magnetic (original version only)
Includes tube seals, piston seals and piston wear strip.

Bore	Part Number
1-1/2"	R432015637
2"	R432015643
2-1/2"	R432015648
3-1/4"	R432015654
4"	R432015659

CUSHION KIT (see Note 1)

Description	Part Number
1-1/2"	R432009056
2, 2-1/2"	R432015238
3-1/4", 4"	R432015240
5"	R432014608
6"	R432014610

MAGNETIC PISTON KIT*

Bore	Part Number
1-1/2	R43201536
2	R432015642
2-1/2	R432015647
3-1/4	R432015653
4	R432009771

*Replacement only, for orig. design Taskmaster. Includes Magnetic piston, followers, seals and magnets.

CYLINDER LUBE GREASE

Description	Part Number
14 oz. tube	R431001590

(The cylinder is pre-lubricated at the factory. However, when replacing seals, lubricate all rubber parts with cylinder lube grease.)

PISTON KITS (see Note 3)

Bore	Part Number
1-1/2	R432009715
2	R432009728
2-1/2	R432009744
3-1/4	R432009760
4	R432009771

Note 1: For Part number starting in "P". Also "TM" or "R" date code later than L10-00 or 00W41.
 Note 2: For part no. starting with "TM" with date code of L09-00 or before, standard seals, with ports @1.
 Note 3: For part numbers starting with "TM" or "R" with date code later than L10-00 or 00W41

TaskMaster® Pneumatic Cylinder

Installation and Service Information

1 1/2" — 6" Bore General Information

OPERATION

Air pressure supplied to the cap-end port moves the piston rod to its extended position. Pressure supplied to the head end port moves the piston rod to its retracted position. See the catalog for forces developed by each cylinder.

STANDARD SPECIFICATIONS

BORE SIZES

NFPA standard, 1-1/2", 2", 2-1/2", 3-1/4", 4", 5", & 6"

PRESSURE RATING

200 PSI air

TEMPERATURE RANGE

0°F TO 160°F ambient

STROKES

Standard strokes furnished to near 1/8". Normal stroke tolerance +/- 1/16". Closer stroke tolerances available; consult factory.

MOUNTING

Basic mounting plus 12 additional NFPA mountings.

CUSHIONING

Optional on both ends for all bore sizes.

PRE-LUBRICATED DESIGN

Teflon-coated piston and rod seals plus factory pre-lubrication eliminates the need for air line lubrication.

ROD END THREADS

KK2 male thread is standard for 1-1/2"—4" bores for "TM-8" and "P" part numbers.

KK1 male thread is standard for 1-1/2"—4" bores for "TM-1" part numbers.

KK1 male thread is standard for 5" and 6" bore.

KK1 female, KK1 (studded) male and either KK1 or KK2 male are optional on all bore sizes.

PISTON ROD

Chrome-plated, high carbon steel polished to 15 microfinish. Stainless steel (316/303) available for maximum corrosion resistance. Oversize rods are available on "TM-1" models of 1-1/2"-4" bores and on 5" and 6" bores.

TUBE

Hard anodized extruded aluminum for lightweight, high strength and maximum corrosion resistance used in 1 1/2" - 4". Seamless aluminum tubing used for 5" and 6" bore.

PORTS

NPTF dryseal tapered threads. Available only in sizes shown

BORE	NPTF*	NPTF**
1-1/2", 2", 2-1/2"	1/4-18	3/8-18
3-1/2", 4"	3/8-18	1/2-14
5"	1/2-14	
6"	3/4-14	

*For "TM-8" or "P" part numbers.

**For "TM-1" part numbers.

CYLINDER WEIGHTS*

BORE SIZE	ROD SIZE	CYLINDER WEIGHT ZERO	ADDITIONAL WEIGHT PER INCH
1-1/2"	5/8	1.65	0.205
2"	5/8	2.50	0.250
2-1/2"	5/8	3.54	0.280
3-1/4"	1	7.00	0.450
4"	1	9.87	0.548
5"	1	10.70	0.640
5"	1-3/8	11.50	0.840
6"	1-3/8	15.60	0.880
6"	1-3/4	16.90	1.140

*Weights based on standard (first) rod size.

ADJUSTMENT

An adjustment needle valve is furnished as an integral part of the head and cap on all cushioned cylinders. This needle valve controls the rate at which trapped air is allowed to vent from the head or cap. Turn the needle valve clockwise to increase the amount of cushioning and counter-clockwise to decrease the amount of cushioning.

GENERAL MAINTENANCE & REPAIR RECOMMENDATIONS

Maintenance periods should be scheduled in accordance with frequency of use and working environment of the cylinder. All cylinders must be visually inspected for wear and given an "in system" operating performance and leakage test at least once a year. If these visual observations indicate cylinder repair is required, the cylinder must be removed, repaired and tested.

A major overhaul is recommended at one million cycles. However where frequency of use is such that it would require more than two years to obtain one million cycles, the cylinder must be overhauled at the two year period.

When it is determined that the cylinder requires a major repair as a result of the one million cycles, one year routine inspection, or the two year service period has elapsed, the device must be disassembled, cleaned, inspected, parts replaced as required, rebuilt and tested for leakage, and proper operation prior to installation. Refer to MAJOR REPAIR, MAINTENANCE INSTRUCTION, and TEST PROCEDURES.

TaskMaster® Pneumatic Cylinder
Installation and Service Information

1-1/2" - 4" Bore Size Basic Cylinder Parts List
(For model numbers beginning with R, or "TM" and date code of L10 or later.)

Basic MS4 Parts List—Single Rod Model*

Ref.	Qty.	Description	Part Number by Bore Size				
			1-1/2"	2"	2-1/2"	3-1/4"	4"
1	4	Screw, Head	R432015529	R432015531	R432015531	R432015533	R432015533
2	1	Head, TM-8 Cylinder	R432009478	R432009493	R432009504	R432009513	R432009520
		Head, TM-1 Cyl., Standard Rod	R432009793	R432009805	R432009818	R432009826	R432009833
		Head, TM-1 Cyl., Oversize Rod	R432009841	R432009843	R43209846	R432009852	R432009857
		Head, TM-1 Cyl., Oversize Rod	R432009841	R432009843	R43209846	R432009852	R432009857
3	1	Rod Cartridge Kit, Standard Rod	R432015242	R432015242	R432015242	R432015245	R432015245
		Rod Cartridge Kit, Oversize Rod	R434001391	R434001391	R434001391	R432014630	R432014630
4	1	Retaining Ring, Rod Bearing	Repair kit includes	Repair kit includes	Repair kit includes	Repair kit includes	Repair kit includes
5	1	Rod Bearing	ref. numbers	ref. numbers	ref. numbers	ref. numbers	ref. numbers
6	1	Rod Wiper	3, 4, 5 & 6	3, 4, 5 & 6	3, 4, 5 & 6	3, 4, 5 & 6	3, 4, 5 & 6
7	2	Rod Seal	R432009056	R432015238	R432015238	R432015240	R432015240
8	2	Cushion Kit	R432015250	R432015256	R432015263	R432015269	R432015279
		Piston & Tube Seal Kit	Repair kit includes	Repair kit includes	Repair kit includes	Repair kit includes	Repair kit includes
9	1	Tube Seal O'ring	ref. numbers	ref. numbers	ref. numbers	ref. numbers	ref. numbers
10	2	Piston Rod Seal	8, 9,10 & 11	8, 9,10 & 11	8, 9,10 & 11	8, 9,10 & 11	8, 9,10 & 11
11	1	Piston Seal	8, 9,10 & 11	8, 9,10 & 11	8, 9,10 & 11	8, 9,10 & 11	8, 9,10 & 11
12	1	Piston Wear Ring	8, 9,10 & 11	8, 9,10 & 11	8, 9,10 & 11	8, 9,10 & 11	8, 9,10 & 11
		Piston Kit, Standard Rod	R432009715	R432009728	R432009744	R432009760	R432009771
13	2	Piston Kit, Oversize Rod	R432009716	R432009729	R432009745	R432009762	R432009773
		Piston	Rep. kit incl.	Rep. kit incl.	Rep. kit incl.	Rep. kit incl.	Rep. kit incl.
14	1	Follower, Piston	ref. numbers	ref. numbers	ref. numbers	ref. numbers	ref. numbers
15	1	Retaining Nut, Piston & Rod	8 thru 14	8 thru 14	8 thru 14	8 thru 14	8 thru 14
15a	1	Piston Rod, Male	various	various	various	various	various
		Std. Rod, KK1 or KK2 Thread	various	various	various	various	various
16	1	Oversize Rod, KK1 Thread	various	various	various	various	various
		Piston Rod, Female	various	various	various	various	various
16	1	Std. Rod, KK1 Thread	various	various	various	various	various
		Oversize Rod, KK1 Thread	various	various	various	various	various
		Male Stud (use with ref. 15a)	various	various	various	-	-
16	1	7/16"-20 UNF-2A Thread	various	various	various	various	various
		1"-14 UNF-2A Thread	-	-	-	various	various
		3/4"-16 UNF-2A Thread	-	-	-	various	various
17	1	Tube, Body	various	various	various	various	various
18	1	Cap, TM-8 (w/needle vlv. assbly)	R432009486	R432009499	R432009508	R432009517	R432009525
		Cap, TM-1 (w/needle vlv. assbly)	R432009800	R432009811	R432009821	R432009829	R432009837
19	4	Screw, Cap	R432015528	R432015530	R432015530	R432015532	R432015532

*Order repair parts for double rod cylinders by description and complete cylinder number. See page 44 for assembly drawing.

*Single Rod Model

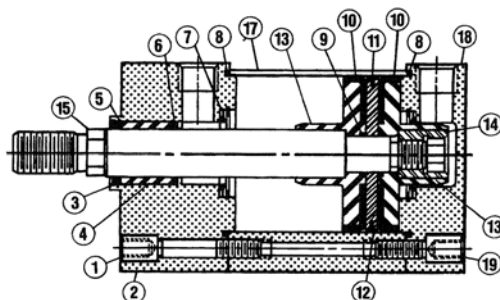

TaskMaster® Pneumatic Cylinder Installation and Service Information

1-1/2" - 4" Bore Size Basic Cylinder Parts List (For part numbers beginning with "P")

Basic MS4 Parts List—Single Rod Model*

Ref.	Qty.	Description	Part Number by Bore Size				
			1-1/2"	2"	2-1/2"	3-1/4"	4"
1	4	Screw, Head	R432015529	R432015531	R432015531	R432015533	R432015533
2	1	Head (w/needle valve assembly)	R432030813	R432030814	R432030815	R432013413	R432013414
3	1	Rod Cartridge Kit	R432015242	R432015242	R432015242	R432015245	R432015245
4	1	Retaining Ring, Rod Bearing	Repair kit includes	Repair kit includes	Repair kit includes	Repair kit includes	Repair kit includes
5	1	Rod Bearing	ref. numbers	ref. numbers	ref. numbers	ref. numbers	ref. numbers
6	1	Rod Wiper	3, 4, 5 & 6	3, 4, 5 & 6	3, 4, 5 & 6	3, 4, 5 & 6	3, 4, 5 & 6
7	2	Rod Seal	R432009056	R432015238	R432015238	R432015240	R432015240
8	2	Cushion Kit	R432015250	R432015256	R432015263	R432015269	R432015279
9	1	Piston & Tube Seal Kit	Repair kit includes	Repair kit includes	Repair kit includes	Repair kit includes	Repair kit includes
10	2	Tube Seal O'ring	ref. numbers	ref. numbers	ref. numbers	ref. numbers	ref. numbers
11	1	Piston Rod Seal	8, 9, 10 & 11	8, 9, 10 & 11	8, 9, 10 & 11	8, 9, 10 & 11	8, 9, 10 & 11
12	1	Piston Seal	8, 9, 10 & 11	8, 9, 10 & 11	8, 9, 10 & 11	8, 9, 10 & 11	8, 9, 10 & 11
13	1	Piston Wear Ring	R432013860	R432013861	R432013862	R432013863	R432013864
14	2	Follower, Piston	R432012506	R432012505	R432012507	R432013281	R432013365
15	1	Retaining Nut, Piston Rod	R432013404	R432013404	R432013404	R432013405	R432013405
15a	1	Piston Rod, Male 1/2"-20 Thread 7/8"-14" Thread	various	various	various	-	-
16	1	Piston Rod, Female 7/16"-20 Thread 3/4"-16 Thread	-	-	-	various	various
17	1	Male Stud (use with ref. 15a) 7/16"-20 Thread 3/4"-16 Thread	-	-	-	R433013685	R433013685
18	1	Tube, Body	various	various	various	various	various
19	1	Cap (w/needle valve assembly)	R432030818	R432030819	R432030820	R432012409	R432012410
19	4	Screw, Cap	R432015528	R432015530	R432015530	R432015532	R432015532

*Order repair parts for double rod cylinders by description and complete cylinder number. See page 44 for assembly drawing.

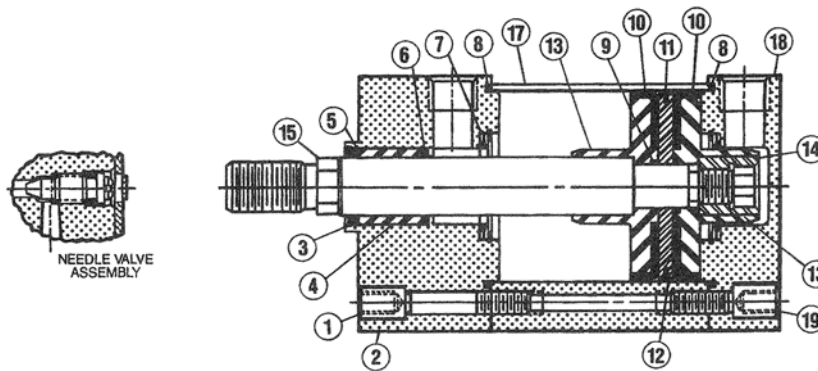

SINGLE ROD MODEL *

TaskMaster® Pneumatic Cylinder

Installation and Service Information

1-1/2" - 4" BORE

MAJOR REPAIR, MAINTENANCE & TESTING

MAJOR REPAIR & MAINTENANCE INSTRUCTIONS

When it is determined that the cylinder requires shop repairs (see GENERAL MAINTENANCE AND REPAIR RECOMMENDATIONS), the following general instructions are recommended.

DISASSEMBLY, CLEANING & LUBRICATION

Follow warnings on page 36. Disconnect air lines from head and cap ports of cylinder. Completely disassemble the cylinder using the assembly views as reference. No special tools are required except internal snap ring pliers and hex wrench set to remove retaining rings, retaining nut, head & cap screws. A 5/32 socket wrench is required to remove needle valve retainer plate (present on older models).

1. Remove head & cap screws.
2. Remove head & cap.
3. Remove piston rod assembly. To disassemble piston rod, clamp piston rod across flats in soft jaws to remove piston retaining nut. Retaining nut is retained to piston rod with LOCTITE R/C 277.
4. Remove internal retaining rings to remove rod cartridge and cushion kits from head and cap.
5. Remove hex head screws and retainer plate to remove needle valve assembly.

Wash all metal parts in a nonflammable solvent. Rinse each part thoroughly and blow dry with a low pressure air jet. Arrange the parts on a clean surface. Examine each part carefully. Replace all rubber parts and all other worn or damaged parts. The use of REPAIR KITS is strongly recommended.

REASSEMBLY

The procedure for reassembly is essentially the reverse of disassembly. However, the following exceptions should be noted:

1. All O-rings should be well coated with Cylinder Lube grease as they are installed in their respective grooves and prior to assembly with the mating part. (**NOTE:** for FOOD SERVICE USE, use NORDSTROM Grease; see page 37) Care must be taken when assembling O-rings and packing that they are not damaged, as this will cause leakage.
2. Assemble the piston followers, piston, and piston seals to the piston rod less lubricant. The piston retaining nut should be assembled with LOCTITE retaining compound R/C 277 and torque specification chart with the piston rod clamped in soft jaws.
3. Reassemble the cylinder using the assembly views as reference. Pay particular attention to the installation of the cushion kit (ref. 7) to insure that the tapered rubber surface marked "THIS SIDE UP" faces to the inside (piston side) of the cylinder. As the assembly proceeds, lubricate the piston seals, cushion seals, rod seal, tube, and the tube seals with Cylinder Lube grease.
4. Torque head and cap screws to torque specification shown on chart.

TESTING

After the cylinder has been completely reassembled, it should be tested, either on a test bench or in the regular installation.

TEST PROCEDURE

The cylinder should be tested for cushioning, travel and leakage.

A. CUSHIONING

1. Turn both cushioning screws clockwise all the way in.
2. Cycle cylinder a few times by alternating supply pressure to head and cap ports.
3. Apply supply pressure to the head port. Rod should retract, decelerate and may stop before completion of stroke.
4. Apply supply pressure to the cap port. Rod should extend, decelerate and may stop before completion of stroke.

B. TRAVEL AND LEAKAGE

1. Turn the cushioning screws counterclockwise on (1) full turn.
2. Apply supply pressure to the head port. Cylinder should have less cushioning and make full stroke + or -.062". Check leakage around rod seal. No leakage permitted.
3. Apply supply pressure to the cap port. Cylinder should have less cushioning and make full stroke + or -.062". Check leakage at head port. 30cc/min. leakage permitted.
4. Return piston rod to retract position by applying supply pressure to head port. Remove supply pressure and install cylinder in service if satisfactory.

CUSHION ADJUSTMENT

Turn the needle valve clockwise to increase the amount of cushioning and counter clockwise to decrease cushioning. To obtain the most effective cushioning, final adjustment must be made while the cylinder is operating under normal conditions at normal operating pressure.

TORQUE SPECIFICATIONS (foot pounds)

Piston Rod Nut:	
Rod Diameter 5/8"	10 Loctite R/C 277
Rod Diameter 1" & 1-3/8"	45 Loctite R/C 277
Head & Cap Screws:	
Bores 1-1/2" - 2-1/2"	8 Non-Lubricated
Bores 3-1/4" - 4"	10 Non-Lubricated

TaskMaster® Pneumatic Cylinder Installation and Service Information

5" & 6" Bore Size Basic Cylinder Parts List & Assembly Drawing

Basic MS4 Parts List - Single Rod Model*

Ref.	Qty.	Description	Part Number by Bore Size			
			5" Bore		6" Bore	
			1" Rod	1-3/8" Rod	1-3/8" Rod	1-3/4" Rod
1	8	Nut, Tie Rod Lock	R431001891	R431001891	R431001891	R431001891
2	4	Tie Rod	various	various	various	various
3	1	Head (w/needle valve assembly)	R432014644	R432014644	R432014648	R432014648
4	1	Rod Bearing and Housing	R432014625	R432014629	R432014636	R432014640
4a	1	Housing, Rod Bearing	R432014602	R432014603	R432014604	R432014605
4b	1	Retaining Ring, Housing	R432012240	R432012240	R432012241	R432012241
4c	1	Washer, Retaining Housing	R432012259	-	R432012260	-
4d	1	Rod Cartridge Kit	R432014626	R432014630	R432014637	R432014641
4e	1	Bearing, Rod	Repair kit includes	Repair kit includes	Repair kit includes	Repair kit includes
4f	1	Seal, Rod	ref. numbers	ref. numbers	ref. numbers	ref. numbers
4g	1	Wiper, Rod	ref. numbers	ref. numbers	ref. numbers	ref. numbers
4g	1	Seal, Housing O-ring	4d,4e,4f & 4g	4d,4e,4f & 4g	4d,4e,4f & 4g	4d,4e,4f & 4g
5	2	Cushion Kit	R432014608	R432014608	R432014610	R432014610
6	1	Piston Assembly Kit, Complete	R432014612	R432014612	R432014618	R432014618
6a	1	Nut, Piston Retaining	Kit incl. ref. 6a thru 6f	Kit incl. ref. 6a thru 6f	Kit incl. ref. 6a thru 6f	Kit incl. ref. 6a thru 6f
6b	2	Piston, Half	6a thru 6f	6a thru 6f	6a thru 6f	6a thru 6f
6c	1	Piston & Tube Seal Kit	R432014614	R432014614	R432014620	R432014620
6d	2	Rod Seal, Piston O-ring	Repair kit includes	Repair kit includes	Repair kit includes	Repair kit includes
6e	1	Piston Seal	ref. numbers	ref. numbers	ref. numbers	ref. numbers
6e	1	Piston Wear Ring	ref. numbers	ref. numbers	ref. numbers	ref. numbers
6f	2	Tube Seal, O-ring	6c,6d,6e & 6f	6c,6d,6e & 6f	6c,6d,6e & 6f	6c,6d,6e & 6f
7	1	Piston Rod Male 3/4"-16 Thread 7/8"-14 Thread 1"-14 Thread 1 1/4"-12 Thread 1 1/2"-12 Thread	various various - - -	- - various various -	- - various various -	- - - various various
7a	1	Piston Rod Female 3/4"-16 Thread 1"-14 Thread 1 1/4"-12 Thread	various - -	- various -	- various -	- - various
8	1	Tube	various	various	various	various
9	1	Cap (w/needle valve assembly)	R432014646	R432014646	R432014650	R432014650

*Order repair parts for double rod cylinders by description and complete cylinder number. See page 44 for assembly drawing.

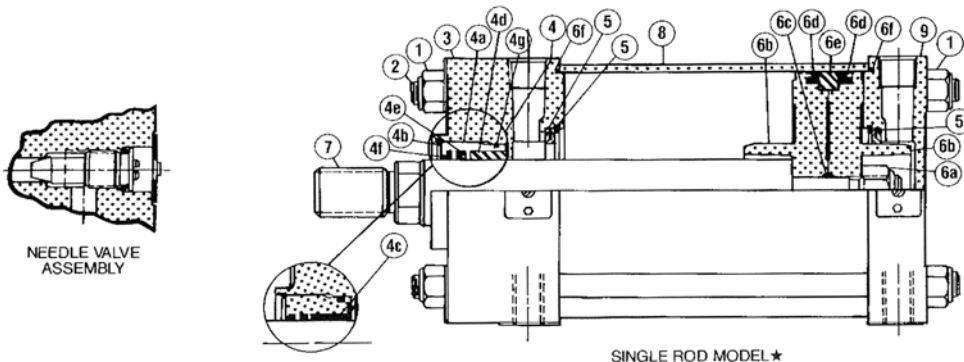

TaskMaster® Pneumatic Cylinder
Installation and Service Information

5" - 6" BORE
MAJOR REPAIR, MAINTENANCE & TESTING

MAJOR REPAIR AND MAINTENANCE INSTRUCTION

When it is determined that the cylinder requires shop repair (see GENERAL MAINTENANCE AND REPAIR RECOMMENDATIONS), the following general instructions are recommended.

DISASSEMBLY, CLEANING AND LUBRICATION

Following warnings on page 36. Disconnect air lines from head and cap ports of cylinder.

Completely disassemble the cylinder using the assembly views as reference. No special tools are required except internal snap ring pliers to remove retaining rings. A 5/32 internal socket wrench is required to remove the needle valve retainer plate (present on older models).

- 1.Remove the tie rod nuts and tie rods.
- 2.Remove head and cap.
- 3.Remove piston rod assembly. To disassemble piston rod, clamp piston rod across flats in soft jaws before removing piston retaining nut. Retaining nut is torque to piston rod.
- 4.Remove internal retaining rings in head and cap assemblies to remove the rod bearing cartridge and cushion kits.
- 5.Remove two hex head screws and retainer plate to remove valve assembly.

Wash all metal parts in a nonflammable solvent. Rinse each part thoroughly and blow dry with a low pressure air jet. Arrange the parts on a clean surface. Examine each part carefully. Replace all rubber parts and all other worn or damaged parts. The use of REPAIR KITS is strongly recommended.

REASSEMBLY

The procedure for reassembly is essentially the reverse of disassembly. However, the following exceptions should be noted.

- 1.All O-rings should be well coated with Cylinder Lube grease as they are installed in their respective grooves and prior to reassembly with the mating part. (NOTE: For FOOD SERVICE USE, use NORDSTROM Grease; see page 37.) Care must be taken when assembling O-rings and packings that they are not damaged, as this will cause leakage.
- 2.Assemble the Teflon wear ring, piston rod seal and piston follower on the lubricant. The piston retaining nut should be assembled less lubricant. The piston retaining nut should be assembled lubricated and torque as shown on specification chart with piston rod clamped across flats in soft jaws.

- 3.Reassemble the cylinder using the assembly views as reference. Pay particular attention to the installation of the cushion kit (ref. 5) to insure that the tapered rubber surface marked "THIS SIDE UP" faces to the inside (piston side) of the cylinder. As the assembly proceeds, lubricate the piston seals, cushion seals, tube seals and tube with Cylinder Lube grease.
- 4.Tie rod threads should be well lubricated to allow tightening the nuts evenly for proper pre-stressing. To avoid twisting of the tie rods during tightening, hold with vise grip or clamp. To ensure equal pre-stressing of the tie rods, first turn on nuts even and snug to align assembly, then the nuts are to be tightened alternately. For proper tie rod pre-stressing, they should be torque as recommended.

TESTING

After the cylinder has been completely reassembled, it should be tested either on a test bench or in the regular installation.

TEST PROCEDURE

The cylinder should be tested for cushioning, travel and leakage.

A. CUSHIONING

1. Turn both cushioning screws clockwise all the way in.
2. Cycle cylinder a few times by alternating supply pressure to head and cap ports.
3. Apply supply pressure to the head port. Rod should retract, decelerate and may stop before completion of stroke.
4. Apply supply pressure to the cap port. Rod should extend, decelerate and may stop before completion of stroke.

B. TRAVEL AND LEAKAGE

- 1.Turn the cushioning screws counterclockwise on (1) full turn.
- 2.Apply supply pressure to the head port. Cylinder should have less cushioning and make full stroke + or -.062". Check leakage at cap port, 30cc/min. leakage permitted. Check leakage around rod seal. No leakage permitted.
- 3.Apply supply pressure to the cap port. Cylinder should have less cushioning and make full stroke + or -.062". Check leakage at head port. 30cc/min. leakage permitted.
- 4.Return piston rod to retract position by applying supply pressure to head port. Remove supply pressure and install cylinder in service if satisfactory.

TORQUE SPECIFICATIONS

CYL. BORE	ROD DIA.	TORQUE (FOOT POUNDS)	
		PISTON ROD NUT	TIE ROD NUT
5"	1", 1-3/8"	60 Lubricated	30 Lubricated
6"	1-3/8", 1-3/4"	120 Lubricated	30 Lubricated

TaskMaster® Pneumatic Cylinder Installation and Service Information

Assembly Drawings for Double Rod Models

1-1/2" - 4" BORE
DOUBLE ROD MODEL

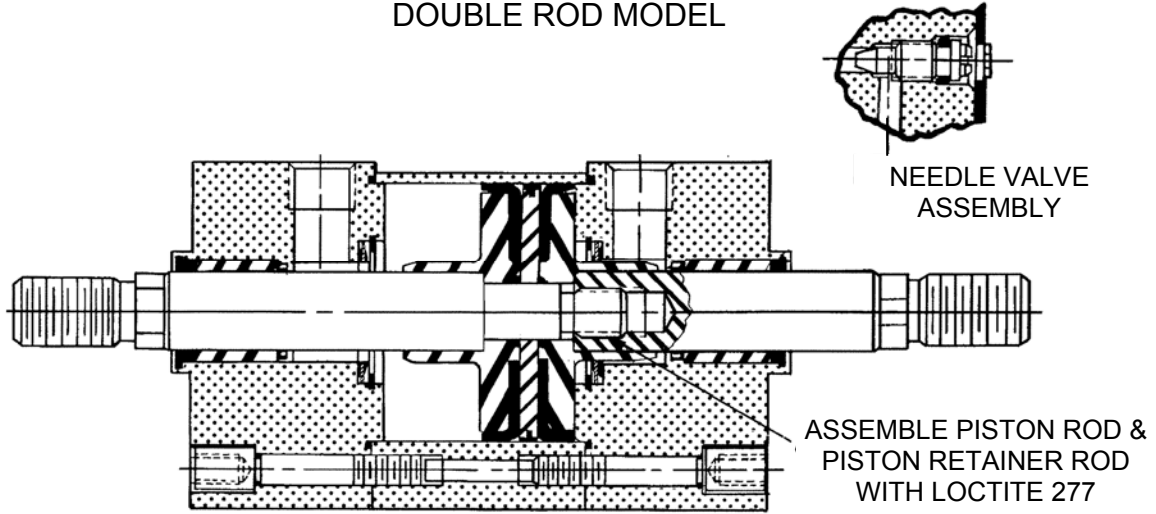

5" AND 6" BORE
DOUBLE ROD MODEL

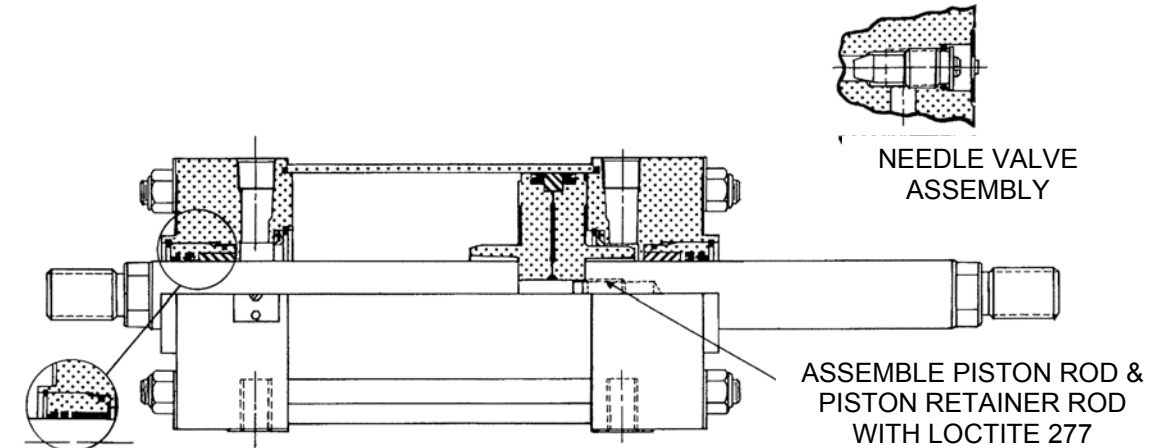

TYPICAL ROD BEARING
ASSEMBLY FOR FIRST
ROD SIZE

TaskMaster® Pneumatic Cylinder

Pneumatic Timing Volumes

Pneumatic Timing Volumes

AVENTICS offers a wide range of timing volumes for a variety of pneumatic system uses. These volumes are rated at 200 psi maximum working pressure with a 5 to 1 safety factor. They are constructed of light weight corrosion resistant anodized aluminum ends and tubing. Two ports are threaded mounting ends and tubing. Two ports are threaded mounting holes are provided.

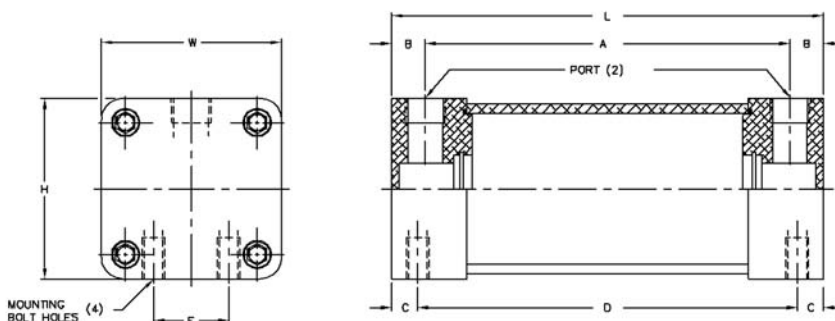

Volume Capacity Cu. Inch*	Overall Size			Dimensions (Ports)			Mounting Holes				Part Number	Weight (lbs.)
	H	W	L	Thread*	A	B	Thread	C	D	E		
5	2	2	5-5/16	1/4-18	4-3/16	9/16	1/4-20	7/16	4-7/16	5/8	R432013441	1.0
8	2	2	7-1/16	1/4-18	5-15/16	9/16	1/4-20	7/16	6-3/16	5/8	R432013442	1.3
8	3	3	4-5/16	1/4-18	3-3/16	9/16	3/8-16	7/16	3-7/16	1-1/4	R434002910	1.8
12	2	2	9-5/16	1/4-18	8-3/16	9/16	1/4-20	7/16	8-7/16	5/8	R432013443	1.5
12	3	3	5-3/16	1/4-18	4-1/16	9/16	3/8-16	7/16	4-5/16	1-1/4	R434002897	2.0
20	2	2	13-13/16	1/4-18	12-11/16	9/16	1/4-20	7/16	12-15/16	5/8	R432013444	2.0
20	3	3	6-13/16	1/4-18	5-11/16	9/16	3/8-16	7/16	5-15/16	1-1/4	R434002896	2.3
20	4-1/2	4-1/2	4-1/8	3/8-18	3-1/8	1/2	1/2-13	9/16	3	2-1/16	R434002906	3.8
30	3	3	8-13/16	1/4-18	7-11/16	9/16	3/8-16	7/16	7-15/16	1-1/4	R434002895	2.6
30	4-1/2	4-1/2	4-7/8	3/8-18	3-7/8	1/2	1/2-13	9/16	3-3/4	2-1/16	R434002905	4.1
45	3	3	11-15/16	1/4-18	10-13/16	9/16	3/8-16	7/16	11-1/16	1-1/4	R434002894	3.2
45	4-1/2	4-1/2	6-1/8	3/8-18	5-1/8	9/16	1/2-13	9/16	5	2-1/16	R434002904	4.7
60	4-1/2	4-1/2	7-3/8	3/8-18	6-3/8	1/2	1/2-13	9/16	6-1/4	2-1/16	R434004028	5.2
80	4-1/2	4-1/2	8-7/8	3/8-18	7-7/8	1/2	1/2-13	9/16	8-1/8	2-1/16	R434002903	5.8
100	4-1/2	4-1/2	10-1/2	3/8-18	9-1/2	1/2	1/2-13	9/16	9-3/8	2-1/16	R434002902	6.6
225	4-1/2	4-1/2	20-1/2	3/8-18	19-1/2	1/2	1/2-13	9/16	19-1/4	2-1/16	R434002899	10.9

*NPTF ports
 Dimensions in inches.
 Other sizes available, contact factory.

TaskMaster® Pneumatic Cylinder
Metric Conversion Chart

METRIC CONVERSION CHART
SELECTED 'SI' UNITS FOR GENERAL PURPOSE
FLUID POWER USAGE

QUANTITY	SI UNIT FOR FLUID POWER	'CUSTOMARY U.S.' UNITS	CONVERSION
Length	millimeter (mm)	inch (in)	25.4 mm = 1 inch
Pressure ⁽¹⁾	Bar (assuming gage unless otherwise stated)	Pounds per square inch (psig or psia)	1 bar = 14.5 psi
Pressure ⁽²⁾	Bar (value less than 1.0)	Inches of mercury (in Hg)	0.034 bar = 1 in Hg @ 60°F
Flow ⁽³⁾	Liters per minute (l/min)	Gallons per minute (USGPM)	3.79 l/min = 1USGPM
Flow ⁽⁴⁾	Normal liters per minute (NL/min)	Standard cubic feet per min.	NL/min -283 = SCFM
Flow ⁽⁴⁾	Cubic decimeters per second (dm ³ /s)	Cubic feet per minute (cfm)	1 dm ³ /s = 2.12 scfm
Force	Newton (N)	Pound (f) lb (f)	4.44 N = 1 lb (f)
Mass	Kilogram (kg)	Pound (m) lb (m)	1 kg = 2.20 lb (m)
Time	Second (s)	Seconds (s)	—————
Volume	Liter (l)	Gallons (US gal)	3.791 = 1 US gal
Temperature	Degrees Celsius (°C)	Degrees Fahrenheit (°F)	°C = 5/9 (°F-32)
Torque	Newton-meters (N-m)	Pounds (f) - inches (lb (f) - in)	1 N-m = 8.88 lb (f) - in
Power	Kilowatt (kW)	Horsepower (HP)	1 kW = 1.34 HP
Shaft Speed	Revolutions per minute (rev/min)	Revolutions per minute (RPM)	—————
Frequency	Hertz (Hz)	Cycles per second (cps)	1 Hz = 1 cps
Displacement	Milliliters per revolutions (ml/rev)	Cubic inches per revolution	1 ml/rev = .061 ciper
Kinematic Viscosity	Centistokes (cSt)	Saybolt (SUS)	1 cSt = 4.635 SUS ⁽⁵⁾
Velocity	Meters per second (m/s)	Feet per second (fps)	1 m/s = 3.28 fps
Lateral Stress	Deka Newtons per square millimeter (da N/mm ²)	Pounds per square inch (psi)	1 da N/mm ² = 1

NOTES:

- (1) Pressure above atmospheric
- (2) Pressure below atmospheric
- (3) Liquid
- (4) Gas - under standard temperature, humidity and pressure conditions per ISO/R 554- 1967
- (5) @ 38°; factor is 4.667 @99°C



PPT PNEUMATIC & PHT HYDRAULIC CYLINDERS

TO 1500 PSI

1-1/2" — 14" BORE

MACHINE TOOL GRADE NFPA DESIGNS

POWERMASTER® PPT PNEUMATIC & PHT HYDRAULIC CYLINDERS

STANDARD CYLINDER SPECIFICATIONS



PNEUMATIC CUSHION (HEAD)

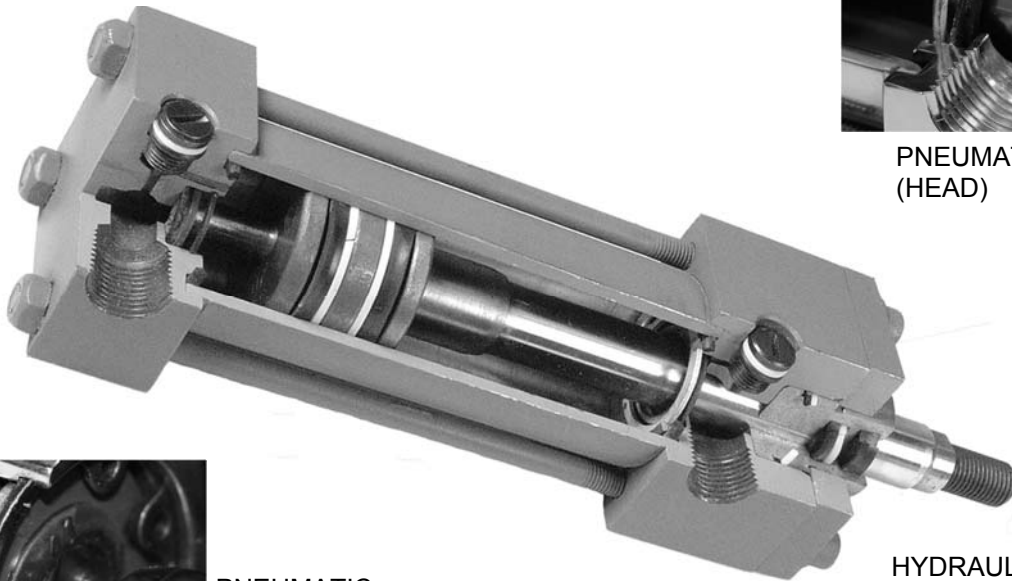

HYDRAULIC



PNEUMATIC CUSHION (CAP)

CYLINDER SPECIFICATIONS

OPERATING PRESSURES BY CYLINDER BORE SIZES

(Max. PSI, Max. Duty Severe Service)

Bore Size	PHT-Hyd.	PPT-Air
1 1/2	1500§	250
2	1500§	250
2 1/2	1500*§	250
3 1/4	1500§	250
4	1000	250
5	750	250
6	750	250
8	500	250
10	400	250
12	250	250
14	250	250

*With 5/8" rod, 1000 psi.

§ MF1 & MF2 Maximum Operating Pressure is 1000 psi.

For Double rod end cylinder pressure ratings, see page 68.

Consult factory for specific applications at pressures higher than shown

Duty– 250 psi pneumatic PP, pre-lubricated.
250 to 1500 psi hydraulic PH

Standards– Meets or exceeds all J. I. C. and NFPA requirements.

Bore Sizes– 1-1/2"-14" (standard), larger available.

Piston Rods– 5/8" -5-1/2" (standard)

Mounting– 21 standard NFPA mountings.

Temperature

Range– Standard Buna-N seals: -65°F to +200°F
Optional Viton® seals -15°F to +400°F
(Consult factory for cylinder applications at extreme temperatures.)

Ports– NPTF dryseal tapered threads. Optional SAE straight thread ports available. (Flange ports available at extra cost.)

Stroke– Standard strokes furnished to nearest 1/8".
Normal stroke tolerance +/- 1/16". Closer stroke tolerance available; consult factory.

Rod End Threads– Standard KK1 male and female threads plus KK2 oversize male thread. Other rod end style optional.

Cushions– Available for all bore sizes, at either or both ends.

Piston Rods– Case hardened to 50-55 Rockwell "C" chrome-plated and finished to 15 microinches or better. (5/8" not case hardened)

Tie Rods– High tensile, 1144 stress proof steel

Cylinder Tube– Honed, steel tubing with chrome plated I.D.

Double End Rod– Available in many mounting styles to meet special needs.

POWERMASTER[®] PPT PNEUMATIC & PHT HYDRAULIC CYLINDERS

CYLINDER SPECIFICATIONS

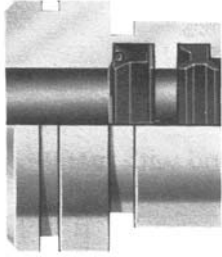

Extra-long rod bearing provides for maximum support against side-loads including external misalignment. Marine-grade 660 bronze material has superior non-scoring properties and dimensional stability. Bearing is pilot fitted into the head assuring true concentricity and long bearing and seal life. Cartridge can be quickly and easily changed without special tools. Ductile iron is used in large bores with certain rod diameters.



Pressure energized rod seal provides positive sealing with minimum friction drag. Self-adjusting seal in the Powermaster Pneumatic and U-cup/O-ring in the Powermaster Hydraulic coordinate operating pressures with sealing forces.

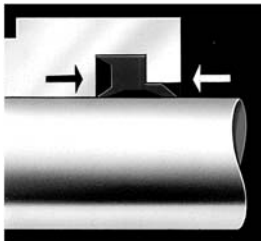

Double Duty Twin Lip rod wiper provides dirt protection for the rod bearing and rod seal. External lip prevents entry of contaminants into the bearing area on in-stroke, and internal lip wipers rod on outstroke and serves as secondary seal. The standard materials are polyurethane, Buna-N and Viton[®]. A metallic wiper is offered as an option (5/8" — 3" rod).

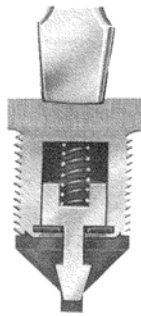

Powermaster's self-aligning cushion design provides a positive sealing leakproof cushion with fast piston breakaway. The Powermaster Pneumatic cushioning consists of a "floating" cushion insert seal on both ends and the Powermaster Hydraulic has floating cushion bushing on the rod end with a floating metal insert seal on the cap end. This design provides for a maximum cushion effect with faster breakaway response.

The AVENTICS Exact-a-just[™] combination needle and check valve eliminates the need for separate ball checks (thus leaving a quadrant free for other possible use).

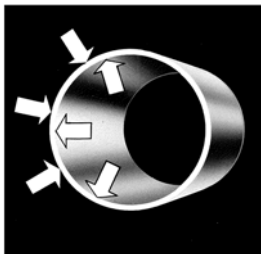

Dent and corrosion resistant tubing. Steel tubing is honed to a 12 micro-inch, or better, finish, then chrome-plated for minimum friction and long seal life. (Chrome-plated I.D. tubing furnished for Powermaster Pneumatic).



Pressure energized U-cup piston seals provide positive sealing with minimum friction. Standard Buna-N has an operating range of -65°F to +200°F with Viton available for high temperatures -15°F to +400°F.

POWERMASTER® PPT PNEUMATIC & PHT HYDRAULIC CYLINDERS

CYLINDER OPTIONS

VITON SEALS

Available for high temperature air service in a temperature range of -15°F to 400°F , and with many special hydraulic fluids. (Special fluids should be checked for compatibility with Viton).

PISTON ROD OPTIONS

Non-standard rod ends are available including rod and thread extensions, special threads and rod end machining, and additional wrench flats. (Catalog dimensional changes must be specified.)

Optional rod materials for specific applications and environmental conditions which includes 303 and 17-4 PH stainless steel.

METALLIC ROD WIPER

Metal scraper available for the removal of tough/hardened matter adhering to piston rod. (Rod boots for exterior rod protection might also be considered.)

PORT OPTIONS

SAE straight thread ports are optional at no additional charge. Other standard size ports, oversize welded coupling ports and multiple ports are also available where design dimensions permit.

STOP TUBE

Internal stop tube is available for reducing excessive bearing loads and jackknifing conditions in long stroke push cylinders. (See page 113 for determining stop tube length required.)

COMBINATION MOUNTING

Additional cylinder mountings are available where design space permits.

WATER SERVICE

Model PW is available for water service and includes: electroless nickel plated head, cap, piston, and cushion parts when applicable. Standard Powermaster tube provides chrome-plated I.D. at no additional charge. Stainless steel piston rod is also recommended.

EPOXY PAINT

Available for additional exterior cylinder protection in corrosive environments. Painting includes one coat of Yellow Zinc Chromate Primer and one coat of Black Epoxy Enamel.

TAPPED RETAINER PLATE

Head retainer plate tapped for tie rods available when bolts or tie rod nuts are not permitted on head end. (Available for 1-1/2" — 6" bore sizes).

EXTRA CHECK VALVE

Available for faster breakaway response for cushioned cylinders.

CUSHIONS (Exact-a-just™)

Available for head, cap or both

CONSULT FACTORY FOR OTHER OPTION REQUIREMENTS NOT SHOWN IN THIS CATALOG.

APPROXIMATE UNCRATED POWERMASTER WEIGHTS*

CYLINDER BORE	1-1/2	2	2-1/2	3-1/4	4	5	6	8	10	12	14
ZERO STROKE	5	7	12	20	30	45	70	100	200	300	490
ADD PER INCH OF STROKE	.3	.4	.6	.8	.9	1.0	1.5	2.0	2.5	4.0	4.5

*Weights based on standard (first) rod sizes.

POWERMASTER® PPT PNEUMATIC & PHT HYDRAULIC CYLINDERS

CYLINDER OPTIONS

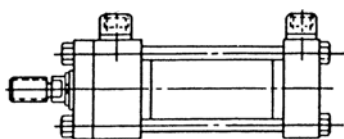

Oversize welded coupling ports are available where design and mounting dimensions permit. (Available on head end only in smaller bore sizes due to limited design space and mounting interference).

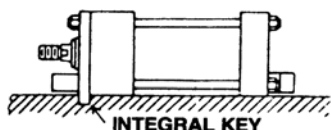

INTEGRAL KEY

AVENTICS offers a standard arrangement of thrust key mounting on the MS2, MS4 and MS7 Powermaster cylinders. This options eliminates the need for fitted bolts or external keys to carry the thrust load. The normal headplate is extended below the head surface of the cylinder and is fitted in a keyway milled into the mounting surface of the machine member. See drawings for details.

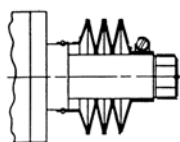

Rod boots are available for additional rod protection from environmental conditions. The oil resistant cover of neoprene-coated nylon fabric is suitable for operation in ambient temperature range of -45°F to 220°F. Consult factory for higher temperature boot requirements.

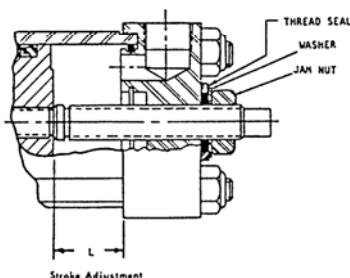

Stroke Adjustment

Stroke adjustment option is available for applications requiring a precise stroke or when infrequent stroke length adjustment is required in the retracted position. Maximum stroke adjustment varies by bore size and must be specified when ordering. Cushioning is not available on the cap end with this design.

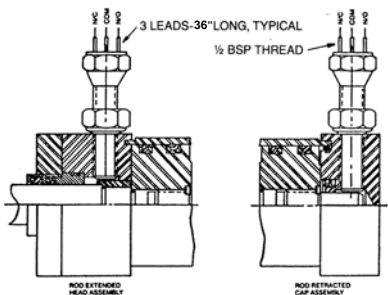

POSITON INDICATOR

Proximity Position Indicator Switches are available for most mounting styles and rod sizes of Powermaster cylinders. These switches are mounted in the head and cap ends to confirm the extended or retracted position of the piston. The switches are actuated by the cushion bushing on the head end and the cushion spear on the cap end. (NOTE: If cap cushioning is required in the 1-1/2", 2" and 2-1/2" bore PP and PH Powermaster cylinder, proximity switches cannot be used on the cap end.) No linkage or external actuator is required. Switches can be assembled in the cylinder head, cap, or rear cap face. The switches are not sensitive to vibration and are suitable for most environments. Switch height is less than four inches; for critical dimensions, contact factory.

Upon request, we can supply most name brand switches, such as Balluff Strokemaster, P & F low profile, Stroke to Go low profile, NAMCO and others.

SENSING DISTANCE

End sensing of .090" (2.25mm) to .110" (2.76mm) when using a ferrous actuator approximately equal the area of the end. The differential (hysteresis) is approximately 1/2 of the sensing range. The GO® Switch is not a "reed switch".

CONTACT RATING

2AMP at 240 VAC (CSA and UL approved)
50mA at 24 VDC (CSA only)

CONTACT ARRANGEMENT

Available in Single Pole, Double Throw.

TEMPERATURE RANGE

Tested to -22°F to +250°F. Impervious to most environments. Recognized by UL at 104°F (40°C) maximum.

CAUTION

THESE UNITS ARE **NOT** INTENDED TO BE USED AS A FINAL SAFETY DEVICE

POWERMASTER® PPT PNEUMATIC & PHT HYDRAULIC CYLINDERS

EXTENDED KEY PLATE

AVENTICS offers a standard arrangement of thrust key mounting on the MS2, MS4 and MS7 PowerMaster cylinders. This option eliminates the need for fitted bolts or external keys to carry the thrust load. The normal headplate is extended below the head surface of the cylinder and is fitted in a keyway milled into the mounting surface of the machine member. See drawings for details.

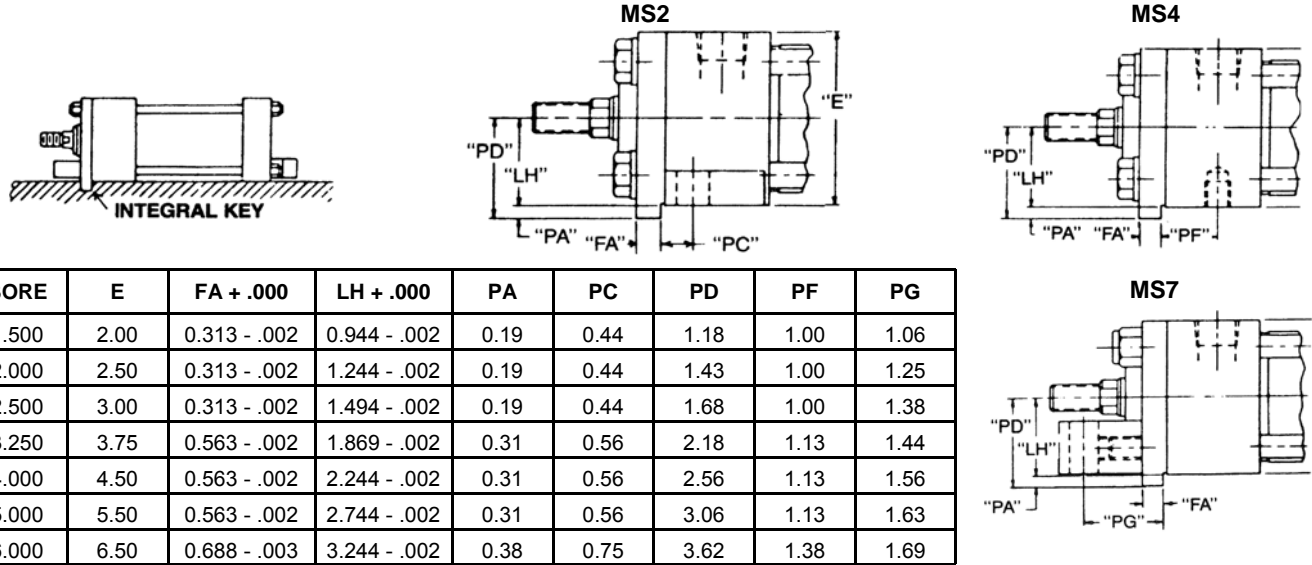

NOTE:

1. Use mounting bolt .06 smaller in diameter than hole size.
2. Fitted bolts or dowel pins are not needed with the trust key headplate.
3. All dimensions not shown are NFPA standard.

POWERMASTER® PHT & HHT HYDRAULIC CYLINDERS

AVAILABLE PORTS FOR "PHT" SERIES CYLINDERS

BORE SIZE (inches)	SAE	NPTF PIPE THD	BSPP PARALLEL THD	BSPT TAPER THD	METRIC STRAIGHT THD	ISO 6149-1 METRIC THD
1	#4	1/4	1/4	1/4	M14 X 1.5	-
1.5	#6	3/8	3/8	3/8	M14 X 1.5	-
2	#6	3/8	3/8	3/8	M14 X 1.5	M14 X 1.5
2.5	#6	3/8	3/8	3/8	M14 X 1.5	M14 X 1.5
3.25	#8	1/2	3/8	3/8	M22 X 1.5	M22 X 1.5
4	#8	1/2	1/2	1/2	M22 X 1.5	M22 X 1.5
5	#8	1/2	1/2	1/2	M22 X 1.5	M22 X 1.5
6	#12	3/4	1/2	1/2	M26 X 1.5	M27 X 1.5

AVAILABLE PORTS FOR "HHT" SERIES CYLINDERS

BORE SIZE (inches)	SAE	NPTF PIPE THD	BSPP PARALLEL THD	SAE 4-BOLT FLANGE NOM. SIZE	BSPT TAPER THD	METRIC STRAIGHT THD	ISO 6149-1 METRIC THD
1.5	#8	1/2	1/2	n/a	1/2	M22 X 1.5	M22 X 1.5
2	#8	1/2	1/2	* 1/2	1/2	M22 X 1.5	M22 X 1.5
2.5	#8	1/2	1/2	* 1/2	1/2	M22 X 1.5	M22 X 1.5
3.25	#12	3/4	3/4	** 1/2	3/4	M27 X 2	M27 X 2
4	#12	3/4	3/4	1/2	3/4	M27 X 2	M27 X 2
5	#12	3/4	3/4	*** 1/2	3/4	M27 X 2	M27 X 2
6	#16	1	1	§ 3/4	1	M33 X 2	M33 X 2
7	#20	1-1/4	1-1/4	§ 1	1-1/4	M42 X 2	M42 X 2
8	#24	1-1/4	1-1/2	§ 1-1/4	1-1/2	M48 X 2	M48 X 2

§ Size 1/2" on 6" bore (4" rod) and 7" bore (5" rod);
Size 1" on 8" bore (5-1/2" rod).

*Cap only

**Not available on 3-1/4" bore (2" rod).

***Not available on 5" bore (3-1/2" rod).

POWERMASTER[®] PPT PNEUMATIC & PHT HYDRAULIC CYLINDERS

MOUNTING INDEX

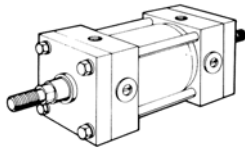
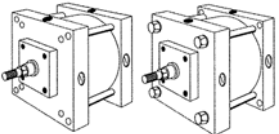
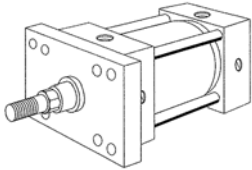
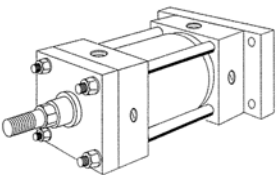
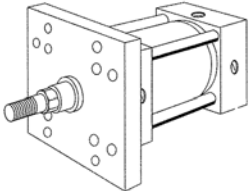
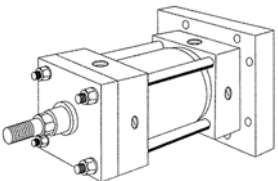
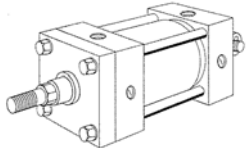
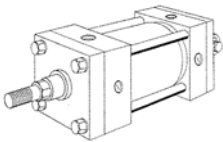
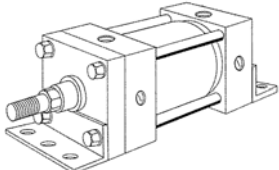
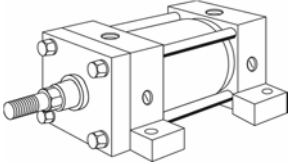
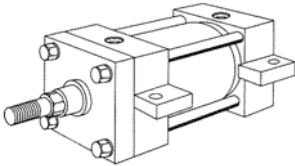
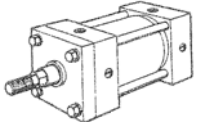
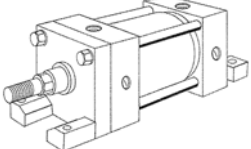
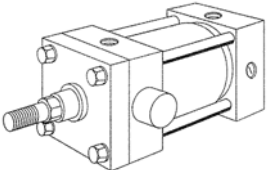
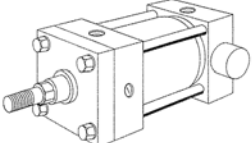
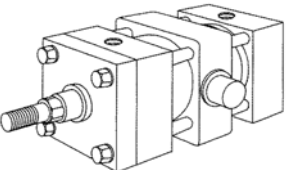
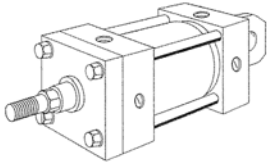
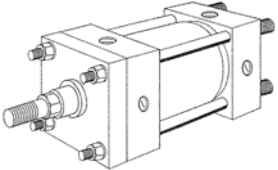
<p>D DOUBLE ROD CYLINDER Bore sizes 1-1/2"–6"..... page 54 Bore sizes 8"–14"</p> 	<p>ME3 HEAD SQUARE FLANGE Bore sizes 8"–14" page 54</p> <p>ME4 CAP SQUARE FLANGE Bore sizes 8" – 14"..... page 54</p> 	<p>MF1 HEAD RECTANGULAR FLANGE Bore sizes 1-1/2"–6" page 56</p> 
<p>MF2 CAP RECTANGULAR FLANGE Bore sizes 1-1/2"–6"..... page 56</p> 	<p>MF5 HEAD SQUARE FLANGE Bore sizes 1-1/2"–6" page 56</p> 	<p>MF6 CAP SQUARE FLANGE Bore sizes 1-1/2"–6"..... page 56</p> 
<p>MP1 CAP FIXED CLEVIS Bore sizes 1-1/2"–14" ...page 58</p> <p>MP3 CAP FIXED EYE Bore sizes 1-1/2"–14".....page 58</p> 	<p>MP2 CAP DETACHABLE CLEVIS Bore sizes 1-1/2"–8" page 58</p> <p>MP4 CAP DETACHABLE EYE Bore sizes 1-1/2"–8" page 58</p> 	<p>MS1 SIDE END ANGLES Bore sizes 1-1/2"–6" page 60 Bore sizes 8"–14"</p> 
<p>MS2 SIDE LUGS Bore sizes 1-1/2"–6"page 62</p> 	<p>MS3 CENTERLINE LUGS Bore sizes 1-1/2"–6" page 62 Bore sizes 8"–14"</p> 	<p>MS4 SIDE TAPPED Bore sizes 1-1/2"–14"page 62</p> <p>MX0 NO MOUNTINGS Bore sizes 1-1/2"–14"page 62</p> 
<p>MS7 SIDE END LUGS Bore sizes 1-1/2"–6"page 60 Bore sizes 8"–14"</p> 	<p>MT1 HEAD TRUNNION Bore sizes 1-1/2"–6" page 64</p> 	<p>MT2 CAP TRUNNION Bore sizes 1-1/2"–6" page 64 Bore sizes 8"–14"</p> 
<p>MT4 INTERMEDIATE FIXED TRUNNION Bore sizes 1-1/2"–6"page 64 Bore sizes 8"–14"</p> 	<p>MU3 UNIVERSAL CLEVIS Bore sizes 1-1/2"–6" page 58</p> 	<p>MX1 TIE ROD EXTENDED Bore sizes 1-1/2"–6" page 66 Bore sizes 8"–14"</p> <p>MX2</p> <p>MX3</p> <p>MX4</p> 

POWERMASTER® PPT PNEUMATIC & PHT HYDRAULIC CYLINDERS

**DOUBLE ROD CYLINDER
HEAD SQUARE FLANGE MOUNT
CAP SQUARE FLANGE MOUNT**

D DOUBLE ROD CYLINDER
1-1/2" - 4"

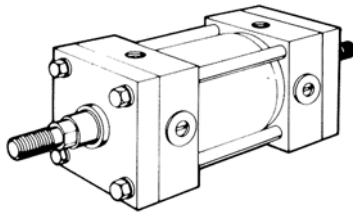

*8" - 14" Bores only
**1-1/2" - 6" Bores only

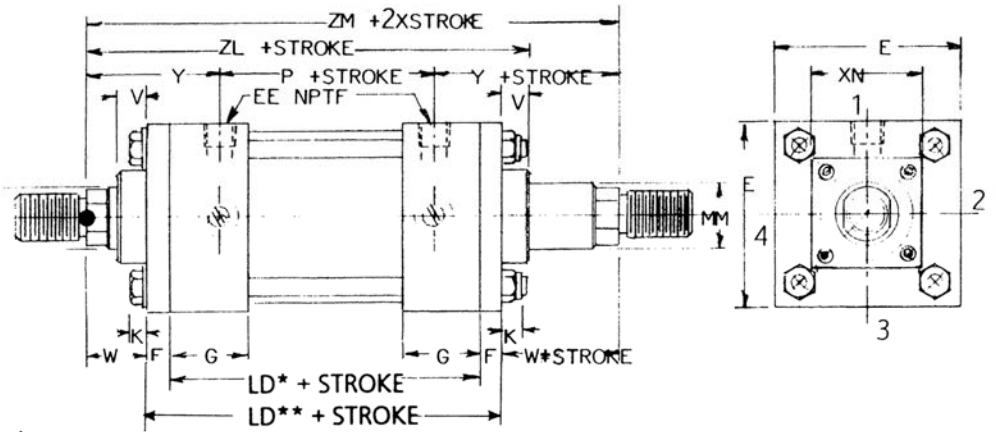

ME3 HEAD SQUARE FLANGE
8" - 14"

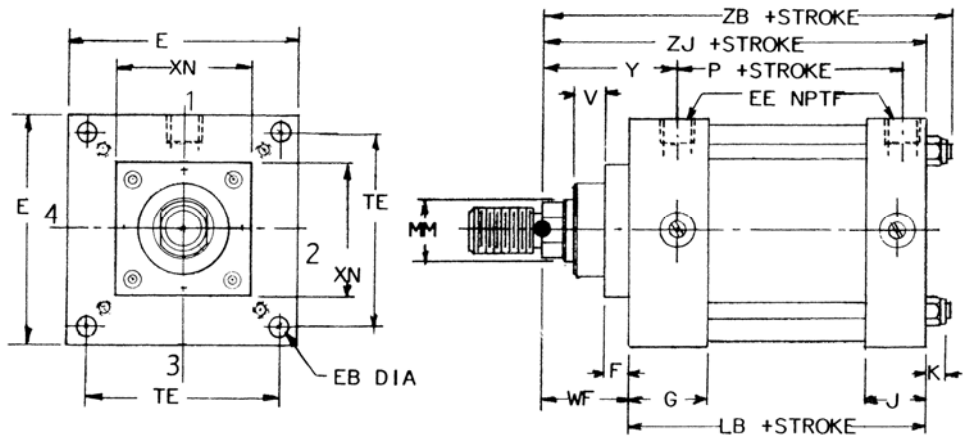
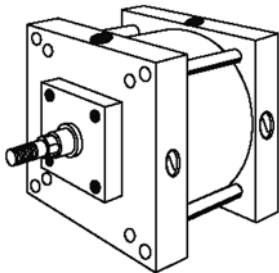

ME4 CAP SQUARE FLANGE
8"-14"

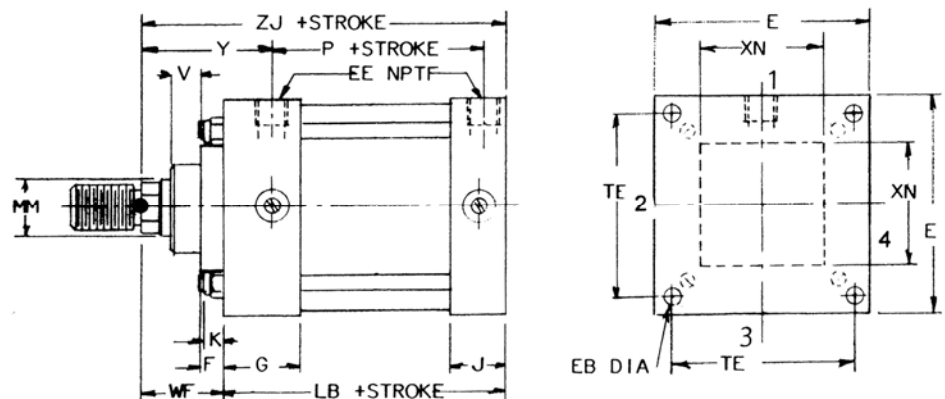
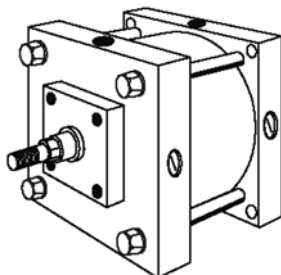

POWERMASTER® PPT PNEUMATIC & PHT HYDRAULIC CYLINDERS

MF1 HEAD RECTANGULAR FLANGE 1-1/2" - 6"

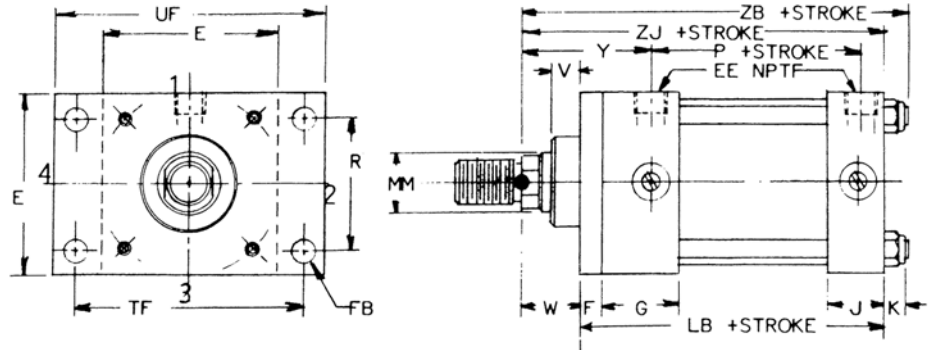
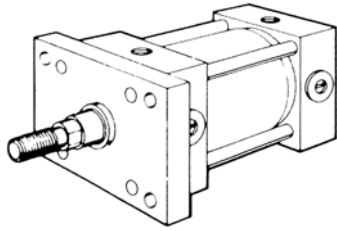

MF2 CAP RECTANGULAR FLANGE 1-1/2" - 6"

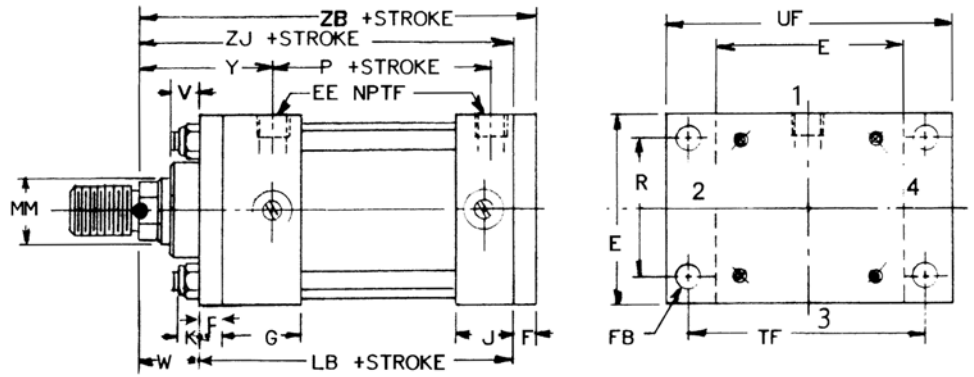
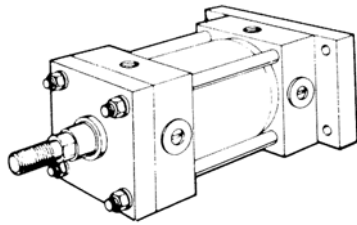

MF5 HEAD SQUARE FLANGE 1-1/2" - 6"

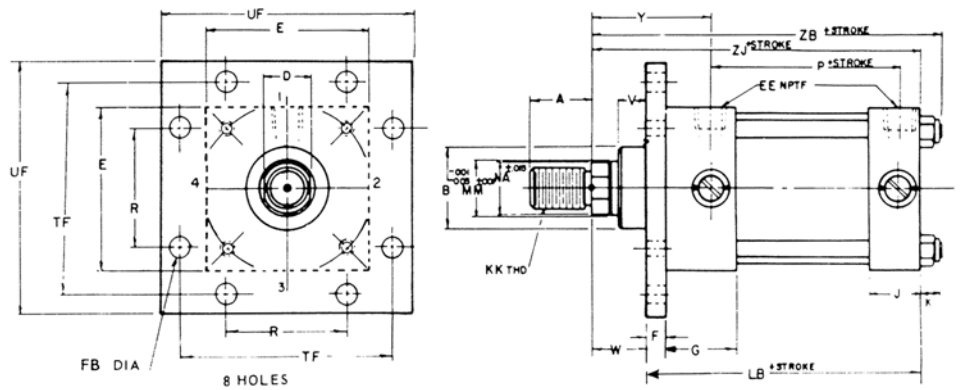
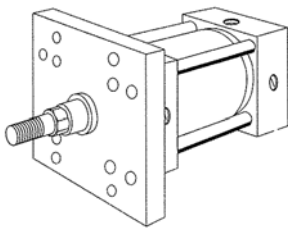

MF6 CAP SQUARE FLANGE 1-1/2" - 6"

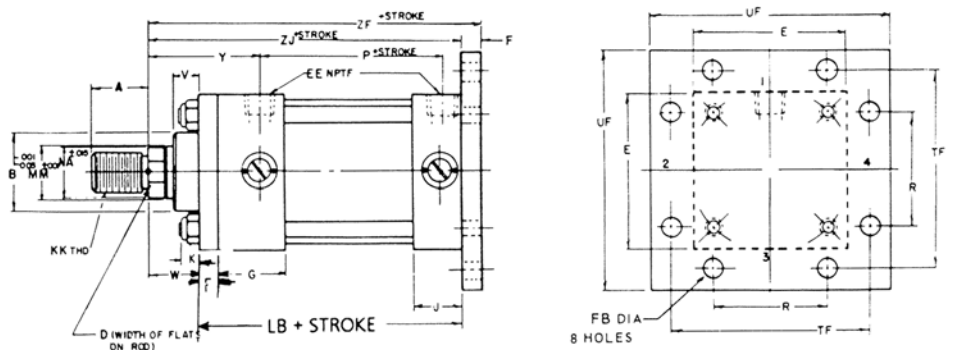
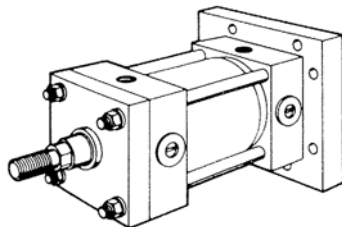

POWERMASTER® PPT PNEUMATIC & PHT HYDRAULIC CYLINDERS
TABLE 1 — Dimensions affected by rod diameter

BORE IN	MM ROD	V	W	Y	ZB	ZF	ZJ
1.500	0.625	0.25	0.63	1.94	4.85	5.00	4.63
	† 1.000	0.50	1.00	2.31	5.22	5.38	5.00
2.000	0.625	0.25	0.63	1.94	4.90	5.00	4.63
	1.000	0.50	1.00	2.31	5.27	5.38	5.00
	† 1.375	0.63	1.25	2.56	5.52	5.62	5.25
2.500	0.625	0.25	0.63	1.94	5.02	5.13	4.75
	1.000	0.50	1.00	2.31	5.40	5.50	5.13
	1.375	0.63	1.25	2.56	5.65	5.75	5.38
	† 1.750	0.75	1.50	2.81	5.90	6.00	5.63
3.250	1.000	0.25	0.75	2.44	5.98	6.25	5.63
	1.375	0.38	1.00	2.69	6.23	6.50	5.88
	1.750	0.50	1.25	2.94	6.48	6.75	6.13
	† 2.000	0.50	1.38	3.06	6.61	6.88	6.25
4.000	1.000	0.25	0.75	2.44	5.98	6.25	5.63
	1.375	0.38	1.00	2.69	6.23	6.50	5.88
	1.750	0.50	1.25	2.94	6.48	6.75	6.13
	2.000	0.50	1.38	3.06	6.61	6.88	6.25
	2.500	0.63	1.63	3.31	6.86	7.13	6.50
5.000	1.000	0.25	0.75	2.44	6.32	6.50	5.88
	1.375	0.38	1.00	2.69	6.57	6.75	6.13
	1.750	0.50	1.25	2.94	6.82	7.00	6.25
	2.000	0.50	1.38	3.06	6.94	7.13	6.50
	2.500	0.63	1.63	3.31	7.19	7.38	6.75
	3.000	0.63	1.63	3.31	7.19	7.38	6.75
6.000	3.500	0.63	1.63	3.31	7.19	7.38	6.75
	1.375	0.25	0.88	2.81	7.07	7.38	6.63
	1.750	0.38	1.13	3.06	7.32	7.63	6.88
	2.000	0.38	1.25	3.19	7.44	7.75	7.00
	2.500	0.50	1.50	3.44	7.69	8.00	7.25
	3.000	0.50	1.50	3.44	7.69	8.00	7.25
	3.500	0.50	1.50	3.44	7.69	8.00	7.25
4.000	0.50	1.50	3.44	7.69	8.00	7.25	

NOTE:

† Available with fixed cushioning on the rod end and Exact-a-just™ cushioning on the blind end.

Removable bearing retainer is not available in the 1-1/2" — 6" bore cylinders.

The bearing retainer plate is the same as the "E" dimension for 1-1/2" — 6" bore sizes.

Rod end options are shown on page 52a.

TABLE 2 — Dimensions not affected by rod diameter

BORE IN	E	F	G	J	K	P	R	EE NPTF	FB BOLT	LB	TF	UF
1.500	2.00	0.38	1.50	1.00	0.22	2.25	1.43	0.38	0.25	4.00	2.75	3.38
2.000	2.50	0.38	1.50	1.00	0.27	2.25	1.84	0.38	0.31	4.00	3.38	4.13
2.500	3.00	0.38	1.50	1.00	0.27	2.38	2.19	0.38	0.31	4.13	3.88	4.63
3.250	3.75	0.63	1.75	1.25	0.34	2.63	2.76	0.50	0.38	4.88	4.69	5.50
4.000	4.50	0.63	1.75	1.25	0.34	2.63	3.32	0.50	0.38	4.88	5.44	6.25
5.000	5.50	0.63	1.75	1.25	0.44	2.88	4.10	0.50	0.50	5.13	6.63	7.63
6.000	6.50	0.75	2.00	1.50	0.44	3.13	4.88	0.75	0.50	5.75	7.63	8.63

FLANGE MOUNTS

Flange mounts are one of the strongest, most rigid methods of mounting. With this type of mount, there is little allowance for misalignment, so when long strokes are required, the free end opposite the mounting should be supported to prevent sagging and possible binding of the cylinder. Blind or cap end mounts are best for thrust load applications, and rod or head end mounts are best in tension applications. If an application exceeds the rectangular flange rating, a solid head or cap flange mount (ME3) or (ME4) is available. (Refer to page 54).

When a less rigid mount can be used and the cylinder can be attached to a panel or bulkhead, an extended tie rod mount could be considered.

Note: The maximum hydraulic pressure rating for MF1 and MF2 mounts in 1000 psi.

POWERMASTER® PPT PNEUMATIC & PHT HYDRAULIC CYLINDERS

FIXED & DETACHABLE CLEVIS MOUNTS AND UNIVERSAL CLEVIS MOUNT

MP1 CAP FIXED CLEVIS
1-1/2" — 14"

MP3 CAP FIXED EYE
1-1/2" — 8"

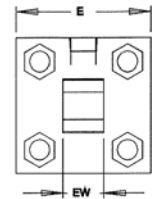
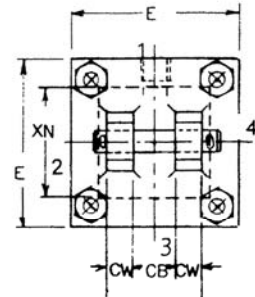
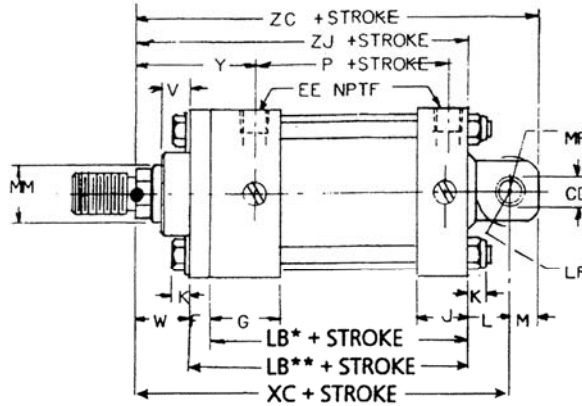
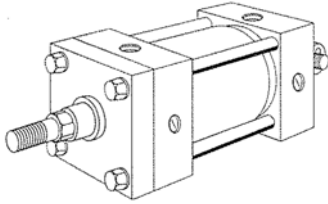

*8" - 14" Bores only
**1-1/2" - 6" Bores only

MP2 CAP DETACHABLE CLEVIS
1-1/2" — 8"

MP4 CAP DETACHABLE EYE
1-1/2" — 8"

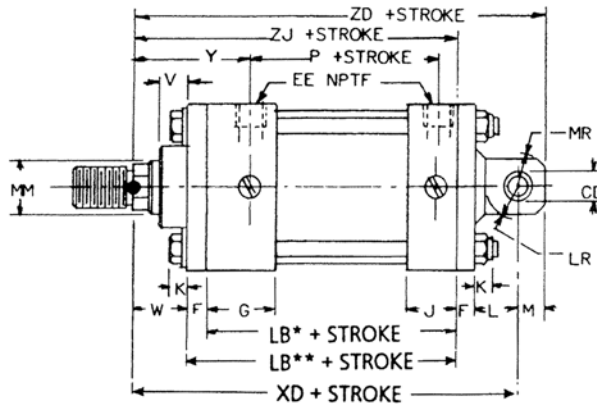
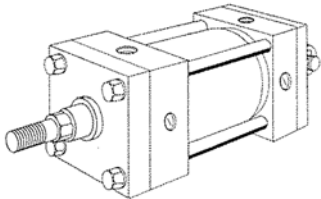

MP3, MP4 Cap

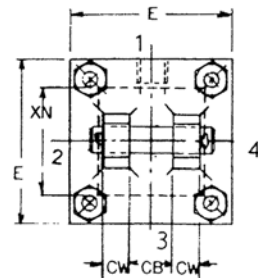

*8" Bore only
**1-1/2" - 6" Bores only

MU3 UNIVERSAL CLEVIS
1-1/2" — 6"

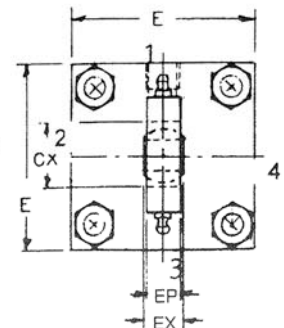
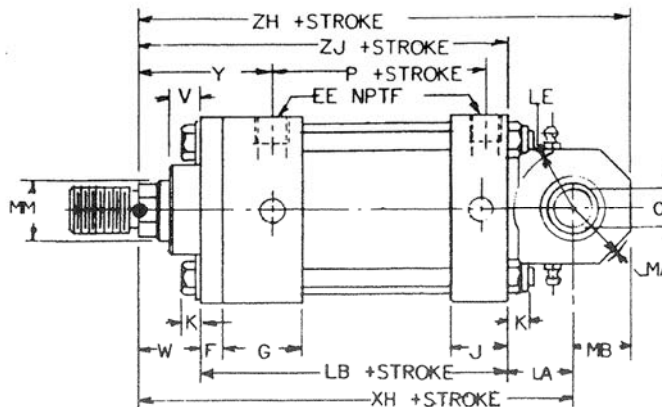
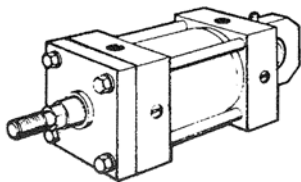

POWERMASTER® PPT PNEUMATIC & PHT HYDRAULIC CYLINDERS

SIDE END LUG & SIDE END ANGLE MOUNT

MS1 SIDE END 1-1/2"–14"

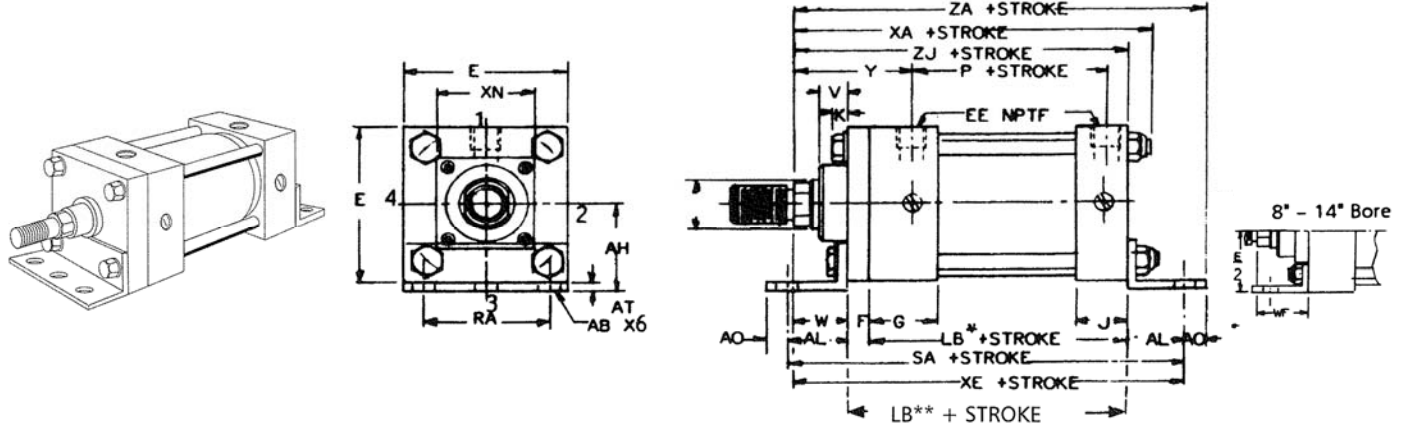

*8" - 14" Bores only
 **1-1/2" - 6" Bores only

MS7 SIDE END LUGS 1-1/2"–14"

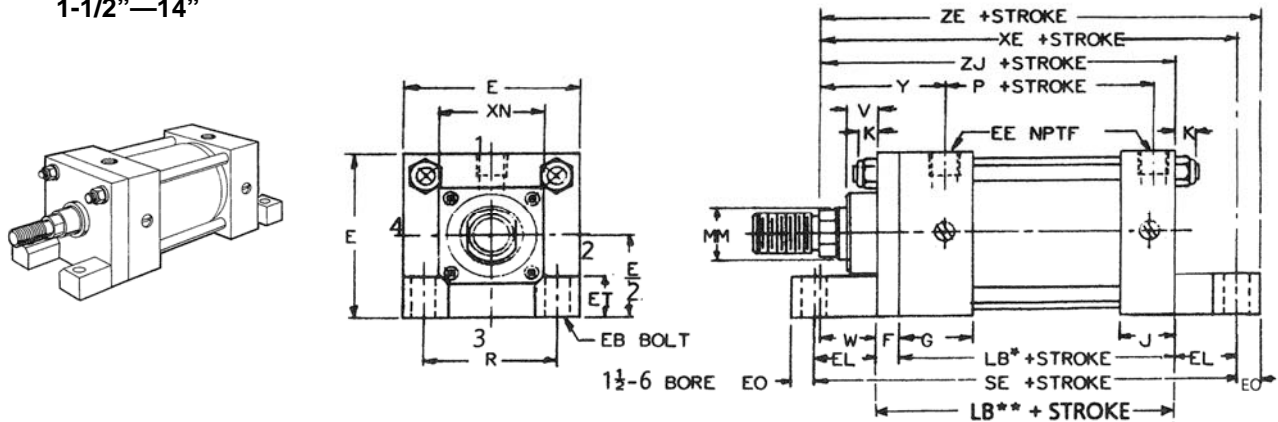

*8" - 14" Bores only
 **1-1/2" - 6" Bores only

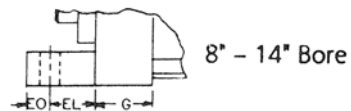

POWERMASTER® PPT PNEUMATIC & PHT HYDRAULIC CYLINDERS

SIDE & CENTERLINE LUG MOUNTS AND SIDE MOUNTS

MS2 SIDE LUGS 1-1/2"–14"

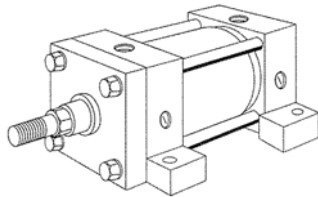

*8" - 14" Bores only
**1-1/2" - 6" Bores only

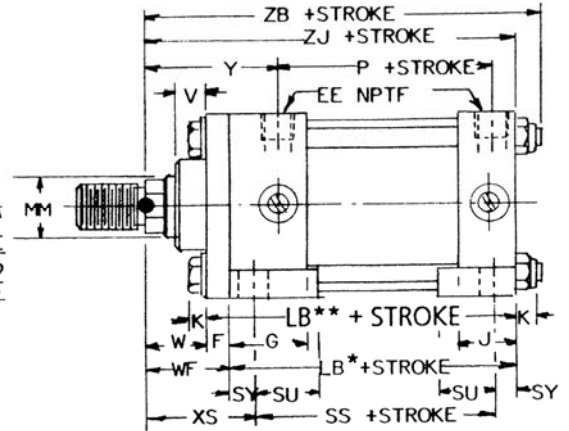
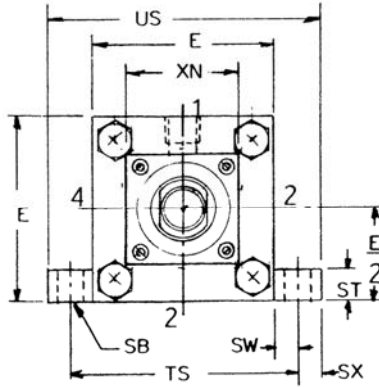

MS3 CENTERLINE LUGS 1-1/2"–14"

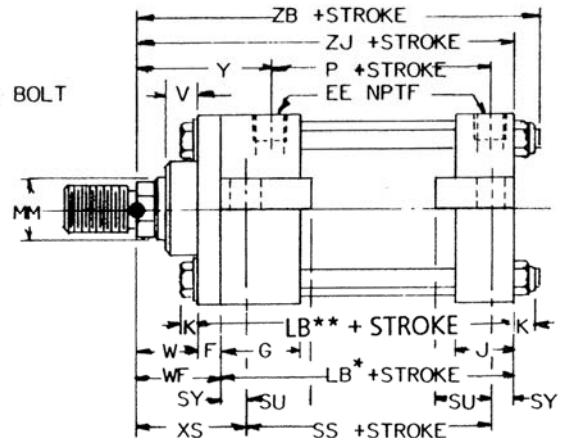
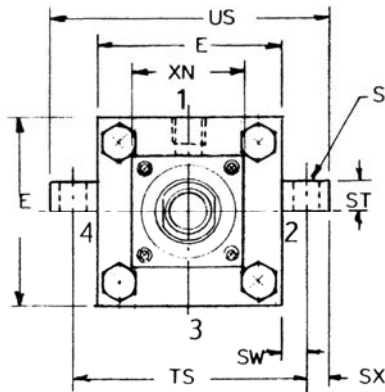
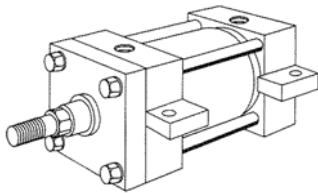

MS4 SIDE TAPPED 1-1/2"–14"

MX0 NO MOUNTING§ 1-1/2"–14"

§ Same as MS4 less mounting holes

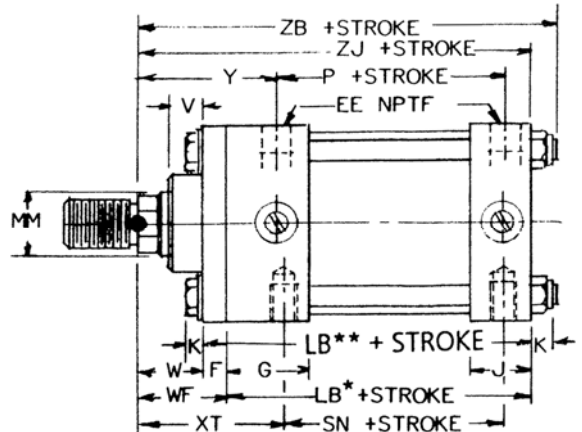
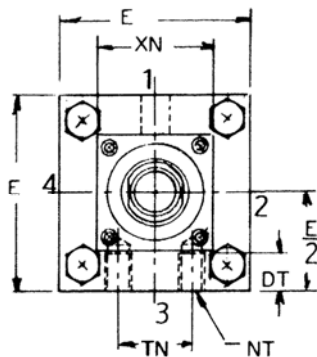
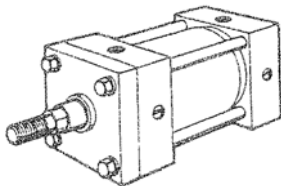

POWERMASTER® PPT PNEUMATIC & PHT HYDRAULIC CYLINDERS

TRUNNION MOUNTS

MT1 HEAD TRUNNION

1-1/2"–14"

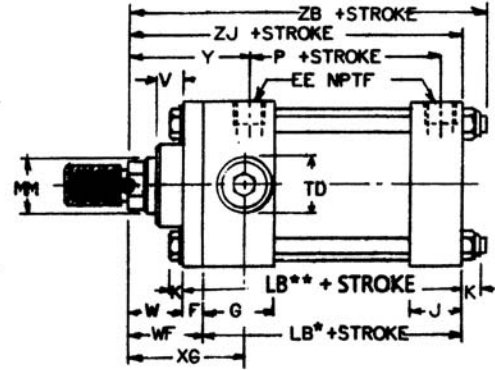
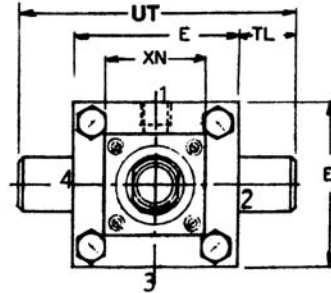
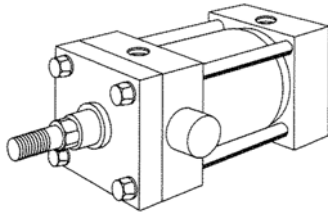

- *8" - 14" Bores only
- **1-1/2" - 6" Bores only

The "XG" and "XJ" dimensions for MT1 and MT2 mounts are longer than NFPA standard.

MT2 CAP TRUNNION

1-1/2"–14"

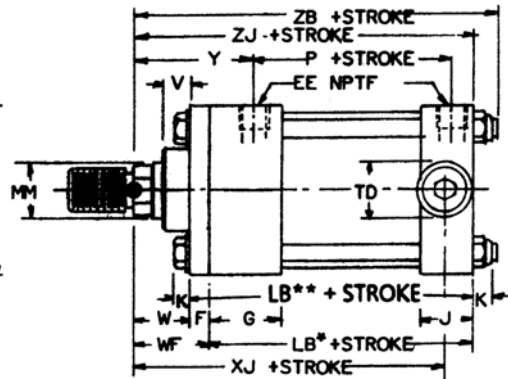
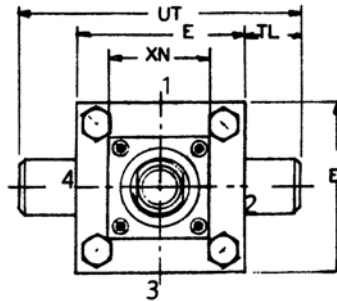
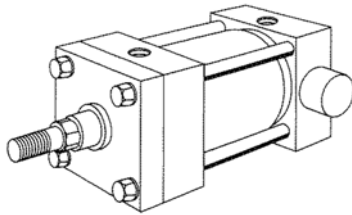

- *8" - 14" Bores only
- **1-1/2" - 6" Bores only

The "XG" and "XJ" dimensions for MT1 and MT2 mounts are longer than NFPA standard.

MT4 INTERMEDIATE FIXED TRUNNION

1-1/2"–14"

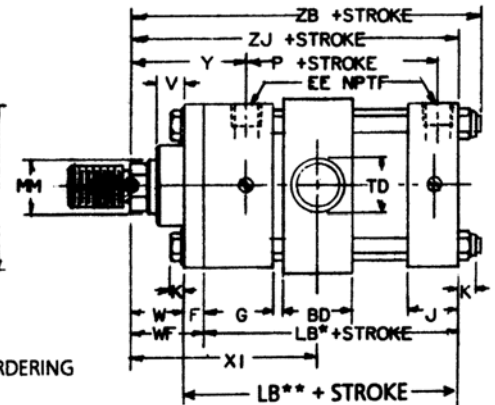
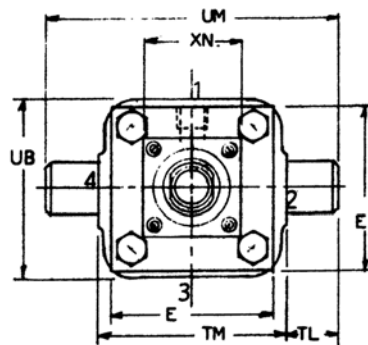
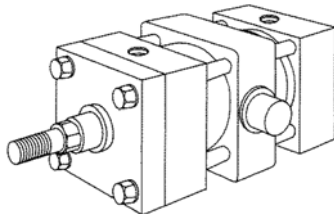

- *8" - 14" Bores only
- **1-1/2" - 6" Bores only

SPECIFY 'XI' DIMENSION WHEN ORDERING

POWERMASTER® PPT PNEUMATIC & PHT HYDRAULIC CYLINDERS

MX1 TIE RODS EXTENDED BOTH ENDS

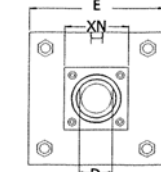
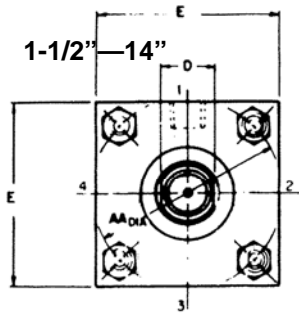
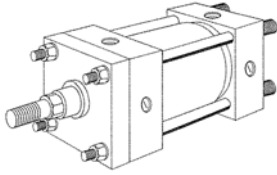

8" - 14" Bore

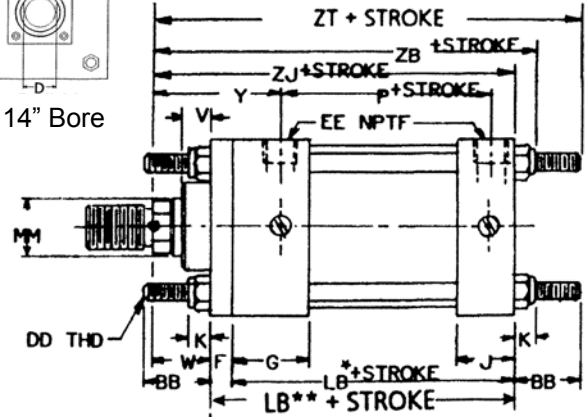

*8" - 14" Bores only (XN See above)
 **1-1/2" - 6" Bores only

MX2 TIE RODS EXTENDED CAP END ONLY

1-1/2" - 14"

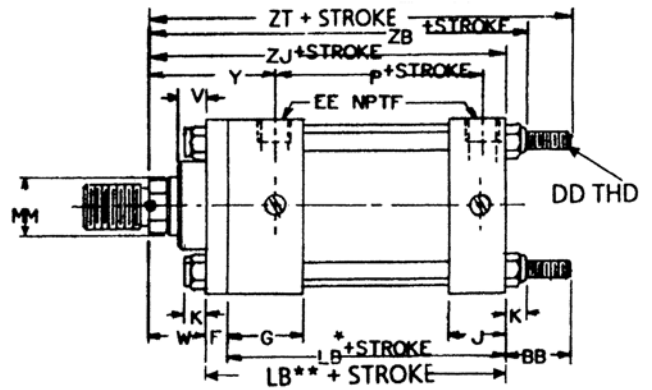
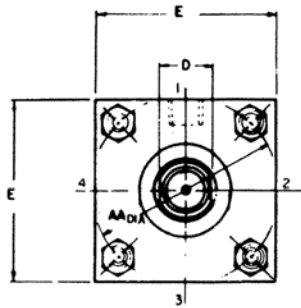
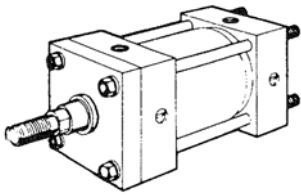

*8" - 14" Bores only (XN See above)
 **1-1/2" - 6" Bores only

MX3 TIE RODS EXTENDED HEAD END ONLY

1-1/2" - 14"

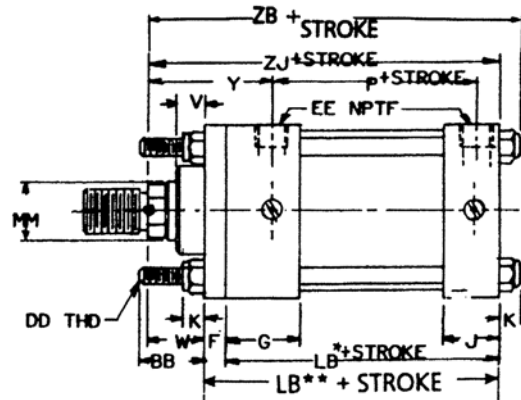
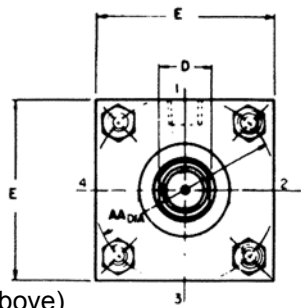
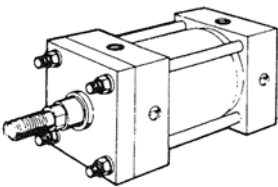

*8" - 14" Bores only (XN See above)
 **1-1/2" - 6" Bores only

MX4 TIE RODS EXTENDED HEAD END ONLY

1-1/2" - 14"

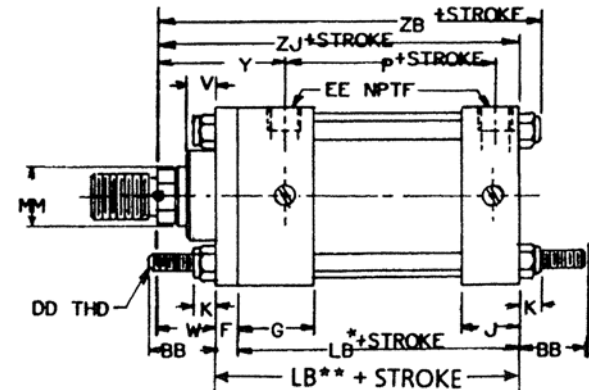
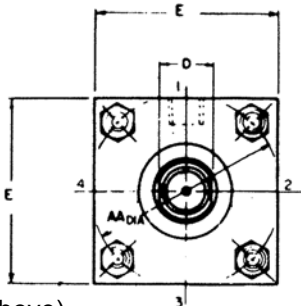
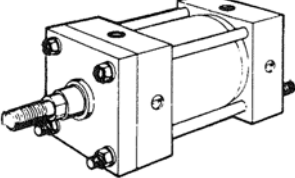

*8" - 14" Bores only (XN See above)
 **1-1/2" - 6" Bores only

POWERMASTER® PPT PNEUMATIC & PHT HYDRAULIC CYLINDERS

TABLE 1—Dimensions affected by rod diameter

Table with 10 columns: BORE IN, MM ROD, V, W, WF, Y, XN, ZB, ZJ, ZT. It lists dimensions for various bore sizes (1.500 to 14.000) and rod diameters (0.25 to 1.50).

* For these or larger size rods on 8" and 10" bores, consult factory before ordering.

EXTENDED TIE ROD MOUNTS

Tie rod and flange mounts are basically the same except that the tie rods are extended and used to mount the cylinder. To prevent misalignment, sagging, or binding of the cylinder when long strokes are required, the free end of the cylinder should be supported. For thrust load applications, blind or cap end tie rod extensions are best. For tension load applications, rod or head end extensions are best. Tie rod mounts are suited for many applications however, it should be noted that they are not as rigid as the flange mount.

NOTES:

† Available with fixed non-adjustable cushion on the rod end and standard Exact-a-just™ cushion on the cap only.

The bearing retainer plate is the same as the "E" dimension for 1-1/2"—6" bore sizes and the "XN" dimension for the 8"—14" bore sizes.

For rod end options see page 52a.

TABLE 2—Dimensions not affected by rod diameter

Table with 12 columns: BORE IN, E, F, G, J, K, P, AA, BB, DD THD, EE NPTF, LB. It lists dimensions for various bore sizes (1.500 to 14.000).

POWERMASTER® PPT PNEUMATIC & PHT HYDRAULIC CYLINDERS

HOW TO ORDER

EXAMPLES (A) 2 x 10 C-MP1-PHT-C;
5/8" Rod, 7/16" - 20 M. Threads

(B) 4 x 36 Effective Stroke, C-MP1-PHT-C 1-3/8" rod, 1"-14 male Threads, 4" Stop Tube "A" = STD + 1", "W" = STD + 1/2", Epoxy Paint Proximity Switch @ Location #4 Head and Cap

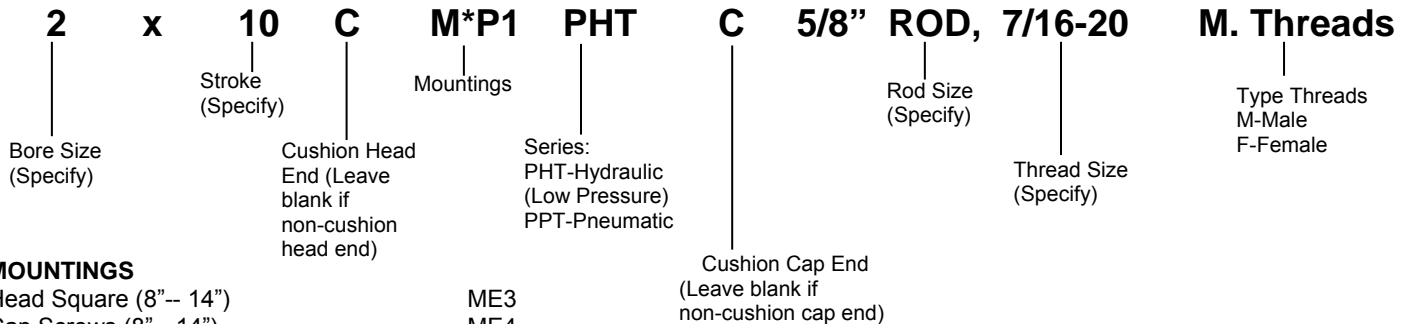

MOUNTINGS

- Head Square (8"– 14") ME3
- Cap Screws (8"– 14") ME4
- Head Rectangular Flange (1-1/2"– 6") MF1
- Cap Rectangular Flange (1-1/2"– 6") MF2
- Head Square Flange (1-1/2"– 6") MF5
- Cap Square Flange (1-1/2"– 6") MF6
- Cap Fixed Clevis MP1
- Cap Detachable Clevis MP2
- Cap Fixed Eye MP3
- Cap Detachable Eye MP4
- Side End Angles MS1
- Side Lug MS2
- Center Line Lug MS3
- Side Tap MS4
- Side End Lug MS7
- Head End Trunnion MT1
- Cap End Trunnion MT2
- Intermediate Fixed Trunnion (specify XI) MT4
- Universal Clevis MU3
- Tie Rod Mounting MX0, 1, 2, 3, 4

* Double Rod End (Example MDE3)
(Specify only when required, available in most mountings. 1-1/2, 2, 2-1/2 bore cylinders with the maximum oversize rod and head cushion have no head cushion adjustment or check valve bypass. These models are not recommended for double end application.)

OPTIONS

- Seals-- Standard, Viton, other
- Piston Rod Stud
- Rod Extension ("W" Dimension)
- Thread Extension ("A" Dimension)
- Stop Tube (Specify Effective Stroke) + inches of stop tube
- Piston Rod Material (Stainless Steel)
- Port Location if other than standard #1 location
- Cushion Location if other than standard #2 location
- Water Service
- Mixed Mountings
- Epoxy Paint
- Additional Ports
- SAE O-ring Straight Thread Ports
- Additional Cushion Adjustment Screws
- Oversized Ports
- Stroke Adjuster in Cap
- Moveable Center Trunnion (MT4)
- Special Items as Required

*PRESSURE RATINGS FOR DOUBLE ROD END POWERMASTER CYLINDERS

BORE SIZE	ROD SIZE	CUSHION ROD END OR NON-CUSHION	CUSHION BOTH ENDS OR EXT.
1.50	.625	1,000 PSI	750 PSI
	1.00	1,000 PSI	1,000 PSI
2.00	.625	800 PSI	450 PSI
	1.00	1,000 PSI	500 PSI
	1.38	1,000 PSI	1,000 PSI
2.50	.625	500 PSI	250 PSI
	1.00	1,000 PSI	500 PSI
	1.38	1,000 PSI	1,000 PSI
	1.75	1,000 PSI	1,000 PSI
3.25	1.00	500 PSI	Not Available
	1.38	1,000 PSI	1,000 PSI
	1.75	1,000 PSI	1,000 PSI
	2.00	1,000 PSI	1,000 PSI
4.00	1.00	400 PSI	Not Available
	1.38	1,000 PSI	1,000 PSI
	1.75	1,000 PSI	1,000 PSI
	2.00	1,000 PSI	1,000 PSI
	2.50	1,000 PSI	1,000 PSI
5.00	1.00	250 PSI	Not Available
	1.38	750 PSI	750 PSI
	1.75	750 PSI	750 PSI
	2.00	750 PSI	750 PSI
	2.50	750 PSI	750 PSI
	3.00	750 PSI	750 PSI
6.00	1.38	250 PSI	Not Available
	1.75	750 PSI	750 PSI
	2.00	750 PSI	750 PSI
	2.50	675 PSI	675 PSI
	3.00	750 PSI	750 PSI
	3.50	750 PSI	750 PSI
	4.00	750 PSI	750 PSI

BORE SIZE	ROD SIZE	CUSHION ROD END OR NON-CUSHION	CUSHION BOTH ENDS OR EXT.
8.00	1.38	200 PSI	Not Available
	1.75	500 PSI	450 PSI
	2.00	500 PSI	500 PSI
	2.50	500 PSI	500 PSI
	3.00	500 PSI	500 PSI
10.00	3.50	500 PSI	500 PSI
	4.00	500 PSI	500 PSI
	1.75	250 PSI	Not Available
	2.00	400 PSI	300 PSI
	2.50	400 PSI	400 PSI
	3.00	400 PSI	400 PSI
12.00	3.50	400 PSI	400 PSI
	4.00	400 PSI	400 PSI
	2.00	175 PSI	Not Available
	2.50	250 PSI	250 PSI
	3.00	250 PSI	250 PSI
14.00	3.50	250 PSI	250 PSI
	4.00	250 PSI	250 PSI
	2.50	150 PSI	Not Available
	3.00	250 PSI	250 PSI
	4.50	250 PSI	250 PSI

This page is intentionally blank.

POWERMASTER® PPT PNEUMATIC & PHT HYDRAULIC CYLINDERS

1-1/2" — 14" BORES

INSTALLATION AND SERVICE INFORMATION

Approximate Uncrated Powermaster Weights (lbs.)* (Air & Hydraulic Models)

CYLINDER BORE	1-1/2"	2	2-1/2	3-1/4	4	5	6	8	10	12	14
ZERO STROKE	5	7	12	20	30	45	70	100	200	300	490
ADD PER INCH OF STROKE	.3	.4	.6	.8	.9	1.0	1.5	2.0	2.5	4.0	4.5

*Weights based on standard (first) rod sizes.

WARNING— Read and follow warnings and directions as listed on the inside back cover of this catalog prior to performing any service or installation.

INSTALLATION— For outline dimensions and other considerations in mounting the Powermaster, see pages 54 and 67.

Before plumbing the cylinder, all lines in the system should be flushed to remove any contamination. To prevent corrosion and accumulation of foreign matter in the air cylinder, a 10 MICRON or better filter should be installed in the supply line to the cylinder control valve.

A very important consideration in mounting the Powermaster cylinder is keeping the cylinder thrust as close as possible to the centerline of the piston rod and free of misalignment or side loading. Off-center thrust or side loads decrease the normal life of the rod bearing and seals and can cause binding in the cylinder or linkage. Forcing rod, clevis pins, or mounting bolts into position indicates that the cylinder is not properly aligned, and permanent damage may result for such installation.

Side End Angles (MS1), Side Lugs (MS2), Centerline Lugs (MS3) and Side End Lugs (MS7): After a cylinder with one of these mountings has been aligned, key or pin it to its support. Properly located shear keys or pins will absorb the major portion of the shear load that can develop in the bolts that fasten the cylinder to its support. Always use high-tensile steel bolts to fasten the cylinder.

Head Rectangular Flange (MF1), Cap Rectangular Flange (MF2), Head Square Flange (MF5 & ME3), and Cap Square Flange (MF6 & ME4): A flange-mounted cylinder can be centered by using the gland in the cylinder head as a pilot. After mounting and alignment, the cylinder should be dowelled to its supports to keep it from shifting. For installations that use maximum operating pressures or have high shock loads, a square flange is recommended.

Head Trunnion (MT1), Cap Trunnion (MT2), and Intermediate Fixed or Movable Trunnion (MT4): Install a trunnion-mounted cylinder in rigid and accurately aligned pillow blocks. These blocks should be well lubricated at all times. Since trunnion pins are designed for shear loads only, provide linkage with a suitable pivot for connection to the rod end of the cylinder.

STANDARD SPECIFICATIONS

Duty: 250 psi Pneumatic, 250-1500 psi Hydraulic (see chart)
Standards: Meet or exceeds all J.I.C. and NFPA requirements
Bore Sizes: 1-1/2" — 14" (standard)
Piston Rods: 5/8" — 5-1/2" (standard)
Mountings: 21 standard NFPA mountings.
Temperature Range: -65°F to +200°F (Buna N Standard seals)
 Optional Viton seals for -15°F to +400°F and many fluids which require chemical resistance.
HYDRAULIC OPERATING PRESSURES BY CYLINDER BORE SIZES

BORE SIZE	1-1/2 2	2-1/2* 3-1/4	4	5	6	8	10	12	14
MAX. PSI, MAX. DUTY, SEVERE SERVICE	1,500	1,500	1,000	750	750	500	400	250	250

* for 5/8" rod, 1000 psi

Fixed Clevis (MP1), Detachable Clevis (MP2) and Universal Clevis (MU3): In the installation of a clevis-mounted cylinder, the centerline of the pivot pin in the rod end linkage must be parallel with the centerline of the clevis pin in the cap end of the cylinder. A universal clevis mount automatically compensates for 5 to 10 degrees of misalignment in any direction. Never allow the cylinder head or cap to stop the piston at the end of its stroke. Either provide external stops to prevent the piston from bottoming or use a cylinder with built-in cushioning. A cushioned cylinder will stop the piston just before it reaches the end of its stroke. Under certain conditions of load, external stops may be required to supplement the cylinder cushioning.

OPERATION— The standard Powermaster pneumatic cylinder has a maximum operating pressure of 250 psi, and the hydraulic cylinder a maximum of 250 - 1500 psi at a temperature range of -65°F to +200°F. For operating temperatures above or below this range, cylinders with special packing and seals are required. Air pressure supplied to the cap-end port moves the piston rod to its extended position. Pressure supplied to the head end port moves the piston rod to its retracted position. See page 107 for forces developed by each cylinder.

ADJUSTMENT— A noncushioned cylinder requires no further adjustment after it has been installed and properly aligned. A cushioned cylinder, after installation and alignment, must be adjusted to obtain the degree of cushioning desired. An adjustment is provided by a screw-type needle and check valve in either or both ends of the cylinder. This Exact-a-just™ valve controls the rate at which trapped air or fluid is allowed to meter from the end of the cylinder when the piston is near the end of its stroke. Turn the needle valve clockwise to increase the amount of cushioning and counter-clockwise to decrease cushioning. To obtain the most effective cushioning, final adjustment must be made while the cylinder is operating under normal conditions at normal operating pressure.

POWERMASTER® PPT PNEUMATIC & PHT HYDRAULIC CYLINDERS

1-1/2” — 14” BORES — MAJOR REPAIR, MAINTENANCE & TESTING

GENERAL MAINTENANCE AND REPAIR RECOMMENDATIONS

Maintenance periods should be scheduled in accordance with frequency of use and working environment of the cylinder. All cylinders must be visually inspected for wear and given an “in system” operating performance and leakage test at least once a year. If these visual observations indicate cylinder repair is required, the cylinder must be removed, repaired and tested. A major overhaul is recommended at one million cycles. However, where frequency of use is such that it would require more than two years to obtain one million cycles, the cylinder must be overhauled at the two year period. When it is determined that the cylinder requires a major repair as a result of the one million cycles, one year routine inspection, or the two year service period has elapsed, the device must be disassembled, cleaned, inspected, parts replaced as required, rebuilt and tested for leakage, and proper operation prior to installation. Refer to MAJOR REPAIR, MAINTENANCE INSTRUCTION, and TEST PROCEDURES.

MAJOR REPAIR AND MAINTENANCE INSTRUCTION.

Always exhaust or drain the pressure from the system before performing any service work. Disconnect lines from head and cap ports of cylinder. Completely disassemble the cylinder using the exploded and assembly views as reference. No special tools are required except internal snap ring pliers. The piston rod assembly consisting of rod, piston and head cushion bushing (where used) are torque and secured at the factory and are not to be disassembled (cylinders built prior to 1985 utilized piston nut). After disassembling the cylinder, wash all metal parts in a non-flammable solvent. Rinse each part thoroughly and blow dry with a low pressure air jet. Arrange the parts on a clean surface. Examine each part carefully. Replace all rubber parts and other worn or damaged parts. The use of REPAIR KITS is strongly recommended. Particular attention should be given to the rod bearing (5a) since cylinder leakage can result from a worn bearing. A scored or rough rod bearing might damage the piston rod and subsequently, the rod packing. Rod cartridge kits are available with or without the rod bearing.

An excellent feature of the POWERMASTER Cylinder is easy replacement of the rod cartridge (5) without loosening the tie rods. On most cylinders with the bore sizes from 1-1/2” - 6 inches, remove the screws and washers (1 & 2) and retainer plate (4a). For all cylinders with bore sizes 8” - 14”, remove screws (3) and retainer plate (4b). The rod cartridge is easily removed from the cylinder hear. To facilitate removal, a screwdriver can be used to pry in the external groove.

REASSEMBLY

The procedure for reassembly is essentially the reverse of disassembly. However, the following exceptions should be noted:

1. All O-rings should be well coated with Cylinder Lube grease for air cylinders or the hydraulic fluid used in the application for hydraulic cylinders, as they are installed in their respective grooves and prior to reassembly with the mating part. Care must be taken when assembling O-rings and packings that they are not damaged, as this will cause leakage.
2. Reassemble the cylinder using the exploded and assembly views as reference. **Pneumatic Only:** As the

assembly proceeds, lubricate the piston seals, cushion seals, rod seal, tube and tube seals with Cylinder Lube grease. Pay particular attention to the installation of the cushion kit (ref. 11 & 19) to insure that the tapered rubber surface marked “THIS SIDE UP” faces to the inside (piston side) of the cylinder.

Hydraulic Only: Lubricate inside diameter of cylinder tube and piston rod, plus all seals, with hydraulic fluid used in cylinder application. The hydraulic fluid specified for use in the cylinder is the only lubricant to be used in assembly.

3. Tie rod threads should be well lubricated to allow tightening the nuts evenly for proper pre-stressing. To avoid twisting of the tie rods during tightening, hold with vise grip or clamp. To assure equal pre-stressing of the tie rods, first turn on nuts even and snug to align assembly, then the nuts are to be tightened alternately. For proper tie rod pre-stressing, they should be torque as recommended. The specific torque value is determined by the diameter of the tie rod. For lubricated tie-rod threads, these torque values are:

CYL. BORE SIZE	TIE ROD DIA.	TORQUE-LUBRICATED POUNDS—FOOT
1-1/2"	1/4"	4.5
2"	5/16"	9
2-1/2"	5/16"	12
3-1/4"	3/8"	23
4"	3/8"	22
5" & 6"	1/2"	45
8"	5/8"	90

TESTING: After the cylinder has been completely reassembled, it should be tested, either on a test bench or in the regular installation.

TEST PROCEDURES:(see maximum psi/style). The cylinder should be tested for cushioning, travel and leakage.

- A. Cushioning (if applicable)
 1. Turn both cushioning screws clockwise all the way in.
 2. Cycle cylinder a few times by alternating supply pressure to head & cap ports.
 3. Apply supply pressure to the head port. Rod should retract, decelerate and may stop before completion of stroke.
 4. Apply supply pressure to the cap port. Rod should extend, decelerate and may stop before completion of stroke.
- B. Travel and Leakage
 1. Turn the cushioning screws counterclockwise one (1) full turn.
 2. Apply supply pressure to the head port. Rod should retract smoothly without binding. Cylinder should retract, has less cushioning and make full stroke + or - .062". Check leakage at cap port, 30cc/min. leakage permitted. Check leakage around rod seal. No leakage permitted.
 3. Apply supply pressure to the cap port. Rod should extend smoothly without binding. Cylinder should have less cushioning and make full stroke + or - .062". Check leakage at head port, 30cc/min. leakage permitted.
 4. Return piston rod to retract position by applying supply pressure to head port. Remove supply pressure and install cylinder in service if satisfactory.

CUSHION ADJUSTMENT

Turn the needle valve clockwise to increase the amount of cushioning and counter-clockwise to decrease cushioning. To obtain the most effective cushioning, final adjustment must be made while the cylinder is operating under normal conditions at normal operating pressure.

POWERMASTER® PPT PNEUMATIC & PHT HYDRAULIC CYLINDERS

POWERMASTER PPT PNEUMATIC CYLINDERS 1-1/2" — 14" BORES

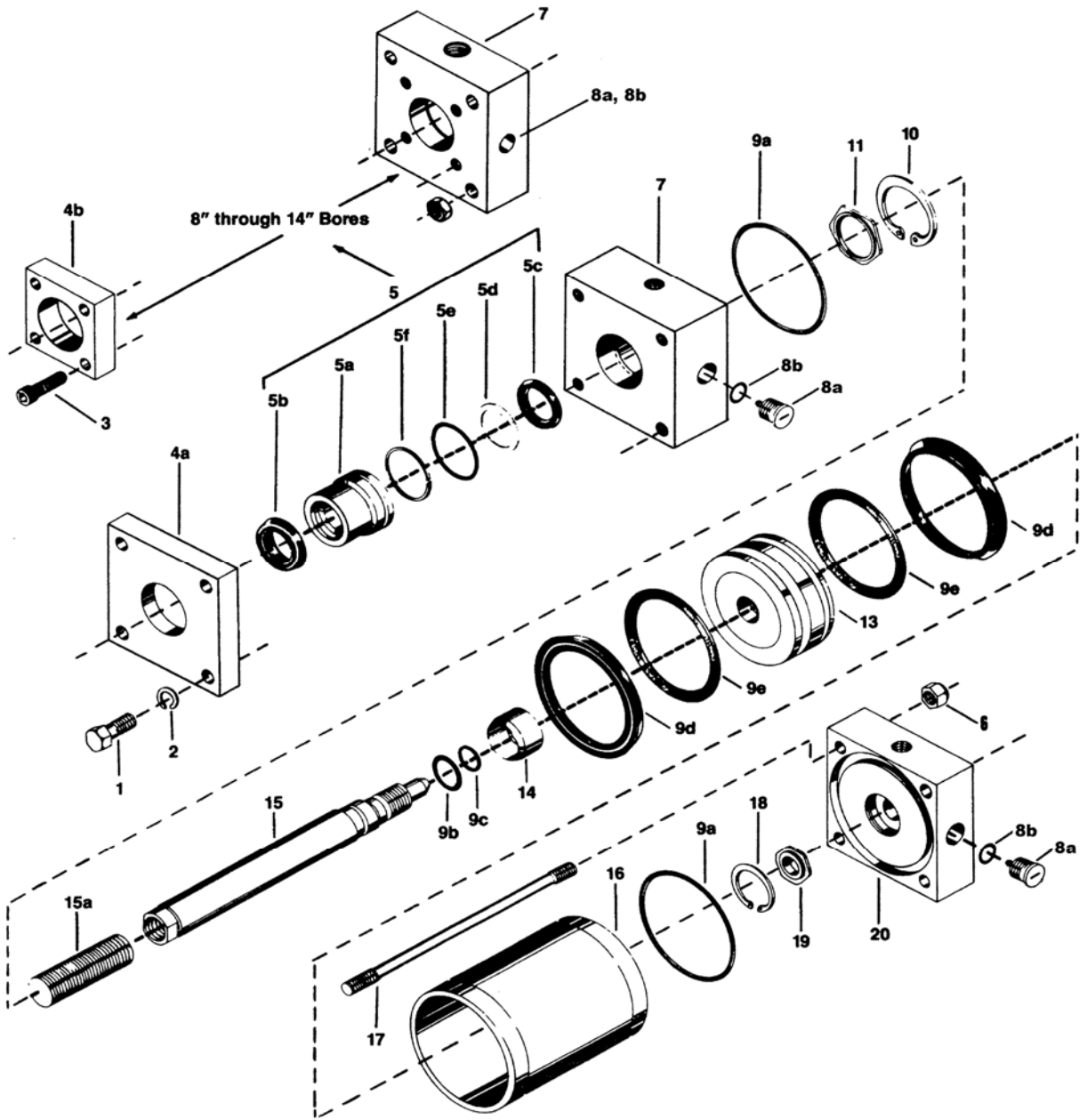

1-1/2" through 6" bores

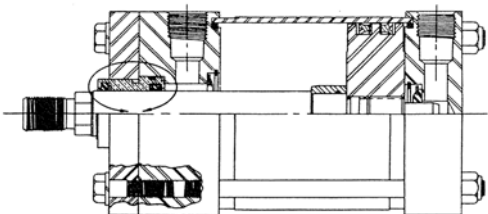

8" through 14" bores

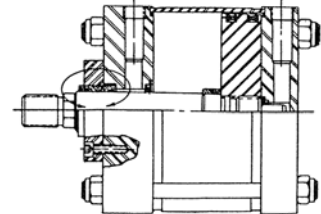

POWERMASTER® PPT PNEUMATIC & PHT HYDRAULIC CYLINDERS

SERVICE INFORMATION — POWERMASTER PPT PNEUMATIC, 1-1/2"—14" BORES

REF.	DESCRIPTION	CUSHIONED BOTH ENDS	CUSHIONED HEAD ONLY	CUSHIONED CAP ONLY	NON-CUSHIONED
1	SCREW, Cap (1-1/2"-6" bores)	4	4	4	4
2	WASHER, Lock (1-1/2"-6" bores)	4	4	4	4
3	SCREW, Socket Head Cap (8"-14" bores)	4	4	4	4
4a	PLATE, Retainer (1-1/2"-6" bores)	1	1	1	1
4b	PLATE, Retainer (8"-14" bores)	1	1	1	1
5*	CARTRIDGE, Rod Kit	1	1	1	1
5a	BEARING, Rod	1	1	1	1
5b	WIPER, Rod	1	1	1	1
5c	PACKING, "U" Rod	1	1	1	1
5d	O-RING, Backup	1	1	1	1
5e	O-RING, Rod Bearing	1	1	1	1
5f	RING, Backup	1	1	1	1
6	NUT, Tie Rod Lock	†	†	†	†
7	HEAD	1	1	1	1
8*	CUSHION, Needle Valve Kit	2	1	1	-
8a	VALVE, Exact-a-just™ Needle & Check (includes Ref. 8)	2	1	1	-
8b	O-RING, Needle Valve	2	1	1	-
9*	PISTON & TUBE Seal Kit	1	1	1	1
9a	O-RING, End Cover	2	2	2	2
9b	O-RING, Head Cushion Bushing	1	1	1	1
9c	O-RING, Piston Bearing	1	1	1	1
9d	SEAL, Piston	2	2	2	2
9e	RING, Piston Backup	2	2	2	2
10	RING, Head Cushion Retaining	1	1	1	1
11	SEAL, Head Cushion Kit	1	1	-	-
12	NUT, Piston Retaining (Not shown - not used after 1984)	1	1	1	1
13	PISTON				
14	BUSHING, Head Cushion	1	1	-	-
15	ROD, Female Piston	1	1	1	1
15a	ADAPTER, Male Piston Rod (when required)	1	1	1	1
16	TUBE, Cylinder	1	1	1	1
17	TIE ROD	4	4	4	4
18	RING, Cap Cushion Retaining	1	-	1	-
19*	SEAL, Cap Cushion Kit	1	-	1	-
20	CAP	1	1	1	1

*Recommended spare parts to be retained in stock at all times. See "REPAIR KITS" below.

† On 8" — 14" bores, 8 are always required. On 1-1/2"—6" bores, 4 are normally required, but may sometimes replace Ref. No. 1 & 2 on some mounting styles.

REPAIR KITS

Repair parts included in the following repair kits are available only in kit form. Kits should be ordered by kit part numbers plus cylinder part number when possible. Some kits may have an excess of parts not used in some cylinder models. Discard these parts or keep for later use. Other parts not included in repair kits must be ordered separately by reference number, description, and cylinder part number.

Rod Cartridge Kit (with Rod Bearing)			Rod Seal Kit (less Rod Bearing)		Head Cushion Seal
Rod Diameter	Buna N With Urethane Rod Wiper (std.) Part Number	Viton Part Number	Buna N With Urethane Rod Wiper (std.) Part Number	Viton Part Number	Buna N* Part Number
0.63"	R433023506	R433023936	R433014982	R433023935	R432029151
1.00"	R433023510	R433014756	R433014984	R433023941	R433023150
1.38"	R433014766	R433023946	R433014986	R433023945	R433015596
1.75"	R433023515	R433023952	R433014988	R433023951	R433022387
2.00"	R433023519	R433023958	R433014990	R433023957	R433022388
2.50"	R433023523	R433023964	R433024068	R433023963	R433023465
3.00"	R433023526	R433014768	R433024071	R433023969	
3.50"	R433014844	R433074988	R433074775	R433024261	
4.00"	R433014682	R433021263	R433014976		
4.50"	R433014684		R433014978		
5.00"	R433014686	R433024267	R433014980	R433024269	
5.50"	R433014688				
Includes Ref. items: 5a, 5b, 5c, 5d, 5e & 5f			Includes Ref. items 5b, 5c, 5d, 5e & 5f		* Buna N rubber For high-temp. opera- consult the factory.
Bore Size	Piston & Tube Seal Kit		Cap Cushion Seal		
	BUNA N Part Number	VITON Part Number	BUNA N* Part Number		
1.50"	R433023971	R433023977	R433015593		
2.00"	R433023981	R433023987	R433015593		
2.50"	R433023993	R433023997	R433015593		
3.25"	R433024002	R433024009	R433015594		
4.00"	R433024012	R433024018	R433015594		
5.00"	R433024022	R433024027	R433015594		
6.00"	R433024031	R433024037	R433015595		
8.00"	R433024041	R433024043	R433015595		
10.00"	R433024045	R433024047	R433022386		
12.00"	R433024049	R433024051	R433022386		
14.00"	R433024053	R433024055	R433015596		
Includes Ref. Items 9a, 9c, 9d & 9e.			*Buna N rubber (Ref. 19) For high-temperature operation, consult factory		
Cushion Needle Valve Assemblies (Exact-a-just™)		Cylinder Lube Grease			
Part Number	Bore Sizes	14 oz. tube	R431001590		
R433015236	1.5", 2", 2.5" Buna-				
R433016568	3.25", 4", 5" Buna-				
R433023258	6" thru 14" Buna-N				
R433072609	1.5", 2", 2.5" Viton				
R433074773	3.25", 4", 5" Viton				
R433023256	6" thru 14" Viton				
Includes Ref. items 8a & 8b					

POWERMASTER® PPT PNEUMATIC & PHT HYDRAULIC CYLINDERS

POWERMASTER PHT PNEUMATIC CYLINDERS 1-1/2" — 14" BORES

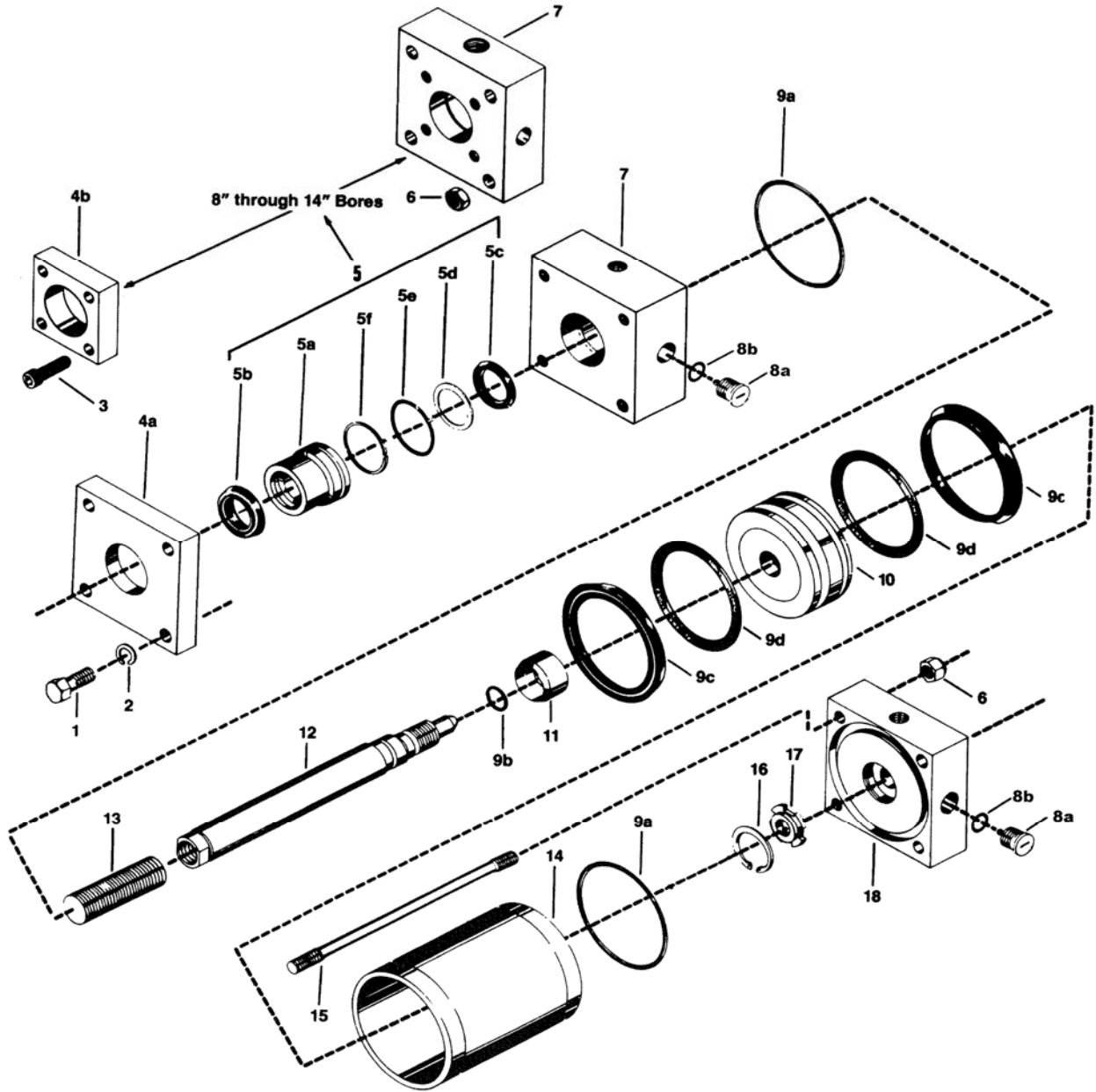

1-1/2" through 6" bores

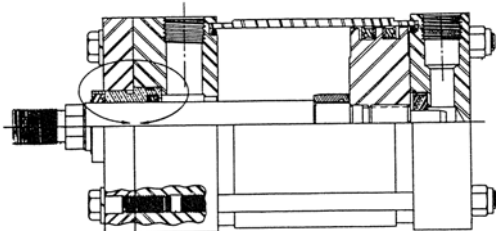

8" through 14" bores

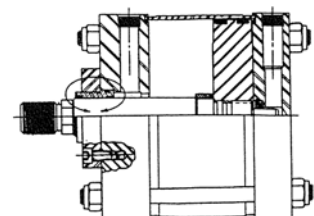

POWERMASTER® PPT PNEUMATIC & PHT HYDRAULIC CYLINDERS

POWERMASTER PHT HYDRAULIC CYLINDER 1-1/2"–14" BORES

REF.	DESCRIPTION	CUSHIONED BOTH ENDS	CUSHIONED HEAD ONLY	CUSHIONED CAP ONLY	NON-CUSHIONED
1	SCREW, Cap (1-1/2"–6" bores)	4	4	4	4
2	WASHER, Lock (1-1/2"–6" bores)	4	4	4	4
3	SCREW, Socket Head Cap (8"–14" bores)	4	4	4	4
4a	PLATE, Retainer (1-1/2"–6" bores)	1	1	1	1
4b	PLATE, Retainer (8"–14" bores)	1	1	1	1
5*	CARTRIDGE, Rod Kit	1	1	1	1
5a	BEARING, Rod	1	1	1	1
5b	WIPER, Rod	1	1	1	1
5c	PACKING, "U" Cup/O-Ring	1	1	1	1
5d	RING, Backup	1	1	1	1
5e	O-RING, Rod Bearing	1	1	1	1
5f	RING, Backup	1	1	1	1
6	NUT, Tie Rod Lock	†	†	†	†
7	HEAD	1	1	1	1
8*	CUSHION, Needle Valve Kit	2	1	1	-
8a	VALVE, Exact-a-just™ Needle & Check (include Ref. 8)	2	1	1	-
8b	O-RING, Needle Valve	2	1	1	-
9*	PISTON & TUBE, Seal Kit	1	1	1	1
9a	O-RING, End Cover	2	2	2	2
9b	O-RING, Piston Bearing	1	1	1	1
9c	SEAL, Piston	2	2	2	2
9d	RING, Piston Seal Backup	2	2	2	2
10	PISTON	1	1	1	1
11	BUSHING, Head Cushion	1	1	-	-
12	ROD, Female Piston	1	1	1	1
13	ADAPTAR, Male Piston Rod (when required)	1	1	1	1
14	TUBE, Cylinder	1	1	1	1
15	TIE ROD	4	4	4	4
16	RING, Cap Cushion Retaining	1	-	1	-
17	SEAL, Cap Cushion	1	-	1	-
18	CAP	1	1	1	1
19	NUT, Piston Retaining (Not shown - not used after 1984)	1	1	1	1

*Recommended spare parts to be retained in stock at all times. See "REPAIR KITS" below.

† On 8" – 14" bores, 8 are always required. On 1-1/2"–6" bores, 4 are normally required, but may sometimes replace Ref. No. 1 & 2 on some mounting styles.

REPAIR KITS

Repair parts included in the following repair kits are available only in kit form. Kits should be ordered by kit part numbers plus cylinder part number when possible. Some kits may have an excess of parts not used in some cylinder models. Discard these parts or keep for later use. Other parts not included in repair kits must be ordered separately by reference number, description, and cylinder part number.

Rod Cartridge Kit (with Rod Bearing)		
Rod Dia.	Buna N With Urethane Rod Wiper (std.) Part Number	Viton Part Number
0.63"	R433022023	R433041184
1.00"	R433022025	R433033115
1.38"	R433022027	R433033112
1.75"	R433022029	R433041191
2.00"	R433022031	R433041203
2.50"	R433022033	R433023964
3.00"	R433022035	R433033105
3.50"	R433014561	
4.00"	R433014690	R433024263
4.50"		R433040358
5.00"	R433074774	
5.50"		

Includes Ref. items: 5a, 5b, 5c, 5d, 5e & 5f

Rod Seal Kit (less Rod Bearing)	
Buna N With Urethane Rod Wiper (std.) Part Number	Viton Part Number
R433023933	R433041186
R433023939	R433033116
R433023943	R433033111
R433023949	R433041189
R433023955	R433041201
R433023961	R433023963
R433023967	R433033107
R433014992	R433041233
R433074792	R433024265
R433074806	R433040356
R433074804	
R433074803	R433024269

Includes Ref. items 5b, 5c, 5d, 5e & 5f

Bore Size	Piston & Tube Seal Kit		Cap Cushion Seal BUNA N* Part Number
	BUNA N Part Number	VITON Part Number	
1.50"	R433023971	R433023977	R433015116
2.00"	R433023981	R433023987	R433015116
2.50"	R433023993	R433023997	R433015116
3.25"	R433024002	R433024009	R433015114
4.00"	R433024012	R433024018	R433015114
5.00"	R433024022	R433024027	R433015114
6.00"	R433024031	R433024037	R433015115
8.00"	R433024041	R433024043	R433015115
10.00"	R433024045	R433024047	R433015120
12.00"	R433024049	R433024051	R433015120
14.00"	R433024053	R433024055	R433015121

Includes Ref. Items 9a, 9c, 9d & 9e. Ref. 17

Cushion Needle Valve Assemblies (Exact-a-just™)	
Part Number	Bore Sizes
R433015236	1.5", 2", 2.5" Buna-N
R433016568	3.25", 4", 5" Buna-N
R433023258	6" thru 14" Buna-N
R433072609	1.5", 2", 2.5" Viton
R433074773	3.25", 4", 5" Viton
R433023256	6" thru 14" Viton

Includes Ref. items 8a & 8b

Cylinder Lube Grease	
14 oz. tube	R431001590

This page is intentionally blank



PRESSUREMASTER[®] HHT HYDRAULIC CYLINDERS

**NOMINAL 3000 PSI
NON-SHOCK 5000 PSI**

(Exceptions to 5,000 psi rating are listed on page 100)

1-1/2" — 14" BORE

MACHINE TOOL GRADE NFPA DESIGNS



**POSITION FEEDBACK
(AHT) HYDRAULIC CYLINDER
for AVENTICS HHT Series NFPA Cylinders
See Page 84**

Note: "LB" dimension is greater than standard PRESSUREMASTER[®] -
consult factory

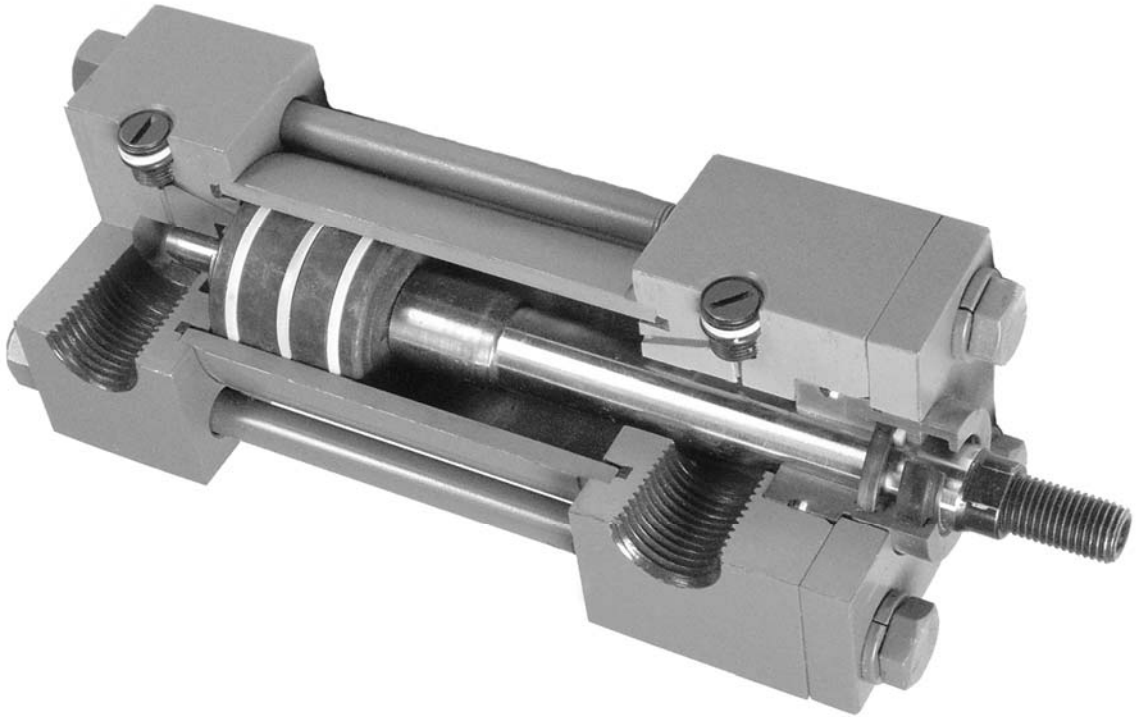
AVENTICS PRESSUREMASTER® HHT HYDRAULIC CYLINDERS
STANDARD CYLINDER SPECIFICATIONS

**Operating Pressures (PSI)
by Cylinder Bore Sizes***

Bore Size	Standard Rod	Nominal* Pressure	Non-Shock** Pressure
1-1/2	5/8	3,000	5,000
2	1		
2-1/2	1		
3-1/4	1-3/8		
4	1-3/4		
5	2		
6	2-1/2		
7	3		
8	3-1/2		
10	5		
12	5-1/2		
14	7		

* See pressure limitations on Double Rod End cylinders on page 87 and Flange Mounted cylinder on page 89.

** Exceptions to 5,000 psi rating are listed on page 100.

§Effective March 1, 1997, SAE O-ring straight thread ports became standard

Duty - Nominal 3000 PSI hydraulic, non-shock 5000 PSI

Standards - Meets or exceeds all J.I.C. and NFPA requirements

Bore Sizes - 1-1/2" through 14" (standard), larger available

Piston Rods - 5/8" through 7" (standard)

Mounting - 22 standard NFPA mounts

Temperature Range - -65°F to +200°F (-54°C to +93°C)

For Buna-N standard seals.

Optional Viton® seals for -15°F to +400°F (-26°C to +204°C) and many fluids.

Ports§- SAE O-Ring straight thread posts; NPTF dryseal tapered threads available. (SAE Flange ports available at extra cost.)

Stroke - Standard strokes furnished to nearest 1/8". Normal stroke tolerance +/-1/16". Closer stroke tolerances available, consult factory.

Rod End Threads - Standard KK1 male and female threads plus KK2 oversize male thread. Other rod end styles optional.

Cushions - Available for all bore sizes, at either or both ends.

Piston Rods - Case hardened to 50-55 Rockwell "C" (except 5/8") chrome-plated and finished to 15 micro-inches or better. Can be certified to meet ASTM B-117 corrosion resistance test.

Tie Rods - High tensile, 1144 stress proof steel

Cylinder Tube - Honed, steel tubing

Double End Rod - Available in many mounting styles to meet special needs

AVENTICS PRESSUREMASTER[®] HHT HYDRAULIC CYLINDERS

CYLINDER SPECIFICATIONS

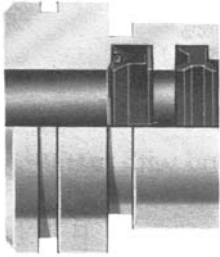

Extra-long rod bearing provides for maximum support against side-loads including external misalignment. Marine-grade 660 bronze material has superior non-scoring properties and dimensional stability. Bearing is pilot fitted into the head assuring true concentricity and long bearing and seal life. Cartridge can be quickly and easily changed without special tools.



Self-aligning U-cup/O-ring seal coordinates operating pressures with sealing forces providing a positive sealing with minimum friction. Urethane Poly-pak rod seal provides long life in an operating range of -65°F to $+200^{\circ}\text{F}$. Viton seals -15°F to $+400^{\circ}\text{F}$ are also available for use with many special fluids. (Special fluids should be checked for compatibility with Viton)

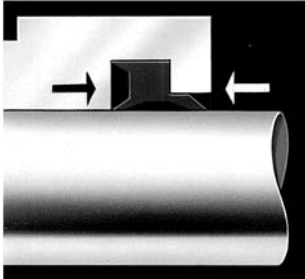

Double Duty Twin Lip rod wiper provides dirt protection for the rod bearing and rod seal. External lip prevents entry of contaminants into the bearing area on instroke and internal lip wipes rod on outstroke and serves as a secondary seal.

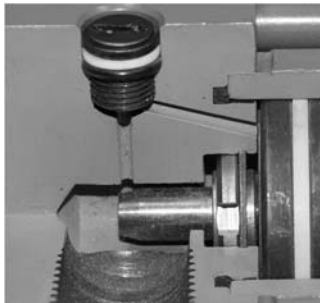

The Pressuremaster self-aligning cushion design provides a positive sealing cushion with fast piston breakaway response. Head cushion is solid with a floating cushion bushing on the rod and the cap end has a floating bronze insert.

The AVENTICS Exact-a-just[™] combination needle and check valve eliminates the need for separate ball checks (thus leaving a quadrant free for other possible use.)

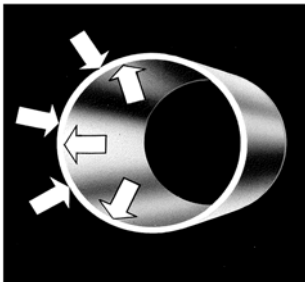

Dent resistant heavy wall steel tubing is honed to a 12 micro-inch, or better, finish, for minimum friction and long seal life.



The unique Pressuremaster piston design incorporates a center filled Teflon[®] seal continuously loaded by an O-ring with two Teflon[®] split rings as load bearings (additional bearing rings are provided above 8" bore sizes). Design provided an ideal coordination of operating pressures with proper sealing forces and result in long, trouble-free service life using petroleum or high water base fluids. Cast iron piston rings, Poly-pak and Viton seals are also available.

Teflon[®] is a registered trademark of the DuPont company

AVENTICS PRESSUREMASTER® HHT HYDRAULIC CYLINDERS**CYLINDER OPTIONS****VITON SEALS**

Available for high temperature air service in a temperature range of -15°F to 400°F , and with many special hydraulic fluids. (Special fluids should be checked for compatibility with Viton).

PISTON ROD OPTIONS

Non-standard rod ends are available including rod and thread extensions, special threads and rod end machining, and additional wrench flats. (Catalog dimensional changes must be specified).

Optional rod materials are also available for specific applications and environmental conditions:
Stainless steel -- 303 and 17-4 PH

METALLIC ROD SCRAPER

Metal scraper available for the removal of tough/hardened matter adhering to piston rod. (Rod boots for exterior rod protection might also be considered).

PISTON SEALS

Poly-pak piston seals are available for positive sealing in continuous holding applications.

U-cup/O-ring loaded provides for tight sealing when pressure vary.

PORT OPTIONS

Effective 3/1/97, SAE O-Ring straight thread ports are standard. NPTF dryseal tapered threads are optional at no additional charge. Other standard size ports, oversize welded coupling ports and multiple ports are also available where design dimensions permit.

SAE 4 Bolt Split Flange ports are available in the bore sizes where design space permits.

TUBE BLEEDS

Available for bleeding hydraulic cylinders.

STOP TUBE

Internal stop tube or dual position is available for reducing excessive bearing loads and jackknifing conditions in long stroke push cylinders. (See page 113 for determining stop tube length required).

COMBINATION MOUNTING

Additional cylinder mountings are available where design space permits.

WATER SERVICE

Model HW is available for water service and includes chrome-plated I.D. tube, electroless nickel plated head, cap piston, and cushion parts. Stainless steel rod is also recommended for water service.

EPOXY PAINT

Available for additional exterior cylinder protection in corrosive environments. Painting includes one coat of Yellow Zinc Chromate Primer and one coat of Black Epoxy Enamel.

TAPPED RETAINER PLATE

Head retainer plate tapped for tie rods available when bolts or tie rod nuts are not permitted on head end. (Available for 1-1/2"–6" bore sizes).

EXTRA CHECK VALVE (Exact-a-just™)

Available for faster breakaway response for cushioned cylinders.

CONSULT FACTORY FOR OTHER OPTION REQUIREMENTS NOT SHOWN IN THIS CATALOG

AVENTICS PRESSUREMASTER® HHT HYDRAULIC CYLINDERS

CYLINDER OPTIONS

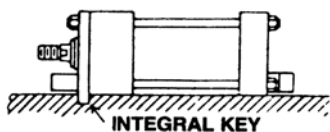
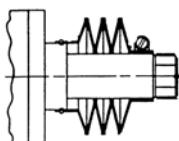
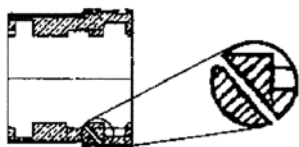
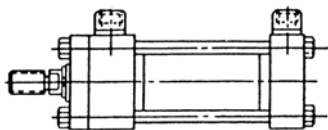
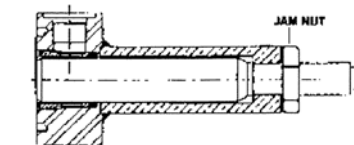

(GO® Switch is not a reed switch)

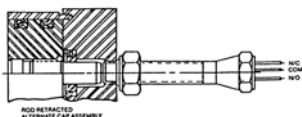
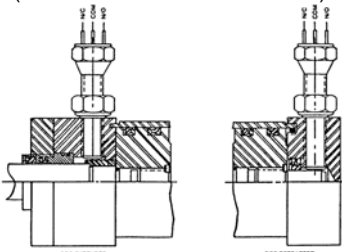

GO® Switch is standard on 7" to 14" bore sizes.

CAUTION

THESE UNITS ARE **NOT** INTENDED TO BE USED AS A FINAL SAFETY DEVICE

AVENTICS offers a standard arrangement to provide cylinder stroke adjustment. When an application requires a precise cylinder stroke or when infrequent stroke length adjustment is required, this retracted stroke adjustment should be specified.

Oversize welded coupling ports are available for most Pressuremaster bore sizes and mountings. (Can not be provided where cylinder design or mounting space prohibits, MF6 and MF2 flange side).

Gland drains are to be used in environments where seepage is not allowable. Threaded port allows fluid to be plumbed away from the application.

Rod boots are available for additional rod protection from environmental conditions. The oil resistant cover of neoprene-coated nylon fabric is suitable for operation in an ambient temperature range of -45°F to 220°F. Consult factory for higher temperature boot requirements.

Thrust Key Retainer is available on Pressuremaster MS2, MS4 and MS7 mountings. This eliminates the need for fitted bolts or external keys to carry the thrust load.

Proximity Limit Switches are available for most styles and rod sizes of Pressuremaster cylinders. These switches are mounted in the head and cap ends to confirm the extended or retracted position of the piston. The switches are actuated by the cushion bushing on the head end and the cushion spear on the cap end. No linkage or external actuator is required. Switches can be assembled in the cylinder head, cap, or rear cap face for simple and accurate piston confirmation. The switches are not sensitive to vibration and are suitable for most environments. Switch height is less than 4 inches; for critical dimensions, contact factory. Note: "Low Profile" switch is standard on 1.5" and 6" bore sizes.

SENSING DISTANCE

End sensing of .090" (2.25mm) to .110" (2.76mm) when using a ferrous actuator approximately equal the area of the end. The differential (hysteresis) is approximately 1/2 of the sensing range. We supply most name brand switches, such as Balluff Strokemaster, P&F Low Profile, Stoke to GO® Low Profile, NAMCO and others.

CONTACT RATING

2 AMP at 240 VAC (CSA and UL approved)
50 mA at 24 VDC (CSA only)

CONTACT ARRANGEMENT

Available in Single Pole, Double Throw.

TEMPERATURE RANGE

Tested to -22°F to +250°F. Impervious to most environments.

Recognized by UL at 104°F (40°C) maximum

GO® is a trademark of General Equipment Manufacturing Company, Inc.

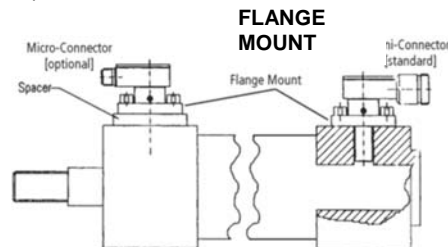

AVENTICS PRESSUREMASTER® HHT HYDRAULIC CYLINDERS

CYLINDER OPTIONS

OVERSIZE PORTS OFFERED IN WELDED BOSSES

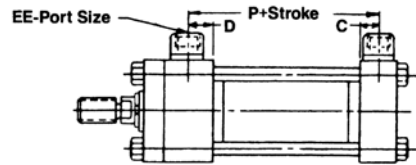
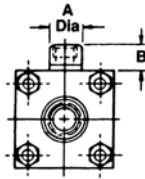

SEE CAUTION ON PAGE 83.

BORE SIZE	PORT SIZE			BOSS DIA. "A"	BOSS HGT "B"	P
	SAE	DASH	NPTF			
1.5"	1-1/16-12	-12	3/4"	1.38"	1"	2.88
2"	1-1/16-12	-12	3/4"	1.38"	1"	2.88
2.5"	1-1/16-12	-12	3/4"	1.38"	1"	3.00
3.25"	1-5/16-12	-16	1"	1.75"	1.19"	3.50
4"	1-5/16-12	-16	1"	1.75"	1.19"	3.75
5"	1-5/16-12	-16	1"	1.75"	1.19"	4.25
6"	1-5/8-12	-20	1-1/4"	2.25"	1.31"	4.88
7"	1-7/8-12	-24	1-1/2"	2.50"	1.56"	5.38
8"	2-1/2-12	-32	2"	3.00"	1.56"	6.12

The above oversize ports cannot be furnished on cylinders with MF6 cap square flange mounts or in position No. 2 or No.4 on cylinders with MF2 cap rectangular flange mounts. Note that oversize ports do not necessarily mean increased flow capacity; consult factory

STANDARD DIMENSIONS

BORE	EE		
	SAE	DASH	NPTF
1.5	3/4-16	-8	1/2"
2	3/4-16	-8	1/2"
* 2.5	3/4-16	-8	1/2"
3.25	1-1/16-12	-12	3/4"
4	1-1/16-12	-12	3/4"
† 5	1-1/16-12	-12	3/4"
6	1-5/16-12	-16	1"
7	1-5/8-12	-20	1-1/4"
8	1-7/8-12	-24	1-1/2"
10	2-1/2-12	-32	2"
12	2-1/2-12	-32	2.5"
14	2-1/2-12	-32	3"

*3/4-16 SAE Max. with 1-3/8 & 1-3/4 Rod Diameter
 †7/8-14SAE Max. with 3-1/2 Rod Diameter

EXTENDED KEY PLATE

AVENTICS offers a standard arrangement of Thrust Key Mountings on the MS2, MS4 and MS7 Pressuremaster cylinders. This option eliminates the need for fitted bolts or external keys to carry the thrust load. The normal headplate is extended below the head surface of the cylinder and is fitted in a keyway milled into the mounting surface of the machine member. See drawings for details.

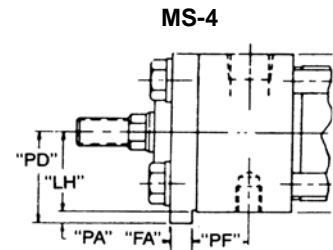
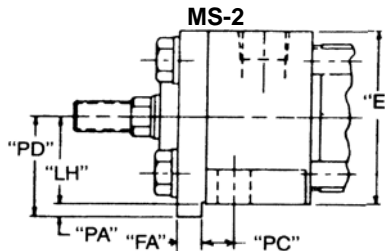
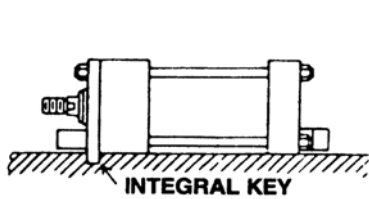

BORE	"E"	"FA"	"LH"	"PA"	"PC"	"PD"	"PF"	"PG"
1.50"	2.50	.312	1.244	.19	.44	1.44	1.06	1.19
2.00"	3.00	.562	1.494	.31	.56	1.81	1.06	1.50
2.50"	3.50	.562	1.744	.31	.75	2.06	1.06	1.50
3.25"	4.50	.687	2.244	.38	.75	2.62	1.19	1.84
4.00"	5.00	.812	2.494	.44	.94	2.94	1.19	1.94
5.00"	6.50	.812	3.244	.44	.94	3.69	1.19	2.31
6.00"	7.50	.937	3.744	.50	1.19	4.25	1.31	2.62

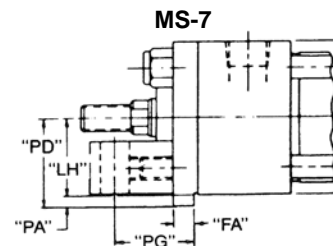

NOTES:

1. Use mounting bolts .06 smaller in diameter than hole size.
2. Fitted bolts or dowel pins are not needed with the trust key headplate.
3. All dimensions not shown are NFPA standard.
4. PD, PA, FA dimensions typical for all mounts.

AVENTICS PRESSUREMASTER® HHT HYDRAULIC CYLINDERS

CYLINDER OPTIONS

ROD PROTECTIVE COVER

AVENTICS offers a standard rod protective cover option on Powermaster cylinders. This option provides a dirt and oil resistant cover to extend piston rod and seal service life in applications where severe environmental conditions exist. The standard cover material is neoprene coated nylon fabric and is suitable for operation in ambient temperatures between -45°F and +220°F. Rod covers are also available for larger rod sizes on special request.

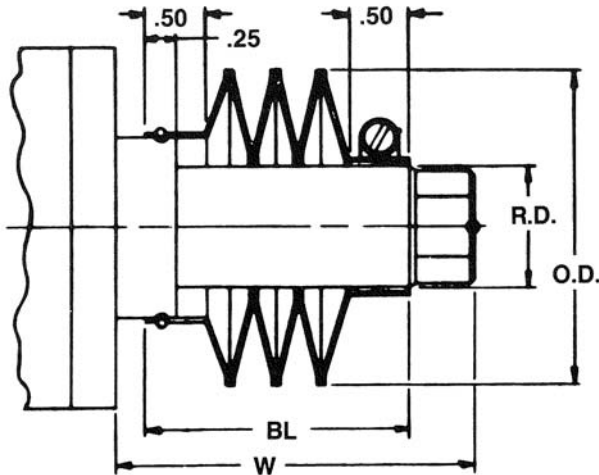

PISTON ROD		COVER O.D.	LENGTH FACTOR LF
CODE	DIAMETER		
D	.63"	2.25	.13
F	1.00"	2.62	.13
G	1.38"	3.00	.13
H	1.75"	3.38	.13
J	2.00"	3.75	.13
K	2.50"	4.38	.13
L	3.00"	5.12	.10

Determine the extra piston rod extension (ERE) required to accommodate the rod cover.

ERE= (cylinder stroke x length factor LF) + .75". See table above for LF.

Adjust cylinder catalog dimension V, WF, etc. as required to insure correct installation dimensions.

BL= ERE + .25

W = ERE +W (from dimension charts)

NOTE: These calculations are needed for cylinder application , but not for pricing.

CAUTION:
OVERSIZE PORTS
 Full flow diameters of oversize ports may not be obtainable with standard cylinder geometry. Consult factory.

AVENTICS ACCUMASTER™ HYDRAULIC LINEAR POSITIONER
INTEGRAL POSITION FEEDBACK—ANALOG OR DIGITAL

Transducer Ready or Transducer Installed

Positioning Accuracy to .001"

Use with Proportional Hydraulic Valves

Optional valve mounting footprints - DO3, DO5, DO7 or DO10

Strokes - up to 90" (for larger strokes consult the factory)

Pressures - up to 3000 psi

(available with or without valve mounting.)

Optional transducer- when installed, external transducer is standard, embedded is optional (contact factory)

Bore Sizes - 2" and larger

Rod Diameter - 1 3/8" and up

Digital Position Feedback-

24 or 25 bits (binary or gray code) TTL single ended - leading edge.

INFORMATION REQUIRED FOR A QUOTATION:

<i>Bore</i>	<i>Cylinder Mounting</i>	<i>Digital or Analog</i>
<i>Stroke</i>	<i>Valve Footprint</i>	<i>Input Voltage</i>
<i>Rod Diameter</i>	<i>Type of Cylinder</i>	<i>Output Signal</i>

TRANSDUCER SPECIFICATIONS

Balluff linear transducer standard, others available upon request

Electrical interface	Analog	Analog	Digital
Electrical type	Voltage	Current	Start/Stop PWM
Output	0...+10V,-5...+5V,-10...+10V	4...20 mA, 0...20 mA	Start/Stop or Pulse-width-Modulated (RS422/RS485)
Output load	>2K Ω (5 mA max)	<500 Ω	Per spec
Resolution	≤ 0.33 mV	≤ 0.66 μ A	Controller dependent
Non-linearity	$\pm 100\mu$ m to 500mm stroke $\pm 0.02\%$ over 500mm stroke	$\pm 100\mu$ m to 500mm stroke $\pm 0.02\%$ over 500mm stroke	$\pm 100\mu$ m to 500mm stroke $\pm 0.02\%$ over 500mm stroke
Repeatability	Resolution / min 2 μ m	Resolution / min 2 μ m	Resolution / min 2 μ m
Hysteresis	$\leq 5\mu$ m	$\leq 5\mu$ m	$\leq 5\mu$ m
Sampling rate	2Khz	2KHz	500 Hz stroke >2000mm 1KHz stroke <2000mm
Temperature coefficient*	[150 μ V/ $^{\circ}$ C+ (5ppm/ $^{\circ}$ C*P*V/NL)]* Δ T	[0.6 μ A/ $^{\circ}$ C+ (10ppm/ $^{\circ}$ C*P*V/NL)]* Δ T	(6 μ m + 5ppm*NL)/ $^{\circ}$ C
Operating voltage	24 Vdc $\pm 20\%$, 10...30 Vdc Or 15 Vdc $\pm 2\%$	24 Vdc $\pm 20\%$, 10...30 Vdc Or 15 Vdc $\pm 2\%$	24 Vdc $\pm 20\%$, 10...30 Vdc Or 15 Vdc $\pm 2\%$
Operating current	<150 mA Nominal, @ 24 Vdc	<150mA Nominal, @ 24 Vdc	<100mA (at 1K Hz sampling rate)

Notes: Analog voltage output versions incorporate both rising and falling outputs. Analog current version must be ordered as rising or falling outputs.

*Temperature coefficient variables:

V= output range in V

P=magnet position

NL=stroke length

I= output range in [mA]

 Δ T=temperature change

AVENTICS PRESSUREMASTER[®] HHT HYDRAULIC CYLINDERS

MOUNTING INDEX

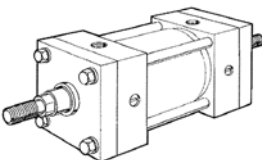
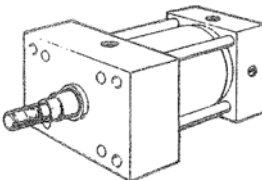
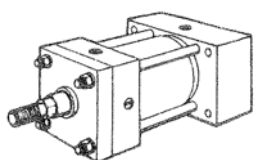
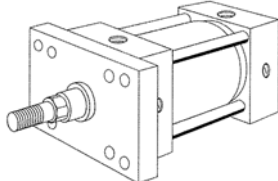
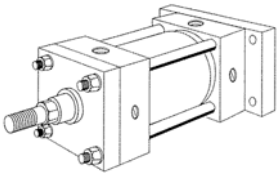
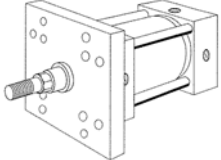
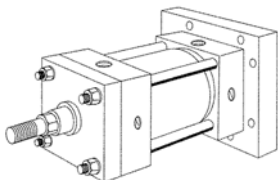
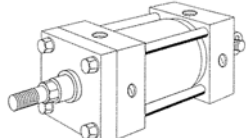
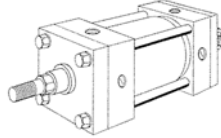
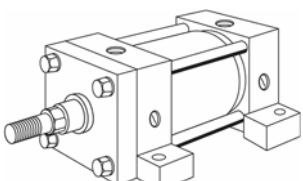
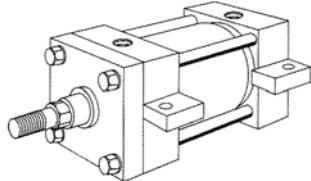
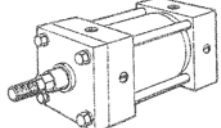
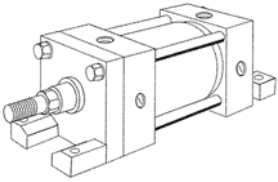
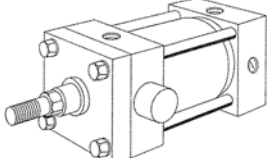
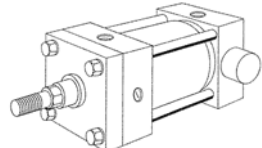
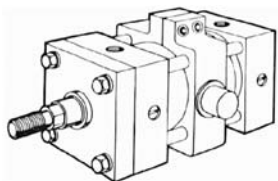
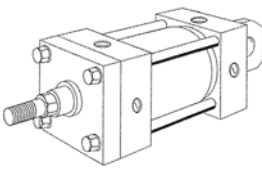
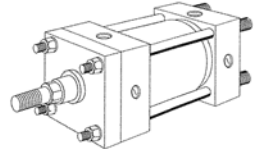
<p>D DOUBLE ROD CYLINDER Bore sizes 1-1/2"–6" page 86</p> 	<p>ME5 HEAD RECTANGULAR Bore sizes 1-1/2"–6" page 86 Bore sizes 7"–14"</p> 	<p>ME6 CAP RECTANGULAR Bore sizes 1-1/2"–6" page 86 Bore sizes 7"–14"</p> 
<p>MF1 HEAD RECTANGULAR FLANGE Bore sizes 1-1/2"–6" page 88</p> 	<p>MF2 CAP RECTANGULAR FLANGE Bore sizes 1-1/2"–6" page 88</p> 	<p>MF5 HEAD SQUARE FLANGE Bore sizes 1-1/2"–6" page 88 Bore sizes 7"–14"</p> 
<p>MF6 CAP SQUARE FLANGE Bore sizes 1-1/2"–6" page 88 Bore sizes 7"–14"</p> 	<p>MP1 FIXED CLEVIS Bore sizes 1-1/2"–14" page 90</p> <p>MP3 FIXED EYE Bore sizes 1-1/2"–14" page 90</p> 	<p>MP2 DETACHABLE CLEVIS Bore sizes 1-1/2"–6" page 90</p> <p>MP4 DETACHABLE EYE Bore sizes 1-1/2"–6" page 90</p> 
<p>MS2 SIDE LUGS Bore sizes 1-1/2"–6" page 92 Bore sizes 7"–14"</p> 	<p>MS3 CENTERLINE LUGS Bore sizes 1-1/2"–6" page 92</p> 	<p>MS4 SIDE TAPPED Bore sizes 1-1/2"–6" page 92</p> <p>MX0 NO MOUNTINGS Bore sizes 1-1/2"–14" page 92</p> 
<p>MS7 SIDE END LUGS Bore sizes 1-1/2"–6" page 92</p> 	<p>MT1 HEAD TRUNNION Bore sizes 1-1/2"–6" page 94 Bore sizes 7"–14"</p> 	<p>MT2 CAP TRUNNION Bore sizes 1-1/2"–6" page 94 Bore sizes 7"–14"</p> 
<p>MT4 INTERMEDIATE FIXED TRUNNION Bore sizes 1-1/2"–6" page 94 Bore sizes 7"–14"</p> 	<p>MU3 UNIVERSAL CLEVIS Bore sizes 1-1/2"–6" page 96</p> 	<p>MX1 TIE ROD EXTENDED Bore sizes 1-1/2"–6" page 98</p> <p>MX2</p> <p>MX3</p> <p>MX4</p> 

AVENTICS PRESSUREMASTER® HHT HYDRAULIC CYLINDERS

RECTANGULAR HEAD AND CAP FLANGE MOUNT DOUBLE ROD END

ME5 HEAD RECTANGULAR

Bore Sizes 1-1/2"–6"
Bore Sizes 7"–14"

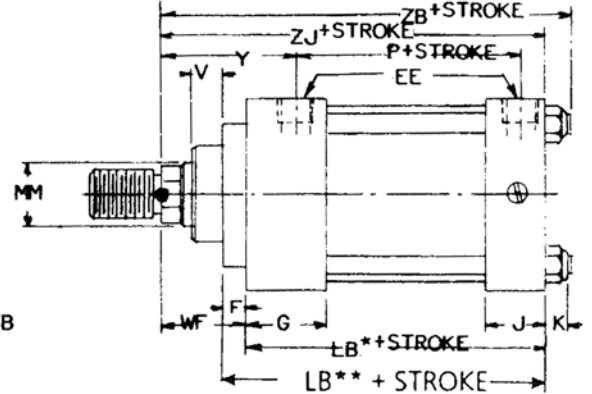
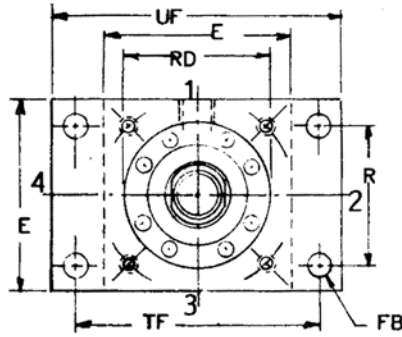
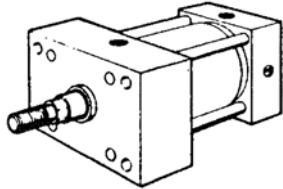

RD TOLERANCES:

(1-1/2–6")

+ .000

- .004

(7–14")

± .015

*7"–14" Bores only

**1-1/2–6" Bores only

CUSHION NEEDLE-CHECK VALVE ONLY ON

ME6 CAP RECTANGULAR

Bore Sizes 1-1/2"–6"
Bore Sizes 7"–14"

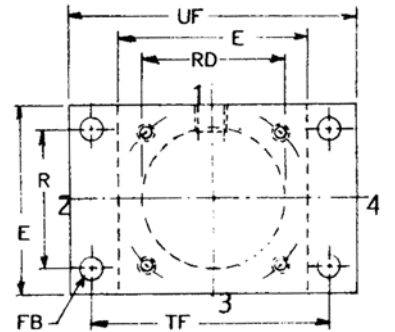
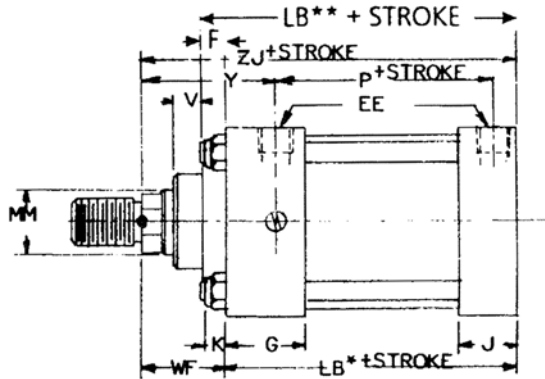
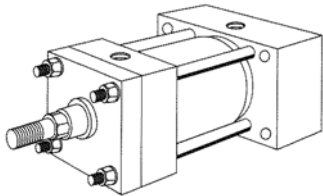

RD TOLERANCES:

(1-1/2–6")

+ .000

- .004

(7–14")

± .015

*7"–14" Bores only

**1-1/2–6" Bores only

CUSHION NEEDLE-CHECK VALVE ONLY ON
SIDE 1 OR 3 FOR FLANGE END

D DOUBLE ROD CYLINDER

Bore Sizes 1-1/2"–6"

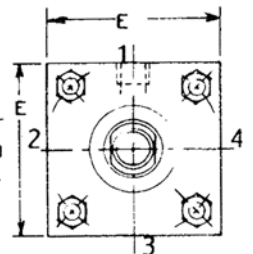
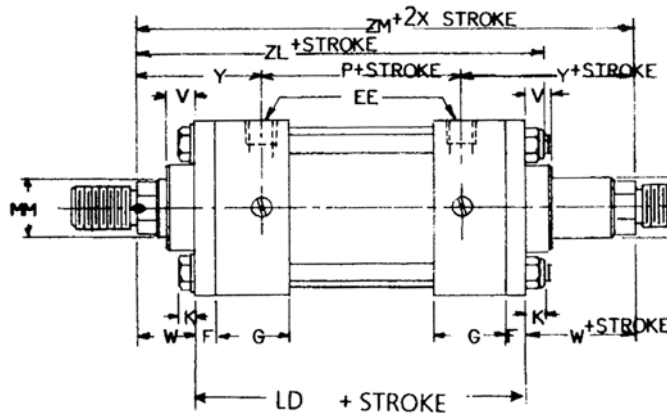
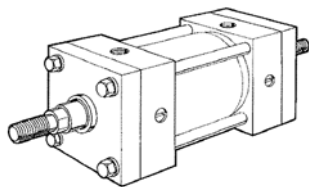

AVENTICS PRESSUREMASTER® HHT HYDRAULIC CYLINDERS

MF1 HEAD RECTANGULAR FLANGE

Bore Sizes 1-1/2"–6"

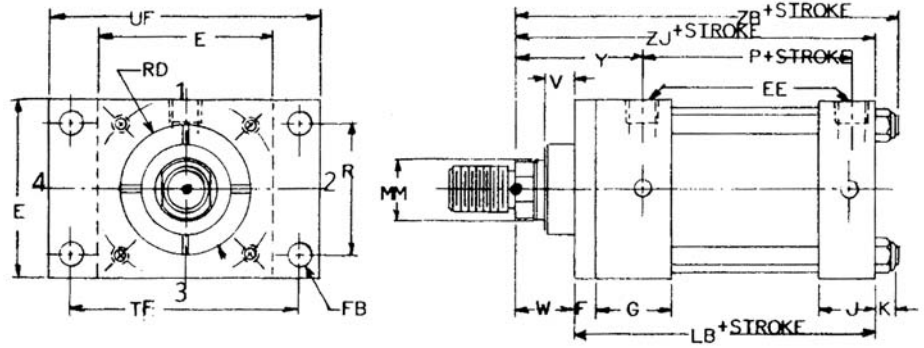
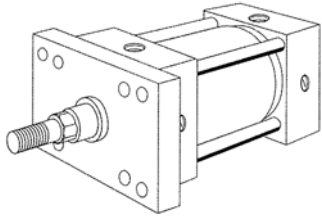

MF2 CAP RECTANGULAR FLANGE

Bore Sizes 1-1/2"–6"

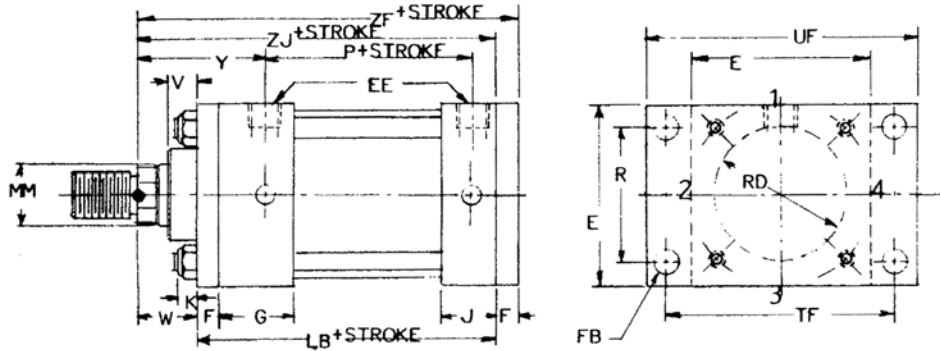
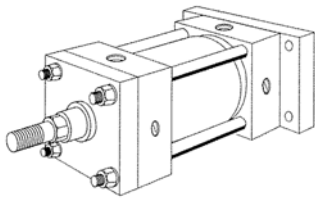

MF5 HEAD SQUARE FLANGE

Bore Sizes 1-1/2"–6"

Bore Sizes 7"–14"

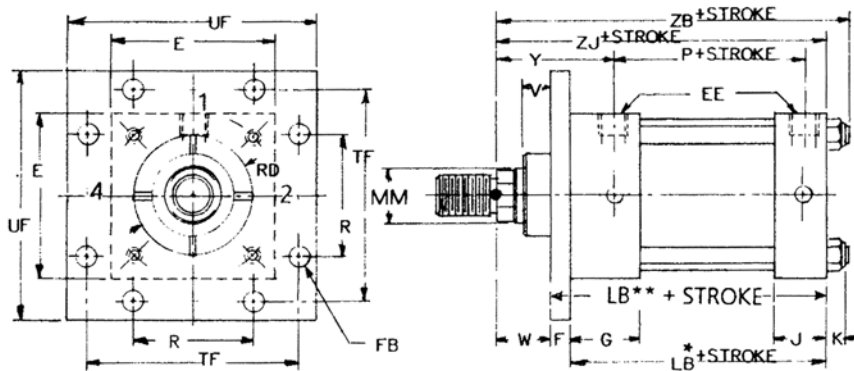
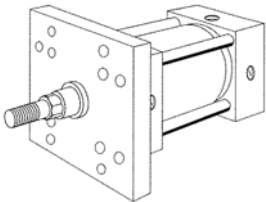

*7"–14" Bores only

**1-1/2"–6" Bores only

MF6 CAP SQUARE FLANGE

Bore Sizes 1-1/2"–6"

Bore Sizes 7"–14"

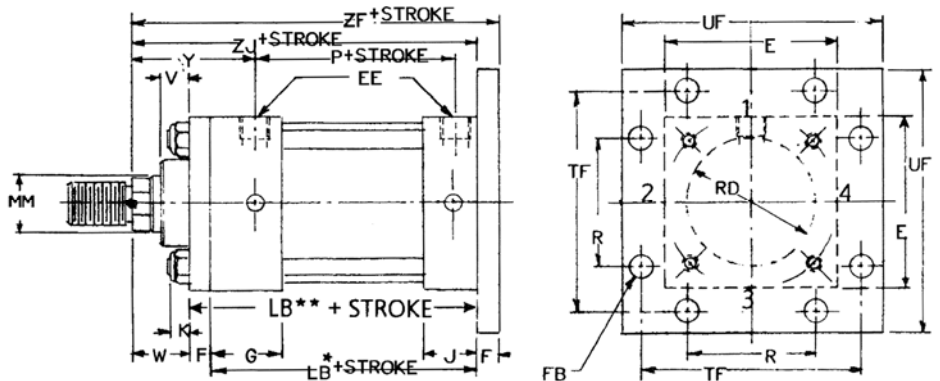
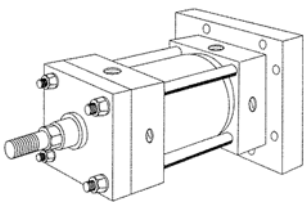

*7"–14" Bores only

**1-1/2"–6" Bores only

AVENTICS PRESSUREMASTER® HHT HYDRAULIC CYLINDERS

CLEVIS MOUNTS

MP1 FIXED CLEVIS
 Bore Sizes 1-1/2"–6"
 Bore Sizes 7"–14"

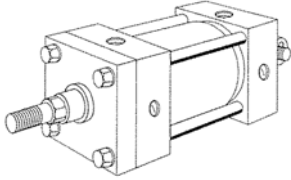

*7"–14" Bores only
 **1-1/2"–6" Bores only

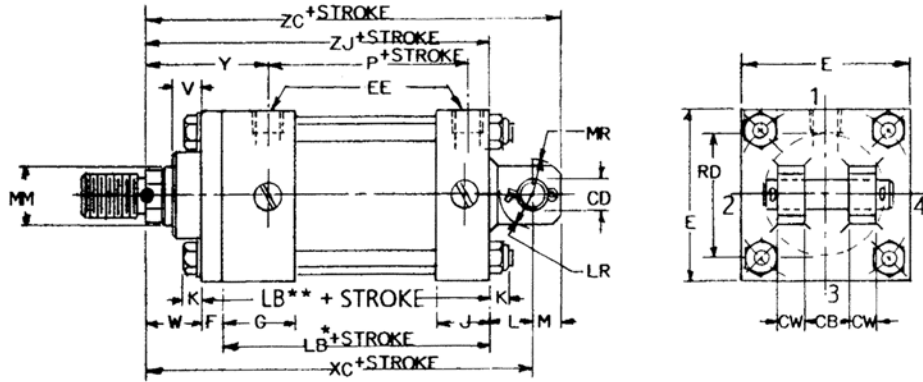

MP2 DETACHABLE CLEVIS
 Bore Sizes 1-1/2"–6"

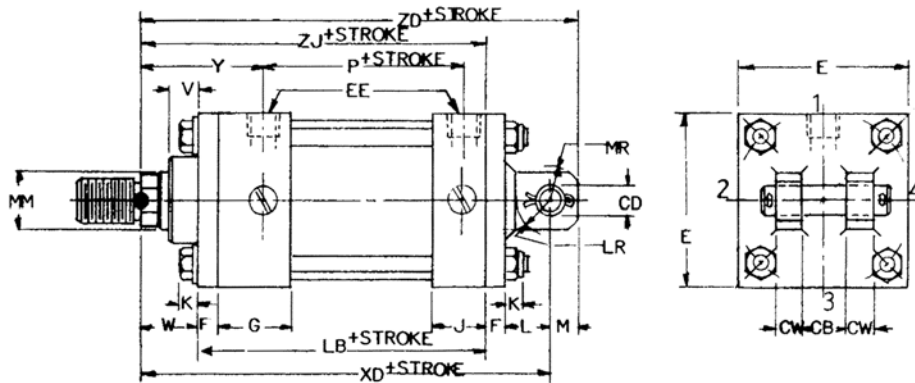
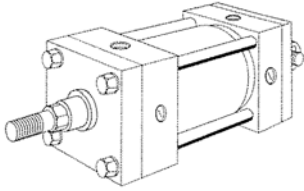

MP3 FIXED EYE
 Bore Sizes 1-1/2"–6"
 Bore Sizes 7"–14"

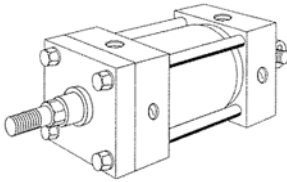

*7"–14" Bores only
 **1-1/2"–6" Bores only

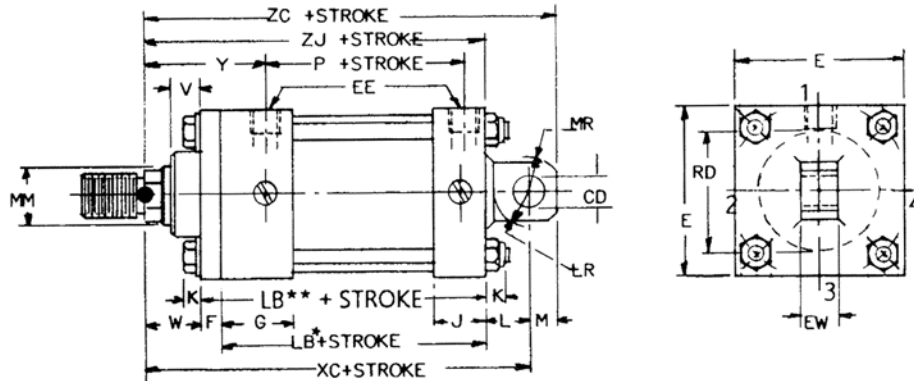

MP4 DETACHABLE EYE
 Bore Sizes 1-1/2"–6"

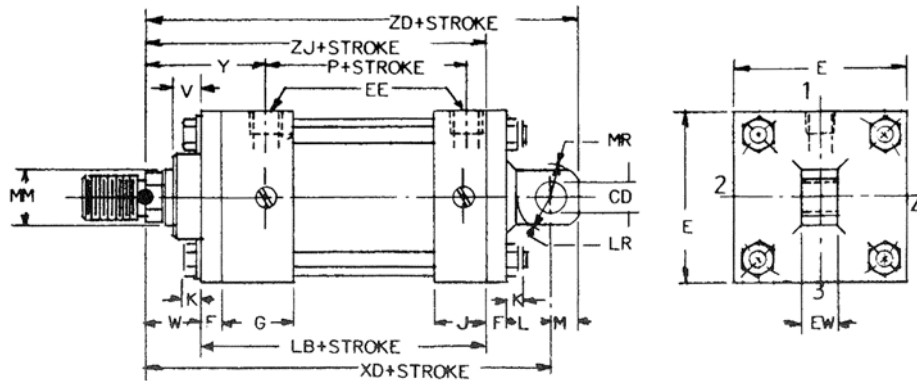
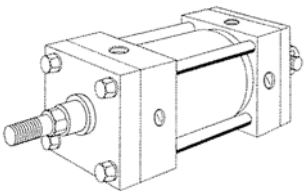

AVENTICS PRESSUREMASTER® HHT HYDRAULIC CYLINDERS

CLEVIS MOUNTS

TABLE 1 - Dimensions affected by rod diameter.

Bore Size	MM Rod	V	W	Y	RD	WF	XC	XD	ZC	ZD	ZJ
1.50"	0.625	0.25	0.63	2.00			6.38	6.75	6.88	7.25	5.63
	1.000	0.50	1.00	2.38			6.75	7.13	7.25	7.63	6.00
2.00"	1.000	0.25	0.75	2.38			7.25	7.88	8.00	8.63	6.00
	1.375	0.38	1.00	2.63			7.50	8.13	8.25	8.88	6.25
2.50"	1.000	0.25	0.75	2.38			7.38	8.00	8.13	8.75	6.13
	1.375	0.38	1.00	2.63			7.63	8.25	8.38	9.00	6.38
	1.750	0.50	1.25	2.88			7.88	8.50	8.63	9.25	6.63
3.25"	1.375	0.25	0.88	2.75			8.63	9.38	9.63	10.38	7.13
	1.750	0.38	1.13	3.00			8.88	9.63	9.88	10.63	7.38
	2.000	0.38	1.25	3.13			9.00	9.75	10.00	10.75	7.50
4.00"	1.750	0.25	1.00	3.00			9.75	10.63	11.13	12.00	7.63
	2.000	0.25	1.13	3.13			9.88	10.75	11.25	12.13	7.75
	2.500	0.38	1.38	3.38			10.13	11.00	11.50	12.38	8.00
5.00"	2.000	0.25	1.13	3.13			10.50	11.38	12.25	13.13	8.25
	2.500	0.38	1.38	3.38			10.75	11.63	12.50	13.38	8.50
	3.000	0.38	1.38	3.38			10.75	11.63	12.50	13.38	8.50
	3.500	0.38	1.38	3.38			10.75	11.63	12.50	13.38	8.50
6.00"	2.500	0.25	1.25	3.50			12.13	13.13	14.13	15.13	9.63
	3.000	0.25	1.25	3.50			12.13	13.13	14.13	15.13	9.63
	3.500	0.25	1.25	3.50			12.13	13.13	14.13	15.13	9.63
	4.000	0.25	1.25	3.50			12.13	13.13	14.13	15.13	9.63
7.00"	3.000	0.25	1.25	3.81	5.75	2.25	13.75		16.25		10.75
	3.500	0.25	1.25	3.81	6.25	2.25	13.75		16.25		10.75
	4.000	0.25	1.25	3.81	6.75	2.25	13.75		16.25		10.75
	5.000	0.25	1.25	3.81	7.63	2.25	13.75		16.25		10.75
8.00"	3.500	0.25	1.25	3.94	6.25	2.25	15.00		17.75		11.75
	4.000	0.25	1.25	3.94	6.75	2.25	15.00		17.75		11.75
	4.500	0.25	1.25	3.94	7.25	2.25	15.00		17.75		11.75
	5.000	0.25	1.25	3.94	7.63	2.25	15.00		17.75		11.75
	5.500	0.25	1.25	3.94	9.00	2.25	15.00		17.75		11.75
10.00"	4.500	0.25	1.25	5.00	7.63	2.94	19.06		22.56		15.06
	5.000	0.25	1.25	5.00	7.63	2.94	19.06		22.56		15.06
	5.500	0.25	1.25	5.00	9.00	2.94	22.19		22.56		15.06
12.00"	7.000	0.25	1.25	5.00	10.50	2.94	19.06		22.56		15.06
	5.500	0.25	1.25	5.75	9.00	3.19	22.19		26.19		17.69
	7.000	0.25	1.25	5.75	10.50	3.19	22.19		26.19		17.69
14.00"	8.500	0.50	1.25	5.75	11.50	3.19	22.19		26.19		17.69
	7.000	0.25	1.25	6.06	10.50	3.44	24.81		29.81		19.06
10.000	0.50	1.25	6.06	13.50	3.44	24.81		29.81		19.06	

The Clevis or Pin mounted cylinder is probably the most widely used of all mounts. For short strokes, medium or small cylinder applications, the clevis mounts are recommended. If this mount is applied where stroke requirements cause the overall length to be excessive, the Cap Trunnion mount can be used. Pivot mounts must always be used with a pivot type rod end attachment.

- NOTES:**
- The bearing retainer plate is the same as the "E" dimension for 1-1/2" -- 6" bore sizes and the "RD" dimension for the 7" -- 14" bore sizes.
 - Rod options shown on page 52a.
 - MP1 and MP2 mounts include pivot pin.

TABLE 2 - Dimensions not affected by rod diameter.

BORE IN	CB	CD	CW	E	EE**	EW	F	G	J	K	L	LB	LR	M	MR	P
1.500	0.75	0.500	0.50	2.50	3/4-16	0.75	0.38	1.75	1.50	0.43	0.75	5.00	0.59	0.50	0.69	2.88
2.000	1.25	0.750	0.63	3.00	3/4-16	1.25	0.63	1.75	1.50	0.57	1.25	5.25	0.88	0.75	0.94	2.88
2.500	1.25	0.750	0.63	3.50	3/4-16	1.25	0.63	1.75	1.50	0.57	1.25	5.38	0.88	0.75	0.94	3.00
3.250	1.50	1.000	0.75	4.50	1-1/16-12	1.50	0.75	2.00	1.75	0.72	1.50	6.25	1.13	1.00	1.25	3.50
4.000	2.00	1.375	1.00	5.00	1-1/16-12	2.00	0.88	2.00	1.75	0.72	2.13	6.63	1.75	1.38	1.63	3.75
5.000	2.50	1.750	1.25	6.50	1-1/16-12	2.50	0.88	2.00	1.75	1.00	2.25	7.13	1.88	1.75	2.00	4.25
6.000	2.50	2.000	1.25	7.50	1-5/16-12	2.50	1.00	2.25	2.25	1.14	2.50	8.38	2.13	2.00	2.38	4.88
7.000	3.00	2.500	1.50	8.50	1-5/8-12	3.00	1.00	2.75	2.75	1.28	3.00	8.50	2.38	2.50	2.88	5.38
8.000	3.00	3.000	1.50	9.50	1-7/8-12	3.00	1.00	3.00	3.00	1.41	3.25	9.50	2.63	2.75	3.13	6.13
10.000	4.00	3.500	2.00	12.63	2-1/2-12	4.00	1.69	3.69	3.69	1.53	4.00	12.13	3.25	3.50	4.25	8.00
12.000	4.50	4.000	2.25	14.88	2-1/2-12	4.50	1.94	4.44	4.44	1.53	4.50	14.51	3.75	4.00	4.38	9.38
14.000	6.00	5.000	3.00	17.25	2-1/2-12	6.00	2.19	4.88	4.88	1.53	5.75	15.63	4.75	5.00	5.38	10.38

**Prior to 3/1/97, NPTF standard. Effective 3/1/97 SAE O-Ring straight thread ports are standard: see page 82 for sizes.

AVENTICS PRESSUREMASTER® HHT HYDRAULIC CYLINDERS

SIDE AND LUG MOUNTS

MS2 SIDE LUGS

Bore Sizes 1-1/2"–6"
Bore Sizes 7"–14"

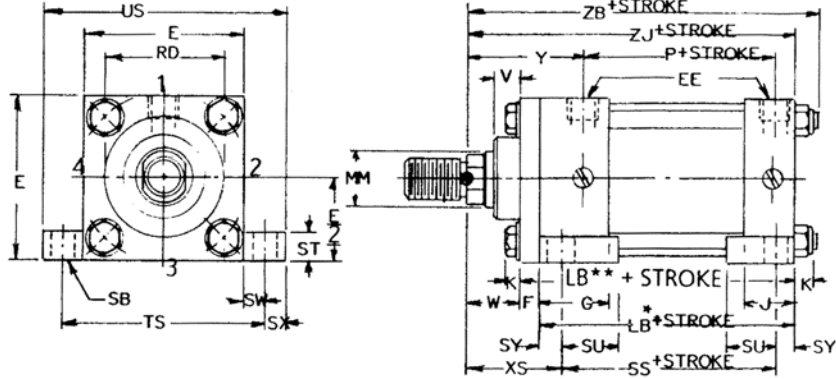
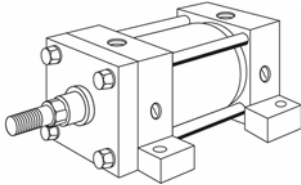

*7"–14" Bores only
**1-1/2"–6" Bores only

MS3 CENTERLINE LUGS

Bore Sizes 1-1/2"–6"

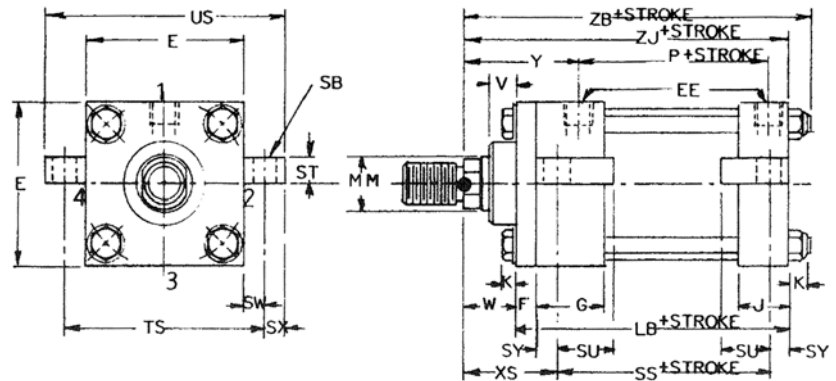
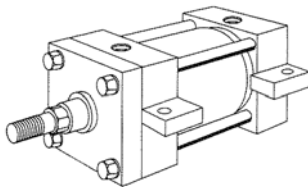

MS4 SIDE TAPPED

Bore Sizes 1-1/2"–6"

MX0 NO MOUNTING

Bore Sizes 1-1/2"–14"

Note: MX0 is MS4 less mounting holes.

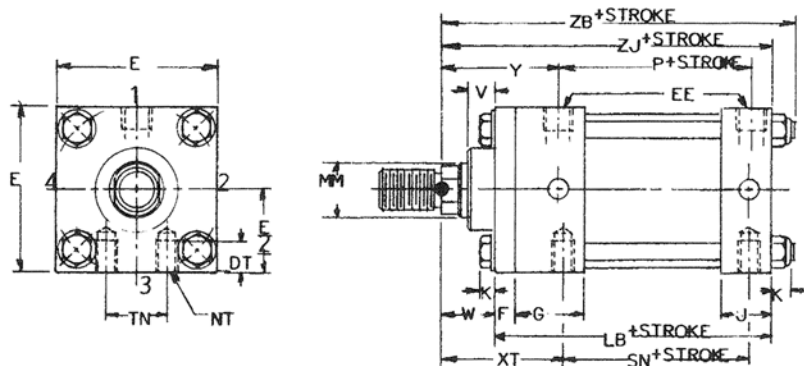
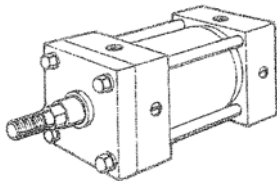

MS7 SIDE END LUGS

Bore Sizes 1-1/2"–6"

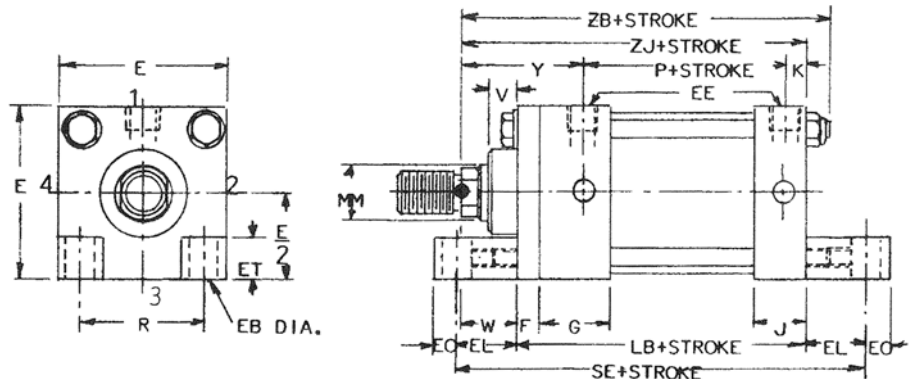
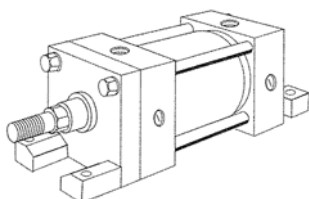

AVENTICS PRESSUREMASTER[®] HHT HYDRAULIC CYLINDERS

TRUNNION MOUNTS

MT1 HEAD TRUNNION

Bore Sizes 1-1/2"–6"
Bore Sizes 7"–14"

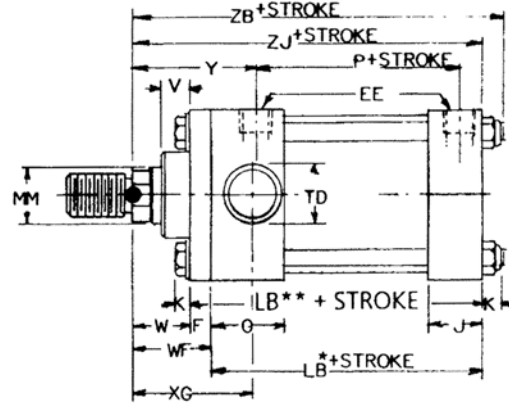
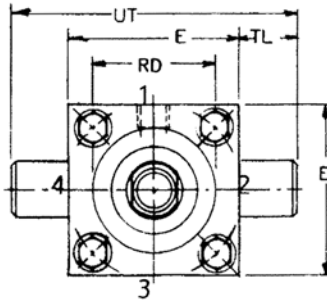
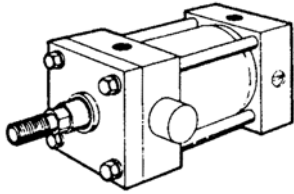

*7"–14" Bores only
**1-1/2"–6" Bores only

MT2 CAP TRUNNION

Bore Sizes 1-1/2"–6"
Bore Sizes 7"–14"

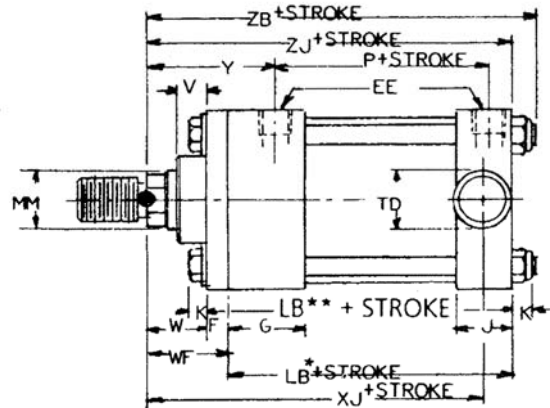
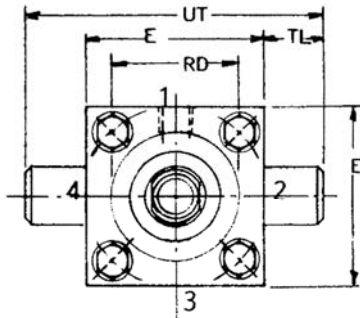
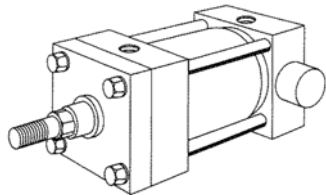

*7"–14" Bores only
**1-1/2"–6" Bores only

MT4 INTERMEDIATE FIXED TRUNNION

Bore Sizes 1-1/2"–6"
Bore Sizes 7"–14"

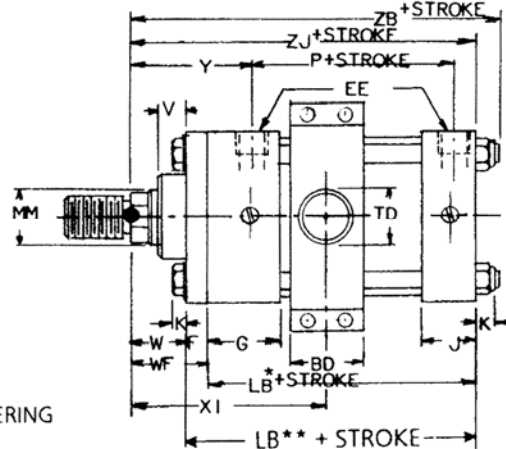
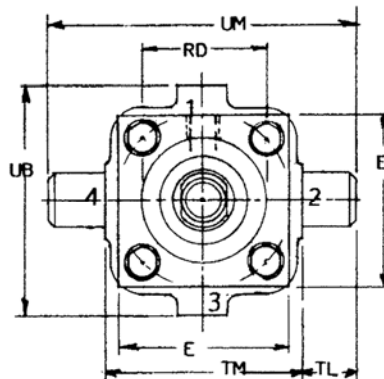
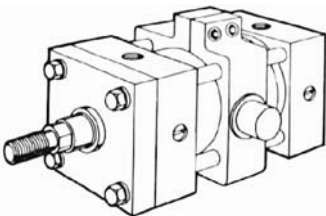

SPECIFY "X1" DIMENSION WHEN ORDERING

*7"–14" Bores only
**1-1/2"–6" Bores only

AVENTICS PRESSUREMASTER® HHT HYDRAULIC CYLINDERS

TRUNNION MOUNTS

TABLE 1 - Dimensions affected by rod diameter.

Bore Size	MM Rod	V	W	Y	RD*	WF	XG	XI MIN	XJ	ZB	ZJ
1.50"	0.625	0.25	0.63	2.00			1.88	3.66	4.88	6.06	5.63
	1.000	0.50	1.00	2.38			2.25	4.03	5.25	6.43	6.00
2.00"	1.000	0.25	0.75	2.38			2.25	4.03	5.25	6.57	6.00
	1.375	0.38	1.00	2.63			2.50	4.28	5.50	6.82	6.25
2.50"	1.000	0.25	0.75	2.38			2.25	4.16	5.38	6.70	6.13
	1.375	0.38	1.00	2.63			2.50	4.41	5.63	6.95	6.38
	1.750	0.50	1.25	2.88			2.75	4.66	5.88	7.20	6.63
3.25"	1.375	0.25	0.88	2.75			2.63	4.78	6.25	7.85	7.13
	1.750	0.38	1.13	3.00			2.88	5.03	6.50	8.10	7.38
	2.000	0.38	1.25	3.13			3.00	5.16	6.63	8.22	7.50
4.00"	1.750	0.25	1.00	3.00			2.88	5.16	6.75	8.35	7.63
	2.000	0.25	1.13	3.13			3.00	5.28	6.88	8.48	7.75
	2.500	0.38	1.38	3.38			3.25	5.53	7.13	8.73	8.00
5.00"	2.000	0.25	1.13	3.13			3.00	5.53	7.38	9.26	8.25
	2.500	0.38	1.38	3.38			3.25	5.72	7.63	9.51	8.50
	3.000	0.38	1.38	3.38			3.38	5.72	7.63	9.51	8.50
	3.500	0.38	1.38	3.38			3.38	5.72	7.63	9.51	8.50
6.00"	2.500	0.25	1.25	3.50			3.38	6.16	8.38	10.77	9.63
	3.000	0.25	1.25	3.50			3.38	6.16	8.38	10.77	9.63
	3.500	0.25	1.25	3.50			3.38	6.16	8.38	10.77	9.63
	4.000	0.25	1.25	3.50			3.38	6.16	8.38	10.77	9.63
7.00"	3.000	0.25		3.81	5.75	2.25	3.63	6.91	9.38	12.03	10.75
	3.500	0.25		3.81	6.25	2.25	3.63	6.91	9.38	12.03	10.75
	4.000	0.25		3.81	6.75	2.25	3.63	6.91	9.38	12.03	10.75
	5.000	0.25		3.81	7.63	2.25	3.63	6.91	9.38	12.03	10.75
8.00"	3.500	0.25		3.94	6.25	2.25	3.75	7.16	10.25	13.16	11.75
	4.000	0.25		3.94	6.75	2.25	3.75	7.16	10.25	13.16	11.75
	4.500	0.25		3.94	7.25	2.25	3.75	7.16	10.25	13.16	11.75
	5.000	0.25		3.94	7.63	2.25	3.75	7.16	10.25	13.16	11.75
	5.500	0.25		3.94	9.00	2.25	3.75	7.16	10.25	13.16	11.75
10.00"	4.500	0.25		5.00	7.63	2.94	4.75	9.13	13.25	16.60	15.06
	5.000	0.25		5.00	7.63	2.94	4.75	9.13	13.25	16.60	15.06
	5.500	0.25		5.00	9.00	2.94	4.75	9.13	13.25	16.60	15.06
	7.000	0.25		5.00	10.50	2.94	4.75	9.13	13.25	16.60	15.06
12.00"	5.500	0.25		5.75	9.00	3.19	5.38	10.75	15.50	19.23	17.69
	7.000	0.25		5.75	10.50	3.19	5.38	10.75	15.50	19.23	17.69
	8.000	0.25		5.75	11.50	3.19	5.38	10.75	15.50	19.23	17.69
14.00"	7.000	0.25		6.06	10.50	3.44	5.81	11.94	16.69	20.60	19.06
	10.000	0.50		6.06	13.50	3.44	5.81	11.94	16.69	20.60	19.06

All trunnion mount cylinders need a provision on both ends for pivoting. These types of cylinders are designed to carry shear loads and the trunnion and pivot pins should be carried by bearings that are rigidly held and closely fit for the entire length of the pin.

CAUTION NOTE:
Rod end trunnion mount cylinders in bore sizes 5"—8" with oversize piston rods and bores 10" - 14" with all diameters should not be used over 1500 PSI. If your application requires higher pressure, consult the factory.

NOTES:
Specify "XI" dimension when ordering MT4 Intermediate Fixed Trunnion mounts. If not specified, trunnion will be located at the center of the tube.
The bearing retainer plate is the same as the "E" dimension for 1-1/2"—6" bore sizes and the "RD" dimension for the 7"—14" bore sizes.
For mounting MT1 1-1/2" through 6" bores only, a design change effective October 1, 2015 resulted in some changes in the XG dimensions column, and the new dimensions are shown here. To confirm the XG dimension for cylinders manufactured prior to October 1, 2015, contact the factory.

Rod end options shown on page 52a.

TABLE 2 - Dimensions not affected by rod diameter.

BORE IN	BD	E	EE**	F	G	J	K	LB	P	TD	TL	TM	UB	UM	UT
1.500	1.44	2.50	3/4-16	0.38	1.75	1.50	0.43	5.00	2.88	1.000	1.00	2.75	4.00	4.75	4.50
2.000	1.44	3.00	3/4-16	0.63	1.75	1.50	0.57	5.25	2.88	1.375	1.38	3.25	4.50	6.00	5.75
2.500	1.69	3.50	3/4-16	0.63	1.75	1.50	0.57	5.38	3.00	1.380	1.38	3.75	5.25	6.50	6.25
3.250	1.94	4.50	1-1/16-12	0.75	2.00	1.75	0.72	6.25	3.50	1.750	1.75	5.00	6.50	8.50	8.00
4.000	2.19	5.00	1-1/16-12	0.88	2.00	1.75	0.72	6.63	3.75	1.750	1.75	5.50	7.38	9.00	8.50
5.000	2.69	6.50	1-1/16-12	0.88	2.00	1.75	1.00	7.13	4.25	1.750	1.75	7.00	9.25	10.50	10.00
6.000	2.94	7.50	1-5/16-12	1.00	2.25	2.25	1.14	8.38	4.88	2.000	2.00	8.00	10.25	12.00	11.50
7.000	3.44	8.50	1-5/8-12	1.00	2.75	2.75	1.28	8.50	5.38	2.500	2.50	9.25	12.25	14.25	13.50
8.000	3.44	9.50	1-7/8-12	1.00	3.00	3.00	1.41	9.50	6.13	3.000	3.00	11.00	14.00	17.00	15.50
10.000	4.66	12.63	2-1/2-12	1.69	3.69	3.69	1.53	12.13	8.00	3.500	3.50	14.00	17.75	21.00	19.63
12.000	5.91	14.88	2-1/2-12	1.94	4.44	4.44	1.53	14.51	9.38	4.000	4.00	17.00	20.50	25.00	22.88
14.000	6.91	17.25	2-1/2-12	2.19	4.88	4.88	1.53	15.63	10.38	4.500	4.50	19.00	23.50	28.00	27.25

**Prior to 3/1/97, NPTF standard. Effective 3/1/97 SAE O-Ring straight thread ports are standard: see page 82 for sizes.

AVENTICS PRESSUREMASTER® HHT HYDRAULIC CYLINDERS

UNIVERSAL CLEVIS MOUNT

MU3 UNIVERSAL CLEVIS Bore Sizes 1-1/2"–6"

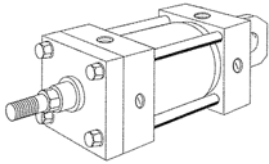

Note: Spherical rod eye shown for critical dimensions only; not included with MU3. For dimensions and ordering, see p. 100a

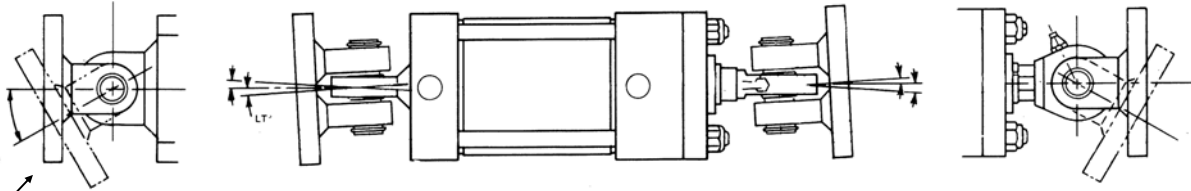
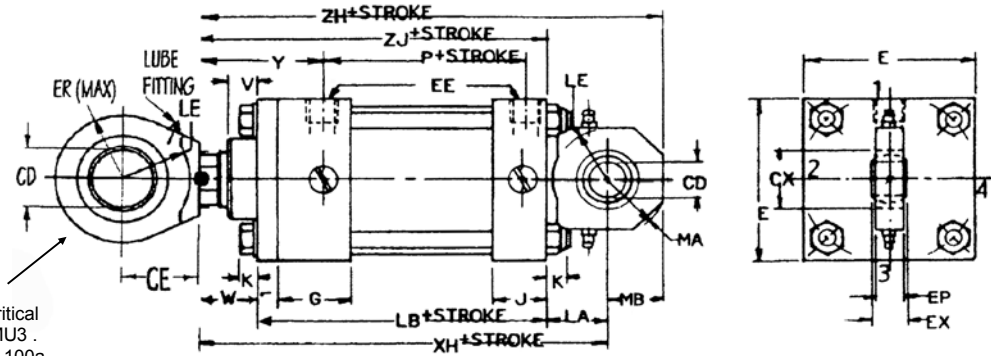

Spherical Bracket (see page 97)

Utilization of spherical bearings compensates for from 5° to 10° of misalignment in any direction.

MULTIPLE TIE ROD CONSTRUCTION

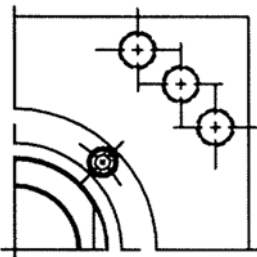

3 tie rods are added at each corner for cylinder bore sizes of 10 inches

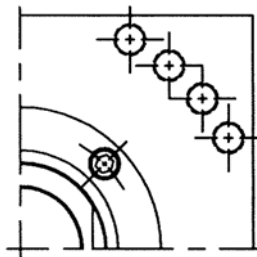

4 tie rods are added at each corner for cylinder bore sizes of 12 inches

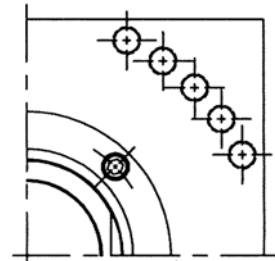

5 tie rods are added at each corner for cylinder bore sizes of 14 inches

AVENTICS PRESSUREMASTER® HHT HYDRAULIC CYLINDERS

UNIVERSAL CLEVIS MOUNT

TABLE 1 - Dimensions affected by rod diameter.

BORE IN	MM ROD	V	W	Y	XH	ZH	ZJ
1.500	0.625	0.25	0.63	2.00	6.38	7.13	5.63
	1.000	0.50	1.00	2.38	6.75	7.50	6.00
2.000	1.000	0.25	0.75	2.38	7.25	8.34	6.00
	1.375	0.38	1.00	2.63	7.50	8.63	6.25
2.500	1.000	0.25	0.75	2.38	7.38	8.50	6.13
	1.375	0.38	1.00	2.63	7.63	8.75	6.38
	1.750	0.50	1.25	2.88	7.88	9.00	6.63
3.250	1.375	0.25	0.88	2.75	8.63	10.13	7.13
	1.750	0.38	1.13	3.00	8.88	10.38	7.38
	2.000	0.38	1.25	3.13	9.00	10.50	7.50
4.000	1.750	0.25	1.00	3.00	9.75	11.69	7.63
	2.000	0.25	1.13	3.13	9.88	11.94	7.75
	2.500	0.38	1.38	3.38	10.13	12.19	8.00
5.000	2.000	0.25	1.13	3.13	10.50	13.19	8.25
	2.500	0.38	1.38	3.38	10.75	13.44	8.50
	3.000	0.38	1.38	3.38	10.75	13.44	8.50
	3.500	0.38	1.38	3.38	10.75	13.44	8.50
6.000	2.500	0.25	1.25	3.50	12.25	15.31	9.63
	3.000	0.25	1.25	3.50	12.25	15.31	9.63
	3.500	0.25	1.25	3.50	12.25	15.31	9.63
	4.000	0.25	1.25	3.50	12.25	15.31	9.63

The MU3 (Universal) type mount is a pivot mount MP3 with a spherical bearing fitted into the pivot to permit 5 to 10 degrees of movement in a plane perpendicular to the major plant of pivot movement. It is probably the most serviceable of the pivoted centerline mounts. For maximum effectiveness, a spherical rod end fitting should be utilized at the same time.

NOTES:
Rod end thread options shown on page 52a. For spherical rod eye, see page 100a.

TABLE 2 - Dimensions not affected by rod diameter.

BORE IN	CD*	CX	E	EE**	EX	EP	F	G	J	K	LA	LB	LE	MA	MB	P
1.500	0.500	0.875	2.50	3/4-16	0.44	0.38	0.38	1.75	1.50	0.43	0.75	5.00	0.63	0.88	0.75	2.88
2.000	0.750	1.250	3.00	3/4-16	0.66	0.56	0.63	1.75	1.50	0.57	1.25	5.25	1.13	1.38	1.13	2.88
2.500	0.750	1.250	3.50	3/4-16	0.66	0.56	0.63	1.75	1.50	0.57	1.25	5.38	1.13	1.38	1.13	3.00
3.250	1.000	1.625	4.50	1-1/16-12	0.88	0.75	0.75	2.00	1.75	0.72	1.50	6.25	1.38	1.84	1.50	3.50
4.000	1.375	2.188	5.00	1-1/16-12	1.19	1.03	0.88	2.00	1.75	0.72	2.13	6.63	1.94	2.25	2.06	3.75
5.000	1.750	2.813	6.50	1-1/16-12	1.53	1.31	0.88	2.00	1.75	1.00	2.25	7.13	2.06	2.88	2.69	4.25
6.000	2.000	3.188	7.50	1-5/16-12	1.75	1.50	1.00	2.25	2.25	1.14	2.50	8.38	2.31	3.31	3.06	4.88

*Cylinder CD

**Prior to 3/1/97, NPTF standard. Effective 3/1/97 SAE O-Ring straight thread ports are standard: see page 82 for sizes.

Spherical "MU3" Bracket

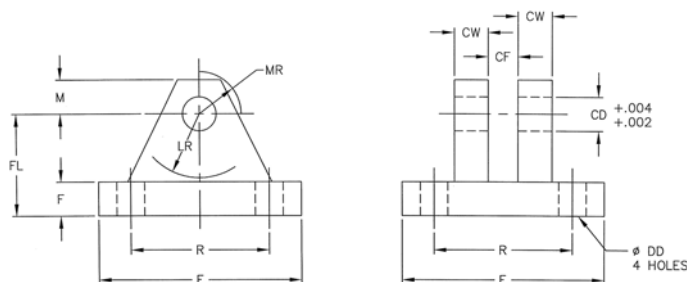

Clevis Bracket - Spherical

Part Number	E	F	M	R	CD	CF	CW	DD	FL	LR	MR
R433078852	10.62	1.50	2.00	7.92	2.00	1.75	1.50	0.91	5.00	3.31	2.38
P -167198-00004	8.50	1.25	1.75	6.58	1.75	1.53	1.25	0.91	4.50	2.88	2.06
R433038164	6.50	0.88	1.38	4.95	1.38	1.19	1.00	0.66	3.58	2.44	1.62
R433038163	5.50	0.75	1.00	4.10	1.00	0.88	0.75	0.53	2.50	1.69	1.19
R433038162	3.75	0.62	0.88	2.76	0.75	0.66	0.62	0.53	2.00	1.38	1.00
R433038161	3.00	0.50	0.50	2.05	0.50	0.44	0.50	0.41	1.50	0.94	0.62

AVENTICS PRESSUREMASTER® HHT HYDRAULIC CYLINDERS

MX1 TIE RODS EXTENDED BOTH ENDS Bore Sizes 1-1/2"—6"

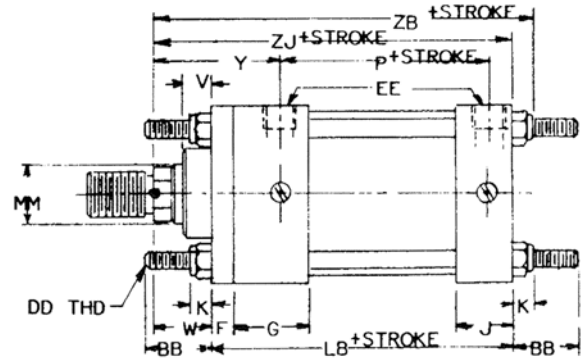
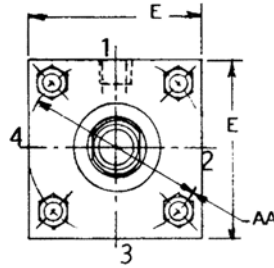
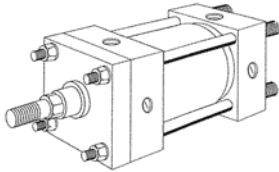

MX2 TIE RODS EXTENDED CAP END ONLY Bore Sizes 1-1/2"—6"

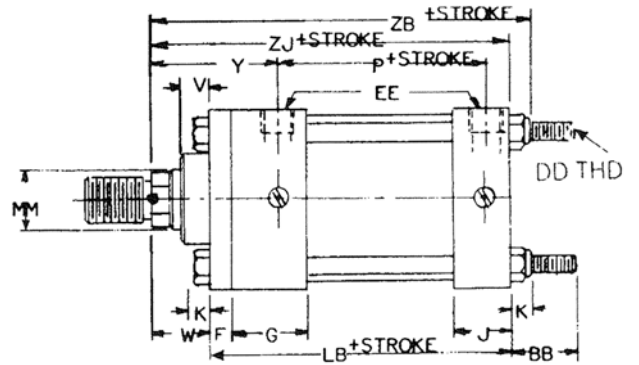
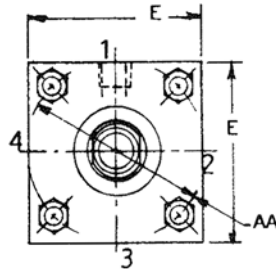
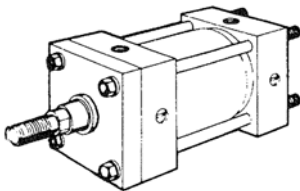

MX3 TIE RODS EXTENDED HEAD END ONLY Bore Sizes 1-1/2"—6"

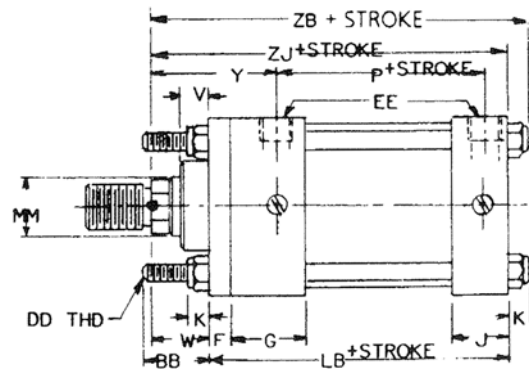
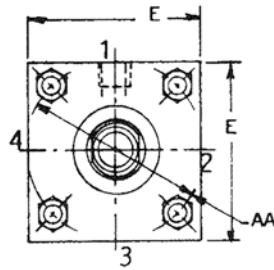
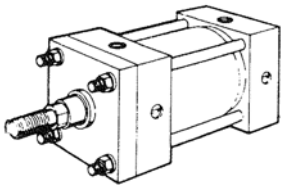

MX4 TIE RODS EXTENDED TWO EACH END Bore Sizes 1-1/2"—6"

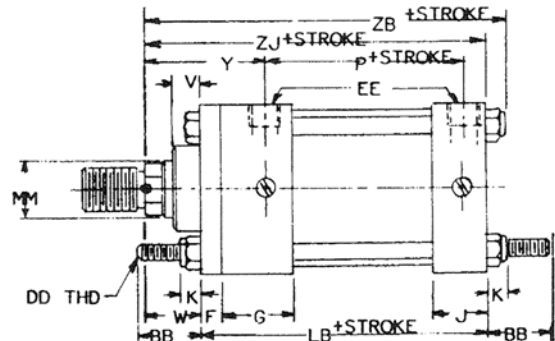
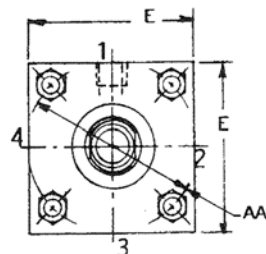
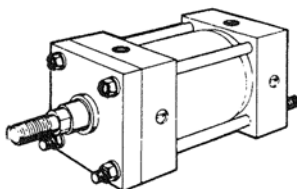

AVENTICS PRESSUREMASTER® HHT HYDRAULIC CYLINDERS

TIE ROD MOUNTS

TABLE 1 - Dimensions affected by rod diameter.

BORE IN	MM ROD	V	W	Y	ZB	ZJ
1.500	0.625	0.25	0.63	2.00	6.06	5.63
	1.000	0.50	1.00	2.38	6.43	6.00
2.000	1.000	0.25	0.75	2.38	6.57	6.00
	1.375	0.38	1.00	2.63	6.82	6.25
2.500	1.000	0.25	0.75	2.38	6.70	6.13
	1.375	0.38	1.00	2.63	6.95	6.38
	1.750	0.50	1.25	2.88	7.20	6.63
3.250	1.375	0.25	0.88	2.75	7.85	7.13
	1.750	0.38	1.13	3.00	8.10	7.38
	2.000	0.38	1.25	3.13	8.22	7.50
4.000	1.750	0.25	1.00	3.00	8.35	7.63
	2.000	0.25	1.13	3.13	8.48	7.75
5.000	2.500	0.38	1.38	3.38	8.73	8.00
	2.000	0.25	1.13	3.13	9.26	8.25
	2.500	0.38	1.38	3.38	9.51	8.50
	3.000	0.38	1.38	3.38	9.51	8.50
6.000	3.500	0.38	1.38	3.38	9.51	8.50
	2.500	0.25	1.25	3.50	10.77	9.63
	3.000	0.25	1.25	3.50	10.77	9.63
	3.500	0.25	1.25	3.50	10.77	9.63
6.000	4.000	0.25	1.25	3.50	10.77	9.63

Tie Rod and Flange Mounts are basically the same except that the tie rods are extended and used to mount the cylinder. To prevent misalignment, sagging or binding of the cylinder when long strokes are required, the free end of the cylinder should be supported. For thrust load applications, blind or cap end tie rod extensions are best. For tension load applications, rod or head end tie rod extensions are best. Tie rod mounts are suited for many applications, however, it should be noted that they are not as rigid as the flange mountings.

NOTES:

The bearing retainer plate is the same as the "E" dimension for 1-1/2"—6" bore sizes.

Rod end options shown on page 52a.

TABLE 2 - Dimensions not affected by rod diameter.

BORE IN	AA	BB	DD-THD	E	EE**	F	G	J	K	LB	P
1.500	2.30	1.38	0.38-24	2.50	3/4-16	0.38	1.75	1.50	0.43	5.00	2.88
2.000	2.90	1.81	0.50-20	3.00	3/4-16	0.63	1.75	1.50	0.57	5.25	2.88
2.500	3.60	1.81	0.50-20	3.50	3/4-16	0.63	1.75	1.50	0.57	5.38	3.00
3.250	4.60	2.31	0.63-18	4.50	1-1/16-12	0.75	2.00	1.75	0.72	6.25	3.50
4.000	5.40	2.31	0.63-18	5.00	1-1/16-12	0.88	2.00	1.75	0.72	6.63	3.75
5.000	7.00	3.19	0.88-14	6.50	1-1/16-12	0.88	2.00	1.75	1.00	7.13	4.25
6.000	8.10	3.63	1.00-14	7.50	1-5/16-12	1.00	2.25	2.25	1.14	8.38	4.88

**Prior to 3/1/97, NPTF standard. Effective 3/1/97 SAE O-Ring straight thread ports are standard; see page 82 for sizes.

AVENTICS PRESSUREMASTER® HHT HYDRAULIC CYLINDERS

HOW TO ORDER

EXAMPLES (A) 2 x 10 C-MP1-HHT-C;
1" Rod, 3/4" - 16 M. Threads

(B) 6 x 48 Effective Stroke, C-MP1-HHT-C; 4" rod, 3" - 12 Male
Threads, 6" Stop Tube. See pages 113 and 114 to calculate
stop tube length and rod diameter.

NOTE: Effective 3/1/97, SAE O-Ring Straight thread ports
standard on HHT cylinders.

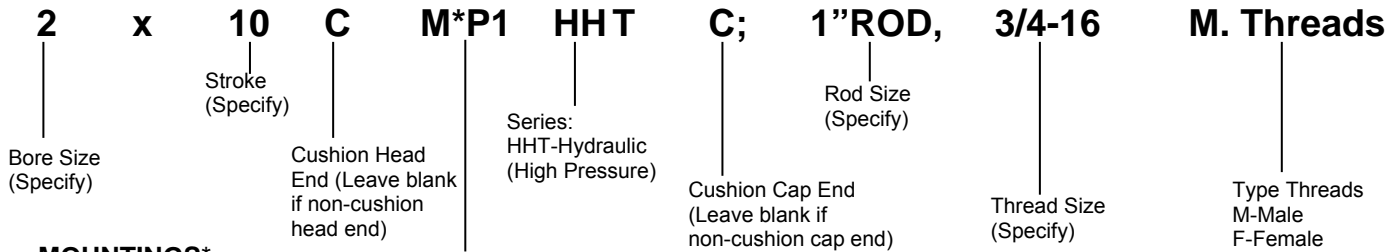

MOUNTINGS*

- Head Rectangle ME5
- Cap Rectangle ME6
- Head Rectangular Flange (1-1/2"—6") MF1
- Cap Rectangular Flange (1-1/2"—6") MF2
- Head Square Flange MF5
- Cap Square Flange MF6
- Cap Fixed Clevis MP1
- Cap Detachable Clevis (1-1/2"—6") MP2
- Fixed Pivot MP3
- Detachable Pivot(1-1/2"—6") MP4
- Side Lug MS2
- Center Line Lug (1-1/2"—6") MS3
- Side Tap MS4
- Side End Lug (1-1/2"—6") MS7
- Head End Trunnion MT1
- Cap End Trunnion MT2
- Intermediate Fixed Trunnion (Specify XI) MT4
- Universal Clevis (1-1/2"—6") MU3
- Tie Rod Mounting MX0,1, 2, 3, 4

* Double Rod End (Example: MDE3)
(Specify only when required, available
in most mountings. 1-1/2, 2, 2-1/2 bore
cylinders with the maximum oversize
rod and head cushion marked in dimension
tables, have no head cushion adjustment or
check valve bypass. These models:
are not recommended for double rod
end application.)

OPTIONS (Specify)

- Seals - Standard, Viton
- Polypak Piston Seals
- Cast Iron Piston Rings
- Piston Rod Studs
- Rod Extension ("W" dimension)
- Thread Extension ("A" dimension)
- Stop Tube (Specify effective stroke)
- Piston Rod Material (Stainless Steel)
- Port Location & Number of Cushions
- Rod Boot
- Stroke Adjustment
- Port Style: SAE O-ring (std.), NPTF, SAE 4 Bolt Flange
- Thrust Key Head Plate
- Proximity Switches
- Epoxy Paint
- Special Items as required

OPERATING PRESSURES (PSI) BY CYLINDER BORE SIZES**

CYLINDER BORE	STANDARD ROD	NOMINAL	NON-SHOCK
1-1/2	5/8	3,000	5,000
2	1		
2-1/2	1		
3-1/4	1-3/8		
4	1-3/4		
5	2		
6	2-1/2		
7	3		
8	3-1/2		
10	5		
12	5-1/2		
14	7		

**1) For flange mounted and double rod cylinders; see
pages 87 and 89

2) Exceptions to 5000 psi non-shock rating:

- A) 1-1/2" bore with 5/8" rod, all mounts.
- B) All bore sizes using the following mounts:
MT1, MT2, MT4, MF1, MF2, ME5, ME6, MS7
- C) The following mounts for bore sizes listed:
MP1: 2-1/2", 12", 14"
MP2: 2-1/2", 8"
MU3: 2-1/2", 3-1/4"
MS2 & MS3: 10", 12", 14"
MS4: 14"
MF5 & MF6: 6" thru 10"
MX0, MX1, MX2, MX3, MX4: for 10" and larger,
consult factory

AVENTICS PRESSUREMASTER® HHT HYDRAULIC CYLINDERS

INSTALLATION AND SERVICE INFORMATION
 1-1/2"–14" BORE
 STANDARD SPECIFICATIONS

OPERATING PRESSURES (PSI) BY CYLINDER BORE SIZES*

CYLINDER BORE	STANDARD ROD	HEAVY DUTY	
		NOMINAL	NON-SHOCK
1-1/2	5/8	3,000	5,000
2	1		
2-1/2	1		
3-1/4	1-3/8		
4	1-3/4		
5	2		
6	2-1/2		
7	3		
8	3-1/2		
10	5		
12	5-1/2		
14	7		

Duty— 3000 psi hydraulic, 5000 psi non-shock, except as noted.

Standards—Meets or exceeds all J.I.C. and NFPA requirements.

Bore Sizes—1-1/2"–14" (standard)

Piston Rods—5/8"–7" (standard)

Mountings—22 standard NFPA mountings.

Temperature Range— -65°F to +200°F (Buna-N standard seals). Optional Viton® seals for -15° to 400°F and many fluids.

* See page 100 for pressure limitations. For flange-mounted and double rod end cylinders, see pages 87 and 89

APPROXIMATE UNCRATED PRESSUREMASTER HYDRAULIC CYLINDER WEIGHTS (LBS.)*

Cylinder Bore	1-1/2	2	2-1/2	3-1/4	4	5	6	7	8	10	12	14
Zero Stroke	7.5	10	16	31	41	73	138	180	310	610	970	1520
Add Per Inch of Stroke	.5	.7	1.17	1.75	2.5	4.0	5.2	6.2	8.7	15.2	21.6	28.5

*Weights based on standard (first) rod sizes

WARNING— Read and follow warnings and directions as listed on the inside back cover of this catalog prior to performing any service or installation.

INSTALLATION—For outline dimensions and other considerations in mounting the Pressuremaster, see pages 86-99. Before mounting the cylinder, be sure all hydraulic lines leading to the cylinder are free of dirt and foreign matter. An accumulation of foreign matter in the supply lines can cause corrosion, less efficient cylinder operation, and shorter cylinder life. A very important consideration in mounting the Pressuremaster is keeping the cylinder thrust as close as possible to the centerline of the piston rod and free of misalignment or side thrust. Off-center thrust or side loads decrease the normal life of the rod bearing and seals and can cause binding in the cylinder or linkage. Forcing rod, clevis pins, or mounting bolts into position indicates that the cylinder is not properly aligned, and permanent damage may result from such installation.

Side Lugs (MS2), Centerline Lugs (MS3) and Side Tapped (MS4): After a cylinder utilizing one of the above mounts has been aligned, key or pin it to its support. Properly located shear keys or pins will absorb the major portion of the shear load. Always use high-tensile bolts to fasten the cylinder to its support.

Head Rectangular Flange (MF1, ME5), Cap Rectangular Flange (MF2, ME6), Head Square Flange (MF5) and Cap Square Flange (MF6): A flange-mounted cylinder can be centered by using the gland in the cylinder head as a pilot. After mounting and alignment, the cylinder should be dowelled to its support to prevent shifting. For installation producing high stock loads or utilizing maximum operating pressures, a square flange is recommended.

Head Trunnion (MT1), Cap Trunnion (MT2) and Intermediate Fixed Trunnion (MT4): Install a trunnion-mounted cylinder in rigid, accurately aligned pillow blocks. These blocks should be well lubricated at all times. Since trunnion pins are designed for shear loads only, provide linkage with a suitable pivot for connection to the rod end of the cylinder.

Fixed Clevis (MP1), Detachable Clevis (MP2) and Universal Clevis (MU3): In the installation of clevis-mounted cylinder, the centerline of the pivot pin in the rod end linkage must be parallel with the centerline of the clevis pin in the cap end of the cylinder. A universal clevis mount automatically compensates for 5 to 10 degrees of misalignment in any direction. Never allow the cylinder head or cap to stop the piston at the end of its stroke. Either provide external stops to prevent the piston from bottoming or use a cylinder with built-in cushioning. A cushioned cylinder will stop the piston just before it reaches the end of its stroke. Under certain conditions of load, external stops may be required to supplement the cylinder cushioning.

OPERATION — The standard Pressuremaster cylinder has an operating temperature range of -65° to +200°F. For operating temperatures above and below this range, special seals are required. Maximum operating pressure of the cylinder is 3000 psi, except some flange mounted and double rod end cylinders, see pages 87 and 89 for limitations. The Pressuremaster cylinder is designed operation with petroleum based hydraulic fluids. Operation using fire-resistant phosphate esters or other special types of fluids requires special packing and seals. Hydraulic pressure supplied to the cap-end port moves the piston rod to its extended position. Pressure supplied to the head end port moves the piston rod to its retracted position. See pages 107 and 108 for forces developed by each cylinder.

ADJUSTMENT— A non-cushioned cylinder requires no further adjustment after it has been installed and properly aligned. A cushion cylinder, after installation and alignment, must be adjusted to obtain the degree of cushioning desired. An adjustment is provided by a screw-type needle and check valve in either or both ends of the cylinder. This Exact-a-just™ valve controls the rate at which trapped fluid is allowed to drain from the end of the cylinder when the piston is near the end of its stroke. Turn the needle valve clockwise to increase the amount of cushioning. Turn it counter-clockwise to decrease cushioning. To obtain the most effective cushioning, final adjustment must be made while the cylinder is operating under normal conditions at normal operating pressure.

AVENTICS PRESSUREMASTER® HHT HYDRAULIC CYLINDERS

MAJOR REPAIR, MAINTENANCE & TESTING

GENERAL MAINTENANCE & REPAIR RECOMMENDATIONS

Maintenance periods should be scheduled in accordance with frequency of use and working environment of the cylinder. All cylinders must be visually inspected for wear and given an "in system" operating performance and leakage test at least once a year. If these visual observations indicate cylinder repair is required, the cylinder must be removed, repaired and tested. A major overhaul is recommended at one million cycles. However, where frequency of use is such that it would require more than two years to obtain one million cycles, the cylinder must be overhauled at the two year period. When it is determined that the cylinder requires a major repair as a result of the one million cycles, one year routine inspection, or the two year service period has elapsed, the device must be disassembled, cleaned, inspected, parts replaced as required, rebuilt and tested for leakage and proper operation prior to installation.

MAJOR REPAIR & MAINTENANCE INSTRUCTION

Always drain the pressure from a hydraulic system before performing any service work. Disconnect hydraulic lines from head and cap ports of cylinder. Completely disassemble the cylinder using the exploded and assembly views as reference. No special tools are required except internal snap ring pliers. The piston rod assembly consisting of rod, piston and head cushion bushing (where used) are torqued and secured at the factory and are not to be disassembled (cylinders built prior to 1986 utilized piston nut, ref. item 18). After disassembling the cylinder, wash all metal parts in a non-flammable solvent. Rinse each part thoroughly and blow dry with a low pressure air jet. Arrange the parts on a clean surface. Examine each part carefully. Replace all rubber parts and other worn or damaged parts. The use of Repair Kits is strongly recommended. Particular attention should be given to the rod bearing (5a) since cylinder leakage can result from a worn bearing. A scored or rough rod bearing might damage the piston rod and, subsequently, the rod packing. Rod cartridge kits are available with or without the rod bearing. An excellent feature of the PRESSUREMASTER hydraulic cylinder is easy replacement of the rod cartridge (5) without loosening the tie rods. On most cylinders with bore sizes from 1-1/2" - 6 inches, remove the screws and washers (1 & 2) and retainer plate (4a). For all cylinders with bore sizes 7 through 14 inches, remove screws (3) and retainer plate (4b). The rod cartridge is easily removed from the cylinder head. To facilitate removal, a screwdriver can be used to pry in the external groove.

REASSEMBLY

The procedure for reassembly is essentially the reverse of the disassembly. However, the following exceptions should be noted: Lubricate inside diameter of cylinder tube and piston rod with hydraulic fluid used in cylinder application. SEALS: Lubricate all seals with hydraulic fluid used in cylinder application. The hydraulic fluid specified for use in the cylinder is the only lubricant to be used in assembly. In reassembling the cylinder, use the exploded and assembly views as reference. Be careful not to cut or damage the rod packing and seals. The tie rod threads should be well lubricated to allow tightening the nuts evenly for proper pre-stressing. To avoid twisting of the tie rod during tightening, hold with vise grip or clamp. To assure equal pre-stressing of tie rods, first turn on nuts even and snug to align assembly, then the nuts are to be tightened alternately. For proper tie rod pre-stressing, they should be torqued as recommended. The specific torque value is determined by the diameter of the tie rod. For lubricated tie-rod threads, see chart above:

CYL. BORE SIZE	TIE ROD DIAMETER	TORQUE-LUBRICATED LBS.-FOOT		
		Prior to March 1992	As of March '92	
			"P" Part No.	"C" Part No.
All mounts except MF1, MF2, MF5, MF6 and MS7:				
1-1/2"	3/8"	19	19	20
2"	1/2"	45	45	35
2-1/2"	1/2"	45	45	55
3-1/4"	5/8"	90	90	110
4"	5/8"	90	125	125
5"	7/8"	255	295	345
6"	1"	360	480	545
7"	1-1/8"	450	720	775
8"	1-1/4"	750	1050	1075
10"	1"(uses 12)	360	425	500
12"	1"(uses 16)	360	460	500
14"	1"(uses 20)	360	500	500
For mounts MF1, MF2, MF5, MF6 and MS7:				
1-1/2"	3/8"	19	19	20
2"	1/2"	45	45	35
2-1/2"	1/2"	45	45	55
3-1/4"	5/8"	90	90	110
4"	5/8"	90	90	125
5"	7/8"	255	225	258
6"	1"	360	360	400
7"	1-1/8"	450	450	480
8"	1-1/4"	750	750	770
10"	1"(uses 12)	360	360	390
12"	1"(uses 16)	360	360	390
14"	1"(uses 20)	360	360	390

TESTING

After the cylinder has been completely reassembled, it should be tested, either on a test bench or in the regular installation.

TEST PROCEDURES (see maximum psi/bore)

The cylinder should be tested for cushioning, travel and leakage.

A. Cushioning (if applicable)

1. Turn both cushioning screws clockwise all the way in.
2. Cycle cylinder a few times by alternating supply pressure to head and cap ports.
3. Apply supply pressure to the head port. Rod should retract, decelerate and may stop before completion of stroke.
4. Apply supply pressure to the cap port. Rod should extend, decelerate and may stop before completion of stroke.

B. Travel and Leakage

1. Turn the cushioning screws counterclockwise one full turn.
2. Apply supply pressure to the head port. Rod should retract smoothly without binding. Cylinder should retract, have less cushioning and make full stroke + or - 0.062". Check leakage at cap port, no leakage permitted. Check leakage around rod seal. No leakage permitted.
3. Apply supply pressure to the cap port. Rod should extend smoothly without binding. Cylinder should extend, have less cushioning and make full stroke + or - 0.062". Check leakage at head port, no leakage permitted.
4. Return piston rod to retract position by applying supply pressure to head port. Remove supply pressure and install cylinder in service if satisfactory.

CUSHIONING ADJUSTMENT

Turn the needle valve clockwise to increase the amount of cushioning and counter-clockwise to decrease cushioning. To obtain the most effective cushioning, final adjustment must be made while the cylinder is operating under normal conditions at normal operating pressure.

AVENTICS PRESSUREMASTER[®] HHT HYDRAULIC CYLINDERS

1-1/2" — 14" BORE

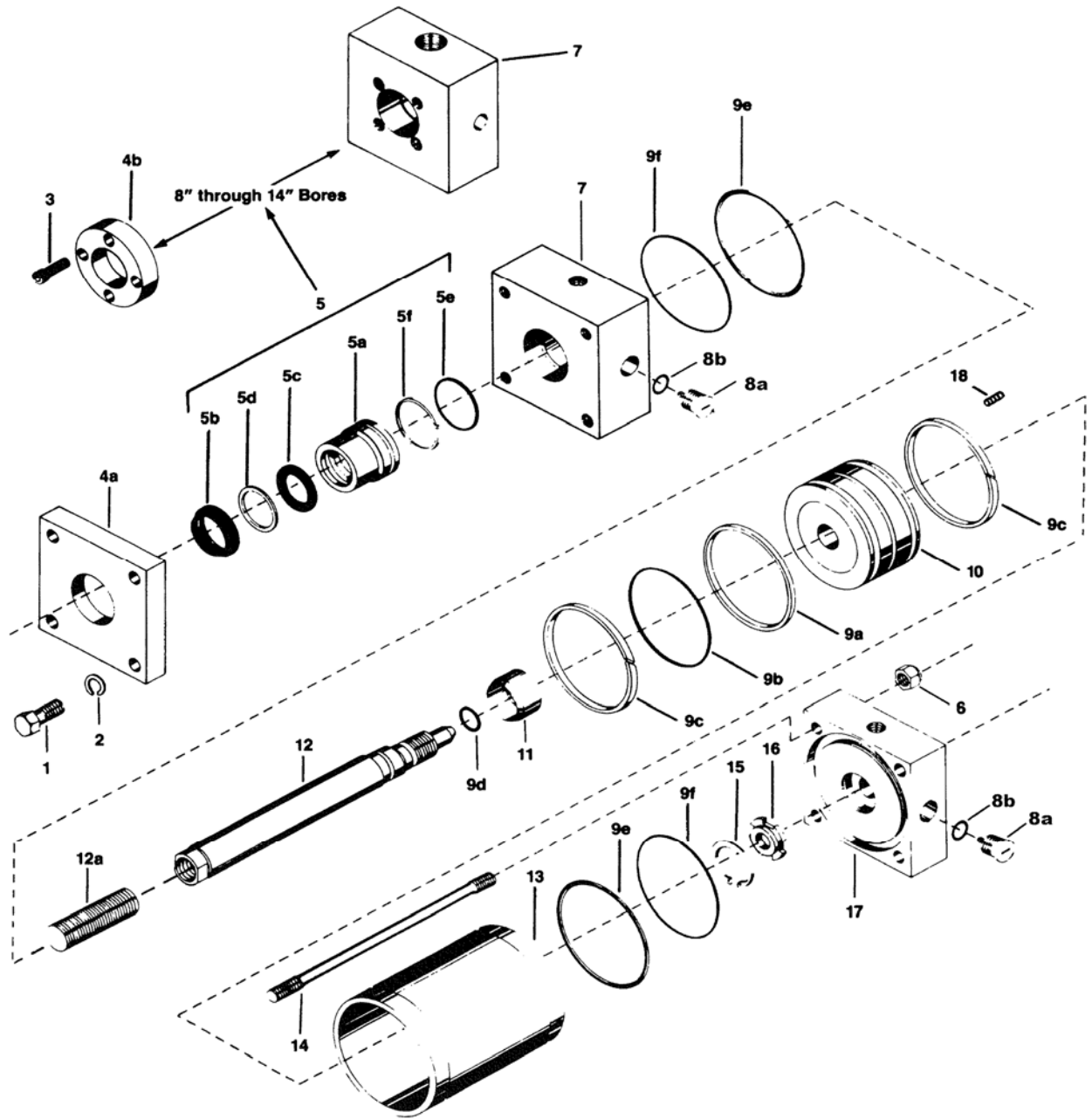

1-1/2" through 6" bores

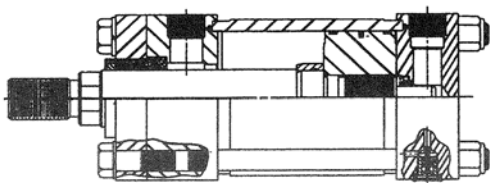

7" through 14" bores

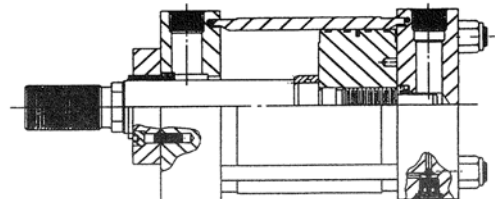

AVENTICS PRESSUREMASTER® HHT HYDRAULIC CYLINDERS

1-1/2" — 14" BORE

REF.	DESCRIPTION	CUSHIONED BOTH ENDS	CUSHIONED HEAD ONLY	CUSHIONED CAP ONLY	NON-CUSHIONED
1	SCREW, Cap (1-1/2"—6" bore sizes)	4	4	4	4
2	WASHER, Lock (1-1/2"—6" bore sizes)	4	4	4	4
3	SCREW, Socket Head Cap (7"—14" bore sizes)	4†	4†	4†	4†
4a	PLATE, Retainer (1-1/2"—6" bore sizes)	1	1	1	1
4b	PLATE, Retainer (7"—14" bore sizes)	1	1	1	1
* 5	CARTRIDGE, Rod Kit	1	1	1	1
5a	BEARING, Rod	1	1	1	1
5b	WIPER, Rod	1	1	1	1
5c	PACKING, U-cup/O-ring	1	1	1	1
5d	RING, Rod Packing Backup	1	1	1	1
5e	RING, Rod Bearing O-ring	1	1	1	1
5f	RING, Backup	1	1	1	1
\$ 6	NUT, Tie Rod Lock	4†	4†	4†	4†
7	HEAD	1	1	1	1
* 8	CUSHION, Needle Valve Kit	2	1	1	—
8a	VALVE, Exact-a-just™ Needle & Check	2	1	1	—
8b	RING, Needle Valve O-ring	2	1	1	—
*#9	PISTON & TUBE, Seal Kit	1	1	1	—
9a	RING, Piston Bearing Seal	1	1	1	1
9b	RING, Piston Bearing O-ring	1	1	1	1
9c	RING, Piston Bearing Guide	2†	2†	2†	2†
9d	RING, Piston Bearing O-ring	1	1	1	1
9e	RING, End Cover O-ring	2	2	2	2
\$9f	RING, Backup	2	2	2	2
10	PISTON	1	1	1	—
11	BEARING, Head Cushion	1	1	—	—
12	ROD, Female Piston	1	1	1	1
12a	ADAPTER, Male Piston Rod (when required)	1	1	1	1
13	TUBE, Cylinder	1	1	1	1
14	TIE ROD	4†	4†	4†	4†
15	RING, Cap Cushion Retaining	1	—	1	—
* 16	INSERT, Cap Cushion Seal	1	—	1	—
17	CAP	1	1	1	1
*	Not shown: NUT, Piston Bearing Retaining (1-1/2"—5" bore)	1	1	1	1
* 18	SCREW, Socket Head Set (6"—14" bore sizes)	1	1	1	1

* Recommended spare parts to be retained in stock at all times, See "Repair Kits".
 • Not standard after 1984
 # See Piston and Tube Seal Kit part numbers, page 105.

† Quantity may be greater depending on mounting style and bore size.
 \$ As of March 1992, 1-1/2" thru 8" bore have Grade 8 nut and lockwasher
 § Not used after 1995.

REPAIR KITS

Repair parts included in the following repair kits are available only in kit form. Kits should be ordered by kit part numbers plus cylinder part number when possible. Other parts not included in repair kits MUST be ordered separately by reference number, description, and cylinder part number. Some kits may have an excess of parts not used in some models. Discard these parts or keep for later use.

Rod Diameter	Bore Size	Urethane (Std.) Part Number	Viton® Part Number
0.63"		R433022023	R433041184
1.00"		R433022025	R433033115
1.38"		R433022027	R433033112
1.75"		R433022029	R433041191
2.00"		R433022031	R433041203
2.50"		R433022033	R433023964
3.00"		R433022035	R433033105
3.50"	6, 7, & 8	R433023458	R433024259
3.50"	5	R433024861	R433041235
4.00"		R433024161	R433024263
4.50"	8	R433073139	R433040358
4.50"	10	R433034135	R433033477
5.00"	7 & 8	R433024192	R433024327
5.00"	10	R433014544	R433024267
5.50"	8	R433024323	R433024329
5.50"	10 & 12	R433023462	R433024271
7.00"	10	R433024325	
7.00"	12 & 14	R433024256	
8.00"	12	R433039747	
8.50"	12	R433024278	

Includes Ref. items: 5a, 5b, 5c, 5d, 5e & 5f

Rod Diameter	Urethane Part Number	Viton Part Number
0.63"	R433023933	R433041186
1.00"	R433023939	R433033116
1.38"	R433023943	R433033111
1.75"	R433023949	R433041189
2.00"	R433023955	R433041201
2.50"	R433023961	R433023963
3.00"	R433023967	R433033107
3.50"	R433014992	R433041233
3.50"	R433014992	R433041233
4.00"	R433024276	R433024265
4.50"	R433034106	R433040356
5.00"	R433014997	R433032988
5.00"	R433014997	R433032988
5.50"	R433014999	R433024273
5.50"	R433014999	R433024273
7.00"	R433024257	R433024275
7.00"	R433024257	R433024275
8.00"	R433039748	R433033372
8.50"	R433024278	

Includes Ref. items 5b, 5c, 5d, 5e & 5f

BUNA N Part Number	Viton® Part Number	Bore Size
R433015236	R433072609	1.5", 2", 2.5"
R433016568	R433074773	3.25", 4", 5"
R433023256	R433023256	6" thru 14"

Includes Ref. Items 8a & 8b.

Bore Size	Part Number	Bore Size	Part Number
1.50"	R433015116	6.00"	R433015117
2.00"	R433015115	7.00"	R433015117
2.50"	R433015115	8.00"	R433015118
3.25"	R433015115	10.00"	R433015119
4.00"	R433015115	12.00"	R433015119
5.00"	R433015115	14.00"	R433015119

Ref. Item 16

AVENTICS PRESSUREMASTER® HHT HYDRAULIC CYLINDERS

Piston and Tube Seal Kit Part Numbers

Series	BN	BN	VV	VV	PP	PP	PV	PV	
Bore In	MM Rod	C Teflon, Buna	P Teflon, Buna	C Teflon, Viton	P Teflon, Viton	C Polypak, Buna	P Polypak, Buna	C Polypak, Viton	P Polypak, Viton
1.5	0.625	R433002317	R433024194	R433002343	R433024220	R433005114	R433040156		
	1	R433002318	R433024195	R433002344	R433024221	R433012121	R433055223		
2	1	R433002321	R433024199	R433002347	R433024224	R433004606	R433039113		
	1.375	R433002321	R433024199	R433002347	R433024224	R433004606	R433039113		
2.5	1	R433002323	R433024201	R433002349	R433024226	R433011752	R433054449	R433003135	R433039987
	1.375	R433002323	R433024201	R433002349	R433024226	R433011752	R433054449	R433003135	R433039987
	1.75	R433002431	R433024696	R433002501	R433030922	R433004662	R433040425		
3.25	1.375	R433002325	R433024203	R433002351	R433024228	R433004625	R433039401		
	1.75	R433002325	R433024203	R433002351	R433024228	R433004724	R433039401		
	2	R433003835	R433034061	R433002577	R433030922	R433004711	R433039361		
4	1.75	R433002327	R433024205	R433002353	R433024230	R433011726	R433054281	R433004998	R433039989
	2	R433002327	R433024205	R433002353	R433024230	R433011726	R433054281	R433004998	R433039989
	2.5	R433002415	R433024556	R433003932	R433034231	R433077813	R433040425		
5	2	R433002329	R433024207	R433002355	R433024232	R433011754	R433054451	R433004994	
	2.5	R433002329	R433024207	R433002355	R433024232	R433011754	R433054451	R433004994	
	3	R433002435	R433024698	R433002535	R433025166	R433072332	R433054368		
6	2.5	R433002331	R433024209	R433002357	R433024234	R433004600	R433039100		R433040148
	3	R433002331	R433024209	R433002357	R433024234	R433004600	R433039100		R433040148
	3.5	R433002388	R433024379	R433002799	R433032903	R433004652	R433039229		
7	3	R433002428	R433024211	R433002359	R433024236	R433005367			
	3.5	R433002428	R433024211	R433002359	R433024236	R433005367			
	4	R433002333	R433074967		R433040526				
8	4	R433002333	R433074967		R433040526				
	5	R433002333	R433074967		R433040526				
	5.5	R433002335	R433024213	R433002361	R433024238				
10	4.5	R433002335	R433024213	R433002361	R433024238				
	5	R433002455	R433024805	R433002503	R433074971				
	5.5	R433002455	R433024805	R433002503	R433074971				
12	4.5	R433002337	R433024215	R433003057	R433024240	R433072202			
	5	R433002337	R433024215	R433003057	R433024240	R433072202			
	5.5	R433002337	R433024215	R433003057	R433024240	R433072202			
14	7	R4330025218	R433025218						
	5.5	R433073898	R433024217		R433024242				
	7	R433005118	R433040191		R433040414				
14	8	R433002390	R433074875		R433040414				
	7	R433002340	R433024219						
	10		R433040703						

Note: "C" kit part numbers refers to new tube design cylinders. If kit part number is not shown, contact factory. For cylinder part numbers beginning with "C" or "R" use the "C" version kit. For cylinder part numbers beginning with "W" or "P", use the "P" version kit.

SIZING

The total load or force expected of the cylinder must be known in order to properly size a cylinder. If it is estimated, it should be on the high side. On air applications, considerably more force must be available than total load for the best operation. The surplus force is transferred into velocity, or it is counterbalanced with back pressure to control velocity. In selecting the MINIMUM force recommended for an application, the following general guidelines apply:

AIR CYLINDERS	FOR GENERAL APPLICATIONS	— minimum force available from the cylinder should be 125% of the total load.
	FOR SPEED CONTROL	— minimum force available from the cylinder should be 150% of the total load.
	FOR MAXIMUM VELOCITY	— minimum force available from the cylinder should be 200% of the total load.
HYDRAULIC CYLINDERS	FOR GENERAL APPLICATIONS	— minimum force available from the cylinder should be 110% of the total load.

FLOW REQUIRED BY CYLINDERS

The flow required to operate a cylinder at a given speed is very often one of the controlling factors in an application. Again, the pneumatic cylinder is more complex and represents an approximation. The following formulas may be useful:

HYDRAULIC FLOW REQUIRED

$$GPM = \frac{Dh \times S \times 60}{T}$$

Where GPM=Flow required in gallons per minute
 Dh= Displacement of cylinder in gallons per inch of stroke, see catalog chart
 S= Stroke of cylinder, inches
 T= Time in seconds to complete above stroke

PNEUMATIC FLOW REQUIRED (Average)

SCFM avg= C x Dp x S x SPM where
 SCFM avg= Average ft³ free air per minute required
 Dp= Displacement of cylinder in ft³ per inch of stroke
 S= Stroke in inches
 SPM=Strokes per minute, count both in and out strokes
 C= Conversion factor for air compression, ratio
 C= $\frac{\text{Supply pressure (psig)+14.7}}{14.7}$

pneumatic cylinders is difficult to predict, and an average based on the total stroke time is normally used as an estimate.

The following formulas may be useful.

* Increased velocity can be realized with different seal arrangement. Contact factory for information.

HYDRAULIC CYLINDER SPEED

$$V_h = \frac{GPM}{Dh \times 720}$$

Vh= Cylinder Speed fps
 GPM= Gallons per minute flow supplied
 Dh= Displacement of cylinder in gallons per inch of stroke (see catalog chart)

PNEUMATIC CYLINDER SPEED

$$V_p = \frac{S}{T \times 12}$$

Vp= Cylinder Speed fps
 S= Stroke, in.
 T= Time to complete above stroke in seconds

CYLINDER SPEED

For adequate seal life, the cylinder linear velocities should be limited to a maximum of 20 inches per second per second for lip-type seal.* On hydraulic cylinders, the speed is controlled by the GPM capacity of the pump or valves and line size. The speed of

CAUTION: OVERSIZE PORTS
 Full flow diameters of oversize ports may not be obtainable with standard cylinder geometry. Consult factory

AVENTICS CYLINDER APPLICATIONS DATA

MOUNTING CONSIDERATIONS FOR CYLINDERS

Selection of mounting style depends primarily upon the operating specifications of the application. Mountings are generally one of the following three types:

1. FIXED CENTERLINE MOUNTINGS

Where the thrust of the cylinder is focused on the centerline of the cylinder rod.

2. FIXED NON-CENTERLINE MOUNTINGS

Where the thrust of the cylinder is aligned parallel to, but not on, the centerline of the cylinder rod.

3. PIVOTED CENTERLINE MOUNTINGS

Where the centerline of the cylinder may swing in one or more directions. Usually major movement is in one plane.

A very important general consideration is to keep the cylinder thrust as close as possible to the centerline of the piston rod and free from misalignment or side thrust. Off-center thrust or side loads subtract substantially from the anticipated rod bearing and rod seal service life.

Off-center thrust and side loading can be caused by cylinder deflection under load, machine frame deflection, rod bending or sagging, cylinder pivot binding, non-linear load movement, shifting of load; some of which are shown below:

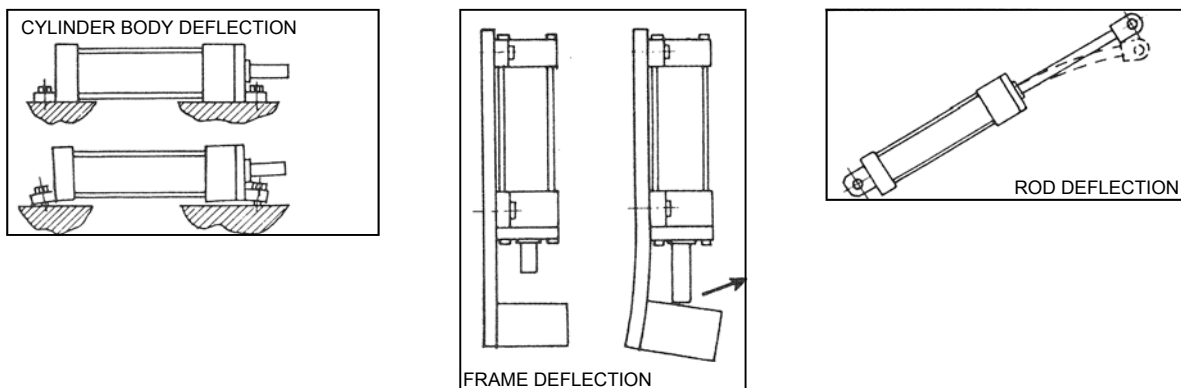

In addition to the mounting styles, several other factors should be considered when mounting a cylinder. Care should be taken to avoid painting or damaging the exposed portion of the piston rod during construction. Threaded pieces should be pulled tight against thread shoulders to minimize bending and reduce fatigue stress. Rotation of the piston rod within the cylinder should be avoided to prevent possible scoring of the cylinder tube and damage to the piston seals. Long cylinders may require additional body support to prevent damaging sag.

Major consideration must be given to the factors which might cause premature failure of the cylinder: unusual acceleration, unusual deceleration, alignment, support of cylinder weight, linear or curvilinear travel path of the load being moved, jackknifing of the cylinder, and the column strength of the rod. Some mounting styles are more suited than others to each of the above application factors.

AVENTICS CYLINDER APPLICATIONS DATA

MOUNTING CONSIDERATIONS FOR CYLINDERS

FIXED CENTERLINE MOUNTINGS

These mounting styles, illustrated below, tend to be more stable against sway on the power extension stroke. Rigid machine frame members are required to prevent misalignment under loads. The travel path of the rod end should be linear and be guided if at all possible. Long supported extension of the rod end must be avoided. Refer to the stop lube calculation data which shows the advantages of supporting and using reliable guiding on the rod end. Long stroke cylinders with fixed end mounts may require additional support at the free end of the cylinder body. This is illustrated in dotted outlines in the sketches below.

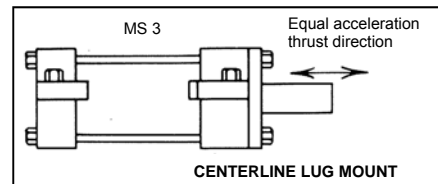
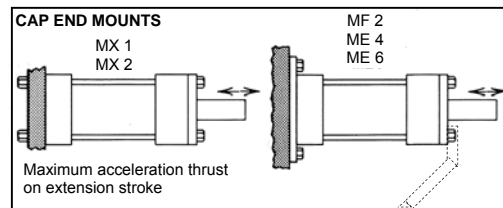
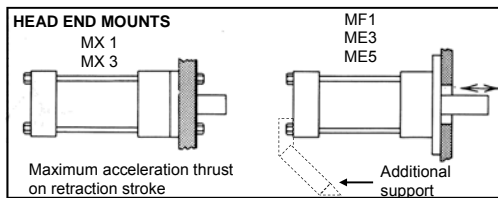

FIXED NON-CENTERLINE MOUNTINGS

These types of mountings are perhaps the easiest to use for mounting and replacement ease. The offset thrust line introduces bending stresses and additional loads on the mounting bolts. This type should be very well aligned for maximum service life. The load must travel in a very linear path and be supported and guided both horizontally and vertically as the data for calculating stop tube and column strength illustrates.

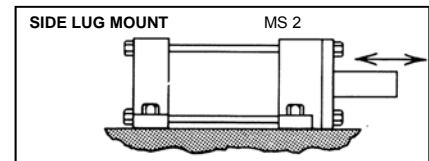
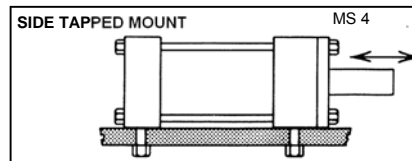
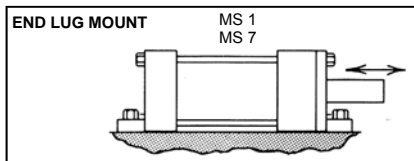

When applying these mounts with offset thrust under high pressures or shock loads, properly located shear pins or keys can be used. These provide positive location and prevent slight movement of the cylinder under shock conditions, which the normal clearance in the mounting bolt holes would allow. Very close tolerances (.001") should be maintained between keys and keyways. Keys should be located as illustrated above, at one end of the cylinder ONLY and extend all the way across the end of the cylinder. When using dowel pins, DO NOT pin across opposite corners, as serious twisting stresses will result.

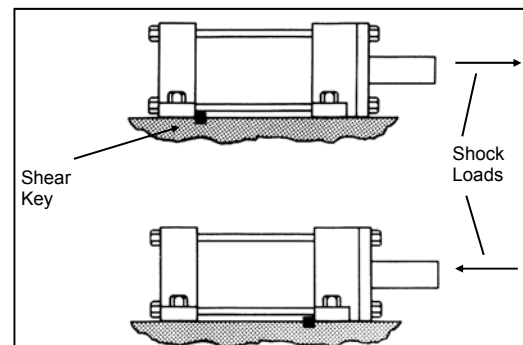

AVENTICS CYLINDER APPLICATIONS DATA

MOUNTING CONSIDERATIONS FOR CYLINDERS

FIXED NON-CENTERLINE MOUNTINGS (continued)

Fixed mount cylinders can tolerate a slight misalignment that is ZERO at full retraction and increases slightly with stroke. With other than very large rods, a misalignment of about .003" to .005" per foot of stroke is usually permissible. Rigid mounted cylinders cannot tolerate a fixed misalignment, particularly at full retraction.

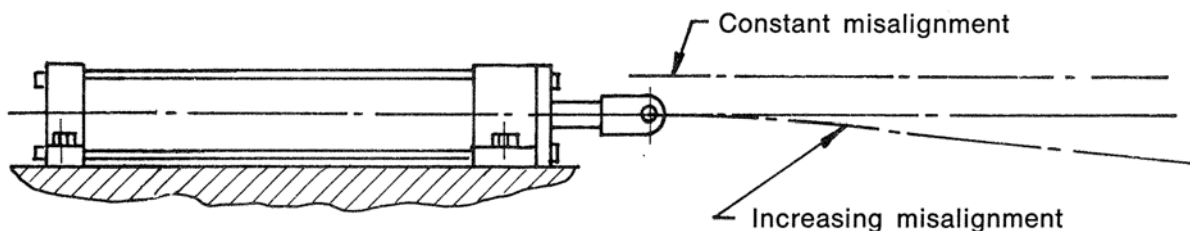

PIVOTED CENTERLINE MOUNTINGS

If the path of the load is curved or misalignment is a problem, a pivoted centerline mounting should be used. This compensation of non-linear travel is in ONE PLANE ONLY, as would occur during the operation of a lever. Pivot mounts require the rod end attachment to also be a pivot type. Close tolerance pins should be used and it is recommended that the cylinder manufacturer's accessory brackets be used to maintain good fits.

For short strokes, medium or smaller bore cylinder applications, the clevis mount is recommended. This is probably the most widely used cylinder mounting. Where the clevis mount would normally be used, but would cause the overall length of the cylinder to be excessive, the cap trunnion mount can be used. Head end trunnions should be carefully applied to either short strokes or to application where the weight of the cylinder falls vertically below the pin.

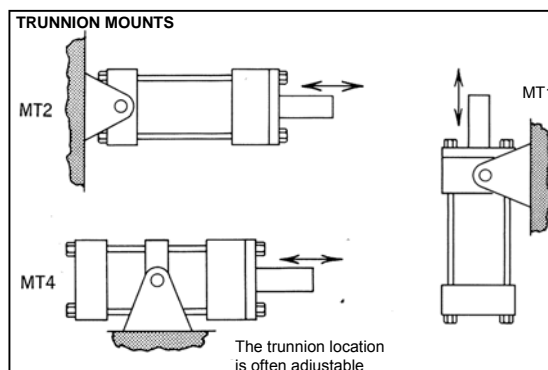
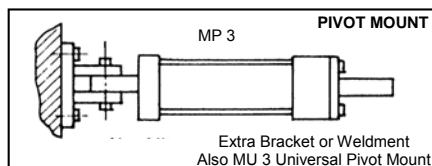
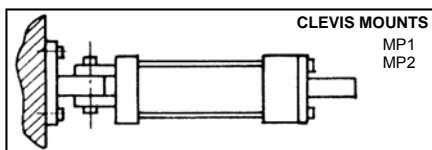

For long stroke cylinders and/or heavy cylinders, the center or intermediate trunnion mount is recommended. This mount supports the weight of the cylinder and should be located near the balance point of the cylinder at the time of maximum thrust. For general applications, a good estimate for the location of the intermediate trunnion is 1/3 back from the head end.

The MU3 (Universal) type mount is a pivot mount MP3 with a spherical bearing fitted into the pivot to permit 5 to 10 degrees of movement in a plane perpendicular to the major place of pivot movement. It is probably the most serviceable of the pivoted centerline mounts. For maximum effectiveness, a spherical bearing type rod end fitting should be utilized at the same time.

AVENTICS CYLINDER APPLICATIONS DATA

STOP TUBE & COLUMN STRENGTH CONSIDERATIONS

STOP TUBE (see page 113)

In long cylinders which are pushing a load, internal stop tubes are used to prevent excessive bearing wear and jackknifing of the cylinder. They are installed between the piston and the head, providing additional bearing support by increasing the distance between the piston and the head in the fully extended position. Actual stop tubes may take the form of a spacer on the rod on a dual piston type design which allows the utilization of standard cushioning arrangements.

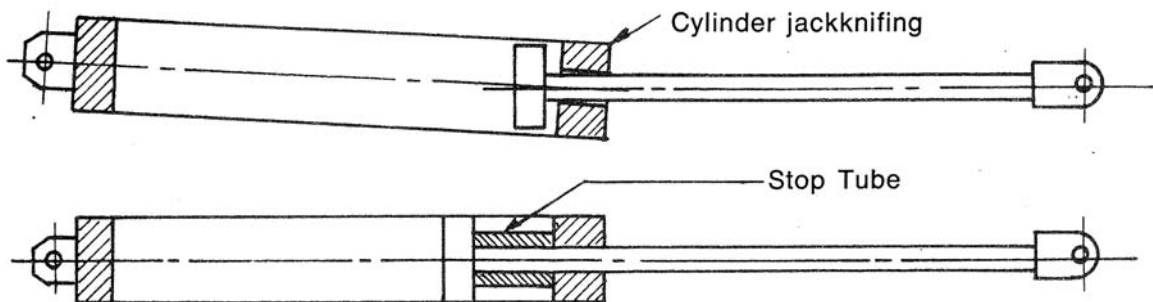

For long, trouble free bearing service, the bearing loads should not exceed about 200 psi. Standard cylinders are not designed for heavy eccentric loads.

The use of oversize rods to reduce bearing loads is not recommended. They are not as effective as stop tubes, and if misalignment occurs the additional rod stiffness will actually increase bearing loads. For long push stroke cylinders, a stop tube may be required to limit radial bearing loads to a safe value and prevent jackknifing. They are especially desirable in long stroke pivoted centerline style mountings. The effect of a stop tube may be duplicated by providing additional unused stroke and stopping the cylinder extension by external means.

COLUMN STRENGTH & OVERSIZE RODS (see page 114)

Standard size rods are recommended for use in cylinder applications where column strength, rod sag, or rate of cylinder return do not require an oversize rod. Being more flexible, standard rods absorb shock loads and minimize bearing loads caused by misalignments. For long push stroke cylinders, an oversize rod may be required to prevent column failure and rod bending. Total cylinder length, extended is considered in column strength. Refer to the tables on the following pages for calculations regarding the column strength and stop tube required for a cylinder application.

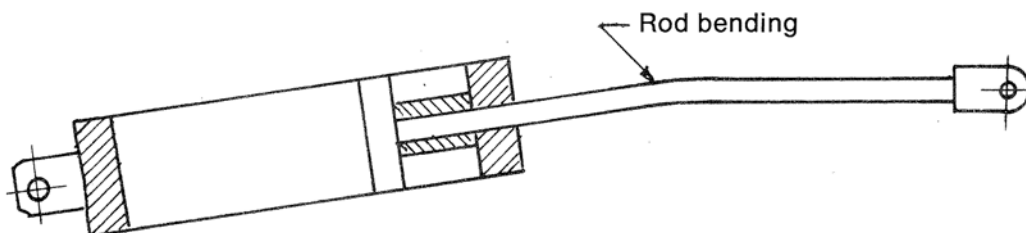

AVENTICS CYLINDER APPLICATIONS DATA

STOP TUBE

To determine whether a stop is required on push stroke cylinders:

STEP 1— Determine which example below corresponds to your application.

STEP 2— Determine the value of "L" from the instructions given. Then find "L" dimension in the table at the right for the required stop tube length. (Specify the **effective stroke** plus the **stop tube length** when ordering).

STEP 3— Add stop tube length to **original "L"** dimension to obtain your **Adjusted "L"** dimension.
 Example: "L"= 96", therefore, Stop Tube = 6". Therefore **Adjusted L=102"** (96+6)

STEP 4— Use **Adjusted "L"** to figure rod column strength at maximum pressure rating of the cylinder, page 114

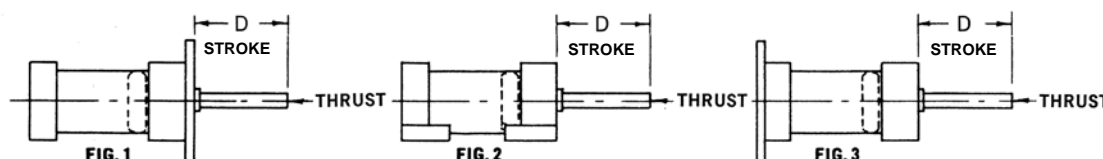

Typical rigidly mounted cylinders with rod **unsupported at free end**. May be mounted either horizontally or vertically. Use the equation $L = 4D$ to determine values of "L" for all cylinder mountings in this category.

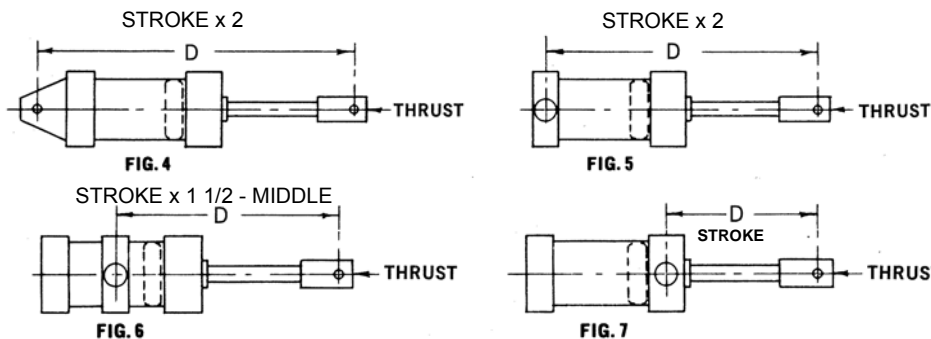

Typical trunnion mounted cylinders may be mounted either horizontally or vertically. Use the equation $L=D$ to determine values of "L" for all cylinder mountings in this category. For center trunnion mounted cylinders (Figure 6), the position of the trunnion for most favorable bearing loads is obtained when "D" dimension with the rod retracted is approximately 1/3 overall length of cylinder with rod retracted.

Typical rigidly mounted cylinder with free end of rod **supported with short guide**. May be mounted either horizontally or vertically. Use the equation $L=D$ to determine values of "L" for all cylinder mountings in this category.

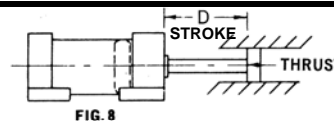

Typical rigidly mounted cylinder with free end of rod **supported with long closely-fitting guide**. May be mounted either horizontally or vertically. Use the equation $L=1/2 D$ to determine values of "L" for all cylinder mountings in this category.

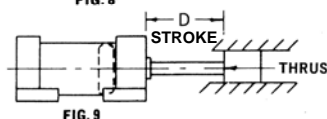

TANDEM AND DUPLEX CYLINDERS (Available in TASKMASTER®, POWERMASTER® & PRESSUREMASTER®)

Please contact factory for dimensions, pricing and delivery. **Tandem cylinders** allow increased output force and are made of two cylinders of inline mounting with pistons connected by a common piston rod and rod seals. Rod seals are installed between the cylinders to permit double acting operation of each.

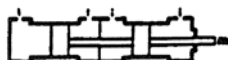

Duplex cylinders are made for three-position operation by joining two cylinders end to end without connecting the pistons with rod seals between them for double action operation. Below left is a back-to-back configuration; at right is an inline application.

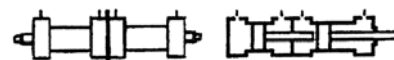

"L" (INCHES)	STOP TUBE LENGTH (INCHES)
0-40	0
41-50	1
51-60	2
61-70	3
71-80	4
81-90	5
91-100	6
101-110	7
111-120	8
121-130	9
131-140	10
141-150	11
151-160	12
161-170	13
171-180	14
181-190	15
191-200	16
201-210	17
211-220	18
221-230	19
231-240	20
241-250	21
251-260	22
261-270	23
271-280	24
281-290	25
291-300	26
301-310	27

AVENTICS CYLINDER APPLICATIONS DATA

COLUMN STRENGTH & OVERSIZE ROD SELECTION

Based on 100,000 psi tensile strength rod material

Standard rod diameters are recommended for all PULL STROKE applications. To determine the correct rod diameter required for PUSH STROKE application, follow these simple steps:

STEP 1— Determine the value of “L” from the illustration shown on page 113.
(Use Adjusted “L” dimension for cylinder with Stop Tube).

STEP 2— For your cylinder size and maximum operating pressure, determine your PUSH STROKE THRUST from the Thrust Chart on page 107 and 108.

STEP 3— Find your thrust in the left hand column and locate your “L” dimension (or Adjusted “L” dimension in the same horizontal line to the right; (if your exact “L” or adjusted “L” dimension is not shown, move to the right in the same horizontal column to the next larger number). Read vertically up from this number to the rod diameter shown. This is the required rod diameter for your application.

EXAMPLE: Adjusted L of 80” at 16,000 # would require 2-1/2” rod in the cylinder.

THRUST IN POUNDS	ROD DIAMETERS														
	5/8	1	1-3/8	1-3/4	2	2-1/2	3	3-1/2	4	4-1/2	5	5-1/2	7	8-1/2	10
50	67														
100	58	110													
150	53	103													
250	43	94	146												
400	37	83	134	186											
700	30	68	118	168	202	275									
1,000	27	60	105	155	190	257	330								
1,400	24	53	92	142	174	244	308	385							
1,800	22	48	82	127	160	230	296	366	440						
2,400	19	45	75	114	145	213	281	347	415	488					
3,200	16	41	67	103	130	194	261	329	400	461					
4,000	13	38	63	94	119	175	240	310	378	446					
5,000	9	34	60	87	110	163	225	289	360	426	494				
6,000		30	56	82	102	152	208	274	342	410	476				
8,000		26	50	76	93	137	188	245	310	375	447				
10,000		21	45	70	89	125	172	222	279	349	412	482			
12,000		17	41	65	84	118	152	210	269	326	388	454			
16,000			34	57	75	110	142	188	235	292	350	420			
20,000			28	52	68	103	136	172	218	270	326	385			
30,000				39	55	87	120	156	189	230	285	330			
40,000				22	43	74	108	142	177	210	248	294			
50,000					30	66	96	130	165	200	234	269	408		
60,000						57	88	119	154	190	225	256	384		
80,000						36	71	104	137	170	204	240	348		
100,000							57	90	120	154	199	222	324	435	605
120,000							45	77	108	146	175	207	313	396	551
140,000								64	98	128	160	194	301	365	510
160,000									47	86	118	148	279	345	476
200,000										67	98	131	260	306	428
250,000											72	109	236	275	380
300,000												86	212	251	350
350,000												52	195	234	324
400,000													182	216	301
500,000														152	269

AVENTICS CYLINDER APPLICATIONS DATA

CYLINDER SPECIFICATION SHEET

Customer: _____ Cylinder Location / Machine: _____

PLEASE CIRCLE EACH ITEM & FILL IN THE APPROPRIATE BLANKS

1. QUANTITY	_____	PRICING
2. BASIC CYL.	MODEL: HHT PPT PHT TM BORE DIA.: 1-1/2 2 2-1/2 3-1/4 4 5 6 7 8 10 12-14 ROD DIA.: 5/8, 1, 1-3/8, 1-3/4, 2, 2-1/2, 3, 3-1/2, 4, 4-1/2, 5, 5-1/2, 7, 8- STD.MOUNTING: MP-1, MP-2, MP-3, MP-4, MU-3, MF-1, MF-2, MF-5, MF-6, ME-3, ME-4, ME-5, ME-6, MS-1, MS-2, MS-3, MS-4, MS-7, MT-1, MT-2, MT-4, X1= _____, MX-0, MX-1, MX-2, MX-3, MX-4 TIE ROD BB = ROD: Single Double Special Mounting	
3. STROKE	* STROKE _____ Inches @ _____ Per inch FOR STOP TUBES SPECIFY: Length: _____ Effective Working Stroke Base Price _____ * Plus _____ Inches @ _____ Per inch	
4. ROD	Rod End Style: Male Female Threads SPECIAL ROD END MODIFICATIONS: Specify with NFPA dimensions _____ SPECIAL ROD MATERIAL _____ Base Price _____ * Plus _____ Inches @ _____ Per inch	
5. CUSHION	Head End: YES NO Head End Adj. Location 1 2 3 4 Cap End: YES NO Cap End Adj. Location 1 2 3 4 SPECIAL CUSHION MODIFICATIONS: Specify Extended, Etc. _____	
6. PORTS	Std. Ports: YES NO Locations: Head End 1 2 3 4 Cap End 1 2 3 EXTRA or SPECIAL Head End: Qty _____ Type _____ Size _____ Location 1 2 3 Cap End: Qty _____ Type _____ Size _____ Location 1 2 3	
7. BLEEDS	Head End _____ Location 1 2 3 4 Cap End _____ Location 1 2 3	
8. SEALS	Standard Viton Cast-Iron Poly-Pak Special _____	
9. OPERATING CONDITIONS	Air _____ Oil _____ Water _____ Other _____ Hydraulic Fluid _____ Temperature _____ Pressure (operating) _____ Pressure (max) _____ Water Fitted _____ Other _____	
10. SPECIAL FEATURES	_____ _____ _____	

Cylinder Part No. _____ **TOTAL LIST PRICE**

ACCESSORIES REQUIRED (specify Part Number and Quantity)

	QTY	PART NUMBER	@ _____
Rod Clevis	_____	_____	_____
Pin	_____	_____	_____
Female Rod Eye	_____	_____	_____
Clevis Bracket	_____	_____	_____
Eye Bracket	_____	_____	_____
Other Accessory	_____	_____	_____

*** NOTE: Fraction of inch priced at next whole inch increment.**

TOTAL LIST PRICE CYLINDER & ACCESSORIES

AVENTICS Cylinders and Actuators Overview

Style	Product Line	Type	Bore Size	Max. Std. Stroke	Std. Porting ^{2/} Rod Threads	Body	Position Sensors	On-line Configurator	Quick Ship ⁵	
1 - NFPA Dimensional Cylinders	TaskMaster®	NFPA dimension profile	1 1/2"-4"	120"	inch	Aluminum	Prox. switch/integral	Yes	Yes	
	TaskMaster®	NFPA dimension tie rod	5"-6"	120"	inch	Aluminum	Proximity switch	No	No	
	PowerMaster®	NFPA tie rod pneumatic	1 1/2" - 14" ¹	120"	inch	Steel	Prox. switch/integral	Yes	Yes	
	PressureMaster®	NFPA tie rod hydraulic	1 1/2" - 14" ¹	120"	inch	Steel	Prox. switch/integral	Yes	Yes	
2 - ISO 15552 Cylinders	Series TRB	ISO 15552 tie rod	32 - 125mm	2600mm (102")	metric/inch	Aluminum	Series ST6	Yes	Yes	
	Series TRB	ISO 15552 tie rod	160 - 250mm	3500mm	metric	Aluminum	Series ST6	Yes	No	
	Series ITS	ISO 15552 tie rod	160 - 320mm	2700mm	metric	Aluminum	Series ST6 & ST8	Yes	No	
	Series PRA	ISO 15552 profile	32 - 125mm	2600mm (102")	metric/inch	Aluminum	Series ST6 & SM6	Yes	Yes	
	Series ICS	ISO 15552 profile	32 - 100mm	1500 (59")	metric/inch	Stainless Steel	Series ST8	Yes	No	
	Series ICL CleanLine	ISO 15552 profile	32 - 125mm	2800 (110")	metric/inch	Aluminum	Series ST6	Yes	No	
3 - Mini Cylinders	Series CSL-RD	Mini ISO (6432)	10 - 25mm	1200 (45")	metric	Stainless Steel	Series ST4 & ST6	Yes	No	
	Series MNI	Mini ISO (6432)	10 - 25mm	1500mm	metric	Stainless Steel	Series ST6 & SM6	No	Yes	
	Series M	Mini	5/16" - 3"	32"	inch	Stainless Steel	None	No	Yes	
	Series ICM	Corrosion resistant	8 - 32mm	250mm	metric	Stainless steel / POM ⁶	ST6	No	No	
	Series MM	Mini	9/16" - 2 1/2"	32"	inch	Stainless Steel	Series MM	No	No	
4 - Rodless Cylinders	Series RTC-BV	Rodless shuttle	16 - 80mm	9900mm (389")	metric/inch	Aluminum	Series ST4	Yes	Yes	
	Series RTC-CG	Guided Rodless shuttle	16 - 40mm	2000mm (78")	metric/inch	Aluminum	Series ST4	Yes	Yes	
	Series RTC-HD	Guided Rodless shuttle	16 - 63mm	4300mm (170")	metric/inch	Aluminum	Series ST4	Yes	Yes	
5 - Automation Devices	Easy-2-Combine:								Yes	
	Series GSU	Guided shuttle	16 - 25mm	1000mm	metric	Aluminum	Series ST4	No ⁴	No	
	Series MSC	Mini slide	8 - 25mm	200mm	metric	Aluminum	Series ST4	Yes ⁴	No	
	Series ZSC	Mini slide	6 - 25mm	100mm	metric	Aluminum	Series SH4 ³	No ⁴	No	
	Series GPC-E	Guided cylinder	12 - 20mm	150mm	metric	Aluminum	Series ST6	No ⁴	No	
	Series GPC-ST	Guided shuttle cylinder	12 - 20mm	150mm	metric	Aluminum	Series ST4	No ⁴	No	
	Series RCM	Rotary module	6 - 25mm	n/a	metric	Aluminum	Series ST4	No ⁴	No	
	Series GSP	Grippers	8 - 64mm	n/a	metric	Aluminum	Series ST4	No ⁴	No	
	Series MSN	Mini slide	6 - 16mm	30mm	metric	Aluminum	Series ST4	No	No	
	Series GPC	Guided cylinder	10 - 100mm	200mm	metric	Aluminum	Series ST6	No	No	
	Series GPC-TL	Guided cyl., top load	12 - 20mm	150mm	metric	Aluminum	Series ST6	No	No	
	Series TWC	Twin rod	6 - 32mm	100mm	metric	Aluminum	Series SH4 ³	No	No	
	Series TWC-HL	Twin rod, end pos. lock	16 - 25mm	80mm	metric	Aluminum	Series SH4 ³	No	No	
	Series NCT-AL	Non-contact transfer	n/a	n/a	metric	Aluminum	None	No	No	
	Series NCT-PK	Non-contact transfer	n/a	n/a	metric	PEEK ⁷	None	No	No	
6 - Compact Cylinders	Series SSI	Short stroke ISO 15524	12 - 100mm	150mm (6")	metric	Aluminum	Series ST4,ST6,SM6	Yes	No	
	Series CCI	Compact ISO 21287	16 - 100mm	300mm (12")	metric/inch	Aluminum	Series ST6 & SM6	Yes	No	
	Series KHZ	Short stroke	8 - 100mm	100mm	metric	Aluminum	Series ST6	No	No	
7 - Other Devices	Series RDC	Rolling diaphragm cyl.	52.5 - 115mm	95mm	metric	Steel	None	No	No	
	Series RPC	Round bodied cylinder	32 - 63mm	1200mm	metric	Stainless Steel	Series ST6	Yes	No	

Notes: 1) Larger bores sizes available.

2) Metric ports are metric or ISO-G (BSPP)

3) Series SH4 sensors have specific part numbers for specific actuators.

4) Included in Easy-2-Combine configurator.

5) Specific models/bore/strokes included in *Quick Ship focused delivery program*: www.aventics.com/us/QuickShip

6) Polyoxymethylene

7) Polyetheretherketone

POWERMASTER® PPT PNEUMATIC & PHT HYDRAULIC CYLINDERS

CYLINDER OPTIONS OVERSIZE PORTS OFFERED IN WELDED BOSS—HEAD ONLY

AVENTICS OFFERS OPTIONAL CYLINDER PORT CONNECTIONS TO MEET SPECIAL SERVICE AND/OR APPLICATION REQUIREMENTS.

1. SAE straight thread ports are offered as an option at no extra charge
2. Oversize ports are located in welded bosses as shown. These ports can be located in any position offered with standard ports. Large rods limit SAE port sizes.
3. Oversize ports do not necessarily mean increased flow capacity; consult factory

BORE	EE			A	B	C	D	P	OVERSIZE PORT		
	NPTF	SAE	DASH						NPTF	SAE	DASH
1.5	3/8	9/16-18	-6	1-1/8	15/16	9/16	1/2	2-1/4	1/2*	3/4-16*	-8
2	3/8	9/16-18	-6	1-1/8	15/16	9/16	1/2	2-1/4	1/2*	3/4-16*	-8
2.5	3/8	9/16-18	-6	1-1/8	15/16	9/16	1/2	2-3/8	1/2*	3/4-16*	-8
3.25	1/2	3/4-16	-8	1-3/8	1	11/16	5/8	2-5/8	3/4*	1-1/16-12*	-12
4	1/2	3/4-16	-8	1-3/8	1	11/16	5/8	2-5/8	3/4*	1-1/16-12*	-12
5	1/2	3/4-16	-8	1-3/8	1	11/16	5/8	2-7/8	3/4*	1-1/16-12*	-12
6	3/4	1-1/16-12	-12	1-3/4	1-3/16	15/16	3/4	3-1/8	1*	1-5/16-12*	-16
8	3/4	1-1/16-12	-12	1-3/4	1-3/16	15/16	3/4	3-1/4	1	1-5/16-12*	-16

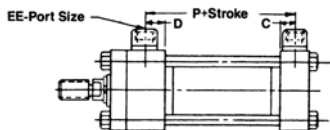
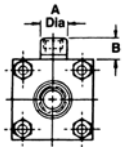

*Available on head end only. No oversize ports offered on cap on standard cylinders, except 8" bore. When cap oversize ports are required, the catalog "LB" dimension becomes equal to the "LD" catalog dimension due to the required increase in cap thickness ("J" dimension).

ROD PROTECTIVE COVER

AVENTICS offers a standard rod protective cover option on Powermaster cylinders. This option provides a dirt and oil resistant cover to extend piston rod and seal service life in applications where severe environmental conditions exist. The standard cover material is nylon fabric neoprene coated and is suitable for operation in ambient temperatures between -45° and +220°F. Rod covers are also available for larger rod sizes on special request.

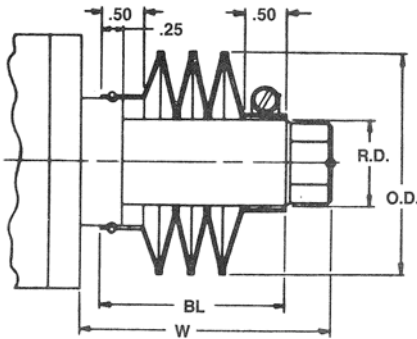

PISTON ROD		COVER OD	LENGTH FACTOR LF
CODE	DIAMETER		
D	.63"	2.25	.13
F	1.00"	2.62	.13
G	1.38"	3.00	.13
H	1.75"	3.38	.13
J	2.00"	3.75	.13
K	2.50"	4.38	.13
L	3.00"	5.12	.10

Determine the extra piston rod extension (ERE) required to accommodate the rod cover.
 $ERE = (\text{cylinder stroke} \times \text{length factor LF}) + .75"$
 (see table above for LF)
 Adjust cylinder catalog dimension V, WF, etc. as required to insure correct installation dimensions.
 $BL = ERE + .25$
 $W = ERE + W$ (from dimension charts)
 NOTE: these calculations are needed for cylinder application, but not for pricing.

STROKE ADJUSTMENT

AVENTICS offers a standard arrangement to provide cylinder stroke adjustment. When an application requires a precise cylinder stroke or when infrequent stroke length adjustment is required, this retracted position stroke adjustment should be specified. The length of the stroke adjustment must be specified when ordered. Cushioning is not available on the cap end when this standard stroke adjuster is utilized. Where cushioning is required, other designs are available.

FOLD OUT

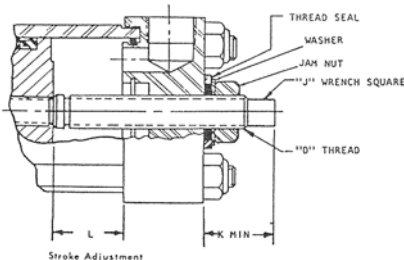

BORE SIZE	D	J	K	L MAX.
1.50"	1/2-20	.31	.94	5.00
2.00"	1/2-20	.31	.94	5.00
2.50"	3/4-16	.44	1.25	8.00
3.25"	3/4-16	.44	1.25	8.00
4.00"	3/4-16	.44	1.25	8.00
5.00"	1-14	.62	1.69	9.00
6.00"	1-14	.62	1.69	9.00
8.00"	1-1/2-12	.94	2.12	18.00

**POWERMASTER® PPT PNEUMATIC & PHT HYDRAULIC CYLINDERS
and PRESSUREMASTER® HHT HYDRAULIC CYLINDERS**

ROD END AND PORT DIMENSIONS

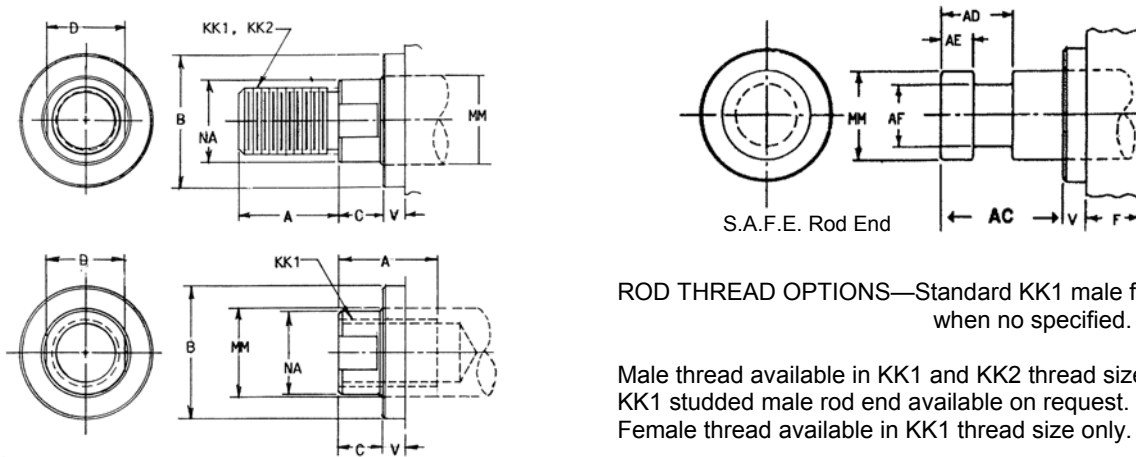

ROD THREAD OPTIONS—Standard KK1 male furnished when no specified.

Male thread available in KK1 and KK2 thread sizes.
KK1 studded male rod end available on request.
Female thread available in KK1 thread size only.

PISTON ROD END

MM Rod Dia.	A	B +0.000 -0.003	C	D	AC	AD	AE +0.000 -0.005	AF	KK1	KK2	NA +0.002 -0.002
0.625	0.750	1.024	0.38	0.50	1.12	0.62	0.250	0.375	7/16-20	1/2-20	0.563
1.000	1.125	1.499	0.50	0.88	1.62	0.94	0.375	0.688	3/4-16	7/8-14	0.938
1.375	1.625	1.999	0.62	1.12	1.75	1.06	0.375	0.875	1-14	1 1/4-12	1.313
1.750	2.000	2.374	0.75	1.50	2.00	1.31	0.500	1.125	1 1/4-12	1 1/2-12	1.688
2.000	2.250	2.624	0.88	1.69	2.62	1.69	0.625	1.380	1 1/2-12	1 3/4-12	1.940
2.500	3.000	3.124	1.00	2.06	3.25	1.94	0.750	1.750	1 7/8-12	2 1/4-12	2.438
3.000	3.500	3.749	1.00	2.62	3.62	2.44	0.875	2.250	2 1/4-12	2 3/4-12	2.938
3.500	3.500	4.249	1.00	3.00	4.38	2.69	1.000	2.500	2 1/2-12	3-12	3.438
4.000	4.000	4.749	1.00	3.38	4.50	2.69	1.000	3.000	3-12	3 1/2-12	3.938
4.500	4.500	5.249	1.00	SH 1	5.25	3.19	1.500	3.500	3 1/4-12	4 1/4-12	4.438
5.000	5.000	5.749	1.00	SH 1	5.38	3.19	1.500	3.875	3 1/2-12	4 3/4-12	4.938
5.500	5.500	6.246	1.00	SH 1	6.25	3.94	1.875	4.375	4-12	5 1/4-12	5.438
7.000	7.000	7.749	1.00	SH 2					5 1/2-12	6-12	6.938
8.000	8.000	8.749	1.00	SH 2					5 3/4-12	7 1/2-12	7.938
10.000	10.000	10.749	1.00	SH 2					7 1/4-12	9 1/2-12	9.875

Spanner Wrench Holes: SH 1 = 0.56" dia., SH 2 = 0.66" dia.

SAE STRAIGHT THREAD O-RINGS BOSS

METRIC ROD THREADS AVAILABLE AS AN OPTION.
TO FIND AVAILABLE PORTING OPTIONS, SEE PAGE 52

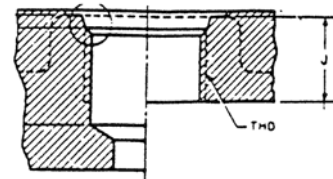

NPTF PIPE THREADS

NOM. SIZE	THDS PER IN.	PIPE OD	EFF. THD. DEPTH
3/8	18	0.68	0.41
1/2	14	0.84	0.54
3/4	14	1.05	0.55
1	11-1/2	1.32	0.68
1-1/4	11-1/2	1.66	0.71
1-1/2	11-1/2	1.90	0.72
2	11-1/2	2.38	0.76
2-1/2	8	2.88	1.14

EQUIV. NPTF	SAE THREAD SIZE	NOMINAL TUBING		THREAD DEPTH J
		SIZE	DASH	
3/8	9/16-18	3/8	-6	.50
1/2	3/4-16	1/2	-8	.56
1/2	7/8-14	5/8	-10	.65
3/4	1-1/16-12	3/4	-12	.75
3/4	1-3/16-12	7/8	-14	.75
1	1-5/16-12	1	-16	.75
1-1/4	1-5/8-12	1-1/4	-20	.75
1-1/2	1-7/8-12	1-1/2	-24	.75
2	2-1/2-12	2	-32	.75

FOLD OUT

AVENTICS ACCESSORIES

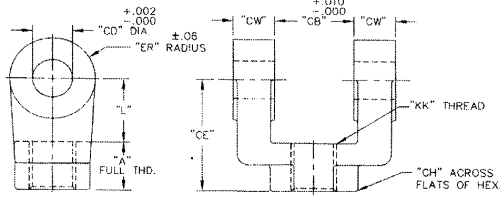
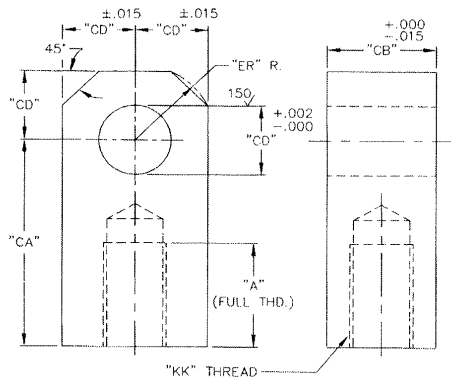

ROD EYE - Select by 'KK' to Match Rod Thread

Part Number	DIMENSIONS (Inches)						Weight (lbs.)
	A	CA	CB	CD	ER	KK	
R433012610	0.75	1.50	0.75	0.500	0.56	7/16 - 20	0.5
R432006533	0.75	1.50	0.75	0.500	0.56	1/2 - 20	0.5
R433012611	1.13	2.06	1.25	0.750	0.81	3/4 - 16	1.0
R433012612	1.13	2.38	1.50	1.000	1.13	7/8 - 14	2.3
R433012613	1.63	2.81	1.50	1.000	1.13	1 - 14	2.3
R433012614	2.00	3.44	2.00	1.375	1.69	1-1/4 - 12	5.5
R433012615	2.25	4.00	2.50	1.750	2.06	1-1/2 - 12	10.5
R433012616	2.25	4.38	2.50	2.000	2.38	1-3/4 - 12	11.3
R433012617	3.00	5.00	2.50	2.000	2.38	1-7/8 - 12	11.5
R433012618	3.50	5.81	3.00	2.500	2.81	2-1/4 - 12	20.5
R433012648	3.50	6.13	3.00	3.000	3.25	2-1/2 - 12	30.0

ROD CLEVIS - Select by 'KK' to Match Rod Thread

Part Number	STD. ROD DIA.	DIMENSIONS (Inches)								Weight (lbs.)
		A	CB	CD	CE	CH	CW	ER	KK	
R433012602	0.625	0.75	0.75	0.500	1.50	1.00	0.50	0.50	7/16 - 20	0.5
R433012665	0.625	0.75	0.75	0.500	1.50	1.00	0.50	0.50	1/2 - 20	0.0
R433012603	1.000	1.13	1.25	0.750	2.38	1.25	0.63	0.75	3/4 - 16	0.5
R433012663	1.000	1.13	1.25	0.750	2.38	1.25	0.63	0.75	7/8 - 14	1.3
R433012604	1.375	1.63	1.50	1.000	3.13	1.63	0.75	1.00	1 - 14	2.5
R433012606	1.750	2.00	2.00	1.375	4.13	2.00	1.00	1.38	1-1/4 - 12	6.4
R433012607	2.000	2.25	2.50	1.750	4.50	2.38	1.25	1.75	1-1/2 - 12	11.5
R433012664	2.000	2.25	2.50	1.750	4.50	2.38	1.25	1.75	1-3/4 - 12	11.5
R433012608	2.500	3.00	2.50	2.000	5.50	2.94	1.25	2.00	1-7/8 - 12	14.8
R433012655*	3.000	3.50	3.00	2.500	6.50	3.50	1.50	2.50	2-1/4 - 12	36.0
R433012656*	3.500	3.50	3.00	3.000	6.75	3.88	1.50	3.00	2-1/2 - 12	19.0

* These clevises include Pivot Pin with Cotter Pins

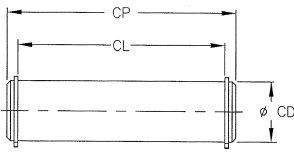
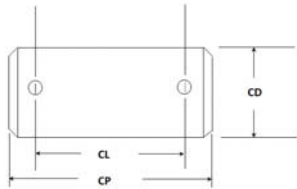

PIVOT PIN With Snap Rings

Part Number	Dimensions (Inches)		
	CD	CL	CP
R433012619	0.500	1.88	2.09
R433012621	0.750	2.62	2.88
R433012623	1.000	3.12	3.38
R433012625	1.375	4.19	4.48
Use cotter pin version	1.750	-	-
R433012629	2.000	5.19	5.54
Use cotter pin version	2.500	-	-
Use cotter pin version	3.000	-	-
Use cotter pin version	3.500	-	-

PIVOT PIN With Cotter Pins

Part Number	Dimensions (Inches)		
	CD	CL	CP
R433014353	0.500	1.94	2.28
R433014354	0.750	2.72	3.10
R433077688	1.000	3.22	3.60
R433014349	1.375	4.25	4.66
R433012627	1.750	5.25	5.66
R433088314	2.000	5.28	5.72
R433012649	2.500	6.31	6.77
R433012650	3.000	6.34	6.84
R433074833	3.500	8.41	8.97

CLEVIS BRACKET - Select by 'CD' to Match Pin

Part Number	DIMENSIONS (Inches)												Weight (lbs.)
	AA	CB	CD	CW	DD	E	F	FL	LR	M	MR	R	
R433012631	2.30	0.75	0.500	0.50	3/8 - 24	2.50	0.38	1.13	0.63	0.50	0.56	1.63	0.3
R433012632	2.90	1.25	0.750	0.63	1/2 - 20	3.00	0.63	1.88	0.88	0.75	0.88	2.06	0.5
R433012633	3.60	1.25	0.750	0.63	1/2 - 20	3.50	0.63	1.88	0.88	0.75	1.00	2.56	0.8
R433012634	4.60	1.50	1.000	0.75	5/8 - 18	4.50	0.75	2.25	1.19	1.00	1.25	3.25	2.0
R433012635	5.40	2.00	1.375	1.00	5/8 - 18	5.00	0.88	3.00	1.75	1.38	1.63	3.81	0.9
R433012636	7.00	2.50	1.750	1.25	7/8 - 14	6.50	0.88	3.13	2.13	1.75	2.12	4.94	5.1
R433012637	8.10	2.50	2.000	1.25	1 - 14	7.50	1.00	3.50	2.44	2.00	2.38	5.72	8.0
R433012653	10.00	2.50	2.500	1.25	1-1/4-12	9.25	1.75	4.75	2.75	2.50	2.50	7.07	14.8
R433012654	11.70	3.00	3.000	1.50	1-1/2-12	11.00	1.75	5.25	3.25	3.00	3.00	8.27	38.0

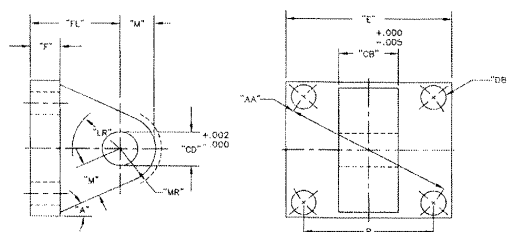
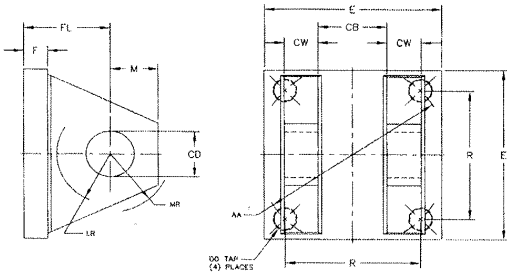

EYE BRACKET - Select by 'CD' to Match Pin

Part Number	DIMENSIONS (Inches)											Weight (lbs.)
	AA	CB	CD	DB	E	F	FL	LR	M	MR	R	
R433012638	2.30	0.75	0.500	0.38	2.50	0.38	1.13	0.69	0.50	0.56	1.63	1.0
R433012639	2.90	1.25	0.750	0.50	3.00	0.63	1.88	1.00	0.75	0.88	2.06	3.0
R433012640	3.60	1.25	0.750	0.50	3.50	0.63	1.88	1.00	0.75	0.88	2.56	3.0
R433012641	4.60	1.50	1.000	0.63	4.50	0.75	2.25	1.38	1.00	1.25	3.25	6.3
R433012642	5.40	2.00	1.375	0.63	5.00	0.88	3.00	2.00	1.38	1.62	3.81	10.3
R433012643	7.00	2.50	1.750	0.88	6.50	0.88	3.13	2.25	1.75	2.12	4.94	16.8
R433012644	8.10	2.50	2.000	1.00	7.50	1.00	3.50	2.50	2.00	2.36	5.72	25.3
R433025221	9.32	2.50	2.500	1.25	8.50	1.00	4.00	3.00	2.50	3.00	6.58	35.7
R433038709	10.60	3.00	3.000	1.25	9.50	2.00	5.25	3.25	3.00	3.25	7.50	

AVENTICS ACCESSORIES

Spherical Rod Eye (without pin)

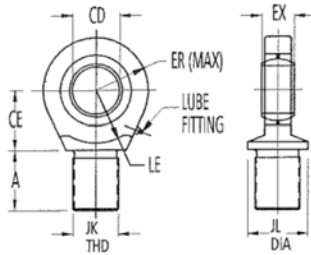

Notes:

- Accessories furnished without pivot pin, unless otherwise noted.
- When ordering, please specify AVENTICS part number and description.
- Should your application require accessories not listed, please consult factory.

Part Number	Old Part Number	Dimensions (Inches)								Load Rating (Lbs.)	Wght. (lbs.)
		A	CD	CE	ER	EX	JK	JL	LE		
R433013001	P -048490-00003	0.69	.5000 + .0000 - .0005	0.88	0.88	0.44	7/16-20	0.88	0.75	2,600	0.3
R433012998	P -048490-00000	1.00	.7500 + .0000 - .0005	1.25	1.25	0.66	3/4-16	1.31	1.06	9,400	0.8
R433012999	P -048490-00001	1.50	1.0000 + .0000 - .0005	1.88	1.38	0.88	1-14	1.50	1.44	16,800	1.8
R433013002	P -048490-00004	2.00	1.3750 + .0000 - .0005	2.13	1.81	1.19	1-1/4-12	2.00	1.88	28,600	3.3
R433013003	P -048490-00005	2.13	1.7500 + .0000 - .0005	2.50	2.19	1.53	1-1/2-12	2.25	2.13	43,000	6.0
R433013000	P -048490-00002	2.88	2.0000 + .0000 - .0005	2.75	2.63	1.75	1-7/8-12	2.75	2.50	70,000	10.0

Self-Aligning Rod End Coupler

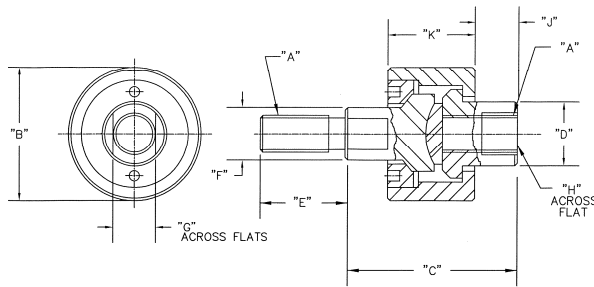

Part Number	Old Part Number	Dimensions (Inches)										*Max. Pull Load	Weight (lbs.)
		A THD.	B	C	D	E	F	G	H	J	K		
R433032614	P -115498-00000	7/16-20	1.56	2.00	0.75	0.75	0.63	0.50	0.63	0.50	1.03	3,250	0.5
R433032615	P -115498-00001	3/4-16	2.13	2.31	1.25	1.13	1.00	0.88	1.13	0.53	1.31	9,050	1.3
R433032616	P -115498-00002	1-14	2.75	3.06	1.50	1.63	1.25	1.13	1.25	0.56	2.00	19,425	3.3
R433032617	P -115498-00003	1-1/4-12	3.50	4.00	2.00	2.00	1.50	1.25	1.69	0.75	2.50	30,825	3.4
R433032618	P -115498-00004	1-1/2-12	4.00	4.38	2.25	2.25	1.75	1.50	1.94	0.87	2.75	45,750	8.3
R433032619	P -115498-00005	1-7/8-12	5.00	5.63	3.00	3.00	2.25	2.00	2.63	1.37	3.37	67,550	14.0
R433032620	P -115498-00006	1-3/4-12	4.00	4.38	2.25	2.25	2.00	1.50	1.94	0.87	2.75	58,350	8.3
R433032621	P -115498-00007	7/8-14	2.12	2.31	1.25	1.12	1.00	0.88	1.12	0.53	1.31	14,450	1.3
R433032622	P -115498-00008	1/2-20	1.56	2.00	0.75	0.75	0.62	0.50	0.62	0.50	1.03	4,450	0.5
R433075033	P -115498-00009	5/8-18	2.12	2.31	1.25	1.12	1.00	0.88	1.12	0.53	1.31	7,150	1.3

*Load rating has a 4 to 1 safety factor based on yield.

FOLD OUT

NOTICE TO PRODUCT USERS

1. WARNING: FLUID MEDIA

AVENTICS pneumatic devices are designed and tested for use with filtered, clean, dry, chemical free air at pressures and temperatures within the specified limits of the device. For use with media other than air or for human life support systems, AVENTICS must be consulted. Hydraulic cylinders are designed for operation with filtered, clean, petroleum based hydraulic fluid; operation using fire-resistant or other special types of fluids may require special packing and seals. Consult the factory.

2. WARNING: MATERIAL COMPATIBILITY

Damage to product seals or other parts caused by the use of non-compatible lubricants, oil additives or synthetic lubricants in the air system compressor or line lubrication devices voids the AVENTICS warranty and can result in product failure or other malfunction. See lubrication recommendations below.

AIR LINE LUBRICANTS! In service higher than 18 cycles per minute or with continuous flow of air through the device, an air line lubricator is recommended.* (Do not use line lubrication with vacuum products.) However, the lubricator must be maintained since the oil will wash out the grease, and lack of lubrication will greatly shorten the life expectancy. The oils used in the lubricator must be compatible with the elastomers in the device. The elastomers are normally BUNA-N, NEOPRENE, VITON, SILICONE and HYTREL. AVENTICS recommends the use of only petroleum based oils without synthetic additives, and with an aniline point between 180° F and 210° F.

COMPRESSOR LUBRICANTS! All compressors (with the exception of special "oil free" units) pass oil mist or vapor from the internal crankcase lubricating system through to the compressed air. Since even small amounts of non-compatible lubricants can cause severe seal deterioration (which could result in component and system failure) special care should be taken in selecting compatible compressor lubricants.

3. WARNING: INSTALLATION AND MOUNTING

The user of these devices must conform to all applicable electrical, mechanical, piping and other codes in the installation, operation or repair of these devices.

INSTALLATION! Do not attempt to install, operate or repair these devices without proper training in the technique of working on pneumatic or hydraulic systems and devices, unless under trained supervision. Compressed air and hydraulic systems contain high levels of stored energy. Do not attempt to connect, disconnect or repair these products

when a system is under pressure. Always exhaust or drain the pressure from a system before performing any service work. Failure to do so can result in serious personal injury.

MOUNTING! Devices should be mounted and positioned in such a manner that they cannot be accidentally operated.

4. WARNING: APPLICATION AND USE OF PRODUCTS

The possibility does exist for any device or accessory to fail to operate properly through misuse, wear or malfunction. The user must consider these possibilities and should provide appropriate safe guards in the application or system design to prevent personal injury or property damage in the event of a malfunction.

5. WARNING: CONVERSION, MAINTENANCE AND REPAIR

When a device is disassembled for conversion to a different configuration, maintenance or repair, the device must be tested for leakage and proper operation after being reassembled and prior to installation.

MAINTENANCE AND REPAIR! Maintenance periods should be scheduled in accordance with frequency of use and working conditions. All AVENTICS products should provide a minimum of 1,000,000 cycles of maintenance free service when used and lubricated as recommended. However, these products should be visually inspected for defects and given an "in system" operating performance and leakage test once a year. Where devices require a major repair as a result of the one million cycles, one year, or routine inspection, the device must be disassembled, cleaned, inspected, parts replaced as required, rebuilt and tested for leakage and proper operation prior to installation. See individual catalogs for specific cycle life estimates.

6. PRODUCT CHANGES

Product changes including specifications, features, designs and availability are subject to change at any time without notice. For critical dimensions or specifications, contact factory.

*Many AVENTICS pneumatic valves and cylinders can operate with or without air line lubrication; see individual sales catalogs for details.

-Refer to the appropriate service manual for parts and service information, most are available for download from www.aventics.com/us/downloads

WARRANTIES

7.1 Emerson warrants that:

- Emerson will transfer title to the Goods (excluding Software and Firmware) to Customer under Clause 4 of our Terms and Conditions of Sale*;
- Goods, Documentation and Services will conform with the Specification;
- Goods made by Emerson or its Affiliates will, under normal use and care, be free from defects in materials or workmanship; and
- Emerson and its Affiliates' Personnel delivering Services are trained and will use reasonable skill and care.

7.2 **Warranty Periods.** Unless otherwise specified by Emerson, the warranties in Clause 7.1 apply as follows:

- Goods:** until the earlier of 12 months from the first installation or 18 months from delivery (90 days from delivery in the case of consumables);
- Services:** for 90 days from completion of the Services;
- Goods repaired, replacement items and Services re-performed:** from delivery of the replacement or completion of the repair or re-performance, for 90 days or until the end of the original warranty period (if later).

7.3 **Warranty Procedure.** Clause 7.3 applies if, within the warranty period, Customer discovers any non-conformity with a warranty in Clause 7.1, tells Emerson in writing and, in the case of Goods, returns the non-conforming items at Customer's cost, freight and insurance pre-paid, to the repair facility chosen by Emerson. Where this Clause applies, Emerson will, at its sole option, either:

- correct any non-conforming Documents and Services; or
- repair or replace non-conforming Goods FCA (Incoterms® 2010) at the repair location; or
- instead refund the price of the non-conforming item.

7.4 Exclusions from Warranty.

- The warranties in Clause 7.1(b), (c) and (d) exclude and Customer will pay the cost of all repairs and replacements caused by any of the following: normal wear and use; inadequate maintenance; unsuitable power sources or environmental conditions; improper handling, storage, installation, or operation; misuse or accident caused by anybody except Emerson; a modification or repair not approved by Emerson in writing; materials or workmanship made, provided or specified by Customer; contamination; the use of unapproved parts, firmware or software; Cyber Attack; any other cause not the fault of Emerson.
- Emerson will not pay any costs relating to non-compliance with a warranty in Clause 7.1, except where agreed in writing in advance. Unless accepted in writing by Emerson, Customer will pay:
 - all costs of dismantling, freight, reinstallation and the time and expenses of Emerson Personnel for travel under Clause 7; and
 - all costs incurred by Emerson in correcting nonconformities for which Emerson is not responsible under Clause 7 and in examining items that comply with the warranties in Clause 7.1.
- If Emerson relies on wrong or incomplete information supplied by Customer, all warranties are void unless Emerson agrees otherwise in writing.
- Customer alone is responsible for the selection, maintenance and use of the Goods.
- Resale Products carry only the warranty given by the original manufacturer. Emerson has no liability for Resale Products beyond making a reasonable commercial effort to arrange procurement and shipping of the Resale Products.

7.5 **Disclaimer.** The limited warranties set out in this Clause 7 are the only warranties made by Emerson and can be changed only with Emerson's signed written agreement. THE WARRANTIES AND REMEDIES IN CLAUSE 7 ARE EXCLUSIVE. THERE ARE NO REPRESENTATIONS OR WARRANTIES OF ANY KIND, EXPRESS OR IMPLIED, ABOUT MERCHANTABILITY, FITNESS FOR PARTICULAR PURPOSE OR ANYTHING ELSE FOR ANY OF THE GOODS, DOCUMENTATION OR SERVICES.

*Additional conditions apply - for full details, visit our website to download our Terms and Conditions of Sale:

For U.S.: www.aventics.com/us/downloads | For Canada: www.aventics.com/ca | (AVENTICS Corporation is owned by Emerson Electric Co.)

Emerson Automation Solutions

1953 Mercer Road Lexington,
KY 40511 Tel 859.254.8031
Fax 800.489.1488
www.aventics.com/us
us.aventics@emerson.com



Further contacts:

www.aventics.com/en/contact

The data specified only serve to describe the product. No statements concerning a certain condition or suitability for a certain application can be derived from our information. The information given does not release the user from the obligation of own judgment and verification. It must be remembered that our products are subject to a natural process of wear and aging.