

# EXEDY

## CATALOG

Clutch Kit / Cable / Hydraulic /  
Fork / Flywheel / AT Parts

**2017**



# EXEDY

EXEDY Globalparts Corporation

## FIRST THINGS FIRST

**Establish the  
reason for a replacement clutch  
being required.**

If this is not due to normal usage, then the root cause of the condition must be established and corrected. These causes may include a slipping clutch, oil contamination, misalignment, faulty or incorrectly adjusted clutch release mechanism, faulty engine or gearbox mountings etc...

***Already in the Future!***

**EXEDY®**

EXEDY Globalparts Corporation

**EXEDY®**

# 2017 Product Catalog

SPECIFIED  
**ORIGINAL**  
EQUIPMENT  
WORLDWIDE

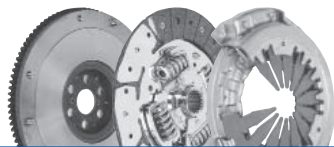

## MAJOR OE CUSTOMERS

### JAPAN

Name	JAPAN	
	EXEDY	DYNAX
<b>OEM Customers</b>		
<b>Automotive</b>		
Isuzu Motors	•	
Nissan Motor	•	•
Nissan Diesel Motor	•	
Honda Motor	•	•
Toyota Motor	•	•
Daihatsu Motor	•	
Mazda Motor	•	•
Fuji Heavy Industries	•	•
Mitsubishi Motors	•	•
Hino Motors	•	
Suzuki Motor	•	•
<b>Construction &amp; Industrial Vehicles</b>		
Nissan Motor	•	
Toyota Automatic Loom Works	•	
Kato Works	•	
Kawasaki Heavy Industries	•	•
Tadano	•	
Furukawa	•	•
Kobe Steel	•	•
Komatsu	•	•
Komatsu Forklift	•	•
Konatsu Mec	•	•
Komatsu Est	•	•
TCM	•	•

Direct transaction clients

Name	JAPAN	
	EXEDY	DYNAX
<b>OEM Customers</b>		
Yutani Heavy Industries	•	
Mitsubishi Heavy Industries	•	•
Shin Caterpillar Mitsubishi	•	•
Hitachi Construction Machinery	•	•
Sumitomo Eaton Hydraulics	•	•
Sumitomo Yale	•	
<b>Agricultural</b>		
Iseki & Co., Ltd	•	•
Ishikawajima Shibaura Machinery	•	
Kubota	•	•
Yanmar Diesel Engine	•	
Mitsubishi Agricultural Machinery	•	
<b>Unit</b>		
Kayaba Industry		•
Nabco		•
Aisin AW		•
Aisin Seiki		•
Jatco	•	•
Aisin AW Seimitsu		•
Toyota Motor Hokkaido		•

### UNITED STATES

Name	Japan		U.S.A.			
	EXEDY	DYNAX	DAIKIN CLUTCH	DAIKIN DRIVE TRAIN COMPONENTS	MERITOR CLUTCH	DYNAX-AMERICA
<b>OEM Customers</b>						
<b>USA</b>						
<b>Automotive</b>						
AAI (Ford/Mazda)				•		
CAMI (GM)				•	•	•
Ford Motor		•				
Freightliner				•	•	
General Motors				•		
HAM				•		
HAM (Honda)				•		
Kenworth				•		
Mack				•		
M.M.M.A.				•		
M.M.M.A. (Mitsubishi)				•		
Navistar				•		
NMMC				•		•
NMMC (Nissan)				•		
Peterbilt				•		
SIA				•		
SIA (Fuji/Isuzu)				•		
Volvo				•		
Western Star				•		
<b>Construction &amp; Industrial Vehicles</b>						
E-HITACHI		•				
EUCLIK-HATACHI		•				
JI Case	•					
KFI	•			•		
Komatsu Forklist U.S.A. Inc.				•		
KMS		•				
Konatsu Mining Systems		•				
TIEM				•		
Toyota Industrial Equipment Mfg.				•		
<b>Unit</b>						
DANA						•
<b>EUROPE</b>						
<b>Automotive</b>						
BENZ		•				
GM		•				
Gm France		•				
<b>Construction &amp; Industrial Vehicles</b>						
Fiat hitachi Excavators		•				
Kawasaki Precision Machinery		•				
Volvo	•					
Komatsu Hanomag A.G.		•				
<b>Unit</b>						
VOITH	•					
ZF		•				
<b>ASIA</b>						
<b>Automotive</b>						
BEML		•				
Bharat Earth Movers Ltd.		•				
Hyundai Motor	•	•				
<b>Construction &amp; Industrial Vehicles</b>						
Daewoo Heavy Industries		•				
Hyundai Heavy Industries		•				
Komatsu Changlin		•				

Distributors/Agents are not listed  
(As of July 1, 1999)



# TABLE OF CONTENTS

## SECTION 1

TERMS AND CONDITIONS OF SALE.....	4-5	1
COMPANY PROFILE.....	6	
BUSSINESS LINE-UP .....	7	
WORLDWIDE NETWORK.....	8	
PARTICIPATION IN EXHIBITIONS.....	9	
AWARDS.....	10-11	
TIPS FOR INSTALLING CLUTCH.....	12	
FUNCTION OF A CLUTCH .....	13-14	
ABBREVIATION OF THE SIZE.....	15	
CLASSIFICATION OF CLUTCH COVER .....	16	
CLASSIFICATION OF CLUTCH DISC .....	17	2
BENCH TESTING .....	18-19	
EXEDY CUSTOMER PORTAL .....	20	
EXEDY APP .....	21	
PRODUCT LEGEND.....	22	

## SECTION 2

VEHICLE APPLICATIONS GUIDE .....	23
----------------------------------	----

## SECTION 3

MEDIUM DUTY TRUCK APPLICATIONS GUIDE.....	169	3
---	-----	---

## SECTION 4

CONVERSIONS METRIC TO INCHES .....	187	4
------------------------------------	-----	---

## SECTION 5

CLUTCH INSTALLATION INSTRUCTIONS.....	191	5
---------------------------------------	-----	---



1. All orders accepted by, and goods/products supplied by, EXEDY GLOBALPARTS CORPORATION, hereafter referred to as the Company, are subject to the following Terms and Conditions of Sale. Any exceptions and/or variations must be specifically agreed to in writing by both parties.
- 2a. Manufacturers' Names, Part Numbers, Symbols or any other references appearing in the Company's listing and/or on the Company Packaging, are used for reference purposes only and in no way indicate the goods/products are made by, for, and/or guaranteed by such manufacturers.
- 2b. No partnership, joint venture, or other such association will be deemed created by opening an account with the Company. Neither party is the agent of the other, and neither party shall represent itself as an agent, officer or principal of the other for any purpose, including, without limitation, entering into any commitment, agreement or other obligation. Purchasing product from the Company does not in any way imply that the customer is an appointed sole Distributor or an **exclusive Distributor of the Company's products**.
3. All data, applications and/or interchanges, contained in the Company's listing and catalog/publications electronic lookup systems have been compiled as carefully as possible from reliable and official sources of information available at the time of publishing and appears as a **general guide only**. The information contained is correct to the best of the Company's knowledge and belief. **However, the Company cannot, and will not, assume any responsibility for possible errors contained in the publications.** Correct selection of goods/products is the responsibility of the Distributor.
- 4a. Standard OEM replacement clutch kits are guaranteed for a period of twelve (12) months or 20,000 miles, whichever ever occurs first, against manufacturers defect. OEM Replacement clutch kits and Automatic Transmission kits used in performance applications are not covered by any warranty.
- 4b. For warranty information on sports and performance clutch products, please refer to EXEDY sports clutch catalog. Sports and performance clutch products do not carry a 12 month or 20,000 mile warranty.
- 4c. All goods/products supplied by the Company are warranted against faulty material and/or workmanship. Warranty does not apply if maltreatment, damage caused by collision or incorrect fitting exists. Warranty does not apply when the goods/products sold are fitted to a vehicle used for speed trials, racing, time trials, commercial and off road vehicles unless specified for that use in the Company's publications.
- 4d. When the Company's clutch covers, clutch discs, or bearings are repackaged with another manufacturer's parts all warranties are void.
- 4e. Standard clutch kits and/or clutch components fitted to modified vehicle and/or clutch components that have been modified to Heavy Duty Specifications and/or any other specification/non-original conversions; Clutch disc and/or clutch disc friction material that have been altered are not covered by any warranty issued by the Company.
- 4f. Standard clutch kits claims will be rejected where clutch kits and/or clutch components have been fitted to incorrect or unlisted applications. Flywheel must be resurfaced/machined to OEM specifications before new clutch kit is fitted otherwise warranty will be void.
- 4g. All clutch kits and components must be installed per OEM factory service procedures.

**\*WARNING:** Do not use EXEDY clutch products in any situation where engine RPM's may exceed manufacturer's specifications. Pressure plate can explode unexpectedly causing serious injury or death to vehicle occupants and bystanders. Clutch cover and bell housing will not protect against exploding pressure plate. Refer to the Application Catalog for correct fitting. For sports and performance applications, please refer to the EXEDY Sports and Performance Publication.

## CLAIM/WARRANTY PROCEDURES

- 5b. No Claim Credit will be issued until the said goods/products have been tested and deemed faulty by the Company.
- 5c. The Company will not pay any claim for goods/products repaired by the Customer and/or claims sight unseen.
- 5d. It is the responsibility of the Company's Distributor to advise their customer on all aspects of this warranty and/or warranty procedures on any claim.
- 5e. No Claim/Warranty will be given for NON-Kit OE replacement components and/or hydraulic components.

## RETURN FOR CREDIT PROCEDURE

- 6a. Goods/Products and packaging must be in resalable condition.
- 6b. Freight must be prepaid by Distributor.
- 6c. All returns must be pre-approved by Company, any returns that arrive without pre-approval will be returned to sender.
- 6e. A reason for the return of goods/products must be indicated at the time of return and be approved by the Company in advance. (Refer to 5a).
- 6f. Stock Adjustments/Returns: Will be at the discretion of the Company.
- 6g. Returns will be subject to 20% restock fee.
- 6h. All special ordered goods/products will not be accepted back for credit.
- 6i. Returns will not be accepted after thirty (30) days from issue date of RGA (Return Goods Authorization).

## FREIGHT/INSURANCE

### Only applicable for EXEDY Globalparts Corporation Authorized Distributors

- 7a. Standard Clutch Kit orders over \$1,000 (US Dollars) will be shipped freight prepaid within the Continental United States. Component orders over \$7,500 (US Dollars) will be shipped freight prepaid within the Continental United States. **NOTE:** Sports and performance kits and products are excluded. (No free shipping on sports products) Please refer to special conditions if negotiated below. Drop shipment requests for orders under \$300 (US Dollars) there will be an additional service fee applied. Freight will also be added.
- 7b. Insurance is not included in the freight charge. Insurance, if required, is the responsibility of the Distributor and must be arranged prior to dispatch of goods/products.
- 7c. Distributors wishing to request another freight company and/or method, other than the one used by the Company, must make arrangements prior to dispatch of goods/products. All costs incurred and insurance, if required, are the responsibility of the Distributor.
- 7d. Any claims for damaged goods/products or shortages in transit must be filed with the carrier at the time of delivery. All claims listed must be identified on the delivery receipt. Any claim not identified on delivery receipt will not be the responsibility of the Company. Any claims of damaged/shortage must be reported to the Company within 2 business days (after receipt of delivery), the signed delivery receipt showing the damage/shortage must accompany this claim.

## COPYRIGHT/TRADEMARK INFRINGEMENT

- 8a. "EXEDY" and/or its Logos are Registered Trademarks with the United States Patent & Trademark Office, (Registration No. 76482354, WIPO No. 1046491).
- 8b. Trademark infringement is a serious violation of Federal law, subject to severe civil penalties; including, without limitation, injunctive relief, destruction of the infringing products, recovery of the infringer's profits and any actual damages caused by the infringement.
- 8c. Distributor is not allowed to use EXEDY" and/or its Logos, without expressed written consent.

**Please draw our attention to any errors, omissions and anomalies. It is the responsibility of the Company's Distributor to advise their staff and customers of the above terms and conditions of sales.**

All Terms and Conditions stated above are effective October 1, 2014 and supersede any other Terms and Conditions. EXEDY reserves the right to update or amend these Terms and Conditions at any time without prior notice.

1

- 1950 Incorporated as DAIKIN Manufacturing Co., Ltd.
- 1973 Established DYNAX Corporation in Hokkaido.
- 1975 Ueno Division Started in Mie.
- 1977 Established DAIKIN Clutch U.S.A., Inc.(present EGP)
- 1981 Kawagoe plant started in Saitama.
- 1995 Changed Corporate name from "Daikin Mfg. Co., Ltd." to "EXEDY Corporation"
- 1997 Listed on 1st Section of Tokyo Stock Exchange.
- 1999 QS-9000 & ISO9001 Certified in March
- 2000 ISO14001 Certified in June
- 2001 Strategic Alliance with Aisin Seiki Co., Ltd.
- 2004 ISO/TS16949 Certified in June



Expectation of the new head building

Established July 1950

President & CEO Hidehito Hisakawa

**Net Sales**  
(For the 2015 Fiscal Year)  
Exchange Rate: \$1= ¥112.68  
**¥268 Billion \$2.38 Billion**  
(EXEDY Group)

**Number of Employees**  
(As of March 31, 2016)  
**17,872 (EXEDY Group)**  
\*Includes an average taken for temporary employees

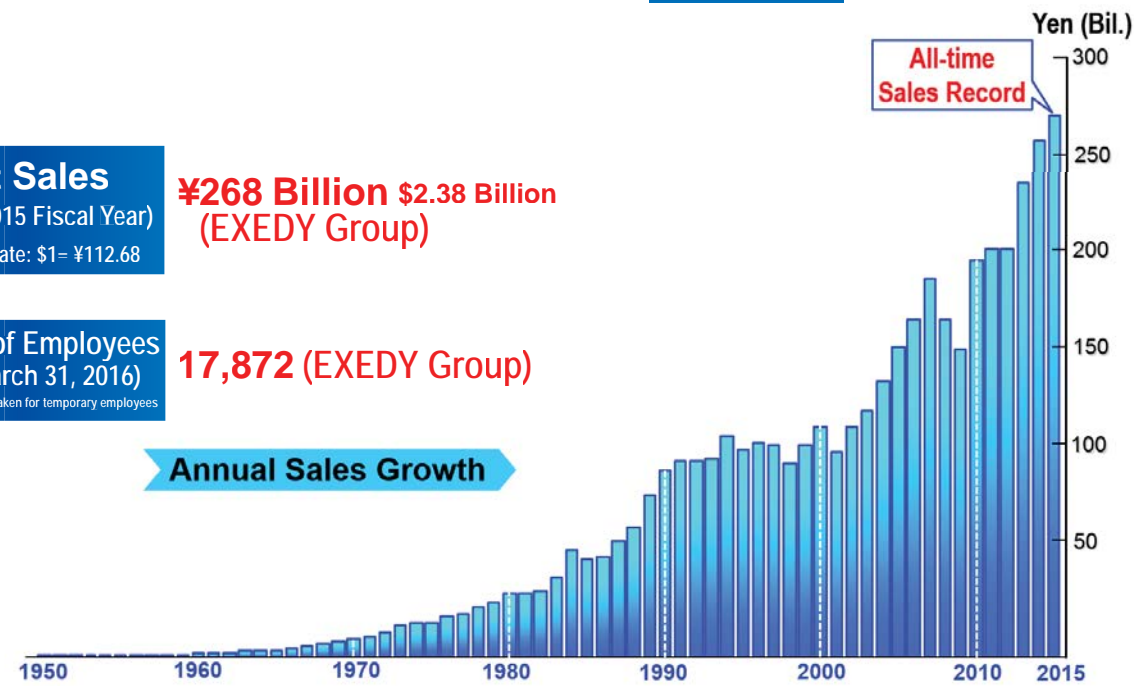

## The leading company of drivetrain components

EXEDY is a general drivetrain systems manufacturer with a main focus on automotive clutches and torque converters, managing from development to production. With the core technologies specializing in friction, vibration and fluid, EXEDY's products have been highly recognized by car manufacturers around the world and widely adopted as a genuine brand. EXEDY continues to hold a large share in both domestic and international markets, establishing 40 group companies covering 23 countries worldwide.

Core Technology

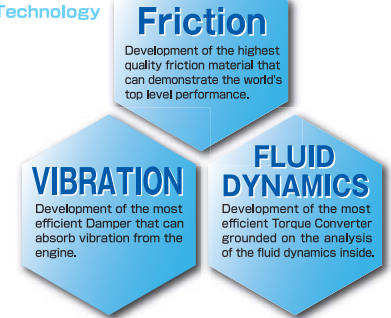

### AT products

EXEDY manufactures Torque Converters and Clutch Packs, providing today's drivers with a smooth and comfortable ride. The Super Squashed Torque Converter with high efficiency grounded on Hydrodynamics has been marking great advances in the American and Chinese automotive markets.



### MT products

The EXEDY group companies manufacture clutch covers and clutch disc assemblies around the world. EXEDY also develops dampers with high efficient noise/vibration control and high performance motor sports clutches.

### TS products

EXEDY supplies uncompromising high quality products with virtually made-to-order, multi-item, small-sized production. EXEDY's power shift transmission for construction and industrial vehicles powerfully support Japanese key industries.

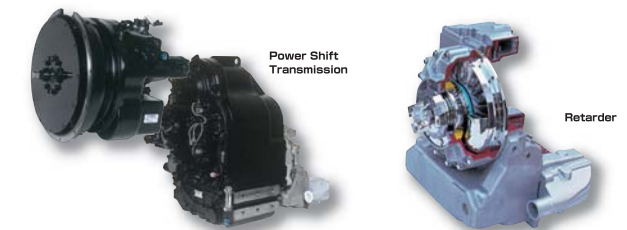

### Motorcycle products

EXEDY manufactures motorcycle clutches in the expanding markets of Southeast Asia. Utilizing the expertise accumulated in automotive clutches, EXEDY group companies in the region produce and supply Wet-type Multi-Plate Clutches and One-Way Clutches for Motorcycles.



1



Winner of the Daihatsu Special Quality Awards 2012

1



President Ina                      President Shimizu

**13 Consecutive Years**

April 16, 2013

Daihatsu Motor Co.  
President Koichi Ina (Left)



2001	2002	2003	2004	2005	2006	2007	2008	2009	2010	2011
1/200	1/207	2/199	2/195	2/196	2/206	2/356	2/338	2/291	1/258	2/289

**2012**  
**2/300**

Jatco Supplier Award 2012

**Global Technical Innovation Award**  
Development of High Performance and Low Cost Torque Converter for CVT8



President Shimizu                      President Hata



July 31, 2013

Quality: Thailand

ISUZU Engine Manufacturing Co., (Thailandia) Ltd.  
**Best in Quality Award**



Four out of 86 companies received this award



April 2010

Nissan Global Supplier Award 2011

Commemorated in regards to our next generation CVT torque converter for small and light applications.



Nissan Motor Co. Chief Executive Officer Toshiyuki Shiga (left) and EXEDY President Haruo Shimizu.



Commemorated Award and Certificate

GM Supplier Award for Quality in 2014



Daimler Supplier Award 2008

**Best Supplier Power Train**



Dr. Dieter Zetsche, Chairman & Mr. Haruo Shimizu



14 companies

Supplier of the Year 2009



HYUNDAI KIA MOTORS  
Award of Appreciation



1



### ① Check for Clutch Disc Appearance

Be sure to handle the clutch carefully and wear clean cotton work globes. Check the clutch disc that is being installed to confirm that the facing is not chipped and there are no scratches on the spline hub teeth.

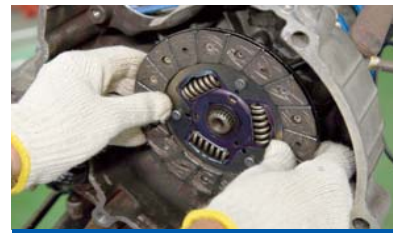

### ② Check for the Movement of Clutch

If no problem is found, fit the clutch disc onto the transmission's top shaft and confirm that it moves smoothly.



### ③ Apply the Grease to Spline Hub Teeth

After confirming that the clutch disc moves smoothly, remove it from the top shaft and use brush to apply the grease to spline hub teeth.

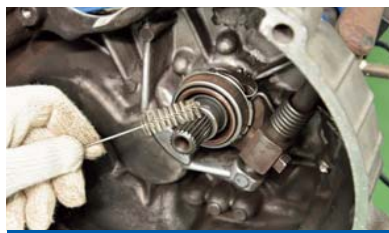

### ④ Apply the Grease to Top Shaft

Also, apply the grease to the top shaft teeth.



### ⑤ Remove Excess Grease

Fit the clutch disc back onto the top shaft and wipe away the excess grease. Excess grease could fly off and cause a juddering noise or slipping problems.



### ⑥ Check for Clutch Cover Appearance

Confirm there are no scratches or other defects on the friction surfaces of the pressure plate. If there are no problems, use a cleaner to de-grease the pressure plate friction's surfaces.



### ⑦ Installing to Fly Wheel

When installing the clutch, use an alignment tool to settle the clutch disc. Align the clutch cover with the flywheel's down pins, and temporarily tighten at least three diagonally opposed bolt.

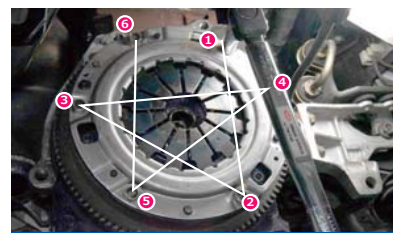

### ⑧ Tighten Diagonally

Before finishing tightening the bolt, re-confirm that the clutch disc is centered. Now, tighten the bolt to the specified torque, alternating between diagonally opposed positions. Do not use impact wrench to tighten the bolt. Differences on diaphragm's height can cause juddering noise or other problems.



### ⑨ Remove Temporary Tightening Part

Clutch cover for middle size and larger vehicles are fitted with red bolts, red wires and red plates for temporary assembly. After installing the clutch, be sure to remove them. ※Check p○,○ for your information.



### ⑩ Reinstalling the Transmission

When reassembling the transmission, position it so that crankshaft and the top shaft are aligned in straight line. While aligning the teeth, carefully insert the top shaft all the way into the clutch disc spline in a single motion.

Stopping midway or forcing the top shaft in could dent spline hub teeth and result in faulty disengagement.

After confirming that the clutch housing is fully contacted with engine's mounting surfaces, tighten the housing mounting bolt to the specified torque alternating between diagonally opposed positions.

Do not use impact wrench to tighten the bolts as the top shaft could be shifted off center.

**Correct handling and installation will prevent malfunction of clutch.**

1

1. Function of transmitting the torque from the engine to the drivetrain.
2. Smoothly deliver the power from the engine to enable smooth vehicle movement.
3. Perform quietly and to reduce drive-related vibration.
4. Protect the drivetrain when given the inappropriate use. Given the situation, the Exedy clutch will fail when given the inappropriate use in turn to protect the rest of the drivetrain, similar to the function of an electric fuse.

### CLUTCH DISENGAGED

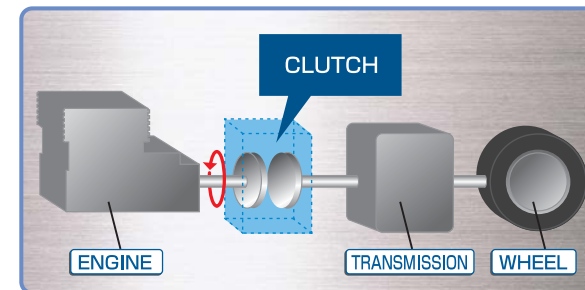

### CLUTCH ENGAGED

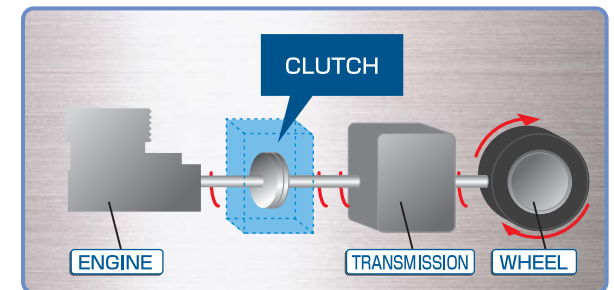

### Structure of the drivetrain and the clutch

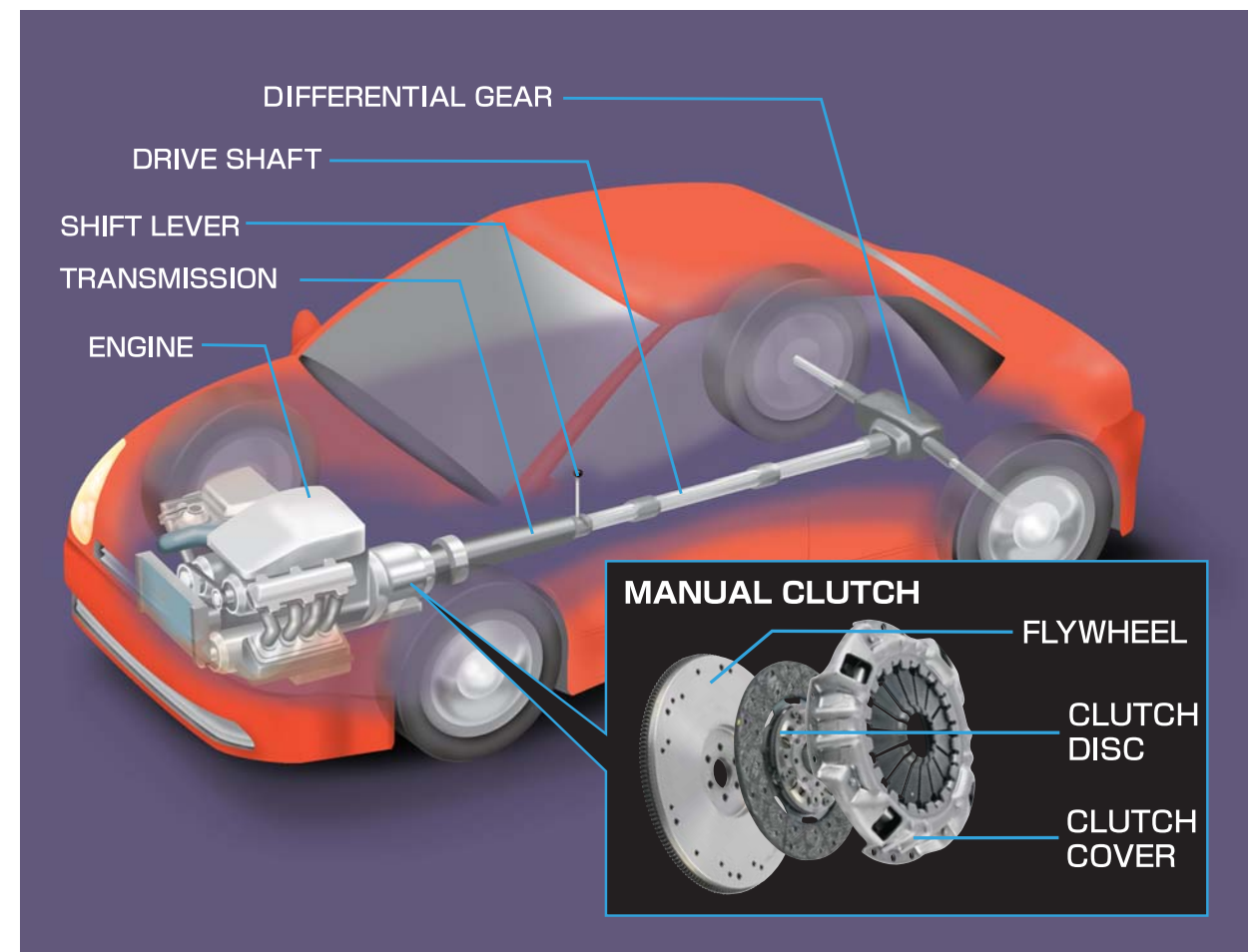



PUSH TYPE MANUAL CLUTCH ASSEMBLY

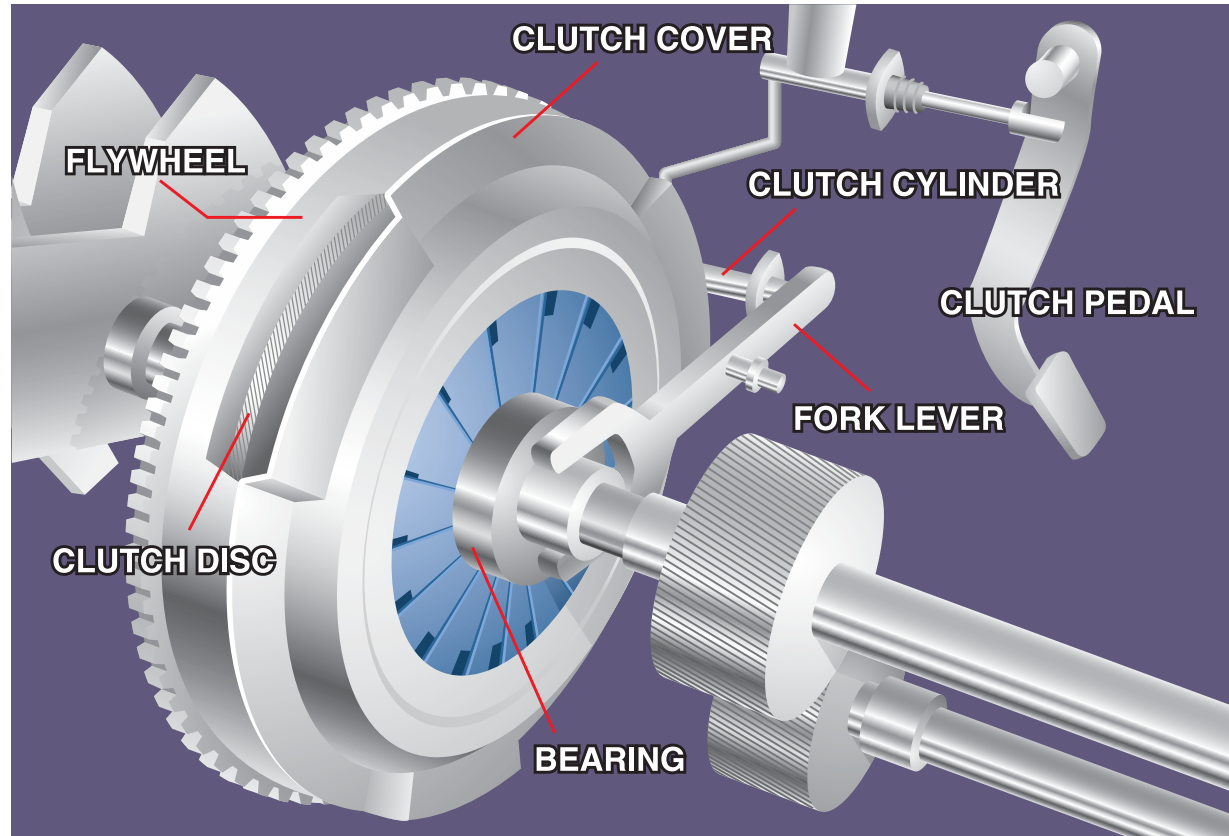

When the clutch pedal is pressed, a cable or hydraulic piston pushes on the release fork, which presses the throw-out bearing against the middle of the diaphragm spring. With the spring pushed, the clutch disc is then disconnected from the rotating flywheel that is attached to the engine. When the pedal is released, the disc will engage contact with the flywheel and transmit the torque from the engine to the rest of the drivetrain.

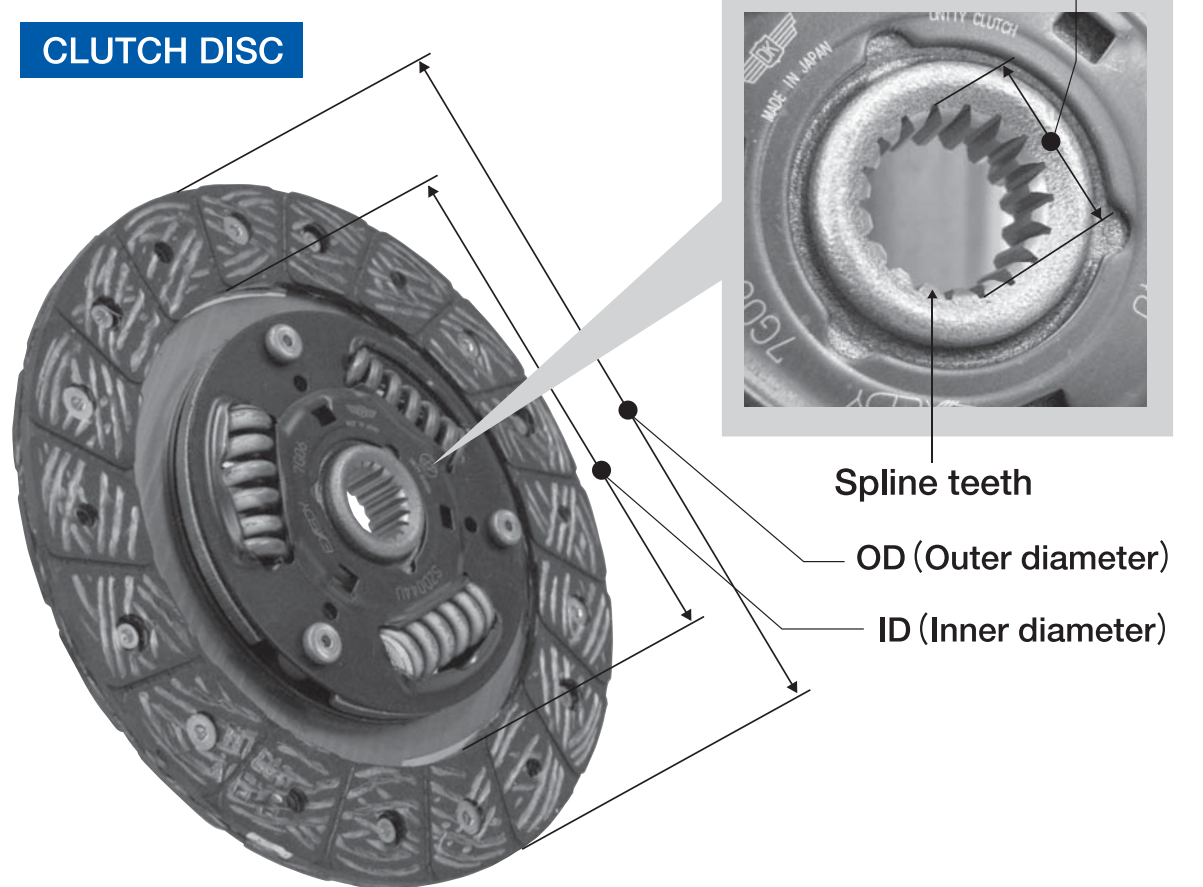
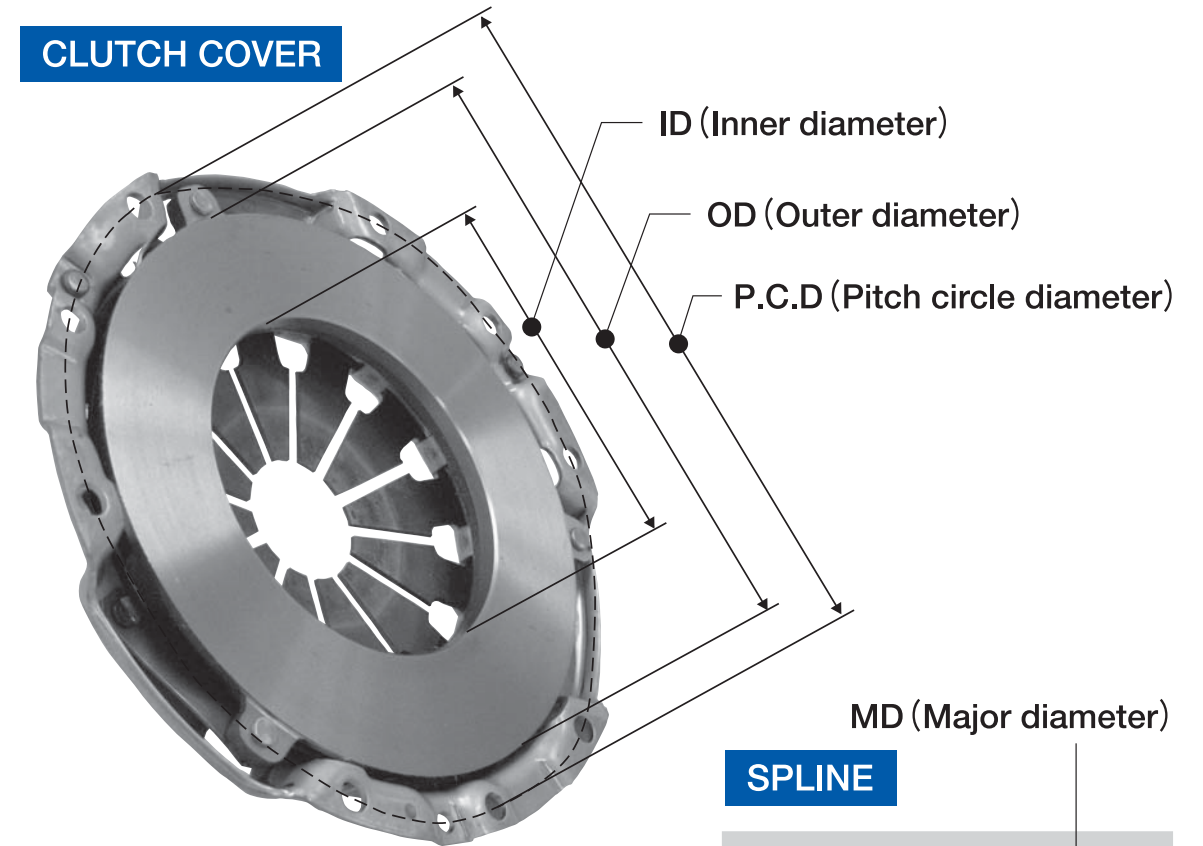
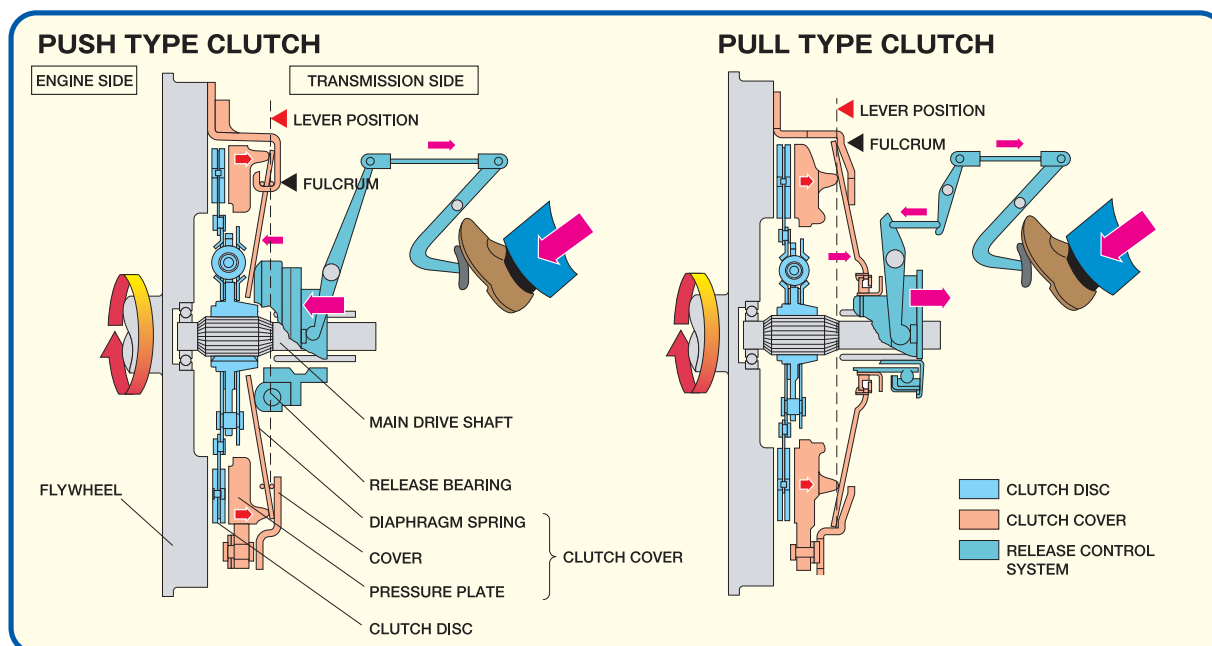



There are functionally 8 different types in clutch cover.

1

## LB LEVER BOSS TYPE



Pressure Plate and Cover are directly clawed and fixed.

## DT DIAPHRAGM TAG TYPE

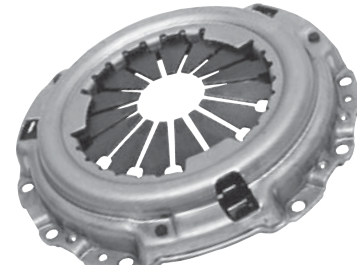

Diaphragm type and Pressure Plate and Cover are fixed by Strap Plate. Cover holds Diaphragm Spring.

## LS LEVER STRAP TYPE



Pressure Plate and Cover are fixed by the strap plate.

## PL PULL TYPE



Release Bearing is fixed on the edge of Diaphragm Spring and pull the Release Bearing.

## DB DIAPHRAGM BOSS TYPE



Diaphragm type and Pressure Plate and Cover are fixed directly.

## TW TWIN PLATE TYPE

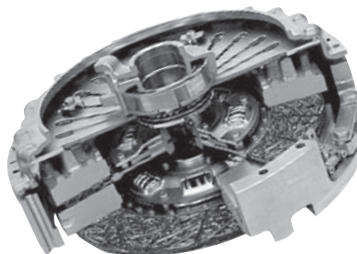

Two Discs are used in one cover.

## DS DIAPHRAGM STRAP TYPE



Diaphragm type and Pressure Plate and Cover are fixed by strap plate. Diaphragm and Cover are fixed by Stud Pins.

## DU UNITY TYPE

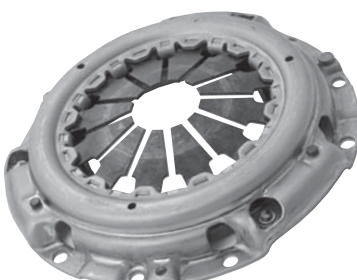

Basically the similar design as DT and, specially designed to utilize common parts.

## Classification to Friction material

### ORGANIC DISC



Clutch disc assembly with asbestos free organic facing

### METAL DISC



Clutch disc assembly with metallic facing

### COMBINATION DISC

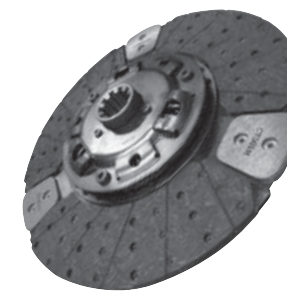

Clutch disc assembly with combination of asbestos free organic facing and metallic facing

1

## Classification to damper type

### SOLID TYPE



Clutch disc assembly with no damper

### NORMAL TYPE



Clutch disc assembly with damper

### SILENT TYPE

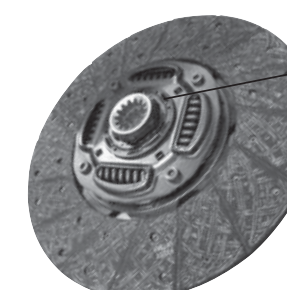

Clutch disc assembly with damper and pre-damper

### WAD TYPE



Clutch disc assembly with Wide Angle Damper to absorb noise and vibration more efficiently



Various benches have been developed by EXEDY. Tests far too dangerous to be conducted in a vehicle are reproduced on these test benches with the reliability of products being evaluated.

1

### Low Inertia/High Torque Dynamometer

Allows for new performance testing methods. Used for evaluations from the standpoint of the vehicle, can reproduce conditions of an actual engine.

Evaluation of damper performance for a moving vehicle. Damper evaluation includes rotational fluctuations similar to an actual car.

Cranking evaluation at engine start-up. Product noise and vibration can be evaluated during cranking.

Evaluation is possible of item such as:

- Damper Attenuation Rate
- Rattling noise when the engine is idling
- Performance when starting up from a stop
- Acceleration shock
- Engine start-up
- Low temperature Automatic Transmission Fluid tests at -30C

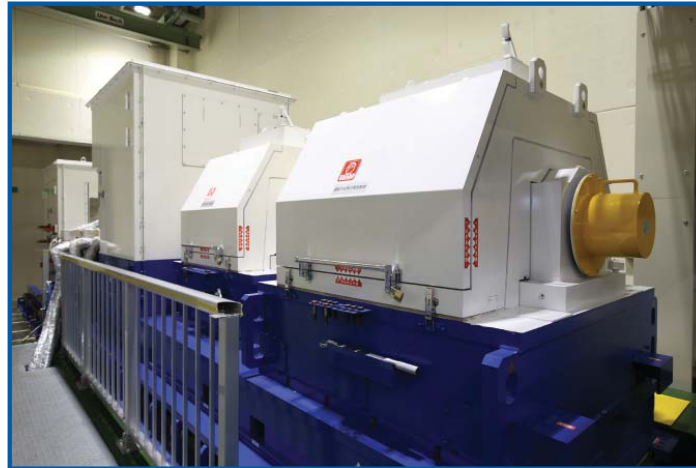

### Burst Tester

Evaluation of rotational intensity at extreme high-speed tester.

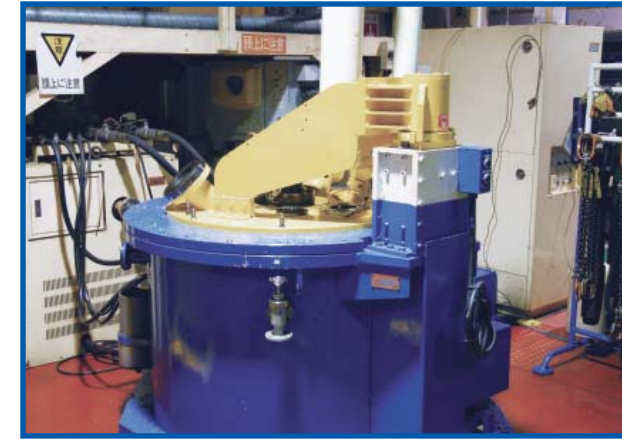

### High Speed Full Sized Tester

Evaluation of friction characteristic and durability of clutch disc.



### Release Durability Tester

Evaluation of the intensity and fatigue of a diaphragm spring.



### Torsional Durability Tester

Evaluation of the durability of clutch disc damper.



1



Customers can place PO's anytime, Check Stock & Track Orders - 24 hours, 365 days, No Human Error, No Retyping from Fax, No phone calls for inventory inquiry.

## ADVANTAGES TO USING THE PORTAL...

### Orders

Create New Order - Upload Excel/CSV/TSV files.  
 Manage Orders - View Open Orders and Completed Orders.

### Inventory

Item Inquiry - Check Availability of Product.

### Pricing

View Price List - Check Current Pricing.  
 Download Price List - Available in Excel/CSV/PDF formats.

### Statement

View Statement - View Open Invoices.  
 Download Statement - Available in Excel/CSV/PDF formats.

### Admin

User Maintenance - Setup Users, Change Passwords.  
 Shipping Settings - Setup Shipping Address and Ship Method.  
 File Upload Settings - Upload Orders from Any Spreadsheet Program.

### Help

Help & Guides - Information to Help You to use the Portal successfully.  
 Contact Us - Give Us Your Comments, Suggestions and Inquiries.

### Points & Rewards

Get points by Web Order & Exchange your point to Rewards or Discounts.

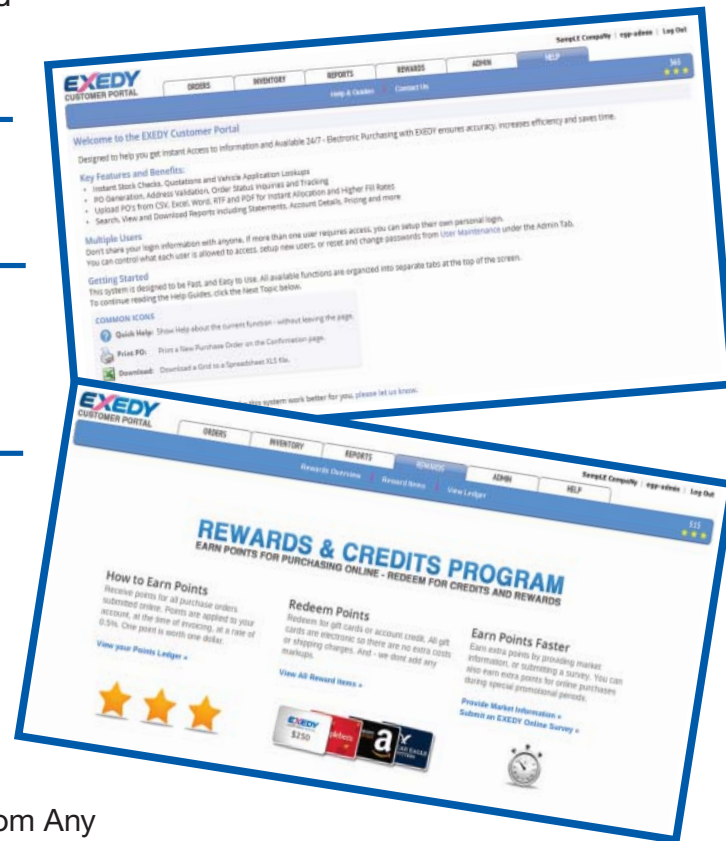

## EXEDY has an App on IOS!

With the App you will be able to search and browse EXEDY's massive product line-up of OEM Replacement Clutches, Performance Clutches and Transmission Parts.

This app will help you find the clutch you need for your application as well as answer some frequently asked questions.

This app will only work on iPhone 5s, 6, 6 plus, 6s, and 6s plus. Will be available for Android soon.



# Product Legend

LEGEND													
MT OEM Product	1	2	3	4	5	6	7	8	9	10	11	12	Note
	Maker	Type	EXD/EGP Number Rule										
Cover (EGP#)	F	M	C (Cover)	9	0	0							
Disc (EGP#)	F	M	D (Disc)	8	0	0							
Flywheel-OE (NEW)	M	B	F (Flywheel)	5	0	0							
Flywheel-Sport (EGP)	M		F (Flywheel)	5	0	1							
Flywheel-Sport (EXD)	M		F (Flywheel)	0	4								
Kit-Domestic	F	J	K (Kit)	1	0	0	0						
Kit-Domestic-Various Suffix								F	W				Flywheel included
Kit-Domestic-Various Suffix								H	D				Heavy Duty
Kit-Domestic-Various Suffix								F	W	H	D		Heavy Duty with Flywheel
Kit-Domestic-Various Suffix								A					Flywheel included
Kit-Domestic-Various Suffix								C	S	C			Concentric Slave Cylinder
Bearing	B	R	G	0	1	9	0						
CSC Bearing (New)	C	S	C	0	1	4	3						
Pilot Bearing	P	B	G	0	0	2							
Pilot Bushing	P	B		0	0	3							
Pilot Tool	P	T		0	0	5							
Master Cylinder	M	C		1	0	1							
Slave Cylinder	S	C		1	1	7							
Bolt	B	L	T	1	0	0							

Legend for OE Kits					
First Alpha Characters - EGP number range 1000-1999 for kit					
AUK - Audi	KIK - Kia	VWK - Volkswagen	16 - Toyota	KHC - Acura/Honda	KMZ - Mazda
BMK - BMW	MBK - Mitsubishi	01 - Jeep	17 - Volkswagen	KHN - Hino	KNS - Nissan
BZK - Mercedes	MFK - Mitsubishi Fuso	02 - Audi	22 - Volvo	KHY - Hyundai	KPO - Porsche
CRK - Chrysler	MZK - Mazda	03 - BMW	23 - Daihatsu	KIS - Isuzu	KPT - Peugeot
DWK - Daewoo	NDK - Nissan Diesel UD	04 - General Motors	KAR - Alfa Romeo	KJP - Jeep	KSA - SAAB
FJK - Subaru	NSK - Nissan	05 - Dodge/Mitsubishi	KBM - BMW	KKI - KIA	KSB - Subaru
FMK - Ford	POK - Porsche	06 - Nissan	KCH - Chrysler	KLN - Lincoln	KSN - Saturn
GMK - General Motors	SBK - Saab	07 - Ford	KDG - Dodge	KMB - Mitsubishi	KSZ - Suzuki
HCK - Acura/Honda	SMK - Smart Car	08 - Acura/Honda	KFI - Fiat	KME - Mercedes	KTY - Toyota
HYK - Hyundai	SZK - Suzuki	09 - Isuzu	KFM - Ford	KMF - Mitsu Fuso	KVO - Volvo
ISK - Isuzu	TYK - Toyota	10 - Mazda	KGM - GM	KMG - Midget	KVW - VW
JDK - John Deere	VLK - Volvo	15 - Subaru			

Legend for OEM Flywheel			
CRF - Chrysler/Dodge	FF - Subaru	FWFMM - Ford	FWHDCXFF - Honda Flex Flywheel
FMF - Ford	NF - Nissan	FWFTF - Ford	FWHY - Hyundai
GMF - General Motors	TY - Toyota	FWME - Ford	FWNS - Nissan
HF - Acura/Honda	FWBM - BMW	FWFME - Ford	FWNV - Navistar
FM - Ford	FWCHR - Chrysler	FWGM - GM	FWSBL - Subaru
GF - GM	FWFM - Ford	FWGMC - GM	FWTY - Toyota
ZF - Mazda	FWFMC - Ford	FWHDA - Acura/Honda	FWVW - VW
MB - Mitsubishi	FWFMF - Ford	FWHDC - Acura/Honda	

Meaning of Kit Suffixs
HD - Heavy Duty
FW - Flywheel included
FWHD - Heavy Duty with Flywheel
LB - Less Bearing
CSC - Includes Concentric Slave Cylinder
HP - High Performance



# SECTION 2

## VEHICLE APPLICATIONS GUIDE



Liter	CC/IN	Cyl	Years		Application Information	Kit	Disc (mm)	Disc (in)	Spline Dia	Splines	Master Cyl	Slave Cyl	Clutch Cable	Clutch Fork	New Flywheel
			To	From											
<b>ACURA (Performance Applications Available)</b>															
<b>CL</b>															
2.2	2156	L4	1997	1997	—	08014	225	8-7/8	1-1/16	24	MC234	SC642	—	—	—
2.3	2254	L4	1998	1999	—	08014	225	8-7/8	1-1/16	24	MC234	SC642	—	—	—
3.2	3210	V6	2003	2003	Sold as kit only	HCK1007	238	9-3/8	1	24	—	—	—	—	—
<b>INTEGRA</b>															
1.6	1590	L4	1986	1989	—	08006	200	7-7/8	7/8	21	—	—	—	—	—
1.7	1678	L4	1992	1993	GSR	08028	219	8-5/8	1-1/16	24	—	—	—	—	—
1.8	1834	L4	1990	1991	—	08017	219	8-5/8	1	24	—	—	CC660	—	—
1.8	1834	L4	1992	1993	—	08028	219	8-5/8	1-1/16	24	—	—	CC660	—	—
1.8	1797	L4	1994	1999	—	KHC05	219	8-5/8	1-1/16	24	MC238	SC646	—	—	—
1.8	1797	L4	1997	1998	Type R	KHC13	210	8-1/4	1-1/16	24	MC238	SC646	—	—	—
1.8	1797	L4	2000	2001	Type R	KHC12	219	8-5/8	1-1/16	24	MC238	SC646	—	—	—
1.8	1834	L4	2000	2001	—	KHC12	219	8-5/8	1-1/16	24	MC238	SC646	—	—	—
<b>LEGEND</b>															
2.5	2494	V6	1986	1987	—	08018	225	8-7/8	1	24	MC504	—	—	—	—
2.7	2675	V6	1987	1990	—	08018	225	8-7/8	1	24	MC504	—	—	—	—
3.2	3206	V6	1994	1995	6 Spd GS, Sold As Kit Only	08033	240	9-1/2	1	24	—	—	—	—	—
<b>RSX</b>															
2.0	1998	L4	2002	2006	5 Spd, Sold As Kit Only	KHC09	215	8-1/2	1-1/6	24	MC502	SC895	—	—	—
2.0	1998	L4	2002	2006	6 Spd, Type S, Sold As Kit Only	KHC10	215	8-1/2	1-1/32	24	MC502	SC899	—	—	—
<b>TL</b>															
3.2	3210	V6	2004	2006	Sold as kit only	HCK1007	238	9-3/8	1	24	MC502	—	—	—	—
3.7	3664	V6	2010	2013	Sold as kit only, AWD, 6 Spd	HCK1012	240	9-1/2	1-1/6	24	—	—	—	—	—
<b>TSX</b>															
2.4	2354	L4	2003	2008	Includes Flywheel, Sold As Kit Only	HCK1001	225	8-7/8	1-1/32	24	MC502	SC895	—	—	FWHDA02
2.4	2354	L4	2009	Up	Sold As Kit Only	HCK1009	225	8-7/8	1	24	MC502	SC895	—	—	HCF001
<b>ALFA ROMEO</b>															
<b>164</b>															
3.0	2959	V6	1991	1995	L & LS Series, Sold As Kit Only	KAR03	228	9	15/16	20	—	—	—	—	—
3.0	2959	V6	1994	1995	Q Series, Sold As Kit Only	KAR04	228	9	15/16	20	—	—	—	—	—
<b>BERLINA, GT VELOCE, SPRINT</b>															
1.8	1779	L4	1969	1971	Sold As Kit Only	KAR01	215	8-1/2	1	10	—	—	—	—	—
2.0	1961	L4	1970	1974	Sold As Kit Only	KAR01	215	8-1/2	1	10	—	—	—	—	—
<b>SPIDER</b>															
2.0	1961	L4	1970	1994	Sold As Kit Only	KAR01	215	8-1/2	1	10	—	—	—	—	—
<b>AMERICAN MOTORS</b>															
<b>AMBASSADOR</b>															
4.7	287	V8	1966	1967	—	01026	265	10-1/2	1-1/8	10	—	—	—	—	—
4.8	293	V8	1968	1968	—	01026	265	10-1/2	1-1/8	10	—	—	—	—	—
5.4	330	V8	1960	1966	4 Spd	01026	265	10-1/2	1-1/8	10	—	—	—	—	—
5.6	342	V8	1967	1968	4 Spd	01026	265	10-1/2	1-1/8	10	—	—	—	—	—
6.4	391	V8	1968	1970	4 Spd	01026	265	10-1/2	1-1/8	10	—	—	—	—	—
<b>AMERICAN</b>															
4.8	293	V8	1967	1968	4 Spd	01026	265	10-1/2	1-1/8	10	—	—	—	—	—
<b>AMX</b>															
4.8	293	V8	1968	1969	—	01026	265	10-1/2	1-1/8	10	—	—	—	—	—
5.6	342	V8	1968	1969	—	01026	265	10-1/2	1-1/8	10	—	—	—	—	—
5.9	360	V8	1970	1970	4 Spd, 4 BBL	01026	265	10-1/2	1-1/8	10	—	—	—	—	—
6.4	391	V8	1969	1970	4 Spd, 4 BBL	01026	265	10-1/2	1-1/8	10	—	—	—	—	—
<b>CLASSIC</b>															
4.7	287	V8	1964	1965	—	01026	265	10-1/2	1-1/8	10	—	—	—	—	—
5.4	330	V8	1966	1966	—	01026	265	10-1/2	1-1/8	10	—	—	—	—	—
<b>CONCORD</b>															
2.5	153	L4	1980	1982	—	01001	232	9-1/8	1-1/8	10	—	SC833	—	—	—

Liter	CC/IN	Cyl	Years		Application Information	Kit	Disc (mm)	Disc (in)	Spline Dia	Splines	Master Cyl	Slave Cyl	Clutch Cable	Clutch Fork	New Flywheel
			To	From											
<b>AMERICAN MOTORS CONT.</b>															
<i>EAGLE, KAMMBACK, SX4</i>															
2.5	153	L4	1983	1984	AMC Engine	01001	232	9-1/8	1-1/8	10	—	SC723	—	—	—
4.2	256	L6	1981	1988	From VIN #011C04	01007	265	10-1/2	1-1/8	10	—	SC832	—	—	—
<i>HORNET</i>															
5.9	360	V8	1971	1972	4 Spd	01026	265	10-1/2	1-1/8	10	—	—	—	—	—
<i>JAVELIN</i>															
5.6	342	V8	1968	1969	4 Spd	01026	265	10-1/2	1-1/8	10	—	—	—	—	—
5.9	360	V8	1970	1970	4 Spd, 4 BBL	01026	265	10-1/2	1-1/8	10	—	—	—	—	—
6.4	391	V8	1968	1970	4 Spd, 4 BBL	01026	265	10-1/2	1-1/8	10	—	—	—	—	—
<i>MARLIN</i>															
4.7	287	V8	1965	1966	—	01026	265	10-1/2	1-1/8	10	—	—	—	—	—
4.8	293	V8	1967	1967	4 Spd	01026	265	10-1/2	1-1/8	10	—	—	—	—	—
5.4	330	V8	1965	1966	—	01026	265	10-1/2	1-1/8	10	—	—	—	—	—
5.6	342	V8	1967	1967	4 Spd	01026	265	10-1/2	1-1/8	10	—	—	—	—	—
<i>REBEL</i>															
4.8	293	V8	1968	1969	3 Spd	01026	265	10-1/2	1-1/8	10	—	—	—	—	—
5.6	342	V8	1968	1969	4 Spd	01026	265	10-1/2	1-1/8	10	—	—	—	—	—
6.4	391	V8	1969	1970	4 Spd, 4 BBL	01026	265	10-1/2	1-1/8	10	—	—	—	—	—
<i>SPIRIT</i>															
2.5	153	L4	1980	1982	—	01001	232	9-1/8	1-1/8	10	—	SC833	—	—	—
<b>AUDI</b>															
<i>100, 100 QUATTRO</i>															
1.8	1760	L4	1970	1971	—	17030	215	8-1/2	13/16	24	—	—	—	—	—
1.9	1872	L4	1972	1974	—	17030	215	8-1/2	13/16	24	—	—	—	—	—
1.9	1871	L4	1975	1977	—	17030	215	8-1/2	13/16	24	—	—	—	—	—
2.3	2309	L5	1989	1989	—	02020	228	9	15/16	23	—	—	—	—	—
2.3	2309	L5	1989	1991	—	02020	228	9	15/16	23	MC102	—	—	—	—
<i>200, 200 QUATTRO</i>															
2.2	2226	L5	1989	1991	Turbo	02021	240	9-1/2	13/16	24	MC102	—	—	—	—
<i>4000, 4000S, 4000 QUATTRO</i>															
1.6	1588	L4	1982	1983	Diesel	17002	190	7-1/2	1	24	MC101	SC509	—	—	—
1.8	1780	L4	1984	1987	—	17031	210	8-1/4	13/16	24	MC101	SC509	—	—	—
2.2	2144	L5	1980	1983	WE eng.	17030	215	8-1/2	13/16	24	MC101	SC509	—	—	—
2.2	2144	L5	1984	1987	—	02011	228	9	13/16	24	MC101	SC509	—	—	—
<i>4000, 4000S, 4000 QUATTRO (CANADA)</i>															
1.8	1780	L4	1987	1987	—	17031	210	8-1/4	13/16	24	MC101	SC509	—	—	—
2.2	2144	L5	1984	1986	—	02011	228	9	13/16	24	MC101	SC509	—	—	—
<i>5000, 5000 QUATTRO</i>															
2.0	1986	L5	1979	1981	Diesel	02019	215	8-1/2	13/16	24	MC102	SC509	—	—	—
2.0	1986	L5	1982	1985	Turbo, Diesel	02011	228	9	13/16	24	MC102	SC509	—	—	—
2.2	2144	L5	1978	1984	Non-Turbo	02011	228	9	13/16	24	MC102	SC509	—	—	—
2.2	2144	L5	1980	1982	Turbo	02011	228	9	13/16	24	MC102	SC509	—	—	—
2.2	2144	L5	1983	1985	Turbo	02018	240	9-1/2	13/16	24	MC102	SC509	—	—	—
2.2	2226	L5	1985	1987	Non-Turbo	02011	228	9	13/16	24	MC102	SC509	—	—	—
2.2	2226	L5	1986	1988	Turbo	02018	240	9-1/2	13/16	24	MC102	SC509	—	—	—
2.3	2309	L5	1987	1988	—	02011	228	9	13/16	24	MC101	—	—	—	—
<i>80, 80 QUATTRO, 90, 90 QUATTRO</i>															
2.0	1983	L4	1988	1990	—	02022	228	9	15/16	23	—	—	—	—	—
2.3	2309	L5	1988	1992	SOHC	02020	228	9	15/16	23	—	—	—	—	—
2.3	2309	L5	1990	1991	DOHC, 20 Valve	02023	240	9-1/2	15/16	23	—	—	—	—	—
<b>A3</b>															
2.0	1984	L4	2006	2007	Turbo, Includes Slave Cylinder, Sold as Kit Only	VWK1005	240	9-7/16	15/16	23	—	—	—	—	—



Liter	CC/IN	Cyl	Years		Application Information	Kit	Disc (mm)	Disc (in)	Spline Dia	Splines	Master Cyl	Slave Cyl	Clutch Cable	Clutch Fork	New Flywheel
			To	From											
<b>AUDI CONT.</b>															
<b>A4, A4 QUATTRO</b>															
1.8	1781	L4	1997	2001	Turbo	VWK1001	228	9	15/16	23	MC108	—	—	—	FWDM02 (1997-99)
1.8	1781	L4	2002	2005	Turbo, Sold as Kit Only	VWK1001	228	9	15/16	23	—	—	—	—	FWDM01 (2000-05)
2.8	2771	V6	1996	1996	—	AUK1001	240	9-7/16	15/16	23	—	—	—	—	—
2.8	2771	V6	1997	1997	—	AUK1001	240	9-7/16	15/16	23	MC108	—	—	—	—
2.8	2771	V6	1998	2001	—	AUK1001	240	9-7/16	15/16	23	—	—	—	—	—
3.0	2976	V6	2002	2004	6 Spd., Sold as Kit Only	AUK1003	240	9-7/16	15/16	23	—	—	—	—	—
3.2	3123	V6	2007	2007	Sold as Kit Only	AUK1006	240	9-7/16	15/16	23	—	—	—	—	—
<b>A6, A6 QUATTRO</b>															
2.7	2671	V6	2000	2004	Turbo	AUK1002	240	9-7/16	15/16	23	—	—	—	—	—
2.8	2771	V6	1995	1997	—	02026	240	9-1/2	15/16	23	MC108	—	—	—	—
<b>ALLROAD QUATTRO</b>															
2.7	2671	V6	2001	2005	Turbo, Sold as Kit Only	AUK1002	240	9-7/16	15/16	23	—	—	—	—	—
<b>COUPE GT, QUATTRO</b>															
2.2	2144	L5	1981	1984	—	17030	215	8-1/2	13/16	24	—	—	—	—	—
2.2	2144	L5	1983	1985	Turbo	02018	240	9-1/2	13/16	24	MC101	—	—	—	—
2.2	2226	L5	1984	1985	—	02011	228	9	13/16	24	—	—	—	—	—
2.2	2226	L5	1986	1986	—	02011	228	9	13/16	24	MC101	SC509	—	—	—
2.2	2226	L5	1987	1987	—	02011	228	9	13/16	24	—	—	—	—	—
2.3	2309	L5	1987	1987	—	02011	228	9	13/16	24	MC101	—	—	—	—
2.3	2309	L5	1990	1991	20 Valve Engine	02023	240	9-1/2	15/16	23	—	—	—	—	—
<b>FOX</b>															
1.5	1471	L4	1973	1974	—	17002	190	7-1/2	1	24	—	—	—	—	—
<b>S4</b>															
2.2	2226	L5	1993	1994	Turbo, 20V, From CH #4AP080001	02026	240	9-1/2	15/16	23	MC102	—	—	—	—
2.7	2671	V6	2000	2002	Turbo	AUK1002	240	9-7/16	15/16	23	—	—	—	—	—
4.2	4163	V8	2004	2004	Sold as Kit Only	AUK1005	240	9-7/16	15/16	23	—	—	—	—	—
4.2	4163	V8	2005	2007	Sold as Kit Only	AUK1004	240	9-7/16	15/16	23	—	—	—	—	—
<b>S6</b>															
2.2	2226	L5	1995	1997	Turbo, 20 Valve Turbo, Sold As Kit Only	AUK1000	240	9-1/2	15/16	23	MC102	—	—	—	—
<b>TT, TT QUATTRO</b>															
1.8	1781	L4	2001	2001	Turbo, 5 Spd, From CH #8N1006001, Includes DMF, Sold As Kit Only	VWK1000	225	8-7/8	7/8	28	MC110	—	—	—	—
1.8	1781	L4	2001	2001	6spd, Slave Cylinder Included, Sold as kit only	VWK1002	240	9-7/16	15/16	23	MC110	—	—	—	—
1.8	1781	L4	2002	2003	Turbo, Sold as kit only, Includes Slave Cylinder, AWP Eng., TT Quattro	VWK1002	240	9-7/16	15/16	23	MC110	—	—	—	—
1.8	1781	L4	2002	2003	Turbo, Includes Dual Mass FW	VWK1000	225	8-7/8	7/8	28	MC110	—	—	—	—
1.8	1781	L4	2004	2004	Turbo, Sold as kit only, Includes Slave Cylinder, TT Quattro	VWK1002	240	9-7/16	15/16	23	MC110	—	—	—	—
1.8	1781	L4	2005	2005	Turbo, Sold as kit only, Includes Slave Cylinder	VWK1002	240	9-7/16	15/16	23	MC110	—	—	—	—
<b>BMW</b>															
<b>2000, 2000C, CS, TI, TII. 2002TI, TII</b>															
2.0	1990	L4	1966	1974	Sold As Kit Only	KBM05	228	9	1-1/8	10	—	—	—	—	—
2.0	1990	L4	1971	1976	Sold As Kit Only	KBM03	215	8-1/2	1-1/8	10	—	—	—	—	—
2.0	1990	L4	1973	1974	Turbo, Sold As Kit Only	KBM05	228	9	1-1/8	10	—	—	—	—	—
<b>2500, 2800, 2800CS, 3.0, BAVARIA</b>															
2.8	2788	L6	1974	1974	2800, Sold As Kit Only	03015	240	9-1/2	1-1/8	10	—	SC516	—	—	—
3.0	2985	L6	1971	1971	3.0CSL	03015	240	9-1/2	1-1/8	10	—	—	—	—	—
3.0	2985	L6	1971	1971	3.0SI	03015	240	9-1/2	1-1/8	10	—	—	—	—	—
3.0	2985	L6	1971	1972	3.0CS	03015	240	9-1/2	1-1/8	10	—	—	—	—	—
3.0	2985	L6	1971	1972	3.0CSI	03015	240	9-1/2	1-1/8	10	—	—	—	—	—
3.0	2985	L6	1971	1972	3.0S	03015	240	9-1/2	1-1/8	10	—	—	—	—	—
3.0	2985	L6	1973	1974	3.0CS	03015	240	9-1/2	1-1/8	10	—	SC516	—	—	—
3.0	2985	L6	1973	1974	3.0CSI	03015	240	9-1/2	1-1/8	10	—	SC516	—	—	—
3.0	2985	L6	1973	1974	3.0S	03015	240	9-1/2	1-1/8	10	—	SC516	—	—	—
3.0	2985	L6	1975	1976	3.0SI	03015	240	9-1/2	1-1/8	10	—	SC516	—	—	—

Liter	CC/IN	Cyl	Years		Application Information	Kit	Disc (mm)	Disc (in)	Spline Dia	Splines	Master Cyl	Slave Cyl	Clutch Cable	Clutch Fork	New Flywheel
			To	From											
<b>BMW CONT.</b>															
<b>318i, IC, IS, TI</b>															
1.8	1796	L4	1991	1995	With Air Conditioning & DMF	03028	215	8-1/2	1-1/8	10	MC116	SC518	—	—	—
1.9	1895	L4	1996	1996	With Air Conditioning	03028	215	8-1/2	1-1/8	10	MC116	SC518	—	—	—
1.9	1895	L4	1997	1997	With Air Conditioning, To 3/97	03028	215	8-1/2	1-1/8	10	MC116	SC518	—	—	—
1.9	1895	L4	1997	1997	With Air Conditioning, From 4/87	03028	215	8-1/2	1-1/8	10	—	SC518	—	—	—
1.9	1895	L4	1998	1999	With Air Conditioning	03028	215	8-1/2	1-1/8	10	—	SC518	—	—	—
<b>323Ci, I, IC</b>															
2.5	2494	L6	1998	1999	—	03011	228	9	1-1/8	10	—	SC518	—	—	—
2.5	2494	L6	2000	2000	—	BMK1004	228	9	1-3/16	10	—	SC894	—	—	—
2.5	2494	L6	1998	1999	—	03011	228	9	1-1/8	10	—	SC518	—	—	—
<b>325, Ci, E, ES, I, IC, IS, IX, XI</b>															
2.5	2494	L6	1987	1989	325IS	03023	228	9	1-9/16	10	MC113	SC517	—	—	—
2.5	2494	L6	1987	1990	325I	03023	228	9	1-9/16	10	MC113	SC517	—	—	—
2.5	2494	L6	1988	1990	325IX	03023	228	9	1-9/16	10	MC113	SC517	—	—	—
2.5	2494	L6	1990	1992	325IS	03011	228	9	1-1/8	10	MC116	SC518	—	—	—
2.5	2494	L6	1991	1991	325I	03023	228	9	1-9/16	10	MC116	SC518	—	—	—
2.5	2494	L6	1991	1991	325IX	03023	228	9	1-9/16	10	MC116	SC517	—	—	—
2.5	2494	L6	1992	1992	325I	03011	228	9	1-1/8	10	MC116	SC518	—	—	—
2.5	2494	L6	1992	1993	325IC	03023	228	9	1-9/16	10	MC116	SC518	—	—	—
2.7	2693	L6	1984	1986	—	03013	228	9	1-1/8	10	MC113	SC517	—	—	—
2.7	2693	L6	1987	1988	—	03011	228	9	1-1/8	10	MC113	SC517	—	—	—
2.5	2494	L6	2004	2004	Sold as Kit Only	BMK1016	240	9 7/16	1 1/8	22	—	SC894	—	—	—
2.5	2494	L6	2005	2005	Sold as Kit Only	BMK1016	240	9 7/16	1 1/8	22	—	SC516	—	—	—
<b>328Ci, I, IC, IS</b>															
2.8	2793	L6	1996	1997	328i, IC, IS Sold As Kit Only	KBM11	240	9-1/2	1-1/8	10	MC116	SC518	—	—	—
2.8	2793	L6	1998	1998	328i, IC, IS Sold As Kit Only	KBM11	240	9-1/2	1-1/8	10	—	SC518	—	—	—
2.8	2793	L6	1999	2000	328i, Ci, Sold As Kit Only	KBM11	240	9-1/2	1-1/8	10	—	SC894	—	—	—
<b>330i, Ci, Xi</b>															
3.0	2979	L6	2001	2003	Sold as Kit Only	BMK1017	240	9-7/16	1-1/8	10	—	SC894	—	—	—
3.0	2979	L6	2004	2004	Sold as Kit Only	BMK1016	240	9 7/16	1 1/8	22	—	SC894	—	—	—
3.0	2979	L6	2005	2005	Sold as Kit Only	BMK1016	240	9 7/16	1 1/8	22	—	SC516	—	—	—
3.0	2979	L6	2001	2003	Sold as Kit Only	BMK1017	240	9-7/16	1-1/8	10	—	SC894	—	—	—
3.0	2979	L6	2004	2004	Sold as Kit Only	BMK1016	240	9 7/16	1 1/8	22	—	SC894	—	—	—
3.0	2979	L6	2005	2005	Sold as Kit Only	BMK1016	240	9 7/16	1 1/8	22	—	SC516	—	—	—
3.0	2996	L6	2006	2006	—	BMK1016	240	9-7/16	1-1/8	22	—	SC516	—	—	—
3.0	2979	L6	2001	2003	Sold as Kit Only	BMK1007	240	9-7/16	1-1/8	10	—	SC894	—	—	—
<b>525i</b>															
2.5	2494	L6	1989	1990	—	03023	228	9	1-9/16	10	MC115	SC516	—	—	—
2.5	2494	L6	1991	1995	Twin Cam with DMF	03011	228	9	1-1/8	10	MC115	SC516	—	—	—
<b>528, E, I</b>															
2.7	2693	L6	1982	1985	528E, Pre-Damped	03013	228	9	1-1/8	10	MC113	SC517	—	—	—
2.7	2693	L6	1986	1986	528E, From 5/1/86	03011	228	9	1-1/8	10	MC113	SC517	—	—	—
2.7	2693	L6	1986	1986	528E, Pre-Damped, To 4/30/86	03013	228	9	1-1/8	10	MC113	SC517	—	—	—
2.7	2693	L6	1987	1988	528E	03011	228	9	1-1/8	10	MC113	SC517	—	—	—
2.8	2788	L6	1979	1981	528I	03015	240	9-1/2	1-1/8	10	MC114	SC517	—	—	—
2.8	2793	L6	1997	1998	528I, Sold As Kit Only	KBM11	240	9-1/2	1-1/8	10	—	SC516	—	—	—
2.8	2793	L6	1999	2000	From 10/98, Sold as Kit Only	BMK1005	240	9-7/16	1-1/8	10	—	SC516(2000)	—	—	—
<b>530i</b>															
3.0	2985	L6	1975	1978	—	03015	240	9-1/2	1-1/8	10	MC114	SC517	—	—	—
3.0	2997	V8	1994	1995	Sold As Kit Only	KBM08	240	9-1/2	1-1/8	10	—	SC516	—	—	—
3.0	2979	L6	2001	2003	Sold as Kit Only	BMK1017	240	9-7/16	1-1/8	10	—	SC516	—	—	—
3.0	2979	L6	2004	2005	Sold as Kit Only	BMK1016	240	9 7/16	1 1/8	22	—	SC516	—	—	—
3.0	2996	L6	2006	2007	—	BMK1016	240	9-7/16	1-1/8	22	—	SC516	—	—	—



Liter	CC/IN	Cyl	Years		Application Information	Kit	Disc (mm)	Disc (in)	Spline Dia	Splines	Master Cyl	Slave Cyl	Clutch Cable	Clutch Fork	New Flywheel
			To	From											
<b>BMW CONT.</b>															
<b>533i</b>															
3.2	3210	L6	1983	1983	—	03015	240	9-1/2	1-1/8	10	—	—	—	—	—
3.2	3210	L6	1984	1984	From 4/1/84, Sold As Kit Only	KBM01	240	9-1/2	1-1/8	10	—	—	—	—	—
3.2	3210	L6	1984	1984	To 3/31/84	03015	240	9-1/2	1-1/8	10	—	—	—	—	—
<b>535i</b>															
3.5	3430	L6	1985	1986	Sold As Kit Only	KBM01	240	9-1/2	1-1/8	10	—	—	—	—	—
3.5	3430	L6	1987	1987	From 12/1/87, Sold As Kit Only	KBM04	240	9-1/2	1-1/8	10	—	—	—	—	—
3.5	3430	L6	1987	1987	To 11/30/87, Sold As Kit Only	KBM01	240	9-1/2	1-1/8	10	—	—	—	—	—
3.5	3430	L6	1988	1988	Sold As Kit Only	KBM04	240	9-1/2	1-1/8	10	—	—	—	—	—
3.5	3430	L6	1989	1993	Sold As Kit Only	KBM04	240	9-1/2	1-1/8	10	MC115	SC516	—	—	—
3.5	3430	L6	1988	1988	—	KBM01	240	9-1/2	1-1/8	10	—	—	—	—	—
<b>540i, IT</b>															
4.4	4398	V8	1997	2003	Sold as Kit Only	BMK1002	240	9-7/16	1-3/8	10	—	SC516	—	—	—
<b>630CSI</b>															
3.0	2985	L6	1977	1977	—	03015	240	9-1/2	1-1/8	10	MC114	SC517	—	—	—
<b>633CSI</b>															
3.2	3210	L6	1978	1981	—	03015	240	9-1/2	1-1/8	10	MC114	SC517	—	—	—
3.2	3210	L6	1982	1982	From 9/82	03015	240	9-1/2	1-1/8	10	MC113	SC517	—	—	—
3.2	3210	L6	1982	1982	To 8/82	03015	240	9-1/2	1-1/8	10	MC114	SC517	—	—	—
3.2	3210	L6	1983	1983	—	03015	240	9-1/2	1-1/8	10	MC113	SC517	—	—	—
3.2	3210	L6	1984	1984	From 4/1/84	KBM07	240	9-1/2	1-1/8	10	MC113	SC517	—	—	—
3.2	3210	L6	1984	1984	To 3/31/84	03015	240	9-1/2	1-1/8	10	MC113	SC517	—	—	—
<b>635CSI</b>															
3.5	3430	L6	1985	1987	To 6/30/87	KBM01	240	9-1/2	1-1/8	10	MC113	SC517	—	—	—
3.5	3430	L6	1987	1989	From 7/1/87	KBM07	240	9-1/2	1-1/8	10	MC113	SC517	—	—	—
<b>733i</b>															
3.2	3210	L6	1978	1984	To 3/31/84	03015	240	9-1/2	1-1/8	10	—	—	—	—	—
3.2	3210	L6	1984	1984	From 4/1/84	KBM01	240	9-1/2	1-1/8	10	MC114	SC516	—	—	—
<b>735i</b>															
3.5	3430	L6	1985	1986	—	KBM01	240	9-1/2	1-1/8	10	MC114	SC516	—	—	—
3.5	3430	L6	1987	1987	—	KBM01	240	9-1/2	1-1/8	10	MC115	SC516	—	—	—
3.5	3430	L6	1988	1992	Sold As Kit Only	KBM07	240	9-1/2	1-1/8	10	MC115	SC516	—	—	—
<b>850Ci, CSI</b>															
5.6	5576	V12	1994	1995	Sold As Kit Only	KBM10	280	11	1-3/8	10	MC115	—	—	—	—
<b>M3</b>															
3.0	2990	L6	1995	1995	Sold As Kit Only	KBM06	240	9-1/2	1-1/8	10	MC116	SC516	—	—	—
3.2	3152	L6	1996	1997	5 Spd, Sold as Kit Only	BMK1003	240	9-1/2	1-1/8	10	MC116	SC516	—	—	—
3.2	3152	L6	1998	1999	5 Spd, Sold as Kit Only	BMK1003	240	9-1/2	1-1/8	10	—	SC516	—	—	—
3.2	3246	L6	2001	2006	6 Spd From 3/01, Sold as Kit Only	BMK1010	240	9-7/16	1-3/8	10	—	SC894	—	—	—
<b>M5</b>															
3.5	3453	L6	1988	1988	Sold As Kit Only	KBM07	240	9-1/2	1-1/8	10	MC113	SC517	—	—	—
3.6	3553	L6	1991	1993	Sold As Kit Only	KBM07	240	9-1/2	1-1/8	10	—	—	—	—	—
5.0	4941	V8	2000	2003	Sold as Kit Only	BMK1006	240	9-7/16	1-3/8	10	—	—	—	—	—
<b>M6</b>															
3.5	3453	L6	1987	1988	Sold As Kit Only	KBM07	240	9-1/2	1-1/8	10	MC113	SC517	—	—	—
<b>X3</b>															
2.5	2494	L6	2004	2005	Sold as Kit Only	BMK1016	240	9 7/16	1 1/8	22	—	SC894	—	—	—
3.0	2979	L6	2004	2005	Sold as Kit Only	BMK1016	240	9 7/16	1 1/8	22	—	SC894	—	—	—
<b>X5</b>															
3.0	2979	L6	2001	2003	Sold as Kit Only	BMK1011	240	9-7/16	1-1/8	10	—	SC516	—	—	—

Liter	CC/IN	Cyl	Years		Application Information	Kit	Disc (mm)	Disc (in)	Spline Dia	Splines	Master Cyl	Slave Cyl	Clutch Cable	Clutch Fork	New Flywheel
			To	From											
<b>BMW CONT.</b>															
<b>Z3</b>															
1.9	1895	L4	1996	1997	To 2/97	03028	215	8-1/2	1-1/8	10	—	SC518	—	—	—
1.9	1895	L4	1997	1998	From 3/97	03028	215	8-1/2	1-1/8	10	—	SC518	—	—	—
2.8	2793	L6	1997	1997	To 2/97	KBM11	240	9-1/2	1-1/8	10	MC116	SC518	—	—	—
2.8	2793	L6	1997	1998	From 3/97, Sold As Kit Only	KBM11	240	9-1/2	1-1/8	10	—	SC518	—	—	—
2.8	2793	L6	1999	2000	From 10/98, Sold as Kit Only	BMK1005	240	9-7/16	1-1/8	10	—	SC516	—	—	—
3.0	2979	L6	2001	2002	Sold as Kit Only	BMK1017	240	9-7/16	1-1/8	10	—	SC516	—	—	—
3.2	3152	L6	1998	2002	5 Spd, Sold as Kit Only	BMK1003	240	9-1/2	1-1/8	10	—	SC516	—	—	—
<b>Z4</b>															
2.5	2494	L6	2003	2005	Sold as Kit Only	BMK1015	240	9-7/16	1-1/8	22	—	SC894	—	—	—
3.0	2979	L6	2003	2005	Sold as Kit Only	BMK1015	240	9-7/16	1-1/8	22	—	SC894	—	—	—
3.0	2996	L6	2006	2007	To Mar 31/2007, Sold as Kit Only	BMK1016	240	9-7/16	1-1/8	22	—	SC894	—	—	—
3.0	2996	L6	2007	2007	Sold as Kit Only	BMK1018	240	9 7/16	1 1/8	22	—	SC894	—	—	—
<b>Z8</b>															
5.0	4941	V8	2000	2000	Sold as Kit Only	BMK1006	240	9-7/16	1-3/8	10	—	—	—	—	—
5.0	4941	V8	2001	2003	Sold as Kit Only	BMK1006	240	9-7/16	1-3/8	10	—	SC516	—	—	—
<b>BUICK</b>															
<i>CENTURION, CENTURY, ELECTRA, GRAN SPORT, LASABRE, REGAL, SKYLARK, SPECIAL, WILDCAT</i>															
2.5	153	L4	1980	1984	X Body	04077	225	8-7/8	15/16	14	—	—	—	—	—
2.5	153	L4	1985	1985	X Body	04077	225	8-7/8	15/16	14	—	SC714	—	—	—
2.5	153	L4	1985	1986	N Body	04005	215	8-1/2	1	14	—	SC714	—	—	—
2.5	153	L4	1987	1988	N Body	04005	215	8-1/2	1	14	MC317	SC714	—	—	—
2.5	153	L4	1989	1989	N Body	04005	215	8-1/2	1	14	—	—	—	—	—
2.8	171	V6	1980	1985	X Body	04077	225	8-7/8	15/16	14	—	—	—	—	FWGM111
2.8	171	V6	1984	1985	—	04077	225	8-7/8	15/16	14	—	—	—	—	FWGM111
2.8	171	V6	1988	1988	—	04088	225	8-7/8	15/16	14	—	—	—	—	FWGM111
3.0	183	V6	1987	1988	—	04005	215	8-1/2	1	14	MC317	SC714	—	—	—
3.2	195	V6	1979	1979	—	04021	265	10-1/2	1-1/8	10	—	—	—	—	—
3.8	232	V6	1976	1977	9-1/8" Disc	04062	232	9-1/8	1-1/8	10	—	—	—	—	—
3.8	232	V6	1976	1977	9-1/8" Disc	04062	232	9-1/8	1-1/8	10	—	—	—	—	—
3.8	232	V6	1977	1977	3 Spd, 10-3/8" Disc	04021	265	10-1/2	1-1/8	10	—	—	—	—	—
3.8	232	V6	1978	1979	4 Spd, 10-3/8" Disc	04021	265	10-1/2	1-1/8	10	—	—	—	—	—
3.8	232	V6	1978	1979	Turbo, 4 Spd, 10-3/8" Disc	04021	265	10-1/2	1-1/8	10	—	—	—	—	—
3.8	232	V6	1980	1980	Turbo, 3 Spd, 10-3/8" Disc	04021	265	10-1/2	1-1/8	10	—	—	—	—	—
3.8	232	V6	1980	1981	3 Spd, 10-3/8" Disc	04021	265	10-1/2	1-1/8	10	—	—	—	—	—
5.6	342	V8	1966	1967	10-3/8" Disc	04021	265	10-1/2	1-1/8	10	—	—	—	—	—
5.6	342	V8	1966	1967	11" Disc	04049	280	11	1-1/8	10	—	—	—	—	—
5.7	348	V8	1968	1973	3 Spd, 10-3/8" Disc	04021	265	10-1/2	1-1/8	10	—	—	—	—	—
5.7	348	V8	1970	1973	3 Spd, 11" Disc	04049	280	11	1-1/8	10	—	—	—	—	—
6.6	403	V8	1966	1966	—	04049	280	11	1-1/8	10	—	—	—	—	—
6.6	403	V8	1967	1969	—	04049	280	11	1-1/8	10	—	—	—	—	—
7.5	458	V8	1970	1970	—	04049	280	11	1-1/8	10	—	—	—	—	—
7.5	458	V8	1970	1973	2 BBL	04049	280	11	1-1/8	10	—	—	—	—	—
7.5	458	V8	1970	1973	4 Spd, 4 BBL	04020	280	11	1-1/8	26	—	—	—	—	—
<b>SKYHAWK</b>															
1.8	110	L4	1983	1983	3 Speed and 5 Speed	04094	215	8-1/2	1	14	—	—	—	—	—
1.8	110	L4	1983	1984	4 Spd, Non-Turbo	04094	215	8-1/2	1	14	—	—	—	—	—
1.8	110	L4	1983	1984	5 Spd, Non-Turbo	04046	215	8-1/2	1	14	MC318	SC714	—	—	—
1.8	110	L4	1984	1984	4 Spd	04094	215	8-1/2	1	14	—	—	—	—	—
1.8	110	L4	1984	1984	5 Spd	04046	215	8-1/2	1	14	MC318	SC714	—	—	—
1.8	110	L4	1984	1984	5 Spd, Turbo	KGM03	215	8-1/2	1	14	—	—	—	—	—
1.8	110	L4	1984	1986	4 Spd, Turbo	KGM01	215	8-1/2	1	14	MC318	SC714	—	—	—
1.8	110	L4	1985	1986	5 Spd, Turbo	KGM03	215	8-1/2	1	14	—	SC714	—	—	—
1.8	110	L4	1986	1986	4 Spd, Non-Turbo	04094	215	8-1/2	1	14	—	SC714	—	—	—
1.8	110	L4	1986	1986	5 Spd, Non-Turbo	04046	215	8-1/2	1	14	MC318	SC714	—	—	—



Liter	CC/IN	Cyl	Years		Application Information	Kit	Disc (mm)	Disc (in)	Spline Dia	Splines	Master Cyl	Slave Cyl	Clutch Cable	Clutch Fork	New Flywheel
			To	From											
<b>BUICK CONT.</b>															
<i>SKYHAWK CONT.</i>															
2.0	122	L4	1983	1984	5 Spd	04005	215	8-1/2	1	14	—	—	—	—	—
2.0	122	L4	1985	1986	5 Spd	04005	215	8-1/2	1	14	—	SC714	—	—	—
2.0	122	L4	1987	1987	4 Spd	04077	225	8-7/8	15/16	14	MC318	SC714	—	—	—
2.0	122	L4	1987	1987	4 Spd, Turbo	04077	225	8-7/8	15/16	14	MC318	SC714	—	—	—
2.0	122	L4	1987	1987	5 Spd	KGM03	215	8-1/2	1	14	—	SC714	—	—	—
2.0	122	L4	1987	1987	5 Spd, Turbo	KGM03	215	8-1/2	1	14	—	SC714	—	—	—
2.0	122	L4	1988	1989	—	KGM01	215	8-1/2	1	14	MC318	SC714	—	—	—
3.8	232	V6	1976	1978	—	04062	232	9-1/8	1-1/8	10	—	—	—	—	—
<i>SOMERSET</i>															
2.5	153	L4	1985	1986	—	04005	215	8-1/2	1	14	MC326	SC714	—	—	—
2.5	153	L4	1987	1987	—	04005	215	8-1/2	1	14	MC317	SC714	—	—	—
3.0	183	V6	1987	1987	—	04005	215	8-1/2	1	14	MC317	SC714	—	—	—
<b>CADILLAC</b>															
<i>CIMARRON</i>															
2.0	122	L4	1983	1986	—	04005	215	8-1/2	1	14	—	—	—	—	—
2.8	171	V6	1985	1986	—	04077	225	8-7/8	15/16	14	MC318	SC714	—	—	—
2.8	171	V6	1987	1988	—	04088	225	8-7/8	15/16	14	MC316	SC714	—	—	—
<i>CTS</i>															
3.2	195	V6	2003	2004	Sold as Kit Only, Includes CSC Hydraulic Slave	GMK1022	240	9-7/16	1	14	—	—	—	—	—
5.7	348	V8	2005	2005	Sold as Kit Only	GMK1023	290	11-7/16	1-1/8	26	—	—	—	—	—
6.0	366	V8	2006	2007	Sold as Kit Only	GMK1023	290	11-7/16	1-1/8	26	—	—	—	—	—
<b>CHECKER</b>															
<i>MARATHON</i>															
3.8	232	L6	1968	1968	11" Disc	04072	280	11	1-1/8	10	—	—	—	—	—
4.1	250	L6	1969	1974	11" Disc	04072	280	11	1-1/8	10	—	—	—	—	—
5.4	330	V8	1968	1969	11" Disc	04072	280	11	1-1/8	10	—	—	—	—	—
5.7	348	V8	1969	1974	—	04064	300	11-3/4	1-1/8	10	—	—	—	—	—
<b>CHEVROLET (Performance Applications Available)</b>															
<i>AVEO</i>															
1.6	98	L4	2004	2006	Sold as kit only	GMK1014	215	8-7/16	13/16	24	MC508	SC910	—	—	—
1.6	98	L4	2007	2007	Sold as kit only	GMK1014	215	8-7/16	13/16	24	—	SC910	—	—	—
1.6	98	L4	2008	2011	Sold as kit only	GMK1014	215	8-7/16	13/16	24	—	—	—	—	—
<i>BEL AIR, BISCAYNE, CAPRICE, IMPALA</i>															
3.8	232	L6	1963	1965	11" Disc	04072	280	11	1-1/8	10	—	—	—	—	—
3.9	238	L6	1955	1959	10-3/8" Diaph Clutch	04021	265	10-1/2	1-1/8	10	—	—	—	—	—
3.9	238	L6	1955	1959	10-3/8" Lever Clutch	04002	265	10-1/2	1-1/8	10	—	—	—	—	—
3.9	238	L6	1955	1959	11" Disc	04072	280	11	1-1/8	10	—	—	—	—	—
3.9	238	L6	1961	1962	10-3/8" Diaph Clutch	04021	265	10-1/2	1-1/8	10	—	—	—	—	—
3.9	238	L6	1961	1962	11" Disc	04072	280	11	1-1/8	10	—	—	—	—	—
4.1	250	L6	1965	1971	11" Disc	04072	280	11	1-1/8	10	—	—	—	—	—
4.1	250	L6	1972	1973	11" Disc	04049	280	11	1-1/8	10	—	—	—	—	—
4.3	262	V8	1956	1957	10-3/8" Disc	04021	265	10-1/2	1-1/8	10	—	—	—	—	—
4.3	262	V8	1956	1957	11" Disc	04072	280	11	1-1/8	10	—	—	—	—	—
4.4	269	V8	1981	1981	10-3/8" Disc	04021	265	10-1/2	1-1/8	10	—	—	—	—	—
4.4	269	V8	1981	1981	11" Disc	04072	280	11	1-1/8	10	—	—	—	—	—
4.6	281	V8	1957	1966	10-3/8" Disc	04021	265	10-1/2	1-1/8	10	—	—	—	—	—
4.6	281	V8	1957	1967	11" Disc	04072	280	11	1-1/8	10	—	—	—	—	—
4.6	281	V8	1967	1967	10-3/8" Disc	04021	265	10-1/2	1-1/8	10	—	—	—	—	FWGM101
5.4	330	V8	1962	1966	10-3/8" Disc	04021	265	10-1/2	1-1/8	10	—	—	—	—	—
5.4	330	V8	1962	1969	11" Disc	04049	280	11	1-1/8	10	—	—	—	—	—
5.4	330	V8	1967	1969	10-3/8" Disc	04021	265	10-1/2	1-1/8	10	—	—	—	—	FWGM101
5.7	348	V8	1958	1961	12" Diaph Clutch	04064	300	11-3/4	1-1/8	10	—	—	—	—	—
5.7	348	V8	1969	1970	12" Diaph Clutch	04064	300	11-3/4	1-1/8	10	—	—	—	—	—
5.7	348	V8	1969	1971	10-3/8" Disc	04021	265	10-1/2	1-1/8	10	—	—	—	—	FWGM101
5.7	348	V8	1969	1971	11", 10 Spline Disc	04049	280	11	1-1/8	10	—	—	—	—	—

Liter	CC/IN	Cyl	Years		Application Information	Kit	Disc (mm)	Disc (in)	Spline Dia	Splines	Master Cyl	Slave Cyl	Clutch Cable	Clutch Fork	New Flywheel
			To	From											
<b>CHEVROLET (Performance Applications Available) CONT.</b>															
<i>BEL AIR, BISCAYNE, CAPRICE, IMPALA</i>															
5.7	348	V8	1971	1971	11", 26 Spline Disc	04020	280	11	1-1/8	26	—	—	—	—	—
5.7	348	V8	1972	1972	—	04049	280	11	1-1/8	10	—	—	—	—	—
6.5	397	V8	1966	1969	—	04049	280	11	1-1/8	10	—	—	—	—	—
6.7	409	V8	1962	1965	—	04021	265	10-1/2	1-1/8	10	—	—	—	—	—
7.0	427	V8	1966	1969	—	04049	280	11	1-1/8	10	—	—	—	—	—
<i>BERETTA, CORSICA</i>															
2.0	122	L4	1987	1987	—	04005	215	8-1/2	1	14	MC323	SC714	—	—	FWGM10
2.0	122	L4	1988	1988	Master Cyl with 4.85" Rod	04005	215	8-1/2	1	14	—	SC714	—	—	FWGM10
2.0	122	L4	1988	1988	Master Cyl with 5.00" Rod	04005	215	8-1/2	1	14	MC323	SC714	—	—	FWGM10
2.0	122	L4	1989	1989	—	04005	215	8-1/2	1	14	MC321	SC714	—	—	FWGM10
2.2	134	L4	1990	1992	—	04005	215	8-1/2	1	14	MC321	SC714	—	—	FWGM10
2.2	134	L4	1992	1993	—	04005	215	8-1/2	1	14	MC321	SC715	—	—	FWGM10
2.2	134	L4	1994	1994	—	04005	215	8-1/2	1	14	MC332	SC715	—	—	FWGM10
2.2	134	L4	1995	1996	Includes Slave Cylinder	04161	215	8-1/2	1	14	MC333	—	—	—	FWGM10
2.3	140	L4	1990	1992	Quad 4	04088	225	8-7/8	15/16	14	MC321	SC715	—	—	—
2.3	140	L4	1993	1994	Quad 4, Includes Slave Cylinder	04136	225	8-7/8	15/16	14	MC330	SC715	—	—	—
2.8	171	V6	1987	1987	—	04088	225	8-7/8	15/16	14	MC323	SC714	—	CF134	FWGM111
2.8	171	V6	1988	1988	Master Cyl with 4.85" Rod	04088	225	8-7/8	15/16	14	—	SC714	—	CF134	FWGM111
2.8	171	V6	1988	1988	Master Cyl with 5.00" Rod	04088	225	8-7/8	15/16	14	—	SC714	—	CF134	FWGM111
2.8	171	V6	1989	1989	—	04088	225	8-7/8	15/16	14	MC321	SC715	—	CF134	—
2.8	171	V6	1989	1989	—	04088	225	8-7/8	15/16	14	MC321	SC715	—	CF134	FWGM111
3.1	189	V6	1990	1992	—	04088	225	8-7/8	15/16	14	MC321	SC715	—	—	—
3.1	189	V6	1993	1993	Includes Slave Cylinder	04132	225	8-7/8	15/16	14	MC330	—	—	—	—
3.1	189	V6	1994	1994	Includes Slave Cylinder	04132	225	8-7/8	15/16	14	MC330	—	—	—	—
<i>CAMARO, Z28</i>															
2.5	153	L4	1982	1983	4 Spd	04052	232	9-1/8	1-1/8	10	—	—	—	—	—
2.5	153	L4	1983	1986	5 Spd, Non Pre-Damped	04053	225	8-7/8	15/16	14	MC315	SC787	—	—	—
2.5	153	L4	1983	1986	5 Spd, Pre-Damped	04129	232	9-1/8	1	14	MC315	SC787	—	—	—
2.5	153	L4	1984	1984	4 Spd	04052	232	9-1/8	1-1/8	10	MC315	SC787	—	—	—
2.8	171	V6	1982	1983	10 Spine Disc	04055	232	9-1/8	1-1/8	10	—	—	—	—	FWGM111
2.8	171	V6	1983	1983	14 Spline Disc	04069	215	8-1/2	1	14	—	—	—	—	—
2.8	171	V6	1984	1984	10 Spine Disc	04055	232	9-1/8	1-1/8	10	MC320	SC787	—	—	FWGM111
2.8	171	V6	1984	1984	14 Spline Disc	04069	215	8-1/2	1	14	MC320	SC787	—	—	—
2.8	171	V6	1985	1986	Non Pre-Damped	04053	225	8-7/8	15/16	14	MC320	SC787	—	—	FWGM111
2.8	171	V6	1985	1986	Pre-Damped	04129	232	9-1/8	1	14	MC320	SC787	—	—	FWGM111
2.8	171	V6	1987	1988	Non Pre-Damped	04053	225	8-7/8	15/16	14	MC320	SC787	—	CF129	FWGM111
2.8	171	V6	1987	1988	Pre-Damped	04129	232	9-1/8	1	14	MC320	SC787	—	CF129	FWGM111
2.8	171	V6	1989	1989	Non Pre-Damped	04053	225	8-7/8	15/16	14	MC320	SC787	—	CF129	—
2.8	171	V6	1989	1989	Pre-Damped	04129	232	9-1/8	1	14	MC320	SC787	—	CF129	—
3.1	189	V6	1990	1990	Non Pre-Damped	04053	225	8-7/8	15/16	14	MC331	SC719	—	CF129	—
3.1	189	V6	1990	1992	Pre-Damped	04129	232	9-1/8	1	14	MC331	SC719	—	CF129	—
3.1	189	V6	1991	1992	Non Pre-Damped	04053	225	8-7/8	15/16	14	MC320	SC719	—	CF129	—
3.4	207	V6	1993	1995	With Master Cyl Pushrod CV601A	04133	246	9-5/8	1-1/8	26	MC331	SC719	—	—	—
3.4	207	V6	1993	1995	With Master Cyl Pushrod H603A	04133	246	9-5/8	1-1/8	26	MC334	SC719	—	—	—
3.8	232	V6	1980	1981	—	04021	265	10-1/2	1-1/8	10	—	—	—	—	—
3.8	232	V6	1980	1981	—	04021	265	10-1/2	1-1/8	10	—	—	—	CF100	—
3.8	232	V6	1996	2002	—	04082	246	9-5/8	1-1/8	26	MC334	SC746	—	—	—
4.1	250	L6	1979	1979	—	04021	265	10-1/2	1-1/8	10	—	—	—	CF100	FWGM101
5.0	305	V8	1967	1968	—	04021	265	10-1/2	1-1/8	10	—	—	—	—	—
5.0	305	V8	1979	1981	10 Spine Disc	04021	265	10-1/2	1-1/8	10	—	—	—	CF100	FWGM101
5.0	305	V8	1982	1983	—	04019	263	10-3/8	1-1/8	26	—	—	—	—	FWGM101
5.0	305	V8	1984	1985	—	04019	263	10-3/8	1-1/8	26	MC315	SC787	—	CF133	FWGM101
5.0	305	V8	1986	1992	Light Weight Nodular Flywheel with 1-PC Crank Seal, Engine Code #F	04019	263	10-3/8	1-1/8	26	MC315	SC787	—	CF133	FWGM13
5.0	305	V8	1986	1992	Light Weight Nodular Flywheel with 1-Piece Crank Seal, Engine Code #E	04019	263	10-3/8	1-1/8	26	MC315	SC787	—	CF133	FWGM12
5.0	305	V8	1986	1992	Light Weight Nodular Flywheel with 2-PC Crank Seal	04019	263	10-3/8	1-1/8	26	MC315	SC787	—	CF133	FWGM14



Liter	CC/IN	Cyl	Years		Application Information	Kit	Disc (mm)	Disc (in)	Spline Dia	Splines	Master Cyl	Slave Cyl	Clutch Cable	Clutch Fork	New Flywheel
			To	From											
<b>CHEVROLET (Performance Applications Available) CONT.</b>															
<i>CAMARO, Z28 CONT.</i>															
5.4	330	V8	1967	1969	—	04021	265	10-1/2	1-1/8	10	—	—	—	—	FWGM101
5.7	348	V8	1967	1970	11", 10 Spline Disc	04049	280	11	1-1/8	10	—	—	—	—	—
5.7	348	V8	1969	1974	10 Spline, Saginaw Trans	04021	265	10-1/2	1-1/8	10	—	—	—	—	FWGM101
5.7	348	V8	1971	1974	26 Spline, Muncie Trans	04020	280	11	1-1/8	26	—	—	—	—	—
5.7	348	V8	1975	1975	10 Spline	04021	265	10-1/2	1-1/8	10	—	—	—	—	FWGM101
5.7	348	V8	1975	1975	26 Spline	04020	280	11	1-1/8	26	—	—	—	—	—
5.7	348	V8	1976	1979	10 Spline	04021	265	10-1/2	1-1/8	10	—	—	—	CF100	FWGM101
5.7	348	V8	1976	1979	26 Spline	04020	280	11	1-1/8	26	—	—	—	CF100	—
5.7	348	V8	1980	1981	26 Spline	04020	280	11	1-1/8	26	—	—	—	—	—
5.7	348	V8	1987	1992	Light Weight Nodular Flywheel with 1-PC Crank Seal, Engine Code #F	04019	263	10-3/8	1-1/8	26	—	—	—	—	FWGM13
5.7	348	V8	1987	1992	Light Weight Nodular Flywheel with 1-Piece Crank Seal, Engine Code #E	04019	263	10-3/8	1-1/8	26	—	—	—	—	FWGM12
5.7	348	V8	1987	1992	Light Weight Nodular Flywheel with 2-PC Crank Seal	04019	263	10-3/8	1-1/8	26	—	—	—	—	FWGM14
5.7	348	V8	1993	1997	LT1, with Master Cyl Pushrod CV601A	04134	280	11	1-1/8	26	MC334	SC719	—	—	—
5.7	348	V8	1993	1997	LT1, with Master Cyl Pushrod H603A	04134	280	11	1-1/8	26	MC334	SC719	—	—	—
5.7	348	V8	1998	2002	LS1, Modular Clutch Includes Flywheel	04173	300	11-3/4	1-1/8	26	MC334	SC746	—	—	—
6.2	378	V8	2010	2015	Sold as Kit Only, Includes CSC Hydraulic Slave Cylinder	GMK1036	290	11-7/16	1-1/8	26	—	—	—	—	—
6.5	397	V8	1967	1970	—	04049	280	11	1-1/8	10	—	—	—	—	—
6.6	403	V8	1970	1972	4Spd, 4 BBL	04020	280	11	1-1/8	26	—	—	—	—	—
<i>CAVALIER, Z24</i>															
2.0	122	L4	1983	1984	5 Spd	04005	215	8-1/2	1	14	—	—	—	CF106	FWGM10
2.0	122	L4	1985	1986	4 Spd	04077	225	8-7/8	15/16	14	MC318	SC714	—	CF106	—
2.0	122	L4	1985	1986	5 Spd	04005	215	8-1/2	1	14	MC318	SC714	—	CF106	FWGM10
2.0	122	L4	1987	1987	4 Spd	04077	225	8-7/8	15/16	14	MC316	SC714	—	CF106	—
2.0	122	L4	1988	1989	4 Spd	04077	225	8-7/8	15/16	14	—	SC714	—	CF106	—
2.2	134	L4	1990	1991	—	04005	215	8-1/2	1	14	MC327	SC714	—	—	—
2.2	134	L4	1992	1994	—	04005	215	8-1/2	1	14	MC327	SC715	—	—	—
2.2	134	L4	1995	1996	Includes Slave Cylinder	04161	215	8-1/2	1	14	MC333	—	—	—	FWGM10
2.2	134	L4	1997	1999	Includes Slave Cylinder	04161	215	8-1/2	1	14	MC333	—	—	—	—
2.2	134	L4	2000	2002	SOHC, Includes Slave Cylinder, Sold As Kit Only	KGM08	215	8-1/2	1	14	—	—	—	—	—
2.2	134	L4	2002	2005	DOHC, Includes Slave Cylinder, Sold As Kit Only	GMK1000	225	8-7/8	1	14	—	—	—	—	—
2.3	140	L4	1995	1995	Includes Slave Cylinder	04158	225	8-7/8	15/16	14	MC333	—	—	—	—
2.4	146	L4	1996	1999	Includes Slave Cylinder	04158	225	8-7/8	15/16	14	MC333	—	—	—	—
2.4	146	L4	2000	2002	Includes Slave Cylinder, Sold As Kit Only	KGM04	225	8-7/8	1	14	—	—	—	—	—
2.8	171	V6	1985	1986	—	04077	225	8-7/8	15/16	14	MC318	SC714	—	—	FWGM111
2.8	171	V6	1987	1988	—	04088	225	8-7/8	15/16	14	MC316	SC714	—	—	FWGM111
2.8	171	V6	1989	1989	—	04088	225	8-7/8	15/16	14	MC316	SC714	—	—	—
3.1	189	V6	1990	1992	—	04088	225	8-7/8	15/16	14	MC327	SC715	—	—	—
3.1	189	V6	1993	1994	Includes Slave Cylinder	04132	225	8-7/8	15/16	14	MC330	—	—	—	—
<i>CELEBRITY</i>															
2.5	153	L4	1984	1986	—	04077	225	8-7/8	15/16	14	—	—	—	—	—
2.8	171	V6	1984	1985	—	04077	225	8-7/8	15/16	14	—	—	—	—	FWGM111
2.8	171	V6	1986	1986	—	04077	225	8-7/8	15/16	14	MC589	SC714	—	—	FWGM111
2.8	171	V6	1987	1988	—	04088	225	8-7/8	15/16	14	MC319	SC714	—	CF134	FWGM111
<i>CHEVELLE, MALIBU, EL CAMINO, MONTE CARLO</i>															
3.3	201	V6	1979	1979	—	04021	265	10-1/2	1-1/8	10	—	—	—	—	—
3.8	232	V6	1980	1981	—	04021	265	10-1/2	1-1/8	10	—	—	—	—	—
4.4	269	V8	1979	1981	—	04021	265	10-1/2	1-1/8	10	—	—	—	—	—
4.6	281	V8	1964	1966	4 Spd	04021	265	10-1/2	1-1/8	10	—	—	—	—	—
4.6	281	V8	1964	1967	4 Spd	04021	265	10-1/2	1-1/8	10	—	—	—	—	FWGM101
5.0	305	V8	1968	1973	4 Spd	04021	265	10-1/2	1-1/8	10	—	—	—	—	FWGM101
5.0	305	V8	1979	1981	—	04021	265	10-1/2	1-1/8	10	—	—	—	CF100	FWGM14
5.0	305	V8	1979	1981	Monte Carlo	04021	265	10-1/2	1-1/8	10	—	—	—	CF100	FWGM101
5.4	330	V8	1964	1968	Raised Diaph	04021	265	10-1/2	1-1/8	10	—	—	—	—	FWGM101
5.7	348	V8	1969	1970	11"Disc	04049	280	11	1-1/8	10	—	—	—	—	—
5.7	348	V8	1969	1975	Raised Diaph	04021	265	10-1/2	1-1/8	10	—	—	—	—	FWGM101

Liter	CC/IN	Cyl	Years		Application Information	Kit	Disc (mm)	Disc (in)	Spline Dia	Splines	Master Cyl	Slave Cyl	Clutch Cable	Clutch Fork	New Flywheel
			To	From											
<b>CHEVROLET (Performance Applications Available) CONT.</b>															
<i>CHEVELLE, MALIBU, EL CAMINO, MONTE CARLO CONT.</i>															
5.7	348	V8	1971	1972	11", 26 Spline Disc	04020	280	11	1-1/8	26	—	—	—	—	—
5.7	348	V8	1973	1977	Raised Diaph	04021	265	10-1/2	1-1/8	10	—	—	—	CF100	FWGM101
5.7	348	V8	1978	1978	—	04021	265	10-1/2	1-1/8	10	—	—	—	CF100	FWGM101
6.5	397	V8	1966	1970	—	04049	280	11	1-1/8	10	—	—	—	—	—
6.6	403	V8	1970	1970	—	04049	280	11	1-1/8	10	—	—	—	—	—
6.6	403	V8	1970	1970	Monte Carlo	04049	280	11	1-1/8	10	—	—	—	—	—
6.6	403	V8	1971	1971	Monte Carlo	04020	280	11	1-1/8	26	—	—	—	—	—
6.6	403	V8	1972	1972	—	04049	280	11	1-1/8	10	—	—	—	—	—
7.4	452	V8	1970	1975	—	04020	280	11	1-1/8	26	—	—	—	—	—
<i>CHEVETTE</i>															
1.4	85	L4	1976	1977	—	04057	184	7-1/4	1	14	—	—	—	—	—
1.6	98	L4	1976	1981	—	04057	184	7-1/4	1	14	—	—	—	—	—
1.8	110	L4	1981	1986	Diesel	04058	200	7-7/8	1	24	—	—	—	—	—
<i>CHEVY II, NOVA</i>															
1.6	98	L4	1985	1988	FWD	16070	200	7-7/8	15/16	21	MC256	SC669	—	—	—
4.1	250	L6	1979	1979	—	04021	265	10-1/2	1-1/8	10	—	—	—	CF100	FWGM101
4.6	281	V8	1964	1966	Raised Diaph Clutch	04021	265	10-1/2	1-1/8	10	—	—	—	—	—
4.6	281	V8	1967	1967	Raised Diaph Clutch	04021	265	10-1/2	1-1/8	10	—	—	—	—	FWGM101
5.0	305	V8	1978	1979	—	04021	265	10-1/2	1-1/8	10	—	—	—	CF100	FWGM101
5.4	330	V8	1965	1966	Raised Diaph Clutch	04021	265	10-1/2	1-1/8	10	—	—	—	—	—
5.4	330	V8	1967	1968	Raised Diaph Clutch	04021	265	10-1/2	1-1/8	10	—	—	—	—	FWGM101
5.7	348	V8	1970	1975	3 Spd	04021	265	10-1/2	1-1/8	10	—	—	—	—	FWGM101
5.7	348	V8	1976	1977	3 Spd	04021	265	10-1/2	1-1/8	10	—	—	—	CF100	FWGM101
6.5	397	V8	1968	1968	—	04049	280	11	1-1/8	10	—	—	—	—	—
6.5	397	V8	1970	1970	—	04049	280	11	1-1/8	10	—	—	—	—	—
<i>CITATION</i>															
2.5	153	L4	1980	1982	—	04077	225	8-7/8	15/16	14	—	—	—	—	—
2.5	153	L4	1982	1985	—	04077	225	8-7/8	15/16	14	—	—	—	CF106	—
2.8	171	V6	1980	1981	—	04077	225	8-7/8	15/16	14	—	—	—	—	FWGM111
2.8	171	V6	1982	1984	—	04077	225	8-7/8	15/16	14	—	—	—	CF106	FWGM111
2.8	171	V6	1985	1985	—	04077	225	8-7/8	15/16	14	—	—	—	—	FWGM111
<i>COBALT</i>															
2.0	122	L4	2005	2007	Supercharged, Luk Original, Includes CSC Hydraulic Slave, Sold as Kit Only	GMK1016	238	9-3/8	1	14	—	—	—	—	—
2.2	134	L4	2005	2010	Includes Slave Cylinder, Sold As Kit Only	GMK1010	225	8-7/8	15/16	14	—	—	—	—	—
2.4	146	L4	2006	2009	Includes Slave Cylinder, Sold As Kit Only	GMK1010	225	8-7/8	15/16	14	—	—	—	—	—
<i>CORVETTE</i>															
4.6	281	V8	1957	1961	Carbureted	04084	254	10	1-1/8	10	—	—	—	—	—
5.4	330	V8	1962	1964	—	04084	254	10	1-1/8	10	—	—	—	—	—
5.4	330	V8	1965	1966	—	04021	265	10-1/2	1-1/8	10	—	—	—	—	—
5.4	330	V8	1967	1968	—	04021	265	10-1/2	1-1/8	10	—	—	—	—	FWGM101
5.7	348	V8	1969	1970	10-3/8" Disc	04021	265	10-1/2	1-1/8	10	—	—	—	—	FWGM101
5.7	348	V8	1969	1970	11" Disc	04049	280	11	1-1/8	10	—	—	—	—	—
5.7	348	V8	1971	1971	3 Spd	04021	265	10-1/2	1-1/8	10	—	—	—	—	FWGM101
5.7	348	V8	1971	1971	4 Spd	04019	263	10-3/8	1-1/8	26	—	—	—	—	FWGM101
5.7	348	V8	1972	1972	4 Spd, 4 BBL	04019	263	10-3/8	1-1/8	26	—	—	—	—	FWGM101
5.7	348	V8	1973	1977	—	04020	280	11	1-1/8	26	—	—	—	—	—
5.7	348	V8	1978	1978	10-3/8" Disc	04021	265	10-1/2	1-1/8	10	—	—	—	—	FWGM101
5.7	348	V8	1978	1978	11" Disc	04020	280	11	1-1/8	26	—	—	—	—	—
5.7	348	V8	1979	1981	—	04020	280	11	1-1/8	26	—	—	—	—	—
5.7	348	V8	1984	1984	—	04019	263	10-3/8	1-1/8	26	MC306	SC704	—	—	FWGM101
5.7	348	V8	1985	1987	With .38" Bushing	04080	273	10-3/4	1-1/8	26	MC307	SC704	—	—	—
5.7	348	V8	1985	1988	With .43" Bushing	04080	273	10-3/4	1-1/8	26	MC306	SC704	—	—	—
5.7	348	V8	1988	1988	—	04080	273	10-3/4	1-1/8	26	MC306	SC704	—	—	—
5.7	348	V8	1989	1990	L98, Cover Includes Bearing	04113	280	11	1-1/8	26	—	SC880	—	—	—
5.7	348	V8	1990	1990	LT5, Cover Includes Bearing	04114	280	11	1-1/8	26	—	SC880	—	—	—
5.7	348	V8	1991	1991	L98, Cover Includes Bearing	04113	280	11	1-1/8	26	—	SC867	—	—	—



Liter	CC/IN	Cyl	Years		Application Information	Kit	Disc (mm)	Disc (in)	Spline Dia	Splines	Master Cyl	Slave Cyl	Clutch Cable	Clutch Fork	New Flywheel
			To	From											
<b>CHEVROLET (Performance Applications Available) CONT.</b>															
<b>CORVETTE CONT.</b>															
5.7	348	V8	1991	1993	LT5, Cover Includes Bearing	04114	280	11	1-1/8	26	—	SC867	—	—	—
5.7	348	V8	1992	1993	LT1 , Cover Includes Bearing	04113	280	11	1-1/8	26	—	SC867	—	—	—
5.7	348	V8	1994	1994	LT1 & LT4 , Cover Includes Bearing	04142	280	11	1-1/8	26	—	SC867	—	—	—
5.7	348	V8	1994	1996	LT5, Cover Includes Bearing	04143	280	11	1-1/8	26	—	SC867	—	—	—
5.7	348	V8	1997	2004	LS1, Modular Clutch Includes Flywheel	04173	300	11-3/4	1-1/8	26	MC423	SC780	—	—	—
6.2	378	V8	2010	2013	Sold as Kit Only, Includes CSC Hydraulic Slave Cylinder	GMK1035	290	11-7/16	1-1/8	26	—	—	—	—	—
7.0	427	V8	1966	1966	10-3/8" Disc	04021	265	10-1/2	1-1/8	10	—	—	—	—	FWGM14
7.0	427	V8	1966	1969	10-3/8" Disc, Nodular Flywheel with 2 PC Crank Seal	04021	265	10-1/2	1-1/8	10	—	—	—	—	FWGM14
7.0	427	V8	1966	1969	11" Disc	04049	280	11	1-1/8	10	—	—	—	—	—
7.0	427	V8	1967	1969	10-3/8" Disc, Standard Flywheel	04021	265	10-1/2	1-1/8	10	—	—	—	—	FWGM101
7.4	452	V8	1970	1974	—	04020	280	11	1-1/8	26	—	—	—	—	—
<b>HHR</b>															
2.2	134	L4	2006	2011	Includes Slave Cylinder, Sold As Kit Only	GMK1010	225	8-7/8	15/16	14	—	—	—	—	—
2.4	146	L4	2006	2011	Includes Slave Cylinder, Sold As Kit Only	GMK1010	225	8-7/8	15/16	14	—	—	—	—	—
<b>LUMINA</b>															
3.4	207	V6	1991	1993	Pull Type Clutch, Sold As Kit Only	04127	246	9-5/8	1	23	MC328	SC716	—	—	—
<b>METRO</b>															
1.0	61	L3	1998	2000	—	04124	170	6-11/16	3/4	18	—	—	—	—	—
1.3	79	L4	1998	2001	—	04100	190	7-1/2	3/4	18	—	—	—	—	—
<b>MONZA, VEGA</b>															
2.0	122	L4	1976	1976	—	04062	232	9-1/8	1-1/8	10	—	—	—	—	—
2.3	140	L4	1973	1977	—	04062	232	9-1/8	1-1/8	10	—	—	—	—	—
2.5	153	L4	1978	1980	—	04062	232	9-1/8	1-1/8	10	—	—	—	—	—
3.2	195	V6	1978	1978	—	04062	232	9-1/8	1-1/8	10	—	—	—	—	—
3.8	232	V6	1978	1978	—	04062	232	9-1/8	1-1/8	10	—	—	—	—	—
4.3	262	V8	1975	1976	—	04062	232	9-1/8	1-1/8	10	—	—	—	—	—
5.0	305	V8	1977	1979	—	04021	265	10-1/2	1-1/8	10	—	—	—	—	FWGM101
<b>PRIZM</b>															
1.8	110	L4	1998	2002	—	KTY03	210	8-1/4	1	21	MC265	SC842	—	—	—
<b>SPECTRUM</b>															
1.5	92	L4	1985	1988	Non-Turbo	04063	184	7-1/4	1	14	—	—	—	—	—
1.5	92	L4	1987	1988	Turbo	04099	215	8-1/2	1	14	—	—	—	—	—
<b>SPRINT</b>															
1.0	61	L3	1985	1988	Non-Turbo	04076	160	6-5/16	3/4	18	—	—	—	—	—
1.0	61	L3	1987	1988	Turbo	04139	190	7-1/2	3/4	18	—	—	—	—	—
1.0	61	L3	1989	1991	Non-Turbo CANADA	04139	190	7-1/2	3/4	18	—	—	—	—	—
1.0	61	L3	1989	1991	Turbo CANADA	04139	190	7-1/2	3/4	18	—	—	—	—	—
<b>CHEVROLET TRUCK, SUV &amp; VAN</b>															
<b>ASTRO</b>															
2.5	153	L4	1985	1989	—	04053	225	8-7/8	15/16	14	MC305	SC703	—	—	FWGM115
4.3	262	V6	1985	1987	—	04086	280	11	1	14	MC305	SC703	—	—	—
4.3	262	V6	1988	1989	—	04086	280	11	1	14	MC305	SC703	—	—	FWGM108
<b>CHEVROLET LIGHT TRUCK, SUV &amp; VAN</b>															
<b>BLAZER (FULL SIZE), C10-30, K10-30, R10-30, V10-30, SILVERADO, TAHOE</b>															
3.8	232	L6	1963	1967	11" Disc	04072	280	11	1-1/8	10	—	—	—	—	—
3.8	232	L6	1969	1969	12" Diaph Clutch	04064	300	11-3/4	1-1/8	10	—	—	—	—	—
3.8	232	L6	1969	1969	12" Diaph Clutch with Ceramic Button	04105	300	11-3/4	1-1/8	10	—	—	—	—	—
3.9	238	L6	1961	1962	12" Diaph Clutch	04064	300	11-3/4	1-1/8	10	—	—	—	—	—
3.9	238	L6	1961	1962	12" Diaph Clutch with Ceramic Button	04105	300	11-3/4	1-1/8	10	—	—	—	—	—
4.1	250	L6	1966	1976	11" Disc	04072	280	11	1-1/8	10	—	—	—	—	—
4.1	250	L6	1977	1984	11" Disc	04049	280	11	1-1/8	10	—	—	—	—	—
4.1	250	L6	1977	1984	12" Diaph Clutch	04064	300	11-3/4	1-1/8	10	—	—	—	—	—
4.1	250	L6	1977	1984	12" Diaph Clutch with Ceramic Button	04105	300	11-3/4	1-1/8	10	—	—	—	—	—
4.3	262	L6	1961	1962	11" Disc	04072	280	11	1-1/8	10	—	—	—	—	—
4.3	262	L6	1961	1962	12" Diaph Clutch	04064	300	11-3/4	1-1/8	10	—	—	—	—	—
4.3	262	L6	1961	1962	12" Diaph Clutch with Ceramic Button	04105	300	11-3/4	1-1/8	10	—	—	—	—	—
4.3	262	V6	1985	1987	—	04089	280	11	1-1/8	10	MC309	SC827	—	—	FWGM108
4.3	262	V6	1988	1991	To 1/31/91	04089	280	11	1-1/8	10	MC310	SC708	—	—	FWGM108

Liter	CC/IN	Cyl	Years		Application Information	Kit	Disc (mm)	Disc (in)	Spline Dia	Splines	Master Cyl	Slave Cyl	Clutch Cable	Clutch Fork	New Flywheel
			To	From											
<b>CHEVROLET LIGHT TRUCK, SUV &amp; VAN CONT.</b>															
<i>BLAZER (FULL SIZE), C10-30, K10-30, R10-30, V10-30, SILVERADO, TAHOE CONT.</i>															
4.3	262	V6	1991	1991	From 1/31/91	04121	280	11	1-1/8	10	MC310	SC708	—	—	FWGM108
4.3	262	V6	1992	1994	—	04121	280	11	1-1/8	10	MC372	SC741	—	—	FWGM108
4.3	262	V6	1995	1995	—	04121	280	11	1-1/8	10	MC380	SC741	—	—	FWGM108
4.3	262	V6	1996	1998	—	KGM10	280	11	1-1/8	10	MC377	SC746	—	—	FWGM108
4.3	262	V6	1999	2000	Silverado	KGM17	280	11	1-1/8	10	MC381	SC746	—	—	—
4.3	262	V6	2001	2007	Slave Cylinder fits 5spd only	KGM21	280	11	1-1/8	10	MC381	SC799	—	—	—
4.6	281	V8	1961	1967	11" Disc	04072	280	11	1-1/8	10	—	—	—	—	—
4.6	281	V8	1961	1967	12" Diaph Clutch	04064	300	11-3/4	1-1/8	10	—	—	—	—	—
4.6	281	V8	1961	1967	12" Diaph Clutch with Ceramic Button	04105	300	11-3/4	1-1/8	10	—	—	—	—	—
4.8	293	L6	1963	1968	11" Disc	04072	280	11	1-1/8	10	—	—	—	—	—
4.8	293	L6	1969	1974	11" Disc	04049	280	11	1-1/8	10	—	—	—	—	—
4.8	293	L6	1974	1974	11" Disc, LPG Gas	04049	280	11	1-1/8	10	—	—	—	—	—
4.8	293	L6	1974	1974	LPG Gas, 11" Disc	04049	280	11	1-1/8	10	—	—	—	—	—
4.8	293	L6	1975	1984	11" Disc	04049	280	11	1-1/8	10	—	—	—	—	FWGM104
4.8	293	L6	1985	1985	11" Disc	04049	280	11	1-1/8	10	MC309	SC827	—	—	FWGM104
4.8	293	L6	1985	1986	—	04081	280	11	1-1/8	10	MC309	SC827	—	CF116	FWGM104
4.8	293	L6	1987	1988	R & V Series	04081	280	11	1-1/8	10	MC309	SC827	—	CF116	FWGM104
4.8	293	V8	1999	2000	Silverado	04181	302	11-7/8	1-1/8	10	MC381	SC746	—	—	—
4.8	293	V8	2001	2003	Silverado	KGM44	302	11-7/8	1-1/8	10	MC381	SC799	—	—	—
4.8	293	V8	2004	2004	Silverado	KGM44	302	11-7/8	1-1/8	10	MC381	SC937	—	—	—
4.8	293	V8	2005	2006	Sold as Kit Only	GMK1020	302	11-7/8	1-1/8	10	MC456	SC801	—	—	—
5.0	305	V8	1968	1973	11" Disc	04049	280	11	1-1/8	10	—	—	—	—	—
5.0	305	V8	1976	1984	11" Disc	04049	280	11	1-1/8	10	—	—	—	—	—
5.0	305	V8	1976	1984	12" Diaph Clutch	04064	300	11-3/4	1-1/8	10	—	—	—	—	—
5.0	305	V8	1976	1984	12" Diaph Clutch with Ceramic Button	04105	300	11-3/4	1-1/8	10	—	—	—	—	—
5.0	305	V8	1985	1987	—	04081	280	11	1-1/8	10	MC309	SC827	—	—	—
5.0	305	V8	1985	1991	—	04081	280	11	1-1/8	10	MC310	SC708	—	—	—
5.0	305	V8	1992	1994	—	04121	280	11	1-1/8	10	MC372	SC741	—	—	—
5.0	305	V8	1995	1996	—	04121	280	11	1-1/8	10	MC387	SC741	—	—	—
5.0	305	V8	1996	1998	—	04160	302	11-7/8	1-1/8	10	MC377	SC746	—	—	—
5.4	330	V8	1962	1962	12" Diaph Clutch	04064	300	11-3/4	1-1/8	10	—	—	—	—	—
5.4	330	V8	1962	1962	12" Diaph Clutch with Ceramic Button	04105	300	11-3/4	1-1/8	10	—	—	—	—	—
5.4	330	V8	1964	1968	12" Diaph Clutch	04064	300	11-3/4	1-1/8	10	—	—	—	—	—
5.4	330	V8	1964	1968	12" Diaph Clutch with Ceramic Button	04105	300	11-3/4	1-1/8	10	—	—	—	—	—
5.7	348	V8	1969	1984	11" Disc	04049	280	11	1-1/8	10	—	—	—	—	—
5.7	348	V8	1969	1984	12" Diaph Clutch	04064	300	11-3/4	1-1/8	10	—	—	—	—	—
5.7	348	V8	1969	1984	12" Diaph Clutch with Ceramic Button	04105	300	11-3/4	1-1/8	10	—	—	—	—	—
5.7	348	V8	1974	1974	11" Disc, LPG Gas	04049	280	11	1-1/8	10	—	—	—	—	—
5.7	348	V8	1974	1974	LPG Gas, 11" Disc	04049	280	11	1-1/8	10	—	—	—	—	—
5.7	348	V8	1974	1974	LPG Gas, 12" Diaph Clutch with Ceramic Button	04105	300	11-3/4	1-1/8	10	—	—	—	—	—
5.7	348	V8	1974	1974	LPG Gas, 12" Diaph Clutch, Non-Pre Damped	04064	300	11-3/4	1-1/8	10	—	—	—	—	—
5.7	348	V8	1978	1981	11" Disc, Diesel	04049	280	11	1-1/8	10	—	—	—	—	—
5.7	348	V8	1978	1981	Diesel, 12" Diaph Clutch	04064	300	11-3/4	1-1/8	10	—	—	—	—	—
5.7	348	V8	1978	1981	Diesel, 12" Diaph Clutch with Ceramic Button	04105	300	11-3/4	1-1/8	10	—	—	—	—	—
5.7	348	V8	1985	1985	12" Diaph Clutch	04064	300	11-3/4	1-1/8	10	MC309	SC827	—	—	—
5.7	348	V8	1985	1985	12" Diaph Clutch with Ceramic Button	04105	300	11-3/4	1-1/8	10	MC309	SC827	—	—	—
5.7	348	V8	1985	1990	11" Disc	04049	280	11	1-1/8	10	MC309	SC827	—	—	—
5.7	348	V8	1986	1987	12" Diaph Clutch	04064	300	11-3/4	1-1/8	10	MC309	SC827	—	—	FWGM103
5.7	348	V8	1986	1987	12" Diaph Clutch with Ceramic Button	04105	300	11-3/4	1-1/8	10	MC309	SC827	—	—	FWGM103
5.7	348	V8	1988	1990	11" Disc	04049	280	11	1-1/8	10	—	SC708	—	—	—
5.7	348	V8	1988	1990	12" Diaph Clutch	04064	300	11-3/4	1-1/8	10	MC309	SC708	—	—	FWGM103
5.7	348	V8	1988	1990	12" Diaph Clutch with Ceramic Button	04105	300	11-3/4	1-1/8	10	MC309	SC708	—	—	FWGM103
5.7	348	V8	1988	1991	R & V Series 12" Diaph Clutch with Ceramic Button	04105	300	11-3/4	1-1/8	10	MC309	SC827	—	—	FWGM103
5.7	348	V8	1988	1991	R & V Series 12" Lever Type Clutch	04502	300	11-3/4	1-1/8	10	MC309	SC827	—	—	FWGM103
5.7	348	V8	1988	1991	R & V Series, 12" Diaph Clutch	04064	300	11-3/4	1-1/8	10	MC309	SC827	—	—	FWGM103

Liter	CC/IN	Cyl	Years		Application Information	Kit	Disc (mm)	Disc (in)	Spline Dia	Splines	Master Cyl	Slave Cyl	Clutch Cable	Clutch Fork	New Flywheel
			To	From											
<b>CHEVROLET LIGHT TRUCK, SUV &amp; VAN CONT.</b>															
<i>BLAZER (FULL SIZE), C10-30, K10-30, R10-30, V10-30, SILVERADO, TAHOE CONT.</i>															
5.7	348	V8	1991	1991	11" Disc, To 1/31/91	04049	280	11	1-1/8	10	—	SC708	—	—	—
5.7	348	V8	1991	1991	11" Disc, To 1/31/91	04049	280	11	1-1/8	10	MC309	SC827	—	—	—
5.7	348	V8	1991	1991	12" Diaph Clutch with Ceramic Button, To 1/31/91	04105	300	11-3/4	1-1/8	10	MC310	SC708	—	—	FWGM103
5.7	348	V8	1991	1991	12" Diaph Clutch, To 1/31/91	04064	300	11-3/4	1-1/8	10	MC310	SC708	—	—	FWGM103
5.7	348	V8	1991	1991	Non Pre-Damped, From 2/1/91	04122	302	11-7/8	1-1/8	10	MC309	SC827	—	—	—
5.7	348	V8	1991	1991	R & V Series Pre-Damped, From 2/1/91	04128	300	11-3/4	1-1/8	10	MC309	SC827	—	—	—
5.7	348	V8	1992	1994	Non Pre-Damped	04122	302	11-7/8	1-1/8	10	MC372	SC741	—	—	—
5.7	348	V8	1992	1994	Pre-Damped	04128	300	11-3/4	1-1/8	10	MC372	SC741	—	—	—
5.7	348	V8	1995	1995	Non Pre-Damped	04122	302	11-7/8	1-1/8	10	MC380	SC741	—	—	—
5.7	348	V8	1995	1995	Pre-Damped	04128	300	11-3/4	1-1/8	10	MC380	SC741	—	—	—
5.7	348	V8	1996	2000	—	04170	305	12	1-1/8	10	MC377	SC746	—	—	—
6.0	366	V8	1999	2000	Silverado	GMK1009	290	11-1/2	1-1/8	10	MC381	BRG0152	—	—	—
6.0	366	V8	2001	2003	Silverado	GMK1009	290	11-1/2	1-1/8	10	MC381	BRG0152	—	—	—
6.0	366	V8	2003	2006	Silverado	GMK1009	290	11-1/2	1-1/8	10	MC381	BRG0152	—	—	—
6.2	378	V8	1982	1987	Diesel	04087	302	11-7/8	1-1/8	10	MC309	SC827	—	—	—
6.2	378	V8	1988	1989	Diesel	04087	302	11-7/8	1-1/8	10	MC310	SC708	—	—	—
6.2	378	V8	1990	1991	Diesel	04122	302	11-7/8	1-1/8	10	MC310	SC708	—	—	—
6.2	378	V8	1991	1991	R & V Series Diesel	04122	302	11-7/8	1-1/8	10	MC309	SC741	—	—	—
6.2	378	V8	1992	1993	Diesel	04122	302	11-7/8	1-1/8	10	MC372	SC741	—	—	—
6.5	397	V8	1968	1969	11" Disc	04049	280	11	1-1/8	10	—	—	—	—	—
6.5	397	V8	1968	1969	Gas	04049	280	11	1-1/8	10	—	—	—	—	—
6.5	397	V8	1992	1994	Turbo Diesel for DMF, Not included	04131	300	11-3/4	1-1/8	10	MC372	SC741	—	—	—
6.5	397	V8	1992	1994	Turbo Diesel with Solid Flywheel Option. Kit includes flywheel.	04163A	302	11-7/8	1-1/8	10	MC372	SC741	—	—	FWGMC126
6.5	397	V8	1992	1994	Turbo, Diesel with Solid Flywheel Option. Kit does not include flywheel.	04163	302	11-7/8	1-1/8	10	MC372	SC741	—	—	FWGMC126
6.5	397	V8	1995	1995	Diesel with Solid Flywheel Option. Kit does not include flywheel.	04163	302	11-7/8	1-1/8	10	MC380	SC741	—	—	FWGMC126
6.5	397	V8	1995	1995	Diesel with Solid Flywheel Option. Kit includes flywheel.	04163A	302	11-7/8	1-1/8	10	MC380	SC741	—	—	FWGMC126
6.5	397	V8	1995	1995	Turbo Diesel for DMF, Not included	04131	300	11-3/4	1-1/8	10	MC380	SC741	—	—	—
6.5	397	V8	1996	2002	Turbo Diesel 5 Spd with LUK type solid flywheel. Kit does not include flywheel.	04154	302	11-7/8	1-1/8	10	MC377	SC746	—	—	FWGMC126
6.5	397	V8	1996	2002	Turbo Diesel 5 Spd with LUK type solid flywheel. Kit includes flywheel.	04154A	302	11-7/8	1-1/8	10	MC377	SC746	—	—	FWGMC126
6.5	397	V8	1996	2002	Turbo Diesel 5 Spd with Valeo type DMF. Kit does not include flywheel.	KGM12	300	11-3/4	1-1/8	10	MC377	SC746	—	—	FWGMC01
6.5	397	V8	1996	2002	Turbo Diesel 5 Spd with Valeo type DMF. Kit includes flywheel.	KGM12A	300	11-3/4	1-1/8	10	MC377	SC746	—	—	FWGMC01
6.6	403	V8	1970	1971	12" Diaph Type Clutch with Ceramic Button	04105	300	11-3/4	1-1/8	10	—	—	—	—	—
6.6	403	V8	1970	1972	12" Diaph Clutch	04064	300	11-3/4	1-1/8	10	—	—	—	—	—
6.6	403	V8	1970	1972	12" Diaph Clutch with Ceramic Button	04105	300	11-3/4	1-1/8	10	—	—	—	—	—
6.6	403	V8	1978	1980	Gas	04020	280	11	1-1/8	26	—	—	—	—	FWGM100
6.6	403	V8	2001	2003	Diesel 6 Spd, with DMF, Kit does not include flywheel, Does not include Release Bearing	KGM13	305	12	1-3/8	10	MC381	BRG0152	—	—	—
6.6	403	V8	2001	2003	Diesel 6 Spd, with DMF, Kit includes flywheel, Does not include Release Bearing	KGM13A	305	12	1-3/8	10	MC381	BRG0152	—	—	DMF029
6.6	403	V8	2004	2005	Diesel 6 Spd, with DMF, Kit does not include flywheel, Does not include Release Bearing	KGM13	305	12	1-3/8	10	MC381	BRG0152	—	—	—
6.6	403	V8	2004	2005	Diesel 6 Spd, with DMF, Kit includes flywheel, Does not include Release Bearing	KGM13A	305	12	1-3/8	10	MC381	BRG0152	—	—	DMF029
6.6	403	V8	2006	2006	Turbo, Diesel, Includes CSC Hydraulic Slave Cylinder, Sold as Kit Only, Fits Dual Mass FW	GMK1029	305	12	1-3/8	10	MC381	BRG0152	—	—	—
7.4	452	V8	1973	1973	12" Diaph Clutch with Ceramic Button	04105	300	11-3/4	1-1/8	10	—	—	—	—	—
7.4	452	V8	1973	1973	Diaph Clutch	04122	302	11-7/8	1-1/8	10	—	—	—	—	—
7.4	452	V8	1974	1984	12" Diaph Type Clutch with Ceramic Button	04105	300	11-3/4	1-1/8	10	—	—	—	—	FWGM102
7.4	452	V8	1974	1984	Diaph Clutch	04122	302	11-7/8	1-1/8	10	—	—	—	—	FWGM102
7.4	452	V8	1985	1986	12" Diaph Clutch with Ceramic Button	04105	300	11-3/4	1-1/8	10	MC309	SC827	—	—	FWGM102
7.4	452	V8	1985	1986	Diaph Clutch	04122	302	11-7/8	1-1/8	10	MC309	SC827	—	—	FWGM102
7.4	452	V8	1987	1991	12" Diaph Clutch, Non-Pre Damped	04064	300	11-3/4	1-1/8	10	MC310	SC708	—	—	FWGM102
7.4	452	V8	1987	1991	Pre-Damped	04122	302	11-7/8	1-1/8	10	MC310	SC708	—	—	FWGM102
7.4	452	V8	1987	1991	R & V Series Pre-Damped	04122	302	11-7/8	1-1/8	10	MC309	SC827	—	—	FWGM102
7.4	452	V8	1988	1988	12" Diaph Clutch, Non-Pre Damped	04064	300	11-3/4	1-1/8	10	MC309	SC741	—	—	FWGM102
7.4	452	V8	1988	1988	R & V Series Pre-Damped	04122	302	11-7/8	1-1/8	10	MC309	SC741	—	—	FWGM102
7.4	452	V8	1988	1991	R & V Series, Non Pre-Damped	04064	300	11-3/4	1-1/8	10	MC309	SC827	—	—	FWGM102
7.4	452	V8	1988	1995	12" Diaph Clutch, Non-Pre Damped	04064	300	11-3/4	1-1/8	10	MC380	SC741	—	—	FWGM102



Liter	CC/IN	Cyl	Years		Application Information	Kit	Disc (mm)	Disc (in)	Spline Dia	Splines	Master Cyl	Slave Cyl	Clutch Cable	Clutch Fork	New Flywheel
			To	From											
<b>CHEVROLET LIGHT TRUCK, SUV &amp; VAN CONT.</b>															
<i>BLAZER (FULL SIZE), C10-30, K10-30, R10-30, V10-30, SILVERADO, TAHOE CONT.</i>															
7.4	452	V8	1988	1995	Pre-Damped	04122	302	11-7/8	1-1/8	10	MC380	SC741	—	—	FWGM102
7.4	452	V8	1990	1995	12" Diaph Clutch, Non-Pre Damped	04064	300	11-3/4	1-1/8	10	MC372	SC741	—	—	FWGM102
7.4	452	V8	1990	1995	Pre-Damped	04122	302	11-7/8	1-1/8	10	MC372	SC741	—	—	FWGM102
7.4	452	V8	1996	2000	—	04154	302	11-7/8	1-1/8	10	MC377	SC746	—	—	—
7.4	452	V8	1996	2000	Turbo Diesel 5 Spd with LUK type solid flywheel. Kit includes flywheel.	04154A	302	11-7/8	1-1/8	10	MC377	SC746	—	—	FWGMC126
8.1	494	V8	2001	2002	5 Spd	KGM18	300	11-3/4	1-1/4	10	MC377	SC801	—	—	—
8.1	494	V8	2001	2003	6 Spd, Sold as Kit Only, Includes Slave Cylinder	GMK1025	295	11-11/16	1-3/8	10	MC377	BRG0152	—	—	—
8.1	494	V8	2004	2006	From Jan 1/2004, Slave Cylinder Included, Sold as Kit Only	GMK1019	295	11-11/16	1-3/8	10	MC377	BRG0152	—	—	—
<b>COLORADO</b>															
2.8	171	L4	2004	2004	Sold as Kit Only, Includes CSC Hydraulic Slave	GMK1015	264	10-3/8	1-1/8	26	MC462	SC801	—	—	—
2.8	171	L4	2005	2006	Sold as Kit Only, Includes CSC Hydraulic Slave	GMK1015	264	10-3/8	1-1/8	26	MC462	SC809	—	—	—
3.5	214	L5	2004	2006	Sold as Kit Only	GMK1028	265	10-7/16	1-3/16	26	MC462	SC809	—	—	—
<b>G10-30 VAN</b>															
3.2	195	L6	1964	1966	11" Disc	04072	280	11	1-1/8	10	—	—	—	—	—
3.8	232	L6	1966	1969	11" Disc	04072	280	11	1-1/8	10	—	—	—	—	—
4.1	250	L6	1967	1976	11" Disc	04072	280	11	1-1/8	10	—	—	—	—	—
4.1	250	L6	1977	1984	11" Disc	04049	280	11	1-1/8	10	—	—	—	—	—
4.1	250	L6	1977	1984	12" Diaph Clutch with Ceramic Button	04105	300	11-3/4	1-1/8	10	—	—	—	—	—
4.1	250	L6	1977	1984	12" Diaph Clutch, Non-Pre Damped	04064	300	11-3/4	1-1/8	10	—	—	—	—	—
4.3	262	V6	1985	1988	—	04089	280	11	1-1/8	10	—	—	—	—	—
4.3	262	V6	1988	1990	—	04089	280	11	1-1/8	10	—	—	—	—	—
4.3	262	V6	1988	1990	—	04089	280	11	1-1/8	10	—	SC708	—	—	FWGM108
4.8	293	L6	1971	1974	11" Disc	04049	280	11	1-1/8	10	—	—	—	—	—
4.8	293	L6	1971	1980	12" Diaph Clutch with Ceramic Button	04105	300	11-3/4	1-1/8	10	—	—	—	—	—
4.8	293	L6	1971	1980	12" Diaph Clutch, Non-Pre Damped	04064	300	11-3/4	1-1/8	10	—	—	—	—	—
4.8	293	L6	1974	1974	11" Disc, LPG Gas	04049	280	11	1-1/8	10	—	—	—	—	—
4.8	293	L6	1974	1974	LPG Gas, 12" Diaph Clutch with Ceramic Button	04105	300	11-3/4	1-1/8	10	—	—	—	—	—
4.8	293	L6	1974	1974	LPG Gas, 12" Diaph Clutch, Non-Pre Damped	04064	300	11-3/4	1-1/8	10	—	—	—	—	—
4.8	293	L6	1975	1980	11" Disc	04049	280	11	1-1/8	10	—	—	—	—	FWGM104
5.0	305	V8	1968	1973	11" Disc	04049	280	11	1-1/8	10	—	—	—	—	—
5.0	305	V8	1977	1984	11" Disc	04049	280	11	1-1/8	10	—	—	—	—	—
5.0	305	V8	1977	1984	12" Diaph Clutch with Ceramic Button	04105	300	11-3/4	1-1/8	10	—	—	—	—	—
5.0	305	V8	1977	1984	12" Diaph Clutch, Non-Pre Damped	04064	300	11-3/4	1-1/8	10	—	—	—	—	—
5.0	305	V8	1985	1990	—	04121	280	11	1-1/8	10	—	—	—	—	—
5.7	348	V8	1970	1984	11" Disc	04049	280	11	1-1/8	10	—	—	—	—	—
5.7	348	V8	1970	1984	12" Diaph Clutch with Ceramic Button	04105	300	11-3/4	1-1/8	10	—	—	—	—	—
5.7	348	V8	1970	1984	12" Diaph Clutch, Non-Pre Damped	04064	300	11-3/4	1-1/8	10	—	—	—	—	—
5.7	348	V8	1974	1974	11" Disc, LPG Gas	04049	280	11	1-1/8	10	—	—	—	—	—
5.7	348	V8	1974	1974	LPG Gas, 12" Diaph Clutch with Ceramic Button	04105	300	11-3/4	1-1/8	10	—	—	—	—	—
5.7	348	V8	1974	1974	LPG Gas, 12" Diaph Clutch, Non-Pre Damped	04064	300	11-3/4	1-1/8	10	—	—	—	—	—
5.7	348	V8	1985	1987	12" Diaph Clutch, Non-Pre Damped	04064	300	11-3/4	1-1/8	10	MC309	SC827	—	—	—
5.7	348	V8	1985	1987	Pre-Damped	04128	300	11-3/4	1-1/8	10	MC309	SC827	—	—	—
5.7	348	V8	1988	1990	12" Diaph Clutch, Non-Pre Damped	04064	300	11-3/4	1-1/8	10	—	—	—	—	FWGM103
5.7	348	V8	1988	1990	Pre-Damped	04128	300	11-3/4	1-1/8	10	—	—	—	—	FWGM103
6.2	378	V8	1983	1990	Diesel, Non Pre-Damped	04087	302	11-7/8	1-1/8	10	—	—	—	—	—
6.2	378	V8	1983	1990	Diesel, Pre-Damped	04128	300	11-3/4	1-1/8	10	—	—	—	—	—
6.6	403	V8	1978	1980	—	04020	280	11	1-1/8	26	—	—	—	—	FWGM100
7.4	452	V8	1973	1973	12" Diaph Clutch, Non-Pre Damped	04064	300	11-3/4	1-1/8	10	—	—	—	—	—
7.4	452	V8	1973	1973	Pre-Damped	04122	302	11-7/8	1-1/8	10	—	—	—	—	—
7.4	452	V8	1974	1976	12" Diaph Clutch, Non-Pre Damped	04064	300	11-3/4	1-1/8	10	—	—	—	—	FWGM102
7.4	452	V8	1974	1976	Pre-Damped	04122	302	11-7/8	1-1/8	10	—	—	—	—	FWGM102
7.4	452	V8	1988	1990	12" Diaph Clutch, Non-Pre Damped	04064	300	11-3/4	1-1/8	10	—	—	—	—	FWGM102
7.4	452	V8	1988	1990	Pre-Damped	04122	302	11-7/8	1-1/8	10	—	—	—	—	FWGM102

Liter	CC/IN	Cyl	Years		Application Information	Kit	Disc (mm)	Disc (in)	Spline Dia	Splines	Master Cyl	Slave Cyl	Clutch Cable	Clutch Fork	New Flywheel
			To	From											
<b>CHEVROLET LIGHT TRUCK, SUV &amp; VAN CONT.</b>															
<i>LUV PICKUP</i>															
1.8	110	L4	1972	1977	—	04058	200	7-7/8	1	24	MC488	—	—	—	—
1.8	110	L4	1978	1979	—	04058	200	7-7/8	1	24	—	—	—	—	—
1.8	110	L4	1980	1982	2 WD	04058	200	7-7/8	1	24	—	—	—	—	—
1.8	110	L4	1980	1982	4 WD	04071	215	8-1/2	1	24	—	—	—	—	—
2.2	134	L4	1981	1982	Diesel	04071	215	8-1/2	1	24	—	—	—	—	—
<i>P10-30 STEPVAN</i>															
3.2	195	L6	1966	1966	11" Disc	04072	280	11	1-1/8	10	—	—	—	—	—
3.8	232	L6	1963	1969	11" Disc	04072	280	11	1-1/8	10	—	—	—	—	—
3.9	238	L6	1961	1962	12" Diaph Clutch	04064	300	11-3/4	1-1/8	10	—	—	—	—	—
3.9	238	L6	1961	1962	12" Diaph Type Clutch with Ceramic Button	04105	300	11-3/4	1-1/8	10	—	—	—	—	—
4.1	250	L6	1966	1966	11" Disc	04072	280	11	1-1/8	10	—	—	—	—	—
4.1	250	L6	1968	1974	11" Disc	04072	280	11	1-1/8	10	—	—	—	—	—
4.1	250	L6	1976	1976	11" Disc	04072	280	11	1-1/8	10	—	—	—	—	—
4.1	250	L6	1979	1979	11" Disc	04049	280	11	1-1/8	10	—	—	—	—	—
4.1	250	L6	1979	1979	12" Diaph Clutch	04064	300	11-3/4	1-1/8	10	—	—	—	—	—
4.1	250	L6	1979	1979	12" Diaph Clutch with Ceramic Button	04105	300	11-3/4	1-1/8	10	—	—	—	—	—
4.3	262	V6	1990	1991	—	04089	280	11	1-1/8	10	MC375	SC744	—	—	FWGM108
4.3	262	V6	1992	1995	—	04121	280	11	1-1/8	10	MC374	SC741	—	—	FWGM108
4.3	262	V6	1996	1996	—	KGM10	280	11	1-1/8	10	MC379	SC746	—	—	FWGM108
4.3	262	V6	1997	1998	—	KGM10	280	11	1-1/8	10	MC379	SC746	—	—	—
4.3	262	V6	1999	1999	—	KGM17	280	11	1-1/8	10	—	—	—	—	—
4.6	281	V8	1961	1962	11" Disc	04072	280	11	1-1/8	10	—	—	—	—	—
4.8	293	L6	1964	1968	11" Disc	04072	280	11	1-1/8	10	—	—	—	—	—
4.8	293	L6	1969	1974	11" Disc	04049	280	11	1-1/8	10	—	—	—	—	—
4.8	293	L6	1974	1974	11" Disc, LPG Gas	04049	280	11	1-1/8	10	—	—	—	—	—
4.8	293	L6	1975	1984	11" Disc	04049	280	11	1-1/8	10	—	—	—	—	FWGM104
4.8	293	L6	1985	1989	—	04081	280	11	1-1/8	10	—	—	—	—	FWGM104
5.0	305	V8	1968	1979	—	04049	280	11	1-1/8	10	—	—	—	—	—
5.7	348	V8	1970	1978	11" Clutch	04049	280	11	1-1/8	10	—	—	—	—	—
5.7	348	V8	1970	1978	12" Diaph Clutch with Ceramic Button	04105	300	11-3/4	1-1/8	10	—	—	—	—	—
5.7	348	V8	1970	1985	12" Diaph Clutch	04064	300	11-3/4	1-1/8	10	—	—	—	—	—
5.7	348	V8	1979	1985	12" Diaph Clutch with Ceramic Button	04105	300	11-3/4	1-1/8	10	—	—	—	—	—
5.7	348	V8	1986	1988	12" Diaph Clutch	04064	300	11-3/4	1-1/8	10	—	—	—	—	FWGM103
5.7	348	V8	1986	1988	12" Diaph Clutch with Ceramic Button	04105	300	11-3/4	1-1/8	10	—	—	—	—	FWGM103
5.7	348	V8	1989	1990	12" Diaph Clutch	04064	300	11-3/4	1-1/8	10	MC375	SC744	—	—	FWGM103
5.7	348	V8	1989	1990	12" Diaph Clutch with Ceramic Button	04105	300	11-3/4	1-1/8	10	MC375	SC744	—	—	FWGM103
5.7	348	V8	1991	1991	12" Diaph Clutch with Ceramic Button, To 1/31/91	04105	300	11-3/4	1-1/8	10	MC375	SC744	—	—	FWGM103
5.7	348	V8	1991	1991	12" Diaph Clutch, To 3/31/91	04064	300	11-3/4	1-1/8	10	MC375	SC744	—	—	FWGM103
5.7	348	V8	1992	1995	Non Pre-Damped	04122	302	11-7/8	1-1/8	10	MC374	SC741	—	—	—
5.7	348	V8	1992	1995	Pre-Damped	04128	300	11-3/4	1-1/8	10	MC374	SC741	—	—	—
5.7	348	V8	1996	1996	—	04160	302	11-7/8	1-1/8	10	MC379	SC746	—	—	—
5.7	348	V8	1997	1999	—	04170	305	12	1-1/8	10	MC379	SC746	—	—	—
6.2	378	V8	1982	1989	Diesel, Non Pre-Damped	04087	302	11-7/8	1-1/8	10	MC309	SC827	—	—	—
6.2	378	V8	1982	1989	Diesel, Pre-Damped	04128	300	11-3/4	1-1/8	10	MC309	SC827	—	—	—
6.2	378	V8	1990	1991	Diesel, Non Pre-Damped	04087	302	11-7/8	1-1/8	10	MC375	SC744	—	—	—
6.2	378	V8	1990	1991	Diesel, Pre-Damped	04128	300	11-3/4	1-1/8	10	MC375	SC744	—	—	—
6.2	378	V8	1992	1993	Diesel, Non Pre-Damped	04087	302	11-7/8	1-1/8	10	MC374	SC741	—	—	—
6.2	378	V8	1992	1993	Diesel, Pre-Damped	04128	300	11-3/4	1-1/8	10	MC374	SC741	—	—	—
6.5	397	V8	1994	1994	Diesel, Non Pre-Damped	04146	302	11-7/8	1-1/8	10	MC372	SC741	—	—	—
6.5	397	V8	1994	1994	Diesel, Pre-Damped	04122	302	11-7/8	1-1/8	10	MC372	SC741	—	—	—
6.5	397	V8	1994	1994	Turbo Diesel, Non Pre-Damped	04146	302	11-7/8	1-1/8	10	MC372	SC741	—	—	—
6.5	397	V8	1994	1994	Turbo Diesel, Pre-Damped	04122	302	11-7/8	1-1/8	10	MC372	SC741	—	—	—
6.5	397	V8	1995	1995	Diesel, Non Pre-Damped	04146	302	11-7/8	1-1/8	10	—	SC741	—	—	—
6.5	397	V8	1995	1995	Diesel, Pre-Damped	04122	302	11-7/8	1-1/8	10	—	SC741	—	—	—
6.5	397	V8	1995	1995	Turbo Diesel, Non Pre-Damped	04146	302	11-7/8	1-1/8	10	—	SC741	—	—	—

Liter	CC/IN	Cyl	Years		Application Information	Kit	Disc (mm)	Disc (in)	Spline Dia	Splines	Master Cyl	Slave Cyl	Clutch Cable	Clutch Fork	New Flywheel
			To	From											
<b>CHEVROLET LIGHT TRUCK, SUV &amp; VAN CONT.</b>															
<i>P10-30 STEPVAN CONT.</i>															
6.5	397	V8	1995	1995	Turbo Diesel, Pre-Damped	04122	302	11-7/8	1-1/8	10	—	SC741	—	—	—
6.5	397	V8	1996	1999	Turbo Diesel 5 Spd with LUK Solid type FW. Kit does not include flywheel.	04154	302	11-7/8	1-1/8	10	MC379	SC746	—	—	FWGMC126
6.5	397	V8	1996	1999	Turbo Diesel 5 Spd with LUK Solid Type FW. Kit includes flywheel.	04154A	302	11-7/8	1-1/8	10	MC379	SC746	—	—	FWGMC126
6.5	397	V8	1996	1999	Turbo Diesel 5 Spd with Valeo type DMF. Kit does not include flywheel.	KGM12	300	11-3/4	1-1/8	10	MC379	SC746	—	—	FWGMC01
6.5	397	V8	1996	1999	Turbo Diesel 5 Spd with Valeo type DMF. Kit includes flywheel.	KGM12A	300	11-3/4	1-1/8	10	MC379	SC746	—	—	FWGMC01
6.6	403	V8	1972	1977	12" Diaph Clutch, Non-Pre Damped	04064	300	11-3/4	1-1/8	10	—	—	—	—	—
6.7	409	V8	1962	1962	12" Diaph Clutch, Non-Pre Damped	04064	300	11-3/4	1-1/8	10	—	—	—	—	—
6.7	409	V8	1964	1965	12" Diaph Clutch, Non-Pre Damped	04064	300	11-3/4	1-1/8	10	—	—	—	—	—
7.4	452	V8	1970	1971	12" Diaph Clutch, Non-Pre Damped	04064	300	11-3/4	1-1/8	10	—	—	—	—	—
7.4	452	V8	1970	1971	Pre-Damped	04122	302	11-7/8	1-1/8	10	—	—	—	—	—
7.4	452	V8	1973	1973	12" Diaph Clutch, Non-Pre Damped	04064	300	11-3/4	1-1/8	10	—	—	—	—	—
7.4	452	V8	1973	1973	Pre-Damped	04122	302	11-7/8	1-1/8	10	—	—	—	—	—
7.4	452	V8	1974	1986	12" Diaph Clutch, Non-Pre Damped	04064	300	11-3/4	1-1/8	10	—	—	—	—	FWGM102
7.4	452	V8	1974	1986	Pre-Damped	04122	302	11-7/8	1-1/8	10	—	—	—	—	FWGM102
7.4	452	V8	1987	1987	12" Diaph Clutch, Non-Pre Damped	04064	300	11-3/4	1-1/8	10	MC309	SC827	—	—	FWGM102
7.4	452	V8	1987	1987	Pre-Damped	04122	302	11-7/8	1-1/8	10	MC309	SC827	—	—	FWGM102
7.4	452	V8	1988	1991	12" Diaph Clutch, Non-Pre Damped	04064	300	11-3/4	1-1/8	10	—	SC827	—	—	FWGM102
7.4	452	V8	1988	1991	Pre-Damped	04122	302	11-7/8	1-1/8	10	—	SC827	—	—	FWGM102
7.4	452	V8	1992	1994	12" Diaph Clutch, Non-Pre Damped	04064	300	11-3/4	1-1/8	10	MC372	SC827	—	—	FWGM118
7.4	452	V8	1992	1994	Pre-Damped	04122	302	11-7/8	1-1/8	10	MC372	SC827	—	—	FWGM118
7.4	452	V8	1995	1995	12" Diaph Clutch, Non-Pre Damped	04064	300	11-3/4	1-1/8	10	MC380	SC827	—	—	FWGM118
7.4	452	V8	1995	1995	Pre-Damped	04122	302	11-7/8	1-1/8	10	MC380	SC827	—	—	FWGM118
7.4	452	V8	1996	1999	—	04154	302	11-7/8	1-1/8	10	—	—	—	—	—
7.4	452	V8	1996	1999	Turbo Diesel 5 Spd with LUK Solid Type FW. Kit includes flywheel.	04154A	302	11-7/8	1-1/8	10	—	—	—	—	FWGMC126
<i>S10/T10, BLAZER</i>															
2.0	122	L4	1983	1983	Non Pre-Damped	04065	228	9	1	14	—	—	—	—	—
2.0	122	L4	1983	1983	Pre-Damped	04130	232	9-1/8	1	14	—	—	—	—	—
2.0	122	L4	1984	1984	Non Pre-Damped	04065	228	9	1	14	MC486	SC705	—	—	—
2.0	122	L4	1984	1984	Pre-Damped	04130	232	9-1/8	1	14	MC486	SC705	—	—	—
2.2	134	L4	1994	1995	Non Pre-Damped	04138	232	9-1/8	1-1/8	26	MC376	SC742	—	CF128	—
2.2	134	L4	1996	2001	Non Pre-Damped	04155	232	9-1/8	1-1/8	26	MC378	SC746	—	—	—
2.5	153	L4	1985	1989	Non Pre-Damped	04065	228	9	1	14	MC308	SC705	—	CF128	FWGM115
2.5	153	L4	1985	1989	Pre-Damped	04130	232	9-1/8	1	14	MC308	SC705	—	CF128	FWGM115
2.5	153	L4	1990	1991	Non Pre-Damped	04065	228	9	1	14	MC308	SC705	—	CF126	FWGM115
2.5	153	L4	1990	1991	Pre-Damped	04130	232	9-1/8	1	14	MC308	SC705	—	CF126	FWGM115
2.5	153	L4	1992	1993	Non Pre-Damped	04065	228	9	1	14	MC373	SC742	—	CF126	FWGM115
2.5	153	L4	1992	1993	Pre-Damped	04130	232	9-1/8	1	14	MC373	SC742	—	CF126	FWGM115
2.8	171	V6	1983	1984	—	04069	215	8-1/2	1	14	MC308	SC743	CC655	—	—
2.8	171	V6	1985	1989	Non Pre-Damped	04065	228	9	1	14	MC308	SC705	—	—	FWGM115
2.8	171	V6	1985	1989	Pre-Damped	04130	232	9-1/8	1	14	MC308	SC705	—	—	FWGM115
2.8	171	V6	1990	1991	Non Pre-Damped	04065	228	9	1	14	MC308	SC705	—	CF126	FWGM115
2.8	171	V6	1990	1991	Pre-Damped	04130	232	9-1/8	1	14	MC308	SC705	—	CF126	FWGM115
2.8	171	V6	1992	1993	Non Pre-Damped	04065	228	9	1	14	MC373	SC742	—	CF126	FWGM115
2.8	171	V6	1992	1993	Pre-Damped	04130	232	9-1/8	1	14	MC373	SC742	—	CF126	FWGM115
4.3	262	V6	1988	1989	—	04089	280	11	1-1/8	10	MC309	SC827	—	—	FWGM108
4.3	262	V6	1990	1991	—	04089	280	11	1-1/8	10	MC308	SC745	—	—	FWGM108
4.3	262	V6	1992	1993	—	04089	280	11	1-1/8	10	MC373	SC743	—	—	FWGM108
4.3	262	V6	1994	1995	—	04168	280	11	1-1/8	10	MC376	SC743	—	—	FWGM108
4.3	262	V6	1996	1998	—	KGM10	280	11	1-1/8	10	MC378	SC746	—	—	FWGM108
4.3	262	V6	1999	2004	—	KGM10	280	11	1-1/8	10	MC378	SC746	—	—	—
<i>SSR</i>															
6.0	366	V8	2005	2006	Sold as Kit Only	GMK1024	290	11-7/16	1-1/8	26	—	—	—	—	—
<i>TRACKER</i>															
1.6	98	L4	1998	1998	—	04137	215	8-7/16	7/8	20	MC503	SC870	—	—	—
1.6	98	L4	1999	2000	—	GMK1044	215	8-7/16	7/8	20	—	—	—	—	—
2.0	122	L4	1999	2003	—	KSZ04	225	8-7/8	15/16	20	MC503	SC870	—	—	—



Liter	CC/IN	Cyl	Years		Application Information	Kit	Disc (mm)	Disc (in)	Spline Dia	Splines	Master Cyl	Slave Cyl	Clutch Cable	Clutch Fork	New Flywheel
			To	From											
<b>CHRYSLER</b>															
<b>300</b>															
6.3	384	V8	1962	1966	10-3/8" Disc	05029	263	10-3/8	1	23	—	—	—	—	—
6.8	415	V8	1959	1965	10-3/8" Disc	05029	263	10-3/8	1	23	—	—	—	—	—
<b>CIRRUS</b>															
2.0	122	L4	2000	2000	Modular Clutch Includes Flywheel	05085	230	9-1/16	15/16	17	—	—	—	—	—
<b>CROSSFIRE</b>															
3.2	195	V6	2004	2006	Sold as Kit Only, Includes CSC Hydraulic Slave Cylinder	CRK1009	240	9-7/16	1-1/8	26	—	—	—	—	—
<b>DAYTONA</b>															
2.2	134	L4	1984	1989	Turbo I	05002	232	9-1/8	13/16	18	—	—	—	—	—
2.2	134	L4	1992	1993	Turbo III, IV	05077	232	9-1/8	15/16	17	—	—	—	—	—
2.5	153	L4	1987	1989	—	05028A	215	8-7/16	13/16	18	—	—	—	—	—
2.5	153	L4	1990	1990	—	05060	232	9-1/8	13/16	18	—	—	—	—	—
2.5	153	L4	1990	1990	Turbo	05067	232	9-1/8	13/16	18	—	—	—	—	—
2.5	153	L4	1991	1992	Turbo	05057	232	9-1/8	15/16	17	—	—	—	—	—
2.5	153	L4	1991	1993	—	05057	232	9-1/8	15/16	17	—	—	—	—	—
3.0	183	V6	1990	1993	—	05067	232	9-1/8	13/16	18	—	—	—	—	—
<b>LASER</b>															
2.2	134	L4	1984	1986	Non-Turbo, Sold As Kit Only	05028A	215	8-7/16	13/16	18	—	—	—	—	—
2.2	134	L4	1984	1986	Turbo I	05002	232	9-1/8	13/16	18	—	—	—	—	—
2.5	153	L4	1986	1986	Non-Turbo	05002	232	9-1/8	13/16	18	—	—	—	—	—
<b>LEBARON</b>															
2.2	134	L4	1982	1989	Non-Turbo, Sold As Kit Only	05028A	215	8-7/16	13/16	18	—	—	—	—	—
2.2	134	L4	1984	1985	Turbo I	05002	232	9-1/8	13/16	18	—	—	—	—	—
2.2	134	L4	1990	1990	Intercooled Turbo II	05067	232	9-1/8	13/16	18	—	—	—	—	—
2.5	153	L4	1986	1989	Non-Turbo	05002	232	9-1/8	13/16	18	—	—	—	—	—
2.5	153	L4	1990	1990	Non-Turbo	05060	232	9-1/8	13/16	18	—	—	—	—	—
2.5	153	L4	1990	1990	Turbo	05067	232	9-1/8	13/16	18	—	—	—	—	—
2.5	153	L4	1991	1992	Turbo	05057	232	9-1/8	15/16	17	—	—	—	—	—
2.5	153	L4	1991	1993	—	05057	232	9-1/8	15/16	17	—	—	—	—	—
3.0	183	V6	1990	1990	—	05067	232	9-1/8	13/16	18	—	—	—	—	—
3.0	183	V6	1991	1993	—	05057	232	9-1/8	15/16	17	—	—	—	—	—
<b>NEWPORT, NEW YORKER, SARATOGA, WINDSOR, 300</b>															
5.9	360	V8	1961	1964	10-3/8" Disc	05029	263	10-3/8	1	23	—	—	—	—	—
5.9	360	V8	1971	1971	10-3/8" Disc	05029	263	10-3/8	1	23	—	—	—	—	—
6.3	384	V8	1959	1961	10-3/8" Disc	05029	263	10-3/8	1	23	—	—	—	—	—
6.3	384	V8	1965	1967	10-3/8" Disc	05029	263	10-3/8	1	23	—	—	—	—	—
6.3	384	V8	1968	1969	—	05032	280	11	1	23	—	—	—	—	FWCHR106
6.8	415	V8	1959	1965	10-3/8" Disc	05029	263	10-3/8	1	23	—	—	—	—	—
<b>PT CRUISER</b>															
2.4	146	L4	2001	2005	Non-Turbo	KCH05	230	9-1/16	15/16	17	MC349	SC726	—	—	—
2.4	146	L4	2003	2005	Turbo, Includes Slave Cylinder, Sold as Kit Only	CRK1000	240	9-1/2	1-1/8	26	MC349	SC726	—	—	—
2.4	146	L4	2005	2005	Turbo, Transmission# 5273472AA, Includes Slave cylinder	CRK1012	240	9-1/2	1-1/8	26	MC349	SC935	—	—	—
2.4	146	L4	2006	2006	Non-Turbo	KCH05	230	9-1/16	15/16	17	MC349	SC926	—	—	—
2.4	146	L4	2006	2006	Turbo, Transmission# 5274888AC or 5274888AD, Includes Slave cylinder	CRK1000	240	9-1/2	1-1/8	26	—	—	—	—	—
2.4	146	L4	2006	2006	Turbo, Includes Slave Cylinder, Sold as Kit Only	CRK1012	240	9-1/2	1-1/8	26	MC349	SC936	—	—	—
<b>SEBRING</b>															
2.0	122	L4	1995	1999	Modular Clutch Includes Flywheel	05085	230	9-1/16	15/16	17	MC401	SC592	—	—	—
2.4	146	L4	2003	2003	Sold As Kit Only	05048	225	8-7/8	7/8	20	MC565	SC844	—	—	—
2.4	146	L4	2004	2004	Sold As Kit Only	05048	225	8-7/8	7/8	20	—	—	—	—	—
3.0	183	V6	2001	2003	Silent Design Disc, Pull Type, Sold As Kit Only	KMB03	230	9-1/16	15/16	23	MC564	SC854	—	—	—
3.0	183	V6	2004	2004	Silent Design Disc, Pull Type, Sold As Kit Only	KMB03	230	9-1/16	15/16	23	—	—	—	—	—
<b>DAEWOO</b>															
<b>LANOS</b>															
1.6	98	L4	1999	2000	From Chassis # E182493, Sold As Kit Only	DWK1000	215	8-7/16	13/16	24	MC508	SC836	—	—	—

Liter	CC/IN	Cyl	Years		Application Information	Kit	Disc (mm)	Disc (in)	Spline Dia	Splines	Master Cyl	Slave Cyl	Clutch Cable	Clutch Fork	New Flywheel
			To	From											
<b>DAEWOO CONT.</b>															
<i>LEGANZA</i>															
2.2	134	L4	1999	2002	Sold As Kit Only	DWK1001	225	8-7/8	13/16	24	MC508	SC836	—	—	—
<i>NUBIRA</i>															
2.0	2000	L4	1999	2002	Sold As Kit Only	DWK1001	225	8-7/8	13/16	24	—	SC836	—	—	—
<b>DAIHATSU</b>															
<i>CHARADE</i>															
1.0	61	L3	1988	1992	—	23001	170	6-11/16	7/8	20	—	—	—	—	—
1.3	79	L4	1989	1992	—	23002	180	7-1/8	7/8	20	—	—	—	—	—
<i>ROCKY</i>															
1.6	98	L4	1990	1992	—	23003	200	7-7/8	7/8	20	—	—	—	—	—
<b>DODGE (Performance Applications Available)</b>															
<i>2000 GTX (CANADA)</i>															
2.0	122	L4	1989	1989	—	05051	215	8-1/2	7/8	20	—	—	—	—	—
<i>ARIES, DAYTONA, LANCER, SHADOW, SPIRIT, 400, 600</i>															
2.2	134	L4	1981	1989	Non-Turbo, Sold As Kit Only	05028A	215	8-7/16	13/16	18	—	—	—	—	—
2.2	134	L4	1984	1989	Turbo I	05002	232	9-1/8	13/16	18	—	—	—	—	—
2.2	134	L4	1990	1990	Intercooled, Turbo II	05067	232	9-1/8	13/16	18	—	—	—	—	—
2.2	134	L4	1990	1990	Non-Turbo	05061	215	8-7/16	13/16	18	—	—	—	—	—
2.2	134	L4	1991	1993	Turbo III, IV	05077	232	9-1/8	13/16	17	—	—	—	—	—
2.2	134	L4	1991	1994	Non-Turbo	05059	215	8-7/16	13/16	17	—	—	—	—	—
2.5	153	L4	1986	1989	Non-Turbo, Sold As Kit Only	05028A	215	8-7/16	13/16	18	—	—	—	—	—
2.5	153	L4	1990	1990	Non-Turbo	05060	232	9-1/8	13/16	18	—	—	—	—	—
2.5	153	L4	1990	1990	Turbo	05067	232	9-1/8	13/16	18	—	—	—	—	—
2.5	153	L4	1991	1992	Turbo	05057	232	9-1/8	15/16	17	—	—	—	—	—
2.5	153	L4	1991	1994	—	05057	232	9-1/8	15/16	17	—	—	—	—	—
3.0	183	V6	1989	1994	—	05067	232	9-1/8	13/16	18	—	—	—	—	—
<i>ASPEN, CORONET, DART, DIPLOMAT, LANCER, MONACO, POLARA, ROYAL, ROYAL MONACO</i>															
4.5	275	V8	1964	1966	10-3/8" Disc	05029	263	10-3/8	1	23	—	—	—	—	—
5.2	317	V8	1961	1978	10-3/8" Disc	05029	263	10-3/8	1	23	—	—	—	—	—
5.6	342	V8	1968	1971	10-3/8" Disc	05029	263	10-3/8	1	23	—	—	—	—	—
5.9	360	V8	1971	1971	10-3/8" Disc	05029	263	10-3/8	1	23	—	—	—	—	—
6.3	384	V8	1963	1969	10-3/8" Disc	05029	263	10-3/8	1	23	—	—	—	—	—
6.3	384	V8	1969	1969	11" Disc	05016	280	11	1	23	—	—	—	—	FWCHR106
<i>AVENGER</i>															
2.0	122	L4	1995	1999	Modular Clutch Includes Flywheel	05085	230	9-1/16	15/16	17	MC401	SC592	—	—	—
2.5	153	V6	1996	1998	Sold As Kit Only	05028A	215	8-7/16	13/16	18	—	—	—	—	—
<i>CALIBER</i>															
1.8	110	L4	2007	2009	Sold as Kit Only, Includes CSC Hydraulic Slave Cylinder, Modular Unit	CRK1017	230	9-1/16	15/16	17	—	—	—	—	—
<i>CHALLENGER</i>															
1.6	98	L4	1978	1979	FWD	05020	200	7-7/8	7/8	20	—	—	—	—	—
2.6	159	L4	1978	1983	—	05041	225	8-7/8	1-1/32	23	—	—	—	—	—
5.2	317	V8	1970	1974	10-3/8" Disc	05029	263	10-3/8	1	23	—	—	—	—	—
5.6	342	V8	1970	1973	10-3/8" Disc	05029	263	10-3/8	1	23	—	—	—	—	—
<i>CHARGER, OMNI</i>															
1.6	98	L4	1983	1986	FWD	05009	200	7-7/8	13/16	18	—	—	—	—	—
1.7	104	L4	1978	1983	—	05009	200	7-7/8	13/16	18	—	—	—	—	—
2.2	134	L4	1981	1989	FWD, Non-Turbo, Sold As Kit Only	05028A	215	8-7/16	13/16	18	—	—	—	—	—
2.2	134	L4	1985	1987	FWD, Turbo I	05002	232	9-1/8	13/16	18	—	—	—	—	—
2.2	134	L4	1990	1990	FWD, Non-Turbo	05061	215	8-7/16	13/16	18	—	—	—	—	—
5.2	317	V8	1967	1974	10-3/8" Disc	05029	263	10-3/8	1	23	—	—	—	—	—
5.2	317	V8	1968	1968	10-3/8" Disc	05029	263	10-3/8	1	23	—	—	—	—	—
5.6	342	V8	1971	1973	10-3/8" Disc	05029	263	10-3/8	1	23	—	—	—	—	—
6.3	384	V8	1967	1969	10-3/8" Disc	05029	263	10-3/8	1	23	—	—	—	—	—
6.3	384	V8	1969	1969	11" Disc	05032	280	11	1	23	—	—	—	—	FWCHR106

Liter	CC/IN	Cyl	Years		Application Information	Kit	Disc (mm)	Disc (in)	Spline Dia	Splines	Master Cyl	Slave Cyl	Clutch Cable	Clutch Fork	New Flywheel
			To	From											
<b>DODGE (Performance Applications Available) CONT.</b>															
<b>COLT</b>															
1.4	85	L4	1979	1979	4 Spd 7-7/8" Disc	05026	200	7-7/8	7/8	20	—	—	—	—	—
1.4	85	L4	1979	1979	Dual Range 4 Spd	05023	184	7-1/4	7/8	20	—	—	—	—	—
1.4	85	L4	1980	1980	4 Spd Luk	05026	200	7-7/8	7/8	20	—	—	—	—	—
1.4	85	L4	1980	1980	Dual Range 4 Spd Luk	05023	184	7-1/4	7/8	20	—	—	—	—	—
1.4	85	L4	1981	1984	4 Spd 7-7/8" Disc	05026	200	7-7/8	7/8	20	—	—	—	—	—
1.4	85	L4	1981	1984	Dual Range 4 Spd	05023	184	7-1/4	7/8	20	—	—	—	—	—
1.5	92	L4	1985	1988	4 Spd	05026	200	7-7/8	7/8	20	—	—	—	—	—
1.5	92	L4	1985	1988	5 Spd	05023	184	7-1/4	7/8	20	MC194	SC580	—	—	—
1.5	92	L4	1989	1994	—	05026	200	7-7/8	7/8	20	MC178	SC580	—	—	—
1.6	98	L4	1971	1972	—	05040	200	7-7/8	7/8	20	—	—	—	—	—
1.6	98	L4	1973	1973	From 10/73	05020	200	7-7/8	7/8	20	—	—	—	—	—
1.6	98	L4	1973	1973	To 9/73	05040	200	7-7/8	7/8	20	—	—	—	—	—
1.6	98	L4	1974	1978	—	05020	200	7-7/8	7/8	20	—	—	—	—	—
1.6	98	L4	1979	1979	Sedan	05023	184	7-1/4	7/8	20	—	—	—	—	—
1.6	98	L4	1979	1981	Sedan, 7-1/4" disc	05023	184	7-1/4	7/8	20	—	—	—	—	—
1.6	98	L4	1979	1981	Wagon	05020	200	7-7/8	7/8	20	—	—	—	—	—
1.6	98	L4	1982	1983	—	05023	184	7-1/4	7/8	20	—	—	—	—	—
1.6	98	L4	1984	1984	Turbo	05022	200	7-7/8	7/8	20	MC203	SC580	—	—	—
1.6	98	L4	1985	1985	Turbo 3 Speed and 5 Speed	05026	200	7-7/8	7/8	20	—	—	—	—	—
1.6	98	L4	1986	1988	Turbo 3 Speed and 5 Speed	05026	200	7-7/8	7/8	20	MC497	SC584	—	—	—
1.6	98	L4	1989	1990	5 Spd	05051	215	8-1/2	7/8	20	MC178	SC581	—	—	—
1.6	98	L4	1989	1990	Turbo, 5 Spd	05051	215	8-1/2	7/8	20	MC178	SC581	—	—	—
1.8	110	L4	1989	1990	—	05051	215	8-1/2	7/8	20	MC178	SC581	—	—	—
1.8	110	L4	1992	1992	—	05051	215	8-1/2	7/8	20	—	SC581	—	—	—
1.8	110	L4	1993	1994	—	05051	215	8-1/2	7/8	20	MC178	SC589	—	—	—
2.0	122	L4	1974	1977	—	05021	215	8-1/2	7/8	20	—	—	—	—	—
2.6	159	L4	1978	1980	—	05041	225	8-7/8	1-1/32	23	—	—	—	—	—
<b>COLT VISTA</b>															
2.0	122	L4	1984	1984	—	05026	200	7-7/8	7/8	20	—	—	—	—	—
2.0	122	L4	1985	1985	4WD	05051	215	8-1/2	7/8	20	MC175	SC583	—	—	—
2.0	122	L4	1985	1985	FWD with 7-7/8" Disc	05026	200	7-7/8	7/8	20	MC175	SC820	—	—	—
2.0	122	L4	1986	1987	2 WD with 7-7/8" Disc	05026	200	7-7/8	7/8	20	MC175	SC581	—	—	—
2.0	122	L4	1986	1991	4 WD	05051	215	8-1/2	7/8	20	MC175	SC820	—	—	—
2.0	122	L4	1987	1991	2 WD with 8-1/4" Disc	05051	215	8-1/2	7/8	20	MC175	SC581	—	—	—
<b>COLT VISTA (CANADA)</b>															
2.4	146	L4	1993	1994	4 WD, Sold As Kit Only	05048	225	8-7/8	7/8	20	—	SC589	—	—	—
<b>NEON</b>															
2.0	122	L4	1995	1999	11th Digit Vin is T	05076	230	9-1/16	15/16	17	—	—	—	—	—
2.0	122	L4	1996	2000	11th Digit Vin is D, Modular Clutch includes Flywheel	05085	230	9-1/16	15/16	17	—	—	—	—	—
2.0	122	L4	2001	2005	11th Digit Vin is D, Modular Clutch includes Flywheel	05085	230	9-1/16	15/16	17	MC460	SC726	—	—	—
2.4	146	L4	2003	2005	Turbo, Sold As Kit Only, Modular design incl. F/W	CRK1001	240	9-1/2	15/16	17	MC464	SC804	—	—	—
<b>STEALTH</b>															
3.0	183	V6	1991	1996	Non-Turbo, Sold As Kit Only	05048	225	8-7/8	7/8	20	MC543	SC837	—	—	—
3.0	183	V6	1991	1996	Turbo, Sold As Kit Only	05075	250	9-7/8	1	23	MC544	SC838	—	—	—
<b>STRATUS</b>															
2.0	122	L4	1995	2000	Modular Clutch Includes Flywheel	05085	230	9-1/16	15/16	17	—	—	—	—	—
2.4	146	L4	1997	1998	Modular Clutch Includes Flywheel	05085	230	9-1/16	15/16	17	—	—	—	—	—
2.4	146	L4	2001	2002	5 Spd with 16 Valve, Sold As Kit Only	MBK1000	225	8-7/8	7/8	20	—	—	—	—	—
2.4	146	L4	2003	2005	5 Spd with 16 Valve, Sold As Kit Only	MBK1000	225	8-7/8	7/8	20	MC565	SC844	—	—	—
3.0	183	V6	2001	2005	Silent Design Disc, Pot F/W, Sold As Kit Only, Fits R/T version 2001-03, Pull Type	KMB03	230	9-1/16	13/16	23	MC564	SC854	—	—	—
<b>VIPER</b>															
8.0	488	V10	1992	2002	—	05088	311	12-1/4	1-1/8	26	MC424	SC781	—	—	—
8.3	506	V10	2003	2006	—	05088	311	12-1/4	1-1/8	26	—	SC781	—	—	—



Liter	CC/IN	Cyl	Years		Application Information	Kit	Disc (mm)	Disc (in)	Spline Dia	Splines	Master Cyl	Slave Cyl	Clutch Cable	Clutch Fork	New Flywheel
			To	From											
<b>DODGE LIGHT TRUCK, SUV &amp; VAN</b>															
<i>100-350, 1500-2500 VAN</i>															
3.7	226	L6	1971	1980	11" Disc	05016	280	11	1	23	—	—	—	—	—
3.9	238	V6	1992	1993	—	05065	265	10-1/2	1-1/8	10	MC385	SC751	—	—	—
5.2	317	V8	1977	1983	10-3/8" Disc	05029	263	10-3/8	1	23	—	—	—	CF115	—
5.2	317	V8	1977	1987	11" Disc	05016	280	11	1	23	—	—	—	—	FWCHR106
5.2	317	V8	1984	1987	10-3/8" Disc	05029	263	10-3/8	1	23	MC383	SC750	—	CF115	—
5.2	317	V8	1988	1991	A435 Trans	05038	280	11	1	23	MC386	SC749	—	—	FWCHR106
5.2	317	V8	1992	1993	—	05063	280	11	1	19	MC386	SC752	—	—	FWCHR106
5.9	360	V8	1971	1980	External Balanced Flywheel	05016	280	11	1	23	—	—	—	—	FWCHR108
5.9	360	V8	1971	1980	Internal Balanced Flywheel	05016	280	11	1	23	—	—	—	—	FWCHR106
6.6	403	V8	1971	1978	—	05062	302	11-7/8	1	23	—	—	—	—	—
7.2	439	V8	1974	1978	—	05062	302	11-7/8	1	23	—	—	—	—	—
<i>CARAVAN, MINI RAM</i>															
2.2	134	L4	1984	1987	—	05002	232	9-1/8	13/16	18	—	—	—	—	—
2.5	153	L4	1987	1988	—	05002	232	9-1/8	13/16	18	—	—	—	—	—
2.5	153	L4	1988	1989	Non-Turbo	05002	232	9-1/8	13/16	18	—	—	—	—	—
2.5	153	L4	1990	1990	Non-Turbo	05060	232	9-1/8	13/16	18	—	—	—	—	—
2.5	153	L4	1990	1990	Turbo	05067	232	9-1/8	13/16	18	—	—	—	—	—
2.5	153	L4	1992	1992	Non-Turbo	05057	232	9-1/8	15/16	17	—	—	—	—	—
2.6	159	L4	1984	1987	—	05041	225	8-7/8	1-1/32	23	—	—	—	—	—
<i>D100-350, R1500-3500 (RAM), W100-350</i>															
3.7	226	L6	1969	1983	11" Disc	05016	280	11	1	23	—	—	—	—	—
3.7	226	V6	2002	2004	—	CRK1010	302	11-7/8	1-1/8	10	MC457	SC800	—	—	—
3.7	226	V6	2006	2006	—	CRK1010	302	11-7/8	1-1/8	10	MC457	SC791	—	—	—
3.9	238	V6	1988	1991	4 Spd	05038	280	11	1	23	MC386	SC749	—	—	FWCHR106
3.9	238	V6	1989	1991	4 Spd	05038	280	11	1	23	MC386	—	—	—	FWCHR106
3.9	238	V6	1992	1993	—	05065	265	10-1/2	1-1/8	10	MC386	SC752	—	—	—
3.9	238	V6	2001	2001	Sold as Kit Only	CRK1010	302	11-7/8	1-1/8	10	MC395	SC757	—	—	—
4.7	287	V8	2004	2004	Sold as Kit Only	CRK1010	302	11-7/8	1-1/8	10	MC457	SC800	—	—	—
4.7	287	V8	2005	2007	Sold as Kit Only	CRK1010	302	11-7/8	1-1/8	10	MC457	SC791	—	—	—
4.7	287	V8	2002	2004	Sold as Kit Only	CRK1010	302	11-7/8	1-1/8	10	MC457	SC800	—	—	—
4.7	287	V8	2005	2005	Sold as Kit Only	CRK1010	302	11-7/8	1-1/8	10	MC457	SC791	—	—	—
5.2	317	V8	1966	1980	11" Disc	05016	280	11	1	23	—	—	—	—	—
5.2	317	V8	1977	1980	10-3/8" Disc	05029	263	10-3/8	1	23	—	—	—	—	—
5.2	317	V8	1981	1985	10-3/8" Disc	05029	263	10-3/8	1	23	—	—	—	CF115	—
5.2	317	V8	1981	1985	11" Disc	05016	280	11	1	23	—	—	—	CF115	—
5.2	317	V8	1986	1987	10-3/8" Disc	05029	263	10-3/8	1	23	MC382	SC750	—	CF115	—
5.2	317	V8	1988	1991	—	05038	280	11	1	23	MC386	SC749	—	—	FWCHR106
5.2	317	V8	1992	1993	—	05063	280	11	1	19	MC386	SC752	—	—	FWCHR106
5.2	317	V8	1994	1997	—	05074	302	11-7/8	1-1/8	10	MC391	SC752	—	—	—
5.2	317	V8	1998	2000	—	05074	302	11-7/8	1-1/8	10	MC395	SC757	—	—	—
5.2	317	V8	2001	2001	—	CRK1010	302	11-7/8	1-1/8	10	MC395	SC757	—	—	—
5.7	348	V8	2003	2008	Sold as Kit Only	CRK1008	290	11-7/16	1-1/8	10	MC457	SC791	—	—	—
5.9	360	V8	1971	1980	External Balanced Flywheel	05016	280	11	1	23	—	—	—	—	FWCHR108
5.9	360	V8	1971	1980	Internal Balanced Flywheel	05016	280	11	1	23	—	—	—	—	FWCHR106
5.9	360	V8	1981	1985	External Balanced Flywheel	05016	280	11	1	23	MC382	SC750	—	CF115	FWCHR108
5.9	360	V8	1981	1985	Internal Balanced Flywheel	05016	280	11	1	23	MC382	SC750	—	CF115	FWCHR106
5.9	360	V8	1986	1987	External Balanced Flywheel	05016	280	11	1	23	MC386	SC749	—	CF115	FWCHR108
5.9	360	V8	1986	1987	Internal Balanced Flywheel	05016	280	11	1	23	MC386	SC749	—	CF115	FWCHR106
5.9	360	V8	1988	1991	External Balanced Flywheel	05038	280	11	1	23	MC386	SC752	—	—	FWCHR108
5.9	360	V8	1988	1991	Internal Balanced Flywheel	05038	280	11	1	23	MC386	SC752	—	—	FWCHR106
5.9	360	V8	1993	1993	External Balanced Flywheel	05063	280	11	1	19	MC386	SC752	—	—	FWCHR108
5.9	360	V8	1993	1993	Internal Balanced Flywheel	05063	280	11	1	19	MC386	SC752	—	—	FWCHR106
5.9	360	L6	1994	1997	Turbo Diesel	05073	311	12-1/4	1-1/4	10	MC391	SC755	—	—	—
5.9	360	V8	1994	1997	Replaces OE 11" System	05074	302	11-7/8	1-1/8	10	MC391	SC752	—	—	—
5.9	360	L6	1998	2000	Turbo Diesel	05092	311	12-1/4	1-1/4	10	MC395	SC757	—	—	—

Liter	CC/IN	Cyl	Years		Application Information	Kit	Disc (mm)	Disc (in)	Spline Dia	Splines	Master Cyl	Slave Cyl	Clutch Cable	Clutch Fork	New Flywheel
			To	From											
<b>DODGE LIGHT TRUCK, SUV &amp; VAN CONT.</b>															
<i>D100-350, R1500-3500 (RAM), W100-350 CONT.</i>															
5.9	360	V8	1998	2000	Replaces OE 11" System	05074	302	11-7/8	1-1/8	10	MC395	SC757	—	—	—
5.9	360	V8	2001	2001	Replaces OE 11" System	05074	302	11-7/8	1-1/8	10	MC395	SC791	—	—	—
5.9	360	L6	2001	2003	Turbo Diesel, 5 Spd	05092	311	12-1/4	1-1/4	10	MC395	SC757	—	—	—
5.9	360	L6	2001	2004	Turbo Diesel, 6 Spd, Economy version, contains Exedy parts	CRK1004	330	13	1-3/8	10	MC395	SC757	—	—	LFW147
5.9	360	L6	2001	2004	Turbo Diesel, 6 Spd, HD Version contains Cushion Button disc suited for 680 ft. lbs./Torque at the wheel	CRK1004HD	330	13	1-3/8	10	MC395	SC757	—	—	LFW147
5.9	360	L6	2001	2004	Turbo Diesel, 6 Spd	05101	330	13	1-3/8	10	MC395	SC757	—	—	LFW147
5.9	360	L6	2001	2004	Turbo Diesel, 6 Spd	05101A	330	13	1-3/8	10	MC395	SC757	—	—	LFW147
5.9	360	V8	2002	2002	Replaces OE 11" System	05074	302	11-7/8	1-1/8	10	MC457	SC800	—	—	—
5.9	360	L6	2002	2003	Turbo Diesel 5 Speed	05092	311	12-1/4	1-1/4	10	MC395	SC757	—	—	—
5.9	360	L6	2005	2009	6 Spd Turbo Diesel, Mercedes Trans, Includes Master and Slave Cylinder Hydraulic system, Sold as Kit Only	CRK1005FW	330	13	1-3/8	10	MC457	SC791	—	—	—
5.9	360	L6	2005	2009	6 Spd Turbo Diesel, Solid FW replacement for OEM Dual Mass FW, Includes Master and Slave Cylinder Hydraulic system, Includes Solid FW, Sold as kit only, HD Version contains Cushion Button disc suited for 680 ft. lbs./Torque at the wheel	CRK1005FWHD	330	13	1-3/8	10	MC457	SC791	—	—	—
5.9	360	L6	2005	2009	6 Spd Turbo Diesel, Includes Master and Slave Cylinder Hydraulic system, Sold as Kit Only	CRK1005FW	330	13	1-3/8	10	MC595	SC934	—	—	—
5.9	360	L6	2005	2009	6 Spd Turbo Diesel, Solid FW replacement for OEM Dual Mass FW, Includes Master and Slave Cylinder Hydraulic system, Includes Solid FW, Sold as kit only, HD Version contains Cushion Button disc suited for 680 ft. lbs./Torque at the wheel	CRK1005FWHD	330	13	1-3/8	10	MC595	SC934	—	—	—
6.3	384	V8	1969	1971	—	05062	302	11-7/8	1	23	—	—	—	—	—
6.6	403	V8	1971	1978	—	05062	302	11-7/8	1	23	—	—	—	—	—
6.7	409	L6	2007	2010	6 Spd Turbo Diesel, Sold as Kit Only	CRK1005FW	330	13	1-3/8	10	—	—	—	—	—
6.7	409	L6	2007	2010	6 Spd Turbo Diesel, Solid FW replacement for OEM Dual Mass FW, Includes Master and Slave Cylinder Hydraulic system, Includes Solid FW, Sold as kit only, HD Version contains Cushion Button disc suited for 680 ft. lbs./Torque at the wheel	CRK1005FWHD	330	13	1-3/8	10	—	—	—	—	—
7.2	439	V8	1973	1978	—	05062	302	11-7/8	1	23	—	—	—	—	—
8.0	488	V10	1994	1997	—	05073	311	12-1/4	1-1/4	10	MC391	SC755	—	—	—
8.0	488	V10	1998	2003	—	05092	311	12-1/4	1-1/4	10	MC395	SC757	—	—	—
8.3	506	V10	2004	2006	SRT-10	05088	311	12-1/4	1-1/8	26	MC465	SC807	—	—	—
<i>D50, RAM 50, POWER RAM 50</i>															
2.0	122	L4	1979	1980	—	05012	215	8-7/16	7/8	20	—	—	CC216	—	—
2.0	122	L4	1981	1983	—	05011	215	8-7/16	7/8	23	—	—	CC216	—	—
2.0	122	L4	1984	1986	—	05011	215	8-7/16	7/8	23	—	—	CC216	—	—
2.0	122	L4	1987	1989	—	05011	215	8-7/16	7/8	23	—	—	—	—	—
2.3	140	L4	1983	1983	Turbo Diesel	05025	225	8-7/8	1-1/32	23	MC194	SC579	—	—	—
2.3	140	L4	1983	1983	Turbo Diesel, From 10/83	05025	225	8-7/8	1-1/32	23	MC176	SC579	—	—	—
2.3	140	L4	1983	1983	Turbo Diesel, To 9/83	05025	225	8-7/8	1-1/32	23	MC194	SC579	—	—	—
2.3	140	L4	1984	1985	Turbo Diesel	05025	225	8-7/8	1-1/32	23	MC176	SC579	—	—	—
2.4	146	L4	1990	1993	—	05041	225	8-7/8	1-1/32	23	—	—	—	—	—
2.6	159	L4	1979	1981	—	05052	225	8-7/8	1-1/32	23	MC203	SC579	—	—	—
2.6	159	L4	1982	1983	—	05025	225	8-7/8	1-1/32	23	—	—	CC216	—	—
2.6	159	L4	1984	1986	—	05041	225	8-7/8	1-1/32	23	—	—	CC216	—	—
2.6	159	L4	1987	1989	—	05041	225	8-7/8	1-1/32	23	—	—	—	—	—
3.0	183	V6	1990	1991	—	05050	240	9-1/2	1-1/8	14	MC176	SC585	—	—	—
<b>DAKOTA</b>															
2.2	134	L4	1987	1987	—	05037	232	9-1/8	1	23	—	—	—	—	—
2.2	134	L4	1988	1988	—	05037	232	9-1/8	1	23	MC384	SC749	—	—	—
2.5	153	L4	1989	1991	—	05037	232	9-1/8	1	23	MC384	SC749	—	—	—
2.5	153	L4	1992	1992	—	05066	232	9-1/8	1	19	MC384	SC751	—	—	—
2.5	153	L4	1993	1994	—	05070	232	9-1/8	1-1/8	10	MC384	SC751	—	—	—
2.5	153	L4	1995	1996	—	05070	232	9-1/8	1-1/8	10	MC393	SC751	—	—	—
2.5	153	L4	1997	1998	—	05089	232	9-1/8	1-1/8	14	MC394	SC756	—	—	—
2.5	153	L4	1999	2002	—	05104	232	9-1/8	1-1/8	19	MC394	SC756	—	—	—
3.7	226	V6	2004	2004	Sold as Kit Only	CRK1010	302	11-7/8	1-1/8	10	MC602	SC756	—	—	—
3.7	226	V6	2005	2007	Sold as Kit Only	CRK1010	302	11-7/8	1-1/8	10	MC602	SC754	—	—	—
3.9	238	V6	1992	1994	—	05065	265	10-1/2	1-1/8	10	MC384	SC751	—	—	—
3.9	238	V6	1995	1996	—	05065	265	10-1/2	1-1/8	10	MC393	SC751	—	—	—
3.9	238	V6	1997	1999	—	05065	265	10-1/2	1-1/8	10	MC394	SC756	—	—	—
3.9	238	V6	2001	2003	Sold as Kit Only	CRK1010	302	11-7/8	1-1/8	10	MC394	SC756	—	—	—
4.7	287	V8	2001	2006	Sold as Kit Only	CRK1010	302	11-7/8	1-1/8	10	MC394	SC756	—	—	—
4.7	287	V8	2007	2007	Sold as Kit Only	CRK1010	302	11-7/8	1-1/8	10	MC602	SC754	—	—	—

Liter	CC/IN	Cyl	Years		Application Information	Kit	Disc (mm)	Disc (in)	Spline Dia	Splines	Master Cyl	Slave Cyl	Clutch Cable	Clutch Fork	New Flywheel
			To	From											
<b>DODGE LIGHT TRUCK, SUV &amp; VAN CONT.</b>															
<i>DAKOTA CONT.</i>															
5.2	317	V8	1994	1994	—	05074	302	11-7/8	1-1/8	10	MC384	SC751	—	—	—
5.2	317	V8	1995	1996	—	05074	302	11-7/8	1-1/8	10	MC393	SC751	—	—	—
5.2	317	V8	1997	1999	—	05074	302	11-7/8	1-1/8	10	MC394	SC756	—	—	—
5.9	360	V8	2000	2000	—	05074	302	11-7/8	1-1/8	10	MC394	SC756	—	—	—
<i>NITRO</i>															
3.7	226	V6	2007	2007	Sold as Kit Only	CRK1006	265	10-7/16	1-1/8	10	—	—	—	—	—
<i>RAIDER</i>															
2.6	159	L4	1987	1989	—	05052	225	8-7/8	1-1/32	23	MC497	SC579	—	—	—
3.0	183	V6	1989	1989	—	05050	240	9-1/2	1-1/8	14	MC497	SC585	—	—	—
<b>EAGLE</b>															
<i>2000GTX (CANADA)</i>															
2.0	122	L4	1991	1991	—	05051	215	8-1/2	7/8	20	—	—	—	—	—
2.0	122	L4	1992	1992	2 WD	05071	225	8-7/8	7/8	20	MC179	SC581	—	—	—
2.0	122	L4	1992	1992	4 WD	05071	225	8-7/8	7/8	20	MC179	SC584	—	—	—
2.0	122	L4	1993	1993	2 WD	05071	225	8-7/8	7/8	20	MC179	SC581	—	—	—
2.0	122	L4	1993	1993	4 WD	05071	225	8-7/8	7/8	20	MC179	SC584	—	—	—
<i>SUMMIT</i>															
1.5	92	L4	1989	1991	7-1/4" Disc	05008	184	7-1/4	7/8	20	MC178	SC584	—	—	—
1.5	92	L4	1989	1994	—	05026	200	7-7/8	7/8	20	MC178	SC580	—	—	—
1.5	92	L4	1991	1992	CANADA	05008	184	7-1/4	7/8	20	MC178	SC584	—	—	—
1.5	92	L4	1996	1996	—	05026	200	7-7/8	7/8	20	MC178	SC589	—	—	—
1.6	98	L4	1989	1990	—	05026	200	7-7/8	7/8	20	MC178	SC581	—	—	—
1.8	110	L4	1992	1993	AWD & Wagon	05051	215	8-1/2	7/8	20	MC183	SC915	—	—	—
1.8	110	L4	1992	1993	Wagon	05051	215	8-1/2	7/8	20	MC178	SC589	—	—	—
1.8	110	L4	1992	1994	Except AWD & Wagon	05051	215	8-1/2	7/8	20	MC178	SC589	—	—	—
1.8	110	L4	1992	1994	FWD	05051	215	8-1/2	7/8	20	MC183	SC589	—	—	—
1.8	110	L4	1993	1994	FWD; Coupe	05051	215	8-1/2	7/8	20	MC183	SC589	—	—	—
1.8	110	L4	1996	1996	Except AWD & Wagon	05051	215	8-1/2	7/8	20	MC178	SC589	—	—	—
1.8	110	L4	1996	1996	FWD	05051	215	8-1/2	7/8	20	MC183	SC589	—	—	—
2.4	146	L4	1992	1992	Except AWD, Sold As Kit Only	05048	225	8-7/8	7/8	20	MC183	SC589	—	—	—
2.4	146	L4	1992	1994	AWD, Sold As Kit Only	05048	225	8-7/8	7/8	20	MC183	SC584	—	—	—
2.4	146	L4	1992	1994	FWD, Sold as Kit Only	05048	225	8-7/8	7/8	20	MC183	SC584	—	—	—
2.4	146	L4	1996	1996	AWD, Sold As Kit Only	05048	225	8-7/8	7/8	20	MC183	SC584	—	—	—
2.4	146	L4	1996	1996	FWD, Sold as Kit Only	05048	225	8-7/8	7/8	20	MC183	SC584	—	—	—
<i>TALON</i>															
1.8	110	L4	1993	1994	—	05026	200	7-7/8	7/8	20	MC180	SC581	—	—	—
2.0	122	L4	1990	1991	Non-Turbo, without Speed Control	05051	215	8-1/2	7/8	20	MC179	SC581	—	—	—
2.0	122	L4	1990	1991	Turbo, With Speed Control, Sold As Kit Only	05048	225	8-7/8	7/8	20	MC180	SC587	—	—	—
2.0	122	L4	1990	1991	Turbo, Without Speed Control, Sold As Kit Only	05048	225	8-7/8	7/8	20	MC179	SC587	—	—	—
2.0	122	L4	1992	1994	Non-Turbo, with Speed Control	05051	215	8-1/2	7/8	20	MC180	SC581	—	—	—
2.0	122	L4	1992	1994	Turbo, Sold As Kit Only	05048	225	8-7/8	7/8	20	MC179	SC587	—	—	—
2.0	122	L4	1995	1998	Non-Turbo, Modular Clutch Includes Flywheel	05085	230	9-1/16	15/16	17	MC188	SC761	—	—	—
2.0	122	L4	1995	1998	Turbo, Sold As Kit Only	05048	225	8-7/8	7/8	20	MC188	SC589	—	—	—
<i>VISTA (CANADA)</i>															
1.5	92	L4	1990	1991	—	05026	200	7-7/8	7/8	20	—	SC589	—	—	—
<b>FIAT</b>															
<i>BRAVA, 131</i>															
1.8	110	L4	1975	1978	Sold As Kit Only	KF101	215	8-1/2	7/8	20	—	—	—	—	—
2.0	122	L4	1979	1981	Sold As Kit Only	KF101	215	8-1/2	7/8	20	—	—	—	—	—
<i>SPIDER, 124</i>															
1.6	98	L4	1971	1973	Sold As Kit Only	KF101	215	8-1/2	7/8	20	—	—	—	—	—
1.6	98	L4	1974	1974	Sold As Kit Only	KF101	215	8-1/2	7/8	20	—	—	—	—	—
1.8	110	L4	1974	1978	Sold As Kit Only	KF101	215	8-1/2	7/8	20	—	—	—	—	—
2.0	122	L4	1979	1981	Sold As Kit Only	KF101	215	8-1/2	7/8	20	—	—	—	—	—
<i>STRADA, X19</i>															
1.5	92	L4	1979	1983	Sold As Kit Only	KF101	215	8-1/2	7/8	20	—	—	—	—	—



Liter	CC/IN	Cyl	Years		Application Information	Kit	Disc (mm)	Disc (in)	Spline Dia	Splines	Master Cyl	Slave Cyl	Clutch Cable	Clutch Fork	New Flywheel
			To	From											
<b>FORD (Performance Applications Available)</b>															
<b>ASPIRE</b>															
1.3	79	L4	1994	1997	—	07068	180	7-1/8	3/4	18	—	—	—	—	—
<b>CONTOUR</b>															
2.0	122	L4	1995	2000	Includes Slave Cylinder	07136	240	9-1/2	1	23	MC119	—	—	—	—
2.5	153	V6	1995	2000	Includes Slave Cylinder	07137	240	9-1/2	1	23	MC119	—	—	—	FWFMC01
2.5	153	V6	1995	2000	Kit does not include Slave Cylinder	07137LB	240	9-1/2	1	23	MC119	—	—	—	FWFMC01
<b>CUSTOM</b>															
3.7	226	L6	1958	1964	10" Disc	07014	254	10	1-1/16	10	—	SC846	—	—	—
3.7	226	L6	1958	1964	11" Lever Clutch	07027L	280	11	1-1/16	10	—	SC846	—	—	—
3.7	226	L6	1958	1964	11"Diaph Clutch	KFM10	280	11	1-1/16	10	—	SC846	—	—	—
3.9	238	L6	1968	1972	10" Disc	07014	254	10	1-1/16	10	—	SC846	—	—	—
3.9	238	L6	1968	1972	11" Lever Clutch	07027L	280	11	1-1/16	10	—	SC846	—	—	—
3.9	238	L6	1968	1972	11"Diaph Clutch	KFM10	280	11	1-1/16	10	—	SC846	—	—	—
<b>ESCORT, EXP, ZX2</b>															
1.6	98	L4	1981	1982	—	07002	200	7-7/8	7/8	20	—	—	CC314	—	—
1.8	110	L4	1991	1996	—	07074	215	8-7/16	15/16	22	MC221	SC629	—	—	FWFME01
1.9	116	L4	1985	1987	—	07010	215	8-7/16	7/8	20	—	—	CC314	—	—
1.9	116	L4	1988	1990	—	07069	215	8-7/16	7/8	20	—	—	CC314	—	—
1.9	116	L4	1991	1996	—	07075	200	7-7/8	7/8	20	MC221	SC839	—	—	—
2.0	122	L4	1997	2002	—	07083	225	8-7/8	15/16	22	MC221	SC877	—	—	—
<b>FAIRLANE, TORINO</b>															
3.6	220	V8	1962	1963	—	07014	254	10	1-1/16	10	—	SC846	—	—	—
4.1	250	L6	1969	1974	—	07014	254	10	1-1/16	10	—	SC846	—	—	—
4.3	262	V8	1963	1964	—	07014	254	10	1-1/16	10	—	SC846	—	—	—
4.7	287	V8	1966	1968	2 BBL	07014	254	10	1-1/16	10	—	SC846	—	—	—
5.0	305	V8	1968	1974	10" Disc	07014	254	10	1-1/16	10	—	SC846	—	—	—
5.0	305	V8	1968	1974	11" Disc	07027	280	11	1-1/16	10	—	SC846	—	—	FWFM121
5.8	351	V8	1969	1974	—	07027	280	11	1-1/16	10	—	SC846	—	—	—
6.4	391	V8	1966	1966	—	07027	280	11	1-1/16	10	—	—	—	—	—
6.4	391	V8	1967	1969	2 BBL	07027	280	11	1-1/16	10	—	—	—	—	FWFM113
<b>FAIRMONT, MAVERICK</b>															
2.3	140	L4	1978	1982	—	07003	215	8-1/2	1-1/32	23	—	—	—	—	—
2.3	140	L4	1983	1983	—	07003	215	8-1/2	1-1/32	23	—	—	—	—	FWFM122
4.1	250	L6	1974	1977	—	07014	254	10	1-1/16	10	—	SC846	—	—	—
5.0	305	V8	1973	1978	—	07014	254	10	1-1/16	10	—	—	—	—	—
5.0	305	V8	1979	1979	—	07005	254	10	1-1/16	10	—	—	—	—	—
<b>FALCON</b>															
4.3	262	V8	1963	1964	—	07014	254	10	1-1/16	10	—	SC846	—	—	—
4.7	287	V8	1966	1968	—	07014	254	10	1-1/16	10	—	SC846	—	—	—
5.0	305	V8	1968	1970	4 BBL	07014	254	10	1-1/16	10	—	SC846	—	—	—
<b>FESTIVA</b>															
1.3	79	L4	1988	1993	—	07068	180	7-1/8	3/4	18	—	—	—	—	—
<b>FIESTA</b>															
1.6	97	L4	2011	—	Includes Slave Cylinder	FMK1032	219	8-5/8	13/16	17	—	BRG0107	—	—	—
<b>FOCUS</b>															
2.0	122	L4	2000	2004	DOHC, ZTS, ZX3, Includes CSC Concentric Slave Cylinder	KFM01	228	9	1	23	MC304	—	—	—	—
2.0	122	L4	2000	2004	SOHC, LX, SE, Includes CSC Concentric Slave Cylinder	KFM02	219	8-5/8	13/16	17	MC304	—	—	—	FWFMF01
2.0	122	L4	2002	2004	SVT,6spd, Kit includes Dual Mass FW and CSC Hydraulic Slave Cylinder	FMK1005	240	9-7/16	1	14	—	—	—	—	FWFMF07
2.0	122	L4	2012	2015	Sold as Kit Only, Includes CSC Hydraulic Slave Cylinder	FMK1033	240	9-7/16	1	23	—	BRG0223	—	—	—
2.3	140	L4	2003	2007	Duratec, Sold as kit only, Must USE FWFMF06 with kit, Includes CSC Hydraulic Slave cylinder	FMK1009	225	8-7/8	1-3/16	23	—	—	—	—	FWFMF06
2.3	140	L4	2003	2007	Duratec, Sold as kit only, Includes Solid FW, Includes CSC Hydraulic Slave cylinder	FMK1009FW	225	8-7/8	1-3/16	23	—	—	—	—	FWFMF06
<b>FUSION</b>															
2.3	140	L4	2006	2007	Sold As Kit Only	FMK1004	225	8-7/8	15/16	22	MC221	SC877	—	—	—
2.3	140	L4	2008	2013	Sold As Kit Only	MZK1008	230	9-1/16	15/16	22	—	—	—	—	—
2.5	152	L4	2010	2011	Sold As Kit Only	MZK1008	230	9-1/16	15/16	22	—	—	—	—	—

Liter	CC/IN	Cyl	Years		Application Information	Kit	Disc (mm)	Disc (in)	Spline Dia	Splines	Master Cyl	Slave Cyl	Clutch Cable	Clutch Fork	New Flywheel
			To	From											
<b>FORD (Performance Applications Available) CONT.</b>															
<i>GALAXIE, GALAXIE 500</i>															
3.7	226	L6	1963	1964	10" Disc	07014	254	10	1-1/16	10	—	SC846	—	—	—
3.7	226	L6	1963	1964	11" Lever Clutch	07027L	280	11	1-1/16	10	—	SC846	—	—	—
3.7	226	L6	1963	1964	11"Diaph Clutch	KFM10	280	11	1-1/16	10	—	SC846	—	—	—
3.9	238	L6	1965	1972	10" Disc	07014	254	10	1-1/16	10	—	SC846	—	—	—
3.9	238	L6	1965	1972	11" Lever Clutch	07027L	280	11	1-1/16	10	—	SC846	—	—	—
3.9	238	L6	1965	1972	11"Diaph Clutch	KFM10	280	11	1-1/16	10	—	SC846	—	—	—
4.3	262	V8	1964	1964	—	07014	254	10	1-1/16	10	—	SC846	—	—	—
4.7	287	V8	1963	1967	—	07014	254	10	1-1/16	10	—	SC846	—	—	—
4.8	293	V8	1959	1962	10" Disc	07014	254	10	1-1/16	10	—	SC846	—	—	—
5.0	305	V8	1968	1970	11" Lever Clutch	07027L	280	11	1-1/16	10	—	—	—	—	FWFM113
5.0	305	V8	1968	1972	10" Disc	07014	254	10	1-1/16	10	—	SC846	—	—	—
5.0	305	V8	1968	1972	11" Diaph Clutch	KFM10	280	11	1-1/16	10	—	SC846	—	—	FWFM113
5.0	305	V8	1971	1972	11" Lever Clutch	07027L	280	11	1-1/16	10	—	—	—	—	—
5.8	351	V8	1963	1965	11" Diaph Clutch	KFM10	280	11	1-1/16	10	—	—	—	—	—
5.8	351	V8	1963	1965	11" Diaph Clutch	KFM10	280	11	1-1/16	10	—	SC846	—	—	—
5.8	351	V8	1963	1965	11" Lever Clutch	07027L	280	11	1-1/16	10	—	—	—	—	—
5.8	351	V8	1963	1965	11" Lever Clutch	07027L	280	11	1-1/16	10	—	SC846	—	—	—
5.8	351	V8	1969	1969	11" Diaph Clutch	KFM10	280	11	1-1/16	10	—	—	—	—	—
5.8	351	V8	1969	1969	11" Diaph Clutch	KFM10	280	11	1-1/16	10	—	SC846	—	—	—
5.8	351	V8	1969	1969	11" Lever Clutch	07027L	280	11	1-1/16	10	—	—	—	—	—
5.8	351	V8	1969	1969	11" Lever Clutch	07027L	280	11	1-1/16	10	—	SC846	—	—	—
5.8	351	V8	1970	1970	11" Clutch	KFM10	280	11	1-1/16	10	—	—	—	—	FWFM113
5.8	351	V8	1970	1970	11" Lever Clutch	07027L	280	11	1-1/16	10	—	—	—	—	FWFM113
5.8	351	V8	1971	1973	11" Diaph Clutch	KFM10	280	11	1-1/16	10	—	—	—	—	—
5.8	351	V8	1971	1973	11" Diaph Clutch	KFM10	280	11	1-1/16	10	—	SC846	—	—	—
5.8	351	V8	1971	1973	11" Lever Clutch	07027L	280	11	1-1/16	10	—	—	—	—	—
5.8	351	V8	1971	1973	11" Lever Clutch	07027L	280	11	1-1/16	10	—	SC846	—	—	—
6.4	391	V8	1963	1966	2 BBL	07027	280	11	1-1/16	10	—	—	—	—	—
6.4	391	V8	1967	1970	2 BBL	07027	280	11	1-1/16	10	—	—	—	—	FWFM113
6.4	391	V8	1971	1971	—	07027	280	11	1-1/16	10	—	—	—	—	—
<i>GRANADA, LTD II</i>															
2.3	140	L4	1981	1983	—	07003	215	8-1/2	1-1/32	23	—	—	—	—	—
4.1	250	L6	1975	1980	—	07016	254	10	1-1/16	10	—	—	—	—	—
4.2	256	V8	1980	1980	—	07016	254	10	1-1/16	10	—	—	—	—	—
5.0	305	V8	1975	1979	—	07016	254	10	1-1/16	10	—	—	—	—	—
<i>MUSTANG, MUSTANG II</i>															
2.3	140	L4	1974	1974	Non-Turbo, German 4 Spd	07003	215	8-1/2	1-1/32	23	—	—	—	—	—
2.3	140	L4	1974	1983	Non-Turbo, Ford 4 Spd	07030	215	8-7/16	1-1/16	10	—	—	—	—	—
2.3	140	L4	1979	1982	Turbo	07006	215	8-7/16	1-1/16	10	—	—	—	—	—
2.3	140	L4	1979	1983	German 4 spd	07003	215	8-1/2	1-1/32	23	—	—	—	—	—
2.3	140	L4	1980	1980	Non-Turbo, 5 Spd, 10/80-11/80	07006	215	8-7/16	1-1/16	10	—	—	—	—	—
2.3	140	L4	1980	1982	Non-Turbo, 5 Spd, From 12/80	07029	215	8-1/2	1-1/16	23	—	—	—	—	—
2.3	140	L4	1981	1982	Non-Turbo, German 4 Spd	07003	215	8-1/2	1-1/32	23	—	—	—	—	—
2.3	140	L4	1983	1983	Turbo, German 4 spd	07003	215	8-1/2	1-1/32	23	—	—	—	—	—
2.3	140	L4	1983	1986	5 Spd	07038	225	8-7/8	1-1/16	10	—	—	—	—	—
2.3	140	L4	1983	1986	Turbo, 5 Spd	07038	225	8-7/8	1-1/16	10	—	—	—	—	—
2.3	140	L4	1983	1986	Turbo, Ford 4 Spd	07030	215	8-7/16	1-1/16	10	—	—	—	—	—
2.3	140	L4	1984	1986	4 Spd	07003	215	8-1/2	1-1/32	23	—	—	—	—	—
2.3	140	L4	1984	1986	Turbo, 4 Spd	07003	215	8-1/2	1-1/32	23	—	—	—	—	—
2.3	140	L4	1987	1992	5 Spd	07030	215	8-7/16	1-1/16	10	—	—	CC853	—	FWFM122
2.3	140	L4	1993	1993	5 Spd	07030	215	8-7/16	1-1/16	10	—	—	—	—	FWFM122
3.8	232	V6	1994	1999	—	07114	280	11	1-1/16	10	—	—	—	—	—
3.8	232	V6	2000	2000	—	07114	280	11	1-1/16	10	—	—	—	—	—
3.8	232	V6	2001	2004	—	07114	280	11	1-1/16	10	—	—	—	—	—
4.0	244	V6	2005	2006	Sold as kit only	FMK1010	254	10	1-1/16	10	—	BRG0159	—	—	—
4.0	244	V6	2005	2010	Sold as kit only, Includes CSC Hydraulic Slave cylinder, Includes Solid Flywheel	FMK1028FW	250	9-7/8	1-1/16	10	—	BRG0159	—	—	—

Liter	CC/IN	Cyl	Years		Application Information	Kit	Disc (mm)	Disc (in)	Spline Dia	Splines	Master Cyl	Slave Cyl	Clutch Cable	Clutch Fork	New Flywheel
			To	From											
<b>FORD (Performance Applications Available) CONT.</b>															
<i>MUSTANG, MUSTANG II CONT.</i>															
4.1	250	L6	1969	1973	—	07014	254	10	1-1/16	10	—	SC846	—	—	—
4.6	281	V8	1996	1999	Cobra	FMK1001	265	10-1/2	1-1/16	10	—	—	—	—	—
4.6	281	V8	1996	2001	GT	07042	265	10-1/2	1-1/16	10	—	—	—	—	—
4.6	281	V8	1999	2001	GT with T45 Transmission, Heavy Duty Version, Sold As Kit Only	KFM08HP	265	10-1/2	1-1/16	10	—	—	—	—	—
4.6	281	V8	2001	2003	GT with TR3650 Transmission, From 2/01	KFM09	280	11	1-1/16	10	—	—	—	—	—
4.6	281	V8	1999	2001	Cobra, T45 Transmission	KFM10	280	11	1-1/16	10	—	—	—	—	—
4.6	281	V8	1999	2001	Cobra, T45 Transmission, HD Version	KFM10HP	280	11	1-1/16	10	—	—	—	—	—
4.6	281	V8	2005	2010	GT, Shelby GT, BULLIT, Sold as Kit only, Includes CSC Hydraulic Slave cylinder, 10th spline	FMK1011	280	11	1-1/16	10	—	BRG0159	—	—	—
4.6	281	V8	2005	2010	GT, Shelby GT, BULLIT, Sold as Kit only, Includes CSC Hydraulic Slave cylinder, 26th spline	FMK1012	280	11	1-1/16	26	—	BRG0159	—	—	—
4.7	287	V8	1966	1967	—	07014	254	10	1-1/16	10	—	SC846	—	—	—
5.0	302	V8	1968	1973	—	07014	254	10	1-1/16	10	—	SC846	—	—	—
5.0	302	V8	1979	1979	—	07005	254	10	1-1/16	10	—	—	—	—	—
5.0	302	V8	1982	1985	—	07005	254	10	1-1/16	10	—	—	CC318	—	FWFM111
5.0	302	V8	1986	1995	—	07042	265	10-1/2	1-1/16	10	—	—	CC318	—	FWFM112
5.0	302	V8	1986	1995	GT with T45 Transmission, Sold As Kit Only	KFM08HP	265	10-1/2	1-1/16	10	—	—	—	—	FWFM112
5.0	302	V8	2011	2016	GT, Sold as Kit only, Includes CSC Hydraulic Slave cylinder	FMK1026	280	11	1	23	—	BRG0186	—	—	—
5.8	351	V8	1969	1973	11" Lever Clutch	07027L	280	11	1-1/16	10	—	SC846	—	—	FWFM113
<i>PINTO</i>															
2.0	122	L4	1971	1974	—	07003	215	8-1/2	1-1/32	23	—	SC846	—	—	—
2.3	140	L4	1974	1980	—	07003	215	8-1/2	1-1/32	23	—	—	—	—	—
<i>PROBE</i>															
2.0	122	L4	1993	1994	—	07094	215	8-1/2	15/16	22	MC213	SC630	—	—	FWFM1222
2.0	122	L4	1995	1997	—	07094	215	8-1/2	15/16	22	MC213	SC630	—	—	—
2.2	134	L4	1989	1989	Turbo, with ABS	07067	240	9-1/2	1-1/16	23	MC212	SC607	—	—	—
2.2	134	L4	1989	1989	Turbo, without ABS	07067	240	9-1/2	1-1/16	23	MC211	SC607	—	—	—
2.2	134	L4	1989	1992	Non-Turbo	10029	225	8-7/8	15/16	22	MC211	SC606	—	—	—
2.2	134	L4	1989	1992	Non-Turbo with Heavy Duty Ductile Iron Cover	10029D	225	8-7/8	15/16	22	MC211	SC606	—	—	—
2.2	134	L4	1990	1990	Turbo, 4-Wheel ABS	07067	240	9-1/2	1-1/16	23	MC212	SC607	—	—	—
2.2	134	L4	1991	1992	Turbo, with ABS	07067	240	9-1/2	1-1/16	23	MC212	SC607	—	—	—
2.2	134	L4	1991	1992	Turbo, without ABS	07067	240	9-1/2	1-1/16	23	MC211	SC607	—	—	—
2.5	153	V6	1993	1997	—	07095	225	8-7/8	15/16	22	MC213	SC630	—	—	—
3.0	183	V6	1990	1992	With ABS	07072	240	9-1/2	1-1/16	23	MC212	SC616	—	—	—
3.0	183	V6	1990	1992	Without ABS	07072	240	9-1/2	1-1/16	23	MC211	SC616	—	—	—
<i>RANCHERO</i>															
4.1	250	L6	1970	1973	—	07014	254	10	1-1/16	10	—	SC846	—	—	—
5.0	305	V8	1968	1974	—	07014	254	10	1-1/16	10	—	SC846	—	—	—
5.8	351	V8	1970	1970	With Externally Balanced Flywheel	07027	280	11	1-1/16	10	—	—	—	—	FWFM116
5.8	351	V8	1970	1970	With Internally Balanced Flywheel	07027	280	11	1-1/16	10	—	—	—	—	FWFM113
5.8	351	V8	1971	1974	—	07027	280	11	1-1/16	10	—	—	—	—	FWFM116
6.4	391	V8	1967	1969	—	07027	280	11	1-1/16	10	—	SC846	—	—	—
<i>TAURUS</i>															
2.5	153	L4	1986	1988	—	07010	215	8-7/16	7/8	20	—	—	—	—	—
3.0	183	V6	1986	1988	—	07010	215	8-7/16	7/8	20	—	—	—	—	—
<i>TEMPO</i>															
2.3	140	L4	1984	1987	—	07010	215	8-7/16	7/8	20	—	—	—	—	FWFM122
2.3	140	L4	1988	1994	—	07069	215	8-7/16	7/8	20	—	—	—	—	FWFM122
<i>THUNDERBIRD</i>															
2.3	140	L4	1983	1986	Turbo	07038	225	8-7/8	1-1/16	10	—	—	—	—	—
2.3	140	L4	1987	1988	Turbo	07038	225	8-7/8	1-1/16	10	MC301	SC700	—	—	—
<b>FORD TRUCK, SUV &amp; VAN</b>															
<i>AEROSTAR</i>															
2.3	140	L4	1986	1987	—	07048	225	8-7/8	1	23	MC352	SC732	—	—	—
2.8	171	V6	1986	1986	—	07048	225	8-7/8	1	23	MC352	SC732	—	—	—
3.0	183	V6	1986	1987	—	07048	225	8-7/8	1	23	MC352	SC732	—	—	—



Liter	CC/IN	Cyl	Years		Application Information	Kit	Disc (mm)	Disc (in)	Spline Dia	Splines	Master Cyl	Slave Cyl	Clutch Cable	Clutch Fork	New Flywheel
			To	From											
<b>FORD TRUCK, SUV &amp; VAN CONT.</b>															
<i>AEROSTAR CONT.</i>															
3.0	183	V6	1988	1990	—	07054	225	8-7/8	1	23	MC353	SC783	—	—	—
3.0	183	V6	1991	1991	—	07054	225	8-7/8	1	23	MC354	SC783	—	—	—
3.0	183	V6	1992	1992	—	07054	225	8-7/8	1	23	MC360	SC783	—	—	—
3.0	183	V6	1993	1994	—	07099	225	8-7/8	1	23	MC363	SC778	—	—	—
<i>BRONCO II</i>															
2.8	171	V6	1984	1984	—	07041	225	8-7/8	1	23	MC352	SC731	—	—	—
2.8	171	V6	1985	1985	—	07048	225	8-7/8	1	23	MC352	SC732	—	—	—
2.9	177	V6	1986	1987	—	07048	225	8-7/8	1	23	MC352	SC732	—	—	—
2.9	177	V6	1988	1990	—	07054	225	8-7/8	1	23	MC353	SC783	—	—	—
<i>BRONCO, F100-550</i>															
3.8	232	V6	1982	1982	—	07014	254	10	1-1/16	10	—	—	—	—	—
3.8	232	V6	1983	1983	—	07016	254	10	1-1/16	10	—	—	—	—	—
3.9	238	L6	1966	1976	—	07027	280	11	1-1/16	10	—	SC846	—	—	—
4.2	256	V8	1981	1982	—	07014	254	10	1-1/16	10	—	—	—	—	FWFM123
4.2	256	V6	1997	1999	—	07129	290	11-1/2	1-1/16	10	MC366	SC778	—	—	—
4.2	256	V6	1997	1999	Non-Self Adjusting Clutch, EXEDY Economy version, Sold as Kit Only	FMK1021	290	11-1/2	1-1/16	10	MC366	SC778	—	—	—
4.2	256	V6	2000	2008	Self-Adjusting OEM version	KFM12	290	11-1/2	1-1/16	10	MC366	SC778	—	—	FWFMC117
4.2	256	V6	2000	2004	Non-Self Adjusting Clutch, EXEDY Economy version, Sold as Kit Only	FMK1020	290	11-1/2	1-1/16	10	MC366	SC778	—	—	FWFMC117
4.6	281	V8	1997	1998	—	KFM11	290	11-1/2	1-1/16	10	MC366	SC778	—	—	—
4.6	281	V8	1997	1998	Non-Self Adjusting Clutch, EXEDY Economy version, Sold as Kit Only	FMK1021	290	11-1/2	1-1/16	10	MC366	SC778	—	—	—
4.6	281	V8	1999	2004	—	KFM12	290	11-1/2	1-1/16	10	MC366	SC778	—	—	FWFMC117
4.6	281	V8	1999	2004	Non-Self Adjusting Clutch, EXEDY Economy version, Sold as Kit Only	FMK1020	290	11-1/2	1-1/16	10	MC366	SC778	—	—	—
4.7	287	V8	1966	1966	10" Disc	07014	254	10	1-1/16	10	—	—	—	—	—
4.7	287	V8	1966	1967	11" Disc	07015	280	11	1-1/16	10	—	SC846	—	—	—
4.9	299	L6	1965	1972	—	07027	280	11	1-1/16	10	—	—	—	—	—
4.9	299	L6	1973	1976	—	07027	280	11	1-1/16	10	—	—	—	CF101	—
4.9	299	L6	1977	1977	11" Disc, From Chassis # Y80,001	07015	280	11	1-1/16	10	—	—	—	CF101	—
4.9	299	L6	1977	1977	To Chassis # Y80,000	07027	280	11	1-1/16	10	—	—	—	CF101	—
4.9	299	L6	1978	1979	11" Disc	07015	280	11	1-1/16	10	—	—	—	CF101	—
4.9	299	L6	1980	1982	10" Disc	07014	254	10	1-1/16	10	—	—	—	—	FWFM117
4.9	299	L6	1980	1982	11" Disc	07015	280	11	1-1/16	10	—	—	—	—	FWFM117
4.9	299	L6	1983	1983	Hydraulic Linkage	07016	254	10	1-1/16	10	MC357	SC729	—	—	FWFM117
4.9	299	L6	1983	1983	Mechanical Linkage	07013	280	11	1-1/16	10	MC442	SC788	—	—	FWFM117
4.9	299	L6	1984	1987	10" Disc	07016	254	10	1-1/16	10	MC357	SC728	—	CF117	FWFM117
4.9	299	L6	1984	1987	11" Disc	07032	280	11	1-1/16	10	MC357	SC728	—	CF117	FWFM117
4.9	299	L6	1988	1990	4 Spd with 10" Disc	07016	254	10	1-1/16	10	MC355	SC728	—	CF117	FWFM117
4.9	299	L6	1988	1990	4 Spd with 11" Disc	07032	280	11	1-1/16	10	MC355	SC728	—	CF117	FWFM117
4.9	299	L6	1988	1990	5 Spd with 10" Disc	07056	254	10	1-1/16	10	MC355	SC783	—	CF117	FWFM117
4.9	299	L6	1988	1990	5 Spd with 11" Disc	07057	280	11	1-1/16	10	MC355	SC783	—	CF117	FWFM117
4.9	299	L6	1991	1991	4 Spd with 10" Disc	07016	254	10	1-1/16	10	MC355	SC728	—	—	FWFM117
4.9	299	L6	1991	1991	4 Spd with 11" Disc	07032	280	11	1-1/16	10	MC355	SC728	—	—	FWFM117
4.9	299	L6	1991	1991	5 Spd with 11" Disc	07057	280	11	1-1/16	10	MC355	SC783	—	—	FWFM117
4.9	299	L6	1991	1992	5 Spd with 10" Disc	07056	254	10	1-1/16	10	MC355	SC783	—	—	FWFM117
4.9	299	L6	1992	1992	4 Spd with 10" Disc	07016	254	10	1-1/16	10	MC361	SC728	—	—	FWFM117
4.9	299	L6	1992	1992	4 Spd with 11" Disc	07032	280	11	1-1/16	10	MC361	SC728	—	—	FWFM117
4.9	299	L6	1992	1992	5 Spd with 11" Disc	07057	280	11	1-1/16	10	MC361	SC783	—	—	FWFM117
4.9	299	L6	1993	1993	4 Spd with 10" Disc	07016	254	10	1-1/16	10	MC429	SC734	—	—	FWFM117
4.9	299	L6	1993	1993	4 Spd with 11" Disc	07032	280	11	1-1/16	10	MC429	SC734	—	—	FWFM117
4.9	299	L6	1993	1996	5 Spd with 10" Disc	07098	254	10	1-1/16	10	MC429	SC778	—	—	FWFM117
4.9	299	L6	1993	1996	5 Spd with 11" Disc	07097	280	11	1-1/16	10	MC429	SC778	—	—	FWFM117
5.0	302	V8	1968	1976	—	07027	280	11	1-1/16	10	—	—	—	—	FWFM116
5.0	302	V8	1977	1977	From Chassis # Y 80, 001	07015	280	11	1-1/16	10	—	—	—	—	—
5.0	302	V8	1977	1977	To Chassis # Y80,000	07027	280	11	1-1/16	10	—	—	—	—	—
5.0	302	V8	1978	1979	—	07015	280	11	1-1/16	10	—	—	—	—	FWFM116

Liter	CC/IN	Cyl	Years		Application Information	Kit	Disc (mm)	Disc (in)	Spline Dia	Splines	Master Cyl	Slave Cyl	Clutch Cable	Clutch Fork	New Flywheel
			To	From											
<b>FORD TRUCK, SUV &amp; VAN CONT.</b>															
<i>BRONCO, F100-550 CONT.</i>															
5.0	302	V8	1980	1982	10" Disc	07014	254	10	1-1/16	10	—	—	—	—	—
5.0	302	V8	1980	1983	11" Disc	07013	280	11	1-1/16	10	—	—	—	—	FWFM116
5.0	302	V8	1983	1983	10" Disc	07016	254	10	1-1/16	10	MC357	—	—	—	—
5.0	302	V8	1984	1986	10" Disc	07016	254	10	1-1/16	10	MC357	SC788	—	—	—
5.0	302	V8	1984	1986	11" Disc	07022	280	11	1-1/16	10	MC357	SC728	—	—	FWFM116
5.0	302	V8	1987	1987	—	07032	280	11	1-1/16	10	MC357	SC728	—	—	FWFM116
5.0	302	V8	1988	1989	4 Spd	07032	280	11	1-1/16	10	MC355	SC728	—	—	—
5.0	302	V8	1988	1989	5 Spd	07057	280	11	1-1/16	10	MC355	SC728	—	—	—
5.0	302	V8	1990	1991	4 Spd	07032	280	11	1-1/16	10	MC355	SC783	—	—	—
5.0	302	V8	1990	1991	5 Spd	07057	280	11	1-1/16	10	MC355	SC783	—	—	—
5.0	302	V8	1992	1992	4 Spd	07032	280	11	1-1/16	10	MC361	SC783	—	—	—
5.0	302	V8	1992	1992	5 Spd	07057	280	11	1-1/16	10	MC361	SC783	—	—	—
5.0	302	V8	1993	1996	5 Spd	07097	280	11	1-1/16	10	MC429	SC778	—	—	—
5.4	330	V8	1999	2007	—	07144	305	12	1-1/4	10	MC368	SC739	—	—	—
5.8	351	V8	1966	1967	—	07027	280	11	1-1/16	10	—	SC846	—	—	—
5.8	351	V8	1977	1979	—	07033	280	11	1-1/16	10	—	—	—	—	—
5.8	351	V8	1980	1980	—	07033	280	11	1-1/16	10	—	—	—	CF107	—
5.8	351	V8	1981	1982	—	07015	280	11	1-1/16	10	—	—	—	CF107	—
5.8	351	V8	1983	1983	—	07013	280	11	1-1/16	10	—	—	—	—	—
5.8	351	V8	1984	1986	—	07016	254	10	1-1/16	10	MC357	SC728	—	—	—
5.8	351	V8	1987	1987	—	KFM04	280	11	1-1/16	10	MC357	SC728	—	—	—
5.8	351	V8	1988	1989	4 Spd	07032	280	11	1-1/16	10	MC355	SC728	—	—	—
5.8	351	V8	1988	1989	5 Spd	07057	280	11	1-1/16	10	MC355	SC728	—	—	—
5.8	351	V8	1990	1990	4 Spd	07032	280	11	1-1/16	10	MC355	SC783	—	—	—
5.8	351	V8	1990	1990	4 Spd	07032	280	11	1-1/16	10	MC355	SC788	—	—	—
5.8	351	V8	1990	1990	5 Spd	07057	280	11	1-1/16	10	MC355	SC783	—	—	—
5.8	351	V8	1990	1990	5 Spd	07057	280	11	1-1/16	10	MC355	SC788	—	—	—
5.8	351	V8	1991	1991	4 Spd	07032	280	11	1-1/16	10	MC355	SC783	—	—	—
5.8	351	V8	1991	1991	5 Spd	07057	280	11	1-1/16	10	MC355	SC783	—	—	—
5.8	351	V8	1992	1992	4 Spd	07032	280	11	1-1/16	10	MC361	SC783	—	—	—
5.8	351	V8	1992	1992	5 Spd	07057	280	11	1-1/16	10	MC361	SC783	—	—	—
5.8	351	V8	1993	1994	—	07097	280	11	1-1/16	10	MC429	SC778	—	—	—
5.8	351	V8	1995	1997	—	07117	305	12	1-1/16	10	MC429	SC778	—	—	—
5.9	360	V8	1968	1977	—	07027	280	11	1-1/16	10	—	SC846	—	—	—
6.0	366	V8	2003	2005	Turbo Diesel, Solid FW, Sold as Kit Only	FMK1016	330	13	1-3/8	10	MC591	SC929	—	—	FWFMF08
6.0	366	V8	2005	2006	Turbo Diesel, Solid FW, Sold as Kit Only	FMK1016	330	13	1-3/8	10	MC592	SC929	—	—	FWFMF08
6.0	366	V8	2007	2007	Turbo Diesel, Solid FW, Sold as Kit Only	FMK1016	330	13	1-3/8	10	—	—	—	—	FWFMF08
6.4	391	V8	1968	1970	—	07027	280	11	1-1/16	10	—	—	—	—	FWFM113
6.4	391	V8	1968	1976	—	07027	280	11	1-1/16	10	—	SC846	—	—	—
6.6	403	V8	1977	1978	—	07050	302	11-7/8	1-1/16	10	—	—	—	—	—
6.6	403	V8	1979	1982	—	07050	302	11-7/8	1-1/16	10	—	—	—	CF103	—
6.8	415	V10	1999	2003	—	KFM21	305	12	1-1/4	10	MC368	SC739	—	—	—
6.8	415	V10	2004	2004	Sold as Kit Only	FMK1018	305	11-15/16	1-1/4	10	MC368	SC739	—	—	—
6.8	415	V10	2004	2005	Sold as Kit Only	FMK1018	305	11-15/16	1-1/4	10	MC591(6/04-2/05)	SC930	—	—	—
6.8	415	V10	2005	2007	Sold as Kit Only	FMK1018	305	11-15/16	1-1/4	10	MC592(3/05-on)	SC930	—	—	—
6.9	421	V8	1983	1986	Diesel, 11" Clutch with Solid Flywheel	07026	280	11	1-1/16	10	MC357	SC729	—	—	—
6.9	421	V8	1983	1986	Diesel, 12" Disc	07065	302	11-7/8	1-1/16	10	MC357	SC729	—	—	—
6.9	421	V8	1987	1987	Diesel, 4 Spd 11" Clutch with Solid Flywheel	07026	280	11	1-1/16	10	MC357	SC729	—	—	—
6.9	421	V8	1987	1987	Diesel, 4 Spd, 12" Disc	07065	302	11-7/8	1-1/16	10	MC357	SC729	—	—	—
7.3	445	V8	1988	1989	Diesel with Indirect Fuel Injection, Non-Turbo and Aftermarket Turbo, with DMF. Valeo type DMF included.	07076A	280	11	1-1/4	10	MC355	—	—	—	FWFTF01
7.3	445	V8	1988	1989	Diesel with Indirect Fuel Injection, Non-Turbo and Aftermarket Turbo, with DMF. Valeo type DMF not included.	07076	280	11	1-1/4	10	MC355	—	—	—	FWFTF01
7.3	445	V8	1988	1989	Diesel with Indirect Fuel Injection, Non-Turbo and Factory Turbo, 8th Digit of VIN K. LUK type solid flywheel replacement kit contains solid flywheel and mounting bolts. Must be used as matched set.	07131B	311	12-1/4	1-1/4	10	MC355	—	—	—	FWFMC128
7.3	445	V8	1988	1989	Diesel, With Indirect Fuel Injection, 8th Digit of VIN# M, Non-Turbo and Aftermarket Turbo, LUK type solid flywheel replacement, kit contains flywheel.	07131A	311	12-1/4	1-1/4	10	MC355	—	—	—	FWFMC127

Liter	CC/IN	Cyl	Years		Application Information	Kit	Disc (mm)	Disc (in)	Spline Dia	Splines	Master Cyl	Slave Cyl	Clutch Cable	Clutch Fork	New Flywheel
			To	From											
<b>FORD TRUCK, SUV &amp; VAN CONT.</b>															
<i>BRONCO, F100-550 CONT.</i>															
7.3	445	V8	1988	1989	Diesel,With Indirect Fuel Injection,8th Digit of VIN# M, Non-Turbo and Aftermarket Turbo, LUK type solid flywheel replacement, kit does not contain flywheel.	07131	311	12-1/4	1-1/4	10	MC355	—	—	—	FWFMC127
7.3	445	V8	1990	1991	Diesel with Indirect Fuel Injection, Non-Turbo and Aftermarket Turbo, with DMF. Valeo type DMF included.	07076A	280	11	1-1/4	10	MC356	—	—	—	FWFTF01
7.3	445	V8	1990	1991	Diesel with Indirect Fuel Injection, Non-Turbo and Aftermarket Turbo, with DMF. Valeo type DMF not included.	07076	280	11	1-1/4	10	MC356	—	—	—	FWFTF01
7.3	445	V8	1990	1992	Diesel with Indirect Fuel Injection, Non-Turbo and Factory Turbo, Stripped Chassis, 8th Digit of VIN K. LUK type solid flywheel replacement, kit contains solid flywheel and mounting bolts. Must be used as matched set.	07131B	311	12-1/4	1-1/4	10	MC356	—	—	—	FWFMC128
7.3	445	V8	1990	1992	Diesel,With Indirect Fuel Injection,8th Digit of VIN# M, Non-Turbo and Aftermarket Turbo, LUK type solid flywheel replacement, kit contains flywheel.	07131A	311	12-1/4	1-1/4	10	MC356	—	—	—	FWFMC127
7.3	445	V8	1990	1992	Diesel,With Indirect Fuel Injection,8th Digit of VIN# M, Non-Turbo and Aftermarket Turbo, LUK type solid flywheel replacement, kit does not contain flywheel.	07131	311	12-1/4	1-1/4	10	MC356	—	—	—	FWFMC127
7.3	445	V8	1990	1994	Diesel with Indirect Fuel Injection, Non-Turbo and Aftermarket Turbo, with DMF. Valeo type DMF not included. With stripped chassis.	07076	280	11	1-1/4	10	MC356	SC735	—	—	FWFTF01
7.3	445	V8	1992	1992	Diesel with Indirect Fuel Injection, Non-Turbo and Aftermarket Turbo, with DMF. Valeo type DMF included.	07076A	280	11	1-1/4	10	MC361	—	—	—	FWFTF01
7.3	445	V8	1992	1992	Diesel with Indirect Fuel Injection, Non-Turbo and Aftermarket Turbo, with DMF. Valeo type DMF not included.	07076	280	11	1-1/4	10	MC361	—	—	—	FWFTF01
7.3	445	V8	1992	1992	Diesel with Indirect Fuel Injection, Non-Turbo and Factory Turbo, 8th Digit of VIN K. LUK type solid flywheel replacement kit contains solid flywheel and mounting bolts. Must be used as matched set.	07131B	311	12-1/4	1-1/4	10	MC361	—	—	—	FWFMC128
7.3	445	V8	1992	1992	Diesel,With Indirect Fuel Injection,8th Digit of VIN# M, Non-Turbo and Aftermarket Turbo, LUK type solid flywheel replacement, kit contains flywheel.	07131A	311	12-1/4	1-1/4	10	MC361	—	—	—	FWFMC127
7.3	445	V8	1992	1992	Diesel,With Indirect Fuel Injection,8th Digit of VIN# M, Non-Turbo and Aftermarket Turbo, LUK type solid flywheel replacement, kit does not contain flywheel.	07131	311	12-1/4	1-1/4	10	MC361	—	—	—	FWFMC127
7.3	445	V8	1993	1993	Diesel with Indirect Fuel Injection, Factory Turbo, 8th Digit of VIN C. LUK type solid flywheel replacement kit contains solid flywheel and mounting bolts. Must be used as matched set.	07131A	311	12-1/4	1-1/4	10	MC429	SC735	—	—	FWFMC127
7.3	445	V8	1993	1993	Diesel,With Indirect Fuel Injection, 8th Digit of VIN# C,Factory Turbo, LUK type solid flywheel replacement, kit contains flywheel.	07131B	311	12-1/4	1-1/4	10	MC429	SC735	—	—	FWFMC128
7.3	445	V8	1993	1993	Diesel,With Indirect Fuel Injection, 8th Digit of VIN# C,Factory Turbo, LUK type solid flywheel replacement, kit does not contain flywheel.	07131	311	12-1/4	1-1/4	10	MC429	SC735	—	—	FWFMC127
7.3	445	V8	1993	1993	Turbo Diesel, 5 Spd with Indirect Fuel Injection, VIN C. LUK Type Solid Flywheel and mounting bolts included.	KFM18A	330	13	1-1/4	10	MC429	SC735	—	—	FWFMC140
7.3	445	V8	1993	1993	Turbo Diesel, 5 Spd with Indirect Fuel Injection, VIN C. LUK Type Solid Flywheel not Included. Use this kit when solid flywheel is present.	KFM18	330	13	1-1/4	10	MC429	SC735	—	—	FWFMC140
7.3	445	V8	1993	1993	Turbo, 5 Spd with Indirect Fuel Injection, VIN C. Exedy/Daikin type includes solid FW.Must be sold as matched set.. Economy version	FMK1007	330	13	1-1/4	10	MC429	SC735	—	—	FWFMC140
7.3	445	V8	1993	1994	Diesel with Indirect Fuel Injection, Non-Turbo and Aftermarket Turbo, with DMF. Valeo type DMF included.	07076A	280	11	1-1/4	10	MC429	SC735	—	—	FWFTF01
7.3	445	V8	1993	1994	Diesel with Indirect Fuel Injection, Non-Turbo and Aftermarket Turbo, with DMF. Valeo type DMF not included.	07076	280	11	1-1/4	10	MC429	SC735	—	—	FWFTF01
7.3	445	V8	1993	1994	Diesel with Indirect Fuel Injection, Non-Turbo and Factory Turbo, 8th Digit of VIN K. LUK type solid flywheel replacement kit contains solid flywheel and mounting bolts. Must be used as matched set.	07131B	311	12-1/4	1-1/4	10	MC429	SC735	—	—	FWFMC128
7.3	445	V8	1993	1994	Diesel, 5 Spd with Indirect Fuel Injection, VIN M. LUK Type Solid Flywheel not Included. Use this kit when solid flywheel is present.	KFM18	330	13	1-1/4	10	MC429	SC735	—	—	FWFMC140
7.3	445	V8	1993	1994	Diesel, 5 Spd with Indirect Fuel Injection, VIN M. LUK Type Solid Flywheel and mounting bolts included.	KFM18A	330	13	1-1/4	10	MC429	SC735	—	—	FWFMC140
7.3	445	V8	1993	1994	Diesel, 5 Spd with Indirect Fuel Injection. Valeo Type Solid Flywheel Replacement Kit Includes Flywheel and Mounting Bolts.	KFM15A	330	13	1-1/4	10	MC429	SC735	—	—	FWFMC445
7.3	445	V8	1993	1994	Diesel,With Indirect Fuel Injection,8th Digit of VIN# M, Non-Turbo and Aftermarket Turbo, LUK type solid flywheel replacement, kit contains flywheel.	07131A	311	12-1/4	1-1/4	10	MC429	SC735	—	—	FWFMC127
7.3	445	V8	1993	1994	Diesel,With Indirect Fuel Injection,8th Digit of VIN# M, Non-Turbo and Aftermarket Turbo, LUK type solid flywheel replacement, kit does not contain flywheel.	07131	311	12-1/4	1-1/4	10	MC429	SC735	—	—	FWFMC127
7.3	445	V8	1993	1994	Turbo Diesel, 5 Spd with Indirect Fuel Injection, VIN K. LUK Type Solid Flywheel and mounting bolts included.	KFM18A	330	13	1-1/4	10	MC429	SC735	—	—	FWFMC140
7.3	445	V8	1993	1994	Turbo Diesel, 5 Spd with Indirect Fuel Injection. Valeo Type Solid Flywheel Replacement Kit Includes Flywheel and Mounting Bolts.	KFM15A	330	13	1-1/4	10	MC429	SC735	—	—	FWFMC445
7.3	445	V8	1994	1994	Diesel with Direct Fuel Injection, 8th digit of VIN # F, Non-Turbo and Factory Turbo, LUK type solid flywheel replacement, kit does not contain flywheel.	07131	311	12-1/4	1-1/4	10	MC429	SC735	—	—	FWFMC127
7.3	445	V8	1994	1994	Diesel with Direct Fuel Injection, Factory Turbo, 8th Digit of VIN F. LUK type solid flywheel replacement kit contains solid flywheel and mounting bolts. Must be used as matched set.	07131A	311	12-1/4	1-1/4	10	MC429	SC735	—	—	FWFMC127
7.3	445	V8	1994	1994	Diesel with Direct Fuel Injection, Non-Turbo and Aftermarket Turbo, with DMF. Valeo type DMF included.	07076A	280	11	1-1/4	10	MC429	SC735	—	—	FWFTF01
7.3	445	V8	1994	1994	Diesel with Direct Fuel Injection, Non-Turbo and Aftermarket Turbo, with DMF. Valeo type DMF not included.	07076	280	11	1-1/4	10	MC429	SC735	—	—	FWFTF01
7.3	445	V8	1994	1994	Diesel with Direct Fuel Injection, Non-Turbo and Factory Turbo, 8th Digit of VIN F. LUK type solid flywheel replacement kit contains solid flywheel and mounting bolts. Must be used as matched set.	07131B	311	12-1/4	1-1/4	10	MC429	SC735	—	—	FWFMC128
7.3	445	V8	1994	1994	Diesel with Indirect Fuel Injection, Factory Turbo, 8th Digit of VIN K. LUK type solid flywheel replacement kit contains solid flywheel and mounting bolts. Must be used as matched set.	07131A	311	12-1/4	1-1/4	10	MC429	SC735	—	—	FWFMC127
7.3	445	V8	1994	1994	Diesel,With Indirect Fuel Injection,8th Digit of VIN# K, Factory Turbo, LUK type solid flywheel replacement, kit contains flywheel.	07131B	311	12-1/4	1-1/4	10	MC429	SC735	—	—	FWFMC128
7.3	445	V8	1994	1994	Diesel,With Indirect Fuel Injection,8th Digit of VIN# K, Factory Turbo, LUK type solid flywheel replacement, kit does not contain flywheel.	07131	311	12-1/4	1-1/4	10	MC429	SC735	—	—	FWFMC127
7.3	445	V8	1994	1994	Turbo Diesel, 5 Spd with Indirect Fuel Injection, VIN K. LUK Type Solid Flywheel not Included. Use this kit when solid flywheel is present.	KFM18	330	13	1-1/4	10	MC429	SC735	—	—	FWFMC140
7.3	445	V8	1994	1994	Turbo, 5 Spd with Indirect Fuel Injection, VIN K. Exedy/Daikin type includes solid FW.Must be sold as matched set.. Economy version	FMK1007	330	13	1-1/4	10	MC429	SC735	—	—	FWFMC140

Liter	CC/IN	Cyl	Years		Application Information	Kit	Disc (mm)	Disc (in)	Spline Dia	Splines	Master Cyl	Slave Cyl	Clutch Cable	Clutch Fork	New Flywheel
			To	From											
<b>FORD TRUCK, SUV &amp; VAN CONT.</b>															
<i>BRONCO, F100-550 CONT.</i>															
7.3	445	V8	1994	1997	Turbo Diesel, 5 Spd with Direct Fuel Injection, VIN F. LUK Type Solid Flywheel and mounting bolts included.	KFM18A	330	13	1-1/4	10	MC429	SC735	—	—	FWFMC140
7.3	445	V8	1994	1997	Turbo Diesel, 5 Spd with Direct Fuel Injection, VIN F. LUK Type Solid Flywheel not Included. Use this kit when solid flywheel is present.	KFM18	330	13	1-1/4	10	MC429	SC735	—	—	FWFMC140
7.3	445	V8	1994	1997	Turbo Diesel, 5 Spd with Direct Fuel Injection. Valeo Type Solid Flywheel Replacement Kit Includes Flywheel and Mounting Bolts.	KFM15A	330	13	1-1/4	10	MC429	SC735	—	—	FWFMC445
7.3	445	V8	1994	1997	Turbo, 5 Spd with Direct Fuel Injection, VIN F. Exedy/Daikin type includes solid FW. Must be sold as matched set. Economy version	FMK1007	330	13	1-1/4	10	MC429	SC735	—	—	FWFMC140
7.3	445	V8	1999	2003	Turbo Diesel, 6 Spd with direct fuel injection and LUK OE solid flywheel. LUK type solid flywheel is included. This kit must be installed as a matched set.	KFM16A	330	13	1-3/8	10	MC356	SC738	—	—	FWFMC140
7.3	445	V8	1999	2003	Turbo Diesel, 6 Spd with direct fuel injection and Valeo OE solid flywheel. Valeo type solid flywheel included.	KFM17A	330	13	1-3/8	10	MC356	SC738	—	—	FWFMC445
7.3	445	V8	1999	2003	Turbo Diesel, 6 Spd with direct fuel injection and Valeo OE solid flywheel. Valeo type solid flywheel not included.	KFM17	330	13	1-3/8	10	MC356	SC738	—	—	FWFMC445
7.3	445	V8	1999	2003	Turbo Diesel, 6 Spd with direct fuel injection. Exedy/Daikin version includes solid FW. This kit must be installed as a matched set. Economy Version	FMK1008	330	13	1-3/8	10	MC356	SC738	—	—	FWFMC140M
7.3	445	V8	1999	2003	Turbo Diesel, 6 Spd with direct fuel injection. Exedy/Daikin version includes solid FW. This kit must be installed as a matched set, HD Version contains Cushion Button disc suited for 680 ft. lbs./Torque at the wheel	FMK1008HD	330	13	1-3/8	10	MC356	SC738	—	—	FWFMC140M
7.5	458	V8	1973	1979	—	07050	302	11-7/8	1-1/16	10	—	—	—	—	—
7.5	458	V8	1983	1983	4 Spd with 11" Disc	07022	280	11	1-1/16	10	MC357	SC729	—	—	—
7.5	458	V8	1983	1983	4 Spd with 12" Disc	07065	302	11-7/8	1-1/16	10	MC357	SC729	—	—	FWFM109
7.5	458	V8	1984	1986	4 Spd with 11" Disc	07022	280	11	1-1/16	10	MC442	SC886	—	—	—
7.5	458	V8	1984	1986	4 Spd with 12" Disc	07065	302	11-7/8	1-1/16	10	MC442	SC886	—	—	FWFM109
7.5	458	V8	1984	1987	4 Spd with 11" Disc	07022	280	11	1-1/16	10	—	—	—	—	—
7.5	458	V8	1984	1987	4 Spd with 12" Disc	07065	302	11-7/8	1-1/16	10	—	—	—	—	FWFM109
7.5	458	V8	1987	1987	4 Spd with 11" Disc	07022	280	11	1-1/16	10	MC443	SC886	—	—	—
7.5	458	V8	1987	1987	4 Spd with 12" Disc	07065	302	11-7/8	1-1/16	10	MC443	SC886	—	—	FWFM109
7.5	458	V8	1988	1991	—	07035	305	12	1-1/4	10	MC355	SC729	—	—	FWFM110
7.5	458	V8	1992	1992	—	07035	305	12	1-1/4	10	MC429	SC729	—	—	FWFM110
7.5	458	V8	1993	1995	—	07092	311	12-1/4	1-1/4	10	MC429	SC735	—	—	—
7.5	458	V8	1996	1997	—	07092	311	12-1/4	1-1/4	10	MC361	SC737	—	—	—
<i>COURIER</i>															
1.8	110	L4	1972	1974	—	07021	215	8-1/2	15/16	22	MC477	SC830	—	—	—
<i>E100-350</i>															
2.8	171	L6	1968	1971	—	07014	254	10	1-1/16	10	—	SC846	—	—	—
3.9	238	L6	1967	1967	—	07014	254	10	1-1/16	10	—	—	—	—	—
3.9	238	L6	1968	1974	—	07027	280	11	1-1/16	10	—	—	—	—	—
4.9	299	L6	1972	1972	11" Disc	07027	280	11	1-1/16	10	—	—	—	—	—
4.9	299	L6	1973	1974	11" Disc	07027	280	11	1-1/16	10	—	—	—	CF101	—
4.9	299	L6	1975	1977	11" Disc	07027	280	11	1-1/16	10	—	—	—	CF102	—
4.9	299	L6	1978	1979	11" Disc	07015	280	11	1-1/16	10	—	—	—	CF102	—
4.9	299	L6	1980	1982	11" Disc	07015	280	11	1-1/16	10	—	—	—	—	FWFM117
4.9	299	L6	1981	1982	10" Disc	07014	254	10	1-1/16	10	—	—	—	—	FWFM117
4.9	299	L6	1983	1983	10" Disc	07016	254	10	1-1/16	10	—	SC728	—	—	FWFM117
4.9	299	L6	1983	1983	11" Disc	07013	280	11	1-1/16	10	—	—	—	—	FWFM117
4.9	299	L6	1984	1984	11" Disc	07032	280	11	1-1/16	10	MC438	SC728	—	CF117	FWFM117
4.9	299	L6	1984	1987	10" Disc	07016	254	10	1-1/16	10	MC438	SC728	—	CF117	FWFM117
4.9	299	L6	1985	1986	11" Disc	KFM04	280	11	1-1/16	10	MC438	SC728	—	CF117	FWFM117
4.9	299	L6	1986	1986	11" Disc	KFM04	280	11	1-1/16	10	MC356	SC728	—	CF117	FWFM117
4.9	299	L6	1986	1987	10" Disc	07016	254	10	1-1/16	10	MC356	SC728	—	CF117	FWFM117
4.9	299	L6	1988	1989	10" Disc	07056	254	10	1-1/16	10	MC438	SC783	—	CF117	FWFM117
4.9	299	L6	1988	1989	11" Disc	07057	280	11	1-1/16	10	MC438	SC783	—	CF117	FWFM117
5.0	302	V8	1968	1974	—	07027	280	11	1-1/16	10	—	—	—	—	FWFM116
5.0	302	V8	1975	1975	—	07027	280	11	1-1/16	10	—	—	—	CF102	FWFM116
5.0	302	V8	1979	1979	—	07015	280	11	1-1/16	10	—	—	—	—	—
5.0	302	V8	1980	1982	10" Disc	07014	254	10	1-1/16	10	—	—	—	—	—
5.0	302	V8	1980	1982	11" Disc	07015	280	11	1-1/16	10	—	—	—	—	FWFM116
5.0	302	V8	1983	1983	10" Disc	07016	254	10	1-1/16	10	—	—	—	—	—
5.0	302	V8	1983	1983	11" Disc	07013	280	11	1-1/16	10	—	SC728	—	—	FWFM116
5.0	302	V8	1984	1986	10" Disc	07016	254	10	1-1/16	10	MC438	SC788	—	—	—
5.0	302	V8	1984	1986	11" Disc	07013	280	11	1-1/16	10	MC438	SC728	—	—	FWFM116
5.0	302	V8	1987	1987	—	07032	280	11	1-1/16	10	MC438	SC728	—	—	FWFM116
5.0	302	V8	1988	1989	—	07057	280	11	1-1/16	10	MC438	SC783	—	—	—
5.8	351	V8	1975	1977	—	07027	280	11	1-1/16	10	—	SC846	—	—	—



Liter	CC/IN	Cyl	Years		Application Information	Kit	Disc (mm)	Disc (in)	Spline Dia	Splines	Master Cyl	Slave Cyl	Clutch Cable	Clutch Fork	New Flywheel
			To	From											
<b>FORD TRUCK, SUV &amp; VAN CONT.</b>															
<i>E100-350 CONT.</i>															
5.8	351	V8	1978	1978	—	07015	280	11	1-1/16	10	—	—	—	—	FWFM116
5.8	351	V8	1979	1979	—	07015	280	11	1-1/16	10	—	—	—	CF102	FWFM116
5.8	351	V8	1980	1982	—	07015	280	11	1-1/16	10	—	—	—	CF107	FWFM116
5.8	351	V8	1983	1983	—	07013	280	11	1-1/16	10	—	—	—	—	FWFM116
5.8	351	V8	1984	1986	10" Disc	07016	254	10	1-1/16	10	MC438	SC728	—	—	—
5.8	351	V8	1984	1986	11" Disc	07022	280	11	1-1/16	10	MC438	SC728	—	—	FWFM116
5.8	351	V8	1986	1986	10" Disc	07016	254	10	1-1/16	10	MC356	SC728	—	—	—
5.8	351	V8	1986	1986	11" Disc	07022	280	11	1-1/16	10	MC356	SC728	—	—	FWFM116
5.8	351	V8	1987	1987	—	KFM04	280	11	1-1/16	10	MC356	SC728	—	—	FWFM116
5.8	351	V8	1987	1987	—	KFM04	280	11	1-1/16	10	MC438	SC728	—	—	FWFM116
5.8	351	V8	1988	1989	—	07057	280	11	1-1/16	10	—	SC728	—	—	—
5.8	351	V8	1988	1989	—	07057	280	11	1-1/16	10	MC438	SC728	—	—	—
6.0	366	V8	2004	2007	Turbo Diesel, Suits Solid FW, Sold as Kit Only	FMK1016	330	13	1-3/8	10	—	—	—	—	FWFMF08
6.8	415	V10	1999	2007	Sold as Kit Only	FMK1018	305	11-15/16	1-1/4	10	—	SC739	—	—	—
<i>ESCAPE</i>															
2.0	122	L4	2001	2004	—	KFM16	225	8-7/8	15/16	22	MC370	SC740	—	—	—
2.3	140	L4	2005	2008	Sold as Kit Only	FMK1019	240	9-7/16	1	23	—	—	—	—	—
<i>EXCURSION</i>															
6.0	366	V8	2004	2005	Turbo Diesel, Suits Solid FW, Sold as Kit Only	FMK1016	330	13	1-3/8	10	—	—	—	—	FWFMF08
6.8	415	V10	2000	2005	Sold as Kit Only	FMK1018	305	11-15/16	1-1/4	10	—	SC739	—	—	—
<i>EXPLORER</i>															
4.0	244	V6	1991	1991	—	07077	254	10	1-1/16	23	MC353	SC783	—	—	—
4.0	244	V6	1992	1992	—	07077	254	10	1-1/16	23	MC359	SC783	—	—	—
4.0	244	V6	1993	1994	—	07096	254	10	1-1/16	23	MC364	SC778	—	—	—
4.0	244	V6	1995	1997	—	07096	254	10	1-1/16	23	MC367	SC778	—	—	—
4.0	244	V6	1998	1999	Self Adjusting Clutch	07139	257	10-1/8	1-1/16	23	MC367	SC778	—	—	—
4.0	244	V6	2000	2000	Self Adjusting Clutch	07139	257	10-1/8	1-1/16	23	MC367	SC778	—	—	—
4.0	244	V6	2001	2003	—	FMK1000	257	10-1/8	1	23	MC367	SC778	—	—	—
<i>P100-350</i>															
2.8	171	L6	1965	1967	—	07014	254	10	1-1/16	10	—	SC846	—	—	—
3.9	238	L6	1968	1972	—	07027	280	11	1-1/16	10	—	SC846	—	—	—
4.9	299	L6	1968	1972	—	07027	280	11	1-1/16	10	—	—	—	—	—
4.9	299	L6	1973	1977	—	07027	280	11	1-1/16	10	—	—	—	CF101	—
<i>RANGER</i>															
2.0	122	L4	1983	1984	—	07041	225	8-7/8	1	23	MC352	SC729	—	—	—
2.0	122	L4	1985	1987	—	07048	225	8-7/8	1	23	MC352	SC732	—	—	—
2.0	122	L4	1988	1988	—	07054	225	8-7/8	1	23	MC353	SC783	—	—	—
2.2	134	L4	1983	1984	Diesel	10008	225	8-7/8	15/16	22	MC352	SC730	—	—	—
2.3	140	L4	1983	1984	—	07041	225	8-7/8	1	23	MC352	SC700	—	—	FWFM122
2.3	140	L4	1985	1987	—	07048	225	8-7/8	1	23	MC352	SC732	—	—	FWFM122
2.3	140	L4	1985	1987	Turbo Diesel	07048	225	8-7/8	1	23	MC352	SC732	—	—	FWFM122
2.3	140	L4	1988	1991	Non Pre-Damped	07054	225	8-7/8	1	23	MC353	SC783	—	—	FWFM122
2.3	140	L4	1988	1991	Pre-Damped	07132	225	8-7/8	1	23	MC353	SC783	—	—	FWFM122
2.3	140	L4	1992	1992	Non Pre-Damped	07054	225	8-7/8	1	23	MC358	SC783	—	—	FWFM122
2.3	140	L4	1992	1992	Pre-Damped	07132	225	8-7/8	1	23	MC358	SC783	—	—	FWFM122
2.3	140	L4	1993	1994	—	07093	225	8-7/8	1	23	MC365	SC778	—	—	—
2.3	140	L4	1995	2008	Non-Self Adjusting Clutch, EXEDY Economy version	KFM07	225	8-7/8	1	23	MC367	SC778	—	—	—
2.3	140	L4	1995	2008	Self Adjusting Clutch	KFM30	225	8-7/8	1	23	MC367	SC778	—	—	—
2.5	153	L4	1998	2004	Non-Self Adjusting Clutch, EXEDY Economy version	KFM07	225	8-7/8	1	23	MC367	SC778	—	—	—
2.5	153	L4	1998	2004	Self Adjusting Clutch	KFM30	225	8-7/8	1	23	MC367	SC778	—	—	—
2.8	171	V6	1983	1983	—	07041	225	8-7/8	1	23	MC352	SC700	—	—	FWFM122
2.8	171	V6	1984	1984	—	07041	225	8-7/8	1	23	MC352	SC732	—	—	—
2.8	171	V6	1985	1985	—	07048	225	8-7/8	1	23	MC352	SC732	—	—	—
2.9	177	V6	1986	1987	—	07048	225	8-7/8	1	23	MC352	SC732	—	—	—
2.9	177	V6	1988	1991	—	07054	225	8-7/8	1	23	MC353	SC783	—	—	—
2.9	177	V6	1992	1992	—	07054	225	8-7/8	1	23	MC358	SC783	—	—	—
3.0	183	V6	1991	1991	—	07054	225	8-7/8	1	23	MC353	SC783	—	—	—

Liter	CC/IN	Cyl	Years		Application Information	Kit	Disc (mm)	Disc (in)	Spline Dia	Splines	Master Cyl	Slave Cyl	Clutch Cable	Clutch Fork	New Flywheel
			To	From											
<b>FORD TRUCK, SUV &amp; VAN CONT.</b>															
<i>RANGER CONT.</i>															
3.0	183	V6	1992	1992	—	07054	225	8-7/8	1	23	MC359	SC783	—	—	—
3.0	183	V6	1993	1994	To Oct 31/1994	07099	225	8-7/8	1	23	MC364	SC738	—	—	—
3.0	183	V6	1995	2007	Non-Self Adjusting Clutch, EXEDY Economy version	KFM06	228	9	1	23	MC367	SC778	—	—	—
3.0	183	V6	1995	2007	Self Adjusting Clutch	KFM30	228	9	1	23	MC367	SC778	—	—	—
4.0	244	V6	1990	1991	—	07077	254	10	1-1/16	23	MC353	SC778	—	—	—
4.0	244	V6	1992	1992	—	07077	254	10	1-1/16	23	MC359	SC778	—	—	—
4.0	244	V6	1993	1994	—	07096	254	10	1-1/16	23	MC364	SC778	—	—	—
4.0	244	V6	1995	1997	—	07096	254	10	1-1/16	23	MC367	SC778	—	—	—
4.0	244	V6	1998	2000	Self Adjusting Clutch	07139	257	10-1/8	1-1/16	23	MC367	SC778	—	—	—
4.0	244	V6	2001	2008	Self Adjusting Clutch	FMK1000	257	10-1/8	1	23	MC367	SC778	—	—	—
<b>GEO (Performance Applications Available)</b>															
<i>METRO</i>															
1.0	61	L3	1989	1997	—	04124	170	6-11/16	3/4	18	—	—	—	—	—
1.3	79	L4	1995	1997	—	04100	190	7-1/2	3/4	18	—	—	—	—	—
<i>PRIZM</i>															
1.6	98	L4	1989	1989	DOHC	16074	210	8-1/4	1	21	MC251	SC818	—	—	—
1.6	98	L4	1989	1989	SOHC	16070	200	7-7/8	15/16	21	MC251	SC818	—	—	—
1.6	98	L4	1990	1990	DOHC	16074	210	8-1/4	1	21	MC265	SC660	—	—	—
1.6	98	L4	1990	1991	SOHC, To 4/30/91	16070	200	7-7/8	15/16	21	MC251	SC660	—	—	—
1.6	98	L4	1991	1991	8th Digit of VIN # is 5, from 5/1/91	KTY03	210	8-1/4	1	21	MC265	SC660	—	—	—
1.6	98	L4	1991	1992	8th Digit of VIN # is 6, from 5/1/91	04152	200	7-7/8	15/16	21	MC265	SC660	—	—	—
1.6	98	L4	1991	1992	SOHC, From 5/1/91	KTY06	200	7-7/8	15/16	21	MC265	SC660	—	—	—
1.6	98	L4	1992	1992	8th Digit of VIN # is 5, from 5/1/91	16074	210	8-1/4	1	21	MC265	SC660	—	—	—
1.6	98	L4	1993	1997	—	KTY03	210	8-1/4	1	21	MC265	SC818	—	—	—
1.8	110	L4	1993	1997	—	KTY03	210	8-1/4	1	21	MC265	SC818	—	—	—
<i>SPECTRUM</i>															
1.5	92	L4	1989	1989	Non-Turbo	04063	184	7-1/4	1	14	—	—	—	—	—
1.5	92	L4	1989	1989	Turbo	04099	215	8-1/2	1	14	—	—	—	—	—
<i>STORM</i>															
1.6	98	L4	1990	1993	—	04112	200	7-7/8	15/16	14	—	—	—	—	—
1.8	110	L4	1992	1993	—	09017	215	8-1/2	1	14	—	—	—	—	—
<b>GEO SUV</b>															
<i>TRACKER</i>															
1.6	98	L4	1989	1996	—	04137	215	8-7/16	7/8	20	—	—	CC809	—	—
<b>GMC LIGHT TRUCK, SUV &amp; VAN</b>															
<i>CABALLERO, SPRINT</i>															
3.3	201	V6	1979	1979	—	04021	265	10-1/2	1-1/8	10	—	—	—	—	—
3.8	232	V6	1980	1981	—	04021	265	10-1/2	1-1/8	10	—	—	—	—	—
5.0	305	V8	1979	1981	—	04021	265	10-1/2	1-1/8	10	—	—	—	—	FWGM101
5.7	348	V8	1971	1975	—	04021	265	10-1/2	1-1/8	10	—	—	—	—	—
5.7	348	V8	1978	1978	—	04021	265	10-1/2	1-1/8	10	—	—	—	—	FWGM101
6.6	403	V8	1971	1972	—	04049	280	11	1-1/8	10	—	—	—	—	FWGM100
7.4	452	V8	1971	1973	12" Diaph Clutch	04064	300	11-3/4	1-1/8	10	—	—	—	—	—
7.4	452	V8	1971	1973	12" Diaph Type Clutch with Ceramic Button	04105	300	11-3/4	1-1/8	10	—	—	—	—	—
7.4	452	V8	1971	1975	11" Disc	04020	280	11	1-1/8	26	—	—	—	—	—
7.4	452	V8	1974	1974	12" Diaph Clutch	04064	300	11-3/4	1-1/8	10	—	—	—	—	FWGM102
7.4	452	V8	1974	1974	12" Diaph Type Clutch with Ceramic Button	04105	300	11-3/4	1-1/8	10	—	—	—	—	FWGM102
7.4	452	V8	1975	1975	12" Diaph Clutch	04064	300	11-3/4	1-1/8	10	—	—	—	—	—
7.4	452	V8	1975	1975	12" Diaph Type Clutch with Ceramic Button	04105	300	11-3/4	1-1/8	10	—	—	—	—	—
<i>CANYON</i>															
2.8	171	L4	2004	2006	—	GMK1015	263	10-3/8	1-1/8	26	MC462	SC809	—	—	—
3.5	214	L5	2004	2006	Sold as Kit Only	GMK1028	265	10-7/16	1-3/16	26	MC462	SC809	—	—	—

Liter	CC/IN	Cyl	Years		Application Information	Kit	Disc (mm)	Disc (in)	Spline Dia	Splines	Master Cyl	Slave Cyl	Clutch Cable	Clutch Fork	New Flywheel
			To	From											
<b>GMC LIGHT TRUCK, SUV &amp; VAN CONT.</b>															
<i>G1500-3500 VAN</i>															
3.2	195	L6	1966	1966	11" Disc	04072	280	11	1-1/8	10	—	—	—	—	—
3.8	232	L6	1964	1969	11" Disc	04072	280	11	1-1/8	10	—	—	—	—	—
4.1	250	L6	1967	1976	11" Disc	04072	280	11	1-1/8	10	—	—	—	—	—
4.1	250	L6	1977	1984	11" Disc	04049	280	11	1-1/8	10	—	—	—	—	—
4.1	250	L6	1977	1984	12" Diaph Clutch	04064	300	11-3/4	1-1/8	10	—	—	—	—	—
4.1	250	L6	1977	1984	12" Diaph Type Clutch with Ceramic Button	04105	300	11-3/4	1-1/8	10	—	—	—	—	—
4.3	262	V6	1985	1986	—	04089	280	11	1-1/8	10	MC309	SC827	—	—	—
4.3	262	V6	1987	1987	—	04089	280	11	1-1/8	10	—	—	—	—	—
4.6	281	V8	1967	1967	11" Disc	04072	280	11	1-1/8	10	—	—	—	—	—
4.8	293	L6	1974	1974	11" Disc	04049	280	11	1-1/8	10	—	—	—	—	—
4.8	293	L6	1974	1978	12" Diaph Clutch	04064	300	11-3/4	1-1/8	10	—	—	—	—	—
4.8	293	L6	1975	1978	11" Disc	04049	280	11	1-1/8	10	—	—	—	—	FWGM104
5.0	305	V8	1968	1973	—	04049	280	11	1-1/8	10	—	—	—	—	—
5.0	305	V8	1977	1984	11" Disc	04049	280	11	1-1/8	10	—	—	—	—	—
5.0	305	V8	1977	1984	12" Diaph Clutch	04064	300	11-3/4	1-1/8	10	—	—	—	—	—
5.0	305	V8	1985	1986	—	04121	280	11	1-1/8	10	MC309	SC827	—	—	—
5.0	305	V8	1987	1987	—	04121	280	11	1-1/8	10	—	—	—	—	—
5.0	305	V8	1988	1990	—	04121	280	11	1-1/8	10	—	SC708	—	—	—
5.7	348	V8	1970	1984	11" Disc	04049	280	11	1-1/8	10	—	—	—	—	—
5.7	348	V8	1970	1984	12" Diaph Clutch	04064	300	11-3/4	1-1/8	10	—	—	—	—	—
5.7	348	V8	1970	1984	12" Diaph Type Clutch with Ceramic Button	04105	300	11-3/4	1-1/8	10	—	—	—	—	—
5.7	348	V8	1985	1985	12" Diaph Clutch, Non-Pre Damped	04064	300	11-3/4	1-1/8	10	MC309	SC827	—	—	—
5.7	348	V8	1985	1985	Pre-Damped	04128	300	11-3/4	1-1/8	10	MC309	SC827	—	—	—
5.7	348	V8	1986	1987	12" Diaph Clutch, Non-Pre Damped	04064	300	11-3/4	1-1/8	10	MC309	SC827	—	—	FWGM103
5.7	348	V8	1986	1987	Pre-Damped	04128	300	11-3/4	1-1/8	10	MC309	SC827	—	—	FWGM103
5.7	348	V8	1988	1990	12" Diaph Clutch, Non-Pre Damped	04064	300	11-3/4	1-1/8	10	—	SC708	—	—	—
5.7	348	V8	1988	1990	Pre-Damped	04128	300	11-3/4	1-1/8	10	—	SC708	—	—	—
6.2	378	V8	1983	1984	Diesel, Non Pre-Damped	04087	302	11-7/8	1-1/8	10	—	—	—	—	—
6.2	378	V8	1983	1984	Diesel, Pre-Damped	04128	300	11-3/4	1-1/8	10	—	—	—	—	—
6.2	378	V8	1985	1986	Diesel, Non Pre-Damped	04087	302	11-7/8	1-1/8	10	MC309	SC827	—	—	—
6.2	378	V8	1985	1986	Diesel, Pre-Damped	04128	300	11-3/4	1-1/8	10	MC309	SC827	—	—	—
6.2	378	V8	1987	1987	Diesel, Non Pre-Damped	04087	302	11-7/8	1-1/8	10	—	—	—	—	—
6.2	378	V8	1987	1987	Diesel, Pre-Damped	04128	300	11-3/4	1-1/8	10	—	—	—	—	—
6.2	378	V8	1988	1990	Diesel, Non Pre-Damped	04087	302	11-7/8	1-1/8	10	—	SC708	—	—	—
6.2	378	V8	1988	1990	Diesel, Pre-Damped	04128	300	11-3/4	1-1/8	10	—	SC708	—	—	—
6.6	403	V8	1978	1980	—	04020	280	11	1-1/8	26	—	—	—	—	FWGM100
7.4	452	V8	1975	1976	12" Diaph Clutch, Non-Pre Damped	04064	300	11-3/4	1-1/8	10	—	—	—	—	FWGM102
7.4	452	V8	1975	1976	Pre-Damped	04122	302	11-7/8	1-1/8	10	—	—	—	—	FWGM102
7.4	452	V8	1988	1990	12" Diaph Clutch, Non-Pre Damped	04064	300	11-3/4	1-1/8	10	—	SC708	—	—	FWGM102
7.4	452	V8	1988	1990	Pre-Damped	04122	302	11-7/8	1-1/8	10	—	SC708	—	—	FWGM102
<i>JIMMY (FULL SIZE), C1500-3500, K1500-3500, R1500-3500, V1500-3500</i>															
3.8	232	L6	1966	1969	11" Disc	04072	280	11	1-1/8	10	—	—	—	—	—
4.1	250	L6	1966	1976	11" Disc	04072	280	11	1-1/8	10	—	—	—	—	—
4.1	250	L6	1977	1984	11" Disc	04049	280	11	1-1/8	10	—	—	—	—	—
4.1	250	L6	1977	1984	12" Diaph Clutch	04064	300	11-3/4	1-1/8	10	—	—	—	—	—
4.1	250	L6	1977	1984	12" Diaph Clutch with Ceramic Button	04105	300	11-3/4	1-1/8	10	—	—	—	—	—
4.3	262	V6	1986	1986	—	04089	280	11	1-1/8	10	MC309	SC827	—	—	FWGM108(1986)
4.3	262	V6	1987	1987	R & V Series	04089	280	11	1-1/8	10	MC309	SC827	—	—	—
4.3	262	V6	1988	1991	To 1/31/91	04089	280	11	1-1/8	10	MC310	SC708	—	—	FWGM108
4.3	262	V6	1991	1991	From 2/1/91	04121	280	11	1-1/8	10	MC310	SC706	—	—	FWGM108
4.3	262	V6	1992	1994	—	04121	280	11	1-1/8	10	MC372	SC741	—	—	FWGM108
4.3	262	V6	1995	1995	—	04121	280	11	1-1/8	10	MC380	SC741	—	—	FWGM108
4.3	262	V6	1996	1998	—	KGM10	280	11	1-1/8	10	MC377	SC746	—	—	FWGM108(1986)
4.3	262	V6	1999	2000	—	KGM17	280	11	1-1/8	10	MC381	SC746	—	—	—

Liter	CC/IN	Cyl	Years		Application Information	Kit	Disc (mm)	Disc (in)	Spline Dia	Splines	Master Cyl	Slave Cyl	Clutch Cable	Clutch Fork	New Flywheel
			To	From											
<b>GMC LIGHT TRUCK, SUV &amp; VAN CONT.</b>															
<i>JIMMY (FULL SIZE), C1500-3500, K1500-3500, R1500-3500, V1500-3500 CONT.</i>															
4.3	262	V6	2001	2005	Slave Cylinder fits 5spd only	KGM21	280	11	1-1/8	10	MC381	SC799	—	—	—
4.6	281	V8	1967	1967	11" Disc	04072	280	11	1-1/8	10	—	—	—	—	—
4.6	281	V8	1967	1967	12" Diaph Clutch	04064	300	11-3/4	1-1/8	10	—	—	—	—	—
4.6	281	V8	1967	1967	12" Diaph Clutch with Ceramic Button	04105	300	11-3/4	1-1/8	10	—	—	—	—	—
4.8	293	L6	1966	1968	11" Disc	04072	280	11	1-1/8	10	—	—	—	—	—
4.8	293	L6	1969	1974	11" Disc	04049	280	11	1-1/8	10	—	—	—	—	—
4.8	293	L6	1975	1984	11" Disc	04049	280	11	1-1/8	10	—	—	—	—	FWGM104
4.8	293	L6	1985	1986	—	04081	280	11	1-1/8	10	MC309	SC827	—	CF116	FWGM104
4.8	293	L6	1987	1988	R&V Series	04081	280	11	1-1/8	10	MC309	SC827	—	CF116	FWGM104
4.8	293	V8	1999	2000	—	04181	302	11-7/8	1-1/8	10	MC381	SC746	—	CF116	—
4.8	293	V8	2001	2003	—	KGM44	302	11-7/8	1-1/8	10	MC381	SC799	—	—	—
4.8	293	V8	2004	2004	—	KGM44	302	11-7/8	1-1/8	10	MC381	SC937	—	—	—
4.8	293	V8	2005	2006	Sold as Kit Only	GMK1020	302	11-7/8	1-1/8	10	MC456	SC937	—	—	—
5.0	305	V6	1966	1967	12" Diaph Clutch	04064	300	11-3/4	1-1/8	10	—	—	—	—	—
5.0	305	V6	1966	1967	12" Diaph Clutch with Ceramic Button	04105	300	11-3/4	1-1/8	10	—	—	—	—	—
5.0	305	V8	1968	1968	—	04049	280	11	1-1/8	10	—	—	—	—	—
5.0	305	V8	1968	1970	12" Lever Clutch	04049	280	11	1-1/8	10	—	—	—	—	—
5.0	305	V8	1976	1984	11" Disc	04049	280	11	1-1/8	10	—	—	—	—	—
5.0	305	V8	1976	1984	12" Diaph Clutch	04064	300	11-3/4	1-1/8	10	—	—	—	—	—
5.0	305	V8	1976	1984	12" Diaph Clutch with Ceramic Button	04105	300	11-3/4	1-1/8	10	—	—	—	—	—
5.0	305	V8	1985	1987	—	04081	280	11	1-1/8	10	MC309	SC827	—	—	—
5.0	305	V8	1987	1987	R&V Series	04081	280	11	1-1/8	10	MC309	SC827	—	—	—
5.0	305	V8	1988	1991	—	04081	280	11	1-1/8	10	MC310	SC708	—	—	—
5.0	305	V8	1992	1994	—	04121	280	11	1-1/8	10	MC372	SC741	—	—	—
5.0	305	V8	1995	1995	—	04121	280	11	1-1/8	10	MC387	SC741	—	—	—
5.0	305	V8	1996	1998	—	04160	302	11-7/8	1-1/8	10	MC377	SC746	—	—	—
5.4	330	V8	1967	1968	12" Diaph Clutch	04064	300	11-3/4	1-1/8	10	—	—	—	—	—
5.4	330	V8	1967	1968	12" Diaph Clutch with Ceramic Button	04105	300	11-3/4	1-1/8	10	—	—	—	—	—
5.7	348	V8	1969	1984	12" Diaph Clutch	04064	300	11-3/4	1-1/8	10	—	—	—	—	—
5.7	348	V8	1969	1984	12" Diaph Clutch with Ceramic Button	04105	300	11-3/4	1-1/8	10	—	—	—	—	—
5.7	348	V8	1969	1986	11" Clutch	04049	280	11	1-1/8	10	—	—	—	—	—
5.7	348	V8	1974	1974	12" Diaph Clutch	04064	300	11-3/4	1-1/8	10	—	—	—	—	FWGM103
5.7	348	V8	1974	1974	12" Diaph Clutch with Ceramic Button	04105	300	11-3/4	1-1/8	10	—	—	—	—	FWGM103
5.7	348	V8	1978	1981	Diesel, 11" Clutch	04049	280	11	1-1/8	10	—	—	—	—	—
5.7	348	V8	1978	1981	Diesel, 12" Diaph Clutch	04064	300	11-3/4	1-1/8	10	—	—	—	—	—
5.7	348	V8	1978	1981	Diesel, 12" Diaph Clutch with Ceramic Button	04105	300	11-3/4	1-1/8	10	—	—	—	—	—
5.7	348	V8	1978	1981	Diesel, 12" Lever Type Clutch	04502	300	11-3/4	1-1/8	10	—	—	—	—	—
5.7	348	V8	1985	1987	12" Diaph Clutch	04064	300	11-3/4	1-1/8	10	MC309	SC827	—	—	—
5.7	348	V8	1985	1987	12" Diaph Clutch with Ceramic Button	04105	300	11-3/4	1-1/8	10	MC309	SC827	—	—	—
5.7	348	V8	1985	1990	11" Clutch	04049	280	11	1-1/8	10	MC309	SC827	—	—	—
5.7	348	V8	1988	1990	11" Clutch	04049	280	11	1-1/8	10	—	—	—	—	—
5.7	348	V8	1988	1990	12" Diaph Clutch	04064	300	11-3/4	1-1/8	10	MC310	SC708	—	—	—
5.7	348	V8	1988	1990	12" Diaph Clutch with Ceramic Button	04105	300	11-3/4	1-1/8	10	MC310	SC708	—	—	—
5.7	348	V8	1988	1990	R&V Series 12" Diaph Clutch with Ceramic Button	04105	300	11-3/4	1-1/8	10	MC309	SC827	—	—	—
5.7	348	V8	1988	1990	R&V Series with 12" Diaph Clutch	04064	300	11-3/4	1-1/8	10	MC309	SC827	—	—	—
5.7	348	V8	1991	1991	11" Disc To 1/31/91	04049	280	11	1-1/8	10	MC309	SC827	—	—	—
5.7	348	V8	1991	1991	12" Diaph Clutch with Ceramic Button, To 1/31/91	04105	300	11-3/4	1-1/8	10	MC310	SC708	—	—	—
5.7	348	V8	1991	1991	12" Diaph Clutch, To 1/31/91	04064	300	11-3/4	1-1/8	10	MC310	SC708	—	—	—
5.7	348	V8	1991	1991	Non Pre-Damped From 2/1/91	04122	302	11-7/8	1-1/8	10	MC310	SC708	—	—	—
5.7	348	V8	1991	1991	Pre-Damped From 2/1/91	04128	300	11-3/4	1-1/8	10	MC310	SC708	—	—	—
5.7	348	V8	1991	1991	R&V Series 12" Diaph Clutch, To 1/31/91	04064	300	11-3/4	1-1/8	10	MC309	SC827	—	—	—
5.7	348	V8	1991	1991	R&V Series with Pre-Damped From 2/1/91	04128	300	11-3/4	1-1/8	10	MC309	SC827	—	—	—
5.7	348	V8	1991	1991	R&V Series with 12" Diaph Clutch with Ceramic Button, To 1/31/91	04105	300	11-3/4	1-1/8	10	MC309	SC827	—	—	—
5.7	348	V8	1991	1991	R&V Series with Non Pre-Damped From 2/1/91	04122	302	11-7/8	1-1/8	10	MC309	SC827	—	—	—
5.7	348	V8	1992	1995	Non Pre-Damped	04122	302	11-7/8	1-1/8	10	MC372	SC741	—	—	—



Liter	CC/IN	Cyl	Years		Application Information	Kit	Disc (mm)	Disc (in)	Spline Dia	Splines	Master Cyl	Slave Cyl	Clutch Cable	Clutch Fork	New Flywheel
			To	From											
<b>GMC LIGHT TRUCK, SUV &amp; VAN CONT.</b>															
<i>JIMMY (FULL SIZE), C1500-3500, K1500-3500, R1500-3500, V1500-3500 CONT.</i>															
5.7	348	V8	1992	1995	Pre-Damped	04128	300	11-3/4	1-1/8	10	MC372	SC741	—	—	—
5.7	348	V8	1996	2000	—	04170	305	12	1-1/8	10	MC377	SC746	—	—	—
6.0	366	V8	1999	2000	—	04171	290	11-1/2	1-1/8	10	MC381	SC746	—	—	—
6.0	366	V8	2001	2003	—	GMK1009	290	11-1/2	1-1/8	10	MC381	BRG0152	—	—	—
6.0	366	V8	2004	2004	—	GMK1009	290	11-1/2	1-1/8	10	MC381	BRG0152	—	—	—
6.2	378	V8	1982	1984	Diesel	04087	302	11-7/8	1-1/8	10	—	—	—	—	—
6.2	378	V8	1985	1986	Diesel	04087	302	11-7/8	1-1/8	10	MC309	SC827	—	—	—
6.2	378	V8	1987	1989	Diesel	04087	302	11-7/8	1-1/8	10	MC310	SC708	—	—	—
6.2	378	V8	1990	1991	Diesel	04122	302	11-7/8	1-1/8	10	MC310	SC708	—	—	—
6.2	378	V8	1991	1991	R&V Series, Diesel	04122	302	11-7/8	1-1/8	10	MC309	SC827	—	—	—
6.2	378	V8	1992	1993	Diesel	04122	302	11-7/8	1-1/8	10	MC372	SC741	—	—	—
6.5	397	V8	1968	1969	—	04049	280	11	1-1/8	10	—	—	—	—	—
6.5	397	V8	1992	1994	Turbo Diesel for DMF, Not included	04131	300	11-3/4	1-1/8	10	MC372	SC741	—	—	—
6.5	397	V8	1992	1994	Turbo, Diesel with Solid Flywheel Option. Kit does not include flywheel.	04163	302	11-7/8	1-1/8	10	MC372	SC741	—	—	FWGMC126
6.5	397	V8	1992	1994	Turbo Diesel with Solid Flywheel Option. Kit includes flywheel.	04163A	302	11-7/8	1-1/8	10	MC372	SC741	—	—	FWGMC126
6.5	397	V8	1995	1995	Turbo Diesel for DMF, Not included	04131	300	11-3/4	1-1/8	10	MC380	SC741	—	—	—
6.5	397	V8	1995	1995	Turbo, Diesel with Solid Flywheel Option. Kit does not include flywheel.	04163	302	11-7/8	1-1/8	10	MC380	SC741	—	—	FWGMC126
6.5	397	V8	1995	1995	Turbo Diesel with Solid Flywheel Option. Kit includes flywheel.	04163A	302	11-7/8	1-1/8	10	MC380	SC741	—	—	FWGMC126
6.5	397	V8	1996	2002	Turbo Diesel 5 Spd with LUK Solid Type FW. Kit does not include flywheel.	04154	302	11-7/8	1-1/8	10	MC377	SC748	—	—	FWGMC126
6.5	397	V8	1996	2002	Turbo Diesel 5 Spd with LUK Solid Type FW. Kit includes flywheel.	04154A	302	11-7/8	1-1/8	10	MC377	SC748	—	—	FWGMC126
6.5	397	V8	1996	2002	Turbo Diesel 5 Spd with Valeo type DMF. Kit does not include flywheel.	KGM12	300	11-3/4	1-1/8	10	MC377	SC748	—	—	FWGMC01
6.5	397	V8	1996	2002	Turbo Diesel 5 Spd with Valeo type DMF. Kit includes flywheel.	KGM12A	300	11-3/4	1-1/8	10	MC377	SC748	—	—	FWGMC01
6.6	403	V8	1970	1972	12" Diaph Clutch	04064	300	11-3/4	1-1/8	10	—	—	—	—	—
6.6	403	V8	1970	1972	12" Diaph Type Clutch with Ceramic Button	04105	300	11-3/4	1-1/8	10	—	—	—	—	—
6.6	403	V8	1978	1980	—	04020	280	11	1-1/8	26	—	—	—	—	FWGM100
6.6	403	V8	2001	2003	Diesel 6 Spd, with DMF, Kit does not include flywheel, Does not include Release Bearing	KGM13	305	12	1-3/8	10	MC381	BRG0152	—	—	—
6.6	403	V8	2001	2003	Diesel 6 Spd, with DMF, Kit includes flywheel, Does not include Release Bearing	KGM13A	305	12	1-3/8	10	MC381	BRG0152	—	—	DMF029
6.6	403	V8	2004	2006	Diesel 6 Spd, with DMF, Kit does not include flywheel, Does not include Release Bearing	KGM13	305	12	1-3/8	10	MC381	BRG0152	—	—	—
6.6	403	V8	2004	2006	Diesel 6 Spd, with DMF, Kit includes flywheel, Does not include Release Bearing	KGM13A	305	12	1-3/8	10	MC381	BRG0152	—	—	DMF029
6.6	403	V8	2006	2006	Turbo, Diesel, Includes CSC Hydraulic Slave Cylinder, Sold as Kit Only, Fits Dual Mass FW	GMK1029	305	12	1-3/8	10	MC381	SC937	—	—	—
7.4	452	V8	1973	1973	12" Diaph Type Clutch with Ceramic Button	04105	300	11-3/4	1-1/8	10	—	—	—	—	—
7.4	452	V8	1973	1973	Diaph Type Clutch	04122	302	11-7/8	1-1/8	10	—	—	—	—	—
7.4	452	V8	1974	1984	12" Diaph Type Clutch with Ceramic Button	04105	300	11-3/4	1-1/8	10	—	—	—	—	FWGM102
7.4	452	V8	1974	1984	Diaph Type Clutch	04122	302	11-7/8	1-1/8	10	—	—	—	—	FWGM102
7.4	452	V8	1985	1986	12" Diaph Type Clutch with Ceramic Button	04105	300	11-3/4	1-1/8	10	MC309	SC827	—	—	FWGM102
7.4	452	V8	1985	1986	Diaph Type Clutch	04122	302	11-7/8	1-1/8	10	MC309	SC827	—	—	FWGM102
7.4	452	V8	1987	1991	R, V Series, Non Pre-Damped	04064	300	11-3/4	1-1/8	10	MC309	SC708	—	—	FWGM102
7.4	452	V8	1987	1991	R, V Series, Pre-Damped	04122	302	11-7/8	1-1/8	10	MC309	SC708	—	—	FWGM102
7.4	452	V8	1988	1991	12" Diaph Clutch, Non-Pre Damped	04064	300	11-3/4	1-1/8	10	MC310	SC708	—	—	FWGM102
7.4	452	V8	1988	1991	Pre-Damped	04122	302	11-7/8	1-1/8	10	MC310	SC708	—	—	FWGM102
7.4	452	V8	1992	1994	12" Diaph Clutch, Non-Pre Damped	04064	300	11-3/4	1-1/8	10	MC372	SC741	—	—	FWGM102
7.4	452	V8	1992	1994	Pre-Damped	04122	302	11-7/8	1-1/8	10	MC372	SC741	—	—	FWGM102
7.4	452	V8	1995	1995	12" Diaph Clutch, Non-Pre Damped	04064	300	11-3/4	1-1/8	10	MC380	SC741	—	—	FWGM102
7.4	452	V8	1995	1995	Pre-Damped	04122	302	11-7/8	1-1/8	10	MC380	SC741	—	—	FWGM102
7.4	452	V8	1996	2000	—	04154	302	11-7/8	1-1/8	10	MC377	SC746	—	—	—
7.4	452	V8	1996	2000	Turbo Diesel 5 Spd with LUK Solid Type FW. Kit includes flywheel.	04154A	302	11-7/8	1-1/8	10	MC377	SC746	—	—	FWGMC126
8.1	494	V8	2001	2004	6 Spd, Sold as Kit Only, Includes Slave Cylinder	GMK1025	295	11-11/16	1-3/8	10	MC377	BRG0152	—	—	—
8.1	494	V8	2001	2002	5 Spd	KGM18	300	11-3/4	1-1/4	10	MC377	SC801	—	—	—
8.1	494	V8	2005	2006	From Jan 1/2004, Slave Cylinder Included, Sold as Kit Only	GMK1019	295	11-11/16	1-3/8	10	MC377	BRG0152	—	—	—
<b>P1500-3500 STEPVAN</b>															
3.8	232	L6	1966	1969	11" Disc	04072	280	11	1-1/8	10	—	—	—	—	—
4.1	250	L6	1966	1974	11" Disc	04072	280	11	1-1/8	10	—	—	—	—	—
4.3	262	V6	1990	1991	—	04089	280	11	1-1/8	10	MC375	SC744	—	—	FWGM108
4.3	262	V6	1992	1995	—	04121	280	11	1-1/8	10	MC374	SC741	—	—	FWGM108

Liter	CC/IN	Cyl	Years		Application Information	Kit	Disc (mm)	Disc (in)	Spline Dia	Splines	Master Cyl	Slave Cyl	Clutch Cable	Clutch Fork	New Flywheel
			To	From											
<b>GMC LIGHT TRUCK, SUV &amp; VAN CONT.</b>															
<i>P1500-3500 STEPVAN CONT.</i>															
4.3	262	V6	1996	1996	—	KGM10	280	11	1-1/8	10	MC379	SC748	—	—	FWGM108(1996)
4.3	262	V6	1999	1999	—	KGM17	280	11	1-1/8	10	—	—	—	—	—
4.6	281	V8	1967	1967	11" Disc	04072	280	11	1-1/8	10	—	—	—	—	—
4.8	293	L6	1966	1968	11" Disc	04072	280	11	1-1/8	10	—	—	—	—	—
4.8	293	L6	1969	1974	11" Disc	04049	280	11	1-1/8	10	—	—	—	—	—
4.8	293	L6	1975	1984	11" Disc	04049	280	11	1-1/8	10	—	—	—	—	FWGM104
4.8	293	L6	1985	1989	—	04081	280	11	1-1/8	10	—	—	—	—	FWGM104
5.0	305	V8	1968	1969	—	04049	280	11	1-1/8	10	—	—	—	—	—
5.7	348	V8	1970	1978	11" Clutch	04049	280	11	1-1/8	10	—	—	—	—	—
5.7	348	V8	1970	1978	12" Diaph Clutch	04064	300	11-3/4	1-1/8	10	—	—	—	—	—
5.7	348	V8	1970	1988	12" Diaph Type Clutch with Ceramic Button	04105	300	11-3/4	1-1/8	10	—	—	—	—	—
5.7	348	V8	1979	1988	12" Diaph Clutch	04064	300	11-3/4	1-1/8	10	—	—	—	—	FWGM104
5.7	348	V8	1989	1991	12" Diaph Clutch	04064	300	11-3/4	1-1/8	10	MC375	SC744	—	—	FWGM103
5.7	348	V8	1989	1991	12" Diaph Type Clutch with Ceramic Button	04105	300	11-3/4	1-1/8	10	MC375	SC744	—	—	FWGM103
5.7	348	V8	1992	1995	Non Pre-Damped	04122	302	11-7/8	1-1/8	10	MC374	SC741	—	—	—
5.7	348	V8	1992	1995	Pre-Damped	04128	300	11-3/4	1-1/8	10	MC374	SC741	—	—	—
5.7	348	V8	1996	1996	—	04160	302	11-7/8	1-1/8	10	MC379	SC746	—	—	—
5.7	348	V8	1997	1999	—	04170	305	12	1-1/8	10	MC379	SC746	—	—	—
6.2	378	V8	1982	1984	Diesel Pre-Damped	04128	300	11-3/4	1-1/8	10	—	—	—	—	—
6.2	378	V8	1982	1984	Diesel, Non Pre-Damped	04087	302	11-7/8	1-1/8	10	—	—	—	—	—
6.2	378	V8	1985	1989	Diesel Pre-Damped	04128	300	11-3/4	1-1/8	10	MC309	SC827	—	—	—
6.2	378	V8	1985	1989	Diesel, Non Pre-Damped	04087	302	11-7/8	1-1/8	10	MC309	SC827	—	—	—
6.2	378	V8	1990	1991	Diesel Pre-Damped	04128	300	11-3/4	1-1/8	10	MC375	SC744	—	—	—
6.2	378	V8	1990	1991	Diesel, Non Pre-Damped	04087	302	11-7/8	1-1/8	10	MC375	SC744	—	—	—
6.2	378	V8	1992	1993	Diesel Pre-Damped	04128	300	11-3/4	1-1/8	10	MC374	SC741	—	—	—
6.2	378	V8	1992	1993	Diesel, Non Pre-Damped	04087	302	11-7/8	1-1/8	10	MC374	SC741	—	—	—
6.5	397	V8	1994	1994	Diesel Pre-Damped	04122	302	11-7/8	1-1/8	10	MC372	SC741	—	—	—
6.5	397	V8	1994	1994	Diesel, Non Pre-Damped	04146	302	11-7/8	1-1/8	10	MC372	SC741	—	—	—
6.5	397	V8	1995	1995	Diesel Pre-Damped	04122	302	11-7/8	1-1/8	10	—	SC741	—	—	—
6.5	397	V8	1995	1995	Diesel, Non Pre-Damped	04146	302	11-7/8	1-1/8	10	—	SC741	—	—	—
6.5	397	V8	1996	1999	Diesel 5 Spd with LUK Solid Type FW. Kit does not include flywheel.	04154	302	11-7/8	1-1/8	10	MC379	SC746	—	—	FWGMC126
6.5	397	V8	1996	1999	Diesel, 5 Speed with LUK Solid Type FW. Kit includes flywheel.	04154A	302	11-7/8	1-1/8	10	MC379	SC746	—	—	FWGMC126
6.5	397	V8	1996	1999	Turbo Diesel 5 Spd with Valeo type DMF. Kit does not include flywheel.	KGM12	300	11-3/4	1-1/8	10	MC379	SC746	—	—	FWGMC01
6.5	397	V8	1996	1999	Turbo Diesel 5 Spd with Valeo type DMF. Kit includes flywheel.	KGM12A	300	11-3/4	1-1/8	10	MC379	SC746	—	—	FWGMC01
6.5	397	V8	1997	1999	Turbo Diesel 5 Spd with LUK Solid Type FW. Kit does not include flywheel.	04154	302	11-7/8	1-1/8	10	MC379	SC746	—	—	FWGMC126
6.5	397	V8	1997	1999	Turbo Diesel 5 Spd with LUK Solid Type FW. Kit includes flywheel.	04154A	302	11-7/8	1-1/8	10	MC379	SC746	—	—	FWGMC126
7.4	452	V8	1970	1971	12" Diaph Clutch, Non-Pre Damped	04064	300	11-3/4	1-1/8	10	—	SC827	—	—	—
7.4	452	V8	1970	1971	Pre-Damped	04122	302	11-7/8	1-1/8	10	—	SC827	—	—	—
7.4	452	V8	1973	1973	12" Diaph Clutch, Non-Pre Damped	04064	300	11-3/4	1-1/8	10	—	SC827	—	—	—
7.4	452	V8	1973	1973	Pre-Damped	04122	302	11-7/8	1-1/8	10	—	SC827	—	—	—
7.4	452	V8	1974	1986	12" Diaph Clutch, Non-Pre Damped	04064	300	11-3/4	1-1/8	10	—	SC827	—	—	FWGM102
7.4	452	V8	1974	1986	Pre-Damped	04122	302	11-7/8	1-1/8	10	—	SC827	—	—	FWGM102
7.4	452	V8	1987	1987	12" Diaph Clutch, Non-Pre Damped	04064	300	11-3/4	1-1/8	10	MC309	SC827	—	—	FWGM102
7.4	452	V8	1987	1987	Pre-Damped	04122	302	11-7/8	1-1/8	10	MC309	SC827	—	—	FWGM102
7.4	452	V8	1988	1991	12" Diaph Clutch, Non-Pre Damped	04064	300	11-3/4	1-1/8	10	—	SC827	—	—	FWGM102
7.4	452	V8	1988	1991	Pre-Damped	04122	302	11-7/8	1-1/8	10	—	SC827	—	—	FWGM102
7.4	452	V8	1992	1994	12" Diaph Clutch, Non-Pre Damped	04064	300	11-3/4	1-1/8	10	MC372	SC827	—	—	FWGM118
7.4	452	V8	1992	1994	Pre-Damped	04122	302	11-7/8	1-1/8	10	MC372	SC827	—	—	FWGM118
7.4	452	V8	1995	1995	12" Diaph Clutch, Non-Pre Damped	04064	300	11-3/4	1-1/8	10	MC380	SC827	—	—	FWGM118
7.4	452	V8	1995	1995	Pre-Damped	04122	302	11-7/8	1-1/8	10	MC380	SC827	—	—	FWGM118
7.4	452	V8	1996	1999	—	04154	302	11-7/8	1-1/8	10	—	—	—	—	FWGMC126
7.4	452	V8	1996	1999	Diesel 5 Spd with LUK Solid Type FW. Kit does not include flywheel.	04154	302	11-7/8	1-1/8	10	—	—	—	—	FWGMC126
<i>S-15, JIMMY, SONOMA</i>															
2.0	122	L4	1983	1983	Non Pre-Damped	04065	228	9	1	14	—	—	—	—	—
2.0	122	L4	1983	1983	Pre-Damped	04130	232	9-1/8	1	14	—	—	—	—	—
2.0	122	L4	1984	1984	Non Pre-Damped	04065	228	9	1	14	MC486	SC705	—	—	—
2.0	122	L4	1984	1984	Pre-Damped	04130	232	9-1/8	1	14	MC486	SC705	—	—	—

Liter	CC/IN	Cyl	Years		Application Information	Kit	Disc (mm)	Disc (in)	Spline Dia	Splines	Master Cyl	Slave Cyl	Clutch Cable	Clutch Fork	New Flywheel
			To	From											
<b>GMC LIGHT TRUCK, SUV &amp; VAN CONT.</b>															
<i>S-15, JIMMY, SONOMA CONT.</i>															
2.2	134	L4	1994	1995	Non Pre-Damped	04138	232	9-1/8	1-1/8	26	MC376	SC742	—	CF128	—
2.2	134	L4	1996	2001	Non Pre-Damped	04155	232	9-1/8	1-1/8	26	MC378	SC746	—	—	—
2.5	153	L4	1985	1989	Non Pre-Damped	04065	228	9	1	14	MC308	SC705	—	CF128	FWGM115
2.5	153	L4	1985	1989	Pre-Damped	04130	232	9-1/8	1	14	MC308	SC705	—	CF128	FWGM115
2.5	153	L4	1990	1993	Non Pre-Damped	04065	228	9	1	14	MC308	SC705	—	CF126	FWGM115
2.5	153	L4	1990	1993	Pre-Damped	04130	232	9-1/8	1	14	MC308	SC705	—	CF126	FWGM115
2.8	171	V6	1983	1984	—	04069	215	8-1/2	1	14	MC308	SC743	CC655	—	—
2.8	171	V6	1985	1987	Non Pre-Damped	04065	228	9	1	14	MC486	SC705	—	—	—
2.8	171	V6	1985	1987	Pre-Damped	04130	232	9-1/8	1	14	MC486	SC705	—	—	—
2.8	171	V6	1987	1987	Non Pre-Damped	04065	228	9	1	14	MC309	SC827	—	—	—
2.8	171	V6	1987	1987	Pre-Damped	04130	232	9-1/8	1	14	MC309	SC827	—	—	—
2.8	171	V6	1988	1988	Non Pre-Damped	04065	228	9	1	14	MC309	SC827	—	—	FWGMC123
2.8	171	V6	1988	1988	Non Pre-Damped	04065	228	9	1	14	MC486	SC705	—	—	FWGMC123
2.8	171	V6	1988	1988	Pre-Damped	04130	232	9-1/8	1	14	MC309	SC827	—	—	FWGMC123
2.8	171	V6	1988	1988	Pre-Damped	04130	232	9-1/8	1	14	MC486	SC705	—	—	FWGMC123
2.8	171	V6	1989	1989	Non Pre-Damped	04065	228	9	1	14	MC308	SC705	—	—	FWGMC123
2.8	171	V6	1989	1989	Pre-Damped	04130	232	9-1/8	1	14	MC308	SC705	—	—	FWGMC123
2.8	171	V6	1990	1993	Non Pre-Damped	04065	228	9	1	14	MC308	SC705	—	CF126	FWGMC123
2.8	171	V6	1990	1993	Pre-Damped	04130	232	9-1/8	1	14	MC308	SC705	—	CF126	FWGMC123
4.3	262	V6	1994	1995	—	04168	280	11	1-1/8	10	MC376	SC743	—	—	FWGM108
4.3	262	V6	1990	1991	—	04089	280	11	1-1/8	10	MC308	SC745	—	—	FWGM108
4.3	262	V6	1992	1993	—	04089	280	11	1-1/8	10	MC373	SC743	—	—	FWGM108
4.3	262	V6	1994	2004	—	KGM10	280	11	1-1/8	10	MC378	SC746	—	—	FWGM108(1994-96)
<b>SAFARI</b>															
2.5	153	L4	1985	1989	—	04053	225	8-7/8	15/16	14	MC305	SC703	—	—	FWGM115
4.3	262	V6	1985	1989	—	04086	280	11	1	14	MC305	SC703	—	—	FWGM108(1988-89)
<b>HONDA (Performance Applications Available)</b>															
<b>ACCORD</b>															
1.6	1599	L4	1976	1978	—	08002	190	7-1/2	1	19	MC230	SC637	—	—	—
1.8	1751	L4	1982	1982	—	08007	200	7-7/8	7/8	21	—	—	CC508	—	—
1.8	1751	L4	1983	1984	—	08006	200	7-7/8	7/8	21	—	—	CC508	—	—
1.8	1829	L4	1985	1985	—	08006	200	7-7/8	7/8	21	—	—	CC509	—	—
2.0	1955	L4	1986	1989	—	08708	210	8-1/4	7/8	21	—	—	CC503	—	—
2.2	2156	L4	1990	1997	—	08014	225	8-7/8	1-1/16	24	MC234	SC642	—	—	FWHDA01
2.3	2254	L4	1998	2002	—	HCK1000	210	8-1/4	1-1/16	24	MC466	SC868	—	—	—
2.4	2354	L4	2003	2007	Sold As Kit Only	HCK1005	225	8-7/8	1-1/16	24	MC502	SC895	—	—	FWHDA02
2.4	2354	L4	2008	2011	Sold As Kit Only	HCK1009	225	8-7/8	1	24	—	—	—	—	HCF001
3.0	2977	V6	2003	2006	Sold As Kit Only	HCK1007	238	9-3/8	1	24	MC502	—	—	—	—
3.5	3471	V6	2008	2010	Sold As Kit Only	HCK1007	238	9-3/8	1	24	MC502	—	—	—	—
<b>CIVIC</b>															
1.2	1237	L4	1973	1979	—	08002	190	7-1/2	1	19	—	—	—	—	—
1.3	1335	L4	1980	1983	—	08003	190	7-1/2	1	19	—	—	—	—	—
1.3	1342	L4	1984	1987	—	08005	190	7-1/2	1	19	—	—	CC511	—	—
1.3	1339	L4	2003	2005	Hybrid, Sold as Kit Only	HCK1008	219	8-5/8	27-32	20	MC553	—	—	—	—
1.3	1339	L4	2006	2007	Hybrid, Sold as Kit Only	HCK1008	219	8-5/8	27-32	20	—	—	—	—	—
1.5	1487	L4	1975	1979	—	08004	190	7-1/2	1	19	—	—	—	—	—
1.5	1487	L4	1980	1983	—	08003	190	7-1/2	1	19	—	—	CC511	—	—
1.5	1487	L4	1984	1987	2 WD	08005	190	7-1/2	1	19	—	—	CC511	—	—
1.5	1487	L4	1985	1987	FWD:Hatchback	08015	190	7-1/2	1	19	—	—	CC511	—	—
1.5	1493	L4	1986	1986	2 WD	08005	190	7-1/2	1	19	—	—	CC511	—	—
1.5	1493	L4	1986	1986	4 WD Wagon	08015	190	7-1/2	1	19	—	—	CC511	—	—
1.5	1487	L4	1987	1987	4 WD Wagon	08015	190	7-1/2	1	19	—	—	CC511	—	—
1.5	1491	L4	1987	1987	2 WD	08005	190	7-1/2	1	19	—	—	CC511	—	—
1.5	1491	L4	1987	1987	4 WD Wagon	08015	190	7-1/2	1	19	—	—	CC511	—	—
1.5	1493	L4	1988	1988	2 WD	08009	190	7-1/2	7/8	21	—	—	CC514	—	—
1.5	1493	L4	1988	1988	4 WD	08010	200	7-7/8	7/8	21	—	—	CC514	—	—
1.5	1493	L4	1988	1988	FWD	08010	200	7-7/8	7/8	21	—	—	CC514	—	—
1.5	1493	L4	1989	1989	—	08011	200	7-7/8	7/8	20	—	—	CC514	—	—
1.5	1493	L4	1990	1990	—	08012	210	8-1/4	7/8	20	—	—	CC514	—	FWHDC01

Liter	CC/IN	Cyl	Years		Application Information	Kit	Disc (mm)	Disc (in)	Spline Dia	Splines	Master Cyl	Slave Cyl	Clutch Cable	Clutch Fork	New Flywheel
			To	From											
<b>HONDA (Performance Applications Available) CONT.</b>															
<i>CIVIC CONT.</i>															
1.5	1493	L4	1991	1991	—	08012	210	8-1/4	7/8	20	—	—	—	—	FWHDC01
1.5	1493	L4	1992	1995	—	08022	210	8-1/4	7/8	20	MC238	SC646	—	—	FWHDC01
1.6	1590	L4	1988	1988	4 WD	08710	210	8-1/4	7/8	20	—	—	—	—	—
1.6	1590	L4	1989	1989	2 WD	08011	200	7-7/8	7/8	20	—	—	—	—	—
1.6	1590	L4	1989	1989	4 WD	08019	200	7-7/8	7/8	20	—	—	—	—	—
1.6	1590	L4	1990	1990	2 WD	08012	210	8-1/4	7/8	20	—	—	—	—	FWHDC01
1.6	1590	L4	1990	1991	4 WD	08020	210	8-1/4	7/8	20	—	—	—	—	FWHDC01
1.6	1590	L4	1991	1991	—	08012	210	8-1/4	7/8	20	—	—	—	—	FWHDC01
1.6	1590	L4	1992	2000	SOHC, Except SI	08022	210	8-1/4	7/8	20	MC238	SC646	—	—	FWHDC01 (92-96)
1.6	1595	L4	1999	2000	DOHC, SI	KHC05	219	8-5/8	1-1/16	24	MC238	SC646	—	—	—
1.7	1700	L4	2001	2005	Sold As Kit Only	KHC08	210	8-1/4	7/8	20	MC553	SC896	—	—	FWHDC02FF
1.8	1799	L4	2006	2009	Sold As Kit Only	HCK1002	215	8-1/2	7/8	20	MC569	SC898	—	—	FWHDC03
1.8	1799	L4	2010	2015	Sold As Kit Only	HCK1002	215	8-1/2	7/8	20	—	SC898	—	—	FWHDC03
2.0	1998	L4	2002	2005	SI, Sold As Kit Only	KHC09	215	8-1/2	1-1/16	24	MC502	SC895	—	—	—
2.0	1998	L4	2006	2008	SI, Sold As Kit Only	KHC10	215	8-1/2	1-1/32	24	MC569	SC899	—	—	—
2.0	1998	L4	2009	2011	SI, Sold As Kit Only	HCK1011	215	8-1/2	1-1/32	24	MC569	SC899	—	—	—
<i>CIVIC DEL SOL</i>															
1.5	1493	L4	1993	1994	—	08022	210	8-1/4	7/8	20	MC238	SC646	—	—	FWHDC01
1.5	1493	L4	1995	1995	SI	08022	210	8-1/4	7/8	20	MC238	SC646	—	—	FWHDC01
1.6	1590	L4	1993	1995	SI	08022	210	8-1/4	7/8	20	MC238	SC646	—	—	FWHDC01
1.6	1590	L4	1994	1994	VTEC	KHC05	219	8-5/8	1-1/16	24	MC238	SC646	—	—	FWHDC01
1.6	1590	L4	1995	1995	Non-VTEC	KHC05	219	8-5/8	1-1/16	24	MC238	SC646	—	—	FWHDC01
1.6	1590	L4	1996	1997	Non-VTEC	08031	200	7-7/8	7/8	20	MC238	SC646	—	—	—
1.6	1590	L4	1996	1997	VTEC	KHC05	219	8-5/8	1-1/16	24	MC238	SC646	—	—	FWHDC01
<i>CRX</i>															
1.3	1342	L4	1984	1984	—	08005	190	7-1/2	1	19	—	—	—	—	—
1.5	1487	L4	1984	1987	—	08005	190	7-1/2	1	19	—	—	CC511	—	—
1.5	1493	L4	1988	1988	—	08009	190	7-1/2	7/8	21	—	—	CC514	—	—
1.5	1493	L4	1989	1989	—	08011	200	7-7/8	7/8	20	—	—	CC514	—	—
1.5	1493	L4	1990	1991	—	08012	210	8-1/4	7/8	20	—	—	CC514	—	—
1.6	1590	L4	1988	1988	—	08010	200	7-7/8	7/8	21	—	—	CC514	—	—
1.6	1590	L4	1989	1989	—	08011	200	7-7/8	7/8	20	—	—	CC514	—	—
1.6	1590	L4	1990	1991	—	08012	210	8-1/4	7/8	20	—	—	CC514	—	—
<i>FIT</i>															
1.5	1497	L4	2007	2008	Sold As Kit Only	HCK1006	190	7-1/2	7/8	20	MC570	SC897	—	—	—
1.5	1497	L4	2009	2011	Sold As Kit Only	HCK1010	190	7-1/2	7/8	20	—	SC898	—	—	—
<i>INSIGHT</i>															
1.0	995	L3	2000	2006	—	KHC11	190	7-1/2	7/8	20	—	—	—	—	—
<i>PRELUDE</i>															
1.8	1829	L4	1983	1987	—	08006	200	7-7/8	7/8	21	—	—	CC505	—	—
2.0	1955	L4	1985	1987	—	08708	210	8-1/4	7/8	21	—	—	CC515	—	—
2.0	1958	L4	1988	1989	—	08013	213	8-3/8	1	24	MC233	SC639	—	—	—
2.2	2156	L4	1992	2001	—	KHC03	219	8-5/8	1-1/16	24	MC234	SC642	—	—	FWHDA01
2.3	2259	L4	1992	1996	—	KHC03	219	8-5/8	1-1/16	24	MC234	SC642	—	—	—
<i>S2000</i>															
2.0	1997	L4	2000	2003	Pull Type	KHC06	213	8-3/8	1-1/32	24	—	—	—	—	—
2.2	2157	L4	2004	2009	Pull Type	KHC06	213	8-3/8	1-1/32	24	—	—	—	—	—
<b>HONDA SUV &amp; VAN</b>															
<i>CR-V</i>															
2.0	1972	L4	1998	2001	—	KHC05	219	8-5/8	1-1/16	24	MC526	SC646	—	—	—
2.4	2354	L4	2002	2006	Sold As Kit Only	HCK1004	228	9	1-1/32	24	MC502	SC895	—	—	—
<i>ELEMENT</i>															
2.4	2354	L4	2003	2009	Sold As Kit Only	HCK1004	228	9	1-1/32	24	MC502	SC895	—	—	—
<i>PASSPORT</i>															
2.6	2559	L4	1994	1996	—	KIS05	240	9-1/2	1	24	MC144	SC552	—	—	—
3.2	3165	V6	1994	1997	Sold As Kit Only	KIS01	260	10-1/4	1	24	MC144	SC550	—	—	—
3.2	3165	V6	1998	2002	Sold As Kit Only	KIS01	260	10-1/4	1	24	MC554	SC550	—	—	—



Liter	CC/IN	Cyl	Years		Application Information	Kit	Disc (mm)	Disc (in)	Spline Dia	Splines	Master Cyl	Slave Cyl	Clutch Cable	Clutch Fork	New Flywheel
			To	From											
<b>HUMMER</b>															
<i>H3</i>															
3.5	214	L5	2006	2006	Sold as Kit Only	GMK1028	265	10-7/16	1-3/16	26	MC462	SC809	—	—	—
3.7	223	L5	2007	2010	Sold as Kit Only	GMK1028	265	10-7/16	1-3/16	26	MC462	SC809	—	—	—
<b>HYUNDAI</b>															
<i>ACCENT</i>															
1.5	1495	L4	1995	1995	—	05091	200	7-7/8	7/8	20	MC538	SC840	—	—	—
1.5	1495	L4	1995	1995	—	05091	200	7-7/8	7/8	20	MC538	SC855	—	—	—
1.5	1495	L4	1996	1997	—	05091	200	7-7/8	7/8	20	MC538	SC590	—	—	—
1.5	1495	L4	1997	1999	—	05091	200	7-7/8	7/8	20	MC557	SC590	—	—	—
1.5	1495	L4	2000	2002	—	05091	200	7-7/8	7/8	20	MC517	SC855	—	—	—
1.6	1600	L4	2001	2003	—	HYK1000	215	8-7/16	7/8	20	MC517	SC855	—	—	—
1.6	1600	L4	2004	2005	—	HYK1000	215	8-7/16	7/8	20	MC519	SC855	—	—	—
1.6	1599	L4	2006	2008	Sold as Kit Only	HYK1004	215	8 7/16	7/8	20	MC518	SC913	—	—	—
1.6	1599	L4	2009	2011	Sold as Kit Only	HYK1012	215	8 7/16	7/8	20	MC518	SC913	—	—	—
<i>ELANTRA</i>															
1.6	1596	L4	1992	1993	To 9/30/93	05022	200	7-7/8	7/8	20	MC178	SC581	—	—	—
1.6	1596	L4	1993	1995	From 10/1/93	05051	215	8-1/2	7/8	20	MC178	SC581	—	—	—
1.8	1796	L4	1996	1998	Pull Type Design, Sold as kit only	05087	215	8-7/16	7/8	20	MC555	SC849	—	—	—
1.8	1796	L4	2011	2014	Sold as Kit Only	KIK1004	236	9-1/4	7/8	20	—	SC913	—	—	—
2.0	1975	L4	1999	2000	Pull Type Design, Sold as kit only	05087	215	8-7/16	7/8	20	MC555	SC596	—	—	—
2.0	1975	L4	2001	2004	Pull Type Design, Sold as kit only	05087	215	8-7/16	7/8	20	MC562	SC596	—	—	—
2.0	1975	L4	2005	2005	Pull Type Design, Sold as kit only	05087	215	8-7/16	7/8	20	MC512	SC596	—	—	—
2.0	1975	L4	2006	2006	Pull Type Design, Sold as kit only	05087	215	8-7/16	7/8	20	MC512	SC849	—	—	—
2.0	1975	L4	2007	2012	Sold as Kit Only	HYK1005	225	8-7/8	7/8	20	—	SC913	—	—	—
<i>EXCEL</i>															
1.5	1468	L4	1986	1988	—	05008	184	7-1/4	7/8	20	—	—	CC550	—	—
1.5	1468	L4	1989	1989	To 6/89	05008	184	7-1/4	7/8	20	MC178	SC584	CC550	—	—
1.5	1468	L4	1990	1994	—	05022	200	7-7/8	7/8	20	MC178	SC584	—	—	—
<i>PONY (CANADA)</i>															
1.4	1393	L4	1983	1987	—	05008	184	7-1/4	7/8	20	—	—	—	—	—
1.5	1468	L4	1986	1986	—	05008	184	7-1/4	7/8	20	—	—	—	—	—
1.6	1596	L4	1984	1987	—	05008	184	7-1/4	7/8	20	—	—	—	—	—
<i>SCOUPE</i>															
1.5	1468	L4	1991	1992	Non-Turbo	05022	200	7-7/8	7/8	20	MC178	SC584	—	—	—
1.5	1495	L4	1993	1993	Non-Turbo	05022	200	7-7/8	7/8	20	MC184	SC590	—	—	—
1.5	1495	L4	1993	1995	Turbo	05051	215	8-1/2	7/8	20	MC184	SC590	—	—	—
<i>SONATA</i>															
2.0	1997	L4	1992	1992	—	05051	215	8-1/2	7/8	20	MC175	SC581	—	—	—
2.0	1997	L4	1993	1993	—	05051	215	8-1/2	7/8	20	MC187	SC581	—	—	—
2.0	1997	L4	1994	1994	From 11/94	05056	225	8-7/8	7/8	20	MC189	SC581	—	—	—
2.0	1997	L4	1994	1994	To 10/94	05051	215	8-1/2	7/8	20	MC187	SC581	—	—	—
2.0	1997	L4	1995	1998	—	05056	225	8-7/8	7/8	20	MC189	SC581	—	—	—
2.4	2351	L4	1989	1991	—	05056	225	8-7/8	7/8	20	MC175	SC580	—	—	—
2.4	2351	L4	1999	2001	Pull Type Design	05100	225	8-7/8	7/8	20	MC560	SC849	—	—	—
2.4	2351	L4	2002	2002	Pull Type Design, Solid FW Conversion, Sold as kit only, Includes FW	HYK1002FW	225	8-7/8	7/8	20	MC560	SC850	—	—	—
2.4	2351	L4	2003	2005	Pull Type Design, Solid FW Conversion, Sold as kit only, Includes FW	HYK1002FW	225	8-7/8	7/8	20	MC560	SC849	—	—	—
2.4	2351	L4	2002	2002	Pull Type Design, 6spd,Fits OEM Dual Mass FW	KHY01	225	8-7/8	7/8	20	MC560	SC850	—	—	—
2.4	2351	L4	2003	2005	Pull Type Design, 6spd,Fits OEM Dual Mass FW	KHY01	225	8-7/8	7/8	20	MC560	SC849	—	—	—
2.5	2493	V6	1999	2001	Pull Type Design	05100	225	8-7/8	7/8	20	—	SC849	—	—	—
2.7	2656	V6	2002	2002	Pull Type Design, 6spd,Solid FW Conversion,Sold as kit only, Includes FW	HYK1003	225	8-7/8	7/8	20	—	—	—	—	—
2.7	2656	V6	2003	2003	Pull Type Design, 6spd,Solid FW Conversion,Sold as kit only, Includes FW	HYK1003	225	8-7/8	7/8	20	MC560	SC849	—	—	—
2.7	2656	V6	2002	2002	Pull Type Design, 6spd,Fits OEM Dual Mass FW	KHY01	225	8-7/8	7/8	20	—	—	—	—	—
2.7	2656	V6	2003	2003	Pull Type Design, 6spd,Fits OEM Dual Mass FW	KHY01	225	8-7/8	7/8	20	MC560	SC849	—	—	—
2.7	2656	V6	2005	2005	Pull Type Design	KHY01	225	8-7/8	7/8	20	MC560	—	—	—	—

Liter	CC/IN	Cyl	Years		Application Information	Kit	Disc (mm)	Disc (in)	Spline Dia	Splines	Master Cyl	Slave Cyl	Clutch Cable	Clutch Fork	New Flywheel
			To	From											
<b>HYUNDAI CONT.</b>															
<i>TIBURON</i>															
1.8	1795	L4	1997	1997	Pull Type Design, Sold as kit only	05087	215	8-7/16	7/8	20	—	—	—	—	—
2.0	1975	L4	1997	2001	Pull Type Design, Sold as kit only	05087	215	8-7/16	7/8	20	MC555	SC849	—	—	—
2.0	1975	L4	2003	2007	Pull Type Design, 5spd, Sold as Kit Only	05087	215	8-7/16	7/8	20	MC562	SC849	—	—	—
2.7	2656	V6	2003	2007	Pull Type Design, 5spd, Sold as Kit Only, Fits Solid FW set up	05087	215	8-7/16	7/8	20	MC562	SC849	—	—	—
2.7	2656	V6	2003	2004	Pull Type Design, 5spd, Sold as Kit Only, Fits Dual Mass FW set up	KHY01	225	8-7/8	7/8	20	MC562	SC849	—	—	—
2.7	2656	V6	2003	2007	Pull Type Design, 6spd, Fits OEM Dual Mass FW	KHY01	225	8-7/8	7/8	20	MC562	SC911	—	—	—
2.7	2656	V6	2003	2008	Pull Type Design, 6spd, Solid FW Conversion, Sold as kit only, Includes FW	HYK1003	225	8-7/8	7/8	20	MC562	SC911	—	—	—
<i>TUCSON</i>															
2.0	1975	L4	2005	2009	—	HYK1001	236	9-1/4	7/8	20	MC513	SC849	—	—	—
<b>HYUNDAI SUV</b>															
<i>SANTA FE</i>															
2.4	2351	L4	2001	2004	Pull Type Design, Fits Dual Mass FW	KHY01	225	8-7/8	7/8	20	MC514	SC849	—	—	—
2.4	2351	L4	2001	2006	Pull Type Design, Fits Solid FW	HYK1002	225	8-7/8	7/8	20	—	—	—	—	—
2.4	2351	L4	2001	2006	Pull Type Design, Solid FW Included, Sold as Kit only	HYK1002FW	225	8-7/8	7/8	20	—	—	—	—	—
<b>INFINITI (Performance Applications Available)</b>															
<i>G20</i>															
2.0	1998	L4	1991	1996	—	KNS02	215	8-1/2	13/16	18	—	—	—	—	—
2.0	2000	L4	1999	2002	—	KNS02	215	8-1/2	13/16	18	—	SC760	—	—	—
<i>G35</i>															
3.5	3498	V6	2003	2006	Sold As Kit Only	NSK1000	250	9-7/8	1	24	—	—	—	—	—
3.5	3498	V6	2003	2006	Sold As Kit Only, Solid FW Conversion for OEM Dual Mass FW, Economy version	NSK1000FW	250	9-7/8	1	24	—	—	—	—	—
3.5	3498	V6	2007	2007	Sold As Kit Only	NSK1000	250	9-7/8	1	24	—	—	—	—	—
3.5	3498	V6	2007	2007	Sold As Kit Only, Solid FW Conversion for OEM Dual Mass FW, Coupe only	NSK1000FW	250	9-7/8	1	24	—	—	—	—	—
3.5	3498	V6	2007	2011	Sold As Kit Only, Solid FW Conversion for OEM Dual Mass FW, Sedan Only	NSK1024FW	250	9-7/8	1	24	—	BRG0163	—	—	—
<i>G37</i>															
3.7	3696	V6	2008	2011	Dual Mass Flywheel Conversion, Sold as Kit Only, Includes Solid Flywheel, Includes CSC Hydraulic Slave	NSK1024FW	250	9-7/8	1	24	—	BRG0163	—	—	—
<i>I30</i>															
3.0	2988	V6	1996	1999	—	06044	240	9-1/2	1	24	MC160	SC851	—	—	—
<b>ISUZU</b>															
<i>I-280, I-290</i>															
2.8	2770	L4	2006	2006	Sold as Kit Only, Includes CSC Hydraulic Slave	GMK1015	264	10-3/8	1-1/8	26	MC462	—	—	—	—
<i>I-MARK</i>															
1.5	1471	L4	1985	1989	Non-Turbo	04063	184	7-1/4	1	14	—	—	CC578	—	—
1.5	1471	L4	1987	1989	Turbo	04099	215	8-1/2	1	14	—	—	CC578	—	—
1.8	1817	L4	1981	1984	Diesel	04058	200	7-7/8	1	24	—	—	—	—	—
1.8	1817	L4	1981	1985	—	04058	200	7-7/8	1	24	—	—	—	—	—
<i>IMPULSE</i>															
1.6	1588	L4	1990	1991	Non-Turbo	04112	200	7-7/8	15/16	14	—	—	—	—	—
1.6	1588	L4	1991	1992	Turbo	09017	215	8-1/2	1	14	—	—	—	—	—
1.8	1817	L4	1992	1992	—	09017	215	8-1/2	1	14	—	—	—	—	—
1.9	1949	L4	1983	1987	—	09012	215	8-1/2	1	24	MC142	SC545	—	—	—
2.0	1994	L4	1985	1989	Turbo	09007	240	9-1/2	1	24	MC142	SC546	—	—	—
2.3	2254	L4	1988	1989	—	09014	215	8-1/2	1	24	MC142	SC546	—	—	—
<i>STYLUS</i>															
1.6	1588	L4	1991	1993	—	04112	200	7-7/8	15/16	14	—	—	—	—	—
1.8	1817	L4	1992	1992	—	09017	215	8-1/2	1	14	—	—	—	—	—
<b>ISUZU LIGHT TRUCK &amp; SUV</b>															
<i>AMIGO</i>															
2.2	2180	L4	1998	2000	MUA Transmission, ID # RMN	KIS05	240	9-1/2	1	24	MC146	SC875	—	—	—
2.3	2254	L4	1989	1990	—	04071	215	8-1/2	1	24	—	—	CC581	—	—
2.3	2254	L4	1991	1993	—	04071	215	8-1/2	1	24	—	—	—	—	—
2.6	2559	L4	1989	1990	—	09015	240	9-1/2	1	24	MC144	SC549	CC581	—	—
2.6	2559	L4	1991	1994	—	09015	240	9-1/2	1	24	MC144	SC547	—	—	—
3.2	3165	V6	1998	2000	Pull Type, Sold As Kit Only	KIS01	260	10-1/4	1	24	MC554	SC550	—	—	—

Liter	CC/IN	Cyl	Years		Application Information	Kit	Disc (mm)	Disc (in)	Spline Dia	Splines	Master Cyl	Slave Cyl	Clutch Cable	Clutch Fork	New Flywheel
			To	From											
<b>ISUZU LIGHT TRUCK &amp; SUV CONT.</b>															
<i>HOMBRE</i>															
2.2	2180	L4	1996	2000	—	04155	232	9-1/8	1-1/8	26	MC378	SC746	—	—	—
4.3	4294	V6	1997	1999	—	KGM10	280	11	1-1/8	10	MC378	SC746	—	—	—
<i>PICKUP</i>															
1.8	1817	L4	1981	1982	2 WD	04058	200	7-7/8	1	24	—	—	—	—	—
1.8	1817	L4	1981	1982	4 WD	04071	215	8-1/2	1	24	—	—	—	—	—
1.9	1949	L4	1983	1987	—	04071	215	8-1/2	1	24	—	—	—	—	—
2.2	2238	L4	1981	1985	Diesel	04071	215	8-1/2	1	24	—	—	—	—	—
2.2	2238	L4	1986	1987	Turbo Diesel	04071	215	8-1/2	1	24	MC493	—	—	—	—
2.3	2254	L4	1986	1995	—	04071	215	8-1/2	1	24	—	—	—	—	—
2.6	2559	L4	1988	1995	—	09015	240	9-1/2	1	24	MC144	SC549	—	—	—
3.1	3137	V6	1991	1994	—	09018	240	9-1/2	1	24	MC144	SC548	—	—	—
<i>RODEO</i>															
2.2	2180	L4	1998	1998	1 Piece Bell Housing	09015	240	9-1/2	1	24	MC146	SC904	—	—	—
2.2	2180	L4	1998	1998	2 Piece Bell Housing	KIS05	240	9-1/2	1	24	MC146	SC904	—	—	—
2.2	2180	L4	1999	2000	2 Piece Bell Housing	KIS05	240	9-1/2	1	24	MC146	SC875	—	—	—
2.2	2180	L4	1999	2001	1 Piece Bell Housing	09015	240	9-1/2	1	24	MC146	SC875	—	—	—
2.2	2180	L4	2002	2003	—	ISK1002	240	9-1/2	1	24	MC554	SC875	—	—	—
2.6	2559	L4	1991	1992	To 10/92	09015	240	9-1/2	1	24	MC144	SC549	—	—	—
2.6	2559	L4	1992	1992	From 11/92	KIS05	240	9-1/2	1	24	MC144	SC552	—	—	—
2.6	2559	L4	1993	1997	—	KIS05	240	9-1/2	1	24	MC144	SC552	—	—	—
3.1	3137	V6	1991	1991	2 WD, Non Pre-Damped	04065	228	9	1	14	MC144	SC548	—	—	—
3.1	3137	V6	1991	1991	2 WD, Pre-Damped	04130	232	9-1/8	1	14	MC144	SC548	—	—	—
3.1	3137	V6	1991	1992	4 WD, MUA Transmission # RMN	09018	240	9-1/2	1	24	MC144	SC548	—	—	—
3.1	3137	V6	1991	1992	4 WD, Transmission # MM5	04065	228	9	1	14	MC144	SC551	—	—	—
3.1	3137	V6	1992	1992	2 WD, Non Pre-Damped	04065	228	9	1	14	MC144	—	—	—	—
3.1	3137	V6	1992	1992	2 WD, Pre-Damped	04130	232	9-1/8	1	14	MC144	—	—	—	—
3.2	3165	V6	1993	1993	Borg Warner Transmission	KIS05	240	9-1/2	1	24	MC144	SC550	—	—	—
3.2	3165	V6	1993	1993	Pull Type, MUA Transmission, Sold As Kit Only	KIS01	260	10-1/4	1	24	MC144	SC550	—	—	—
3.2	3165	V6	1994	1995	Pull Type, Sold As Kit Only	KIS01	260	10-1/4	1	24	MC144	SC550	—	—	—
3.2	3165	V6	1996	1997	Borg Warner Transmission	KIS05	240	9-1/2	1	24	MC144	SC550	—	—	—
3.2	3165	V6	1996	1997	Pull Type, MUA Transmission, Sold As Kit Only	KIS01	260	10-1/4	1	24	MC144	SC550	—	—	—
3.2	3165	V6	1998	1999	Borg Warner Transmission	KIS05	240	9-1/2	1	24	MC554	SC550	—	—	—
3.2	3165	V6	1998	1999	Pull Type, MUA Transmission, Sold As Kit Only	KIS01	260	10-1/4	1	24	MC554	SC550	—	—	—
3.2	3165	V6	2000	2004	Pull Type, Sold As Kit Only	KIS01	260	10-1/4	1	24	MC144	SC550	—	—	—
<i>TROOPER</i>															
1.9	1949	L4	1984	1985	—	04071	215	8-1/2	1	24	—	—	—	—	—
2.2	2238	L4	1984	1984	Diesel	04071	215	8-1/2	1	24	—	—	—	—	—
2.2	2238	L4	1986	1987	Turbo Diesel	04071	215	8-1/2	1	24	—	—	—	—	—
2.3	2254	L4	1986	1987	—	04071	215	8-1/2	1	24	—	—	—	—	—
2.6	2559	L4	1988	1991	—	09015	240	9-1/2	1	24	MC143	SC549	—	—	—
2.8	2827	V6	1989	1991	—	09016	230	9-1/16	1	24	MC143	SC548	—	—	—
3.2	3165	V6	1992	1997	Pull Type, Sold As Kit Only	KIS01	260	10-1/4	1	24	MC144	SC550	—	—	—
3.5	3475	V6	1998	2002	Pull Type, Sold As Kit Only	KIS06	273	10-3/4	1	24	—	SC550	—	—	—
<b>JEEP LIGHT TRUCK &amp; SUV</b>															
<i>CHEROKEE, GRAND CHEROKEE, COMANCHE, WAGONEER, GRAND WAGONEER</i>															
2.5	153	L4	1984	1984	9-1/8" Disc	01001	232	9-1/8	1-1/8	10	MC346	—	—	—	—
2.5	153	L4	1984	1984	9-1/8" Disc	01001	232	9-1/8	1-1/8	10	MC346	SC723	—	—	—
2.5	153	L4	1986	1986	8-7/8" Disc	01020	225	8-7/8	15/16	14	MC346	SC723	—	—	—
2.5	153	L4	1987	1990	Includes Slave Cylinder	01033	225	8-7/8	15/16	14	MC342	—	—	—	—
2.5	153	L4	1991	1992	Includes Slave Cylinder	01033	225	8-7/8	15/16	14	MC390	—	—	—	—
2.5	153	L4	1993	1993	Includes Slave Cylinder	01036	225	8-7/8	15/16	14	MC390	—	—	—	—
2.5	153	L4	1994	1996	—	01040	225	8-7/8	15/16	14	MC390	SC754	—	—	—
2.5	153	L4	1997	2000	—	01040	225	8-7/8	15/16	14	MC396	SC754	—	—	—
2.8	171	V6	1984	1984	—	01018	228	9	1	14	MC346	SC723	—	—	—
2.8	171	V6	1985	1985	9-1/8" Disc	01024	228	9	1	14	MC347	SC723	—	—	—

Liter	CC/IN	Cyl	Years		Application Information	Kit	Disc (mm)	Disc (in)	Spline Dia	Splines	Master Cyl	Slave Cyl	Clutch Cable	Clutch Fork	New Flywheel
			To	From											
<b>JEEP LIGHT TRUCK &amp; SUV CONT.</b>															
<i>CHEROKEE, GRAND CHEROKEE, COMANCHE, WAGONEER, GRAND WAGONEER CONT.</i>															
2.8	171	V6	1985	1985	9-11/16" Disc	01018	228	9	1	14	MC347	SC723	—	—	—
2.8	171	V6	1985	1986	—	01024	228	9	1	14	MC347	SC723	—	—	—
3.8	232	L6	1965	1965	—	01026	265	10-1/2	1-1/8	10	—	—	—	—	—
3.8	232	L6	1971	1971	Includes Slave Cylinder	01035	265	10-1/2	1-1/8	10	MC342	—	—	—	—
4.0	244	L6	1987	1988	Includes Slave Cylinder	01035	265	10-1/2	1-1/8	10	MC342	—	—	—	—
4.0	244	L6	1989	1989	Aisin Transmission, Includes Slave Cylinder	01034	265	10-1/2	1-1/8	10	MC100	—	—	—	—
4.0	244	L6	1989	1989	Aisin Transmission, Includes Slave Cylinder	01034	265	10-1/2	1-1/8	10	MC342	—	—	—	—
4.0	244	L6	1989	1989	Peugeot Transmission, Includes Slave Cylinder	01035	265	10-1/2	1-1/8	10	MC100	—	—	—	—
4.0	244	L6	1989	1989	Peugeot Transmission, Includes Slave Cylinder	01035	265	10-1/2	1-1/8	10	MC342	—	—	—	—
4.0	244	L6	1990	1990	Includes Slave Cylinder	01034	265	10-1/2	1-1/8	10	MC342	—	—	—	—
4.0	244	L6	1991	1992	Includes Slave Cylinder	01034	265	10-1/2	1-1/8	10	MC390	—	—	—	—
4.0	244	L6	1993	1993	Includes Slave Cylinder	01037	265	10-1/2	1-1/8	10	MC388	SC751	—	—	—
4.0	244	L6	1993	1993	Includes Slave Cylinder	01037	265	10-1/2	1-1/8	10	MC390	—	—	—	—
4.0	244	L6	1994	1994	—	05065	265	10-1/2	1-1/8	10	MC388	SC751	—	—	—
4.0	244	L6	1994	1996	—	05065	265	10-1/2	1-1/8	10	MC390	SC754	—	—	—
4.0	244	L6	1997	2001	—	05065	265	10-1/2	1-1/8	10	MC396	SC751	—	—	—
4.2	256	L6	1972	1974	10-3/8" Disc	01026	265	10-1/2	1-1/8	10	—	—	—	—	—
4.2	256	L6	1975	1975	—	01026	265	10-1/2	1-1/8	10	—	—	—	—	—
4.2	256	L6	1982	1986	—	01017	265	10-1/2	1-1/8	10	—	—	—	—	—
<b>CJ SERIES, SCRAMBLER, WRANGLER</b>															
2.4	146	L4	2003	2004	—	KJP03	228	9	1	19	MC396	SC754	—	—	—
2.4	146	L4	2005	2006	Sold as Kit Only	CRK1007	226	8-15/16	15/16	19	MC396	SC933	—	—	—
2.5	153	L4	1980	1983	GM Engine	01001	232	9-1/8	1-1/8	10	MC344	SC833	—	—	—
2.5	153	L4	1984	1985	AMC Engine	01001	232	9-1/8	1-1/8	10	MC344	SC723	—	—	—
2.5	153	L4	1986	1986	—	01020	225	8-7/8	15/16	14	MC344	SC723	—	—	—
2.5	153	L4	1987	1987	Includes Slave Cylinder	01033	225	8-7/8	15/16	14	MC341	—	—	—	—
2.5	153	L4	1988	1990	Includes Slave Cylinder	01033	225	8-7/8	15/16	14	MC341	—	—	—	—
2.5	153	L4	1991	1991	Includes Slave Cylinder	01033	225	8-7/8	15/16	14	MC389	—	—	—	—
2.5	153	L4	1991	1992	Includes Slave Cylinder	01033	225	8-7/8	15/16	14	MC390	—	—	—	—
2.5	153	L4	1993	1993	Includes Slave Cylinder	01036	225	8-7/8	15/16	14	MC390	—	—	—	—
2.5	153	L4	1994	1995	—	01040	225	8-7/8	15/16	14	MC392	SC754	—	—	—
2.5	153	L4	1997	2002	—	01040	225	8-7/8	15/16	14	MC396	SC754	—	—	—
3.8	232	L6	1972	1973	—	01026	265	10-1/2	1-1/8	10	—	—	—	—	—
3.8	232	L6	1974	1975	—	01026	265	10-1/2	1-1/8	10	—	—	—	CF111	—
3.8	232	L6	2007	2011	Sold as Kit Only	KJP02	263	10-3/8	1-1/8	10	—	—	—	—	—
4.0	244	L6	1991	1992	Includes Slave Cylinder	01034	265	10-1/2	1-1/8	10	MC390	—	—	—	—
4.0	244	L6	1993	1993	Includes Slave Cylinder	01037	265	10-1/2	1-1/8	10	MC389	—	—	—	—
4.0	244	L6	1994	1995	—	05065	265	10-1/2	1-1/8	10	MC392	SC754	—	—	—
4.0	244	L6	1997	2006	—	05065	265	10-1/2	1-1/8	10	MC396	SC754	—	—	—
4.2	256	L6	1972	1975	10-1/2" Disc	01026	265	10-1/2	1-1/8	10	—	—	—	—	—
4.2	256	L6	1976	1981	CJ5, CJ7	01017	265	10-1/2	1-1/8	10	MC344	—	—	—	—
4.2	256	L6	1982	1985	—	01017	265	10-1/2	1-1/8	10	MC344	—	—	—	—
4.2	256	L6	1986	1986	—	01007	265	10-1/2	1-1/8	10	MC344	SC833	—	—	—
4.2	256	L6	1987	1988	Includes Slave Cylinder	01035	265	10-1/2	1-1/8	10	MC341	—	—	—	—
4.2	256	L6	1989	1989	Aisin Transmission, Includes Slave Cylinder	01034	265	10-1/2	1-1/8	10	MC341	—	—	—	—
4.2	256	L6	1989	1989	Peugeot Transmission, Includes Slave Cylinder	01035	265	10-1/2	1-1/8	10	MC341	—	—	—	—
4.2	256	L6	1990	1990	Includes Slave Cylinder	01034	265	10-1/2	1-1/8	10	—	—	—	—	—
5.0	305	V8	1972	1975	10" Disc	01026	265	10-1/2	1-1/8	10	—	—	—	—	—
<b>DJ SERIES</b>															
3.8	232	L6	1972	1973	—	01026	265	10-1/2	1-1/8	10	—	—	—	—	—
3.8	232	L6	1974	1974	—	01026	265	10-1/2	1-1/8	10	—	—	—	CF111	—
4.2	256	L6	1973	1974	10-3/8" Disc	01026	265	10-1/2	1-1/8	10	—	—	—	—	—
5.0	305	V8	1974	1974	10-3/8" Disc	01026	265	10-1/2	1-1/8	10	—	—	—	—	—
<b>GLADIATOR</b>															
3.8	232	L6	1966	1967	—	01026	265	10-1/2	1-1/8	10	—	—	—	—	—



Liter	CC/IN	Cyl	Years		Application Information	Kit	Disc (mm)	Disc (in)	Spline Dia	Splines	Master Cyl	Slave Cyl	Clutch Cable	Clutch Fork	New Flywheel
			To	From											
<b>JEEP LIGHT TRUCK &amp; SUV CONT.</b>															
<i>J SERIES</i>															
3.8	232	L6	1966	1971	—	01026	265	10-1/2	1-1/8	10	—	—	—	—	—
4.2	256	L6	1972	1973	—	01026	265	10-1/2	1-1/8	10	—	—	—	—	—
4.2	256	L6	1973	1973	—	01026	265	10-1/2	1-1/8	10	—	—	—	CF111	—
4.2	256	L6	1982	1985	—	01017	265	10-1/2	1-1/8	10	—	—	—	—	—
4.2	256	L6	1986	1986	—	01007	265	10-1/2	1-1/8	10	—	—	—	—	—
4.2	256	L6	1987	1987	Includes Slave Cylinder	01035	265	10-1/2	1-1/8	10	—	—	—	—	—
<i>JEEPSTER</i>															
3.8	232	L6	1972	1973	—	01026	265	10-1/2	1-1/8	10	—	—	—	—	—
4.2	256	L6	1972	1973	10-3/8" Disc	01026	265	10-1/2	1-1/8	10	—	—	—	—	—
<i>LIBERTY</i>															
2.4	146	L4	2002	2004	—	KJP01	228	9	1	19	MC455	SC798	—	—	—
2.4	146	L4	2005	2005	Sold as Kit Only	CRK1007	226	8-15/16	15/16	19	MC455	SC934	—	—	—
3.7	226	V6	2002	2004	Sold As Kit Only, Sprung Disc	KJP02	263	10-3/8	1-3/8	10	MC455	SC798	—	—	—
3.7	226	V6	2005	2007	Sold as Kit Only, Rigid Disc	CRK1006	265	10-7/16	1-1/8	10	MC455	—	—	—	—
<b>KIA</b>															
<i>FORTE</i>															
2.0	1975	L4	2010	2013	Sold as Kit Only	KIK1004	236	9-1/4	7/8	20	—	SC913	—	—	—
<i>OPTIMA</i>															
2.4	2351	L4	2001	2006	Pull Type Design, Solid FW Included, Sold as Kit only	HYK1002FW	225	8-7/8	7/8	20	MC560	SC546	—	—	—
<i>RIO</i>															
1.5	1493	L4	2001	2002	—	KKI02	200	7-7/8	7/8	20	—	—	—	—	—
1.6	1594	L4	2003	2005	—	KKI02	200	7-7/8	7/8	20	—	—	—	—	—
<i>SEPHIA</i>															
1.6	1597	L4	1994	1997	—	10040	200	7-7/8	7/8	20	MC225	SC628	—	—	—
1.8	1839	L4	1995	1997	—	KKI01	225	8-7/8	15/16	22	MC225	SC629	—	—	—
1.8	1793	L4	1998	1998	—	10040	200	7-7/8	7/8	20	MC225	SC633	—	—	—
1.8	1793	L4	1998	1999	—	KKI01	225	8-7/8	15/16	22	MC559	SC633	—	—	—
1.8	1793	L4	2000	2001	—	KKI01	225	8-7/8	15/16	22	MC225	SC633	—	—	—
<i>SORENTO</i>															
3.5	3497	V6	2004	2006	Sold as kit only	KIK1001	240	9-1/2	1	23	MC576	—	—	—	—
<i>SPECTRA</i>															
1.8	1793	L4	2000	2004	—	KKI01	225	8-7/8	15/16	22	MC559	SC859	—	—	—
2.0	1975	L4	2004	2004	—	KKI01	225	8-7/8	15/16	22	—	—	—	—	—
2.0	1975	L4	2005	2006	Sold as kit only	KIK1000	215	8-1/2	13/16	20	—	SC849	—	—	—
2.2	—	—	2005	—	—	05087	215	8-7/16	7/8	20	—	—	—	—	—
<b>KIA SUV</b>															
<i>SPORTAGE</i>															
2.0	1998	L4	1995	2002	—	KKI01	225	8-7/8	15/16	22	MC226	SC635	—	—	—
2.0	1975	L4	2005	2008	—	HYK1001	236	9-1/4	7/8	20	MC513	SC849	—	—	—
<i>SOUL</i>															
1.6	1597	L4	2010	2014	Sold as Kit Only	KIK1002	215	8-7/16	7/8	20	—	—	—	—	—
2.0	1975	L4	2011	2013	Sold as Kit Only	HYK1005	225	8-7/8	7/8	20	—	—	—	—	—
2.0	1975	L4	2012	2013	Sold as Kit Only	KIK1004	236	9-1/4	7/8	20	—	SC913	—	—	—
<b>LAND ROVER</b>															
<i>DEFENDER</i>															
3.9	3950	V8	1993	1995	Sold As Kit Only	KLR09	265	10-1/2	1	23	—	—	—	—	—
<i>DISCOVERY</i>															
3.9	3950	V8	1994	1995	Sold As Kit Only	KLR10	265	10-1/2	1	23	—	SC810	—	—	—
4.0	3950	V8	1996	1997	Sold As Kit Only	KLR10	265	10-1/2	1	23	—	SC810	—	—	—
<b>LEXUS (Performance Applications Available)</b>															
<i>ES250</i>															
2.5	2508	V6	1990	1991	—	16082	236	9-1/4	1-3/16	21	MC246	SC653	—	—	—
3.0	2959	V6	1992	1993	—	16082	236	9-1/4	1-3/16	21	MC540	SC654	—	—	—
<i>IS300</i>															
3.0	2997	L6	2002	2003	—	KTY17	238	9-3/8	1-3/16	21	—	—	—	—	—
<i>SC300</i>															
3.0	2997	L6	1992	1997	—	16085	236	9-1/4	1-3/16	21	MC268	SC674	—	—	—

Liter	CC/IN	Cyl	Years		Application Information	Kit	Disc (mm)	Disc (in)	Spline Dia	Splines	Master Cyl	Slave Cyl	Clutch Cable	Clutch Fork	New Flywheel
			To	From											
<b>LINCOLN</b>															
<b>LS</b>															
3.0	—	V6	2000	2002	Includes Slave Cylinder	KLN01	238	9-3/8	1-1/8	10	—	—	—	—	—
<b>MAZDA (Performance Applications Available)</b>															
<b>2</b>															
1.5	1498	L4	2011		Sold as Kit Only	MZK1010	225	8-7/8	15/16	22	—	—	—	—	—
<b>3</b>															
2.0	2000	L4	2004	2014	Sold As Kit Only	MZK1003	225	8-7/8	31/32	22	—	—	—	—	—
2.0	2000	L4	2012	2014	Skyactive	MZK1012	230	9-1/16	1	23	—	—	—	—	—
2.3	2260	L4	2004	2009	Sold As Kit Only	MZK1003	225	8-7/8	31/32	22	—	—	—	—	—
2.5	2260	L4	2009	2013	Sold As Kit Only	MZK1009	230	9-1/16	15/16	22	—	—	—	—	—
<b>323, GLC</b>															
1.3	1272	L4	1977	1978	—	10004	184	7-1/4	7/8	20	—	—	—	—	—
1.4	1415	L4	1979	1980	—	10004	184	7-1/4	7/8	20	—	—	—	—	—
1.5	1490	L4	1981	1985	—	10018	190	7-1/2	7/8	20	—	—	—	—	—
1.6	1597	L4	1986	1986	—	10018	190	7-1/2	7/8	20	—	—	CC606	—	—
1.6	1597	L4	1987	1987	From 7/87	07079	190	7-1/2	7/8	20	—	—	CC606	—	—
1.6	1597	L4	1987	1987	To 6/87	10018	190	7-1/2	7/8	20	—	—	CC606	—	—
1.6	1597	L4	1988	1989	—	07079	190	7-1/2	7/8	20	MC494	SC609	CC606	—	—
1.6	1597	L4	1988	1989	Turbo	10029	225	8-7/8	15/16	22	MC494	SC609	—	—	—
1.6	1597	L4	1990	1994	—	10043	190	7-1/2	7/8	20	MC221	SC628	—	—	—
<b>5</b>															
2.3	2260	L4	2006	2010	Sold As Kit Only	MZK1003	225	8-7/8	31/32	22	—	—	—	—	—
2.5	2260	L4	2012	2014	Sold As Kit Only	MZK1015	230	9-1/16	31/32	22	—	—	—	—	—
<b>6</b>															
2.3	2260	L4	2003	2006	Sold As Kit Only	MZK1000	215	8-1/2	15/16	22	MC221	SC877	—	—	—
2.3	2260	L4	2007	2008	Sold As Kit Only	MZK1000	215	8-1/2	15/16	22	MC221	—	—	—	—
2.5	2260	L4	2009	2013	Sold As Kit Only	MZK1008	230	9-1/16	15/16	22	—	—	—	—	—
3.0	2968	V6	2003	2008	Sold As Kit Only	MZK1001	240	9-1/2	1-1/16	23	MC221	SC877	—	—	—
<b>616</b>															
1.6	1586	L4	1971	1971	—	10011	200	7-7/8	15/16	22	—	—	—	—	—
<b>618</b>															
1.8	1796	L4	1972	1972	—	10010	215	8-1/2	15/16	22	—	—	—	—	—
<b>626, MX-6</b>															
2.0	1970	L4	1979	1980	Non-Turbo	10005	215	8-1/2	15/16	22	MC203	SC623	—	—	—
2.0	1970	L4	1981	1981	Non-Turbo	10005	215	8-1/2	15/16	22	MC206	SC624	—	—	—
2.0	1970	L4	1982	1982	8-1/2" Disc, Non-Turbo	10005	215	8-1/2	15/16	22	MC206	SC624	—	—	—
2.0	1970	L4	1982	1982	8-7/8" Disc, Non-Turbo	10029	225	8-7/8	15/16	22	MC206	SC816	CC607	—	—
2.0	1970	L4	1983	1983	Non-Turbo	10029	225	8-7/8	15/16	22	—	—	CC607	—	—
2.0	1998	L4	1984	1985	Diesel	10029	225	8-7/8	15/16	22	—	—	CC607	—	—
2.0	1998	L4	1984	1986	Non-Turbo	10029	225	8-7/8	15/16	22	—	—	CC607	—	—
2.0	1998	L4	1986	1987	Turbo	10015	225	8-7/8	15/16	22	—	—	CC607	—	—
2.0	1991	L4	1993	2002	—	07094	215	8-1/2	15/16	22	MC213	SC630	—	—	—
2.2	2184	L4	1988	1992	Heavy Duty, Ductile Iron Cover	10029D	225	8-7/8	15/16	22	MC211	SC606	—	—	—
2.2	2184	L4	1988	1992	Non-Turbo	10029	225	8-7/8	15/16	22	MC211	SC606	—	—	—
2.2	2184	L4	1988	1992	Turbo with ABS	07067	240	9-1/2	1-1/16	23	MC212	SC607	—	—	—
2.2	2184	L4	1988	1992	Turbo without ABS	07067	240	9-1/2	1-1/16	23	MC211	SC607	—	—	—
2.2	2184	L4	1991	1991	Non-Turbo 8-7/8 Disc	10029	225	8-7/8	15/16	22	MC211	SC606	—	—	—
2.5	2497	V6	1993	2002	—	07095	225	8-7/8	15/16	22	MC213	SC630	—	—	—
<b>808</b>															
1.6	1587	L4	1972	1973	—	10011	200	7-7/8	15/16	22	MC479	—	—	—	—
1.6	1587	L4	1974	1977	—	10011	200	7-7/8	15/16	22	MC479	SC623	—	—	—
<b>929</b>															
3.0	2954	V6	1988	1988	—	10032	240	9-1/2	1-1/16	23	—	SC828	—	—	—
<b>COSMO</b>															
1.3	1308	R2	1976	1978	—	07021	215	8-1/2	15/16	22	MC203	—	—	—	—

Liter	CC/IN	Cyl	Years		Application Information	Kit	Disc (mm)	Disc (in)	Spline Dia	Splines	Master Cyl	Slave Cyl	Clutch Cable	Clutch Fork	New Flywheel
			To	From											
<b>MAZDA (Performance Applications Available) CONT.</b>															
<i>MIATA, MX-5 MIATA</i>															
1.6	1597	L4	1990	1993	—	10036	200	7-7/8	15/16	22	MC229	SC825	—	—	—
1.8	1839	L4	1994	2005	—	KMZ03	215	8-1/2	15/16	22	MC229	SC825	—	—	—
2.0	2000	L4	2006	2014	5spd, Sold as Kit Only	MZK1005	215	8-1/2	31/32	22	MC575	SC908	—	—	—
2.0	2000	L4	2006	2014	6spd, Sold as Kit Only	MZK1006	215	8-1/2	1-1/32	23	MC575	SC908	—	—	—
<i>MIZER</i>															
1.3	1272	L4	1976	1977	—	KMZ05	184	7-1/4	7/8	20	MC479	SC812	—	—	—
<i>MX-3</i>															
1.6	1597	L4	1992	1993	—	10043	190	7-1/2	7/8	20	MC221	SC628	—	—	—
1.6	1597	L4	1994	1995	—	KMZ04	200	7-7/8	7/8	20	MC221	SC628	—	—	—
1.8	1845	V6	1992	1994	—	KMZ02	225	8-7/8	15/16	22	MC221	SC630	—	—	—
<i>PROTEGE</i>															
1.5	1489	L4	1995	1998	—	KMZ04	200	7-7/8	7/8	20	MC221	SC628	—	—	—
1.6	1589	L4	1999	2001	—	KMZ04	200	7-7/8	7/8	20	MC213	SC628	—	—	—
1.8	1839	L4	1990	1991	4 WD	07074	215	8-7/16	15/16	22	MC221	SC629	—	—	—
1.8	1839	L4	1990	1995	2 WD	10040	200	7-7/8	7/8	20	MC221	SC628	—	—	—
1.8	1839	L4	1996	1998	—	10040	200	7-7/8	7/8	20	MC221	SC628	—	—	—
1.8	1839	L4	1999	2000	—	KMZ04	200	7-7/8	7/8	20	MC213	SC860	—	—	—
2.0	2000	L4	2001	2003	—	KMZ08	225	8-7/8	15/16	22	MC213	—	—	—	—
<i>R100</i>															
1.1	1146	R2	1971	1972	—	KMZ07	200	7-7/8	13/16	13	—	—	—	—	—
<i>RX-2</i>															
1.1	1146	R2	1971	1974	—	07021	215	8-1/2	15/16	22	—	—	—	—	—
<i>RX-3</i>															
1.1	1146	R2	1972	1978	—	07021	215	8-1/2	15/16	22	MC479	—	—	—	—
<i>RX-4</i>															
1.3	1308	R2	1974	1978	—	07021	215	8-1/2	15/16	22	MC203	—	—	—	—
<i>RX-7</i>															
1.1	1146	R2	1979	1979	To 3/79	07020	215	8-1/2	15/16	22	MC203	—	—	—	—
1.1	1146	R2	1979	1982	From 4/79	07020	215	8-1/2	15/16	22	MC205	SC611	—	—	—
1.1	1146	R2	1983	1983	—	10025	225	8-7/8	15/16	22	MC205	SC612	—	—	—
1.1	1146	R2	1984	1985	—	10025	225	8-7/8	15/16	22	MC207	SC612	—	—	—
1.3	1308	R2	1984	1988	Non-Turbo	10025	225	8-7/8	15/16	22	MC210	SC611	—	—	—
1.3	1308	R2	1987	1988	Turbo	07067	240	9-1/2	1-1/16	23	MC210	SC614	—	—	—
1.3	1308	R2	1989	1991	Non-Turbo	10038	225	8-7/8	15/16	22	MC210	SC613	—	—	—
1.3	1308	R2	1989	1991	Turbo, Sold As Kit Only	10037	230	9-1/16	1-1/16	23	MC210	SC614	—	—	—
1.3	1308	R2	1993	1995	Pull Type, Turbo, Sold As Kit Only	KMZ01	237	9-5/16	1-1/16	23	MC495	—	—	—	—
<i>RX-8</i>															
1.3	1308	R2	2003	2003	Sold As Kit Only	MZK1002	236	9-1/4	1-1/32	23	MC487	—	—	—	—
1.3	1308	R2	2006	2008	Sold As Kit Only, WAD Style Patented Disc	MZK1007	236	9-1/4	1-1/32	23	MC487	—	—	—	—
1.3	1308	R2	2009	2012	Sold As Kit Only	MZK1014	236	9-1/4	1-1/32	23	—	—	—	—	—
<b>MAZDA LIGHT TRUCK, SUV &amp; VAN</b>															
<i>B1600</i>															
1.6	1586	L4	1972	1975	—	10011	200	7-7/8	15/16	22	MC477	—	—	—	—
1.6	1586	L4	1976	1976	—	10011	200	7-7/8	15/16	22	MC480	SC623	—	—	—
<i>B1800</i>															
1.8	1796	L4	1977	1978	—	07021	215	8-1/2	15/16	22	MC203	SC623	—	—	—
<i>B2000</i>															
2.0	1970	L4	1979	1979	—	07020	215	8-1/2	15/16	22	—	SC623	—	—	—
2.0	1970	L4	1980	1984	—	07020	215	8-1/2	15/16	22	MC219	SC623	—	—	—
2.0	1998	L4	1986	1987	—	10029	225	8-7/8	15/16	22	MC202	SC620	—	—	—
<i>B2200</i>															
2.2	2209	L4	1982	1984	Diesel	10025	225	8-7/8	15/16	22	MC219	SC618	—	—	—
2.2	2184	L4	1987	1993	—	10029	225	8-7/8	15/16	22	MC202	SC620	—	—	—

Liter	CC/IN	Cyl	Years		Application Information	Kit	Disc (mm)	Disc (in)	Spline Dia	Splines	Master Cyl	Slave Cyl	Clutch Cable	Clutch Fork	New Flywheel
			To	From											
<b>MAZDA LIGHT TRUCK, SUV &amp; VAN CONT.</b>															
<i>B2300</i>															
2.3	2295	L4	1994	1994	—	07093	225	8-7/8	1	23	MC365	SC778	—	—	—
2.3	2295	L4	1995	2006	Self Adjusting Clutch	KFM30	225	8-7/8	1	23	MC367	SC778	—	—	—
2.3	2294	L4	1995	2006	Non Self Adjusting Clutch, Economy EXEDY version	KFM07	225	8-7/8	1	23	MC367	SC778	—	—	—
<i>B2500</i>															
2.5	2492	L4	1998	2001	Non Self Adjusting Clutch, Economy EXEDY version	KFM07	225	8-7/8	1	23	MC367	SC778	—	—	—
2.5	2492	L4	1998	2001	Self Adjusting Clutch	KFM30	225	8-7/8	1	23	MC367	SC778	—	—	—
<i>B2600</i>															
2.6	2555	L4	1987	1988	Carbureted	07067	240	9-1/2	1-1/16	23	MC202	SC624	—	—	—
2.6	2606	L4	1989	1993	Fuel Injected	10042	250	9-7/8	1-1/16	23	MC202	SC626	—	—	—
<i>B3000</i>															
3.0	2983	V6	1994	1994	To Oct 31/1998	07099	225	8-7/8	1	23	MC364	SC778	—	—	—
3.0	2983	V6	1995	2006	Non Self Adjusting Clutch, Economy EXEDY version	KFM06	228	9	1	23	MC367	SC778	—	—	—
3.0	2983	V6	1995	2006	Self Adjusting Clutch	KFM30	228	9	1	23	MC367	SC778	—	—	—
<i>B4000</i>															
4.0	4016	V6	1994	1998	—	07096	254	10	1-1/16	23	MC367	SC778	—	—	—
4.0	4016	V6	1999	2000	Self Adjusting Clutch	07139	257	10-1/8	1-1/16	23	MC367	SC778	—	—	—
4.0	4016	V6	2001	2008	Self Adjusting Clutch	FMK1000	257	10-1/8	1	23	MC367	SC778	—	—	—
<i>CX-5</i>															
2.0	1998	L4	2012	2014	—	MZK1016	230	9-1/16	1	23	—	—	—	—	—
<i>MPV</i>															
2.6	2606	L4	1989	1991	—	10034	250	9-7/8	1-1/16	23	MC220	SC622	—	—	—
3.0	2954	V6	1989	1991	—	10034	250	9-7/8	1-1/16	23	MC220	SC625	—	—	—
<i>NAVAJO</i>															
4.0	4016	V6	1991	1991	—	07077	254	10	1-1/16	23	MC353	SC783	—	—	—
4.0	4016	V6	1992	1992	From 4/92	07077	254	10	1-1/16	23	MC364	SC783	—	—	—
4.0	4016	V6	1992	1992	To 3/92	07077	254	10	1-1/16	23	MC359	SC783	—	—	—
4.0	4016	V6	1993	1994	—	07096	254	10	1-1/16	23	MC364	SC778	—	—	—
<i>TRIBUTE</i>															
2.0	1991	L4	2001	2004	—	KFM16	225	8-7/8	15/16	22	MC370	SC740	—	—	—
2.3	2299	L4	2005	2008	Sold as Kit Only, Includes CSC Hydraulic Slave Cylinder	FMK1019	240	9-7/16	1	23	—	—	—	—	—
<b>MERCEDES-BENZ</b>															
<i>190 SERIES</i>															
2.2	2197	L4	1984	1985	Diesel, Sold As Kit Only	KME02	203	8	1-1/8	26	—	—	—	—	—
2.3	2299	L4	1984	1987	8 Valve	11005	215	8-1/2	1-1/16	26	—	—	—	—	—
2.3	2299	L4	1986	1987	16 Valve	11007	211	8-5/16	1-1/8	26	—	—	—	—	—
2.3	2299	L4	1988	1988	—	11009	215	8-1/2	1-1/8	24	—	—	—	—	—
2.3	2299	L4	1991	1993	Sold As Kit Only	KME01	228	9	1-1/8	26	—	—	—	—	—
2.5	2497	L5	1986	1989	Diesel	11008	215	8-1/2	1-1/16	26	—	—	—	—	—
2.6	2599	L6	1987	1989	—	11009	215	8-1/2	1-1/8	24	—	—	—	—	—
2.6	2599	L6	1990	1990	From Chassis # F640695, Sold As Kit Only	KME01	228	9	1-1/8	26	—	—	—	—	—
2.6	2599	L6	1990	1990	To Chassis # F640694	11009	215	8-1/2	1-1/8	24	—	—	—	—	—
2.6	2599	L6	1991	1993	Sold As Kit Only	KME01	228	9	1-1/8	26	—	—	—	—	—
<i>C230</i>															
1.8	1796	L4	2003	2003	Includes Slave Cylinder, Sold As Kit Only	KME03	232	9-1/8	1-1/8	26	—	—	—	—	—
1.8	1796	L4	2004	2004	Sold as Kit Only, Includes CSC Hydraulic Slave Cylinder	BZK1000	240	9-7/16	1-1/16	26	—	—	—	—	—
1.8	1796	L4	2005	2005	Sold as Kit Only, Includes CSC Hydraulic Slave Cylinder	BZK1002	228	9	1-1/16	26	—	—	—	—	—
2.5	2496	V6	2006	2007	Sold as Kit Only, Includes CSC Hydraulic Slave Cylinder	BZK1002	228	9	1-1/16	26	—	—	—	—	—
<i>C240 SERIES</i>															
2.6	2597	V6	2001	2003	Includes Slave Cylinder, Sold As Kit Only	KME03	232	9-1/8	1-1/8	26	—	—	—	—	—
3.2	3199	V6	2003	2003	Includes Slave Cylinder, Sold As Kit Only	KME03	232	9-1/8	1-1/8	26	—	—	—	—	—
3.2	3199	V6	2004	2005	Sold as Kit Only, Includes CSC Hydraulic Slave Cylinder	BZK1003	240	9-7/16	1-1/16	26	—	—	—	—	—
<i>SLK230</i>															
2.3	2295	L4	2001	2003	Sold as Kit Only	BZK1005	228	9	1 1/16	26	—	—	—	—	—
2.3	2295	L4	2004	2004	Sold as Kit Only, Includes CSC Hydraulic Slave Cylinder	BZK1001	228	9	1-1/16	26	—	—	—	—	—



Liter	CC/IN	Cyl	Years		Application Information	Kit	Disc (mm)	Disc (in)	Spline Dia	Splines	Master Cyl	Slave Cyl	Clutch Cable	Clutch Fork	New Flywheel
			To	From											
<b>MERCEDES-BENZ CONT.</b>															
<i>SLK280</i>															
3.0	2996	V6	2006	2008	Sold as Kit Only	BZK1004	239	9 3/8	1 1/8	26	—	—	—	—	—
<i>SLK320</i>															
3.2	3199	V6	2001	2004	Sold as Kit Only, Includes CSC Hydraulic Slave Cylinder	CRK1009	240	9-7/16	1-1/8	26	—	—	—	—	—
<i>SLK350</i>															
3.5	3498	V6	2005	2008	Sold as Kit Only	BZK1004	239	9 3/8	1 1/8	26	—	—	—	—	—
<b>MERCURY</b>															
<i>BOBCAT</i>															
2.3	140	L4	1975	1980	—	07003	215	8-1/2	1-1/32	23	—	—	—	—	—
<i>CALIENTE, CYCLONE, MARQUIS, MONTCLAIR, MONTEREY, PARK LANE</i>															
4.3	262	V8	1964	1964	—	07014	254	10	1-1/16	10	—	—	—	—	—
5.0	302	V8	1968	1970	—	07014	254	10	1-1/16	10	—	—	—	—	—
5.8	354	V8	1971	1972	Diaph Clutch	KFM10	280	11	1-1/16	10	—	—	—	—	—
5.8	354	V8	1971	1972	Lever Clutch	07027L	280	11	1-1/16	10	—	—	—	—	—
6.4	391	V8	1962	1970	Diaph Clutch	KFM10	280	11	1-1/16	10	—	—	—	—	—
6.4	391	V8	1962	1970	Lever Clutch	07027L	280	11	1-1/16	10	—	—	—	—	—
<i>CAPRI</i>															
1.6	98	L4	1991	1994	Non-Turbo	10040	200	7-7/8	7/8	20	—	SC607	—	—	—
1.6	98	L4	1991	1994	Turbo	10029	225	8-7/8	15/16	22	—	—	—	—	—
2.3	140	L4	1976	1977	Ford 4 Spd, Non-Turbo, 10 Spline Disc	07006	215	8-7/16	1-1/16	10	—	—	—	—	—
2.3	140	L4	1979	1979	Turbo	07006	215	8-7/16	1-1/16	10	—	—	—	—	—
2.3	140	L4	1979	1986	Non-Turbo, 4 Spd, 23 Spline Disc	07003	215	8-1/2	1-1/32	23	—	—	—	—	—
2.3	140	L4	1980	1983	Ford 4 Spd, Non-Turbo, 10 Spline Disc	07030	215	8-7/16	1-1/16	10	—	—	—	—	—
2.3	140	L4	1981	1981	5 Spd, Non-Turbo, 10 Spline Disc, 10/1/80-11/30/80	07006	215	8-7/16	1-1/16	10	—	—	—	—	—
2.3	140	L4	1981	1983	5 Spd, Non-Turbo, 23 Spline Disc, From 12/1/80	07029	215	8-1/2	1-1/16	23	—	—	—	—	—
2.3	140	L4	1982	1983	Turbo	07006	215	8-7/16	1-1/16	10	—	—	—	—	—
2.3	140	L4	1983	1985	5 Spd, 10 Spline Disc	07038	225	8-7/8	1-1/16	10	—	—	CC315	—	—
2.3	140	L4	1986	1986	3 Spd, 10 Spline Disc	07038	225	8-7/8	1-1/16	10	—	—	CC315	—	—
3.3	201	L6	1979	1982	—	07003	215	8-1/2	1-1/32	23	—	—	—	—	—
5.0	302	V8	1979	1979	—	07005	254	10	1-1/16	10	—	—	—	—	—
5.0	302	V8	1982	1985	—	07005	254	10	1-1/16	10	—	—	CC318	—	—
5.0	302	V8	1986	1986	Heavy Duty, Sold As Kit Only	KFM08HP	265	10-1/2	1-1/16	10	—	—	CC318	—	FWFM112
5.0	302	V8	1986	1986	Standard	07042	265	10-1/2	1-1/16	10	—	—	CC318	—	FWFM112
<i>COMET</i>															
4.1	250	L6	1974	1977	—	07016	254	10	1-1/16	10	—	—	—	—	—
4.3	262	V8	1963	1964	—	07014	254	10	1-1/16	10	—	—	—	—	—
4.7	287	V8	1966	1967	—	07014	254	10	1-1/16	10	—	—	—	—	—
5.0	302	V8	1968	1969	—	07014	254	10	1-1/16	10	—	—	—	—	—
5.0	302	V8	1971	1974	—	07014	254	10	1-1/16	10	—	—	—	—	—
5.0	302	V8	1975	1977	—	07016	254	10	1-1/16	10	—	—	—	—	—
5.8	354	V8	1969	1969	Diaph Clutch	KFM10	280	11	1-1/16	10	—	—	—	—	FWFM113
5.8	354	V8	1969	1969	Heavy Duty Diaph Clutch	KFM10HP	280	11	1-1/16	10	—	—	—	—	FWFM113
5.8	354	V8	1969	1969	Lever Clutch	07027L	280	11	1-1/16	10	—	—	—	—	FWFM113
6.4	391	V8	1966	1969	Diaph Clutch	KFM10	280	11	1-1/16	10	—	—	—	—	FWFM113
6.4	391	V8	1966	1969	Heavy Duty Diaph Clutch	KFM10HP	280	11	1-1/16	10	—	—	—	—	FWFM113
6.4	391	V8	1966	1969	Lever Clutch	07027L	280	11	1-1/16	10	—	—	—	—	FWFM113
<i>COUGAR</i>															
2.0	122	L4	1999	2002	Includes Slave Cylinder	07136	240	9-1/2	1	23	MC119	—	—	—	—
2.3	140	L4	1985	1986	Turbo	07038	225	8-7/8	1-1/16	10	—	—	CC315	—	—
2.5	153	V6	1999	2002	Includes Slave Cylinder	07137	240	9-1/2	1	23	MC119	—	—	—	—
2.5	153	V6	1999	2002	Kit does not include Slave Cylinder	07137LB	240	9-1/2	1	23	MC119	—	—	—	—
4.7	287	V8	1967	1968	—	07014	254	10	1-1/16	10	—	—	—	—	—
5.0	302	V8	1968	1970	—	07014	254	10	1-1/16	10	—	—	—	—	—
5.8	354	V8	1969	1973	Diaph Clutch with External Balance Flywheel	KFM10	280	11	1-1/16	10	—	—	—	—	FWFM116
5.8	354	V8	1969	1973	Heavy Duty Diaph Clutch with External Balance Flywheel	KFM10HP	280	11	1-1/16	10	—	—	—	—	FWFM116
5.8	354	V8	1969	1973	Heavy Duty Diaph Clutch with Internal Balance Flywheel	KFM10HP	280	11	1-1/16	10	—	—	—	—	FWFM113

Liter	CC/IN	Cyl	Years		Application Information	Kit	Disc (mm)	Disc (in)	Spline Dia	Splines	Master Cyl	Slave Cyl	Clutch Cable	Clutch Fork	New Flywheel
			To	From											
<b>MERCURY CONT.</b>															
<i>COUGAR CONT.</i>															
5.8	354	V8	1969	1973	Lever Clutch with Internal Balance Flywheel	07027L	280	11	1-1/16	10	—	—	—	—	FWFM113
6.4	391	V8	1967	1969	Diaph Clutch	KFM10	280	11	1-1/16	10	—	—	—	—	FWFM113
6.4	391	V8	1967	1969	Heavy Duty Diaph Clutch	KFM10HP	280	11	1-1/16	10	—	—	—	—	FWFM113
6.4	391	V8	1967	1969	Lever Clutch	07027L	280	11	1-1/16	10	—	—	—	—	FWFM113
<i>LYNX, LN7</i>															
1.6	98	L4	1981	1982	—	07002	200	7-7/8	7/8	20	—	—	—	—	—
1.9	116	L4	1985	1987	—	07010	215	8-7/16	7/8	20	—	—	—	—	—
<i>MILAN</i>															
2.3	140	L4	2006	2009	Sold As Kit Only	FMK1004	225	8-7/8	15/16	22	MC221	SC877	—	—	—
<i>MONARCH</i>															
4.1	250	L6	1975	1980	—	07016	254	10	1-1/16	10	—	—	—	—	—
5.0	302	V8	1977	1979	3 Spd	07016	254	10	1-1/16	10	—	—	—	—	—
<i>MONTEGO</i>															
4.1	250	L6	1969	1973	—	07014	254	10	1-1/16	10	—	—	—	—	—
5.0	302	V8	1969	1974	—	07014	254	10	1-1/16	10	—	—	—	—	—
5.8	354	V8	1969	1974	Diaph Clutch	KFM10	280	11	1-1/16	10	—	—	—	—	FWFM113
5.8	354	V8	1969	1974	Heavy Duty Diaph Clutch	KFM10HP	280	11	1-1/16	10	—	—	—	—	FWFM113
5.8	354	V8	1969	1974	Lever Clutch	07027L	280	11	1-1/16	10	—	—	—	—	FWFM113
6.4	391	V8	1968	1969	Diaph Clutch	KFM10	280	11	1-1/16	10	—	—	—	—	FWFM113
6.4	391	V8	1968	1969	Heavy Duty Diaph Clutch	KFM10HP	280	11	1-1/16	10	—	—	—	—	FWFM113
6.4	391	V8	1968	1969	Lever Clutch	07027L	280	11	1-1/16	10	—	—	—	—	FWFM113
<i>MYSTIQUE</i>															
2.0	122	L4	1995	2000	Includes Slave Cylinder	07136	240	9-1/2	1	23	MC119	—	—	—	—
2.5	153	V6	1995	2000	Includes Slave Cylinder	07137	240	9-1/2	1	23	—	—	—	—	FWFMC01
2.5	153	V6	1995	2000	Kit does not include Slave Cylinder	07137LB	240	9-1/2	1	23	—	—	—	—	FWFMC01
<i>TOPAZ</i>															
2.3	140	L4	1984	1987	—	07010	215	8-7/16	7/8	20	—	—	—	—	—
2.3	140	L4	1988	1994	—	07069	215	8-7/16	7/8	20	—	—	—	—	—
<i>TRACER</i>															
1.6	98	L4	1987	1989	—	10018	190	7-1/2	7/8	20	—	—	—	—	—
1.8	110	L4	1991	1996	—	07074	215	8-7/16	15/16	22	MC221	SC629	—	—	—
1.9	116	L4	1991	1996	—	07075	200	7-7/8	7/8	20	MC221	SC839	—	—	—
2.0	122	L4	1997	1997	—	07083	225	8-7/8	15/16	22	MC221	SC877	—	—	—
2.0	122	L4	1998	1998	—	07083	225	8-7/8	15/16	22	MC221	—	—	—	—
<i>ZEPHYR</i>															
2.3	140	L4	1978	1983	—	07003	215	8-1/2	1-1/32	23	—	—	—	—	—
3.3	201	L6	1978	1981	—	07003	215	8-1/2	1-1/32	23	—	—	—	—	—
5.0	302	V8	1978	1978	—	07016	254	10	1-1/16	10	—	—	—	—	—
5.0	302	V8	1979	1979	—	07005	254	10	1-1/16	10	—	—	—	—	—
<b>MERKUR</b>															
<i>SCORPIO</i>															
2.9	177	V6	1988	1989	—	07088	240	9-1/2	1	23	—	—	—	—	—
<i>XR4TI</i>															
2.3	140	L4	1985	1989	Turbo	07039	228	9	1	23	—	—	—	—	—
<b>MG</b>															
<i>MGB, MGB GT</i>															
1.8	1798	L4	1963	1980	Sold As Kit Only	KMG04	200	7-7/8	1	23	MC491	SC888	—	—	—
1.8	1798	L4	1981	1981	Sold As Kit Only	KMG04	200	7-7/8	1	23	—	—	—	—	—
<b>MINI (Performance Applications Available)</b>															
<i>COOPER</i>															
1.6	1600	L4	2002	2004	5 Spd, Sold As Kit Only	BMK1000	200	7-7/8	13/16	18	—	—	—	—	—
1.6	1600	L4	2005	2005	From 7/04, Sold as Kit Only	BMK1013	200	7-7/8	13/16	17	—	—	—	—	—
1.6	1600	L4	2006	2007	From 11/06, Sold as Kit Only	BMK1014	200	7-7/8	3/4	17	—	—	—	—	—
<i>COOPER S</i>															
1.6	1600	L4	2002	2008	6 Spd Supercharged, Sold as Kit Only, Fits Dual Mass FW	BMK1001	215	8-1/2	1	14	—	—	—	—	—
1.6	1600	L4	2002	2008	6 Spd Supercharged, Solid FW Conversion, Sold as Kit Only, Includes Solid FW	BMK1001FW	215	8-1/2	1	14	—	—	—	—	—

Liter	CC/IN	Cyl	Years		Application Information	Kit	Disc (mm)	Disc (in)	Spline Dia	Splines	Master Cyl	Slave Cyl	Clutch Cable	Clutch Fork	New Flywheel
			To	From											
<b>MITSUBISHI (Performance Applications Available)</b>															
<b>3000GT</b>															
3.0	2972	V6	1991	1991	Turbo, 1/1/91 - 1/31/91, Sold As Kit Only	05075	250	9-7/8	1	23	MC544	SC582	—	—	—
3.0	2972	V6	1991	1999	Non-Turbo, Sold As Kit Only	05048	225	8-7/8	7/8	20	MC543	SC837	—	—	—
3.0	2972	V6	1992	1999	Turbo, Sold As Kit Only	05075	250	9-7/8	1	23	MC544	SC588	—	—	—
<b>CORDIA, TREDIA</b>															
1.8	1795	L4	1983	1983	—	05026	200	7-7/8	7/8	20	MC194	—	—	—	—
1.8	1795	L4	1984	1988	Turbo	05026	200	7-7/8	7/8	20	MC194	SC582	—	—	—
2.0	1997	L4	1984	1988	—	05026	200	7-7/8	7/8	20	MC194	—	—	—	—
<b>ECLIPSE</b>															
1.8	1755	L4	1990	1990	Without Speed Control	05026	200	7-7/8	7/8	20	MC529	SC580	—	—	—
1.8	1755	L4	1990	1994	With Speed Control	05026	200	7-7/8	7/8	20	MC180	SC581	—	—	—
2.0	1997	L4	1990	1990	2 WD Non-Turbo without Speed Control	05051	215	8-1/2	7/8	20	MC529	SC580	—	—	—
2.0	1997	L4	1990	1990	2 WD, GS Turbo without Speed Control, Sold As Kit Only	05048	225	8-7/8	7/8	20	MC529	SC820	—	—	—
2.0	1997	L4	1990	1992	4 WD, Turbo GSX	05071	225	8-7/8	7/8	20	MC180	SC587	—	—	—
2.0	1997	L4	1990	1994	2 WD Non-Turbo with Speed Control	05051	215	8-1/2	7/8	20	MC180	SC581	—	—	—
2.0	1997	L4	1990	1994	2 WD, GS Turbo with Speed Control, Sold As Kit Only	05048	225	8-7/8	7/8	20	MC180	SC581	—	—	—
2.0	1997	L4	1993	1993	4 WD, Turbo GSX, Sold As Kit Only	05048	225	8-7/8	7/8	20	MC180	SC587	—	—	—
2.0	1997	L4	1994	1999	4 WD, Turbo GSX, Sold As Kit Only	05048	225	8-7/8	7/8	20	MC188	SC589	—	—	—
2.0	1997	L4	1995	1998	GST, Sold As Kit Only	05048	225	8-7/8	7/8	20	MC401	SC581	—	—	—
2.0	1997	L4	1995	1999	2 WD, Non-Turbo, Modular Clutch Includes Flywheel	05085	230	9-1/16	15/16	17	MC401	SC761	—	—	—
2.4	2351	L4	1996	1999	Sold As Kit Only	05048	225	8-7/8	7/8	20	MC188	SC589	—	—	—
2.4	2351	L4	2000	2005	Sold As Kit Only	MBK1000	225	8-7/8	7/8	20	MC565	SC593	—	—	—
2.4	2378	L4	2006	2012	Sold as Kit Only	MBK1010	230	9	7/8	20	—	SC593	—	—	—
3.0	2972	V6	2000	2005	Sold As Kit Only, Silent Design Disc, Pull Type, Flat Flywheel, GT	KMB02	225	8-7/8	1	23	MC564	SC854	—	—	—
3.0	2972	V6	2003	2005	GTS, Sold As Kit Only, Silent Design Disc, Pull Type, Flat Flywheel, Sold As Kit Only	MBK1003	232	9-1/16	1	23	MC564	SC854	—	—	—
3.8	232	V6	2006	2010	Sold as Kit Only, Includes CSC Hydraulic Slave Cylinder	MBK1015	240	9-7/16	1	23	—	BRG0162	—	—	—
<b>GALANT</b>															
2.0	1997	L4	1989	1989	GS SOHC	05051	215	8-1/2	7/8	20	MC179	SC581	—	—	—
2.0	1997	L4	1989	1992	—	05051	215	8-1/2	7/8	20	MC529	SC580	—	—	—
2.0	1997	L4	1990	1991	GSX DOHC AWD	05051	215	8-1/2	7/8	20	MC179	SC584	—	—	—
2.0	1997	L4	1990	1992	GS, GSR DOHC	05071	225	8-7/8	7/8	20	MC179	SC581	—	—	—
2.0	1997	L4	1991	1992	VR4 AWD Turbo, Sold As Kit Only	05048	225	8-7/8	7/8	20	MC179	SC584	—	—	—
2.0	1997	L4	1992	1992	GSX DOHC AWD	05071	225	8-7/8	7/8	20	MC179	SC584	—	—	—
2.0	1997	L4	1993	1993	LS SOHC	05051	215	8-1/2	7/8	20	MC529	SC580	—	—	—
2.4	2351	L4	1987	1987	—	05056	225	8-7/8	7/8	20	MC177	SC580	—	—	—
2.4	2351	L4	1994	1998	Sold As Kit Only	05048	225	8-7/8	7/8	20	MC536	SC589	—	—	—
<b>LANCER</b>															
2.0	2000	L4	2002	2003	Does not include Hydraulic CSC, Sold As Kit Only	MBK1004LB	215	8-1/2	7/8	20	MC520	—	—	—	—
2.0	2000	L4	2002	2003	Includes Slave Cylinder, Sold As Kit Only	MBK1004	215	8-1/2	7/8	20	MC520	—	—	—	—
2.0	2000	L4	2003	2006	Pull Type, Turbo Evolution, Sold As Kit Only	MBK1001	240	9-1/2	1	23	MC520	SC854	—	—	—
2.0	2000	L4	2004	2006	Sold as kit only	MBK1008	215	8-1/2	7/8	20	MC520	SC593	—	—	—
2.0	1998	L4	2008	2010	Sold as Kit Only, Includes CSC Hydraulic Slave Cylinder	MBK1011	225	8-7/8	7/8	20	—	—	—	—	—
2.0	1998	L4	2008	2008	Pull Type, Turbo Evolution, Sold As Kit Only	MBK1009	240	9-1/2	1	23	—	—	—	—	—
2.4	2400	L4	2004	2006	Sold as kit only	MBK1007	228	9	7/8	20	MC522	SC844	—	—	—
2.4	2400	L4	2009	2010	Sold as Kit Only, Includes CSC Hydraulic Slave Cylinder	MBK1018	230	9	7/8	20	—	BRG0162	—	—	—
<b>MIRAGE</b>															
1.5	1468	L4	1985	1987	4 Spd, To 3/31/88	05022	200	7-7/8	7/8	20	—	—	—	—	—
1.5	1468	L4	1985	1987	5 Spd, To 3/31/88	05023	184	7-1/4	7/8	20	—	—	—	—	—
1.5	1468	L4	1988	1988	5 Spd, To 3/31/88	05023	184	7-1/4	7/8	20	MC178	SC584	—	—	—
1.5	1468	L4	1988	1991	4 Spd, To 3/31/88	05022	200	7-7/8	7/8	20	MC178	SC580	—	—	—
1.5	1468	L4	1989	1992	5 Spd	05026	200	7-7/8	7/8	20	MC178	SC584	—	—	—
1.5	1468	L4	1993	1996	5 Spd	05026	200	7-7/8	7/8	20	MC193	SC589	—	—	—
1.5	1468	L4	1997	2002	5 Spd	05026	200	7-7/8	7/8	20	MC193	SC593	—	—	—
1.6	1597	L4	1985	1987	5 Spd Turbo	05022	200	7-7/8	7/8	20	MC194	SC580	—	—	—
1.6	1597	L4	1988	1988	5 Spd Turbo, To 3/31/88	05022	200	7-7/8	7/8	20	MC194	SC580	—	—	—

Liter	CC/IN	Cyl	Years		Application Information	Kit	Disc (mm)	Disc (in)	Spline Dia	Splines	Master Cyl	Slave Cyl	Clutch Cable	Clutch Fork	New Flywheel
			To	From											
<b>MITSUBISHI (Performance Applications Available) CONT.</b>															
<i>MIRAGE CONT.</i>															
1.6	1597	L4	1988	1989	5 Spd Turbo, From 4/1/86	05051	215	8-1/2	7/8	20	MC178	SC581	—	—	—
1.6	1597	L4	1991	1992	—	05022	200	7-7/8	7/8	20	MC178	SC581	—	—	—
1.8	1834	L4	1993	1996	—	05051	215	8-1/2	7/8	20	MC178	SC589	—	—	—
1.8	1834	L4	1997	2002	—	05051	215	8-1/2	7/8	20	MC193	SC593	—	—	—
<i>PRECIS</i>															
1.5	1468	L4	1987	1988	—	05023	184	7-1/4	7/8	20	—	—	CC550	—	—
1.5	1468	L4	1989	1989	From 7/1/89	05022	200	7-7/8	7/8	20	MC178	SC580	—	—	—
1.5	1468	L4	1989	1989	To 6/30/89	05023	184	7-1/4	7/8	20	—	—	CC550	—	—
1.5	1468	L4	1990	1994	—	05022	200	7-7/8	7/8	20	MC178	SC580	—	—	—
<i>SIGMA</i>															
3.0	2972	V6	1988	1988	—	05056	225	8-7/8	7/8	20	—	SC580	—	—	—
<i>STARION</i>															
2.6	2555	L4	1983	1987	Non Intercooled Turbo	05025	225	8-7/8	1-1/32	23	MC175	SC579	—	—	—
2.6	2555	L4	1985	1987	Intercooled Turbo, To 5/31/87	05046	225	8-7/8	1-1/32	23	MC175	SC579	—	—	—
2.6	2555	L4	1987	1989	Intercooled Turbo, From 6/1/87	05049	240	9-1/2	1-1/16	23	MC175	SC579	—	—	—
<b>MITSUBISHI LIGHT TRUCK &amp; SUV</b>															
<i>EXPO, EXPO LRV</i>															
1.8	1834	L4	1992	1994	—	05051	215	8-1/2	7/8	20	—	SC589	—	—	—
2.4	2351	L4	1992	1992	Sold As Kit Only	05048	225	8-7/8	7/8	20	—	SC584	—	—	—
2.4	2351	L4	1993	1995	Sold As Kit Only	05048	225	8-7/8	7/8	20	—	SC589	—	—	—
<i>MIGHTY MAX</i>															
2.0	1997	L4	1983	1986	—	05011	215	8-7/16	7/8	23	—	—	—	—	—
2.0	1997	L4	1987	1989	—	05011	215	8-7/16	7/8	23	—	—	CC815	—	—
2.3	2346	L4	1983	1983	Turbo Diesel From 10/83	05025	225	8-7/8	1-1/32	23	MC176	SC579	—	—	—
2.3	2346	L4	1983	1983	Turbo Diesel To 9/83	05025	225	8-7/8	1-1/32	23	MC194	SC579	—	—	—
2.3	2346	L4	1984	1985	Turbo Diesel	05025	225	8-7/8	1-1/32	23	MC176	SC579	—	—	—
2.4	2351	L4	1990	1993	—	05041	225	8-7/8	1-1/32	23	—	—	CC815	—	—
2.4	2351	L4	1994	1996	—	05041	225	8-7/8	1-1/32	23	—	—	—	—	—
2.6	2555	L4	1983	1986	—	05025	225	8-7/8	1-1/32	23	—	—	—	—	—
2.6	2555	L4	1987	1989	—	05041	225	8-7/8	1-1/32	23	—	—	CC815	—	—
3.0	2972	V6	1990	1994	—	05050	240	9-1/2	1-1/8	14	MC176	SC585	—	—	—
<i>MONTERO, MONTERO SPORT</i>															
2.4	2351	L4	1997	1999	—	05041	225	8-7/8	1-1/32	23	MC505	SC579	—	—	—
2.6	2555	L4	1983	1985	—	05025	225	8-7/8	1-1/32	23	MC497	SC579	—	—	—
2.6	2555	L4	1986	1986	—	05046	225	8-7/8	1-1/32	23	MC194	SC579	—	—	—
2.6	2555	L4	1987	1989	—	05052	225	8-7/8	1-1/32	23	MC194	SC579	—	—	—
3.0	2972	V6	1989	1990	—	05050	240	9-1/2	1-1/8	14	MC194	SC585	—	—	—
3.0	2972	V6	1991	1991	From 10/91	05050	240	9-1/2	1-1/8	14	MC528	SC835	—	—	—
3.0	2972	V6	1991	1991	To 9/91	05050	240	9-1/2	1-1/8	14	MC497	SC585	—	—	—
3.0	2972	V6	1992	1996	—	05050	240	9-1/2	1-1/8	14	MC528	SC591	—	—	—
3.0	2972	V6	1997	1999	—	05050	240	9-1/2	1-1/8	14	MC505	SC591	—	—	—
3.5	3497	V6	1997	1997	—	05050	240	9-1/2	1-1/8	14	MC528	SC845	—	—	—
<i>OUTLANDER</i>															
2.4	2378	L4	2005	2005	Sold as kit only	MBK1007	228	9	7/8	20	MC522	SC593	—	—	—
2.4	2378	L4	2006	2006	—	MBK1014	228	9	7/8	20	MC522	SC593	—	—	—
<b>NISSAN</b>															
<i>1200</i>															
1.2	1171	L4	1971	1973	—	06016	184	7-1/4	13/16	18	—	SC558	—	—	—
<i>200SX</i>															
1.6	1597	L4	1995	1998	—	06040	190	7-1/2	13/16	18	—	—	—	—	—
1.8	1809	L4	1984	1987	Turbo	06028	225	8-7/8	1	24	MC167	SC560	—	—	—
2.0	1952	L4	1977	1978	—	06008	200	7-7/8	1	24	MC152	SC560	—	—	—
2.0	1952	L4	1979	1979	To 5/79	06008	200	7-7/8	1	24	MC153	SC560	—	—	—
2.0	1952	L4	1979	1981	From 6/79	06008	200	7-7/8	1	24	MC152	SC560	—	CF114	—
2.0	1974	L4	1984	1988	—	06037	225	8-7/8	1	24	MC167	SC560	—	—	—



Liter	CC/IN	Cyl	Years		Application Information	Kit	Disc (mm)	Disc (in)	Spline Dia	Splines	Master Cyl	Slave Cyl	Clutch Cable	Clutch Fork	New Flywheel
			To	From											
<b>NISSAN CONT.</b>															
<i>200SX CONT.</i>															
2.0	1998	L4	1995	1998	—	KNS02	215	8-1/2	13/16	18	—	—	—	—	—
2.2	2187	L4	1982	1983	—	06004	225	8-7/8	1	24	MC153	SC560	—	—	—
3.0	2960	V6	1987	1988	—	06031	240	9-1/2	1	24	MC153	SC572	—	—	—
<i>210</i>															
1.2	1237	L4	1979	1982	—	06001	184	7-1/4	13/16	18	MC153	SC558	—	—	—
1.4	1393	L4	1979	1982	—	06001	184	7-1/4	13/16	18	MC153	SC558	—	—	—
1.5	1488	L4	1980	1982	—	06001	184	7-1/4	13/16	18	MC153	SC558	—	—	—
<i>240SX</i>															
2.4	2389	L4	1989	1990	—	06009	225	8-7/8	1	24	MC153	SC560	—	—	—
2.4	2389	L4	1991	1998	—	06054	225	8-7/8	1	24	MC153	SC563	—	—	—
<i>240Z</i>															
2.4	2393	L6	1970	1972	To 6/72	06029	225	8-7/8	1	24	MC169	SC571	—	—	—
2.4	2393	L6	1972	1972	From 7/72	06029	225	8-7/8	1	24	MC169	SC559	—	—	—
2.4	2393	L6	1973	1973	—	06029	225	8-7/8	1	24	MC169	SC563	—	—	—
<i>260Z</i>															
2.6	2565	L6	1974	1975	—	06029	225	8-7/8	1	24	MC169	SC559	—	—	—
<i>280Z</i>															
2.8	2753	L6	1975	1975	2 Seater To 3/75	06009	225	8-7/8	1	24	MC169	SC559	—	—	—
2.8	2753	L6	1975	1978	2 Seater From 4/75	06009	225	8-7/8	1	24	MC166	SC559	—	—	—
2.8	2753	L6	1975	1975	2+2 To 3/75	06030	240	9-1/2	1	24	MC169	SC559	—	—	—
2.8	2753	L6	1975	1978	2+2 From 4/75	06030	240	9-1/2	1	24	MC166	SC559	—	—	—
<i>280ZX</i>															
2.8	2753	L6	1979	1983	2 Seater Non-Turbo	06009	225	8-7/8	1	24	MC153	SC563	—	—	—
2.8	2753	L6	1979	1983	2+2 Non-Turbo	06030	240	9-1/2	1	24	MC153	SC563	—	—	—
2.8	2753	L6	1981	1983	Turbo	06032	240	9-1/2	1	24	MC168	SC563	—	—	—
<i>300ZX</i>															
3.0	2960	V6	1984	1989	Non-Turbo To 1/30/89	06031	240	9-1/2	1	24	MC168	SC572	—	CF114	—
3.0	2960	V6	1984	1986	Turbo	06032	240	9-1/2	1	24	MC168	SC572	—	—	—
3.0	2960	V6	1987	1989	Turbo	06055	250	9-7/8	1	24	MC168	SC572	—	CF114	—
3.0	2960	V6	1989	1996	Non-Turbo From 2/1/89	06045	240	9-1/2	1	24	—	SC572	—	—	—
3.0	2960	V6	1990	1990	Twin Turbo	06046	250	9-7/8	1	24	MC507	SC572	—	—	—
3.0	2960	V6	1991	1991	Twin Turbo	06046	250	9-7/8	1	24	—	SC572	—	—	—
3.0	2960	V6	1992	1992	Twin Turbo	06046	250	9-7/8	1	24	MC506	SC572	—	—	—
3.0	2960	V6	1993	1994	Twin Turbo	06046	250	9-7/8	1	24	—	SC572	—	—	—
3.0	2960	V6	1995	1996	Twin Turbo	06046	250	9-7/8	1	24	MC506	SC572	—	—	—
<i>310</i>															
1.5	1488	L4	1981	1981	From 8/81	06021	184	7-1/4	13/16	18	MC153	—	—	—	—
1.5	1488	L4	1982	1982	—	06021	184	7-1/4	13/16	18	—	—	—	—	—
<i>350Z</i>															
3.5	3498	V6	2003	2006	Sold As Kit Only	NSK1000	250	9-7/8	1	24	—	—	—	—	—
3.5	3498	V6	2003	2006	Sold As Kit Only, Solid FW Conversion for OEM Dual Mass FW, Economy version	NSK1000FW	250	9-7/8	1	24	—	—	—	—	—
3.5	3498	V6	2007	2009	Dual Mass Flywheel Conversion, Will only work with EXEDY cover and disc, VQ35HR, Sold as Kit Only, Includes Solid Flywheel, Includes CSC Hydraulic Slave	NSK1024FW	250	9-7/8	1	24	—	BRG0163	—	—	—
<i>370Z</i>															
3.7	3696	V6	2009	2011	Dual Mass Flywheel Conversion, Will only work with EXEDY cover and disc, VQ35HR, Sold as Kit Only, Includes Solid Flywheel, Includes CSC Hydraulic Slave	NSK1024FW	250	9-7/8	1	24	—	BRG0163	—	—	—
<i>411</i>															
1.6	1595	L4	1967	1967	—	06022	200	7-7/8	1	24	—	—	—	—	—
<i>510</i>															
1.6	1595	L4	1968	1969	To 2/69	06020	200	7-7/8	1	24	MC161	SC569	—	—	—
1.6	1595	L4	1969	1973	From 3/69	06020	200	7-7/8	1	24	MC165	SC569	—	—	—
2.0	1952	L4	1978	1981	—	06008	200	7-7/8	1	24	MC151	SC560	—	—	—
<i>610</i>															
1.8	1770	L4	1973	1973	—	06020	200	7-7/8	1	24	MC165	SC563	—	—	—
2.0	1952	L4	1974	1975	To 10/75	06008	200	7-7/8	1	24	MC165	SC559	—	—	—
2.0	1952	L4	1975	1976	From 11/75	06008	200	7-7/8	1	24	MC166	SC559	—	—	—
<i>710</i>															
1.8	1770	L4	1974	1974	—	06008	200	7-7/8	1	24	MC165	SC563	—	—	—
2.0	1952	L4	1975	1977	—	06008	200	7-7/8	1	24	MC151	SC563	—	—	—

Liter	CC/IN	Cyl	Years		Application Information	Kit	Disc (mm)	Disc (in)	Spline Dia	Splines	Master Cyl	Slave Cyl	Clutch Cable	Clutch Fork	New Flywheel
			To	From											
<b>NISSAN CONT.</b>															
<b>810</b>															
2.4	2393	L6	1977	1980	—	06034	225	8-7/8	1	24	MC151	SC563	—	—	—
2.4	2393	L6	1981	1981	—	06034	225	8-7/8	1	24	MC153	SC563	—	—	—
2.8	2793	L6	1981	1981	Diesel	06034	225	8-7/8	1	24	MC153	SC563	—	—	—
<b>ALTIMA</b>															
2.4	2389	L4	1993	1997	—	KNS04	225	8-7/8	1	24	MC500	SC565	—	—	—
2.4	2389	L4	1998	2001	—	KNS06	225	8-7/8	1	24	MC549	SC565	—	—	—
2.5	2500	L4	2002	2006	—	NSK1003	240	9-1/2	1	24	MC541	SC864	—	—	—
2.5	2500	L4	2007	2011	Sold as Kit Only, Includes CSC Hydraulic Slave Cylinder	NSK1008	240	9-1/2	15/16	21	—	BRG0166	—	—	—
3.5	3498	V6	2002	2003	Sold As Kit Only	NSK1002	240	9-1/2	1	24	MC541	SC864	—	—	—
3.5	3498	V6	2004	2006	Sold As Kit Only	NSK1002	240	9-1/2	1	24	MC541	SC865	—	—	—
<b>B210</b>															
1.4	1393	L4	1975	1975	4 Spd,7-1/8"	06018	180	7-1/8	1	18	MC165	SC558	—	—	—
1.4	1393	L4	1975	1978	4 Spd,7-1/4"	06001	184	7-1/4	13/16	18	MC467	SC558	—	—	—
1.4	1393	L4	1976	1976	4 Spd,7-1/8"	06018	180	7-1/8	1	18	MC467	SC558	—	—	—
1.4	1393	L4	1977	1978	4 Spd,7-1/8"	06018	180	7-1/8	1	18	MC152	SC560	—	—	—
<b>MAXIMA</b>															
2.4	2393	L6	1982	1984	—	06034	225	8-7/8	1	24	—	SC563	—	—	—
3.0	2960	V6	1985	1988	—	06044	240	9-1/2	1	24	MC153	SC562	—	—	—
3.0	2960	V6	1989	1993	—	06044	240	9-1/2	1	24	MC168	SC565	—	—	—
3.0	2960	V6	1994	1994	To 1/94	06044	240	9-1/2	1	24	MC153	SC565	—	—	—
3.0	2960	V6	1994	1994	From 2/94	06044	240	9-1/2	1	24	MC547	SC851	—	—	—
3.0	2988	V6	1995	1999	To 3/99	06044	240	9-1/2	1	24	MC160	SC565	—	—	—
3.0	2988	V6	1999	2001	From 4/99	06044	240	9-1/2	1	24	MC162	SC565	—	—	—
3.5	3498	V6	2002	2003	Sold As Kit Only	NSK1002	240	9-1/2	1	24	MC545	SC864	—	—	—
3.5	3498	V6	2004	2006	Sold As Kit Only	NSK1002	240	9-1/2	1	24	MC541	SC864	—	—	—
<b>MICRA (CANADA)</b>															
1.2	1229	L4	1984	1991	—	06041	160	6-5/16	11/16	16	—	—	CC806	—	—
<b>NX</b>															
1.6	1597	L4	1991	1993	—	06040	190	7-1/2	13/16	18	—	—	—	—	—
2.0	1998	L4	1991	1993	—	KNS02	215	8-1/2	13/16	18	—	—	—	—	—
<b>PULSAR</b>															
1.5	1488	L4	1983	1984	Turbo	06007	200	7-7/8	13/16	18	—	—	CC800	—	—
1.6	1597	L4	1983	1986	SOHC	06021	184	7-1/4	13/16	18	—	—	CC800	—	—
1.6	1597	L4	1987	1987	DOHC	06049	200	7-7/8	13/16	18	—	—	CC807	—	—
1.6	1597	L4	1987	1990	SOHC	06040	190	7-1/2	13/16	18	—	—	CC806	—	—
1.8	1809	L4	1988	1989	DOHC	06050	215	8-7/16	1	24	—	SC655	CC806	—	—
<b>SENTRA</b>															
1.5	1488	L4	1982	1983	—	06021	184	7-1/4	13/16	18	—	—	—	—	—
1.6	1597	L4	1983	1985	—	06021	184	7-1/4	13/16	18	—	—	—	—	—
1.6	1597	L4	1986	1987	—	06040	190	7-1/2	13/16	18	—	—	CC807	—	—
1.6	1597	L4	1988	1988	To 7/88	06040	190	7-1/2	13/16	18	—	—	CC807	—	—
1.6	1597	L4	1989	1990	—	06040	190	7-1/2	13/16	18	—	—	—	—	—
1.6	1597	L4	1990	1990	4 WD Canada	06007	200	7-7/8	13/16	18	—	—	—	—	—
1.6	1597	L4	1991	1991	—	06040	190	7-1/2	13/16	18	—	—	CC810	—	—
1.6	1597	L4	1991	1991	Canada	06040	190	7-1/2	13/16	18	—	—	CC810	—	—
1.6	1597	L4	1992	1993	Canada	06040	190	7-1/2	13/16	18	—	—	—	—	—
1.6	1597	L4	1992	1994	—	06040	190	7-1/2	13/16	18	—	—	—	—	—
1.6	1597	L4	1995	1999	—	KNS05	190	7-1/2	13/16	18	—	—	—	—	—
1.7	1688	L4	1983	1986	Diesel	06021	184	7-1/4	13/16	18	—	—	—	—	—
1.7	1688	L4	1987	1987	Diesel Canada	06048	190	7-1/2	13/16	18	—	—	—	—	—
1.8	1809	L4	2000	2000	—	KNS02	215	8-1/2	13/16	18	—	—	—	—	—
1.8	1809	L4	2001	2006	—	KNS02	215	8-1/2	13/16	18	MC542	SC760	—	—	—
2.0	1998	L4	1991	2000	—	KNS02	215	8-1/2	13/16	18	—	—	—	—	—
2.0	1998	L4	2001	2001	—	KNS02	215	8-1/2	13/16	18	MC542	SC760	—	—	—
2.0	1997	L4	2007	2011	Sold as Kit Only, Includes CSC Hydraulic Slave Cylinder	NSK1009	225	8-7/8	15/16	21	—	BRG0166	—	—	—
2.5	2500	L4	2002	2006	—	NSK1003	240	9-1/2	1	24	MC542	SC864	—	—	—
2.5	2500	L4	2007	2010	SE-R Spec-V,Sold as Kit Only, Includes CSC Hydraulic Slave Cylinder	NSK1008	240	9-1/2	15/16	21	—	BRG0166	—	—	—

Liter	CC/IN	Cyl	Years		Application Information	Kit	Disc (mm)	Disc (in)	Spline Dia	Splines	Master Cyl	Slave Cyl	Clutch Cable	Clutch Fork	New Flywheel
			To	From											
<b>NISSAN CONT.</b>															
<b>STANZA</b>															
2.0	1974	L4	1982	1985	—	06007	200	7-7/8	13/16	18	—	—	—	—	—
2.0	1974	L4	1986	1986	—	06043	225	8-7/8	1	24	MC153	SC564	—	—	—
2.0	1974	L4	1987	1987	From 9/87	06043	225	8-7/8	1	24	MC153	SC565	—	—	—
2.0	1974	L4	1987	1987	To 8/87	06043	225	8-7/8	1	24	MC153	SC564	—	—	—
2.0	1974	L4	1988	1988	—	06043	225	8-7/8	1	24	MC153	SC565	—	—	—
2.4	2389	L4	1990	1992	—	06053	225	8-7/8	1	24	MC153	SC565	—	—	—
<b>VERSA</b>															
1.8	1798	L4	2007	2011	Sold as Kit Only, Includes CSC Hydraulic Slave Cylinder	NSK1009	225	8-7/8	15/16	21	—	BRG0166	—	—	—
1.8	1798	L4	2007	2011	Sold as kit only, Solid Flywheel Conversion, Includes Solid flywheel, Includes CSC Hydraulic Slave Cylinder	NSK1026FW	225	8-7/8	15/16	21	—	BRG0166	—	—	FWNS01
<b>NISSAN LIGHT TRUCK, SUV &amp; VAN</b>															
<b>520 PICKUP</b>															
1.3	1299	L4	1965	1968	—	06019	200	7-7/8	1	24	—	—	—	—	—
<b>521 PICKUP</b>															
1.3	1299	L4	1969	1969	—	06019	200	7-7/8	1	24	MC501	—	—	—	—
1.6	1595	L4	1970	1971	—	06022	200	7-7/8	1	24	MC501	—	—	—	—
1.6	1595	L4	1972	1972	—	06022	200	7-7/8	1	24	MC151	SC574	—	—	—
<b>620 PICKUP</b>															
1.6	1595	L4	1972	1973	—	06022	200	7-7/8	1	24	MC165	SC574	—	—	—
1.8	1770	L4	1974	1974	—	06033	225	8-7/8	1	24	MC165	SC574	—	—	—
2.0	1952	L4	1975	1976	2 WD To 2/76	06004	225	8-7/8	1	24	MC151	SC574	—	CF114	—
2.0	1952	L4	1976	1979	2 WD From 3/76	06004	225	8-7/8	1	24	MC152	SC574	—	CF114	—
<b>720 PICKUP</b>															
2.0	1952	L4	1980	1980	2 WD	06004	225	8-7/8	1	24	MC153	SC574	—	CF114	—
2.0	1952	L4	1980	1980	4 WD	06004	225	8-7/8	1	24	MC153	SC883	—	CF114	—
2.0	1952	L4	1983	1985	2 WD To 10/85	06006	240	9-1/2	1	24	MC153	SC574	—	CF114	FWNS28
2.0	1952	L4	1985	1985	2 WD From 11/85	06006	240	9-1/2	1	24	MC157	SC577	—	CF114	FWNS28
2.0	1952	L4	1985	1985	4 WD To 10/85	06006	240	9-1/2	1	24	MC153	SC575	—	CF114	FWNS28
2.0	1952	L4	1985	1985	4 WD From 11/85	06006	240	9-1/2	1	24	MC157	SC576	—	CF114	FWNS28
2.2	2187	L4	1981	1982	4 WD	06004	225	8-7/8	1	24	MC153	SC575	—	CF114	—
2.2	2164	L4	1981	1983	Diesel 2 WD	06004	225	8-7/8	1	24	MC153	SC574	—	CF114	—
2.2	2164	L4	1981	1983	Diesel 4 WD	06004	225	8-7/8	1	24	MC153	SC883	—	CF114	—
2.2	2187	L4	1981	1983	2 WD/4 WD	06004	225	8-7/8	1	24	MC153	SC574	—	CF114	—
2.4	2389	L4	1983	1985	2 WD	06006	240	9-1/2	1	24	MC153	SC574	—	CF114	FWNS28
2.4	2389	L4	1983	1985	4 WD	06006	240	9-1/2	1	24	MC153	SC575	—	CF114	FWNS28
2.4	2389	L4	1986	1986	2 WD	06006	240	9-1/2	1	24	—	SC574	—	CF114	FWNS28
2.4	2389	L4	1986	1986	4 WD	06006	240	9-1/2	1	24	—	SC575	—	CF114	FWNS28
2.5	2488	L4	1983	1985	Diesel	06034	225	8-7/8	1	24	—	SC883	—	—	—
2.5	2488	L4	1986	1986	Diesel	06034	225	8-7/8	1	24	MC157	SC883	—	—	—
<b>AXXESS</b>															
2.4	2389	L4	1990	1991	2 WD	06053	225	8-7/8	1	24	MC158	SC565	—	—	—
2.4	2389	L4	1991	1991	4 WD	06051	240	9-1/2	1	24	MC158	SC565	—	—	—
<b>CUBE</b>															
1.8	1798	L4	2009	2011	Sold as Kit Only, Includes CSC Hydraulic Slave Cylinder	NSK1009	225	8-7/8	15/16	21	—	—	—	—	—
<b>D21 PICKUP</b>															
2.4	2389	L4	1986	1988	—	06006	240	9-1/2	1	24	MC157	SC882	—	CF114	FWNS28
2.4	2389	L4	1989	1992	—	06006	240	9-1/2	1	24	MC157	SC882	—	—	FWNS28
2.4	2389	L4	1993	1993	—	KNS03	240	9-1/2	1	24	MC157	SC882	—	—	—
3.0	2960	V6	1986	1988	—	06042	250	9-7/8	1	24	MC157	SC576	—	CF114	FWNS27
3.0	2960	V6	1989	1993	—	06042	250	9-7/8	1	24	MC157	SC576	—	—	FWNS27
<b>FRONTIER</b>															
2.4	2389	L4	1998	1999	—	06059	240	9-1/2	1	24	MC550	SC572	—	—	—
2.4	2389	L4	2000	2004	—	NSK1004	240	9-1/2	1	24	MC552	SC572	—	—	—
2.5	2500	L4	2006	2006	Sold as kit only	NSK1005	240	9 1/2	1	24	MC571	SC902	—	—	—
2.5	2500	L4	2007	2008	Sold as kit only, Fits Dual Mass FW	NSK1005	240	9 1/2	1	24	MC571	SC903	—	—	—
2.5	2500	L4	2009	2014	Sold as kit only, Fits Dual Mass FW	NSK1005	240	9 1/2	1	24	MC571	—	—	—	—
3.3	3275	V6	2000	2004	—	KNS10	250	9-7/8	1	24	MC552	SC572	—	—	—
3.3	3275	V6	2001	2004	Supercharged	NSK1007	250	9-7/8	1	24	MC552	SC572	—	—	—
4.0	3954	V6	2005	2014	Sold as kit only	NSK1006	260	10 1/4	1	24	MC571	SC903	—	—	—

Liter	CC/IN	Cyl	Years		Application Information	Kit	Disc (mm)	Disc (in)	Spline Dia	Splines	Master Cyl	Slave Cyl	Clutch Cable	Clutch Fork	New Flywheel
			To	From											
<b>NISSAN LIGHT TRUCK, SUV &amp; VAN CONT.</b>															
<b>JUKE</b>															
1.6	1618	L4	2011	2012	Sold as kit only, Solid Flywheel Conversion, Includes Solid flywheel, Includes CSC Hydraulic Slave Cylinder	NSK1026FW	225	8-7/8	15/16	21	—	BRG0166	—	—	FWNS01
<b>PATHFINDER</b>															
2.4	2389	L4	1987	1988	—	06006	240	9-1/2	1	24	MC157	SC884	—	—	FWNS28
3.0	2960	V6	1987	1989	—	06042	250	9-7/8	1	24	MC157	SC576	—	—	FWNS27
3.0	2960	V6	1990	1995	—	06042	250	9-7/8	1	24	MC157	SC576	—	—	—
3.3	3275	V6	1996	1996	—	KNS12	250	9-7/8	1	24	MC162	SC572	—	CF114	—
3.3	3275	V6	1997	1999	—	06058	250	9-7/8	1	24	MC162	SC572	—	—	—
3.3	3275	V6	2000	2000	—	KNS10	250	9-7/8	1	24	MC162	SC572	—	—	—
3.5	3498	V6	2001	2002	—	KNS07	250	9-7/8	1	24	MC551	SC872	—	—	—
<b>PICKUP</b>															
2.4	2389	L4	1994	1995	—	KNS03	240	9-1/2	1	24	MC157	SC577	—	—	—
2.4	2389	L4	1996	1996	2 WD, From 2/1/96	06059	240	9-1/2	1	24	MC161	SC577	—	—	—
2.4	2389	L4	1996	1996	4 WD, From 2/1/96	06059	240	9-1/2	1	24	MC161	SC576	—	—	—
2.4	2389	L4	1996	1996	RWD	06059	240	9-1/2	1	24	MC161	SC576	—	—	—
2.4	2389	L4	1996	1996	To 1/31/96	KNS03	240	9-1/2	1	24	MC157	SC884	—	—	—
2.4	2389	L4	1997	1997	2 WD	06059	240	9-1/2	1	24	MC161	SC577	—	—	—
2.4	2389	L4	1997	1997	4 WD	06059	240	9-1/2	1	24	MC161	SC576	—	—	—
3.0	2960	V6	1994	1996	—	06042	250	9-7/8	1	24	MC157	SC884	—	—	—
<b>VAN</b>															
2.4	2389	L4	1987	1988	—	06034	225	8-7/8	1	24	MC156	SC563	—	—	—
<b>XTERRA</b>															
2.4	2389	L4	2000	2000	—	06059	240	9-1/2	1	24	MC548	SC572	—	—	—
3.3	3275	V6	2000	2004	—	KNS10	250	9-7/8	1	24	MC548	SC572	—	—	—
3.3	3275	V6	2002	2003	Supercharged	NSK1007	250	9-7/8	1	24	MC548	SC572	—	—	—
4.0	3954	V6	2005	2015	Sold as kit only	NSK1006	260	10 1/4	1	24	MC571	SC903	—	—	—
<b>OLDSMOBILE (Performance Applications Available)</b>															
<b>ACHIEVA</b>															
2.3	140	L4	1992	1992	Quad 4, 8th Digit of VIN is A with CSC	04088	225	8-7/8	15/16	14	MC330	SC715	—	—	—
2.3	140	L4	1992	1992	Quad 4, 8th Digit of VIN is A with External CSC Slave	04088	225	8-7/8	15/16	14	MC330	SC715	—	—	—
2.3	140	L4	1992	1994	SOHC, 8th Digit of VIN is 3	04135	225	8-7/8	15/16	14	MC325	SC715	—	—	—
2.3	140	L4	1993	1994	Quad 4, 8th Digit of VIN is A, Includes Slave Cylinder	04136	225	8-7/8	15/16	14	MC330	SC715	—	—	—
2.3	140	L4	1995	1995	Includes Slave Cylinder	04162	225	8-7/8	15/16	14	MC330	SC715	—	—	—
2.4	146	L4	1996	1997	Includes Slave Cylinder	04162	225	8-7/8	15/16	14	MC330	—	—	—	—
<b>ALERO</b>															
2.2	134	L4	2002	2004	DOHC, Includes Slave Cylinder, Sold As Kit Only	GMK1000	225	8-7/8	1	14	—	—	—	—	—
2.4	146	L4	2000	2001	Includes Slave Cylinder, Sold As Kit Only	KGMO4	225	8-7/8	1	14	—	—	—	—	—
<b>CALAIS (FWD)</b>															
2.5	153	L4	1986	1986	—	04005	215	8-1/2	1	14	MC326	SC723	—	—	—
2.5	153	L4	1987	1987	—	04005	215	8-1/2	1	14	MC317	SC723	—	—	—
<b>CUTLASS CIERA (FWD)</b>															
2.5	153	L4	1984	1984	—	04077	225	8-7/8	15/16	14	—	—	—	—	—
<b>CUTLASS, DELMONT 88, DELTA 88, DYNAMIC, F85, JET STAR 88, OMEGA, STARFIRE, VISTA CRUISER</b>															
2.3	140	L4	1976	1977	—	04062	232	9-1/8	1-1/8	10	—	—	—	—	—
2.5	153	L4	1978	1980	—	04062	232	9-1/8	1-1/8	10	—	—	—	—	—
2.5	153	L4	1980	1984	14 Spline Disc	04077	225	8-7/8	15/16	14	—	—	—	—	—
2.8	171	V6	1980	1984	—	04077	225	8-7/8	15/16	14	—	—	—	—	FWGM111
2.8	171	V6	1988	1988	—	04088	225	8-7/8	15/16	14	MC322	SC715	—	—	FWGM111
2.8	171	V6	1989	1989	Quad 4	04088	225	8-7/8	15/16	14	MC322	SC715	—	—	—
3.1	189	V6	1989	1990	—	04116	225	8-7/8	15/16	14	—	SC715	—	—	—
3.4	207	V6	1991	1992	Pull Type, Sold As Kit Only	04127	246	9-5/8	1	23	MC238	SC716	—	—	—
3.8	232	V6	1975	1975	3 Speed	04062	232	9-1/8	1-1/8	10	—	—	—	—	—
3.8	232	V6	1976	1977	4 Spd	04062	232	9-1/8	1-1/8	10	—	—	—	—	—
3.8	232	V6	1977	1977	3 Speed	04062	232	9-1/8	1-1/8	10	—	—	—	—	—
3.8	232	V6	1978	1978	9-1/8" Disc	04062	232	9-1/8	1-1/8	10	—	—	—	—	—
3.8	232	V6	1979	1981	—	04021	265	10-1/2	1-1/8	10	—	—	—	—	—
5.0	305	V8	1979	1979	—	04021	265	10-1/2	1-1/8	10	—	—	—	—	FWGM101
5.4	330	V8	1965	1967	11" Disc	04049	280	11	1-1/8	10	—	—	—	—	—



Liter	CC/IN	Cyl	Years		Application Information	Kit	Disc (mm)	Disc (in)	Spline Dia	Splines	Master Cyl	Slave Cyl	Clutch Cable	Clutch Fork	New Flywheel
			To	From											
<b>OLDSMOBILE (Performance Applications Available) CONT.</b>															
<i>CUTLASS, DELMONT 88, DELTA 88, DYNAMIC, F85, JET STAR 88, OMEGA, STARFIRE, VISTA CRUISER CONT.</i>															
5.7	348	V8	1969	1970	W-31	04021	265	10-1/2	1-1/8	10	—	—	—	—	FWGM101
5.7	348	V8	1971	1973	3 Spd, 4 BBL	04021	265	10-1/2	1-1/8	10	—	—	—	—	FWGM101
5.7	348	V8	1971	1973	4 Spd, 4 BBL with 10-3/8" Disc	04019	263	10-3/8	1-1/8	26	—	—	—	—	FWGM101
5.7	348	V8	1971	1973	4 Spd, 4 BBL with 11" Disc	04020	280	11	1-1/8	26	—	—	—	—	—
6.6	403	V8	1966	1969	—	04049	280	11	1-1/8	10	—	—	—	—	—
7.0	427	V8	1965	1965	—	04021	265	10-1/2	1-1/8	10	—	—	—	—	—
7.0	427	V8	1965	1967	—	04049	280	11	1-1/8	10	—	—	—	—	—
7.5	458	V8	1968	1973	3 Spd	04049	280	11	1-1/8	10	—	—	—	—	—
7.5	458	V8	1971	1973	4 Spd	04020	280	11	1-1/8	26	—	—	—	—	—
<b>FIRENZA</b>															
1.8	110	L4	1983	1986	—	04046	215	8-1/2	1	14	MC318	SC714	—	—	—
2.0	122	L4	1985	1985	5 Spd	04005	215	8-1/2	1	14	MC316	SC714	—	—	—
2.0	122	L4	1985	1986	4 Spd	04077	225	8-7/8	15/16	14	MC318	SC714	—	—	—
2.0	122	L4	1986	1986	OHV, 5 Spd	04005	215	8-1/2	1	14	MC316	SC714	—	—	—
2.0	122	L4	1987	1987	4 Spd	04077	225	8-7/8	15/16	14	—	SC714	—	—	—
2.0	122	L4	1988	1988	OHC,TBI,OHV	04046	215	8-1/2	1	14	MC316	SC714	—	—	—
2.8	171	V6	1985	1986	—	04077	225	8-7/8	15/16	14	MC318	SC714	—	—	FWGM111
2.8	171	V6	1987	1987	—	04088	225	8-7/8	15/16	14	MC316	SC714	—	—	FWGM111
<b>PEUGEOT</b>															
<b>505</b>															
2.0	1971	L4	1983	1987	Sold As Kit Only	KPT03	215	8-7/16	1-1/8	10	—	—	—	—	—
<b>PLYMOUTH (Performance Applications Available)</b>															
<b>ACCLAIM</b>															
2.5	153	L4	1989	1989	Non-Turbo	05002	232	9-1/8	13/16	18	—	—	—	—	—
2.5	153	L4	1990	1990	Non-Turbo	05060	232	9-1/8	13/16	18	—	—	—	—	—
2.5	153	L4	1990	1990	Turbo	05067	232	9-1/8	13/16	18	—	—	—	—	—
2.5	153	L4	1991	1993	Non-Turbo	05057	232	9-1/8	15/16	17	—	—	—	—	—
<b>ARROW</b>															
1.6	98	L4	1976	1980	—	05020	200	7-7/8	7/8	20	—	—	—	—	—
2.0	122	L4	1976	1977	—	05012	215	8-7/16	7/8	20	—	—	—	—	—
2.6	159	L4	1979	1979	GT	05041	225	8-7/8	1-1/32	23	—	—	—	—	—
2.6	159	L4	1979	1980	—	05052	225	8-7/8	1-1/32	23	—	—	—	—	—
<i>BARRACUDA, BELVEDERE, DUSTER, FURY, GRAND FURY, GTX, PLAZA, ROADRUNNER, SATELLITE, SAVOY, SCAMP, VALIANT, VOLARE</i>															
4.5	275	V8	1956	1956	10-3/8" Disc	05029	263	10-3/8	1	23	—	—	—	—	—
4.5	275	V8	1956	1957	10-3/8" Disc	05029	263	10-3/8	1	23	—	—	—	—	—
4.5	275	V8	1964	1969	10-3/8" Disc	05029	263	10-3/8	1	23	—	—	—	—	—
5.2	317	V8	1957	1958	10-3/8" Disc	05029	263	10-3/8	1	23	—	—	—	—	—
5.2	317	V8	1958	1978	10-3/8" Disc	05029	263	10-3/8	1	23	—	—	—	—	—
5.6	342	V8	1968	1973	10-3/8" Disc	05029	263	10-3/8	1	23	—	—	—	—	—
5.9	360	V8	1959	1979	10-3/8" Disc	05029	263	10-3/8	1	23	—	—	—	—	—
6.3	384	V8	1960	1971	10-3/8" Disc	05029	263	10-3/8	1	23	—	—	—	—	—
6.3	384	V8	1968	1969	10-3/8" Disc	05029	263	10-3/8	1	23	—	—	—	—	FWCHR106
7.0	427	V8	1963	1971	10-3/8" Disc	05029	263	10-3/8	1	23	—	—	—	—	—
<b>BREEZE</b>															
2.0	122	L4	1996	2000	Modular Clutch Includes Flywheel	05085	230	9-1/16	15/16	17	—	—	—	—	—
2.4	146	L4	1998	2000	Modular Clutch Includes Flywheel	05085	230	9-1/16	15/16	17	—	—	—	—	—
<b>CHAMP</b>															
1.4	85	L4	1979	1982	2 Door Hatchback	05022	200	7-7/8	7/8	20	—	—	—	—	—
1.4	85	L4	1979	1982	Dual Range 4 Spd	05023	184	7-1/4	7/8	20	—	—	—	—	—
1.6	98	L4	1979	1982	2 Door Hatchback	05023	184	7-1/4	7/8	20	—	—	—	—	—
<b>COLT</b>															
1.4	85	L4	1979	1982	4 Spd Luk	05026	200	7-7/8	7/8	20	—	—	—	—	—
1.4	85	L4	1979	1984	Dual Range 4 Spd Luk	05023	184	7-1/4	7/8	20	—	—	—	—	—
1.4	85	L4	1983	1984	7-7/8" Disc 4 Spd	05026	200	7-7/8	7/8	20	—	—	—	—	—
1.5	92	L4	1985	1986	4 Spd,7-7/8"	05026	200	7-7/8	7/8	20	—	—	—	—	—

Liter	CC/IN	Cyl	Years		Application Information	Kit	Disc (mm)	Disc (in)	Spline Dia	Splines	Master Cyl	Slave Cyl	Clutch Cable	Clutch Fork	New Flywheel
			To	From											
<b>PLYMOUTH (Performance Applications Available) CONT.</b>															
<i>COLT CONT.</i>															
1.5	92	L4	1985	1986	5 Speed ,7-1/4"	05023	184	7-1/4	7/8	20	MC194	SC580	—	—	—
1.5	92	L4	1985	1988	4 Spd	05026	200	7-7/8	7/8	20	—	—	—	—	—
1.5	92	L4	1985	1988	5 Spd	05023	184	7-1/4	7/8	20	MC194	SC580	—	—	—
1.5	92	L4	1989	1994	—	05026	200	7-7/8	7/8	20	MC178	SC580	—	—	—
1.6	98	L4	1976	1978	—	05020	200	7-7/8	7/8	20	—	—	—	—	—
1.6	98	L4	1979	1981	Wagon	05020	200	7-7/8	7/8	20	—	—	—	—	—
1.6	98	L4	1979	1982	Sedan	05023	184	7-1/4	7/8	20	—	—	—	—	—
1.6	98	L4	1983	1983	Hatchback	05023	184	7-1/4	7/8	20	—	—	—	—	—
1.6	98	L4	1984	1984	Dual Range 4 Spd	05022	200	7-7/8	7/8	20	MC203	SC580	—	—	—
1.6	98	L4	1984	1984	Turbo, Dual Range 4 Spd	05022	200	7-7/8	7/8	20	MC203	SC580	—	—	—
1.6	98	L4	1985	1988	Turbo 3 Speed and 5 Speed	05026	200	7-7/8	7/8	20	—	—	—	—	—
1.6	98	L4	1989	1990	5 Spd	05051	215	8-1/2	7/8	20	MC178	SC581	—	—	—
1.6	98	L4	1989	1990	Turbo, 5 Spd	05051	215	8-1/2	7/8	20	MC178	SC581	—	—	—
1.8	110	L4	1989	1990	5 Spd	05051	215	8-1/2	7/8	20	MC178	SC589	—	—	—
1.8	110	L4	1992	1992	2 WD with 8-3/8" Disc	05051	215	8-1/2	7/8	20	MC175	SC589	—	—	—
1.8	110	L4	1992	1992	FWD 8-1/2" Disc	05021	215	8-1/2	7/8	20	MC175	SC589	—	—	—
1.8	110	L4	1992	1994	—	05051	215	8-1/2	7/8	20	—	—	—	—	—
1.8	110	L4	1992	1994	2 WD	05051	215	8-1/2	7/8	20	—	SC589	—	—	—
1.8	110	L4	1992	1994	4 WD	05021	215	8-1/2	7/8	20	—	SC589	—	—	—
2.0	122	L4	1976	1978	—	05021	215	8-1/2	7/8	20	—	—	—	—	—
2.0	122	L4	1984	1984	8-1/2" Disc FWD	05021	215	8-1/2	7/8	20	—	—	—	—	—
2.0	122	L4	1984	1985	2 WD with 7-7/8" Disc	05026	200	7-7/8	7/8	20	—	—	—	—	—
2.0	122	L4	1985	1989	4 WD	05021	215	8-1/2	7/8	20	MC175	SC583	—	—	—
2.0	122	L4	1986	1986	3 Speed and 5 Speed	05026	200	7-7/8	7/8	20	—	—	—	—	—
2.0	122	L4	1986	1986	5 Speed	05023	184	7-1/4	7/8	20	MC194	SC580	—	—	—
2.0	122	L4	1986	1987	2 WD with 7-7/8" Disc	05026	200	7-7/8	7/8	20	MC175	SC581	—	—	—
2.0	122	L4	1987	1987	2 WD with 8-3/8" Disc	05051	215	8-1/2	7/8	20	MC175	—	—	—	—
2.0	122	L4	1988	1989	2 WD	05051	215	8-1/2	7/8	20	MC175	—	—	—	—
2.0	122	L4	1990	1990	2 WD 8-1/4" Disc	05051	215	8-1/2	7/8	20	MC175	—	—	—	—
2.0	122	L4	1990	1990	FWD 8-1/2" Disc	05021	215	8-1/2	7/8	20	MC175	SC583	—	—	—
2.0	122	L4	1991	1991	2 WD	05051	215	8-1/2	7/8	20	MC175	—	—	—	—
2.0	122	L4	1991	1991	4 WD	05021	215	8-1/2	7/8	20	MC175	SC583	—	—	—
2.4	146	L4	1992	1992	Sold As Kit Only	05048	225	8-7/8	7/8	20	—	SC584	—	—	—
2.4	146	L4	1993	1994	Sold As Kit Only	05048	225	8-7/8	7/8	20	—	SC589	—	—	—
2.6	159	L4	1978	1980	—	05041	225	8-7/8	1-1/32	23	—	—	—	—	—
<i>CONQUEST</i>															
2.6	159	L4	1984	1984	Non Intercooled Turbo	05025	225	8-7/8	1-1/32	23	MC175	SC579	—	—	—
2.6	159	L4	1984	1986	Non-intercooled, Turbo	05025	225	8-7/8	1-1/32	23	MC175	SC821	—	—	—
2.6	159	L4	1985	1986	Turbo, Intercooled	05046	225	8-7/8	1-1/32	23	MC175	SC579	—	—	—
2.6	159	L4	1987	1987	—	05046	225	8-7/8	1-1/32	23	MC175	SC579	—	—	—
2.6	159	L4	1988	1989	Intercooled Turbo	05049	240	9-1/2	1-1/16	23	MC175	SC679	—	—	—
<i>HORIZON, SCAMP, TURISMO</i>															
1.6	98	L4	1983	1986	—	05009	200	7-7/8	13/16	18	—	—	—	—	—
1.7	104	L4	1978	1983	—	05009	200	7-7/8	13/16	18	—	—	—	—	—
2.2	134	L4	1981	1989	Sold As Kit Only	05028A	215	8-7/16	13/16	18	—	—	—	—	—
2.2	134	L4	1990	1990	—	05061	215	8-7/16	13/16	18	—	—	—	—	—
<i>LASER</i>															
1.8	110	L4	1990	1991	—	05022	200	7-7/8	7/8	20	MC179	SC581	—	—	—
1.8	110	L4	1992	1994	—	05022	200	7-7/8	7/8	20	MC180	SC581	—	—	—
2.0	122	L4	1990	1991	Non-Turbo with Speed Control	05051	215	8-1/2	7/8	20	MC180	SC581	—	—	—
2.0	122	L4	1990	1991	Non-Turbo without Speed Control	05051	215	8-1/2	7/8	20	MC179	SC581	—	—	—
2.0	122	L4	1990	1991	Turbo, 2 WD with Speed Control, Sold As Kit Only	05048	225	8-7/8	7/8	20	MC180	SC586	—	—	—
2.0	122	L4	1990	1991	Turbo, 4 WD with Speed Control, Sold as Kit Only	05048	225	8-7/8	7/8	20	MC180	SC587	—	—	—
2.0	122	L4	1990	1991	Turbo, 4 WD without Speed Control, Sold as Kit Only	05048	225	8-7/8	7/8	20	MC179	SC587	—	—	—
2.0	122	L4	1990	1992	Turbo, 2 WD without Speed Control, Sold As Kit Only	05048	225	8-7/8	7/8	20	MC529	SC820	—	—	—
2.0	122	L4	1992	1992	2 WD with Speed Control, Sold As Kit Only	05048	225	8-7/8	7/8	20	MC180	SC586	—	—	—

Liter	CC/IN	Cyl	Years		Application Information	Kit	Disc (mm)	Disc (in)	Spline Dia	Splines	Master Cyl	Slave Cyl	Clutch Cable	Clutch Fork	New Flywheel
			To	From											
<b>PLYMOUTH (Performance Applications Available) CONT.</b>															
<i>LASER CONT.</i>															
2.0	122	L4	1992	1992	4 WD with Speed Control, Sold As Kit Only	05048	225	8-7/8	7/8	20	MC180	SC587	—	—	—
2.0	122	L4	1992	1992	4 WD without Speed Control, Sold As Kit Only	05048	225	8-7/8	7/8	20	MC179	SC587	—	—	—
2.0	122	L4	1992	1994	Non-Turbo	05051	215	8-1/2	7/8	20	MC180	SC581	—	—	—
2.0	122	L4	1993	1994	Turbo, 2 WD, Sold As Kit Only	05048	225	8-7/8	7/8	20	MC180	SC586	—	—	—
2.0	122	L4	1993	1994	Turbo, 4 WD, Sold As Kit Only	05048	225	8-7/8	7/8	20	MC180	SC587	—	—	—
<i>NEON</i>															
2.0	122	L4	1995	1999	11th Digit Vin is T	05076	230	9-1/16	15/16	17	—	—	—	—	—
2.0	122	L4	1996	2000	Modular Clutch Includes Flywheel	05085	230	9-1/16	15/16	17	—	—	—	—	—
2.0	122	L4	2001	2001	Modular Clutch Includes Flywheel	05085	230	9-1/16	15/16	17	MC346	SC790	—	—	—
<i>RELIANT</i>															
2.2	134	L4	1981	1983	Sold As Kit Only	05028A	215	8-7/16	13/16	18	—	—	—	—	—
2.2	134	L4	1986	1988	Sold As Kit Only	05028A	215	8-7/16	13/16	18	—	—	—	—	—
2.5	153	L4	1986	1988	—	05002	232	9-1/8	13/16	18	—	—	—	—	—
<i>SAPORO</i>															
1.6	98	L4	1978	1979	—	05020	200	7-7/8	7/8	20	—	—	—	—	—
2.6	159	L4	1978	1983	—	05041	225	8-7/8	1-1/32	23	—	—	—	—	—
<i>SUNDANCE</i>															
2.2	134	L4	1987	1988	Turbo	05002	232	9-1/8	13/16	18	—	—	—	—	—
2.2	134	L4	1987	1989	Non-Turbo, Sold As Kit Only	05048	225	8-7/8	7/8	20	—	—	—	—	—
2.2	134	L4	1990	1990	Non-Turbo	05061	215	8-7/16	13/16	18	—	—	—	—	—
2.2	134	L4	1991	1994	Non-Turbo	05059	215	8-7/16	13/16	17	—	—	—	—	—
2.5	153	L4	1988	1989	Non-Turbo	05002	232	9-1/8	13/16	18	—	—	—	—	—
2.5	153	L4	1990	1990	Non-Turbo	05060	232	9-1/8	13/16	18	—	—	—	—	—
2.5	153	L4	1990	1990	Turbo	05067	232	9-1/8	13/16	18	—	—	—	—	—
2.5	153	L4	1991	1991	Turbo	05057	232	9-1/8	15/16	17	—	—	—	—	—
2.5	153	L4	1991	1994	Non-Turbo	05057	232	9-1/8	15/16	17	—	—	—	—	—
3.0	183	V6	1993	1994	Non-Turbo	05057	232	9-1/8	15/16	17	—	—	—	—	—
<b>PLYMOUTH LIGH TRUCK, SUV &amp; VAN</b>															
<i>ARROW PICKUP</i>															
2.0	122	L4	1979	1980	—	05012	215	8-7/16	7/8	20	—	—	—	—	—
2.0	122	L4	1981	1982	—	05011	215	8-7/16	7/8	23	—	—	—	—	—
2.6	159	L4	1979	1982	—	05041	225	8-7/8	1-1/32	23	—	—	CC216	—	—
<i>TRAILDUSTER</i>															
3.7	226	L6	1975	1980	11" Disc	05016	280	11	1	23	—	—	—	—	—
5.2	317	V8	1974	1981	10-3/8" Disc	05029	263	10-3/8	1	23	—	—	—	—	—
5.2	317	V8	1974	1981	11" Disc	05016	280	11	1	23	—	—	—	—	—
5.9	360	V8	1974	1981	—	05016	280	11	1	23	—	—	—	—	—
<i>VOYAGER</i>															
2.2	134	L4	1984	1987	—	05002	232	9-1/8	13/16	18	—	—	—	—	—
2.5	153	L4	1987	1989	Non-Turbo	05002	232	9-1/8	13/16	18	—	—	—	—	—
2.5	153	L4	1990	1990	Non-Turbo	05060	232	9-1/8	13/16	18	—	—	—	—	—
2.5	153	L4	1990	1990	Turbo	05067	232	9-1/8	13/16	18	—	—	—	—	—
2.5	153	L4	1992	1992	—	05057	232	9-1/8	15/16	17	—	—	—	—	—
2.6	159	L4	1984	1986	—	05052	225	8-7/8	1-1/32	23	—	—	—	—	—
3.0	183	V6	1990	1990	Modular Clutch Includes Flywheel	05060	232	9-1/8	13/16	18	—	—	—	—	—
3.0	183	V6	1991	1992	—	05057	232	9-1/8	15/16	17	—	—	—	—	—
<b>PONTIAC</b>															
<i>6000</i>															
2.5	153	L4	1984	1984	—	04077	225	8-7/8	15/16	14	—	—	—	—	—
2.5	153	L4	1987	1988	—	04088	225	8-7/8	15/16	14	MC319	—	—	—	FWGM111
2.8	171	V6	1986	1986	—	04088	225	8-7/8	15/16	14	MC319	—	—	—	FWGM111
2.8	171	V6	1987	1988	—	04088	225	8-7/8	15/16	14	MC319	SC714	—	—	FWGM111
<i>ASTRE</i>															
2.3	140	L4	1975	1977	—	04062	232	9-1/8	1-1/8	10	—	—	—	—	—
2.5	153	L4	1977	1977	—	04062	232	9-1/8	1-1/8	10	—	—	—	—	—

Liter	CC/IN	Cyl	Years		Application Information	Kit	Disc (mm)	Disc (in)	Spline Dia	Splines	Master Cyl	Slave Cyl	Clutch Cable	Clutch Fork	New Flywheel
			To	From											
<b>PONTIAC CONT.</b>															
<i>BONNEVILLE, CATALINA, CHIEFTAN, EXECUTIVE, GRAND PRIX, GRANDVILLE</i>															
2.8	171	V6	1988	1988	FWD	04088	225	8-7/8	15/16	14	MC322	SC715	—	—	FWGM111
2.8	171	V6	1989	1989	FWD	04088	225	8-7/8	15/16	14	MC322	SC715	—	—	—
3.1	189	V6	1989	1990	Turbo, FWD	04116	225	8-7/8	15/16	14	MC322	SC715	—	—	—
3.1	189	V6	1989	1992	FWD	04116	225	8-7/8	15/16	14	MC322	SC715	—	—	—
3.4	207	V6	1991	1993	FWD, Pull Type, Sold As Kit Only	04127	246	9-5/8	1	23	MC328	SC716	—	—	—
6.4	391	V8	1959	1960	12" Diaph Clutch	04064	300	11-3/4	1-1/8	10	—	—	—	—	—
6.4	391	V8	1964	1964	4 BBL	04021	265	10-1/2	1-1/8	10	—	—	—	—	—
6.4	391	V8	1965	1966	4 BBL	04049	280	11	1-1/8	10	—	—	—	—	—
6.6	403	V8	1967	1970	11" Disc	04049	280	11	1-1/8	10	—	—	—	—	—
6.6	403	V8	1970	1970	10-3/8" Disc	04021	265	10-1/2	1-1/8	10	—	—	—	—	FWGM101
6.6	403	V8	1971	1972	3 Spd	04021	265	10-1/2	1-1/8	10	—	—	—	—	—
6.6	403	V8	1971	1972	4 Spd	04019	263	10-3/8	1-1/8	26	—	—	—	—	FWGM101
6.6	403	V8	1971	1972	4 Spd	04019	263	10-3/8	1-1/8	26	—	—	—	—	FWGM101
7.0	427	V8	1967	1969	—	04049	280	11	1-1/8	10	—	—	—	—	—
7.5	458	V8	1970	1971	3 Spd	04049	280	11	1-1/8	10	—	—	—	—	—
7.5	458	V8	1971	1972	4 Spd	04020	280	11	1-1/8	26	—	—	—	—	—
<i>FIERO</i>															
2.5	153	L4	1985	1985	—	04005	215	8-1/2	1	14	MC531	SC829	—	—	—
2.5	153	L4	1986	1988	—	04005	215	8-1/2	1	14	—	SC829	—	—	—
2.8	171	V6	1985	1985	4 Spd	04077	225	8-7/8	15/16	14	—	SC829	—	—	FWGM111
2.8	171	V6	1985	1985	4 Spd	04077	225	8-7/8	15/16	14	MC531	—	—	—	FWGM111
2.8	171	V6	1986	1986	4 Spd	04077	225	8-7/8	15/16	14	—	—	—	—	FWGM111
2.8	171	V6	1986	1988	5 Spd	04088	225	8-7/8	15/16	14	—	—	—	—	FWGM111
<i>FIREBIRD, TRANS AM</i>															
2.5	153	L4	1982	1982	—	04052	232	9-1/8	1-1/8	10	—	—	—	—	—
2.5	153	L4	1983	1983	Non Pre-Damped	04053	225	8-7/8	15/16	14	—	—	—	—	—
2.5	153	L4	1983	1986	Pre-Damped	04129	232	9-1/8	1	14	MC315	SC787	—	—	—
2.5	153	L4	1984	1986	Non Pre-Damped	04053	225	8-7/8	15/16	14	MC315	SC787	—	—	—
2.8	171	V6	1982	1982	—	04055	232	9-1/8	1-1/8	10	—	—	—	—	FWGM111
2.8	171	V6	1983	1983	—	04069	215	8-1/2	1	14	—	—	—	—	—
2.8	171	V6	1984	1984	—	04069	215	8-1/2	1	14	MC315	SC787	—	—	—
2.8	171	V6	1984	1984	4 Spd	04055	232	9-1/8	1-1/8	10	MC315	SC787	—	—	FWGM111
2.8	171	V6	1985	1987	Non Pre-Damped	04053	225	8-7/8	15/16	14	MC320	SC787	—	CF129	FWGM111
2.8	171	V6	1985	1987	Pre-Damped	04129	232	9-1/8	1	14	MC320	SC787	—	CF129	FWGM111
2.8	171	V6	1988	1988	Non Pre-Damped	04053	225	8-7/8	15/16	14	MC320	SC787	—	—	FWGM111
2.8	171	V6	1988	1988	Pre-Damped	04129	232	9-1/8	1	14	MC320	SC787	—	—	FWGM111
2.8	171	V6	1989	1989	Non Pre-Damped	04053	225	8-7/8	15/16	14	MC320	SC787	—	—	—
2.8	171	V6	1989	1989	Pre-Damped	04129	232	9-1/8	1	14	MC320	SC787	—	—	—
3.1	189	V6	1990	1992	Non Pre-Damped	04053	225	8-7/8	15/16	14	MC320	SC787	—	CF129	—
3.1	189	V6	1990	1992	Pre-Damped	04129	232	9-1/8	1	14	MC320	SC787	—	CF129	—
3.4	207	V6	1993	1994	—	04133	246	9-5/8	1-1/8	26	MC331	SC719	—	—	—
3.4	207	V6	1995	1995	With Pushrod CV601A	04133	246	9-5/8	1-1/8	26	MC331	SC719	—	—	—
3.4	207	V6	1995	1995	With Pushrod H603A	04133	246	9-5/8	1-1/8	26	MC334	SC719	—	—	—
3.8	232	L6	1967	1967	2 BBL	04021	265	10-1/2	1-1/8	10	—	—	—	—	—
3.8	232	V6	1977	1977	9-1/8" Disc	04062	232	9-1/8	1-1/8	10	—	—	—	—	—
3.8	232	V6	1979	1980	—	04021	265	10-1/2	1-1/8	10	—	—	—	—	—
3.8	232	V6	1980	1981	—	04021	265	10-1/2	1-1/8	10	—	—	—	CF100	—
3.8	232	V6	1996	2002	—	04082	246	9-5/8	1-1/8	26	MC334	SC746	—	—	—
4.9	299	V8	1977	1977	—	04021	265	10-1/2	1-1/8	10	—	—	—	—	—
4.9	299	V8	1979	1979	—	04019	263	10-3/8	1-1/8	26	—	—	—	—	—
4.9	299	V8	1980	1980	—	04021	265	10-1/2	1-1/8	10	—	—	—	—	—
4.9	299	V8	1980	1980	Turbo	04021	265	10-1/2	1-1/8	10	—	—	—	—	—
5.0	305	V8	1979	1981	—	04021	265	10-1/2	1-1/8	10	—	—	—	CF100	FWGM101
5.0	305	V8	1981	1981	26 Spline Disc	04019	263	10-3/8	1-1/8	26	—	—	—	CF100	FWGM101
5.0	305	V8	1981	1981	26 Spline Disc, California Emission	04020	280	11	1-1/8	26	—	—	—	CF100	—

Liter	CC/IN	Cyl	Years		Application Information	Kit	Disc (mm)	Disc (in)	Spline Dia	Splines	Master Cyl	Slave Cyl	Clutch Cable	Clutch Fork	New Flywheel
			To	From											
<b>PONTIAC CONT.</b>															
<i>FIREBIRD, TRANS AM CONT.</i>															
5.0	305	V8	1982	1982	10 Spline Disc	04021	265	10-1/2	1-1/8	10	—	—	—	—	FWGM101
5.0	305	V8	1982	1982	26 Spline Disc	04019	263	10-3/8	1-1/8	26	—	—	—	—	FWGM101
5.0	305	V8	1983	1983	—	04019	263	10-3/8	1-1/8	26	—	—	—	CF133	FWGM101
5.0	305	V8	1984	1985	—	04019	263	10-3/8	1-1/8	26	MC315	SC787	—	CF133	FWGM101
5.0	305	V8	1986	1992	—	04019	263	10-3/8	1-1/8	26	MC315	SC787	—	CF133	FWGM12
5.3	323	V8	1967	1967	—	04021	265	10-1/2	1-1/8	10	—	—	—	—	—
5.7	348	V8	1969	1971	High Output Engine	04021	265	10-1/2	1-1/8	10	—	—	—	—	FWGM101
5.7	348	V8	1975	1975	4 Speed	04019	263	10-3/8	1-1/8	26	—	—	—	—	FWGM101
5.7	348	V8	1976	1977	4 Speed	04019	263	10-3/8	1-1/8	26	—	—	—	CF100	FWGM101
5.7	348	V8	1978	1978	—	04021	265	10-1/2	1-1/8	10	—	—	—	CF100	FWGM101
5.7	348	V8	1987	1992	—	04019	263	10-3/8	1-1/8	26	—	—	—	—	—
5.7	348	V8	1998	2002	Modular Clutch Includes Flywheel	04173	300	11-3/4	1-1/8	26	MC334	SC746	—	—	—
6.6	403	V8	1967	1968	—	04021	265	10-1/2	1-1/8	10	—	—	—	—	FWGM101
6.6	403	V8	1971	1972	3 Spd, Ram Air	04021	265	10-1/2	1-1/8	10	—	—	—	—	FWGM101
6.6	403	V8	1971	1974	4 Spd, 2 BBL	04019	263	10-3/8	1-1/8	26	—	—	—	—	FWGM101
6.6	403	V8	1975	1977	4BBL	04019	263	10-3/8	1-1/8	26	—	—	—	—	FWGM101
6.6	403	V8	1978	1979	—	04020	280	11	1-1/8	26	—	—	—	—	—
7.5	458	V8	1973	1976	—	04020	280	11	1-1/8	26	—	—	—	—	—
<i>FIREFLY (CANADA)</i>															
1.0	61	L3	1985	1988	Non-Turbo	04104	190	7-1/2	15/16	20	—	—	—	—	—
1.0	61	L3	1987	1990	Turbo	04100	190	7-1/2	3/4	18	—	—	—	—	—
1.0	61	L3	1989	1991	Non-Turbo	04124	170	6-11/16	3/4	18	—	—	—	—	—
<b>G5</b>															
2.2	134	L4	2007	2008	Includes Slave Cylinder, Sold As Kit Only	GMK1010	225	8-7/8	15/16	14	—	—	—	—	—
2.4	146	L4	2007	2008	Includes Slave Cylinder, Sold As Kit Only	GMK1010	225	8-7/8	15/16	14	—	—	—	—	—
<b>G8</b>															
6.2	378	V8	2009	2009	GPX, 6 Spd, Sold as Kit Only, Includes FW	GMK1021	295	11-11/16	1-1/8	26	—	—	—	—	—
<i>GRAND AM, GRAND SAFARI, LA MANS, TEMPEST, VENTURA</i>															
2.0	122	L4	1987	1988	Turbo	KGM02	215	8-1/2	1	14	MC318	SC714	—	—	FWGM10
2.2	134	L4	2002	2004	Includes Slave Cylinder, Sold As Kit Only	GMK1000	225	8-7/8	1	14	—	—	—	—	—
2.3	140	L4	1989	1991	Quad 4, 8th Digit of VIN Is A, Includes Slave Cylinder	04088	225	8-7/8	15/16	14	MC325	SC715	—	—	—
2.3	140	L4	1992	1992	Quad 4, 8th Digit of VIN Is A, Includes Slave Cylinder	04088	225	8-7/8	15/16	14	MC330	SC715	—	—	—
2.3	140	L4	1992	1992	With External Slave Cylinder	04088	225	8-7/8	15/16	14	MC330	SC715	—	—	—
2.3	140	L4	1993	1994	8th Digit of VIN is 3, SOHC	04135	225	8-7/8	15/16	14	MC325	SC715	—	—	—
2.3	140	L4	1993	1994	Quad 4, 8th Digit in VIN Is A, Includes Slave Cylinder	04136	225	8-7/8	15/16	14	MC330	—	—	—	—
2.3	140	L4	1995	1995	—	04162	225	8-7/8	15/16	14	MC330	SC715	—	—	—
2.4	146	L4	1996	1998	Includes Slave Cylinder	04162	225	8-7/8	15/16	14	MC330	SC715	—	—	—
2.4	146	L4	2000	2001	Includes Slave Cylinder, Sold As Kit Only	KGM04	225	8-7/8	1	14	—	—	—	—	—
2.5	153	L4	1977	1985	—	04005	215	8-1/2	1	14	—	SC714	—	—	—
2.5	153	L4	1986	1986	—	04005	215	8-1/2	1	14	MC328	SC714	—	—	—
2.5	153	L4	1987	1991	—	04005	215	8-1/2	1	14	MC317	SC714	—	CF134	—
3.8	232	L6	1966	1967	—	04021	265	10-1/2	1-1/8	10	—	—	—	—	—
3.8	232	V6	1977	1977	2BBL; 3 Speed and 5 Speed	04062	232	9-1/8	1-1/8	10	—	—	—	—	—
3.8	232	V6	1979	1979	—	04021	265	10-1/2	1-1/8	10	—	—	—	—	—
4.1	250	L6	1968	1969	2 BBL	04021	265	10-1/2	1-1/8	10	—	—	—	—	—
4.9	299	V8	1979	1979	—	04021	265	10-1/2	1-1/8	10	—	—	—	—	—
5.7	348	V8	1968	1969	4 BBL	04021	265	10-1/2	1-1/8	10	—	—	—	—	FWGM101
5.7	348	V8	1975	1975	3 Spd, 4 BBL 26 SPLINE	04019	263	10-3/8	1-1/8	26	—	—	—	—	FWGM101
5.7	348	V8	1975	1976	2BBL	04019	263	10-3/8	1-1/8	26	—	—	—	—	FWGM101
5.7	348	V8	1975	1977	3 Spd, 4 BBL	04019	263	10-3/8	1-1/8	26	—	—	—	—	FWGM101
6.4	391	V8	1964	1964	4 BBL	04021	265	10-1/2	1-1/8	10	—	—	—	—	—
6.4	391	V8	1965	1965	11" Disc	04049	280	11	1-1/8	10	—	—	—	—	—
6.6	403	V8	1968	1972	4 Spd, 2 BBL	04021	265	10-1/2	1-1/8	10	—	—	—	—	FWGM101
6.6	403	V8	1973	1977	4 Spd, 4 BBL	04019	263	10-3/8	1-1/8	26	—	—	—	—	FWGM101
6.6	403	V8	1975	1975	3 Speed	04019	263	10-3/8	1-1/8	26	—	—	—	—	FWGM101



Liter	CC/IN	Cyl	Years		Application Information	Kit	Disc (mm)	Disc (in)	Spline Dia	Splines	Master Cyl	Slave Cyl	Clutch Cable	Clutch Fork	New Flywheel
			To	From											
<b>PONTIAC CONT.</b>															
<i>GRAND AM, GRAND SAFARI, LA MANS, TEMPEST, VENTURA CONT.</i>															
6.6	403	V8	1976	1976	2BBL	04019	263	10-3/8	1-1/8	26	—	—	—	—	FWGM101
6.6	403	V8	1977	1977	4 Spd, 4 BBL	04019	263	10-3/8	1-1/8	26	—	—	—	—	FWGM101
7.5	458	V8	1970	1971	3 Spd, 4 BBL	04049	280	11	1-1/8	10	—	—	—	—	—
7.5	458	V8	1971	1973	4 Spd	04020	280	11	1-1/8	26	—	—	—	—	—
<b>GTO</b>															
5.7	348	V8	1970	1970	—	04021	265	10-1/2	1-1/8	10	—	—	—	—	FWGM101
5.7	348	V8	2004	2004	Modular Clutch Includes Flywheel	04173	—	11-3/4	1-1/8	26	—	—	—	—	—
6.0	366	V8	2005	2006	6 Spd, Sold as Kit Only, Includes Flywheel	GMK1021	295	11-11/16	1-1/8	26	—	SC923	—	—	—
6.4	391	V8	1964	1966	—	04021	265	10-1/2	1-1/8	10	—	—	—	—	—
6.6	403	V8	1967	1970	—	04021	265	10-1/2	1-1/8	10	—	—	—	—	FWGM101
6.6	403	V8	1971	1971	4 Spd, 4 BBL 26 SPLINE	04019	263	10-3/8	1-1/8	26	—	—	—	—	FWGM101
6.6	403	V8	1971	1973	10 SPLINE	04021	265	10-1/2	1-1/8	10	—	—	—	—	FWGM101
6.6	403	V8	1972	1973	26 SPLINE	04019	263	10-3/8	1-1/8	26	—	—	—	—	FWGM101
7.5	458	V8	1970	1970	3 Spd, 4 BBL	04049	280	11	1-1/8	10	—	—	—	—	—
7.5	458	V8	1971	1973	4 Spd	04020	280	11	1-1/8	26	—	—	—	—	—
<b>J2000, SUNBIRD, SUNFIRE</b>															
1.8	110	L4	1982	1982	Optional 9-1/8" Disc	04077	225	8-7/8	15/16	14	—	—	—	—	—
1.8	110	L4	1983	1983	4 Spd	04094	215	8-1/2	1	14	—	—	—	—	—
1.8	110	L4	1983	1984	5 Spd, Non-Turbo	04046	215	8-1/2	1	14	—	—	—	—	—
1.8	110	L4	1984	1986	4 Spd, Turbo	KGM01	215	8-1/2	1	14	MC318	SC714	—	—	—
1.8	110	L4	1985	1986	5 Spd, Non-Turbo	04046	215	8-1/2	1	14	MC318	SC714	—	—	—
1.8	110	L4	1986	1986	5 Spd, Turbo	KGM03	215	8-1/2	1	14	MC318	SC714	—	—	—
2.0	122	L4	1983	1983	5 Spd, with Optional 9-1/8" Disc	04077	225	8-7/8	15/16	14	MC318	SC714	—	—	—
2.0	122	L4	1983	1984	5 Spd with Standard 8-1/2" Disc	04005	215	8-1/2	1	14	—	—	—	—	FWGM10
2.0	122	L4	1984	1986	5 Speed, with Optional 9-1/8" Disc	04077	225	8-7/8	15/16	14	MC318	SC714	—	—	—
2.0	122	L4	1985	1985	5 Spd with Standard 8-1/2" Disc	04005	215	8-1/2	1	14	—	SC714	—	—	FWGM10
2.0	122	L4	1987	1988	Non-Turbo	04046	215	8-1/2	1	14	MC316	SC714	—	—	FWGM10
2.0	122	L4	1987	1988	Turbo	KGM02	215	8-1/2	1	14	MC318	SC714	—	—	FWGM10
2.0	122	L4	1989	1990	Turbo	KGM02	215	8-1/2	1	14	—	SC714	—	—	FWGM10
2.0	122	L4	1989	1991	Non-Turbo	04046	215	8-1/2	1	14	MC327	SC714	—	—	FWGM10
2.0	122	L4	1992	1994	—	04046	215	8-1/2	1	14	MC327	SC714	—	—	FWGM10
2.2	134	L4	1995	1996	Includes Slave Cylinder	04161	215	8-1/2	1	14	MC333	SC715	—	—	FWGM10
2.2	134	L4	1997	1999	Includes Slave Cylinder	04161	215	8-1/2	1	14	MC333	SC715	—	—	—
2.2	134	L4	2000	2002	Includes Slave Cylinder, Sold As Kit Only	KGM08	215	8-1/2	1	14	MC333	—	—	—	—
2.2	134	L4	2002	2005	SFI with VIN F, Includes Slave Cylinder, Sold As Kit Only	GMK1000	225	8-7/8	1	14	—	—	—	—	—
2.3	140	L4	1995	1995	Includes Slave Cylinder	04158	225	8-7/8	15/16	14	MC333	SC715	—	—	—
2.4	146	L4	1996	1999	Includes Slave Cylinder	04158	225	8-7/8	15/16	14	MC333	SC715	—	—	—
2.4	146	L4	2000	2002	Includes Slave Cylinder, Sold As Kit Only	KGM04	225	8-7/8	1	14	—	—	—	—	—
2.5	153	L4	1977	1980	—	04062	232	9-1/8	1-1/8	10	—	—	—	—	—
3.1	189	V6	1991	1992	—	04088	225	8-7/8	15/16	14	MC327	SC715	—	—	—
3.1	189	V6	1993	1994	Includes Slave Cylinder	04132	225	8-7/8	15/16	14	MC330	SC715	—	—	—
3.8	232	V6	1976	1978	—	04062	232	9-1/8	1-1/8	10	—	—	—	—	—
3.8	232	V6	1979	1980	—	04021	265	10-1/2	1-1/8	10	—	—	—	—	—
<b>PHOENIX</b>															
2.5	153	L4	1980	1984	—	04077	225	8-7/8	15/16	14	—	—	—	—	—
2.8	171	V6	1980	1981	—	04077	225	8-7/8	15/16	14	—	—	—	—	—
2.8	171	V6	1982	1984	—	04077	225	8-7/8	15/16	14	—	—	—	—	FWGM111
3.8	232	V6	1979	1979	—	04021	265	10-1/2	1-1/8	10	—	—	—	—	—
5.0	305	V8	1979	1979	—	04021	265	10-1/2	1-1/8	10	—	—	—	—	—
<b>T1000</b>															
1.6	98	L4	1981	1981	—	04057	184	7-1/4	1	14	—	—	—	—	—
<b>VIBE</b>															
1.8	110	L4	2003	2006	5 Speed	KTY03	210	8-1/4	1	21	MC524	SC873	—	—	—
1.8	110	L4	2003	2006	GT, DOHC with 6 Spd	KTY14	210	8-1/4	1	21	MC524	SC873	—	—	—

Liter	CC/IN	Cyl	Years		Application Information	Kit	Disc (mm)	Disc (in)	Spline Dia	Splines	Master Cyl	Slave Cyl	Clutch Cable	Clutch Fork	New Flywheel
			To	From											
<b>PORSCHE</b>															
<b>911</b>															
2.0	1991	H6	1965	1969	Sold As Kit Only	KPO02	215	8-1/2	13/16	24	—	—	—	—	—
2.2	2195	H6	1970	1971	Sold As Kit Only	KPO05	225	8-7/8	13/16	24	—	—	—	—	—
3.2	3163	H6	1987	1989	Carrera, Sold As Kit Only	KPO03	240	9-1/2	1-1/32	23	—	—	—	—	—
3.2	3163	H6	1989	1989	Speedster, Sold As Kit Only	KPO03	240	9-1/2	1-1/32	23	—	—	—	—	—
3.3	3294	H6	1987	1988	Turbo with 930 Transmission, Sold As Kit Only	KPO15	240	9-1/2	1	23	—	—	—	—	—
3.3	3294	H6	1991	1992	Turbo, Sold As Kit Only	KPO12	240	9-1/2	1-1/32	23	—	—	—	—	—
3.6	3606	H6	1990	1993	Carrera, Sold As Kit Only	KPO12	240	9-1/2	1-1/32	23	—	—	—	—	—
3.6	3606	H6	1990	1994	Carrera 4, Sold As Kit Only	KPO12	240	9-1/2	1-1/32	23	—	—	—	—	—
3.6	3606	H6	1992	1994	Turbo Look, Sold As Kit Only	KPO12	240	9-1/2	1-1/32	23	—	—	—	—	—
3.6	3606	H6	1993	1993	Carrera 4, Turbo Look, Sold As Kit Only	KPO12	240	9-1/2	1-1/32	23	—	—	—	—	—
3.6	3606	H6	1993	1994	RS, Sold As Kit Only	KPO12	240	9-1/2	1-1/32	23	—	—	—	—	—
3.6	3606	H6	1994	1994	Speedster, Sold As Kit Only	KPO12	240	9-1/2	1-1/32	23	—	—	—	—	—
3.6	3606	H6	1994	1994	Turbo 3.6, Sold As Kit Only	KPO12	240	9-1/2	1-1/32	23	—	—	—	—	—
3.6	3606	H6	1996	1997	Turbo, Sold As Kit Only	KPO12	240	9-1/2	1-1/32	23	—	—	—	—	—
3.6	3596	H6	2002	2003	Carrera 4, Sold As Kit Only	KPO18	240	9-1/2	15/16	23	—	—	—	—	—
3.6	3606	H6	2002	2003	6 Spd Turbo, Sold as Kit Only	POK1001	240	9-7/16	1-1/16	23	—	—	—	—	—
3.6	3606	H6	2002	2005	Turbo, Sold as Kit Only	POK1000	240	9-7/16	1-1/16	23	—	—	—	—	—
3.6	3596	H6	2003	2003	Carrera 2, Sold As Kit Only	KPO18	240	9-1/2	15/16	23	—	—	—	—	—
3.6	3606	H6	2004	2004	GT3, Sold As Kit Only	KPO12	240	9-1/2	1-1/32	23	—	—	—	—	—
3.6	3596	H6	2004	2005	Sold as Kit Only	POK1003	240	9-7/16	1-1/16	23	—	—	—	—	—
3.6	3606	H6	2005	2005	6 Spd Turbo, Sold as Kit Only	POK1001	240	9-7/16	1-1/16	23	—	—	—	—	—
3.6	3596	H6	2007	2007	Turbo, Sold as Kit Only	POK1002	240	9-7/16	1-1/16	23	—	—	—	—	—
<b>912</b>															
1.6	1582	H4	1965	1969	Sold As Kit Only	KPO04	200	7-7/8	13/16	24	—	—	—	—	—
2.0	1991	H6	1971	1971	Sold As Kit Only	KPO16	215	8-1/2	13/16	24	—	—	—	—	—
2.0	1971	H4	1974	1975	Sold As Kit Only	KPO16	215	8-1/2	13/16	24	—	—	—	—	—
2.0	1967	H4	1976	1976	Sold As Kit Only	KPO16	215	8-1/2	13/16	24	—	—	—	—	—
<b>924</b>															
2.0	1983	L4	1977	1982	Sold As Kit Only	KPO17	215	8-1/2	13/16	24	—	—	—	—	—
<b>928</b>															
5.0	4950	V8	1985	1991	GT, S, S4, Sold As Kit Only	KPO06	250	9-7/8	1-1/32	23	—	—	—	—	—
<b>930</b>															
3.3	3294	H6	1978	1979	Turbo, Sold As Kit Only	KPO15	240	9-1/2	1	23	—	—	—	—	—
<b>944</b>															
2.5	2475	L4	1986	1989	Turbo, Sold As Kit Only	KPO01	240	9-1/2	1-1/32	23	—	—	—	—	—
2.5	2475	L4	1987	1988	S, Sold As Kit Only	KPO07	225	8-7/8	1-1/32	24	—	—	—	—	—
3.0	2999	L4	1989	1989	S, Sold As Kit Only	KPO07	225	8-7/8	1-1/32	24	—	—	—	—	—
3.0	2983	L4	1990	1991	S, Sold As Kit Only	KPO07	225	8-7/8	1-1/32	24	—	—	—	—	—
<b>BOXSTER</b>															
3.2	3179	H6	2000	2006	Sold As Kit Only	KPO18	240	9-1/2	15/16	23	—	—	—	—	—
<b>RENAULT</b>															
<b>FUEGO</b>															
1.6	1565	L4	1982	1984	Turbo	14009	215	8-1/2	15/16	21	—	—	—	—	—
2.2	2152	L4	1984	1985	—	14009	215	8-1/2	15/16	21	—	—	—	—	—
<b>R17</b>															
1.6	1647	L4	1972	1976	R1313, R1317, R1318, R1323, R1327, R1328	14008	215	8-1/2	15/16	21	—	—	—	—	—
<b>R18</b>															
2.2	2152	L4	1984	1986	R18i	14009	215	8-1/2	15/16	21	—	—	—	—	—
<b>SAAB</b>															
<b>9-2X</b>															
2.0	1994	H4	2005	2005	WAD Type Disc	KSB03	230	9-1/16	1	24	—	—	—	—	—
2.0	1994	H4	2005	2005	Economy version	FJK1006	228	9	1	24	—	—	—	—	—
2.5	2458	H4	2005	2005	—	KSB04	225	8-7/8	1	24	—	—	—	—	—
2.5	2458	H4	2006	2006	Turbo, Sold as Kit Only	FJK1001	230	9-1/16	1	24	MC585	SC919	—	—	—
2.5	2458	H4	2006	2006	Turbo, Sold As Kit Only, Push Type Clutch, Includes FW	FJK1001FW	230	9-1/16	1	24	MC585	SC919	—	—	—
<b>9-3</b>															
2.0	1985	L4	1999	2001	Turbo, Sold As Kit Only	SBK1000	228	9	1	14	—	—	—	—	—
2.3	2290	L4	2002	2002	Turbo, Sold As Kit Only, Includes Slave Cylinder	KSA04	228	9	1	14	—	—	—	—	—

Liter	CC/IN	Cyl	Years		Application Information	Kit	Disc (mm)	Disc (in)	Spline Dia	Splines	Master Cyl	Slave Cyl	Clutch Cable	Clutch Fork	New Flywheel
			To	From											
<b>SAAB CONT.</b>															
<b>9-5</b>															
2.3	2290	L4	1999	2003	Turbo, Sold As Kit Only, Includes Slave Cylinder	KSA04	228	9	1	14	—	—	—	—	—
2.3	2290	L4	2004	2004	Sold as Kit Only, Includes Slave Cylinder	KSA04	228	9	1	14	—	—	—	—	—
3.0	2961	V6	2002	2002	Sold as Kit Only, Includes Slave Cylinder	KSA04	228	9	1	14	—	—	—	—	—
<b>900</b>															
2.0	1985	L4	1979	1990	—	21006	215	8-7/16	3/4	17	MC130	SC531	—	—	—
2.0	1985	L4	1979	1993	Turbo	21006	215	8-7/16	3/4	17	MC130	SC531	—	—	—
2.0	1985	L4	1994	1998	Turbo	21006	215	8-7/16	3/4	17	—	—	—	—	—
2.1	2119	L4	1994	1994	Sold As Kit Only	21006	215	8-7/16	3/4	17	—	—	—	—	—
2.3	2290	L4	1994	1994	Sold As Kit Only, To eng. #R129242	KSA01	228	9	1	14	—	—	—	—	—
2.3	2290	L4	1994	1998	—	KSA03	228	9	1	14	—	—	—	—	—
2.5	2498	V6	1994	1995	Sold As Kit Only	KSA02	228	9	1	14	—	—	—	—	—
<b>9000</b>															
2.0	1985	L4	1987	1989	—	21007	215	8-7/16	3/4	17	—	—	—	—	—
2.3	2290	L4	1990	1993	—	21007	215	8-7/16	3/4	17	—	—	—	—	—
2.3	2290	L4	1991	1993	Turbo	21011	240	9-1/2	3/4	17	—	—	—	—	—
2.3	2290	L4	1994	1994	Turbo, Sold As Kit Only	KSA05	228	9	1	14	—	—	—	—	—
2.3	2290	L4	1995	1998	Turbo, Sold As Kit Only	KSA05	228	9	1	14	—	—	—	—	—
3.0	2961	V6	1995	1997	Sold As Kit Only	KSA05	228	9	1	14	—	—	—	—	—
<b>99</b>															
2.0	1985	L4	1976	1980	—	21006	215	8-7/16	3/4	17	MC130	SC531	—	—	—
2.0	1985	L4	1978	1978	Turbo	21006	215	8-7/16	3/4	17	MC130	SC531	—	—	—
<b>SATURN</b>															
<b>ION</b>															
2.0	122	L4	2004	2007	Supercharged, Includes CSC Hydraulic Slave, Sold as Kit Only	GMK1016	238	9-3/8	1	14	—	—	—	—	—
2.2	134	L4	2003	2007	Includes CSC Hydraulic Slave Cylinder	GMK1017	228	9	1	14	—	—	—	—	—
<b>L SERIES</b>															
2.2	134	L4	2000	2003	—	KSN01	228	9	1	14	—	SC717	—	—	—
<b>S SERIES</b>															
1.9	116	L4	1991	1999	—	04115	215	8-7/16	15/16	22	MC329	SC717	—	—	—
1.9	116	L4	2000	2002	—	KSN02	215	8-7/16	15/16	22	MC454	SC717	—	—	—
<b>SATURN SUV</b>															
<b>VUE</b>															
2.2	134	L4	2002	2007	Includes CSC Hydraulic Slave Cylinder	KSN03	228	9	1	14	—	—	—	—	—
3.5	3474	V6	2002	2007	Includes CSC Hydraulic Slave Cylinder	KSN03	228	9	1	14	—	—	—	—	—
<b>SCION</b>															
<b>FR-S</b>															
2.0	1994	H4	2013	2016	Sold as Kit Only	FJK1005	230	9-1/16	1	24	—	—	—	—	TYF001
<b>TC</b>															
2.4	2398	L4	2005	2010	—	TYK1506	236	9-1/4	1-3/16	21	MC524	SC861	—	—	—
2.5	2398	L4	2011	2012	Sold as Kit Only, Includes CSC Hydraulic Slave Cylinder	TYK1507	225	8-7/8	1-1/32	23	—	BRG0182	—	—	—
<b>XA, XB</b>															
1.5	1497	L4	2004	2005	—	KTY15	210	8-1/4	1	21	MC535	SC841	—	—	—
1.5	1497	L4	2005	2006	—	KTY15	210	8-1/4	1	21	MC534	SC841	—	—	—
<b>XB</b>															
2.4	2398	L4	2008	2015	—	TYK1506	236	9-1/4	1-3/16	21	—	SC907	—	—	—
<b>STERLING</b>															
<b>825</b>															
2.5	2494	V6	1987	1988	—	08018	225	8-7/8	1	24	—	—	—	—	—
<b>SUBARU</b>															
<b>1600, 1800</b>															
1.6	1595	H4	1976	1980	—	15002	200	7-7/8	3/4	23	—	—	—	—	—
1.6	1595	H4	1981	1984	—	15001	200	7-7/8	7/8	21	—	—	—	—	—
1.8	1781	H4	1980	1984	2 WD	15001	200	7-7/8	7/8	21	—	—	—	—	—
1.8	1781	H4	1983	1984	2 WD, Turbo	15001	200	7-7/8	7/8	21	—	—	—	—	—
1.8	1781	H4	1985	1989	2 WD	15001	200	7-7/8	7/8	21	—	—	CC892	—	—
1.8	1781	H4	1985	1989	2 WD, Turbo	15001	200	7-7/8	7/8	21	—	—	CC892	—	—
1.8	1781	H4	1985	1989	4 WD	15008	225	8-7/8	1	24	—	—	CC894	—	—
1.8	1781	H4	1985	1989	Turbo, 4WD	15008	225	8-7/8	1	24	—	—	CC894	—	—

Liter	CC/IN	Cyl	Years		Application Information	Kit	Disc (mm)	Disc (in)	Spline Dia	Splines	Master Cyl	Slave Cyl	Clutch Cable	Clutch Fork	New Flywheel
			To	From											
<b>SUBARU CONT.</b>															
<b>BAJA</b>															
1.6	1595	H4	1978	1980	—	15002	200	7-7/8	3/4	23	—	—	—	—	—
1.8	1781	H4	1980	1980	—	15002	200	7-7/8	3/4	23	—	—	—	—	—
2.5	2458	H4	2003	2006	SOHC, Sold As Kit Only	KSB04	225	8-7/8	1	24	MC567	SC919	—	—	FWSBL02FF
2.5	2458	H4	2004	2005	DOHC, Turbo, WAD Type Disc, Sold As Kit Only	KSB03	228	9	1	24	MC586	SC920	—	—	—
2.5	2458	H4	2004	2005	DOHC, Turbo, Economy Version, Sold As Kit Only	FJK1006	228	9	1	24	MC586	SC920	—	—	—
2.5	2458	H4	2006	2006	Turbo, Solid FW Replacement for OEM Dual Mass FW, Sold as Kit Only	FJK1001FW	230	9-1/16	1	24	MC586	—	—	—	—
<b>BRAT</b>															
1.8	1781	H4	1981	1982	4WD	15001	200	7-7/8	7/8	21	—	—	—	—	—
1.8	1781	H4	1983	1987	2WD	15001	200	7-7/8	7/8	21	—	—	—	—	—
1.8	1781	H4	1984	1984	2 WD, Turbo	15001	200	7-7/8	7/8	21	—	—	—	—	—
<b>BRZ</b>															
2.0	1994	H4	2013	2016	Sold as Kit Only	FJK1005	230	9-1/16	1	24	—	—	—	—	TYF001
<b>IMPREZZA, IMPREZZA OUTBACK, RS, TS, WRX</b>															
1.8	1781	H4	1993	1993	4 WD	15012	215	8-1/2	1	24	—	—	—	—	—
1.8	1781	H4	1993	1994	2 WD	15014	200	7-7/8	7/8	21	—	—	—	—	—
1.8	1781	H4	1994	1994	AWD	15014	200	7-7/8	7/8	21	—	—	—	—	—
1.8	1781	H4	1995	1995	2 WD	KSB02	200	7-7/8	7/8	21	—	—	—	—	—
1.8	1781	H4	1995	1995	4 WD	15010	225	8-7/8	1	24	—	—	—	—	—
1.8	1781	H4	1996	1997	—	15010	225	8-7/8	1	24	—	—	—	—	—
2.0	1994	H4	2002	2005	WRX, Turbo, Sold As Kit Only	KSB03	230	9-1/16	1	24	—	SC918	—	—	—
2.0	1994	H4	2002	2005	Pull Type, WRX, Turbo, Economy Version, Sold As Kit Only	FJK1006	228	9	1	24	—	SC920	—	—	—
2.0	1999	H4	2013	2016	Non-Turbo, Sold As Kit Only	KSB04	225	8-7/8	1	24	—	—	—	—	—
2.2	2212	H4	1995	2001	—	15010	225	8-7/8	1	24	—	—	—	—	FWSBL01
2.5	2458	H4	1998	1998	—	15015	225	8-7/8	1	24	MC582	SC847	—	—	FWSBL01
2.5	2458	H4	1999	1999	Sold As Kit Only	KSB04	225	8-7/8	1	24	MC567	SC847	—	—	—
2.5	2458	H4	2000	2002	Sold As Kit Only	KSB04	225	8-7/8	1	24	MC567	SC847	—	—	FWSBL02FF
2.5	2458	H4	2002	2004	Sold As Kit Only	KSB04	225	8-7/8	1	24	MC584	SC847	—	—	FWSBL02FF
2.5	2458	H4	2004	2005	Pull Type, WRX-STI, Turbo	FJK1000	240	9-1/2	1	24	—	—	—	—	—
2.5	2458	H4	2005	2012	Non-Turbo, Sold As Kit Only	KSB04	225	8-7/8	1	24	MC585	SC919	—	—	—
2.5	2458	H4	2006	2014	6spd WRX Sti, Turbo, Pull Type, Sold as Kit Only	FJK1000	240	9-1/2	1	24	—	—	—	—	—
2.5	2458	H4	2006	2014	WRX, Turbo, Sold As Kit Only	FJK1001	230	9-1/16	1	24	—	—	—	—	—
3.0	3000	H6	2001	2003	Sold As Kit Only	KSB04	225	8-7/8	1	24	—	—	—	—	—
<b>JUSTY</b>															
1.2	1189	L3	1987	1990	—	15006	184	7-1/4	3/4	23	—	—	—	—	—
1.2	1189	L3	1991	1991	From 12/1/90	15011	184	7-1/4	3/4	23	—	—	—	—	—
1.2	1189	L3	1991	1991	To 11/30/90	15006	184	7-1/4	3/4	23	—	—	—	—	—
1.2	1189	L3	1992	1994	—	15011	184	7-1/4	3/4	23	—	—	—	—	—
<b>LEGACY, LEGACY OUTBACK</b>															
2.2	2212	H4	1990	1996	Non-Turbo	15010	225	8-7/8	1	24	—	—	—	—	FWSBL01
2.2	2212	H4	1991	1991	Pull Type, Turbo, Sold As Kit Only	KSB01	225	8-7/8	1	24	MC581	—	—	—	—
2.2	2212	H4	1992	1994	Pull Type, Turbo, Sold As Kit Only	KSB01	225	8-7/8	1	24	MC581	SC917	—	—	—
2.2	2212	H4	1997	1999	Non-Turbo	15010	225	8-7/8	1	24	—	—	—	—	—
2.5	2458	H4	1996	1998	Sold As Kit Only	KSB04	225	8-7/8	1	24	—	—	—	—	—
2.5	2458	H4	1999	1999	Sold As Kit Only	KSB04	225	8-7/8	1	24	MC582	SC847	—	—	FWSBL02FF
2.5	2458	H4	2000	2002	Sold As Kit Only	KSB04	225	8-7/8	1	24	MC567	SC847	—	—	FWSBL02FF
2.5	2458	H4	2003	2004	Sold As Kit Only	KSB04	225	8-7/8	1	24	MC567	SC919	—	—	FWSBL02FF
2.5	2458	H4	2005	2006	Turbo, Solid FW Replacement for OEM Dual Mass FW, Sold as Kit Only, Includes Solid FW	FJK1001FW	230	9-1/16	1	24	MC586	SC921	—	—	TYF001
2.5	2458	H4	2005	2009	Sold As Kit Only	KSB04	225	8-7/8	1	24	—	SC919	—	—	FWSBL02FF
2.5	2458	H4	2007	2009	5spd Turbo, Solid FW Replacement for OEM Dual Mass FW, Sold as kit only	FJK1001	230	9-1/16	1	24	MC586	SC921	—	—	TYF001
2.5	2458	H4	2007	2009	6 Spd, Turbo, Pull Type, Sold as Kit Only	FJK1007	230	9-1/16	1	24	—	—	—	—	—
2.5	2458	H4	2007	2008	Pull Type, 6 Spd Turbo, Sold as Kit Only	FJK1002	240	9-7/16	1	24	MC586	—	—	—	—
2.5	2458	H4	2010	2012	6 Spd Turbo, Solid FW Replacement for OEM Dual Mass FW, Sold as kit only	FJK1001	230	9-1/16	1	24	—	—	—	—	TYF001
2.5	2458	H4	2010	2016	6 Spd Non-Turbo, Sold as Kit Only	FJK1004	230	9-1/16	1	24	—	—	—	—	—
<b>LOYALE</b>															
1.8	1781	H4	1990	1990	Turbo	15008	225	8-7/8	1	24	—	—	—	—	—
1.8	1781	H4	1990	1994	Non-Turbo	15001	200	7-7/8	7/8	21	—	—	—	—	—
<b>RX</b>															
1.8	1781	H4	1986	1989	Turbo	15008	225	8-7/8	1	24	—	—	—	—	—

Liter	CC/IN	Cyl	Years		Application Information	Kit	Disc (mm)	Disc (in)	Spline Dia	Splines	Master Cyl	Slave Cyl	Clutch Cable	Clutch Fork	New Flywheel
			To	From											
<b>SUBARU CONT.</b>															
<i>WRX</i>															
2.0	1994	H4	2015	2016	WRX, Turbo, Sold As Kit Only	FJK1001	230	9-1/16	1	24	—	—	—	—	—
2.5	2458	H4	2015	2016	6spd WRX Sti, Turbo, Sold as Kit Only	FJK1000	240	9-1/2	1	24	—	—	—	—	—
<i>XT</i>															
1.8	1781	H4	1985	1987	Turbo	15008	225	8-7/8	1	24	—	—	—	—	—
1.8	1781	H4	1985	1991	Non-Turbo	15001	200	7-7/8	7/8	21	—	—	—	—	—
<b>SUBARU SUV</b>															
<i>FORESTER</i>															
2.5	2458	H4	1998	1998	Non-Turbo, Sold As Kit Only	KSB04	225	8-7/8	1	24	MC582	SC847	—	—	—
2.5	2458	H4	1999	2000	Non-Turbo, Sold As Kit Only	KSB04	225	8-7/8	1	24	MC567	SC847	—	—	—
2.5	2458	H4	2001	2001	Non-Turbo, Sold As Kit Only	KSB04	225	8-7/8	1	24	MC567	SC847	—	—	FWSBL02FF
2.5	2458	H4	2002	2004	Non-Turbo, Sold As Kit Only	KSB04	225	8-7/8	1	24	MC585	SC847	—	—	FWSBL02FF
2.5	2458	H4	2004	2005	Turbo, WAD Type Disc, Sold As Kit Only	KSB03	230	9-1/16	1	24	—	SC918	—	—	—
2.5	2458	H4	2004	2005	Turbo, Economy Version, Sold As Kit Only	FJK1006	228	9	1	24	—	SC918	—	—	—
2.5	2458	H4	2005	2013	Non-Turbo, Sold As Kit Only	KSB04	225	8-7/8	1	24	MC585	SC919	—	—	—
2.5	2458	H4	2014	2016	6 Spd NON-Turbo, Sold as Kit Only	FJK1004	230	9-1/16	1	24	—	—	—	—	—
2.5	2458	H4	2006	2008	Turbo, Solid FW Replacement for OEM Dual Mass FW, Sold as Kit Only	FJK1001	230	9-1/16	1	24	—	SC921	—	—	TYF001
<i>OUTBACK</i>															
2.5	2458	H4	2005	2006	Turbo, Solid FW Replacement for OEM Dual Mass FW, Sold as Kit Only	FJK1001FW	230	9-1/16	1	24	MC586	SC921	—	—	TYF001
2.5	2458	H4	2007	2009	5 Spd Turbo, Sold as Kit Only	FJK1001	230	9-1/16	1	24	—	—	—	—	—
2.5	2458	H4	2010	2016	Sold As Kit Only	FJK1004	230	9-1/16	1	24	—	—	—	—	—
<i>XV CROSSTREK</i>															
2.0	1999	H4	2013	2016	Non-Turbo, Sold As Kit Only	KSB04	225	8-7/8	1	24	—	—	—	—	—
<b>SUZUKI</b>															
<i>AERIO/AERIO SX</i>															
2.0	2000	L4	2003	2003	—	SZK1000	200	7-7/8	7/8	20	MC510	SC869	—	—	—
2.3	2290	L4	2004	2007	—	SZK1001	215	8-7/16	7/8	20	MC510	SC869	—	—	—
<i>ESTEEM</i>															
1.6	1590	L4	1995	2000	—	04100	190	7-1/2	3/4	18	—	—	—	—	—
1.8	1790	L4	1999	2002	—	SZK1000	200	7-7/8	7/8	20	MC533	SC869	—	—	—
<i>FORSA (CANADA)</i>															
1.0	993	L3	1985	1988	Non-Turbo	04076	160	6-5/16	3/4	18	—	—	—	—	—
1.0	993	L3	1987	1988	Turbo	04139	190	7-1/2	3/4	18	—	—	—	—	—
<i>SX4</i>															
2.0	1995	L4	2007	2008	Sold as Kit Only, Includes CSC Hydraulic Slave Cylinder	SZK1003	215	8-1/2	7/8	20	—	—	—	—	—
<b>SUZUKI SUV &amp; VAN</b>															
<i>GRAND VITARA</i>															
2.5	2500	V6	2004	2005	Sold As Kit Only	KSZ03	225	8-7/8	1-13/16	21	MC503	SC870	—	—	—
2.7	2700	V6	2004	2005	—	SZK1002	236	9-1/4	1-3/16	21	MC503	—	—	—	—
<i>SAMURAI, SJ410</i>															
1.6	1590	L4	1985	1985	—	04076	160	6-5/16	3/4	18	—	—	—	—	—
1.3	1325	L4	1986	1995	—	04104	190	7-1/2	15/16	20	—	—	CC414	—	—
<i>SIDEKICK</i>															
1.3	1325	L4	1989	1989	—	04104	190	7-1/2	15/16	20	—	—	CC809	—	—
1.6	1590	L4	1989	1991	2 Door	04108	200	7-7/8	7/8	20	—	—	CC809	—	—
1.6	1590	L4	1991	1991	4 Door	04137	215	8-7/16	7/8	20	—	—	CC809	—	—
1.6	1590	L4	1992	1998	—	04137	215	8-7/16	7/8	20	—	—	—	—	—
1.8	1840	L4	1996	1998	—	04137	215	8-7/16	7/8	20	MC533	—	—	—	—
<i>SJ410 (CANADA)</i>															
1.0	993	L3	1982	1984	—	KSZ02	180	7-1/8	3/4	18	—	—	—	—	—
<i>SWIFT</i>															
1.3	1298	L4	1989	2001	—	04100	190	7-1/2	3/4	18	—	—	—	—	—
<i>X-90</i>															
1.6	1590	L4	1996	1998	—	04137	215	8-7/16	7/8	20	—	—	—	—	—



Liter	CC/IN	Cyl	Years		Application Information	Kit	Disc (mm)	Disc (in)	Spline Dia	Splines	Master Cyl	Slave Cyl	Clutch Cable	Clutch Fork	New Flywheel
			To	From											
<b>TOYOTA</b>															
<b>CAMRY</b>															
1.8	1839	L4	1984	1986	Turbo Diesel	16047	225	8-7/8	1-1/8	20	MC246	SC670	—	—	—
2.0	1995	L4	1983	1985	—	16047	225	8-7/8	1-1/8	20	MC246	SC670	—	—	—
2.0	1974	L4	1986	1986	Turbo Diesel, From 8/86	16047	225	8-7/8	1-1/8	20	MC246	SC670	—	—	—
2.0	1974	L4	1986	1986	Turbo Diesel, To 7/86	16047	225	8-7/8	1-1/8	20	MC246	SC653	—	—	—
2.0	1995	L4	1986	1986	From 8/86	16047	225	8-7/8	1-1/8	20	MC246	SC653	—	—	—
2.0	1995	L4	1986	1986	To 7/86	16047	225	8-7/8	1-1/8	20	MC246	SC670	—	—	—
2.0	1998	L4	1987	1989	—	16047	225	8-7/8	1-1/8	20	MC246	SC653	—	—	—
2.0	1998	L4	1988	1991	ALL TRAC	16082	236	9-1/4	1-3/16	21	MC246	SC653	—	—	—
2.0	1998	L4	1990	1990	To 4/30/90	16047	225	8-7/8	1-1/8	20	MC246	SC653	—	—	—
2.0	1998	L4	1991	1991	—	16073	225	8-7/8	1-1/8	20	MC248	SC654	—	—	—
2.2	2164	L4	1992	1996	—	16073	225	8-7/8	1-1/8	20	MC540	SC654	—	—	—
2.2	2164	L4	1997	2001	—	16073	225	8-7/8	1-1/8	20	MC558	SC653	—	—	—
2.4	2362	L4	2002	2006	—	TYK1506	236	9-1/4	1-3/16	21	MC525	SC861	—	—	—
2.4	2362	L4	2007	2009	Sold as Kit Only	TYK1506	236	9-1/4	1-3/16	21	—	SC861	—	—	—
2.5	2508	V6	2010	2011	Sold as Kit Only, Includes CSC Hydraulic Slave Cylinder	TYK1507	225	8-7/8	1-1/32	23	—	BRG0182	—	—	—
2.5	2508	V6	1988	1991	—	16082	236	9-1/4	1-3/16	21	MC246	SC653	—	—	—
3.0	2959	V6	1992	1994	—	16062	236	9-1/4	1-3/16	21	MC248	SC654	—	—	—
3.0	2995	V6	1997	2001	—	16062	236	9-1/4	1-3/16	21	MC558	SC661	—	—	—
3.0	2995	V6	2004	2006	Sold as Kit Only	TYK1506	236	9-1/4	1-3/16	21	—	SC861	—	—	—
3.3	3275	V6	2004	2006	Sold as Kit Only	TYK1506	236	9-1/4	1-3/16	21	—	SC861	—	—	—
3.5	3498	V6	2007	2009	Sold as Kit Only	TYK1506	236	9-1/4	1-3/16	21	—	SC861	—	—	—
<b>CARINA</b>															
1.6	1588	L4	1972	1973	—	16005	190	7-1/2	15/16	21	MC250	SC655	—	—	—
<b>CELICA</b>															
1.6	1587	L4	1990	1990	ST	16064	210	8-1/4	1	21	MC258	SC660	—	—	—
1.6	1587	L4	1991	1991	ST, From 6/1/91	KTY03	210	8-1/4	1	21	MC258	SC660	—	—	—
1.6	1587	L4	1991	1991	ST, To 5/31/91	16064	210	8-1/4	1	21	MC258	SC660	—	—	—
1.6	1587	L4	1992	1993	ST	KTY03	210	8-1/4	1	21	MC258	SC660	—	—	—
1.8	1762	L4	1994	1995	—	KTY03	210	8-1/4	1	21	MC258	SC660	—	—	—
1.8	1762	L4	1994	1997	ST	KTY18	210	8-1/4	1	21	MC566	SC818	—	—	—
1.8	1794	L4	2000	2005	GT, GTS	KTY14	210	8-1/4	1	21	MC524	SC856	—	—	—
1.9	1898	L4	1971	1971	—	16019	200	7-7/8	1-3/16	21	MC471	SC819	—	—	—
2.0	1968	L4	1972	1974	—	16007	225	8-7/8	1-3/16	21	MC250	SC656	—	—	—
2.0	1995	L4	1986	1986	ST	16072	225	8-7/8	1-1/8	20	MC263	SC653	—	—	—
2.0	1998	L4	1986	1987	GT,GTS,ST	16072	225	8-7/8	1-1/8	20	MC263	SC670	—	—	—
2.0	1998	L4	1988	1988	ALL TRAC Turbo	16082	236	9-1/4	1-3/16	21	MC263	SC653	—	—	—
2.0	1998	L4	1989	1989	ALL TRAC Turbo, To 8/89	16082	236	9-1/4	1-3/16	21	MC263	SC653	—	—	—
2.0	1998	L4	1988	1989	GT,ST	16072	225	8-7/8	1-1/8	20	MC263	SC653	—	—	—
2.0	1998	L4	1989	1989	ALL TRAC Turbo, From 9/89	16082	236	9-1/4	1-3/16	21	MC258	SC661	—	—	—
2.0	1998	L4	1990	1993	ALL TRAC Turbo	KTY11	236	9-1/4	1-3/16	21	MC258	SC661	—	—	—
2.2	2189	L4	1975	1975	From 10/75	16034	225	8-7/8	1-3/16	21	MC252	SC658	—	—	—
2.2	2189	L4	1975	1975	To 9/75	16034	225	8-7/8	1-3/16	21	MC250	SC658	—	—	—
2.2	2189	L4	1976	1976	—	16034	225	8-7/8	1-3/16	21	MC252	SC658	—	—	—
2.2	2189	L4	1977	1977	6/77 - 7/77	16034	225	8-7/8	1-3/16	21	MC250	SC658	—	—	—
2.2	2189	L4	1977	1977	From 8/77	16032	225	8-7/8	1-3/16	21	MC254	SC658	—	—	—
2.2	2189	L4	1977	1977	To 5/77	16034	225	8-7/8	1-3/16	21	MC252	SC658	—	—	—
2.2	2189	L4	1978	1980	—	16032	225	8-7/8	1-3/16	21	MC254	SC659	—	—	—
2.2	2164	L4	1990	1990	GT,GTS From 5/1/90	16073	225	8-7/8	1-1/8	20	MC258	SC653	—	—	—
2.2	2164	L4	1990	1990	GT,GTS To 4/30/90	16072	225	8-7/8	1-1/8	20	MC258	SC653	—	—	—
2.2	2164	L4	1991	1993	GT,GTS	16073	225	8-7/8	1-1/8	20	MC258	SC653	—	—	—
2.2	2164	L4	1994	1999	GT	16073	225	8-7/8	1-1/8	20	MC566	SC653	—	—	—
2.4	2366	L4	1981	1981	GT,ST From 8/81	16084	225	8-7/8	1-3/16	21	MC254	SC659	—	—	—
2.4	2366	L4	1981	1981	GT,ST To 7/81	16084	225	8-7/8	1-3/16	21	MC254	SC659	—	—	—
2.4	2366	L4	1982	1985	GT,GTS,ST	16084	225	8-7/8	1-3/16	21	MC256	SC659	—	—	—
<b>COROLLA</b>															
1.2	1166	L4	1974	1974	From 5/1/74	16004	184	7-1/4	7/8	19	—	SC655	—	—	—
1.2	1166	L4	1977	1979	—	16004	184	7-1/4	7/8	19	—	—	—	—	—
1.6	1588	L4	1971	1973	—	16005	190	7-1/2	15/16	21	MC261	SC655	—	—	—
1.6	1588	L4	1974	1974	—	16005	190	7-1/2	15/16	21	MC261	SC667	—	—	—

Liter	CC/IN	Cyl	Years		Application Information	Kit	Disc (mm)	Disc (in)	Spline Dia	Splines	Master Cyl	Slave Cyl	Clutch Cable	Clutch Fork	New Flywheel
			To	From											
<b>TOYOTA CONT.</b>															
<b>COROLLA CONT.</b>															
1.6	1588	L4	1975	1976	—	16005	190	7-1/2	15/16	21	MC250	SC658	—	—	—
1.6	1588	L4	1977	1977	—	16005	190	7-1/2	15/16	21	MC471	SC658	—	—	—
1.6	1588	L4	1978	1979	—	16066	190	7-1/2	15/16	21	MC471	SC659	—	—	—
1.6	1587	L4	1983	1983	RWD, From 8/83	16042	200	7-7/8	15/16	21	MC263	SC668	—	—	—
1.6	1587	L4	1983	1983	RWD, To 7/83	16013	210	8-1/4	1	21	MC263	SC668	—	—	—
1.6	1587	L4	1984	1987	RWD	16042	200	7-7/8	15/16	21	MC263	SC668	—	—	—
1.6	1587	L4	1984	1989	FWD	16070	200	7-7/8	15/16	21	MC256	SC669	—	—	—
1.6	1587	L4	1985	1987	RWD, GTS	16029	200	7-7/8	15/16	21	MC256	SC669	—	—	—
1.6	1587	L4	1987	1988	FWD, FX	16082	236	9-1/4	1-3/16	21	MC256	SC669	—	—	—
1.6	1587	L4	1988	1988	ALL TRAC	16065	225	8-7/8	1-3/16	21	MC253	SC660	—	—	—
1.6	1587	L4	1988	1989	FWD	16074	210	8-1/4	1	21	MC251	SC818	—	—	—
1.6	1587	L4	1988	1991	RWD, GTS	16074	210	8-1/4	1	21	MC265	SC660	—	—	—
1.6	1587	L4	1988	1992	RWD	16074	210	8-1/4	1	21	MC265	SC660	—	—	—
1.6	1587	L4	1989	1989	ALL TRAC from 8/89	16065	225	8-7/8	1-3/16	21	MC266	SC660	—	—	—
1.6	1587	L4	1989	1989	ALL TRAC to 7/89	16065	225	8-7/8	1-3/16	21	MC253	SC660	—	—	—
1.6	1587	L4	1990	1992	ALL TRAC	16065	225	8-7/8	1-3/16	21	MC266	SC660	—	—	—
1.6	1587	L4	1990	1992	FWD	16070	200	7-7/8	15/16	21	MC265	SC660	—	—	—
1.6	1587	L4	1992	1997	—	KTY03	210	8-1/4	1	21	MC265	SC660	—	—	—
1.8	1770	L4	1980	1982	4 Speed	16051	210	8-1/4	1	21	MC473	SC659	—	—	—
1.8	1770	L4	1980	1982	5 Speed	16042	200	7-7/8	15/16	21	MC473	SC659	—	—	—
1.8	1770	L4	1981	1981	5 Spd	16042	200	7-7/8	15/16	21	MC262	SC668	—	—	—
1.8	1770	L4	1981	1982	4 Spd, 8-1/4"	16051	210	8-1/4	1	21	MC262	SC668	—	—	—
1.8	1770	L4	1981	1982	5 Spd, 7-7/8"	16042	200	7-7/8	15/16	21	MC262	SC668	—	—	—
1.8	1839	L4	1984	1985	Diesel	16054	211	8-5/16	1-3/16	20	MC264	SC670	—	—	—
1.8	1762	L4	1993	1993	4WD	KTY14	210	8-1/4	1	21	MC265	SC818	—	—	—
1.8	1762	L4	1993	1997	FWD	KTY03	210	8-1/4	1	21	MC265	SC818	—	—	—
1.8	1794	L4	1998	2001	FWD	KTY03	210	8-1/4	1	21	MC265	SC842	—	—	—
1.8	1794	L4	2002	2002	FWD	KTY03	210	8-1/4	1	21	MC265	SC842	—	—	—
1.8	1794	L4	2003	2008	FWD, Sold As Kit Only	TYK1501	213	8-3/8	15/16	21	MC524	SC874	—	—	—
1.8	1795	L4	2005	2008	6 Speed, XRS	KTY14	210	8-1/4	1	21	MC525	SC874	—	—	—
1.8	1795	L4	2009	2013	Sold as Kit Only	TYK1518	212	8-1/4	15/16	21	MC573	—	—	—	—
1.8	1795	L4	2014	2015	Sold as Kit Only, Include CSC Hydraulic Slave Cylinder	TYK1522	210	8-1/4	1	21	—	BRG0222	—	—	—
2.4	2362	L4	2010	2011	6 Speed, XRS	TYK1506	236	9-1/4	1-3/16	21	MC573	SC907	—	—	—
<b>CORONA</b>															
1.9	1898	L4	1967	1970	—	16003	200	7-7/8	15/16	21	MC271	SC656	—	—	—
1.9	1898	L4	1967	1970	—	16030	200	7-7/8	15/16	21	MC269	SC656	—	—	—
1.9	1858	L4	1969	1969	Mark II from 2/69	16003	200	7-7/8	15/16	21	MC271	SC656	—	—	—
1.9	1858	L4	1969	1971	Mark II	16003	200	7-7/8	15/16	21	MC269	SC819	—	—	—
1.9	1858	L4	1970	1970	Mark II to 1/70	16003	200	7-7/8	15/16	21	MC271	SC656	—	—	—
1.9	1898	L4	1970	1970	—	16019	200	7-7/8	1-3/16	21	MC269	SC819	—	—	—
1.9	1858	L4	1971	1971	—	16003	200	7-7/8	15/16	21	MC271	SC656	—	—	—
1.9	1858	L4	1971	1971	—	16019	200	7-7/8	1-3/16	21	MC289	SC656	—	—	—
1.9	1858	L4	1971	1971	Mark II	16030	200	7-7/8	15/16	21	MC269	SC656	—	—	—
2.0	1968	L4	1972	1972	—	16007	225	8-7/8	1-3/16	21	MC270	SC656	—	—	—
2.0	1968	L4	1972	1972	Mark II	16034	225	8-7/8	1-3/16	21	MC475	SC676	—	—	—
2.0	1968	L4	1973	1973	From 8/73	16007	225	8-7/8	1-3/16	21	MC254	SC656	—	—	—
2.0	1968	L4	1973	1973	To 7/73	16007	225	8-7/8	1-3/16	21	MC270	SC656	—	—	—
2.0	1968	L4	1974	1974	—	16007	225	8-7/8	1-3/16	21	MC254	SC656	—	—	—
2.2	2189	L4	1975	1977	—	16007	225	8-7/8	1-3/16	21	MC252	SC657	—	—	—
2.2	2189	L4	1978	1980	—	16016	225	8-7/8	1-3/16	21	MC254	SC677	—	—	—
2.4	2366	L4	1981	1982	—	16084	225	8-7/8	1-3/16	21	MC254	SC659	—	—	—
<b>CRESSIDA</b>															
2.8	2754	L6	1983	1987	—	16018	236	9-1/4	1-3/16	21	MC274	SC666	—	—	—
<b>CROWN</b>															
2.3	2253	L6	1967	1969	To 1/70	16033	225	8-7/8	15/16	21	—	SC676	—	—	—
2.3	2253	L6	1970	1970	From 2/70	16034	225	8-7/8	1-3/16	21	—	SC676	—	—	—
<b>ECHO</b>															
1.5	1497	L4	2000	2005	—	KTY15	210	8-1/4	1	21	MC535	SC841	—	—	—

Liter	CC/IN	Cyl	Years		Application Information	Kit	Disc (mm)	Disc (in)	Spline Dia	Splines	Master Cyl	Slave Cyl	Clutch Cable	Clutch Fork	New Flywheel
			To	From											
<b>TOYOTA CONT.</b>															
<b>GT86</b>															
2.0	1994	H4	2013	2015	Sold as Kit Only	FJK1005	230	9-1/16	1	24	—	—	—	—	TYF001
<b>MARK II</b>															
2.3	2253	L6	1972	1972	—	16034	225	8-7/8	1-3/16	21	—	SC676	—	—	—
2.6	2563	L6	1973	1974	—	16034	225	8-7/8	1-3/16	21	—	SC676	—	—	—
<b>MATRIX</b>															
1.8	1794	L4	2003	2008	5 Speed, XR	TYK1501	213	8-3/8	15/16	21	MC524	SC874	—	—	—
1.8	1795	L4	2003	2006	6 Speed, XRS	KTY14	210	8-1/4	1	21	MC525	SC874	—	—	—
1.8	1795	L4	2009	2011	Sold as Kit Only	TYK1518	212	8-1/4	15/16	21	MC573	—	—	—	—
2.4	2362	L4	2009	2011	6 Speed, XRS	TYK1506	236	9-1/4	1-3/16	21	MC573	SC907	—	—	—
<b>MR2, MR2 SPYDER</b>															
1.6	1587	L4	1985	1985	—	16029	200	7-7/8	15/16	21	MC289	SC688	—	—	—
1.6	1587	L4	1986	1989	—	16064	210	8-1/4	1	21	MC289	SC688	—	—	—
1.6	1587	L4	1988	1989	Supercharged	16075	225	8-7/8	1-3/16	21	MC289	—	—	—	—
1.8	1794	L4	2000	2004	Excludes Sequential Shift Trans	KTY03	210	8-1/4	1	21	—	SC857	—	—	—
2.0	1998	L4	1991	1991	Turbo	16062	236	9-1/4	1-3/16	21	MC290	SC690	—	—	—
2.0	1998	L4	1992	1995	Turbo	16062	236	9-1/4	1-3/16	21	MC290	SC691	—	—	—
2.2	2164	L4	1991	1991	—	16073	225	8-7/8	1-1/8	20	—	—	—	—	—
2.2	2164	L4	1992	1995	—	16073	225	8-7/8	1-1/8	20	—	SC691	—	—	—
<b>PASEO</b>															
1.5	1497	L4	1992	1995	To 8/95	16029	200	7-7/8	15/16	21	MC285	SC684	—	—	—
1.5	1497	L4	1995	1999	From 9/95	16029	200	7-7/8	15/16	21	MC285	SC685	—	—	—
<b>SOLARA</b>															
2.2	2164	L4	1999	2001	—	16073	225	8-7/8	1-1/8	20	MC558	SC653	—	—	—
2.4	2362	L4	2002	2003	—	TYK1506	236	9-1/4	1-3/16	21	MC558	SC861	—	—	—
2.4	2362	L4	2004	2006	—	TYK1506	236	9-1/4	1-3/16	21	MC524	SC861	—	—	—
3.0	2995	V6	1999	2001	—	16062	236	9-1/4	1-3/16	21	MC558	SC661	—	—	—
3.0	2995	V6	2002	2002	—	16062	236	9-1/4	1-3/16	21	—	SC661	—	—	—
<b>STARLET</b>															
1.3	1290	L4	1981	1982	—	16004	184	7-1/4	7/8	19	—	—	—	—	—
1.3	1290	L4	1983	1983	—	16037	190	7-1/2	3/4	19	—	—	—	—	—
<b>SUPRA</b>															
2.6	2563	L6	1979	1980	—	16016	225	8-7/8	1-3/16	21	MC254	SC665	—	—	—
2.8	2759	L6	1981	1981	To 7/81	16084	225	8-7/8	1-3/16	21	MC254	SC665	—	—	—
2.8	2754	L6	1982	1982	—	16018	236	9-1/4	1-3/16	21	MC255	SC666	—	—	—
2.8	2754	L6	1983	1983	—	16018	236	9-1/4	1-3/16	21	MC256	SC666	—	—	—
2.8	2754	L6	1984	1985	—	16018	236	9-1/4	1-3/16	21	MC255	SC666	—	—	—
3.0	2954	L6	1986	1988	Non-Turbo	16018	236	9-1/4	1-3/16	21	MC257	SC672	—	—	—
3.0	2954	L6	1987	1992	Turbo	16063	240	9-1/2	1-3/16	21	MC257	SC673	—	—	—
3.0	2954	L6	1989	1993	Non-Turbo	16069	236	9-1/4	1-3/16	21	MC257	SC666	—	—	—
3.0	2997	L6	1990	1993	Turbo	16063	240	9-1/2	1-3/16	21	MC257	SC673	—	—	—
3.0	2997	L6	1994	1997	Non-Turbo	16085	236	9-1/4	1-3/16	21	MC268	SC674	—	—	—
3.0	2997	L6	1994	1998	Turbo	16093	250	9-7/8	1-1/4	14	MC268	—	—	—	—
<b>TERCEL</b>															
1.5	1452	L4	1980	1982	—	16009	190	7-1/2	1	21	—	—	—	—	—
1.5	1452	L4	1983	1985	—	16039	190	7-1/2	1	21	—	—	—	—	—
1.5	1452	L4	1986	1988	—	16039	190	7-1/2	1	21	MC283	SC684	—	—	—
1.5	1456	L4	1987	1987	4 Spd	16064	210	8-1/4	1	21	MC283	SC684	—	—	—
1.5	1456	L4	1987	1988	5 Spd	16060	190	7-1/2	15/16	21	MC283	SC684	—	—	—
1.5	1456	L4	1988	1988	EZ Model	16064	210	8-1/4	1	21	MC283	SC684	—	—	—
1.5	1456	L4	1989	1989	Except EZ Model to 4/89	16060	190	7-1/2	15/16	21	MC283	SC684	—	—	—
1.5	1456	L4	1989	1990	Except EZ Model from 5/89	16060	190	7-1/2	15/16	21	MC284	SC684	—	—	—
1.5	1456	L4	1990	1990	EZ Model	16064	210	8-1/4	1	21	MC284	SC684	—	—	—
1.5	1456	L4	1990	1994	5 Spd	16060	190	7-1/2	15/16	21	MC285	SC684	—	—	—
1.5	1456	L4	1991	1994	4 Spd	16070	200	7-7/8	15/16	21	MC285	SC684	—	—	—
1.5	1497	L4	1996	1998	—	16070	200	7-7/8	15/16	21	MC285	SC685	—	—	—
<b>YARIS</b>															
1.5	1497	L4	2006	2006	Sold as kit only	TYK1504	210	8-1/4	1	21	—	—	—	—	—
1.5	1497	L4	2007	2011	Sold as kit only	TYK1504	210	8-1/4	1	21	MC572	SC905	—	—	—

Liter	CC/IN	Cyl	Years		Application Information	Kit	Disc (mm)	Disc (in)	Spline Dia	Splines	Master Cyl	Slave Cyl	Clutch Cable	Clutch Fork	New Flywheel
			To	From											
<b>TOYOTA LIGHT TRUCK, SUV &amp; VAN</b>															
<b>4RUNNER</b>															
2.4	2366	L4	1984	1984	—	16084	225	8-7/8	1-3/16	21	MC274	SC677	—	—	—
2.4	2366	L4	1985	1986	Turbo	16018	236	9-1/4	1-3/16	21	MC274	SC680	—	—	—
2.4	2366	L4	1985	1988	Non-Turbo	16057	225	8-7/8	1-3/16	21	MC274	SC677	—	—	—
2.4	2366	L4	1987	1987	Turbo from 6/87	16069	236	9-1/4	1-3/16	21	MC274	SC680	—	—	—
2.4	2366	L4	1987	1987	Turbo to 5/87	16018	236	9-1/4	1-3/16	21	MC274	SC680	—	—	—
2.4	2366	L4	1989	1995	2 WD	16058	225	8-7/8	1-3/16	21	MC272	SC677	—	—	—
2.4	2366	L4	1993	1995	4 WD	16069	236	9-1/4	1-3/16	21	MC272	SC677	—	—	—
2.7	2694	L4	1996	2000	—	16090	250	9-7/8	1-3/16	21	MC276	SC683	—	—	—
3.0	2959	V6	1988	1995	—	16059	236	9-1/4	1-3/16	21	MC272	SC677	—	—	—
3.4	3378	V6	1996	2001	—	16087	250	9-7/8	1-3/16	21	MC276	SC682	—	—	—
<b>FJ CRUISER</b>															
4.0	3956	V6	2007	2014	Sold as Kit Only	TYK1503	275	10-7/8	1-3/16	21	—	—	—	—	—
<b>LAND CRUISER</b>															
3.4	3431	L4	1981	1985	Diesel	16040	273	10-3/4	1-3/32	10	—	SC814	—	—	—
3.9	3878	L6	1967	1970	To 6/70	16040	273	10-3/4	1-3/32	10	MC294	SC698	—	—	—
3.9	3878	L6	1971	1973	—	16040	273	10-3/4	1-3/32	10	MC490	SC813	—	—	—
3.9	3878	L6	1974	1974	—	16040	273	10-3/4	1-3/32	10	MC490	SC815	—	—	—
4.2	4227	L6	1975	1979	—	16006	273	10-3/4	1-3/32	10	MC468	SC815	—	—	—
4.2	4227	L6	1980	1980	—	16006	273	10-3/4	1-3/32	10	MC297	SC697	—	—	—
4.2	4227	L6	1981	1985	To 5/85	16006	273	10-3/4	1-3/32	10	MC297	SC697	—	—	—
4.2	4227	L6	1985	1987	From 6/85	16006	273	10-3/4	1-3/32	10	MC298	SC699	—	—	—
<b>PICKUP</b>															
1.9	1858	L4	1970	1971	—	16045	225	8-7/8	15/16	21	MC278	SC819	—	—	—
2.0	1968	L4	1972	1972	To 4/72	16007	225	8-7/8	1-3/16	21	MC278	SC656	—	—	—
2.0	1968	L4	1972	1972	From 5/72	16007	225	8-7/8	1-3/16	21	MC279	SC556	—	—	—
2.0	1968	L4	1973	1973	To 4/73	16007	225	8-7/8	1-3/16	21	MC279	SC656	—	—	—
2.0	1968	L4	1973	1973	From 5/73	16007	225	8-7/8	1-3/16	21	MC279	SC657	—	—	—
2.0	1968	L4	1974	1974	To 7/74	16007	225	8-7/8	1-3/16	21	MC279	SC657	—	—	—
2.0	1968	L4	1974	1974	From 8/74	16007	225	8-7/8	1-3/16	21	MC280	SC657	—	—	—
2.2	2189	L4	1975	1975	—	16007	225	8-7/8	1-3/16	21	MC280	SC657	—	—	—
2.2	2189	L4	1976	1976	From 9/76	16007	225	8-7/8	1-3/16	21	MC281	SC657	—	—	—
2.2	2189	L4	1976	1976	To 8/76	16007	225	8-7/8	1-3/16	21	MC280	SC657	—	—	—
2.2	2189	L4	1977	1977	—	16007	225	8-7/8	1-3/16	21	MC281	SC657	—	—	—
2.2	2189	L4	1978	1978	From 8/1/78	16032	225	8-7/8	1-3/16	21	MC274	SC677	—	—	—
2.2	2189	L4	1978	1978	To 7/1/78	16007	225	8-7/8	1-3/16	21	MC281	SC657	—	—	—
2.2	2189	L4	1979	1980	—	16032	225	8-7/8	1-3/16	21	MC274	SC677	—	—	—
2.2	2188	L4	1981	1981	Diesel, to 3/81	16057	225	8-7/8	1-3/16	21	MC274	SC817	—	—	—
2.2	2188	L4	1982	1982	Diesel, from 9/82	16057	225	8-7/8	1-3/16	21	MC274	SC677	—	—	—
2.2	2188	L4	1983	1983	Diesel	16057	225	8-7/8	1-3/16	21	MC274	SC677	—	—	—
2.2	2188	L4	1983	1983	Diesel	16057	225	8-7/8	1-3/16	21	MC481	SC666	—	—	—
2.4	2366	L4	1981	1986	—	16057	225	8-7/8	1-3/16	21	MC274	SC677	—	—	—
2.4	2446	L4	1984	1984	Diesel	16057	225	8-7/8	1-3/16	21	—	SC686	—	—	—
2.4	2446	L4	1984	1985	Diesel	16057	225	8-7/8	1-3/16	21	MC274	SC686	—	—	—
2.4	2366	L4	1985	1985	Turbo, to 5/87	16018	236	9-1/4	1-3/16	21	—	—	—	—	—
2.4	2446	L4	1985	1985	Turbo Diesel	16057	225	8-7/8	1-3/16	21	MC274	SC677	—	—	—
2.4	2366	L4	1986	1986	Diesel	16057	225	8-7/8	1-3/16	21	—	SC666	—	—	—
2.4	2366	L4	1986	1986	Diesel	16057	225	8-7/8	1-3/16	21	MC274	SC666	—	—	—
2.4	2366	L4	1986	1987	Turbo, to 5/87	16018	236	9-1/4	1-3/16	21	MC274	SC677	—	—	—
2.4	2366	L4	1987	1987	Diesel	16057	225	8-7/8	1-3/16	21	MC481	SC666	—	—	—
2.4	2366	L4	1987	1987	Turbo, from 6/87	16069	236	9-1/4	1-3/16	21	MC274	SC677	—	—	—
2.4	2366	L4	1987	1988	Non-Turbo	16057	225	8-7/8	1-3/16	21	MC274	SC677	—	—	—
2.4	2366	L4	1988	1988	Turbo, from 6/87	16069	236	9-1/4	1-3/16	21	—	—	—	—	—
2.4	2366	L4	1989	1992	—	16058	225	8-7/8	1-3/16	21	MC272	SC677	—	—	—
2.4	2366	L4	1993	1995	2 WD	16058	225	8-7/8	1-3/16	21	MC272	SC677	—	—	—
2.4	2366	L4	1993	1995	4 WD	16069	236	9-1/4	1-3/16	21	MC272	SC677	—	—	FWTY26
3.0	2959	V6	1988	1995	—	16059	236	9-1/4	1-3/16	21	MC272	SC677	—	—	—

Liter	CC/IN	Cyl	Years		Application Information	Kit	Disc (mm)	Disc (in)	Spline Dia	Splines	Master Cyl	Slave Cyl	Clutch Cable	Clutch Fork	New Flywheel
			To	From											
<b>TOYOTA LIGHT TRUCK, SUV &amp; VAN CONT.</b>															
<i>PREVIA VAN</i>															
2.4	2438	L4	1991	1993	—	KTY13	236	9-1/4	1-3/16	21	MC287	SC687	—	—	—
<i>RAV4</i>															
2.0	1998	L4	1996	2000	—	TYK1502	236	9-1/4	1-3/16	21	MC523	SC661	—	—	—
2.0	1998	L4	2001	2003	—	TYK1502	236	9-1/4	1-3/16	21	MC521	SC661	—	—	—
2.4	2362	L4	2004	2005	—	16082	236	9-1/4	1-3/16	21	MC521	SC861	—	—	—
<i>T100</i>															
2.7	2694	L4	1994	1998	—	16090	250	9-7/8	1-3/16	21	MC275	SC681	—	—	—
3.0	2959	V6	1993	1994	2WD	16059	236	9-1/4	1-3/16	21	MC275	SC677	—	—	—
3.0	2959	V6	1993	1994	4 WD	KTY16	250	9-7/8	1-3/16	21	MC275	SC677	—	—	—
3.4	3378	V6	1995	1998	—	16087	250	9-7/8	1-3/16	21	MC275	SC682	—	—	—
<i>TACOMA</i>															
2.4	2438	L4	1995	2000	—	KTY13	236	9-1/4	1-3/16	21	MC275	SC683	—	—	—
2.4	2438	L4	2001	2004	2 WD	KTY13	236	9-1/4	1-3/16	21	MC275	SC683	—	—	—
2.4	2438	L4	2001	2004	4 WD	16090	250	9-7/8	1-3/16	21	MC275	SC683	—	—	—
2.7	2694	L4	1995	2004	—	16090	250	9-7/8	1-3/16	21	MC275	SC683	—	—	—
2.7	2694	L4	2005	2011	Fits 2WD and 4WD	KTY16	250	9-7/8	1-3/16	21	—	SC879	—	—	—
3.4	3378	V6	1995	2004	—	16087	250	9-7/8	1-3/16	21	MC275	SC682	—	—	—
4.0	3956	V6	2005	2015	Sold as Kit Only	TYK1515	275	10-7/8	1-3/16	21	—	SC878	—	—	—
<i>TUNDRA</i>															
3.4	3378	V6	2000	2004	—	16087	250	9-7/8	1-3/16	21	MC275	SC682	—	—	—
4.0	3956	V6	2005	2006	Sold as Kit Only	TYK1503	275	10-7/8	1-3/16	21	MC530	SC878	—	—	—
<i>VAN</i>															
2.0	1998	L4	1984	1985	—	16046	225	8-7/8	1-3/16	21	MC469	SC687	—	—	—
2.2	2237	L4	1986	1988	—	16046	225	8-7/8	1-3/16	21	MC469	SC687	—	—	—
2.2	2237	L4	1989	1989	—	KTY02	225	8-7/8	1-3/16	21	MC469	SC677	—	—	—
<b>TRIUMPH</b>															
<i>GT6</i>															
2.0	1998	L6	1968	1973	Sold As Kit Only	KMG05	215	8-1/2	1-1/4	10	—	—	—	—	—
<b>VOLKSWAGEN</b>															
<i>BEETLE (NEW)</i>															
1.8	1781	L4	1999	2004	Turbo, Includes DMF. Cover has 3 bolt sections with 4 bolts per section, Sold As Kit Only	VWK1000	225	8-7/8	7/8	28	MC110	—	—	—	—
1.9	1896	L4	1998	1998	Turbo Diesel, LUK Version, Sold As Kit Only	VWK1000	225	8-7/8	7/8	28	MC110	—	—	—	—
1.9	1896	L4	1998	1998	Turbo Diesel, Sachs Version, Sold As Kit Only	KVW03	228	9	7/8	28	MC110	—	—	—	—
1.9	1896	L4	1999	2000	Turbo Diesel, LUK Version, Sold As Kit Only	VWK1000	225	8-7/8	7/8	28	MC110	SC512	—	—	—
1.9	1896	L4	1999	2000	Turbo Diesel, Sachs Version, Sold As Kit Only	KVW03	228	9	7/8	28	MC110	SC512	—	—	—
1.9	1896	L4	2001	2003	Turbo Diesel, LUK Version, Sold As Kit Only	VWK1000	225	8-7/8	7/8	28	MC110	—	—	—	—
1.9	1896	L4	2001	2005	Turbo Diesel, Sachs Version, Sold As Kit Only	KVW03	228	9	7/8	28	MC110	—	—	—	—
2.0	1984	L4	1998	2005	Sold As Kit Only	KVW05	215	8-7/16	7/8	28	MC110	—	—	—	—
2.5	2480	L5	2006	2008	Sold as Kit Only	VWK1004	228	9	7/8	28	MC110	—	—	—	—
<i>BEETLE, GHIA (TYPE I)</i>															
1.2	1192	H4	1954	1966	—	17015	184	7-1/4	13/16	24	—	—	—	—	—
1.3	1285	H4	1966	1966	—	17015	184	7-1/4	13/16	24	—	—	—	—	—
<i>CABRIO</i>															
2.0	1984	L4	1995	1997	—	17038	210	8-1/4	7/8	28	MC107	SC511	—	—	—
2.0	1984	L4	1998	2002	—	17038	210	8-1/4	7/8	28	—	—	—	—	—
<i>CABRIOLET</i>															
1.8	1780	L4	1985	1989	—	17012	210	8-1/4	13/16	24	—	—	CC953	—	—
1.8	1780	L4	1990	1993	—	17012	210	8-1/4	13/16	24	—	—	—	—	—
<i>CORRADO</i>															
1.8	1780	L4	1990	1992	—	17034	228	9	7/8	28	MC103	SC900	—	—	—
2.8	2792	V6	1992	1992	VR6	17036	228	9	7/8	28	MC103	SC900	—	—	—
2.8	2792	V6	1993	1993	VR6, From 9/93	17036	228	9	7/8	28	MC106	SC900	—	—	—
2.8	2792	V6	1993	1993	VR6, To 8/93	17036	228	9	7/8	28	MC103	SC900	—	—	—
2.8	2792	V6	1994	1995	VR6	17036	228	9	7/8	28	MC106	SC900	—	—	—



Liter	CC/IN	Cyl	Years		Application Information	Kit	Disc (mm)	Disc (in)	Spline Dia	Splines	Master Cyl	Slave Cyl	Clutch Cable	Clutch Fork	New Flywheel
			To	From											
<b>VOLKSWAGEN CONT.</b>															
<b>DASHER</b>															
1.5	1471	L4	1974	1975	Gas	17002	190	7-1/2	1	24	—	—	—	—	—
1.5	1471	L4	1979	1980	Diesel	17002	190	7-1/2	1	24	—	—	—	—	—
1.6	1588	L4	1981	1981	Diesel	17002	190	7-1/2	1	24	—	—	—	—	—
<b>EOS</b>															
2.0	1984	L4	2007	2007	Turbo, Includes Slave Cylinder, Sold as Kit Only	VWK1005	240	9-7/16	15/16	23	—	—	—	—	—
<b>FASTBACK, SQUAREBACK (TYPE III)</b>															
1.6	1584	H4	1966	1969	Rigid Disc Option	17022	200	7-7/8	13/16	24	—	—	—	—	—
1.6	1584	H4	1970	1970	Rigid Disc Option, From 8/1/70	17023	200	7-7/8	13/16	24	—	—	—	—	—
1.6	1584	H4	1970	1970	To 7/31/70, Rigid Disc Option	17022	200	7-7/8	13/16	24	—	—	—	—	—
1.6	1584	H4	1970	1973	Rigid Disc Option, From 8/1/70	17022	200	7-7/8	13/16	24	—	—	—	—	—
<b>FOX</b>															
1.8	1780	L4	1987	1990	—	17032	210	8-1/4	13/16	24	—	—	CC971	—	—
1.8	1780	L4	1991	1993	—	17032	210	8-1/4	13/16	24	—	—	—	—	—
<b>GOLF</b>															
1.6	1588	L4	1985	1988	Diesel to CH # 1GL015951	17004	200	7-7/8	13/16	24	—	—	—	—	—
1.8	1780	L4	1985	1992	—	17012	210	8-1/4	13/16	24	—	—	—	—	—
1.8	1780	L4	1987	1989	GTI 16 Valve	17027	210	8-1/4	7/8	28	—	—	CC968	—	—
1.8	1780	L4	1990	1992	GTI 8 Valve	17012	210	8-1/4	13/16	24	—	—	—	—	—
1.8	1781	L4	2000	2000	Turbo, Includes DMF. Cover has 3 bolt sections with 4 bolts per section, Sold As Kit Only	VWK1000	225	8-7/8	7/8	28	—	—	—	—	—
1.8	1781	L4	2001	2005	Turbo, Includes DMF. Cover has 3 bolt sections with 4 bolts per section, Sold As Kit Only	VWK1000	225	8-7/8	7/8	28	MC110	—	—	—	—
1.8	1781	L4	2006	2006	Turbo, Includes DMF. Cover has 3 bolt sections with 4 bolts per section, Sold As Kit Only	VWK1000	225	8-7/8	7/8	28	—	—	—	—	—
1.9	1896	L4	2000	2003	Turbo Diesel, LUK Version, Sold As Kit Only	VWK1000	225	8-7/8	7/8	28	—	—	—	—	—
1.9	1896	L4	2000	2003	Turbo Diesel, Sachs Version, Sold As Kit Only	KVV03	228	9	7/8	28	—	—	—	—	—
1.9	1896	L4	2004	2004	Turbo Diesel, LUK Version, Sold As Kit Only	VWK1000	225	8-7/8	7/8	28	MC110	—	—	—	—
1.9	1896	L4	2004	2004	Turbo Diesel, Sachs Version, Sold As Kit Only	KVV03	228	9	7/8	28	MC110	—	—	—	—
2.0	1984	L4	1990	1992	GTI 16 Valve	17027	210	8-1/4	7/8	28	—	—	—	—	—
2.0	1984	L4	1993	1994	—	17027	210	8-1/4	7/8	28	—	—	—	—	—
2.0	1984	L4	1995	1998	—	17038	210	8-1/4	7/8	28	—	—	—	—	—
2.0	1984	L4	1999	2003	Sold As Kit Only	KVV05	215	8-7/16	7/8	28	MC110	—	—	—	—
2.0	1984	L4	2004	2005	Turbo, Includes DMF. Cover has 3 bolt sections with 4 bolts per section, Sold As Kit Only	VWK1000	225	8-7/8	7/8	28	MC110	—	—	—	—
2.0	1984	L4	2006	2006	Turbo, Sold As Kit Only	KVV05	215	8-7/16	7/8	28	MC110	—	—	—	—
2.0	1984	L4	2007	2007	Turbo, Includes Slave Cylinder, Sold as Kit Only	VWK1005	240	9-7/16	15/16	23	—	—	—	—	—
2.8	2792	V6	1995	1998	GTI VR6	17036	228	9	7/8	28	MC107	SC900	—	—	—
2.8	2792	V6	1999	2002	GTI VR6	17036	228	9	7/8	28	MC109	SC512	—	—	—
3.2	3189	V6	2004	2004	Sold as Kit Only	VWK1006	240	9 7/16	15/16	23	MC110	—	—	—	—
<b>GOLF (CANADA)</b>															
1.6	1588	L4	1989	1989	Diesel to CH # 1GL015951	17004	200	7-7/8	13/16	24	—	—	—	—	—
1.6	1588	L4	1990	1992	Diesel from Ch # 1GL015951	17035	200	7-7/8	13/16	24	—	—	—	—	—
1.8	1788	L4	1993	1993	To Chassis # 1H-R038 600	17012	210	8-1/4	13/16	24	—	—	—	—	—
1.8	1788	L4	1995	1995	From Chassis # 1H-R-038 601, Sold As Kit Only	KVV01	210	8-1/4	13/16	24	—	—	—	—	—
1.8	1780	L4	1996	1997	From Chassis # 1H-R-038 601, Sold As Kit Only	KVV01	210	8-1/4	13/16	24	—	—	—	—	—
1.9	1896	L4	1996	1997	Turbo Diesel	17034	228	9	7/8	28	—	SC900	—	—	—
<b>JETTA</b>															
1.6	1588	L4	1980	1980	—	17004	200	7-7/8	13/16	24	—	—	—	—	—
1.6	1588	L4	1981	1989	Diesel to Chassis # 1G-L-015 951	17004	200	7-7/8	13/16	24	—	—	—	—	—
1.6	1588	L4	1983	1988	Turbo Diesel to Chassis # 1G-L-015 951	17004	200	7-7/8	13/16	24	—	—	—	—	—
1.6	1588	L4	1990	1992	Diesel from Chassis # 1G-L-015 952	17035	200	7-7/8	13/16	24	—	—	—	—	—
1.7	1715	L4	1981	1984	—	17004	200	7-7/8	13/16	24	—	—	—	—	—
1.8	1780	L4	1984	1984	—	17012	210	8-1/4	13/16	24	—	—	CC953	—	—
1.8	1780	L4	1985	1992	—	17012	210	8-1/4	13/16	24	—	—	—	—	—
1.8	1780	L4	1987	1989	GLI 16 Valve	17027	210	8-1/4	7/8	28	—	—	—	—	—
1.8	1788	L4	1993	1994	—	17012	210	8-1/4	13/16	24	—	—	—	—	—
1.8	1788	L4	1995	1995	From Chassis # 1H-R-0380601, Sold As Kit Only	KVV01	210	8-1/4	13/16	24	—	—	—	—	—
1.8	1781	L4	2000	2000	Turbo, Includes DMF. Cover has 3 bolt sections with 4 bolts per section, Sold As Kit Only	VWK1000	225	8-7/8	7/8	28	—	—	—	—	—

Liter	CC/IN	Cyl	Years		Application Information	Kit	Disc (mm)	Disc (in)	Spline Dia	Splines	Master Cyl	Slave Cyl	Clutch Cable	Clutch Fork	New Flywheel
			To	From											
<b>VOLKSWAGEN CONT.</b>															
<b>JETTA CONT.</b>															
1.8	1781	L4	2001	2004	Turbo, Includes DMF. Cover has 3 bolt sections with 4 bolts per section, Sold As Kit Only	VWK1000	225	8-7/8	7/8	28	MC110	—	—	—	—
1.9	1896	L4	1996	1997	Turbo Diesel	17034	228	9	7/8	28	—	SC900	—	—	—
1.9	1896	L4	1998	1998	Turbo Diesel, Sachs Version, Sold As Kit Only	KVW03	228	9	7/8	28	—	SC900	—	—	—
1.9	1896	L4	1999	1999	Turbo Diesel, LUK Version, Sold As Kit Only	VWK1000	225	8-7/8	7/8	28	MC110	SC512	—	—	—
1.9	1896	L4	1999	1999	Turbo Diesel, Sachs Version, Sold As Kit Only, Fits DMF	KVW03	228	9	7/8	28	MC110	SC512	—	—	—
1.9	1896	L4	2000	2003	Turbo Diesel, LUK Version, Sold As Kit Only	VWK1000	225	8-7/8	7/8	28	MC110	—	—	—	—
1.9	1896	L4	2004	2004	Turbo Diesel, Sachs Version, Sold As Kit Only, Fits DMF	KVW03	228	9	7/8	28	MC110	SC512	—	—	—
1.9	1896	L4	2005	2006	BRM Engine	VWK1004	228	9	7/8	28	—	—	—	—	—
2.0	1984	L4	1990	1993	16 Valve	17027	210	8-1/4	7/8	28	—	—	—	—	—
2.0	1984	L4	1994	1994	From CH #1H-R-038601	17027	210	8-1/4	7/8	28	—	—	—	—	—
2.0	1984	L4	1994	1994	To CH #1H-R-038600	17038	210	8-1/4	7/8	28	—	—	—	—	—
2.0	1984	L4	1995	1998	—	17038	210	8-1/4	7/8	28	—	—	—	—	—
2.0	1984	L4	1999	1999	—	17038	210	8-1/4	7/8	28	MC110	SC512	—	—	—
2.0	1984	L4	2000	2005	Sold As Kit Only	KVW05	215	8-7/16	7/8	28	MC110	—	—	—	—
2.0	1984	L4	2006	2007	Turbo, Includes Slave Cylinder, Sold as Kit Only	VWK1005	240	9-7/16	15/16	23	—	—	—	—	—
2.5	2480	L5	2005	2008	Sold as Kit Only	VWK1004	228	9	7/8	28	—	—	—	—	—
2.8	2792	V6	1994	1998	AFP Engine	17036	228	9	7/8	28	—	SC900	—	—	—
2.8	2792	V6	1999	1999	—	17036	228	9	7/8	28	MC110	SC512	—	—	—
2.8	2792	V6	1999	2002	AFP Engine	17036	228	9	7/8	28	MC110	—	—	—	—
2.8	2792	V6	2002	2002	Includes Slave Cylinder, Sold as kit only	VWK1002	240	9-7/16	15/16	23	MC110	—	—	—	—
2.8	2792	V6	2002	2004	Includes Slave Cylinder, Sold as kit only, BDF Engine	VWK1002	240	9-7/16	15/16	23	MC110	—	—	—	—
<b>PASSAT</b>															
1.8	1781	L4	1998	1998	Turbo	VWK1001	228	9	15/16	23	MC108	—	—	—	—
1.8	1781	L4	1999	2001	Turbo	VWK1001	228	9	15/16	23	—	—	—	—	—
1.8	1781	L4	2002	2005	Turbo, Sold as Kit Only	VWK1001	228	9	15/16	23	—	—	—	—	—
1.9	1896	L4	1993	1994	Diesel	17034	228	9	7/8	28	MC106	SC511	—	—	—
1.9	1896	L4	1996	1997	Turbo Diesel	17034	228	9	7/8	28	MC106	SC511	—	—	—
2.0	1984	L4	1990	1993	—	17034	228	9	7/8	28	MC103	SC511	—	—	—
2.0	1984	L4	1994	1996	—	17034	228	9	7/8	28	MC106	SC511	—	—	—
2.0	1984	L4	2006	2007	Turbo, Includes Slave Cylinder, Sold as Kit Only	VWK1005	240	9-7/16	15/16	23	—	—	—	—	—
2.8	2792	V6	1993	1993	—	17036	228	9	7/8	28	MC103	SC511	—	—	—
2.8	2792	V6	1994	1997	—	17036	228	9	7/8	28	MC106	SC511	—	—	—
2.8	2771	V6	1998	2005	—	AUK1001	240	9-7/16	15/16	23	MC108	—	—	—	—
4.0	3998	W8	2003	2004	Sold as Kit Only	VWK1007	240	9 7/16	15/16	23	—	—	—	—	—
<b>QUANTUM</b>															
1.8	1780	L4	1984	1985	—	17031	210	8-1/4	13/16	24	—	—	—	—	—
2.2	2144	L5	1983	1984	Cable Release	17030	215	8-1/2	13/16	24	—	—	—	—	—
2.2	2226	L5	1985	1986	Cable Release	17030	215	8-1/2	13/16	24	—	—	—	—	—
2.2	2226	L5	1985	1988	Hydraulic Release	02011	228	9	13/16	24	MC101	SC509	—	—	—
<b>RABBIT</b>															
1.5	1471	L4	1975	1975	Gas	17003	190	7-1/2	13/16	24	—	—	—	—	—
1.5	1471	L4	1977	1980	Diesel	17003	190	7-1/2	13/16	24	—	—	—	—	—
1.5	1457	L4	1978	1980	Gas	17003	190	7-1/2	13/16	24	—	—	—	—	—
1.6	1588	L4	1976	1977	Gas	17003	190	7-1/2	13/16	24	—	—	—	—	—
1.6	1588	L4	1980	1980	Gas	17003	190	7-1/2	13/16	24	—	—	—	—	—
1.6	1588	L4	1981	1984	Diesel	17004	200	7-7/8	13/16	24	—	—	—	—	—
1.7	1715	L4	1981	1984	Gas with Rectangular Headlights	17004	200	7-7/8	13/16	24	—	—	—	—	—
1.7	1715	L4	1981	1984	Gas with Round Headlights	17003	190	7-1/2	13/16	24	—	—	—	—	—
1.8	1780	L4	1983	1983	GTI, 16 Valve	17027	210	8-1/4	7/8	28	—	—	—	—	—
1.8	1780	L4	1983	1984	Gas, 8 Valve	17012	210	8-1/4	13/16	24	—	—	CC953	—	—
2.5	2480	L5	2006	2008	Sold as Kit Only	VWK1004	228	9	7/8	28	—	—	—	—	—

Liter	CC/IN	Cyl	Years		Application Information	Kit	Disc (mm)	Disc (in)	Spline Dia	Splines	Master Cyl	Slave Cyl	Clutch Cable	Clutch Fork	New Flywheel
			To	From											
<b>VOLKSWAGEN CONT.</b>															
<i>SCIROCCO</i>															
1.5	1471	L4	1975	1975	—	17003	190	7-1/2	13/16	24	—	—	—	—	—
1.5	1457	L4	1978	1978	—	17003	190	7-1/2	13/16	24	—	—	—	—	—
1.6	1588	L4	1976	1977	—	17003	190	7-1/2	13/16	24	—	—	—	—	—
1.6	1588	L4	1979	1979	—	17003	190	7-1/2	13/16	24	—	—	—	—	—
1.6	1588	L4	1980	1980	—	17004	200	7-7/8	13/16	24	—	—	—	—	—
1.7	1715	L4	1981	1983	—	17003	190	7-1/2	13/16	24	—	—	—	—	—
1.8	1780	L4	1983	1989	8 Valve	17012	210	8-1/4	13/16	24	—	—	—	—	—
<b>VOLKSWAGEN LIGHT TRUCK &amp; VAN</b>															
<i>CAMPMOBILE</i>															
1.7	1679	H4	1972	1973	—	17016	210	8-1/4	13/16	24	—	—	—	—	—
1.8	1795	H4	1974	1974	—	17016	210	8-1/4	13/16	24	—	—	—	—	—
1.8	1795	H4	1975	1975	—	17017	215	8-7/16	13/16	24	—	—	—	—	—
2.0	1970	H4	1976	1979	—	17010	228	9	13/16	24	—	—	—	—	—
<i>EUROVAN</i>															
2.5	2459	L5	1993	1995	—	17036	228	9	7/8	28	MC105	SC900	—	—	—
<i>EUROVAN (CANADA)</i>															
2.5	2459	L5	1992	1995	—	17036	228	9	7/8	28	MC105	SC900	—	—	—
2.4	2370	L5	1996	1996	Diesel	17036	228	9	7/8	28	MC105	SC900	—	—	—
<i>RABBIT PICKUP</i>															
1.6	1588	L4	1980	1980	Gas	17004	200	7-7/8	13/16	24	—	—	—	—	—
1.6	1588	L4	1981	1983	Diesel	17004	200	7-7/8	13/16	24	—	—	—	—	—
1.7	1715	L4	1981	1983	—	17004	200	7-7/8	13/16	24	—	—	—	—	—
<i>TRANSPORTER</i>															
1.2	1192	H4	1954	1962	Rigid Disc	17015	184	7-1/4	13/16	24	—	—	—	—	—
1.7	1679	H4	1972	1973	—	17016	210	8-1/4	13/16	24	—	—	—	—	—
1.8	1795	H4	1974	1974	—	17016	210	8-1/4	13/16	24	—	—	—	—	—
1.8	1795	H4	1975	1975	—	17017	215	8-7/16	13/16	24	—	—	—	—	—
1.9	1915	H4	1985	1985	Syncro CANADA	17017	215	8-7/16	13/16	24	MC133	SC536	—	—	—
1.9	1915	H4	1985	1985	Water Cooled CANADA	17010	228	9	13/16	24	MC133	SC536	—	—	—
2.0	1970	H4	1976	1979	—	17010	228	9	13/16	24	—	—	—	—	—
2.1	2109	H4	1986	1991	—	17010	228	9	13/16	24	MC133	SC536	—	—	—
2.5	2459	L5	1992	1993	CANADA	17034	228	9	7/8	28	—	—	—	—	—
<i>VANAGON (TYPE II)</i>															
1.6	1588	L4	1982	1985	Diesel	17011	215	8-1/2	13/16	24	MC133	SC876	—	—	—
1.9	1915	H4	1983	1985	—	17010	228	9	13/16	24	MC133	SC876	—	—	—
2.0	1970	H4	1980	1983	—	17010	228	9	13/16	24	MC133	SC876	—	—	—
2.1	2109	H4	1986	1991	—	17010	228	9	13/16	24	MC133	SC876	—	—	—
<b>VOLVO</b>															
<i>240 SERIES</i>															
2.1	2127	L4	1984	1984	Intercooled Turbo	22019	228	9	1	22	—	—	—	—	—
2.1	2127	L4	1985	1985	Intercooled Turbo with 9° Disc	22020	228	9	1	22	—	—	—	—	—
2.3	2316	L4	1987	1993	—	22021	228	9	1	22	—	—	—	—	—
2.4	2383	L6	1982	1984	Diesel	22015	228	9	1	22	—	—	—	—	—
<i>260 SERIES</i>															
2.4	2383	L6	1980	1981	Diesel	22007	228	9	1	22	—	—	—	—	—
2.7	2673	V6	1979	1979	Sold As Kit Only	KVO03	230	9-1/16	1	22	—	—	—	—	—
2.8	2849	V6	1980	1982	Sold As Kit Only	KVO03	230	9-1/16	1	22	—	—	—	—	—
<i>740</i>															
2.3	2316	L4	1985	1990	5 Spd, Non-Turbo	22021	228	9	1	22	—	—	—	—	—
2.3	2316	L4	1985	1992	Turbo with 9° Disc	22023	228	9	1	22	—	SC890	—	—	—
2.3	2316	L4	1990	1990	16 Valve, Non-Turbo	22023	228	9	1	22	—	—	—	—	—
2.4	2383	L6	1985	1985	Turbo Diesel	22015	228	9	1	22	—	SC890	—	—	—
2.4	2377	L6	1986	1986	Turbo Diesel	22015	228	9	1	22	—	SC890	—	—	—

Liter	CC/IN	Cyl	Years		Application Information	Kit	Disc (mm)	Disc (in)	Spline Dia	Splines	Master Cyl	Slave Cyl	Clutch Cable	Clutch Fork	New Flywheel
			To	From											
<b>VOLVO CONT.</b>															
<i>760</i>															
2.3	2316	L4	1985	1986	Turbo	22023	228	9	1	22	—	SC890	—	—	—
2.8	2849	V6	1985	1986	—	22015	228	9	1	22	—	—	—	—	—
<i>C70</i>															
2.3	2319	L5	2003	2003	Turbo, Sold as Kit Only, Includes CSC Hydraulic Slave Cylinder	VLK1003	240	9-7/16	1	23	—	—	—	—	—
<i>S60</i>															
2.3	2319	L5	2002	2004	Turbo, Sold as Kit Only, Includes CSC Hydraulic Slave Cylinder	VLK1003	240	9-7/16	1	23	—	—	—	—	—
2.4	2435	L5	2002	2003	Turbo, Sold as Kit Only, Includes CSC Hydraulic Slave Cylinder	VLK1003	240	9-7/16	1	23	—	—	—	—	—
<i>V70</i>															
2.3	2319	L5	2001	2004	Turbo, From Chassis # 395002, Sold as Kit Only, Includes CSC Hydraulic Slave Cylinder	VLK1003	240	9-7/16	1	23	—	—	—	—	—
2.4	2435	L5	2002	2003	Turbo, Sold as Kit Only, Includes CSC Hydraulic Slave Cylinder	VLK1003	240	9-7/16	1	23	—	—	—	—	—





Liter	cc / in	Cyl	Years	Application Information	Engine Number	Kit	Cover	Disc	Rel Brg	Disc (mm)	Disc (in)	Spline Dia	Splines	Master Cyl	Slave Cyl	Clutch Cable	Clutch Fork	New Flywheel	
<b>CHEVROLET MEDIUM TRUCK CONT.</b>																			
<i>C40, 50, 60, 70 CONT.</i>																			
6.0L	366	8	1998-90	13" Clutch		04149	—	—	—	330	13	1-1/2	10	—	—	—	CF127	FWGM16	
6.0L	366	8	1998-90	13" Clutch with Ceramic Button		04150	—	—	—	330	13	1-1/2	10	—	—	—	CF127	FWGM16	
6.0L	366	8	1968-65	13" Diaph Clutch		04106	—	—	—	330	13	1-1/2	10	—	—	—	—	—	
6.0L	366	8	1989-69	13" Diaph Clutch		04106	—	—	—	330	13	1-1/2	10	—	—	—	CF127	FWGM16	
6.0L	366	8	1968-65	13" Diaph Clutch with Ceramic Button		04107	—	—	—	330	13	1-1/2	10	—	—	—	—	—	
6.0L	366	8	1989-69	13" Diaph Clutch with Ceramic Button		04107	—	—	—	330	13	1-1/2	10	—	—	—	CF127	FWGM16	
6.0L	366	8	1989-69	13" Lever Clutch		GMK1002	—	—	—	330	13	1-1/2	10	—	—	—	CF127	FWGM16	
6.0L	366	8	1968-65	13" Lever Clutch		GMK1002	—	—	—	330	13	1-1/2	10	—	—	—	—	—	
6.0L	366	8	1968-65	13" Lever Clutch with Ceramic Button		GMK1003	—	—	—	330	13	1-1/2	10	—	—	—	—	—	
6.0L	366	8	1989-69	13" Lever Clutch with Ceramic Button		GMK1003	—	—	—	330	13	1-1/2	10	—	—	—	CF127	FWGM16	
6.7L	409	8	1972-62	13" Diaph Clutch		04106	—	—	—	330	13	1-1/2	10	—	—	—	—	—	
6.7L	409	8	1972-62	13" Diaph Clutch with Ceramic Button		04107	—	—	—	330	13	1-1/2	10	—	—	—	—	—	
6.7L	409	8	1972-62	13" Lever Clutch		GMK1002	—	—	—	330	13	1-1/2	10	—	—	—	—	—	
6.7L	409	8	1972-62	13" Lever Clutch with Ceramic Button		GMK1003	—	—	—	330	13	1-1/2	10	—	—	—	—	—	
7.0L	427	8	1993-90	13" Clutch		04149	—	—	—	330	13	1-1/2	10	—	—	—	—	—	
7.0L	427	8	1993-90	13" Clutch with Ceramic Button		04150	—	—	—	330	13	1-1/2	10	—	—	—	—	—	
7.0L	427	8	1989-65	13" Diaph Clutch		04106	—	—	—	330	13	1-1/2	10	—	—	—	—	—	
7.0L	427	8	1989-65	13" Diaph Clutch with Ceramic Button		04107	—	—	—	330	13	1-1/2	10	—	—	—	—	—	
7.0L	427	8	1989-65	13" Lever Clutch		GMK1002	—	—	—	330	13	1-1/2	10	—	—	—	—	—	
7.0L	427	8	1989-65	13" Lever Clutch with Ceramic Button		GMK1003	—	—	—	330	13	1-1/2	10	—	—	—	—	—	
7.0L	427	8	2001-94	Gas, Valeo Push Type Clutch		KGM40	—	—	—	330	13	1-1/2	10	—	—	—	—	—	
7.2L	439	6	2006-90	Cat 3116, 3169 with Eaton Transmission, Pull style		KGM41	—	—	—	356	14	1-3/4	10	—	—	—	—	—	
7.2L	439	6	2001-97	Cat 3126 Turbo with Eaton Transmission		KGM42	—	—	—	356	14	1-3/4	10	—	—	—	—	—	
7.2L	439	8	2001-94	CAT 3116/31126 with Eaton Transmission		KGM41	—	—	—	356	14	1-3/4	10	—	—	—	—	—	
7.2L	439	8	1999-90	CAT 3126 with Eaton Transmission, T Series		KGM42	—	—	—	356	14	1-3/4	10	—	—	—	—	—	
<i>TILTMASTER W4000, W7000</i>																			
3.9L	3900	4	1997-91			KGM20	—	—	—	300	11-13/16	1-1/8	21	—	—	—	—	—	
3.9L	3900	4	1986-84	Turbo Diesel		09011	—	—	—	273	10-3/4	1	24	—	—	—	—	—	
3.9L	3900	4	1986-84	Turbo Diesel, with Ceramic Button		KIS03	—	—	—	273	10-3/4	1	24	—	—	—	—	—	
3.9L	3900	4	2001-98	w Hydro Brake Booster	4HE1	KGM15	—	—	—	324	12-3/4	1-1/2	10	—	—	—	—	—	
3.9L	3900	4	2001-98	w/o Hydro Brake Booster, Heavy Duty Clutch, Silent Design Disc	4HE1	KGM16	—	—	—	300	11-13/16	1-1/8	21	—	—	—	—	—	
3.9L	3900	4	1990-87	W4000, Turbo	4BD1, 4BD2	KGM14	—	—	—	300	11-13/16	1	24	—	—	—	—	—	
5.8L	5800	8	2002-84	W7000	6BD1T	KIS02	—	—	—	356	14	1-1/2	10	—	—	—	—	—	
<b>DODGE MEDIUM TRUCK</b>																			
<i>D400, 500</i>																			
5.2L	318	8	1982-60			05047	CA1919	CD3734	N1484	330	13	1-3/8	10	—	—	—	—	—	
5.8L	354	8	1982-67	Diesel		05047	CA1919	CD3734	N1484	330	13	1-3/8	10	—	—	—	—	—	
5.9L	361	8	1982-67			05047	CA1919	CD3734	N1484	330	13	1-3/8	10	—	—	—	—	—	
<b>FORD MEDIUM TRUCK</b>																			
<i>F400, 450, 500, 550, 600, 700, 800, 900, 1000</i>																			
3.8L	232	6	1983			07016	CA0030	CD4184	N1714SA	254	10	1-1/16	10	—	—	—	—	—	
3.8L	232	6	1982-81			07014	CA0030	CD4184	N1439SA	254	10	1-1/16	10	—	—	—	—	—	
3.9L	240	6	1976-55	Diaph Clutch		KFM10	FMC903	FMD808	N1714SA	280	11	1-1/16	10	—	—	—	—	—	
3.9L	240	6	1976-55	Lever Clutch		07027	CA0465	CD1226	N1439SA	280	11	1-1/16	10	—	—	—	—	—	
4.2L	255	6	2005-97			KFM12	CA1947	CD1947	N8134	290	11-1/2	1-1/16	10	—	—	—	—	—	
4.9L	300	6	1979-65	11" Diaph Clutch		KFM10	FMC903	FMD808	N1714SA	280	11	1-1/16	10	—	—	—	—	—	
4.9L	300	6	1979-65	11" Lever Clutch		07027	CA0465	CD1226	N1439SA	280	11	1-1/16	10	—	—	—	—	—	
4.9L	300	6	1972-66	13" Clutch		07125	CA1919	CD0629	N1495	330	13	1-3/8	10	—	—	—	—	—	
4.9L	300	6	1979-73	13" Clutch		07125	CA1919	CD0629	N1495	330	13	1-3/8	10	—	—	—	—	FWFM121	
4.9L	300	6	1972-66	13" Clutch with Ceramic Button		07126	CA1919	CD0629CB	N1495	330	13	1-3/8	10	—	—	—	—	—	
4.9L	300	6	1979-73	13" Clutch with Ceramic Button		07126	CA1919	CD0629CB	N1495	330	13	1-3/8	10	—	—	—	—	FWFM121	
5.4L	330	8	1986-55	13" Clutch		07125	CA1919	CD0629	N1495	330	13	1-3/8	10	—	—	—	—	—	
5.4L	330	8	1986-55	13" Clutch with Ceramic Button		07126	CA1919	CD0629CB	N1495	330	13	1-3/8	10	—	—	—	—	—	
5.9L	359	8	1986-67	13" Clutch		07125	CA1919	CD0629	N1495	330	13	1-3/8	10	—	—	—	—	—	
5.9L	359	8	1986-67	13" Clutch with Ceramic Button		07126	CA1919	CD0629CB	N1495	330	13	1-3/8	10	—	—	—	—	—	
5.9L	361	8	1986-55	13" Clutch		07125	CA1919	CD0629	N1495	330	13	1-3/8	10	—	—	—	—	—	
5.9L	361	8	1986-55	13" Clutch with Ceramic Button		07126	CA1919	CD0629CB	N1495	330	13	1-3/8	10	—	—	—	—	—	

Liter	cc / in	Cyl	Years	Application Information	Engine Number	Kit	Cover	Disc	Rel Brg	Disc (mm)	Disc (in)	Spline Dia	Splines	Master Cyl	Slave Cyl	Clutch Cable	Clutch Fork	New Flywheel	
<b>FORD MEDIUM TRUCK CONT.</b>																			
<i>F400, 450, 500, 550, 600, 700, 800, 900, 1000 CONT.</i>																			
6.0L	363	8	1982-79	13" Clutch		07125	CA1919	CD0629	N1495	330	13	1-3/8	10	—	—	—	—	—	
6.0L	363	8	1982-79	13" Clutch with Ceramic Button		07126	CA1919	CD0629CB	N1495	330	13	1-3/8	10	—	—	—	—	—	
6.1L	370	8	1988-79	13" Clutch		07125	CA1919	CD0629	N1495	330	13	1-3/8	10	—	—	—	CF122	—	
6.1L	370	8	1993-89	13" Clutch		07125	CA1919	CD0629	N1495	330	13	1-3/8	10	—	—	—	—	—	
6.1L	370	8	1988-79	13" Clutch with Ceramic Button		07126	CA1919	CD0629CB	N1495	330	13	1-3/8	10	—	—	—	CF122	—	
6.1L	370	8	1993-89	13" Clutch with Ceramic Button		07126	CA1919	CD0629CB	N1495	330	13	1-3/8	10	—	—	—	—	—	
6.4L	389	8	1979-65	13" Clutch		07125	CA1919	CD0629	N1495	330	13	1-3/8	10	—	—	—	—	—	
6.4L	389	8	1979-65	13" Clutch with Ceramic Button		07126	CA1919	CD0629CB	N1495	330	13	1-3/8	10	—	—	—	—	—	
6.4L	391	8	1978-65	13" Clutch		07125	CA1919	CD0629	N1495	330	13	1-3/8	10	—	—	—	—	—	
6.4L	391	8	1978-65	13" Clutch with Ceramic Button		07126	CA1919	CD0629CB	N1495	330	13	1-3/8	10	—	—	—	—	—	
6.8L	415	10	2003-99			KFM21	CA2053	CD2069	N8126	305	12	1-1/4	10	—	—	—	—	—	
7.0L	429	8	1986-79	13" Clutch		07125	CA1919	CD0629	N1495	330	13	1-3/8	10	—	—	—	CF122	—	
7.0L	429	8	1993-87	13" Clutch		07125	CA1919	CD0629	N1495	330	13	1-3/8	10	—	—	—	—	—	
7.0L	429	8	1993-87	13" Clutch with Ceramic Button		07126	CA1919	CD0629CB	N1495	330	13	1-3/8	10	—	—	—	—	—	
7.0L	429	8	1986-79	13" Clutch with Ceramic Button		07126	CA1919	CD0629CB	N1495	330	13	1-3/8	10	—	—	—	CF122	—	
7.3L	446	8	1998-94	5 Spd with Direct Fuel Injection, VIN F. LUK Type Solid Flywheel and mounting bolts included.		KFM18A	LMX107X	Modular	N1753	330	13	1-1/4	10	MC362	SC735	—	—	—	
7.3L	446	8	1998-94	5 Spd with Direct Fuel Injection, VIN F. LUK Type Solid Flywheel not Included. Use this kit when solid flywheel is present.		KFM18	LMX107X	Modular	N1753	330	13	1-1/4	10	MC362	SC735	—	—	—	
7.3L	446	8	1998-94	5 Spd with Direct Fuel Injection. Valeo Type Solid Flywheel Replacement Kit Includes Flywheel and Mounting Bolts.		KFM15A	LMS107V	Modular	N1753	330	13	1-1/4	10	MC362	SC735	—	—	—	
7.3L	446	8	2003-99	6 Spd with direct fuel injection and Valeo OE solid flywheel. Valeo type solid flywheel included.		KFM17A	CA2442	CD3578	N8126	330	13	1-1/4	10	MC356	SC738	—	—	—	
7.3L	446	8	2003-99	6 Spd with direct fuel injection and Valeo OE solid flywheel. Valeo type solid flywheel not included.		KFM17	CA2442	CD3578	N8126	330	13	1-1/4	10	MC356	SC738	—	—	—	
7.3L	446	8	2003-99	Turbo Diesel 6 speed with direct fuel injection and LUK OE solid flywheel. LUK type solid flywheel is included. This kit must be installed as a matched set.		KFM16A	LMS108	Modular	N8126	330	13	1-3/8	10	—	—	—	—	—	
7.3L	446	8	1998-94	With Indirect Fuel Injection, Factory Turbo, with DMF. Heavy Duty 12" option. Valeo type DMF included.		07100B	CA5081	CD5081	N1753	302	11-7/8	1-1/4	10	MC362	SC735	—	—	—	
7.3L	446	8	1993-87	With Indirect Fuel Injection, Factory Turbo, with DMF. Heavy Duty 12" option. Valeo type DMF included.		07100B	CA5081	CD5081	N1753	302	11-7/8	1-1/4	10	MC356	SC720	—	—	—	
7.3L	446	8	1993-87	With Indirect Fuel Injection, Non-Turbo and Aftermarket Turbo, with DMF. Valeo type DMF included.		07076A	CA0065	CD1064	N1753	280	11	1-1/4	10	MC356	SC720	—	—	—	
7.3L	446	8	1998-94	With Indirect Fuel Injection, Non-Turbo and Aftermarket Turbo, with DMF. Valeo type DMF included.		07076A	CA0065	CD1064	N1753	280	11	1-1/4	10	MC362	SC735	—	—	—	
7.3L	446	8	1993-87	With Indirect Fuel Injection, Non-Turbo and Aftermarket Turbo, with DMF. Valeo type DMF not included. With Stripped chassis.		07076	CA0065	CD1064	N1753	280	11	1-1/4	10	MC356	SC735	—	—	—	
7.3L	446	8	1998-94	With Indirect Fuel Injection, Non-Turbo and Aftermarket Turbo, with DMF. Valeo type DMF not included. With Stripped chassis.		07076	CA0065	CD1064	N1753	280	11	1-1/4	10	MC356	SC735	—	—	—	
7.3L	446	8	1993-87	With Indirect Fuel Injection, Non-Turbo and Aftermarket Turbo, with DMF. Heavy Duty 12" option with rigid disc. Valeo type DMF included.		07100A	CA5081	CD5081	N1753	302	11-7/8	1-1/4	10	MC356	SC720	—	—	—	
7.3L	446	8	1998-94	With Indirect Fuel Injection, Non-Turbo and Aftermarket Turbo, with DMF. Heavy Duty 12" option with rigid disc. Valeo type DMF included.		07100A	CA5081	CD5081	N1753	302	11-7/8	1-1/4	10	MC362	SC735	—	—	—	
7.3L	446	8	1998-94	With Indirect Fuel Injection, Non-Turbo and Aftermarket Turbo, with DMF. Heavy Duty 12" option. Valeo type DMF not included.		07100	CA5081	CD5081	N1753	302	11-7/8	1-1/4	10	MC362	SC735	—	—	—	

Liter	cc / in	Cyl	Years	Application Information	Engine Number	Kit	Cover	Disc	Rel Brg	Disc (mm)	Disc (in)	Spline Dia	Splines	Master Cyl	Slave Cyl	Clutch Cable	Clutch Fork	New Flywheel
-------	---------	-----	-------	-------------------------	---------------	-----	-------	------	---------	-----------	-----------	------------	---------	------------	-----------	--------------	-------------	--------------

**FORD MEDIUM TRUCK CONT.**

*F400, 450, 500, 550, 600, 700, 800, 900, 1000 CONT.*

7.3L	446	8	1993-87	With Indirect Fuel Injection, Non-Turbo and Aftermarket Turbo, with DMF. Heavy Duty 12" option. Valeo type DMF not included.		07100	CA5081	CD5081	N1753	302	11-7/8	1-1/4	10	MC356	SC720	—	—	—
7.3L	446	8	1998-94	With Indirect Fuel Injection, Non-Turbo and Factory Turbo, 8th Digit of VIN K or M. LUK type solid flywheel replacement kit contains solid flywheel and mounting bolts. Must be used as matched set.		07131A	LMS105X	—	N1753	311	12-1/4	1-1/4	10	MC362	SC735	—	—	—
7.3L	446	8	1993-87	With Indirect Fuel Injection, Non-Turbo and Factory Turbo, 8th Digit of VIN K or M. LUK type solid flywheel replacement kit contains solid flywheel and mounting bolts. Must be used as matched set.		07131A	LMS105X	—	N1753	311	12-1/4	1-1/4	10	MC356	SC720	—	—	—
7.3L	446	8	1998-94	With Indirect Fuel Injection, Non-Turbo and Factory Turbo, 8th Digit of VIN K. LUK type solid flywheel replacement kit contains solid flywheel and mounting bolts. Must be used as matched set.		07131B	LMS105X	—	N1753	311	12-1/4	1-1/4	10	MC362	SC735	—	—	—
7.3L	446	8	1993-87	With Indirect Fuel Injection, Non-Turbo and Factory Turbo, 8th Digit of VIN K. LUK type solid flywheel replacement kit contains solid flywheel and mounting bolts. Must be used as matched set.		07131B	LMS105X	—	N1753	311	12-1/4	1-1/4	10	MC356	SC720	—	—	—
7.3L	446	8	1993-87	With Indirect Fuel Injection, Non-Turbo and Factory Turbo, LUK type solid flywheel replacement, kit does not contain flywheel.		07131	LMS105X	—	N1753	311	12-1/4	1-1/4	10	MC356	SC720	—	—	—
7.7L	471	8	1984-63	13" Clutch		07125	CA1919	CD0629	N1495	330	13	1-3/8	10	—	—	—	—	—
7.7L	471	8	1984-63	13" Clutch with Ceramic Button		07126	CA1919	CD0629CB	N1495	330	13	1-3/8	10	—	—	—	—	—
7.8L	477	8	1984-63	13" Clutch		07125	CA1919	CD0629	N1495	330	13	1-3/8	10	—	—	—	—	—
7.8L	477	8	1984-63	13" Clutch with Ceramic Button		07126	CA1919	CD0629CB	N1495	330	13	1-3/8	10	—	—	—	—	—

**GMC MEDIUM TRUCK**

*C55, 65, 75*

3.5L	212	4	1967-63	4-53 Detroit Diesel with Diaph Clutch		04106	—	—	—	330	13	1-1/2	10	—	—	—	—	—
3.5L	212	4	1967-63	4-53 Detroit Diesel with Diaph Clutch with Ceramic Button		04107	—	—	—	330	13	1-1/2	10	—	—	—	—	—
3.5L	212	4	1967-63	4-53 Detroit Diesel with Lever Clutch		GMK1002	—	—	—	330	13	1-1/2	10	—	—	—	—	—
3.8L	230	6	1969-63	12" Diaph Clutch		04064	—	—	—	300	11-3/4	1-1/8	10	—	—	—	—	—
3.8L	230	6	1969-63	12" Diaph Clutch with Ceramic Button		04105	—	—	—	300	11-3/4	1-1/8	10	—	—	—	—	—
3.8L	230	6	1969-63	12" Lever Clutch		04502	—	—	—	300	11-3/4	1-1/8	10	—	—	—	—	—
3.8L	230	6	1969-63	12" Lever Clutch with Ceramic Button		04517	—	—	—	300	11-3/4	1-1/8	10	—	—	—	—	—
3.8L	230	6	1969-63	13" Diaph Clutch		04106	—	—	—	330	13	1-1/2	10	—	—	—	—	—
3.8L	230	6	1969-63	13" Diaph Clutch with Ceramic Button		04107	—	—	—	330	13	1-1/2	10	—	—	—	—	—
3.8L	230	6	1969-63	13" Lever Clutch		GMK1002	—	—	—	330	13	1-1/2	10	—	—	—	—	—
3.8L	230	6	1969-63	13" Lever Clutch with Ceramic Button		GMK1003	—	—	—	330	13	1-1/2	10	—	—	—	—	—
3.9L	235	4	2001-98	w/ Hydro Brake Booster		KGM15	—	—	—	324	12-3/4	1-1/2	10	—	—	—	—	—
3.9L	235	4	2001-98	w/o Hydro Brake Booster, Heavy Duty Clutch, Silent Design Disc	4HE1	KGM16	—	—	—	300	11-13/16	1-1/8	21	—	—	—	—	—
3.9L	235	6	1962-54	12" Diaph Clutch		04064	—	—	—	300	11-3/4	1-1/8	10	—	—	—	—	—
3.9L	235	6	1962-54	12" Diaph Clutch with Ceramic Button		04105	—	—	—	300	11-3/4	1-1/8	10	—	—	—	—	—
3.9L	235	6	1962-54	12" Lever Clutch		04502	—	—	—	300	11-3/4	1-1/8	10	—	—	—	—	—
3.9L	235	6	1962-54	12" Lever Clutch with Ceramic Button		04517	—	—	—	300	11-3/4	1-1/8	10	—	—	—	—	—
4.3L	261	6	1962-55	12" Diaph Clutch		04064	—	—	—	300	11-3/4	1-1/8	10	—	—	—	—	—
4.3L	261	6	1962-55	12" Diaph Clutch with Ceramic Button		04105	—	—	—	300	11-3/4	1-1/8	10	—	—	—	—	—
4.3L	261	6	1962-55	12" Lever Clutch		04502	—	—	—	300	11-3/4	1-1/8	10	—	—	—	—	—
4.3L	261	6	1962-55	12" Lever Clutch with Ceramic Button		04517	—	—	—	300	11-3/4	1-1/8	10	—	—	—	—	—
4.6L	283	8	1970-56	13" Diaph Clutch		04106	—	—	—	330	13	1-1/2	10	—	—	—	—	—
4.6L	283	8	1970-56	13" Diaph Clutch with Ceramic Button		04107	—	—	—	330	13	1-1/2	10	—	—	—	—	—
4.6L	283	8	1970-56	13" Lever Clutch		GMK1002	—	—	—	330	13	1-1/2	10	—	—	—	—	—
4.6L	283	8	1970-56	13" Lever Clutch with Ceramic Button		GMK1003	—	—	—	330	13	1-1/2	10	—	—	—	—	—
4.8L	292	6	1989-63	12" Diaph Clutch		04064	—	—	—	300	11-3/4	1-1/8	10	—	—	—	—	—

Liter	cc / in	Cyl	Years	Application Information	Engine Number	Kit	Cover	Disc	Rel Brg	Disc (mm)	Disc (in)	Spline Dia	Splines	Master Cyl	Slave Cyl	Clutch Cable	Clutch Fork	New Flywheel	
<b>GMC MEDIUM TRUCK CONT.</b>																			
<i>C55, 65, 75 CONT.</i>																			
4.8L	292	6	1989-63	12" Diaph Clutch with Ceramic Button		04105	—	—	—	300	11-3/4	1-1/8	10	—	—	—	—	—	—
4.8L	292	6	1989-63	12" Lever Clutch		04502	—	—	—	300	11-3/4	1-1/8	10	—	—	—	—	—	—
4.8L	292	6	1989-63	12" Lever Clutch with Ceramic Button		04517	—	—	—	300	11-3/4	1-1/8	10	—	—	—	—	—	—
4.8L	292	6	1989-63	13" Diaph Clutch		04106	—	—	—	330	13	1-1/2	10	—	—	—	—	—	—
4.8L	292	6	1989-63	13" Diaph Clutch with Ceramic Button		04107	—	—	—	330	13	1-1/2	10	—	—	—	—	—	—
4.8L	292	6	1989-63	13" Lever Clutch		GMK1002	—	—	—	330	13	1-1/2	10	—	—	—	—	—	—
4.8L	292	6	1989-63	13" Lever Clutch with Ceramic Button		GMK1003	—	—	—	330	13	1-1/2	10	—	—	—	—	—	—
5.2L	321	8	1968-64	13" Diaph Clutch		04106	—	—	—	330	13	1-1/2	10	—	—	—	—	—	—
5.2L	321	8	1968-64	13" Diaph Clutch with Ceramic Button		04107	—	—	—	330	13	1-1/2	10	—	—	—	—	—	—
5.2L	321	8	1968-64	13" Lever Clutch		GMK1002	—	—	—	330	13	1-1/2	10	—	—	—	—	—	—
5.2L	321	8	1968-64	13" Lever Clutch with Ceramic Button		GMK1003	—	—	—	330	13	1-1/2	10	—	—	—	—	—	—
5.4L	327	8	1972-62	13" Diaph Clutch		04106	—	—	—	330	13	1-1/2	10	—	—	—	—	—	—
5.4L	327	8	1972-62	13" Diaph Clutch with Ceramic Button		04107	—	—	—	330	13	1-1/2	10	—	—	—	—	—	—
5.4L	327	8	1972-62	13" Lever Clutch		GMK1002	—	—	—	330	13	1-1/2	10	—	—	—	—	—	—
5.4L	327	8	1972-62	13" Lever Clutch with Ceramic Button		GMK1003	—	—	—	330	13	1-1/2	10	—	—	—	—	—	—
5.7L	348	8	1972-62	13" Diaph Clutch		04106	—	—	—	330	13	1-1/2	10	—	—	—	—	—	—
5.7L	348	8	1972-62	13" Diaph Clutch with Ceramic Button		04107	—	—	—	330	13	1-1/2	10	—	—	—	—	—	—
5.7L	348	8	1972-62	13" Lever Clutch		GMK1002	—	—	—	330	13	1-1/2	10	—	—	—	—	—	—
5.7L	348	8	1972-62	13" Lever Clutch with Ceramic Button		GMK1003	—	—	—	330	13	1-1/2	10	—	—	—	—	—	—
5.7L	350	8	1989-65	12" Lever Clutch		04502	—	—	—	300	11-3/4	1-1/8	10	—	—	—	—	—	—
5.7L	350	8	1989-65	12" Lever Clutch		04502	—	—	—	300	11-3/4	1-1/8	10	—	—	—	—	—	—
5.7L	350	8	1989-65	12" Lever Clutch with Ceramic Button		04517	—	—	—	300	11-3/4	1-1/8	10	—	—	—	—	—	—
5.7L	350	8	1989-65	12" Lever Clutch with Ceramic Button		04517	—	—	—	300	11-3/4	1-1/8	10	—	—	—	—	—	—
5.7L	350	8	1993-85	13" Clutch		04149	—	—	—	330	13	1-1/2	10	—	—	—	—	—	—
5.7L	350	8	1993-85	13" Clutch with Ceramic Button		04150	—	—	—	330	13	1-1/2	10	—	—	—	—	—	—
5.7L	350	8	1972-65	13" Diaph Clutch		04106	—	—	—	330	13	1-1/2	10	—	—	—	—	—	—
5.7L	350	8	1993-73	13" Diaph Clutch		04106	—	—	—	330	13	1-1/2	10	—	—	—	CF127	—	—
5.7L	350	8	1972-65	13" Diaph Clutch with Ceramic Button		04107	—	—	—	330	13	1-1/2	10	—	—	—	—	—	—
5.7L	350	8	1993-73	13" Diaph Clutch with Ceramic Button		04107	—	—	—	330	13	1-1/2	10	—	—	—	—	—	—
5.7L	350	8	1972-65	13" Lever Clutch		GMK1002	—	—	—	330	13	1-1/2	10	—	—	—	—	—	—
5.7L	350	8	1993-73	13" Lever Clutch		GMK1002	—	—	—	330	13	1-1/2	10	—	—	—	CF127	—	—
5.7L	350	8	1972-65	13" Lever Clutch with Ceramic Button		GMK1003	—	—	—	330	13	1-1/2	10	—	—	—	—	—	—
5.7L	350	8	1993-73	13" Lever Clutch with Ceramic Button		GMK1003	—	—	—	330	13	1-1/2	10	—	—	—	CF127	—	—
6.0L	366	8	1998-90	13" Clutch		04149	—	—	—	330	13	1-1/2	10	—	—	—	CF127	FWGM16	—
6.0L	366	8	1998-90	13" Clutch with Ceramic Button		04150	—	—	—	330	13	1-1/2	10	—	—	—	CF127	FWGM16	—
6.0L	366	8	1968-65	13" Diaph Clutch		04106	—	—	—	330	13	1-1/2	10	—	—	—	—	—	—
6.0L	366	8	1989-69	13" Diaph Clutch		04106	—	—	—	330	13	1-1/2	10	—	—	—	CF127	FWGM16	—
6.0L	366	8	1968-65	13" Diaph Clutch with Ceramic Button		04107	—	—	—	330	13	1-1/2	10	—	—	—	—	—	—
6.0L	366	8	1989-69	13" Diaph Clutch with Ceramic Button		04107	—	—	—	330	13	1-1/2	10	—	—	—	CF127	FWGM16	—
6.0L	366	8	1989-69	13" Lever Clutch		GMK1002	—	—	—	330	13	1-1/2	10	—	—	—	CF127	FWGM16	—
6.0L	366	8	1968-65	13" Lever Clutch		GMK1002	—	—	—	330	13	1-1/2	10	—	—	—	—	—	—
6.0L	366	8	1989-69	13" Lever Clutch with Ceramic Button		GMK1003	—	—	—	330	13	1-1/2	10	—	—	—	CF127	FWGM16	—
6.0L	366	8	1968-65	13" Lever Clutch with Ceramic Button		GMK1003	—	—	—	330	13	1-1/2	10	—	—	—	—	—	—
6.7L	409	8	1972-62	13" Diaph Clutch		04106	—	—	—	330	13	1-1/2	10	—	—	—	—	—	—
6.7L	409	8	1972-62	13" Diaph Clutch with Ceramic Button		04107	—	—	—	330	13	1-1/2	10	—	—	—	—	—	—
6.7L	409	8	1972-62	13" Lever Clutch		GMK1002	—	—	—	330	13	1-1/2	10	—	—	—	—	—	—
6.7L	409	8	1972-62	13" Lever Clutch with Ceramic Button		GMK1003	—	—	—	330	13	1-1/2	10	—	—	—	—	—	—
7.0L	427	8	1993-90	13" Clutch		04149	—	—	—	330	13	1-1/2	10	—	—	—	—	—	—
7.0L	427	8	1993-90	13" Clutch with Ceramic Button		04150	—	—	—	330	13	1-1/2	10	—	—	—	—	—	—
7.0L	427	8	1989-65	13" Diaph Clutch		04106	—	—	—	330	13	1-1/2	10	—	—	—	—	—	—
7.0L	427	8	1989-65	13" Diaph Clutch with Ceramic Button		04107	—	—	—	330	13	1-1/2	10	—	—	—	—	—	—
7.0L	427	8	1989-65	13" Lever Clutch		GMK1002	—	—	—	330	13	1-1/2	10	—	—	—	—	—	—
7.0L	427	8	1989-65	13" Lever Clutch with Ceramic Button		GMK1003	—	—	—	330	13	1-1/2	10	—	—	—	—	—	—
7.0L	427	8	2001-94	Gas, Valeo Push Type Clutch		KGM40	—	—	—	330	13	1-1/2	10	—	—	—	—	—	—
7.2L	439	6	2006-90	Cat 3116, 3169 with Eaton Transmission		KGM41	—	—	—	356	14	1-3/4	10	—	—	—	—	—	—
7.2L	439	6	2001-97	Cat 3126 Turbo with Eaton Transmission		KGM42	—	—	—	356	14	1-3/4	10	—	—	—	—	—	—
7.2L	439	8	2001-94	CAT 3116/31126 with Eaton Transmission		KGM41	—	—	—	356	14	1-3/4	10	—	—	—	—	—	—
7.2L	439	8	1999-90	CAT 3126 with Eaton Transmission, T Series		KGM42	—	—	—	356	14	1-3/4	10	—	—	—	—	—	—

Liter	cc / in	Cyl	Years	Application Information	Engine Number	Kit	Cover	Disc	Rel Brg	Disc (mm)	Disc (in)	Spline Dia	Splines	Master Cyl	Slave Cyl	Clutch Cable	Clutch Fork	New Flywheel	
<b>GMC MEDIUM TRUCK CONT.</b>																			
<i>W5500</i>																			
4.75L			2004	6 Speed	4HE1-TC	GMK1005	—	—	—	350	13-3/4	1-1/2	10	—	—	—	—	—	—
<b>HINO TRUCK</b>																			
<i>FA1517</i>																			
5.3L			2004-03	Diaph Clutch with Cearmic Button	J05C-TD	HNK1000	—	—	—	356	14	1-3/4	10	—	—	—	—	—	—
<i>FB14</i>																			
3.9L	4		1991-87	Turbo	W04C-T	KHN04	—	—	—	300	11-13/16	1-1/2	10	—	—	—	—	—	—
<i>FB1817</i>																			
5.3L			2004-03	Diaph Clutch with Cearmic Button	J05C-TD	HNK1000	—	—	—	356	14	1-3/4	10	—	—	—	—	—	—
<i>FD SERIES</i>																			
6.0L	6		1988-80		W06E	KHN01	—	—	—	325	12-13/16	1-1/2	10	—	—	—	—	—	—
8.0L			2004-03	Diaph Clutch with Cearmic Button	J05C-TD	HNK1000	—	—	—	356	14	1-3/4	10	—	—	—	—	—	—
<i>FE SERIES</i>																			
6.0L	6		1988-84		W06E	KHN01	—	—	—	325	12-13/16	1-1/2	10	—	—	—	—	—	—
6.5L	6		1992-89		H06C-T	KHN02	—	—	—	352	13-7/8	1-3/4	10	—	—	—	—	—	—
6.7L	6		1988-84		H06C, H07C	KHN02	—	—	—	352	13-7/8	1-3/4	10	—	—	—	—	—	—
8.0L	6		1998-89	Diaph Clutch with Cearmic Button	J08C-T	HNK1000	—	—	—	356	14	1-3/4	10	—	—	—	—	—	—
<i>FF SERIES</i>																			
6.5L	6		1992-89		H06C-T	KHN02	—	—	—	352	13-7/8	1-3/4	10	—	—	—	—	—	—
8.0L	6		1998-89	Diaph Clutch with Cearmic Button	J08C-T	HNK1000	—	—	—	356	14	1-3/4	10	—	—	—	—	—	—
<i>FG SERIES</i>																			
6.5L	6		1988-84		H06TH	KHN03	—	—	—	381	15	1-3/4	10	—	—	—	—	—	—
<i>SG SERIES</i>																			
6.5L	6		1988-84		H06TH	KHN03	—	—	—	381	15	1-3/4	10	—	—	—	—	—	—
<b>ISUZU MEDIUM DUTY TRUCK</b>																			
<i>EVR, W7T</i>																			
			1991-90		MLH5G	ISK1004	—	—	—	356	14	1-1/12	10	—	—	—	—	—	—
			1992		MLD6F	ISK1004	—	—	—	356	14	1-1/12	10	—	—	—	—	—	—
			2004			ISK1005	—	—	—	356	14	1-1/12	10	—	—	—	—	—	—
			1989-87	12/87-5/89, Spicer Diaph Clutch with Ceramic Button		ISK1004	—	—	—	356	14	1-1/12	10	—	—	—	—	—	—
			1988-87	To 8/88, Spicer Diaph Clutch with Ceramic Button	MT	ISK1004	—	—	—	356	14	1-1/12	10	—	—	—	—	—	—
<i>FTR, FVR, W7M, T70, T7000</i>																			
			1993-88	2/88-5/93, Spicer Diaph Clutch with Ceramic Button	6BD1	ISK1004	—	—	—	356	14	1-1/12	10	—	—	—	—	—	—
			1991-87	From 11/87, Spicer Diaph Clutch with Ceramic Button	6BD1, MT	ISK1004	—	—	—	356	14	1-1/12	10	—	—	—	—	—	—
			1996-93	From 6/93, Spicer Diaph Clutch with Ceramic Button		ISK1004	—	—	—	356	14	1-1/12	10	—	—	—	—	—	—
			1991-90	Spicer Diaph Clutch with Ceramic Button	MLH5G/FS6106A	ISK1004	—	—	—	356	14	1-1/12	10	—	—	—	—	—	—
			2002-97	Spicer Diaph Clutch with Ceramic Button		ISK1004	—	—	—	356	14	1-1/12	10	—	—	—	—	—	—
			2005-04	Spicer Diaph Clutch with Ceramic Button		ISK1005	—	—	—	356	14	1-1/12	10	—	—	—	—	—	—
			1996-90	Spicer Diaph Clutch with Ceramic Button	MLD6F	ISK1004	—	—	—	356	14	1-1/12	10	—	—	—	—	—	—
			1988-84	To 6/88, Spicer Diaph Clutch with Ceramic Button	6BD1T	ISK1004	—	—	—	356	14	1-1/12	10	—	—	—	—	—	—
<i>NPR</i>																			
3.9L	3900	4	1990-86		W4	KGM14	—	—	—	300	11-13/16	1	24	—	—	—	—	—	—
3.9L	3900	4	1997-91		W4	KGM20	—	—	—	300	11-13/16	1-1/8	21	—	—	—	—	—	—
3.9L	3900	4	2003-99			ISK1001	—	—	—	300	11-13/16	1-1/8	21	—	—	—	—	—	—
3.9L	3900	4	2003-99			ISK1006	—	—	—	300	11-13/16	1-1/8	21	—	—	—	—	—	—
3.9L	3900	4	1999-95	From 7/95		ISK1000	—	—	—	300	11-13/16	1-1/8	21	—	—	—	—	—	—
3.9L	3900	4	2001-98	Heavy Duty Clutch with Silent Design Disc	4HJ1	KGM16	—	—	—	300	11-13/16	1-1/8	21	—	—	—	—	—	—
3.9L	3900	4	1990-85	To 5/90	W4	09011	—	—	—	273	10-3/4	1	24	—	—	—	—	—	—
3.9L	3900	4	1997-90	Turbo	4BD1, 4BD2	KGM20	—	—	—	300	11-13/16	1-1/8	21	—	—	—	—	—	—
3.9L	3900	4	1994-87	Turbo	4BD1, 4BD2	KGM14	—	—	—	300	11-13/16	1	24	—	—	—	—	—	—



Liter	cc / in	Cyl	Years	Application Information	Engine Number	Kit	Cover	Disc	Rel Brg	Disc (mm)	Disc (in)	Spline Dia	Splines	Master Cyl	Slave Cyl	Clutch Cable	Clutch Fork	New Flywheel
<b>ISUZU MEDIUM DUTY TRUCK CONT.</b>																		
<i>NPR CONT.</i>																		
3.9L	3900	4	1987-84	With Ceramic Disc	W4	KIS03	—	—	—	273	10-3/4	1	24	—	—	—	—	—
<b>MACK MIDLINER (RENAULT) (RVI)</b>																		
<i>MS200, MS250</i>																		
5.5L		6	1999-83	Spicer Transmission	MS200	MKM1000S	—	—	—	330	12-7/8	1-1/2	13	—	—	—	—	—
5.5L		6	1999-83	Spicer Transmission		MKM1001	—	—	—	350	13-3/4	1-1/2	14	—	—	—	—	—
6.2L		6	1999-83			MKM1002	—	—	—	350	13-3/4	1-1/2	14	—	—	—	—	—
6.2L		6	1999-83	Eaton Transmi+E341ssion	MS250	MKM1000E	—	—	—	350	13-3/4	1-1/2	13	—	—	—	—	—
6.2L		6	1999-83	Spicer Transmission		MKM1001	—	—	—	350	13-3/4	1-1/2	14	—	—	—	—	—
8.8L		6	1999-83			MKM1003	—	—	—	350	13-3/4	1-3/4	14	—	—	—	—	—
8.8L		6	1999-83	Spicer Transmission	MS250	MKM1001	—	—	—	350	13-3/4	1-1/2	14	—	—	—	—	—
<b>MITSUBISHI FUSO</b>																		
<i>FE</i>																		
3.3L		4	1991-87	FE434, FE444, Organic Disc		MFK1002	—	—	—	350	13-3/4	1-1/2	14	—	—	—	—	—
3.9L		4	1991-87	FE434, FE444, Ceramic Disc		MFK1003	—	—	—	350	13-3/4	1-1/2	14	—	—	—	—	—
3.9L		4	1995-92	FE439, FE649, Ceramic Disc		MFK1004	—	—	—	300	11-13/16	1-3/8	14	—	—	—	—	—
3.9L		4	1995-92	FE439, FE649, Organic Disc		MFK1001	—	—	—	300	11-13/16	1-3/8	14	—	—	—	—	—
3.9L		4	2003-96	FE639, FE649, Ceramic Disc		MFK1004	—	—	—	300	11-13/16	1-3/8	14	—	—	—	—	—
3.9L		4	2003-96	FE639, FE649, Organic Disc		MFK1001	—	—	—	300	11-13/16	1-3/8	14	—	—	—	—	—
<i>FG</i>																		
3.9L		4	1991-90	FG434, Organic Disc		MFK1005	—	—	—	275	10-3/4	1-5/32	14	—	—	—	—	—
3.9L		4	1993-92	FG439, Ceramic Disc		MFK1004	—	—	—	300	11-13/16	1-3/8	14	—	—	—	—	—
3.9L		4	1993-92	FG439, Organic Disc		MFK1001	—	—	—	300	11-13/16	1-3/8	14	—	—	—	—	—
3.9L		4	2003-98	FG639, Ceramic Disc		MFK1004	—	—	—	300	11-13/16	1-3/8	14	—	—	—	—	—
3.9L		4	2003-98	FG639, Organic Disc		MFK1001	—	—	—	300	11-13/16	1-3/8	14	—	—	—	—	—
<i>FH</i>																		
5.9L			2002-98	5 & 6 Speed, Coil Spring, Ceramic Disc	6D34-0AT2	MFK1012	—	—	—	325	12-13/16			—	—	—	—	—
5.9L			1995-90	FH100, Ceramic Disc		MFK1007	—	—	—	300	11-13/16			—	—	—	—	—
5.9L			2003-96	FH211, Ceramic Disc		MFK1008	—	—	—	300	11-13/16			—	—	—	—	—
5.9L			1999-88	FH100, Organic Disc		MFK1006	—	—	—					—	—	—	—	—
<i>FK</i>																		
7.5L			2003-98	5 & 6 Speed, Coil Spring, Ceramic Disc	6D16-2AT3	MFK1013	—	—	—	350	13-3/4	1-3/8	14	—	—	—	—	—
7.5L			1991-89	FK415, Ceramic Disc		MFK1011	—	—	—	325	12-13/16	1-3/8	14	—	—	—	—	—
7.5L			1988	FK415, Organic Disc		MFK1010	—	—	—	325	12-13/16	1-3/8	14	—	—	—	—	—
7.5L			1987-86	FK415, Organic Disc		MFK1009	—	—	—	325	12-13/16	1-3/8	14	—	—	—	—	—
<i>FM-SP</i>																		
7.5L			2003-98	6 & 10 Speed, Coil Spring, Ceramic Disc		MFK1014	—	—	—	380	15	1-3/4	14	—	—	—	—	—
<b>NAVISTAR</b>																		
<i>392, 406, 450, 461, 501, BC150, BC100, D354, DV550, RD372, V304, V345, V549, VS401, VS478, VS549</i>																		
			1996-65	Diaph Clutch		GMK1005	—	—	—	350	13-3/4	1-1/2	10	—	—	—	—	—
3.9L			1996-87	Diaph Clutch		NVK1000	—	—	—	310	12-1/4	1-1/4	10	—	—	—	—	—
6.9L			1996-87	Diaph Clutch		NVK1000	—	—	—	310	12-1/4	1-1/4	10	—	—	—	—	—
7.3L			1996-87	Diaph Clutch		NVK1000	—	—	—	310	12-1/4	1-1/4	10	—	—	—	—	—
<i>530, DT360, DT466, DT530</i>																		
			2002-85			7683-5	—	—	—	356	14	1-3/4	10	—	—	—	—	—
			2002-88			7237-10	—	—	—	356	14	1-3/4	10	—	—	—	—	—
<b>NISSAN DIESEL TRUCK - UD</b>																		
6.9L		6	1987-86	CLA83, CMA83, CPB12	FE6	KNS01	—	—	—	330	13	1-3/16	16	—	—	—	—	—
7.4L		6	1987-85	CPB12, CPC12	NE6T	NDK1001	—	—	—	325	12-13/16	1-3/8	10	—	—	—	—	—
7.4L		6	1987	CPB14, CPC14, CPC15, with RL Plate		NDK1002	—	—	—	380	14-7/8	1-5/8	10	—	—	—	—	—
7.4L		6	1987	CPC12, Lever Clutch w/o RL Plate	NE6T	NDK1000	—	—	—	381	15	1-3/4	10	—	—	—	—	—
<i>1100</i>																		
			1991-89	Organic disc	FD35T	NDK1003	—	—	—	275	10-7/8	1	24	—	—	—	—	—

Liter	cc / in	Cyl	Years	Application Information	Engine Number	Kit	Cover	Disc	Rel Brg	Disc (mm)	Disc (in)	Spline Dia	Splines	Master Cyl	Slave Cyl	Clutch Cable	Clutch Fork	New Flywheel	
<b>NISSAN DIESEL TRUCK - UD CONT.</b>																			
<i>1200, 1300, 1400</i>																			
			0			—	—	—	—					—	—	—	—	—	
			0			—	—	—	—					—	—	—	—	—	
			2004-99	Organic disc	FD46TA	NDK1006	—	—	—	300	11-13/16	1	24	—	—	—	—	—	
			1994-92	Organic disc	TD42T	NDK1003	—	—	—	275	10-7/8	1	24	—	—	—	—	—	
			1998-95	Organic disc	TD42T	NDK1005	—	—	—	300	11-13/16	1	24	—	—	—	—	—	
<i>1800</i>																			
			0			—	—	—	—					—	—	—	—	—	
			0			—	—	—	—					—	—	—	—	—	
			2004-92	Ceramtallic disc	FE6T, FE6TA	NDK1004	—	—	—	350	13-3/4	1-1/2	10	—	—	—	—	—	
			2004-99	Ceramtallic disc	FD46TA	NDK1007	—	—	—	325	12-13/16	1-3/8	16	—	—	—	—	—	
			2004-92	Organic disc	FE6T, FE6TA	NDK1011	—	—	—	350	13-3/4	1-1/2	10	—	—	—	—	—	
			1991-89	Organic disc	FE6T	NDK1008	—	—	—	325	12-13/16	1-3/8	16	—	—	—	—	—	
<i>2000</i>																			
			0			—	—	—	—					—	—	—	—	—	
			0			—	—	—	—					—	—	—	—	—	
			2004-92	Ceramtallic disc	FE6T, FE6TE	NDK1004	—	—	—	350	13-3/4	1-1/2	10	—	—	—	—	—	
			2004-92	Organic disc	FE6T, FE6TE	NDK1011	—	—	—	350	13-3/4	1-1/2	10	—	—	—	—	—	
			1991-89	Organic disc	FE6T	NDK1008	—	—	—	325	12-13/16	1-3/8	16	—	—	—	—	—	
<i>2300</i>																			
			0			—	—	—	—					—	—	—	—	—	
			0			—	—	—	—					—	—	—	—	—	
			2004-89	Ceramtallic disc	FE6T, FE6TE	NDK1004	—	—	—	350	13-3/4	1-1/2	10	—	—	—	—	—	
			2004-89	Organic disc	FE6T, FE6TE	NDK1011	—	—	—	350	13-3/4	1-1/2	10	—	—	—	—	—	
<i>2600</i>																			
			0			—	—	—	—					—	—	—	—	—	
			0			—	—	—	—					—	—	—	—	—	
			2004-89	Ceramtallic disc	FE6T, FE6TE	NDK1004	—	—	—	350	13-3/4	1-1/2	10	—	—	—	—	—	
			2004-89	Organic disc	FE6T, FE6TE	NDK1011	—	—	—	350	13-3/4	1-1/2	10	—	—	—	—	—	
<i>2800</i>																			
			0			—	—	—	—					—	—	—	—	—	
			0			—	—	—	—					—	—	—	—	—	
			1994-89	Ceramtallic disc	FE6T, FE6TE	NDK1004	—	—	—	350	13-3/4	1-1/2	10	—	—	—	—	—	
			1994-89	Organic disc	FE6T, FE6TE	NDK1011	—	—	—	350	13-3/4	1-1/2	10	—	—	—	—	—	
<i>3000</i>																			
			0			—	—	—	—					—	—	—	—	—	
			0			—	—	—	—					—	—	—	—	—	
			2000-92	Ceramtallic disc	FE6T, FE6TE	NDK1004	—	—	—	350	13-3/4	1-1/2	10	—	—	—	—	—	
			2000-92	Organic disc	FE6T, FE6TE	NDK1011	—	—	—	350	13-3/4	1-1/2	10	—	—	—	—	—	
			1994-92	Organic disc	NE6TA	NDK1002	—	—	—	380	14-7/8	1-5/8	10	—	—	—	—	—	
			1991-89	Organic disc	NE6T	NDK1009	—	—	—	350	13-3/4	1-1/2	10	—	—	—	—	—	
<i>3300</i>																			
			2000-99	Ceramtallic disc	FE6TA	NDK1004	—	—	—	350	13-3/4	1-1/2	10	—	—	—	—	—	
			1994-89	Organic disc	NE6T, NE6TA	NDK1002	—	—	—	380	14-7/8	1-5/8	10	—	—	—	—	—	
			2000-99	Organic disc	FE6TA	NDK1011	—	—	—	350	13-3/4	1-1/2	10	—	—	—	—	—	
<i>550, 600T</i>																			
			1994-89	Organic disc	NE6T, NE6TA	NDK1002	—	—	—	380	14-7/8	1-5/8	10	—	—	—	—	—	
<b>VOLVO TRUCK</b>																			
<i>FE</i>																			
7.2L	439		1995-93	CAT Engine 3116		VLK1002	—	—	—	356	14	1	10	—	—	—	—	—	
7.2L	439		1992-90	CAT Engine 3116		VLK1000	—	—	—	356	14	1	10	—	—	—	—	—	



SECTION 4  
CONVERSIONS  
METRIC TO INCHES

To Convert	Formula
Cubic Inches to Liters	LITERS times 61.024 equals CUBIC INCHES
Liters to Cubic Inches	CUBIC INCHES divided by 61.024 equals LITERS

To Convert	Formula
Cubic Inches to Liters	LITERS times 61.024 equals CUBIC INCHES
Liters to Cubic Inches	CUBIC INCHES divided by 61.024 equals LITERS

LITERS	CC / CI	LITERS	CC / CI	LITERS	CC / CI	LITERS	CC / CI
1.0L	61	1.6L	1588	2.0L	1952	2.3L	2299
1.0L	948	1.6L	1588	2.0L	1955	2.3L	2300
1.0L	995	1.6L	1589	2.0L	1958	2.3L	2302
1.0L	1000	1.6L	1590	2.0L	1967	2.3L	2307
1.0L	1146	1.6L	1595	2.0L	1968	2.3L	2309
1.1L	1100	1.6L	1596	2.0L	1970	2.3L	2316
1.1L	1116	1.6L	1597	2.0L	1971	2.3L	2341
1.1L	1146	1.6L	1599	2.0L	1972	2.4L	145
1.2L	1166	1.6L	1600	2.0L	1974	2.4L	146
1.2L	1189	1.6L	1606	2.0L	1975	2.4L	148
1.2L	1196	1.6L	1639	2.0L	1983	2.4L	150
1.2L	1200	1.7L	104	2.0L	1984	2.4L	2351
1.2L	1237	1.7L	1678	2.0L	1985	2.4L	2366
1.3L	79	1.7L	1700	2.0L	1986	2.4L	2389
1.3L	81	1.7L	1715	2.0L	1989	2.4L	2393
1.3L	1272	1.7L	1721	2.0L	1990	2.4L	2398
1.3L	1275	1.8L	107	2.0L	1991	2.4L	2400
1.3L	1289	1.8L	110	2.0L	1994	2.4L	2435
1.3L	1290	1.8L	112	2.0L	1997	2.4L	2438
1.3L	1295	1.8L	113	2.0L	1998	2.5L	148
1.3L	1300	1.8L	1590	2.0L	2792	2.5L	150
1.3L	1301	1.8L	1597	2.1L	126	2.5L	151
1.3L	1308	1.8L	1751	2.1L	2056	2.5L	152
1.3L	1328	1.8L	1754	2.1L	2100	2.5L	153
1.3L	1335	1.8L	1760	2.1L	2109	2.5L	173
1.3L	1342	1.8L	1762	2.1L	2119	2.5L	262
1.4L	85	1.8L	1770	2.1L	2127	2.5L	2451
1.4L	1393	1.8L	1780	2.2L	132	2.5L	2458
1.4L	1397	1.8L	1781	2.2L	133	2.5L	2459
1.4L	1400	1.8L	1790	2.2L	134	2.5L	2475
1.4L	1410	1.8L	1793	2.2L	135	2.5L	2492
1.4L	1415	1.8L	1795	2.2L	2109	2.5L	2493
1.5L	90	1.8L	1796	2.2L	2144	2.5L	2494
1.5L	92	1.8L	1797	2.2L	2147	2.5L	2497
1.5L	1452	1.8L	1798	2.2L	2155	2.5L	2498
1.5L	1456	1.8L	1800	2.2L	2156	2.5L	2500
1.5L	1457	1.8L	1809	2.2L	2163	2.5L	2508
1.5L	1468	1.8L	1817	2.2L	2164	2.6L	156
1.5L	1471	1.8L	1829	2.2L	2180	2.6L	2555
1.5L	1475	1.8L	1834	2.2L	2184	2.6L	2557
1.5L	1487	1.8L	1836	2.2L	2187	2.6L	2559
1.5L	1488	1.8L	1839	2.2L	2189	2.6L	2563
1.5L	1489	1.8L	1840	2.2L	2195	2.6L	2565
1.5L	1490	1.8L	1845	2.2L	2197	2.6L	2588
1.5L	1491	1.9L	116	2.2L	2200	2.6L	2597
1.5L	1493	1.9L	119	2.2L	2212	2.6L	2599
1.5L	1495	1.9L	1858	2.2L	2226	2.6L	2600
1.5L	1497	1.9L	1872	2.2L	2237	2.6L	2606
1.5L	1500	1.9L	1895	2.3L	138	2.7L	165
1.5L	1508	1.9L	1896	2.3L	140	2.7L	167
1.6L	97	1.9L	1898	2.3L	173	2.7L	294
1.6L	98	1.9L	1900	2.3L	2253	2.7L	2656
1.6L	1565	1.9L	1915	2.3L	2254	2.7L	2671
1.6L	1573	1.9L	1949	2.3L	2259	2.7L	2672
1.6L	1586	2.0L	121	2.3L	2290	2.7L	2673
1.6L	1587	2.0L	122	2.3L	2295		

LITERS	CC / CI	LITERS	CC / CI	LITERS	CC / CI	LITERS	CC / CI
2.7L	2675	3.4L	207	4.8L	292	7.4L	455
2.7L	2688	3.4L	3378	4.8L	294	7.5L	455
2.7L	2693	3.4L	3400	4.9L	300	7.5L	460
2.7L	2694	3.4L	3431	4.9L	301	7.8L	477
2.7L	2700	3.5L	212	5.0L	302	8.0L	488
2.8L	170	3.5L	3430	5.0L	304	8.0L	490
2.8L	171	3.5L	3453	5.0L	305	8.1L	496
2.8L	173	3.5L	3475	5.0L	307	8.3L	505
2.8L	231	3.5L	3500	5.0L	4950		
2.8L	2753	3.5L	3524	5.2L	316		
2.8L	2754	3.5L	3540	5.2L	318		
2.8L	2771	3.5L	3543	5.3L	326		
2.8L	2788	3.6L	221	5.4L	327		
2.8L	2792	3.6L	223	5.4L	329		
2.8L	2793	3.6L	3562	5.4L	330		
2.8L	2800	3.6L	3590	5.5L	330		
2.8L	2827	3.6L	3596	5.6L	340		
2.8L	2849	3.6L	3606	5.6L	343		
2.9L	177	3.7L	225	5.6L	5576		
2.9L	179	3.7L	226	5.7L	347		
3.0L	181	3.8L	229	5.7L	348		
3.0L	182	3.8L	230	5.7L	350		
3.0L	183	3.8L	231	5.7L	351		
3.0L	2954	3.8L	232	5.8L	351		
3.0L	2959	3.8L	3800	5.8L	352		
3.0L	2960	3.9L	235	5.8L	354		
3.0L	2961	3.9L	240	5.8L	5800		
3.0L	2966	3.9L	2950	5.9L	360		
3.0L	2967	3.9L	3900	5.9L	361		
3.0L	2969	3.9L	3950	6.0L	363		
3.0L	2972	4.0L	242	6.1L	370		
3.0L	2980	4.0L	244	6.2L	379		
3.0L	2983	4.0L	3950	6.3L	383		
3.0L	2985	4.0L	3982	6.4L	389		
3.0L	2988	4.0L	4016	6.4L	390		
3.0L	2997	4.1L	250	6.4L	391		
3.0L	2999	4.2L	255	6.5L	395		
3.0L	3000	4.2L	258	6.5L	396		
3.1L	189	4.2L	4172	6.6L	400		
3.1L	191	4.2L	4196	6.6L	401		
3.1L	3137	4.2L	4200	6.6L	402		
3.2L	194	4.3L	260	6.6L	403		
3.2L	196	4.3L	261	6.6L	406		
3.2L	198	4.3L	262	6.7L	409		
3.2L	3165	4.3L	265	6.8L	413		
3.2L	3179	4.3L	4294	6.8L	415		
3.2L	3200	4.4L	265	6.9L	420		
3.2L	3206	4.4L	267	6.9L	421		
3.3L	185	4.4L	270	7.0L	425		
3.3L	200	4.5L	273	7.0L	427		
3.3L	3210	4.6L	281	7.0L	428		
3.3L	3230	4.6L	283	7.0L	429		
3.3L	3275	4.7L	285	7.2L	439		
3.3L	3294	4.7L	287	7.2L	440		
3.3L	3300	4.7L	289	7.3L	446		
3.4L	204	4.8L	290	7.4L	454		

To Convert		Formula
Millimeters to Inches		MILLIMETERS divided by 25.4 equals INCHES
Inches to Millimeters		INCHES times 25.4 equals MILLIMETERS

DISC (IN)	DISC (MM)	DISC (IN)	DISC (MM)	DISC (IN)	DISC (MM)
6-1/4	159	8-3/4	222	10-3/8	264
6-5/16	160	8-13/16	224	10-1/2	267
6-1/2	165	8-7/8	225	10-3/4	273
6-11/16	170	9	229	10-7/8	276
6-3/4	172	9-1/16	230	11	279
7	178	9-1/8	232	11-1/2	292
7-1/8	181	9-1/4	235	11-3/4	298
7-1/4	184	9-5/16	237	11-13/16	300
7-3/8	187	9-3/8	238	11-7/8	302
7-1/2	190	9-7/16	240	12	305
7-7/8	200	9-1/2	241	12-1/4	311
8	203	9-5/8	244	12-3/4	324
8-1/4	210	9-11/16	246	12-13/16	325
8-5/16	211	9-3/4	248	13	330
8-3/8	213	9-7/8	248	13-7/8	352
8-7/16	214	10	254	14	356
8-1/2	216	10-1/8	257	15	381
8-5/8	219	10-1/4	260		

To Convert		Formula
Millimeters to Inches		MILLIMETERS divided by 25.4 equals INCHES
Inches to Millimeters		INCHES times 25.4 equals MILLIMETERS

DISC (MM)	DISC (IN)	DISC (MM)	DISC (IN)	DISC (MM)	DISC (IN)
159	6-1/4	222	8-3/4	264	10-3/8
160	6-5/16	224	8-13/16	267	10-1/2
165	6-1/2	225	8-7/8	273	10-3/4
170	6-11/16	229	9	276	10-7/8
172	6-3/4	230	9-1/16	279	11
178	7	232	9-1/8	292	11-1/2
181	7-1/8	235	9-1/4	298	11-3/4
184	7-1/4	237	9-5/16	300	11-13/16
187	7-3/8	238	9-3/8	302	11-7/8
190	7-1/2	240	9-7/16	305	12
200	7-7/8	241	9-1/2	311	12-1/4
203	8	244	9-5/8	324	12-3/4
210	8-1/4	246	9-11/16	325	12-13/16
211	8-5/16	248	9-3/4	330	13
213	8-3/8	248	9-7/8	352	13-7/8
214	8-7/16	254	10	356	14
216	8-1/2	257	10-1/8	381	15
219	8-5/8	260	10-1/4		



# SECTION 5

## CLUTCH

### INSTALLATION

### INSTRUCTIONS



*How to get it right the first time...*

**FITTING INSTRUCTIONS: INSTALLING YOUR NEW DAIKIN CLUTCH.**

Failure to observe these instructions when fitting your Daikin Clutch will void any warranty.

1. *Getting it right the first time. It is vital to diagnose the cause of clutch malfunction before clutch replacement, i.e. check hydraulic system - bearing free travel - clutch cable, oil leaks and check for any signs of red dust when old clutch is being removed. Any or all of these problems must be corrected before installing a new clutch.*
2. Ensure clutch supplied is correct for the application. If you're unsure, consult your Daikin Clutch Catalogue or your supplier, as fitting a clutch to the wrong application will void the warranty.
3. Flywheel must be machined as shown below (Fig 2.) or warranty will be void and check spigot bearing or the pilot bush and replace if necessary. Please note pilot bush noises are more apparent when the engine and transmission systems are cold (i.e. in the mornings).
4. Before fitting, check the clutch for any shipping damage. Next clean the gear box main drive shaft splines, then check that clutch disc slides freely on the shaft. Lightly grease the shaft splines with high melting point grease. Always ensure bell housing is degreased and is free of any dust and that fibres from the worn clutch are removed. If the clutch is a large size pull type clutch check the ID of the bearing head for correct spline size before installation. Lack of lubrication/dry splines will cause failure to disengage gears and also cause clutch drag.
5. Check clutch release fork for cracks, check the clutch cable for stretch signs and check the release bearing guide tube for any wear. Always lightly grease the outside diameter of the tube. This will allow smooth sliding of the bearing carrier. Always check bearing on clutch release fork after installing the bearing on it. Move the fork forwards and backwards i.e. in both directions, to ensure bearing is secure and does not fall on any part (clutch fork or bell housing) before refitting gear box.
6. Place the clutch cover pressure plate assembly over the clutch disc, after checking that the disc is the right way around and the hub section of the disc does not fall on the casting of the clutch cover assembly or the flywheel. A suitable clutch aligning tool will ensure correct alignment, assist in ease of installation and avoid spline damage. (Burr on splines are a major cause of difficult gear disengagement). Ensure pressure plate dowels are aligned to the cover. Tighten bolts in a diagonal pattern and never use air tools to install a clutch cover assembly. Torquing down bolts in an uneven pattern in some instances could cause the lever strut to dislodge itself from the pressure plate casting.
7. When the pressure plate has been torqued down securely to the flywheel, ensure that the diaphragm tips (in the case of a lever type cover assembly, the release lever tips) are in a parallel position (see Fig 3) and do not go over center of the parallel position.
8. Refit gear box, taking care not to bend the clutch disc. Never hang the gear box off the clutch disc or use any force to align gear box shaft.
9. Check all bell housing dowels are in correct position and tighten bell housing bolts. Ensure there is no dirt or foreign material between the mating surfaces of the engine and the bell housing.
10. Perform any clutch adjustments to vehicle manufacturer's specifications and always reset the clutch master cylinder push rod to obtain comfortable pedal release position (clutch taking up as close as possible to the floor prevents clutch shudder and in most cases preferred by vehicle drivers). Keep in mind that the diaphragm tip position has changed with the installation of the new clutch.
11. Always check the clutch cable if you are unable to obtain disengagement when a new clutch is fitted. Start off your checking process by replacing the cable. If it is a hydraulic clutch start by checking the clutch master cylinder and the clutch slave cylinder, ensuring there is no air in the system. This is essential to obtain maximum travel for disengagement.
12. Road test vehicle and never abuse a newly fitted clutch. Allow 750 mi break in and always adjust free travel on your new clutch at 750 mi and 1500 mi. Thereafter, adjust at every 7500mi.

**WARNING:** Do not use DAIKIN clutches in any situation where engine RPM's may exceed manufacturer's specifications - a pressure plate could explode unexpectedly causing serious injury or death to vehicle occupants and bystanders. Clutch cover and bell housing will not protect against exploding pressure plates. Refer to the Application Catalogue for correct fit.

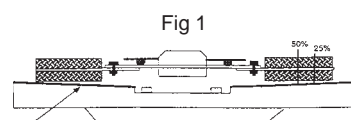

Fig 1  
Belled out surface might look smooth but uneven

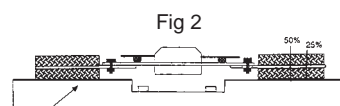
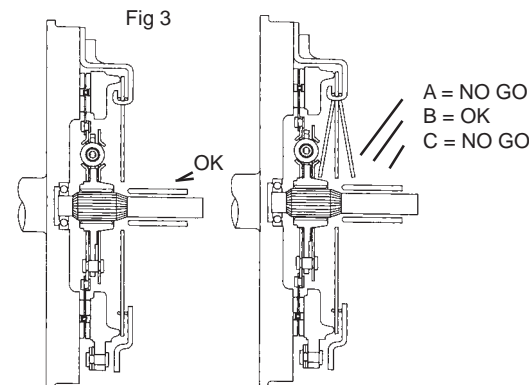
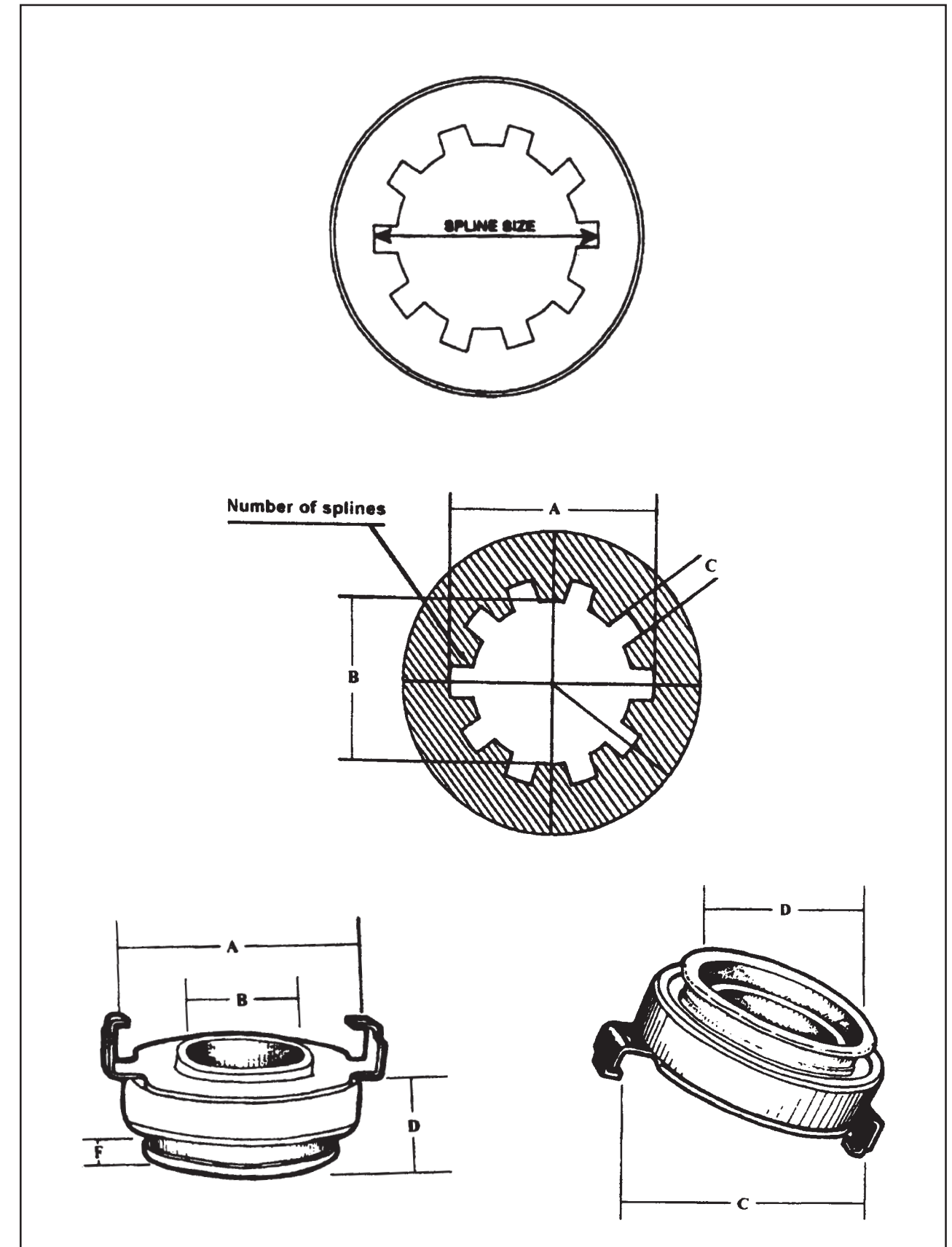

Fig 2  
Good flat machined surface



5



5

# NEW TECHNOLOGY DESIGN CLUTCH

**STUDY BEFORE DISASSEMBLY**

**STUDY BEFORE INSTALLATION**

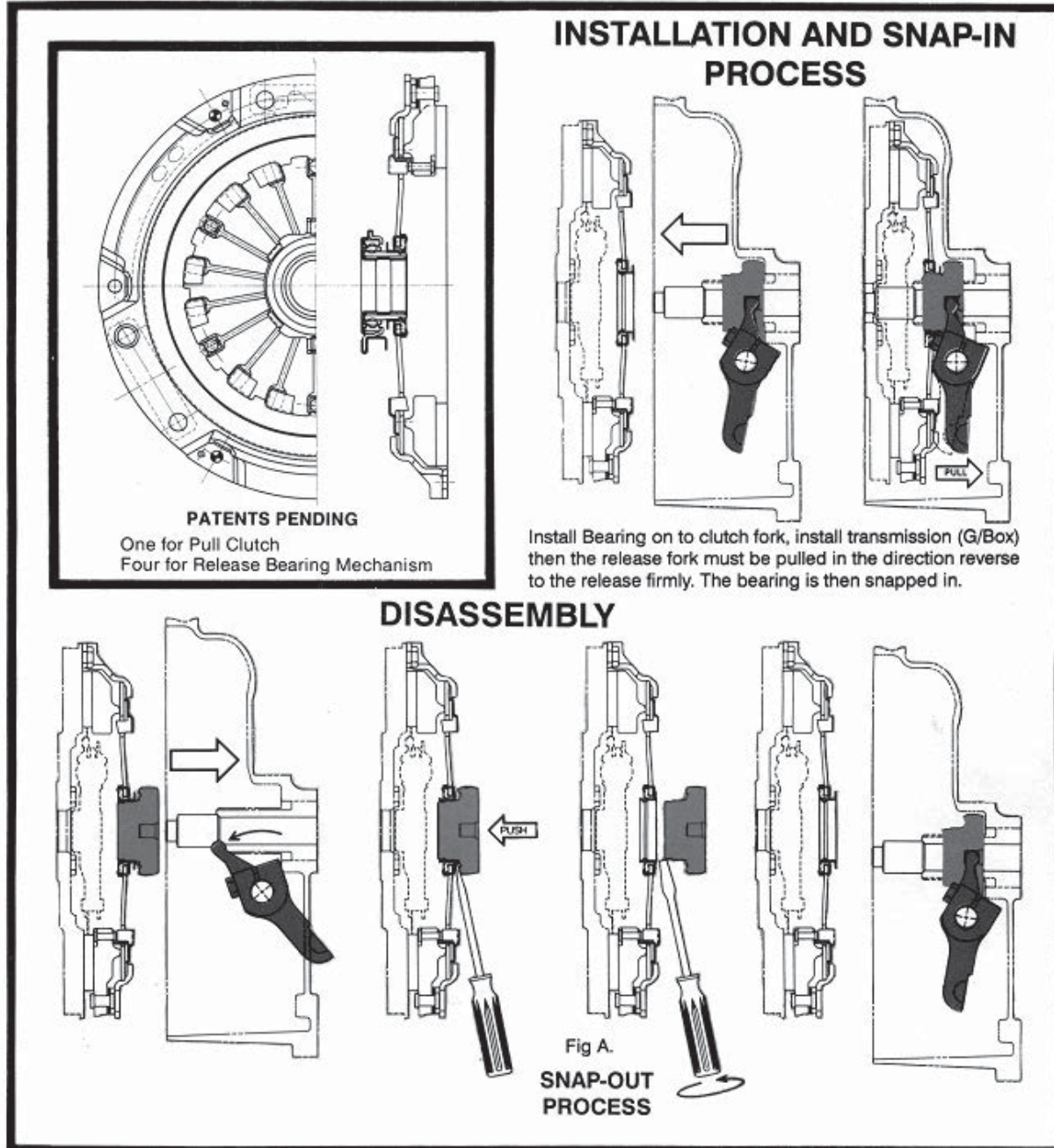

Move Bellhousing back approximately 30 to 40mm, insert screwdriver and twist as in figure A. Bearing will then snap out from clip mechanism.

# BED IN PROCEDURE DRIVER EDUCATION TO BE FOLLOWED

IMPORTANT NOTICE

AFTER INSTALLATION OF THIS CLUTCH PLEASE NOTE DUE TO HIGH PERFORMANCE T5000 FRICTION MATERIAL BEING USED IN YOUR DISC YOU MAY ENCOUNTER SLIGHT CLUTCH SHUDDER AS WITH ANY CERAMETALLIC CLUTCH SYSTEM THERE WILL BE SOME COMPROMISE OF START UP DRIVEABILITY AS COMPARED TO A STOCK CLUTCH (CHATTER ON LIGHT THROTTLE, AT LOW RPM START UPS.)

THESE CHARACTERISTICS ARE GENERALLY ACCEPTABLE IN MODIFIED PERFORMANCE CARS. DRIVERS WHO CHOOSE CERAMETALLIC CLUTCHES MUST BE AWARE OF THIS.



For Exedy Sport & Performance Listings  
please refer to our 2017 Sports Catalog

Stage 1 - Single Plate  
Organic

Stage 2 - Single Plate  
Cerametallic, Thick & Thin

Stage 3 - Hyper Single Plate

Stage 4 - Hyper Twin Plate

Stage 5 - Hyper Triple Plate,  
Carbon Series

D-Core Series

Replacement Parts

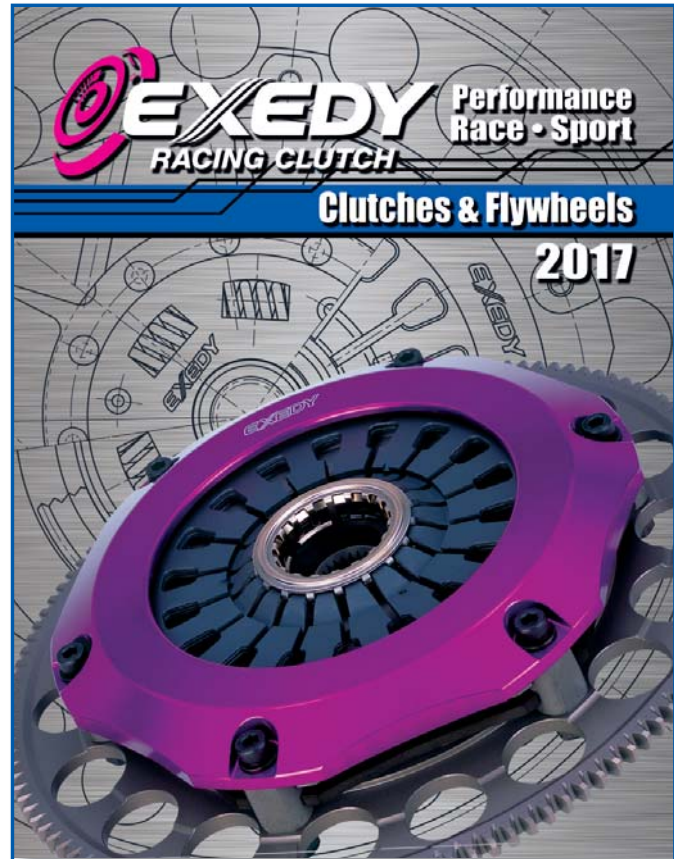

# EXEDY



Friction • Damper • Fluid

## TECHNICS

EXEDY FDF

