

Knitting

More patterns, more style

magazine

OVER £400
WORTH OF
PRIZES TO BE
WON

Fun & Feminine

17 KNITS FOR FEBRUARY

- Angora motif top
- Nordic cardigan
- Alpaca ankle socks

LAYERED V NECK
SIAN BROWN

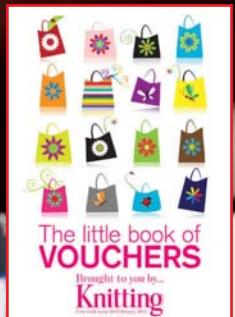

Pattern writers
Where are the next generation?

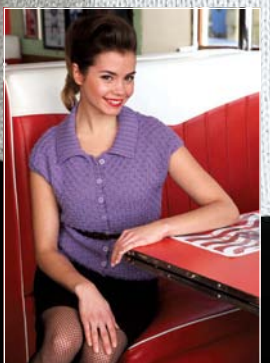
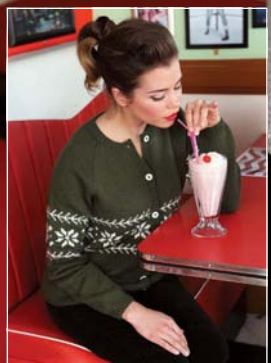

SNUGGLY BABY
SPECKLE DK



Leaflet 1359 Book 416

SIRDAR
knitting made fashionable

*Another gorgeously Snuggly
baby yarn for trendy girls and boys*

www.sirdar.co.uk

To find your nearest stockist telephone: 01924 371501 email: enquiries@sirdar.co.uk or knitting-helpline@sirdar.co.uk



Editor's letter

Emma Kennedy emmak@thegmcgroup.com

Fun might not be a noun that is naturally attributed to February, and it is precisely for that reason that we chose to include a healthy dose of it to showcase this month's collection of fifties-inspired feminine knits. As Christmas becomes a distant memory, and the grip of winter settles in, we are all in need of something to remind us of the brighter days to come.

Our location was a fabulous American diner-style restaurant on a very windy seafront in Brighton, and our lovely model looked every bit the part with her gorgeous hair and cute make up. But don't be fooled by the styling. Each piece stands the test of time and will certainly work with current fashions should you not feel the desire to dress up as a fifties starlet!

The opening garment of the gallery is Sian Brown's *Angora motif cardigan* (**page 19**). Knitted in The Little Knitting Company's adorable Angora 50, it was the softest yarn on the shoot, capturing the theme perfectly. Classic and timeless, *Loretta* by Marie Wallin (**page 27**) will always be chic and the *Draped Jacket* by Pat Menchini (**page 25**) is such an interesting shape, you'll be able to style it any way you want. Turn to **page 18** for the start of our stunning gallery to view the gorgeous patterns in this issue.

If you have ever been confused by a pattern, spare a thought for the poor souls behind the scenes, who not only write them but then have to check and double check each calculation. Good pattern writers and checkers are hard to come by. As an Editor and a knitter, this is an issue that frequently pops up, so I asked *Knitting's* Clare Kelly to investigate where the next generation of pattern writers will come from.

I will sign off now, and turn my attention to next month's 100th issue of *Knitting*. Without giving too much away, it involves a lot of extra pages to accommodate a whopping 50 patterns! Now that's a lot of checking!

Emma



SIMPLE CARDIGAN
PAGE 23



LORETTA
PAGE 27



DRAPED JACKET
PAGE 25



PATTERN PRESERVATION
PAGE 45



ANGORA MOTIF CARDIGAN
PAGE 19

Contents

ISSUE 99 FEBRUARY 2012

On the cover



ON THE COVER

Styling by
Emma Kennedy
Photograph by
Laurel Guilfoyle

- 4 Knitting offers and giveaways**
Goodies to win
- 45 Pattern preservation**
Is pattern writing a dying art?
- 60 EXCLUSIVE**
Angora motif cardigan
Playful sequin cherries shrug
- 62 EXCLUSIVE Cap sleeve shirt**
Gorgeous moss stitch top
- 72 EXCLUSIVE Layered v neck**
V neck top with striking layering effect
- 73 EXCLUSIVE Draped jacket**
Unique wrap-around jacket with moss stitch edging
- 78 EXCLUSIVE Nordic cardigan**
Classic cardi with intarsia detailing
- 82 EXCLUSIVE Ankle socks**
Fun and flirty socks with ribbon embellishment
- 83 Mohair dress and crown**
Snuggly dress with lace detailing that's fit for a princess



FLARED CUFF
JUMPER
PAGE 76

Knitting is published 13 times a year by GMC Publications Ltd, 86 High Street, Lewes East Sussex, BN7 1XN
Tel: 01273 402838
ISSN 1740 6943

EDITOR Emma Kennedy
emma@thegmcgroup.com
DEPUTY EDITOR Katy Evans
katye@thegmcgroup.com
ASSISTANT EDITOR Jemima Greaves
jemimag@thegmcgroup.com

PATTERN EDITORS Rachel Vowles, Sue Culligan
patternqueries@thegmcgroup.com
DESIGNER Claire Stevens
STUDIO MANAGER Oliver Prentice
PHOTOGRAPHY Laurel Guilfoyle, Anthony Bailey
STYLING Emma Kennedy
HAIR AND MAKEUP Jeni Dodson
PRODUCTION MANAGER Jim Bulley
Tel: 01273 402810
jim@thegmcgroup.com

PRODUCTION CONTROLLERS
Rebecca Braisby, Clare Disano
repro@thegmcgroup.com
CIRCULATION MANAGER
Tony Loveridge
MARKETING Anne Guillot
PUBLISHER Jonathan Grogan
DISTRIBUTION Seymour Distribution Ltd
Tel: 0207 4294 000
PRINTER Precision Colour Printers
ADVERTISING SALES Rhoda Barker
Tel: 01273 402820
rhodab@thegmcgroup.com

GROUP ADVERTISING MANAGER
Dominique Langham
Tel: 01273 402819
dominique@thegmcgroup.com
SUBSCRIPTIONS Sue Bennett
Tel: +44 (0)1273 488005
Email: sueb@thegmcgroup.com
Subscribe online at:
www.thegmcgroup.com
UK £59.88 for 12 issues;
£119.76 for 24 issues;
Europe £74.85 for 12 issues;
£149.70 for 24 issues;

Rest of world \$83.83 for 12 issues;
\$167.66 for 24 issues.
US customers should call the Subscriptions Department for subscription rates in USD (\$).
Cheques should be made payable to GMC Publications Ltd, and sent to The Subscription Department
GMC Publications Ltd, 166 High Street
Lewes, East Sussex BN7 1XU
See page 63 for more details

Views and comments expressed by individuals do not necessarily represent those of the publishers and no legal responsibility can be accepted for the result of the use by readers of information or advice of whatever kind given in this publication, either in editorial or advertisements. No part of this publication may be reproduced, stored in a retrieval system or transmitted in any form or by any means without the prior permission of the Guild of Master Craftsman Publications Ltd.



OFF THE SHOULDER TOP
PAGE 69



MOHAIR DRESS AND CROWN
PAGE 83



NORDIC CARDIGAN
PAGE 78



LORETTA
PAGE 65



A WEEK IN THE LIFE OF...
PAGE 42



SPOTLIGHT ON KNITWEAR FOR MEN
PAGE 32

Regulars

- 1 **Editor's letter**
Fun in February
- 4 **Knitting offers and giveaways**
Goodies to win
- 6 **In stitches**
The latest knitting news
- 8 **Events diary**
- 10 **6 of the best**
Crafty cards
- 30 **Style file**
Alternative styling ideas for this month's garments
- 32 **Spotlight on**
Knitwear for men
- 34 **Coming next month**
Knitting turns 100!
- 36 **Casting on**
Write, email, or tweet...
Let us know what you think!
- 94 **Ask Jeanette**
Our expert knitter unravels your knitting mysteries
- 96 **Purl About Town**
Purl princess embraces therapeutic destruction

Reviews

- 12 **Book review**
Crafty books we love
- 14 **Yarn review**
Last of the winter yarn

Features

- 38 **Feature pattern**
Super-cute Maggie mouse & Dotty dress
- 42 **A week in the life of...**
Crafts Council Participation & Learning Manager Katy Bevan
- 45 **Pattern preservation**
Is pattern writing a dying art?
- 50 **Weekend knits**
Romantic knits for the family and home

How to

- 54 **Gallery garment techniques**
Handy hints for techniques from this month's gallery
- 86 **Tips for success**
Abbreviations and know-hows

Patterns

- 18 The knitting gallery
- 59 Pattern index

Fashion knits

- 60 **EXCLUSIVE**
Angora motif cardigan
Playful sequin cherries shrug
- 62 **EXCLUSIVE** **Cap sleeve shirt**
Gorgeous moss stitch top
- 65 **Loretta**
Classic top with cable detail and moss stitch collar
- 68 **Simple cardigan**
Simply stunning!
- 69 **EXCLUSIVE**
Off the shoulder top
Dramatic chenille garment
- 72 **EXCLUSIVE** **Layered v neck**
V neck top with striking layering effect
- 73 **EXCLUSIVE** **Draped jacket**
Unique wrap-around jacket with moss stitch edging
- 76 **EXCLUSIVE** **Flared cuff jumper**
Eye-catching roll neck jumper
- 78 **EXCLUSIVE** **Nordic cardigan**
Classic cardi with intarsia detailing
- 82 **EXCLUSIVE** **Ankle socks**
Fun and flirty socks with ribbon embellishment
- 83 **Mohair dress and crown**
Snuggly dress with lace detailing that's fit for a princess

Mini knits

Offers & Giveaways

STAR GIVEAWAY

YARN TO MAKE THE SIMPLE CARDI

We have teamed up with Designer Yarns to offer three lucky readers the chance to win the yarn to make the lovely *Simple cardigan*, worth £60, from this month's gallery. Designed by Debbie Bliss in her own yarn, Glen, and featured in her *Glen* pattern book, this pattern, with its delicately shaped puffed shoulders and long ribbed cuffs has an unmistakably retro shape that is both flattering and very chic. Glen, an alpaca, merino and acrylic mix, has a lovely fleck and softly graduating shades that when knitted up gives the garment an interestingly textured look. For more information on Designer Yarns visit www.designeryarns.uk.com or call 01535 664222.

A MITTENS KIT FROM RENAISSANCE DYEING

We have three of these cute mitten kits from Renaissance Dyeing in their lovely Poll Dorset yarn to give away. Named *Les Mitaines D'Elis*, they are an exclusive design to Renaissance Dyeing, knitted up in their gorgeous Organic Poll Dorset, a soft and strong worsted 4 ply. The main shade is Maddest with six contrasting colours in dotted bands, giving a cute striped effect as well as highlighting the excellent stitch definition. To find out more about Organic Poll Dorset turn to page 14 for our yarn review. For more information on Renaissance Dyeing visit www.renaissancedyeing.com.

20 X TICKETS FOR BRITISH ALPACA FUTURITY

If alpacas are your thing then this show is for you and we've got 20 family tickets to give away! Held on the 16 and 17 March at the NEC, Birmingham, the British Alpaca Futurity 2012 holds everything from trade stands selling alpaca fibre products, an alpaca halter show with 300 alpacas competing, an international fleece show, a fashion show, international speakers, seminars and workshops. Don't miss the fantastic new Alpaca Fibre Arts Village where you can shop 'til you drop too. Tickets are £5 for a family and you can buy tickets and find out more by visiting www.britishalpacafulurity.com or by calling 01884 243579.

3 X CLIPPER TEA COSY KNITTING KITS

We have three of these lovely Tea Cosy Knitting Kits, worth £30, from tea supremos Clipper to give away. Clipper are known for their Fair Trade, organic and delicious teas, coffees and hot chocolates. Now they have branched out even further with their new gifting range, with gift sets including the rather cute Tea Cosy Knitting Kit. This lovely gift set contains everything you need to knit your own tea cosy, including needles, wool, a tea cosy pattern and even a box of Clipper's delicious English Breakfast teabags to drink whilst you knit. Sounds pretty perfect to us. For more info on Clipper, their drinks and gift sets visit www.clipper-teas.com or call 01308 863344.



WIN!



WIN!



WIN!



WIN!

Knitting magazine

OFFERS & GIVEAWAYS ENTRY FORM

Just tick the box of the competition(s) you would like to enter and send this form back to us, to arrive no later than 29 February 2012.

- Simple cardi Glen yarn
- British alpaca tickets
- Clipper Tea Cosy Kit
- Mittens kit

Send your entry to: **K99 Offers & Giveaways Knitting magazine, 86 High Street, Lewes, East Sussex BN7 1XN** or email knittingcomps@thegmcgroup.com putting the competition you are entering in the subject title and your contact details in your email.

Mr/Mrs/Miss/Ms/Other: Name:

Address:

Tel: Email:

Date of birth: *You can photocopy this form to avoid cutting your magazine.

Which yarn is top of your sales must-buy list?

- 1
- 2
- 3

The competition is open to UK residents only. Only completed entries received by the closing date, 29 February 2012, will be eligible. No entries received after that date will be considered. No cash alternatives will be offered for any prize. The judges' decision is final and no correspondence can be entered into. The winner will be expected to be in possession of a copy of this issue of Knitting magazine. One entry per giveaway, per household. Employees of GMC Publications, their associated companies and families are not eligible to enter. By entering the competition, winners agree that their names may be used in future marketing by GMC Publications. We would like to contact you with information on services, publications and future offers we provide. Please tick here if you DO NOT wish to receive this information by Post Email Phone

So Soft - It's Baby Time

PBN0000-03843

Available From 1st Feb 2012

6 Styles

Easy to intermediate skill levels

Using Fairytale Soft



www.coatscrafts.co.uk

Call for your local stockist 01484 681881. Email consumer.ceuk@coats.com

Coats Crafts UK, Green Lane Mill, Holmfirth, HD9 2DX

In stitches

Find out what's caught our eye this month...

Make 2012 the year of how to 'earn your living from the things you love to do', the subtitle of this great little book, *Make Your Creativity Pay* by Pete Mosley. If you are seriously looking at how to make your hobby pay, Pete has a wealth of experience, ideas and advice aimed specifically at creative people and will help get you heading in the right direction. www.makeyourcreativitypay.com

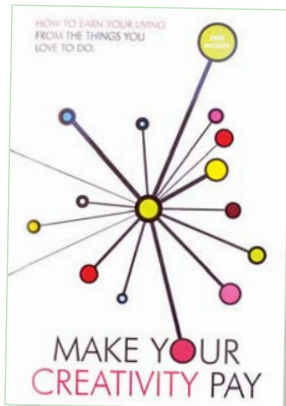

If you've decided this is the year you're going to live the dream and set up your crafty shop then look no further than the excellent Mr Site, who have just released a brand new product, Storefront. An incredibly easy to use website-building package with all the tools you need to create an individual looking online shop. We've tried it, and trust us, if we can do it, so can you! Jargon-free and brilliantly simple (with excellent customer service if you need it), Storefront is a great way to get your dream off the ground. www.mrsite.co.uk/storefront
0844 414 5158



These cute little magnets from The Knitting Goddess are perfect little treats for the knitter in your life. Just under one inch each, the sentiments range from wise to silly and there are 12 different ones to choose from. Also available as badges and mirrors too. www.theknittinggoddess.co.uk 07801 997750



Coastal Knits is a lovely book by American designers Alana Dakos and Hannah Fettig, who live on the East and West coasts of America and have joined together to compile 10 patterns inspired by their respective coastlines, accompanied by photographs and essays on the local beauty spots. Available from www.tangled-yarns.co.uk 01614 942053

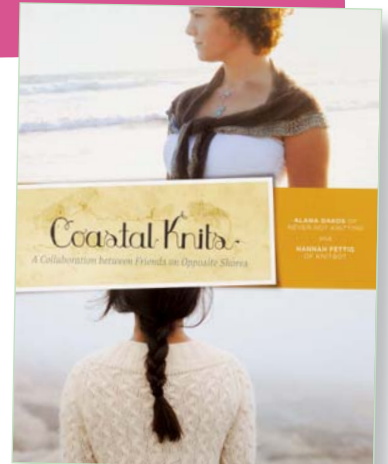

If your New Year's resolutions include reading the literary canon, why not treat yourself to the gorgeous new Clothbound Classics from Penguin. 29 of your favourite literary classics bound in cloth and individually designed by Coralie Bickford-Smith – we were immediately drawn to *Little Women* and *A Tale of Two Cities* with their lovely knitting and sewing covers. www.penguin.co.uk
0845 313 4444



Bergere de France's luxury line Origin' has a new collection out in their latest *Collection 004* book. Fashionable and chic knits with on-trend sculptural cables, eyelet patterns, mixed stitches and unusual shapes, this is head-turning knitwear. www.originbergeredefrance.com
01606 883149





Hand of Good, Hand of God
by Freddie Robbins, 1997.

IMAGE © HEINI SCHNEEBELI

Digital viewing

In 2011 the Crafts Council turned the big 4-O and one of the many ways they are celebrating is the fantastic new *40:40 Forty Objects for Forty Years* online exhibition. Since it was founded in 1971, the Crafts Council has acquired, documented and made accessible the best and most interesting examples of contemporary craft. The exhibition features 40 pieces from its collection, including Freddie Robbins's *Hand of Good*, *Hand of God*, each selected by an invited commentator and featuring their personal response as well as audio/visual clips and supporting information. 40:40 is an ambitious exploration into digital online presentations, as well as bringing curated displays to people who may not be able to access them otherwise. You can view the exhibition online now at onviewonline.craftscouncil.org.uk/4040/.



Softer than you think

Staffordshire Bull Terriers may get a bad rep but Battersea Dogs and Cats Home is determined to show their softer side by appealing to crafty knitters. Their newest campaign, 'Staffies, they're softer than you think', features a knitted Staffie designed exclusively by Sally Muir and Joanna Osborne, authors of *Best in Show: Knit Your Own Dog*. Taken to the House of Commons for his official launch, a Facebook competition will decide on the cute mascot's name.

Having both owned Battersea rescue dogs, Sally and Joanna hope their knitted pet will encourage people to see Staffies in a different light.

Claire Horton, Battersea's Chief Executive agrees: "The Staffordshire Bull Terrier has become stigmatised in this country because of a small minority of people who own them for the wrong reasons. We hope that our knitted Staffie will encourage more people to see their softer side and that more people will want to give one a home." The knitted Staffie pattern is available from Battersea's website for £2. All proceeds will go directly towards the Home.

To find out more visit www.battersea.org.uk/staffie.

Knitted Staffie, designed by Sally Muir and Joanna Osborne



COMPETITION WINNERS

ISSUE 95 – NOVEMBER 2011
Sheep EOS Gradiance Shawl
 Ms Amanda Watson of Peebles
SMC Tweed Deluxe
 Mrs J Lansley of Cardiff
 Mrs Judith Cullingworth of Old Harlow
 Mrs Claire Nunn of Halesworth
Socktopus
 Mrs Cheryl Harmer of Mansfield
 Mrs M Silcock of Bristol
 Miss Angela Waterman of Hunts Cross
 Mrs Shelagh Murdock of Abredeen
 Mrs A Mulligan of Liverpool

The Pink Pom-Pom Project

If you haven't come across the lovely Pink Pom-Pom Project® yet, then you will love the idea behind it. A small charity dedicated to supporting women fighting breast and other cancers, it uses craft as a form of therapy as well as supporting women going through chemotherapy and other treatments, with crafty gifts. The brainchild of Alex Currie, they run events and organise items such as hats and gloves to be knitted up and donated to their beneficiary charities in London such as The Haven and MacMillan Cancer Support, to help women through a difficult time and let them know they are not alone. As they say, to warm a head is to warm a heart, and The Pink Pom-Pom Project needs you! London-based for now, they are aiming to get more support centres involved across the UK, and then eventually, internationally. For more information, free downloadable *Pom Bomb Scarf* pattern, the newsletter, giveaways and to keep up to date on the blog visit www.stayabreast.co.uk or www.thepompomproject.com.



What's in store...

Café Knit, the gorgeous online store has opened a brand new shop on the high street in Lavenham, Suffolk. Open Mondays, Tuesdays, Thursdays and Saturdays, pop in and say hello!

Tricolette, who have recently celebrated their first birthday have launched a new online shop www.tricoletteyarns.com with a wealth of yarns, needles, accessories, books and workshop information.

Check out Yarnsmith's new website www.yarnsmith.co.uk for an amazing range of yarn brands, accessories, books, information on finishing services and an excellent 'tips & techniques' section.

If you haven't checked out www.hobbybuddies.com then pop by and get in on the action. With thousands of patterns to buy and sell (free of charge), it's a great place to find that thing you are looking for or to dip your toe into selling your own patterns.

Please send details of your knitting events and news at least eight weeks in advance to: **Katy Evans, Deputy Editor, Knitting, 86 High Street, Lewes, East Sussex, BN7 1XN** or email katye@thegmcgroup.com

Events Diary

An up-to-date listing on what's happening in your area

WIN 10 PAIRS OF TICKETS TO THE TWO EVENTS BELOW IN FEBRUARY!

02-04

Craft 4 Crafters

The ideal place to buy crafting supplies, get inspiration and advice on all your crafting needs.

Westpoint Arena, Exeter
www.craft4crafters.co.uk
0845 3040 222

24-25

Make it Craft and Make it Homemade

Celebrating crafts with a 'homemade' theme and plenty of shopping!

FIVE, Farnborough
www.make-it.org.uk
0844 4771 000

TO ENTER

Send your name, address and contact details on a postcard marked **Crafts 4 Crafters** or **Make It giveaway** to the giveaway address on page 4, or email knittingcomps@thegmcgroup.com, putting the giveaway title in the subject line and your contact details in your email, by no later than 30 January 2012.

Now until 19 February

Lost in Lace

20 UK and international artists exhibition inspired by the language of lace.
Birmingham Museum & Art Gallery, Birmingham
www.bmag.org.uk
01213 031966

January 2012

28 Knitting for beginners

A one day course where you will master a range of basic techniques and be able to follow a simple knitting pattern.
City College, Brighton
www.ccb.ac.uk 01273 667788

28 Introduction to knitted socks

Learn how to knit basic socks on multiple needles
Knit and Stitch, Maltby
www.knitandstitchonline.com
01709 817944

28 Knitted luxury bed socks

Knit Alison Crowther-Smith's luxurious Kidsilk Haze bed socks from the toe up.
Court Cottage, Somerset
www.alisoncrowthersmith.com
alison@alisoncrowthersmith.com

28 Crochet: The Next Step

One day workshop with Fiona Morris explaining how to read crochet charts and crochet stitch patterns from them.
Pack Lane Wool, Basingstoke
www.packlanewool.co.uk
01256 462590

31 Beginners knitting: Pattern reading

In this evening class Fiona Morris will be explaining the basic information provided in knitting patterns.
The Knitting Habit, Alton
01420 541977

February 2012

02-05

Creative Stitches & Hobbycrafts

Supplies, workshops, demonstrations and inspiration for all creative crafts.
Glow, Bluewater Events Venue, Kent
www.ichf.co.uk 01425 272711

04 Felting for Valentine

How to needlefelt and create a Valentine's gift
Knitshop, London
www.knitshop.co.uk
020 8144 4523

05 Finishing Class

Learn the tricks of the trade to turn your homemade bits into handmade items.
Knit Nottingham, Nottingham
www.knitnottingham.co.uk
01159 474239

08 Finishing Techniques; Seamless Finishes one day workshop

Fiona Morris covers short row shoulder shaping, 3 needle cast off, mattress stitch and back stitch seams.
Liss Wools, Hampshire
www.lisswools.co.uk
01730 893941

10 Top down knitting

Learn how to do top down knitting, to use circular needles and stitch markers, to create a cardigan.
Knitshop, London
www.knitshop.co.uk
020 8144 4523

9-11

The Creative Crafts Show
The Trafford Centre, Event City, Manchester
Contact details below

16-18

The Creative Crafts Show
Five Lakes, Maldon
Activities, features, stalls and much more to see and do all under one roof.
www.sccshows.co.uk
01822 614671

19 Learn to Crochet

A nice introduction to an ancient craft for complete beginners. We'll be making a kitschy granny square or two.
Knit Nottingham, Nottingham
www.knitnottingham.co.uk
01159 474239

22 Continental Knitting

Fiona Morris will demonstrate how to knit using the continental method working with the yarn in your left hand.
Liss Wools, Hampshire
www.lisswools.co.uk
01730 893941

25 Colour knitting techniques

Covering intarsia, Fairisle, pattern and chart reading.
Knitshop, London
www.knitshop.co.uk
020 8144 4523

25-26 Unravel

Two days of all things woollen – demonstrations, workshops, talks, a marketplace and a knitting surgery.
Farnham Maltings, Surrey
www.farnhammaltings.com
01252 745444

1 2 3 4 5 6 7 8 9 10 11 12 13 14 15 16 17 18 19 20 21 22 23 24 25 26 27 28 29 30 31

February

Knitting issue 100 March 2012 goes on sale

INTRODUCING...



Moments 013

Available from 1st Feb 2012



Design 1903 using SMC Select Reflect

www.coatscrafts.co.uk

Call for your local stockist 01484 681881. Email consumer.ccuk@coats.com
Coats Crafts UK, Green Lane Mill, Holmfirth, HD9 2DX

6 of the Best:

Crafty cards

With Valentine's Day just around the corner let a card do the talking. **By Jemima Greaves**

1 Sewing Lady greetings card

This beautiful crafty card is the handmade creation of Steve Lenton, the man behind 2dScrumptious. The lovely lady, inspired by vintage haberdashery, is one of Steve's newest characters and, luckily for us, she's only one of the striking designs available! Visit his Etsy store or 2dScrumptious.com for more.



RRP: £2.50
Website: www.etsy.com
Email: support@etsy.com

3 Not so sheepish greetings cards

Now in its thirteenth year, Penny Lindop Designs is a small business offering big designs. The wonderful handmade card shown here is crafted using real sheep's fleece. Luckily it is only one of a selection from the extensive range on offer online, so don't panic if you can't see the perfect one straightaway. 'Baaa'rilliant!

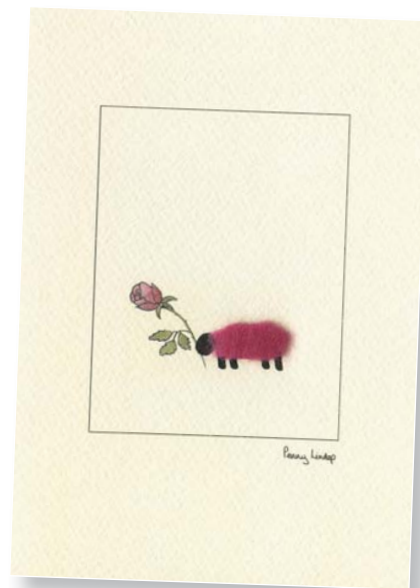

RRP: £3.40
Tel: 01953 681990
Website: www.pennyindop.com
Email: info@pennyindop.com

2 Hand printed greetings cards

Not On The High Street is probably best described as an online boutique that takes the stress out of finding those quirky and unique items. Every product is designed, made or selected by an independent small business. The beautiful yarn-tastic card shown here is from Wild Ink and is just one of the gorgeous designs that caught our eye. So many cards and so little space!



RRP: £3.25
Tel: 08452 591359
Website: www.notonthehighstreet.com
Email: info@notonthehighstreet.com

4 Sheepy cards

From the makers of the now legendary 'Sheep Poo Paper' we bring you environmentally responsible and completely adorable handmade cards. With Creative Paper Wales the fun doesn't stop after you've opened the card, as the nifty little 'Florelopes' turn into beautiful wildflowers when you soak them overnight! More designs and information are available on their website.



RRP: From £2.49
Tel: 07870 418745
Website: www.creativepaperwales.co.uk
Email: Please use the form on their website

5 Herdy Peep cards

Herdy have once again topped the cute list with this set of five fun and colourful cards featuring their instantly recognisable Peep sheep. You can buy them individually or as a 5-card pack. For a wider selection and individual cards please see their website. They're b'ewe'tiful!



RRP: £4.99 for a pack
Tel: 01539 739202
Website: www.herdy.co.uk
Email: mailus@herdy.co.uk

6 Recycled fabric greetings cards

Folsy launched in 2008 and, based on a belief in makers and a philosophy of strength in numbers, has continued to grow ever since – us crafty folk know when we're onto a good thing! The stunning cards shown here are handmade and designed by Folsy seller Helen Limbrick and are just a couple of the lovely designs available in this bustling online marketplace.



RRP: £1.50
Website: www.folsy.com
Email: support@folsy.com

Top knits

This month: **Sarah Freeman of Spins & Needles**

Tel: 01522 522865

Email: Please use the form on the website

Website: www.spinsandneedles.co.uk

After 13 years in the army where I had been a keen crocheter and even took up my needles on operational tours in Northern Ireland and Afghanistan, I decided to turn my hobby into a business. I left the army and opened Spins & Needles a year ago, since then the business has gained a loyal customer base and gone from strength to strength.

We stock **Rowan, Debbie Bliss, Rico, Louisa Harding, Cygnef, Colinette, Noro, Schoppel Wolle, Sublime, Mini Mochi, Sausalito, British Breeds, local Lincolnshire Longwool, Aracuania, Excelana, locally spun alpaca and Chroma Yarns** (a locally dyed yarn) as well as **Artesano** and **Manos del Uruguay**. Plus, we sell locally made needle rolls from **Nic's Knots**, wooden buttons made less than one mile from the shop and are just about to launch our own range of polymer clay crochet hooks, again locally made.

We also stock **Brittany** birch needles and **KnitPro**, some **Clover** products, **DMC** stranded cottons and **Aida**. We are always keeping a beady eye out for new lines that are quirky and different and we've got some exciting plans for the coming months. Everything is added onto our Facebook page so you can keep up to date with the latest Spins & Needles news.

We have our Stitch and Bitch on the last Monday of the month from 5.30pm onwards and everyone is welcome, sometimes they have a theme and other times just a good gossip. We have a monthly competition where customers bring in what they have made to be photographed and added to our Facebook, with the winner selected at random to win a £10 shop voucher

Recently the best selling yarn has been **Rico Melange Chunky**, which is a really soft wool blend. The cardigan knitted in it on display has definitely helped and we have a good selection of items knitted for show. **Rowan Felted Tweed** is also popular, as are the scarf yarns and the super chunkies.

The shop is very cozy and there is always a friendly welcome and a comfy chair for long-suffering partners to sit in or for customers to browse patterns. We are a modern yarn shop with traditional values and a great service for all our customers.



Spins & Needles Wall of Fame



Chroma yarns



Cardigan in Rico Melange Chunky

Sarah's yarn bombed bike



Colinette yarns



DMC figures



Book reviews

This month's selection of knitting books to inspire you. **By Katy Evans**

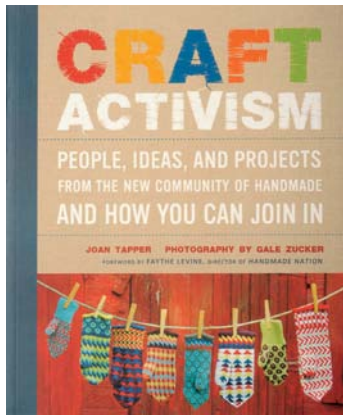

Craft Activism

By Joan Tapper and
Gale Zucker

£16.99

Published by Potter Craft
ISBN 978 0 30758 662 9

An inspiring look at the 'craft activism' grass roots movement on the rise and what this means; build a community, craft to make a statement, highlight a cause or even save the world. Featuring socially and politically conscious crafty superstars, sharing their stories and experiences as well as ideas and projects, this book challenges you to see and understand how craft skills can impact and to use these skills to make a difference. Whether you want to learn a craft, connect with people, think local, think green or just want to read about living the DIY lifestyle dream, this book is a fascinating read.

READER OFFER

Readers of *Knitting magazine* can buy *Craft Activism* for the special price of £12.75 plus p&p. To order, please call 01273 488005 or go to www.thegmcgroup.com and quote reference code R3434. Offer ends 19 April 2012.



All You Knit is Love

By Debbie Harrold

£5.99

Published by Collins
& Brown
ISBN 978 1 90844 904 7

OK, it may be cheesy and you may roll your eyes but, boy, is this cute. Debbie Harrold is the designer behind the successful *Knit & Purl* range of greetings cards, her classic *Ha Pea Valentine's* and birthday cards being the most successful. Now you can knit 20 of her cute characters from the range, whether you are going for saucy (*Hot Stuff* chilli peppers), corny (*Perfect Match* matches in a box), sweet (*Cuddle Bunny*), flirty (*Perfect Catch* fish in a net), or just plain old romantic (*On Our Anniversary* swans entwined). Forget flowers and chocolate and say it with knitting.



A Stitch in Time Vol 2

By Susan Crawford & Jane Waller
£35

Published by Arbour House
Publishing
ISBN 978 0 95562 065 2

After a bit of delay, Susan Crawford and Jane Waller's second volume of their successful *A Stitch in Time* is now available and was definitely worth the wait. This is a beautiful book, gorgeously photographed, oozing style and quality. This time focusing on the knitting history, patterns and fashions from 1930 to 1959, there are 80 carefully chosen classic patterns, updated, re-knitted and re-written for today's knitters. The garments are stunning, photographed on models of different size and shape to reflect modern women, though styled with a retro twist. Studying the vintage patterns are fascinating but I'm glad Susan and Jane have done all the hard work for us!



Finishing School

By Deborah Newton
£19.99

Published by Sixth & Spring Books
ISBN 978 1 93609 619 0

Most people hate finishing garments; blocking, sewing up, seaming, edging, but without a good finish all your knitting hard work can be for nothing if your project doesn't look neat and tidy at the end. Knitter and designer Deborah Newton actually loves finishing techniques and shares them here in her informative master class. Taking readers step-by-step through the different techniques and aspects of finishing, with on-the-page workshops, case studies and 12 patterns (with variations) means you not only learn the skills, but can actually incorporate this knowledge to plan ahead before you even start knitting.



Inspirational displays, supplies, demonstrations, talks & workshops for all creative crafters

2012 SPRING SHOWS



8th - 11th March 2012

CREATIVE STITCHES / HOBBYCRAFTS

SECC, Glasgow

2 shows
for the
price of 1

22nd - 25th March 2012

HOBBYCRAFTS SEWING FOR PLEASURE FASHION, EMBROIDERY & STITCH

NEC, Birmingham

3 shows
for the
price of 1

26th - 28th April 2012

CREATIVE STITCHES & HOBBYCRAFTS

Aintree Racecourse, Liverpool

27th - 29th April 2012

CAKE INTERNATIONAL THE CAKE DECORATING AND BAKING SHOW

ExCeL, London

NEW
SHOW!

10th - 12th May 2012

CREATIVE STITCHES & HOBBYCRAFTS

The Brighton Centre

Buy tickets on-line www.ichf.co.uk
or phone Ticket Hotline **01425 277988**

SAVE UP TO £2 OFF
EACH ADULT & SENIOR TICKET
IF ORDERED AT LEAST ONE WEEK BEFORE THE SHOW.

ICHF Events

YARN REVIEW

Jeanette Sloan looks at the latest offering of winter yarns



1. **Stylecraft** Highlights DK with Mohair
2. **Artesano** Superchunky
3. **Rico** Creative Galaxy Chunky
4. **Sirdar** Bohemia
5. **Fyberspates** Gloucester Tweed
6. **Bergere de France** Chambery
7. **Jeanette Sloan** Baby Alpaca Silk 4 ply
8. **Renaissance Dyeing** Organic Poll Dorset
9. **Oxford Kitchen Yarns** Sock Weight



Stylecraft Highlights DK with Mohair

Highlights with Mohair is a blend of acrylic and wool with a touch of mohair that knits as a standard DK. It's variegated, which means it produces 'flashes' of colour when knitted rather than obvious stripes. The range of six autumnal shades have horoscope inspired names such as Pisces (1467), a turquoise, navy and purple mix and Aquarius (1464), shown here, which is a mix of emerald, fuchsia and purple. The mohair content adds a slight blurring quality but in spite of this it has quite good stitch definition and with the price of a 50g ball it's an excellent value yarn. Pattern support is available in a collection of six ladies designs including a sweater dress, sleeveless jacket and a jacket and matching scarf set. Gentle machine washing at 30°C is recommended.

Composition: 60% acrylic, 20% wool, 20% mohair

Weight: 50g

Length: 137m

Rec needle size: 4mm

RRP: £2.69

Contact: Stylecraft

PO Box, 62 Goulbourne Street, Keighley
West Yorkshire BD21 1PP

Tel: 01535 609798

Email: general@stylecraftltd.co.uk



Artesano Superchunky

Superchunky is a mega chunky blend of superfine alpaca and Peruvian highland wool. The yarn is made up of three ends of roving twisted together, which makes it both incredibly soft and strong. It knits up smoothly in no time with a standard tension of 7.5 sts and 9 rows to 10cm on 12mm needles and there's plenty of pattern support in the Artesano Superchunky booklet of 20 fashion and home accessories. As well as five neutral colours, including Creme, Latte, Cappucino, Frappe and Mocha there are 12 other fashion shades to choose from including Mulberry shown above. Hand washing is recommended but avoid dry cleaning.

Composition: 50% superfine alpaca, 50% Peruvian highland wool

Weight: 100g

Length: 33m

Rec needle size: 12mm

RRP: £8.75

Contact: Artesano

Unit G Lamb's Farm Business Park

Basingstoke Road

Swallowfield, Reading

Berkshire RG7 1PQ

Tel: 01189 503350

Website: www.artesanoyarns.co.uk



Rico Creative Galaxy Chunky

Creative Galaxy Chunky cleverly brings together a soft blend of 71% polyacrylic and 27% wool with graded striping effects and a splash of sequins. The sequins are threaded onto a fine synthetic binder which is twisted around the main roving yarn allowing the shimmering effect to be placed randomly throughout the knitted fabric. The yarn comes in a choice of six multi-colour effects, each with its specially toning sequins, and knits to a tension of 14 sts and 19 rows on 6mm needles. The yarn comes in 100g balls, with 100m of yarn per ball it's equally suited to both garment and accessory knitting projects.

Composition: 71% acrylic, 27% new wool, 2% sequins

Weight: 100g

Length: 100m

Rec needle size: 6mm

RRP: £5.99

Contact: RICO Design

Website: www.rico-design.co.uk

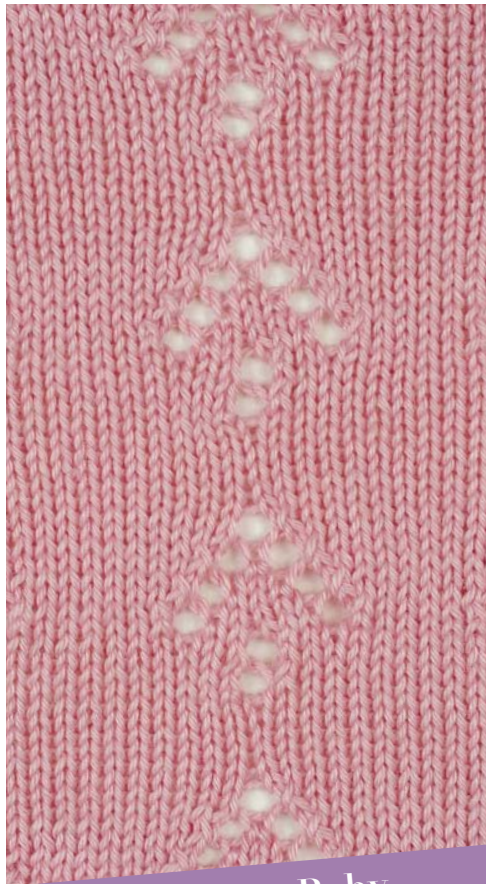

Jeanette Sloan Baby Alpaca Silk 4 ply

Jeanette Sloan Baby Alpaca Silk 4 ply is another one of mine! A luxurious mix of 70% baby alpaca and 30% silk, which produces a buttery soft yarn with a silky lustre. Because alpaca is a denser fibre than wool it has little to no 'crimp' giving the yarn a slightly leaner appearance than other 'standard' 4 plys and it works particularly well when used in lace designs. There's a select palette of five fashion shades including Caramel, Olive, Lippy, Spice and Icing, shown here, and it has a generous metreage of 200m per 50g ball. Specific pattern support such as the Lozenge Lace Collar are available in both print and in PDF download form from the website. Hand washing with care is recommended.

Composition: 70% baby alpaca, 30% silk
Weight: 50g
Length: 200m
Rec needle size: 2.75-3.25mm
RRP: £9.40
Contact: AC Wood Speciality Fibres Limited
 CCL House, Inmoor Road
 Tong, Bradford
 BD11 2PS
Tel: 01138 151125
Email: sales@knitglobal.com
Website: www.knitglobal.com



Oxford Kitchen Yarns Sock Weight

Oxford Kitchen Yarns is a small yarn brand based in Oxford with a strong ethical policy that means they sell only British wool, dyed with locally grown natural dyestuffs. This use of natural dyes means their **Sock Weight**, which is 100% Bluefaced Leicester, has a gentle lustre, smooth handle and knits up with great stitch definition. There are currently 12 colours in the range from the wonderfully original 'A Nice Game of Battleships' to Gingerbeer and Raspberry, shown above, but as the dyes used are seasonal you should keep checking the website for new shades. It's an ideal yarn for sock knitting, producing a firm fabric when knitted but it will also work well for lace accessories such as shawls and stoles. Gentle hand washing in a mild detergent is recommended.

Composition: 100% British Bluefaced Leicester
Weight: 100g
Length: 425m
Rec needle size: 2.5mm
RRP: £12
Contact: Oxford Kitchen Yarns
 17 Stile Road, Headington
 Oxford OX3 8AG
Email: katie@oxfordkitchenyarns.com
Website: www.oxfordkitchenyarns.com



Renaissance Dyeing Organic Poll Dorset

Organic Poll Dorset is sourced from certified organic Poll Dorset sheep that are raised near to Renaissance Dyeing's French dye house in the foothills of the Pyrenees. After combing and spinning in Italy it is hand dyed with natural plant dyes by Andie Luijk producing a beautifully springy yarn with brilliant stitch definition. The colour range, largely based on medieval dyes, is inspired by Renaissance's regional history with evocative names such as Ermengard, Trobadour and Comtessa, shown here, which is named after the Comtessa of Tripoli and dyed with cochineal. This versatile and lustrous yarn knits up evenly on 2-3.75mm needles (depending on your project) and is perfect for both intricate Fairisle designs and lace patterns alike. Although not superwash treated it doesn't felt easily but cold machine washing or hand washing at 30°C is recommended.

Composition: 100% wool
Weight: 100g **Length:** 344m
Rec needle size: 2-3.75mm
RRP: £15.71
Contact: Renaissance Dyeing
 Le Fort, 09300, Lieurac, Ariège France
Tel: 0033 (0)5 61 05 27 60
Website: www.renaissancedyeing.com



**Bergere de France
Chambery**

Five ends of yarn are twisted together to make up the super chunky **Chambery**. The resulting yarn knits up very quickly on either 15mm or 20mm needles with the lustre of the synthetic binder adding bright flecks of interest to the knitted fabric. The blend of 83% acrylic, 14% polyamide and 3% polyester is extremely light to wear in spite of its bulky appearance and there are nine classic, wearable shades available, including Daphne shown above. With only 22m per 100g ball it works well both as an accent yarn or when used for accessories – leaflet no 31054 includes pattern instructions for a ladies hat and snood. Gentle machine washing at 30°C is recommended.

Composition: 83% acrylic, 14% polyamide, 3% polyester
Weight: 100g
Length: 22m
Rec needle size: 15-20mm
RRP: 5.99
Contact: Bergere de France
 11 White Hart Gardens
 Hartford, Northwich
 Cheshire CW8 2FA
Tel: 01606 883149
Email: gordonjleslie@bergeredefrance.co.uk
Website: www.bergeredefrance.com

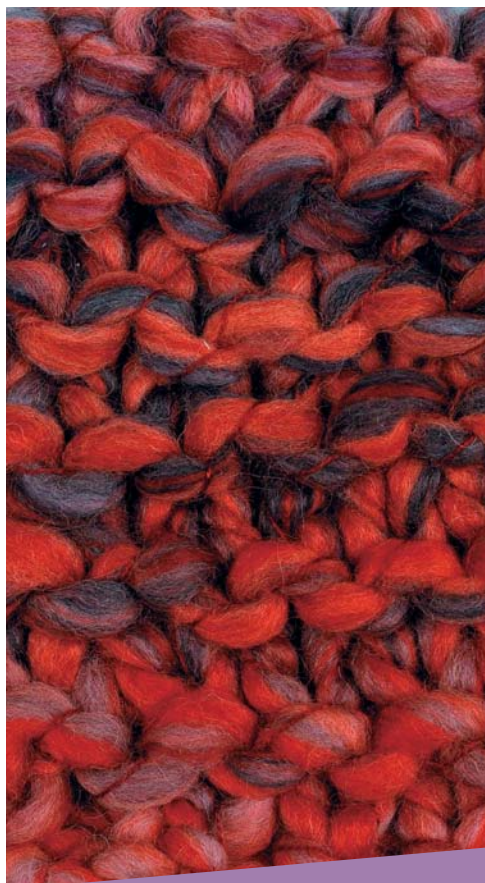

Sirdar Bohemia

Bohemia is a super chunky blend of 66% acrylic and 34% wool that knits up on 20mm needles for super quick results. The yarn is made up of a chunky central core of roving wrapped with a much finer plain coloured binder. There are six richly coloured shades available; three multi coloured, including blues, purples, berry reds and three multi tonal, including oranges, purples and blues – each creating intense bands of 'boho' colour when knitted. As well as being quick to knit it's easy to care for and with instructions for a cosy drop stitch scarf printed on the ball band, it's an ideal yarn for new knitters.

Composition: 66% acrylic, 34% wool
Weight: 100g
Length: 45m
Rec needle size: 20mm
RRP: £8.91
Contact: Sirdar Spinning Ltd
 Flanshaw Lane
 Wakefield
 West Yorkshire
 WF2 9ND
Tel: 01924 371501
Email: enquiries@sirdar.co.uk
Website: www.sirdar.co.uk



**Fyberspates Gloucester
Tweed**

Gloucester Tweed is a twisted 4 ply merino and nylon blend with tweedy nups that add tiny splashes of texture to the finished fabric as you knit. It's soft to handle with excellent stitch definition and a slight lustre that enlivens each shade. With 400m per 100g hank the metreage is excellent and though there aren't any specific patterns currently available it can be used for any design that calls for a standard 4 ply/fingering weight yarn. At the time of writing there are four shades available; Chocolate, Sea Mist, Storm 2 and the beautifully bright Lox shown above, but keep checking the website for information on new additions to the colour range. Machine washing is recommended.

Composition: 85% superwash merino, 15% nylon
Weight: 100g **Length:** 400m
Rec needle size: 2.5mm for socks, 3mm for garments
RRP: £14
Contact: Fyberspates Ltd
 Unit 6, Oxleaze Farm Workshops
 Broughton Poggs, Filkins
 Lechlade, Gloucester GL7 3RB
Tel: 07540 656660
Email: fyberspates@btinternet.com
Website: www.fyberspates.co.uk

Fabulous Fifties Fun

ANGORA MOTIF
CARDIGAN BY
SIAN BROWN
*Yarn The Little
Knitting Company
Angora 50
Pattern page 60*









THIS PAGE
CAP SLEEVE SHIRT
BY SIAN BROWN
Yarn Debbie Bliss Baby
Cashmerino
Pattern page 62

OPPOSITE PAGE
LAYERED V NECK TOP
BY SIAN BROWN
Yarn Sublime Baby Silk
and Bamboo
Pattern page 72





THIS PAGE

SIMPLE CARDIGAN

BY DEBBIE BLISS

Yarn Debbie Bliss Glen

Pattern page 68

OPPOSITE PAGE

OFF THE SHOULDER

TOP BY MAISIE SMITH

Yarn Louisa Harding

Nerissa

Pattern page 69



THIS PAGE
FLARED CUFF JUMPER
BY PAT MENCHINI
Yarn Sublime Lustrous
Extrafine Merino DK
Pattern page 76

OPPOSITE PAGE
DRAPED JACKET
BY PAT MENCHINI
Yarn King Cole Baby
Alpaca DK
Pattern page 73



THIS PAGE

NORDIC CARDIGAN

BY SIRDAR

Yarn Sirdar Country Style DK

Pattern page 78

OPPOSITE PAGE

LORETTA BY

MARIE WALLIN

Yarn Rowan Pure Wool DK

Pattern page 65





THIS PAGE
ANKLE SOCKS
BY MAISIE SMITH
Yarn Artesano Alpaca DK
Pattern page 82

OPPOSITE PAGE
MOHAIR DRESS
AND CROWN
BY LANG YARNS
Yarn Lang Yarns
Mohair Luxe
Pattern page 83



Style File

Angora motif cardigan in **The Little Knitting Company Angora 50**



Silver Grey



Violet



Rich Chestnut

Cap sleeve shirt in **Debbie Bliss Baby Cashmerino**

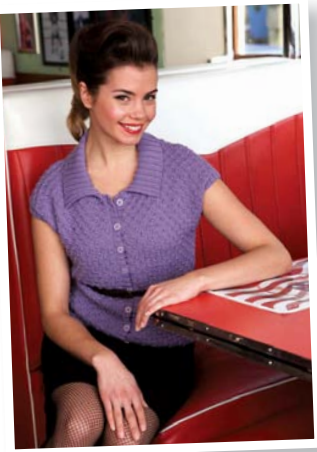

009



002



700

Off the shoulder top in **Louisa Harding Nerissa**

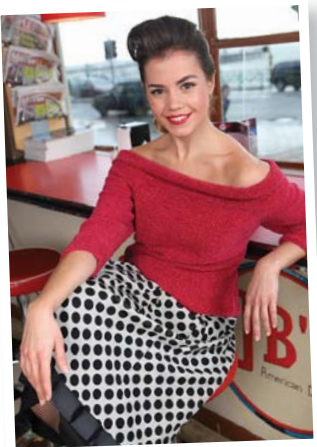

2 Icing



3 Damson



6 Teal

Jemima Greaves takes three knits from this month's gallery and offers you alternative shades and styling ideas

February is the month of love but after the stresses of Christmas and the whirlwind of New Year you deserve some self-love. Team the fun and flirty short-sleeved cardi with a pretty dress and your boots will be made

for walking, with a spring in their step! For sophisticated glamour with a modern edge try pairing the off the shoulder top with gorgeous accessories and peg trousers. The classic capped sleeve shirt is

the incarnation of versatility and pairing it with a fitted jacket will take you seamlessly from day to night. So, pat yourself on the back, relax and lavish some attention on yourself for a change.

Jem



Double buckle suede effect boot, £55, Fashion Union, www.fashionunion.com, 08445 730900



Felted fedora hat, £9.99, New Look, www.newlook.co.uk, 0500 454094



Autograph 60 denier velvet opaque tights, £8, Marks & Spencer, www.marksandspencer.com, 08456 090200



Meeko dress, £70, Monsoon, www.monsoon.co.uk, 08448 110068



Laura Scott faux sheepskin jacket, £110, Freemans, www.freemans.com, 08719 871030



Anya print skirt, £59, Mint Velvet, www.mintvelvet.co.uk, 08454 562200



Clasp belt, £10, M&Co, www.mandco.com, 08000 317200



Tan and brown leather effect handbag, £23.99, A-Shu, www.a-shu.co.uk



Enamel anchor studs, £1.99, Internationale, www.internacionale.co.uk, 01415 522020



Embellished shoulder bag, £35, East, www.east.co.uk, 020 8877 6543



Peg trousers, £12, Matalan, www.matalan.co.uk, 08453 303330



Suede heeled loafer, £70, Isme, www.isme.com, 08448 118112

Spotlight on... Knitwear FOR Men

With Valentine's day just around the corner we thought it was the ideal time to take some inspiration from men's fashion. Cue subtle shades, stunning tonal detail and knitwear that will have your needles drooling.
By Jemima Greaves

Between the deconstructed mish-mash beauty of **James Long's** chunky jumper and the more understated designs shown by **Missoni** and **Marc Jacobs**, there is a thread of continuity to be found in A/W11 menswear. The shabby chic of Long, Jacobs' impeccable tailoring and Missoni's carefully detailed cardigan are united by natural shades and graduating hues. These colour palettes are perfect for creating a smart-casual look that will last for years to come, regardless of the changeable nature of fashion. Plus, they are brilliant wintery shades for knitting your man a February treat he'll treasure!



Marc Jacobs A/W 2011



Missoni A/W 2011



James Long A/W 2011

DIY (Knit it yourself)

Men's knitwear is as diverse as women's and the array of styles can be overwhelming for the knitter and wearer alike. But help is at hand and these three gorgeous knits are a great place to start your quest for a fashionable man! Bergere's cable jumper is reminiscent of Missoni's AW/11 style and will keep him warm and snug while the shawl neck and button detailing add a special something. SMC's Fairisle turtleneck is the perfect winter warmer and you can't go wrong with a bit of Scandi chic. Rowan's loose fitting graduated sweater is subtly stylish, think toned down Long, and the natural hues will go with almost anything.



Pattern 264 from Bergere de France, www.bergere.co.uk

Explore more

If you ever need insight into how a 'fashionable' man thinks about style then take a look at www.thesartorialist.com. Set up by super stylish writer/photographer/founder/blogger Scott Schuman, this now internationally acclaimed blog started out with the aim of creating a dialogue, open to fashionistas and us mere mortals alike, about the fashion world's relationship to everyday life. Inspiration abounds within *The Sartorialist* archives and you'll always have something pretty to look at!



The Sartorialist by Scott Schuman, £19.99, Particular Books, ISBN 978 18 46142 505, www.penguin.co.uk



The idea of knitting a full garment for your man may seem too daunting a task, but you can always start small with this lovely scarf from Sirdar. **Pattern 945** by Sirdar, www.sirdar.co.uk

Like most good things the blog snowballed and the multi-talented Mr Schuman has even brought out an accompanying book. Photographs of well-known fashion figures sit comfortably alongside street snaps of anonymous passers-by from around the world. A true celebration of individual imagination and taste, proving that everyone can have their own style regardless of gender, age, wage, or location – now you've just got to convince him.



Earthy by Erika Knight from *Rowan Magazine 49*, www.knitrowan.com



Pattern 1691 by SMC Select, www.knitsmc.com



Mad Men

If you want to subtly nudge your man in the fashionable direction try putting some *Mad Men* on the TV. It's no surprise the Madison Avenue boys are so devilishly well-dressed as many of the show's suits are crafted by America's oldest men's clothier chain, Brooks Brothers, and they even released a limited edition *Mad Men* suit in 2009! If the gorgeous tailoring doesn't tickle his fancy then the female attention garnered by the dapper Don Draper might just persuade him to rethink his out-dated wardrobe!

RIGHT: Brooks Brothers limited edition *Mad Men* Suit released in 2009



What to wear with

Smart casual is a great look for men of all ages and shapes and requires minimum effort on his part, definitely a winner! Try toning down the *Mad Men* look and adding a hint of Marc Jacobs with jeans, a relaxed blazer, beautiful on-trend boots and, of course, a fabulous hand-knitted item from you!



Light wash denim jeans, £35, River Island, www.riverisland.com

Varsity grey herringbone blazer, £40, Matalan, www.matalan.co.uk



Navy boots, £69, Marks & Spencer, www.marksandspencer.com

On course

If you want to polish up your knitting skills before settling down to create a gorgeous garment for the man in your life then pop along to one of Toft Alpaca's courses. There are several throughout the year covering a wide range of techniques and abilities.

The lovely lasses at Toft Alpaca, www.thoftalpashop.co.uk



NEXT MONTH IN

Knitting magazine

URNS **100**

We celebrate with...

50 PATTERNS

Timeless Classics

& Modern Brights

- *Women*
- *Men*
- *Kids*
- *Babies*
- *Home &*
- *Accessories*



ON SALE 16 FEBRUARY 2012

Knitting magazine

Hand this coupon to your local newsagent. Please order every issue of Knitting for me from now on!

Knitting is published 13 times a year and the March 2012 issue goes on sale 16 February 2012.

- I will collect
- Please deliver

Name

Address

Post code Tel:.....

Signed

Date

Publisher: GMC Publications Ltd 01273 477374

Distributor: Seymour Distribution Ltd 0207 429 4000

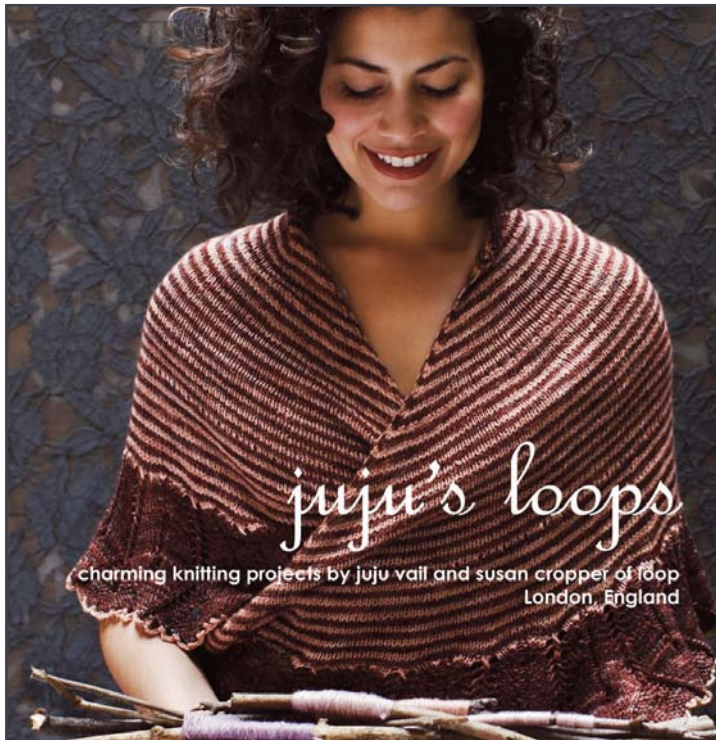

charming knitting projects by juju vail and susan cropper of loop
London, England

New lovely knitting book available from Loop as well as other independent shops around the world. Happy knitting!

www.loopknitting.com

15 Camden Passage, Islington, London N1 8EA
020 7288 1160

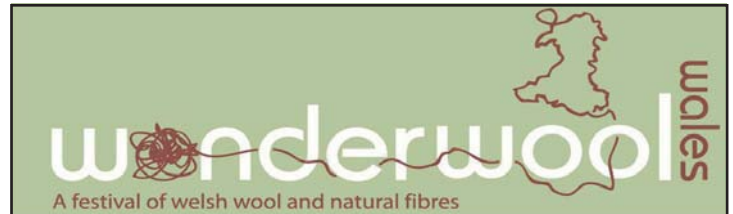

Saturday 28th & Sunday 29th April 2012

Sat ~ 10am - 5.30pm, Sun ~ 10am to 4.30pm

Admission £8.00 Under 16's Free



THE PREMIER WOOL & FIBRE FESTIVAL IN WALES

*Yarn, fibre, fleece & equipment
Woolschools & Demonstrations
Sheepwalk, Designer Products
Disabled Facilities, Camping,
Weekend Tickets available
On site Catering, Free Parking*



ROYAL WELSH SHOWGROUND

Llanelwedd, Builth Wells, Powys LD2 3SY Wales

www.wonderwoolwales.co.uk

enquiries@wonderwoolwales.co.uk

Tel: 01938 820495 or 01873 821205

Get Knitted

...inspiration & creation

www.getknitted.com
sales@getknitted.com
 0117 300 5211

Come and visit us in our massive shop!
 39 Brislington Hill, Bristol BS4 5BE

farnham maltings

interknit café
 selvedge

image: Clare Doornbos

unravel

a festival of knitting
 handspun yarns, talks, workshops and more...

Sat 25 - Sun 26 February 2012, 10am-5pm (Sun 4pm)
 Tickets: £6.50 advance, £9 on the door

Farnham Maltings, Bridge Square, Farnham, Surrey, GU9 7QR
 01252 745444 www.farnhammaltings.com

Busting on...

STAR LETTER GIVEAWAY

Judith Bell is this month's star letter winner. **Judith** wins a copy of *Finishing School: A Master Class for Knitters* by Deborah Newton.

Send us your thoughts, views and comments and you could win a fabulous prize.



STAR LETTER PRIZE



STAR LETTER

Because he's worth it

I am always delighted to see the selection of stash busting Weekend knits in the magazine and have knitted a good many of them. I was really pleased to see the Fisherman's rib scarf in issue 96, something to knit for a man for a change! I went straight to my stash and found some left over Debbie Bliss Aran. I had about two balls each of black and cream and the resulting houndstooth-effect scarf started off really well. I foolishly didn't pay attention, however, to the meterage of the yarn featured in the pattern, which is around twice as long as my stash yarn. As a result I have had to buy more yarn as well as using my stash yarn up!

Don't get me wrong, I am not complaining. The yarn is fabulous to work with and the resulting scarf is super soft and warm. A perfect gift for my husband! Also, this has been a great opportunity to learn this ribbing technique. Just a word of advice to others, check the meterage of your stash yarn or be prepared

for a shock when you fall short and either have to abandon the project or buy more yarn! Thank you, I love the magazine and have had a subscription for many years.

Judith Bell, via email

Ed's reply

It's funny that no matter how good your intentions are your stash just continues to grow! February is certainly the time of year to be knitting for the man in your life and hopefully our 'Spotlight on...' this month will give our readers plenty of inspiration, and maybe even help feed the stash monster taking up residence in every knitter's home. But, if you're halfway through a project when catastrophe strikes and your yarn runs out I would recommend 'Ask Jeanette' in *Knitting* issue 97 Christmas 2011. The ever-helpful Jeanette Sloan provided an ingenious guide to substituting yarn that is definitely worth a look.

In answer to Priscilla's question in *Knitting* issue 96 December 2011.



Button it

Men's garments should have buttons on the right hand side and buttonholes on the left. This dates back to the days when men had a servant to dress them and made it easier for the servant to do them up when

facing the gentleman.

I'm a support worker and I have noticed the difference this makes when doing up buttons on men's and women's garments. Hope this helps to shed some light on the matter.

Sarah Robinson (daughter) & Ann Robinson (mother), Derbyshire via email

With reference to the letter from Priscilla in France, I understand that the reason for

the fastening being different for men and women dates back to the age of stately homes when ladies had maids to dress them in the morning. With her mistress facing her, it was easier for the maid to fasten the garment on what has now become the lady's side. Since only the rich few wore fashionable clothes, this seems a reasonable explanation.

Can I also echo Priscilla's comments on the recent trend in your patterns – rather too much emphasis on fashion for the young and slim with not enough classic timeless patterns. Knitters come in all ages, and those with the most time to knit, (and who can knit quickest), are often the retired. Knitters also enjoy knitting for others, so why are there almost no patterns for men folk?

Digressing slightly, many of the patterns use very expensive yarn – way beyond the pocket of the average reader. Could you perhaps include the price of the suggested yarn, and include a cheaper alternative?

Elsbeth Macpherson, Thurso Caithness

Ed's Reply

If it's timeless and classic knits you want you are going to love next month's issue. To celebrate *Knitting's* 100th issue we are putting together a bumper issue with 50 patterns, which means two design stories, one of which is literally 'Timeless classics'. With such a large age range in readers we do try and include something for everyone, which is why the other design story is 'Modern brights'.

Your question about yarn prices is an important and popular one too. Unfortunately, but for obvious reasons, it's very difficult to recommend yarns that differ from the one stated without upsetting the company who has supplied the pattern or yarn. And, as much as we love to help our readers, it is also problematic to supply a price alongside the yarn as this varies from retailer to retailer and we wouldn't want to misinform readers in any way!

nest

102 Weston Park, Crouch End, London,
N8 9PP • 020 8340 8852



Knitting and crochet yarns,
needles and hooks, felting tops,
books and patterns, haberdashery,
handmade gifts and cards.

We also run workshops and
knitting groups (complete
with tea and homemade
cakes!)



www.handmadenest.co.uk

visit our new online shop!

yarns we stock include: Debbie Bliss, Drops, Excelana, Fyberspates, JC Rennie,
John Arbon, Malabrigo, Natural Dye Studio, Rico, Rowan & Skein Queen



©2011 Blue Sky Alpacos

blueskyalpacos.com

blue
sky
ALPACAS™

Cotton Sweet Cardi
Blue Sky Skinny Cotton | 308 mallard

purlescence

making knitting beautiful

buttonshooksbagscases
needlesnotionstoolsyarn
patternstreatsshawl-pins



The Unique Sheep



namaste

HAND & MAIDEN
fine yarn



www.purlescence.co.uk



Maggie Mouse & Dotty Dress

By Nancy Atkinson

Maggie Mouse in her polka dot dress is the perfect project to combine sewing and knitting skills to create a cuddly cotton friend that children will delight in.

MATERIALS

1 pair 4mm needles
 1 x 50g **Debbie Bliss Eco Baby** (100% organic cotton) in shade 20 Pale Green
 A pair of 6mm black toy eyes
 Scraps of cotton in a design of your choice
 Pink embroidery thread
 40cm (16in) of bias binding
 (I have used a floral Liberty print binding)
 Toy stuffing
 Darning needle
 Stitch holder or safety pin
 Sewing machine or needle and thread to hand sew

NB Safety warning! If you are making this toy for a child under 3 years, darn the eyes rather than use plastic toy eyes.

LEGS (MAKE 2)

Cast on 16 sts.
 Slip the first stitch of each row.
 Starting with a knit row work in st st for 21 rows ending on a knit row.
 Purl 5 sts and turn work.
 Continue to work these 5 stitches in st st for 5 rows, ending on a knit row.
 P2, p2tog, p1. (4 sts).
 Knit row.
 Break the yarn and put these 4 stitches on a stitch holder.
 Place the 6 central stitches onto another stitch holder leaving you with 5 working stitches. With WS facing, attach yarn to these 5 sts.
 Purl 5.
 Turn work and work in st st for 5 rows.

P1, p2tog, p2. (4 sts).
 K4.
 Pick up four sts along the inside edge of the heel. Next pick up the 6 sts on your central stitch holder. Then pick up 4 sts from the inside edge of the heel and pick up the 4 remaining sts on the holder. (22 sts).
 Purl row.
 Increase row, k7, inc1, k6, inc1, k7 (24 sts).
 Purl row.
 K7, k2tog, k6, k2tog, k7. (22 sts).
 Purl row.
 K6, k2tog, k6, k2tog, k6. (20 sts).
 Purl row.
 K5, k2tog, k6, k2tog, k5. (18 sts).
 Purl row.
 K4, k2tog, k6, k2tog, k4. (16 sts).
 Purl row.

K3, k2tog, k6, k2tog, k4. (14 sts).
Purl row.
K2, *k2tog, k2* repeat 3 times. (11 sts).
Purl row.
K2, *k2tog, k1* repeat 3 times. (8 sts).
Purl row.
K2tog across row. (4 sts).
Thread yarn through the remaining stitches to cast off. Leave a long tail to sew up.

ARMS (MAKE 2)

Cast on 8 sts.
Starting with a knit row, work in st st for 8 rows.
K2, inc1, k2, inc1, k2. (10 sts).
Starting with a purl row work in st st for 7 rows.
K3, inc1, k2, inc1, k3. (12 sts).
Starting with a purl row work in st st for 9 rows.
K3, k2tog, k2, k2tog, k3. (10 sts).
Purl row.
K2, k2tog, k2, k2tog, k2. (8 sts).
Purl row.
K2tog across row. (4 sts).
Thread your yarn through the remaining stitches to cast off.
Leave a long tail to sew up.

EARS (MAKE 2)

Cast on 10 sts.
Knit 2 rows.
K1, inc1, knit 8, inc1, k1. (12 sts).
Knit row.
K1, inc1, knit 10, inc1, k1. (14 sts).
Knit 5 rows.
K1, k2tog, k3, k2tog, k3, k2tog, k1. (11 sts).
Knit row.
K1, k2tog, k to last three, k2tog, k1. (9 sts).
Knit.
K1, k2tog, k to last three, k2tog, k1. (7 sts).
K1, k2tog across row. (4 sts).
K2tog, k2tog. (2 sts).
K2tog.
Cast off.

BODY (MAKE 1)

Cast on 5 sts.
K1, inc1, k1, inc1, k1. (7 sts).
Purl row.
K1 *inc1, rep from * to end. (13 sts).
Purl row.
K1, *inc1, rep from * to end. (25 sts).
Purl row.
K1, *inc1, k2, rep from * to end. (33 sts).
Purl row.
K1 *inc1, k3, rep from * to end. (41 sts).
Purl row.
K1 *inc1, k4, rep from * to end. (49 sts).
Purl row.
K1 *inc1, k5, rep from * to end. (57 sts).
Work in st st for 7 rows ending on a purl.
K1, *k2tog, k5, rep from * to end. (49 sts).
Purl row.
K1, *k2tog, k4, rep from * to end. (41 sts).
Purl row.
K1, *k2tog, k3, rep from * to end. (33 sts).

Purl row.
K1, *k2tog, k1, rep from * to end. (25 sts).
K1, K2tog across row. (13 sts).
Cast off.

HEAD (MAKE 1)

Cast on 5 sts.
Purl row.
K1, inc1, k1, inc1, k1. (7).
Purl row.
K1, *inc1, rep from * to end. (13 sts).
Purl row.
K1 *inc1, rep from * to end. (25 sts).
Purl purl.
K1, *inc1, k2, rep from * to end. (33 sts).
Starting and ending with a purl row work in st st for 5 rows.
K8, k2tog, k2, k2tog, k5, k2tog, k2, k2tog, k8. (29 sts).
Purl row.
K8, k2tog, k9, k2og, k8. (27 sts).
Purl row.
K8, k2tog, k7, k2tog, k8. (25 sts).
Purl row.
K3, k2tog, k3, k2tog, k5, k2tog. K3, k2tog, k3. (21 sts).
Purl row.
K7, k2tog, k3, k2tog, k7. (19 sts).
Purl row.
K3, k2tog, k2, k2tog, k1, k2tog, k2, k2tog, k3. (15 sts).
Purl row.
K5, k2tog, k1, k2tog, k5. (13 sts).
Purl row.
K1, k2tog to end. (7 sts).
Thread yarn through the remaining stitches to cast off.
Leave a long tail to sew up.

MAKING UP

Using mattress stitch and stuffing as you go, sew the seams of the arms and legs. Next, sew and stuff the body piece seam from the bottom to the neck, leaving an opening at the top where your cast off stitches are – this is going to be the neck. Next sew and stuff your head piece. Before you close the seam, position your toy eyes and secure the backs inside the head. Now you can close the seam and sew the head to the neck hole on the body piece.
Fold your ear pieces in half and sew the cast on edges together. Position and pin to the head and sew in place. Using pink embroidery thread or yarn oddment embroider a nose. Attach your arms and legs and weave in all loose ends. Squeak with joy! Your Maggie Mouse is finished!

DOTTY DRESS

Cut one large piece of fabric 10 x 30.5cm (4 x 12in) for the skirt, and two small rectangles 10 x 5.7cm (4 x 2.25in) for the vest top. Place your two small rectangles

together and cut out armholes and neck holes as shown in image. Sew a seam along one of the long sides of your skirt piece. Next gather in the skirt. To do this, set your sewing machine to the longest stitch size. Sew along the long edge of the skirt piece (not the one you have seamed) using a 32mm (0.125in) seam.

Do not reverse your machine when you reach the end. Cut the cotton and pull to gather the fabric up. When the gathered edge of your skirt is drawn in to measure 18cm (7in) then sew the two short edges of your skirt together (right sides facing) to create a gathered tube.

Add bias binding to the raw edges along the neck and armholes of your two dress top pieces. Place the two pieces together, right sides facing, and sew along the shoulders and sides to create a vest. Lastly you need to attach your skirt to the vest top. Turn the skirt piece inside out so the wrong side is facing outwards. Next place the vest, right sides facing outwards, inside the skirt. The right sides of the fabric from the skirt and vest should be facing each other and the bottom seam of the vest should be against the top seam of the skirt. Pin in place and sew the two pieces together around the gathered circumference of the skirt using a 6mm (0.25in) seam.

Turn the dress the right way round and you are finished! ●

Nancy Atkinson is co-author of *Knitted Nursery* published by GMC Publications, £14.99. ISBN 978 1 86108 669 3

READER OFFER

Readers of *Knitting magazine* can buy *Knitted Nursery* for the special price of £10.50 plus p&p. To order, please call 01273 488005 or go to www.thegmcgroup.com and quote reference code R3427. Offer ends 19 April 2012.

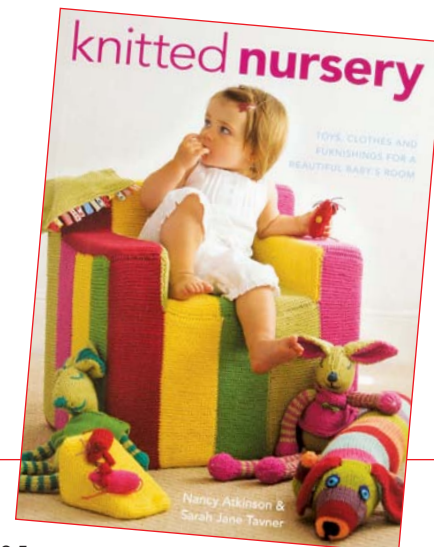

MILLAMIA UK STOCKISTS INCLUDE

ANGLESEY

COPPERFIELD CRAFTS, FOUR MILE BRIDGE ROAD,
VALLEY, ANGLESEY, NORTH WALES, LL65 3HB
TEL: 01407 740982, WWW.COPPERFIELD-CRAFTS.CO.UK

BUCKINGHAMSHIRE

THE KNITTING HUT, 65 HIGH STREET, WOBURN
SANDS, BUCKINGHAMSHIRE, MK17 8QY
TEL: 01908 586244, WWW.THEKNITTINGHUT.COM

CHESHIRE

GREENGINGER FABRICS, 50 GREENWOOD STREET,
ALTRINCHAM, WA14 1RZ, TEL: 0161 929 8837
WWW.GREENGINGERFABRICS.CO.UK

CUMBRIA

LOOPY, 2 UPPER BROOK STREET, ULVERSTON,
LA12 7BH, TEL: 01229 480080
WWW.LOOPYWOOLULVERSTON.CO.UK

THE QUILTED SHEEP, THE OLD BAKEHOUSE, MAIN
STREET, MILNTHORPE, CUMBRIA, LA7 7PN
TEL: 015395 65800, WWW.THEQUILTEDSHEEP.CO.UK

EAST SUSSEX

OWL AND SEWING CAT, 5 GRAND HOTEL BUILDINGS,
COMPTON STREET, EASTBOURNE, BN21 4EJ
TEL: 01323 325342, WWW.OWLANDSEWINGCAT.COM

FLINTSHIRE

ABAKHAN FABRICS, HOBBY & HOME, MOSTYN,
COAST ROAD, LLANERCH-Y-MOR, MOSTYN, NORTH
WALES, CH8 9DX, TEL: 01745 562100
WWW.ABAKHAN.CO.UK

GREATER LONDON

FRINGE@STUDIO108, ALEXANDRA PARK ROAD,
MUSWELL HILL, LONDON, N10 2AE
TEL: 020 8883 9478, WWW.STUDIO108.ORG

MOO TOO, 45 LORDSHIP LANE, LONDON, SE22 8EP
TEL: 020 8299 6105

MRS MOON, 41 CROWN ROAD, ST MARGARETS,
TWICKENHAM, TW1 3EJ, TEL: 020 8744 1190
WWW.MRSMOON.CO.UK

HAMPSHIRE

NATURE'S THREADS, 72 CLARENCE ROAD, FLEET,
HAMPSHIRE, GU51 3RS, TEL: 07778 507167
WWW.NATURESTHREADS.CO.UK

LEICESTERSHIRE

KNIT ONE, 60C QUEENS ROAD, LEICESTER, LE2 1TU
TEL: 0116 270 0337, WWW.KNITONE.UK.COM

LINCOLNSHIRE

A GOOD YARN, 53 CAMBRIDGE STREET,
CLEETHORPES, DN35 8HD, TEL: 01472 508707
WWW.AGOODYARN.CO.UK

NORTHUMBERLAND

THE NEEDLEWORKS, 54 HIDE HILL, BERWICK UPON
TWEED, TD15 1AB, TEL: 01289 330503
WWW.NEEDLEWORKSBERWICK.BLOGSPOT.COM

NOTTINGHAMSHIRE

KNITWORKING, 5 MAIN ROAD, GEDLING,
NOTTINGHAM, NG4 3HQ, TEL: 0115 9613081
WWW.KNITWORKING.CO.UK

SHROPSHIRE

ANCA, RADBROOK CENTRE, BANK FARM ROAD,
SHREWSBURY, SY3 6DU, TEL: 01743 249504
WWW.ANCA-WOOLS.CO.UK

SOMERSET

CROSS PATCH CRAFT STORE, 66 MEADOW STREET,
WESTON-SUPER-MARE, SOMERSET, BS23 1QN
TEL: 01934 418005, WWW.CROSSPATCHCRAFTS.WEBS.COM

STAFFORDSHIRE

NANNA B'S, 1 THE MALTINGS, UTTOXETER, ST14 7LN
TEL: 01889 568221, WWW.NANNABS-KNITTING.ME.UK

SUFFOLK

WIBBLING WOOLS, 24B ANGEL HILL, BURY ST
EDMUNDS, IP33 1UZ, TEL: 01284 749555
WWW.WIBBLINGWOOLS.CO.UK

SUSSEX

THE BLACK SHEEP, 8 WEST STREET, MIDHURST, WEST
SUSSEX, GU29 9NQ, TEL: 01730 812862
WWW.BLACKSHEEPMIDHURST.CO.UK

TYNE AND WEAR

WOOLABALLOO, 3 CHOPWELL ROAD, BLACKHALL
MILL, NEWCASTLE UPON TYNE, NE17 7TN
TEL: 0191 580 0103, WWW.WOOLABALLOO.COM

WILTSHIRE

CRAFTY YARN, UNIT 42 STUDLEY GRANGE CRAFT
VILLAGE, HAY LANE, WROUGHTON, SWINDON, SN4
9QT, TEL: 01793 855535, WWW.CRAFTY-YARN.CO.UK

YORKSHIRE

LITTLE HOUNDALES KNITS (BY APPOINTMENT),
LITTLE HOUNDALES FARM, NAFFERTON, DRIFFIELD,
EAST YORKSHIRE, YO25 4LF, TEL: 01377 255093
WWW.LITTLEHOUNDALESKNITS.COM

SALTAIRE YARNS, 3 OASTLER ROAD, SALTAIRE, BD18 4SE
TEL: 01274 270142, WWW.SALTAIREYARNS.CO.UK



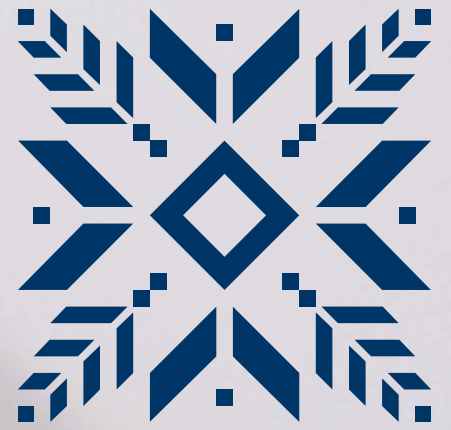

MILLAMIA

SWEDEN

Featuring the Gabrielle Jumpers from our Knitting Pattern Book "The Close Knit Gang", RRP £14.95.

All knitted using MillaMia Naturally Soft Merino Yarn in colours Peacock (144), Fuchsia (143) and Daisy Yellow (142)

A week in the life of...



Katy Bevan

Participation & Learning Manager at the Crafts Council

As told to **Shannon Denny**

As Participation & Learning Manager at the Crafts Council, Katy Bevan has her finger on the pulse of British craft. She's particularly interested in textiles, and so she's aiming to teach the whole country to knit – one stitch at a time. We caught up with her last year to follow a week in her busy life.

Monday

In my day job at the Crafts Council, my mission is to promote contemporary craft making in schools, galleries, shops and community groups. There are five of us managing the educational projects, including Firing Up to get school kilns in use, the Handling Collection, an accessible educational resource of over 600 objects, and the Craft Action Network, our innovative way of bringing professionals from the craft and education sectors together online.

Today I head over to the Saatchi gallery to visit COLLECT, the international art fair for contemporary objects. I love Eleanor Bolton's chunky rope-like necklaces. At COLLECT I notice quite a bit of work that explores the use of digital technologies in craft. I recently bought myself a remarkably light bracelet from Nora's latest range of jewellery made from a 3D printer. Digital technology is the theme of one of our current touring exhibitions – Lab Craft – which features some extraordinary objects including table lights created by a 3D printer and a ceramic vessel that incorporates a QR code.

Tuesday

In my work at the Crafts Council our largest project is Craft Club, which is a campaign to encourage volunteers to pass on their yarn skills to young people. Sometimes we are shocked by the number of young people who don't know how to knit or sew. So that they don't miss out on the joy of craft, we're asking volunteers to get out and help the process along. With over 300 clubs there's a lot to do, although there's plenty of room for

expansion. With the support of the National Federation of Women's Institutes and the UK Hand Knitting Association, who advocate Craft Club through the big knitting shows, I'm positive we can increase the number of clubs significantly.

Today our team is gaining a new project co-ordinator as it's going to be a busy year for Craft Club including film events planned across the country, which is really exciting.

Wednesday

A Boreray fleece arrives in the post. This sheep is on the Rare Breeds Survival Trust's critically endangered list. The package has been sent by the Woolsack Project, an initiative that encourages people to make a cushion from British wool. The cushions produced by the project will be given as a personal welcome gift from the people of Britain to the London 2012 Olympic and Paralympic athletes. I'm designing a simple pattern for our Craft Club website.

Later we are having a 'swish' in the office to help save on landfill garments. I've made a pledge to myself to try not to buy anything new but to mend and make my own clothes. I've been inspired by the Labour Behind the Label campaign, which is doing great work opening people's eyes to the realities of the cotton industry. It's not just about shopping.

Thursday

I visit my favourite haberdashery shop, Prick Your Finger, for a late night view of their new window display. Owners Rachael Matthews and Louise Harries asked artist Felicity Ford to come and record customers knitting as part of her Knitsonik project. Knitsonik fuses new digital sound recording technologies with the old garment making technology of knitting. My favourite knitting audio clips are the sound of the kettle boiling and the quiet noise of counting stitches.

Friday

Back in the office we are delighted to see some new images on the Craft Club website.

The clubs are so creative. One started off with the ubiquitous garter stitch square, but then stitched all the squares together and wrapped up a tree in the playground. Graffiti knit in the schoolyard!

Saturday

Often on a Saturday I attend trade shows for knitting shops, such as The Knit Show organised by the UK Hand Knitting Association. I go along to talk to sales teams from all the yarn companies about Craft Club. We're hoping to branch out from the classroom to having clubs in a range of community settings, so we need all the contacts and resources we can discover.

Sunday

At last I get to be at home to do my own knitting! I'm busy making things for my daughter's school fair using up some of my yarn stash along the way. Over the last few months I have been busily making accessories. My husband will be delighted if the stash reduces in size, but then I have seen some lovely yarn at the show that I'm sure will come in handy one day soon...

www.craftscouncil.org.uk
www.craft-action.org.uk
www.craftclub.org.uk

Crafts Council 2012 Diary Dates

25 February to 7 April Lab Craft, digital adventures in contemporary craft, is at Oriel Myrddin, Carmarthen.

11 to 14 May COLLECT, the annual fair for contemporary objects, will take place at the Saatchi Gallery in London.

Craft Club has expanded into the community in 2012 with a range of new venues hosting clubs; check the website for more details

www.craftclub.org.uk.

Visit www.prickyourfinger.com to find out more about the exhibitions programme.



PHOTOGRAPH © ELEANOR BOLTON

"Sometimes we are shocked by the number of young people who don't know how to knit or sew. So that they don't miss out on the joy of craft, we're asking volunteers to get out and help the process along."



PHOTOGRAPHS UNLESS STATED © CRAFTS COUNCIL



Anne Genevieve Hanway



Edwina MacKinnon



Brenda Scarman



Annette Emms



Sian Martin

Jersey Textile Showcase

5th - 11th March 2012

The Harbour Gallery and associated venues, within 5 minutes walk, around the picturesque harbour village of St Aubin, Jersey.

An exciting, colourful event for stitchers, quilters and knitters in friendly surroundings with friendly people on a beautiful island.

Tutors for 2012: new tutor Sian Martin member of the 62 Group, Fay Maxwell, Annette Emms and Fiona King, you asked for their return. New 2012, Edwina MacKinnon for quilters to push the boundaries. Christine Witham and Naomi Renouf from Jersey. New 2012, Brenda Scarman from the UK and Ruth Skinner from Jersey, a workshop from Ruth can be seen in November Stitch magazine. From France, Sylvie Cambet Knitting, Anne Genevieve Hanway Workshop programme out early November. All materials, sewing machines, embellishers provided.

Exhibitions; Fay Maxwell, Sian Martin, Anne Genevieve Hanway, Jersey Textile Artists, Diversity Group, Caesarea Quilters, Diane Bates new jewellery, UK groups, Beaulieu Secondary School art / textiles, the competition entries.

FREE ENTRY TO ALL THE EXHIBITIONS.

For quilters and stitchers welcome to Jenny Bromley, Atelier Needlecrafts of Southampton.

The world wide **OPEN COMPETITION** title:

"Your Local Landscape"

No entry fee but £6 for return postage.

£1000 worth of cash prizes, request a flyer for details of categories.

Charity Challenge supporting Jersey Mencap, knit a scarf, necktie or similar, send it to us we will display it and sell it at the Showcase

WITH ALL PROCEEDS GOING TO JERSEY MENCAP.

Request a Flyer.

Evening Events, Optional Welcome Meal, Official Opening Party, seminar on Marketing Your Work, Grand Gala Dinner, Drinks Reception and Fashion Show.

Welcome to Angie and Paul Boyer Craft & Design magazine.

More being added weekly. Fantastic Travel Deal...no added charges for luggage, seats booked etc Transfers from sea or airport.

Contact Destination Specialists **01534 617677** or email: mail@dsljersey.je For more information email; partintheframe@yahoo.co.uk or leave a message with your contact details on

01534 853395

We look forward to welcoming you to Jersey Textile Showcase 2012



Fay Maxwell



Fiona King

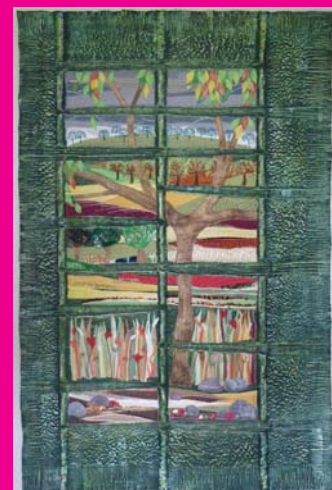

Naomi Renouf



Sylvie Cambet's Shop - Dinan



Christine Witham

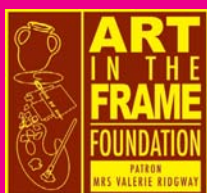



Pattern preservation

Clare Kelly questions whether we should be doing more to preserve the art of knitting pattern writing

It has come to the attention of *Knitting* that there is something going on with pattern writing. We know that people are continuing to discover knitting

and all its benefits, but have you ever considered who is generating the patterns you pick up? How are we keeping the tradition of pattern writing alive? ▶

Look for an inspirational knitting book and you might be fooled into thinking that there are an abundance of pattern writers in the business. Now try and find a course that teaches solely pattern writing and you may well struggle. You can find courses that teach pattern writing for knitting machines (Knit-1 in Brighton is a good place to start) but getting back to basics and writing for hand knitters is a different matter altogether.

Penny Hill is a pattern writer and has been writing instructions for 40 years; working primarily with designer Debbie Bliss. Such skills are highly prized and there are few people who can offer such experience especially when you consider that Penny works predominantly by hand; sometimes considering how to tackle a pattern for several days. When Penny and her contemporaries retire, she worries about who might take over:

“I am not sure that there are as many spinners who take on trainees for apprenticeships anymore and I am so busy that I have not had chance to teach anyone else,” she adds, “it needs to be some one who has a full understanding of knitting yarns, how they react to different stitches, for example. I was lucky that I also did pattern cutting at college so have a basic knowledge of grading which also helps.” Beginning her career with Emu Wools, Penny undertook a four-year apprenticeship, which, at the time was “rather tedious but stood me in good stead for the future.”

Apprenticeships are still available but there are fewer opportunities than you might think. Hand knitting company Rowan used to offer internships although this is no longer the case and Marie Wallin, head designer at Rowan explains the situation today: “We currently work with a freelance pattern writer in Spain but as we have no one else currently in the pipeline, we feel it is an area of the business which makes us quite vulnerable.”

Marie is an experienced designer who can write her own patterns but does not have the time to do so. Creating show-stopping knitwear requires Marie to generate a large quantity of designs before handing over the specifications to a writer who can create the perfect pattern. So, are pattern writers really that essential? Marie thinks so: “Pattern writers underpin all that we do. Without them, we couldn’t produce the volume of patterns we do. It is a vital part of the business.”

Sirdar Spinning Limited is one company who do offer pattern writer internships, but how does it work? And is it enough to keep these skills safe? At any one time, Sirdar has no more than three trainees to ensure that each one is given the highest level of training by an experienced pattern writer.

Julie Langham is Sirdar’s head designer and explains how it all works: “Sirdar has always

recruited and trained its own pattern writers in-house and we choose to continue this practice so that everyone works in the same way and to the same high standard. We have a dedicated trainer to take care of the trainee pattern writers. We are temporarily without a trainee and this is the way the training ebbs and flows, according to commercial needs. Our trainer is one of our most experienced pattern writers and passes her skills on to our next generation of pattern writers, but all of our pattern writers are happy to help where they can.”

Just as Marie at Rowan believes, Julie is also keen to point out that pattern writing is absolutely vital to the success of the business. She says: “I’m sure that if the public understood the complexity of transforming an initial design into a printed instruction they would look at knitting patterns in a completely different way. People seem to assume that we press a button on a computer and the finished product pops out, but that really isn’t the case. We haven’t yet found a

before specialising in knitting and you might think that today’s knitwear students spend a large proportion of their time writing patterns. But do they?

Leigh Bagley, Knit Subject Leader at Glasgow School of Art says: “Here at the GSA the actual process of writing down a knitting pattern is somewhat ad hoc. As a textile course, our students very rarely write patterns from which to make garments from and it’s not a skill we formally teach.” Rather more, students are advised to take a more organic approach. “When our students are technically sampling or designing fabrics we encourage them to note down their process in a manner from which they can refer back to rather than teaching them a specific method. This is usually documented through written and visual notes and diagrams depending on the complexity of the fabric structure,” Leigh adds.

At the University of Brighton, textile students are taught to write patterns in their second year and learn to write manually and

“People seem to assume that we press a button on a computer and the finished product pops out, but that really isn’t the case. We haven’t yet found a computer program that can write patterns as well as people, so we use pencils, graph paper, basic maths and a magic ingredient – the unadulterated skill of our pattern writers.”

computer program that can write patterns as well as people, so we use pencils, graph paper, basic maths and a magic ingredient – the unadulterated skill of our pattern writers.”

Maths is a big part of life as a pattern writer but creativity is also a key skill. Pattern writers such as Penny Hill will often work directly with a designer such as Debbie Bliss, so building a good working relationship is absolutely essential. How does it work for them? Debbie says: “Penny and I have worked together for many years and she has been crucial to the success and development of my business. It would be impossible for me to still compile and grade my patterns now that I am designing almost 150 knits a year, plus sourcing new yarns, choosing colour palettes and organising shoots. It is not just working with someone who can do the maths from my swatches and measurements, after 20 years Penny and I have our own ‘shorthand’, so we are able to discuss the ways we can achieve shapes, sizings, and the way the knitted fabric works.”

Penny studied fashion at an art college

digitally depending on their own preference. Toni Hicks, Area Leader for Knitted Textiles began her own career designing and calculating patterns for Lyric Patterns Services and Hayfield Wools so is perfectly placed to pass on her own skills.

Toni believes that “there is no one definitive method. I urge students to knit up swatches and then take measurements taking into consideration how the fabric behaves when relaxed and extended. Simple calculations can also be employed and visual aids are essential for the process, I often show how to transpose onto graph paper.”

Toni’s students are in demand and it is common for them to travel to New York for placements, where they can demonstrate techniques in knitwear construction not currently taught at universities in the US. Brighton students are also taught how to write patterns for Japanese Shima Seiki knitting machines which are widely used in the industry, but Toni is keen that they understand how to create patterns in the traditional way too. ▶



“We all know that good business works on a supply and demand basis so if you are considering a career as a pattern writer, take this as a sign that you would definitely be in demand.”



The Godfather by Louise Dungate

Nationwide however, there seems to be not one university that offers a course in solely pattern writing but surely it is about time they did? Designer Amy Hall taught herself to write patterns and it has obviously been a success as her work has been much acclaimed by the fashion press including *Vogue*. Why does Amy think less people are taking up pattern writing? Amy believes that “many people are terrified of it, they just don’t know how simple it is to write a pattern.”

Fellow self-taught knitwear designer Louise Dungate agrees: “I think the fear of going wrong or trying something different can hold people back, but really if it doesn’t work out, you’ve not really lost anything.”

And quite right she is too. Although, if you would like attend a short pattern writing course, look no further than Prick Your Finger, a textile collective, online knit shop and gallery in east London run by Louise Harries and Rachael Matthews. Together, they felt the need to offer a special course to help knitters demystify the process. “Lots of people today are turning away from knitting because they think they have done it wrong but my grandma would often hold her work up to the light and under graph paper and try and understand how it was made up. It is such a joy when you work something out for yourself and complete a project. This course give knitters the freedom to create their fantasy sweater,” explains Rachael.

On a domestic scale, writing patterns is

a valuable skill for any knitter but in order for designers to continue producing original patterns for us all to enjoy, it’s an essential skill. With this in mind, what can be done to ensure that we do not run out of original patterns in the future? One suggestion might be to start talking to people who can write patterns and ask them if they would be kind enough to teach you their methods.

It might also be worth enquiring at your local community centre or college to see if they know anyone who could teach a pattern writing course – there could even be someone with these skills on the street where you live so get talking to each other!

Perhaps you are a skilled pattern writer and are keen to pass on whatever you have learned. Whatever the case, it is important

that we act now if we are to ensure this valuable skill is not lost forever. We all know that good business works on a supply and demand basis so if you are considering a career as a pattern writer, take this as a sign that you would definitely be in demand. ●

We would love to hear your thoughts on this topic. Do you think more should be done to preserve the art of pattern writing? How might people be encouraged to write patterns? Follow *Knitting magazine* on Twitter @KnittingMag to discuss this; or write to us at the usual address.

Find out more
www.prickyourfinger.com
www.gsa.ac.uk
louisedungate.com
www.amy-hall.co.uk
www.knitrowan.com
www.shimaseiki.com
www.brighton.ac.uk
www.debbieblissonline.com



Penny wearing one of her designs



Penny knitted the booties and designed her own cardigan (far right)



Penny and her younger sisters – Penny knitted all the short sleeves

PHOTOGRAPHS BY PENNY HILL

InToKnit.co.uk

Specialists in

BERGERE de France

★★★★★
Rated 5/5
on Google

buy online at www.intoknit.co.uk

Bergere de France new baby book BER160



lo-call order line 0845 8383 762

email shop@intoknit.co.uk

Sew-In of Marple Didsbury & Buxton

Stockists of

Rowan, Sublime, Millamia
Debbie Bliss, Noro, Sirdar and more.

Hundreds of knitting patterns,
books and accessories.

Friendly, weekly knitting club at Marple & Didsbury
Expert advice, Knitting up service.

DMC Main Agent, Anchor Needlecraft Specialist.
Cross-Stitch/Tapestry/Embroidery/Haberdashery.

All major credit cards accepted,
postal service a pleasure.

Debbie Bliss ROWAN

0161-427-2529

0161-445-5861

46 Market Street
Marple SK6 7AD

741 Wilmslow Road
Didsbury M20 6RN

01298-26636

1 Spring Gardens
Buxton SK17 6BJ

www.knitting-and-needlework.co.uk
Monday – Saturday, 9am – 5.30pm

MODERN knitting.co.uk

inspiration for the creative knitter

Everything for your latest knitting project is just
a click away on our easy to use website!

Fast and friendly service. UK p&p just £2,
free over £20. International shipping.



Choose from thousands of
patterns to buy online, plus a
great range of yarns, including:

- Sirdar • Sublime
- Wendy • Twilley's
- King Cole • Katia
- Debbie Bliss • Cygnet
- Stylecraft • James Brett
- Patons



Knitting for babies - the latest
patterns and the best yarns,
including:

- Sirdar Snuggly
- Patons Fairytale and
Dreamtime
- Peter Pan
- Debbie Bliss Baby
Cashmerino and Ecobaby
- Stylecraft Wondersoft



Socks, gloves, hats,
wristwarmers, legwarmers,
scarves, snoods, cowls... You'll
find just what you need to dress
up your winter wardrobe and
stay toasty warm this winter.
Choose from hundreds of sock
yarns including the new Vincent
van Gogh and Graffiti from Opal.

Plus a great Sale department!



We've got scarf knitting all
wrapped up! Choose from
a huge selection of scarf
yarns including Katia Rocio,
Ronda, Ondas, Triana and
Park Avenue plus Wendy Frills,
Sirdar Bohemia and many others
– including sale specials.

www.modernknitting.co.uk

Weekend Knits

Sarah Hazell brings you the chicest stash projects that are always quick to make but never scrimp on style



Hot stripes scarf

YARN

Would suit any mohair or DK yarn

Sarah used:

2 x 50g balls **Rowan Kidsilk Stripe** in 205 Circus

NEEDLES

4mm circular needle (80cm)

TENSION

22 sts and 30 rows using 4mm needles and measured over 10 sts.

MEASUREMENTS

21 x 170cm (with fringing)

Using 4mm circular needle, cast on 94 sts and taking care not to twist sts, join in the round, remembering to place marker to denote beginning of row.

Knit every round until work measures approx 140cm (or desired length, bearing in mind you will need some of the yarn for fringing). Cast off.

FINISHING

Lay out tube so that it is flat. Cut 20cm lengths of yarn and knot groups of six of these lengths through both pieces of knitted fabric of the cast-on and cast-off edges. Trim so that all fringes are of equal length. ●

Baby love blanket

YARN

Would suit any DK yarn
 Sarah used:
 4 x 50g balls **Rowan Wool Cotton** in 931 Tender

NEEDLES

4mm needles
 4mm crochet hook

TENSION

22 sts and 30 rows to 10cm
 using 4mm needles and
 measured over pattern.

SPECIAL ABBREVIATIONS

Yfwd = Yarn forward
K2tog = Knit 2 together
T2F = K2tog, but do not
 slip sts off the needle, then
 insert RH needle between
 these 2 sts and knit the first
 st again, slipping both sts
 off the needle
Skpo = S11, K1, pass the
 slipped st over
Ss = Slipstitch
Ch = Chain

MEASUREMENTS

Approx 54 x 80cm

MAIN PANEL

Using 4mm needles,
 cast on 103 sts.

Row 1 (RS): P43, K17, P43.

Row 2 and every alt row (WS): K43, P17, K43.

Row 3: P43, T2F, K13, T2F, P43.

Row 4: As row 2.

Repeat last 4 rows once
 more.

Row 9: P43, K7, K2tog, yfwd,
 K8, P43.

Row 11: P43, T2F, K4, K2tog,
 yfwd, K1, yfwd, skpo, K4, T2F
 P43.

Row 13: P43, K5, K2tog, yfwd,
 K3, yfwd, skpo, K5, P43.

Row 15: P43, T2F, K2, K2tog,
 yfwd, K5, yfwd, skpo, K2, T2F
 P43.

Row 17: P43, K3, K2tog,
 yfwd, K7, yfwd, skpo, K3,
 P43.

Row 19: P43, T2F, K2tog,
 yfwd, K9, yfwd, skpo, T2F,
 P43.

Row 21: P43, K2, skpo, yfwd,
 K3, K2tog, yfwd, K4, yfwd,
 K2tog, K2, P43.

Row 23: P43, T2F, K2, yfwd,



skpo, K2tog, yfwd, K1, yfwd,
 skpo, K2tog, yfwd, K2, T2F,
 P43.

Row 24: As row 2.

These 24 rows form the
 pattern.
 Repeat 8 more times and
 then work rows 1 to 8 once
 more.

Cast off.

FINISHING

Weave in any loose ends
 and press according to ball
 brand instructions.

Crocheted Picot Edging

Row 1: With RS of work
 facing and using a 4mm

crochet hook, attach yarn
 with a ss to any st along
 one of the sides, 3ch, 1ss in
 same place as 3-ch, *work
 [1ss, 3ch, 1ss] all into next st;
 rep from * until all 4 sides
 have been completed,
 working 3 picots into each
 corner. ●

Lavender hearts

YARN

Would suit any DK yarn

Sarah used:

1 x 50g ball of **Rowan Handknit Cotton DK** in 303 Sugar (A), 310 Shell (B) and 263 Bleached (C)

NEEDLES

4mm needles

BUTTONS

56 size 6 beads in shell pink

112 size 6 beads in hot pink

MATERIALS

Small amount of toy stuffing

Dried lavender

TENSION

Not essential for this project

SPECIAL ABBREVIATIONS

B1 = bead one

MEASUREMENTS

Each heart measures approx 10cm at its widest point and 10cm deep

TEXTURED HEART (MAKE 2)

Using 4mm needles and yarn A, cast on 3 sts and work from chart A.

Break yarn, but leave sts on needle.

Work a second peak using chart A, but do not break yarn.

Continue to work from Chart B, working across both sets of sts on the LH needle.

HOT PINK HEARTS (MAKE 2)

Thread 56 hot pink beads onto yarn B and then work as for Textured heart, but this time following charts C and D.

CENTRE HEART (MAKE 1)

Thread 56 shell pink beads onto yarn B and then work as for Hot Pink hearts.

BACKS

Follow charts E and F, making 2 in yarn A, two in yarn B and 1 in yarn C.

FINISHING

Each heart is completed in the same way. Place front and back of each heart with right sides together and join seam using backstitch, leaving a small seam for stuffing. Pop a couple of handfuls of stuffing into each heart along with some dried lavender and then close seam with mattress st. Attach ribbon or add a crocheted chain to centre of heart and then hang as a group. ●

Chart A

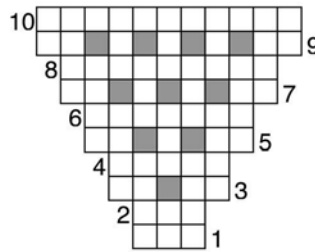

Chart B

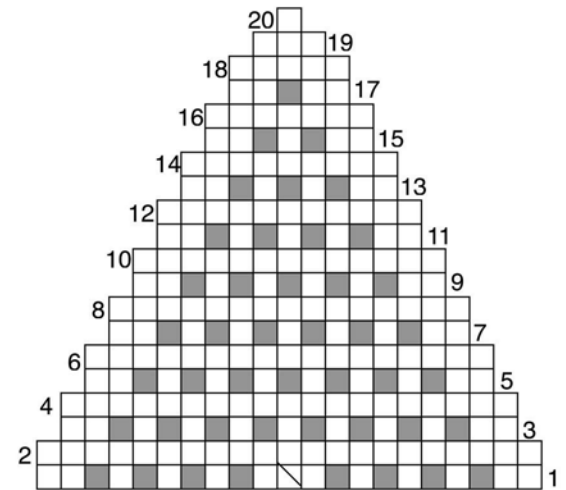

Chart C

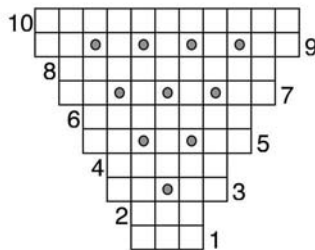

Chart D

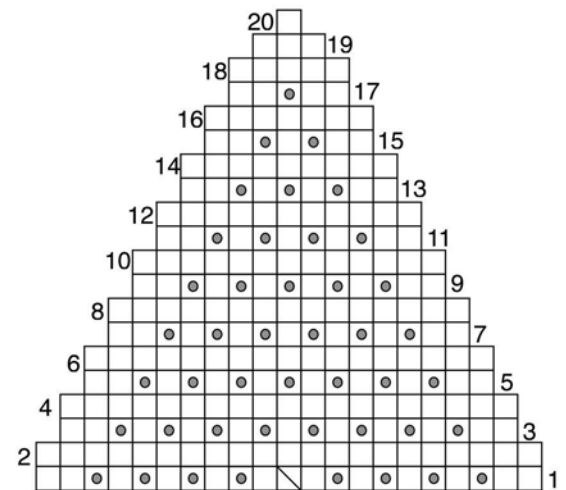

Chart E

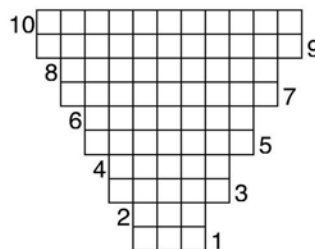
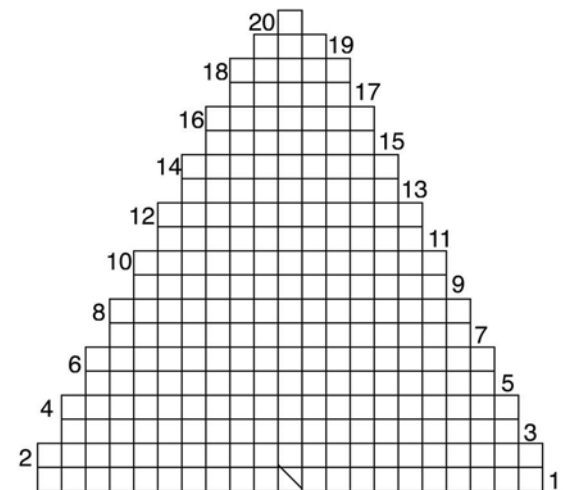





Chart F



Key

-  K on RS, P on WS
-  P on RS, K on WS
-  K2tog
-  Place bead

Work all odd (RS) rows from R to L and all even (WS) rows from L to R.



QUICK KNITS

Cabled heart cushion

YARN

Would suit any DK yarn
Sarah used:
2 x 50g balls **Rowan Baby Alpaca** in 225 Blossom

NEEDLES

4mm needles

FABRIC

Co-ordinating fabric
measuring 33 x 33cm
Cushion pad 33 x 33cm

TENSION

22 sts and 30 rows to 10cm
using 4mm needles and
measured over st st

SPECIAL ABBREVIATIONS

See chart

MEASUREMENTS

33 x 33cm

FRONT PANEL

Using 4mm needles,
cast on 67 sts.

Row 1 (WS): Knit.

Row 2 (RS): Purl.

Row 3: Knit.

Repeat last 2 rows,
12 more times, ending with
RS facing.

Row 28: P20, work row 1
of chart, P20.

Row 29: K20, work row 2
of chart, K20.

The last 2 rows, set the
position of the chart.
Continue with pattern as
set until row 36 of chart has
been worked.

Row 64: as row 2.

Row 65: as row 3.

Repeat last 2 rows, 12 more
times and then row 2 once
more. Cast off.

FINISHING

Weave in any loose ends
and avoiding heart motif,
press very lightly according
to ball band instructions.
Allowing a 1.5cm seam
allowance on fabric, slip
stitch 3 sides of cushion
panel to fabric. Insert
cushion pad and oversew
fourth side. ●



Heart cushion chart

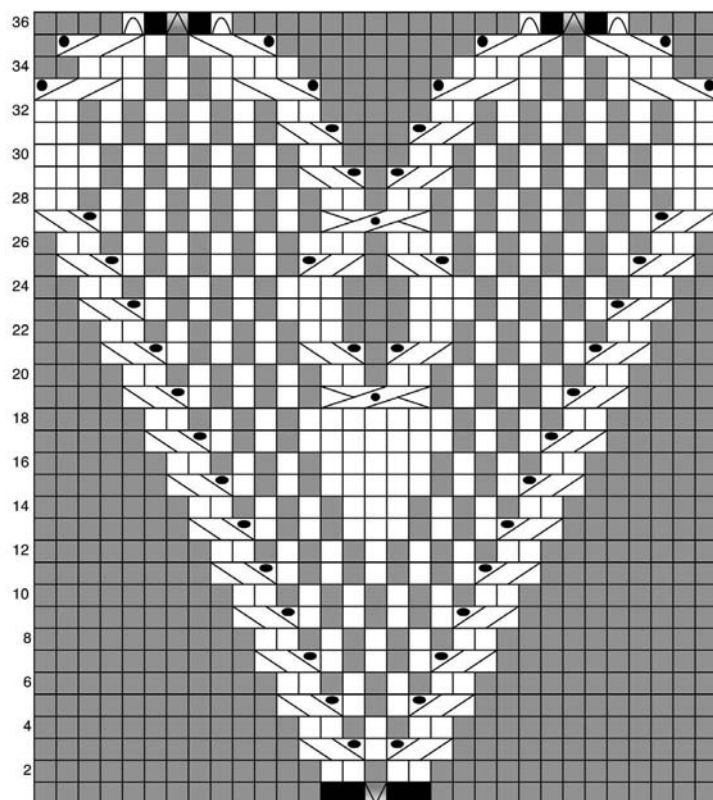

Key

- K on RS, P on WS
- P on RS, K on WS
- No stitch
- ◊ K2tog
- ◊ ssk
- ◊ P2tog
- ◊ c4fp = sl 2 sts onto CN and hold at front of work, P2, then K2 from CN
- ◊ c4bp = sl 2 sts onto CN and hold at back of work, K2, then P2 from CN
- yo
- ◊ c3fp = slip 2 sts onto CN, hold at front, P1, then K2 from CN
- ◊ c3bp = slip 1 st onto CN, hold at back, k2, then p1 from CN
- ◊ Sl 3 to CN hold at back, k2, sl nearest st from CN to LH ndl, p this st then k2 from CN
- ◊ wyif sl 3 to RH ndl, *on RH ndl sl 2nd st over first st, sl this st back to LH ndl, sl 2nd st over it ** sl this st back to R ndl, rep from * to ** once more leaving 1 st on LH ndl, wyib k this st.
- ◊ M1 in next st, k1tbl then kfl, insert point of LH ndl behind vertical strand between 2 sts just made and ktbl, m1
- ◊ M1 on WS



write

Writing books about Knitting

Have you ever thought of writing, or have you written, a book about your passion for knitting? Do you long to fill the gaps of your existing library?

Then why not contact us with your original idea or fresh approach to your specialist subject? New and inexperienced writers will be given expert advice and guidance by our friendly and professional team.

for us

Write to:

Emma Foster, Publishing Assistant,
 The Guild of Master Craftsmen Publications Ltd,
 86 High Street, Lewes, East Sussex BN7 1XN
Telephone: +44 (0) 1273 477374
Email: emmaf@thegmcgroup.com
Website: www.thegmcgroup.com



uppingham yarns

30 North Street East, Uppingham,
 Rutland, LE15 9QL (Quote K)
 01572 823747
 e: uppyarn@wools.co.uk
 Shop on-line available
 www.wools.co.uk

10% off all Debbie Bliss yarns

see voucher booklet
 (not to be used in conjunction with any other offer)
 To receive the offer please call 01132 503777

Stockists of

Sublime Debbie Bliss Noro Millamia SMC (Gedifra)
 Crystal Palace yarns (mochis) Bergere de France
 and Origin' plus knitting accessories

A large selection of beads including:
 Italian glass, Pandora style synthetic
 beads plus findings

Superb selection of knitting accessories
NOW AVAILABLE ONLINE

85 High Street, Yeadon,
 Leeds LS19 7TA
 t: 0113 2503 777

e: info@thewoolandbeadstudio.co.uk



The Wooland Bead Studio
 85 High Street, Yeadon, Leeds LS19 7TA
 tel: 0113 2503 777
 email: info@thewoolandbeadstudio.co.uk
 www.woolandbeadstudio.co.uk

www.thewoolandbeadstudio.co.uk

GALLERY GARMENT TECHNIQUES

Jeanette Sloan's guide to techniques used in this month's gallery



Cap sleeve shirt by Sian Brown – Unravelling the knot stitch

Pattern page: 62

This pretty design features flattering cap sleeves with a cute knot stitch which creates tiny star shaped beads of texture to an otherwise plain garment and is very easy to master.



1. To make the knot bring the yarn to the front of the work and p3tog.

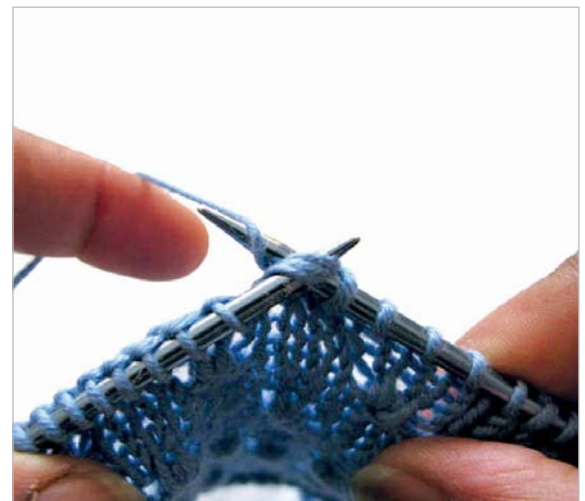

2. Next, take the yarn between the needles to the back of the work. Leaving the sts on left hand needle, knit the same 3 sts tog.

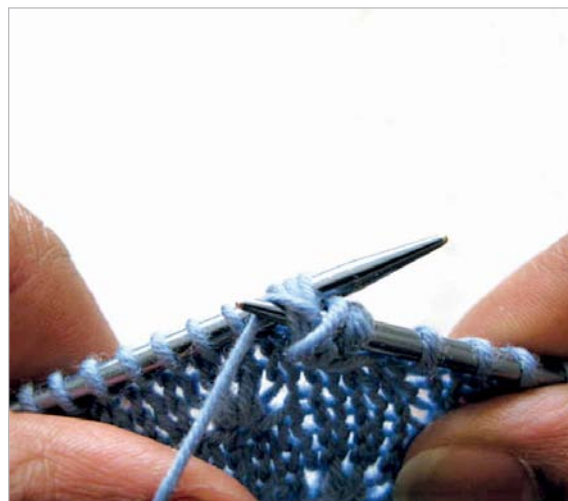

3. Then bring the yarn between the needle to the front of the work. Purl the same 3 sts tog once more then slip them off the needle.



4. Knot stitch completed. It will look more star shaped once the following wrong side row has been completed.



Loretta by Marie Wallin – Tackling the mock cable rib pattern

Pattern page: 65

This pretty polo top designed by Marie Wallin combines gentle waist shaping, moss stitch and a cable effect rib pattern, which emphasizes the garment's simple silhouette. Although the stitch pattern is much simpler than it first appears you'll need to take care as the number of stitches

changes over the 4 row repeat.

For example, let's look at the first 8 sts of the Back where the first 3 edge sts form a neat finish to the garment, whilst the next 5 sts form the cable effect pattern which is repeated 6 times on each side.

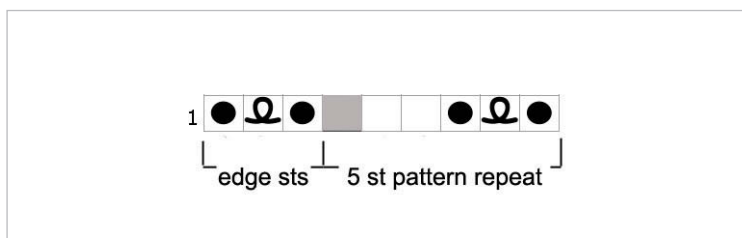

1. On Row 1 (a WS row) the first 3 edge sts are worked 'K1, p1 tbl, k1' followed by 5 sts worked 'p2, k1, p1tbl, k1' = 8 sts.

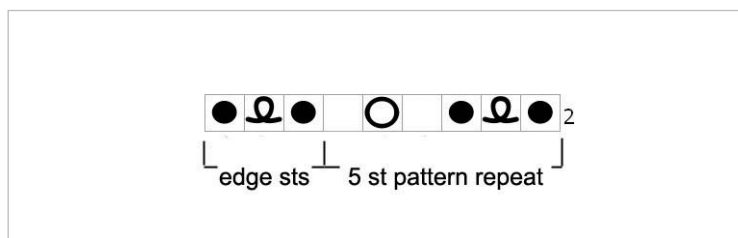

2. On Row 2 the first 3 edge sts are worked 'P1, k1tbl, p1' followed by 'k1, yfwd, k1, p1, k1 tbl, p1'. The yfwd creates an extra stitch so the stitch count = 9 sts.

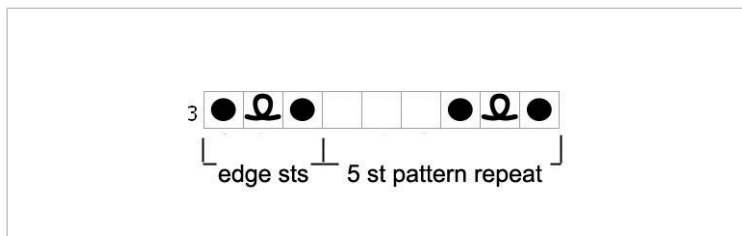

3. On Row 3 the first 3 edge sts are worked 'K1, p1 tbl, k1' followed by 'p3, k1, p1 tbl, k1'. The stitch count remains 9 sts.

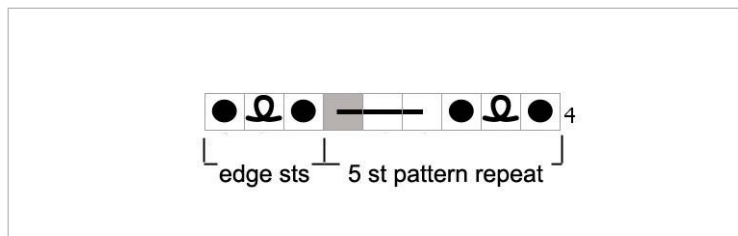

4. On Row 4 the first 3 edge sts are worked 'P1, k1tbl, p1' followed by the working of the mock cable. Lifting one of the stitches over the neighbouring 2 sts creates the mock cable and returns the stitch count to 8 sts.

Mock cable



5. To create the mock cable 'K3, lift 3rd st on right needle over 1st and 2nd sts and off right needle, p1, k1 tbl, p1'.



WWW.TEXTILEGARDEN.COM

Chiaogoo
FOR EVERY PROJECT - EVERY TIME

HANTEX.CO.UK | CHIAOGOO.COM | INFO@CHIAOGOO.COM
OTHER DISTRIBUTOR INQUIRIES WELCOMED

Peachey Ethknits

Sirdar, Sublime, Rowan, Stylecraft, Regia, Debbie Bliss - *Knitting Yarns:*
Beth Russell, Historical Sampler, Heritage, Derwentwater, Vervaco - *Needlework & Rug Kits:*
Denise needle & Crochet Hook Sets

Tel: 01245 327006
E: ethknits@gmail.com
www.ethknits.co.uk

Made
Yarn Specialists

36 SEAVIEW RD LISCARD CH45 4LA
0151 638 0304
www.madewirral.co.uk

The Origin Craft Awards 2011
Craft Hobby + Stitch
AWARD WINNER

Wool for Two

- KnitPro & Brittany needles •Lantern Moon baskets
- Artesano •Debbie Bliss •Manos •Mirasol •Rennie •Rico
- Sirdar •Twillies •King Cole •Rowan & more

A variety of classes available for all skill levels

83-85 Rosemount Place
Aberdeen, AB25 2YE
01224 643738
www.woolforewe.com

Your pattern instructions start here



ANGORA MOTIF CARDIGAN
Sian Brown
 The Little Knitting Company
 Angora 50
 Main page: 19. Pattern page: 60.



CAP SLEEVE SHIRT
Sian Brown
 Debbie Bliss Baby Cashmerino
 Main page: 21. Pattern page: 62.



LORETTA
Marie Wallin
 Rowan Pure Wool DK
 Main page: 27. Pattern page: 65.



SIMPLE CARDIGAN
Debbie Bliss
 Debbie Bliss Glen
 Main page: 23. Pattern page: 68.



OFF THE SHOULDER TOP
Maisie Smith
 Louisa Harding Nerissa
 Main page: 22. Pattern page: 69.



LAYERED V NECK TOP
Sian Brown
 Sublime Baby Silk and Bamboo
 Main page: 20. Pattern page: 72.



DRAPED JACKET
Pat Menchini
 King Cole Baby Alpaca DK
 Main page: 25. Pattern page: 73.



FLARED CUFF JUMPER
Pat Menchini
 Sublime Lustrous Extrafine Merino DK
 Main page: 24. Pattern page: 76.

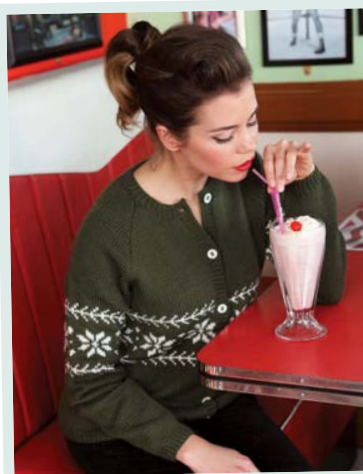

NORDIC CARDIGAN
Sirdar
 Sirdar Country Style DK
 Main page: 26. Pattern page: 78.



ANKLE SOCKS
Maisie Smith
 Artesano Alpaca DK
 Main page: 28. Pattern page: 82.



MOHAIR DRESS AND CROWN
Lang Yarns
 Lang Yarns Mohair Luxe
 Main page: 29. Pattern page: 83.

Instructions



SPECIAL OFFER 10% OFF

The Little Knitting Company are offering Knitting readers 10% off TLKC Angora 50 until 29 February 2012. Visit www.thelittleknittingcompany.co.uk and quote KN99 to receive your discount.

Angora motif cardigan by Sian Brown

SIZE

To fit:

82[86:92:97:102:107:112:117:122:127]cm
(32[34:36:38:40:42:44:46:48:50]in)

Actual measurements:

88[93:98:103:108:113:118:123:128:133]cm
(35.75[37.75:39.75:41.75:43.75:45.75:47.75:
49.75:51.75:53.75]in)

Length to shoulder:

48[49:50:51:52:53:54:55:56:57]cm
(19[19.25:19.75:20:20.5:21:21.25:21.5:22:22.5]in)

Sleeve length: 15cm (6in)

YOU WILL NEED

The Little Knitting Company Angora 50

50% angora, 30% wool, 20% nylon
(approx 115m per 25g ball)
6[6:7:7:7:8:8:8:9:9] x 25g balls 09 Deep Pink
Pair each 3mm and 4mm needles
3.25mm circular needle
1 small button
2 motifs

Note: yarn amounts given are based on average requirements and are approximate.

TENSION

22 sts and 30 rows to 10cm over st st using 4mm needles.
Use larger or smaller needles if necessary to obtain correct tension.

ABBREVIATIONS SEE PAGE 86

BACK

Using 3mm needles cast on
82[90:94:102:106:114:118:126:130:138] sts.

Row 1: K2, (p2, k2) to end.

Row 2: P2, (k2, p2) to end.

Rep the last 2 rows 4 times more, inc 2 sts evenly across last row on 1st, 3rd, 5th, 7th and 9th sizes only.

84[90:96:102:108:114:120:126:132:138] sts.

Change to 4mm needles.

Beg with a k row, cont in st st and work 8 rows.

Next row (inc): K3, m1, k to last 3 sts, m1, k3.

Work 11 rows.

Rep the last 12 rows 4 times more and the inc row again.

96[102:108:114:120:126:132:138:144:150] sts.

Work 9[9:11:11:13:13:15:15:17:17] rows.

Shape armholes

Cast off 7[7:7:8:8:8:9:9:10] sts at beg of next 2 rows.

82[88:94:98:104:110:114:120:126:130] sts.

Next row (dec): K2, skpo, k to last 4 sts, k2tog, k2.

Next row: P to end.

Rep the last 2 rows 5[6:7:7:8:9:9:10:11:11] times more.

70[74:78:82:86:90:94:98:102:106] sts.

Cont in st st until armhole measures

18[19:20:21:22:23:24:25:26:27]cm
(7.25[7.5:8:8.25:8.75:9:9.5:9.75:10.25:10.75]in),
ending with a p row.

Shape shoulders

Cast off 7[7:8:8:8:9:9:10:10:11] sts at beg of next 4 rows and 6[7:7:8:9:9:10:9:11:11] sts at beg of foll 2 rows.

Cast off rem

30[32:32:34:36:36:38:40:40:40] sts.

LEFT FRONT

Using 3mm needles cast on
40[44:44:48:52:56:56:60:64:68] sts.

Rib row 1 (RS): (K2, p2) to last 4 sts, k4.

Rib row 2: (K2, p2) to end.

These 2 rows form the rib with g-st front border.

Rep the last 2 rows 3 times more and the 1st row again.

Next row: Work the foll inc/dec,
0[dec1:inc2:inc1:0:dec1:inc2:inc1:0:dec1] sts
evenly across rib section to end.

40[43:46:49:52:55:58:61:64:67] sts.

Change to 4mm needles.

Row 1 (RS): K to end.

Row 2: K2, p to end.

These 2 rows form the st st with g-st front border.

Work a further 6 rows.

Next row (inc): K3, m1, k to end.

Work 11 rows.

Rep the last 12 rows 4 times more and the inc row again.

46[49:52:55:58:61:64:67:70:73] sts.

Work 9 rows.

Shape armhole

Next row: Cast off 7[7:7:8:8:8:9:9:10] sts, k to end. 39[42:45:47:50:53:55:58:61:63] sts.

Next row: P to end.

Next row (dec): K2, skpo, k to end.

Next row: P to end.

Rep the last 2 rows 5[6:7:7:8:9:9:10:11:11] times more.

33[35:37:39:41:43:45:47:49:51] sts.

Work straight until armhole measures

10[10:11:11:12:12:13:13:14:14]cm
(4[4:4.25:4.25:4.75:4.75:5.25:5.25:5.5:5.5]in),
ending with a wrong side row.

Shape neck

Next row: K to last 8[9:9:10:11:11:12:13:13:14] sts, turn and cont on these

25[26:28:29:30:32:33:34:36:37] sts only, leave rem sts on a holder.

Next row: P to end.

Next row: K to last 2 sts, k2tog.

Rep the last 2 rows 4 times more.

20[21:23:24:25: 27:28:29:31:32] sts.

Cont in st st until armhole measures

19[20:21:22:23:24:25:26:27:28]cm
(7.5[8:8.25:8.75:9:9.5:9.75:10.25:10.75:11]in),
ending at armhole edge.

Shape shoulder

Cast off 7[7:8:8:8:9:9:10:10:11] sts at beg of next and foll right side row.

Work 1 row.

Cast off rem 6[7:7:8:9:9:10:9:11:10] sts.

RIGHT FRONT

Using 3mm needles cast on
40[44:44:48:52:56:56:60:64:68] sts.

Rib row 1 (RS): K4, [p2, k2] to end.

Rib row 2: (P2, k2) to end.

These 2 rows form the rib with g-st front border.

Rep the last 2 rows 3 times more and the 1st row again.

Next row: Work the foll inc/dec,
0[dec1:inc2:inc1:0:dec1:inc2:inc1:0:dec1] sts
evenly across rib section to end.

40[43:46:49:52:55:58:61:64:67] sts.

Change to 4mm needles.

Row 1 (RS): K to end.

Row 2: P to last 2 sts, k2.

These 2 rows form the st st with g-st front border.

Work a further 6 rows.

Next row (inc): K to last 3 sts, m1, k3.

Work 11 rows.

Rep the last 12 rows 4 times more and the inc row again.

46[49:52:55:58:61:64:67:70:73] sts.

Work 10 rows.

Shape armhole

Next row: Cast off 7[7:7:8:8:8:9:9:10] sts, p to end.

39[42:45:47:50:53:55:58:61:63] sts.

Next row (dec): K to last 4 sts, k2tog, k2.

Next row: P to end.

Rep the last 2 rows 5[6:7:7:8:9:9:10:11:11] times more. 33[35:37:39:41:43:45:47:49:51] sts.

Work straight until armhole measures

10[10:11:11:12:12:13:13:14:14]cm
(4[4:4.25:4.25:4.75:4.75:5.25:5.25:5.5:5.5]in),
ending with a wrong side row.

Shape neck

Next row: K8[9:9:10:11:11:12:13:13:14] sts, leave these sts on a holder, k to end.

25[26:28:29:30:32:33:34:36:37] sts.

Next row: P to end.

Next row: Skpo, k to end.

Rep the last 2 rows 4 times more.

20[21:23:24:25: 27:28:29:31:32] sts.

Cont in st st until armhole measures

19[20:21:22:23:24:25:26:27:28]cm

(7.5[8:8.25:8.75:9:9.5:9.75:10.25:10.75:11]in), ending at armhole edge.

Shape shoulders

Cast off 7[7:8:8:8:9:9:10:10:11] sts at beg of next and foll wrong side row.

Work 1 row.

Cast off rem 6[7:7:8:9:9:10:9:11:10] sts.

SLEEVES

Using 3mm needles cast on

46[50:54:58:60:64:68:72:76:80] sts.

Row 1: K2, (p2, k2) to end.

Row 2: P2, (k2, p2) to end.

Rep the last 2 rows 4 times more.

Change to 4mm needles.

Beg with a k row cont in st st.

Work 6 rows.

Next row (inc): K3, m1, k to last 3 sts, m1, k3.

Work 3 rows.

Rep the last 4 rows 6 times more.

60[64:68:72:74:78:82:86:90:94] sts.

Cont straight until sleeve measures 15cm

(6in) from cast on edge, ending with a p row.

Shape sleeve top

Cast off 7[7:7:8:7:8:8:8:9] sts at beg of next 2 rows. 46[50:54:56:60:64:66:70:74:76] sts.

Next row: K2, skpo, k to last 4 sts, k2tog, k2.

Next row: P to end.

Rep the last 2 rows 5[6:7:7:8:9:9:10:11:11] times more. 34[36:38:40:42:44:46:48:50:52] sts.

Next row: K2, skpo, k to last 4 sts, k2tog, k2.

Work 5 rows.

Rep the last 6 rows 4[4:4:4:5:5:5:6:6:6] times more.

24[26:28:30:30:32:34:34:36:38] sts.

Next row: K1, (k2tog) to last st, k1.

Cast off.

COLLAR

Join shoulder seams.

Using 3.25mm circular needle and with RS facing slip 8[9:9:10:11:11:12:13:13:14] sts from right front neck holder onto needle, pick up and k22[25:25:27:27:30:30:32:32:36] sts up right front neck,

30[32:32:34:36:36:38:40:40:40] sts from back neck,

22[25:25:27:27:30:30:32:32:36] sts down left front neck, slip 8[9:9:10:11:11:12:13:13:14] sts from left front neck holder.

90[100:100:108:112:118:122:130:130:140] sts.

Row 1: K2, p to last

30[34:34:37:38:41:42:45:45:49] sts, turn.

Row 2: K to last

30[34:34:37:38:41:42:45:45:49] sts, turn.

Row 3: P to last

25[28:28:30:31:33:34:36:36:39] sts, turn.

Row 4: K to last

25[28:28:30:31:33:34:36:36:39] sts, turn.

Row 5: P to last

20[22:22:23:24:25:26:27:27:29] sts, turn.

Row 6: K to last

20[22:22:23:24:25:26:27:27:29] sts, turn.

Row 7: P to last 15[16:16:16:17:17:18:18:18:19] sts, turn.

Row 8: K to last 15[16:16:16:17:17:18:18:18:19] sts, turn.

Row 9: P to last 10 sts, turn.

Row 10: K to last 10 sts, turn.

Row 11: P to last 2 sts, k2.

Change to 4mm needles.

Row 1: K2, p to last 2 sts, k2.

Row 2: K2, m1, k to last 2 sts, k2.

Row 3: K2, p to last 2 sts, k2.

Row 4: K to end.

Rep the last 4 rows 4 times more.

K 2 rows.

Cast off.

TO FINISH OFF

Join side and sleeve seams. Sew sleeves

into armholes, easing to fit. Sew on motifs.

Sew button to left front under collar.

Make a button loop on right front. ●

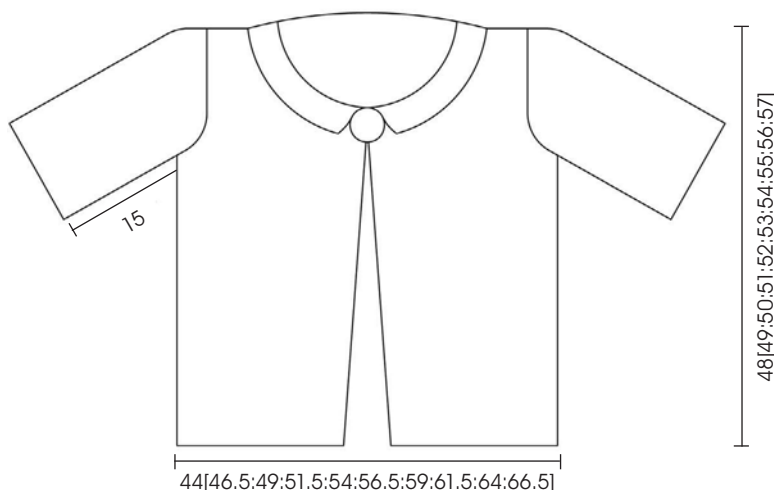

Measurements are given in cm

Instructions



SPECIAL OFFER 10% OFF

deramores are offering *Knitting* readers 10% off Debbie Bliss Baby Cashmerino until 29 February 2012. Visit www.deramores.com and quote KM99DEB to receive your discount.

Cap sleeve shirt by Sian Brown

SIZE

To fit: 82[86:92:97:102:107:112:117]cm (32[34:36:38:40:42:44:46]in)

Actual measurements:

86[92:99:105:112:118:125:131]cm (34[36:25:39:41.25:44.46.5:49.25:51.5]in)

Length to shoulder:

54[55:56:57:58:59:60:61]cm (21.25[21.5:22:22.5:23:23.25:23.5:24]in)

YOU WILL NEED

Debbie Bliss Baby Cashmerino 55% Merino wool, 33% microfibre, 12% cashmere (approx 125m per 50g ball)
8[8:9:9:10:10:11:11] x 50g balls 33 Lilac
Pair each 3mm and 3.25mm needles
9 small buttons

Note: yarn amounts given are based on average requirements and are approximate.

TENSION

25 sts and 34 rows to 10cm over st st using 3.25mm needles.
Use larger or smaller needles if necessary to obtain correct tension.

ABBREVIATIONS

Make knot = p3tog, leaving sts on left hand needle, now k the same 3 sts tog, then p the same 3 sts tog, slipping them off the needle.
For more abbreviations see page 86

BACK

Using 3mm needles cast on

106[114:122:130:138:146:154:162] sts.

Row 1: K2, (p2, k2) to end.

Row 2: P2, (k2, p2) to end.

Rep the last 2 rows 3 times more increasing one st at centre of last row.

107[115:123:131:139:147:155:163] sts.

Change to 3.25mm needles.

Cont in pattern.

Row 1 (RS): K to end.

Row 2: P to end.

Row 3: K1[2:3:4:5:3:4:5], (make knot, k3) to last 4[5:6:7:8:6:7:8] sts, make knot, k1[2:3:4:5:3:4:5].

Row 4: P to end.

Row 5: K to end.

Row 6: P to end.

Row 7: K4[5:6:7:2:6:7:2], (make knot, k3) to last 7[8:9:10:5:9:10:5] sts, make knot, k4[5:6:7:2:6:7:2].

Row 8: P to end.

These 8 rows set the patt.

Next row (dec): K2, skpo, patt to last 4 sts, k2tog, k2.

Patt 3 rows.

Rep the last 4 rows 5 times more and the dec row again.

93[101:109:117:125:133:141:149] sts.

Work a further 9[11:11:13:15:17:17:19] rows.

Next row (inc): K1, m1, patt to last st, m1, k1. Patt 9 rows.

Rep the last 10 rows 6 times more.

107[115:123:131:139:147:155:163] sts.

Shape armhole and cap sleeves

Cast off 5 sts at beg of next 2 rows.

97[105:113:121:129:137:145:153] sts.

Work a further 2[4:4:6:6:8:8:10] rows.

Next row (inc): K1, m1, patt to last st, m1, k1.

Patt 5 rows.

Rep the last 6 rows 8 times more and the inc row again.

117[125:133:141:149:157:165:173] sts.

Work 3[3:5:5:7:7:9:9] rows straight.

Shape upper sleeves

Cast off 3 sts at beg of next

14[14:16:16:18:18:20:20] rows.

75[83:85:93:95:103:105:113] sts.

Shape shoulders

Cast off 8[9:9:11:11:12:12:14] sts at beg of next 2 rows and 7[9:9:10:10:12:12:13] sts at beg of foll 2 rows.

Leave rem 45[47:49:51:53:55:57:59] sts on a holder.

LEFT FRONT

Using 3mm needles cast on

51[55:59:63:67:71:75:79] sts.

Row 1: K2, (p2, k2) to last 5 sts, p2, k3.

Row 2: P3, (k2, p2) to end.

Rep the last 2 rows 3 times more.

Change to 3.25mm needles.

Cont in pattern.

Row 1: K to end.

Row 2: P to end.

Row 3: K1[2:3:4:5:3:4:5], (make knot, k3)

to last 8[5:8:5:8:8:5:8] sts, make knot,

k5[2:5:2:5:2:5].

Row 4: P to end.

Row 5: K to end.

Row 6: P to end.

Row 7: K4[5:6:7:2:6:7:2], (make knot, k3) to last 5[8:5:8:5:5:8:5] sts, make knot, k2[5:2:5:2:2:5:2].

Row 8: P to end.

These 8 rows set the patt.

Next row (dec): K2, skpo, patt to end.

Patt 3 rows.

Rep the last 4 rows 5 times more and the dec row again. 44[48:52:56:60:64:68:72] sts. Work a further 9[11:11:13:15:17:17:19] rows.

Next row (inc): K1, m1, patt to end.

Patt 9 rows.

Rep the last 10 rows 6 times more.

51[55:59:63:67:71:75:79] sts.

Shape armhole and cap sleeves

Next row: Cast off 5 sts, patt to end.

46[50:54:58:62:66:70:74] sts.

Work a further 3[5:5:7:7:9:9:11] rows.

Next row (inc): K1, m1, patt to end.

Patt 5 rows.

Rep the last 6 rows 6 times more and the inc row again. 54[58:62:66:70:74:78:82] sts.

Work 1 row

Shape neck

Next row: Patt to last 10[11:12:13:14:15:16:17] sts, turn leave rem sts on a holder.

Next row: Cast off 2 sts, patt to end.

Next row: Patt to end.

Next row: Cast off 2 sts, patt to end.

Next row: K1, m1, patt to end.

Next row: Cast off 2 sts, patt to end.

Next row: Patt to end.

Rep the last 2 rows once more.

Next row: Cast off 2 sts, patt to end.

Next row: K1, m1, patt to end.

36[39:42:45:48:51:54:57] sts.

Work 3[3:5:5:7:7:9:9] rows straight.

Shape upper sleeves

Cast off 3 sts at beg of next and

6[6:7:7:8:8:9:9] foll right side rows.

Work 1 row.

Shape shoulder

Next row: Cast off 8[9:9:11:12:12:14] sts, patt to end.

Work 1 row.

Cast off rem 7[9:9:10:12:12:13] sts.

RIGHT FRONT

With 3mm needles cast on

51[55:59:63:67:71:75:79] sts.

Row 1: K3, (p2, k2) to end.

Row 2: P2, (k2, p2) to last 5 sts, k2, p3.

Rep the last 2 rows 3 times more.

Change to 3.25mm needles.

Cont in pattern.

Row 1: K to end.

Row 2: P to end.

Row 3: K5[2:5:2:5:5:2:5], (make knot, k3)

to last 4[5:6:7:8:6:7:8] sts, make knot,

k1[2:3:4:5:3:4:5].

Row 4: P to end.

Row 5: K to end.

Row 6: P to end.

SAVE 30%!

WHEN YOU SUBSCRIBE TO 12 ISSUES OF KNITTING MAGAZINE

AND RECEIVE A NANTUCKET KNITTING BAG FREE

Available in Pink or Lime

RRP
£32.25

HURRY! WHILE STOCKS LAST!
ONLY LIMITED STOCK AVAILABLE



● SORRY, UK SUBSCRIBERS ONLY!

2 EASY WAYS TO SUBSCRIBE



1 +44 (0)1273 488005



2 SEND THE COMPLETED FORM TO:
GMC Publications Ltd,
FREEPOST BR2265,
Lewes, East Sussex,
BN7 1BR

QUOTE ORDER CODE A3422

YES! I would like to subscribe to Knitting magazine (please tick your choice)

Pay By: Cheque or debit/credit card

	12 issues SAVE 10%	24 issues SAVE 20%
UK	<input type="checkbox"/> £53.89	<input type="checkbox"/> £95.81
Europe	<input type="checkbox"/> £67.37	<input type="checkbox"/> £119.76
Rest of World	<input type="checkbox"/> £75.45	<input type="checkbox"/> £134.13

Title (Mr/Mrs/Miss/Ms/Other) Name Surname

Address

Postcode

Telephone

Email

CREDIT/DEBIT PAYMENTS

I enclose a cheque made payable to GMC Publications Ltd.
OR
 Please debit my credit/debit card *TO THE VALUE OF: £

*Please indicate VISA MASTERCARD AMEX DISCOVER OTHER Issue No.

Please charge my card number

Start Date Expiry Date Security Code (The last 3 or 4 digits on the signature strip)

Signature Date

Guild of Master Craftsmen Publications will ensure that you are kept up to date on other products which will be of interest to you. If you would prefer to not to be informed of future offers, please tick this box

Offer expires 31/03/2012
Plus free gift with some issues.
Sorry, not available overseas.

Pay By: Direct Debit SAVE 30%!

£20.96 every 6 issues £41.92 every 12 issues **UK OFFER ONLY**



Direct Debit
Instructions to your Bank or Building Society



Name(s) of account holder(s)

Originator's identification number

Bank or Building Society account number

Reference number (office use only)

Bank or Building Society sort code

Name and full postal address of your Bank or Building Society

Name

Address

Postcode

Instruction to your Bank or Building Society:
Please pay GMC Publications Ltd Direct Debits from the account detailed in this instruction subject to the safeguards assumed by the Direct Debit guarantee. I understand that this Instruction may remain with GMC Publications Ltd and, if so, details will be passed electronically to my Bank/Building Society.

Signature(s)

Date

Banks and building societies may not accept direct debits for some types of accounts.

The Direct Debit Guarantee

This guarantee is offered by all Banks and Building Societies that take part in the Direct Debit Scheme. This efficiency and security of the Scheme is monitored and protected by your own Bank or Building Society. If the amounts to be paid or the payment dates change GMC Publications Ltd will notify you 14 working days in advance of your account being debited or as otherwise agreed. If an error is made by GMC Publications Ltd or your Bank or Building Society, you are guaranteed a full and immediate refund from your branch of the amount paid. You can cancel a Direct Debit at any time by writing to your Bank or Building Society. Please also send a copy of your letter to us.

QUOTE ORDER CODE A3422

Instructions

Row 7: K2[5:2:5:2:2:5:2], (make knot, k3) to last 7[8:9:10:5:9:10:5] sts, make knot, k4[5:6:7:2:6:7:2].

Row 8: P to end.

These 8 rows set the patt.

Next row (dec): Patt to last 4 sts, k2tog, k2. Patt 3 rows.

Rep the last 4 rows 5 times more and the dec row again.

Work a further 9[11:11:13:15:17:17:19] rows.

Next row (inc): Patt to last 2 sts, m1, k1. Patt 9 rows.

Rep the last 10 rows 6 times more.

51[55:59:63:67:71:75:79] sts.

Patt 1 row.

Shape armhole and cap sleeves

Next row: Cast off 5 sts, patt to end. 46[50:54:58:62:66:70:74] sts.

Work a further 2[4:4:6:6:8:8:10] rows.

Next row (inc): Patt to last st, m1, k1.

Patt 5 rows.

Rep the last 6 rows 6 times more and the inc row again. 54[58:62:66:70:74:78:82] sts.

Work 1 row

Shape neck

Next row: Patt 10[11:12:13:14:15:16:17] sts, leave these sts on a holder, patt to end.

Next row: Patt to end.

Next row: Cast off 2 sts, patt to end.

Next row: Patt to end.

Next row: Cast off 2 sts, patt to last st, m1, k1.

Next row: Patt to end.

Next row: Cast off 2 sts, patt to end.

Next row: Patt to end.

Rep the last 2 rows once more.

Next row: Cast off 2 sts, patt to last st, m1, k1. 36[39:42:45:48:51:54:57] sts.

Work 4[4:6:6:8:8:10:10] rows straight.

Shape upper sleeves

Cast off 3 sts at beg of next and 6[6:7:7:8:8:9:9] foll wrong side rows.

Work 1 row.

Shape shoulder

Next row: Cast off 8[9:9:11:12:12:14] sts, patt to end.

Work 1 row.

Cast off rem 7[9:9:10:12:12:13] sts.

COLLAR

Join shoulder and upper sleeve seams.

With right side facing, 3mm needles, slip 10[11:12:13:14:15:16:17] sts from right front holder onto a needle, pick up and k31[31:33:33:35:35:37:37] sts up right side of front neck, k45[47:49:51:53:55:57:59] sts from back neck holder, pick up and k30[30:32:32:34:34:36:36] sts down left side of front neck, k across

10[11:12:13:14:15:16:17] sts from left front holder. 126[130:138:142:150:154:162:166] sts.

Row 1: P2, (k2, p2) to end.

This row sets the rib.

Next 2 rows: Rib to last 40[42:44:46:48:50:52:54] sts, turn.

Next 2 rows: Rib to last 36[38:40:42:44:46:48:50] sts, turn.

Next 2 rows: Rib to last 32[34:36:38:40:42:44:46] sts, turn.

Next 2 rows: Rib to last 28[30:32:34:36:38:40:42] sts, turn.

Next 2 rows: Rib to last 24[26:28:30:32:34:36:38] sts, turn.

Next 2 rows: Rib to last 20[22:24:26:28:30:32:34] sts, turn.

Next 2 rows: Rib to last 16[18:18:20:22:22:24:26] sts, turn.

Next 2 rows: Rib to last 12[12:12:12:14:14:16:18] sts, turn.

Next row: Rib to end.

Change to 3.25mm needles.

Work a further 7cm (2.75in) in rib.

Cast off loosely in rib.

ARMBANDS

With right side facing, using 3mm needles, pick up and k 88[92:96:100:104:108:112:116] sts evenly along row ends of armhole edge (this should be 3 sts from every 4 rows).

Row 1: P3, (k2, p2) to last 5 sts, k2, p3.

Row 2: K3, (p2, k2) to last 5 sts, p2, k3.

Rep the last 2 rows once more and the first row again.

Cast off in rib.

BUTTON BAND

With right side facing, using 3mm needles, pick up and k126[130:134:134:138:142:142:146] sts evenly down left front edge (this should be 3 sts from every 4 rows).

Row 1: P2, (k2, p2) to end.

Row 2: K2, (p2, k2) to end.

Rep the last 2 rows once more and the first row again.

Cast off in rib.

BUTTONHOLE BAND

With right side facing, using 3mm needles, pick up and k126[130:134:134:138:142:142:146] sts evenly up right front edge (this should be 3 sts from every 4 rows).

Row 1: P2, (k2, p2) to end.

Row 2: K2, (p2, k2) to end.

Buttonhole row: Rib 4, k2tog, yrn, (rib 12[13:14:14:14:15:15:15], work 2 tog, yrn, rib 13[13:13:13:14:14:14:15], work 2 tog, yrn) 4 times, rib 4.

Rib 2 rows.

Cast off in rib.

TO FINISH OFF

Join side seams. Sew row ends of armbands to cast off sts at underarm.

Sew on buttons. ●

Find us on Twitter at @KnittingMag, on Facebook and Ravelry by searching for Knitting magazine, or visit www.knittinginstitute.co.uk.

twitter
Find us on Facebook
ravelry
Knitting

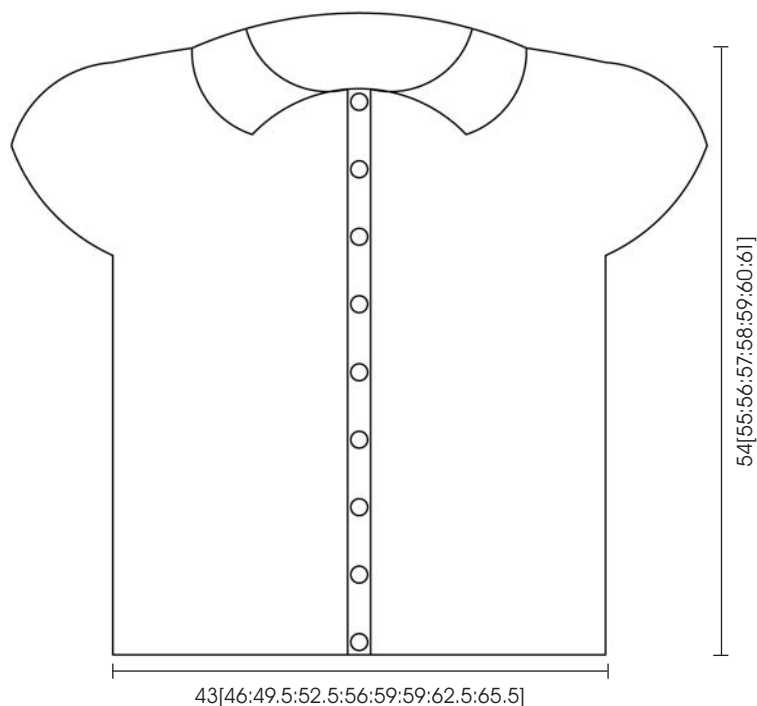

Measurements are given in cm



SPECIAL OFFER 15% OFF

Knits in the City are offering *Knitting* readers 15% off all shades of Rowan Pure Wool DK until 29 February 2012. Visit www.knitsinthecity.co.uk and quote KN99 to receive your discount.

Loretta by Marie Wallin

SIZES

To fit: 81-86[91-97:102-107:112-117:122-127]cm (32-34[36-38:40-42:44-46:48-50]in)

Actual measurement: 84[96:106:118:133]cm (33[37:42:46:52]in)

Length to shoulder: 54[56:58:60:62]cm (21.5[22:23:23.5:24.5]in)

Figures in square brackets refer to larger sizes: where there is only one set of figures this applies to all sizes.

YOU WILL NEED

Rowan Pure Wool DK 100% wool (approx 125m per 50g)
7[8:10:11:12] x 50g balls 028 Raspberry
1 pair each 3.25mm and 3.75mm needles
Stitch markers
Row counter

Note: Yarn amounts given are based on average requirements and are approximate.

TENSION

24 sts and 30 rows to 10cm over st st using 3.75mm needles.

Use larger or smaller needles if necessary to obtain correct tension.

ABBREVIATIONS SEE PAGE 86

PATTERN NOTES

The number of sts varies whilst working patt. All st counts given presume there are 5 sts in each side patt panel repeat at all times.

BACK

Using 3.25mm needles cast on 113[125:139:153:171] sts.

Row 1 (RS): K1, (p1, k1) to end.

Row 2 (WS): As Row 1.

These 2 rows form moss st (m-st). Work in m-st for a further 13 rows, ending with WS facing for next row. Change to 3.75mm needles.

Cont in patt as follows:

Row 1 (WS): K1, p1tbl, k1, (p2, k1, p1tbl, k1) 6 times, place marker on RH needle, p to last 33 sts, place marker on RH needle, (k1, p1tbl, k1, p2) 6 times, k1, p1tbl, k1.

Row 2 (RS): P1, k1tbl, p1, (k1, yfwd, k1, p1, k1tbl, p1) 6 times, slip marker, k to next marker, slip marker, (p1, k1tbl, p1, k1, yfwd, k1) 6 times, p1, k1tbl, p1.

Row 3: K1, p1tbl, k1, (p3, k1, p1tbl, k1) 6 times, slip marker, p to next marker, slip marker, (k1, p1tbl, k1, p3) 6 times, k1, p1tbl, k1.

Row 4: P1, k1tbl, p1, (k3, lift 3rd st on RH needle over 1st and 2nd sts and off RH needle, p1, k1tbl, p1) 6 times, slip marker, k to next marker, slip marker, (p1, k1tbl, p1, k3, lift 3rd st on RH needle over 1st and 2nd sts and off RH needle) 6 times, p1, k1tbl, p1. These 4 rows form patt.

Keeping patt correct throughout (see pattern note), cont as follows:

Work 1 row, ending with RS facing for next row.

Next row (RS): Patt to marker, slip marker, k2, skpo, k to within 4 sts of next marker, k2tog, k2, slip marker, patt to end. 111[123:137:151:169] sts.

Working all decs as set by last row, dec 1 st at each end of 4th and 5th foll 4th rows. 99[111:125:139:157] sts.

Cont straight until back meas 18[19:20:21:22]cm, (7[7.5:8:8.25:8.75]in) ending with RS facing for next row.

Next row (RS): Patt to marker, slip marker, k3, m1, k to within 3 sts of next marker, m1, k3, slip marker, patt to end. 101[113:127:141:159] sts.

Working all incs as set by last row, inc 1 st at each end of 12th and 3rd foll 12th rows, ending with WS facing for next row. 109[121:135:149:167] sts.

Shape cap sleeves

Inc 1 st at beg and end (rather than next to markers) of next 5 rows, taking inc sts into patt. 119[131:145:159:177] sts.

Mark both ends of last row to denote base of armhole openings.

Next row (RS): Patt to marker, slip marker, k to next marker, slip marker, patt to end.

Next row: Patt to marker, slip marker, p to next marker, slip marker, patt to end. These 2 rows set the sts.**

Now working all incs next to markers again, inc 1 st at each end of 5th and 2[2:2:3:3] foll 12th rows. 125[137:151:167:185] sts.

Work 11[15:17:9:11] rows, ending with RS facing for next row.

(Work should meas 14[15:16:17:18]cm

Instructions

(5.5[6:6.25:6.75:7]in) from markers.)

Shape shoulders and back neck

Cast off 7[8:9:10:12] sts at beg of next 8 rows. 69[73:79:87:89] sts.

Next row (RS): Cast off 7[8:9:11:11] sts, k until there are 10[11:12:14:14] sts on RH needle and turn, leaving rem sts on a holder.

Work each side of neck separately.

Cast off 3 sts at beg of next row.

Cast off rem 7[8:9:11:11] sts.

With RS facing, rejoin yarn to rem sts, cast off centre 35[35:37:37:39] sts, k to end.

Complete to match first side, reversing shapings.

FRONT

Work as given for back to **.

Now working all incs next to markers again, inc 1 st at each end of 5th and 0[0:0:1:1] foll 12th row. 121[133:147:163:181] sts.

Work 4[8:8:0:0] rows, ending with WS facing for next row.

Divide for front opening

Next row (WS): Patt 60[66:73:81:90] sts and slip these sts onto a holder, cast off 1 st, patt to end. 60[66:73:81:90] sts.

Work each side of neck separately.

Work 17 rows, inc 1 st at armhole edge of 7th[3rd:3rd:11th:11th] and foll 0[12th:12th:0:0] of these rows and ending with WS facing for next row. 61[68:75:82:91] sts.

Shape neck

Keeping patt correct, cast off 9 sts at beg of next row. 52[59:66:73:82] sts.

Dec 1 st at neck edge of next 7 rows, then on foll 2[2:3:3:4] alt rows and at same time inc 1[0:0:1:1] st at armhole edge of next 1[0:0:5th:5th] row. 44[50:56:64:72] sts.

Work 1 row, ending with RS facing for next row.

Shape shoulder

Cast off 7[8:9:10:12] sts at beg of next and foll 3 alt rows, then 7[8:9:11:11] sts at beg of foll alt row and at same time dec 1 st at neck edge of next and foll 4th row.

Work 1 row.

Cast off rem 7[8:9:11:11] sts.

With RS facing, rejoin yarn to rem sts, patt to end.

Complete to match first side, reversing shapings.

FRONT BANDS

Press.

With RS facing and using 3.25mm needles, pick up and knit 15 sts evenly along one side of front opening, between base of opening and neck shaping.

Work in m-st as given for back for 2 rows, ending with WS facing for next row.

Cast off in m-st (on WS).

Lay right front band over left front band and sew row-end edges to base of opening.

Join both shoulder seams using back stitch, or mattress stitch if preferred.

COLLAR

With RS facing and using 3.25mm needles, beg and ending at edge of front bands, pick up and knit 31[31:33:33:35] sts up right side of neck, 41[41:43:43:45] sts from back, then 31[31:33:33:35] sts down left side of neck. 103[103:109:109:115] sts.

Work in m-st as given for back for 2 rows.

Next row: M-st 2 sts, inc twice in next st, m-st to last 3 sts, inc twice in next st, m-st 2 sts. 107[107:113:113:119] sts.

Work 3 rows.

Rep last 4 rows until collar meas approx 10cm (4in), ending after 3 rows without shaping. Cast off in m-st.

ARMHOLE BORDERS

With RS facing and using 3.25mm needles, pick up and knit 67[73:77:81:87] sts evenly along armhole opening edges between marked points.

Work in m-st as given for back for 7 rows, ending with RS facing for next row.

Cast off in m-st.

TO FINISH OFF

Sew up side seams. Darn in loose ends. ●

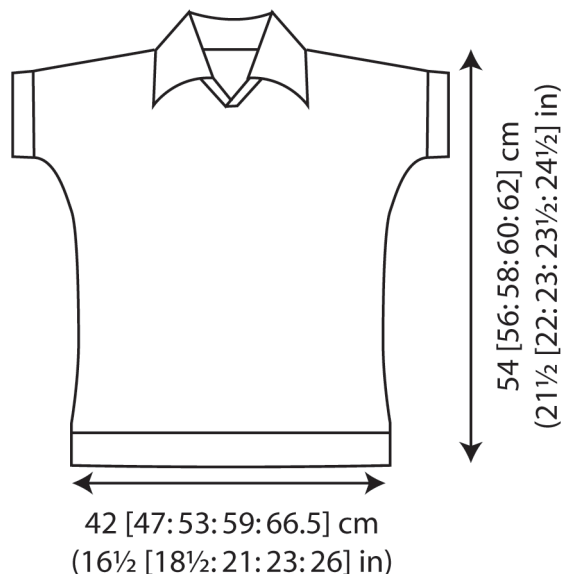
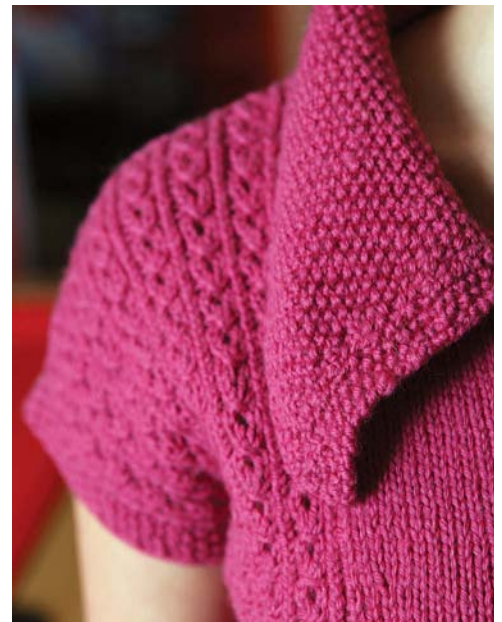

Plan-knit Wool

Plan-knit Wool is a Traditional Wool and Contemporary Yarn Store.

Our stock includes Sirdar, Twilleys, Artesano, Brittany needles, Stylecraft, Peter Pan, Fantastic Bamboo Needles Circulars and DPNs.

DMC THREADS & KITS NOW AVAILABLE

If you are in the area why not pop into our Pattern Browsing Lounge and Discover Designs to suit every style. A warm and friendly welcome awaits you. Mail order available.



Plan-knit Wool
83 High Street
Poole, Dorset
BH15 1AH
tel: 01202 785686
email: shop@plan-knitwool.co.uk
www.wool-yarns.co.uk



Follow the thread...

discover
unique yarns

and gorgeous,
exclusive kits

Continue your journey
on-line on www.tlkc.co.uk



Wibbling Wools

24b Angel Hill Bury St Edmunds
Suffolk IP33 1UZ

★
Open: mon 10am – 3pm
Tues – Sat 9.30- 5pm

★
Contact: 01284 749555
lynz@wibblingwools.co.uk



★
please check our website for
updated list of classes at:

www.wibblingwools.co.uk

You will find
a gorgeous range
of the very best
things to knit &
crochet with

Purl & Jane

KNITTING EMPORIUM

We offer support, help and advice as well as everything you need to start or continue you on your inspiring journey into the wonderful world of wool!

01756 228247
www.purlandjane.co.uk

4 Mount Pleasant, High Street,
Skipton, North Yorkshire BD23 1JZ



Instructions



SPECIAL OFFER 10% OFF

Laughing Hens are offering *Knitting readers* 10% off all Debbie Bliss Glen until 29 February 2012.

Visit www.laughinghens.com and quote KN99 to receive your discount.

Simple cardigan by Debbie Bliss

SIZES

To fit: 81[86:92:97:102:107:112:117]cm
(32[34:36:38:40:42:44:46]in)

Actual measurement:

90[95:101:107:113:118:124:130]cm
(35.5[37.5:39.75:42:44.5:46.5:48.75:51.25]in)

Length to shoulder:

55[56:57:58:59:60:61:62]cm
(21.75[22:22.5:23:23.25:23.75:24:24.5]in)

Sleeve length: 44[44:44:45:45:45:46:46]cm
(17.25[17.25:17.25:17.75:17.75:17.75:18:18]in)

Figures in square brackets refer to larger sizes: where there is only one set of figures this applies to all sizes.

YOU WILL NEED

Debbie Bliss Glen 30% fine alpaca, 30% Merino wool, 40% nylon (approx 90m per 50g)
8[9:9:10:10:11:11:12] x 50g balls 05 Oatmeal
1 pair each 5.5mm and 6.5mm needles
2 stitch holders
7 buttons
Row counter

Note: Yarn amounts given are based on average requirements and are approximate.

TENSION

14 sts and 21 rows to 10cm over st st using 6.5mm needles.
Use larger or smaller needles if necessary to obtain correct tension.

ABBREVIATIONS SEE PAGE 86

BACK

With 5.5mm needles, cast on 65[69:73:77:81:85:89:93] sts.

Knit 5 rows.

Change to 6.5mm needles.
Beg with a k row, work in st st until back meas 17cm (6.75in) from cast on edge, ending with a p row.

Change to 5.5mm needles.

Work a further 14 rows.

Change to 6.5mm needles.
Cont in st st until back meas 35[35:36:36:37:37:38:38]cm
(13.75[13.75:14.25:14.25:14.5:14.5:15:15]in)
from cast on edge, ending with a p row.

Shape armholes

Cast off 4 sts at beg of next 2 rows.

57[61:65:69:73:77:81:85] sts.

Next row: K1, skpo, k to last 3 sts, k2tog, k1.

Next row: Purl.

Rep last 2 rows 6[6:7:7:8:8:9] times more.

43[47:49:53:55:59:61:65] sts.

Cont straight until back meas 53[54:55:56:57:58:59:60]cm
(21[21:25:21:25:22:22.5:23:23.25:23.5]in)
from cast on edge, ending with a p row.

Shape back neck and shoulders

Next row: K12[13:14:15:16:17:18:19], turn and work on these sts only for first side of neck.

Next row: P2tog, p to end.

Next row: K to last 2 sts, k2tog.

Next row: Purl.

Next row: Cast off 5[5:6:6:7:7:8:8] sts, k to end.

Next row: Purl.

Cast off rem 5[6:6:7:7:8:8:9] sts.

With RS facing, slip centre 19[21:21:23:23:25:25:27] sts onto a holder, rejoin yarn to rem 12[13:14:15:16:17:18:19] sts, k to end.

Next row: P to last 2 sts, p2tog.

Next row: Skpo, k to end.

Next row: Purl.

Next row: Knit.

Next row: Cast off 5[5:6:6:7:7:8:8] sts, p to end.

Next row: Knit.

Cast off rem 5[6:6:7:7:8:8:9] sts.

LEFT FRONT

With 5.5mm needles, cast on 32[34:36:38:40:42:44:46] sts.

Knit 5 rows.

Change to 6.5mm needles.
Beg with a k row, work in st st until front meas 17cm (6.75in) from cast on edge, ending with a p row.

Change to 5.5mm needles.

Work a further 14 rows.

Change to 6.5mm needles.

Cont in st st until front meas 35[35:36:36:37:37:38:38]cm
(13.75[13.75:14.25:14.25:14.5:14.5:15:15]in)
from cast on edge, ending with a p row.

Shape armhole

Next row: Cast off 4 sts, k to end.

28[30:32:34:36:38:40:42] sts.

Next row: Purl.

Next row: K1, skpo, k to end.

Next row: Purl.

Rep last 2 rows 6[6:7:7:8:8:9] times more.
21[23:24:26:27:29:30:32] sts.

Work straight until front meas 42[43:44:45:46:47:48:49]cm
(16.5[17:17.25:17.75:18:18.5:19:19.35]in)
from cast on edge, ending with a p row.

Shape neck

Next row: K14[16:17:19:19:21:22:24], turn, and work on these sts only, leave rem 7[7:7:8:8:8:8] sts on a holder.

Dec one st at neck edge on every row until 10[11:12:13:14:15:16:17] sts rem.

Work straight until front meas same as Back to shoulder, ending at armhole edge.

Shape shoulder

Next row: Cast off 5[5:6:6:7:7:8:8] sts, k to end.

Next row: Purl.

Cast off rem 5[6:6:7:7:8:8:9] sts.

RIGHT FRONT

With 5.5mm needles, cast on 32[34:36:38:40:42:44:46] sts.

Knit 5 rows.

Change to 6.5mm needles.

Beg with a k row, work in st st until front meas 17cm (6.75in) from cast on edge, ending with a p row.

Change to 5.5mm needles.

Work a further 14 rows.

Change to 6.5mm needles.

Cont in st st until front meas 35[35:36:36:37:37:38:38]cm
(13.75[13.75:14.25:14.25:14.5:14.5:15:15]in)
from cast on edge, ending with a k row.

Shape armhole

Next row: Cast off 4 sts, p to end.

28[30:32:34:36:38:40:42] sts.

Next row: K to last 3 sts, k2tog, k1.

Next row: Purl.

Rep last 2 rows 6[6:7:7:8:8:9] times more.

21[23:24:26:27:29:30:32] sts.

Work straight until front meas 42[43:44:45:46:47:48:49]cm
(16.5[17:17.25:17.75:18:18.5:19:19.25]in)
from cast on edge, ending with a p row.

Shape neck

Next row: K7[7:7:7:8:8:8:8], leave these sts on a holder, k to end.

Dec one st at neck edge on every row until 10[11:12:13:14:15:16:17] sts rem.

Work straight until front meas same as Back to shoulder, ending at armhole edge.

Shape shoulder

Next row: Cast off 5[5:6:6:7:7:8:8] sts, p to end.

Next row: Knit.

Cast off rem 5[6:6:7:7:8:8:9] sts.

SLEEVES

With 5.5mm needles, cast on 28[30:32:34:36:38:40:42] sts.

Rib row: (K1, p1) to end.

Rep last row 20 times more.

Inc row: Rib 2[3:4:2:3:4:2:3], (m1, rib 3) to last

2[3:4:2:3:4:2:3] sts, m1, rib 2[3:4:2:3:4:2:3].
37[39:41:45:47:49:53:55] sts.
Change to 6.5mm needles.
Beg with a k row, work in st st.

Work 4 rows.

Next row: K3, m1, k to last 3 sts, m1, k3.

Work 3 rows.

Rep last 4 rows 13 times more and inc row again. 67[69:71:75:77:79:83:85] sts.

Cont straight until sleeve meas

44[44:44:45:45:45:46:46]cm

(17.25[17.25:17.25:17.75:17.75:17.75:18:18]in)

from cast on edge, ending with a p row.

Shape sleeve top

Cast off 4 sts at beg of next 2 rows.

59[61:63:67:69:71:75:77] sts.

Next row: K1, skpo, k to last 3 sts, k2tog, k1.

Next row: Purl.

Rep last 2 rows 6[6:7:7:8:8:9:9] times more.

45[47:47:51:51:53:55:57] sts.

Work 18 rows straight, so ending with a p row.

Next row: K1, (k2tog) to end.

23[24:24:26:26:27:28:29] sts.

Next row: P1[0:0:0:0:1:0:1], (p2tog) to end.

Cast off.

NECKBAND

Join shoulder seams.

With 5.5mm needles, slip 7[7:7:7:8:8:8:8] sts

from right front onto a needle, pick up and

k16 sts up right front neck, 5 sts down right

back neck, k19[21:21:23:23:25:25:27] sts from

back neck holder, pick up and k5 sts up

left back neck, 16 sts down left front neck,

then k7[7:7:7:8:8:8:8] sts from left front holder.

75[77:77:79:81:83:83:85] sts.

Knit 5 rows.

Cast off.

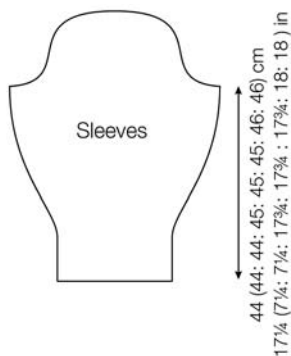
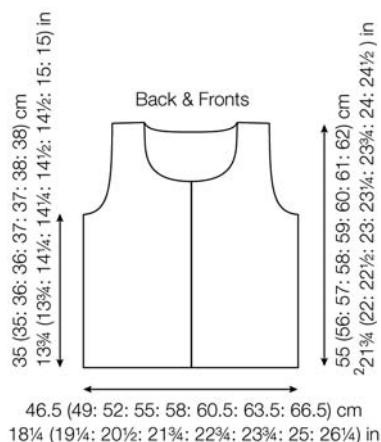

BUTTON BAND

With RS facing and 5.5mm needles, pick up and k6[6:6:6:7:7:7:7] sts evenly along left front edge.

Knit 5 rows.

Cast off.

BUTTONHOLE BAND

With RS facing and 5.5mm needles, pick up and k6[6:6:6:7:7:7:7] sts evenly along right front edge.

Knit 1 row.

Buttonhole row: K2[2:3:4:2:2:3:4], (k2tog, yf, k8[8:8:8:9:9:9:9]) 6 times, k2tog, yf, k2[3:4:4:2:3:4:4].

Knit 3 rows.

Cast off.

TO FINISH OFF

Join side and sleeve seams.

Sew sleeves into armholes, easing to fit.

Sew on buttons. ●



SPECIAL OFFER 10% OFF

Little Houndales Knits are offering Knitting readers 10% off all Louisa Harding Nerissa until 29 February 2012. Call **01377 255093** or email Kath@LittleHoundalesKnits.com to receive your discount.

Off the shoulder top by Maisie Smith

SIZES

To fit: 81[86:92:97:102:107:112]cm (32[34:36:38:40:42:44]in)

Actual measurement: 86[91:96:101:106:111:116]cm (34[36:38:40:42:44:46]in)

Length to shoulder: 54[55:56:57:58:59:60]cm (21.25:21.5:22:22.5:24.5:22.75:23.5]in)

Sleeve length: 27cm (10.5in)

Instructions

Figures in square brackets refer to larger sizes: where there is only one set of figures this applies to all sizes.

YOU WILL NEED

Louisa Harding Nerissa 100% cotton (approx 90m per 50g)
7[7:8:8:9:9:10] x 50g balls 07 Cherry
1 pair each 4mm and 4.5mm needles
Stitch holders
Row counter

Note: Yarn amounts given are based on average requirements and are approximate.

TENSION

17 sts and 26 rows to 10cm over st st using 4mm needles.
Use larger or smaller needles if necessary to obtain correct tension.

ABBREVIATIONS SEE PAGE 86

BACK AND FRONT (BOTH ALIKE)

With 4mm needles, using the simple cast on method, cast on 76[81:86:91:96:101:106] sts.

Next row: (K1tbl) to end.

Beg with a p row work 9 rows in rev st st.

Dec row: K4, skpo, k to last 6 sts, k2tog, k4. Work 5 rows.

Rep last 6 rows 3 times more and dec row again. 66[71:76:81:86:91:96] sts.

Work 11 rows in rev st st.

Inc row: K3, m1, k to last 3 sts, m1, k3.

Work 7 rows.

Rep last 8 rows twice more and inc row again. 74[79:84:89:94:99:104] sts.

Cont in st st until work meas 29[29:29:29:30:30:30]cm

(11.5[11.5:11.5:11.5:11.75:11.75]in)

from cast on edge, ending with a k row.

Shape raglan armhole

Cast off 4[5:5:6:6:7:7] sts at beg of next 2 rows. 66[69:74:77:82:85:90] sts.

Next row: Purl.

Next row: K3, skpo, k to last 5 sts, k2tog, k3.

Rep last 2 rows until 42[43:44:45:46:47:48] sts

rem, ending with a k row.

Leave these sts on a spare needle.

SLEEVES

With 4mm needles, using the simple cast on method, cast on 38[41:41:44:44:47:47] sts.

Next row: (K1tbl) to end.

Beg with a p row work 9 rows in rev st st.

Inc row: K3, m1, k to last 3 sts, m1, k3.

Work 5 rows in rev st st.

Rep last 6 rows 8 times more and inc row again. 58[61:61:64:64:67:67] sts.

Cont straight until sleeve meas 27cm (10.5in) from cast-on edge, ending with a k row.

Shape raglan top

Cast off 4[5:5:6:6:7:7] sts at beg of next 2 rows. 50[51:51:52:52:53:53] sts.

Work 5[5:5:7:7:5:5] rows.

Next row: K3, skpo, k to last 5 sts, k2tog, k3.

Work 5[5:7:7:9:9:11] rows.

Rep last 6[6:8:8:10:10:12] rows twice more.

44[45:45:46:46:47:47] sts.

Next row: Knit.

Leave these sts on a spare needle.

COLLAR

With RS facing, using 4mm needles,

p43[44:44:45:45:46:46] sts of left

sleeve, p last st tog with first st on front,

p40[41:42:43:44:45:46] sts on front

holder, p last st tog with first st on right

sleeve, p42[43:43:44:44:45:45] sts of right

sleeve, p last st tog with first st on back,

p41[42:43:44:45:46:47] sts on back holder.

169[173:175:179:181:185:187] sts.

Beg with a k row work 6 rows rev st st, ending with a p row.

Beg with a p row, work 4 rows in st st.

Change to 4.5mm needles.

Beg with a p row, work 16 rows in st st.

Cast off loosely.

TO FINISH OFF

Join both front raglans and right back raglan seam.

Join left back and neckband seams.

Join side and sleeve seams. ●

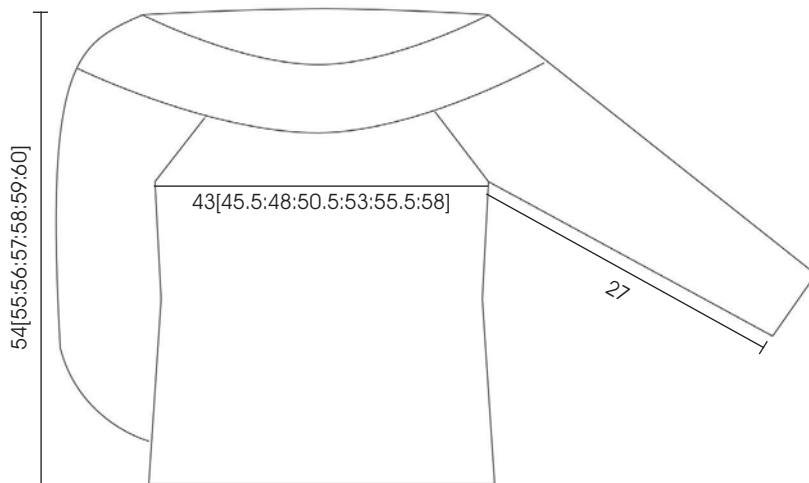

Measurements are given in cm

YOUR FAVOURITE MAGAZINE
AVAILABLE ON YOUR

SAVE
UP TO 42%!
ON SUBSCRIPTION PRICE

IPHONE OR
IPAD



SUBSCRIBE FROM £18.99

DISCOVER

our other crafts
magazine apps and
get the first issue for
JUST £1.99!

Making
Jewellery



● For novices
and advanced
hobbyists alike



Making



● Beautiful crafts
for your home



The Dolls' House
Magazine



● It's a small world
but we're big
on ideas!



Available on the iPhone
App Store

Available on
Android

ALSO AVAILABLE FROM POCKET MAGS



www.pocketmags.com

Instructions



Layered v neck top by Sian Brown

SIZES

To fit: 82[86:92:97:102:107:112:117:122:127]cm
(32[34:36:38:40:42:44:46:48:50]in)

Actual measurement:

88[93:98:103:108:113:118:123:128:133]cm
(35.75[37.75:39.75:41.75:43.75:45.75:47.75:
49.75:51.75:53.75]in)

Length to shoulder:

51[52:53:54:55:56:57:58:59:60]cm
(20[20.5:21:21.25:21.5:22:22.5:22.75:
23.25:23.75]in)

Sleeve length: 33cm (13in)

Figures in square brackets refer to larger sizes: where there is only one set of figures this applies to all sizes.

YOU WILL NEED

Sublime Baby Silk and Bamboo

80% bamboo viscose, 20% silk
(approx 95m per 50g)
9[9:10:10:11:12:12:13:14:14] x 50g balls
269 Bib (A)

1 x 50g balls 268 Milk Pudding (B)
1 pair each 3.25mm and 4mm needles
1 x 3.25mm and 4mm circular needles
Row counter

Note: Yarn amounts given are based on average requirements and are approximate.

TENSION

22 sts and 28 rows to 10cm over st st using 4mm needles.
Use larger or smaller needles if necessary to obtain correct tension.

ABBREVIATIONS SEE PAGE 86

BACK

With 3.25mm circular needle and A cast on 100[106:112:118:124:130:136:142:148:154] sts. Work backwards and forwards in rows.

Knit 3 rows.

Change to 4mm circular needle.

Beg with a k row, work in st st.

Work 4 rows.

Dec row: K3, skpo, k to last 5 sts, k2tog, k3.

Work 5 rows.

Rep last 6 rows 6 times more and the dec row again.

84[90:96:102:108:114:120:126:132:138] sts.

Work 17 rows.

Inc row: K3, m1, k to last 3 sts, m1, k3.

Work 7 rows.

Rep last 8 rows 4 times more and inc row again.

96[102:108:114:120:126:132:138:144:150] sts **.

Work 9 rows.

Shape armholes

Cast off 7[7:7:8:8:8:9:9:10] sts at beg of next 2 rows.

82[88:94:98:104:110:114:120:126:130] sts.

Next row: K2, skpo, k to last 4 sts, k2tog, k2.

Next row: Purl.

Rep last 2 rows 5[6:7:7:8:8:9:9:10:11] times more. 70[74:78:82:86:90:94:98:102:106] sts.

Cont in st st until armhole meas

18[19:20:21:22:23:24:25:26:27]cm

(7[7.5:8:8.25:8.75:9:9.5:9.75:10.25:10.75]in), ending with a p row.

Shape shoulders

Cast off 8[8:9:10:10:11:12:12:13:14] sts at

beg of next 2 rows and

8[9:10:10:11:12:12:13:14:14] sts at beg of foll 2 rows.

Leave rem 38[40:40:42:44:44:46:48:48:50] sts on a spare needle.

FRONT

Work as given for back to **.

Work 1 row.

Shape front neck

Next row: K44[47:50:53:56:59:62:65:68:71],

k2tog, k2, turn and work on these sts for first side of neck shaping.

47[50:53:56:59:62:65:68:71:74] sts.

Work 1 row.

Next row: K to last 4 sts, k2tog, k2.

Work 1 row.

Rep last 2 rows twice more.

44[47:50:53:56:59:62:65:68:71] sts.

Shape armhole

Next row: Cast off 7[7:7:8:8:8:9:9:10] sts,

k to last 4 sts, k2tog, k2.

36[39:42:44:47:50:52:55:58:60] sts.

Next row: Purl.

Next row: K2, skpo, k to last 4 sts, k2tog, k2

Rep last 2 rows 5[6:7:7:8:8:9:9:10:11] times

more. 24[25:26:28:29:30:32:33:34:36] sts.

Keeping armhole edge straight cont to dec

at neck edge on every 4th row until

16[17:19:20:21:23:24:25:27:28] sts rem.

Cont in st st until armhole meas

18[19:20:21:22:23:24:25:26:27]cm

(7[7.5:8:8.25:8.75:9:9.5:9.75:10.25:10.75]in),

ending at armhole edge.

Shape shoulder

Next row: Cast off 8[8:9:10:10:11:12:12:13:14] sts,

k to end.

Work 1 row.

Cast off rem 8[9:10:10:11:12:12:13:14:14] sts.

With RS facing, rejoin yarn to rem sts, k2, skpo, k to end.

Work 1 row.

Next row: K2, skpo, k to end.

Work 1 row.

Rep last 2 rows twice more and first row

again.

Shape armhole

Next row: Cast off 7[7:7:8:8:8:9:9:10] sts,

p to end.

Next row: K2, skpo, k to last 4 sts, k2tog, k2.

Next row: Purl.

Rep last 2 rows 5[6:7:7:8:8:9:9:10:11] times

more. 24[25:26:28:29:30:32:33:34:36] sts.

Keeping armhole edge straight cont to dec

at neck edge on every 4th row until

16[17:19:20:21:23:24:25:27:28] sts rem.

Cont in st st until armhole meas

18[19:20:21:22:23:24:25:26:27]cm

(7[7.5:8:8.25:8.75:9:9.5:9.75:10.25:10.75]in),

ending at armhole edge.

Shape shoulder

Next row: Cast off 8[8:9:10:10:11:12:12:13:14] sts,

k to end.

Work 1 row.

Cast off rem 8[9:10:10:11:12:12:13:14:14] sts.

SLEEVES

Edging

With 3.25mm needles and B cast on

44[48:52:56:60:64:68:72:76:80] sts.

Knit 3 rows.

Beg with a k row cont in st st.

Work 8 rows.

Cut off yarn and leave these sts on a spare needle.

Main part

With 3.25mm needles and A cast on

44[48:52:56:60:64:68:72:76:80] sts.

Knit 3 rows.

Change to 4mm needles.

Joining row: Place needle holding cuff sts,

behind needle hold main part, (k next st of

main part tog with next st of cuff) to end of

row. 44[48:52:56:60:64:68:72:76:80] sts.

Next row: Purl.

Inc row: K3, m1, k to last 3 sts, m1, k3.

Work 9 rows.

Rep last 10 rows 7 times more.

60[64:68:72:76:80:84:88:92:96] sts.

Cont straight until sleeve meas 33cm (13in)

from cast on edge, ending with a p row.

Shape sleeve top

Cast off 7[7:7:8:8:8:9:9:10] sts at beg of

next 2 rows.

46[50:54:56:60:64:66:70:74:76] sts.

Next row: K2, skpo, k to last 4 sts, k2tog, k2.

Next row: Purl.

Rep last 2 rows 5[6:7:7:8:8:9:9:10:11] times

more. 34[36:38:40:42:44:46:48:50:52] sts.

Next row: K2, skpo, k to last 4 sts, k2tog, k2.

Work 3 rows.

Rep last 4 rows 4 times more.

Next row: K2, skpo, k to last 4 sts, k2tog, k2.

Next row: Purl.

Rep last 2 rows once more.

20[22:24:26:28:30:32:34:36:38] sts.

Cast off 2 sts at beg of next 4 rows.

Cast off.

NECK EDGING

Join right shoulder seam.

With 3.25mm circular needle and A,

pick up and

k46[48:50:52:54:56:58:60:62:64]

sts down left side of front neck,

46[48:50:52:54:56:58:60:62:64] sts

up right side of front neck,

k38[40:42:44:46:48:50] sts

from back neck.

130[136:140:146:150:154:160:166:170:178] sts.

Next row: Knit.

Next row: K44[46:48:50:52:54:56:58:60:62],

skpo, k2tog, k to end.

Next row: Knit.

Cast off, dec on this row as before.

COLLAR

With 4mm circular needle and B,

cast on 38[40:42:44:46:48:50] sts,

Beg with a k row, work backwards and forwards in rows.

Knit 1 row.

Cast on 6[8:10:12:14:7:9:11:13:15] sts at beg

of next 2 rows and 9 sts at beg of next

8[8:8:8:10:10:10:10] rows.

122[128:132:138:144:148:154:160:164:170] sts.

Next row: Knit.

Next row: K1, skpo, k to last 3 sts, k2 tog, k1.

Rep last 2 rows once more.

Cast off.

TO FINISH OFF

Join side and sleeve seams. Sew sleeves into armholes, easing to fit. Join last 4 rows of Collar to form centre front seam.

Sew Collar to back of pick up row of neck band. ●

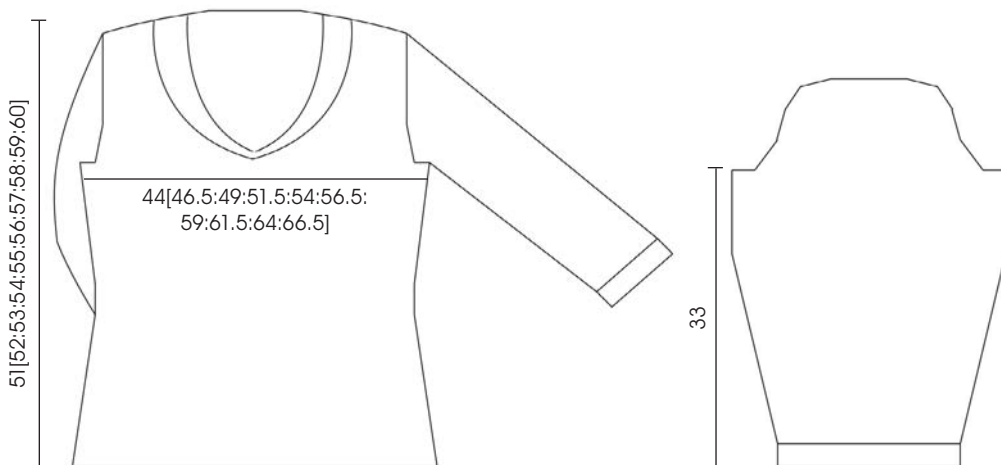

Measurements are given in cm

Draped jacket by Pat Menchini

SIZES

To fit:

76-81[87-91:97-102:107-112:117-122:127-132]cm

(30-32[34-36:38-40:42-44:46-48:50-52]in)

Actual measurement across back

at underarm: 43[48:54:59:65:70]cm

(17[19:21.25:23.25:25.5:27.5]in)

Length to shoulder: 60[60:60:62:62:62]cm

(23.5[23.5:23.5:24.5:24.5:24.5]in)

Figures in square brackets refer to larger sizes: where there is only one set of figures this applies to all sizes.

YOU WILL NEED

King Cole Baby Alpaca DK 100% alpaca (approx 100m per 50g)

9[9:10:10:11:11] x 50g balls 505 Sage

1 pair 4mm needles

Instructions

2 buttons from Duttons for Buttons (see stockists page)
Optional leather belt
Row counter

Note: Yarn amounts given are based on average requirements and are approximate.

TENSION

22 sts and 28 rows to 10cm over st st using 4mm needles.
Use larger or smaller needles if necessary to obtain correct tension.

ABBREVIATIONS SEE PAGE 86

PATTERN NOTES

Can be worn with or without a leather belt.

RIGHT FRONT

Using 4mm needles, cast on 73[79:85:91:97:103] sts.
Work in Double Moss st patt.

Row 1 (RS): K1, (p1, k1) to end.

Row 2: As row 1.

Rows 3 to 4: P1, (k1, p1) to end.

Rows 5 to 6: As rows 1 to 2. **

Change to st st with front edging in patt

Row 1: P1, (k1, p1) 3 times, k to end.

Row 2: P to last 6 sts, (k1, p1) 3 times.

Row 3: (K1, p1) 3 times, k to end.

Row 4: P to last 7 sts, k1, (p1, k1) 3 times.

Rep these 4 patt rows until work meas 38cm (15in) from beg, ending after row 4.

Shape sleeve

Row 1: P1, (k1, p1) 3 times, k to end of row, cast on 10 sts. 83[89:95:101:107:113] sts

Row 2: (P1, k1) 5 times, p to last 6 sts, (k1, p1) 3 times.

Row 3: (K1, p1) 3 times, k to last 10 sts, (p1, k1) 5 times.

Row 4: (K1, p1) 5 times, p to last 7 sts, k1, (p1, k1) 3 times.

Row 5: P1, (k1, p1) 3 times, k to last 9 sts, p1, (k1, p1) 4 times.

Rep rows 2 to 5 until work meas 10cm (4.25in) ending after row 2.

Work buttonholes

Next row: Work across 43[44:45:46:47:48] sts, cast off 3 sts, work to end.

Next row: Work across row casting on 3 sts where sts were cast off.

Work 12 rows.

Work the 2 buttonhole rows once more.

Now change to Double Moss st patt on all sts and work 7 rows.

Shape neck

Next row (WS): Patt to last 45[46:47:48:49:50] sts, cast off these 45[46:47:48:49:50] sts very loosely.

Break yarn.

Turn work and neatly rejoin yarn to rem 38[43:48:53:58:63] sts.

Work 7[7:7:15:15:15] rows straight, thus ending at sleeve edge.

Shape shoulder

Cast off 5[5:6:6:7:7] sts loosely at beg of next

row, then 5[6:6:7:7:8] sts at beg of next alt row.

Work 1 row.

Finally cast off 7[8:9:10:11:12] sts at beg of next and every foll alt row until all sts are cast off.

LEFT FRONT

Work as right front to **.

Change to st st with front edging in patt.

Row 1: K to last 7 sts, p1, (k1, p1) 3 times.

Row 2: (P1, k1) 3 times, p to end.

Row 3: K to last 6 sts, (p1, k1) 3 times.

Row 4: (K1, p1) 3 times, k1, p to end.

Rep these 4 rows until work meas 38cm (15in) from beg, ending after row 4.

Shape sleeve

Row 1: Cast on 10 sts, k to last 7 sts, (p1, k1) 3 times, k1.

Row 2: (P1, k1) 3 times, p to last 10 sts, (k1, p1) 5 times.

Row 3: (K1, p1) 5 times, k to last 6 sts, (p1, k1) 3 times.

Row 4: (K1, p1) 3 times, k1, p to last 10 sts, (p1, k1) 5 times.

Row 5: P1, (k1, p1) 4 times, k to last 7 sts, p1, (k1, p1) 3 times.

Cont straight until work meas same as right front up to row where all sts are worked in patt, thus ending after a WS row.

Now change to Double Moss st patt on all sts and work 7 rows.

Shape neck

Next row (WS): Cast off 45[46:47:48:49:50] sts very loosely in patt, patt to end. 38[43:48:53:58:63] sts.

Work 6[6:6:14:14:14] rows straight, thus ending at sleeve edge.

Shape shoulder

Work as for right front.

BACK

Commencing with 93[105:117:129:141:153] sts work as right front to **.

Change to st st and beg k row cont straight until back meas 38cm (15in) from beg, ending after a p row.

Shape sleeves

Next row: Cast on 10 sts, k to end, cast on 10 sts. 113[125:137:149:161:173] sts.

Next row: (P1, k1) 5 times, p to last 10 sts, (k1, p1) 5 times.

Cont straight working sleeve border sts in patt until back meas same as fronts up to row where all sts are worked in patt, ending after a WS row.

Now change to Double Moss st patt on all sts and work straight until back meas same as left front up to shoulder shaping, ending after a WS row.

Shape shoulders

Cast off 5[5:6:6:7:7] sts loosely at beg of next 2 rows, then 5[6:6:7:7:8] sts at beg of next 2 rows.

Now cast off 7[8:9:10:11:12] sts at beg of next 8 rows.

Cast off rem 37[39:41:43:45:47] sts in patt.

TO FINISH OFF

With WS facing, block out pieces to shape by pinning out round edges.

Press following pressing instructions.

Join shoulders.

Join side and sleeve seams leaving a gap free at waist level on right side seam only to fit your belt.

Sew on buttons.

Press seams. ●

For close up photographs see page 76 ►

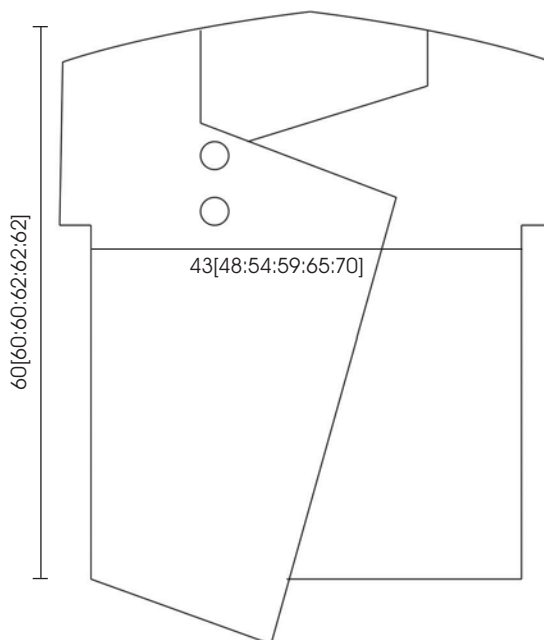

Measurements are given in cm

fibre
+ clay

KNIT STUDIO
+ CONTEMPORARY
CRAFT GALLERY



Online shop: www.fibreandclay.com
T/F: 01565 652035 E: fibreandclay@aol.com
11-13 Minshull Street Knutsford Cheshire WA16 6HG

The Button Lady

Huge range in all shapes and sizes including buttons for Embroidered Village Bag

- * Agents for Cash's and address labels
- * Personal shopping by appointment
- * Catalogue £2 (incl. stamp) refundable



16 Holyfield Road South, Sutton Coldfield, W. Midlands B76 1NX
Tel/Fax: 0121 329 3234



Do you want to reach a committed and enthusiastic knitting community? Then contact Rhoda Barker on 01273 402820 or rhodab@thegmcgroup.com

knitting yarns • patterns • needles



Laughing Hens

your on line shop for all your knitting needs
Rowan • Debbie Bliss • Noro • Cascade • Rooster
All new season Rowan pattern books now in stock

sales@laughinghens.com
www.laughinghens.com
01829 740903



Readers of *Knitting* can now claim **10% off** Debbie Bliss Glen until end of February. Visit our website and quote **KN99** to get your discount.

15 pairs

of best quality 34 cm Bamboo Needles sizes 0 to 15 for only



£17.44

inc UK postage

See our Silky Satin Needle Case at only **£13.68**

Cheques may be made out to Irina Beighton and sent to 16, Maple Street, Birkenhead CH41 2SZ
www.bamboo-knitting-centre.com
or phone 0785 494 3405

Instructions



Flared cuff jumper by Pat Menchini

SIZES

To fit: 81[86:91:97:102:107]cm
(32[34:36:38:40:42]in)

Actual measurement:

86[91:97:102:107:112]cm
(34[36:38:40:42:44]in)

Length to shoulder: 62[63:64:65:66:67]cm
(24.5[25:25.25:25.75:26.25:26.5]in)

Sleeve length: 45cm (17.75in)

Figures in square brackets refer to larger sizes: where there is only one set of figures this applies to all sizes.

YOU WILL NEED

Sublime Lustrous Extrafine Merino DK

67% extra fine merino, 33% nylon
(approx 95m per 25g)

15[16:17:17:18:18] x 25g balls 0297
Blackcurrant

1 pair each 3.25mm, 3.75mm and
4mm needles

2 stitch holders

Row counter

Note: Yarn amounts given are based on average requirements and are approximate.

TENSION

23 sts and 33 rows to 10cm over patt using
4mm needles.

Use larger or smaller needles if necessary
to obtain correct tension.

ABBREVIATIONS

tw2 = slip next st, k1, pass slipped st over st
just knitted and k into back of it.

For more abbreviations see page 86

FRONT

Using 4mm needles, cast on
141[149:153:161:165:173] sts.

Row 1 (RS): K1, (p1, k1) to end.

Row 2: Purl.

Rep last 2 rows for 8cm, (3in) ending after
a purl row.

Work in main patt.

Row 1: (K1, p1) 7[9:10:10:11:13] times, *tw2,
k13, tw2, (p1, k1) 3[3:3:4:4:4] times, p1;
rep from * three times more, tw2, k13, tw2,
(p1, k1) 7[9:10:10:11:13] times.

Row 2: Purl.

Rep last 2 rows four times more.

Work shaping.

Dec row 1: (K1, p1) 7[9:10:10:11:13] times,
*tw2, k5, sl1, k2tog, pssso, k5, tw2, patt
7[7:7:9:9:9]; rep from * three times more,
tw2, k5, sl1, k2tog, pssso, k5, tw2, patt to end.
131[139:143:151:155:163] sts.

Work 23 rows straight in patt.

Dec row 2: (K1, p1) 7[9:10:10:11:13] times,
* tw2, k4, sl1, k2tog, pssso, k4, tw2, patt
7[7:7:9:9:9]; rep from * three times more,
tw2, k4, sl1, k2tog, pssso, k4, tw2, patt to end.
121[129:133:141:145:153] sts.

Work 23 rows straight in patt.

Dec row 3: (K1, p1) 7[9:10:10:11:13] times,
* tw2, k3, sl1, k2tog, pssso, k3, tw2, patt
7[7:7:9:9:9]; rep from * three times more,
tw2, k3, sl1, k2tog, pssso, k3, tw2, patt to end.
111[119:123:131:135:143] sts.

Work 23 rows straight in patt.

Dec row 4: (K1, p1) 7[9:10:10:11:13] times,
* tw2, k2, sl1, k2tog, pssso, k2, tw2, patt
7[7:7:9:9:9]; rep from * three times more,
tw2, k2, sl1, k2tog, pssso, k2, tw2, patt to end.
101[109:113:121:125:133] sts.

Shaping is now complete.

Change to 3.75mm needles and cont
straight in patt until work meas 46cm (18in)
from beg, ending after a purl row.

Shape armholes

Cast off 6[7:7:8:8:9] sts at beg of next 2 rows.
89[95:99:105:109:115] sts.

Dec 1 st at each end of next 5 rows,
then on every foll alt row until
75[79:83:87:91:95] sts rem.

Cont straight until work meas
9[10:11:11:12:13]cm, (3.5[4:4.5:4.5:4.75:5.25]in)
from beg of armhole shaping, ending after
a purl row.

Shape neck

Next row: Patt 23[24:25:27:28:29], turn.
Cont on these sts for left half of neck.

Dec 1 st at neck edge on next 3 rows,
then on 2 foll alt rows. 18[19:20:22:23:24] sts.
Cont straight until front meas
17[18:19:20:21:22]cm,

(6.5[7:7.5:8:8.25:8.75]in) from beg of armhole
shaping, ending at armhole edge.

Shape shoulder

Cast off 6[6:7:7:8:8] sts at beg of next and
foll alt row.

Work 1 row.

Cast off rem 6[7:6:8:7:8] sts.

With RS facing, sl next 29[31:33:33:35:37] sts
(centre sts) on a holder and leave.

Rejoin yarn to rem sts and patt to end.

Complete right half of neck to match left half.

BACK

Omitting neck shaping, work as back to shoulder shaping, ending after a purl row.

Shape shoulders

Cast off 6[6:7:7:8:8] sts at beg of next 4 rows, then 6[7:6:8:7:8] sts at beg of next 2 rows. Sl rem 39[41:43:43:45:47] sts on a holder and leave.

SLEEVES

Using 4mm needles, cast on 61[63:65:67:69:71] sts.

Work in main patt.

Row 1 (RS): K1[2:1:2:1:2], p1, (k1, p1) 12[12:13:13:14:14] times, tw2, k5, tw2, (p1, k1) 12[12:13:13:14:14] times, p1, k1[2:1:2:1:2].

Row 2: Purl.

These 2 rows set centre 9 patt sts.

Work 2 more rows in patt.

Cont in patt dec 1 st at each end of next row, then on every foll 4th row until 43[45:47:49:51:53] sts rem.

Work a few rows straight until sleeve meas 13cm (5in) at centre, ending after a purl row.

Now cont shaping sleeve by inc 1 st at each end of next row, then on every foll 8th[6th:6th:4th:4th:4th] row until there are 59[63:73:57:65:73] sts, then on every foll 8th[8th:8th:6th:6th:6th] row until there are 69[75:79:85:89:95] sts, working extra sts into patt.

Cont straight until sleeve meas 45cm (17.75in), ending after a purl row.

Shape top

Cast off 6[7:7:8:8:9] sts at beg of next 2 rows. 57[61:65:69:73:77] sts.

Dec 1 st at each end of next row, then on every foll 4th row until 47[51:55:59:63:67] sts rem, then on every foll alt row until 33[35:37:41:43:45] sts rem.

Dec 1 st at each end of next 5 rows.

Cast off rem 23[25:27:31:33:35] sts loosely.

POLO NECK

Join left shoulder seam.

Using 3.25mm needles, RS facing, k across back neck sts inc 6 sts evenly across, k up 24[24:24:28:28:28] sts evenly down left front neck, k across centre sts inc 8 sts evenly across, finally k up 25[25:25:29:29:29] sts evenly up right front neck. 131[135:139:147:151:155] sts.

Row 1: K1, (p1, k1) to end.

Row 2: Purl.

Rep last 2 rows for 20cm (8in), ending after row 1.

Cast off loosely knitways.

TO FINISH OFF

Join right shoulder and neckband.

Sew sleeve tops to armholes.

Join side and sleeve seams. ●

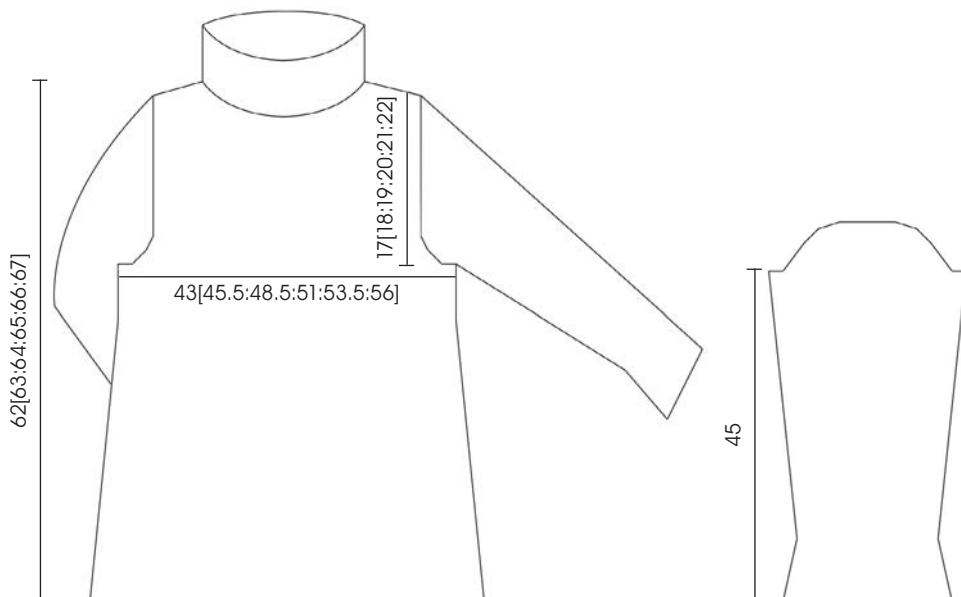

Measurements are given in cm

Instructions



Nordic cardigan by Sirdar

SIZES

To fit:

81-86[91-97:102-107:112-117:122-127:132-137]cm
(32-34[36-38:40-42:44-46:48-50:52-54]in)

Actual measurement:

90[101:112:121:132:141]cm
(35.5[39.75:44:47.75:52:55.5]in)

Length to shoulder: 58[60:62:64:66:68]cm
(22.75[23.75:24.5:25.25:26:26.75]in)

Sleeve length: 46[46:47:47:48:48]cm
(18[18:18.5:18.5:19:19]in)

Figures in square brackets refer to larger sizes: where there is only one set of figures this applies to all sizes.

YOU WILL NEED

Sirdar Country Style DK 40% nylon,

30% wool, 30% acrylic
(approx 155m per 50g)

6[7:8:9:10:10] x 50g balls 610 Sage (A)

1 x 50g ball 411 Ecru (B)

1 pair each 3.25mm and 4mm needles

6[6:6:7:7:7] buttons

Row counter

Note: Also suitable for Wash 'n' Wear Double Crepe DK, Click DK and Denim Tweed DK, amounts may vary.

Yarn amounts given are based on average requirements and are approximate.

TENSION

22 sts and 28 rows to 10cm over st st using 4mm needles.

Use larger or smaller needles if necessary to obtain correct tension.

ABBREVIATIONS SEE PAGE 86

BACK

Using 3.25mm needles, yarn A and thumb method cast on 99[111:123:133:145:155] sts.

Row 1 (RS): (K1, p1) to last st, k1.

Row 2 (WS): P1, (k1, p1) to end.

These 2 rows form 1x1 rib.

Work 6 rows more in 1x1 rib.

Change to 4mm needles and cont in st-st until back meas 20[21:22:23:24:25]cm, (8[8.25:8.75:9:9.5:9.75]in), ending with a WS row.

Work next 35 rows from chart A.

Working in yarn A only (throughout)

work 11 rows.

Back should meas 36[37:38:39:40:41]cm, (14[14.5:15:15.5:15.75:16]in), in length.

Shape raglan

Cast off 4[5:6:7:8:9] sts at beg of next 2 rows. 91[101:111:119:129:137] sts.

Work 8[14:20:26:32:38] rows dec 1 st at each end of every row. 75[73:71:67:65:61] sts.

Work 40[38:34:30:26:22] rows dec 1 st at each end of next and every foll alt row.

35[35:37:37:39:39] sts.

Cast off rem 35[35:37:37:39:39] sts.

LEFT FRONT

Using 3.25mm needles, yarn A and thumb method cast on 48[54:60:66:72:76] sts.

Row 1 (RS): (K1, p1) to end.

Last row sets rib.

Work 7 rows more in rib dec 1[1:1:2:2:1] sts evenly across last row.

47[53:59:64:70:75] sts.

Change to 4mm needles and cont in st st until left front meas 20[21:22:23:24:25]cm, (8[8.25:8.75:9:9.5:9.75]in), ending with a WS row.

Work next 35 rows from chart A.

Working in yarn A only (throughout)

work 11 rows.

Left front should meas

36[37:38:39:40:41]cm, (14[14.5:15:15.5:15.75:16]in), in length.

Shape raglan

Next row (RS): Cast off 4[5:6:7:8:9] sts, k to end. 43[48:53:57:62:66] sts.

Next row: Purl.

Next row: K2tog (raglan edge), k to end. 42[47:52:56:61:65] sts.

Next row: P to last 2 sts, p2tog.

41[46:51:55:60:64] sts.

Work 6[12:18:24:30:36] rows dec 1 st at raglan edge in every row.

35[34:33:31:30:28] sts.

Next row: K2tog, k to end.

34[33:32:30:29:27] sts.

Next row: Purl.

Work 21[19:17:11:7:3] rows dec 1 st at raglan edge in next and every foll alt row.

23[23:23:24:25:25] sts.

Shape neck

Next row: Cast off 6[6:8:7:8:8] sts,

purl to end. 17[17:15:17:17:17] sts.

Work 14[14:12:14:14:14] rows dec 1 st at each end of next and every foll alt row. 3 sts.

Next row: K2tog, k1, 2 sts.

Next row: P2tog.

Fasten off.

RIGHT FRONT

Using 3.25mm needles, yarn A and thumb method cast on 48[54:60:66:72:76] sts.

Row 1: (P1, K1) to end.

1st row sets rib.

Work 7 rows more in rib dec 1[1:1:2:2:1] sts evenly across last row.

47[53:59:64:70:75] sts.

Change to 4mm needles and cont in st st until right front meas 20[21:22:23:24:25]cm, (8[8.25:8.75:9:9.5:9.75]in), ending with a WS row.

Work next 35 rows from chart A.

Working in yarn A only (throughout)

work 12 rows.

Right front should meas 36[37:38:39:40:41]cm, (14[14.5:15:15.5:15.75:16]in), in length.

Shape raglan

Next row: Cast off 4[5:6:7:8:9] sts, p to end. 43[48:53:57:62:66] sts.

Next row: K to last 2 sts, k2tog (raglan edge). 42[47:52:56:61:65] sts.

Next row: P2tog, p to end.

41[46:51:55:60:64] sts.

Work 6[12:18:24:30:36] rows dec 1 st at raglan edge every row.

35[34:33:31:30:28] sts.

Next row: K to last 2 sts, k2tog.

34[33:32:30:29:27] sts.

Next row: Purl.

Work 20[18:16:10:6:2] rows dec 1 st at raglan edge in next and every foll alt[alt:alt:alt:alt:0] row.

24[24:24:25:26:26] sts.

Shape neck

Next row: Cast off 6[6:8:7:8:8] sts,

k to last 2 sts, k2tog. 17[17:15:17:17:17] sts.

Next row: Purl.

Work 14[14:12:14:14:14] rows dec 1 st at each end of next and every foll alt row. 3 sts.

Next row: K1, k2tog. 2 sts.

Next row: P2tog.

Fasten off.

SLEEVES

Using 3.25mm needles, yarn A and thumb method cast on 45[47:49:51:53:55] sts.

Work 8 rows in 1x1 rib.

Change to 4mm needles and cont in st-st (throughout) inc 1 st at each end of 5th and every foll 6th[6th:6th:6th:4th:4th] row to 53[71:75:77:59:67] sts.

For 1st, 5th and 6th sizes only

Inc 1 st at each end of every foll 8th[6th:6th] row to 65[81:85] sts.

For all 6 sizes

Work 5[5:1:1:1:1] rows more without shaping, ending with a WS row.

Work 35 rows from chart B as folls:

Inc 1 st at each end of

3rd[3rd:5th:5th:5th:5th] and every

foll 8th[8th:6th:6th:6th:6th] row to

75[81:79:89:93:97] sts.

For 3rd size only

Inc 1 st at each end of every foll 8th row to 85 sts.

SUBSCRIBE TODAY & SAVE UP TO 30%!

Save 10% on any of these magazines – or 30% if you pay by Direct Debit



WAS £4.99 PER ISSUE
NOW PAY ONLY £3.49*



WAS £3.99 PER ISSUE
NOW PAY ONLY £2.79*



WAS £4.99 PER ISSUE
NOW PAY ONLY £3.49*

For novices and advanced hobbyists alike!

Making Jewellery is the UK's first and best-selling jewellery magazine. We feature more than 30 fully illustrated step-by-step projects to make stylish, fashionable and professional-looking jewellery. There are projects for every skill level, using a variety of techniques from simple stringing to metal clays and lampwork. *Making Jewellery* offers an innovative approach to jewellery making with insight into the creative minds of leading makers.

MAKING JEWELLERY	ORDER CODE: A3224
UK	£53.89
UK (DIRECT DEBIT)	£41.92
EUROPE	£67.37
OVERSEAS	£75.45

It's a small world but we're big on ideas!

The Dolls' House Magazine is Britain's best magazine for dolls' house enthusiasts and collectors. It focuses on dolls' house and miniature projects and period inspiration, particularly Georgian and Victorian. Each month sees a variety of projects, techniques, kit reviews, interviews with makers. It's packed with new products to furnish and decorate your dolls' house, plus money-saving tips, competitions and offers.

DOLLS' HOUSE	ORDER CODE: A3226
UK	£43.09
UK (DIRECT DEBIT)	£33.52
EUROPE	£53.87
OVERSEAS	£60.33

Beautiful crafts for your home

Making is the UK's first-ever modern creative craft magazine for the home covering a wide array of craft projects, techniques and topical features. Every issue the reader is given around 30 projects ideas for the wardrobe, kitchen, bathroom, garden and other living areas of their home. *Making* is essential reading for those seeking inspiration and expertise to create their own style of projects for the home, family celebrations, or to share with friends.

MAKING	ORDER CODE: A3223
UK	£53.89
UK (DIRECT DEBIT)	£41.92
EUROPE	£67.37
OVERSEAS	£75.45

ORDER FORM

YES! I would like to subscribe to... (Please tick all that apply) for 12 issues

- Making Jewellery (A3224)** **Dolls' House (A3226)** **Making (A3223)**

Pay By: Cheque or debit/credit card **SAVE 10%**

- UK price £ _____ Europe price £ _____
 Rest of World price £ _____

Title (Mr/Mrs/Miss/Ms/Other) Name Surname _____

Address _____

Postcode _____ Country _____

Telephone _____

Email _____

CREDIT/DEBIT PAYMENTS

- I enclose a cheque made payable to GMC Publications Ltd.
OR
 Please debit my credit/debit card **TO THE VALUE OF: £ _____

*Please indicate VISA MASTERCARD AMERICAN EXPRESS DISCOVER OTHER _____

Please charge my card number _____

Expiry Date _____ Security Code _____ (The last 3 or 4 digits on the signature strip)

Signature _____ Date _____

Pay By: Direct Debit **SAVE 30%!**

- UK price £ _____

Direct Debit
Instructions to your Bank or Building Society

Name(s) of account holder(s) _____

Bank or Building Society account number _____

Bank or Building Society sort code _____

Name and full postal address of your Bank or Building Society _____

Name _____

Address _____

Postcode _____

Originator's identification number

6 5 9 9 5 7

Reference number (office use only)

Instruction to your Bank or Building Society:

Please pay GMC Publications Ltd Direct Debits from the account detailed in this instruction subject to the safeguards assured by the Direct Debit guarantee. I understand that this instruction may remain with GMC Publications Ltd and, if so, details will be passed electronically to my Bank/Building Society.

Signature(s) _____

Date _____

Banks and building societies may not accept direct debits for some types of accounts.

The Direct Debit Guarantee

This guarantee is offered by all Banks and Building Societies that take part in the Direct Debit Scheme. This efficiency and security of the Scheme is monitored and protected by your own Bank or Building Society. If the amounts to be paid or the payment dates change, GMC Publications Ltd will notify you. If working days in advance of your account being debited or as otherwise agreed. If an error is made by GMC Publications Ltd or your Bank or Building Society, you are guaranteed a full and immediate refund from your branch of the amount paid. You can cancel a Direct Debit at any time by writing to your Bank or Building Society. Please also send a copy of your letter to us.

Offer expires 31/03/2012. Plus free gift with some issues. Sorry, not available overseas.

3 easy ways to subscribe

Call: +44 (0) 1273 488005

Visit: www.thegmcgroup.com

Post the form to:
GMC Publications Ltd,
FREEPOST BR2265, Lewes,
East Sussex, BN7 1BR. UK.

Please tick magazine(s), region which applies and fill in corresponding price as detailed above as well as all payment details.

Guild of Master Craftsman Publications will ensure that you are kept up to date on other products which will be of interest to you. If you would prefer not to be informed of future offers, please tick this box

Please quote relevant order code.

Instructions

For all 6 sizes

35 rows of chart are now complete.

Work 11 rows more without shaping.

(Sleeve should meas approx

46[46:47:47:48:48]cm,
(18[18:18.5:18.5:19:19]in)).

Using yarn A only (throughout) cont as folls:

Shape raglan

Cast off 4[5:6:7:8:9] sts at beg of next 2 rows.

67[71:73:75:77:79] sts. **

For 1st and 2nd sizes only

Work 2 rows dec 1 st at each end of every row. 63[67] sts.

For 5th and 6th sizes only

Work 4 rows dec 1 st at each end of 1st row. 75[77] sts.

For all 6 sizes

Work 46[50:54:56:54:56] rows dec 1 st at each end of next and every foll alt row. 17[17:19:19:21:21] sts.

Cast off rem 17[17:19:19:21:21] sts.

NECKBAND

Join raglan seams.

With RS facing, using 3.25mm needles and yarn A, pick up and

k16[16:18:18:18:18] sts evenly along right

side of neck, 14[14:16:16:18:18] sts from

17[17:19:19:21:21] cast off sts at top of

right sleeve, 35[35:37:37:39:39] sts from

back of neck, 14[14:16:16:18:18] sts from

17[17:19:19:21:21] cast off sts at top of left

sleeve and 16[16:18:18:18:18] sts evenly

along left side of neck.

95[95:105:105:111:111] sts.

Starting with 1st row of 1x1 rib work 7 rows.

Cast off in rib.

RIGHT FRONT BORDER

With RS facing, using 3.25mm needles and main yarn, pick up and k7 sts evenly along rib, 115[123:129:131:137:143] sts evenly along front edge and 7 sts evenly along neckband.

129[137:143:145:151:157] sts.

Starting with 2nd row of 1x1 rib work 2 rows.

Next row: Rib 4[3:3:3:3:3], cast off 1 st,

(rib 22[24:25:21:22:23], cast off 1 st)

5[5:5:6:6:6] times, rib 3[2:3:2:2:2].

Next row: Rib 4[3:4:3:3:3], cast on 1 st,

(rib 23[25:26:22:23:24], cast on 1 st)

5[5:5:6:6:6] times, rib 4[3:3:3:3:3].

Work 3 rows more in rib.

Cast off in rib.

LEFT FRONT BORDER

With RS facing, using 3.25mm needles and yarn A, pick up and k7 sts evenly along neckband, 115[123:129:131:137:143] sts evenly along front edge and 7 sts evenly along rib. 129[137:143:145:151:157] sts.

Starting with 2nd row of 1x1 rib work 7 rows.

Cast off in rib.

TO FINISH OFF

Join side and sleeve seams.

Sew on buttons.

Pin out garment to the measurement given.

Cover with damp cloths and leave until dry.

See ball band for washing and further care

instructions. ●

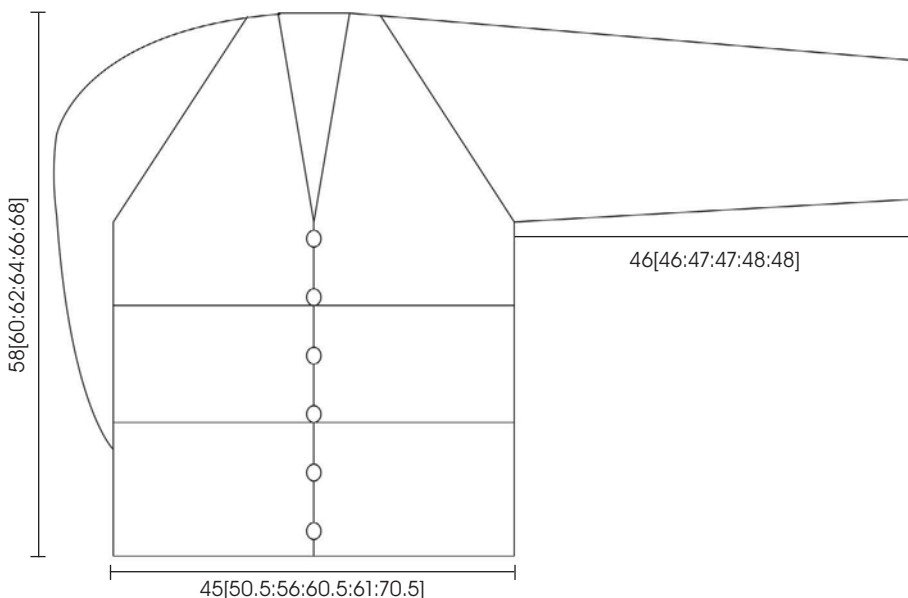

Measurements are given in cm

Nordic cardi – Chart A

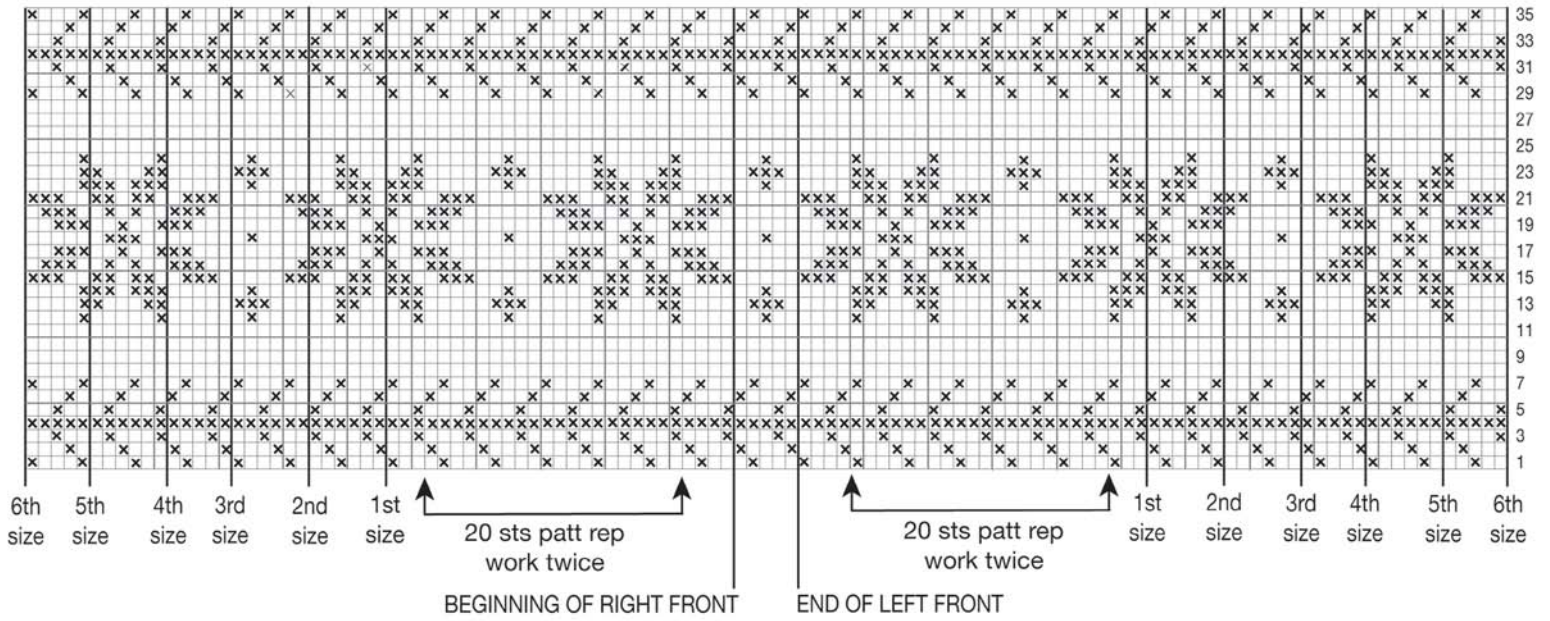

Nordic cardi – Chart B

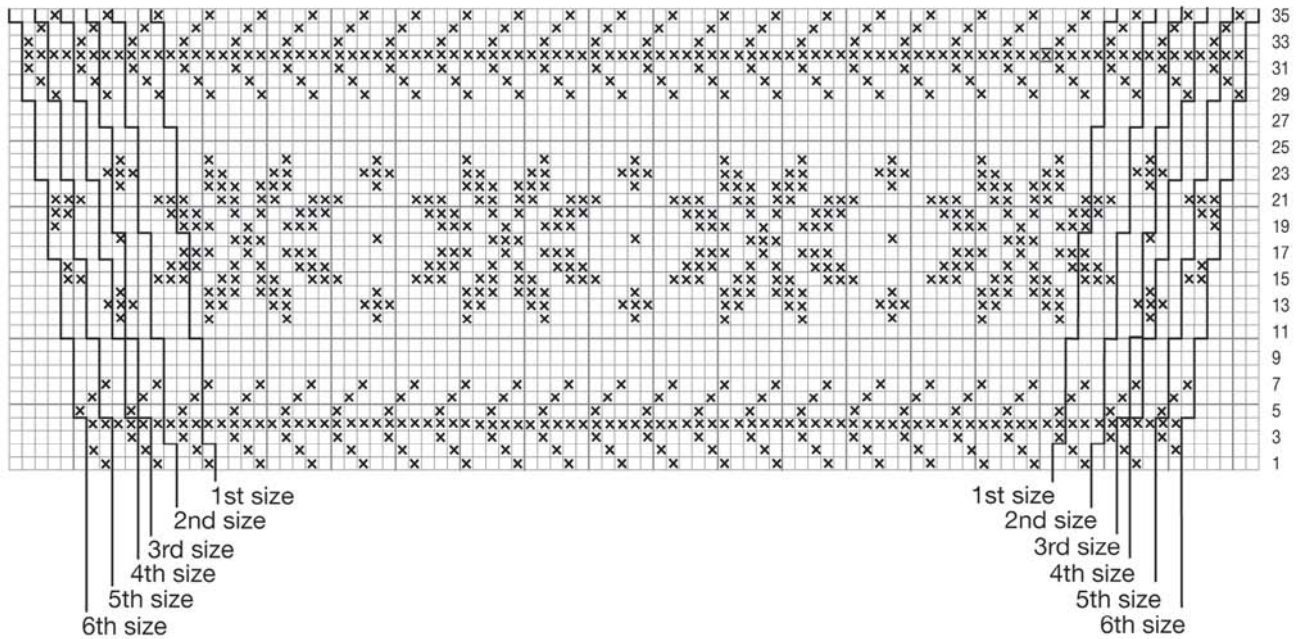

Nordic cardi – Key

- Yarn A
- ⊗ Yarn B

Instructions



Ankle socks by Maisie Smith

SIZE

To fit: Shoe size 5-6 (UK)

YOU WILL NEED

Artesano Alpaca DK 100% pure superfine alpaca (approx 100m per 50g ball)
2 x 50g balls Cream

Set each 3.75mm and 4mm double pointed needles

2 metres of narrow ribbon

Note: yarn amounts given are based on average requirements and are approximate.

TENSION

24 sts and 32 rows to 10cm over pattern using 3.75mm needles.

Use larger or smaller needles if necessary to obtain correct tension.

ABBREVIATIONS SEE PAGE 86

PATTERN NOTE

Panel A (worked over 5 sts)

Round 1: K1, yfwd, k3, yfwd, k1.

Round 2: K7.

Round 3: K2, sl1, k2tog, pss0, k2.

Round 4: K5.

These 4 rows form the patt.

Panel B (worked over 11 sts)

Round 1: P2, k2tog, (k1, yfwd) twice, k1, skpo, p2.

Round 2 and every foll alt round: P2, k7, p2.

Round 3: P2, k2tog, yfwd, k3, yfwd, skpo, p2.

Round 5: P2, k1, yfwd, skpo, k1, k2tog, yfwd, k1, p2.

Round 7: P2, k2, yfwd, sl1, k2tog, pss0, yfwd, k2, p2.

These 8 rows form the patt.

SOCKS (MAKE TWO)

Using 4mm needles cast on 48 sts. Arrange these sts evenly on 3 needles and cont in rounds as follows:

Rib round: (K1, p1) to end.

Rep rib round 3 more times.

Eyelet round: K2tog, yfwd, k1) to end.

Cont in patt as follows:

Round 1: (Work across row 1 of panel A, work across row 1 of panel B) 3 times.

This round sets the position of the panels.

Cont in pattern for a further 35 rounds.

Break yarn and change to 3.75mm needles dividing the sts at follows: sl first 14 sts onto first needle, next 12 sts onto second needle and next 13 sts onto third needle, sl last 9 sts onto other end of first needle.

Shape heel

With RS facing, join yarn to 23 sts on first needle.

Working on these 23 sts only cont as foll:

Beg with a k row work 13 rows in st st.

Row 1: Sl1, p to end.

Row 2: Sl1, k12, skpo, k1, turn.

Row 3: Sl1, p4, p2tog, p1, turn.

Row 4: Sl1, k5, skpo, k1, turn.

Row 5: Sl1, p6, p2tog, p1, turn.

Row 6: Sl1, k7, skpo, k1, turn.

Row 7: Sl1, p8, p2tog, p1, turn.

Row 8: Sl1, k9, skpo, k1, turn.

Row 9: Sl1, p10, p2tog, p1, turn.

Row 10: Sl1, k11, skpo, turn.

Row 11: Sl1, p11, p2tog, turn. (13 sts).

Shape foot

With RS facing, k13, pick up and k11 sts down side of heel flap, p1 from next needle, place marker, patt 23 sts from needles, place marker, p1, pick up and k11 sts along second side of heel flap. (60 sts).

Arrange these sts evenly on 3 needles and cont in rounds as folls:

Round 1: K to within 3 sts of marker, k2tog, p1, sl marker, patt to next marker, sl marker, p1, skpo, k to end.

Round 2: Working 25 sts between markers in patt cont to end of round.

Rep the last 2 rounds 5 times more.

(48 sts).

Slipping markers on every round, cont without shaping until sock measures 19cm (7.5in) from back of heel.

Shape toe

Round 1: K to within 4 sts of marker, k2tog, k2, sl marker, skpo, k to within 3 sts of next marker, k2tog, k1, sl marker, k1, skpo, k to end.

Round 2: K to end.

Rep last 2 rounds until 24 sts rem.

Sl first 6 sts onto one needle, next 12 sts onto a second needle, rem 6 sts on to end of first needle.

Transfer the two groups of sts onto safety pins, fold sock outside in, transfer the sts back onto two needles and knitting one st from each needle tog cast off.

TO FINISH OFF

Cut ribbon in half, thread through eyelet round to tie at centre front. ●





Mohair dress and crown by Lang Yarns

DRESS SIZES

To fit: Age 4[5:6] years

Actual measurement: 72[77:82]cm
(28.25[30.25:32]in)

Length to shoulder: 54[59:64]cm
(21.25[23.25:25.25]in)

Sleeve length: 26[28:30]cm (10.25[11:11.75]in)
Figures in square brackets refer to larger sizes: where there is only one set of figures this applies to all sizes.

YOU WILL NEED

Lang Yarns Mohair Luxe 77% superkid mohair, 23% silk (approx 175m per 25g) 4[5:5] x 25g balls 698.0094 Off White
1 pair each 4mm and 4.5mm needles
1 circular 4mm needle
Stitch holders
Stitch markers
3 buttons
Row counter

Note: Yarn amounts given are based on average requirements and are approximate.

TENSION

21 sts and 27 rows to 10cm over Zig Zag Lace Patt using 4mm needles.
Use larger or smaller needles if necessary to obtain correct tension.

ABBREVIATIONS

sk2po = slip 1, knit 2 sts together, pass slip st over.

For more abbreviations see page 86

PATTERN NOTES

The dress is knitted in one piece with the seam up the middle of the back.

Zig Zag Lace Patt (using 4mm needles)

Row 1: K6, (yo, skpo, k6) to end.

Row 2 and all WS rows: Purl.

Row 3: K4, (k2tog, yo, k1, yo, skpo, k3) to end but end final rep with k2.

Rows 5 and 11: K3, (k2tog, yo, k3, yo, skpo, k1) to end but end final rep with k3.

Row 7: K2, k2tog, (yo, k2, yo, skpo, k1, yo, sk2po) to end but end final rep with yo, k2, yo, sk2po, k1, yo, skpo, k3.

Row 9: As row 3.

Row 11: As row 5.

Row 13: K2, k2tog, yo, (k5, yo, sk2po, yo) to end but end final rep with k5, yo, skpo, k3.

Row 14: Purl.

Cont rep rows 1-14.

BODY Edging

Using 4.5mm needles, cast on 26 sts.
Work in patt according to chart.
Rep chart rows 1-12 23[25:27] times].
Loosely cast off all sts.

Dress

With 4mm circular needle pick up from the straight side edge 246[262:278] sts.
Beg with a k row work 3 rows in st st.
Change to Zig Zag Lace Patt and work 14 rows.

Change to st st and cont as folls:

Next row (RS): Dec 27[29:31] sts evenly across row. 219[233:247] sts.

Work 9[11:13] rows in st st.

Next row (RS): Dec 26[28:30] sts evenly across row. 193[205:217] sts.

Work 11[13:15] rows in st st.

Next row (RS): Dec 24[26:26] sts evenly across row. 169[179:191] sts

Cont working straight.

In foll 12th[14th:16th] row evenly dec

18[18:20] sts. 151[161:171] sts.

Cont without shaping until work meas 25[29:34]cm (9.75[11.25:13.25]in) from pick up edge ending with a WS row.

Shape armholes

Next row (RS): Patt 37[39:42] sts. Turn.

Leave rem sts on holder and cont on these 37[39:42] sts only to form Left Back.

Next row (WS): Cast off 3[3:4] sts, p to end. 34[36:38] sts.

Next row (RS): Knit.

Next row (WS): Cast off 2 sts p to end. 32[34:36] sts.

Next row (RS): Knit.

Next row (WS): Cast off 1 st, p to end. 31[33:35] sts.

Next row (RS): Knit.

Rep last 2 rows 0[1:1] time. 31[32:34] sts.

Cont without shaping until armhole meas 13[14:14]cm (5[5.5:5.5]in) ending with a WS row.

Next row (RS): Cast off 9[10:11] sts k to end. 22[22:23] sts.

Next row (WS): Cast off 7[7:8] sts p to end. 15 sts.

Next row (RS): Cast off 4 sts k to end. 11 sts.

Next row (WS): Cast off 8 sts, p to end. 3 sts.

Next row (RS): Cast off 3 sts.

Shape front

With RS facing rejoin yarn to rem sts.

Next row (RS): K77[83:87] sts. Turn.

Leave rem 37[39:42] sts on holder.

Working on 77[83:87] sts for Front section complete as folls:

Next row (WS): Purl.

Cast off 3[3:4] sts at beg of next 2 rows. 71[77:79] sts.

Cast off 2 sts at beg of next 2 rows.

67[73:75] sts.

Cast off 1 st at beg of next 2 rows.

65[71:73] sts.

Rep last 2 rows 0[1:1] time. 65[69:71] sts.

Cont without shaping until work meas 33[37:42]cm (13[14.5:16.5]in) from pick up edge.

Shape left front neck

Next row (RS): K25[26:27]. Turn.

Work on these sts only and when work meas the same as back to shoulder, complete shoulder shaping as given for back.

Next row (WS) (At neck edge): Cast off 4 sts, p20[21:22].

Next row: Knit.

Next row: Cast off 3 sts, p to end.

18[19:20] sts.

Next row: Knit.

Next row: Cast off 2 sts at beg of next row.

16[17:18] sts.

Next row: Knit.

Next row: Cast off 1 st at beg of next row.

15[16:17] sts.

Next row: Knit.

Cast off 1 st at beg of next row. 14[15:16] sts.

Rejoin yarn to rem 40[43:44]sts.

Next row: Cast off 15[17:17] sts k to end.

Next row: Purl.

Next row (RS) (at neck edge): Cast off 4 sts, k to end. K20[21:22].

Complete as for left front neck reversing all shaping.

Rejoin yarn to rem 37[39:42] sts.

Right Back.

Work as for Left Back reversing all shaping.

SLEEVES

With 4mm needles cast on 37[39:42] sts.
Knit 4 rows.

Cont working in st st.

Inc 1 st at each end of every 6th row 5 times then every 8th row 5[5:4] times.

57[59:60] sts.

Cont without shaping until sleeve meas 26[28:30]cm (10.25[11:11.25]in) from cast on edge ending with a WS row.

Sleeve cap

Cast off 3 sts at beg of next 2 rows.

51[53:54] sts.

Cast off 2 sts at beg of next 2 rows.

47[49:50] sts.

Cast off 1 st at beg of next 10 rows.

37[39:40] sts.

Cast off 3 sts at beg of next 2 rows.

Instructions

31[33:34] sts.
Cast off rem sts.

NECKBAND

Sew seams, at same time leave back seam on left edge open for 14cm (5in).

With RS facing using 4mm needles and starting at top Left Back pick up and k18[19:20] sts across left back neck, 46[48:50] sts across front, 18[19:20] sts across right back neck. 82[86:90] sts.
Knit 4 rows.

Next row (WS): K1, (yo, k2tog) ending with yo, k1.

Work 2 rows, cast off 10 sts evenly over each row. 62[66:70] sts.

Purl 3 rows.

Cast off knitwise.

RIGHT BUTTON BAND

With RS facing and 4mm needles pick up and k31 sts along right back neck opening.
Knit 4 rows.

Cast off loosely p-wise.

LEFT BUTTON BAND

With RS facing and 4mm needles pick up and k31 sts along left back neck opening.
Knit 1 row.

Buttonhole row: Work 3 sts, cast off 2 sts as

follows: (sl next 2 sts on to RH needle, pass first st over 2nd. Sl another st and rep so you have cast off 2 sts. Put last slipped st back onto LH needle. Cast on 2sts. K10) three times ending last rep k3.

Knit 2 rows.

Cast off loosely p-wise.

TO FINISH OFF

Fit in sleeves.

Sew on buttons.

Darn in loose ends.

CROWN SIZES

Head circumference approx:

49cm (19.25in)

Figures in square brackets refer to larger sizes: where there is only one set of figures this applies to all sizes.

YOU WILL NEED

Lang Yarns Yak 50% Yak, 50% extrafine merino (approx 130m per 50g)

1 x 50g ball 772.0094 Off White

1 x 2.25mm crochet hook

Small beads.

Note: Yarn amounts given are based

on average requirements and are

approximate.

TENSION

Not critical.

PATTERN NOTE

Picot

Work 3 ch, sl st into first chain.

ABBREVIATIONS SEE PAGE 86

CROWN

Work a foundation chain of 112 ch sts + 1 ch. Turn.

Row 1: Miss 1 ch. Work 1 dc into each ch to end, 1 ch. Turn.

Rows 2 to 4: Work dc to end work 1ch at end of each row to turn.

Row 5: Ch 4, (1 htr in 3rd dc, 2 ch, miss 2 dc) to last dc, work 1 htr into last dc, 1 ch. Turn.

Row 6: (Dc into htr, 2 dc into ch loop space) to end.

Rep last 2 rows.

Row 9: (2 dc, 4 ch, miss 3 dc, 3 dc) to end.

Row 10: (5 tr, 3 picots, 5 tr into each ch loop space, 1 dc into 2nd dc) to end.

Cut thread.

From narrow edge after bottom edge crochet approx 12 sts and approx 24 rows of dc.

Work 1 row dc along other narrow edge to close crown.

Sew 1 bead into each group of picots. ●

Edging

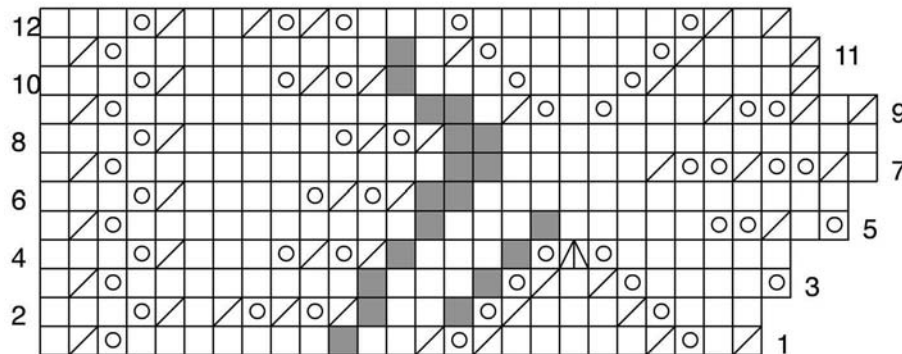

Read RS (odd) rows from R to L and WS (eve) rows from L to R. NB: St count changes from row to row.

- No stitch
- K RS and WS
- k2tog
- yo
- Sl k2tog, pss0

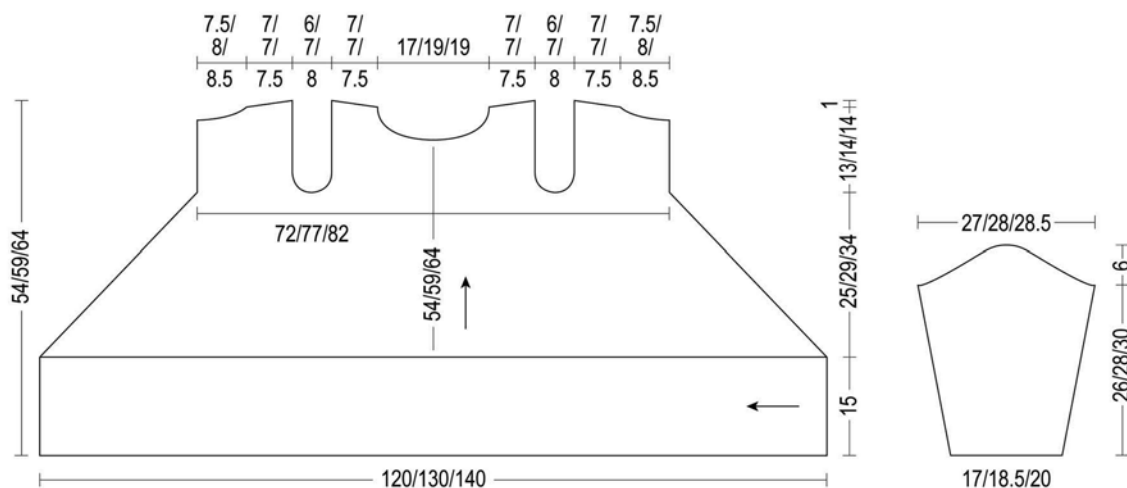

Measurements are given in cm

ARTESANO

Unit G Lambs Farm Business Park
Basingstoke Road
Swallowfield
Reading
Berkshire
RG7 1PQ
Tel: 01189 503350
Website: www.artesanoyarns.co.uk

DEBBIE BLISS/LOUISA HARDING Designer Yarns Ltd

Units 8-10 Newbridge Industrial Estate
Pitt Street
Keighley
West Yorkshire
BD21 4PQ
Tel: 01535 664222
Email: enquiries@designeryarns.uk.com
Website: www.designeryarns.uk.com

DUTTONS FOR BUTTONS

Oxford Street
Harrogate
HG1 1QE
Tel: 01423 502092
Email: michelle@duttonsforbuttons.co.uk
Website: www.duttonsforbuttons.co.uk

KING COLE

Merrie Mills
Elliott Street
Keighley
West Yorkshire
BD20 0DE
Tel: 01535 650230
Email: info@kingcole.co.uk
Website: www.kingcole.co.uk

LANG YARNS Art Yarn

10 High Street
Pointin
Sleaford
Lincolnshire
NG34 0LX
Tel: 01529 240510
Website: www.artyarn.co.uk

THE LITTLE KNITTING COMPANY

Manor Green
Stanford in the Vale
Oxfordshire
SN7 8LU, United Kingdom
Tel: 07980 439587
Website: www.thelittleknittingcompany.co.uk

ROWAN

Green Lane Mill
Holmfirth
West Yorkshire
HD9 2DX
Tel: 01484 681881
Email: mail@knitrowan.com
Website: www.knitrowan.com

SIRDAR Sirdar Spinning Ltd

Flanshaw Lane
Wakefield
West Yorkshire
WF2 9ND
Tel: 01924 371501
Email: enquiries@sirdar.co.uk
Website: www.sirdar.co.uk

SUBLIME

Flanshaw Lane
Wakefield
West Yorkshire
WF2 9ND
Tel: 01924 371501
Sublime helpline: 01924 369666
Email: contactus@sublimeyarns.com

Knitting at your needles

DOWNLOAD KNITTING MAGAZINE TO YOUR IPHONE OR IPAD!



www.pocketmags.com

Knitting

MATCH THE SWATCH

To match the sizes and measurements given in our patterns you must make a tension swatch (gauge) before knitting the project. If your swatch turns out larger than ours, try again using smaller needles. If it is too small, try larger needles.

SEWING UP

- 1 Before you sew knitted pieces together, pin the pieces flat to the measurements given on our diagrams.
- 2 Steam press, lightly steam or spray lightly with water depending on washing instructions on the ball band.
- 3 Allow pieces to cool and dry before sewing up.
- 4 To sew up use the yarn you knitted with. Or, if the yarn is textured and hard to sew, use a smooth matching yarn – cotton with cotton, wool with wool, etc.
- 5 Many garments can be made up by sewing shoulder seams first, then setting in sleeve head to armhole, then completing by sewing along the long seam of the sides and sleeves. Each pattern has extra tips where necessary.
- 6 Darn in all ends and finish seams by lightly steaming from wrong side, provided the yarn can be steamed.

CHOOSING ALTERNATIVE YARNS

- 1 Choose a modern yarn that you like, with a similar look, composition and weight to the one in the old pattern.
- 2 Knit a tension swatch (gauge) and compare it to the one given in the pattern. If they both come out to the same size, you're onto a winner!
- 3 Calculate how much yarn to buy. Many patterns tell you the length of yarn in each ball as well as the weight. So if the pattern uses 10 balls at 130 metres per ball, you know you need up to 1,300 metres of yarn. Check the length per ball of your new yarn and divide the total yarn length by the length in one ball to get the number of balls you need to make the item.
- 4 Compare the total weight of each yarn length. For example if the original pattern had 10 balls at 50g each, the total weight would be 500g. Now that you have worked out how many balls of new yarn you are buying, just multiply the number of balls by the weight per ball. That should roughly match the 500g total that you had for the old yarn. It's just another way to check that you are on the right track.
- 5 Use this same method to substitute yarns for modern patterns, where the yarn is too expensive or difficult to obtain, or if you just want to use up yarn in your stash.

NEEDLE KNOW-HOW

Metric (mm)	Old UK	USA	Metric (mm)	Old UK	USA
2	14	0	5	6	8
2.25	13	1	5.5	5	9
2.5	–	–	6	4	10
2.75	12	2	6.5	3	10.5
3	11	–	7	2	–
3.25	10	3	7.5	1	–
3.5	–	4	8	0	11
3.75	9	5	9	00	13
4	8	6	10	000	15
4.5	7	7			

ABBREVIATIONS

Knit and crochet specific

- alt** alternate, alternating
beg begin(ning)
dec decrease(s), decreased, decreasing
CC contrast colour (sometimes known as C)
CC1/2/3 contrast colour 1/2/3
circ circular
corresp correspond(ing)
cont continue, continues, continuing
DK double knit(ting)
DPN(s) double-pointed needle(s)
est establish(ed)
fol follow, following
fol follows
inc increase(s), increased, increasing
LH left-hand (side)
lp(s) loop(s)
PM place marker (place stitch marker at this point)
MC main colour (sometimes known as M)
meas measure(s), measuring
mult multiple(s)
patt(s) pattern(s)
RH right-hand (side)
rep repeat(ing)
reps repeats
rev reverse, reversing
rnd round
rem remain(s), remaining
RS(s) right side(s)
SH(s) stitch holder(s)
sk skip
sts stitch(es)
sp(s) space(s)
tbi through back loop (work into back loop only)
tfl through front loop (work into front loop only)
WS(s) wrong side(s)
yf yarn forward (also known as yfwd)
yfb yarn to back (bring yarn to back of work)
yff yarn to front (bring yarn to front of work)
yo yarn over (bring the yarn over the needle or hook, frequently used to make a new stitch in lacework)
0 no stitches or times
Knit specific only
g-st garter stitch (every row knit)

- kfb** knit front and back (knit into the front and back of the next stitch – to increase)
k-wise knit-wise (as if to knit)
k2tog knit 2 together (knit next two stitches together as one – to decrease)
m1 make 1 (make one stitch by picking up and knitting the horizontal 'bar' between the current stitch and the next stitch – to increase one stitch)
m-st moss stitch (on first row – (k1, p1) to end: on foll rows, k over p sts and p over k sts)
n1[2:3] needle 1[2:3]
p-wise purl-wise (as if to purl)
patt(s) pattern(s)
patt 2 tog pattern 2 together (work next two stitches together as one, keeping in pattern – to decrease)
p2tog purl 2 together (purl next two stitches together as one – to decrease)
skpo slip, knit, pass over (slip the next stitch, knit the following stitch, then pass the slipped stitch over the knitted stitch – to decrease one stitch)
ssk slip, slip knit (slip one stitch, slip the next stitch, then knit both stitches together)
psso pass slipped stitch over
st st stocking stitch (knit on RS rows, purl on WS rows), also known as stockinette stitch
rev st st reverse stocking stitch (purl on RS, knit on WS)
yon yarn over needle (like yo, but specific to knitting)
y2rn yarn wrapped twice around needle

Measurements

- cm** centimetre(s)
ft feet, foot
g gramme(s)
in inch(es)
mm millimetre(s)
m metre(s)
oz ounce(s)
yd yard(s)

BATH

wool

Bath's Premier Knitting Emporium



01225 469144
www.woolbath.co.uk

BERKSHIRE

THE PINCUSHION

1 ST. MARKS CRESCENT, MAIDENHEAD BERKSHIRE SL6 5DA

Tel/Fax: 01628 777266

280 DEDWORTH ROAD, WINDSOR, BERKSHIRE SL4 4JR

Tel: 01753 860162

STOCKISTS OF:

Sirdar, Wendy, Patons, Stylecraft, Katia, Artesano and Rico yarns.

Rico Can Can, Loopy & Pompom, Katia Ondas, Rizos & Triana. Huge range of colours in Sirdar Snuggly DK, Peter Pan DK, Debbie Bliss Baby

Cashmerino & Sublime Baby Yarns.

Knit Pro and Brittany Birchwood Needles.

More new yarns due in stock soon!

CO. DURHAM

A Fine Yarn

Stocking extensive range of yarns from King Cole, Sirdar, Sublime, Patons, Cygnet, Opal Sock Yarns, some very special Hand Dyed Lace yarns from Ripples Crafts and much, much more.



76a Skinnergate, Darlington, County Durham DL3 7LX
Tel: 07875 146422

CORNWALL



CORNISH WOOLS

Choose from a wide and varied range of knitting wools and accessories, pure Cornish, luxury & exotic yarns, a huge selection and lots of well known brands.

Find us online or visit our shop in Perranuthnoe, Cornwall.

T: 01736 711288

E: INFO@CORNISHWOOLS.CO.UK

W: WWW.CORNISHWOOLS.CO.UK

DERBYSHIRE

The Compleat Knit

Derbyshire's Best Yarn Shop

22 Firs Parade, Matlock, Derbyshire DE4 3AS

Tel: 01629 593700

email: ann@patchworkdirect.com

DEVON

fiddlesticks

for knitting yarns, patterns, needles & lots of buttons

01404 47676

www.fiddlesticksdevon.co.uk

17 New Street, Honiton, Devon EX14 1HA

opening hours Tues - Sat 10:00 to 16:30

DEVON

Inspirations Handicraft Shop

- ◆ Rowan, Noro & Debbie Bliss
- ◆ Sirdar, Patons and Wendy Knitting yarns
- ◆ Appleton Crewel wool and Oliver Twists
- ◆ Amy Butler, Kaffe Fassett and Ebor patchwork fabrics and more
- ◆ Cross stitch, tapestry and embroidery kits
- ◆ Vast range of hand & machine embroidery threads
- ◆ Fantastic selection of unusual beads & buttons
- ◆ Wonderful 'make do and mend' haberdashery section

5, Central Station Buildings, Queen Street, Exeter, Devon, UK. EX4 3SB

Phone: (01392) 435115

DEVON



Spin A Yarn

26 Fore Street, Bovey Tracey, Devon, TQ13 9AD

Specialising in natural fibres in a kaleidoscope of colour & texture. Yarns in stock include Touchyarns & Rareyarns from NZ, Rowan, Sirdar, Artesano, Auracania, Debbie Bliss, Louisa Harding, Lang & Lanartus, Noro, Alchemy, Lantern Moon, Opal & Regia sock yarns & more! Local, organic, hand dyed yarn, plus a huge range of books & accessories.

See web site for details of our list of workshops.

www.spinayarndevon.co.uk

Tel: Joyce on 01626 836203 or Email: info@spinayarndevon.co.uk



EAST SUSSEX

- ◆ Gorgeous yarns
- ◆ Knits and bits
- ◆ Knitting & felting workshops
- ◆ Childrens craft clubs



PURL

16 Upper Hamilton Road BN1 5DF

01273 248642 or 07976 883121

www.purl-brighton.co.uk

purl.brighton@googlemail.com

To advertise in Yarnfinder call Rhoda on 01273 402820 or email rhodab@thegmcgroup.com

Yarnfinder

To advertise in Yarnfinder call Rhoda on 01273 402820 or email rhodab@thegmgroup.com

EAST SUSSEX

Village Crafts

The Square
Forest Row
East Sussex
RH18 5ES

'The little shop with the big heart'

Pure yarns from King Cole, Artesano, Brittany Needles, Bergere de France, Twilleys, Opal sock wools

Haberdashery and patterns

Lay by and Mail order

01342 823238

www.village-crafts.co.uk
village.crafts@virgin.net



ESSEX

twist & yarns

Hand-picked beautiful yarns from the best on offer in the UK and abroad.

We stock Malabrigo, Fyberspates, Millamia, herdy, Shilasdair, Cascade 220, Artesano, KnitPro, Manos del Uruguay, Brittany and many others.

info@twistyarns.co.uk
www.twistyarns.co.uk

ESSEX

Roses & Rue

A passion for all things crafty, an eye on 'make do and mend' and a love of all things vintage

Amazing courses, quality yarns, haberdashery fabrics and much more.

100 Leigh Road, Leigh-on-Sea, Essex SS9 1BU

Tel: 01702 474177
info@rosesandrue.co.uk
www.rosesandrue.co.uk

ESSEX

Gades

Knitting & Needle Craft Specialists

Purely devoted to knitting & needlework. Large range of hand knitting yarn including:

- Sirdar ■ Debbie ■ Bliss ■ Stycraft ■
- Rowan ■ Jaeger ■ Wendy ■ Patons ■

40 years in the trade with staff that are willing to help and solve your queries.

10-12 Clarence Street, Southend-on-sea,
Essex SS1 1BD
Tel: 01702 435730

HAMPSHIRE

The South of England's knitting haven



1,000+ yarns
600+ patterns
Lots of space
Comfy sofas... &
even a cuppa!

Liss Wools

40 Station Road, Liss, Hants, GU33 7DP
01730 893941 – lisswools.co.uk

Order on-line at KnitStation.com

HAMPSHIRE

Pack Lane Wool & Crafts

Stockist of: Sirdar, Wendy, Araucania, Artesano, Debbie Bliss, Louisa Harding, Mirasol, Noro, Patons, Regia, Sublime, Rico, Twilleys, Rowan, Rowan Classic, Stylecraft, Brittany Needles, Knit Pro Needles



We also stock Amy Butler, Free Spirit, Kaffe Fassett Patchwork Fabric, Anchor & DMC, Cross Stitch, Beading, Crochet, Crafts and lots more...



171 Pack Lane, Basingstoke,
Hampshire, RG22 5HN
Tel: 01256 462590
email: enquiries@packlanewool.co.uk
www.packlanewool.co.uk

KENT

C Wool

Knitting Yarn & Accessories

Regular Workshops

Artesano • Bergere de France
Louisa Harding • Knit Pro
Manos De Uruguay
Mirasol • Rowan • Ni Mu

17 High Street, Broadstairs
Kent CT10 1LP
t: 01843 862 848 e: info@cwool.co.uk
www.cwool.co.uk

LEICESTERSHIRE



Threads of Life

In the heart of Castle Donington

An Aladdin's cave of lovely things for yarn addicts, including Adriafile, Bergere de France, James C Brett, Debbie Bliss, Louisa Harding, Noro, Patons, Rico, Rowan, Sirdar, Wendy, Woolcraft, Twilleys and more.

Also knitting and crochet accessories and haberdashery. Details of workshops & classes & other news on the website... and helpful advice. Free parking nearby.

67 Borough Street, Castle Donington, DE74 2LB
Tel: 01332 811597
info@threadsoflife.co.uk www.threadsoflife.co.uk

LINCOLNSHIRE

Spins & Needles

6 Clasketgate, Lincoln, LN2 1JS
(opposite the Theatre Royal)

Lincoln's newest yarn boutique stocking: MilliaMia, Noro, Rowan, Debbie Bliss, Colinette, Sublime, Schoppel Wolle, Louisa Harding, Cygnet and more.

As well as Knit Pro, Brittany needles, Clover and Nic's Knots.

Call: 01522 522865
Email: create@spinsandneedles.co.uk
www.spinsandneedles.co.uk
Join us on facebook or Ravelry too. For news, events and offers.



LONDON

Mrs Moon

YARN & HABERDASHERY

www.mrsmoon.co.uk

41 Crown Road, St Margarets, London TW1 3EJ

LONDON

TRICOLETTE YARNS
93 Boundary Road
Off Abbey Road
St. John's Wood
London NW8 0RG

TRICOLETTE

020 7372 4944
lynn@tricoletteyarns.com
tricoletteyarns.com

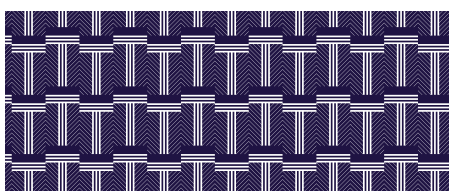

NEWCASTLE UPON TYNE

Woolaballoo.com

Visit us online for the finest yarns

10% off
Online

- * Rico Design
- * Debbie Bliss
- * Katia
- * Adriafile
- * Biggan Design
- * MillaMia
- * Noro
- * Manos

+44 (0)191 580 0103
service@woolaballoo.com

10% discount
with this code:
WINTERWARMER

NEWCASTLE UPON TYNE



a unique knitting destination in the heart of Newcastle upon Tyne

The Knit Studio, Blackfriars, 6 Friars Green, Newcastle upon Tyne NE1 4XN

Tel: 0191 340 8478

Email: theknitstudio@gmail.com

Thurs: 12 noon - 8pm.

Wed, Fri & Sat: 10am - 4.30pm.

www.theknitstudio.co.uk

Free P&P for all UK orders

NORFOLK



Stocking a stunning collection of original and exciting wools and yarns including:

- Debbie Bliss • Noro • Colinette • Opal • Kaalund • Artesano Alpaca • Manos del Uruguay • Ashford Spinning Supplies • Knit Pro • Brittany Needles • Louisa Harding • plus much more!

288 Aylsham Road, Norwich, Norfolk NR3 2RG

Tel: 01603 417001 email: info@norfolkyarn.co.uk

www.norfolkyarn.co.uk

NORFOLK



Everything you need for knitting, crochet & needlework

We stock Sirdar, Stylecraft, Katia, King Cole, Rico, Wendy, Peter Pan, Rowan, Patons, Woolcraft, Designer Yarns and more Knit Pro Symfonie Birchwood needles and accessories.

Good range of DMC, Maia & Anchor Cross Stitch

NEW QUILTING DEPARTMENT NOW OPEN

Full Haberdashery range, ribbons, trims, buttons, zips etc

Find us in the Heart of Norfolk

4a Market Place, Dereham, Norfolk, NR19 2AW

01362 652961

www.knitwitsdereham.co.uk

NORFOLK

Les Tricoteuses
designer yarn

debbie bliss • louisa harding • noro
fyberspates scrumptious • austermann
icelandic lopi • rooster aran • artesano
bergere de france • manos del uruguay
knit pro needles • milistyle accessories

12 Chapel Yard, Albert Street, Holt, Norfolk, NR25 6HG
01263 712770

info@lestricoteuses.co.uk

www.lestricoteuses.co.uk

NORTH YORKSHIRE

needlecase

knitting and sewing supplies

NEW Autumn ranges arriving soon. We stock Sirdar, Artesano, Lang, Debbie Bliss plus DMC Threads, Derwentwater Designs, Bothy Threads and more...



22 Kirkgate, Tadcaster LS24 9AD

01937 830 422 | www.needlecase.co.uk

SOMERSET

MANDY WOOLS



Remember the traditional wool shop? ...
That's us!

Mixing the old with the new...vintage and latest fashion trends in yarns and patterns. We pride ourselves on good, old fashioned service with friendly help and advice.

All the important haberdashery items you need!

Tel. 01749 677548

Online Shop: www.mandywools.co.uk

5 Mill Street, Wells, Somerset, BA5 2AS

SOMERSET



MONKTON ELM

GARDEN & PET CENTRE

Sirdar • King Cole • Stylecraft
Rico • Colinette • James C Brett
Katia • Lang

Large free car park • Open 7 days a week

www.monktonelmgardencentre.co.uk

Tel: 01823 412381

SUFFOLK



Beccles Sewing & Handicrafts

- FABRICS • HABERDASERY
- CRAFT REQUIREMENTS • SEWING MACHINES
- REPAIRS & SALES • KNITTING YARNS

Authorised dealer for:

JANOME, BROTHER, BABYLOCK, PFAFF, ELNA, SINGER, JUKI & FRISTER + ROSSMANN

01502 714234

15A, Blyburgate, Beccles, Suffolk NR34 9TB

SUFFOLK

Wibbling Wools

24b Angel Hill Bury St Edmunds
Suffolk IP33 1UZ



★
Open: mon 10am - 3pm
Tues - Sat 9.30- 5pm

★
Contact: 01284 749555
lynz@wibblingwools.co.uk

★
please check our website for updated list of classes at

www.wibblingwools.co.uk

photos courtesy of Emma Osborne

WARWICKSHIRE

Warwick Wools

17 Market Place, Warwick CV34 4SA

We stock a large selection of yarns including Debbie Bliss, Sirdar, Sublime, Rowan, Wendy, Stylecraft, Katia

We have a vast range of patterns both knitting and crochet.

We also stock knitting needles, crochet hooks, circular needles, Britnay needles and the best selection of buttons for miles.

Friendly service and helpful advice.

Tel: 01926 492853



WILTSHIRE



Crafty Yarn

Stockists of Artesano, Rico, Manos del Uruguay, Bergere de France, Clover, MillaMia, Brittany Needles, Hooks and DPN's

Studley Grange Craft Village, Hay Lane, Wroughton, Swindon, Wilts, SN4 9QT

info@crafty-yarn.co.uk 01793 855535

www.crafty-yarn.co.uk

Classified

To advertise in Classifieds call Rhoda on 01273 402820 or email rhodab@thegmcgroup.com



alpacaselect
Colour your life
www.alpaca-select.com

BEAUTIFUL 100% PURE ALPACA FLEECE
www.alpaca-select.com

- Super soft pure alpaca yarn in natural, dyed and hand dyed variegated shades in DK, 4ply and now in Aran weight.
- Very successful tried and tested patterns and designer kits, specifically designed to knit or crochet. They have been knitted by thousands of customers during the past five years from the knitting shows. Now they are being combined to produce booklets of 3-10 designs for the high street shops, to promote these delightful yarns
- We also offer an extensive range of luxury alpaca garments and accessories.
- Shade cards available in 100% and 50%. Alpaca Fleece £3 each or two for £5.

VIEW OUR NEW WEBSITE AND ORDER BY WEB OR PHONE
WHOLESALE ENQUIRIES ARE WELCOME!
Alpaca Select (Manufacturers and distributors) 82 Frobisher Road, Coventry CV3 6NA
Tel/Fax: 024 7641 1776 Email: sales@alpaca-select.com



Annie Cole

*Traditional Cotton Hand Knitting Kits By Mail Order
Baby Blankets/Bedspreads/Cushions*

For a catalogue contact: annicole54@aol.com
54 Freehold Road Ipswich Suffolk IP4 5HY 01473 721180



Beckside Yarns & Needlecrafts

A Gallery full of fabulous yarns by Noro, Colinette, Debbie Bliss, Rowan, Araucania, Mirasol, Brigantia, Lang, Louisa Harding, RYC Rico and many more

Help and advice always on hand

Open 7 days a week
10am - 5pm
www.becksideyarns.co.uk
info@becksideyarns.co.uk

Beckside Gallery
Church Avenue, Clapham
North Yorkshire LA2 8EA
Tel: 015242 51122

Yarn Gathering of Stone

2B RADFORD STREET
STONE, ST15 8DA

01785 330 474



**FOR ALL YOUR KNITTING & CROCHET SUPPLIES
WORKSHOPS & ADVICE**

INFO@YARNGATHERINGOFSTONE.CO.UK

British Wool Weekend

THE 2nd BRITISH WOOL WEEKEND
1st and 2nd of September 2012
Hall 2 the Yorkshire Event Centre
The Great Yorkshire Showground, Harrogate

For further information on being an exhibitor or visiting this exciting show contact:
JUNE ONIGBANJO PROMOTIONS
Tel: 07790 391142
Email: info@britishwool.net
(Box 3) 19 Rooley Lane, Sowerby, West Yorkshire. HX6 1JG

**Thinking Yarn...
...Think Blacker**

Beautiful natural yarns from British animals spun in Cornwall
Try our new range of Classic Yarns!



Blacker Yarns
NATURAL FIBRES

T: 01566 777635
www.blackeryarns.co.uk

Classified

ATOMIC
knitting

Hand beaded designer stitch markers,
Snag Free Stitch Markers
Crochet Markers, Row Counters,
Needles, Yarn, Hooks, Notions
& Knitting accessories



www.atomicknitting.co.uk
Artesano Stockists
Shop online today
Wholesale Available too!

markers@atomicknitting.co.uk 07787 526592

Patterns for Creative Knitters



download from
www.clairecrompton.co.uk

Westcliffe westcliffehotel@aol.com
Knitting Holidays
46 King Edward Avenue Blackpool FY2 9TA

Paula provides a full and varied programme of knitting and crochet weekends and four-day breaks throughout the year at her nationally accredited Guest House. Holidays are all-inclusive and tailored packages are available to knitting groups.

For further details please call 01253 352943.
www.westcliffe-knitting.co.uk

NWC
NATIONAL WEAVING COMPANY

Specialists in custom woven labels, craft and hobby labels, high quality woven sew in name tapes, woven iron on name tapes, printed name tapes and shoe and property labels. All suitable for identifying school uniforms, workwear and all personal clothing and property.

Fast turnaround & low minimum order!

www.nationalweaving.co.uk

HULU

Quality Knitting Yarns
Knitting Patterns and Books
Accessories and Notions



01548 831911
www.hulucrafts.co.uk

Sentinel House, Poundwell, Modbury, Devon, PL21 0XX Same Day Shipping for online orders

Stockists of luxury yarn, specialising in natural fibres and hand-dyed yarn.

Tangled Yarn

Malabrigo, Debbie Bliss, Louisa Harding, Dream in Color, Natural Dye Studio, Fyberspates, Wild Fire Fibre, Zauberball, Shilasdair and more

FREE SHIPPING TO UK

Beautiful range of essential knitting accessories including Lauren Hill Fiber Art Tools, Addi, Lexie Barnes and Namaste

Email: info@tangled-yarn.co.uk
www.tangled-yarn.co.uk

scottish fibres

THE SPECIALIST mail order suppliers of **wooden** knitting needles, crochet and Tunisian hooks including

Suzanne's **KnitPro** **Silky**

and made to order in most sizes and supplies for spinning, weaving, dyeing, felting and other crafts

0845 388 0023 or 0131 445 3899
enquiries@scottishfibres.co.uk
Secure on-line buying at
www.scottishfibres.co.uk

Renaissance Dyeing

Natural dyer of fine knitting yarns and designer kits



Together with Kate Davis we present **The Funchal Moebius kit**

www.renaissancedyeing.com

eucalan[®]
no rinse | delicate wash

0117.300.5244
www.eucalan.com

grapefruit
lavender
unscented
eucalyptus



Did you know that 86% of our readers knit more than one pattern from every issue of Knitting magazine? Want to find out how your business can share in our success?

Then contact Rhoda Barker on 01273 402820 or rhodab@thegmcgroup.com

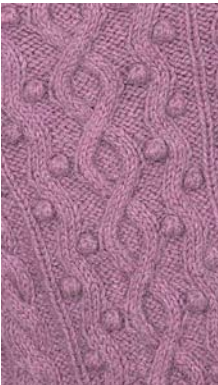

luxurious yarns, naturally

www.inachisyarns.co.uk



To advertise in Classifieds call Rhoda on 01273 402820 or email rhodab@thegmcgroup.com

Web Directory

To advertise in Classifieds call Rhoda on 01273 402820 or email rhodab@thegmcgroup.com

DermaGuard *...discover the difference...your hands will love it!*

Skin protection lotion - the knitter's best friend! No more snagging on roughened skin.

100ml Personal Dispenser Bottle £3.25 • 250ml Pump Dispenser Bottle £6.15
500ml Pump Dispenser Bottle £11.80

**ORDER NOW
POSTAGE FREE!**

To Order Call **FREE** on **0800 917 2219**
Web Order Page www.dermaguard.com
Mail Order: The Skin Care Company Ltd., St Asaph LL17 0HH



 **THE WOOLHUNTER**
Yarns to dye for! 'Because life's just too short for boring yarns!'
WWW.WOOLHUNTER.COM

 Beautiful natural yarns from British animals spun in Cornwall
Blacker Yarns  T: 01566 777635
www.blackeryarns.co.uk

 **We Three**
Knitting Wools and Haberdashery
16 Crown Street, Brentwood, Essex CM14 4BA
Tel: 01277 221709
Email: suzannecarron@aol.com
www.wethree2knitnew.co.uk

 **the little wool company**
WE STOCK 100% BRITISH ALPACA FROM OUR OWN HERD, OR FROM REPUTABLE LOCAL BREEDERS.
STOCKISTS OF ARTESANO, MANOS DEL URUGUAY & BRITANNY BIRCH NEEDLES
www.thelittlewoolcompany.com or call 01409 221699 for a brochure



www.iriss.co.uk
iriss of Penzance

knitwitspenzance.co.uk
Your Wool Shop On-Line
Tel: **01736 367069** 

Frangipani
5-ply Guernsey Wool
www.guernseywool.co.uk 

 **A Bit Woolly**
Online quality Yarns & Knitting Accessories Store
www.abitwoolly.co.uk

Carreg Yarns *The Icelandic Wool Specialists*
E-mail: admin@carregyarns.com Tel: 01547 510002
www.carregyarns.com 

 **TEESWATER WOOLS**
from HIGHER GILLS FARM
Fine long stapled lustrous wool with a natural permanent curl
T: 01200 445370 W: www.teeswaterwools.co.uk 

 **Careloom Knitting Kit**
vintage baby wear in machine washable merino wool
Easy to knit. Affordable prices.
www.careloomkits.com 

 **British Alpaca Hand Knit Yarns**
01884 243579
info@ukalpaca.com
www.ukalpaca.com 

 **eucalan**
www.eucalan.com a whole new spin on laundry!
and On The Go Clothing Care™ line

www.loopknitting.com
happy christmas from loop 

findacraftsman.com

Special USA Subscription Offer

**SAVE
40%!**



SUBSCRIBE
For less than \$80!*



* Online prices are in British Pounds. Full price for 12 issues is £83.83, normal web price is £75.45; however pay just £50.30 (a 40% discount) by using the order code below at checkout. This equals to less than \$80 based on January 2011 exchange rate. Offer ends 03/31/2012.

VISIT: www.thegmcgroup.com

and quote Order Code A2541



Ask Jeanette

Your queries answered by Jeanette Sloan

Star letter kit giveaway

SPONSORED BY artesano



From machine to hand

Q I have been knitting since I was a child and started machine knitting as well in 1982, accruing some 2/30s industrial yarn along the way. I then stopped knitting altogether in 1992 because of work commitments. I have recently started hand knitting again (three granddaughters!). I came across *Knitting magazine* in my newsagents. What a wealth of ideas, advice and patterns! I noticed that most of the patterns are for double knit, not the 2 ends of hb 2/30s that I was used to knitting on the machine nor the 4 ply that I used to hand knit with all those years ago. I was stumped and didn't know where to go for advice. My query is about how many ends of 2/30s high bulk industrial yarn do I need to knit with to use the double knit patterns in the magazine? I have to use up the yarn I have before my husband will let me buy any more!

Thanks for your help.

Lorraine Lyons by email

A Firstly welcome back to hand knitting! It's really lovely to hear that you like the magazine and find all of the features, patterns and advice both interesting and helpful. As someone who's flicked between hand and machine knitting over the years I know it's far too easy to accumulate cone upon cone of yarn, which seems 'redundant' to the uncrafty eyes of husbands or partners. As hand knitters we're used to referring to the thickness of yarn in terms of 'ply', which describes the number of single ends twisted together to make the

final yarn. Whilst we generally understand the difference between a '2 ply' and a '4 ply' yarn these terms are notional and really don't describe the yarn's precise thickness or thinness. (This explains why there are often differences between the 4 plys produced by different yarn brands.) There isn't enough space here to explain in detail the different systems and terms used to calculate yarn counts so we'll look specifically at your yarn. The 'hb 2/30s' tells us that it's a high bulk acrylic made up of two ends of 30s count yarn twisted together. In terms of hand knitting this equates to around a 1 ply so with this in mind you'll need about three to four ends to make up to '4 ply' and six to eight ends to make up to DK. Of course, you should look at this as a guide to get you started, since this doesn't give you the yarn's length, and always knit a tension swatch before embarking on a finished project. Also bear in mind that holding multiple ends together will give different results compared to twisting the yarns together, which can have the effect of compacting or reducing the thickness of the resulting yarn. Good luck!



Lorraine Lyons is this month's star letter winner.

Lorraine wins two gorgeous patterns, *Orange Blossom* by Sue Hanmore and *Purple Rain* by Pat Menchini, as well as a 100g skein of Manos del Uruguay Maxima yarn, 100% Extrafine Merino Wool, to make them. Each month, Artesano will be giving away a kit to the star query published. To be in with a chance to win a kit send your queries to: **Ask Jeanette, Knitting, GMC Publications Ltd, 86 High Street, Lewes, East Sussex BN7 1XN** or email jeanettes@thegmcgroup.com
Note: Jeanette regrets that she cannot enter into any personal correspondence with readers and can only answer letters that are chosen for publication in *Knitting*.



PHOTOGRAPH © WWW.THINKSTOCKPHOTOS.CO.UK

Fairisle Fantasy

Q As all knitters understand, as the nights close in, we get that itch to knit something. Having sorted through mine and my mother's old patterns, I came across this pattern (included) and thought 'YES', I would really like to tackle this.

I don't know whether any of your readers can help. This pattern was on the back page of a booklet that was included in an issue of *Woman and Home* in February 1988! However, it was a free extra pattern to be sent for at the time and obviously neither my mother nor I thought to do so.

I was wondering if any of your readers, their mothers, or, as I am in my early sixties, grandmothers, might have sent for this pattern and still have it, as I would love a copy of it to give it a go. My alternative is to find a cardigan pattern the same shape (any suggestion?) and then work out

the Fairisle pattern on graph paper, which shouldn't be too difficult. The pattern in between looks to me like cable stitch. It is the number of stitches and decreasing which is the main problem.

Denise R Siddons, Jersey

A Unfortunately, despite doing a lot of research, I haven't managed to track down a copy of the pattern you are after, which was designed using Hayfield yarn. It's very distinctive and typical of the 1980s with bold patterning, lots of texture and of course big shoulders. If you have access to the internet then try searching eBay (www.ebay.co.uk) as there are hundreds of vintage knitting patterns listed for sale. I would however love to get hold of the pattern for you so if there are any readers out there who may have a copy stashed away in a folder please email me at

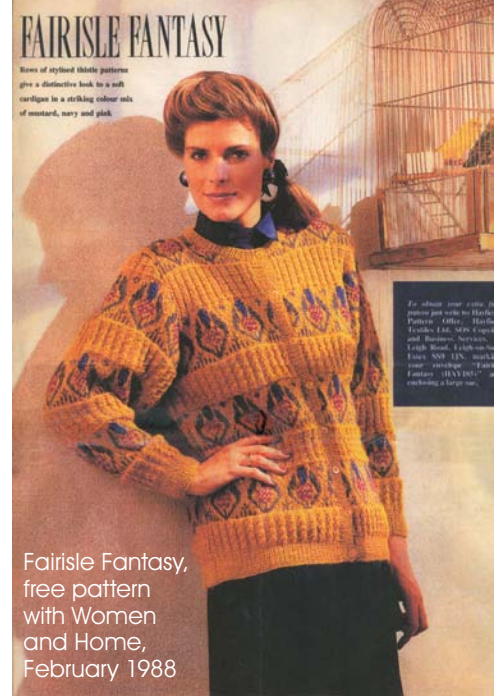

Fairisle Fantasy, free pattern with *Women and Home*, February 1988

jeanettes@thegmcgroup.com with Fairisle Fantasy as the subject and hopefully we'll come up trumps for you.

Backward loop cast on

Q Recently I have found some lovely lace patterns I would like to try but each instructs the knitter to start with a 'backward loop' cast on. Although I know of the cable lace cast on, I've never heard of this and can't find a reference to it in instruction books. So I'd be most grateful for any help with this – I'm sure other readers must have come across this too.

C Fletcher, Essex

A The backward loop method is actually the first cast on I was taught at the age of seven but I found it frustratingly difficult to keep it neat and tidy. It is however really useful for casting on stitches in the middle of a row, for example when working buttonholes or when needing to add extra stitches at the base of fingers when making gloves. Here's a step-by-step guide to get you started:



1. Make a slipknot and place on the knitting needle.



3. Now turn the palm of your hand away from you to create a loop on your left thumb and with your right hand push the needle into the loop.



2. *With the palm of the left hand facing you position thread the yarn over your left thumb so that the end attached to the ball is on the outside of your hand and the yarn travels across your palm to the slip knot placed on the needle held by the right hand.



4. Remove your left thumb – you've created a backward loop on the needle*. Repeat from * to * as required.

jeanettes@thegmcgroup.com



BRITTANY

KNITTING NEEDLES & CROCHET HOOKS



UK and European Distributors for Brittany Needles
0118 9503350 www.artesano.co.uk



PURL About TOWN

Laura 'Purl Princess' Parkinson tackles a skeleton in her yarn cupboard and finally puts a knitting disaster to rest

PHOTOGRAPHS BY LAURA DAVIS



At the beginning of each year I like to get organised and so I take a look at my stash, what projects I hope to knit in the coming months and what has been left unfinished from the year before. There is one project that has been coming back to haunt me year after year and I always end up quietly tucking it away at the bottom of the stash and putting it out of my mind for another twelve months: this is my denial of the **Batwing Jumper**. I knitted the offending item back in 2005 and it was my first ever knitted garment. Sadly I chose completely the wrong pattern for my body shape; the slash neck, short length and wide batwing style just made me look enormous – what a rookie mistake. I was so new to knitting that I must have thought the craft had magical powers to alter your actual body shape!

Years ago I had earmarked this monstrosity for ripping and re-knitting into something worthy of the expensive yarn it was made with, but there was always something stopping me. I can't pinpoint an exact reason why I had procrastinated over the ripping of an un-wearable jumper for so long. There was something about it being my first ever jumper, about the yarn costing me so much and about it being a complete finished and

sewn up garment, which made it hard for me to just frog. However, this year, as I pulled the batwing jumper out of its hole, I remembered that 2012 is a leap year. I have always found it strange how every four years we get this 'extra day' and we just let it pass us by without using it. There is that silly outdated tradition of women being 'permitted' to propose to men on the 29 February, but come on girls, we live in a modern world, just ask him! So why don't we embrace the fact that we have an 'extra day' this year and use this time to do something you've been meaning to do?

With the jumper sat in front of me like a sad old sack, I decided that there was no time like the present. It was time to rip this bad boy. My sewing up skills were clearly horrific in 2005 as I seemed to have sewn up



The offending article
RIGHT: The joy of ripping

the entire garment in back stitch. This again hadn't helped the hideousness of the jumper as the chunky seams tussled for room against the wearer, but it did help me find the ends of the yarn and quickly start to unpick the seams. As the jumper slowly disassembled I felt the weight of this woolly skeleton in my closet lifting from my shoulders and this spurred me on to rip, rip, rip! Usually no one likes ripping back their work but this was satisfying stuff. The black mark on my knitting record was being erased stitch by stitch.

It took me a lot longer than I thought it would to wind off the seven balls of chunky

yarn used to knit the jumper. As I went along I thought about what I would have been doing all those years ago when I knitted the stitches. I would have just finished University and been living at home with my parents, the Mr and I would not be married yet and we wouldn't have our daughter Flo... I didn't even have this column in my life! Reflecting back made me feel very grateful for everything that got me to where I am today. Perhaps one of the reasons that it took me so many years to face up to ripping this jumper could have been its connection to the past. The batwing disaster was a reminder of how far I've come, not just

in knitting and sewing up skills but in life. Nevertheless it was time for the jumper to stop being my guilty secret at the bottom of the yarn stash.

When the final stitches were unravelled I sat with the balls of yarn at my feet and felt relieved and strangely proud to have used the idea of the 'extra day' to do something that I'd been putting off for almost seven years. Hopefully the yarn will now go on to make something more beautiful that I can wear with pride.

For more ramblings of a Purl About Town visit Purlabout.blogspot.com

Must Knit:

The amazing Woolly Wormhead can only be described as a hat architect as her knitted hats are constructions of pure beauty. Why not use up some of your stash to keep the heads in your family cosy for the remaining winter months. Go to woollywormhead.com for free patterns and patterns available to buy.

Must Read:

After a couple of delays *A Stitch in Time Volume 2* came out last year and this vintage knitwear book was well worth the wait. With a huge 80 patterns, the hefty hardback could be a coffee table book with its sumptuous photography and the original patterns printed in all their glory. Get yours from knitonthenet.com

"As the jumper slowly disassembled I felt the weight of this woolly skeleton in my closet lifting from my shoulders and this spurred me on to rip, rip, rip! Usually no one likes ripping back their work but this was satisfying stuff."



*KnitPro*TM

FOR THOSE WHO LOVE TO KNIT

www.knitpro.eu

R O W A N



Relax, Handknit, Create...

Knitting & Crochet
Magazine 51 ZM51

Become a R O W @ N member by visiting

www.knitrowan.com



Collection



Brought to you by...

Knitting

magazine

Free with issue 99 February 2012



Mandy Wools

01749 677548

"We're a
proper wool
shop!!"

5 Mill Street
Wells
BA5 2AS



www.mandywools.co.uk

GILLIANGADRAG

SAVE 15%

on our Basic Feltmaking Kit

PLUS get a FREE Gilliangladrag "Fluffy Stuff"
Project / Wool Bag with everyone one ordered.

Use code KNITTING212

Offer ends Feb 28th 2012



The basic felt making kit comes in a smart
drawstring bag and includes:

- ★ A 100g rainbow bag of merino wool tops
- ★ A large bamboo rolling mat 180 x 60cm
- ★ A piece of net 1 metre long
- ★ Full clear illustrated instructions

Email: gill@giliangladrag.co.uk

Tel: 01306 898144

The Fluff-a-torium, 20 West Street, Dorking, Surrey RH4 1BL

WWW.GILLIANGADRAG.CO.UK

ball and needle

An online only store specialising in
a lively mix of knitting & crochet
supplies that we keep on adding to!

Check out our new items and
bestselling Cygnet yarns this season.

www.ballandneedle.co.uk

nicki@ballandneedle.co.uk

tel 01761 435269

or 07870 436089

deramores

THE KNITTING SUPERSTORE



10% OFF USE COUPON KM882

www.deramores.com



Collection

We bring you 5 patterns from the Cozy series including 2 brand new exclusives from *Knitted Finger Puppets* and *Tea Cozies 3*

Exclusive pre-publication discounts

Knitted Finger Puppets and *Tea Cozies 3* are published March 2012



Readers can order *Knitted Finger Puppets* for the special price of £7 (RRP £9.99) plus p&p. To order, please call 01273 488005 and quote reference code R3423. Offer closes 19 April 2012.



Readers can order *Tea Cozies 3* for the special price of £7 (RRP £9.99) plus p&p. To order, please call 01273 488005 and quote reference code R3433. Offer closes 19 April 2012.

You can also buy the following books in the Cozy series for the special price of £7 each (RRP £9.99) plus p&p, available now. To order, please call 01273 488005 or go to www.themcgroup.com and quote reference code R3424. Offer closes 19 April 2012.

Gloves



Hats



Scarves



Socks



Tea Cozies



Tea Cozies 3



Coffee Cozies



Techno Cozies



Mug Hugs



Pots to Knit & Crochet



Hot-Water Bottle Covers



Toilet Roll Covers



Amigurumi



Crocheted Finger Puppets



Egg Cozies



This cozy was inspired by traditional Scandinavian designs, using the familiar shapes of embroidered snowflakes but with wooden beads adding a twist. Using the retro colours suggested will bring a winter folk look to your table.

Winter Fairisle
by Sian Brown
Yarn Rowan Kid Classic
Pattern page 7



Overseeing the circus entertainment is an important job and Russell, with his smart red tail coat, bow tie, top hat and dapper moustache, is ready to crack his whip and keep everything under control.



Russell ringmaster
by Susie Johns
Yarn Any 4 ply yarn
Pattern page 8

Flip over the top of these simple, yet stylish mittens to transform them into fingerless gloves. Clean and natural looking with a gorgeous floral design, they offer the best of both worlds.

First flip-tops
by **Susette Palmer**
Yarn Jamieson's Shetland
Spindrift 4 ply
Pattern page 9



This young, fun design is just right for relaxing at home. The yarn is used double throughout for extra snugness.



Snug Slouch
by Chrissie Day
Yarn Cygnet Aran
Pattern page 10

This simple but stunning cover in unusual shades was inspired by rows of vines in a Tuscan vineyard. The diagonal pattern is easy but effective.



Diagonal Stripe
by **Chrissie Day**
Yarn Rowan Kid Classic
Pattern page 11

Cozy pattern instructions



Winter Fairisle by Sian Brown

MATERIALS

Rowan Kid Classic 70% lambswool, 26% kid mohair, 4% nylon (153yd/140m per 50g ball)
1 x 50g ball in each of 828 Feather (A), 854 Tea Rose (B), 862 Teal (C), 853 Spruce (D)
A pair of 5mm (UK6/US8) needles

MEASUREMENTS

Height: 6½in (17cm)
Lower edge circumference: 18in (46cm)

TENSION

18 sts and 23 rows to 4in (10cm) over st st using 5mm needles.
Use larger or smaller needles to obtain correct tension.

PATTERN NOTES

The tea cozy is worked using the Fairisle method (see page 13) and the intarsia method (see page 13), where separate balls of yarn are used for each block of colour. Read the chart from right to left on right-side rows and from left to right on wrong-side rows.

MAIN PIECE (MAKE 2)

With 5mm needles and A, cast on 44 sts.

Knit 3 rows. Join in D.

Row 1: K2A, (p1A, p1D) 20 times, k2A.

Row 2: K2A, (k1A, k1D) 20 times, k2A.

These 2 rows set the pattern for chart 1 and g-st edgings.

Continue to follow chart 1, working in st st and g-st edges throughout until 11 rows have been worked.

Starting with a purl row, work 4 rows st st, dec 1 st on last row (43 sts).

Cont as follows.

Row 1: K13A, follow row 1 of chart 2, k13A.

Row 2: K2A, p11, follow row 2 of chart 2, p11A, k2A.

These 2 rows set the pattern.

Continue to follow chart 2 until 20 rows have been worked.

Shape top

Row 21: K2A, (k2A tog, k2A) 3 times, K5A, follow centre 5 sts of chart 2, k5A, (k2A, k2A tog) 3 times, k2A (37 sts).

Row 22: K2A, p15D; p3A; p15D, k2A.

Row 23: K2A, (k2A tog, k1A) 4 times, k2A, (k1D, k1A) twice, k1D, k2A, (k1A, k2A tog) 4 times, k2A (29 sts).

Working with A only, continue as follows:

Next and following alt row: K2, p to last 2 sts, k2.

Next row: K2, (k2 tog) 6 times, k1, (k2 tog) 6 times, k2 (17 sts).

Next row: (K2 tog) 4 times, K1, (K2 tog) 4 times (9 sts).

Cast off.

MAKING UP

Press pieces according to ball band. Using B and straight stitch, embroider snowflakes around main motif as shown.

Sew on wooden beads. Sew side seams, leaving gaps for handle and spout.

TIES

Cut six 30in (76cm) lengths of yarn. Form into a plait, tie in a bow and sew on to top of cozy. ●

Pattern taken from *Tea Cozies 3*

Winter Fairisle chart 1

(10 sts x 11 rows)

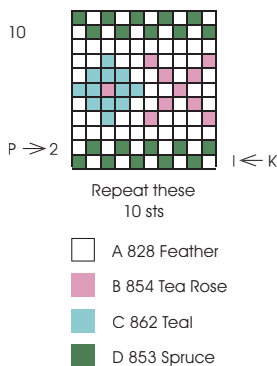

Winter Fairisle chart 2

(17 sts x 23 rows)

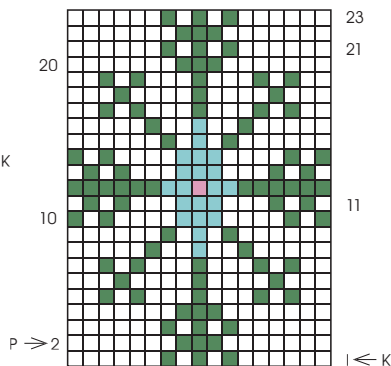

1 square represents 1 stitch and 1 row

Cozy pattern instructions



Russell ringmaster by Susie Johns

MATERIALS

4 ply knitting yarn in black (A), pale grey (B), turquoise (C), white (D), beige (E), geranium red (F) and chocolate (G)

Black embroidery thread
1 small red button

Button or circle of plastic approximately 1in (2.5cm) in diameter

Pair of 2.75mm (UK12:US2) knitting needles

2 x 2.75mm (UK12:US2) double-pointed knitting needles

4 x 2.25mm (UK13:US1) double-pointed knitting needles

Tapestry needle

Plastic drinking straw

SIZE

Russell's body measures approximately 2½in (6.25cm) in length.

TENSION

15 sts and 20 rows to 2in (5cm), measured over stocking stitch on 2.75mm (UK12:US2) needles, using 4 ply yarn.

The exact tension is not critical.

TROUSERS

Using two 2.75mm double-pointed needles and A, cast on 10 sts; do not cut A but slide sts to other end of needle and join in B.

Row 1: Using B, k to end; do not cut B but turn work and pick up A.

Row 2: Using A, p to end; do not cut A but slide sts to other end of needle and pick up B.

Row 3: Using B, p to end; turn. Continue in this way, working single rows in alternate colours until 35 rows have been worked, ending with a row in B.

Cast off using A.

Cut B; using A, and with RS facing, pick up and k24 sts along one long edge of work.

Knit 2 rows and cast off knitwise; cut yarn and fasten off.

CUMMERBUND, TORSO AND HEAD

Cummerbund

On opposite edge of trousers, using 2.75mm needles and C, and with RS facing, pick up and k24 sts.

Knit 3 rows, cut yarn.

Torso and head

Using D, beg with a k row, work 8 rows in stocking stitch.

Row 12: K1, k2tog, (k2, k2tog) 5 times, k1 (18 sts).

Row 13: P to end; cut yarn and join in E.

Row 14: Using E, k to end.

Row 15: P to end.

Row 16: K1, inc1, (k2, inc1) 5 times, k1 (24 sts).

Beg with a p row, work 11 rows in stocking stitch.

Row 28: (K2tog) 12 times (12 sts).

Row 29: (P2tog) 6 times.

Cut yarn and thread through rem 6 sts.

ARMS (MAKE 2)

Using 2.75mm needles and E, cast on 4 sts.

Row 1: K to end.

Row 2: P to end.

Row 3: Inc1 in each st (8 sts).

Row 4: P to end.

Row 5: K to end.

Row 6: P to end; cut E and join in D.

Rows 7-9: Using D, k to end.

Beg with a p row, work 19 rows in stocking stitch.

Cast off.

JACKET Main part

Using 2.75mm needles and F, cast on 28 sts.

Row 1 (WS): K each st tbl.

Row 2: K to end.

Row 3: K1, p to last st, k1.

Rep rows 2 and 3 eight times more.

Row 20: K4, [(k2tog) twice, k4] 3 times (22 sts).

Row 21: P to end.

Row 22: (K2tog) 11 times (11 sts).

Row 23: P to end.

Cast off.

SLEEVES (MAKE 2)

Using 2.75mm needles and F, cast on 11 sts.

Row 1 (WS): K each st tbl.

Row 2: K to end.

Beg with a p row, work 11 rows in stocking stitch.

Row 14: K1, sl1, k1, pss0, k5, k2tog, k1 (9 sts).

Row 15: P to end.

Row 16: K1, sl1, k1, pss0, k3, k2tog, k1 (7 sts).

Row 17: P to end.

Cast off.

HAT

Using 2.25mm needles and A, cast on 1 st and k into front, back and front of this st (3 sts).

Row 1: Inc1 in each st (6 sts).

Row 2: P to end.

Row 3: Inc1 in each st (12 sts).

Row 4: P to end.

Row 5: Inc1 in each st (24 sts).

Beg with a p row, work 11 rows in stocking stitch.

Row 17: (K1, inc1) 12 times (36 sts).

Row 18: P to end.

Row 19: (K2, inc1) 12 times (48 sts).

Row 20: P to end.
Cast off.

BOW TIE

Using 2.25mm needles and A, cast on 11 sts.

Row 1: K each st tbl.

Row 2: P to end.

Row 3: K to end.

Cast off knitwise.

WHIP

Using 2.25mm needles and G, cast on 28 sts.

Row 1: K each st tbl.

Knit 2 rows. Cast off.

MAKING UP

Stitch back seam of trousers, torso and head. Run a length of yarn through the stitches at neckline, stuff head and draw up yarn to close opening and shape neck. Wrap jacket around body, placing the two side edges at centre front.

Stitch edges together about ½in (1cm) down from cast-off edge and stitch button on top of this join.

Fold back edges above this point and stitch in place to form lapels.

Stitch arm seams, stuffing with any remaining yarn ends, then fold over approximately ½in (1cm) at top of each one, to create extra bulk; attach to top of main piece of jacket at shoulders. Stitch sleeve seams, slip each one over one of the arms and stitch to jacket. Using yarn E, make ears from bullion stitch and oversew the central line of stitches to form a nose.

Use black embroidery thread to embroider eyes, eyebrows, a moustache and small mouth.

(See page 13 for more details about embroidering facial features.) Stitch the seam on the hat, place button on top of hat and stuff, then stitch

the hat to top of the head. To make the bow tie, fold under ¼in (3mm) on each short edge then bind tail of yarn two or three times around centre to form a bow shape.

Stitch to front of neck. To make up the whip, cut a 3in (7.5cm) length from a narrow plastic drinking straw, wrap the strip of knitting around it and oversew cast-on and cast-off edges together.

Tuck in end, leaving one yarn end dangling. Fold one of the ringmaster's hands over the whip handle and stitch in place. ●

Pattern taken from *Knitted Finger Puppets*



First flip-tops by Susette Palmer

SIZE

To fit average adult

Circumference above thumb 8in (20cm)

Note: Because of the 'palm' thumb this may be more comfortable if worked a little wider than usual.

TENSION

32 sts and 46 rows to 4in (10cm) measured over st st using 3mm needles

Use larger or smaller needles to achieve correct tension

MATERIALS

Jamieson's Shetland Spindrift 4 ply 100% Shetland wool (105m/115yds per 25g ball) OR any 4 ply yarn that knits to the right tension
3 x 25g balls in 105 Eesit

Sets of 2.75mm (UK12:US2) and 3mm (UK11:US2-3) double-pointed needles
Oddments of yarn for embroidery

SPECIAL TECHNIQUES

3-needle cast-off method

METHOD

The mittens start at the wrist with a 2x2 rib. The main hand section is then worked. The thumb opening is created by working 10 sts in waste yarn then continuing to work over these again in the main yarn. Finger openings are edged individually with 5 rounds of 1x1 rib and loose ends are sewn in at this point. The flip-top of the mitten is then worked, followed by lazy daisy embroidery on the backs of both hands.

MITTENS

With 2.75mm needles cast on 60 sts over 3 needles and work in the round in 2x2 rib for 2in (5cm), inc 4 sts evenly in the final round as folls: (M1, k15) 4 times. 64 sts.

Change to 3mm needles and work even in st st for 2in (5cm) from end of rib.

BEGIN THUMB

K42 (for right mitten) or k32 (for left), place the last 10 sts back on LH needle and knit again in waste yarn, knit to end of round in main yarn. Work in rounds for a further 1¾in (4.5cm) to the base of the fingers.

Break off yarn and put all sts on waste yarn tied in a bow at the opp end to the first of the 10 thumb sts.

BOTH MITTENS

Work fingers (see page 12).

Right-hand fingers are worked starting palm facing, left-hand back facing.

LITTLE FINGER

Place 7 sts from one end of waste

Cozy pattern instructions

yarn on a dpn and 7 sts from the other end on another dpn. Inc 2, work these and the rem 7 sts from first needle in 1x1 rib, then rib 7 sts from other needle (16 sts) to form circle. Work 5 rounds 1x1 rib. Cast off loosely in rib.

THIRD (RING) FINGER

Place the next 8 sts from each end of waste yarn on a dpn. Inc 2, then rib these 2 sts and the 8 sts onto one needle, pick up and rib 2 sts from the base of the previous finger, rib the 8 sts on the other needle. 20 sts. Rib 5 rows and cast off. Rep above for second finger.

FIRST FINGER

Place rem 18 sts on 2 dpns. Rib 2 sts from base of second finger, rib the 9 sts from one dpn, then the 9 sts from the second dpn. Rib 5 rows. Cast off.

THUMB

Pick up 10 sts from each side of waste yarn (see page 12), inc 2 sts at each end. 24 sts. Work for 2in (5cm).

Shape top

Next round: (k2, k2tog) to end. 18 sts.

Knit 1 round.

Next round: (k1, k2tog) to end. 12 sts.

Knit 1 round.

Next round: (k2tog) to end.

Pull yarn through rem 6 sts to close.

Note: Darn in ends now, as it is easier to do this before the flip top is knitted.

FLIP TOP

Cast on 32 sts and work as follows:

Row 1: K1, (p2, k2) to last st, k1.

Work in this rib for 5 more rows. Now pick up 32 sts along the back of the mitten 5 rows down. This should give you a circle of 64 sts around the finger tops. Rearrange over 3 needles.

Knit on this circle for 2in (5cm).

Shape top

Note: I found I could do this using only 3 dpns, but continue to use 4 if preferred).

Next round: (K2tog, k28, k2tog tbl) twice. 60 sts.

Next round: (K2tog, k26, k2tog tbl) twice. 56 sts.

Next round: Knit.

Rep these last 2 rounds, knitting 2 sts fewer bet decs until (k2tog, k20, k2tog tbl) is worked.

Knit 1 round.

Cast off using the 3-needle method.

MAKING UP

Embroider lazy daisy flowers at random (see page 13). Darn in all ends and leave under a damp cloth overnight. ●

Pattern taken from *Gloves*



Snug Slouch by Chrissie Day

SIZE

To suit UK size 4-5(5-6:6-7)

Foot length 8½(9½:10½)in (22(24:27)cm)

TENSION

11 sts and 15 rows to 4in (10cm) over

patt on 7mm needles, using yarn double throughout. Use larger or smaller needles to achieve correct tension.

MATERIALS AND EQUIPMENT

Cygnét Aran, 75% British wool and 25% polyamide (224m per 100g). 3 x 100g balls 233 Lavender Set of 7mm (UK2:US10.5) double-pointed needles

SPECIAL TECHNIQUES

M1

Kitchener stitch

LEG

Cast on 28(30:32) sts divided evenly between 4 needles.

Join, taking care not to twist sts.

Size 4-5 only: K1, *p2, k2 rep from * to last 3 sts, p2, k1.

Rep until work measures 10in (26cm).

Size 5-6 only: K1, p3 *p2, k2, rep from * to last 4 sts, p3, k1.

Rep until sock measures 5in (12cm), then dec 1 st in each p3 section (28 sts).

Next round: K1, p2 *p2, k2, rep from * to last 4 sts, p2, k1.

Cont until work measures 10½in (26cm).

Size 6-7 only: K1, p4, *p2, k2, rep from * to last 7 sts, k2, p4, k1.

Rep until sock measures 5½in (14cm), then dec 1 st in each p4 section (30 sts).

Next round: K1, p3 *p2, k2, rep from * to last 4 sts, p3, k1.

Cont until work measures 11in (28cm), then dec 1 st in each p3 section.

Next round: K1, p3 *p2, k2, rep from * to last 4 sts, p3, k1.

Cont until work measures 12in (30cm).

Divide for heel (all sizes)

Set aside 14 sts (7 sts on either side) for gusset and work back on the rem 14 sts for heel for 2(2½:3)in or 5(6:7)

cm.

Place marking thread here.

Decrease for heel

Row 1: K until 5(6:6)sts left on row, k2tog turn.

Row 2: P until 5(6:7)sts left on row, p2tog turn.

Row 3: K until 4(5:5)sts left on row, k2tog, turn.

Row 4: P until 4(5:5)sts left on row, p2tog turn.

Cont in this way, leaving one st fewer before each dec, until 6(7:8)sts rem.

FOOT

Pick up 7(9:10) sts on each side of heel. Arrange all 34 (38:42) sts, including those set aside, on double-pointed needles.

Next round: Work the centre 16 sts in rib and the rest in st st.

Next round: Work in st st and rib but dec by working k2tog into the back of the 2 sts before the rib and working the 2 sts after the rib as k2 tog.

Rep last 2 rounds until 24(26:28) sts rem.

Work straight until foot measures approx 7(8:8½)in or 18(20:22)cm from heel.

Insert a marker thread on each side 12(13:14) sts between each marker.

Decrease for toe

Cont in st st on all sts, dec on either side of each marker thread (MT) thus:

Next round: k2tog, k1, MT, k1, k2tog into back of st.

Next round: Work in st st.

Rep the last 2 rows a total of 3 times
Dec on every row 1(1:2) times (8:10:8) sts.

MAKING UP

Using Kitchener stitch graft sts together. ●

Pattern taken from *Socks*



Diagonal Stripe by Chrissie Day

MATERIALS

Rowan Kid Classic (140m per 50g ball)

1 x 50g ball 854 Tea Rose (A)

1 x 50g ball Aubergine 852 (B)

1 x 50g ball 845 Green (C)

A pair of 4mm (UK8:US9) needles

A pair of 5mm (UK6:US8) needles

4.50mm (UK7:US7) crochet hook

Ready-made template or card to make pompons

MEASUREMENTS

9in (23cm) wide x 14½in (37cm) long including top gathering

TENSION

20 sts and 24 rows to 4in (10cm) over st st using 5mm needles

SPECIAL TECHNIQUES

Pompons (see below)

yrn = yarn round needle

Intarsia method = use separate small balls of yarn for each block of colour, twisting yarns securely at back of work to avoid gaps

FRONT

Using C and 4mm needles, cast on 45 sts and foll chart 1, working in st st and using the intarsia method.

Row 1 (RS): K15C, k15B, k15A.

Next row: Foll chart from row 2 for 4 rows.

Change to 5mm needles and work until row 72 has been completed,

ending with RS facing for next row.

Next row (eyelets): Keeping the stripe sequence as set, *k2, yrn, k2tog, k6; rep from * to last 3 sts, yrn, k2tog, k1. Foll chart until row 88 has been worked, ending with RS facing for next row.

Change to 4mm needles.
Using C only, work 3 rows g-st (every row knit).
Cast off k-wise.

BACK

Using C and 5mm needles, cast on 45 sts.

Change to A.

Next row (RS): K15A, k15B, k15C. Foll chart 2 from row 2, working the diagonal stripes as marked, for 4 rows.

Change to 5mm needles and work until row 72 has been completed, ending with RS facing for next row. Work eyelet row as for front.

Cont to foll chart until row 88 has been worked.

Next row: Change to 4mm needles and work edging as for front.
Cast off knitwise.

MAKING UP

Pin out the pieces and damp press. Using mattress st, join sides and bottom edge.

Drawstring

Using 4.5mm crochet hook and 2 strands of B make a chain 26in (66cm) long, leaving approx 4in (10cm) at each end of drawstring to tie on pompons.

Thread drawstring through eyelets, starting and ending at centre front of cover.

Note: If you cannot crochet, make a cord by finger knitting or plaiting.

POMPONS (MAKE 2)

Use a ready-made template or make a template from two pieces of card,

Cozy pattern instructions

cut into a 2in (5cm) circles with smaller circles cut in the centre of each. Using A and C, wrap yarn round template until it is tightly packed. Using a pair of

narrow-pointed scissors, cut between the 2 cards. Tie the loose ends of the cord tightly into centre of pompons. Ease off both pieces of card and fluff

up pompons. Trim edges to form a smooth ball. ●

Pattern taken from *Hot-Water Bottle Covers*

Techniques



FINGERS AND THUMBS

For gloves, a set of gusset stitches, also known as a fourchette (see instructions, right), is added between the fingers. If you are knitting on 2 needles, an extra stitch is added for the seam. Before knitting the fingers all stitches, except for those required for the first finger to be worked, are put on a thread of different coloured yarn. Stitches and fourchettes are worked according to the number given in the pattern. The first and last fingers only have a fourchette on one side.

WORKING THE DIGITS

A Little finger

Pick up the given number of sts from back and front on 2 needles. Working from the fourchette end, inc in first st as instructed, then knit across sts on first needle. Now, working towards the fourchette, knit sts from back needle. Join into a round and work finger on these sts using 2 or 3 needles.

B Third (ring) finger

Pick up sts from fourchette end, inc in the first st as instructed and knit across sts on the first needle. For the other fourchette, inc as required by picking up sts from the base of the previous finger. Work across sts on back needle. Join into a round and work the finger on these sts using 2 or 3 needles.

C Second finger

As for third finger.

D Forefinger (first finger)

Starting at the fourchette end, pick up sts from base of previous finger. Rotate work and knit across sts on back needle, then across sts on front needle. Join into a round and work finger on these sts on 2 or 3 needles.

E Thumb

When working on 2 needles, work the thumb as you reach it. When working on 4 needles, place the thumb stitches on a length of spare yarn and work according to the instructions given in the pattern.

F Fourchettes

Fourchettes are the gussets between fingers. In a normal glove, there will be a fourchette between the little finger and third finger, between the third finger and the second finger and between the second finger and the forefinger. You will need to add extra stitches to make these fourchettes.

Points A to D on the left explain how this is done.

For the little finger, it is usual to cast on 2 or 3 stitches at the front.

For the two middle fingers, 2 or 3 sts are added to the front and 2 or 3 are picked up from the base of the previous finger. For the forefinger, 2 or 3 sts are picked up from the base of the forefinger/second finger gap. Fingers are knitted with the palm facing for the right hand and with the back facing for the left hand.

The thumb is always to the right. If both hands are worked the same, work the fingers with the thumb to the right.

G Thumb gusset

The easiest way to work the thumb gusset is to place it in the centre. You may find the fit more comfortable if the thumb gusset is moved towards the palm of the glove or mitten by about 3 sts.

This means that there will be a right and a left-hand glove.

EMBROIDERING LAZY DAISIES

Work detached chain stitches in a circle to form petals, as shown. Five or six petals works best.

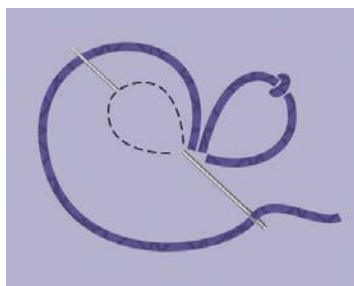

COLOUR KNITTING

Fairisle

Fairisle knitting uses the stranding technique, which involves picking up and dropping yarns as they are needed but, unlike intarsia, they are then carried across the row. Loops are formed along the back of the work, which should not exceed about 5 stitches in length.

Make sure the loops are of even tension, otherwise your fabric may pucker.

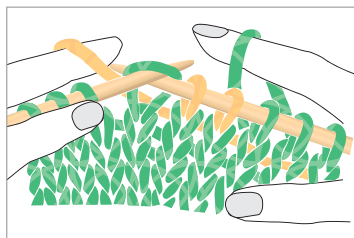

1 Start knitting with the first colour (A), which is dropped when you need to incorporate the second colour (B). To pick up A again, bring under B and knit the next stitch with A.

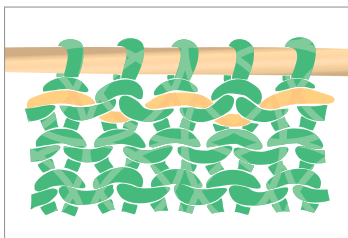

2 To pick up B again, drop A, bring B over A and knit the next stitch with B.

Intarsia

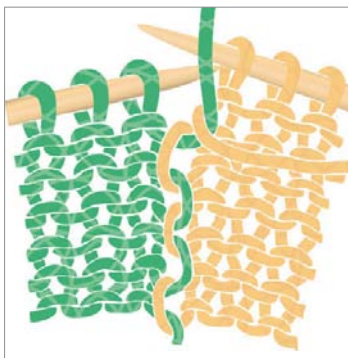

Blocks of colour are created by using the intarsia technique of twisting the yarns at the back of the work with each colour change (see diagram above). It is better to wind a small amount of yarn onto bobbins rather than using whole balls to prevent tangling. They are smaller and can hang at the back of the work out of the way. Once finished, the ends are woven in at the back and pressed carefully under a damp cloth to help neaten any distorted stitches.

FACIAL FEATURES

Begin by threading a blunt needle with a single strand of yarn in the colour required. Insert the needle into an inconspicuous point, such as

the nape of the neck, and bring it through the work to the point where you wish to add embroidery stitches, so that the end of the yarn is lost inside the stuffing.

Straight stitch

As the name implies, this is a single straight stitch.

It is used to create simple details such as a small mouth or an eyebrow.

Couching

By couching a straight stitch, you can create a curved line, ideal for an eyebrow or a wide smile.

Satin stitch

Use this filling-in stitch for noses or for hairstyles that follow the contours of the head. Bring the needle to one edge of the area you wish to embroider then work straight stitches, close together, to fill in the area.

Detached buttonhole

This stitch is used to make ears. Bring the threaded needle through the fabric, emerging at the point where you wish one end of the stitch to be, then take it down through the point where the other end of the stitch will be and back up through the first point. Repeat this process until you have two small loops of yarn. Work buttonhole stitches over and around the two strands that form the loops, then take the needle back down through the end of the stitch and fasten off. ●





Laughing Hens

Your Ultimate Knitting & Fabrics Website

Latest Rowan & Debbie Bliss Yarns & Patterns
Excellent Range of Yarns & Patterns
Gorgeous New Fabrics Just Arrived!
Beautiful Accessories

Top Brands * Top Designers * Latest Books
Wide Range of Products * Large Stock

Excellent Customer Service

Knitting: sales@laughinghens.com: 01829 740903

Fabric: fabrics@laughinghens.com: 07966 382115

www.laughinghens.com

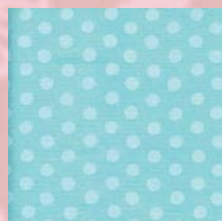



The little book of **VOUCHERS**

Brought to you by...

Knitting
magazine

Free with issue 99 February 2012

wool & buttons



Passionate about beautiful yarns, amazing pattern designs & handmade buttons

15% OFF

All orders for readers of Knitting magazine
Use code KN15 online or by phone

OFFER VALID UNTIL 28 FEBRUARY 2012



www.woolandbuttons.co.uk

Email: joanne@woolandbuttons.co.uk

Tel: 01757 269120

TO SUBSCRIBE TO KNITTING CALL 01273 488005

Knits in the City

Specialist on-line supplier of Quality Yarns

Patterns and Accessories including,

Rowan, SMC Select, Debbie Bliss

Louisa Harding, Mirasol, Noro,

Patons Araucania, Freedom and More



15% OFF

all products
purchased in January
and February 2012.

Please quote
KITC12 at the
checkout.



Tel 0151 426 0539

www.knitsinthecity.co.uk



ADDICTED2KNIT

www.addicted2knit.co.uk
info@addicted2knit.co.uk
020 8455 4990

Beautiful yarns, gorgeous needles and pins you'll love!



15% DISCOUNT AT THE CHECKOUT USING CODE GMCK0112

Valid until 20 February 2012.
One purchase per customer.



Mrs Moon
YARN & HABERDASHERY

Mrs Moon is your local yarn store online



**Mrs Moon is offering
10% OFF BLUE SKY
ALPACAS' YARN
to readers of Knitting magazine**

The yarns range from the incredibly snuggly Bulky to the extreme luxuriousness of Alpaca Silk. Don't miss this great opportunity to sample a little bit of luxury, shop online at mrsmoon.co.uk using voucher code **KNITBS**.

One voucher per customer. Offer ends 29 February.

www.mrsmoon.co.uk

Tel 020 8744 1190 Email info@mrsmoon.co.uk
Shop 41 Crown Road, St Margarets, Twickenham, London TW1 3ES

The
WoolandBead
Studio

85 High Street, Yeadon, Leeds LS19 7TA

Offer

10% OFF ALL DEBBIE BLISS WOOLS/YARNS UNITL 31 MARCH 2012

Please quote: DB10 in the shipping section if ordering online – a refund will then be applied.

Or call 0113 2503 777 quoting DB10.

Not to be used in conjunction with any other offer.

Wonderful Wools

Stockists of:
Debbie Bliss, Noro,
Sublime, SMC Select,
Millamia, Rowan,
Crystal Palace Yarns,
Bergere de France
(including the Origin' range)

Brilliant Beads

We also stock a wide
selection of beads and
findings including:
Czech glass,
Italian glass and
Swarovski crystal

www.thewoolandbeadstudio.co.uk

tel: 0113 2503 777 email: info@thewoolandbeadstudio.co.uk



TRICOLETTE

**10% OFF ALL
PURCHASES**

Pop into the shop or call 020 7372 4944
to receive your discount.

One purchase per customer.

Valid until the end of February 2012.

While stocks last.

TRICOLETTE YARNS

93 Boundary Road,
St Johns Wood,
London NW8 0RG

020 7372 4944

lynn@tricoletteyarns.com

www.tricoletteyarns.com

twist
yarns

www.twistyarns.co.uk

10% OFF

PLEASE USE KTG20 AT CHECKOUT

OFFER VALID UNTIL 29 FEBRUARY 2012

OFFER ONCE PER CUSTOMER DOES NOT APPLY TO SALE STOCK

Stockists of Malabrigo, Scrumptious, Zauberball, Shilasdair, KnitPro, Yarnscape, Woolly Wormhead, Cascade 220, Sparkleduck, Sunflower Swifts, Artesano, Manos del Uruguay.

Loyalty scheme for all customers – discounts throughout the year.

Organizers of **Twist@Home** yarn parties.

www.twistyarns.co.uk

Tel: 07971 631606 Email: Info@twistyarns.co.uk



TO SUBSCRIBE TO KNITTING CALL 01273 488005

simply the best
skin protection
available today...

**DERMA
GUARD**



The Skin Care Company

DermaGuard Skin Protection
Lotion... a knitter's best friend!
No more roughened skin to
cause 'snagging'!

SPECIAL OFFER 20% OFF
500ml Pump Dispenser Bottle
Usual price **£11.80** NOW **£9.44**



**POST
FREE**

Order now quoting
DG2613
Freephone 0800 917 2219
or send this voucher with
your payment to
The Skin Care Co Ltd,
Bont Newydd Mill,
St Asaph LL17 0HH



DermaGuard Discover the
difference... your hands will love it!



Soliloquy Sock Lace

...special offer...

...free pattern & 10% discount...

...enter SOLKNITTING
during check out...

...valid until end of February...

...for details
see website...



tall
yarns
n tales

www.tallyarns.co.uk



TO SUBSCRIBE TO KNITTING CALL 01273 488005

Your local yarn & stitch boutique

15%
OFF

- SIRDAR ESCAPE
- SIRDAR CROFTER
- DEBBIE BLISS GLEN
- BLUE FACED LEICESTER
DK AND ARAN



This is only while stocks last.

Colours and stocks are limited.

Please call 01522 522865 to take advantage of this offer.

www.spinsandneedles.co.uk

Tel: 01522 522865 Email: create@spinsandneedles.co.uk



CORNISH
WOOLS



Lynfield Craft Centre, Perranuthnoe, Cornwall TR20 9NF

10% OFF

ALL WEBSITE PURCHASES
QUOTING CHECKOUT CODE KT12

OFFER VALID UNTIL 31 MARCH 2012

www.cornishwools.co.uk

Email: cornishwools@live.co.uk

Tel: 01736 711808



TO SUBSCRIBE TO KNITTING CALL 01273 488005

Wensleydale Longwool Sheepshop

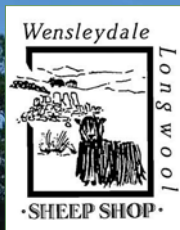

10% OFF ALL WOOL

OFFER VALID ONCE PER CUSTOMER, EXCLUDING P&P.
OFFER VALID UNTIL 29 FEBRUARY 2012
QUOTING CODE K99



To see our range of soft, lustrous Wensleydale wool and knitting patterns please send £2 for shade card and brochure.

www.wensleydalelongwoolssheepshop.co.uk

Email: wensleydalesheepshop@btconnect.com

Tel: 01969 623840

Cross Lanes Farm, Garriston, Leyburn, North Yorkshire DL8 5JU

TO SUBSCRIBE TO KNITTING CALL 01273 488005



Great British Yarns

Online and mail order stockists of a wide variety of beautiful knitting yarns, fabrics and gifts



The new Rowan Kidsilk Haze Stripe is a self-striping yarn in fabulous colourways designed by Kaffe Fassett.

One ball is sufficient to make a lovely scarf, the pattern for which is on the ball band.

The usual retail price for this is £17.95.

Great British Yarns is offering 10%

off to customers who key in KIDSILKSTRIPE at checkout

This offer is available until 29 February 2012

www.greatbritishyarns.co.uk

Email: info@greatbritishyarns.co.uk Tel: 01255 462776

Unit 9 Brassmill Enterprise Centre, Brassmill Lane, Bath BA1 3JN

TO SUBSCRIBE TO KNITTING CALL 01273 488005

the **littlewool**
company

15% OFF

All orders until 15 March 2012
using code KNIT12



Specialist online and mail order supplier of luxury yarns including Chilla Valley Alpaca, Artesano, Manos Del Uruguay, Shilasdair, Brittany Needles, Namaste, Eucalan, patterns, haberdashery and more...

www.thelittlewoolcompany.com
Tel: 01409 221699

TO SUBSCRIBE TO KNITTING CALL 01273 488005