

# H-MOSS® Controls Passive Infrared Wall Mount Sensors

# HUBBELL

## Features

- Passive infrared, low voltage sensor
- Coverage 1600 sq. ft.
- Adaptive technology - "Install and forget" operation
- 110° coverage provides complete room sensing when corner mounted
- Swivel mounting bracket included for wall or ceiling mounting

## Ordering Information

Description	Device Color	UPC Number	Catalog Number
Low voltage sensor	Office White	783585349220	ATP1600W

## Listings

cULus listed to UL 244A  
CEC Title 24 compliant  
ASHRAE 90.1 compliant

## Specifications

Housing	Flame retardant UL 94 V-0 ABS
Lens	Polyethylene
Dimensions	6"H x 2"W x 1.5"D
Mounting Height	8 to 12 feet

## Performance

<b>Controls</b>	
Sensitivity	Adaptive 0 to 100%
Time Delay	Test (8 seconds), adaptive 8 to 40 minutes
<b>Electrical</b>	
Power Requirements	24V DC nominal, 33mA from Hubbell CU series control unit
<b>Environmental</b>	
Operating Temperature	32°F to 104°F (0°C to 40°C) with rate of change not exceeding 20°F (11°C) per hour
Storage Temperature	-20°F to 150°F (-29°C to 65°C); 0% to 95% non-condensing relative humidity
<b>Sensing Indicators</b>	
Passive Infrared	Red LED

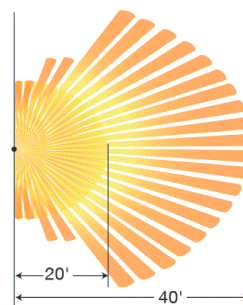
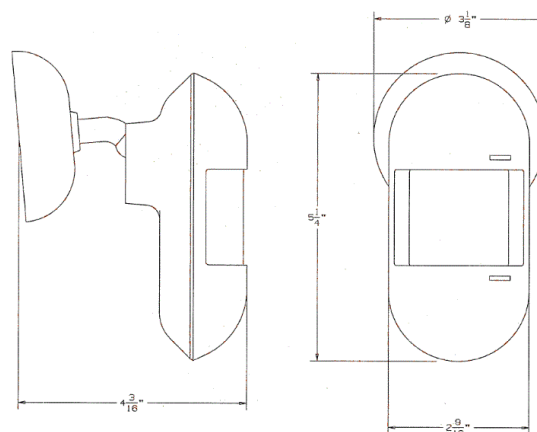

Minor Motion: ■ Ultrasonic ■ PIR Major Motion: ■ Ultrasonic ■ PIR

## Complementary Products

CU300A	Control Unit Manual-ON
CU300M	Control Unit, HD, Latching, Auto/Manual-ON
CU300HD	Wall Switch Wire Guard

## Online Resources

Customer Use Drawing  
eCatalog  
Installation Instructions

Dimensions in Inches (mm)

Hubbell Wiring Device-Kellems • Hubbell Incorporated (Delaware) • 40 Waterview Drive • Shelton, CT 06484

Phone (800) 288-6000 • Fax (800) 255-1031 • Specifications subject to change without notice.

