



CLUTCH PUMP KIT

KIT NUMBER CHEV/GMC/INT/6.6
700592

Chevrolet/GMC 4500-5500-6500, Inter. CV 6.6L : D, 2019+, PH14 Pump, Side Port

Bolt Packages:

Bracket	716258	(Inc. item 3, 9, 10, 11, 13)
Idler	None	
Crank pulley	None	
Tensioner	None	

Belt Dia. Decal	702176
Issue Date	10/30/18
Revision Date	NC

Item	Part No.	Description
1.	710099	Pump mount bracket
2.	716257	Idler bracket
3.	111074	M10 x 80 x 1.5 Flange Bolt
4.	740294	Idler pulley, flat 3.00"
5.	716256	Pump plate
6.	-----	-----
7.	*	Pump / Side port
8.	742016	Clutch
9.	111173	M10 x 70 x 1.5 Flange Bolt
10.	110953	M10 x 30 x 1.5 Flange Bolt
11.	110265	M10 x 1.5 Flange Nut
12.	-----	-----
13.	110395	3/8-16 x 1 Socket head bolt
14.	110440	3/8-16 x 1 Flange bolt
15.	740458	Belt, Micro-V K061401

FIG. 1
BELT DIAGRAM

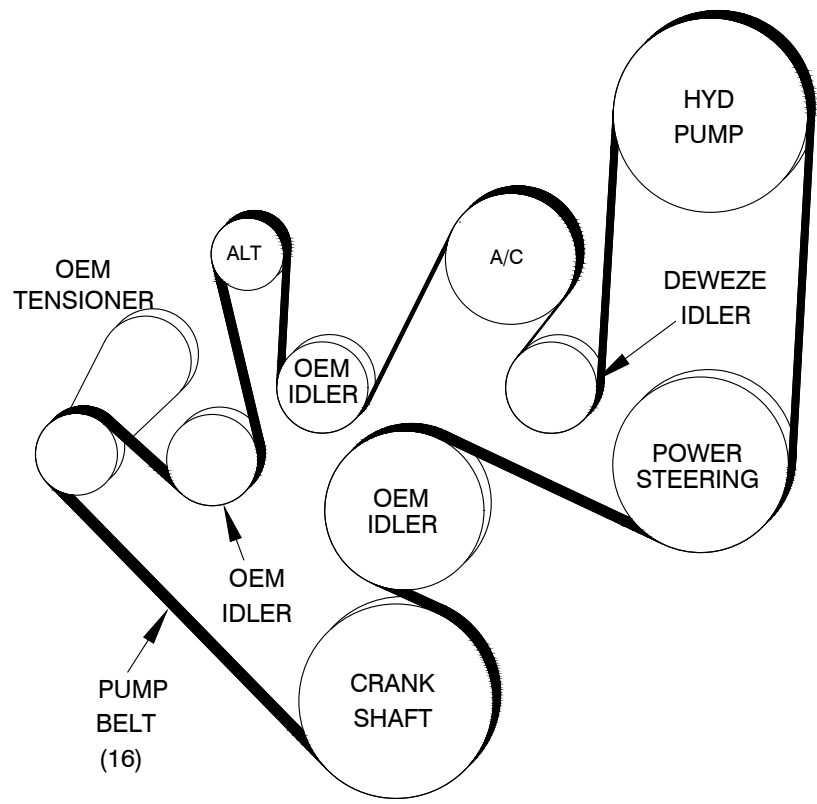
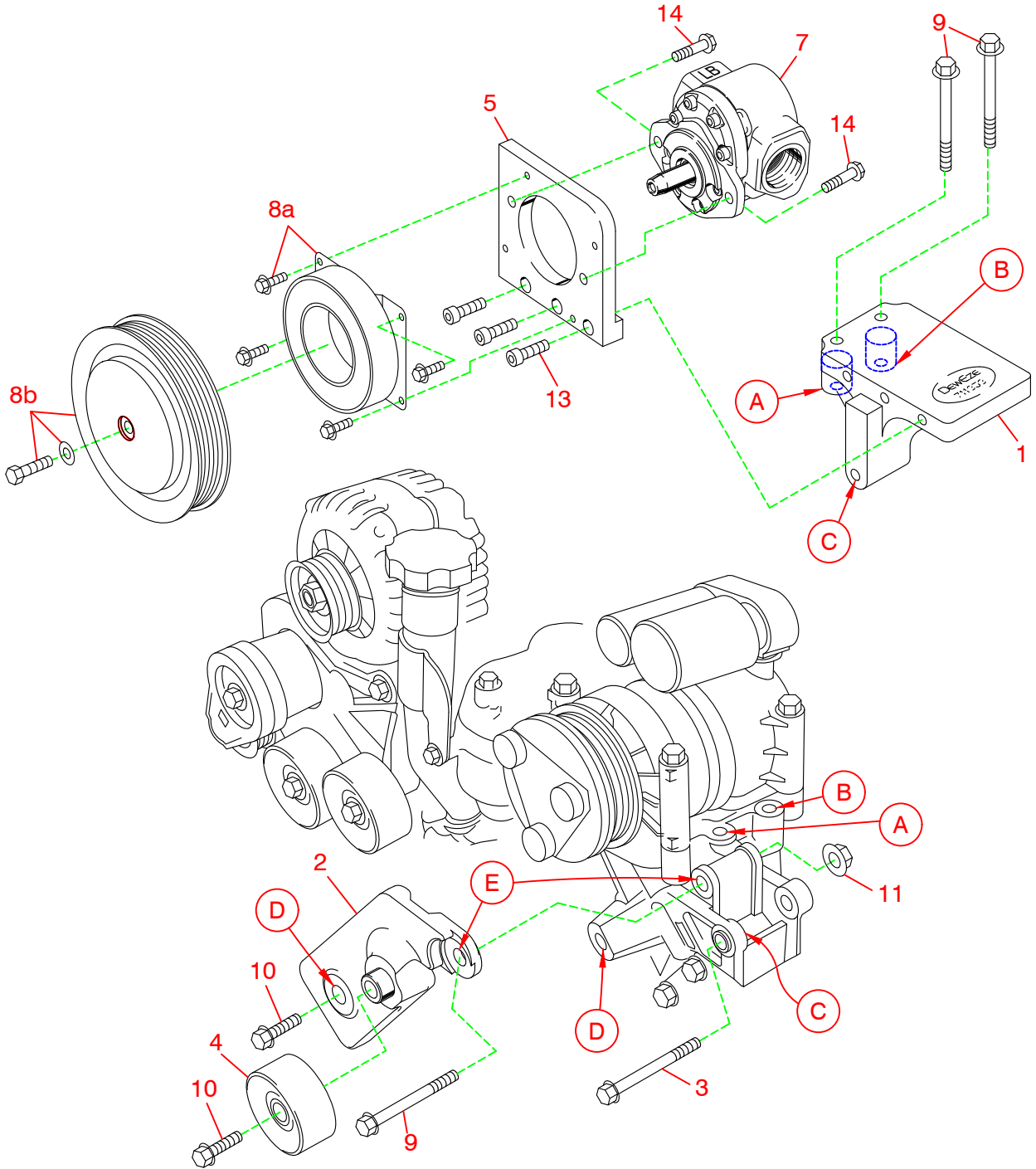

FIG. 2
ASSEMBLY



DewEZE Clutch Pump Kit 700592

Chevy/GMC, Int. CV, 6.6L: D, PH14 Pump, 2019+

INSTALLATION INSTRUCTIONS

The installation of this kit requires trained decision-making concerning clearances, tying components together, rerouting, or relocating OEM components, etc. It is impossible to describe all of the clearance and vibration points, etc. in the installation instructions. Therefore, the technician must exercise professional judgment to achieve the best quality installation.

1. Disconnect the battery.
2. Remove the OEM fan belt. Remove the long OEM main belt.
3. Idler bracket must be installed before pump mount bracket. Attach idler bracket (2) at Location D using M10 x 30 flange bolt (10) and at Location E using M10 x 70 flange bolt (9) and M10 flange nut (11). Mount idler pulley (4) onto idler bracket with M10 x 30 flange bolt (10).
4. Press bushing at Location C (secondary alternator mounting location) forward to allow clearance for pump mount bracket (1).
5. Insert the two M10 x 70 bolts (9) through the holes in the notched end of the base plate (1) and into the air conditioner mounting bracket at locations A and B. Thread the M10 x 80 flange head bolt (3) into the hole at Location C and through the bottom lug of the pump bracket. Tighten item 3 (M10 x 80mm flange head bolt) first to insure that bracket is aligned properly (25 ft-lbs). Tighten (9) bolts next and torque to 25 ft-lb.
6. Bolt pump (7) onto pump plate (5) with two 3/8 x 1 flange bolts (14). Bolt the pump plate (5) to the base plate (1) with three 3/8 x 1 socket head bolts (13). Attach coil (8a) with four 1/4 x 1/2 flange bolts supplied with clutch. Torque these to 35 in-lb. Attach clutch pulley (8b) to pump shaft with 5/16NF x 1 1/4 bolt and heavy washer supplied with clutch. Torque to 170 in-lb.
7. Install the long DewEze belt (16) as shown in the belt diagram (Fig. 1). Replace the OEM fan belt.
8. Connect the battery.
9. Run the engine and check for any belt clearance or alignment problems. Adjust as needed.

STARTUP INSTRUCTIONS

After the installation of the kit, start up of a hydraulic system requires that the hydraulic pump be started following professional fluid power standards.

Our testing shows that running a pump for as little as **30 seconds without oil** can cause damage that shortens the life of the pump. Therefore the pump with a non-flooded inlet must be primed; air bled out of the system, so oil reaches the pump immediately.