



HP PS1810 Switch

Installation and Getting Started Guide

HP PS1810-8G (J9833A)
HP PS1810-24G (J9834A)



Power over Ethernet PD

HP PS1810 Switches

Installation and Getting Started Guide

© Copyright 2013 Hewlett-Packard Development Company, L.P.

The information contained herein is subject to change without notice.

This document contains proprietary information, which is protected by copyright. No part of this document may be photocopied, reproduced, or translated into another language without prior written consent of Hewlett-Packard.

Manual Part Number

5998-4329

June 2013

Applicable Products

HP PS1810-8G (J9833A)

HP PS1810-24G (J9834A)

Safety

Before installing and operating this product, please read the “Installation precautions” in Chapter 2, “Installing the switch”, and the safety statements in General Safety and Regulatory Information booklet included with the product.

Disclaimer

HEWLETT-PACKARD COMPANY MAKES NO WARRANTY OF ANY KIND WITH REGARD TO THIS MATERIAL, INCLUDING, BUT NOT LIMITED TO, THE IMPLIED WARRANTIES OF MERCHANTABILITY AND FITNESS FOR A PARTICULAR PURPOSE. Hewlett-Packard shall not be liable for errors contained herein or for incidental or consequential damages in connection with the furnishing, performance, or use of this material.

The only warranties for HP products and services are set forth in the express warranty statements accompanying such products and services. Nothing herein should be construed as constituting an additional warranty. HP shall not be liable for technical or editorial errors or omissions contained herein.

Hewlett-Packard assumes no responsibility for the use or reliability of its software on equipment that is not furnished by Hewlett-Packard.

Warranty

For the latest license and warranty information, see www.hp.com/support/networking-warranties.

For a copy of the warranty terms specific to your HP products, contact an HP authorized dealer or the HP Sales and Service Office in your country/region.

Contents

1 Switch overview

Switch hardware description	1-2
Network ports	1-3
LEDs	1-4
Reset button	1-5
Clear button	1-5
Power connector	1-5
Switch features	1-6

2 Installing the switch

Included parts	2-1
Installation precautions	2-3
Installation procedure	2-4
1. Prepare the installation site	2-5
2. Mount the switch	2-5
3. Connect the network cables	2-14
4. Power on the switch and verify that self-test completes normally	2-15
SFP installation notes	2-18
Connections to HP ProLiant Gen8 Servers	2-19

3 Configuring the HP PS1810 Switches

Initial configuration	3-1
Managing the switch via the 192.168.2.10 address	3-3
Restoring DHCP addressing to the switch	3-4
Next steps	3-5

4 Troubleshooting

Basic troubleshooting tips	4-1
Diagnosing with the LEDs	4-2

Diagnostic tips:	4-2
Testing the switch by resetting it	4-4
Restoring to factory defaults	4-4
HP Customer Support Services	4-5
Before calling support	4-5

A Specifications

Switch Specifications	A-1
Physical	A-1
Electrical	A-1
Environmental	A-2
Acoustics	A-2
Safety	A-2
Standards	A-3
Cabling and Technology Information	A-4
Cabling Specifications	A-4
Technology Distance Specifications	A-5
Mode Conditioning Patch Cord	A-6
Installing the Patch Cord	A-6
Twisted-Pair Cable/Connector Pin-Outs	A-8
Straight-through Twisted-Pair Cable for 10 Mb/s or 100 Mb/s Network Connections	A-10
Crossover Twisted-Pair Cable for 10 Mb/s or 100 Mb/s Network Connection	A-11
Straight-Through Twisted-Pair Cable for 1000 Mb/s Network Connections	A-12

B EMC Regulatory Statements

Regulatory Statements	B-1
-----------------------------	-----

Index	Index-1
--------------------	---------

Switch overview

The PS1810-8G and PS1810-24G switches are multiport managed gigabit switches that enable you to build high-performance switched workgroup networks and to work with HP ProLiant Gen8 Servers. These switches are store-and-forward devices that offer low latency for high-speed networking.

Throughout this manual, these switches are referred as the PS1810-8G and PS1810-24G Switches.

- The PS1810-8G Switch has 8 auto-sensing 10/100/1000BASE-T RJ-45 ports. Port 1 is a Power over Ethernet Powered Device (PoE PD) port. The switch can be powered by a network connection to port 1 from PoE power sourcing equipment (PSE), such as a PoE switch.
- The PS1810-24G Switch has 24 auto-sensing 10/100/1000BASE-T RJ-45 ports and two SFP slots (ports 25 and 26) for supported HP SFP fiber-optic transceivers.
- The PS1810-8G switch has a unique enclosure that allows physical stacking on the HP ProLiant MicroServer Gen8 product.

You can connect these switches directly to computers, printers, and servers to provide dedicated bandwidth to those devices, and you can build a switched network infrastructure by connecting these switches to hubs, other switches, or routers. The PS1810 switches have the built-in technology that reports real-time health status for each Gen8 Server in the network. In addition, these switches offer limited network management capabilities as well.

Switch hardware

HP PS1810-8G (J9833A)

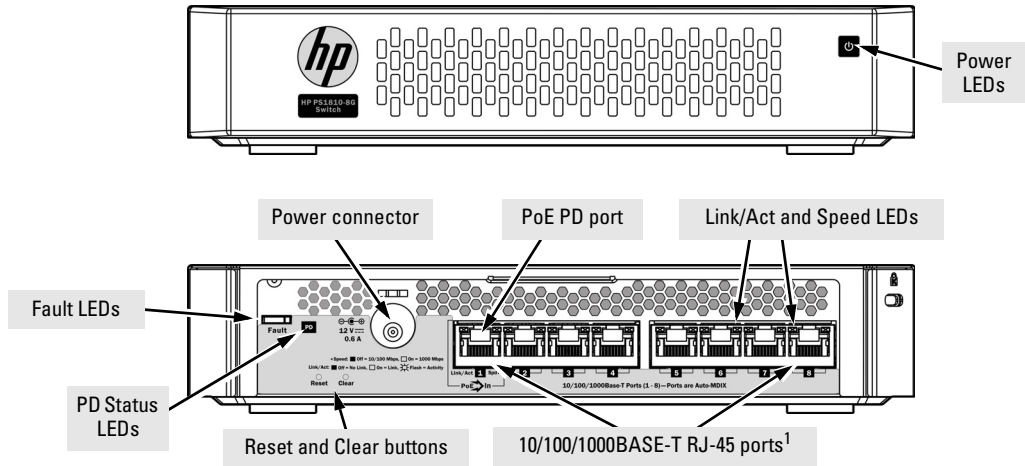

¹ All RJ-45 ports have the Auto-MDIX feature.

HP PS1810-24G (J9834A)

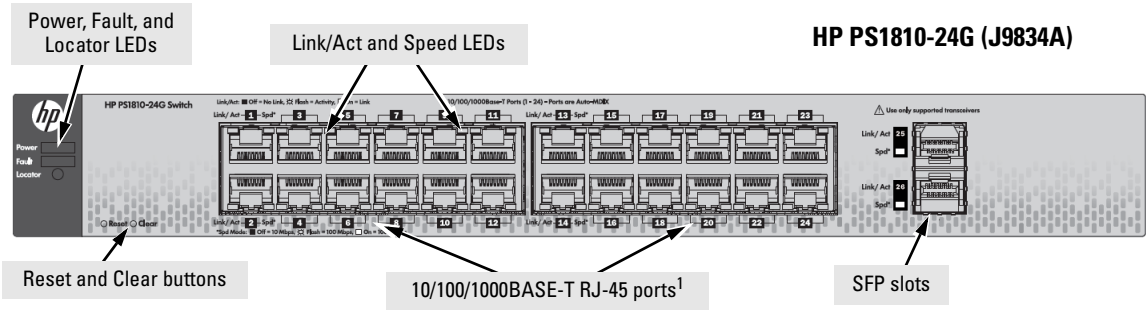

¹ All RJ-45 ports have the Auto-MDIX feature.

The back of the PS1810-24G has the AC power connector.

Network ports

- Auto-sensing 10/100/1000BASE-T ports.
These ports support the “Auto-MDIX” feature, a feature that allows you to use either straight-through or crossover twisted-pair cables to connect network devices to the switch.
- PoE PD port (PS1810-8G Switch only)
A network connection to the PoE PD port from a PoE PSE device can provide power to the switch.
- SFP slots for fiber or copper uplinks (PS1810-24G Switch only). SFPs support the following network connectivity:

Optional Network Connectivity, Speeds, and Technologies			
Speed	Technology	Cabling	SFP Connector ¹
100 Mb/s	100-FX	Fiber (multimode)	LC
1 Gbps	1000-T	Copper (twisted-pair)	RJ-45
	1000-SX	Fiber (multimode)	LC
	1000-LX	Fiber (multimode or single mode)	LC

¹ To get information about the supported transceivers, see www.hp.com/networking/support.

1. In the Auto Search textbox, type **J4858** (for 100-Mb and Gigabit information).
2. Select one or more products that are displayed in the list. Click **Display selected**.
3. Click **Product support information**. The support page opens. In the support page, click **Manuals** and find the **Transceiver Support Matrix**.

For technical details of cabling and technologies, see “Cabling and Technology Information” in Appendix A.

LEDs

The front and back panels of the switches provide status LEDs for system monitoring. The following table lists the functions of the various indicators.

LED	State	Meaning
Power (green)	On	The switch is receiving power.
	Off	The switch is not receiving power.
Fault (orange)	On	On, after the switch is powered on or reset, at the beginning of switch self test. If the LED remains on, it indicates a detected hardware failure during the self test.
	Blinking*	Indicates a fault condition on the switch or one of the switch ports. The Link LED for the port with the fault blinks simultaneously.
	Off	The normal state; indicates that there are no fault conditions on the switch.
Locator (blue) PS1810-24G Switch only	Blinking**	The Locator LED helps you locate a specific switch in an area full of switches. The LED blinks for 30 minutes when activated through the switch software.
	Off	The Locator LED is disabled by default.
PD (green) PS1810-8G Switch only	On	Power is available on the PoE In port (Port 1).
	Blinking*	Power is no longer available on the PoE In port. The switch is powered from the external power adapter. The LED continues to blink until power is restored on the PoE In port or the switch is reset.
	Off	Power is not available on the PoE In port.
Link/Act (green)	On	The port is enabled and receiving a link indication from the connected device.
	Off	One of these conditions exist: <ul style="list-style-type: none"> • An active network cable is not connected to the port. • The port is not receiving link beat or sufficient light. • Green Mode is enabled.
	Blinking*	Indicates that there is network activity on the port.
Spd (green)	On	Indicates the port is operating at 1000 Mb/s.
	Blinking	Indicates the port is operating at 100 Mb/s.
	Off	Indicates the port is operating at 10 Mb/s.
<p>* The blinking behavior is an on/off cycle once every 1.6 seconds, approximately.</p> <p>** The blinking behavior is an on/off cycle once every 0.8 seconds, approximately.</p>		

Reset button

Use the Reset button to reset the switch while it is powered on. This action clears any temporary error conditions that might have occurred and runs the switch self test. Use the Reset button with the Clear button to restore Factory Default settings.

Clear button

Use the Clear button for the following purposes:

- **Deleting Passwords** - When pressed, for at least three seconds, the button deletes any switch web interface access passwords that you may have configured. Use this feature if you have misplaced the password and need console access.

This button is provided for your convenience. If you are concerned that this button may be misused, install the switch in a secure location, such as in a locked wiring closet.

- **Restoring Factory Default Configuration** - When the Reset button is pressed in a specific pattern, any configuration changes you may have made through the switch console, the web browser interface, and SNMP management are removed, and the factory default configuration is restored to the switch. For the specific method to restore the factory default configuration, see “Restoring the Factory Default Configuration” in chapter 4, “Troubleshooting” of this manual.

Power connector

The PS1810-8G and PS1810-24G switches do not have a power button. They are powered on when connected to an AC power source.

The PS1810-8G uses an external AC/DC power adapter, either wall mount or inline. The external AC/DC power adapter supplies 12 volts DC to the switch and automatically adjusts to any AC voltage between 100-240 volts and a frequency of either 50 or 60 Hz. It is not necessary to set a voltage range.

The PS1810-8G Switch can also be powered on by a PoE PD connection to Port 1.

The PS1810-24G Switch has an internal power supply and connects to the AC power source via a power cable. The switch automatically adjusts to any voltage between 100-127 and 200-240 volts and to a frequency of either 50 or 60 Hz. It is not necessary to set voltage range.

Switch features

The features of the HP PS1810 Switches include:

- Plug-and-play networking—all ports are enabled, just connect the network cables to active network devices and your switched network is operational.
- Auto-MDIX on all twisted-pair ports—all connections can be made using straight-through twisted-pair cables. Cross-over cable is not required, although it works.
- Support for IEEE 802.3az Energy Efficient Ethernet (EEE) features that reduce power consumption when connected with EEE-compliant devices.
- Support for automatic discovery and health status reporting of HP ProLiant Gen8 Servers.
- Automatically negotiated full-duplex operation for all 10/100/1000BASE-T RJ-45 ports when connected to other auto-negotiating devices.
- Easy management of the switch through several available interfaces:
 - Switch-web interface —an easy-to-use built-in graphical interface that can be accessed from common Web browsers.
 - HP Intelligent Management Center (IMC)— allows network administrators to discover and map the switches within their network and launch the built-in graphical interface from within IMC to configure the switches.
- Support for up to 4 trunks for the PS1810-8G and up to 12 trunks for the PS1810-24G so that you can assign physical links to one logical link (trunk) that functions as a single, higher-speed link providing dramatically increased bandwidth. Also known as Link Aggregation.
- Support for up to 64 IEEE 802.1Q-compliant VLANs so you can divide the attached end nodes into logical groups that fit your business needs.
- Support for many advanced features to enhance network performance—for a description, see the *PS1810 Switch Management and Configuration Guide*.
- Support for downloading new switch software for product enhancements and bug fixes.

Installing the switch

The HP PS1810 Switches are easy to install. They are packed with accessory kits that allow them to be mounted in a number of different ways. This chapter describes how to install the PS1810-8G and PS1810-24G switches.

Included parts

The following components are shipped with an HP PS1810 switch:

- Documentation kit
 - Quick Setup Guide and Safety/Regulatory Information
 - Software License, Warranty, and Support information
- Accessory kits:

PS1810-24G Switch

Kit number 5066-0620

- three 3/4" (20-mm M4) screws for wall and under-table mounting
- three wall anchors

Kit number 5066-2506

- two mounting brackets
- eight 8-mm M4 screws to attach the mounting brackets to the switch
- four 5/8-inch number 12-24 screws to attach the switch to a rack

Kit number 5064-4254

- four rubber feet

PS1810-8G Switch

Kit number 5066-0621

- three 3/4" (20-mm M4) screws for wall and under-table mounting
- three wall anchors
- cable tie for power cord

Kit number 5066-3084

- four rubber feet
-

- PS1810-8G external AC/DC power adapters and power cords:
 - **Universal Inline AC/DC Power Adapter**
All countries/regions 5066-1122*
 - Power Cords for Inline AC/DC Power Adapter**
 - Australia/New Zealand 8121-0870
 - Philippines/Thailand 8121-0664
 - China 8120-8373
 - India 8121-0702
 - Indonesia/Israel/Vietnam 8120-6314
 - Japan 8120-6316
 - South Africa 8120-6314
 - South Korea 8120-8441
 - Taiwan 8121-0963
 - United Kingdom/Hong Kong/Singapore/Malaysia 8120-8699
 - Brazil 8121-1081
 - Argentina 8120-8367
 - Chile 8121-0514
 - **Wall Plug-in AC/DC Power Adapters**
(AC Power cords are not used)
 - United States/Canada/Mexico 5184-5863*
 - Continental Europe/Denmark/Norway/Sweden/Switzerland 5184-5864*
- * Complies with Energy Star 5.0 standards.

- PS1810-24G Power cords:
 - Australia/New Zealand 8121-0833
 - China 8120-8377
 - Continental Europe 8120-6802
 - Denmark 8120-6806
 - Japan 8120-6804
 - Switzerland 8120-6807
 - United Kingdom/Hong Kong/Singapore/Malaysia 8120-8709
 - United States/Canada/Mexico 8120-6805
 - South Africa 8120-6808
 - South Korea/Indonesia/Vietnam 8120-6802
 - India 8121-0772
 - Israel 8121-1035
 - Philippines/Thailand 8121-0667
 - Taiwan 8121-0964
 - Argentina 8120-6871
 - Brazil 8121-1069
 - Chile 8120-6979

**Japan Power Cord
Warning**

製品には、同梱された電源コードをお使い下さい。
同梱された電源コードは、他の製品では使用出来ません。

Installation precautions

Follow these precautions when installing the switch.

WARNINGS

- **When you mount PS1810-8G Switch under HP ProLiant MicroServer Gen8s, do not stack more than two servers on top of the switch.**
- **Before you mount the PS1810-24G Switch in a rack or cabinet, ensure the rack or cabinet is adequately secured to prevent it from becoming unstable and falling over.**

Devices installed in a rack or cabinet must be mounted as low as possible, with the heaviest devices at the bottom and progressively lighter devices installed at the top.

- **When you mount the switch on the wall, ensure that the network ports are facing up or down to meet national and international safety requirements. The side vents cannot be placed facing up or down.**

Cautions

- When installing the switch, ensure that the AC outlet is located near the switch and is easily accessible in case the switch must be powered off.
- Ensure that the AC power source circuits are properly grounded.
- Use only the AC/DC power adapter and power cord (if applicable), supplied with the switch. Use of other adapters or power cords, including those that came with other HP Networking products, might result in damage to the equipment.
For those switches that use a power cord, if your installation requires a different power cord than the one supplied with the switch, be sure to use a power chord that has the symbol of the safety agency that defines the regulations for power cords in your country. The mark is your assurance that the power cord can be used safely with the switch.
- Ensure the switch does not overload the power circuits, wiring, and over-current protection. To determine the possibility of overloading the supply circuits, add together the ampere ratings of all the devices installed on the same circuit as the switch and compare the total with the rating limit for the circuit. The maximum ampere ratings are usually indicated on the devices near the AC power connectors.
- Do not install the switch in an environment where the operating ambient temperature might exceed 40 °C (104 °F).
- Ensure the air flow around the sides of the switch is not restricted.

Installation procedure

The following steps summarize switch installation. The rest of this chapter provides details on these steps.

1. **Prepare the installation site (page 2-5).** Ensure that the physical environment into which you will install the switch is properly prepared. The environment must have the correct network cabling ready to connect to the switch and have an appropriate location for the switch. See [page 2-5](#) for some installation precautions.
2. **Mount the switch (page 2-5).** The PS1810-8G Switch is designed to be stacked with an HP ProLiant MicroServer Gen8. You can mount the switch on a wall or, under or on top of a horizontal surface. The PS1810-24G Switch can be mounted in a 19-inch Telco rack; in an equipment cabinet, on a wall or; under or on top of a horizontal surface.
3. **Connect the network devices (page 2-14).** Using the appropriate network cables, connect the network devices to the switch ports.
4. **Optional: Install the SFP transceivers for the PS1810-24G Switch (page 2-14).** The PS1810-24G Switch has two slots for installing SFP transceivers. Depending on where you install the switch, it might be easier to install the SFPs first. SFPs can be hot swapped - you can install or remove while the switch is powered on.
5. **Connect the switch to the AC power source.** Once the switch is mounted and connected to the network devices, plug it into the main power source.

At this point, your switch is fully installed. See the rest of this chapter if you need detailed information about any of these installation steps.

1. Prepare the installation site

Follow the installation guidelines to ensure proper operation of the switch in the network:

- Verify that all the cables meet the requirements of the **“Cabling Specifications”** in Appendix A.
- Protect the switch from radio frequency interference emissions.
- Use electrical surge suppression.
- Use safe connections. The cables, connectors, or shields must not be damaged.

Installation space requirements.

Switch face	Clearance requirements
Front	At least 3 inches (7.6 cm) of space for the twisted-pair and fiber-optic cabling.
Back	At least 1-1/2 inches (3.8 cm) of space for the power cord and switch cooling.
Sides	At least 3 inches (7.6 cm) for cooling, except if the switch is installed in an open EIA/TIA rack.

2. Mount the switch

HP PS1810-8G Switch

You can stack the HP PS1810-8G Switch with HP ProLiant MicroServers, mount it on a wall, or on top of or under a horizontal surface.

Before stacking it with HP servers or positioning the switch on a horizontal surface, attach the rubber feet that are supplied in the accessory kit.

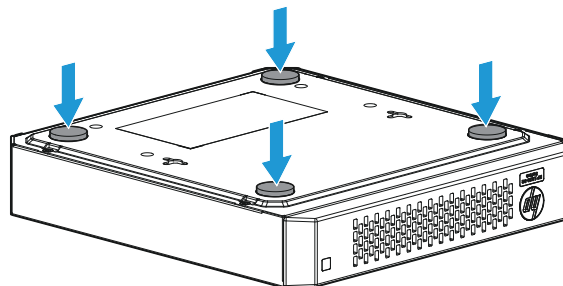

Note

If you are mounting the switch on a wall or under a surface, do not attach the rubber feet.

Stack with the HP ProLiant MicroServer Gen8 .

Stack the switch under **1** or on top of **2** the server.

Caution

The switch has a limitation on how much weight can be placed on top of it. To reduce the risk of personal injury or damage to the equipment, stack no more than two servers on top of the switch.

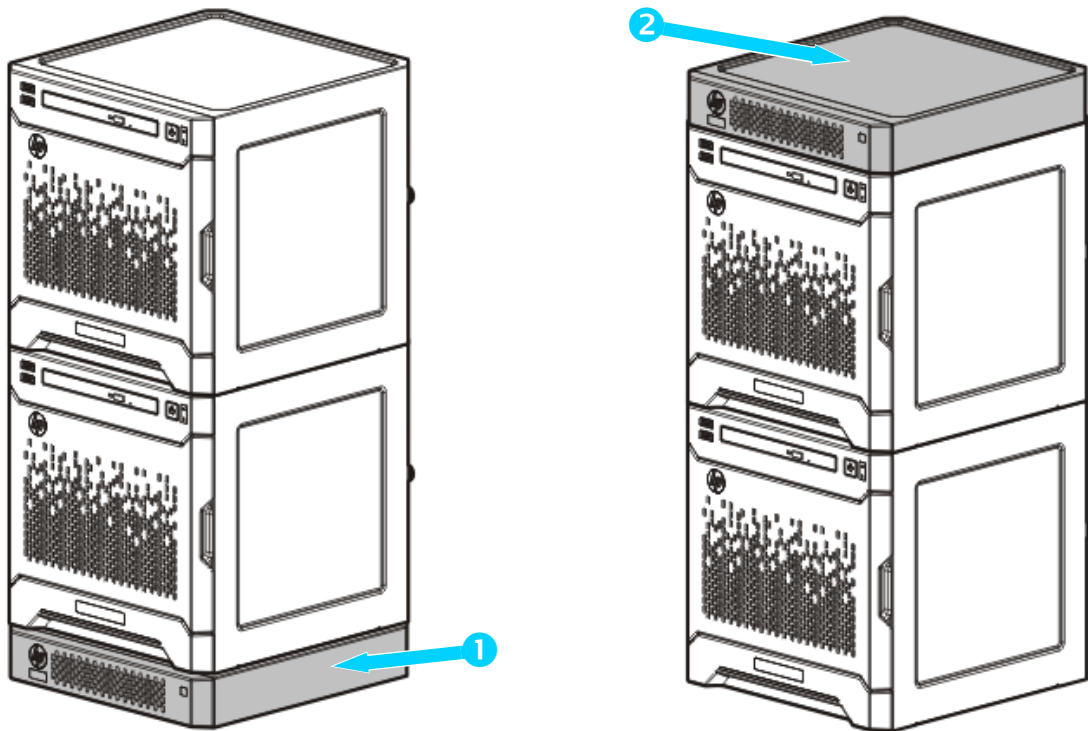

Mounting to a wall.

Important

Wall mount the switch with the network ports facing up or down.

Caution

Mount the switch only to a wall or wood surface that is at least 3/4-inch (19 mm) plywood or its equivalent.

1. Install two 3/4-inch (19 mm) M4 screws (included) into the mounting surface. The base of the screw head should be distanced approximately 2 mm from the wall face. Position the screws 6.3 inches (160 mm) apart for the PS1810-8G Switch. Use the wall anchors if necessary.

Note

The mounting holes on the PS1810-8G are not aligned horizontally (as shown in the illustration). They are offset from each other by 20 mm.

2. Position the switch over the screws, and then slide it down to lock it in place.

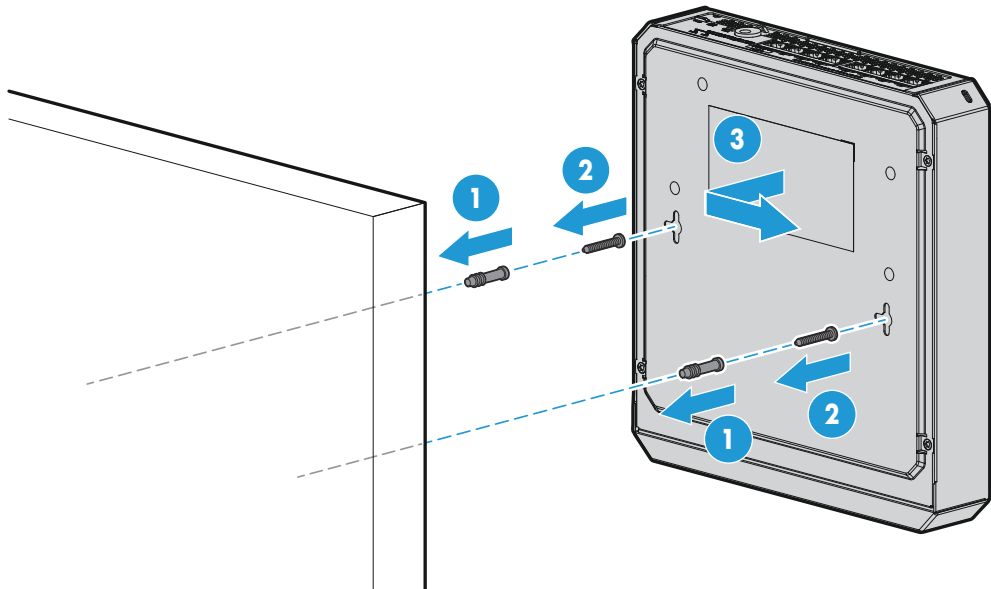

Mounting under a horizontal surface.

You can mount the switch under a horizontal surface.

Caution

Mount the switch only to a surface that is at least 1-inch (25.4 mm) thick.

1. Install two 3/4-inch (19 mm) M4 screws (included) into the mounting surface. The base of the screw head should be distanced approximately 2 mm from the wall face. Position the screws 6.3 inches (160 mm) apart for the PS1810-8G Switch. Use the wall anchors if necessary.
2. Position the switch over the screws and slide to lock in place.
3. Optional: Install the third screw at the side of the switch to prevent it from sliding out of the locked position.

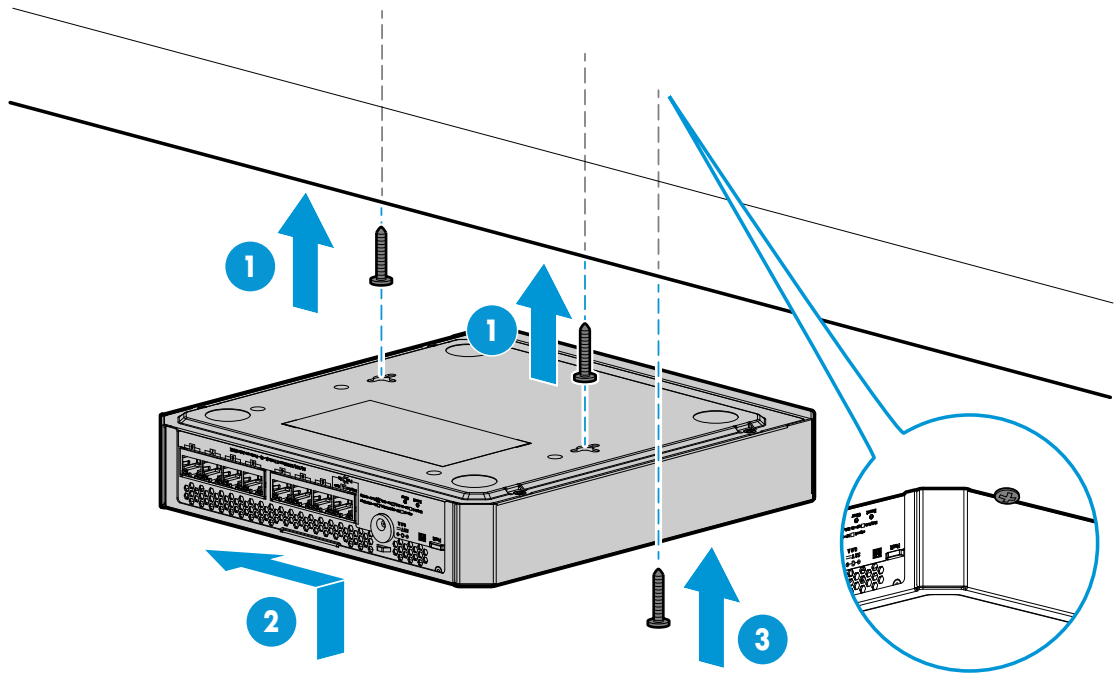

Mounting on top of a horizontal surface.

Place the switch on a table or any other horizontal surface. The switch comes with rubber feet in the accessory kit. The feet can be used to help keep the switch from sliding on the surface.

Attach the rubber feet to the four corners on the bottom of the switch within the embossed angled lines. Use a sturdy surface in an uncluttered area. You might want to secure the networking cables and switch power cord to the table leg or other part of the surface structure to help prevent tripping over the cords.

Using a Kensington Security Cable

To prevent unauthorized removal of the switch, you can use a Kensington Slim MicroSaver security cable (not included) to attach the switch to an immovable object.

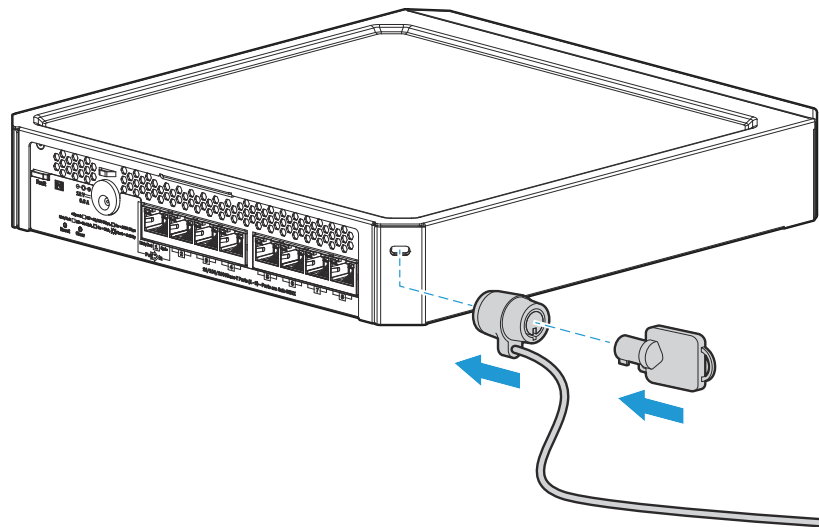

HP PS1810-24G Switch

You can mount the HP PS1810-24G in 19-inch Telco rack or equipment cabinet, on a wall or on top of a horizontal surface or under a horizontal surface.

Mounting to a Rack or a cabinet .

The PS1810-24G Switches are designed to be mounted in any EIA-standard 19-inch Telco rack or communication equipment cabinet. The mounting brackets have multiple mounting holes, and the mounting brackets can be rotated allowing for a wide variety of mounting options.

Important

For safe operation, read the “Installation Precautions” on [page 2-3](#), before mounting the switch.

Equipment Cabinet Note

The screws supplied with the switch are the correct threading for standard EIA/TIA open 19-inch racks. If you are installing the switch in an equipment cabinet such as a server cabinet, use the clips and screws that came with the cabinet in place of the screws that are supplied with the switch.

Complete the following step 1 to attach brackets to the switch. Decide on the four holes in the cabinet, and then install all the four clips. Then proceed to step 2 to install the switch in the cabinet.

1. Use a #1 Phillips (cross-head) screwdriver to attach the mounting brackets to the switch with the included 8-mm M4 screws.

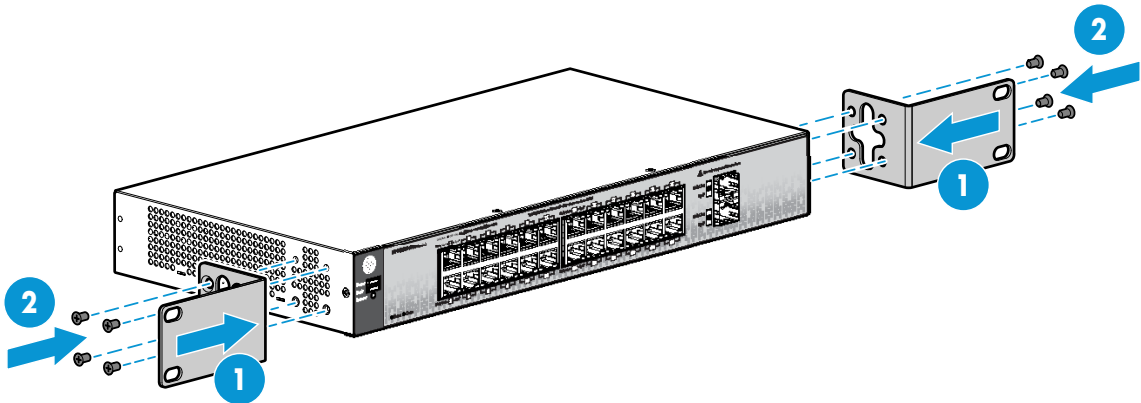

Note

The mounting brackets have multiple mounting holes and can be rotated allowing for a wide variety of mounting options. These include mounting the switch so its front face is flush with the face of the rack as shown in the illustration, or rotating the brackets so the switch is in a more balanced position with its face forward of the rack face.

2. Hold the switch with attached brackets in the rack and move it vertically until rack holes line up with the bracket holes, then insert and tighten the four 12-24 screws holding the brackets to the rack.

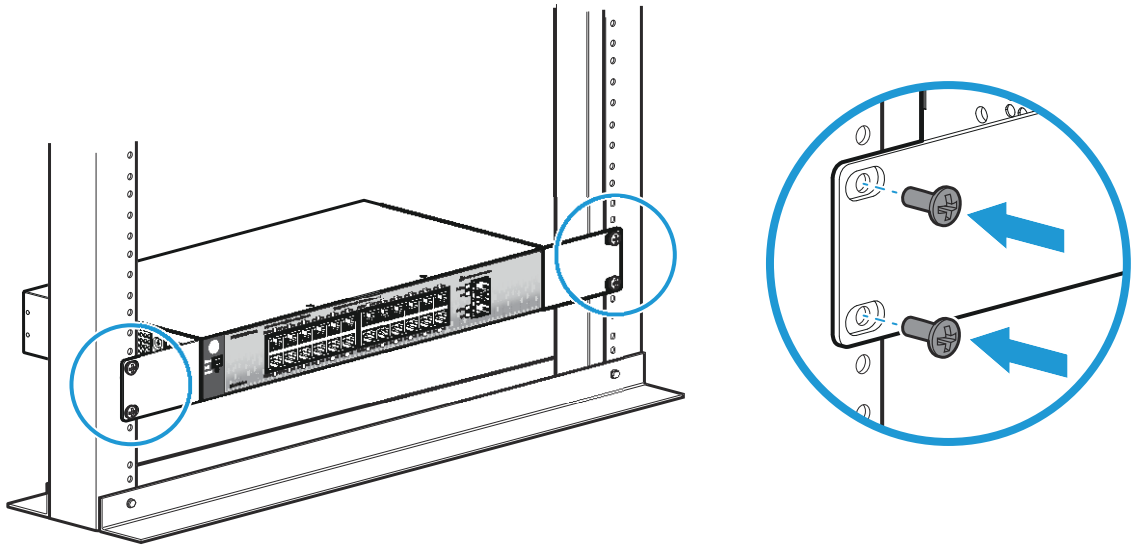

Mounting to a wall .

Important

For safe operation, read the “Installation Precautions” on [page 2-3](#), before mounting the switch.

Wall mount the switch with the network ports facing up or down.

Caution

The switch must be mounted only to a wall or to a wood surface that is at least 3/4-inch (19.1 mm) plywood or its equivalent.

1. Install two 3/4-inch (19 mm) M4 screws, (included) into the mounting surface. The base of the screw head must be at a distance of approximately 2 mm from the wall face. Position the screws 10 inches (254 mm) apart for the PS1810-24G Switch. Use the wall anchors if necessary.
2. Position the switch over the screws, and then slide it down to lock it in place.

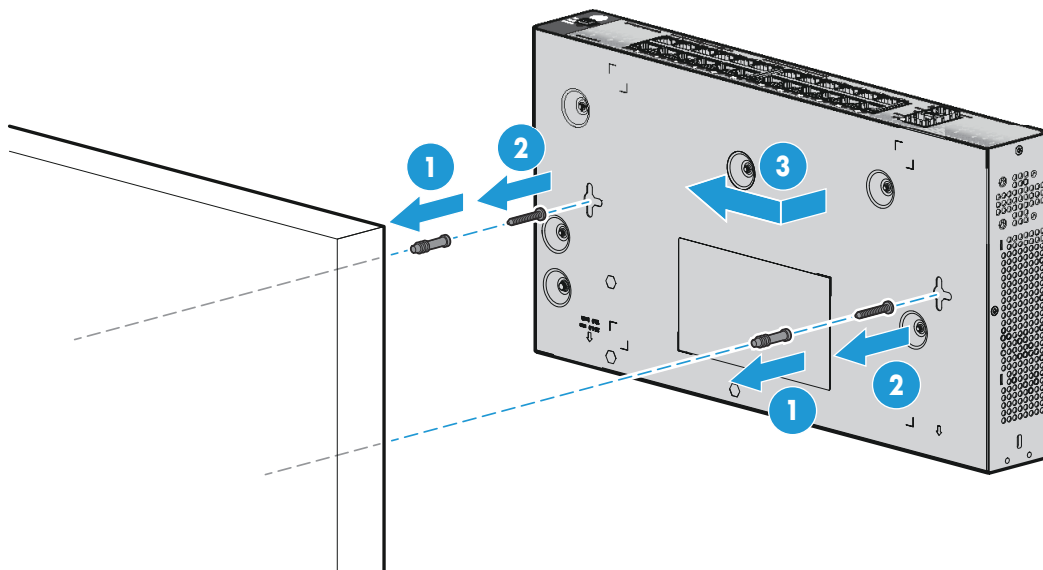

Mounting under a horizontal surface.

You can use the same screws and a similar technique used to mount the switch on the wall to mount the switch under a horizontal surface.

Caution

The switch must be mounted only to a horizontal surface that is at least 1-inch (25.4 mm) thick.

1. Install two 3/4-inch (19 mm) M4 screws, (included) into the mounting surface. The base of the screw head must be at a distance of approximately 2 mm from the wall face. Position the screws 10 inches (254 mm) apart for the PS1810-24G Switch. Use the wall anchors, if necessary.
2. Position the switch over the mounting screws, and then slide the switch sideways to lock it in place.
3. Screw a third M4 screw (included) into the table against one side of the switch to prevent it from sliding out of the locked position.

Mounting on top of a horizontal surface..

Place the switch on a table or other horizontal surface. The switch comes with rubber feet in the accessory kit. The feet can be used to help keep the switch from sliding on the surface.

Attach the rubber feet to the four corners on the bottom of the switch within the embossed angled lines. Use a sturdy surface in an uncluttered area. Secure the networking cables and switch power cord to the table leg or any other part of the surface structure to help prevent tripping over the cords.

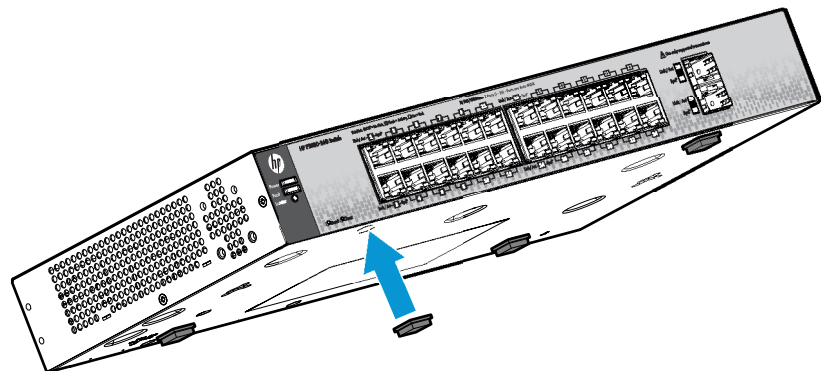

Figure

3. Connect the network cables

Connect network devices, such as the HP ProLiant Gen8 Servers, to any of the PS1810 Switch's RJ-45 network ports using Class 5E or better Ethernet cables. For more information, see [“Connections to HP ProLiant Gen8 Servers” on page 2-19](#). You can also connect other devices to the switch, such as printers and PCs, to form your local network.

Optional for the PS1810-24G Switch: Fiber-optic connections. For the PS1810-24G Switch, as shown in the illustrations below, you can also install SFPs and then connect network devices via fiber optic cables. For more information about using SFPs, see [“SFP installation notes” on page 2-18](#).

For network cable requirements and specifications, see [Appendix A, “Specifications”](#)

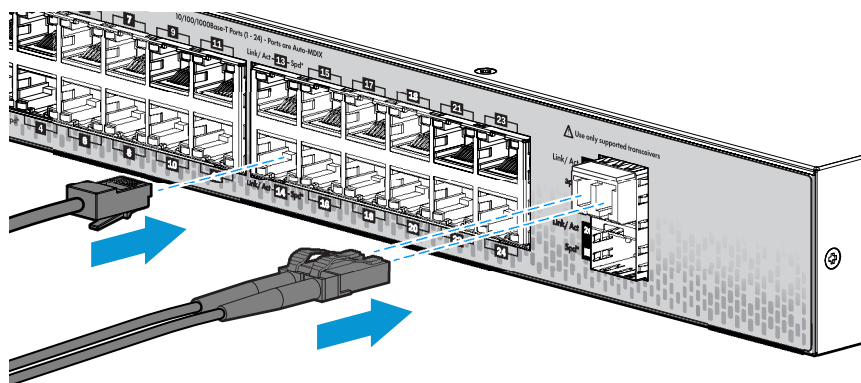
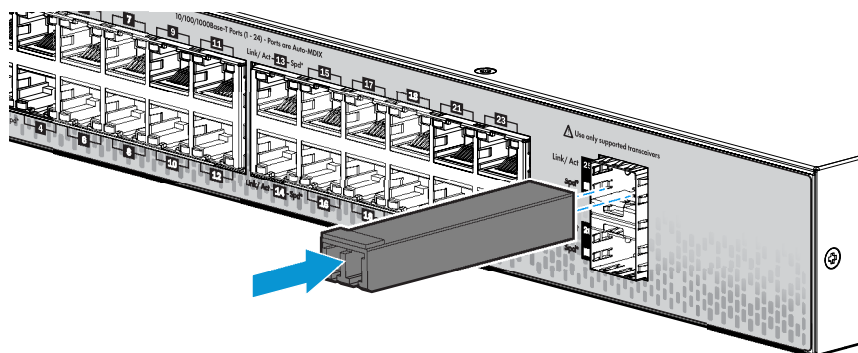

4. Power on the switch and verify that self-test completes normally

The PS1810 Switches do not have power switches. They are powered on by connecting them to an AC power source. For safety reasons, the power outlet must be located near the switch installation.

When the switch is powered on, it performs a diagnostic self test. The self test takes approximately 45 seconds to complete.

PS1810-8G Switch

1. For the PS1810-8G Switch, connect the AC/DC adapter's power cord to the power connector on the back of the switch, and then do one of the following:
 - Plug the AC/DC wall power adapter into a nearby properly grounded electrical outlet

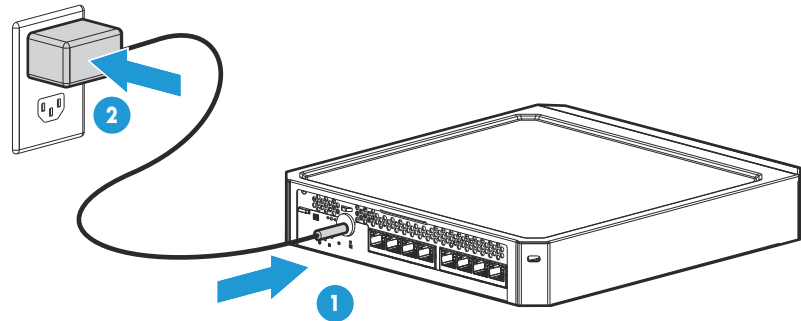

- Connect the power cord to the AC/DC inline power adapter and then into a nearby properly grounded electrical outlet.

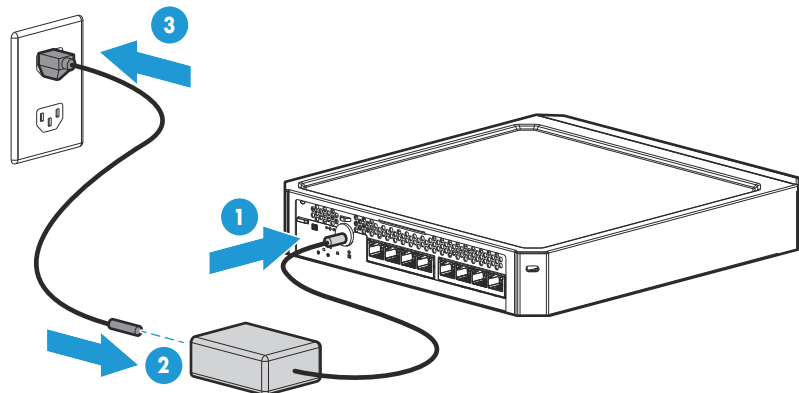

The external AC/DC power adapters automatically adjust to any voltage between 100-240 volts and 50 or 60 Hz.

2. Check the LEDs to assure that self test completed successfully:

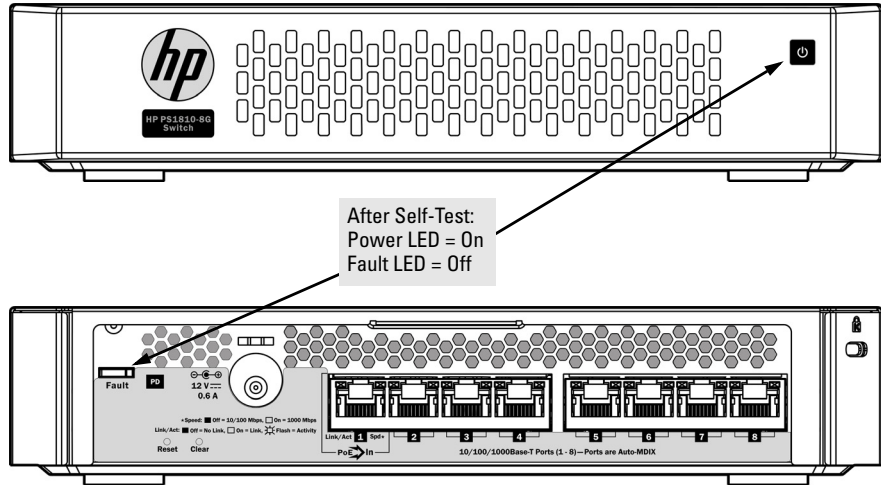

PS1810-24G Switch

1. For the PS1810-24G Switch, connect the power cord supplied with the switch to the power connector on the back of the switch, and then into a properly grounded electrical outlet.

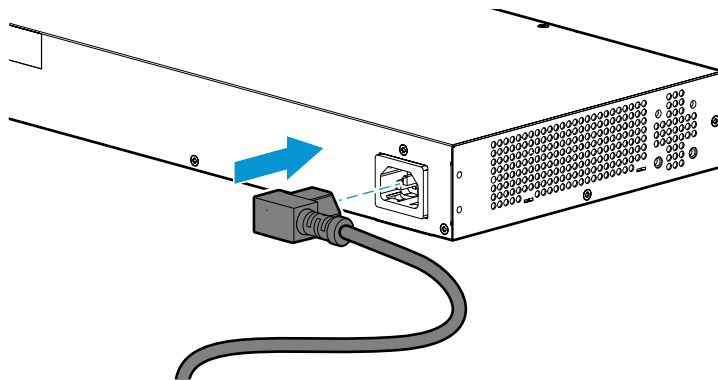

The switch automatically adjusts to any voltage between 100-127 or 200-240 volts and 50 or 60 Hz. It is not necessary to set a voltage range.

2. Check the LEDs on the switch as described below.

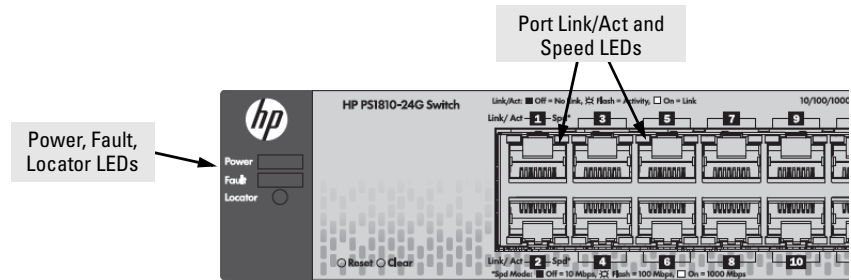

Self Test LED Behavior:

During the self test:

- Initially, the **Power**, **Fault**, **Locator**, and all port LEDs turn on.
- After several seconds, the **Power**, **Fault** and **Locator** LEDs remain on, and the port LEDs turn off. Then, each port **Link** LED is sequentially turned on, and then turned off.
- The **Fault** and **Locator** LEDs turn off when the self test completes.

When the self test completes successfully:

- The **Power** LED remains on.
- The **Fault**, and **Locator** LEDs stay off.
- The port LEDs on the front of the switch go into their normal operational mode:
 - If the ports are connected to active network devices, the **Link/Act** LEDs stay on or blink to indicate port activity. The **Spd** LEDs turn on for 1000 Mb/s links, blink for 100 Mb/s links, or remains off for 10 Mb/s links.
 - If the ports are not connected to active network devices, the **Link/Act** and **Spd** LEDs remains off.

If the LED display is different than what is described above, the self test has not completed correctly. For diagnostic help, see [Chapter 4, "Troubleshooting"](#).

SFP installation notes

Caution

Use only supported genuine HP SFPs with your switch. Non-HP SFPs are not supported, and their use might result in product malfunction. If you require additional HP SFPs, contact your HP Sales and Service Office or authorized dealer. For information about supported SFPs and mini-GBICs, see [“Network ports” on page 1-3](#).

Ensure that the network cable is NOT connected when you install or remove an SFP.

WARNING

The HP SFPs are Class 1 laser devices. Avoid direct eye exposure to Hot Swapping SFP transceivers. Supported SFP transceivers that you can install in your HP switch can be “hot swapped” – removed and installed while the switch is receiving power. Disconnect the network cables from the SFP transceivers before hot-swapping them, though.

- **SFP port configuration considerations when changing SFP type.** When you replace an SFP transceiver with another of a different type, the switch might retain selected port-specific configuration settings that were configured for the replaced unit. Be sure to validate or reconfigure port settings as required.
- **SFP connections to devices with fixed speed/duplex configurations.** When you connect a device to your switch port that contains an SFP transceiver, the speed and duplex settings of the switch port and the connected device must match; otherwise, the device might not link properly. For some older network devices, including some older HP devices, the default speed/duplex settings might be predefined (for example, to 1000 Mb/s/Full Duplex), or otherwise set differently from the default configuration of your switch port. Because of these default speed/duplex considerations, make sure that devices connected to your SFP ports are properly configured. *At a minimum, make sure the configurations match.*
- **Environmental limitations.** If you are using SFPs with the switch, make sure that the operating temperature range at the switch installation site does not exceed the range allowed for the SFP.

Installing the SFPs

Remove the fiber-optic protective cover and retain it for later use. Hold the SFP by its sides and gently insert it into either of the slots on the switch until the SFP clicks into place.

Removing the SFPs

Note

You should disconnect the network cable from the SFP before removing it from the switch.

Depending on when you purchased your HP SFP, it may have either of three different release mechanisms: a plastic tab on the bottom of the SFP, a plastic collar around the SFP, or a wire bail.

- To remove the SFPs that have the plastic tab or plastic collar, push the tab or collar toward the switch until you see the SFP release from the switch (you can see it move outward slightly), and then pull it from the slot.
- To remove the SFPs that have the wire bail, lower the bail until it is approximately horizontal, and then using the bail, pull the SFP from the slot.

After removing the SFP, replace the fiber-optic protective cover.

Connections to HP ProLiant Gen8 Servers

Connect network devices, such as an HP ProLiant MicroServer Gen8 to any of the PS1810 Switch's RJ-45 ports using Class 5E or better Ethernet cables.

Note

Any of the switch's network ports can be used for the following connections. You do not have to use the specific ports shown in the illustrations.

As shown in the following illustrations, for connection to an HP ProLiant MicroServer Gen8, it is recommended that you make the following connections:

- **1** to **2** – to provide internet access for the switch and server, connect any of the switch ports(1 - 8) to your ISP connection, or to a router that is connected to the internet.
- **3** to **4** – for data communication between the switch and the server, connect a network cable between *any* of the available switch ports and either one of the server's Ethernet ports. Connection to server ethernet port 2 is shown.
- **5** to **6** – to be able to discover and monitor the health status of HP servers from the switch, connect a network cable between *any* of the available switch ports and the server's iLO port.

Note

It is also possible to use a single cable between the switch and server for data and iLO communications, but this requires that you connect to server Ethernet port 1, and requires changes to the server configuration to cause the server Ethernet 1 port to be "shared" for data and iLO communications. For more information on shared iLO, see the server documentation.

Installing the switch
Installation procedure

PS1810-8G Switch

Connect the PS1810-8G Switch to an HP ProLiant MicroServer Gen8.

HP ProLiant MicroServer Gen8

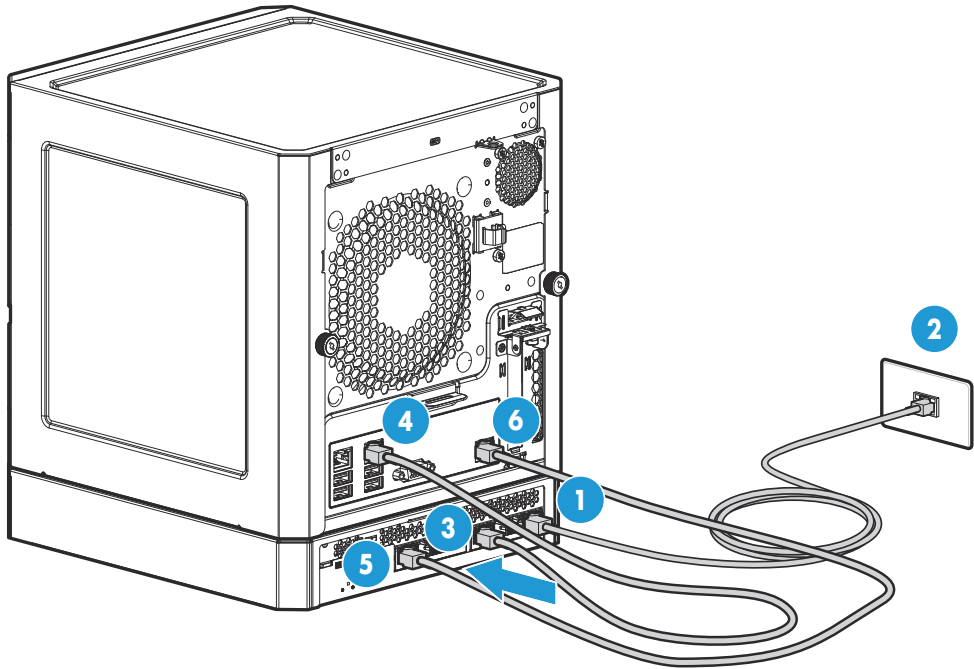

PS1810-24G Switch

Connect the PS1810-24G Switch to an HP ProLiant ML310e Gen8 v2 Server or an HP ProLiant DL320e Gen8 v2 Server.

HP ProLiant ML310e Gen8 v2 Server

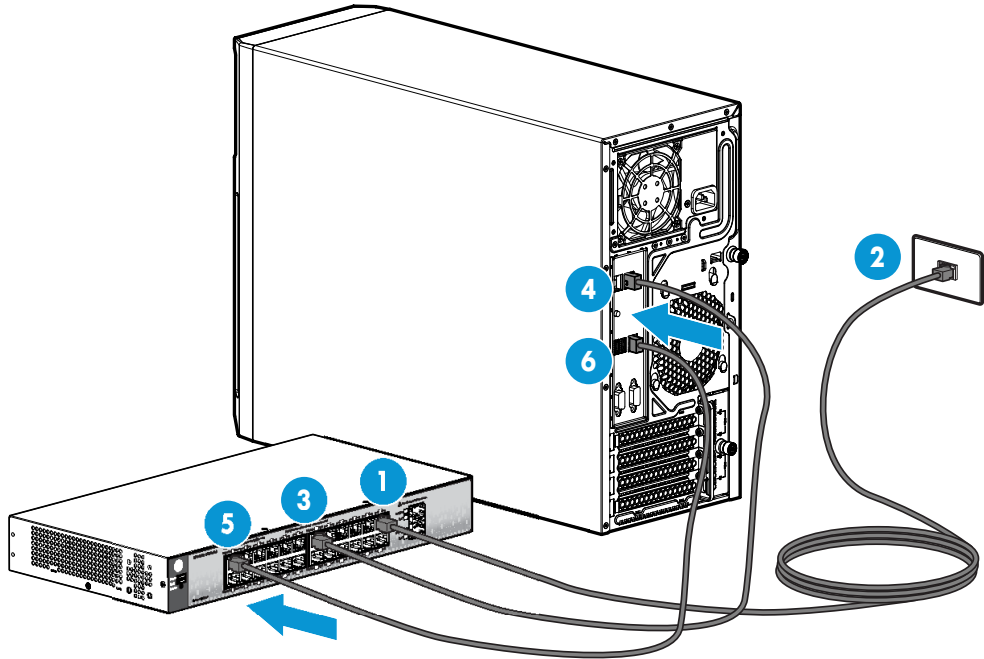

HP ProLiant DL320e Gen8 v2 Server

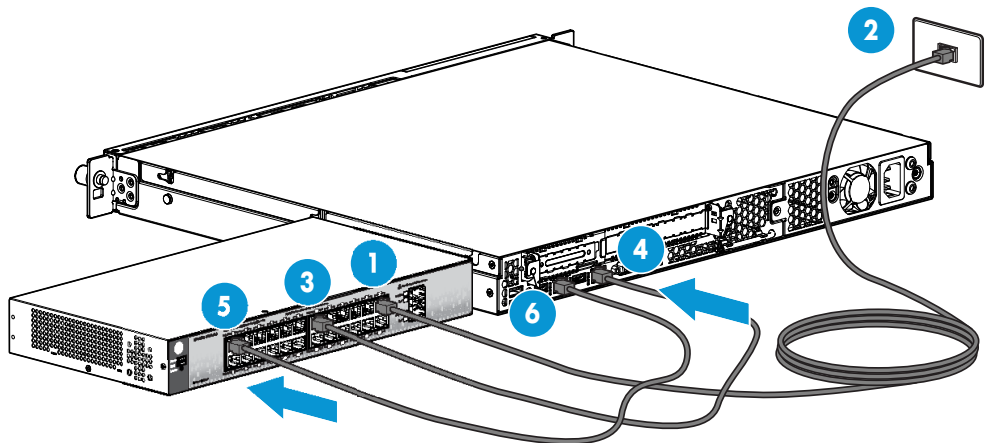

Installing the switch
Installation procedure

Configuring the HP PS1810 switch

Initial configuration

The HP PS1810 Switches can be managed through a web interface that you can access from any PC or workstation connected to the switch.

To access the web interface, you must have the switch's Internet Protocol (IP) address. In the factory default configuration, the IP address is automatically acquired from a Dynamic Host Configuration Protocol (DHCP) service that is available on your network or from your Internet Service Provider (ISP). Most routers provide this service. The DHCP service automatically provides a network IP address configuration to devices that request it, such as the HP PS1810 Switches.

Many features are configurable on the HP PS1810 Switches. HP recommends that at minimum, you configure a management password for switch security. Follow these procedures to access the switch's web interface to perform the switch configuration:

1. Place the switch close to the PC that you will use for configuration. It helps if you can see the front panel of the switch while working from your PC.
2. Connect power to the switch, and then start your PC (if it is not already running) and wait until the switch and PC have finished their start-up sequences.
3. Connect the PC to any port on the switch using a standard Ethernet LAN cable. Verify that there is a link between the switch and PC by checking the LEDs for the network port that you are using (For more information on LEDs, see [“LEDs” on page 1-4](#)).
4. If the switch has access to a DHCP service, it automatically acquires an IP address. Determine the IP address of the switch by examining the client IP address table on your router (see the router documentation for how to get this information), or talk to your ISP representative to get the IP address of the switch.

If DHCP service is not available in your network, or for some reason the switch does not acquire an IP address from the service, the switch defaults to IP address **192.168.2.10** after 120 seconds of automatically attempting to acquire an IP address.

Note

Alternatively, if you cannot determine the switch’s IP address, you can force it to use the 192.168.2.10 address by first disconnecting the switch from any router or internet connection and then unplugging and reconnecting power to it.

To communicate with the switch using the 192.168.2.10 address, see the section “Managing the switch via the 192.168.2.10 address” on page 3-3” before continuing these steps.

5. From the PC connected to the switch, open a web-browser session and enter the switch’s IP address as the URL. This opens the login screen for the switch’s web-browser interface from which you perform the next steps.
6. Click **Login** to start a switch web-browser interface session. By default, there is no password.

A screen similar to the following appears:

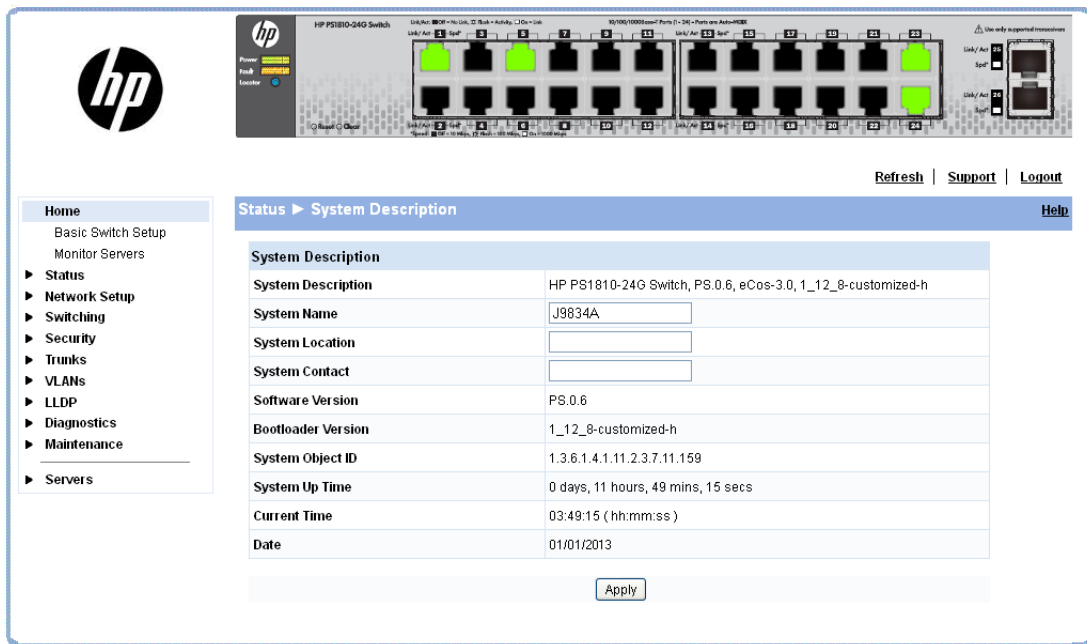

Figure 1-2. HP PS1810 Switch web interface home page

7. To configure a password on the switch web interface, click **Maintenance > Password Manager** and **New Password**. Reenter the new password in the **Confirm New Password** field. Passwords can be up to 64 alpha-numeric and special characters in length, and are case sensitive.

8. Click **Apply** on the browser configuration screen to save your settings to retain them when the switch is rebooted.

See the switch's *Management and Configuration Guide* for more switch configuration information.

Note

If you cannot remember the switch's IP address or password, you can restore the factory default settings by following the procedure described in the "Troubleshooting" section of this manual.

Managing the switch via the 192.168.2.10 address

If the switch does not acquire an IP address via the DHCP request, it defaults to the following configuration:

Parameter	Factory Default Setting
Password	<blank>
IP address	192.168.2.10
Subnet mask	255.255.255.0
Default gateway	not set

To communicate with the switch via the 192.168.2.10 address:

1. Connect a PC directly to any of the switch's network ports using a standard Ethernet cable.
2. Configure the PC's IP Address and Subnet Mask to allow it to communicate with the switch through your PC's Web browser.

For example, for Windows 7, follow these steps:

- a. Click **Start**, and then click **Control Panel**. In the Control Panel, click **Network and Internet** and then **Network and Sharing Center**.
- b. Click **Local Area Connection**, and then click **Properties**. If you are prompted for an administrator password or for a confirmation, type the password or provide confirmation.
- c. Click **Internet Protocol Version 4 (TCP/IPv4)** and then click **Properties**.

Note: Record your PC's current IP settings to be able to restore them later, if needed.

3. Click **Use the following IP address**, and then, in the **IP address** and **Subnet mask** fields, type the IP address settings:
 - a. For **IP address**, enter an IP address in the same range as the switch's IP address, for example, enter **192.168.2.12**.
 - b. For **Subnet mask**, enter **255.255.255.0**, then click **OK**.
 - c. Click **Close** (or **OK**) to close the **Local Area Connection Properties** screen.
 4. Open the Web browser on the PC, and enter the switch address, **http://192.168.2.10** to access the switch's web interface.
 5. Go back to step 6 on the [page 3-2](#) to configure the switch.
-

Restoring DHCP addressing to the switch

If you subsequently decide to use automatic IP addressing via a DHCP service in your network, reconfigure the switch using the following procedures:

1. In the switch's web interface, click on **Network Setup > Get Connected**.
2. In the **Get Connected** page, select **DHCP** and then click on **Apply**. See [Figure 1-3 on page 3-5](#).

Note: When you make this selection, you will lose connection with the switch.
3. Reboot the switch.

Note: If the DHCP server is ready after the reboot, the switch automatically obtains an IP address.
4. Now you can use the automatic IP addresses acquired by the switch and your PC to communicate as described starting with step 4 on [page 3-1](#).

Network Setup ► Get Connected

Network Details

Protocol Type	<input type="radio"/> Static <input checked="" type="radio"/> DHCP
IP Address	10.9.61.231 (xxxx)
Subnet Mask	255.255.255.0
Gateway Address	10.9.61.1
MAC Address	00:9c:02:6f:10:40

Web Parameters

Session Timeout	5 (0 - 60 Default: 5) minutes
-----------------	---------------------------------

Management Access

Management VLAN ID	1
Management Port	None

SNMP

Enable	<input checked="" type="checkbox"/>
Community Name	public

Apply

Figure 1-3. Get Connected page – selecting DHCP for automatic IP address

Next steps

For more information about the Web browser interface and all the features that can be configured on the HP 1810 Switch Series, see the *HP PS1810 Switches Management and Configuration Guide*, which is available on the HP Website, <http://www.hp.com/networking/support>.

To access the manuals web page for the PS1810 switches:

1. Auto Search for PS1810 on <http://www.hp.com/networking/support> page.
2. Select the switch in the listed items, and click Display selected.
3. The Warranty support and product information page appears.
4. Click Product support information (manuals, FAQs, knowledge base) in the list.
5. The Business Support Center page for the switch opens, click “Manuals” to open the documentation page for the switch.

Troubleshooting

This section describes how to troubleshoot the switch. For more information, see the chapter “Troubleshooting” in the *HP PS1810 Switch Series Management and Configuration Guide*, available on the HP web site, <http://www.hp.com/networking/support>.

This chapter describes the following:

- Basic troubleshooting tips ([page 4-1](#))
 - Diagnosing with the LEDs ([page 4-2](#))
 - Testing the switch by resetting it ([page 4-4](#))
 - Forgotten the IP address or password ([page 4-4](#))
 - HP Customer Support Services ([page 4-5](#))
-

Basic troubleshooting tips

Common problems and their solutions are listed in the following table.

Problem	Resolution
Switch fails Power-On Self Test (POST)	Troubleshoot using the LEDs. See “ Diagnosing with the LEDs ” on page 4-2
Link light does not light when a cable is connected.	The switch may be enabled in Green Mode, where port Link LEDs would be off. Look for loose or obviously faulty connections. If they appear to be OK, make sure the connections are snug. If that does not correct the problem, try a different cable.

Diagnosing with the LEDs

When resetting the switch, or during a power-on self test (POST), LED patterns on the switch may indicate a problem condition.

1. Check in the table below for the LED pattern you see on your switch.
2. Refer to the corresponding diagnostic tips on the next few pages.

LED Pattern Indicating Problems				Diagnostic Tips
Power	Fault	PD LED ³	Port LED	
Off with power cord or power adapter plugged in	¹	Off	¹	1
On	Prolonged On	¹	¹	2
On	Blinking ²	¹	Blinking ²	3
On	Off	¹	Off with cable connected	4
Off	Off	Off with cable connected to port 1 ³	¹	5

¹ This LED is not important for the diagnosis.
² The blinking behavior is an on/off cycle once every 1.6 seconds, approximately.
³ Applies only to the HP PS1810-8G Switch.

Diagnostic tips:

Tip	Problem	Solution
1	The switch is not plugged into an active AC power source, or the power adapter (if applicable) of the switch might have failed.	<ol style="list-style-type: none"> 1. Verify that the power cord or power adapter is plugged into an active AC power source and to the switch. Make sure these connections are snug. 2. Try power cycling the switch by unplugging the power cord or power adapter from the AC outlet and then plugging it back in. 3. If the Power LED is still not on, verify that the AC power source works by plugging another device into the outlet, or try plugging the switch into a different outlet, or try a different power cord (if applicable). <p>If the power source and power cord are OK and this condition persists, the switch's internal power supply or power adapter might have failed. Call your HP authorized network reseller, or use the electronic support services from HP to get assistance.</p>

Tip	Problem	Solution
②	A switch hardware failure has occurred. All the LEDs will stay on indefinitely.	Try power cycling the switch. If the fault indication reoccurs, the switch might have failed. Call your HP authorized network reseller, or use the electronic support services from HP to get assistance.
③	The network port for which the Link LED is blinking has experienced a self test or initialization failure.	<p>Try power cycling the switch. If the fault indication reoccurs, the switch port might have failed. To confirm, try a different port that appears to be good. Call your HP authorized network reseller, or use the electronic support services from HP to get assistance.</p> <p>If the port is an SFP, verify that it is one of the SFPs supported by the switch. Unsupported SFPs are identified with this fault condition. The supported SFPs are listed in Chapter 1, “Switch Overview” on page 1-3. The SFPs are also tested by the switch when they are “hot-swapped”— installed or changed while the switch is powered on.</p> <p>To verify that the port has failed, try removing and reinstalling the SFP without powering off the switch. If the port fault indication reoccurs, replace the SFP.</p>
④	The network connection is not working properly.	<p>Try the following steps:</p> <ul style="list-style-type: none"> • For the indicated port, verify that both ends of the cabling, at the switch and the connected device, are secure. • Verify that the connected device and the switch are both powered <i>on</i> and are operating correctly. • Verify that the connected devices comply with the appropriate IEEE 802.3 standard, including transmission of the Link signal. • If these steps do not resolve the problem, try using a different port or a different network cable.
⑤	A PoE power sourcing equipment (PSE) device is connected to port 1 on an HP PS1810-8G Switch, but PoE power is not being supplied.	<p>Try the following steps:</p> <ul style="list-style-type: none"> • Make sure that the PSE device is powered on. • Make sure that the network cable between the PSE and the switch is fully connected at both ends. • On the PSE, make sure that the port being used to provide the PoE power has appropriate PoE capabilities and priority, and that PoE delivery is enabled on that port. • If these steps do not resolve the problem, try using a different network cable.

Testing the switch by resetting

If you believe the switch is not operating correctly, you can reset the switch to test its circuitry and operating code. To reset the switch, unplug and plug in the power cord (power cycling).

Power cycling the switch will cause the switch to perform its power-on self test.

You can reset the switch from the web interface. Login to the switch web interface, and from the home page, select **Diagnostics > Reboot Switch**.

Restoring to factory defaults

If you forget the switch IP address or password, you can restore the factory default configuration by pressing the Reset and Clear buttons.

To restore the factory default settings on the switch, perform these steps:

1. Using a small, thin tool with blunt ends (such as a paper clip), simultaneously press both the Reset and Clear buttons on the front of the switch.
2. Continue to press the Clear button while releasing the Reset button.
3. Release the Clear button.

The switch will then complete its self test and begin operating with its configuration restored to the factory default settings.

After completing this procedure, there will be no password, the switch will return to attempting to automatically acquire an IP address via a DHCP service, and all configuration settings will be set to factory defaults.

You can restore the factory default configuration to the switch from the web interface. Login to the switch web interface, and from the home page, select **Diagnostics > Factory Defaults**.

HP Customer Support Services

If you are still having trouble with your switch, Hewlett-Packard offers support 24 hours a day, seven days a week through the use of a number of automated electronic services.

The HP web site, <http://www.hp.com/networking/support> also provides up-to-date support information.

Additionally, your HP authorized network reseller can provide you with assistance, both with services they offer and with services offered by HP.

Before calling HP support

Before you call your networking dealer or HP Support, to make the support process most efficient, you first should have retrieved the following information:

Information Item	Information Location
<ul style="list-style-type: none">• Product identification, including for the switch and any installed SFPs.	The front of the switch, and on labels on the SFPs.
<ul style="list-style-type: none">• Details about the switch's status including the operating software (OS) version, a copy of the switch configuration, and the contents of the Support file.	Switch's web interface. For more information about using the web interface, see the Management and Configuration Guide for your switch.
<ul style="list-style-type: none">• Copy of your network topology map, including network addresses assigned to the relevant devices.	Your network records.

Specifications

Switch Specifications

Physical

	Width	Depth	Height	Weight
PS1810-8G (J9833A)	23 cm (9.055 in)	24.5 cm (9.64 in)	4.5 cm (1.77 in)	1.25 kg (2.74 lbs)
PS1810-24G (J9834A)	33.0 cm (13.0 in)	17.7 cm (6.96 in)	4.5 cm (1.77 in)	1.35 kg (3.0 lbs)

Electrical

	AC voltage	Maximum current	Frequency range
PS1810-8G (J9833A) ^{1,3}	100-240 volts	0.5A	50/60 Hz
PS1810-24G (J9834A) ²	100-127 volts 200-240 volts	0.4 A / 0.3 A	50/60 Hz

¹ Requires a connection to an external power adapter. The adapter automatically adjusts to any voltage between 100-127 or 200-240 volts and either 50 or 60 Hz.

² The switch automatically adjusts to any voltage between 100-127 or 200-240 volts and either 50 or 60 Hz.

³ The switch can also be powered by a PoE PSE connected to Port 1. Port 1 is an IEEE 802.3af Compatible PD (PoE Powered Device) - Class 3.

Environmental

	Operating	Non-Operating
Temperature	0°C to 40°C (32°F to 104°F)	-40°C to 70°C (-40°F to 158°F)
Relative humidity (non-condensing)	15% to 90% at 40°C (104°F)	15% to 90% at 65°C (149°F)
Maximum altitude	3.0 Km (10,000 ft)*	4.57 Km (15,000 ft)

* The operating maximum altitude should not exceed that of any accessory that is connected to any PS1810 Switch.

Acoustics

Power: 0 dB (no fans)

Safety

Complies with:

- **HP PS1810-8G**
- Standards: EN60950-1:2006+A11:2009+A1:2010+A12:2011 / IEC60950-1:2005; Am 1:2009 CSA22.2 No. 60950-1-07 2nd; UL60950-1 2nd
- **HP PS1810-24G**
- Standards: EN60950-1:2006+A11:2009+A1:2010+A12:2011 / IEC60950-1:2005; Am 1:2009 CSA22.2 No. 60950-1-07 2nd; UL60950-1 2nd
- Lasers: EN 60825-1:2007 / IEC 60825-1:2007 Class 1; Class 1 Laser Products / Laser Klasse 1 (Use only supported HP SFPs)

Standards

Technology Standards and Safety Compliance			
		Laser safety information	
Technology	Compatible with these IEEE standards	EN/IEC standard compliance	SFP Lasers
10-T	IEEE 802.3 10BASE-T		
100-TX	IEEE 802.3u 100BASE-TX		
1000-T	IEEE 802.3ab 1000BASE-T		
100-FX	IEEE 802.3u 100BASE-FX	EN/IEC 60825	Class 1 Laser Product Laser Klasse 1
1000-SX	IEEE 802.3z 1000BASE-SX	EN/IEC 60825	Class 1 Laser Product Laser Klasse 1
1000-LX	IEEE 802.3z 1000BASE-LX	EN/IEC 60825	Class 1 Laser Product Laser Klasse 1

Cabling and Technology Information

Cabling Specifications

Cabling Specifications		
Twisted-pair copper	10 Mb/s Operation	Category 3, 4 or 5, 100-ohm unshielded twisted-pair (UTP) or shielded twisted-pair (STP) cable, complying with IEEE 802.3 10BASE-T specifications.
	100 Mb/s Operation	Category 5, 100-ohm UTP or STP cable, complying with IEEE 802.3u 100BASE-TX specifications.
	1000 Mb/s Operation	Category 5, 100-ohm 4-pair UTP or STP cable, complying with IEEE 802.3ab 1000BASE-T specifications—Category 5e or better is recommended. See note on 1000BASE-T Cable Requirements below.
Multimode fiber		62.5/125 μm or 50/125 μm (core/cladding) diameter, low metal content, graded index fiber-optic cables, complying with the ITU-T G.651 and ISO/IEC 793-2 Type A1b or A1a standards respectively. ¹
Single mode fiber		9/125 μm (core/cladding) diameter, low metal content fiber-optic cables, complying with the ITU-T G.652 and ISO/IEC 793-2 Type B1 standards.
¹ A mode conditioning patch cord may be required for some Gigabit-LX installations. See "Mode Conditioning Patch Cord" on page A-6 for more information.		

Note on 1000BASE-T Cable Requirements. The Category 5 networking cables that work for 100BASE-TX connections should also work for 1000BASE-T, as long as all four-pairs are connected. But, for the most robust connections, you should use cabling that complies with the Category 5e specifications, as described in Addendum 5 to the TIA-568-A standard (ANSI/TIA/EIA-568-A-5).

Because of the increased speed provided by 1000BASE-T (Gigabit-T), network cable quality is more important than for either 10BASE-T or 100BASE-TX. Cabling plants being used to carry 1000BASE-T networking must comply with the IEEE 802.3ab standards. In particular, the cabling must pass tests for Attenuation, Near-End Crosstalk (NEXT), and Far-End Crosstalk (FEXT). Additionally, unlike the cables for 100BASE-TX, the 1000BASE-T cables must pass tests for Equal-Level Far-End Crosstalk (ELFEXT) and Return Loss.

When testing your cabling, be sure to include the patch cables that connect the switch and the other end devices to the patch panels on your site. The patch cables are frequently overlooked when testing cable. The patch cables must also comply with the cabling standards.

Technology Distance Specifications

Technology Distance Specifications			
Technology	Supported cable type	Multimode fiber modal bandwidth	Supported distances
100-FX	multimode fiber	any	up to 2,000 meters
1000-T	twisted-pair copper	N/A	up to 100 meters
1000-SX	multimode fiber	160 MHz*km 200 MHz*km 400 MHz*km 500 MHz*km	2 - 220 meters 2 - 275 meters 2 - 500 meters 2 - 550 meters
1000-LX	multimode fiber single mode fiber	400 MHz*km 500 MHz*km N/A	2 - 550 meters 2 - 550 meters 2 - 10,000 meters

Mode Conditioning Patch Cord

The following information applies to installations in which multimode fiber-optic cables are connected to a Gigabit-LX port. Multimode cable has a design characteristic called “Differential Mode Delay”, which requires the transmission signals be “conditioned” to compensate for the cable design and thus prevent resulting transmission errors.

Under certain circumstances, depending on the cable used and the lengths of the cable runs, an external Mode Conditioning Patch Cord may need to be installed between the Gigabit-LX transmitting device and the multimode network cable to provide the transmission conditioning. If you experience a high number of transmission errors on those ports, usually CRC or FCS errors, you may need to install one of these patch cords between the fiber-optic port in your switch and your multimode fiber-optic network cabling, at both ends of the network link.

The patch cord consists of a short length of single mode fiber cable, coupled to graded-index multimode fiber cable on the transmit side, and only multimode cable on the receive side. The section of single mode fiber is connected in such a way that it minimizes the effects of the differential mode delay in the multimode cable.

Note

Most of the time, if you are using good quality graded-index multimode fiber cable that adheres to the standards listed in this appendix, there should not be a need to use mode conditioning patch cords in your network. This is especially true if the fiber runs in your network are relatively short.

Installing the Patch Cord

As shown in the illustration below, connect the patch cord to the transceiver with the section of single mode fiber plugged in to the Tx (transmit) port. Then, connect the other end of the patch cord to your network cabling patch panel, or directly to the network multimode fiber.

If you connect the patch cord directly to the network cabling, you may need to install a female-to-female adapter to allow the cables to be connected together.

Specifications Mode Conditioning Patch Cord

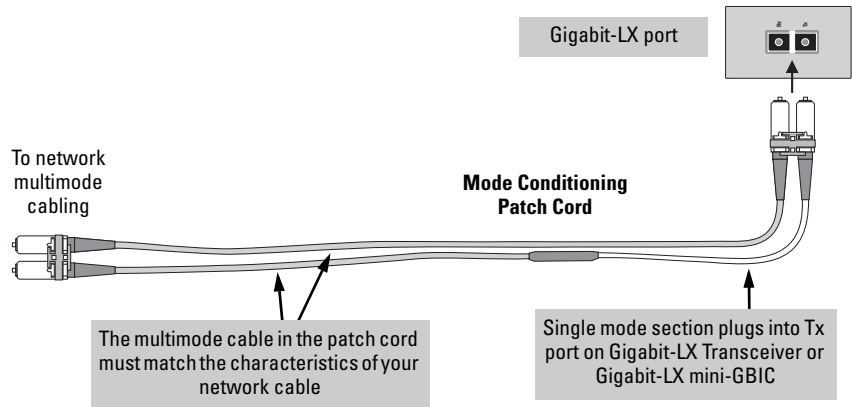

Example: Connecting a Mode Conditioning Patch Cord for Gigabit-LX

Make sure you purchase a patch cord that has appropriate connectors on each end, and has multimode fibers that match the characteristics of the multimode fiber in your network. Most important, the core diameter of the multimode patch cord must match the core diameter of the multimode cable infrastructure (either 50 or 62.5 microns).

Twisted-Pair Cable/Connector Pin-Outs

The Auto-MDIX Feature: In the default configuration, “Auto”, the fixed 10/100/1000BASE-T ports on the switches all automatically detect the type of port on the connected device and operate as either an MDI or MDI-X port, whichever is appropriate. So for any connection, a straight-through twisted-pair cable can be used—you no longer have to use crossover cables, although crossover cables can also be used for any of the connections. (The 10/100/1000-T ports support the IEEE 802.3ab standard, which includes the “Auto-MDIX” feature.)

If you connect a switch twisted-pair port to another switch or hub, which typically have MDI-X ports, the switch port automatically operates as an MDI port. If you connect it to an end node, such as a server or PC, which typically have MDI ports, the switch port operates as an MDI-X port. In all cases, you can use standard straight-through cables or crossover cables.

If you use a correctly wired crossover cable, though, the switch will still be able to automatically detect the MDI/MDI-X operation and link correctly to the connected device.

Note

Using Fixed Configurations. If the port configuration is changed to any of the fixed configurations though, for example 100 Mb/s/full duplex, the port operates as MDI-X only and the correct cable type must be used: for connections to MDI ports, such as end nodes, use a straight-through cable; for connections to MDI-X ports, such as on hubs and other switches, use a crossover cable.

Other Wiring Rules:

- All twisted-pair wires used for 10 Mb/s, and 100 Mb/s operation must be twisted through the entire length of the cable. The wiring sequence must conform to EIA/TIA 568-B (not USOC). See “Twisted-Pair Cable Pin Assignments” later in this appendix for a listing of the signals used on each pin.
- For 1000BASE-T connections, all four pairs of wires in the cable must be available for data transmission.
- For 10 Mb/s connections to the ports, you can use Category 3, 4, or 5 unshielded twisted-pair cable, as supported by the IEEE 802.3 Type 10BASE-T standard.
- For 100 Mb/s connections to the ports, use 100-ohm Category 5 UTP or STP cable only, as supported by the IEEE 802.3u Type 100BASE-TX standard.
- For 1000 Mb/s connections, 100-ohm Category 5e or better cabling is recommended.

Straight-through Twisted-Pair Cable for 10 Mb/s or 100 Mb/s Network Connections

Because of the Auto-MDIX operation of the 10/100 ports on the switch, for all network connections, to PCs, servers or other end nodes, or to hubs or other switches, you can use straight-through cables.

If any of these ports are given a fixed configuration, for example 100 Mb/s/Full Duplex, the ports operate as MDI-X ports, and straight-through cables must be then used for connections to PC NICs and other MDI ports.

Cable Diagram

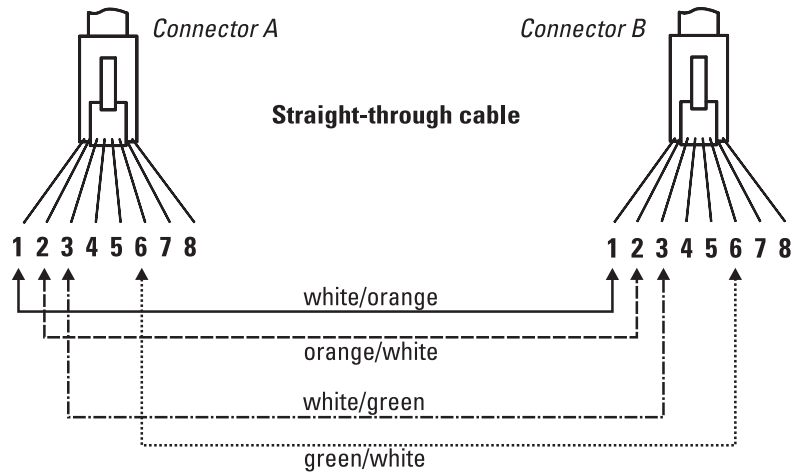

Note

Pins 1 and 2 on connector “A” *must* be wired as a twisted pair to pins 1 and 2 on connector “B”.

Pins 3 and 6 on connector “A” *must* be wired as a twisted pair to pins 3 and 6 on connector “B”.

Pins 4, 5, 7, and 8 are not used in this application, although they may be wired in the cable.

Pin Assignments

Switch End (MDI-X)		Computer, Transceiver, or Other End	
Signal	Pins	Pins	Signal
receive +	1 ←	1	transmit +
receive -	2 ←	2	transmit -
transmit +	3 →	3	receive +
transmit -	6 →	6	receive -

Crossover Twisted-Pair Cable for 10 Mb/s or 100 Mb/s Network Connection

The Auto-MDIX operation of the 10/100 ports on the switch also allows you to use crossover cables for all network connections, to PCs, servers or other end nodes, or to hubs or other switches.

If any of these ports are given a fixed configuration, for example 100 Mb/s/Full Duplex, the ports operate as MDI-X ports, and crossover cables *must* be then used for connections to hubs or switches or other MDI-X network devices.

Cable Diagram

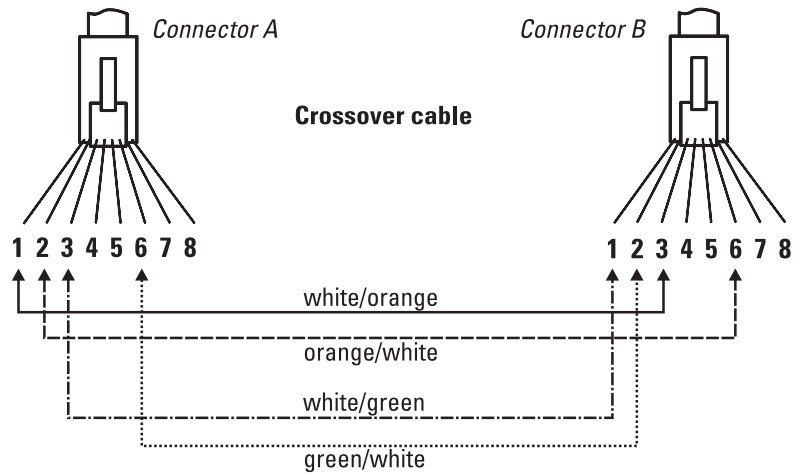

Note

Pins 1 and 2 on connector “A” *must* be wired as a twisted pair to pins 3 and 6 on connector “B”.

Pins 3 and 6 on connector “A” *must* be wired as a twisted pair to pins 1 and 2 on connector “B”.

Pins 4, 5, 7, and 8 are not used in this application, although they may be wired in the cable.

Pin Assignments

Switch End (MDI-X)		Hub or Switch Port, or Other MDI-X Port End	
Signal	Pins	Pins	Signal
receive +	1	6	transmit -
receive -	2	3	transmit +
transmit +	3	2	receive -
transmit -	6	1	receive +

Straight-Through Twisted-Pair Cable for 1000 Mb/s Network Connections

1000BASE-T connections require that all four pairs of wires be connected.

Cable Diagram

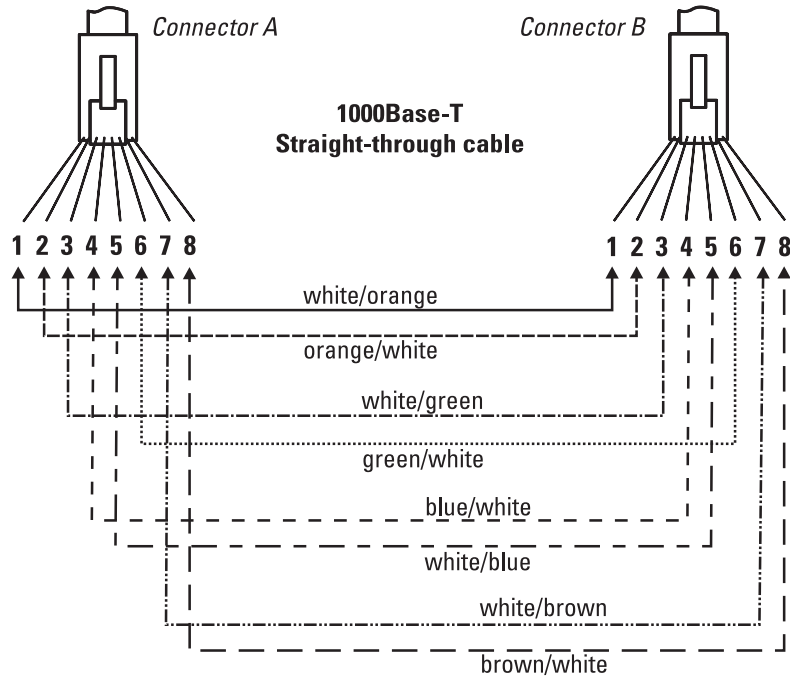

Note

Pins 1 and 2 on connector “A” *must* be wired as a twisted pair to pins 1 and 2 on connector “B”.

Pins 3 and 6 on connector “A” *must* be wired as a twisted pair to pins 3 and 6 on connector “B”.

Pins 4 and 5 on connector “A” *must* be wired as a twisted pair to pins 4 and 5 on connector “B”.

Pins 7 and 8 on connector “A” *must* be wired as a twisted pair to pins 7 and 8 on connector “B”.

Pin Assignments

For 1000BASE-T operation, all four pairs of wires are used for both transmit and receive.

Specifications

Twisted-Pair Cable/Connector Pin-Outs

EMC Regulatory Statements

Regulatory Statements

U.S.A.

FCC Class A

This equipment has been tested and found to comply with the limits for a Class A digital device, pursuant to part 15 of the FCC Rules. These limits are designed to provide reasonable protection against harmful interference when the equipment is operated in a commercial environment. This equipment generates, uses, and can radiate radio frequency energy and, if not installed and used in accordance with the instruction manual, may cause harmful interference to radio communications. Operation of this equipment in a residential area is likely to cause harmful interference in which case the user will be required to correct the interference at his own expense.

You are cautioned that changes or modifications not expressly approved by the party responsible for compliance could void your authority to operate the equipment.

Canada

This product complies with Class A Canadian EMC requirements.

Australia/New Zealand



This product complies with Australia/New Zealand EMC Class A requirements.

Japan

VCCI Class A

この装置は、情報処理装置等電波障害自主規制協議会（VCCI）の基準に基づくクラスA情報技術装置です。この装置を家庭環境で使用すると電波妨害を引き起こすことがあります。この場合には使用者が適切な対策を講ずるよう要求されることがあります。

Korea

사용자 안내문 : A 급기기

이 기기는 업무용으로 전자파 적합등록을 받은 기기 이오니, 판매자 또는 사용자는 이점을 주의하시기 바라며, 만약 잘못 구입하셨을 때에는 구입한 곳에서 비업무용으로 교환하시기 바랍니다.

Taiwan

警告使用者：這是甲類的資訊產品，在居住的環境中使用時，可能會造成射頻干擾，在這種情況下，使用者會被要求採取某些適當的對策。

Index

Numerics

- 10/100BASE-TX ports
 - location on switch ... 1-2
- 1000BASE-T
 - fiber-optic cable specifications ... A-5

A

- acoustic specifications ... A-2
- auto MDI/MDI-X operation ... A-10, A-12
 - HP Auto-MDIX feature ... A-8

B

- back of switch
 - power connector ... 1-5
- basic troubleshooting tips ... 4-1
- blinking LEDs
 - error indications ... 4-2, 4-4
- buttons
 - Clear button ... 1-5
 - Reset button ... 1-5

C

- cabinet
 - mounting the switch in ... 2-6, 2-10, 2-12
- cables
 - connecting cables to switch ports ... 2-14
 - infrastructure requirements ... 2-5
- cables, twisted pair
 - category 3, 4, 5 ... A-8
 - cross-over cable pin-out ... A-11
 - MDI-X to MDI connections ... A-10, A-12
 - MDI-X to MDI-X connections ... A-11
 - pin-outs ... A-10, A-12
 - straight-through cable pin-out ... A-10, A-12
 - switch-to-computer connection ... A-10, A-12
 - switch-to-switch or hub connection ... A-11
- cables, twisted-pair
 - HP Auto-MDIX feature ... A-8
 - wiring rules ... A-8
- cables, twisted-pair connector pin-outs ... A-8
- cabling infrastructure ... 2-5

- Clear button
 - deleting passwords ... 1-5
 - description ... 1-5
 - location on switch ... 1-2, 1-5
 - restoring factory default configuration ... 1-5, 4-4
- configuration
 - restoring factory defaults ... 1-5
- console port
 - location on switch ... 1-2
- cross-over cable
 - pin-out ... A-11

D

- deleting passwords ... 1-5
- description
 - front of switch ... 1-2
 - LEDs ... 1-4
 - switch ... 1-1

E

- electrical specifications, switch ... A-1
- environmental specifications, switch ... A-2

F

- factory default configuration, restoring ... 1-5
- Fault LED
 - location on switch ... 1-2
 - showing error conditions ... 4-2
- fiber-optic cables
 - 1000BASE-T ... A-5
- front of switch ... 1-2
 - 10/100BASE-TX ports ... 1-2
 - Clear button ... 1-5
 - description ... 1-2
 - network ports ... 1-3
 - Reset button ... 1-5

H

- horizontal surface
 - mounting switch on ... 2-13

HP Auto-MDIX
feature description ... A-8

I

included parts ... 2-1
installation
horizontal surface mounting ... 2-13
location considerations ... 2-5
network cable requirements ... 2-5
precautions ... 2-3
rack or cabinet mounting ... 2-6, 2-10, 2-12
site preparation ... 2-5

L

LEDs
behavior during self test ... 2-17
descriptions of ... 1-4
error indications ... 4-2, 4-4
Fault
showing error conditions ... 4-2
location on switch ... 1-2
Power ... 1-4
behavior during self test ... 2-17
location for the switch, considerations ... 2-5

M

MDI-X to MDI network cable ... A-10, A-12
MDI-X to MDI-X network cable ... A-11
mounting the switch
in a rack or cabinet ... 2-6, 2-10, 2-12
precautions ... 2-3
on a horizontal surface ... 2-13

N

network cables
HP Auto-MDIX feature ... A-8
required types ... 2-5
twisted-pair connector pin-outs ... A-8
twisted-pair, wiring rules ... A-8
network devices
connecting to the switch ... 2-14

network ports
connecting to ... 2-14
location on switch ... 1-3
types of ... 1-3

P

parts, included with the switch ... 2-1
passwords, deleting ... 1-5
physical specifications, switch ... A-1
pin-outs
twisted-pair cables ... A-8
port LEDs
normal operation ... 2-17
ports
10/100BASE-TX, location on switch ... 1-2
10/100Base-TX, location on switch ... 1-2
connecting to ... 2-14
HP Auto-MDIX feature ... A-8
network connections ... 2-14
power connector ... 1-5
Power LED ... 1-4
behavior during self test ... 2-17
behaviors ... 1-4
location on switch ... 1-2
precautions
mounting the switch ... 2-3
power requirements ... 2-3
preparing the installation site ... 2-5

R

rack
mounting precautions ... 2-3
mounting the switch in ... 2-6, 2-10, 2-12
Reset button
description ... 1-5
location on switch ... 1-2, 1-5
restoring factory default configuration ... 4-4
resetting the switch
location of Reset button ... 1-5

S

safety and regulatory statements ... B-1
safety specifications ... A-2

- self test
 - LED behavior during ... 2-17
 - Power LED behavior ... 2-17
- SFPs
 - slot, location on switch ... 1-2
- slots for SFPs
 - location on switch ... 1-2
- specifications
 - acoustic ... A-2
 - cabling ... A-4
 - electrical ... A-1
 - environmental ... A-2
 - physical ... A-1
 - safety ... A-2
- straight-through cable
 - pin-out ... A-10, A-12
- switch
 - description ... 1-1
 - electrical specifications ... A-1
 - environmental specifications ... A-2
 - front panel description ... 1-2
 - included parts ... 2-1
 - mounting in a rack or cabinet ... 2-6, 2-10, 2-12
 - mounting on horizontal surface ... 2-13
 - physical specifications ... A-1
- switch operation
 - verifying after installation ... 2-15

T

- tips for troubleshooting ... 4-1
- troubleshooting ... 4-1
 - basic tips ... 4-1
 - common network problems ... 4-1
- twisted-pair cable
 - cross-over cable pin-out ... A-11
 - pin-outs ... A-8, A-10, A-12
 - straight-through cable pin-out ... A-10, A-12
 - switch-to-computer connection ... A-10, A-12
 - switch-to-switch or hub connection ... A-11
- twisted-pair ports
 - HP Auto-MDIX feature ... A-8

W

- wiring rules for twisted-pair cables ... A-8

Technology for better business outcomes

To learn more, visit www.hp.com/networking

© Copyright 2013 Hewlett-Packard Development Company, L.P.

The information contained herein is subject to change without notice. The only warranties for HP products and services are set forth in the express warranty statements accompanying such products and services. Nothing herein should be construed as constituting an additional warranty. HP will not be liable for technical or editorial errors or omissions contained herein.



June 2013

Manual Part Number
5998-4329