



22" Dual Touch screen, based on Optical Touch Screen Technology

The T2252MTS is Windows® compatible and ready for the emerging business and consumer software packages. The monitor lets you browse the web, email and draw while working on multiple screens, docking or typing on the on-screen keyboard. You can scroll and rotate pictures, draw, zoom in and out using certain tap, flick, grab and pincer gestures. The multi touch is not only fast but also fun to work with. Multiple inputs (VGA/ HDMI/ DVI) are available for flexible connectivity along with USB for the Touch Interface.



TOUCH TECHNOLOGY - OPTICAL

This technology uses cameras. A touch event is registered with great accuracy when light is blocked by a finger or stylus. It's the only touch technology that does not rely on an overlay or substrate to register a touch, so it's impossible to physically "wear out" the touchscreen. In fact you don't really have to physically touch the screen.



OVERDRIVE ON / OFF

When very fast graphics are displayed your monitor can sometimes get blurry. Turning on the OverDrive feature will eliminate that.

1. DISPLAY CHARACTERISTICS

DIAGONAL

21.5"; 54.7cm

ASPECT RATIO	16 : 9
PANEL	TN LED-backlit
NATIVE RESOLUTION	Full HD 1080p, 1920 x 1080 (2.1 megapixel)
BRIGHTNESS	250 cd/m ² typical
BRIGHTNESS	220 cd/m ² with touch panel
CONTRAST	1000 : 1 typical
CONTRAST	12 000 000 : 1 ACR
RESPONSE TIME	2 ms
VIEWING ZONE	horizontal/vertical: 170° / 160° ; right/left: 85° / 85° ; up/down: 80° / 80°
DISPLAY COLOUR	16.7 million
BLUE LIGHT REDUCER	yes
TOUCHTECHNOLOGY	optical, multi touch (2 compatible touch points - HID, supported only under Windows® 7), activated by finger or stylus
TOUCH POINTS	2
LIGHT TRANSMITTANCE	88%
DISPLAY AREA H X W	268.11 x 476.64 mm; 10.6" x 18.8"
PIXEL PITCH H X V	0.248 x 0.248 mm
HORIZONTAL SYNC	30 - 80 KHz
VERTICAL SYNC	55 - 75 Hz
SYNCHRONIZATION	Separate Sync

2. INTERFACES & CONNECTORS

ANALOG INPUT CONNECTOR	VGA
DIGITAL INPUT CONNECTOR	DVI, HDMI
HDCP	yes;
HEADPHONE CONNECTOR	Yes
INPUTS	USB (for touch connectivity)

3. FEATURES

PLUG & PLAY	VESA DDC2B™
CONTROLS	On-Screen-Display in 8 languages (EN, FR, DE, NL, PL, RU, JP, Chinese (simplified and traditional)) and 5 front controls (Power, Select/ Input Select, Scroll up/ Audio, Scroll down/ i-Style Colour, Menu)
USER CONTROLS	auto adjust, picture adjust (contrast, brightness, ACR, ECO, OD), input select (volume, mute, HDMI audio), colour adjust (cool, normal, warm, user colour, i-Style colour), information, manual image adjust (H./V. position, clock, phase, sharpness, video mode adjust, blue light reducer), setup menu (language select, OSD position, OSD time out, OSD background, opening logo, LED), memory recall
SPEAKERS	2 x 1 W (Stereo)
ANTI-THEFT-DEVICE	Kensington-lock™ prepared
REGULATIONS	CE, TÜV-Bauart, CU, ENERGY STAR®

TILT ANGLE	73° up; 3° down
VESA MOUNTING	100 x 100 mm
COLOUR	Black

4. ACCESSORIES

DRIVER	single touch: XP, Vista, Linux
INCLUDED ACCESSORIES	power cable, VGA cable, DVI cable, USB cable, audio cable, stand, touch pen, quick start guide, safety guide

5. POWER MANAGEMENT

POWER SUPPLY	AC 100 - 240 V, 50 / 60 Hz
POWER SUPPLY UNIT	internal
POWER USAGE	15 W typical; max. 0.5 W in Power management mode
POWER MANAGEMENT	VESA DPMS

6. EU ENERGY EFFICIENCY LABEL

ENERGY EFFICIENCY CLASS	A
ON MODE POWER CONSUMPTION	20.2W
ANNUAL ENERGY CONSUMPTION	30 kWh/annum*
VISIBLE SCREEN DIAGONAL	54.7 cm; 21.5"; (22" segment)

This is information under Regulation (EU) No 1062/2010.

**Based on the power consumption of the television operating 4 hours per day for 365 days. The actual energy consumption will depend on how the television is used.*

7. EPEAT SILVER

EPEAT	EPEAT is a comprehensive environmental rating that helps identify greener computers and other electronic equipment. The Silver certification means the monitor meets all required criteria plus at least 50% of the optional requirements. EPEAT Silver is valid in countries where iiyama registers the product. Please visit www.epeat.net for the registration status in your country.
-------	--

8. DIMENSIONS & WEIGHT

DIMENSIONS W X H X D	516.5 x 371.5 x 220.5 mm
WEIGHT	5.7 kg

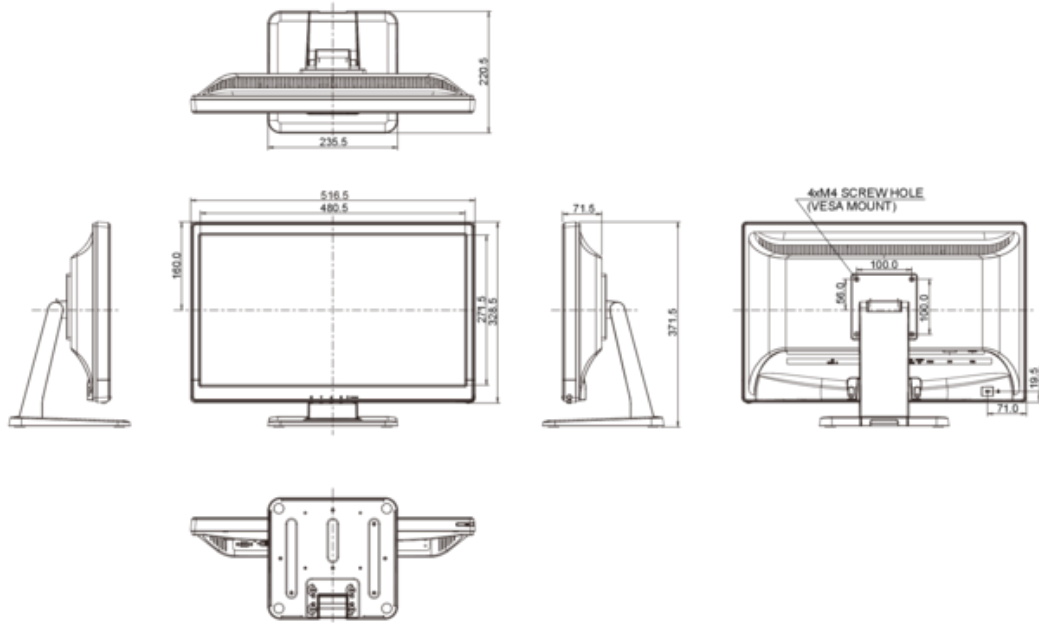

All trademarks and registered trademarks acknowledged. E & O E. Specification subject to change without notice. All LCD's comply with ISO-9241-307:2008 in connection with pixel defects.

© IIYAMA CORPORATION (). ALL RIGHTS RESERVED.