

fi-7600/fi-7700/fi-7700S

Image Scanner

Operator's Guide

Thank you for purchasing our image scanner.
 This manual explains about the basic operations and handling of the scanner.
 For information on scanner installation and connection, refer to the Quick Installation Sheet.

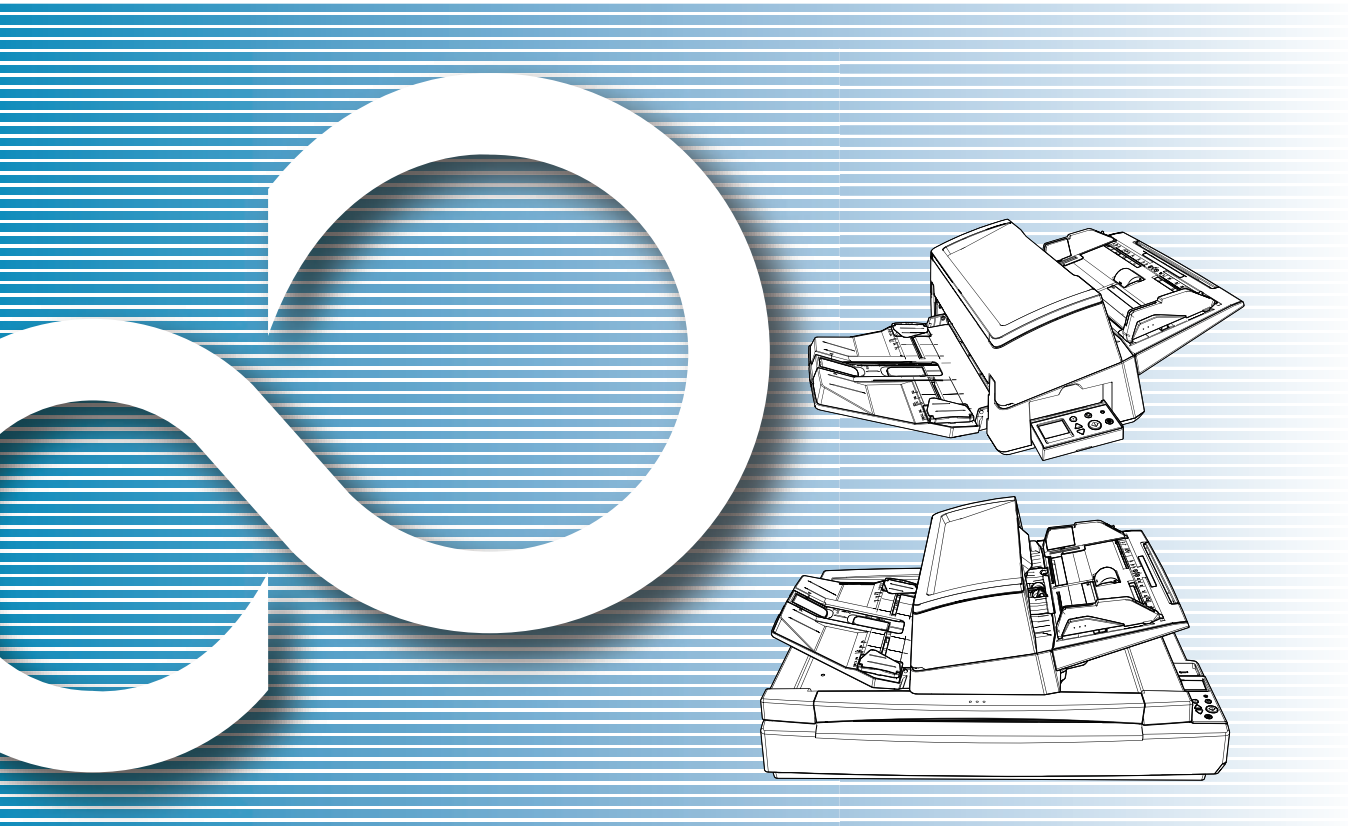

	TOP
	Contents
	Index
	Introduction
Explains the names and functions of parts and basic scanner operation.	Scanner Overview
Explains how to load documents on the scanner.	How to Load Documents
Explains how to use the operator panel.	How to Use the Operator Panel
Explains about various ways of scanning.	Various Ways to Scan
Explains how to clean the scanner.	Daily Care
Explains how to how to replace the consumables.	Replacing the Consumables
Explains about troubleshooting.	Troubleshooting
Explains how to configure settings in the Software Operation Panel.	Operational Settings
	Appendix
	Glossary

How to Use This Manual

The following shows the tips for using this manual.

- To display or print this manual, either Adobe® Acrobat® (7.0 or later) or Adobe® Reader® (7.0 or later) is required.
- In this manual, you can use the Search tool of Adobe® Acrobat® or Adobe® Reader®.
For details, refer to the Adobe® Acrobat® or Adobe® Reader® Help.
- Use the [Page Up] key to return to the previous page, and the [Page Down] key to go to the next page.
- Click a blue character string, tab or contents/index title (where the mouse cursor changes into a shape such as ) to jump to the link.

- Common for All Pages

Jumps to the first page of each chapter.
This tab is on every page.

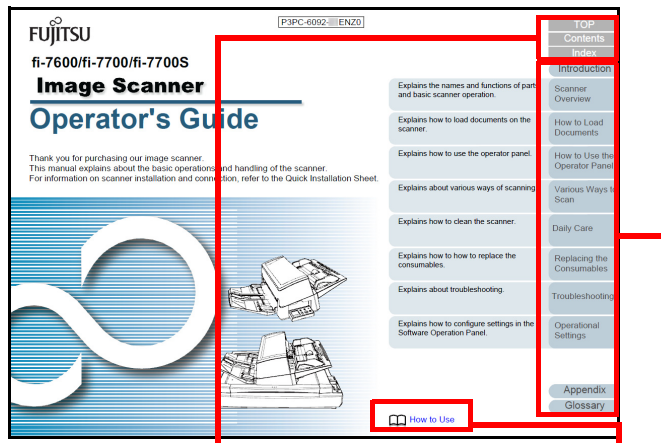

TOP: Jumps to the cover page.
Contents: Jumps to the contents page.
Index: Jumps to the index page.

Jumps to this page.
Click on a blue character string to jump to the link.

- Contents Page

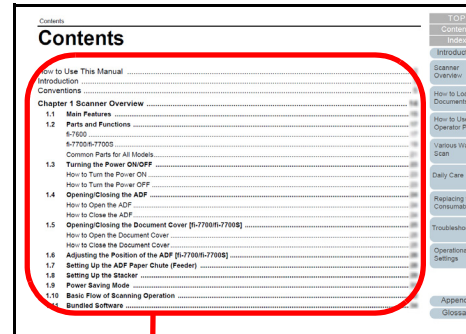

Click on a title to jump to the link.

- Index Page

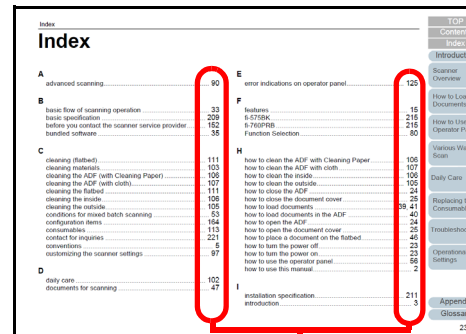

Click on a page number to jump to the link.

- TOP
- Contents
- Index
- Introduction
- Scanner Overview
- How to Load Documents
- How to Use the Operator Panel
- Various Ways to Scan
- Daily Care
- Replacing the Consumables
- Troubleshooting
- Operational Settings
- Appendix
- Glossary

Introduction

Thank you for purchasing our image scanner.

About This Product

"This product" refers to three scanner models, which are the fi-7600, fi-7700, and fi-7700S.

Each scanner is equipped with an Automatic Document Feeder (ADF) that allows you to feed documents automatically.

The following table shows the differences between each model.

Model	Scanner Type		Scanning speed (*2)
	ADF	Flatbed (*1)	
fi-7600	Yes	-	ADF: Simplex 100 ppm ADF: Duplex 200 ipm
fi-7700	Yes	Yes	ADF: Simplex 100 ppm ADF: Duplex 200 ipm Flatbed 0.9 sec./sheet
fi-7700S	Yes (*3)	Yes	ADF: Simplex 75 ppm Flatbed 0.9 sec./sheet

Yes: Available

-: Not available

*1: Flatbed allows you to scan thin paper and thick documents such as a book.

*2: The figures for the ADF are the speed rates at which A4 size landscape documents are scanned at 300 dpi.

The figures for the flatbed are the speed rates at which A4 portrait documents are scanned at 300 dpi.

*3: Only simplex scan is supported.

Manuals

The following manuals are included for this product. Read them as needed.

Manual	Description
Safety Precautions (paper, PDF)	Contains important information about the safe use of this product. Make sure to read this manual before using the scanner. The PDF version is included in the Setup DVD-ROM.
Quick Installation Sheet (paper)	Explains about scanner installation and setup.
Operator's Guide (this manual) (PDF)	Provides detailed information on how to operate and maintain the scanner daily, how to replace the consumables, and how to troubleshoot problems. Included in the Setup DVD-ROM.
fi-760PRB Imprinter Operator's Guide (PDF)	The fi-760PRB imprinter is an optional unit to the scanner. The manual provides detailed information on how to operate and maintain the imprinter daily, how to replace the consumables, and how to troubleshoot problems. Included in the Setup DVD-ROM.

Manual	Description
Scanner Central Admin User's Guide (PDF)	Explains about the overview, installation, operation and maintenance of Scanner Central Admin. Included in the Setup DVD-ROM.
Error Recovery Guide (HTML Help)	Details the status of the scanner and explains how to resolve problems encountered. Contains movie segments that explain operation procedures such as cleaning this product and replacing the consumables. Included in the Setup DVD-ROM.
Help (scanner driver)	Explains how to use and configure the settings for the scanner drivers. Can be referenced from each scanner driver.
Help (application)	Explains how to use and configure the settings for the application software. Read them as needed. Can be referenced from each application.

Trademarks

Microsoft, Windows, Windows Server, Excel, and SharePoint are either registered trademarks or trademarks of Microsoft Corporation in the United States and/or other countries. Word is the product of Microsoft Corporation in the United States.

ISIS is a registered trademark of EMC Corporation in the United States.

Adobe, Acrobat, and Reader are either registered trademarks or trade names of Adobe Systems Incorporated in the United States and/or other countries.

Intel, Pentium, and Intel Core are registered trademarks or trademarks of Intel Corporation in the United States and other countries.

ABBYY™ FineReader™ Engine © ABBYY. OCR by ABBYY ABBYY and FineReader are trademarks of ABBYY Software, Ltd. which may be registered in some jurisdictions.

ScanSnap, ScanSnap Manager, and PaperStream are registered trademarks of PFU Limited in Japan.

Other company names and product names are the registered trademarks or trademarks of the respective companies.

Manufacturer

PFU Limited

YOKOHAMA i-MARK PLACE, 4-4-5 Minatomirai, Nishi-ku, Yokohama, Kanagawa, 220-8567, Japan

© PFU Limited 2017

TOP

Contents

Index

Introduction

Scanner Overview

How to Load Documents

How to Use the Operator Panel

Various Ways to Scan

Daily Care

Replacing the Consumables

Troubleshooting

Operational Settings

Appendix

Glossary

Conventions

Safety Information

The attached "Safety Precautions" manual contains important information about the safe and correct use of this product. Make sure that you read and understand it before using the scanner.

Symbols Used in This Manual

The following indications are used in this manual to obviate any chance of accident or damage to you, people near you, and your property. Warning labels consist of a symbol indicating the severity and a warning statement. The symbols and their meanings are as follows.



WARNING This indication alerts operators of an operation that, if not strictly observed, may result in severe injury or death.



CAUTION This indication alerts operators of an operation that, if not strictly observed, may result in safety hazards to personnel or damage to the product.

Abbreviations Used in This Manual

The operating systems and products in this manual are indicated as follows.

Name	Indication
Windows Server® 2008 Standard (32-bit/64-bit)	Windows Server 2008 (*1)
Windows Server® 2008 R2 Standard (64-bit)	
Windows® 7 Home Premium (32-bit/64-bit)	Windows 7 (*1)
Windows® 7 Professional (32-bit/64-bit)	
Windows® 7 Enterprise (32-bit/64-bit)	
Windows® 7 Ultimate (32-bit/64-bit)	
Windows Server® 2012 Standard (64-bit)	Windows Server 2012 (*1)
Windows Server® 2012 R2 Standard (64-bit)	Windows Server 2012 R2 (*1)
Windows® 8.1 (32-bit/64-bit)	Windows 8.1 (*1)
Windows® 8.1 Pro (32-bit/64-bit)	
Windows® 8.1 Enterprise (32-bit/64-bit)	

TOP

Contents

Index

Introduction

Scanner
OverviewHow to Load
DocumentsHow to Use the
Operator PanelVarious Ways to
Scan

Daily Care

Replacing the
Consumables

Troubleshooting

Operational
Settings

Appendix

Glossary

Name	Indication
Windows® 10 Home (32-bit/64-bit)	Windows 10 (*1)
Windows® 10 Pro (32-bit/64-bit)	
Windows® 10 Enterprise (32-bit/64-bit)	
Windows® 10 Education (32-bit/64-bit)	
Windows Server® 2016 Standard (64-bit)	Windows Server 2016 (*1)
Microsoft® Word	Word
Microsoft® Office Word	
Microsoft® Excel®	Excel
Microsoft® Office Excel®	
PaperStream IP (TWAIN)	PaperStream IP driver
PaperStream IP (TWAIN x64)	
PaperStream IP (ISIS) Bundle	

*1: Where there is no distinction between the different versions of the above operating system, the general term "Windows" is used.

Arrow Symbols in This Manual

Right-arrow symbols (→) are used to separate icons or menu options you should select in succession.

Example: Click [Start] menu → [Control Panel].

Screen Examples in This Manual

Microsoft product screenshots are reprinted with permission from Microsoft Corporation.

The screen examples in this manual are subject to change without notice in the interest of product development.

If the actual displayed screen differs from the screen examples in this manual, operate by following the actual displayed screen while referring to the user's manual of the scanner application that you are using.

The screen examples used in this manual are of the PaperStream IP driver.

The screenshots used in this manual are of Windows 7. The actual windows and operations may differ depending on the operating system. Also note that with some scanner models, the screens and operations may differ from this manual when you update the PaperStream IP driver. In that case, refer to the manual provided upon updating the driver.

Contents

How to Use This Manual	2
Introduction	3
Conventions	5
Chapter 1 Scanner Overview	14
1.1 Main Features	15
1.2 Parts and Functions	17
fi-7600	17
fi-7700/fi-7700S	19
Common Parts for All Models.....	21
1.3 Turning the Power ON/OFF	23
How to Turn the Power ON	23
How to Turn the Power OFF	23
1.4 Opening/Closing the ADF	24
How to Open the ADF	24
How to Close the ADF	24
1.5 Opening/Closing the Document Cover [fi-7700/fi-7700S]	25
How to Open the Document Cover	25
How to Close the Document Cover	25
1.6 Adjusting the Position of the ADF [fi-7700/fi-7700S]	26
1.7 Setting Up the ADF Paper Chute (Feeder)	29
1.8 Setting Up the Stacker	30
1.9 Power Saving Mode	32
1.10 Basic Flow of Scanning Operation	33

TOP
Contents
Index
Introduction
Scanner Overview
How to Load Documents
How to Use the Operator Panel
Various Ways to Scan
Daily Care
Replacing the Consumables
Troubleshooting
Operational Settings
Appendix
Glossary

1.11	Bundled Software	35
	Overview of the Bundled Software	35
	System Requirements	36
	Installing the Bundled Software	37
Chapter 2	How to Load Documents	39
2.1	Loading Documents in the ADF	40
	Preparation	40
	How to Load Documents	41
2.2	Placing a Document on the Flatbed [fi-7700/fi-7700S]	46
2.3	Documents for Scanning	47
	Paper Size	47
	Paper Type	47
	Paper Weight (Thickness)	47
	Documents That Cannot Be Scanned Successfully	47
	Documents That Cannot Be Scanned	47
	Precautions	48
	Loading Capacity	50
	Area Not to Be Perforated	51
	How to Load Documents with a Tab or Non-Rectangular Documents	51
	Conditions for Multifeed Detection	52
	Conditions for Mixed Batch Scanning	53
	Conditions for Automatic Page Size Detection	55
Chapter 3	How to Use the Operator Panel	56
3.1	Operator Panel	57
	Names and Functions	57
	Indications on LCD	59
	Indicator	61

TOP
Contents
Index
Introduction
Scanner Overview
How to Load Documents
How to Use the Operator Panel
Various Ways to Scan
Daily Care
Replacing the Consumables
Troubleshooting
Operational Settings
Appendix
Glossary

3.2	Settings Menu	62
	How to Use Settings Menu	63
	Items Configurable in the Settings Menu	72
3.3	Function Selection	80
	How to Use the Function Selection	80
	Item Configurable in Function Selection.....	81
Chapter 4	Various Ways to Scan	82
4.1	Summary	83
4.2	Scanning Documents of Different Types and Sizes	84
	Scanning Documents with Different Widths	84
	Scanning Documents Folded in Half	85
	Scanning Documents such as Envelopes or Multi-Layered Transfer Paper	87
	Long Page Scanning	88
	Scanning a Book [fi-7700/fi-7700S].....	89
4.3	Advanced Scanning	91
	Using a Button on the Scanner to Start Scanning	91
	Feeding Documents Manually in the ADF	94
	Sorting the Images Scanned in Simplex Scanning Mode in the Same Order in Which the Images Scanned in Duplex Scanning Mode Are Arranged [fi-7700S]	96
	Scanning Documents with the Document Cover Open [fi-7700/fi-7700S].....	97
4.4	Customizing the Scanner Settings	98
	Ignoring Multifeed for a Set Pattern.....	98
	Disabling Paper Protection for a Single Scan After Paper Protection Is Set Off	101
Chapter 5	Daily Care	103
5.1	Cleaning Materials and Locations that Require Cleaning	104
	Cleaning Materials.....	104
	Location and Frequency.....	105

5.2	Cleaning the Outside	106
	fi-7600	106
	fi-7700/fi-7700S	106
5.3	Cleaning the Inside	107
	Cleaning the ADF (with Cleaning Paper)	107
	Cleaning the ADF (with Cloth).....	108
	Cleaning the Flatbed [fi-7700/fi-7700S].....	112
Chapter 6	Replacing the Consumables	113
6.1	Consumables and Replacement Cycles	114
6.2	Replacing the Brake Roller	115
6.3	Replacing the Pick Roller	118
Chapter 7	Troubleshooting	124
7.1	Paper Jam	125
7.2	Error Indications on Operator Panel	126
	Temporary Errors	127
	Device Errors.....	129
7.3	Troubleshooting	135
	Scanner cannot be powered ON.	136
	The LCD or the [Power] button light or both switch OFF.....	137
	Scanning does not start.....	138
	Scanning takes a long time.	139
	Image quality is poor.	140
	Quality of scanned text or lines is unsatisfactory.	141
	Images are distorted or not clear.....	142
	Vertical streaks appear on the scanned image.	143
	An error (error code "U0:10", "U4:40" or "U5:4A") is already displayed in the LCD after power-on.....	144
	Multifeed error occurs frequently.....	145

TOP
Contents
Index
Introduction
Scanner Overview
How to Load Documents
How to Use the Operator Panel
Various Ways to Scan
Daily Care
Replacing the Consumables
Troubleshooting
Operational Settings
Appendix
Glossary

Situation in which the document is not fed into the ADF occurs frequently.....	147
Paper protection is set off frequently.....	148
Paper jams/pick errors occur frequently.....	149
Scanned images turn out elongated.....	150
A shadow appears at the top or the bottom of the scanned image.....	151
There are black traces on the document.....	152
7.4 Before You Contact the Scanner Service Provider	153
General.....	153
Error Status	153
7.5 Checking the Product Labels	155
Location.....	155
Chapter 8 Operational Settings	156
8.1 Starting Up the Software Operation Panel	157
8.2 Password Setting for the Software Operation Panel	159
Setting a Password	159
Setting [View Only mode].....	160
Exiting [View Only mode]	161
Changing the Password	162
Clearing the Password	163
Resetting the Password	164
8.3 Configuration Items	165
Device Setting	165
Device Setting 2	167
8.4 Settings Related to Sheet Counters	174
Checking and Resetting the Sheet Counters	174
Scanner Cleaning Cycle [Cleaning Cycle].....	177
Replacement Cycle of Consumables [Life Counter Alarm Setting].....	177

TOP
Contents
Index
Introduction
Scanner Overview
How to Load Documents
How to Use the Operator Panel
Various Ways to Scan
Daily Care
Replacing the Consumables
Troubleshooting
Operational Settings
Appendix
Glossary

8.5	Settings Related to Scanning	179
	Adjusting the Position to Start the Scan [Offset Setting/Vertical magnification Adjustment]	179
	Removing Shadows/Streaks that Appear around the Scanned Image [Page Edge Filler (ADF)]/[Page Edge Filler (FB)] (fi-7700/fi-7700S)	181
	Removing a Color from the Scanned Image [Dropout color].....	182
	Shortening the Scanning Intervals [Pre-Pick].....	183
	Number of Paper Feeding Retries.....	184
	Document Feed Speed [Pick Speed]	185
	Cropping the Image Boundary [AutoCrop Boundary].....	186
	Protecting the Documents from Being Damaged [Paper Protection]	187
	Specifying the Sensitivity Level for Paper Protection [Paper Protection Sensitivity]	188
	Scan Setting for Documents with Tabs or Non-Rectangular Documents [Scan Setting for Document with Tab (Automatic Page Size Detection)]	190
	Adjusting the Paper Picking Pressure [Pick Pressure].....	191
	Adjusting the Output Result for Overscan [Overscan Control]	192
	Scanning at High Altitude [High Altitude Mode].....	193
	Setting the Image Quality for Scanning [Image Quality Mode].....	193
	Low-speed Scan at Lower Resolution [Low-speed Feed Mode]	194
	Specifying the Paper Ejecting Speed [Stacking Control].....	195
8.6	Settings Related to Multifeed Detection	196
	Specifying a Multifeed Detection Method [Multifeed]	196
	Specifying the Area to Detect Multifeed [Document check area specification for Multifeed Detection].....	198
	Specifying an Area Not to Detect Multifeed [Intelligent Multifeed Function]	201
8.7	Settings Related to Waiting Time	202
	Waiting Time in Manual Feeding [Manual Feeding]	202
	Waiting Time for the Scanner to Enter Power Saving Mode [Power saving]	203
8.8	Settings Related to Power ON/OFF	205
	Method of Turning the Scanner ON/OFF [Power SW Control].....	205

8.9 Settings Related to Scanner Maintenance	206
Detecting Vertical Streaks [Vertical Streak Detection]	206
Specifying the Sensitivity Level for Vertical Streak Detection [Vertical Streak Sensitivity].....	207
Scanner Maintenance and Inspection Cycle [Maintenance and Inspection Cycle]	208
Appendix	209
A.1 Basic Specification	210
A.2 Installation Specification	212
A.3 Outer Dimensions	214
fi-7600	214
fi-7700/fi-7700S	215
A.4 Scanner Options	216
A.5 Uninstalling the Software	217
A.6 Notes on Repackaging [fi-7700/fi-7700S]	218
Fixing the Transport Lock.....	218
Fixing the ADF.....	219
Installing the ADF Paper Chute (Feeder) and the Stacker.....	221
Contact for Inquiries	222
Glossary	223
Index	232

TOP

Contents

Index

Introduction

Scanner
Overview

How to Load
Documents

How to Use the
Operator Panel

Various Ways to
Scan

Daily Care

Replacing the
Consumables

Troubleshooting

Operational
Settings

Appendix

Glossary

Chapter 1 Scanner Overview

This chapter explains about the names and functions of the scanner components, as well as the methods for basic operations.

1.1 Main Features.....	15
1.2 Parts and Functions.....	17
1.3 Turning the Power ON/OFF.....	23
1.4 Opening/Closing the ADF.....	24
1.5 Opening/Closing the Document Cover [fi-7700/fi-7700S].....	25
1.6 Adjusting the Position of the ADF [fi-7700/fi-7700S].....	26
1.7 Setting Up the ADF Paper Chute (Feeder).....	29
1.8 Setting Up the Stacker.....	30
1.9 Power Saving Mode.....	32
1.10 Basic Flow of Scanning Operation.....	33
1.11 Bundled Software.....	35

1.1 Main Features

This section explains about the main features of this product. The scanner is equipped with the following features:

High speed scanning

Each model has achieved a scanning speed that is shown below (*1):

- fi-7600
ADF: Simplex 100 ppm, Duplex 200 ipm
- fi-7700
ADF: Simplex 100 ppm, Duplex 200 ipm
Flatbed: 0.9 sec./sheet
- fi-7700S
ADF: Simplex 75 ppm
Flatbed: 0.9 sec./sheet

Furthermore, you can load up to 300 sheets of A4 size documents or 100 sheets of A3 size documents in the ADF for continuous scanning which allows you to quickly digitize a large volume of documents.

Capable of scanning documents folded in half, envelopes, multi-layered transfer paper

In order to scan documents folded in half, envelopes, and multi-layered transfer paper, the scanner is equipped with a feed mode switch that is used to switch the mode to Manual/Single mode. Manual/Single mode reduces the load on documents placed in the feeder so that documents are fed without any fault for a successful scan.

LCD

The scanner mounts the LCD that displays the operational settings for scanning documents, the number of sheets scanned, and error status. It is used to easily check the status of the scanner.

Improved efficiency for pre-scan work

The scanner can perform "batch scanning" which allows you to scan documents with different paper weights and sizes at once. This simplifies the process of sorting the documents before scanning.

Reduced work loss caused by multifeeds

The scanner mounts an ultrasonic multifeed sensor that accurately detects "multifeed" errors where two or more sheets are fed through the scanner at once. This multifeed detection is reliable even when

scanning a mixed batch of documents with different paper weights and sizes, avoiding potential work loss.

Intelligent Multifeed function

When there is paper of the same size attached to a designated location on the page, the Intelligent Multifeed function enables the scanner to recognize the location of the attachment. This allows you to continue scanning instead of pausing the scan by detecting every paper attachment as multifeed. Furthermore, the "paper protection" function will reduce the risk of damaging your valuable documents.

Paper protection function by detecting paper jam noise

This function reduces the risk of having the documents damaged by stopping the scan when the scanner detects paper jam noise.

Equipped with a movable ADF [fi-7700/fi-7700S]

The scanner is equipped with an ADF that can slide to the right or left or rotate by 180 degrees. This allows you to reduce the space that is required for setting up the scanner.

Scanning Documents with the Document Cover Open [fi-7700/fi-7700S]

The scanner allows you to scan documents with the document cover open for the flatbed. It automatically corrects a scanned image that is skewed or recognizes the size of a document and outputs the image in that size.

Imprinter option [fi-7600]

Imprinter is available as an option, which is often demanded for managing/verifying documents. Having the capability to print on the scanned documents could drastically improve usability.

Scanning on a black background [fi-7700/fi-7700S]

A black document pad is available as an option, which allows you to perform scanning on a black background when the flatbed is used. It can be used to automatically correct skewed images or accurately detect the size of the scanned document when scanning with the flatbed.

The black document pad can be used on fi-7700/fi-7700S.

Centralized management of multiple scanners

The bundled "Scanner Central Admin Agent" application allows you to manage multiple scanners together. For example, you can update the scanner settings and drivers, as well as monitor the operating status of each scanner.

For details, refer to the Scanner Central Admin User's Guide.

*1: When scanning A4 size landscape documents at 300 dpi.

TOP

Contents

Index

Introduction

Scanner
Overview

How to Load
Documents

How to Use the
Operator Panel

Various Ways to
Scan

Daily Care

Replacing the
Consumables

Troubleshooting

Operational
Settings

Appendix

Glossary

1.2 Parts and Functions

This section shows the names of the scanner parts.

fi-7600

■ Front

Subtray

Allows you to temporarily place documents to be scanned.

Stacker

Stacks up documents that are ejected from the ADF.

The height can be adjusted to either a higher or lower position.

Stoppers

Lift up either one according to the document length.

Stacker Extension

Pull this out to adjust it to the document length.

Stacker Side Guide

Positions the documents in place when the documents are stacked in the stacker.

ADF (Automatic Document Feeder)

Pulls and feeds the documents one sheet at a time from the ADF paper chute (feeder).

Both sides of a document can be scanned at one time.

Open this to replace consumables or to clean the inside of the scanner.

ADF Paper Chute (Feeder)

Holds the documents to be scanned.

Chute Extension

Pull this out to adjust it to the document length.

Chute Roller Cover

Prevents your fingers from getting caught in the chute roller.

Side Guide

Positions the documents in place when the documents are loaded in the ADF paper chute (feeder) as they are fed into the scanner.

Side Guide Button

Press and hold this to unlock the side guide for adjusting the position. The side guide is locked when the button is released.

Status Indicator (LED)

Used to check the status of the scanner.

Operator Panel

Consists of an LCD, buttons, and LED indicator.

It can be used to operate the scanner or check the status.

The scanner carries an operator panel on each side. You can use whichever is convenient for you. The operator panel can be fitted into the side of the scanner when it is not used. For details, refer to "[Chapter 3 How to Use the Operator Panel](#)" (page 56).

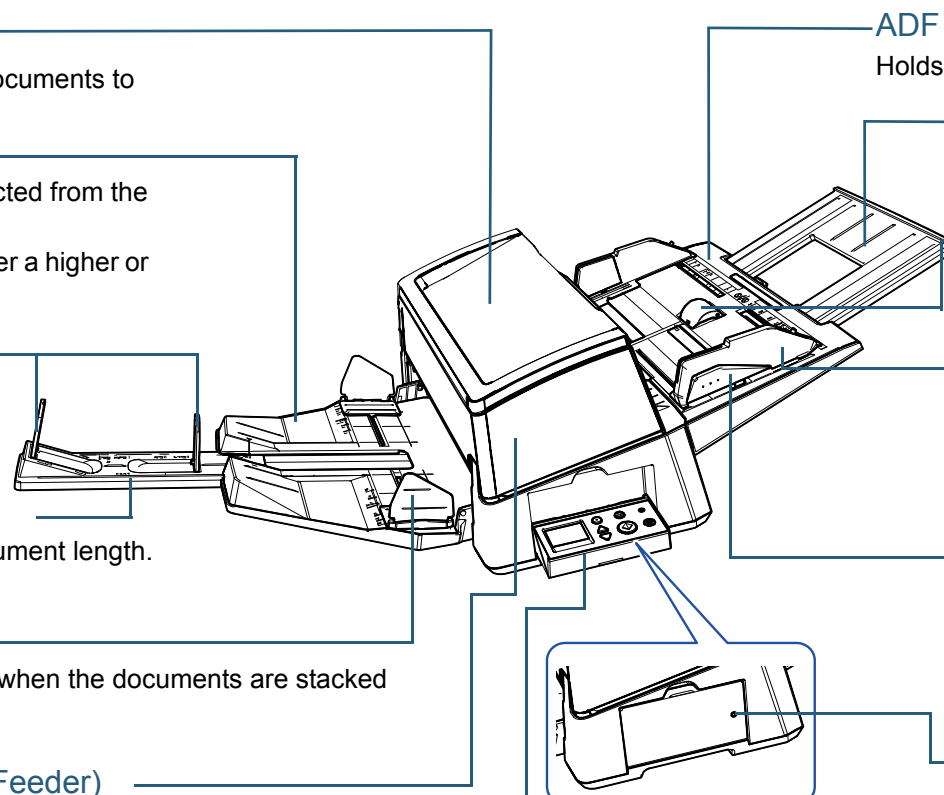

TOP

Contents

Index

Introduction

Scanner
OverviewHow to Load
DocumentsHow to Use the
Operator PanelVarious Ways to
Scan

Daily Care

Replacing the
Consumables

Troubleshooting

Operational
Settings

Appendix

Glossary

■ Back

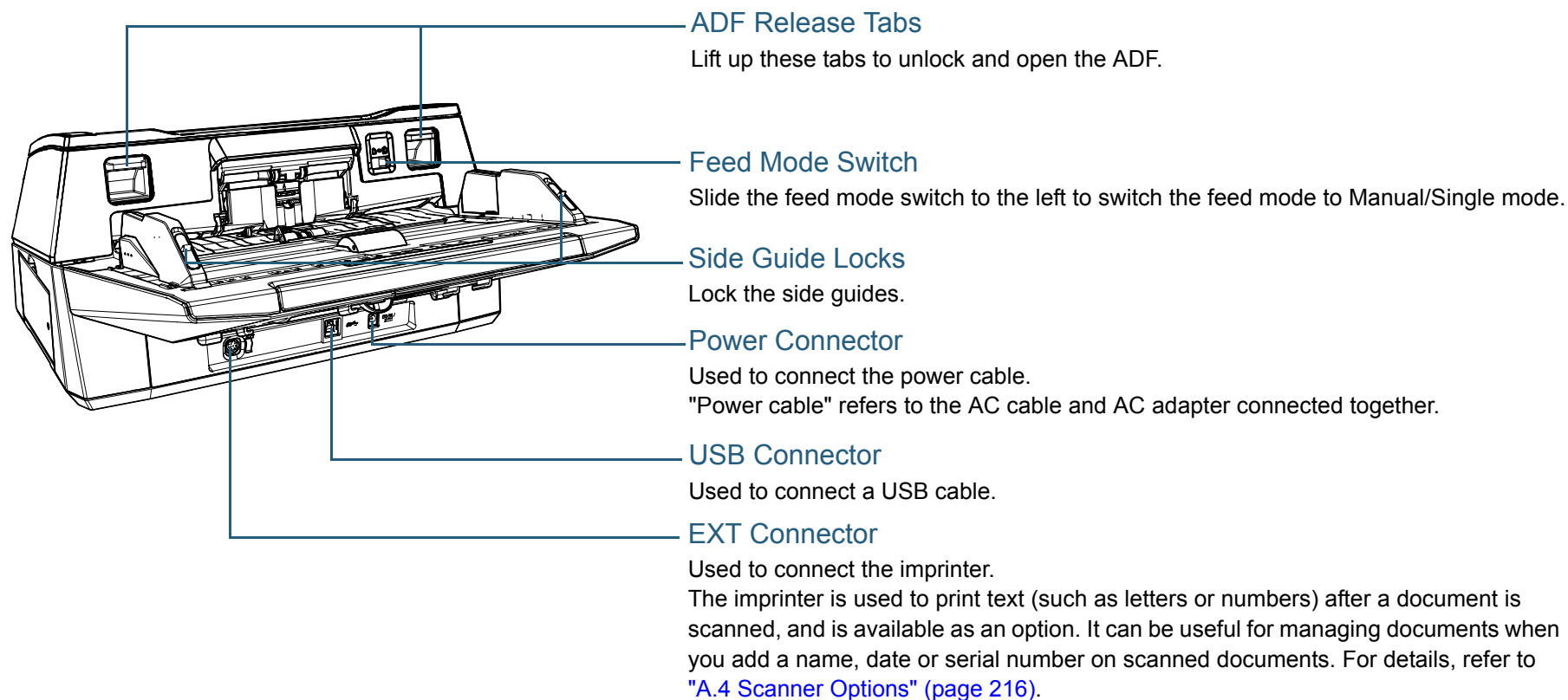

- TOP
- Contents
- Index
- Introduction
- Scanner Overview**
- How to Load Documents
- How to Use the Operator Panel
- Various Ways to Scan
- Daily Care
- Replacing the Consumables
- Troubleshooting
- Operational Settings
- Appendix
- Glossary

fi-7700/fi-7700S**■ Front****ADF (Automatic Document Feeder)**

Pulls and feeds the documents one sheet at a time from the ADF paper chute (feeder).
For the fi-7700, it allows you to scan both sides of a document at the same time.

Open this to replace consumables or to clean the inside of the scanner.

Stacker Extension

Pull this out to adjust it to the document length.

Stoppers

Lift up either one according to the document length.

Stacker

Stacks up documents that are ejected from the ADF.
The height can be adjusted to either a higher or lower position.

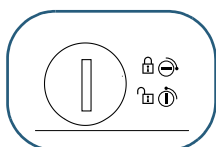
**Transport Lock**

Locks the carrier unit (which is inside the flatbed) to prevent damage during transportation.
Use a coin or similar to unlock it.
Position the slot vertically to unlock it.
Position the slot horizontally to lock it.

Stacker Side Guide

Positions the documents in place when the documents are stacked in the stacker.

Flatbed

When you scan a document that cannot be scanned with the ADF, such as thin paper or a thick document such as a book, place the document on the glass section.

Subtray

Allows you to temporarily place documents to be scanned.

ADF Paper Chute (Feeder)

Holds the documents to be scanned.

Chute Extension

Pull this out to adjust it to the document length.

Chute Roller Cover

Prevents your fingers from getting caught in the chute roller.

Operator Panel

Consists of an LCD, buttons, and LED indicator. It can be used to operate the scanner or check the status.
For details, refer to "[Chapter 3 How to Use the Operator Panel](#)" (page 56).

Side Guide

Positions the documents in place when the documents are loaded in the ADF paper chute (feeder) as they are fed into the scanner.

Side Guide Button

Press and hold this to unlock the side guide for adjusting the position.
The side guide is locked when the button is released.

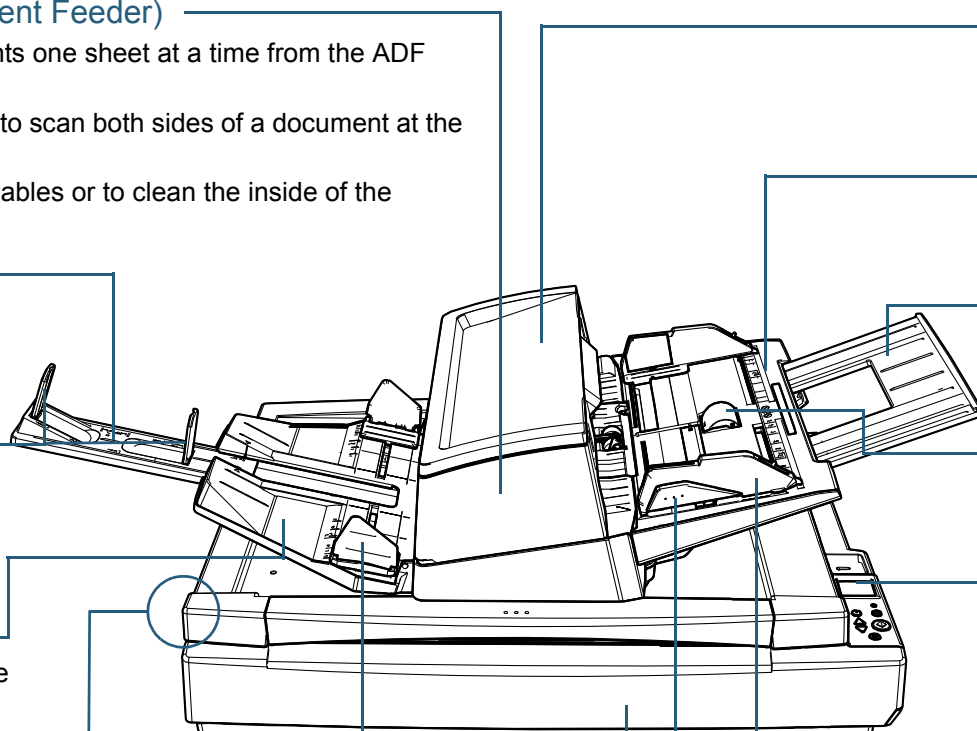

■ Back

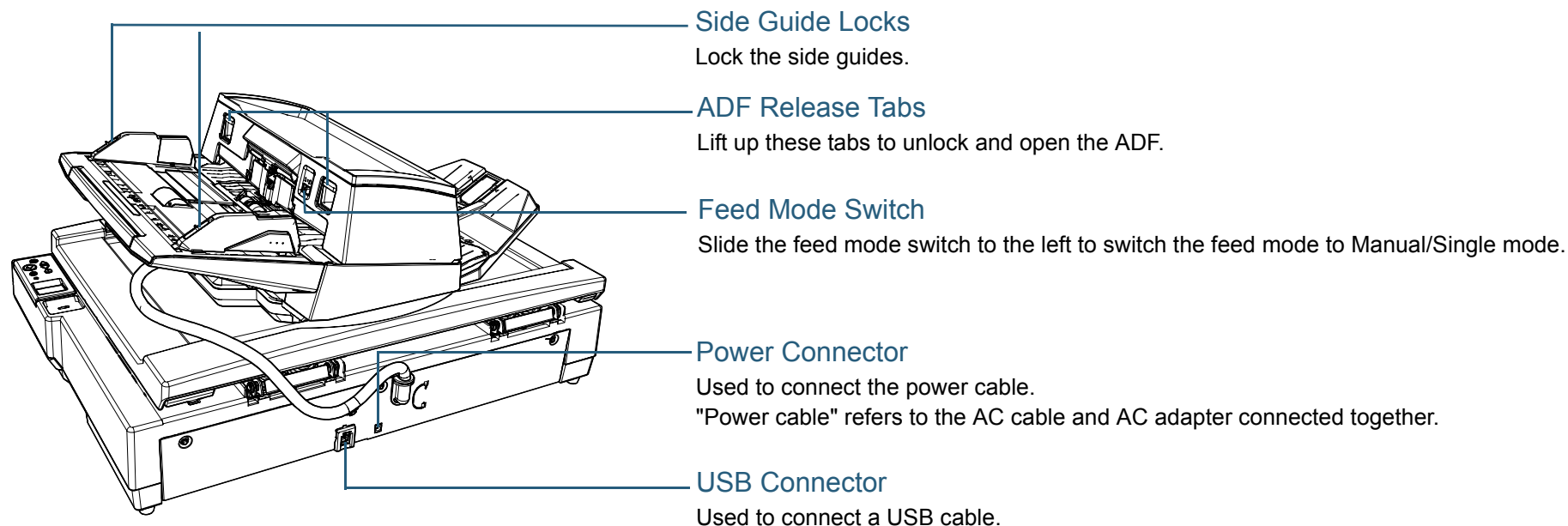

■ Inside (Flatbed)

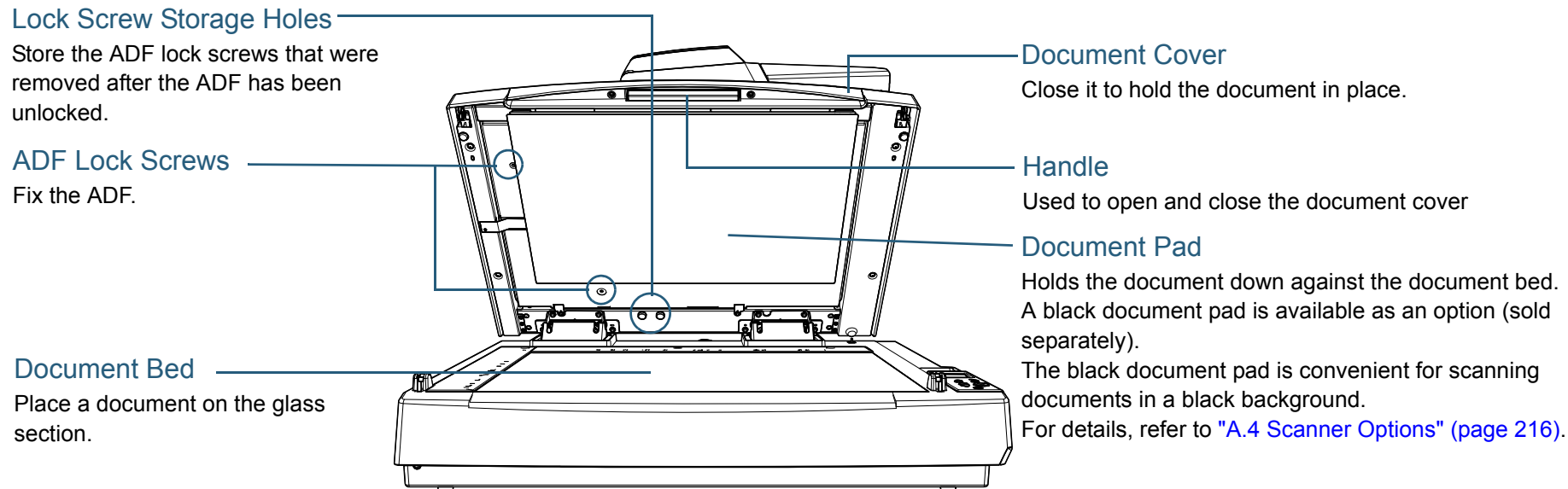

Common Parts for All Models

■ Inside (ADF)

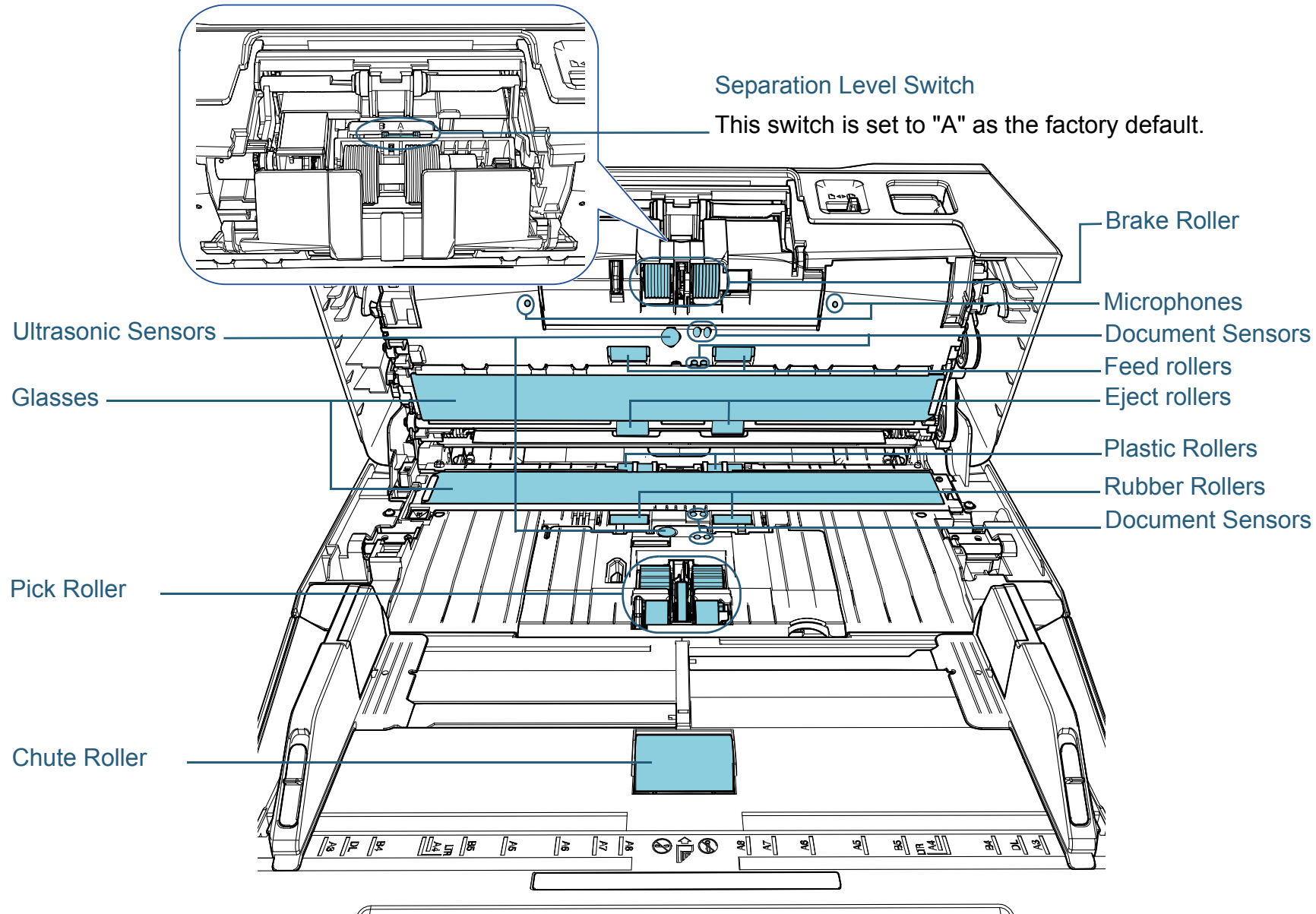

TOP

Contents

Index

Introduction

Scanner
Overview

How to Load
Documents

How to Use the
Operator Panel

Various Ways to
Scan

Daily Care

Replacing the
Consumables

Troubleshooting

Operational
Settings

Appendix

Glossary

Removable Parts

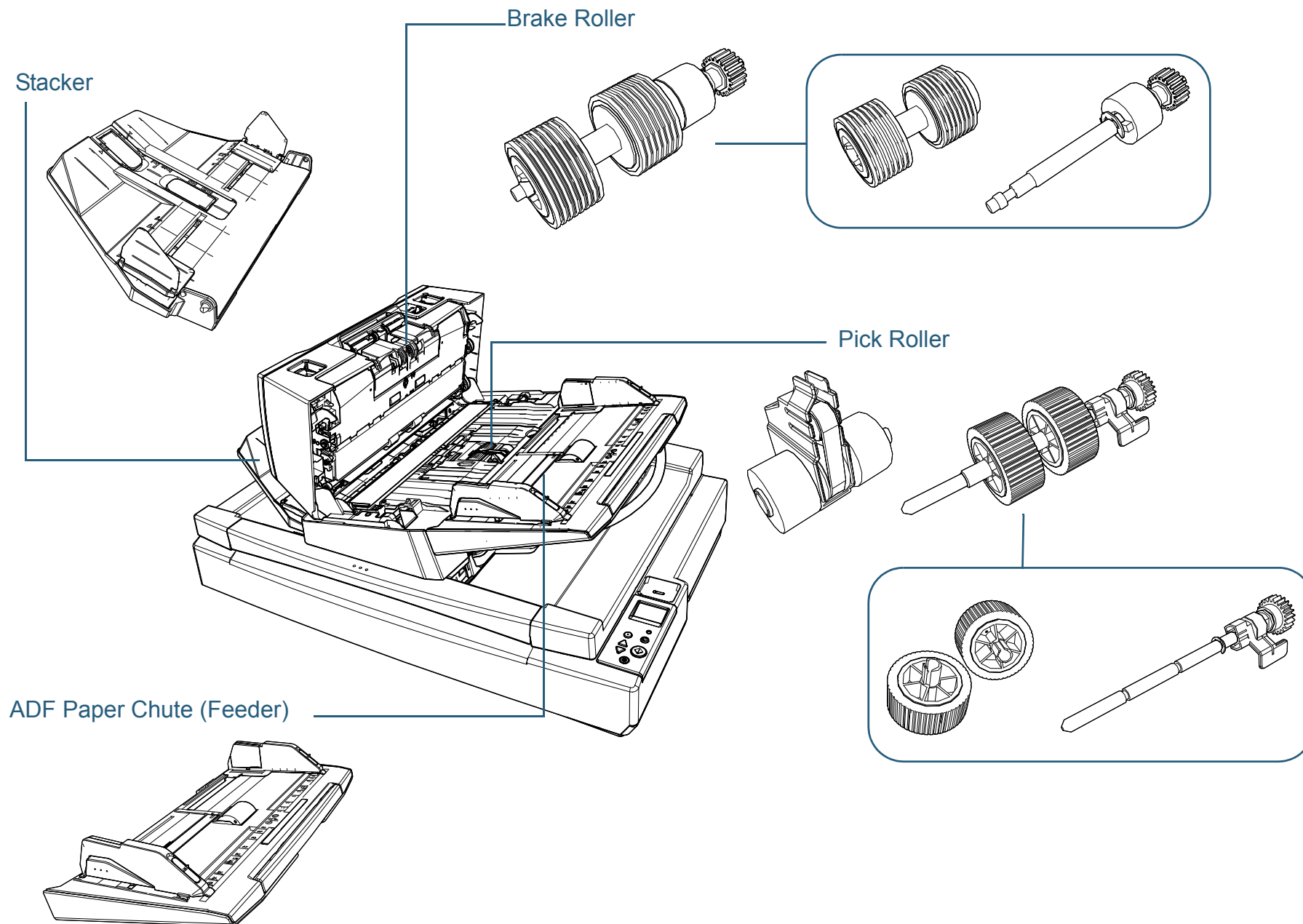

TOP

Contents

Index

Introduction

Scanner Overview

How to Load Documents

How to Use the Operator Panel

Various Ways to Scan

Daily Care

Replacing the Consumables

Troubleshooting

Operational Settings

Appendix

Glossary

1.3 Turning the Power ON/OFF

This section explains how to power on/off the scanner.

HINT

The method by which the scanner is powered on/off can be specified from one of the following:

- Press the [Power] button on the operator panel.
- Use an AC power strip to control power supply for peripherals such as a scanner in accordance with the computer's power.
- Turn on/off the scanner in accordance with the computer's power.

For details, refer to "Method of Turning the Scanner ON/OFF [Power SW Control]" (page 205).

How to Turn the Power ON

- 1 Press the [Power] button on the operator panel.

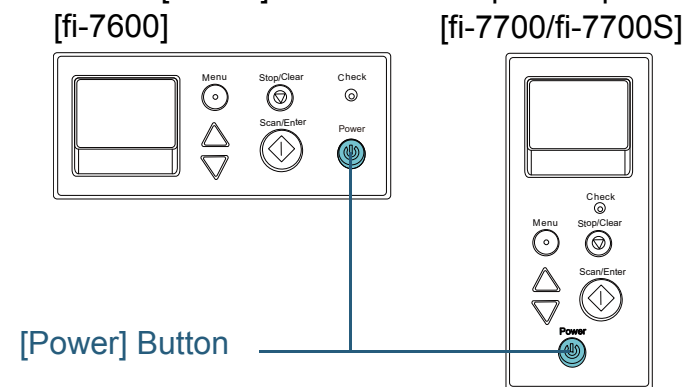

- ⇒ The scanner is turned on, and the [Power] button lights in green. During initialization, the following image is displayed on the LCD of the operator panel.



The scanner is ready to scan when [Ready] is displayed.

How to Turn the Power OFF

- 1 Press the [Power] button on the operator panel for more than 2 seconds.
 - ⇒ The scanner is turned off, and the [Power] button switches off.

1.4 Opening/Closing the ADF

This section describes how to open and close the ADF.

How to Open the ADF

- 1 Remove all documents from the ADF paper chute (feeder).
- 2 Lift up the ADF release tabs to open the ADF.

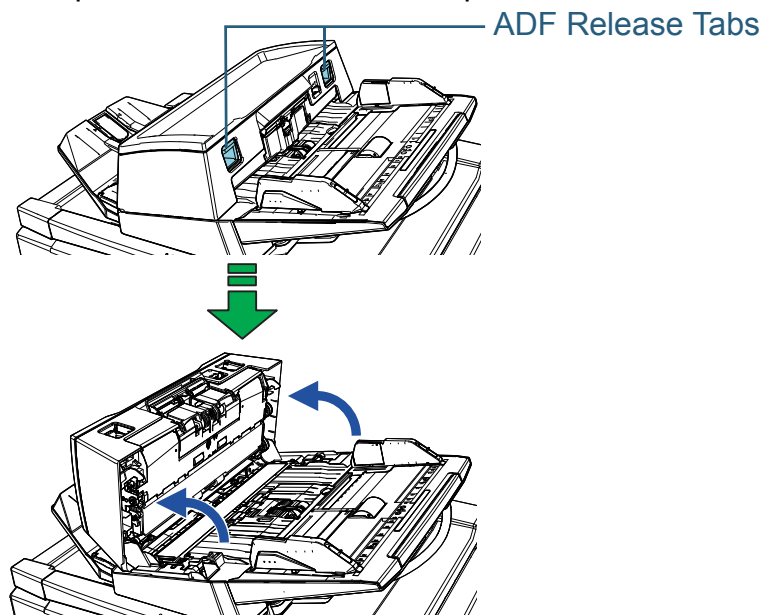

When the ADF is open, it might close accidentally. Be careful not to get your fingers caught.

ATTENTION

Check that the document cover is closed and then open the ADF. If you open the ADF with the document cover open, an error may occur.

How to Close the ADF

- 1 Close the ADF.
Push the center of the ADF until it locks in place.

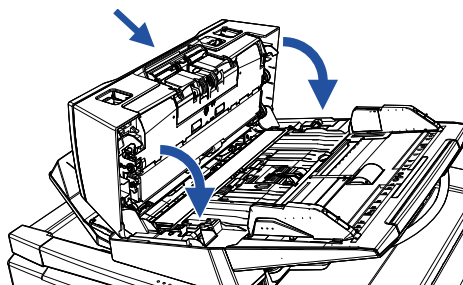

Be careful not to get your fingers caught when closing the ADF.

ATTENTION

Check that there is no foreign matter caught inside the ADF and then close it.

TOP

Contents

Index

Introduction

Scanner
OverviewHow to Load
DocumentsHow to Use the
Operator PanelVarious Ways to
Scan

Daily Care

Replacing the
Consumables

Troubleshooting

Operational
Settings

Appendix

Glossary

1.5 Opening/Closing the Document Cover [fi-7700/fi-7700S]

This section describes how to open and close the document cover.

How to Open the Document Cover

- 1 Take hold of the handle and open the document cover.

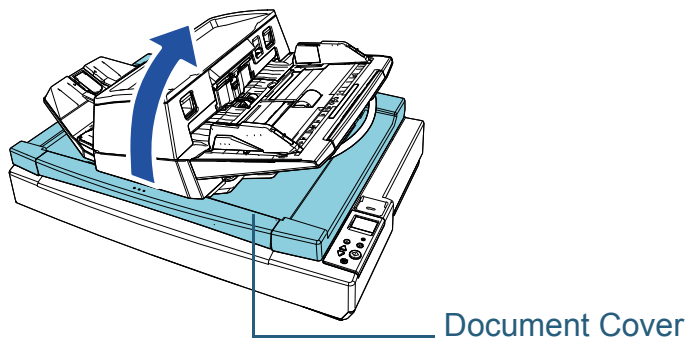

The document cover does not stay open at the point where you stop opening or closing it. Therefore, be careful not to let the document cover close down on your hands.

ATTENTION

Check that the ADF is closed and then open the document cover. If you open the ADF with the document cover open, an error may occur.

How to Close the Document Cover

- 1 Take hold of the handle and gently close the document cover. Push it until it locks in place.

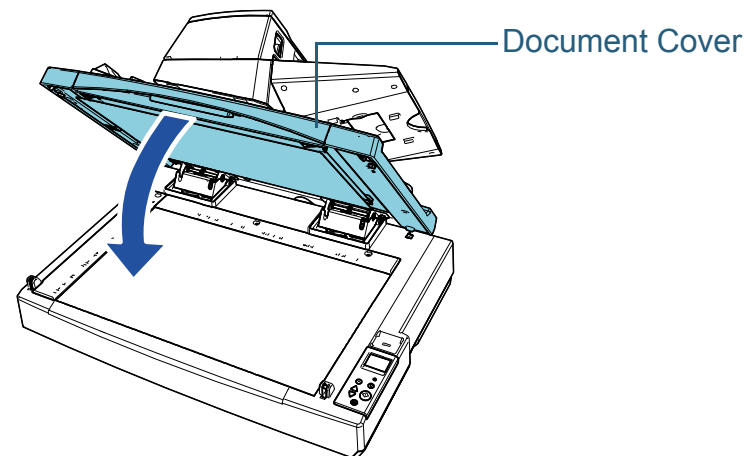

The document cover does not stay open at the point where you stop opening or closing it. Therefore, be careful not to let the document cover close down on your hands.

1.6 Adjusting the Position of the ADF [fi-7700/fi-7700S]

This section explains how to adjust the position of the ADF. The available positions are as follows:

- Position 1 (factory default)

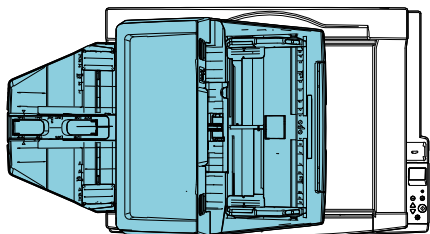

- Position 2 (space-saving type: documents loaded on the right)

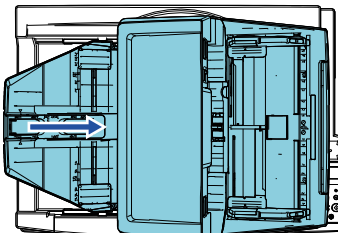

- Position 3 (space-saving type: documents loaded on the left)

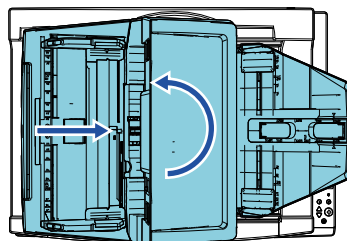

- 1 Open the document cover.

For details, refer to "1.5 Opening/Closing the Document Cover [fi-7700/fi-7700S]" (page 25).

- 2 Remove the two ADF lock screws and insert them into the lock screw storage holes.

The ADF is fixed with the ADF lock screws in place. If the ADF lock screws are removed, the position of the ADF can be adjusted.

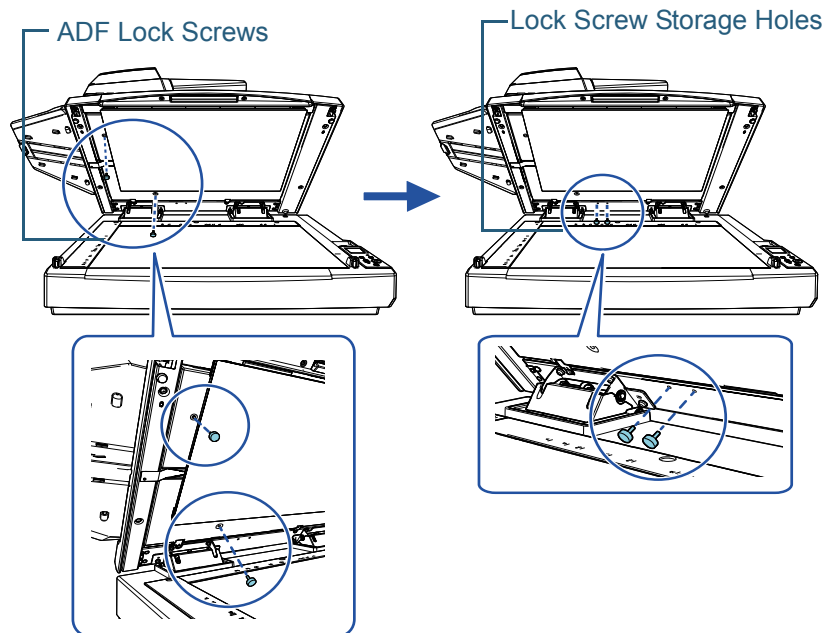

ATTENTION

Before adjusting the position of the ADF, make sure that the ADF lock screws are placed in the lock screw storage holes.

TOP

Contents

Index

Introduction

Scanner
OverviewHow to Load
DocumentsHow to Use the
Operator PanelVarious Ways to
Scan

Daily Care

Replacing the
Consumables

Troubleshooting

Operational
Settings

Appendix

Glossary

HINT

- Remove the document pad if the ADF lock screws are difficult to remove.
- If you remove the document pad, attach the document pad in the following procedure:
 - 1 Place the document pad against the upper left corner on the document bed. Make sure the groove in the document pad is in the correct place.

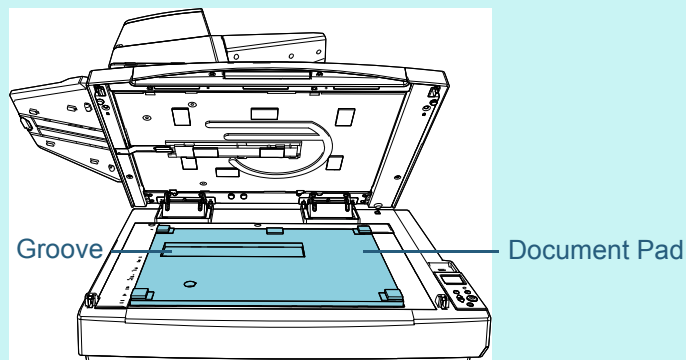

- 2 Close the document cover slowly. When you close the document cover, the document pad is attached to the document cover.

- 3 Gently close the document cover. For details, refer to "1.5 Opening/Closing the Document Cover [fi-7700/fi-7700S]" (page 25).

- 4 Lift up the stacker.

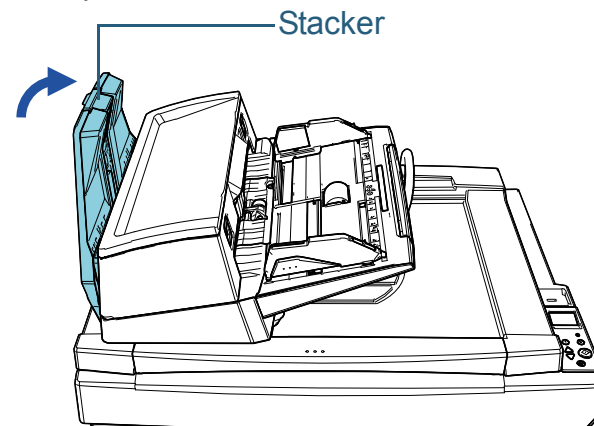

- 5 Change the position of the ADF. Move the ADF until it locks in place. Make sure that the ADF is fixed in place.
 - To change position 1 to position 2
Slide the ADF to the center of the scanner.

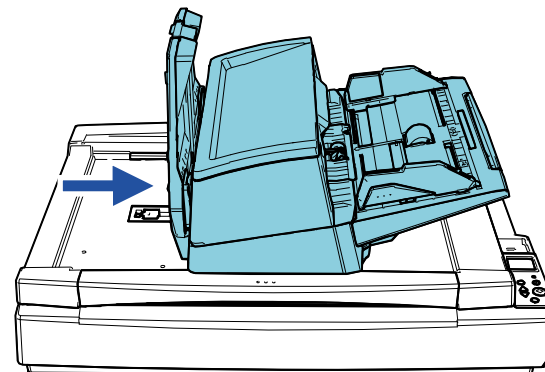

- To change position 1 to position 3
Slide the ADF to the center of the scanner, and then rotate it counterclockwise by 180 degrees.

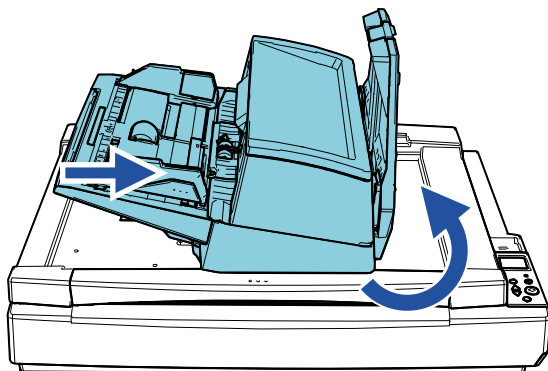

- Be careful not to get your fingers caught when moving the ADF.
- Do not rotate the ADF by more than 180 degrees. The ADF may be damaged.

- 6 Lower the stacker down.

1.7 Setting Up the ADF Paper Chute (Feeder)

Documents loaded in the ADF paper chute (feeder) are fed into the ADF one by one when scanning starts.

Using the chute extension as described in the following procedure will keep the documents straight and feed them smoothly.

- 1 Pull out the chute extension.

Chute Extension

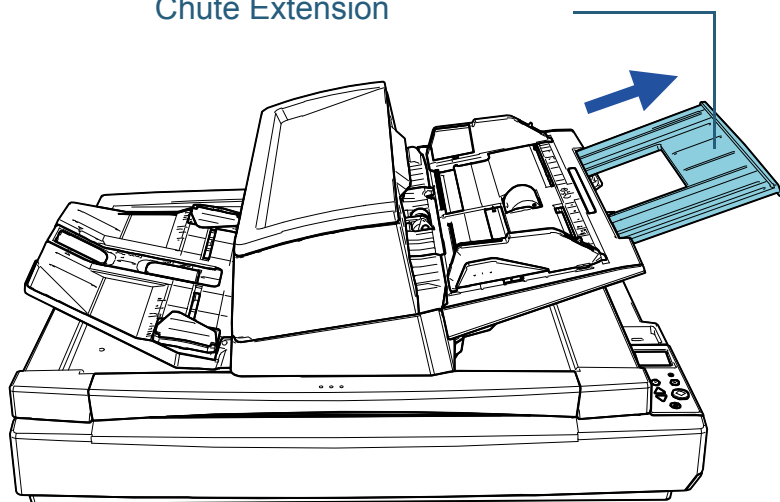

HINT

Make sure you hold the scanner while pulling out the chute extension.

TOP

Contents

Index

Introduction

Scanner
Overview

How to Load
Documents

How to Use the
Operator Panel

Various Ways to
Scan

Daily Care

Replacing the
Consumables

Troubleshooting

Operational
Settings

Appendix

Glossary

1.8 Setting Up the Stacker

Documents loaded in the ADF paper chute (feeder) are ejected onto the stacker one by one when scanning starts. Using the stacker extension and the stacker side guides as described in the following procedure will keep the documents straight and stack them neatly.

- 1 Pull out the stacker extension and adjust it to the length of the document, and then lift up the stopper to stop the document.

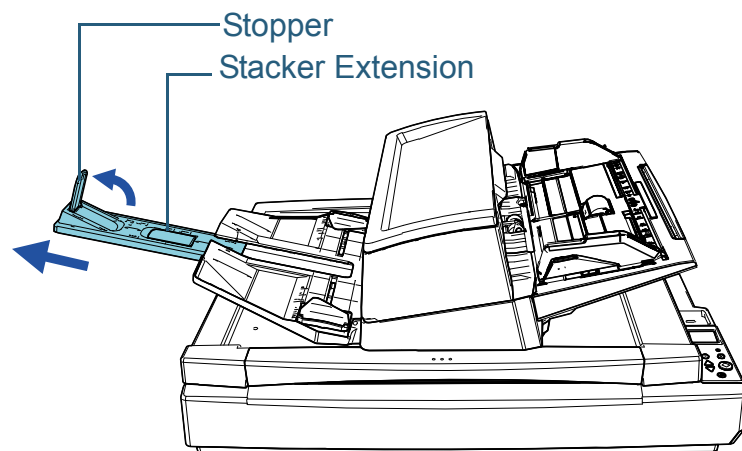

ATTENTION

- Do not hold the stopper to pull out the stacker extension. The stopper may be damaged.
- Make sure the distance between the stopper and the sheet ejection outlet is longer than the length of the documents. If you place the stopper so that there is little space between the stopper and the ejected documents, ejected documents can be stacked neatly.

HINT

- When scanning short documents such as business cards, lift up the right stopper.
- When scanning documents longer than A3 size, pull out the stacker extension all the way without lifting up the stopper.
- When scanning A4/Letter landscape documents, if you lift up the right stopper, ejected documents can be stacked neatly.

- 2 Lift up the stacker side guides and adjust the distance between them to the width of the documents.

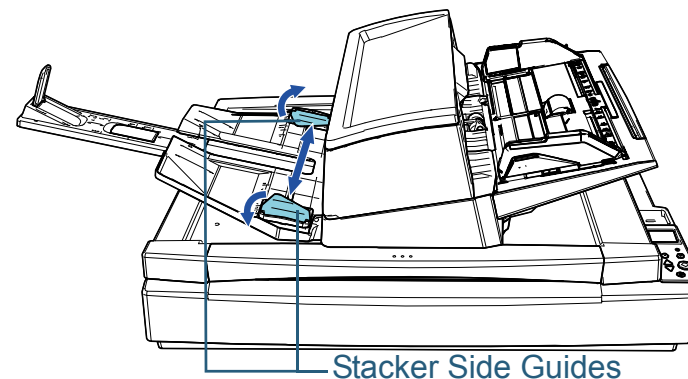

ATTENTION

Make sure the distance between the stacker side guides are wider than the width of the documents.

TOP

Contents

Index

Introduction

Scanner
OverviewHow to Load
DocumentsHow to Use the
Operator PanelVarious Ways to
Scan

Daily Care

Replacing the
Consumables

Troubleshooting

Operational
Settings

Appendix

Glossary

HINT

- Adjust the height of the stacker according to the paper type of the document.
Select the lower position for ordinary use. When scanning a thin or curled document, select the upper position. When it is placed in the upper position, the number of documents that can be loaded in the ADF paper chute (feeder) is reduced. The suggested number is 100 if the paper weight is 80 g/m² (20 lb).

- Lower Position (Normal Paper)

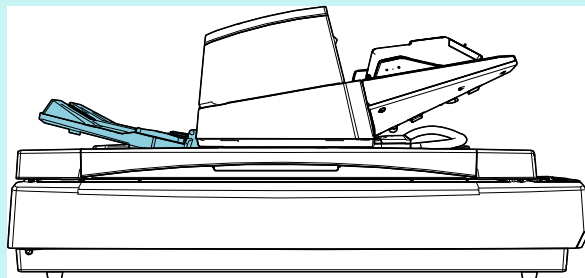

- Upper Position (Thin or Curled Paper)

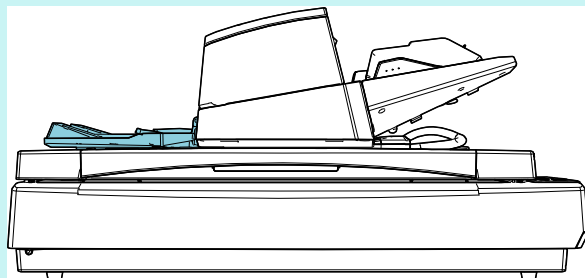
**HINT**

- You can place the stacker in the upper position smoothly if you hold both sides of the stacker firmly and push it forward while lifting it up.

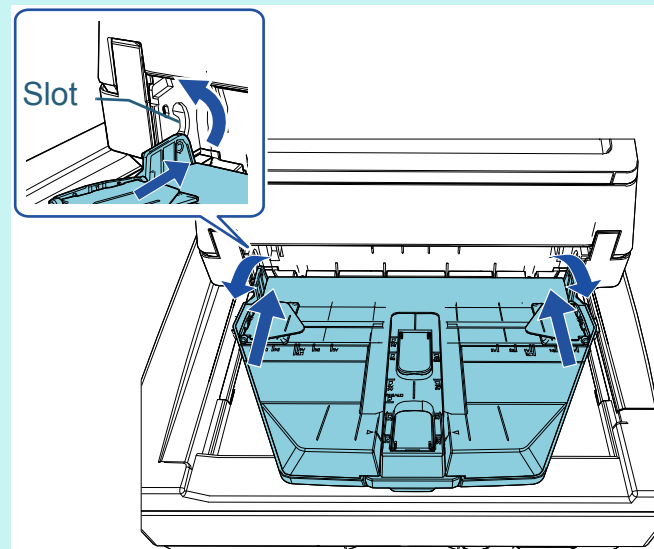

- The sheet ejection speed can be slowed down in one of the following ways. Slowing down the sheet ejection speed prevents documents from scattering.
 - [11: Stacking Control] in the [Settings Menu] screen of the operator panel
For details, refer to "[Chapter 3 How to Use the Operator Panel](#)" (page 56) and "[3.2 Settings Menu](#)" (page 62).
 - [Stacking Control] in the Software Operation Panel
For details, refer to "[Specifying the Paper Ejecting Speed \[Stacking Control\]](#)" (page 195).

1.9 Power Saving Mode

Power saving mode keeps the power consumption low when the scanner has not been used for a certain period of time. If the scanner is left powered on for 15 minutes (factory default setting) without being used, it automatically enters power saving mode.

When the scanner enters power saving mode, the LCD on the operator panel switches off. The [Power] button flashes in green.

To resume from power saving mode, perform one of the following:

- Load a document in the ADF paper chute (feeder)
- Press any button on the operator panel
Note that pressing the [Power] button for more than 2 seconds will turn the power off.
- Perform scanning from an application

The scanner is turned off automatically if it is left on for a certain period of time (set to 4 hours as the factory default) without being used, reducing the power consumption until the next scan.

To prevent the scanner from being turned off automatically, clear the [Power off after a certain period of time] check box in [Device Setting] on the Software Operation Panel. For details, refer to ["Waiting Time for the Scanner to Enter Power Saving Mode \[Power saving\]" \(page 203\)](#).

To turn the power back on after the power is turned off automatically, press the [Power] button on the operator panel. For details, refer to ["1.3 Turning the Power ON/OFF" \(page 23\)](#).

ATTENTION

- The scanner may not enter power saving mode if there is a document remaining on the paper path. In this case, remove the document.
For details, refer to ["7.1 Paper Jam" \(page 125\)](#).
- For some applications, the scanner may not be turned off even if the [Power off after a certain period of time] check box is selected.
- If the scanner is automatically turned off while you are using the image scanning application, exit the application, and then turn the power on.

HINT

- By using one of the following, you can change the waiting time for the scanner to enter power saving mode.
 - [22: Power saving] in the [Settings Menu]screen on the operator panel
For details, refer to ["Chapter 3 How to Use the Operator Panel" \(page 56\)](#) and ["3.2 Settings Menu" \(page 62\)](#).
 - [Device Setting] on the Software Operation Panel
For details, refer to ["Waiting Time for the Scanner to Enter Power Saving Mode \[Power saving\]" \(page 203\)](#).

TOP

Contents

Index

Introduction

Scanner
OverviewHow to Load
DocumentsHow to Use the
Operator PanelVarious Ways to
Scan

Daily Care

Replacing the
Consumables

Troubleshooting

Operational
Settings

Appendix

Glossary

1.10 Basic Flow of Scanning Operation

This section explains about the basic flow of performing a scan.

In order to perform a scan, you need a scanner driver and an image scanning application that supports the scanner driver. The following scanner drivers and image scanning applications are bundled with the scanner:

- Scanner driver
 - PaperStream IP (TWAIN)
 - PaperStream IP (TWAIN x64)
 - PaperStream IP (ISIS) Bundle
- Image scanning application
 - PaperStream Capture
 - ScanSnap Manager for fi Series

HINT

For details about the scanner drivers and image scanning applications, refer to ["1.11 Bundled Software" \(page 35\)](#).

Scanning procedures and operations slightly vary depending on the image scanning application.

For details, refer to the image scanning application manual. The following describes the normal procedure for scanning.

- 1** Turn on the scanner.
For details, refer to ["1.3 Turning the Power ON/OFF" \(page 23\)](#).
- 2** Load documents in the ADF paper chute (feeder).
Load the documents face-down in the ADF paper chute (feeder).

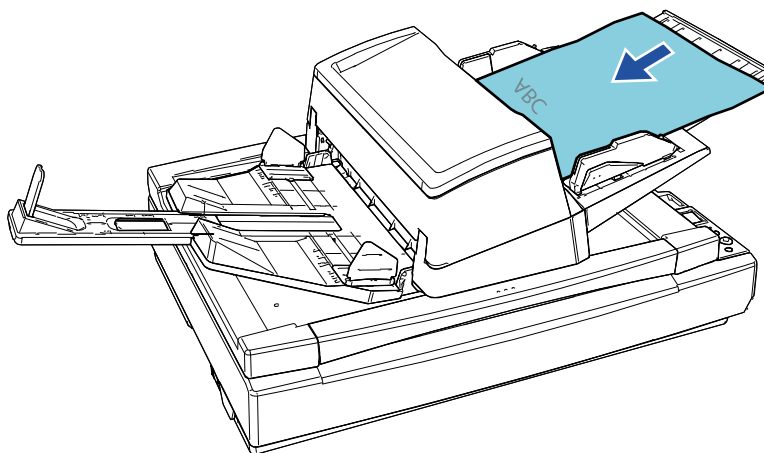

For details, refer to ["Chapter 2 How to Load Documents" \(page 39\)](#).

- 3** Start an image scanning application.
- 4** Select a scanner driver.
For some image scanning applications, selection of a scanner driver may not be needed.

TOP

Contents

Index

Introduction

Scanner
OverviewHow to Load
DocumentsHow to Use the
Operator PanelVarious Ways to
Scan

Daily Care

Replacing the
Consumables

Troubleshooting

Operational
Settings

Appendix

Glossary

5 Select a scanner.

Make sure to select the scanner model that is connected to the computer.

For some image scanning applications, selection of a scanner may not be needed.

6 In the setup window for the scanner driver, configure the scan settings.

For some image scanning applications, the setup window for the scanner driver may not appear.

7 Scan the document with the image scanning application.

ATTENTION

When the scanner and the computer are communicating, for instance, during scanning, do not perform an operation that causes disconnection of their communication, such as unplugging the USB cable or logging off the user account.

TOP

Contents

Index

Introduction

Scanner Overview

How to Load Documents

How to Use the Operator Panel

Various Ways to Scan

Daily Care

Replacing the Consumables

Troubleshooting

Operational Settings

Appendix

Glossary

1.11 Bundled Software

Overview of the Bundled Software

HINT

The software can be installed from the bundled Setup DVD-ROM or downloaded from the download website to which the bundled Setup DVD-ROM links and then installed.

This product is bundled with the following software.

- PaperStream IP driver

The PaperStream IP driver is a scanner driver that conforms to the TWAIN/ISIS standard.

There are three types of PaperStream IP drivers.

 - PaperStream IP (TWAIN)

Conforms to the TWAIN standard. Used when you operate the scanner using TWAIN-compliant 32-bit applications.
 - PaperStream IP (TWAIN x64)

Conforms to the TWAIN standard. Used when you operate the scanner using TWAIN-compliant 64-bit applications.

It can be installed on 64-bit operating systems.
 - PaperStream IP (ISIS) Bundle

Conforms to the ISIS standard. Used when you operate the scanner using ISIS-compliant applications.

For details, refer to the PaperStream IP driver Help.
- 2D Barcode for PaperStream

This application recognizes two-dimensional codes.

It can be used with the PaperStream IP driver and PaperStream Capture. Download it from the download website and install it. It is available as an option (sold separately) for the fi-7700S.
- Software Operation Panel

You can configure various settings for operating the scanner and managing consumable parts. It is installed together with the PaperStream IP driver.

For details, refer to "[Chapter 8 Operational Settings](#)" (page 156).

- Error Recovery Guide

Details the status of the scanner and explains how to resolve problems encountered. It is installed together with the PaperStream IP driver.
- PaperStream Capture

An image scanning application which supports both PaperStream IP (TWAIN) and PaperStream IP (ISIS) Bundle. By defining scan settings as document profiles, you can customize the settings according to your preference.
- ScanSnap Manager for fi Series

An image scanning application which uses the scan settings dedicated to ScanSnap Manager for fi Series.

PaperStream IP (TWAIN) is required for this application. Using this application makes it easy to create an image file (a PDF, JPG, or searchable PDF file) with a single button. Download it from the download website and install it.
- Scan to Microsoft SharePoint

This application allows you to easily upload files from ScanSnap Manager for fi Series to the SharePoint site.

It can be used when you scan documents with ScanSnap Manager for fi Series. Download it from the download website and install it.
- ABBYY FineReader for ScanSnap™

This application converts the scanned images into files for applications such as Word or Excel(*1).

It can be used when you scan documents with ScanSnap Manager for fi Series. Download it from the download website and install it.
- Manuals

Safety Precautions, the Operator's Guide, and the fi-760PRB Imprinter Operator's Guide are installed.
- Scanner Central Admin Agent

This application allows you to update firmware for multiple scanners at the same time and centralize the management and monitoring of multiple scanners. It can be used to monitor the operating status of scanners and check the information on scanners.

Required applications vary depending on the type of operation. For details, refer to the Scanner Central Admin User's Guide.

TOP

Contents

Index

Introduction

Scanner
OverviewHow to Load
DocumentsHow to Use the
Operator PanelVarious Ways to
Scan

Daily Care

Replacing the
Consumables

Troubleshooting

Operational
Settings

Appendix

Glossary

- fi Series Online Update

This application checks for the latest software and firmware updates for fi Series and applies them.

For details, refer to the fi Series Online Update Help.

*1: Microsoft® Office products need to be installed.

For details about how to configure the scanner settings to scan different types of documents with the image scanning application, refer to ["Chapter 4 Various Ways to Scan" \(page 82\)](#).

System Requirements

The system requirements are as follows:

Operating system	<ul style="list-style-type: none"> ● Windows Server® 2008 Standard (32-bit/64-bit) (Service Pack 2) ● Windows Server® 2008 R2 Standard (64-bit) (Service Pack 1) ● Windows® 7 Home Premium (32-bit/64-bit) (Service Pack 1) ● Windows® 7 Professional (32-bit/64-bit) (Service Pack 1) ● Windows® 7 Enterprise (32-bit/64-bit) (Service Pack 1) ● Windows® 7 Ultimate (32-bit/64-bit) (Service Pack 1) ● Windows Server® 2012 Standard (64-bit) (*1) ● Windows Server® 2012 R2 Standard (64-bit) (*1) ● Windows® 8.1 (32-bit/64-bit) (including updates) (*1) ● Windows® 8.1 Pro (32-bit/64-bit) (including updates) (*1) ● Windows® 8.1 Enterprise (32-bit/64-bit) (including updates) (*1) ● Windows® 10 Home (32-bit/64-bit) (*1) ● Windows® 10 Pro (32-bit/64-bit) (*1) ● Windows® 10 Enterprise (32-bit/64-bit) (*1) ● Windows® 10 Education (32-bit/64-bit) (*1) ● Windows Server® 2016 Standard (64-bit) (*1)
CPU	Intel® Pentium® 4 1.8 GHz or higher (Recommended: Intel® Core™ i5 2.5 GHz or higher, excluding those for mobile devices)
Memory	1 GB or more (Recommended: 4 GB or more)
Hard disk drive	5,400 rpm or more (Recommended: 7,200 rpm or more)

Display resolution	1024 × 768 pixels or more, 65,536 colors or more
Hard disk space	11 GB or more of free hard disk space (*2)
DVD drive	Required for installing the software
Interface	USB 3.1 Gen 1/USB 3.0/USB 2.0/USB 1.1

*1: The bundled software operates as a desktop application.

*2: Required disk space for scanning documents varies according to the file size of the scanned images.

Installing the Bundled Software

This section explains about the procedure to install the software from the bundled Setup DVD-ROM.

Note that there are two ways to install the bundled software: select [Installation (Recommended)] to install all the software required to operate the scanner at one time, or [Installation (Custom)] to select and install the software that you need.

ATTENTION

If an old version of the software is installed, uninstall it first. For details about the procedure to uninstall the software, refer to "[A.5 Uninstalling the Software](#)" (page 217).

■ Installation (Recommended)

When [Installation (Recommended)] is selected, the following software is installed:

- PaperStream IP (TWAIN)
- PaperStream IP (TWAIN x64)
- Software Operation Panel
- Error Recovery Guide
- PaperStream Capture
- Manuals
- Scanner Central Admin Agent
- fi Series Online Update

- 1 Turn on the computer and log onto Windows as a user with administrator privileges.
- 2 Insert the Setup DVD-ROM into the DVD drive.
⇒ The [fi Series Setup] window appears.

HINT

If the [fi Series Setup] window does not appear, double-click "Setup.exe" in the Setup DVD-ROM via [Windows Explorer] or [Computer].

- 3 Click the model name of the scanner to be used.
- 4 Click the [Installation (Recommended)] button.

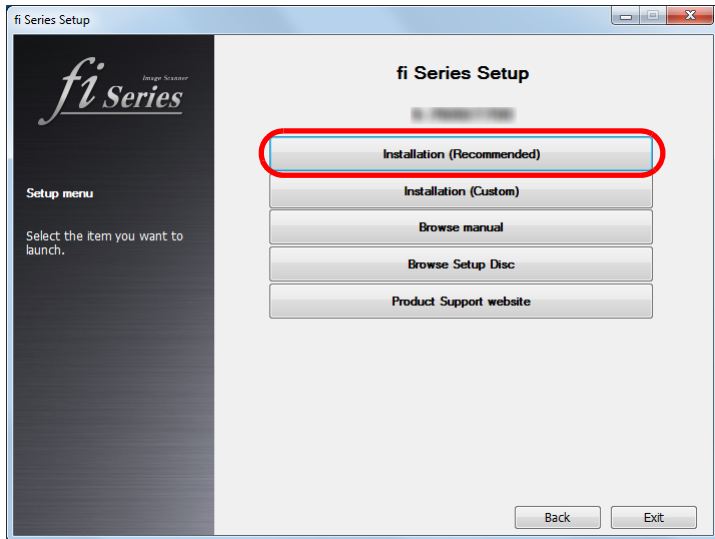

- 5 Install the software by following the instructions displayed in the window.

Installation (Custom)

- 1 In the same way as in "Installation (Recommended)" (page 37), perform steps 1 through 3.
- 2 Click the [Installation (Custom)] button.

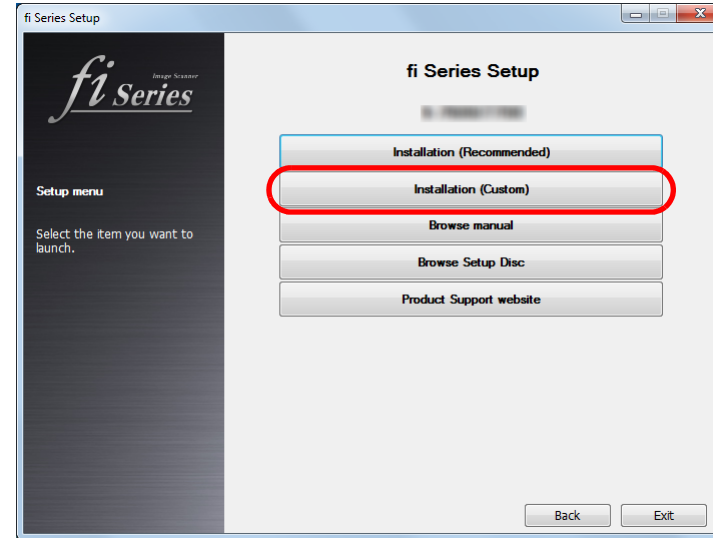

- 3 Check the displayed contents and click the [Next] button.
- 4 Select the check boxes for the software to be installed and click the [Next] button.
- 5 Install the software by following the instructions displayed in the window.

- TOP
- Contents
- Index
- Introduction
- Scanner Overview
- How to Load Documents
- How to Use the Operator Panel
- Various Ways to Scan
- Daily Care
- Replacing the Consumables
- Troubleshooting
- Operational Settings
- Appendix
- Glossary

Chapter 2 How to Load Documents

This chapter explains how to load documents on the scanner.

2.1 Loading Documents in the ADF.....	40
2.2 Placing a Document on the Flatbed [fi-7700/fi-7700S].....	46
2.3 Documents for Scanning	47

TOP

Contents

Index

Introduction

Scanner
Overview

How to Load
Documents

How to Use the
Operator Panel

Various Ways to
Scan

Daily Care

Replacing the
Consumables

Troubleshooting

Operational
Settings

Appendix

Glossary

2.1 Loading Documents in the ADF

This section explains how to load documents in the ADF.

Preparation

HINT

For details about the paper size and quality required for normal operations, refer to ["2.3 Documents for Scanning" \(page 47\)](#).

1 If you are loading multiple sheets, check the documents.

- 1 Check if the documents to be loaded are of the same width or different widths.

Ways to load documents differ depending on whether they are the same width or not.

If the document width varies, refer to ["Conditions for Mixed Batch Scanning" \(page 53\)](#) or ["Scanning Documents with Different Widths" \(page 84\)](#).

- 2 Check the number of sheets.

The number of sheets that can be loaded is as follows:

- A4/Letter size documents or smaller
300 sheets (with paper weight of 80 g/m² [20 lb] and thickness of the document stack under 30 mm)
- Documents larger than A4/Letter size
100 sheets (with paper weight of 80 g/m² [20 lb] and thickness of the document stack under 10 mm)

For details, refer to ["Loading Capacity" \(page 50\)](#).

2 Fan the documents.

- 1 Take out a stack of documents, according to the thickness in the following guidelines:

- A4/Letter size documents or smaller
30 mm or less
- Documents larger than A4/Letter size
10 mm or less

- 2 Hold both ends of the documents and fan them a few times.

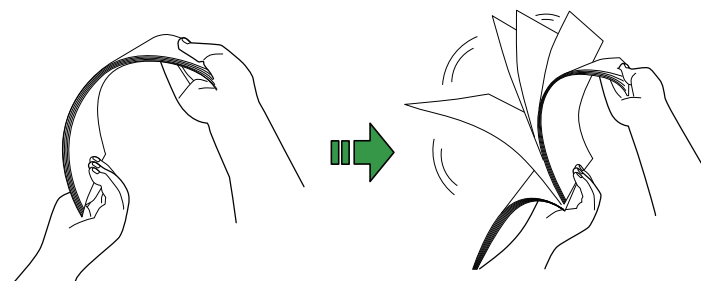

- 3 Rotate the documents by 90 degrees and fan them in the same manner.
- 4 Perform steps 1 to 3 for all documents.
- 5 Align the edges of the documents.

HINT

For more details about how to fan documents, refer to the Error Recovery Guide.

TOP

Contents

Index

Introduction

Scanner
OverviewHow to Load
DocumentsHow to Use the
Operator PanelVarious Ways to
Scan

Daily Care

Replacing the
Consumables

Troubleshooting

Operational
Settings

Appendix

Glossary

How to Load Documents

There are two ways to load documents.

- Loading documents at the center of the ADF paper chute (feeder)
This way is used mainly when the documents are of the same size.
- Loading documents to the left or right side of the ADF paper chute (feeder)
This way is used mainly when the documents are in different sizes or when you want to shift the center of the documents.

ATTENTION

Note that different conditions apply for some functions such as multifeed detection when you load documents to the left or right side of the ADF paper chute (feeder).

■ Loading Documents at the Center of the ADF Paper Chute (Feeder)

- 1 Adjust the ADF paper chute (feeder) according to the length of the documents.
For details, refer to "[1.7 Setting Up the ADF Paper Chute \(Feeder\)](#)" (page 29).
- 2 Adjust the stacker according to the length of the documents.
For details, refer to "[1.8 Setting Up the Stacker](#)" (page 30).
- 3 Load documents in the ADF paper chute (feeder).
Load the documents face-down in the ADF paper chute (feeder).

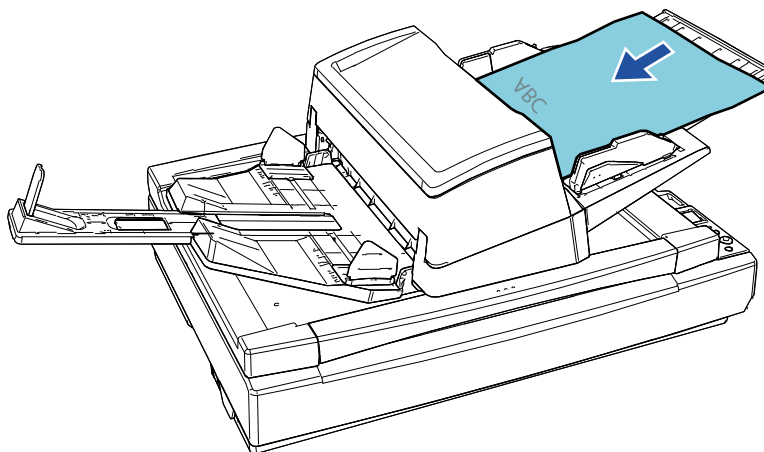

ATTENTION

- Remove all paper clips and staples.
- Reduce the number of sheets if a multifeed or pick error occurs.

TOP

Contents

Index

Introduction

Scanner
OverviewHow to Load
DocumentsHow to Use the
Operator PanelVarious Ways to
Scan

Daily Care

Replacing the
Consumables

Troubleshooting

Operational
Settings

Appendix

Glossary

- 4** Adjust the side guides to the width of the documents. Move the side guides by pressing the side guide button so that there is no space between the side guides and the documents.

Otherwise, the documents may be fed skewed.

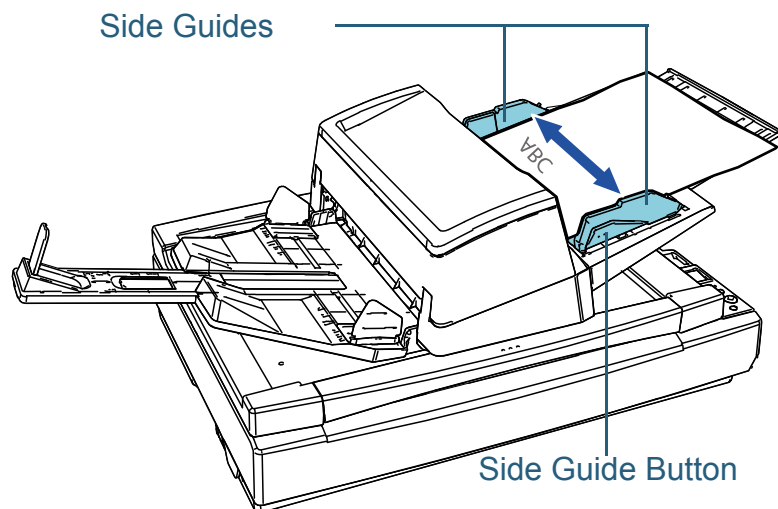

- 5** Scan the documents with the image scanning application. For details, refer to the image scanning application manual.

■ Loading Documents to the Left or Right Side of the ADF Paper Chute (Feeder)

- 1** Adjust the ADF paper chute (feeder) according to the length of the documents. For details, refer to ["1.7 Setting Up the ADF Paper Chute \(Feeder\)" \(page 29\)](#).
- 2** Adjust the stacker according to the length of the documents. For details, refer to ["1.8 Setting Up the Stacker" \(page 30\)](#).
- 3** Slide the side guides fully outward.

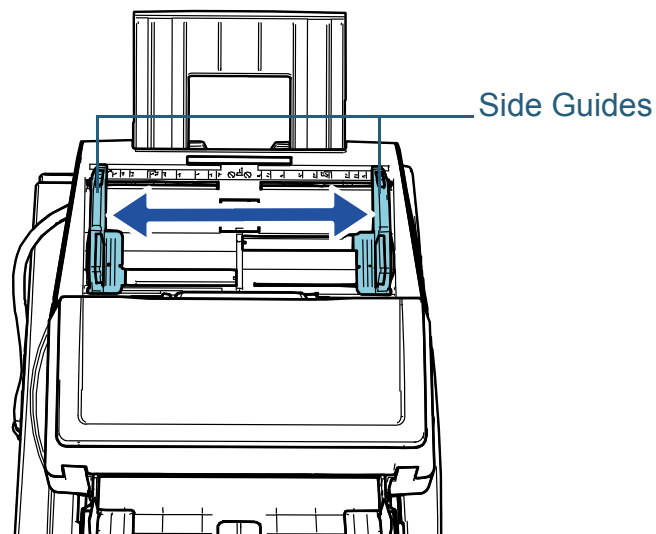

4 Load the documents in the ADF paper chute (feeder) so that the narrowest document can be picked by the pick rollers.

Load the documents face-down in the ADF paper chute (feeder).

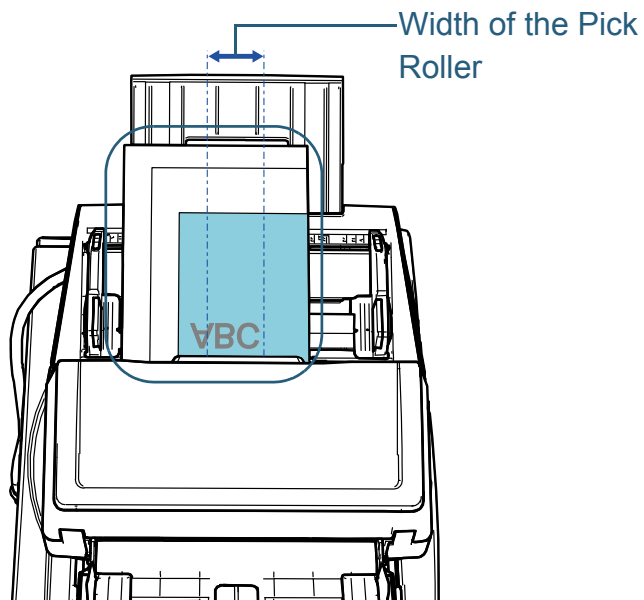

ATTENTION

- Remove all paper clips and staples.
- Reduce the number of sheets if a multifeed or pick error occurs.

ATTENTION

- Make sure that all documents are placed underneath the pick roller. Otherwise, some documents may be skewed or not fed into the ADF.

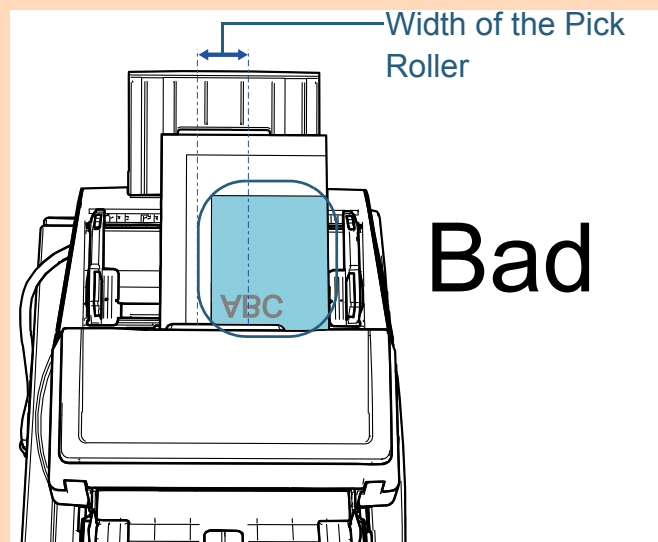
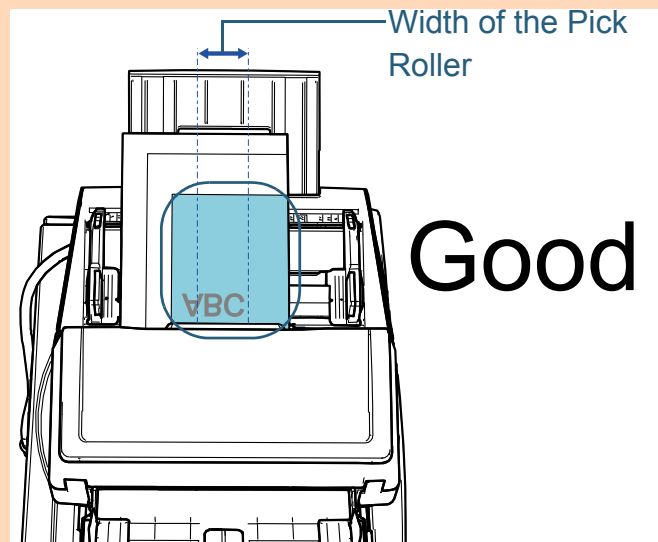

- 5** Adjust the side guides to the width of the documents. Move the side guides by pressing the side guide button so that there is no space between the side guides and the widest document.

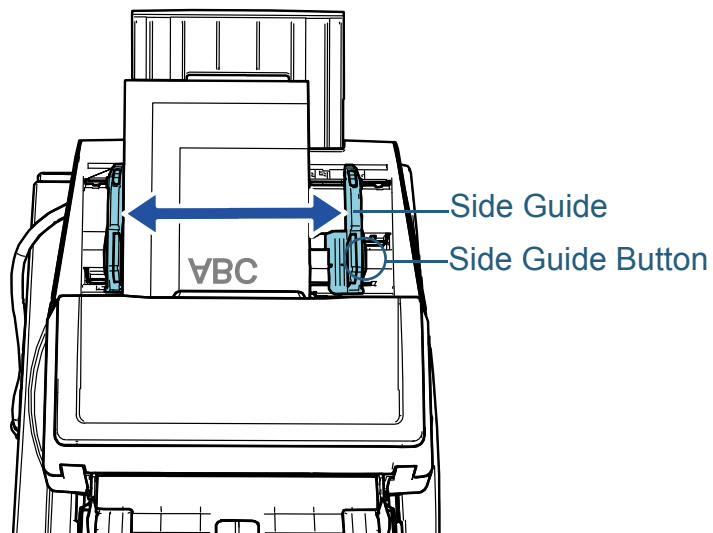

- 6** Lock one of the side guides. Slide the side guide lock on the left side guide in the direction of the arrow to lock the side guide.

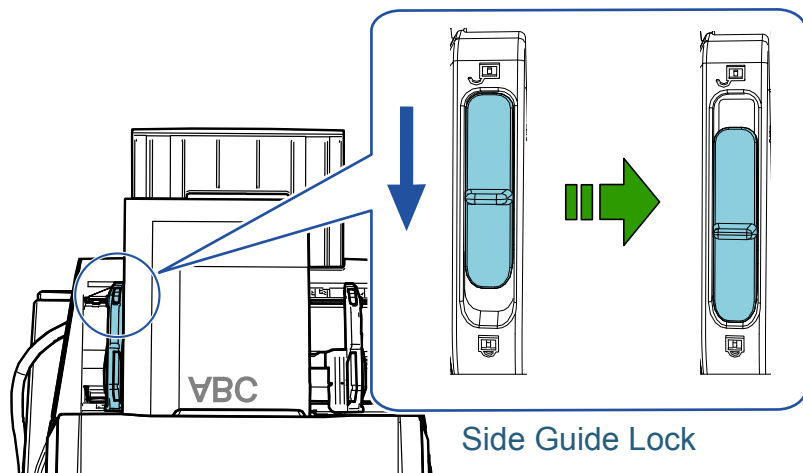

- 7** Adjust the other side guide to the intended position by pressing the side guide button. Do not leave space between the side guides and the documents. Otherwise, the documents may be fed skewed.

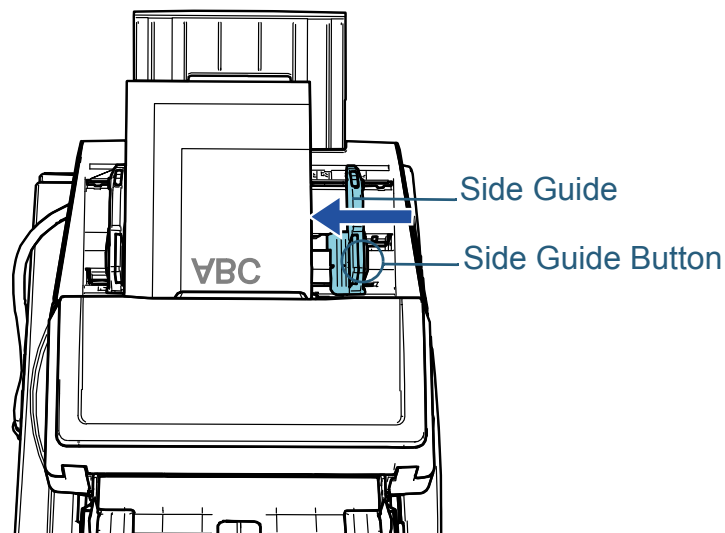

- 8** Scan the documents with the image scanning application. For details, refer to the image scanning application manual.

- TOP
- Contents
- Index
- Introduction
- Scanner Overview
- How to Load Documents
- How to Use the Operator Panel
- Various Ways to Scan
- Daily Care
- Replacing the Consumables
- Troubleshooting
- Operational Settings
- Appendix
- Glossary

HINT

The procedure to unlock the side guides and change the position of the side guides so that you can place documents in the center of the ADF chute (feeder) is as follows:

- 1 Slide the side guide lock of the side guide that is locked in the direction of the arrow.

Side Guide Lock

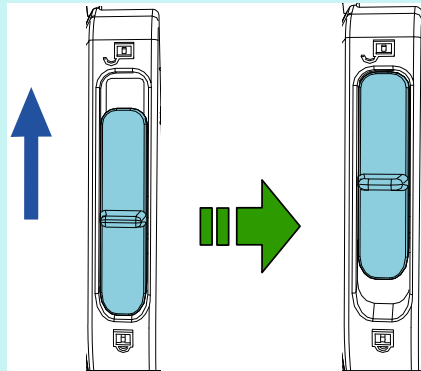

- 2 Hold both side guides while pressing the side guide buttons on them and move them all the way to the center.

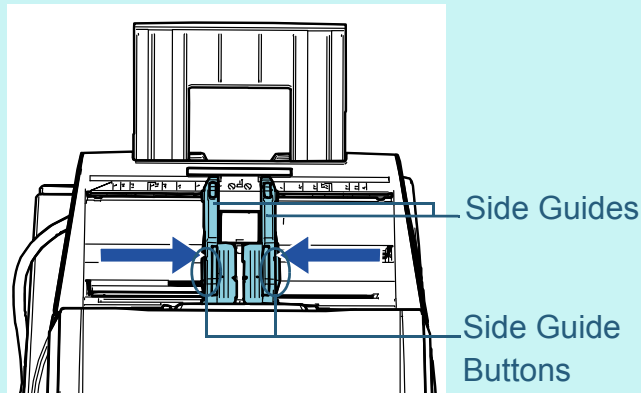

⇒When you move the side guides while pressing the side guide buttons, the left and right side guides move in conjunction with each other, which allows you to place documents in the center of the ADF paper chute (feeder).

2.2 Placing a Document on the Flatbed [fi-7700/fi-7700S]

- 1 Open the document cover.
For details, refer to "1.5 Opening/Closing the Document Cover [fi-7700/fi-7700S]" (page 25).
- 2 Place a document on the document bed.
Place the document face-down to align its top left-hand corner with the reference point.

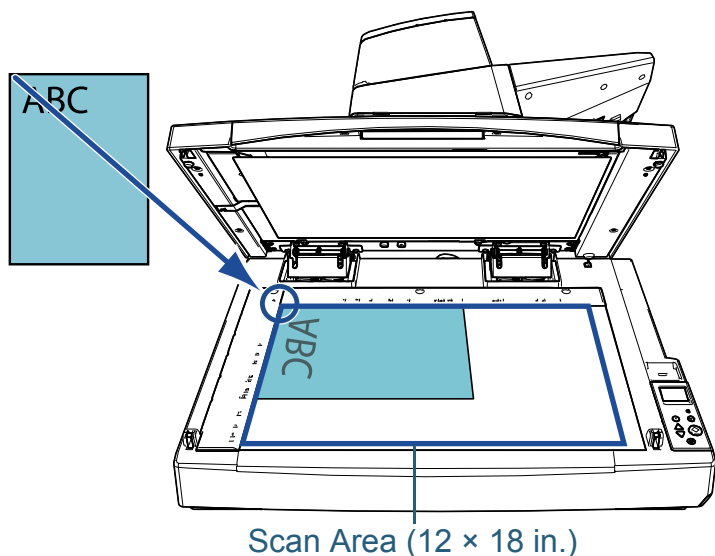

ATTENTION

Note that a curled or folded document may create a small gap between the document and the document bed, causing the scanned image to be blurred.

- 3 Gently close the document cover.
For details, refer to "1.5 Opening/Closing the Document Cover [fi-7700/fi-7700S]" (page 25).

HINT

- A document can be scanned with the document cover open. For details, refer to "Scanning Documents with the Document Cover Open [fi-7700/fi-7700S]" (page 97)
- To scan documents on a black background, use an optional black document pad (sold separately). For details about the black document pad, refer to "A.4 Scanner Options" (page 216).

- 4 Scan the document with the image scanning application.
For details, refer to the image scanning application manual.

TOP

Contents

Index

Introduction

Scanner
OverviewHow to Load
DocumentsHow to Use the
Operator PanelVarious Ways to
Scan

Daily Care

Replacing the
Consumables

Troubleshooting

Operational
Settings

Appendix

Glossary

2.3 Documents for Scanning

Paper Size

The following paper sizes can be scanned:

ADF	<ul style="list-style-type: none"> ● Maximum size (width × length) <ul style="list-style-type: none"> - 304.8 × 431.8 mm/12.0 × 17.0 in. (A3 portrait (297 × 420 mm/11.7 × 16.5 in.)) - Long Page (*1) (304.8 × 863 mm/12.0 × 34.0 in., 304.8 × 5,588 mm/12.0 × 220.0 in., 304.8 mm × 200 m/12.0 in. × 218.8 yd.) ● Minimum size (width × length) 50.8 × 69 mm/2.0 × 2.72 in.
Flatbed	<ul style="list-style-type: none"> ● Maximum size (width × length) 304.8 × 457.2 mm/12.0 × 18.0 in.

*1: Depending on the application or the scan settings for the scanner driver, there may be insufficient memory to perform scanning. Long page scanning supports documents with a length of up to 5,588 mm (220 in.) when the resolution is set to 200 dpi or less. If you scan a long page document and split the scanned image into multiple pages, a document of up to 200 m (218.8 yd.) can be scanned.

Paper Type

The following paper types are recommended:

- Wood-free paper
- Wood-containing paper
- PPC paper (recycled)
- Plastic card

When using paper types other than the above, make sure you test with the same type of paper first to check if the document can be scanned.

Paper Weight (Thickness)

Documents with the following paper weights can be scanned:

- 20 to 413 g/m² (5.3 to 110 lb)
- 27 to 413g/m² (7.2 to 110 lb) for the size larger than A4/Letter
- 128 to 209 g/m² (34 to 56 lb) for A8 size
- 1.4 mm (0.06 in.) or less for plastic cards

Documents That Cannot Be Scanned Successfully

The following types of documents may not be scanned with the ADF successfully:

- Documents of non-uniform thickness (such as envelopes or documents with attachments)
- Wrinkled or curled documents
- Folded or torn documents
- Tracing paper
- Coated paper
- Carbon paper
- Photosensitive paper
- Perforated documents
- Documents that are not square or rectangular
- Very thin paper/very thick paper
- Photographs (photographic paper)

Documents That Cannot Be Scanned

The following types of documents must not be scanned with the ADF:

- Paper-clipped or stapled documents
- Documents on which the ink is still wet
- Documents smaller than 50.8 × 69 mm (2 × 2.72 in.)
- Documents wider than 304.8 mm (12 in.)

TOP

Contents

Index

Introduction

Scanner
OverviewHow to Load
DocumentsHow to Use the
Operator PanelVarious Ways to
Scan

Daily Care

Replacing the
Consumables

Troubleshooting

Operational
Settings

Appendix

Glossary

- Documents other than paper/plastic card such as fabric, metal foil and OHP film
- Important documents that must not be damaged or smeared

Precautions

Notes on the documents to be scanned

Depending on the documents to be scanned, take note of the following:

- Since carbonless papers contain chemical substances that may harm the rollers (such as a pick roller), take note of the following.
 - Cleaning

If paper jams occur frequently, clean the brake roller and pick roller.

For details, refer to ["Chapter 5 Daily Care" \(page 103\)](#).
 - Replacing the consumables

The life of the brake roller and pick roller may end sooner compared to scanning wood-free paper.
- When scanning wood containing papers, the life of the brake roller and pick roller may end sooner compared to scanning wood-free papers.
- Brake roller and pick roller may be damaged when a photo/sticky note on the document contacts these parts during scanning.
- The surface of the document may be damaged when gloss papers such as photographs are scanned.
- The light of the LED may reflect brightly when gloss papers are scanned.
- When scanning semi-transparent documents, increase the brightness for scanning in the scanner driver to avoid bleed-through.
- When you scan documents written in lead pencil, make sure you clean the rollers frequently. Otherwise, the rollers will be contaminated which may leave black traces on the document or cause feeding errors.

For details about cleaning, refer to ["Chapter 5 Daily Care" \(page 103\)](#).
- If multifeeds, pick errors, or paper jams occur frequently, refer to ["7.3 Troubleshooting" \(page 135\)](#).

- When you scan documents with the ADF, all documents must be flat on the leading edge. Make sure that curls on the leading edge of the documents are kept within the following range:

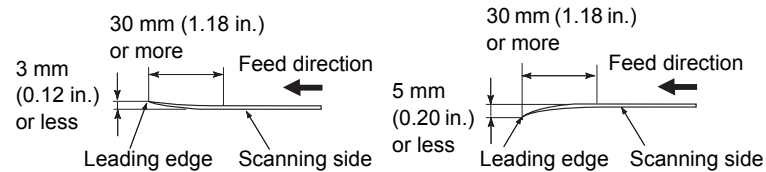

Notes on plastic cards

When you scan plastic cards, take note of the following.

- Make sure you use a card that contains the following specifications, and check if the card can be fed before scanning it.
 - Compliant with the ISO7810 ID-1 type
 - Size: 85.6 × 53.98 mm
 - Thickness: 1.4 mm or less
 - Material: PVC (polyvinyl chloride) or PVCA (polyvinyl chloride acetate)
- Up to three plastic cards can be loaded in the ADF paper chute (feeder).

Note that you can only load one card at a time if the plastic card is embossed.

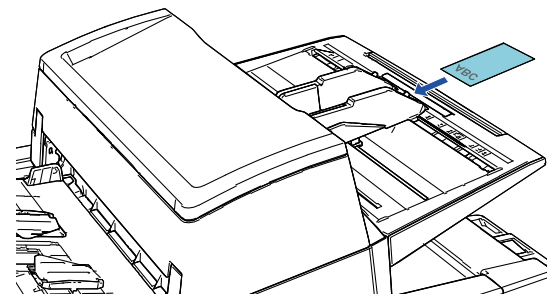

- Plastic cards should be loaded vertically.
- It is recommended that the card should be placed face-down in the ADF paper chute.
- Thick or rigid cards that are difficult to bend may be fed skewed.

- If there is dirt on the surface of the card, such as grease marks (fingerprints), perform scanning after wiping the dirt off.
- Plastic cards cannot be scanned when the imprinter is connected.
- Scanning thick documents such as plastic cards will be falsely detected as multifeed.

In that case, specify one of the following settings and try scanning again.

- Use the Intelligent Multifeed function.
- Disable the multifeed detection setting.
- Use the Manual/Single mode.

TOP

Contents

Index

Introduction

Scanner
Overview

How to Load
Documents

How to Use the
Operator Panel

Various Ways to
Scan

Daily Care

Replacing the
Consumables

Troubleshooting

Operational
Settings

Appendix

Glossary

Loading Capacity

The number of sheets that can be loaded in the ADF paper chute (feeder) is determined by the paper size and paper weight. See the graph below.

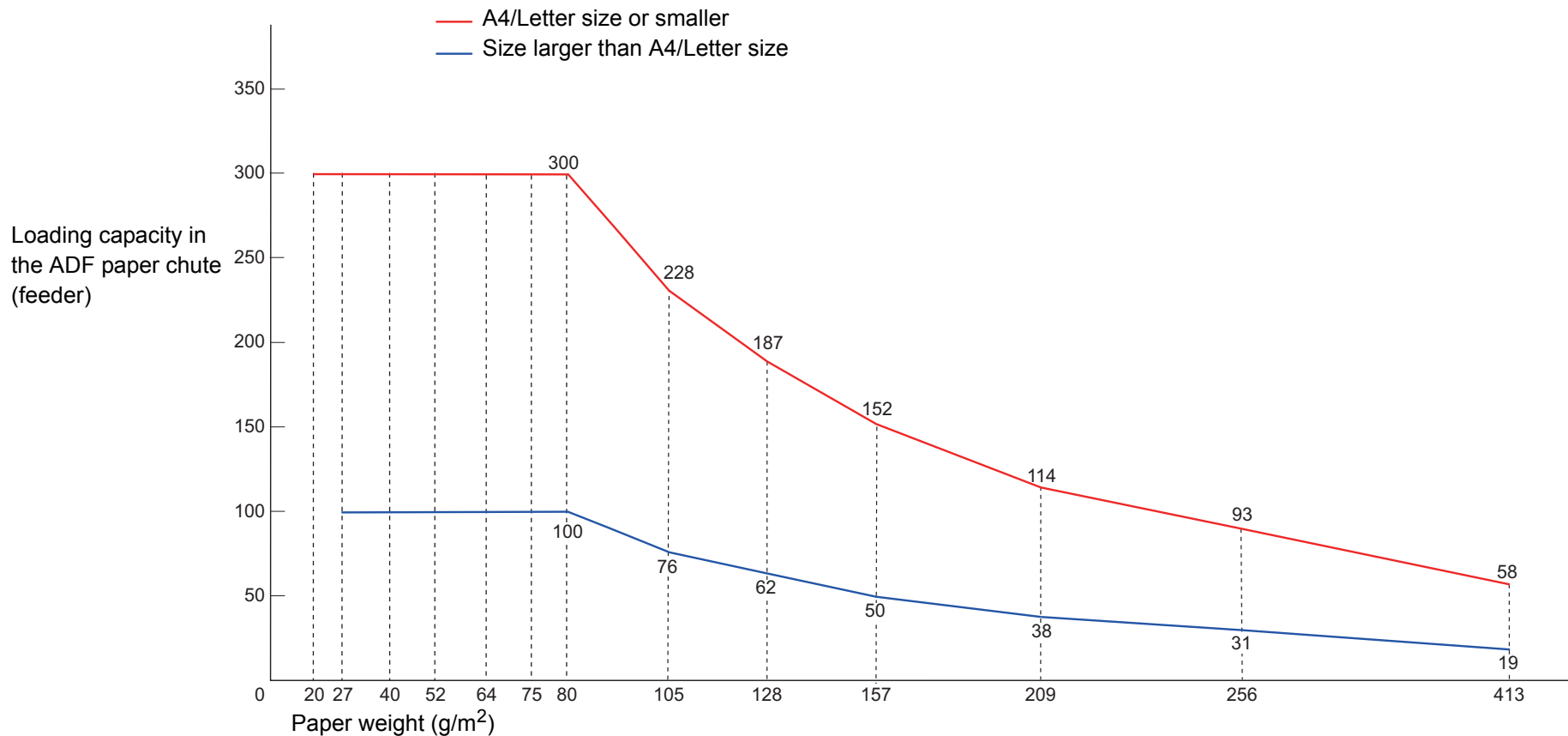

Unit	Conversion												
g/m ²	20	27	40	52	64	75	80	105	128	157	209	256	413
lb	5.3	7.2	11	14	17	20	21	28	34	42	56	68	110
kg	17	23	34.5	45	55	65	69	90	110	135	180	220	355

- TOP
- Contents
- Index
- Introduction
- Scanner Overview
- How to Load Documents**
- How to Use the Operator Panel
- Various Ways to Scan
- Daily Care
- Replacing the Consumables
- Troubleshooting
- Operational Settings
- Appendix
- Glossary

Area Not to Be Perforated

An error may occur when there are punched holes in the area shaded in light blue in the figure below.

Use the flatbed (fi-7700/fi-7700S) to scan such documents.

Fig. 1

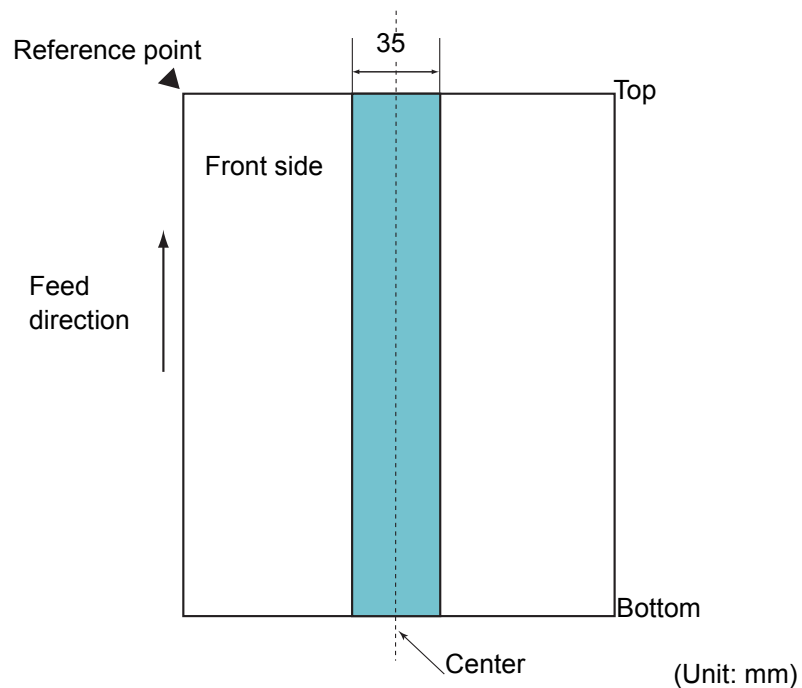

ATTENTION

The above condition applies when the document is set to the center of the pick roller width.

HINT

If there are any holes in the 35 mm-wide central column, you can move the document to the left or right to avoid an error.

How to Load Documents with a Tab or Non-Rectangular Documents

When scanning documents with a tab or non-rectangular documents, load them so that they are not caught while they are being fed.

Good Example

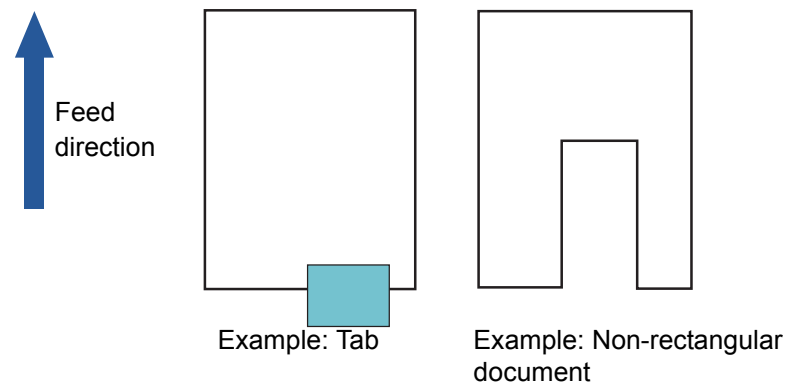

Bad Example

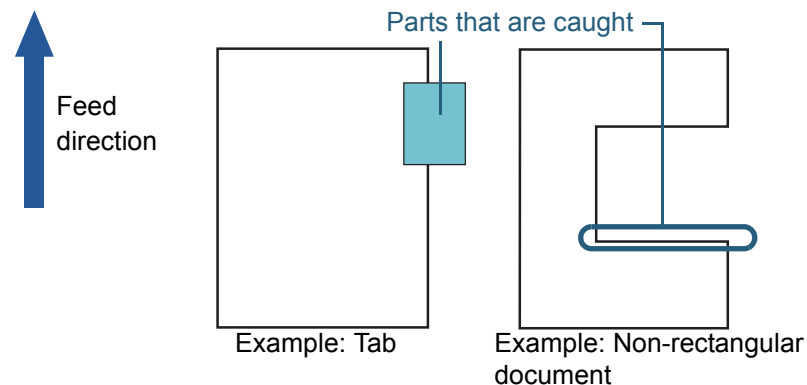

ATTENTION

If you load a document as shown in the bad example, the document may get caught while it is being fed, be scanned skewed, or it may get jammed and damaged.

Conditions for Multifeed Detection

Multifeed is an error where two or more sheets are fed through the ADF at once. When a different document length is detected, this detected result is also called a multifeed. Multifeed detection is performed by either checking the overlapping of documents, length of the documents, or the combination of both. The following conditions are required for an accurate detection.

Detection by Overlapping

- Paper weight: 20 to 413 g/m² (5.3 to 110 lb)
- Do not punch holes within 35 mm (1.38 in.) over the center of the document. See ["Fig. 1" \(page 51\)](#).
- Do not attach other documents within 35 mm (1.38 in.) over the center of the document. See ["Fig. 1" \(page 51\)](#).

Detection by Length

- Load documents of the same length in the ADF paper chute (feeder).
- Variance in document lengths: 1% or less
- Do not punch holes within 35 mm (1.38 in.) over the center of the document. See ["Fig. 1" \(page 51\)](#).

Detection by Overlapping and Length

- Load documents of the same length in the ADF paper chute (feeder).
- Paper weight: 20 to 413 g/m² (5.3 to 110 lb)
- Variance in document lengths: 1% or less
- Do not punch holes within 35 mm (1.38 in.) over the center of the document. See ["Fig. 1" \(page 51\)](#).
- Do not attach other documents within 35 mm (1.38 in.) over the center of the document. See ["Fig. 1" \(page 51\)](#).

ATTENTION

- The above condition applies when the document is set to the center of the pick roller width.
- When you use detection by overlapping, scanning thick documents such as plastic cards will be falsely detected as multifeed. In that case, specify one of the following settings and try scanning again.
 - Use the Intelligent Multifeed function.
 - Disable the multifeed detection setting.
 - Use the Manual/Single mode.

HINT

- Accuracy of multifeed detection may drop with some documents. Multifeed cannot be detected for the top 30 mm of a document.
- For the shaded area in ["Fig. 1" \(page 51\)](#), you can also specify a length not to detect multifeeds in the Software Operation Panel. For details, refer to ["8.6 Settings Related to Multifeed Detection" \(page 196\)](#).

TOP

Contents

Index

Introduction

Scanner
OverviewHow to Load
DocumentsHow to Use the
Operator PanelVarious Ways to
Scan

Daily Care

Replacing the
Consumables

Troubleshooting

Operational
Settings

Appendix

Glossary

Conditions for Mixed Batch Scanning

The following conditions apply when a mixed batch of documents with different paper weights/friction coefficients/sizes is scanned.

Make sure you test a few sheets first to check if the mixed batch of documents can be fed.

For details, refer to "[Scanning Documents with Different Widths](#)" (page 84).

Paper Direction

Align the direction of the paper fiber with the feed direction.

Paper Weight (Thickness)

The following paper weights can be used:

20 to 413 g/m² (5.3 to 110 lb)

Friction Coefficient

It is recommended that the same type of paper from the same manufacturer should be used.

When papers of different manufacturers/brands are mixed, it affects the feeding performance as the difference in the friction coefficient increases.

The following friction coefficients are recommended:

0.35 to 0.60 (reference value for paper friction coefficient)

Document Position

Use paper sizes that fit the 48 mm width of the pick roller in the center.

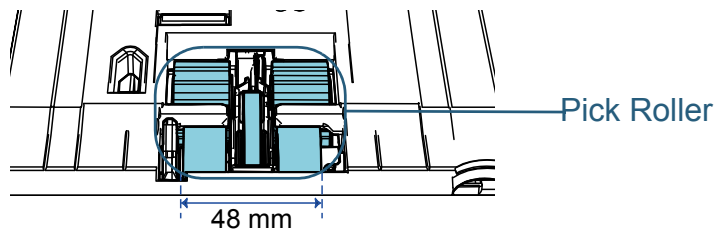

Paper Size

When you scan a mixed batch with different sizes, not feeding the documents straight may cause troubles such as paper jams or part of the image to appear missing.

It is recommended that you check the documents thoroughly before scanning and also check the image if the document was skewed.

ATTENTION

- When a mixed batch with different sizes is scanned, documents are more likely to skew because the side guides do not contact every sheet.
- Do not use [Check Length] or [Check Overlapping and Length] for multifeed detection.

Documents That Cannot Be Scanned in a Mixed Batch

The following types of documents cannot be mixed in the same batch:

- Carbonless paper
- Bond paper
- Perforated documents
- Thermal paper
- Carbon-backed paper
- OHP film
- Tracing paper

TOP

Contents

Index

Introduction

Scanner
Overview

How to Load
Documents

How to Use the
Operator Panel

Various Ways to
Scan

Daily Care

Replacing the
Consumables

Troubleshooting

Operational
Settings

Appendix

Glossary

Combinations of Standard Paper Sizes in a Mixed Batch

Refer to the table below for a guideline of the range available for mixed batch scanning.

However, note that not feeding the documents straight may cause troubles such as paper jams or part of the image to appear missing.

It is recommended that you check the documents thoroughly before scanning and also check the image if the document was skewed.

Maximum size		A3 (P) A3 (L)	DL (P) LTR (L)	B4 (P) B5 (L)	LTR (P)	A4 (P) A5 (L)	B5 (P) B6 (L)	A5 (P) A6 (L)	B6 (P) B7 (L)	A6 (P) A7 (L)	B7 (P)	A7 (P)	B8 (P)	A8 (P)
Width (mm) (*1)		297	279	257	216	210	182	149	129	105	91	74.3	64.3	52.5
Minimum size	A3 (P) A3 (L)	297												
	DL (P) LTR (L)	279												
	B4 (P) B5 (L)	257												
	LTR (P)	216												
	A4 (P) A5 (L)	210												
	B5 (P) B6 (L)	182			Available range									
	A5 (P) A6 (L)	149												
	B6 (P) B7 (L)	129												
	A6 (P) A7 (L)	105												
	B7 (P)	91												
	A7 (P)	74.3												
	B8 (P)	64.3												
A8 (P)	52.5													

DL: Double Letter size

LTR: Letter size

(P): Portrait

(L): Landscape

- TOP
- Contents
- Index
- Introduction
- Scanner Overview
- How to Load Documents
- How to Use the Operator Panel
- Various Ways to Scan
- Daily Care
- Replacing the Consumables
- Troubleshooting
- Operational Settings
- Appendix
- Glossary

*1: The figure below shows how to load the widest and the narrowest documents of the batch between the side guides.

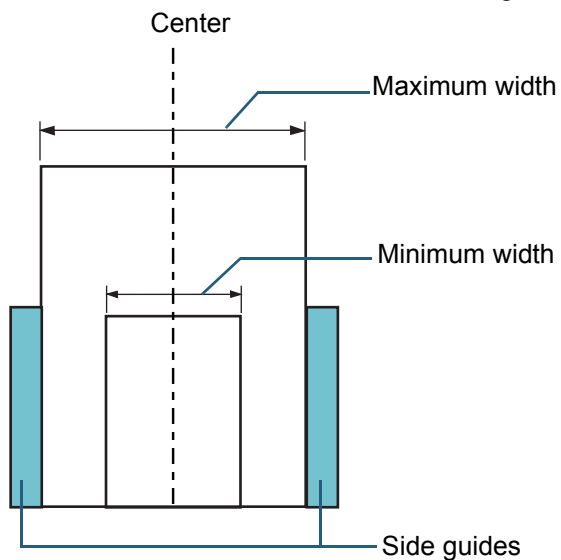

ATTENTION

A8 (portrait) cannot be scanned with paper of other sizes.

Conditions for Automatic Page Size Detection

[Automatic Page Size Detection] does not work with the following types of documents:

- Non-rectangular documents

[Automatic Page Size Detection] may not work with the following types of documents:

- Thin paper (52 g/m² [14 lb] or less)
- White documents with glossy edges
- Documents with darkish (gray) edges

Chapter 3 How to Use the Operator Panel

This chapter explains how to use the operator panel.

3.1 Operator Panel	57
3.2 Settings Menu.....	62
3.3 Function Selection	80

[TOP](#)

[Contents](#)

[Index](#)

[Introduction](#)

[Scanner
Overview](#)

[How to Load
Documents](#)

[How to Use the
Operator Panel](#)

[Various Ways to
Scan](#)

[Daily Care](#)

[Replacing the
Consumables](#)

[Troubleshooting](#)

[Operational
Settings](#)

[Appendix](#)

[Glossary](#)

3.1 Operator Panel

The operator panel consists of an LCD, buttons and an LED indicator.

Names and Functions

■ fi-7600

The scanner carries an operator panel on each side. You can use whichever is convenient for you. The operator panel can be fitted into the side of the scanner when it is not used.

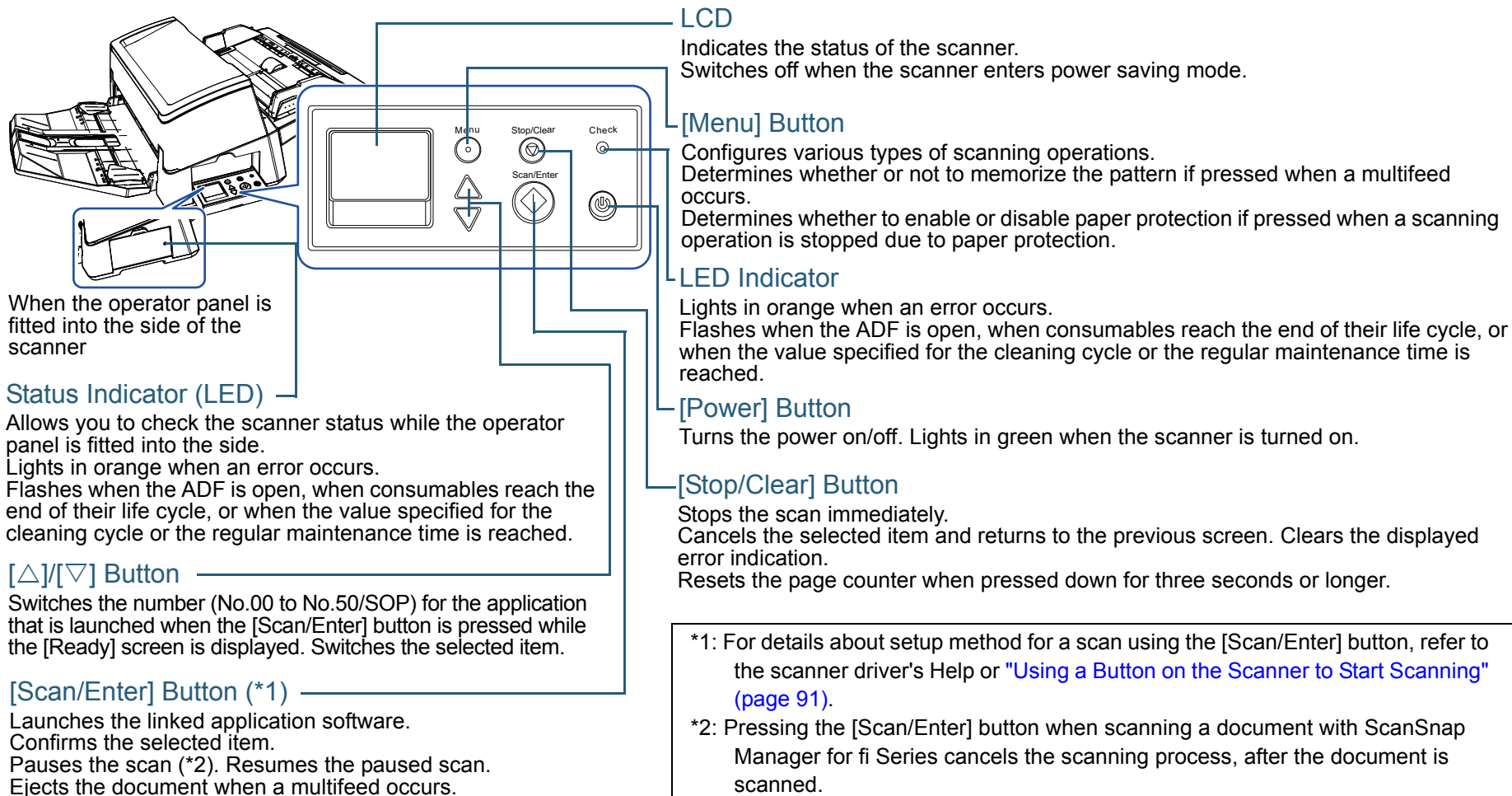

*1: For details about setup method for a scan using the [Scan/Enter] button, refer to the scanner driver's Help or "[Using a Button on the Scanner to Start Scanning](#)" (page 91).

*2: Pressing the [Scan/Enter] button when scanning a document with ScanSnap Manager for fi Series cancels the scanning process, after the document is scanned.

■ fi-7700/fi-7700S

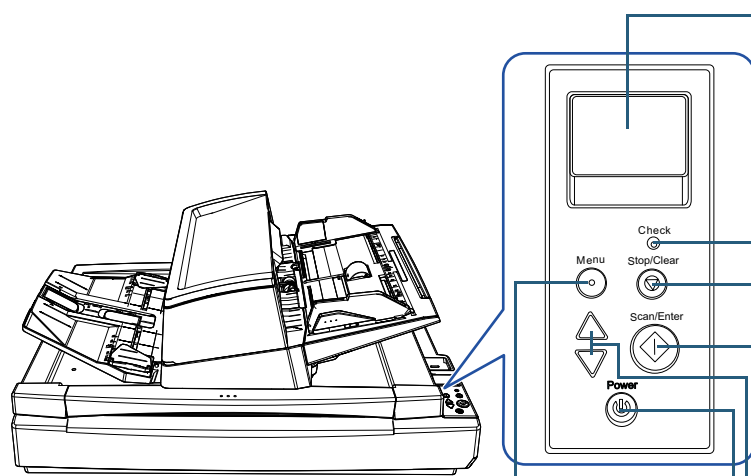

LCD

Indicates the status of the scanner.
Switches off when the scanner enters power saving mode.

LED Indicator

Lights in orange when an error occurs.
Flashes when the ADF is open, when consumables reach the end of their life cycle, or when the value specified for the cleaning cycle or the regular maintenance time is reached.

[Stop/Clear] Button

Stops the scan immediately.
Cancels the selected item and returns to the previous screen. Clears the displayed error indication.
Resets the page counter when pressed down for three seconds or longer.

[Scan/Enter] Button (*1)

Launches the linked application software.
Confirms the selected item.
Pauses the scan (*2). Resumes the paused scan.
Ejects the document when a multifeed occurs.

[△]/[▽] Button

Switches the number (No.00 to No.50/SOP) for the application that is launched when the [Scan/Enter] button is pressed while the [Ready] screen is displayed.
Switches the selected item.

[Menu] Button

Configures various types of scanning operations.
Determines whether or not to memorize the pattern if pressed when a multifeed occurs.
Determines whether to enable or disable paper protection if pressed when a scanning operation is stopped due to paper protection.

[Power] Button

Turns the power on/off.
Lights in green when the scanner is turned on.

*1: For details about setup method for a scan using the [Scan/Enter] button, refer to the scanner driver's Help or ["Using a Button on the Scanner to Start Scanning"](#) (page 91).



*2: Pressing the [Scan/Enter] button when scanning a document with ScanSnap Manager for fi Series cancels the scanning process, after the document is scanned.

- TOP
- Contents
- Index
- Introduction
- Scanner Overview
- How to Load Documents
- How to Use the Operator Panel
- Various Ways to Scan
- Daily Care
- Replacing the Consumables
- Troubleshooting
- Operational Settings
- Appendix
- Glossary

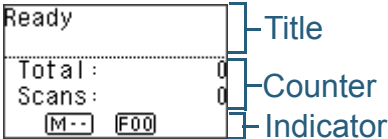
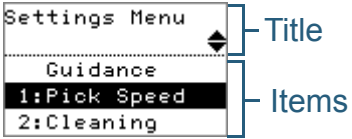
Indications on LCD

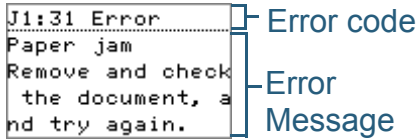
Display	Description
	Processing initialization.
 <p>Title Counter Indicator</p>	Ready to start scanning. Indicates that the initialization was successfully completed. For more details about the indicators, refer to "Indicator" (page 61) .
 <p>Title Items</p>	An item from the menu can be selected. When you press the [Menu] button while the [Ready] screen is displayed, the [Settings Menu] screen is displayed. The Settings Menu can be used to configure various operational settings upon scanning. For details about the Settings Menu screen, refer to "3.2 Settings Menu" (page 62) .

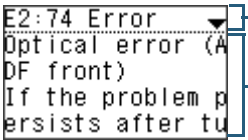
Display	Description
 <p>Title Items</p>	A function item can be selected. When you press the [△] or [▽] button while the [Ready] screen is displayed, the [Function Selection] screen is displayed. By using the Function Selection, you can configure the application you want to launch when you press the [Scan/Enter] button while the [Ready] screen is displayed. For details about the Function Selection screen, refer to "3.3 Function Selection" (page 80) .
 <p>Error code Error Message</p>	Indicates that a temporary error occurred during scanning. Error codes beginning with the letter "J" or "U" are displayed. For more details about the errors, refer to "Temporary Errors" (page 127) . You can clear the displayed error by pressing the [Stop/Clear] button.

Display	Description
	<p>Indicates that a device error (alarm) occurred during initialization or scanning.</p> <p>Error codes beginning with the letter "E", "F", "C", "H", "A" or "L" are displayed. For more details about the errors, refer to "Device Errors" (page 129).</p> <p>When this alarm occurs, turn the power off then back on. If the problem still persists, contact your FUJITSU scanner dealer or an authorized FUJITSU scanner service provider.</p>
	<p>When the scanner has not been in operation for the set sleep interval, it enters power saving mode. Press any button on the operator panel to return to the previous screen.</p>

- TOP
- Contents
- Index
- Introduction
- Scanner Overview
- How to Load Documents
- How to Use the Operator Panel
- Various Ways to Scan
- Daily Care
- Replacing the Consumables
- Troubleshooting
- Operational Settings
- Appendix
- Glossary

Indicator

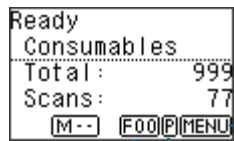

Information

MENU flashes when there is a message for replacing consumables/cleaning/glass cleaning/regular maintenance. [Consumables], [Cleaning], [Clean glass!], or [maintenance] also flashes on the second line in the [Ready] screen.

MENU For information regarding appropriate actions to take when "3.2 Settings Menu" (page 62) flashes, refer to .

Prioritize Panel Settings

P appears when the operator panel settings are prioritized. For details, refer to "3.2 Settings Menu" (page 62).

Application Number

Displays the number for the application that you want to launch when you press the [Scan/Enter] button while the [Ready] screen is displayed. For details, refer to "3.3 Function Selection" (page 80).

iMFF Setting

Displays the iMFF setting as follows:

Icon	Mode
M--	Manual mode
A1-0	Auto mode 1
A2-0	Auto mode 2

In Manual mode, **M--** is displayed at all times.

In Auto mode 1 and Auto mode 2, the number of multifeed patterns memorized (max. of 8 patterns) is displayed. For details, refer to "3.2 Settings Menu" (page 62).

3.2 Settings Menu

This section explains about the Settings Menu.

When you press the [Menu] button while the [Ready] screen is displayed, the [Settings Menu] screen is displayed.

The Settings Menu can be used to configure various operational settings upon scanning.

There are two menus in the [Settings Menu] screen.

- User menu

You can configure basic settings for operating the scanner and using the operator panel.

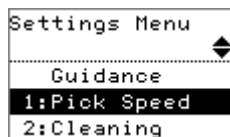

- Administrator menu

You can configure advanced settings for operating the scanner and using the operator panel.

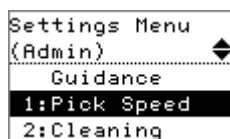

To switch between the menus, press down both the [Δ] and [∇] buttons at the same time for three seconds or longer while the [Settings Menu] screen is displayed.

When the scanner is turned off, the user menu appears.

[TOP](#)[Contents](#)[Index](#)[Introduction](#)[Scanner
Overview](#)[How to Load
Documents](#)[How to Use the
Operator Panel](#)[Various Ways to
Scan](#)[Daily Care](#)[Replacing the
Consumables](#)[Troubleshooting](#)[Operational
Settings](#)[Appendix](#)[Glossary](#)

How to Use Settings Menu

This section explains how to use the Settings Menu of the operator panel by the following categories.

Operation	Description	Item	User menu	Administrator menu
			Yes: Available -: Not Available	
Checking the guidance contents	You can check the way to reset the page counter. For more details, refer to " Checking the Guidance Contents " (page 66).	Guidance	Yes	Yes
Checking the information	MENU flashes when there is a message for replacing consumables/cleaning/glass cleaning/regular maintenance. Read the message and take measures accordingly. For more details, refer to " Checking the Information " (page 67).	Information	Yes	Yes
Operational settings	You can configure various settings for operating the scanner and using the operator panel. For more details, refer to " Operational Settings " (page 69).	1: Pick Speed	Yes	Yes
		5: Language	Yes	Yes
		6: LCD Contrast	Yes	Yes
		7: Backlight lighting time	Yes	Yes
		8: Check LED Blink Speed	Yes	Yes
		9: LCD Scroll Speed	Yes	Yes
		10: Low-speed Feed Mode	Yes	Yes
		11: Stacking Control	Yes	Yes
		13: iMFF Setting	-	Yes
14: No. of Paper Feed Retries	-	Yes		

TOP

Contents

Index

Introduction

Scanner
OverviewHow to Load
DocumentsHow to Use the
Operator PanelVarious Ways to
Scan

Daily Care

Replacing the
Consumables

Troubleshooting

Operational
Settings

Appendix

Glossary

Operation	Description	Item	User menu	Administrator menu
			Yes: Available -: Not Available	
Operational settings	You can configure various settings for operating the scanner and using the operator panel. For more details, refer to "Operational Settings" (page 69) .	15: Pick pressure	-	Yes
		16: Manual/Continuous Feed Setting	-	Yes
		17: Manual Feed Timeout	-	Yes
		18: Paper Protection	-	Yes
		19: Vertical streak detection	-	Yes
		20: Prioritize panel settings	-	Yes
		21: Ope. Panel Initialization	-	Yes
		22: Power saving	-	Yes
		23: Power-off time	-	Yes
		24: Pre-pick	-	Yes
25: Overscan Control	-	Yes		
Cleaning the scanner	You can clean the scanner by using Cleaning Paper, Cleaning Wipe, or cloth. For more details, refer to "Chapter 5 Daily Care" (page 103) .	2: Cleaning	Yes	Yes
Test print for Imprinter	You can run a test print when the imprinter is installed. For more details, refer to the fi-760PRB Imprinter Operator's Guide.	3: Test Print	Yes	Yes
Checking and resetting the sheet counter	You can check the replacement cycle of the consumables and the total page count. Also use it to reset the counter when you have replaced the consumables or performed cleaning. For more details, refer to "Checking and Resetting the Sheet Counters" (page 70) .	4: Consumable counters	Yes	Yes

Operation	Description	Item	User menu	Administrator menu
			Yes: Available -: Not Available	
Counting documents	You can count the number of scanned documents in Doc Counting Mode. For more details, refer to "Counting Documents" (page 71) .	12: Doc Counting Mode	Yes	Yes

- TOP
- Contents
- Index
- Introduction
- Scanner Overview
- How to Load Documents
- How to Use the Operator Panel
- Various Ways to Scan
- Daily Care
- Replacing the Consumables
- Troubleshooting
- Operational Settings
- Appendix
- Glossary

■ Checking the Guidance Contents

[fi-7600]

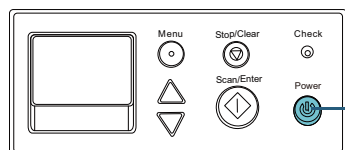

[fi-7700/fi-7700S]

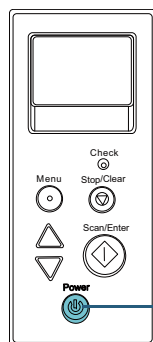

```
Ready
-----
Total : 0
Scans : 0
[M--] [F00]
```

② [Menu] Button

```
Settings Menu
-----
Guidance
1:Pick Speed
2:Cleaning
```

③ [Δ]/[▽] Button
[Scan/Enter] Button

```
Guidance
-----
1:Clear counter
```

④ [Δ]/[▽] Button
[Scan/Enter] Button

```
Clear counter
-----
To clear the T
otal counter, p
ress the Stop b
```

⑤ [Δ]/[▽] Button

```
Clear counter
-----
leared when the
batch is starte
d.
```

① [Power] Button

- 1 Press the [Power] button on the operator panel.
⇒The [Ready] screen is displayed on the LCD.
- 2 Press the [Menu] button.
⇒The [Settings Menu] screen is displayed on the LCD.
- 3 Press the [Δ] or [▽] button and select [Guidance], then press the [Scan/Enter] button to confirm.
⇒The [Guidance] screen is displayed on the LCD.
- 4 Press the [Δ] or [▽] button and select [1: Clear counter], then press the [Scan/Enter] button to confirm.
⇒The [Clear counter] screen is displayed on the LCD.
- 5 Press the [Δ] or [▽] button to check the contents of the guidance.
You can check the way to reset the page counter.

TOP

Contents

Index

Introduction

Scanner
OverviewHow to Load
DocumentsHow to Use the
Operator PanelVarious Ways to
Scan

Daily Care

Replacing the
Consumables

Troubleshooting

Operational
Settings

Appendix

Glossary

■ Checking the Information

[fi-7600]

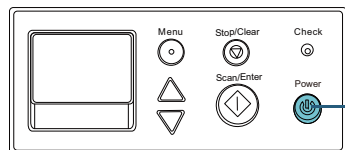

[fi-7700/fi-7700S]

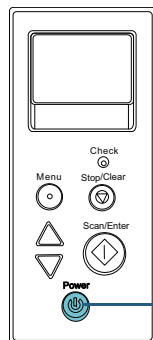

```
Ready
Consumables
Total: 9999
Scans: 77
[M--] [F01] [MENU]
```

② [Menu] Button

```
Settings Menu
Information
1:Pick Speed
2:Cleaning
```

③ [Δ]/[▽] Button
[Scan/Enter] Button

```
i02:Information
The consumable n
eeds to be repla
ced soon. If the
feeding perform
```

④ [Δ]/[▽] Button

```
i02:Information
umable counters]
menu.
Brake Roller
250500/250000
```

① [Power] Button

- 1 Press the [Power] button on the operator panel.
⇒The [Ready] screen is displayed on the LCD.
- 2 Press the [Menu] button.
⇒The [Settings Menu] screen is displayed on the LCD.
- 3 Press the [Δ] or [▽] button and select [Information], then press the [Scan/Enter] button to confirm.
⇒The [Information] screen is displayed on the LCD.

ATTENTION

[Information] can be selected only when there is a message for replacing consumables/cleaning/glass cleaning/regular maintenance.

- 4 Press the [Δ] or [▽] button to check the contents of the information.
You can check the messages for replacing consumables/cleaning/glass cleaning/regular maintenance.
When the message prompts replacing consumables/cleaning, the corresponding counter that requires consumable replacement/cleaning is highlighted. The counter will appear highlighted when:
 - The page count after the consumable is replaced reaches 95% of the value configured in "[Replacement Cycle of Consumables \[Life Counter Alarm Setting\]](#)" (page 177) in the Software Operation Panel. (For the brake roller/pick roller counters)
 - The page count after the scanner is cleaned reaches 100% of the value configured in "[Scanner Cleaning Cycle \[Cleaning Cycle\]](#)" (page 177) in the Software Operation Panel. (For the cleaning counter)
 - The amount of remaining ink is below 33%. This is only displayed when the imprinter is installed. (For the ink counter)

TOP

Contents

Index

Introduction

Scanner
OverviewHow to Load
DocumentsHow to Use the
Operator PanelVarious Ways to
Scan

Daily Care

Replacing the
Consumables

Troubleshooting

Operational
Settings

Appendix

Glossary

5 Take measures according to the contents of [Information].

Follow the instructions in the message if it prompts consumable replacement/cleaning/glass cleaning.

For details about replacing consumables, refer to the following:

- Brake roller
["6.2 Replacing the Brake Roller" \(page 115\)](#)
- Pick roller
["6.3 Replacing the Pick Roller" \(page 118\)](#)

For details about cleaning, refer to ["Chapter 5 Daily Care" \(page 103\)](#).

If the message prompts regular maintenance, please have the scanner checked by a service engineer for regular maintenance/inspection.

For regular maintenance and inspection on the scanner by a service engineer, contact your FUJITSU scanner dealer or an authorized FUJITSU scanner service provider.

TOP

Contents

Index

Introduction

Scanner
Overview

How to Load
Documents

How to Use the
Operator Panel

Various Ways to
Scan

Daily Care

Replacing the
Consumables

Troubleshooting

Operational
Settings

Appendix

Glossary

Operational Settings

[fi-7600]

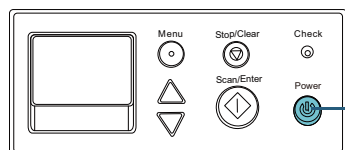

[fi-7700/fi-7700S]

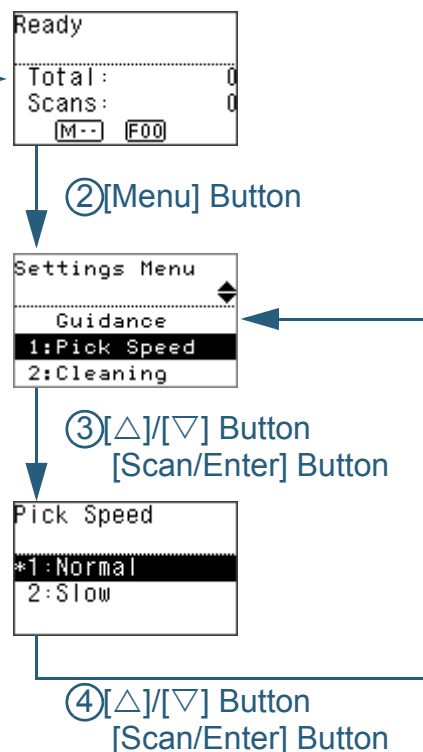
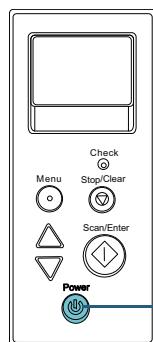

- 4** Press the [Δ] or [∇] button and select a parameter, then press the [Scan/Enter] button to confirm.
For more details about the setting parameters, refer to ["Items Configurable in the Settings Menu"](#) (page 72).

HINT

- "*" is displayed for the factory default setting.
- When you select an item in the screen, the parameter currently selected is highlighted.

⇒ If the [Settings Menu] screen is displayed on the LCD, it indicates that the setup has been completed.
If the LCD displays a setting item, repeat step 4 until it shows the [Settings Menu] screen.

- 1** Press the [Power] button on the operator panel.
⇒ The [Ready] screen is displayed on the LCD.
- 2** Press the [Menu] button.
⇒ The [Settings Menu] screen is displayed on the LCD.
- 3** Press the [Δ] or [∇] button and select a setting item, then press the [Scan/Enter] button to confirm.
For more details about the setting items, refer to ["Items Configurable in the Settings Menu"](#) (page 72).
⇒ The selected item is displayed on the LCD.

TOP

Contents

Index

Introduction

Scanner
OverviewHow to Load
DocumentsHow to Use the
Operator PanelVarious Ways to
Scan

Daily Care

Replacing the
Consumables

Troubleshooting

Operational
Settings

Appendix

Glossary

■ Checking and Resetting the Sheet Counters

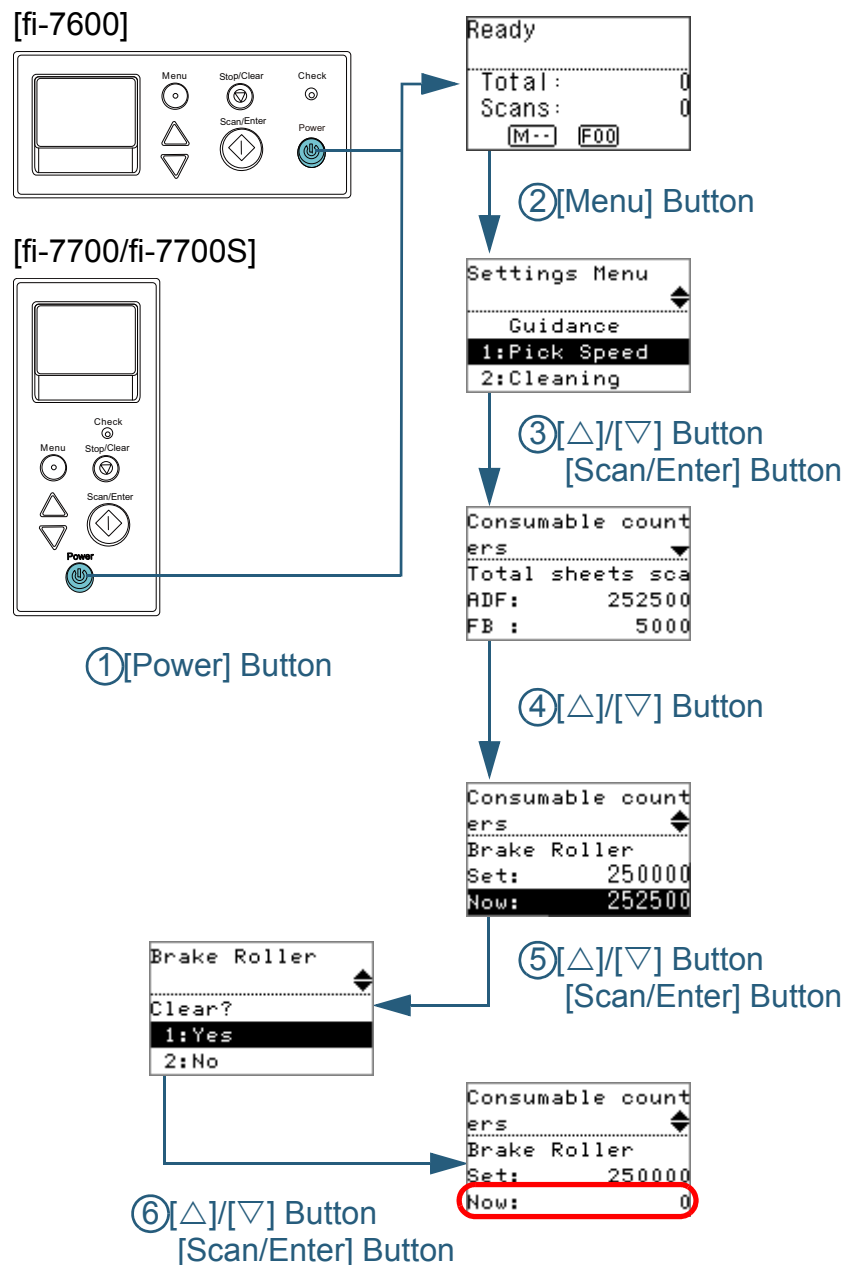

- 1 Press the [Power] button on the operator panel.
⇒The [Ready] screen is displayed on the LCD.
 - 2 Press the [Menu] button.
⇒The [Settings Menu] screen is displayed on the LCD.
 - 3 Press the [Δ] or [∇] button and select [4: Consumable counters], then press the [Scan/Enter] button to confirm.
⇒The [Consumable counters] screen is displayed on the LCD.
 - 4 Press the [Δ] or [∇] button and check the counter.
Counters are highlighted when consumable replacement or cleaning is required. The counter will appear highlighted when:
 - The page count after the consumable is replaced reaches 95% of the value configured in "[Replacement Cycle of Consumables \[Life Counter Alarm Setting\]](#)" (page 177) in the Software Operation Panel. (For the brake roller/pick roller counters)
 - The page count after the scanner is cleaned reaches 100% of the value configured in "[Scanner Cleaning Cycle \[Cleaning Cycle\]](#)" (page 177) in the Software Operation Panel. (For the cleaning counter)
 - The amount of remaining ink is below 33%. This is only displayed when the imprinter is installed. (For the ink counter)
- HINT**
The total number of sheets that have been scanned after purchase is displayed in the total sheets scanned counter. The total sheets scanned counter cannot be cleared.
- 5 After replacing the consumables or cleaning the scanner, select the highlighted counter with the [Δ] or [∇] button, and press the [Scan/Enter] button.
⇒A message appears to confirm that you want to clear the counter.
 - 6 Select [1: Yes] with the [Δ] or [∇] button, and press the [Scan/Enter] button to confirm.
⇒The counter is reset to 0.
For the ink counter, the value is set to 100.

Counting Documents

[fi-7600]

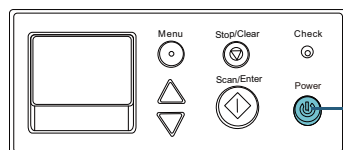

[fi-7700/fi-7700S]

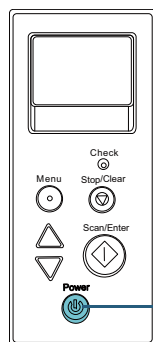

```
Ready
-----
Total: 0
Scans: 0
[M--] [F00]
```

② [Menu] Button

```
Settings Menu
-----
Guidance
1: Pick Speed
2: Cleaning
```

③ [△]/[▽] Button
[Scan/Enter] Button

```
Doc Counting Mod
(More documents)
-----
Total: 0
Count: 0
[M--] [F00]
```

④ [Scan/Enter] Button

```
Doc Counting Mod
(More documents)
-----
Total: 100
Count: 100
[M--] [F00]
```

① [Power] Button

- Load a document in the ADF paper chute (feeder), and press the [Scan/Enter] button.

⇒ The number of sheets that are scanned is counted.

The number of counted sheets is displayed in Count.

ATTENTION

Documents may not be counted correctly if a multifeed occurs during scanning.

HINT

- To reset Count, press the [Stop/Clear] button while the [Doc Counting Mode (More documents)] screen is displayed.
- To end Doc Counting Mode, press the [Stop/Clear] button for three seconds or longer while the [Doc Counting Mode (More documents)] screen is displayed.

- Press the [Power] button on the operator panel.
⇒ The [Ready] screen is displayed on the LCD.
- Press the [Menu] button.
⇒ The [Settings Menu] screen is displayed on the LCD.
- Press the [△] or [▽] button and select [12: Doc Counting Mode], then press the [Scan/Enter] button to confirm.
⇒ The [Doc Counting Mode (More documents)] screen is displayed on the LCD.

TOP

Contents

Index

Introduction

Scanner
OverviewHow to Load
DocumentsHow to Use the
Operator PanelVarious Ways to
Scan

Daily Care

Replacing the
Consumables

Troubleshooting

Operational
Settings

Appendix

Glossary

Items Configurable in the Settings Menu

Item	Description	Parameter (*1)/Value	Factory Default (*2)
		-: No parameters/values	
Guidance	Displays the way to reset the page counter.	1: Clear counter	1: Clear counter
Information	[Information] appears as an item in the [Settings Menu] screen only if MENU is flashing on the LCD.	Message for replacing consumables/cleaning/glass cleaning/regular maintenance	Only displayed when there is information
1: Pick Speed	When multifeeds and paper jams occur frequently, you may be able to improve the performance by slowing down the speed in which documents are picked or fed. This setting can also be configured from the Software Operation Panel.	1: Normal 2: Slow	1: Normal
2: Cleaning	Use this setting when you clean the scanner. For more details, refer to " Chapter 5 Daily Care " (page 103).	1: Cleaning Paper 2: Roller Wipe	-

TOP

Contents

Index

Introduction

Scanner
OverviewHow to Load
DocumentsHow to Use the
Operator PanelVarious Ways to
Scan

Daily Care

Replacing the
Consumables

Troubleshooting

Operational
Settings

Appendix

Glossary

Item	Description	Parameter (*1)/Value	Factory Default (*2)
		-: No parameters/values	
3: Test Print	Use this option to run a test print when the Imprinter is installed. For more details, refer to the fi-760PRB Imprinter Operator's Guide.	No. of sheets scanned: 1: Single sheet only 2: Multiple sheets Print Pattern: 1: (L)ABCDEFGHIJKLMNOPQRSTUVWXYZ[]^_`00000000 2: (L)abcdefghijklmnopqrstuvwxyz{ }~ 00000000 3: (L)!"#\$%&'()*+,-./0123456789:;<=>?@00000000 4: (P)ABCDEFGHIJKLMNOPQRSTUVWXYZ[]^_`00000000 5: (P)abcdefghijklmnopqrstuvwxyz{ }~ 00000000 6: (P)!"#\$%&'()*+,-./0123456789:;<=>?@00000000 Test Print: 1: Yes 2: No	(*3)
4: Consumable counters	Check the counters to determine when to replace the consumables and to perform cleaning. Also use it to reset the counters when you have replaced the consumables or performed cleaning.	Total sheets scanned/Brake Roller/Pick Roller/Cleaning	0
		Remaining Ink (only when the imprinter is installed)	Only displayed when the imprinter is installed

- TOP
- Contents
- Index
- Introduction
- Scanner Overview
- How to Load Documents
- How to Use the Operator Panel**
- Various Ways to Scan
- Daily Care
- Replacing the Consumables
- Troubleshooting
- Operational Settings
- Appendix
- Glossary

Item	Description	Parameter (*1)/Value	Factory Default (*2)
		-: No parameters/values	
5: Language	Specify the language in which data is displayed.	1: Japanese 2: English 3: French 4: German 5: Italian 6: Spanish 7: Russian 8: Chinese (S) 9: Chinese (T) 10: Portuguese 11: Turkish 12: Korean 13: Arabic	2: English
6: LCD Contrast	Specify the contrast for the LCD on the operator panel.	Weak Strong ■□□□□ ■ ■□□□□ ■ ■ ■□□□□ ■ ■ ■ ■□□□□ ■ ■ ■ ■ ■□□□□	■■■□□
7: Backlight lighting time	Specify the duration for which the backlight is lit ON for the LCD on the operator panel. Until initialization is complete after the power is turned on, this item operates in [ON] regardless of the setting configured.	OFF, ON, 5, 10, 20, 30, 40, 60, 90, 120, 150, 180, 210, 240, 270, 300 (seconds)	ON
8: Check LED Blink Speed	Specify the flash interval for MENU and LED indicator when MENU is flashing on the LCD.	0.5, 1.0, 1.5, 2.0, 2.5 (seconds)	2.0
9: LCD Scroll Speed	Specify the speed in which the display is horizontally scrolled. The displayed item is scrolled horizontally when the text does not fit in the LCD.	1: Fast 2: Normal 3: Slow 4: OFF	2: Normal

Item	Description	Parameter (*1)/Value	Factory Default (*2)
		-: No parameters/values	
10: Low-speed Feed Mode	Specify whether or not to reduce the scanning speed to prevent paper damage. This setting can also be configured from the Software Operation Panel.	1: Enable 2: Disable	2: Disable
11: Stacking Control	Specify whether or not to lower the paper ejecting speed. This setting can also be configured from the Software Operation Panel.	1: Enable 2: Disable	2: Disable
12: Doc Counting Mode	You can count the number of scanned documents in Doc Counting Mode.	-	-
13: iMFF Setting	When there is a paper of the same size attached to a designated location on the page, you can configure the scanner to memorize the location of the attachment and not detect multifeeds for that location. Note that you need to specify [Check Overlapping (Ultrasonic)] in either the scanner driver or the multifeed detection setting in " Specifying a Multifeed Detection Method [Multifeed] " (page 196) beforehand. By selecting [4: Clear pattern], you can clear the overlapping patterns (length, location) that were previously memorized in Auto mode. This setting can also be configured from the Software Operation Panel.	1: Manual mode 2: Auto mode 1 3: Auto mode 2 4: Clear pattern	1: Manual mode
14: No. of Paper Feed Retries	Configure this setting to change the number of feeding retries when a pick error occurs. This setting can also be configured from the Software Operation Panel.	1 to 12 (times)	3

Item	Description	Parameter (*1)/Value	Factory Default (*2)
		-: No parameters/values	
15: Pick pressure	Set the pick pressure for feeding paper. This setting can also be configured from the Software Operation Panel.	1: Weak 2: Normal 3: Strong	2: Normal
16: Manual/ Continuous Feed Setting	Select whether to enable or disable the continuous feed mode. This setting can also be configured from the Software Operation Panel.	1: Enable 2: Disable	2: Disable
17: Manual Feed Timeout	Specify the waiting time for the scanner to cancel manual feeding. This setting can also be configured from the Software Operation Panel.	510, 20, 30, 40, 50, 60, 70, 80, 90, 100, 110, 120, 180, 240, 300, 360, 420, 480, 540, 600, 900, 1200, 1500, 1800, 1999 (seconds)	10

- TOP
- Contents
- Index
- Introduction
- Scanner Overview
- How to Load Documents
- How to Use the Operator Panel**
- Various Ways to Scan
- Daily Care
- Replacing the Consumables
- Troubleshooting
- Operational Settings
- Appendix
- Glossary

Item	Description	Parameter (*1)/Value	Factory Default (*2)
		-: No parameters/values	
18: Paper Protection	<p>Select a paper protection detection method. This function can reduce the risk of having the documents damaged by detecting a feeding error and stopping the scan in the following cases:</p> <ul style="list-style-type: none"> ● When the scanner detects a document that was unusually warped by a feeding error ● When the scanner detects paper jam noise ● When the scanner either detects a document that was unusually warped by a feeding error or detects paper jam noise <p>Specify the sensitivity level to detect anomalies upon feeding the documents when paper protection is enabled.</p> <p>Documents are deformed (for example, warped) or paper jam noise is made when documents are not being fed by the rollers properly. To detect such symptoms and stop the scan, select [1: Low] to only detect documents that are highly deformed or loud paper jam noise. To detect documents that are slightly deformed or small paper jam noise, select [3: High].</p> <p>You can also configure the paper protection detection method from the scanner driver or the Software Operation Panel. When the operator panel setting is prioritized, the operator panel setting is prioritized over the Software Operation Panel setting. Note that even if the operator panel setting is prioritized, the scanner driver setting has the highest priority.</p> <p>You can also configure the sensitivity level to detect warped documents and paper jam noise from the Software Operation Panel. When the operator panel setting is prioritized, the operator panel setting is prioritized over the Software Operation Panel setting.</p>	<p>1: Disable 2: Feeding accuracy 3: Feeding noise 4: Feeding accuracy and noise</p> <p>Sensitivity for feeding accuracy: 1: Low 2: Normal 3: High</p> <p>Sensitivity for feeding noise: 1: Low 2: Normal 3: High</p>	<p>2: Feeding accuracy</p> <p>Sensitivity for feeding accuracy: 2: Normal</p> <p>Sensitivity for feeding noise: 2: Normal</p>

- TOP
- Contents
- Index
- Introduction
- Scanner Overview
- How to Load Documents
- How to Use the Operator Panel**
- Various Ways to Scan
- Daily Care
- Replacing the Consumables
- Troubleshooting
- Operational Settings
- Appendix
- Glossary

Item	Description	Parameter (*1)/Value	Factory Default (*2)
-: No parameters/values			
19: Vertical streak detection	<p>Select whether to enable or disable vertical streak detection.</p> <p>After enabling this setting, MENU flashes on the LCD when a vertical streak may occur in the images that are scanned through the ADF. [Clean glass!] also flashes on the second line in the [Ready] screen. Check the information, and then clean the glass. For details about checking the information, refer to "Checking the Information" (page 67). For details about cleaning, refer to "Chapter 5 Daily Care" (page 103). Specify the sensitivity level to detect vertical streaks (dirt on the glass) when vertical streak detection is enabled. Select [1: Low] to only detect large amounts of dirt on the glass. Select [3: High] to also detect small amounts of dirt on the glass. Enable/Disable can also be configured in the scanner driver or the Software Operation Panel. Sensitivity can also be specified in the Software Operation Panel.</p>	<p>1: Enable 2: Disable</p> <p>Sensitivity: 1: Low 2: Normal 3: High</p>	<p>2: Disable</p> <p>Sensitivity: 2: Normal</p>
20: Prioritize panel settings	<p>For the paper protection setting, prioritize the operator panel setting over the Software Operation Panel setting. You cannot prioritize the operator panel setting over the scanner driver setting. When [1: Paper Protection] is selected, the Paper Protection setting of the operator panel is prioritized. When [2: Clear] is selected, the Paper Protection setting is no longer prioritized.</p>	<p>1: Paper Protection 2: Clear</p>	<p>2: Clear</p>

Item	Description	Parameter (*1)/Value	Factory Default (*2)
		-: No parameters/values	
21: Ope. Panel Initialization	Initialize the settings of the operator panel. Note that the language setting and any items without a factory default setting are not initialized.	1: Yes 2: No	(*4)
22: Power saving	Specify the waiting time for the scanner to enter power saving mode. This setting can also be configured from the Software Operation Panel.	5 to 235 (in increments of 5) (minutes)	15
23: Power-off time	Specify the period of time for the scanner to be automatically turned off. This setting can also be configured from the Software Operation Panel.	Disable, 1, 2, 4, 8 (hours)	4
24: Pre-Pick	Select [1: Yes] to prioritize the processing speed. Otherwise, select [2: No]. This settings can also be configured from the scanner driver or the Software Operation Panel. Note that priority is given to the scanner driver setting.	1: Yes 2: No	1: Yes
25: Overscan Control	Expands the amount of overscan and outputs an image if part of the image appears missing due to an abnormal skew during overscan. This setting can also be configured from the Software Operation Panel.	1: Normal 2: Expand	1: Normal

*1: When you select an item in the screen, the parameter currently selected is highlighted.

2: "" is displayed for the factory default setting in the screen.

*3: Although there is no factory default setting, the settings are configured as follows when you turn on the power:

[2: Multiple sheets] for [No. of sheets scanned], [1:(L)ABCDEFGHIJKLMNOPQRSTUVWXYZ[^_`00000000]] for [Print Pattern], and [1: Yes] for [Test Print]. The settings do not change even when you initialize the operator panel because there is no factory default setting.

*4: Although there is no factory default setting, it is set to [2: No] when you turn on the power. The settings do not change even when you initialize the operator panel because there is no factory default setting.

TOP

Contents

Index

Introduction

Scanner
OverviewHow to Load
DocumentsHow to Use the
Operator PanelVarious Ways to
Scan

Daily Care

Replacing the
Consumables

Troubleshooting

Operational
Settings

Appendix

Glossary

3.3 Function Selection

This section explains about the Function Selection.

When you press the [Δ] or [∇] button while the [Ready] screen is displayed, the [Function Selection] screen is displayed.

By using the Function Selection, you can configure the application you want to launch when you press the [Scan/Enter] button while the [Ready] screen is displayed.

The configured applications are applied to the application numbers (F00 to F50/SOP) that are displayed in the indicator.

How to Use the Function Selection

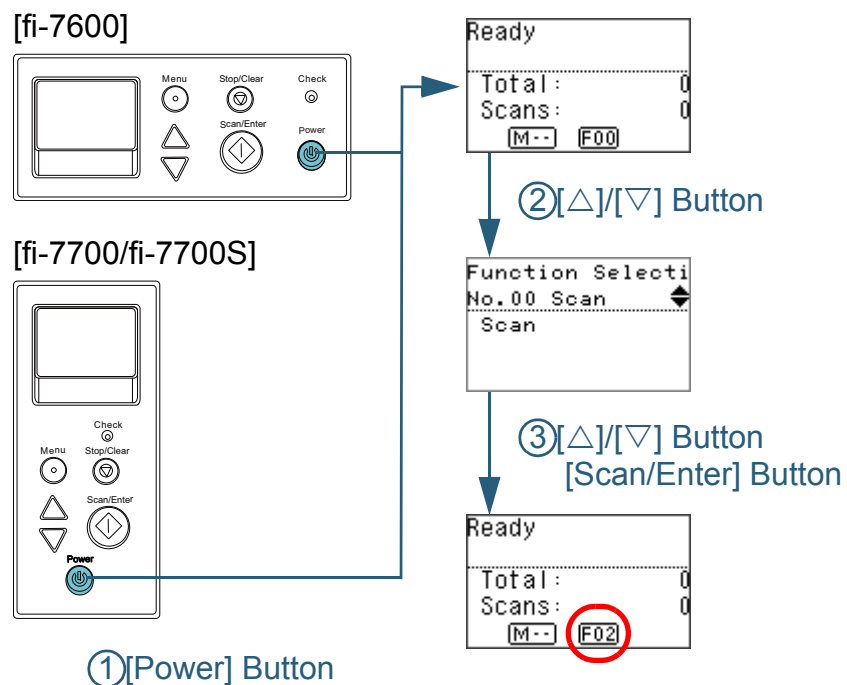

- 1 Press the [Power] button on the operator panel.
⇒The [Ready] screen is displayed on the LCD.
The indicator displays [F00] when the power has just been turned on.
- 2 Press the [Δ] or [∇] button.
⇒The [Function Selection] screen is displayed on the LCD.
- 3 Press the [Δ] or [∇] button and select a parameter, then press the [Scan/Enter] button to confirm.
For more details about the setting parameters, refer to "[Item Configurable in Function Selection](#)" (page 81).
⇒The setup is completed when the LCD displays the [Ready] screen.
The indicator displays the configured parameter.
In this example, the indicator displays "F02" because "No.02" is selected.

HINT

- When "No.00" to "No.50" are selected, the indicator displays "F00" to "F50".
- When "SOP" is selected, "SOP" is displayed on the indicator. SOP indicates the Software Operation Panel.

Item Configurable in Function Selection

Item	Description	Setting	Factory Default
Function Selection	<p>Configure the application you want to launch when you press the [Scan/Enter] button while the [Ready] screen is displayed. It displays a scanner button event configured in the computer ([Scan Button]/[Send to 01] to [Send to 50]).</p> <p>For "No.00", the [Scan Button] event is displayed.</p> <p>For "No.01" to "No.50", an event from [Send to 01] to [Send to 50] is displayed.</p> <p>For information on how to configure scanner button events, refer to "Using a Button on the Scanner to Start Scanning" (page 91).</p>	No.00 to No.50/SOP (SOP indicates the Software Operation Panel)	(*1)

*1: Although there is no factory default setting, it is set to [No.00] when you turn on the power. The settings do not change even when you initialize the operator panel because there is no factory default setting.

TOP

Contents

Index

Introduction

Scanner
OverviewHow to Load
DocumentsHow to Use the
Operator PanelVarious Ways to
Scan

Daily Care

Replacing the
Consumables

Troubleshooting

Operational
Settings

Appendix

Glossary

Chapter 4 Various Ways to Scan

This chapter explains how to configure scanner settings and scan different types of documents with the image scanning application.

4.1 Summary	83
4.2 Scanning Documents of Different Types and Sizes.....	84
4.3 Advanced Scanning.....	91
4.4 Customizing the Scanner Settings	98

4.1 Summary

This section lists the main ways of scanning documents.

Scanning Documents of Different Types and Sizes

- ["Scanning Documents with Different Widths" \(page 84\)](#)
- ["Scanning Documents Folded in Half" \(page 85\)](#)
- ["Scanning Documents such as Envelopes or Multi-Layered Transfer Paper" \(page 87\)](#)
- ["Long Page Scanning" \(page 88\)](#)
- ["Scanning a Book \[fi-7700/fi-7700S\]" \(page 89\)](#)

Advanced Scanning

- ["Using a Button on the Scanner to Start Scanning" \(page 91\)](#)
- ["Feeding Documents Manually in the ADF" \(page 94\)](#)
- ["Sorting the Images Scanned in Simplex Scanning Mode in the Same Order in Which the Images Scanned in Duplex Scanning Mode Are Arranged \[fi-7700S\]" \(page 96\)](#)
- ["Scanning Documents with the Document Cover Open \[fi-7700/fi-7700S\]" \(page 97\)](#)

Customizing the Scanner Settings

- ["Ignoring Multifeed for a Set Pattern" \(page 98\)](#)
- ["Disabling Paper Protection for a Single Scan After Paper Protection Is Set Off" \(page 101\)](#)

For information on other ways of scanning, refer to the scanner driver's Help.

TOP

Contents

Index

Introduction

Scanner
Overview

How to Load
Documents

How to Use the
Operator Panel

Various Ways to
Scan

Daily Care

Replacing the
Consumables

Troubleshooting

Operational
Settings

Appendix

Glossary

4.2 Scanning Documents of Different Types and Sizes

Scanning Documents with Different Widths

ATTENTION

When you scan a mixed batch with different widths, some of the smaller documents may be skewed or not fed into the ADF. In that case, separate the documents by their widths, and scan them in different batches.

HINT

For details about document requirements for scanning a mixed batch of documents, refer to ["Conditions for Mixed Batch Scanning"](#) (page 53).

1 Align the top of the documents.

- Aligning at the center

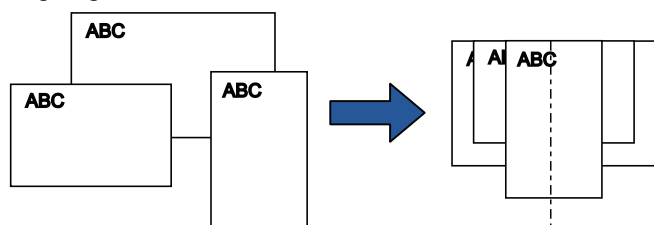

- Aligning on one side

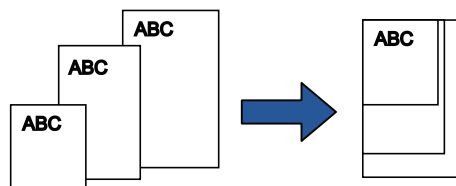

2 Place the documents at the center of the ADF paper chute (feeder), and adjust the side guides to the widest document in the batch.

For details, refer to ["Chapter 2 How to Load Documents"](#) (page 39).

ATTENTION

Make sure that all documents are placed underneath the pick roller. Otherwise, some documents may be skewed or not fed into the ADF.

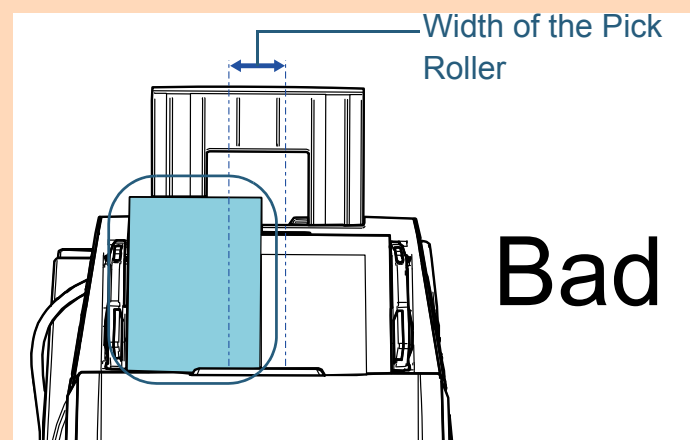
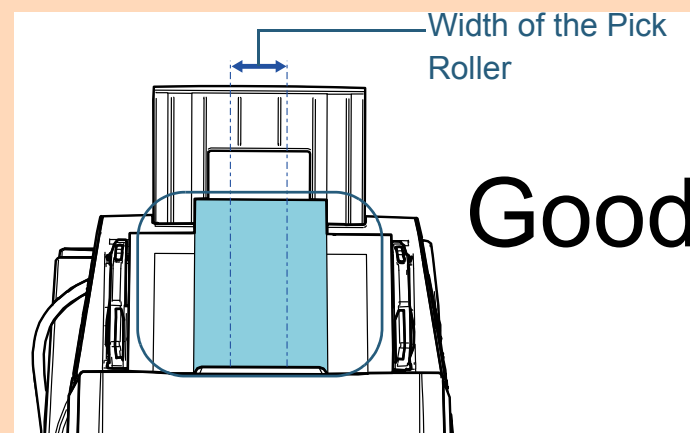

TOP

Contents

Index

Introduction

Scanner
OverviewHow to Load
DocumentsHow to Use the
Operator PanelVarious Ways to
Scan

Daily Care

Replacing the
Consumables

Troubleshooting

Operational
Settings

Appendix

Glossary

- 3 Adjust the stacker to fit the longest document.
For details, refer to "1.8 Setting Up the Stacker" (page 30).
- 4 In the scanner driver, configure the scan settings to detect the paper size automatically.
For details, refer to the scanner driver's Help.
- 5 Scan the document with the image scanning application.
For details, refer to the image scanning application manual.

Scanning Documents Folded in Half

Sliding the feed mode switch to the left to switch the feed mode to Manual/Single mode allows you to scan a document folded in half (a document of up to A1 or A2 in width that is folded in half) as it is.

ATTENTION

When a document folded in half is scanned, the document may be fed skewed if the folded part is too thick.

- 1 Fold the document in half so that the sides to be scanned are facing out.
Fold it firmly and smooth out any creases.
Otherwise, it may cause the document to skew while the feeding is in progress.

Example 1: A2 size

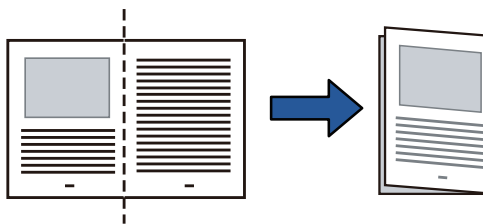

Example 2: A1 size

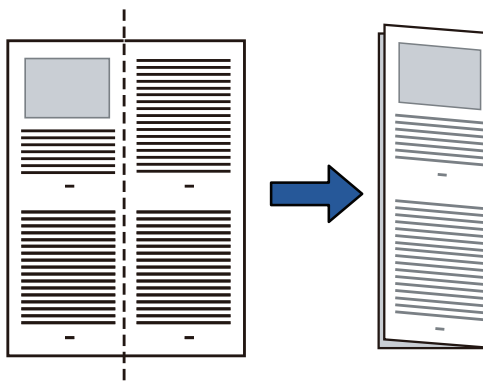

- 2** Load a document folded in half in the ADF paper chute (feeder).
Secure the documents folded in half with the side guides to avoid skewing.

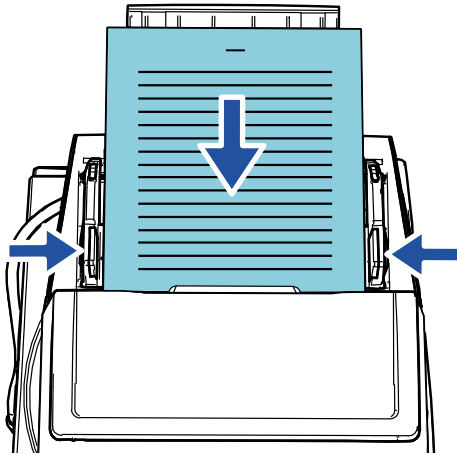

HINT

Adjusting the side guides and the stacker side guides to the width of the document can prevent the document from being skewed.

- 3** Slide the feed mode switch to the left to switch the feed mode to Manual/Single mode.

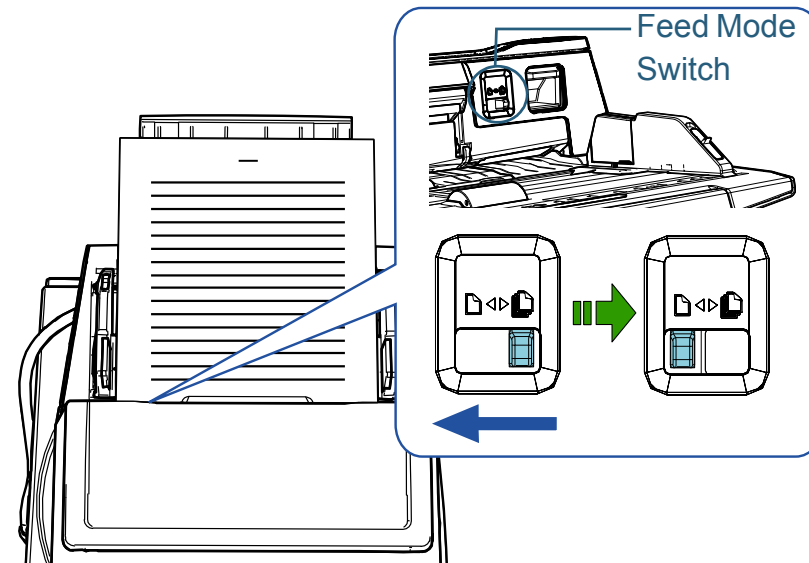

⇒ The following screen is displayed on the LCD of the operator panel.

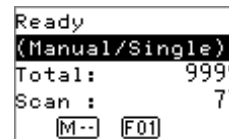

- TOP
- Contents
- Index
- Introduction
- Scanner Overview
- How to Load Documents
- How to Use the Operator Panel
- Various Ways to Scan**
- Daily Care
- Replacing the Consumables
- Troubleshooting
- Operational Settings
- Appendix
- Glossary

4 Scan the document with the image scanning application.

For details, refer to the image scanning application manual.

ATTENTION

- Moving the feed mode switch during a scan causes an error.
- Setting the feed mode switch to Manual/Single mode disables [Check Overlapping (Ultrasonic)] in the multifeed detection setting.
- When you scan an A1 size document folded in half, support the document from below with your hand so that it does not tilt.

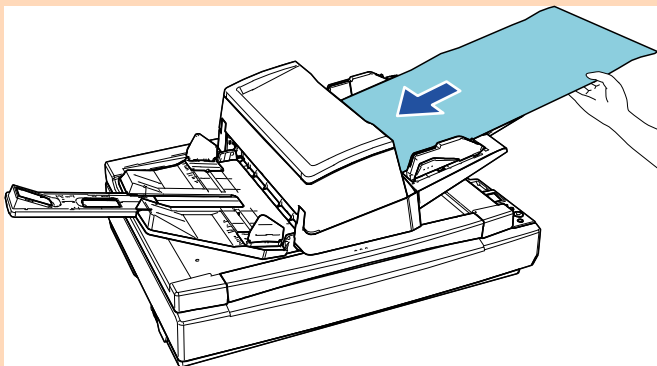

HINT

The scanner will wait for the next document to be loaded until the time specified for the Timeout time elapses, even if there is no document in the ADF paper chute (feeder).

Scanning Documents such as Envelopes or Multi-Layered Transfer Paper

Sliding the feed mode switch to the left to switch the feed mode to Manual/Single mode allows you to scan documents such as envelopes and multi-layered transfer paper. Manual/Single mode reduces the load on documents placed in the feeder so that documents are fed without any fault for a successful scan.

ATTENTION

For details about the paper weights of the documents that can be scanned, refer to ["2.3 Documents for Scanning" \(page 47\)](#).

- 1 Load a document in the ADF paper chute (feeder).
To scan a multi-layered transfer paper, position the bound edge first when loading the paper.

For details, refer to ["Chapter 2 How to Load Documents" \(page 39\)](#).

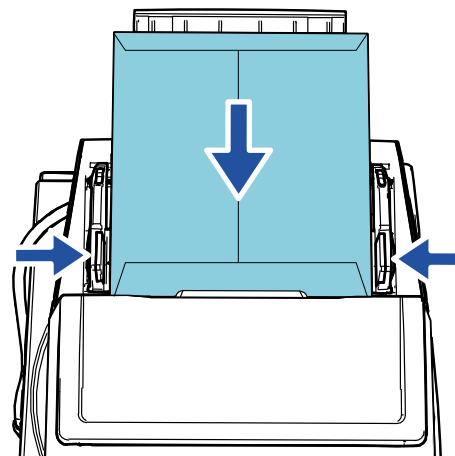

TOP

Contents

Index

Introduction

Scanner
OverviewHow to Load
DocumentsHow to Use the
Operator PanelVarious Ways to
Scan

Daily Care

Replacing the
Consumables

Troubleshooting

Operational
Settings

Appendix

Glossary

- 2** Slide the feed mode switch to the left to switch the feed mode to Manual/Single mode.

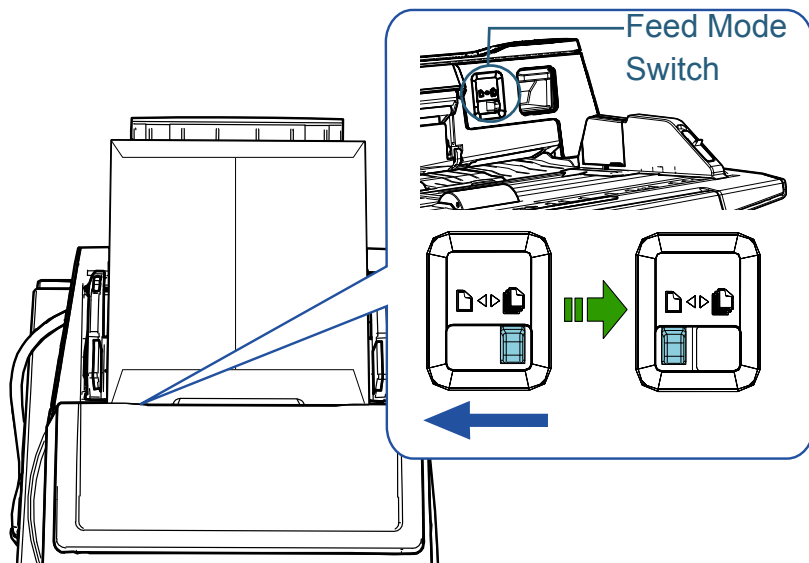

⇒ The following screen is displayed on the LCD of the operator panel.

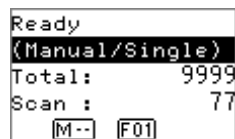

- 3** Scan the document with the image scanning application.
For details, refer to the image scanning application manual.

ATTENTION

- Moving the feed mode switch during a scan causes an error.
- Setting the feed mode switch to Manual/Single mode disables [Check Overlapping (Ultrasonic)] in the multifeed detection setting.

HINT

The scanner will wait for the next document to be loaded until the time specified for the Timeout time elapses, even if there is no document in the ADF paper chute (feeder).

Long Page Scanning

Documents with a length up to 5,588 mm (220 in.) can be scanned by long page scanning.

If you scan a long page document and split the scanned image into multiple pages, a document of up to 200 m (218.8 yd.) can be scanned.

Depending on the resolution setting or the image scanning application, the document sizes that can be scanned may differ.

For details, refer to the image scanning application manual.

- 1** Load a document in the ADF paper chute (feeder).

For details, refer to "[Chapter 2 How to Load Documents](#)" (page 39).

ATTENTION

- Long page documents should be loaded one sheet at a time in the ADF paper chute (feeder).
- When you scan long pages, take note of the following:
 - Loading
Hold the document with your hand so it does not fall out of the ADF paper chute (feeder).

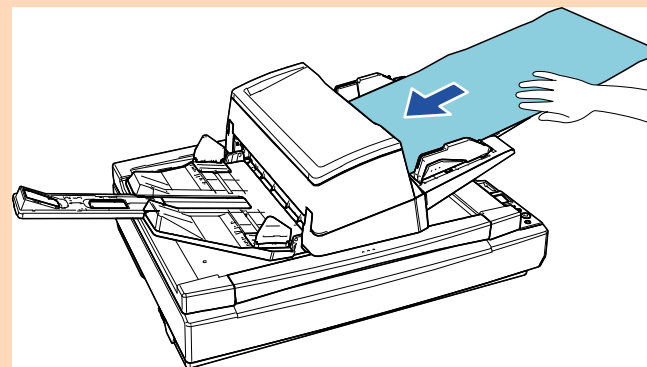

ATTENTION

- Removing
Secure enough space around the stacker to prevent the ejected sheet from falling off the stacker.

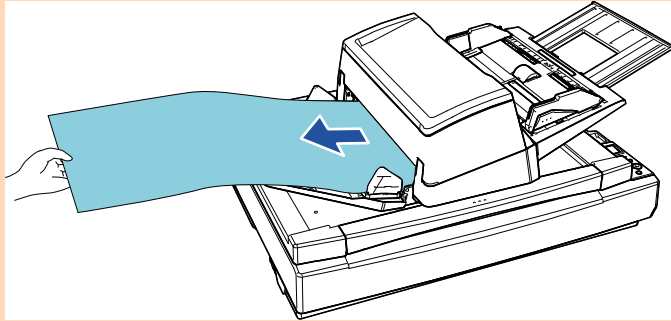
**HINT**

To scan documents longer than A3 size, perform the following:

- Pull out the chute extension.
For details, refer to "1.7 Setting Up the ADF Paper Chute (Feeder)" (page 29).
- Pull out the stacker extension all the way.
For details, refer to "1.8 Setting Up the Stacker" (page 30).

- 2 In the scanner driver, configure the scan settings to scan the paper size of the long page.

For details, refer to the scanner driver's Help.

ATTENTION

If you scan a long page document and split the scanned image into multiple pages at a lower resolution (less than 400 dpi), the document is scanned slowly regardless of the resolution setting.

- 3 Scan the document with the image scanning application.
For details, refer to the image scanning application manual.

Scanning a Book [fi-7700/fi-7700S]

- 1 Open the document cover.
For details, refer to "1.5 Opening/Closing the Document Cover [fi-7700/fi-7700S]" (page 25).
- 2 Place a document on the document bed.
Place the document face-down to align its top left-hand corner with the reference point.

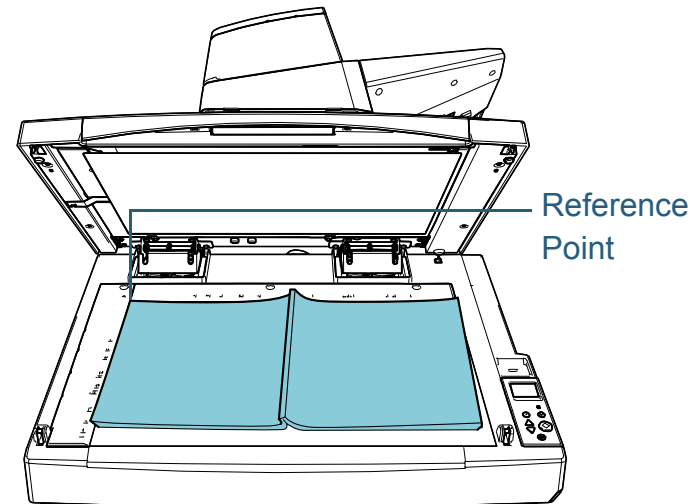
**ATTENTION**

Note that a curled or folded document may create a small gap between the document and the document bed, causing the scanned image to be blurred.

TOP

Contents

Index

Introduction

Scanner
OverviewHow to Load
DocumentsHow to Use the
Operator PanelVarious Ways to
Scan

Daily Care

Replacing the
Consumables

Troubleshooting

Operational
Settings

Appendix

Glossary

3 Gently close the document cover.

For details, refer to "[1.5 Opening/Closing the Document Cover \[fi-7700/fi-7700S\]](#)" (page 25).

HINT

- A document can be scanned with the document cover open. For details, refer to "[Scanning Documents with the Document Cover Open \[fi-7700/fi-7700S\]](#)" (page 97)
- To scan documents on a black background, use an optional black document pad (sold separately). For details about the black document pad, refer to "[A.4 Scanner Options](#)" (page 216).

4 In the scanner driver, configure the scan settings for using the flatbed.

For details, refer to the scanner driver's Help.

5 Scan the document with the image scanning application.

For details, refer to the image scanning application manual.

TOP

Contents

Index

Introduction

Scanner
Overview

How to Load
Documents

How to Use the
Operator Panel

Various Ways to
Scan

Daily Care

Replacing the
Consumables

Troubleshooting

Operational
Settings

Appendix

Glossary

4.3 Advanced Scanning

Using a Button on the Scanner to Start Scanning

The [Scan/Enter] button on the operator panel can be used to start scanning.

For this purpose, you first need to assign an application to be launched when the [Scan/Enter] button is pressed.

- **Settings on a computer** (Refer to "[Settings on a Computer](#)" (page 91))
Configure settings for an event on a computer. An event here means pressing the [Scan/Enter] button.
In the [Events] tab of the properties window for the scanner, assign an application to be launched when the [Scan/Enter] button is pressed. You can configure the settings for an event that is linked with an application number that is displayed on the operator panel of the scanner.
For details about the operator panel of the scanner as well as the application number, refer to "[3.1 Operator Panel](#)" (page 57).
- **Settings on the scanner** (Refer to "[Settings on the Scanner](#)" (page 93))
Configure the settings for the Function Selection on the operator panel of the scanner.
By using the Function Selection, you can link the event that is configured on a computer with the application number that is displayed on the operator panel.
For details about the Function Selection, refer to "[3.3 Function Selection](#)" (page 80).
For details about the operator panel of the scanner as well as the application number, refer to "[3.1 Operator Panel](#)" (page 57).
- **Settings on an application to be launched**
Depending on an application to be launched when the [Scan/Enter] button is pressed, you also need to configure the settings on the application (such as an image scanning application or a scanner driver).
For details, refer to the manual or Help for the application to be launched.

Settings on a Computer

- 1** Confirm that the scanner is connected to the computer, then turn on the scanner.
For details about how to connect the scanner to the computer, refer to the Quick Installation Sheet.
For details about how to turn on the scanner, refer to "[1.3 Turning the Power ON/OFF](#)" (page 23).
- 2** Display the [Control Panel] window.
 - Windows Server 2008/Windows 7
Click [Start] menu → [Control Panel].
 - Windows Server 2012
Right-click the Start screen, and select [All apps] on the app bar → [Control Panel] under [Windows System].
 - Windows Server 2012 R2/Windows 8.1
Click [↓] on the lower left side of the Start screen → [Control Panel] under [Windows System].
To display [↓], move the mouse cursor.
 - Windows 10/Windows Server 2016
Right-click [Start] menu, and then click [Control Panel].
- 3** Click [View devices and printers].
⇒The [Devices and Printers] window appears.
- 4** Right-click on the scanner icon, and select [Scan properties] from the displayed menu.
⇒The properties window of the scanner appears.

- 5** Click the [Events] tab and select an event.
From the [Select an event] drop-down list, select an event from which you want to launch an application.

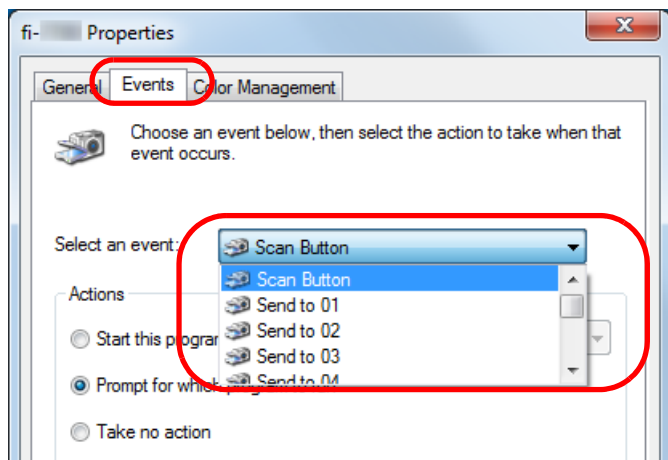

In this function, the following events can be specified:

The event you select is linked with the settings described in "[Settings on the Scanner](#)" (page 93).

- [Scan Button]
Select this event when you press the [Scan/Enter] button with the application number "F00" displayed on the operator panel of the scanner.
- [Send to 01] to [Send to 50]
Select one of the events when you press the [Scan/Enter] button with the application number from "F01" to "F50" displayed on the operator panel of the scanner.

- 6** Select an action and an application to be launched by the scanner button event.
Click [Start this program] under [Actions], and select an application from the drop-down list on the right.

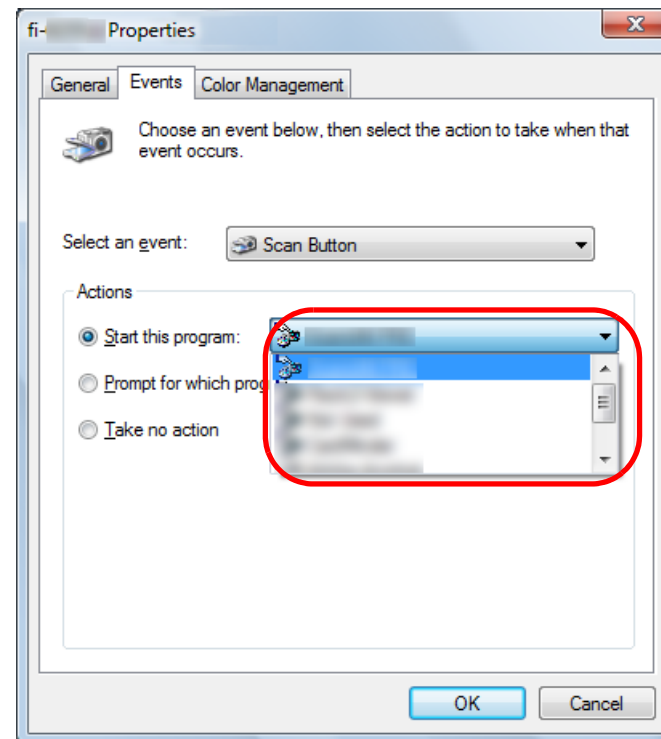

- 7** Click the [OK] button.
The setup of the computer is completed. Proceed to configure the scanner settings.
Depending on the application, the application settings may also need to be configured. For details, refer to the manual or help for the application that you want to launch.

HINT

To configure multiple events, repeat steps 4 to 7.

- TOP
- Contents
- Index
- Introduction
- Scanner Overview
- How to Load Documents
- How to Use the Operator Panel
- Various Ways to Scan**
- Daily Care
- Replacing the Consumables
- Troubleshooting
- Operational Settings
- Appendix
- Glossary

Settings on the Scanner

[fi-7600]

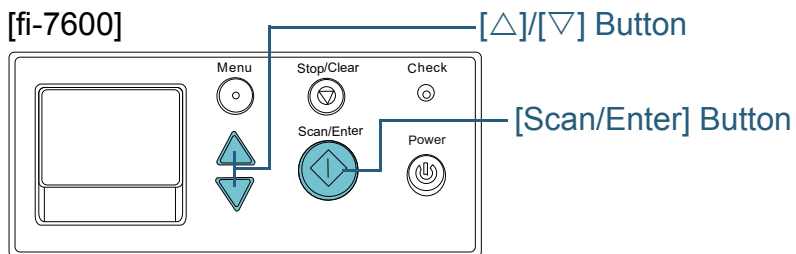

[fi-7700/fi-7700S]

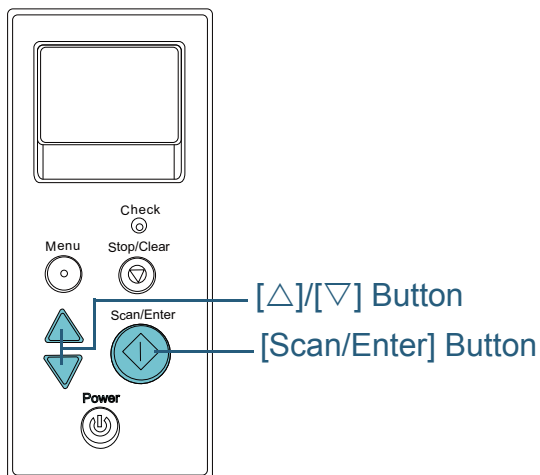

- 1 Press the [Δ] or [▽] button while the [Ready] screen is displayed on the operator panel.
⇒ The [Function Selection] screen is displayed.

- 2 Press the [Δ] or [▽] button and select a parameter, then press the [Scan/Enter] button to confirm.
Configure the application you want to launch when you press the [Scan/Enter] button while the [Ready] screen is displayed. Parameters in the [Function Selection] screen, application numbers in the indicator, and events configured on the computer correspond to one another as follows:

Parameter in the [Function Selection] screen	Application number in the indicator	Event configured on the computer
No.00	F00	[Scan Button]
No.01 to No.50	F01 to F50	[Send to 01] to [Send to 50]
SOP	SOP	N/A

As an example, the following indicator displays an application number "F02". This number is displayed by selecting [No.02] in the [Function Selection] screen and performs the [Send to 02] event configured on the computer.

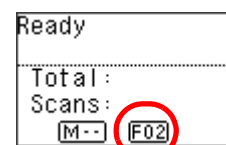

- 3 Press the [Scan/Enter] button.
⇒ The specified application is launched.

- TOP
- Contents
- Index
- Introduction
- Scanner Overview
- How to Load Documents
- How to Use the Operator Panel
- Various Ways to Scan
- Daily Care
- Replacing the Consumables
- Troubleshooting
- Operational Settings
- Appendix
- Glossary

Feeding Documents Manually in the ADF

Documents can also be loaded manually one sheet at a time in the ADF.

Normally, in automatic feeding, the scanner stops scanning once all the documents loaded in the ADF paper chute (feeder) have been scanned. In manual feeding, the scanner waits for the next document to be loaded within a specified time. Scanning will continue as long as another document is loaded within the set time, and stops if no document is loaded. By using this method, you can perform scanning as you check the documents one by one.

Manual feeding is effective in the following cases:

- To scan as you check the contents of each sheet.
- To scan documents that cause multifeeds or paper jams when the documents are loaded together in the same batch.
- To continue scanning documents such as magazine or newspaper clippings that cannot be loaded together.
- To scan a document folded in half, an envelope, or a multi-layered transfer paper one at a time

1 Enable manual feeding.

- When scanning more than one document in succession manually
 - 1 Perform one of the following operations:
 - Select the Enable option for [16: Manual/Continuous Feed Setting] and set [17: Manual Feed Timeout] in the [Settings Menu] screen of the operator panel.
For details, refer to ["3.2 Settings Menu" \(page 62\)](#).
 - For [Manual Feeding] in the Software Operation Panel, select the Enable option for [Continuous Feed Mode] and set [Timeout Time].
For details, refer to ["Waiting Time in Manual Feeding \[Manual Feeding\]" \(page 202\)](#).
- When scanning a document folded in half, an envelope, or a multi-layered transfer paper one at a time manually
 - 1 Slide the feed mode switch to the left to switch the feed mode to Manual/Single mode.
 - 2 Perform one of the following operations:
 - Set [17: Manual Feed Timeout] in the [Settings Menu] screen of the operator panel.
For details, refer to ["3.2 Settings Menu" \(page 62\)](#).
 - Set [Timeout Time] for [Manual Feeding] on the Software Operation Panel.
For details, refer to ["Waiting Time in Manual Feeding \[Manual Feeding\]" \(page 202\)](#).

ATTENTION

For details about the paper weights of the documents that can be scanned, refer to ["2.3 Documents for Scanning" \(page 47\)](#). When a document folded in half is scanned, the document may be fed skewed if the folded part is too thick.

TOP

Contents

Index

Introduction

Scanner
OverviewHow to Load
DocumentsHow to Use the
Operator PanelVarious Ways to
Scan

Daily Care

Replacing the
Consumables

Troubleshooting

Operational
Settings

Appendix

Glossary

- 2** Load a document in the ADF paper chute (feeder).
Load the document face-down in the ADF paper chute (feeder).
To scan a multi-layered transfer paper, position the bound edge first when loading the paper.

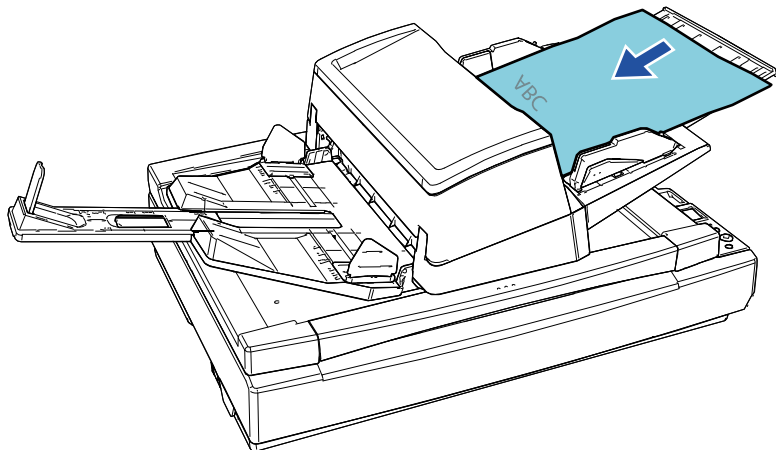

- 3** Scan the document with the image scanning application.
For details, refer to the image scanning application manual.
⇒ After the document is scanned, the rollers inside the ADF keep rotating, waiting for the next document to be loaded until the time specified in the operator panel or Software Operation Panel.
- 4** Load the next document in the ADF paper chute (feeder).
⇒ The document is scanned.

- 5** Repeat step 4 until all documents are scanned.
⇒ Scanning will stop if no document is loaded within the set time.

HINT

- Pressing the [Stop/Clear] button on the operator panel while the scanner is waiting for the next document to be loaded will stop the scan immediately.
- When the Timeout time is set, the scanner will wait for the next document to be loaded until the time specified for the Timeout time elapses, even if you start scanning with no document in the ADF paper chute (feeder).
- When you use manual feeding frequently, the replacement cycle of the consumables may be shortened.

TOP

Contents

Index

Introduction

Scanner
Overview

How to Load
Documents

How to Use the
Operator Panel

Various Ways to
Scan

Daily Care

Replacing the
Consumables

Troubleshooting

Operational
Settings

Appendix

Glossary

Sorting the Images Scanned in Simplex Scanning Mode in the Same Order in Which the Images Scanned in Duplex Scanning Mode Are Arranged [fi-7700S]

The scanner supports virtual duplex scanning, with which front-side pages of documents are scanned first, back-side pages are scanned in succession, and then scanned images are sorted automatically.

In this case, you need an image scanning application that supports the virtual duplex scan function. You also need to configure the settings in the scanner driver.

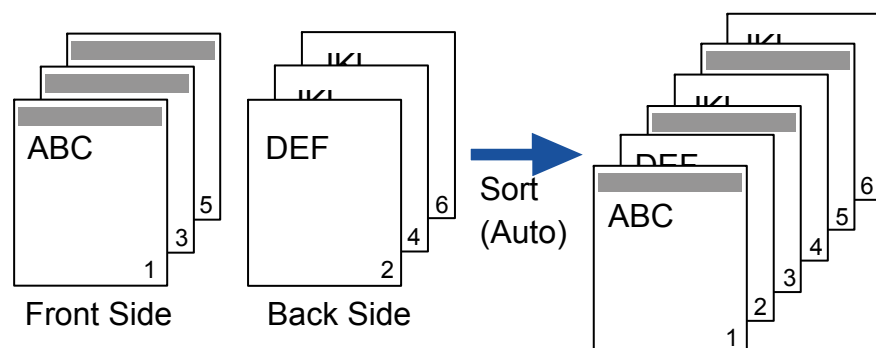

- 1** Load documents with the front side face-down in the ADF paper chute (feeder).
For details, refer to "[Chapter 2 How to Load Documents](#)" (page 39).
- 2** In the scanner driver, configure the settings for scanning both sides of documents virtually.
For details, refer to the scanner driver's Help.
- 3** Scan the document with the image scanning application.
For details, refer to the image scanning application manual.
⇒When the scanning is complete, a message appears to prompt you to load the documents face-up.

- 4** Load the documents with the back side face-down in the ADF paper chute (feeder).
For details, refer to "[Chapter 2 How to Load Documents](#)" (page 39).

ATTENTION

When scanning the back side pages, take note of the following:

- Load the documents so that they are scanned in the same order as front-side pages.
- Load the documents so that they are not scanned up-side-down.

⇒When you respond to the message shown, the back side pages of the documents are scanned.

- 5** When the scanning is complete, the scanned pages are sorted automatically.

ATTENTION

If the number of the documents are different between the front side and the back side, the documents are not sorted.

TOP

Contents

Index

Introduction

Scanner
OverviewHow to Load
DocumentsHow to Use the
Operator PanelVarious Ways to
Scan

Daily Care

Replacing the
Consumables

Troubleshooting

Operational
Settings

Appendix

Glossary

Scanning Documents with the Document Cover Open [fi-7700/fi-7700S]

The scanner allows you to scan documents with the document cover open for the flatbed. It automatically corrects a scanned image that is skewed or recognizes the size of a document and outputs the image in that size.

In this case, you need to configure the settings in the scanner driver.

- 1 Open the document cover.
For details, refer to "1.5 Opening/Closing the Document Cover [fi-7700/fi-7700S]" (page 25).

- 2 Place a document on the document bed.
Place the document face-down to align its top left-hand corner with the reference point.

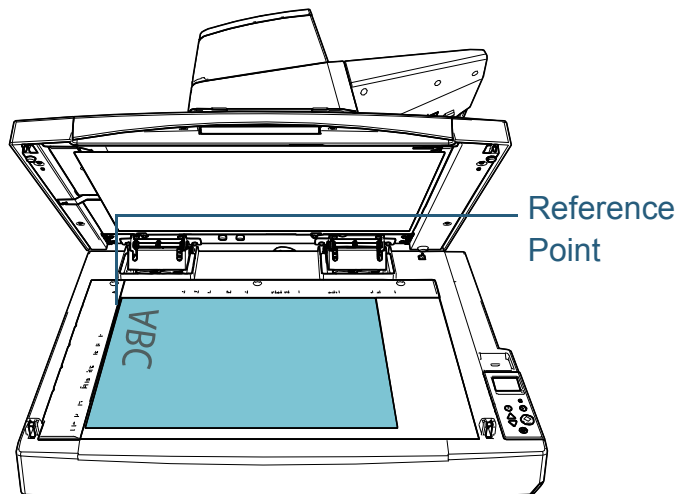

ATTENTION

Note that a curled or folded document may create a small gap between the document and the document bed, causing the scanned image to be blurred.

- 3 In the scanner driver, configure the scan settings for the flatbed so that the ambient light can be removed.
For details, refer to the scanner driver's Help.

ATTENTION

Depending on the way ambient light is exposed on the document bed, the scanner may not be able to automatically correct a scanned image that is skewed or output the image in the recognized size. For details, refer to the scanner driver's Help.

- 4 Scan the documents with the image scanning application.
For details, refer to the image scanning application manual.



Never look into the light source directly during scanning.

TOP

Contents

Index

Introduction

Scanner
Overview

How to Load
Documents

How to Use the
Operator Panel

Various Ways to
Scan

Daily Care

Replacing the
Consumables

Troubleshooting

Operational
Settings

Appendix

Glossary

4.4 Customizing the Scanner Settings

Ignoring Multifeed for a Set Pattern

If you attempt to scan a document with an attachment such as sticky note, receipt, or photo while multifeed detection is enabled, the scanner may falsely recognize this as a multifeed error and stop the scan. To scan these types of documents, the "Intelligent Multifeed Function" is available.

There are two modes in this function. In one mode, you can suppress multifeeds forcibly by using the operator panel on the scanner. In the other mode, you can suppress multifeeds automatically by letting the scanner memorize the location and the length of the attachment.

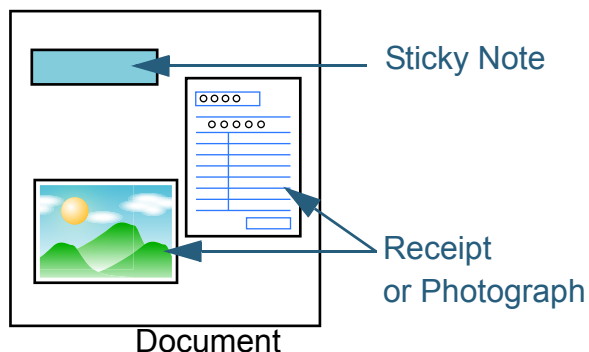

Intelligent Multifeed Function

The following three modes are available:

Mode	Description
Manual mode (Bypass by front panel button)	Checks for any paper attached every time a multifeed occurs, and continues scanning.
Auto mode 1 (Bypass by combination of length and position)	Used to scan documents with paper of the same size attached in the same location.
Auto mode 2 (Bypass by length)	Used to scan documents with paper of the same size attached in different locations.

ATTENTION

Irregular images may be output when multifeeds occur.

Select the mode by performing one of the following:

- Select the mode in [13: iMFF Setting] on the [Settings Menu] screen of the operator panel.
For details, refer to ["3.2 Settings Menu" \(page 62\)](#).
- Select the mode in the Software Operation Panel.
For details, refer to ["Specifying an Area Not to Detect Multifeed \[Intelligent Multifeed Function\]" \(page 201\)](#).

Operational Procedure

[fi-7600]

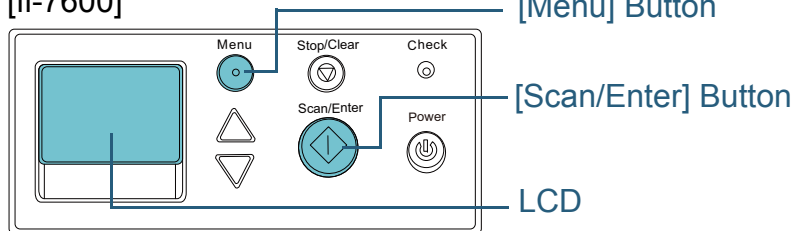

[fi-7700/fi-7700S]

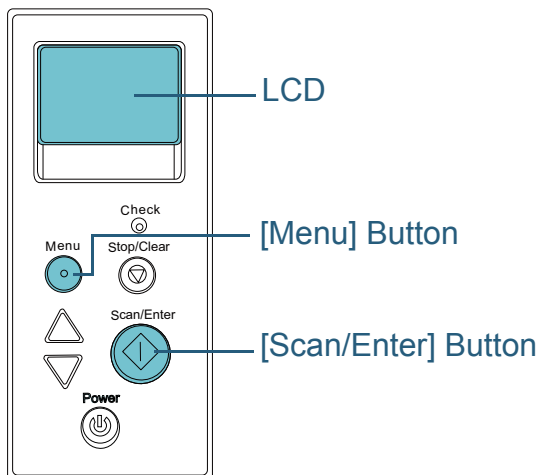

- 1 After a multifeed error occurs, either press the [Scan/Enter] button to eject the document from the paper path or open the ADF to remove the document.

After the document is removed, indication on the LCD of the operator panel changes as follows:

When a multifeed occurs	When a document is ejected
Multifeed detected (Overlap) Press the [Scan/Enter] button to eject the document. After ejecting the document, multifeed detection for the next document can be enabled/disabled from the [Menu] button.	Specify whether to detect multifeed for the next document. ----- Detect: Scan/Enter (Switch:Menu)
Multifeed detected (Overlap) Press the [Scan/Enter] button to eject the document. Press the Menu button to memorize the multifeed pattern.	Specify whether to memorize the pattern. ----- Do not remember: Scan/Enter (Switch:Menu)
Multifeed detected (Overlap) Press the [Scan/Enter] button to eject the document.	Specify whether to keep or discard MF images. ----- Keep:Scan/Enter (Switch:Menu)
Multifeed detected (Length) Press the [Scan/Enter] button to eject the document.	[Ready] screen

CAUTION When the ADF is open, it might close accidentally. Be careful not to get your fingers caught.

- TOP
- Contents
- Index
- Introduction
- Scanner Overview
- How to Load Documents
- How to Use the Operator Panel
- Various Ways to Scan**
- Daily Care
- Replacing the Consumables
- Troubleshooting
- Operational Settings
- Appendix
- Glossary

- 2** If you open the ADF to remove the document, close it.
For details, refer to "1.4 Opening/Closing the ADF" (page 24).



Be careful not to get your fingers caught when closing the ADF.

ATTENTION

Confirm that the ADF is closed properly. Otherwise, the document may not be fed into the ADF.

- 3** Load the documents back in the ADF paper chute (feeder).
If a multifeed by difference in length is detected, press the [Scan/Enter] button or perform a scan from the computer (do not press the [Menu] button).
If there is an attachment which is likely to be the cause of the multifeed error, then proceed to the next step.
- 4** Press the [Menu] button and confirm that the LCD displays [Do not detect] or [Remember], and then either press the [Scan/Enter] button or perform a scan from the computer.
From this point, note that the indication on the LCD switches between [Detect]↔[Do not detect] or [Remember]↔[Do not remember] every time you press the [Menu] button. When [Do not detect] or [Remember] is displayed, the scanner operates in each mode as follows:
- Manual mode (Bypass by front panel button)
Scans the next sheet without multifeed detection, and from the second sheet, multifeeds are detected based on the setting configured in the scanner driver or the Software Operation Panel.
 - Auto mode 1 (Bypass by combination of length and position)
Memorizes the length and location of the paper attachment that was detected as multifeed, and continues scanning. When a paper attachment of a similar pattern is detected, multifeed detection is automatically suppressed.(*1)(*2)
 - Auto mode 2 (Bypass by length)
Memorizes the length of the longest paper attachment that was

detected as multifeed, and continues scanning. When a paper attachment of the same length or shorter is detected, multifeed detection is automatically suppressed.(*2)

- *1: Eight overlap patterns can be memorized in this mode. When it exceeds this limit, the first pattern that was memorized is erased from the memory.
- *2: To erase the memorized overlap patterns and the longest overlap length, use [13: iMFF Setting] on the [Settings Menu] screen of the operator panel, or Software Operation Panel. After erasing is completed, the indication on the LCD changes to **A1-0** or **A2-0**. This allows you to erase multifeed patterns and the longest overlap length that were not supposed to be memorized. Be careful with this operation because all memorized patterns will be erased.

Disabling Paper Protection for a Single Scan After Paper Protection Is Set Off

If you attempt to scan a wrinkled document while paper protection is on, the scanner may detect it as a paper jam, which causes paper protection to be set off and forces a scan to be stopped even though paper is fed normally. In this case, you can disable paper protection on the operator panel for a single scan after paper protection is set off.

Note that, in some ambient conditions, you may not be able to successfully scan documents with the document cover open.

Operational Procedure

[fi-7600]

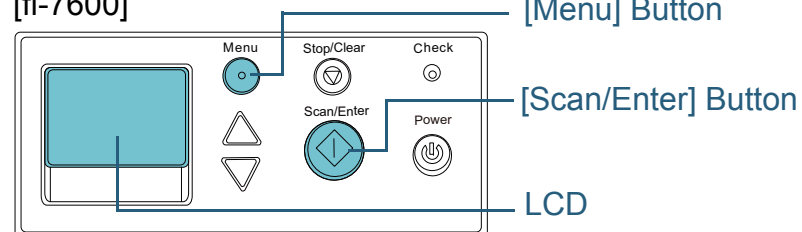

[fi-7700/fi-7700S]

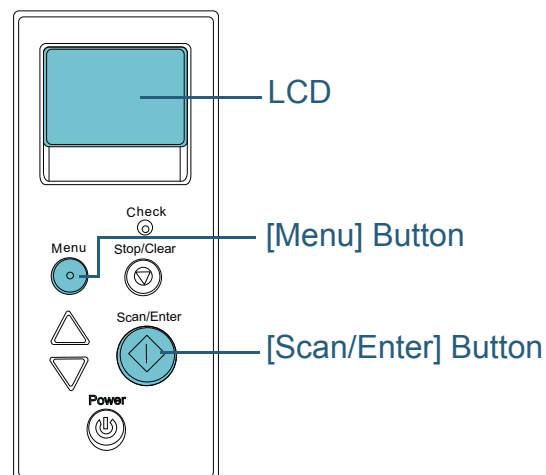

- 1 After paper protection is set off, open the ADF and remove the document.
After the document is removed, indication on the LCD of the operator panel changes as follows:

When paper protection is set off	When a document is ejected
Paper protection (feeding noise) Remove and check the document, and then try again carefully.	Disable paper protection. ----- Enable:Scan/Enter (Switch:Menu)
Paper protection (feeding accuracy) Remove and check the document, and then try again carefully.	



When the ADF is open, it might close accidentally. Be careful not to get your fingers caught.

- 2 If you open the ADF to remove the document, close it.
For details, refer to "1.4 Opening/Closing the ADF" (page 24).



Be careful not to get your fingers caught when closing the ADF.

ATTENTION

Confirm that the ADF is closed properly. Otherwise, the document may not be fed into the ADF.

- 3 Load the documents back in the ADF paper chute (feeder).

- 4** Press the [Menu] button and confirm that the LCD displays [Disable], and then either press the [Scan/Enter] button or perform a scan from the computer.

From this point, note that the indication on the LCD switches between [Enable]↔[Disable] every time you press the [Menu] button. When [Disable] is displayed, the next document is scanned with paper protection disabled. After that, the subsequent documents are scanned according to the paper protection setting of either scanner driver, Software Operation Panel, or operator panel.

HINT

If paper protection is set off frequently, refer to "[Paper protection is set off frequently.](#)" (page 148).

TOP

Contents

Index

Introduction

Scanner
Overview

How to Load
Documents

How to Use the
Operator Panel

Various Ways to
Scan

Daily Care

Replacing the
Consumables

Troubleshooting



Operational
Settings



Appendix

Glossary

Chapter 5 Daily Care

This chapter describes how to clean the scanner.



	Do not use aerosol spray or spray that contains alcohol. Paper dust blown up by strong air from the spray may enter inside the scanner which may cause the scanner to fail or malfunction. Also note that sparks generated by static electricity may cause a fire.
	

	The inside of the ADF becomes very hot when the scanner is being used.
	Before you start cleaning the inside, make sure to turn off the power, unplug the power cable and wait at least 15 minutes for the inside of the ADF to cool down.
	

5.1 Cleaning Materials and Locations that Require Cleaning.....	104
5.2 Cleaning the Outside	106
5.3 Cleaning the Inside.....	107

5.1 Cleaning Materials and Locations that Require Cleaning

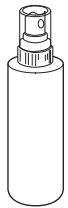
Cleaning Materials

Name	Part No.	Notes
Cleaner F1 	PA03950-0352	100 ml Liquid cleaner to use for removing dirt and stains
Cleaning Paper 	CA99501-0012	10 sheets Used to clean the inside of the scanner with ease. Spray it with Cleaner F1 and scan it with the scanner in the same way as a document.
Cleaning Wipe 	PA03950-0419	24 packets Pre-moistened with Cleaner F1. It can be used instead of moistening a cloth with Cleaner F1.
Cotton swab	Commercially available	Used to clean a tiny part such as the ultrasonic sensor.
Dry cloth		Used to wipe off dirt and stains. Moisten it with Cleaner F1 for cleaning.

ATTENTION

In order to use the cleaning materials safely and correctly, read the precautions on each product thoroughly.

For more information about the cleaning materials, contact your FUJITSU scanner dealer or an authorized FUJITSU scanner service provider.

TOP

Contents

Index

Introduction

Scanner
OverviewHow to Load
DocumentsHow to Use the
Operator PanelVarious Ways to
Scan

Daily Care

Replacing the
Consumables

Troubleshooting

Operational
Settings

Appendix

Glossary

Location and Frequency

Location		Frequency
ADF	Brake roller	Every 10,000 sheets
	Pick roller	
	Plastic roller	
	Rubber roller	
	Chute roller	
	Paper path	
	Glass	
	Ultrasonic sensor	
	Document sensor	
	Feed roller	
Eject roller		
Flatbed [fi-7700/fi-7700S]	Document pad	
	Document bed	

ATTENTION

Cleaning cycles may vary depending on the condition of the documents. Also, cleaning must be performed more frequently when the following types of documents are scanned:

- Smooth-faced documents such as coated paper
- Documents with printed text/graphics that almost cover the entire surface
- Chemically-treated documents such as carbonless paper
- Documents containing a large amount of calcium carbonate
- Documents written in lead pencil
- Documents on which the toner is not sufficiently fused

TOP

Contents

Index

Introduction

Scanner
OverviewHow to Load
DocumentsHow to Use the
Operator PanelVarious Ways to
Scan

Daily Care

Replacing the
Consumables

Troubleshooting

Operational
Settings

Appendix

Glossary

5.2 Cleaning the Outside

The outside of the scanner, including the ADF paper chute (feeder) and the stacker, should be cleaned with either a piece of dry cloth, a cloth moistened with Cleaner F1/mild detergent, or a sheet of Cleaning Wipe.

ATTENTION

- To avoid deformation and discoloration, never use paint thinner or any other organic solvents.
- Be careful not to let any moisture or water inside the scanner during cleaning.
- It may take a long time to dry if an excessive amount of Cleaner F1/mild detergent is used. Use it in small quantity. Wipe off the cleaner completely to leave no residue on the cleaned parts.

fi-7600

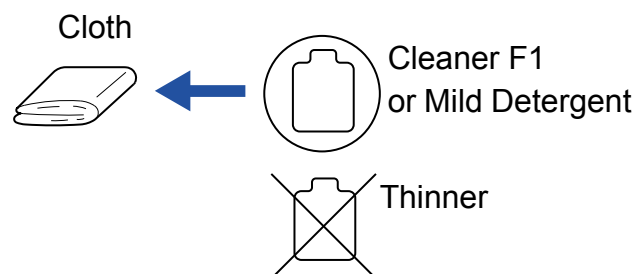

Cleaning Wipe

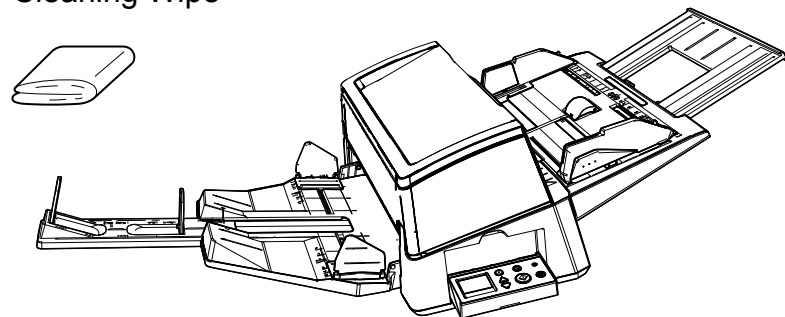

fi-7700/fi-7700S

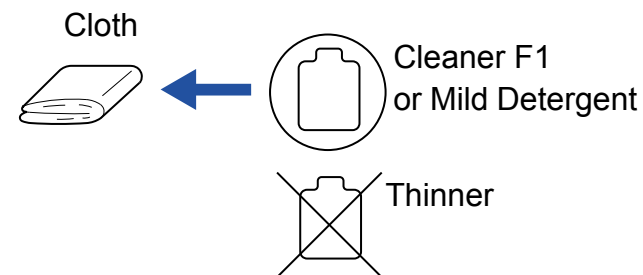

Cleaning Wipe

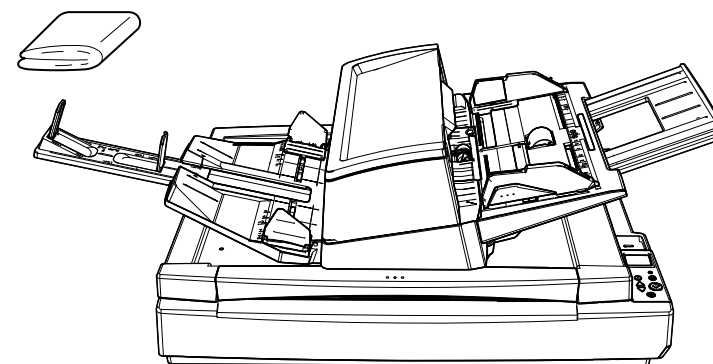
[TOP](#)
[Contents](#)
[Index](#)
[Introduction](#)
[Scanner
Overview](#)
[How to Load
Documents](#)
[How to Use the
Operator Panel](#)
[Various Ways to
Scan](#)
[Daily Care](#)
[Replacing the
Consumables](#)
[Troubleshooting](#)
[Operational
Settings](#)
[Appendix](#)
[Glossary](#)

5.3 Cleaning the Inside

Cleaning the ADF (with Cleaning Paper)

The ADF can be cleaned with a sheet of Cleaning Paper moistened with Cleaner F1.

As the scanner continues to feed the documents, paper dust will accumulate inside the ADF and it may cause scanning errors.

Cleaning should be performed approximately every 10,000 sheets scanned. Note that this guideline varies depending on the types of documents you scan. For instance, it may be necessary to clean the scanner more frequently when you scan documents on which the toner is not sufficiently fused.

ATTENTION

- Do not use water or mild detergent to clean the ADF.
- It may take a long time to dry if an excessive amount of Cleaner F1 is used. Use it in small quantity.

- 1 Turn on the scanner.
For details, refer to ["1.3 Turning the Power ON/OFF" \(page 23\)](#).
⇒The [Ready] screen is displayed on the LCD.
- 2 Press the [Menu] button.
⇒The [Settings Menu] screen is displayed on the LCD.
- 3 Press the [△] or [▽] button and select [2: Cleaning], then press the [Scan/Enter] button to confirm.
⇒The [Cleaning] screen is displayed on the LCD.

- 4 Select [1: Cleaning Paper] by the [△] or [▽] button, and press the [Scan/Enter] button to confirm.
⇒A message is displayed on the LCD.

ATTENTION

Do not perform scanning from the scanner driver during cleaning.

- 5 Spray the Cleaning Paper with Cleaner F1.
- 6 Pull out the chute extension according to the length of the Cleaning Paper.
For details, refer to ["1.7 Setting Up the ADF Paper Chute \(Feeder\)" \(page 29\)](#).
- 7 Pull out the stacker extension and lift up the stopper according to the length of the Cleaning Paper.
For details, refer to ["1.8 Setting Up the Stacker" \(page 30\)](#).
- 8 Load the Cleaning Paper in the ADF paper chute (feeder).

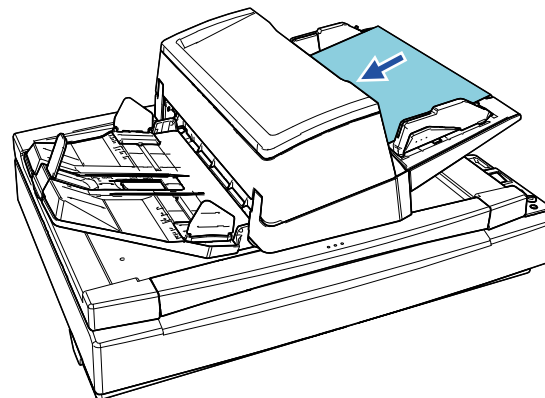

TOP

Contents

Index

Introduction

Scanner
OverviewHow to Load
DocumentsHow to Use the
Operator PanelVarious Ways to
Scan

Daily Care

Replacing the
Consumables

Troubleshooting

Operational
Settings

Appendix

Glossary

- 9** Adjust the side guides to the width of the Cleaning Paper. Move the side guides by pressing the side guide buttons so that there is no space between the side guides and the Cleaning Paper. Otherwise, the Cleaning Paper may be fed skewed.

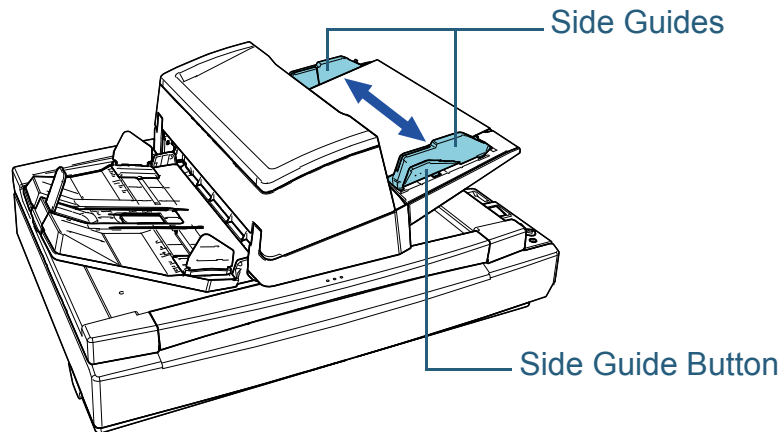

- 10** Press the [Scan/Enter] button.
⇒ The Cleaning Paper is fed and ejected onto the stacker.

- 11** Reset the counter after cleaning.
Reset the counter by performing one of the following actions:
- Reset the counter in [4: Consumable counters] on the [Settings Menu] screen of the operator panel.
For details, refer to ["3.2 Settings Menu"](#) (page 62).
 - Reset the counter in the Software Operation Panel.
For details, refer to ["Resetting the Sheet Counters"](#) (page 175).

Cleaning the ADF (with Cloth)

The ADF can be cleaned with a piece of cloth moistened with Cleaner F1, or a sheet of Cleaning Wipe.

As the scanner continues to feed the documents, paper dust will accumulate inside the ADF and it may cause scanning errors.

Cleaning should be performed approximately every 10,000 sheets scanned. Note that this guideline varies depending on the types of documents you scan. For instance, it may be necessary to clean the scanner more frequently when you scan documents on which the toner is not sufficiently fused.



CAUTION The inside of the ADF becomes very hot when the scanner is being used. Before you start cleaning the inside, make sure to turn off the power, unplug the power cable and wait at least 15 minutes for the inside of the ADF to cool down.

ATTENTION

- Do not use water or mild detergent to clean the ADF.
- It may take a long time to dry if an excessive amount of Cleaner F1 is used. Use it in small quantity. Wipe off the cleaner completely to leave no residue on the cleaned parts.

- 1** Turn off the scanner and wait for at least 15 minutes.
For details, refer to ["1.3 Turning the Power ON/OFF"](#) (page 23).
- 2** Unplug the power cable.

- 3** Open the ADF.
 For details, refer to "1.4 Opening/Closing the ADF" (page 24).



CAUTION

When the ADF is open, it might close accidentally. Be careful not to get your fingers caught.

- 4** Clean the following locations with a cloth moistened with Cleaner F1 or a sheet of Cleaning Wipe.

Glass (× 2)

Brake Roller (× 2)

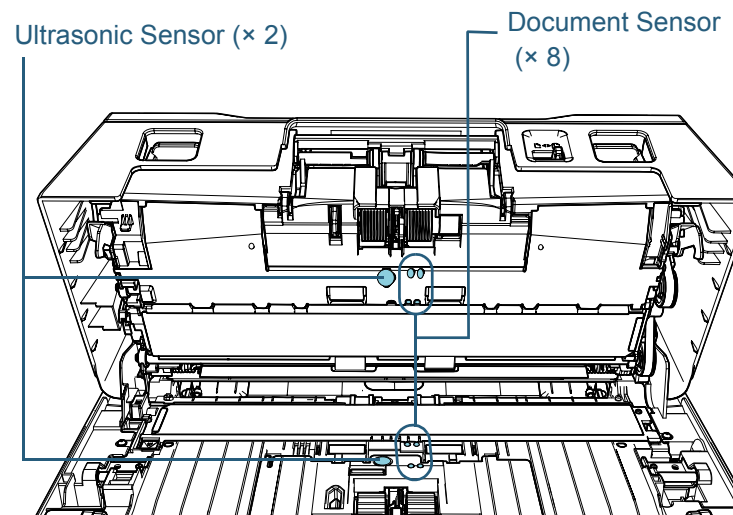
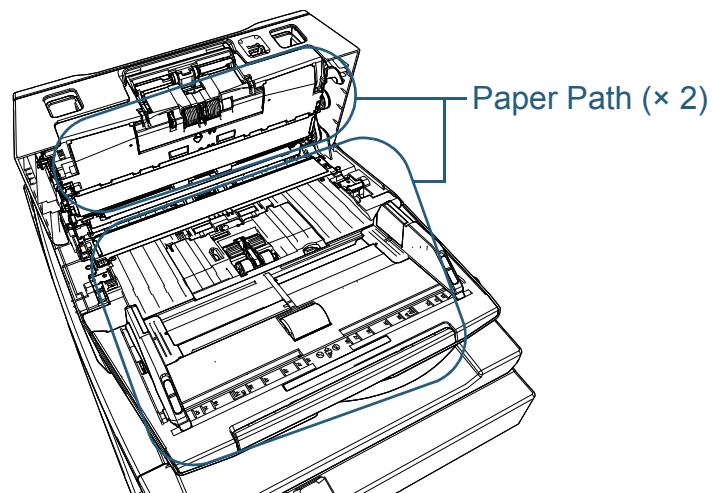
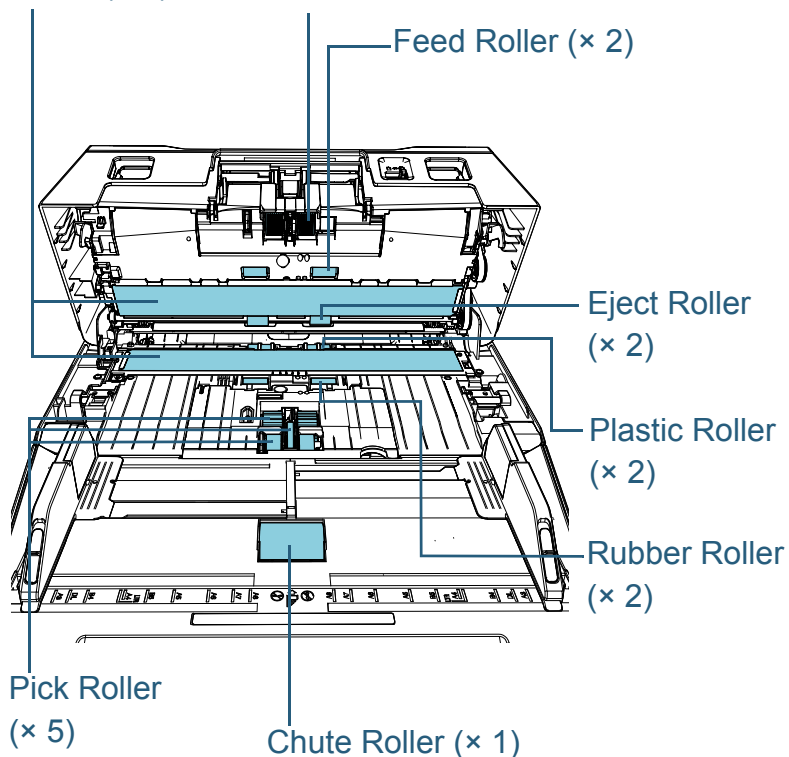

- TOP
- Contents
- Index
- Introduction
- Scanner Overview
- How to Load Documents
- How to Use the Operator Panel
- Various Ways to Scan
- Daily Care**
- Replacing the Consumables
- Troubleshooting
- Operational Settings
- Appendix
- Glossary

Brake Roller (× 2)

Remove the roller from the scanner.

For details about removing the brake roller, refer to "6.2 Replacing the Brake Roller" (page 115).

Gently wipe off any dirt or dust along the grooves, taking care not to damage the roller surface.

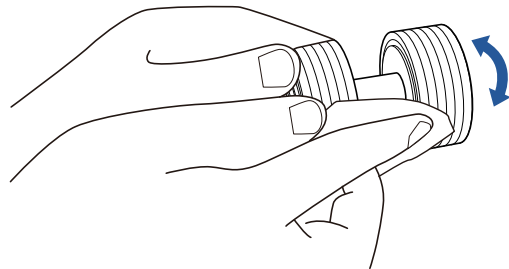
**Pick Roller (× 5)**

Gently wipe dirt and dust off the roller surface (and along the grooves if it has grooves) as you rotate the roller by hand, taking care not to damage the roller surface. Make sure that it is wiped properly because black residue on the roller will affect the feeding performance.

Plastic Roller (× 2)

Gently wipe off any dirt or dust on the surface of the roller. Make sure that it is wiped properly because black residue on the rollers will affect the feeding performance.

Be careful not to damage the sponge that is attached to the roller.

Rubber Roller (× 2)

Gently wipe off any dirt or dust on the surface of the roller. Make sure that it is wiped properly because black residue on the rollers will affect the feeding performance.

Chute Roller (× 1)

With the chute roller cover open, gently wipe off any dirt or dust on the surface of the roller. Make sure that it is wiped properly because black residue on the roller will affect the feeding performance.

Paper Path (× 2)

Gently wipe the dirt and dust off the surface of the paper path.

Glass (× 2)

Gently wipe the dirt and dust off the surface of the glass sections.

ATTENTION

Vertical streaks may appear on the scanned image when the glass is dirty.

Ultrasonic Sensor (× 2)/Document Sensor (× 8)

Gently wipe the dirt and dust off the surface of the ultrasonic/document sensors.

HINT

If it is difficult to clean, use a cotton swab.

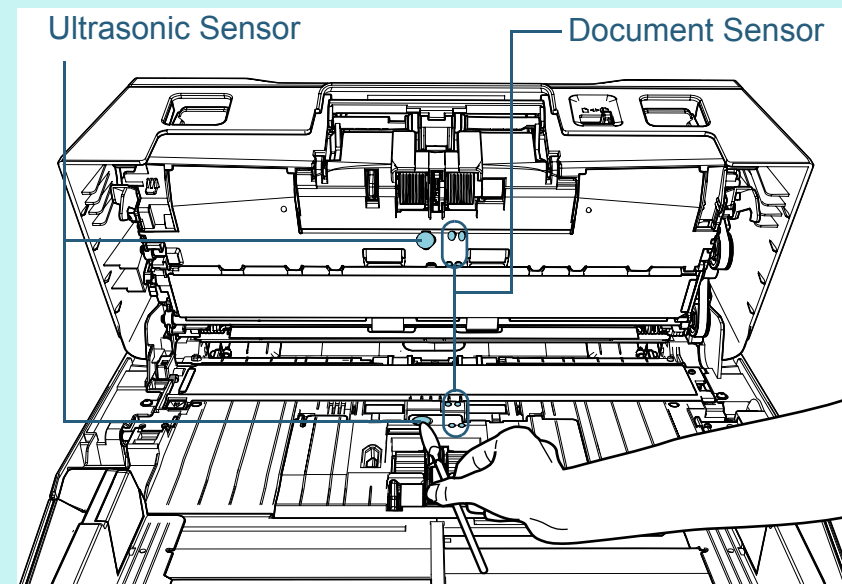

Feed Roller (× 2)/Eject Roller (× 2)

The power must be turned on to rotate the feed/eject rollers.

- 1 Plug in the power cable and turn on the scanner.
For details, refer to "1.3 Turning the Power ON/OFF" (page 23).
⇒ The [Ready] screen is displayed on the LCD.
- 2 Press the [Menu] button.
⇒ The [Settings Menu] screen is displayed on the LCD.
- 3 Press the [△] or [▽] button and select [2: Cleaning], then press the [Scan/Enter] button to confirm.
⇒ The [Cleaning] screen is displayed on the LCD.
- 4 Press the [△] or [▽] button and select [2: Roller Wipe], then press the [Scan/Enter] button to confirm.
⇒ A message is displayed on the LCD.

ATTENTION

Do not perform scanning from the scanner driver during cleaning.

- 5 Open the ADF.
For details, refer to "1.4 Opening/Closing the ADF" (page 24).



When the ADF is open, it might close accidentally. Be careful not to get your fingers caught.

- 6 When you press the [Scan/Enter] button, the feed/eject rollers rotate a certain amount.

[fi-7600]

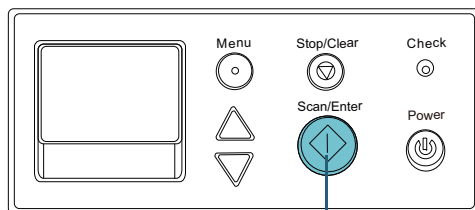

[Scan/Enter] Button

[fi-7700/fi-7700S]

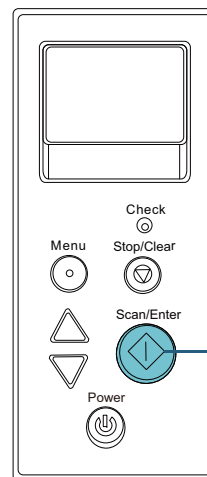

[Scan/Enter] Button



When you press the [Scan/Enter] button, the feed/eject rollers rotate at the same time. Be careful not to touch the rollers with your hand while they are rotating.

- 7 Put a piece of cloth moistened with Cleaner F1 or a sheet of Cleaning Wipe against the surface of the feed rollers/eject rollers, and wipe horizontally.
Wipe off any dirt or dust on the surface by pressing the [Scan/Enter] button to rotate the rollers.
Make sure that it is wiped properly because black residue on the roller will affect the feeding performance.
As a guideline, pressing the [Scan/Enter] button seven times will rotate the feed/eject rollers one revolution.

5 Close the ADF.

For details, refer to ["1.4 Opening/Closing the ADF" \(page 24\)](#).



Be careful not to get your fingers caught when closing the ADF.

ATTENTION

Confirm that the ADF is closed properly. Otherwise, the document may not be fed into the ADF.

6 Reset the counter after cleaning.

Reset the counter by performing one of the following actions:

- Reset the counter in [4: Consumable counters] on the [Settings Menu] screen of the operator panel.
For details, refer to ["3.2 Settings Menu" \(page 62\)](#).
- Reset the counter in the Software Operation Panel.
For details, refer to ["Resetting the Sheet Counters" \(page 175\)](#).

Cleaning the Flatbed [fi-7700/fi-7700S]

The flatbed can be cleaned with a piece of cloth moistened with Cleaner F1, or a sheet of Cleaning Wipe.

- 1** Open the document cover.
For details, refer to ["1.5 Opening/Closing the Document Cover \[fi-7700/fi-7700S\]" \(page 25\)](#).
- 2** Clean the document pad and the document bed with a cloth moistened with Cleaner F1 or a sheet of Cleaning Wipe.

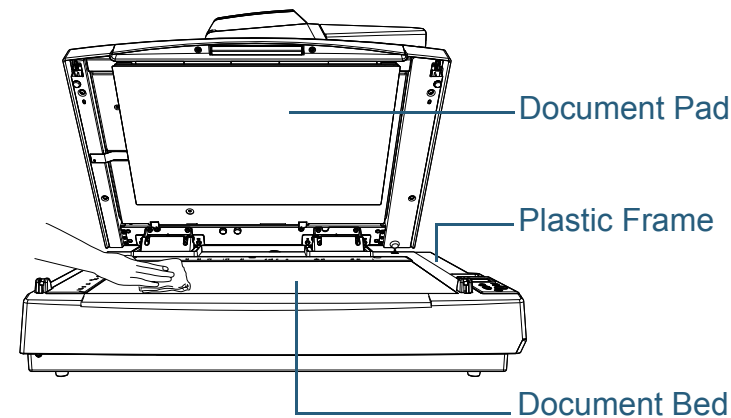
**ATTENTION**

Be careful not to let the cleaner in between the document bed and the plastic frame.

- 3** Wait for the cleaned parts to dry.
- 4** Gently close the document cover.
For details, refer to ["1.5 Opening/Closing the Document Cover \[fi-7700/fi-7700S\]" \(page 25\)](#).

TOP

Contents

Index

Introduction

Scanner
OverviewHow to Load
DocumentsHow to Use the
Operator PanelVarious Ways to
Scan

Daily Care

Replacing the
Consumables

Troubleshooting



Operational
Settings

Appendix

Glossary

Chapter 6 Replacing the Consumables

This chapter describes how to replace the consumables for the scanner.

 CAUTION	The inside of the ADF becomes very hot when the scanner is being used. Before you replace the consumables, make sure to turn off the power, unplug the power cable and wait at least 15 minutes for the inside of the ADF to cool down.
	
	

6.1 Consumables and Replacement Cycles.....	114
6.2 Replacing the Brake Roller.....	115
6.3 Replacing the Pick Roller	118

6.1 Consumables and Replacement Cycles

The following table shows the consumables used for the scanner.

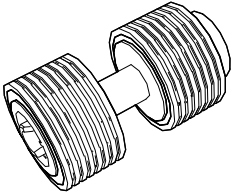
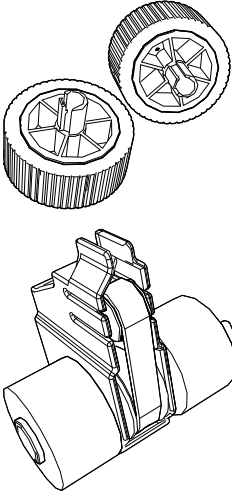
Name	Part No.	Suggested Replacement Cycle
BRAKE ROLLER 	PA03740-K010	250,000 sheets or one year
PICK ROLLER SET 	PA03740-K011	250,000 sheets or one year

Consumables need to be replaced periodically. It is recommended that you keep a stock of new consumables and replace them before it reaches the end of the consumable life. The scanner records the number of sheets scanned after replacing the consumables (brake roller/pick roller), which allows you to check the status on each consumable. For details, refer to ["8.4 Settings Related to Sheet Counters" \(page 174\)](#).

Note that the suggested replacement cycles are guidelines for using A4 (80 g/m² [20 lb]) wood-free or wood-containing paper, as these cycles vary depending on the type of documents scanned and how often the scanner is used and cleaned.

HINT

Only use the specified consumables.

To purchase the consumables, contact your FUJITSU scanner dealer or an authorized FUJITSU scanner service provider.

TOP

Contents

Index

Introduction

Scanner
OverviewHow to Load
DocumentsHow to Use the
Operator PanelVarious Ways to
Scan

Daily Care

Replacing the
Consumables

Troubleshooting

Operational
Settings

Appendix

Glossary

6.2 Replacing the Brake Roller

Replace the brake roller in following procedure.

- 1 Turn off the scanner and wait for at least 15 minutes.
For details, refer to "1.3 Turning the Power ON/OFF" (page 23).
- 2 Unplug the power cable.
- 3 Remove all documents from the ADF paper chute (feeder).
- 4 Open the ADF.
For details, refer to "1.4 Opening/Closing the ADF" (page 24).



When the ADF is open, it might close accidentally. Be careful not to get your fingers caught.

- 5 Open the brake roller cover in the direction of the arrow.

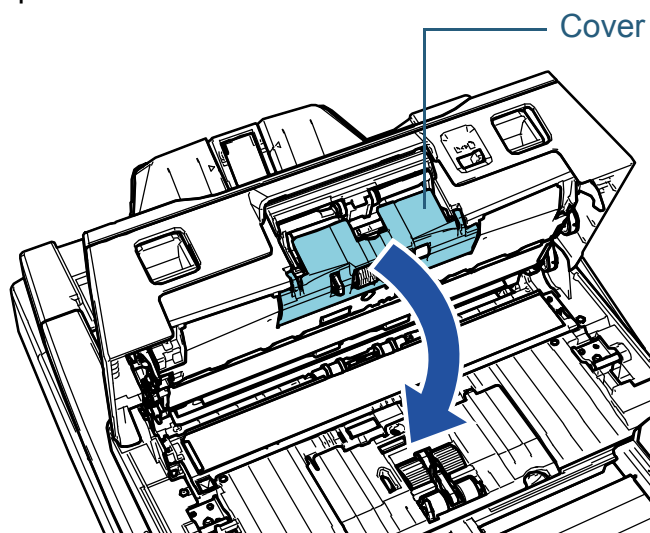

- 6 Remove the brake roller.

Lift the left side of the roller in the direction of the arrow ① first, then pull out the shaft from the slot on the right in the direction of the arrow ②.

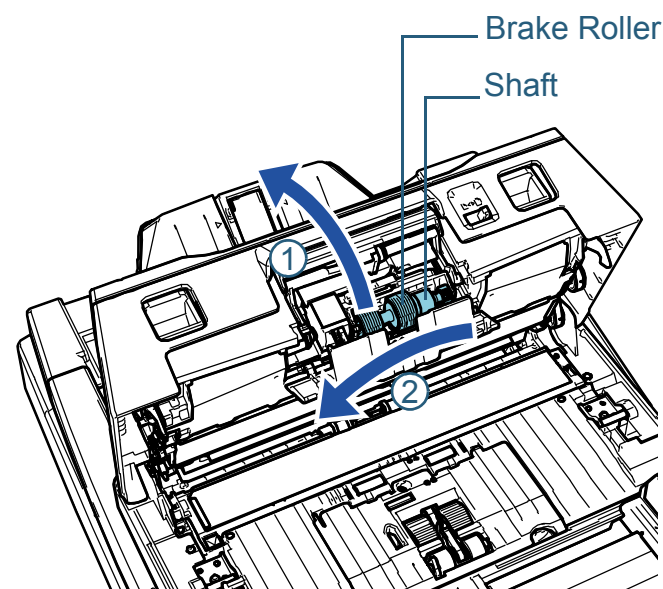

- 7 Remove the brake roller from its shaft.

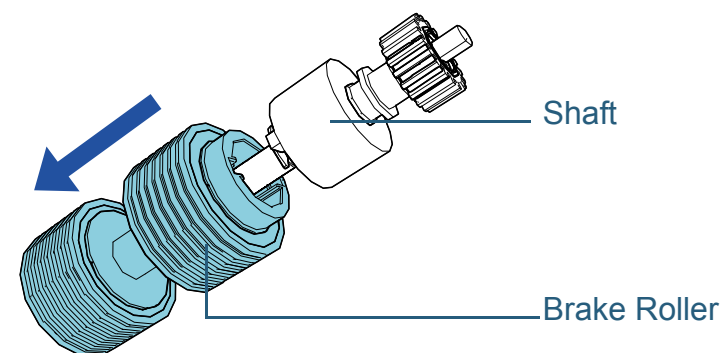

TOP

Contents

Index

Introduction

Scanner
OverviewHow to Load
DocumentsHow to Use the
Operator PanelVarious Ways to
Scan

Daily Care

Replacing the
Consumables

Troubleshooting

Operational
Settings

Appendix

Glossary

- 8** Attach a new brake roller on the shaft.
Insert the protrusion on the shaft into the slot.

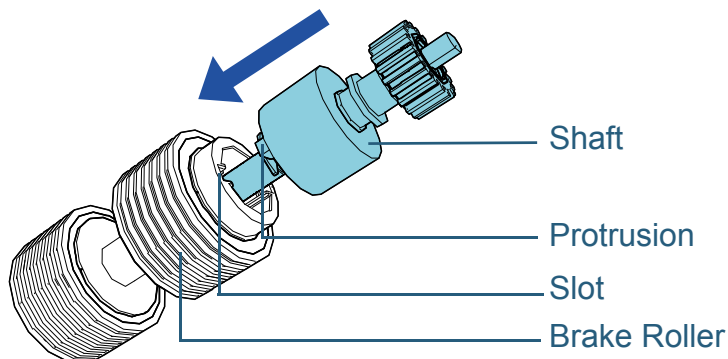

ATTENTION

Confirm that the brake roller is attached properly. Otherwise, it may cause feeding errors such as paper jams. Make sure you insert the roller until it locks in place.

- 9** Attach the shaft.
Insert the right end of the shaft into the hole in accordance with the hole shape in the direction of the arrow ①, and then attach the left side of the shaft in the direction of the arrow ②.

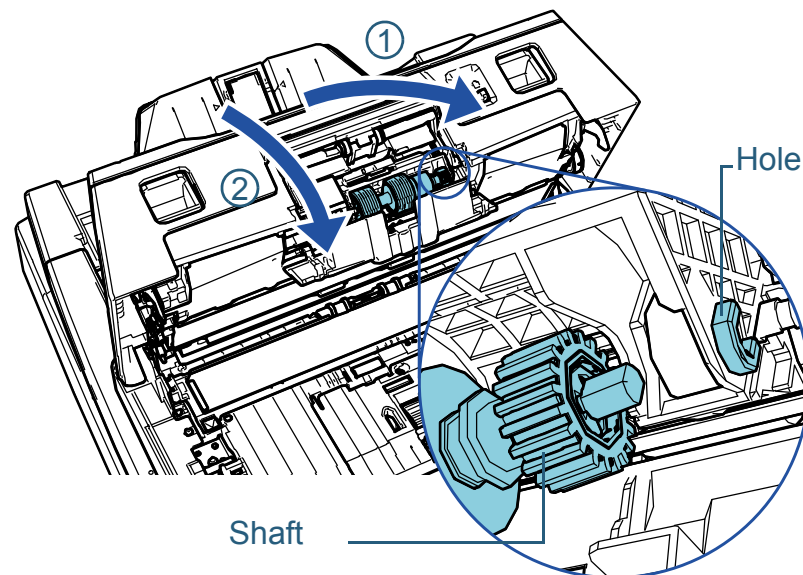

ATTENTION

Confirm that the brake roller is installed properly. Otherwise, it may cause feeding errors such as paper jams.

- 10** Close the cover.

- 11** Close the ADF.
For details, refer to ["1.4 Opening/Closing the ADF" \(page 24\)](#).



Be careful not to get your fingers caught when closing the ADF.

12 Plug in the power cable and turn on the scanner.

For details, refer to "[1.3 Turning the Power ON/OFF](#)" (page 23).

13 Reset the brake roller counter.

Reset the counter by performing one of the following actions:

- Reset the counter in [4: Consumable counters] on the [Settings Menu] screen of the operator panel.
For details, refer to "[3.2 Settings Menu](#)" (page 62).
- Reset the counter in the Software Operation Panel.
For details, refer to "[Resetting the Sheet Counters](#)" (page 175).

TOP

Contents

Index

Introduction

Scanner
Overview

How to Load
Documents

How to Use the
Operator Panel

Various Ways to
Scan

Daily Care

Replacing the
Consumables

Troubleshooting

Operational
Settings

Appendix

Glossary

6.3 Replacing the Pick Roller

Replace the pick roller in following procedure.

ATTENTION

There are two types of pick rollers. When replacing pick rollers, make sure you replace both types at the same time.

- 1 Turn off the scanner and wait for at least 15 minutes. For details, refer to "1.3 Turning the Power ON/OFF" (page 23).
- 2 Unplug the power cable.
- 3 Remove all documents from the ADF paper chute (feeder).
- 4 Open the ADF. For details, refer to "1.4 Opening/Closing the ADF" (page 24).



When the ADF is open, it might close accidentally. Be careful not to get your fingers caught.

- 5 Open the sheet guide. Slide the side guides all the way by pressing the side guide buttons, and pull the sheet guide open from the dip.

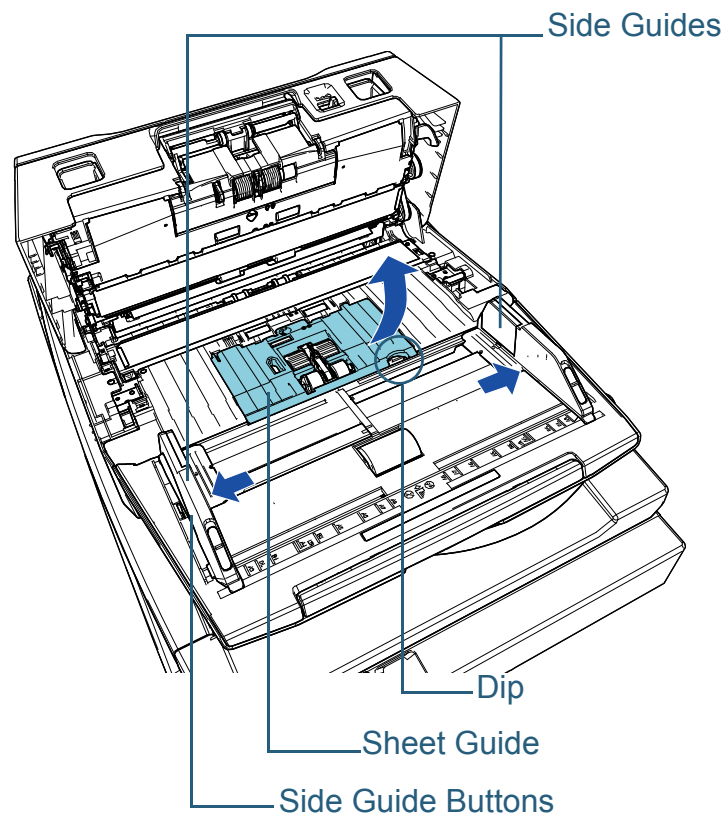

TOP

Contents

Index

Introduction

Scanner
OverviewHow to Load
DocumentsHow to Use the
Operator PanelVarious Ways to
Scan

Daily Care

Replacing the
Consumables

Troubleshooting

Operational
Settings

Appendix

Glossary

6 Remove the pick roller closer to you.

1 Rotate the bushing (× 2) on the shaft in the direction of the arrow.

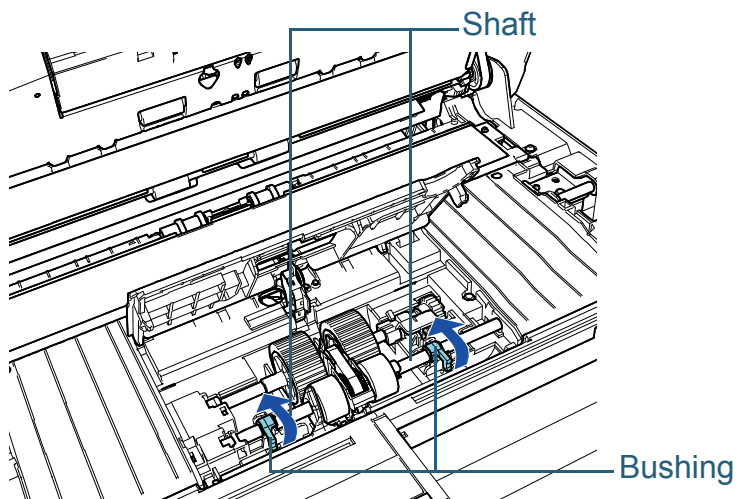

2 Slide the bushing (× 2) on the shaft in the direction of the arrow.

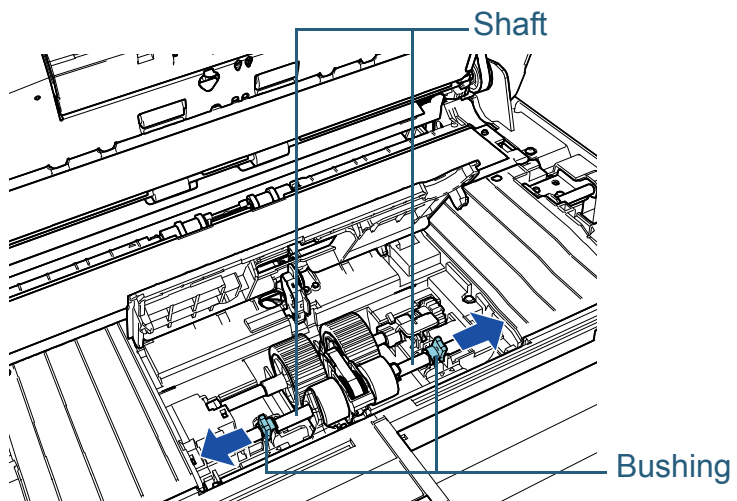

3 Remove the pick roller.

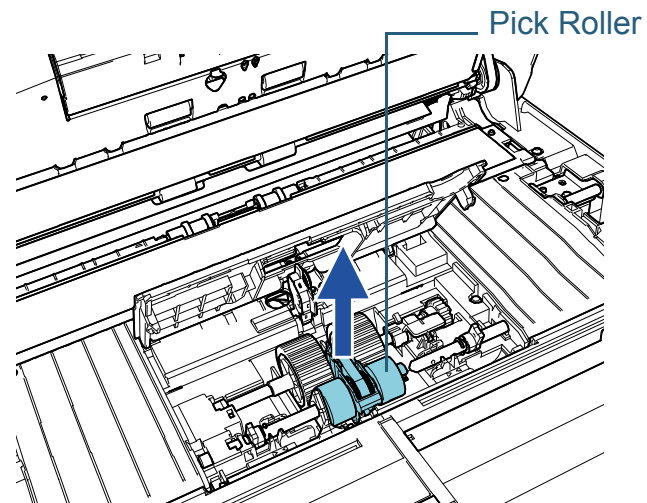

7 Remove the shaft of the pick roller that is away from you.

1 Rotate the bushing on the shaft in the direction of the arrow.

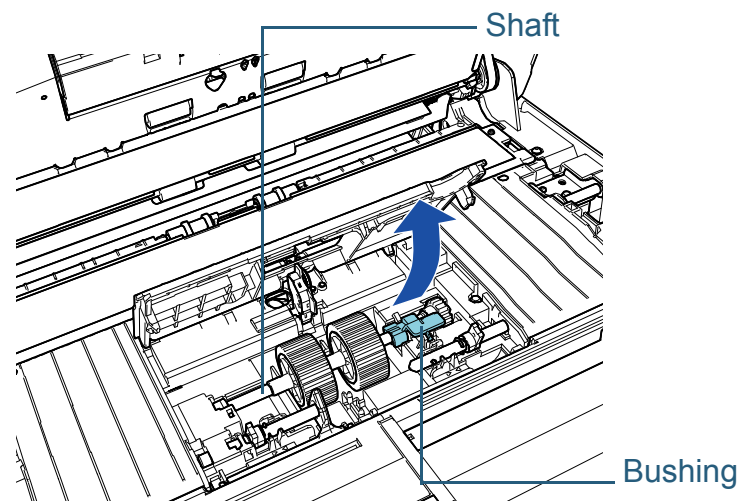

- TOP
- Contents
- Index
- Introduction
- Scanner Overview
- How to Load Documents
- How to Use the Operator Panel
- Various Ways to Scan
- Daily Care
- Replacing the Consumables
- Troubleshooting
- Operational Settings
- Appendix
- Glossary

- 2 Lift up the bushing in direction ① (about 5 mm), and slide the shaft in direction ② to pull out the leading end from the slot, then lift the shaft in direction ③ to remove it.

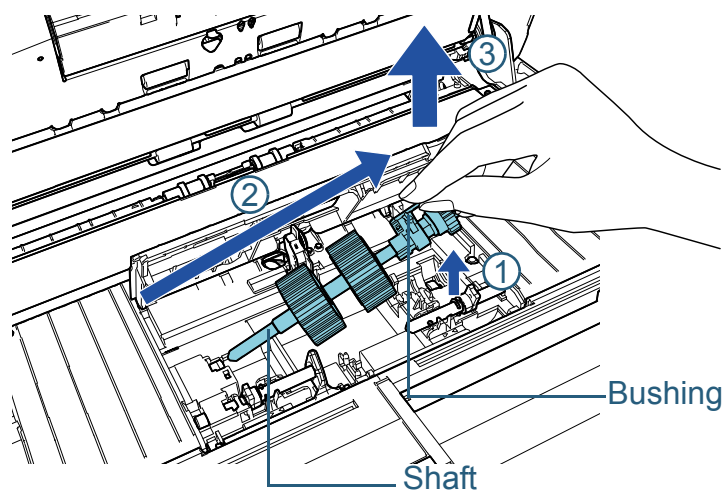

ATTENTION

Be careful not to touch the gear near the bushing on the shaft as it contains grease.

8 Remove the pick rollers (× 2) from the shaft one at a time.

- 1 Pull out the pick roller from the shaft as you lift the retaining clip.

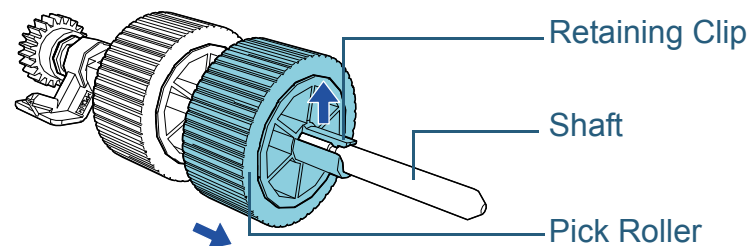

- 2 Pull out the other pick roller from the shaft as you lift the retaining clip.

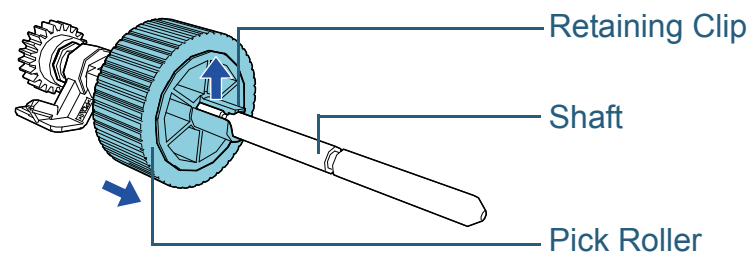

- TOP
- Contents
- Index
- Introduction
- Scanner Overview
- How to Load Documents
- How to Use the Operator Panel
- Various Ways to Scan
- Daily Care
- Replacing the Consumables**
- Troubleshooting
- Operational Settings
- Appendix
- Glossary

9 Attach new pick rollers (× 2) on the shaft on at a time.

- 1 Hold the bushing of the shaft in one hand and the pick roller with the retaining clip facing towards you in the other hand, and then put the pick roller on the shaft in the direction of the arrow ①. If you rotate the pick roller in the direction of the arrow ②, you can put it on the shaft more easily.

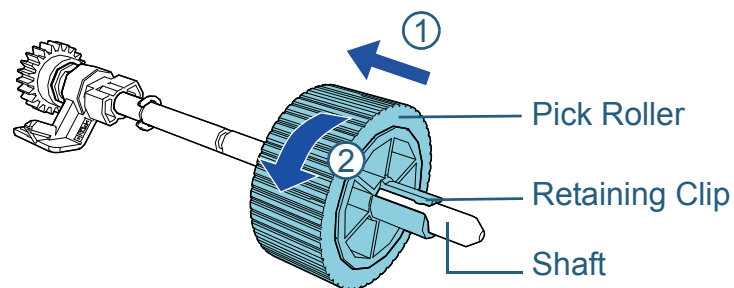

- 2 Hold the bushing of the shaft in one hand and the other pick roller with the retaining clip facing towards you in the other hand, and then put the pick roller on the shaft in the direction of the arrow ①. If you rotate the pick roller in the direction of the arrow ②, you can put it on the shaft more easily.

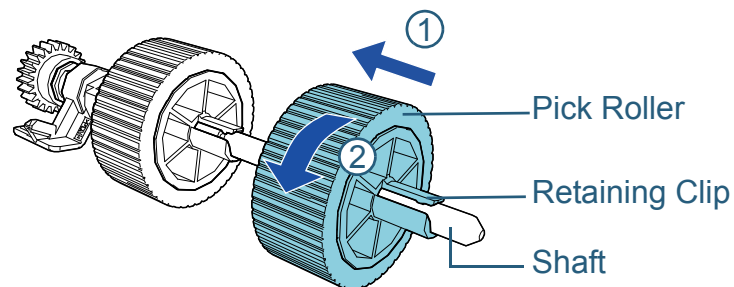

ATTENTION

Confirm that the pick rollers are attached properly. Otherwise, it may cause feeding errors such as paper jams. Make sure to insert the pick roller until it locks in place.

10 Install the shaft of the pick roller in the side away from you.

- 1 Insert the left end of the shaft into the slot, and lower the other end gradually.

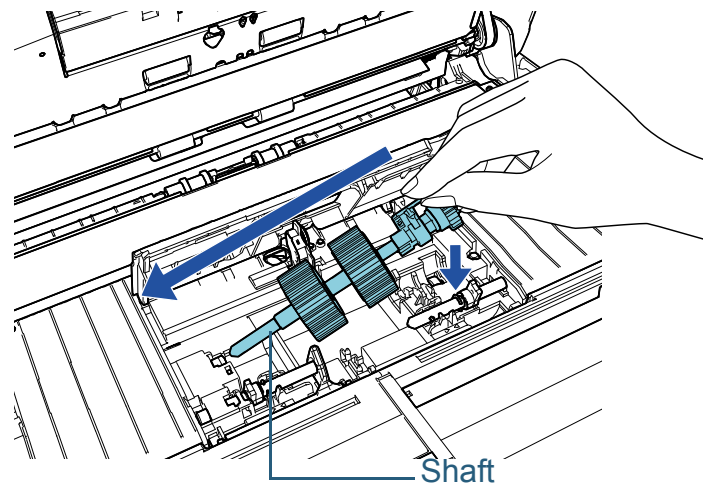

- 2 Rotate the bushing on the shaft in the direction of the arrow.

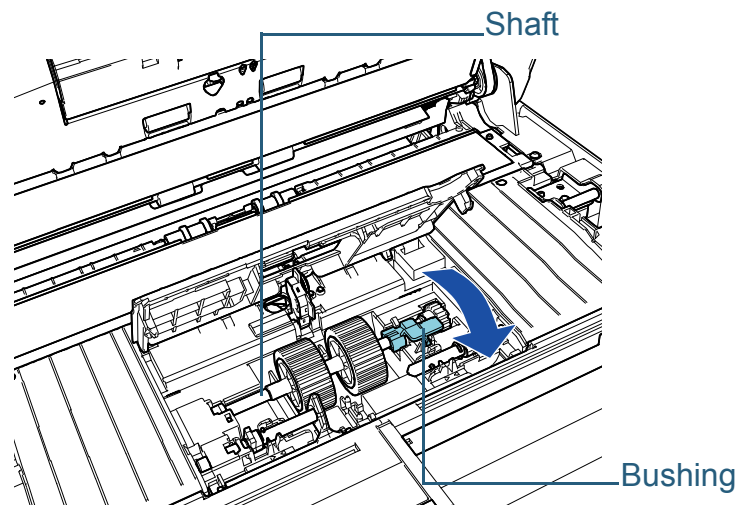

- TOP
- Contents
- Index
- Introduction
- Scanner Overview
- How to Load Documents
- How to Use the Operator Panel
- Various Ways to Scan
- Daily Care
- Replacing the Consumables
- Troubleshooting
- Operational Settings
- Appendix
- Glossary

11 Install the new pick roller in the side closer to you.

- 1 Insert the protrusion (× 2) on the scanner into the hole (× 2) on the pick roller.

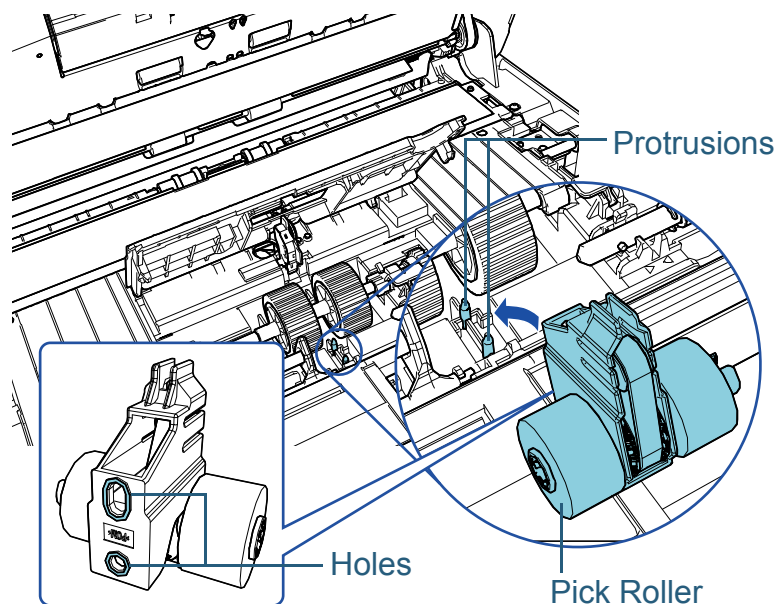

- 2 Slide the bushing on the left shaft in the direction of the arrow.

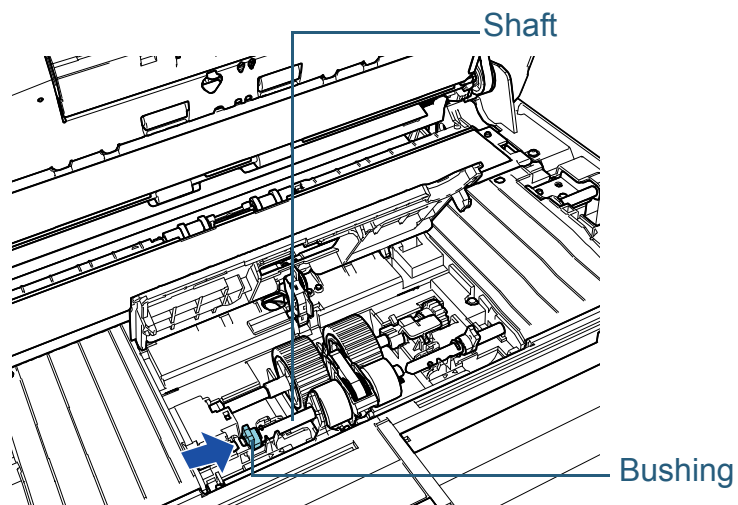

- 3 Fit the protrusion on the right shaft into the notch on the pick roller and slide the bushing on the right shaft in the direction of the arrow.

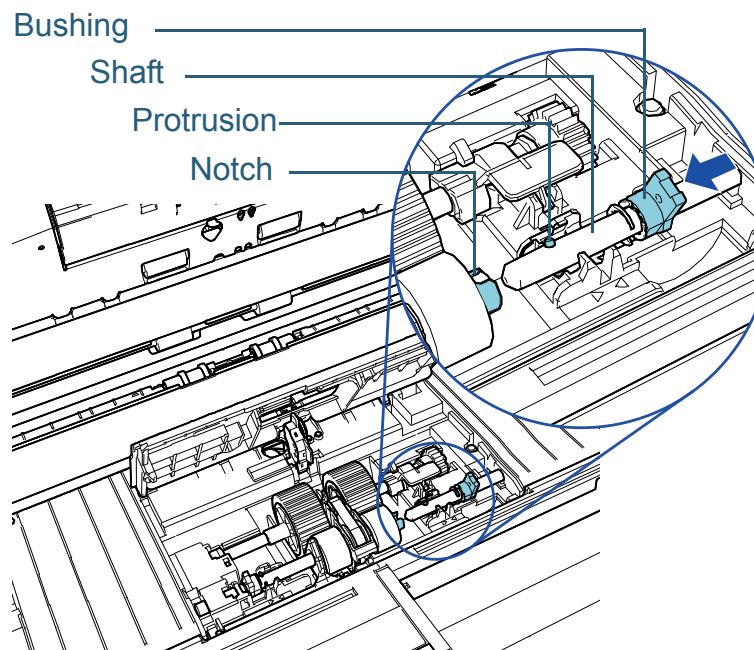

- 4 Rotate the bushing (× 2) on the shaft in the direction of the arrow.

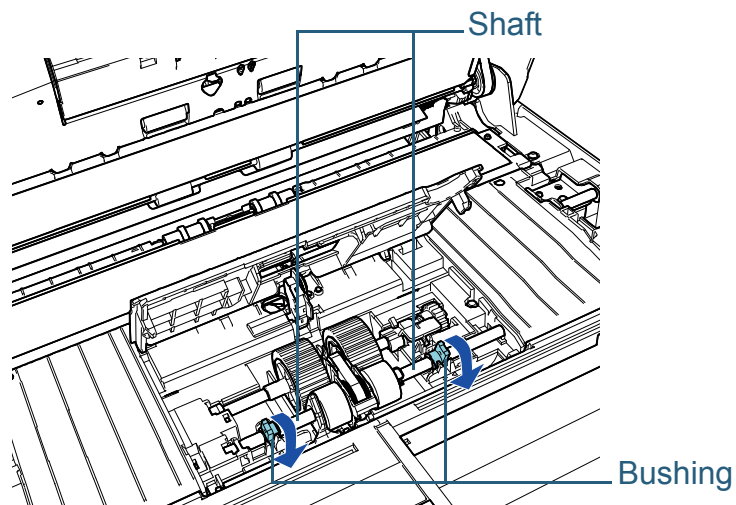

- TOP
- Contents
- Index
- Introduction
- Scanner Overview
- How to Load Documents
- How to Use the Operator Panel
- Various Ways to Scan
- Daily Care
- Replacing the Consumables
- Troubleshooting
- Operational Settings
- Appendix
- Glossary

12 Close the sheet guide.

Make sure that both ends of the sheet guide are locked firmly.

ATTENTION

Confirm that the pick rollers are installed properly. Otherwise, it may cause feeding errors such as paper jams.

13 Close the ADF.

For details, refer to ["1.4 Opening/Closing the ADF" \(page 24\)](#).



Be careful not to get your fingers caught when closing the ADF.

14 Plug in the power cable and turn on the scanner.

For details, refer to ["1.3 Turning the Power ON/OFF" \(page 23\)](#).

15 Reset the pick roller counter.

Reset the counter by performing one of the following actions:

- Reset the counter in [4: Consumable counters] on the [Settings Menu] screen of the operator panel.
For details, refer to ["3.2 Settings Menu" \(page 62\)](#).
- Reset the counter in the Software Operation Panel.
For details, refer to ["Resetting the Sheet Counters" \(page 175\)](#).

TOP

Contents

Index

Introduction

Scanner
Overview

How to Load
Documents

How to Use the
Operator Panel

Various Ways to
Scan

Daily Care

Replacing the
Consumables

Troubleshooting

Operational
Settings

Appendix

Glossary

Chapter 7 Troubleshooting

This chapter explains about the countermeasures against paper jams and other troubles, items to check before contacting your scanner service provider, and how to read the product labels on the scanner.

ATTENTION

For details about other errors/troubles that are not covered in this chapter, refer to the scanner driver's Help or the Error Recovery Guide.

7.1 Paper Jam	125
7.2 Error Indications on Operator Panel	126
7.3 Troubleshooting	135
7.4 Before You Contact the Scanner Service Provider	153
7.5 Checking the Product Labels.....	155

7.1 Paper Jam

When your document is jammed inside the scanner, remove the document in the following procedure:



- Do not use force to pull out the jammed document, and make sure to open the ADF first.
- Be careful not to touch any sharp parts upon removing jammed documents.
- Be careful not to get things such as hair, a tie or necklaces caught inside the scanner.
- The inside of the ADF may become extremely hot during operation.

1 Remove all documents from the ADF paper chute (feeder).

2 Open the ADF.
For details, refer to ["1.4 Opening/Closing the ADF" \(page 24\)](#).



When the ADF is open, it might close accidentally. Be careful not to get your fingers caught.

3 Remove the jammed document.

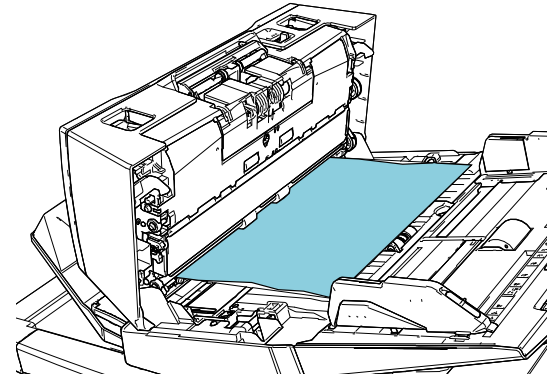

ATTENTION

- Make sure you check the documents and the paper path thoroughly. Remove any metal objects such as staples or paper clips to prevent paper jams.
- Be careful not to damage the glass surface and the guides when removing documents with metal objects such as staples or paper clips.

4 Close the ADF.

For details, refer to ["1.4 Opening/Closing the ADF" \(page 24\)](#).



Be careful not to get your fingers caught when closing the ADF.

ATTENTION

- Confirm that the ADF is closed properly. Otherwise, the document may not be fed into the ADF.
- Occasionally when scanning is complete or canceled, documents may remain in the ADF without any error message displayed. In that case, remove the documents by following the above steps **1** to **4**.

7.2 Error Indications on Operator Panel

When an error occurs during operation, the LED indicator lights in orange.

In addition, the indication on the LCD changes as follows:

- For temporary errors
Error codes beginning with the letter "J" or "U" are displayed.
- For device errors
Error codes beginning with the letter "E", "F", "C", "H", "A", or "L" are displayed.

Temporary errors can be recovered by the operator, whereas device errors require troubleshooting by a service engineer. You can clear the error display by pressing the [Stop/Clear] button. Note that a paper jam message disappears after a certain period of time elapses if there are no documents ([Ready] status) in the scanner.

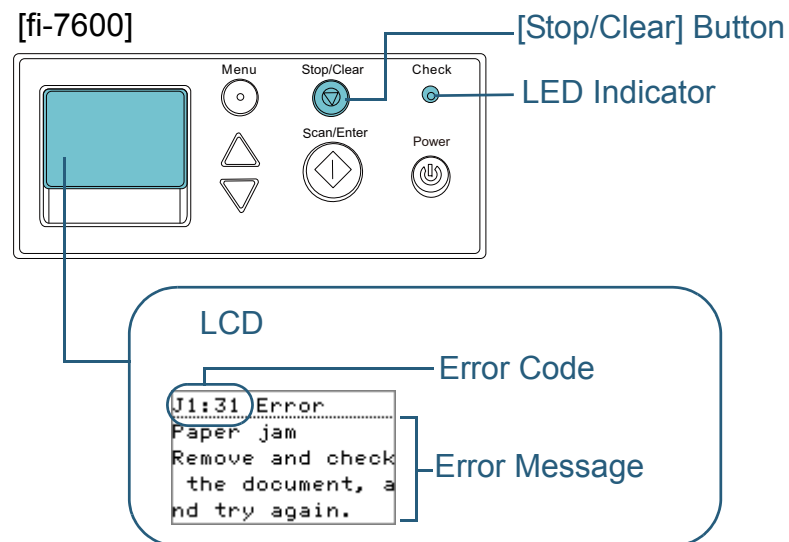

[fi-7700/fi-7700S]

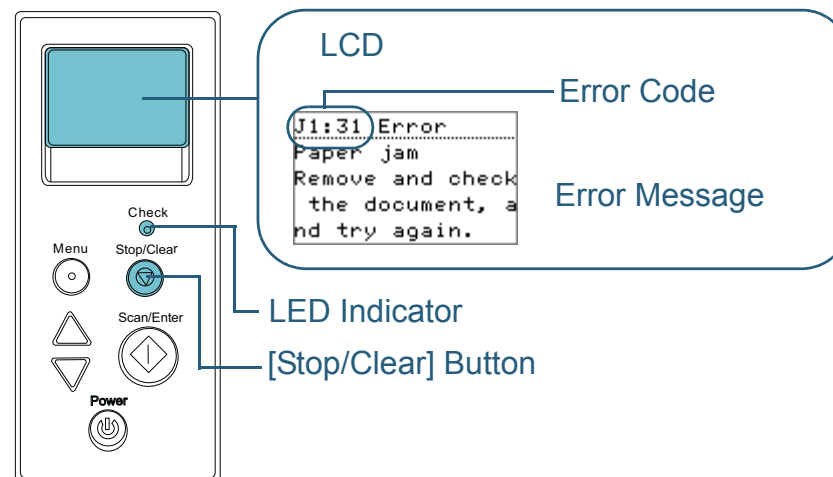

If the Error Recovery Guide is installed in the computer, the Error Recovery Guide window appears when the Windows operating system is started up. When an error occurs, the Error Recovery Guide window displays related information such as the name of the error and the error code (number). Write down the information shown in the window and click the [More Info] button to check for troubleshooting methods.

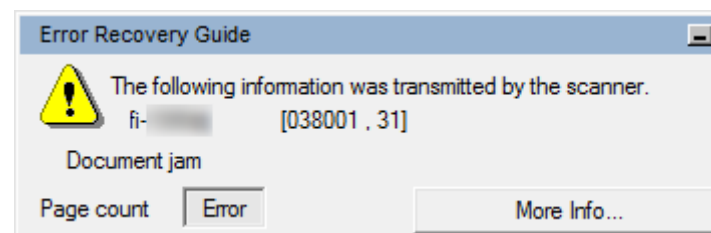

Temporary Errors

The following are lists of temporary errors which can be recovered by operators.

■ Paper Feeding Errors

Error codes beginning with the letter "J" are displayed.

Error code	Error messages	Action
J0:37	Paper protection (feeding noise) Remove and check the document, and then try again carefully.	<ol style="list-style-type: none"> 1 Remove the jammed document. For details, refer to "7.1 Paper Jam" (page 125). 2 Check if the document is suitable for scanning by ADF. For details, refer to "2.3 Documents for Scanning" (page 47). 3 Press the [Menu] button on the operator panel, select whether to enable or disable the document protection function, and then press the [Scan/Enter] button or perform a scan from the computer.

Error code	Error messages	Action
J0:51	Paper protection (feeding accuracy) Remove and check the document, and then try again carefully.	<ol style="list-style-type: none"> 1 Remove the jammed document. For details, refer to "7.1 Paper Jam" (page 125). 2 Make sure that documents that are folded or documents that do not conform to the paper specifications, such as thin paper, are not included. For details, refer to "2.3 Documents for Scanning" (page 47). 3 Press the [Menu] button on the operator panel, select whether to enable or disable the document protection function, and then press the [Scan/Enter] button or perform a scan from the computer.
J1:31 J1:36	Paper jam Remove and check the document, and try again.	<ol style="list-style-type: none"> 1 Remove the jammed document. For details, refer to "7.1 Paper Jam" (page 125). For "J1:5A", remove the document in the imprinter. For details, refer to the fi-760PRB Imprinter Operator's Guide.
J1:5A (*1)		
J1:50	Pick error Remove and check the document, and try again.	<ol style="list-style-type: none"> 2 Check if the document is suitable for scanning with the ADF or the imprinter. For details, refer to "2.3 Documents for Scanning" (page 47) or the fi-760PRB Imprinter Operator's Guide. 3 Clean the rollers. For details, refer to "Chapter 5 Daily Care" (page 103).

Error code	Error messages	Action
J2:55	Multifeed detected (Overlap) Press the Scan/Enter button to eject the document. After ejecting the document, multifeed detection for the next document can be enabled/disabled from the Menu button.	<ol style="list-style-type: none"> 1 Press the [Scan/Enter] button on the operator panel to eject the documents. 2 Press the [Menu] button on the operator panel, select whether or not to detect multifeed, and then press the [Scan/Enter] button or perform a scan from the computer.
	Multifeed detected (Overlap) Press the Scan/Enter button to eject the document. Press the Menu button to memorize the multifeed pattern.	<ol style="list-style-type: none"> 1 Press the [Scan/Enter] button on the operator panel to eject the documents. 2 Press the [Menu] button on the operator panel, select whether or not to memorize the pattern, and then press the [Scan/Enter] button or perform a scan from the computer.
	Multifeed detected (Overlap) Press the Scan/Enter button to eject the document.	<ol style="list-style-type: none"> 1 Press the [Scan/Enter] button on the operator panel to eject the documents. 2 Press the [Scan/Enter] button on the operator panel or perform a scan from the computer.

Error code	Error messages	Action
J2:56	Multifeed detected (Length) Press the Scan/Enter button to eject the document.	<ol style="list-style-type: none"> 1 Press the [Scan/Enter] button on the operator panel to eject the documents. 2 Press the [Scan/Enter] button on the operator panel or perform a scan from the computer.
J7:5F	Feed mode switched Check the feed mode switch setting, reload the documents and try again.	Check the position of the feed mode switch, reload the documents and try again.
J8:01	Sensor(s) dirty Clean the Pick Sensor.	Open the ADF and clean the eight document sensors. For details, refer to " Chapter 5 Daily Care " (page 103).
J8:04	Sensor(s) dirty Clean the READ-TOP Sensor.	
J9:39	Paper jam Please clean rollers.	Open the ADF and clean the rollers. For details, refer to " Chapter 5 Daily Care " (page 103).

*1: Displayed when the imprinter is installed.

■ Transport Lock, Cover Open, and Print Errors

Error codes beginning with the letter "U" are displayed.

Error code	Error messages	Action
U0:10	Transport lock error Unlock the transport lock switch.	[fi-7700/fi-7700S] Unlock the transport lock. For details, refer to the Quick Installation Sheet.
U4:40 (*1)	ADF open	Close the ADF and reload the documents.
U5:4A (*2) (*3)	Imprinter Cover Open	Close the print section of the imprinter, and load the document again.
U6:B4 (*3)	Print cartridge not installed Check if the Print Cartridge is mounted correctly.	This error is related to the imprinter. For details, refer to the fi-760PRB Imprinter Operator's Guide.
U7:B9 (*3)	Imprinting area error	Adjust the imprinting start position and the imprinter strings to fit the imprinting area in the document. For details, refer to the fi-760PRB Imprinter Operator's Guide.

*1: When you open the ADF while the scanner is in standby, only an error message will appear without an error code.

Also, note that buttons on the operator panel are disabled while the ADF is open.

*2: When you open the imprinter print section while the scanner is in standby, only an error message will appear without an error code.
Also, note that buttons on the operator panel are disabled while the imprinter print section is open.

*3: Displayed when the imprinter is installed.

Device Errors

The following are lists of device errors which require troubleshooting by a service engineer.

■ Internal and Optical Errors

Error codes beginning with the letter "E" are displayed.

Error code	Error messages	Action
E0:87	FB carrier error Unlock the transport lock switch.	[fi-7700/fi-7700S] Unlock the transport lock. For details, refer to the Quick Installation Sheet.
E1:7E	Optical error (FB) If the problem persists after turning the power back on, please inform your service provider of the above error code.	[fi-7700/fi-7700S] 1 Check whether the transport lock is unlocked. For details, refer to the Quick Installation Sheet. 2 Turn the scanner off then back on. If the problem persists, write down the displayed error code and contact your FUJITSU scanner dealer or an authorized FUJITSU scanner service provider.

Error code	Error messages	Action
E2:74	Optical error (ADF Front) If the problem persists after turning the power back on, please inform your service provider of the above error code.	1 Clean the glass section. For details, refer to " Chapter 5 Daily Care " (page 103). 2 Turn the scanner off then back on. If the problem persists, write down the displayed error code and contact your FUJITSU scanner dealer or an authorized FUJITSU scanner service provider.
E3:75	Optical error (ADF Back) If the problem persists after turning the power back on, please inform your service provider of the above error code.	

Error code	Error messages	Action
E6:D3	Operator Panel error If the problem persists after turning the power back on, please inform your service provider of the above error code.	Turn the scanner off then back on. If the problem persists, write down the displayed error code and contact your FUJITSU scanner dealer or an authorized FUJITSU scanner service provider.
E7:D2	EEPROM error If the problem persists after turning the power back on, please inform your service provider of the above error code.	
E9:F5	Image memory read-write error (Front) If the problem persists after turning the power back on, please inform your service provider of the above error code.	
E9:F6	Image memory read-write error (Back) If the problem persists after turning the power back on, please inform your service provider of the above error code.	

TOP

Contents

Index

Introduction

Scanner
OverviewHow to Load
DocumentsHow to Use the
Operator PanelVarious Ways to
Scan

Daily Care

Replacing the
Consumables

Troubleshooting

Operational
Settings

Appendix

Glossary

■ Overrun Error

Error codes beginning with the letter "F" are displayed.

Error code	Error messages	Action
F2:C4	Pick arm malfunction If the problem persists after turning the power back on, please inform your service provider of the above error code.	Turn the scanner off then back on. If the problem persists, write down the displayed error code and contact your FUJITSU scanner dealer or an authorized FUJITSU scanner service provider.
F4:C2	Background switching mechanism error (ADF Front) If the problem persists after turning the power back on, please inform your service provider of the above error code.	Open the ADF to check that there is no document left inside, turn off the scanner, and then turn it back on. If the problem persists, write down the displayed error code and contact your FUJITSU scanner dealer or an authorized FUJITSU scanner service provider.
F4:C3	Background switching mechanism error (ADF Back) If the problem persists after turning the power back on, please inform your service provider of the above error code.	

■ Chip Error

Error codes beginning with the letter "C" are displayed.

Error code	Error messages	Action
C0:E5	Memory error (Front) If the problem persists after turning the power back on, please inform your service provider of the above error code.	Turn the scanner off then back on. If the problem persists, write down the displayed error code and contact your FUJITSU scanner dealer or an authorized FUJITSU scanner service provider.
C0:E6	Memory error (Back) If the problem persists after turning the power back on, please inform your service provider of the above error code.	
C0:E9	LSI error (Front) If the problem persists after turning the power back on, please inform your service provider of the above error code.	
C0:EA	LSI error (Back) If the problem persists after turning the power back on, please inform your service provider of the above error code.	

TOP

Contents

Index

Introduction

Scanner
OverviewHow to Load
DocumentsHow to Use the
Operator PanelVarious Ways to
Scan

Daily Care

Replacing the
Consumables

Troubleshooting

Operational
Settings

Appendix

Glossary

Error code	Error messages	Action
C8:F2	Internal communication error of the scanner If the problem persists after turning the power back on, please inform your service provider of the above error code.	Turn the scanner off then back on. If the problem persists, write down the displayed error code and contact your FUJITSU scanner dealer or an authorized FUJITSU scanner service provider.

■ Motor Circuit Error

Error codes beginning with the letter "H" are displayed.

Error code	Error messages	Action
H0:83 H1:80 H2:81 H8:88	Motor circuit error If the problem persists after turning the power back on, please inform your service provider of the above error code.	Turn the scanner off then back on. If the problem persists, write down the displayed error code and contact your FUJITSU scanner dealer or an authorized FUJITSU scanner service provider.
H6:B1 (*1)	Imprinter system error If the problem persists after turning the power back on, please inform your service provider of the above error code.	
H7:84	Lamp circuit error If the problem persists after turning the power back on, please inform your service provider of the above error code.	

*1: Displayed when the imprinter is installed.

[TOP](#)
[Contents](#)
[Index](#)
[Introduction](#)
[Scanner Overview](#)
[How to Load Documents](#)
[How to Use the Operator Panel](#)
[Various Ways to Scan](#)
[Daily Care](#)
[Replacing the Consumables](#)
[Troubleshooting](#)
[Operational Settings](#)
[Appendix](#)
[Glossary](#)

■ Option Error (When the Imprinter Is Installed)

Error codes beginning with the letter "A" are displayed.

Error code	Error messages	Action
A1:B3	Imprinter error (communication timeout) If the problem persists after turning the power back on, please inform your service provider of the above error code.	1 Confirm that the EXT cable of the imprinter is connected properly to the EXT connector on the back of the scanner. For details about the EXT cable, refer to "Back" (page 18) . For details about how to connect the EXT cable, refer to the fi-760PRB Imprinter Operator's Guide.
A3:B6	Imprinter error (EEPROM) If the problem persists after turning the power back on, please inform your service provider of the above error code.	2 Confirm that the print cartridge is installed correctly. For details, refer to the fi-760PRB Imprinter Operator's Guide.
A4:B8	Imprinter error (ROM) If the problem persists after turning the power back on, please inform your service provider of the above error code.	3 Turn the scanner off then back on. If the problem persists, write down the displayed error code and contact your FUJITSU scanner dealer or an authorized FUJITSU scanner service provider.

Error code	Error messages	Action
A2:B5	Imprinter error (print head) If the problem persists after turning the power back on, please inform your service provider of the above error code.	<ol style="list-style-type: none"> 1 Check that the EXT cable of the imprinter is connected properly to the EXT connector on the back of the scanner. For details about the EXT connector, refer to "Back" (page 18). For details about how to connect the EXT cable, refer to the fi-760PRB Imprinter Operator's Guide. 2 Check that the print cartridge is installed correctly. For details, refer to the fi-760PRB Imprinter Operator's Guide. 3 If you have a replacement print cartridge, replace the print cartridge. For details, refer to the fi-760PRB Imprinter Operator's Guide. 4 Turn the scanner off then back on. If the problem persists, write down the displayed error code and contact your FUJITSU scanner dealer or an authorized FUJITSU scanner service provider.

■ Sensor Error

Error codes beginning with the letter "L" are displayed.

Error code	Error messages	Action
L0:11 L2:13	Sensor error If the problem persists after turning the power back on, please inform your service provider of the above error code.	<ol style="list-style-type: none"> 1 Clear any paper dust around the document sensors. 2 Turn the scanner off then back on. If the problem persists, write down the displayed error code and contact your FUJITSU scanner dealer or an authorized FUJITSU scanner service provider.
L6:1B	Sensor error If the problem persists after turning the power back on, please inform your service provider of the above error code.	<ol style="list-style-type: none"> 1 Clear any paper dust around the ultrasonic sensors. 2 Turn the scanner off then back on. If the problem persists, write down the displayed error code and contact your FUJITSU scanner dealer or an authorized FUJITSU scanner service provider.

TOP

Contents

Index

Introduction

Scanner
OverviewHow to Load
DocumentsHow to Use the
Operator PanelVarious Ways to
Scan

Daily Care

Replacing the
Consumables

Troubleshooting

Operational
Settings

Appendix

Glossary

7.3 Troubleshooting

This section describes the actions to take for troubles that may occur while you are using the scanner. Please check the following items before you request a repair. If the problem persists, check each item in ["7.4 Before You Contact the Scanner Service Provider" \(page 153\)](#), and then contact your FUJITSU scanner dealer or an authorized FUJITSU scanner service provider.

The following are some examples of troubles that you may experience.

Symptoms
"Scanner cannot be powered ON." (page 136)
"The LCD or the [Power] button light or both switch OFF." (page 137)
"Scanning does not start." (page 138)
"Scanning takes a long time." (page 139)
"Image quality is poor." (page 140)
"Quality of scanned text or lines is unsatisfactory." (page 141)
"Images are distorted or not clear." (page 142)
"Vertical streaks appear on the scanned image." (page 143)
"An error (error code "U0:10", "U4:40" or "U5:4A") is already displayed in the LCD after power-on." (page 144)
"Multifeed error occurs frequently." (page 145)
"Situation in which the document is not fed into the ADF occurs frequently." (page 147)
"Paper protection is set off frequently." (page 148)

Symptoms
"Paper jams/pick errors occur frequently." (page 149)
"Scanned images turn out elongated." (page 150)
"A shadow appears at the top or the bottom of the scanned image." (page 151)
"There are black traces on the document." (page 152)

TOP

Contents

Index

Introduction

Scanner
OverviewHow to Load
DocumentsHow to Use the
Operator PanelVarious Ways to
Scan

Daily Care

Replacing the
Consumables

Troubleshooting

Operational
Settings

Appendix

Glossary

Scanner cannot be powered ON.

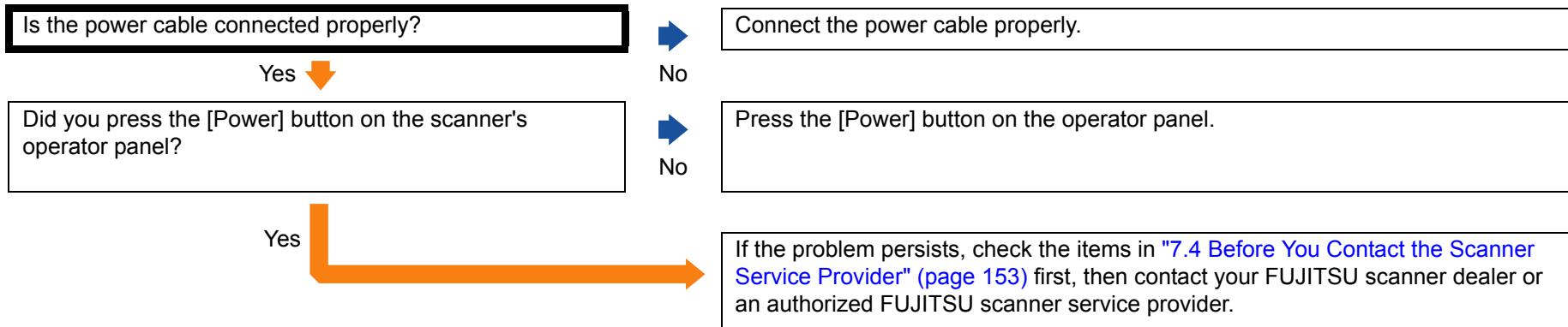

The LCD or the [Power] button light or both switch OFF.

Has the scanner been left out of operation for a long time after being powered on?

Yes

The scanner has entered power saving mode or has been automatically turned off.

- If the scanner has entered power saving mode
The LCD turns off and the [Power] button flashes in green.
Resume from power saving mode by one of the following methods:
 - Load a document in the ADF paper chute (feeder)
 - Press any button on the operator panel
Note that pressing the [Power] button for more than 2 seconds will turn the power off.
 - Perform scanning from an application
- If the scanner has been automatically turned off
The LCD and the [Power] button light are off.
Turn on the scanner.
For details, refer to "[1.3 Turning the Power ON/OFF](#)" (page 23).

No

Do the LCD and the [Power] button light remain off even if you turn the scanner off and then on again?

No

The scanner is operating correctly.

Yes

If the problem persists, check the items in "[7.4 Before You Contact the Scanner Service Provider](#)" (page 153) first, then contact your FUJITSU scanner dealer or an authorized FUJITSU scanner service provider.

[TOP](#)[Contents](#)[Index](#)[Introduction](#)[Scanner Overview](#)[How to Load Documents](#)[How to Use the Operator Panel](#)[Various Ways to Scan](#)[Daily Care](#)[Replacing the Consumables](#)[Troubleshooting](#)[Operational Settings](#)[Appendix](#)[Glossary](#)

Scanning does not start.

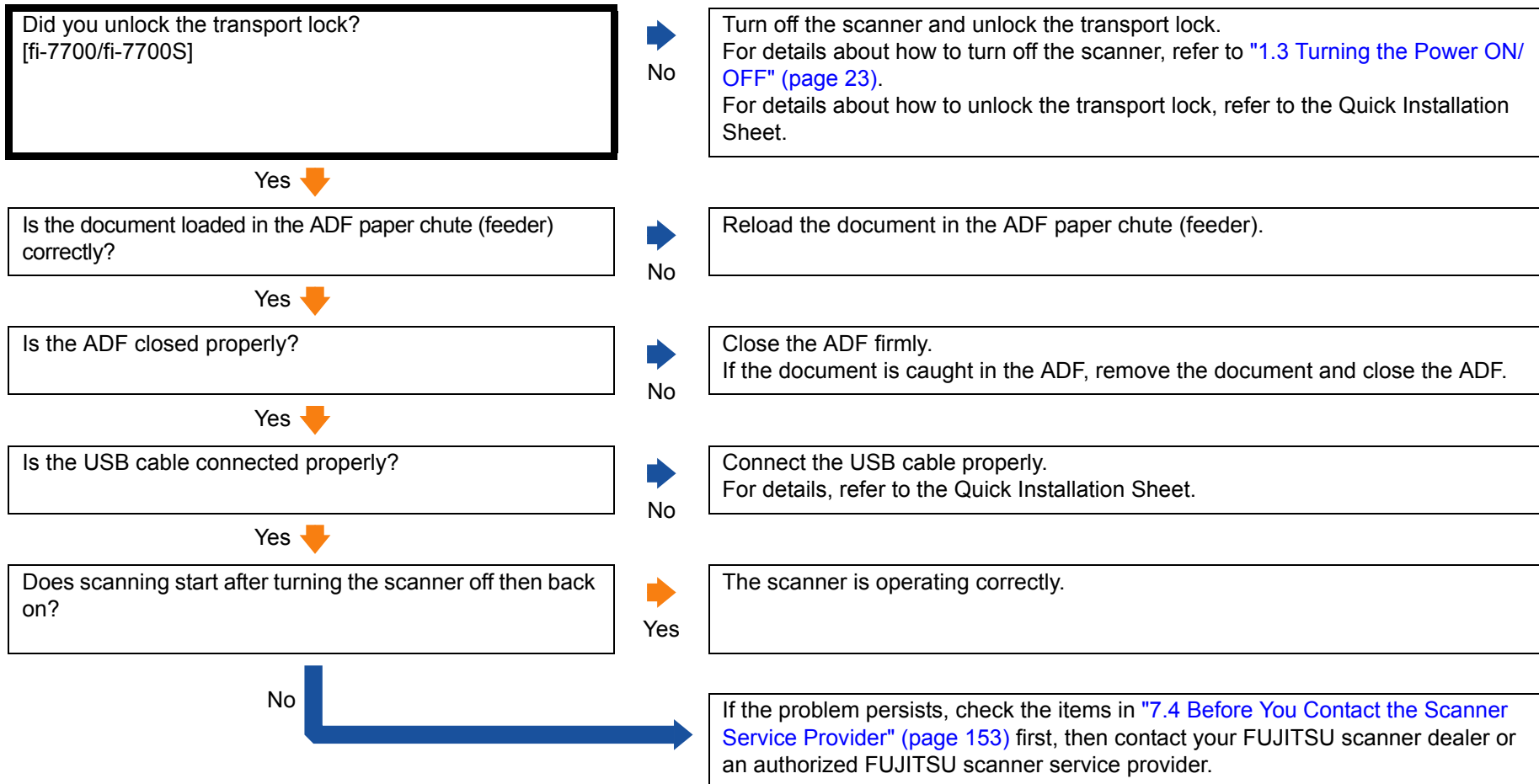

TOP

Contents

Index

Introduction

Scanner
OverviewHow to Load
DocumentsHow to Use the
Operator PanelVarious Ways to
Scan

Daily Care

Replacing the
Consumables

Troubleshooting

Operational
Settings

Appendix

Glossary

Scanning takes a long time.

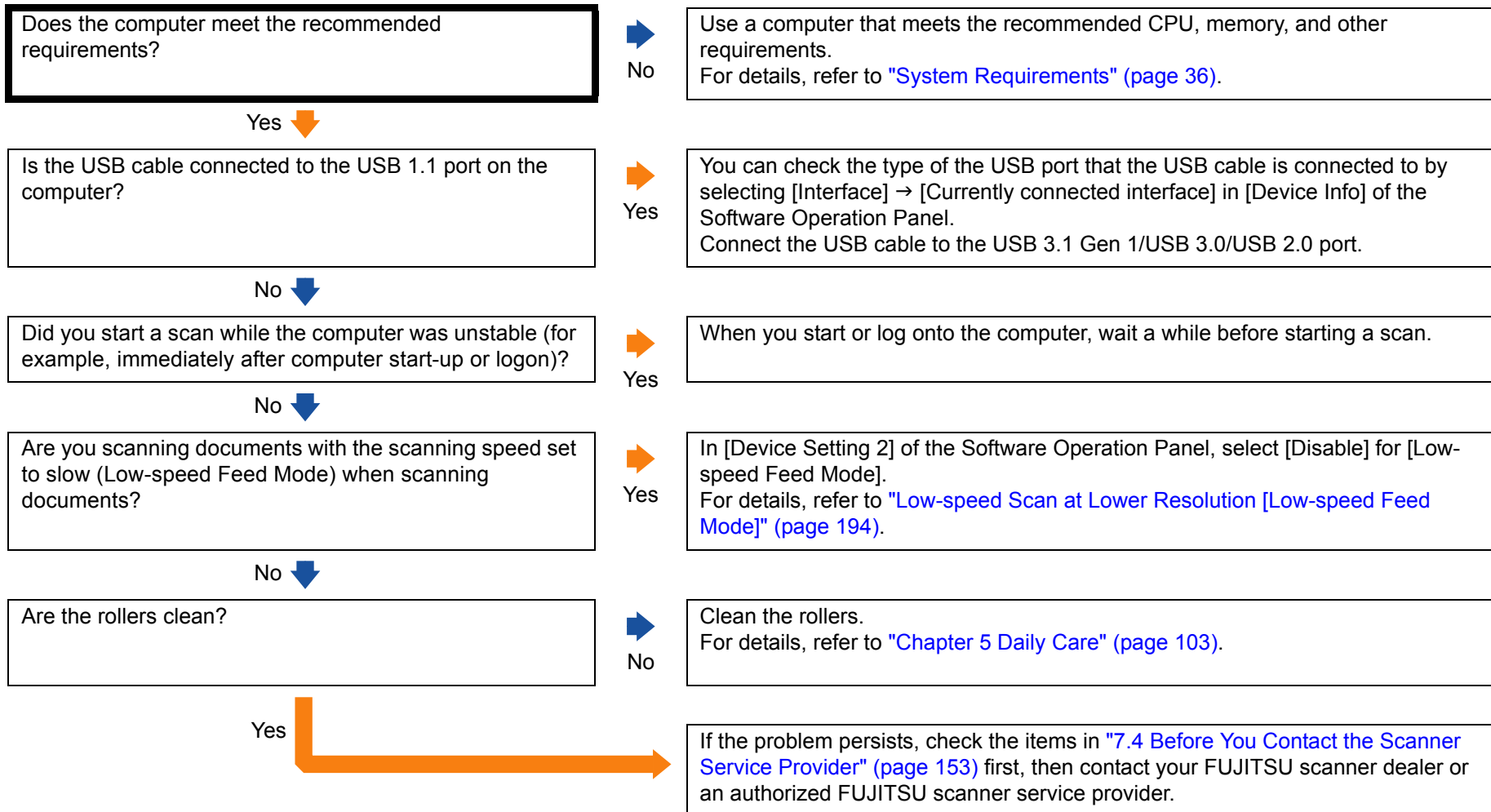

TOP

Contents

Index

Introduction

Scanner
OverviewHow to Load
DocumentsHow to Use the
Operator PanelVarious Ways to
Scan

Daily Care

Replacing the
Consumables

Troubleshooting

Operational
Settings

Appendix

Glossary

Image quality is poor.

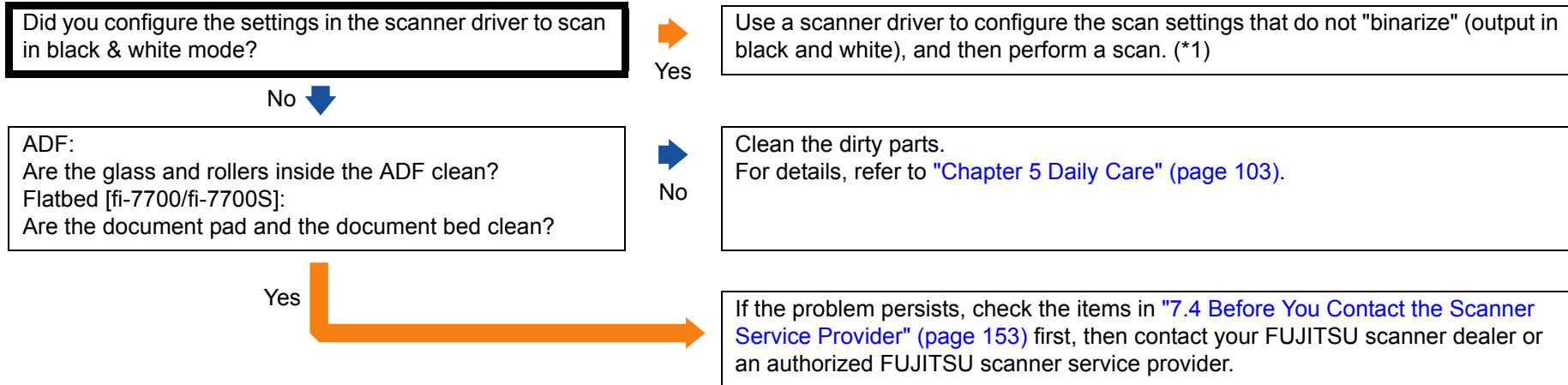

*1: The scanned image may differ from the original image significantly if you simply "binarize" (output in black & white) a picture or a photo.

- TOP
- Contents
- Index
- Introduction
- Scanner Overview
- How to Load Documents
- How to Use the Operator Panel
- Various Ways to Scan
- Daily Care
- Replacing the Consumables
- Troubleshooting**
- Operational Settings
- Appendix
- Glossary

Quality of scanned text or lines is unsatisfactory.

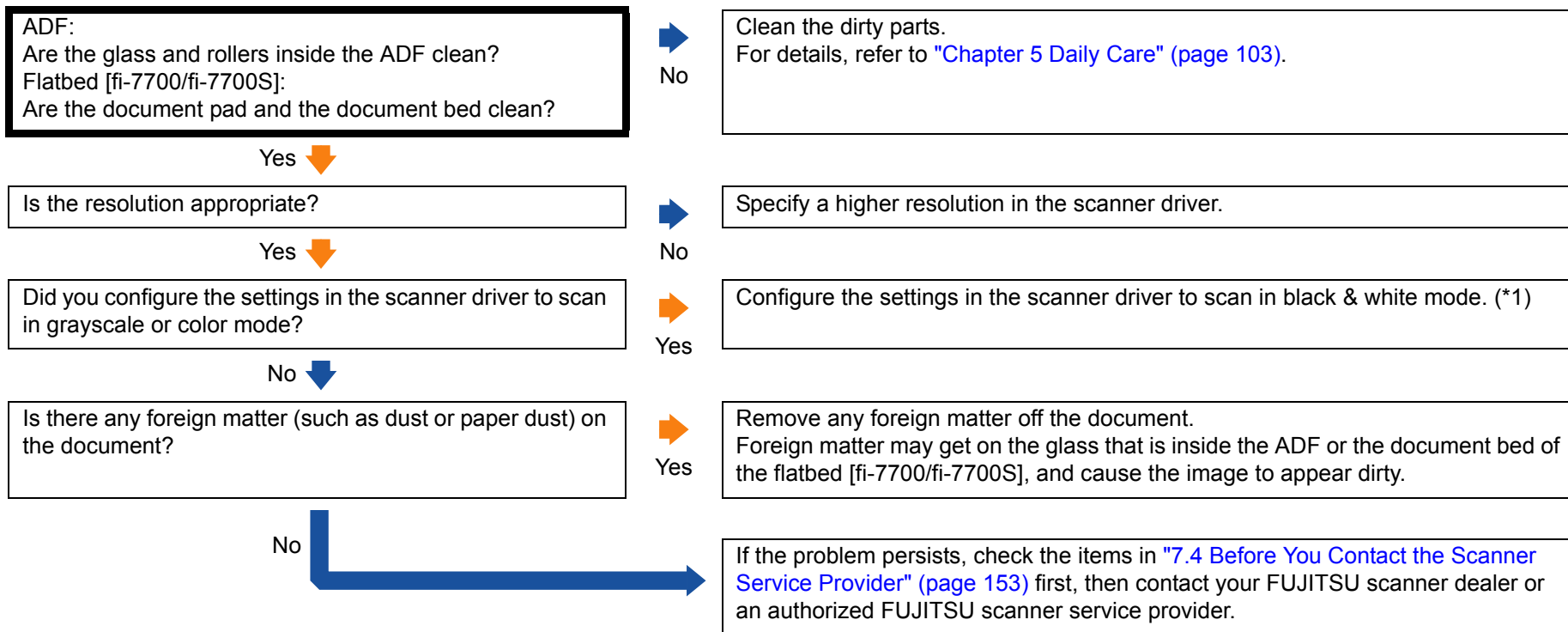

*1: When you scan in grayscale or in color mode, the scanned image may not become sharp and clear.

Images are distorted or not clear.

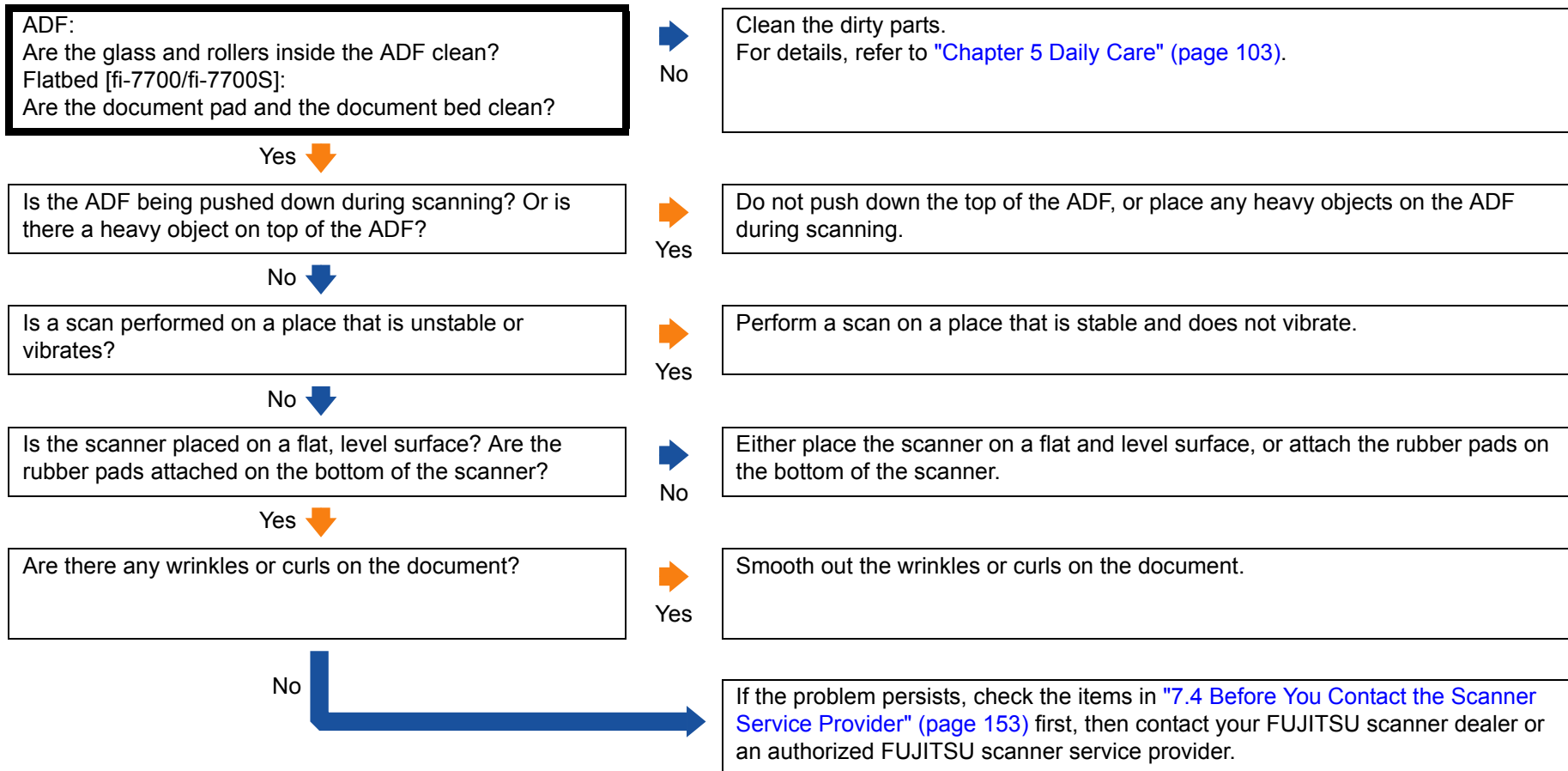

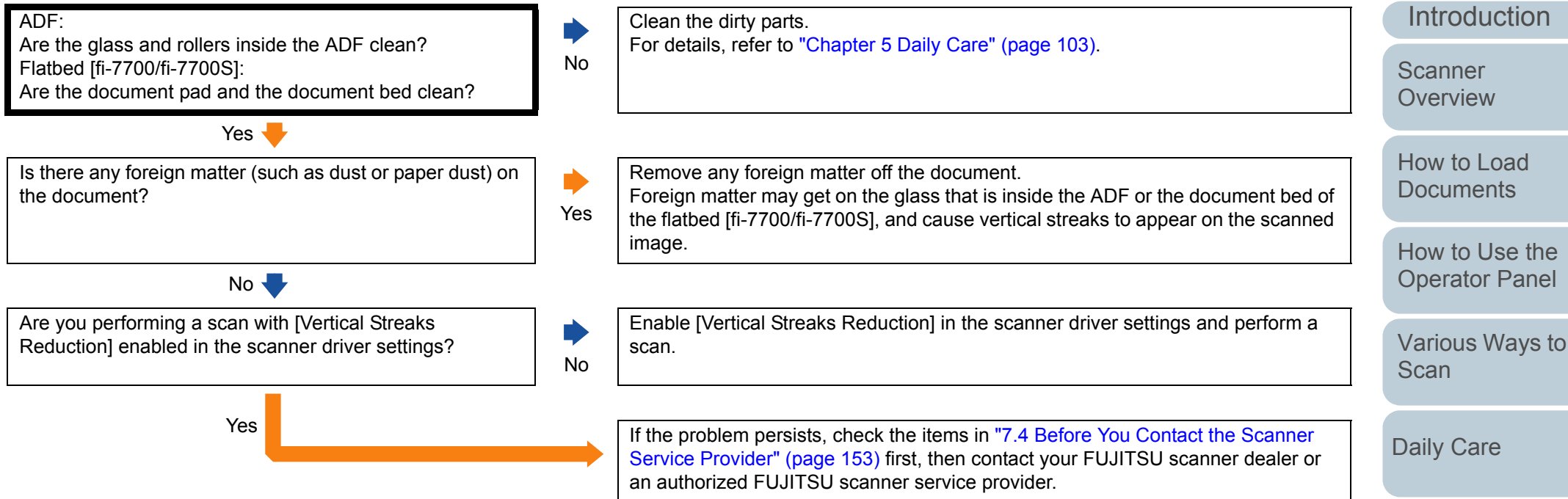
Vertical streaks appear on the scanned image.

TOP

Contents

Index

Introduction

Scanner
OverviewHow to Load
DocumentsHow to Use the
Operator PanelVarious Ways to
Scan

Daily Care

Replacing the
Consumables

Troubleshooting

Operational
Settings







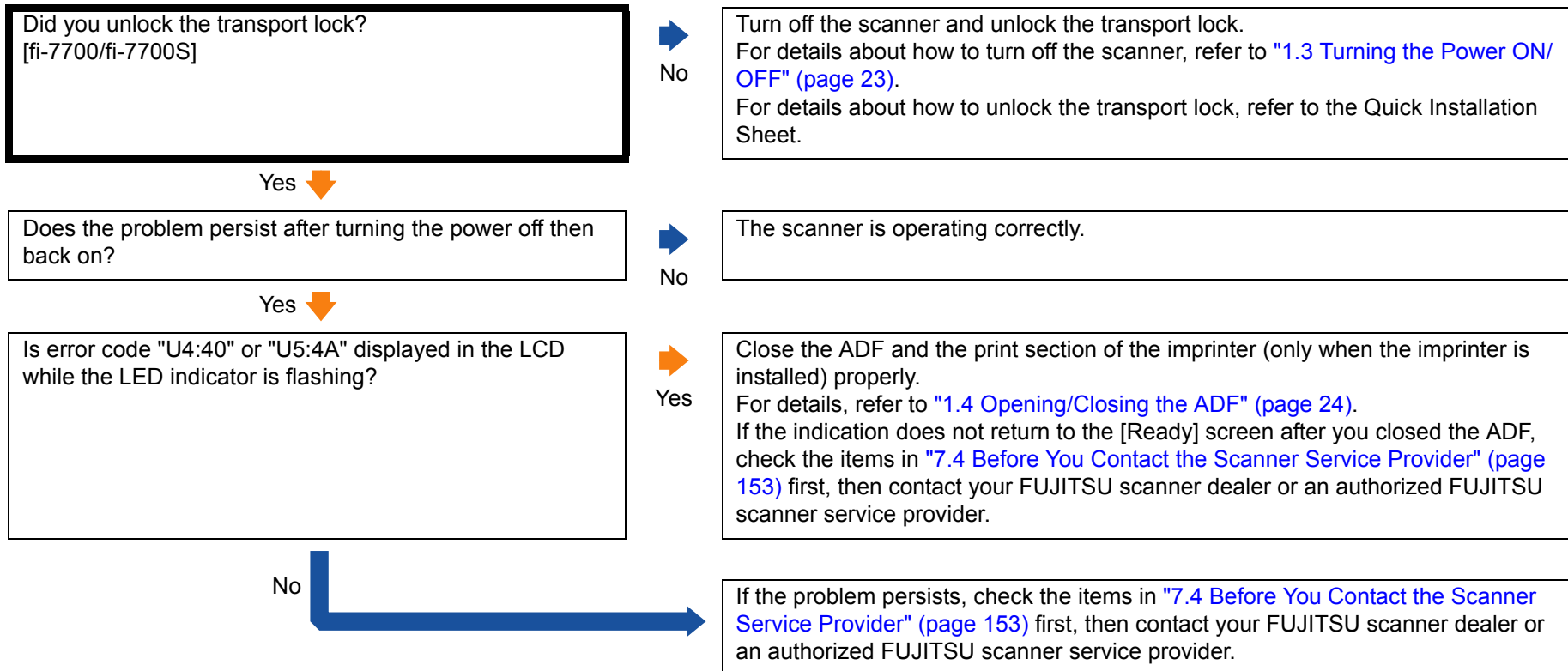







Appendix

Glossary

An error (error code "U0:10", "U4:40" or "U5:4A") is already displayed in the LCD after power-on.



Multifeed error occurs frequently.

<p>Do the documents meet the requirements described in "2.3 Documents for Scanning" (page 47)?</p> <p>Yes </p>	<p> No</p>	<p>Use documents that meet the requirements. For details, refer to "2.3 Documents for Scanning" (page 47).</p>
<p>If multifeed detection is enabled, does the batch of documents fulfill the conditions for an accurate detection?</p> <p>Yes </p>	<p> No</p>	<p>Fulfill the conditions for an accurate multifeed detection. For details, refer to "Conditions for Multifeed Detection" (page 52). Also specify the multifeed detection area if necessary ("Specifying the Area to Detect Multifeed [Document check area specification for Multifeed Detection]" (page 198)).</p>
<p>Did you scan a plastic card or any other thick document?</p> <p>No </p>	<p> Yes</p>	<p>Specify one of the following settings and try scanning again.</p> <ul style="list-style-type: none"> ● Use the Intelligent Multifeed function. ● Disable the multifeed detection setting. ● Use the Manual/Single mode.
<p>Did you fan the documents before loading them?</p> <p>Yes </p>	<p> No</p>	<p>Fan the documents before loading them.</p>
<p>Have the documents just been printed out from a copy machine or a laser printer?</p> <p>No </p>	<p> Yes</p>	<p>Fan the documents a few times to remove static electricity.</p>
<p>Are the consumables (*1) installed correctly?</p> <p>Yes </p>	<p> No</p>	<p>Install the consumables (*1) correctly. For details, refer to "Chapter 6 Replacing the Consumables" (page 113).</p>
<p>Are the consumables (*1) clean?</p> <p>Yes </p>	<p> No</p>	<p>Clean the consumables (*1). For details, refer to "Chapter 5 Daily Care" (page 103).</p>

Yes (continued) ↓

Are the consumables (*1) worn out?

Yes

Check the consumable counters and replace them if necessary.
For details, refer to "[Chapter 6 Replacing the Consumables](#)" (page 113).

No ↓

Are you using the scanner at an altitude of 2,000 m or higher?

Yes

Select [Enable] for [High Altitude Mode] (*2) in [Device Setting 2] on the Software Operation Panel.
For details, refer to "[Scanning at High Altitude \[High Altitude Mode\]](#)" (page 193).

No

If the problem persists, check the items in "[7.4 Before You Contact the Scanner Service Provider](#)" (page 153) first, then contact your FUJITSU scanner dealer or an authorized FUJITSU scanner service provider.

*1: "Consumables" refers to the brake roller and the pick roller.

*2: If the scanner is used at an altitude lower than 2,000 m with [Enable] selected for [High Altitude Mode], multifeeds may not be detected.

Situation in which the document is not fed into the ADF occurs frequently.

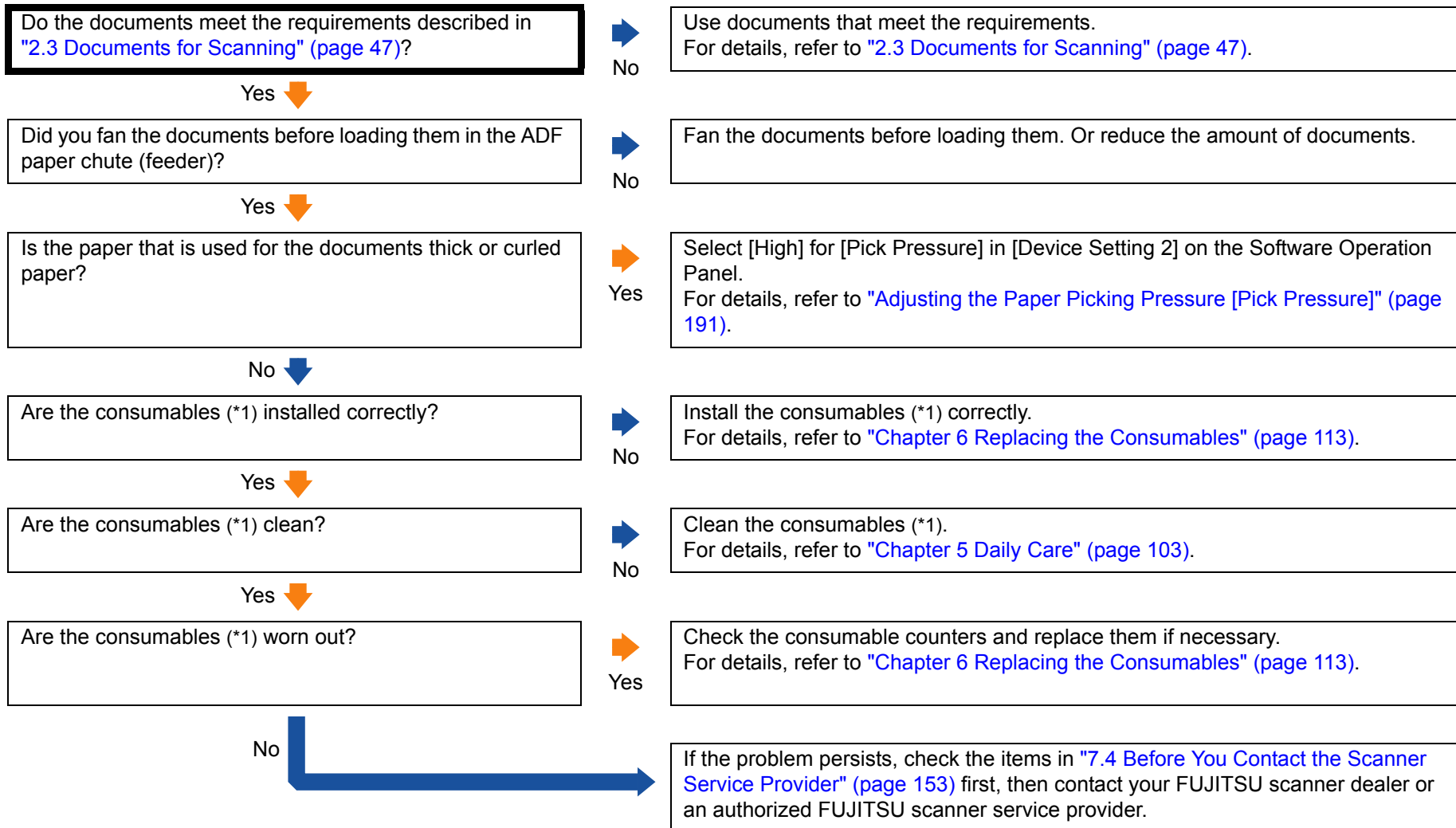

*1: "Consumables" refers to the brake roller and the pick roller.

Paper protection is set off frequently.

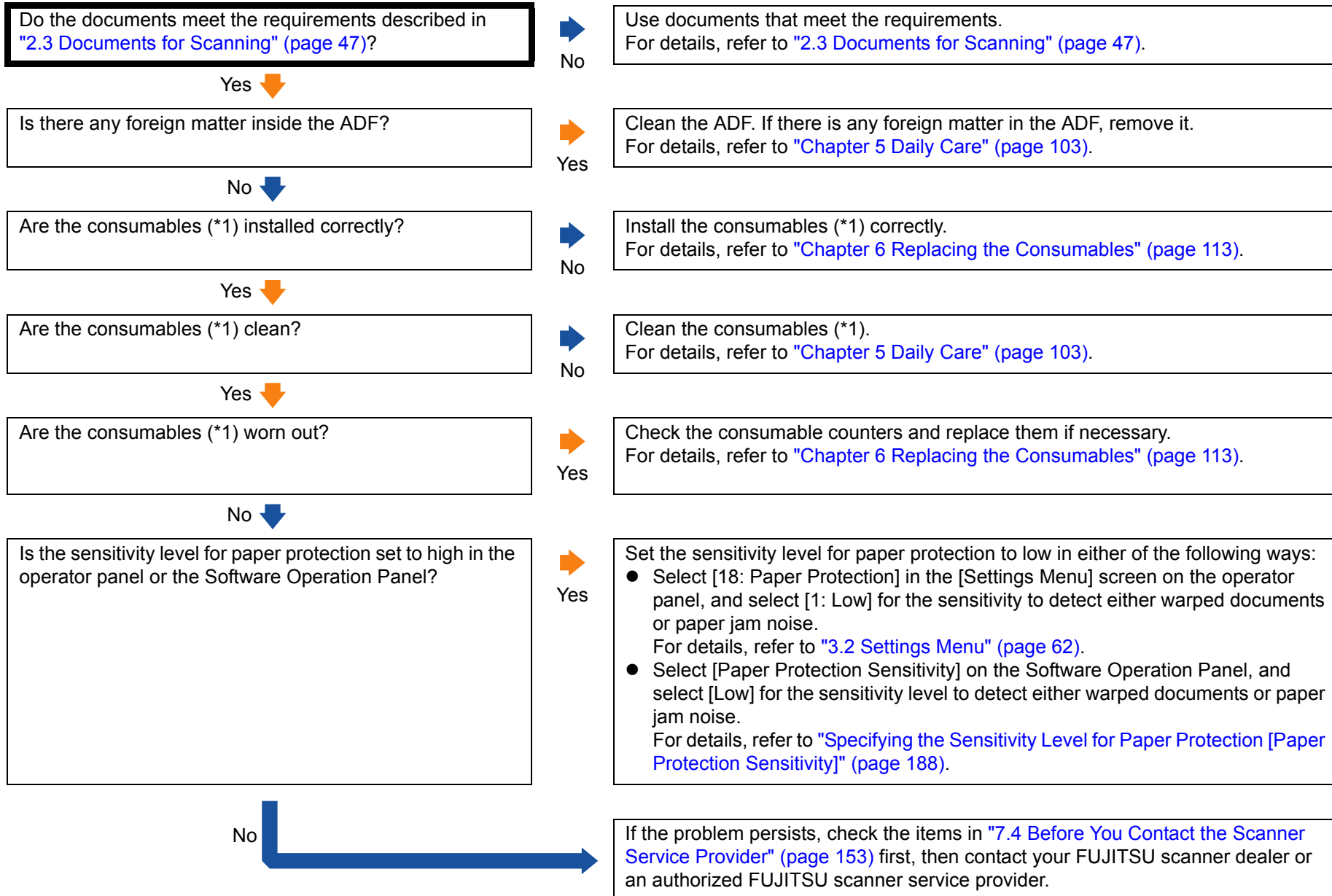

*1: "Consumables" refers to the brake roller and the pick roller.

Paper jams/pick errors occur frequently.

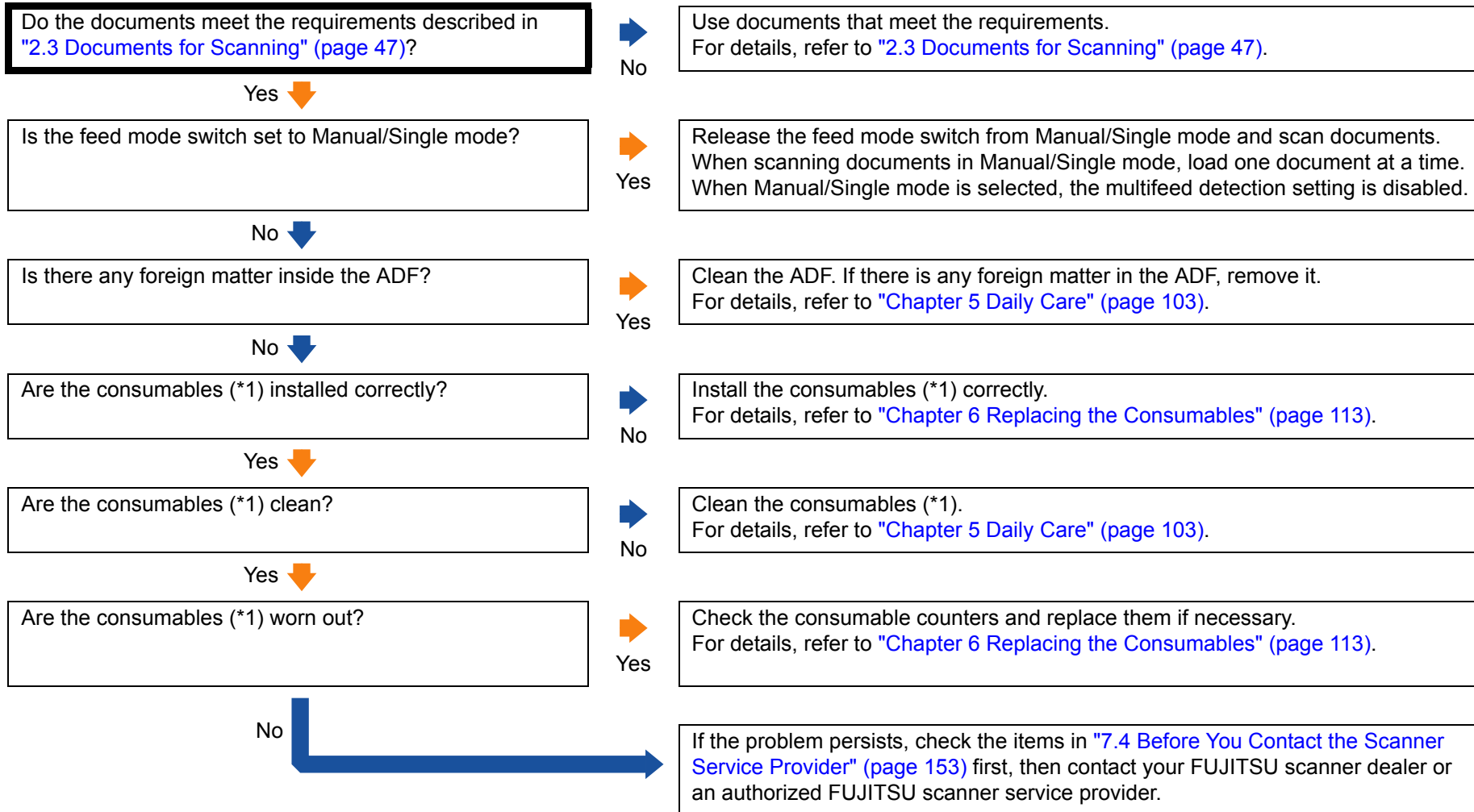

*1: "Consumables" refers to the brake roller and the pick roller.

TOP

Contents

Index

Introduction

Scanner
OverviewHow to Load
DocumentsHow to Use the
Operator PanelVarious Ways to
Scan

Daily Care

Replacing the
Consumables

Troubleshooting

Operational
Settings

Appendix

Glossary

Scanned images turn out elongated.

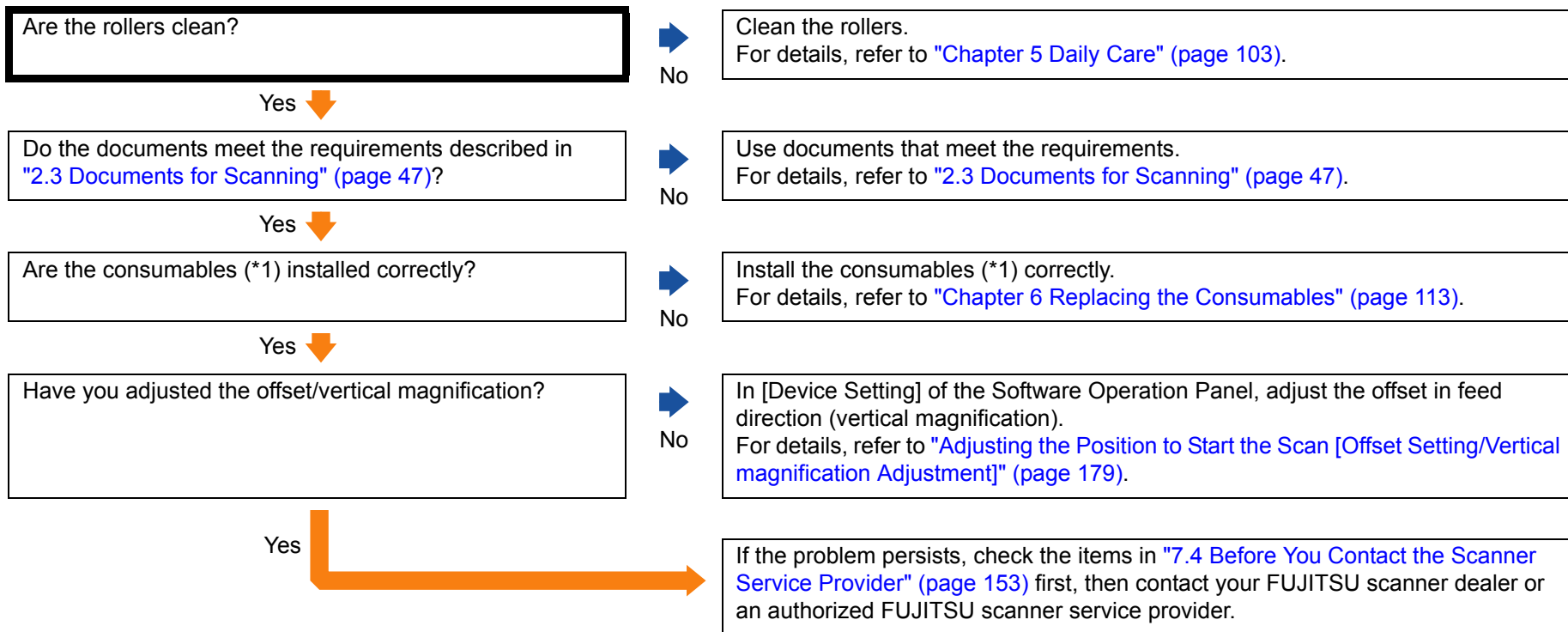

*1: "Consumables" refers to the brake roller and the pick roller.

A shadow appears at the top or the bottom of the scanned image.

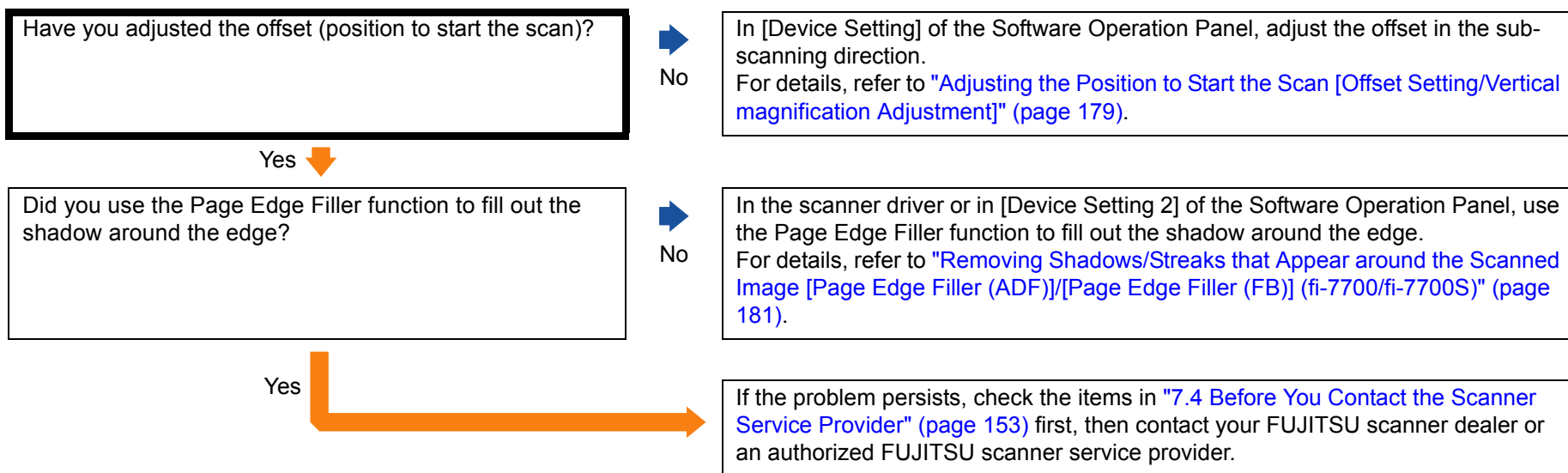

There are black traces on the document.

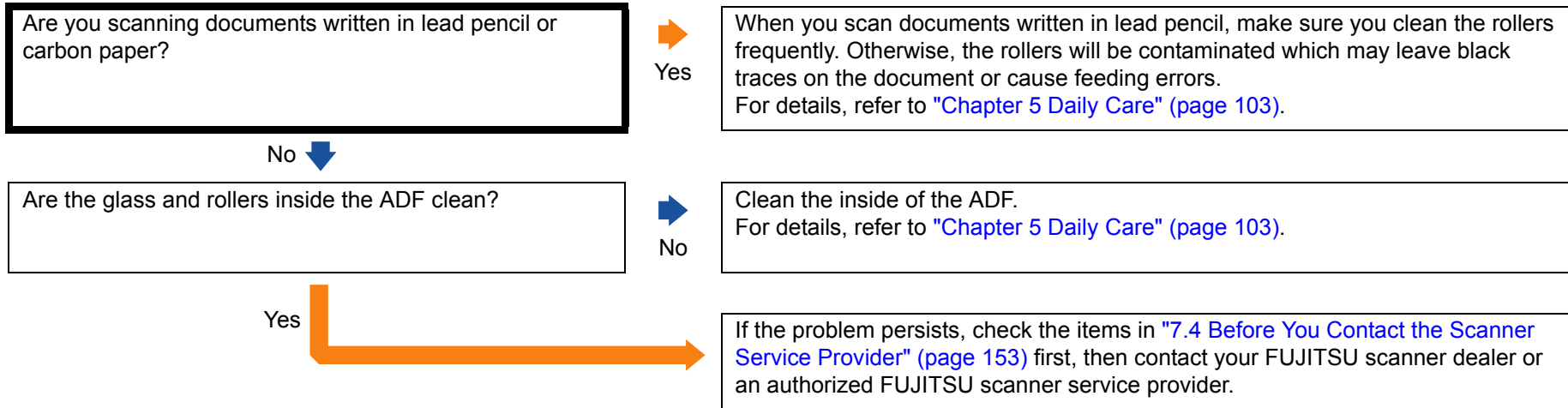

7.4 Before You Contact the Scanner Service Provider

Please check the following items before contacting your FUJITSU scanner dealer or an authorized FUJITSU scanner service provider.

General

Item	Findings
Scanner model name	Example: fi-7600 For details, refer to "7.5 Checking the Product Labels" (page 155) .
Serial No.	Example: XXXX000001 For details, refer to "7.5 Checking the Product Labels" (page 155) .
Date of manufacture	Example: 2017-01 (January 2017) For details, refer to "7.5 Checking the Product Labels" (page 155) .
Date of purchase	
Symptom	
Frequency of trouble	
Warranty	
Options used	Example: fi-760PRB For details, refer to "A.4 Scanner Options" (page 216) .

Error Status

■ Computer Connection Issues

Item	Findings
Operating system (Windows)	
Error message	
Interface	Example: USB interface
Interface controller	

■ Feeding Issues

Item	Findings
Paper type	
Main purpose of use	
Date of last cleaning	
Date of consumable replacement	
Operator panel status	

TOP

Contents

Index

Introduction

Scanner
OverviewHow to Load
DocumentsHow to Use the
Operator PanelVarious Ways to
Scan

Daily Care

Replacing the
Consumables

Troubleshooting

Operational
Settings

Appendix

Glossary

■ Image Quality Issues

Item	Findings
Scanner driver and version	
Interface controller	
Operating system (Windows)	
Application	Example: PaperStream Capture
Scanning sides	Example: front, back, both
Resolution	Example: 600 dpi, 75 dpi
Image mode	Example: color, grayscale, black & white

■ Other

Item	Findings
Can you send the output image and a photo that shows the paper condition by e-mail or fax?	

TOP

Contents

Index

Introduction

Scanner
OverviewHow to Load
DocumentsHow to Use the
Operator PanelVarious Ways to
Scan

Daily Care

Replacing the
Consumables

Troubleshooting

Operational
Settings

Appendix

Glossary

7.5 Checking the Product Labels

This section explains about the product labels on the scanner.

Location

The label is located on the place indicated in the following figures:

■ fi-7600

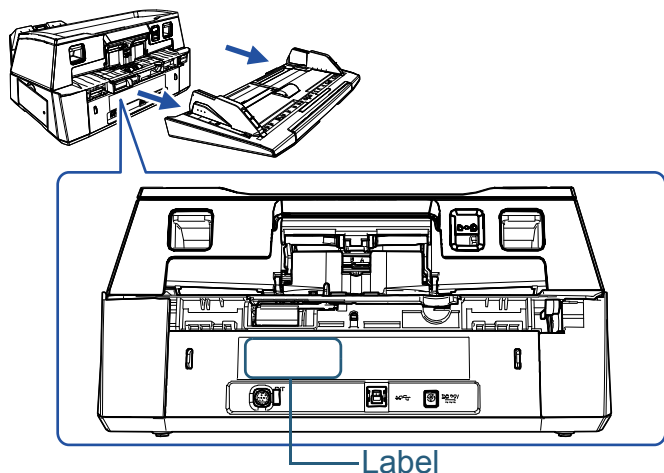

■ fi-7700/fi-7700S

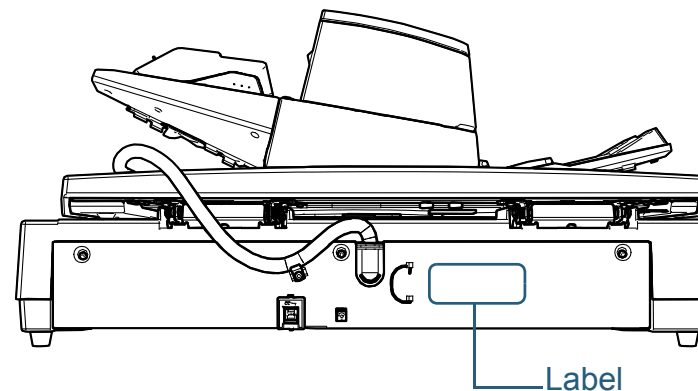

Label (example): Shows the scanner information.

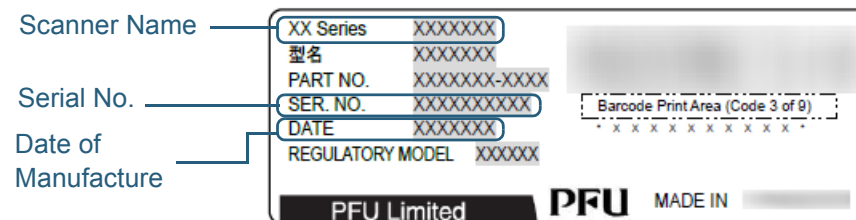

- TOP
- Contents
- Index
- Introduction
- Scanner Overview
- How to Load Documents
- How to Use the Operator Panel
- Various Ways to Scan
- Daily Care
- Replacing the Consumables
- Troubleshooting
- Operational Settings
- Appendix
- Glossary

Chapter 8 Operational Settings

This chapter explains how to use the Software Operation Panel to configure the scanner settings.

8.1 Starting Up the Software Operation Panel.....	157
8.2 Password Setting for the Software Operation Panel	159
8.3 Configuration Items	165
8.4 Settings Related to Sheet Counters	174
8.5 Settings Related to Scanning	179
8.6 Settings Related to Multifeed Detection	196
8.7 Settings Related to Waiting Time	202
8.8 Settings Related to Power ON/OFF	205
8.9 Settings Related to Scanner Maintenance	206

8.1 Starting Up the Software Operation Panel

The Software Operation Panel is installed together with the PaperStream IP driver.

This application allows you to configure various settings such as the operation of the scanner and management of the consumables.

ATTENTION

- Do not start up the Software Operation Panel during scanning.
- If you change the Software Operation Panel settings while the setup window for the scanner driver is displayed, the changes may not be applied to the scanned image.
- Do not use the operator panel while the Software Operation Panel is running.
- If you connect multiple scanners, the second scanner as well as subsequent scanners will not be recognized. Connect only one scanner at a time.

1 Confirm that the scanner is connected to the computer, then turn on the scanner.

For details about how to connect the scanner to the computer, refer to the Quick Installation Sheet.

For details about how to turn on the scanner, refer to "1.3 Turning the Power ON/OFF" (page 23).

2 Display the [Software Operation Panel] window.

- Windows Server 2008/Windows 7
Click [Start] menu → [All Programs] → [fi Series] → [Software Operation Panel].
- Windows Server 2012
Right-click the Start screen, and select [All apps] on the app bar → [Software Operation Panel] under [fi Series].
- Windows Server 2012 R2/Windows 8.1
Click [↓] on the lower left side of the Start screen and select [Software Operation Panel] under [fi Series]. To display [↓], move the mouse cursor.
- Windows 10/Windows Server 2016
Click [Start] menu → [fi Series] → [Software Operation Panel].

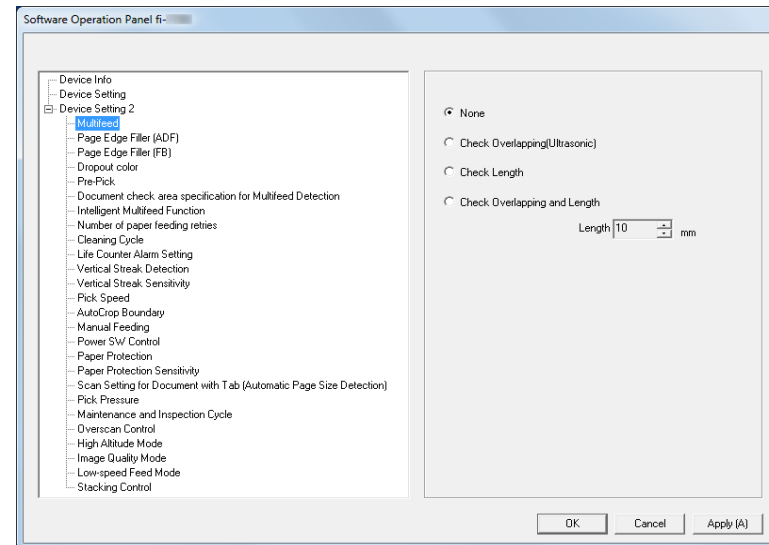

⇒ The Software Operation Panel icon is displayed in the menu that appears when you click  in the notification area.

To have the Software Operation Panel icon always displayed in the notification area, drag the icon and drop it onto the notification area. The notification area is located at the far right of the taskbar.

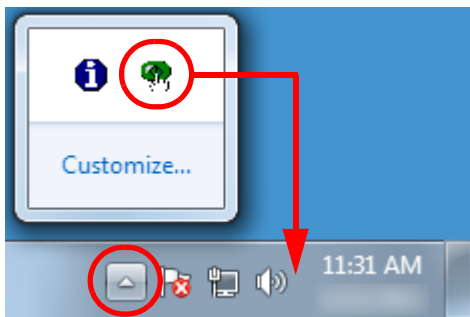

Procedures from here will be explained under the assumption that the Software Operation Panel icon is always displayed in the notification area.

TOP

Contents

Index

Introduction

Scanner
Overview

How to Load
Documents

How to Use the
Operator Panel

Various Ways to
Scan

Daily Care

Replacing the
Consumables

Troubleshooting

Operational
Settings

Appendix

Glossary

8.2 Password Setting for the Software Operation Panel

By setting a password, the Software Operation Panel can run in [View Only mode] which allows users to only view the scanner settings.

The scanner settings can be configured if no password is set. In order to prevent unnecessary changes to the settings, a password can be used to restrict user operations.

Setting a Password

Set a password in the following procedure:

- 1 Right-click the Software Operation Panel icon in the notification area, and select [Password Setting] from the menu.

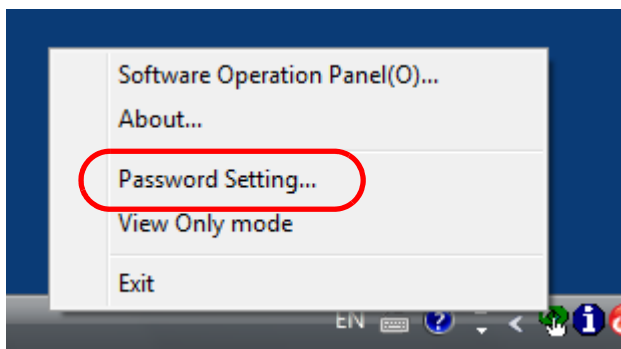

⇒The [Password setting] window appears.

- 2 Enter a new password then again to confirm, and click the [OK] button.

Up to 32 characters can be used for the password.

Note that only alphanumeric characters (a to z, A to Z, 0 to 9) are allowed.

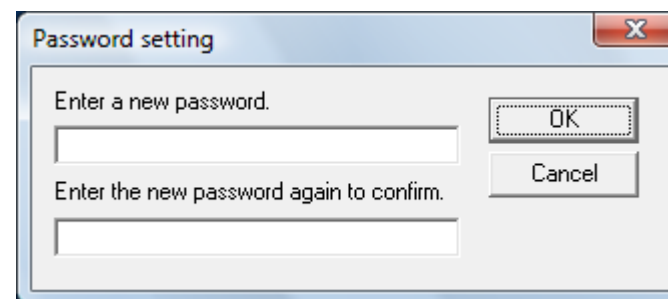

⇒A confirmation message appears.

- 3 Click the [OK] button.
⇒The password is set.

Setting [View Only mode]

Set the Software Operation Panel to [View Only mode] in the following procedure:

- 1 Set a password.
For details, refer to "Setting a Password" (page 159).
- 2 Right-click the Software Operation Panel icon in the notification area, and select [View Only mode] from the menu.

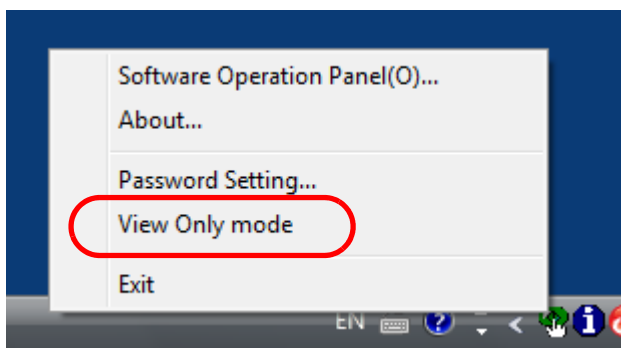

⇒ The Software Operation Panel enters [View Only mode].

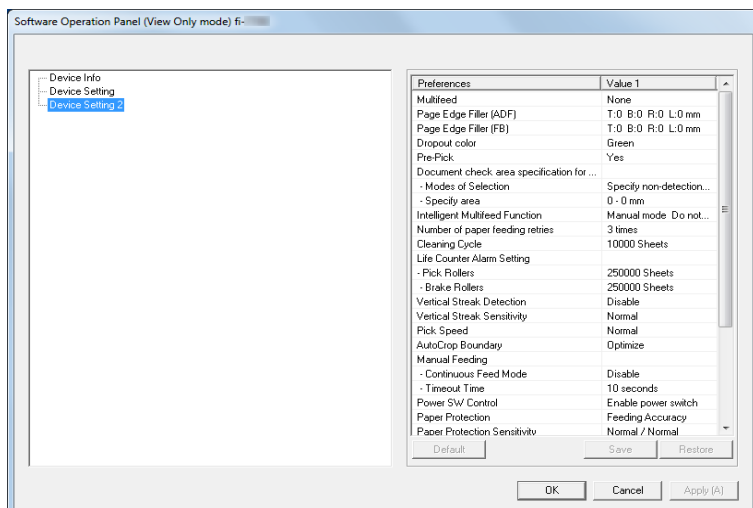

HINT

In [View Only mode], a check mark appears next to [View Only mode] in the menu that is displayed by right-clicking the Software Operation Panel icon in the notification area.

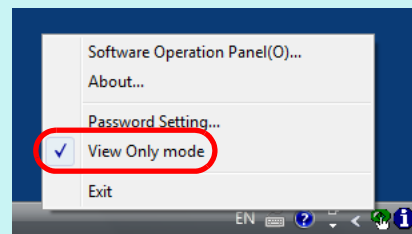

TOP

Contents

Index

Introduction

Scanner
OverviewHow to Load
DocumentsHow to Use the
Operator PanelVarious Ways to
Scan

Daily Care

Replacing the
Consumables

Troubleshooting

Operational
Settings

Appendix

Glossary

Exiting [View Only mode]

Exit [View Only mode] in the following procedure:

- 1 Right-click the Software Operation Panel icon in the notification area, and select [View Only mode] from the menu.

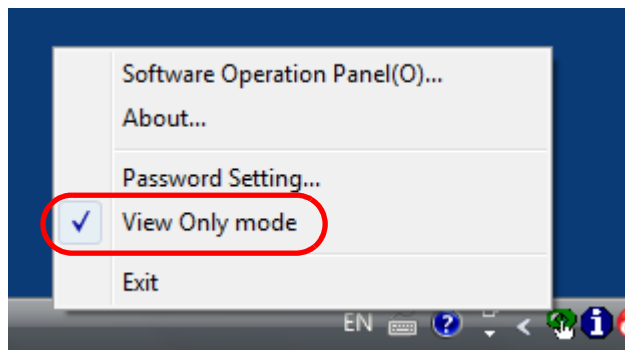

⇒ The [Password setting] window appears.

- 2 Enter the current password and click the [OK] button.

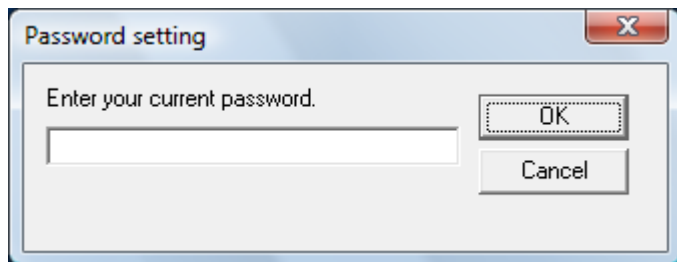

⇒ You exited [View Only mode], and the scanner settings can now be changed.

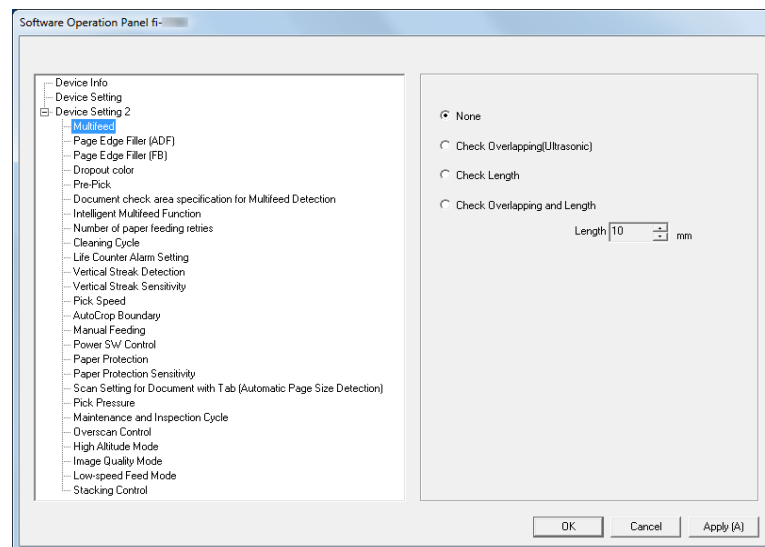

HINT

When you exit [View Only mode], the check mark next to [View Only mode] disappears from the menu that is displayed by right-clicking the Software Operation Panel icon in the notification area.

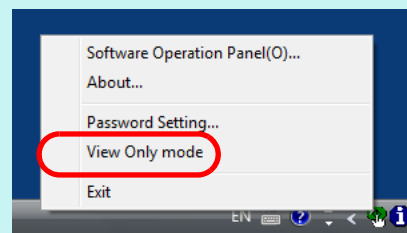

Changing the Password

Change the password in the following procedure:

- 1 Right-click the Software Operation Panel icon in the notification area, and select [Password Setting] from the menu.

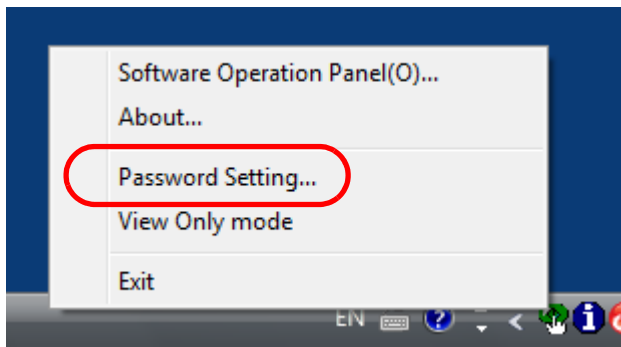

⇒The [Password setting] window appears.

- 2 Enter the current password and click the [OK] button.

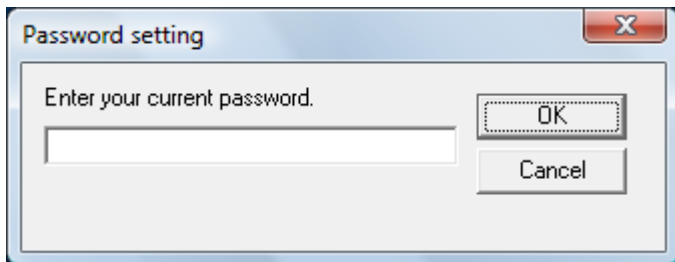

⇒The [Password setting] window appears.

- 3 Enter a new password then again to confirm, and click the [OK] button.

Up to 32 characters can be used for the password.

Note that only alphanumeric characters (a to z, A to Z, 0 to 9) are allowed.

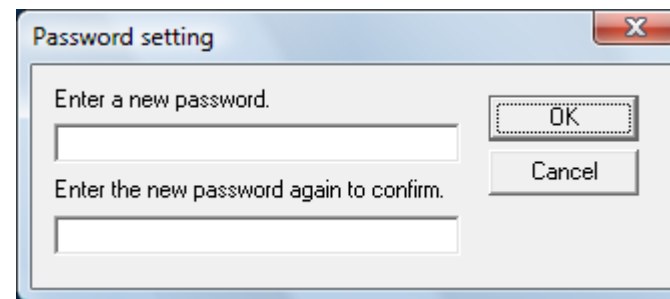

⇒A confirmation message appears.

- 4 Click the [OK] button.
⇒The password is set.

Clearing the Password

Clear the password in the following procedure:

- 1 Right-click the Software Operation Panel icon in the notification area, and select [Password Setting] from the menu.

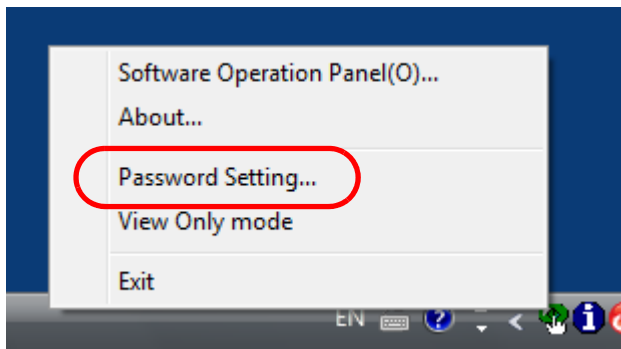

⇒The [Password setting] window appears.

- 2 Enter the current password and click the [OK] button.

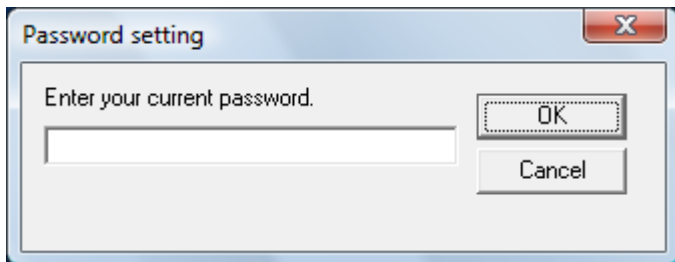

⇒The [Password setting] window appears.

- 3 Leave both fields blank and click the [OK] button.

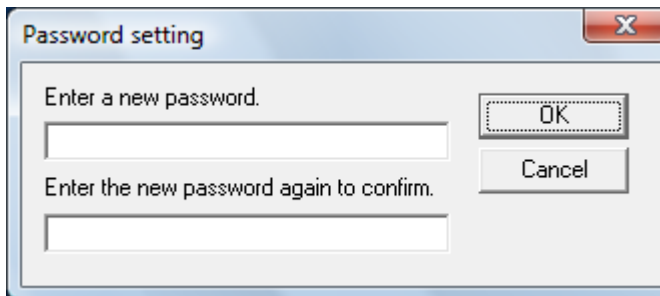

⇒A confirmation message appears.

- 4 Click the [OK] button.
⇒The password is cleared.

TOP
Contents
Index
Introduction
Scanner Overview
How to Load Documents
How to Use the Operator Panel
Various Ways to Scan
Daily Care
Replacing the Consumables
Troubleshooting
Operational Settings
Appendix
Glossary

Resetting the Password

In case you forgot your password, it can be reset in the following procedure:

- 1 Right-click the Software Operation Panel icon in the notification area, and select [Password Setting] from the menu.

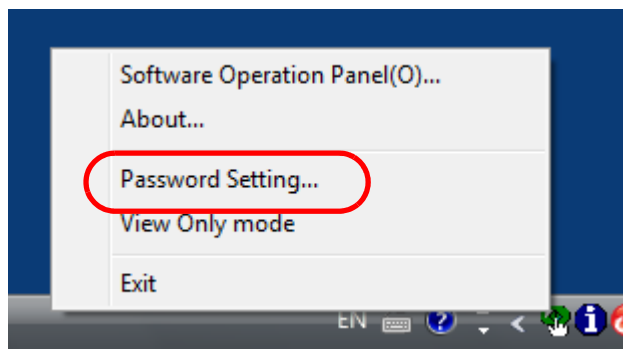

⇒The [Password setting] window appears.

- 2 Enter the default password which is "fi-scanner", and click the [OK] button.

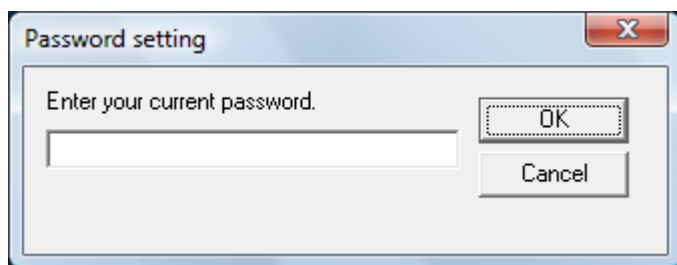

⇒The [Password setting] window appears.

- 3 Enter a new password then again to confirm, and click the [OK] button.

Up to 32 characters can be used for the password.

Note that only alphanumeric characters (a to z, A to Z, 0 to 9) are allowed.

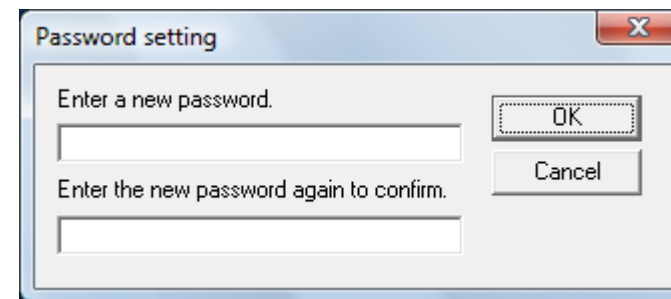

⇒A confirmation message appears.

- 4 Click the [OK] button.

⇒The password is set.

8.3 Configuration Items

The Software Operation Panel allows the configuration of the following settings for the scanner that is connected to the computer.

Device Setting

- 1 Start up the Software Operation Panel.
For details, refer to "8.1 Starting Up the Software Operation Panel" (page 157).
- 2 From the listing on the left, select [Device Setting].

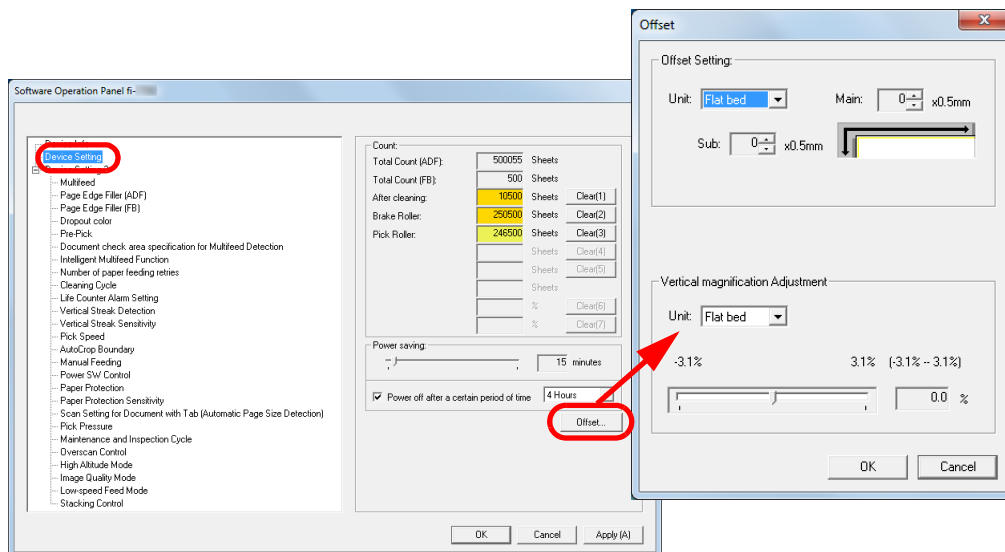

Items that can be configured in the above window are shown in the next page.

Item	Description	Parameter/Value	Factory Default
Count (page 174)	Check the counters to determine when to replace the consumables and to perform cleaning. Also use it to reset the counters when you have replaced the consumables or performed cleaning. This setting can also be configured with the operator panel.	Total Count(ADF)/Total Count (FB) [fi-7700/fi-7700S]/After cleaning/Brake Roller/Pick Roller	0
		Remaining Ink (when the imprinter is installed)	Only displayed when the imprinter is installed
Power saving (page 203)	Specify the waiting time for the scanner to enter power saving mode. This setting can also be configured with the operator panel. Power off after a certain period of time: Select to set the scanner to turn the power off automatically if the scanner is left on for a certain period of time without being used. Specify the timeout period for the scanner to be automatically turned off. This setting can also be configured with the operator panel.	Range: 5 to 235 min. (in increments of 5)	15 min.
		[Power off after a certain period of time] check box	Selected
		1 Hour/2 Hours/4 Hours/8 Hours (When the [Power off after a certain period of time] check box is selected)	4 Hours
Offset Setting (page 179)	Adjust the position to start a scan on the selected scanning side.	Unit: Flatbed [fi-7700/fi-7700S]/ADF (front)/ADF (back) Main/Sub: -2 to 3 mm (in increments of 0.5)	Main/Sub: 0 mm
Vertical magnification Adjustment (page 179)	Adjust the magnification level in feed direction for the selected scanning method.	Unit: Flatbed [fi-7700/fi-7700S]/ADF Range: -3.1 to 3.1% (in increments of 0.1)	0%

Device Setting 2

- 1 Start up the Software Operation Panel.
For details, refer to "8.1 Starting Up the Software Operation Panel" (page 157).
- 2 From the listing on the left, select [Device Setting 2].

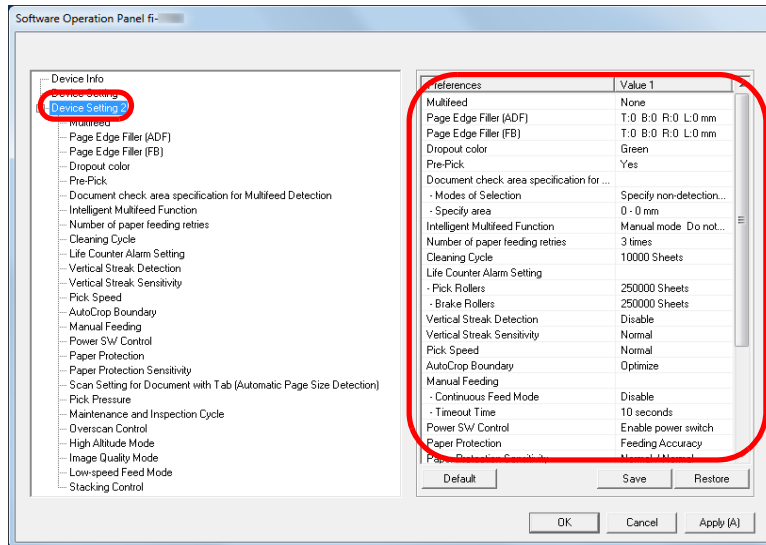

The settings that are currently configured in [Device Setting 2] are listed on the right of the window.

Items that can be configured in the above window are shown in the next page.

HINT

- The Software Operation Panel settings can be restored to the factory default.
To restore the settings to the factory default, click the [Default] button. After a message is displayed, click the [OK] button. Note that the settings you have configured will be cleared.
- The Software Operation Panel settings can be backed up.
To back up the settings, click the [Save] button, then specify the file name and click the [Save] button in the displayed window.
- You can use a backup file of the Software Operation Panel settings to restore the settings on other scanners only if the scanner type is the same.
To restore the settings, click the [Restore] button, then specify the backup file and click the [Open] button in the displayed window. After a message is displayed, click the [OK] button. Note that restoration cannot be performed for other types of scanners.

TOP

Contents

Index

Introduction

Scanner
OverviewHow to Load
DocumentsHow to Use the
Operator PanelVarious Ways to
Scan

Daily Care

Replacing the
Consumables

Troubleshooting

Operational
Settings

Appendix

Glossary

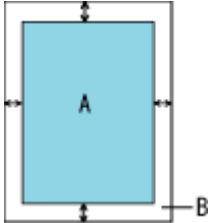
Item	Description	Parameter/Value	Factory Default
Multifeed (page 196)	Specify a method for multifeed detection. Detect multifeeds by monitoring the overlap, document length, or the combination of both. This setting can also be configured in the scanner driver. Note that priority is given to the scanner driver setting.	None/Check Overlapping (Ultrasonic)/Check Length/Check Overlapping and Length Length (When [Check Length] is specified): Select from 10/15/20 mm)	None Length: 10 mm
Page Edge Filler (ADF) Page Edge Filler (FB) [fi-7700/fi-7700S] (page 181)	Specify a width for the margin around the scanned image to fill the margin in white or black. The specified area is filled in white or black, according to the background color. This setting can also be configured in the scanner driver. In that case, Page Edge Filler of the scanner driver is used on the output image.	ADF: Top/Left/Right: 0 to 15 mm Bottom: -7 to 7 mm (in increments of 1) FB [fi-7700/fi-7700S]: Top/Bottom/Left/Right: 0 to 15 mm (in increments of 1)  (A: image, B: filled area, A+B: output)	Top/Bottom/Left/ Right: 0 mm
Dropout color (page 182)	Select a color to be removed from the scanned image (only available in black & white or grayscale mode). This setting can also be configured in the scanner driver. Note that priority is given to the scanner driver setting.	Red/Green/Blue/White/None	Green
Pre-Pick (page 183)	Select [Yes] to prioritize the processing speed. Otherwise, select [No]. This setting can also be configured in the scanner driver or with the operator panel. Note that priority is given to the scanner driver setting.	Yes/No	Yes

Item	Description	Parameter/Value	Factory Default
Document check area specification for Multifeed Detection (page 198)	Selected range: Select this item to restrict the area to run multifeed detection.	[Selected range] check box	Not selected
	Enable/Disable (Middle): Specify whether to enable or disable multifeed detection in the selected area.	Enable/Disable (When [Selected range] is selected)	Disable
	Start (Middle): Specify the start position of the area in length (mm) from the leading edge of the document.	0 to 510 mm (in increments of 2)	0 mm
	End (Middle): Specify the end position of the area in length (mm) from the leading edge of the document.	0 to 510 mm (in increments of 2)	0 mm
Intelligent Multifeed Function (page 201)	When there is a paper of the same size attached to a designated location on the page, you can configure the scanner to memorize the location of the attachment and not detect multifeeds for that location. Note that you first need to select [Check Overlapping (Ultrasonic)] or [Check Overlapping and Length] in either the scanner driver or the multifeed detection setting in " Specifying a Multifeed Detection Method [Multifeed] " (page 196). This setting can also be configured with the operator panel.	Manual mode/Auto mode 1/Auto mode 2	Manual mode
	Select to clear the overlap pattern (length, location) memorized in Auto mode. This setting can also be configured with the operator panel.	[Clear overlap pattern] check box	Not selected
	Select to record the multifeed pattern on the window to check an image that is detected as multifeed.	[Auto-Memorize MF Pattern (only when MF images are displayed)] check box	Not selected
	Specify whether or not to memorize the multifeed pattern upon power-off.	Remember/Do not remember	Do not remember

Item	Description	Parameter/Value	Factory Default
Number of paper feeding retries (page 184)	Configure this setting to change the number of feeding retries when a pick error occurs. This setting can also be configured with the operator panel.	1 to 12 times	3 times
Cleaning Cycle (page 177)	Specify the scanner cleaning cycle. Select whether or not to display the cleaning instruction message from the scanner driver.	1,000 to 255,000 sheets (in increments of 1,000) [Show cleaning instructions] check box	10,000 sheets Not selected
Life Counter Alarm Setting (page 177)	Specify the replacement cycle for the consumables.	Pick Rollers/Brake Rollers: 10,000 to 2,550,000 sheets (in increments of 10,000)	Pick Rollers: 250,000 sheets Brake Rollers: 250,000 sheets
Vertical Streak Detection (page 206)	Select whether to enable or disable vertical streak detection. Enable to detect vertical streaks (dirt on the glass) when you perform scanning with the ADF. This setting can also be configured with the operator panel.	Enable/Disable	Disable
Vertical Streak Sensitivity (page 207)	Specify the sensitivity level to detect vertical streaks (dirt on the glass) when vertical streak detection is enabled. This setting can also be configured with the operator panel.	Low/Normal/High	Normal
Pick Speed (page 185)	When multifeeds and paper jams occur frequently, you may be able to improve the performance by slowing down the speed in which documents are picked or fed. This setting can also be configured with the operator panel.	Normal/Slow	Normal
AutoCrop Boundary (page 186)	Specify whether or not to optimize (round up/down) the fractional part of the scanned image data.	Optimize/Round Down	Optimize

Item	Description	Parameter/Value	Factory Default
Manual Feeding (page 202)	Select whether to enable or disable the continuous feed mode. This setting can also be configured with the operator panel.	Disable/Enable	Disable
	Timeout Time: Specify the waiting time for the scanner to cancel manual feeding. This setting can also be configured with the operator panel.	5, 10, 20, 30, 40, 50, 60, 70, 80, 90, 100, 110, 120, 180, 240, 300, 360, 420, 480, 540, 600, 900, 1200, 1500, 1800, 1999 (seconds)	10 seconds
Power SW Control (page 205)	Specify the method by which the scanner is powered on/off.	Enable power switch/Disable power switch/ Enable USB power feeding	Enable power switch
Paper Protection (page 187)	Select a paper protection detection method. This function can reduce the risk of having the documents damaged by detecting a feeding error and stopping the scan in the following cases: <ul style="list-style-type: none"> ● When the scanner detects a document that was unusually warped by a feeding error ● When the scanner detects paper jam noise ● When the scanner either detects a document that was unusually warped by a feeding error or detects paper jam noise This setting can also be configured in the scanner driver or with the operator panel. When the operator panel setting is prioritized, the operator panel setting is prioritized over the Software Operation Panel setting. Note that even if the operator panel setting is prioritized, the scanner driver setting has the highest priority.	Disable/Feeding Accuracy/Feeding Noise/ Feeding Accuracy & Noise	Feeding Accuracy

Item	Description	Parameter/Value	Factory Default
Paper Protection Sensitivity (page 188)	Specify the sensitivity level to detect anomalies upon feeding the documents when paper protection is enabled. This setting can also be configured with the operator panel. When the operator panel setting is prioritized, the operator panel setting is prioritized over the Software Operation Panel setting.	Detect: Feeding Accuracy/Feeding Noise Low/Normal/High	Normal
Scan Setting for Document with Tab (Automatic Page Size Detection) (page 190)	For a document that includes index sheets or a document with index stickers (or tabs) attached at the bottom edge, you can specify whether or not to include the index portion (or tab) images during scanning with the Auto Paper Size Detection setting.	Document with tab/Document without tab/ Non-rectangular document	Document without tab
Pick Pressure (page 191)	Set the pick pressure for feeding paper.	Low/Default/High	Default
Maintenance and Inspection Cycle (page 208)	Specify the period of time for regular maintenance and inspection of the scanner by a service engineer.	Disable/Enable Maintenance and inspection cycle: 1 to 12 months	Disable
Overscan Control (page 192)	Set this to expand the amount of overscan and output an image if part of the image appears missing due to an abnormal skew during overscan. This setting can also be configured with the operator panel.	Normal/Expand	Normal
High Altitude Mode (page 193)	Select whether to enable or disable high altitude mode. Enable this mode to use the scanner at an altitude of 2,000 m or higher.	Enable/Disable	Disable
Image Quality Mode (page 193)	Set the image quality mode. To obtain an image quality that is close to the image quality for scanning with fi-6670/fi-6770/fi-6750S, set the image quality mode.	fi-6670/fi-6770/fi-6750S/Disable	Disable

Item	Description	Parameter/Value	Factory Default
Low-speed Feed Mode (page 194)	Specify whether or not to reduce the scanning speed to prevent paper damage. This setting can also be configured with the operator panel.	Disable/Enable	Disable
Stacking Control (page 195)	Specifies whether to lower the paper ejecting speed.	Enable/Disable	Disable

- TOP
- Contents
- Index
- Introduction
- Scanner Overview
- How to Load Documents
- How to Use the Operator Panel
- Various Ways to Scan
- Daily Care
- Replacing the Consumables
- Troubleshooting
- Operational Settings
- Appendix
- Glossary

8.4 Settings Related to Sheet Counters

Checking and Resetting the Sheet Counters

■ Checking the Sheet Counters

The status of each consumable part can be viewed to determine when to replace or clean the consumables. The color of the counter gradually changes when a replacement for a consumable is needed or when cleaning is needed. The color of each counter changes as follows:

- **Brake roller counter/pick roller counter**
These counters turn light yellow when the sheet count after the consumable replacement reaches 95% of the value specified in "[Replacement Cycle of Consumables \[Life Counter Alarm Setting\]](#)" (page 177) in the Software Operation Panel, and turn yellow when the sheet count reaches 100%.
- **Counter after cleaning**
This counter turns yellow when the sheet count after cleaning reaches the value specified in "[Scanner Cleaning Cycle \[Cleaning Cycle\]](#)" (page 177) in the Software Operation Panel.
- **Ink counter**
This counter turns yellow when the amount of remaining ink reaches below 33% (only displayed when the imprinter is installed).

- 1 Start up the Software Operation Panel.
For details, refer to "[8.1 Starting Up the Software Operation Panel](#)" (page 157).
- 2 From the listing on the left, select [Device Setting].

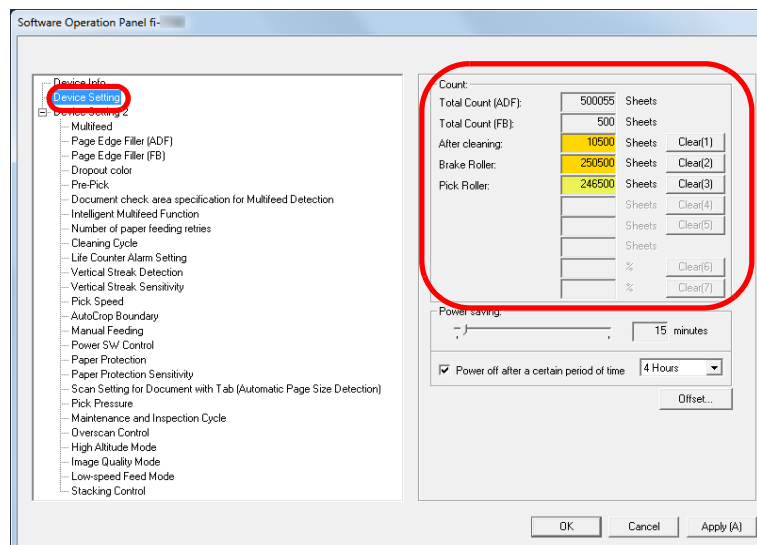

In this window, you can check the following items:

Item	Description
Total Count (ADF)	Total number of sheets scanned using the ADF
Total Count (FB) [fi-7700/fi-7700S]	Total number of sheets scanned using the flatbed [fi-7700/fi-7700S]:
After cleaning	Total number of sheets scanned after cleaning
Brake Roller	Number of sheets scanned after the brake roller is replaced

TOP

Contents

Index

Introduction

Scanner
OverviewHow to Load
DocumentsHow to Use the
Operator PanelVarious Ways to
Scan

Daily Care

Replacing the
Consumables

Troubleshooting

Operational
Settings

Appendix

Glossary

Item	Description
Pick Roller	Number of sheets scanned after the pick roller is replaced
Remaining Ink	Amount of ink remaining in the print cartridge of the imprinter (only displayed when the imprinter is installed)

ATTENTION

If you turned off the scanner by unplugging the power cable, or selected [Disable power switch], the number of scanned sheets may not be counted in [Total Count].

For details about disabling the power switch, refer to "[Method of Turning the Scanner ON/OFF \[Power SW Control\]](#)" (page 205).

Resetting the Sheet Counters

When you have replaced or cleaned a consumable part, reset the corresponding counter by using the following procedure:

- 1 If you have replaced a consumable, click the [Clear] button of the consumable that you replaced. If you performed cleaning, click the [Clear] button of [After cleaning].

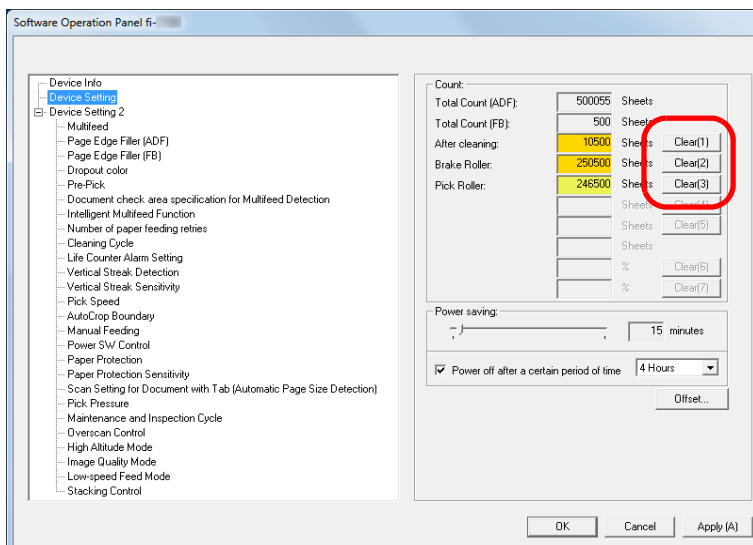

⇒ The counter is reset to 0.
For the ink counter, the value will be set to 100.

- 2 Click the [OK] button.
⇒ A confirmation message appears.
- 3 Click the [OK] button.
⇒ The settings are saved.

TOP

Contents

Index

Introduction

Scanner
OverviewHow to Load
DocumentsHow to Use the
Operator PanelVarious Ways to
Scan

Daily Care

Replacing the
Consumables

Troubleshooting

Operational
Settings

Appendix

Glossary

■ Messages for Cleaning or Replacing Consumables

The following message may appear while the scanner is in use:

Example message for replacing consumables

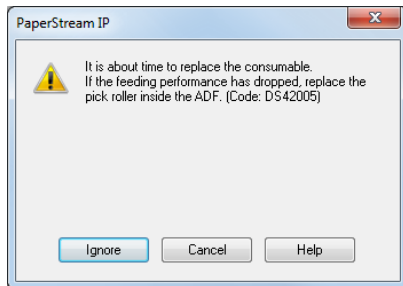

Example message for cleaning

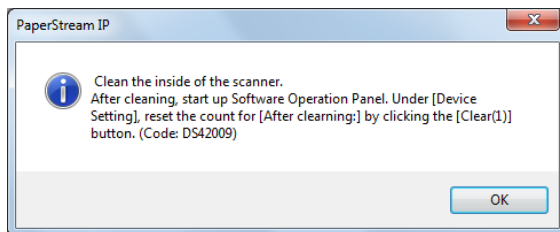

Check the message, and replace the consumable or perform cleaning accordingly.

If you click the [Ignore] button, the message disappears and the scan can be continued. However, it is recommended that you replace the consumable as soon as possible.

To stop the scan and replace the consumable right away, click the [Cancel] button.

Also, while this message appears, **MENU** flashes on the LCD.

Depending on the message, one of the following indications appears on the second line in the [Ready] screen.

- Message for replacing consumables
[Consumables] flashes.
- Message for cleaning
[Cleaning] flashes.

Check the information, and replace the consumable or perform cleaning accordingly.

For details about checking the information, refer to "[Checking the Information](#)" (page 67).

For details about replacing consumables, refer to the following:

- Brake roller
["6.2 Replacing the Brake Roller"](#) (page 115)
- Pick roller
["6.3 Replacing the Pick Roller"](#) (page 118)

For details about cleaning, refer to "[Chapter 5 Daily Care](#)" (page 103).

Scanner Cleaning Cycle [Cleaning Cycle]

The cleaning cycle for the scanner can be specified.
The background color of the counter after cleaning in [Device Setting] turns yellow when the sheet count after cleaning is performed reaches the specified value.
You can also display a cleaning instruction message (page 176).

- 1 Start up the Software Operation Panel.
For details, refer to "8.1 Starting Up the Software Operation Panel" (page 157).
- 2 From the listing on the left, select [Device Setting 2] → [Cleaning Cycle].

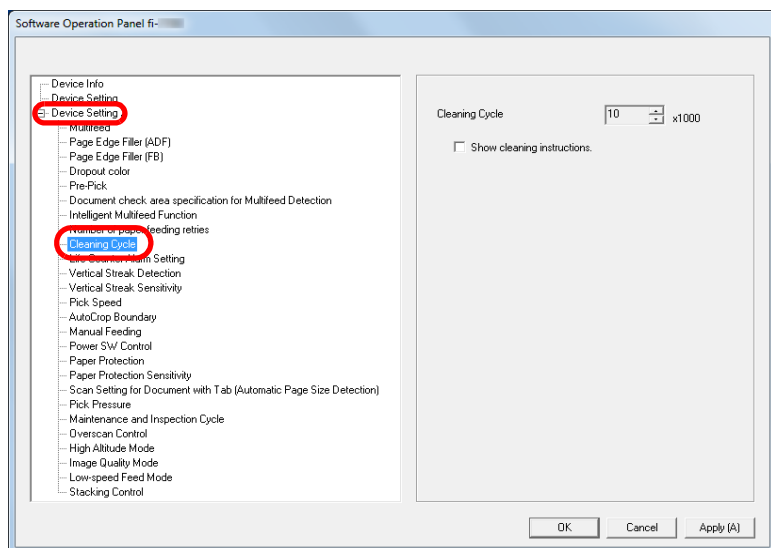

- 3 Specify a value for the cleaning cycle.
The value can range from 1,000 to 255,000 sheets (in increments of 1,000).
Specify whether or not to display the cleaning instruction message.

Replacement Cycle of Consumables [Life Counter Alarm Setting]

The replacement cycle for each consumable can be specified.
The background color of the brake roller/pick roller counter in [Device Setting] changes to light yellow when the sheet count after a consumable replacement reaches 95% of the value specified here, and turns yellow when the sheet count reaches 100%.
You can also display the message for replacing consumables (page 176).

- 1 Start up the Software Operation Panel.
For details, refer to "8.1 Starting Up the Software Operation Panel" (page 157).
- 2 From the listing on the left, select [Device Setting 2] → [Life Counter Alarm Setting].

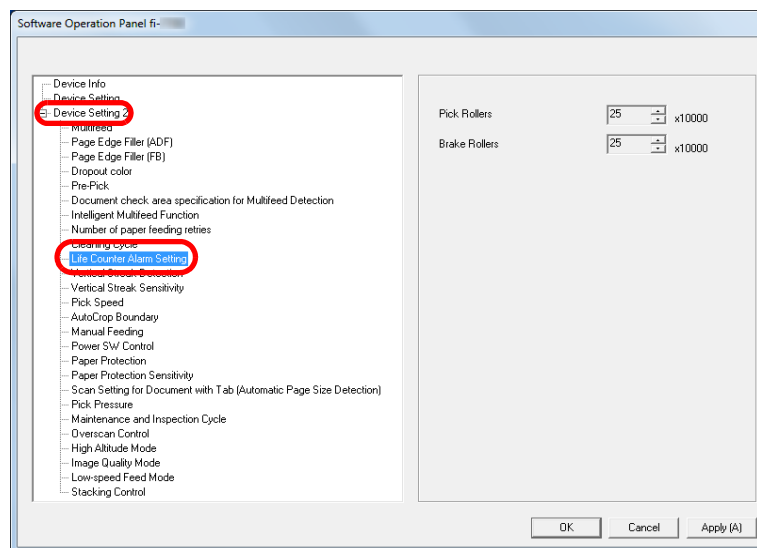

- 3** Specify a value as the replacement cycle for each of the consumables (brake roller and pick roller).

The value can range from 10,000 to 2,550,000 sheets (in increments of 10,000).

TOP

Contents

Index

Introduction

Scanner
Overview

How to Load
Documents

How to Use the
Operator Panel

Various Ways to
Scan

Daily Care

Replacing the
Consumables

Troubleshooting

Operational
Settings

Appendix

Glossary

8.5 Settings Related to Scanning

Adjusting the Position to Start the Scan [Offset Setting/Vertical magnification Adjustment]

When the output position of the scanned image is not correct or the image appears shortened/elongated (vertically), adjust the offset and the vertical magnification in the following procedure.

ATTENTION

Normally, you should not have to make any adjustments as the factory default settings are configured at appropriate values.

- 1 Start up the Software Operation Panel.
For details, refer to "8.1 Starting Up the Software Operation Panel" (page 157).

- 2 From the listing on the left, select [Device Setting] and click the [Offset] button.

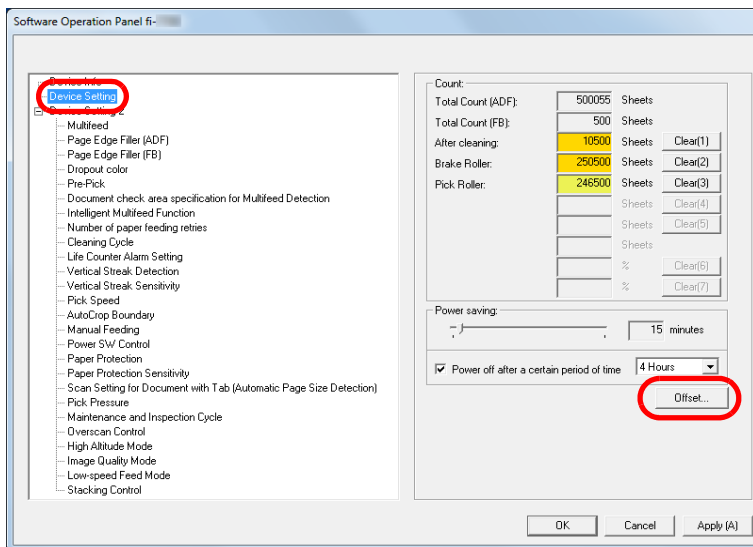

TOP

Contents

Index

Introduction

Scanner
OverviewHow to Load
DocumentsHow to Use the
Operator PanelVarious Ways to
Scan

Daily Care

Replacing the
Consumables

Troubleshooting

Operational
Settings

Appendix

Glossary

3 Adjust the level of offset/vertical magnification as needed.

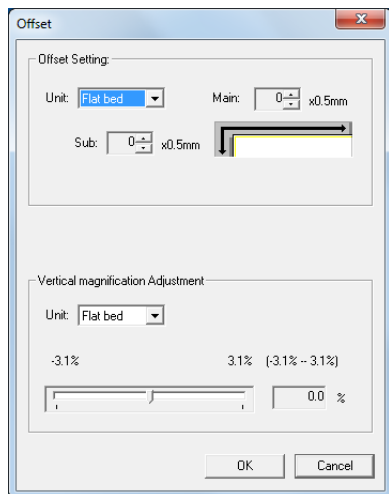

Offset Setting	Description
Unit	Select [Flat bed] (fi-7700/fi-7700S), [ADF (front)], or [ADF (back)] as the target for an offset adjustment.
Main	Adjusts the horizontal (width) offset. The value can range from -2 to +3 mm (in increments of 0.5).
Sub	Adjusts the vertical (length) offset. The value can range from -2 to +3 mm (in increments of 0.5).

Vertical magnification Adjustment	Description
Unit	Select [Flat bed] (fi-7700/fi-7700S) or [ADF] as the target for a vertical magnification adjustment.

Vertical magnification Adjustment	Description
Vertical magnification Adjustment (Sub: length)	Adjusts the vertical (length) magnification. The value can range from -3.1 to +3.1% (in increments of 0.1).

- TOP
- Contents
- Index
- Introduction
- Scanner Overview
- How to Load Documents
- How to Use the Operator Panel
- Various Ways to Scan
- Daily Care
- Replacing the Consumables
- Troubleshooting
- Operational Settings**
- Appendix
- Glossary

Removing Shadows/Streaks that Appear around the Scanned Image

[Page Edge Filler (ADF)]/[Page Edge Filler (FB)] (fi-7700/fi-7700S)

Depending on the condition of the documents that you scan, the shadow of the document may appear as black streaks. In that case, you can improve the image quality around the edges of the document by using the "Page Edge Filler" function to fill in the edges.

- 1 Start up the Software Operation Panel.
For details, refer to "8.1 Starting Up the Software Operation Panel" (page 157).
- 2 From the listing on the left, select [Device Setting 2] → [Page Edge Filler (ADF)] or [Page Edge Filler (FB)] (fi-7700/fi-7700S).

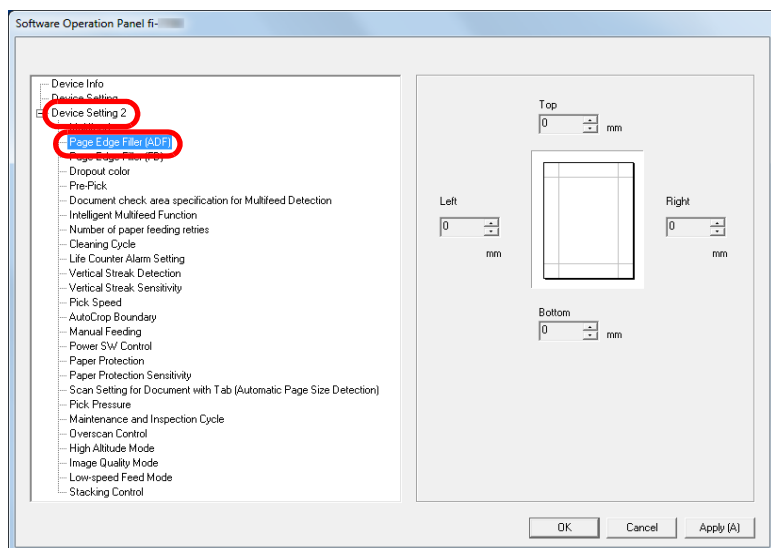

- 3 Specify the width of each margin to fill in: top/bottom/left/right.

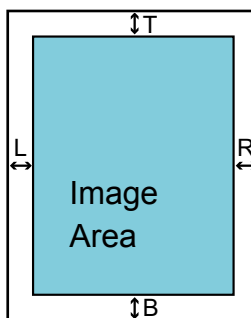

ADF

T: top = 0 to 15 mm

B: bottom = -7 to 7 mm

R: right = 0 to 15 mm

L: left = 0 to 15 mm

FB [fi-7700/fi-7700S]

T: top = 0 to 15 mm

B: bottom = 0 to 15 mm

R: right = 0 to 15 mm

L: left = 0 to 15 mm

(in 1 mm increments)

The specified area is filled in white or black, according to the background color.

ATTENTION

Note that if the target range of Page Edge Filler is too wide, some characters near the edge may appear missing.

TOP

Contents

Index

Introduction

Scanner
OverviewHow to Load
DocumentsHow to Use the
Operator PanelVarious Ways to
Scan

Daily Care

Replacing the
Consumables

Troubleshooting

Operational
Settings

Appendix

Glossary

HINT

- The color of the background is normally white. You can change the background to black in the scanner driver. For details, refer to the scanner driver's Help.
- Depending on the value you specify for the bottom margin in [Page Edge Filler (ADF)], the Page Edge Filler function operates as follows:
 - 1 to 7 mm
Fills in the margin with a background color, from the detected page bottom.
 - -1 to -7 mm
Outputs the image without filling in the margin with a background color. (Outputs the image with the specified area added when the page end detection mode is set.)"Detected page bottom" refers to the bottom edge of the scanned document detected by the scanner.
- This setting can also be configured in the scanner driver. In that case, Page Edge Filler of the scanner driver is used on the output image.

Removing a Color from the Scanned Image [Dropout color]

With "Dropout color", you can select either green, red, blue (primary colors), or white to remove the details of the selected color from a scanned image.

For example, when scanning a document with black characters and a green background, you can only scan the black characters of the document by selecting green for the dropout color.

ATTENTION

Dropout color works the best with light (low intensity) colors, and dark colors may not drop out.

HINT

Dropout color is only available in black & white or grayscale mode.

- 1 Start up the Software Operation Panel.
For details, refer to ["8.1 Starting Up the Software Operation Panel"](#) (page 157).

TOP

Contents

Index

Introduction

Scanner
OverviewHow to Load
DocumentsHow to Use the
Operator PanelVarious Ways to
Scan

Daily Care

Replacing the
Consumables

Troubleshooting

Operational
Settings

Appendix

Glossary

- 2 From the listing on the left, select [Device Setting 2] → [Dropout color].

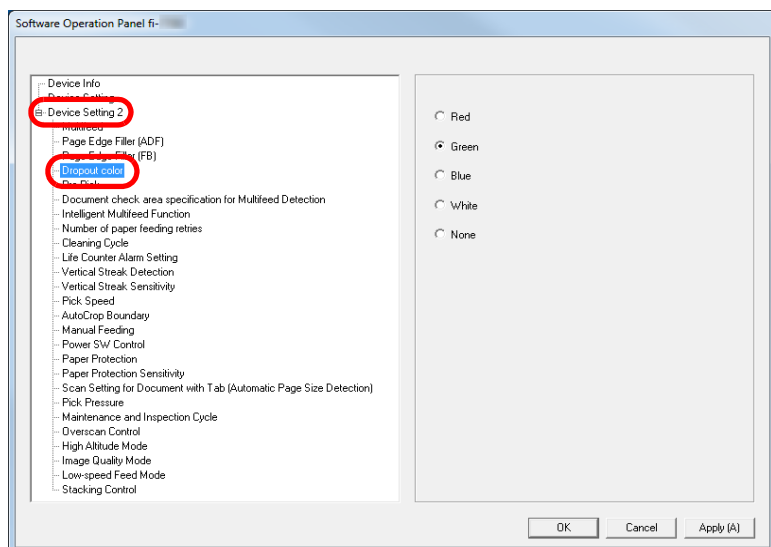

- 3 Select a color to drop out.
 Red, Green, Blue, White: The selected color is dropped out.
 None: No color is dropped out.

ATTENTION

The Software Operation Panel allows you to choose the color from red, green, blue, and white only. To drop out other colors, configure the setting in the scanner driver.
 For details, refer to the scanner driver's Help.

HINT

This setting can also be configured in the scanner driver. Note that priority is given to the scanner driver setting.

Shortening the Scanning Intervals [Pre-Pick]

"Pre-pick" refers to feeding the document to the starting position for scanning before the next scan.
 Enabling [Pre-Pick] shortens the interval between scanning each document.

- 1 Start up the Software Operation Panel.
 For details, refer to "8.1 Starting Up the Software Operation Panel" (page 157).
- 2 From the listing on the left, select [Device Setting 2] → [Pre-Pick].

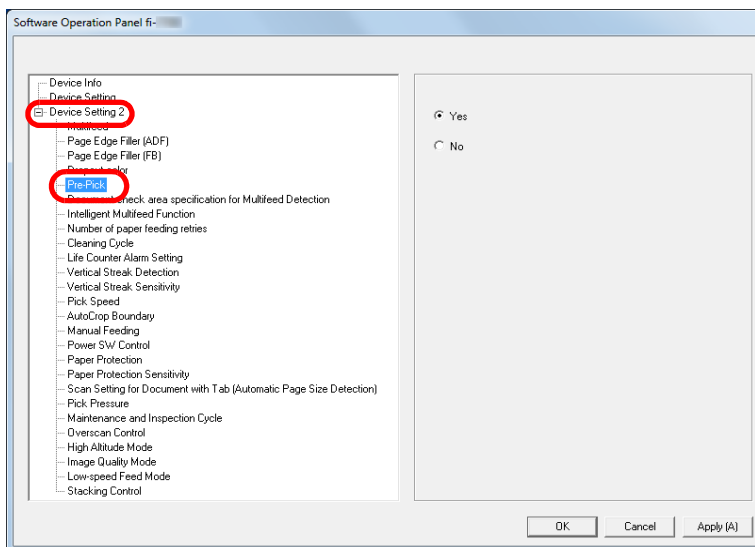

- 3** Specify whether or not to enable pre-pick.
Select [Yes] or [No].

HINT

- If you cancel in the middle of scanning while pre-pick is enabled, you will have to remove the pre-picked document, then load the document again.
- This setting can also be configured in the scanner driver or with the operator panel. Note that priority is given to the scanner driver setting.

Number of Paper Feeding Retries

Configure this setting to change the number of feeding retries when a pick error occurs.

- 1** Start up the Software Operation Panel.
For details, refer to "[8.1 Starting Up the Software Operation Panel](#)" (page 157).
- 2** From the listing on the left, select [Device Setting 2] → [Number of paper feeding retries].

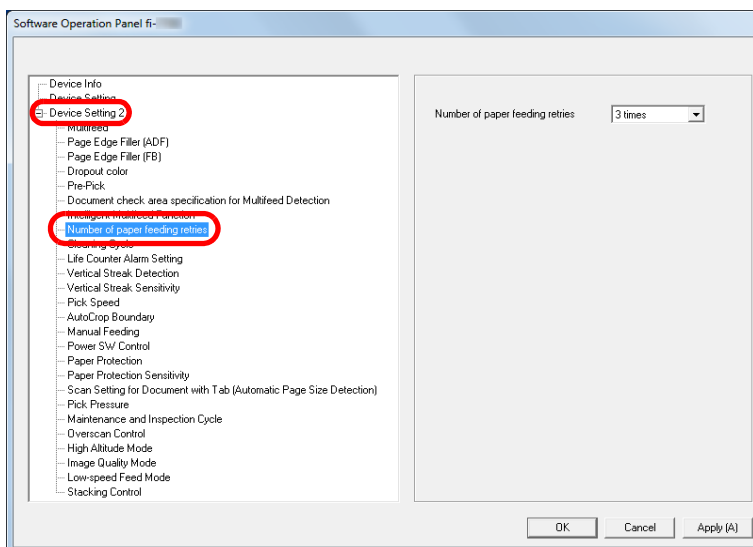

- 3** Specify the number of paper feeding retries.
The value can range from 1 to 12 times.

HINT

This setting can also be configured with the operator panel.

TOP

Contents

Index

Introduction

Scanner
OverviewHow to Load
DocumentsHow to Use the
Operator PanelVarious Ways to
Scan

Daily Care

Replacing the
Consumables

Troubleshooting

Operational
Settings

Appendix

Glossary

Document Feed Speed [Pick Speed]

When multifeeds and paper jams occur frequently, you may be able to improve the performance by slowing down the speed in which documents are picked or fed.

This setting is effective when you scan thin paper.

- 1 Start up the Software Operation Panel.
For details, refer to "8.1 Starting Up the Software Operation Panel" (page 157).
- 2 From the listing on the left, select [Device Setting 2] → [Pick Speed].

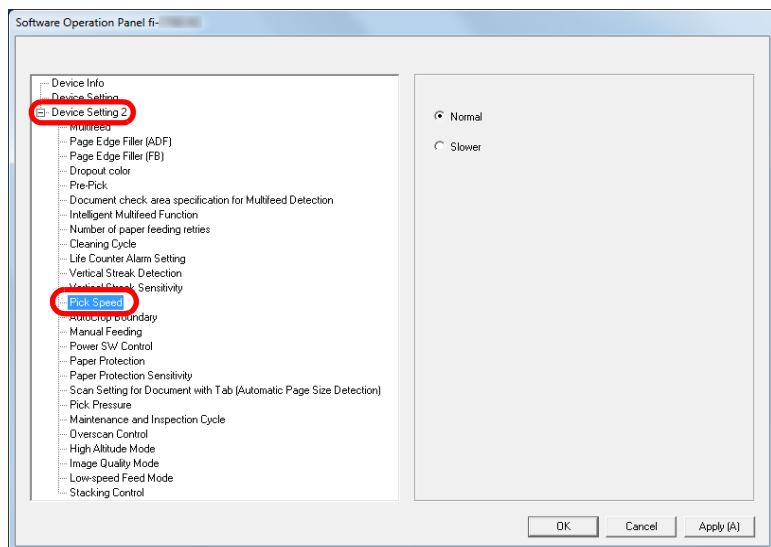

- 3 Specify the document feed speed.
Normal: Normal document feed speed

Slow: The document feed speed is slower than normal

ATTENTION

The total time for scanning is longer because the document feed speed slows down.

HINT

This setting can also be configured with the operator panel.

TOP

Contents

Index

Introduction

Scanner
OverviewHow to Load
DocumentsHow to Use the
Operator PanelVarious Ways to
Scan

Daily Care

Replacing the
Consumables

Troubleshooting

Operational
Settings

Appendix

Glossary

Cropping the Image Boundary [AutoCrop Boundary]

Some fractional data may be generated in the images in the process of scanning. You can specify whether to include or exclude such fractional data by using the "AutoCrop Boundary" function.

- 1 Start up the Software Operation Panel.
For details, refer to "8.1 Starting Up the Software Operation Panel" (page 157).
- 2 From the listing on the left, select [Device Setting 2] → [AutoCrop Boundary].

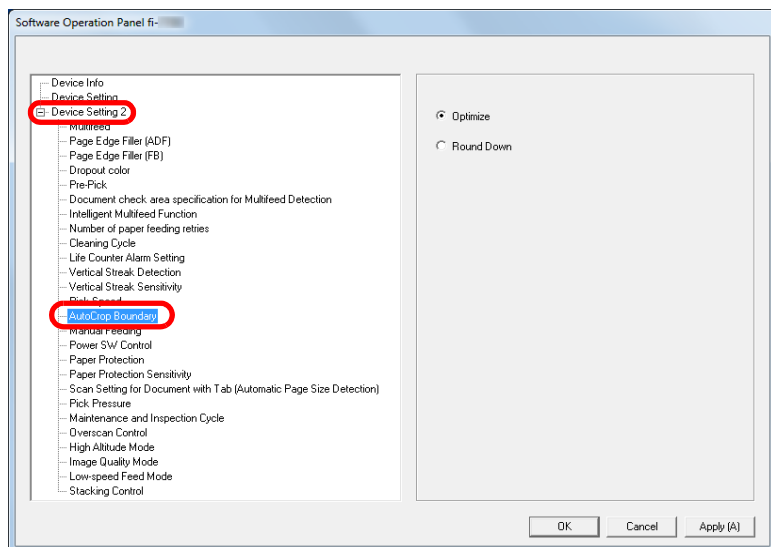

- 3 Select whether to include or exclude the fractional data. Select [Optimize] to prevent any exclusion of fractional data from scanned images.

ATTENTION

- While selecting [Optimize] can prevent data loss, a shadow may appear near the right edge.
- When you scan a document with text near the right edge while [Round Down] is selected, some pixel data there may be lost.
- For details about setting automatic page size detection, refer to the scanner driver's Help.

HINT

This setting is only applied in black & white mode.

TOP

Contents

Index

Introduction

Scanner
OverviewHow to Load
DocumentsHow to Use the
Operator PanelVarious Ways to
Scan

Daily Care

Replacing the
Consumables

Troubleshooting

Operational
Settings

Appendix

Glossary

Protecting the Documents from Being Damaged [Paper Protection]

Select a paper protection detection method.

Feeding errors during scanning could damage or tear valuable documents.

This function can reduce the risk of having the documents damaged by detecting a feeding error and stopping the scan in the following cases:

- When the scanner detects a document that was unusually warped by a feeding error
- When the scanner detects paper jam noise
- When the scanner either detects a document that was unusually warped by a feeding error or detects paper jam noise

This function can be used to scan documents such as thin papers which are difficult to feed.

- 1 Start up the Software Operation Panel.
For details, refer to "8.1 Starting Up the Software Operation Panel" (page 157).

- 2 From the listing on the left, select [Device Setting 2] → [Paper Protection].

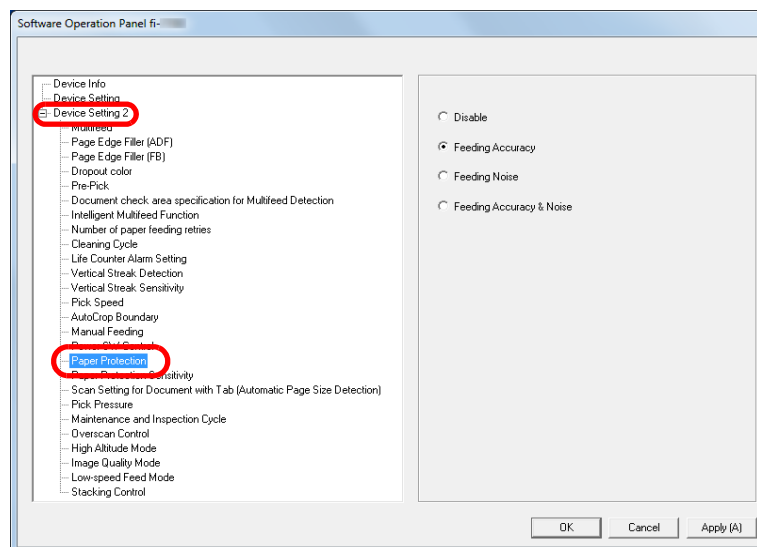

- 3 Click the detection method.

Detection Method	Description
None	Disables paper protection.
Feeding Accuracy	Stops the scan when the scanner detects a document that was unusually warped by a feeding error.
Feeding Noise	Stops the scan when the scanner detects a paper jam noise.
Feeding Accuracy & Noise	Stops the scan when the scanner detects a document that was unusually warped by a feeding error, or when the scanner detects a paper jam noise.

ATTENTION

- Note that paper protection is a function that suppresses the documents from being damaged, and does not guarantee all documents to be saved.
- When you use paper protection, make sure to load the documents with their top edges aligned (especially for a mixed batch with different lengths).
If the top edges are not aligned properly, the paper protection function may be activated and stop the scan even when the documents are being fed correctly.

HINT

- If you scan a wrinkled document, paper protection may be set off forcing a scan to be stopped even though paper is fed normally. In this case, you can disable paper protection with the operator panel for a single scan after paper protection is set off. For details, refer to "[Disabling Paper Protection for a Single Scan After Paper Protection Is Set Off](#)" (page 101).
- If paper protection is set off frequently, refer to "[Paper protection is set off frequently.](#)" (page 148).
- This setting can also be configured in the scanner driver or with the operator panel. When the operator panel setting is prioritized, the operator panel setting is prioritized over the Software Operation Panel setting. Note that even if the operator panel setting is prioritized, the scanner driver setting has the highest priority.

Specifying the Sensitivity Level for Paper Protection

[Paper Protection Sensitivity]

Specify the sensitivity level to detect anomalies upon feeding the documents when paper protection is enabled.

Documents are deformed (for example, warped) or paper jam noise is made when documents are not being fed by the rollers properly. To detect such a symptom and stop the scan, select [Low] to only detect documents that are highly deformed or paper jam noise that is loud. Select [High] to also detect documents that are slightly deformed or mild paper jam noise.

- 1 Start up the Software Operation Panel.
For details, refer to "[8.1 Starting Up the Software Operation Panel](#)" (page 157).

TOP

Contents

Index

Introduction

Scanner
OverviewHow to Load
DocumentsHow to Use the
Operator PanelVarious Ways to
Scan

Daily Care

Replacing the
Consumables

Troubleshooting

Operational
Settings

Appendix

Glossary

- 2 From the listing on the left, select [Device Setting 2] → [Paper Protection Sensitivity].

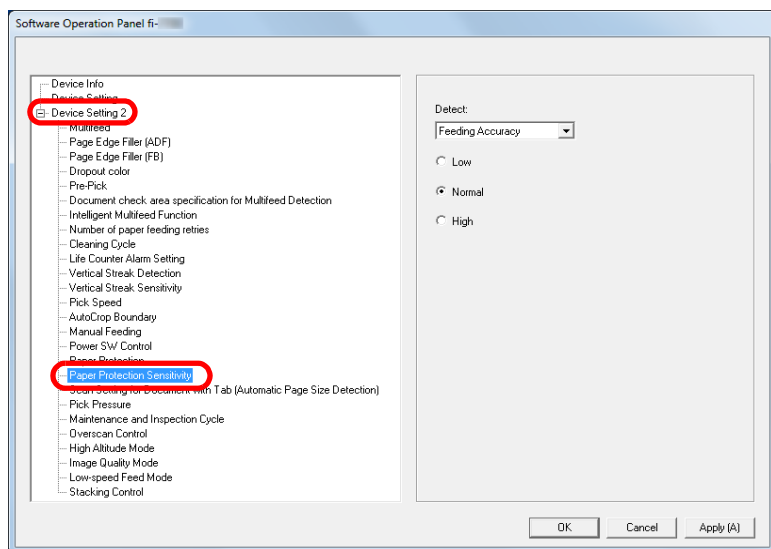

- 3 Select a paper protection detection method which you want to change the sensitivity level for.
 Feeding Accuracy: Select this to detect a document that is unusually warped when a feeding error occurs.
 This is available when you have selected [Feeding Accuracy] or [Feeding Accuracy & Noise] for the paper protection detection method.

Feeding Noise: Select this to detect paper jam noise.
 This is available when you have selected [Feeding Noise] or [Feeding Accuracy & Noise] for the paper protection detection method.

- 4 Specify the sensitivity level.

Low: Decreases the sensitivity level to detect warped documents or paper jam noise.

Normal: Monitors warped documents or paper jam noise with normal sensitivity.

Keep this setting for normal use.

High: Increases the sensitivity level to detect warped documents or paper jam noise.

HINT

- To detect paper warp or paper jam noise faster and stop the scan, select [High].
- To decrease the frequency of paper jam detection if paper jams occur frequently in the feeder, select [Low].
- This setting can also be configured with the operator panel. When the operator panel setting is prioritized, the operator panel setting is prioritized over the Software Operation Panel setting.

Scan Setting for Documents with Tabs or Non-Rectangular Documents

[Scan Setting for Document with Tab (Automatic Page Size Detection)]

For a document that includes index sheets or a document with index stickers (or tabs) attached at the bottom edge, you can specify whether or not to include the index portion (or tab) images during scanning using the Auto Paper Size Detection setting.

- 1 Start up the Software Operation Panel.
For details, refer to ["8.1 Starting Up the Software Operation Panel" \(page 157\)](#).
- 2 From the listing on the left, select [Device Setting 2] → [Scan Setting for Document with Tab (Automatic Page Size Detection)].

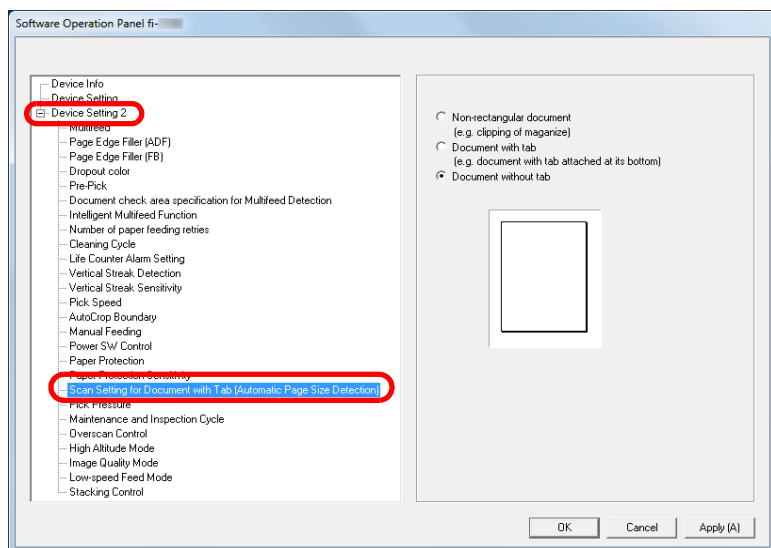

- 3 Select [Non-rectangular document], [Document with tab], or [Document without tab].

Detection Method	Description
Non-rectangular document	Scan extra 120 mm from the detected bottom edge of the document.
Document with tab	Scan extra 35 mm from the detected bottom edge of the document.
Document without tab	Terminates scanning at the time the bottom edge of the document is detected.

ATTENTION

- The scanning speed slows down if [Document with tab] or [Non-rectangular document] is selected.
- When scanning documents with a tab or non-rectangular documents, refer to ["How to Load Documents with a Tab or Non-Rectangular Documents" \(page 51\)](#).
- For details about setting automatic page size detection, refer to the scanner driver's Help.

HINT

This setting can also be configured with the operator panel.

Adjusting the Paper Picking Pressure [Pick Pressure]

When scanning thin paper or when paper is not being fed smoothly and the pick rollers repetitively rotate aimlessly until paper is fed, adjusting the paper picking pressure improves the performance of the scan.

- 1 Start up the Software Operation Panel.
For details, refer to "8.1 Starting Up the Software Operation Panel" (page 157).
- 2 From the listing on the left, select [Device Setting 2] → [Pick Pressure].

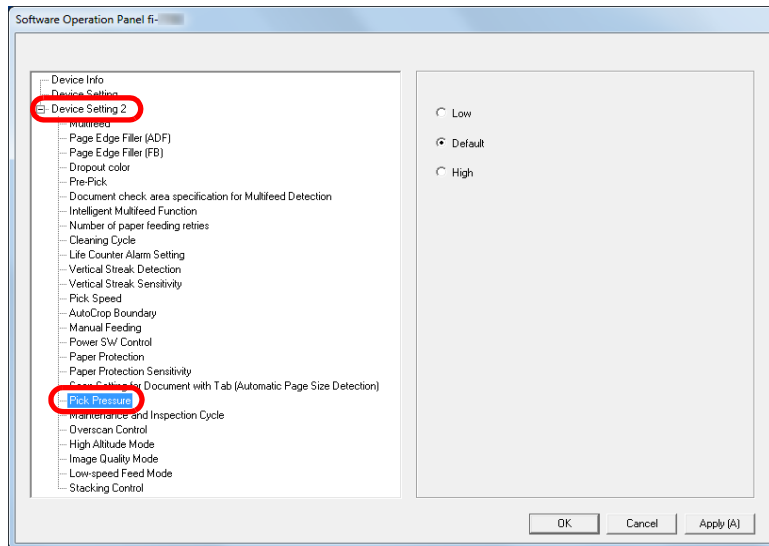

- 3 Set the pick pressure for feeding paper.
Low: Select this option for thick or curled paper
Default: Default paper picking pressure. Keep this setting for normal use.
High: Select this option for thin paper.

ATTENTION

- Scanning thin paper with [High] selected may cause a paper jam.
- Scanning thick paper with [Low] selected may not feed the paper properly, making the pick rollers repetitively rotate aimlessly.

HINT

- Selecting [High] strengthens the feeding force of the pick rollers, feeding hard-to-feed documents quickly.
- The [High] option is effective for scanning relatively thick documents.
- Selecting [Low] allows you to feed thin paper. However, if you scan a document with a paper type that is not recommended, make sure you test the same type of paper first to check if the document can be scanned.
- The [Low] option is effective for scanning relatively thin documents.
- This setting can also be configured with the operator panel.

TOP

Contents

Index

Introduction

Scanner
OverviewHow to Load
DocumentsHow to Use the
Operator PanelVarious Ways to
Scan

Daily Care

Replacing the
Consumables

Troubleshooting

Operational
Settings

Appendix

Glossary

Adjusting the Output Result for Overscan [Overscan Control]

The scanner can be configured to increase the amount of black margin on the top and the bottom of the scanning area so that part of the scanned image is not missing even when an unusual skew occurs during overscan.

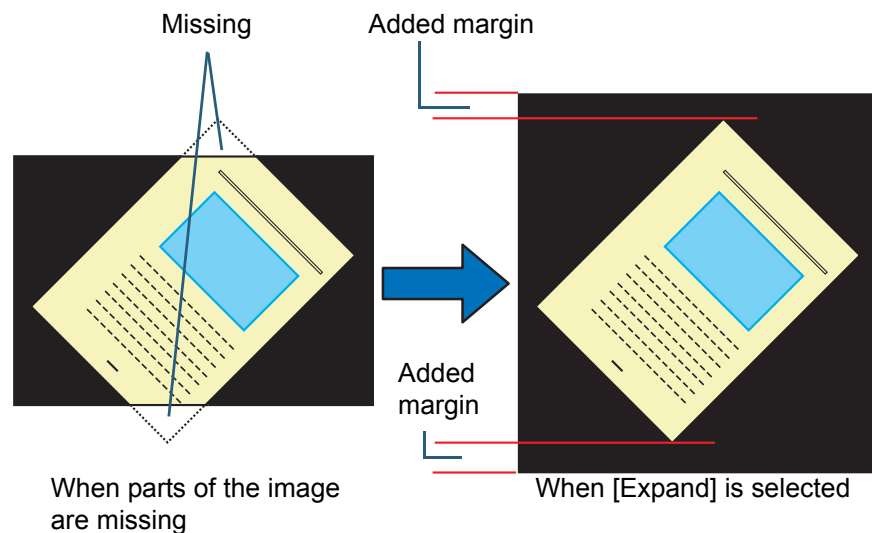

- 1 Start up the Software Operation Panel.
For details, refer to "8.1 Starting Up the Software Operation Panel" (page 157).
- 2 From the listing on the left, select [Device Setting 2] → [Overscan Control].

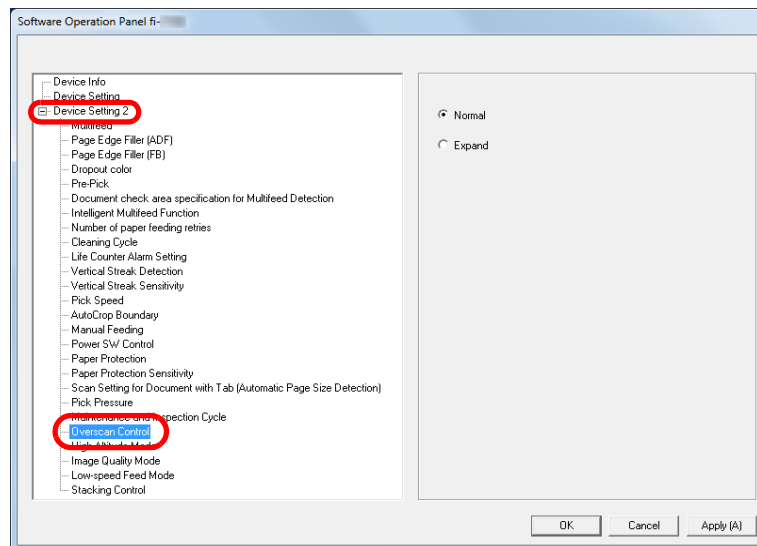

- 3 Select the black margin amount.

HINT

- Specifying the maximum document size that can be scanned is recommended.
- This setting can also be configured with the operator panel.

Scanning at High Altitude [High Altitude Mode]

Select whether to enable or disable high altitude mode. Low atmospheric pressure at high altitudes may lower the accuracy in multifeed detection by the ultrasonic sensor. Enabling the high altitude mode allows you to use the scanner at 2,000 m or higher altitudes.

- 1 Start up the Software Operation Panel.
For details, refer to "8.1 Starting Up the Software Operation Panel" (page 157).
- 2 From the listing on the left, select [Device Setting 2] → [High Altitude Mode].

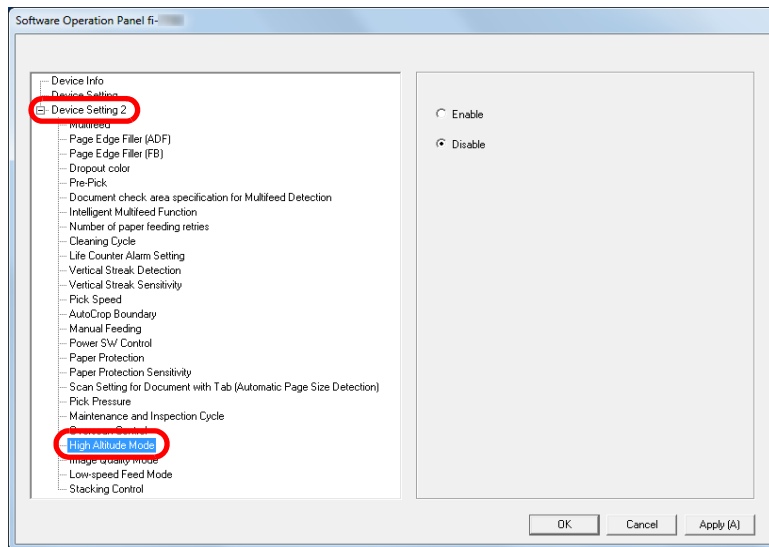

- 3 Select whether to enable or disable [High Altitude Mode].

Setting the Image Quality for Scanning [Image Quality Mode]

Set the image quality mode. To obtain an image quality that is close to the image quality for scanning with fi-6670/fi-6770/fi-6750S, set the image quality mode.

- 1 Start up the Software Operation Panel.
For details, refer to "8.1 Starting Up the Software Operation Panel" (page 157).
- 2 From the listing on the left, select [Device Setting 2] → [Image Quality Mode].

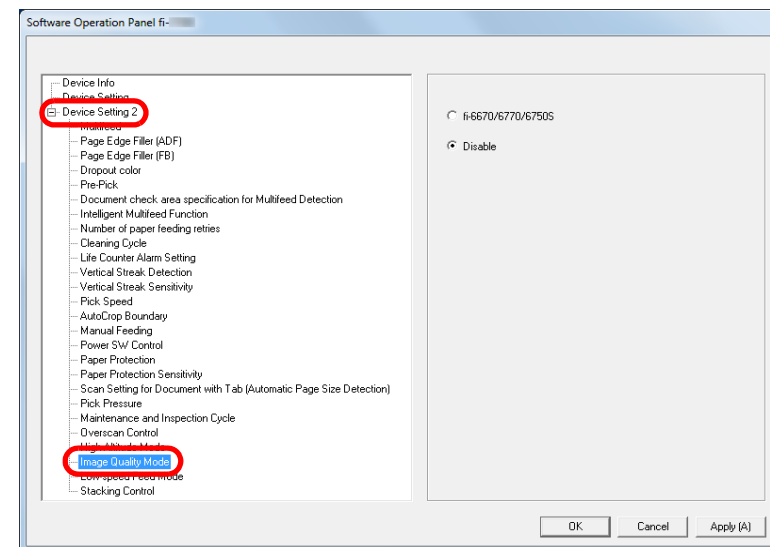

- 3 Select whether to obtain an image quality that is close to the image quality of the fi-6670/fi-6770/fi-6750S.

Low-speed Scan at Lower Resolution [Low-speed Feed Mode]

When scanning at a lower resolution (less than 400 dpi), you can configure the scanner to scan documents slowly regardless of the resolution setting.

Scanning documents slowly can prevent the documents from being damaged.

This setting is effective when you scan long page documents.

- 1 Start up the Software Operation Panel.
For details, refer to "8.1 Starting Up the Software Operation Panel" (page 157).
- 2 From the listing on the left, select [Device Setting 2] → [Low-speed Feed Mode].

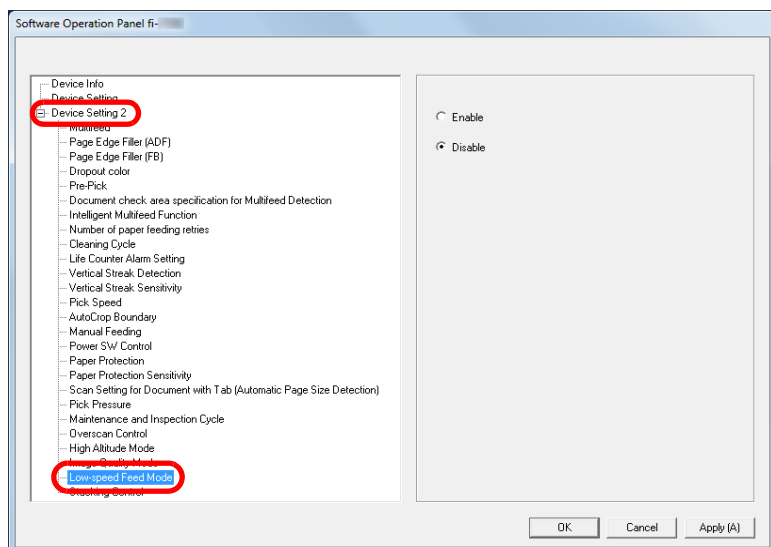

- 3 Select whether to disable or enable [Low-speed Feed Mode].

HINT

This setting can also be configured with the operator panel.

TOP

Contents

Index

Introduction

Scanner
OverviewHow to Load
DocumentsHow to Use the
Operator PanelVarious Ways to
Scan

Daily Care

Replacing the
Consumables

Troubleshooting

Operational
Settings

Appendix

Glossary

Specifying the Paper Ejecting Speed [Stacking Control]

This option allows you to slow down the ejecting speed when documents are ejected, preventing scanned documents from scattering.

This setting is effective when you scan documents of different sizes.

- 1 Start up the Software Operation Panel.
For details, refer to "8.1 Starting Up the Software Operation Panel" (page 157).
- 2 From the listing on the left, select [Device Setting 2] → [Stacking Control].

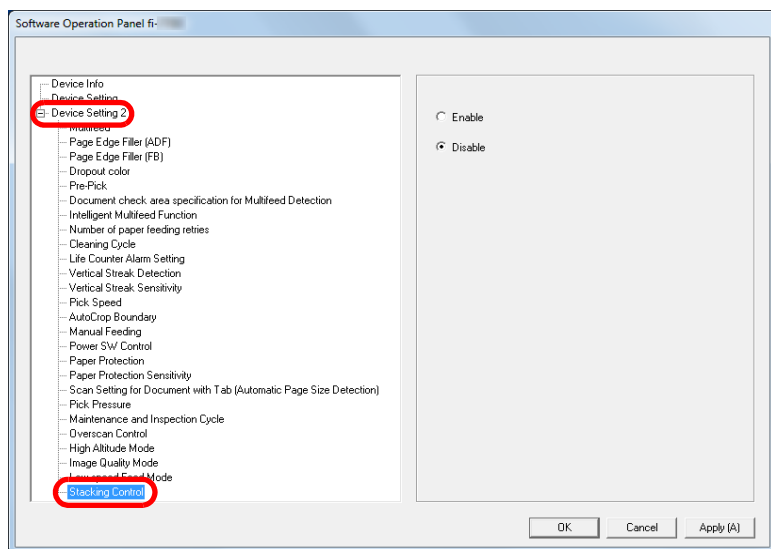

- 3 Select whether to enable or disable [Stacking Control].

ATTENTION

The scanning speed slows down if the Stacking Control is enabled.

HINT

This setting can also be configured with the operator panel.

TOP

Contents

Index

Introduction

Scanner
OverviewHow to Load
DocumentsHow to Use the
Operator PanelVarious Ways to
Scan

Daily Care

Replacing the
Consumables

Troubleshooting

Operational
Settings

Appendix

Glossary

8.6 Settings Related to Multifeed Detection

Specifying a Multifeed Detection Method [Multifeed]

Multifeed is an error where two or more sheets are fed through the ADF at once. When a different document length is detected, this detected result is also called a multifeed. Not noticing multifeed errors while scanning may put you in a situation where important data are missing from the scanned images.

Multifeed detection can be used to prevent such troubles. When this function is enabled, an error message is displayed as soon as it detects a multifeed, and stops the scan. Note that multifeed cannot be detected within 30 mm from the leading edge of the document.

- 1 Start up the Software Operation Panel.
For details, refer to "8.1 Starting Up the Software Operation Panel" (page 157).

- 2 From the listing on the left, select [Device Setting 2] → [Multifeed].

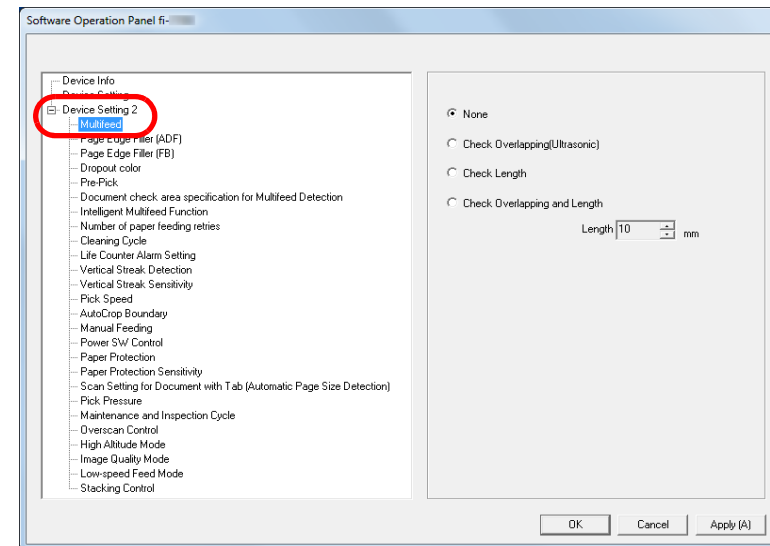

TOP

Contents

Index

Introduction

Scanner
OverviewHow to Load
DocumentsHow to Use the
Operator PanelVarious Ways to
Scan

Daily Care

Replacing the
Consumables

Troubleshooting

Operational
Settings

Appendix

Glossary

3 Select a detection method.

Method	Description
None	Does not detect multifeed.
Check Overlapping (Ultrasonic)	<p>Detects multifeed by the overlapping of documents.</p> <p>When this is selected, you can also specify the following two options:</p> <ul style="list-style-type: none"> Specify the detection range by the length from the top of the document. Proceed to "Specifying the Area to Detect Multifeed [Document check area specification for Multifeed Detection]" (page 198) for more details. Ignore the multifeed when there is paper of the same size attached to a designated location on the page. Proceed to "Ignoring Multifeed for a Set Pattern" (page 98) for more details.
Check Length	<p>Detects multifeed by the difference in length of the documents.</p> <p>Note that multifeeds cannot be detected accurately when a mixed batch of different sizes is scanned.</p>

Method	Description
Check Overlapping and Length	<p>Detects multifeed by the combination of [Check Overlapping (Ultrasonic)] and [Check Length]. Note that multifeeds cannot be detected accurately when a mixed batch of different sizes is scanned.</p> <p>When this is selected, you can also specify the following two options:</p> <ul style="list-style-type: none"> Specify the detection range by the length from the top of the document. Proceed to "Specifying the Area to Detect Multifeed [Document check area specification for Multifeed Detection]" (page 198) for more details. Ignore the multifeed when there is paper of the same size attached to a designated location on the page. Proceed to "Ignoring Multifeed for a Set Pattern" (page 98) for more details.
Length	<p>Select a length difference from 10/15/20 mm when detecting a multifeed by the difference in length of the documents. Any length under the specified value will not be detected as multifeed.</p>

ATTENTION

- To scan documents with different lengths, specify [Check Overlapping (Ultrasonic)].
- When an attachment such as a sticky note, receipt, or photo is attached on the document, the overlapping part of the document may be falsely detected as multifeed if [Check Overlapping (Ultrasonic)] is specified. In that case, specify [Check Length].
Note however that you can still use [Check Overlapping (Ultrasonic)] by restricting the detection range.

HINT

This setting can also be configured in the scanner driver. Note that priority is given to the scanner driver setting.

Specifying the Area to Detect Multifeed [Document check area specification for Multifeed Detection]

The following setting is only available when you specified [Check Overlapping (Ultrasonic)] or [Check Overlapping and Length].

- From the listing on the left, select [Device Setting 2] → [Document check area specification for Multifeed Detection]. Select the [Selected range] check box in the window.

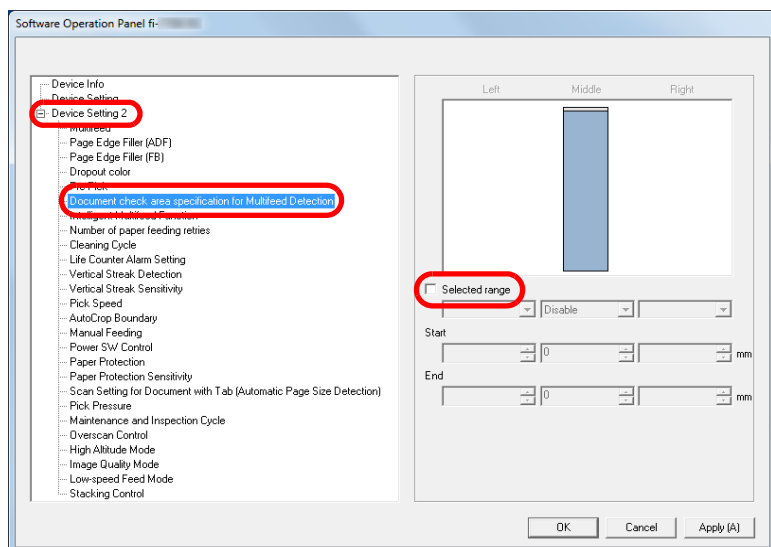

- Specify the detection range.

Range	Description
Selected range	<p>Select the check box to specify the detection range (colored in light blue) in the picture below.</p> <p>Select the check box to enable the setting in this window. Clear the check box to disable the setting. Clearing this check box sets both start and end positions to "0", making the whole document to be detected for multifeeds.</p> <p>The above condition applies when the document is set to the center of the pick roller width.</p> <p>Multifeed cannot be detected for the top 30 mm of a document.</p>
Disable (Middle)	Does not detect multifeeds for the selected area.
Enable (Middle)	Detects multifeeds for the selected area.

Range	Description
Start (Middle)	Displays the start position of the detection by the length from the leading edge of the document. Range: 0 to 510 mm, in 2 mm increments, Start<End
End (Middle)	Displays the end position of the detection by the length from the leading edge of the document. Range: 0 to 510 mm, in 2 mm increments, Start<End

HINT

- When both [Start] and [End] are set to "0", multifeed detection is performed for the whole area regardless of whether it is enabled or disabled.
- To disable multifeed detection for the whole document, select [Disable] and set the start position to "0" and the end position to equal the document length or longer.
- If you set a value larger than the document length for the start position, selecting [Disable] detects the whole length of the document and selecting [Enable] disables the multifeed detection.
- To detect multifeeds, the detection range must be at least 5 mm in length.
Configure the setting so that the value of the end position minus the start position is 6 mm or more.
- You can also set the start and the end positions by the following methods:
 - Draw an area with the mouse on the displayed image.
 - Drag the handles for [Start] and [End] positions on the displayed image.

Example 1:

Position: Middle

Selected range = Enable, Start = 50 mm, End = 200 mm

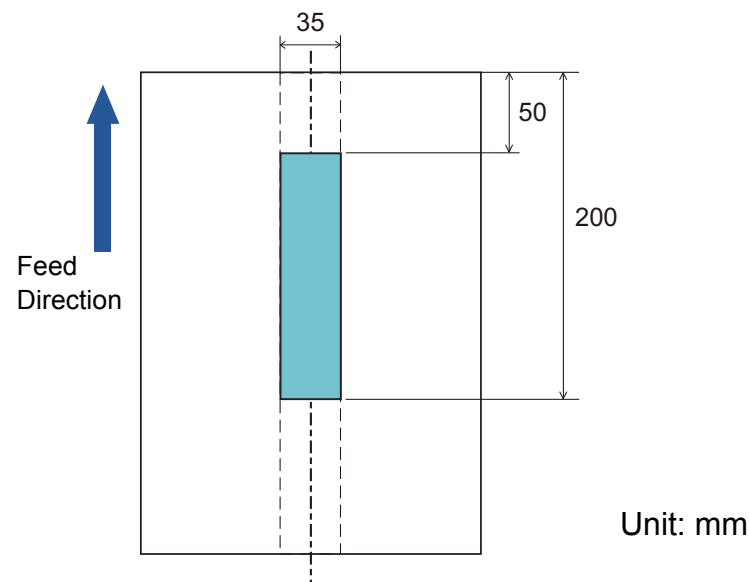

Multifeeds are detected only within the area of light blue.

Example 2:

Position: Middle

Selected range = Enable, Start = 0 mm, End = 300 mm

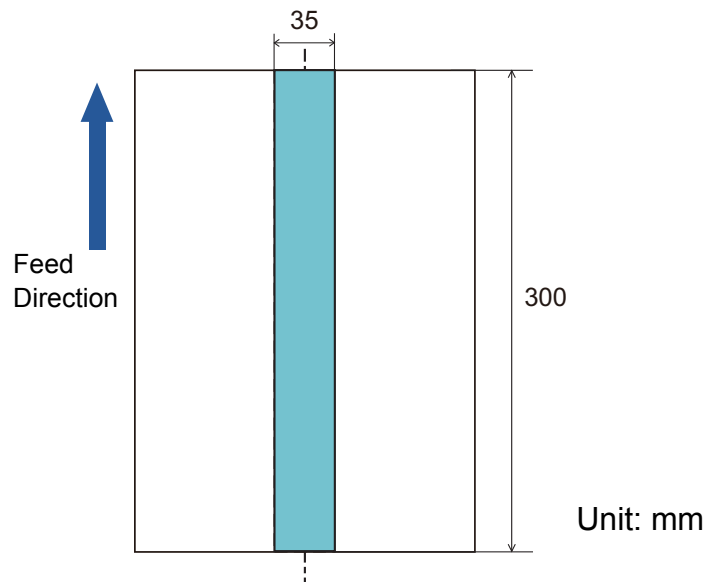

Multifeeds are detected only within the area of light blue.

HINT

When you use detection by overlapping, accuracy of multifeed detection may drop if the documents are glued firmly or attached together by static electricity.

Example 3: (Bad Example)

Position: Middle

Selected range = Enable, Start = 100 mm, End = 102 mm

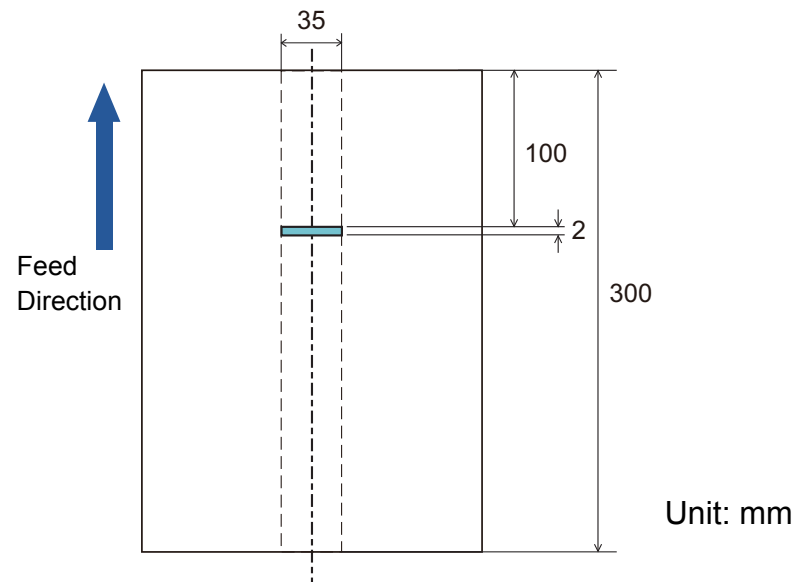

Since the detection range (length) is less than 5 mm, multifeeds cannot be detected accurately.

- TOP
- Contents
- Index
- Introduction
- Scanner Overview
- How to Load Documents
- How to Use the Operator Panel
- Various Ways to Scan
- Daily Care
- Replacing the Consumables
- Troubleshooting
- Operational Settings
- Appendix
- Glossary

Specifying an Area Not to Detect Multifeed [Intelligent Multifeed Function]

When there is paper of the same size attached to a designated location on the page, the scanner memorizes the location of the attachment and can be configured not to detect multifeeds for that location. Note that you first need to select [Check Overlapping (Ultrasonic)] or [Check Overlapping and length] in either the scanner driver or the multifeed detection setting in "Specifying a Multifeed Detection Method [Multifeed]" (page 196).

- 1 Start up the Software Operation Panel.
For details, refer to "8.1 Starting Up the Software Operation Panel" (page 157).
- 2 From the listing on the left, select [Device Setting 2] → [Intelligent Multifeed Function].

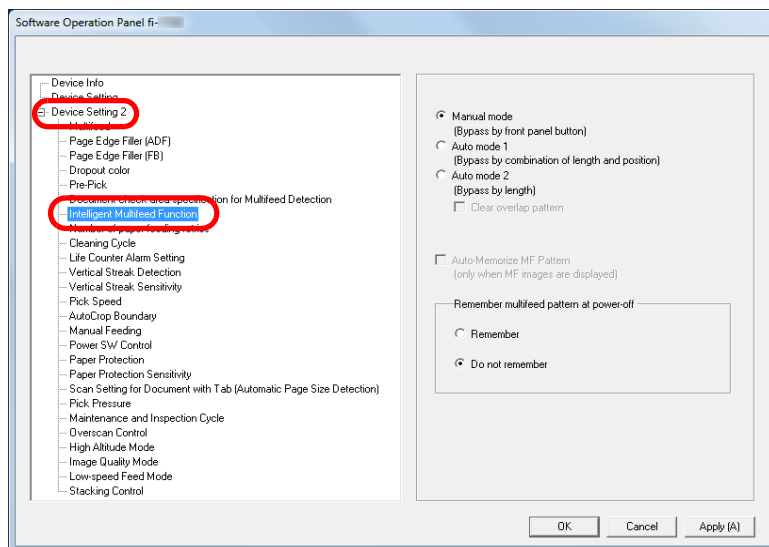

3 Specify an operation mode.

Mode	Description
Manual mode	Ignores the multifeed when you load the documents back in the ADF paper chute (feeder) and scan them again. Does not memorize the size or location of the paper attachment when a multifeed is detected.
Auto mode 1	Memorizes the size and location of the paper attachment when a multifeed is detected. The memorized pattern is ignored from the next scan.
Auto mode 2	Memorizes the size of the paper attachment when a multifeed is detected. The memorized pattern (including any length less than the attachment) is ignored from the next scan.

HINT

- By selecting the [Clear overlap pattern] check box, you can erase the overlapping patterns (length, position) that were memorized in Auto mode.
- By selecting the [Auto-Memorize MF Pattern (only when MF images are displayed)] check box, you can record the multifeed pattern on the window to check an image that was detected as multifeed.
- In [Remember multifeed pattern at power-off], you can select whether or not to keep the multifeed pattern upon turning the power off. When [Remember] is selected, you can use eight of the most recent patterns the next time the scanner is powered on.
- This setting can also be configured with the operator panel.

For details about the procedure after this step, refer to "Ignoring Multifeed for a Set Pattern" (page 98).

8.7 Settings Related to Waiting Time

Waiting Time in Manual Feeding [Manual Feeding]

When you scan by manually loading one sheet at a time, you can specify the waiting time (interval) for loading the next document in the ADF paper chute (feeder). This enables continuous scanning as long as you load a document within the specified time.

If the specified time is exceeded, the scan is finished automatically and manual feeding will be canceled.

Note that you can also press the [Stop/Clear] button on the operator panel to cancel manual feeding.

- 1 Start up the Software Operation Panel.
For details, refer to "8.1 Starting Up the Software Operation Panel" (page 157).

- 2 From the listing on the left, select [Device Setting 2] → [Manual Feeding].

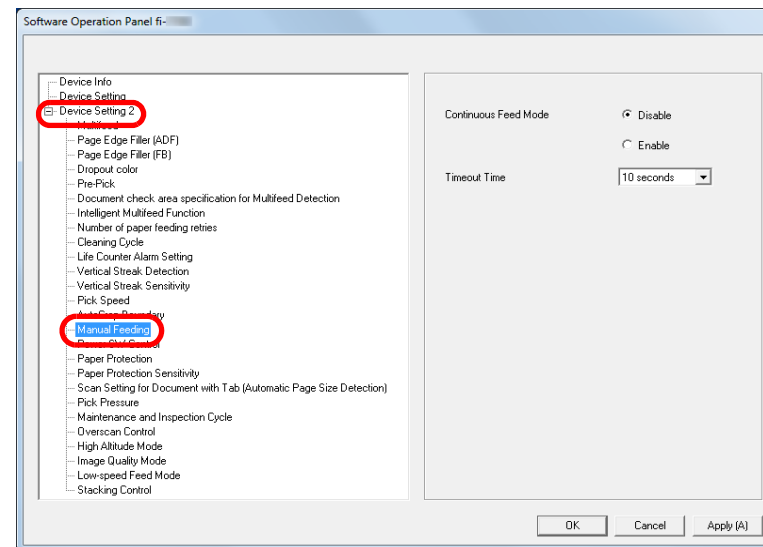

- 3 Set [Timeout Time].
For [Timeout Time], specify the time period for which the scanner waits to confirm that no documents are loaded in the ADF paper chute (feeder), which is the interval between the time when the scanner scanned the last document and the time when the scanner checks whether the next document to be scanned is loaded.
 - When scanning more than one document in succession manually
 - 1 Select the Enable option for [Continuous Feed Mode].
 - 2 Select the time for [Timeout Time].
 - To scan a document folded in half, an envelope, or a multi-layered transfer paper manually one by one
 - 1 Slide the feed mode switch to the left to switch the feed mode to Manual/Single mode.
 - 2 Select the time for [Timeout Time].

TOP

Contents

Index

Introduction

Scanner
OverviewHow to Load
DocumentsHow to Use the
Operator PanelVarious Ways to
Scan

Daily Care

Replacing the
Consumables

Troubleshooting

Operational
Settings

Appendix

Glossary

HINT

- When [Continuous Feed Mode] is enabled, the scanner will wait for the next document to be loaded until the specified time elapses even if you start scanning with no document in the ADF paper chute (feeder).
- When the feed mode switch is set to Manual/Single mode, even if the Enable option is selected for [Continuous Feed Mode] in [Manual Feeding], the scanner operates in Manual/Single mode.
- This setting can also be configured with the operator panel.

Waiting Time for the Scanner to Enter Power Saving Mode [Power saving]

The waiting time for the scanner to enter power saving mode can be specified.

- 1 Start up the Software Operation Panel.
For details, refer to "[8.1 Starting Up the Software Operation Panel](#)" (page 157).
- 2 From the listing on the left, select [Device Setting].

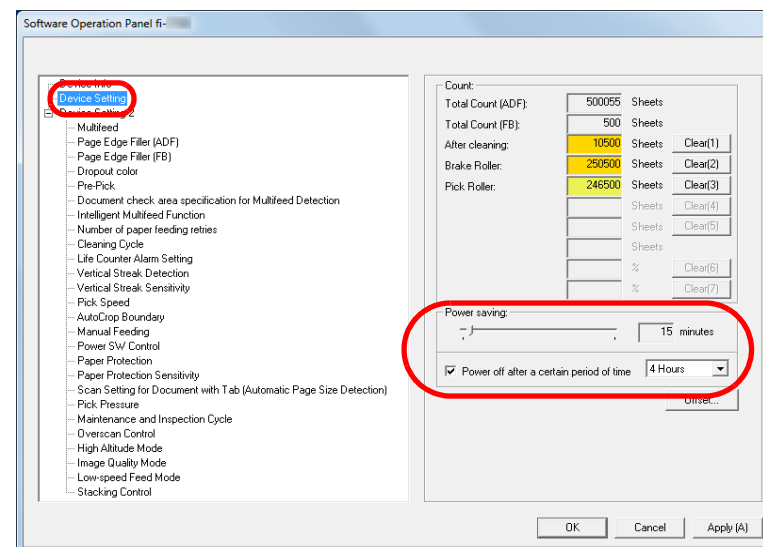

TOP

Contents

Index

Introduction

Scanner
OverviewHow to Load
DocumentsHow to Use the
Operator PanelVarious Ways to
Scan

Daily Care

Replacing the
Consumables

Troubleshooting

Operational
Settings

Appendix

Glossary

3 Use the slider to specify the waiting time for the scanner to enter power saving mode.

The value can range from 5 to 235 minutes (in increments of 5).

HINT

- Selecting the [Power off after a certain period of time] check box turns the power off automatically if the scanner is left on for a certain period of time without being used.
You can select the timeout period for the scanner to be automatically turned off by [1 Hour]/[2 Hours]/[4 Hours]/[8 Hours].
- This setting can also be configured with the operator panel.

8.8 Settings Related to Power ON/OFF

Method of Turning the Scanner ON/OFF [Power SW Control]

The method by which the scanner is powered on/off can be specified from one of the following:

- Press the [Power] button on the operator panel
- Use an AC power strip to control power supply for peripherals such as a scanner in accordance with the computer's power.
- Turn on/off the scanner in accordance with the computer's power.

1 Start up the Software Operation Panel.

For details, refer to "8.1 Starting Up the Software Operation Panel" (page 157).

2 From the listing on the left, select [Device Setting 2] → [Power SW Control].

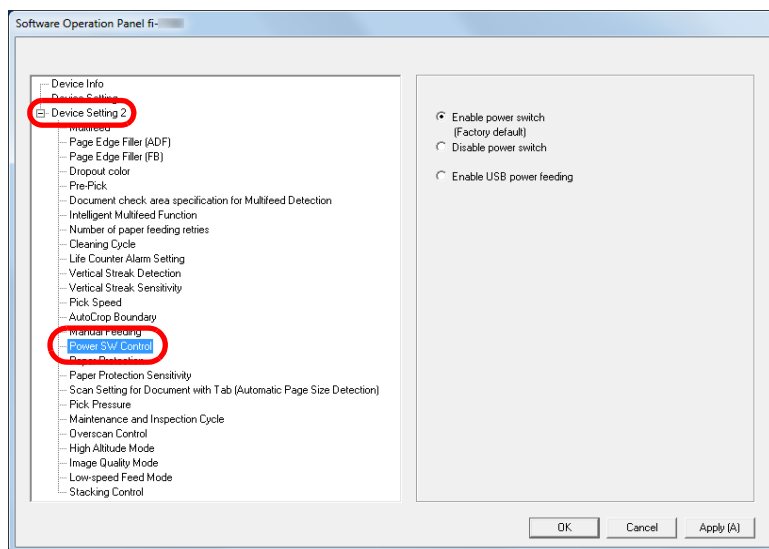

3 Select one of the following:

[Enable power switch]: Press the [Power] button on the operator panel.

[Disable power switch]: Use an AC power strip to control the power supply for peripherals such as a scanner in accordance with the computer's power.

[Enable USB power feeding]: Turn on/off the scanner in accordance with the computer's power.

ATTENTION

- When you select [Disable power switch], the scanner is not turned off even if the [Power off after a certain period of time] check box is selected in [Device Setting] on the Software Operation Panel.
- Some types of computers and USB hubs keep supplying power to the USB bus even after the computer is turned off. In that case, the [Enable USB power feeding] mode may not work properly.

8.9 Settings Related to Scanner Maintenance

Detecting Vertical Streaks [Vertical Streak Detection]

Select whether to enable or disable vertical streak detection. After enabling this setting, **MENU** flashes on the LCD when a vertical streak may occur in the images that are scanned through the ADF.

[Clean glass!] also flashes on the second line in the [Ready] screen.

Check the information, and then clean the glass.

For details about checking the information, refer to ["Checking the Information"](#) (page 67).

For details about cleaning, refer to ["Chapter 5 Daily Care"](#) (page 103).

- 1 Start up the Software Operation Panel.
For details, refer to ["8.1 Starting Up the Software Operation Panel"](#) (page 157).
- 2 From the listing on the left, select [Device Setting 2] → [Vertical Streak Detection].

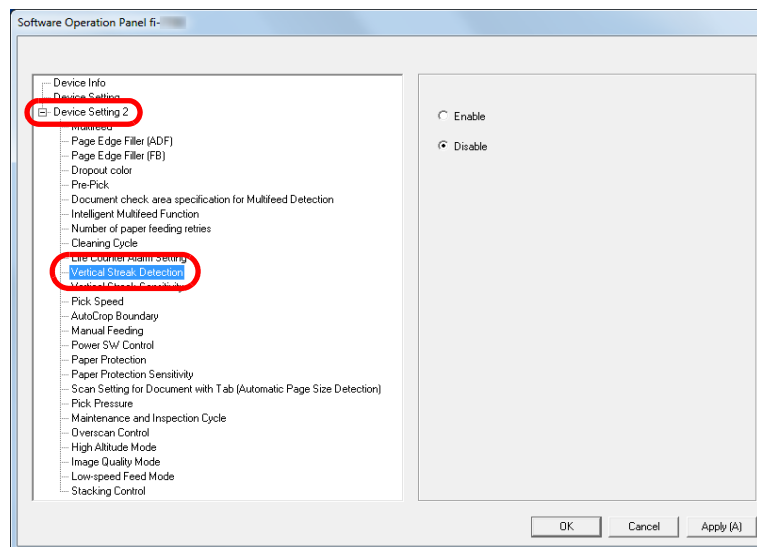

- 3 Select whether to enable or disable [Vertical Streak Detection].
When you select [Enable], the scanner detects vertical streaks (dirt on the glass) during scanning with the ADF.

HINT

This setting can also be configured with the operator panel.

TOP

Contents

Index

Introduction

Scanner
OverviewHow to Load
DocumentsHow to Use the
Operator PanelVarious Ways to
Scan

Daily Care

Replacing the
Consumables

Troubleshooting

Operational
Settings

Appendix

Glossary

Specifying the Sensitivity Level for Vertical Streak Detection

[Vertical Streak Sensitivity]

Specify the sensitivity level to detect vertical streaks (dirt on the glass) when vertical streak detection is enabled.

Select [Low] to only detect large amounts of dirt on the glass.
Select [High] to also detect small amounts of dirt on the glass.

- 1 Start up the Software Operation Panel.
For details, refer to "8.1 Starting Up the Software Operation Panel" (page 157).
- 2 From the listing on the left, select [Device Setting 2] → [Vertical Streak Sensitivity].

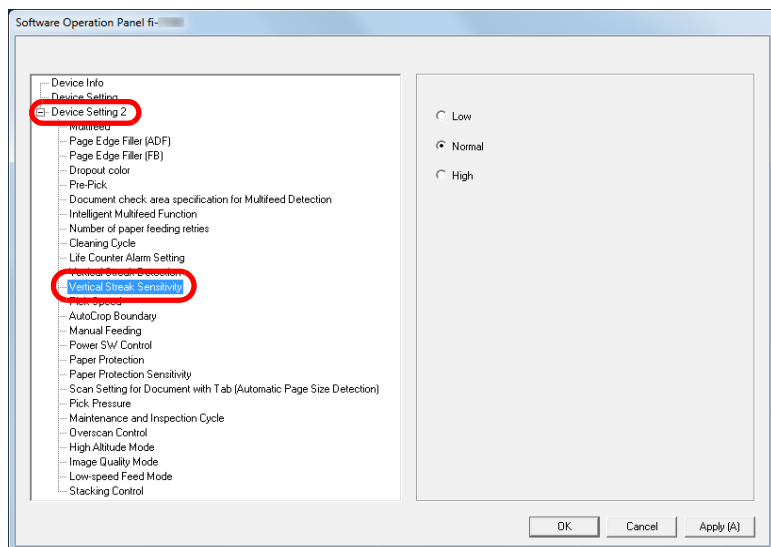

- 3 Specify the sensitivity level.
Low: Decreases the sensitivity level to detect dirt on the glass.
Normal: Monitors dirt on the glass with normal sensitivity.
Keep this setting for normal use.
High: Increases the sensitivity level to detect dirt on the glass.

HINT

- If [Clean glass!] frequently flashes on the second line in the [Ready] screen, select [Low].
- This setting can also be configured with the operator panel.

TOP

Contents

Index

Introduction

Scanner
OverviewHow to Load
DocumentsHow to Use the
Operator PanelVarious Ways to
Scan

Daily Care

Replacing the
Consumables

Troubleshooting

Operational
Settings

Appendix

Glossary

Scanner Maintenance and Inspection Cycle [Maintenance and Inspection Cycle]

Specify the period of time for regular maintenance and inspection of the scanner by a service engineer. When the specified period has passed after the last regular maintenance and inspection date, **MENU** flashes on the LCD.

In this case, [maintenance] flashes on the second line in the [Ready] screen.

Check the information and perform a regular maintenance and inspection on the scanner by a service engineer.

For details about checking the information, refer to "[Checking the Information](#)" (page 67).

For regular maintenance and inspection on the scanner by a service engineer, contact your FUJITSU scanner dealer or an authorized FUJITSU scanner service provider.

- 1 Start up the Software Operation Panel.
For details, refer to "[8.1 Starting Up the Software Operation Panel](#)" (page 157).
- 2 From the listing on the left, select [Device Setting 2] → [Maintenance and Inspection Cycle].

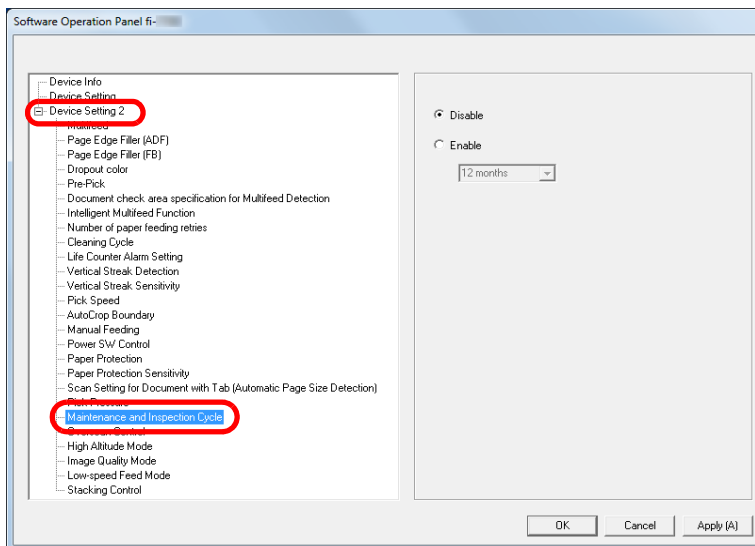

- 3 Select whether to enable or disable [Maintenance and Inspection Cycle].
If you select [Enable], select the period of time for regular maintenance and inspection of the scanner by a service engineer.

TOP

Contents

Index

Introduction

Scanner
OverviewHow to Load
DocumentsHow to Use the
Operator PanelVarious Ways to
Scan

Daily Care

Replacing the
Consumables

Troubleshooting

Operational
Settings

Appendix

Glossary

Appendix

This appendix provides the following information.

A.1 Basic Specification	210
A.2 Installation Specification	212
A.3 Outer Dimensions	214
A.4 Scanner Options	216
A.5 Uninstalling the Software	217
A.6 Notes on Repackaging [fi-7700/fi-7700S]	218

[TOP](#)

[Contents](#)

[Index](#)

[Introduction](#)

[Scanner
Overview](#)

[How to Load
Documents](#)

[How to Use the
Operator Panel](#)

[Various Ways to
Scan](#)

[Daily Care](#)

[Replacing the
Consumables](#)

[Troubleshooting](#)

[Operational
Settings](#)

[Appendix](#)

[Glossary](#)

A.1 Basic Specification

Item		Specification			Notes
		fi-7600	fi-7700	fi-7700S	
Scanner type		ADF	ADF + flatbed		Manual feeding (Single/Continuous) is available with the ADF.
Image sensor		Color CCD × 2 (front, back)	Color CCD × 3 (front, back, flatbed)	Color CCD × 2 (front, flatbed)	-
Light source		White LED × 4 (front × 2, back × 2)	White LED × 6 (front × 2, back × 2, flatbed × 2)	White LED × 4 (front × 2, flatbed × 2)	-
Scanning area	Minimum size (width × length)	50.8 × 69 mm/2 × 2.72 in.			
	Maximum size (width × length)	ADF	304.8 × 431.8 mm/12.0 × 17.0 in. (A3 portrait (297 × 420 mm)/11.7 × 16.5 in.)		(*1)
		Flatbed	-	304.8 × 457.2 mm/12.0 × 18.0 in.	
Paper weight (thickness)		ADF	20 to 413 g/m ² (5.3 to 110 lb) 27 to 413g/m ² (7.2 to 110 lb) for the size larger than A4/Letter 128 to 209 g/m ² (34 to 56 lb) for A8 size 1.4 mm (0.06 in.) or less for plastic cards (*2)		(*3)
ADF Scanning speed (A4 landscape) (*4)	Binary (black & white)	Simplex 100 ppm, Duplex 200 ipm		Simplex 75 ppm	300 dpi
	Grayscale				
	Color				

Item		Specification			Notes
		fi-7600	fi-7700	fi-7700S	
Flatbed Scanning speed (A4 portrait) (*4)	Binary (black & white)	-	0.9 sec./sheet		300 dpi
	Grayscale				
	Color				
Loading capacity (*5)		A4/Letter size documents or smaller: 300 sheets Documents larger than A4/Letter size: 100 sheets			Paper weight: 80 g/m ² (20 lb)
Optical resolution		600 dpi			-
Output resolution	Binary (black & white)	50 to 600 dpi, 1200 dpi			50 to 600 dpi: configurable in 1 dpi increments 1,200 dpi: created by scanner driver
	Grayscale				
	Color				
Grayscale level		256 gradation levels			4096 gradation levels (12-bit) during internal processing
Interface		USB 3.1 Gen 1/USB 3.0/USB 2.0/USB 1.1 (*6)			Type B
LCD		Display: Monochrome FSTN Displayed dots: 110 × 65 dots Displayed lines: 16 × 5 (character × row)			Comes with a backlight

*1: Long page scanning supports documents with a length of up to 5,588 mm (220 in.) when the resolution is set to 200 dpi or less.

If you split and output a scanned image of a long page document into multiple pages, a document of up to 200 m (218.8 yd.) can be scanned.

*2: When scanning plastic cards from the ADF, you can load up to 3 cards in the ADF paper chute (feeder).

*3: Values measured when the ADF is used. There is no paper weight limit when a document is scanned with the flatbed.

*4: Note that this is the hardware limitation, and the software's processing time such as data transfer time is added to the actual time of scanning.

*5: The capacity varies depending on the paper weight. For details, refer to ["2.3 Documents for Scanning" \(page 47\)](#).

*6: Use the USB cable that is supplied.

When connecting the USB cable to a USB hub, make sure you connect it to a USB hub that is connected to the USB port of a computer.

Connection with USB 3.1 Gen 1/USB 3.0/USB 2.0 requires the USB port and the hub to support USB 3.1 Gen 1/USB 3.0/USB 2.0. Also note that the scanning speed slows down when USB 1.1 is used.

A.2 Installation Specification

Item		Specification		
		fi-7600	fi-7700	fi-7700S
Outer dimensions (W × D × H)(*1)		236 × 432 × 214 mm/9.29 × 17.01 × 8.43 in.(*2)	706 × 500 × 345 mm/27.80 × 19.69 × 13.58 in.	
Installation space (W × D × H) (*3)		1220×614×388 mm/ 48.03×24.17×15.28 in.	1285×815×704 mm/50.59×32.09×27.72 in.	
Weight		11 kg (24.26 lb) or less	35 kg (77.18 lb) or less	
Input power	Voltage range	AC 100 to 240 V ± 10%		
	Phase	Single phase		
	Frequency range	50/60 Hz ± 3 Hz		
Power consumption	Operation	64 W or less	55 W or less	
	Power saving	1.7 W or less		
	Power OFF	0.35 W or less		
Ambient conditions	Temperature	Operating: 5 to 35°C (41 to 95°F), Not operating: -20 to 60°C (-4 to 140°F)		
	Humidity	Operating: 20 to 80%, Not operating: 8 to 95%		
Calorific value	Operation	55 kcal/Hr or less	47 kcal/Hr or less	
	Power saving	1.5 kcal/Hr or less		
	Power OFF	0.3 kcal/Hr or less		
Shipping weight (*4)		15 kg (33.08 lb) or less	44 kg (97.02 lb) or less	
Support period		5 years		

*1: The width and the height indicate the size of the scanner without the ADF paper chute (feeder) and the stacker. Protruding parts on the scanner are not included in the size.

*2: The depth indicates the size of the scanner with the operator panels fitted into the sides.

*3: The required installation space is a reference for scanning A3 size documents.

*4: Includes the package weight.

[TOP](#)

[Contents](#)

[Index](#)

[Introduction](#)

[Scanner
Overview](#)

[How to Load
Documents](#)

[How to Use the
Operator Panel](#)

[Various Ways to
Scan](#)

[Daily Care](#)

[Replacing the
Consumables](#)

[Troubleshooting](#)

[Operational
Settings](#)

[Appendix](#)

[Glossary](#)

A.3 Outer Dimensions

The outer dimensions are as follows:

fi-7600

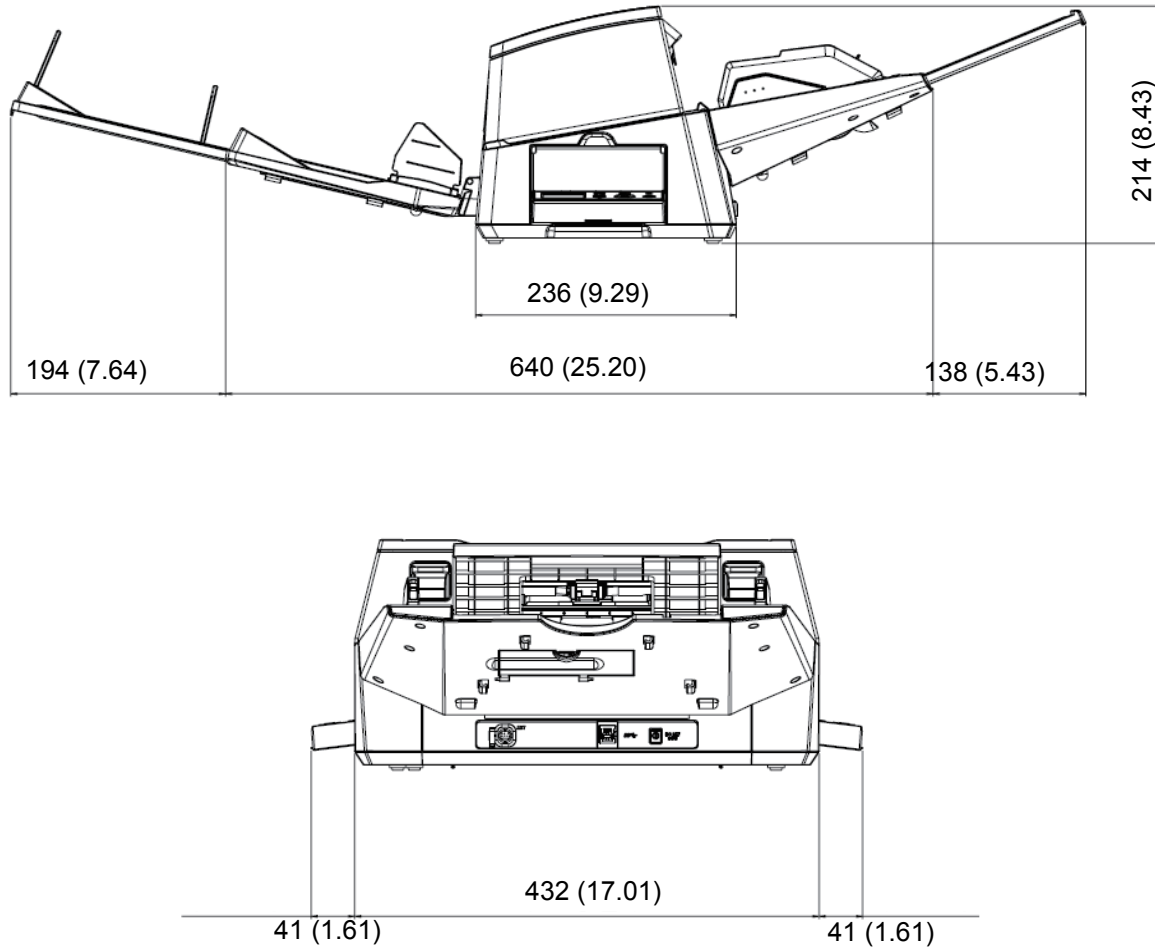

Unit: mm (in.)

[TOP](#)[Contents](#)[Index](#)[Introduction](#)[Scanner Overview](#)[How to Load Documents](#)[How to Use the Operator Panel](#)[Various Ways to Scan](#)[Daily Care](#)[Replacing the Consumables](#)[Troubleshooting](#)[Operational Settings](#)[Appendix](#)[Glossary](#)

fi-7700/fi-7700S

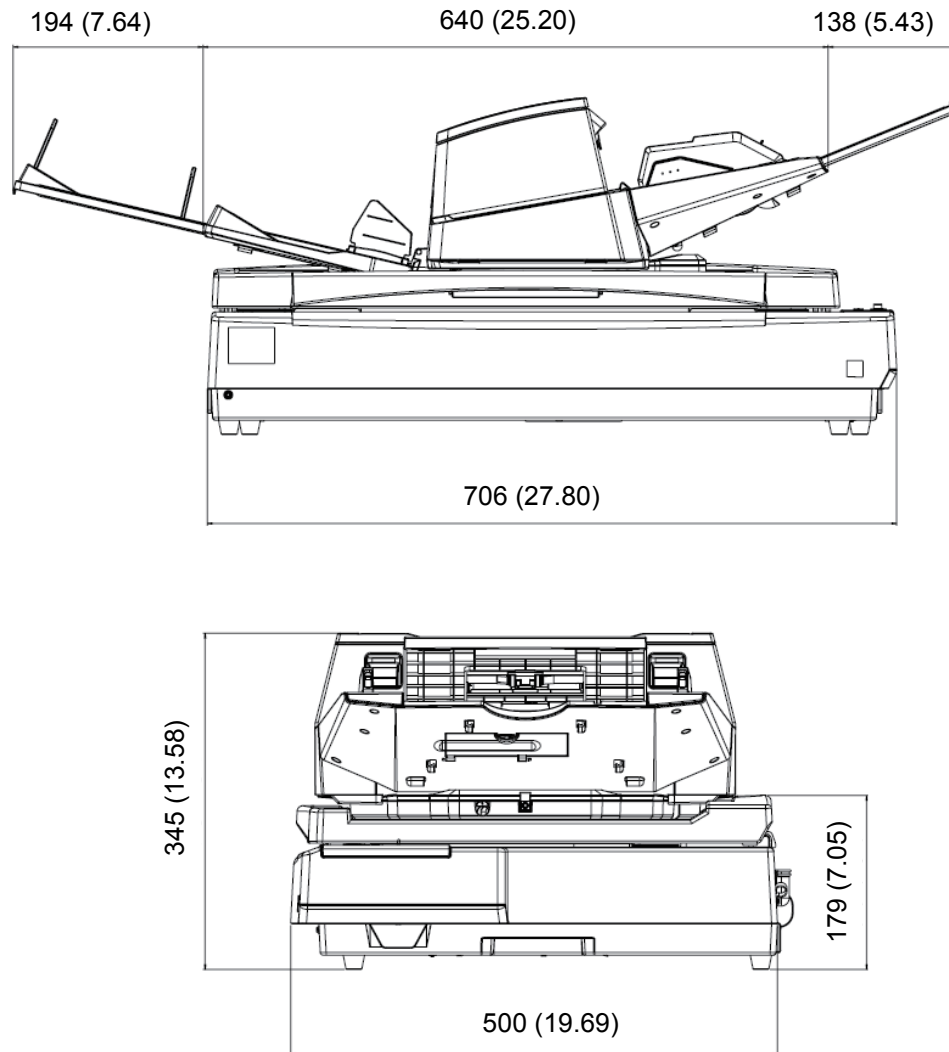

Unit: mm (in.)

TOP

Contents

Index

Introduction

Scanner
Overview

How to Load
Documents

How to Use the
Operator Panel

Various Ways to
Scan

Daily Care

Replacing the
Consumables

Troubleshooting

Operational
Settings

Appendix

Glossary

A.4 Scanner Options

Name	Part No.	Supported model	Description
fi-760PRB	PA03740-D101	fi-7600	An option imprinter that can print text (such as alphabets and numbers) on the back of the document after scanning. It can be used to organize your documents by printing a name, date or serial number on the scanned document. For details, refer to the fi-760PRB Imprinter Operator's Guide.
fi-575BK	PA03338-D960	fi-7700 fi-7700S	An option that allows you to perform scanning on a black background when the flatbed is used. This is a black document pad that is used as a replacement for the standard white document pad. It can be used to automatically correct skewed images or accurately detect the size of the scanned document when scanning with the flatbed.

For details about purchasing the scanner options and more information, contact your FUJITSU scanner dealer or an authorized FUJITSU scanner service provider.

TOP

Contents

Index

Introduction

Scanner
OverviewHow to Load
DocumentsHow to Use the
Operator PanelVarious Ways to
Scan

Daily Care

Replacing the
Consumables

Troubleshooting

Operational
Settings

Appendix

Glossary

A.5 Uninstalling the Software

- 1 Turn on the computer and log onto Windows as a user with administrator privileges.
- 2 Exit all running software.
- 3 Display the [Control Panel] window.
 - Windows Server 2008/Windows 7
Click [Start] menu → [Control Panel].
 - Windows Server 2012
Right-click the Start screen, and select [All apps] on the app bar → [Control Panel] under [Windows System].
 - Windows Server 2012 R2/Windows 8.1
Click [↓] on the lower left side of the Start screen → [Control Panel] under [Windows System].
To display [↓], move the mouse cursor.
 - Windows 10/Windows Server 2016
Right-click [Start] menu, and then click [Control Panel].
- 4 Select [Uninstall a Program].
 - ⇒ The [Programs and Features] window appears with a list of the currently installed software.
- 5 Select a software to uninstall.
 - When Uninstalling PaperStream IP Driver
Select one of the following:
 - PaperStream IP (TWAIN)
 - PaperStream IP (TWAIN x64)
 - PaperStream IP (ISIS) Bundle
 - When Uninstalling 2D Barcode for PaperStream
Select [2D Barcode for PaperStream].
 - When Uninstalling Software Operation Panel
Select [Software Operation Panel].
The Software Operation Panel is installed together with the PaperStream IP driver.
 - When Uninstalling Error Recovery Guide
Select [Error Recovery Guide for fi-7600/7700/7700S].
 - When Uninstalling PaperStream Capture
Select [PaperStream Capture].
 - When Uninstalling ScanSnap Manager for fi Series
Select [ScanSnap Manager for fi Series].
 - When Uninstalling Scan to Microsoft SharePoint
Select [Scan to Microsoft SharePoint].
 - When Uninstalling ABBYY FineReader for ScanSnap™
Select [ABBYY FineReader for ScanSnap(TM)].
 - When Uninstalling Manuals
Select [fi Series manuals for fi-7600/7700/7700S].
 - When Uninstalling Scanner Central Admin Agent
Select [Scanner Central Admin Agent].
 - When Uninstalling fi Series Online Update
Select [fi Series Online Update].
- 6 Click the [Uninstall] button or the [Uninstall/Change] button.
- 7 If a confirmation message appears, click [OK] or [Yes].
 - ⇒ The software is uninstalled.

TOP

Contents

Index

Introduction

Scanner
OverviewHow to Load
DocumentsHow to Use the
Operator PanelVarious Ways to
Scan

Daily Care

Replacing the
Consumables

Troubleshooting

Operational
Settings

Appendix

Glossary

A.6 Notes on Repackaging [fi-7700/fi-7700S]

Fixing the Transport Lock

Fix the transport lock so that the flatbed is not damaged during transport.

The procedure for fixing the transport lock is as follows:

- 1 Turn on the scanner.
⇒ The carrier unit stops in about 10 seconds.
- 2 Turn off the scanner.
- 3 Remove the ADF paper chute (feeder), stacker, and cables.

Cables

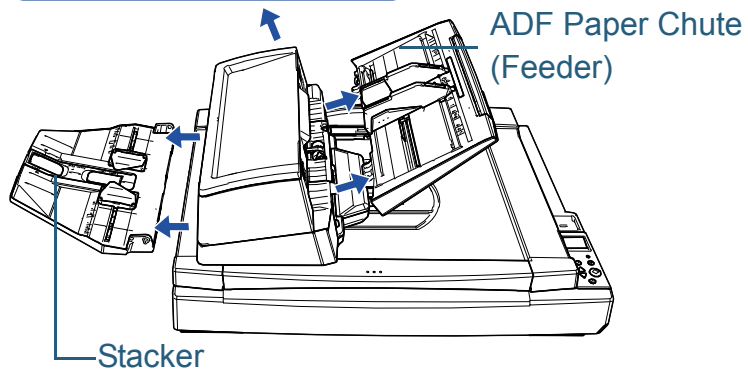
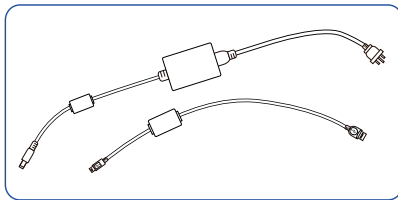

Remove the stacker in the following procedure:

- 1 Check that the stacker is placed in the lower position.
- 2 Hold the center (①) of the stacker and slightly bend it to remove the right side (②) of the stacker from the slot in the direction of the arrow.

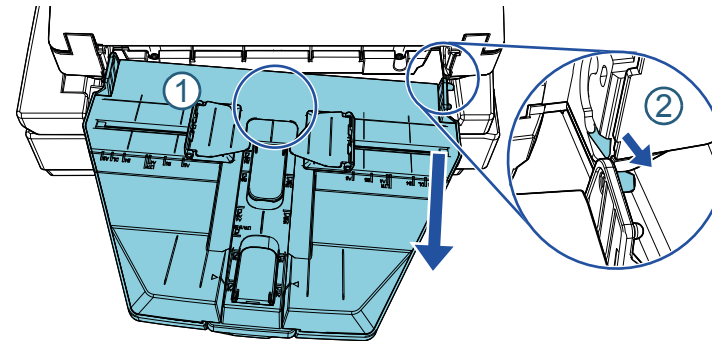

- 4 Turn the transport lock towards the fixing side by using a coin or something similar to fix it.

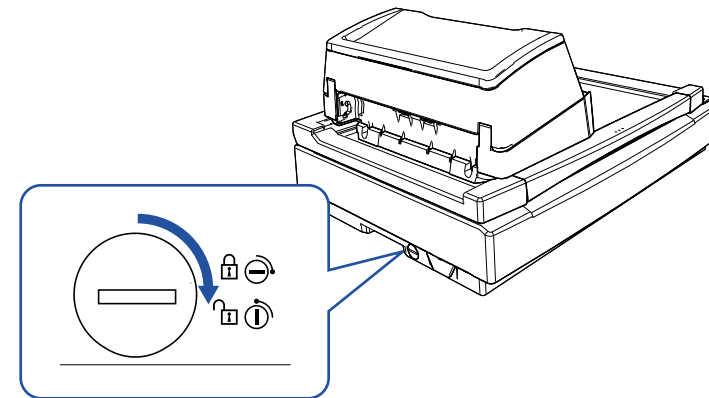

Fixing the ADF

Fix the ADF in place with the ADF lock screws so that the ADF is not damaged during transport.

The procedure for fixing the ADF in place is as follows:

- 1 Turn off the scanner.
- 2 Remove the ADF paper chute (feeder), stacker, and cables.
For details, refer to step 3 in "[Fixing the Transport Lock](#)" (page 218).

- 3 Move the ADF to the left side.

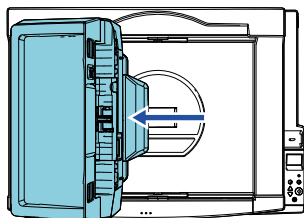

- 4 Open the document cover.
For details, refer to "[1.5 Opening/Closing the Document Cover \[fi-7700/fi-7700S\]](#)" (page 25).

- 5 Remove the two ADF lock screws from the lock screw storage holes and attach them to the points to lock the ADF.

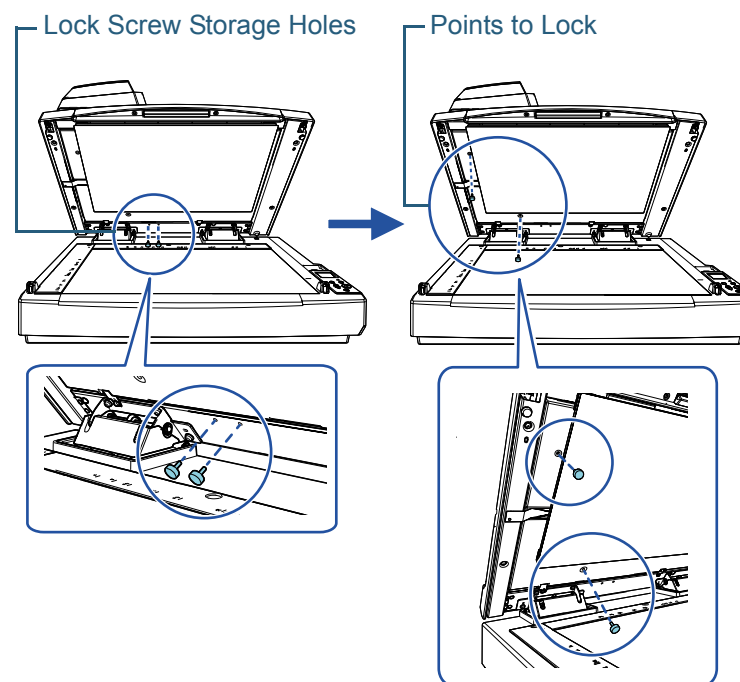

HINT

- Remove the document pad if the ADF lock screws are difficult to remove.
- If you remove the document pad, attach the document pad in the following procedure:
 - 1 Place the document pad against the upper left corner on the document bed.
Make sure the groove in the document pad is in the correct place.

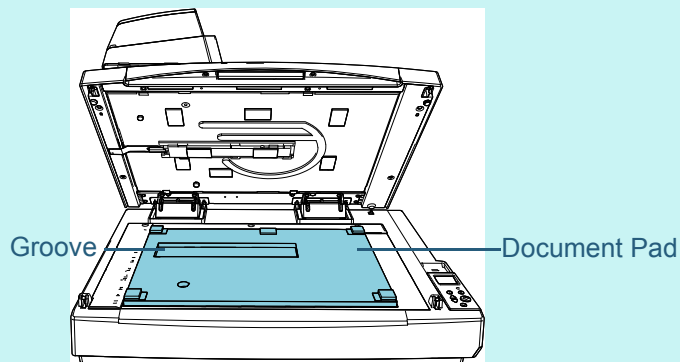

- 2 Close the document cover slowly.
When you close the document cover, the document pad is attached to the document cover.

6 Gently close the document cover.

For details, refer to "[1.5 Opening/Closing the Document Cover \[fi-7700/fi-7700S\]](#)" (page 25).

TOP

Contents

Index

Introduction

Scanner
OverviewHow to Load
DocumentsHow to Use the
Operator PanelVarious Ways to
Scan

Daily Care

Replacing the
Consumables

Troubleshooting

Operational
Settings

Appendix

Glossary

Installing the ADF Paper Chute (Feeder) and the Stacker

The procedure to install the ADF paper chute (feeder) and the stacker after opening the package for the scanner is as follows:

For details about how to connect the scanner to the computer, refer to the Quick Installation Sheet.

- 1 Install the ADF paper chute (feeder) and the stacker.

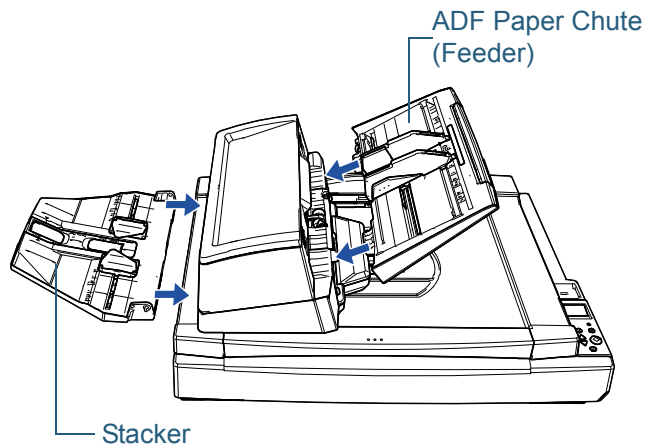

Install the stacker in the following procedure:

- 1 Insert the protrusion on the right side of the stacker into the slot ① and then push the left side of the stacker along the slot ② in the direction of the arrow.

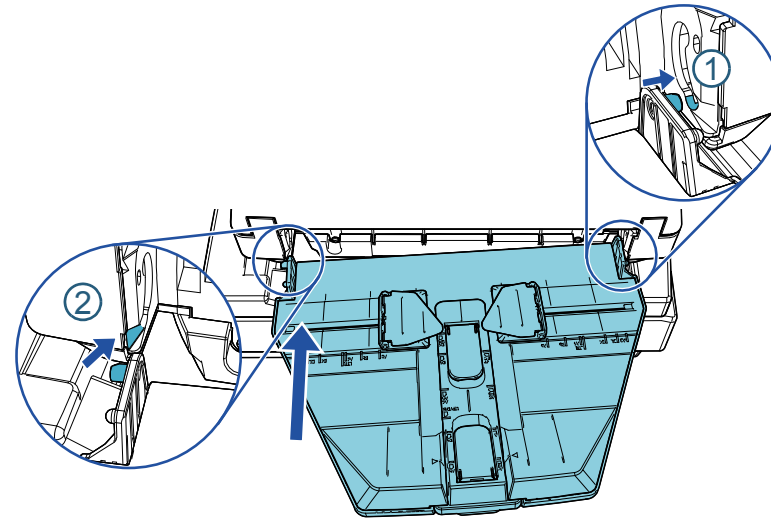

Contact for Inquiries

Contact for Inquiries

Refer to the contact list on the last page of the Safety Precautions manual.

- ABBYY FineReader for ScanSnap™.
 - Windows Server 2008/Windows 7
Select [Start] menu → [All Programs] → [ABBYY FineReader for ScanSnap (TM)] → [User's Guide] → [Technical Support].
 - Windows Server 2012
Right-click the Start screen, select [All apps] on the app bar, and then select [User's Guide] under [ABBYY FineReader for ScanSnap (TM)] → [Technical Support].
 - Windows Server 2012 R2/Windows 8.1
Click [↓] on the lower left side of the Start screen, and then select [User's Guide] under [ABBYY FineReader for ScanSnap (TM)] → [Technical Support].
To display [↓], move the mouse cursor.
 - Windows 10/Windows Server 2016
Select [Start] menu → [ABBYY FineReader for ScanSnap (TM)] → [User's Guide] → [Technical Support].

- Image Scanner fi Series

For other inquiries regarding the scanner, refer to the following web page:

<http://imagescanner.fujitsu.com/g-support.html>

If the solution to your problem cannot be found on the above web page, refer to the contact information for your Fujitsu office on the following web page:

<http://imagescanner.fujitsu.com/warranty.html>

Contact for Purchasing Consumables or Cleaning Materials

http://www.fujitsu.com/global/shop/computing/IMAGE_index.html

TOP

Contents

Index

Introduction

Scanner
Overview

How to Load
Documents

How to Use the
Operator Panel

Various Ways to
Scan

Daily Care

Replacing the
Consumables

Troubleshooting

Operational
Settings

Appendix

Glossary

Glossary

A4 size	Dropout color	Moiré patterns	Ultrasonic sensor
A5 size	Duplex scanning mode	Multi Image	USB
A6 size	Edge Extract	Multifeed	White reference sheet
A7 size	Eject roller	Noise removal	
A8 size	Emphasis	OCR (Optical Character Recognition)	
ADF (Automatic Document Feeder)	Error diffusion	Operator panel	
Ambient conditions	Feed roller	Overscan	
Automatic size/skew detection	Filter	Paper jam	
Blank Page Skip	Flatbed	Paper Protection	
Brake roller	Gamma	Patch code	
Brightness	Grayscale	Pick roller	
CCD (Charge-Coupled Device) Image Sensor	Halftone	Pick start time	
Default setting	Image processing	Pixel	
Density	Imprinter	Portrait	
Device errors	Intelligent Multifeed Function	Pre-pick	
Dither	Interface	Resolution	
Document sensor	Inversion	Simplex scanning mode	
Double Letter size	ISIS	Smoothing	
dpi (dots per inch)	Job Separator	Temporary error	
Driver	Landscape	Threshold	
	Legal size	TWAIN	
	Letter size		

[TOP](#)[Contents](#)[Index](#)[Introduction](#)[Scanner Overview](#)[How to Load Documents](#)[How to Use the Operator Panel](#)[Various Ways to Scan](#)[Daily Care](#)[Replacing the Consumables](#)[Troubleshooting](#)[Operational Settings](#)[Appendix](#)[Glossary](#)

A4 size

A standard paper size which is 210 × 297 mm (8.27 × 11.7 in.).

A5 size

A standard paper size which is 148 × 210 mm (5.83 × 8.27 in.).

A6 size

A standard paper size which is 105 × 148 mm (4.13 × 5.83 in.).

A7 size

A standard paper size which is 74 × 105 mm (2.91 × 4.13 in.).

A8 size

A standard paper size which is 52 × 74 mm (2.05 × 2.91 in.).

ADF (Automatic Document Feeder)

A paper feeding mechanism which allows multiple sheets of documents to be scanned one sheet at a time.

Ambient conditions

Conditions (such as temperature and humidity) required to operate or store the scanner.

Automatic size/skew detection

End of Page Detection:

Detects the end of the page and scans the length of the document.

Automatic Page Size Detection:

Detects the paper size and outputs the image data in the same size.

Black Background:

Sets the background color to black for scanning.

Blank Page Skip

A function that detects and automatically deletes blank (white or black) pages in a batch of documents.

Brake roller

A roller that prevents more than one sheet of documents to be fed into the ADF at once.

Brightness

Refers to the brightness of a scanned image.

CCD (Charge-Coupled Device) Image Sensor

A sensor which perceives the light reflected from the document and converts it into digital form. CCD technology is the basis of high quality image acquisition in scanners, cameras and other devices.

Default setting

(Hardware)

Preset values from the factory.

(Software)

Values set upon installation of software.

Density

Refers to the deepness of a color in an image.

Device errors

Errors that require troubleshooting by a service engineer.

Dither

The process by which a group of dots is arranged to reproduce the density of grayscale. Grayscale density is reproduced by configuring preset dot patterns. This method requires less memory compared to multilevel gray.

Document sensor

A sensor which detects the changes in the amount of light transmission. Paper feeding errors such as multifeed and paper jam are detected by monitoring the passing of documents.

Double Letter size

A standard paper size used in the United States and other countries (11 × 17 in.).

dpi (dots per inch)

A measurement of resolution which is used for scanners and printers. Higher dpi indicates better resolution.

Driver

A program specifically designed for operating systems, which enables interaction with a hardware device.

Dropout color

A function which removes a specified color from a scanned image.

Duplex scanning mode

A mode for scanning both sides of the document at once. (⇔ simplex scanning mode)

Edge Extract

A function which traces the boundaries between black and white areas, and extracts them as outlines.

Eject roller

Rollers that feed documents from the ADF onto the stacker.

Emphasis

A function which decreases the density of bright colors (except for white) around black areas. Increasing the value for this function removes dotted image noise and also produces "softened" images.

Error diffusion

Method of halftone (pseudo-grayscale) image processing which is based on black & white pixel binarization. It sums the optical density of a pixel and its adjacent pixels, then relocates black pixels in the order of density to minimize the difference between scanned and output images. By diffusing the errors onto other pixels, the density data of adjacent pixels can be binarized. This function suppresses moire patterns of dotted halftone images such as newspapers, and reproduces its grayscale gradation.

Feed roller

A roller that feeds the document through the ADF.

Filter

A function that applies a type of filter operation process on a scanned image.

Types of filtering are as follows:

Digital Endorser:

Adds alphanumeric character strings on the scanned image data.

Page Edge Filler:

Fills in the margins of the scanned image in a specified color.

Flatbed

An input device of the scanner. Place documents one by one on the document bed (glass section) and scan each document. This is used to scan documents that cannot be scanned with the ADF, such as books and magazines.

TOP

Contents

Index

Introduction

Scanner
Overview

How to Load
Documents

How to Use the
Operator Panel

Various Ways to
Scan

Daily Care

Replacing the
Consumables

Troubleshooting

Operational
Settings

Appendix

Glossary

Gamma

A unit which indicates the changes in the brightness of an image. It is expressed as a function of the electric input power to devices (such as a scanner and a display) and the brightness of the image. If the gamma rate is larger than 1, the brightness of an image increases and vice versa. Normally, set the gamma rate to 1 when reproducing the same brightness as the original.

Grayscale

A method which expresses the gradation (density) from black to white in 256 levels. Suitable for scanning images such as photographs.

Halftone

Reproduces the color density in black & white by using dot patterns. This method is effective for scanning images such as photographs in black & white.

Image processing

Refers to processing and outputting the scanned image via specified scan parameters.

Imprinter

A printer that can print text (such as letters and numbers) on the back or front of scanned documents. It can be use to manage the documents by adding a name, date or serial number on the scanned document.

Intelligent Multifeed Function

A function that excludes certain patterns of overlapping of documents that is detected as multifeed, by letting the scanner memorize the overlap pattern. For instance, when there is paper of the same size attached to a designated location on the page, the scanner memorizes the location of the attachment and can be configured not to detect multifeeds for that location.

Interface

The connection that allows communication between the computer and the scanner.

Inversion

A scanning method in which the black part and the white part of the image are inverted.

ISIS

ISIS (Image Scanner Interface Specification) is an API (Application Program Interface) standard for imaging devices (such as scanners and digital cameras) which was developed by Captiva, a division of EMC Corporation (the former Pixel Translations) in 1990. In order to use devices that comply with this standard, it is necessary to install a driver software that supports ISIS standard.

Job Separator

A sheet to insert between documents in a batch for separating different jobs.

The following types of job separators are available:

Job separator with patch codes:

A sheet with patch codes printed.

Job separator with barcodes:

A sheet with barcodes printed.

Job separator for hardware (job separation sheet):

A special sheet with a notch of 20 × 15 mm (length × width) located in the top middle.

Legal size

A standard paper size used in the United States and other countries (8.5 × 14 in.).

Landscape

Orientation in which the short side of the document is set parallel to the feed direction.

Letter size

A standard paper size used in the United States and other countries (8.5 × 11 in.).

Moiré patterns

Recurrent patterns on scanned images caused by incorrect settings of angles.

Multi Image

A function which outputs the image in both color/grayscale and black & white at once.

Multifeed

Multifeed is an error when two or more sheets are fed through the ADF at once. When a different document length is detected, this detected result is also called a multifeed.

Noise removal

A function which improves the quality of an image by removing isolated noise that appear as black dots in a white area (or vice versa).

TOP

Contents

Index

Introduction

Scanner
OverviewHow to Load
DocumentsHow to Use the
Operator PanelVarious Ways to
Scan

Daily Care

Replacing the
Consumables

Troubleshooting

Operational
Settings

Appendix

Glossary

OCR (Optical Character Recognition)

A device or a technology that recognizes the text on documents and converts them into text data that can be edited. The shape of the characters are recognized by the differences in the light reflected off the documents.

Operator panel

A panel that consists of a display and buttons. It is used for scanner operations such as selecting functions and changing settings.

Overscan

A function that scans the document in a size larger than the specified paper size.

Paper jam

Refers to an error in which a document is jammed inside the paper path or feeding is interrupted by documents slipping.

Paper Protection

A function that detects anomalies upon feeding the documents and stops the scan when:

- When the scanner detects a document that was unusually warped by a feeding error
- When the scanner detects paper jam noise
- When the scanner either detects a document that was unusually warped by a feeding error or detects paper jam noise

Patch code

A special code to let the scanner recognize the start and the end of each job or image mode.

Pick roller

A set of rollers which separates one sheet off the documents loaded in the ADF paper chute (feeder), and feeds the document into the ADF.

Pick start time

The period of time between setting the document and until picking starts after the document passes the hopper empty sensor.

Pixel

The dots that make up a scanned image.

Portrait

Orientation in which the long side of the document is set parallel to the feed direction. Documents/images are set/displayed vertically.

Pre-pick

Refers to feeding the document in advance to the position to start scanning.

It shortens the interval between setting the document and feeding the document to the starting position.

Resolution

A measurement to indicate the quality (fineness) of an image. Resolution is displayed by the number of pixels within an inch. An image is a collection of small dots (pixels). If the same image contains different amount of pixels, the one with more pixels can express greater details. Therefore, the higher the resolution, the finer the image becomes.

Simplex scanning mode

A mode for scanning only one side (front or back) of the document. (↔ duplex scanning mode)

Smoothing

Refers to the removal of irregularities on diagonal lines and curves. It is a processing method commonly used in OCR applications.

Temporary error

An error that can be fixed by the operator.

Threshold

The value which is used to determine whether a certain color is black or white. Threshold value must be configured in order to scan images with grayscale gradation. Each pixel is converted into black or white according to the specified value.

TWAIN

TWAIN (Technology Without Any Interesting Name) is an API (Application Program Interface) standard for imaging devices (such as scanners and digital cameras) developed by TWAIN Working Group. In order to use devices that comply with this standard, it is necessary to install a driver software that supports TWAIN standard.

Ultrasonic sensor

A sensor that detects multifeed errors by ultrasonic soundwave. It detects multifeeds by monitoring the difference in the amount of ultrasonic waves transmitted through the documents.

[TOP](#)[Contents](#)[Index](#)[Introduction](#)[Scanner
Overview](#)[How to Load
Documents](#)[How to Use the
Operator Panel](#)[Various Ways to
Scan](#)[Daily Care](#)[Replacing the
Consumables](#)[Troubleshooting](#)[Operational
Settings](#)[Appendix](#)[Glossary](#)

USB

USB (Universal Serial Bus) is a standard for interfaces used to connect devices such as keyboards and scanners. Up to 127 devices can be connected by this interface. It can be connected and disconnected without powering off the devices.

For USB 3.1 Gen 1/USB 3.0, the data transfer rate is a maximum of 480 Mbps in Hi-Speed and a maximum of 5 Gbps in Super-Speed mode.

For USB 2.0, the data transfer rate is 1.5 Mbps in Low-Speed, 12 Mbps in Full-Speed, and a maximum of 480 Mbps in Hi-Speed mode.

White reference sheet

The white part located inside the ADF which the scanner defines as white, in order to adjust the brightness of all other areas accordingly.

TOP

Contents

Index

Introduction

Scanner
Overview

How to Load
Documents

How to Use the
Operator Panel

Various Ways to
Scan

Daily Care

Replacing the
Consumables

Troubleshooting

Operational
Settings

Appendix

Glossary

Index

A		
advanced scanning.....	91	
B		
basic flow of scanning operation	33	
basic specification	210	
before you contact the scanner service provider.....	153	
bundled software	35	
C		
cleaning (flatbed).....	112	
cleaning materials.....	104	
cleaning the ADF (with Cleaning Paper)	107	
cleaning the ADF (with cloth).....	108	
cleaning the flatbed	112	
cleaning the inside.....	107	
cleaning the outside.....	106	
conditions for mixed batch scanning	53	
configuration items	165	
consumables	114	
contact for inquiries	222	
conventions	5	
customizing the scanner settings	98	
D		
daily care	103	
documents for scanning	47	
E		
error indications on operator panel.....	126	
F		
features	15	
fi-575BK.....	216	
fi-760PRB	216	
Function Selection.....	80	
H		
how to clean the ADF with Cleaning Paper.....	107	
how to clean the ADF with cloth	108	
how to clean the inside.....	107	
how to clean the outside.....	106	
how to close the ADF	24	
how to close the document cover.....	25	
how to load documents	39, 41	
how to load documents in the ADF	40	
how to open the ADF.....	24	
how to open the document cover	25	
how to place a document on the flatbed.....	46	
how to turn the power off.....	23	
how to turn the power on.....	23	
how to use the operator panel.....	56	
how to use this manual.....	2	
I		
installation specification.....	212	
introduction.....	3	

TOP

Contents

Index

Introduction

Scanner
OverviewHow to Load
DocumentsHow to Use the
Operator PanelVarious Ways to
Scan

Daily Care

Replacing the
Consumables

Troubleshooting

Operational
Settings

Appendix

Glossary

L			
	loading documents (ADF).....	40	
	locations that require cleaning.....	104	
M			
	main features of this product.....	15	
	manual feeding.....	94	
O			
	operational settings.....	156	
	operator panel.....	57	
	options.....	216	
	outer dimensions.....	214	
P			
	Page Edge Filler.....	181	
	paper jam.....	125	
	parts and functions.....	17	
	password setting for the Software Operation Panel.....	159	
	placing a document (flatbed).....	46	
	position of the ADF.....	26	
	power saving mode.....	32	
	Power SW Control.....	205	
	product label.....	155	
R			
	replacement cycles.....	114	
	replacing consumables.....	113	
	replacing the brake roller.....	115	
	replacing the pick roller.....	118	
S			
	[Scan/Enter] button.....	91	
	scanner overview.....	14	
	scanning documents of different types and sizes.....	84	
	setting up the ADF paper chute (feeder).....	29	
	setting up the stacker.....	30	
	Settings Menu.....	62	
	settings related to multifeed detection.....	196	
	settings related to power on/off.....	205	
	settings related to scanner maintenance.....	206	
	settings related to scanning.....	179	
	settings related to sheet counters.....	174	
	settings related to waiting time.....	202	
	starting up the Software Operation Panel.....	157	
	summary.....	83	
T			
	troubleshooting.....	124, 135	
U			
	uninstalling software.....	217	
V			
	various ways to scan.....	82	

TOP

Contents

Index

Introduction

Scanner
OverviewHow to Load
DocumentsHow to Use the
Operator PanelVarious Ways to
Scan

Daily Care

Replacing the
Consumables

Troubleshooting

Operational
Settings

Appendix

Glossary

TOP

Contents

Index

Introduction

Scanner
Overview

How to Load
Documents

How to Use the
Operator Panel

Various Ways to
Scan

Daily Care

Replacing the
Consumables

Troubleshooting

Operational
Settings

Appendix

Glossary

fi-7600/fi-7700/fi-7700S Image Scanner

Operator's Guide

P3PC-6092-02ENZ0

Issue date: June 2017

Issued by: PFU Limited

- The contents of this manual are subject to change without notice.
- PFU Limited assumes no liability for incidental or consequential damages arising from the use of this product, and any claims by a third party.
- Copying of the contents of this manual, in whole or in part, as well as the scanner applications is prohibited under the copyright law.