



REPORT

issued by an FCC listed Laboratory Reg. no. 93866
The test site complies with RSS-Gen, IC file no: 3482A-1



Accred. No. 1002
Testing
ISO/IEC 17025

Contact person
Andreas Johnson
Electronics
+46 10 516 57 86
andreas.johnson@ri.se

Date
2017-05-16

Reference
7P01338-FW

Page
1 (2)

Ericsson AB
Anders Karlsson
BURA DURA RP QRM
Torshamnsgatan 21
164 80 Stockholm

Radio measurements on Radio 2219 B5 radio equipment with FCC ID TA8AKRC161678-1 and IC: 287AB-AS1616781

(8 appendices)

Test object

Product name: Radio 2219 B5
Product number: KRC 161 678/1

Summary

See appendix 1 for details.

Standard	Compliant	Appendix
FCC CFR 47 / IC RSS-132 ISSUE 3		
2.1046 / RSS-132 5.4 RF power output	Yes	2
2.1049 / RSS-Gen 4.6.1 Occupied bandwidth	Yes	3
2.1051 / RSS-132 5.5 Band edge	Yes	4
2.1051 / RSS-132 5.5 Spurious emission at antenna terminals	Yes	5
2.1053 / RSS-132 5.5 Field strength of spurious radiation	Yes	6
2.1055 / RSS-132 5.3 Frequency stability	Yes	7

SP Technical Research Institute of Sweden

Electronics – EMC

Performed by

Examined by

Signed by: Tomas Lennhager
Reason: I am the author of this document
Date & Time: 2017-05-16 16:40:58 +02:00

Signed by: Monika Fuller
Reason: I have reviewed this document
Date & Time: 2017-05-17 08:47:33 +02:00

Tomas Lennhager

Monika Fuller

SP Technical Research Institute of Sweden

Postal address
SP
Box 857
SE-501 15 BORÅS
Sweden

Office location
Västeråsen
Brinellgatan 4
SE-504 62 BORÅS

Phone / Fax / E-mail
+46 10 516 50 00
+46 33 13 55 02
info@sp.se

Laboratories are accredited by the Swedish Board for Accreditation and Conformity Assessment (SWEDAC) under the terms of Swedish legislation. This report may not be reproduced other than in full, except with the prior written approval of the issuing laboratory.

Table of contents

Description of the test object	Appendix 1
Purpose of test	Appendix 1
Operation modes during measurements	Appendix 1
RF power output	Appendix 2
Occupied bandwidth	Appendix 3
Band edge	Appendix 4
Spurious emission at antenna terminals	Appendix 5
Field strength of spurious radiation	Appendix 6
Frequency stability	Appendix 7
External photos	Appendix 8

Appendix 1

Description of the test object related to single RAT WCDMA mode

Equipment:	Radio equipment Radio 2219 B5 Product number KRC 161 678/1 FCC ID TA8AKRC161678-1 IC: 287AB-AS1616781
HVIN:	AS1616781
Hardware revision state:	R1A
Frequency band (3GPP B5):	TX: 869 - 894 MHz RX: 824 - 849 MHz
IBW:	25 MHz
Output power:	Max 80 W/ carrier Max output power 80 W/ antenna port
Antenna ports:	2 TX/RX ports
RF configurations:	Single and multi carrier, 1-4 carriers/ port 2x2 MIMO Contiguous Spectrum (CS) and Non-Contiguous Spectrum (NCS)
RF power Tolerance:	+0.6/ - 2.0 dB
CPRI Speed	9.8 Gbit/s
Channel bandwidths:	3.8 MHz and 5 MHz
Modulations :	QPSK, 16QAM and 64QAM
Nominal power voltage:	-48VDC

The information above is supplied by the manufacturer.

Appendix 1

Operation mode during measurements

Measurements were performed with the test object transmitting test models as defined in 3GPP TS 25.141. Test model 1 (TM1) was used to represent QPSK. Test model 5 (TM5) to represent 16QAM modulation and Test model 6 (TM6) to represent 64QAM modulation.

All measurements were performed with the test object configured for maximum transmit power. The measured configurations covers worst case settings. The settings below were used for all measurements if not otherwise noted.

Single carrier

TM1: 64 DPCH:s at 30 ksps (SF=128)

MIMO mode, single carrier

TM5: 8 HS-PDSCH at 240 ksps + 30 DPCH:s at 30 ksps (SF=128)

MIMO mode, multi carrier, 2 carriers

TM5: 8 HS-PDSCH at 240 ksps +30 DPCH:s at 30 ksps (SF=128)

Channel bandwidth 5 MHz

Conducted measurements

The test object was supplied with -48 VDC by an external power supply. Additional connections are documented in the set-up drawings for conducted measurements.

Radiated measurements

The test object was powered with -48 VDC by an external power supply. Additional connections are documented in the set-up drawings for radiated measurements.

Purpose of test

The purpose of the tests is to verify compliance to the performance characteristics specified in applicable items of FCC CFR 47 and Industry Canada RSS-132 and RSS-Gen. Test scope limited to single RAT WCDMA mode.

References

Measurements were done according to relevant parts of the following standards:

ANSI 63.4-2014

ANSI/TIA/EIA-603-D-2010

CFR 47 part 2, April, 2017

CFR 47 part 22, April, 2017

KDB 662911 D01 Multiple Transmitter Output v02r02

KDB 971168 D01 Power Meas License Digital Systems v02r02

KDB 971168 D03 IM Emission Repeater Amp v01

RSS-Gen Issue 4

RSS-132 Issue 3

3GPP TS 25.141 V13.3.0

Appendix 1

Test frequencies used for conducted and radiated measurements

TX test frequencies, conducted measurements:

UARFCN Downlink	Frequency [MHz]	Symbolic name	Comment
4357	871.4	B	Single carrier TX bottom frequency
4357 4382	871.4 876.4	B2	2 carrier TX bottom constellation
4357 4382 4458	871.4 876.4 891.6	B3	3 carrier TX bottom constellation
4408	881.6	M	Single carrier TX mid frequency
4395 4420	879.0 884.0	M2	2 carrier TX mid constellation
4370 4395 4420 4445	874.0 879.0 884.0 889.0	M4	4 carrier TX mid constellation
4458	891.6	T	Single carrier TX top frequency
4433 4458	886.6 891.6	T2	2 carrier TX top constellation
4357 4433 4458	871.4 886.6 891.6	T3	3 carrier TX top constellation

TX test frequencies, radiated measurements:

UARFCN Downlink	Frequency [MHz]	Symbolic name	Comment
4357	871.4	B _w	Single carrier TX bottom frequency
4407	881.4	M _w	Single carrier TX mid frequency
4458	891.6	T _w	Single carrier TX top frequency
4357 4382 4458	871.4 876.4 891.6	BIM _w	3 carrier TX bottom constellation according to KDB 971168 D03
4357 4433 4458	871.4 886.6 891.6	TIM _w	3 carrier TX top constellation according to KDB 971168 D03

All RX frequencies were configured 45 MHz below the corresponding TX frequency according the applicable duplex offset for the operating band.

Appendix 1

Test setup: Conducted measurements

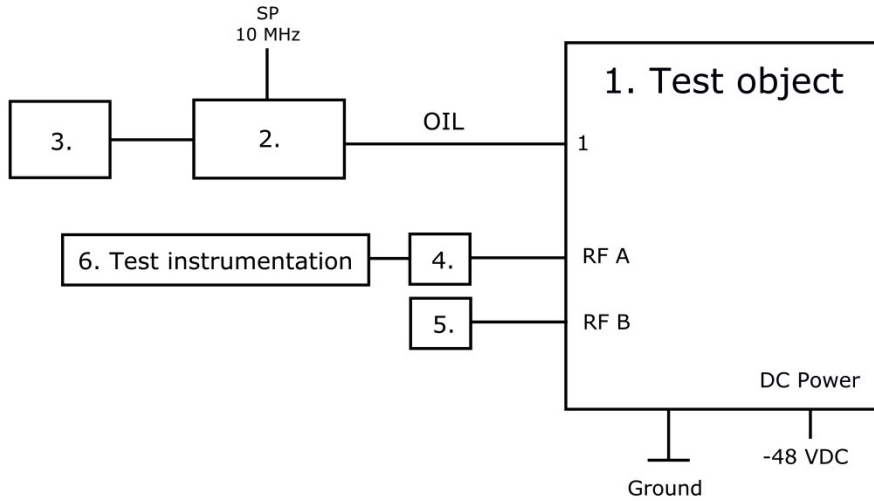

Test object:

1.	Radio 2219 B5, KRC 161 678/1, rev. R1A, s/n: D825138266 With Radio Software: CXP 901 7316/2, rev. R64HS. FCC ID TA8AKRC161678-1 and IC: 287AB-AS1616781
----	--

Associated equipment:

2.	Testing Equipment: CT10, LPC 102 487/1, rev. R1C, s/n: T01F265031, BAMS – 1000797753 with software CXA 104 446/1, rev. R8U
----	--

Functional test equipment:

3.	HP EliteBook 8560w, BAMS – 1001236850
4.	RF Attenuator: SP number: 902 282
5.	Terminator, 50 ohm
6.	SP Test Instrumentation according to measurement equipment list for each test. The signal analyzer was connected to the SP 10 MHz reference standard during all measurements.

Appendix 1

Test setup: Radiated measurements

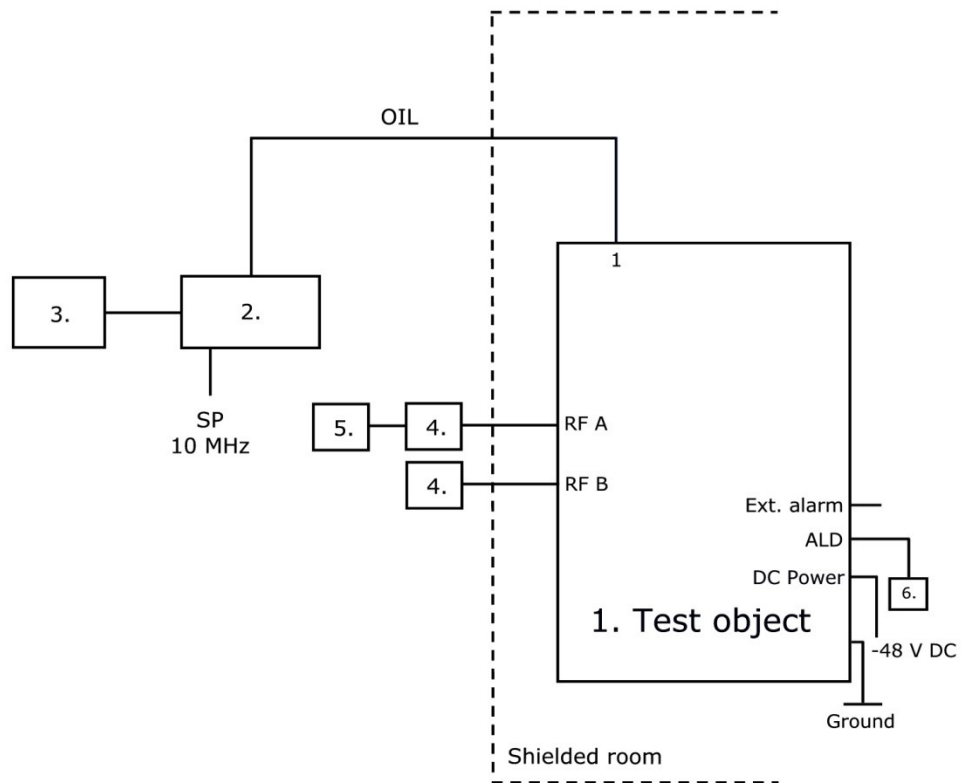

Test object:

1.	Radio 2219 B5, KRC 161 678/1, rev. R1A, s/n: D825138266 With Radio Software: CXP 901 7316/2, rev. R64HS. FCC ID TA8AKRC161678-1 and IC: 287AB-AS1616781
----	--

Associated equipment:

2.	Testing Equipment: CT10, LPC 102 467/1, rev. R1C, s/n: T01F375047, BAMS – 1001466801 with software CXA 104 446/1, rev. R8U
----	--

Functional test equipment:

3.	HP EliteBook 8560w, BAMS – 1001236850
4.	Attenuator/ Terminator
5.	R&S ESIB 26, SP no: 503 292, for supervision purpose only

Interfaces:

Type of port:

Power: -48VDC	DC Power
RF port A, 4.3-10 connector, combined TX/RX	Antenna
RF port B, 4.3-10 connector, combined TX/RX	Antenna
1, optical interface	Signal
2, optical interface, not used in this configuration	Signal
EXT Alarm, shielded multi-wire	Signal
ALD, shielded multi-wire	Signal
Ground wire	Ground

Appendix 1

Measurement equipment

	Calibration Due	SP number
Test site Tesla	2019-12	503 881
R&S ESU 40	2017-07	901 385
R&S FSQ 40	2017-07	504 143
R&S FSW 43	2017-08	902 073
Control computer with R&S software EMC32 version 9.15.0	-	503 899
High pass filter 1-18 GHz	2017-06	901 501
High pass filter 1-20 GHz	2017-06	901 373
RF attenuator Weinschel 6905-40-11-LIM	2018-03	902 282
Coaxial cable Sucoflex 102EA	2018-03	BX50191
Coaxial cable Sucoflex 102EA	2018-03	BX50236
ETS Lindgren BiConiLog Antenna 3142E	2019-03	BX61914
EMCO Horn Antenna 3115	2019-12	502 175
µComp Nordic, Low Noise Amplifier	2017-12	901 545
Temperature and humidity meter, Testo 635	2017-05	504 023
Temperature and humidity meter, Testo 625	2017-06	504 188

Uncertainties

Measurement and test instrument uncertainties are described in the quality assurance documentation "SP-QD 10885". The uncertainties are calculated with a coverage factor $k=2$ (95% level of confidence).

Compliance evaluation is based on a shared risk principle with respect to the measurement uncertainty.

Appendix 1

Reservation

The test results in this report apply only to the particular test object as declared in the report.

Delivery of test object

The test object was delivered 2017-02-14.

Manufacturer's representative

Mikael Jansson, Ericsson AB.

Test engineers

Tomas Lennhager, Tomas Isbring and Andreas Johnson, RISE.

Test participant

None.

Appendix 2

RF power output measurements according to CFR 47 2.1046 / IC RSS-132 5.4

Date	Temperature	Humidity
2017-03-20	22 °C ± 3 °C	29% ± 5 %
2017-03-23	22 °C ± 3 °C	21% ± 5 %
2017-03-24	22 °C ± 3 °C	20% ± 5 %

Test set-up and procedure

The test object was connected to a signal analyzer measuring peak and RMS output power in CDF mode. A RBW of 80 MHz was used.

Measurement equipment	SP number
Rohde & Schwarz signal analyser FSW 43	902 073
RF attenuator	502 282
Testo 635 temperature and humidity meter	504 203

Measurement uncertainty: 1.1 dB

Results

Single carrier

Rated output power level at RF connector 1 x 49 dBm. Total nominal RF power 52 dBm

Tested channel BW, Symbolic name, modulation	Port RF A [RMS dBm/ dB PAR]	Port RF B [RMS dBm/ dB PAR]	Total power ¹⁾ [RMS dBm]
5 MHz, B, TM1	48.40/ 6.52	48.69/ 6.92	51.56
5 MHz, M, TM1	48.70/ 6.86	48.78/ 6.88	51.75
5 MHz, T, TM1	48.75/ 6.90	48.70/ 6.88	51.74
3.8 MHz, M TM1	48.57/ 7.04	48.61/ 7.04	51.60
5 MHz, B, TM5	48.49/ 6.90	48.67/ 6.90	51.59
5 MHz, M, TM5	48.66/ 6.90	48.76/ 6.88	51.72
5 MHz, T, TM5	48.73/ 6.84	48.70/ 6.84	51.73
5 MHz, B, TM6	48.56/ 6.92	48.67/ 6.92	51.63
5 MHz, M, TM6	48.70/ 6.92	48.76/ 6.88	51.74
5 MHz, T, TM6	48.73/ 6.88	48.73/ 6.84	51.74

¹⁾: summed output power according to FCC KDB662911 Multiple transmitter output

Appendix 2

Multi carrier

Rated output power level at RF connector 2x 46dBm. Total nominal RF power 52 dBm

Tested channel BW, Symbolic name, modulation	Port RFA [RMS dBm/ dB PAR]	Port RFB [RMS dBm/ dB PAR]	Total power ¹⁾ [RMS dBm]
5 MHz, B2, TM1	48.65/ 6.80	48.75/ 6.78	51.71
5 MHz, M2, TM1	48.85/ 6.60	48.85/ 6.60	51.86
5 MHz, T2, TM1	48.85/ 6.64	48.83/ 6.64	51.85
5 MHz, B2, TM5	48.66/ 6.78	48.75/ 6.78	51.72
5 MHz, M2, TM5	48.85/ 6.60	48.84/ 6.68	51.86
5 MHz, T2, TM5	48.86/ 6.64	48.84/ 6.62	51.86
5 MHz, B2, TM6	48.65 6.76	48.75/ 6.76	51.71
5 MHz, M2, TM6	48.84/ 6.58	48.88/ 6.58	51.87
5 MHz, T2, TM6	48.87/ 6.62	48.84/ 6.62	51.87

¹⁾: summed output power according to FCC KDB662911 Multiple transmitter output

Rated output power level at RF connector 4x 43dBm. Total nominal RF power 52 dBm

Tested channel BW, Symbolic name, modulation	Port RFA [RMS dBm/ dB PAR]	Port RFB [RMS dBm/ dB PAR]	Total power ¹⁾ [RMS dBm]
5 MHz, M4, TM1	48.82/ 6.80	48.85/ 6.80	51.85
5 MHz, M4, TM5	48.84/ 6.88	48.84/ 6.86	51.85
5 MHz, M4, TM6	48.80/ 6.78	48.83/ 6.80	51.83

¹⁾: summed output power according to FCC KDB662911 Multiple transmitter output

Power Spectrum Density

Single carrier

Power Spectrum Density E-TM1.1

Rated output power 1 x 43 dBm/ port.Total nominal RF power 49 dBm

Tested channel BW, Symbolic name, modulation	Output power per 1 MHz [RMS dBm]		
	Port RFA	Port RFB	Total power ¹⁾
5 MHz, M, TM1	43.58	43.62	43.61
3.8 MHz, M TM1	43.60	43.61	43.62

¹⁾: summed output power according to FCC KDB662911 Multiple transmitter output

Appendix 2

Remark

This unit is tested without antenna. ERP/EIRP compliance is addressed at the time of licensing, as required by the responsible FCC/IC Bureau(s). Licensee's are required to take into account maximum allowed antenna gain used in combination with above power settings to prevent the radiated output power to exceed the limits.

Limits

CFR47 § 22.913: The effective radiated power ERP shall not exceed 1000 W or 800 W/ MHz (PSD) per sector.

The PAR (0.1%) shall not exceed 13 dB.

RSS-132 5.4: The average equivalent isotropically radiated power (e.i.r.p.) limits in SRSP-503 apply, resulting in a maximum EIRP of 1640 W.

The PAR (0.1%) shall not exceed 13 dB.

Complies?	Yes
-----------	-----

Appendix 3

Occupied bandwidth measurements according to CFR47 2.1049 / RSS-Gen 4.6.1

Date	Temperature	Humidity
2017-03-21	22 °C ± 3 °C	29% ± 5 %
2017-05-10	22 °C ± 3 °C	21% ± 5 %

Test set-up and procedure

The measurements were made per definition in § 2.1049. The output was connected to a signal analyser with the Peak detector activated. The signal analyser was connected to an external 10 MHz reference standard during the measurements.

Measurement equipment	SP number
Rohde & Schwarz signal analyser FSW 43	902 073
RF attenuator	502 282
Testo 635 temperature and humidity meter	504 203

Measurement uncertainty: 3.7 dB

Results

Single carrier TM1

Diagram	BW configuration	Symbolic name	Tested Port	Occupied BW (99%) [MHz]
1	5 MHz	B	RF B	4.165
2	5 MHz	M	RF B	4.165
3	5 MHz	T	RF B	4.165
4	5 MHz	M	RF A	4.165
5	3.8 MHz	M	RFB	3.579

Single carrier TM5

Diagram	BW configuration	Symbolic name	Tested Port	Occupied BW (99%) [MHz]
6	5 MHz	M	RF B	4.181

Appendix 3

Single carrier TM6

Diagram	BW configuration	Symbolic name	Tested Port	Occupied BW (99%) [MHz]
7	5 MHz	M	RF B	4.191

The diagrams are shown on the following pages.

Appendix 3

Diagram 1:

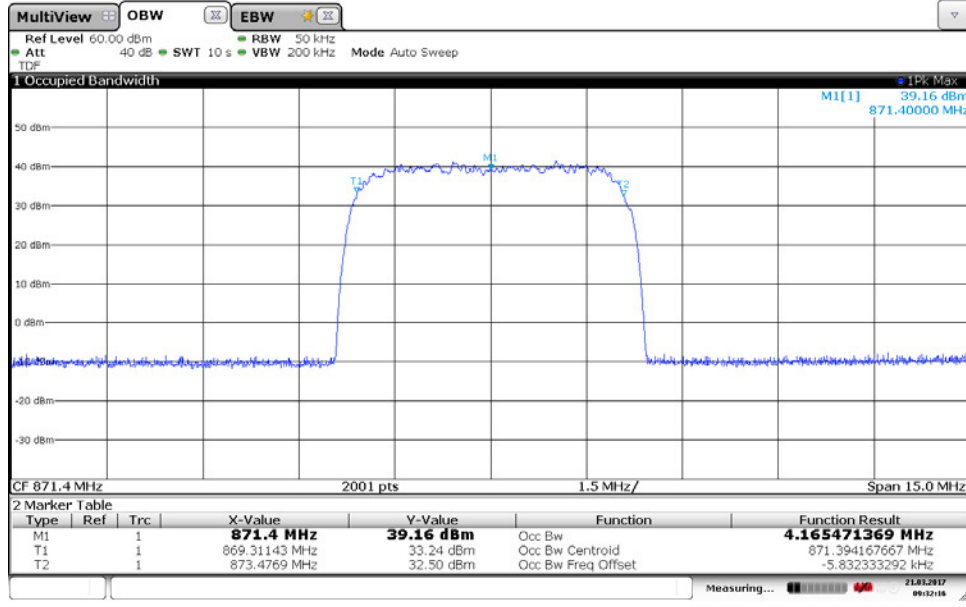

09:32:17 21.03.2017

Diagram 2:

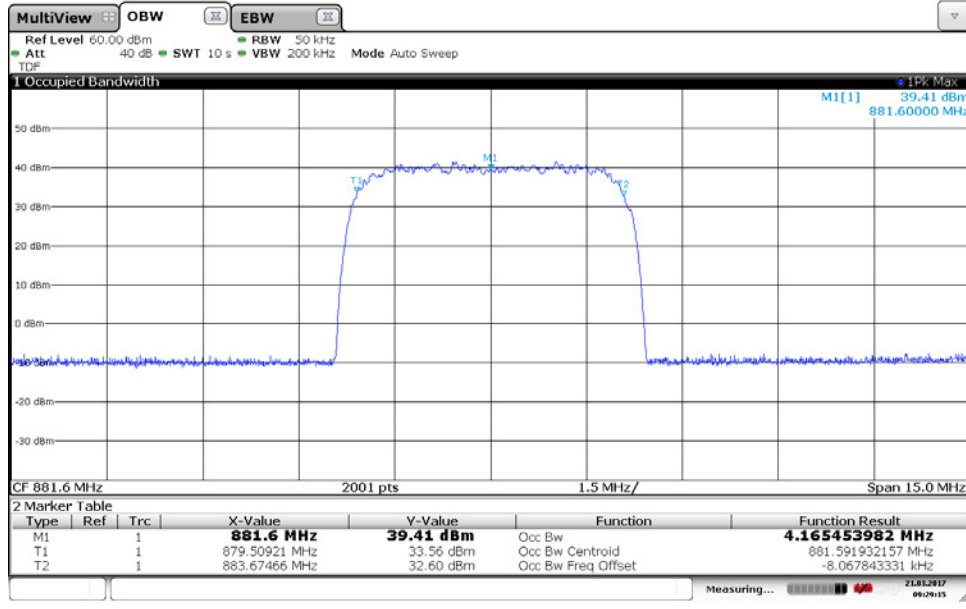

09:29:15 21.03.2017

Appendix 3

Diagram 3:

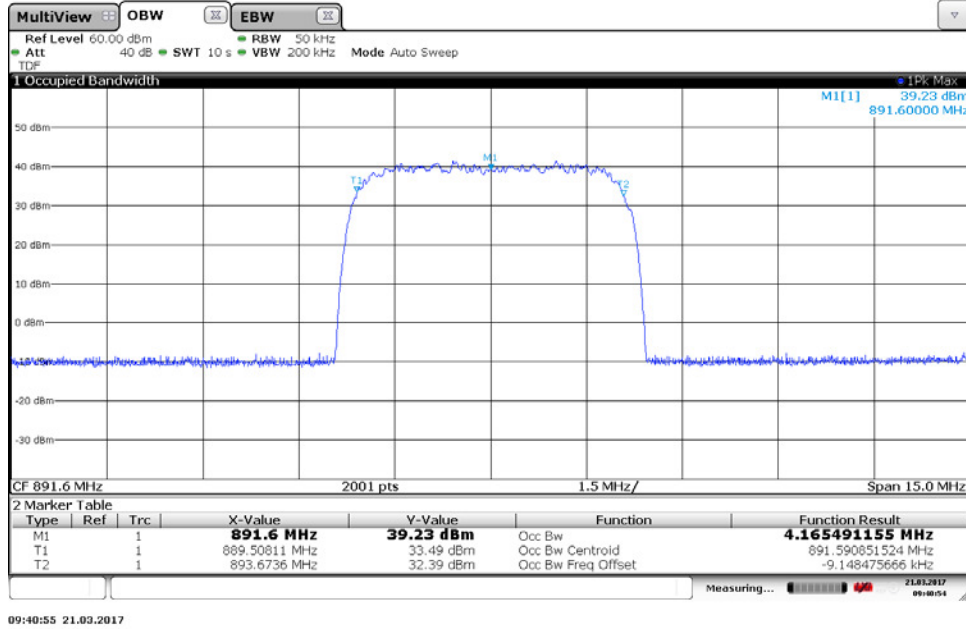
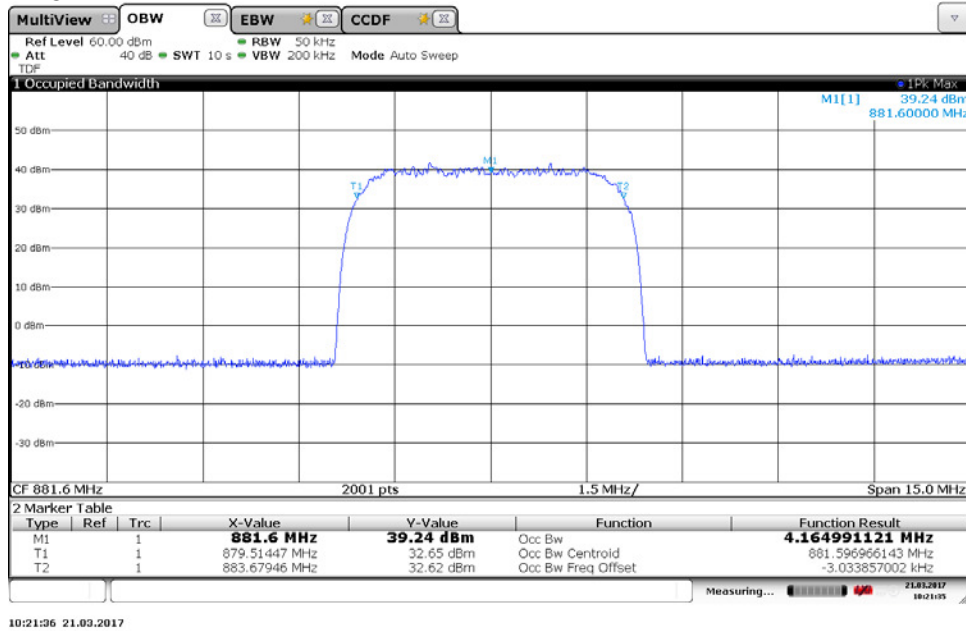
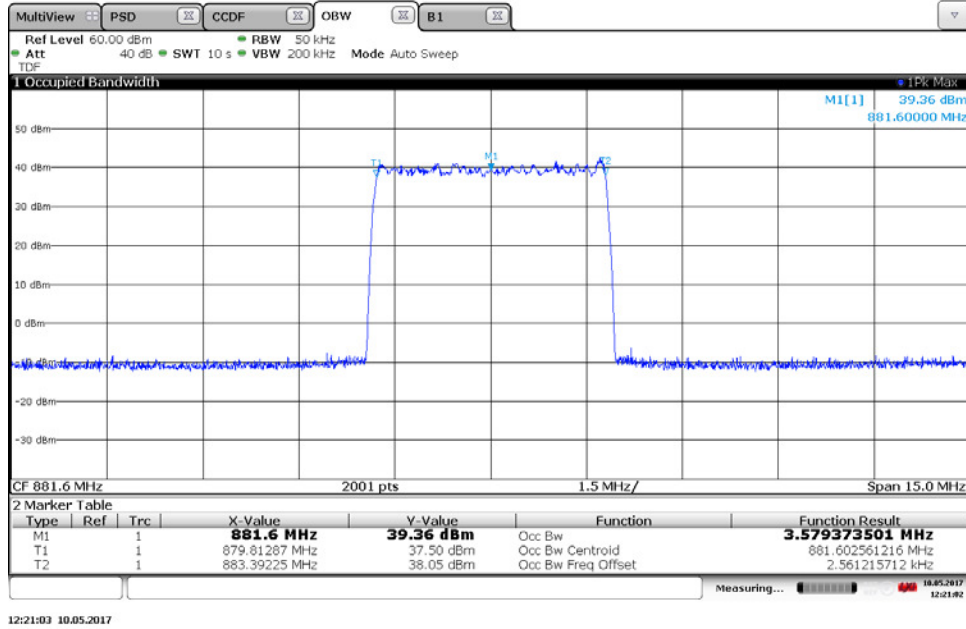

Diagram 4:



Appendix 3

Diagram 5:



12:21:03 10.05.2017

Diagram 6:

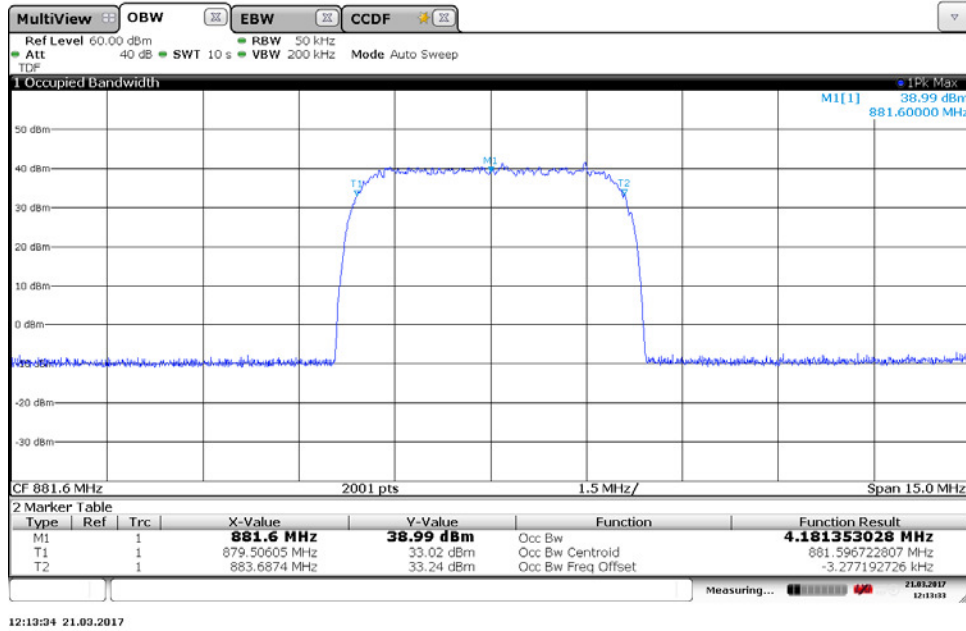

12:13:34 21.09.2017

Appendix 3

Diagram 7:

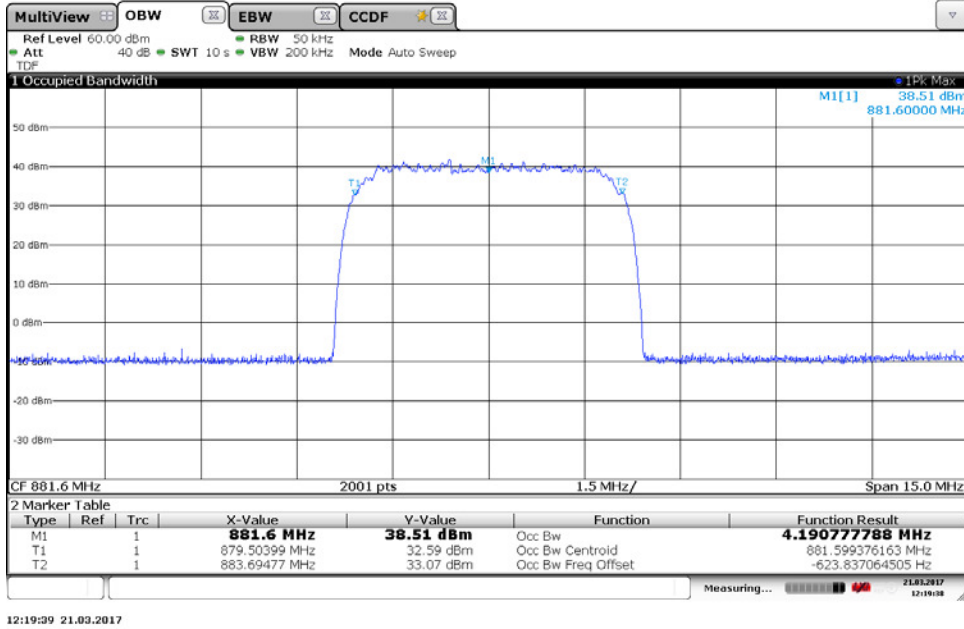

Appendix 4

Band edge measurements according to CFR 47 §2.1051 / IC RSS-132 5.5

Date	Temperature	Humidity
2017-03-21	22 °C ± 3 °C	29% ± 5 %
2017-03-22	23 °C ± 3 °C	30% ± 5 %
2017-03-24	22 °C ± 3 °C	20% ± 5 %

Test set-up and procedure

The measurements were made per definition in § 22.917. The test object was connected to a spectrum analyser with the RMS detector activated. The spectrum analyser was connected to an external 10 MHz reference standard during the measurements.

FCC rules specify a RBW of at least 1% of the fundamental emission bandwidth (EBW) for offsets up to 1 MHz from the band edge and a RBW of 100 kHz for measurements of emissions more than 1 MHz away from the band edges.

Where a smaller RBW was used as compared to the rules the limit in the plot is adjusted by $10 \cdot \log(\text{RBW}_{\text{used}}/\text{RBW}_{1\% \text{EBW}})$ [dB].

BW configuration	Emission BW [MHz]	RBW used	Adjusted limit [dBm]
5 MHz	4.65	20 kHz	-16.66
5 MHz	4.65	10 kHz	-19.67

Before comparing the results to the limit, 3 dB [10 log (2)] should be added according to method c “measure and add 10 log(N_{ANT})” of FCC KDB662911 D01 Multiple Transmitter Output

Measurement equipment	SP number
Rohde & Schwarz signal analyser FSW 43	902 073
RF attenuator	502 282
Testo 635 temperature and humidity meter	504 203

Measurement uncertainty: 3.7 dB

Appendix 4

Results

Single carrier TM 1

Diagram	BW configuration	Symbolic name	Tested Port
1 a-b	5 MHz	B	RFA
2 a-b	5 MHz	B	RFB
3 a-b	5 MHz	T	RFA
4 a-b	5 MHz	T	RFB

Single carrier TM 5

Diagram	BW configuration	Symbolic name	Tested Port
5 a-b	5 MHz	B	RFB
6 a-b	5 MHz	T	RFB

Single carrier TM 6

Diagram	BW configuration	Symbolic name	Tested Port
7 a-b	5 MHz	B	RFB
8 a-b	5 MHz	T	RFB

MIMO mode, multi carrier TM5

Diagram	BW configuration	Symbolic name	Tested Port
9 a-b	5 MHz	B2	RFB
10 a-b	5 MHz	T2	RFB
11 a-b	5 MHz	B3	RFB
12 a-b	5 MHz	T3	RFB

The diagrams are shown on the following pages.

Remark

Where multiple requirements apply, the most stringent requirement is considered for compliance assessment.

Limits

CFR 47 § 22.917: Outside a licensee's frequency band(s) of operation the power of any emission shall be attenuated below the transmitter power (P) by at least $43 + 10 \log (P)$ dB, resulting in a limit of -13 dBm per 100 kHz RBW below 1 GHz and 1MHz RBW above 1 GHz.

IC RSS-132 5.5: Outside a licensee's frequency band(s) of operation the power of any emission shall be attenuated below the transmitter power (P) by at least $43 + 10 \log (P)$ dB per any 100 kHz RBW.

Complies?	Yes
-----------	-----

Appendix 4

Diagram 1 a:

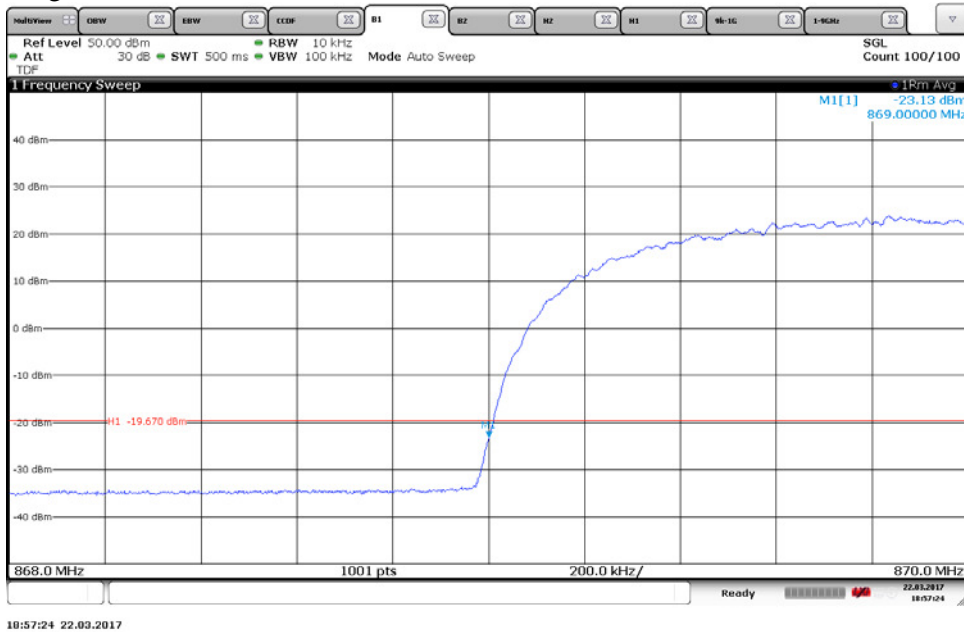
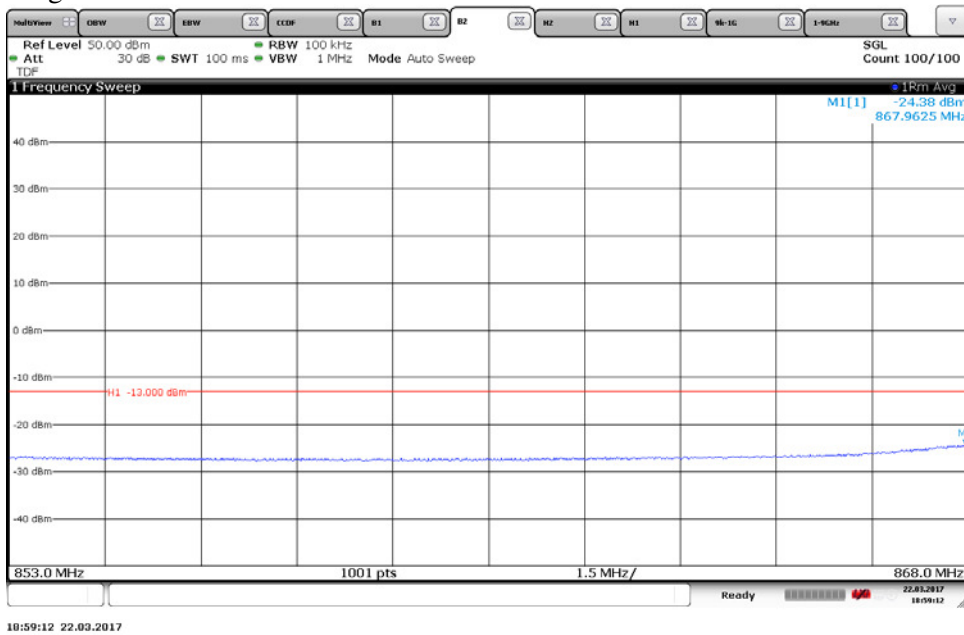

Diagram 1 b:



Appendix 4

Diagram 2 a:

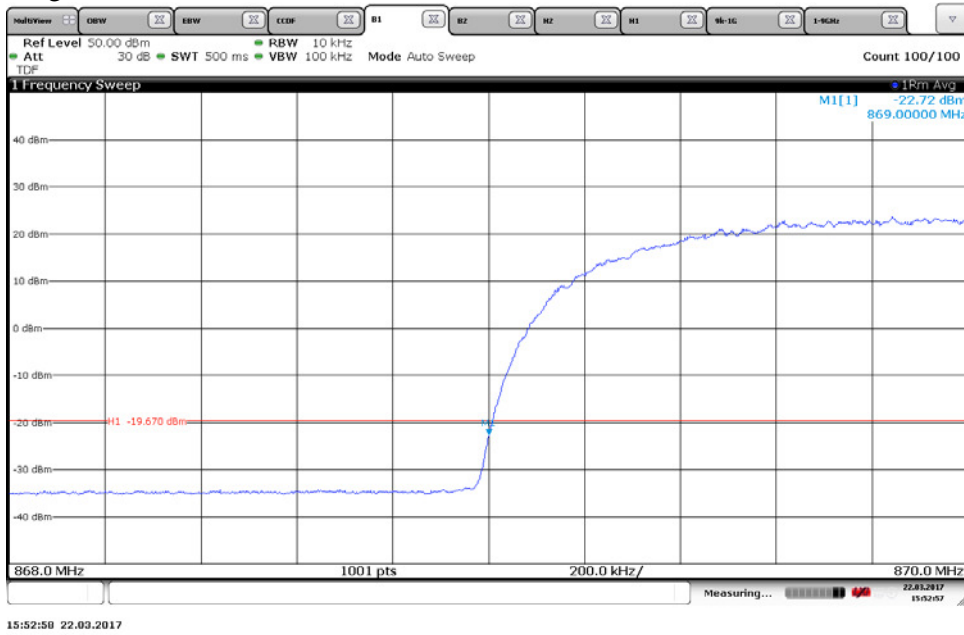
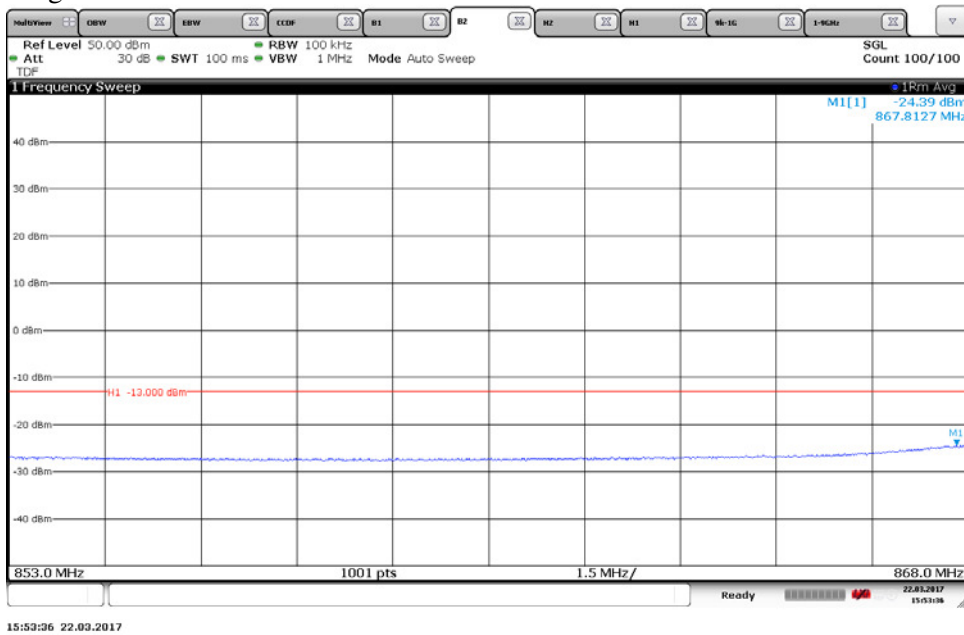
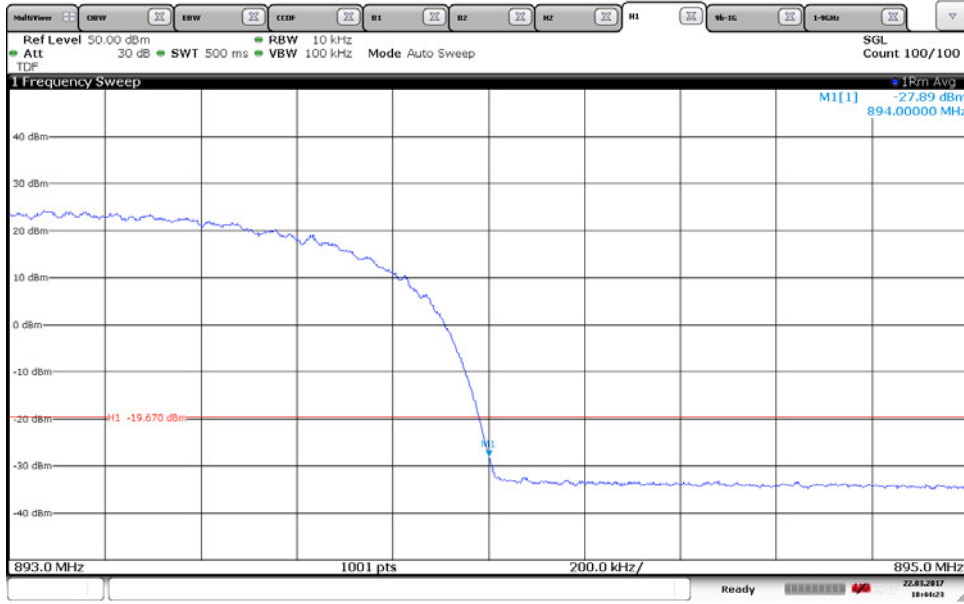

Diagram 2 b:



Appendix 4

Diagram 3 a:



18:44:23 22.03.2017

Diagram 3 b:

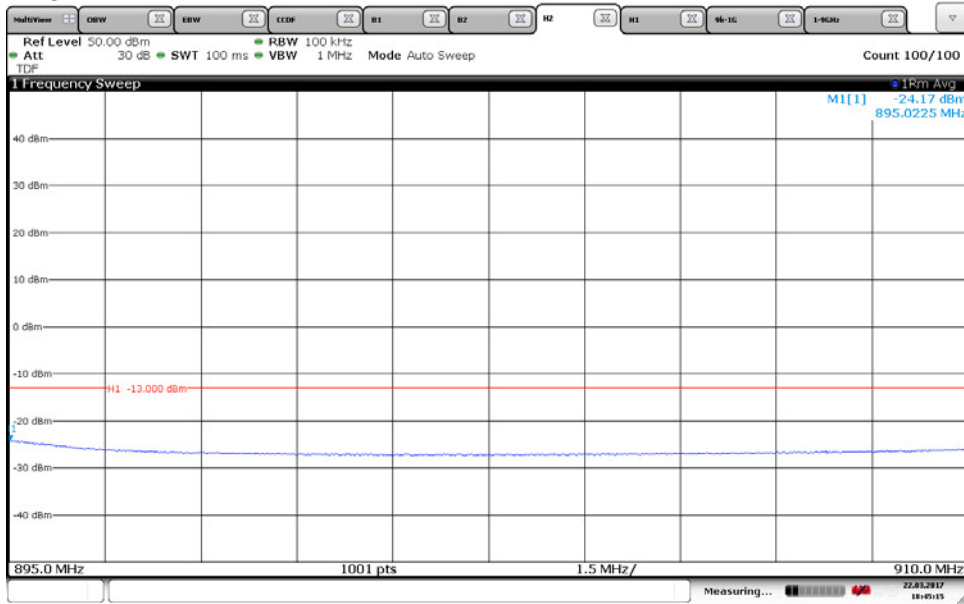

18:45:15 22.03.2017

Appendix 4

Diagram 4 a:

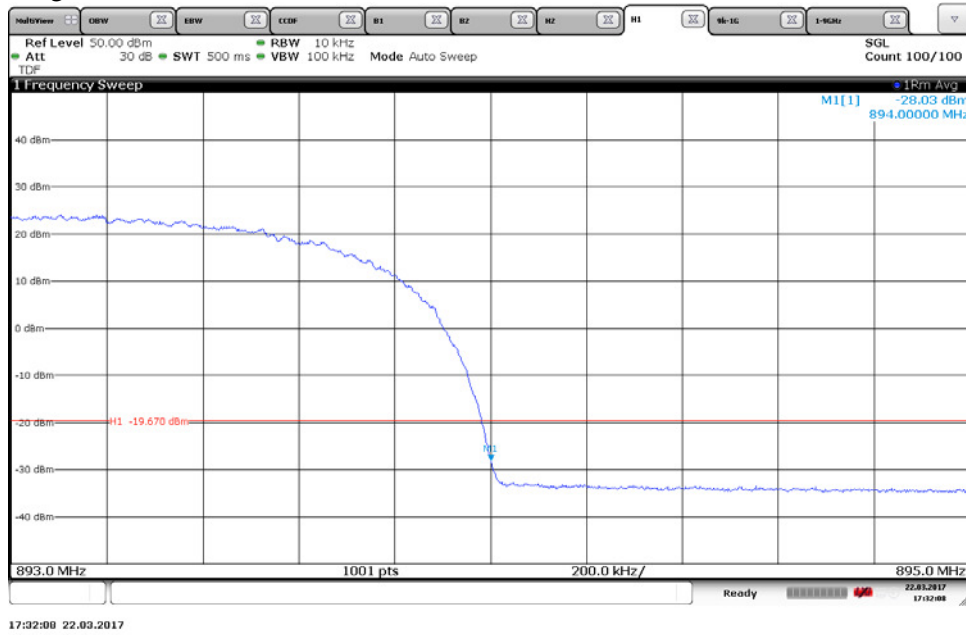
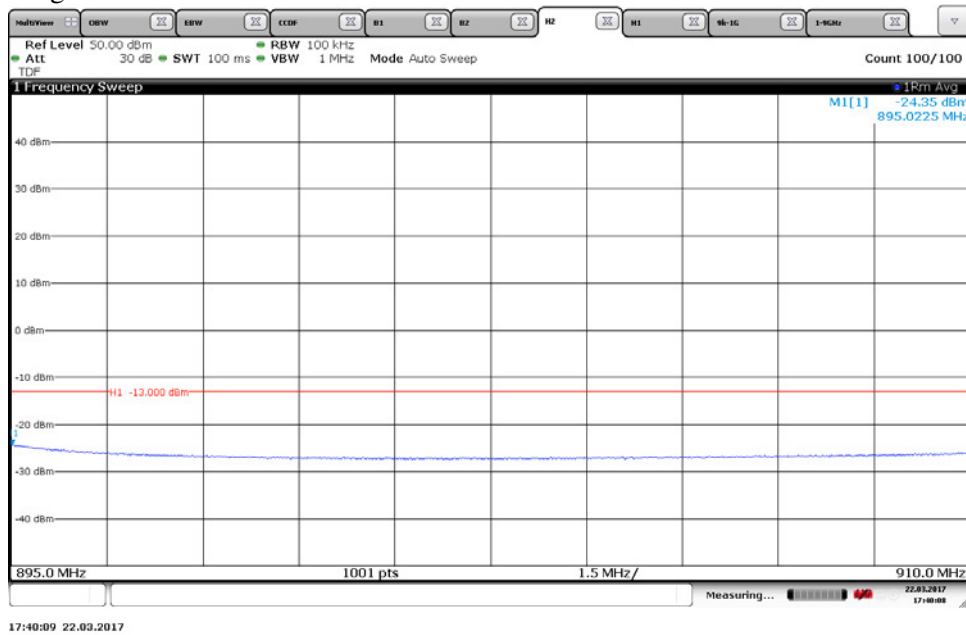

Diagram 4 b:



Appendix 4

Diagram 5 a:

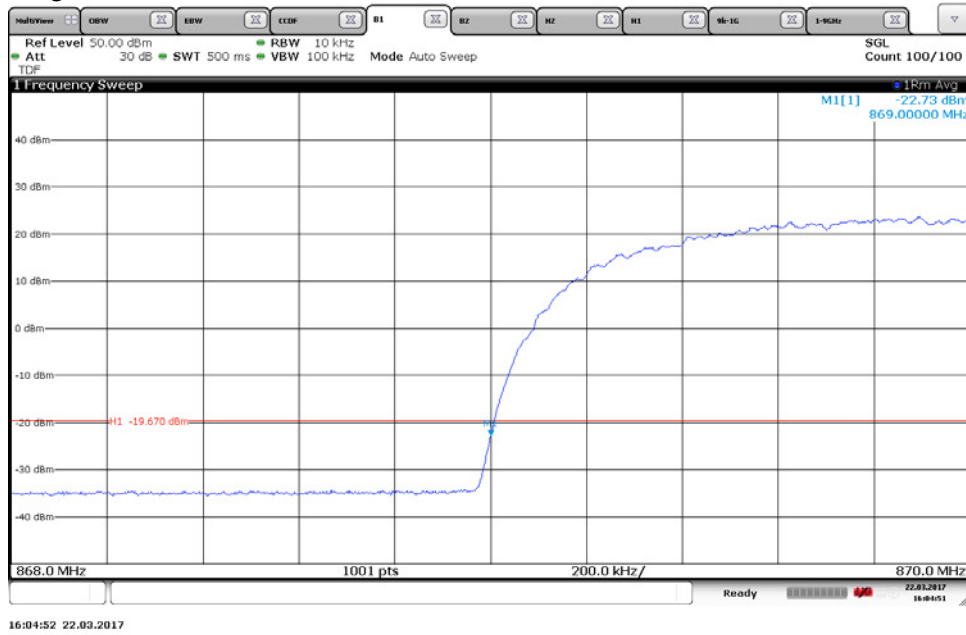
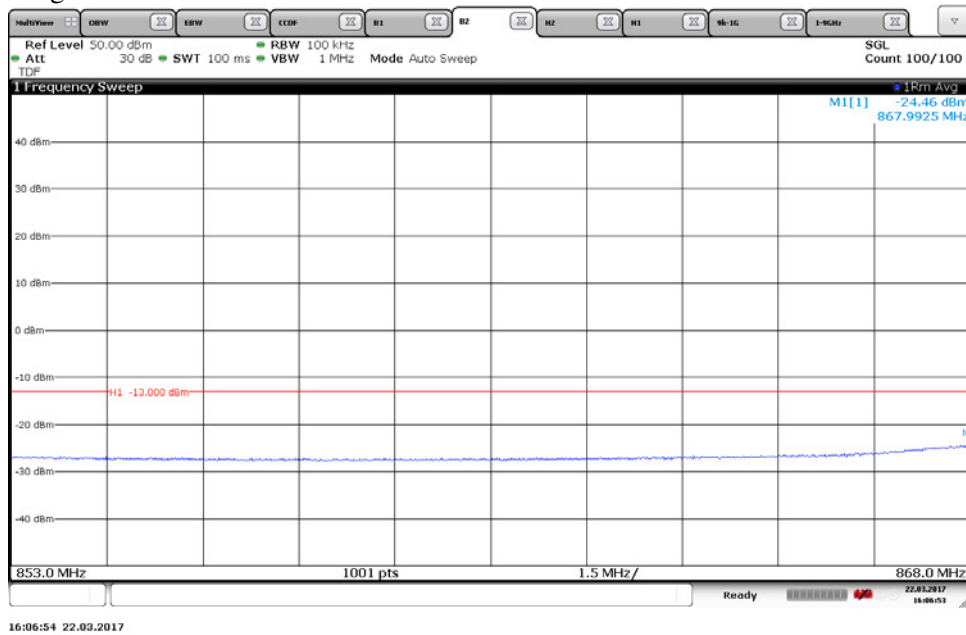

Diagram 5 b:



Appendix 4

Diagram 6 a:

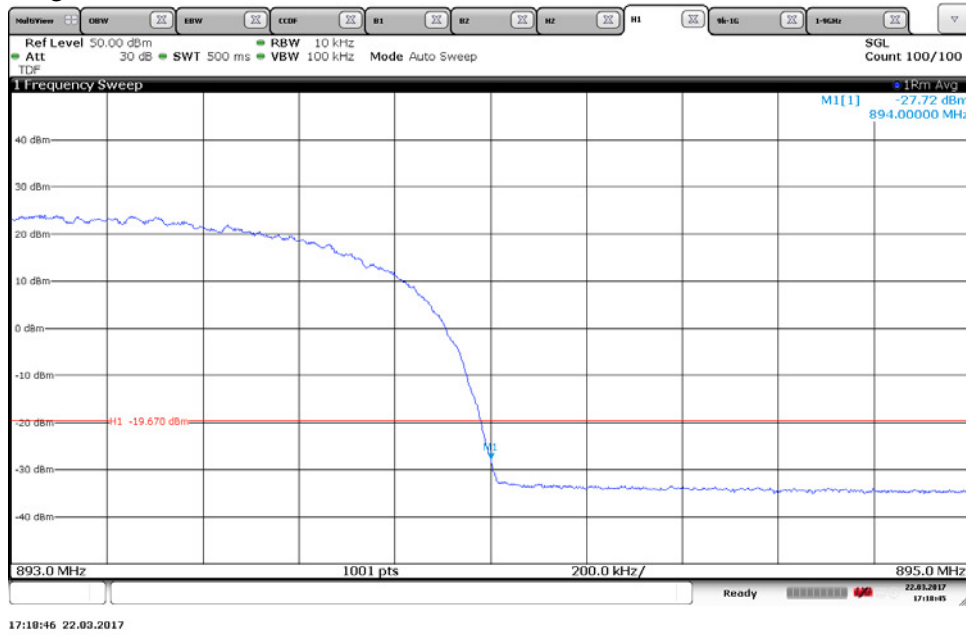
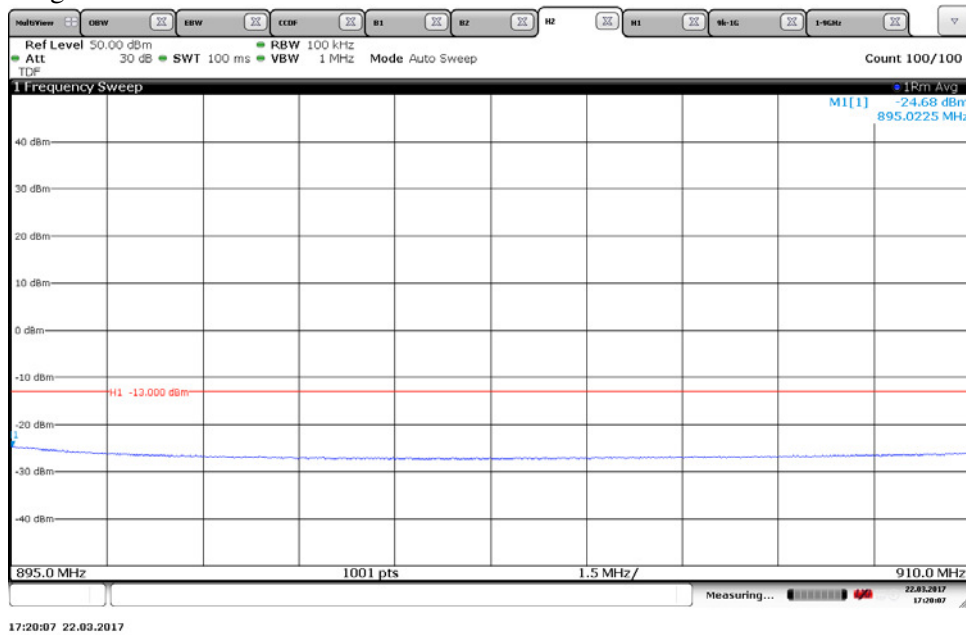

Diagram 6 b:



Appendix 4

Diagram 7 a:

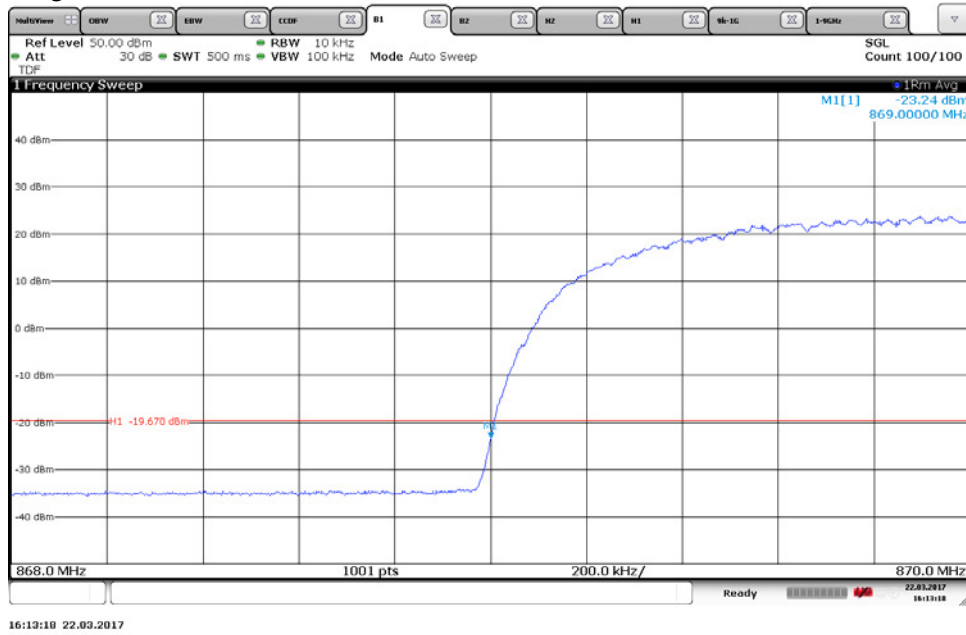
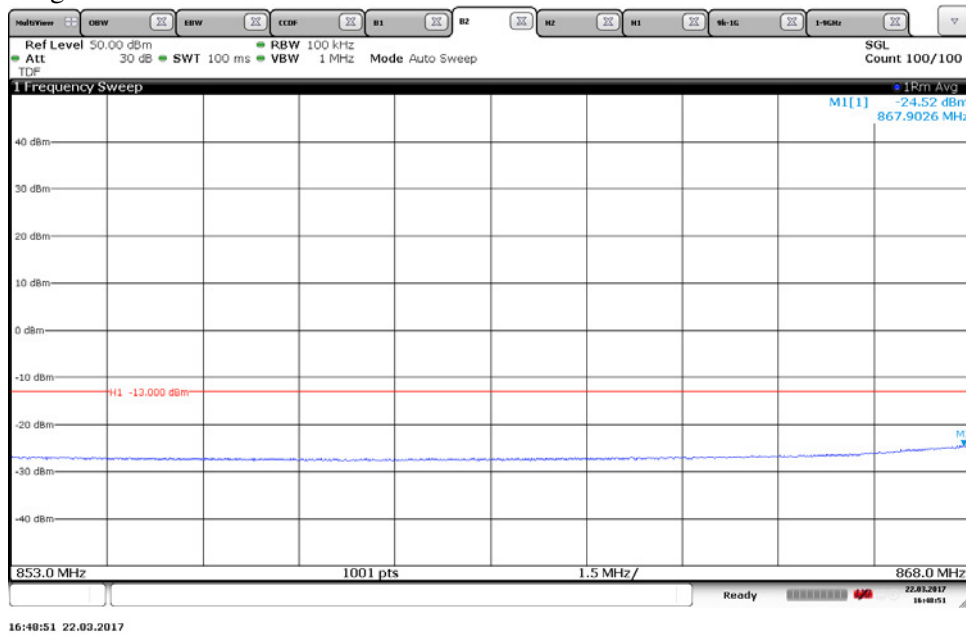

Diagram 7 b:



Appendix 4

Diagram 8 a:

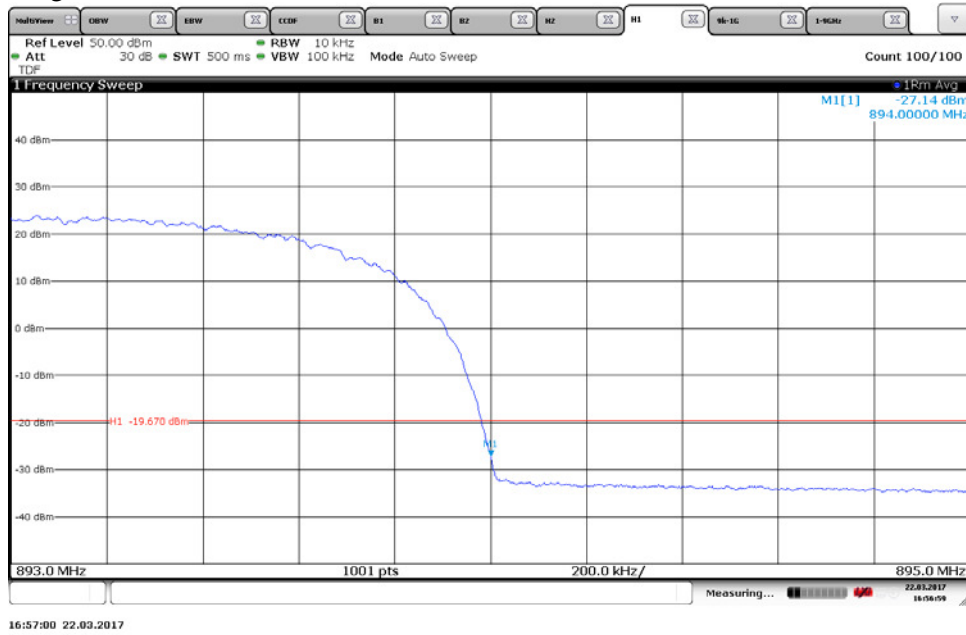
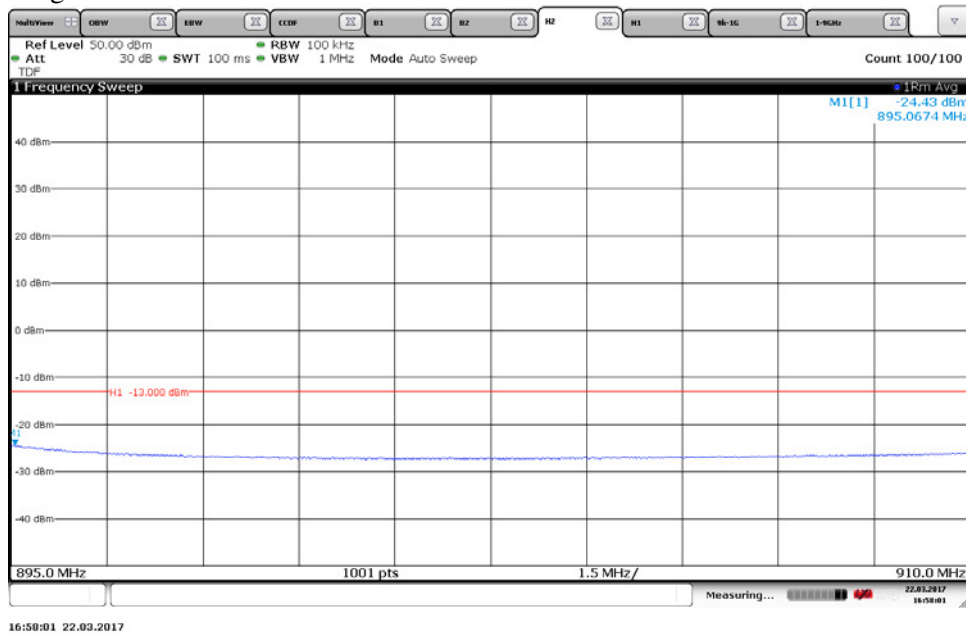

Diagram 8 b:



Appendix 4

Diagram 9 a:

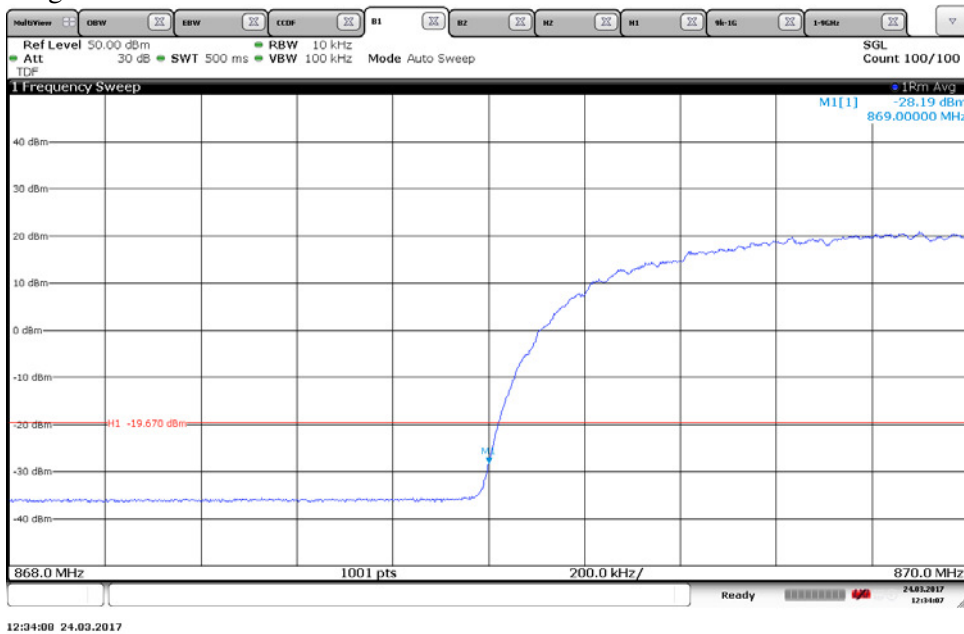
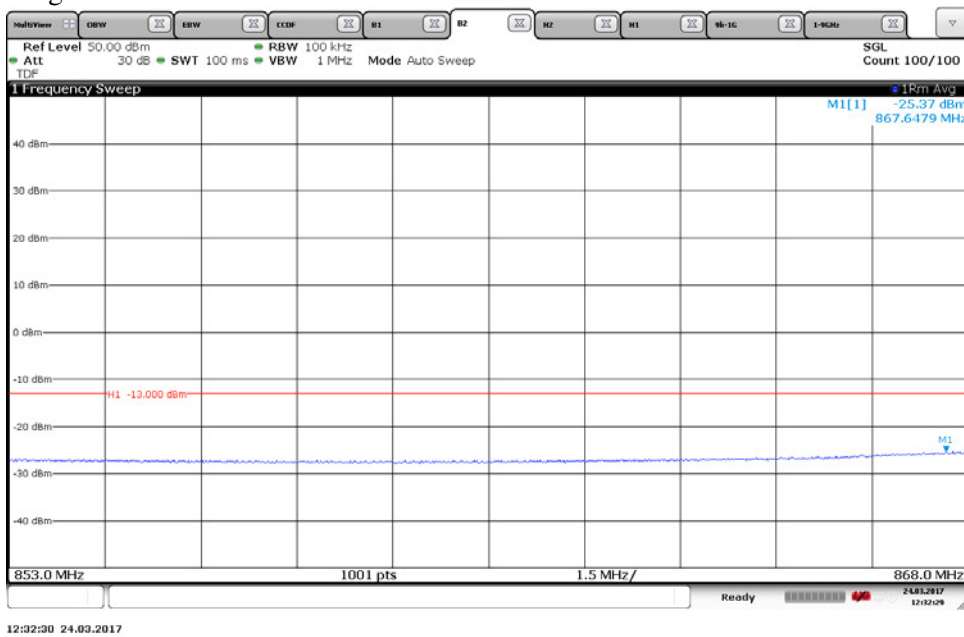

Diagram 9 b:



Appendix 4

Diagram 10 a:

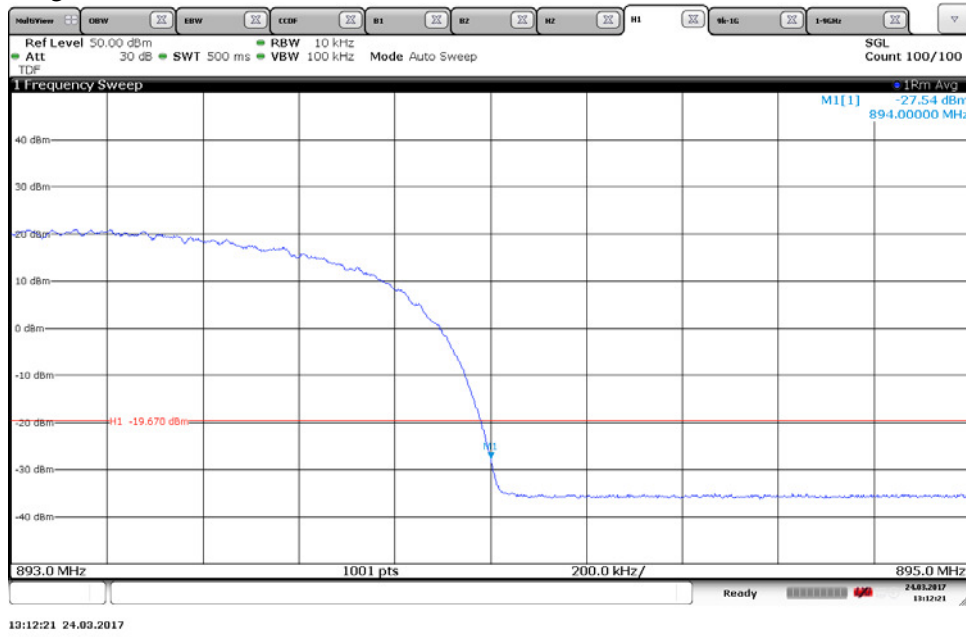
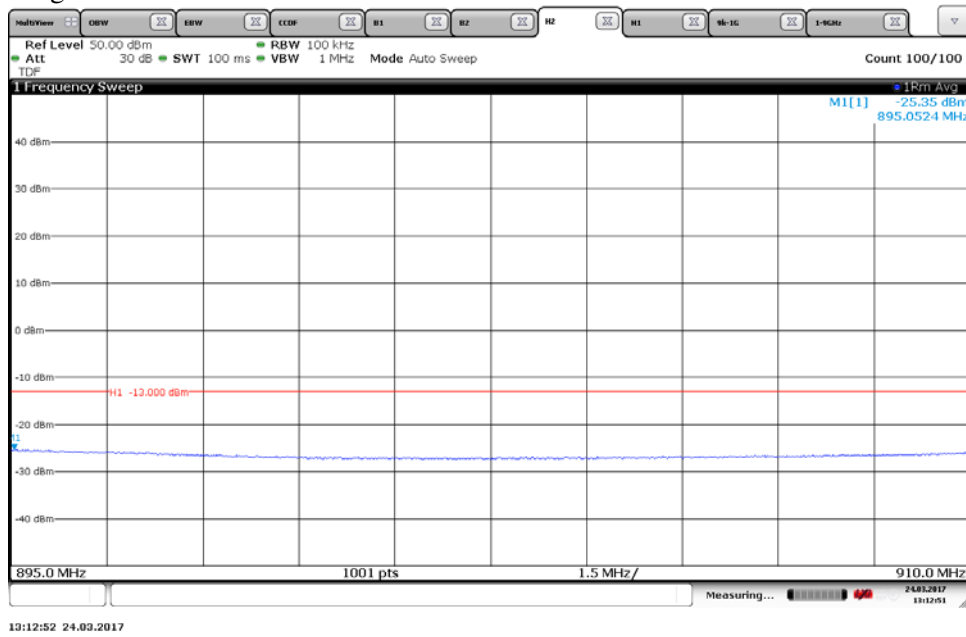
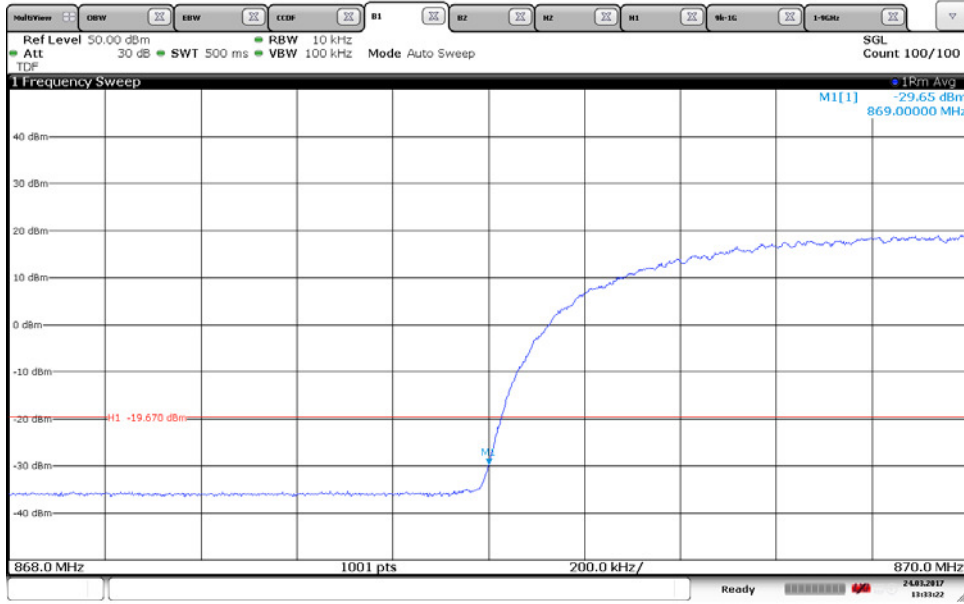

Diagram 10 b:



Appendix 4

Diagram 11 a:



13:33:23 24.03.2017

Diagram 11 b:

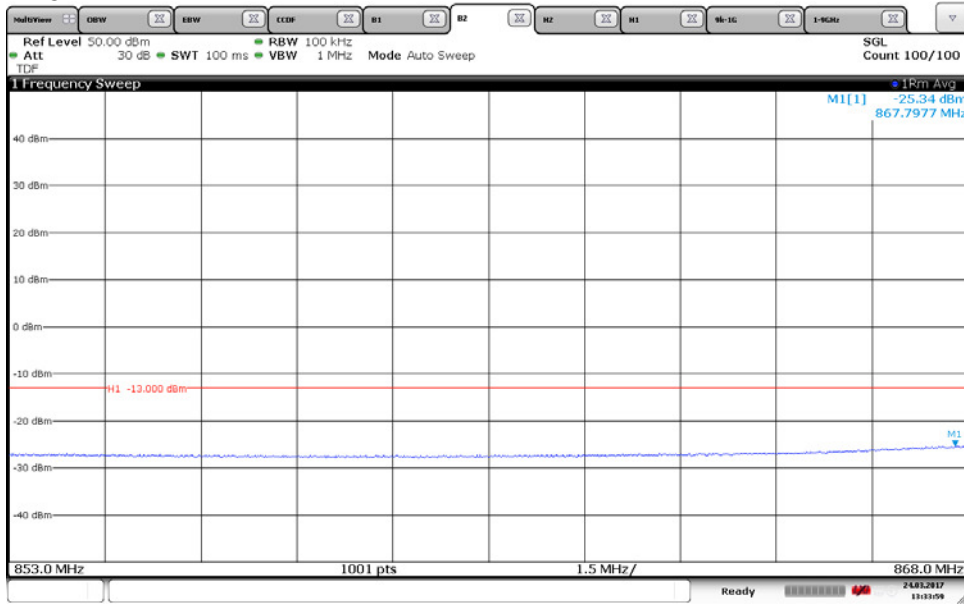

13:33:59 24.03.2017

Appendix 4

Diagram 12 a:

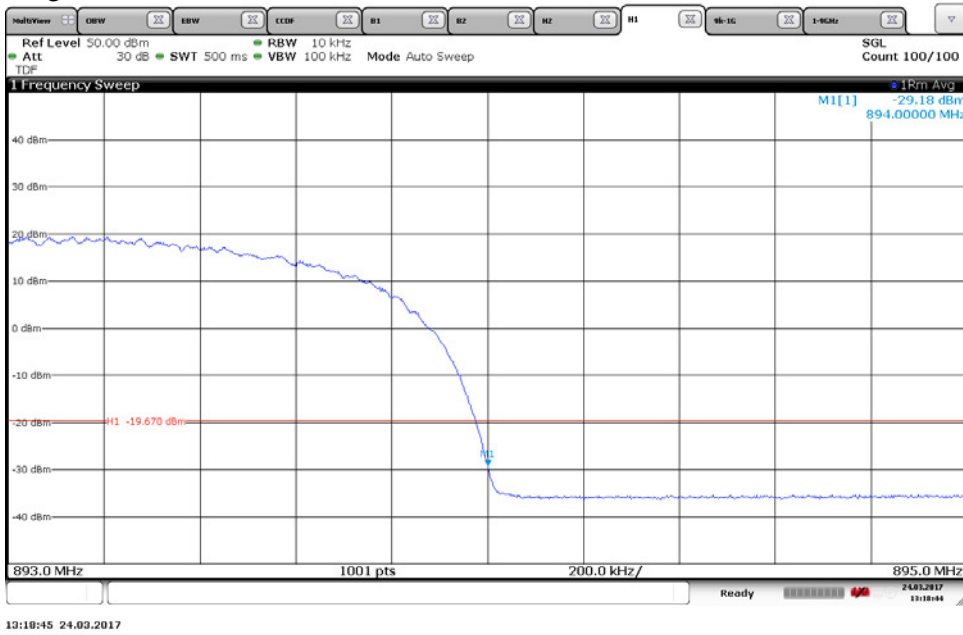
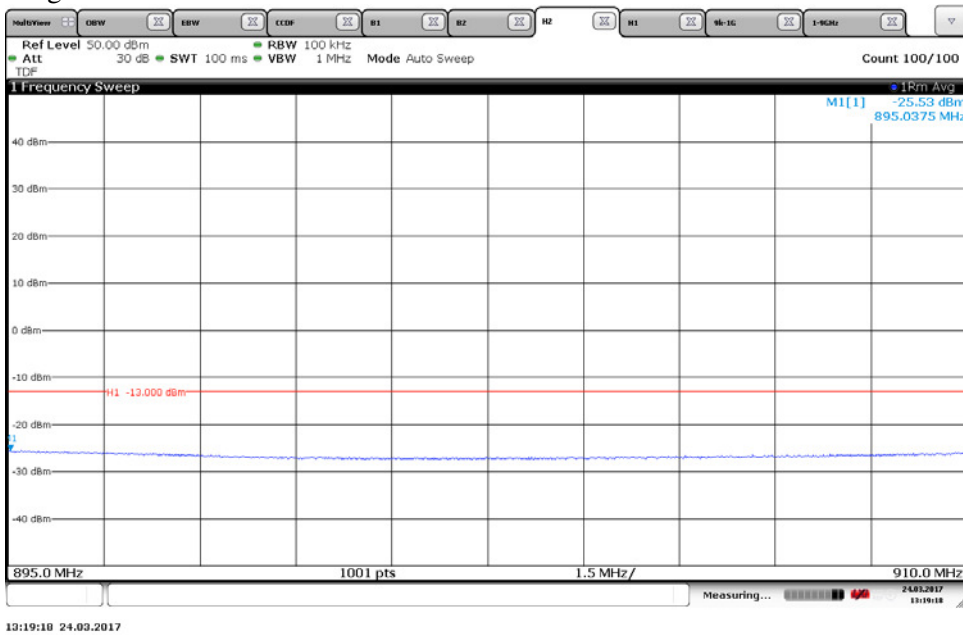

Diagram 12 b:



Appendix 5

Conducted spurious emission measurements according to CFR 47 2.1051 / IC RSS-132 5.5

Date	Temperature	Humidity
2017-03-22	23 °C ± 3 °C	30% ± 5 %
2017-03-24	22 °C ± 3 °C	20% ± 5 %
2017-03-30	22 °C ± 3 °C	31% ± 5 %

Test set-up and procedure

The measurements were made per definition in § 22.917. The output was connected to a spectrum analyzer with the RMS detector activated. The spectrum analyzer was connected to an external 10 MHz reference standard during the measurements.

Before comparing the results to the limit, 3 dB [10 log (2)] should be added according to method c “measure and add 10 log(N_{ANT})” of FCC KDB662911 D01 Multiple Transmitter Output v02.

Measurement equipment	SP number
Rohde & Schwarz signal analyser FSW 43	902 073
RF attenuator	502 282
High pass filter	901 373
Testo 635 temperature and humidity meter	504 203

Measurement uncertainty: 3.7 dB

Appendix 5

Results

Single carrier TM 1

Diagram	BW configuration[MHz]	Symbolic name	Tested Port
1 a+b	5 MHz	B	RF A
2 a+b	5 MHz	B	RF B
3 a+b	5 MHz	M	RF A
4 a+b	5 MHz	M	RF B
5 a+b	5 MHz	T	RF A
6 a+b	5 MHz	T	RF B

Single carrier TM 5

Diagram	BW configuration[MHz]	Symbolic name	Tested Port
7 a+b	5 MHz	M	RF B

Single carrier TM 6

Diagram	BW configuration[MHz]	Symbolic name	Tested Port
8 a+b	5 MHz	M	RF B

MIMO mode, multi carrier TM 5

Diagram	BW configuration[MHz]	Symbolic name	Tested Port
9 a+b+c	5 MHz	B2	RF B
10 a+b+c	5 MHz	T2	RF B
11 a+b+c	5 MHz	B3	RF B
12 a+b+c	5 MHz	T3	RF B
13 a+b+c	5 MHz	M4	RF B

Appendix 5

Remarks

The upper frequency boundary covers 10x the highest TX fundamental frequency.
The highest fundamental frequency is 894MHz. The measurements were made up to 9 GHz
(10x894 MHz = 8.94 GHz).

Limits

CFR 47 § 22.917: Outside a licensee's frequency band(s) of operation the power of any emission shall be attenuated below the transmitter power (P) by at least $43 + 10 \log (P)$ dB, resulting in a limit of -13 dBm per 100 kHz RBW below 1 GHz and 1MHz RBW above 1 GHz.

IC RSS-132 5.5: Outside a licensee's frequency band(s) of operation the power of any emission shall be attenuated below the transmitter power (P) by at least $43 + 10 \log (P)$ dB per any 100 kHz RBW.

Complies?	Yes
-----------	-----

Appendix 5

Diagram 1 a:

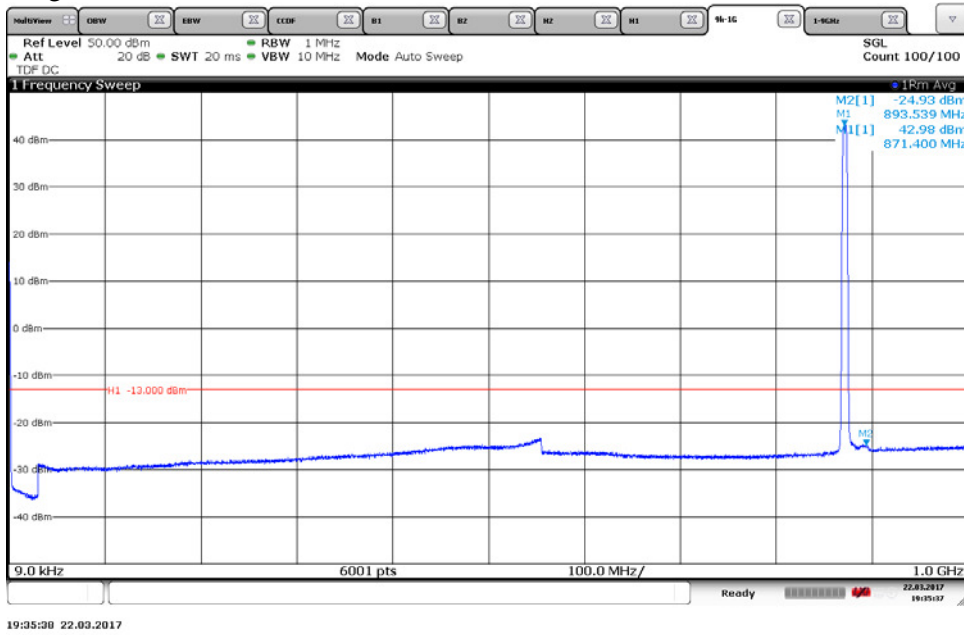
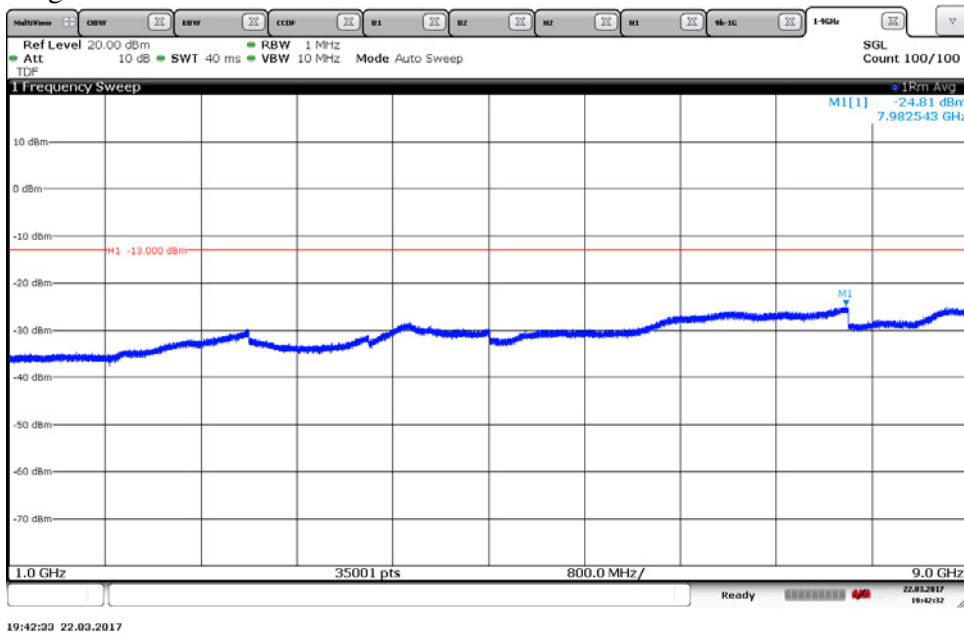

Diagram 1 b:



Appendix 5

Diagram 2 a:

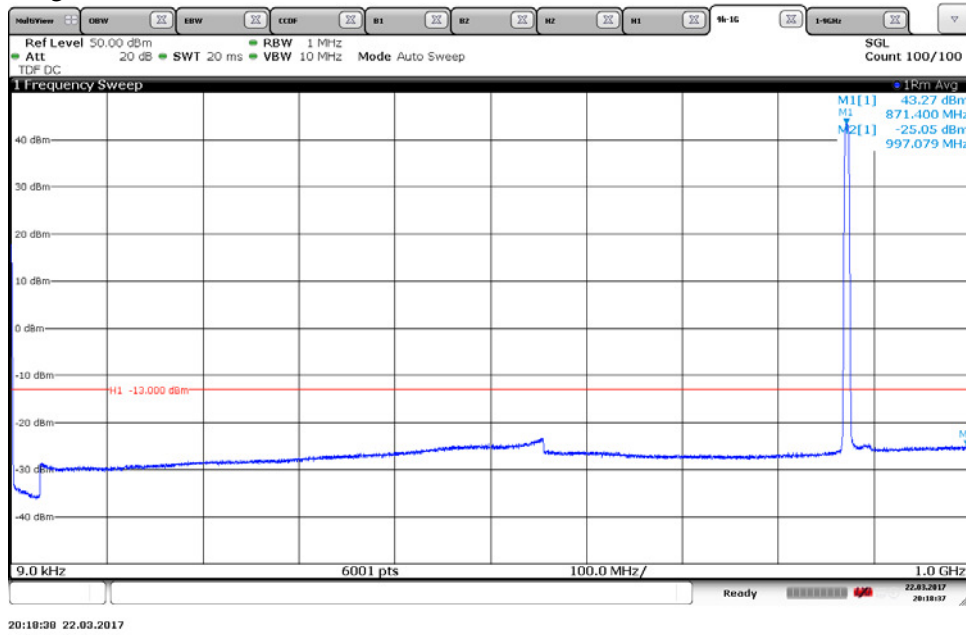
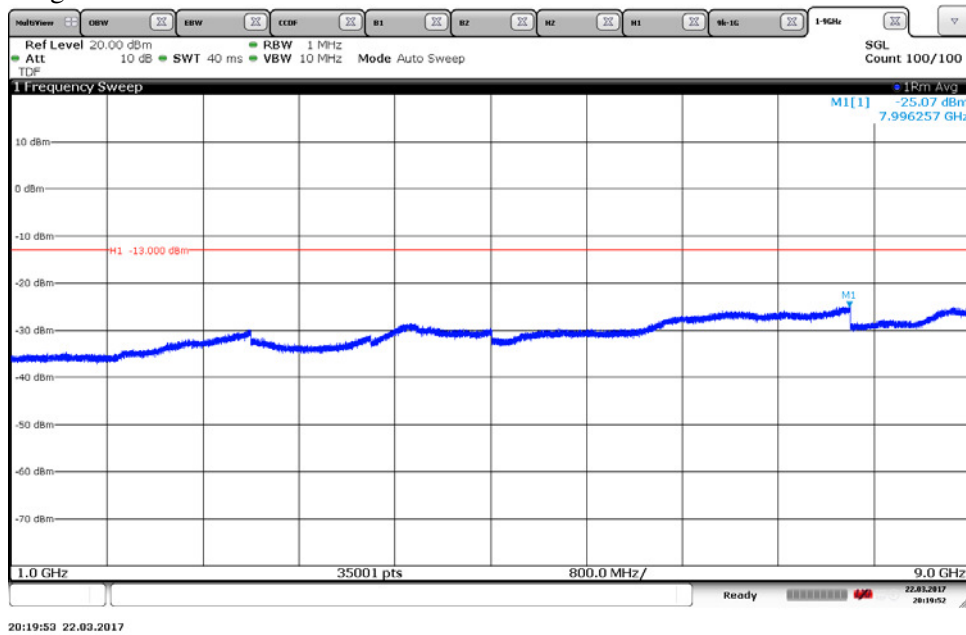

Diagram 2 b:



Appendix 5

Diagram 3 a:

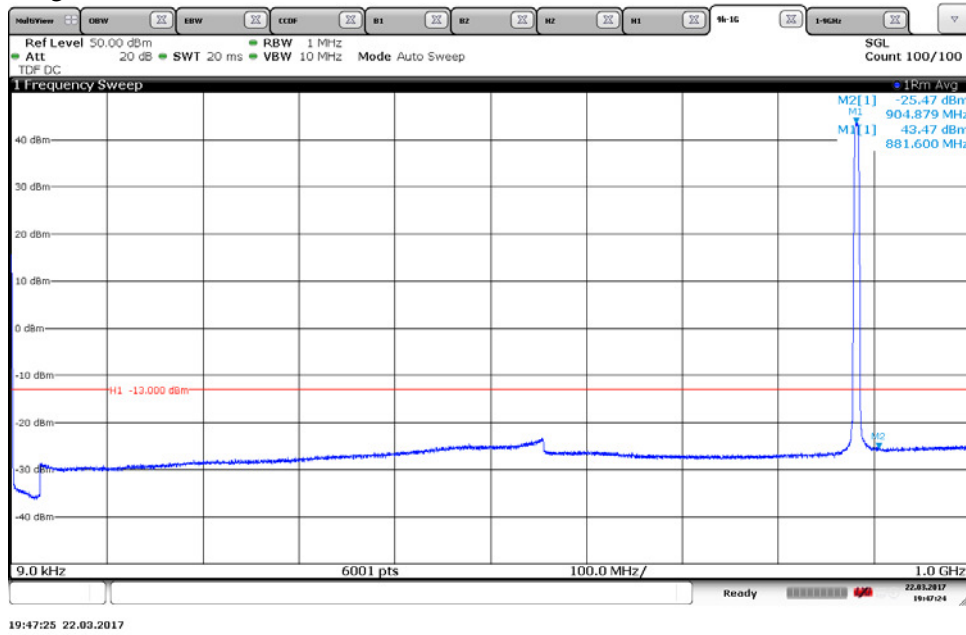
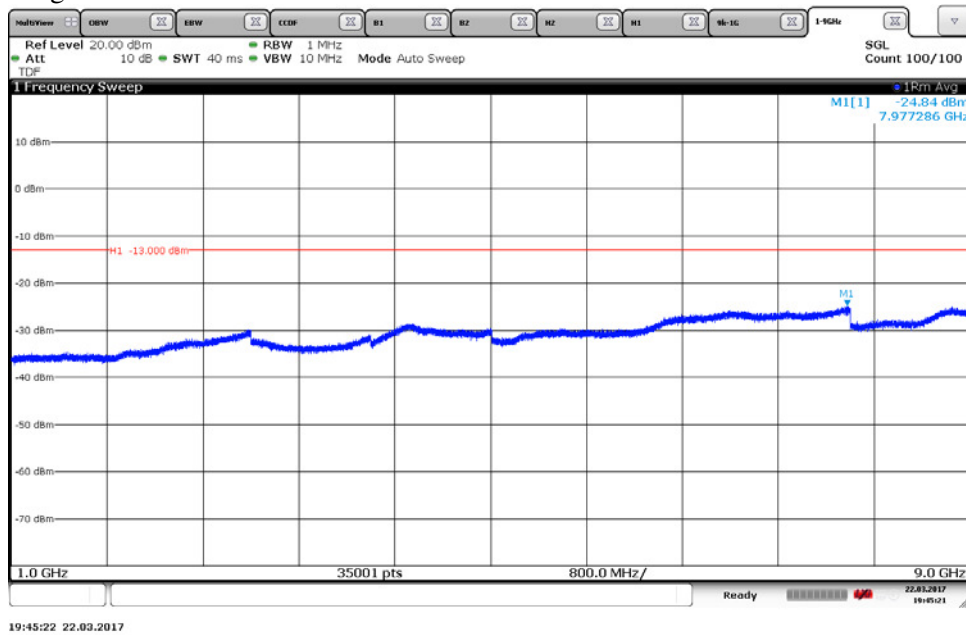
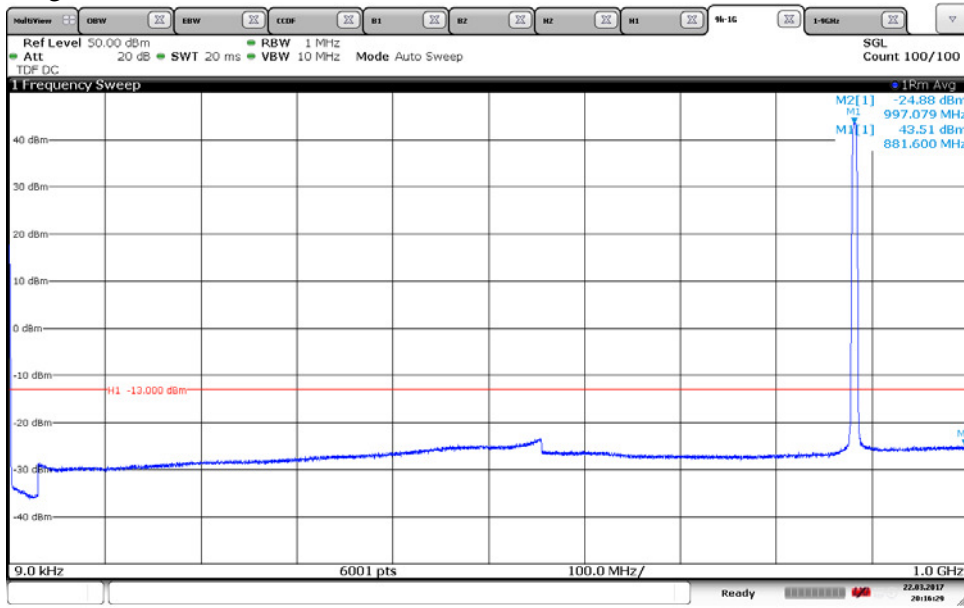

Diagram 3 b:



Appendix 5

Diagram 4 a:



20:16:30 22.03.2017

Diagram 4 b:

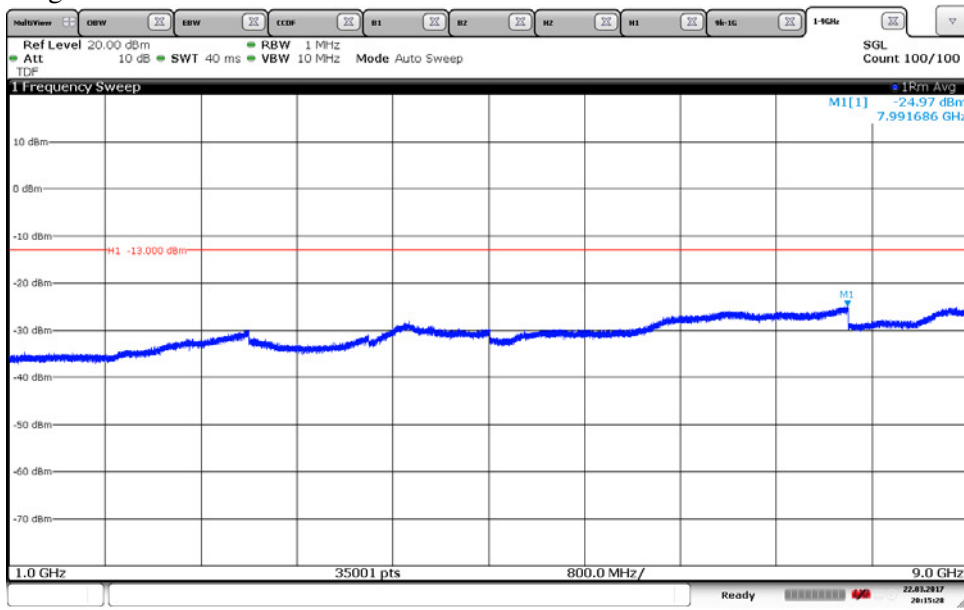

20:15:28 22.03.2017

Appendix 5

Diagram 5 a:

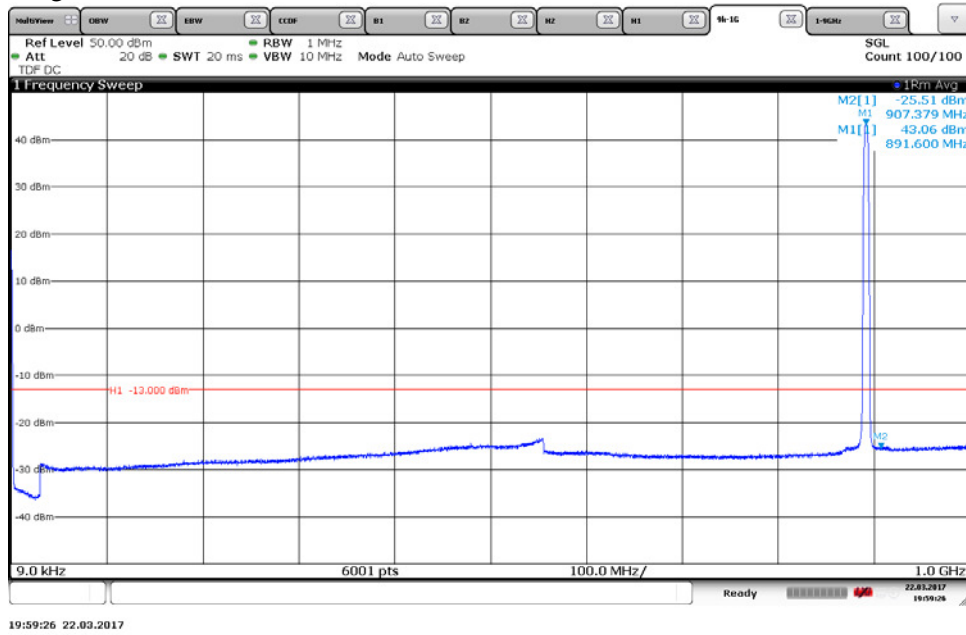
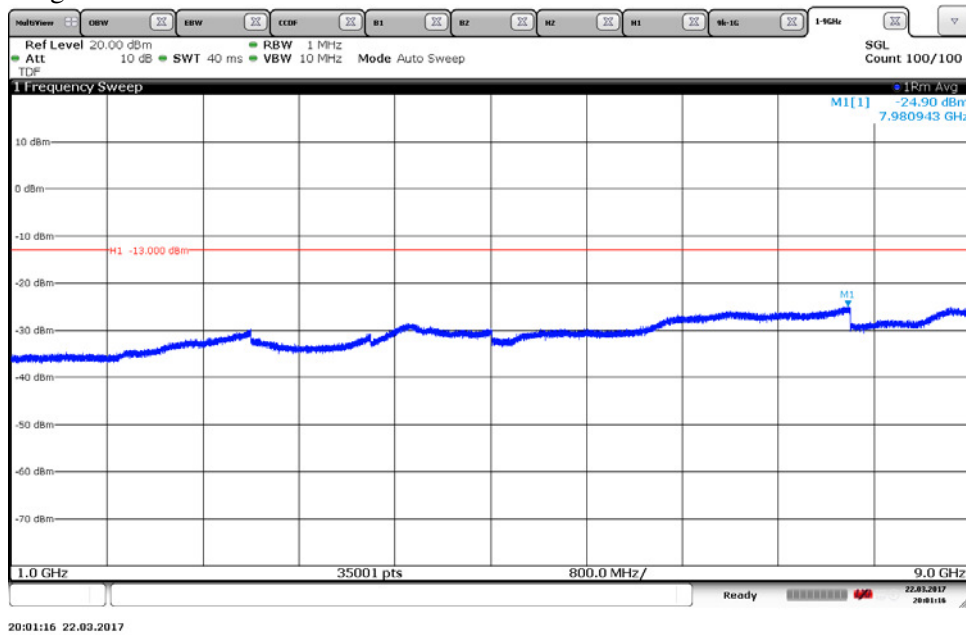

Diagram 5b:



Appendix 5

Diagram 6 a:

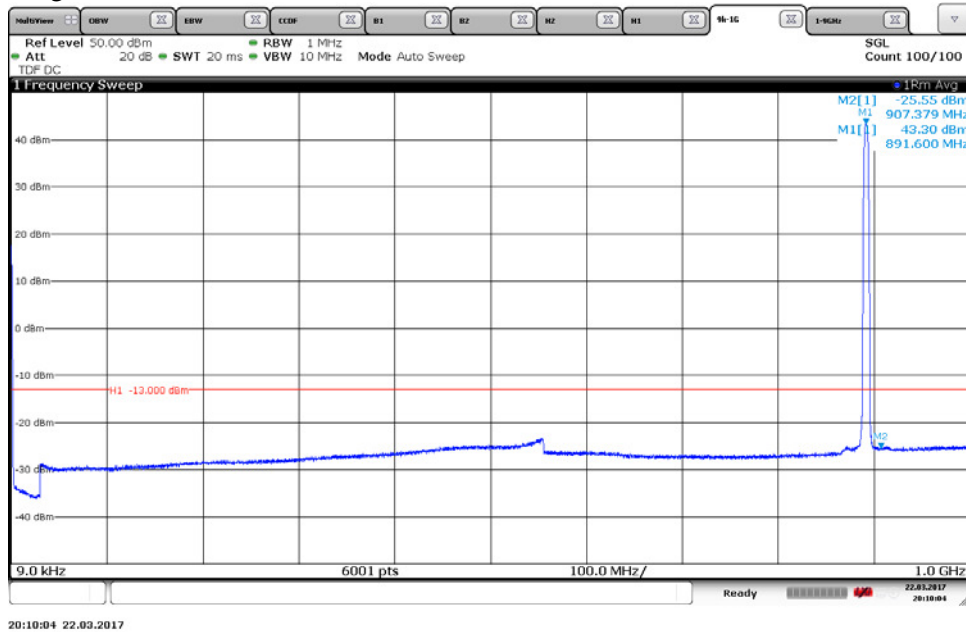
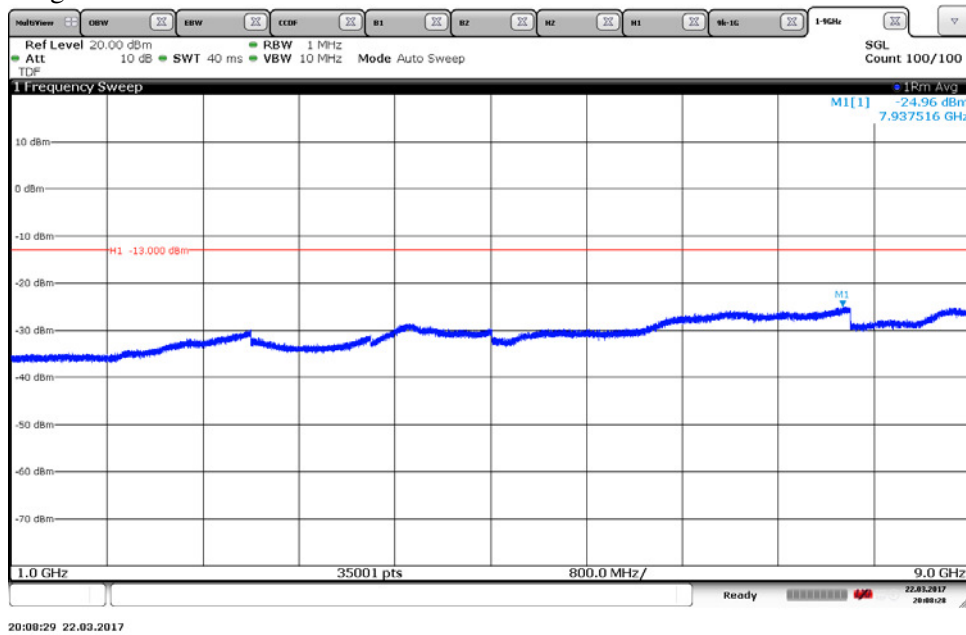
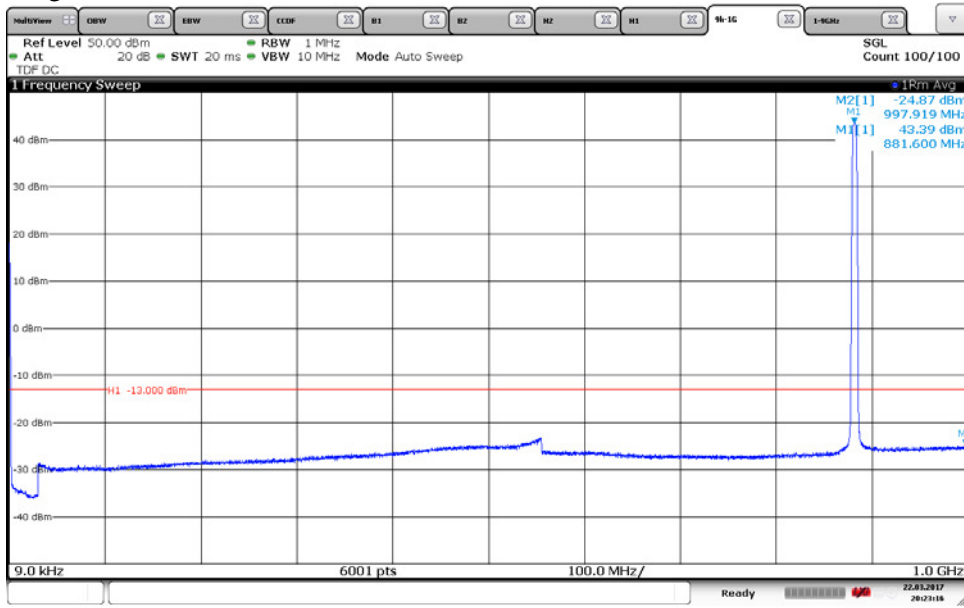

Diagram 6 b:



Appendix 5

Diagram 7 a:



20:23:17 22.03.2017

Diagram 7 b:

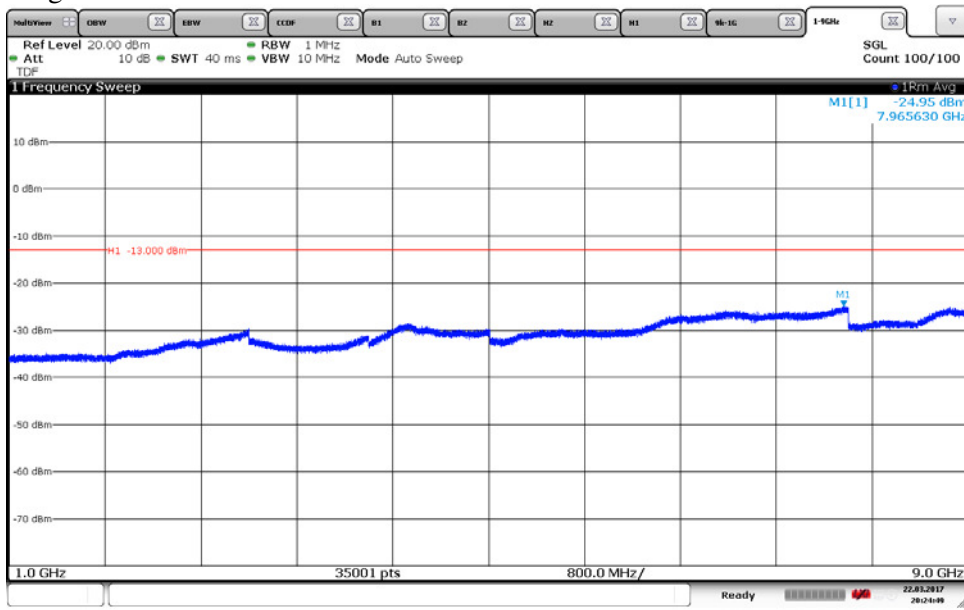

20:24:49 22.03.2017

Appendix 5

Diagram 8 a:

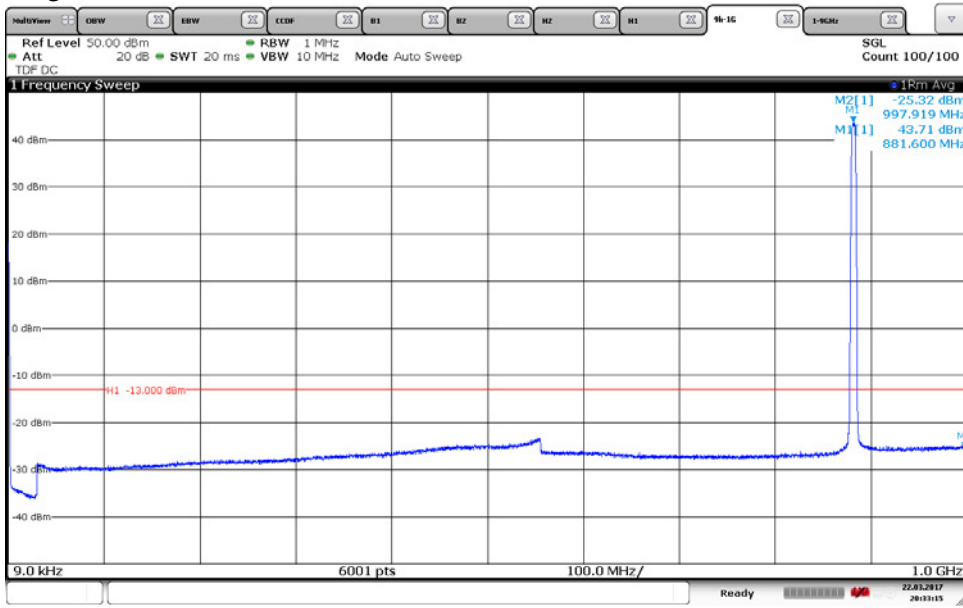

20:03:16 22.03.2017

Diagram 8 b:

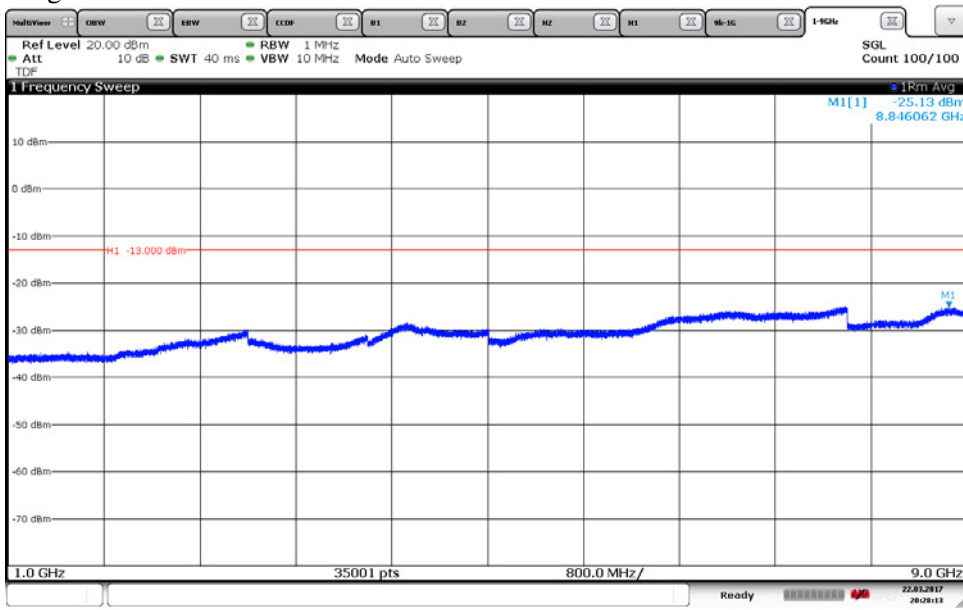

20:28:14 22.03.2017

Appendix 5

Diagram 9 a:

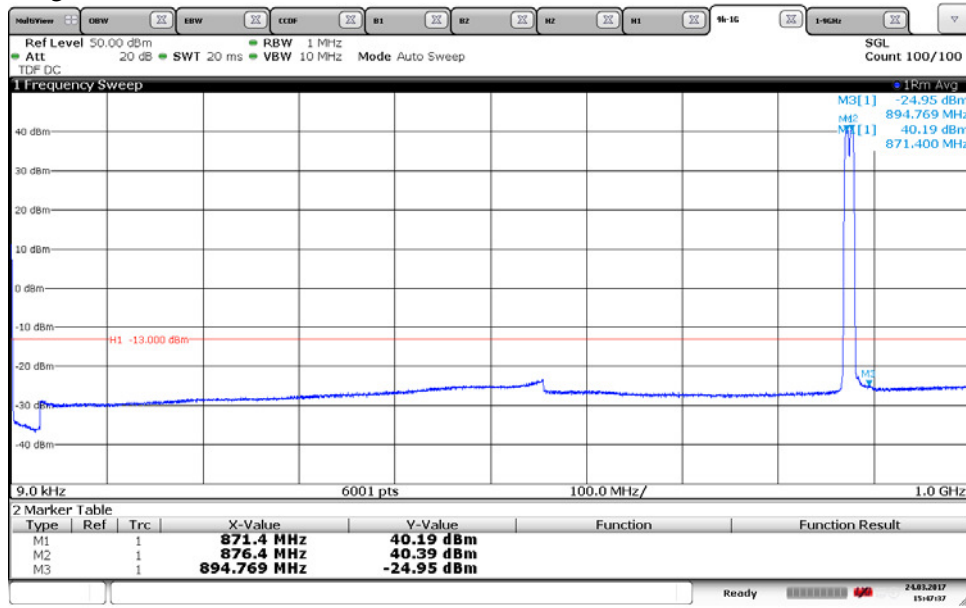

15:47:38 24.03.2017

Diagram 9 b:

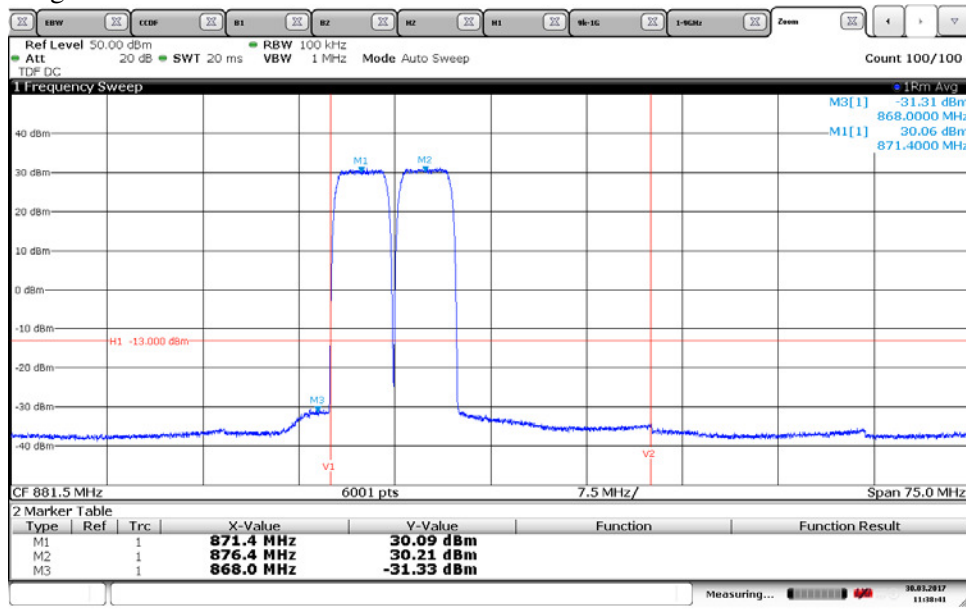

11:08:41 30.03.2017

Appendix 5

Diagram 9 c:

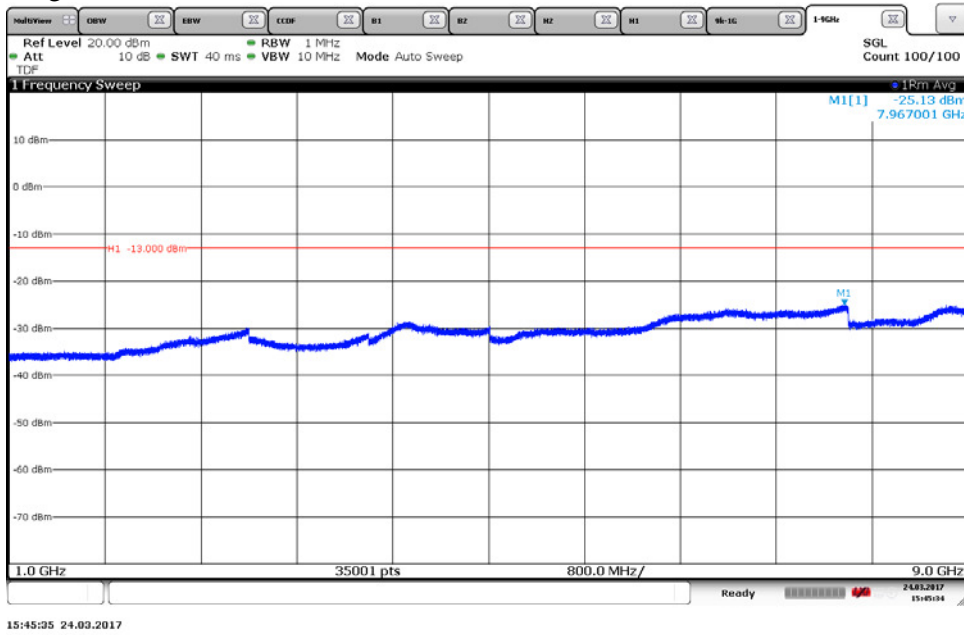

Appendix 5

Diagram 10 a:

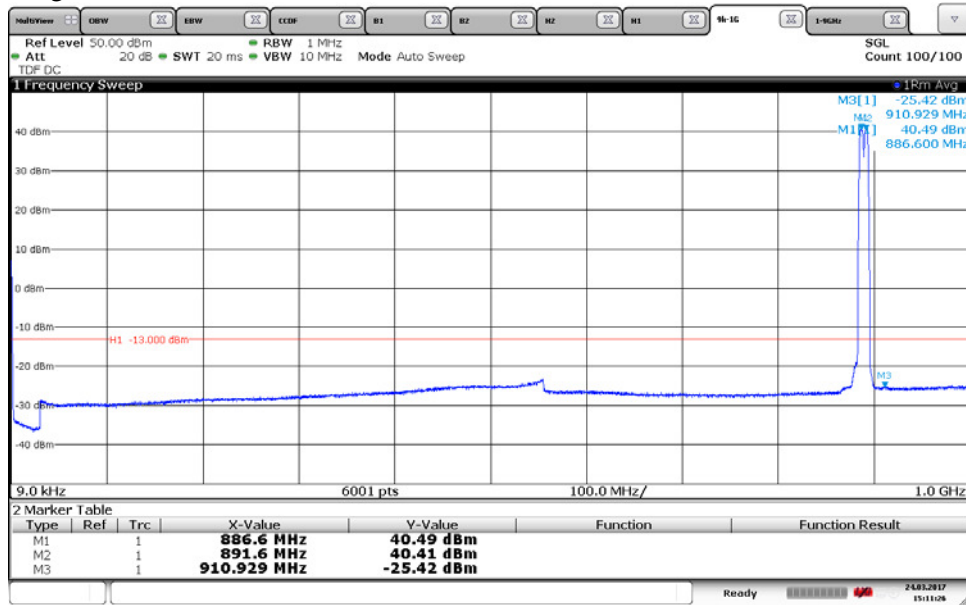

15:11:26 24.03.2017

Diagram 10 b:

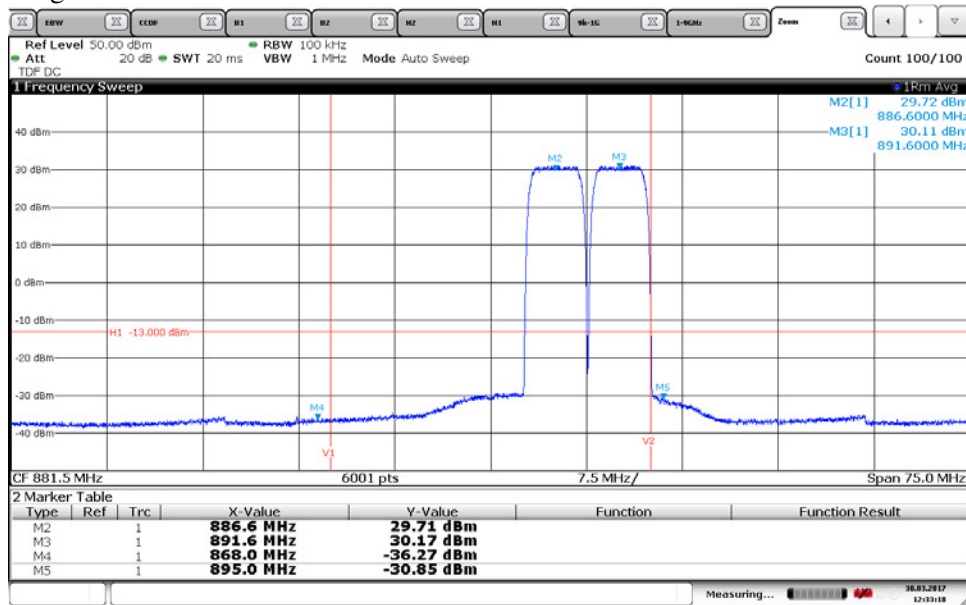

12:33:18 30.03.2017

Appendix 5

Diagram 10 c:

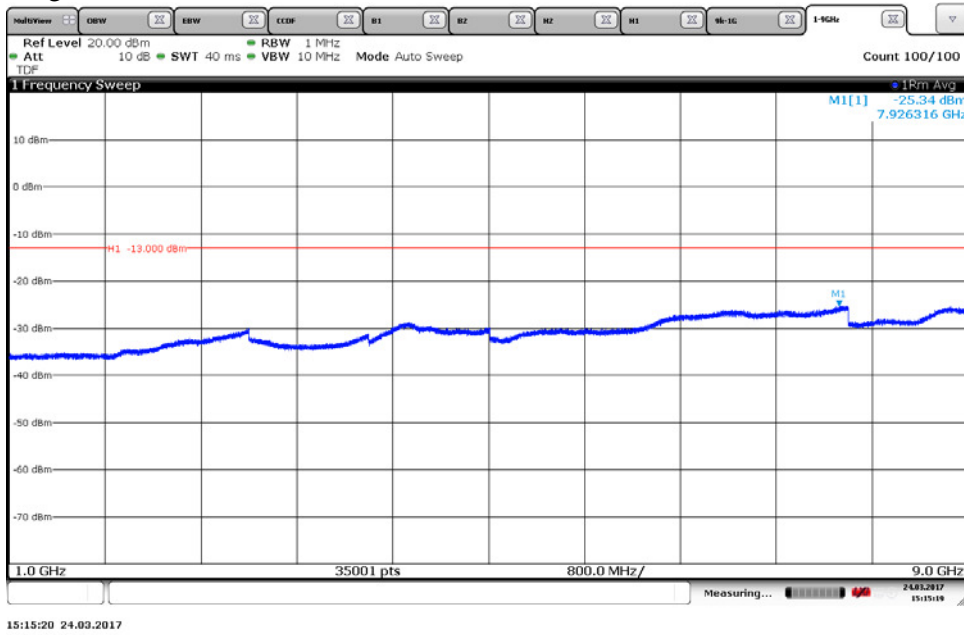

Appendix 5

Diagram 11 a:

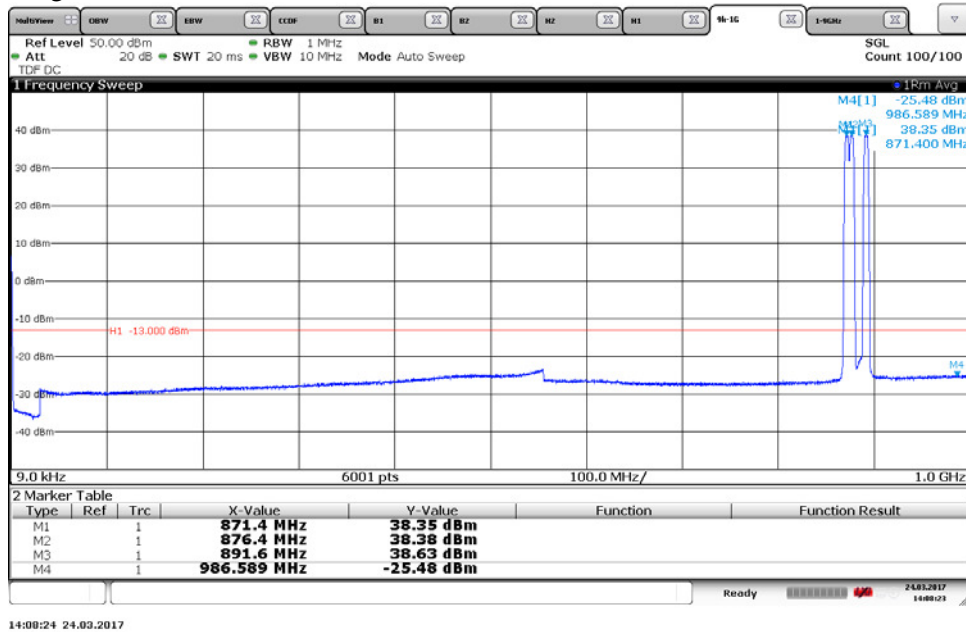
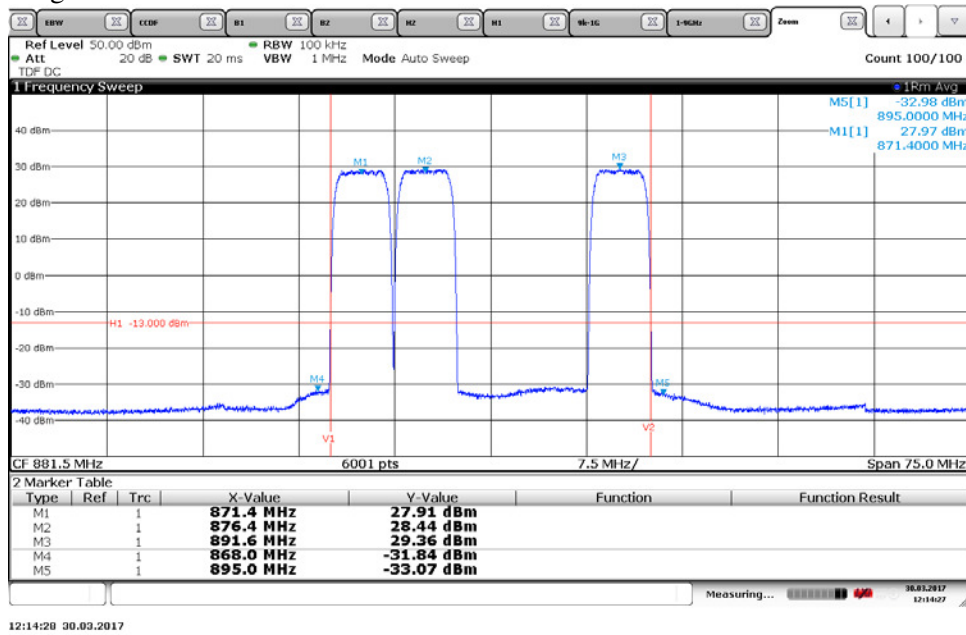
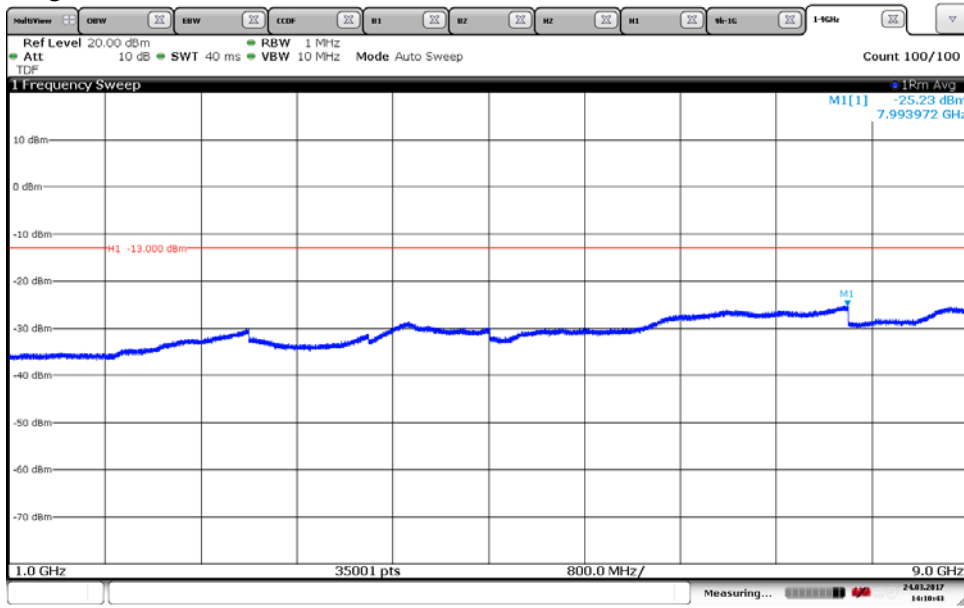

Diagram 11 b:



Appendix 5

Diagram 11 c:



14:10:43 24.05.2017

Appendix 5

Diagram 12 a:

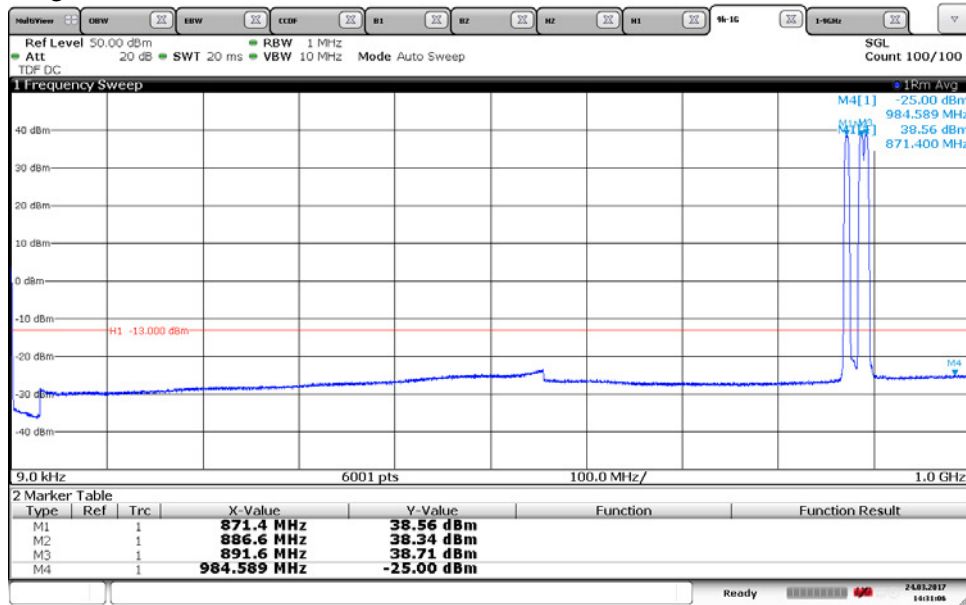

14:31:07 24.03.2017

Diagram 12 b:

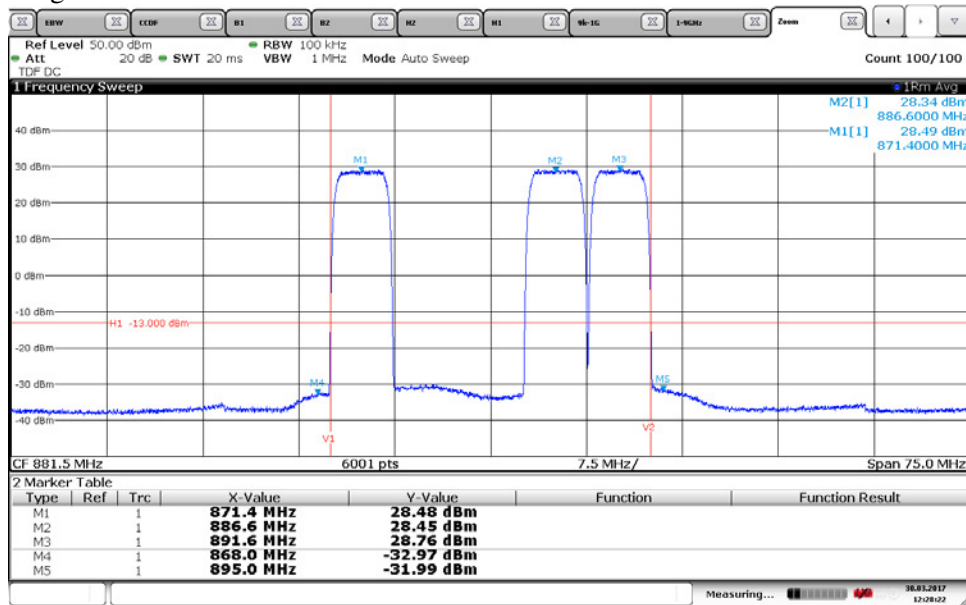

12:28:22 30.03.2017

Appendix 5

Diagram 12 c:

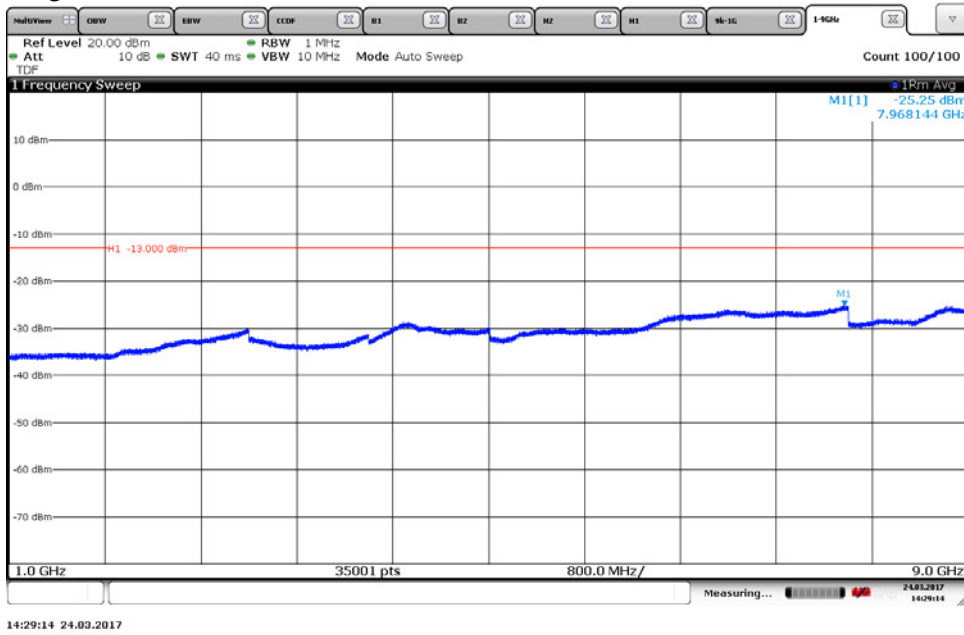

Appendix 5

Diagram 13 a:

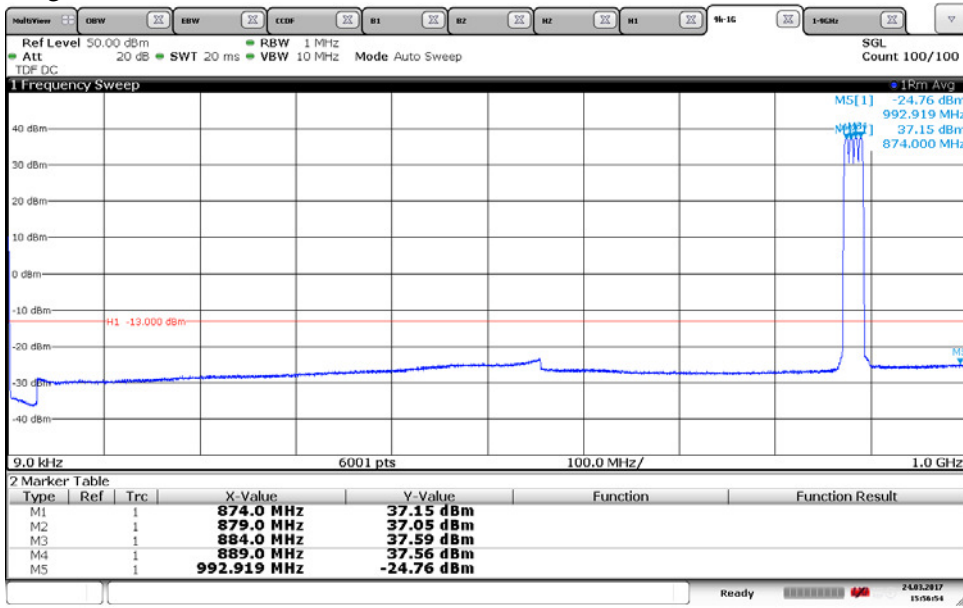

15:56:55 24.03.2017

Diagram 13 b:

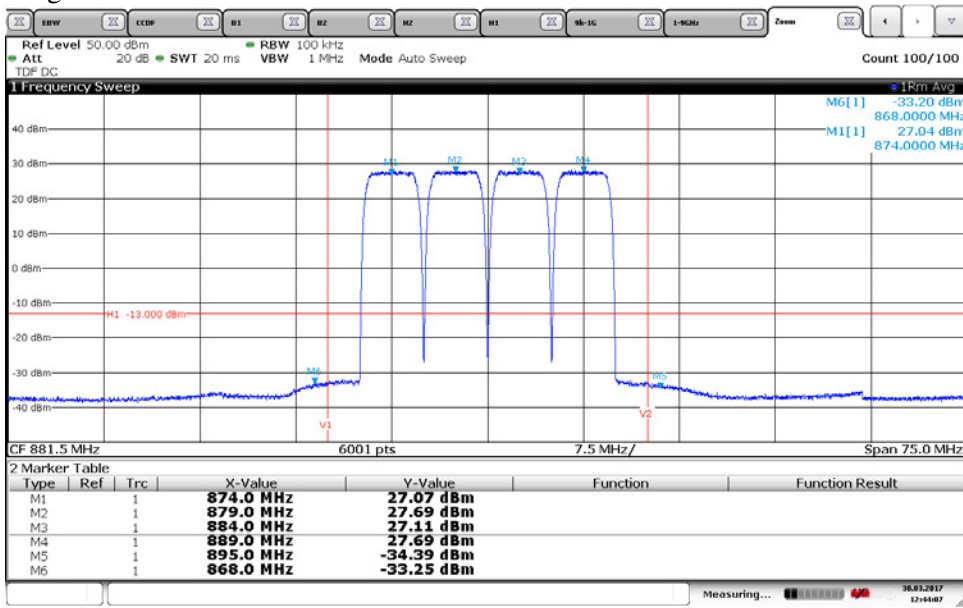

12:44:07 30.03.2017

Appendix 5

Diagram 13 c:

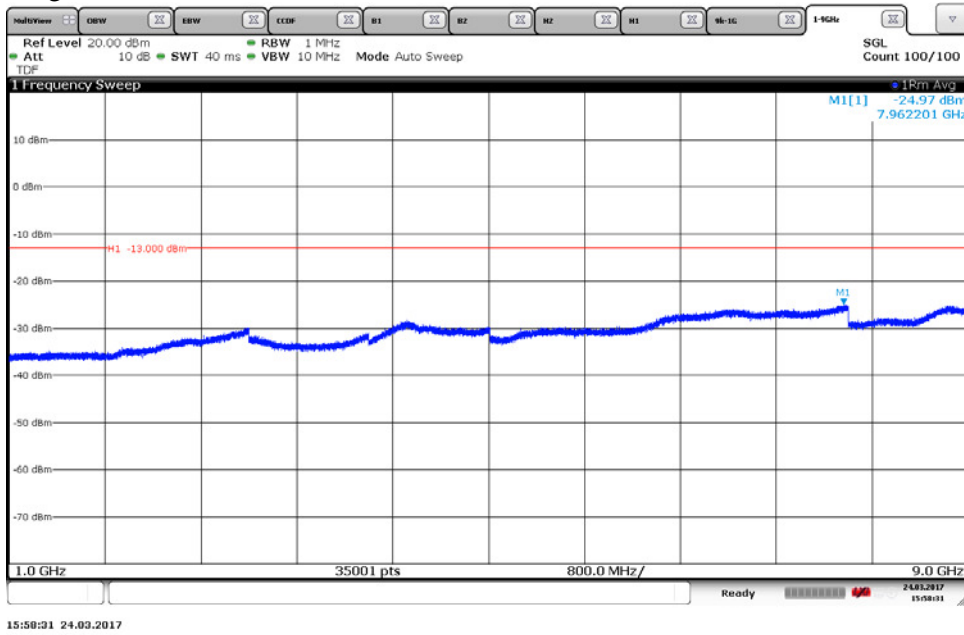

Appendix 6

Field strength of spurious radiation measurements according to 47 CFR 2.1053 / IC RSS-133 5.5

Date	Temperature	Humidity
2017-02-22	22 °C ± 3 °C	31 % ± 5 %
2017-02-24	22 °C ± 3 °C	25 % ± 5 %

The test sites are listed at FCC, Columbia with registration number: 93866. The test site complies with RSS-Gen, Industry Canada file no. 3482A-1.

The measurements were performed with both horizontal and vertical polarization of the antenna. The antenna distance was 3 m in the frequency range 30 MHz – 9 GHz.

The measurement was performed with a RBW of 1 MHz.

A propagation loss in free space was calculated. The used formula was

$$\gamma = 20 \log \left(\frac{4\pi D}{\lambda} \right), \gamma \text{ is the propagation loss and } D \text{ is the antenna distance.}$$

The measurement procedure was as the following:

1. A pre-measurement is performed with peak detector. For measurement < 1 GHz the test object was measured in eight directions with the antenna at three heights, 1.0 m, 1.5 m and 2.0. For measurements > 1 GHz the test object was measured in seventeen directions with the antenna at 1.0 m height.
2. Spurious radiation on frequencies closer than 20 dB to the limit in the pre-measurement is scanned 0-360 degrees and the antenna is scanned 1- 4 m for maximum response. The emission is then measured with the RMS detector and the RMS value is reported. Frequencies closer than 10 dB to the limit when measured with the RMS detector were measured with the substitution method according to ANSI/TIA/-603-D-2010.

Appendix 6

The test set-up during the spurious radiation measurements is shown in the picture below:

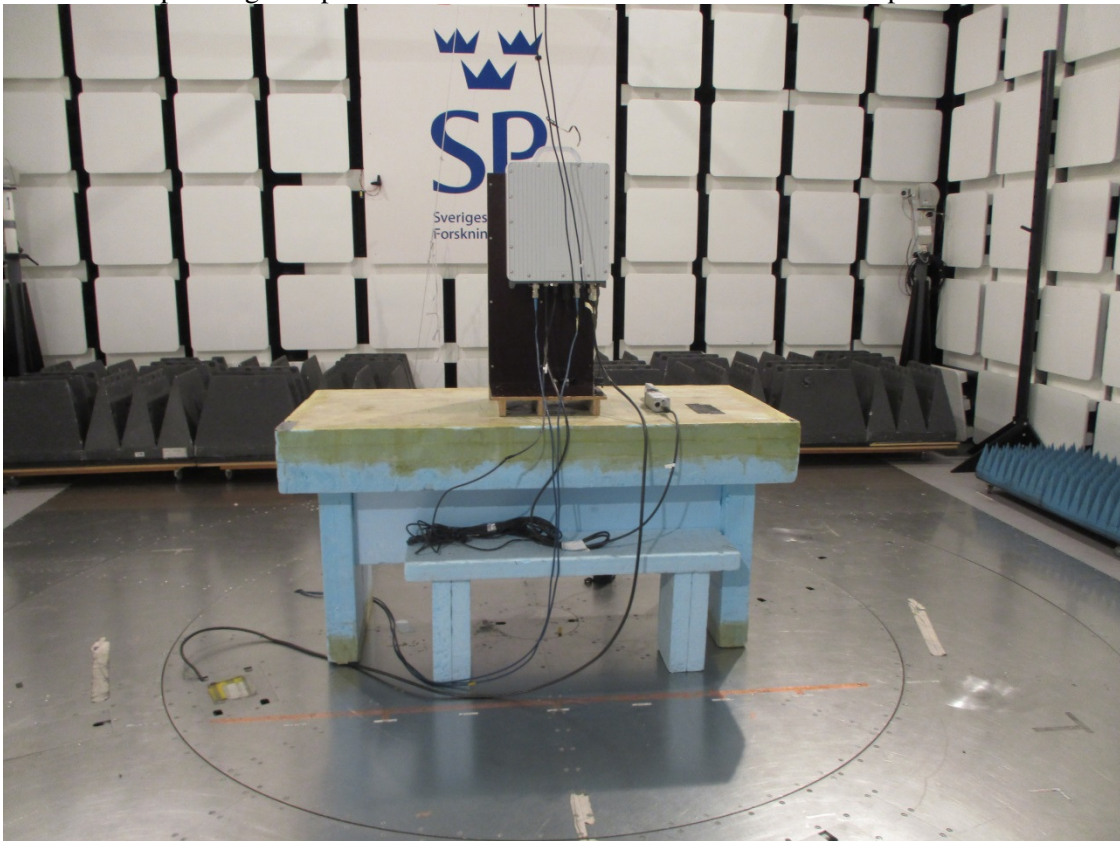

Measurement equipment

Measurement equipment	SP number
Semi anechoic chamber Tesla	503 881
R&S ESU 40	901 385
EMC 32 ver. 9.15.0	503 899
ETS Lindgren BiConiLog 3142E	BX61914
ETS Lindgren Horn Antenna 3115	502 175
µComp Nordic, Low Noise Amplifier	901 545
HP Filter 1-18 GHz	901 501
Temperature and humidity meter, Testo 625	504 188

Appendix 6

Test frequencies

WCDMA
Symbolic name
B_w
M_w
T_w
BIM_w
TIM_w

Results

representing worst case:

Single RAT WCDMA, TM1, symbolic name T_w , Diagram 1 a-b

Frequency (MHz)	Spurious emission level (dBm)	
	Vertical	Horizontal
30-9000	All emission > 20 dB below limit	All emission > 20 dB below limit

Measurement uncertainty: 3.1 dB

Limits

CFR 47 §22.917 and IC RSS-132 5.6

Outside a licensee's frequency band(s) of operation the power of any emission shall be attenuated below the transmitter power (P) by at least $43 + 10 \log (P)$ dB, resulting in a limit of -13 dBm.

Complies?	Yes
-----------	-----

Appendix 6

Diagram 1a:

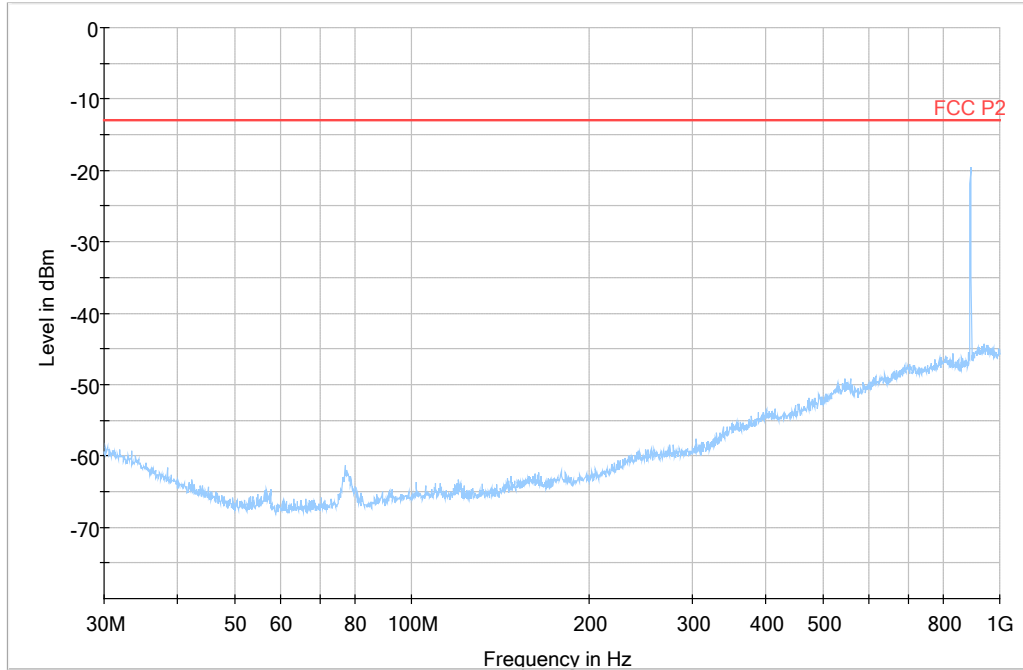

Note: The emission at 891.6 MHz is the carrier frequency and shall be ignored in the context.

Diagram 1b:

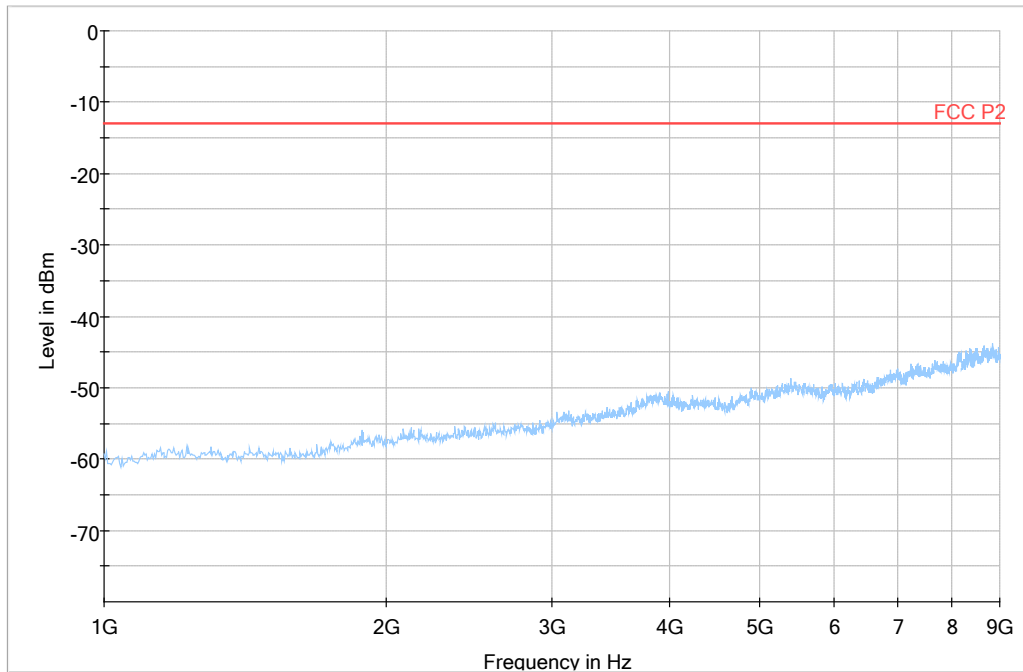

Appendix 7

Frequency stability measurements according to CFR 47 §22.355 , 2.1055 / IC RSS 132 5.3

Date	Temperature (test equipment)	Humidity (test equipment)
2017-04-06	22 °C ± 3 °C	24% ± 5 %
2017-04-07	24 °C ± 3 °C	29% ± 5 %

Test set-up and procedure

The measurement was made per 3GPP TS 25.141. The output was connected to a spectrum analyzer. The spectrum analyzer was connected to an external 10 MHz reference standard during the measurements.

Measurement equipment	SP number
R&S FSQ	504 143
EAB RF attenuator	-
Temperature Chamber	501 031
Testo 635, temperature and humidity meter	504 203
Multimeter Fluke 87	502 190

Appendix 7

Results

Nominal Voltage: -48 V DC

Maximum output power at mid channel (M)

Channel Bandwidth: 5MHz

Test conditions		Frequency error (Hz)
Supply voltage DC (V)	T (°C)	TM1
-48.0	+20	+3
-55.2	+20	+3
-40.8	+20	+4
-48.0	+30	+8
-48.0	+40	+5
-48.0	+50	+10
-48.0	+10	-3
-48.0	0	3
-48.0	-10	3
-48.0	-20	4
-48.0	-30	-3
Maximum freq. error (Hz)		10
Measurement uncertainty		$< \pm 1 \times 10^{-7}$

Remark

It was deemed sufficient to test one combination of TX frequency, channel bandwidth configuration and test model (modulation), as all combinations share a common internal reference from which the TX frequency derives.

Appendix 7

Limits

Limit according to:

3GPP TS 25.141:

The frequency error shall be within $\pm 0.05 \text{ PPM} \pm 12 \text{ Hz}$ ($\pm 44.08\text{Hz}$).

§22.355

The frequency stability shall be within $\pm 1.5 \text{ ppm}$ ($\pm 1322.4 \text{ Hz}$).

RSS-132 5.3 Frequency:

The carrier frequency shall not depart from the reference frequency in excess of $\pm 1.5 \text{ ppm}$ ($\pm 1322.4 \text{ Hz}$) for base stations when tested to the temperature and supply voltage variations specified in RSS-Gen.

Complies?	Yes
-----------	-----

Appendix 8

External photos

Front side



Rear side



Left side

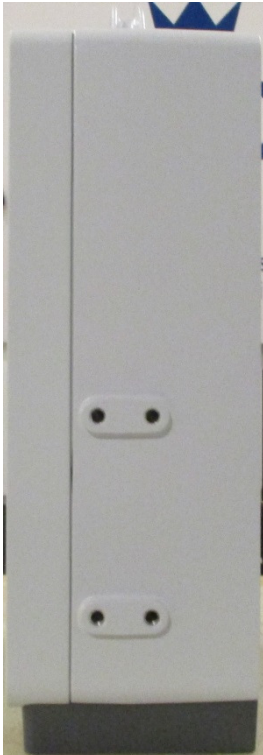

Right side



Appendix 8

Top side



Bottom side



Test object label:

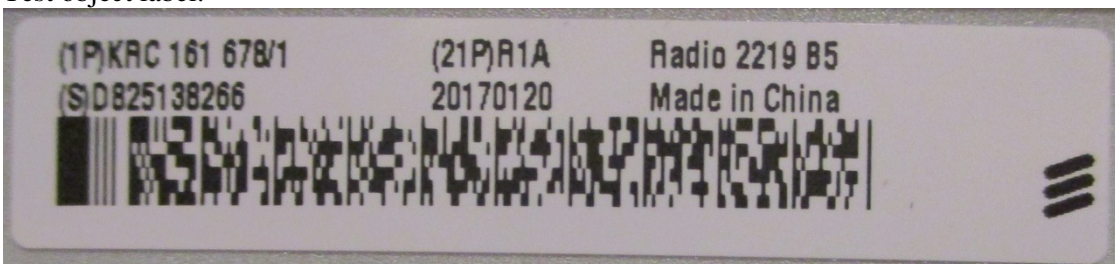

SFP module:

