

# Quick start manual

## VP1801 Reader Motor Control

THIS SHEET IS ONLY INTENDED AS QUICK START. SEE SERVICE MANUAL FOR DETAILED INSTRUCTIONS

The VP1801 is a Velos component that is used to identify animals for feeding, weighing, milking, heat detection etc. The VP1801 is equipped with an internal switch to support a double Ethernet connection (web interface ready) and the existing VC3 interface. The Ethernet channel is used for the main functionality and communication like software updates and service. An extra communication channel is available for the VC3 systems. The function is the same as the existing Single Feeder. The VP1801 can be installed in a V-box.

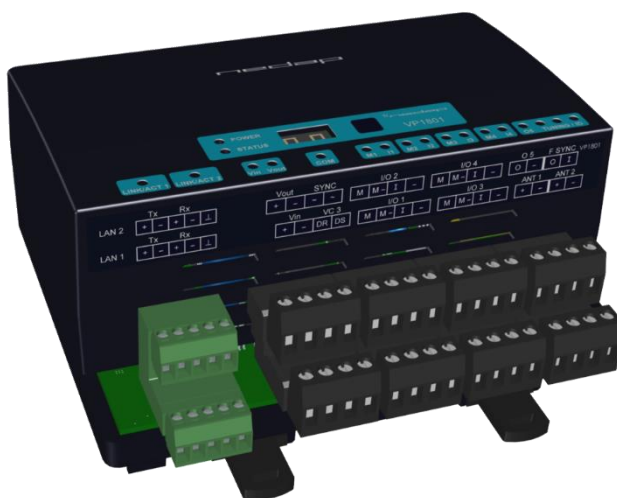

A VP1801 can be connected in different ways:

- To a shielded Ethernet cable and controlled by a switch or VPU:

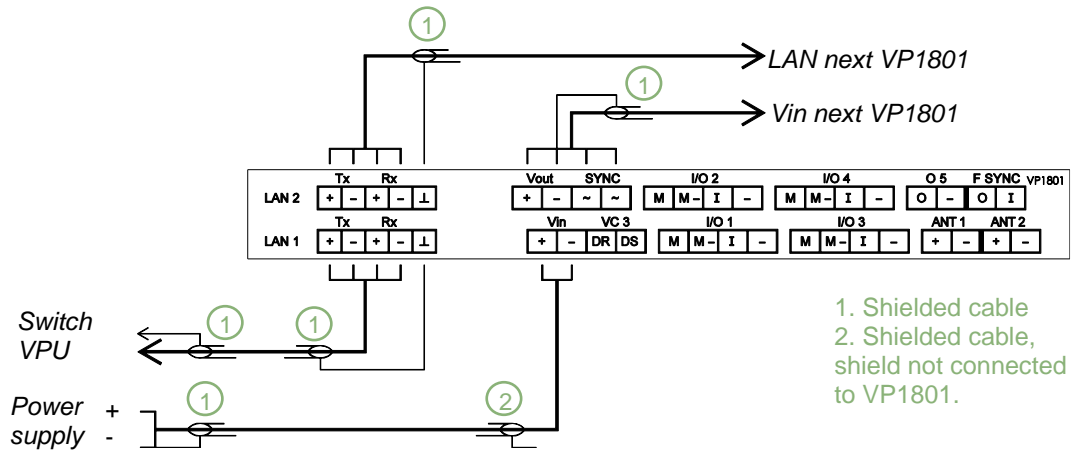

When connecting the Ethernet cable, the VP1801 automatically detects TX/RX , plus and minus connections, and switches to the correct connection.

- To a shielded four wire cable and controlled by a VC3 host:

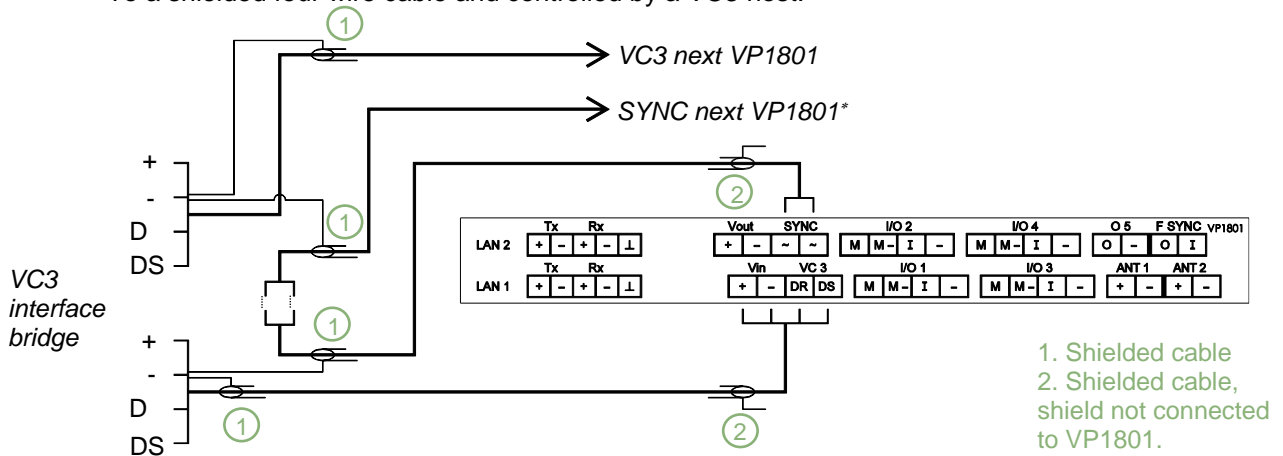

\* The SYNC connection is necessary for HDX ISO synchronization between other readers. For FDX a SYNC connection is possible, but not necessary if only one antenna is used. When two antennas are used the SYNC connection is always needed, even when FDX-only (no ISO) mode is enabled. The switching between the two antennas uses the ISO timing.

The F SYNC connection is necessary when the distance between two antennas is  $\leq 3$  m. Connect the F SYNC as shown in the picture below.

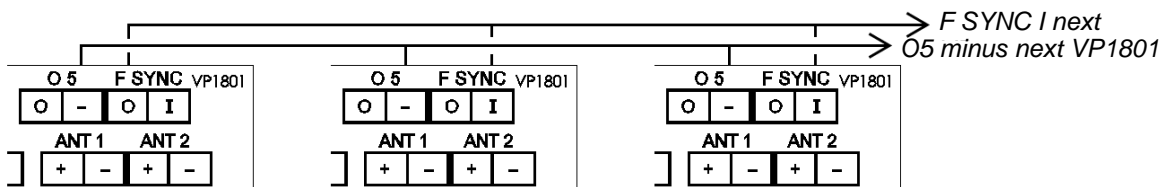

## Installation steps Ethernet

---

- Step 1** Install the VP1801 in the V-box (or other box). See the manual of the relevant equipment (feeding station, separation unit etc.) where is indicated how to install the V-box.
- Step 2** Connect all required wiring. See the manual of the relevant equipment and the manual of the required behaviour component.
- Step 3** Power up and check the LED indicators, see also the overview on page 9.
- Step 4** When the system is equipped with the auto-addressing function, the host computer requires the address. Select "Sp > y" in the display menu of the VP1801, see page 6. Go to **Step 8**.
- Step 5** When auto-addressing is not available, set the required address manually via "Ad" in the display menu, see page 6.
- Step 6** Check the ip settings via "IP" in the display menu, see page 6. Default DHCP is on. When DHCP must be switched off, set the required ip address settings via "IP" in the display menu. When DHCP is switched off, the default IP address is 192.168.1.100.
- Step 7** Check the antenna tuning. Select "HF > H1 > tu" in the display menu to start and enable autotune, see page 7. If external manual adjustment is used (e.g. adjustable antenna-trafo), select "AA" in the display menu, see page 7.
- Step 8** Test the functioning. See manual of the behaviour component. In case of malfunctioning of the connected devices like sensors, motors, execute a test with options from menu option "It", see page 7.

## Installation steps VC3

---

- Step 1** Install the VP1801 in the V-box (or other box). See the manual of the relevant equipment (feeder, separation unit etc.) where is indicated how to install the V-box.
- Step 2** Connect all required wiring. See the manual of the relevant VC3 application.
- Step 3** Power up and check the LED indicators, see also overview on page 9.
- Step 4** Set the required VC4 address via "CO > SA" in the display menu, see page 8.
- Step 5** Select the VC3 application and other relevant VC3 settings via "CO > AP", see page 8.
- Step 6** Check the antenna tuning. Select "HF > H1 > tu" in the display menu to start and enable autotune, see page 7. If external manual adjustment is used (e.g. adjustable antenna-trafo), select "AA" in the display menu, see page 7.
- Step 7** Test the functioning. See the manual of the VC3 application. In case of malfunctioning of the connected devices like sensors or valves, execute a test with options from menu option "It", see page 7.

## Connections

See the manual of the concerning behaviour component for a detailed overview of the connections. O5 is default controlled by the identification process of the VP1801 itself, and can be overruled by the behaviour component. If the V-box has a signal light, connect it default to O5.

When connecting the Ethernet cable, the VP1801 automatically detects TX/RX , plus and minus connections, and switches to the correct connection.

## Details VP1801 inputs and outputs

LAN	<b>Tx +</b>	Transmit (shielded CAT5E FTP (Foiled Twister Pair, also called S/UTP) stranded AWG26 or AWG24 (preferred)). Cable length max. 100 m.
	<b>Tx -</b>	Transmit
	<b>Rx +</b>	Receive
	<b>Rx -</b>	Receive
	⊥	Ethernet shielding
Vin	<b>+</b>	Input voltage 25 VDC, +20% -20%
	<b>-</b>	Minus
Vout	<b>+</b>	Output (max 4A)
	<b>-</b>	Minus
VC3	<b>DR</b>	VC3 data receive. Shielded cable, cable length max. 40 m.
	<b>DS</b>	VC3 data send
SYNC	<b>~</b>	Synchronisation for HDX or 2 installed antennas, AC (no plus or minus, cable must be shielded twisted pair). Max. 20 devices parallel, total cable length max. 300 m.
	<b>~</b>	See above
I/O 1 .. 4	<b>M</b>	Motor output or normal output max 3.5A as total current for the 4 outputs. Cable length max. 3 m.
	<b>M-</b>	Minus for motor output or normal output
	<b>I</b>	Input of motor or normal input
	<b>-</b>	Minus for motor input or normal input
O5	<b>O</b>	Output max 400mA continue. Cable length max. 3 m.
	<b>-</b>	Minus for output (O) and minus input (I)
ANT 1	<b>+</b>	Antenna 1 (core of coax). Cable length max. 10 m.
	<b>-</b>	Minus for antenna 1 (shield of coax)
ANT 2	<b>+</b>	Antenna 2 (core of coax). Cable length max. 10 m.
	<b>-</b>	Minus for antenna 2 (shield of coax)
F SYNC	<b>O</b>	Output for FDX synchronization of the antenna signal phase (core of coax: shield connected with minus of O5). Cable length max. 3 m.
	<b>I</b>	Input for synchronization of antenna signal phase (core of coax: shield connected with minus of O5). Cable length max. 3 m.

## Antennas

The VP1801 has two antenna connections and one internal reader. When two antennas are connected, the used application determines if the second antenna is used or not. In case the reader has to control both antennas, the reader switches fast between the two antennas in a smart way. That means the identification time is divided over the two antennas with a switching time that can vary between 24ms and 120ms in case both antennas have the same priority. Priority is controlled by Ethernet control like a behaviour component.

## Autotune

The VP1801 is equipped with the autotune function. This means it can tune an antenna by itself due to an integrated internal tuning-circuit on board. Tuning can be started with the display menu "HF > H1 > tu", remote from an external command over Ethernet or with the web-interface of the VP1801.



### Important!

Autotune works with all Nedap antennas. In case external antenna adjustment is used (e.g. adjustable antenna-trafo), the autotune function must be switched off to achieve the maximum reading distance. This can be done via "HF > HI > AA" in the menu display of the VP1801, see page 6. Then the autotune function is disabled until it is started again with the display menu "HF > H1 > tu".

# Display menu

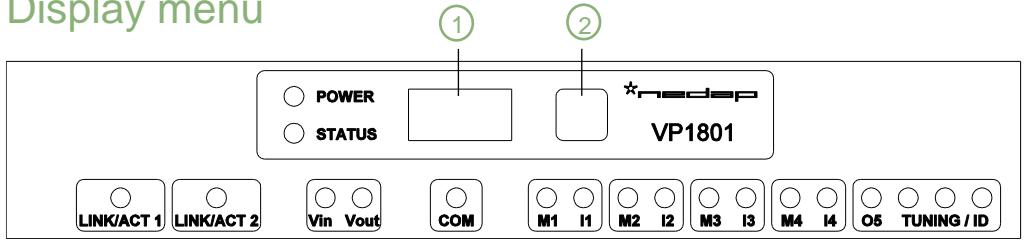

1. Display  
2. Push button

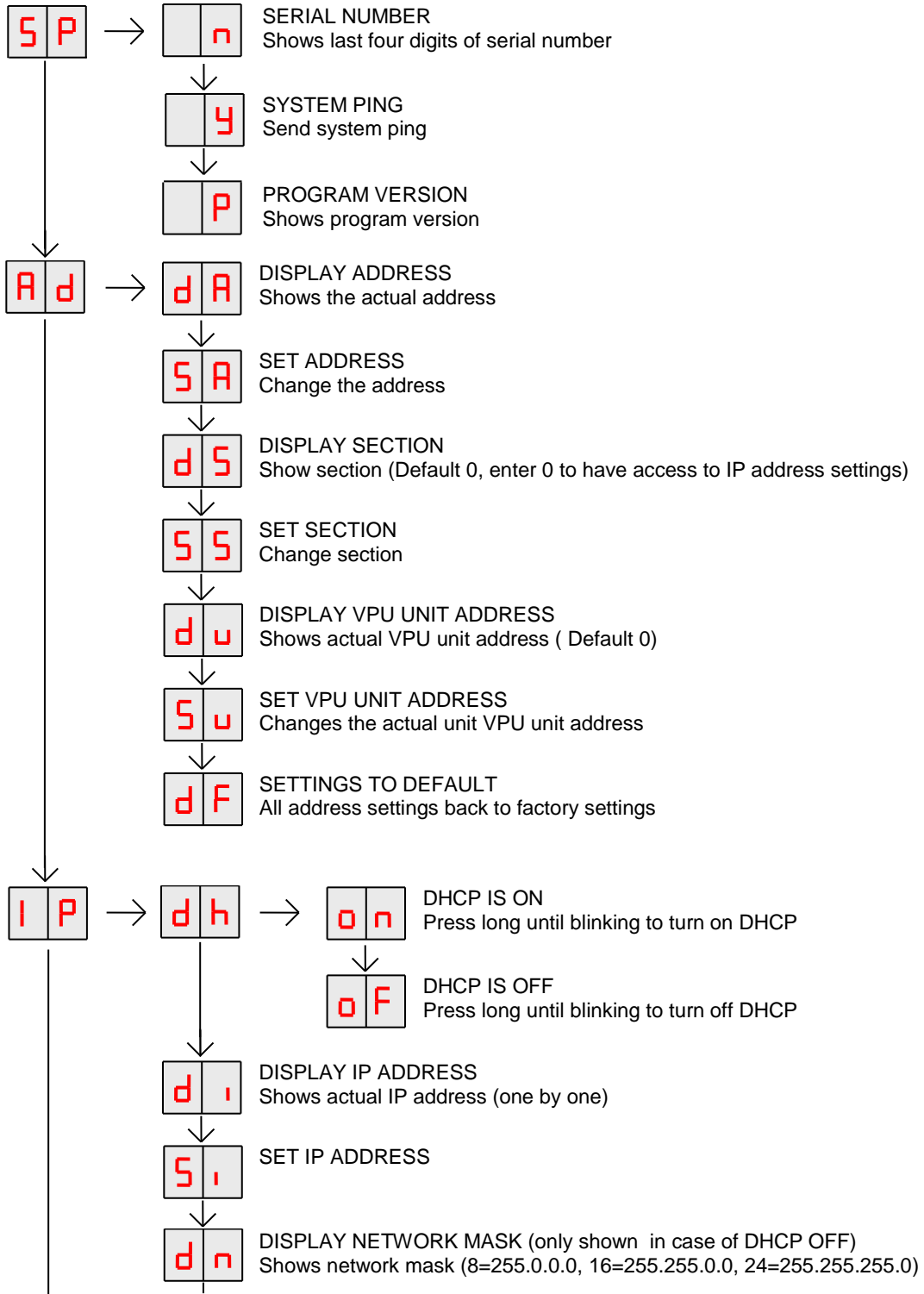

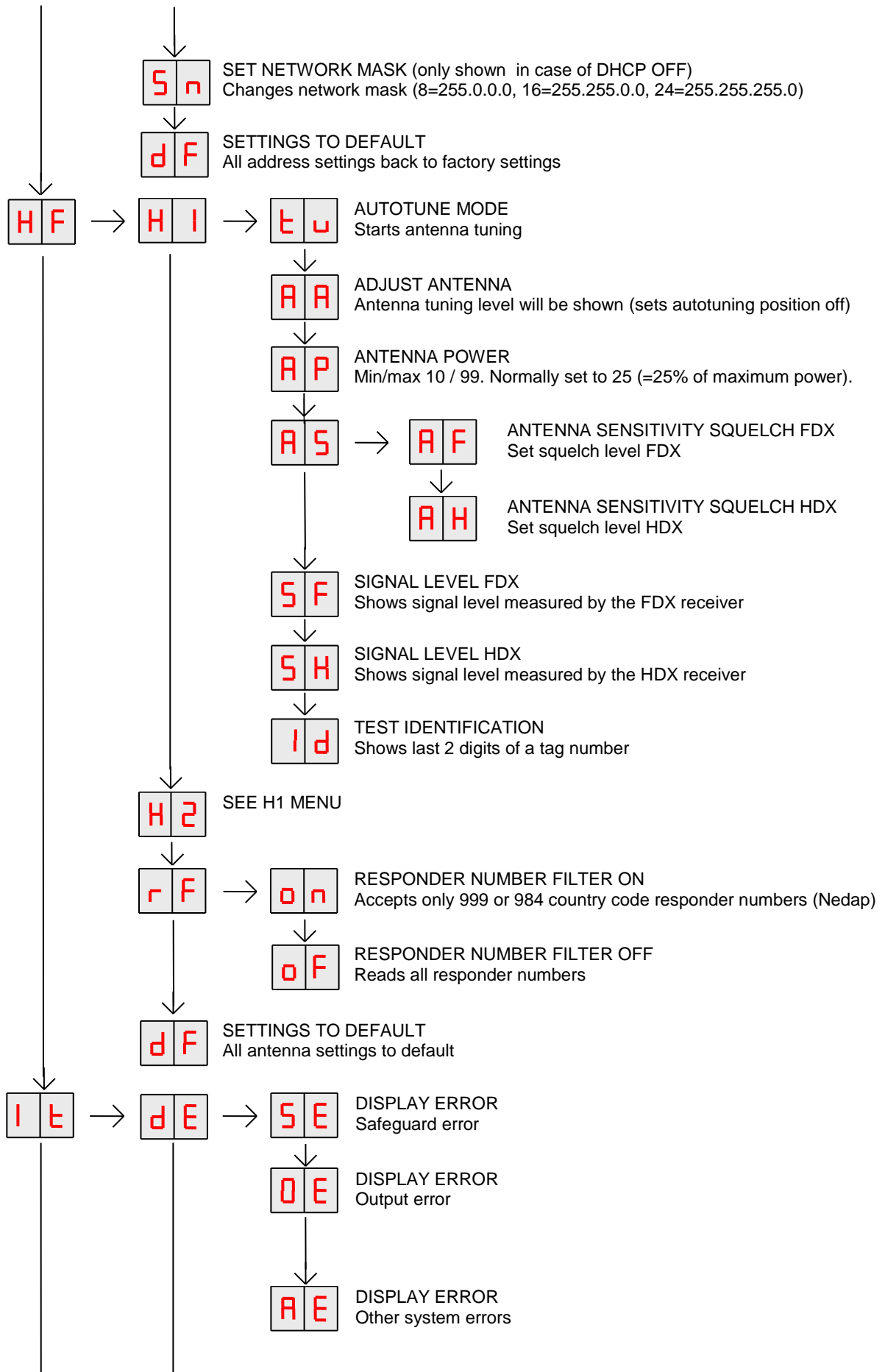

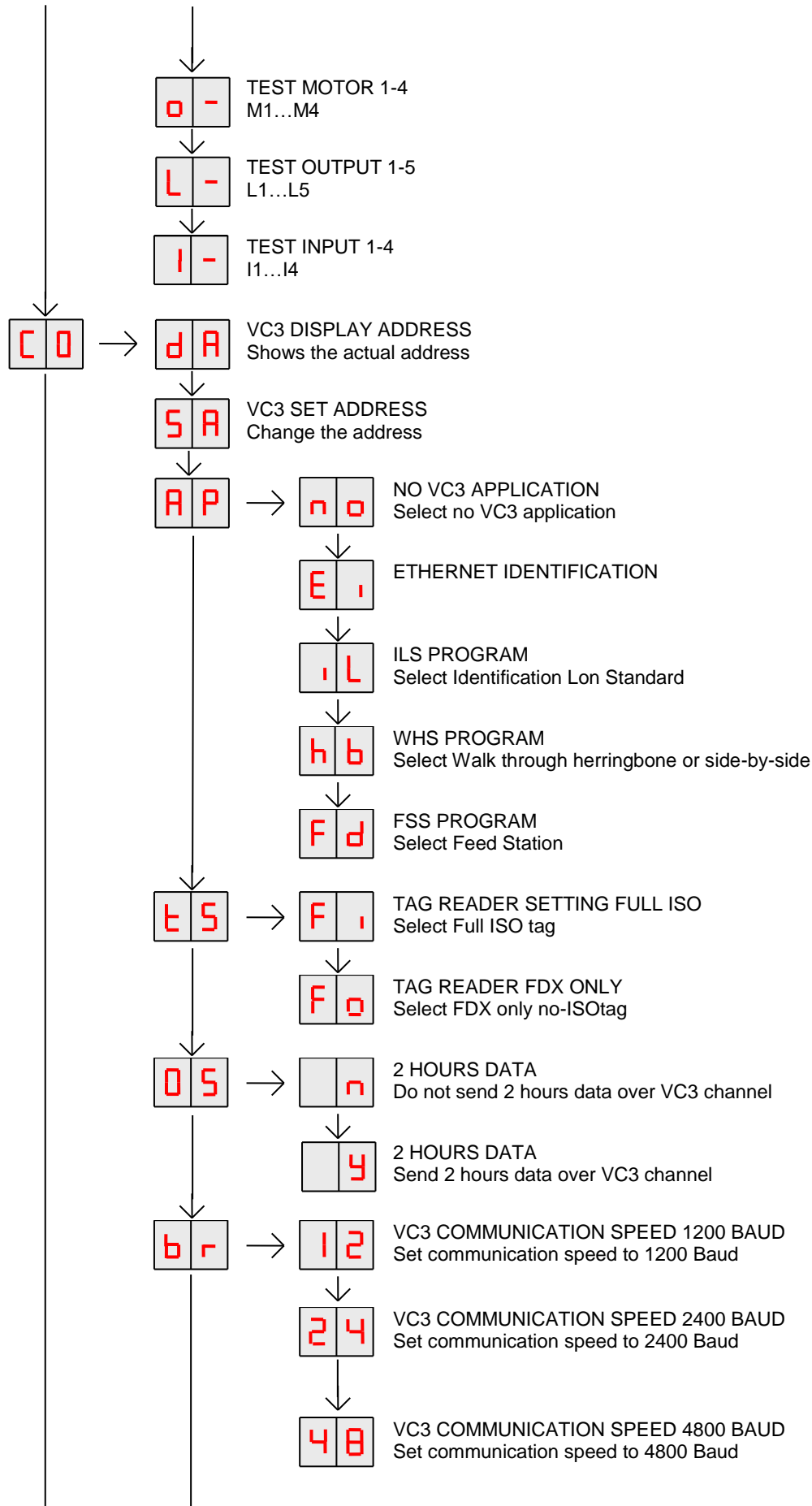

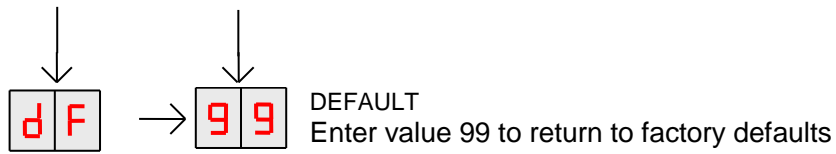

## How to use the display and push button

Activate the menu	press short on the button, the display menu is shown
Scroll down	press short
Select	press until blinking
Change and store	select item to change, open item by pressing till blinking, change by pressing short, store by pressing to blinking
Check a setting	select the item to check, press until blinking, first value shown is actual setting



## LED indicators

- = OK  
● = not OK

<b>POWER</b>	<span style="color: green;">●</span>	Green on	Power on
	○	off	No power
<b>STATUS</b>	<span style="color: blue;">●</span>	Slow blinking Fast blinking Short blinking Long blinking	Operating ok Downloading or error during download Not connected to the host Connection established to the host
<b>Display</b>	on	Address indicated	No communication
	off		Communication status ok
<b>LINK/ACT</b>	<span style="color: green;">●</span>	Green on	Connection ok
	<span style="color: green;">●</span>	Green blinking	Data transmit
<b>V in</b>	<span style="color: green;">●</span>	Green on	Input power applied
	○	Off	No power
	<span style="color: red;">●</span>	Red	Error, plus and minus swapped
<b>V out</b>	<span style="color: green;">●</span>	Green on	Output power
	○	off	No power
	<span style="color: orange;">●</span>	Orange blinking	Low power
	<span style="color: red;">●</span>	Red blinking	Error, plus and minus swapped
<b>COM</b>	<span style="color: green;">●</span>	Green on	Connection VC3 channel
	<span style="color: green;">●</span>	Green blinking	Data transmit VC3 channel
<b>M1...M4</b>	<span style="color: green;">●</span>	Green on	Output on
	○	Off	Output off
	<span style="color: red;">●</span>	Red blinking	Output error
<b>I1...I4</b>	<span style="color: green;">●</span>	Green on	Input contact closed
	○	Off	Input contact open
<b>O5</b>	<span style="color: green;">●</span>	Green on	Output on
	○	Off	Output off
	<span style="color: red;">●</span>	Red blinking	Output error
<b>Tuning/ID</b>	○ <span style="color: red;">●</span> ○	Red blinking	Tuning
<b>One antenna</b>	○ <span style="color: green;">●</span> ○	Green on	Antenna tuning ok
	<span style="color: red;">●</span> ○ ○	Red on	Antenna not tuned
	<span style="color: red;">●</span> ○ <span style="color: red;">●</span>	Red blinking	No antenna connected or low antenna signal
	○ ○ ○	Off	Antenna off
<b>Two antennas *</b>	<span style="color: green;">●</span> ○ ○	Green on	Antenna 1 tuning ok
	<span style="color: green;">●</span> ○ ○	Green blinking	Antenna 1 tag identified
	<span style="color: red;">●</span> ○ ○	Red on	Antenna 1 not tuned
	<span style="color: red;">●</span> ○ ○	Red/green blinking	Antenna 1 tag identified + not tuned
	○ ○ ○	Off	Antenna 1 off

\* The described LED indicators apply to antenna 1 (left LED indicator). The same indicators are used for antenna 2 (right LED indicator).

## Specifications VP 1801

<b>Dimensions</b>	143 x 120 x 68 mm LxWxH (excluding mounting rail). Weight ± 430 gr
<b>Power</b>	Input voltage 25 VDC, +20% -20% Max current consumption without connected I/O = 300 mA Maximum (total) motor output current 3,5 A Protected against reverse connection power supply
<b>Software</b>	Check for available updates
<b>Inputs I1 – I4</b>	0V – 35V DC Suitable for NPN sensors
<b>Outputs O1 – O4</b>	In total max. 3.5 Amp continue, short-circuiting and overload protected
<b>O5</b>	Max. 400mA continue, short-circuiting and overload protected
<b>V out</b>	Max. 4A continue, short-circuiting and overload protected
<b>Synchronization</b>	Synchronization according to ISO 11785
<b>Environment</b>	Temperature: Operating: -10 – 50 °C, Storage: -25 – 50 °C Relative humidity: 10 – 93% non-condensing Maximum noise level: 10 dBµA/m quasi peak, according CISPR 16-1-1 Conducted noise: according EN55022
<b>IP class</b>	IP 30. When installed in V-box IP 65 (cover and cables installed correctly !)

*Always use a NEDAP power supply. The Nedap guarantee-regulations are only valid when is installed as indicated in this manual. Install data cables at a safe distance from (high) powered cables. For more detailed information contact your local Nedap supplier or check the internet site.*

Hereby, Nedap N.V. declares that the subject equipment is in compliance with the Directives 2014/53/EU (Radio Equipment Directive) and 2011/65/EU (restriction of the use of certain hazardous substances). The full text of the EU declaration of conformity is available at the Nedap Livestock Management Business Portal.

**Model** : VP1801B  
**FCC ID** : CGDVP1801  
**IC** : 1444A-VP1801

### FCC and IC Compliance statement

This device complies with part 15 of the FCC Rules and to RSS of Industry Canada. Operation is subject to the following two conditions:

- (1) this device may not cause harmful interference, and
- (2) this device must accept any interference received, including interference that may cause undesired operation.

Changes or modifications not expressly approved by the party responsible for compliance could void the user's authority to operate the equipment.

Changes or modifications not expressly approved by the party responsible for compliance could void the user's authority to operate the equipment.

Cet appareil se conforme aux normes RSS exemptés de license du Industry Canada. L'opération est soumis aux deux conditions suivantes:

- (1) cet appareil ne doit causer aucune interférence, et
- (2) cet appareil doit accepter n'importe quelle interférence, y inclus interférence qui peut causer une operation non pas voulu de cet appareil.

Les changements ou modifications n'ayant pas été expressément approuvés par la partie responsable de la conformité peuvent faire perdre à l'utilisateur l'autorisation de faire fonctionner le matériel

### FCC and ISED Radiation Exposure Statement

This equipment complies with FCC and Canadian radiation exposure limits set forth in RSS-102 for a controlled environment. This equipment should be installed and operated with a minimum distance of 3 cm between the radiator and your body. This transmitter must not be co-located or operating in conjunction with any other antenna or transmitter.

Cet équipement est conforme a RSS limites énoncées pour un environne- ment non contrôlé. Cet équipement doit être installé et utilisé avec une distance minimale de 3 cm entre le radiateur et votre corps.

### ISED EMC Declaration

This Class B digital apparatus complies with Canadian ICES-003.

Cet appareil numérique de Classe B est conforme à la norme Canadienne ICES-003.

### FCC Information to the user

Note: This equipment has been tested and found to comply with the limits for a class B digital devices, pursuant to part 15 of the FCC Rules. These limits are designed to provide reasonable protection against harmful interference in a residential installation. This equipment generates, uses and can radiate radio frequent energy and, if not installed and used in accordance with the instructions, may cause harmful interference to radio communications.

However, there is no guarantee that interference will not occur in a particular installation. If this equipment does not cause harmful interference to radio or television reception, which can be determine by turning the equipment off and on, the user is encouraged to try to correct the interference by one or more of the following measures:

- Reorient or relocate the receiving antenna.
- Increase the separation between the equipment and receiver.
- Connect the equipment into an outlet on a circuit different from that to which the receiver.
- Any changes or modifications not expressly approved by the party responsible for compliance could void the user's authority to operate the equipment.
- To ensure compliance with FCC regulations, use only the shielded interface cables provided with the product, or additional specified components or accessories that can be used with the installation of the product.

The VP1801 may be used with the following Nedap antennas: Single Loop Walk Through, Single Loop Walk Over, VP6011, VP6012, VP6030, VP6040, VP6041, VP6042 and VP6050

Antenna VP6041 and VP6042 are identical. However, model VP6041 is adjusted for environments with lots of steel for short distances. The VP6042 is adjusted for longer distances (1 m) recognition.

#### Disclaimer

Nedap N.V. has made every effort to ensure the accuracy of the information contained in this document. However, Nedap N.V. makes no representations or warranties whatsoever whether express or implied as to the accuracy, correctness, completeness or fit-for-purpose or suitability for the purpose of this product. You use the products at your own risk. Nedap N.V. excludes any liability to the maximum extent permitted by applicable law for the damages caused by errors or failures made during the installation or improper use of this product or by not applying the instructions stated in this document.

Nedap N.V. reserves the right to make improvements or amendments to this document and/or the products described therein at any time without any notification. The latest version of this document can be found on the Nedap Livestock Management Business Portal ([portal.nedap-livestockmanagement.com](http://portal.nedap-livestockmanagement.com), Login required). Please contact your reseller for the latest version of this document and keep a copy for your own records.

This document can be published in various languages but only the English language version will prevail. Nedap N.V. assumes no responsibility for any errors caused for the translations into another language.

#### Warranty and spare parts

Please consult the Nedap products dealer from whom you purchased this product, in regards to the applicable warranty conditions. This product cannot be used for any other purpose as described in this document. If the product is not installed according to this document; the warranty provided is not applicable. At the sole discretion of Nedap N.V., Nedap N.V. may decide to change the conditions of the warranty policy. You agree that Nedap N.V. is able to compensate you the pro-rata value of the warranty involved rather than replacing or repairing the product depending on the technical or economical value of the product.

Prior to applying the warranty, please verify if you comply with the warranty conditions of the warranty policy, whether you can successfully apply for the replacement or repair of a defective part.

Parts can only be replaced with original Nedap parts, otherwise the warranty policy will not be applicable on the product.

If the warranty is applicable, please contact the dealer or send the defective parts to the dealer.

The products will be disposed of by the end-user and discharge Nedap for any liability or responsibility thereof.

*This information is furnished for guidance, and with no guarantee as to its accuracy or completeness; its publication conveys no licence under any patent or other right, nor does the publisher assume liability for any consequence of its use; specifications and availability of goods mentioned in it are subject to change without notice; it is not to be reproduced in any way, in whole or in part, without the written consent of the publisher.*

© Nedap N.V., Livestock management P.O. Box 104 NL-7140 AC GROENLO The Netherlands.

*Please note that any translation of this document which may be provided to you is intended solely as a convenience. Any deviations in a translation shall not be binding and have no legal effect. Nedap assumes no responsibility for any errors contained in such translation*