

**NEW YORK STATE  
DEPARTMENT OF  
ENVIRONMENTAL CONSERVATION**

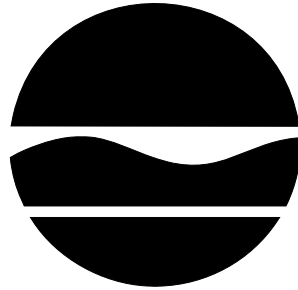

**6 NYCRR PART 373  
HAZARDOUS WASTE MANAGEMENT  
PERMIT**

**FOR**

**CWM CHEMICAL SERVICES L.L.C  
MODEL CITY FACILITY  
NIAGARA COUNTY**

**DEC PERMIT No. 9-2934-00022/00097**

**EPA ID No. NYD049836679**

**VOLUME 5 OF 5**

# Table of Contents – Volume 5 of 5

- K Application Appendix D-9 – RMU-1 Landfill Response Action Plan; and  
Application Appendix D-11 – RMU-1 Minimum Waste Strength Curves
- L Application Appendix D-10 – Fugitive Dust Control Plan
- M Surface Water Sampling and Analysis Plan
- N Air & Meteorological Monitoring Plan
- O Major / Minor Modifications

# **ATTACHMENT K**

## **Sections D-9 & D-11 RMU-1 Response Action Plan & RMU-1 Minimum Waste Strength Curves**

**APPENDIX D-9**  
**RMU-1 RESPONSE ACTION PLAN**

**RESPONSE ACTION PLAN  
RESIDUALS MANAGEMENT UNIT 1  
MODEL CITY TSDR FACILITY**

**Prepared For:**

**CWM Chemical Services, Inc.  
1550 Balmer Road  
Model City, New York 14107**

**Prepared By:**

**Rust Environment & Infrastructure  
412 Lincoln Highway  
Fairless Hills, Pennsylvania 19030**

**February 1993**

**Rust Environment & Infrastructure Project No. 17365**

**Revised: June 2005**

# TABLE OF CONTENTS

Cover Letter

<u>SECTION</u>	<u>PAGE</u>
1.0 INTRODUCTION . . . . .	1
1.1 General . . . . .	1
1.2 Project Description . . . . .	2
1.3 Landfill Description and Operation Summary . . . . .	3
1.3.1 Description . . . . .	3
1.3.2 Hydrogeologic Setting . . . . .	5
1.3.3 Operation . . . . .	6
2.0 POTENTIAL SOURCES OF LIQUIDS IN THE SECONDARY LEACHATE COLLECTION SYSTEM . . . . .	7
2.1 General . . . . .	7
2.2 Construction Liquids . . . . .	7
2.2.1 General . . . . .	7
2.2.2 Potential Liquids . . . . .	8
2.3 Permeation and Leakage Through the Primary Liner System . . . . .	8
2.3.1 General . . . . .	8
2.3.2 Primary Bottom Liner System . . . . .	8
2.3.3 Side Slope Liners . . . . .	9
2.3.4 Discussion of Results . . . . .	10
2.4 Liquids from Inside Sources . . . . .	10
2.4.1 General . . . . .	10
2.4.2 Consolidation Liquids from the Primary Clay Liner . . . . .	10
2.4.3 Discussion of Results . . . . .	11
2.5 Liquids from Outside the Secondary HDPE Geomembrane . . . . .	12
2.5.1 General . . . . .	12
2.5.2 Consolidation Liquids from the Secondary Clay Liner . . . . .	12
2.5.3 Inflow Resulting from Groundwater . . . . .	12
2.5.4 Discussion of Results . . . . .	13
2.6 Summary . . . . .	14
3.0 RESPONSE ACTION LEVELS . . . . .	16
3.1 Action Leakage Rate (ALR) . . . . .	16
3.2 Response Rate (RR) . . . . .	17

## TABLE OF CONTENTS (Continued)

4.0 RESPONSE ACTIONS .....	19
4.1 General .....	19
4.2 Flow Rates at or Below at RR of 75 GPAD .....	19
4.3 Flow Rates Between the RR of 75 GPAD and the ALR of 778 GPAD .....	19
4.4 Flow Rates Greater than the ALR of 778 GPAD .....	22
REFERENCES .....	24

### TABLES

TABLE 1 - Cell Areas	
TABLE 2 - Calculated Limited SLCS Rates for Establishing the Unit-Specified Action Leakage Rate for Cells of RMU-1.	
TABLE 3 - Sources and Unit-Specific Quantities of Liquid Expected to Reach the SLCS Sumps of RMU-1	
TABLE 4 - Priority Pollutants to be Analyzed for if the Action Leakage Rate is Exceeded	

### FIGURES & DRAWINGS

FIGURE 1	- Detailed Location of CWM Model City Facility
FIGURE 2	- Site Layout and Proposed Site of RMU-1
FIGURE 3A	- Secondary Clay Liner Grades
FIGURE 4A	- Typical Liner Sections for Cells 7 through 14
FIGURE 4B	- Riser Details
FIGURE 5a	- Cross Section 16 + 50E
FIGURE 5b	- Cross Section 23 + 25E
FIGURE 7A	- Sump Construction Grades Cells 1 through 4
FIGURE 7B	- Sump Construction Grades Cells 7 and 8
FIGURE 8	- Sump Construction Grades Cell 10
FIGURE 8A	- Sump Construction Grades Cell 13
FIGURE 8B	- Sump Construction Grades Cell 14
DRAWING 25	- Leachate Extraction Details Cells 1 through 4
DRAWING 25A	- Leachate Extraction Details Cells 5, 6, 7, 10, 13 & 14

## TABLE OF CONTENTS (Continued)

### APPENDICES

- APPENDIX A - Final Rule for Liners and Leak Detection Systems for Hazardous Waste Land Disposal Units
- APPENDIX B - Calculations of Critical Design Components Defining the Action Leakage Rate (ALR)
- APPENDIX C - Calculations of Critical Design Components Defining the Response Rate (RR)



## 1.0 INTRODUCTIONS

### 1.1 General

CWM Chemical Services, Inc. (CWM) owns and operates the Model City Treatment Storage, Disposal and Recovery (TSDR) Facility, in Niagara County, New York. The facility is regulated under the Resource Conservation and Recovery Act (RCRA) and the Toxic Substances Control Act (TSCA). The facility location is shown on Figure 1. The general site layout, shown on Figure 2, comprises waste receiving areas, storage and mixing tanks, metal hydroxide ponds (out of service), chemical treatment facilities, biological treatment impoundments, and secure landfills. Current operations include treatment, recovery, stabilization, disposal, and transfer of hazardous and industrial waste.

As part of the permit application for Residuals Management Unit 1 (RMU-1) and as required by the U.S. Environmental Protection Agency (USEPA) Final Rule 40 CFR Parts 260, 264, 265, 270 and 271-Liners and Leachate Detection Systems for Hazardous Land Disposal Units (Federal Register Vol. 57, No. 19, January 29, 1992), a Response Action Plan (RAP) must be submitted prior to receipt of any waste. A copy of pertinent sections of the Final Rule is provided in Appendix A. The RAP is a site specific plan that the owner develops to address leakage through the top liner to the secondary leachate collection system to assure the liquids do not migrate out of the unit. CWM contracted Rust Environment & Infrastructure, formerly SEC Donohue, to prepare a RAP for RMU-1. This RAP describes the criteria used to evaluate and the response required to address liquids in the secondary leachate detection, collection and removal systems of RMU-1. RMU-1 consists of fourteen (14) cells, each divided by a cell separation berm and numbered: 1 through 14. This RAP pertains to all fourteen (14) cells. The layout of RMU-1 is shown on Figure 3A.

This RAP addresses all potential sources of liquids in RMU-1 and discusses the development of site specific performance characteristics for these individual cells. It should be noted that liquids encountered in the leachate collection systems of RMU-1 are not necessarily derived from contact with waste materials. Responses to various inflows of liquid to the secondary leachate collection systems (SLCSs) of RMU-1 include no action, modifying operating procedures, and, where appropriate, notifying the USEPA and the New York State Department of Environmental Conservation (NYSDEC).

This RAP was developed in accordance with, and to address, USEPA's final rules as outlined, in the double liner and leak detection rules for hazardous waste and disposal units (57 FR 3686 et. seq.).

The proposed rule of May 29, 1987 set many triggers to establish a Response Action. The two most pertinent triggers were the Action Leakage Rate (ALR) and the Rapid and Large Leakage Rate (RLL). In the Final Rule of January 29, 1992, USEPA has chosen to establish only one leakage rate that will trigger a response. The Final Rule ALR is based on an approach that is similar to the proposed definition of the rapid and large leakage rate. The ALR is based on the capacity of the SLCS sump and on the maximum design leakage rate that the SLCS can remove without the fluid head on the bottom liner exceeding 1 foot. The ALR will be discussed in Section 3.1.

In addition to the ALR trigger level, a second trigger level called a Response Rate (RR) will be developed. The RR could be used in identifying potential problems with the primary liner. A unit specific value for RMU-1 is discussed in Section 3.2.

## **1.2 Project Description**

RMU-1 is designed to meet or exceed the minimum technology standards defined by the Hazardous and Solid Waste Amendments of 1984 (HSWA) and its implementing regulations. RMU-1 has both primary leachate collection systems (PLCSs) and secondary leachate collection systems (SLCSs), as illustrated on Figures 4a - 5b and Drawings 25 & 25A. These systems are designed and managed to control and remove liquids in a manner consistent with USEPA's liquid management strategy. Sumps located at the low point of individual cells collect liquids that enter the leachate collection systems. Liquids will be removed from each PLCS at regular intervals with dedicated automatic pumps to provide effective leachate management and to minimize the hydrostatic head on the lining systems. The performance of the PLCS of RMU-1 will be monitored based on regular documentation of the liquid volume encountered in and removed from the SLCS of the fourteen cells.

This RAP, which is part of CWM's overall leachate management program, describes the sources of liquids potentially entering the SLCS of each cell of RMU-1, and the proposed response to action to protect the environment from flow rate changes potentially indicating unanticipated flows into an SLCS. This RAP includes: (1) a description of the landfill unit; (2) a description of the sources of liquid that may be present in the SLCS; (3) the criteria that govern implementation of the RAP of appropriate responses; and (4) a proposed outline of the reporting procedures to state and federal agencies.

Various potential liquid sources and liquid inflow rates to the SLCS's of RMU-1 and proposed responses thereto are discussed in this RAP. Two descriptive terms of importance to this text are: "unit-specific" and "cell-specific". The term "unit-specific" relates to a unit area (e.g., one acre), whereas "cell-specific" is a function of each cell area. Potential liquid source, estimated flow rates into the SLCS of each cell and proposed responses to inflow rates in excess of the cell-specific RRs and ALRs are discussed in detail in Sections 2.0 through 4.0.

### 1.3 Landfill Description and Operation Summary

#### 1.3.1 Description

The Model City TSDR Facility has been a waste treatment, storage, disposal, and recovery facility since 1972. The proposed location of RMU-1 is shown on Figure 3A.

The portion of the Model City TSDR Facility accommodating RMU-1 encompasses approximately 47 acres. A simplified plan view and a cross-section are shown on Figures 4A, 4B, 5A and 5B, respectively, and individual cell acreage are provided in Table 1-1. Each cell (1 through 14) is separated by a cell separation berm. Each cell is equipped with both a PLCS and an SLCS and separate riser pipes for each system. The cells of RMU-1 are hydraulically independent.

Each cell of RMU-1 is designed and constructed to meet or exceed EPA guidelines for landfill construction as set forth in the final rule outlined in the Federal Register Vol. 57, No. 19, January 29, 1992. As shown on Figures 4A and 4B the base (bottom) of each cell is lined with a double

composite lining system consisting of the following components listed from bottom to top:

1. A secondary composite liner consisting of 3 feet of clay with a maximum saturated hydraulic conductivity of  $1 \times 10^{-7}$  cm/s overlain by 80-mil high density polyethylene (HDPE) geomembrane.
2. A SLCS consisting of one layer of PN-3000 geonet (or a geocomposite in Cells 7 through 14) overlain by a 1 foot of granular material with a minimum hydraulic conductivity of  $1 \times 10^{-2}$  cm/s ( $8 \times 10^{-2}$  cm/s for Cells 9-14). The geonet and granular layer are separated by a non-woven geotextile; Trevira 1145. Low areas (except for cells 7 through 14 which have a 8" perforated pipe) and areas through sumps have four layer of PN 3000 geonet (except for Cells 7 through 14).
3. A primary composite liner consisting of 1.5 feet of clay with a maximum saturated hydraulic conductivity of  $1 \times 10^{-7}$  cm/s overlain by a 80-mil HDPE geomembrane. The clay is separated from the underlying portions of the SLCS by a non-woven geotextile; Trevira 1145.
4. A PLCS consisting of one layer of PN-3000 geonet (or a geocomposite in Cells 7 through 14) overlain by 1 foot of granular material comprised of 3/8-inch stone (NYSDOT 1A). A non-woven geotextile separates the geonet and the gravel. Low areas (except for cells 7 through 14 which have a 8" perforated pipe) and areas through sumps have four layers of PN-3000 geonet (except for Cells 7 through 14).
5. A 1-foot thick granular operations layer comprised of Run-of-Crusher Stone or equal is separated from the PLCS by a non-woven geotextile on the bottom.

On the RMU-1 perimeter side slopes, the clay portion of the primary liner and the primary drainage layer have been omitted. However, both the primary and secondary HDPE geomembranes extend up the perimeter sides slopes. A one (1) foot thick operations layer will be maintained during filling to protect the geonet and geomembranes from damage by operating equipment. On the base of RMU-1 the operations layer will be Run-of-Crusher Stone or Equal. On the perimeter side slope, the operations layer will be select fill.

### 1.3.2 Hydrogeologic Setting

As shown on Figure 2, RMU-1 occupies a relatively small portion of the Model City TSDR Facility. The hydrogeology at the Model City site was evaluated in detail in the "Hydrogeologic Characterization" report (Reference 2) and more recently in the "Hydrogeologic Characterization Update" report (Reference 3). A brief description of the geologic setting at the site is summarized below.

The upper portion of the Model City site consists of the Upper Till sequence (Upper Clay Till and Upper Silt till) underlain by a Glaciolacustrine Clay. The clay is underlain by a Glaciolacustrine Silt/Sand unit which forms the uppermost aquifer at the site. A lodgement till (Basal Red Till) underlies the aquifer, which in turn is underlain by shale bedrock of the Queenston Formation. In the northwest portion of the site, a Middle Silt Till exists either between the Glaciolacustrine Clay and the Glaciolacustrine Silt/Sand or between and upper and lower Glaciolacustrine Clay sequence. Surficial post-glacial alluvial deposits exist discontinuously across the site. Because of variations in topography, thickness of the prevailing materials, and the subgrade of the sub-cells, RMU-1 penetrates either one or both of the Upper Tills and the Glaciolacustrine Clay units.

A varying thickness of in-situ glacial till will be left in place above the in-situ glaciolacustrine clay formation to withstand hydrostatic pressures and provide a suitable surface for construction equipment. The thickness varies because of the irregularity of the surface of the glaciolacustrine clay.

Surface elevations adjacent to RMU-1 are between approximately 315 feet and 330 feet above Mean Sea Level (MSL). The bottom of the secondary sumps for cells 1 through 14 range between approximate elevations of 304 to 309 feet MSL. The top of the secondary liner is approximately at elevations of 305 to 310 feet MSL at the top edge of the secondary sumps (Figures 7A, 7B, 8, 8A and 8B). The highest seasonal local groundwater table in the area is 313 feet MSL, which is approximately to 9 feet above the level of the secondary HDPE geomembrane at the edge of the sumps in the RMU-1 cell.

A 10 foot wide compacted clay cut-off wall will be keyed 1 foot into the Glaciolacustrine Clay Layer as shown in Figures 4A and 4B. The cut-off wall will facilitate construction of RMU-1. This wall will also significantly restrict groundwater flow beneath RMU-1 after it is constructed.

### 1.3.3 Operation

Liquids entering RMU-1 are collected in PLCS and SLCS sumps at the low point in each cell and are removed by pumping through the HDPE riser pipes. A typical section through the PLCS and SLCS sumps. is shown on Drawing 25.

## **2.0 POTENTIAL SOURCES OF LIQUIDS IN THE SECONDARY LEACHATE COLLECTION SYSTEM**

### **2.1 General**

The purpose of this section is to: (1) establish the basis for the unit-specific and cell-specific RRs and ALRs described in Section 3.0, which were used to formulate the specific response actions proposed in Section 4.0; (2) identify potential sources of liquids that could impact the quantity of liquid collected in the SLCS sumps of each cell; (3) describe the basis for determining various proposed response actions described in Section 4.0; and (4) aid operations personnel in understanding and locating leakage sources, if any occur.

As noted in Section 1.2, two descriptive terms of importance to this text are: "unit-specific" and "cell-specific". The term "unit-specific" relates to a unit area (e.g., one acre), whereas "cell-specific" is a function of each cell area.

Liquids entering an SLCS have been considered from four potential sources. These sources include: (1) construction liquids (including precipitation); (2) permeation and leakage of liquids through the primary liner system; (3) liquids entering the SLCS due to consolidation of the soil components of the primary clay liner; and (4) groundwater and other liquid sources located outside the secondary geomembrane permeating and leaking through the secondary composite liner system. These sources are discussed in the following sections.

### **2.2 Construction Liquids**

#### **2.2.1 General**

The term "construction liquids" is used in this RAP to identify liquids that have entered the cell during the SLCS construction period. Construction liquids include rainfall and snow melt (precipitation) and water used to adjust the moisture content of the material placed as part of the SLCS construction.

### 2.2.2 Potential Liquids

Construction liquids will drain from the SLCS drainage layer under the force of gravity. Because the hydraulic conductivity of the drainage layer is  $2 \times 10^{-2}$  cm/sec., construction liquids will normally drain out of the SLCS within 3 months following completion of PLCS construction. As such, the amount of liquid trapped in the system during construction has not been included in the calculation of the Unit Specific RR as shown in Table 3. This is considered to be a conservative approach.

## 2.3 Permeation and Leachate Through the Primary Liner System

### 2.3.1 General

This section addresses permeation and leakage through the primary composite liner system, which is one of the three main long term sources for liquids entering the SLCS sumps. The following discussion of this liquid source is divided into two sections. Section 2.2.3 discusses potential liquid migration through the primary composite liner on the base of the landfill. Section 2.3.3 discusses potential leakage through the primary side slope liner.

Based on detailed studies conducted for the EPA (Reference 7), even when good construction practices are followed and thorough construction quality/quality assurance procedures are used, defects equivalent to numerous 1/4-inch holes per acre of lined area may reasonably be expected. Assuming good contact between the primary HDPE geomembrane and the underlying primary clay liner, the maximum flow through a single 1/4-inch defect per acre with a hydrostatic head of 1 foot is calculated to be less than 1 gallon per acre day (gpad). However, the number, shape and size of holes may differ on a site-specific basis and EPA has proposed a range of 5 gpad and 20 gpad for leakage through the primary liner system.

### 2.3.2 Primary Bottom Liner System

The primary liner system at the bottom of RMU-1 (cells 1 through 14) is illustrated on Figures 4A, 4B, 5A and 5B. Flow mechanisms through the primary liner system include permeation through intact liner systems and flow through liner defects. The calculations provided in Appendices C2 and C3 apply to permeation and leakage through both the primary and the secondary composite



liner system respectively. Calculations of permeation and flow through defects in the geomembranes provided in Appendices C2 and C3 corroborate the data developed by the EPA.

Liquid migration through the primary composite liner system is expected to be relatively independent of single rainfall events, but is expected to vary with seasonal rainfall. If liner defects are present, temporary, slight increases in flow rates may develop after major storms since temporary ponding of surface water may result in higher flows into the PLCS and through defects in the sideslope liner into the SLCS. Depending on the amount of waste present in the landfill, increased flow could lag the rainfall event by several days or weeks.

Based on CWM's experience with composite-lined landfills, flows in the SLCS increase during winter and spring, because higher precipitation will cause increased flows in the PLCS. Higher flows in the PLCS cause higher heads in the primary liner system with a corresponding increase in flow to the SLCS due to permeation and leakage through the primary HDPE geomembrane. In addition, increased flows above the PLCS increase the probability of liquids coming in contact with a defect in the primary HDPE geomembrane, particularly on landfill side (perimeter) slopes.

### 2.3.3 Side Slope Liners

As shown in Figures 4A and 4B the perimeter side slope liner system includes both the primary and secondary HDPE geomembranes but excludes the primary granular drainage layer and the primary clay liner. Fluid migration through the side slope liner will be relatively small due to the presence of the 12-inch thick select fill operations layer in combination with the primary and secondary HDPE geomembranes. However, in connection with rainfalls or snow melt events, significant liquid quantities could enter the SLCS if defects are present in the perimeter side slope primary HDPE geomembrane. The flow rate that occurs from leak in the perimeter side slope liner would be expected to vary with precipitation and to be relatively independent of the rate of placement. However, as discussed to a greater level of detail in Section 3.0, no additional inflow from precipitation events due to leakage in the side slope liner has been incorporated in the unit-specific or the cell-specific RRs.

### **2.3.4 Discussion of Results**

Although the calculated permeation and leakage through the primary composite liner in Appendices C2 and C3 is on the order of 1 gpad, a value of 20 gpad was selected in compliance with pertinent EPA guidelines to accommodate: uncertainties in numerical calculations (both assumptions and theory); potential leakages associated with unique design features (sumps); and potential liquid sources not accounted for in other quantified components of the RR.

## **2.4 Liquids from Inside Sources**

### **2.4.1 General**

Most, if not all, of the inside liquids entering the SLCS sumps are expected to be produced from the consolidation of the primary clay liner due to loads resulting from waste placement. The resulting flow rate will depend on, and is expected to temporarily lag slightly behind, the filling rate.

### **2.4.2 Consolidation Liquids from the Primary Clay Liner**

The inflow of consolidation liquids to the SLCS sumps from the primary clay liner is time dependent and specific to individual SLCS sumps, because of varying cell sizes. The calculated unit-specific average flow rate into the SLCS sumps of RMU-1 resulting from the consolidation of the primary clay liner is 42 gpad (Appendix CI), based upon the quantity of consolidation water at the time of 90% consolidation.

The contribution from consolidation of the primary clay liner will continue well after the closure of the cell and gradually decrease thereafter with time.

A preconsolidation pressure of 500 psf was used in the analysis. This value is only about 200 psf greater than the applied vertical stress of the primary clay liner, drainage, and operation layers prior to waste placement. The 200 psf increase over the applied stress is considered a reasonable estimate of the prestress applied to the clay by placement and compaction equipment.

An initial void ratio of 0.6 was used in the analysis. This value is slightly less than the initial, void ratio of 0.62 and reflects the judgment that the in-place clay liner has a higher degree of compaction than the laboratory samples. This value also reflects the information from the Golder Letter in Appendix C 1.

A compression index of 0.24 was used in the analysis. This value is based on the values obtained from the empirical formula provided in the December 13, 1991 Golder Assoc. Inc. letter in Appendix C 1.

A coefficient of compression of  $0.00075 \text{ cm}^2/\text{sec}$  was used in the analysis. This value was obtained from a correlation between the liquid limit of the clay and the coefficient of compression. (Reference 5)

The clay was calculated to be 76 percent saturated in the analysis. This value is considered reasonable for a clay compacted at moisture contents typically above the optimum moisture and exposed to liquids from the landfill.

If the parameters described above and used in Appendix C 1 differ from actual values in situ, the rate at which liquid enters the SLCS sumps will vary. However, all of the above values are considered to be on the conservative end of potentially expected ranges. This results in a lower calculated value for consolidation water and, therefore, lower values for the RRs.

#### 2.4.3 Discussion of Results

In selecting the unit-specific contribution to the RR from inside liquid sources, as shown in Table 3, only the contribution from the consolidation of the primary clay liner of 42 gpad (Appendix C1) was deemed to be of sufficient duration to affect the RR.

## **2.5 Liquids from Outside the Secondary HDPE Geomembrane**

### **2.5.1 General**

The two potential outside sources of liquid considered are liquids resulting from consolidation of the clay component of the secondary composite liner and groundwater. These two sources are the most significant potential continuous liquid sources of inflow to the SLCS for landfill cells located below the groundwater table, which is the case for RMU-1. Liquids from these sources enter the SLCS via permeation through the intact secondary HDPE geomembrane or leakage through local defects in the secondary HDPE geomembrane.

### **2.5.2 Consolidation Liquids from the Secondary Clay Liner**

Flow resulting from the consolidation of the clay portion of the secondary clay liner is expected to behave similarly to that resulting from consolidation of the primary clay liner. However, whereas all liquid from the primary clay liner is drained directly into the SLCS, flow from the secondary clay liner to the SLCS will be inhibited by the overlying secondary HDPE geomembrane and drainage in two directions. Flow from the secondary clay liner will depend on the clay moisture content, character of base grade material, and the waste placement rate. After waste placement (filling) is completed, the flow rate will decrease and eventually become negligible. The surface contact area between the secondary HDPE liner and the clay liner will be cell-specific and as a result the amount of fluid migration will also be cell-specific.

The calculated average flow rates through the intact secondary HDPE geomembrane generated by the consolidation (pore pressure) of the secondary clay liner is 6.5 gpad (Appendix C4). The inflow through defects in the geomembrane under this condition is estimate to be approximately 1 gpad (Appendix C5).

### **2.5.3 Inflow Resulting from Groundwater**

As described in Section 1.3.2, the average elevation of the secondary HDPE geomembrane of RMU-1 is between 3 to 9 feet below the seasonal high groundwater table. Resulting hydrostatic

pressure exerted on the geomembrane by the groundwater will cause liquids to enter the SLCS by permeation through the intact secondary HDPE geomembrane and by flow through defects in the secondary HDPE geomembrane, similar to the mechanisms described in Section 2.3.

Groundwater inflow will vary seasonally during the landfill life. The inflow to the SLCS resulting from flow through defects in the HDPE geomembrane and permeation depends upon the prevailing hydrostatic head. Since the groundwater table fluctuates, seasonal flows into the SLCS also fluctuate. Flow rates through the side walls (berms) and the bottom of each cell will also vary as a function of the prevailing hydrostatic head.

With regard to the leakage of groundwater into the SLCS, the presence of an outside hydrostatic head acting upon the secondary HDPE geomembrane is continuous, but it varies in magnitude. Hence, groundwater is considered the most likely and predominant outside liquid source that may contribute to the liquid encountered in the SLCS sumps.

The calculation of the side wall inflow rates for individual cells provided in Appendices C2 and C3 was simplified by equating the larger side wall area but lower average hydrostatic head on the side wall with the smaller planar area (projection) of the side wall but higher average hydrostatic head at the bottom of the cell. In other words, only the horizontal projection of each cell and the average hydrostatic heads at the bottom of the RMU-1 cells were used in the calculations.

The calculated inflows of groundwater through the intact secondary HDPE geomembrane and local defects in the secondary HDPE geomembrane are 11.9 gpad (Appendix C2) and 1.3 gpad (Appendix C3), respectively for RMU-1. Hence, as shown in Table 3, the calculated cumulative total is 13 gpad for groundwater entering the SLCS sumps of RMU-1.

#### 2.5.4 Discussion of Results

For the purpose of establishing a realistic value attributable to flow from outside liquid sources, the performance characteristics of liquid sources were analyzed (Appendix C).

With regard to the consolidation of the secondary clay liner and related increases in pore, pressure and releases of liquid, it seems more reasonable that these liquids will tend to migrate toward the natural base material rather than toward the secondary HDPE liner. Therefore, the outside liquid source component from consolidation of the secondary clay liner has been neglected in the RR.

With regard to the leakage of groundwater into the SLCS, the presence of an outside hydrostatic head acting upon the secondary HDPE geomembrane is continuous, but it varies in magnitude. Hence, groundwater is considered the most likely and predominant outside liquid source that may contribute to the liquid encountered in the SLCS sumps.

## 2.6 Summary

As discussed in the preceding text of this section, the three main liquid sources expected to reach the SLCS sumps over a long term period are: (1) permeation and leakage through the primary liner system, (2) liquids trapped between the primary and secondary HDPE geomembranes (inside liquids), and (3) liquids from outside the secondary HDPE geomembrane (outside liquids).

Although the calculated permeation and leakage through the primary composite liner in Appendices C2 and C3 is on the order of 1 gpad, a value of 20 gpad was selected in compliance with pertinent EPA guidelines to accommodate: uncertainties in numerical calculations (both assumptions and theory); potential leakages associated with unique design features (sumps); and potential liquid sources not accounted for in other quantified components of the RR.

Liquids trapped between the primary and secondary HDPE geomembranes (inside liquids) are calculated in Appendix C 1. The consolidation of the primary clay liner generates liquid that decreases in flow rate with time. In establishing a realistic unit-specific RR value for this category of liquids, the liquid generated by the primary clay liner of 42 gpad, shown in Table 3, was selected for this liquid source based on material characteristics.

Liquids from outside the secondary HDPE geomembrane (outside liquids) are calculated in Appendices C2 through C5. In establishing realistic unit-specific RR values for SLCS liquids, 13 gpad was selected resulting from groundwater only and based on material characteristics. The inflow to the SLCS sumps of outside liquids is expected to be continuous, but vary depending upon seasonal fluctuations in groundwater table elevations.

### 3.0 RESPONSE ACTION LEVELS

#### 3.1 Action Leakage Rate (ALR)

The EPA defines the ALR as the maximum design leakage rate that the leakage detection system can remove without the fluid head on the bottom liner exceeding one foot (Appendix A). In other words, the ALR is exceeded when the liquid head is greater than the thickness of the SLCS drainage layer. Also, the limiting value on the amount of liquid that can enter an SLCS without adversely affecting landfill performance is partially a function of the ability of the SLCS to efficiently remove liquids.

The analysis performed in Appendix B to evaluate the SLCS capacity of each cell is based on conservative assumptions including: (1) the flow head in the SLCS drainage layer will not exceed 1 foot; and (2) the ALR is governed by the SLCS component that has the lowest flow capacity. Also, the minimum pump capacity of each cell of RMU-1 is considered in evaluating the SLCS capacity.

The calculations in Appendix B account for the different head elevations above the drainage layer and the riser pipes. These calculations determine the minimum and maximum flows that the SLCS can accept. The minimum flow allowable will be selected as the ALR.

As shown in Appendix B and summarized in Table 2, Cells 1 through 14 have identical yields of 3181 gallons per day (gpd) which includes a safety factor of 2. A factor of safety of 2.0 has been suggested in the preamble of the January 29, 1992 Final Rule. This will allow for uncertainties in the design (e.g., slope, hydraulic conductivity, thickness of drainage material), construction, operation, and location of the SLCS, waste and leachate characteristics, likelihood and amounts of other sources of liquids in the SLCS, and proposed response actions (e.g., the ALR must consider decreases in the flow capacity of the system over time resulting from siltation and clogging, rib layover and creep of synthetic components of the system, overburden pressure, etc.). The value of 3181 gpd was selected as the basis for the cell specific yield for all cells. The selected cell specific yield of 3181 gpd converts to the lowest unit-specific limiting flow rate of 778 gallons per acre day (gpad). The selected unit-specific ALR of 778 gpad is



considered a conservative measurement of performance for all cells in RMU-1.

As illustrated in Table 2, minimum SLCS sump pump capacities, based on the manufacturer's specifications, are more than one order of magnitude greater than the selected unit-specific ALR.

It should be noted that the calculated values for maximum cell yields presented in Table 2 are controlled by the flow characteristics of the secondary drainage layer adjacent to individual SLCS sumps and that these values are independent of cell size, whereas the selected unit-specific ALR is dependent on cell size. The individual SLCS sumps of each cell have the same layout and characteristics as shown on Figures 7A, 7B, 8, 8A and 8B.

### 3.2 Response Rate (RR)

Before EPA's final rule was enacted in January 1992, the proposed rule (May 1987) contained requirements for calculations and response actions for three distinct levels, i.e., the Action Leakage Rate (ALR), the Intermediate Leakage Rate (ILR) and the Rapid and Large Leakage Rate (RLR).

Based on comments from NYSDEC's review of the Draft RAP for RMU-1, this RAP provides an additional trigger level, the Response Rate (RR), which is calculated similar to the ALR under the proposed rule, i.e., pre-January 1992.

The double liner and leak detection rules proposed by EPA (52FR20218, May 29, 1987) allowed development of a site-specific ALR (40 CFR Part 264.22[k][2]) based on the unit design, the potential for liquids to migrate through the primary liner, and other factors. These guidelines proposed for the ALR calculations have been followed to generate CWM's RR. Because of differences in size between cells (Table 1), unit-specific and cell-specific RRs have been developed for RMU-1 cells instead of a site-specific RR. In the case of RMU-1, long term sources of liquids included in the unit-specific and cell-specific RRs discussed in this section are: (1) liquids resulting from permeation and leakage through the primary composite liner system; (2) liquids squeezed from the clay component of the primary liner due to consolidation; and (3) liquids from groundwater permeating through the secondary HDPE geomembrane and leaking through small defects in the secondary HDPE geomembrane.

Liquids that are included in the RR consist mainly of sources other than leachate. Differentiating these liquids from leachate is extremely difficult.

As discussed in Section 2.0, the unit-specific and cell-specific RRs shown in Table 3 do not include potential liquid contributions from construction liquids, precipitation, or consolidation of the secondary clay liner. The unit-specific and cell-specific RRs are based on liquid quantities expected to enter the SLCS after the closure of each cell.

The selected unit-specific RR component for permeation and leakage through the primary liner (liquid source 1 above) is 20 gpad (Section 2.3). This value is based on the permeation/leakage band suggested by the EPA.

As stated previously in Section 2.3.4, the calculated permeation and leakage through the primary composite liner in Appendices C2 and C3 is on the order of 1 gpad. A value of 20 gpad was selected in compliance with pertinent EPA guidelines to accommodate: uncertainties in numeral calculations (both assumptions and theory); potential leakages associated with unique design features (sumps); and potential liquid sources not accounted for in other quantified components of the RR.

The selected unit-specific RR component for compression and consolidation liquid from the soils located between the primary and secondary HDPE geomembranes (liquid source 2 above) of 42 gpad, is based on the value calculated in Appendix C 1 for the consolidation of the primary clay liner only. As discussed in Section 2.4.2 and 2.4.3, this considered to be a reasonable and conservative initial post-closure value.

The selected unit-specific RR component for outside liquids migrating through the secondary HDPE geomembrane (liquid source 3 above) is 13 gpad. As discussed in Section 2.5.4, this value is based on the calculated inflow of groundwater only.

As shown in Table 3, the cumulative unit-specific RRs resulting from liquid sources 1-3 above is 75 gpad for RMU-1. Cell-specific RRs are also presented in Table 3.

The RR of 75 gpad shall apply during the period of initial waste placement in any RMU-1 cell until exactly one (1) year after the final cover is complete over the cell. Subsequent to one (1) year after the final cover is complete over a cell, a RR of 20 gpad shall apply to the cell.

## 4.0 RESPONSE ACTIONS

### 4.1 General

The response actions required to respond to various flow rates in the SLCS sumps of each cell of RMU-1 are provided in this section. As discussed in Section 3.0 and summarized in Tables 2 and 3, a Response Rate (RR) and an Action Leakage Rate (ALR) have been selected. The cell-specific ALRs shown in Table 2 are based strictly on the calculations presented in Appendix B. The cell specific RRs shown in Table 3 are based on the calculations presented in Appendix C.

For all flow rates the following procedure is required for monitoring of the SLCS:

- o Each SLCS sump will be monitored at least once every 7 days for the presence of liquids. Pumpable amounts of liquids contained in the sump will be removed and the liquid quantity measured and recorded. If the sump is monitored or if liquids are removed more frequently, the inflow will be determined for each pumping event. The inflow value will be determined by adding the liquid volumes removed within the time interval between pumping events divided by the number of days between pumping events. The pumped amount of liquid will be divided by the days since the previous pumping event to establish a daily average inflow. However, the inflow value compared against the trigger level outlined in this RAP will be the weekly average value.

### 4.2 Flow Rates at or Below the RR of 75 GPAD

(Note: The RR for an RMU-1 cell shall become 20 gpad subsequent to one (1) year after the final cover is completed over the cell)

Routine monitoring should continue. No action is required.

### 4.3 Flow Rates Between the RR of 75 GPAD and the ALR of 778 GPAD

(Note: The RR for an RMU-1 cell shall become 20 gpad subsequent to one (1) year after the final cover is completed over the cell)

1. Verbally notify the NYSDEC within three working days of an apparent exceedance of the RR. Complete one or more of the following activities to determine whether the apparent exceedance was actually due to an electronic or mechanical equipment malfunction:

- a. Evaluate the SLCS volume data transferred from the RMU-1 Lift Station PLC to the AWTS computer terminal by checking recent level trends and alarm summary logs.
- b. Verify proper operation of the SLCS pump via computer control and by manually switching it on and off.
- c. Inspect the SLCS flow meter and verify its proper operation using timed pumping and comparing the estimated volume with the meter flow readings.
- d. Remove the SLCS pump and level probe and inspect for any obvious defects. Verify proper operation of level probe by either electrical simulation or by manually placing the probe in water.

2. If the average daily flow to a SLCS sump for a weekly pumping event exceeds the RR, and if not conclusively determined within two (2) weeks of an apparent RR exceedance to be clearly attributable to an operational failure, e.g., equipment or power failures based on the investigation specified in Item 1 above, the following will be performed:

- a. Conduct a review of the most recent SLCS and Primary Leachate Collection System (PLCS) analytical data available from the sampling programs required by the site permit.
- b. Immediately perform the following tests and observations on samples of the SLCS and PLCS liquids:
  - Color
  - Turbidity
  - Specific Conductance and
  - pH

Make a preliminary comparison of these values with the previous results and record the information.

- c. Perform, within a week after the RR exceedance, the sampling and analysis of the SLCS liquid which would normally occur on a quarterly basis. Test results are to be available within 45 days of the exceedance. Results will be reviewed with the NYSDEC to determine what, if any, additional response actions are necessary based on the results. This sampling will satisfy the next quarterly sampling requirements for that sump and cell.
  - d. Increase monitoring and pumping frequency of the SLCS sump of the cell involved, if pumpable quantities are present, to every day until flow decreases below the RR. Also, verify that the automatic removal of liquid from the PLCS sumps is occurring as designed. If the automatic pumping of the PLCS is unable to maintain a level of 12 inches or less in the PLCS, evaluate whether increasing the pumping rate and prioritization of that cell is needed.
  - e. Review all analytical data and investigate alternative sources of liquid.
3. If the flow is between the RR and the ALR for seven consecutive additional daily pumping events, provide written notification to the NYSDEC within 14 days and implement the following steps:
- a. Remove all standing water, if any, from within the landfill.
  - b. Assess the potential cause or causes of the RR exceedance. In the affected cell, examine any exposed portions of the cell liner.
  - c. Repair any observed damaged.
  - d. If no obvious defects are detected, propose mitigative actions to return the leakage rate to below the RR. Upon approval, sequentially inspect side slope liner and likely locations of base liner, if necessary, removing waste as needed. Repair any observed damage.

e. Document location, type and extent of liner damage, if any.

4. If the leakage rate can't be returned and maintained below the RR after all feasible mitigative measures have been taken, then automatic pumping and volume measurement of the secondary collection system must be instituted.

#### 4.4 Flow Rates Greater than the ALR of 778 GPAD

1. Notify in writing the USEPA and NYSDEC within 7 working days if the average flow to an SLCS sump for one pumping event exceeds the ALR, if not clearly attributable to an operational disturbance. Determine the need to temporarily stop placing waste into the affected cell during the cells normal operation except if the ALR value is exceeded within the first 30 days of operation of the cell when flows are not truly representative and except during post-closure operations. If the ALR value is exceeded after the first 30 days of cell operation, determine if waste placement in the cell should cease until repairs to the lining system or other appropriate actions are completed, and flows to the SLCS sump have decreased to below the ALR. Prepare a written preliminary assessment report describing the amount of liquids, likely source of liquids, possible location, size and cause of any leaks and short-term actions taken and planned. Submit this report to USEPA and NYSDEC within 14 days of exceedance. Waste placement may not resume in the cell until written notification is given by NYSDEC.
2. Increase monitoring and pumping frequency from the SLCS sump of the cell involved, if pumpable quantities are present, to every day until flow decreases below the ALR. Also, verify that the automatic removal of liquid from the PLCS sumps is occurring as designed.
3. Perform the following tests and observations on samples of the SLCS and PLCS liquids:
  - color
  - turbidity
  - specific conductance; and
  - pHMake a preliminary comparison of these values with previous results and record the information.

4. Determine to the extent practicable the location, size and cause of any leak.
5. Determine any other short-term and longer term actions to be taken to mitigate or stop any leaks.
6. Within 30 days after the notification that the ALR has been exceeded submit to the USEPA and NYSDEC the results of the analyses of responses 1 through 5 above, as well as the results of actions taken and actions planned.
7. If the average flow exceeds the ALR for two consecutive pumping events implement the following steps:
  - a. Test a sample of the liquid obtained from the SLCS for constituents listed in Table 4,
  - b. Remove all standing water inside RMU-1,
  - c. Examine any exposed portion of the cell liner,
  - d. Repair any observed damage.
8. If flow continues to exceed the ALR for an additional two pumping events, provide third party inspection by a registered professional engineer who will investigate alternative sources of liquid, review available analytical and pumping event data for the cell to identify any trends, and prepare a written report to the USEPA and NYSDEC on the findings and recommended actions to protect human health and the environment. The Groundwater Monitoring Plan will also be evaluated to determine if supplemental response actions are necessary.
9. As long as the flow rate in the SLCS exceeds the ALR, submit monthly reports to the USEPA and NYSDEC summarizing actions taken and planned.
10. If the ALR value continues to be exceeded after taking all reasonable corrective measures, closure of the affected cell shall be considered.

## REFERENCES

1. U.S. EPA, Minimum Technology Guidance on Double Liner Systems for Landfills and Surface Impoundments -- Design, Construction, and Operation, EPA/530-SW-85-014, Second version, May 1985.
2. Golder Associates Inc., "Hydrogeologic Characterization, Chemical Waste Management, Inc., Model City, New York Facility, Volumes I through IV", March 1985.
3. Golder Associates Inc., "Hydrogeologic Characterization Update, Chemical Waste Management, Inc., Model City, New York Facility", February 1988.
4. U.S. EPA, Background Document on Proposed Liner and Leak Detection Rule, EPA/530-SW-87-015, May 1987.
5. Holtz, R.D. and Kovacs, W.D., An Introduction to Geotechnical Engineering, Prentice-Hall, Inc., Englewood Cliffs, New Jersey, 1981.
6. Koerner, R.M., Designing with Geosynthetics 2nd Edition, Prentice Hall, Inc., New Jersey, 1986, 1990.
7. U.S. EPA, Action Leakage Rates for Leak Detection Systems, (Supplemental Background Document for the Final Double Liners and Leak Detection Systems Rule for Hazardous Waste Landfills, Waste Piles, and Surface Impoundments), January, 1992.
8. Donohue & Associates, Inc., "Engineering Report for CWM Chemical Services, Inc., Model City Facility, Residuals Management Unit 1, Model City, Niagara County, New York", February, 1991.
9. Bouwer, H., Groundwater Hydrology, McGraw-Hill, Inc., New York, 1978.
10. Serrine Environmental Consultants, Inc., Response Action Plan, Secure Landfill No. 12, Model City TSDR Facility, January, 1992.



TABLE 1  
CELL AREAS

CELL	APPROXIMATE PLAN AREA (ACRES)
1	2.45
2	1.99
3	2.37
4	1.92
5	3.23
6	3.08
7	3.40
8	3.60
9	3.02
10	2.67
11	2.49
12	2.18
13	3.00
14	4.09

3949

CALCULATED LIMITING SLCS RATES FOR ESTABLISHING THE UNIT-SPECIFIC ACTION LEAKAGE RATE FOR CELLS OF RMU-1

CELL NUMBER	LIMITING PUMP CAPACITY* (GALLONS/DAY)	CALCULATED CELL-SPECIFIC LIMITING FLOW RATE** (GALLONS/DAY)	AREA (ACRES)	CORRESPONDING UNIT-SPECIFIC LIMITING FLOW RATE (GALLONS/ACRES/DAY)	SELECTED UNIT-SPECIFIC ALR (GALLONS/ACRE/DAY)
RMU-1					
CELL 1	64,800	3,181	2.45	1,294.4	778
CELL 2	64,800	3,181	1.99	1,598.5	778
CELL 3	64,800	3,181	2.37	1,342.2	778
CELL 4	64,800	3,181	1.92	1,656.8	778
CELL 5	64,800	3,181	3.23	984.8	778
CELL 6	64,800	3,181	3.08	1,032.8	778
CELL 7	64,800	3,181	3.40	935.6	778
CELL 8	64,800	3,181	3.60	883.6	778
CELL 7/8 (All)	64,800	3,181	7.00	454.4	454
CELL 9	64,800	3,181	3.02	1,053.3	778
CELL 10	64,800	3,181	2.67	1,191.4	778
CELL 9/10 (All)	64,800	3,181	5.69	559.1	559
CELL 11	64,800	3,181	2.49	1,277.5	778
CELL 12	64,800	3,181	2.18	1,459.1	778
CELL 13	64,800	3,181	3.00	1,060.3	778
CELL 14	64,800	3,181	4.09	777.7	778
CELL 11/13(All)	64,800	3,181	5.49	579.4	579
CELL 12/14(All)	64,800	3,181	6.27	507.3	507

\* REFERENCE B  
 \*\* SEE APPENDIX B FOR DETAILS

4/5/98  
 Revised: Date Approved

3  
 SOURCES, UNIT-SPECIFIED AND CELL-SPECIFIC QUANTITIES OF LIQUID  
 EXPECTED TO REACH THE SLCS SUMPS OF RMU-1

CELL	CONSTRUCTION LIQUIDS (1) (GPAD)	LEAKAGE THROUGH PRIMARY LINER (1) (GPAD)	INSIDE LIQUID SOURCES (1) (GPAD)	OUTSIDE LIQUID SOURCES (1) (GPAD)	TOTAL (1) - UNIT-SPECIFIC RESPONSE RATE (GPAD)	APPROXIMATE PLAN AREA (ACRES)	CELL-SPECIFIC RESPONSE RATE (GPD)
1	0	20	42	13	75	2.45	184
2	0	20	42	13	75	1.99	149
3	0	20	42	13	75	2.37	178
4	0	20	42	13	75	1.92	144
5	0	20	42	13	75	3.23	242
6	0	20	42	13	75	3.08	231
7	0	20	42	13	75	3.40	255
8	0	20	42	13	75	3.60	270
All.-Combined 7/8		20	42	13	75	7.00	525
9	0	20	42	13	75	3.02	227
10	0	20	42	13	75	2.67	200
All.-Combined 9/10	0	20	42	13	75	5.69	427
11	0	20	42	13	75	2.49	187
12	0	20	42	13	75	2.18	164
13	0	20	42	13	75	3.00	225
14	0	20	42	13	75	4.09	307
All.-Combined 11/13	0	20	42	13	75	5.49	412
All.-Combined 12/14	0	20	42	13	75	6.27	470

NOTE: (1) THESE VALUES ARE UNIT-SPECIFIC AND BASED ON CALCULATIONS PRESENTED IN APPENDIX C.

4/5/98  
 Revised: Date Approved

TABLE 4

PRIORITY POLLUTANTS  
TO BE ANALYZED FOR IF THE  
ACTION LEAKAGE RATE IS EXCEEDED

NDPES  
NO. COMPOUND

ACIDS

1A 2-Chlorophenol  
2A 2,4-Dichlorophenol  
3A 2,4-Dimethylphenol  
4A 4,6-Dinitro-o-cresol  
5A 2,4-Dinitrophenol  
6A 2-Nitrophenol  
7A 4-Nitrophenol  
8A p-Chloro-m-cresol  
9A Pentachlorophenol  
10A Phenol  
11A 2,4,6-Trichlorophenol

BASE/NEUTRALS

1S Acenaphthene  
2S Acenaphtylene  
3S Anthracene  
4S Benzidine  
5S Benzo(a)anthracene  
6S Benzo(a)pyrene  
7S Benzo(b)fluoranthene  
8S Benzo(ghi)perylene  
9S Benzo(k)fluoranthene  
10B bis(2-Chloroethoxy)methane  
11B bis(2-Chloroethyl)ether  
12B bis(2-Chloroisopropyl)ether  
13B bis(2-Ethylhexyl)phthalate  
14B 4-Bromophenyl phenyl ether  
15B Butyl benzyl phthalate  
16B 2-Chlornaphthalene  
17B 4-Chlorophenyl phenyl ether  
18B Chrysene  
19B Dibenzo(a,h)anthracene  
20B 1,2-Dichlorobenzene  
21B 1,3-Dichlorobenzene  
22B 1,4-Dichlorobenzene  
23B 3,3-Dichlorobenzidine  
24B Diethyl phthalate  
25B Dimethyl phthalate  
26B Di-n-butyl phthalate  
27B 2,4-Dinitrotoluene

NDPES  
NO. COMPOUND

BASE/NEUTRALS (CONTINUED)

28B 2,6-Dinitrotoluene  
29B Di-n-octyl phthalate  
30B 1,2-Diphenylhydrazine  
31B Fluoranthene  
32B Fluorene  
33B Hexachlorobenzene  
34B Hexachlorobutadiene  
35B Hexachlorocyclopentadiene  
36B Hexachloroethane  
37B Indeno (1,2,3-c,d)pyrene  
38B Isophorone  
39B Naphthalene  
40B Nitrobenzene  
41B N-Nitrosodimethylamine  
42B N-Nitrosodi-n-propylamine  
43B N-Nitrosodiphenylamine  
44B Phenanthrene  
45B Pyrene  
46B 1,2,4-Trichlorobenzene

METALS (TOTAL)

Antimony  
Arsenic  
Beryllium  
Cadmium  
Chromium  
Copper  
Lead  
Mercury  
Nickel  
Selenium  
Silver  
Thallium  
Zinc

TABLE 4

PRIORITY POLLUTANTS  
TO BE ANALYZED FOR IF THE  
ACTION LEAKAGE RATE IS EXCEEDED  
(Continued)

NDPES  
NO. COMPOUND

NDPES  
NO. COMPOUND

PESTICIDES/PCB

1P Aldrin  
2P Alpha-BHC  
3P Beta-BHC  
4P Gamma-BHC  
5P Delta-BHC  
6P Chlordane  
7P 4,4'-DDT  
8P 4,4'-DDE  
9P 4,4'-DDD  
10P Dieldrin  
11P Endosulfan I  
12P Endosulfan II  
13P Endosulfan sulfate  
14P Endrin  
  
15P Endrin aldehyde  
16P Heptachlor  
17P Heptachlor epoxide  
18P PCB-1242  
19P PCB-1254  
20P PCB-1221  
21P PCB-1232  
22P PCB-1248  
23P PCB-1260  
24P PCB-1016

VOLATILES (CONTINUED)

10V 2-Chloroethylvinyl ether  
11V Chloroform  
12V Dichlorobromomethane  
  
14V 1,1-Dichloroethane  
15V 1,2-Dichloroethane  
16V 1,1-Dichloroethylene  
17V 1,2-Dichloropropane  
18V cis-1,3-Dichloropropylene  
19V Ethylbenzene  
20V Methyl bromide  
21V Methyl chloride  
22V Methylene chloride  
23V 1,1,2,2-Tetrachloroethane  
24V Tetrachloroethylene  
25V Toluene  
26V 1,2-Trans-dichloroethylene  
27V 1,1,1-Trichloroethane  
28V 1,1,2-Trichloroethane  
29V Trichloroethylene  
  
31V Vinyl chloride  
18V trans-1,3-Dichloropropylene

VOLATILES

3V Benzene  
  
5V Bromoform  
6V Carbon tetrachloride  
7V Chlorobenzene  
8V Chlorodibromomethane  
9V Chloroethane

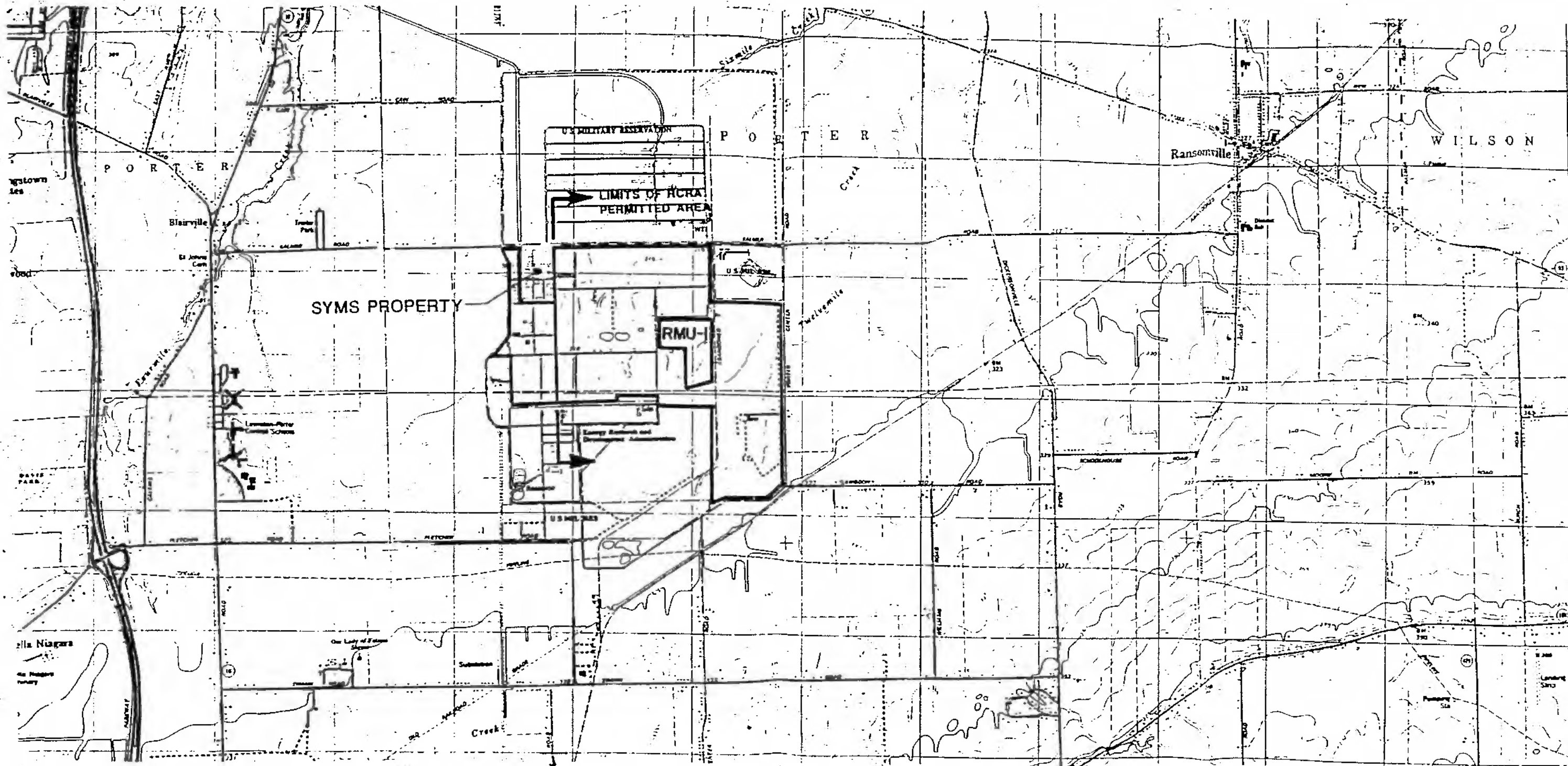

SOURCE: USGS 7.5 MINUTE SERIES  
RANSOMVILLE AND LEWISTON QUADRANGLE (1980)

APPROXIMATE SCALE:  
1" = 1600'

TO MODEL CITY 0.55 MILES

- NOTES:
1. PROPERTY LINES ARE APPROXIMATE
  2. 710 TOTAL ACRES
  3. 630 RCRA PERMITTED ACRES

**FIGURE 1**  
**DETAILED LOCATION OF**  
**CWM MODEL CITY FACILITY**  
CWM CHEMICAL SERVICES, INC.  
MODEL CITY, NEW YORK

APRIL, 1992

17365

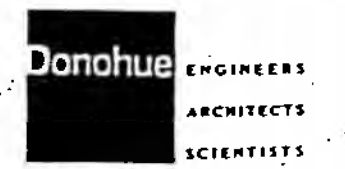

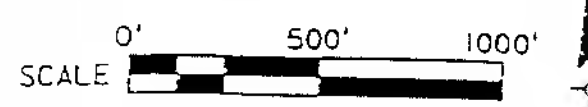
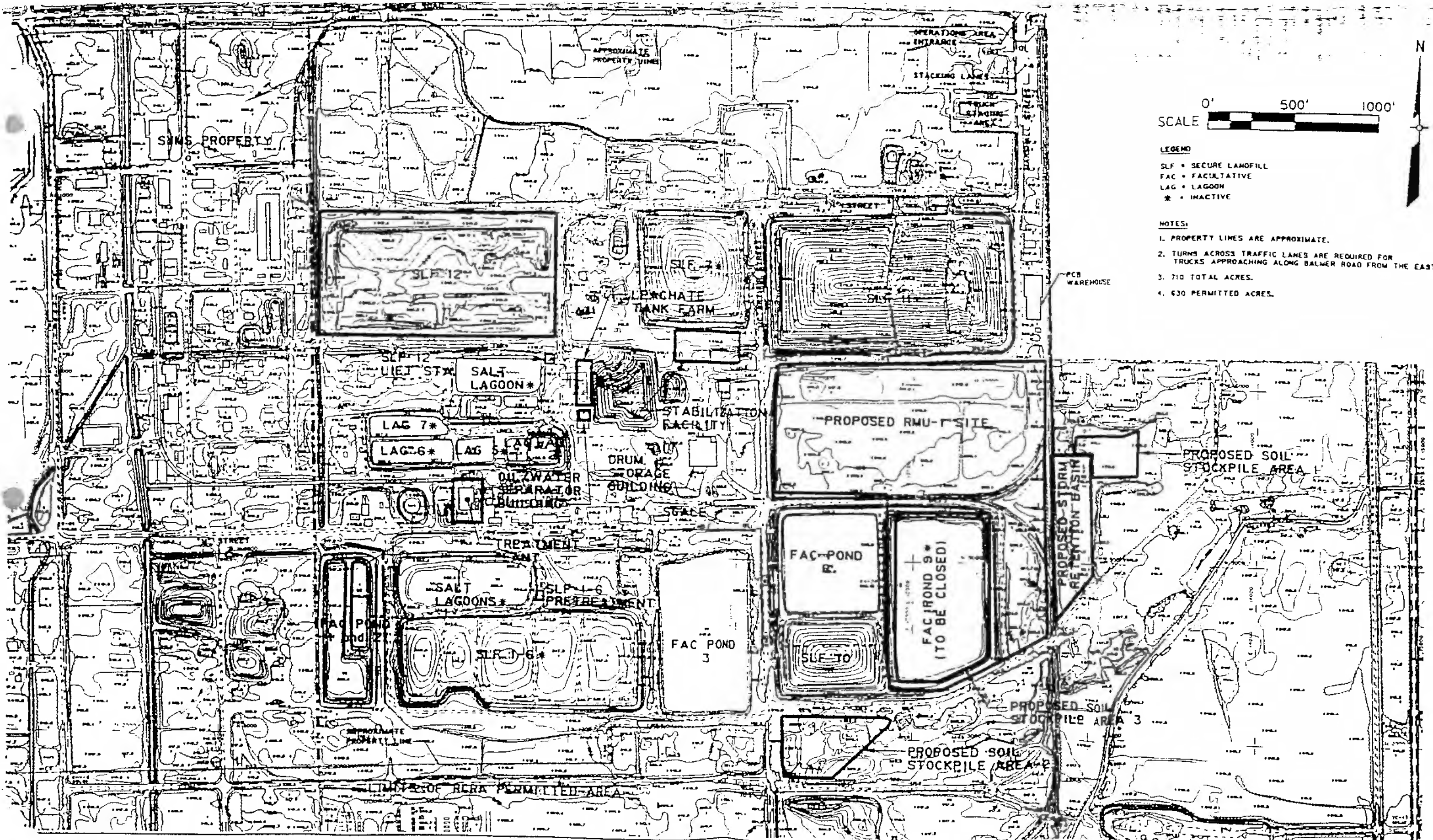

LEGEND

- SLF = SECURE LANDFILL
- FAC = FACULTATIVE
- LAG = LAGOON
- \* = INACTIVE

NOTES:

1. PROPERTY LINES ARE APPROXIMATE.
2. TURNS ACROSS TRAFFIC LANES ARE REQUIRED FOR TRUCKS APPROACHING ALONG BALMER ROAD FROM THE EAST.
3. 710 TOTAL ACRES.
4. 630 PERMITTED ACRES.

APRIL 1982

FIGURE 2  
SITE LAYOUT AND PROPOSED SITE OF RMU-1

CWM CHEMICAL SERVICES, INC.  
MODEL CITY, NEW YORK





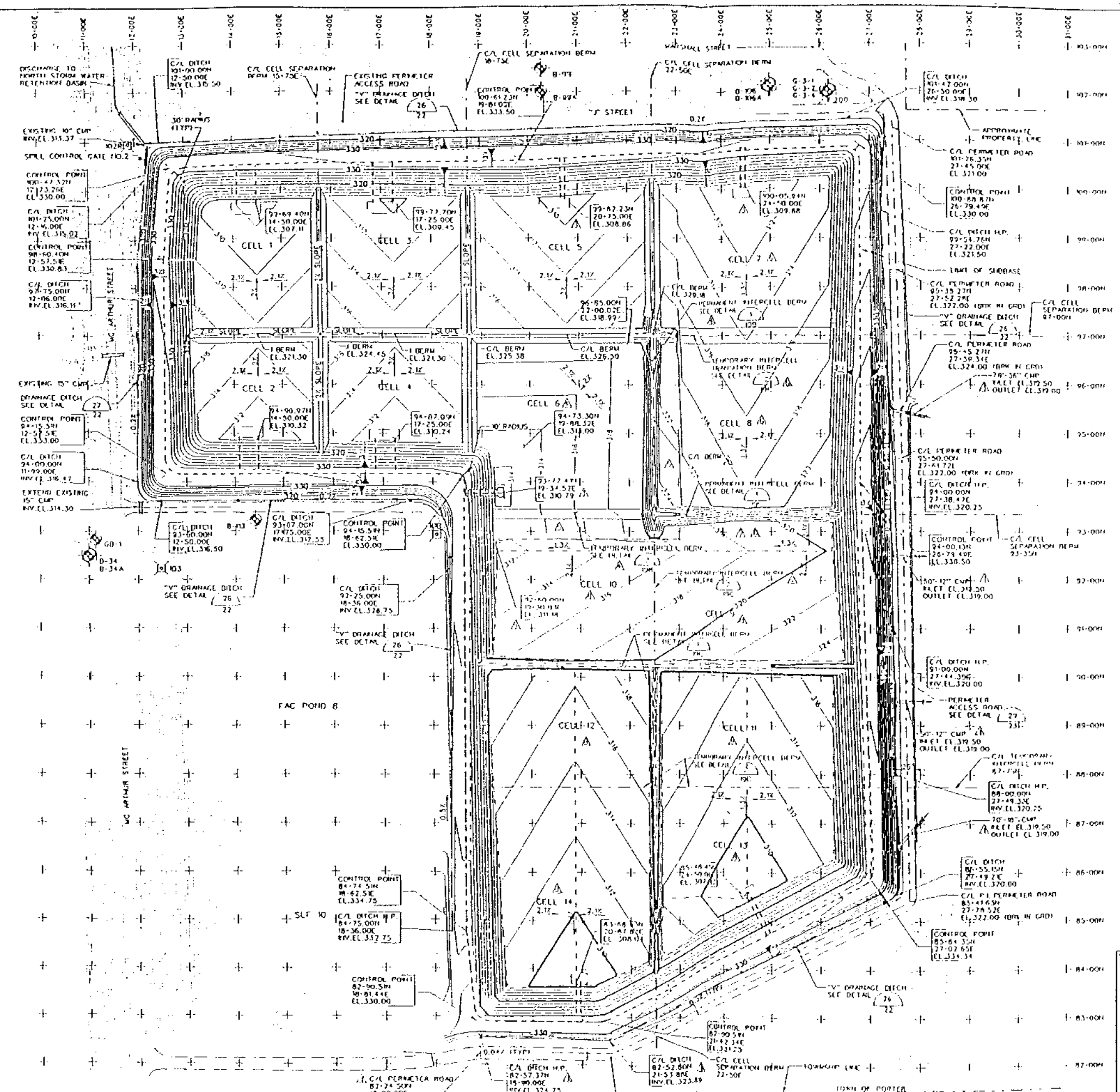

- EXISTING GRADE  
 PROPOSED GRADE  
 LIMIT OF SUBGRADE  
 SLOPE INDICATOR  
 DRAINAGE DITCH  
 ACCESS ROAD  
 TOP OF BERM  
 APPROXIMATE PROPERTY LINE  
 TOWNSHIP LINE  
 GROUNDWATER MONITORING WELL  
 GROUNDWATER MONITORING WELL HEAD  
 SOLE BOARD  
 PERMANENT CONTROL MONUMENT  
 CULVERT

- NOTES:
1. TOPOGRAPHIC BASE MAP WAS PROVIDED BY AEROMETRIC ENGINEERING, SHERBOURNE, WISCONSIN. DATED DECEMBER 1983. GROUND CONTROL BY FRANK J. ISHMAN ASSOC. P.C.
  2. COORDINATES LABELED ON THESE PLANS ARE ACCORDING TO RAIL-SIDE GRID. REFER TO DRAWING NO. 2 FOR FULL COORDINATES.
  3. PROPOSED GRADES INDICATED ARE TOP OF SECONDARY CLAY LINER EXCEPT WHERE SHOWN OTHERWISE.
  4. UPON COMPLETION OF SECONDARY CLAY GRADES, THE SECONDARY CLAY IS TO BE EXCAVATED ONLY TO THE POINTS OF SHOWN EXCAVATION. SEE DRAWINGS FOR CONSTRUCTION GRADES. SEE DRAWINGS FOR MATERIALS, METHODS, AND TESTS.
  5. PRIOR TO BERM ELEVATION INSTALLATION, SLOPE REINFORCEMENT WILL BE EXCAVATED. SEE DETAIL 22.
  6. UPON COMPLETING INSTALLATION OF ONE LAYER OF GEOTEXTILE FOR BERM FLOWED, THE BASE SECONDARY HOLE LINER, THREE ADDITIONAL LAYERS OF GEOTEXTILE 30 FEET WIDE, ARE TO BE INSTALLED ALONG CENTER LINE OF CELL SEPARATION BERM 7 AND 8. FROM TOP OF GEOTEXTILE TO TOP OF CELL SEPARATION BERM ONE ADDITIONAL LAYER OF GEOTEXTILE FOR FLOWED IS TO BE INSTALLED ALONG TOP OF THE CELL SIDE SLOPE. SEE DRAWING NO. 10, 11 AND 12A.



NO.	DESCRIPTION	DATE	BY	CHECKED
1	DESIGN			
2	REVISED			
3	REVISED			
4	REVISED			
5	REVISED			
6	REVISED			
7	REVISED			
8	REVISED			
9	REVISED			
10	REVISED			
11	REVISED			
12	REVISED			
13	REVISED			
14	REVISED			
15	REVISED			
16	REVISED			
17	REVISED			
18	REVISED			
19	REVISED			
20	REVISED			
21	REVISED			
22	REVISED			
23	REVISED			
24	REVISED			
25	REVISED			
26	REVISED			
27	REVISED			
28	REVISED			
29	REVISED			
30	REVISED			
31	REVISED			
32	REVISED			
33	REVISED			
34	REVISED			
35	REVISED			
36	REVISED			
37	REVISED			
38	REVISED			
39	REVISED			
40	REVISED			
41	REVISED			
42	REVISED			
43	REVISED			
44	REVISED			
45	REVISED			
46	REVISED			
47	REVISED			
48	REVISED			
49	REVISED			
50	REVISED			
51	REVISED			
52	REVISED			
53	REVISED			
54	REVISED			
55	REVISED			
56	REVISED			
57	REVISED			
58	REVISED			
59	REVISED			
60	REVISED			
61	REVISED			
62	REVISED			
63	REVISED			
64	REVISED			
65	REVISED			
66	REVISED			
67	REVISED			
68	REVISED			
69	REVISED			
70	REVISED			
71	REVISED			
72	REVISED			
73	REVISED			
74	REVISED			
75	REVISED			
76	REVISED			
77	REVISED			
78	REVISED			
79	REVISED			
80	REVISED			
81	REVISED			
82	REVISED			
83	REVISED			
84	REVISED			
85	REVISED			
86	REVISED			
87	REVISED			
88	REVISED			
89	REVISED			
90	REVISED			
91	REVISED			
92	REVISED			
93	REVISED			
94	REVISED			
95	REVISED			
96	REVISED			
97	REVISED			
98	REVISED			
99	REVISED			
100	REVISED			

SIGNATURE \_\_\_\_\_  
 DATE \_\_\_\_\_  
 PROJECT: \_\_\_\_\_  
 SHEET: \_\_\_\_\_  
 OF \_\_\_\_\_  
 DRAWING TITLE: **SECONDARY CLAY LINER GRADES**  
 34



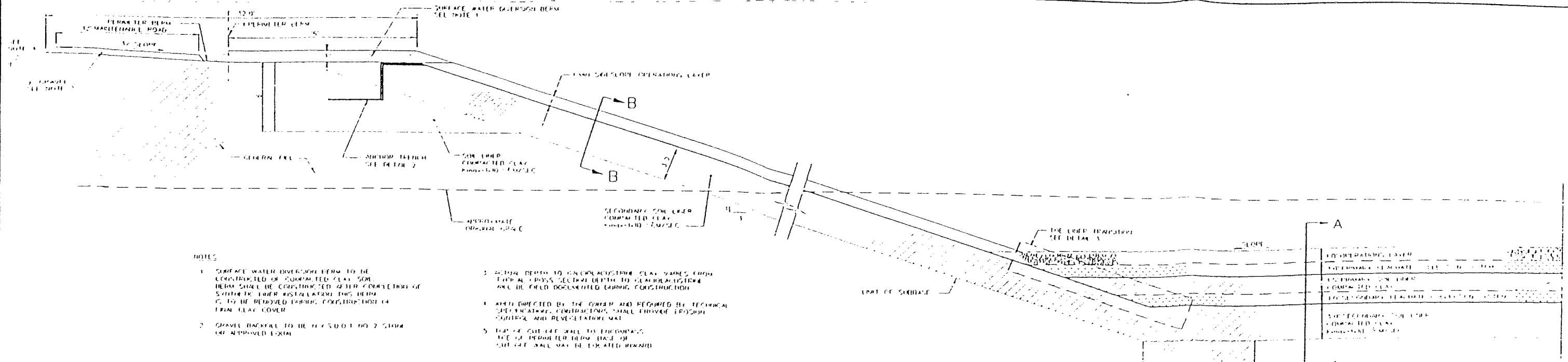

- NOTES
1. SURFACE WATER OVERFLOW BERM TO BE CONSTRUCTED OF COMPACTED CLAY. SOIL BERM SHALL BE CONSTRUCTED AFTER COMPLETION OF SLOPE LINER INSTALLATION. THIS BERM IS TO BE REMOVED DURING CONSTRUCTION OF FINAL CLAY COVER.
  2. GRAVEL BACKFILL TO BE #57 OR #2 STORM OR APPROVED EQUAL.
  3. ANCHOR TRENCH TO BE CONSTRUCTED FROM TOP OF FINISH GRADE TO BOTTOM OF SLOPE LINER. THIS TRENCH SHALL BE FILL DOCUMENTED DURING CONSTRUCTION.
  4. WHEN DIRECTED BY THE OWNER AND REQUIRED BY TECHNICAL SPECIFICATIONS, CONTRACTORS SHALL EXPOSE PROPOSED SLOPE AND REVEALATION MAT.
  5. TOP OF OVERFLOW WALL TO BE LOCATED 10' TO 12' FROM FACE OF SLOPE WALL. WALL MAY BE LOCATED REWARD.

PERIMETER BERM SECTION (TYPICAL) FOR CELLS 7 AND 8

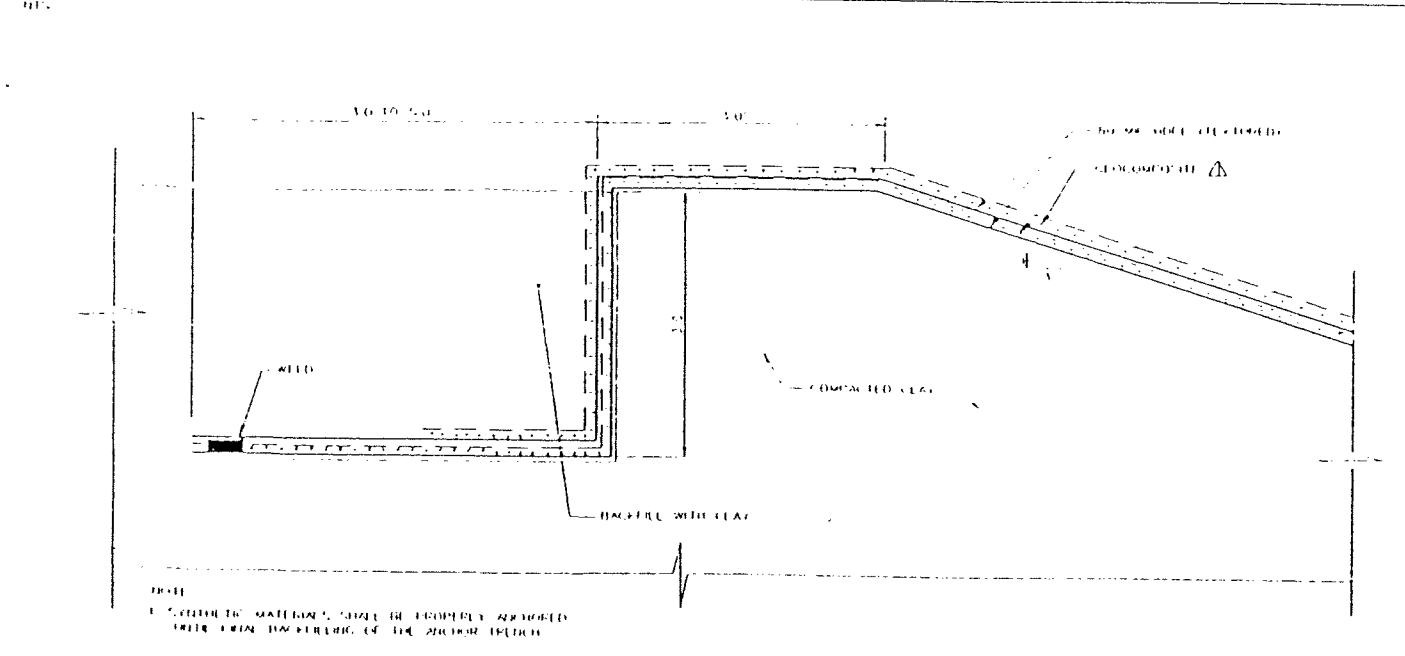

ANCHOR TRENCH (TYPICAL) FOR CELLS 7 AND 8

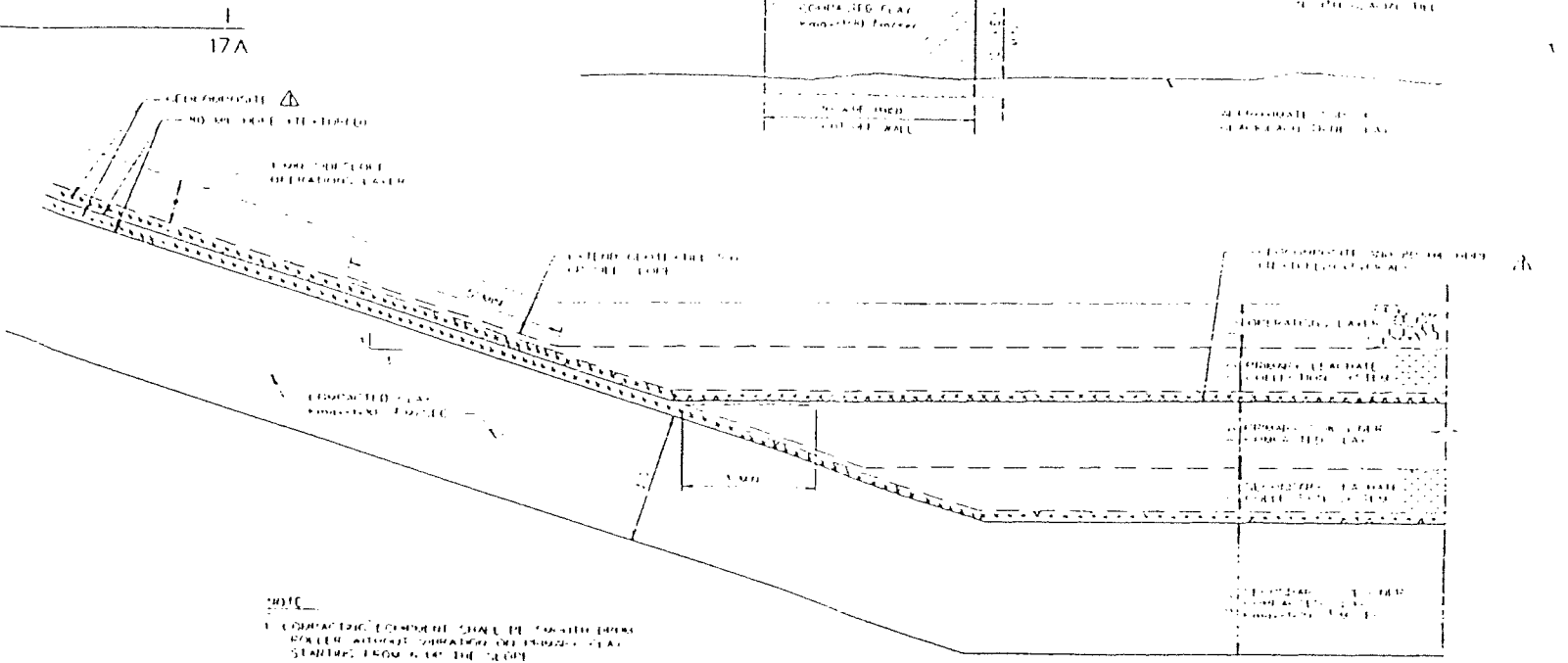

TOE LINER TRANSITION (TYPICAL) FOR CELLS 7 THROUGH 14

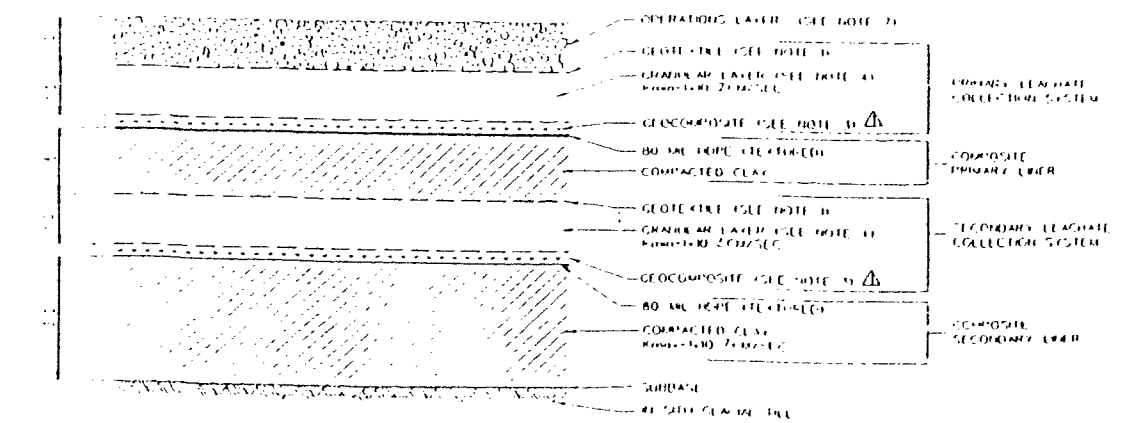

SECTION A-A BASE LINER

- NOTES
1. GEOTEXTILE SHALL BE THERMA 1145 OR EQUIV. CONTINUOUS FRAGMENT FABRIC, UNLESS SPECIFICALLY STATED.
  2. GEOCOMPOSITE FOR SLOPE LINER IN ONE LAYER OF TENSAR 3002 OR EQUAL.
  3. GEOCOMPOSITE FOR THE BASE SHALL BE ONE LAYER OF TENSAR 3002 OR EQUAL.
  4. PRIMARY AND SECONDARY LEACHATE LAYERS SHALL BE NEW LENO STATE OR IN STATE OR APPROVED EQUIV. HAVING A MINIMUM HYDRAULIC CONDUCTIVITY OF 1.0E-10 CM/SEC.

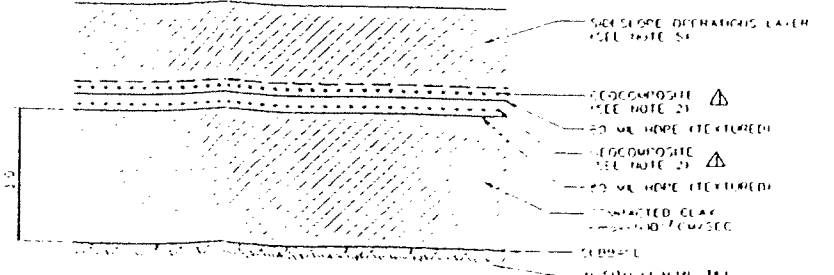

SECTION B-B SIDESLOPE LINER

5. SAND LAYER OPERATIONS LAYER SHALL BE A MINIMUM OF ONE FOOT THICK OR EQUAL.
6. BASE OPERATIONS LAYER SHALL BE NORMAL ONE FOOT THICK OR GREATER OR 2' STORM OR EQUAL.
7. FOR ANCHOR TRENCH SYSTEM DETAILS AS SHOWN HERE, SEE DRAWING 100-10A.

ENVIRONMENT & INFRASTRUCTURE

SIGNATURE \_\_\_\_\_

DATE \_\_\_\_\_

REV	DATE	BY	DESCRIPTION
1			
2			
3			
4			
5			

TYPICAL LINER SECTIONS FOR CELLS 7 THROUGH 14

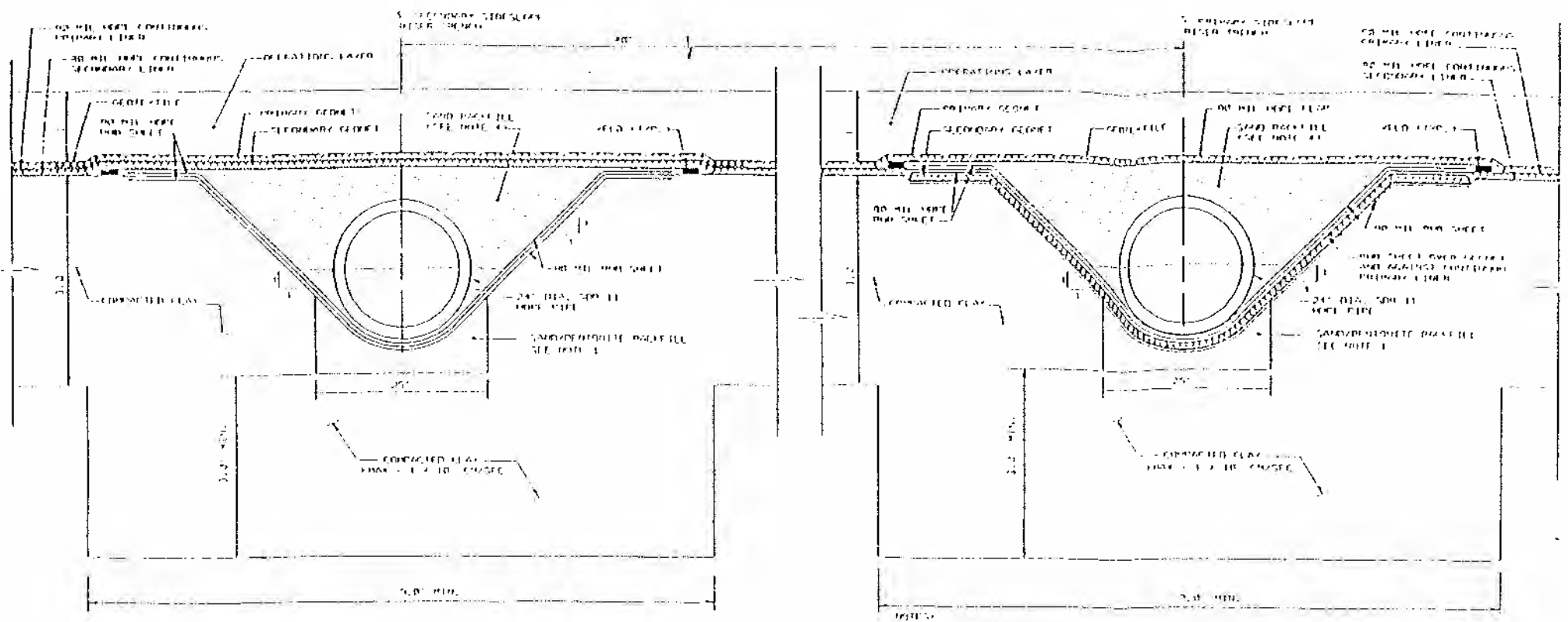

- NOTES:
1. UNDESIRABLE TREE SPECIES SHOULD BE REMOVED FROM THE AREA OF THE TRENCH. UNDESIRABLE TREE SPECIES SHOULD BE REMOVED FROM THE AREA OF THE TRENCH.
  2. TREES SHOULD BE INSTALLED WITH A MINIMUM 10' TO 15' SPACING.
  3. SLOPES SHOULD BE PROTECTED TO BE EROSION PROTECTED WITH AN APPROPRIATE EROSION PROTECTION.
  4. SAND BACKFILL SHALL BE TO A MINIMUM 18\"/>
- | NO. | DESCRIPTION | QTY | UNIT |
|-----|-------------|-----|------|
| 1   | 24\"/>      |     |      |
- SEE DRAWING NO. 10 FOR PRIMARY AND SECONDARY RISER TRENCH DETAIL. SEE DRAWING NO. 11 FOR RISER TRENCH DETAIL.

PRIMARY AND SECONDARY SIDESLOPE RISER TRENCH DETAIL 12

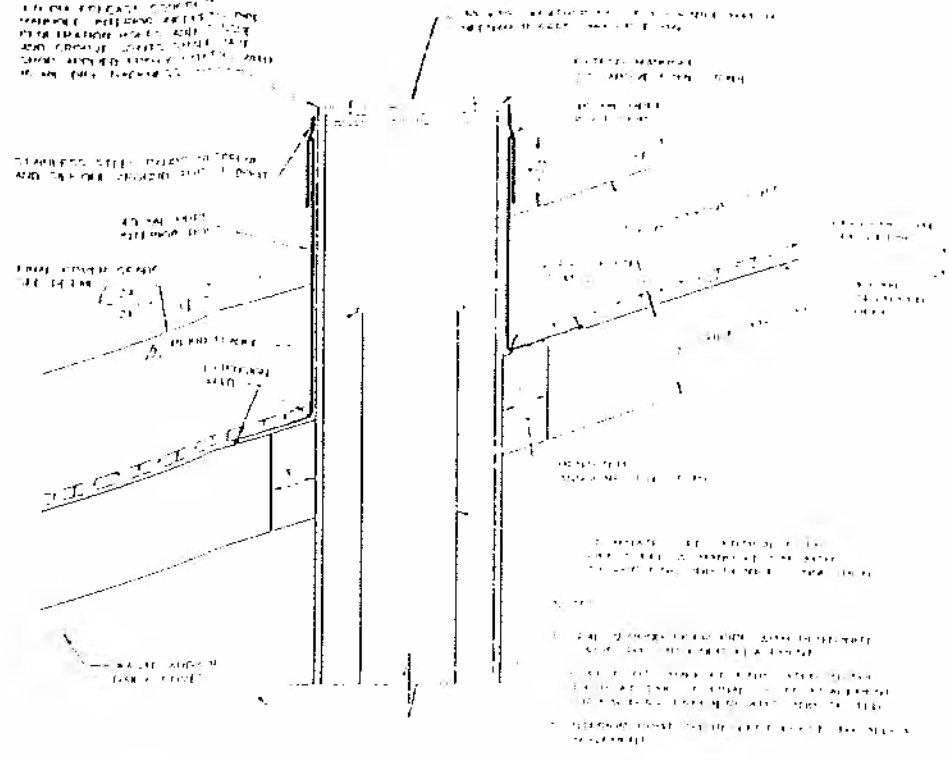

FINAL CAP VERTICAL RISER PENETRATION 15

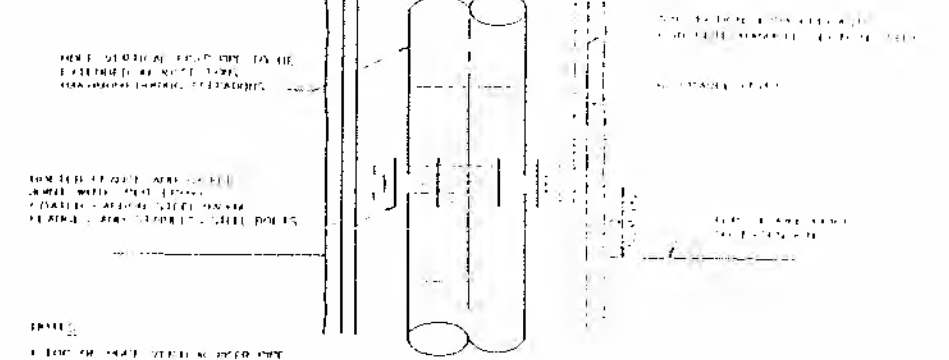

VERTICAL RISER PROTECTION AND EXTENSION DETAIL 16

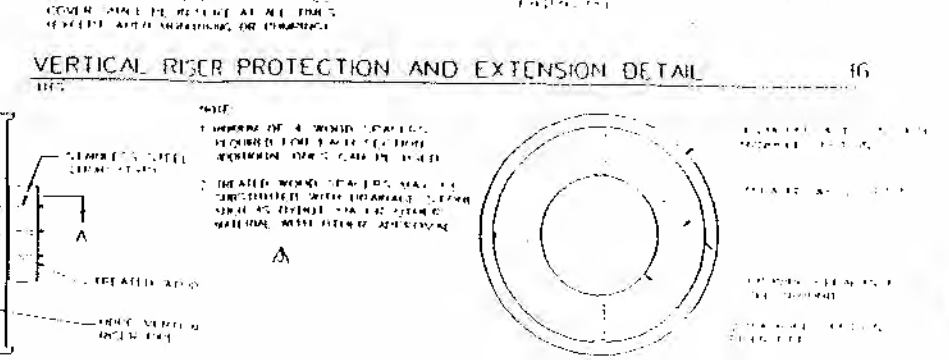

VERTICAL RISER SPACER 17

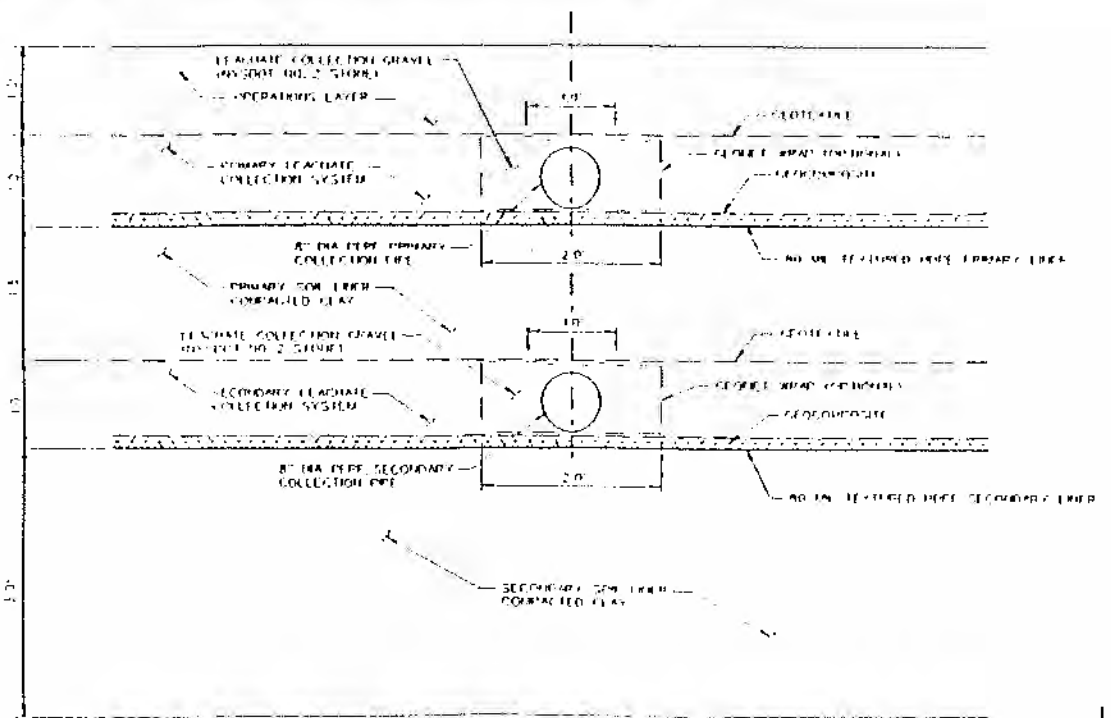

PRIMARY LEACHATE COLLECTION PIPE WITH SECONDARY LEACHATE COLLECTION PIPE CELLS 7 AND 8, 10 AND 9, 14 AND 12, 13 AND 11 18

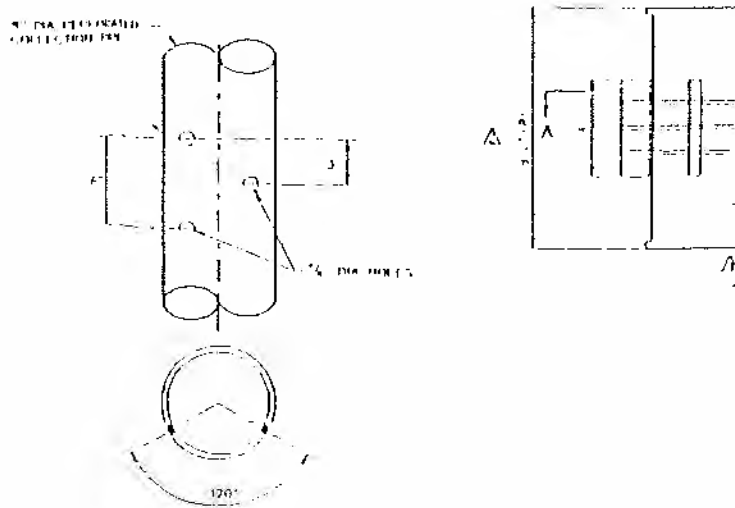

LEACHATE COLLECTION PIPING PERFORATION 19

**ENVIRONMENT & INFRASTRUCTURE**

SIGNATURE: \_\_\_\_\_ DATE: \_\_\_\_\_

NO.	DESCRIPTION	DATE	BY
1	DESIGN		
2	CONSTRUCTION		
3	OPERATION		
4	MAINTENANCE		
5	REPAIR		
6	REPLACEMENT		
7	REMOVAL		

**RISER DETAILS**

48

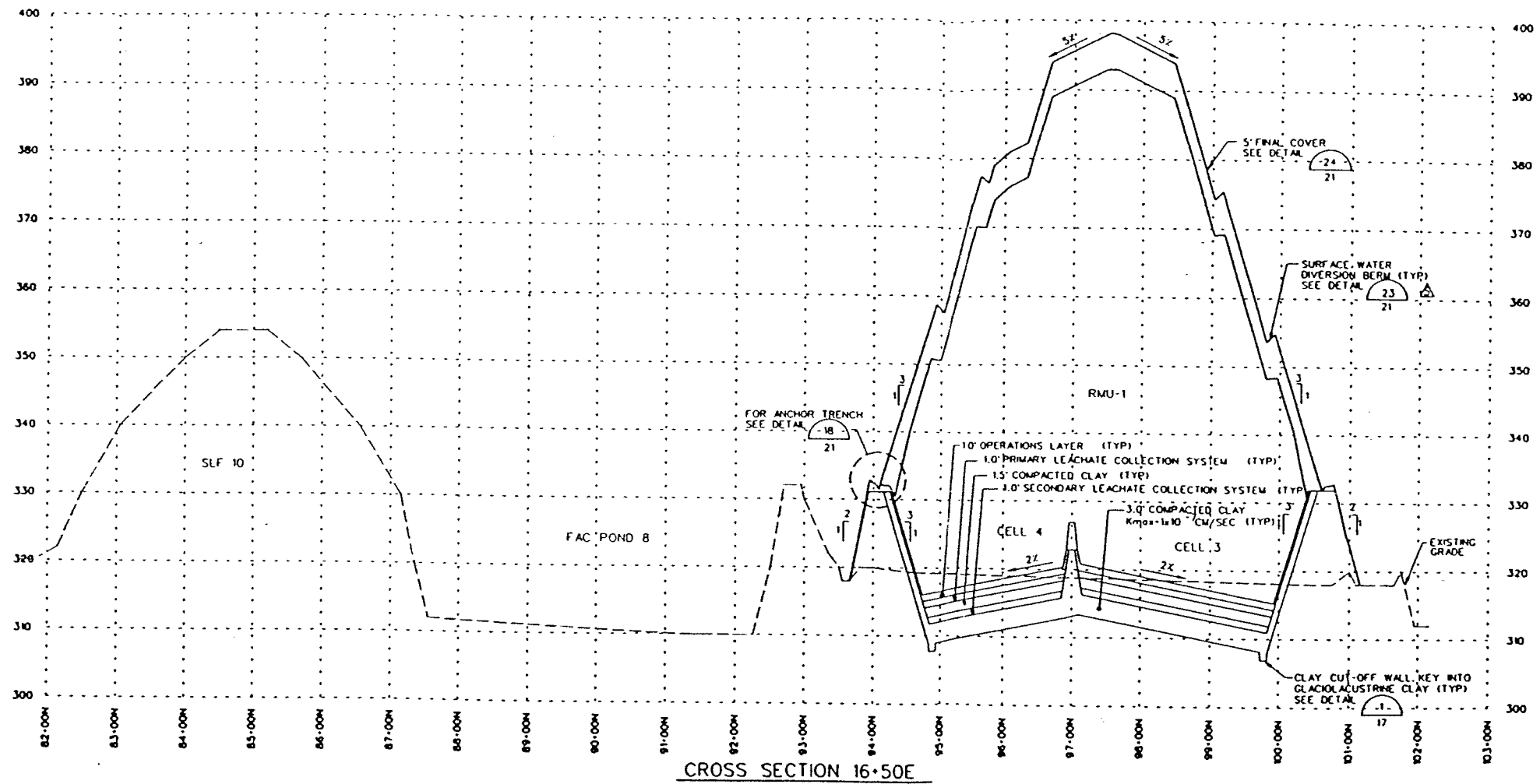

CROSS SECTION 16+50E

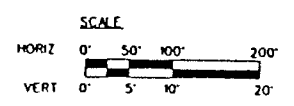
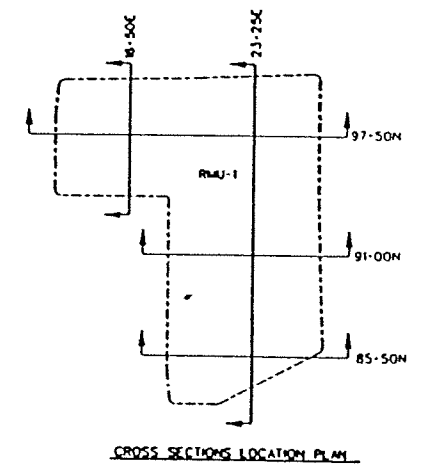
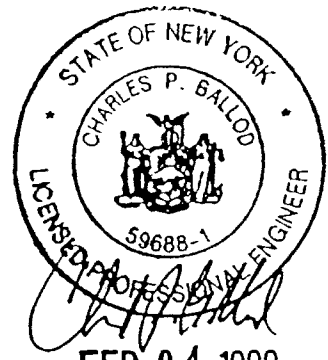

REV	DATE	DESCRIPTION	DR BY	APP
11-98		REMOVE FINAL COVER ACCESS ROAD	FAS	CF
5-98		REVISED CROSS SECTION FOR AIRSPACE ENHANCEMENT	FAS	CF
4-98		REVISED SURFACE WATER DIVERSION BERMS PHASE I, II AND III CAP AREAS	FAS	CF
6-97		MODIFY CELLS 9 THROUGH 14	FAS	CF
4-97		MODIFY CELL 9	FAS	CF
11-96		MODIFY CELLS 7 AND 8	FAS	CF
6-92		NOTICE OF DEFICIENCY RESPONSES	FLD	GR

  

DES BY	BRJ/TJP	PROJECT NO.	17365	DATE	FEBRUARY 1999
DRN BY	FLD	PROJECT	RESIDUALS MANAGEMENT UNIT 1		
CHK BY	MGR	DRAWING TITLE			
ERV BY	TJB	CROSS SECTIONS 16+50E			
GRV BY	CFF				
APP BY	GRW				

**RUST** ENVIRONMENT & INFRASTRUCTURE

SIGNATURE \_\_\_\_\_

DATE \_\_\_\_\_

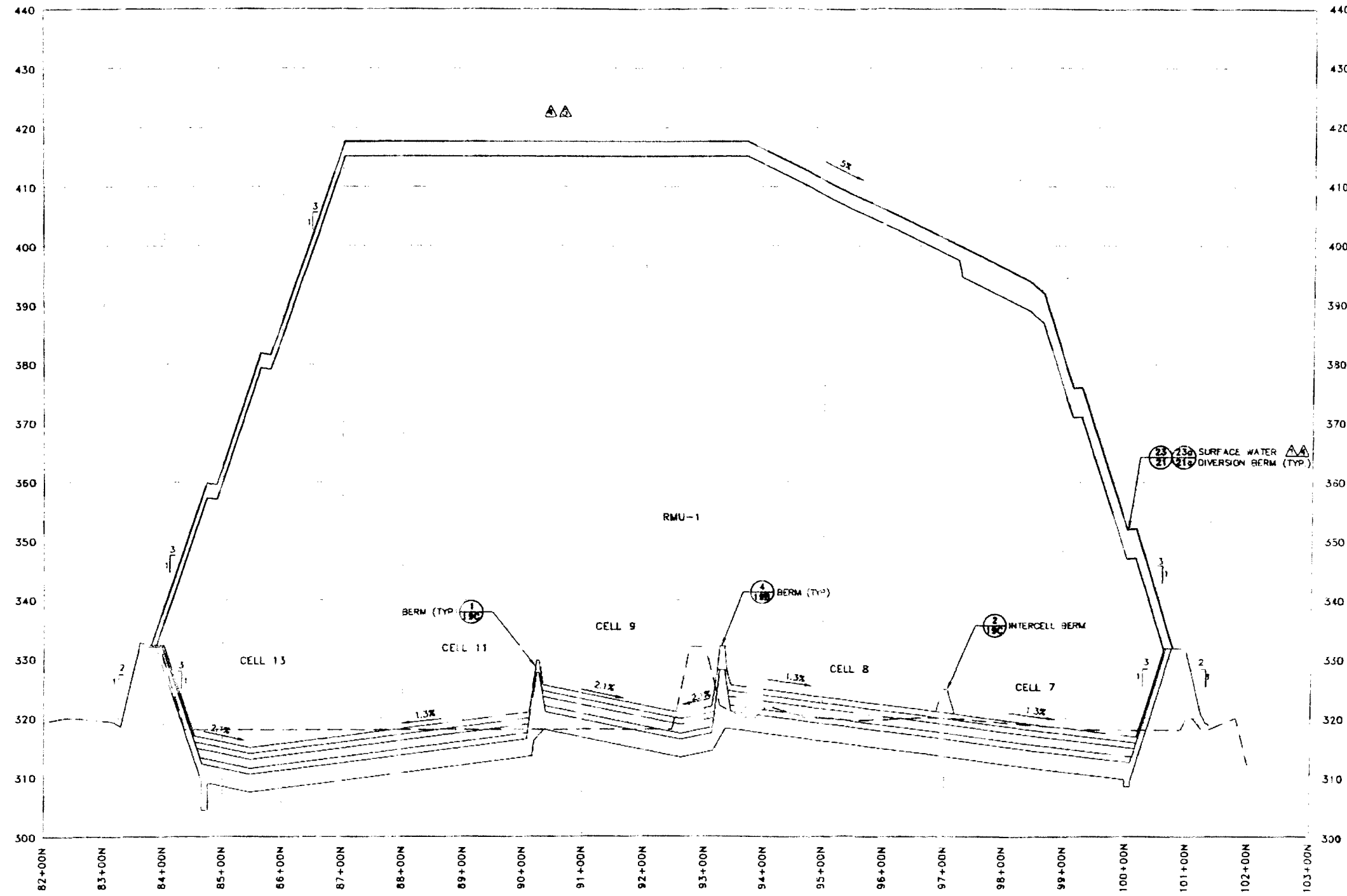

**CROSS SECTION 23+25E**

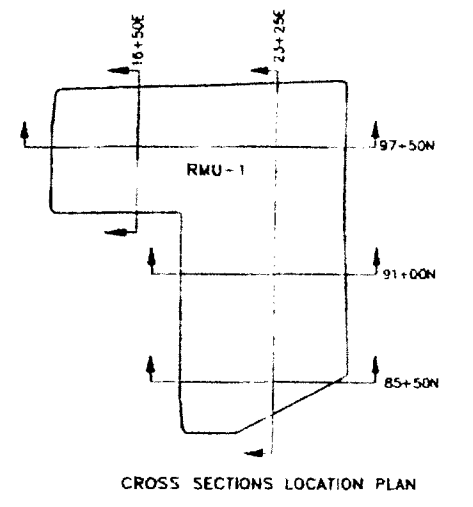
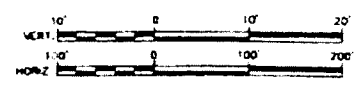

**CROSS SECTIONS LOCATION PLAN**

- GENERAL NOTES:**
1. THIS DRAWING BASED ON DRAWING NUMBER 15A-a "CROSS SECTIONS 23+25E" PREPARED BY BBL DECEMBER 2003.
  2. PRIOR REVISIONS TO DRAWING NUMBER 15A BY EARTHTECH INCLUDE THE FOLLOWING:
    1. REVISED SURFACE WATER DIVERSION BERMS (DATED 5/98, DRAWN BY FAS, APPROVED BY CPB).
    2. REMOVE FINAL COVER ACCESS ROAD (DATED 11/98, DRAWN BY FAS, APPROVED BY CPB).
    3. REVISED MAXIMUM ELEVATION (DATED 2/99, DRAWN BY FAS, APPROVED BY CPB).
  3. BBL REVISIONS INCLUDE THE FOLLOWING:
    4. REVISED DRAWING FOR AIRSPACE ENHANCEMENT (12/03).
    5. REVISED DRAWING FOR FINAL COVER MODIFICATION (03/08).

CWM CHEMICAL SERVICES, LLC  
 MODEL CITY FACILITY  
 RESIDUALS MANAGEMENT UNIT 1

---

**CROSS SECTIONS 23+25E**

---

**BBL**  
 BLAIR AND BOICK & LEE, INC.  
 engineers & scientists

Modified: 07/09



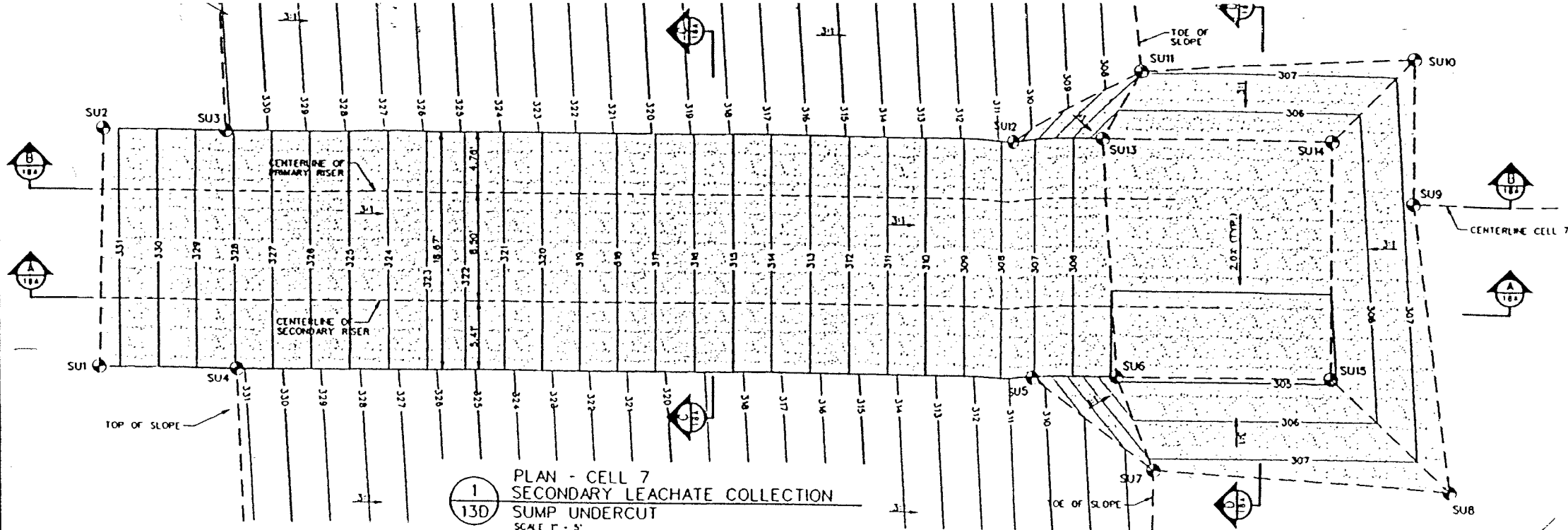

1 PLAN - CELL 7  
SECONDARY LEACHATE COLLECTION  
SUMP UNDERCUT  
SCALE 1" = 5'

POINT	NORTHING	EASTING	EL.
SU1	10089.98	2436.10	331.54
SU2	10085.58	2454.71	331.43
SU3	10079.97	2454.71	331.13
SU4	10079.24	2436.08	331.22
SU5	10018.55	2436.01	330.36
SU6	10009.89	2438.94	307.83
SU7	10006.84	2438.94	307.29
SU8	9984.59	2427.80	301.60
SU9	9981.31	2450.00	307.15
SU10	9981.32	2460.98	307.34
SU11	10007.97	2460.17	307.03
SU12	10018.76	2439.70	330.92
SU13	10010.95	2454.69	302.24
SU14	9991.42	2454.69	302.24
SU15	9981.26	2436.00	304.81

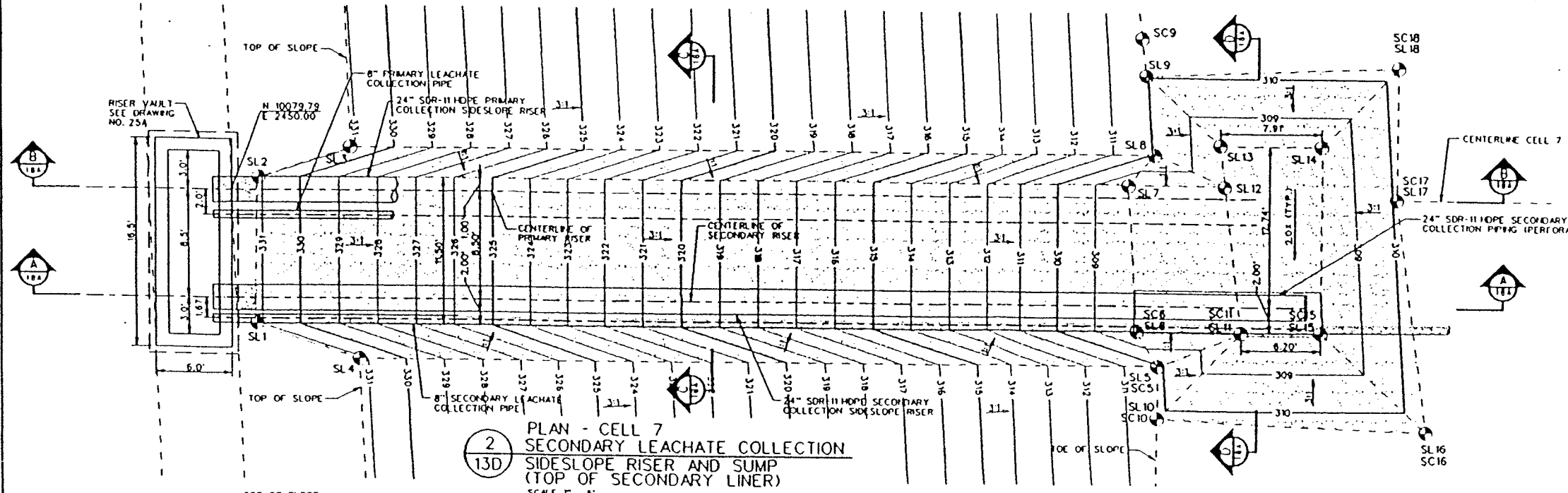

2 PLAN - CELL 7  
SECONDARY LEACHATE COLLECTION  
SIDESLOPE RISER AND SUMP  
(TOP OF SECONDARY LINER)  
SCALE 1" = 5'

POINT	NORTHING	EASTING	EL.
SL1	10077.82	2442.50	331.20
SL2	10077.82	2442.50	331.20
SL3	10010.43	2453.43	331.13
SL4	10010.03	2449.91	331.18
SL5	10013.62	2449.91	331.18
SL6	10013.62	2442.50	309.19
SL7	10013.62	2451.00	309.19
SL8	10013.62	2451.00	309.19
SL9	10006.33	2451.00	309.19
SL10	10006.33	2453.92	309.19
SL11	9991.32	2453.92	309.19
SL12	9991.32	2449.91	309.19
SL13	10005.89	2449.91	309.19
SL14	10005.89	2447.49	309.19
SL15	10005.89	2447.49	309.19
SL16	10015.66	2440.58	332.79
SL17	9988.88	2439.89	312.88
SL18	9982.28	2450.00	312.88
SL19	10014.95	2462.10	332.88

POINT	NORTHING	EASTING	EL.
PL1	10077.82	2442.50	331.16
PL2	10077.82	2451.00	331.15
PL3	10010.43	2453.43	331.13
PL4	10010.03	2449.91	331.18
PL5	10013.62	2449.91	331.18
PL6	10013.62	2442.50	309.19
PL7	10013.62	2451.00	309.19
PL8	10013.62	2451.00	309.19
PL9	10006.33	2451.00	309.19
PL10	10006.33	2453.92	309.19
PL11	9991.32	2453.92	309.19
PL12	9991.32	2449.91	309.19
PL13	10005.89	2449.91	309.19
PL14	10005.89	2447.49	309.19
PL15	10005.89	2447.49	309.19
PL16	10015.66	2440.58	332.79
PL17	9988.88	2439.89	312.88
PL18	9982.28	2450.00	312.88
PL19	10014.95	2462.10	332.88

POINT	NORTHING	EASTING	EL.
SC1	10077.82	2442.50	331.20
SC2	10077.82	2442.50	331.20
SC3	10010.43	2453.43	331.13
SC4	10010.03	2449.91	331.18
SC5	10013.62	2449.91	331.18
SC6	10013.62	2442.50	309.19
SC7	10013.62	2451.00	309.19
SC8	10013.62	2451.00	309.19
SC9	10006.33	2451.00	309.19
SC10	10006.33	2453.92	309.19
SC11	9991.32	2453.92	309.19
SC12	9991.32	2449.91	309.19
SC13	10005.89	2449.91	309.19
SC14	10005.89	2447.49	309.19
SC15	10005.89	2447.49	309.19
SC16	10015.66	2440.58	332.79
SC17	9988.88	2439.89	312.88
SC18	9982.28	2450.00	312.88
SC19	10014.95	2462.10	332.88

NOTES:  
1. COORDINATES OF RISER PIPES MAY VARY IN THE FIELD. AS-BUILT LOCATIONS AND ELEVATIONS WILL BE PROVIDED WITH THE CELL CERTIFICATION REPORT.  
2. SECONDARY COLLECTION POINTS (SC) ARE DIRECTLY ABOVE TOP OF SECONDARY CLAY. SEE DETAIL D DWG. 10A.

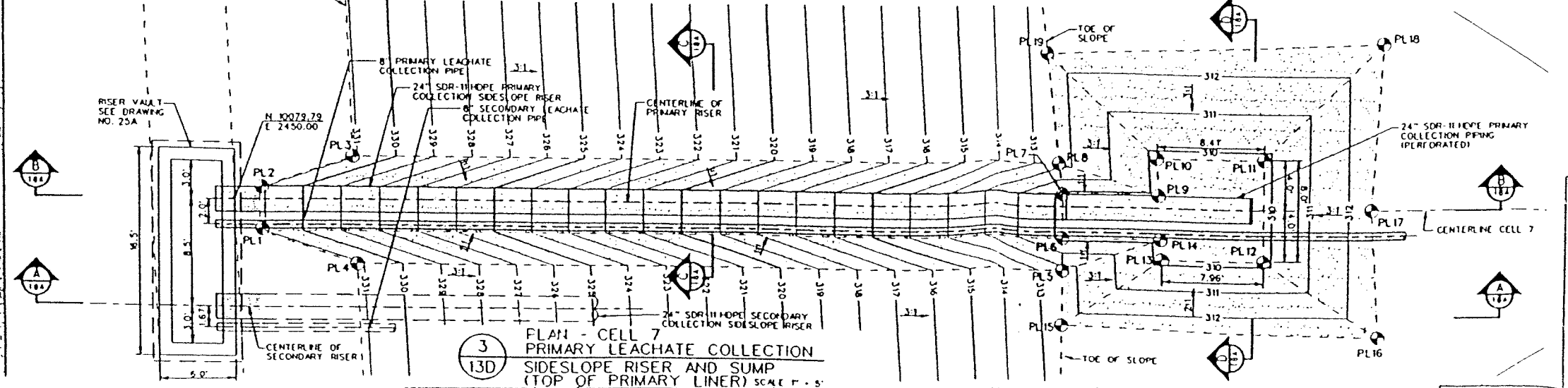

3 PLAN - CELL 7  
PRIMARY LEACHATE COLLECTION  
SIDESLOPE RISER AND SUMP  
(TOP OF PRIMARY LINER) SCALE 1" = 5'

SIGNATURE	11/96	MODIFY FOR NEW BASE GRADES	FAS	CPM
	1/96	ADD TOP OF SECONDARY COLLECTION AND AND REVISED COORDINATES. ADDED NOTE	FAS	CPM
DATE	NOVEMBER 1995	DESCRIPTION	DRN BY	APP
DATE		PROJECT NO. 34202100	SCALE: AS SHOWN	
DRN BY	FAS	PROJECT:	RESURFACING UNIT 1	
CHK BY	CPB	SHEET TITLE:	SUMP CONSTRUCTION GRADES CELL 7	
REV BY	AME			
APP BY	CPB			

**ENVIRONMENT & INFRASTRUCTURE**  
CWM Chemical Services, Inc.  
Model City Facility

DRAWING NO. **FIGURE 7B**



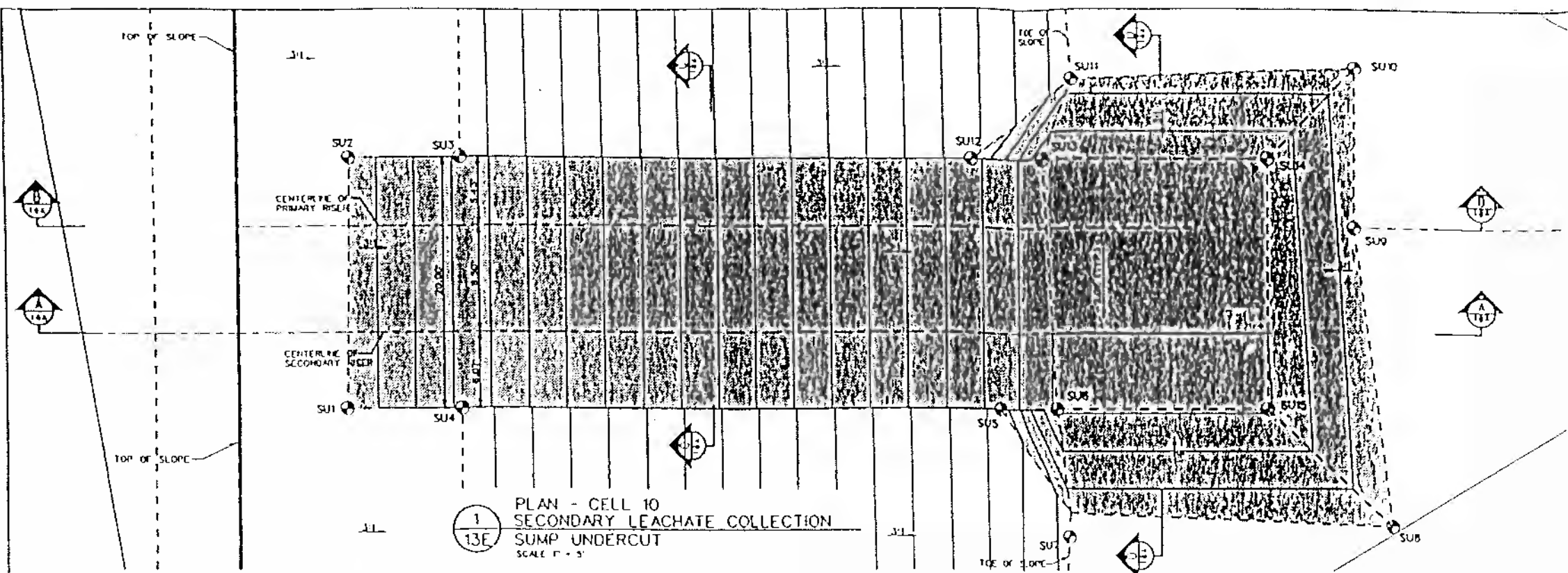

1  
13E  
PLAN - CELL 10  
SECONDARY LEACHATE COLLECTION  
SUMP UNDERCUT  
SCALE 1" = 5'

POINT	NORTHING	EASTING	ELEVATION
SU1	2245.43	1871.22	304.49
SU2	2242.41	1871.51	304.72
SU3	2245.43	1880.51	304.86
SU4	2245.43	1872.26	304.61
SU5	2245.42	1872.27	305.88
SU6	2237.15	1872.30	308.63
SU7	2236.16	1872.30	308.63
SU8	2236.16	1854.19	308.93
SU9	2236.00	1851.13	308.44
SU10	2237.32	1851.44	308.73
SU11	2231.80	1827.46	308.47
SU12	2265.43	1826.98	305.29
SU13	2265.43	1827.03	305.29
SU14	2265.43	1844.61	305.28
SU15	2245.43	1844.61	305.28

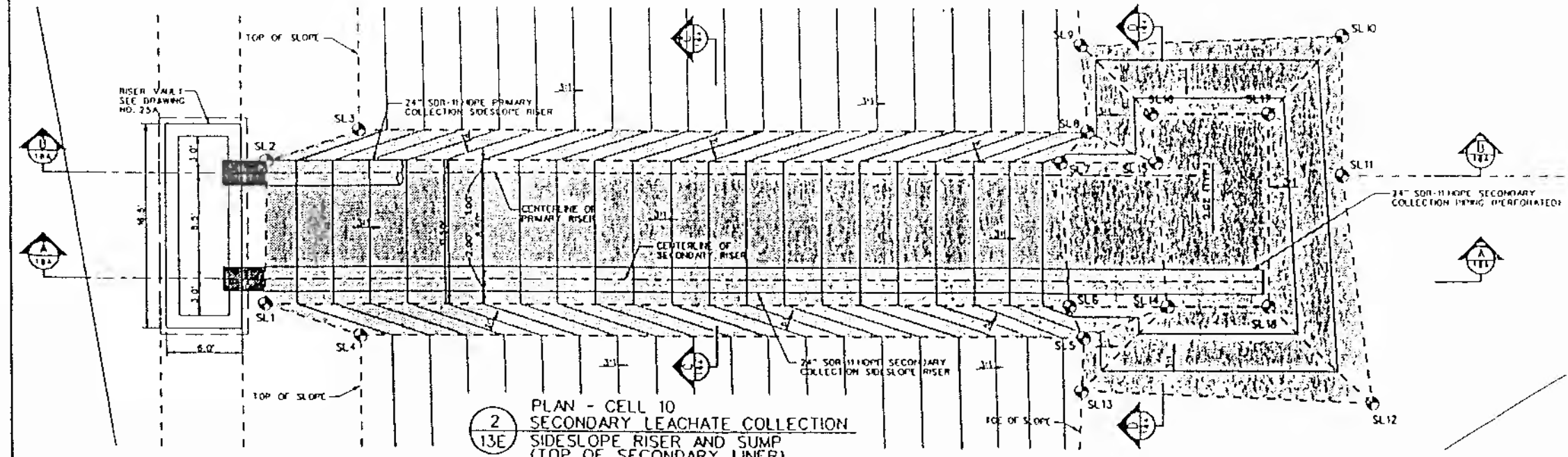

2  
13E  
PLAN - CELL 10  
SECONDARY LEACHATE COLLECTION  
SIDESLOPE RISER AND SUMP  
(TOP OF SECONDARY LINER)  
SCALE 1" = 5'

POINT	NORTHING	EASTING	ELEVATION
SL1	2242.50	1864.34	310.84
SL2	2241.00	1864.52	310.78
SL3	2242.48	1872.00	310.73
SL4	2242.48	1872.00	310.85
SL5	2241.50	1872.06	309.27
SL6	2261.00	1828.37	309.50
SL7	2261.48	1830.57	311.22
SL8	2270.42	1830.58	311.23
SL9	2271.27	1830.58	311.23
SL10	2260.00	1850.47	311.43
SL11	2241.17	1852.81	311.85
SL12	2242.11	1850.03	311.53
SL13	2245.50	1837.11	309.73
SL14	2261.00	1836.85	309.50
SL15	2265.00	1835.54	309.58
SL16	2265.00	1844.61	309.58
SL17	2242.50	1844.61	309.73
SL18	2242.50	1844.61	309.73

POINT	NORTHING	EASTING	ELEVATION
PL1	2251.50	1864.48	310.80
PL2	2251.00	1864.42	310.53
PL3	2253.48	1872.00	310.71
PL4	2253.48	1872.00	310.83
PL5	2252.50	1872.06	310.81
PL6	2272.24	1830.51	311.02
PL7	2272.24	1830.51	311.02
PL8	2272.24	1830.51	311.02
PL9	2272.24	1830.51	311.02
PL10	2272.24	1830.51	311.02
PL11	2272.24	1830.51	311.02
PL12	2272.24	1830.51	311.02
PL13	2272.24	1830.51	311.02
PL14	2272.24	1830.51	311.02
PL15	2272.24	1830.51	311.02
PL16	2272.24	1830.51	311.02
PL17	2272.24	1830.51	311.02
PL18	2272.24	1830.51	311.02
PL19	2272.24	1830.51	311.02

NOTES:  
1. COORDINATES OF RISER POINTS MAY VARY IN THE FIELD AS DUE TO LOCATIONS AND ELEVATIONS WILL BE PROVIDED WITH THE CELL CONSTRUCTION REPORT.

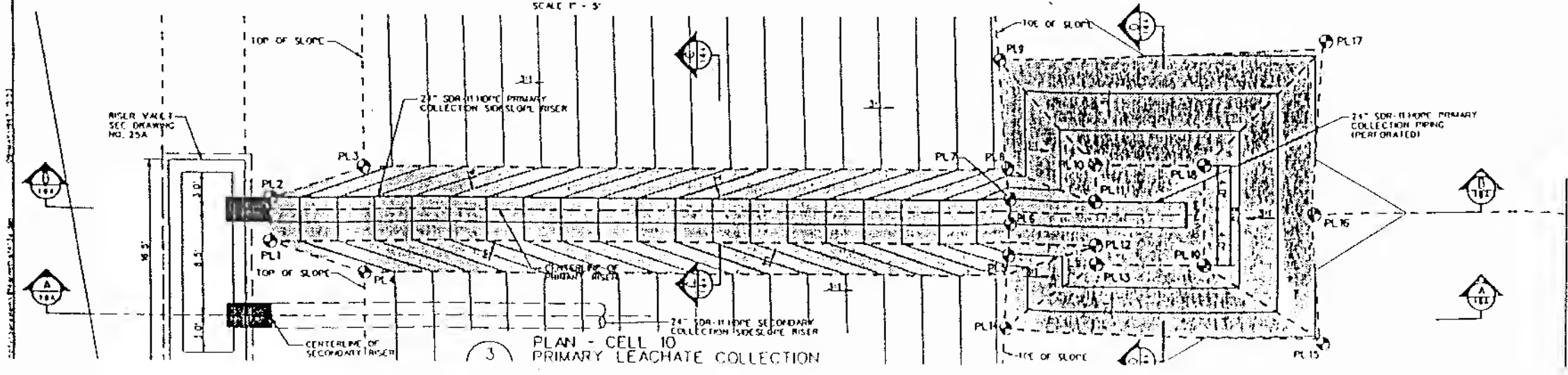

3  
13E  
PLAN - CELL 10  
PRIMARY LEACHATE COLLECTION  
SCALE 1" = 5'

**RUST ENVIRONMENTAL & INFRASTRUCTURE**

DATE: JULY 1996  
PROJECT: 32444 MO  
SHEET: 11 OF 11  
SUMP CONSTRUCTION GRADES CELL 10

DATE: 4/97  
REV: MOODY CELL 10 BASE GRADES  
DATE: 7/96  
REV: FAS  
DATE: 7/96  
REV: FAS  
DATE: 7/96  
REV: CFB  
DATE: 7/96  
REV: AWE  
DATE: 7/96  
REV: CFB

PROJECT NO: 32444 MO  
SHEET: 11 OF 11  
SUMP CONSTRUCTION GRADES CELL 10

CWM Chemical

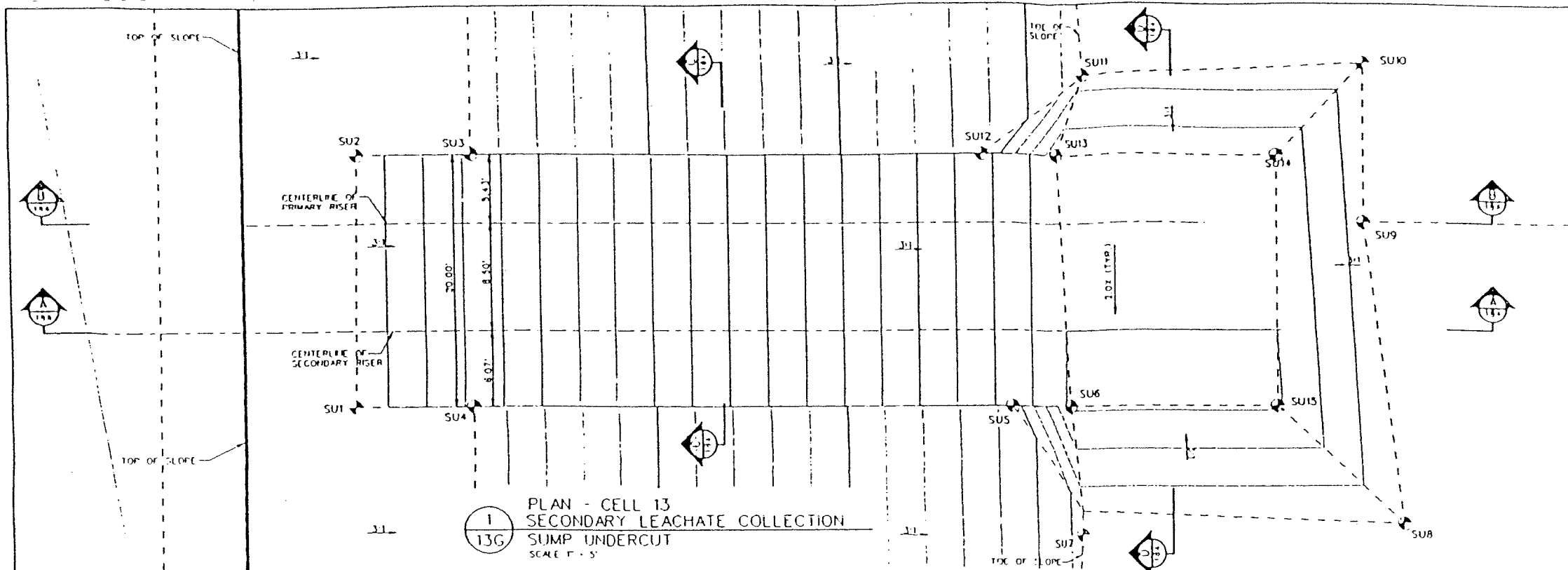

1  
13G PLAN - CELL 13  
SECONDARY LEACHATE COLLECTION  
SUMP UNDERCUT  
SCALE F - 5'

CELL 13 SECONDARY SUMP UNDERCUT CONSTRUCTION CONTROL COORDINATES

POINT	NORTHING	EASTING	EL
SU1	8489.64	2505.15	327.25
SU2	8489.61	2485.30	327.16
SU3	8497.81	2498.87	327.20
SU4	8521.81	2479.22	327.01
SU5	8555.88	2468.21	326.91
SU6	8560.02	2476.81	326.84
SU7	8583.53	2464.81	326.74
SU8	8573.14	2450.00	326.14
SU9	8563.72	2433.03	326.37
SU10	8544.26	2444.49	326.00
SU11	8540.19	2451.04	327.73
SU12	8545.33	2451.36	327.81
SU13	8560.90	2443.19	327.81
SU14	8570.18	2469.31	327.81

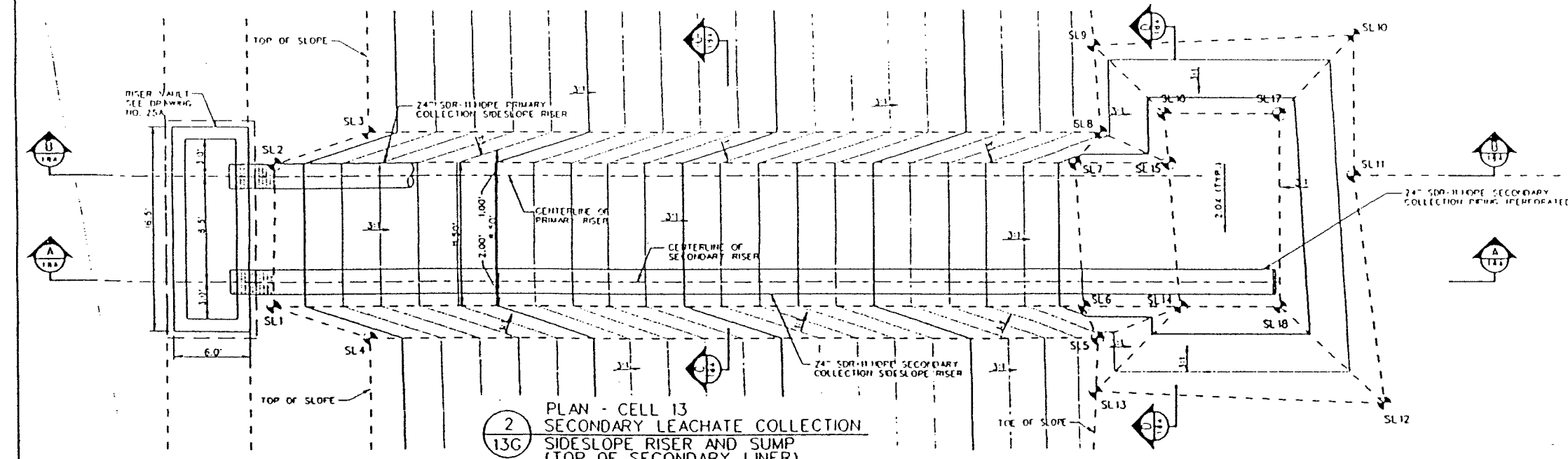

2  
13G PLAN - CELL 13  
SECONDARY LEACHATE COLLECTION  
SIDESLOPE RISER AND SUMP  
(TOP OF SECONDARY LINER)  
SCALE F - 5'

CELL 13 SECONDARY SUMP CLAY LINER CONSTRUCTION CONTROL COORDINATES

POINT	NORTHING	EASTING	EL
SL1	8481.69	2503.77	331.24
SL2	8476.21	2492.51	331.19
SL3	8488.88	2501.43	331.26
SL4	8524.24	2472.66	326.26
SL5	8554.24	2462.51	326.19
SL6	8518.93	2454.65	326.02
SL7	8479.81	2451.68	327.87
SL8	8561.46	2445.46	326.72
SL9	8561.26	2444.72	326.11
SL10	8572.05	2450.01	326.12
SL11	8579.44	2460.43	326.44
SL12	8588.13	2471.45	326.39
SL13	8561.32	2460.96	326.11
SL14	8555.22	2451.17	326.02
SL15	8553.03	2447.77	326.10
SL16	8561.17	2443.57	326.10
SL17	8568.24	2457.30	326.73

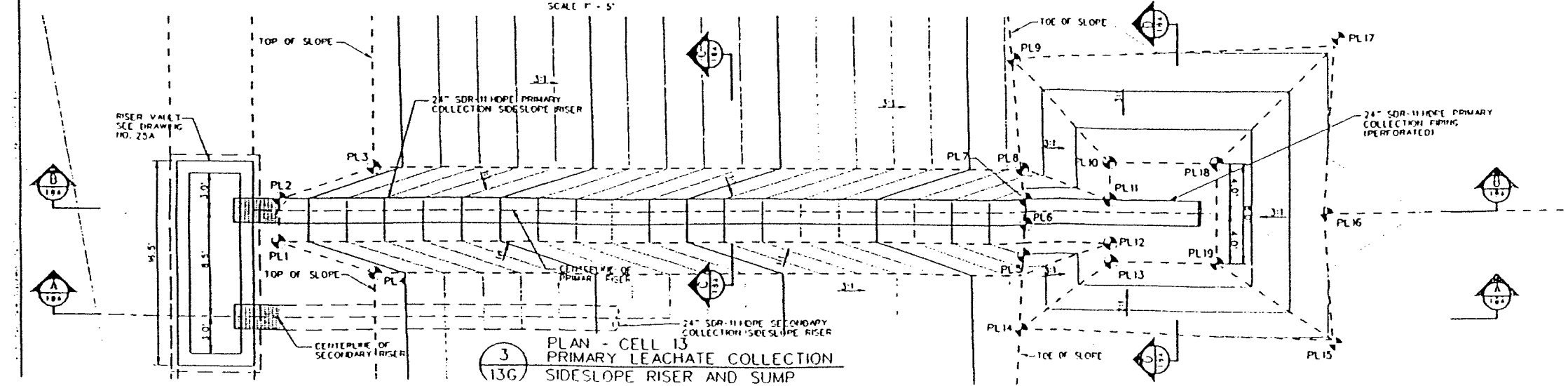

3  
13G PLAN - CELL 13  
PRIMARY LEACHATE COLLECTION  
SIDESLOPE RISER AND SUMP  
SCALE F - 5'

CELL 13 PRIMARY SUMP CLAY LINER CONSTRUCTION CONTROL COORDINATES

POINT	NORTHING	EASTING	EL
PL1	8477.27	2492.63	333.20
PL2	8476.21	2482.21	333.19
PL3	8488.88	2491.12	333.26
PL4	8524.24	2462.19	328.19
PL5	8554.24	2452.04	328.12
PL6	8518.93	2444.18	327.95
PL7	8479.81	2441.21	329.80
PL8	8561.46	2435.04	328.65
PL9	8561.26	2434.30	328.04
PL10	8572.05	2439.59	328.36
PL11	8579.44	2449.01	328.68
PL12	8588.13	2460.03	328.63
PL13	8561.32	2449.54	328.35
PL14	8555.22	2439.35	328.26
PL15	8553.03	2435.95	328.34
PL16	8561.17	2431.75	328.26
PL17	8568.24	2445.48	328.89

NOTES:  
1. COORDINATES OF RISER PILES MAY VARY IN THE FIELD. AS-BUILT LOCATIONS AND ELEVATIONS SHALL BE PROVIDED WITH THE CELL CERTIFICATION REPORT.

**RUST** ENVIRONMENTAL & INFRASTRUCTURE

DATE: APRIL 1997

PROJECT NO: 200308

SCALE: AS SHOWN

DESIGNED BY: FAS

CHECKED BY: CFB

REVIEWED BY: AWE

APPROVED BY: CFB

SHEET TITLE: SUMP CONSTRUCTION GRADES CELL 13

CWM Chemical Services, Inc.



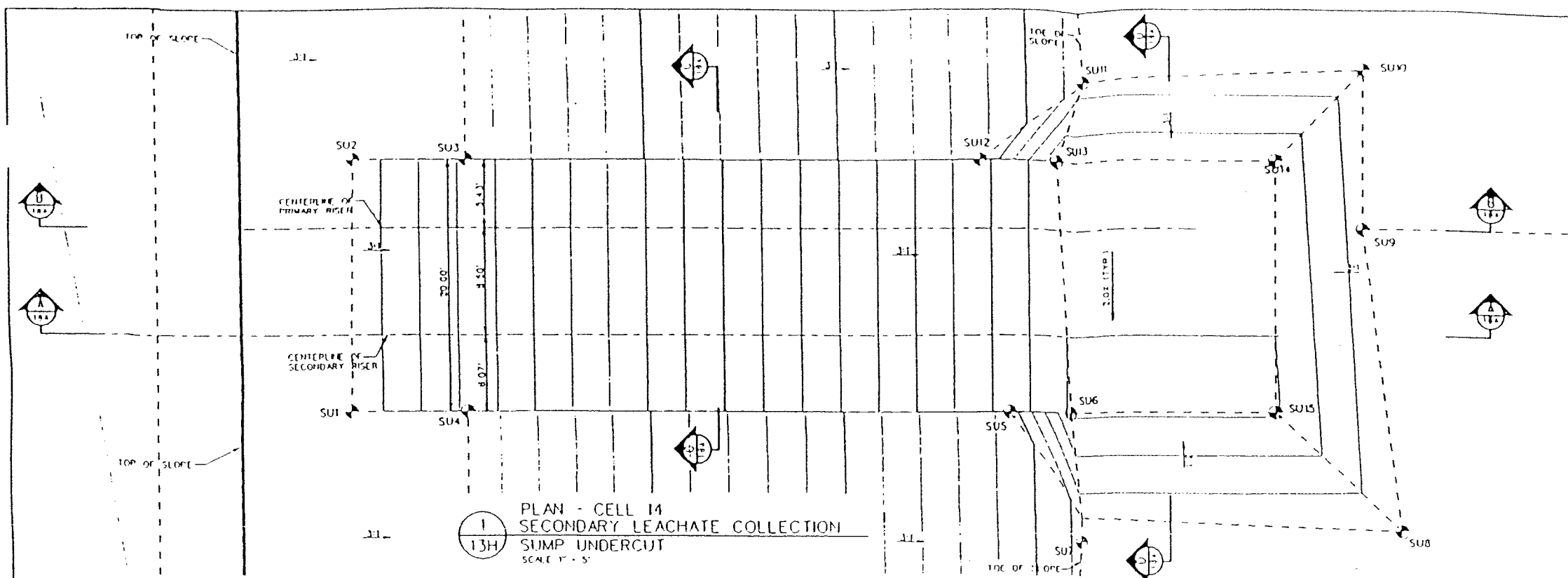

1 PLAN - CELL 14  
SECONDARY LEACHATE COLLECTION  
SUMP UNDERCUT  
SCALE 1" = 5'

CELL 14 SECONDARY SUMP UNDERCUT CONSTRUCTION CONTROL COORDINATES

POINT	NORTHING	EASTING	EL.
SU1	8373.70	2087.40	306.35
SU2	8373.70	2087.40	306.35
SU3	8368.51	2087.40	306.35
SU4	8368.51	2087.40	306.35
SU5	8368.51	2087.40	306.35
SU6	8368.51	2087.40	306.35
SU7	8368.51	2087.40	306.35
SU8	8368.51	2087.40	306.35
SU9	8368.51	2087.40	306.35
SU10	8368.51	2087.40	306.35
SU11	8368.51	2087.40	306.35
SU12	8368.51	2087.40	306.35
SU13	8368.51	2087.40	306.35
SU14	8368.51	2087.40	306.35
SU15	8368.51	2087.40	306.35

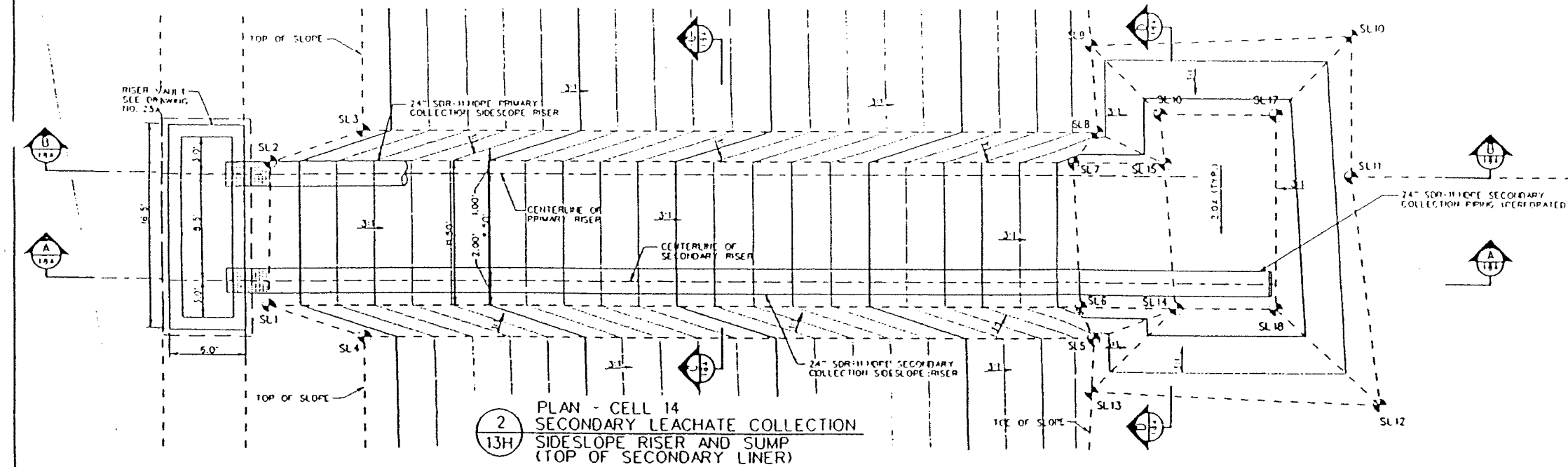

2 PLAN - CELL 14  
SECONDARY LEACHATE COLLECTION  
SIDESLOPE RISER AND SUMP  
(TOP OF SECONDARY LINER)  
SCALE 1" = 5'

CELL 14 SECONDARY SUMP CLAY LINER CONSTRUCTION CONTROL COORDINATES

POINT	NORTHING	EASTING	EL.
SL1	8373.70	2087.40	306.35
SL2	8373.70	2087.40	306.35
SL3	8368.51	2087.40	306.35
SL4	8368.51	2087.40	306.35
SL5	8368.51	2087.40	306.35
SL6	8368.51	2087.40	306.35
SL7	8368.51	2087.40	306.35
SL8	8368.51	2087.40	306.35
SL9	8368.51	2087.40	306.35
SL10	8368.51	2087.40	306.35
SL11	8368.51	2087.40	306.35
SL12	8368.51	2087.40	306.35
SL13	8368.51	2087.40	306.35
SL14	8368.51	2087.40	306.35
SL15	8368.51	2087.40	306.35
SL16	8368.51	2087.40	306.35
SL17	8368.51	2087.40	306.35
SL18	8368.51	2087.40	306.35

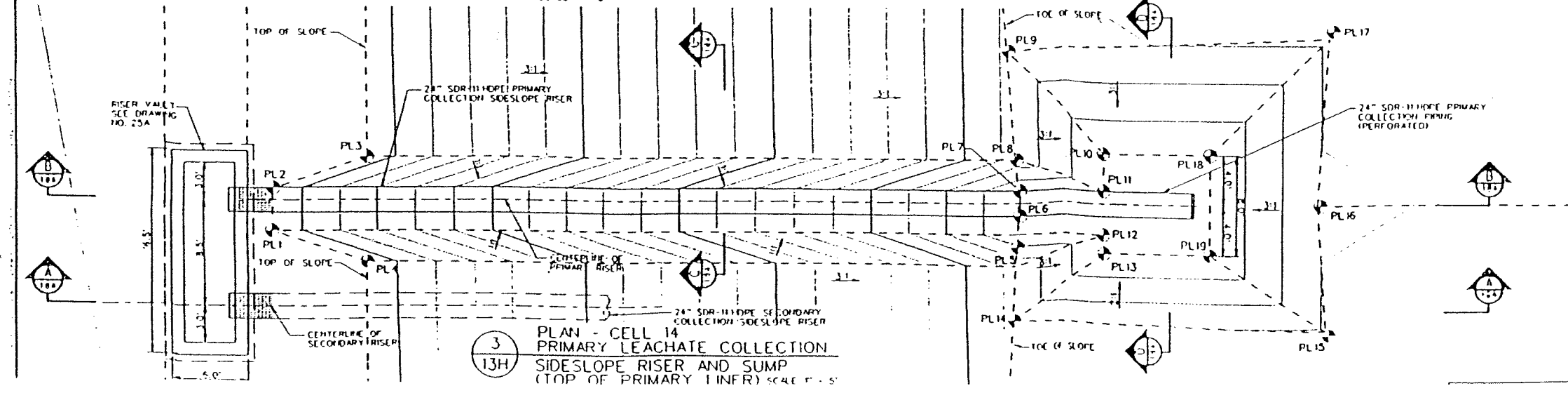

3 PLAN - CELL 14  
PRIMARY LEACHATE COLLECTION  
SIDESLOPE RISER AND SUMP  
(TOP OF PRIMARY LINER)  
SCALE 1" = 5'

CELL 14 PRIMARY SUMP CLAY LINER CONSTRUCTION CONTROL COORDINATES

POINT	NORTHING	EASTING	EL.
PL1	8373.70	2087.40	306.35
PL2	8373.70	2087.40	306.35
PL3	8368.51	2087.40	306.35
PL4	8368.51	2087.40	306.35
PL5	8368.51	2087.40	306.35
PL6	8368.51	2087.40	306.35
PL7	8368.51	2087.40	306.35
PL8	8368.51	2087.40	306.35
PL9	8368.51	2087.40	306.35
PL10	8368.51	2087.40	306.35
PL11	8368.51	2087.40	306.35
PL12	8368.51	2087.40	306.35
PL13	8368.51	2087.40	306.35
PL14	8368.51	2087.40	306.35
PL15	8368.51	2087.40	306.35
PL16	8368.51	2087.40	306.35
PL17	8368.51	2087.40	306.35
PL18	8368.51	2087.40	306.35
PL19	8368.51	2087.40	306.35

NOTES:  
1 COORDINATES OF RISER TOPS MAY VARY IN THE FIELD. AS BUILT LOCATIONS AND ELEVATIONS WILL BE PROVIDED WITH THE CELL CERTIFICATION REPORT.

**RUST** ENVIRONMENT & INFRASTRUCTURE

REVISIONS:

REV. #	DATE	DESCRIPTION	OWN BY	APP BY
1	APR 1997			

DATE: APR 1997 PROJECT NO: 200390 SCALE: AS SHOWN

DESIGN BY: FAS PROJECT: RESINUS MANAGEMENT TREATMENT

DRAWN BY: FAS SHEET TITLE: SUMP CONSTRUCTION GRADES CELL 14

CHECK BY: CFB

REV BY: AWE

APP BY: CFB

**CWM Chemical Services, Inc.**

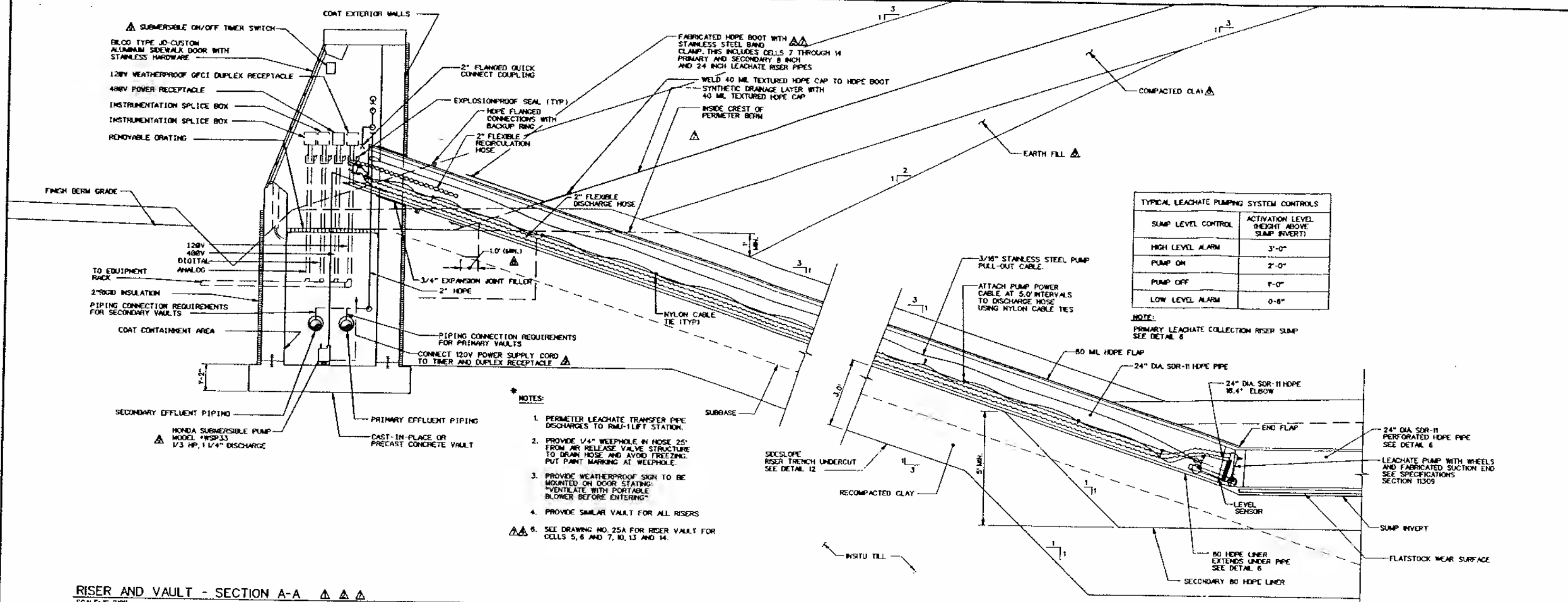

SUMP LEVEL CONTROL	ACTIVATION LEVEL HEIGHT ABOVE SUMP INVERT
HIGH LEVEL ALARM	3'-0"
PUMP ON	2'-0"
PUMP OFF	1'-0"
LOW LEVEL ALARM	0'-8"

- \* NOTES:**
- PERIMETER LEACHATE TRANSFER PIPE DISCHARGES TO RMU-1 LIFT STATION.
  - PROVIDE 1/4" WEEP HOLE IN HOSE 25' FROM AIR RELEASE VALVE STRUCTURE TO DRAIN HOSE AND AVOID FREEZING. PUT PAINT MARKING AT WEEP HOLE.
  - PROVIDE WEATHERPROOF SIGN TO BE MOUNTED ON DOOR STATING: "VENTILATE WITH PORTABLE BLOWER BEFORE ENTERING"
  - PROVIDE SIMILAR VAULT FOR ALL RISERS
- SEE DRAWING NO. 25A FOR RISER VAULT FOR CELLS 5, 6 AND 7, 10, 13 AND 14.

RISER AND VAULT - SECTION A-A  
SCALE: 1"=2'-0"

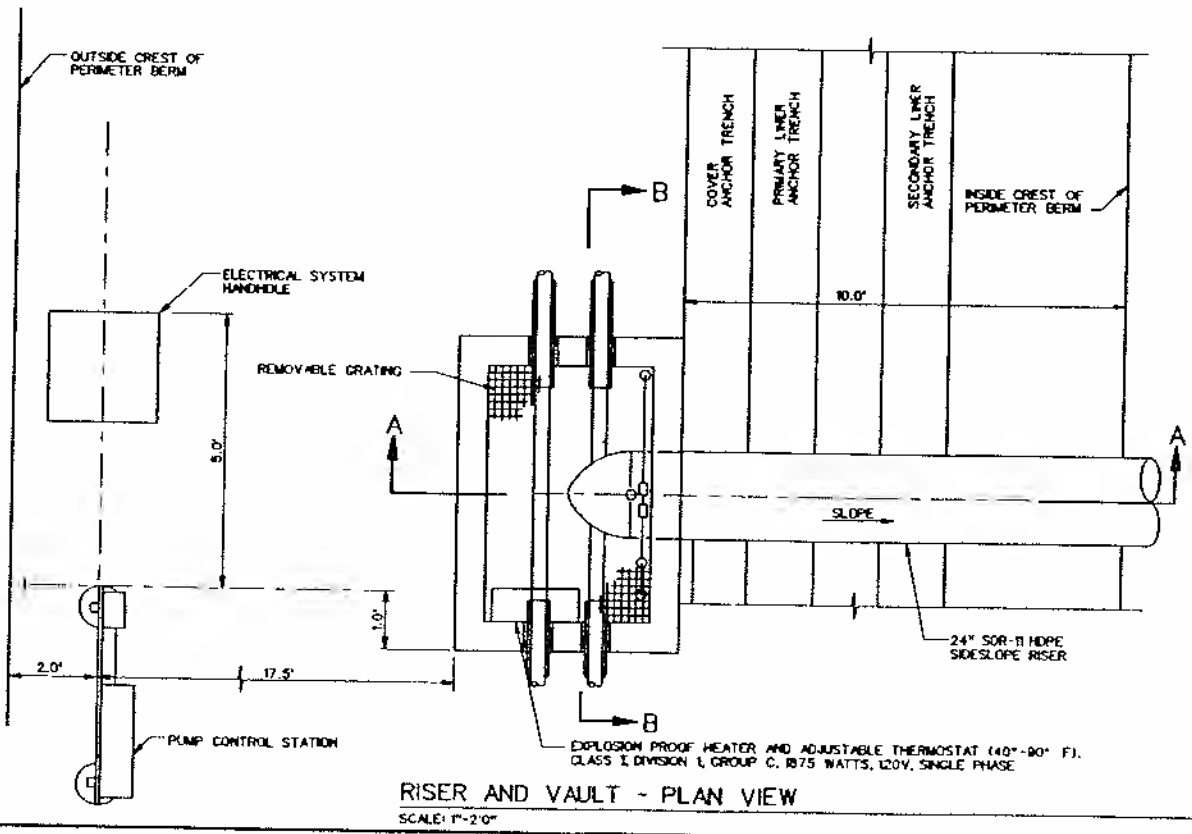

RISER AND VAULT - PLAN VIEW  
SCALE: 1"=2'-0"

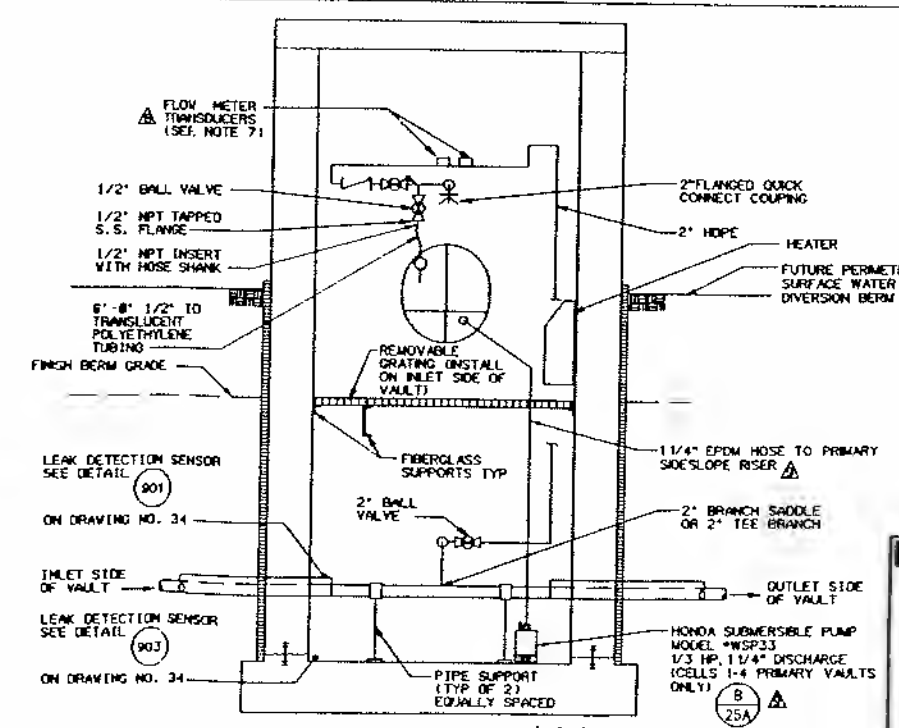

RISER VAULT - SECTION B-B  
SCALE: 1"=2'-0"

- NOTES:**
- THIS CONFIGURATION IS TYPICAL OF ALL VAULTS.
  - MODULAR MECHANICAL SEAL SYSTEM EQUAL TO LINK SEAL.
  - PROVIDE 1/8" STAINLESS STEEL LEVEL CONTROL SENSOR PULLOUT CABLE.
  - PROVIDE 2" HOSE OR SCH 40 STEEL PIPE FROM BALL VALVE TO QUICK COUPLING.
  - LEAK SENSOR DETECTION: PROBE (TYP): WARRICK SERIES 27 ELECTRODE FITTING, MODEL 3E2C AND ELECTRODES (2), OR EQUAL. RELAY (TYP): WARRICK SERIES 27 INTRINSICALLY SAFE CONTROL RELAY MODEL 27A02, OR EQUAL.
  - SEE DRAWING NO. 25A FOR RISER VAULT FOR CELLS 5, 6 AND 7, 10, 13 AND 14.
  - PRIMARY FLOW METER ELEMENT IS OPTIONAL. IF FLOW METER ELEMENT IS ELIMINATED, PIPING MAY BE RUN IN A DIRECT LINE ELIMINATING THE PIPE TRAP.

35  
FEB 21 2002

STATE OF NEW YORK  
CHARLES P. BALLO  
LICENSED PROFESSIONAL ENGINEER  
59688-1

REV	DATE	DESCRIPTION	DR BY	APP BY
2-02		ADDED SUBMERSIBLE PUMP	FAS	CPB
7-97		MODIFIED FINAL CAP ON SECTION A-A	FAS	CPB
6-97		MODIFIED FINAL CAP ON SECTION A-A	FAS	CPB
4-97		ADDED NOTE 7	FAS	CPB
2-97		ADDED CELL 7 BOOT NOTE	FAS	CPB
11-96		ADDED NOTES	FAS	CPB
7-93		SECONDARY FORCE MAIN UPGRADE	MJ	MGR
11-92		NOTICE OF DEFICIENCY RESPONSES	FLD	GRM
6-92		NOTICE OF DEFICIENCY RESPONSES	FLD	GRM

SIGNATURE	DATE	PROJECT NO. 17365	DATE FEBRUARY 1991
DES BY BRJ/TJP	DRN BY FLD	PROJECT RESIDUALS MANAGEMENT UNIT 1	
CHK BY MGR	ERV BY TJB	DRAWING TITLE	
GRV BY CFF	APP BY GRM	LEACHATE EXTRACTION DETAILS CELLS 1 THROUGH 4	

ENVIRONMENT & INFRASTRUCTURE

FILE NO. A-55275  
DRAWING NO. 25

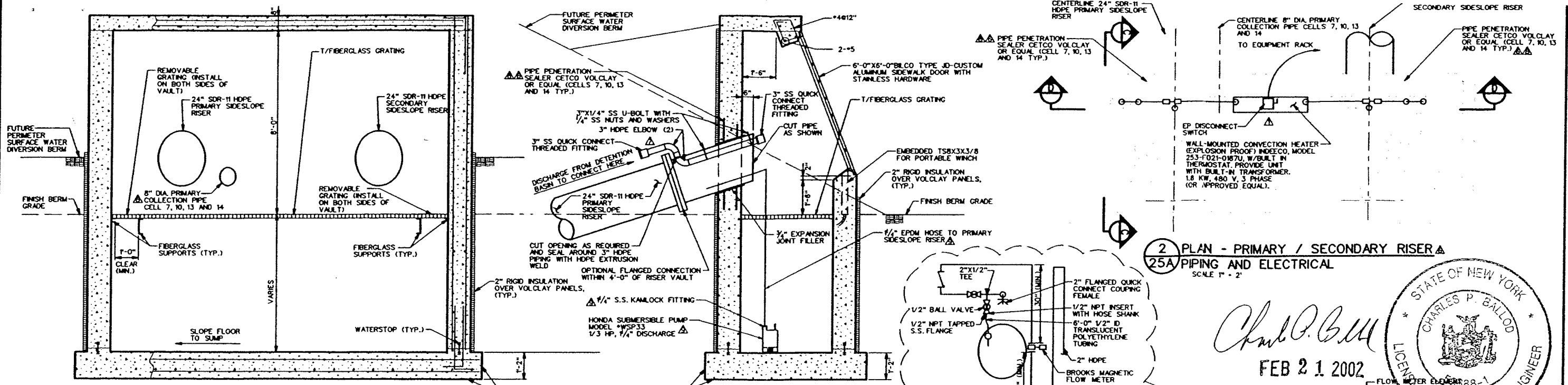

**A SECTION A-A**  
**25A PRIMARY / SECONDARY RISER VAULT**  
 SCALE 1" = 2'

**B SECTION B-B**  
**25A PRIMARY / SECONDARY RISER VAULT**  
 SCALE 1" = 2'

**2 PLAN - PRIMARY / SECONDARY RISER VAULT PIPING AND ELECTRICAL**  
 SCALE 1" = 2'



*Charles P. Ballo*  
 FEB 21 2002

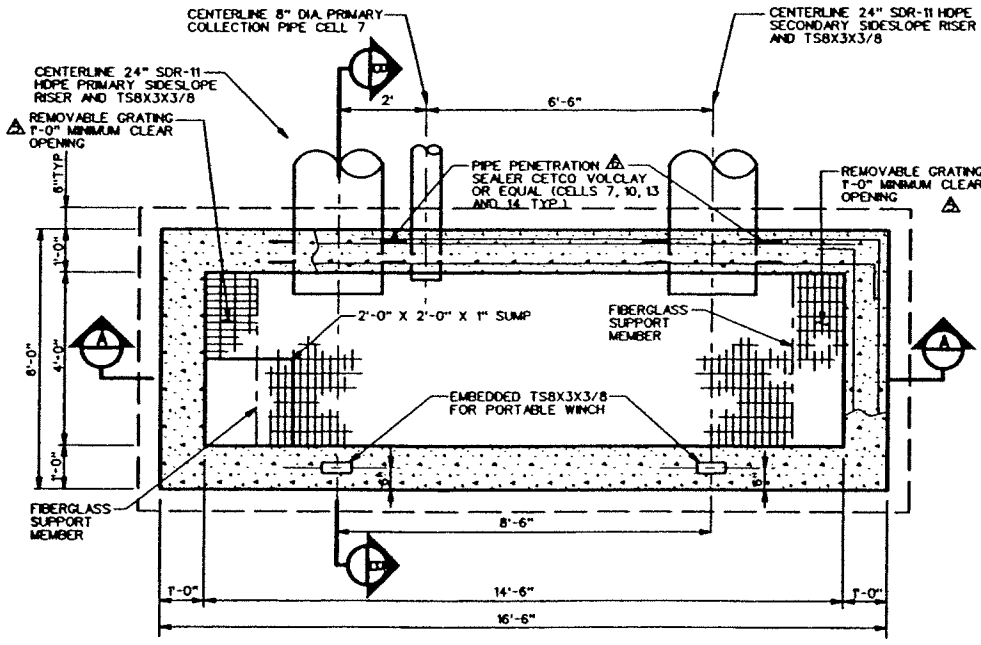

**1 PLAN**  
**25A PRIMARY / SECONDARY RISER VAULT**  
 SCALE 1" = 2'

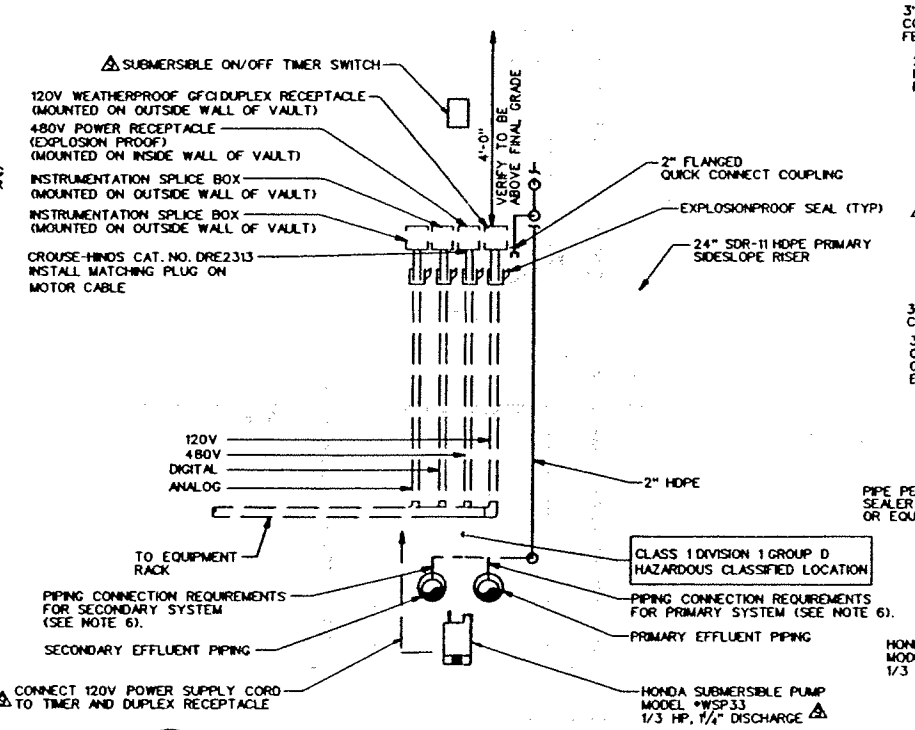

**C SECTION C-C PRIMARY AND SECONDARY RISER VAULT PIPING AND ELECTRICAL**  
 SCALE 1" = 2'

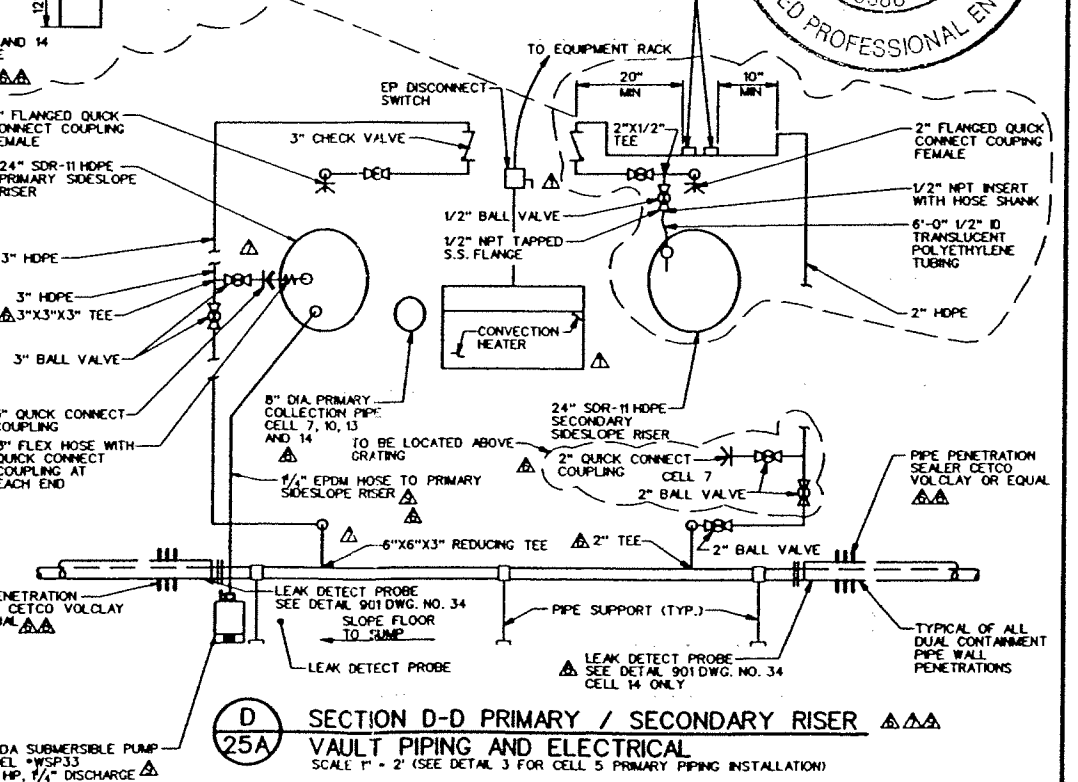

**D SECTION D-D PRIMARY / SECONDARY RISER VAULT PIPING AND ELECTRICAL**  
 SCALE 1" = 2' (SEE DETAIL 3 FOR CELL 5 PRIMARY PIPING INSTALLATION)

- GENERAL NOTES**
- SEE SPECIFICATIONS SECTION 0615 FOR DETAILS OF FIBERGLASS GRATING AND SUPPORTS.
  - ALL GRATING SHALL BE REMOVABLE. HOLD DOWN CLIPS SHALL BE EASILY REMOVED. SECTIONS OVER 1'-0" CLEAR OPENING SHALL NOT BE FASTENED DOWN AND PROVIDED IN TWO PIECES.
  - PROVIDE 1-THERM MODEL 473A/2B (115-1-60) ELECTRIC WINCH.
  - COATINGS:
    - APPLY IN ACCORDANCE WITH MANUFACTURER'S REQUIREMENTS.
    - INTERIOR CONCRETE BELOW BOTTOM OF DOOR OPENING SHALL BE COATED WITH SOLUCCOAT 400, CONIPUR 152/372 OR APPROVED EQUAL.
  - INSTALL SIGN PROVIDED BY OWNER ON SIDEWALK DOOR WITH FOUR STAINLESS STEEL FASTENERS.
  - ALL PIPING SHALL BE HOPE. VALVES SHALL BE AS SPECIFIED.
  - MIRROR INSTALLATION OF PIPING, CONVECTION HEATER, AND ELECTRICAL EQUIPMENT WITHIN VAULTS DEPENDING UPON WHICH SIDE INLET PIPING ENTERS VAULT. SEE PLAN NOTE 3.
  - RISER VAULT PIPING CONFIGURATIONS MAY VARY WITH FIELD CONDITIONS.

- PLAN NOTES**
- LX DENOTES RISER TYPE (P)-PRIMARY RISER (S)-SECONDARY RISER Y DENOTES CELL NUMBER.
  - LOCATE VAULT MOISTURE ELEMENT ON INLET SIDE OF VAULT. COORDINATE WITH SITE LEACHATE COLLECTION PIPING.
  - MIRROR PIPING AND ELECTRICAL EQUIPMENT INSTALLATION DEPENDING ON INLET SIDE OF MANHOLE. PIPES PASSING THRU GRATING SHALL BE ON OPPOSITE SIDE OF REMOVABLE GRATING SECTION.
  - AT EACH PRIMARY VAULT, VALVE SHALL BE TURNED TO OPEN POSITION WHILE IN OBSERVATION OF OWNER AND HANDLE REMOVED AND GIVEN TO OWNER.
  - 1'-0" LONG SECTION 1" HOPE PIPE FASTENED TO INSIDE WALL OF 24" HOPE SECURE TO 24" HOPE WITH STAINLESS STEEL CLAMPS AND SCREWS OR HEAT FUSE.

- 6.2" HOPE RISER PUMP DISCHARGE PIPING TO CONNECT TO APPROPRIATE EFFLUENT PIPING:**
- PRIMARY RISER PUMP DISCHARGE PIPING SHALL CONNECT TO PRIMARY EFFLUENT PIPING.
  - SECONDARY RISER PUMP DISCHARGE PIPING SHALL CONNECT TO SECONDARY EFFLUENT PIPING.
- 7. MOISTURE ELEMENT FOR PIPE LEAK DETECT SHALL BE INSTALLED ON PRIMARY AND SECONDARY INFLUENT (INLET SIDE) PIPE, IN VAULT.**
- 8. PRIMARY FLOW METER ELEMENT IS OPTIONAL. IF FLOW METER ELEMENT IS ELIMINATED, PIPING MAY BE RUN IN A DIRECT LINE ELIMINATING THE PIPE TRAP.**

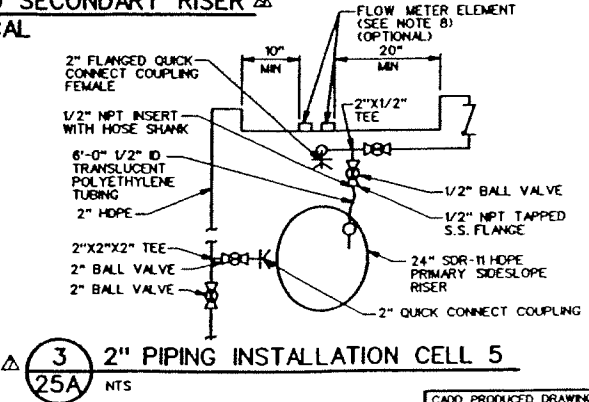

**3 2" PIPING INSTALLATION CELL 5**  
 SCALE 1" = 2'

NO.	DATE	DESCRIPTION	DRN BY	APP BY
2-02		ADDED SUBMERSIBLE PUMP	FAS	CPB
10-97		MODIFY FOR CELLS 8 THROUGH 14	FAS	CPB
8-97		ADDED 3" PIPE FROM DET. BASH/WOOFY DETAILS B.D.3	FAS	CPB
6-97		DELETED SECONDARY CLEANOUT PIPE AND ADDED SEAL	FAS	CPB
4-97		ADDED CELL 9	FAS	CPB
11-96		ADDED COLLECTION PIPES CELL 7	FAS	CPB
10-96		ADD 3" PIPING OPTION	FAS	CPB
7-96		ADDED CELL 10	FAS	CPB
4-96		RELOCATED CONVECTION HEATER AND EP	FAS	CPB
		DISCONNECT SWITCH		

DATE: NOVEMBER 1995 PROJECT NO. 34282.100 SCALE: AS SHOWN  
 PROJECT: RESIDUALS MANAGEMENT UNIT 1  
 SHEET TITLE: LEACHATE EXTRACTION DETAILS CELLS 5, 6, 7, 10, 13 AND 14  
 CWM Chemical Services, Inc. Model City Facility  
 DRAWING NO. 25A

**APPENDIX A**

**Final Rule For Liners and Leak Detection  
Systems for Hazardous Waste Land Disposal Units**

nds, Water pollution control, Water supply.

Dated: January 15, 1992.

William K. Reilly,

Administrator.

For the reasons set out in the preamble, chapter I of title 40 of the Code of Federal Regulations is amended as follows:

**PART 260—HAZARDOUS WASTE MANAGEMENT SYSTEM: GENERAL**

1. The authority citation for part 260 continues to read as follows:

Authority: 42 U.S.C. 6905, 6912(a), 6921-6927, 6930, 6934, 6935, 6937, 6938, 6939, and 6974.

2. Section 260.10 is amended by adding the definition of "replacement unit" in alphabetical order, and revising the definition of "sump" to read as follows:

§ 260.10 Definitions.

*Replacement unit* means a landfill, surface impoundment, or waste pile unit (1) from which all or substantially all of the waste is removed, and (2) that is subsequently reused to treat, store, or dispose of hazardous waste.

Replacement unit" does not apply to a unit from which waste is removed during closure, if the subsequent reuse solely involves the disposal of waste from that unit and other closing units or corrective action areas at the facility, in accordance with an approved closure plan or EPA or State approved corrective action.

*Sump* means any pit or reservoir that meets the definition of tank and those troughs/trenches connected to it that serve to collect hazardous waste for transport to hazardous waste storage, treatment, or disposal facilities; except that as used in the landfill, surface impoundment, and waste pile rules, "sump" means any lined pit or reservoir that serves to collect liquids drained from a leachate collection and removal system or leak detection system for subsequent removal from the system.

**PART 264—STANDARDS FOR OWNERS AND OPERATORS OF HAZARDOUS WASTE TREATMENT, STORAGE, AND DISPOSAL FACILITIES**

1. The authority citation for part 264 continues to read as follows:

Authority: 42 U.S.C. 6905, 6912(a), 6924, and 6925.

2. Section 264.15 is amended by revising paragraph (b)(4) to read as follows:

§ 264.15 General inspection requirements.

(b) . . .  
 (4) The frequency of inspection may vary for the items on the schedule. However, it should be based on the rate of deterioration of the equipment and the probability of an environmental or human health incident if the deterioration, malfunction, or any operator error goes undetected between inspections. Areas subject to spills, such as loading and unloading areas, must be inspected daily when in use. At a minimum, the inspection schedule must include the items and frequencies called for in §§ 264.174, 264.193, 264.195, 264.228, 264.254, 264.278, 264.303, 264.347, 264.602, 264.1033, 264.1052, 264.1053, and 264.1058, where applicable.

3. Subpart B is amended by adding § 264.19 as follows:

§ 264.19 Construction quality assurance program.

(a) *COA program.* (1) A construction quality assurance (CQA) program is required for all surface impoundment, waste pile, and landfill units that are required to comply with §§ 264.221 (c) and (d), 264.251 (c) and (d), and 264.301 (c) and (d). The program must ensure that the constructed unit meets or exceeds all design criteria and specifications in the permit. The program must be developed and implemented under the direction of a CQA officer who is a registered professional engineer.

(2) The CQA program must address the following physical components, where applicable:

- (i) Foundations;
- (ii) Dikes;
- (iii) Low-permeability soil liners;
- (iv) Geomembranes (flexible membrane liners);
- (v) Leachate collection and removal systems and leak detection systems; and
- (vi) Final cover systems.

(b) *Written CQA plan.* The owner or operator of units subject to the CQA program under paragraph (a) of this section must develop and implement a written CQA plan. The plan must identify steps that will be used to monitor and document the quality of materials and the condition and manner of their installation. The CQA plan must include:

- (1) Identification of applicable units, and a description of how they will be constructed.

(2) Identification of key personnel in the development and implementation of the CQA plan, and CQA officer qualifications.

(3) A description of inspection and sampling activities for all unit components identified in paragraph (a)(2) of this section, including observations and tests that will be used before, during, and after construction to ensure that the construction materials and the installed unit components meet the design specifications. The description must cover: Sampling size and locations; frequency of testing; data evaluation procedures; acceptance and rejection criteria for construction materials; plans for implementing corrective measures; and data or other information to be recorded and retained in the operating record under § 264.71.

(c) *Contents of program.* (1) The CQA program must include observations, inspections, tests, and measurements sufficient to ensure:

- (i) Structural stability and integrity of all components of the unit identified in paragraph (a)(2) of this section;
- (ii) Proper construction of all components of the liners, leachate collection and removal system, leak detection system, and final cover system, according to permit specifications and good engineering practices, and proper installation of all components (e.g., pipes) according to design specifications;
- (iii) Conformity of all materials used with design and other material specifications under §§ 264.221, 264.251, and 264.301.

(2) The CQA program shall include test fills for compacted soil liners, using the same compaction methods as in the full scale unit, to ensure that the liners are constructed to meet the hydraulic conductivity requirements of §§ 264.221(c)(1)(i)(B), 264.251(c)(1)(i)(B), and 264.301(c)(1)(i)(B) in the field. Compliance with the hydraulic conductivity requirements must be verified by using in-situ testing on the constructed test fill. The Regional Administrator may accept an alternative demonstration, in lieu of a test fill, where data are sufficient to show that a constructed soil liner will meet the hydraulic conductivity requirements of §§ 264.221(c)(1)(i)(B), 264.251(c)(1)(i)(B), and 264.301(c)(1)(i)(B) in the field.

(d) *Certification.* Waste shall not be received in a unit subject to § 264.19 until the owner or operator has submitted to the Regional Administrator by certified mail or hand delivery a certification signed by the CQA officer that the approved CQA plan has been successfully carried out and that the unit

meets the requirements of §§ 284.221 (c) or (d), 284.251 (c) or (d), or 284.301 (c) or (d); and the procedure in § 270.301(1)(2)(ii) of this chapter has been completed. Documentation supporting the CQA officer's certification must be furnished to the Regional Administrator upon request.

4. Section 284.73 is amended by revising paragraph (b)(6) to read as follows:

§ 284.73 Operating record.

(b) \* \* \*  
 (6) Monitoring, testing or analytical data, and corrective action where required by subpart F and §§ 284.19, 284.191, 284.193, 284.195, 284.222, 284.223, 284.228, 284.252-284.254, 284.276, 284.278, 284.280, 284.302-284.304, 284.309, 284.347, 284.802, 284.1034(c)-284.1034(f), 284.1035, 284.1063(d)-284.1063(i), and 284.1064.

5. Section 284.221 is amended by redesignating paragraphs (f), (g), and (h) as paragraphs (g), (h), and (i), respectively; by revising paragraphs (c) and (d); and by adding new paragraph (j) to read as follows:

§ 284.221 Design and operating requirements.

(c) The owner or operator of each new surface impoundment unit on which construction commences after January 29, 1992, each lateral expansion of a surface impoundment unit on which construction commences after July 29, 1992 and each replacement of an existing surface impoundment unit that is to commence reuse after July 29, 1992, must install two or more liners and a leachate collection and removal system between such liners. "Construction commences" is as defined in § 280.10 of this chapter under "existing facility."

(1)(i) The liner system must include:  
 (A) A top liner designed and constructed of materials (e.g., a geomembrane) to prevent the migration of hazardous constituents into such liner during the active life and post-closure care period; and

(B) A composite bottom liner, consisting of at least two components. The upper component must be designed and constructed of materials (e.g., a geomembrane) to prevent the migration of hazardous constituents into this component during the active life and post-closure care period. The lower component must be designed and constructed of materials to minimize the migration of hazardous constituents if a breach in the upper component were to occur. The lower component must be constructed of at least 3 feet (91 cm) of

compacted soil material with a hydraulic conductivity of no more than  $1 \times 10^{-7}$  cm/sec.

(ii) The liners must comply with paragraphs (a) (1), (2), and (3) of this section:

(2) The leachate collection and removal system between the liners, and immediately above the bottom composite liner in the case of multiple leachate collection and removal systems, is also a leak detection system. This leak detection system must be capable of detecting, collecting, and removing leaks of hazardous constituents at the earliest practicable time through all areas of the top liner likely to be exposed to waste or leachate during the active life and post-closure care period. The requirements for a leak detection system in this paragraph are satisfied by installation of a system that is, at a minimum:

(i) Constructed with a bottom slope of one percent or more;

(ii) Constructed of granular drainage materials with a hydraulic conductivity of  $1 \times 10^{-7}$  cm/sec or more and a thickness of 12 inches (30.5 cm) or more; or constructed of synthetic or geonet drainage materials with a transmissivity of  $3 \times 10^{-7}$  m<sup>2</sup>/sec or more;

(iii) Constructed of materials that are chemically resistant to the waste managed in the surface impoundment and the leachate expected to be generated, and of sufficient strength and thickness to prevent collapse under the pressures exerted by overlying wastes and any waste cover materials or equipment used at the surface impoundment;

(iv) Designed and operated to minimize clogging during the active life and post-closure care period; and

(v) Constructed with sumps and liquid removal methods (e.g., pumps) of sufficient size to collect and remove liquids from the sump and prevent liquids from backing up into the drainage layer. Each unit must have its own sump(s). The design of each sump and removal system must provide a method for measuring and recording the volume of liquids present in the sump and of liquids removed.

(3) The owner or operator shall collect and remove pumpable liquids in the sumps to minimize the head on the bottom liner.

(4) The owner or operator of a leak detection system that is not located completely above the seasonal high water table must demonstrate that the operation of the leak detection system will not be adversely affected by the presence of ground water.

(d) The Regional Administrator may approve alternative design or operating

practices to those specified in paragraph (c) of this section if the owner or operator demonstrates to the Regional Administrator that such design and operating practices, together with location characteristics:

(1) Will prevent the migration of any hazardous constituent into the ground water or surface water at least as effectively as the liners and leachate collection and removal system specified in paragraph (c) of this section; and

(2) Will allow detection of leaks of hazardous constituents through the top liner at least as effectively.

(f) The owner or operator of any replacement surface impoundment unit is exempt from paragraph (c) of this section if:

(1) The existing unit was constructed in compliance with the design standards of sections 3004 (o)(1)(A)(i) and (o)(5) of the Resource Conservation and Recovery Act; and

(2) There is no reason to believe that the liner is not functioning as designed.

6. New §§ 284.222 and 284.223 are added to read as follows:

§ 284.222 Action leakage rate.

(a) The Regional Administrator shall approve an action leakage rate for surface impoundment units subject to § 284.221 (c) or (d). The action leakage rate is the maximum design flow rate that the leak detection system (LDS) can remove without the fluid head on the bottom liner exceeding 1 foot. The action leakage rate must include an adequate safety margin to allow for uncertainties in the design (e.g., slope, hydraulic conductivity, thickness of drainage material), construction, operation, and location of the LDS, waste and leachate characteristics, likelihood and amounts of other sources of liquids in the LDS, and proposed response actions (e.g., the action leakage rate must consider decreases in the flow capacity of the system over time resulting from siltation and clogging, rib layover and creep of synthetic components of the system, overburden pressures, etc.).

(b) To determine if the action leakage rate has been exceeded, the owner or operator must convert the weekly or monthly flow rate from the monitoring data obtained under § 284.226(d) to an average daily flow rate (gallons per acre per day) for each sump. Unless the Regional Administrator approves a different calculation, the average daily flow rate for each sump must be calculated weekly during the active life and closure period, and if the unit is



in accordance with § 264.228(b), monthly during the post-closure care period when monthly monitoring is required under § 264.226(d).

#### § 264.223 Response actions.

(a) The owner or operator of surface impoundment units subject to § 264.221 (c) or (d) must have an approved response action plan before receipt of waste. The response action plan must set forth the actions to be taken if the action leakage rate has been exceeded. At a minimum, the response action plan must describe the actions specified in paragraph (b) of this section.

(b) If the flow rate into the leak detection system exceeds the action leakage rate for any sump, the owner or operator must:

(1) Notify the Regional Administrator in writing of the exceedance within 7 days of the determination;

(2) Submit a preliminary written assessment to the Regional Administrator within 14 days of the determination, as to the amount of liquids, likely sources of liquids, possible location, size, and cause of any leak, and short-term actions taken and planned;

(3) Determine to the extent practicable the location, size, and cause of any leak;

(4) Determine whether waste receipt should cease or be curtailed, whether any waste should be removed from the unit for inspection, repairs, or controls, and whether or not the unit should be closed;

(5) Determine any other short-term and longer-term actions to be taken to mitigate or stop any leaks; and

(6) Within 30 days after the notification that the action leakage rate has been exceeded, submit to the Regional Administrator the results of the analyses specified in paragraphs (b) (3), (4), and (5) of this section, the results of actions taken, and actions planned. Monthly thereafter, as long as the flow rate in the leak detection system exceeds the action leakage rate, the owner or operator must submit to the Regional Administrator a report summarizing the results of any remedial actions taken and actions planned.

(c) To make the leak and/or remediation determinations in paragraphs (b) (3), (4), and (5) of this section, the owner or operator must:

(1)(i) Assess the source of liquids and amounts of liquids by source.

(ii) Conduct a fingerprint, hazardous constituent, or other analyses of the liquids in the leak detection system to identify the source of liquids and possible location of any leaks, and the hazard and mobility of the liquid; and

(iii) Assess the seriousness of any leaks in terms of potential for escaping into the environment or

(2) Document why such assessments are not needed.

7. Section 264.228 is amended by adding new paragraph (d) to read as follows:

#### § 264.226 Monitoring and inspection.

(d)(1) An owner or operator required to have a leak detection system under § 264.221 (c) or (d) must record the amount of liquids removed from each leak detection system sump at least once each week during the active life and closure period.

(2) After the final cover is installed, the amount of liquids removed from each leak detection system sump must be recorded at least monthly. If the liquid level in the sump stays below the pump operating level for two consecutive months, the amount of liquids in the sumps must be recorded at least quarterly. If the liquid level in the sump stays below the pump operating level for two consecutive quarters, the amount of liquids in the sumps must be recorded at least semi-annually. If at any time during the post-closure care period the pump operating level is exceeded at units on quarterly or semi-annual recording schedules, the owner or operator must return to monthly recording of amounts of liquids removed from each sump until the liquid level again stays below the pump operating level for two consecutive months.

(3) "Pump operating level" is a liquid level proposed by the owner or operator and approved by the Regional Administrator based on pump activation level, sump dimensions, and level that avoids backup into the drainage layer and minimizes head in the sump.

8. Section 264.228 is amended by redesignating paragraphs (b)(2) and (b)(3) as paragraphs (b)(3) and (b)(4) respectively, and by adding a new paragraph (b)(2) to read as follows:

#### § 264.228 Closure and post-closure care.

(b) . . .  
(2) Maintain and monitor the leak detection system in accordance with §§ 264.221(c)(2)(iv) and (3) and 264.228(d), and comply with all other applicable leak detection system requirements of this part.

9. Section 264.251 is amended by redesignating paragraphs (c), (d), (e), (f), and (g) as paragraphs (g), (h), (i), (j) and (k), respectively, and by adding new paragraphs (c), (d), (e), and (f) to read as follows:

#### § 264.251 Design and operating requirements.

(c) The owner or operator of each new waste pile unit on which construction commences after January 29, 1992, each lateral expansion of a waste pile unit on which construction commences after July 29, 1992, and each replacement of an existing waste pile unit that is to commence reuse after July 29, 1992 must install two or more liners and a leachate collection and removal system above and between such liners. "Construction commences" is as defined in § 260.10 under "existing facility".

(1)(i) The liner system must include:

(A) A top liner designed and constructed of materials (e.g., a geomembrane) to prevent the migration of hazardous constituents into such liner during the active life and post-closure care period; and

(B) A composite bottom liner, consisting of at least two components. The upper component must be designed and constructed of materials (e.g., a geomembrane) to prevent the migration of hazardous constituents into this component during the active life and post-closure care period. The lower component must be designed and constructed of materials to minimize the migration of hazardous constituents if a breach in the upper component were to occur. The lower component must be constructed of at least 3 feet (91 cm) of compacted soil material with a hydraulic conductivity of no more than  $1 \times 10^{-7}$  cm/sec.

(ii) The liners must comply with paragraphs (a)(1)(i), (ii), and (iii) of this section.

(2) The leachate collection and removal system immediately above the top liner must be designed, constructed, operated, and maintained to collect and remove leachate from the waste pile during the active life and post-closure care period. The Regional Administrator will specify design and operating conditions in the permit to ensure that the leachate depth over the liner does not exceed 30 cm (one foot). The leachate collection and removal system must comply with paragraphs (c)(3)(iii) and (iv) of this section.

(3) The leachate collection and removal system between the liners, and immediately above the bottom composite liner in the case of multiple leachate collection and removal systems, is also a leak detection system. This leak detection system must be capable of detecting, collecting, and removing leaks of hazardous constituents at the earliest practicable time through all areas of the top liner

likely to be exposed to waste or leachate during the active life and post-closure care period. The requirements for a leak detection system in this paragraph are satisfied by installation of a system that is, at a minimum:

(i) Constructed with a bottom slope of one percent or more;

(ii) Constructed of granular drainage materials with a hydraulic conductivity of  $1 \times 10^{-2}$  cm/sec or more and a thickness of 12 inches (30.5 cm) or more; or constructed of synthetic or geonet drainage materials with a transmissivity of  $3 \times 10^{-6}$  m<sup>2</sup>/sec or more;

(iii) Constructed of materials that are chemically resistant to the waste managed in the waste pile and the leachate expected to be generated, and of sufficient strength and thickness to prevent collapse under the pressures exerted by overlying wastes, waste cover materials, and equipment used at the waste pile;

(iv) Designed and operated to minimize clogging during the active life and post-closure care period; and

(v) Constructed with sumps and liquid removal methods (e.g., pumps) of sufficient size to collect and remove liquids from the sump and prevent liquids from backing up into the drainage layer. Each unit must have its own sump(s). The design of each sump and removal system must provide a method for measuring and recording the volume of liquids present in the sump and of liquids removed.

(4) The owner or operator shall collect and remove pumpable liquids in the leak detection system sumps to minimize the head on the bottom liner.

(5) The owner or operator of a leak detection system that is not located completely above the seasonal high water table must demonstrate that the operation of the leak detection system will not be adversely affected by the presence of ground water.

(d) The Regional Administrator may approve alternative design or operating practices to those specified in paragraph (c) of this section if the owner or operator demonstrates to the Regional Administrator that such design and operating practices, together with location characteristics:

(1) Will prevent the migration of any hazardous constituent into the ground water or surface water at least as effectively as the liners and leachate collection and removal systems specified in paragraph (c) of this section; and

(2) Will allow detection of leaks of hazardous constituents through the top liner at least as effectively.

(e) Paragraph (c) of this section does not apply to monofills that are granted a

waiver by the Regional Administrator in accordance with § 284.221(e).

(f) The owner or operator of any replacement waste pile unit is exempt from paragraph (c) of this section if:

(1) The existing unit was constructed in compliance with the design standards of section 3004(o)(1)(A)(i) and (o)(5) of the Resource Conservation and Recovery Act; and

(2) There is no reason to believe that the liner is not functioning as designed.

10. New §§ 284.252 and 284.253 are added to read as follows:

§ 284.252 Action leakage rate.

(a) The Regional Administrator shall approve an action leakage rate for surface impoundment units subject to § 284.251(c) or (d). The action leakage rate is the maximum design flow rate that the leak detection system (LDS) can remove without the fluid head on the bottom liner exceeding 1 foot. The action leakage rate must include an adequate safety margin to allow for uncertainties in the design (e.g., slope, hydraulic conductivity, thickness of drainage material), construction, operation, and location of the LDS, waste and leachate characteristics, likelihood and amounts of other sources of liquids in the LDS, and proposed response actions (e.g., the action leakage rate must consider decreases in the flow capacity of the system over time resulting from siltation and clogging, rib layover and creep of synthetic components of the system, overburden pressures, etc.).

(b) To determine if the action leakage rate has been exceeded, the owner or operator must convert the weekly flow rate from the monitoring data obtained under § 284.254(c) to an average daily flow rate (gallons per acre per day) for each sump. Unless the Regional Administrator approves a different calculation, the average daily flow rate for each sump must be calculated weekly during the active life and closure period.

§ 284.253 Response actions.

(a) The owner or operator of waste pile units subject to § 284.251 (c) or (d) must have an approved response action plan before receipt of waste. The response action plan must set forth the actions to be taken if the action leakage rate has been exceeded. At a minimum, the response action plan must describe the actions specified in paragraph (b) of this section.

(b) If the flow rate into the leak detection system exceeds the action leakage rate for any sump, the owner or operator must:

(1) Notify the Regional Administrator in writing of the exceedance within 7 days of the determination;

(2) Submit a preliminary written assessment to the Regional Administrator within 14 days of the determination, as to the amount of liquids, likely sources of liquids, possible location, size, and cause of any leaks, and short-term actions taken and planned;

(3) Determine to the extent practicable the location, size, and cause of any leak;

(4) Determine whether waste receipt should cease or be curtailed, whether any waste should be removed from the unit for inspection, repairs, or controls, and whether or not the unit should be closed;

(5) Determine any other short-term and long-term actions to be taken to mitigate or stop any leak; and

(6) Within 30 days after the notification that the action leakage rate has been exceeded, submit to the Regional Administrator the results of the analyses specified in paragraphs (b) (3), (4), and (5) of this section, the results of actions taken, and actions planned. Monthly thereafter, as long as the flow rate in the leak detection system exceeds the action leakage rate, the owner or operator must submit to the Regional Administrator a report summarizing the results of any remedial actions taken and actions planned.

(c) To make the leak and/or remediation determinations in paragraphs (b) (3), (4), and (5) of this section, the owner or operator must:

(i) Assess the source of liquids and amounts of liquids by source;

(ii) Conduct a fingerprint, hazardous constituent, or other analyses of the liquids in the leak detection system to identify the source of liquids and possible location of any leaks, and the hazard and mobility of the liquid; and

(iii) Assess the seriousness of any leaks in terms of potential for escaping into the environment; or

(2) Document why such assessments are not needed.

11. Section 284.254 is amended by adding new paragraph (c) to read as follows:

§ 284.254 Monitoring and inspection.

(c) An owner or operator required to have a leak detection system under § 284.251(c) must record the amount of liquids removed from each leak detection system sump at least once each week during the active life and closure period.

12. Section 284.301 is amended by redesignating paragraphs (f), (g), (h), (i),



), and (k) as paragraphs (g), (h), (i), (j), (k), and (l), respectively, by revising paragraphs (c) and (d), and by adding new paragraph (f) to read as follows:

**§ 264.301 Design and operating requirements.**

(c) The owner or operator of each new landfill unit on which construction commences after January 29, 1992, each lateral expansion of a landfill unit on which construction commences after July 29, 1992, and each replacement of an existing landfill unit that is to commence reuse after July 29, 1992 must install two or more liners and a leachate collection and removal system above and between such liners. "Construction commences" is as defined in § 260.10 of this chapter under "existing facility".

(1)(i) The *liner system* must include:

(A) A top liner designed and constructed of materials (e.g., a geomembrane) to prevent the migration of hazardous constituents into such liner during the active life and post-closure care period; and

(B) A composite bottom liner, consisting of at least two components. The upper component must be designed and constructed of materials (e.g., a geomembrane) to prevent the migration of hazardous constituents into this component during the active life and post-closure care period. The lower component must be designed and constructed of materials to minimize the migration of hazardous constituents if a breach in the upper component were to occur. The lower component must be constructed of at least 3 feet (91 cm) of compacted soil material with a hydraulic conductivity of no more than  $1 \times 10^{-7}$  cm/sec.

(ii) The liners must comply with paragraphs (a)(1)(i), (ii), and (iii) of this section.

(2) The *leachate collection and removal system* immediately above the top liner must be designed, constructed, operated, and maintained to collect and remove leachate from the landfill during the active life and post-closure care period. The Regional Administrator will specify design and operating conditions in the permit to ensure that the leachate depth over the liner does not exceed 30 cm (one foot). The leachate collection and removal system must comply with paragraphs (3)(c)(iii) and (iv) of this section.

(3) The *leachate collection and removal system* between the liners, and immediately above the bottom composite liner in the case of multiple leachate collection and removal systems, is also a *leak detection system*. This leak detection system must be

capable of detecting, collecting, and removing leaks of hazardous constituents at the earliest practicable time through all areas of the top liner likely to be exposed to waste or leachate during the active life and post-closure care period. The requirements for a leak detection system in this paragraph are satisfied by installation of a system that is, at a minimum:

(i) Constructed with a bottom slope of one percent or more;

(ii) Constructed of granular drainage materials with a hydraulic conductivity of  $1 \times 10^{-3}$  cm/sec or more and a thickness of 12 inches (30.5 cm) or more; or constructed of synthetic or geonet drainage materials with a transmissivity of  $3 \times 10^{-6}$  m<sup>2</sup>/sec or more;

(iii) Constructed of materials that are chemically resistant to the waste managed in the landfill and the leachate expected to be generated, and of sufficient strength and thickness to prevent collapse under the pressures exerted by overlying wastes, waste cover materials, and equipment used at the landfill;

(iv) Designed and operated to minimize clogging during the active life and post-closure care period; and

(v) Constructed with sumps and liquid removal methods (e.g., pumps) of sufficient size to collect and remove liquids from the sump and prevent liquids from backing up into the drainage layer. Each unit must have its own sump(s). The design of each sump and removal system must provide a method for measuring and recording the volume of liquids present in the sump and of liquids removed.

(4) The owner or operator shall collect and remove pumpable liquids in the leak detection system sumps to minimize the head on the bottom liner.

(5) The owner or operator of a leak detection system that is not located completely above the seasonal high water table must demonstrate that the operation of the leak detection system will not be adversely affected by the presence of ground water.

(d) The Regional Administrator may approve alternative design or operating practices to those specified in paragraph (c) of this section if the owner or operator demonstrates to the Regional Administrator that such design and operating practices, together with location characteristics:

(1) Will prevent the migration of any hazardous constituent into the ground water or surface water at least as effectively as the liners and leachate collection and removal systems specified in paragraph (c) of this section; and

(2) Will allow detection of leaks of hazardous constituents through the top liner at least as effectively.

(f) The owner or operator of any replacement landfill unit is exempt from paragraph (c) of this section if:

(1) The existing unit was constructed in compliance with the design standards of section 3004(o)(1)(A)(i) and (o)(5) of the Resource Conservation and Recovery Act; and

(2) There is no reason to believe that the liner is not functioning as designed.

13. New § 264.302 is added to read as follows:

**§ 264.302 Action leakage rate.**

(a) The Regional Administrator shall approve an action leakage rate for surface impoundment units subject to § 264.301(c) or (d). The action leakage rate is the maximum design flow rate that the leak detection system (LDS) can remove without the fluid head on the bottom liner exceeding 1 foot. The action leakage rate must include an adequate safety margin to allow for uncertainties in the design (e.g., slope, hydraulic conductivity, thickness of drainage material), construction, operation, and location of the LDS, waste and leachate characteristics, likelihood and amounts of other sources of liquids in the LDS, and proposed response actions (e.g., the action leakage rate must consider decreases in the flow capacity of the system over time resulting from siltation and clogging, rib layover and creep of synthetic components of the system, overburden pressures, etc.).

(b) To determine if the action leakage rate has been exceeded, the owner or operator must convert the weekly or monthly flow rate from the monitoring data obtained under § 264.303(c), to an average daily flow rate (gallons per acre per day) for each sump. Unless the Regional Administrator approves a different calculation, the average daily flow rate for each sump must be calculated weekly during the active life and closure period, and monthly during the post-closure care period when monthly monitoring is required under § 264.303(c).

14. Section 264.303 is amended by adding new paragraph (c) to read as follows:

**§ 264.303 Monitoring and inspection.**

(c)(1) An owner or operator required to have a leak detection system under § 264.301(c) or (d) must record the amount of liquids removed from each leak detection system sump at least

once each week during the active life and closure period.

(2) After the final cover is installed, the amount of liquids removed from each leak detection system sump must be recorded at least monthly. If the liquid level in the sump stays below the pump operating level for two consecutive months, the amount of liquids in the sumps must be recorded at least quarterly. If the liquid level in the sump stays below the pump operating level for two consecutive quarters, the amount of liquids in the sumps must be recorded at least semi-annually. If at any time during the post-closure care period the pump operating level is exceeded at units on quarterly or semi-annual recording schedules, the owner or operator must return to monthly recording of amounts of liquids removed from each sump until the liquid level again stays below the pump operating level for two consecutive months.

(3) "Pump operating level" is a liquid level proposed by the owner or operator and approved by the Regional Administrator based on pump activation level, sump dimensions, and level that avoids backup into the drainage layer and minimizes head in the sump.

15. New § 264.304 is added to read as follows:

§ 264.304 Response actions.

(a) The owner or operator of landfill units subject to § 264.301(c) or (d) must have an approved response action plan before receipt of waste. The response action plan must set forth the actions to be taken if the action leakage rate has been exceeded. At a minimum, the response action plan must describe the actions specified in paragraph (b) of this section.

(b) If the flow rate into the leak detection system exceeds the action leakage rate for any sump, the owner or operator must:

(1) Notify the Regional Administrator in writing of the exceedance within 7 days of the determination;

(2) Submit a preliminary written assessment to the Regional Administrator within 14 days of the determination, as to the amount of liquids, likely sources of liquids, possible location, size, and cause of any leaks, and short-term actions taken and planned;

(3) Determine to the extent practicable the location, size, and cause of any leak;

(4) Determine whether waste receipt should cease or be curtailed, whether any waste should be removed from the unit for inspection, repairs, or controls, and whether or not the unit should be closed;

(5) Determine any other short-term and longer-term actions to be taken to mitigate or stop any leaks; and

(6) Within 30 days after the notification that the action leakage rate has been exceeded, submit to the Regional Administrator the results of the analyses specified in paragraphs (b)(3), (4), and (5) of this section, the results of actions taken, and actions planned. Monthly thereafter, as long as the flow rate in the leak detection system exceeds the action leakage rate, the owner or operator must submit to the Regional Administrator a report summarizing the results of any remedial actions taken and actions planned.

(c) To make the leak and/or remediation determinations in paragraphs (b)(3), (4), and (5) of this section, the owner or operator must:

(1)(i) Assess the source of liquids and amounts of liquids by source.

(ii) Conduct a fingerprint, hazardous constituent, or other analyses of the liquids in the leak detection system to identify the source of liquids and possible location of any leaks, and the hazard and mobility of the liquid; and

(iii) Assess the seriousness of any leaks in terms of potential for escaping into the environment or

(2) Document why such assessments are not needed.

16. Section 264.310 is amended by redesignating paragraphs (b)(3), (4), and (5) as paragraphs (b)(4), (5), and (6) respectively, and by adding a new paragraph (b)(3) to read as follows:

§ 264.310 Closure and post-closure care.

(b)

(3) Maintain and monitor the leak detection system in accordance with §§ 264.301(c)(3)(iv) and (4) and 264.303(c), and comply with all other applicable leak detection system requirements of this part

PART 265—INTERIM STATUS STANDARDS FOR OWNERS AND OPERATORS OF HAZARDOUS WASTE TREATMENT, STORAGE, AND DISPOSAL FACILITIES

1. The authority citation for Part 265 is revised to read as follows:

Authority: 42 U.S.C. 6905, 6921(a), 6924, 6925, 6935, and 6936.

2. Section 265.15 is amended by revising paragraph (b)(4) to read as follows:

§ 265.15 General inspection requirements.

(b)

(4) The frequency of inspection may vary for the items on the schedule. However, it should be based on the rate of deterioration of the equipment and the probability of an environmental or human health incident if the deterioration, malfunction, or any operator error goes undetected between inspections. Areas subject to spills, such as loading and unloading areas, must be inspected daily when in use. At a minimum, the inspection schedule must include the items and frequencies called for in §§ 265.174, 265.193, 265.195, 265.226, 265.260, 265.278, 265.304, 265.347, 265.377, 265.403, 265.1033, 265.1052, 265.1053, and 265.1058, where applicable.

3. Subpart B is amended by adding § 265.19 to read as follows:

§ 265.19 Construction quality assurance program.

(a) CQA program: (1) A construction quality assurance (CQA) program is required for all surface impoundment, waste pile, and landfill units that are required to comply with §§ 265.221(a), 265.254, and 265.301(a). The program must ensure that the constructed unit meets or exceeds all design criteria and specifications in the permit. The program must be developed and implemented under the direction of a CQA officer who is a registered professional engineer.

(2) The CQA program must address the following physical components, where applicable:

(i) Foundations;

(ii) Dikes;

(iii) Low-permeability soil liners;

(iv) Geomembranes (flexible membrane liners);

(v) Leachate collection and removal systems and leak detection systems; and

(vi) Final cover systems.

(b) Written CQA plan. Before construction begins on a unit subject to the CQA program under paragraph (a) of this section, the owner or operator must develop a written CQA plan. The plan must identify steps that will be used to monitor and document the quality of materials and the condition and manner of their installation. The CQA plan must include:

(1) Identification of applicable units, and a description of how they will be constructed.

(2) Identification of key personnel in the development and implementation of the CQA plan, and CQA officer qualifications.

(3) A description of inspection and sampling activities for all unit components identified in paragraph

**APPENDIX B**

**Calculations of Critical Design Components**

**Defining the Action Leakage Rate (ALR)**

# SEC DONOHUE

## CALCULATION SHEET

IT CWM-CHEMICAL SERVICES LOCATION MODEL CITY, N.Y. JOB NO. P. 2241  
 SUBJECT RESPONSE ACTION PLAN FOR RMI-1  
 BY cmj DATE 3-24-92 CHECKED BY DCZ DATE 3/30/92

### PURPOSE:

DETERMINE FLOW CAPACITY OF VARIOUS SUMP COMPONENTS TO DETERMINE THE ACTION LEAKAGE RATE (ALR).

### COMPONENTS:

- ① FLOW TO PIPE
- ② PIPE PERFORATIONS
- ③ CAPACITY THROUGH SECONDARY LEACHATE COLLECTION SYSTEM AT ENTRANCE TO SUMP.

### 1 FLOW TO PIPE THROUGH DRAINAGE LAYER

THE FLOW TO THE PIPE CAN BE ESTIMATED BY DRAWING A FLOW NET

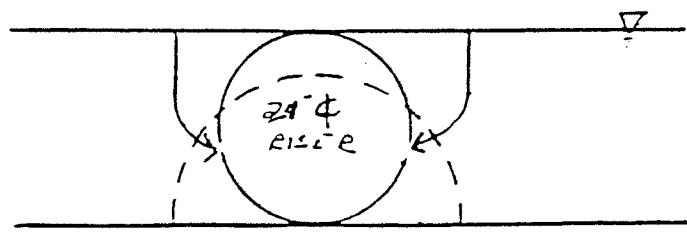

$N_f = 3$  Darcy's LAW IS APPLICABLE AND FLOW  
 $N_d = 2$  NET IS SIMILAR TO NET USED IN  
 THE GENERIC RAP.

PIPE IS PERFORATED HDPE WITH  $\frac{1}{8}$ " HOLES SPACED 6" EACH WAY. REFER TO FIGURE 6.

# SEC DONOHUE

## CALCULATION SHEET

CONTRACT CHM - MEDICAL SERVICES INC LOCATION MORRIS CITY N.J. JOB NO. P-2244  
 SUBJECT PERFORATED METAL PAN FOR EMU-1  
 BY CHM DATE 3-24-92 CHECKED BY DCZ DATE 3/30/92

### ASSUMPTIONS

- PIPE AND PUMP CAPACITY ARE GREATER THAN FLOW THAT WILL REACH THE PIPE THROUGH THE DRAINAGE MATERIAL.
- DARCY'S LAW IS VALID AND FLOW QUANTITY CAN BE ESTIMATED USING A FLOW NET.
- CONDITIONS WITHIN THE DRAIN REMAIN SATURATED.
- THE MAXIMUM HEAD IS EQUAL TO THE DRAIN THICKNESS; THE AVERAGE HEAD ON ALL SUMPS IS ASSUMED TO BE 2.5 FT
- LENGTH OF SECTION OF PIPE WITH PERFORATIONS IS 4 FT.

### METHOD:

- DRAW APPROXIMATE FLOW NET (SEE ABOVE)
- DETERMINE Q USING DARCY'S LAW FOR FLOW NETS

$$Q = K h_L \left( \frac{N_f}{N_j} \right) L ; L = \text{LENGTH OF PIPE}$$

### CALCULATION:

$$K = 2.0 \times 10^{-2} \text{ cm/SEC } (56.7 \text{ FT/DAY})$$

$$Q = (56.7 \text{ FT/DAY}) (2.5 \text{ FT}) \left( \frac{3}{2} \right) (4 \text{ FT}) \left( \frac{7.48 \text{ GAL}}{1 \text{ FT}^3} \right)$$

$$Q = 6,361.7 \text{ GPD}$$

$$Q_{\text{ALLOWABLE}} = \left( \frac{1}{F.S.} \right) (Q_{\text{ULT}})$$

$$= \frac{1}{3} (6361.7) = 3180.8 \text{ GPD}$$

## SEC DONOHUE

## CALCULATION SHEET

CITY CUM-CHEMICAL SERVICES LOCATION MODEL CITY, NY JOB NO. P-2244  
 SUBJECT RESPONSE ACTION PLAN FOR RMLI-1  
 BY mm DATE 7-24-92 CHECKED BY DGZ DATE 7/30/92

## 2. PIPE PERFORATIONS

THE FLOW THROUGH THE PIPE PERFORATIONS CAN BE ESTIMATED USING THE BERNOULLI CRIFICE EQUATION.

## ASSUMPTIONS:

- FREE FLOWS OCCUR THROUGH THE HOLES
- THE HEAD IS CONSTANT AND EQUAL TO THE DEPTH OF DRAW AT THE SUMP; THE AVERAGE HEAD FOR ALL SUMPS IS ASSUMED TO BE 1 FOOT.
- THE PERFORATIONS HAVE SHARP EDGES;  $C=0.61$ .
- THERE ARE NO HOLES IN THE SIDE SLOPE RICE PIPE.

## CALCULATIONS:

AREA OF  $\frac{1}{2}$ " DIA. HOLE:

$$A = \frac{\pi d^2}{4} = 0.00136 \text{ FT}^2$$

22 HOLES PER FOOT (SEE FIGURE 6)

$$Q = CA \sqrt{2gh}$$

$$= (0.61)(0.00136) \sqrt{2(32.2 \frac{\text{ft}}{\text{sec}^2}) (1 \text{ FT})} (22)$$

$$= 0.146 \frac{\text{FT}^3}{\text{SEC}} \approx 94,656 \frac{\text{GPD}}{\text{FT}}$$

OK.

FOR A 4' SECTION OF PIPE

$$4' (94,656 \frac{\text{GPD}}{\text{FT}}) = \underline{\underline{378,625 \text{ GPD.}}}$$

## SEC DONOHUE

## CALCULATION SHEET

PROJECT CUM-CUM-CAL SERVICES LOCATION MOORE CITY, N.Y. JOB NO. P2244  
 SUBJECT REPAIR ACTION PLAN FOR RMU-1  
 BY emm DATE 2/24/92 CHECKED BY DC DATE 3/30/92

### 3. CAPACITY THROUGH SECONDARY LEACHATE COLLECTION SYSTEM AT ENTRANCE TO SUMP.

#### METHOD:

- DETERMINE THE QUANTITY OF FLOW PER LINEAL FOOT OF SUMP PERIMETER USING DARCY'S EQUATION  $Q = K i a$
- APPLY A FACTOR OF SAFETY

#### ASSUMPTIONS:

- $i$  = SLOPE OF LINER SYSTEM
- $h$  IS LESS THAN OR EQUAL TO THICKNESS OF DRAINAGE LAYER
- ASSUME UNIFORM 2% SLOPE TO EDGE OF SUMP
- TRANSMISSIVITY FOR 1 LAYER OF GEONET (Plynet PN3000) AT THE SPECIFIED LOAD =  $1.94 \times 10^{-2} \text{ ft}^2/\text{sec}$

#### CALCULATION:

$$Q = K i a \quad \begin{array}{l} K = \text{HYDRAULIC CONDUCTIVITY OF DRAINAGE LAYER} \\ i = \text{HYDRAULIC GRADIENT} = 2\% \\ a = \text{AREA} \end{array}$$

$$\text{TRANSMISSIVITY (IN PLANE PERMEABILITY)} = K (\text{THICKNESS})$$

$$Q = \frac{T}{t} i a = \frac{T}{t} i (t) (w)$$

$$Q = T i w$$

$$Q = 1.94 \times 10^{-2} \frac{\text{ft}^2}{\text{SEC}} \times \frac{60 \text{ SEC}}{1 \text{ MIN}} \times \frac{60 \text{ MIN}}{1 \text{ hr}} \times \frac{24 \text{ hr}}{1 \text{ DAY}} (1.00) w$$

$$Q = 33.52 \frac{\text{ft}^3}{\text{DAY}} / \text{LINEAL FT. OF PERIMETER.}$$

## SEC DONOHUE

## CALCULATION SHEET

CLIENT CLUM CHEMICAL SERVICES, INC. LOCATION WHEELER CITY, N.Y. JOB NO. P. 2244  
 SUBJECT RESPONSE ACTION PLAN FOR RMU-1  
 BY cm DATE 3/24/92 CHECKED BY DC DATE 3/30/92

## SUMP PERIMETERS

$$\text{LENGTH} \approx 60 \text{ FT (FIGURES 7-8)}$$

$$\text{WIDTH} \approx 40 \text{ FT (FIGURES 7-8)}$$

$$\text{TOTAL PERIMETER} = 2(60') + 2(40') = 200'$$

## CELL ULTIMATE CAPACITY

$$Q_{ULT} = (200') (33.52 \frac{\text{FP}}{\text{IN/FT}}) (7.48 \frac{\text{GPD}}{\text{FT}^3}) = 50,150 \text{ GPD}$$

A FACTOR OF SAFETY = 2.0 HAS BEEN SUGGESTED IN THE PREAMBLE OF THE JANUARY 29, 1992 FINAL RULE. THIS WILL ALLOW FOR UNCERTAINTIES IN THE DESIGN (E.G., SLOPE, HYDRAULIC CONDUCTIVITY, THICKNESS OF DRAINAGE MATERIAL), CONSTRUCTION, OPERATION, AND LOCATION OF THE SLCs, WASTE AND LEACHATE CHARACTERISTICS, LIKELIHOOD AND AMOUNTS OF OTHER SOURCES OF LIQUIDS IN THE SLCs, AND PROPOSED RESPONSE ACTIONS (E.G., THE ALR MUST CONSIDER DECREASES IN THE FLOW CAPACITY OF THE SYSTEM OVER TIME RESULTING FROM SILTATION AND CLOGGING, AIR LAYOVER AND CREEP OF SYNTHETIC COMPONENTS OF THE SYSTEM, OVERBURDEN PRESSURE, ETC.)

$$Q_{ALLOWABLE} = \left(\frac{1}{F.S.}\right) (Q_{ULT})$$

$$= \left(\frac{1}{2}\right) (50,150 \text{ GPD}) = \underline{\underline{25,075 \text{ GPD}}}$$



# APPENDIX B-1

## RMU-1 CELLS 7 & 8

### PURPOSE

Determine flow capacity of various secondary leachate collection system (SLCS) components to determine the action leakage rate (ALR).

### Components

1. Flow to the 24" secondary leachate collection riser pipe through the drainage layer.
2. Capacity through the pipe perforations of the secondary leachate riser pipe.
3. Capacity through the secondary leachate collection system at entrance to sump.
  - A. Capacity through the geocomposite.
  - B. Capacity through the secondary leachate collection pipe.
  - C. Capacity through the pipe perforations of the 8" secondary leachate collection pipe.
  - D. Flow to the 8" secondary leachate collection pipe through the drainage layer.

### Factor of Safety

A factor of safety of 2.0 has been suggested in the preamble of the January 29, 1991, Final Rule. This will allow for uncertainties in the design (e.g., slope, hydraulic conductivity, thickness of drainage material), construction, operation, and location of the SLCS, waste and leachate characteristics, likelihood and amounts of other sources of liquids in the SLCS, and proposed response actions. The ALR must consider decreases in the flow capacity of the system over the time resulting from siltation and clogging, rib layover and creep of synthetic components of the system, overburden pressure, etc.

### **1. Flow to the 24" Secondary Leachate Collection Riser Pipe Through the Drainage Layer.**

The flow to the pipe can be estimated by drawing a flow net.

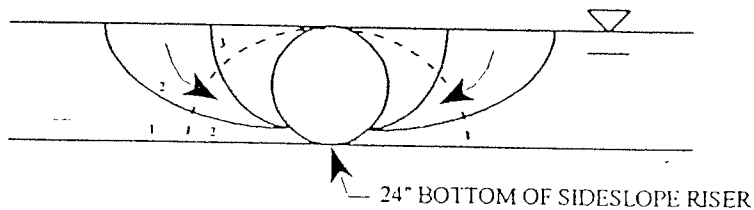

$N_f$  = number of flow tubes = 3

$N_d$  = divisions of head in flow net = 2

Darcy's Law is applicable and flow net is similar to net used in the generic RAP.

Pipe is perforated HDPE with 1/2-inch holes spaced 6 inches each way. Refer to Figure 6.

Assumptions:

- Pipe and pump capacity are greater than flow that will reach the pipe through the drainage material.
- Darcy's Law is valid and flow quantity can be estimated using a flow net.
- Conditions within the drain remain saturated.
- The maximum head is equal to the drain thickness; the average head on all sumps is assumed to be 2.5 feet.
- Length of section of pipe with perforations is 4 feet.

Method:

- Draw approximate flow net (see above).
- Determine  $Q_{act}$  using Darcy's Law for flow nets.

$$Q_{actual} = Kh_L \frac{N_f}{N_d} L$$

$L$  = Length perpendicular to flow net (length of pipe)

$K$  =  $2.0 \times 10^{-2}$  cm/sec (56.7 ft/day) for NYSDOT 2" ROC stone

$$Q_{actual} = (56.7 \text{ ft/day}) (2.5 \text{ ft}) (3/2) (4 \text{ ft}) \frac{(7.48 \text{ gal})}{1 \text{ ft}^3}$$

$$Q_{actual} = 6,361.7 \text{ GPD}$$

$$Q_{allowable} = \frac{1}{\text{safetyfactor}} \times Q_{actual}$$

$$Q_{allowable} = \frac{1}{2} \times 6361.7 \text{ GPD}$$

$$= 3180.8 \text{ GPD}$$

## 2. Capacity Through the Pipe Perforations of the Secondary Leachate Riser Pipe.

The flow through the pipe perforations can be estimated using the Bernoulli orifice equation.

### Assumptions:

- Free flows occur through the holes.
- The head is constant and equal to the depth of drain at the sump; the average head for all sumps is assumed to be 1 foot.
- The perforations have sharp edges;  $C=0.61$ .
- There are no holes in the side slope riser pipe.

### Calculations:

Area of 1/2-inch diameter hole

$$A = \frac{\pi d^2}{4} = 0.00136 \text{ ft}^2$$

22 holes per foot (See Figure 6)

$$\begin{aligned} Q &= CA \sqrt{2gh} \\ &= (0.61)(0.00136)\sqrt{2(32.2 \text{ ft/sec}^2) 1 \text{ ft}} (22) \\ &= 0.146 \text{ ft}^3/\text{sec} \\ &= 94,656 \text{ GPD/ft} \end{aligned}$$

For a 4-foot section of pipe

$$4 \text{ ft} (94,656 \text{ GPD/ft}) = 378,625 \text{ GPD}$$

Assuming a safety factor of 2:

$$\begin{aligned} Q_{\text{allowable}} &= 378,625 \text{ GPD} / 2.0 \\ &= 189,313 \text{ GPD} \end{aligned}$$

### 3. Capacity Through the Secondary Leachate Collection System at Entrance to Sump.

Calculate the total capacity of the secondary leachate collection system at the sump. The following flows are evaluated: (A) Capacity through the geocomposite, (B) Capacity through the secondary leachate collection pipe, (C) Capacity through the pipe perforations of the 8" secondary leachate collection pipe and (D) Flow to the 8" secondary leachate collection header pipe through the drainage layer.

#### A. Capacity Through the Geocomposite.

##### Method:

- Determine the quantity of flow per lineal foot of sump perimeter using Darcy's equation  $Q = Kia$ .
- Apply a factor of safety.

##### Assumptions:

- $i$  = Slope of liner system.
- $h$  is less than or equal to thickness of drainage layer.

- Assume uniform 1.0% slope to edge of sump.
- Transmissivity for one layer of geocomposite (TN3002-1620C) at the specified load =  $2.94 \times 10^{-3} \text{ ft}^2/\text{sec}$ .

Calculation:

$$Q = Kia \quad \begin{array}{l} K = \text{hydraulic conductivity of drainage layer} \\ i = \text{hydraulic gradient} = 1.0\% \\ a = \text{area} \end{array}$$

Transmissivity (in plane permeability) =  $K$  (thickness)

$$Q = \frac{Ti a}{t} = \frac{Ti}{t} (l)(w)$$

$$Q = Tiw$$

$$Q = 2.94 \times 10^{-3} \text{ ft}^2/\text{sec} \times 60 \text{ sec}/1 \text{ min} \times 60 \text{ min}/1 \text{ hr} \times 24 \text{ hr}/1 \text{ day} (0.01)w$$

$$Q = \frac{2.54 \text{ ft}^2/\text{day}}{\text{Lineal ft of perimeter}}$$

Secondary Sump Perimeters:

Length = 21 ft (Drawing 13D)

Width = 27 ft (Drawing 13D)

$$\text{Total Perimeter} = 2(21 \text{ ft}) + 2(27 \text{ ft}) = 96 \text{ ft}$$

Cell Ultimate Capacity:

$$Q_{\text{ult}} = (96 \text{ ft}) (2.54 \text{ ft}^2/\text{day}/\text{LF})(7.48 \text{ gal}/\text{ft}^3) = 1824 \text{ GPD}$$

Assuming a safety factor of 2:

$$\begin{aligned} Q_{\text{allowable}} &= 1824 \text{ GPD} / 2.0 \\ &= 912 \text{ GPD} \end{aligned}$$

**B. Capacity Through the Secondary Leachate Collection Header Pipe.**

The capacity of the 8" perforated SDR 13.5 HDPE pipe can be determined by the Manning formula.

Where: Q = flow rate (cfs)  
 n = Manning's roughness coefficient  
 n = 0.012 for plastic pipe

$$Q = \frac{1.49}{n} A R^{2/3} S^{1/2}$$

$$A = \text{Pipe AREA} = \frac{1}{4} \pi d^2$$

For 8" SDR13.5, inner diameter = 7.347 in

$$A = \frac{1}{4} \pi \left( \frac{7.347}{12} \right)^2$$

$$= 0.294 \text{ ft}^2$$

$$R = \text{Hydraulic Radius} = \frac{\text{Diameter}}{4} \text{ for full flowing pipes}$$

$$R = \frac{7.347}{4} \times \frac{1 \text{ ft}}{12 \text{ in}} = 0.153$$

$$s = \text{Pipe Slope} = \cancel{1.3\%} = \cancel{0.013 \text{ ft/ft}} \quad 1.0\% = 0.01 \text{ ft/ft} \quad \text{JSA}$$

$$Q_{\text{pipe}} = \frac{1.49}{0.012} (0.294 \text{ ft}^2) (0.153)^{2/3} (0.01)^{1/2} = 1.04 \text{ ft}^3/\text{s}$$

$$= 1.04 \frac{\text{ft}^3}{\text{sec}} \times \frac{7.48 \text{ gal}}{1 \text{ ft}^3} \times \frac{86400 \text{ sec}}{1 \text{ day}} = 674,879 \text{ GPD}$$

### C. Capacity Through the Pipe Perforations of the 8" Secondary Leachate Collection Pipe.

The flow through the pipe perforations can be estimated using the Bernoulli orifice equation.

#### Assumptions:

- Free flows occur through the holes.
- The maximum head is equal to the thickness of the drainage stone which is 1 foot.

- The perforations have sharp edges;  $C=0.61$ .
- The head is constant and is per unit foot of pipe length

Calculations:

Area of 5/8-inch diameter hole

$$A = \frac{\pi d^2}{4} = 0.00213 \text{ ft}^2$$

4 holes per foot (See Engineering Report, Appendix G-1, Section 4, Page 9)

$$\begin{aligned} Q &= CA \sqrt{2gh} \\ &= (0.61)(0.00213)\sqrt{2(32.2 \text{ ft/sec}^2) 1 \text{ ft}} (4) \\ &= 0.042 \text{ ft}^3/\text{sec} \\ &= 27,143 \text{ GPD/ft} \end{aligned}$$

Assuming a safety factor of 2:

$$\begin{aligned} Q_{\text{allowable}} &= 27,143 \text{ GPD} / 2.0 / \text{ft} \\ &= (13,571 \text{ GPD} / \text{ft})(697 \text{ ft}) \\ &= 9,458,987 \text{ GPD} \end{aligned}$$

**D. Flow to the 8" Secondary Leachate Collection Header Pipe the Through Drainage Layer.**

The flow to the pipe can be estimated by drawing a flow net.

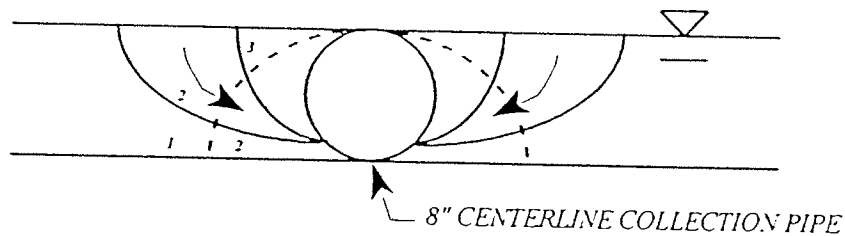

$$N_f = \text{number of flow tubes} = 3$$

$$N_d = \text{divisions of head in flow net} = 2$$

Darcy's Law is applicable and flow net is similar to net used in the generic RAP.

Pipe is perforated HDPE with 5/8-inch holes spaced 120° apart in an alternating pattern, 3 inches each way. (See Engineering Report, Appendix G-1, Section 4, Page 9)

Assumptions:

- Pipe and pump capacity are greater than flow that will reach the pipe through the drainage material.
- Darcy's Law is valid and flow quantity can be estimated using a flow net.
- Conditions within the drain remain saturated.
- The maximum head is equal to the drainage layer thickness which is 1 foot.
- Length of section of pipe with perforations is 697 feet.

Method:

- Draw approximate flow net (see above).
- Determine  $Q_{act}$  using Darcy's Law for flow nets.

$$Q_{actual} = Kh_L \frac{N_f}{N_d} L$$

$L$  = Length perpendicular to flow net (length of pipe)

$K$  =  $1.0 \times 10^{-2}$  cm/sec (28.3 ft/day) for NYSDOT 1A stone

Calculation:

$$Q_{actual} = (28.3 \text{ ft/day}) (1.0 \text{ ft}) (3/2) \frac{(7.48 \text{ gal})}{1 \text{ ft}^3}$$

$$Q_{actual} = 317.5 \text{ GPD} / 1 \text{ ft}$$

$$Q_{allowable} = \frac{1}{\text{safety factor}} \times Q_{actual}$$

$$Q_{allowable} = \frac{1}{2} \times 317.5 \text{ GPD}$$

$$= [158.7 \text{ GPD} / 1 \text{ ft}] \times 697 \text{ ft}$$

$$= 110,649 \text{ GPD}$$



## Conclusions

Considering the flow through the secondary leachate collection header pipe, flow through the drainage stone governs. Therefore, the maximum flow is the amount through the drainage stone.

$$Q_{\text{stone}} = 110,649 \text{ GPD (From Item 3D)}$$

$$Q_{\text{geocomposite}} = 912 \text{ GPD (From Item 3A)}$$

The combined flow through the drainage stone and the geocomposite at the sump entrance is:

$$\begin{aligned} Q_{\text{sump entrance}} &= 110,649 \text{ GPD} + 912 \text{ GPD} \\ &= 111,561 \text{ GPD} \end{aligned}$$

Therefore,

$$Q_{\text{ult}} = 111,561 \text{ GPD}$$

APPENDIX B-2  
CELLS 9 THROUGH 14  
ACTION LEAKAGE RATE CALCULATIONS

RMU-1  
CELLS 9 THROUGH 14

PURPOSE

Determine flow capacity of various secondary leachate collection system (SLCS) components to determine the action leakage rate (ALR).

Components

1. Flow to the 24" secondary leachate collection riser pipe through the drainage layer.
2. Capacity through the pipe perforations of the secondary leachate riser pipe.
3. Capacity through the secondary leachate collection system at entrance to sump.
  - A. Capacity through the geocomposite.
  - B. Capacity through the secondary leachate collection pipe.
  - C. Capacity through the pipe perforations of the 8" secondary leachate collection pipe.
  - D. Flow to the 8" secondary leachate collection pipe through the drainage layer.

Factor of Safety

A factor of safety of 2.0 has been suggested in the preamble of the January 29, 1991, Final Rule. This will allow for uncertainties in the design (e.g., slope, hydraulic conductivity, thickness of drainage material), construction, operation, and location of the SLCS, waste and leachate characteristics, likelihood and amounts of other sources of liquids in the SLCS, and proposed response actions. The ALR must consider decreases in the flow capacity of the system over the time resulting from siltation and clogging, rib layover and creep of synthetic components of the system, overburden pressure, etc.

1. **Flow to the 24" Secondary Leachate Collection Riser Pipe Through the Drainage Layer.**

The flow to the pipe can be estimated by drawing a flow net.

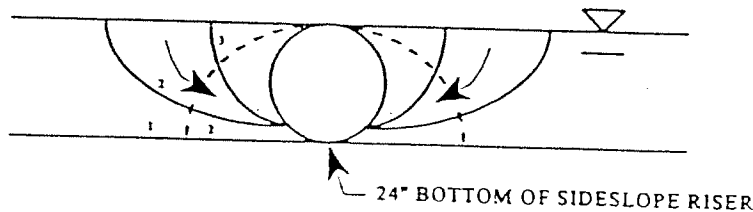

$N_f$  = number of flow tubes = 3

$N_d$  = divisions of head in flow net = 2

Darcy's Law is applicable and flow net is similar to net used in the generic RAP.

Pipe is perforated HDPE with 1/2-inch holes spaced 6 inches each way. Refer to Figure 6.

Assumptions:

- Pipe and pump capacity are greater than flow that will reach the pipe through the drainage material.
- Darcy's Law is valid and flow quantity can be estimated using a flow net.
- Conditions within the drain remain saturated.
- The maximum head is equal to the drain thickness; the average head on all sumps is assumed to be 2.5 feet.
- Length of section of pipe with perforations is 4 feet.

Method:

- Draw approximate flow net (see above).
- Determine  $Q_{act}$  using Darcy's Law for flow nets.

$$Q_{actual} = Kh_L \frac{N_f}{N_d} L$$

$L$  = Length perpendicular to flow net (length of pipe)

$K$  =  $2.0 \times 10^{-2}$  cm/sec (56.7 ft/day) for NYSDOT 2" ROC stone

$$Q_{actual} = (56.7 \text{ ft/day}) (2.5 \text{ ft}) (3/2) (4 \text{ ft}) \frac{(7.48 \text{ gal})}{1 \text{ ft}^3}$$

$$Q_{actual} = 6,361.7 \text{ GPD}$$

$$Q_{allowable} = \frac{1}{\text{safetyfactor}} \times Q_{actual}$$

$$Q_{allowable} = \frac{1}{2} \times 6361.7 \text{ GPD}$$

$$= 3180.8 \text{ GPD}$$

## 2. Capacity Through the Pipe Perforations of the Secondary Leachate Riser Pipe.

The flow through the pipe perforations can be estimated using the Bernoulli orifice equation.

### Assumptions:

- Free flows occur through the holes.
- The head is constant and equal to the depth of drain at the sump; the average head for all sumps is assumed to be 1 foot.
- The perforations have sharp edges;  $C=0.61$ .
- There are no holes in the side slope riser pipe.

### Calculations:

Area of 1/2-inch diameter hole

$$A = \frac{\pi d^2}{4} = 0.00136 \text{ ft}^2$$

22 holes per foot (See Figure 6)

$$\begin{aligned}
 Q &= CA \sqrt{2gh} \\
 &= (0.61)(0.00136) \sqrt{2(32.2 \text{ ft/sec}^2) 1 \text{ ft}} \quad (22) \\
 &= 0.146 \text{ ft}^3/\text{sec} \\
 &= 94,656 \text{ GPD/ft}
 \end{aligned}$$

For a 4-foot section of pipe

$$4 \text{ ft} (94,656 \text{ GPD/ft}) = 378,625 \text{ GPD}$$

Assuming a safety factor of 2:

$$\begin{aligned}
 Q_{\text{allowable}} &= 378,625 \text{ GPD} / 2.0 \\
 &= 189,313 \text{ GPD}
 \end{aligned}$$

### 3. Capacity Through the Secondary Leachate Collection System at Entrance to Sump.

Calculate the total capacity of the secondary leachate collection system at the sump. The following flows are evaluated: (A) Capacity through the geocomposite, (B) Capacity through the secondary leachate collection pipe, (C) Capacity through the pipe perforations of the 8" secondary leachate collection pipe and (D) Flow to the 8" secondary leachate collection header pipe through the drainage layer.

#### A. Capacity Through the Geocomposite.

##### Method:

- Determine the quantity of flow per lineal foot of sump perimeter using Darcy's equation  $Q = Kia$ .
- Apply a factor of safety.

##### Assumptions:

- $i$  = Slope of liner system.
- $h$  is less than or equal to thickness of drainage layer.

- Assume uniform 1.0% slope to edge of sump.
- Transmissivity for one layer of geocomposite (TN3002-1620C) at the specified load =  $2.94 \times 10^{-3} \text{ ft}^2/\text{sec}$ .

Calculation:

$$Q = Kia \quad \begin{array}{l} K = \text{hydraulic conductivity of drainage layer} \\ i = \text{hydraulic gradient} = 1.0\% \\ a = \text{area} \end{array}$$

Transmissivity (in plane permeability) =  $K$  (thickness)

$$Q = \frac{Tia}{t} = \frac{Ti}{t} (t)(w)$$

$$Q = Tiw$$

$$Q = 2.94 \times 10^{-3} \text{ ft}^2/\text{sec} \times 60 \text{ sec}/1 \text{ min} \times 60 \text{ min}/1 \text{ hr} \times 24 \text{ hr}/1 \text{ day} (0.01)w$$

$$Q = \frac{2.54 \text{ ft}^2/\text{day}}{\text{Lineal ft of perimeter}}$$

Secondary Sump Perimeters:

Length = 21 ft (Drawing 13D)

Width = 27 ft (Drawing 13D)

$$\text{Total Perimeter} = 2(21 \text{ ft}) + 2(27 \text{ ft}) = 96 \text{ ft}$$

Cell Ultimate Capacity:

$$Q_{\text{ult}} = (96 \text{ ft}) (2.54 \text{ ft}^2/\text{day}/\text{LF})(7.48 \text{ gal}/\text{ft}^3) = 1824 \text{ GPD}$$

Assuming a safety factor of 2:

$$\begin{aligned} Q_{\text{allowable}} &= 1824 \text{ GPD} / 2.0 \\ &= 912 \text{ GPD} \end{aligned}$$

**B. Capacity Through the Secondary Leachate Collection Header Pipe.**

The capacity of the 8" perforated Schedule 80 PVC pipe can be determined by the Manning formula.

Where:  $Q$  = flow rate (cfs)  
 $n$  = Manning's roughness coefficient  
 $n$  = 0.012 for plastic pipe

$$Q = \frac{1.49}{n} A R^{2/3} S^{1/2}$$

$$A = \text{Pipe AREA} = \frac{1}{4} \pi d^2$$

For 8" Schedule 80 PVC, inner diameter = 7.625 in

$$A = \frac{1}{4} \pi \left( \frac{7.625}{12} \right)^2$$

$$= 0.317 \text{ ft}^2$$

$$R = \text{Hydraulic Radius} = \frac{\text{Diameter}}{4} \text{ for full flowing pipes}$$

$$R = \frac{7.625}{4} \times \frac{1 \text{ ft}}{12 \text{ in}} = 0.159$$

$$s = \text{Pipe Slope} = 1.0\% = .01 \text{ ft/ft}$$

$$Q_{\text{pipe}} = \frac{1.49}{.012} (.317 \text{ ft}^2) (0.159)^{2/3} (.01)^{1/2} = 1.16 \text{ ft}^3/\text{s}$$

$$= 1.16 \frac{\text{ft}^3}{\text{sec}} \times \frac{7.48 \text{ gal}}{1 \text{ ft}^3} \times \frac{86400 \text{ sec}}{1 \text{ day}} = 746,582 \text{ GPD}$$

### C. Capacity Through the Pipe Perforations of the 8" Secondary Leachate Collection Pipe.

The flow through the pipe perforations can be estimated using the Bernoulli orifice equation.

#### Assumptions:

- Free flows occur through the holes.
- The maximum head is equal to the thickness of the drainage stone which is 1 foot.



- The perforations have sharp edges;  $C=0.61$ .
- The head is constant and is per unit foot of pipe length
- The length of pipe for combined cells are Cells 10 and 9 (697 ft.), Cells 12 and 14 (650 ft) and Cells 11 and 13 (470 ft.).

Calculations:

Area of 5/8-inch diameter hole

$$A = \frac{\pi d^2}{4} = 0.00213 \text{ ft}^2$$

4 holes per foot (See Engineering Report, Appendix G-1, Section 4, Page 9)

$$\begin{aligned} Q &= CA \sqrt{2gh} \\ &= (0.61)(0.00213)\sqrt{2(32.2 \text{ ft/sec}^2) 1 \text{ ft}} (4) \\ &= 0.042 \text{ ft}^3/\text{sec} \\ &= 27,143 \text{ GPD/ft} \end{aligned}$$

Assuming a safety factor of 2:

$$\begin{aligned} Q_{\text{allowable}} &= 27,143 \text{ GPD} / 2.0 / \text{ft} \\ &= (13,571 \text{ GPD} / \text{ft})(697 \text{ ft}) \\ &= 9,458,987 \text{ GPD} \end{aligned}$$

**D. Flow to the 8" Secondary Leachate Collection Header Pipe the Through Drainage Layer.**

The flow to the pipe can be estimated by drawing a flow net.

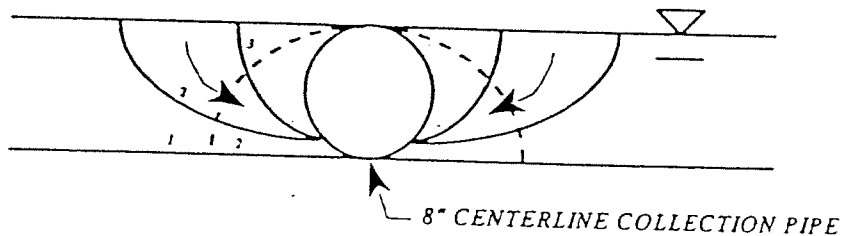

$$N_f = \text{number of flow tubes} = 3$$

$$N_d = \text{divisions of head in flow net} = 2$$

Darcy's Law is applicable and flow net is similar to net used in the generic RAP.

Pipe is perforated HDPE with 5/8-inch holes spaced 120° apart in an alternating pattern, 3 inches each way. (See Engineering Report, Appendix G-1, Section 4, Page 9)

Assumptions:

- Pipe and pump capacity are greater than flow that will reach the pipe through the drainage material.
- Darcy's Law is valid and flow quantity can be estimated using a flow net.
- Conditions within the drain remain saturated.
- The maximum head is equal to the drainage layer thickness which is 1 foot.
- The length of pipe for combined cells are Cells 10 and 9 (697 ft.), Cells 12 and 14 (650 ft.) and Cells 11 and 13 (470 ft.).

Method:

- Draw approximate flow net (see above).
- Determine  $Q_{act}$  using Darcy's Law for flow nets.

$$Q_{actual} = Kh_L \frac{N_f}{N_d} L$$

$L$  = Length perpendicular to flow net (length of pipe)

$K$  =  $8 \times 10^2$  cm/sec (226 ft/day) for NYSDOT 1A stone

Calculation:

$$Q_{actual} = (226 \text{ ft/day}) (1.0 \text{ ft}) (3/2) \frac{(7.28 \text{ gal})}{1 \text{ ft}^3}$$

$$Q_{actual} = 2535.7 \text{ GPD/1 ft.}$$

$$Q_{allowable} = \frac{1}{\text{safety factor}} \times Q_{actual}$$

$$Q_{allowable} = \frac{1}{2} \times 2535.7 \text{ GPD}$$

$$= [1267.9 \text{ GPD/1 ft}] \times 697 \text{ ft (Cells 10 and 9)}$$

$$= 883,726 \text{ GPD (worst case combined Cells 10 and 9)}$$

## Conclusions

Considering the flow through the secondary leachate collection header pipe, flow through the drainage stone governs. Therefore, the maximum flow is the amount through the drainage stone.

$$Q_{\text{stone}} = 883,726 \text{ GPD (From Item 3D)}$$

$$Q_{\text{geocomposite}} = 912 \text{ GPD (From Item 3A)}$$

The combined flow through the drainage stone and the geocomposite at the sump entrance is:

$$\begin{aligned} Q_{\text{sump entrance}} &= 883,726 \text{ GPD} + 912 \text{ GPD} \\ &= 884,638 \text{ GPD} \end{aligned}$$

Therefore,

$$Q_{\text{lt}} = 884,638 \text{ GPD}$$

**APPENDIX C**

**Calculations of Critical Design Components**

**Defining the Response Rate (RR)**

Consolidation of Clay Primary Layer

RMU-1 RAP

Given:

Initial Void Ratio, e	e	0.60
Compression Index	CI	0.24
Coefficient of Compression, cm <sup>2</sup> /sec	Cc	0.00075
or Coeff. of Consolidation, ft <sup>2</sup> /month	Cc	2.12
Saturation, %	%Sat	76
Thickness of Layer, ft	b	1.5
Area of Loading, acres	A	1
Pre-Consolidation Pressure, psf	Pp	500
Applied Load, psf	Pa	6500
Load Time Period, months	t	24

Assumptions:

Soil is Normally Consolidated.  
Terzaghi One-dimensional Consolidation Theory Applies

Procedure:

- 1)  $\Delta P = Pa / t$
- 2)  $\Delta e = CI * \log\{(Pp + \Delta P) / Pp\}$
- 3)  $s = \Delta e / (1 + e) * b$
- 4)  $Tv = Cc * (n \text{ months}) / b^2$
- 5) For  $U > 60\%$ ,  $Tv = 1.181 - 0.933 \log(100 - U\%)$   
- Solve for U
- 6) For Month  $n=1$   
 $S = s * U$   
For Month  $n > 1$   
 $S = s(1) * U(n) + \dots s(n) * s(1)$
- 7)  $q = S * (43560 \text{ ft}^2/\text{acre}) * \%Sat$
- 8) Consolidation Water  $Q = q(n) - q(n-1) / 30 \text{ days}$
- 9) Flow at 90% Consolidation:  
take  $90\% * S(24)$ , Find Q

	Month (n):	1	2	3	4	5	6	7
Initial Po	Po	500	770.8	1041.7	1312.5	1583.3	1854.2	2125.0
Delta P	ΔP	270.8	270.8	270.8	270.8	270.8	270.8	270.8
Final P	P1	770.8	1041.7	1312.5	1583.3	1854.2	2125.0	2395.8
Change in Void Ratio	Δe	0.0451	0.0314	0.0241	0.0196	0.0165	0.0142	0.0125
Settlement in Month	s	0.0423	0.0294	0.0226	0.0183	0.0154	0.0133	0.0117
Time Factor, Tv	Tv	0.9429	1.8858	2.8288	3.7717	4.7146	5.6575	6.6004
Degree of Consolidation, U	U	0.92088383	0.99227969	0.99924663	0.99992648	0.99999282	0.99999993	0.99999993
Settlement achieved in Month	S	0.0390	0.0691	0.0923	0.1110	0.1267	0.1402	0.1521
Water expelled in Month, ft <sup>3</sup> gal	q	1289.5 9646.8	2286.5 17105.2	3054.3 22849.0	3674.2 27487.0	4193.9 31374.8	4641.4 34722.0	5034.2 37661.1
Consolidation water, gpad	Q	321.6	248.6	191.5	154.6	129.6	111.6	98.0
<b>TOTAL SETTLEMENT FOR ENTIRE LAYER</b>		0.0423	0.0717	0.0943	0.1126	0.1281	0.1414	0.1531

8	9	10	11	12	13	14	15	16	17	18
2395.8	2666.7	2937.5	3208.3	3479.2	3750.0	4020.8	4291.7	4562.5	4833.3	5104.2
270.8	270.8	270.8	270.8	270.8	270.8	270.8	270.8	270.8	270.8	270.8
2666.7	2937.5	3208.3	3479.2	3750.0	4020.8	4291.7	4562.5	4833.3	5104.2	5375.0
0.0112	0.0101	0.0092	0.0084	0.0078	0.0073	0.0068	0.0064	0.0060	0.0057	0.0054
0.0105	0.0095	0.0086	0.0079	0.0073	0.0068	0.0064	0.0060	0.0056	0.0053	0.0051
7.5433	8.4863	9.4292	10.3721	11.3150	12.2579	13.2009	14.1438	15.0867	16.0296	16.9725
0.99999999	0.99999999	0.99999999	1	1	1	1	1	1	1	1
0.1626	0.1722	0.1809	0.1889	0.1962	0.2031	0.2095	0.2155	0.2212	0.2265	0.2316
5384.5	5700.4	5988.2	6252.4	6496.7	6723.8	6935.9	7135.2	7322.6	7499.9	7668.0
40281.1	42644.7	44797.5	46774.3	48601.6	50300.5	51887.8	53378.6	54780.6	56106.8	57364.0
87.3	78.8	71.8	65.9	60.9	56.6	52.9	49.7	46.7	44.2	41.9
0.1636	0.1730	0.1816	0.1896	0.1969	0.2037	0.2101	0.2161	0.2217	0.2270	0.2321

S @ t18 = 90% of S @ t24. 0.2321

19	20	21	22	23	24	25	26	27	28	29
5375.0	5645.8	5916.7	6187.5	6458.3	6729.2	7000.0	7270.8	7541.7	7812.5	8083.3
270.8	270.8	270.8	270.8	270.8	270.8	270.8	270.8	270.8	270.8	270.8
5645.8	5916.7	6187.5	6458.3	6729.2	7000.0	7270.8	7541.7	7812.5	8083.3	8354.2
0.0051	0.0049	0.0047	0.0045	0.0043	0.0041	0.0040	0.0038	0.0037	0.0036	0.0034
0.0048	0.0046	0.0044	0.0042	0.0040	0.0039	0.0037	0.0036	0.0034	0.0033	0.0032
17.9155	18.8584	19.8013	20.7442	21.6871	22.6300	23.5730	24.5159	25.4588	26.4017	27.3446
1	1	1	1	1	1	1	1	1	1	1
0.2364	0.2410	0.2454	0.2496	0.2537	0.2575	0.2613	0.2648	0.2683	0.2716	0.2749
							0.2225	0.1966	0.1773	0.1622
7827.7	7980.0	8125.3	8264.5	8397.9	8526.0	8649.2	8767.9	8882.4	8993.0	9100.0
58559.2	59698.1	60785.7	61826.6	62824.5	63782.9	64704.8	65592.9	66449.5	67276.8	68076.8
39.8	38.0	36.3	34.7	33.3	31.9	30.7	29.6	28.6	27.6	26.7
0.2369	0.2414	0.2458	0.2500	0.2540	0.2579	0.2616	0.2652	0.2686	0.2719	0.2752

90 % of S @ t24 = 0.2321

30	31	32	33
8354.2	8625.0	8895.8	9166.7
270.8	270.8	270.8	270.8
8625.0	8895.8	9166.7	9437.5
0.0033	0.0032	0.0031	0.0030
0.0031	0.0030	0.0029	0.0028
28.2876	29.2305	30.1734	31.1163
1	1	1	1
0.2780	0.2810	0.2840	0.2868
0.1499	0.1396	0.1309	0.1232
9203.5	9303.8	9401.0	9495.5
68851.1	69601.5	70329.2	71035.8
25.8	25.0	24.3	23.6
0.2783	0.2813	0.2842	0.2871





**Golder Associates Inc.**  
CONSULTING ENGINEERS

December 13, 1991

914-1030

CWM Chemical Services, Inc.  
Model City TSDR Facility  
1550 Balmer Road  
Model City, New York 14107

Attention: Mr. John B. Hino

RE: LABORATORY AND FIELD DATA EVALUATION  
SECURE LANDFILL (SLF) NO. 12 CELLS A-D  
MODEL CITY FACILITY  
MODEL CITY, NEW YORK

Gentlemen:

In response to the recent request from CWM Chemical Services, Inc., (CWM), Golder Associates Inc. (Golder Associates) has performed an evaluation of selected laboratory and field testing data for the above referenced project. This letter report presents the results of this evaluation. The evaluation was performed to estimate the consolidation characteristics (i.e. Initial Void Ratio ( $e_0$ ) and Compression Index ( $C_c$ )) of the clay materials used during the construction of Cells A-D of SLF No. 12. The estimated values have been calculated based on the material classification properties (i.e. Liquid Limits, Dry Density, and Specific Gravity) presented in the As-built Documentation and Construction Certification Report for Secure Landfill No. 12, Cells A-D, prepared by Golder Associates in 1990.

In the absence of laboratory test results for the determination of  $e_0$  and  $C_c$ , the following equations (Holtz & Kovacs, 1991) were used to estimate the  $e_0$  and  $C_c$  values of the SLF-12 construction materials:

$$e_0 = \frac{\text{Specific Gravity} \times \text{Density of Water}}{\text{Dry Density of Soils}} - 1$$

$$C_c = 0.007 (\text{Liquid Limit} - 7)$$

The laboratory and field testing data used in this evaluation are summarized in Table 1 and the calculated  $e_0$  and the  $C_c$  values are summarized in Table 2. The calculated values

for  $e_c$  and  $C_c$  should be viewed as typical values. For example, the calculated compression indices ( $C_c$ ) are based on an empirical equation which has a reliability range of about  $\pm 30\%$  (Holtz & Kovacs, 1981). Therefore, it is recommended that laboratory consolidation testing of the materials be performed to confirm the estimated  $e_c$  and  $C_c$  values.

Golder Associates trusts that this information is sufficient for your needs at this time. As always, Golder Associates appreciates the opportunity to provide engineering services to CWM Chemical Services, Inc. If you have any questions concerning this letter or if we may be of further assistance, please call.

Very truly yours,

GOLDER ASSOCIATES INC.

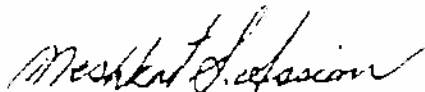
  
Meshkat S. Aslan  
Project Engineer

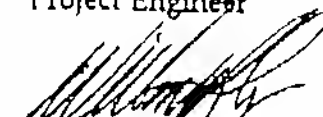
  
William B. Lorier, P.E.  
Associate

MSA/WBL:dml

Attachments

EN5LP-12

TABLE 1  
SUMMARY OF LABORATORY AND FIELD TEST RESULTS  
SECURE LANDFILL NO. 12, CELLS A-D, PRIMARY CLAY LINER

Laboratory Results*			PRE-CONSTRUCTION		DURING CONSTRUCTION									
			Truesdale	Niag. Front.	Cell A		Cell B		Cell C			Cell D		
					Truesdale	Niag. Front.	Truesdale	Niag. Front.	Truesdale	Niag. Front.	TuN.F. (1)	Truesdale	Niag. Front.	TuN.F.
Soil Classification			Silty Clay (CL)	Silty Clay (CL)	---	Silty Clay (CL)	---	Silty Clay (CL)	Silty Clay (CL)	Silty Clay (CL)	---	Silty Clay (CL)	Silty Clay (CL)	
LL %	High	29.0	41.8	---	38.9	---	44.7	---	---	41.9	---	42.2	39.3	
	Low	34.1	38.4	---	36.7	---	31.5	---	---	30.0	---	41.9	31.8	
	Mean	29.9	40.6	---	33.8	---	48.1	---	28.5 (2)	---	35.9	---	42.1	35.8
G		2.78	2.72	2.78(3)	2.72(4)	2.78(5)	2.72(4)	2.78(5)	2.72(4)	2.74(5)	2.78(5)	2.72(4)	2.74(5)	
e <sub>o</sub>		0.459	0.618	---	---	---	---	---	---	---	---	---	---	
Field Results*														
In-Place Dry Density (lb/ft <sup>3</sup> )	High	---	---	123.1	118.4	122.2	111.2	---	---	---	---	121.1	112.2	---
	Low	---	---	116.5	104.0	114.7	104.4	---	---	---	---	114.3	103.9	---
	Mean	---	---	118.8	107.1	116.8	107.0	116.8	---	---	---	117.6	108.5	---

\* Laboratory results from Shelby tubes  
Field results from nuclear density gauge

(3) - Initial void ratio determined as part of permeability testing  
LL - Liquid Limit  
G - Specific Gravity

NOTES:

- (1) TuN.F. - Mixture of Truesdale and Niagara Frontier clays
- (2) Only one test was performed
- (3) Based on the pre-construction data from Truesdale clay
- (4) Based on the pre-construction data from Niagara Frontier clay
- (5) Average values of the Truesdale clay and Niagara Frontier clay from the pre-construction data

TABLE 2  
SUMMARY OF CALCULATED INITIAL VOID RATIO AND COMPRESSION INDEX VALUES  
SECURE LANDFILL NO. 12, CELLS A-D, PRIMARY CLAY LINER

		Cell A		Cell B		Cell C			Cell D		
		Truesdale	Niag. Front.	Truesdale	Niag. Front.	Truesdale	Niag. Front.	Tr/N.F.(1)	Truesdale	Niag. Front.	Tr/N.F.
Cc	High	-----	0.22	-----	0.26	-----	-----	0.24	-----	0.25	0.23
	Low	-----	0.17	-----	0.17	-----	-----	0.16	-----	0.24	0.17
	Mean	-----	0.18	-----	0.23	0.21	-----	0.20	-----	0.25	0.20
C <sub>o</sub>	High	0.49	0.63	0.50	0.63	-----	-----	-----	0.51	0.63	-----
	Low	0.40	0.47	0.41	0.53	-----	-----	-----	0.42	0.51	-----
	Mean	0.45	0.53	0.47	0.59	0.48	-----	-----	0.47	0.59	-----

NOTES:

(1) Tr/N.F. = Mixture of Truesdale and Niagara Frontier Clays

C<sub>o</sub> = Calculated Initial Void Ratio

C<sub>c</sub> = Compression Index

TABLE 9-3 Typical Values of the Coefficient of Consolidation  $c_v$

Soil	$c_v$	
	$\text{cm}^2/\text{s} \times 10^{-9}$	$\text{m}^2/\text{yr}$
Boston blue clay (CL) (Ladd and Leitch, 1965)	40 $\pm$ 20	12 $\pm$ 6
Organic silt (OH) (Lowe, Zaccaro, and Feldman, 1964)	2-10	0.6-3
Glacial lake clays (CL) (Wallace and Otto, 1964)	6.5-8.7	2.0-2.7
Chicago silty clay (CL) (Terzaghi and Peck, 1967)	8.5	2.7
Swedish medium sensitive clays (CL-CH) (Holtz and Brown, 1972)		
1. laboratory	0.4-0.7	0.1-0.2
2. field	0.7-3.0	0.2-1.0
San Francisco Bay Mud (CL)	2-4	0.6-1.2
Mexico City clay (MH) (Leonards and Girault, 1961)	0.9-1.5	0.3-0.5

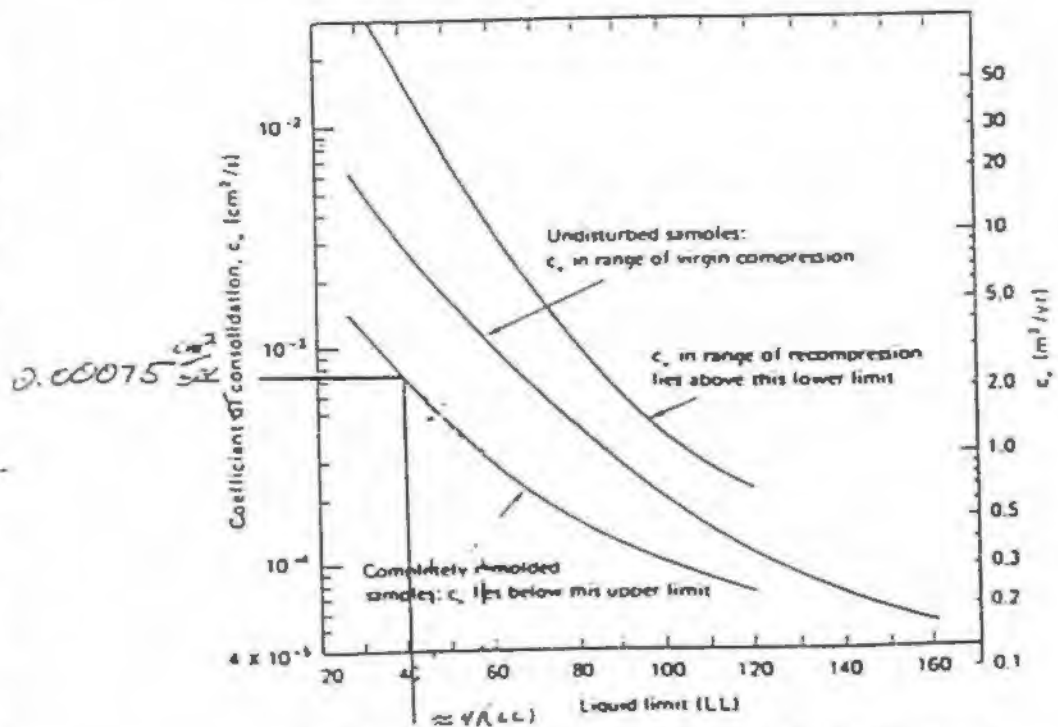

Fig. 9.10 Approximate correlations of the coefficient of consolidation  $c_v$  with the liquid limit (after U.S. Navy, 1971).

TABLE I-U-2  
SUMMARY OF PRE-CONSTRUCTION TESTING  
TRUESDALE AND NIAGARA FRONTIER CLAY SOURCES

LAB SAMPLE NO.	SAMPLE DATE	CLAY SOURCE	NATURAL MOISTURE CONT. (%)	ATTERBERG LIMITS			GRAIN SIZE ANALYSIS FIG. NO.	MODIFIED PROCTOR			LABORATORY PERMEABILITY TESTING			
				PLASTIC LIMIT	LIQUID LIMIT	PLASTICITY INDEX		MAX. DRY DENSITY (pcf)	OPTIMUM MOISTURE CONT. (%)	FIGURE NO.	LABORATORY PERMEABILITY (cm/sec)	DRY DENSITY (pcf)	% OF MAX. DRY DENSITY	MOIST CONT. (%)
ASTM TEST METHOD			D 2922	D 4318			D 422-63	D 1557			SITE PROTOCOL			
5	11/7/89	T	14.7	16.3	28.6	12.3	5	129.6	9.6	5				
6	11/7/89	T	14.0	15.0	26.0	11.0	6	128.6	11.0	6				
7	11/7/89	T	14.8	13.5	27.1	13.6	7	129.7	10.6	7				
8	11/7/89	T	13.5	15.6	27.8	12.2	8	129.7	10.7	8				
9	11/7/89	T	13.8	14.9	28.2	13.3	9	129.7	10.6	9				
10	11/7/89	T	17.1	15.0	27.0	12.0	10	125.6	11.4	10				
11	11/20/89	T	25.7	17.7	34.1	16.4	11	122.3	12.6	11				
12	11/20/89	T	19.1	15.3	29.7	14.4	12	126.4	11.8	12				
16	11/29/89	T	17.4	15.8	31.1	15.3	16				1.8x10-8	115.6	90.5	17.4
17	12/6/89	T	12.9	15.6	28.2	12.6	7							

(FN: TAB-IU2.VK1)

T - Truesdale Clay

NF - Niagara Frontier Clay

(1) Based on Revision 0 of Truesdale Clay Acceptance Compaction Window (127.7 pcf @ 11.1% OMC)

(2) Based on Revision 0 of Niagara Frontier Clay Acceptance Compaction Window (115.4 pcf @ 12.8% OMC)  
• Standard Proctor Test (ASTM D 698)

TABLE I-U-2  
SUMMARY OF PRE-CONSTRUCTION TESTING  
TRUESDALE AND NIAGARA FRONTIER CLAY SOURCES

LAB SAMPLE NO.	SAMPLE DATE	CLAY SOURCE	NATURAL MOISTURE CONT. (%)	ATTERBERG LIMITS			GRAIN SIZE ANALYSIS FIG. NO.	MODIFIED PROCTOR			LABORATORY PERMEABILITY TESTS			
				PLASTIC LIMIT	LIQUID LIMIT	PLASTICITY INDEX		MAX. DRY DENSITY (pcf)	OPTIMUM MOISTURE CONT. (%)	FIGURE NO.	LABORATORY PERMEABILITY (cm/sec)	DRY DENSITY (pcf)	% OF MAX. DRY DENSITY	MC
ASTM TEST METHOD			D 2922	D 4318			D 422-63	D 1557			SITE PROTOCOL			
24	12/7/89	T	13.5	15.0	29.3	14.3	24T				2.3x10-8	122.2	95.7	(1)
25	12/7/89	T	14.5	16.1	33.2	17.1	25T				2.2x10-8	122.7	96.1	(1)
30	1/16/90	NF	16.2	20.0	41.8	21.8	19	115.4	12.9	19	6.2x10-8	104.5	90.6	(2)
31	1/16/90	NF	14.2	17.7	39.4	21.7	20	115.3	12.7	20	8.2x10-8	105.6	91.5	(2)
32A	1/24/90	T	16.0					115.7*	15.2*	22	2.5x10-8	116.9	91.5	(1)
32B	1/24/90	T	17.4	13.1	28.9	15.8	21	125.4	10.5	22	8.3x10-8	113.8	89.1	(1)
36	2/28/90	T					27							
37	2/28/90	T					28							
62	3/27/90	T	12.7	16.3	30.0	13.7	55	126.4	11.3	56	4.2x10-8	120.3	94.2	(1)
66	4/2/90	T	14.2	14.4	30.3	15.9	60	127.3	11.2	61	2.1x10-8	119.6	93.7	(1)

IFN: TAB-IU2.WKT

T - Truesdale Clay

NF - Niagara Frontier Clay

(1) Based on Revision 0 of Truesdale Clay Acceptance Compaction Window (127.7 pcf @ 11.1% OMC)

(2) Based on Revision 0 of Niagara Frontier Clay Acceptance Compaction Window (115.4 pcf @ 12.8% OMC)

\* Standard Proctor Test (ASTM D 698)

Permeation Through the Intact Primary and Secondary  
HDPE Geomembranes due to Hydrostatic Heads

RMU-1 RAP

Assumptions:

Piezometric Head above Secondary HDPE Liner, ft.		9
No Piezometric Head exists in the Secondary Drainage System.		
Permeability of HDPE Liner, cm/sec.		1.000E-11
Primary Drainage Layer is saturated.		
Piezometric Head above HDPE Liner, feet		1

GRADIENT OF OUTSIDE HEAD

Head on HDPE, ft	H	9
Thickness of HDPE, 80 mil, ft	L	0.007
Hydraulic Gradient, ft/ft	$I = (H + L) / L$	1286.7

GRADIENT OF INSIDE HEAD

Head on HDPE, ft	H	1
Thickness of HDPE, 80 mil, ft	L	0.007
Hydraulic Gradient, ft/ft	$I = (H + L) / L$	143.9

FLOW RATE THROUGH HDPE LINER

Darcy's Law	$Q = KIA$	
Permeability, cm/sec	K	1.0E-11
Permeability, ft/day		2.8E-08
Outside Liquids Flow, gpad	Q	11.9
Inside Liquids Flow, gpad	Q	1.3



Leakage through Defects in the Secondary  
HDPE Geomembranes due to Hydrostatic Heads

Assumptions:

Darcy's Law for Flow Nets applies,  $q = K \cdot h \cdot Nf / Nd$

Generic RAP Flow Net is applicable.

Piezometric Head Outside RMU-1, ft.	H	9
Circular Wetted Area, ft.	A	5.5
One hole 1/4-inch diameter per acre.		
Hydraulic Conductivity, K, cm/sec	K	1.0E-07
" " " " " " " "		2.8E-04
" " " " " " " "		ft/day

CONVERT CIRCULAR WETTED AREA TO EQUIVALENT  
RECTANGULAR AREA AS DONE IN GENERIC RAP

Circular Area = $\pi \cdot (d^2) / 4$ , ft <sup>2</sup>	A	23.76
Rectangular Area = wL, solve for w:		
w = $A/L$ , ft.	w	4.32

CALCULATE FLOW THROUGH FLOW NET USING DARCY'S LAW

$q = K \cdot Nf / Nd \cdot H$

Nf/Nd = 8/3, from generic RAP	Nf/Nd	2.66666666
Flow for 1' width, ft <sup>3</sup> /day/ft	q	6.80E-03
For effective width = 4.3'	eff. w	4.3
eff. q = $q_1 \cdot \text{eff. w}$ , ft <sup>3</sup> /day	eff. q	2.94E-02
eff. q, gal/day/hole	eff. q	0.220

At one hole per acre (assumed),		
eff. q, gpad	eff. q/acre	0.220, therefore, use q = 1.0 gpad.

Permeation through the Intact Secondary HDPE Geomembrane  
Due to Elevated Pore Pressure in the Secondary Clay Liner

RMU-1 RAP

Parameters:

Site Specific Clay

Thickness of Liner, ft	t	3
Area of Load, acres	A	1
Loading Applied, psf	A	6500
Loading Time Period, months		24
Soil is normally consolidated.		
Coefficient of Compression, cm <sup>2</sup> /sec		0.00075
" " " " ,ft <sup>2</sup> /month	Cv	2.13
Saturation, %		100

CALCULATE AVERAGE PORE PRESSURE OVER LOAD INCREMENT  
CAUSED BY CONSOLIDATION

$$T = C_v \cdot t / H_{dr}^2 \quad T = 2.13 / (1.5')^2 \cdot t$$

where  $H_{dr} = 1.5'$

For saturated soil, the initial load = initial pore pressure

$$\text{Pore pressure} = \text{Load} / \text{time period} \quad U_i = 270.8$$

Pore pressure increases incrementally

$$U = (1 - U_c) \cdot U_i$$

\* T and U<sub>c</sub> taken from Calculation C-1.

t (month)	T	U <sub>c</sub>	U <sub>1</sub>	U <sub>2</sub>	U <sub>3</sub>	U <sub>4</sub>	U <sub>5</sub>	U <sub>6</sub>	U <sub>7</sub>	U max
0	0	0	270.8							270.833
1	0.9429	0.920884	21.427296	270.8						293.181
2	1.8858	0.992280	2.090917	21.427296	270.8					295.343
3	2.8288	0.999247	0.204038	2.090917	21.427296	270.8				295.554
4	3.7717	0.999926	0.019912	0.204038	2.090917	21.427296	270.8			295.575
5	4.7146	0.999993	0.001945	0.019912	0.204038	2.090917	21.427296	270.8		295.577
6	5.6575	0.999999	0.000190	0.001945	0.019912	0.204038	2.090917	21.427296	270.8	295.577

U max = approx. 296

DETERMINE Q CAUSED BY PERMEATION THROUGH SECONDARY HDPE LINER

$$Q = KIA$$

$$k = 3.28 \times 10^{-13} \text{ ft/sec}$$

$$I = 296 / 62.4 \text{ pcf} = 4.74 \text{ ft.}$$

$$L = 0.08 \text{ in.} = 0.0067 \text{ ft}$$

Q =	1.01E-05 ft <sup>3</sup> /sec/acre
Q =	6.53 gpad

Leakage through Defects in the Secondary HDPE Geomembrane due to Elevated Pore Pressure in the Secondary Clay Liner

RMU-1 RAP

POSSIBLE CONSOLIDATION WATER FLOW RATE THROUGH A 1/4" DIA. DEFECT

Assumptions:

Terzaghi One-dimensional consolidation theory applies with no secondary compression. Lower half of Secondary Clay Liner drains toward natural soil, therefore clay liner is double drained.

Method:

1. Determine amount of water expelled from 1.5 ft. clay liner due to consolidation per load step.
2. Determine lateral extent of phreatic surface based on charts.
3. Calculate volume of water within wetted area.
4. Determine Possible Flow Rate of Consolidation Water that can pass through a 1/4 in. diameter defect.

VOLUMES OF WATER EXPELLED

Month	Water Expelled (gpad)	Water Expelled (gpd/ft <sup>2</sup> )
1	38.4	0.00088
2	33.1	0.00076
3	29.3	0.00067
4	26.5	0.00061
5	24.2	0.00056
6	22.4	0.00051
7	20.9	0.00048
8	19.6	0.00045
9	18.5	0.00042
10	17.5	0.00040

Values from analysis of consolidation of primary clay liner which also represents half of the secondary clay liner due to drainage assumptions.

The lateral extent of the phreatic surface cannot be great enough to produce much water through a 1/4" diameter defect based on these values of gpad.

The volume of consolidation water is so small in gpd/ft<sup>2</sup> that it can be neglected.

**APPENDIX D-11**  
**RMU-1 MINIMUM WASTE STRENGTH CURVES**

# MODEL CITY FACILITY, RMU-1 WASTE STRENGTH CURVES

1.5 Line => 1300 psf to 24 deg.  
Min. Line => 700 psf to 16 deg.

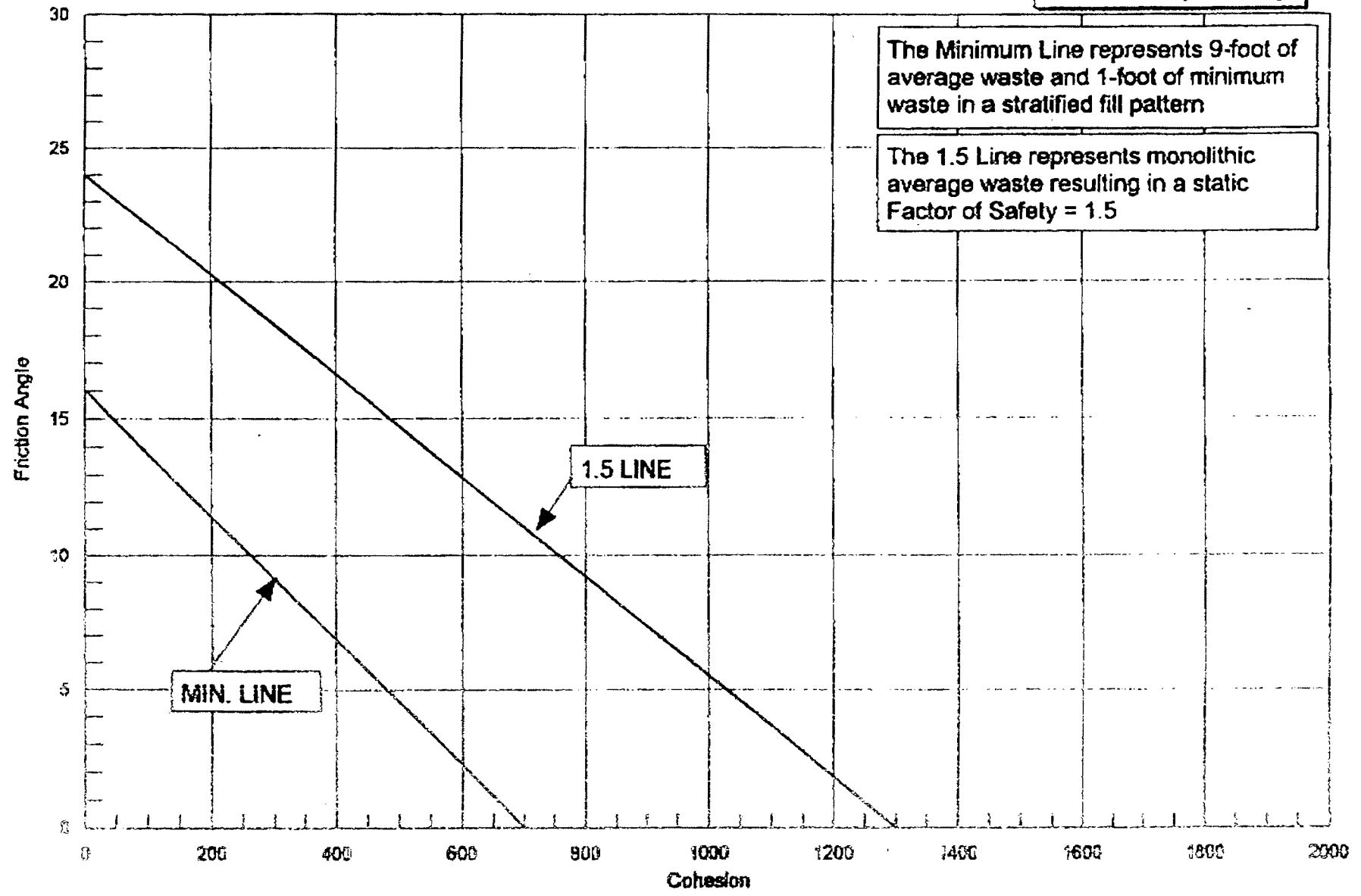

The Minimum Line represents 9-foot of average waste and 1-foot of minimum waste in a stratified fill pattern

The 1.5 Line represents monolithic average waste resulting in a static Factor of Safety = 1.5

# **ATTACHMENT L**

## **Sections D-10 Fugitive Dust Control Plan**

**TABLE OF CONTENTS**

**FUGITIVE DUST CONTROL PLAN**

FUGITIVE DUST CONTROL PLAN..... 1

I. Control of Potentially Contaminated Dust..... 1

    A. Landfill Operations ..... 1

    B. Roadways Used By Waste Hauling Vehicles ..... 2

II. Control of General Particulate Dust ..... 3

    A. Construction Projects ..... 3

    B. Erosion..... 3

    C. Other Site Roads ..... 3

III. Air Monitoring - Fugitive Dust Emissions ..... 3

    A. PM-10 Monitoring ..... 3

3



## FUGITIVE DUST CONTROL PLAN

As a hazardous waste management facility, the possibility exists that potentially contaminated dust could be released to the atmosphere. 6 NYCRR 373-2.14(c)(9) specifies that if a landfill contains any particulate matter which may be subject to wind dispersal, the owner or operator must cover or otherwise manage the landfill to control wind dispersal. Controls, such as wetting, must be applied to dusty waste streams when they are disposed of in the landfill to prevent particulate emissions. Vehicles exiting the landfill are cleaned of any gross contamination at the exit of the landfill. In order to control any potentially contaminated dust that may accumulate on the roads outside the landfill which are used by waste hauling vehicles, road maintenance is performed.

In addition to the control of potentially contaminated dust from waste management activities, CWM employs best management practices to reduce the amount of soil-type particulate dust. The practices are employed during construction, site and stockpile maintenance and the maintenance of roadways which are used by non-waste hauling vehicles.

### **I. Control of Potentially Contaminated Dust**

#### **A. Landfill Operations**

##### **1. Waste stream evaluation.**

- a) Waste streams are evaluated for dusting potential during the approval process. Recommendations for dust control, including wetting, containerization, stabilization treatment, etc. will be included on the disposal decision for any wastes identified with dusting potential.
- b) Recommendations for dust control will be considered by the On-Site DEC Monitors during their review and approval of the landfill waste stream. DEC comments will be incorporated into the management approach as appropriate.
- c) Upon receipt of the first shipment of any new waste, the sampler will inspect the load and consider its potential for dusting. The disposal decision may be updated if necessary.
- d) A dusty load for direct landfill disposal will be flagged for special handling by the landfill personnel and the control method prescribed on the Waste Tracking Form.

##### **2. Waste Disposal**

- a) If the prescribed method for dust control is wetting, an operator with a water canon may wet the load in the container in the landfill. If required, an operator may use a backhoe to mix the water and the material in the container prior to dumping to ensure proper wetting of the waste. Additional water may be sprayed during the unloading or after waste placement.

- b) Any excess or free liquid resulting from the operations contemplated by the activity above shall be treated as liquid from a precipitation event and shall not be deemed to constitute the disposal of free liquids or bulk waste containing free liquids. This interpretation is in keeping with USEPA policy contained in a statutory interpretative guidance document issued in April, 1986.
- c) If a dusty waste load not previously identified as having a dusting potential is noted by the landfill personnel, the lab will be notified and the disposal decision amended as needed to specify controls.
- d) If the specified dust controls are unsuccessful during a trial load, CWM shall cease disposal of additional loads and revise the dust control procedure.
- e) In addition, a trash fence is employed to prevent wind blown debris from escaping the landfill. On a routine basis, all plastic and paper debris escaping the boundaries of the waste management area will be collected.
- f) Additional water may be applied to the landfill operating area to control dust. DEC approved cover material such as ConCover may be used to provide dust control of the waste placed in the landfill.
- g) All exposed waste is covered at the end of each day of operation using a DEC approved cover material.

NOTE: The procedures specified above in sections 1. a)-c) and 2. c)-d) must be included in this and any future versions of CWM's Fugitive Dust Control Plan according to a Memorandum of Understanding (89-151) between CWM and NYSDEC.

## B. Roadways Used By Waste Hauling Vehicles

### 1. Potential Contamination Control

- a) Vehicles or any other equipment which have entered the landfill facility where it has come into direct contact with waste, shall be inspected for gross contamination prior to leaving the landfill area.
- b) Any gross contamination identified on the wheels or equipment will be physically removed before leaving the area to prevent contamination of on-site roads.
- c) Despite the efforts described above, the potential exists that contaminated dust may be present on the roadways outside the landfill. These roadways will be cleaned and maintained. A sweeper or other road cleaning equipment may be employed to minimize dust accumulation on these roads. Water trucks may also be employed to wet the road surfaces and to minimize air borne dust. Note: If truck washing is

performed at the landfill exit, the potential for contaminated dust on the roadway will be eliminated.

- d) In addition, the site traffic control plan has generally limited these roadways to waste hauling vehicles. A low speed limit has been posted and speed bumps are employed to minimize dust generation.

## **II. Control of General Particulate Dust**

### **A. Construction Projects**

Dust management procedures for new site and landfill construction projects are addressed in the related permit applications where appropriate. A Stormwater Pollution Prevention Plan has been developed for construction projects affecting areas of at least 5 acres to control soil erosion and contain sediments.

### **B. Erosion**

Vegetative cover is maintained using on-site and contracted services. This includes the application of clay, top soil, fertilizer, hydroseeding and hand seeding. Some berm areas may also be covered with stone or gravel. The use of gabion mats and especially Miramet geotextile fabric has reduced erosion and enhanced vegetative growth.

### **C. Other Site Roads**

Roadways other than those used by waste hauling vehicles will be cleaned and maintained as good housekeeping dictates. In general, the paved roads will be swept as needed, weather permitting. These roads may be wetted down as needed to provide general dust management, adequate visibility and nuisance control.

## **III. Air Monitoring - Fugitive Dust Emissions**

CWM has an Ambient Air Monitoring Program. This program determines the impact, if any, of the hazardous waste activities and other site activities on the surrounding air quality at the Model City facility. This Ambient Air Monitoring Program has been approved by NYSDEC.

### **A. PM-10 Monitoring**

A detailed discussion of the PM-10 monitoring network relative to dust emissions is presented in the PM-10 monitoring system QA/QC manual previously approved by NYSDEC (H. Sandonato to J. Pizzuto, 9/26/90). This monitoring program demonstrates CWM's compliance with the national primary and secondary 24 hour ambient air quality standard for particulate matter of 150 micrograms/cubic meter, 24 hour average concentration. The level of the national primary and secondary annual standards for particulate matter is 50 micrograms/cubic meter, annual arithmetic mean.

The fugitive dust control measures discussed in this plan have consistently resulted in particulate matter levels below the ambient air quality standards. If this monitoring network begins to show levels above the standards, CWM will investigate the cause and revise the Fugitive Dust Control Plan, if necessary.

# **ATTACHMENT M**

## **Surface Water Sampling & Analysis Plan**

**(The contents of Attachment M have been derived from the Permit application submitted by CWM Chemical Services, L.L.C.)**

**SURFACE WATER**  
**SAMPLING AND ANALYSIS PLAN**

Revised September 2015

Modified: Sept. 2015

## DISCLAIMER

It should be noted that some of the State Pollutant Discharge Elimination System (SPDES) monitoring and compliance requirements which are applicable to this Facility, are not included in their entirety in this Surface Water Sampling & Analysis Plan (SWSAP), but are referenced in this SWSAP. Adherence to this SWSAP in no way obviates CWM from fulfilling its SPDES monitoring and compliance obligations.

Modified: Sept. 2015

\*\*\*\*\*

\*

## TABLE OF CONTENTS

SECTION .....	PAGE
1.0 INTRODUCTION.....	1
2.0 SITE BACKGROUND .....	1
2.1 SITE DESCRIPTION.....	1
2.2 SITE STRATIGRAPHY .....	2
2.3 SOIL CLASSIFICATION AND USE .....	2
3.0 SURFACE WATER CONDITIONS .....	5
3.1 SURFACE WATER DRAINAGE SYSTEM .....	5
3.2 CONTROL GATE OPERATION AND INSPECTION.....	5
3.3 SURFACE WATER MONITORING .....	6
3.4 OTHER SURFACE WATER RUN-OFF LOCATIONS.....	7
3.5 MONITORING PARAMETERS, FREQUENCIES, AND METHODOLOGIES .....	7
4.0 GENERAL RESPONSIBILITIES.....	10
4.1 PERSONNEL.....	10
4.2 ANALYTICAL LABORATORIES .....	10
5.0 PRE-SAMPLING PROCEDURES .....	10
5.1 LABORATORY NOTIFICATION/VERIFICATION.....	10
5.2 PROCUREMENT, INSPECTION AND CALIBRATION OF EQUIPMENT .....	10
5.3 PROCUREMENT AND PREPARATION OF SAMPLE BOTTLES .....	11
5.4 STORAGE AND HANDLING OF SAMPLING EQUIPMENT .....	11
6.0 SAMPLING PROCEDURES.....	11
6.1 FIELD OBSERVATIONS .....	11
6.2 FIELD MEASUREMENTS .....	12
6.3 GRAB SAMPLE COLLECTION .....	12
6.4 COMPOSITE SAMPLE COLLECTION.....	12
6.5 ORDER OF SAMPLE COLLECTION .....	13
6.6 DUPLICATE SAMPLES.....	13
6.7 TRIP BLANKS AND FIELD BLANKS.....	13
6.8 SAMPLE PACKAGING AND SHIPMENT PROCEDURES .....	13
6.9 SAMPLE RECEIPT .....	13
7.0 FIELD RECORDS AND DOCUMENTATION .....	13
7.1 CHAIN-OF-CUSTODY FORM .....	14
7.2 FIELD INFORMATION FORM.....	14
8.0 LABORATORY HANDLING AND ANALYTICAL PROTOCOLS .....	15
8.1 LABORATORY PROCESSING PROCEDURES.....	15
8.2 LABORATORY METHODOLOGIES.....	15
8.3 QUALITY ASSURANCE .....	15
8.4 QUALITY CONTROL .....	15
9.0 DATA EVALUATION.....	15
10.0 REPORTING.....	16



SURFACE WATER SAMPLING AND ANALYSIS PLAN  
REVISED 9/15

\*\*\*\*\*

\*

10.1 RECORDS ..... 16

\*\*\*\*\*

\*

## LIST OF TABLES AND FIGURES

FIGURE 1	SITE LOCATION MAP .....	3
FIGURE 2	SURFACE WATER MONITORING POINT LOCATION MAP .....	4
FIGURE 3	STORM WATER FLOW MONITORING FLUME INSPECTION .....	8
TABLE A	NYSDEC SURFACE WATER MONITORING REQUIREMENTS .....	9

\*\*\*\*\*

\*

## 1.0 INTRODUCTION

CWM Chemical Services, L.L.C. (CWM) owns and operates a Treatment, Storage, Disposal and Recovery (TSDR) Facility at Model City, New York. As a condition of the Part 373-2 Operating Permit, the New York State Department of Environmental Conservation (NYSDEC) has required the preparation of a Surface Water Sampling and Analysis Plan (SWSAP).

The overall purpose of the SWSAP is to demonstrate that there is no migration of hazardous constituents from the Model City Facility into surface water run-off, (i.e. stormwater). This sampling and analysis program in which long term trends of surface water quality are monitored meets the objective.

The SWSAP provides procedures for collecting surface water samples that are:

- 1) fully comprehensive to cover any sampling circumstance that might occur during the routine monitoring program;
- 2) technically sound so that the surface water samples collected are subject to minimal sampling and analytical bias; and
- 3) uniform so that all the surface water samples are collected and analyzed in a consistent manner for comparison purposes.

The SWSAP has been prepared to satisfy some of the *routine surface and storm water monitoring requirements of the above-mentioned Operating Permit and CWM's current State Pollutant Discharge Elimination System (SPDES) Discharge Permit (NY 007 2061)*. If the SPDES Permit is modified, it may be necessary to update this SWSAP.

This document only addresses the current monitoring requirements of the site's routine surface water monitoring programs. These programs are very specific as to sample collection, location, parameters, and frequencies. Other monitoring programs (Groundwater Monitoring, Air Monitoring, etc.) have sampling and analysis plans developed specifically for them.

## 2.0 SITE BACKGROUND

The Model City TSDR Facility is located in Niagara County, New York, near the Niagara River and Lake Ontario (see Figure 1). The facility was used for a variety of industrial purposes by the U.S. Government between 1942 and 1959.

The site was sold to a real estate company in 1966. In 1972, Chem-Trol Pollution Services purchased the site and began to use it as a private industrial waste operations facility. Chem-Trol was purchased by SCA Services, Inc. in 1973, then in 1984, SCA Services, Inc. was acquired by a WMI affiliate, Waste Management Acquiring Corporation, making SCA Chemical Services, Inc. a wholly-owned subsidiary of WMI.

In 1987, SCA Chemical Services, Inc. became a wholly owned subsidiary of Chemical Waste Management, Inc. and in July 1988, the facility name was changed to CWM Chemical Services, Inc. In 1998, CWM became a Limited Liability Company (L.L.C.) while its parent company, Waste Management, Inc. merged with USA Waste.

### 2.1 SITE DESCRIPTION

Current operations at the facility include treatment, recovery, disposal, and transfer of hazardous and industrial waste. The operations are comprised of waste receiving areas, storage and mixing tanks, chemical treatment facilities, biological treatment impoundments, and secure landfills.

The general site layout is shown on Figure 2.

Modified: Sept. 2015
----------------------

\*\*\*\*\*

\*

## **2.2 SITE STRATIGRAPHY**

The Model City Facility is situated on the Ontario Plain, an area of low topographic relief located between the Niagara Escarpment and Lake Ontario. The ground surface slopes northward at less than one percent with elevations ranging between approximately 310 and 320 feet above mean sea level.

Basically, the unconsolidated geology at the site consists of about 30 feet to 60 feet of glacial and glaciolacustrine deposits of Late Wisconsin Age. The glacial deposits overlie an estimated 1,000-foot thick sequence of red shale, siltstone, and sandstone of the Queenston Formation of Upper Ordovician Age.

## **2.3 SOIL CLASSIFICATION AND USE**

The surface of the site is composed of low permeability soils. The U.S. Soil Conservation Service classifies many of the surface soil types present as Group C and Group D. These soil groups are characterized as having moderately high to high run-off potential, respectively, due to very slow infiltration rates.

Group C soil groups include the Appleton Silt Loam and the Ovid Silt Loam. Group D soil groups include the Canandaigua Silt Loam, Cheektowaga Fine Sandy Loam, Rhinebeck Silt Loam, Sun Silt Loam, and Madalin Silt Loam. Each group comprises approximately 50% of the soils on site.

The various land uses at the Model City Facility also influence site drainage characteristics. These uses are described in terms of the three general areas identified below:

1. Non-containment operational areas,
2. Active containment and disposal areas, and
3. Natural buffer area.

Each of these areas has different run-off and storage characteristics.

The non-containment operational areas include closed landfills, buildings, roads, parking lots, and open areas being prepared for future operations. These areas are not classified with a particular soil type as discussed above; rather they are referred to as "made land." The blacktop, roofing, and grading characteristics of these operational areas typically make them areas of rapid run-off.

The active containment and disposal areas include Stabilization, RMU-1, which is bermed, active tank farms, which have secondary containment, and the full trailer park, which has secondary containment. These areas act to contain surface water and prevent run-off and would not normally contribute to general site run-off.

The natural buffer areas consist of wooded areas, wetlands, ponds, and topographically low areas that generally act as water storage areas. These buffer areas are mostly located in the central and northern portions of the site.

Modified: Sept. 2015
----------------------

\*\*\*\*\*

\*

**FIGURE 1**  
**SITE LOCATION MAP**



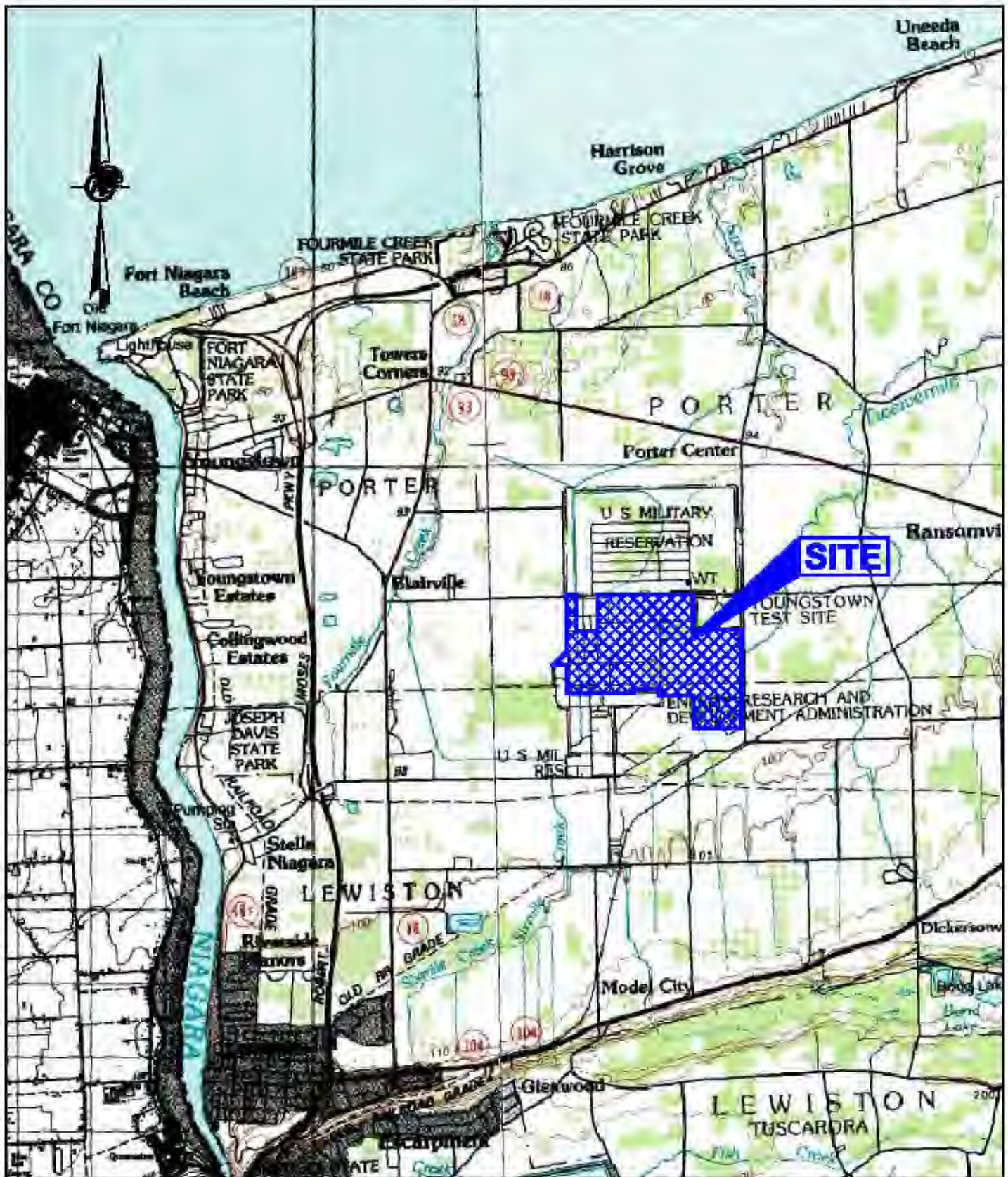

**REFERENCE**

1.) DRAWING WAS ADAPTED FROM THE USGS TOPOGRAPHIC QUADRANGLE OF RANSOMVILLE, NEW YORK, OBTAINED FROM [www.topozone.com](http://www.topozone.com).

 <p><b>Golder Associates</b> Buffalo, New York</p>	SCALE	1:28,000	<p>TITLE</p> <p><b>SITE LOCATION MAP</b></p>				
	DATE	1/31/14					
	DESIGN	AJN					
	CADD	AJN					
	CHECK	RJM					
PROJECT No.	123-89494	REV.	0	REVIEW	DCW	<p>CWM CHEMICAL SERVICES, L.L.C./MODEL CITY TBD FACILITY</p>	<p>FIGURE</p> <p style="font-size: 2em;"><b>1</b></p>

\*\*\*\*\*

\*

**FIGURE 2**

### FIGURE 2 - MODEL CITY SURFACE WATER MONITORING POINT LOCATIONS

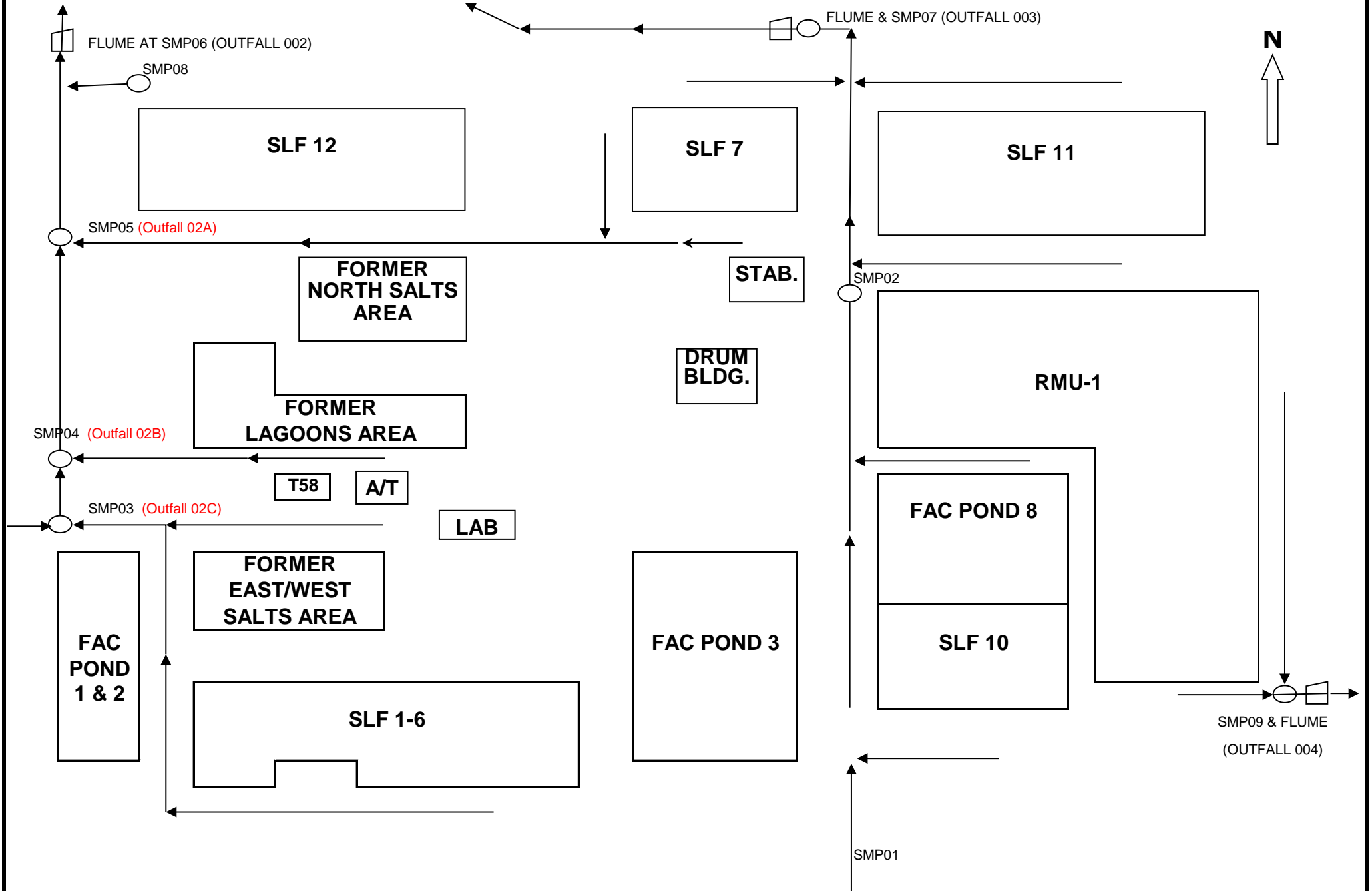

Revised: September 2015

N.T.S.



\*\*\*\*\*

\*

### **3.0 SURFACE WATER CONDITIONS**

The Model City Facility receives 2.40 inches of precipitation (as rainfall) per month and 28.82 inches per year on average. (Based on data collected at the Model City Facility from June 1976 through December 2009). Surface water run-off from the Model City Facility ultimately flows to either Four Mile Creek (Surface Water Index No. H-156-1C, C) or Twelve Mile Creek (Surface Water Index No. H-156-1C-3, C). Most of the Facility drains north and west until it finally reaches Four Mile Creek approximately one-quarter mile north of the Facility's northwestern boundary. Four Mile Creek then flows north to Lake Ontario. According to 6 NYCRR Part 701.8, Four Mile Creek and its tributaries contain Class C fresh surface waters, which are suitable for fish propagation and survival.

Twelve Mile Creek receives some surface water discharge from a small part of the Facility's southeastern property. On January 6 2004, approval was received from NYSDEC to allow additional run-off from the eastern and southern portions of RMU-1. This run-off is discharged to a Storm Water Retention Basin and then through Outfall 004 (SMP09) to Twelve Mile Creek, which flows northward to Lake Ontario. According to 6 NYCRR Part 701.8, Twelve Mile Creek also contains Class C fresh surface waters in the area of the Model City Facility. (See W. Mirabile to J. Knickerbocker, 01/06/04).

Figure 2 relates the locations of the various waterways at the Facility.

### **3.1 SURFACE WATER DRAINAGE SYSTEM**

Surface water run-off at the Facility is managed in a complex series of man-made and natural ditches, swales, basins, and control gates. Retention capacity for a 25-year, 24-hour storm is required under the Facility's Part 373 Operating Permit. The construction of retention basins and the placement of six control gates {SMP03, SMP04, SMP05, SMP07, SMP08, and SMP09} have achieved this retention. A seventh internal control gate {SMP02} is located upstream of SMP07. It is routinely left open, but may be closed if control or isolation of this area is desired.

Three main drainage channels receive all of the surface water run-off from the Facility. One channel receives run-off from the western and central portion of the Facility and is managed by 4 control gates. The second channel receives run-off from the eastern portion of the Facility and is managed by a control gate located at a retention basin north of the Facility. The third drainage channel flows to the southeast and receives controlled run-off from a portion of RMU-1.

Site surface water collects behind each of the six control gates in dedicated surface water holding areas; release occurs only after sampling and analytical qualification has occurred. Control gates are opened regularly to discharge storm water and ensure that storage capacity is available for a large storm. The flow in all channels is intermittent; only occurring when there is sufficient precipitation to promote surface run-off.

### **3.2 CONTROL GATE OPERATION AND INSPECTION**

As previously mentioned, storm water control gates are used to retain surface water until analytical qualification has occurred. These gates are equipped with manually-operated valves, which are used to release run-off.

Prior to release, water on the upstream side of each gate is visually inspected for an oil sheen or other visible evidence of potential contamination. Then it is sampled and analyzed for specific conductance. The results are compared with a "Site-Wide Alarm Value" of 2500  $\mu$ mhos. (This value has been selected to prevent the unnecessary shutdown of operations due to groundwater infiltration, road salting, or other site wide construction activities; yet this value is still adequate for the determination of potential contamination based on the historic specific conductivity readings of landfill leachate and other on-site wastewaters.)

Modified: Sept. 2015
----------------------

SURFACE WATER SAMPLING AND ANALYSIS PLAN  
REVISED 5/14

\*\*\*\*\*

\*

If the conductivity of the sample exceeds the alarm level, another sample is collected from the same location. If the conductivity of the resample exceeds the alarm level, then either the Technical Manager or Environmental Monitoring Manager is immediately notified. These individuals then determine whether to sample and analyze the surface water for VOCs, PCBs, or any other suspected contaminants.

Regardless of the conductivity level, CWM will sample and analyze the surface water at the control gates for VOCs, PCBs, or other suspected contaminants, if requested to do so by the On-Site NYSDEC Monitors or other NYSDEC staff, unless it is demonstrated to the staff's satisfaction that such sampling is unnecessary. Also, CWM will, upon notification, allow the On-Site NYSDEC Monitors or other NYSDEC staff to collect surface water samples for NYSDEC analysis prior to, or during any release of surface water from a control gate.

Based on the results of any additional analyses and the manager's knowledge of activities (past or present) in the area, a decision will be made regarding the disposition of the stormwater. The manager will notify On-Site NYSDEC Monitors if elevated VOCs, PCBs, or other contamination is found. The presence of significant contamination may require the water to be processed to remove the constituent(s).

No storm water is released from the Facility at an SMP without prior testing if the manager has found or suspects contamination. All surface water released from control gates must meet the contamination concentration limits in the Facility's SPDES Permit at the respective Outfalls.

Continuous flow meters are installed at SMP06, SMP07, and SMP09 for measuring totalized flow exiting the Facility. Monthly, each flow meter is inspected to ensure that the equipment is in proper operating condition, (see Figure 3). The flow meters are routinely calibrated and maintained as necessary.

### **3.3 SURFACE WATER MONITORING LOCATIONS**

The surface water monitoring point (SMP) sampling locations coincide with control gate locations unless noted and are as follows:

- SMP01 - southwest of SLF 10, upgradient of all process areas. SMP01 is not equipped with a Control Gate. SMP01 is no longer routinely sampled. SMP01 was designated as an upgradient surface water reference point, which may be sampled in an investigation of a surface water contamination event.
- SMP02 - northwest corner of RMU-1, receives surface water from the south of SLF 10 and from the west of SLF 10, Fac Pond 8, and RMU-1. SMP02 is an internal control gate, which is routinely maintained in an open position. It is no longer routinely sampled. It may be sampled in an investigation of a surface water contamination event.
- SMP03 – SPDES internal Outfall 02C, northwest corner of FAC Ponds 1 & 2, receives surface water from a retention basin to the west and several smaller channels to the south and east. The water in SMP03 is routinely inspected and sampled for conductivity prior to opening the control gate. This location has an ISCO Refrigerated Auto-Sampler or similar equipment.
- SMP04 – SPDES internal Outfall 02B, northwest corner of former West Drum Area, receives surface water from low lying areas in the vicinity of Tank 58 and the Aqueous Wastewater Treatment Facility. The water in SMP04 is routinely inspected and sampled for conductivity prior to opening the control gate. This location has an ISCO Refrigerated Auto-Sampler or similar equipment.
- SMP05 – SPDES internal Outfall 02A, southwest corner of SLF 12, receives surface water from south of SLF 12 and north and west of the inactive Lagoons/Salts Areas. The water in SMP05 is routinely inspected and sampled for conductivity prior to opening the control gate. This location has an ISCO Refrigerated Auto-Sampler or similar equipment.

\*\*\*\*\*

\*

SMP06 - SPDES Outfall 002, northwest of SLF 12, not equipped with a Control Gate, receives all water from SMP03, SMP04, SMP05, and SMP08. This location has a flow meter for measuring totalized flow and an ISCO Refrigerated Auto-Sampler or similar equipment.

SMP07 - SPDES Outfall 003, north of SLF 7 and SLF 11, this man-made Retention Basin receives all water from the northeast half of SLF 7, SLF 11, north of RMU-1, and SMP02. This location has a flow meter for measuring totalized flow and an ISCO Refrigerated Auto-Sampler or similar equipment.

SMP08 - a man-made Retention Basin north of SLF 12 and east of Castle Garden Road. The water in SMP08 is routinely inspected and sampled for conductivity prior to opening the control gate. Additional sampling and analysis may be performed.

SMP09 - SPDES Outfall 004 is located southeast of RMU-1. This location has a flow meter for measuring totalized flow and an ISCO refrigerated Auto-Sampler or similar equipment.

### **3.4 OTHER SURFACE WATER RUN-OFF LOCATIONS**

On occasion, precipitation from major rainfall events (or spring meltwater) may collect at locations other than those indicated above. For such occurrences, this water may be sampled and analyzed for Specific Conductance and/or PCBs and/or Volatile Organic Constituents and qualified for release at the nearest SMP location, if appropriate.

Water is released only after reviewing the analytical results. Careful consideration is given to the operating area from which the water may have come. Presence of significant contamination may require the water to be processed to remove the constituent(s). The manager will notify On-Site NYSDEC Monitors if elevated VOCs, PCBs, or other contamination is found.

### **3.5 MONITORING PARAMETERS, FREQUENCIES, AND METHODOLOGIES**

Table A outlines the outfalls, parameters, analytical methodologies, and frequencies required by the current "Radiation Environmental Monitoring Plan" ((REMP) under Part 373 Permit) for surface water radiological monitoring. Outfall monitoring requirements for chemical constituents are specified in the facility's SPDES Permit.

USEPA/TSCA requirements for surface water monitoring were eliminated effective July 1996.

\*\*\*\*\*

\*

**FIGURE 3**  
**CWM CHEMICAL SERVICES, L.L.C.**  
**MODEL CITY, NEW YORK**  
**GENERAL FACILITY SITE INSPECTION REPORT**

**FREQUENCY:** Monthly

**DATE AND TIME OF INSPECTION:**      /      /      :      .  
 MM DD YY TIME

**EQUIPMENT/PROCESS UNIT NAME:** Storm Water Flow Monitoring Flumes and ISCO Auto Samplers

**INSPECTION CHECKLIST**

INSPECTION ITEM	Y/N	COMMENTS
Are the Flow Level Indicators (SMP06, SMP07, SMP09) and ISCO Auto Samplers receiving power?		
Are the Flow Level Indicators (SMP06, SMP07, SMP09) and ISCO Auto Samplers in good operating condition and functioning properly? (SMP06, SMP07, SMP09)		
Is the water level indicated appropriate? (SMP06, SMP07, SMP09)		
Is the recorder marking and printing properly? (SMP06, SMP07, SMP09)		
Is there sufficient chart paper? (SMP06, SMP07, SMP09)		
Is each flume free of cracks, debris, and blockage? (SMP06, SMP07, SMP09)		
Acceptable ISCO calibration check performed? (I.e. Actual calibration volume between 100% and 110% of expected?)		SMP03: Expected Vol. = 200 mL. Actual Vol. =
		SMP04: Expected Vol. = 200 mL. Actual Vol. =
		SMP05: Expected Vol. = 200 mL. Actual Vol. =
		SMP06: Expected Vol. = 200 mL. Actual Vol. =
		SMP07: Expected Vol. = 200 mL. Actual Vol. =
		SMP09: Expected Vol. = 200 mL. Actual Vol. =

**NAME/TITLE:** \_\_\_\_\_

**SIGNATURE:** \_\_\_\_\_

\*\*\*\*\*

\*

**TABLE A**  
**NYSDEC SURFACE WATER MONITORING REQUIREMENTS**

OUTFALL	FREQUENCY	PARAMETER	ANALYTICAL METHOD
002, 003, 004	As required by Radiation Environmental Monitoring Plan	ISOTOPIC URANIUM	USDOE A-01-R MOD
		ISOTOPIC THORIUM	USDOE A-01-R MOD
		RADIUM-226	USEPA 903.0 MOD
		RADIUM-228	USEPA 904.MOD
		GAMMA Cs-137 & HITS	USEPA 901.1

NOTES: The Frequencies, Parameters, and Analytical Methods for chemical monitoring are prescribed by CWM's SPDES Permit. Adjustments to the above requirements may be made if the Radiation Environmental Monitoring Plan (REMP) is modified.

\*\*\*\*\*

\*

#### **4.0 GENERAL RESPONSIBILITIES**

#### **4.1 PERSONNEL RESPONSIBILITIES**

Surface water monitoring at the Model City Facility is performed under the direction of the Environmental Monitoring Manager.

The Environmental Monitoring Manager is responsible for:

- communication between the laboratory and regulatory personnel,
- (re)-training sample personnel,
- scheduling, supervision, and proper execution of the sampling event, including field equipment procurement, calibration, maintenance, field parameter measurements, sample event documentation, prompt sample shipment, and inspections, and
- accurate data evaluation and timely reporting.

#### **4.2 ANALYTICAL LABORATORIES AND RESPONSIBILITIES**

Primary radiological services are provided by Test America in St. Louis, Missouri or another laboratory certified by NYSDOH ELAP for radiological parameters. For chemical parameters, a laboratory certified by NYSDOH ELAP will be utilized in accordance with the facility's SPDES Permit.

Each laboratory provides the Facility with all sampling containers and associated paperwork in a sealable container (cooler). The Laboratory Contact shall notify the Environmental Monitoring Manager if sample containers do not arrive on schedule or intact after a sampling event. The Laboratory Contact is also responsible for overseeing the laboratory analysis and notifying the Environmental Monitoring Manager if problems arise.

#### **5.0 PRE-SAMPLING PROCEDURES**

All procedures for radiological sampling, sample preservation, sample storage, chain-of-custody and sample transfer, and equipment calibration and field measurements will follow all applicable requirements specified in this plan, conditions in the Part 373 Permit and the REMP. Preservation will be in accordance with 40 CFR 136. Pre-sampling procedures for chemical sampling must meet the requirements in the facility's SPDES Permit.

Pre-sampling procedures include the procurement and calibration of equipment and procurement and preparation of sample containers. Each of these procedures is addressed in the following sections.

#### **5.1 LABORATORY NOTIFICATION/VERIFICATION**

The Environmental Monitoring Manager works closely with the laboratory to schedule sampling events for each month. Two weeks prior to each sampling event, the Environmental Monitoring Manager notifies the laboratory of tentative sampling dates, number and types of samples, and numbers and types of blanks. The laboratory prepares the necessary sample containers and sends them to the site in coolers. The Monitoring personnel check in the coolers and notifies the lab of any discrepancies.

#### **5.2 PROCUREMENT, INSPECTION, AND CALIBRATION OF EQUIPMENT**

The procurement of equipment is the responsibility of the Environmental Monitoring Manager.

Field measurements along with proper documentation are integral parts of the monitoring program. Before the actual trip to the field, all equipment necessary for a sampling event is cleaned, checked, and calibrated, as necessary. Prior to use in the field, all meters are calibrated to ensure proper working order and to render integrity to the measured values. Calibration procedures provided by the manufacturer are followed.

Modified: Sept. 2015
----------------------

SURFACE WATER SAMPLING AND ANALYSIS PLAN  
REVISED 5/14

\*\*\*\*\*

\*

For chemical and physical parameters, procurement, inspection and calibration of equipment must meet requirements in the facility's SPDES Permit.

**NOTE:** Instrument-specific calibration procedures are subject to change as newer field equipment is put into use. CWM will continue to follow the Manufacturer's recommendations and standard QA/QC procedures.

A Log Book is maintained for all field meters. The log book contains information including field meter serial number, name and model of meter, year purchased, QA results, calibration notes for each day the equipment is used, etc.

**5.3 PROCUREMENT AND PREPARATION OF SAMPLE BOTTLES**

The preparation of sample bottles is the responsibility of the laboratory. As necessary, pre-measured amounts of preserving reagents are supplied by the laboratory along with the sample bottles. The appropriate preservative is attached to each bottle in a small vial or has been attached to each container as required by the analytical method or 40 CFR 136.

The lab sends sample bottles to the site in sealed coolers. Upon arrival, the cooler seal is checked for intactness. The cooler is then "checked in" which involves removing the Chain-of-Custody (COC), visually examining, inventorying, and labeling the sample bottles, and ensuring the appropriate number and types of preservatives are present.

**5.4 STORAGE AND HANDLING OF SAMPLING EQUIPMENT**

The sample bottles are stored inside coolers. When unattended, the coolers (and bottles) are stored in a designated "clean area" with limited access during the day. This building is kept locked overnight.

All equipment is handled in a responsible manner to prevent breakage or contamination. New clean, powderless PVC or Latex gloves may be worn when handling any equipment that will come in contact with the sample water.

**6.0 SAMPLING PROCEDURES**

Sampling is performed during run-off events caused by either precipitation or snow/ice melt. When rain falls (or a thaw occurs) at a greater rate than water can be absorbed by the soil, the excess water flows over the ground surface and into the drainage courses. The rate at which this process occurs is dependent upon storm intensity, soil type, cover, grading, etc.

If there is no flow through a given outfall during a given week, then the sampling event is canceled and a record is made of the cancellation.

**6.1 FIELD OBSERVATIONS**

Upon arrival at the sample point, various field observations regarding conditions at the sample point and its surrounding area are made and recorded in the field notes. These observations may include:

- The presence and condition of the sample point identification marker;
- Physical surroundings that may bias the sample (i.e. high weeds, stagnant water - no flow, nearby activities, etc.);
- Weather conditions;
- Any upwind or upstream site activity; and
- Evidence of contamination such as a visual sheen.

Modified: Sept. 2015
----------------------

\*\*\*\*\*

\*

## **6.2 FIELD MEASUREMENTS**

Field measurements for chemical and physical parameters are taken as required by the facility's SPDES Permit, and recorded in the field log book.

The duplicate field measurements, if any, are also recorded.

## **6.3 GRAB SAMPLE COLLECTION**

For chemical and physical parameters, grab sample collection shall be conducted in accordance with the facility's SPDES Permit. Grab sampling and analysis for radiological parameters will be conducted in accordance with Table A, the conditions in the Part 373 Permit and the REMP.

Prior to sampling, the sample point identity is recorded on the COC. The sample bottles and COC are rechecked to ensure that all match with respect to sample point, parameter, and preservative.

Samples, which are to be split with regulatory agencies, are also checked for consistent sample point ID numbers and for other methods of identification if used by the agency.

Grab surface water samples are collected under flow conditions. Grab samples may be taken using a dedicated, long-handled, polyethylene dipper. If used, the dipper is rinsed at least 3 times at each outfall before each use. New, disposable, powderless PVC or latex gloves may be worn at each sample point during sampling and are changed when dirty, torn, etc.

When filling sample bottles, the following procedures and precautions are followed:

1. Bottle caps are removed carefully so that the inside of the cap is not touched. Bottle caps are not interchanged between sample bottles.
2. The sample bottles are filled with a minimal amount of air contact and without contacting the inside of the bottles.
3. Sample bottles containing preservatives are filled with as little overflow as possible and are inverted to mix the preservative with the sample. If the required preservative(s) are not in the bottles, the bottles should be filled, leaving adequate space to add the preservative(s) later.

No substitutes for the chemical preservatives supplied are used as the reagents are special high grade and are metal free. Arrangements may be made with the laboratory if the storage of additional preservatives at the site is necessary. If substitutions are made from on-site storage, it is noted on the COC form.

4. All sample bottles, once filled and preserved as necessary, are put on ice or refrigerated upon sample collection and shipped as such.
5. Sample bottles, caps, or septa, which fall on the ground before filling, are thoroughly rinsed with sample water before being used or are discarded. All circumstances regarding dropped caps or bottles, and their subsequent rinsing and use, are noted in the field notes.

## **6.4 COMPOSITE SAMPLE COLLECTION**

Composite sample collection for chemical parameters shall be in conducted in accordance with the facility's SPDES Permit. Composite sample collection is not allowed for radiological parameters.



\*\*\*\*\*

\*

### **6.5 ORDER OF SAMPLE COLLECTION**

If there was insufficient sample volume available to completely fill all sample bottles, sample collection for chemical and physical parameters required by the facility's SPDES Permit shall take precedence.

### **6.6 FIELD DUPLICATE SAMPLES**

Field duplicate samples must be collected as specified in the facility's SPDES Permit and in accordance with the analytical method to be employed. The duplicate sample, identified as "DUP," receives the same analyses as the other routine samples. The actual identity of the duplicate sample is noted in the Comments section of the field log book.

### **6.7 TRIP BLANKS AND FIELD BLANKS**

Trip blanks and field blanks are used as controls and/or external QA/QC samples. They indicate contamination that may have been introduced in the field, in transit to or from the sampling site, during bottle preparation, sample log-in, or sample storage at the laboratory. The blanks may also reflect contamination that may have occurred during the analytical process. Trip and Field Blank frequencies and procedures related to sampling for chemical parameters shall be in accordance with the facility's SPDES Permit and the analytical method to be employed.

### **6.8 SAMPLE PACKAGING AND SHIPMENT PROCEDURES**

After sampling, samples are placed in coolers containing loose ice or are otherwise refrigerated in a clean, secure area until shipping arrangements can be made.

There are three important reminders for repacking the coolers:

1. Glass should not be packed in contact with glass. Ice or packing sleeves are placed around and between bottles.
2. Completed COC forms must be placed in the cooler before the cooler is sealed.
3. Sample coolers are sealed.

Once the samples have been placed on ice, the COC is completed, then all paper work is put into a plastic bag and placed inside the cooler. A member of the sampling team arranges for sample pickup and transportation to the laboratory. Coolers are transported via courier for receipt at the laboratory within 72 hours of sample collection; often samples are received within 24 hours. (NOTE: Although samples are chilled after sampling, it is a priority to ship the samples to the lab as soon as possible. As a result, some of the samples may arrive at the lab with a temperature of greater than 4°C. The Lab notes this on the COC and these "warm" samples are typically analyzed as usual.)

### **6.9 SAMPLE RECEIPT**

Upon arrival at the laboratory, the samples are logged-in and COC procedures are maintained until the analyses are completed and reported.

Once a cooler is received at the laboratory, the Environmental Monitoring Manager is notified if the Sample Control Group encounters any discrepancies. Prompt notification is essential since analyses could be delayed beyond the allowable holding times.

### **7.0 FIELD RECORDS AND DOCUMENTATION**

Standard COC and field log books are filled out during a sampling event and are used to establish and document COC, sampling conditions, field measurements, and sampler's names. The original forms are

SURFACE WATER SAMPLING AND ANALYSIS PLAN  
REVISED 5/14

\*\*\*\*\*

\*

sent with the samples to the laboratory and copies are included in the Technical Report when the analysis is complete. All forms are completed using permanent ink only.

The Technical Report, including copies of the COC are maintained by the Environmental Monitoring Manager for easy reference. Analytical data is also permanently maintained in the site files.

### **7.1 CHAIN-OF-CUSTODY FORM**

In order to maintain and document sample integrity, strict COC procedures are necessary.

From the time the empty sample bottles leave the laboratory until the analytical results are issued, the sample and/or sample containers are in the custody of trained CWM environmental monitoring or laboratory personnel. In order to maintain COC, the samples must be either:

- in sight of the assigned custodian;
- locked in a tamper-proof location; or
- sealed with a tamper-proof seal.

A written record of sample bottle possession and transfer is maintained and documented on the COC form.

The COC form is signed with the date and time for the following activities:

- Initially, when the cooler is opened for inspection, the COC is signed and the condition is noted.
- Whenever the cooler is transferred to a new sample custodian.
- When the cooler is finally sealed for transport to the laboratory. If samples collected from one sample point are placed in more than one cooler, a COC is placed in each cooler.

Additional information on the COC includes the sample point ID, sample date, and sample start time. Any problems with cooler or its contents are also noted on the form. Upon receipt of the cooler at the laboratory, the date and time of receipt, the condition of the samples, and the temperature, are recorded on the COC form.

### **7.2 FIELD INFORMATION FORM**

Field information is completed in the field log book for each sample point, unless no sample is collected. Information to be documented is as follows:

Sample Point - which is contained on the COC.

Sampling Information - Includes the types of equipment used for sample collection.

Field Measurements - For surface water sampling events, temperature, and dissolved oxygen are determined, as required by the facility's SPDES Permit.

Field Comments - The section on field comments may include the following field observations:

- Condition of the sample point and dedicated equipment;
- Weather conditions (e.g. wind speed and direction, precipitation, temperature, upwind activities, etc.);
- Sample appearance - odor, color, etc.;

\*\*\*\*\*

\*

- Location where field blank or duplicate is prepared;
- Duplicate field measurement results;
- Any other uncommon sampling conditions, such as sample splits with regulatory agencies, potential safety or health hazards (i.e. presence of flying, stinging insects, etc.).

## **8.0 LABORATORY HANDLING AND ANALYTICAL PROTOCOLS**

The following information provides a brief description of how samples are analyzed.

### **8.1 LABORATORY PROCESSING PROCEDURES**

The laboratory receives, logs-in samples, and maintains the COC procedures until the analyses are completed and reported, as described in Section 6.9.

### **8.2 LABORATORY METHODOLOGIES**

For the routine surface water monitoring at the site, samples are analyzed according to Table A for radiological constituents and in accordance with the requirements specified in the facility's SPDES Permit for chemical constituents.

For the analysis of samples outside the routine monitoring program, the methodology will be specified by the Environmental Monitoring Manager and will depend on the Data Quality Objectives.

### **8.3 QUALITY ASSURANCE**

The analytical laboratory used for the analysis of surface water samples has NYSDOH ELAP certification and CWM approval. In addition, QA is provided by following the standard analytical methods referenced in Table A and as referenced in the facility's SPDES Permit. Technical Reports contain analytical results and methodologies, dates sampled and received, sample identification and COC.

### **8.4 QUALITY CONTROL**

Quality control is provided in the field through the collection of duplicate samples, field blanks, trip blanks, and duplicate field measurements. Trip Blank, Field Blank and duplicate sample frequencies and procedures related to chemical sampling shall be in accordance with the facility's SPDES Permit and the analytical method employed.

## **9.0 DATA EVALUATION**

Typically, all analytical results are reviewed within five days of receipt from the analytical laboratory.

For chemical parameters, data from SMP06, SMP07, and SMP09 are compared with the discharge limitations established in the Facility's SPDES Permit. Any exceedences are noted in accordance with the SPDES Permit.

If any potentially contaminated surface water has been determined to have been released from the Facility, then a follow-up investigation would be performed to determine the source and extent of contamination. This investigation would be based upon current SPDES Permit requirements for chemical releases, or upon requirements in the REMP for radiological releases, as well as guidance received from NYSDEC.

Modified: Sept. 2015
----------------------

\*\*\*\*\*

\*

**10.0 REPORTING**

For chemical analyses, the results shall be reported as specified in the Facility's SPDES Permit. For radiological analysis, the results shall be reported as specified in the facility's Part 373 Permit (Exhibit B, Condition D.3 in Schedule 1 of Module I).

**10.1 RECORDS**

Records of all surface water monitoring activities, including Technical Reports, QA/QC Reports and COCs are maintained at the Model City Facility. The analytical labs also maintain the data in a computer data base system.

Modified: Sept. 2015
----------------------

# **ATTACHMENT N**

## **Air & Meteorological Monitoring Plan**

## **Air & Meteorological Monitoring Plan**

### Monitoring Network

A NYSDEC-approved ambient air and meteorological monitoring network shall be operated and maintained at the CWM Model City facility. This program shall consist of a minimum of six (6) monitoring sites established at NYSDEC-approved locations and equipped with sampling devices and other equipment as necessary for ambient air quality and one (1) meteorological monitoring.

### Air Quality Monitoring

Air samples shall be obtained from the monitoring network and analyzed for PM-10 in accordance with Methods published by the USEPA. CWM will sample for PM-10 once every six calendar days. Additional air sampling and analysis for Volatile Organic Compounds (VOCs) and/or Polychlorinated biphenals (PCBs) shall be performed if deemed necessary by the NYSDEC.

### Meteorological Monitoring

Temperature, wind speed and wind direction shall be continuously measured at CWM's on-site meteorological station and recorded. CWM shall also measure and record the date, or dates, duration (in hours) and amount (in inches) of all precipitation events at the facility's meteorological station. Other parameters shall also be measured if deemed necessary by the NYSDEC.

### Quality Assurance / Quality Control (QA/QC)

The ambient air and meteorological monitoring network shall be maintained and all sampling and analysis shall be performed in accordance with the November 2000 and any subsequently Department approved revisions of the "CWM Meteorological Monitoring Network - Quality Assurance Project Plan", which is incorporated by reference into this Permit by **Condition B in Schedule 1 of Module I** of this Permit, and in accordance with the May 2005 and any subsequently Department approved revisions of the "PM-10 Air Monitoring Program QA/QC Manual". CWM shall compensate the NYSDEC for the costs incurred in the oversight and validation of the network QA/QC that are reported to CWM. Compensation procedures shall be the same as those specified by **Condition E in Schedule 1 of Module I** of this Permit for the environmental monitors.

### Reporting of Monitoring Data

A monthly report of air monitoring data collected during each calendar month shall be submitted to the Region 9 Air and Solid & Hazardous Materials Engineers within ninety (90) days from the end of each calendar month or in accordance with an alternative Department approved submission schedule. Meteorological monitoring data shall be made available upon request.

# **ATTACHMENT O**

## **Major / Minor Modifications**

**ATTACHMENT O - MAJOR/MINOR MODIFICATIONS**

All Permit modifications shall be listed in the following Permit Modification Log.



**PERMIT MODIFICATION LOG**

The name of the specific document being modified (sections, and/or attachments)	Modified page numbers		Date of Revised pages	The effective date of permit modification	The nature of the modifications
	Old	New			
Schedule 1 of Module I	S1-1 & S1-3 thru S1-5	S1-1 & S1-3 thru S1-5	09/2013	11/07/2013	<b>Minor Modification:</b> AWTS – Replace Multi-Media Filtration System Tanks T-3004 & T-3005 (delete closed tanks from Permit) with Arsenic Treatment System Tanks T-3010A, T-3010B, T-3010C, T-3010D and Cartridge Filter Units. Replacement results in a Net 70-gallon reduction in facility tank capacity. Tanks T-3010A/B/C/D treat aqueous waste by adsorption, and Cartridge Filter Units are used for filtration prior to adsorption.
Schedule I of Module I, Exhibit D (tanks)	D-3 thru D-15	D-3 thru D-17			
Attachment A	Page 3 of 6	Page 3 of 6			
Attachment D, Appendix D-3 (text)	TofC I, 2, 3, 6, 7 & 19 thru 22	TofC I, 2, 3, 6, 7 & 19 thru 22			
Attachment D, Appendix D-3, Section VIII	2 & 3	2 & 3			
Attachment D, Appendix D-3, Figures & Calcs.	Fig. 20 cover page, Fig. 20 & Calc pages 1&2	Fig. 20 cover page, Fig. 20 & Calc pages 1&2			
Attachment F (Inspection Forms)	1	1			
Attachment I, Section I.1 (Site-Wide Closure Plan)	Cover page & 8	Cover page & 8			

The name of the specific document being modified (sections, and/or attachments)	Modified page numbers		Date of Revised pages	The effective date of permit modification	The nature of the modifications
	Old	New			
<p><b>Incorporated Documents:</b> P&amp;IDs</p> <p>AWTS O&amp;M Manual</p>	<p>Sheets 1, 24 &amp; 25</p> <p>Entire text, P&amp;IDs Sheets 1, 24, 25 and AppD</p>	<p>Sheets 1, 24, 25 &amp; 25a</p> <p>Entire text, P&amp;IDs Sheets 1, 24, 25 &amp; 25a</p>	09/2013	11/07/2013 (continued)	
<p>Schedule 1 of Module I</p> <p>Schedule I of Module I, Exhibit E (surface impoundments)</p> <p>Attachment A</p> <p>Attachment D, Appendix D-2</p> <p>Attachment I, Section I.1 (Site-Wide Closure Plan)</p>	<p>S1-1</p> <p>E-1</p> <p>Page 3 of 6</p> <p>2</p> <p>Cover page &amp; 7</p>	<p>S1-1</p> <p>E-1</p> <p>Page 3 of 6</p> <p>2</p> <p>Cover page &amp; 7</p>	10/2013	11/07/2013	<b>Minor Modification:</b> Revised to correct error in surface impoundment capacities.
<p>Permit Table of Contents</p> <p>Schedule 1 of Module I</p> <p>Schedule I of Module I, Exhibit A</p>	<p>TofC Pages i thru iii</p> <p>S1-2 thru S1-4 &amp; S1-14</p> <p>A-8 thru A-10</p>	<p>TofC Pages i thru iii</p> <p>S1-2 thru S1-4 &amp; S1-14</p> <p>A-8 thru A-10</p>	11/2013	12/12/2013	<b>Minor Modification:</b> Revisions to: 1) better clarify existing Permit conditions; 2) correct typographical and update/correct citations; 4) correct inadvertent omission of certain DOT containers; 5) re-instate some corrective action groundwater monitoring requirements which were inadvertently omitted; 6) make admin. changes to the Contingency Plan; and 7) add Attachment P, Permit condition index.

The name of the specific document being modified (sections, and/or attachments)	Modified page numbers		Date of Revised pages	The effective date of permit modification	The nature of the modifications
	Old	New			
Schedule I of Module I, Exhibit B	B-7 thru B-13	B-7 thru B-13	11/2013 (cont.)	12/12/2013 (cont.)	<b>Minor Modification:</b> Continued
Schedule I of Module I, Exhibit C	C-6 thru C-10	C-6 thru C-10			
Schedule I of Module I, Exhibit D	D-8 & D-12 thru D-17	D-8 & D-12 thru D-17			
Schedule I of Module I, Exhibit F	F-1, F-10 & F-51 thru F-71	F-1, F-10 & F-51 thru F-71			
Module IV	IV-2 thru IV-7	IV-2 thru IV-7			
Attachment C	Cover page & pgs. C-79, C-80, C-84 thru C-90, C-95, C-96 & C-98 thru C-110	Cover page & pgs. C-79, C-80, C-84 thru C-90, C-95, C-96 & C-98 thru C-109			
Permit Volume 2 Table of Contents	Tof C page	Tof C page			
Attachment D, Appendix D-1	5	5			
Attachment E	47 thru 64	47 thru 70			
Attachment F (Inspection Forms)	1 thru 18	1 thru 18			

The name of the specific document being modified (sections, and/or attachments)	Modified page numbers		Date of Revised pages	The effective date of permit modification	The nature of the modifications
	Old	New			
Attachment G	Cover page & pgs. 2 thru 4, 7 thru 9, 18, 25, 32, 56 & 57	Cover page & pgs. 2 thru 4, 7 thru 9, 18, 25, 32, 56 & 57	11/2013 (cont.)	12/12/2013 (cont.)	<b>Minor Modification:</b> Continued
Attachment P (new)	N/A	Cover page & pgs. P1 thru P-3			
<b>Incorporated Documents:</b> 1. Groundwater Extraction Systems O&M Manual; 2. Stabilization Facility O&M Manual; 3. RMU-1 O&M Manual; 4. Groundwater Sampling & Analysis Plan (SAP); 5. Site Radiological Survey Plan; 6. Radiation Environmental Monitoring Plan; and 7. Generic Small Project Soil Excavation Monitoring & Management Plan.	See instruction sheets after this table	See instruction sheets after this table			

The name of the specific document being modified (sections, and/or attachments)	Modified page numbers		Date of Revised pages	The effective date of permit modification	The nature of the modifications
	Old	New			
<b>Incorporated Documents:</b> 1.P&IDs 2.Groundwater Sampling & Analysis Plan (SAP)	Sheet 3 Cover Page, Tabs. 1,2,3&6, Figs. 1,2&5, App.D (entire)	Sheet 3 Cover Page, Tabs. 1,2,3&6, Figs. 1,2&5, App.D (entire)	12/2013	01/21/2014	<b>Minor Modification:</b> Revisions to make administrative changes such as correcting errors and updating information.
Schedule I of Module I, Exhibit F  Attachment M	F-32 thru F-71  Cover Page & pg. 10	F-32 thru F-71  Cover Page & pg. 10	03/2014	05/21/2014	<b>Minor Modification:</b> Revisions to make RMU-1 leachate analytical parameters consistent with SLF 11 & SLF 12 leachate parameters, and to allow use of alternate NYSDOH ELAP laboratories for surface water analysis.
<b>Incorporated Documents:</b> 1.P&IDs  2.AWTS O&M Manual	Sheets 1,15, 18,24,25&25a  Cover Page, Appendix C Cover and P&ID Sheets 1,15,18,25 & 25a	Sheets 1,15, 18,24,25&25a  Cover Page, Appendix C Cover and P&ID Sheets 1,15,18,25 & 25a	04/2014	05/21/2014	<b>Minor Modification:</b> Revisions to update P&IDs to reflect previous tank system piping changes and to install new automatic overflow control valves for Tank T-3009.
<b>Schedule 1 of Module I, Exhibit F</b>	F-17	F-17	06/2014	06/23/2014	<b>Department Initiated Modification:</b> Revision to remove allowance for the storage in containers of stabilized LDR wastes awaiting TCLP testing results within the RMU-1 landfill, in conformance with EPA Memorandum.

The name of the specific document being modified (sections, and/or attachments)	Modified page numbers		Date of Revised pages	The effective date of permit modification	The nature of the modifications
	Old	New			
<b>Incorporated Documents:</b> 1.P&IDs  2.AWTS O&M Manual	Sheets 2,24 & 26  Cover Page and P&ID Sheets 2,24 & 26	Sheets 2,24 & 26  Cover Page and P&ID Sheets 2,24 & 26	05/2014	07/08/2014	<b>Minor Modification:</b> Revisions to update P&IDs to reflect tank system piping changes.
Schedule 1 of Module I, Exhibit F	F-17 & F-29	F-17 & F-29	06/2014	07/08/2014	<b>Minor Modification:</b> Revisions to make administrative changes to better clarify existing Permit conditions with respect to the storage of LDR stabilized wastes.
Schedule 1 of Module I	S1-5	S1-5	08/2015	08/20/15	<b>Minor Modification:</b> Revision to Interim Compliance date.
Attachment M	Cover, disclaimer page, ToFC pages i-iii & pages 1-19	Cover, disclaimer page, ToFC pages i-iii & pages 1-16	09/2015	09/25/15	<b>Minor Modification:</b> Revisions to make Surface Water Sampling & Analysis Plan (SWSAP) requirements consistent with CWM's renewed/modified SPDES Permit.

The name of the specific document being modified (sections, and/or attachments)	Modified page numbers		Date of Revised pages	The effective date of permit modification	The nature of the modifications
	Old	New			
Schedule 1 of Module I Schedule 1 of Module I, Exhibit D Attachment A Attachment C, Table C-1 Attachment D, Appendix D-3 Attachment D, Appendix D-3, Section VIII Attachment D, Appendix D-3, Figures & Calcs. Attachment F (Inspection Forms) Attachment G  Attachment I, Section I.1 (Site-Wide Closure Plan)  <b>Incorporated Documents:</b> 1.P&IDs  2.AWTS O&M Manual	S1-1 & S1-15 D-3 thru D-17 Page 3 of 6 C-7 7  2 Fig. 22 & Calc. Page 1 1 Cover Page, Pgs. 6, 8, 61 & Org. Chart Cover Page & Pg. 10   Sheets 14 & 19  Cover Page, Pgs. 19 & 40, Fig. 1.1 and P&ID Sheet 19	S1-1 & S1-15 D-3 thru D-16 Page 3 of 6 C-7 7  2 Fig. 22 & Calc. Page 1 1 Cover Page, Pgs. 6, 8, 61 & Org. Chart Cover Page & Pg. 10   Sheets 14 & 19  Cover Page, Pgs. 19 & 40, Fig. 1.1 and P&ID Sheet 19	09/2015	11/04/15	<b>Minor Modification:</b> Revisions to remove certified closed Tank T-3001 from Permit, and to make administrative changes to update and correct minor errors.
Schedule 1 of Module I, Exhibit D	F-37 thru F-59	F-37 thru F-59	12/2015	02/ 10/16	<b>Minor Modification:</b> Extension of the closure period for Residuals Management Unit - One

The name of the specific document being modified (sections, and/or attachments)	Modified page numbers		Date of Revised pages	The effective date of permit modification	The nature of the modifications
	Old	New			
Attachment I, Section I.1 (Site-Wide Closure Plan)	31	31	03/2016	04/15/16	<b>Minor Modification:</b> Allows use of NYSDEC approved off-site borrow areas for Fac Pond 8 fill material at Closure.
Schedule 1 of Module I, Exhibit D Attachment C (Waste Analysis Plan)	D-10 & D-16 Cover Page, TofC Pgs. i-iv, Pgs. C-1, C-3, C-66, C-68 thruC-70, C-94thruC-97, C-102, C-106 thruC-109 & App. Pgs. A-1 & A-2	D-10 & D-16 Cover Page, TofC Pgs. i-iv, Pgs. C-1, C-3, C-66, C-68 thruC-70, C-94thruC-97, C-102, C-106 thruC-110 & App. Pgs. A-1 & A-2	06/2016	08/31/16	<b>Minor Modification:</b> Makes the following revisions to the Permit:  <ul style="list-style-type: none"> <li>- Clarifies that Mix Pit Tanks will be inspected on operating days;</li> <li>- Adds optional procedure for periodic replacement of treatment media in Tanks T-3010A-D;</li> <li>- Prohibits acceptance of off-site wastewaters categorized as CWT metals per SPDES permit prohibition;</li> <li>- Revisions to waste analysis testing requirements for off-site wastewaters;</li> <li>- Revision to certain waste analysis procedures and analytical methods;</li> <li>- Revisions to Contingency Plan personnel; and</li> <li>- Various revisions to update information in Permit.</li> </ul>
Attachment D, Appendix D-3	20	20			
Attachment D, Appendix D-3, Section VIII	2 & 3	2 & 3			
Attachment F (Inspection Forms)	19 & 22	19 & 22			
Attachment G	5, 6 & 8	5, 6 & 8			
<b>Incorporated Documents:</b>					
1. AWTS O&M Manual	Cover Page, TofC, Pgs. 2, 3,16-18,20-22, 24 & 43-45	Cover Page, TofC, Pgs. 2, 3,16-18,20-22, 24 & 43-45			
2.Stabilization Facility O&M Manual	Cover Page, Pgs. 4-8 & 10- 13	Cover Page, Pgs. 4-8 & 10- 13			



The name of the specific document being modified (sections, and/or attachments)	Modified page numbers		Date of Revised pages	The effective date of permit modification	The nature of the modifications
	Old	New			
<b>Incorporated Documents:</b> 1.Closure, Post-Closure & Corrective Measures Cost Estimate	Summary Table 1 & Sect. 5.13 Pgs. 1-4	Summary Table 1 & Sect. 5.13 Pgs. 1-4	07/2016	08/31/16	<b>Minor Modification:</b> Department approved closure cost estimate reduction for completed closure of Tank T-3001.

**SUMMARY OF PROPOSED MODIFICATIONS TO SITEWIDE PERMIT  
TO UPDATE PERMIT REFERENCES AND CORRECT INCONSISTENCIES  
November 2013**

- **CWM Meteorological Monitoring Network - Quality Assurance Project Plan** (entire plan)
- **Groundwater Extraction Systems O&M Manual**, (entire plan)
  - Cover Page, added revision date of November 2013.
  - Pages 1 and 9, updated to current permit condition citation.
  - Page 1, clarify timing of report submittals.
  - Pages 3 and 7, update descriptions of PA III and PA IV extraction systems to indicate that installation has been completed and systems are operational.
  - Page 8, corrections to consistently reference list of site specific constituents for monitoring as Site “Specific Indicator Parameters (27 VOCs)” Clarifications to the description of organic priority pollutant organics and metals to be consistent with conditions K.1.e. and f. of Exhibit F.
  - Page 11, corrected reference to CWM H&S Manual.
  - Pages 15 through 17, revised tables to clarify when DNAPL measurements are required.
- **Stabilization Facility O&M Manual**, (entire plan)
  - Cover Page, added revision date of November 2013.
  - Pages 2, 3, 5, 6, 7, 10, 11, and 12, general updates to reflect current operations
- **RMU-1 O&M Manual**, (entire text of plan)
  - Cover Page and Table of Contents.
  - Pages 1, 7, 7A, 8, 9, 10, 10 A, 12, 14A and 20G, corrected references to permit conditions.
  - Page 7, clarification on use of GPS to document disposal grid.
  - Page 10, correct language on operation of the leachate tank farm to be consistent with permit language.
  - Page 10A, 11 and 12, delete discussion of special requirements for waste placement on first lift; all first lifts have been completed in RMU-1.
  - Page 16 A, 17A and 20A, update of language concerning stormwater and Interim Storage to be consistent with new permit language.
  - Pages 18-19, 20A, update references to current drawings of landfill roads and truck routes.
  - Entire Text repaginated for clarity.
- **Groundwater Sampling and Analysis Plan** (entire text)
  - Pages 1, 5 and 16, corrected references to permit conditions. Update dates of most recent activities throughout document.
  - Page 5, 16, 18, 19, and Table 5, clarification to consistently reference list of site specific constituents for monitoring as “Site Specific Indicator Parameters (27 VOCs)”.
  - Page 21, updated to reflect data reporting requirements in new permit.

**SUMMARY OF PROPOSED MODIFICATIONS TO SITEWIDE PERMIT  
TO UPDATE PERMIT REFERENCES AND CORRECT INCONSISTENCIES  
November 2013**

- Pages 22-23, updated references.
- Appendix C-2, updated reference information for preservation and holding times.
- **Site Radiological Survey Plan (SRSP)**, page 1, for clarification, added date of previous permit that required submittal of this plan.
- **Radiation Environmental Monitoring Plan (REMP)**
  - Page 2, corrected references to permit conditions.
  - Page 3, change frequency of performing radiological analysis on groundwater to annually based on a letter from DEC dated 8/28/08. Corrected identity of well to be tested using drinking water protocol to W1201UD/S.
  - Page 4, corrected data reporting requirement to be consistent with new permit language.
- **Generic Small Project Soil Excavation Monitoring and Maintenance Plan**, page 1, corrected references to permit conditions.

# **ATTACHMENT P**

## **Permit Cross-Reference Index**

**(The contents of Attachment P have been derived from a Permit modification application submitted by CWM Chemical Services, L.L.C.)**

**[NOTE: The index contained in this attachment is solely intended to assist in Permit compliance by listing Permit conditions which are applicable to each unit type (e.g., containers, tanks, etc.). However, should there be any condition in the Permit not listed in this index; the Permittee may NOT use such an omission as a defense for non-compliance with such Permit condition(s).]**

## ATTACHMENT P Cross-Reference Index

### Corrective Action

Section	Condition	Description
Mod I	B	Definitions
Mod I, Sched 1	D	Due dates for Process Area III & IV Groundwater Extraction Systems
	F	Due dates for routine corrective action reporting
Mod I, Sched 1, Exh A	G.2	Verification of groundwater quantities assumed in post-closure cost estimate
Mod I, Sched 1, Exh B	All	List of corrective action areas and site-specific requirements
Mod I, Sched 1, Exh D	C.1.h	Requirements for corrective action tanks T-8009 and T-8010
Mod II	All	General regulatory terms and conditions
Att E	All	List of corrective action areas and site-specific requirements
Att F	Inspection forms	Inspection criteria for extraction systems and tanks
GWSAP	All	Methods for sampling and analyzing groundwater
GWES O&M	All	Operation & maintenance of groundwater extraction systems
Statement of Basis		Statement of Basis, Selection of Final Corrective Measures, CWM (2001)

### Container Management

Section	Condition	Description
Mod I, Sched 1	A	Total facility quantity of permitted containers
	F	Annual secondary containment assessment report due date
Mod I, Sched 1, Exh A	C	Six month storage report and on-site waste tracking
	D	Receiving containers; transporter requirements
	G.1	Verification of waste inventory assumed in closure cost estimate
Mod I, Sched 1, Exh C	All	List of container storage areas and site-specific requirements
Mod I, Sched 1, Exh F	E.1.b	Department waste stream review and approval
	E.1.c & E.1.d	Waste stream disposal restrictions and limitations
	E.1.e	Disposal of lab packs in landfill
	E.1.g	Final waste screening for containerized waste
	E.1.h	Improper disposal and waste retrieval
Mod III	All	General regulatory terms and conditions
Mod VI	H, I & J	Special requirements for reactive, incompatible and liquid waste
	K & L	Special requirements for containers and small containers
	M	Special requirements for F020-F023 and F026-F027
Mod VIII	B	Commingling and fuels blending hazardous waste
	C	Storage of LDR restricted waste
	E	Management of lab packs
Att A	Sections 7 and 9	Total facility container storage quantity and management methods
Att C (WAP)	C-1	Landfill disposal limits and waste codes
	C-2	Analytical requirements
	C-2c(2)(a)	Container sampling methods
	C-2d(1)(a)	Exceptions - no sample is required
	C-2e(2)	Inspection and sampling of containers
	C-2f(1)(a)	Container storage and segregation
	C-2f(2)(c)	Fuels blending sampling
	C-2f(2)(d)	Transformer decommissioning sampling
Att D, App D-1	All	Description of permitted container storage areas and procedures
Att F	Inspection forms	Inspection criteria for each permitted container storage area
Att I	Sitewide Closure Plan	Requirements for closure of container storage areas
Dioxin Mgt Plan	All	Requirements for storage of dioxin containing waste
O&M AWT	6.1	Transfer from containers
O&M AWT	2.1.2.6	Container storage at AWT

## ATTACHMENT P Cross-Reference Index

### Tank Systems

Section	Condition	Description
Mod I, Sched 1	A	Types and total facility quantity of permitted tanks
	F	Annual secondary containment and tank assessment reports due dates
Mod I, Sched 1, Exh A	C	Six month storage report and on-site waste tracking
	G.1	Verification of waste inventory assumed in closure cost estimate
Mod I, Sched 1, Exh B	B	Requirements for corrective action tanks T-8009 and T-8010
Mod I, Sched 1, Exh D	All	List of permitted tanks and site-specific requirements
Mod I, Sched 1, Exh F	E.1.b	Department waste stream review and approval
	E.1.c & E.1.d	Waste stream disposal restrictions and limitations
	F.3.d	Storage requirements for leachate tank farm
	K..2	Perpetual post-closure care for closed process area tanks
Mod IV	All	General regulatory terms and conditions
Mod VI	H, I & J	Special requirements for reactive, incompatible and liquid waste
	M	Special requirements for F020-F023 and F026-F027
Mod VIII	B	Commingling and fuels blending hazardous waste
	C	Storage of LDR restricted waste
Att A	Sections 7 and 9	Total facility tank storage quantity and management methods
Att C (WAP)	C-1	Landfill disposal limits and waste codes
	C-2	Analytical requirements
	C-2c(2)(a)	Tank sampling methods
	C-2f(1)(b)	Tank storage and segregation
	C-2f(2)(b)	Aqueous Waste Treatment sampling
	C-2f(2)(c)	Fuels blending sampling
Att D, App D-3	All	Description of permitted tank storage areas and procedures
Att D, App D-3	Table	Aboveground Ancillary Equipment without Secondary Containment
P&IDs for Tank Systems	All	P&IDs for tTank Systems
Att F	Inspection forms	Inspection criteria for each permitted tank storage area
Att I	Sitewide Closure Plan	Requirements for closure of tank storage areas
Att I	Sitewide Post-Closure Plan	Perpetual post-closure care for closed process area tanks
O&M AWT	All	Operations & Maintenance for Aqueous Waste Treatment System
RMU-1 Leachate Level Compliance Plan		Leachate processing plan to maintain compliant leachate levels
O&M Stabilization	All	Treating waste in mixing tanks (pits)

### Surface Impoundments

Section	Condition	Description
Mod I, Sched 1	A	Total facility quantity of permitted surface impoundments
	C	Compliance schedule for Fac Pond 8 closure
	F	Fac Pond discharge pre-qualification report due date
Mod I, Sched 1, Exh B	D.1	Rad survey requirement for out-of-service Fac Ponds
	D.3.d	Rad analysis for Fac Pond batch qualification
Mod I, Sched 1, Exh E	All	List of permitted surface impoundments and site-specific requirements
Mod I, Sched 1, Exh F	K.3	Perpetual post-closure care for closed lagoons and salts
	L	Groundwater monitoring for active surface impoundments
Mod V	All	General regulatory terms and conditions
Att A	Sections 7 and 9	Total facility surface impoundment quantity and management methods
Att C (WAP)	C-2c(2)(d)	Surface impoundment sampling methods
	C-2f(2)(b)	Fac Pond sampling
Att D, App D-2	All	Description of permitted active surface impoundments and procedures
Att E, App E-1	All	Groundwater monitoring for closed salts areas
Att F	Inspection forms	Inspection criteria for active and closed surface impoundments
Att I	Sitewide Closure Plan	Requirements for closure of surface impoundments
Att I	Sitewide Post-Closure Plan	Perpetual post-closure care for surface impoundments
O&M AWT	6.1.10.2	Transfer of effluent to Fac Pond 1/2
O&M AWT	6.1.11	Fac Pond 1/2
Fac Pond 8 Water TsF	All	Fac Pond 8 water transfer procedure
Rad Env Monitoring	Section 4.0	Rad testing requirements for pond qualification
GWSAP	All	Methods for sampling and analyzing groundwater

## ATTACHMENT P Cross-Reference Index

### Waste Blending

Module VIII	All	Requirements for waste blending and shipment off-site
Att C (WAP)	C-1	Landfill disposal limits and waste codes
	C-2	Analytical requirements
	C-2f(2)©	Fuels Blending/Incinerables

### Landfills

Section	Condition	Description
Mod I, Sched 1	A	Total facility quantity of permitted active landfills
	F	List and due dates for landfill reporting
Mod I, Sched 1, Exh A	G.2	Verification of leachate quantities assumed in post-closure cost estimate
Mod I, Sched 1, Exh F	A-J	Site-specific requirements for active landfill
	K	Perpetual post-closure care for closed landfills
	L	Groundwater monitoring for active and closed landfills
Mod VI	All	General regulatory terms and conditions
Att A	Sections 7 and 9	Total facility active landfill quantity and management methods
Att C (WAP)	C-1	Landfill disposal limits and waste codes
	C-2	Analytical requirements
	C-2c(2)(e)	LDR sampling methods
	C-2d	Waste pre-acceptance procedure
	C-2d(1)(a)	Exceptions - no sample is required
	C-2e	Incoming waste load procedures
	C-2f(5)	Sampling/analysis program for landfill disposal
	C-2f(6)	Sampling/analysis program for stabilization pre-treatment
Att F	Inspection forms	Inspection criteria for active and closed landfills
Att I	RMU-1 Closure Plan	Requirements for closure of active landfill RMU-1
	RMU-1 Post-Closure Plan	Perpetual post-closure care for active landfill RMU-1
	Sitewide Post-Closure Plan	Perpetual post-closure care for previously closed landfills
App D-5	All	RMU-1 Engineering Report
Att J, App D-6	All	RMU-1 landfill drawings
Att J, App D-7	All	RMU-1 landfill technical specifications
Att J, App D-8	All	RMU-1 landfill quality assurance manual
Att K, App D-9	All	RMU-1 landfill response action plan
Att K, App D-11	All	RMU-1 landfill minimum waste strength curves
Att D, App D-3	Table	Aboveground Ancillary Equipment without Secondary Containment
O&M Stabilization	All	Treating waste to LDR standards
O&M RMU-1	All	Operations & Maintenance Manual for RMU-1
RMU-1 Leachate Level Compliance Plan		Leachate processing plan to maintain compliant leachate levels
GWSAP	All	Methods for sampling and analyzing groundwater
RMU-1 Supp. Leachate	All	RMU-1 Supplemental Primary Leachate Pumping System
Att L, App D-10	All	Fugitive dust control plan for RMU-1 landfill and site roads