



Installation, Operation, and Maintenance

Tracer[®] UC400/UC400-B

Programmable Controllers

For Blower Coil, Fan Coil, and Unit Ventilator

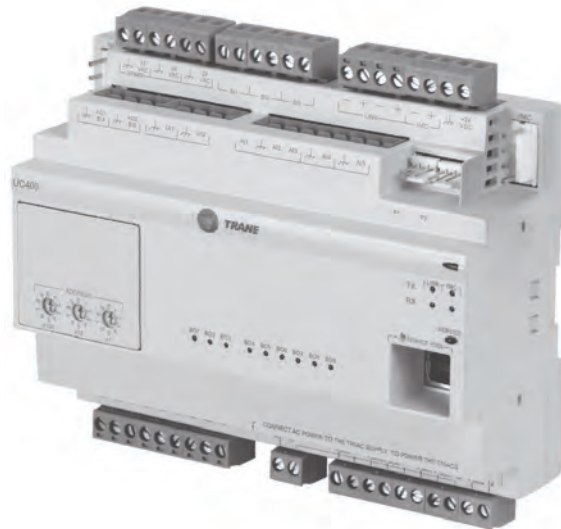

⚠ SAFETY WARNING

Only qualified personnel should install and service the equipment. The installation, starting up, and servicing of heating, ventilating, and air-conditioning equipment can be hazardous and requires specific knowledge and training. Improperly installed, adjusted or altered equipment by an unqualified person could result in death or serious injury. When working on the equipment, observe all precautions in the literature and on the tags, stickers, and labels that are attached to the equipment.



Introduction

Note: Specific reference to either UC400 or UC400-B is made throughout this document. All other content cited in this document about the UC400 is referred to as **UC400 Controller**.

The UC400/UC400-B is a multi-purpose, programmable (or application-specific controller) that provides direct-digital zone temperature control. The controller can operate as a stand-alone device or as part of a building automation system (BAS). Communication between the controller and a BAS occurs on an open standard with inter-operable protocols used in Building Automation and Control Networks (BACnet®). Programming is done by means of the Tracer® TU service tool.

This guide provides installation and configuration information for the UC400 Controller with specific operation description for Blower Coil, Fan Coil, and Unit Ventilation.

Refer to the Resource section for documentation related to concepts discussed throughout this manual.

Copyright

This document and the information in it are the property of Trane, and may not be used or reproduced in whole or in part without written permission. Trane reserves the right to revise this publication at any time, and to make changes to its content without obligation to notify any person of such revision or change.

Trademarks

All trademarks referenced in this document are the trademarks of their respective owners.

Agency Listings and Compliance

The European Union (EU) Declaration of Conformity is available from your local Trane® office.

Revision History

Corrected Face/Bypass terminations in [Figure 6, p. 23](#) and [Figure 12, p. 29](#)



Table of Contents

BACnet Protocol	6
BACnet® Testing Laboratory (BTL) Certification	6
Specifications and Dimensions	7
Device Connections	9
Additional Components	11
Water, Discharge, and Outdoor Air Temperature Sensors	11
Binary Input Switching Devices	11
Zone Temperature Sensors	11
Valve and Damper Actuators	12
Zone Humidity Sensor	12
CO ₂ Sensor	12
Expansion Modules	12
Typical Applications and Terminations	13
Binary Inputs	14
BI1; Occupancy	14
BI2; Condensate Overflow	14
BI3; Low Coil Temp Detection	15
BI4; Frost Detection	15
BI5; Fan Status	15
Analog Inputs	15
Ground Terminals	15
AI1; Space Temperature	15
AI2; Space Temperature Local Setpoint	15
AI3; Local Fan Mode Input	16
AI4; Discharge Air Temperature Sensor	16
AI5; Entering Water Temperature	16
Universal Inputs	16
UI1; Relative Humidity or CO ₂ Sensor	16
UI2; Outdoor Air Temperature	17
Binary Outputs	17
Override Outputs	17
Wiring Requirements	17
UC400 Wiring Diagrams	19
UC400-B Wiring Diagrams	25
Wiring Installation	31
Connecting Wires to Terminals	31
BACnet MS/TP Link	31
MAC Address	31
BACnet Device ID	31

BACnet Networks, With or Without Tracer SC Controller	31
Without a Tracer SC Controller	31
With a Tracer SC Controller	31
BACnet MS/TP Link Wiring	32
Power Supply	33
Transformer Recommendations	33
Wiring Requirements	33
Connecting 24 Vac Secondary Wires	34
Power On Check	35
LED Description, Activities, and Troubleshooting	36
Sequence of Operation	39
Power-up Sequence	39
Random Start	39
Occupancy Modes	39
Occupied Mode	39
Unoccupied Mode	40
Occupied Standby Mode	40
Occupied Bypass Mode	40
Timed Override Control	40
Zone Temperature Control	40
Discharge Air Tempering	42
Heating or Cooling Mode	42
Auto-Changeover Entering Water Temperature Sampling Function	42
Fan Operation	43
Manual Fan Speed Control	43
Auto Fan Operation; 1-, 2-, 3-Speed	43
Single Zone VAV	43
Exhaust Control	44
Valve Operation	45
Modulating Valve Operation	45
3-Wire Floating Point Valve Calibration	45
2-Position Valve Operation	45
Face/Bypass Damper Operation	45
Modulating Outdoor/Return Air Damper	45
ASHRAE Cycle 1 Conformance	46
ASHRAE Cycle 2 Conformance	46
Economizing (Free Cooling)	47
Outdoor Air Damper Control With Varying Fan Speed	47
CO ₂ -Based Demand Controlled Ventilation	48
Fan Operating at Multiple Speeds or Single-Zone VAV Control	48
DX Cooling Operation, 1 or 2 Circuits	49

Heat Pump Operation, 1 or 2 Circuits	50
Defrost Operation	50
Electric Heat Operation	50
Dehumidification Operation	50
Unit Protection Strategies	51
Smart Reset	51
Low Coil Temperature Protection	51
Condensate Overflow	51
Fan Status	51
Fan Off Delay	52
Filter Maintenance Timer	52
Freeze Avoidance	52
Freeze Protection, Discharge Air Temperature Low Limit	52
Output Testing	53
Diagnostics	53
Diagnostic Types	53
Diagnostic Generated by the UC400	54
Operational Causes and Diagnostics	57
Configuration and Maintenance	60
Settings for CO ₂ -Based Demand Controlled Ventilation	63
Resources	67



BACnet Protocol

The Building Automation and Control Network (BACnet®) protocol is ANSI/ASHRAE Standard 135. This standard allows building automation systems or components from different manufacturers to share information and control functions. BACnet® provides building owners the capability to connect various types of building control systems or subsystems together for many uses. Multiple vendors can use this protocol to share information for monitoring and supervisory control between systems and devices in a multi-vendor interconnected system. The BACnet® protocol defines standard objects (data points) called BACnet® objects. Each object has a defined list of properties that provide context information about that object. In addition, BACnet® defines a number of application services that are used to interact with objects in a BACnet® device.

BACnet® Testing Laboratory (BTL) Certification

The UC400 Controller supports the BACnet communication protocol and has been designed to meet the requirements of the application-specific control profile. For more details, refer to the BTL web site at www.bacnetinternational.org. The UC400 Controller supports the following equipment when used as an application-specific unit:

- Blower Coils
- Fan Coils
- Unit Ventilators
- WSHP (Variable Speed)
- VAV



Specifications and Dimensions

Table 1. UC400/UC400-B Specifications

Storage	
Temperature:	-48°F to 203°F (-44°C to 95°C)
Relative Humidity:	Between 5% and 95% (non-condensing)
Operating	
Temperature:	-40°F to 158°F (-40°C to 70°C)
Humidity:	Between 5% and 95% (non-condensing)
Input Power:	20.4–27.6 Vac (24, ±15% nominal), 50Hz to 60Hz, 24 VA (24 VA plus binary output loads for a maximum of 12 VA for each binary output)
Mounting Weight of Controller:	Supporting mounting surface: must be 0.80 lb. (.364 kg)
Environmental Rating (Enclosure):	NEMA 1
Altitude:	6,500 ft. maximum (1,981 m)
Installation:	U.L. 840: Category 3
Pollution:	U.L. 840: Degree 2
Housing Material: ^(a)	Polycarbonate/ABS Blend UV protected U.L. 94-5VA flammability rating
Mounting:	UC400: Mounts on EN 50 022 - 35 X 15 DIN rail. UC400-B: Pre-mounted.
Agency Listing	
UL916 PAZX, Open Energy Management Equipment UL94-5V, Flammability CE Marked FCC Part 15, Subpart B, Class B Limit AS/NZS CISPR 22:2006 VCCI V-3/2008.04 ICES-003, Issue 4:2004 Communications BACnet® MS/TP, supports BACnet Protocol ASHRAE 135-2004 and Meets BACnet Testing Laboratory (BTL) as an Application Specific Controller (ASC) Profile Device	

^(a) Not applicable for the UC400-B model.

Figure 1. UC400 and UC400-B Dimensions

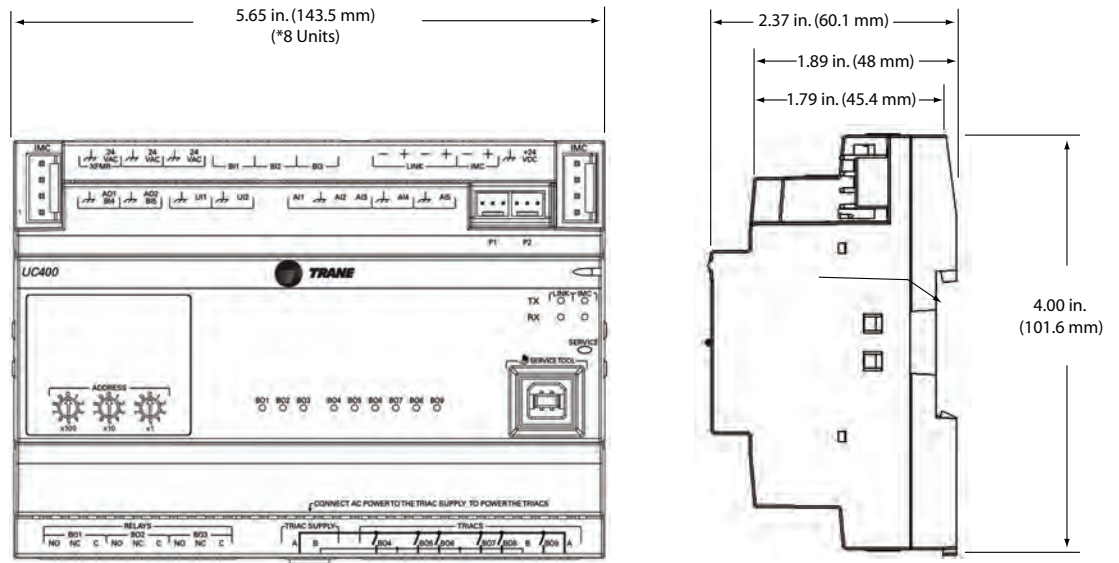

*DIN Standard 43 880, Built-in Equipment for Electrical Installation. Overall Dimensions and Related Mounting Dimensions.

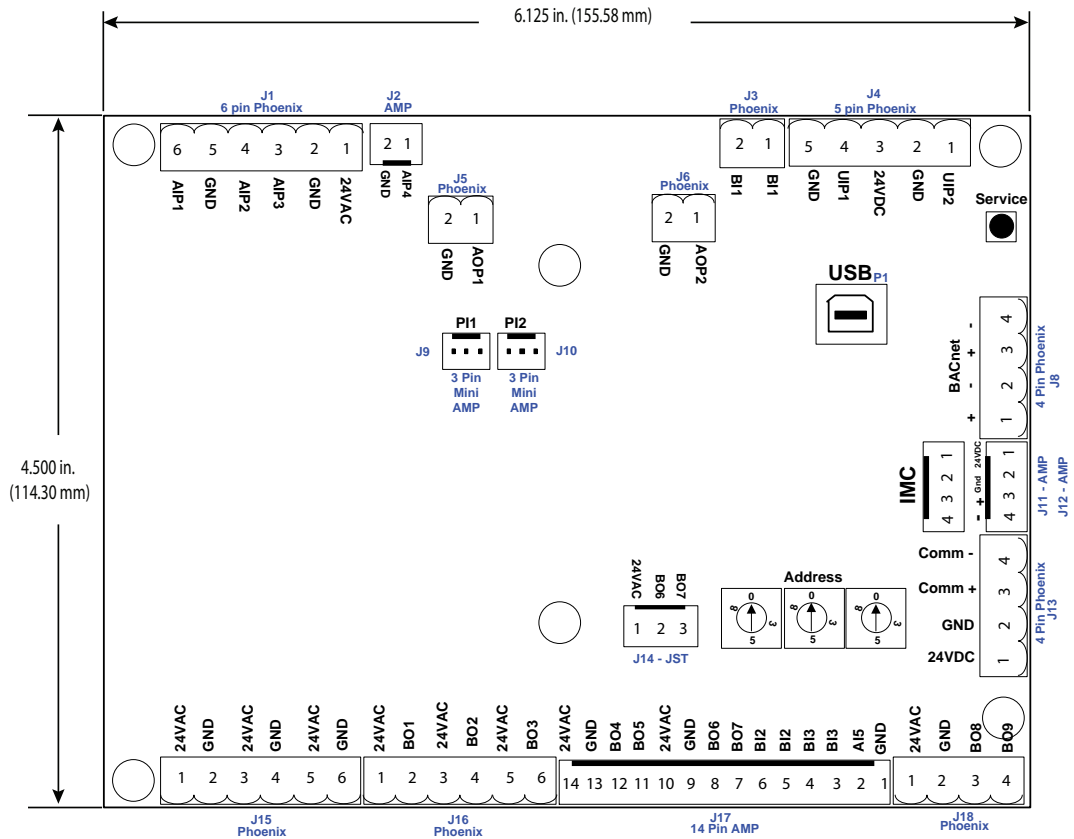



Device Connections

The following table provides details of the hardware termination configuration options. The hardware terminations are pre-configured for proper equipment operation for blower coil/fan coil applications.

⚠ WARNING

Live Electrical Components!
 Failure to follow all electrical safety precautions when exposed to live electrical components could result in death or serious injury.
 When it is necessary to work with live electrical components, have a qualified licensed electrician or other individual who has been properly trained in handling live electrical components perform these tasks.

Table 2. Connections

Connection	Quantity	Types	Range	Notes
Analog input (AI1 to AI5)	5	Temperature	10 kΩ thermistor	AI1 to AI4 can be configured for timed override capability.
		Setpoint	189 Ω to 889 Ω	
		Resistive	100 Ω to 100 kΩ	Typically used for fan speed switch.
Universal input (UI1 and UI2)	2	Linear	0–20 mA	These inputs may be configured to be thermistor or resistive inputs, 0–10 Vdc inputs, or 0–20 mA inputs.
		Linear	0–10 Vdc	
		Temperature	10 kΩ thermistor	
		Setpoint	189 Ω to 889 Ω	
		Resistive	100 Ω to 100 kΩ	
		Binary	Open collector/dry contact	Low impedance relay contacts recommended.
		Pulse	Solid state open collector	Minimum dwell time is 25 milliseconds On and 25 milliseconds Off.
Binary input (BI1 to BI3) ^(a)	3		24 Vac detect	The UC400 controller provides the 24 Vac required to drive the binary inputs when using the recommended connections.
Binary output (BO1 to BO3) ^(a)	3	UC400:Relay	<ul style="list-style-type: none"> • 2.88 A @24 Vac C pilot duty • Gen Purpose <ul style="list-style-type: none"> – 10 A max up 277 Vac – 10 A max up to 30 Vdc • Motor Duty <ul style="list-style-type: none"> – 1/3 hp @ 125 VAC (7.5 A max) – 1/2 hp @ 277 VAC (7.5 A max) 	Power needs to be wired to the binary output. All outputs are isolated from each other and from ground or power. Note: Ranges given are per contact.
		Other Ranges	UC400-B:TRIAC	
Binary output (BO4 to BO9) ^(a)	6	TRIAC	<ul style="list-style-type: none"> • UC400: 0.5 A max @24-277 Vac, resistive and pilot duty • UC400-B: 24 Vac Powered 	Use for modulating TRIAC. User determines whether closing high side (providing voltage to the grounded load) or low side (providing ground to the power load). Note: Ranges given are per contact and power comes from TRIAC SUPPLY circuit.



Device Connections

Table 2. Connections (continued)

Connection	Quantity	Types	Range	Notes
Analog output/ binary input (AO1/BI4 and AO2/BI5)	2	Linear output	0–20 mA	Each termination must be configured as either an analog output or binary input.
		Linear output	0–10 Vdc	
		Binary input	Dry contact	
		PWM output	80 Hz signal @ 15 Vdc	
Pressure inputs (PI1 and PI2)	2	3-wire	0–5 in H ₂ O	<ul style="list-style-type: none"> • UC400: Pressure inputs supplied with 5 volts of power. Designed for Kavlico™ pressure transducers. • UC400-B: Used as a binary input for condensate on WSHP.
Overall Point Total	23			

^(a) Do Not mix Class 1 and Class 2 voltage wiring in an enclosure or on a controller without an approved barrier between the wiring.



Additional Components

The UC400 Controller requires the use of additional components for monitoring and proper control of associated equipment. The use of specific components is dependent on the type of application.

Note: Additional components are not included with the UC400 Controller.

Water, Discharge, and Outdoor Air Temperature Sensors

Temperature sensors must be Trane 10 kΩ (at 25°C) thermistors. Entering water and discharge air inputs can use a sealed temperature sensor (part numbers 4190 1100 and 4190 1133). A discharge air temperature sensor is required for proper operation.

Binary Input Switching Devices

Occupancy, condensate overflow, low-coil temperature, and fan status inputs accept switching devices that may have normally open (NO) or normally closed (NC) dry contacts.

Zone Temperature Sensors

The following table provides the sensor types and features supported by the UC400 Controller.

Table 3. UC400 Controller Supported Sensors and Features

Sensor Type	Features					Part Number	BAYSENS	Global Parts
	Setpoint	Fan Control	System	Occupancy	LEDs			
Temperature Sensor	No	No	No	No	No	X1351152801	BAYSENS077A	SEN01448
	No			Yes		X1351153001	BAYSENS073A	SEN01450
Temperature Sensors w/ Fan Control	Single	<ul style="list-style-type: none"> • Off • Auto 	No	Yes	No	X1379084501	N/A	SEN01521
	Single	<ul style="list-style-type: none"> • Off • Auto • Low • High 		Yes		X1379084801		SEN01524
	Single	<ul style="list-style-type: none"> • Off • Auto • Low • Medium • High 		Yes		X1379084201		SEN01518
Temperature Sensor w/ LCD Display ^(a)	Single	<ul style="list-style-type: none"> • Off • Auto • Low • Medium • High 	No	Can be configured for occupancy	No	X1379088604	N/A	N/A



Additional Components

Table 3. UC400 Controller Supported Sensors and Features (continued)

Sensor Type	Setpoint	Features				Part Number	BAYSENS	Global Parts
		Fan Control	System	Occupancy	LEDs			
Wireless Zone Sensor w/Fan Control	Single	<ul style="list-style-type: none"> • Off • Auto • Low • Medium • High 	No	Yes	No	X1379082201 (Sensor Only)	N/A	N/A
						X1379082401 (Sensor Set)		

^(a) This sensor can be field configured to match the applicable unit controller options. Unit controller inputs for system status, fan, and service required are not available on this sensor. If replacing a BAYSENS031A or a BAYSENS035A sensor, and status indicators are required, replace with non-display sensor BAYSENS109A or BAYSENS110A.

Valve and Damper Actuators

The 2-position analog and 3-wire floating point modulating actuators cannot exceed 12 VA draw at 24 Vac. For 2-position valves, use actuators with ON/OFF and spring actions that returns the valve to normally open (NO) or closed (NC), which are dependent on the desired default position. For modulating actuators, use actuators with or without a spring return, as required by the application.

Zone Humidity Sensor

For measurement of relative humidity (RH), the UC400 Controller requires a zone humidity sensor with a 4–20 mA output, where 4 mA is 0% RH and 20 mA is 100% RH. The controller provides 24 Vdc to power the zone humidity sensor.

Note: As an option, the UC400 Controller can receive humidity from a Trane Air-fi™ Wireless Sensor with Humidity.

CO₂ Sensor

The UC400 Controller assumes (by default) that the CO₂ sensor provides a 4-20 mA output when measuring carbon dioxide (CO₂). The controller provides 24 Vdc to power the CO₂ sensor.

Expansion Modules

The UC400 Controller can power a maximum of two (2) DC expansion modules (either the Tracer XM30 or Tracer XM32) without an additional power supply. It can support a maximum of 32 additional XM30, XM32 or XM70 hardware terminations when properly applying power.



Typical Applications and Terminations

The following tables provide information about supported applications and termination wiring.

Table 4. UC400 Controller Typical Applications

Application	Electric Heat	Auto Minimum Damper Adjust	Economizing
2-Pipe Cooling Only	X	X	X
2-Pipe Changeover	X	X	X
2-Pipe Heating Only		X	X
2-Pipe Steam Only		X	X
2-Pipe Face and Bypass Heat Only (Hot Water or Steam) ^(a)		X	X
4-Pipe		X	X
4-Pipe Changeover		X	X
4-Pipe Face and Bypass Changeover		X	X
4-Pipe Face and Bypass (Hot Water/Chilled Water)		X	X
Electric Heat Only ^(a)	X		X
4-Pipe Steam/chilled Water		X	X
DX Cooling	X	X	X
DX Cooling with 2-Pipe Heating		X	X
DX cCooling with 2-Pipe Steam Heat	X	X	X
DX Heat Pump Only		X	X

^(a) Tracer UC400 supports single-stage, two-stage, and modulating electric heat.

Table 5. Factory Programmed Terminations

Inputs/Outputs/Communication	Terminations	Factory Programmed Assumed Terminations
Analog Inputs	AI1	Space Temperature Local/Return Air Temperature Sensor
	AI2	Space Temperature Setpoint Local
	AI3	Local Fan Switch
	AI4	Discharge Air Temperature Sensor
	AI5	Entering Water Temperature Sensor
Universal Inputs	UI1	Relative Humidity Sensor or CO ₂ Sensor
	UI2	Outside Air Temperature Sensor
Binary Inputs	BI1	Occupancy Sensor
	BI2	Condensate Overflow Sensor
	BI3	Low Limit Protection Sensor
Binary Outputs (Relay)	BO1	Fan High
	BO2	Fan Medium/Exhaust Fan
	BO3	Fan Low

Typical Applications and Terminations

Table 5. Factory Programmed Terminations (continued)

Inputs/Outputs/Communication	Terminations	Factory Programmed Assumed Terminations
Binary Outputs (TRIAC)	BO4	Cooling, 2-Position Cooling, 3-Wire Floating Point Open Compressor 1
	BO5	<ul style="list-style-type: none"> Cooling, 3-Wire Floating Point Close Compressor 2 Heating, 2-Position^(a)
	BO6	<ul style="list-style-type: none"> Heating, 2-Position Heating, 3-Wire Floating Point Open Electric Heat Stage 1 Face and Bypass Damper Open
	BO7	<ul style="list-style-type: none"> Heating, 3-Wire Floating Point Close Electric Heat Stage 2 Face and Bypass Damper closed Reversing Valve
	BO8	<ul style="list-style-type: none"> Outside Air Damper, 2-Position Economizer, 3-Wire Floating Point Open
	BO9	Economizer, 3-Wire Floating Point close
Analog Outputs/Binary Inputs	AO1/BI4	<ul style="list-style-type: none"> Frost protection Status Cooling, Analog valve
	AO2/BI5	<ul style="list-style-type: none"> Fan Status Heating, Analog Valve Heating, SCR Modulating Electric Heat
Communication	IMC	ECM Engine Module
Pressure Inputs	PI1	Unused
	PI2	Unused

^(a) For face and bypass damper control applications.

Binary Inputs

The UC400 Controller has three (3) binary inputs and two (2) analog outputs/binary inputs (labeled BI1 through BI5), that can be configured as either analog outputs or binary inputs. Each binary input associates an input signal of 0 Vac with open contacts and 24 Vac with closed contacts. If changes are required, use the Tracer TU service tool to unlock the points on and configure each of the inputs as normally open (NO) or normally closed (NC).

BI1; Occupancy

Occupancy BI1 saves energy by spreading space temperature setpoints when the zone is unoccupied. Used as an occupancy input, BI1 has two (2) related functions:

- It changes the mode from occupied to occupied standby for controllers receiving a BAS-communicated occupancy request.
- It can be hard wired to a binary switch or time clock to determine the occupancy mode as either occupied or unoccupied for stand-alone controllers.

BI2; Condensate Overflow

Condensate Overflow BI2 prevents the condensate drain pan from overflowing and causing water damage to the building. If BI2 is wired to a condensate overflow switch, and the level of

condensate reaches the trip point, the UC400 Controller detects the condition and generates a Condensate Overflow diagnostic.

BI3; Low Coil Temp Detection

Low Coil Temperature Detection BI3 protects the coil from freezing. If BI3 is wired to a binary low coil temperature detection device (freeze-protection switch) and a low coil temperature condition exists, the UC400 Controller detects the condition and generates a Low Coil Temperature Detection diagnostic.

Note: This input is for Hydronic or Steam Coils only.

BI4; Frost Detection

Frost detection BI4 detects conditions that produce frost on the coil surface. When these conditions are present, the UC400 Controller detects the condition and generates a Frost Detection Input alarm.

Note: This input is for only DX.

BI5; Fan Status

Fan Status BI5 provides feedback to the UC400 Controller regarding the operating status of the fan. If BI5 is wired to a fan status switch, and the input indicates that the fan is not operating when the controller has the fan controlled to ON, the controller generates a Low Airflow Supply Fan Failure diagnostic.

Analog Inputs

The UC400 Controller has seven (7) analog inputs.

Ground Terminals

Use the  terminal as the common ground for all space temperature sensor analog inputs.

AI1; Space Temperature

Space Temperature AI1 functions as the local (hard wired) space temperature input. The UC400 Controller receives the space temperature as a resistance signal from a 10 k Ω thermistor in a standard Trane space temperature sensor that is wired to analog input AI1. A space temperature value communicated by means of a BACnet link, can be used for controllers operating on a BAS. When both a hard wired and communicated space temperature value are present, and in service, the controller uses the communicated value.

If neither a hard wired nor a communicated space temperature value is present, the space temperature local and active points go into a fault state and generates an alarm. If neither the hard wired or communicated space temperature are valid, the controller runs discharge air control as backup. The space temperature setpoint is used as the discharge air temperature setpoint. At the same time, the air valve modulates and reheat is used (if needed) to control the discharge air temperature to the DAT setpoint.

AI2; Space Temperature Local Setpoint

Space Temperature Local Setpoint AI2 functions as the local (hard wired) space temperature setpoint input for applications utilizing a Trane space temperature sensor with a temperature setpoint thumbwheel or digital setpoint input. A setpoint value communicated by means of a BACnet link, can be used for controllers operating on a BAS. If both hard wired and communicated setpoint values are present, and in service, the UC400 Controller uses the communicated value.

In addition, the controller can be configured to use the local (hard wired) input value instead of the communicated value using the Tracer TU service tool. If neither a hard wired nor a communicated setpoint value is present, the controller uses the space temperature setpoint default analog value, which is configured using the Tracer TU service tool. If a valid local setpoint value is established, and then is no longer present, the controller generates a Space Temperature Setpoint Local alarm.



Typical Applications and Terminations

AI3; Local Fan Mode Input

Local Fan Mode Input AI3 functions as the local (hard wired) fan mode switch input for applications using the Trane space temperature sensor with a fan mode switch option. The various fan mode switch positions (OFF, LOW, MEDIUM, HIGH, AUTO) provide different resistances that are interpreted by the UC400 Controller.

Note: *The local fan speed switch can be disabled by taking out of service the multi-state point, supply fan speed local and setting the value for each to AUTO.*

A communicated fan mode request by means of the BACnet communications link, can be used for controllers operating on a BAS. If both hard wired and communicated fan mode values are present and in service, the UC400 Controller uses the communicated value. However, the controller can be configured to use the local (hard wired) input value instead of the communicated BAS value. The supply fan speed source (local or BAS) can be selected on the Tracer TU Setup Parameters page. If neither a hard wired nor a communicated fan mode value is present, the controller recognizes the fan mode value as AUTO and operates according to the default configuration. If a valid hard wired or communicated fan mode value is established, and then is no longer present, the controller generates a Supply Fan Speed Local alarm.

AI4; Discharge Air Temperature Sensor

Discharge Air Temperature Sensor AI4 functions as the local discharge air temperature input.

Note: *A valid discharge air temperature value is required for normal operation.*

The UC400 Controller receives the temperature as a resistance signal from a 10 k Ω thermistor wired to analog input AI4. The thermistor is typically located downstream from all unit heating and cooling coils at the unit discharge area. If a discharge air temperature value is invalid, or is not present, the controller generates a Discharge Air Temp Failure alarm. If there is a discharge air temperature failure, the controller runs a simplified zone control algorithm and controls the space to the unoccupied setpoints.

AI5; Entering Water Temperature

Entering Water Temperature AI5 functions as the local (hard wired) entering water temperature input. An entering water temperature communicated by means of the BACnet communications link, can be used for controllers operating on a BAS. If both hard wired and communicated entering water temperature values are present, and in service, the UC400 Controller uses the communicated value. If a valid hard wired or communicated entering water temperature value is established, and then is no longer present, the UC400 Controller generates an Entering Water Temperature Failure diagnostic.

For units configured as 2-pipe or 4-pipe changeover units, the entering water temperature is used to make heating/cooling operation decisions. If neither a hard wired nor a communicated entering water temperature value is present on changeover units, the UC400 Controller always operates in heating mode.

Note: *For units not configured as changeover units, the entering water temperature can be manually configured and used for information and troubleshooting. It will not affect the operation of the controller.*

Universal Inputs

The UC400 Controller has two (2) universal inputs.

UI1; Relative Humidity or CO₂ Sensor

If the UC400 Controller is configured for a local hard wired RH sensor, the factory programming assumes it is wired to UI1. The pre-configured unit requires a 4-20 mA analog input corresponding linearly to a 0%-100% relative humidity. If the controller is configured for a local hard wired CO₂ sensor, the factory programming also assumes it is wired to UI1. The pre-configured unit requires a 4-20 mA analog input.

UI2; Outdoor Air Temperature

If UI2 is configured as the local (hard wired) outdoor air temperature input, the UC400 Controller receives the temperature as a resistance signal from a 10 k Ω thermistor wired to UI2. An outdoor air temperature value communicated by means of a BACnet link, can be used for controllers operating on a BAS. If both hard wired and communicated outdoor air temperature values are present, and in service, the controller uses the communicated value. If a valid hard wired or communicated outdoor air temperature value is established, and then is no longer present, the controller generates an Outdoor Air Temperature Failure alarm.

The economizing (free cooling) function uses outdoor air is used as a source of cooling before using hydronic or DX cooling. The controller uses the outdoor air temperature value to determine whether economizing is feasible. Economizing is not possible without a valid outdoor air temperature. The outdoor air temperature value is used for the freeze avoidance function. This function is used for low coil temperature protection when the fan is OFF. The controller enters the freeze avoidance mode when the outdoor air temperature is below the freeze avoidance setpoint (configured using the Tracer TU service tool).

Binary Outputs

The UC400 includes nine (9) binary outputs. BO1, BO2, and BO3 are relay outputs and BO4 through BO9 are TRIAC outputs.

Important: 24 Vac must be provided to the TRIAC supply input.

The UC400 supports the following blower coil, fan coil, and unit ventilator applications:

- Supply fan with 1-, 2-, or 3-speed or variable speeds.
- Face/bypass damper for some hydronic Unit Ventilator applications.
- DX cooling single- or dual-stage.
- Electric heat single stage, two stage, or modulating.
- A 2-position or 3-wire floating point modulating outdoor/return air damper.

Override Outputs

Analog and multi-state value request points are included in order to safely override outputs without disrupting TGP2 program operation. To override valves and dampers for commissioning or testing purposes, access the following points on the Analog or Multi-state tabs of the Tracer TU service tool :

- **Cool Valve Request:** analog value point for 2-position and modulating hydronic cooling and changeover valve.
- **DX Cool Request:** analog value point for 1- and 2-stage DX cooling and heat pump.
- **Heat Valve Request:** analog value point for 2-position and modulating hydronic heating valve.
- **Electric Heat Request:** analog value point for modulating, 1- and 2-stage electric heating.
- **Economizer Request:** analog value point for 2-position and modulating outdoor air damper.
- **Supply Fan Speed Request:** analog value point for variable speed (0-100%) fan applications, including Trane ECM engine module.
- **Supply Fan Speed BAS:** multi-state value point for fixed 1-, 2-, and 3-speed fan.

Wiring Requirements

The following table lists the required UC400 Controller inputs for minimum proper operation of all applications. The following wiring diagrams are separated to show first the UC400 and then the UC400-B



Typical Applications and Terminations

Table 6. Inputs

Function	Input source	Related information
24 Vac Power	Terminals: Ground, 24 Vac	For more details on power wiring requirements, refer to "Resources," p. 67.
Space Temperature Local	Terminals: AI1, Ground	AI1; Space Temperature Local
Discharge Air Temperature	Terminals: AI4	AI4; Discharge Air Temperature Sensor
Entering Water Temperature (Required Only for Units with Auto-changeover)	Terminal: AI5 or Communicated	AI5; Entering Water Temperature
Outdoor Air Temperature Local (Required Only for Economizing)	Terminals: UI2 or Communicated	UI2; Outdoor Air Temperature
<p>CO₂ Sensor (Required Only for CO₂-based Demand Controlled Ventilation)</p> <p>CO₂ and an Economizer Damper are Required for Demand Control Ventilation Operation. Demand Control Ventilation is Disabled When:</p> <ul style="list-style-type: none"> The Economizer Damper is not Installed. No CO₂ Sensor or Value does Not Exist The Mode of Operation is Unoccupied, Pre-cool, Morning Warm-up, or Anytime When the Fan is OFF. 	Terminals: UI1 or Communicated	UI1; Relative Humidity or CO ₂ Sensor

UC400 Wiring Diagrams

Figure 2. Common Input/Sensor Connections

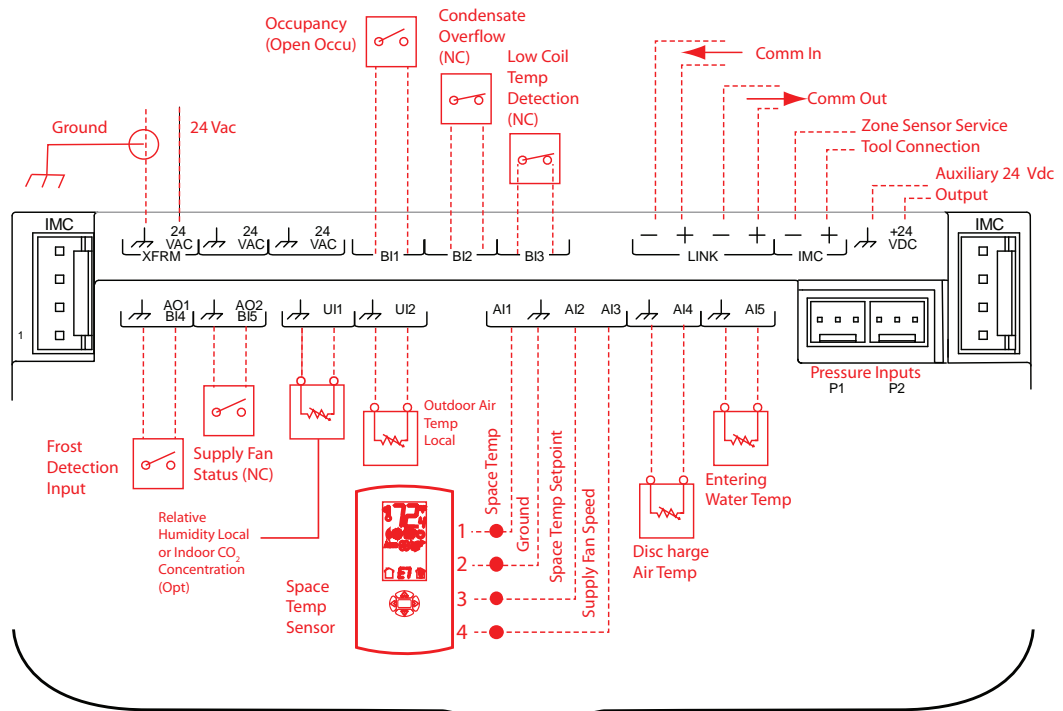

Two-Tier Terminal Connections

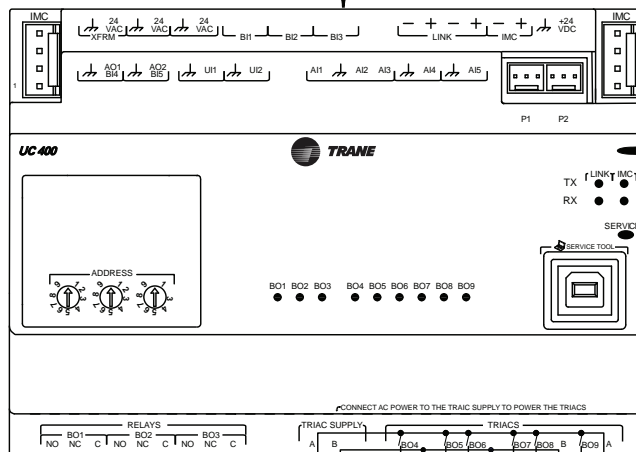

• BI4 Frost Detect Input used to detect freeze conditions that produce frost on the coil surface.

• UI1 Relative Humidity Sensor can be used with dehumidifying unit instead of a BAS-communicated valve or CO2 Sensor can be used for Demand Controlled Ventilation instead of a BAS-communicated valve.

• AI5 Entering Water Temp Sensor used for auto-changeover units.

Figure 3. 2-Position Ventilation and Modulating Economizer

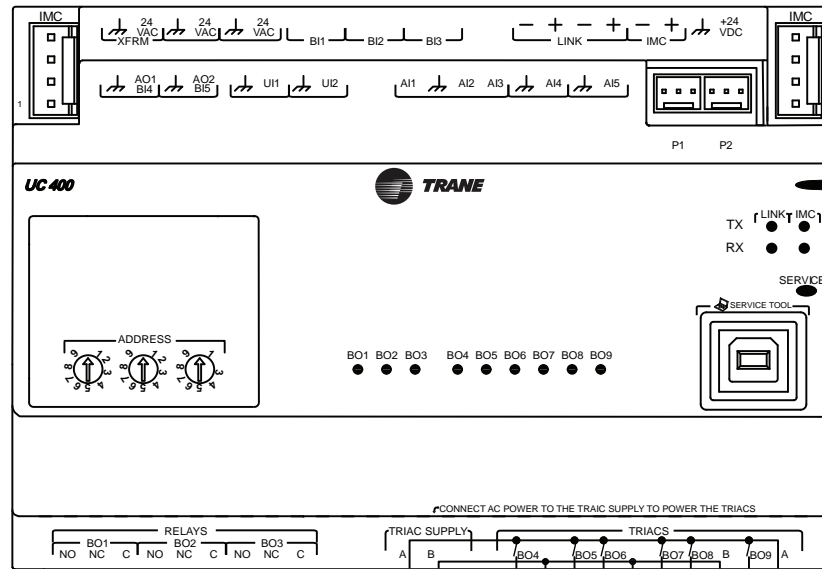

Single-Tier Terminal Connections

2-position Ventilation Terminal Connections

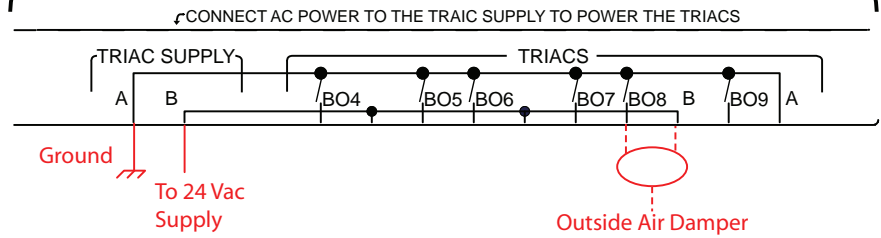

Modulating Economizer Damper Terminal Connections

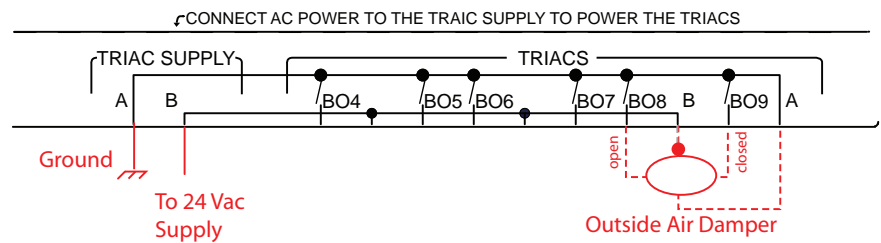
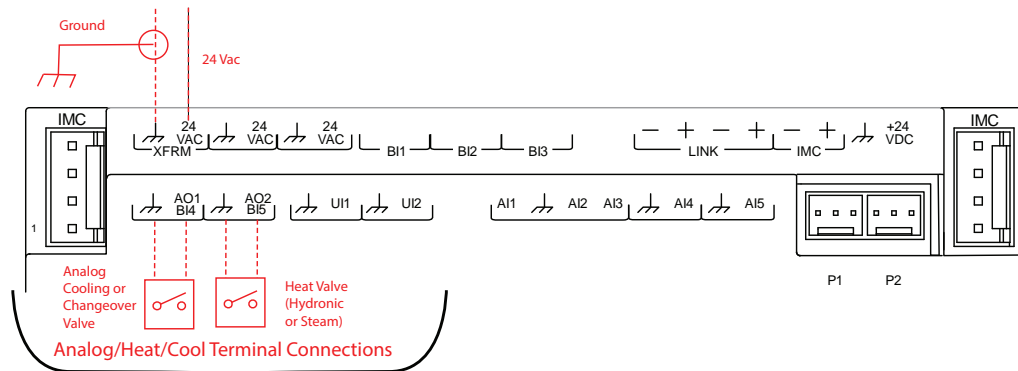
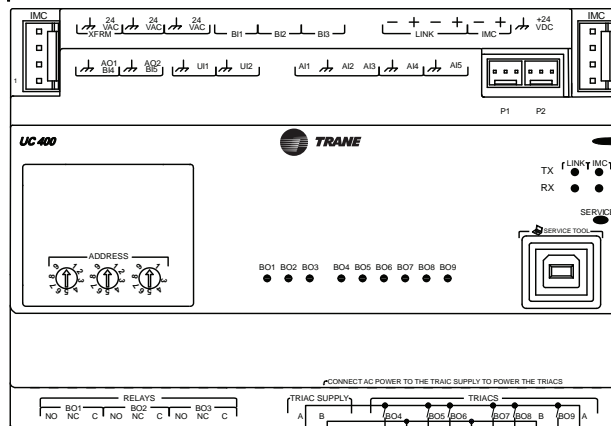

Figure 4. 2-Position and Modulating Valve



Two-Tier Terminal Connections

Single-Tier Terminal Connections



2-Position Cooling, Changeover, Heating Valve Terminal Connections

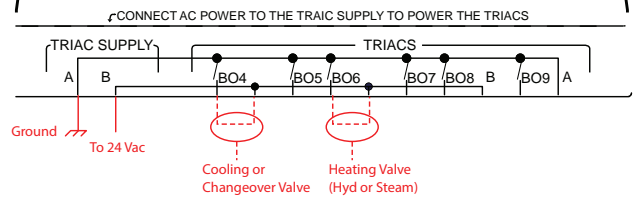

Modulating Valve Terminal Connections

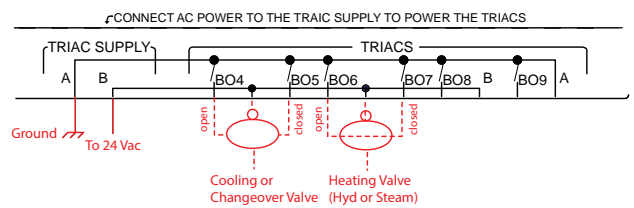

Typical Applications and Terminations

Figure 5. DX Heat Pump, Electric Heat, and SCR Electric Heat

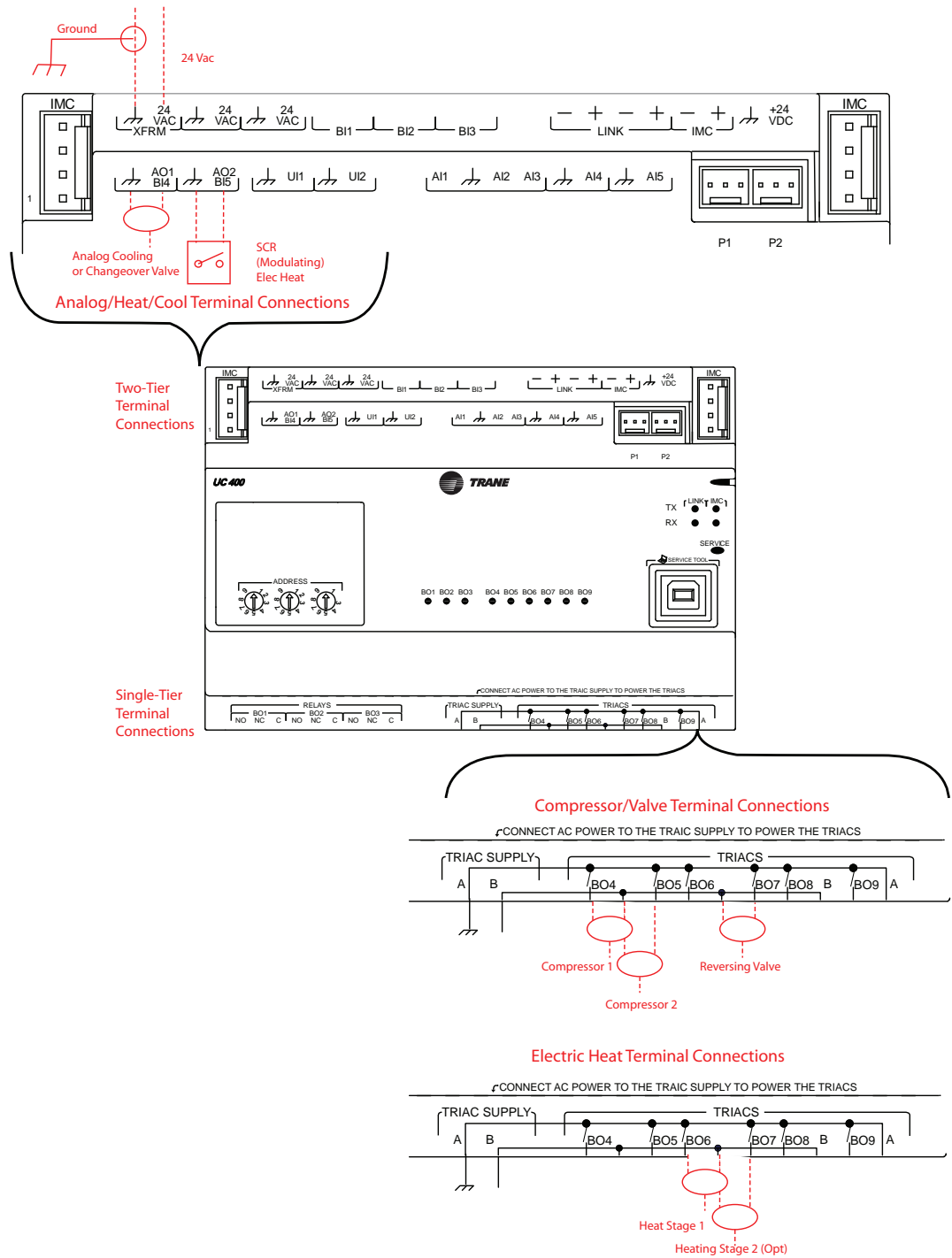

Figure 6. 2-Position Cooling/Heating w/Face and Bypass Damper

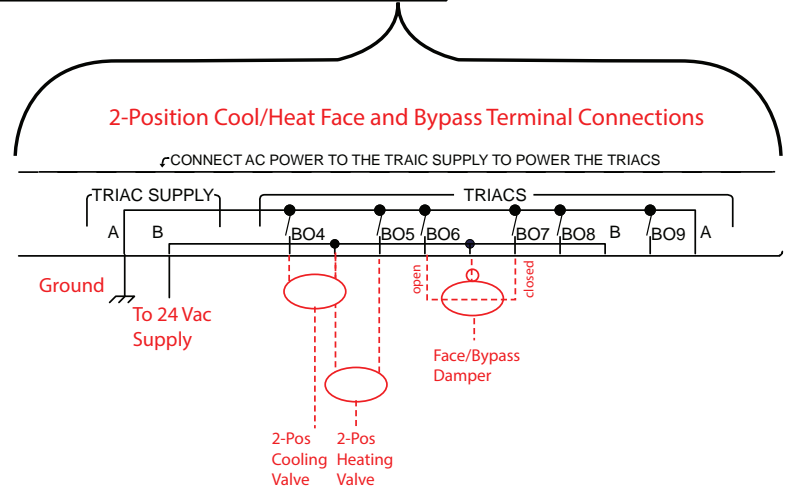
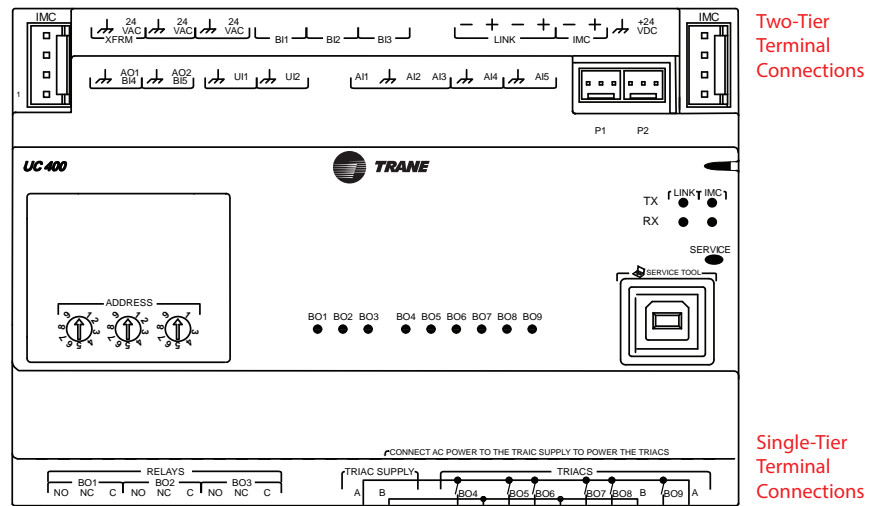
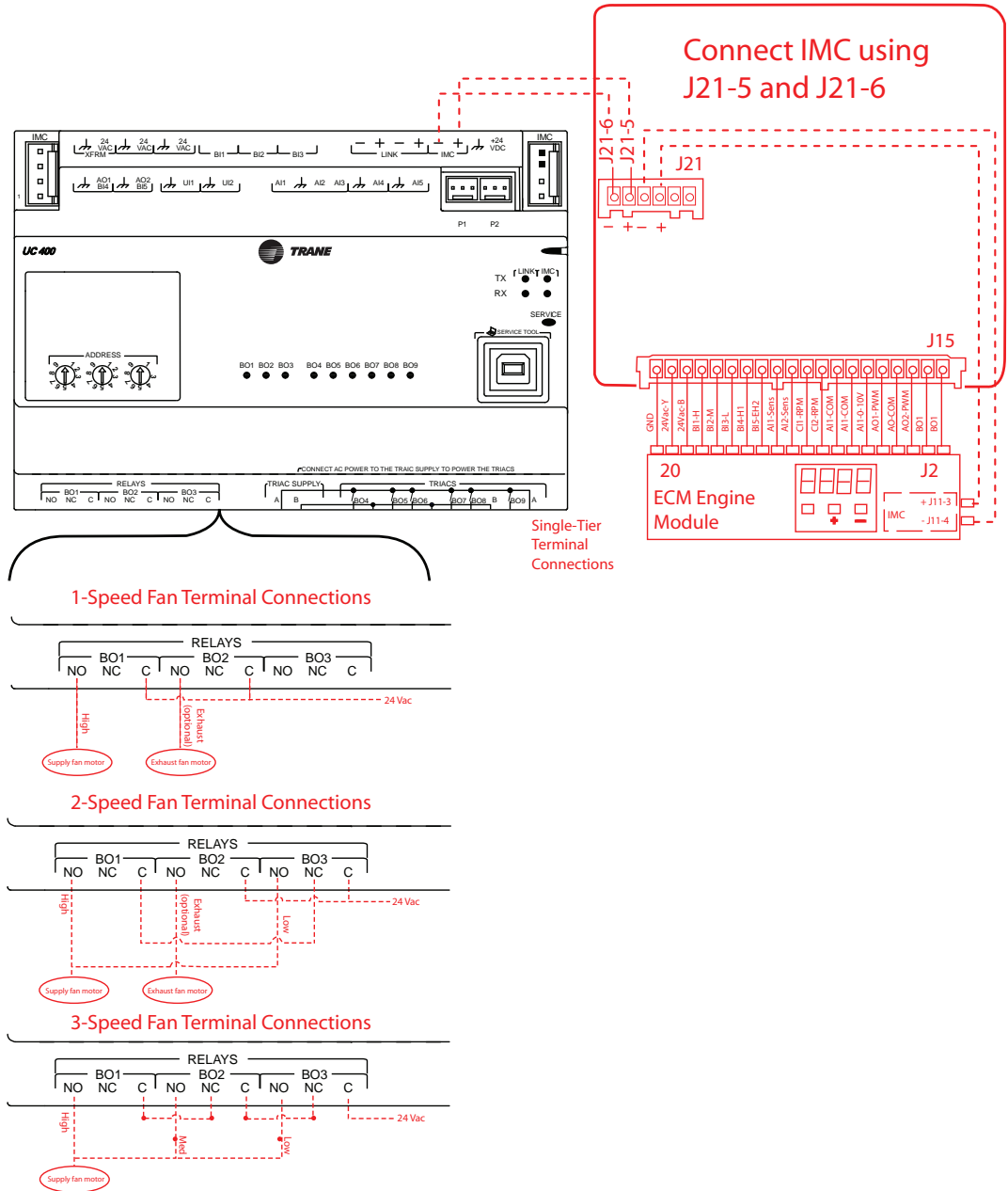

Figure 7. 1,2,3 Motor Speeds and ECM Var Speed Supply Fans (Opt Exh Fan)



UC400-B Wiring Diagrams

Figure 8. Common Input/Sensor Connections

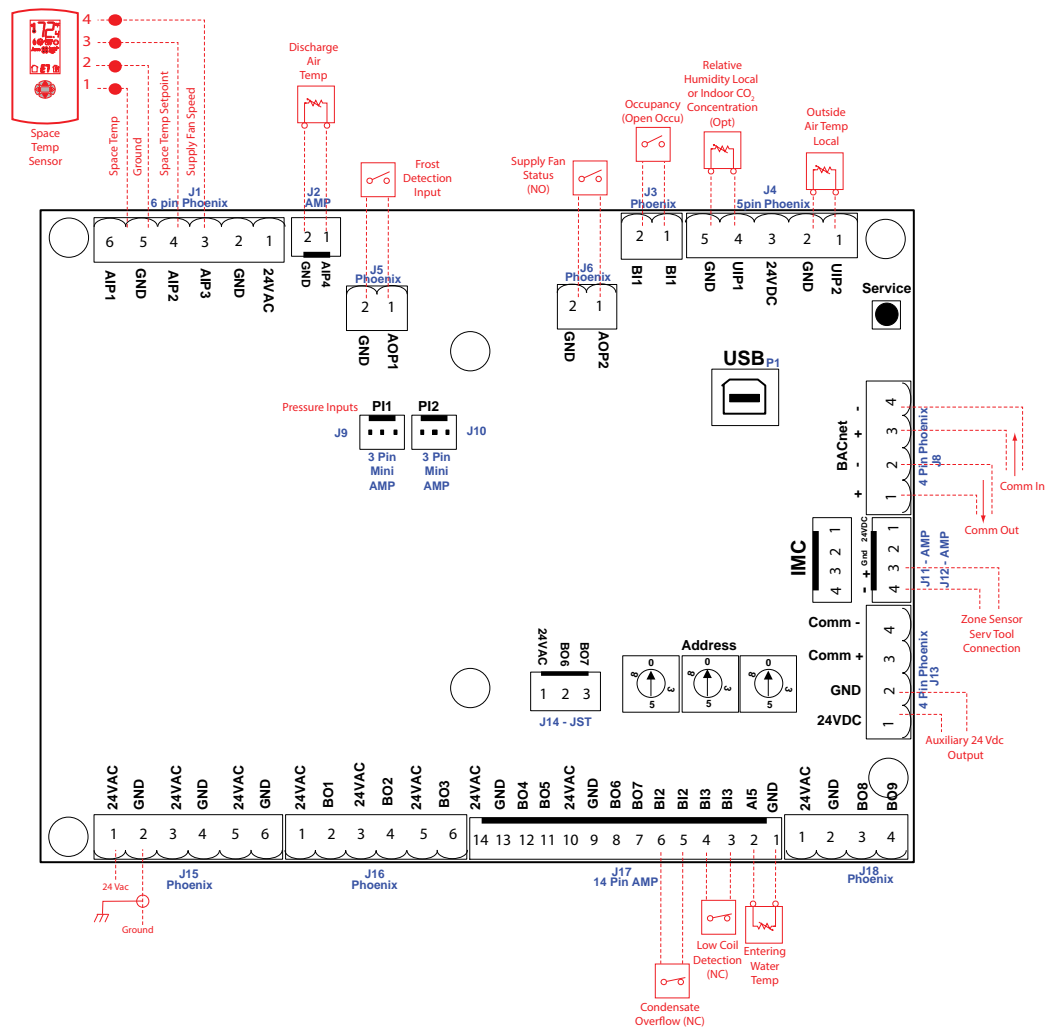
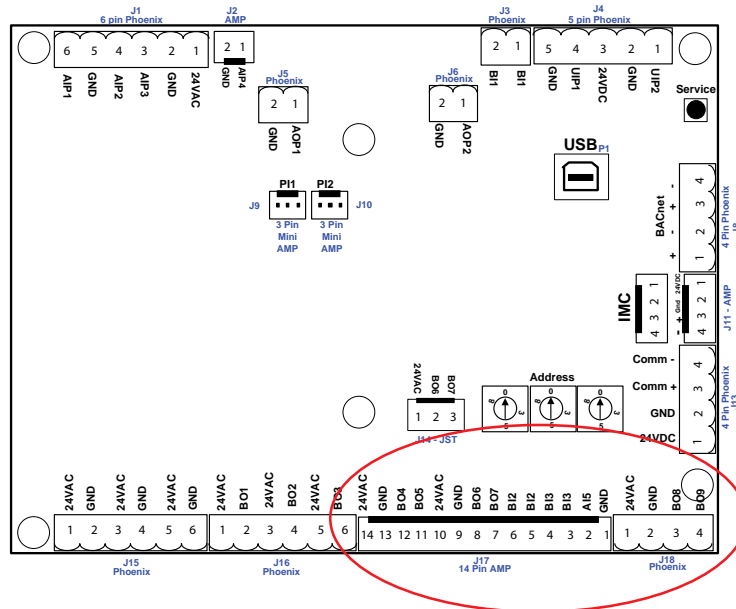
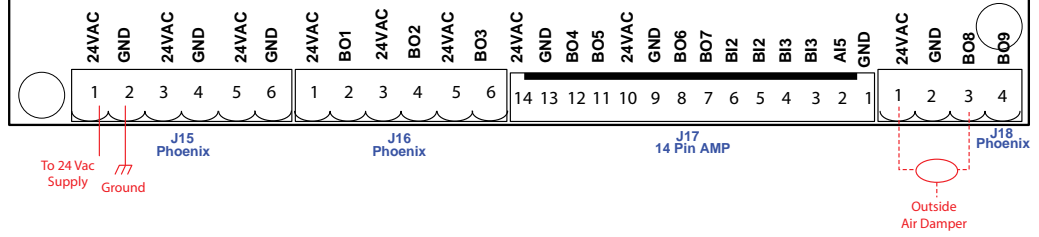

Figure 9. 2-Position Ventilation and Modulating



2-Position Ventilation Terminal Connections



Modulating Economizer Damper Terminal Connections

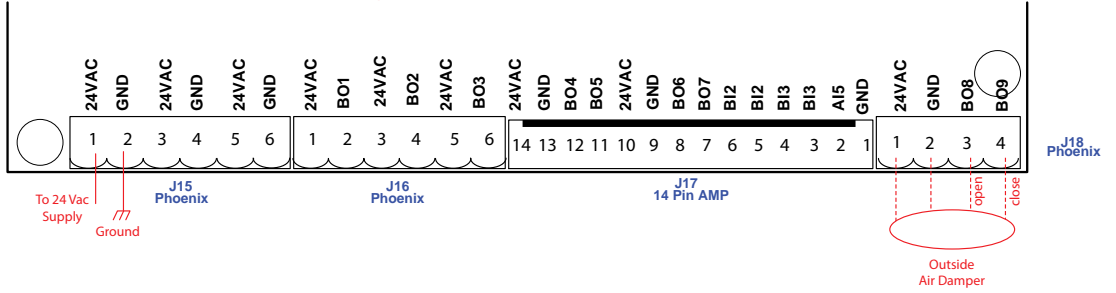

Figure 10. 2-Position and Modulating Valve

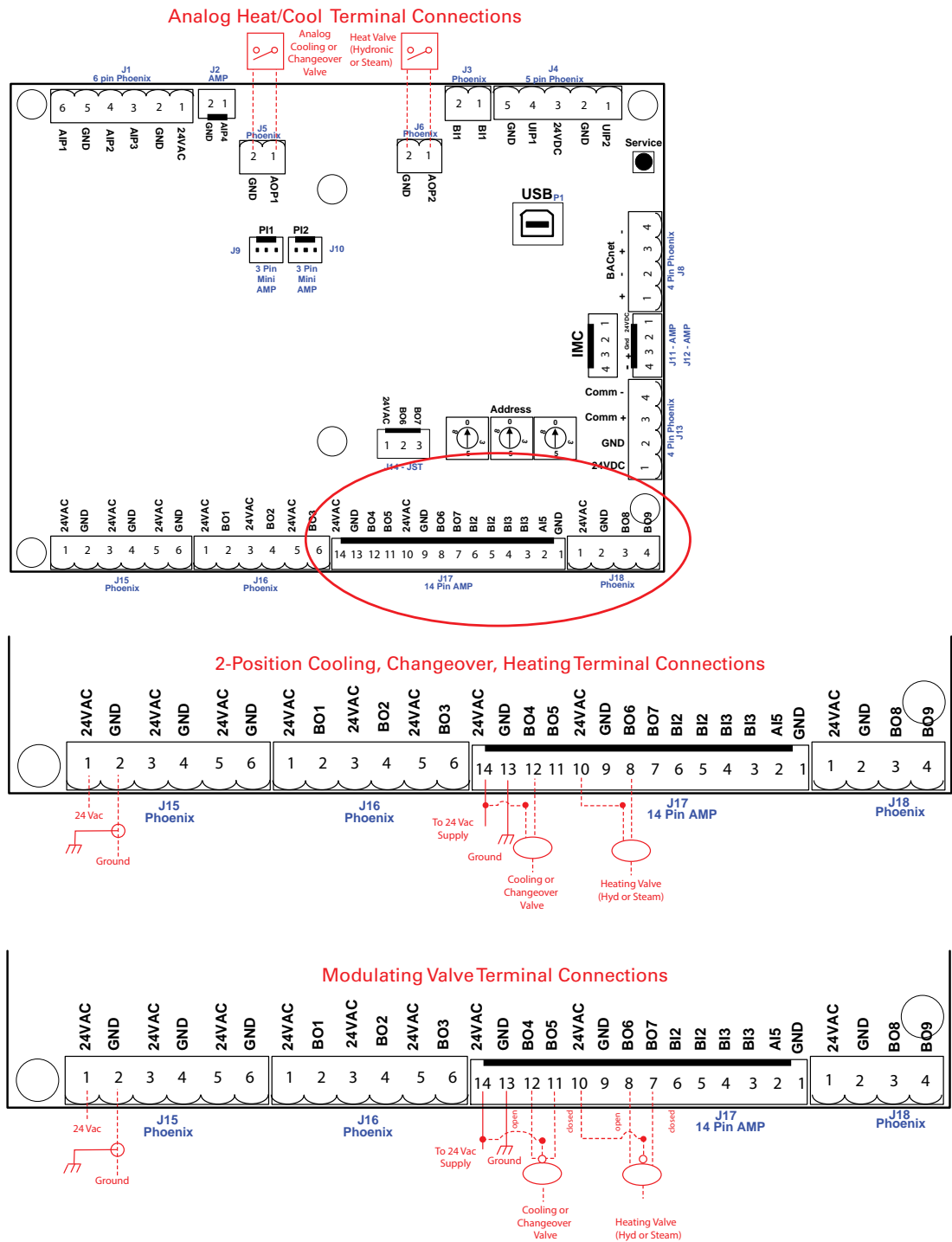

Figure 11. DX Heat Pump, Electric Heat, and SCR Electric Heat

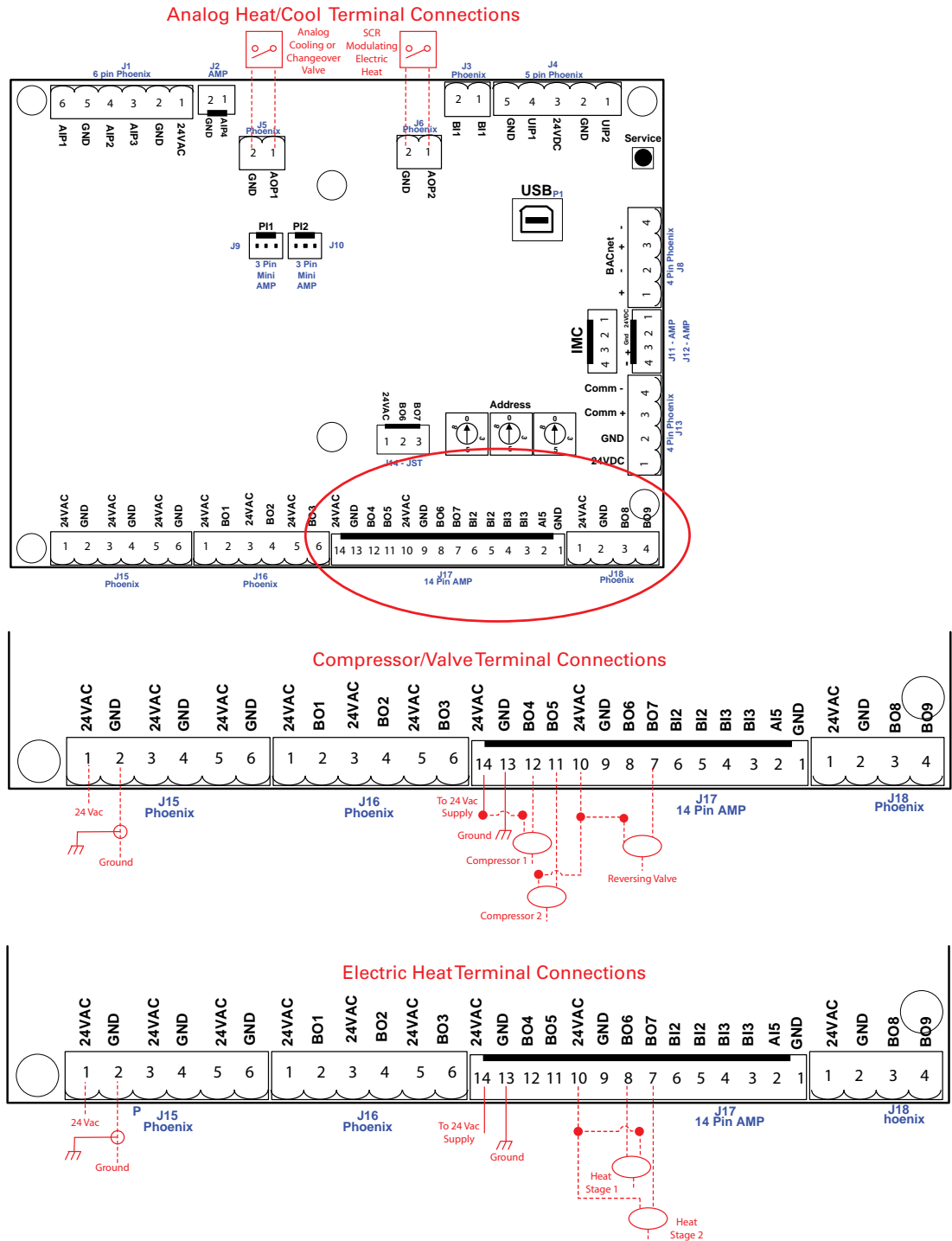
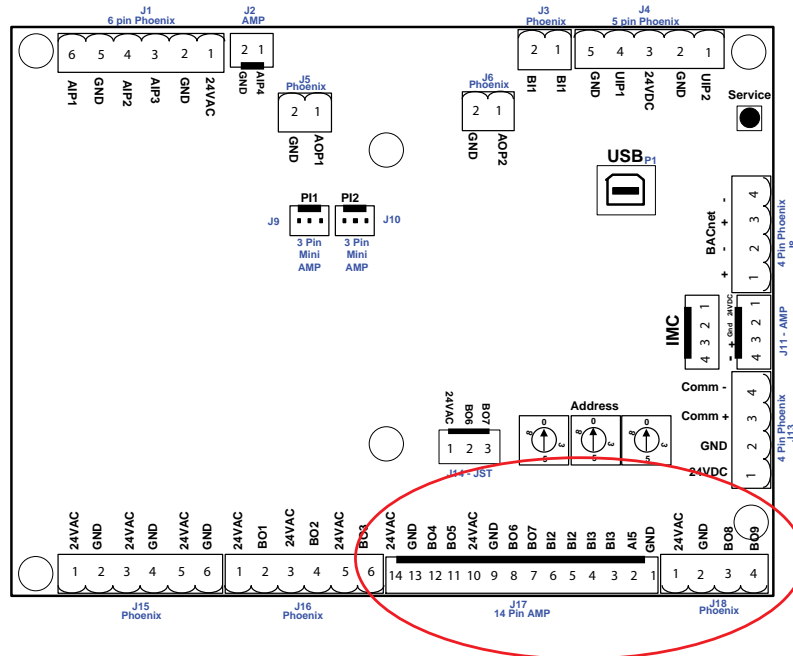

Figure 12. 2-Position Cooling/Heating w/Face and Bypass Damper



2-Position Cool/Heat Face and Bypass Terminal Connections

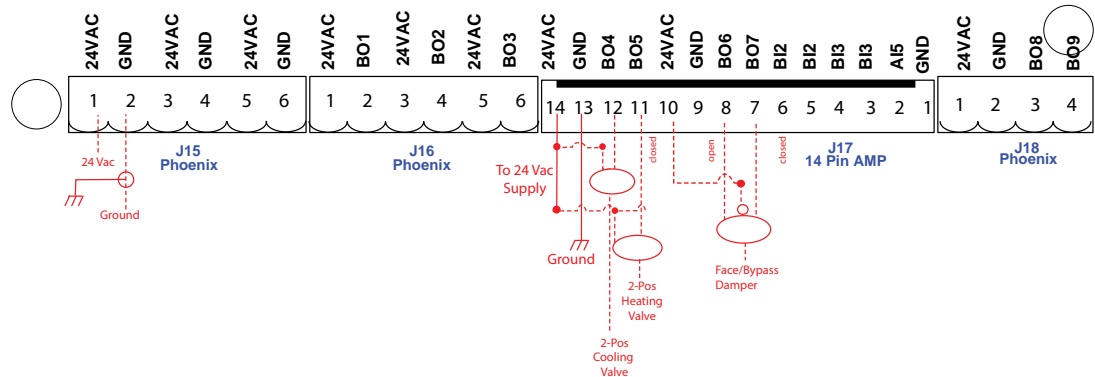
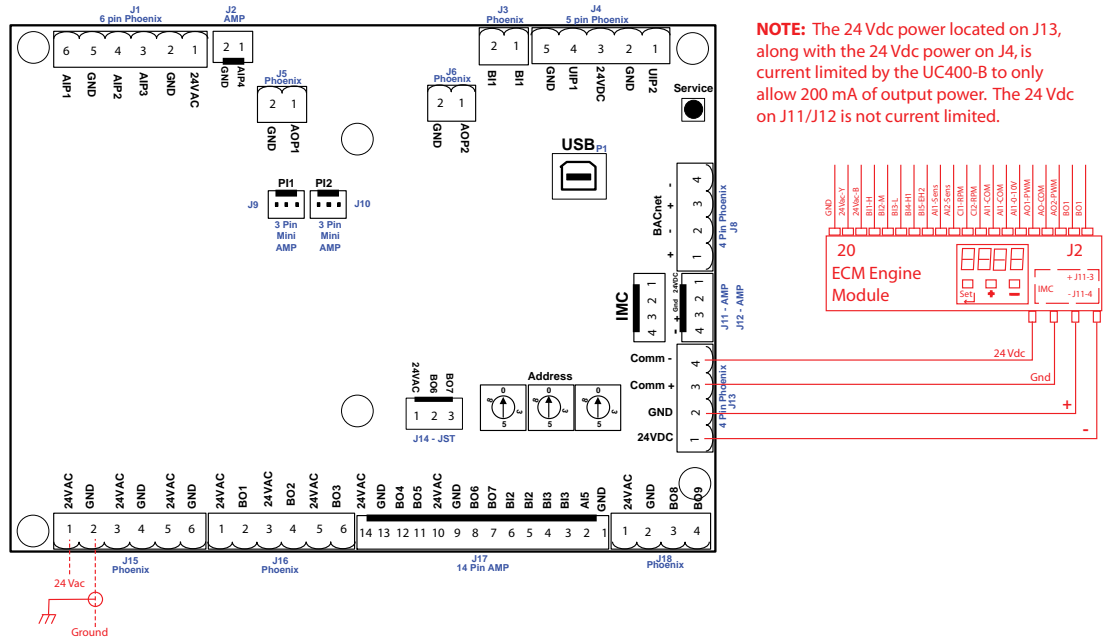

Figure 13. 1,2,3 Motor Speeds and ECM Var Speed Supply Fans (Opt Exh Fan)





Wiring Installation

The Tracer UC400 Controller can be installed on a BACnet MS/TP link, or with the Trane® Wireless Communication Interface (WCI), which enables wireless communication. All wiring must comply with the National Electrical Code (NEC™) and local electrical codes.

Connecting Wires to Terminals

1. Strip the wires to expose approximately a 0.28 inch of bare wire.
2. Insert the stripped wire end into the terminal connector.
3. Tighten the terminal screw 0.5 to 0.6 N-m (71 to 85 ozf-in or 4.4 to 5.3 lbf-in.).
4. Tug on the connected wires after tightening down the terminal screws to ensure all wires are secure.

BACnet MS/TP Link

The UC400 Controller rotary address dials serve one or two purposes (depending upon the network) in that they are always used for the MAC Address, which is sometimes all or part of the BACnet Device ID.

MAC Address

The MAC Address is required by the RS-485 communication protocol on which BACnet operates. A UC400 Controller can use a MAC Address from 001 to 120. Each device on the link must have a unique MAC Address/Device ID. The controller rotary addresses should be sequentially set, with no gaps in the numbering, starting with 001 on each link (for example 001, 002, 003, 004 and so on). A duplicate address or a 000 address setting interrupts communications and cause the Tracer SC device installation process to fail.

BACnet Device ID

The BACnet Device ID is required by the BACnet network. Each device must have a unique number from 001 to 4094302.

BACnet Networks, With or Without Tracer SC Controller

Without a Tracer SC Controller

On BACnet networks without a Tracer SC system controller, the Device ID can be assigned by two methods:

- It can be the same number as the MAC Address, determined by the rotary address dials on the UC400 Controller. For example, if the rotary address dials are set to 042, both the MAC Address and the BACnet Device ID are 042.
- It can be soft set by using the Tracer TU service tool. If the BACnet Device ID is set using the Tracer TU service tool, the rotary address dials will only affect the MAC Address and will not affect the BACnet Device ID.

With a Tracer SC Controller

On BACnet networks with a Tracer SC system controller, the Device ID for the UC400 Controller is always soft set by the system controller (refer to the following table).

Note: The BACnet Device ID is displayed as the Software Device ID on the Tracer TU Controller Settings page in the Protocol group.

Table 7. BACnet Device ID Calculations

Tracer SC Rotary Switch Value (21)	0	2	1				
Tracer SC BACnet MS/TP Link Number (1)				1			

Table 7. BACnet Device ID Calculations (continued)

Unit Controller MAC Address (38)					0	3	8
BACnet Device ID: 211038	0	2	1	1	0	3	8

BACnet MS/TP Link Wiring

The wire must be low-capacitance, 18-gauge, stranded, tinned-copper, shielded, twisted-pair. The illustration below shows an example of BACnet link wiring with multiple UC400 Controller controllers.

Figure 14. BACnet MS/TP Link Wiring for UC400 and UC400-B

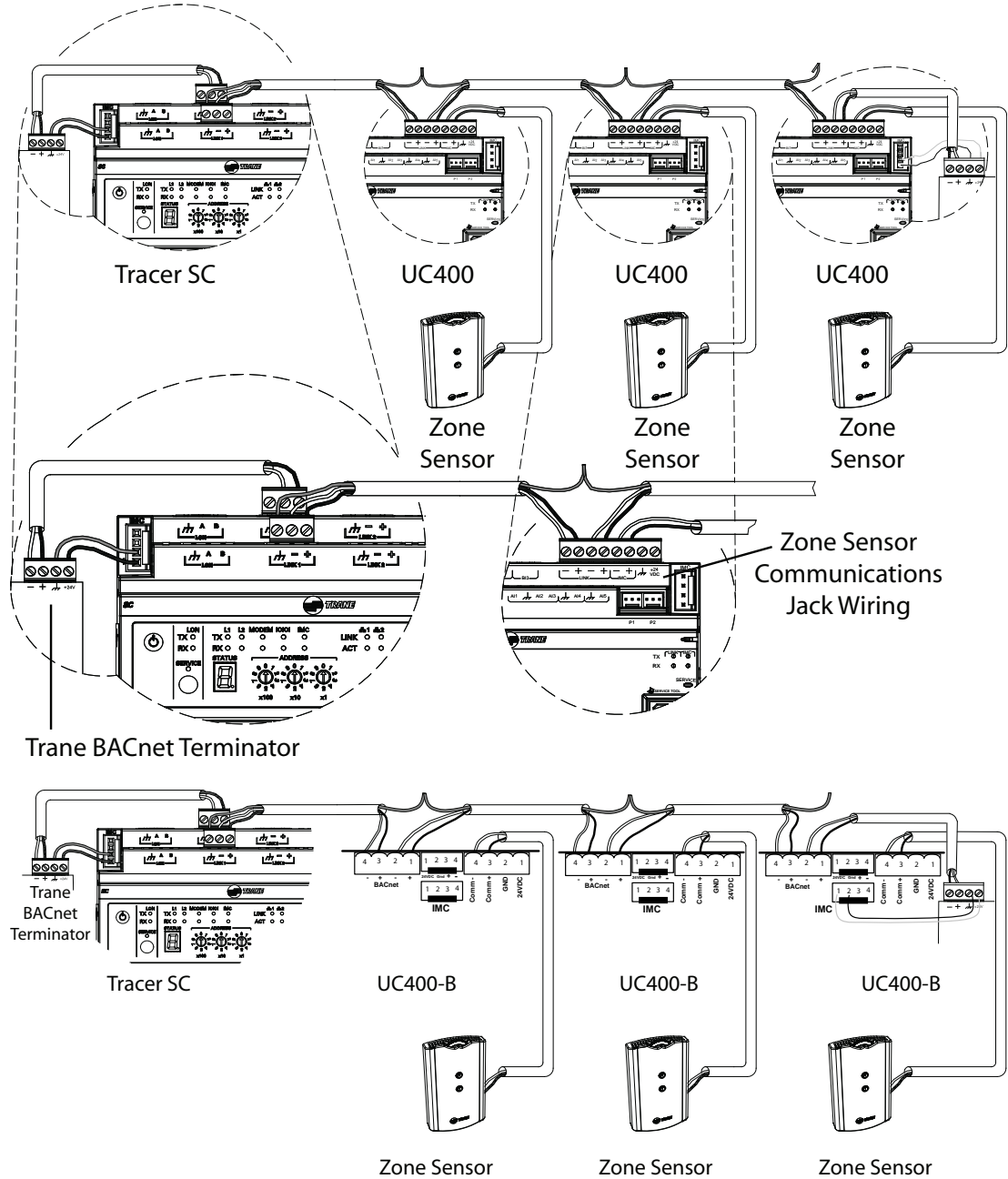

Power Supply

Read the following Warnings, Cautions, and Notices before proceeding.

⚠ WARNING

Hazardous Voltage!

Failure to disconnect power before servicing could result in death or serious injury. Disconnect all electric power, including remote disconnects before servicing. Follow proper lockout/tagout procedures to ensure the power can not be inadvertently energized. Verify that no power is present with a voltmeter.

NOTICE

Equipment Damage!

Sharing 24 Vac power between controllers could result in equipment damage.

Important: After installation, ensure that the 24 Vac transformer is grounded through the controller. Measure the voltage between chassis ground and any ground terminal on the UC400 Controller. Expected measurement :Vac £4.0 V

A separate transformer is recommended for each UC400 Controller. The line input to the transformer must be equipped with a circuit breaker sized to handle the maximum transformer line current. If a single transformer is shared by multiple UC400 Controllers:

- The transformer must have sufficient capacity.
- Polarity must be maintained for every controller powered by the transformer.

Important: If the polarity is inadvertently reversed between two controllers powered by the same transformer, a difference of 24 Vac occurs between the grounds of each controller, which can result in:

- Partial or full loss of communication on the entire BACnet MS/TP link.
- Improper function of the UC400 Controller outputs.
- Damage to the transformer or a blown transformer fuse.

Transformer Recommendations

A 24 Vac power supply must be used for proper operation of the binary inputs, which requires 24 Vac detection. In addition, the spare 24 Vac outputs can be used to power relays and TRIACS:

- AC transformer requirements:

Note: The transformer must be sized to provide adequate power to the controller (12 VA) and outputs (maximum 12 VA per binary output).

- UL listed, Class 2 power transformer.
 - 24 Vac \pm 15%, device max load 24 VA.
- CE-compliant installations: The transformer must be CE marked and SELV compliant per IEC standards.

Wiring Requirements

Install the power supply circuit in accordance with the following guidelines to ensure proper operation of the UC400 Controller:

- A dedicated power circuit disconnect switch must be near the controller, easily accessible by the operator, and marked as the disconnecting device for the controller.
- 18 AWG (0.823 mm²) copper wire is recommended for the circuit between the transformer and the controller.

Important: The controller must receive AC power from a dedicated power circuit. Failure to comply may cause the controller to malfunction. Do Not run AC power wires in the same wire bundle with input/output wires. Failure to comply may cause the controller to malfunction due to electrical noise.

Connecting 24 Vac Secondary Wires

1. Connect the 24 Vac secondary wires from the transformer to the 24 Vac and terminals on the UC400 Controller (refer to the illustration below). Perform one of the following methods to ensure the controller is adequately grounded:
 - a. Connect a grounding pigtail at some point along the secondary wire that runs between the controller terminal and the transformer.
 - b. Ground one of the terminals on the controller to the enclosure (if the enclosure is adequately grounded) or to an alternate earth ground.
2. Connect the 24 Vac secondary wires from the transformer to the 24 Vac and ground terminals on the controller as shown below.

Figure 15. Connecting 24 Vac Secondary Wires for UC400 and UC400-B

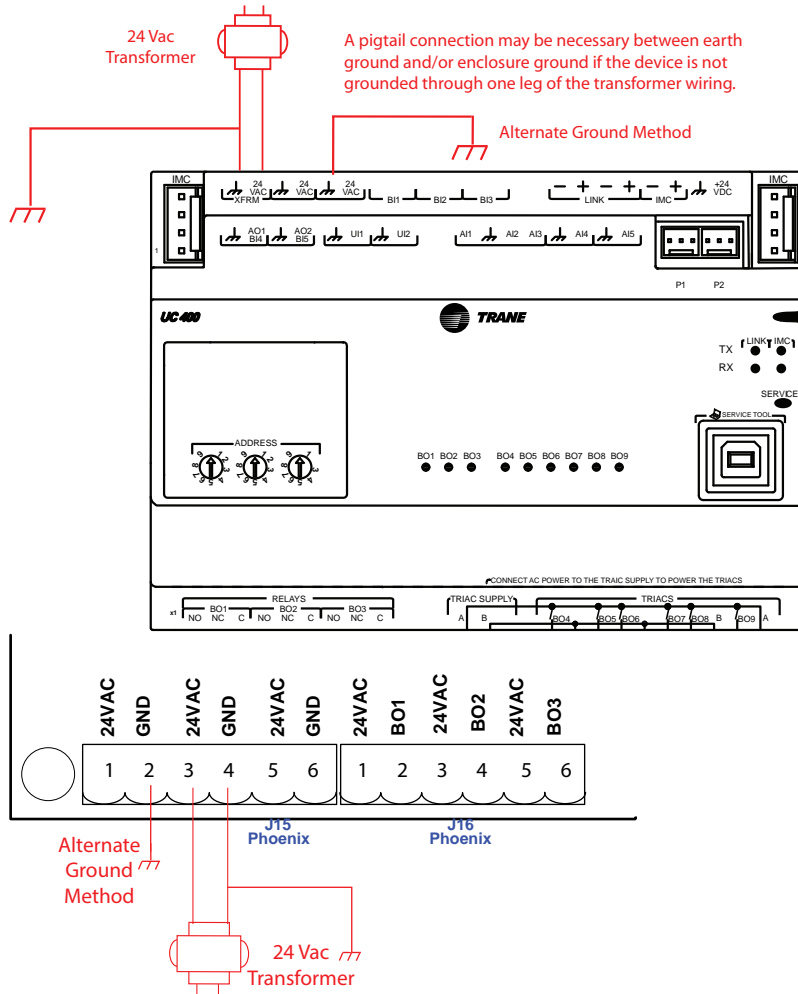

3. Ground the unit using one of the following methods:

Note: The UC400-B is grounded through mounting screws so external grounded is not required.

- a. Connect a grounding pigtail at some point along the secondary wire that runs between

the controller ground terminal and the transformer.

- b. If the enclosure is adequately grounded, then ground one of the ground terminals on the controller to the enclosure or to an alternate earth ground.

Power On Check

1. Verify that the 24 Vac connector and the chassis ground are properly wired.
2. Remove the lockout/tagout from the line voltage power to the electrical cabinet.
3. Energize the transformer to apply power to the UC400 Controller.
4. Observe the controller when power is applied to verify the power check sequence performs as follows:
 - a. The power LED is lit red for one (1) second.
 - b. The power LED is lit green if:
 - The sequencing above is completed as described and the controller is properly booted and ready to receive the application code.
 - The power LED flashes red indicating a fault condition exists.

LED Description, Activities, and Troubleshooting

LEDs are used to provide controller serviceability. The UC400/UC400-B has the following LEDs located on the front. Refer to the legend in the second image in the figure below for LED placements.

- Marquee LED.
- Communication status LEDs and IMC status LEDs.
- Service button LED.
- Three (3) binary output relay and nine (9) TRIAC status LEDs.

Figure 16. LEDs for UC400 and UC400-B

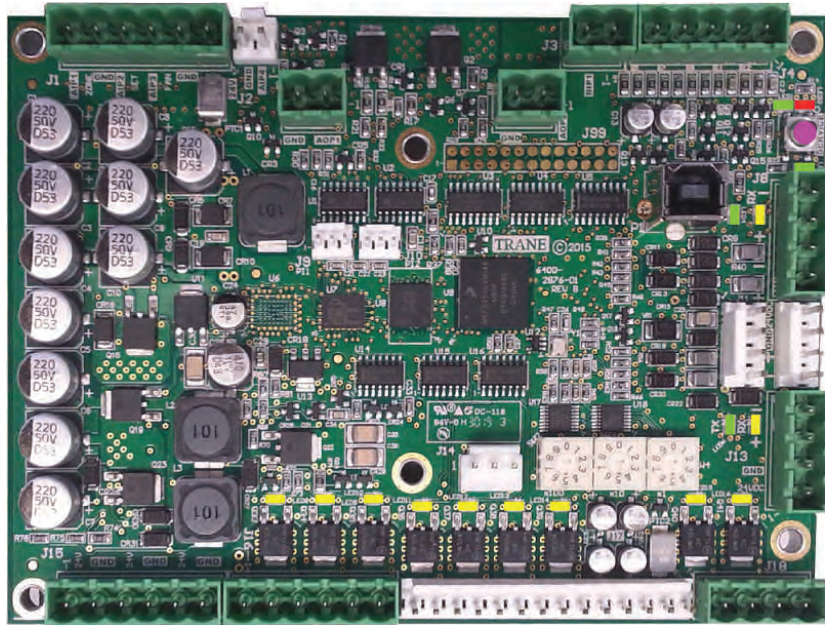
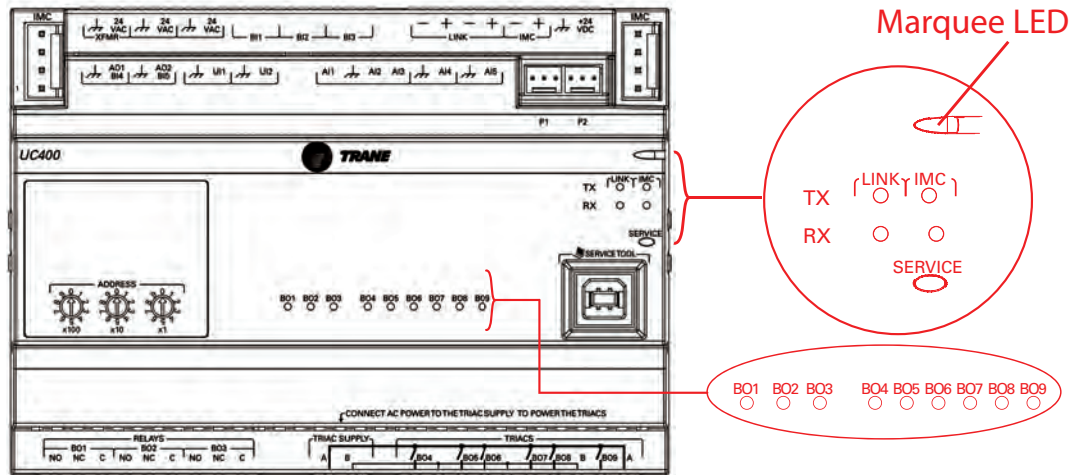

LEGEND

From the top right-hand side down:

- LED1 Green Status LED
- LED2 Red Status LED
- Service Button Magenta
- LED3 Green Service LED
- LED4 Green BACnet TX
- LED5 Yellow BACnet RX
- LED6 Green IMC TX
- LED7 Yellow IMC RX

From the bottom, left to right:

- LED8 Yellow BOP1
- LED9 Yellow BOP2
- LED10 Yellow BOP3
- LED11 Yellow BOP4
- LED12 Yellow BOP5
- LED13 Yellow BOP6
- LED14 Yellow BOP7
- LED15 Yellow BOP8
- LED16 Yellow BOP9

There are 15 LEDs on the front of the UC400 controller. The following table provides a description of LED activities, an indication or troubleshooting tip for each, and any relative notes.

LED Description, Activities, and Troubleshooting

Table 8. UC400 LEDs

LED Description	Activities	Indication and Troubleshooting Tips	Notes
Marquee LED	Shows solid green when the unit is powered and no alarm exists.	Indicates normal operation.	When powering the UC400 and expansion module, the Marquee LED will blink RED, blink GREEN (indicating activated and the controller/ expansion module are communicating), and then stay Green Continuously (indicating normal power operation).
	Shows blinking green during a device reset or firmware download.	Indicates normal operation.	
	Shows solid red when the unit is powered, but represents low power or a malfunction.	If low power; could be under voltage or the microprocessor has malfunction. If malfunction; un-power and then re-power unit to bring the unit back up to normal operation.	
	Shows blinking red when an alarm or fault exists	An alarm or fault condition will occur if the value for a given point is invalid or outside the configured limits for the point. Alarm and fault conditions vary, and they can be configured by the programmer.	
	LED not lit	Indicates power is OFF or there is a malfunction. OFF or malfunction; cycle the power.	
Link and IMC	TX blinks green.	Blinks at the data transfer rate when the unit transfers data to other devices on the link.	TX LED: Regardless of connectivity or not, this LED will constantly blink as it continually looks for devices to communicate to. LED not lit: Determine if, for example, a Tracer SC or BACnet device is trying to talk to the controller or if it is capable of talking to the controller. Also determine if the communication status shows down all of the time. In addition, check polarity and baud rate.
	RX blinks yellow.	Blinks at the data transfer rate when the unit transfers data to other devices on the link. ON solid yellow; indicates there is reverse polarity.	
	LED not lit.	Indicates that the controller is not detecting communication. Not lit; cycle the power to reestablish communication.	
Service	Shows solid green when the LED has been pressed.	Indicates controller is operating normally.	When the UC400 is placed into boot mode, the system will not run any applications such as trending, scheduling, and TGP2 runtime. The controller is placed into boot mode if the service pin is held in when power is applied. In boot mode, the controller is non-operational and is waiting for a new main application to be downloaded.
	LED not lit.		



LED Description, Activities, and Troubleshooting

Table 8. UC400 LEDs (continued)

LED Description	Activities	Indication and Troubleshooting Tips	Notes
Binary B01 through B09	Shows solid yellow.	<p>Indicates a corresponding binary output has been commanded ON.</p> <p>Relay coil; indicates that a command has been made to energize.</p> <p>TRIAC; indicates that a command has been made to turn ON.</p>	<p>If the user is currently powering the UC400 from a USB port, the Led lights will turn ON. However, the binary outputs will not be activated.</p> <p>Commanded ON; As an example of commanded ON, a command could be a manual command such as an override or a command could be from TGP2 based on a list of conditions that are met telling these outputs to turn ON.</p>
	LED not lit.	<p>Indicates that a relay output is de-energized or no power to the board.</p> <p>Not lit; cycle power to reestablish communication.</p>	LED not lit; Did the user command it to be ON? If yes, see the Marquee LED at the top of this table.



Sequence of Operation

The UC400 Controller operates to maintain the space temperature setpoint.

Power-up Sequence

1. The following sequence occurs when 24 Vac power is initially applied to the UC400 Controller:
 - The Power Marquee LED turns on as red, then
 - Flashes green, and then
 - Stays lit as constant green.
2. All outputs are controlled OFF and all modulating valves and dampers close.
3. The controller reads all input local values to determine initial values.
4. The random start timer begins.
5. The random start timer expires.
6. Normal operation begins, assuming there are no generated diagnostics. If any points are in fault or alarm mode, the Power Marquee LED flashes red.

Important: *Flashing red does not indicate that the UC400 Controller fails to operate. Instead, the point(s) that are in fault or alarm mode should be checked to determine if the status of the point(s) is acceptable to allow equipment operation.*

Random Start

Random start prevents all units in a building from energizing at the same time. The random start timer delays the fan and any heating or cooling startup from 5 to 30 seconds.

Occupancy Modes

Occupancy modes can be controlled by the following methods:

- The state of the local (hard wired) occupancy binary input BI1.
- A timed override request from a Trane zone sensor.
- A communicated signal from either a Tracer SC or BAS.

A communicated request, from either a Tracer SC or BAS, takes precedence over local requests. If a communicated occupancy request has been established, and is no longer present, the UC400 Controller reverts to the default (occupied) occupancy mode after 15 minutes (if no hard wired occupancy request exists). The controller has the following occupancy modes:

- Occupied
- Unoccupied
- Occupied Standby
- Occupied Bypass

Occupied Mode

In Occupied Mode, the UC400 Controller maintains the space temperature based on the occupied space temperature setpoint \pm occupied offset. When occupied, the fan can be configured to operate continuously (default) or cycle ON/OFF with demand, based on BV/1 (Supply Fan Configuration Command). The controller uses the occupied mode as a default mode when other forms of occupancy requests are not present. The outdoor air damper, if present, closes when the fan is OFF. The temperature setpoints can be local (hard wired), communicated, or stored default values (configured using the Tracer TU service tool).



Unoccupied Mode

In unoccupied mode, the UC400 Controller attempts to maintain the space temperature based on the unoccupied heating or cooling setpoint. The fan cycles between HIGH speed and OFF. In addition, the outdoor air damper remains closed, unless economizing. The controller always uses the stored default setpoint values (configured using the Tracer TU service tool), regardless of the presence of a hard wired or communicated setpoint value.

Occupied Standby Mode

The UC400 Controller is placed in occupied standby mode only when a communicated occupied request is combined with an unoccupied request from occupancy binary input BI1. In occupied standby mode, the controller maintains the space temperature based on the occupied standby heating or cooling setpoints. Because the occupied standby setpoints have a typical temperature spread of 2°F (1.1°C) in either direction, and the outdoor air damper is closed, the occupied standby mode reduces the demand for heating, and cooling the space. The fan continuously runs as configured for occupied mode. The controller always uses the stored default setpoint values (configured using the Tracer TU service tool), regardless of hard wired or communicated setpoint values. In addition, the outdoor air damper uses the economizer occupied standby minimum position setpoint to reduce the ventilation rate.

Occupied Bypass Mode

The UC400 Controller is placed in occupied bypass mode when:

- The controller is operating in the unoccupied mode.
- Either the timed override ON button on the Trane zone sensor is pressed or the controller receives a communicated occupied bypass signal from a BAS.

In occupied bypass mode, the controller maintains the space temperature based on the occupied heating or cooling setpoints. The fan runs as configured (continuous or cycling). The outdoor air damper closes when the fan is OFF. The controller remains in occupied bypass mode until either the CANCEL button is pressed on the Trane zone sensor or the occupied bypass time expires (configured using the Tracer TU service tool). The temperature setpoints can be configured as local (hard wired), communicated, or stored default values using the Tracer TU service tool.

Timed Override Control

If the UC400 Controller has a timed override option (ON/CANCEL buttons), pushing the ON button initiates a timed override on request. A timed override upon request changes the occupancy mode from unoccupied mode to occupied bypass mode. In occupied bypass mode, the controller controls the space temperature based on the occupied heating or cooling setpoints. The occupied bypass time, which defines the duration of the override and resides in the controller, is configured from 0 to 240 minutes (default value of 120 minutes). When the occupied bypass time expires, the controller transitions from occupied bypass mode to unoccupied mode.

Pushing the CANCEL button cancels the timed override request. In addition, it ends the timed override before the occupied bypass time has expired and transitions the unit from occupied bypass mode to unoccupied mode. If the controller is in any mode other than unoccupied mode when the ON button is pressed, it still starts the occupied bypass timer without changing to occupied bypass mode. If the controller is placed in unoccupied mode before the occupied bypass timer expires, it is placed into occupied bypass mode and remains in this mode until either the CANCEL button is pressed on the Trane zone sensor or the occupied bypass time expires.

Zone Temperature Control

The UC400 Controller has the following four (4) methods of zone temperature control:

- **Single Zone VAV Control:** varies the speed of the ECM fan motor as the zone cooling or heating load changes. When the zone is at design cooling load, the UCU400 Controller operates the fan at maximum speed and cooling capacity modulates or cycles to deliver the air at the design discharge air temperature (DAT) setpoint for cooling. As the zone cooling

load decreases, the fan speed is reduced to maintain zone temperature at cooling setpoint, while cooling capacity (and/or economizer) modulates or cycles to maintain DAT at the same design setpoint as show below.

Figure 17. Single Zone VAV Control

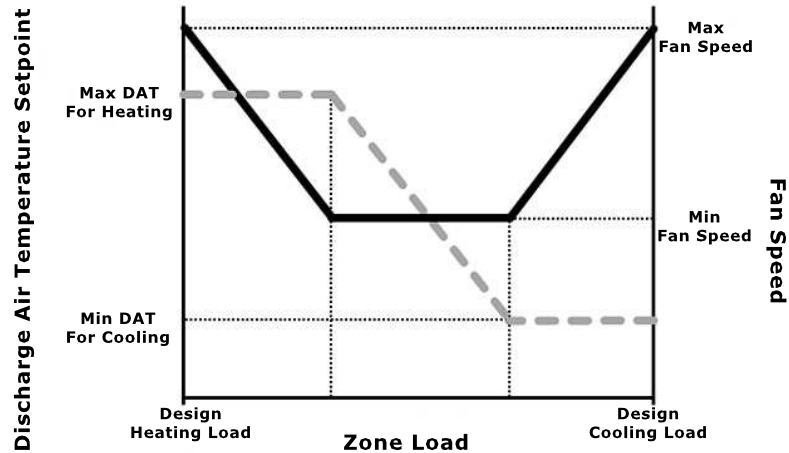

When the fan reaches minimum speed and the zone cooling load continues to decrease, the fan continues to operate at minimum speed while the DAT setpoint begins to reset upward to maintain zone temperature at cooling setpoint. Cooling capacity (and/or economizer) modulates or cycles to maintain this DAT setpoint. When the zone temperature drops to heating setpoint, the fan continues to operate at minimum speed and the DAT setpoint resets further upward. Heating capacity modulates or stages to maintain this DAT setpoint. If the zone heating load increases to where the DAT reaches the maximum limit, the fan speed again, increases while heating capacity modulates or stages to maintain DAT at this maximum limit.

- Cascade Zone Control:** used in the occupied, occupied bypass, and occupied standby modes. It maintains zone temperature by controlling the discharge air temperature to control the zone temperature while minimizing the fan speed. The UC400 Controller uses the difference between the measured zone temperature and the active zone temperature setpoint to produce a discharge air temperature setpoint. In addition, it compares the discharge air temperature setpoint with the discharge air temperature and calculates a unit heating/cooling capacity accordingly (refer to the illustration below). The end devices (outdoor air damper, valves, and so on) operate in sequence based on the unit heating/cooling capacity (0–100%).

If the discharge air temperature falls below the discharge air temperature low limit setpoint, (configured using the Tracer TU service tool), and the cooling capacity is at a minimum, the available heating capacity is used to raise the discharge air temperature to the low limit (refer to the following section, Discharge Air Tempering.).

Figure 18. Discharge Air Comparison

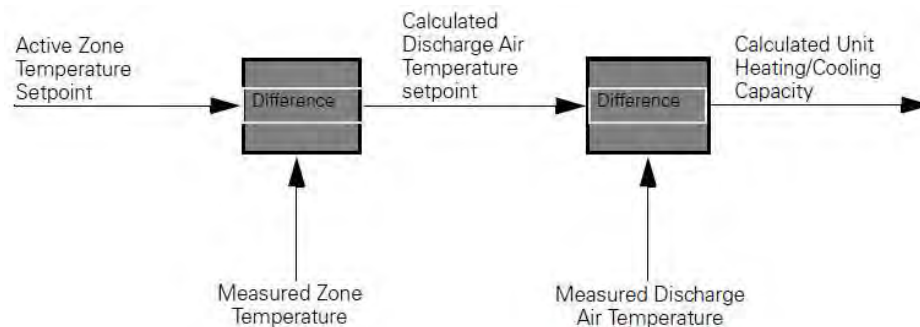



- **Simplified Zone Control:** if discharge air temperature failure occurs, then the UC400 Controller switches to simplified zone control algorithm, whereby, the space is controlled to the unoccupied setpoints by means of the valve modulation and a cycling fan. This is similar to the unoccupied operating mode. In the unoccupied mode, the controller maintains the zone temperature by calculating the required heating or cooling capacity (0–100%) according to the measured zone temperature and the active zone temperature setpoint.
- **Discharge Air Temperature Control:** is the backup mode that runs only if there is not valid zone temperature. In this mode, the active space temperature setpoint is used as the discharge air temperature setpoint.

Note: This is not a normal operating mode. The source of the invalid zone temperature needs to be corrected to restore normal operation.

Discharge Air Tempering

If the UC400 Controller is in cooling mode, cascade zone control initiates a discharge air tempering function when:

- The discharge air temperature falls below the discharge air temperature low limit setpoint (configured using the Tracer TU service tool).
- All cooling capacity is at a minimum. The discharge air tempering function allows the UC400 Controller to provide heating capacity (if available) to raise the discharge air temperature to the discharge air temperature low limit setpoint.
- The cold outdoor air is brought in through the outdoor air damper and when the damper is at (HIGH) minimum position. This causes the discharge air temperature to fall below the discharge air temperature low limit setpoint.

Heating or Cooling Mode

The heating or cooling mode can be determined by the following methods:

- By a communicated signal from a BAS or a peer controller.
- Automatically, as determined by the UC400 Controller.

A communicated heating signal permits the UC400 Controller to only heat and a communicated cooling signal permits the unit to only cool. A communicated auto signal allows the controller to automatically change from heating to cooling and conversely. In heating or cooling mode, the controller maintains the zone temperature based on the active heating setpoint and the active cooling setpoint, respectively. The active heating and cooling setpoints are determined by the occupancy mode of the controller.

For 2-pipe and 4-pipe changeover units, normal heat/cool operation does not begin until the ability to conduct the desired heating or cooling operation is verified. This is achieved using the entering water temperature sampling function that requires a valid entering water temperature is required. When neither a hard wired nor a communicated entering water temperature value is present on changeover units, the controller operates in only heating mode and assumes the coil water is hot. The sampling function is not used. The entering water temperature sampling function is used only for changeover applications and for information and troubleshooting. It does not affect the operation of the controller.

Auto-Changeover Entering Water Temperature Sampling Function

The auto-changeover entering water temperature sampling function is used with 2-pipe and 4-pipe changeover units (including those with face and bypass dampers) and requires a valid entering water temperature value. If the entering water temperature value is less than 5°F (2.8°C) above a valid zone temperature value for hydronic heating, and greater than 5°F (2.8°C) below a valid zone temperature value for hydronic cooling, the sampling function is enabled. When the sampling function is enabled, the UC400 Controller opens the main hydronic valve to allow the water temperature to stabilize. After three (3) minutes, the controller again compares the entering water temperature value to the zone temperature value to determine if the desired heating or cooling function can be accomplished. If the entering water temperature value remains out of range to accomplish the desired heating/cooling function, the controller closes the

main hydronic valve and waits 60 minutes to attempt another sampling. If the entering water temperature value falls within the required range, it resumes normal heating/cooling operation and disables the sampling function.

Fan Operation

The UC400 Controller supports 1-, 2-, 3-speed fans and variable-speed fans. The fan continuously operates while either heating or cooling during occupied, occupied standby, and occupied bypass operation. During unoccupied operation, the fan cycles between OFF and HIGH, regardless of the fan configuration. When running in AUTO mode, the fan operates differently based on the mode and the type of fan. For 1-, 2-, and 3-speed fans, each time the fan is enabled, the fan begins operation and runs on high speed for a period of time (0.5 seconds for fan coils and 3 seconds for unit ventilators and blower coils) before changing to another speed. Initially running on high speed provides adequate torque to start the fan motor from the OFF position.

Note: *In occupied mode, the UC400 Controller requires continuous fan operation because of cascade zone control. In unoccupied mode, the fan cycles.*

Manual Fan Speed Control

Regardless of the fan type, the fan continuously runs at the desired fan speed during occupied, occupied standby, and occupied bypass operation as follows:

- When the UC400 Controller receives a communicated fan speed signal (HIGH, MEDIUM, LOW).
- The associated fan speed switch is set to a specific fan speed.
- The Supply Fan Speed Request point is overridden.

During unoccupied operation, the fan cycles between OFF and HIGH, regardless of the communicated fan speed signal or fan speed switch setting (unless either of these is OFF, which in turn, will control the fan OFF). The fan turns OFF when:

- The UC400 Controller receives a communicated OFF signal.
- The fan speed switch is set to OFF.
- Specific diagnostics are generated.
- The default fan speed is set to OFF and the fan is operating in the AUTO mode.

Note: *The supply fan speed source can be configured for BAS, local, or default value control using the Tracer TU service tool.*

Auto Fan Operation; 1-, 2-, 3-Speed

When the UC400 Controller receives a communicated auto signal (or the associated fan speed switch is set to AUTO with no communicated value present), the fan operates in the AUTO mode. In AUTO mode, the fan operates according to the fan default (configured using the Tracer TU service tool). The fan speed has multiple speed configurations (default is AUTO) or set to OFF for both heating and cooling operation. When configured as AUTO (and with multiple speeds available), the fan changes based on the required capacity calculated by the controller algorithm.

Single Zone VAV

The UC400 Controller varies the speed of the fan motor as the zone cooling or heating load changes as shown below. At high cooling loads, the fan speed modulates to maintain the zone temperature at cooling setpoint, while the cooling capacity modulates or cycles to maintain the discharge air temperature (DAT) at minimum limit setpoint. At lower cooling loads, once the fan has turned down to minimum speed, it remains at minimum speed while cooling capacity modulates or cycles to maintain the zone temperature at cooling setpoint.

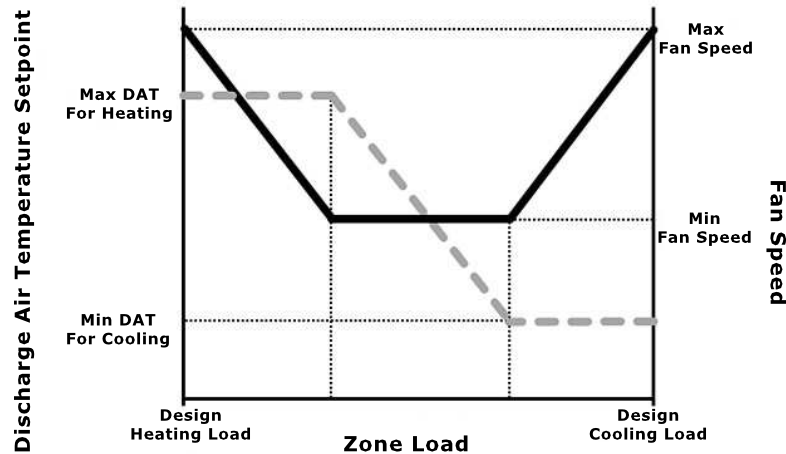
Figure 19. Cooling/Heating Load Changes

At high heating loads, the fan speed modulates to maintain the zone temperature at heating setpoint, while the heating capacity modulates or stages to maintain the DAT at the maximum limit. At lower heating loads, the fan operates at minimum speed, while heating capacity modulates or stages to maintain the zone temperature at heating setpoint.

- **ECM Energy Efficiency Mode:** when the UC400 Controller is configured for Energy Efficient Mode by means of the Fan Operating Mode Request MV point, the controller and daughter board minimizes energy use by running the fan at the lowest possible speed while maintaining space temperature. The controller fully utilizes valves, economizer, or electric heat which increases fan speed to meet space temperature (unless the fan has been manually controlled).
- **ECM Acoustical Mode:** when the UC400 Controller is configured for Acoustical Mode by means of the Fan Operating Mode Request MV point, the controller and daughter board minimizes acoustical nuisance by balancing changes in fan speed and total fan noise. The controller fully opens the cooling and heating valves before increasing fan speed to meet space temperature unless the fan has been manually controlled. If multiple stages of electric heat exist, the controller uses a single minimum air flow for each stage.

Exhaust Control

Exhaust control is achieved by a single-speed exhaust fan and controlled by binary output 2 (BO2). Exhaust control, if not present, can be enabled by selecting **Yes** under the Exhaust Fan Selection on the Tracer TU Configuration page under the Equipment Options group.

Note: Exhaust fan configuration cannot be selected with 3-speed fan operation.

Important: If exhaust control is added to an existing configuration, all other configuration options should be verified to match the correct equipment options. Temperature and flow setpoints revert to default values.

The exhaust function is coordinated with the supply fan and outdoor/return air dampers as follows:

- The exhaust fan energizes when the fan is running and when the outdoor air damper position is greater than or equal (\geq) to the exhaust fan enable position (or the outside air damper position at which the exhaust fan turns ON)..
- The exhaust fan turns OFF when the fan either turns OFF or the outdoor air damper closes to 10% below the exhaust fan enable position.
- If the exhaust fan/damper enable setpoint is less than 10%, the exhaust output is energized if the outdoor air damper position is at the setpoint and de-energized at 0.

Valve Operation

The UC400 Controller supports 1-, 2-modulating or 2-position valves, depending on the application. The controller opens and closes the appropriate valve(s) to maintain the active zone temperature setpoint at the heating setpoint in heating mode or the cooling setpoint in cooling mode.

Modulating Valve Operation

The UC400 Controller supports 3-wire floating point and analog modulating valve control. Two (2) binary outputs control each valve: one to drive the valve open and one to drive the valve closed. The stroke time for each valve is configured using the Tracer TU service tool. The controller supports the following:

- Heating.
- Cooling.
- Heat/cool changeover with a single valve and coil for 2-pipe applications.
- Cooling or heat, cool changeover with the main valve, and coil.
- Only heating with the auxiliary valve and coil for 4-pipe applications.

The UC400 moves the modulating valve to the desired positions based on heating or cooling requirements.

3-Wire Floating Point Valve Calibration

The 3-wire floating point valve calibration is automatic. During normal operation, the UC400 Controller overdrives the actuator (135% of the stroke time) whenever there is a request for a position of 0% or 100%. At either power-up, after a power outage, or when the occupancy status changes to unoccupied, the controller first drives all modulating valves (and dampers) to the closed position. The controller calibrates to the fully CLOSED position by over driving the actuator (135% of the stroke time) and then resumes normal operation.

2-Position Valve Operation

The UC400 Controller supports 2-position valves with a single binary output for each valve. Controllers used for 2-pipe applications support heating, cooling, or heat/cool changeover with a single valve/coil. A controller used for 4-pipe applications supports cooling or heat/cool changeover with a main valve/coil and heating only with an auxiliary valve/coil.

Face/Bypass Damper Operation

When configured for use, the face and bypass damper actuates to modulate a percentage of air to the face of the coil and around the coil (bypass) in order to maintain space comfort. Isolation valves are used to control water flow through the unit during heating and cooling operation.

Modulating Outdoor/Return Air Damper

The UC400 Controller operates the modulating outdoor/return air dampers based on the following:

- Occupancy mode.
- Outdoor air temperature (communicated or hard wired sensor).
- Zone temperature.
- Setpoint.
- Discharge air temperature.
- Discharge air temperature setpoint.

The minimum position for an outdoor air damper is configured using the Tracer TU service tool for both occupied mode and occupied standby mode and for low-speed fan operation. The UC400 Controller can receive a BAS-communicated outdoor air damper minimum position. A BAS-communicated minimum position setpoint has priority over all locally configured setpoints. When a communicated minimum position setpoint is not present, the controller uses the

configured minimum position for low fan speed whenever the fan is running at low speed, regardless of the occupancy state. Refer to the following tables for more information about how the unit determines the position of the modulating outdoor air damper.

Table 9. Position Setpoint Determination

Occupancy	BAS-Communicated Setpoint	Fan Speed	Active Minimum Setpoint
Unoccupied	Any Value	Any Value	0% (closed).
<ul style="list-style-type: none"> • Occupied • Occupied Bypass • Occupied Standby 	Valid	Any Value	BAS-communicated.
<ul style="list-style-type: none"> • Occupied • Occupied Bypass • Occupied Standby 	Invalid	Low	Occupied Low Fan Minimum.
<ul style="list-style-type: none"> • Occupied • Occupied Bypass 	Invalid	Medium/High	Occupied Minimum.
Occupied Standby	Invalid	Medium/High	Occupied Standby Minimum.

Table 10. OA Temp and Damper Position Relationship

Outdoor Air Temperature	Modulating Outdoor Air Damper Position		
	Occupied or Occupied Bypass	Occupied Standby	Unoccupied
No or invalid outdoor air temperature.	Open to occupied minimum position.	Open to occupied standby minimum position.	Closed.
Failed outdoor air sensor.	Open to occupied minimum position.	Open to occupied standby minimum position.	Closed.
Outdoor air temperature present and economizing possible (Refer to the section, Economizing (Free Cooling), p. 46).	Economizing; damper controlled between occupied minimum position and 100%.	Economizing; damper controlled between occupied standby minimum position and 100%.	Open and economizing during unit operation; otherwise closed.
Outdoor air temperature present and economizing not possible (Refer to the section, Economizing (Free Cooling), p. 46).	Open to occupied minimum position.	Open to occupied standby minimum position.	Closed.

ASHRAE Cycle 1 Conformance

ASHRAE Cycle 1 admits 100% outdoor air at all times except during a warm-up cycle. To configure the UC400 Controller for ASHRAE Cycle 1 conformance, the occupied outdoor air damper minimum position is set to 100% open. During occupied periods, the modulating damper opens 100%. If the space temperature drops 3°F below the active setpoint, the UC400 Controller closes the outdoor air damper regardless of the active minimum damper position. The controller moves the modulating valve to the desired positions based on heating or cooling requirements.

ASHRAE Cycle 2 Conformance

The UC400 Controller conforms to the ASHRAE Cycle 2 by allowing the modulating outdoor damper to completely close when the space temperature drops 3°F, or more, below the effective setpoint. When the space temperature rises within 2°F of the effective setpoint, the damper is

allowed to open to the occupied or occupied standby minimum damper positions. When the space temperature is between 2°F and 3°F below the setpoint, the damper is set between 0 and the minimum damper position. If the discharge air temperature is between the discharge air temperature low limit and the discharge air temperature low setpoint, the damper modulates between closed and the minimum position. When this function and ASHRAE Cycle 2 are both active, the minimum of the two control points is chosen. The ASHRAE Cycle 2 operation is available only on units equipped with a modulating outdoor air damper.

Economizing (Free Cooling)

Cooling with outdoor air (during the times when the temperature is low enough to allow) is referred to as economizing (free cooling). The UC400 Controller and applications with modulating outside air damper support economizing. The modulating outdoor air damper provides the first source of cooling for the controller. The controller initiates economizing if the outdoor air temperature is below the economizer enable point (configured using the Tracer TU service tool). If economizing is initiated, the controller modulates the outdoor air damper (between the active minimum damper position and 100%) to control the amount of outdoor air cooling capacity. When the outdoor air temperature rises 5°F (2.8°C) above the economizer enable point, the controller disables economizing and moves the outdoor air damper back to its predetermined minimum position, based on the current occupancy mode or communicated minimum outdoor air damper position. If an outdoor air temperature value is not present, economizing is disabled.

Outdoor Air Damper Control With Varying Fan Speed

To ensure proper ventilation as the fan speed changes in AUTO fan mode, the UC400 Controller is configured with two (2) outdoor air damper position setpoints for occupied operation. As the fan speed changes to LOW or HIGH, the damper adjusts position to maintain proper ventilation.

Note: The damper position does not adjust when the fan speed changes to medium.

With the fan operating at maximum speed, the Design Minimum OA Damper Position at Maximum Fan Speed setpoint (bubble 1 on graph) is set in order to bring in the required amount of outdoor airflow. With the fan operating at minimum speed, the Design Minimum OA Damper Position at Minimum Fan Speed setpoint (bubble 2 on graph) is set in order to bring in the same required amount of outdoor airflow. As the fan speed varies between minimum and maximum speeds, the position of the outdoor air damper is adjusted in proportion to the changing fan speed as shown below.

Figure 20. OA Damper Adjustment

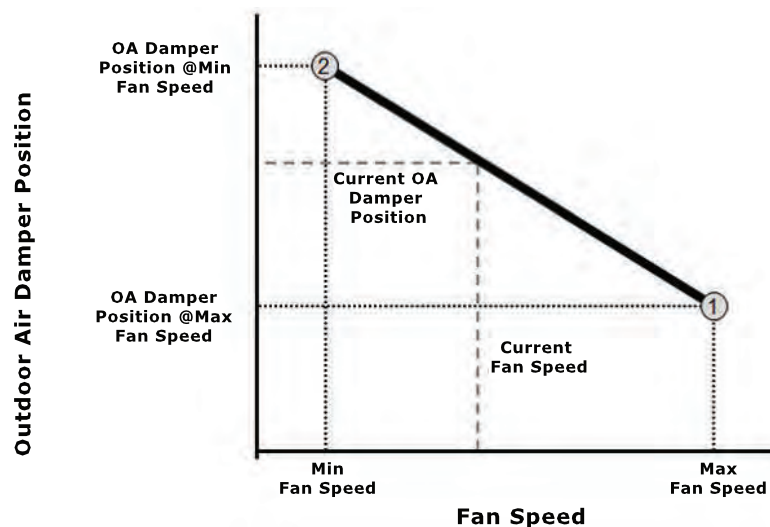

CO₂-Based Demand Controlled Ventilation

CO₂-based demand controlled ventilation measures the concentration of carbon dioxide (CO₂) in the zone as a means to vary the outdoor airflow delivered as the population of the zone changes. DCV calculates the required minimum OA damper position based on the current zone CO₂ concentration. However, the OA damper may be opened greater than the design minimum setpoint if air side economizing is possible.

The UC400 supports CO₂-based DCV in blower coil, fan coil, and unit ventilator products when equipped with a modulating outdoor air damper and CO₂ sensor (hard wired or communicated via the BAS). DCV functions only during occupied modes (Occupied, Occupied Standby, Occupied Bypass), in either heating or cooling, as long as the fan is operating (HIGH, MEDIUM, LOW, ON, or AUTO).

Note: The UC400 continues to maintain space comfort control while DCV is active. DCV can be enabled/disabled through the controller configuration/setup.

When the fan operates at a constant (single) speed, the controller uses two (2) OA damper position setpoints and two (2) CO₂ setpoints as shown below:

- When the CO₂ concentration in the zone is equal to, or higher than, the CO₂ Design Setpoint, the OA damper adjusts to the Design Minimum OA Damper Position setpoint.
- When the CO₂ concentration in the zone is equal to, or lower than, the CO₂ Minimum Setpoint, the OA damper adjusts to the DCV Minimum OA Damper Position setpoint.
- When the CO₂ concentration in the zone is between the CO₂ Minimum Setpoint and the CO₂ Design Setpoint, the OA damper is determined using a straight proportional calculation between the two OA damper setpoints.

Figure 21. CO₂Setpoints

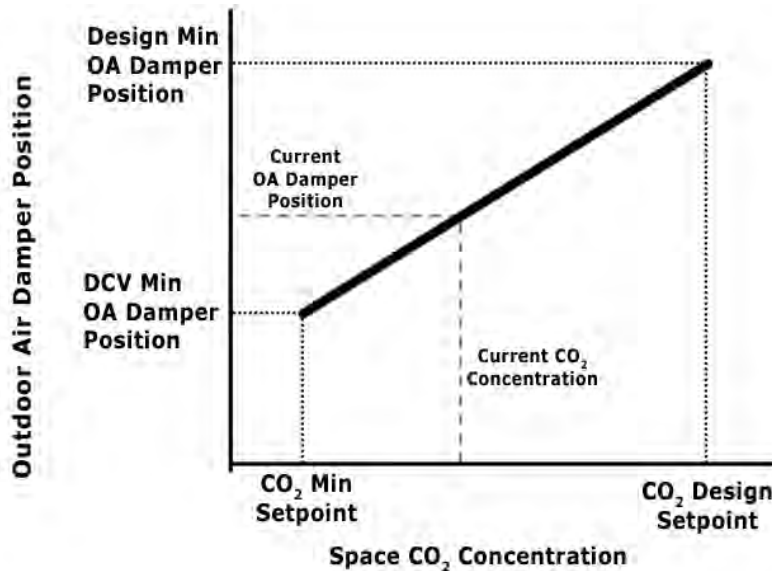

Fan Operating at Multiple Speeds or Single-Zone VAV Control

The UC400 Controller uses four (4) OA damper position setpoints and two (2) CO₂ setpoints as shown below.

Figure 22. OA Damper Position Setpoints

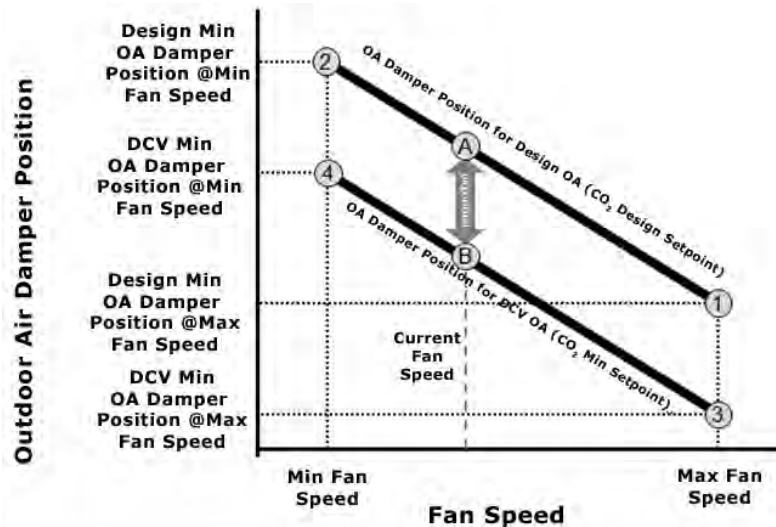

- Based on the current fan speed, the controller calculates a Design Minimum OA Damper Position setpoint (A) using a straight proportional calculation (the upper line on the chart above) between the Design Minimum OA Damper Position at Maximum Fan Speed (1) and the Design Minimum OA Damper Position at Minimum Fan Speed (2).
- The UC400 Controller calculates a DCV Minimum OA Damper Position setpoint (B) using a straight proportional calculation (the lower line on the chart) between the DCV Minimum OA Damper Position at Maximum Fan Speed (3) and the DCV Minimum OA Damper Position at Minimum Fan Speed (4).
- When the CO₂ concentration in the zone is equal to, or higher than, the CO₂ Design Setpoint, the OA damper is adjusted to the calculated Design Minimum OA Damper Position setpoint (A) for the current fan speed.
- When the CO₂ concentration in the zone is equal to, or lower than, the CO₂ Minimum Setpoint, the OA damper is adjusted to the calculated DCV Minimum OA Damper Position setpoint (B) for the current fan speed.
- When the CO₂ concentration in the zone is between the CO₂ Minimum Setpoint and the CO₂ Design Setpoint, the OA damper position is determined using a straight proportional calculation between the calculated Design Minimum OA Damper Position (A) and DCV Minimum OA Damper Position (B) setpoints for the current fan speed.

Refer to the section, “[Settings for CO₂-Based Demand Controlled Ventilation](#),” p. 63, for instructions on calculating and adjusting the following setpoints used for DCV:

- Design minimum OA Damper position at maximum speed is one of the following depending on Occupancy mode:
 - Standby Minimum Position Setpoint.
 - Economizer Minimum Position Setpoint Local.
- Design minimum OA Damper position at minimum speed is Occupied Low Fan Min Position Setpoint.
- DCV minimum OA damper position at maximum fan speed is DCV Minimum Economizer Position at Maximum Speed.
- DCV minimum OA damper position at minimum fan speed is DCV Minimum Economizer Position at Minimum Speed.

DX Cooling Operation, 1 or 2 Circuits

The UC400 Controller supports 1- or 2-stage direct expansion (DX) cooling for space temperature cooling. DX cooling function applies to cooling operation for a cooling-only unit and for a heat



Sequence of Operation

pump unit when in cooling mode (using the reversing valve). Compressor(s) are held to a minimum ON/OFF time of three (3) minutes and an inter-stage delay timer of three (3) minutes.

Important: *The UC400 Controller algorithms allow for opening of the economizer damper and running the compressors simultaneously without tripping the frost sensor. The controller supports one stage of direct expansion (DX) compressor operation for only cooling.*

Heat Pump Operation, 1 or 2 Circuits

The UC400 Controller supports 1- or 2-stage heat pump for space temperature heating and cooling. The heat pump unit may also include electric or hydronic auxiliary heating as backup heating sources. In cooling mode, the controller commands the reversing valve to cooling mode when the entering of cooling operation. It cycles the compressor(s) ON and OFF in order to maintain the cooling space temperature setpoint. In heating mode, the controller commands the reversing valve to heating mode and cycles the compressor(s) ON and OFF in order to maintain the heating space temperature setpoint. In both heating and cooling modes, the compressor(s) are held to a minimum ON/OFF time of three (3) minutes and an inter-stage delay timer of three (3) minutes.

Important: *The UC400 Controller algorithms allow for opening of the economizer damper and running the compressors simultaneously without tripping the frost sensor. The controller supports both 1-stage and 2-stage electric heat. Electric heat is cycled ON and OFF to maintain the discharge air temperature at the active heating setpoint. Two-pipe changeover units with electric heat use only electric heat when hot water is not available. The use of both electric and hydronic heat is not supported.*

Defrost Operation

The UC400 Controller is equipped with a wired frost detection sensor BI4 for DX units. The controller enters defrost mode when the sensor opens and shuts off the compressor(s) when minimum ON times expire. During defrost, the fan and economizer damper continue to operate and defrost the coil. Upon sensing completion of defrost, the controller immediately returns to normal cooling control, clears the defrosting and compressor lockout status, and returns the diagnostic binary point to NORMAL.

Important: *The minimum OFF time for DX compressors is still obeyed, so the compressor may not turn ON immediately when the defrost condition ends.*

Electric Heat Operation

The UC400 Controller supports both SCR (modulating) and 1- or 2-staged electric heat. SCR heat is only a field-installed option. If the controller is configured with staged electric heat, the electric heating circuit(s) cycle ON and OFF to maintain the desired space temperature at the active heating setpoint. If the controller is configured with SCR (modulating) electric heat, the unit sends a 0 to 10 Volt DC signal to adjust SCR capacity in order to maintain the desired space temperature. In both staged and modulating electric heat applications, the simultaneous use of electric and hydronic heat is not supported. The UC400 Controller operates electric heat only when hot water is not available (for example, in a changeover unit). In addition, the controller runs the supply fan for 30 seconds after electric heat is turned OFF in order to dissipate heat from the unit.

Note: *This delay does not apply to steam or hydronic heating.*

Factory-configured electric heat units have built-in mechanical protections to prevent dangerously high discharge air temperatures.

Dehumidification Operation

The UC400 Controller supports space dehumidification when:

- Mechanical (DX or hydronic) cooling is available.
- The heating capacity is located in the reheat position.

- The space relative humidity is valid.

The space relative humidity can be a BAS-communicated value or come directly from a wired relative humidity sensor. The UC400 Controller begins to dehumidify the space when the space humidity exceeds the humidity setpoint. The controller continues to dehumidify until the sensed humidity falls below the setpoint, minus the relative humidity offset.

Unit Protection Strategies

The following unit protection strategies are initiated when specific conditions exist in order to protect the unit or building from damage:

- Smart Reset
- Low Coil Temperature Protection
- Condensate Overflow
- Fan Status
- Fan Off Delay
- Filter Maintenance Timer
- Freeze Avoidance
- Freeze Protection (Discharge Air Temperature Low Limit)

Smart Reset

The UC400 Controller automatically restarts a unit that is locked out as a result of a Low Coil Temp Detection (BI3) diagnostic. Referred to as smart reset, this automatic restart occurs 30 minutes after the diagnostic occurs. If the unit is successfully restarted, the diagnostic is cleared. If the unit undergoes another Low Coil Temp Detection diagnostic within a 24-hour period, the unit is locked out until it is manually reset.

Note: Freeze protection will also perform a smart reset.

Low Coil Temperature Protection

Refer to the section, “[BI3; Low Coil Temp Detection](#),” p. 15 and to the previous section about *Smart Reset*.

Condensate Overflow

Refer to the section, “[BI2; Condensate Overflow](#),” p. 14.

Fan Status

In 1-, 2-, and 3-speed fans, the status is based on the statuses of the supply fan output multi-state and analog points dedicated to fan control. The fan status is reported as HIGH, MEDIUM, LOW, and as a percentage, whenever the fan is running. The fan status is reported as OFF whenever the fan is not running. In addition, a fan status switch can be connected to binary input 5 (BI5) to monitor the status of the fan for belt-driven or direct-driven units (except Trane Macon factory ECM fan motor units). The fan status switch provides feedback to the controller as follows:

- If the fan is not operating when the UC400 Controller has the fan controlled to ON, the unit generates a Low Airflow-Supply Fan Failure diagnostic.
- If the UC400 Controller energizes the fan output for one (1) minute, and the fan status switch indicates no fan operation, then the controller performs a unit shutdown and generates a Low Airflow-Supply Fan Failure diagnostic.
- If the fan has been operating normally for one minute, but the fan status switch indicates no fan operation, the same diagnostic is generated.

This manual diagnostic discontinues unit operation until the diagnostic has been cleared from the UC400 Controller. If a diagnostic reset is sent to the unit and the fan condition still exists, the controller attempts to run the fan for one (1) minute before generating another diagnostic and performing a unit shutdown. A diagnostic reset can be sent to the unit from the Tracer TU Alarms

page or by temporarily overriding the Reset Diagnostic Request on the Tracer TU Binary Status page.

Note: In the ECM fan application, the ECM engine board monitors the status of the fan. In case of a failure, the engine board disables the motor immediately, and the low airflow diagnostic is sent.

Fan Off Delay

After heating has been controlled OFF, the UC400 Controller keeps the fan energized for an additional 30 seconds in order to remove residual heat from the heating source.

Filter Maintenance Timer

The filter maintenance timer tracks the amount of time (in hours) that the fan is enabled. The Filter Runtime Hours Setpoint (configured using the Tracer TU service tool) is used to set the amount of time until maintenance (typically, a filter change) is required. The timer can be enabled/disabled from the Supply Fan group on the Setup Parameters page in Tracer TU. The UC400 Controller compares the fan run time to filter runtime hours setpoint. Once the setpoint is reached, the controller generates a Filter Change Required diagnostic. When the diagnostic is cleared, the controller resets the filter maintenance timer to zero and the timer begins accumulating fan run time again. The diagnostics can be cleared and the filter timer reset by temporarily overriding the Filter Timer Reset Request on the Binary Status page or by using the reset button on the Alarms page in Tracer TU.

Freeze Avoidance

Freeze avoidance is used for low ambient temperature protection. It is initiated only when the fan is OFF. The UC400 Controller enters the freeze avoidance mode when the outdoor air temperature is below the freeze avoidance setpoint (configured using the Tracer TU service tool). The controller disables freeze avoidance when the outdoor air temperature rises 3°F (1.7°C) above the freeze avoidance setpoint. The following occurs when the controller is in freeze avoidance mode:

- Valves are driven open to allow water to flow through the coil.
- Fan is OFF.
- Economizing is disabled.
- The outdoor/return air damper is closed.
- DX cooling is OFF.
- Electric heat stages are OFF.

Freeze Protection, Discharge Air Temperature Low Limit

The UC400 Controller monitors the discharge air temperature with a 10 kΩ thermistor wired to AI4. The freeze protection operation is initiated whenever the discharge air temperature falls below the discharge air temperature low limit. The discharge air temperature low limit is configured using the Tracer TU service tool. During freeze protection, the controller increases the heating capacity or decreases the cooling capacity in order to raise the discharge air temperature above the low limit. If the discharge air temperature remains below the low limit for 3 minutes, the controller generates a Discharge Air Temp Limit diagnostic.

Note: Freeze protection also performs a smart reset.



Output Testing

Important: The code does not allow directly overwriting the outputs.

Output testing can be accomplished by overriding the following analog and multi-state value points in the desired state or position:

- **Cool Valve Request:** analog value point for 2-position and modulating hydronic cooling and changeover valve applications.
- **DX Cool Request:** analog value point for 1 and 2-stage DX Cooling and Heat Pump applications.
- **Heat Valve Request:** analog value point for 2-position and modulating hydronic heating valve applications.
- **Electric Heat Request:** analog value point for Modulating, 1- and 2-stage electric heating configurations.
- **Economizer Request:** analog value point for 2-position and Modulating outdoor air damper applications.
- **Supply Fan Speed Request:** analog value point for variable speed (0-100%) fan applications, including Trane ECM engine module application.
- **Supply Fan Speed BAS:** multi-state value point for fixed 1-, 2-, and 3-speed fan applications.

The points can be overridden on the Tracer TU analog or multi-state pages by clicking on the Override icon in the control column. A higher priority (lower number) must be chosen over the current control setting.

Diagnostics

Diagnostics are informational messages that indicate the operational status of the UC400 Controller. In response to most diagnostics, the controller attempts to protect the equipment by enabling/disabling, or by opening/closing specific outputs. Other diagnostics provide information about the status of the controller, but have no effect on outputs. Diagnostics are reported in the order in which they occur. Multiple diagnostics can be present simultaneously. Diagnostic messages are viewed using the Tracer TU service tool or through a BAS.

Note: Tracer TU reports only active diagnostics.

Diagnostic Types

The following diagnostics are categorized according to the clearing method each uses and the type of information each provides.

- Manual- Latching
- Automatic- Non-Latching
- Smart Reset
- Informational

Note: Clearing diagnostics refers to deleting diagnostics from the software; it does not affect the problem that generated the message.

Manual- Latching

Manual diagnostics (also referred to as latching) cause the unit to shut down. Manual diagnostics can be cleared from the UC400 Controller in one of the following methods:

- By using the Tracer TU service tool to reset latching diagnostics on the Alarms Status tab or by temporarily overriding the Reset Diagnostic Request (bv/2) on the Binary Status tab.
- Through a building automation system.
- By cycling power to the UC400 Controller— when the 24 Vac power to the controller is cycled OFF and then ON again, a power-up sequence occurs.

Automatic— Non-Latching

Automatic diagnostics clear automatically when the problem that generated the diagnostic is solved.

Smart Reset

Smart Reset Diagnostics are latching diagnostics that auto-recover if the condition is corrected. After the UC400 Controller detects the first smart reset diagnostic, the unit waits 30 minutes before initiating the smart reset function. If another diagnostic of this type occurs again within 24 hours after an automatic clearing, clear the diagnostic manually by using any of the ways listed under the section above, Manual (Latching) Diagnostics.

Informational

Informational diagnostics provide information about the status of the UC400Unit. They do not affect machine operation, but can be cleared from the unit using the BAS or Tracer SC.

Diagnostic Generated by the UC400

The table below lists each diagnostic that can be generated by the UC400 Controller, the diagnostic effect on outputs (consequences), and diagnostic type.

Note: The generic binary output is unaffected by diagnostics.

Table 11. Diagnostics

Diagnostic	Probable Cause	Consequences	Diagnostic Type
Filter Change Required	Fan run hours exceed the time set to indicate filter change.	<ul style="list-style-type: none"> Fan Unaffected Valves Unaffected Electric Heat Unaffected 	Informational
Condensate Overflow	The drain pan is full of water.	<ul style="list-style-type: none"> Fan OFF Valves Closed Outdoor Air Damper Closed DX/Electric Heat OFF 	Manual
Low Coil Temp Detection	The leaving fluid temperature may be close to freezing.	<ul style="list-style-type: none"> Fan OFF Valves Open Outdoor Air Damper Closed DX/Electric Heat OFF 	Smart reset/Manual
Low Airflow Supply Fan Failure	The fan drive belt, contactor, or motor has failed.	<ul style="list-style-type: none"> Fan OFF Valves Closed Outdoor Air Damper Closed DX/Electric Heat OFF 	Manual
Space Temperature Failure	Invalid or missing value for zone temperature.	<ul style="list-style-type: none"> Discharge Air Temperature Control Runs Unit Shuts OFF if Both Space Temperature and Discharge Air Temperature Fail 	Automatic

Table 11. Diagnostics (continued)

Diagnostic	Probable Cause	Consequences	Diagnostic Type
Entering Water Temp Failure	Invalid or missing value for zone temperature.	<ul style="list-style-type: none"> • Fan Unaffected (Enabled) • Valves Unaffected • Outdoor Air Damper Unaffected • DX/Electric Heat Unaffected 	Automatic
Discharge Air Temp Low Limit	Discharge air temperature has fallen below the Discharge Air Temperature Low Limit.	<ul style="list-style-type: none"> • Fan OFF • Valves Open • Outdoor Air Damper Closed • DX/Electric Heat OFF 	Smart reset/manual
Discharge Air Temp Failure	Invalid or missing value for discharge air temperature.	<ul style="list-style-type: none"> • Simplified Zone Control Algorithm Runs • Unit Shuts OFF if Zone Temperature Fails 	Automatic
Outdoor Air Temp failure	Invalid or missing value for outdoor air temperature.	<ul style="list-style-type: none"> • Fan Unaffected • Valved Unaffected • Outdoor Air Damper Minimum Position • DX Cooling/ Electric Heat Unaffected 	Automatic
Humidity Input Failure	Invalid or missing value for relative humidity.	<ul style="list-style-type: none"> • Fan Unaffected • Valves Unaffected • Outdoor Air Damper Unaffected • DX Cooling/ Electric Heat Unaffected 	Automatic
CO ₂ Sensor Failure	Invalid or missing value for CO ₂ .	<ul style="list-style-type: none"> • Fan Unaffected • Valves Unaffected • Outdoor Air Damper Unaffected • DX Cooling/ Electric Heat Unaffected 	Informational

Output Testing

Table 11. Diagnostics (continued)

Diagnostic	Probable Cause	Consequences	Diagnostic Type
Generic AIP Failure	Invalid or missing value for generic analog input.	<ul style="list-style-type: none"> • Fan Unaffected • Valves Unaffected • Outdoor Air Damper Unaffected • DX Cooling/ Electric Heat Unaffected 	Informational
Local Fan Mode Failure	Invalid or missing fan-speed switch (reverts to default fan speed).	<ul style="list-style-type: none"> • Fan Unaffected • Valves Unaffected • Outdoor Air Damper Unaffected • DX Cooling/ Electric Heat Unaffected 	Automatic
Local Setpoint Failure	Invalid or missing value for zone temperature setpoint (reverts to default setpoint).	<ul style="list-style-type: none"> • Fan Unaffected • Valves Unaffected • Outdoor Air Damper Unaffected • DX Cooling/ Electric Heat Unaffected 	Automatic



Operational Causes and Diagnostics

Table 12. Diagnostic Causes and Diagnostics

Probable Cause	Diagnostic
Fan Not Energizing	
Unit Wiring	The wiring between the UC400 Controller outputs, fan relays, and contacts must be present and correct for normal fan operation.
Failed End Device	The fan motor and relay must be checked to ensure proper operation.
Normal Operation	<p>The fan turns OFF when:</p> <ul style="list-style-type: none"> • The UC400 Controller receives a communicated off signal. • The fan-speed switch is set to OFF if no communicated value is present. • Specific diagnostics are generated. • The default fan speed is set to OFF and the fan is operating in the Auto mode. <p>If the UC400 Controller is in unoccupied mode, the fan cycles between OFF and the highest fan speed.</p>
No power to the Controller	If the UC400 Controller does not have power, the unit fan does not operate. For the controller to operate normally, it must have an input voltage of 24 Vac. If the Marquee/Power LED is OFF continuously, the controller does not have sufficient power or has failed.
Diagnostic Present	Several diagnostics affect fan operation.
Unit Configuration	The UC400 Controller must be properly configured based on the actual installed end devices and application. If the unit configuration does not match the actual end device, the fans may not work correctly.
Random Start Observed	After power-up, the UC400 Controller always observes a random start from 5 to 30 seconds. The unit remains OFF until the random start time expires.
Cycling Fan Operation/Continuous	The UC400 Controller continuously operates the fan when in the occupied, occupied standby, or occupied bypass mode. When the controller is in the unoccupied mode, the fan is cycled between high speed and OFF with capacity.
Unoccupied Operation	Even if the UC400 Controller is configured for continuous fan operation, the fan normally cycles with capacity during unoccupied mode. While unoccupied, the fan cycles ON or OFF with heating/cooling to provide varying amounts of heating or cooling to the space.
Fan Mode Off	If a local fan mode switch determines the fan operation, the OFF position controls the fan to off.
Requested Mode Off	The user can communicate a desired operating mode (such as OFF, heat, and cool) to the controller. If OFF is communicated to the controller, the controller controls the fan to off. There is no heating or cooling.
Isolation Valves Remain Closed	
Unit Wiring	The wiring between the UC400 Controller outputs and the valve(s) must be present and correct for normal valve operation. Refer to applicable wiring diagram.
Failed End Device	The valves must be checked to ensure proper operation.
No power to the Controller	If the UC400 Controller does not have power, the unit valve(s) will not operate. For the unit to operate normally, apply an input voltage of 24 Vac. If the Marquee/Power LED is OFF continuously, the controller does not have sufficient power or has failed.
Diagnostic Present	Several diagnostics affect valve operation. For detailed information about these diagnostics, refer to Table 13, p. 46.
Normal Operation	The UC400 Controller opens and closes the valves to meet the unit capacity requirements.
Unit Configuration	The UC400 Controller must be properly configured based on the actual installed end devices and application. If the unit configuration does not match the actual end device, the valves may not work correctly.
Random Start Observed	After power-up, the UC400 Controller always observes a random start from 5 to 30 seconds. The controller remains OFF until the random start time expires.

Operational Causes and Diagnostics

Table 12. Diagnostic Causes and Diagnostics (continued)

Probable Cause	Diagnostic
Requested Mode Off	The user can communicate a desired operating mode (such as OFF, heat, and cool) to the controller. If OFF is communicated to the UC400 Unit, it controls the fan to off. There is no heating or cooling.
Entering Water Temperature Sampling Logic	The UC400 Controller includes entering water temperature sampling logic It is automatically initiated during 2-pipe and 4-pipe changeover if the entering water temperature is either too cool or too hot for the desired heating or cooling.
Valve Configuration	Ensure the valves are correctly configured, using the Tracer TU service tool, as normally open (NO) or normally closed (NC) as dictated by the application.
Isolation Valves Remain Open	
Unit wiring	The wiring between the UC400 Controller outputs and the valve(s) must be present and correct for normal valve operation. Refer to applicable wiring diagram.
Failed End Device	The valves must be checked to ensure proper operations.
Normal Operation	The UC400 Controller opens and closes the valves to meet the unit capacity requirements.
Diagnostic Present	Several diagnostics affect valve operation.
Unit Configuration	The UC400 Controller must be properly configured based on the actual installed end devices and application. If the unit configuration does not match the actual end device, the valves may not work correctly.
Entering Water Temperature Sampling Logic	The UC400 Controller includes entering water temperature sampling logic. It is automatically initiated during 2-pipe and 4-pipe changeover if the entering water temperature is either too cool or too hot for the desired heating or cooling.
Valve Configuration	Ensure the valves are correctly configured, using the Tracer TU service tool, as normally open (NO) or normally closed (NC) as dictated by the application.
Freeze Avoidance	When the fan is OFF with no demand for capacity (0%), and the outdoor air temperature is below the freeze avoidance setpoint, the UC400 Controller opens the water valves (100%) to prevent coil freezing. This includes unoccupied mode when there is no call for capacity or any other time the fan is OFF.
DX or Electric Heat Outputs Do Not Energize	
Unit Wiring	The wiring between the UC400 Controller outputs and the end devices must be present and correct for normal operation.
Failed End Device	Check the UC400 Controller contactors or the electric heat element, including any auxiliary safety interlocks, to ensure proper operation.
No Power to the Controller	If the UC400 Controller does not have power, heat outputs do not operate. For the controller to operate normally, apply an input voltage of 24 Vac. If the Marquee/Power LED is OFF continuously, the controller does not have sufficient power or has failed.
Diagnostic Present	Several diagnostics affect DX and electric heat operation.
Normal Operation	The UC400 Controller controls compressor or electric heat outputs as needed to meet the unit capacity requirements.
Unit Configuration	The UC400 Controller must be properly configured based on the actual installed end devices and application. If the unit configuration does not match the actual end device, DX or electric heat may not operate correctly.
Requested Mode Off	The user can communicate a desired operating mode (such as OFF, heat, and cool) to the controller. If OFF is communicated to the UC400 Controller, the controller shuts off the compressor or electric heat.
Freeze Avoidance	When the fan is OFF with no demand for capacity (0%), and the outdoor air temperature is below the freeze avoidance setpoint, the UC400 Controller disables compressors and electric heat outputs (100%) to prevent coil freezing. This includes unoccupied mode when there is no call for capacity or any other time the fan is OFF.
Outdoor Air Damper Remains Closed	
Unit Wiring	The wiring between the UC400 Controller outputs and the outdoor air damper must be present and correct for normal outdoor air damper operation. Refer to applicable wiring diagram.

Table 12. Diagnostic Causes and Diagnostics (continued)

Probable Cause	Diagnostic
Failed End Device	Check damper actuator to ensure proper operation.
No Power to the Controller	If the UC400 Controller does not have power, the outdoor air damper does not operate. For the controller to operate normally, apply an input voltage of 24 Vac. If the Marquee/Power LED is OFF continuously, the controller does not have sufficient power or has failed.
Diagnostic Present	Several diagnostics affect outdoor air damper operation.
Normal Operation	The UC400 Controller opens and closes the outdoor air damper based on the occupancy mode of the controller and the fan status. Normally, the outdoor air damper is open during occupied mode when the fan is running and closed during unoccupied mode.
Unit Configuration	The UC400 Controller must be properly configured based on the actual installed end devices and application. If the unit configuration does not match the actual end device, the outdoor air damper may not work correctly.
Warm-up and Cool-down Sequence	The UC400 Controller includes both a morning warm-up and cool-down sequence to keep the outdoor air damper closed during the transition from unoccupied to occupied. This is an attempt to bring the space under control as quickly as possible.
Requested Mode Off	The user can communicate a desired operating mode (such as OFF, heat, or cool) to the controller. If OFF is communicated to the UC400 Controller, the controller closes the outdoor air damper.
Outdoor Air Damper Remains Open	
Unit Wiring	The wiring between the UC400 Controller outputs and the outdoor air damper must be present and correct for normal outdoor air damper operation. Refer to applicable wiring diagram.
Failed End Device	Check damper actuator to ensure proper operation.
Normal Operation	The UC400 Controller opens and closes the outdoor air damper based on the controller occupancy mode and fan status. Normally, the outdoor air damper is open during occupied mode when the fan is running and closed during unoccupied mode.
Unit Configuration	The UC400 Controller must be properly configured based on the actual installed end devices and application. If the unit configuration does not match the actual end device, the outdoor air damper may not work correctly.



Configuration and Maintenance

This section outlines the tasks to configure and maintain the UC400 Controller using the Tracer TU service tool.

Note: *The UC400 Controller is a self-serviceable unit and is not intended to be disassembled for maintenance.*

1. **Load Application Code on a Blank UC400:** all field programmable UC400 Controllers ship without application code (firmware). Before configuring the controller, check for the unit application code using the Tracer TU service tool, as follows:
 - a. Start the Tracer TU service tool to establish a connection with the UC400 Controller. If no firmware is present, the following message displays: *This UC400 Controller has no application code loaded. Please launch File Transfer wizard and load an appropriate configuration.*
 - b. Click **OK**. To load or upgrade the firmware, follow the procedure in the TU Online Help, *Upgrading Controller Firmware* under the book, *Managing Configurations, Firmware, and Programs*.
2. **Choose a UC400 Configuration Option:**
 - a. First, get an overview of the parts of a UC400 Controller configuration. Refer to TU Online Help, *The Main Parts of Device Setup and Configuration* under the book, *An Overview of Device Setup and Configuration* book in the *Tracer TU Help for Programmable Controllers*.
 - b. Carefully read the topic, *Point Configuration Overview* under the book, *Configuring and Managing Points*, for an explanation of available configuration options.

There are two main configuration options:

 - Use the Tracer TU Configuration Screen to create a factory configuration.

Note: *Some modifications can be made to the Trane factory blower coil, fan coil, or unit ventilator configurations. The VAV code cannot be modified, but side programs can be added that can add to or change the sequence of operation.*
 - Create or edit a custom (field programmed) configuration.
3. **Specify Controller Settings:**
 - a. Configure units of measure.
 - b. Specify the unit date and time
 - c. Specify the baud rate, if other than the default (76800).
4. **Set Up and Discover XM30/XM32/XM70 Expansion Modules:**
 - a. Mount, wire, address, and power the expansion module as described in the Installation Instructions that accompany the unit
 - b. Click the **Discover** button in the Expansion Modules box on the Controller Settings screen.

Note: *When adding an expansion module on the Controller Settings page, but the module is not connected to the controller, then discover it on the Controller Status screen after it is connected and powered.*

Refer to the topic, *Setting Up And Discovering Expansion Modules* under the book, *Modifying Controller Settings*, for the procedural information.
5. **Specifying an Equipment Configuration:** go to the information sources supporting the chosen configuration option.
 - a. **Option 1:** use the Tracer TU Configuration Screen to Create a Factory Configuration. Refer to the topics under the *VAV Boxes, Trane Factory Blower Coils, Fan Coils, and Unit Vents* or the *Variable-Speed Water Source Heat Pumps (VS-WSHPs)* sub-books about *Configuring and Commissioning Equipment*.
 - b. **Option 2:** create a Custom Configuration. This option requires a thorough knowledge of the devices and the network to be installed, including an understanding of the TGP2

programs and the points they use. Complete the following steps:

- Create points or open a previously created points file, make any edits, and save them to the UC400 Controller. When configuring points for the unit, it is important to note that points are not pre-configured on the controller board. Instead, the board has a certain amount of memory set aside to create a point. The maximum number of points are listed in the following table.

Table 13. Max Number of Points

Type	Number
Analog Input	40
Analog Output	16
Analog Value	128
Binary Input	32
Binary Output	24
Binary Value	48
Multistate Input	8
Multistate Output	8
Multistate Value	32

Note: Create, edit, and load points, either in Tracer TU, or in the TGP2 Editor.

- Specify setpoint values and equipment parameters on the Setpoints and Setup Parameters screens (Equipment Utility).
6. **Commissioning the Hard-Wired Points:** after all points are configured, saved, and downloaded to the UC400 Controller, commission or test them by overriding Output and Value points. Refer to the topics under the book, *Overriding, Comparing, and Changing the Service Status of Points* .
 - **Out of Service:**
 - **Inputs/Outputs:** The out of service mode disconnects the point from its reference. With inputs, the point no longer gets the value from its reference, but allows the capability of writing to an input. With outputs, the point no longer pushes its value to its reference. In addition, the value of the point can be changed without affecting the value of reference. However, this still requires the use of the priority table.
 - **Values:** value objects will not accept a written value from on-box applications, such as TGP2 or an area when out of service. An off-box application, such as Tracer TU or Tracer SC, allows the capability of writing to a value object. However, this still requires the use of the priority table. Existing points can be placed in or out of service by clicking the **Control** icon corresponding to the point on the Analog, Binary, or Multi-state tab screens on Status Utility.
- Note: The priority number must be lower than what the point is currently controlled at in order for the override to be applied. Verify that the device ID and baud rate are correct after restoring a controller using a backup file that was created with a different controller.*
7. **Adding Side TGP2 Programs, As Needed:** after completing the hardware points and testing, create or edit TGP2 programs that will run the equipment according to the specified sequence of operations for the job. (Refer to the topics under the *Developing and Managing TGP2 Programs TOC* book in the Tracer Graphical Programming (TGP2) Editor Help for programming procedures. Also refer to the TGP2 Block Reference TOC book to learn how the various blocks work and for information about their properties.
 8. **Monitoring and Viewing Point, Alarm, and Controller Status:** refer to the topics under the book, *Viewing the Status of Points and Alarms* .
 9. **Backing Up and Restoring Files and Configurations:** upload, backup, replace, or update



Configuration and Maintenance

configuration files, controller firmware, and TGP2 programs using the File Transfer Utility and the Backup Utility. Refer to the topics under book, *Managing Configurations, Firmware, and Files*.



Settings for CO₂-Based Demand Controlled Ventilation

The CO₂-based DCV sequence used in UC400 Controller is based on the sequence suggested in the ASHRAE Standard 62.1 User Manual, Appendix A.

Note: This sequence is intended for a fan-coil, blower-coil, and unit ventilator product that is applied as a single-zone ventilation system. That is to say, outdoor air enters through an intake and is delivered to a single ventilation zone, which would be typical of a terminal unit that is equipped with its own OA damper.

The following describes how to determine the appropriate OA damper and CO₂ setpoints for this DCV sequence:

- Calculate the required outdoor airflow ($V_{ot-Design}$) at design occupancy using Equations 6-1, 6-2- and 6-3 from ASHRAE Standard 62.1

$$V_{bz} = R_p \times P_z + R_a \times A_z \text{ (Equation 6-1)}$$

$$V_{oz} = V_{bz} / E_z \text{ (Equation 6-2)}$$

$$V_{ot} = V_{oz} \text{ (Equation 6-3, for single-zone ventilation systems), where}$$

V_{bz} = minimum outdoor airflow required in the breathing zone, cfm

R_p = outdoor airflow required per person (from Table 6-1 in ASHRAE Standard 62.1), cfm/person

R_a = outdoor airflow required per unit of floor area (from Table 6-1 in ASHRAE Standard 62.1), cfm/ft²

P_z = zone population, number of people

A_z = zone floor area, ft²

V_{oz} = zone outdoor airflow required, cfm

E_z = zone air distribution effectiveness (from Table 6-2 in ASHRAE Standard 62.1)

V_{ot} = outdoor air intake flow required, cfm

Example: Consider an example K-12 classroom with a design population (P_z) of 35 people and a floor area (A_z) of 1000 ft². Table 6-1 in ASHRAE Standard 62.1-2010 requires 10 cfm of outdoor air per person (R_p) plus 0.12 cfm of outdoor air per square foot of floor area (R_a) for this type of space. The zone air-distribution effectiveness (from Table 6-2 in Standard 62.1) is determined to be 1.0 for this system configuration.

$$V_{bz-Design} = 10 \text{ cfm/p} \times 35 \text{ people} + 0.12 \text{ cfm/ft}^2 \times 1000 \text{ ft}^2 = 470 \text{ cfm}$$

$$V_{oz-Design} = 470 \text{ cfm} / 1.0 = 470 \text{ cfm}$$

$$V_{ot-Design} = 470 \text{ cfm}$$

- Use the same equations to calculate the required outdoor airflow ($V_{ot-DCVmin}$) if no occupants are currently present in the zone ($P_z = 0$).

Note: This setpoint may need to be increased if the zone requires makeup air to replace air that is exhausted directly from the zone (for example in a kitchen, a laboratory, an art or science classroom, or any space with a restroom connected to it). In this case, the $V_{ot-DCVmin}$ setpoint may need to be adjusted so that it is slightly above the local exhaust airflow to ensure positive building pressurization.

Example:

$$V_{bz-DCVmin} = 10 \text{ cfm/p} \times 0 \text{ people} + 0.12 \text{ cfm/ft}^2 \times 1000 \text{ ft}^2 = 120 \text{ cfm}$$

$$V_{oz-DCVmin} = 120 \text{ cfm} / 1.0 = 120 \text{ cfm}$$

$$V_{ot-DCVmin} = 120 \text{ cfm}$$

- Use Equation A-J from the ASHRAE Standard 62.1-2010 User's Manual to calculate the steady-state indoor CO₂ concentration ($CO_{2space-Design}$) when the zone is fully occupied and at its design outdoor airflow rate ($V_{bz-Design}$).

$$CO_{2space} = CO_{2outdoors} + [1,000,000 \times N / (V_{bz} / P_z)] \text{ (rearrangement of Equation A-J) where,}$$

CO_{2space} = concentration of CO₂ in the breathing zone, ppm

Settings for CO₂-Based Demand Controlled Ventilation

CO_{2outdoors} = concentration of CO₂ in the outdoor air, ppm

N = rate at which CO₂ is generated by the zone occupants, cfm/person

The rate at which the occupants produce carbon dioxide (N) varies with diet and health, as well as with the duration and intensity of physical activity. The following table suggests typical values for various activity levels:

Occupant Activity Level (a)	Met	CO ₂ Generation Rate (N), cfm/ Person
Sleeping	0.7	0.0059
Seated, Quiet	1	0.0084
Seated, Typing	1.1	0.0092
Seated, Filing	1.2	0.0101
Walking (2 mph)	2	0.0168
Lifting/Packing	2.1	0.0176
Light Machine Work	2.2	0.0185
Heavy Machine Work	4	0.0336

(a) A more complete table of Met levels for various activities can be found in Chapter 9 (Table 4) of the 2013 ASHRAE Handbook-Fundamentals. According to the Standard 62.1 User's Manual (Appendix A), the CO₂ generation rate (N) averages about 0.0084 cfm/met/person over the general adult population.

Unless the outdoor air intake is located very close to an area with heavy traffic, it is fairly common for design engineers to assume the outdoor concentration (CO_{2outdoors}) to be 400 ppm.

Example: For this example K-12 classroom, the CO₂ generation rate (N) of the occupants is assumed to be 0.0101 cfm/person, and the outdoor CO₂ concentration (CO_{2outdoors}) is assumed to be 400 ppm. As calculated in Step 1, when this zone is fully occupied (P_z = 35), its design outdoor airflow rate (V_{bz-Design}) is 470 cfm.

$$CO_{2space-Design} = CO_{2outdoors} + [1,000,000 \times N / (V_{bz-Design} / P_{z-Design})]$$

$$CO_{2space-Design} = 400 \text{ ppm} + [1,000,000 \times 0.0101 \text{ cfm/p} / (470 \text{ cfm} / 35 \text{ people})] = 1200 \text{ ppm}$$

- The steady-state indoor CO₂ concentration (CO_{2space-DCVmin}) when the zone has no occupants (P_z = 0) will be equal to the outdoor CO₂ concentration.

Example: For this example K-12 classroom, the outdoor CO₂ concentration is assumed to be 400 ppm.

$$CO_{2space-DCVmin} = CO_{2outdoors} = 400 \text{ ppm}$$

If the information is not known to complete the calculations in Steps 1 through 4 above, then as long as the Occupancy Category and zone floor area (ft²) are known, these values can be calculated using the default occupant density from ASHRAE Standard 62.1 and an assumed CO₂ generation rate (N). Refer to the following table for common occupancy categories.

Settings for CO₂-Based Demand Controlled Ventilation

Figure 23. Occupancy Categories

Occupancy Category	Rp, cfm/p	Ra, cfm/sqft	Pz, people/ 1000 sqft	Step 1	Step 2	CO ₂		Step 3	Step 4
				Vbz-design, cfm/sqft	Vbz-DCVmin, cfm/sqft	Generation, cfm/p	outdoor CO ₂ , ppm	CO ₂ space-design, ppm	CO ₂ space-DCVmin, ppm
Classroom (ages 5 - 8)	10	0.12	25	0.370	0.120	0.0168	400	1535	400
Classroom (age 9 plus)	10	0.12	35	0.470	0.120	0.0101	400	1151	400
Lecture hall (fixed seats)	7.5	0.06	150	1.185	0.060	0.0092	400	1570	400
Art classroom	10	0.18	20	0.380	0.180	0.0101	400	931	400
Science laboratory	10	0.18	25	0.430	0.180	0.0185	400	1474	400
Computer lab	10	0.12	25	0.370	0.120	0.0092	400	1024	400
School media center	10	0.12	25	0.370	0.120	0.0092	400	1024	400
Music/theater/dance	10	0.06	35	0.410	0.060	0.0185	400	1978	400
School multi-use assembly	7.5	0.06	100	0.810	0.060	0.0084	400	1437	400
Hotel guest room	5	0.06	10	0.110	0.060	0.0059	400	935	400
Barracks sleeping area	5	0.06	20	0.160	0.060	0.0059	400	1135	400
Hotel lobby	7.5	0.06	30	0.285	0.060	0.0168	400	2168	400
Office breakroom	5	0.12	50	0.370	0.120	0.0101	400	1762	400
Conference/meeting room	5	0.06	50	0.310	0.060	0.0084	400	1755	400
Main entry lobby	5	0.06	10	0.110	0.060	0.0168	400	1927	400
Office space	5	0.06	5	0.085	0.060	0.0101	400	993	400
Reception area	5	0.06	30	0.210	0.060	0.0092	400	1720	400

If the fan operates at a constant (single) speed, the UC400 Controller uses two (2) OA damper position setpoints and two CO₂ setpoints (refer to the illustrations in the section, “CO₂-Based Demand Controlled Ventilation (DCV),” p. 47):

- With the fan operating, set the Design Minimum OA Damper Position setpoint so that in brings in outdoor airflow equal to the $V_{ot-Design}$ value calculated in Step 1 (470 cfm in this example).
- With the fan operating, set the DCV Minimum OA Damper Position setpoint so that in brings in outdoor airflow equal to the $V_{ot-DCVmin}$ value calculated in Step 2 (120 cfm in this example).
- Set the CO₂ Design Setpoint equal to the CO_{2space-Design} value calculated in Step 3 (1200 ppm in this example).
- Set the CO₂ Minimum Setpoint equal to the CO_{2space-DCVmin} value calculated in Step 4 (400 ppm in this example).

If the fan operates at multiple speeds (or with single-zone VAV control), the UC400 Controller uses four OA damper position setpoints and two (2) CO₂ setpoints (refer to the illustrations in the section, “CO₂-Based Demand Controlled Ventilation (DCV),” p. 47):

- With the fan operating at maximum speed, set the Design Minimum OA Damper Position at Maximum Fan Speed setpoint so that in brings in outdoor airflow equal to the $V_{ot-Design}$ value calculated in Step 1 (470 cfm in this example).
- With the fan operating at maximum speed, set the DCV Minimum OA Damper Position at Maximum Fan Speed setpoint so that in brings in outdoor airflow equal to the $V_{ot-DCVmin}$ value calculated in Step 2 (120 cfm in this example).
- With the fan operating at minimum speed, set the Design Minimum OA Damper Position at Minimum Fan Speed setpoint so that in brings in outdoor airflow equal to the $V_{ot-Design}$ value calculated in Step 1 (470 cfm in this example).
- With the fan operating at minimum speed, set the DCV Minimum OA Damper Position at Minimum Fan Speed setpoint so that in brings in outdoor airflow equal to the $V_{ot-DCVmin}$ value calculated in Step 2 (120 cfm in this example).
- Set the CO₂ Design Setpoint equal to the CO_{2space-Design} value calculated in Step 3 (1200 ppm in this example).
- Set the CO₂ Minimum Setpoint equal to the CO_{2space-DCVmin} value calculated in Step 4 (400 ppm in this example).

The best way to adjust the OA damper setpoints is to operate the fan as stated above, and then use an airflow measurement hood (or other airflow measurement technique) to determine the OA damper position (%) setpoint that corresponds to the required outdoor airflow (V_{ot}).

However, if airflow measurement is not possible or practical, a less-accurate approach could be to calculate the OA damper position (%) setpoint that by dividing the required outdoor airflow (V_{ot}) by the fan airflow at the corresponding speed. Since damper performance is not linear (% change in damper position does not always equal the same % change in airflow passing through



Settings for CO₂-Based Demand Controlled Ventilation

the damper), this is less accurate than setting the OA damper position setpoints based on measured outdoor airflow.

Example: For the unit ventilator serving this example K-12 classroom, the fan airflow when operating at maximum speed is 1200 cfm, and the fan airflow at minimum speed is 720 cfm. As calculated in Steps 1 and 2, the design outdoor airflow rate ($V_{ot-Design}$) is 470 cfm and the DCV minimum outdoor airflow rate ($V_{ot-DCVmin}$) is 120 cfm.

- Design Minimum OA Damper Position at Maximum Fan Speed = $470 \text{ cfm} / 1200 \text{ cfm} = 40\%$
- DCV Minimum OA Damper Position at Maximum Fan Speed = $120 \text{ cfm} / 1200 \text{ cfm} = 10\%$
- Design Minimum OA Damper Position at Minimum Fan Speed = $470 \text{ cfm} / 720 \text{ cfm} = 65\%$
- DCV Minimum OA Damper Position at Minimum Fan Speed = $120 \text{ cfm} / 720 \text{ cfm} = 15\%$



Resources

- Tracer UC400 Programmable Controller Installation, Operation, and Maintenance Manual (BAS-SVX20-EN).
- Tracer UC400 Programmable Controller Installation Sheet (X39641064-01).
- Tracer TU Online Help Tracer TU Service Tool Getting Started Guide (TTU-SVN01-EN).
- Tracer SC System Controller Installation and Setup (BAS-SVX31-EN).
- BACnet Best Practices and Troubleshooting Guide (BAS-SVX51-EN).
- Tracer Graphics Editor Online Help Tracer Graphical Programming 2 (TGP2) Editor Online Help Tracer Graphical Programming (TGP2) Application Guide (BAS-APG008-EN).
- Tracer XM30 and XM32 Expansion Modules Installation, Operation, and Maintenance Manual (BAS-SVX46-EN).

Trane - by Trane Technologies (NYSE: TT), a global innovator - creates comfortable, energy efficient indoor environments for commercial and residential applications. For more information, please visit trane.com or tranetechnologies.com.

Trane has a policy of continuous product and product data improvements and reserves the right to change design and specifications without notice. We are committed to using environmentally conscious print practices.

BAS-SVX48H-EN 15 Apr 2020
Supersedes BAS-SVX48G-EN (November 2018)

©2020 Trane