

53-1003990-01
16 December 2015

Brocade G620

Hardware Installation Guide

BROCADE 

© 2015, Brocade Communications Systems, Inc. All Rights Reserved.

ADX, Brocade, Brocade Assurance, the B-wing symbol, DCX, Fabric OS, HyperEdge, ICX, MLX, MyBrocade, OpenScript, The Effortless Network, VCS, VDX, Vplane, and Vyatta are registered trademarks, and Fabric Vision and vADX are trademarks of Brocade Communications Systems, Inc., in the United States and/or in other countries. Other brands, products, or service names mentioned may be trademarks of others.

Notice: This document is for informational purposes only and does not set forth any warranty, expressed or implied, concerning any equipment, equipment feature, or service offered or to be offered by Brocade. Brocade reserves the right to make changes to this document at any time, without notice, and assumes no responsibility for its use. This informational document describes features that may not be currently available. Contact a Brocade sales office for information on feature and product availability. Export of technical data contained in this document may require an export license from the United States government.

The authors and Brocade Communications Systems, Inc. assume no liability or responsibility to any person or entity with respect to the accuracy of this document or any loss, cost, liability, or damages arising from the information contained herein or the computer programs that accompany it.

The product described by this document may contain open source software covered by the GNU General Public License or other open source license agreements. To find out which open source software is included in Brocade products, view the licensing terms applicable to the open source software, and obtain a copy of the programming source code, please visit <http://www.brocade.com/support/oscd>.

Contents

- Preface..... 7**
 - Document conventions..... 7
 - Text formatting conventions..... 7
 - Command syntax conventions..... 7
 - Notes, cautions, and warnings..... 8
 - Brocade resources..... 9
 - Contacting Brocade Technical Support..... 9
 - Document feedback..... 10

- About This Document..... 11**
 - Supported hardware and software..... 11
 - What's new in this document..... 11

- Device Overview..... 13**
 - Hardware features..... 13
 - License options..... 14
 - Port-side view..... 14
 - Nonport-side view..... 15
 - Device management options..... 15

- Preparing for Installation..... 17**
 - Safety precautions..... 17
 - General precautions..... 17
 - ESD precautions..... 18
 - Power precautions..... 18
 - Lifting and weight-related precautions..... 19
 - Laser precautions..... 20
 - Facility requirements..... 20
 - Quick installation checklist..... 21
 - Shipping carton contents..... 23

- Mounting the Device..... 25**
 - Mounting options..... 25
 - Precautions specific to mounting..... 25
 - Standalone installation 26
 - Installing the Universal Four-Post Rack Kit (XBR-R000296)..... 26
 - Installation requirements..... 27
 - Time and items required..... 28
 - Flush-front mounting..... 30
 - Flush-rear (recessed) mounting..... 35
 - Installing the Universal Two-Post Rack kit (XBR-R000294)..... 40
 - Installation requirements..... 41
 - Time and items required..... 41
 - Flush-front mounting..... 42
 - Mid-mounting..... 46

Initial Setup and Verification.....	51
Items required.....	51
Providing power to the device.....	51
Establishing a first-time serial connection.....	52
Configuring the IP address.....	53
Using DHCP to set the IP address.....	53
Setting a static IP address.....	53
Setting the date and time.....	53
Setting the time zone.....	54
Synchronizing local time with an external source.....	55
Customizing the chassis name and switch name.....	55
Establishing an Ethernet connection.....	56
Setting the domain ID.....	56
Verifying correct operation.....	56
Backing up the configuration.....	57
Powering down the device.....	58
Installing Transceivers and Cables.....	59
Time and items required.....	59
Precautions specific to transceivers and cables.....	60
Cleaning the fiber-optic connectors.....	60
Managing cables.....	60
Installing an SFP+ transceiver.....	61
Replacing an SFP+ transceiver.....	62
Installing a QSFP transceiver.....	63
Replacing a QSFP transceiver.....	64
Verifying the operation of new transceivers.....	65
Monitoring the Device.....	67
Interpreting port-side LEDs.....	67
System power LED.....	67
System status LED.....	68
FC port status LED.....	69
QSFP port status LED.....	69
Interpreting nonport-side LEDs.....	70
Power supply and fan assembly status LED.....	71
Interpreting the POST results.....	71
Interpreting the BOOT results.....	72
Running diagnostic tests.....	72
Power Supply and Fan Assembly.....	75
Power supply and fan assembly overview.....	75
Precautions specific to the power supply and fan assemblies.....	76
Identifying the airflow direction.....	77
Power supply and fan assembly status LED.....	78
Power supply and fan assembly unit fault indicators.....	78
Power supply and fan assembly task guide.....	78
Time and items required.....	79
Recording power supply and fan assembly critical information.....	79
Removing a power supply and fan assembly.....	80
Inserting a new power supply and fan assembly.....	81
Verifying the operation of the power supply and fan assemblies.....	82

Brocade G620 Technical Specifications.....	83
Regulatory Statements.....	91
BSMI statement (Taiwan).....	91
Canadian requirements.....	91
CE statement.....	91
China CC statement.....	92
China ROHS.....	93
FCC warning (US only).....	93
Germany statement.....	93
KCC statement (Republic of Korea).....	93
VCCI statement.....	93
Cautions and Danger Notices.....	95
Danger Notices.....	95
Cautions.....	98

Preface

- Document conventions..... 7
- Brocade resources..... 9
- Contacting Brocade Technical Support..... 9
- Document feedback..... 10

Document conventions

The document conventions describe text formatting conventions, command syntax conventions, and important notice formats used in Brocade technical documentation.

Text formatting conventions

Text formatting conventions such as boldface, italic, or Courier font may be used in the flow of the text to highlight specific words or phrases.

Format	Description
bold text	Identifies command names Identifies keywords and operands Identifies the names of user-manipulated GUI elements Identifies text to enter at the GUI
<i>italic text</i>	Identifies emphasis Identifies variables Identifies document titles
<code>Courier font</code>	Identifies CLI output Identifies command syntax examples

Command syntax conventions

Bold and italic text identify command syntax components. Delimiters and operators define groupings of parameters and their logical relationships.

Convention	Description
bold text	Identifies command names, keywords, and command options.
<i>italic text</i>	Identifies a variable.
value	In Fibre Channel products, a fixed value provided as input to a command option is printed in plain text, for example, --show WWN.

Convention	Description
[]	Syntax components displayed within square brackets are optional. Default responses to system prompts are enclosed in square brackets.
{ x y z }	A choice of required parameters is enclosed in curly brackets separated by vertical bars. You must select one of the options. In Fibre Channel products, square brackets may be used instead for this purpose.
x y	A vertical bar separates mutually exclusive elements.
< >	Nonprinting characters, for example, passwords, are enclosed in angle brackets.
...	Repeat the previous element, for example, <i>member[member...]</i> .
\	Indicates a “soft” line break in command examples. If a backslash separates two lines of a command input, enter the entire command at the prompt without the backslash.

Notes, cautions, and warnings

Notes, cautions, and warning statements may be used in this document. They are listed in the order of increasing severity of potential hazards.

NOTE

A Note provides a tip, guidance, or advice, emphasizes important information, or provides a reference to related information.

ATTENTION

An Attention statement indicates a stronger note, for example, to alert you when traffic might be interrupted or the device might reboot.



CAUTION

A Caution statement alerts you to situations that can be potentially hazardous to you or cause damage to hardware, firmware, software, or data.



DANGER

A Danger statement indicates conditions or situations that can be potentially lethal or extremely hazardous to you. Safety labels are also attached directly to products to warn of these conditions or situations.

Brocade resources

Visit the Brocade website to locate related documentation for your product and additional Brocade resources.

You can download additional publications supporting your product at www.brocade.com. Select the Brocade Products tab to locate your product, then click the Brocade product name or image to open the individual product page. The user manuals are available in the resources module at the bottom of the page under the Documentation category.

To get up-to-the-minute information on Brocade products and resources, go to [MyBrocade](#). You can register at no cost to obtain a user ID and password.

Release notes are available on [MyBrocade](#) under Product Downloads.

White papers, online demonstrations, and data sheets are available through the [Brocade website](#).

Contacting Brocade Technical Support

As a Brocade customer, you can contact Brocade Technical Support 24x7 online, by telephone, or by e-mail. Brocade OEM customers contact their OEM/Solutions provider.

Brocade customers

For product support information and the latest information on contacting the Technical Assistance Center, go to <http://www.brocade.com/services-support/index.html>.

If you have purchased Brocade product support directly from Brocade, use one of the following methods to contact the Brocade Technical Assistance Center 24x7.

Online	Telephone	E-mail
<p>Preferred method of contact for non-urgent issues:</p> <ul style="list-style-type: none"> • My Cases through MyBrocade • Software downloads and licensing tools • Knowledge Base 	<p>Required for Sev 1-Critical and Sev 2-High issues:</p> <ul style="list-style-type: none"> • Continental US: 1-800-752-8061 • Europe, Middle East, Africa, and Asia Pacific: +800-AT FIBREE (+800 28 34 27 33) • For areas unable to access toll free number: +1-408-333-6061 • Toll-free numbers are available in many countries. 	<p>support@brocade.com</p> <p>Please include:</p> <ul style="list-style-type: none"> • Problem summary • Serial number • Installation details • Environment description

Brocade OEM customers

If you have purchased Brocade product support from a Brocade OEM/Solution Provider, contact your OEM/Solution Provider for all of your product support needs.

- OEM/Solution Providers are trained and certified by Brocade to support Brocade® products.
- Brocade provides backline support for issues that cannot be resolved by the OEM/Solution Provider.

- Brocade Supplemental Support augments your existing OEM support contract, providing direct access to Brocade expertise. For more information, contact Brocade or your OEM.
- For questions regarding service levels and response times, contact your OEM/Solution Provider.

Document feedback

To send feedback and report errors in the documentation you can use the feedback form posted with the document or you can e-mail the documentation team.

Quality is our first concern at Brocade and we have made every effort to ensure the accuracy and completeness of this document. However, if you find an error or an omission, or you think that a topic needs further development, we want to hear from you. You can provide feedback in two ways:

- Through the online feedback form in the HTML documents posted on www.brocade.com.
- By sending your feedback to documentation@brocade.com.

Provide the publication title, part number, and as much detail as possible, including the topic heading and page number if applicable, as well as your suggestions for improvement.

About This Document

- [Supported hardware and software](#)..... 11
- [What's new in this document](#)..... 11

Supported hardware and software

The following tables list the power supply and fan assemblies, and rack mount kits supported on the Brocade G620 FC switch running Fabric OS 8.0.0 or later.

TABLE 1 Power supply and fan assemblies

Part number	Description	Introduced (OS)	Currently supported (OS)
XBR-G250WPSAC-F	250W AC power supply with nonport-side exhaust airflow	Fabric OS 8.0.0	Yes
XBR-G250WPSAC-R	250W AC power supply with nonport-side intake airflow	Fabric OS 8.0.0	Yes

TABLE 2 Rack mount kits

Part number	Description
XBR-R000294	Universal two-post mid-mount or flush-mount rack kit
XBR-R000296	Universal four-post fixed rack mount kit

What's new in this document

This is a new document.

What's new in this document

Device Overview

- [Hardware features](#)..... 13
- [License options](#)..... 14
- [Port-side view](#)..... 14
- [Nonport-side view](#)..... 15
- [Device management options](#)..... 15

Hardware features

The Brocade G620 offers the following features and capabilities:

- Up to 48 auto-sensing ports supporting high-performance 32-Gbps SFP+ ports technology in a single domain.
- Up to four 128-Gbps (4 x 32-Gbps) QSFP ports to connect to the QSFP ports of another Brocade G620 device.
- Dynamic Ports on Demand (Dynamic-POD) scaling from a base configuration of 24 ports to 64 ports (two 12-port SFP+ PODs and one 16-port QSFP POD).
- 4-, 8-, 16-, and 32-Gbps auto-sensing Fibre Channel switch and router ports.
 - A 32-Gbps optical transceiver can auto-negotiate to 32 Gbps, 16 Gbps, or 8 Gbps.
 - A 16-Gbps optical transceiver can auto-negotiate to 16 Gbps, 8 Gbps, or 4 Gbps.

NOTE

The port speed is determined by the maximum speed supported by the optical transceiver at the other end of the link.

- 10-Gbps manually set capability on FC ports (requires the optional 10-Gigabit FCIP/Fibre Channel license).
 - 10-Gbps performance is enabled by 10-Gbps SFP+ transceivers.
 - Ports can be configured for 10-Gbps for metro connectivity.
- Universal ports self-configure as a E_Ports, F_Ports, M_Ports, or D_Ports. EX_Ports can be activated on a per-port basis with the optional Integrated Routing license.
 - A Diagnostic Port (D_Port) provides diagnostics, troubleshooting, and verification services for the physical media.
- Support for port-side exhaust or nonport-side exhaust airflow for cooling.
- Brocade small form-factor pluggable plus (SFP+) optical transceivers support any combination of Short Wavelength (SWL), Long Wavelength (LWL) or Extended Long Wavelength (ELWL) optical media among the switch ports.
- Extended distance Fibre Channel to support long distance native FC connectivity.
- 10-Gbps Fibre Channel integration on any selected port provides DWDM metro connectivity on the same switch.
- Port-to-port latency is minimized to 700 nanoseconds by using cut-through frame switching at 32 Gbps.
- High performance T1022 processor with two cores operating at 1.2 GHz delivers high performance, scalability, and advanced Fabric Vision functionality.

- One 10BASE-T / 100BASE-TX / 1000BASE-T RJ45 connector Ethernet port for management connection. In conjunction with EZSwitchSetup, this port supports switch IP address discovery and configuration, eliminating the need to attach a serial cable to configure the switch IP address.
- One RS-232 3-wire (Tx, Rx, and Gnd) universal asynchronous receiver/transmitter (UART) serial port to BMC with RJ-45 connector for debugging initial switch setup (if not using EZSwitch Setup) and factory default restoration. Integral LEDs remain unlit at all times.
- One internal e-USB module provides 2 GB of persistent storage, increased serviceability, and error logging functionality by facilitating easier firmware upgrades and downloads of the system log files.
- One external USB connector.
- Two hot-swappable redundant integrated power supply and fan assembly field-replaceable units.
- 48 hot-pluggable SFP+ optical transceiver slots and 4 hot-pluggable QSFP optical transceiver slots.
- 64 bicolor (green/amber) LEDs to indicate the status for each port.
- One green LED to indicate valid system power.
- One bicolor (green/amber) LED to indicate the system status.
- Two Ethernet LEDs: one bicolor (green/amber) LED to indicate link at 1000/100/10 Mbps and one green LED to indicate activity.
- SEEPROM for switch identification.
- Real-time power monitoring.
- Real-time voltage monitoring.
- Real-time fan monitoring including airflow direction.
- Real-time digital thermometers for temperature monitoring.
- Real-time clock (RTC) with battery.

License options

The Brocade G620 uses a capacity-based Ports on Demand (POD) license method. Refer to the *Brocade Fabric OS Software Licensing Guide* for more details.

Port-side view

The following illustration shows the port-side view of the Brocade G620 Fibre Channel switch.

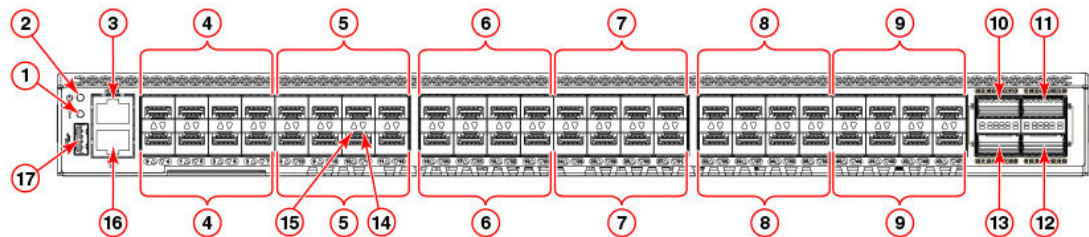

- | | |
|---|---|
| 1 System status LED | 5 SFP+ FC (four upper and four lower ports 8-15) |
| 2 System power LED | 6 SFP+ FC (four upper and four lower ports 16-23) |
| 3 UART RJ-45 serial console port | 7 SFP+ FC (four upper and four lower ports 24-31) |
| 4 SFP+ FC (four upper and four lower ports 0-7) | |

- | | |
|---|--|
| 8 SFP+ FC (four upper and four lower) ports 32-39 | 13 QSFP port 1 (FC ports 52-55) |
| 9 SFP+ FC (four upper and four lower) ports 40-47 | 14 SFP+ (lower) port 14 status LED |
| 10 QSFP port 0 (FC ports 48-51) | 15 SFP+ (upper) port 10 status LED |
| 11 QSFP port 2 (FC ports 56-59) | 16 1000Base-T/100Base-TX/10Base-T RJ-45 Ethernet management port |
| 12 QSFP port 3 (FC ports 60-63) | 17 USB port |

FIGURE 1 Port-side view

NOTE

All the ports are connected to a single ASIC.

Nonport-side view

The following illustration shows the nonport-side view of the Brocade G620 FC switch.

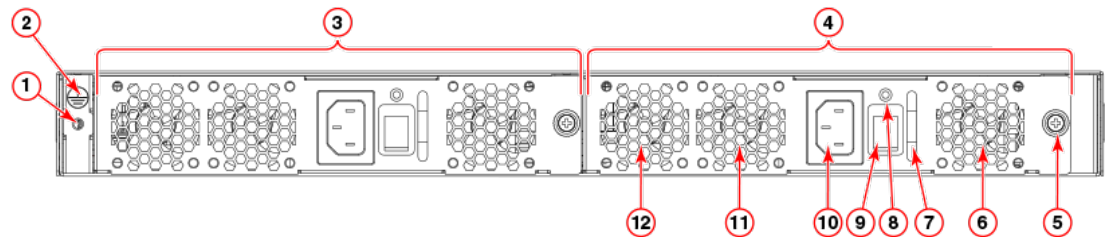

- | | |
|-----------------------------------|--|
| 1 Ground sticker | 8 Power supply and fan assembly status LED |
| 2 Ground cable connector | 9 Power-on switch |
| 3 Power supply and fan assembly 2 | 10 Power supply receptacle |
| 4 Power supply and fan assembly 1 | 11 Fan 2 |
| 5 Captive screw | 12 Fan 3 |
| 6 Fan 1 | |
| 7 Handle | |

FIGURE 2 Nonport-side view with AC power supply and fan assembly units

Device management options

You can use the management functions built into the device to monitor the fabric topology, port status, physical status, and other information to help you analyze switch performance and to accelerate system debugging. The device automatically performs power-on self-test (POST) each time it is turned on. Any errors are recorded in the RASlog messages.

You can manage the device using any of the management options listed in the following table.

TABLE 3 Management options for the device

Management tool	Out-of-band support	In-band support	Reference documents
Command line interface (CLI) Up to two admin sessions and four user sessions simultaneously.	Ethernet or serial connection	IP over Fibre Channel	<i>Fabric OS Administrator's Guide</i> <i>Fabric OS Command Reference</i>
Brocade EZSwitchSetup EZSwitchSetup helps to complete the basic configuration for single-switch setup.	Ethernet or serial connection	IP over Fibre Channel	<i>Brocade G620 EZSwitchSetup QuickStart Guide</i> <i>Brocade EZSwitchSetup Administrator's Guide</i>
Brocade Web Tools	Ethernet or serial connection	IP over Fibre Channel	<i>Web Tools Administrator's Guide</i>
Standard SNMP applications	Ethernet or serial connection	IP over Fibre Channel	<i>Fabric OS MIB Reference</i>
Management Server	Ethernet or serial connection	Native in-band interface (over HBA only)	<i>Fabric OS Administrator's Guide</i> <i>Fabric OS Command Reference</i>
Brocade Network Advisor (BNA) BNA must be purchased separately.	Ethernet or serial connection	IP over Fibre Channel	Brocade Network Advisor documentation set

Preparing for Installation

- Safety precautions..... 17
- Facility requirements..... 20
- Quick installation checklist..... 21
- Shipping carton contents..... 23

Safety precautions

When using this product, observe all danger, caution, and attention notices in this manual. The safety notices are accompanied by symbols that represent the severity of the safety condition

Refer to Cautions and Danger Notices at the end of this guide for translations of safety notices for this product.

General precautions



DANGER

The procedures in this manual are for qualified service personnel.



DANGER

Before beginning the installation, see the precautions in "Power precautions."



DANGER

Be careful not to accidentally insert your fingers into the fan tray while removing it from the chassis. The fan may still be spinning at a high speed.



CAUTION

Changes or modifications made to this device that are not expressly approved by the party responsible for compliance could void the user's authority to operate the equipment.



CAUTION

Disassembling any part of the power supply and fan assembly voids the warranty and regulatory certifications. There are no user-serviceable parts inside the power supply and fan assembly.



CAUTION

Make sure the airflow around the front, sides, and back of the device is not restricted.



CAUTION

Ensure that the airflow direction of the power supply unit matches that of the installed fan tray. The power supplies and fan trays are clearly labeled with either a green arrow with an "E", or an orange arrow with an "I."



CAUTION

Never leave tools inside the chassis.



CAUTION

To protect the serial port from damage, keep the cover on the port when not in use.



CAUTION

If you do not install a module or a power supply in a slot, you must keep the slot filler panel in place. If you run the chassis with an uncovered slot, the system will overheat.



CAUTION

Do not install the device in an environment where the operating ambient temperature might exceed 40°C (104°F).

ESD precautions



DANGER

For safety reasons, the ESD wrist strap should contain a series 1 megaohm resistor.



CAUTION

Before plugging a cable into any port, be sure to discharge the voltage stored on the cable by touching the electrical contacts to ground surface.



CAUTION

Static electricity can damage the chassis and other electronic devices. To avoid damage, keep static-sensitive devices in their static-protective packages until you are ready to install them.

NOTE

Wear a wrist grounding strap connected to the chassis ground (if the device is plugged in) or to a bench ground.

Power precautions



DANGER

Make sure that the power source circuits are properly grounded, then use the power cord supplied with the device to connect it to the power source.



DANGER

If the installation requires a different power cord than the one supplied with the device, make sure you use a power cord displaying the mark of the safety agency that defines the regulations for power cords in your country. The mark is your assurance that the power cord can be used safely with the device.



DANGER

This device might have more than one power cord. To reduce the risk of electric shock, disconnect all power cords before servicing.



DANGER

Remove both power cords before servicing.



DANGER

Disconnect the power cord from all power sources to completely remove power from the device.



DANGER

To avoid high voltage shock, do not open the device while the power is on.



DANGER

Risk of explosion if battery is replaced by an incorrect type. Dispose of used batteries according to the instructions.



CAUTION

Use a separate branch circuit for each power cord, which provides redundancy in case one of the circuits fails.



CAUTION

Ensure that the device does not overload the power circuits, wiring, and over-current protection. To determine the possibility of overloading the supply circuits, add the ampere (amp) ratings of all devices installed on the same circuit as the device. Compare this total with the rating limit for the circuit. The maximum ampere ratings are usually printed on the devices near the input power connectors.



CAUTION

The power supply switch must be in the off position when you insert the power supply into the chassis. Damage to the switch can result if a live power supply is installed.



CAUTION

Carefully follow the mechanical guides on each side of the power supply slot and make sure the power supply is properly inserted in the guides. Never insert the power supply upside down.

Lifting and weight-related precautions



DANGER

Use safe lifting practices when moving the product.



DANGER

Mount the devices you install in a rack as low as possible. Place the heaviest device at the bottom and progressively place lighter devices above.



DANGER

Make sure the rack housing the device is adequately secured to prevent it from becoming unstable or falling over.



CAUTION

Do not use the port cover tabs to lift the module. They are not designed to support the weight of the module, which can fall and be damaged.



CAUTION

To prevent damage to the chassis and components, never attempt to lift the chassis using the fan or power supply handles. These handles were not designed to support the weight of the chassis.

Laser precautions



DANGER

All fiber-optic interfaces use Class 1 lasers.



DANGER

Use only optical transceivers that are qualified by Brocade Communications Systems, Inc. and comply with the FDA Class 1 radiation performance requirements defined in 21 CFR Subchapter I, and with IEC 825 and EN60825. Optical products that do not comply with these standards might emit light that is hazardous to the eyes.

Facility requirements

Before installing the device, be sure the following facilities requirements are met.

TABLE 4 Facility requirements

Type	Requirements
Electrical	<ul style="list-style-type: none">Adequate supply circuit, line fusing, and wire size, as specified by the electrical rating on the switch nameplateCircuit protected by a circuit breaker and grounded in accordance with local electrical codes <p>Refer to the Technical Specifications at the end of this guide for complete power supply specifications.</p>

TABLE 4 Facility requirements (Continued)

Type	Requirements
Thermal	<ul style="list-style-type: none"> A minimum airflow of 79.8 cubic meters/hour (47 cubic ft/min.) available in the immediate vicinity of the switch
	<p>NOTE</p> <p>Although this airflow may exceed the airflow maximum listed in the device Technical Specifications, the additional airflow is recommended to pressurize the inlet (cool side) of rack installations relative to the exhaust side to minimize recirculation of hot air back to the inlet side.</p>
Rack (when rack-mounted)	<ul style="list-style-type: none"> One rack unit (1U) in a 48.3 cm (19-inch) rack All equipment in the rack grounded through a reliable branch circuit connection Additional weight of switch not to exceed the rack's weight limits Rack secured to ensure stability in case of unexpected movement

Quick installation checklist

This checklist provides a high-level overview of the basic installation process from the planning stage to the point where the device comes online and is ready to be deployed. Completing all the tasks in the suggested order ensures successful installation. Brocade recommends that you print this checklist and take it to the installation site.

Pre-installation tasks

Review all installation requirements ahead of time as part of your site preparation. Careful planning and site preparation ensures seamless installation, especially when installing multiple devices.

TABLE 5 Installation prerequisites

Task	Task details or additional information	Completed
Unpack the device.	Take an inventory of the hardware components included in your shipment. Refer to Shipping carton contents on page 23.	
Gather necessary components and required tools.	Review the time and items required information at the beginning of each chapter to ensure you have gathered all necessary components required for the following installation tasks: <ul style="list-style-type: none"> Mounting the Device on page 25 Power Supply and Fan Assembly on page 75 Installing Transceivers and Cables on page 59 	
Review the safety precautions.	Refer to Safety precautions on page 17. For translations, refer to Cautions and Danger Notices on page 95 at the end of this guide.	

TABLE 5 Installation prerequisites (Continued)

Task	Task details or additional information	Completed
Plan the installation.	Decide whether you want to install the unit on a flat surface or in a rack. For rack installation, obtain the appropriate rack mount kit. Refer to Mounting options on page 25.	
Review and verify installation requirements.	Verify that the following requirements are met. Refer to Facility requirements on page 20. <ul style="list-style-type: none"> • Power requirements • Environmental requirements • Clearance for standalone or rack installation 	
Gather network configuration parameters.	<ul style="list-style-type: none"> • IP address: • Subnet mask: • Default gateway: • Domain ID: • Time zone: 	

Installation and initial configuration

The initial setup includes mounting the device on a flat surface or in a rack and completing the configuration tasks necessary to bring the device online and verify the operation.

TABLE 6 Installation and basic system configuration

Task	Task details or additional information	Completed
Mount the device.	Choose one of the following mounting options: <ul style="list-style-type: none"> • Mount the device as a standalone unit. Refer to Standalone installation on page 26. • Mount the device in a four-post rack. Refer to Installing the Universal Four-Post Rack Kit (XBR-R000296) on page 26. • Mount the device in a two-post rack. Refer to Installing the Universal Two-Post Rack kit (XBR-R000294) on page 40. 	
Check the airflow of the power supply and fan assembly	The airflow direction of the power supply and fan should match. The power supplies and fan trays are clearly labeled with either a green arrow with an "E", or an orange arrow with an "I." For more details, refer to Identifying the airflow direction on page 77.	
Gather all components required for the initial setup.	Refer to Items required on page 51.	
Provide power to the device.	Refer to Providing power to the device on page 51.	
Attach a management station, establish a serial connection, and change the default passwords (optional).	Refer to Establishing a first-time serial connection on page 52. After completing this task, log in to the serial port to configure the device.	
Set the IP address, subnet mask, and the default gateway IP address.	Use the <code>ipaddrset</code> command to configure a static device IP address, subnet mask, and gateway IP address, or you can use a DHCP server to obtain the information dynamically. Refer to Configuring the IP address on page 53.	

TABLE 6 Installation and basic system configuration (Continued)

Task	Task details or additional information	Completed
Set the date and time.	<ul style="list-style-type: none"> Use the date command to display and set the date and time. Use the timezone command to display and set the time zone. Use the clockserver command to synchronize the time with an external NTP server. <p>Refer to Setting the date and time on page 53 for more information.</p>	
Customize the switch name and chassis name.	<ul style="list-style-type: none"> Use the switchname command to change the default switch name. Use the chassisname command to change the default chassis name. <p>Refer to Customizing the chassis name and switch name on page 55 for more information.</p>	
Establish an Ethernet connection.	By establishing an Ethernet connection, you can complete the device configuration using a serial session, Telnet, or management application, such as Brocade Network Advisor. Refer to Establishing an Ethernet connection on page 56.	
Optional: Configure the DNS service.	Use the dnsconfig command to create DNS server entries. Refer to the <i>Fabric OS Administrator's Guide</i> .	
Optional: Customize the domain ID.	Use the configure command to change the domain ID (default ID is 1). Refer to Setting the domain ID on page 56 for more information.	
Verify that the device operates correctly.	<ul style="list-style-type: none"> Check the LEDs to verify operation of functional parts. Refer to Interpreting port-side LEDs on page 67 and Interpreting nonport-side LEDs on page 70. The following commands can be useful to establish an operational baseline for the device. Refer to the <i>Fabric OS Command Reference</i> for more information on these commands. <ul style="list-style-type: none"> psshow fanshow tempshow historyshow errdump 	
Back up the configuration.	Use the interactive configupload command to back up the configuration. Refer to Verifying correct operation on page 56 for more information.	
Optional: Power off the devices.	Enter the shutdown command and wait for the device to power down, and then unplug the power cords. Refer to Powering down the device on page 58 for more information.	

Shipping carton contents

When unpacking the device, verify that the contents of the shipping carton is complete. Save the shipping carton and packaging in the event you need to return the shipment.

- The Brocade G620 device
- An accessory kit containing the following items:
 - A serial cable
 - Two 6-ft. power cords

Preparing for Installation

- Power cord retainer clips
- Rubber feet.
- China-RoHS Hazardous/Toxic Substance statement
- Network Advisor web pointer card.
- EZSwitch web pointer card
- Brocade documentation web pointer card
- Inner foam

Mounting the Device

- Mounting options..... 25
- Precautions specific to mounting..... 25
- Standalone installation 26
- Installing the Universal Four-Post Rack Kit (XBR-R000296)..... 26
- Installing the Universal Two-Post Rack kit (XBR-R000294)..... 40

Mounting options

You can install the device in several ways:

- As a standalone unit on a flat surface, for example, a table top. Use the rubber feet included with the shipment to secure the device on the surface. No other equipment is required for desktop installation.
- In a four-post EIA rack: You will need a Universal Four-Post Rack Kit (XBR-R000296) to install devices in EIA racks that are between L-13.7 to 81.28 cm deep (L-5.0 to 32.0 in.), where L is the chassis depth.
- In a two-post Telco rack: You will need a Universal Two-Post Rack Kit (XBR-R000294) to install 1U and 2U devices in a two-post telecommunications (Telco) rack.

NOTE

Review the Safety Precautions before mounting the device.

Precautions specific to mounting

The following precautions specifically apply to mounting the device.



DANGER

Use safe lifting practices when moving the product.



DANGER

Mount the devices you install in a rack as low as possible. Place the heaviest device at the bottom and progressively place lighter devices above.



CAUTION

Make sure the airflow around the front, sides, and back of the device is not restricted.



CAUTION

Never leave tools inside the chassis.



CAUTION

Do not use the port cover tabs to lift the module. They are not designed to support the weight of the module, which can fall and be damaged.



CAUTION

To prevent damage to the chassis and components, never attempt to lift the chassis using the fan or power supply handles. These handles were not designed to support the weight of the chassis.

Standalone installation

Complete the following steps to install the device as a standalone unit on a table.

1. Unpack the device and verify the items listed under [Shipping carton contents](#) on page 23 are present and undamaged.
2. Apply the adhesive rubber feet to the underside of the device. The rubber feet help prevent the device from sliding off the supporting surface.
 - a) Clean the indentations at each corner of the bottom of the device to ensure that they are free of dust or other debris that might lessen the adhesion of the feet.
 - b) With the adhesive side against the chassis, place one rubber foot in each indentation and press into place.
3. Place the device on a sturdy flat surface.
4. Provide power to the device as described in [Providing power to the device](#) on page 51.

NOTE

Do not connect the device to the network until the IP address is set correctly. For instructions on how to set the IP address, refer to [Configuring the IP address](#) on page 53.

Installing the Universal Four-Post Rack Kit (XBR-R000296)

Use the following instructions to install a device in EIA racks that are between L-12.7 to 81.28 cm deep (L-5.0 to 32.0 in.), where L is the chassis depth, using the *Universal Four-Post Rack Kit (XBR-R000296)*.

There are two ways you can mount the device in a four-post rack:

- With the port side flush with the front posts
- With the nonport side flush with the rear posts in a recessed position

A recessed position allows a more gradual bend in the fiber-optic cables connected to the switch and less interference in the aisle at the front of the rack.

NOTE

Although this document describes how to install both single height (1U) and double height (2U) switches, the illustrations show a 1U switch as a typical installation.

NOTE

Hardware devices illustrated in these procedures are only for reference and may not depict the device you are installing into the rack.

Installation requirements

Provide space in an EIA rack with the following minimum and maximum distances between the front and back posts.

NOTE

For 1U and 2U devices, two people are required to install the device in a rack. One person holds the device, while the other screws in the front and rear "L" brackets.

TABLE 7 Space requirements

Chassis with port-side side vents	Notes	Chassis depth	Minimum rack depth	Maximum rack depth
No	Applicable to port-side and nonport-side flush mounts.	L	L-12.7 cm (L-5 in.)	81.28 cm (32 in.)
Yes	Applicable to port-side flush mounts.	L	L-12.7 cm (L-5 in.)	81.28 cm (32 in.)
Yes	Applicable to nonport-side flush mounts.	L	L	81.28 cm (32 in.)

Note that if chassis depth (L) is less than 40.64 cm (16 in.), the chassis will not fit into a rack with a maximum depth of 81.28 cm (32 in.) using the universal four-post rack kit. The maximum rack depth for a chassis less than 40.64 cm (16 in.) is 81.28 cm (32 in.) minus the difference between the chassis depth and 40.64 cm (16 in.). For example, a chassis with a depth (L) of 35.56 cm (14 in.) is 5.08 cm (2 in.) smaller than 40.64 cm (16 in.), so it will install into a rack with a maximum depth of 81.28 cm (32 in.) - 5.08 cm (2 in.) = 76.2 cm (30 in.).

- Verify that the additional weight of the device does not exceed the rack weight limits.
- Ensure that an electrical branch circuit with the following characteristics is available:
 - Required voltage and frequency as indicated in the Technical Specifications (200-240 VAC is always preferred).
 - Protection by a circuit breaker in accordance with local electrical codes.
 - Supply circuit, line fusing, and wire size that conform to the electrical rating on the device nameplate.
 - Grounded outlet compatible with the power cord and installed by a licensed electrician.
- Ensure that all equipment installed in the rack is grounded through a reliable branch circuit connection. Do not rely on a secondary connection to a branch circuit, such as a power strip.
- Ensure that the rack is mechanically secured to ensure stability.
- Ensure that the air temperature at the fan inlet is less than 40°C (104°F) during device operation.
- Ensure that the airflow available at the air vents meets the minimum requirements for the device.

NOTE

Install the device with the airflow aligned with any other devices in the rack. Some devices have airflow running from port side to fan side and others have the opposite arrangement. Make sure that the airflow for all devices moves in the same direction to maximize cooling.

Time and items required

Allow 15 to 30 minutes to complete the installation.

The following items are required to install the device using the Universal Four-Post Rack Kit:

- #2 Phillips torque screwdriver
- 1/4-inch slotted-blade torque screwdriver

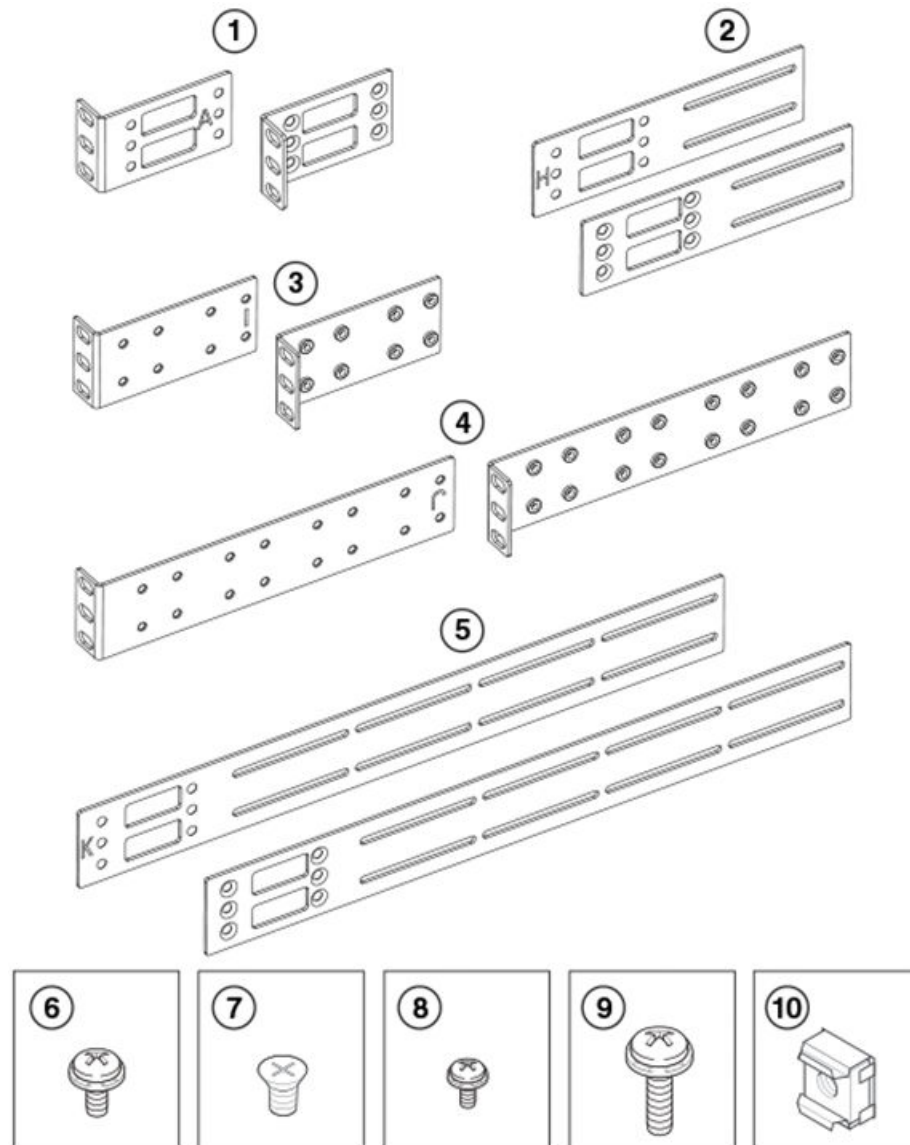

- | | | | |
|---|--|----|--|
| 1 | Front brackets (2) | 7 | Screw, 8-32 x 5/16-in., flathead Phillips (16) |
| 2 | Extension brackets, medium (2) | 8 | Screw, 6-32 x 1/4-in., panhead Phillips (8) |
| 3 | Rear brackets, short (2) | 9 | Screw, 10-32 x 5/8-in., panhead Phillips (8) |
| 4 | Rear brackets, long (2) | 10 | Retainer nut, 10-32 (8) |
| 5 | Extension brackets, long (2) | | |
| 6 | Screw, 8-32 x 5/16-in., panhead Phillips (8) | | |

FIGURE 3 Items in the Universal Four-Post Rack Kit

Ensure that the items listed and illustrated in [Figure 3](#) are included in the kit. Note that not all parts may be used with certain installations depending on the device type.



CAUTION

Use the screws specified in the procedure. Using longer screws can damage the device.

Flush-front mounting



CAUTION

The device must be turned off and disconnected from the fabric during this procedure.

NOTE

The illustrations in the rack installation procedures show a 1U device, but the instructions are the same for a 2U device. The illustrations in the rack installation procedures are for reference only and may not show the actual device.

Complete the following tasks to install the device in a four-post rack:

1. [Attaching the front brackets](#) on page 30
2. [Attaching the extension brackets to the device](#) on page 31
3. [Installing the device in the rack](#) on page 32
4. [Attaching the rear brackets to the extensions](#) on page 33
5. [Attaching the rear brackets to the rack posts](#) on page 34

Attaching the front brackets

Complete the following steps to attach the front brackets to the device.

1. Position the right front bracket with the flat side against the right side of the device at the front of the device, as shown in [Figure 4](#).
2. Insert four 8-32 x 5/16-in. flathead screws through the vertically aligned holes in the bracket and then into the holes on the side of the device. Use the upper and lower screw holes, leaving the center holes empty.
3. Repeat step 1 and step 2 to attach the left front bracket to the left side of the device.
4. Tighten all the 8-32 x 5/16-in. screws to a torque of 15 in-lb (17 cm-kg).

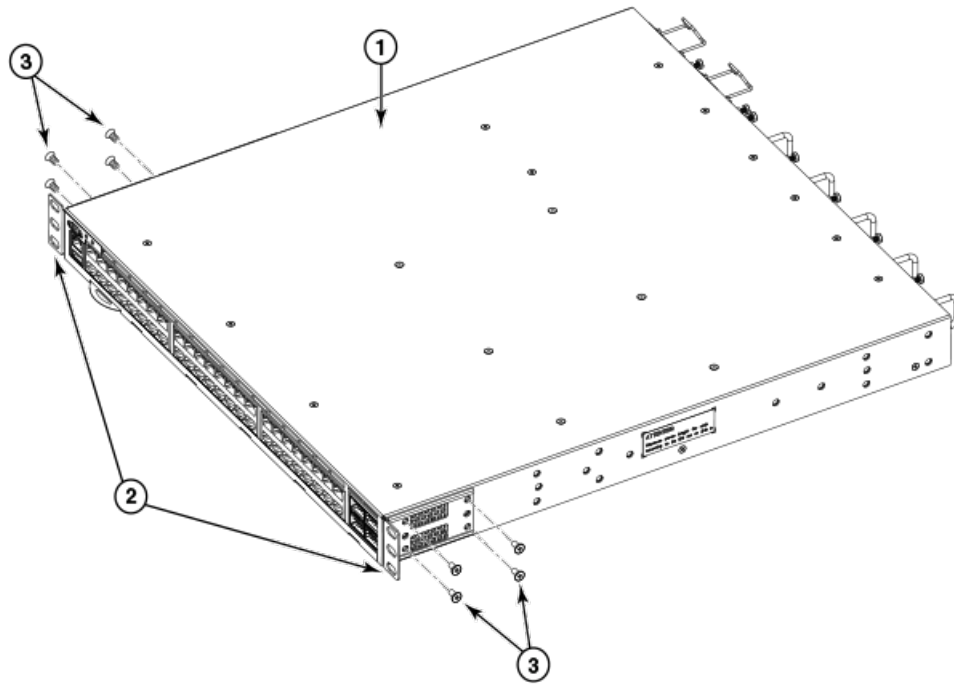

- 1 The Brocade device
- 2 Front brackets
- 3 Screws, 8-32 x 5/16-in., flathead Phillips

FIGURE 4 Attaching the front brackets

Attaching the extension brackets to the device

Complete the following steps to attach the extension brackets to the device. There are medium and long extension brackets that you can use for this step. Choose the correct extension bracket for the depth of your rack.

1. Select the proper length extension bracket for your rack depth.
2. Position the right extension bracket along the side of the device as shown in [Figure 5](#) .
3. Insert four 8-32 x 5/16-in. flathead screws through the vertically aligned holes in the extension bracket and then into the holes on the side of the device. Use the upper and lower screw holes, leaving the center holes empty.
4. Repeat step 1 and step 2 to attach the left extension bracket to the left side of the device.
5. Tighten all the 8-32 x 5/16-in. screws to a torque of 15 in-lb (17 cm-kg).

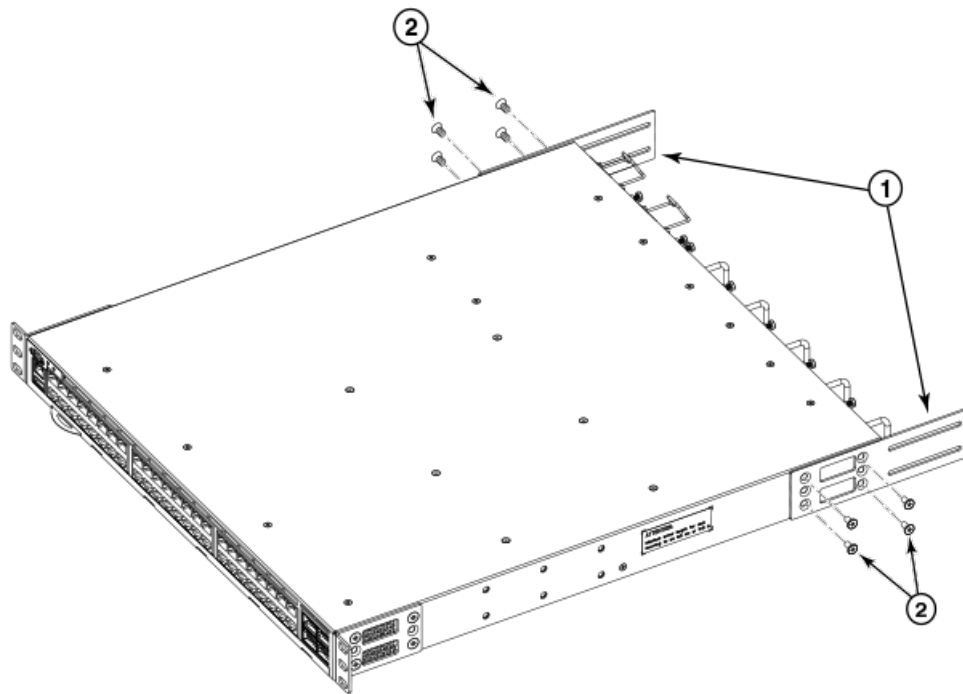

- 1 Extension brackets
- 2 Screws, 8-32 x 5/16-in., flathead Phillips

FIGURE 5 Attaching the extension brackets to the device

Installing the device in the rack

Complete the following steps to install the device in the rack.

1. Position the device in the rack, as shown in [Figure 6](#) , providing temporary support under the device until the rail kit is secured to the rack.
2. Attach the right front bracket to the right front rack post using two 10-32 x 5/8-in. panhead screws and two retainer nuts. Use the upper and lower holes in the bracket.
3. Attach the left front bracket to the left front rack post using two 10-32 x 5/8-in. panhead screws and two retainer nuts. Use the upper and lower holes in the bracket.
4. Tighten all the 10-32 x 5/8-in. screws to a torque of 25 in-lb (29 cm-kg).

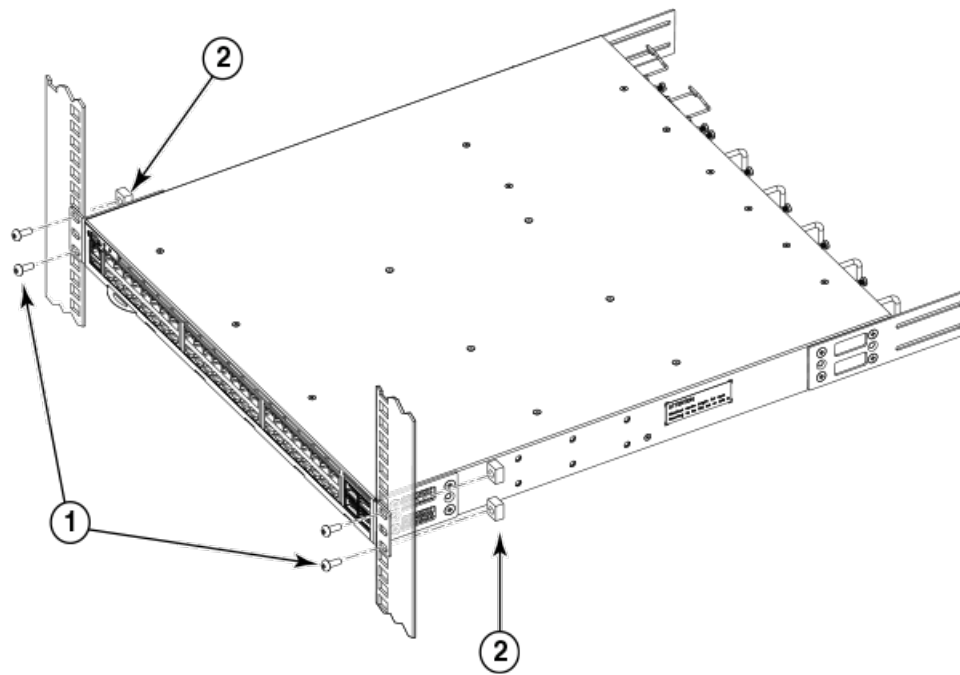

- 1 Screws, 10-32 x 5/8-in., panhead Phillips
- 2 Retainer nuts, 10-32

FIGURE 6 Positioning the device in the rack

Attaching the rear brackets to the extensions

Complete the following steps to attach the rear brackets to the extensions. There are short and long rear brackets that you can use for this step. Choose the correct bracket for the depth of your rack.

1. Select the proper length rear bracket for your rack depth.
2. Slide the right rear bracket onto the right extension and attach to the extension by inserting four 6-32 x 1/4-in. panhead screws through the bracket holes. If possible, leave at least one empty vertical pair of holes between the screws for better support.
3. Repeat step 2 to attach the left rear bracket to the left extension.
4. Adjust the brackets to the rack depth and tighten all the 6-32 x 1/4-in. screws to a torque of 9 in-lb (10 cm-kg).

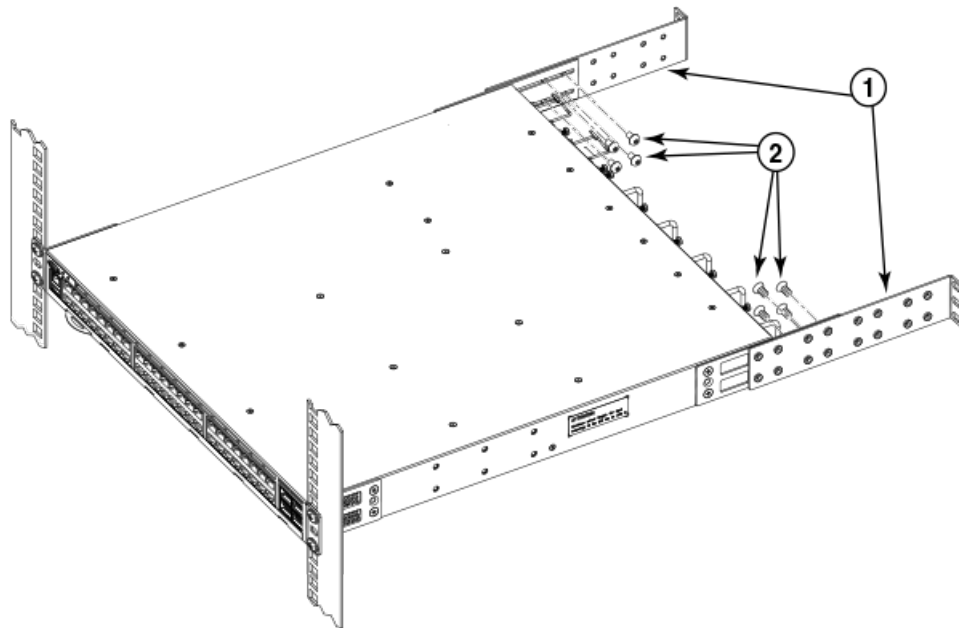

- 1 Rear brackets
- 2 Screws, 6-32 x 1/4-in., panhead Phillips

FIGURE 7 Attaching the rear brackets to the extensions

Attaching the rear brackets to the rack posts

Complete the following steps to attach the rear brackets to the rack posts.

1. Attach the right rear bracket to the right rear rack post using two 10-32 x 5/8-in. panhead screws and two retainer nuts, as shown in [Figure 8](#) . Use the upper and lower holes in the bracket.
2. Attach the left rear bracket to the left rear rack post using two 10-32 x 5/8-in. panhead screws and two retainer nuts. Use the upper and lower holes in the bracket.
3. Tighten all the 10-32 x 5/8-in. screws to a torque of 25 in-lb (29 cm-kg).

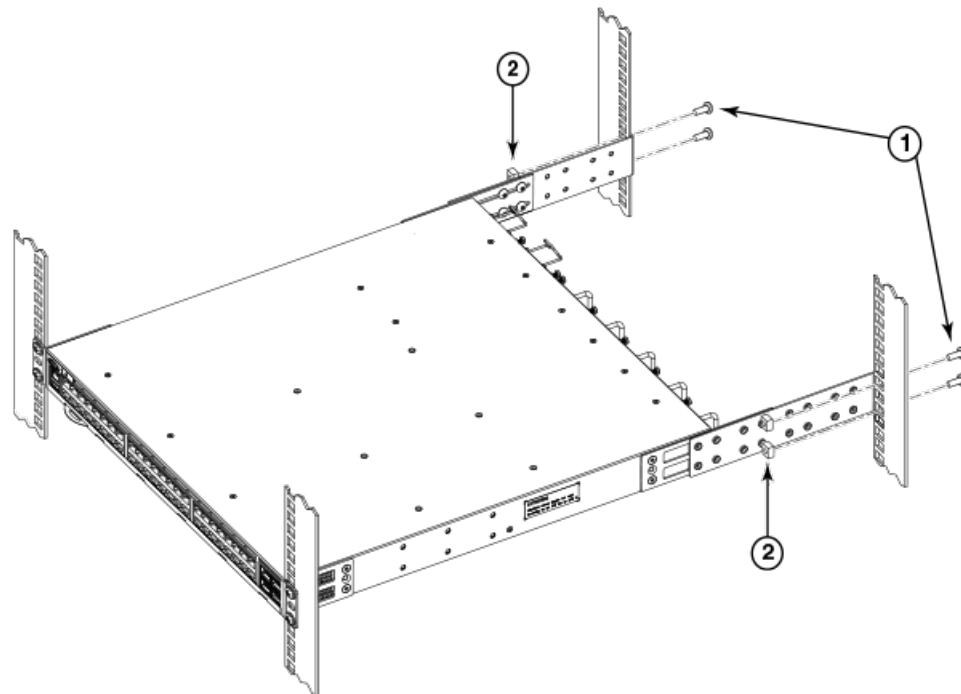

- 1 Screws, 10-32 x 5/8-in., panhead Phillips
- 2 Retainer nuts, 10-32

FIGURE 8 Attaching the rear brackets to the rack posts

Flush-rear (recessed) mounting

The flush-rear (recessed) mounting is similar to the flush-front mounting except that the brackets are reversed on the device.



CAUTION

The device must be turned off and disconnected from the fabric during this procedure.

NOTE

The illustrations in the rack installation procedures show a 1U device, but the instructions are the same for a 2U device. The illustrations in the rack installation procedures are for reference only and may not show the actual device.

Complete the following tasks to install the device in a four-post rack:

1. [Attaching the front brackets to the rear of the device](#) on page 36
2. [Attaching the extensions to the front of the device](#) on page 36
3. [Installing the device in the rack](#) on page 37
4. [Attaching the rear brackets to the extensions at the front of the device](#) on page 38
5. [Attaching the rear brackets to the front rack posts](#) on page 40

Attaching the front brackets to the rear of the device

NOTE

In this installation, the brackets are named as listed in the parts list even though the installation of the brackets is reversed from the flush-front installation.

Complete the following steps to attach the front brackets to the rear of the device.

1. Position the right front bracket with the flat side against the right rear side of the device, as shown in [Figure 9](#).
2. Insert four 8-32 x 5/16-in. flathead screws through the vertically aligned holes in the bracket and then into the holes on the side of the device. Use the upper and lower screw holes, leaving the center holes empty.
3. Repeat step 1 and step 2 to attach the left rear bracket to the left side of the device.
4. Tighten all the 8-32 x 5/16-in. screws to a torque of 15 in-lb (17 cm-kg).

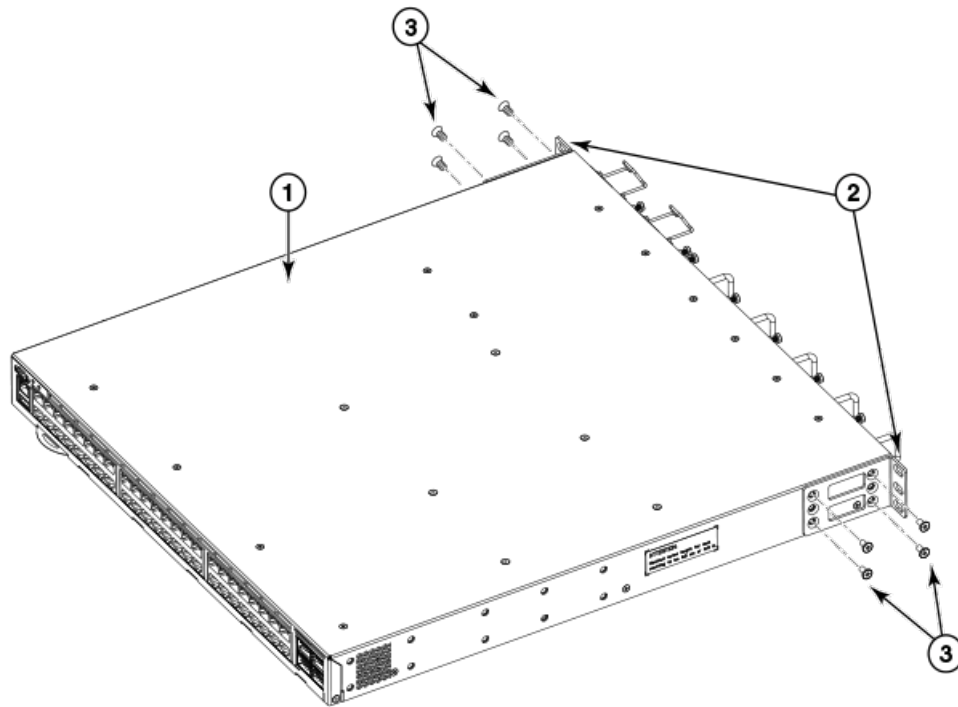

- 1 The Brocade device
- 2 Screws, 8-32 x 5/16-in., flathead
Phillips
- 3 Front brackets

FIGURE 9 Attaching the front brackets to the rear of the device

Attaching the extensions to the front of the device

Complete the following steps to attach the extension brackets to the front of the device. There are medium and long extension brackets that you can use for this step. Choose the correct extension for the depth of your rack.

1. Select the proper length extension bracket for your rack depth.
2. Position the right extension along the side of the device as shown in [Figure 10](#).

3. Attach the bracket using four 8-32 x 5/16-in. flathead screws.
4. Repeat step 1 and step 2 to attach the left front extension to the left side of the device.
5. Tighten all the 8-32 x 5/16-in. screws to a torque of 15 in-lb (17 cm-kg).

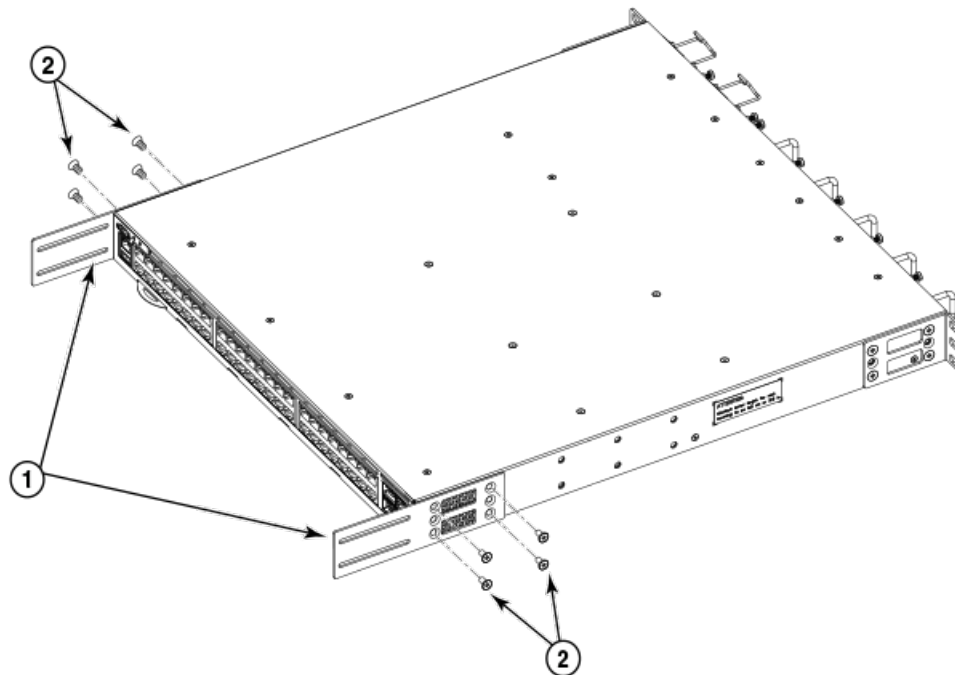

- 1 Extension brackets
- 2 Screws, 8-32 x 5/16-in., flathead
Phillips

FIGURE 10 Attaching the bracket extensions to the device

Installing the device in the rack

Complete the following steps to install the device in the rack.

1. Position the device in the rack, as shown in [Figure 11](#) , providing temporary support under the device until the rail kit is secured to the rack.
2. Attach the right front bracket to the right rear rack post using two 10-32 x 5/8-in. panhead screws and two retainer nuts. Use the upper and lower holes in the bracket.
3. Attach the left front bracket to the left rear rack post using two 10-32 x 5/8-in. panhead screws and two retainer nuts. Use the upper and lower holes in the bracket.
4. Tighten all the 10-32 x 5/8-in. screws to a torque of 25 in-lb (29 cm-kg).

Attaching the rear brackets to the extensions at the front of the device

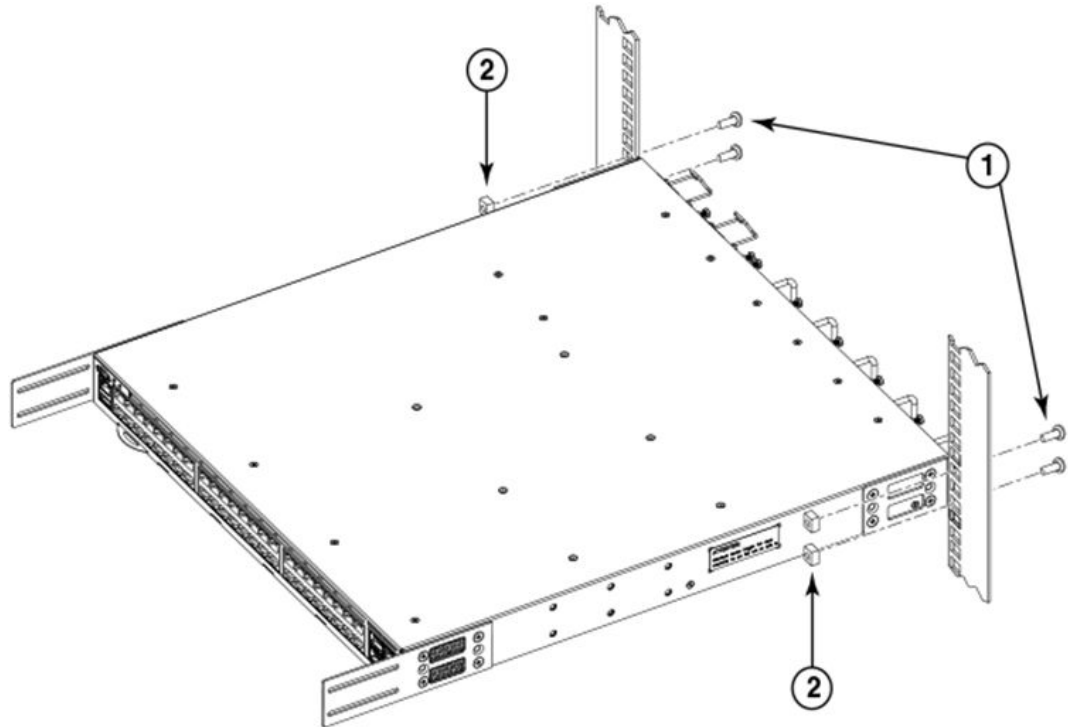

- 1 Screws, 10-32 x 5/8-in., panhead Phillips
- 2 Retainer nuts, 10-32

FIGURE 11 Positioning the device in the rack

Attaching the rear brackets to the extensions at the front of the device

Complete the following steps to attach the rear brackets to the extensions. There are short and long front brackets that you can use for this step. Choose the correct bracket for the depth of your rack.

1. Select the proper length rear bracket for your rack depth.
2. Slide the right rear bracket onto the right extension, as shown in [Figure 12](#).

The short rear brackets are shown. Use the first and third vertical pairs of holes for the screws.

Refer to [Figure 13](#) for the positioning of the short or long brackets and screws.

3. Attach the brackets using four 6-32 x 1/4-in. screws.
4. Repeat step 2 and step 3 to attach the left rear bracket to the left extension.
5. Adjust the brackets to the rack depth and tighten all the 6-32 x 1/4-in. screws to a torque of 9 in-lb (10 cm-kg).

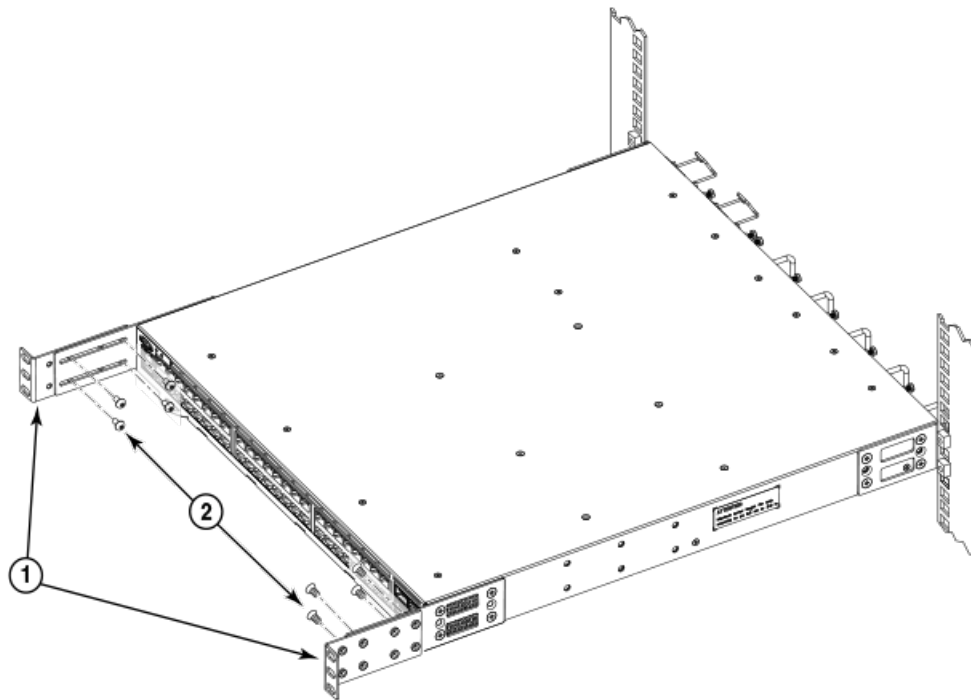

- 1 Rear brackets, short
- 2 Screws, 6-32 x 1/4-in., panhead Phillips

FIGURE 12 Attaching the rear brackets to the extensions at the front of the device

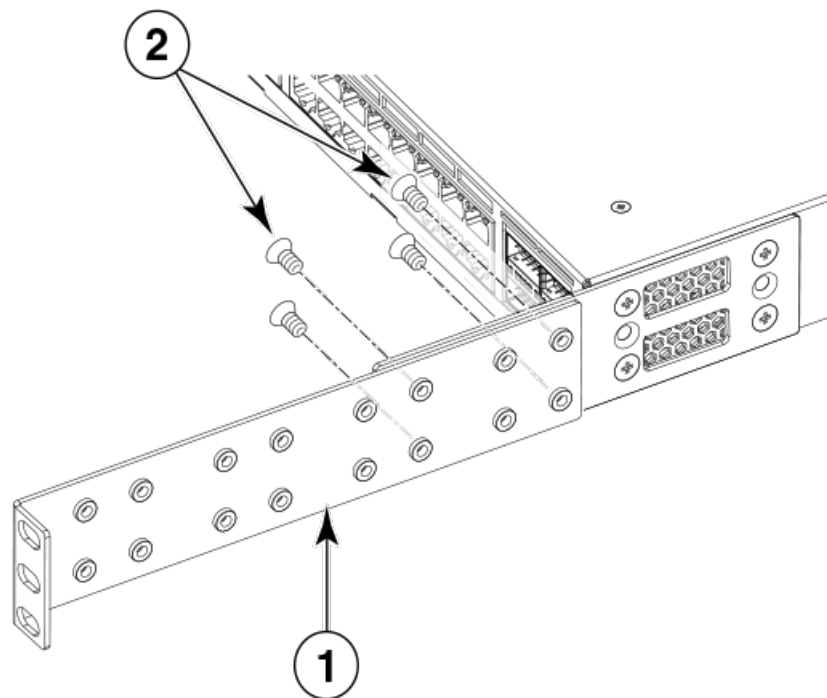

- 1 Rear bracket, short or long
- 2 Screws, 6-32 x 1/4-in., panhead Phillips

FIGURE 13 Attaching the short or long rear brackets to the extensions

Attaching the rear brackets to the front rack posts

Complete the following steps to attach the rear brackets to the front rack posts.

1. Attach the right rear bracket to the right front rack post using two 10-32 x 5/8-in. screws and two retainer nuts, as shown in [Figure 14](#) . Use the upper and lower holes in the bracket.
2. Attach the left rear bracket to the left front rack post using two 10-32 x 5/8-in. screws and two retainer nuts. Use the upper and lower holes in the bracket.
3. Tighten all the 10-32 x 5/8-in. screws to a torque of 25 in-lb (29 cm-kg).

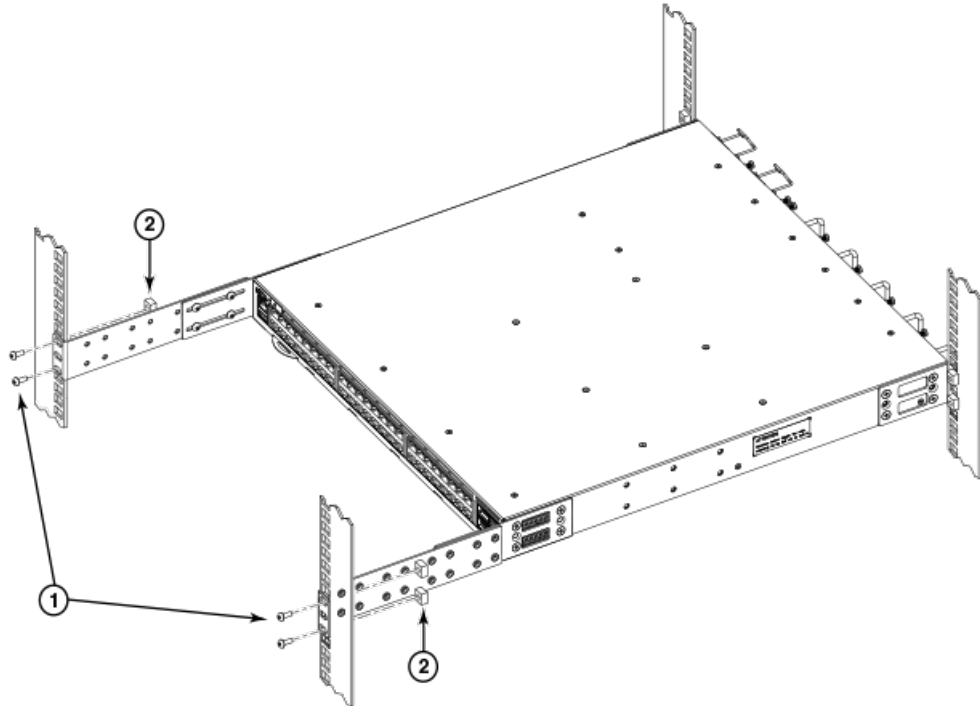

- 1 Screws, 10-32 x 5/8-in., panhead Phillips
- 2 Retainer nuts, 10-32

FIGURE 14 Attaching the rear brackets to the front rack posts

Installing the Universal Two-Post Rack kit (XBR-R000294)

Use the following instructions to install a Brocade 1U or 2U switch in a two-post telecommunications (Telco) rack using the *Universal Two-Post Rack Kit (XBR-R000294)*.

There are two ways you can mount the device in a two-post rack:

- With the port side flush with the front posts
- With the posts mounted to the midsection of the device

NOTE

Hardware devices illustrated in these procedures are only for reference and may not depict the device you are installing into the rack.

Installation requirements

Note the following requirements to ensure correct installation and operation:

- Verify that the additional weight of the device does not exceed the rack's weight limits.
- Ensure that an electrical branch circuit with the following characteristics is available:
 - Required voltage and frequency as indicated in the Technical Specifications (200-240 VAC is always preferred).
 - Protection by a circuit breaker in accordance with local electrical codes.
 - Supply circuit, line fusing, and wire size that conform to the electrical rating on the device nameplate.
 - Grounded outlet compatible with the power cord and installed by a licensed electrician.
- Ensure that all equipment installed in the rack is grounded through a reliable branch circuit connection. Do not rely on a secondary connection to a branch circuit, such as a power strip.
- Ensure that the rack is mechanically secured to ensure stability.
- Ensure that the air temperature at the fan inlet is less than 40°C (104°F) during device operation.
- Ensure that the airflow available at the air vents meets the minimum requirements for the device.

NOTE

Install the device with the airflow aligned with any other devices in the rack. Some devices have airflow running from port side to fan side and others have the opposite arrangement. Make sure that the airflow for all devices moves in the same direction to maximize cooling.

Lifting requirements

For 1U and 2U devices, two people are required to install the device in a rack. One person holds the device, while the other screws in the front and rear "L" brackets.

Time and items required

Allow 15 to 30 minutes to complete the installation.

The following items are required to install the device using the Universal Two-Post Rack Kit:

- #2 Phillips torque screwdriver
- 1/4-inch slotted-blade torque screwdriver

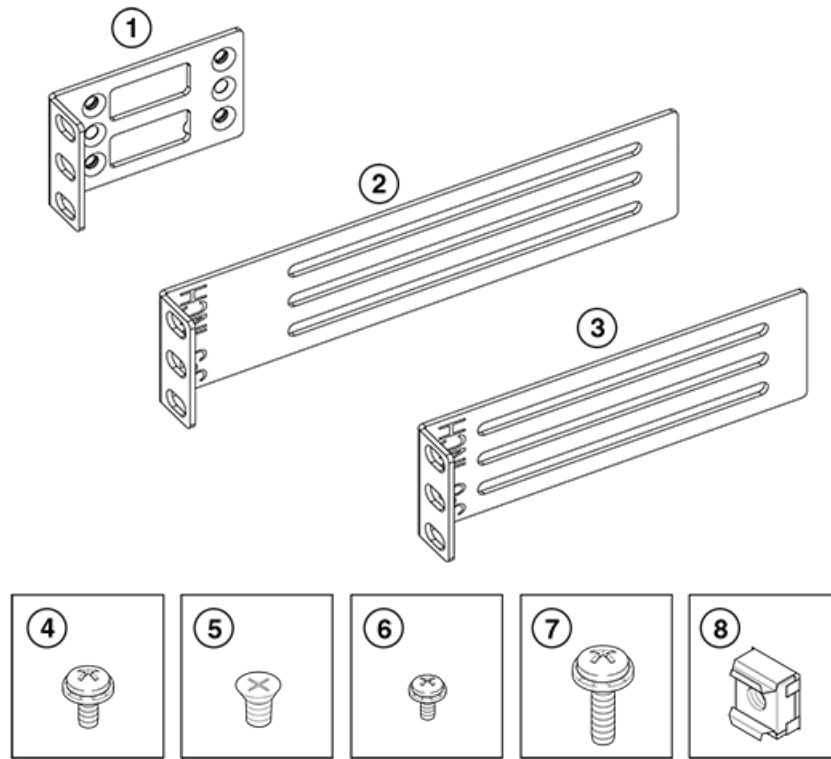

- | | | | |
|---|--|---|--|
| 1 | Front brackets (2) | 6 | Screw, 6-32 x 1/4-in., panhead Phillips (8) |
| 2 | Rear brackets, 3-5 inch post (2) | 7 | Screw, 10-32 x 5/8-in., panhead Phillips (8) |
| 3 | Rear brackets, 5-6 inch post (2) | 8 | Retainer nut, 10-32 (8) |
| 4 | Screw, 8-32 x 5/16-in., panhead Phillips (8) | | |
| 5 | Screw, 8-32 x 5/16-in., flathead Phillips (16) | | |

FIGURE 15 Items in the Universal Two-Post Rack Kit



CAUTION

Use the screws specified in the procedure. Using longer screws can damage the device.

Ensure that the items listed and illustrated in [Figure 15](#) are included in the kit. Note that not all parts may be used with certain installations depending on the device type.

Flush-front mounting

Observe the following notes when using this procedure:

- The device must be turned off and disconnected from the fabric during this procedure.
- The illustrations in this document show a 1U device, but the instructions are the same for a 2U device.
- The illustrations for this procedure show a two-post rack with narrow posts (3- to 5-inch) as an example.
- The illustrations in the rack installation procedures are for reference only and may not show the actual device.

Complete the following tasks to install the device in a rack:

- 1. [Attaching the front brackets to the device](#) on page 43
- 2. [Attaching the front brackets to the rack](#) on page 43
- 3. [Attaching the rear brackets to the rack](#) on page 44
- 4. [Attaching the rear brackets to the device](#) on page 45

Attaching the front brackets to the device

Complete the following steps to attach the front brackets to the device.

- 1. Position the right front bracket with the flat side against the right side of the device, as shown in [Figure 16](#).
- 2. Insert four 8-32 x 5/16-in. flathead screws through the vertically aligned holes in the bracket and then into the holes on the side of the device. Use the upper and lower screw holes, leaving the center holes empty.
- 3. Repeat step 1 and step 2 to attach the left front bracket to the left side of the device.
- 4. Tighten all the 8-32 x 5/16-in. screws to a torque of 15 in-lb (17 cm-kg).

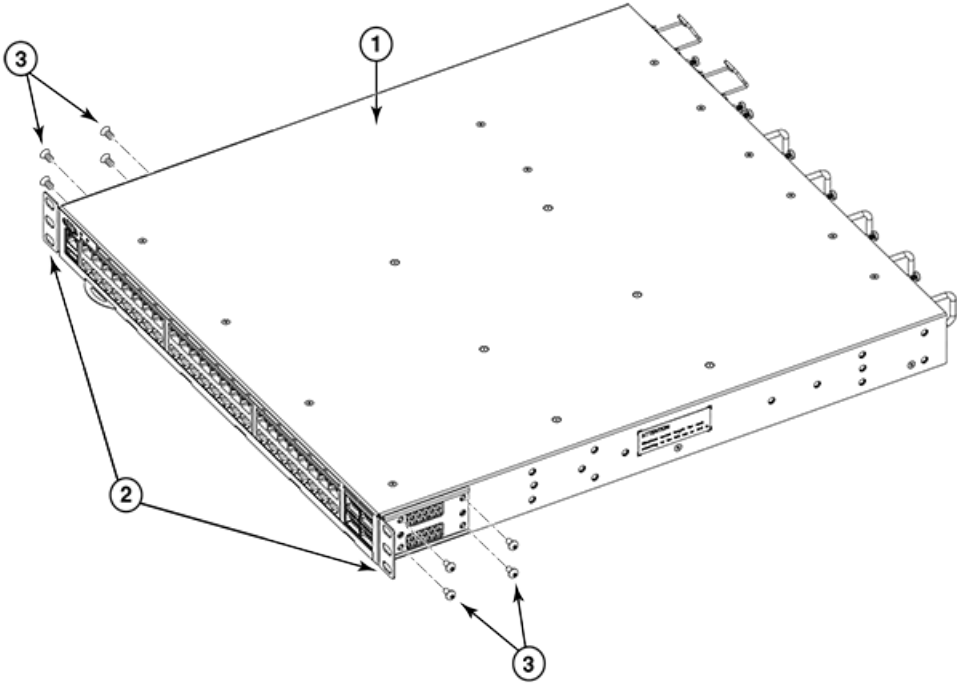

- 1 The Brocade device
- 2 Front brackets, right and left
- 3 Screws, 8-32 x 5/16-in., flathead Phillips

FIGURE 16 Attaching the front brackets

Attaching the front brackets to the rack

Complete the following steps to install the device in the rack.

Attaching the rear brackets to the rack

1. Position the device in the rack, as shown in (Figure 17), providing temporary support under the device until the rack kit is fully secured to the rack.
2. Attach the right front bracket to the right rack upright using two 10-32 x 5/8-in. panhead screws and two retainer nuts. Use the upper and lower holes in the bracket.
3. Attach the left front bracket to the left rack upright using two 10-32 x 5/8-in. panhead screws and two retainer nuts.
4. Use the upper and lower holes in the bracket. Tighten all the 10-32 x 5/8-in. screws to a torque of 25 in-lb. (29 cm-kg).

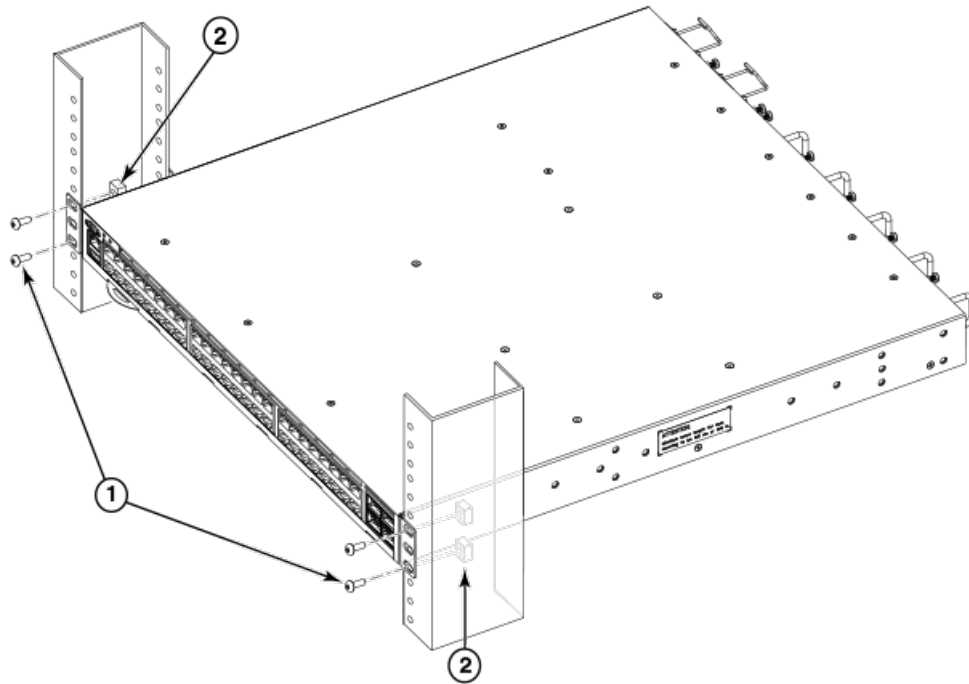

- 1 Screws, 10-32 x 5/8-in., panhead Phillips
- 2 Retainer nuts, 10-32

FIGURE 17 Attaching front brackets to a rack

Attaching the rear brackets to the rack

Complete the following steps to attach the rear brackets to the rack.

1. Select the proper length bracket for your post width. If your posts are three to five inches wide, use the brackets marked 3-5 INCH. If your posts are five to six inches wide, use the brackets marked 5-6 INCH.
2. Position the right rear bracket in the right rear of the device, as shown in Figure 18 .
3. Attach the bracket to the right rack upright using two 10-32 x 5/8-in. panhead screws and two retainer nuts. Use the upper and lower holes in the bracket.
4. Repeat step 2 and step 3 to attach the left rear bracket to the left rack upright.
5. Tighten all the 10-32 x 5/8-in. screws to a torque of 25 in-lb. (29 cm-kg).

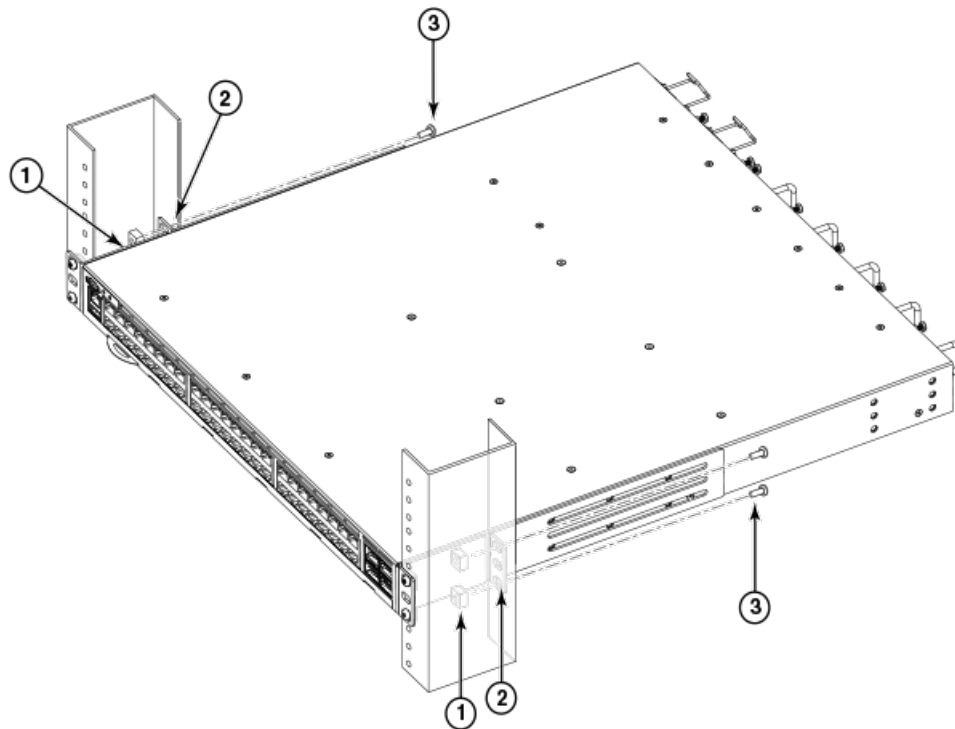

- 1 Retainer nuts, 10-32
- 2 Rear brackets
- 3 Screws, 10-32 x 5/8-in., panhead
Phillips

FIGURE 18 Attaching the rear brackets to a rack

Attaching the rear brackets to the device

Complete the following steps to attach the rear brackets to the device.

1. Align the right rear bracket to the right rear of the device and use four 8-32 x 5/16-in. panhead screws to attach the bracket to the device, as shown in [Figure 19](#) . Be sure to insert the screws through the upper and lower slots in the bracket.
2. Align the left rear bracket to the left rear of the device and use four 8-32 x 5/16-in. panhead screws to attach the bracket to the device. Again, use the upper and lower slots in the bracket.
3. Tighten all the 8-32 x 5/16-in. screws to a torque of 15 in-lb (17 cm-kg).

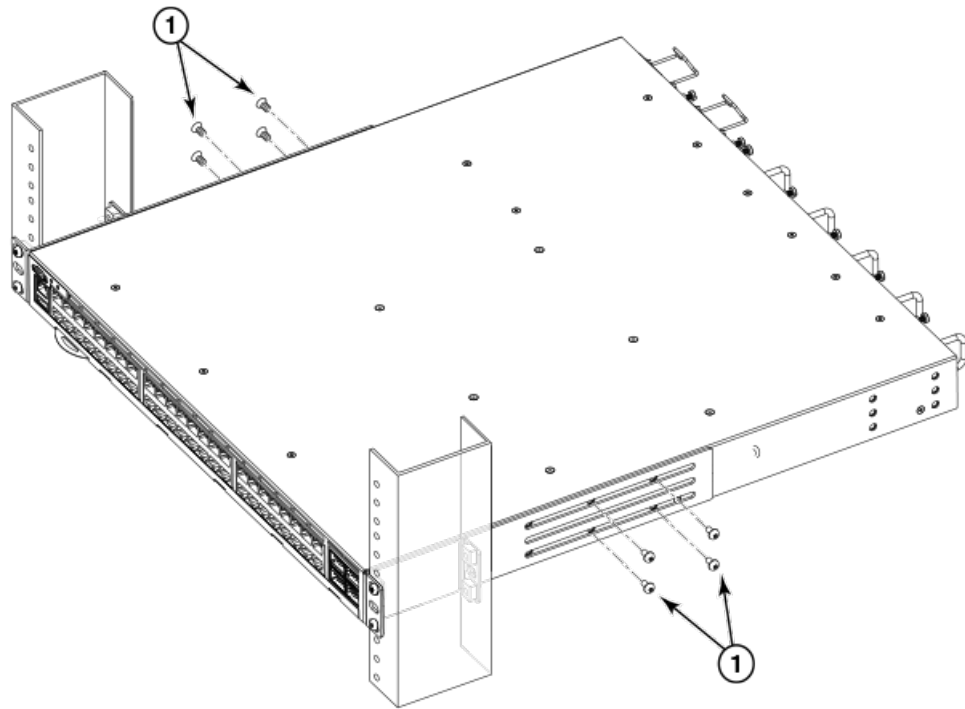

- 1 Screws, 8-32 x 5/16-in., panhead
Phillips

FIGURE 19 Attaching the rear brackets to the device

Mid-mounting

Observe the following notes when using this procedure:

- The device must be turned off and disconnected from the fabric during this procedure.
- The illustrations in this document show a 1U device, but the instructions are the same for a 2U device.
- The illustrations in the rack installation procedures are for reference only and may not show the actual device.

Complete the following tasks to install the device in a rack:

1. [Attaching the front brackets to the device](#) on page 46
2. [Attaching the front brackets to the rack](#) on page 47
3. [Attaching the rear brackets to the rack](#) on page 48
4. [Attaching the rear brackets to the device](#) on page 49

Attaching the front brackets to the device

Complete the following steps to attach the front brackets to the device.

1. Position the right front bracket with the flat side against the right side of the device, as shown in [Figure 20](#).
2. Insert four 8-32 x 5/16-in. flathead screws through the vertically aligned holes in the bracket and then into the holes on the side of the device. Use the upper and lower screw holes, leaving the center holes empty.

3. Repeat step 1 and step 2 to attach the left front bracket to the left side of the device.
4. Tighten all the 8-32 x 5/16-in. screws to a torque of 15 in-lb (17 cm-kg).

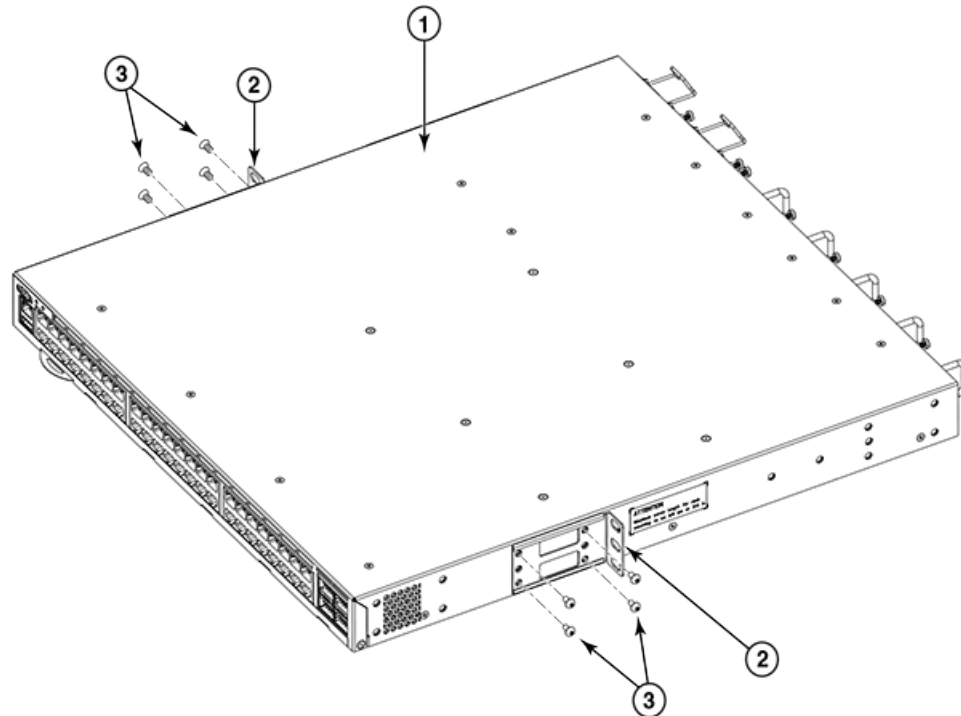

- 1 The Brocade device
- 2 Front brackets, right and left
- 3 Screws, 8-32 x 5/16-in., flathead Phillips

FIGURE 20 Attaching the front brackets

Attaching the front brackets to the rack

Complete the following steps to install the device in the rack.

1. Position the device in the rack, as shown in [Figure 21](#) , providing temporary support under the device until the rack kit is fully secured to the rack.
2. Attach the right front bracket to the right rack upright using two 10-32 x 5/8-in. screws and two retainer nuts. Use the upper and lower holes in the bracket.
3. Attach the left front bracket to the left rack upright using two 10-32 x 5/8-in. screws and two retainer nuts. Use the upper and lower holes in the bracket.
4. Tighten all the 10-32 x 5/8-in. screws to a torque of 25 in-lb (29 cm-kg).

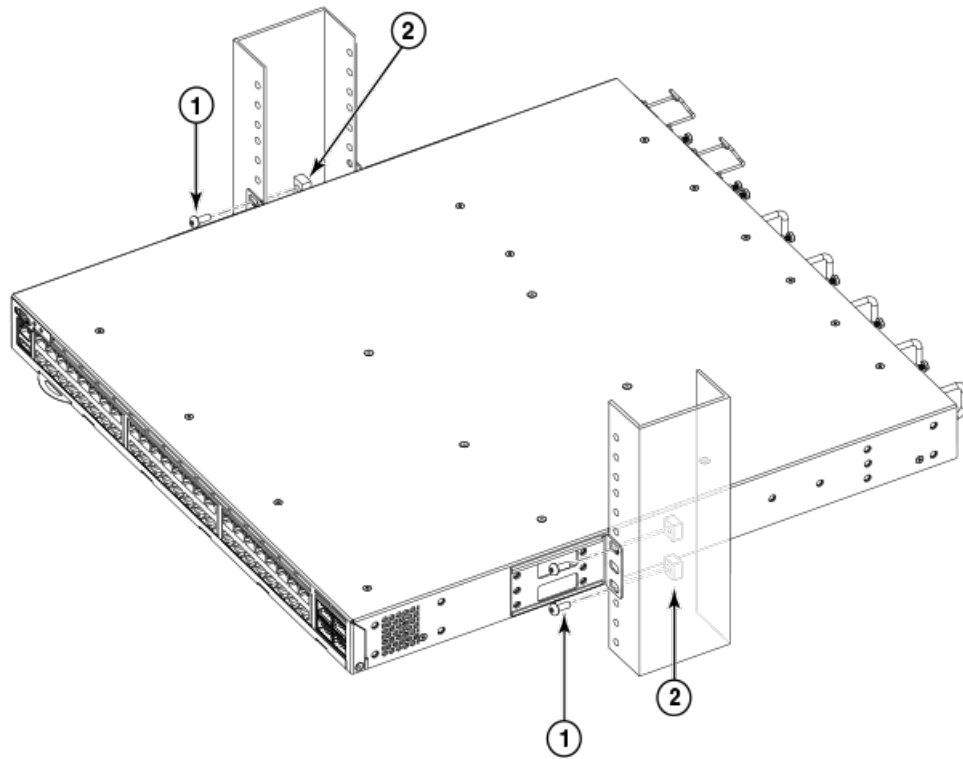

- 1 Screws, 10-32 x 5/8-in., panhead Phillips
- 2 Retainer nuts, 10-32

FIGURE 21 Attaching front brackets to a rack

Attaching the rear brackets to the rack

Complete the following steps to attach the rear brackets to the rack.

1. Select the proper length bracket for your post width. If your posts are three to five inches wide, use the brackets marked 3-5 INCH. If your posts are five to six inches wide, use the brackets marked 5-6 INCH.
2. Position the right rear bracket in the right rear of the device, as shown in the following figure. Whether you are using the 3-5 inch or the 5-6 inch bracket, the rear end of the bracket will be flush with the back of the device.
3. Attach the brackets to the right rack upright using two 10-32 x 5/8-in. panhead screws and two retainer nuts.
4. Repeat step 2 and step 3 to attach the left rear bracket to the left rack upright.
5. Tighten all the 10-32 x 5/8-in. screws to a torque of 25 in-lb (29 cm-kg).

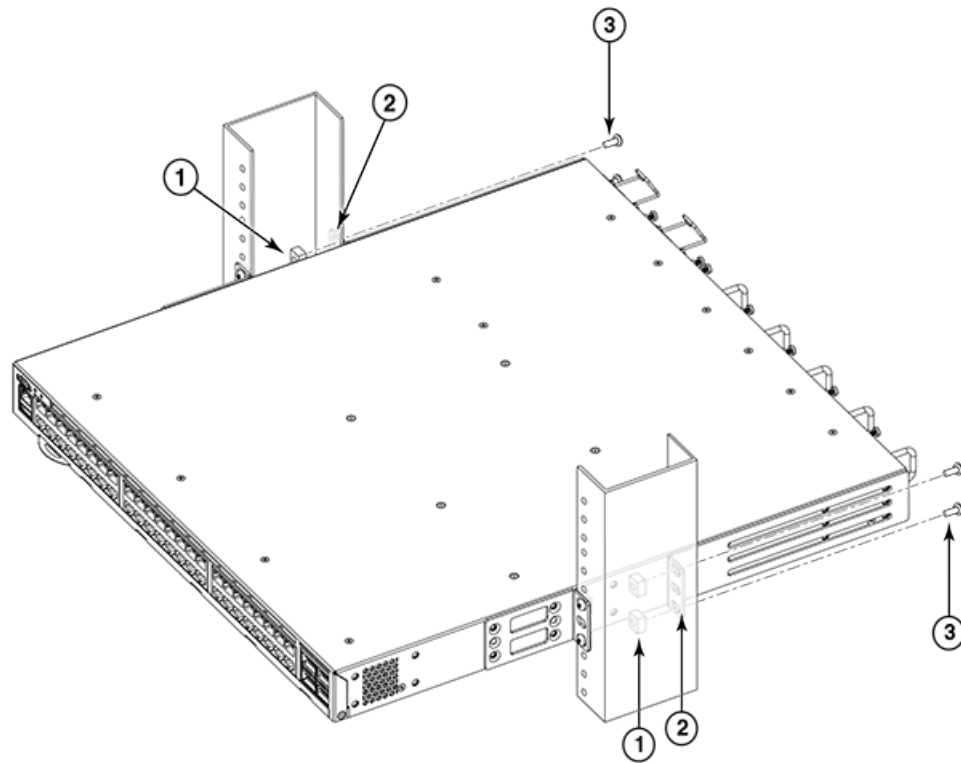

- | | | | |
|---|----------------------|---|---|
| 1 | Retainer nuts, 10-32 | 3 | Rear brackets (right and left) |
| 2 | Retainer nuts, 10-32 | 4 | Screws, 10-32 x 5/8-in., panhead Phillips |

FIGURE 22 Attaching the rear brackets to a rack

Attaching the rear brackets to the device

Complete the following steps to attach the rear brackets to the device.

1. Align the right rear bracket to the right rear of the device and use four 8-32 x 5/16-in. panhead screws to attach the bracket to the device, as shown in [Figure 23](#) . Be sure to insert the screws through the upper and lower slots in the bracket.
2. Align the left rear bracket to the left rear of the device and use four 8-32 x 5/16-in. panhead screws to attach the bracket to the device. Again, use the upper and lower slots in the bracket.
3. Tighten all the 8-32 x 5/16-in. screws to a torque of 15 in-lb (17 cm-kg).

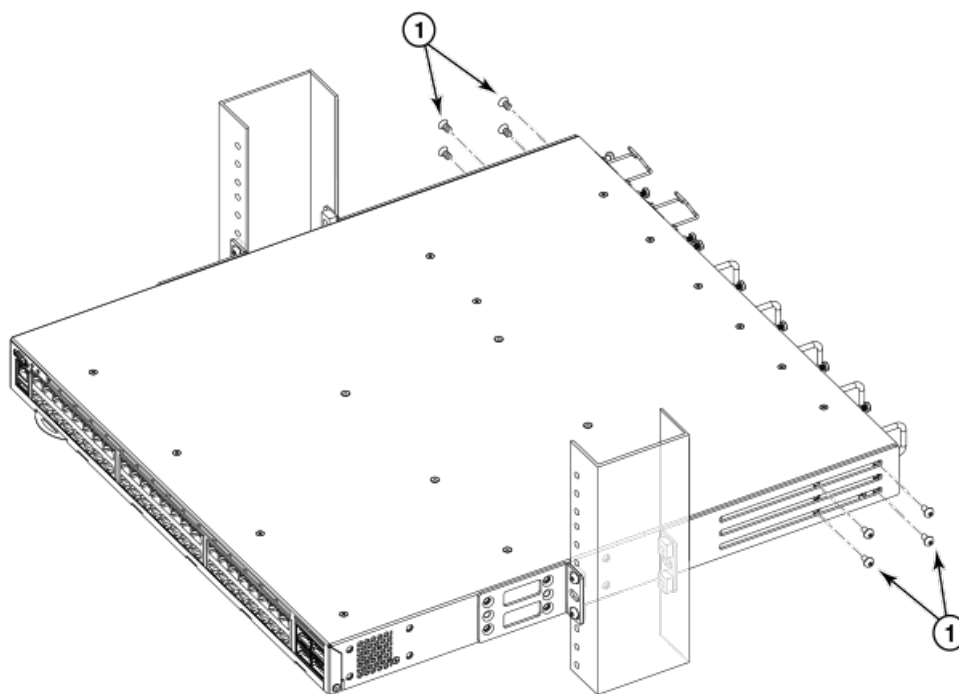

- 1 Screws, 8-32 x 5/16-in., panhead Phillips

FIGURE 23 Attaching the rear brackets to the device

Initial Setup and Verification

- Items required..... 51
- Providing power to the device..... 51
- Establishing a first-time serial connection..... 52
- Configuring the IP address..... 53
- Setting the date and time..... 53
- Customizing the chassis name and switch name..... 55
- Establishing an Ethernet connection..... 56
- Setting the domain ID..... 56
- Verifying correct operation..... 56
- Backing up the configuration..... 57
- Powering down the device..... 58

Items required

The following items are required for initial setup and verification of the device:

- The device, mounted and installed with the required power supply and fan assemblies, transceivers, and cables; and connected to a power source
- A workstation computer with a terminal emulator application installed, such as HyperTerminal for Windows
- An unused IP address with corresponding subnet mask and gateway address
- A serial cable with an RJ-45 connector
- RJ-45 to DB-9 adapter
- An Ethernet cable
- Access to an FTP server or USB device for backing up (uploading) or downloading the device configuration (optional)

Providing power to the device

Perform the following steps to provide power to the device.

1. Connect the power cords to both power supplies, and then to power sources on separate circuits to protect against power failure. Ensure that the power cords have a minimum service loop of 6 inches available and are routed to avoid stress.
2. Power on the power supplies by flipping both switches to the on position (the "I" symbol). The power supply LEDs display amber until power-on self-test (POST) is complete, and then change to green. The switch usually requires several minutes to boot and complete POST.

NOTE

Power is supplied to the device as soon as the first power supply is connected and turned on.

3. After POST is complete, verify that the switch power and switch status LEDs are green.

For more information about how to interpret POST, BOOT, and diagnostics tests, refer to [Monitoring the Device](#) on page 67.

Establishing a first-time serial connection

Perform the following steps to log in to the device through the serial connection.

1. Connect the serial cable to the serial port on the device and to an RS-232 serial port on the workstation.

If the serial port on the workstation is RJ-45 instead of RS-232, remove the adapter on the end of the serial cable and insert the exposed RJ-45 connector into the RJ-45 serial port on the workstation.

2. Disable any serial communication programs running on the workstation such as synchronization programs.
3. Open a terminal emulator application such as HyperTerminal on a Windows PC, or TERM, TIP, or Kermit in a UNIX environment, and configure the application as follows:

- In a Windows environment

Parameter	Value
Bits per second	9600
Databits	8
Parity	None
Stop bits	1
Flow control	None

- In a UNIX environment using TIP, enter the following string at the prompt:

```
tip /dev/ttyb -9600.
```

If ttyb is already in use, use ttya instead and enter the following string at the prompt:

```
tip /dev/ttya -9600
```

4. When the terminal emulator application stops reporting information, press **Enter** to display the login prompt.

```
Switch Console Login:
```

5. Log in to the device as admin, using the default password: **password**. You are prompted to change the default admin and user passwords at initial login. Make sure to write down the new passwords and keep this information in a secure location.

```
Fabric OS (swDir)
swDir login: admin
Password:
Please change your passwords now.
Use Control-C to exit or press 'Enter' key to proceed.
swDir:admin>
```

6. (Optional) Modify passwords. To skip modifying the password, press **Ctrl+C**.

NOTE

Passwords can be 8 to 40 characters long. They must begin with an alphabetic character. They can include numeric characters, the period (.), and the underscore (_) only. Passwords are case-sensitive, and they are not displayed when you enter them on the command line.

Configuring the IP address

You can configure the device with a static IP address, or you can use a Dynamic Host Configuration Protocol (DHCP) server to set the IP address of the switch. DHCP is enabled by default. The device supports both IPv4 and IPv6 addresses.

Using DHCP to set the IP address

When using DHCP, the switch obtains its IP address, subnet mask, and default gateway address from the DHCP server. The DHCP client can only connect to a DHCP server that is on the same subnet as the switch. If your DHCP server is not on the same subnet as the switch, use a static IP address.

Setting a static IP address

To set a static IP address for the device, complete the following steps.

1. Log in to the device as admin.
2. Use the **ipaddrset** command to set the Ethernet IP address.
 - If you are going to use an IPv4 address, enter the IP address in dotted decimal notation as prompted.

```
Ethernet IP Address: [192.168.74.102]
```

- If you are going to use an IPv6 address, enter the network information in colon-separated notation as prompted.

```
device:admin> ipaddrset -ipv6 --add 1080::8:800:200C:417A/64
IP address is being changed...Done.
```

3. Complete the rest of the network information as prompted. (IPv4 format shown):

```
Ethernet Subnetmask: [255.255.255.0]
Ethernet IP Address: [192.168.74.102]
Gateway IP Address: [192.168.74.1]
```

4. Enter **off** to disable DHCP when prompted.

```
DHCP [OFF]: off
```

Setting the date and time

The date and time settings are used for logging events, error detection, and troubleshooting. However, device operation does not depend on the date and time; a device with incorrect date or time values still functions properly.

You can synchronize the local time of the principal or primary fabric configuration server (FCS) device to that of an external Network Time Protocol (NTP) server.

Perform the following steps to set the date and time.

1. Log in to the device as admin.
2. Enter the **date** ["*newdate*"] command at the command line.

The *newdate* variable specifies the new date and time enclosed in double quotation marks. The operand is optional; if omitted, the current date and time is displayed. Date and time are specified as a string in the *mmddhhmm* format:

- *mm*: Specifies the month. Valid values are 01 to 12.
- *dd*: Specifies the date. Valid values are 01 to 31.
- *hh*: Specifies the hour. Valid values are 00 to 23.
- *mm*: Specifies the minutes. Valid values are 00 to 59.
- *yy*: Specifies the year, valid values are 00 to 37 and 70 to 99. Year values from 70 to 99 are interpreted as 1970 to 1999; year values from 00 to 37 are interpreted as 2000 to 2037.

```
device:admin> date
Fri May 22 14:05:10 UTC 2015
device:admin> date "0522140615"
Fri May 22 14:06:00 UTC 2015
```

Setting the time zone

The default time zone is Coordinated Universal Time (UTC). The time zone must be set only once because the value is stored in nonvolatile memory. Use the following procedure to set the time zone.

1. Log in as admin.
2. Use the **tsTimeZone --interactive** command and follow the prompts, or enter the **tsTimeZone [houroffset [, minuteoffset]]** command as follows:

For Pacific Standard Time, enter **tsTimeZone -8,0**.

For Central Standard Time, enter **tsTimeZone -6,0**.

For Eastern Standard Time, enter **tsTimeZone -5,0**.

TABLE 8 tsTimeZone command parameter selection for the US time zones

Local time	tsTimeZone parameter (difference from UTC)
Atlantic Standard	-4,0
Atlantic Daylight	-3,0
Eastern Standard	-5,0
Eastern Daylight	-4,0
Central Standard	-6,0
Central Daylight	-5,0
Mountain Standard	-7,0
Mountain Daylight	-6,0

TABLE 8 tsTimeZone command parameter selection for the US time zones (Continued)

Local time	tsTimeZone parameter (difference from UTC)
Pacific Standard	-8,0
Pacific Daylight	-7,0
Alaskan Standard	-9,0
Alaskan Daylight	-8,0
Hawaiian Standard	-10,0

Synchronizing local time with an external source

Perform the following steps to synchronize the local time of the principal or primary FCS device with that of an external NTP server.

1. Log in as admin.
2. Enter the **tsClockServer** *ipaddr* command.

The *ipaddr* variable represents the IP address of the NTP server that the device can access. This argument is optional; by default, the value is "LOCL".

```
switch:admin> tsclockserver 192.168.126.60
Updating Clock Server configuration...done.
Updated with the NTP servers
```

Customizing the chassis name and switch name

Changing the chassis and switch names is important for distinguishing and identifying the device uniquely and for accurate tracking of logs and errors. The messages that appear in the log are labeled with the device or chassis name, which makes tracking the errors much easier. Specify an easily understandable and meaningful name for the chassis and switch names.

Perform the following steps to change the chassis name and then the switch name.

1. Log in to the device through Telnet using the admin account.
2. Change the chassis name by using the **chassisName** command.

```
device:admin> chassisname Chassis_001
```

3. Change the switch name by using the **switchName** command.

```
device:admin> switchname Switch_001
Committing configuration...
Done
Switch name has been changed. Please re-login to the switch for the change to
applied
```

Establishing an Ethernet connection

Perform the following steps to establish an Ethernet connection to the device.

1. Remove the plug from the Ethernet port.
2. Connect an Ethernet cable to the device Ethernet port and to the workstation or to an Ethernet network containing the workstation.

NOTE

At this point, the device can be accessed remotely, by command line or by Web Tools. Ensure that the device is not being modified from any other connections during the remaining tasks in this chapter. The Ethernet management port also supports Auto MDI/MDIX.

Setting the domain ID

Perform the following steps to set the switch domain ID.

1. Log in to the switch through Telnet using the admin account.
2. Modify the domain ID if required.

The default domain ID is 1. If the switch is not powered on until after it is connected to the fabric and the default domain ID is already in use, the domain ID for the new switch is automatically reset to a unique value. If the switch is connected to the fabric after it has been powered on and the default domain ID is already in use, the fabric segments. To find the domain IDs that are currently in use, enter the **fabricShow** command on another switch in the fabric.

Perform the following steps to modify the domain ID.

- a) Disable the switch by entering the **switchDisable** command.
- b) Enter the **configure** command. The command prompts display sequentially; enter a new value or press **Enter** to accept each default value.
- c) Enter **y** after the "Fabric param" prompt.

```
Fabric param (yes, y, no, n): [no] y
```

- d) Enter a unique domain ID (such as the domain ID used by the previous switch, if still available).

```
Domain: (1..239) [1] 3
```

- e) Complete the remaining prompts or press **Ctrl+D** to accept the remaining settings without completing all the prompts.
- f) Re-enable the switch by entering the **switchEnable** command.

Verifying correct operation

Perform the following steps to verify correct operation of the device.

1. Check the LEDs to verify that all components are functional.
2. Verify the correct operation of the device by entering the following commands from the workstation.

Command	Description
psShow	Displays power supply status and information
fanShow	Displays fans status and information
switchShow	Displays switch status and information
tempShow	Displays temperature status and information
historyShow	Displays the device history
errDump	Displays any errors

The **switchShow** command provides the following information about the device and ports status.

```
sb_70:admin> switchshow
switchName:      sb_70
switchType:      162.0
switchState:     Online
switchMode:      Native
switchRole:      Subordinate
switchDomain:    70
switchId:        fffc46
switchWwn:       10:00:00:05:1e:65:79:04
zoning:          ON (PERF_CFG)
switchBeacon:    OFF
FC Router:       OFF
Fabric Name:     abcfabric
Allow XISL Use:  OFF
LS Attributes:   [FID: 128, Base Switch: No, Default Switch: Yes, Address Mode 0]
```

Index	Port	Address	Media	Speed	State	Proto		
0	0	460000	id	N32	Online	FC	F-Port	20:05:00:11:0d:a8:01:00
1	1	460100	id	N32	Online	FC	F-Port	20:01:00:11:0d:bb:01:00
2	2	460200	id	N32	Online	FC	F-Port	20:03:00:11:0d:84:01:00
3	3	460300	id	N32	Online	FC	F-Port	20:07:00:11:0d:26:01:00
4	4	460400	id	N32	Online	FC	F-Port	10:00:8c:7c:ff:5c:c5:00
5	5	460500	id	N32	Online	FC	F-Port	10:00:8c:7c:ff:58:4c:00
6	6	460600	id	N32	Online	FC	F-Port	10:00:8c:7c:ff:5c:c9:01
7	7	460700	id	N32	Online	FC	F-Port	10:00:8c:7c:ff:5c:bd:00
8	8	460800	--	N32	No_Module	FC		
9	9	460900	--	N32	No_Module	FC		
10	10	460a00	--	N32	No_Module	FC		
11	11	460b00	--	N32	No_Module	FC		
12	12	460c00	--	N32	No_Module	FC		
13	13	460d00	--	N32	No_Module	FC		
14	14	460e00	--	N32	No_Module	FC		
15	15	460f00	--	N32	No_Module	FC		
16	16	461000	--	N32	No_Module	FC		
17	17	461100	--	N32	No_Module	FC		
18	18	461200	--	N32	No_Module	FC		
19	19	461300	--	N32	No_Module	FC		
20	20	461400	--	N32	No_Module	FC		
21	21	461500	--	N32	No_Module	FC		
22	22	461600	--	N32	No_Module	FC		
23	23	461700	--	N32	No_Module	FC		

<Output truncated>

Backing up the configuration

Brocade recommends backing up the configuration on a regular basis to ensure that a complete configuration is available for downloading to a replacement switch.

1. Log in to the device as the admin user.
2. Back up the device configuration to an FTP server by entering the **configUpload** command and following the prompts.

```
sb_70:admin> configupload
Protocol (scp, ftp, local) [ftp]:
Server Name or IP Address [host]: 192.168.0.100
User Name [user]: anonymous
Path/Filename [<home dir>/config.txt]: /dumps/supportsave/pz/switch85/G20-1.txt
Section (all|chassis|switch [all]): all
configUpload complete: All selected config parameters are uploaded
```

This command uploads the device configuration to the server, making it available for downloading to a replacement device if necessary.

NOTE

If Virtual Fabrics (VF) is enabled, you must enter **configUpload** for each VF separately.

Powering down the device

Complete the following steps to power down the device.

1. Shutdown the Fabric OS software.
2. Identify the power-on switches in the nonport-side of the device.
3. Power off both power supplies by setting each power switch to the “O” position.
4. Unplug the power cables from the power source before servicing the device or FRUs.

All devices are returned to their initial state the next time the switch is powered on.

Installing Transceivers and Cables

- Time and items required..... 59
- Precautions specific to transceivers and cables..... 60
- Cleaning the fiber-optic connectors..... 60
- Managing cables..... 60
- Installing an SFP+ transceiver..... 61
- Replacing an SFP+ transceiver..... 62
- Installing a QSFP transceiver..... 63
- Replacing a QSFP transceiver..... 64
- Verifying the operation of new transceivers..... 65

Time and items required

The installation or replacement procedure for one transceiver takes less than five minutes. Ensure that the following items are available:

- Required number of compatible power cables
- Required number of supported Brocade-branded transceivers

Refer to the *Fabric OS Release Notes* for the list of supported transceivers and cables.

- Required number of compatible fiber-optic cables
- Optical transceiver extraction tool (for 10-Gbps transceiver only)

NOTE

Most Brocade switches and backbones come with a transceiver extraction tool and holster. The extraction tool is designed to remove transceivers from modules where the space is limited.

FIGURE 24 Optical transceiver extraction tool



Precautions specific to transceivers and cables



DANGER

All fiber-optic interfaces use Class 1 lasers.



DANGER

Use only optical transceivers that are qualified by Brocade Communications Systems, Inc. and comply with the FDA Class 1 radiation performance requirements defined in 21 CFR Subchapter I, and with IEC 825 and EN60825. Optical products that do not comply with these standards might emit light that is hazardous to the eyes.



CAUTION

Before plugging a cable into any port, be sure to discharge the voltage stored on the cable by touching the electrical contacts to ground surface.

Cleaning the fiber-optic connectors

To avoid problems with the connection between the fiber-optic transceiver (SFP+ or QSFP) and the fiber cable connectors, Brocade strongly recommends cleaning both connectors each time you disconnect and reconnect them. Dust can accumulate on the connectors and cause problems such as reducing the optic launch power.

To clean the fiber cable connectors, Brocade recommends using a fiber-optic reel-type cleaner. When not using an SFP+, or QSFP connector, make sure to keep the protective covering in place.

Managing cables

The minimum bend radius for a 50 micron cable is 2 inches under full tensile load and 1.2 inches with no tensile load. Cables can be organized and managed in a variety of ways, for example, using cable channels on the sides of the rack or patch panels to minimize cable management. Follow these recommendations:

NOTE

You should not use tie wraps with optical cables because they are easily overtightened and can damage the optic fibers.



CAUTION

Before plugging a cable into any port, be sure to discharge the voltage stored on the cable by touching the electrical contacts to ground surface.

- Plan for rack space required for cable management before installing the switch.
- Leave at least 1 m (3.28 ft) of slack for each port cable. This provides room to remove and replace the switch, allows for inadvertent movement of the rack, and helps prevent the cables from being bent to less than the minimum bend radius.

- If you are using Brocade ISL Trunking, consider grouping cables by trunking groups. The cables used in trunking groups must meet specific requirements, as described in the *Fabric OS Administrator's Guide* .
- For easier maintenance, label the fiber-optic cables and record the devices to which they are connected.
- Keep LEDs visible by routing port cables and other cables away from the LEDs.
- Use hook and loop style straps to secure and organize fiber-optic cables.

Installing an SFP+ transceiver

The device supports only Brocade-qualified transceivers. If you use an unqualified transceiver, the **switchshow** command output shows the port in a Mod_Inv state. Fabric OS also logs the issue in the system error log. To insert an SFP+ transceiver, complete the following steps:

NOTE

The 16- and 32-Gbps SFP+ transceivers do not have bails. Always use the pull tab to insert or remove the transceivers, as the SFP might be hot.

1. Use the pull tab on the 16- and 32-Gbps SFP+ transceivers to help push the transceiver into the port. Transceivers are keyed so that they can only be inserted with the correct orientation. If a transceiver does not slide in easily, ensure that it is correctly oriented. Push the correctly oriented transceiver into the port until it is firmly seated and the latching mechanism clicks.

NOTE

Each SFP+ transceiver has a 10-pad gold-plated PCB-edge connector on the bottom. The correct position to insert an SFP+ transceiver into the upper row of ports is with the gold edge down. The correct position to insert an SFP+ transceiver into the lower row of ports is with the gold edge up.

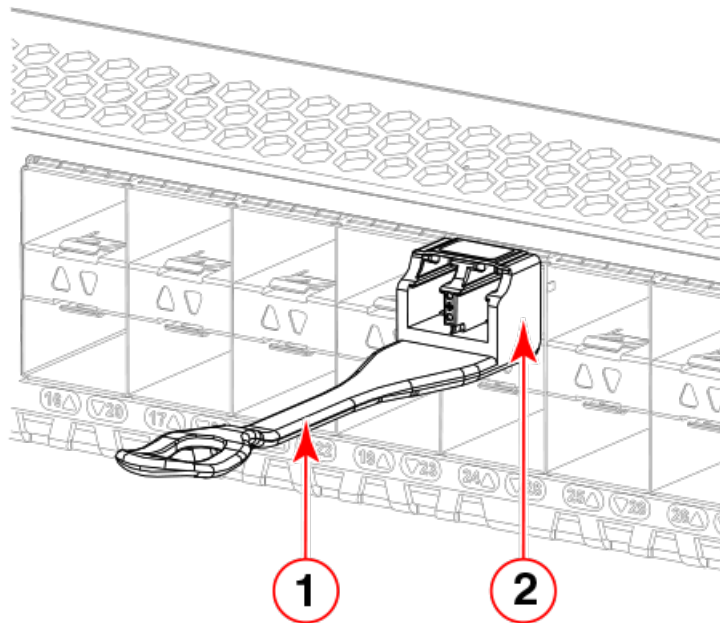

- 1 Pull tab
- 2 Transceiver

FIGURE 25 Installing a 32-Gbps SFP+ transceiver into an upper port

2. Position a cable so that the key (the ridge on one side of the cable connector) is aligned with the slot in the transceiver. Insert the cable into the transceiver until the latching mechanism clicks.

NOTE

Cables are keyed so that they can be inserted in only one way. If a cable does not slide in easily, ensure that it is correctly oriented. Do not insert any unsupported cable intended for an other type of transceiver into a regular SFP+ transceiver. You may damage the cable as well as the transceiver.

Replacing an SFP+ transceiver

Complete the following steps to remove and then install a new SFP+ transceiver.

NOTE

The 16- and 32-Gbps SFP+ transceivers do not have bails but pull tabs. Always use the pull tab to insert or remove the SFP+ transceivers, as the SFP might be hot.

1. Remove any cables that are inserted into the transceiver.
2. Grasp the SFP+ transceiver pull tab and pull the tab straight out.

NOTE

Grasp the tab near the body of the transceiver to reduce the chances of bending the pull tab. As the SFP may be hot, avoid touching it.

- To insert the replacement transceiver, use the pull tab on the SFP+ transceiver to carefully push the transceiver into the port. Transceivers are keyed so that they can only be inserted with the correct orientation. If a transceiver does not slide in easily, ensure that it is correctly oriented.

NOTE

Each SFP+ transceiver has a 10-pad gold-plated PCB-edge connector on the bottom. The correct position to insert an SFP+ transceiver into the upper row of ports is with the gold edge down. The correct position to insert an SFP+ transceiver into the lower row of ports is with the gold edge up.

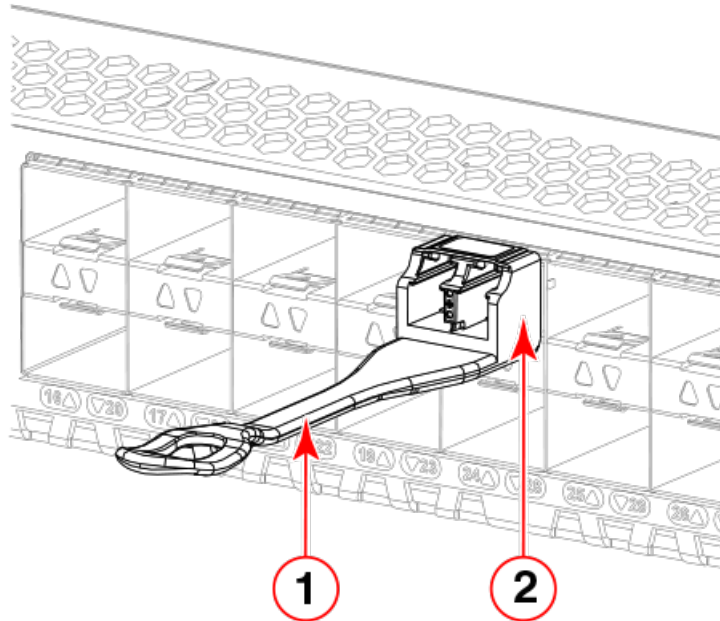

- Pull tab
- Transceiver

FIGURE 26 Replacing a 32-Gbps SFP+ optical transceiver

- Position a cable so that the key (the ridge on one side of the cable connector) is aligned with the slot in the transceiver. Insert the cable into the transceiver until the latching mechanism clicks.

Cables are keyed so that they can be inserted in only one way. If a cable does not slide in easily, ensure that it is correctly oriented.

Installing a QSFP transceiver

The device supports only Brocade-qualified transceivers. If you use an unqualified transceiver, the **switchshow** command output shows the port in a Mod_Inv state. Fabric OS also logs the issue in the system error log. To insert an QSFP transceiver, complete the following steps:

NOTE

The QSFP transceivers do not have bails but pull tabs. Always use the pull tab to insert or remove the QSFP transceivers, as the QSFP might be hot.

1. Use the pull tab on these transceivers to help push the transceiver into the port. Transceivers are keyed so that they can only be inserted with the correct orientation. If a transceiver does not slide in easily, ensure that it is correctly oriented. Push the correctly oriented transceiver into the port until it is firmly seated and the latching mechanism clicks.

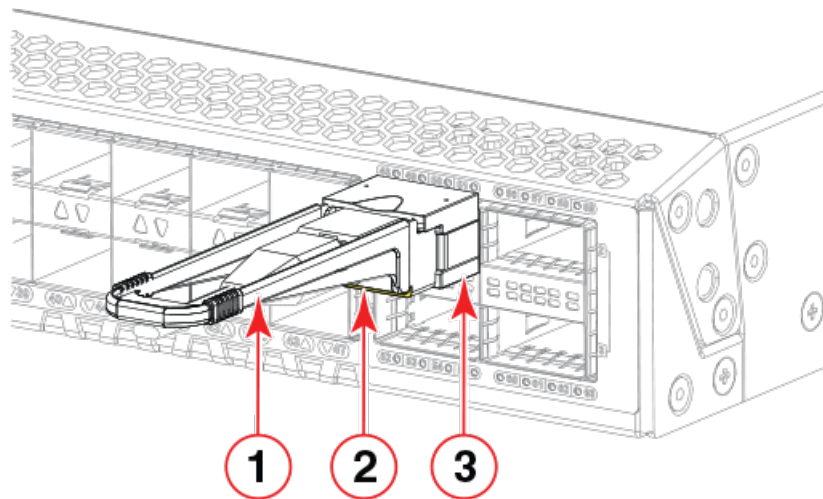

- 1 Pull tab
- 2 QSFP cable
- 3 QSFP transceiver

FIGURE 27 Installing a 32-Gbps QSFP transceiver in an upper port

2. Position a cable so that the key (the ridge on one side of the cable connector) is aligned with the slot in the transceiver. Insert the cable into the transceiver until the latching mechanism clicks.

NOTE

Cables are keyed so that they can be inserted in only one way. If a cable does not slide in easily, ensure that it is correctly oriented. Do not insert any unsupported cable intended for an other type of transceiver into a regular QSFP transceiver. You may damage the cable as well as the transceiver.

Replacing a QSFP transceiver

Complete the following steps to remove and then install a new QSFP transceiver.

NOTE

The QSFP transceivers do not have bails but pull tabs. Always use the pull tab to insert or remove the QSFP transceivers, as the QSFP might be hot.

1. Remove any cables that are inserted into the transceiver.
2. Grasp the QSFP transceiver pull tab and gently pull the tab straight out.

NOTE

Grasp the pull tab near the body of the transceiver to reduce the chances of bending the pull tab. As the QSFP may be hot, avoid touching it.

3. To insert the replacement transceiver, use the pull tab to carefully push the transceiver into the port. Transceivers are keyed so that they can only be inserted with the correct orientation. If a transceiver does not slide in easily, ensure that it is correctly oriented. Gently push the correctly oriented QSFP transceiver until the latching mechanism clicks.

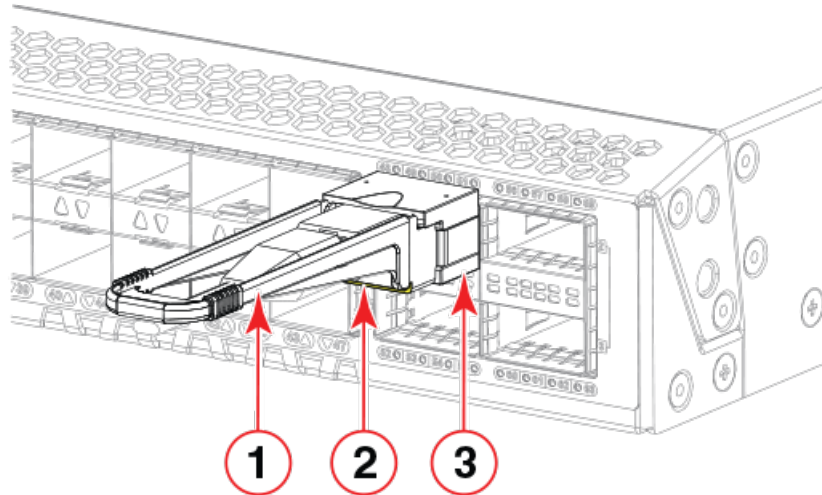

- 1 Pull tab
- 2 QSFP cable
- 3 QSFP transceiver

FIGURE 28 Replacing a QSFP optical transceiver

4. Position a cable so that the key (the ridge on one side of the cable connector) is aligned with the slot in the transceiver. Insert the cable into the transceiver until the latching mechanism clicks.

Cables are keyed so that they can be inserted in only one way. If a cable does not slide in easily, ensure that it is correctly oriented.

Verifying the operation of new transceivers

You can use the following commands to verify if the transceivers are working correctly:

- **sfpShow**
- **switchShow**
- **errDump**
- **fabricShow**

Refer to the *Fabric OS Command Reference* for output examples and descriptions.

Verifying the operation of new transceivers

Monitoring the Device

- [Interpreting port-side LEDs](#)..... 67
- [Interpreting nonport-side LEDs](#)..... 70
- [Interpreting the POST results](#)..... 71
- [Interpreting the BOOT results](#)..... 72
- [Running diagnostic tests](#)..... 72

Interpreting port-side LEDs

System activity and status can be determined through the activity of the LEDs on the switch. There are three possible LED states: no light, a steady light, and a flashing light. Flashing lights may be slow, fast, or flickering. The lights are green or amber. Sometimes, the LEDs flash either of the colors during boot, POST, or other diagnostic tests. This is normal; it does not indicate a problem unless the LEDs do not indicate a healthy state after all boot processes and diagnostic tests are complete.

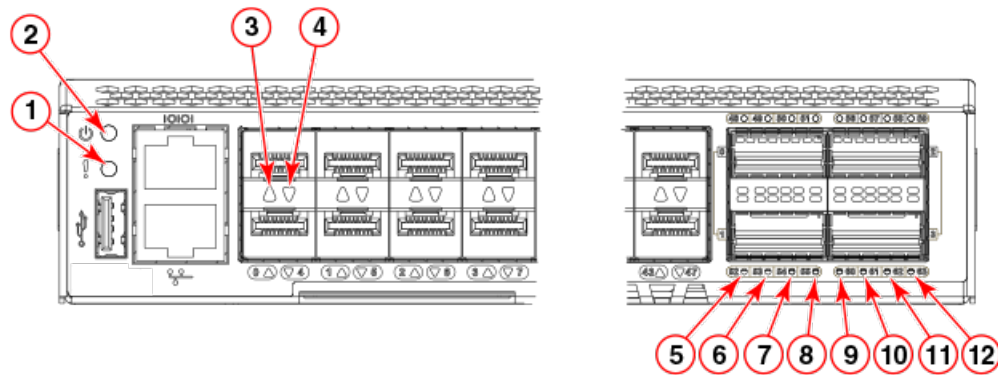

- | | |
|----------------------------------|-----------------------------------|
| 1 System status LED | 7 FC port 54 (QSFP 1) status LED |
| 2 System power LED | 8 FC port 55 (QSFP 1) status LED |
| 3 SFP+ (upper) port 0 status LED | 9 FC port 60 (QSFP 3) status LED |
| 4 SFP+ (lower) port 4 status LED | 10 FC port 61 (QSFP 3) status LED |
| 5 FC port 52 (QSFP 1) status LED | 11 FC port 62 (QSFP 3) status LED |
| 6 FC port 53 (QSFP 1) status LED | 12 FC port 63 (QSFP 3) status LED |

FIGURE 29 Brocade G620 port-side LEDs

NOTE

The two LEDs on the serial console port are not used.

System power LED

Refer to the following table to interpret the system power status LED.

TABLE 9 System power LED patterns during normal operation

LED color	Status of hardware	Recommended action
No light	System is off or there is an internal power supply failure.	Verify that system is powered on, the power cables attached, and your power source is live. If the system power LED is not green, the unit may be faulty. Contact your solution provider.
Steady green	System is on and power supplies are functioning properly.	No action required.

System status LED

Refer to the following table to interpret the system status LED.

TABLE 10 System status LED patterns during normal operation

LED color	Status of hardware	Recommended action
No light	System is off or there is no power.	Verify that system is on and has completed booting.
Steady green	POST and initialization is completed. System is on and functioning properly.	No action required.
Steady amber (for more than five seconds—can take over a minute to complete POST)	System is going through the power-up process.	No action required.
Steady amber (for more than a few minutes)	Unknown state, boot failed, or the system is faulty. NOTE Once POST completes and the switch has failed, steady amber may result.	Perform the following steps: 1. Connect a serial cable to the system. 2. Reboot the system. 3. Check the failure indicated on the system console 4. Contact your solution provider.
Flashing amber/green	Attention is required. A number of variables can cause this status, including a single power supply failure, a fan failure, or one or more environmental ranges have been exceeded.	Check the management interface and the error log for details on the cause of the status. Contact your solution provider.

FC port status LED

Refer to the following table to interpret the FC port status LEDs.

TABLE 11 SFP+ FC port status LED patterns during normal operation

LED color	Status of hardware	Recommended action
No light	Indicates one of the following: <ul style="list-style-type: none"> No signal or light carrier (media or cable) detected. Device may be currently initializing. Connected device is configured in an offline state. 	<ul style="list-style-type: none"> Verify the power LED is on, and check the SFP+ and cable. Verify the device is not currently being initialized. Verify the status of the connected device.
Steady green	Port is online (connected to external device) but has no traffic.	No action required.
Slow-flashing green (on 1/2 second; then off 1/2 second)	Port is online but segmented because of a loopback cable or incompatible device connection.	Verify that the correct device is attached to the switch.
Fast-flashing green (on 1/4 second; then off 1/4 second)	Port is online and an internal loopback diagnostic test is running.	No action required.
Flickering green	Port is online and frames are flowing through the port.	No action required.
Steady amber	Port is receiving light or signal carrier, but it is not online yet.	No action required.
Slow-flashing amber (on 2 seconds; then off 2 seconds)	Port is disabled because of diagnostics or the portDisable command.	<p>Reset the port.</p> <p>The portCfgPersistentDisable command is persistent across reboots.</p>
Fast-flashing amber (on 1/2 second; then off 1/2 second)	SFP+ or port is faulty.	<p>Reset the port.</p> <p>Replace the SFP+. Must be a Brocade-branded SFP+.</p>

QSFP port status LED

Refer to the following table to interpret the QSFP port status LEDs

TABLE 12 QSFP port status LED patterns during normal operation

LED color	Status of hardware	Recommended action
No light	Indicates one of the following: <ul style="list-style-type: none"> No signal or light carrier (media or cable) detected. Device may be currently initializing. Connected device is configured in an offline state. 	<ul style="list-style-type: none"> Verify the power LED is on, and check the QSFP and cable. Verify the device is not currently being initialized. Verify the status of the connected device.
Steady green	Port is online (connected to external device) but has no traffic.	No action required.
Slow-flashing green (on 1/2 second; then off 1/2 second)	Port is online but segmented because of a loopback cable or incompatible device connection.	Verify that the correct device is attached to the switch.
Fast-flashing green (on 1/4 second; then off 1/4 second)	Port is online and an internal loopback diagnostic test is running.	No action required.
Flickering green	Port is online and frames are flowing through the port.	No action required.
Steady amber	Port is receiving light or signal carrier, but it is not online yet.	No action required.
Slow-flashing amber (on 2 seconds; then off 2 seconds)	Port is disabled because of diagnostics or the portDisable command.	Reset the port. The portCfgPersistentDisable command is persistent across reboots.
Fast-flashing amber (on 1/2 second; then off 1/2 second)	QSFP or port is faulty.	Reset the port. Replace the QSFP. Must be a Brocade-branded QSFP.

NOTE

For the QSFP ports, if the port is configured as individual SFP+ FC ports on the other end using breakout cables, then the four individual port status LEDs for each QSFP should be monitored.

Interpreting nonport-side LEDs

Each field-replaceable power supply and fan assembly unit contains a status LED.

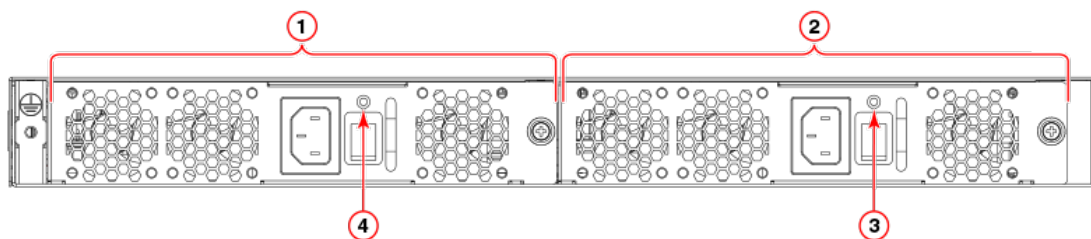

- | | | | |
|---|---------------------------------|---|--|
| 1 | Power supply and fan assembly 2 | 3 | Power supply and fan assembly 1 status LED |
| 2 | Power supply and fan assembly 1 | 4 | Power supply and fan assembly 2 status LED |

FIGURE 30 Nonport-side LEDs

Power supply and fan assembly status LED

Refer to the following table to interpret the power supply and fan assembly status LED during normal operation.

TABLE 13 Power supply and fan assembly status LED patterns during normal operation

LED color	Description	Action required
No light	Power supply and fan assembly is not receiving power, or is off.	Verify that the power supply and fan assembly is on and seated and the power cord is connected to a functioning power source.
Steady green	Power supply and fan assembly is operating normally.	No action is required.
Flashing green (for more than 5 seconds)	Power supply and fan assembly is faulty for one of the following reasons: <ul style="list-style-type: none"> The assembly is switched off (flashing for ~ 5 seconds, then off). The power cable is disconnected (flashing for ~ 5 seconds, then off). The power supply and fan assembly has failed. <p>NOTE: When the device is first powered on, the power supply and fan assembly status LED flashes until POST has completed.</p>	Try one of the following: <ul style="list-style-type: none"> Check the power cable connection. Verify that the assembly is powered on. Replace the power supply and fan assembly.

Interpreting the POST results

Each time the switch is powered on, rebooted, or reset, the switch performs a power-on self-test (POST). Total boot time with the POST can be several minutes. The POST can be omitted after subsequent reboots by using the **fastboot** command or entering the **diagDisablePost** command to

persistently disable the POST. The success or failure results of the diagnostic tests that run during POST can be monitored through LED activity, the error log, or the command line interface. During the POST, the LEDs flash different colors.

The POST includes the following tasks:

- Conducts preliminary POST diagnostics.
- Initializes the operating system.
- Initializes hardware.
- Runs diagnostic tests on several functions, including circuitry, port functionality, memory, statistics counters, and serialization.

Perform the following steps to determine whether POST completed successfully and whether any errors were detected.

1. Verify that the LEDs on the device indicate that all components are healthy. If one or more LEDs do not display a healthy state:
 - a) Verify that the LEDs are not set to "beacon" (this can be determined through the **switchShow** command or Web Tools).
 - b) Follow the recommended action for the observed LED behavior.
2. Verify the **diagShow** command displays that the diagnostic status for all ports in the device is OK.
3. Review the system log for errors. Errors detected during POST are written to the system log, which can be viewed by using the **errShow** command.

Interpreting the BOOT results

BOOT includes the following tasks after POST is complete.

1. Performs universal port configuration.
2. Initializes links.
3. Analyzes the fabric. If any ports are connected to other switches, the switch participates in a fabric configuration.
4. Obtains a domain ID and assigns port addresses.
5. Constructs unicast routing tables.
6. Enables normal port operation.

Running diagnostic tests

In addition to the POST, Fabric OS includes diagnostic tests to help you troubleshoot the hardware and firmware. This includes tests of internal connections and circuitry, fixed media, and the transceivers and cables in use.

The tests are implemented by command, either through a Telnet session or through a terminal set up for a serial connection to the device. Some tests require the ports to be connected by external cables to allow diagnostics to verify the serializer/deserializer interface, transceiver, and cable. Some tests require loopback plugs.

Diagnostic tests are run at supported link speeds depending on the speed of the link being tested and the type of port.

NOTE

Diagnostic tests may temporarily lock the transmit and receive speed of the links during diagnostic testing.

Brocade recommends that you power-cycle the device after completing offline diagnostics tests.

Power Supply and Fan Assembly

- Power supply and fan assembly overview..... 75
- Precautions specific to the power supply and fan assemblies..... 76
- Identifying the airflow direction..... 77
- Power supply and fan assembly status LED..... 78
- Power supply and fan assembly unit fault indicators..... 78
- Power supply and fan assembly task guide..... 78
- Time and items required..... 79
- Recording power supply and fan assembly critical information..... 79
- Removing a power supply and fan assembly..... 80
- Inserting a new power supply and fan assembly..... 81
- Verifying the operation of the power supply and fan assemblies..... 82

Power supply and fan assembly overview

The power supply and fan assembly units in the Brocade G620 chassis can be removed and replaced without special tools. The device can continue operating during the replacement.

The device supports the following types of power supplies.

- AC power supply with nonport-side air exhaust. This unit moves the air from the port-side to the nonport-side of the device.
- AC power supply with nonport-side air intake. This unit moves the air from the nonport-side to the port-side of the device.

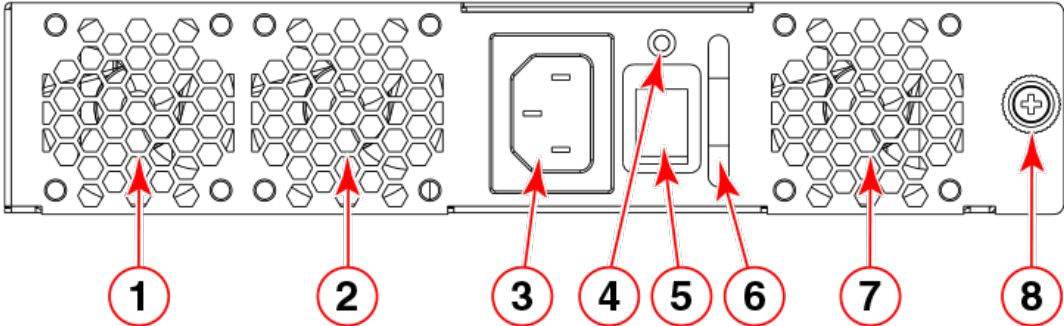

- | | |
|--|--|
| 1 Fan 3 | 5 Power-on switch |
| 2 Fan 2 | 6 Power supply and fan assembly handle |
| 3 AC power cable receptacle | 7 Fan 1 |
| 4 Power supply and fan assembly status LED | 8 Captive screw |

FIGURE 31 AC power supply and fan assembly

NOTE

The two power supply and fan assemblies concurrently installed in the chassis must be of the same type (AC), model (airflow direction), and part number. If the airflow directions are different, an error is generated on the console.

NOTE

The power supply and fan assembly units are hot-swappable if they are replaced one at a time. They are identical and fit into either slot.

NOTE

The device can operate all the ports with one power supply and fan assembly unit if you do not require redundancy.

The device fans are fixed inside the combined power supply and fan assemblies to provide necessary airflow to cool the whole system. There are three fans located in each unit. The system software sets fan speed and measures fan speed through the tachometer interface.

Precautions specific to the power supply and fan assemblies



DANGER

Make sure that the power source circuits are properly grounded, then use the power cord supplied with the device to connect it to the power source.



DANGER

If the installation requires a different power cord than the one supplied with the device, make sure you use a power cord displaying the mark of the safety agency that defines the regulations for power cords in your country. The mark is your assurance that the power cord can be used safely with the device.



CAUTION

Disassembling any part of the power supply and fan assembly voids the warranty and regulatory certifications. There are no user-serviceable parts inside the power supply and fan assembly.



CAUTION

Ensure that the airflow direction of the power supply unit matches that of the installed fan tray. The power supplies and fan trays are clearly labeled with either a green arrow with an "E", or an orange arrow with an "I."



CAUTION

If you do not install a module or a power supply in a slot, you must keep the slot filler panel in place. If you run the chassis with an uncovered slot, the system will overheat.

**CAUTION**

Use a separate branch circuit for each power cord, which provides redundancy in case one of the circuits fails.

**CAUTION**

To prevent damage to the chassis and components, never attempt to lift the chassis using the fan or power supply handles. These handles were not designed to support the weight of the chassis.

NOTE

The equipment installation must meet NEC/CEC code requirements. Consult local authorities for regulations.

NOTE

If the ambient temperature is above the recommended operational limits, the power supply units shutdown, which in turn shuts down the device without any warning message.

Identifying the airflow direction

The power supply and fan assemblies are identified by the following airflow directions:

- **Intake power supply and fan assembly with an orange "I" label or without any label:** Pulls air from the nonport-side of the switch and exhausts it out the port side.



- Nonport-side air intake
- Port-side air exhaust
- Back-to-front (nonport-side to port-side) airflow
- Part numbers ending with **-R**

- **Exhaust power supply and fan assembly with a green "E" label:** Pulls air from the port side of the switch and exhausts it out the nonport-side.



- Nonport-side air exhaust
- Port-side air intake
- Front-to-back (port-side to nonport-side) airflow
- Part numbers ending with **-F**

Power supply and fan assembly status LED

Refer to the following table to interpret the power supply and fan assembly status LED during normal operation.

TABLE 14 Power supply and fan assembly status LED patterns during normal operation

LED color	Description	Action required
No light	Power supply and fan assembly is not receiving power, or is off.	Verify that the power supply and fan assembly is on and seated and the power cord is connected to a functioning power source.
Steady green	Power supply and fan assembly is operating normally.	No action is required.
Flashing green (for more than 5 seconds)	Power supply and fan assembly is faulty for one of the following reasons: <ul style="list-style-type: none"> The assembly is switched off (flashing for ~ 5 seconds, then off). The power cable is disconnected (flashing for ~ 5 seconds, then off). The power supply and fan assembly has failed. <p>NOTE: When the device is first powered on, the power supply and fan assembly status LED flashes until POST has completed.</p>	Try one of the following: <ul style="list-style-type: none"> Check the power cable connection. Verify that the assembly is powered on. Replace the power supply and fan assembly.

Power supply and fan assembly unit fault indicators

Use one of the following methods to determine the status of the power supply and fan assemblies:

- Check the power supply and fan assembly status LED.
- In Web Tools, click the Power Status icon.
- Enter the **psShow** command at the prompt to display power supply and fan assembly status, as shown in the following example:

```
Device:admin> psshow
Power Supply #1 is OK
Power Supply #2 is OK
```

Power supply and fan assembly task guide

You can perform an easy set of steps to install or replace a power supply and fan assembly or to replace both power supply and fan assemblies. By default, both of the power supply and fan assemblies are installed in the device.

Installing an additional power supply and fan assembly (hot-install)

If your device is up and running with a single power supply and fan assembly and you want to install an additional power supply, complete the following steps.

1. Remove the existing filler panel.
2. Insert the new power supply and fan assembly.
3. Power on the power supply and an assembly.
4. Verify the power supply and fan assembly status LED.

Replacing a power supply and fan assembly (hot-swap)

If your device is up and running with two power supply and fan assemblies, but one of them has failed, complete the following steps.

1. Power down the old or failed power supply and fan assembly.
2. Remove the old or failed power supply and fan assembly.
3. Insert the new power supply and fan assembly.
4. Power on the power supply and fan assembly.
5. Verify the power supply and fan assembly status LED.

Replacing both power supply and fan assemblies (cold-swap)

If your device is up and running with both power supply and fan assemblies, but you want to replace both of them, complete the following steps..

1. Shut down the system using the **sysShutdown** command.
2. Power down the device/both FRUs.
3. Remove the old/failed FRUs.
4. Insert the new FRUs.
5. Power on the FRUs.
6. Verify the FRU status LEDs.

Time and items required

Installing or removing and replacing a power supply and fan assembly should require less than five minutes to complete.

The following items are required to replace a power supply and fan assembly:

- New power supply and fan assembly (must have the same airflow direction as the power supply and fan assembly being replaced)
- #1 Phillips-head screwdriver

Recording power supply and fan assembly critical information

You can use the following commands to record the power supply and fan assembly configuration and operations information:

- **chassisshow**
- **fanshow**
- **psshow**
- **historyshow**
- **tempshow**
- **sensorshow**

Refer to the *Fabric OS Command Reference* for output examples and descriptions.

Removing a power supply and fan assembly

Complete the following steps to remove a faulty power supply and fan assembly.



CAUTION

The power supply switch must be in the off position when you insert the power supply into the chassis. Damage to the switch can result if a live power supply is installed.

1. To leave the device in service while replacing a power supply and fan assembly, verify that the other power supply and fan assembly (the one not being replaced) has been powered on for at least four seconds and has a steady green LED.

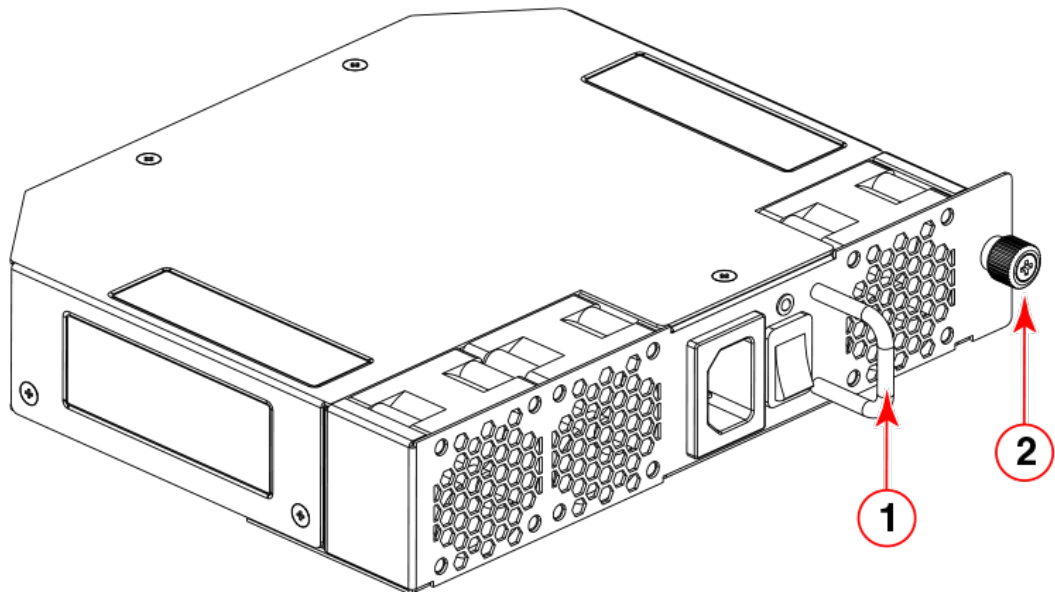

- 1 Power supply and fan assembly handle
- 2 Captive screw

FIGURE 32 AC power supply and fan assembly

2. Power off the power supply to be replaced by flipping the AC power switch to the off position (the "O" symbol). The fans in the other power supply will automatically switch to high speed to maintain adequate cooling.
3. Unplug the power cord from the power supply and fan assembly that is being replaced.

4. Using a Phillips screwdriver, unscrew the captive screw.
5. Remove the power supply and fan assembly from the chassis by pulling the handle out and away from the chassis.

Inserting a new power supply and fan assembly

Complete the following steps to insert a new power supply and fan assembly into the chassis.



CAUTION

The power supply switch must be in the off position when you insert the power supply into the chassis. Damage to the switch can result if a live power supply is installed.

The new power supply and fan assembly must have the same part number and airflow label (or lack thereof) as the power supply and fan assembly already installed.

1. To leave the device in service while installing a power supply and fan assembly, verify that the other power supply and fan assembly (the one already installed) has been powered on for at least four seconds and has a steady green LED.
2. Using a Phillips screwdriver, unscrew the captive screw of the filler panel that is located in the empty power supply and fan assembly slot.
3. Orient the new power supply and fan assembly with the captive screw on the right, as shown in the figure.

Do not force the installation. If the power supply and fan assembly does not slide in easily, ensure that it is correctly oriented before continuing.



CAUTION

Carefully follow the mechanical guides on each side of the power supply slot and make sure the power supply is properly inserted in the guides. Never insert the power supply upside down.

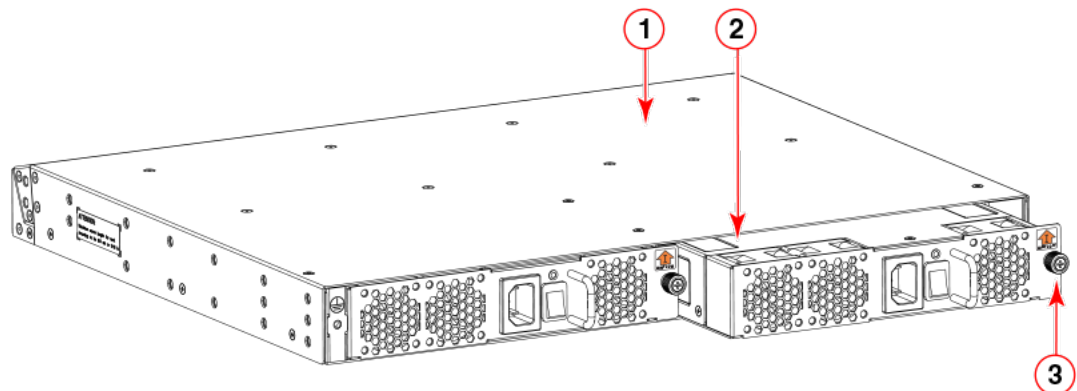

- 1 The device
- 2 AC power supply and fan assembly
- 3 Captive screw

FIGURE 33 Insert an AC power supply and fan assembly

4. Gently push the power supply and fan assembly into the chassis until it is firmly seated.

5. Using the Phillips screwdriver, secure the power supply and fan assembly to the chassis by tightening the captive screw.
6. Plug the power cord into the power supply and fan assembly and power on the unit by flipping the AC power switch to the on position (the "I" symbol).
7. Verify that the LED on the new power supply and fan assembly displays a steady green light while the device is operating. If the LED is not a steady green, ensure that the power supply is securely installed and seated properly.
8. Optional: If you are using the CLI, enter the **psShow** command at the command line prompt to display the status. Power supply and fan assembly status can also be viewed using Web Tools.

Verifying the operation of the power supply and fan assemblies

You can use the following commands to verify that the power supply and fan assemblies are operational:

- **psShow**
- **fanShow**
- **switchShow**
- **errDump**

Refer to the *Fabric OS Command Reference* for output examples and descriptions.

Brocade G620 Technical Specifications

This document highlights the features and specifications for the Brocade G620 switch.

System specifications

System component	Description
Enclosure	1U, nonport-side front-to-back exhaust airflow, power from back
Power inlet	C14
Power supplies	Dual, hot-swappable redundant power supplies with integrated system cooling fans
Fans	Three fans per power supply and fan assembly unit
Cooling	Port side to the nonport-side of the switch (nonport-side exhaust) and nonport-side to the port side (port-side exhaust)
System architecture	Nonblocking shared memory switch
System processors	Freescale T1022 CPU
Port-to-port latency	<700 nanoseconds with no contention (destination port is free)

Fibre Channel

System component	Description
Fibre Channel ports	<p>48 SFP+ ports that support any combination of Short Wavelength (SWL) and Long Wavelength (LWL) or Extended Long Wavelength (ELWL) optical media.</p> <p>4 QSFP ports that support 32-Gbps QSFP transceivers.</p> <p>The SFP+ ports are capable of auto-negotiating to 4, 8, 16, or 32 Gbps speed depending on the SFP+ model and the minimum supported speed of the optical transceiver at the other end of the link.</p> <ul style="list-style-type: none">• 4-, 8-, and 16-Gbps performance is enabled by 16-Gbps SFP+ transceivers provided the other end of the connection is minimum of 4 Gbps speed.• 8-, 16-, and 32-Gbps performance is enabled by 32-Gbps SFP+ transceivers provided the other end of the connection is minimum of 8 Gbps speed.
	<hr/> <p>NOTE 2- and 4-Gbps transceivers are not supported.</p> <hr/>

System component	Description
ANSI Fibre Channel protocol	FC-PH (Fibre Channel Physical and Signaling Interface standard)
Modes of operation	Fibre Channel Class 2 and Class 3
Fabric initialization	Complies with FC-SW-3 Rev. 6.6
FCIP (IP over Fibre Channel)	Complies with FC-IP 2.3 of FCA profile
Port Status	Bicolor LED (amber/green)

Other

System component	Description
Serial console port	One three-wire (Tx, Rx, Gnd) UART serial port
Ethernet management port	One 1000Base-X / 100Base-TX port / 10Base-T
USB port	One external USB port

LEDs

System component	Description
System power LED	One green system power status LED (upper) on the port side.
System status LED	One bicolor (green/amber) system status LED (lower) on the port side.
Ethernet port link LED	One link LED on the left of the RJ45 connector. Glows green for 1000 Mbps and amber for 100/10 Mbps.
Ethernet port activity LED	One activity LED on the right of the RJ45 connector.
Serial console port LED	The serial console port LEDs remain off at all times, even when a cable is inserted and the link is active.
FC port status LED	64 bicolor (green/amber) port status LEDs. One for each SFP+ port and four for each QSFP port on the switch.
Power supply and fan assembly status LED	One green power supply and fan assembly status LED on each power supply and fan assembly on the nonport-side of the switch.

Other

System component	Description
Serial cable	RJ-45 console cable
RJ-45 to DB9 adapter	RJ-45 to DB9 for console cable
RJ-45 connector	Uses an RJ-45 connector for the serial port

Weight and physical dimensions

Empty weight refers to the device with two power supply and fan assemblies installed but no SFP+ or QSFP transceivers.

Model	Height	Width	Depth	Weight (empty)	Weight (fully loaded)
Brocade G620 switch	4.39 cm	44.00 cm	35.56 cm	7.71 kg	8.53 kg
	1.73 inches	17.32 inches	14.00 inches	17.00 lb	18.80 lb

Environmental requirements

Condition	Operational	Non-operational
Ambient temperature	0°C to 40°C (32°F to 104°F)	-25°C to 70°C (-13°F to 158°F)
Relative humidity (non-condensing)	10% to 85% at 40°C (104°F)	10% to 90% non-condensing
Altitude (above sea level)	0 to 3000 m (9,842 feet)	0 to 12000 m (39,370 feet)
Shock	20.0 G, 6 ms, half-sine wave	33.0 G, 11 ms, half-sine wave, 3G Axis
Vibration	0.5 G sine, 0.4 gms random, 5 – 500 Hz	2.0 G sine, 1.1 gms random, 5 – 500 Hz
Airflow	Maximum: 71.36 cmh (42 cfm) Nominal: 59.47 cmh (35 cfm)	N/A
Heat dissipation	Refer to the Power consumption table	N/A
Operating noise	Maximum: 65 dB	N/A

Power supply specifications (per PSU)

Power supply model	Maximum output power rating (DC)	Input voltage	Input line frequency	Maximum input current	Input line protection	Maximum inrush current
XBR-G250WPSAC-F	250 W	100 – 240 VAC (nominal) 90 – 264 VAC (range)	50/60 Hz (nominal) 47 – 63 Hz (range)	3.5 A	Line fused	50 A peak @ 240 VAC for <10 ms, 10 ms - 150 ms, <15 A peak. 50 A peak @ 240 VAC at cold start for <10 ms. 15 A peak for cycles 10 ms - 150 ms. <3.5 A peak for >150 ms
XBR-G250WPSAC-R	250 W	100 – 240 VAC (nominal) 90 – 264 VAC (range)	50/60 Hz (nominal) 47 – 63 Hz (range)	3.5 A	Line Fused	50 A peak @ 240 VAC for <10 ms, 10 ms - 150 ms, <15 A peak. 50 A peak @ 240 VAC at cold start for <10 ms. 15 A peak for cycles 10 ms - 150 ms. <3.5 A peak for >150 ms

Power consumption (typical configuration)

Model name	@100 VAC input	@200 VAC input	@48 VDC input	Minimum number of power supplies	Notes
Brocade G620 switch	1.93 A 192 W 655 BTU/hr	0.97 A 190 W 649 BTU/hr	N/A	1 (But, input current is for 1 PSU. Watts and BTUs/hr are with 2 PSUs).	Fully configured all ports with 25% traffic rate, fans at high speed, and input power +/- 5% tolerance.

Power consumption (maximum configuration)

Model name	@100 VAC input	@200 VAC input	@48 VDC input	Minimum number of power supplies	Notes
Brocade G620 switch	2.07 A 204 W 696 BTU/hr	1.03 A 202 W 690 BTU/hr	N/A	2 (But, input current is for 1 PSU. Watts and BTUs/hr are with 2 PSUs).	Fully configured all ports with 100% traffic rate, fans at high speed, and input power +/- 5% tolerance.

Power consumption (idle configuration)

Model name	@100 VAC input	@200 VAC input	@48 VDC input	Minimum number of power supplies	Notes
Brocade G620 switch	1.54 A 155 W 529 BTU/hr	0.77 A 154 W 526 BTU/hr	N/A	1 (But, input current is for 1 PSU. Watts and BTUs/hr are with 2 PSUs).	All optics loaded but not initialized and the system completed boot up, fans at nominal speed, and input power +/- 5% tolerance.

Data port specifications (Fibre Channel)

Name	Port Numbers	Media Type	Description
Brocade G620 switch	0 to 47	10-, 16-, or 32-Gbps SFP+ optical ports	Can be an F_Port, N_Port, E_Port, or EX_Port
	48 to 63	4 x 32-Gbps (128 Gbps) QSFP optical ports	Can be an E_Port or EX_Port

Fibre Channel data transmission ranges

Port speed (Gbps)	Cable size (microns)	Short wavelength (SWL)	Long wavelength (LWL)	Extended long wavelength (ELWL)	
4	50	150 m (492 ft) (OM2)	N/A	N/A	
		380 m (1,264 ft) (OM3)			
		400 m (1,312 ft) (OM4)			
8	50	50 m (164 ft) (OM2)	N/A	N/A	
		150 m (492 ft) (OM3)			
		190 m (623 ft) (OM4)			
8	62.5	70 m (229 ft)	N/A	N/A	
		9	N/A	30 km (18.6 miles)	N/A
		9	N/A	10 km (6.2 miles)	N/A

Port speed (Gbps)	Cable size (microns)	Short wavelength (SWL)	Long wavelength (LWL)	Extended long wavelength (ELWL)			
10	50	82 m (269 ft) (OM2)	N/A	N/A			
		300 m (984 ft) (OM3)					
		550 m (1,804 ft) (OM4)					
16	50	35 m (115 ft) (OM2)	N/A	N/A			
		100 m (328 ft) (OM3)					
		125 m (410 ft) (OM4)					
32	50	70 m (230 ft) (OM3)	N/A	N/A			
		100 m (328 ft) (OM4)					
		125 m (410 ft) (OM4)					
10	62.5	33 m (108 ft)	N/A	N/A			
		9			10 km (6.2 miles)	N/A	
		9			N/A	10 km (6.2 miles)	N/A
16	62.5	15 m (49 ft)	N/A	N/A			
		9			N/A	10 km (6.2 miles)	N/A
		9			N/A	10 km (6.2 miles)	N/A
32	62.5	N/A	N/A	N/A			
		9			N/A	N/A	
		9			N/A	N/A	

Serial port specifications (pinout RJ-45)

Pin	Signal	Description
1	Not supported	N/A
2	Not supported	N/A
3	UART1_TXD	Transmit data
4	GND	Logic ground
5	GND	Logic ground
6	UART1_RXD	Receive data
7	Not supported	N/A
8	Not supported	N/A

Serial port specifications (protocol)

Parameter	Value
Baud	9600
Data bits	8
Parity	None
Flow control	None
Stop bits	1

Memory specifications

Memory	Type	Size
Main Memory	DDR3L SDRAM with 8-bit ECC, SODIMM package, operating at 1200 MT/s	4 GB, 64-bit
Boot Flash	Parallel NOR flash embedded memory	8 MB
eUSB Module	-	2 GB

Regulatory compliance (EMC)

- FCC Part 15, Subpart B (Class A)
- EN 55022 (CE mark) (Class A)
- EN 55024 (CE mark) (Immunity) for Information Technology Equipment
- ICES-003 (Canada) (Class A)
- AS/NZ 55022 (Australia) (Class A)
- VCCI (Japan) (Class A)
- EN 61000-3-2
- EN 61000-3-3
- EN 61000-6-1

Regulatory compliance (safety)

- CAN/CSA-C22.2 No. 60950-1-07/UL60950-1 - Safety of Information Technology Equipment
- EN 60825-1 Safety of Laser Products - Part 1: Equipment Classification, Requirements and User's Guide
- EN 60825-2 Safety of Laser Products - Part 2: Safety of Optical Fibre Communications Systems
- EN 60950-1, IEC 60950-1 Safety of Information Technology Equipment

Regulatory compliance (environmental)

- 2011/65/EU - Restriction of the use of certain hazardous substance in electrical and electronic equipment (EU RoHS)
- 2012/19/EU - Waste electrical and electronic equipment (EU WEEE)
- 94/62/EC - packaging and packaging waste (EU)
- 2006/66/EC - batteries and accumulators and waste batteries and accumulators (EU battery directive)
- 1907/2006 of the European Parliament and of the Council of 18 December 2006 concerning the Registration, Evaluation, Authorisation and Restriction of Chemicals (EU REACH)
- Section 1502 of the Dodd-Frank Wall Street Reform and Consumer Protection Act of 2010 - U.S. Conflict Minerals
- 30/2011/TT-BCT - Vietnam circular.
- SJ/T 11363-2006 Requirements for Concentration Limits for Certain Hazardous Substances in EIPs (China)
- SJ/T 11364-2006 Marking for the Control of Pollution Caused by EIPs (China)
- NEBS-compliant

Regulatory Statements

- BSMI statement (Taiwan)..... 91
- Canadian requirements..... 91
- CE statement..... 91
- China CC statement..... 92
- China ROHS..... 93
- FCC warning (US only)..... 93
- Germany statement..... 93
- KCC statement (Republic of Korea)..... 93
- VCCI statement..... 93

BSMI statement (Taiwan)

警告使用者：
這是甲類的資訊產品，在居住的環境中使用時，可能會造成射頻干擾，
在這種情況下，使用者會被要求採取某些適當的對策。

Warning:

This is Class A product. In a domestic environment this product may cause radio interference in which case the user may be required to take adequate measures.

Canadian requirements

This Class A digital apparatus meets all requirements of the Canadian Interference-Causing Equipment Regulations, ICES-003 Class A.

Cet appareil numérique de la classe A est conforme à la norme NMB-003 du Canada.

CE statement

ATTENTION

This is a Class A product. In a domestic environment, this product might cause radio interference, and the user might be required to take corrective measures.

The standards compliance label on this device contains the CE mark which indicates that this system conforms to the provisions of the following European Council directives, laws, and standards:

China ROHS

Refer to the latest revision of the China ROHS document (P/N 53-1000428-xx) which ships with the product.

FCC warning (US only)

This equipment has been tested and complies with the limits for a Class A computing device pursuant to Part 15 of the FCC Rules. These limits are designed to provide reasonable protection against harmful interference when the equipment is operated in a commercial environment.

This equipment generates, uses, and can radiate radio frequency energy, and if not installed and used in accordance with the instruction manual, might cause harmful interference to radio communications. Operation of this equipment in a residential area is likely to cause harmful interference, in which case the user will be required to correct the interference at the user's own expense.

Germany statement

Machine noise information regulation - 3. GPSGV, the highest sound pressure level value is 70.0 dB(A) in accordance with EN ISO 7779.

Maschinenlärminformations-Verordnung - 3. GPSGV, der höchste Schalldruckpegel beträgt 70.0 dB(A) gemäss EN ISO 7779.

KCC statement (Republic of Korea)

A급 기기(업무용 방송통신기기): 이 기기는 업무용(A급)으로 전자파적합등록을 한 기기이오니 판매자 또는 사용자는 이 점을 주의하시기 바라며, 가정외의 지역에서 사용하는 것을 목적으로 합니다.

Class A device (Broadcasting Communication Device for Office Use): This device obtained EMC registration for office use (Class A), and may be used in places other than home. Sellers and/or users need to take note of this.

VCCI statement

この装置は、クラスA情報技術装置です。この装置を家庭環境で使用すると電波妨害を引き起こすことがあります。この場合には使用者が適切な対策を講ずるよう要求されることがあります。 VCCI-A

Regulatory Statements

This is a Class A product based on the standard of the Voluntary Control Council for Interference by Information Technology Equipment (VCCI). If this equipment is used in a domestic environment, radio disturbance might arise. When such trouble occurs, the user might be required to take corrective actions.

Cautions and Danger Notices

- [Danger Notices](#)..... 95
- [Cautions](#)..... 98

Danger Notices

A Danger statement indicates conditions or situations that can be potentially lethal or extremely hazardous to you. Safety labels are also attached directly to products to warn of these conditions or situations.

Ein Gefahrenhinweis warnt vor Bedingungen oder Situationen die tödlich sein können oder Sie extrem gefährden können. Sicherheitsetiketten sind direkt auf den jeweiligen Produkten angebracht um vor diesen Bedingungen und Situationen zu warnen.

Un paragraphe Danger indique des conditions ou des situations potentiellement mortelles ou extrêmement dangereuses. Des labels de sécurité sont posés directement sur le produit et vous avertissent de ces conditions ou situations

Una advertencia de peligro indica condiciones o situaciones que pueden resultar potencialmente letales o extremadamente peligrosas. También habrá etiquetas de seguridad pegadas directamente sobre los productos para advertir de estas condiciones o situaciones.

General dangers



DANGER

The procedures in this manual are for qualified service personnel.

GEFAHR	Die Vorgehensweisen in diesem Handbuch sind für qualifiziertes Servicepersonal bestimmt.
--------	--

DANGER	Les procédures décrites dans ce manuel doivent être effectuées par un personnel de maintenance qualifié.
--------	--

PELIGRO	Los procedimientos de este manual deben llevarlos a cabo técnicos cualificados.
---------	---



DANGER

Be careful not to accidentally insert your fingers into the fan tray while removing it from the chassis. The fan may still be spinning at a high speed.

GEFAHR	Die Finger dürfen nicht versehentlich in das Ventilatorblech gesteckt werden, wenn dieses vom Gehäuse abgenommen wird. Der Ventilator kann sich unter Umständen noch mit hoher Geschwindigkeit drehen.
--------	--

DANGER	Faites attention de ne pas accidentellement insérer vos doigts dans le boîtier du ventilateur lorsque vous l'enlevez du châssis. Il est possible que le ventilateur tourne encore à grande vitesse
--------	--

PELIGRO	Procure no insertar los dedos accidentalmente en la bandeja del ventilador cuando esté desmontando el chasis. El ventilador podría estar girando a gran velocidad.
---------	--

Electrical dangers



DANGER

For safety reasons, the ESD wrist strap should contain a series 1 megaohm resistor.

GEFAHR	Aus Sicherheitsgründen sollte ein EGB-Armband zum Schutz von elektronischen gefährdeten Bauelementen mit einem 1 Megaohm-Reihenwiderstand ausgestattet sein.
--------	--

DANGER	Pour des raisons de sécurité, la dragonne ESD doit contenir une résistance de série 1 méga ohm.
--------	---

PELIGRO	Por razones de seguridad, la correa de muñeca ESD deberá contener un resistor en serie de 1 mega ohmio.
---------	---



DANGER

Make sure that the power source circuits are properly grounded, then use the power cord supplied with the device to connect it to the power source.

GEFAHR	Stellen Sie sicher, dass die Stromkreise ordnungsgemäß geerdet sind. Benutzen Sie dann das mit dem Gerät gelieferte Stromkabel, um es an die Stromquelle anzuschließen.
--------	---

DANGER	Vérifiez que les circuits de sources d'alimentation sont bien mis à la terre, puis utilisez le cordon d'alimentation fourni avec le dispositif pour le connecter à la source d'alimentation.
--------	--

PELIGRO	Verifique que circuitos de la fuente de corriente están conectados a tierra correctamente; luego use el cordón de potencia suministrado con el instrumento para conectarlo a la fuente de corriente
---------	---



DANGER

Remove both power cords before servicing.

GEFAHR	Trennen Sie beide Netzkabel, bevor Sie Wartungsarbeiten durchführen.
--------	--

DANGER	Retirez les deux cordons d'alimentation avant toute maintenance.
--------	--

PELIGRO	Desconecte ambos cables de alimentación antes de realizar reparaciones.
---------	---

**DANGER**

Disconnect the power cord from all power sources to completely remove power from the device.

GEFAHR Ziehen Sie das Stromkabel aus allen Stromquellen, um sicherzustellen, dass dem Gerät kein Strom zugeführt wird.

DANGER Débranchez le cordon d'alimentation de toutes les sources d'alimentation pour couper complètement l'alimentation du dispositif.

PELIGRO Para desconectar completamente la corriente del instrumento, desconecte el cordón de corriente de todas las fuentes de corriente.

**DANGER**

To avoid high voltage shock, do not open the device while the power is on.

GEFAHR Das eingeschaltete Gerät darf nicht geöffnet werden, da andernfalls das Risiko eines Stromschlags mit Hochspannung besteht.

DANGER Afin d'éviter tout choc électrique, n'ouvrez pas l'appareil lorsqu'il est sous tension.

PELIGRO Para evitar una descarga de alto voltaje, no abra el dispositivo mientras esté encendido.

**DANGER**

Risk of explosion if battery is replaced by an incorrect type. Dispose of used batteries according to the instructions.

GEFAHR Es besteht Explosionsgefahr, wenn ein unzulässiger Batterietyp eingesetzt wird.
Verbrauchte Batterien sind entsprechend den geltenden Vorschriften zu entsorgen.

DANGER Risque d'explosion en cas de remplacement de la pile par un modèle incorrect.
Débarrassez-vous des piles usagées conformément aux instructions.

PELIGRO Riesgo de explosión si se sustituye la batería por una de tipo incorrecto.
Deshágase de las baterías usadas de acuerdo con las instrucciones.

Dangers related to equipment weight

**DANGER**

Make sure the rack housing the device is adequately secured to prevent it from becoming unstable or falling over.

GEFAHR	Stellen Sie sicher, dass das Gestell für die Unterbringung des Geräts auf angemessene Weise gesichert ist, so dass das Gestell oder der Schrank nicht wackeln oder umfallen kann.
DANGER	Vérifiez que le bâti abritant le dispositif est bien fixé afin qu'il ne devienne pas instable ou qu'il ne risque pas de tomber.
PELIGRO	Verifique que el bastidor que alberga el instrumento está asegurado correctamente para evitar que pueda hacerse inestable o que caiga.

Laser dangers



DANGER
All fiber-optic interfaces use Class 1 lasers.

GEFAHR	Alle Glasfaser-Schnittstellen verwenden Laser der Klasse 1.
DANGER	Toutes les interfaces en fibres optiques utilisent des lasers de classe 1.
PELIGRO	Todas las interfaces de fibra óptica utilizan láser de clase 1.

Cautions

A Caution statement alerts you to situations that can be potentially hazardous to you or cause damage to hardware, firmware, software, or data.

Ein Vorsichtinweis warnt Sie vor potenziellen Personengefahren oder Beschädigung der Hardware, Firmware, Software oder auch vor einem möglichen Datenverlust

Un message de mise en garde vous alerte sur des situations pouvant présenter un risque potentiel de dommages corporels ou de dommages matériels, logiciels ou de perte de données.

Un mensaje de precaución le alerta de situaciones que pueden resultar peligrosas para usted o causar daños en el hardware, el firmware, el software o los datos.

General cautions



CAUTION
Changes or modifications made to this device that are not expressly approved by the party responsible for compliance could void the user's authority to operate the equipment.

VORSICHT	Falls dieses Gerät verändert oder modifiziert wird, ohne die ausdrückliche Genehmigung der für die Einhaltung der Anforderungen verantwortlichen Partei einzuholen, kann dem Benutzer der weitere Betrieb des Gerätes untersagt werden.
----------	---

MISE EN GARDE	Les éventuelles modifications apportées à cet équipement sans avoir été expressément approuvées par la partie responsable d'évaluer la conformité sont susceptibles d'annuler le droit de l'utilisateur à utiliser cet équipement.
---------------	--

PRECAUCIÓN	Si se realizan cambios o modificaciones en este dispositivo sin la autorización expresa de la parte responsable del cumplimiento de las normas, la licencia del usuario para operar este equipo puede quedar anulada.
------------	---

**CAUTION**

Do not install the device in an environment where the operating ambient temperature might exceed 40°C (104°F).

VORSICHT	Das Gerät darf nicht in einer Umgebung mit einer Umgebungsbetriebstemperatur von über 40°C (104°F) installiert werden.
----------	--

MISE EN GARDE	N'installez pas le dispositif dans un environnement où la température d'exploitation ambiante risque de dépasser 40°C (104°F).
---------------	--

PRECAUCIÓN	No instale el instrumento en un entorno en el que la temperatura ambiente de operación pueda exceder los 40°C (104°F).
------------	--

**CAUTION**

Make sure the airflow around the front, sides, and back of the device is not restricted.

VORSICHT	Stellen Sie sicher, dass an der Vorderseite, den Seiten und an der Rückseite der Luftstrom nicht behindert wird.
----------	--

MISE EN GARDE	Vérifiez que rien ne restreint la circulation d'air devant, derrière et sur les côtés du dispositif et qu'elle peut se faire librement.
---------------	---

PRECAUCIÓN	Asegúrese de que el flujo de aire en las inmediaciones de las partes anterior, laterales y posterior del instrumento no esté restringido.
------------	---

Electrical cautions**CAUTION**

Before plugging a cable into any port, be sure to discharge the voltage stored on the cable by touching the electrical contacts to ground surface.

VORSICHT	Bevor Sie ein Kabel in einen Anschluss einstecken, entladen Sie jegliche im Kabel vorhandene elektrische Spannung, indem Sie mit den elektrischen Kontakten eine geerdete Oberfläche berühren.
----------	--

MISE EN GARDE	Avant de brancher un câble à un port, assurez-vous de décharger la tension du câble en reliant les contacts électriques à la terre.
---------------	---

PRECAUCIÓN	Antes de conectar un cable en cualquier puerto, asegúrese de descargar la tensión acumulada en el cable tocando la superficie de conexión a tierra con los contactos eléctricos.
------------	--



CAUTION

Static electricity can damage the chassis and other electronic devices. To avoid damage, keep static-sensitive devices in their static-protective packages until you are ready to install them.

VORSICHT	Statische Elektrizität kann das System und andere elektronische Geräte beschädigen. Um Schäden zu vermeiden, entnehmen Sie elektrostatisch empfindliche Geräte erst aus deren antistatischer Schutzhülle, wenn Sie bereit für den Einbau sind.
----------	--

MISE EN GARDE	L'électricité statique peut endommager le châssis et les autres appareils électroniques. Pour éviter tout dommage, conservez les appareils sensibles à l'électricité statique dans leur emballage protecteur tant qu'ils n'ont pas été installés.
---------------	---

PRECAUCIÓN	La electricidad estática puede dañar el chasis y otros dispositivos electrónicos. A fin de impedir que se produzcan daños, conserve los dispositivos susceptibles de dañarse con la electricidad estática dentro de los paquetes protectores hasta que esté listo para instalarlos.
------------	---



CAUTION

If you do not install a module or a power supply in a slot, you must keep the slot filler panel in place. If you run the chassis with an uncovered slot, the system will overheat.

VORSICHT	Falls kein Modul oder Netzteil im Steckplatz installiert wird, muss die Steckplatztafel angebracht werden. Wenn ein Steckplatz nicht abgedeckt wird, läuft das System heiß.
----------	---

MISE EN GARDE	Si vous n'installez pas de module ou de bloc d'alimentation dans un slot, vous devez laisser le panneau du slot en place. Si vous faites fonctionner le châssis avec un slot découvert, le système surchauffera.
---------------	--

PRECAUCIÓN	Si no instala un módulo o un fuente de alimentación en la ranura, deberá mantener el panel de ranuras en su lugar. Si pone en funcionamiento el chasis con una ranura descubierta, el sistema sufrirá sobrecalentamiento.
------------	---



CAUTION

Carefully follow the mechanical guides on each side of the power supply slot and make sure the power supply is properly inserted in the guides. Never insert the power supply upside down.

VORSICHT	Beachten Sie mechanischen Führungen an jeder Seite des Netzteils, das ordnungsgemäß in die Führungen gesteckt werden muss. Das Netzteil darf niemals umgedreht eingesteckt werden.
----------	--

MISE EN GARDE	Suivez attentivement les repères mécaniques de chaque côté du slot du bloc d'alimentation et assurez-vous que le bloc d'alimentation est bien inséré dans les repères. N'insérez jamais le bloc d'alimentation à l'envers.
---------------	--

PRECAUCIÓN	Siga cuidadosamente las guías mecánicas de cada lado de la ranura del suministro de energía y verifique que el suministro de energía está insertado correctamente en las guías. No inserte nunca el suministro de energía de manera invertida.
------------	--

**CAUTION**

The power supply switch must be in the off position when you insert the power supply into the chassis. Damage to the switch can result if a live power supply is installed.

VORSICHT	Der Schalter des Netzteils muss in der Stellung „Aus“ stehen, wenn das Netzteil in das Gehäuse eingesetzt wird. Wenn ein spannungsführendes Netzteil (Schalterstellung "Ein") eingebaut wird, kann dies zu Beschädigungen am Switch führen.
----------	---

MISE EN GARDE	Le commutateur d'alimentation doit être en position d'arrêt lorsque vous insérez la source d'alimentation dans le châssis. Si une source d'alimentation sous tension est installée, des dommages peuvent être causés.
---------------	---

PRECAUCIÓN	El interruptor de la fuente de alimentación debe estar en la posición de apagado en el momento de introducirla en el chasis. El conmutador puede resultar dañado si se instala una fuente de alimentación activa.
------------	---

**CAUTION**

All devices with DC power supplies are intended for installation in restricted access areas only. A restricted access area is where access can be gained only by service personnel through the use of a special tool, lock and key, or other means of security, and is controlled by the authority responsible for the location.

VORSICHT	Alle Geräte mit DC-Netzteil sind nur für die Installation in Bereichen mit beschränktem Zugang gedacht. Ein Bereich mit beschränktem Zugang ist ein Bereich, zu dem nur Wartungspersonal mit Spezialwerkzeug, Schlüssel oder anderen Sicherheitsvorrichtungen Zugang hat. Dieser Zugang wird von für den Bereich zuständigen Personen überwacht.
----------	--

MISE EN GARDE	Tous les dispositifs avec bloc d'alimentation C.C. sont conçus pour l'installation dans des zones à accès réglementé uniquement. Une zone à accès réglementé est une zone dont l'accès n'est possible qu'au personnel de service utilisant un verrou, une clé ou un outil spécial, ou d'autres moyens de sécurité, et qui est contrôlée par les autorités responsables du site.
---------------	---

PRECAUCIÓN	Todos los instrumentos con suministros de corriente continua han sido diseñados únicamente para instalación en áreas restringidas. Se entiende como área de acceso restringido un lugar al que solo puede acceder personal de servicio mediante el uso de una herramienta especial, llave y cerrojo u otro medio de seguridad similar, y que esté controlado por la autoridad responsable de esa ubicación.
------------	---



CAUTION

For the DC input circuit to the system, make sure there is a 10 Amp circuit breaker, maximum 60 VDC, double pole, on the input terminal block to the power supply. The input wiring for connection to the product should be copper wire, 16 AWG, marked VW-1, and rated minimum 90°C.

VORSICHT Für den Eingangs-Gleichstromkreis zum System ist ein 10 A, maximum -60 V DC, doppelpoliger Stromkreisunterbrecher am Eingang zur Reihenklemme zu installieren. Bei der Eingangsverdrahtung zum Anschluss des Produkts sollte es sich um einen 16 AWG-Kupferdraht (VW-1) und einer Mindestnenntemperatur von 90° C handeln.

MISE EN GARDE Pour le circuit d'alimentation C.C du système, assurez-vous de la présence d'un disjoncteur de 10 ampères, minimum -60 V C.C., double coupure, sur l'entrée vers le bloc d'alimentation. Les câbles d'alimentation pour le produit doivent être en fils de cuivre, 16 AWG (American Wire Gauge), marqués VW-1 et classés 90 degrés Celsius.

PRECAUCIÓN Para el circuito de entrada de CC al sistema, verifique que existe un cortacircuitos catalogado de 10 amperios, como mínimo, -60 VCC, bipolar, en la entrada al bloque terminal. El cableado de entrada para la conexión al producto deberá ser de cable de cobre catalogado, 16 AWG, marcado con VW-1, y tener una capacidad nominal mínima para 90 grados centígrados.



CAUTION

For a DC system, use grounding wire of at least 16 American Wire Gauge (AWG). The grounding wire should be attached to the DC input connector; the other end connects to the building ground.

VORSICHT Für ein Gleichstromsystem verwenden Erdungskabel von mindestens 16 AWG (1.31 mm²) (amerikanische Norm für Drahtquerschnitte). Der Erdungsdraht sollte DC-Eingang angeschlossen werden, das andere Ende verbindet sich mit dem Baugrund.

MISE EN GARDE Pour les systèmes d'alimentation courant continu (C.C), utilisez un fil de mise à terre d'au moins de 16 AWG (ou 1.31mm²). Le fil de mise à terre doit être relié au connecteur du circuit d'alimentation; l'autre extrémité se connecte à la prise terre du bâtiment.

PRECAUCIÓN Para un sistema de CC, usar alambre de puesta a tierra de por lo menos 16 AWG (American Wire Gauge). El cable de tierra debe ser conectada a enchufe CC; el otro extremo se conecta a la tierra del edificio.



CAUTION

DC return shall be isolated from the chassis ground (DC-I) when connections to the power supply are made.

VORSICHT Der Gleichstromrücklauf soll von der Gehäuseerdung isoliert werden (DC-I), wenn Verbindungen zur Stromversorgung hergestellt werden.

MISE EN GARDE La prise de terre de courant continu (CC) doit être isolée de la masse (CC-I) lorsqu'elle est connectée au bloc d'alimentation.

PRECAUCIÓN El retorno de CC debe estar aislado de la toma de tierra de chasis (CC-I) cuando se realicen conexiones con la fuente de alimentación.
