

NMEA2000® Sender Averaging Module

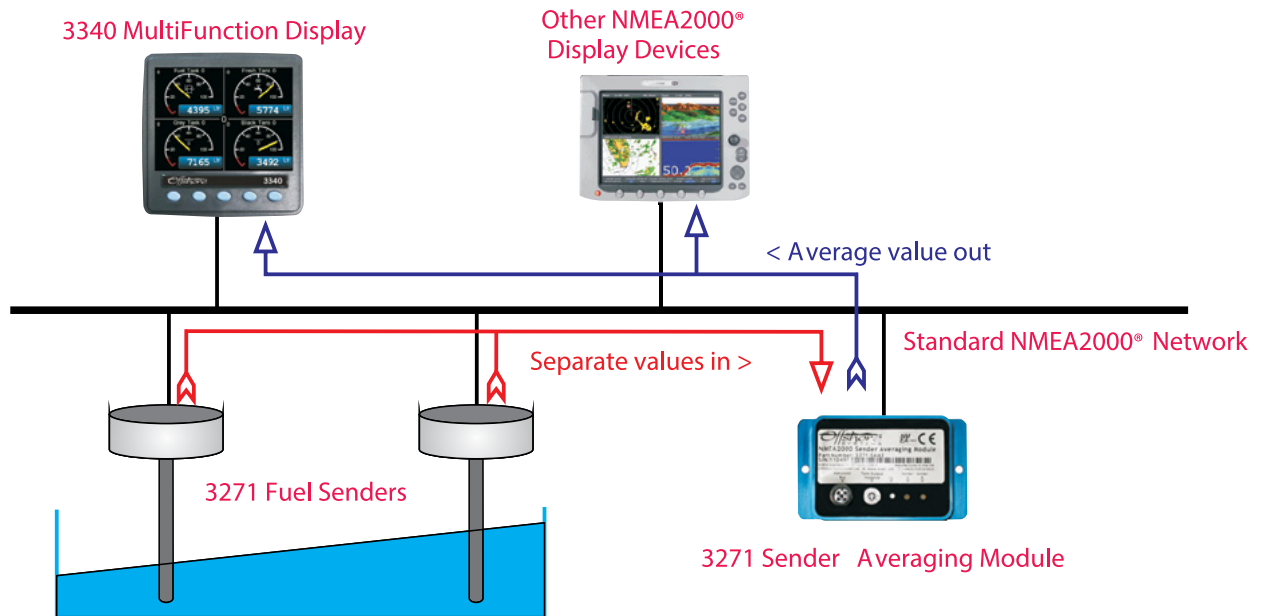

- Maintains accurate tank level displays for long tanks when the boat is moving or stopped
- Calculates the average of 2 x 3271 Fuel Tank Senders
- High Accuracy
- Robust Aluminium Construction
- Easy to install - Just plug on network
- Switch settable Device Instance
- No complicated menu setups required
- Certified to NMEA2000®

The Oceanic Systems' 3271-SAM Sender Averaging Module solves the problem of inaccurate tank level gauge readings caused by the tank contents moving to the aft of a long tank when the boat is in a bows up attitude whilst under power.

The module calculates a mathematical average of two tank senders mounted in the tank and outputs that result in a standard Tank Level PGN 127505 so that all attached displays display the average value of the tank level.

The unit is designed to greatly simplify installation with NO user setup or calibration required and NO display menus to struggle through. Simply set the Device Instance switch on the front of the unit to the required Tank Instance and the unit takes care of everything else.

The 3271-SAM signals if either sender is missing or has detected water in the tank so that the user can be confident of the quality of the readings.

It is fully waterproof to IP67 and ruggedly constructed in an aluminium frame for years of reliable and accurate service.

The unit comes with a detailed User Manual and is certified to the NMEA2000 network standard.



NMEA2000® Sender Averaging Module

Part Nos: 3271-SAM2

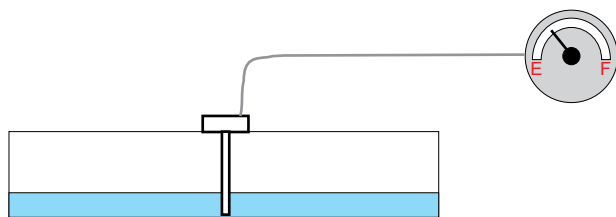
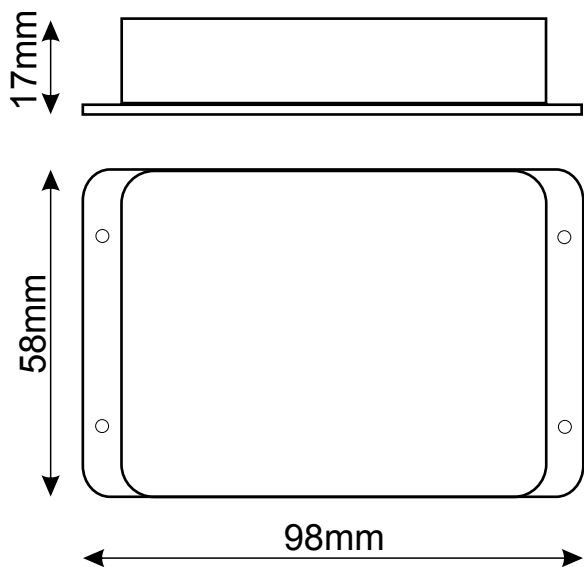

Boat not moving - Tank level reads correctly

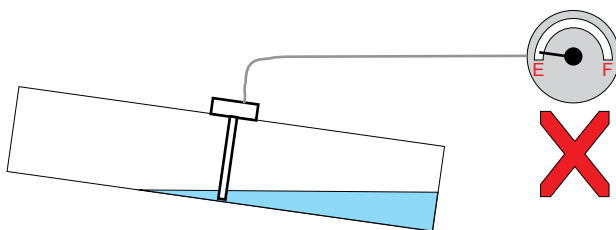

Boat under power with bows up attitude
Tank level reads **Incorrectly**

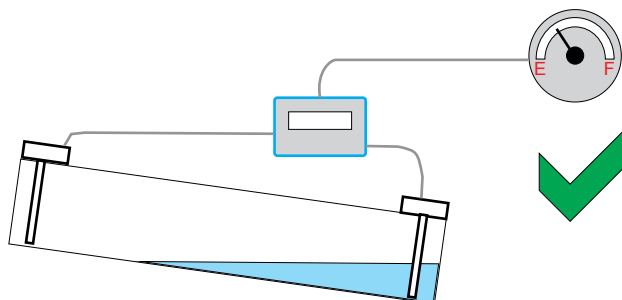

With Sender Averaging Module
Tank Levels always reads Correctly

Certifications

NMEA2000	Level B
Maritime Nav & RadioComm	IEC60945
CE & FCC	Electromagnetic Compatibility

NMEA2000 Parameter Group Numbers (PGNs)

Type	PGN No.	PGN Name
Periodic	PGN127505	Tank Level
Protocol	PGN126464	Tx/Rx PGN List
	PGN126996	Product Information
	PGN059392	ISO Acknowledge
	PGN059904	ISO Request
	PGN060928	ISO Address Claim
	PGN126208	Command/Request Group

Electrical and Mechanical

Operating Voltage	9 to 32 Volts
Power Consumption	< 50mA
Load Equivalence Number	1
Reverse Battery Protection	Indefinitely
Load Dump Protection	Yes to SAE J1113
Size	98 x 58 x 17
Weight	225 grams

Electrical and Mechanical

6954 Classification	Exposed
Degree of protection	IP67
Operating Temperature	-25C to 50C
Storage Temperature	-40C to 70C
Relative Humidity	93%RH @ 40C per IEC 60945-8.2
Electromagnetic Emission	Conduct/Radiated per IEC 60945-9
Electromagnetic Immunity	Conducted/Radiated per IEC 60945-10