

LIGO VACUUM EQUIPMENT FINAL DESIGN REPORT

VOLUME II ATTACHMENT 4 - CALCULATIONS

CONTRACT NO: PC175730

CDRL NO: 03

PSI DOCUMENT NO: V049-1-097

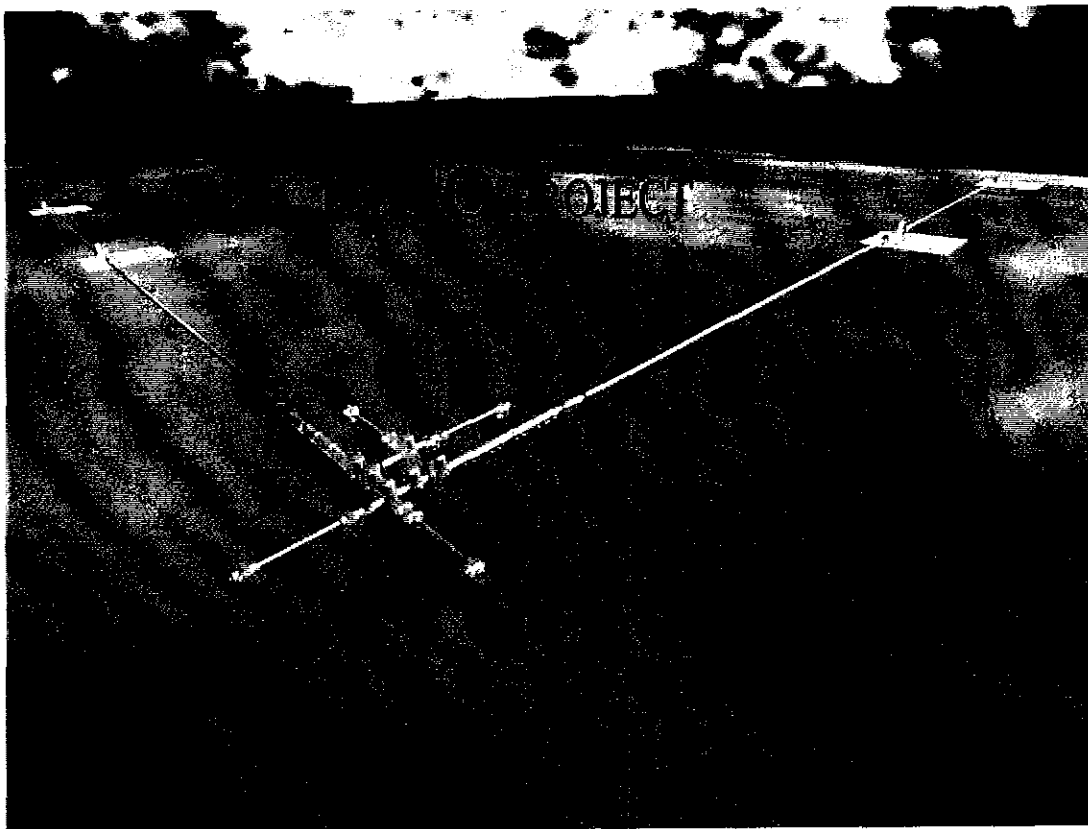

CALIFORNIA INSTITUTE OF TECHNOLOGY
MASSACHUSETTS INSTITUTE OF TECHNOLOGY



LIGO PROJECT

PROCESS SYSTEMS INTERNATIONAL
20 WALKUP DRIVE
WESTBOROUGH, MASSACHUSETTS 01581

VOLUME II ATTACHMENTS

ATTACHMENT 4

2. VACUUM AND PROCESS CALCULATIONS

TITLE	DOCUMENT NO.	REV.
Vacuum Calculations		
Pressure Drop in Vacuum Header	V049-1-006	2
Turbomolecular Pump Intermediate Pumpdown	V049-1-007	2
Main TMP Port Conductance	V049-1-044	0
Station Pumpdown & Ultimate Pressure	V049-1-078	0
Flange Annulus Conductance	V049-1-012	0
80K Pumps		
80K Pumps - Heat Load Calculations	V049-1-033	1
80K Pumps - Heat Steady State LN ₂ Consumption	V049-1-037	1
80K Pumps - Roughdown Pressure Drop Analysis	V049-1-072	0
80K Pumps - Regeneration System Process Calculations	V049-1-096	0
80K Pumps - Regeneration System Pressure Drop Analysis	V049-1-092	0
80K Pumps - Relief Valve Sizing	V049-1-094	0
Bakeout System		
Bakeout System Heat Transfer Analysis	V049-1-065	0
Bakeout Control System Functionality	V049-1-086	0
Utilities		
Equipment Power Requirements	V049-1-047	0
Cooling Water Requirements	V049-1-010	1
Instrument Air Requirements	V049-1-043	0
Cooling Water Line Sizing	V049-1-034	1
Instrument Air Line Sizing	V049-1-093	0

3. SAFETY AND RELIABILITY ANALYSIS

TITLE	DOCUMENT NO.	REV.
Hazards Analysis	V049-2-093	0
Failure Modes, Effects and Criticality Analysis	V049-2-094	0

PROCESS SYSTEMS INTERNATIONAL, INC.					ENGINEERING	NO: V049-1-006
WESTBOROUGH, MA					CALCULATIONS	PAGE 1 OF 14
REV	DEO#	DATE	BY:	CHECK	TITLE:	
0	0007	10/26/95	R. Than	DMW	PRESSURE DROP VACUUM HEADER LINES	
1		10/31/95	R. Than		ROUGHING PUMPS EDWARDS' EDP200	
2	0127	04/16/96	R.Than	D.M.W.	with EH2600 ROOTS BLOWER	
					BY: R. THAN	DEPT: 744
PROJECT: LIGO					PROJECT NO: V59049	

PURPOSE:

To determine the intermediate header size required to operate one (1) roughing pump set

METHOD:

Viscous Regime

Turbulent flow: Colebrook formula, "Moody chart"

Laminar flow: Hagen-Poiseuille Flow

Free molecular regime: Long tube formula

ASSUMPTIONS:

See calculations

INPUTS:

Pumping speed curves: EDP-200 / EH2600 COMBO

Equipment layout drawing V049-5-001

REFERENCE:

Theory and Practice of vacuum Technology, ISBN 3-528-08908-3

Perry's Chemical Engineers handbook, 6th edition, McGrawHill, 1984

CALCULATIONS:

see Attachments

CONCLUSIONS: 6" line is required for a single pump in order to operate the roots blower to a suction pressure of 0.05 mbar.

NOTES:

A 6 inch (150 mm) line is required to operate the roots blower EH2600 at a suction of 0.05 mbar. The compression ratio required will be about 10. Pressure drop at higher pressures is less than a few percent with this configuration. At a header pressure of 0.1 mbar, the ultimate pressure of the backing pump is being approach, with the roots blower operating at a suction of 0.01 mbar. But at this point the chamber pressure is low enough for the turbo to operate at sufficient capacity.

Pump	Chamber	Header	Header			
operating	Pressure	Pressure	Flow rate	ΔP	$\Delta P/P$	
	mbar	mbar	m ³ /hr	mbar		
EDP200+EH2600	1000	~1000	300	5	0.5%	
EDP200+EH2600	100	~140	300	0.8	0.8%	
EDP200+EH2600	10	~40	290	0.4	1.0%	
EDP200+EH2600	1	9	286	0.23	2.3%	
EDP200+EH2600	0.1	1	180	0.15	14.5%	
EDP200+EH2600	0.05	0.5	107	0.09	17.4%	
EDP200+EH2600	0.02	0.2	28	0.02	11%	

The current piping configuration allows at least one pump to pump on any beam-manifold, vertex or diagonal section.

ROUGHING LINE

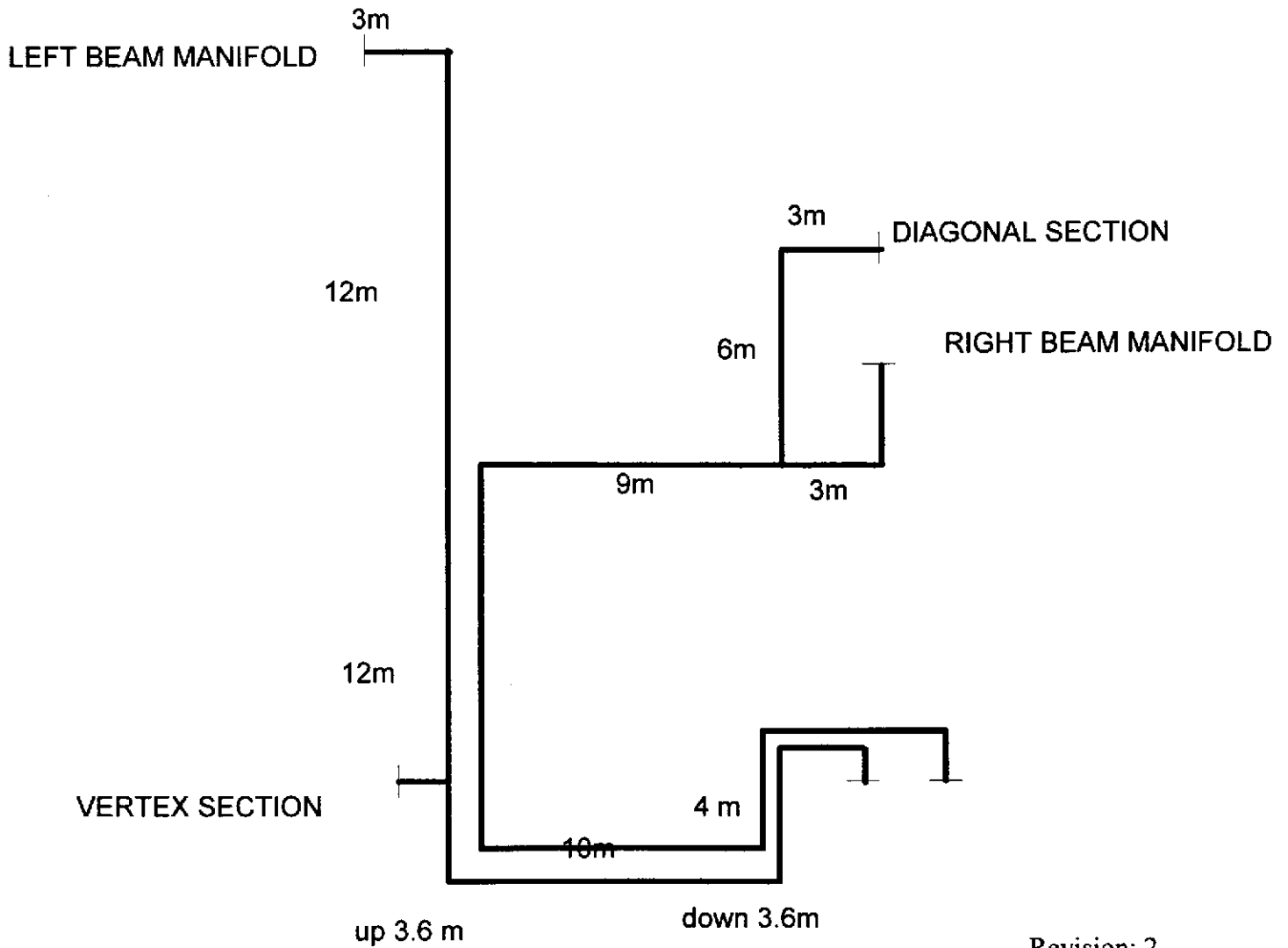

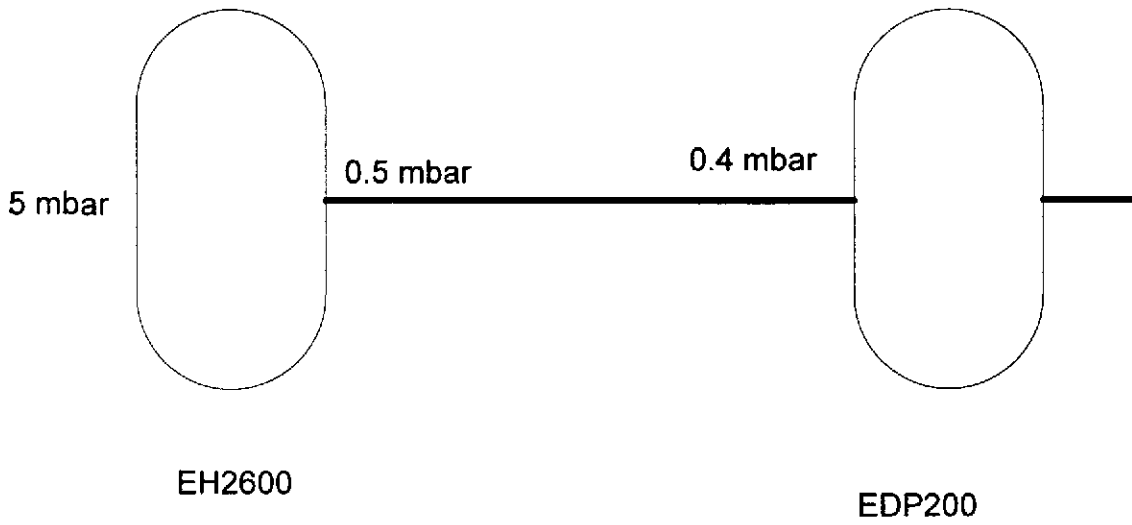

PROJECT: LIGO
 PROJECT NO:V59049
 TITLE: ROOTS PUMP,BACKING PUMP VACUUM HEADER

BY: R. THAN
 DATE: 4/17/**
 PAGE: 1 OF

PRESSURE DROP ROUTE OR LINE ID:EH2600 DISCHARGE 1000mbar

PRESSURE: 100000.0 Pa 1.000 BAR
 TEMPERATURE: 293.000 K 293.000 K
 DENSITY : 1.150 KG/M^3 0.115E+01 KG/M^3
 QUALITY : 1.000

ITEMNAME	FLOWRATE KG/S	I.D. METER	K / DO	CV	LENGTH M	PRESSURE Pa	Z1 METER	Z2 METER	DP-F Pa	DP-Z Pa	DP-T Pa	DP-SUM Pa	DENSITY KG/M^3	RE NO	Knunsen	Regime
4" FLEX LINE,3M	0.954E-01	0.100			15.0	99793.9	0.00	0.00	206.05	0.00	206.05	206.05	0.115E+01	0.69E+05	0.65E-06	VISCOUS
6" ELBOW LR-90	0.954E-01	0.146	0.220			99790.8	0.00	0.00	3.11	0.00	3.11	209.16	0.115E+01			
6" ELBOW LR-90	0.954E-01	0.146	0.220			99787.7	0.00	0.00	3.11	0.00	3.11	212.27	0.115E+01			
6" FLEX LINE,3M	0.954E-01	0.146			15.0	99755.3	0.00	0.00	32.40	0.00	32.40	244.67	0.115E+01	0.47E+05	0.45E-06	VISCOUS
6" PIPE LENGTH	0.954E-01	0.146			3.0	99748.8	0.00	0.00	6.48	0.00	6.48	251.15	0.115E+01	0.47E+05	0.45E-06	VISCOUS
6" ELBOW LR-90	0.954E-01	0.146	0.220			99745.7	0.00	0.00	3.11	0.00	3.11	254.26	0.115E+01			
6" PIPE LENGTH	0.954E-01	0.146			6.0	99732.8	0.00	0.00	12.96	0.00	12.96	267.23	0.115E+01	0.47E+05	0.45E-06	VISCOUS
6" TEE BRANCH	0.954E-01	0.146	0.650			99723.6	0.00	0.00	9.20	0.00	9.20	276.42	0.115E+01			
6" PIPE LENGTH	0.954E-01	0.146			9.0	99704.1	0.00	0.00	19.45	0.00	19.45	295.87	0.115E+01	0.47E+05	0.45E-06	VISCOUS
6" PIPE LENGTH	0.954E-01	0.146			9.0	99684.7	0.00	0.00	19.45	0.00	19.45	315.33	0.115E+01	0.47E+05	0.45E-06	VISCOUS
6" TEE BRANCH	0.954E-01	0.146	0.650			99675.5	0.00	0.00	9.20	0.00	9.20	324.53	0.115E+01			
6" PIPE LENGTH	0.954E-01	0.146			12.0	99649.5	0.00	0.00	25.95	0.00	25.95	350.47	0.115E+01	0.47E+05	0.45E-06	VISCOUS
6" TEE LINE	0.954E-01	0.146	0.220			99646.4	0.00	0.00	3.11	0.00	3.11	353.59	0.115E+01			
6" ELBOW LR-90	0.954E-01	0.146	0.220			99643.3	0.00	0.00	3.11	0.00	3.11	356.70	0.115E+01			
6" PIPE LENGTH	0.954E-01	0.146			3.6	99595.0	0.00	3.60	7.79	40.48	48.27	404.97	0.115E+01	0.47E+05	0.45E-06	VISCOUS
6" ELBOW LR-90	0.954E-01	0.146	0.220			99591.9	3.60	3.60	3.12	0.00	3.12	408.08	0.115E+01			
6" PIPE LENGTH	0.954E-01	0.146			10.0	99570.3	3.60	3.60	21.64	0.00	21.64	429.72	0.115E+01	0.47E+05	0.45E-06	VISCOUS
6" ELBOW LR-90	0.954E-01	0.146	0.220			99567.2	3.60	3.60	3.12	0.00	3.12	432.84	0.115E+01			
6" PIPE LENGTH	0.954E-01	0.146			3.6	99599.8	3.60	0.00	7.79	-40.45	-32.66	400.18	0.115E+01	0.47E+05	0.45E-06	VISCOUS
6" ELBOW LR-90	0.954E-01	0.146	0.220			99596.7	0.00	0.00	3.12	0.00	3.12	403.30	0.115E+01			
6" PIPE LENGTH	0.954E-01	0.146			3.0	99590.2	0.00	0.00	6.49	0.00	6.49	409.79	0.115E+01	0.47E+05	0.45E-06	VISCOUS
6" ELBOW LR-90	0.954E-01	0.146	0.220			99587.1	0.00	0.00	3.12	0.00	3.12	412.91	0.115E+01			
6" PIPE LENGTH	0.954E-01	0.146			10.0	99565.4	0.00	0.00	21.64	0.00	21.64	434.55	0.115E+01	0.47E+05	0.45E-06	VISCOUS
6" ELBOW LR-90	0.954E-01	0.146	0.220			99562.3	0.00	0.00	3.12	0.00	3.12	437.67	0.115E+01			
6" FLEX LINE,2M	0.954E-01	0.146			10.0	99540.7	0.00	0.00	21.65	0.00	21.65	459.31	0.115E+01	0.47E+05	0.45E-06	VISCOUS

TOTAL 459.2829 0.0309 459.3138

EH2600 DISCHARGE PRESSURE:100000.000 Pa FORELINE SPEED : 0.0826 M^3/S PUMP PRESSURE : 99562.332 Pa PUMP SPEED : 0.0830 M^3/S

REVISION : 2
 DOC NO: V049-1-006
 PAGE OF

PROJECT: LIGO BY: R. THAN
 PROJECT NO:V59049 DATE: 4/17/**
 TITLE: ROOTS PUMP,BACKING PUMP VACUUM HEADER PAGE: 1 OF

PRESSURE DROP ROUTE OR LINE ID:EH2600 DISCHARGE 100mbar

PRESSURE: 10000.0 Pa 0.100 BAR
 TEMPERATURE: 293.000 K 293.000 K
 DENSITY : 0.115 KG/M^3 0.115E+00 KG/M^3
 QUALITY : 1.000

ITEMNAME	FLOWRATE KG/S	I.D. METER	K / DO	CV	LENGTH M	PRESSURE Pa	Z1 METER	Z2 METER	DP-F Pa	DP-Z Pa	DP-T Pa	DP-SUM Pa	DENSITY KG/M^3	RE NO	Knunsen	Regime
4" FLEX LINE,3M	0.961E-02	0.100			15.0	9966.1	0.00	0.00	33.91	0.00	33.91	33.91	0.115E+00	0.69E+04	0.65E-05	VISCOUS
6" ELBOW LR-90	0.961E-02	0.146	0.220			9965.8	0.00	0.00	0.32	0.00	0.32	34.23	0.115E+00			
6" ELBOW LR-90	0.961E-02	0.146	0.220			9965.5	0.00	0.00	0.32	0.00	0.32	34.54	0.115E+00			
6" FLEX LINE,3M	0.961E-02	0.146			15.0	9959.8	0.00	0.00	5.66	0.00	5.66	40.20	0.115E+00	0.48E+04	0.45E-05	VISCOUS
6" PIPE LENGTH	0.961E-02	0.146			3.0	9958.7	0.00	0.00	1.13	0.00	1.13	41.33	0.115E+00	0.48E+04	0.45E-05	VISCOUS
6" ELBOW LR-90	0.961E-02	0.146	0.220			9958.3	0.00	0.00	0.32	0.00	0.32	41.65	0.115E+00			
6" PIPE LENGTH	0.961E-02	0.146			6.0	9956.1	0.00	0.00	2.26	0.00	2.26	43.92	0.115E+00	0.48E+04	0.45E-05	VISCOUS
6" TEE BRANCH	0.961E-02	0.146	0.650			9955.1	0.00	0.00	0.94	0.00	0.94	44.85	0.115E+00			
6" PIPE LENGTH	0.961E-02	0.146			9.0	9951.8	0.00	0.00	3.40	0.00	3.40	48.25	0.114E+00	0.48E+04	0.45E-05	VISCOUS
6" PIPE LENGTH	0.961E-02	0.146			9.0	9948.4	0.00	0.00	3.40	0.00	3.40	51.65	0.114E+00	0.48E+04	0.45E-05	VISCOUS
6" TEE BRANCH	0.961E-02	0.146	0.650			9947.4	0.00	0.00	0.94	0.00	0.94	52.59	0.114E+00			
6" PIPE LENGTH	0.961E-02	0.146			12.0	9942.9	0.00	0.00	4.53	0.00	4.53	57.12	0.114E+00	0.48E+04	0.45E-05	VISCOUS
6" TEE LINE	0.961E-02	0.146	0.220			9942.6	0.00	0.00	0.32	0.00	0.32	57.44	0.114E+00			
6" ELBOW LR-90	0.961E-02	0.146	0.220			9942.2	0.00	0.00	0.32	0.00	0.32	57.75	0.114E+00			
6" PIPE LENGTH	0.961E-02	0.146			3.6	9936.8	0.00	3.60	1.36	4.04	5.40	63.15	0.114E+00	0.48E+04	0.45E-05	VISCOUS
6" ELBOW LR-90	0.961E-02	0.146	0.220			9936.5	3.60	3.60	0.32	0.00	0.32	63.47	0.114E+00			
6" PIPE LENGTH	0.961E-02	0.146			10.0	9932.7	3.60	3.60	3.78	0.00	3.78	67.25	0.114E+00	0.48E+04	0.45E-05	VISCOUS
6" ELBOW LR-90	0.961E-02	0.146	0.220			9932.4	3.60	3.60	0.32	0.00	0.32	67.57	0.114E+00			
6" PIPE LENGTH	0.961E-02	0.146			3.6	9935.1	3.60	0.00	1.36	-4.03	-2.67	64.90	0.114E+00	0.48E+04	0.45E-05	VISCOUS
6" ELBOW LR-90	0.961E-02	0.146	0.220			9934.8	0.00	0.00	0.32	0.00	0.32	65.22	0.114E+00			
6" PIPE LENGTH	0.961E-02	0.146			3.0	9933.6	0.00	0.00	1.14	0.00	1.14	66.35	0.114E+00	0.48E+04	0.45E-05	VISCOUS
6" ELBOW LR-90	0.961E-02	0.146	0.220			9933.3	0.00	0.00	0.32	0.00	0.32	66.67	0.114E+00			
6" PIPE LENGTH	0.961E-02	0.146			10.0	9929.5	0.00	0.00	3.78	0.00	3.78	70.45	0.114E+00	0.48E+04	0.45E-05	VISCOUS
6" ELBOW LR-90	0.961E-02	0.146	0.220			9929.2	0.00	0.00	0.32	0.00	0.32	70.77	0.114E+00			
6" FLEX LINE,2M	0.961E-02	0.146			10.0	9925.4	0.00	0.00	3.79	0.00	3.79	74.56	0.114E+00	0.48E+04	0.45E-05	VISCOUS

TOTAL 74.5533 0.0040 74.5573

EH2600 DISCHARGE PRESSURE: 10000.000 Pa FORELINE SPEED : 0.0839 M^3/S PUMP PRESSURE : 9929.229 Pa PUMP SPEED : 0.0845 M^3/S

REVISION : 2
 DOC NO: V049-1-006
 PAGE OF

PROJECT: LIGO BY: R. THAN
 PROJECT NO:V59049 DATE: 4/17/**
 TITLE: ROOTS PUMP, BACKING PUMP VACUUM HEADER PAGE: 1 OF

PRESSURE DROP ROUTE OR LINE ID:EH2600 DISCHARGE 10mbar

PRESSURE: 1000.0 Pa 0.010 BAR
 TEMPERATURE: 293.000 K 293.000 K
 DENSITY : 0.012 KG/M³ 0.115E-01 KG/M³
 QUALITY : 1.000

ITEMNAME	FLOWRATE KG/S	I.D. METER	K / DO	CV	LENGTH M	PRESSURE Pa	Z1 METER	Z2 METER	DP-F Pa	DP-Z Pa	DP-T Pa	DP-SUM Pa	DENSITY KG/M ³	RE NO	Knunsen	Regime
4" FLEX LINE,3M	0.882E-03	0.100			15.0	991.7	0.00	0.00	8.25	0.00	8.25	8.25	0.115E-01	0.64E+03	0.65E-04	VISCOUS
6" ELBOW LR-90	0.882E-03	0.146	2.091			991.5	0.00	0.00	0.25	0.00	0.25	8.51	0.114E-01			
6" ELBOW LR-90	0.882E-03	0.146	2.091			991.2	0.00	0.00	0.25	0.00	0.25	8.76	0.114E-01			
6" FLEX LINE,3M	0.882E-03	0.146			15.0	989.4	0.00	0.00	1.83	0.00	1.83	10.59	0.114E-01	0.44E+03	0.45E-04	VISCOUS
6" PIPE LENGTH	0.882E-03	0.146			3.0	989.0	0.00	0.00	0.37	0.00	0.37	10.96	0.114E-01	0.44E+03	0.45E-04	VISCOUS
6" ELBOW LR-90	0.882E-03	0.146	2.091			988.8	0.00	0.00	0.25	0.00	0.25	11.21	0.114E-01			
6" PIPE LENGTH	0.882E-03	0.146			6.0	988.1	0.00	0.00	0.73	0.00	0.73	11.95	0.114E-01	0.44E+03	0.45E-04	VISCOUS
6" TEE BRANCH	0.882E-03	0.146	2.091			987.8	0.00	0.00	0.26	0.00	0.26	12.20	0.114E-01			
6" PIPE LENGTH	0.882E-03	0.146			9.0	986.7	0.00	0.00	1.10	0.00	1.10	13.31	0.114E-01	0.44E+03	0.45E-04	VISCOUS
6" PIPE LENGTH	0.882E-03	0.146			9.0	985.6	0.00	0.00	1.10	0.00	1.10	14.41	0.113E-01	0.44E+03	0.45E-04	VISCOUS
6" TEE BRANCH	0.882E-03	0.146	2.091			985.3	0.00	0.00	0.26	0.00	0.26	14.67	0.113E-01			
6" PIPE LENGTH	0.882E-03	0.146			12.0	983.9	0.00	0.00	1.47	0.00	1.47	16.14	0.113E-01	0.44E+03	0.45E-04	VISCOUS
6" TEE LINE	0.882E-03	0.146	2.091			983.6	0.00	0.00	0.26	0.00	0.26	16.40	0.113E-01			
6" ELBOW LR-90	0.882E-03	0.146	2.091			983.3	0.00	0.00	0.26	0.00	0.26	16.65	0.113E-01			
6" PIPE LENGTH	0.882E-03	0.146			3.6	982.5	0.00	3.60	0.44	0.40	0.84	17.50	0.113E-01	0.44E+03	0.45E-04	VISCOUS
6" ELBOW LR-90	0.882E-03	0.146	2.091			982.2	3.60	3.60	0.26	0.00	0.26	17.75	0.113E-01			
6" PIPE LENGTH	0.882E-03	0.146			10.0	981.0	3.60	3.60	1.23	0.00	1.23	18.99	0.113E-01	0.44E+03	0.45E-04	VISCOUS
6" ELBOW LR-90	0.882E-03	0.146	2.091			980.8	3.60	3.60	0.26	0.00	0.26	19.24	0.113E-01			
6" PIPE LENGTH	0.882E-03	0.146			3.6	980.7	3.60	0.00	0.44	-0.40	0.05	19.29	0.113E-01	0.44E+03	0.45E-04	VISCOUS
6" ELBOW LR-90	0.882E-03	0.146	2.091			980.5	0.00	0.00	0.26	0.00	0.26	19.55	0.113E-01			
6" PIPE LENGTH	0.882E-03	0.146			3.0	980.1	0.00	0.00	0.37	0.00	0.37	19.92	0.113E-01	0.44E+03	0.45E-04	VISCOUS
6" ELBOW LR-90	0.882E-03	0.146	2.091			979.8	0.00	0.00	0.26	0.00	0.26	20.17	0.113E-01			
6" PIPE LENGTH	0.882E-03	0.146			10.0	978.6	0.00	0.00	1.24	0.00	1.24	21.41	0.113E-01	0.44E+03	0.45E-04	VISCOUS
6" ELBOW LR-90	0.882E-03	0.146	2.091			978.3	0.00	0.00	0.26	0.00	0.26	21.67	0.113E-01			
6" FLEX LINE,2M	0.882E-03	0.146			10.0	977.1	0.00	0.00	1.24	0.00	1.24	22.90	0.113E-01	0.44E+03	0.46E-04	VISCOUS
TOTAL									22.9025	0.0011						

EH2600 DISCHARGE PRESSURE: 1000.000 Pa FORELINE SPEED : 0.0795 M³/S PUMP PRESSURE : 978.334 Pa PUMP SPEED : 0.0813 M³/S

PROJECT: LIGO BY: R. THAN
 PROJECT NO:V59049 DATE: 4/17/**
 TITLE: ROOTS PUMP, BACKING PUMP VACUUM HEADER PAGE: 1 OF

PRESSURE DROP ROUTE OR LINE ID:EH2600 DISCHARGE 1mbar

PRESSURE: 100.0 Pa 0.001 BAR
 TEMPERATURE: 293.000 K 293.000 K
 DENSITY : 0.001 KG/M³ 0.115E-02 KG/M³
 QUALITY : 1.000

ITEMNAME	FLOWRATE KG/S	I.D. METER	K / DO	CV	LENGTH M	PRESSURE Pa	Z1 METER	Z2 METER	DP-F Pa	DP-Z Pa	DP-T Pa	DP-SUM Pa	DENSITY KG/M ³	RE NO	Knunsen	Regime
4" FLEX LINE,3M	0.573E-04	0.100			15.0	94.6	0.00	0.00	5.36	0.00	5.36	5.36	0.115E-02	0.41E+02	0.65E-03	VISCOUS
6" ELBOW LR-90	0.573E-04	0.146	14.980			94.6	0.00	0.00	0.08	0.00	0.08	5.44	0.109E-02			
6" ELBOW LR-90	0.573E-04	0.146	14.980			94.5	0.00	0.00	0.08	0.00	0.08	5.52	0.109E-02			
6" FLEX LINE,3M	0.573E-04	0.146			15.0	93.2	0.00	0.00	1.25	0.00	1.25	6.77	0.109E-02	0.28E+02	0.47E-03	VISCOUS
6" PIPE LENGTH	0.573E-04	0.146			3.0	93.0	0.00	0.00	0.25	0.00	0.25	7.02	0.107E-02	0.28E+02	0.48E-03	VISCOUS
6" ELBOW LR-90	0.573E-04	0.146	14.980			92.9	0.00	0.00	0.08	0.00	0.08	7.11	0.107E-02			
6" PIPE LENGTH	0.573E-04	0.146			6.0	92.4	0.00	0.00	0.51	0.00	0.51	7.61	0.107E-02	0.28E+02	0.48E-03	VISCOUS
6" TEE BRANCH	0.573E-04	0.146	14.980			92.3	0.00	0.00	0.08	0.00	0.08	7.70	0.106E-02			
6" PIPE LENGTH	0.573E-04	0.146			9.0	91.5	0.00	0.00	0.77	0.00	0.77	8.46	0.106E-02	0.28E+02	0.48E-03	VISCOUS
6" PIPE LENGTH	0.573E-04	0.146			9.0	90.8	0.00	0.00	0.77	0.00	0.77	9.24	0.105E-02	0.28E+02	0.49E-03	VISCOUS
6" TEE BRANCH	0.573E-04	0.146	14.980			90.7	0.00	0.00	0.08	0.00	0.08	9.32	0.104E-02			
6" PIPE LENGTH	0.573E-04	0.146			12.0	89.6	0.00	0.00	1.04	0.00	1.04	10.36	0.104E-02	0.28E+02	0.49E-03	VISCOUS
6" TEE LINE	0.573E-04	0.146	14.980			89.6	0.00	0.00	0.09	0.00	0.09	10.45	0.103E-02			
6" ELBOW LR-90	0.573E-04	0.146	14.980			89.5	0.00	0.00	0.09	0.00	0.09	10.53	0.103E-02			
6" PIPE LENGTH	0.573E-04	0.146			3.6	89.1	0.00	3.60	0.32	0.04	0.35	10.88	0.103E-02	0.28E+02	0.50E-03	VISCOUS
6" ELBOW LR-90	0.573E-04	0.146	14.980			89.0	3.60	3.60	0.09	0.00	0.09	10.97	0.102E-02			
6" PIPE LENGTH	0.573E-04	0.146			10.0	88.1	3.60	3.60	0.88	0.00	0.88	11.85	0.102E-02	0.28E+02	0.50E-03	VISCOUS
6" ELBOW LR-90	0.573E-04	0.146	14.980			88.1	3.60	3.60	0.09	0.00	0.09	11.94	0.101E-02			
6" PIPE LENGTH	0.573E-04	0.146			3.6	87.8	3.60	0.00	0.32	-0.04	0.29	12.23	0.101E-02	0.28E+02	0.51E-03	VISCOUS
6" ELBOW LR-90	0.573E-04	0.146	14.980			87.7	0.00	0.00	0.09	0.00	0.09	12.31	0.101E-02			
6" PIPE LENGTH	0.573E-04	0.146			3.0	87.4	0.00	0.00	0.27	0.00	0.27	12.58	0.101E-02	0.28E+02	0.51E-03	VISCOUS
6" ELBOW LR-90	0.573E-04	0.146	14.980			87.3	0.00	0.00	0.09	0.00	0.09	12.67	0.101E-02			
6" PIPE LENGTH	0.573E-04	0.146			10.0	86.4	0.00	0.00	0.90	0.00	0.90	13.57	0.100E-02	0.28E+02	0.51E-03	VISCOUS
6" ELBOW LR-90	0.573E-04	0.146	14.980			86.3	0.00	0.00	0.09	0.00	0.09	13.66	0.994E-03			
6" FLEX LINE,2M	0.573E-04	0.146			10.0	85.4	0.00	0.00	0.91	0.00	0.91	14.57	0.993E-03	0.28E+02	0.52E-03	VISCOUS
TOTAL									14.5689	0.0006						14.5695

EH2600 DISCHARGE PRESSURE: 100.000 Pa FORELINE SPEED : 0.0501 M³/S PUMP PRESSURE : 86.341 Pa PUMP SPEED : 0.0580 M³/S

REVISION : 2
 DOC NO: V049-1-006
 PAGE OF

PROJECT: LIGO BY: R. THAN
 PROJECT NO:V59049 DATE: 4/17/**
 TITLE: ROOTS PUMP,BACKING PUMP VACUUM HEADER PAGE: 1 OF

PRESSURE DROP ROUTE OR LINE ID:EH2600 DISCHARGE 0.5mbar

PRESSURE: 50.0 Pa 0.001 BAR
 TEMPERATURE: 293.000 K 293.000 K
 DENSITY : 0.001 KG/M³ 0.575E-03 KG/M³
 QUALITY : 1.000

ITEMNAME	FLOWRATE KG/S	I.D. METER	K / DO	CV	LENGTH M	PRESSURE Pa	Z1 METER	Z2 METER	DP-F Pa	DP-Z Pa	DP-T Pa	DP-SUM Pa	DENSITY KG/M ³	RE NO	Knunsen	Regime
4" FLEX LINE,3M	0.170E-04	0.100			15.0	46.8	0.00	0.00	3.18	0.00	3.18	3.18	0.575E-03	0.12E+02	0.13E-02	VISCOUS
6" ELBOW LR-90	0.170E-04	0.146	43.411			46.8	0.00	0.00	0.04	0.00	0.04	3.22	0.538E-03			
6" ELBOW LR-90	0.170E-04	0.146	43.411			46.7	0.00	0.00	0.04	0.00	0.04	3.27	0.538E-03			
6" FLEX LINE,3M	0.170E-04	0.146			15.0	46.0	0.00	0.00	0.75	0.00	0.75	4.02	0.537E-03	0.84E+01	0.95E-03	VISCOUS
6" PIPE LENGTH	0.170E-04	0.146			3.0	45.8	0.00	0.00	0.15	0.00	0.15	4.17	0.529E-03	0.84E+01	0.97E-03	VISCOUS
6" ELBOW LR-90	0.170E-04	0.146	43.411			45.8	0.00	0.00	0.04	0.00	0.04	4.21	0.527E-03			
6" PIPE LENGTH	0.170E-04	0.146			6.0	45.5	0.00	0.00	0.31	0.00	0.31	4.52	0.527E-03	0.84E+01	0.97E-03	VISCOUS
6" TEE BRANCH	0.170E-04	0.146	43.411			45.4	0.00	0.00	0.04	0.00	0.04	4.56	0.523E-03			
6" PIPE LENGTH	0.170E-04	0.146			9.0	45.0	0.00	0.00	0.46	0.00	0.46	5.02	0.523E-03	0.84E+01	0.98E-03	VISCOUS
6" PIPE LENGTH	0.170E-04	0.146			9.0	44.5	0.00	0.00	0.47	0.00	0.47	5.49	0.517E-03	0.84E+01	0.99E-03	VISCOUS
6" TEE BRANCH	0.170E-04	0.146	43.411			44.5	0.00	0.00	0.04	0.00	0.04	5.53	0.512E-03			
6" PIPE LENGTH	0.170E-04	0.146			12.0	43.8	0.00	0.00	0.63	0.00	0.63	6.16	0.511E-03	0.84E+01	0.10E-02	VISCOUS
6" TEE LINE	0.170E-04	0.146	43.411			43.8	0.00	0.00	0.04	0.00	0.04	6.21	0.504E-03			
6" ELBOW LR-90	0.170E-04	0.146	43.411			43.7	0.00	0.00	0.04	0.00	0.04	6.25	0.504E-03			
6" PIPE LENGTH	0.170E-04	0.146			3.6	43.5	0.00	3.60	0.19	0.02	0.21	6.46	0.503E-03	0.84E+01	0.10E-02	VISCOUS
6" ELBOW LR-90	0.170E-04	0.146	43.411			43.5	3.60	3.60	0.04	0.00	0.04	6.51	0.501E-03			
6" PIPE LENGTH	0.170E-04	0.146			10.0	43.0	3.60	3.60	0.54	0.00	0.54	7.04	0.500E-03	0.84E+01	0.10E-02	VISCOUS
6" ELBOW LR-90	0.170E-04	0.146	43.411			42.9	3.60	3.60	0.05	0.00	0.05	7.09	0.494E-03			
6" PIPE LENGTH	0.170E-04	0.146			3.6	42.7	3.60	0.00	0.20	-0.02	0.18	7.27	0.494E-03	0.84E+01	0.10E-02	VISCOUS
6" ELBOW LR-90	0.170E-04	0.146	43.411			42.7	0.00	0.00	0.05	0.00	0.05	7.31	0.491E-03			
6" PIPE LENGTH	0.170E-04	0.146			3.0	42.5	0.00	0.00	0.16	0.00	0.16	7.48	0.491E-03	0.84E+01	0.10E-02	VISCOUS
6" ELBOW LR-90	0.170E-04	0.146	43.411			42.5	0.00	0.00	0.05	0.00	0.05	7.52	0.489E-03			
6" PIPE LENGTH	0.170E-04	0.146			10.0	41.9	0.00	0.00	0.55	0.00	0.55	8.07	0.489E-03	0.84E+01	0.10E-02	VISCOUS
6" ELBOW LR-90	0.170E-04	0.146	43.411			41.9	0.00	0.00	0.05	0.00	0.05	8.12	0.482E-03			
6" FLEX LINE,2M	0.170E-04	0.146			10.0	41.3	0.00	0.00	0.56	0.00	0.56	8.68	0.482E-03	0.84E+01	0.11E-02	VISCOUS

TOTAL 8.6759 0.0003 8.6762

EH2600 DISCHARGE PRESSURE: 50.000 Pa FORELINE SPEED : 0.0298 M³/S PUMP PRESSURE : 41.881 Pa PUMP SPEED : 0.0356 M³/S

REVISION : 2
 DOC NO: V049-1-006
 PAGE OF

PROJECT: LIGO BY: R. THAN
 PROJECT NO:V59049 DATE: 4/17/**
 TITLE: ROOTS PUMP,BACKING PUMP VACUUM HEADER PAGE: 1 OF

PRESSURE DROP ROUTE OR LINE ID:EH2600 DISCHARGE 0.2mbar

PRESSURE: 20.0 Pa 0.000 BAR
 TEMPERATURE: 293.000 K 293.000 K
 DENSITY : 0.000 KG/M³ 0.230E-03 KG/M³
 QUALITY : 1.000

ITEMNAME	FLOWRATE KG/S	I.D. METER	K / DO	CV	LENGTH M	PRESSURE Pa	Z1 METER	Z2 METER	DP-F Pa	DP-Z Pa	DP-T Pa	DP-SUM Pa	DENSITY KG/M ³	RE NO	Knunsen	Regime
4" FLEX LINE,3M	0.177E-05	0.100			15.0	19.2	0.00	0.00	0.83	0.00	0.83	0.83	0.230E-03	0.13E+01	0.33E-02	VISCOUS
6" ELBOW LR-90	0.177E-05	0.146	366.549			19.2	0.00	0.00	0.01	0.00	0.01	0.84	0.221E-03			
6" ELBOW LR-90	0.177E-05	0.146	366.549			19.2	0.00	0.00	0.01	0.00	0.01	0.85	0.220E-03			
6" FLEX LINE,3M	0.177E-05	0.146			15.0	19.0	0.00	0.00	0.19	0.00	0.19	1.04	0.220E-03	0.88E+00	0.23E-02	VISCOUS
6" PIPE LENGTH	0.177E-05	0.146			3.0	18.9	0.00	0.00	0.04	0.00	0.04	1.07	0.218E-03	0.88E+00	0.24E-02	VISCOUS
6" ELBOW LR-90	0.177E-05	0.146	366.549			18.9	0.00	0.00	0.01	0.00	0.01	1.08	0.218E-03			
6" PIPE LENGTH	0.177E-05	0.146			6.0	18.8	0.00	0.00	0.08	0.00	0.08	1.16	0.218E-03	0.88E+00	0.24E-02	VISCOUS
6" TEE BRANCH	0.177E-05	0.146	366.549			18.8	0.00	0.00	0.01	0.00	0.01	1.17	0.217E-03			
6" PIPE LENGTH	0.177E-05	0.146			9.0	18.7	0.00	0.00	0.12	0.00	0.12	1.29	0.217E-03	0.88E+00	0.24E-02	VISCOUS
6" PIPE LENGTH	0.177E-05	0.146			9.0	18.6	0.00	0.00	0.12	0.00	0.12	1.40	0.215E-03	0.88E+00	0.24E-02	VISCOUS
6" TEE BRANCH	0.177E-05	0.146	366.549			18.6	0.00	0.00	0.01	0.00	0.01	1.41	0.214E-03			
6" PIPE LENGTH	0.177E-05	0.146			12.0	18.4	0.00	0.00	0.16	0.00	0.16	1.57	0.214E-03	0.88E+00	0.24E-02	VISCOUS
6" TEE LINE	0.177E-05	0.146	366.549			18.4	0.00	0.00	0.01	0.00	0.01	1.58	0.212E-03			
6" ELBOW LR-90	0.177E-05	0.146	366.549			18.4	0.00	0.00	0.01	0.00	0.01	1.59	0.212E-03			
6" PIPE LENGTH	0.177E-05	0.146			3.6	18.4	0.00	3.60	0.05	0.01	0.05	1.64	0.212E-03	0.88E+00	0.24E-02	VISCOUS
6" ELBOW LR-90	0.177E-05	0.146	366.549			18.3	3.60	3.60	0.01	0.00	0.01	1.65	0.211E-03			
6" PIPE LENGTH	0.177E-05	0.146			10.0	18.2	3.60	3.60	0.13	0.00	0.13	1.78	0.211E-03	0.88E+00	0.24E-02	VISCOUS
6" ELBOW LR-90	0.177E-05	0.146	366.549			18.2	3.60	3.60	0.01	0.00	0.01	1.79	0.209E-03			
6" PIPE LENGTH	0.177E-05	0.146			3.6	18.2	3.60	0.00	0.05	-0.01	0.04	1.83	0.209E-03	0.88E+00	0.24E-02	VISCOUS
6" ELBOW LR-90	0.177E-05	0.146	366.549			18.2	0.00	0.00	0.01	0.00	0.01	1.84	0.209E-03			
6" PIPE LENGTH	0.177E-05	0.146			3.0	18.1	0.00	0.00	0.04	0.00	0.04	1.88	0.209E-03	0.88E+00	0.25E-02	VISCOUS
6" ELBOW LR-90	0.177E-05	0.146	366.549			18.1	0.00	0.00	0.01	0.00	0.01	1.89	0.208E-03			
6" PIPE LENGTH	0.177E-05	0.146			10.0	18.0	0.00	0.00	0.13	0.00	0.13	2.03	0.208E-03	0.88E+00	0.25E-02	VISCOUS
6" ELBOW LR-90	0.177E-05	0.146	366.549			18.0	0.00	0.00	0.01	0.00	0.01	2.04	0.207E-03			
6" FLEX LINE,2M	0.177E-05	0.146			10.0	17.8	0.00	0.00	0.14	0.00	0.14	2.17	0.207E-03	0.88E+00	0.25E-02	VISCOUS

TOTAL 2.1729 0.0001 2.1730

EH2600 DISCHARGE PRESSURE: 20.000 Pa FORELINE SPEED : 0.0078 M³/S PUMP PRESSURE : 17.962 Pa PUMP SPEED : 0.0086 M³/S

REVISION : 2
 DOC NO: V049-1-006
 PAGE OF

EDP200/Booster Combinations

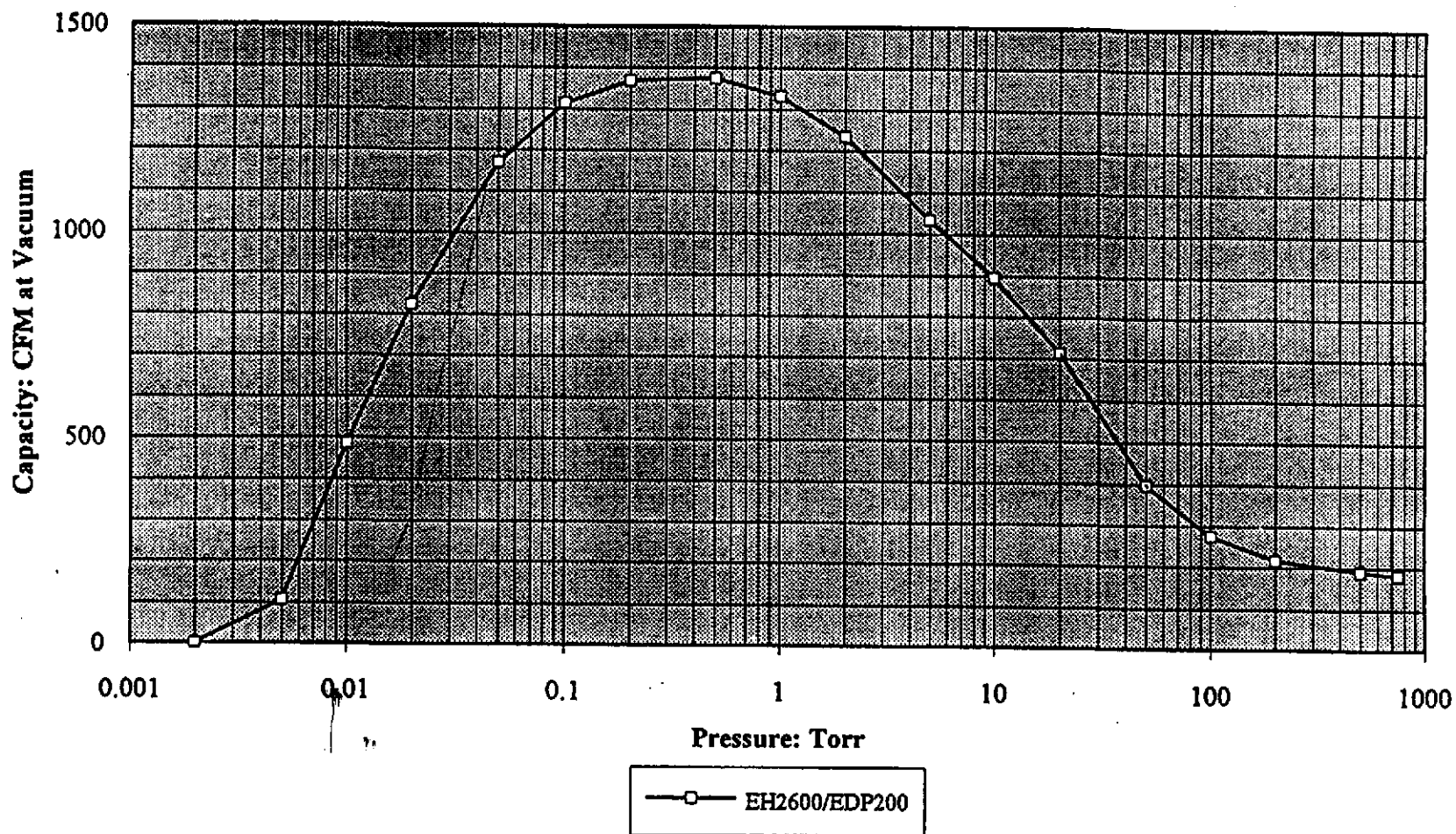

	EDP100	EDP200	EDP300
Nominal pumping speed, ACFM	80	190	250
Maximum sound level, dB(A)	75*	80	80
Ultimate pressure, Torr	0.1	0.1	0.1
Motor size, HP	10	20	30
Motor power at vacuum, HP	5	9	12
Cooling water, GPM	0.7	1	1
Inlet connection	3" ANSI	3" ANSI	3" ANSI
Outlet connection	1½" ANSI	2" ANSI	2" ANSI
Weight with motor and frame, lb.	620	1700	1800

* EDP100 fitted with acoustic enclosure

- Protective instrumentation
- Facilities for liquid flush or gas purge
- Seals and bearings in cartridges for simple replacement
- Short gas path for enhanced pumping of entrained liquids and solids
- Compact footprint for ease of installation

PERFORMANCE DATA

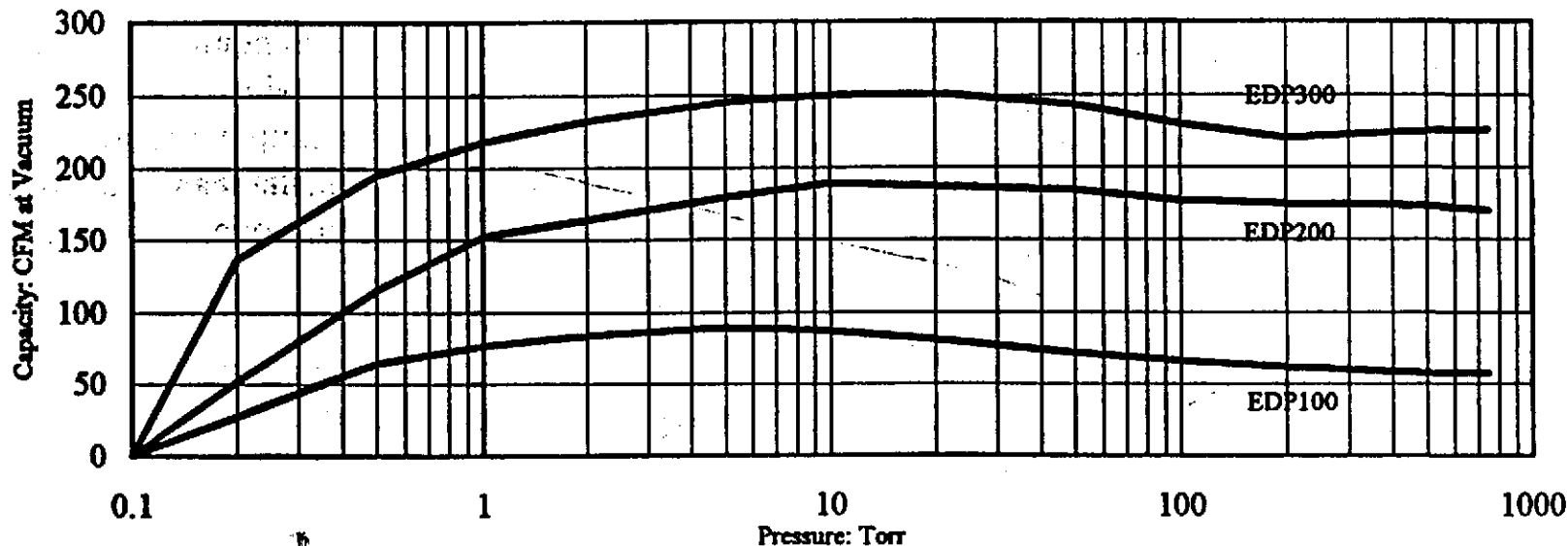

Edwards is a ISO 9001 approved company
 Edwards and the stripe symbols are trade marks of The BOC Group
 © Edwards High Vacuum International 1995
 Printed in the USA
 Publication 12-A***-895

Edwards High Vacuum International
 301 Ballardvale Street
 Wilmington MA 01950
 Tel: 800 848 9800
 Fax: 508 658 7969

Revision:
 Doc no.
 Page of

Table 5.3 Calculation of the pumping speed S for a combination of a Roots pump type RUWAC WA 1000 with the rotary plunger pumps E250 and E75. Theoretical pumping speed of the Roots pump from which a 2.5% slip must be subtracted: $S_{th} = 1000 \text{ m}^3\text{h}^{-1} (1 - 0.025) = 975 \text{ m}^3\text{h}^{-1}$. Pumping speed of the rotary plunger pumps are taken from their pumping speed curves with closed gas ballast valve. See also fig. 5.45 for comparison.

p_v in mbar	S_v in $\text{m}^3 \cdot \text{h}^{-1}$	$K_{th} = \frac{S_{th}}{S_v} = \frac{975 \text{ m}^3\text{h}^{-1}}{S_v}$ equ. (5.59)	K_o (measured) fig. 5.41	$\frac{K_o}{K_{th}}$	$\eta_V = \frac{\frac{K_o}{K_{th}}}{1 + \frac{K_o}{K_{th}}}$ equ. (5.60)	$S = \eta_V \cdot S_{th}$ equ. (5.61)	$p_A = \frac{p_v \cdot S_v}{S}$ In mbar equ. (5.58)
E250							
133	250	3.9	13	3.34	0.77	750	44.3
53	250	3.9	16.5	4.23	0.81	789	16.8
13	250	3.9	27	6.93	0.874	851	3.82
7	250	3.9	34	8.72	0.898	875	2
1	250	3.9	52	13.3	0.93	906	0.276
$7 \cdot 10^{-1}$	245	3.98	49.5	12.4	0.929	905	0.189
$1 \cdot 10^{-1}$	185	5.26	27	5.14	0.838	817	$2.3 \cdot 10^{-3}$
$5 \cdot 10^{-2}$	105	9.28	19	2.05	0.673	656	$8 \cdot 10^{-3}$
E75							
100	74	13.2 *	13	0.985	0.496	484	15.3
40	74	13.2	16.5	1.25	0.556	542	5.5
10	74	13.2	27	2.04	0.673	656	1.13
5	74	13.2	34	2.58	0.722	704	0.53
1	74	13.2	52	3.94	0.798	778	$9.5 \cdot 10^{-1}$
$5 \cdot 10^{-1}$	71	13.7	49.5	3.61	0.784	764	$4.7 \cdot 10^{-1}$
$1 \cdot 10^{-1}$	52	18.7	27	1.44	0.59	575	$9 \cdot 10^{-2}$
$4 \cdot 10^{-2}$	27	36.1 *	19	0.53	0.35	341	$3 \cdot 10^{-2}$
$p_{v, \text{end}} = 2 \cdot 10^{-2}$			$K_{o, \text{end}} = 14.0$				$p_o = 1.5 \cdot 10^{-2}$

* theoretical value, since we must not have $K_{th} > K_o$, since then we would have $\eta_V < 0.5$

5.4 Roots pumps 5.4.4

Table 8.1. Conductance equations for vacuum systems. μ = gas viscosity, \bar{p} = mean pressure, g = conversion factor is Newton's Law, R_u = universal gas constant, M = molecular weight, γ = specific heat ratio, L = tube length, D = tube diameter

Element	Sketch of Element	Flow Regime																																													
		Continuum (Laminar Flow)	Free Molecular																																												
1. Long tube, $L/D > 30$		$C = \frac{gD^3\bar{p}}{128\mu L}$	$C = \left(\frac{gR_u T}{18M}\right)^{1/2} \frac{D^3}{L}$																																												
2. Short tube, $L/D < 30$ D_1 = larger diameter D_2 = smaller diameter	Same as (1)	$C = \frac{gD^3\bar{p}}{128\mu L} \left(1 + \frac{64}{22\pi L}\right)^{-1/2}$	$C = \frac{(gR_u T/18M)^{1/2} D^3}{L/D + (8\pi)^{1/2} - (D_2/D)^2}$																																												
3. Orifice or aperture D_1 = tube diameter D_2 = orifice diameter $r_o = D_2/D_1$		$C = KD^3 \left[\frac{gR_u R_u T}{8(\gamma - 1)M}\right]^{1/2}$ (a) For $r_o \geq [2(\gamma + 1)]^{1/(\gamma - 1)}$ $K = \frac{1 - r_o^{2\gamma}}{r_o^2(1 - r_o^2)}$ (b) For $r_o < [2(\gamma + 1)]^{1/(\gamma - 1)}$ $K = \frac{[(\gamma - 1)(\gamma + 1)]^{1/2}}{[2(\gamma + 1)]^{1/(\gamma - 1)}(1 - r_o^2)}$	$C = \frac{(gR_u T/32M)^{1/2} D^3}{1 - (D_2/D_1)^2}$																																												
4. Annular flow passage D_1 = larger diameter D_2 = smaller diameter		$C = \frac{g\bar{p}}{128\mu L} \left[(D_1^4 - D_2^4) - \frac{(D_1^2 - D_2^2)^2}{\ln(D_1/D_2)} \right]$	$C = \left(\frac{gR_u T}{18M}\right)^{1/2} \frac{(D_1 - D_2)(D_1 + D_2)K}{L + (8\pi)^{1/2}(D_1 - D_2)}$ where K is given as follows: <table border="1"> <tr> <td>D_2/D_1</td> <td>0</td> <td>0.259</td> <td>0.500</td> </tr> <tr> <td>K</td> <td>1</td> <td>1.072</td> <td>1.154</td> </tr> </table> <table border="1"> <tr> <td>D_2/D_1</td> <td>0.707</td> <td>0.866</td> <td>0.966</td> </tr> <tr> <td>K</td> <td>1.254</td> <td>1.430</td> <td>1.675</td> </tr> </table>	D_2/D_1	0	0.259	0.500	K	1	1.072	1.154	D_2/D_1	0.707	0.866	0.966	K	1.254	1.430	1.675																												
D_2/D_1	0	0.259	0.500																																												
K	1	1.072	1.154																																												
D_2/D_1	0.707	0.866	0.966																																												
K	1.254	1.430	1.675																																												
5. Rectangular tube $a/b \leq 1$		$C = \frac{g\bar{p}a^3b^3K}{87.4\mu L}$ where K is given as follows: <table border="1"> <tr> <td>a/b</td> <td>1.00</td> <td>0.90</td> <td>0.80</td> <td>0.70</td> <td>0.60</td> </tr> <tr> <td>K</td> <td>1.00</td> <td>0.99</td> <td>0.98</td> <td>0.95</td> <td>0.90</td> </tr> <tr> <td>a/b</td> <td>0.50</td> <td>0.40</td> <td>0.30</td> <td>0.20</td> <td>0.10</td> </tr> <tr> <td>K</td> <td>0.82</td> <td>0.71</td> <td>0.58</td> <td>0.42</td> <td>0.23</td> </tr> </table>	a/b	1.00	0.90	0.80	0.70	0.60	K	1.00	0.99	0.98	0.95	0.90	a/b	0.50	0.40	0.30	0.20	0.10	K	0.82	0.71	0.58	0.42	0.23	$C = \left(\frac{32gR_u T}{9\pi M}\right)^{1/2} \frac{a^3b^3K}{(a + b)L + 8ab}$ where K is given as follows: <table border="1"> <tr> <td>a/b</td> <td>1.000</td> <td>0.667</td> <td>0.500</td> <td>0.333</td> </tr> <tr> <td>K</td> <td>1.108</td> <td>1.126</td> <td>1.151</td> <td>1.198</td> </tr> <tr> <td>a/b</td> <td>0.200</td> <td>0.125</td> <td>0.100</td> <td>0.000</td> </tr> <tr> <td>K</td> <td>1.297</td> <td>1.400</td> <td>1.444</td> <td>1.667</td> </tr> </table>	a/b	1.000	0.667	0.500	0.333	K	1.108	1.126	1.151	1.198	a/b	0.200	0.125	0.100	0.000	K	1.297	1.400	1.444	1.667
a/b	1.00	0.90	0.80	0.70	0.60																																										
K	1.00	0.99	0.98	0.95	0.90																																										
a/b	0.50	0.40	0.30	0.20	0.10																																										
K	0.82	0.71	0.58	0.42	0.23																																										
a/b	1.000	0.667	0.500	0.333																																											
K	1.108	1.126	1.151	1.198																																											
a/b	0.200	0.125	0.100	0.000																																											
K	1.297	1.400	1.444	1.667																																											
6. 90° elbow r = mean radius		$C = \frac{g\bar{p}KD^3}{128\mu}$ where K is given as follows: <table border="1"> <tr> <td>r/D</td> <td>0.000</td> <td>1.000</td> <td>2.000</td> <td>3.000</td> <td>4.000</td> </tr> <tr> <td>K</td> <td>0.017</td> <td>0.050</td> <td>0.083</td> <td>0.083</td> <td>0.073</td> </tr> <tr> <td>r/D</td> <td>6.0</td> <td>8.0</td> <td>10</td> <td>12</td> <td>14</td> </tr> <tr> <td>K</td> <td>0.056</td> <td>0.042</td> <td>0.034</td> <td>0.029</td> <td>0.026</td> </tr> </table>	r/D	0.000	1.000	2.000	3.000	4.000	K	0.017	0.050	0.083	0.083	0.073	r/D	6.0	8.0	10	12	14	K	0.056	0.042	0.034	0.029	0.026	$C = \left(\frac{2gR_u T}{9\pi M}\right)^{1/2} \frac{D^3}{r}$																				
r/D	0.000	1.000	2.000	3.000	4.000																																										
K	0.017	0.050	0.083	0.083	0.073																																										
r/D	6.0	8.0	10	12	14																																										
K	0.056	0.042	0.034	0.029	0.026																																										

$$\Delta P = \frac{P \cdot \dot{V}}{C} \quad [Pa]$$

PROCESS SYSTEMS INTERNATIONAL, INC.					ENGINEERING	NO: V049-1-007
WESTBOROUGH, MA					CALCULATIONS	PAGE 1 OF 13
REV	DEO#	DATE	BY:	CHECK	TITLE: TURBO PUMP INTERMEDIATE HEADER PRESSURE DROP ANALYSIS	
0	0007	10/28/95	R. Than	DMW		
1		10/31/95	R. Than			
2	0127	04/16/96	R.Than	D.M.W.		
					BY: R. THAN	DEPT: 744
PROJECT: LIGO					PROJECT NO: V59049	
<u>PURPOSE:</u> Pressure drop calcs for vacuum header for 1400 L/s Main turbo molecular pumps with QDP80 dry backing pump.						
<u>METHOD:</u> Viscous Regime: Turbulent flow: Colebrook formula, "Moody chart" Laminar flow: hagen-Poiseuille flow Free molecular regime: Long tube formula						
<u>ASSUMPTIONS:</u> Operation of one main TurboMolecular Pump into header						
<u>INPUTS:</u> Per equipment layout, 4 inch header						
<u>REFERENCE:</u> Theory and Practice of vacuum Technology, ISBN 3-528-08908-3 Perry's Chemical Engineers handbook, 6th edition, McGrawHill, 1984						
<u>CALCULATIONS:</u> see Attachments						
<u>CONCLUSIONS:</u> 4 inch pipe header is adequate to handle flow of 90 m ³ /hr (Edwards' QDP80 dry backing pump)						
<u>NOTES:</u>						

PROJECT: LIGO _____ BY: R.THAN DEPT: 744 _____

PROJECT NO: V59049 DATE: 04/17/96

TITLE: MAIN TMP VACUUM HEADER DP PAGE : 2 OF 13

Pressure drop calculations were done with the current piping layout using 4 inch headers, 2.5 inch flexline from the turbo discharge to the header.

The pressure drop in the 1 mbar range is about 0.33 mbar. To meet the through put of 5 Torr-L/s or 6.5 mbar-L/s at a backing pressure of 1 Torr (1.3 mbar), the backing pump needs to have a capacity of 6.5 L/s or 24 m³/hr at a suction pressure of 1 mbar.

The pressure drop through the lines at a header inlet pressure of 1 mbar is 0.33 mbar at a through put 11 mbar-L/s. Pumping speed curves of the QDP80 indicates that the pump has a speed of 61 m³/hr at suction pressure of 0.66 mbar.

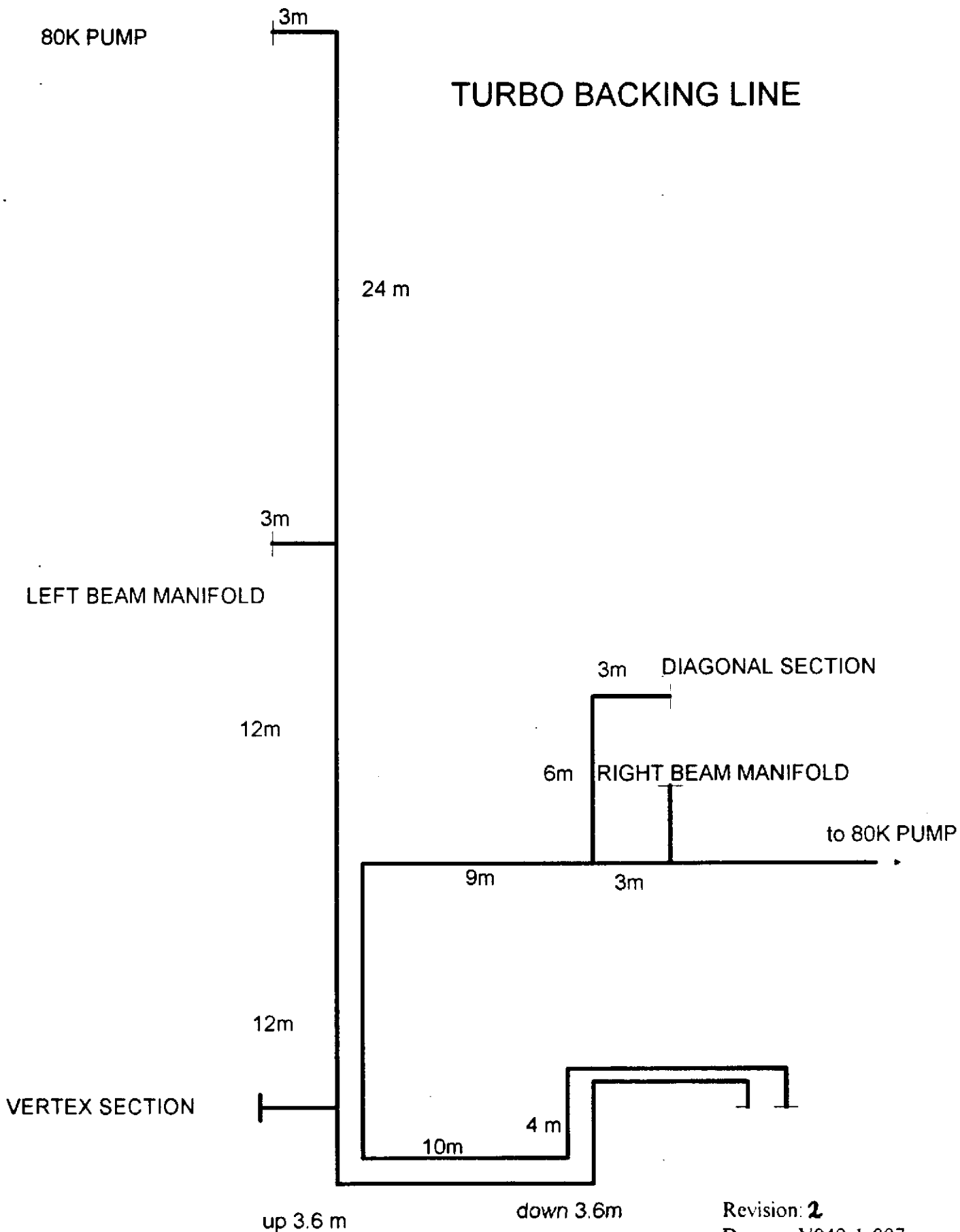

PROJECT: LIGO
 PROJECT NO:V59049
 TITLE: TURBO PUMP VACUUM HEADER

BY: R. THAN
 DATE: 4/17/**
 PAGE: 1 OF

PRESSURE DROP ROUTE OR LINE ID:TURBO BACKING PUMP QDP80

PRESSURE: 100000.0 Pa 1.000 BAR
 TEMPERATURE: 293.000 K 293.000 K
 DENSITY : 1.150 KG/M³ 0.115E+01 KG/M³
 QUALITY : 1.000

ITEMNAME	FLOWRATE KG/S	I.D. METER	K / DO	CV	LENGTH M	PRESSURE Pa	Z1 METER	Z2 METER	DP-F Pa	DP-Z Pa	DP-T Pa	DP-SUM Pa	DENSITY KG/M ³	RE NO	Knuisen	Regime		
1.5" BYPASS	0.218E-01	0.038			4.0	99569.8	0.00	0.00	430.25	0.00	430.25	430.25	0.115E+01	0.41E+05	0.17E-05	VISCOUS		
2.5"ELBOW LR-90	0.218E-01	0.063	1.000			99548.4	0.00	0.00	21.34	0.00	21.34	451.59	0.115E+01					
2.5" FLEX LINE,2M	0.218E-01	0.063			10.0	99459.1	0.00	0.00	89.33	0.00	89.33	540.92	0.115E+01	0.25E+05	0.10E-05	VISCOUS		
4" ELBOW LR-90	0.218E-01	0.100	1.000			99455.7	0.00	0.00	3.37	0.00	3.37	544.28	0.114E+01					
4" PIPE LENGTH	0.218E-01	0.100			3.0	99452.8	0.00	0.00	2.87	0.00	2.87	547.15	0.114E+01	0.16E+05	0.66E-06	VISCOUS		
4" ELBOW LR-90	0.218E-01	0.100	1.000			99449.5	0.00	0.00	3.37	0.00	3.37	550.52	0.114E+01					
4" PIPE LENGTH	0.218E-01	0.100			24.0	99426.5	0.00	0.00	22.95	0.00	22.95	573.47	0.114E+01	0.16E+05	0.66E-06	VISCOUS		
4" TEE LINE	0.218E-01	0.100	1.000			99423.2	0.00	0.00	3.37	0.00	3.37	576.84	0.114E+01					
4" PIPE LENGTH	0.218E-01	0.100			12.0	99411.7	0.00	0.00	11.48	0.00	11.48	588.32	0.114E+01	0.16E+05	0.66E-06	VISCOUS		
4" TEE BRANCH	0.218E-01	0.100	1.000			99408.3	0.00	0.00	3.37	0.00	3.37	591.69	0.114E+01					
4" PIPE LENGTH	0.218E-01	0.100			10.0	99398.7	0.00	0.00	9.57	0.00	9.57	601.25	0.114E+01	0.16E+05	0.66E-06	VISCOUS		
4" TEE LINE	0.218E-01	0.100	1.000			99395.4	0.00	0.00	3.37	0.00	3.37	604.62	0.114E+01					
4" PIPE LENGTH	0.218E-01	0.100			2.0	99393.5	0.00	0.00	1.91	0.00	1.91	606.54	0.114E+01	0.16E+05	0.66E-06	VISCOUS		
4" ELBOW LR-90	0.218E-01	0.100	1.000			99390.1	0.00	0.00	3.37	0.00	3.37	609.90	0.114E+01					
4" PIPE LENGTH	0.218E-01	0.100			3.6	99346.3	0.00	3.60	3.45	40.38	43.82	653.73	0.114E+01	0.16E+05	0.66E-06	VISCOUS		
4" ELBOW LR-90	0.218E-01	0.100	1.000			99342.9	3.60	3.60	3.37	0.00	3.37	657.10	0.114E+01					
4" PIPE LENGTH	0.218E-01	0.100			10.0	99333.3	3.60	3.60	9.57	0.00	9.57	666.67	0.114E+01	0.16E+05	0.66E-06	VISCOUS		
4" ELBOW LR-90	0.218E-01	0.100	1.000			99330.0	3.60	3.60	3.37	0.00	3.37	670.04	0.114E+01					
4" PIPE LENGTH	0.218E-01	0.100			3.6	99366.9	3.60	0.00	3.45	-40.35	-36.91	633.14	0.114E+01	0.16E+05	0.66E-06	VISCOUS		
4" ELBOW LR-90	0.218E-01	0.100	1.000			99363.5	0.00	0.00	3.37	0.00	3.37	636.50	0.114E+01					
4" PIPE LENGTH	0.218E-01	0.100			3.0	99360.6	0.00	0.00	2.87	0.00	2.87	639.38	0.114E+01	0.16E+05	0.66E-06	VISCOUS		
4" ELBOW LR-90	0.218E-01	0.100	1.000			99357.3	0.00	0.00	3.37	0.00	3.37	642.75	0.114E+01					
4" PIPE LENGTH	0.218E-01	0.100			10.0	99347.7	0.00	0.00	9.57	0.00	9.57	652.32	0.114E+01	0.16E+05	0.66E-06	VISCOUS		
4" ELBOW LR-90	0.218E-01	0.100	1.000			99344.3	0.00	0.00	3.37	0.00	3.37	655.69	0.114E+01					
4" FLEX LINE,3M	0.218E-01	0.100			10.0	99334.7	0.00	0.00	9.57	0.00	9.57	665.26	0.114E+01	0.16E+05	0.66E-06	VISCOUS		
TOTAL									665.2391	0.0244						665.2635		

CHAMBER PRESSURE:100000.000 Pa CHAMBER SPEED : 0.0190 M³/S PUMP PRESSURE : 99334.736 Pa PUMP SPEED : 0.0191 M³/S

PROJECT: LIGO
 PROJECT NO:V59049
 TITLE: TURBO PUMP VACUUM HEADER

BY: R. THAN
 DATE: 4/17/**
 PAGE: 1 OF

PRESSURE DROP ROUTE OR LINE ID:TURBO BACKING PUMP QDP80

PRESSURE: 10000.0 Pa 0.100 BAR
 TEMPERATURE: 293.000 K 293.000 K
 DENSITY : 0.115 KG/M³ 0.115E+00 KG/M³
 QUALITY : 1.000

ITEMNAME	FLOWRATE KG/S	I.D. METER	K / DO	CV	LENGTH M	PRESSURE Pa	Z1 METER	Z2 METER	DP-F Pa	DP-Z Pa	DP-T Pa	DP-SUM Pa	DENSITY KG/M ³	RE NO	Knunsen	Regime
1.5" BYPASS	0.271E-02	0.038			4.0	9899.1	0.00	0.00	100.88	0.00	100.88	100.88	0.115E+00	0.52E+04	0.17E-04	VISCOUS
2.5"ELBOW LR-90	0.271E-02	0.063	1.000			9895.8	0.00	0.00	3.33	0.00	3.33	104.21	0.114E+00			
2.5" FLEX LINE,2M	0.271E-02	0.063			10.0	9872.7	0.00	0.00	23.11	0.00	23.11	127.32	0.114E+00	0.31E+04	0.10E-04	VISCOUS
4" ELBOW LR-90	0.271E-02	0.100	1.016			9872.1	0.00	0.00	0.53	0.00	0.53	127.85	0.114E+00			
4" PIPE LENGTH	0.271E-02	0.100			3.0	9871.6	0.00	0.00	0.51	0.00	0.51	128.37	0.114E+00	0.20E+04	0.66E-05	VISCOUS
4" ELBOW LR-90	0.271E-02	0.100	1.016			9871.1	0.00	0.00	0.53	0.00	0.53	128.90	0.114E+00			
4" PIPE LENGTH	0.271E-02	0.100			24.0	9867.0	0.00	0.00	4.12	0.00	4.12	133.02	0.114E+00	0.20E+04	0.66E-05	VISCOUS
4" TEE LINE	0.271E-02	0.100	1.016			9866.5	0.00	0.00	0.53	0.00	0.53	133.55	0.113E+00			
4" PIPE LENGTH	0.271E-02	0.100			12.0	9864.4	0.00	0.00	2.06	0.00	2.06	135.61	0.113E+00	0.20E+04	0.66E-05	VISCOUS
4" TEE BRANCH	0.271E-02	0.100	1.016			9863.9	0.00	0.00	0.53	0.00	0.53	136.14	0.113E+00			
4" PIPE LENGTH	0.271E-02	0.100			10.0	9862.1	0.00	0.00	1.72	0.00	1.72	137.86	0.113E+00	0.20E+04	0.66E-05	VISCOUS
4" TEE LINE	0.271E-02	0.100	1.016			9861.6	0.00	0.00	0.53	0.00	0.53	138.39	0.113E+00			
4" PIPE LENGTH	0.271E-02	0.100			2.0	9861.3	0.00	0.00	0.34	0.00	0.34	138.74	0.113E+00	0.20E+04	0.66E-05	VISCOUS
4" ELBOW LR-90	0.271E-02	0.100	1.016			9860.7	0.00	0.00	0.53	0.00	0.53	139.27	0.113E+00			
4" PIPE LENGTH	0.271E-02	0.100			3.6	9856.1	0.00	3.60	0.62	4.01	4.62	143.89	0.113E+00	0.20E+04	0.66E-05	VISCOUS
4" ELBOW LR-90	0.271E-02	0.100	1.016			9855.6	3.60	3.60	0.53	0.00	0.53	144.43	0.113E+00			
4" PIPE LENGTH	0.271E-02	0.100			10.0	9853.9	3.60	3.60	1.72	0.00	1.72	146.15	0.113E+00	0.20E+04	0.66E-05	VISCOUS
4" ELBOW LR-90	0.271E-02	0.100	1.016			9853.3	3.60	3.60	0.53	0.00	0.53	146.68	0.113E+00			
4" PIPE LENGTH	0.271E-02	0.100			3.6	9856.7	3.60	0.00	0.62	-4.00	-3.38	143.30	0.113E+00	0.20E+04	0.66E-05	VISCOUS
4" ELBOW LR-90	0.271E-02	0.100	1.016			9856.2	0.00	0.00	0.53	0.00	0.53	143.83	0.113E+00			
4" PIPE LENGTH	0.271E-02	0.100			3.0	9855.7	0.00	0.00	0.52	0.00	0.52	144.35	0.113E+00	0.20E+04	0.66E-05	VISCOUS
4" ELBOW LR-90	0.271E-02	0.100	1.016			9855.1	0.00	0.00	0.53	0.00	0.53	144.88	0.113E+00			
4" PIPE LENGTH	0.271E-02	0.100			10.0	9853.4	0.00	0.00	1.72	0.00	1.72	146.60	0.113E+00	0.20E+04	0.66E-05	VISCOUS
4" ELBOW LR-90	0.271E-02	0.100	1.016			9852.9	0.00	0.00	0.53	0.00	0.53	147.13	0.113E+00			
4" FLEX LINE,3M	0.271E-02	0.100			10.0	9851.1	0.00	0.00	1.72	0.00	1.72	148.85	0.113E+00	0.20E+04	0.66E-05	VISCOUS

TOTAL 148.8497 0.0030 148.8527

CHAMBER PRESSURE: 10000.000 Pa CHAMBER SPEED : 0.0237 M³/S PUMP PRESSURE : 9851.147 Pa PUMP SPEED : 0.0240 M³/S

PROJECT: LIGO
 PROJECT NO:V59049
 TITLE: TURBO PUMP VACUUM HEADER

BY: R. THAN
 DATE: 4/17/**
 PAGE: 1 OF

PRESSURE DROP ROUTE OR LINE ID: TURBO BACKING PUMP QDP80

PRESSURE: 1000.0 Pa 0.010 BAR
 TEMPERATURE: 293.000 K 293.000 K
 DENSITY : 0.012 KG/M³ 0.115E-01 KG/M³
 QUALITY : 1.000

ITEMNAME	FLOWRATE KG/S	I.D. METER	K / DO	CV	LENGTH M	PRESSURE Pa	Z1 METER	Z2 METER	DP-F Pa	DP-Z Pa	DP-T Pa	DP-SUM Pa	DENSITY KG/M ³	RE NO	Knunsen	Regime
1.5" BYPASS	0.230E-03	0.038			4.0	972.5	0.00	0.00	27.50	0.00	27.50	27.50	0.115E-01	0.44E+03	0.17E-03	VISCOUS
2.5" ELBOW LR-90	0.230E-03	0.063	2.835			971.8	0.00	0.00	0.69	0.00	0.69	28.19	0.112E-01			
2.5" FLEX LINE, 2M	0.230E-03	0.063			10.0	962.4	0.00	0.00	9.37	0.00	9.37	37.56	0.112E-01	0.26E+03	0.11E-03	VISCOUS
4" ELBOW LR-90	0.230E-03	0.100	3.846			962.3	0.00	0.00	0.15	0.00	0.15	37.71	0.111E-01			
4" PIPE LENGTH	0.230E-03	0.100			3.0	961.8	0.00	0.00	0.45	0.00	0.45	38.15	0.111E-01	0.17E+03	0.68E-04	VISCOUS
4" ELBOW LR-90	0.230E-03	0.100	3.846			961.7	0.00	0.00	0.15	0.00	0.15	38.30	0.111E-01			
4" PIPE LENGTH	0.230E-03	0.100			24.0	958.1	0.00	0.00	3.58	0.00	3.58	41.88	0.111E-01	0.17E+03	0.68E-04	VISCOUS
4" TEE LINE	0.230E-03	0.100	3.846			958.0	0.00	0.00	0.15	0.00	0.15	42.03	0.110E-01			
4" PIPE LENGTH	0.230E-03	0.100			12.0	956.2	0.00	0.00	1.80	0.00	1.80	43.83	0.110E-01	0.17E+03	0.68E-04	VISCOUS
4" TEE BRANCH	0.230E-03	0.100	3.846			956.0	0.00	0.00	0.15	0.00	0.15	43.98	0.110E-01			
4" PIPE LENGTH	0.230E-03	0.100			10.0	954.5	0.00	0.00	1.50	0.00	1.50	45.48	0.110E-01	0.17E+03	0.68E-04	VISCOUS
4" TEE LINE	0.230E-03	0.100	3.846			954.4	0.00	0.00	0.15	0.00	0.15	45.63	0.110E-01			
4" PIPE LENGTH	0.230E-03	0.100			2.0	954.1	0.00	0.00	0.30	0.00	0.30	45.93	0.110E-01	0.17E+03	0.68E-04	VISCOUS
4" ELBOW LR-90	0.230E-03	0.100	3.846			953.9	0.00	0.00	0.15	0.00	0.15	46.08	0.110E-01			
4" PIPE LENGTH	0.230E-03	0.100			3.6	953.0	0.00	3.60	0.54	0.39	0.93	47.00	0.110E-01	0.17E+03	0.68E-04	VISCOUS
4" ELBOW LR-90	0.230E-03	0.100	3.846			952.8	3.60	3.60	0.15	0.00	0.15	47.15	0.110E-01			
4" PIPE LENGTH	0.230E-03	0.100			10.0	951.3	3.60	3.60	1.50	0.00	1.50	48.66	0.110E-01	0.17E+03	0.68E-04	VISCOUS
4" ELBOW LR-90	0.230E-03	0.100	3.846			951.2	3.60	3.60	0.15	0.00	0.15	48.81	0.109E-01			
4" PIPE LENGTH	0.230E-03	0.100			3.6	951.0	3.60	0.00	0.54	-0.39	0.16	48.97	0.109E-01	0.17E+03	0.68E-04	VISCOUS
4" ELBOW LR-90	0.230E-03	0.100	3.846			950.9	0.00	0.00	0.15	0.00	0.15	49.12	0.109E-01			
4" PIPE LENGTH	0.230E-03	0.100			3.0	950.4	0.00	0.00	0.45	0.00	0.45	49.57	0.109E-01	0.17E+03	0.68E-04	VISCOUS
4" ELBOW LR-90	0.230E-03	0.100	3.846			950.3	0.00	0.00	0.15	0.00	0.15	49.72	0.109E-01			
4" PIPE LENGTH	0.230E-03	0.100			10.0	948.8	0.00	0.00	1.51	0.00	1.51	51.23	0.109E-01	0.17E+03	0.68E-04	VISCOUS
4" ELBOW LR-90	0.230E-03	0.100	3.846			948.6	0.00	0.00	0.15	0.00	0.15	51.38	0.109E-01			
4" FLEX LINE, 3M	0.230E-03	0.100			10.0	947.1	0.00	0.00	1.51	0.00	1.51	52.89	0.109E-01	0.17E+03	0.69E-04	VISCOUS
TOTAL									52.8895	0.0011	52.8907					

CHAMBER PRESSURE: 1000.000 Pa CHAMBER SPEED : 0.0201 M³/S PUMP PRESSURE : 947.109 Pa PUMP SPEED : 0.0212 M³/S

PROJECT: LIGO
 PROJECT NO:V59049
 TITLE: TURBO PUMP VACUUM HEADER

BY: R. THAM
 DATE: 4/17/**
 PAGE: 1 OF

PRESSURE DROP ROUTE OR LINE ID:TURBO BACKING PUMP QDP80

PRESSURE: 100.0 Pa 0.001 BAR
 TEMPERATURE: 293.000 K 293.000 K
 DENSITY : 0.001 KG/M³ 0.115E-02 KG/M³
 QUALITY : 1.000

ITEMNAME	FLOWRATE KG/S	I.D. METER	K / DO	CV	LENGTH M	PRESSURE Pa	Z1 METER	Z2 METER	DP-F Pa	DP-Z Pa	DP-T Pa	DP-SUM Pa	DENSITY KG/M ³	RE NO	Knunsen	Regime
1.5" BYPASS	0.132E-04	0.038			4.0	84.2	0.00	0.00	15.80	0.00	15.80	15.80	0.115E-02	0.25E+02	0.17E-02	VISCOUS
2.5"ELBOW LR-90	0.132E-04	0.063	25.697			84.0	0.00	0.00	0.24	0.00	0.24	16.04	0.968E-03			
2.5" FLEX LINE,2M	0.132E-04	0.063			10.0	77.7	0.00	0.00	6.23	0.00	6.23	22.26	0.966E-03	0.15E+02	0.12E-02	VISCOUS
4" ELBOW LR-90	0.132E-04	0.100	38.768			77.7	0.00	0.00	0.06	0.00	0.06	22.33	0.894E-03			
4" PIPE LENGTH	0.132E-04	0.100			3.0	77.4	0.00	0.00	0.32	0.00	0.32	22.64	0.893E-03	0.95E+01	0.84E-03	VISCOUS
4" ELBOW LR-90	0.132E-04	0.100	38.768			77.3	0.00	0.00	0.06	0.00	0.06	22.71	0.890E-03			
4" PIPE LENGTH	0.132E-04	0.100			24.0	74.7	0.00	0.00	2.56	0.00	2.56	25.26	0.889E-03	0.95E+01	0.84E-03	VISCOUS
4" TEE LINE	0.132E-04	0.100	38.768			74.7	0.00	0.00	0.06	0.00	0.06	25.33	0.860E-03			
4" PIPE LENGTH	0.132E-04	0.100			12.0	73.4	0.00	0.00	1.32	0.00	1.32	26.65	0.859E-03	0.95E+01	0.87E-03	VISCOUS
4" TEE BRANCH	0.132E-04	0.100	38.768			73.3	0.00	0.00	0.06	0.00	0.06	26.71	0.844E-03			
4" PIPE LENGTH	0.132E-04	0.100			10.0	72.2	0.00	0.00	1.12	0.00	1.12	27.84	0.843E-03	0.95E+01	0.89E-03	VISCOUS
4" TEE LINE	0.132E-04	0.100	38.768			72.1	0.00	0.00	0.07	0.00	0.07	27.90	0.830E-03			
4" PIPE LENGTH	0.132E-04	0.100			2.0	71.9	0.00	0.00	0.23	0.00	0.23	28.13	0.829E-03	0.95E+01	0.90E-03	VISCOUS
4" ELBOW LR-90	0.132E-04	0.100	38.768			71.8	0.00	0.00	0.07	0.00	0.07	28.20	0.827E-03			
4" PIPE LENGTH	0.132E-04	0.100			3.6	71.4	0.00	3.60	0.41	0.03	0.44	28.64	0.826E-03	0.95E+01	0.91E-03	VISCOUS
4" ELBOW LR-90	0.132E-04	0.100	38.768			71.3	3.60	3.60	0.07	0.00	0.07	28.71	0.821E-03			
4" PIPE LENGTH	0.132E-04	0.100			10.0	70.1	3.60	3.60	1.16	0.00	1.16	29.86	0.820E-03	0.95E+01	0.91E-03	VISCOUS
4" ELBOW LR-90	0.132E-04	0.100	38.768			70.1	3.60	3.60	0.07	0.00	0.07	29.93	0.807E-03			
4" PIPE LENGTH	0.132E-04	0.100			3.6	69.7	3.60	0.00	0.42	-0.03	0.39	30.33	0.806E-03	0.95E+01	0.93E-03	VISCOUS
4" ELBOW LR-90	0.132E-04	0.100	38.768			69.6	0.00	0.00	0.07	0.00	0.07	30.39	0.801E-03			
4" PIPE LENGTH	0.132E-04	0.100			3.0	69.3	0.00	0.00	0.35	0.00	0.35	30.75	0.801E-03	0.95E+01	0.93E-03	VISCOUS
4" ELBOW LR-90	0.132E-04	0.100	38.768			69.2	0.00	0.00	0.07	0.00	0.07	30.82	0.796E-03			
4" PIPE LENGTH	0.132E-04	0.100			10.0	68.0	0.00	0.00	1.19	0.00	1.19	32.01	0.796E-03	0.95E+01	0.94E-03	VISCOUS
4" ELBOW LR-90	0.132E-04	0.100	38.768			67.9	0.00	0.00	0.07	0.00	0.07	32.08	0.782E-03			
4" FLEX LINE,3M	0.132E-04	0.100			10.0	66.7	0.00	0.00	1.21	0.00	1.21	33.29	0.781E-03	0.95E+01	0.96E-03	VISCOUS

TOTAL 33.2902 0.0007 33.2909

CHAMBER PRESSURE: 100.000 Pa CHAMBER SPEED : 0.0115 M³/S PUMP PRESSURE : 66.709 Pa PUMP SPEED : 0.0172 M³/S

PROJECT: LIGO
 PROJECT NO:V59049
 TITLE: TURBO PUMPVACUUM HEADER

BY: R. THAN
 DATE: 4/17/**
 PAGE: 1 OF

PRESSURE DROP ROUTE OR LINE ID:TURBO BACKING PUMP QDP80

PRESSURE: 10.0 Pa 0.000 BAR
 TEMPERATURE: 293.000 K 293.000 K
 DENSITY : 0.000 KG/M³ 0.115E-03 KG/M³
 QUALITY : 1.000

ITEMNAME	FLOWRATE KG/S	I.D. METER	K / DO	CV	LENGTH M	PRESSURE Pa	Z1 METER	Z2 METER	DP-F Pa	DP-Z Pa	DP-T Pa	DP-SUM Pa	DENSITY KG/M ³	RE NO	Knunsen	Regime
1.5" BYPASS	0.237E-06	0.038			4.0	7.2	0.00	0.00	2.84	0.00	2.84	2.84	0.115E-03	0.45E+00	0.17E-01	SLIP
2.5"ELBOW LR-90	0.237E-06	0.063	1144.091			7.1	0.00	0.00	0.04	0.00	0.04	2.88	0.823E-04			
2.5" FLEX LINE,2M	0.237E-06	0.063			10.0	5.8	0.00	0.00	1.32	0.00	1.32	4.20	0.819E-04	0.27E+00	0.15E-01	SLIP
4" ELBOW LR-90	0.237E-06	0.100	1802.388			5.8	0.00	0.00	0.01	0.00	0.01	4.21	0.667E-04			
4" PIPE LENGTH	0.237E-06	0.100			3.0	5.7	0.00	0.00	0.08	0.00	0.08	4.29	0.665E-04	0.17E+00	0.11E-01	SLIP
4" ELBOW LR-90	0.237E-06	0.100	1802.388			5.7	0.00	0.00	0.01	0.00	0.01	4.30	0.657E-04			
4" PIPE LENGTH	0.237E-06	0.100			24.0	5.1	0.00	0.00	0.62	0.00	0.62	4.93	0.655E-04	0.17E+00	0.11E-01	SLIP
4" TEE LINE	0.237E-06	0.100	1802.388			5.1	0.00	0.00	0.01	0.00	0.01	4.94	0.583E-04			
4" PIPE LENGTH	0.237E-06	0.100			12.0	4.7	0.00	0.00	0.35	0.00	0.35	5.29	0.582E-04	0.17E+00	0.13E-01	SLIP
4" TEE BRANCH	0.237E-06	0.100	1802.387			4.7	0.00	0.00	0.02	0.00	0.02	5.31	0.541E-04			
4" PIPE LENGTH	0.237E-06	0.100			10.0	4.4	0.00	0.00	0.32	0.00	0.32	5.62	0.540E-04	0.17E+00	0.14E-01	SLIP
4" TEE LINE	0.237E-06	0.100	1802.387			4.4	0.00	0.00	0.02	0.00	0.02	5.64	0.503E-04			
4" PIPE LENGTH	0.237E-06	0.100			2.0	4.3	0.00	0.00	0.07	0.00	0.07	5.71	0.502E-04	0.17E+00	0.15E-01	SLIP
4" ELBOW LR-90	0.237E-06	0.100	1802.387			4.3	0.00	0.00	0.02	0.00	0.02	5.72	0.494E-04			
4" PIPE LENGTH	0.237E-06	0.100			3.6	4.2	0.00	3.60	0.12	0.00	0.13	5.85	0.492E-04	0.17E+00	0.15E-01	SLIP
4" ELBOW LR-90	0.237E-06	0.100	1802.387			4.1	3.60	3.60	0.02	0.00	0.02	5.87	0.477E-04			
4" PIPE LENGTH	0.237E-06	0.100			10.0	3.8	3.60	3.60	0.36	0.00	0.36	6.23	0.475E-04	0.17E+00	0.16E-01	SLIP
4" ELBOW LR-90	0.237E-06	0.100	1802.387			3.8	3.60	3.60	0.02	0.00	0.02	6.24	0.434E-04			
4" PIPE LENGTH	0.237E-06	0.100			3.6	3.6	3.60	0.00	0.14	0.00	0.14	6.38	0.432E-04	0.17E+00	0.17E-01	SLIP
4" ELBOW LR-90	0.237E-06	0.100	1802.386			3.6	0.00	0.00	0.02	0.00	0.02	6.40	0.416E-04			
4" PIPE LENGTH	0.237E-06	0.100			3.0	3.5	0.00	0.00	0.12	0.00	0.12	6.53	0.413E-04	0.17E+00	0.18E-01	SLIP
4" ELBOW LR-90	0.237E-06	0.100	1802.386			3.5	0.00	0.00	0.02	0.00	0.02	6.55	0.399E-04			
4" PIPE LENGTH	0.237E-06	0.100			10.0	3.0	0.00	0.00	0.43	0.00	0.43	6.98	0.397E-04	0.17E+00	0.19E-01	SLIP
4" ELBOW LR-90	0.237E-06	0.100	1802.386			3.0	0.00	0.00	0.02	0.00	0.02	7.00	0.348E-04			
4" FLEX LINE,3M	0.237E-06	0.100			10.0	2.5	0.00	0.00	0.49	0.00	0.49	7.50	0.345E-04	0.17E+00	0.22E-01	SLIP

TOTAL 7.4952 0.0002 7.4954

CHAMBER PRESSURE: 10.000 Pa CHAMBER SPEED : 0.0021 M³/S PUMP PRESSURE : 2.505 Pa PUMP SPEED : 0.0084 M³/S

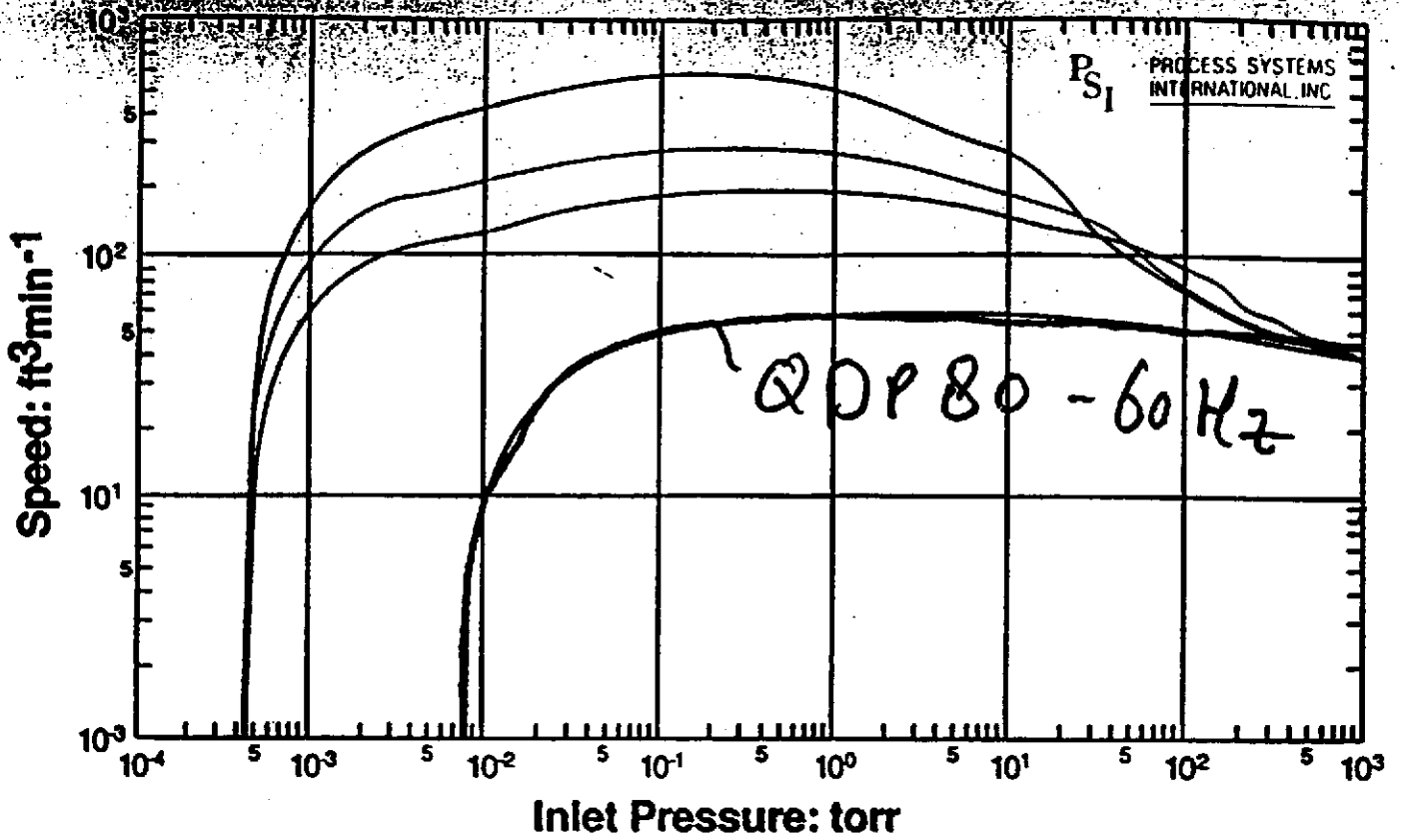

QMB1200 + QDP80 50Hz QMB500 + QDP80 50Hz
QMB250 + QDP80 50Hz QDP80 50Hz

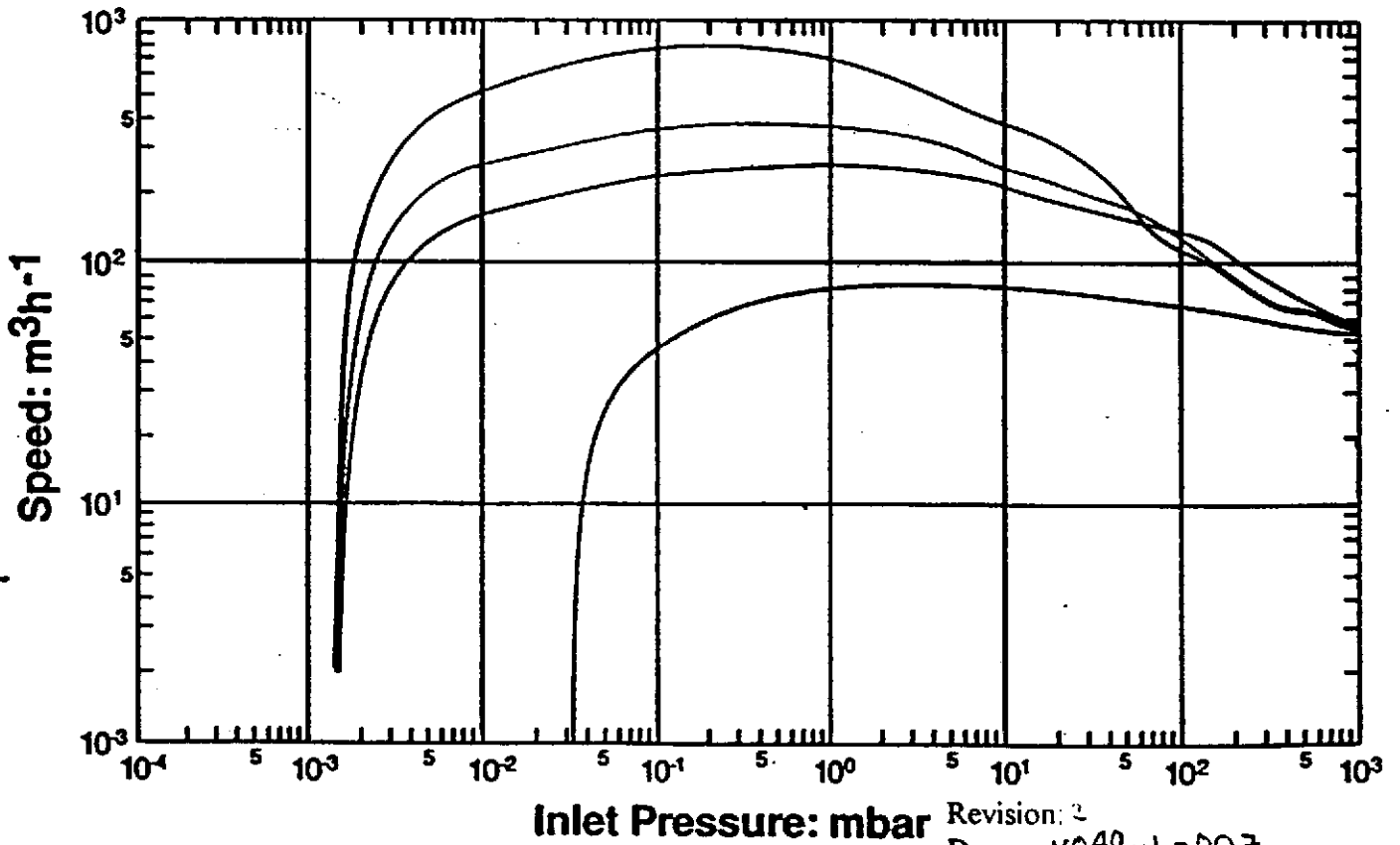

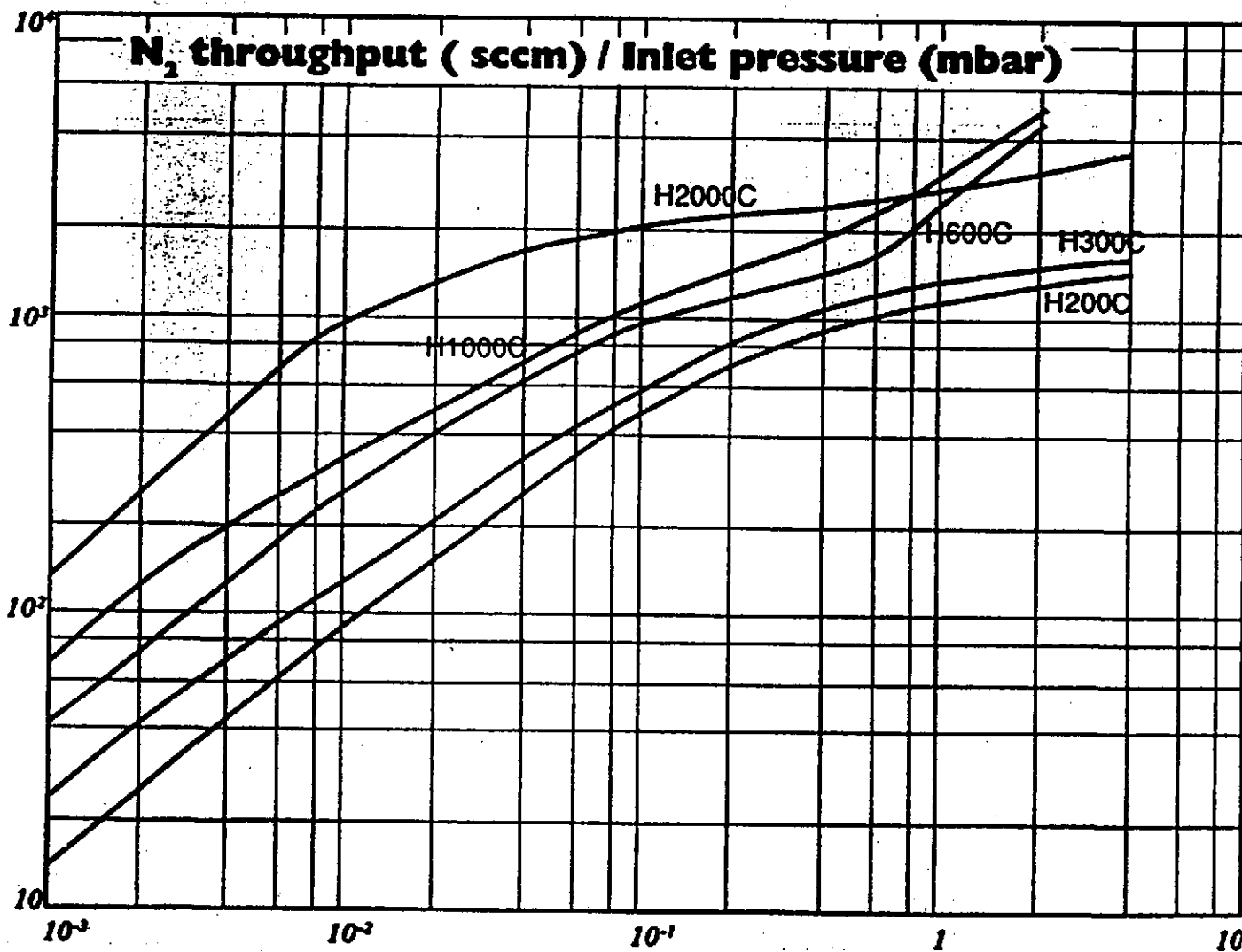

H200C and H300C used with 14m³h⁻¹ rotary pump, H600C and H1000C used with 14m³h⁻¹ rotary pump, H2000C used with 30m³h⁻¹ rotary pump.

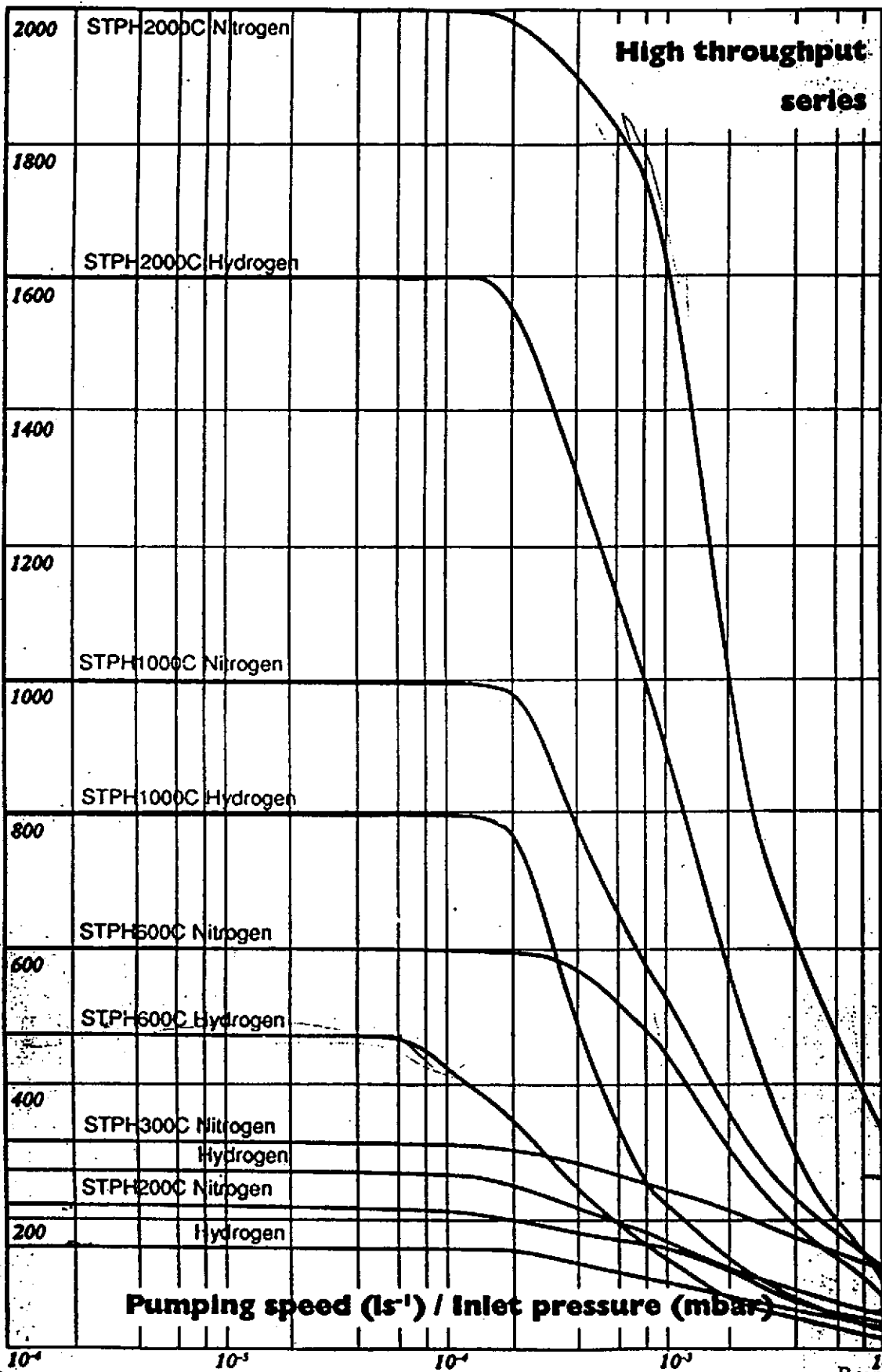

Revision: 2

Doc no: V049-1-007

Page 11 of 13

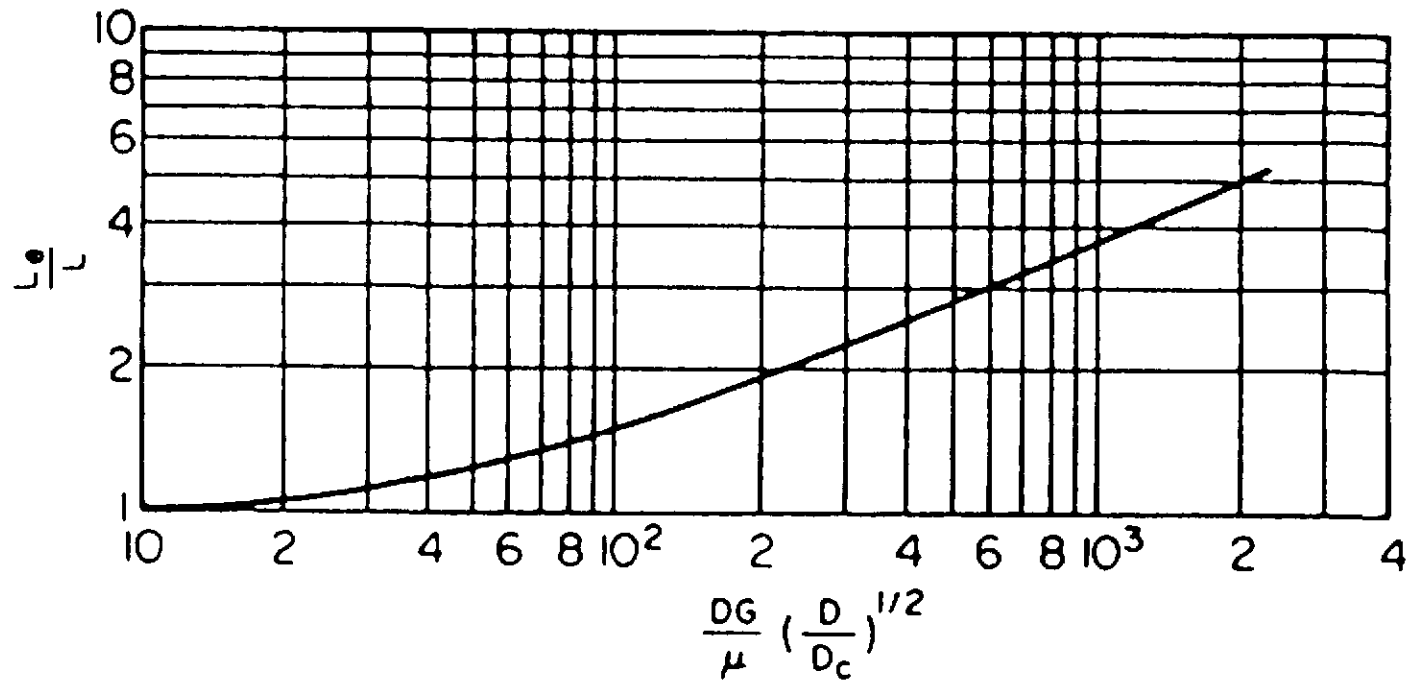

FIG. 5-46 Equivalent length for curved pipe in laminar flow. $L_e/L = 1$ for $(DG/\mu)(D/D_c)^{1/2} < 10$ [White, Proc R Soc (London), A123, 645 (1929)]

Table 8.1. Conductance equations for vacuum systems. μ = gas viscosity, P = mean pressure, g = conversion factor in Newton's Law, R_u = universal gas constant, M = molecular weight, γ = specific heat ratio, L = tube length, D = tube diameter

Element	Sketch of Element	Flow Regime																																													
		Continuum (Laminar Flow)	Free Molecular																																												
1. Long tube, $L/D > 30$		$C = \frac{\pi D^3 g P}{12 \mu L}$	$C = \left(\frac{\pi g R_u T}{18 M} \right)^{1/2} \frac{D^3}{L}$																																												
2. Short tube, $L/D < 30$ D_1 = larger diameter D_2 = smaller diameter	Same as (1)	$C = \frac{\pi D^3 g P}{12 \mu L} \left(1 + \frac{m}{22 \mu L} \right)^{-1}$	$C = \frac{(\pi g R_u T / 18 M)^{1/2} D^3}{L/D + (8/3) [1 - (D_2/D_1)^2]}$																																												
3. Orifice or aperture D_1 = tube diameter D_2 = orifice diameter $r_o = P_2/P_1$		$C = K D^3 \left[\frac{\gamma^2 g R_u T_1}{8(\gamma - 1) M} \right]^{1/2}$ (a) For $r_o \geq [2(\gamma + 1)]^{1/(\gamma - 1)}$ $K = \frac{1 - r_o^{2(\gamma - 1)}}{r_o^{2\gamma} (1 - r_o^2)}$ (b) For $r_o < [2(\gamma + 1)]^{1/(\gamma - 1)}$ $K = \frac{[(\gamma - 1)(\gamma + 1)]^{1/2}}{[2(\gamma + 1)]^{(\gamma - 1)/2} (1 - r_o^2)}$	$C = \frac{(\pi g R_u T / 32 M)^{1/2} D^2}{1 - (D_2/D_1)^2}$																																												
4. Annular flow passage D_1 = larger diameter D_2 = smaller diameter		$C = \frac{\pi g P}{12 \mu L} \left[(D_1^3 - D_2^3) - \frac{(D_1^2 - D_2^2)^2}{\ln(D_1/D_2)} \right]$	$C = \left(\frac{\pi g R_u T}{18 M} \right)^{1/2} \frac{(D_1 - D_2)(D_1 + D_2) K}{L + (8/3)(D_1 - D_2)}$ where K is given as follows: <table border="1"> <tr> <td>D_2/D_1</td> <td>0</td> <td>0.259</td> <td>0.500</td> </tr> <tr> <td>K</td> <td>1</td> <td>1.072</td> <td>1.154</td> </tr> </table> <table border="1"> <tr> <td>D_2/D_1</td> <td>0.707</td> <td>0.866</td> <td>0.966</td> </tr> <tr> <td>K</td> <td>1.234</td> <td>1.430</td> <td>1.675</td> </tr> </table>	D_2/D_1	0	0.259	0.500	K	1	1.072	1.154	D_2/D_1	0.707	0.866	0.966	K	1.234	1.430	1.675																												
D_2/D_1	0	0.259	0.500																																												
K	1	1.072	1.154																																												
D_2/D_1	0.707	0.866	0.966																																												
K	1.234	1.430	1.675																																												
5. Rectangular tube $a/b \leq 1$		$C = \frac{\pi g a^3 b^3 K}{87.4 \mu L}$ where K is given as follows: <table border="1"> <tr> <td>a/b</td> <td>1.00</td> <td>0.90</td> <td>0.80</td> <td>0.70</td> <td>0.60</td> </tr> <tr> <td>K</td> <td>1.00</td> <td>0.99</td> <td>0.98</td> <td>0.95</td> <td>0.90</td> </tr> <tr> <td>a/b</td> <td>0.50</td> <td>0.40</td> <td>0.30</td> <td>0.20</td> <td>0.10</td> </tr> <tr> <td>K</td> <td>0.82</td> <td>0.71</td> <td>0.58</td> <td>0.42</td> <td>0.23</td> </tr> </table>	a/b	1.00	0.90	0.80	0.70	0.60	K	1.00	0.99	0.98	0.95	0.90	a/b	0.50	0.40	0.30	0.20	0.10	K	0.82	0.71	0.58	0.42	0.23	$C = \left(\frac{32 g R_u T}{9 \pi M} \right)^{1/2} \frac{a^2 b^3 K}{(a + b)L + 8ab}$ where K is given as follows: <table border="1"> <tr> <td>a/b</td> <td>1.000</td> <td>0.667</td> <td>0.500</td> <td>0.333</td> </tr> <tr> <td>K</td> <td>1.108</td> <td>1.126</td> <td>1.151</td> <td>1.198</td> </tr> <tr> <td>a/b</td> <td>0.200</td> <td>0.125</td> <td>0.100</td> <td>0.000</td> </tr> <tr> <td>K</td> <td>1.297</td> <td>1.400</td> <td>1.444</td> <td>1.667</td> </tr> </table>	a/b	1.000	0.667	0.500	0.333	K	1.108	1.126	1.151	1.198	a/b	0.200	0.125	0.100	0.000	K	1.297	1.400	1.444	1.667
a/b	1.00	0.90	0.80	0.70	0.60																																										
K	1.00	0.99	0.98	0.95	0.90																																										
a/b	0.50	0.40	0.30	0.20	0.10																																										
K	0.82	0.71	0.58	0.42	0.23																																										
a/b	1.000	0.667	0.500	0.333																																											
K	1.108	1.126	1.151	1.198																																											
a/b	0.200	0.125	0.100	0.000																																											
K	1.297	1.400	1.444	1.667																																											
6. 90° elbow r = mean radius		$C = \frac{\pi g K D^3}{12 \mu r}$ where K is given as follows: <table border="1"> <tr> <td>r/D</td> <td>0.000</td> <td>1.000</td> <td>2.000</td> <td>3.000</td> <td>4.000</td> </tr> <tr> <td>K</td> <td>0.017</td> <td>0.050</td> <td>0.083</td> <td>0.083</td> <td>0.073</td> </tr> <tr> <td>r/D</td> <td>6.0</td> <td>8.0</td> <td>10</td> <td>12</td> <td>14</td> </tr> <tr> <td>K</td> <td>0.056</td> <td>0.042</td> <td>0.034</td> <td>0.029</td> <td>0.026</td> </tr> </table>	r/D	0.000	1.000	2.000	3.000	4.000	K	0.017	0.050	0.083	0.083	0.073	r/D	6.0	8.0	10	12	14	K	0.056	0.042	0.034	0.029	0.026	$C = \left(\frac{2 g R_u T}{9 \pi M} \right)^{1/2} \frac{D^3}{r}$																				
r/D	0.000	1.000	2.000	3.000	4.000																																										
K	0.017	0.050	0.083	0.083	0.073																																										
r/D	6.0	8.0	10	12	14																																										
K	0.056	0.042	0.034	0.029	0.026																																										

$$\Delta P = \frac{P \cdot \dot{V}}{C} \quad [Pa]$$

PROCESS SYSTEMS INTERNATIONAL, INC.					ENGINEERING	NO: V049-1-044
WESTBOROUGH, MA					CALCULATIONS	PAGE 1 OF 5
REV	DEO#	DATE	BY:	CHECK	TITLE:	
0	0126	4/17/96	R. Than	D.W.(L)	MAIN TURBO MOLECULAR PUMP PORT 250 mm (10")	
					BY: R. THAN	DEPT: 744
PROJECT: LIGO					PROJECT NO: V59049	
<p><u>PURPOSE:</u> Determine allowable length for 250 mm (10") main turbo port, for Turbo pump STPH2000, with vibration isolator, gate valve, by-pass / gauge spool piece</p>						
<p><u>METHOD:</u> Free molecular regime: Long tube formula / short tube formula Monte Carlo simulations</p>						
<p><u>ASSUMPTIONS:</u> 1400 L/s speed for N2</p>						
<p><u>INPUTS:</u></p>						
<p><u>REFERENCE:</u> Theory and Practice of vacuum Technology, ISBN 3-528-08908-3</p>						
<p><u>CALCULATIONS:</u> see Attachments</p>						
<p><u>CONCLUSIONS:</u> A overall length of no more than 21 inches is allotted to meet the net speed of 1000 L/s for nitrogen through the 10" port. This include the nozzle, gate valve, vibration isolation spool, and by-pass/gauge spool.</p>						
<p><u>NOTES:</u></p>						

PROJECT: LIGO
PROJECT NO: V59049

BY: R. THAN
DATE: 02/08/96

TITLE: MAIN TURBO PORT, 250 mm

Pumping speed

To meet the required pumping speed of 1000 L/s for the turbo, the allowable length of the pumpout port configuration needs to be less than 21 inches.

The by-pass / gauge spool is required at the end and mid stations for roughing of the vacuum volume with the QDP80 backing pump.

Vibration isolation bellows

The allowable length for the vibration isolation bellows is about 5 inches.

6" GATE VALVE: WEIGHT: 40-65 Lbs
10" GATE VALVE: WEIGHT: 100 - 130 Lbs
BELLOWS: WEIGHT: 50 Lbs
Turbo Pump will be supported vertically to take weight off nozzles, but axially will be supported with the bellows onto nozzle / chamber wall.

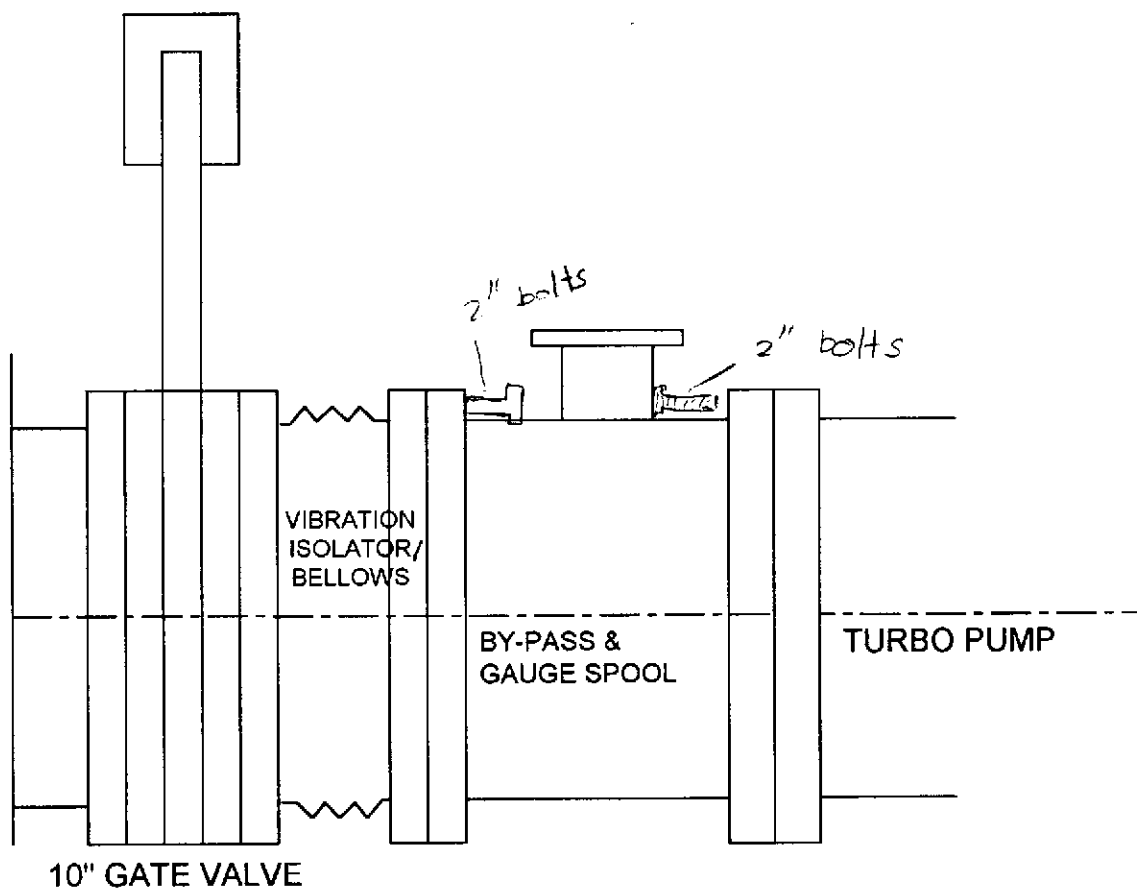

10" GATE VALVE

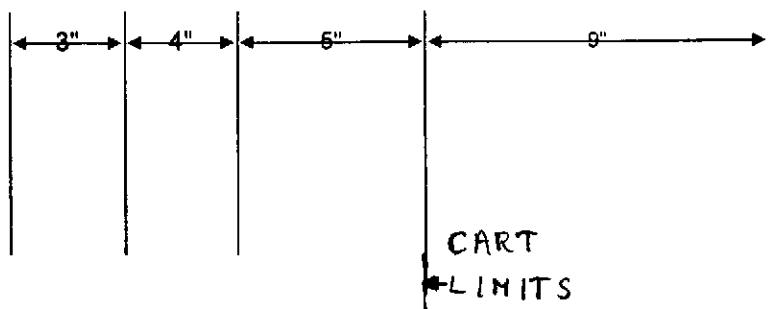

MAIN TURBO PORT 250 mm Diameter

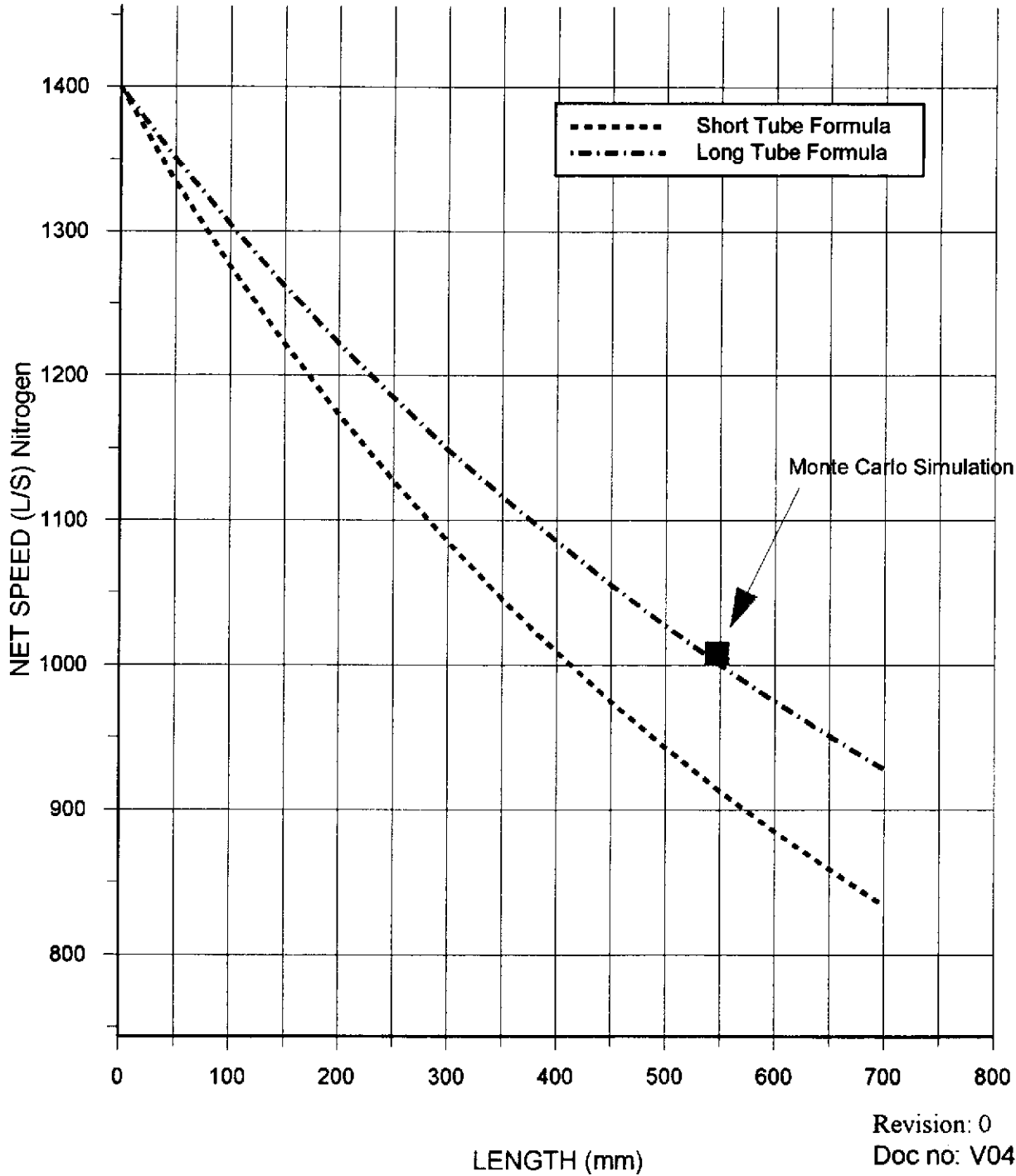

MONTE CARLO SIMULATION

TURBO PORT 250 MM DIAMETER, 550 MM LONG

ENTER NUMBER OF TRIALS 30000

	NUMBER	FRACTION	90% ERROR LIMIT
REFLECTED	24711	.8244695	3.603708E-03
CAPTURED	5261	.1755305	3.603708E-03
THROUGH	0	0	0
TOTAL TRIALS	30000		
NO CONTACT TRIALS	28		

PRINT BOUNCE TABLE ? Y/N

BOUNCES	THROUGH	CAPTURED	REFLECTED
0	0	487	0
1	0	327	7118
2	0	446	3693
3	0	440	2364
4	0	429	1861
5	0	381	1378
6	0	328	1129
7	0	295	949
8	0	255	809
9	0	226	713
10	0	202	577
11	0	178	529
12	0	171	462
13	0	128	413
14	0	130	319
15	0	100	311
16	0	92	244
17	0	94	235
18	0	73	224
19	0	66	179
20	0	54	166
21	0	41	155
22	0	32	92
23	0	28	109
24	0	41	87
25	0	34	80
26	0	20	77
27	0	20	58
28	0	20	39
29	0	13	38
30	0	14	44
31	0	11	32
32	0	8	31
33	0	8	19
34	0	4	25
35	0	10	24
36	0	10	20
37	0	0	7
38	0	2	13
39	0	8	11
40	0	4	14

BOUNCES	THROUGH	CAPTURED	REFLECTED
41	0	0	6
42	0	3	5
43	0	2	8
44	0	3	5
45	0	5	10
46	0	0	3
47	0	3	6
48	0	5	3
49 +	0	10	17

RUN TIME 0 6.555338

TURBO NITROGEN SPEED : 1400 L/S

PUMP CAPTURE FRACTION : 0.243

VOLUMETRIC SPEED : 5773 L/S

NET CAPTURE FRACTION : 0.1755

NET SPEED : 1013 L/S

PROCESS SYSTEMS INTERNATIONAL, INC.					ENGINEERING	NO: V049-1-078
WESTBOROUGH, MA					CALCULATIONS	PAGE 1 OF 49
REV	DEO#	DATE	BY:	CHECK	TITLE: STATIONS PUMPDOWN & ULTIMATE PRESSURES	
0	133	04/22/96	R. Than	D. Miller		
					BY: R. THAN	DEPT: 744
PROJECT: LIGO					PROJECT NO: V59049	

PURPOSE:

Pumpdown of the End Station
Pumpdown of the Mid Station
Pumpdown of Vertex & Beam manifold isolatable section WA Corner station
Pumpdown of Vertex isolatable section WA Corner station with only 1 roughing and 1 main turbo system.
Pumpdown of Vertex & Beam manifold isolatable section LA Corner station
with selected vacuum system.

METHOD:

Computer simulation
Standard calcs

ASSUMPTIONS:

See calculations

INPUTS:

REFERENCE: See page 9

CALCULATIONS: see Attachments

CONCLUSIONS: Pumpdown of stations isolatable sections to a total pressure of less than 2×10^{-8} Torr

NOTES:

PROJECT: LIGO BY: R.THAN DEPT: 744

PROJECT NO: V59049 DATE:

TITLE: PUMPDOWN & ULTIMATE PRESSURES

PRESSURE MEASUREMENT

Partial pressure of gasses will vary depending where the pressure gauge / RGA is located relative to the pumps. Partial pressures will be measured at the ion pumps. Because the attainable partial pressure of water is based on the pumping speed of water at the cryopump, the partial pressure of water at other locations will be higher. Thus measurement of the partial pressure of water at the ion pumps may not be representative of the outgassing rates for water. Rather measurements at two locations one at the ion pumps and one at the cryopump is recommended.

OUTGASSING RATES

Outgassing from Viton O-rings

The available data on outgassing of unbaked and baked O-ring material is limited.

The following table contains selected outgassing data for Viton-A from W.G. Perkins' "Permeation and Outgassing of Vacuum Materials," *Journal of Vacuum Science & Technology*, Vol. 10, No.4, 1973. Outgassing experiments were also done by L. de Csernatony with o-rings in their grooves and outside their grooves, see article: L. de Csernatony, "The properties of Viton "A" elastomers III", *Vacuum*, Vol. 16, No.5, 1967.

	Pumpdown time hours	Outgassing Rate Torr-L/s-cm ²	Dominant Species
Unbaked samples			
Unbaked Pumpdown Viton-A	51	1 X 10 ⁻⁷	H ₂ O, H ₂ , O ₂ , N ₂
Baked Pumpdown (200 °C) Viton-A	24	20 X 10 ⁻¹⁰	H ₂ O

	Pumpdown time hours	Outgassing Rate Torr-L/s-cm ²	Dominant Species
Pre-baked samples air-exposed for 0.5 hr			
Unbaked pumpdown Viton-A	5	1.5 X 10 ⁻⁸	H ₂ O
Baked Pumpdown (200 °C) Viton-A	12	1 X 10 ⁻¹⁰	H ₂ O

PROJECT: LIGO BY: R.THAN DEPT: 744

PROJECT NO: V59049 DATE:

TITLE: PUMPDOWN & ULTIMATE PRESSURES

The total outgassing rate of a Viton o-ring can be reduced to 1×10^{-10} Torr-L/s-cm² through baking under vacuum. Since the vacuum system needs to be re-opened, the total outgassing rate will vary depending on the amount of time the o-ring is re-exposed to air. The outgassing of a baked Viton o-ring which has been re-exposed to normal air will be dominated by water. Since the vacuum system is purged with dry air when open for service, the re-adsorption of moisture can be minimized; however the readsorption of other gasses will be dictated by exposure time. For short exposure times to air, the amount of gases other than water that are readsorbed is minimal. Water outgassing dominates for short exposure times, such as 0.5 hour. However, since in practice the O-rings are re-exposed to air for a longer period than 0.5 hour, the actual amount of gasses readsorbed can only be determined from further experiments.

If re-exposure is limited to a short time the outgassing rate of a baked O-ring will be about 1.5×10^{-8} Torr-L/s-cm², mostly water, after 5 hours. Assuming the outgassing is dictated by diffusion, i.e. the decay behaves as function of time to the -0.5 power, the outgassing rate for water will be about 3×10^{-9} Torr-L/s-cm² after 100 hours of pumping. Since the outgassing rate for short term re-exposure is dominated by water, assuming that the total outgassing rate for the other gasses is no more than 10% of that of water, the outgassing rate of the other gasses will be approximately 3×10^{-10} Torr-L/s-cm².

L. de Csernatony (Ref.13,14) experiments with baked o-ring without re-exposure gives a rate of 2×10^{-10} Torr-L/s-cm² after 25 hours for an o-ring in the chamber and 8×10^{-9} Torr-L/s-cm² after 25 hours with the o-ring in the groove.

The o-ring grooves are designed with vents to vent the trap volume in the o-ring groove. This will prevent the outgassing of the o-ring to retard and allow the outgassing rate to approach that of an o-ring inside a chamber.

PROJECT: LIGO BY: R.THAN DEPT: 744

PROJECT NO: V59049 DATE: _____

TITLE: PUMPDOWN & ULTIMATE PRESSURES

Outgassing from Stainless Steel.

Various sources provide data on outgassing of hydrogen from stainless steel for unbaked and baked specimens.

G.Moraw and R. Dobrozemsky report a total outgassing rate of about 8×10^{-12} Torr-L/s-cm² after a 20-hour vacuum bakeout at 100 °C, with H₂ dominating at a rate of 7×10^{-12} Torr-L/s-cm², and CO outgassing at a rate of less than 4×10^{-13} Torr-L/s-cm², and CO₂, CH₄, and water each at less than 1×10^{-13} Torr-L/s-cm².

Calder and Lewin report a total outgassing rate of 1.4×10^{-11} Torr-L/s-cm² after 40 hours of pumping for a specimen bake in vacuum at 350 °C for 2 days and re-expose to air for 3 hours.

Barton and Govier report a total outgassing of 7×10^{-12} Torr-L/s-cm² after a 100 hours of pumping for a specimen that has been prebaked in vacuum at 400°C and re-exposed to air for 24 hours with water being the predominant outgassing specie.

For an unbaked vapor degreased specimen the total outgassing rate was about 1×10^{-11} Torr-L/s-cm² after 100 hours of pumping, with water being the predominant outgassing specie. Partial pressure measurements after 70 hours indicated that about 60% was water and about 30% CO and CO₂.

Dylla et al. report outgassing rates of between 6×10^{-11} to 1×10^{-11} Torr-L/s-cm² after 100 hours of pumping for specimens baked at 150 °C for 48 hours and re-exposed to air. The predicted decay and outgassing rates at the end of 100 hours vary depending on exposure time to air, and dew point of the air. Analysis of species after 100 minutes into pumpdown indicates that the outgassing rate is dominated by water, with CO, CO₂, and CH₄ contributing less than 10% to the outgassing rate (5%,3%, and 2% respectively).

S. Rezaie-Serej and R.A. Outlaw report for a baked stainless steel specimen the amount of hydrogen desorbed is about 38 times the amount of CO desorbed. No outgassing rates were given.

Okamura, Miyauchi, and Hisatsugu report a total outgassing rate approaching 5×10^{-13} Torr-L/s-cm² for finely polished stainless steel surface and a 1×10^{-12} Torr-L/s-cm² for a standard electropolished surface after 100 hours of pumping preceded by an 80-hour vacuum bake-out at 250 °C. H₂ dominates with water being the next dominant specie, and with CO and CO₂ contributing less than 20% to the outgassing rate. (2×10^{-13} Torr-L/s-cm²).

Santeler predicts an outgassing rate of stainless steel based on a diffusion model of about 2×10^{-11} Torr-L/s-cm², with a 200 hour, 150 °C bake, and 6×10^{-12} Torr-L/s-cm², with a 20 hour, 250 °C bake.

PROJECT: LIGO BY: R.THAN DEPT: 744

PROJECT NO: V59049 DATE: _____

TITLE: PUMPDOWN & ULTIMATE PRESSURES

Outgassing rates:

Stainless steel

H2: 1.0×10^{-11} Torr-L/s-cm²

H2O:

Re-exposure to air	
Time	Q
min.	Torr-L/s-cm ²
10	7×10^{-8}
100	5×10^{-9}
1000	3.5×10^{-10}
1440	2.4×10^{-10}
6000	5×10^{-11}

No Re-exposure	
Time	Q
min.	Torr-L/s-cm ²
10	2.8×10^{-9}
100	5.6×10^{-10}
1000	1.1×10^{-10}
1440	8.6×10^{-11}
6000	3.0×10^{-11}

Other gasses: 10% of water rate.

Viton:

H2O:

Short Re-exposure to air. (Ref.1)	
Time	Q
min.	Torr-L/s-cm ²
300	1.5×10^{-8}
6000	3×10^{-9}

No Re-exposure (Ref.1)	
Time	Q
min.	Torr-L/s-cm ²
720	1×10^{-10}
6000	4×10^{-11}

Other gasses: 10% of water rate.

PROJECT: LIGO BY: R.THAN DEPT: 744

PROJECT NO: V59049 DATE: _____

TITLE: PUMPDOWN & ULTIMATE PRESSURES

END STATION / MID STATION PUMPDOWN

Pumpdown of the End station section using one the QDP80 dry pump set, and one main turbomolecular pump and 1 Main ion pump.

Roughing pump

The QDP80 pump is used to rough down the end or mid stations. It also serves as the backing pump to the main turbo: STPH2000.

Turbo pump

The main turbo, STPH2000, is turned on when a pressure of 1 mbar has been reached using the QDP80. The bypass is closed across the turbo pump and the turbo pump starts pumping. The STPH2000 is a wide range turbo which has a drag stage to pump at high inlet pressures. The backing pump of the main turbo is located in the mechanical room.

Main Ion pump

The main ion pump is a 2500 L/s (N2) Varian Ion Pump with a 350 mm inlet tube, which can be isolated by a 350 mm (14 inch) gate valve. The End Station and Mid Station are each equipped with one Main ion pump.

PROJECT: LIGO BY: R.THAN DEPT: 744

PROJECT NO: V59049 DATE: _____

TITLE: PUMPDOWN & ULTIMATE PRESSURES

CORNER STATION PUMPDOWN

Pumpdown of the corner station sections is accomplished using two the EDP200/EH2600 dry pump set, and two main turbomolecular pump and several Main ion pumps.

WA CORNER STATION

The WA corner station has two roughing cart sets, two turbomolecular pump sets, and 8 main ion pumps. 4 Main ion pumps are on the Vertex section, one each on the beam manifold sections, and two on the diagonal (offset) section.

LA CORNER STATION

The LA corner station has two roughing cart sets, two turbomolecular pump sets, and 4 main ion pumps. 4 Main ion pumps are on the Vertex section.

Roughing pump

The roughing system is separated in two skids. The EDP200 is located in the mechanical room, and the EH2600 Roots blower is move around the detector building. Two 6 inch headers runs in the detector building back to the mechanical room.

Turbo pump

The main turbo, STPH2000C, is turned on when a pressure of 0.1 Torr has been reached. The backing pump of the main turbo is located in the mechanical room.

Main Ion pump

The main ion pump is a 2500 L/s (N2) Varian Ion Pump with a 350 mm inlet tube, which can be isolated by a 350 mm (14 inch) gate valve.

PROJECT: LIGO BY: R.THAN DEPT: 744

PROJECT NO: V59049 DATE:

TITLE: PUMPDOWN & ULTIMATE PRESSURES

Pumpdown curves:

END STATION PUMPDOWN

Figure V049-1-078-1a: 0-100 hours

Figure V049-1-078-1b 0-32 hours

MID STATION PUMPDOWN

Figure V049-1-078-2a 0-100 hours

Figure V049-1-078-2b 0-32 hours

WA. CORNER STATION PUMPDOWN

Figure V049-1-078-3a 0-100 hours

Figure V049-1-078-3b 0-32 hours

LA. CORNER STATION PUMPDOWN

Figure V049-1-078-4a 0-100 hours

Figure V049-1-078-4b 0-32 hours

WA. VERTEX ISOLATABLE SECTION, CORNER STATION PUMPDOWN

Figure V049-1-078-5 0-24 hours

PROJECT: LIGO BY: R.THAN DEPT: 744

PROJECT NO: V59049 DATE: _____

TITLE: PUMPDOWN & ULTIMATE PRESSURES

References

1. W.G. Perkins' "Permeation and Outgassing of Vacuum Materials," *Journal of Vacuum Science & Technology*, Vol. 10, No.4, 1973.
2. R.S. Barton and R.P. Govier. "The effect of cleaning technique on the outgassing rate of 18/9/1 stainless steel," *Vacuum* , Vol. 20, No.1, 1970.
3. G. Moraw and R. Dobrozemsky, "Attainment of outgassing rates below 10^{-13} Torr-liters/sec-cm² for Aluminum and stainless steel after bakeout at moderate temperatures," *Proceedings 6th International Vacuum Congress*, 1974.
4. H.F. Dylla, D.M. Manos, P.H. LaMarche, "Correlation of outgassing of stainless steel and aluminum with various surface treatments." *Journal of Vacuum Science & Technology*, Vol. A11, No.5, 1993.
5. M. Li and H.F. Dylla, "Model for outgassing from metal surfaces II." *Journal of Vacuum Science & Technology*, Vol. A12, No.4, 1994.
6. S. Okamura, E. Miyauchi, and T. Hisatsugu, "Outgassing measurements of finely polished stainless steel." *Journal of Vacuum Science & Technology*, Vol. A 9, No.4, 1991.
7. R. Calder and G. Lewin, " Reduction of stainless steel outgassing in ultra-high vacuum," *Journal of Applied Physics*, Vol 18, 1967.
8. D. J. Santeler, " Estimating the gas partial pressure due to diffusive outgassing" *Journal of Vacuum Science & Technology*, Vol. A10, No.4, 1992.
9. D. Wu, R.M.Stephens, R.A. Outlaw, and P. Hopson, "An Auger Electron Spectroscopy Study of Surface-Preparation Contaminants", *NASA Technical Paper 2972*, Feb. 1990
10. S. Rezaie-Serej, R.A. Outlaw, "Thermal desorption of CO and H₂ from degassed 304 and 347 stainless steel", *Journal of Vacuum Science & Technology*, Vol. A12, No.5, 1994.
11. J.D Herbert, A.E. Groome, "Study of cleaning agents for stainless steel for ultrahigh vacuum use", *Journal of Vacuum Science & Technology*, Vol. A12, No.4, 1994.
12. B.C Moore, "Recombination limited outgassing of stainless steel", *Journal of Vacuum Science & Technology*, Vol. A13, No.3, 1995, pp. 545-548
13. L. de Csernatony, "The properties of Viton "A" elastomers II", *Vacuum* , Vol. 16, No.3, 1966.

PROJECT: LIGO BY: R.THAN

PROJECT NO: V59049 DATE:

TITLE: FIGURE V049-1-078-1a, END STATION PUMPDOWN

STEEL AREA: 119 m², Volume: 56 m³, H₂=1X10⁻¹¹ Torr-L/s-cm², H₂O=1X10⁻⁶t^{-1.15}, t=min, OTHER GASSES: 10%

VITON AREA: 0.77m², Baked, re-exposed to air 0.5 hr, 100 hr: H₂O=3X10⁻⁹ Torr-L/s-cm², OTHER GASSES=3X10⁻¹⁰ Torr-L/s-cm²

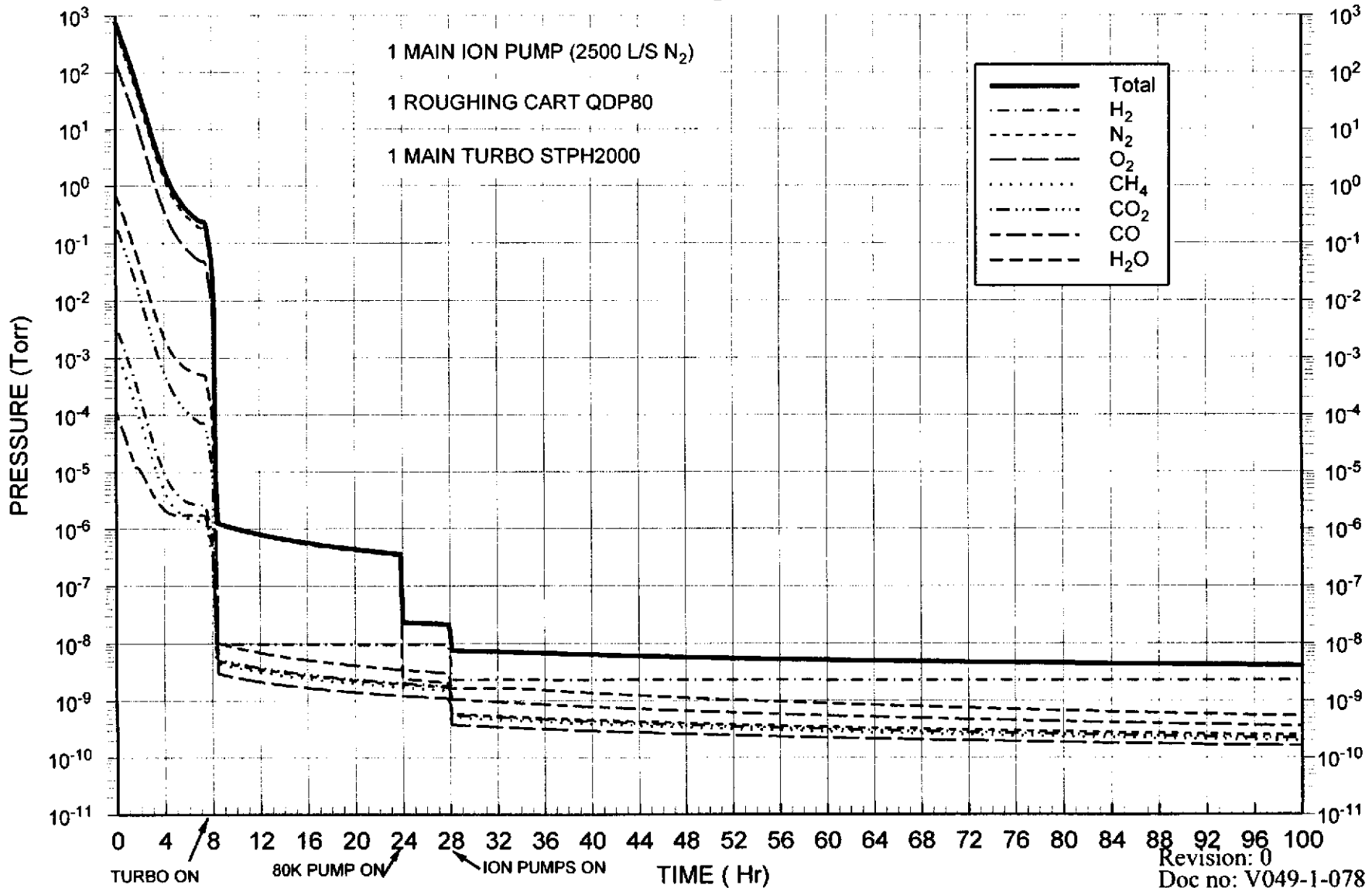

PROJECT: LIGO BY: R.THAN
 PROJECT NO: V59049 DATE:
 TITLE: FIGURE V049-1-078-1b, END STATION PUMPDOWN

STEEL AREA: 119 m², Volume: 56 m³, H₂=1X10⁻¹¹ Torr-L/s-cm², H₂O=1X10^{-6+t-1.15}, t=min, OTHER GASSES: 10%

VITON AREA: 0.77m², Baked, re-exposed to air 0.5 hr, 100 hr: H₂O=3X10⁻⁹ Torr-L/s-cm², OTHER GASSES=3X10⁻¹⁰ Torr-L/s-cm²

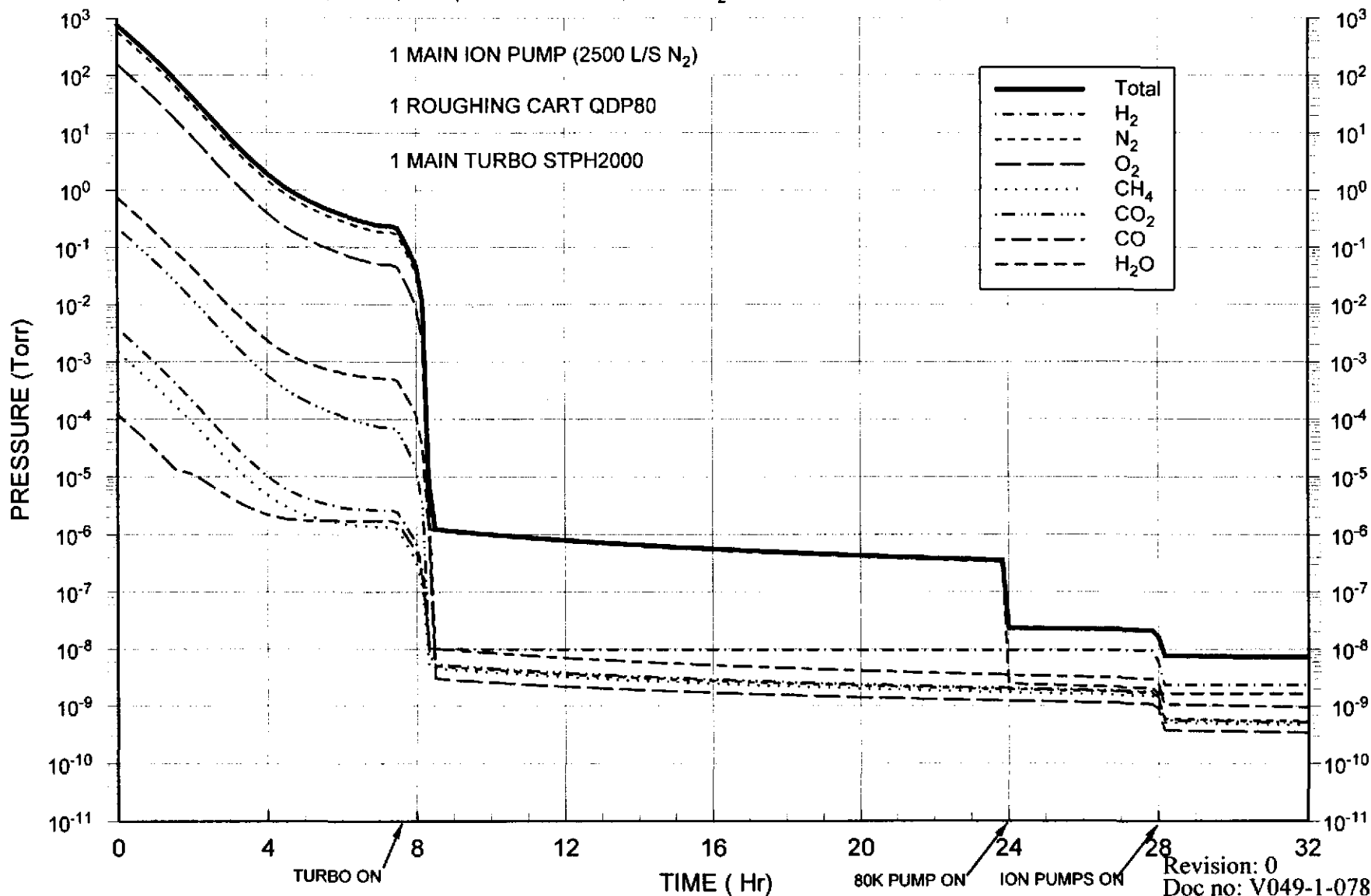

PROJECT: LIGO BY: R.THAN

PROJECT NO: V59049 DATE:

TITLE:FIGURE V049-1-078-2a, MID STATION PUMPDOWN

STEEL AREA: 162 m², Volume: 72 m³, H₂=1X10⁻¹¹ Torr-L/s-cm², H₂O=1X10⁻⁶*t^{-1.15}, t=min, OTHER GASSES: 10%

VITON AREA: 1.17m², Baked, re-exposed to air 0.5 hr, 100 hr: H₂O=3X10⁻⁹ Torr-L/s-cm², OTHER GASSES=3X10⁻¹⁰ Torr-L/s-cm²

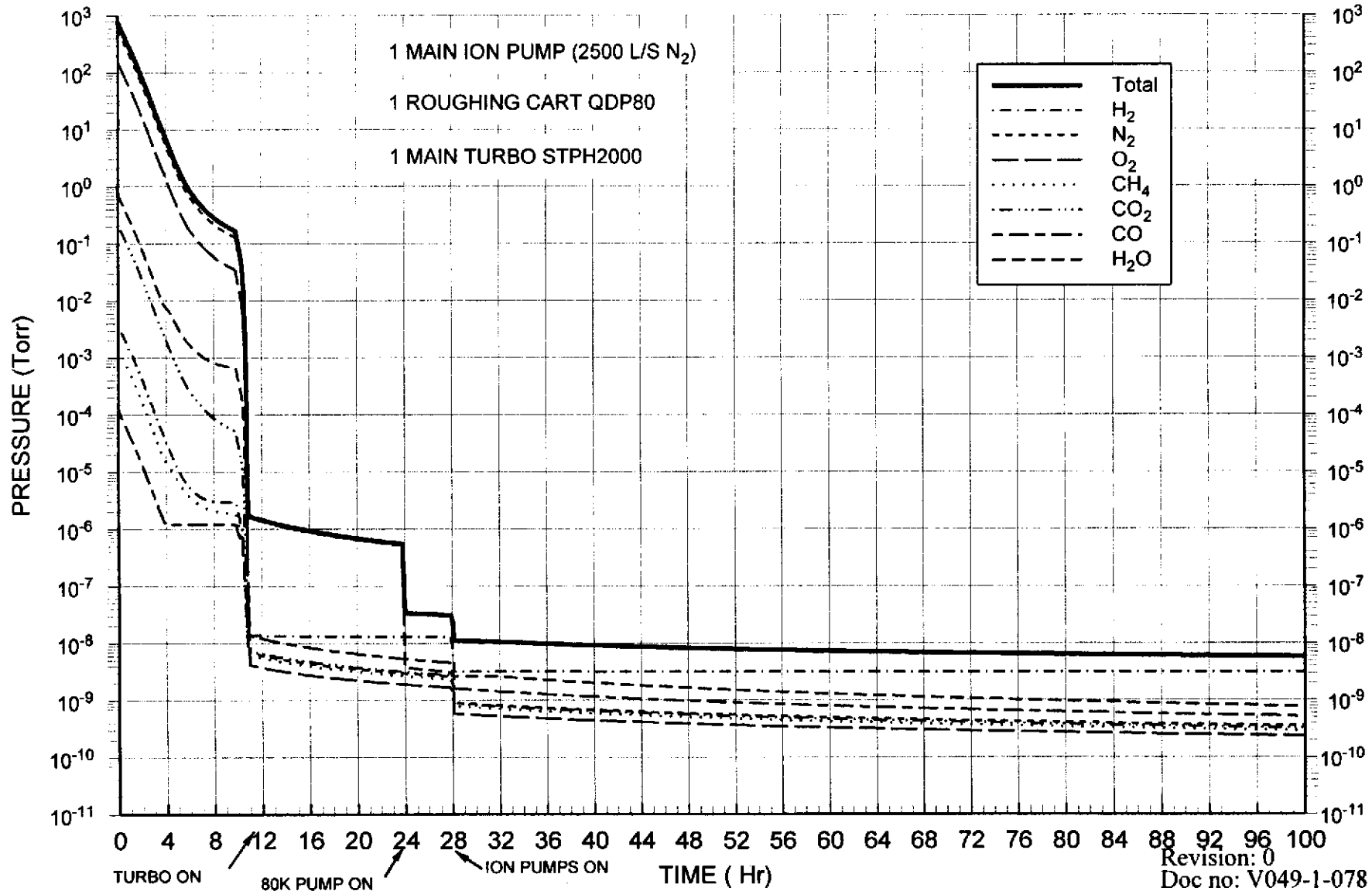

PROJECT: LIGO BY: R.THAN

PROJECT NO: V59049 DATE:

TITLE: FIGURE V049-1-078-2b, MID STATION PUMPDOWN

STEEL AREA: 162 m², Volume: 72 m³, H₂=1X10⁻¹¹ Torr-L/s-cm², H₂O=1X10⁻⁶t^{-1.15}, t=min, OTHER GASSES: 10%

VITON AREA: 1.17m², Baked, re-exposed to air 0.5 hr, 100 hr: H₂O=3X10⁻⁹ Torr-L/s-cm², OTHER GASSES=3X10⁻¹⁰ Torr-L/s-cm²

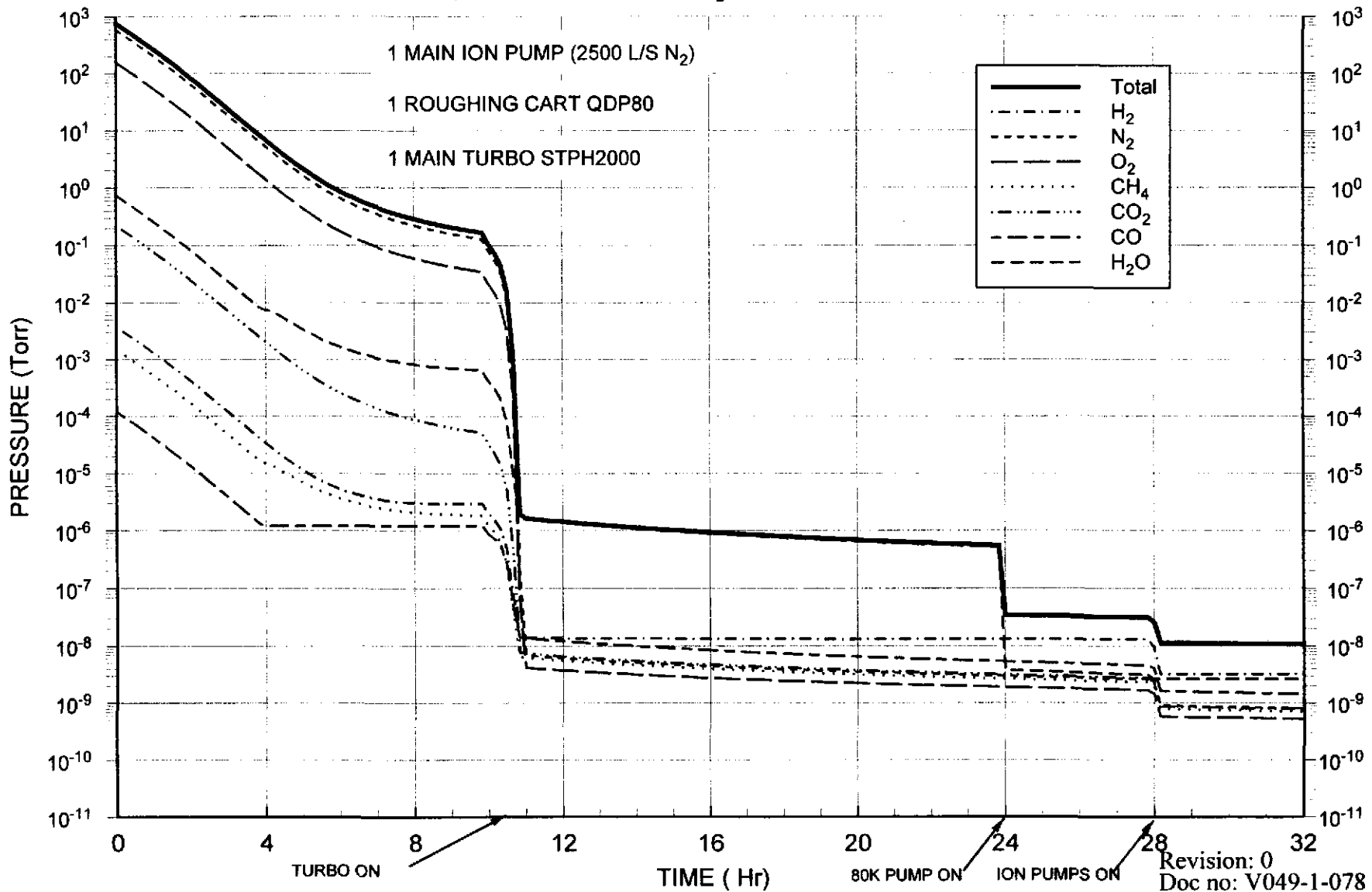

PROJECT: LIGO BY: R.THAN

PROJECT NO: V59049 DATE:

TITLE: FIGURE V049-1-078-3a, VERTEX & BEAM MANIFOLD-CORNER STATION PUMPDOWN, WA

STEEL AREA: 732 m², Volume: 316 m³, H₂=1X10⁻¹¹ Torr-L/s-cm², H₂O=1X10⁻⁶*t^{-1.15}, t=min, OTHER GASSES: 10%

VITON AREA: 3.7m², Baked, re-exposed to air 0.5 hr, 100 hr: H₂O=3X10⁻⁹ Torr-L/s-cm², OTHER GASSES=3X10⁻¹⁰ Torr-L/s-cm²

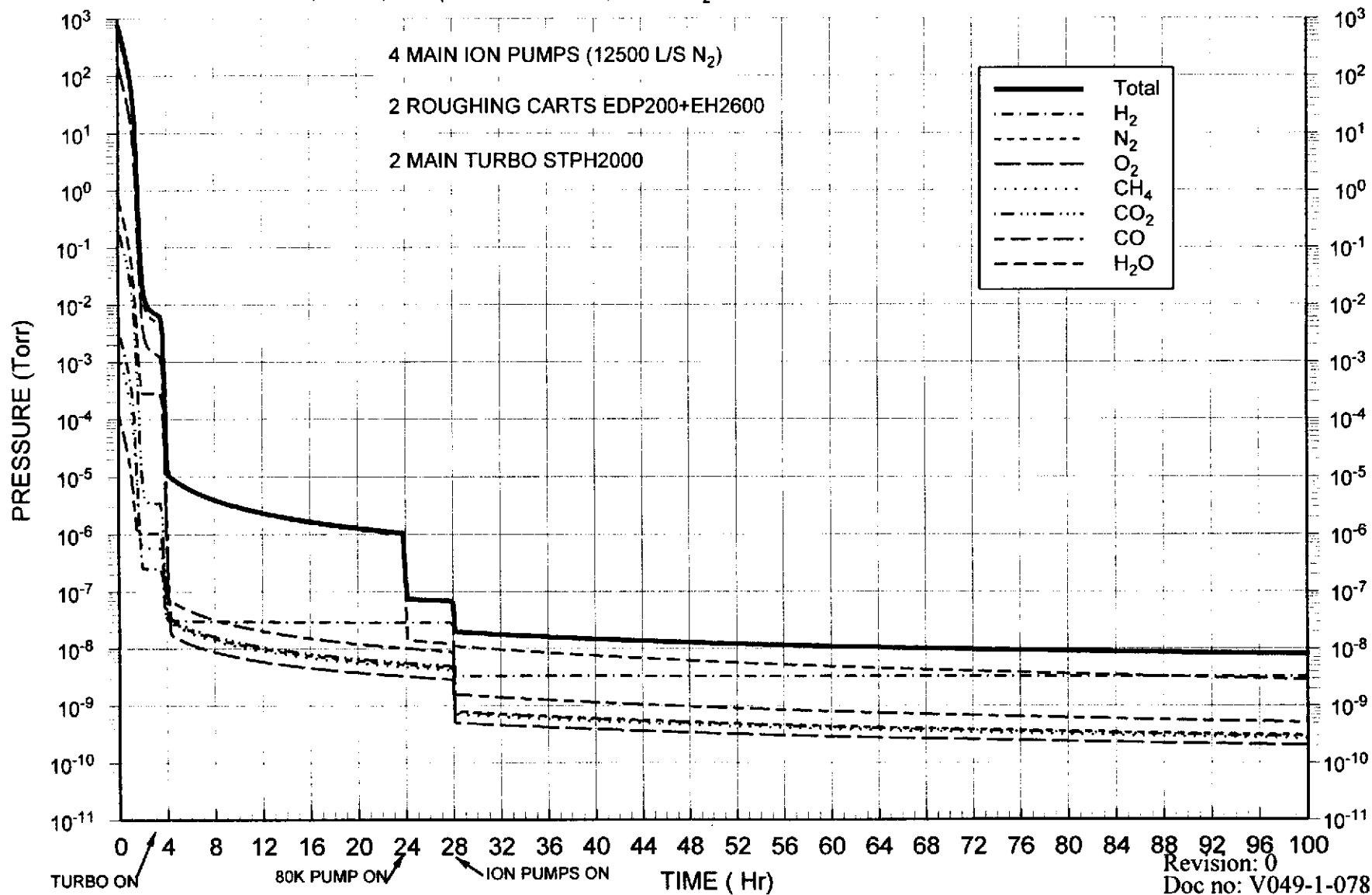

PROJECT: LIGO BY: R.THAN

PROJECT NO: V59049 DATE:

TITLE: FIGURE V049-1-078-3b, VERTEX & BEAMMANIFOLD-CORNER STATION PUMPDOWN, WA

STEEL AREA: 732 m², Volume: 316 m³, H₂=1X10⁻¹¹ Torr-L/s-cm², H₂O=1X10⁻⁶*t^{-1.15}, t=min, OTHER GASSES: 10%

VITON AREA: 3.7m², Baked, re-exposed to air 0.5 hr, 100 hr: H₂O=3X10⁻⁹ Torr-L/s-cm², OTHER GASSES=3X10⁻¹⁰ Torr-L/s-cm²

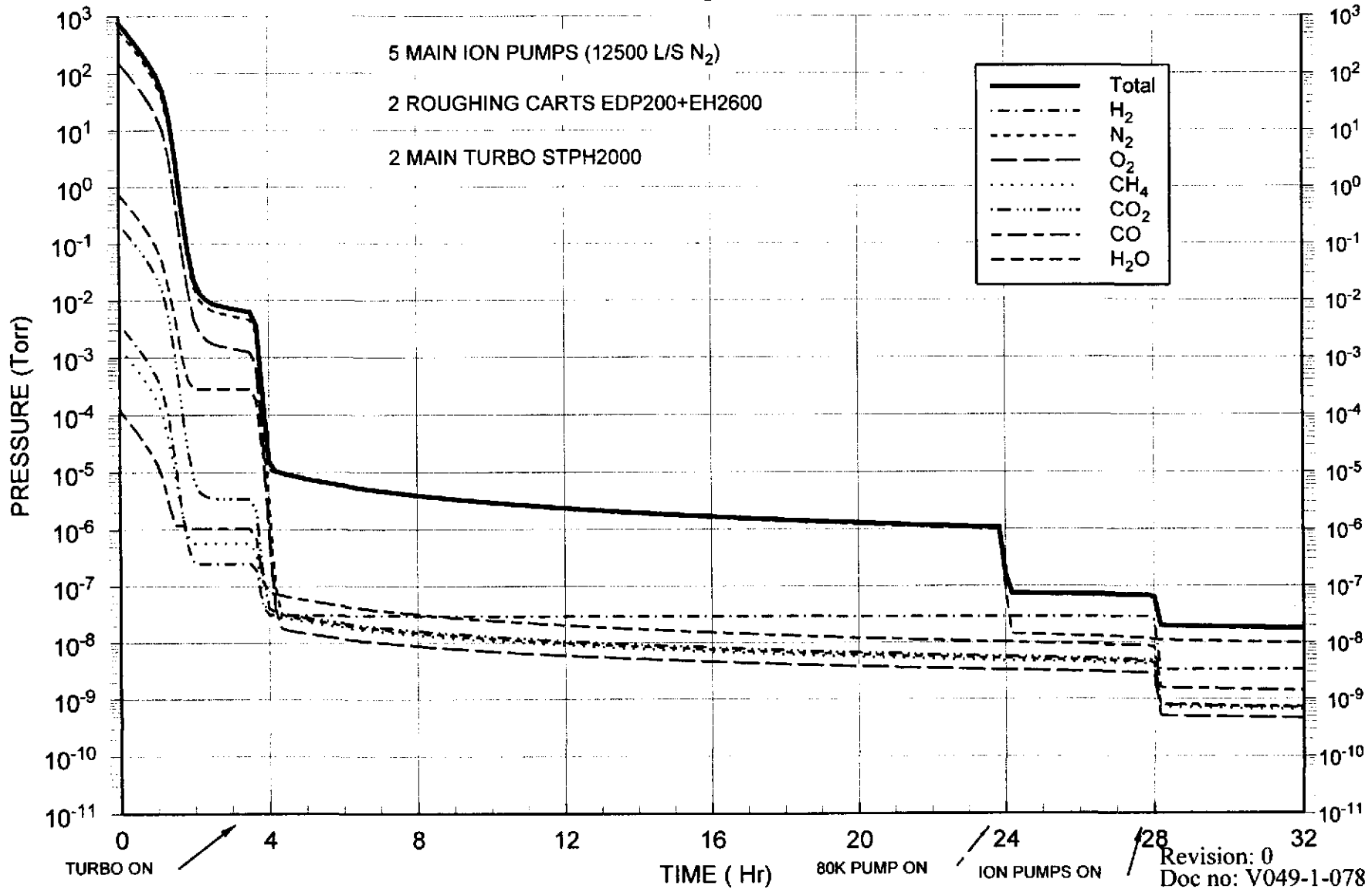

PROJECT: LIGO BY: R.THAN

PROJECT NO: V59049 DATE:

TITLE:FIGURE V049-1-078-4a, VERTEX & BEAM MANIFOLD-CORNER STATION PUMPDOWN, LA

STEEL AREA: 695 m², Volume: 298 m³, H₂=1X10⁻¹¹ Torr-L/s-cm², H₂O=1X10⁻⁶*t^{1.15}, t=min, OTHER GASSES: 10%

VITON AREA: 3.7m², Baked, re-exposed to air 0.5 hr, 100 hr: H₂O=3X10⁻⁹ Torr-L/s-cm², OTHER GASSES=3X10⁻¹⁰ Torr-L/s-cm²

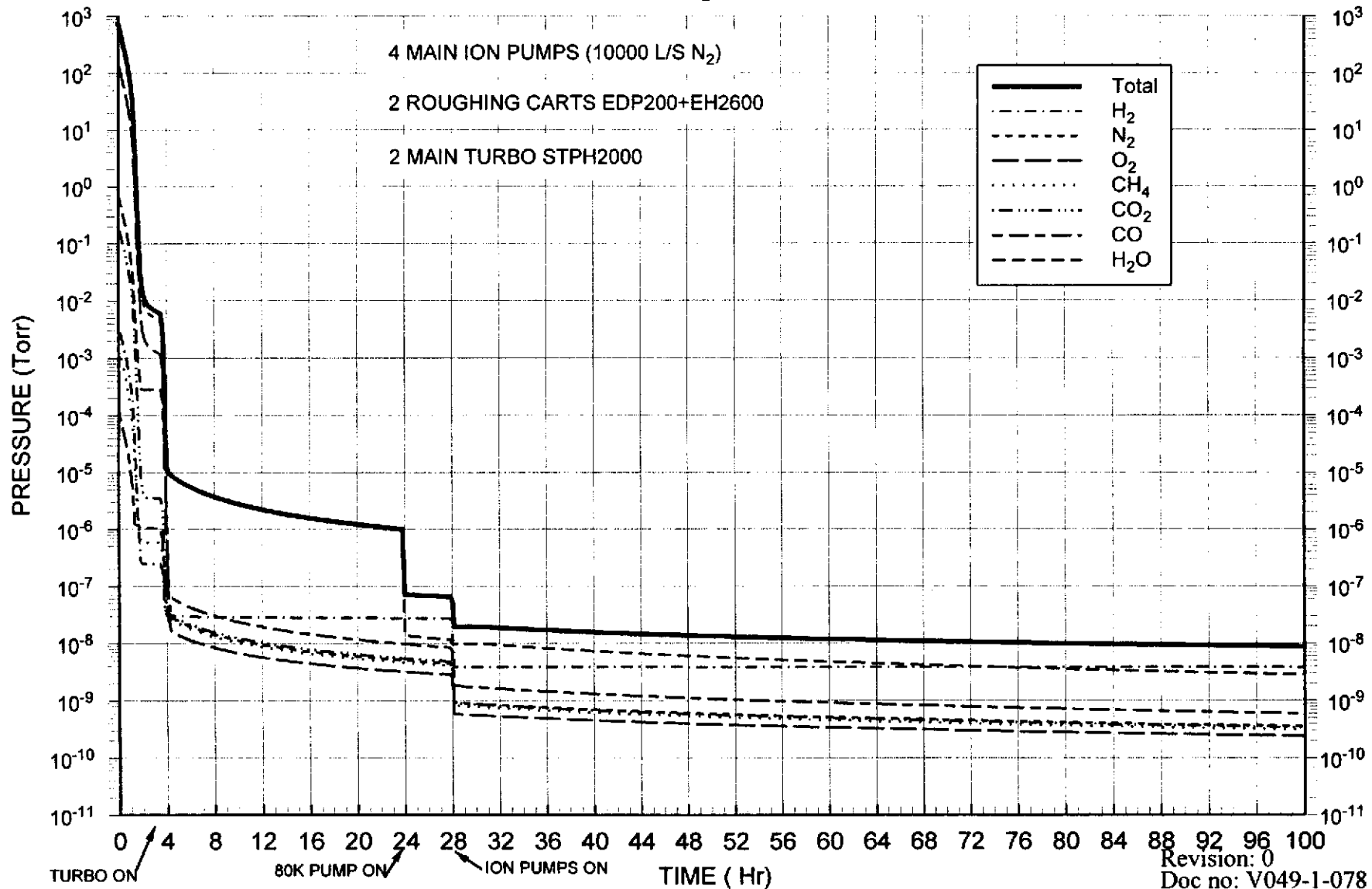

PROJECT: LIGO BY: R.THAN

PROJECT NO: V59049 DATE:

TITLE: FIGURE V049-1-078-4b, VERTEX & BEAMMANIFOLD-CORNER STATION PUMPDOWN, LA

STEEL AREA: 695 m², Volume: 298 m³, H₂=1X10⁻¹¹ Torr-L/s-cm², H₂O=1X10⁻⁶*t^{1.15}, t=min, OTHER GASSES: 10%

VITON AREA: 3.7m², Baked, re-exposed to air 0.5 hr, 100 hr: H₂O=3X10⁻⁹ Torr-L/s-cm², OTHER GASSES=3X10⁻¹⁰ Torr-L/s-cm²

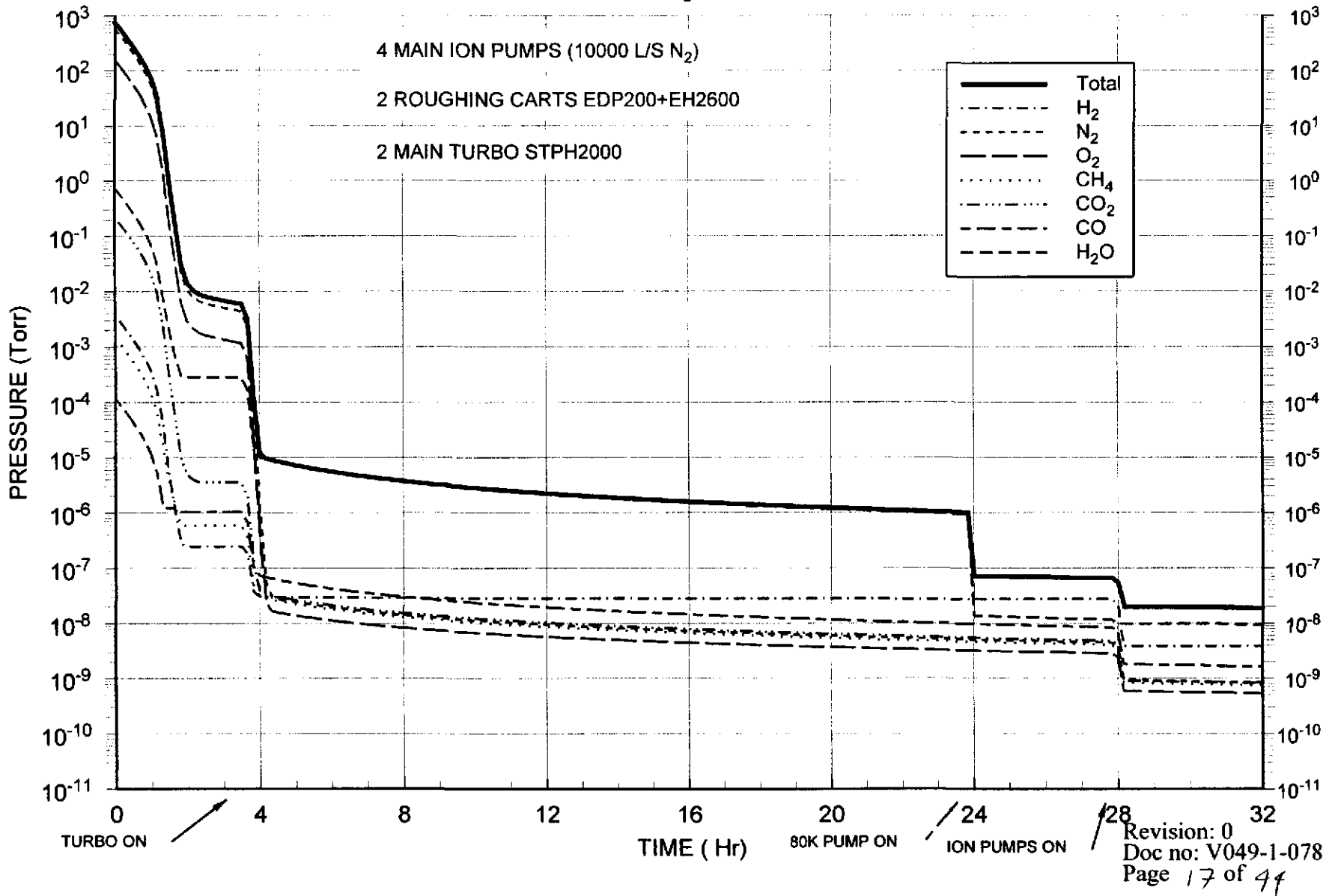

PROJECT: LIGO BY: R.THAN

PROJECT NO: V59049 DATE:

TITLE: FIGURE V049-1-078-5, VERTEX SECTION, CORNER STATION PUMPDOWN, WA

STEEL AREA: 430 m², Volume: 187 m³, H₂=1X10⁻¹¹ Torr-L/s-cm², H₂O=1X10⁻⁶*t^{1.15}, t=min, OTHER GASSES: 10%

VITON AREA: 2.5m², Baked, re-exposed to air 0.5 hr, 100 hr: H₂O=3X10⁻⁹ Torr-L/s-cm², OTHER GASSES=3X10⁻¹⁰ Torr-L/s-cm²

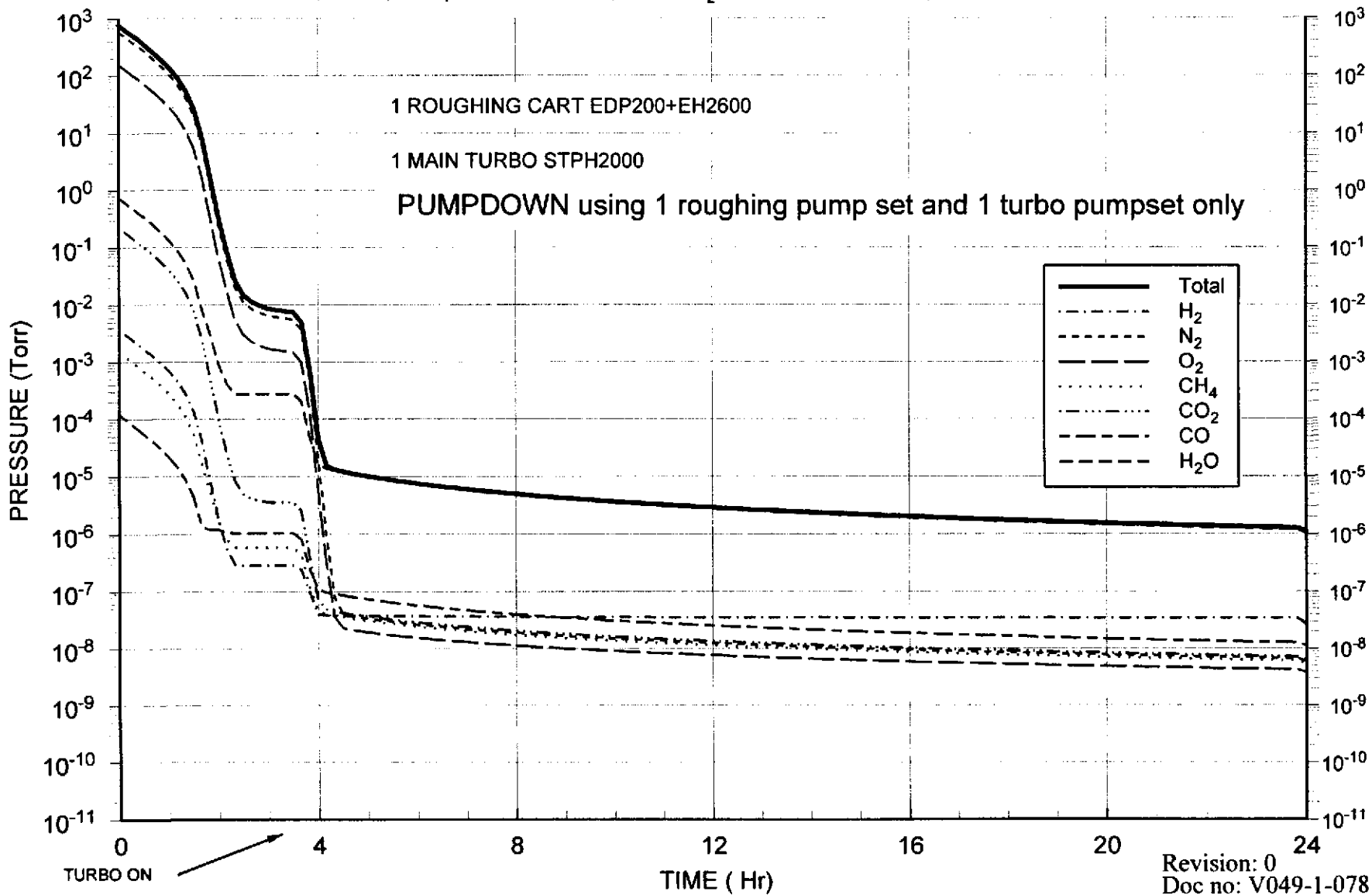

PROJECT: LIGO BY: R. THAN DEPT: 744
 PROJECT NO: V59049 DATE:
 TITLE: END STATION PRESSURES

END STATION PARAMETERS

END STATIONS with 80K Pump										
Outgassing area	119	M ²				Viton 7757 3.00E-09	cm ² Torr-L/s-cm ²			
Gas species	Partial pressure		Final Outgassing rates					Partial pressure		
	Goals	Ion Pump	80K pump	Vacuum Vessel	Metal	O-rings	Total	Metal	O-ring	Total
	100 hrs of pumping Torr	peed (1 pumps) L/s	L/s	Torr-L/s-cm ²	Torr-L/s	Torr-L/s	Torr-L/s	contribution Torr	contribution Torr	Torr
N2	5.00E-10	2,000		2.00E-13	2.38E-07	3.88E-07	6.26E-07	1.19E-10	1.94E-10	3.13E-10
CO	5.00E-10	1,900		5.00E-13	5.96E-07	3.88E-07	9.84E-07	3.14E-10	2.04E-10	5.18E-10
CO2	2.00E-10	2,150		2.00E-13	2.38E-07	3.88E-07	6.26E-07	1.11E-10	1.80E-10	2.91E-10
CH4	2.00E-10	2,200		2.00E-13	2.38E-07	3.88E-07	6.26E-07	1.08E-10	1.76E-10	2.85E-10
Others	5.00E-10	1,700		2.00E-13	2.38E-07	3.88E-07	6.26E-07	1.40E-10	2.28E-10	3.68E-10
H2	5.00E-09	4,200		1.00E-11	1.19E-05	3.88E-07	1.23E-05	2.84E-09	9.23E-11	2.93E-09
H2O	5.00E-09		142,000	5.00E-11	5.96E-05	2.33E-05	8.29E-05	4.20E-10	1.64E-10	5.8349E-10
TOTAL gasses	1.90E-09				1.55E-06	2.33E-06	3.88E-06	7.92E-10	9.83E-10	1.78E-09
TOTAL with H2	6.40E-09				1.35E-05	2.33E-06	1.58E-05	3.63E-09	1.08E-09	4.70E-09
TOTAL with H2O,H2	1.90E-09				7.31E-05	2.56E-05	9.86E-05	4.05E-09	1.24E-09	5.29E-09

PROJECT: LIGO BY: R.THAN DEPT: 744
 PROJECT NO: V59049 DATE:
 TITLE: END STATION PRESSURES

END STATION PARAMETERS

END STATIONS with 80K Pump							
	Qty'	Length m		Area m ²		Volume m ³	Weight kg
Short 80K cryopump chamber	1	2.5		16.59		9.95	915.33
Short 80K cryopump surface	1	1.2		9.80		0.00	
183 cm beam manifold		3.3		18.97		8.68	1046.91
157 cm intercon spool		1		4.93		1.94	272.17
116 cm intercon spool		3.2		11.66		3.74	643.50
BSC	1	1.5		57.21		31.67	3157.10
Total		12.70		119		56	6035
VACUUM SYSTEM							
	Qty'	Pump Speed l/s	Net Speed l/s	Total Speed l/s	Total Net Speed l/s	Specific speed/ Vol l/s-m ³	Specific speed/ Area l/s-m ²
ION PUMPS , 0.5m intercon	1						
N2	1	2500	2000	2500	2000	35.73	16.78
CO	1	2350	1900	2350	1900	33.94	15.94
CO2	1	2940	2150	2940	2150	38.41	18.04
CH4	1	2650	2200	2650	2200	39.30	18.46
O2	1	2100	1700	2100	1700	30.37	14.27
He	1	295	290	295	290	5.18	2.43
Ar	1	590	550	590	550	9.83	4.62
H2	1	4700	4200	4700	4200	75.03	35.24
H2O	1	2940	2400				
TURBO MOLECULAR *	1	1500	1000	1500	1000	17.86	8.39
* Nitrogen speed							
DRY PUMP QDP80	1	22	18	22	18	0.32	0.15
80K CRYOPUMP **	1	142000	142000	142000	142000	2536.68	1191.59
** Water speed							

PROJECT: LIGO BY: R.THAN DEPT: 744
 PROJECT NO: V59049 DATE:
 TITLE: VITON O-RING AREA END STATION

FLANGE SIZE	Qty'	Length	Area
INCH		m	cm^2
104	1	8.54	937
84	0	6.94	0
72	1	5.98	657
60	4	5.03	2206
48	0	4.07	0
44	4	3.75	1646
Bonnet/Gate	6	3.51	2311
			7757

PROJECT: LIGO BY: R. THAN DEPT: 744
 PROJECT NO: V59049 DATE:
 TITLE: MID STATION PRESSURES

MID STATION
PARAMETERS

MID STATIONS with 80K Pumps										
Outgassing area	162	M ²				Viton 11715 3.00E-09	cm ² Torr-L/s-cm ²			
Gas species	Partial pressure		Final Outgassing rates					Partial pressure		
	Goals 100 hrs of pumping Torr	Ion Pump Speed L/s	80K pump L/s	Vacuum Vessel Torr-L/s-cm ²	Metal Torr-L/s	O-rings Torr-L/s	Total Torr-L/s	Metal contribution Torr	O-ring contribution Torr	Total Torr
N2	5.00E-10	2,000		2.00E-13	3.25E-07	5.86E-07	9.10E-07	1.62E-10	2.93E-10	4.55E-10
CO	5.00E-10	1,900		5.00E-13	8.11E-07	5.86E-07	1.40E-06	4.27E-10	3.08E-10	7.35E-10
CO2	2.00E-10	2,150		2.00E-13	3.25E-07	5.86E-07	9.10E-07	1.51E-10	2.72E-10	4.23E-10
CH4	2.00E-10	2,200		2.00E-13	3.25E-07	5.86E-07	9.10E-07	1.48E-10	2.66E-10	4.14E-10
Others	5.00E-10	1,700		2.00E-13	3.25E-07	5.86E-07	9.10E-07	1.91E-10	3.45E-10	5.35E-10
H2	5.00E-09	4,200		1.00E-11	1.62E-05	5.86E-07	1.68E-05	3.86E-09	1.39E-10	4.00E-09
H2O	5.00E-09		284,000	5.00E-11	8.11E-05	3.51E-05	1.16E-04	2.86E-10	1.24E-10	4.0945E-10
TOTAL gasses	1.90E-09				2.11E-06	3.51E-06	5.62E-06	1.08E-09	1.48E-09	2.56E-09
TOTAL with H2	6.40E-09				1.83E-05	3.51E-06	2.19E-05	4.94E-09	1.62E-09	6.57E-09
TOTAL with H2O,H2	1.19E-08				9.95E-05	3.87E-05	1.38E-04	5.23E-09	1.75E-09	6.98E-09

PROJECT: LIGO BY: R. THAN DEPT: 744
 PROJECT NO: V59049 DATE:
 TITLE: MID STATION PRESSURES

MID STATION
PARAMETERS

MID STATIONS with 80K Pumps							
	Qty'	Length m		Area m ²		Volume m ³	Weight Approx
Short 80K cryopump chamber	2	2.5		33.18		19.91	1830.66
Short 80K cryopump surface	2	1.2		19.60		0.00	
183 cm beam manifold		3.8		21.85		9.99	1205.53
116 cm intercon spool		7		25.51		8.18	1407.67
157 cm intercon spool		1		4.93		1.94	272.17
BSC	1	3.5		57.21		31.67	3157.10
Total		19.00		162		72	7873
VACUUM SYSTEM							
	Qty'	Pump Speed l/s	Net Speed l/s	Total Speed l/s	Total Net Speed l/s	Specific speed/ Vol l/s-m ³	Specific speed/ Area l/s-m ²
ION PUMPS , 0.5m intercon	1						
N2	1	2500	2000	2500	2000	27.90	12.32
CO	1	2350	1900	2350	1900	26.50	11.71
CO2	1	2940	2150	2940	2150	29.99	13.25
CH4	1	2650	2200	2650	2200	30.69	13.56
O2	1	2100	1700	2100	1700	23.71	10.48
He	1	295	290	295	290	4.05	1.79
Ar	1	590	550	590	550	7.67	3.39
H2	1	4700	4200	4700	4200	58.59	25.88
H2O	1	2940	2400	2940	2400	33.48	14.79
TURBO MOLECULAR *	1	1500	1000	1500	1000	13.95	6.16
* Nitrogen speed							
DRY PUMP QDP80	1	22	18	22	18	0.25	0.11
80K CRYOPUMP **	2	142000		284000		3961.58	1750.06
** Water speed							

PROJECT: LIGO BY: R.THAN DEPT: 744
 PROJECT NO: V59049 DATE:
 TITLE: VITON O-RING AREA MID STATION

FLANGE SIZE		Length	Area
INCH	Qty'	m	cm^2
104	1	8.54	937
84	0	6.94	0
72	1	5.98	657
60	4	5.03	2206
48	0	4.07	0
44	8	3.75	3292
Bonnet/Gate	12	3.51	4623
			11715

PROJECT: LIGO BY: R. THAN DEPT: 744
 PROJECT NO: V59049 DATE:
 TITLE: CORNER STATION PRESSURES

CORNER STATION, WA
 PARAMETERS

CORNER STATION (WA) VERTEX & ARM ISOLATABLE SECTION with 80K Pump											
Outgassing area:	732	M ²				VITON					
						37639	cm ²				
						3.00E-09	Torr-L/s-cm ²				
Gas species	Partial pressure		80K pump	Final Outgassing rates			Total	Partial pressure		Total	
	Goals	Ion Pump		Vacuum	Vessel	Metal		O-rings	Metal		O-ring
	100 hrs of pumping	speed		L/s	Torr-L/s-cm ²	Torr-L/s		Torr-L/s	contribution		contribution
	Torr	L/s	L/s	Torr-L/s-cm ²	Torr-L/s	Torr-L/s	Torr-L/s	Torr	Torr	Torr	
N2	5.00E-10	10000		2.00E-13	1.46E-06	1.88E-06	3.35E-06	1.46E-10	1.88E-10	3.35E-10	
CO	5.00E-10	9500		5.00E-13	3.66E-06	1.88E-06	5.54E-06	3.85E-10	1.98E-10	5.83E-10	
CO2	2.00E-10	10750		2.00E-13	1.46E-06	1.88E-06	3.35E-06	1.36E-10	1.75E-10	3.11E-10	
CH4	2.00E-10	11000		2.00E-13	1.46E-06	1.88E-06	3.35E-06	1.33E-10	1.71E-10	3.04E-10	
Others	5.00E-10	8500		2.00E-13	1.46E-06	1.88E-06	3.35E-06	1.72E-10	2.21E-10	3.94E-10	
H2	5.00E-09	21000		1.00E-11	7.32E-05	1.88E-06	7.50E-05	3.48E-09	8.96E-11	3.57E-09	
H2O	5.00E-09		142,000	5.00E-11	3.66E-04	1.13E-04	4.79E-04	2.58E-09	7.95E-10	3.3712E-09	
TOTAL gasses	1.90E-09				9.51E-06	1.13E-05	2.08E-05	9.73E-10	9.54E-10	1.93E-09	
TOTAL with H2	6.40E-09				8.27E-05	1.13E-05	9.40E-05	4.46E-09	1.04E-09	5.50E-09	
TOTAL with H2O,H2	1.90E-09				4.48E-04	1.24E-04	5.73E-04	7.03E-09	1.84E-09	8.87E-09	

PROJECT: LIGO BY: R. THAN DEPT: 744
 PROJECT NO: V59049 DATE:
 TITLE: CORNER STATION PRESSURES

**CORNER STATION, WA
 PARAMETERS**

CORNER STATION (WA) VERTEX & ARM ISOLATABLE SECTION with 80K Pump							
	Qty'	Length m	Area m ²	Volume m ³	Weight kg		
Long 80K Cryopump chamber	1	4.2	31.67	19.00	1747.45		
Long 80K Cryopump surface	1	3.7	30.22				
183 cm beam manifold		25.6	147.18	67.33	8121.47		
157m intercon spool		6.7	33.05	12.97	1823.55		
122 cm intercon spool		7.3	27.98	8.53	1543.92		
116 cm intercon spool		3	10.93	3.17	603.29		
BSC	4	4	228.85	126.68	12628.40		
HAM	6		164.40	67.53	9071.65		
76 cm cleaner tube		24	57.30	10.89	3162.05		
Total		78.50	732	316	38702		
VACUUM SYSTEM							
	Qty'	Pump Speed l/s	Net Speed l/s	Total Speed l/s	Total Net Speed l/s	Specific speed/ Vol l/s-m ³	Specific speed/ Area l/s-m ²
ION PUMPS , 0.5m intercon	5						
N2	5	2500	2000	12500	10000	31.63	13.67
CO	5	2350	1900	11750	9500	30.05	12.99
CO2	5	2940	2150	14700	10750	34.01	14.69
CH4	5	2650	2200	13250	11000	34.80	15.04
O2	5	2100	1700	10500	8500	26.89	11.62
He	5	295	290	1475	1450	4.59	1.98
Ar	5	590	550	2950	2750	8.70	3.76
	5						
H2	5	4700	4200	23500	21000	66.43	28.71
H2O	5	2940	2400				
TURBO MOLECULAR *	1	1500	1000	1500	1000	3.16	1.37
* Nitrogen speed							
ROOTS 10 Torr - 0.01 Torr	2	600	438	1200	876	2.77	1.20
Claw&Root 760 Torr - 10 Torr	2	83	78	166	156	0.49	0.21
80K CRYOPUMP **	1	142000	142000	142000	142000	449.21	184.10
** Water speed							

PROJECT: LIGO BY: B. THAN DEPT: 744
 PROJECT NO: V59049 DATE:
 TITLE: CORNER STATION PRESSURES

CORNER STATION, WA
 PARAMETERS

CORNER STATION (WA) BEAM MANIFOLD with 80K Pump							
	Qty'	Length m		Area m ²	Volume m ³	Weight kg	
Long 80K Cryopump chamber	1	4.2	m	31.67	19.00	1747.45	
Long 80K Cryopump surface	1	3.7	m	30.22			
183 cm beam manifold		25.6	m	147.18	67.33	8121.47	
157 cm intercon spool		1.2	m	5.92	2.32	326.61	
122 cm intercon spool		4.9	m	18.78	5.73	1036.33	
116 cm intercon spool	0	3	m	10.93	3.17	603.29	
BSC	1	4	m	57.21	31.67	3157.10	
HAM	0		m	0.00	0.00	0.00	
76 cm cleaner tube		0	m	0.00	0.00	0.00	
Total		46.60	m	302	129	14992	
VACUUM SYSTEM							
	Qty'	Pump Speed l/s	Net Speed l/s	Total Speed l/s	Total Net Speed l/s	Specific speed/ Vol l/s-m ³	Specific speed/ Area l/s-m ²
ION PUMPS . 0.5m intercon	1						
N2	1	2500	2000	2500	2000	15.48	6.62
CO	1	2350	1900	2350	1900	14.70	6.29
CO2	1	2940	2150	2940	2150	16.64	7.12
CH4	1	2650	2200	2650	2200	17.02	7.29
O2	1	2100	1700	2100	1700	13.16	5.63
He	1	295	290	295	290	2.24	0.96
Ar	1	590	550	590	550	4.26	1.82
	1		0	0	0	0.00	0.00
H2	1	4700	4200	4700	4200	32.50	13.91
H2O	1	2940	2400				
TURBO MOLECULAR *	1	1500	1000	1500	1000	7.74	3.31
* Nitrogen speed							
ROOTS 10 Torr - 0.01 Torr	2	600	438	1200	876	6.78	2.90
Claw&Root 760 Torr - 10 Torr	2	83	78	166	156	1.21	0.52
80K CRYOPUMP **	1	142000	142000	142000	142000	1098.86	470.34
** Water speed							

PROJECT: LIGO BY: R. THAN DEPT: 744
 PROJECT NO: V59049 DATE:
 TITLE: CORNER STATION PRESSURES

**CORNER STATION, WA
 PARAMETERS**

DIAGONAL (OFFSET) SECTION, WA							
	Qty	Length m		Area m ²	Volume m ³	Weight kg	
183 cm beam manifold		0	m	0.00	0.00	0.00	
157 cm intercon spool		2.2	m	10.85	4.26	598.78	
122 cm intercon spool		6.7	m	25.68	7.83	1417.03	
116 cm intercon spool	0	0	m	0.00	0.00	0.00	
BSC	1	4	m	57.21	31.67	3157.10	
HAM	6			164.40	67.53	9071.65	
76 cm cleaner tube		24	m	57.30	10.89	3162.05	
Total		36.90	m	315	122	17407	
VACUUM SYSTEM							
	Qty	Pump Speed l/s	Net Speed l/s	Total Speed l/s	Total Net Speed l/s	Specific speed/ Vol l/s-m ³	Specific speed/ Area l/s-m ²
ION PUMPS , 0.5m intercon	2						
N2	2	2500	2000	5000	4000	32.74	12.68
CO	2	2350	1900	4700	3800	31.10	12.05
CO2	2	2940	2150	5880	4300	35.19	13.63
CH4	2	2650	2200	5300	4400	36.01	13.95
O2	2	2100	1700	4200	3400	27.83	10.78
He	2	295	290	590	580	4.75	1.84
Ar	2	590	550	1180	1100	9.00	3.49
	2			0	0	0.00	0.00
H2	2	4700	4200	9400	8400	68.75	26.63
H2O	2	2940	2400				
TURBO MOLECULAR *	1	1500	1000	1500	1000	8.18	3.17
* Nitrogen speed							
ROOTS 10 Torr - 0.01 Torr	1	600	438	600	438	3.58	1.39
Claw&Root 760 Torr - 10 Torr	1	83	78	83	78	0.64	0.25
80K CRYOPUMP **	1	142000	142000	142000	142000	1162.21	450.16
** Water speed							

PROJECT: LIGO BY: R. THAN DEPT: 744
 PROJECT NO: V59049 DATE:
 TITLE: CORNER STATION PRESSURES

**CORNER STATION, WA
 PARAMETERS**

VERTEX SECTION, WA							
	Qty'	Length		Area		Volume	Weight
		m		m ²		m ³	kg
183 cm beam manifold		0	m	0.00		0.00	0.00
157 cm intercon spool		5.5	m	27.13		10.65	1496.94
122 cm intercon spool		2.4	m	9.20		2.81	507.59
116 cm intercon spool	0	0	m	0.00		0.00	0.00
BSC	3	4	m	171.64		95.01	9471.30
HAM	6			164.40		67.53	9071.65
76 cm cleaner tube		24	m	57.30		10.89	3162.05
Total		35.90	m	430		187	23710
VACUUM SYSTEM							
	Qty'	Pump Speed	Net Speed	Total Speed	Total Net Speed	Specific speed/ Vol	Specific speed/ Area
		l/s	l/s	l/s	l/s	l/s-m ³	l/s-m ²
ION PUMPS . 0.5m intercon	4						
N2	4	2500	2000	10000	8000	65.48	25.36
CO	4	2350	1900	9400	7600	62.20	24.09
CO2	4	2940	2150	11760	8600	70.39	27.26
CH4	4	2650	2200	10600	8800	72.02	27.90
O2	4	2100	1700	8400	6800	55.65	21.56
He	4	295	290	1180	1160	9.49	3.58
Ar	4	590	550	2360	2200	18.01	6.97
	4			0	0	0.00	0.00
H2	4	4700	4200	18800	16800	137.50	53.26
H2O	4	2940	2400				
TURBO MOLECULAR *	1	1500	1000	1500	1000	8.18	3.17
* Nitrogen speed							
ROOTS 10 Torr - 0.01 Torr	1	600	438	600	438	3.58	1.39
Claw&Root 760 Torr - 10 Torr	1	83	78	83	78	0.64	0.25
80K CRYOPUMP **	1	142000	142000	142000	142000	1162.21	450.16
** Water speed							

PROJECT: LIGO BY: R.THAN DEPT: 744
 PROJECT NO: V59049 DATE:
 TITLE: VITON O-RING AREA CORNER STATION ,WA

RIGHT/LEFT BEAM MANIFOLD			
FLANGE SIZE		Length	Area
INCH	Qty'	m	cm^2
104	1	8.54	937
84	0	6.94	0
72	5	5.98	3283
60	4	5.03	2206
48	3	4.07	1340
Bonnet/Gate	7	3.51	2697
44	4	3.75	1646
		TOTAL	12109
VERTEX			
FLANGE SIZE		Length	Area
INCH	Qty'	m	cm^2
104	3	8.54	2810
84	12	6.94	9141
72	0	5.98	0
60	23	5.03	12686
48	2	4.07	893
44	0	3.75	0
		TOTAL	25530
DIAGONAL			
FLANGE SIZE		Length	Area
INCH	Qty'	m	cm^2
104	1	8.54	937
84	12	6.94	9141
72	0	5.98	0
60	15	5.03	8274
48	4	4.07	1786
Bonnet	2	3.51	770
44	0	3.75	0
		TOTAL	20908
		DIAGONAL	20908
		VERTEX	25530
		RIGHT BEAM MANIFOLD	12109
		LEFT BEAM MANIFOLD	12109
			70655

PROJECT: LIGO BY: R. THAN DEPT: 744
 PROJECT NO: V59049 DATE:
 TITLE: LA. CORNER STATION PRESSURES

CORNER STATION, LA
 PARAMETERS

CORNER STATION (LA) VERTEX & BEAM MANIFOLD ISOLATABLE SECTION with 80K Pump										
Outgassing area	695	M ²				36746	cm ²			
						3.00E-09	Torr-L/s-cm ²			
Gas species	Partial pressure		Final Outgassing rates					Partial pressure		
	Goals	Ion Pump	80K pump	Vacuum Vessel	Metal	O-rings **	Total	Metal	O-ring	Total
	100 hrs of pumping	peed (1 pumps)	L/s	Torr-L/s-cm ²	Torr-L/s	Torr-L/s	Torr-L/s	contributio	contributio	Torr
	Torr	L/s						Torr	Torr	Torr
N2 *	5.00E-10	8,000		2.00E-13	1.39E-06	1.84E-06	3.23E-06	1.74E-10	2.30E-10	4.03E-10
CO	5.00E-10	7,600		5.00E-13	3.47E-06	1.84E-06	5.31E-06	4.57E-10	2.42E-10	6.99E-10
CO2	2.00E-10	8,600		2.00E-13	1.39E-06	1.84E-06	3.23E-06	1.62E-10	2.14E-10	3.75E-10
CH4	2.00E-10	8,800		2.00E-13	1.39E-06	1.84E-06	3.23E-06	1.58E-10	2.09E-10	3.67E-10
Others	5.00E-10	6,800		2.00E-13	1.39E-06	1.84E-06	3.23E-06	2.04E-10	2.70E-10	4.74E-10
H2	5.00E-09	16,800		1.00E-11	6.95E-05	1.84E-06	7.13E-05	4.13E-09	1.09E-10	4.24E-09
H2O	5.00E-09		142,000	5.00E-11	3.47E-04	1.10E-04	4.58E-04	2.45E-09	7.76E-10	3.222E-09
TOTAL gasses	1.90E-09				9.03E-06	1.10E-05	2.01E-05	1.15E-09	1.16E-09	2.32E-09
TOTAL with H2	6.40E-09				7.85E-05	1.10E-05	8.95E-05	5.29E-09	1.27E-09	6.56E-09
TOTAL with H2O,H2	1.90E-09				4.26E-04	1.21E-04	5.47E-04	7.73E-09	2.05E-09	9.78E-09

PROJECT: LIGO BY: R. THAN DEPT: 744
 PROJECT NO: V59049 DATE:
 TITLE: LA CORNER STATION PRESSURES

CORNER STATION, LA
 PARAMETERS

CORNER STATION (LA) VERTEX & BEAM MANIFOLD ISOLATABLE SECTION with 80K Pump							
	Qty'	Length		Area		Volume	Weight
		m		m ²		m ³	kg
Long 80K Cryopump chamber	1	4.2	m	31.67		19.00	1747.45
Long 80K Cryopump surface	1	3.7	m	30.22			
183 cm beam manifold		37	m	212.72		97.32	11738.06
122 cm intercon spool		6	m	23.00		7.01	1268.98
116 cm intercon spool		1	m	3.64		1.06	201.10
BSC	3	4	m	171.64		95.01	9471.30
HAM	6		m	164.40		67.53	9071.65
76 cm cleaner tube		24	m	57.30		10.89	3162.05
Total		79.90	m	695		298	36661
VACUUM SYSTEM							
	Qty'	Pump		Total	Total	Specific	Specific
		Speed	Net Speed	Speed	Net Speed	speed/ Vol	speed/ Area
ION PUMPS , 0.5m intercon	4	l/s	l/s	l/s	l/s	l/s-m ³	l/s-m ²
N2	4	2500	2000	10000	8000	26.86	11.52
CO	4	2350	1900	9400	7600	25.52	10.94
CO2	4	2940	2150	11760	8600	28.88	12.38
CH4	4	2650	2200	10600	8800	29.55	12.67
O2	4	2100	1700	8400	6800	22.83	9.79
He	4	295	290	1180	1160	3.89	1.67
Ar	4	590	550	2360	2200	7.39	3.17
	4						
H2	4	4700	4200	18800	16800	56.41	24.19
H2O	4	2940	2400			0.00	
TURBO MOLECULAR *	1	1500	1000	1500	1000	3.36	1.44
* Nitrogen speed							
ROOTS 10 Torr - 0.01 Torr	2	600	438	1200	876	2.94	1.26
ROTARY 760 Torr - 10 Torr	2	138	100	276	200	0.67	0.29
80K CRYOPUMP **	1	142000	142000	142000	142000	476.80	204.44
** Water speed							

PROJECT: LIGO BY: B. THAN DEPT: 744
 PROJECT NO: V59049 DATE:
 TITLE: LA. CORNER STATION PRESSURES

CORNER STATION, LA
 PARAMETERS

CORNER STATION (LA) entire station with 80K Pumps										
Outgassing area	898	M ²				47961	cm ²			
						3.00E-09	Torr-L/s-cm ²			
Gas species	Partial pressure		Final Outgassing rates					Partial pressure		
	Goals	Ion Pump	80K pump	Vacuum Vessel	Metal	O-rings **	Total	Metal	O-ring	Total
	100 hrs of pumping	peed (1 pumps)	L/s	Torr-L/s-cm ²	Torr-L/s	Torr-L/s	Torr-L/s	contributio	contributio	Torr
	Torr	L/s	L/s	Torr-L/s-cm ²	Torr-L/s	Torr-L/s	Torr-L/s	Torr	Torr	Torr
N2 *	5.00E-10	8,000		2.00E-13	1.80E-06	2.40E-06	4.19E-06	2.25E-10	3.00E-10	5.24E-10
CO	5.00E-10	7,600		5.00E-13	4.49E-06	2.40E-06	6.89E-06	5.91E-10	3.16E-10	9.07E-10
CO2	2.00E-10	8,600		2.00E-13	1.80E-06	2.40E-06	4.19E-06	2.09E-10	2.79E-10	4.88E-10
CH4	2.00E-10	8,800		2.00E-13	1.80E-06	2.40E-06	4.19E-06	2.04E-10	2.73E-10	4.77E-10
Others	5.00E-10	6,800		2.00E-13	1.80E-06	2.40E-06	4.19E-06	2.64E-10	3.53E-10	6.17E-10
H2	5.00E-09	16,800	16800	1.00E-11	8.98E-05	2.40E-06	9.22E-05	5.35E-09	1.43E-10	5.49E-09
H2O	5.00E-09		284,000	5.00E-11	4.49E-04	1.44E-04	5.93E-04	1.58E-09	5.07E-10	2.0885E-09
TOTAL gasses	1.90E-09				1.17E-05	1.44E-05	2.61E-05	1.49E-09	1.52E-09	3.01E-09
TOTAL with H2	6.40E-09				1.02E-04	1.44E-05	1.18E-04	6.84E-09	1.66E-09	8.50E-09
TOTAL with H2O,H2	1.90E-09				5.51E-04	1.58E-04	7.09E-04	8.42E-09	2.17E-09	1.06E-08

PROJECT: LIGO BY: R. THAN DEPT: 744
 PROJECT NO: V59049 DATE:
 TITLE: LA CORNER STATION PRESSURES

**CORNER STATION, LA
 PARAMETERS**

CORNER STATION (LA) entire station with 80K Pumps							
	Qty'	Length		Area		Volume	Weight
		m		m ²		m ³	kg
Long 80K Cryopump chamber	2	4.2	m	63.33		38.00	3494.89
Long 80K Cryopump surface	2	3.7	m	60.44			
183 cm beam manifold		60	m	344.95		157.81	19034.69
122 cm intercon spool		9.5	m	36.41		11.11	2009.22
116 cm intercon spool	0	9.5	m	0.00		0.00	0.00
BSC	3	4	m	171.64		95.01	9471.30
HAM	6		m	164.40		67.53	9071.65
76 cm cleaner tube		24	m	57.30		10.89	3162.05
Total		114.90	m	898		380	46244
VACUUM SYSTEM							
	Qty'	Pump		Total	Total	Specific	Specific
		Speed	Net Speed	Speed	Net Speed	speed/ Vol	speed/ Area
ION PUMPS , 0.5m intercon	4	l/s	l/s	l/s	l/s	l/s-m ³	l/s-m ²
N2	4	2500	2000	10000	8000	21.03	8.90
CO	4	2350	1900	9400	7600	19.98	8.46
CO2	4	2940	2150	11760	8600	22.61	9.57
CH4	4	2650	2200	10600	8800	23.14	9.79
O2	4	2100	1700	8400	6800	17.88	7.57
He	4	295	290	1180	1160	3.05	1.29
Ar	4	590	550	2360	2200	5.78	2.45
	4						
H2	4	4700	4200	18800	16800		18.70
H2O	4	2940	2400			0.00	
TURBO MOLECULAR *	1	1500	1000	1500	1000	2.63	1.11
* Nitrogen speed							
ROOTS 10 Torr - 0.01 Torr	2	600	438	1200	876	2.30	0.97
ROTARY 760 Torr - 10 Torr	2	138	100	276	200	0.53	0.22
80K CRYOPUMP **	2	142000	142000	284000	284000	746.68	316.09
** Water speed							

PROJECT: LIGO BY: R.THAN DEPT: 744
 PROJECT NO: V59049 DATE:
 TITLE VITON O-RING AREA, CORNER STATION ,LA

RIGHT/LEFT BEAM MANIFOLD			
FLANGE SIZE		Length	Area
INCH	Qty'	m	cm^2
104	1	8.54	937
84	0	6.94	0
72	5	5.98	3283
60	0	5.03	0
48	1	4.07	447
Bonnet/Gate	7	3.51	2697
44	4	3.75	1646
TOTAL			9009
VERTEX			
FLANGE SIZE		Length	Area
INCH	Qty'	m	cm^2
104	3	8.54	2810
84	12	6.94	9141
72	0	5.98	0
60	23	5.03	12686
48	2	4.07	893
44	0	3.75	0
TOTAL			25530
VERTEX			25530
RIGHT BEAM MANIFOLD			9009
LEFT BEAM MANIFOLD			9009
			43549

VIT 142	(E.H.V.) O-ring
Section	0.353 cm
ID	3.769 cm
Surface area	14.3 cm ²
Length	13 cm
L/A	0.91 cm ⁻¹
Volume	1.26 cm ³
Initial gas content (estimated) 5.7 cm ³ air at NTP	

Curve No	Position of O-ring	Baking time (h)	Baking temperature °C
1	In chamber	—	—
2	In groove	—	—
3	In groove	16	100
4	In chamber	16	

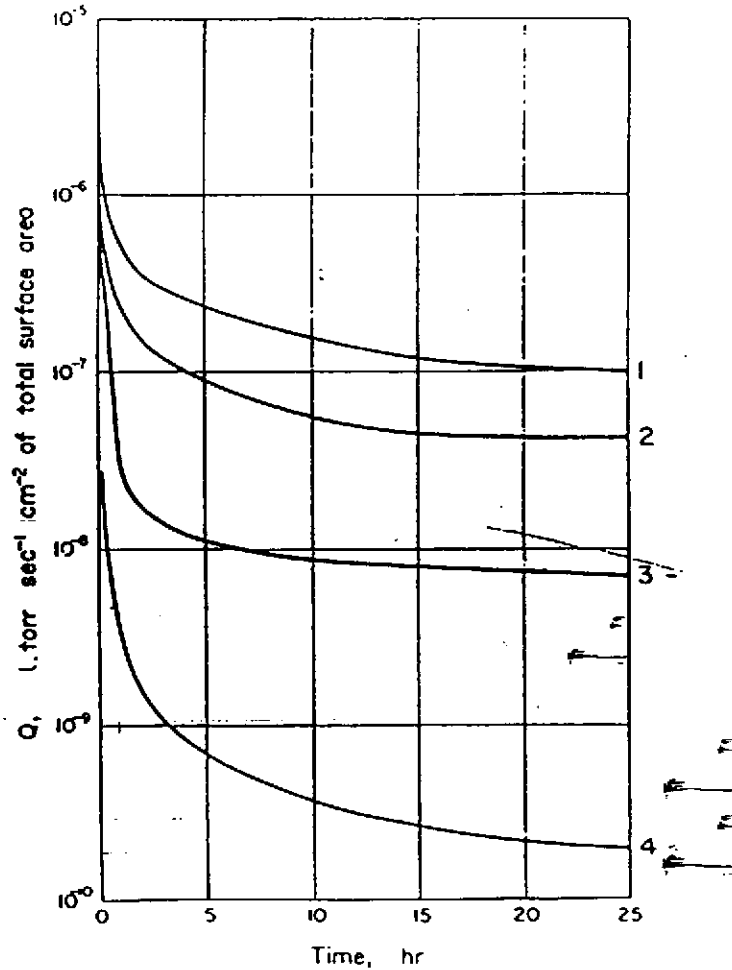

Figure 1. Gas evolution rates in litre torr sec⁻¹ cm⁻² of total area of O-ring against time in hours. See Table 2 for key.

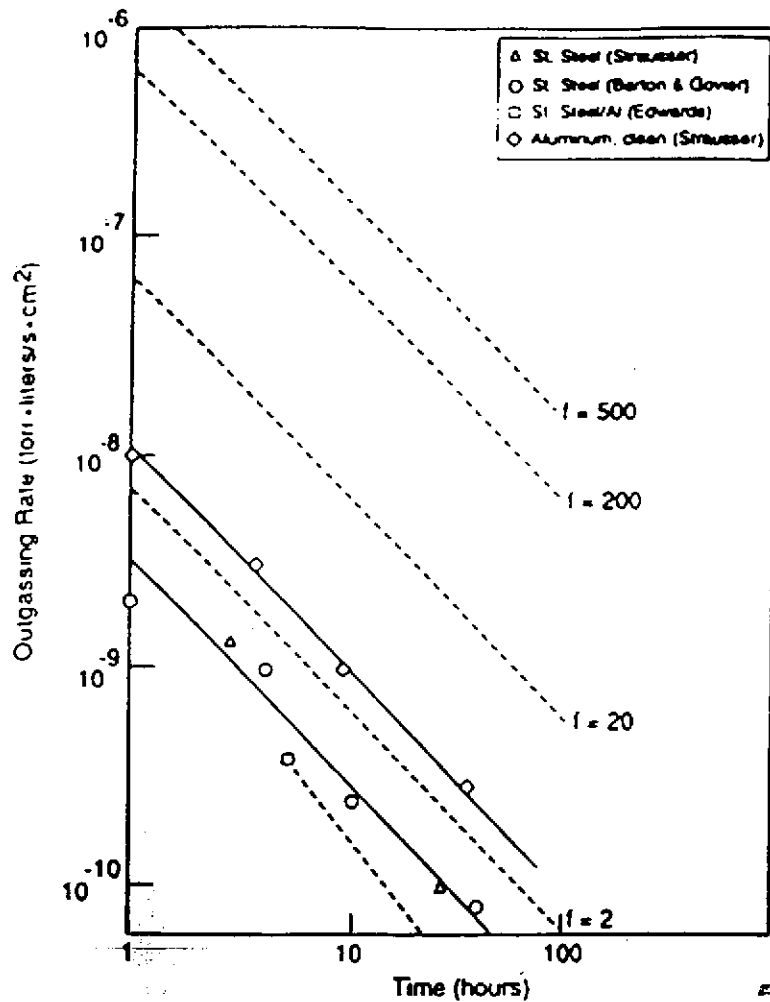
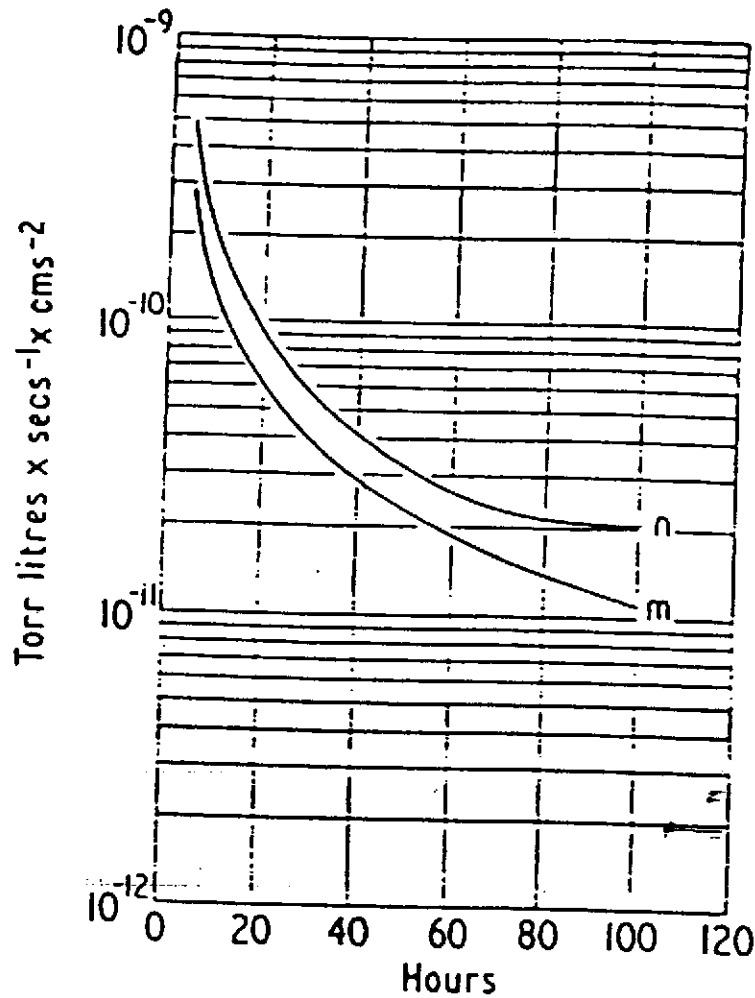

FIG. 1. A compilation of selected outgassing results from the literature for the outgassing of stainless steel and aluminum at ambient temperature. Measurements of Edwards (Ref. 1), Strausser (Ref. 5), and Barton and Govier (Ref. 6) are shown. The lower solid line indicates the literature average used for comparative stainless steel outgassing in this study. The dotted lines indicate the effect of increasing values of the surface roughness factor f .

The effect of cleaning technique on the outgassing rate of 18/9/1 stainless steel

received 6 October 1969; accepted 3 November 1969 VACUUM VOL 20 NO 1

R S Barton and R P Govier, UKAEA Research Group, Culham Laboratory, Abingdon, Berkshire



- m. New sample machined & degreased. (Sample 10, Exp. 31).
- n. Same sample following vapour blasting & degreasing. (Sample 10, Exp. 32).

Figure 8. Total outgassing per cm² of sample as a function of pumping time.

3 M. Li and H. F. Dylla: Water outgassing from metal surfaces. II

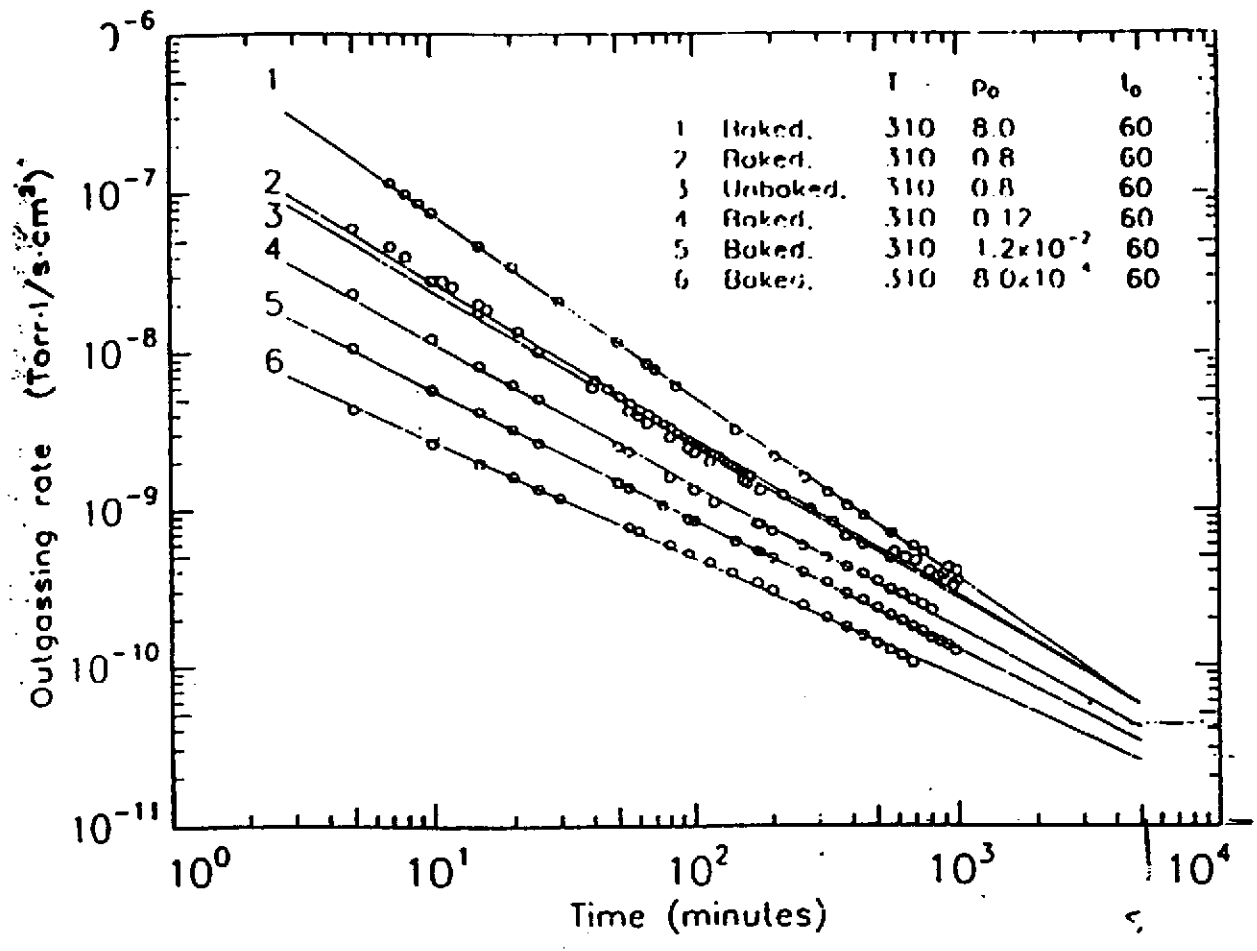
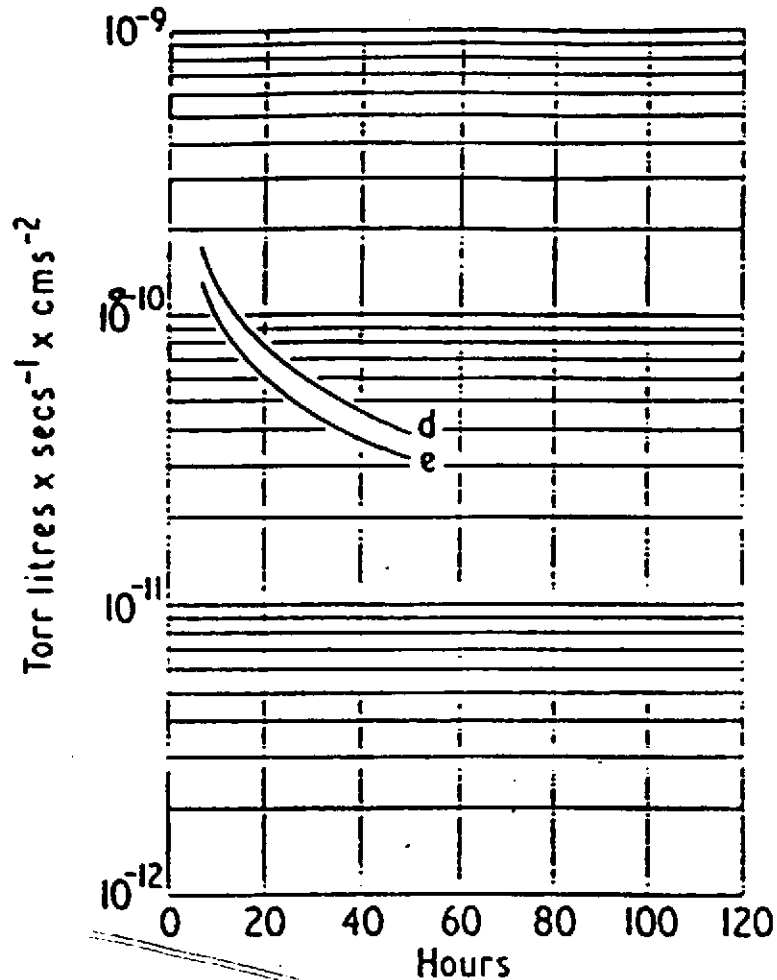

FIG. 1. Typical outgassing measurements for different H₂O exposure pressures in a log(Q) vs log(t) plot.

R S Barton and R P Govier : The effect of cleaning technique on



d. Sample honed & degreased (Sample 2, Exp.5)

e. Sample machined & degreased (Sample 2, Exp.9)

Figure 6. Total outgassing per cm² of sample as a function of pumping time.

EDP200/Booster Combinations

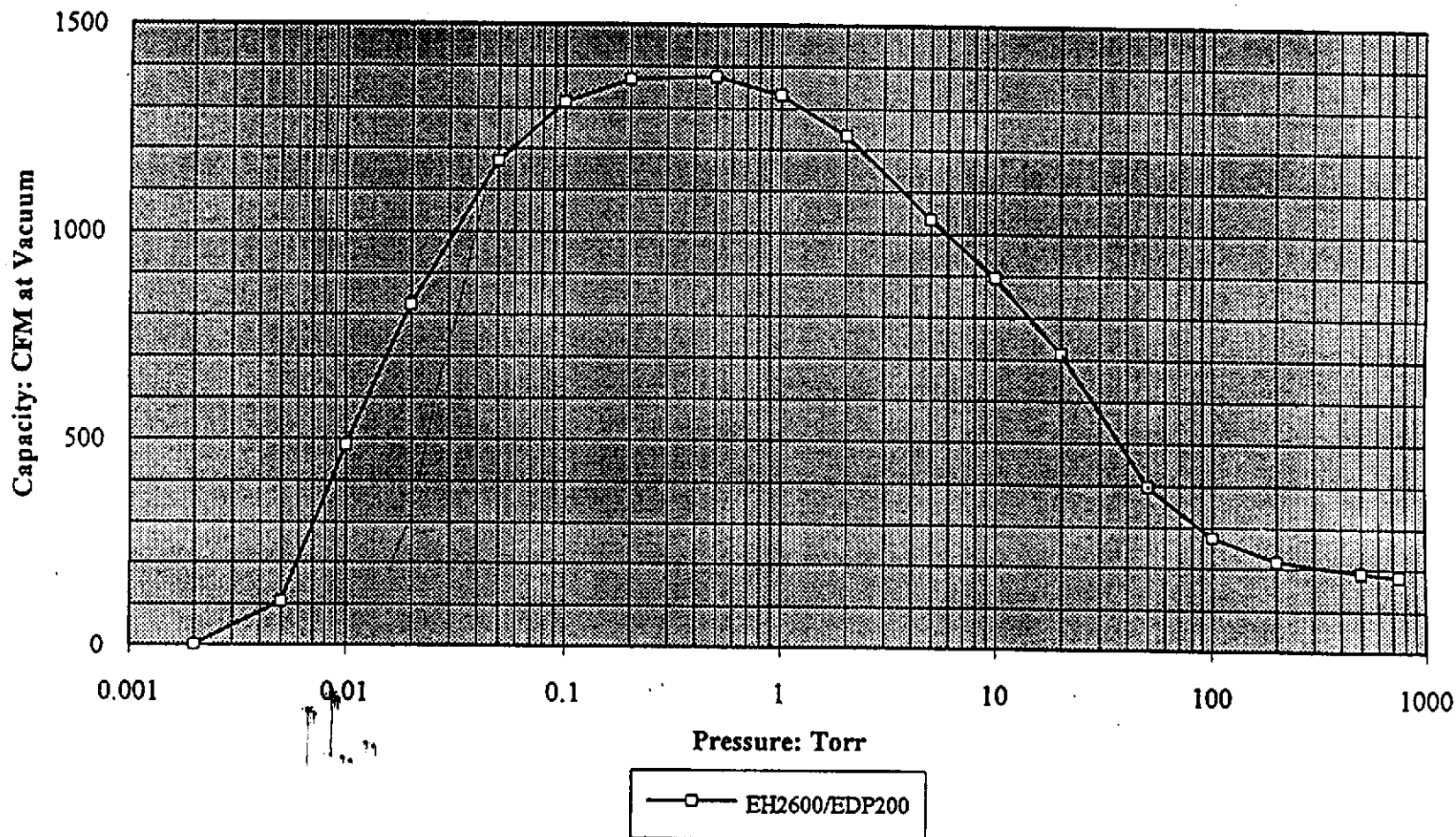

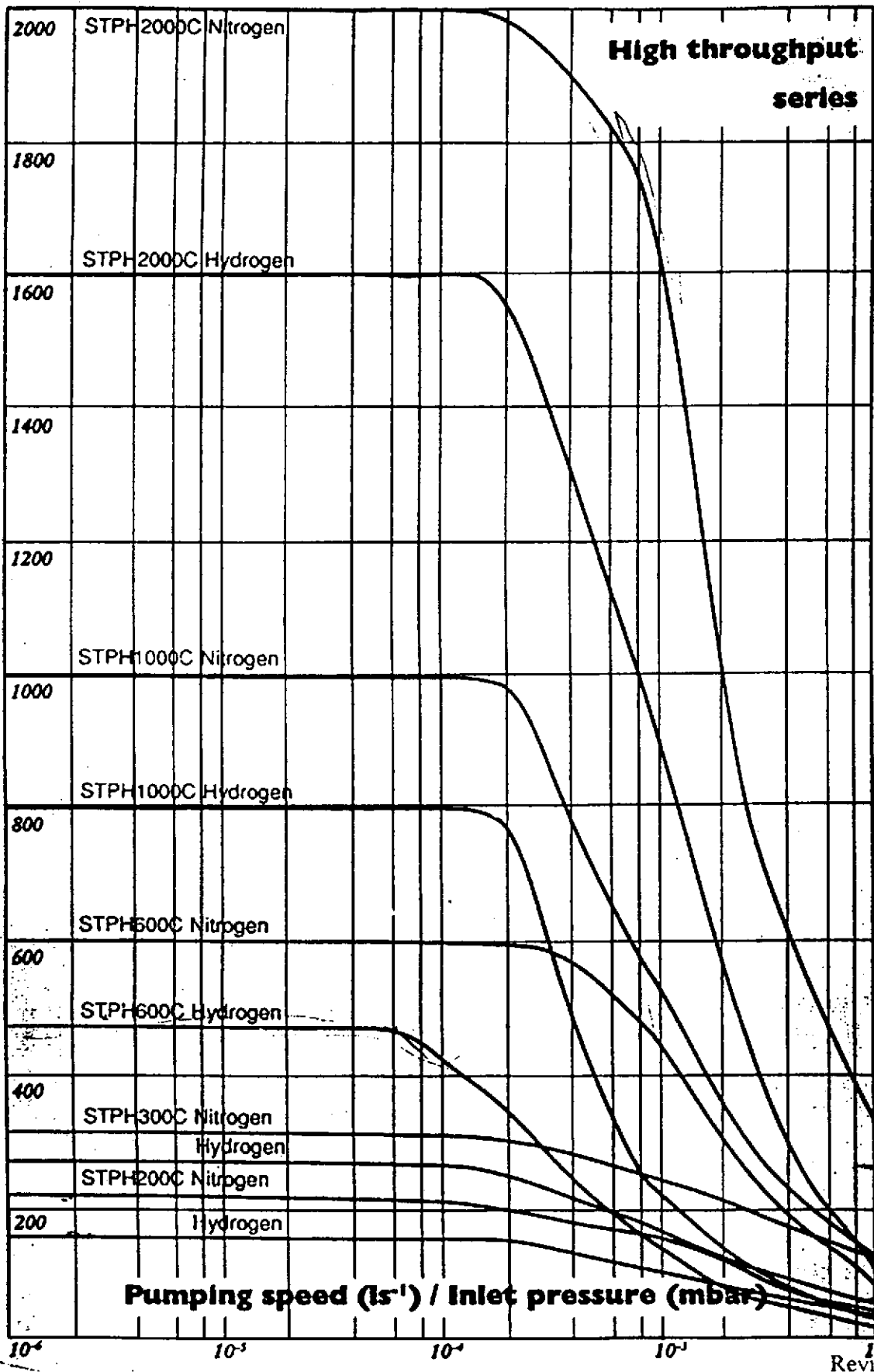

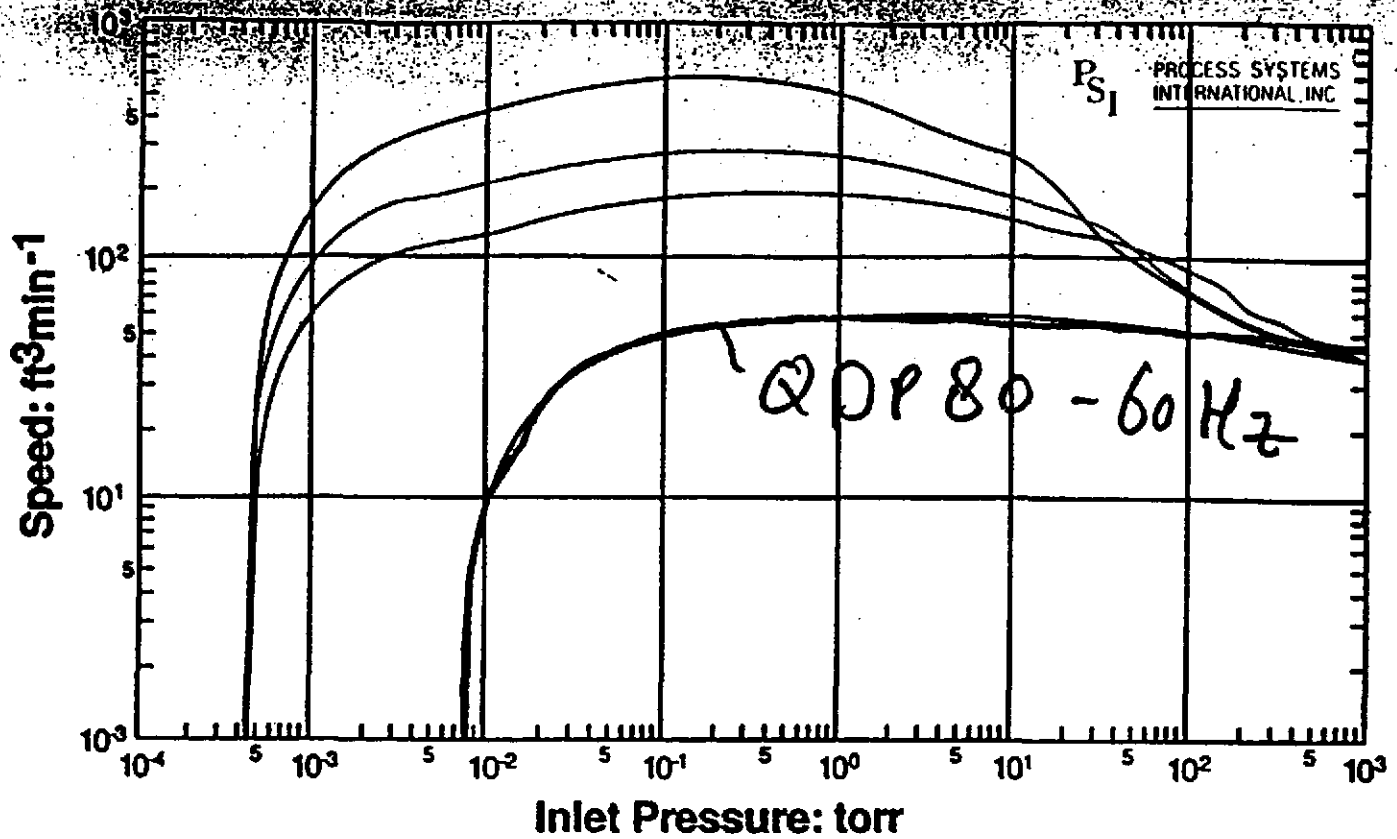

QMB1200 + QDP80 50Hz QMB500 + QDP80 50Hz
 QMB250 + QDP80 50Hz QDP80 50Hz

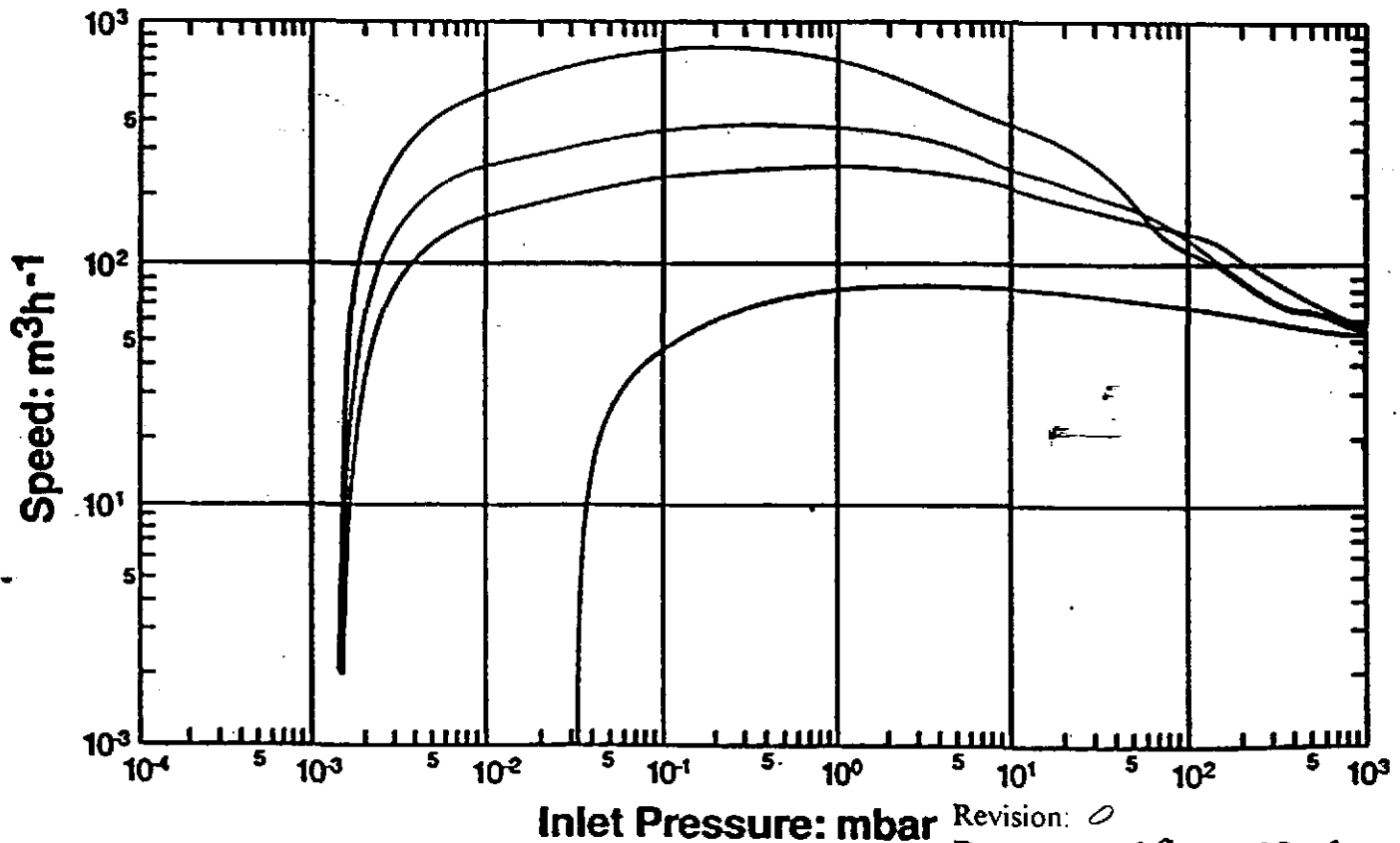

Revision: 0
 Doc no: V049-1-078
 Page 43 of 44

49 of 44

PROCESS SYSTEMS INTERNATIONAL, INC.					ENGINEERING	NO: V049-1-012
WESTBOROUGH, MA					CALCULATIONS	PAGE 1 OF 19
REV	DEO#	DATE	BY:	CHECK	TITLE:	
0	109	3/29/96	R. Than	Am	ANNULUS CHANNEL SIZING	
					ANNULI MANIFOLDING, ION PUMP	
					BY: R. THAN	DEPT: 744
PROJECT: LIGO					PROJECT NO: V59049	

PURPOSE: Sizing: Annulus channel, External Tubing, Manifold, Beamtube-Manifold Annuli header

METHOD:
Long tube formula: Circular section, Rectangular section.

ASSUMPTIONS:
Minimum 0.20 L/s pumping speed at any location in annulus
75 L/s Ion pump per chamber
25 L/s Large gate valves

INPUTS:

REFERENCE:
Theory and Practice of vacuum Technology
ISBN 3-528-08908-3

CALCULATIONS:
see Attachments

CONCLUSIONS: Some flange annuli requires multiport pumpout configuration (104") to meet pumping speed in annulus and to keep annulus channel at reasonable size. A 0.687 inch X 0.500 inch or a 0.687 X 0.375 inch annulus channel size is used, depending on flange sizes.

NOTES:

PROJECT NO: V59049 DATE: 03/28/96

TITLE: ANNULUS CHANNEL, MANIFOLDING

FLANGE ANNULI**Annulus Channels**

To minimize diffusion of gasses from atmosphere through the double Viton o-ring seal, the space between the two o-rings is pumped out and maintained at a certain vacuum pressure using an ion pump. There are 7 sizes of flange connections which require a double Viton o-ring seal:

inches	cm
30	76
44	112
48	122
60	152
72	183
84	213
104	264

Diffusion rate

A diffusion rate of 2×10^{-6} [Torr - L/s]·[m/m² ·bar] is used for diffusion of air through Viton. A nominal o-ring diameter of 1/4 inch (6.35 mm) was assumed in the calculation of the amount of gas diffused through the o-rings.

Annulus Pressure and Pumping Speed

To achieve a diffusion rate into the ultra-high vacuum (UHV) side, which does not require a significant pumping speed on the UHV side, a certain pressure must be maintained in the annulus space. A diffusion rate per o-ring on the order of 1×10^{-5} Torr - L/s is expected from the atmospheric side. The annulus channel was sized to meet the specified pumping speed of 0.20 L/s anywhere in the annulus channel. With a pumping speed of 0.20 L/s and a diffusion rate of 1×10^{-5} Torr - L/s, the annulus pressure will be on the order of 5×10^{-5} Torr. This gives a diffusion rate into the UHV section on the order of 1×10^{-12} Torr - L/s. The high pumping speed in the channel would allow a leak rate from the atmosphere of 1×10^{-4} Torr - L/s and still maintain a rate into the UHV side on the order of 1×10^{-11} Torr - L/s.

PROJECT NO: V59049 DATE: 03/28/96

TITLE: ANNULUS CHANNEL, MANIFOLDING

Annulus Channel Size

The annulus channel was sized for a pumping speed of 0.20 L/s anywhere in the annulus.

Annulus port

The diameter of the annulus pump out port must be large enough to allow a pumping speed of over 1 L/s. The port is sized at 0.62 inch diameter, the same size as the jumper.

Annulus Interconnecting jumper to header

Because of the location of the annulus channel the the interconnecting jumper tube to the header cannot be too large to allow space for welding. A 0.75 tube jumper is used with an ID of 0.620 inch, the allowable length should be no longer than 6 inches.

Annulus Pumpout Interconnecting tubing / Pump Manifold

A typical vessel is about 2.8 m diameter. Because of space limitations the pump may need to be located away from the chamber. The length of the tube from the annuli ports to the manifold could therefore be a longer than 5 m. The size of the tube that runs from the annulus pump out port to the manifold where the auxiliary turbo pump and ion pump are connected will need to be approximately 1 to 1.5 inch diameter (25 mm - 38 mm) to prevent the conductance of this path from dominating the overall conductance. In order to have an effective speed at the annulus port the pumping speed at the pumpmanifold needs to be 10 L/s. A 2.5 inch manifold is proposed.

Pump Size and Capacity

A 75 L/s pump is proposed for each manifolded annuli group: BSC, TMC, HAM, 183 Beam manifold. A separate 25 liters/s Ion pump is proposed for the 122 / 111 cm Gate valve's gate-seals and flange annuli. This would give a pump life of about 40,000 hours with an average gas load of 1×10^{-5} Torr - L/s per annulus. With a higher gas load due to high leakage, the pump life will be shortened.

Valving

Each manifolded annuli group has an single roughing port 63 mm HV valve for pumpout using the auxilliary pumping cart. An isolation valve separates the Ion pump from the pump manifold. A separate roughing valve is provided for the ion pump, either on the pump housing or off the spool piece.

PROJECT: LIGO BY: R.THAN DEPT: 744

**PROCESS SYSTEMS
INTERNATIONAL, INC.**

PROJECT NO: V59049 DATE: 03/28/96

TITLE: ANNULUS CHANNEL, MANIFOLDING

Annulus Speed

The net speed / conductance is calculated for a point that is midway between two exit ports. This will give the minimum conductance between this point and the pump. All gas molecules at other points in the annulus will have an equal or higher probability. In the case of a single port this point would be located 180 degrees across from the exit port.

The probability (conductance) that a gas molecule from this point reaches the pump is determined by all possible gas path back to the pump. So for the BSC 104" annulus the conductance calculated from the midpoint between two exitports back to pump via one port is about 0.12 L/s. But gas molecules at this point has twice the probability of reaching the pump, because of the other parallel path through the other 60" flange. The effective speed for a point in the 104 inch annulus is therefor 0.24 L/s. Note that for a point closer to the port, the effective speed would remain almost unchanged because for one path the probability has increased (approximately linearly, long tube formula) for the other path the probabily has decreased.

For the flanges with a single port, the parallel path is only for the section of the path in the flange until the molecule reaches the exit port, where it becomes a single path to the pump.

PROJECT NO: V59049 DATE: 03/28/96

TITLE: ANNULUS CHANNEL, MANIFOLDING

Annulus channels sizes for flanges

	Annulus Width inch (mm)	Annulus Height inch (mm)	No ports	Annulus Speed L/s	Interconnecting Piping I.D. inch
BSC 60" *	0.6875 (17.5)	0.500 (12.7)	1 (2)	0.24	1.37
BSC 104" *	0.6875 (17.5)	0.375 (12.7)	4	0.12 x2=0.24	0.87
HAM 84"	0.6875 (17.5)	0.500 (12.7)	1	0.21	1.37
HAM 60"	0.6875 (17.5)	0.500 (12.7)	1	0.25	1.37
HAM 30"	0.6875 (17.5)	0.375 (9.53)	1	0.25	1.37
B-M 72"	0.6875 (17.5)	0.500 (12.7)	1	0.23	1.20 (tube) 2.37" (header) (header 10m long)
GATE-VALVE 48"	0.6875 (17.5)	0.375 (9.53)	1	0.26	1.12
GATE VALVE 44"	0.6875 (17.5)	0.375 (9.53)	1	0.27	1.12
GATE Bonnet	0.3750 (9.53)	0.410 (10.41)	2	0.18	1.12
GATE Seal	0.3125 (7.9)	0.500 (12.7)	2	0.22	1.12

* BSC 104" flange in series with 60" flange

Terminology used in tables:

Lo	Orifice conductance
Li	Effective conductance
So	Orifice speed
Si	Effective Speed
P	Tranmission Probability

PROJECT NO: V59049 DATE: 03/28/96

TITLE: ANNULUS CHANNEL, MANIFOLDING

O-ring grooves vents

To ensure that there are no trapped volumes that could serve as virtual leaks, the O-ring grooves needs to be vented. The vents need to be sized such that they can allow the trapped O-ring volumes to be evacuated to the same pressures during the roughing cycle.

The cross sectional area of the trapped O-ring channel (on the UHV side, dovetail side) is approximately 0.01 in^2 or 0.07 cm^2 .

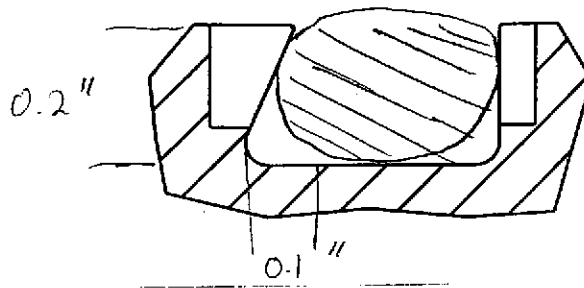

For the corner station there is about 300 m of o-ring length. The total trapped o-ring volume is therefore about 2.1 liters.

The ratio of trapped o-ring volume ($2.1 \times 10^{-3} \text{ m}^3$) to corner station volume (196 m^3) is approximately 1×10^{-5} .

The required pumping speed is about $1 \times 10^{-5} \times 2000 \text{ L/s} = 0.02 \text{ L/s}$ for total trapped volume.

Per meter length of o-ring the required speed is $0.02/300 = 7 \times 10^{-5} \text{ L/s}$ per meter o-ring.
For efficient pumping the conductance should be about 10 times the required speed or $7 \times 10^{-4} \text{ L/s}$ per meter o-ring.

Conductance of trapped o-ring channel.

The hydraulic diameter of the trapped channel is about 10 mm.

The conductance of this channel is approximately 0.0027 L/s per m length of o-ring.

The requirements for venting based on roughing of the trapped volume is a vent every 3 to 4 m of o-ring length.

PROJECT NO: V59049 DATE: 03/28/96

TITLE: ANNULUS CHANNEL, MANIFOLDING

The proposed vent dimension of 0.015 inches high by 0.500 inches wide has a conductance of about 0.08 L/s which is sufficient compared to the trapped channel conductance.

Outgassing.

The outgassing of the o-ring is on the order of 1×10^{-8} Torr-L/s-cm².

With about 3 m of o-ring length the outgassing rate would 300×10^{-8} Torr-L/s-cm²

The pressure in the channel at the vent location would be in 10^{-5} Torr range and at the far end between vents the pressure in the channel would be in the 10^{-3} Torr range.

The same size vent is used for the vent for the trapped volume of the annulus side of the UHV o-ring. The same size vent is also used for the annulus side of the atmospheric o-ring. A vent for the atmospheric side of the atmospheric o-ring is not required.

Flange size inches	Flange size m	Circumference m	No vents
30	0.76	2.39	1
44	1.12	3.52	2
48	1.22	3.83	2
60	1.52	4.78	3
72	1.83	5.75	3
84	2.13	6.69	3
104	2.64	8.29	4

TITLE: ANNULUS CHANNEL, MANIFOLDING

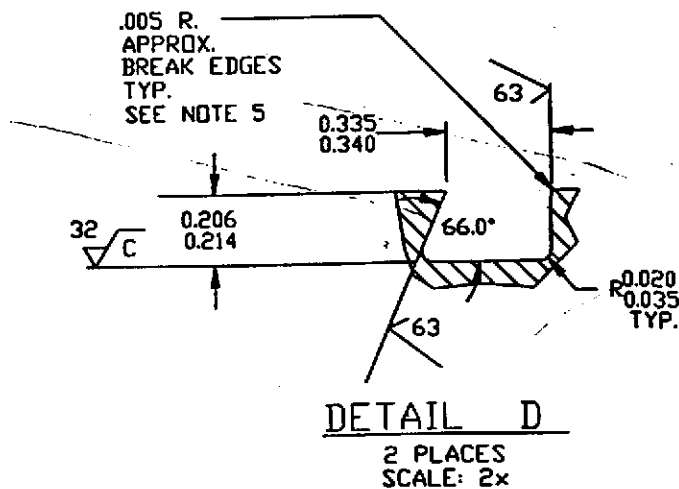
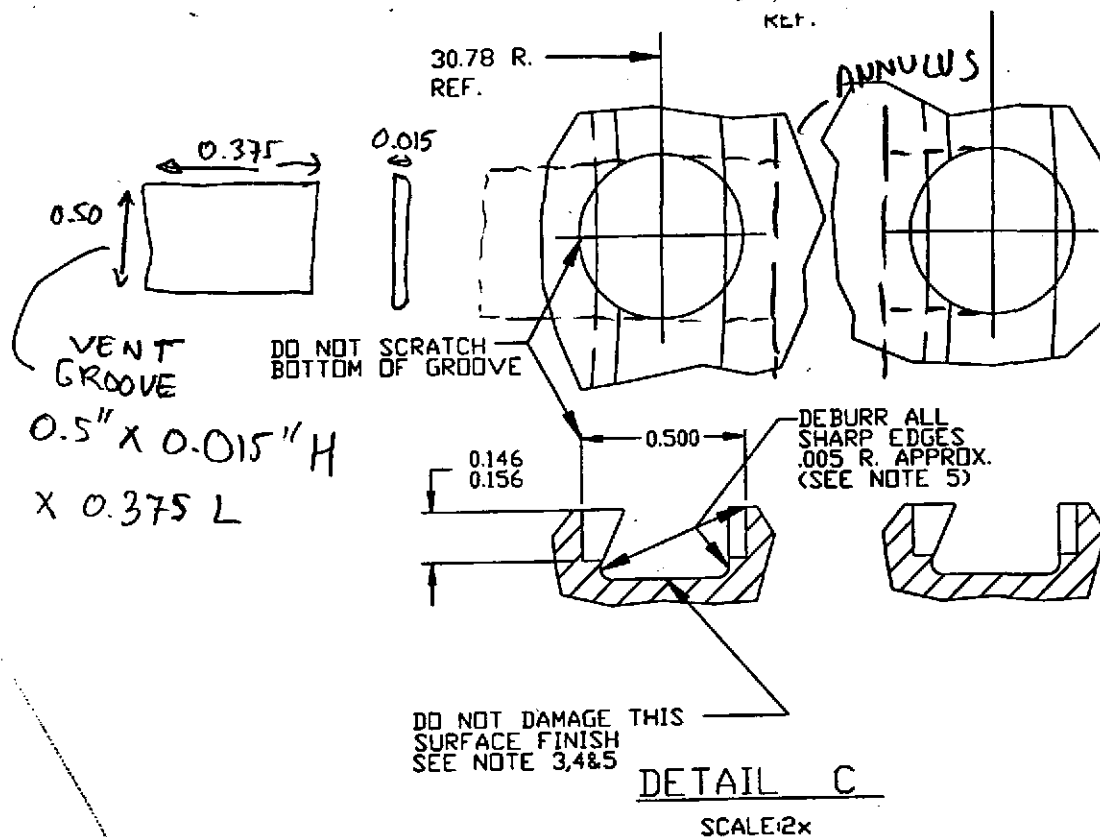

PROJECT: LIGO BY: R.Than
 PROJECT NO: V59049 3/28/96
 TITLE: BSC FLANGES, ANNULI CONFIGURATION

BSC, 4 PORT 104 FLANGE, SERIES WITH 60 FLANGE,																						
																		Temp	293			
																		Mol W	29			
DESCRIPTION	TYPE	Flange Diameter		No. Ports	Circ Section Length		channel Width or tube dia		channel Height		Channel Area		Vol Vel	Lo	P	LI	1/LI	parallel circuit	1/L-t	SI		
		m	In		m	In	In	In	mm	In	In	mm									m^2	In^2
ANNULUS	RECT	2.74	108	4	1.08	42.36	11/16	0.6875	17.5	3/8	0.3750	9.5	1.66E-04	0.258	115,628	19.2	0.018	0.34	2.962	1.00	2.962	
PORT	TUBE				0.03	1.00	31/60	0.6200	15.7				1.95E-04	0.302	115,628	22.5	0.4526	10.19	0.098	1.00	0.098	
JUMPER	TUBE				0.04	1.50	31/60	0.6200	15.7				1.95E-04	0.302	115,628	22.5	0.3569	8.02	0.125	1.00	0.125	
INTERCONN	TUBE				0.89	35.00	87/77	0.8700	22.1				3.84E-04	0.594	115,628	44.3	0.0321	1.42	0.703	1.00	0.703	
JUMPER	TUBE				0.04	1.50	31/60	0.6200	15.7				1.95E-04	0.302	115,628	22.5	0.3569	8.02	0.125	1.00	0.125	
ANNULUS	RECT	1.6	63	2	2.51	98.95	11/16	0.6875	17.5	1/2	0.5000	12.7	2.22E-04	0.344	115,628	25.6	0.009	0.23	4.414	2.00	2.207	
PORT	TUBE				0.03	1.00	31/60	0.6200	15.7				1.95E-04	0.302	115,628	22.5	0.4526	10.19	0.098	1.00	0.098	
JUMPER	TUBE				0.08	3.00	31/60	0.6200	15.7				1.95E-04	0.302	115,628	22.5	0.2160	4.87	0.206	1.00	0.206	
INTERCONN	TUBE				6.00	236.22	1 10/27	1.3700	34.8				9.51E-04	1.474	115,628	110.0	0.0077	0.84	1.185	1.00	1.185	
																		1/L tot=	7.71			
																		ANNULUS SPEED		0.13		
																		PUMP MANIFOLD SPEED		10		
																		2 paths		0.26		
BSC, 60 FLANGE																						
																		Temp	293			
																		Mol W	29			
DESCRIPTION	TYPE	Flange Diameter		No. Ports	Circ Section Length		channel Width or tube dia		channel Height		Channel Area		Vol Vel	Lo	P	LI	1/LI	parallel circuit	1/L-t	SI		
		m	In		m	In	In	In	mm	In	In	mm									m^2	In^2
ANNULUS	RECT	1.6	63	1	2.51	98.95	11/16	0.6875	17.5	1/2	0.5000	12.7	2.22E-04	0.344	115,628	25.6	0.009	0.23	4.414	2.00	2.207	
PORT	TUBE				0.03	1.00	31/60	0.6200	15.7				1.95E-04	0.302	115,628	22.5	0.4526	10.19	0.098	1.00	0.098	
JUMPER	TUBE				0.08	3.00	31/60	0.6200	15.7				1.95E-04	0.302	115,628	22.5	0.2160	4.87	0.206	1.00	0.206	
INTERCONN	TUBE				6.00	236.22	1 10/27	1.3700	34.8				9.51E-04	1.474	115,628	110.0	0.0077	0.84	1.185	1.00	1.185	
																		1/L tot=	3.70			
																		ANNULUS SPEED		0.26		
																		PUMP MANIFOLD SPEED		10		

PROJECT: LIGO BY: R.Than
 PROJECT NO: V59049 3/28/96
 TITLE: HAM FLANGES ANNULI CONFIGURATION

HAM, 94 INCH FLANGE, 1 PORT																		Temp	293				
																		Mol W	29			SI	
DESCRIPTION	TYPE	Flange Diameter		No. Ports	Circ Section Length		channel Width or tube I.D			channel Height			Channel Area		Vol Vel	Lo	P	LI	1/LI	parallel	1/L-t	1/L-t	
		m	In		m	In	In	In	mm	In	In	mm	m^2	In^2	U/s	U/s	L/s	L/s	s/L	s/L	s/L	s/L	L/s
ANNULUS	RECT	2.21	87	1	3.47	136.67	11/16	0.8875	17.5	1/2	0.5000	12.7	2.22E-04	0.344	115,628	25.6	0.006	0.16	6.136	2.00	3.07		
PORT	TUBE				0.03	1.00	31/50	0.8200	15.7				1.95E-04	0.302	115,628	22.5	0.4526	10.19	0.098	1.00	0.10		
JUMPER	TUBE				0.15	6.00	31/50	0.8200	15.7				1.95E-04	0.302	115,628	22.5	0.1211	2.73	0.367	1.00	0.37		
INTERCONN	TUBE				6.00	236.22	1 10/27	1.3700	34.8				9.51E-04	1.474	115,628	110.0	0.0077	0.84	1.185	1.00	1.19		
																		1/L tot=		4.72			
																		ANNULUS SPEED		0.21			
																		PUMP MANIFOLD SPEED		10			
HAM, 60 INCH, 1 PORT																		Temp	293				
																		Mol W	29			SI	
DESCRIPTION	TYPE	Flange Diameter		No. Ports	Circ Section Length		channel Width or tube dia			channel Height			Channel Area		Vol Vel	Lo	P	LI	1/LI	parallel	1/L-t	1/L-t	
		m	In		m	In	In	In	mm	In	In	mm	m^2	In^2	U/s	U/s	L/s	L/s	s/L	s/L	s/L	s/L	L/s
ANNULUS	RECT	1.6	63	1	2.51	98.95	11/16	0.8875	17.5	1/2	0.5000	12.7	2.22E-04	0.344	115,628	25.6	0.009	0.23	4.414	2.00	2.207		
PORT	TUBE				0.03	1.00	31/50	0.8200	15.7				1.95E-04	0.302	115,628	22.5	0.4526	10.19	0.098	1.00	0.098		
JUMPER	TUBE				0.15	6.00	31/50	0.8200	15.7				1.95E-04	0.302	115,628	22.5	0.1211	2.73	0.367	1.00	0.367		
INTERCONN	TUBE				6.00	236.22	1 10/27	1.3700	34.8				9.51E-04	1.474	115,628	110.0	0.0077	0.84	1.185	1.00	1.185		
																		1/L tot=		3.86			
																		ANNULUS SPEED		0.26			
																		PUMP MANIFOLD SPEED		10			
HAM, 30 INCH MODE CLEANER FLANGE, 1 PORT																		Temp	293				
																		Mol W	29			SI	
DESCRIPTION	TYPE	Flange Diameter		No. Ports	Circ Section Length		channel Width or tube I.D			channel Height			Channel Area		Vol Vel	Lo	P	LI	1/LI	parallel	1/L-t	1/L-t	
		m	In		m	In	In	In	mm	In	In	mm	m^2	In^2	U/s	U/s	L/s	L/s	s/L	s/L	s/L	s/L	L/s
ANNULUS	RECT	0.838	33	1	1.32	51.82	11/16	0.8875	17.5	3/8	0.3750	9.5	1.66E-04	0.258	115,628	19.2	0.015	0.28	3.580	2.00	1.780		
PORT	TUBE				0.03	1.00	31/50	0.8200	15.7				1.95E-04	0.302	115,628	22.5	0.4526	10.19	0.098	1.00	0.098		
JUMPER	TUBE				0.15	6.00	31/50	0.8200	15.7				1.95E-04	0.302	115,628	22.5	0.1211	2.73	0.367	1.00	0.367		
INTERCONN	TUBE				8.00	314.96	1 10/27	1.3700	34.8				9.51E-04	1.474	115,628	110.0	0.0058	0.63	1.577	1.00	1.577		
																		1/L tot=		3.82			
																		ANNULUS SPEED		0.25			
																		PUMP MANIFOLD SPEED		10			

PROJECT: LIGO BY: R.Than
 PROJECT NO: V59049 3/28/96
 TITLE: BEAM MANIFOLD FLANGES, ANNULI CONFIGURATION

BEAM MANIFOLD, 72 INCH FLANGE																								
																		Temp	293					
																		Mol Wt	29			SI		
DESCRIPTION	TYPE	Flange		No.	Annulus Channel															LI	1/LI	parallel circuit	1/LI	SI
		Diameter			Circ Section Length		channel Width or tube dia			channel Height			Channel Area		Vol Vel	Lo	P	L/s	s/L					
		m	in			m	in	in	in	mm	in	in	mm	m^2	in^2	l/s	L/s		L/s	s/L	parallel circuit	s/L	L/s	
ANNULUS	RECT	1.905	75	1	2.99	117.81	1 1/8	0.6875	17.5	1/2	0.5000	12.7	2.22E-04	0.344	115,628	25.6	0.007	0.19	6.256	2.00	2.628			
PORT	TUBE				0.03	1.00	31/60	0.6200	15.7				1.95E-04	0.302	115,628	22.5	0.4526	10.19	0.098	1.00	0.098			
JUMPER	TUBE				0.15	6.00	31/60	0.6200	15.7				1.95E-04	0.302	115,628	22.5	0.1210	2.73	0.387	1.00	0.367			
INTERCONN	TUBE				2.00	78.74	1 1/8	1.1250	28.6				6.41E-04	0.994	115,628	74.2	0.0187	1.39	0.721	1.00	0.721			
HEADER	TUBE				10.00	393.70	2 10/27	2.3700	60.2				2.85E-03	4.412	115,628	329.1	0.0080	2.62	0.382	1.00	0.382			
																		1/L tot=				4.20		
																				ANNULUS SPEED		0.23		
																				PUMP MANIFOLD HEADER SPEED		10		

PROJECT: LIGO BY: R.Than
 PROJECT NO: V59049 3/28/96
 TITLE: LARGE GATE VALVE FLANGES ANNULI / BONNET GATE SEAL CONFIGURATION

GATE VALVE, 44 INCH FLANGE																													
																		Temp	293										
																		Mol W	29		SI								
DESCRIPTION	TYPE	Flange Diameter		No. Ports	Circ Section Length		Annulus Channel channel Width or tube I.D			channel Height			Channel Area		Vol Vel	Lo	P	LI	1/LI	parallel circuit	1/LIt	L/s							
		m	In		m	In	In	In	mm	In	In	mm	m^2	In^2									l/s	L/s	L/s	s/L	s/L		
ANNULUS	RECT	1.194	47	1	1.88	73.84	11/16	0.6875	17.5	3/8	0.3750	9.5	1.66E-04	0.258	115,628	19.2	0.010	0.20	6.073	2.00	2.536								
PORT	TUBE				0.03	1.00	31/60	0.6200	15.7				1.95E-04	0.302	115,628	22.5	0.4526	10.19	0.098	1.00	0.098								
JUMPER	TUBE				0.15	6.00	31/60	0.6200	15.7				1.95E-04	0.302	115,628	22.5	0.1210	2.73	0.367	1.00	0.367								
INTERCONN	TUBE				2.50	98.43	1 3/25	1.1200	28.4				6.36E-04	0.985	115,628	73.5	0.0149	1.10	0.910	1.00	0.910								
																		1/L tot=		3.91		ANNULUS SPEED		0.26					
																						PUMP MANIFOLD SPEED		10					
GATE VALVE, 48 INCH FLANGE																													
																		Temp	293										
																		Mol W	29		SI								
DESCRIPTION	TYPE	Flange Diameter		No. Ports	Circ Section Length		Annulus Channel channel Width or tube I.D			channel Height			Channel Area		Vol Vel	Lo	P	LI	1/LI	parallel circuit	1/LIt	L/s							
		m	In		m	In	In	In	mm	In	In	mm	m^2	In^2									l/s	L/s	L/s	s/L	s/L		
ANNULUS	RECT	1.295	51	1	2.03	80.09	11/16	0.6875	17.5	3/8	0.3750	9.5	1.66E-04	0.258	115,628	19.2	0.009	0.18	6.502	2.00	2.751								
PORT	TUBE				0.03	1.00	31/60	0.6200	15.7				1.95E-04	0.302	115,628	22.5	0.4526	10.19	0.098	1.00	0.098								
JUMPER	TUBE				0.15	6.00	31/60	0.6200	15.7				1.95E-04	0.302	115,628	22.5	0.1210	2.73	0.367	1.00	0.367								
INTERCONN	TUBE				2.50	98.43	1 1/8	1.1250	28.6				6.41E-04	0.994	115,628	74.2	0.0150	1.11	0.898	1.00	0.898								
																		1/L tot=		4.11		ANNULUS SPEED		0.24					
																						PUMP MANIFOLD SPEED		10					

PROJECT: LIGO BY: R.Than
 PROJECT NO: V59049 3/28/96
 TITLE: LARGE GATE VALVE FLANGES ANNULI / BONNET GATE SEAL CONFIGURATION

BONNET FLANGE ANNULUS																						
																		Temp	293			
																		Mol W	29			SI
DESCRIPTION	TYPE	Flange Diameter		No. Ports	Circ Section Length		Annulus Channel				Channel Area		Vol Vel	Lo	P	LI	1/LI	parallel circuit	1/L-t	L/s		
		m	in		m	in	channel Width or tube dia		channel Height		m^2	in^2										
ANNULUS	RECT	1.4	55	2	1.10	43.29	3/8	0.3750	9.5	16/32	0.4100	10.4	9.92E-05	0.154	115,628	11.5	0.013	0.15	6.698	2.00	3.349	
PORT	PORT				0.01	0.38	3/8	0.3750	9.5					7.13E-05	0.110	115,628	8.2	0.5714	4.71	0.212	2.00	0.106
JUMPER	JUMPER				0.09	3.54	3/7	0.4300	10.9					9.37E-05	0.145	115,628	10.8	0.1393	1.51	0.663	2.00	0.331
INTERCONN	TUBE				4.00	157.48	1 1/8	1.1250	28.6					6.41E-04	0.994	115,628	74.2	0.0094	0.70	1.429	1.00	1.429
																		1/L tot=				5.22
																				ANNULUS SPEED		0.18
																				PUMP MANIFOLD SPEED		5
GATE SEAL ANNULUS																						
																		Temp	293			
																		Mol W	29			SI
DESCRIPTION	TYPE	Flange Diameter		No. Ports	Circ Section Length		Annulus Channel				Channel Area		Vol Vel	Lo	P	LI	1/LI	parallel circuit	1/L-t	L/s		
		m	in		m	in	channel Width or tube dia		channel Height		m^2	in^2										
ANNULUS	RECT	1.14	45	2	0.90	35.25	5/16	0.3125	7.9	1/2	0.5000	12.7	1.01E-04	0.156	115,628	11.7	0.015	0.17	6.733	2.00	2.867	
PORT	TUBE				0.10	3.94	3/8	0.3750	9.5					7.13E-05	0.110	115,628	8.2	0.1127	0.93	1.077	2.00	0.539
JUMPER	TUBE				0.08	3.00	3/7	0.4300	10.9					9.37E-05	0.145	115,628	10.8	0.1604	1.74	0.575	2.00	0.288
INTERCONN	TUBE				2.00	78.74	1 3/25	1.1200	28.4					6.36E-04	0.985	115,628	73.5	0.0186	1.37	0.731	1.00	0.731
																		1/L tot=				4.42
																				ANNULUS SPEED		0.22
																				PUMP MANIFOLD SPEED		10

PROJECT: LIGO
PROJECT NO: V59049 DATE: 3/28/96
TITLE: BSC ANNULI CONFIGURATION

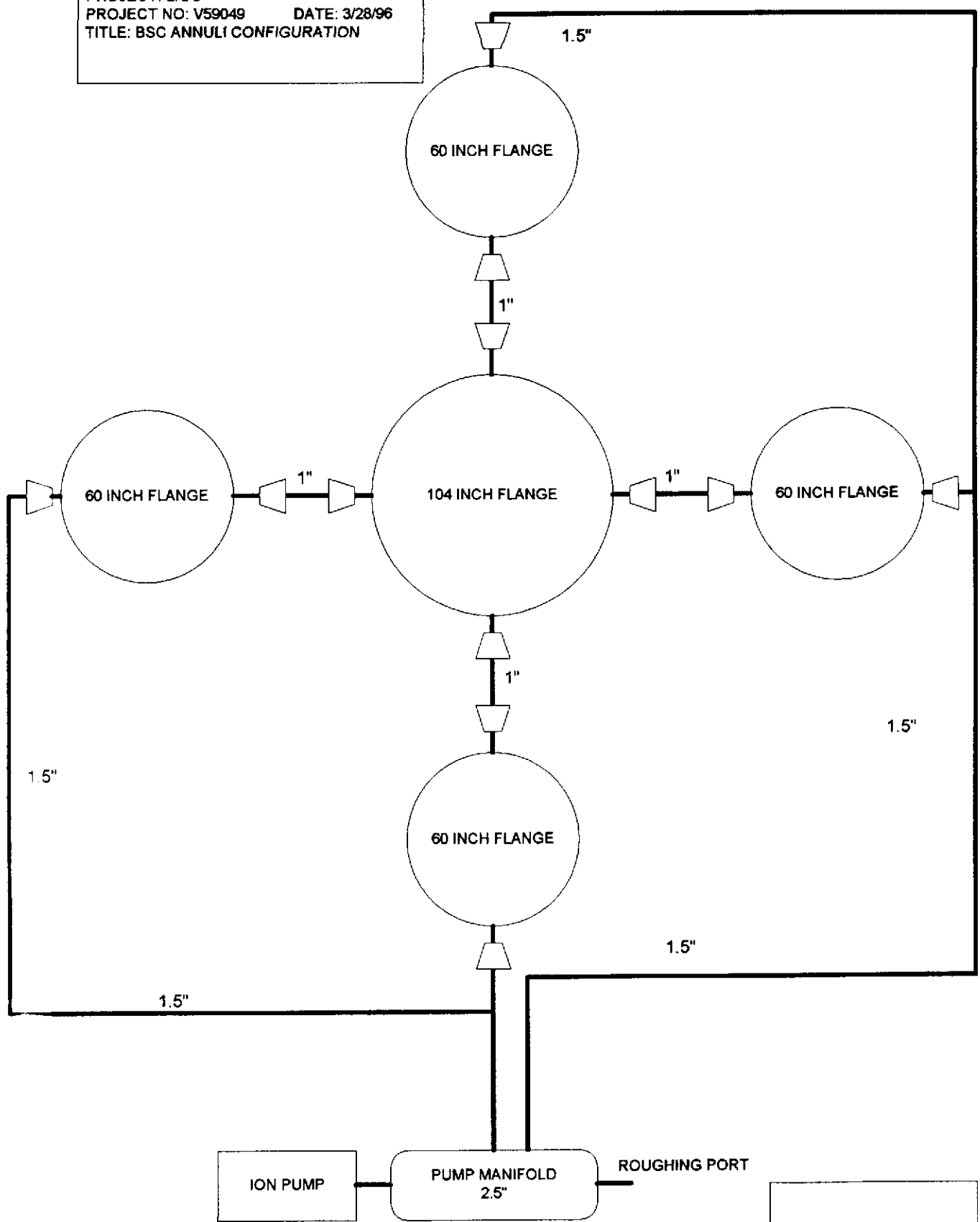

REVISION: 0
DOC NO: V049-1-012
PAGE 14 OF 19

PROJECT: LIGO
PROJECT NO: V59049 DATE: 3/28/96
TITLE: HAM ANNULI CONFIGURATION

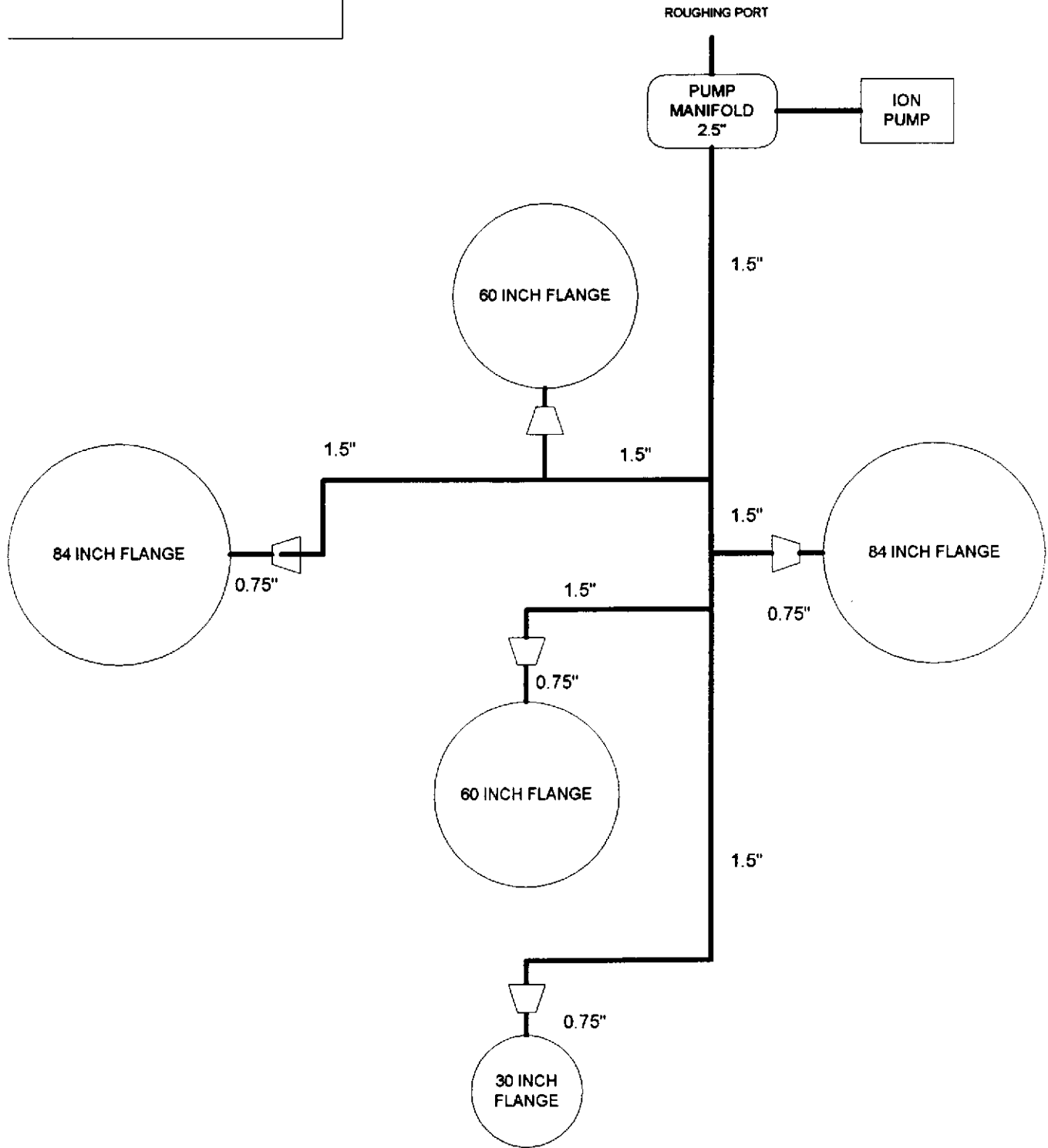

REVISION: 0
DOC NO: V049-1-012
PAGE 15 OF 19

PROJECT: LIGO
PROJECT NO: V59049 DATE: 3/28/96
TITLE: BEAM MANIFOLD ANNULI
CONFIGURATION

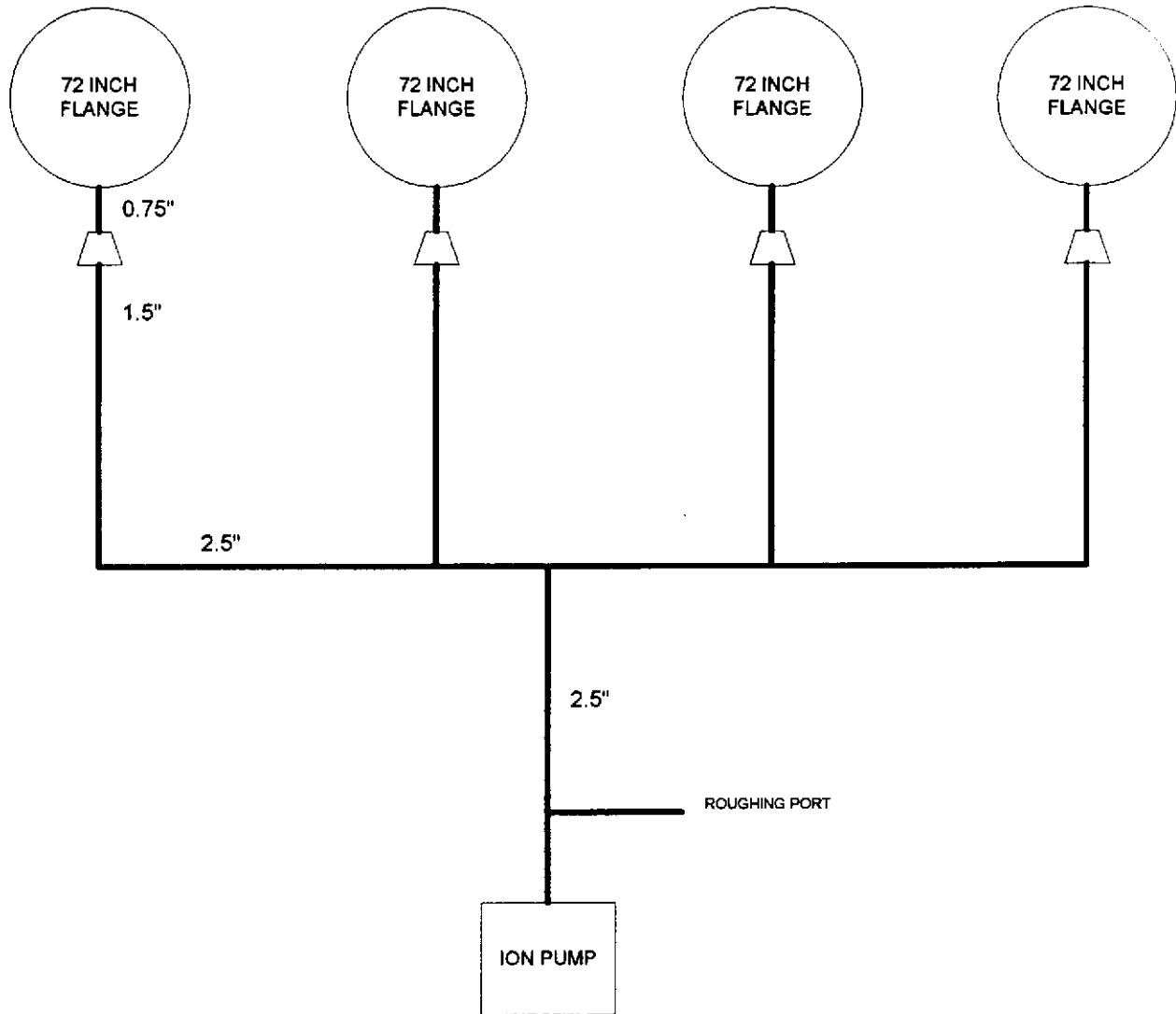

REVISION: 0
DOC NO: V049-1-012
PAGE 16 OF 19

PROJECT: LIGO
PROJECT NO: V59049 DATE: 3/28/96
TITLE: 48" / 44" GATE VALVES ANNULI CONFIGURATION

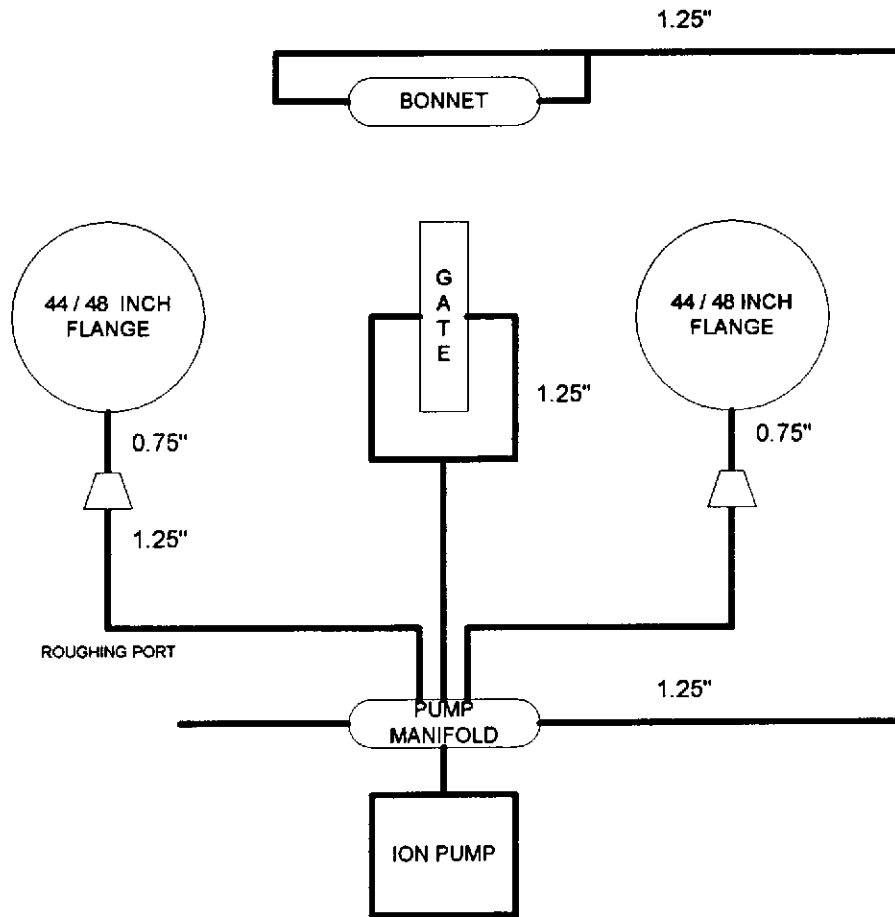

REVISION: 0
DOC NO: V049-1-012
PAGE 17 OF 19

PROJECT: LIGO BY: R.Than
 PROJECT NO: V59049 3/28/96
 TITLE: DIFFUSION, UHV O-RING

DIFFUSION: UHV O-RING								
Permeability	O-ring		Flange		Diffusion	Differential	Diffusion	
Viton	dia		dia		Area	pressure	Rate	
r-L/s)(m/m ²	m	in	m	in	m ²	bar	mbar-L/s	Torr-L/s
2.00E-06	0.00635	1/4	0.76	30	0.015161	1.00E-06	4.78E-12	3.581E-12
2.00E-06	0.00635	1/4	1.12	44	0.022343	1.00E-06	7.04E-12	5.278E-12
2.00E-06	0.00635	1/4	1.22	48	0.024338	1.00E-06	7.67E-12	5.749E-12
2.00E-06	0.00635	1/4	1.52	60	0.030323	1.00E-06	9.55E-12	7.163E-12
2.00E-06	0.00635	1/4	1.83	72	0.036507	1.00E-06	1.15E-11	8.624E-12
2.00E-06	0.00635	1/4	2.13	84	0.042492	1.00E-06	1.34E-11	1.004E-11
2.00E-06	0.00635	1/4	2.64	104	0.052666	1.00E-06	1.66E-11	1.244E-11
2.00E-06	0.00635	1/4	0.35	14	0.006982	1.00E-06	2.20E-12	1.649E-12
2.00E-06	0.001588	1/16	0.152	5.98	0.000758	1.00E-06	9.55E-13	7.163E-13
2.00E-06	0.001588	1/16	0.035	1.38	0.000175	1.00E-06	2.20E-13	1.649E-13
2.00E-06	0.001588	1/16	0.063	2.48	0.000314	1.00E-06	3.96E-13	2.969E-13

PROJECT: LIGO BY: R.Than
 PROJECT NO: V59049 3/28/96
 TITLE: DIFFUSION, ATMOSPHERIC O-RING

DIFFUSION ATMOSPHERIC O-RING									
Permeability	O-ring		Flange		Diffusion	Differential	Diffusion		Ion-pump
Viton	dia		dia		Area	pressure	Rate		Speed for
									40,000 hrs life
(mbar-L/s)(m/m ² -bar)	m	in	m	in	m ²	bar	mbar-L/s	Torr-L/s	L/s
2.00E-06	0.00635	1/4	0.76	30	0.015161	1	4.78E-06	3.58E-06	3.58
2.00E-06	0.00635	1/4	1.12	44	0.022343	1	7.04E-06	5.28E-06	5.28
2.00E-06	0.00635	1/4	1.22	48	0.024338	1	7.67E-06	5.75E-06	5.75
2.00E-06	0.00635	1/4	1.52	60	0.030323	1	9.55E-06	7.16E-06	7.16
2.00E-06	0.00635	1/4	1.83	72	0.036507	1	1.15E-05	8.62E-06	8.62
2.00E-06	0.00635	1/4	2.13	84	0.042492	1	1.34E-05	1E-05	10.04
2.00E-06	0.00635	1/4	2.64	104	0.052666	1	1.66E-05	1.24E-05	12.44
2.00E-06	0.00635	1/4	0.35	14	0.006982	1	2.20E-06	1.65E-06	1.65

PROCESS SYSTEMS INTERNATIONAL, INC. WESTBOROUGH, MA					ENGINEERING CALCULATIONS	NO: V049-1-033
REV.	DEO #	DATE	BY:	CHECK	PAGE 1 OF 26	
0	0038	1/3/96	D. Moore	D.M. (2)	TITLE: Heat Load Calculations on Clean (No frost) 80K Pumps from Beam Tube & Vacuum Chamber	
1	0052	1/29/96	D. Moore	D.M. (2)		
					By: David Moore	DEPT.: 744
<u>PROJECT:</u> LIGO					<u>PROJECT NO:</u> V59049	
<u>PURPOSE:</u> To determine heat loads on long and short pumps in their clean condition due to thermal radiation exchange with the pump vacuum chamber and the beam tube.						
<u>METHOD:</u> Radiation network equations.						
<u>ASSUMPTIONS:</u> 1. One radiation shield in the vacuum annulus surrounding the pump LN ₂ reservoir. 2. Low emissivity (.06) thermal sleeves in beam tube. 3. Pumps in clean condition.						
<u>INPUTS:</u>						
<u>REFERENCES:</u> 1. Heat Transfer, J.P. Holman, 3rd ed., McGraw-Hill. 2. Thermal Radiation Heat Transfer, Siegel & Howell, McGraw-Hill						
<u>CALCULATIONS:</u> (SEE ATTACHED)						
<u>CONCLUSIONS:</u> Radiation shield temp. = 269.5 K Long Pump : 249 watts (from beam tube) (clean) 176 watts (from vac. cham.) 425 watts Total Short Pump: 116.0 watts (clean) 69.0 watts 180.0 total						
<u>NOTES:</u>						



Short Pump (No Frost)

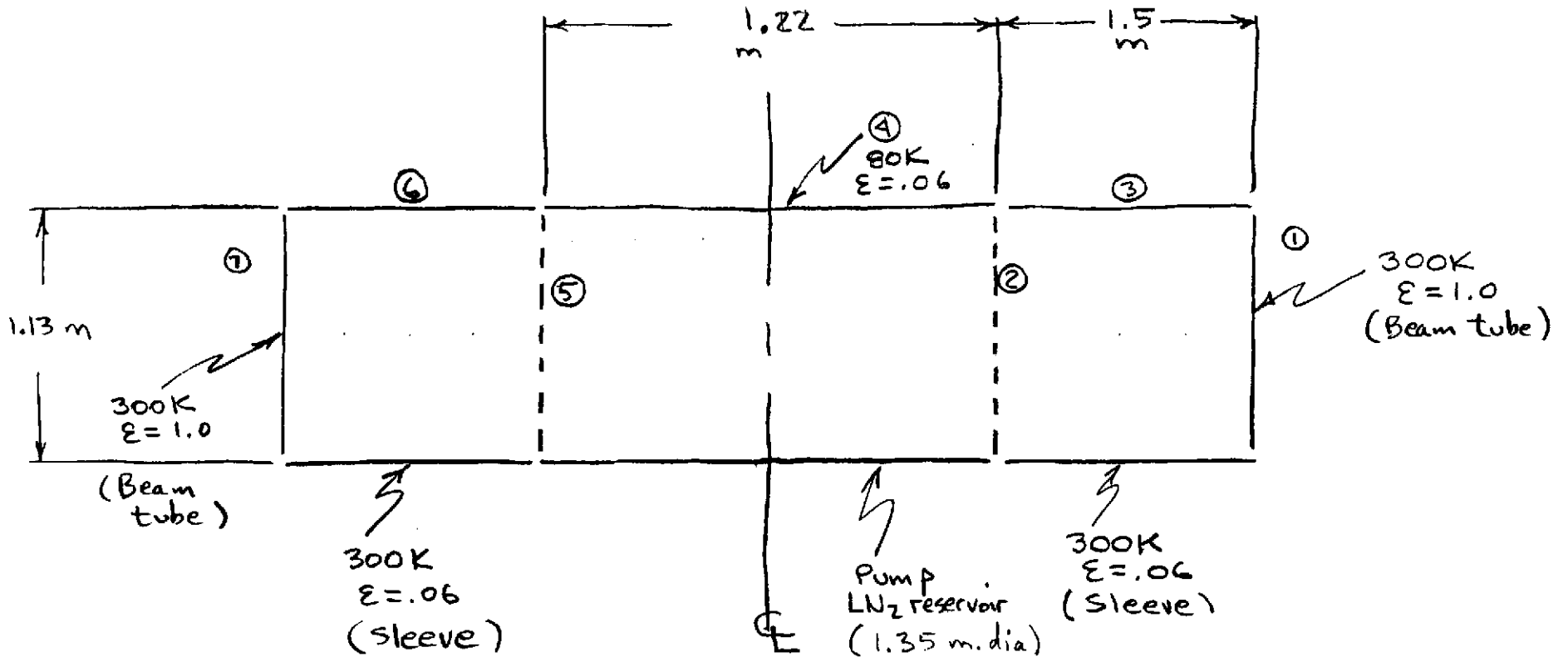

Surfaces ② & ⑤
 are fictitious sur-
 faces used to simplify
 view factor calculations

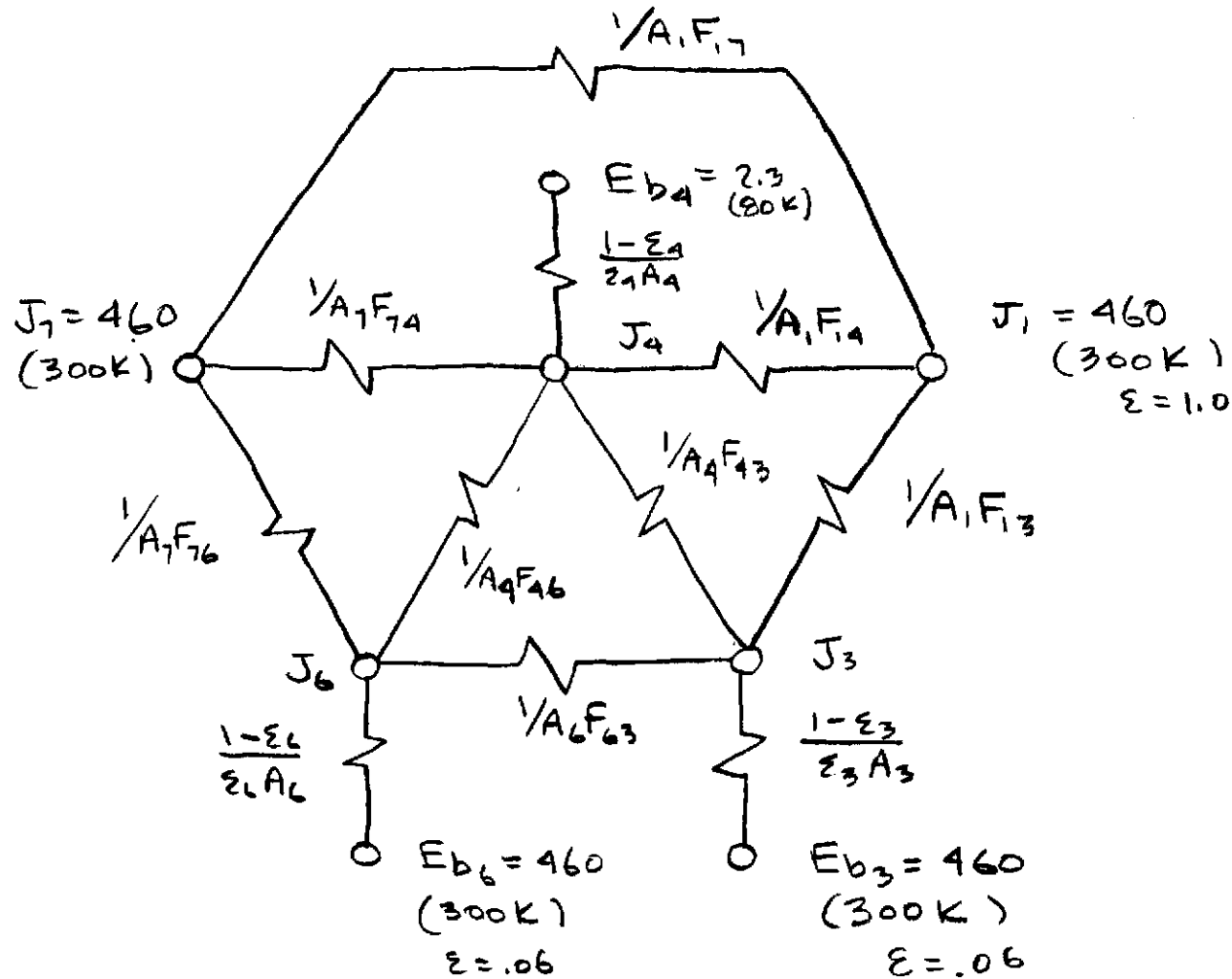

Clean Pump
 $\epsilon_1 = .06$

View Factors

$$F_{12} = \frac{d}{x} = \frac{1.13}{1.5} = 0.75$$

$$\therefore F_{12} = 0.12$$

(Heat Transfer, Holman, 3rd ed., pp. 249')

$$F_{13} = 1 - F_{12} = 0.88$$

$$F_{15} = \frac{d}{x} = \frac{1.13}{(1.5 + 1.22)} = 0.42$$

$$F_{15} = 0.05$$

$$\therefore F_{14} = F_{12} - F_{15} = 0.12 - 0.05 = 0.07$$

$$F_{17} = \frac{d}{x} = \frac{1.13}{2(1.5) + 1.22} = 0.27$$

$$F_{17} = 0.04$$

$$F_{76} = F_{13} = 0.88$$

$$F_{41} = \frac{A_1}{A_4} F_{14} = \frac{\pi/4 (1.13)^2}{\pi (1.35)(1.22)} (0.07)$$

$$F_{41} = .014$$

$$F_{25} = \frac{d}{x} = \frac{1.12}{1.22} = 0.92$$

$$F_{25} = 0.15$$

$$F_{24} = 1 - F_{25} = 0.85$$

Fig. 8-13 Radiation shape factor for radiation between parallel disks.

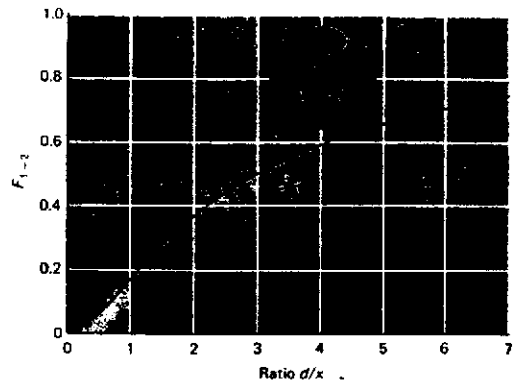



$$\begin{aligned}
 F_{42} &= \frac{A_2}{A_4} F_{24} \\
 &= \frac{(\pi/4)(1.13)^2}{\pi(1.35)(1.22)} (.85) \\
 &= 0.164
 \end{aligned}$$

$$\begin{aligned}
 F_{43} &= F_{42} - F_{41} \\
 &= 0.164 - .014 \\
 &= 0.15
 \end{aligned}$$

Surface resistances

$$\begin{aligned}
 \frac{1 - \epsilon_4}{\epsilon_4 A_4} &= \frac{1 - .06}{.06 \pi (1.35)(1.22)} \\
 &= 3.03
 \end{aligned}$$

$$\begin{aligned}
 \frac{1 - \epsilon_3}{\epsilon_3 A_3} &= \frac{1 - 0.06}{.06 \pi (1.13)(1.5)} \\
 &= 2.94
 \end{aligned}$$

Geometry resistance:

$$\frac{1}{A_1 F_{14}} = 1 / \left(\frac{\pi}{4} (1.13)^2 (.07) \right) = 14.25$$

$$\frac{1}{A_4 F_{43}} = 1 / \left(\pi (1.35)(1.22)(.15) \right) = 1.29$$

$$\frac{1}{A_1 F_{13}} = 1 / \left(\frac{\pi}{4} (1.13)^2 (.88) \right) = 1.13$$

Sum currents

$$\textcircled{1} \quad \frac{2.3 - J_4}{3.03} + 2 \frac{(460 - J_4)}{14.25} + 2 \frac{(J_3 - J_4)}{1.29} = 0$$

($J_3 = J_6$)

$$\textcircled{3} \quad \frac{460 - J_3}{1.13} + \frac{460 - J_3}{2.94} + \frac{J_4 - J_3}{1.29} = 0$$

From $\textcircled{1}$

$$\begin{aligned} .759 - .330 J_4 + 64.56 - .140 J_4 \\ + 1.55 J_3 - 1.55 J_4 = 0 \end{aligned}$$

$$1.55 J_3 - 2.02 J_4 = -65.32$$

From $\textcircled{3}$

$$\begin{aligned} 407.08 - .885 J_3 + 156.46 - .340 J_3 \\ + .775 (J_4 - J_3) = 0 \end{aligned}$$

$$-2.00 J_3 + .775 J_4 = -563.54$$

1.55	-2.02	matrix	-65.32	constants
-2	0.775		-563.54	

-0.27301	-0.71158	
-0.70454	-0.54601	inverse

J3 =	418.8371	solution
J4 =	353.7215	





$$\begin{aligned} Q_A &= (J_4 - E_{b4}) / \frac{1 - \epsilon_4}{\epsilon_4 A_4} \\ &= (353.72 - 2.3) / 3.03 \\ &= 116 \text{ watts} \end{aligned}$$



Long Pump (No Frost)

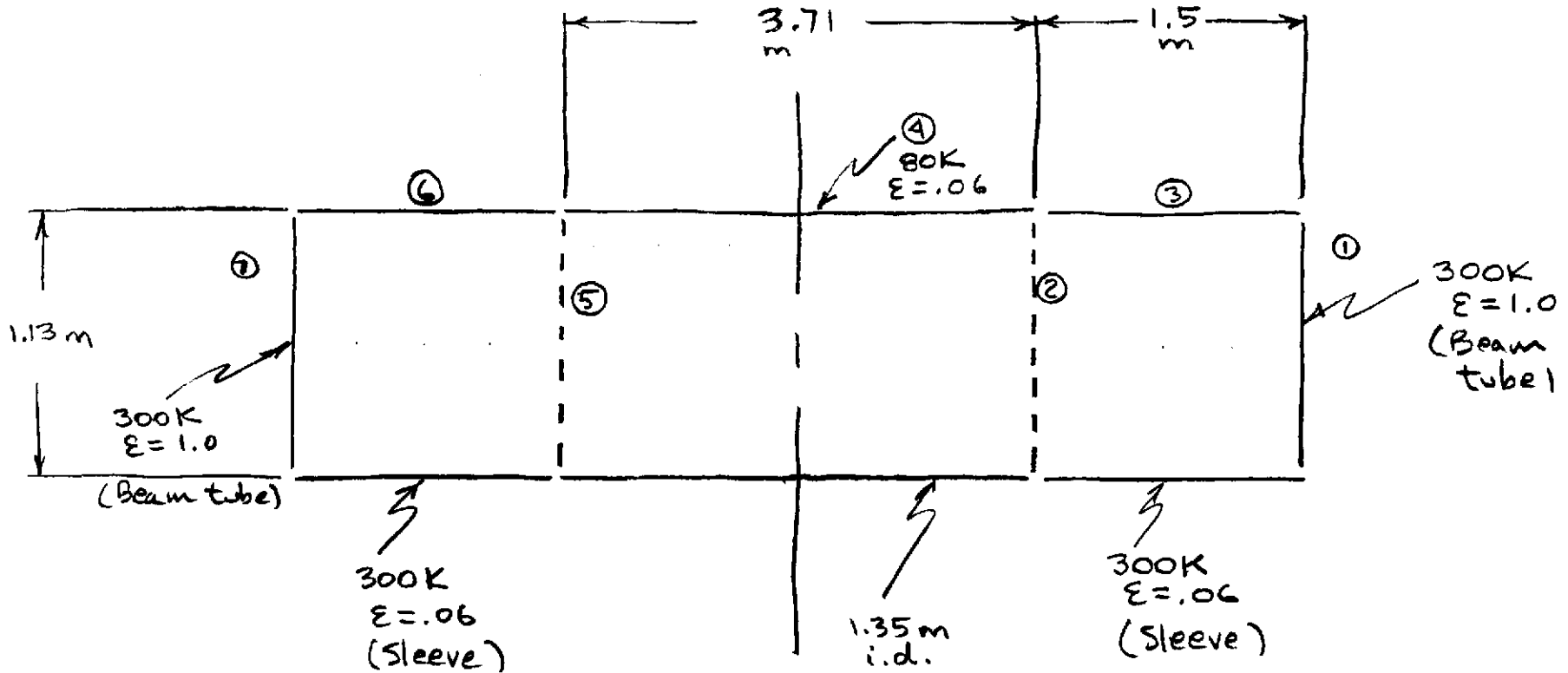

Surfaces ② & ⑤
are fictitious surfaces
used to simplify view factor
calculations.

View Factors :

$$F_{12} : \frac{d}{x} = \frac{1.13}{1.5} = 0.75$$

$$\therefore F_{12} = .12 \quad (\text{Heat Transfer, Holman, 3rd ed., pp 299})$$

$$F_{13} = 1 - F_{12} \\ = .88$$

$$F_{15} : \frac{d}{x} = \frac{1.13}{(1.5+3.71)} = .217$$

$$F_{15} = 0.03$$

$$\therefore F_{14} = F_{12} - F_{15} \\ = .12 - .03 = .09$$

$$F_{17} : \frac{d}{x} = \frac{1.13}{2(1.5)+3.71} = .168 \quad F_{17} = .02$$

$$F_{76} = F_{13} = .88$$

$$F_{41} = \frac{A_1}{A_4} F_{14} = \frac{\pi/4 (1.13)^2}{\pi (1.35)(3.71)} (.09)$$

$$F_{41} = .006$$

$$F_{25} : \frac{d}{x} = \frac{1.13}{3.71} = .30$$

$$F_{25} = .04$$

$$\therefore F_{24} = 1 - F_{25} \\ = .96$$

$$\begin{aligned}
 F_{42} &= \frac{A_2}{A_4} F_{24} \\
 &= \frac{(\pi/4)(1.13)^2}{\pi(1.35)(3.71)} (.96) \\
 &= .061
 \end{aligned}$$

$$\begin{aligned}
 F_{43} &= F_{42} - F_{41} \\
 &= .061 - .006 \\
 &= .055
 \end{aligned}$$

Surface resistances :

$$\begin{aligned}
 \frac{1 - \epsilon_4}{\epsilon_4 A_4} &= \frac{1 - .06}{.06 (\pi)(1.35)(3.71)} \\
 &= 1.00
 \end{aligned}$$

$$\begin{aligned}
 \frac{1 - \epsilon_3}{\epsilon_3 A_3} &= \frac{1 - .06}{.06 (\pi)(1.13)(1.5)} \\
 &= 2.94
 \end{aligned}$$

Geometry resistance :

$$\frac{1}{A_1 F_{14}} = \frac{1}{\frac{\pi}{4}(1.13)^2(.09)} = 11.08$$

$$\frac{1}{A_4 F_{43}} = \frac{1}{\pi(1.35)(3.71)(.055)} = 1.16$$

$$\frac{1}{A_1 F_{13}} = \frac{1}{\frac{\pi}{4}(1.13)^2(.88)} = 1.13$$

Sum currents:

$$\textcircled{4} \quad \frac{2.3 - J_4}{1.00} + 2 \frac{(460 - J_4)}{11.08} + 2 \frac{(J_3 - J_4)}{1.16} = 0$$

($J_3 = J_6$)

$$\textcircled{3} \quad \frac{460 - J_3}{1.13} + \frac{460 - J_3}{2.94} + \frac{J_4 - J_3}{1.16} = 0$$

From $\textcircled{4}$

$$2.30 - 1.00 J_4 + 83.03 - .181 J_4 + 1.72 J_3 - 1.72 J_4 = 0$$

$$1.72 J_3 - 2.90 J_4 = -85.33$$

From $\textcircled{3}$

$$407.08 - .885 J_3 + 156.46 - .340 J_3 + .862 (J_4 - J_3) = 0$$

$$-2.087 J_3 + .862 J_4 = -563.54$$

1.72	-2.9	matrix	-85.33	constants
-2.087	0.862		-563.54	

-0.18864	-0.63462	
-0.45671	-0.3764	inverse

J3=	373.7303	solution
J4=	251.0849	



$$\begin{aligned} Q_1 &= (J_1 - E_{b1}) / \frac{1 - \epsilon_1}{\epsilon_1 A_1} \\ &= (251.08 - 2.3) / 1.00 \\ &= 249 \text{ watts} \end{aligned}$$

22-141 50 SHEETS
22-142 100 SHEETS
22-144 200 SHEETS



V049-1-033

Pg 12 of 23

22-141 50 SHEETS
22-142 100 SHEETS
22-144 200 SHEETS



Pump Radiation Shield Thermal Calculations

V049-1-033

Pg 13 of 23



Short Pump Radiation Shield

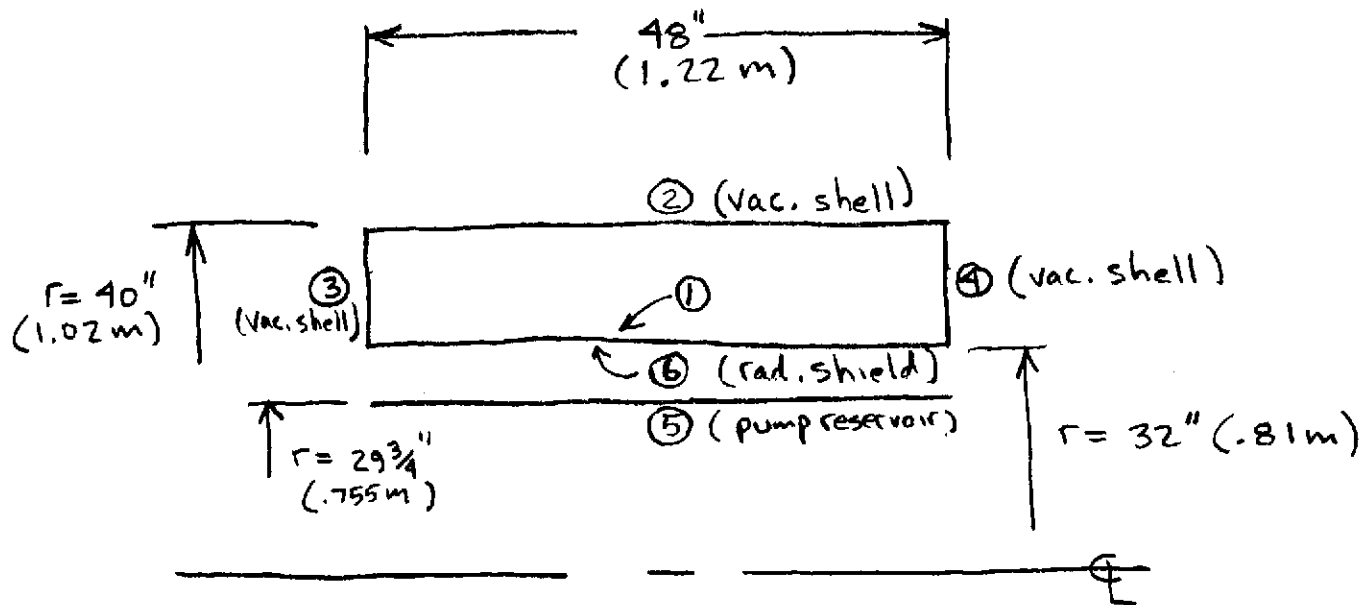

$$A_1 = \frac{2\pi(32)(48)}{(39.4)^2} = 6.22 \text{ m}^2$$

$$A_2 = \frac{2\pi(40)(48)}{(39.4)^2} = 7.77 \text{ m}^2$$

$$A_3 = \pi(40^2 - 32^2) / (39.4)^2 = 1.17 \text{ m}^2$$

$$A_5 = \frac{2\pi(29.75)(48)}{(39.4)^2} = 5.78 \text{ m}^2$$

$$A_4 = A_3 = 1.17 \text{ m}^2$$



Pump Thermal Model with Radiation Shield

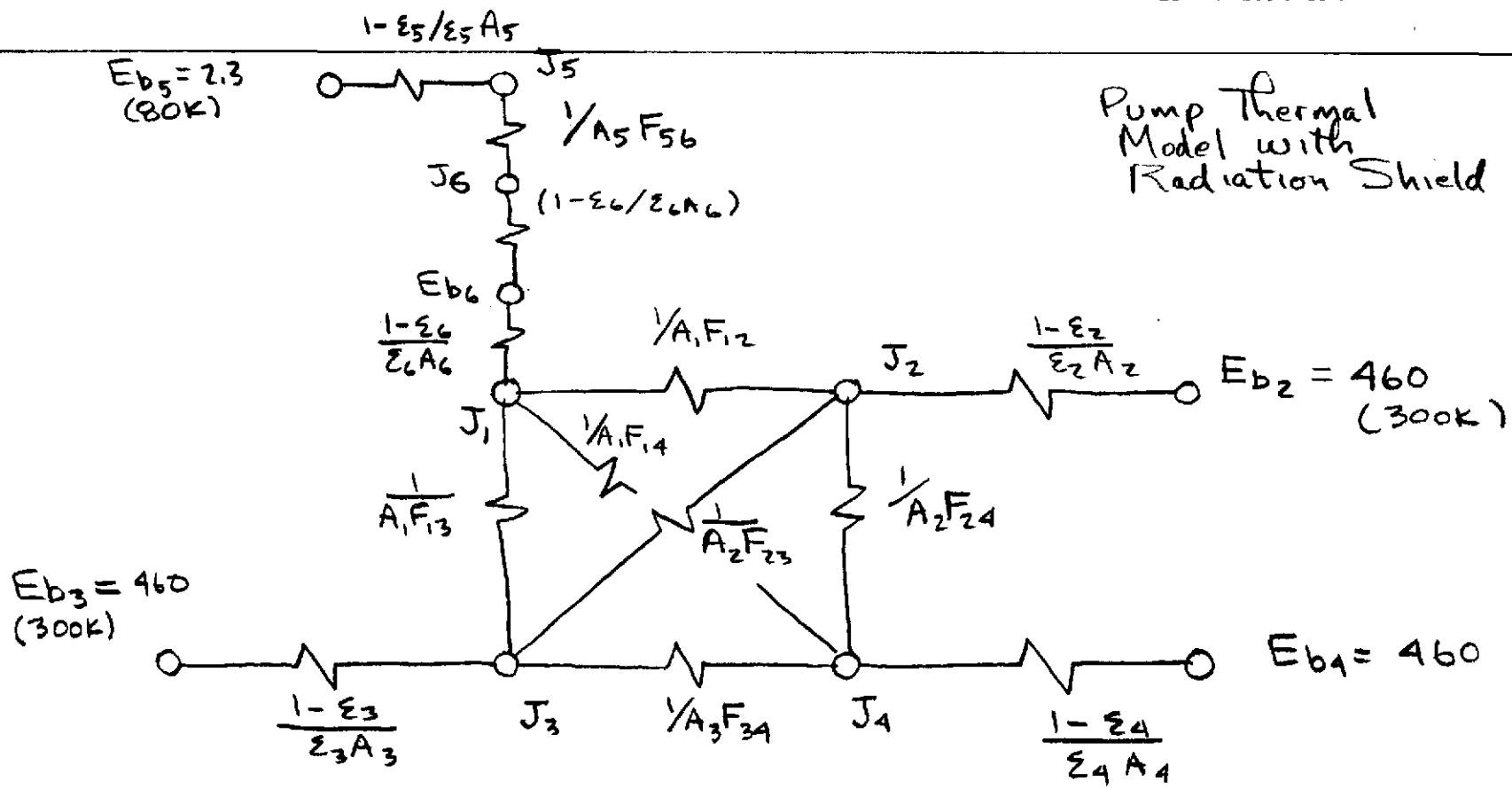

V049-1-033

Pg 15 of 23

Pump View Factor Shield to Chamber

CATALOG OF SELECTED CONFIGURATION FACTORS 789

(Siegel & Howell)

25

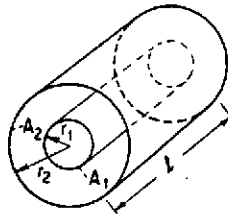

Two concentric cylinders of same finite length.

$$R = \frac{r_2}{r_1} \quad L = \frac{l}{r_1}$$

$$A = L^2 + R^2 - 1$$

$$B = L^2 - R^2 + 1$$

$$F_{2-1} = \frac{1}{R} - \frac{1}{\pi R} \left\{ \cos^{-1} \left(\frac{B}{A} \right) - \frac{1}{2L} \left[\sqrt{(A+2)^2 - (2R)^2} \cos^{-1} \left(\frac{B}{RA} \right) + B \sin^{-1} \left(\frac{1}{R} \right) - \frac{\pi A}{2} \right] \right\}$$

$$F_{2-2} = 1 - \frac{1}{R} + \frac{2}{\pi R} \tan^{-1} \left(\frac{2\sqrt{R^2-1}}{L} \right)$$

$$- \frac{L}{2\pi R} \left\{ \frac{\sqrt{4R^2+L^2}}{L} \sin^{-1} \left[\frac{4(R^2-1) + (L^2/R^2)(R^2-2)}{L^2 + 4(R^2-1)} \right] \right.$$

$$\left. - \sin^{-1} \left(\frac{R^2-2}{R^2} \right) + \frac{\pi}{2} \left(\frac{\sqrt{4R^2+L^2}}{L} - 1 \right) \right\}$$

where for any argument ξ :

$$-\frac{\pi}{2} \leq \sin^{-1} \xi \leq \frac{\pi}{2}$$

$$0 \leq \cos^{-1} \xi \leq \pi$$

Short Pump:

$$R = \frac{40''}{32''} = 1.25$$

$$L = 48/32 = 1.5$$

$$A = 1.5^2 + 1.25^2 - 1 = 2.81$$

$$B = 1.5^2 - 1.25^2 + 1 = 1.69$$

$$\cos^{-1} \left(\frac{B}{A} \right) = .926$$

$$\cos^{-1} \left(\frac{B}{RA} \right) = 1.069$$

$$\sin^{-1} \left(\frac{1}{R} \right) = .927$$

VO49-1-033

Pg 16 of 23

$$F_{2-1} = \frac{1}{1.25} - \frac{1}{\pi(1.25)} \left\{ .926 - \frac{1}{2(1.5)} \left[\sqrt{4.81^2 - 2.5^2} \right. \right. \\ \left. \left. \times 1.069 + 1.69(.927) - \frac{\pi(2.81)}{2} \right] \right\}$$

$$F_{2-1} = .695 \text{ (Results same for long pump)}$$

From view factor algebra

$$A_1 F_{1-2} = A_2 F_{2-1}$$

$$F_{1-2} = \frac{A_2}{A_1} F_{2-1} = \frac{D_2}{D_1} F_{2-1}$$

$$\therefore F_{1-2} = \left(\frac{80}{64} \right) (.695)$$

$$\underline{F_{1-2} = .869}$$

$$F_{2-2} : \tan^{-1} \left(\frac{2\sqrt{1.25^2 - 1}}{1.5} \right) = .7854$$

$$\sin^{-1} \left(\frac{1.25^2 - 2}{1.25^2} \right) = -.284$$

$$\frac{\sqrt{4(1.25)^2 + (1.5)^2}}{1.5} = 1.944$$

$$\sin^{-1} \left(\frac{4(1.25^2 - 1) + (1.5^2 / 1.25^2)(1.25^2 - 2)}{1.5^2 + 4(1.25^2 - 1)} \right) = .368$$



$$F_{2-2} = 1 - \frac{1}{1.25} + \frac{2}{\pi(1.25)} (.785)$$

$$- \frac{1.5}{2\pi(1.25)} \left\{ 1.944(.368) - (-.284) + \frac{\pi}{2}(1.302 - 1) \right\}$$

$$F_{2-2} = .318$$

From view factor algebra

$$F_{2-1} + F_{2-2} + F_{2-3} + F_{2-4} = 1.0$$

$$.695 + .318 + 2F_{2-3} = 1.0 \quad \left(\begin{array}{l} \text{Not exactly} \\ = 1.0 \text{ due to} \\ \text{round-off error} \end{array} \right)$$

$$\therefore F_{2-3} < .01 \quad (\text{Use } .01)$$

$$\nmid F_{2-4} < .01$$

$$\nmid F_{1-2} + F_{1-3} + F_{1-4} = 1.0$$

$$F_{1-2} + 2F_{1-3} = 1.0$$

$$.869 + 2F_{1-3} = 1.0$$

$$F_{1-3} = .0655$$

$$F_{1-4} = .0655$$

$$A_2 F_{2-3} = A_3 F_{3-2}$$

$$F_{3-2} = \left(\frac{7.77}{1.17} \right) (.01) = .066$$

$$A_1 F_{1-3} = A_3 F_{3-1}$$

$$F_{3-1} = \left(\frac{6.22}{1.17} \right) (.0655) = .348$$

$$F_{3-1} + F_{3-2} + F_{3-4} = 1.0$$

$$\therefore F_{3-4} = .586$$

$$\nmid F_{4-3} = .586$$

$$\nmid F_{1-5} \approx 1.0$$

$$E_{b5} = \sigma(80)^4 = 2.3 \text{ w/m}^2$$

$$E_{b2} = E_{b3} = E_{b4} = \sigma(300)^4 = 460 \text{ w/m}^2$$

Unknowns: J_1, J_2, J_3 ; $J_3 = J_4$ by symmetry
 J_6, E_{b6}, J_5

$$\frac{1 - \epsilon_5}{\epsilon_5 A_5} = \frac{1 - .06}{.06(5.78)} = 2.710$$

$$\frac{1 - \epsilon_3}{\epsilon_3 A_3} = \frac{1 - 0.3}{0.3(1.17)} = 1.999$$

$$\frac{1 - \epsilon_2}{\epsilon_2 A_2} = \frac{1 - 0.3}{0.3(7.77)} = 0.300$$

$$\frac{1 - \epsilon_4}{\epsilon_4 A_4} = 1.999$$

$$\frac{1 - \epsilon_6}{\epsilon_6 A_6} = \frac{1 - .06}{.06(6.22)} = 2.519$$

$$\frac{1}{A_1 F_{12}} = \frac{1}{6.22(.869)} = .185$$

$$\frac{1}{A_1 F_{13}} = \frac{1}{6.22(.0655)} = 2.455$$

$$\frac{1}{A_2 F_{29}} = \frac{1}{7.77(.01)} = 12.87$$

$$\frac{1}{A_1 F_{14}} = \frac{1}{6.22(.0655)} = 2.455$$

$$\frac{1}{A_2 F_{23}} = \frac{1}{7.77(.01)} = 12.87$$

$$\frac{1}{A_3 F_{39}} = \frac{1}{1.17(.586)} = 1.459$$

$$\frac{1}{A_1 F_{15}} = \frac{1}{6.22(1.0)} = .1608$$

$$\frac{1}{A_5 F_{56}} = \frac{1}{5.78(1.0)} = .1730$$

Sum the currents into the nodes

$$\textcircled{1} \quad J_1: \quad \frac{E_{b6} - J_1}{2.519} + \frac{J_2 - J_1}{.185} + \frac{J_2 - J_1}{2.455} + \frac{J_4 - J_1}{2.455} = 0 \quad \checkmark$$

$$\textcircled{2} \quad J_2: \quad \frac{J_1 - J_2}{.185} + \frac{460 - J_2}{0.300} + \frac{J_3 - J_2}{12.87} + \frac{J_4 - J_2}{12.87} = 0$$

$$\textcircled{3} \quad J_3: \quad \frac{460 - J_3}{1.994} + \frac{J_1 - J_3}{2.455} + \frac{J_2 - J_3}{12.87} + \frac{J_4 - J_3}{1.459} = 0$$

$$\textcircled{4} \quad J_4: \quad \frac{460 - J_4}{1.994} + \frac{J_2 - J_4}{12.87} + \frac{J_1 - J_4}{2.455} + \frac{J_3 - J_4}{1.459} = 0$$

(not an independent equation)

$$\textcircled{5} \quad J_5: \quad \frac{2.3 - J_5}{2.710} + \frac{J_6 - J_5}{.1730} = 0$$

$$\textcircled{6} \quad J_6: \quad \frac{J_5 - J_6}{.1730} + \frac{E_{b6} - J_6}{2.519} = 0$$

$$\textcircled{7} \quad E_{b6}: \quad \frac{J_6 - E_{b6}}{2.519} + \frac{J_1 - E_{b6}}{2.519} = 0$$

$$\text{From } \textcircled{1} \quad .397E_{b6} - .397J_1 + 5.405J_2 - 5.405J_1 + .107J_3 - .407J_1 \\ + .407J_3 - .407J_1 = 0$$

$$.397E_{b6} = 6.618J_1 + 5.405J_2 + .814J_3 = 0$$

$$\text{From } \textcircled{2} \quad 5.405J_1 - 5.405J_2 + 1533.33 - 3.333J_2 + .0777J_3$$

$$- .0777J_2 + .0777J_3 - .0777J_2 = 0$$

$$5.405J_1 - 8.893J_2 + .1554J_3 = -1533.33$$

$$\text{From } \textcircled{3} \quad 230.692 - .502J_3 + .407J_1 - .407J_3$$

$$+ .0777J_2 - .0777J_3 = 0$$

$$.407J_1 + .0777J_2 - .987J_3 = -230.692$$

$$\begin{aligned} \text{From } \textcircled{5} \quad .849 - .369 J_5 + 5.78 J_6 - 5.78 J_5 &= 0 \\ -6.149 J_5 + 5.78 J_6 &= -.849 \end{aligned}$$

$$\begin{aligned} \text{From } \textcircled{6} \quad 5.78 J_5 - 5.78 J_6 + .397 E_{b6} - .397 J_6 &= 0 \\ 5.78 J_5 - 6.177 J_6 + .397 E_{b6} &= 0 \end{aligned}$$

$$\begin{aligned} \text{From } \textcircled{7} \quad .397 J_6 - .397 E_{b6} + .397 J_1 - .397 E_{b6} &= 0 \\ .397 J_1 + .397 J_6 - .794 E_{b6} &= 0 \end{aligned}$$

$$\begin{bmatrix} -6.618 & 5.405 & .814 & 0 & 0 & .397 \\ 5.405 & -8.893 & .1554 & 0 & 0 & 0 \\ .407 & .0777 & -.987 & 0 & 0 & 0 \\ 0 & 0 & 0 & -6.149 & 5.78 & 0 \\ 0 & 0 & 0 & 5.78 & -6.177 & .397 \\ .397 & 0 & 0 & 0 & .397 & -.794 \end{bmatrix} \begin{bmatrix} J_1 \\ J_2 \\ J_3 \\ J_5 \\ J_6 \\ E_{b6} \end{bmatrix} = \begin{bmatrix} 0 \\ -1533 \\ -230.692 \\ -.849 \\ 0 \\ 0 \end{bmatrix}$$



-6.618	5.405	0.814	0	0	0.397	0
5.405	-8.893	0.1554	0	0	0	-1533.33
0.407	0.0777	-0.987	0	0	0	-230.692
0	0	0	-6.149	5.78	0	-0.849
0	0	0	5.78	-6.177	0.397	0
0.397	0	0	0	0.397	-0.794	0

-0.37828	-0.23296	-0.34865	-0.12942	-0.137687	-0.25798	
-0.23296	-0.25607	-0.23244	-0.0797	-0.084793	-0.15888	
-0.17433	-0.11622	-1.17524	-0.05964	-0.063452	-0.11889	
-0.12942	-0.0797	-0.11929	-1.8271	-1.770734	-0.95008	
-0.13769	-0.08479	-0.1269	-1.77073	-1.883779	-1.01073	
-0.25798	-0.15888	-0.23778	-0.95008	-1.010733	-1.8938	

(Matrix inversion)

solution

J1= 437.7435
 J2= 446.3248
 J3= 449.3749
 J5= 151.283
 J6= 160.7942
 Eb6= 299.2688

∴ Heat load on pump reservoir is

$$\frac{J_5 - E_{b5}}{\left(\frac{1 - \epsilon_5}{\epsilon_5 A_5}\right)} = \frac{151.28 - 2.3}{2.71}$$

$$= 55 \text{ watts}$$

For long pump the load may be scaled up by the length ratios to give a good approximation

$$\therefore Q_{\text{Long Pump}} = 55 \left(\frac{146''}{48''}\right)$$

$$= 167 \text{ watts}$$

$$\text{Shield temp} = \left(\frac{299.27}{5.67 \times 10^{-8}}\right)^{1/4} = 269.5 \text{ K}$$

Calculation of Heat Load From Ends of 80K Pump *

For floating shield, the temperature of the shield was calculated from the computer model of the single pump shield as 269.5 K

$$\begin{aligned}
 \text{Area of ends: } A &= \frac{\pi}{4} (D_o^2 - D_i^2) \times 2 \text{ ends} \\
 &= \frac{\pi}{4} (57.5^2 - 53^2) \times 2 \times 6.45 \\
 &= 5038 \text{ cm}^2
 \end{aligned}$$

$$\begin{aligned}
 Q &= \sigma A \epsilon F (T_1^4 - T_2^4) \\
 &= (5.67 \times 10^{-12}) (5038) (.06) ((269.5)^4 - (80)^4) \\
 &= \underline{9.0 \text{ watts}}
 \end{aligned}$$

* Ends of pump LN₂ reservoir are shielded from pump vacuum chamber.



PROCESS SYSTEMS INTERNATIONAL, INC.
WESTBOROUGH, MA

ENGINEERING
CALCULATIONS

NO: V049-1-037

PAGE 1 OF 7

REV.	DEO #	DATE	BY:	CHECK
0	0091	1/9/96	D. Moore	D. Moore
1	0056	1/30/96	D. Moore	D. Moore

TITLE: Steady State LN₂ Pump Requirements for 80K Pump and Two Phase Flow Regime Calculations for Supply Line

By: David Moore DEPT.: 744

PROJECT: LIGO

PROJECT NO: V59049

PURPOSE: To determine LN₂ consumption for 80K pump & determine supply line size / two phase flow regime

METHOD: Standard methods on a spreadsheet and use of published charts for two phase flow.

ASSUMPTIONS: Steady state conditions

INPUTS: Heat flux calculations

REFERENCES:

1. LIGO doc. # V049-1-033
2. Published charts for two phase flow in vertical & horizontal pipes
3. Nitrogen properties from GASPAC (see pg. 8)

CALCULATIONS: (SEE ATTACHED)

CONCLUSIONS:

1. Short pump consumption: range = .0224 - .0619 gpm
2. Long pump consumption: range = .0479 - .0781 gpm
3. Use 1/2" pipe for supply line. Slug flow unavoidable if supply line downstream of control valve is vertical.

NOTES:

LN2 Requirements for
80K pumps

1/30/96

Heat Load Summary
(watts)

	Short Pump Clean	Short Pump Frosted	Long Pump Clean	Long Pump Frosted
Beam Tube Load	116	499	249	546
Vac. chamber	64	64	176	176
Supports (est.)	9	9	14	14
Pump subtotal	189	572	439	736
VJ pipe (55')	6.06	6.06	6.06	6.06
Valves (3)	12.1	12.1	12.1	12.1
Bayonets	12.39	12.39	12.39	12.39
Supply line subtotal	30.55	30.55	30.55	30.55
Pump & supply line total (watts)	219.55	602.55	469.55	766.55
LN2 Consump. (gpm)				
-pump	0.01926359	0.05830038	0.04474453	0.0750159
-supply line	0.00311377	0.00311377	0.00311377	0.0031138
Total (gpm)	0.02237736	0.06141416	0.0478583	0.0781297

V049-1-037

Pg 2 of 7

LIGO 80K Pump

1/30/96

Flow Regime in
supply line

```
+-----+
|Two Phase Flow|
|Horizontal pipe|
+-----+
```

Pipe dia. 1/2 in. 0.0562 ft.

		Long pump Clean	Long Pump Frosted	Short Pump Clean	Short Pump Frosted
Transf. line					
heat leak	watts	30.55	30.55	30.55	30.55
Pump heat leak	watts	439	736	189	736
Total heat leak	watts	469.55	766.55	219.55	766.55
Mixture quality		0.11970043	0.09493444	0.19248617	0.10559136
Liquid Flow Rate	gpm	0.0478583	0.0781297	0.02237736	0.06141416
Liquid Flow Rate	lb/min.	0.3206762	0.52351077	0.14994028	0.41150771
Vapor Flow Rate	lb/min.	0.03838508	0.0496992	0.02886143	0.04345166
Liquid density	lb/ft**3	50.12	50.12	50.12	50.12
Vapor density	lb/ft**3	0.3293	0.3293	0.3293	0.3293
Surface tension	dyne/cm	12.26	12.26	12.26	12.26
Liquid viscosity	cp	0.1449	0.1449	0.1449	0.1449
Mixture velocity	ft/sec	0.82636998	1.08446858	0.60911571	0.94194922
Lambda(flow param.)		1.87943254	1.87943254	1.87943254	1.87943254
Psi(flow param.)		1.100466	1.100466	1.100466	1.100466
Pipe area	ft**2	0.00248	0.00248	0.00248	0.00248
Gf(flow/unit area)	lb/hr				
	-ft**2	7758.29523	12665.5832	3627.58738	9955.83179
Gg(flow/unit area)	lb/hr				
	-ft**2	928.67129	1202.4	698.260403	1051.24984
Gg/lambda		494.123237	639.767576	371.52725	559.344279
Gf(lambda)(Psi)/Gg		17.2785643	21.7861051	10.7449362	19.5873182
Flow Regime		stratified	stratified	stratified	stratified

V049-1-037

Pg 3 of 7

+-----+
 | Two Phase Flow |
 | Vertical pipe |
 +-----+

Volumetric gas					
fraction	Fv	0.94796708	0.93527163	0.96699312	0.94142174
Froude No.	NFr	0.37783024	0.65070118	0.20528029	0.49091084
Flow Regime		slug	slug	slug	slug

The boundaries between flow regimes are not sharp and the pictures used to describe them represent idealized descriptions of a very complex distribution of phases.

Figure 9 shows the flow regimes which have been identified by Baker [6] in a horizontal pipe, and Fig. 10 is the flow regime map. The slug and plug regimes are

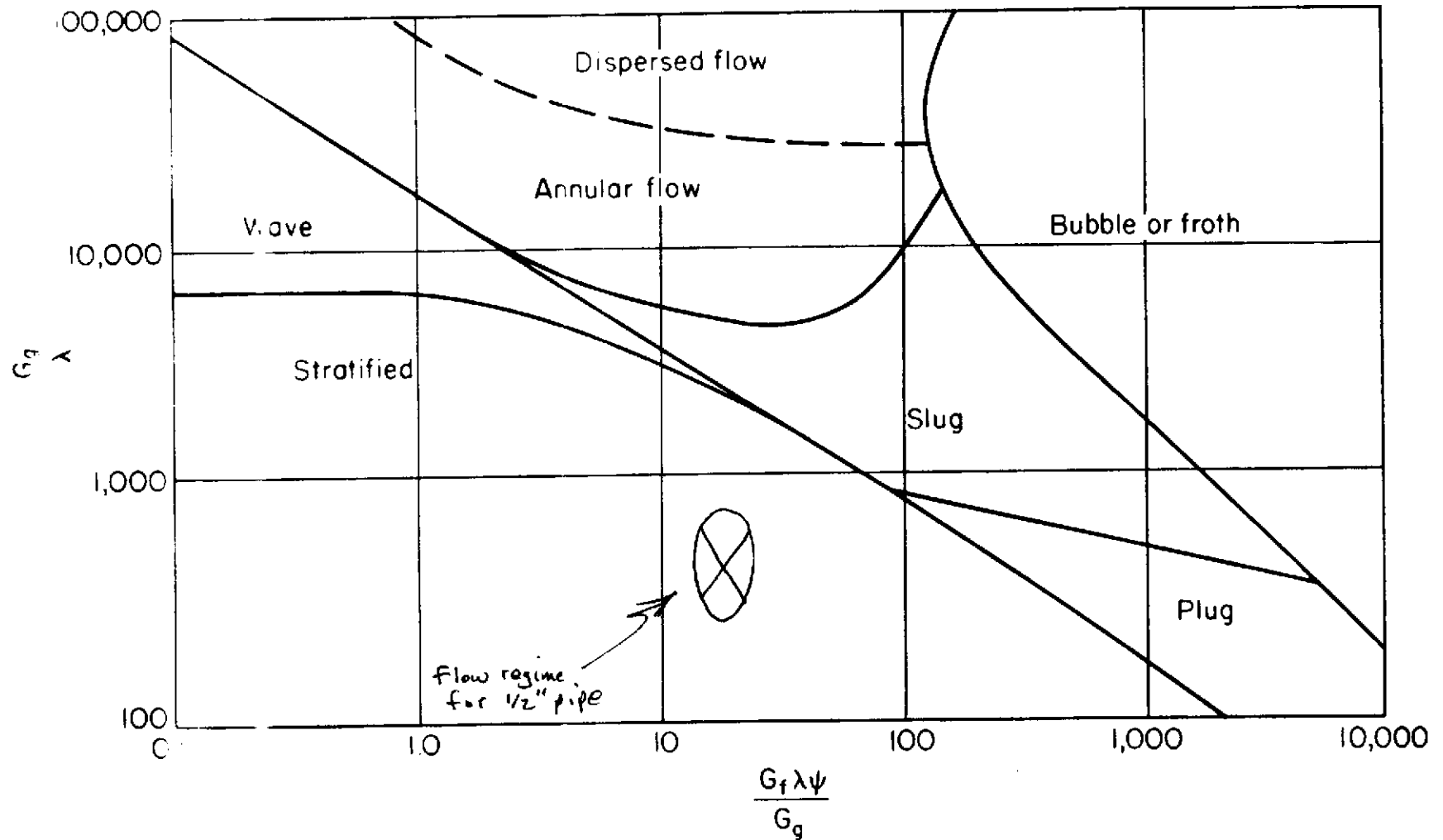
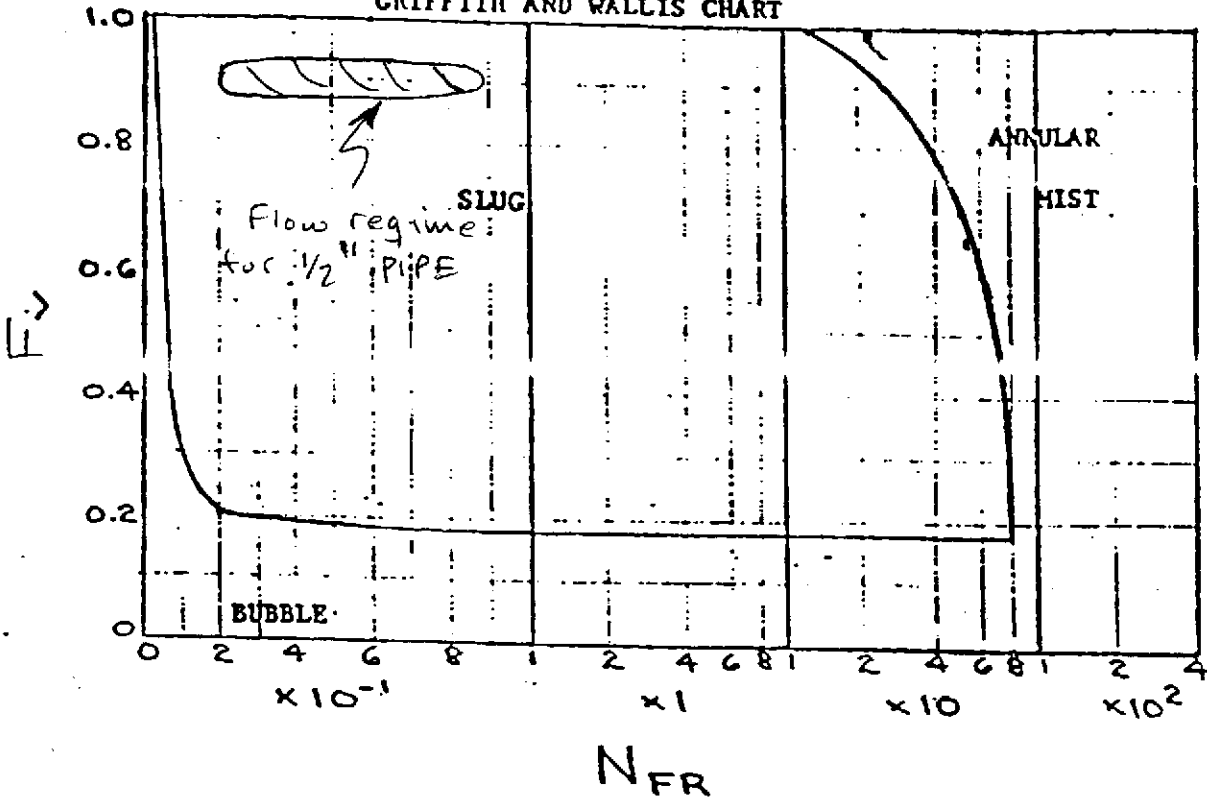

Fig. 10. Flow regime map for a horizontal pipe [6].

II. FLOW REGIME

B) Vertical Lines

GRIFFITH AND WALLIS CHART



Nomenclature:

- F_v - $Q_G / (Q_G + Q_L)$, flowing volumetric gas fraction
- N_{FR} - $\frac{(V_m)^2}{(g_c)(D_p)}$, Froude Number
- Q_G - gas flow, $ft^3/sec.$
- Q_L - liquid flow, $ft^3/sec.$
- V_m - $\frac{(Q_G + Q_L)}{(A_p)}$, two phase mixture velocity, $ft/sec.$
- A_p - cross sectional area of pipe, ft^2
- D_p - diameter of pipe, ft
- g_c - gravitational constant, $32.2 ft/sec^2$

Nitrogen

```

INPUT NEW VALUE ONLY FOR TEMP          INPUT 1
QUIT                                    INPUT Q
YOUR CHOICE .....                      P
  
```

NAME THE FIRST INPUT VARIABLE
 (B BACKS UP ONE STEP, Q STOPS, ? FOR HELP)..... PRESS

NAME THE SECOND INPUT VARIABLE
 (B BACKS UP ONE STEP, Q STOPS, ? FOR HELP)..... SAT

INPUT VALUE OF PRESSURE [PSI] 29.7

FLUID = NITROGEN

PRESSURE [PSI]	TEMP [K]	DENSITY [LB/PT3]	CP [J/G-K]	QUALITY [-]	ENTHALPY [J/G]	VISC [LBM/FT-S]
29.70	83.88	48.54	2.088	0.0000	-107.8	0.8097E-04
29.70	83.88	0.5525	1.179	1.000	81.76	0.3888E-05

```

DECIDE WHAT TO DO NEXT:
RETURN TO THE MAIN MENU          INPUT M
SELECT NEW INPUT PARAMETERS     INPUT P
INPUT NEW VALUE ONLY FOR PRESSURE INPUT 1
QUIT                              INPUT Q
YOUR CHOICE .....
  
```

NAME THE SECOND INPUT VARIABLE
 (B BACKS UP ONE STEP, Q STOPS, ? FOR HELP)..... ENTHALPY

INPUT VALUE OF PRESSURE [PSI] 17

INPUT INITIAL VALUE OF ENTHALPY [J/G] -107.8

INPUT ITS INCREMENT (0 FOR ONE POINT)..... 0

FLUID = NITROGEN

PRESSURE [PSI]	TEMP [K]	DENSITY [LB/PT3]	CP [J/G-K]	QUALITY [-]	ENTHALPY [J/G]	VISC [LBM/PT-S]
17.00	78.62	50.12	2.066	0.0000	-118.8	0.9726E-04
47.00	78.62	5.313	0.0000	0.5578E-01	-107.8	0.0000
17.00	78.62	0.3293	1.132	1.000	78.17	0.3613E-05

```

DECIDE WHAT TO DO NEXT:
RETURN TO THE MAIN MENU          INPUT M
SELECT NEW INPUT PARAMETERS     INPUT P
INPUT NEW VALUES FOR BOTH PARAMETERS INPUT B
INPUT NEW VALUE ONLY FOR PRESSURE INPUT 1
INPUT NEW VALUES ONLY FOR ENTHALPY INPUT 2
QUIT                              INPUT Q
YOUR CHOICE .....
  
```

VO49-1-037

PROCESS SYSTEMS INTERNATIONAL, INC. WESTBOROUGH, MA					ENGINEERING CALCULATIONS	NO: V049-1-072 PAGE 1 OF 15
REV.	DEO #	DATE	BY:	CHECK	TITLE: 80K Pump Roughdown ΔP Analyses	
0		3/19/96	DM	R. Bar.		
					BY: David Moore	DEPT.: 744
PROJECT: LIGO					PROJECT NO: V59049	
<p><u>PURPOSE: Determine if any significant pressure differential exists across the 5/16" gap separating the low e liner and the thermal radiation shield in the 80K pump during pumpdown which could structurally damage either of these components.</u></p>						
<p><u>METHOD: Computer simulation of the roughdown of the 80K pump chamber volume. The computer program is a finite difference code which utilizes the Newton- Raphson method to solve the system equations.</u></p>						
<p><u>ASSUMPTIONS: The gap which separates the low e liner and the radiation shield is modelled as a short pipe of equivalent diameter with entrance and exit losses equal to 1.5 velocity heads. The roughing process is assumed to be executed with the turbo backing pump, whose speed (90 cu. m./hr.) is approximately constant during the pressure range of interest.</u></p>						
<p><u>INPUTS: Input file attached.</u></p>						
<p><u>REFERENCES:</u></p>						
<p><u>CALCULATIONS: Related calculations attached.</u></p>						
<p><u>CONCLUSIONS: Delta P across the gap is insignificant. No significant structural loads.</u></p>						

Roughdown of Short 80K Pump Gate Valves Closed

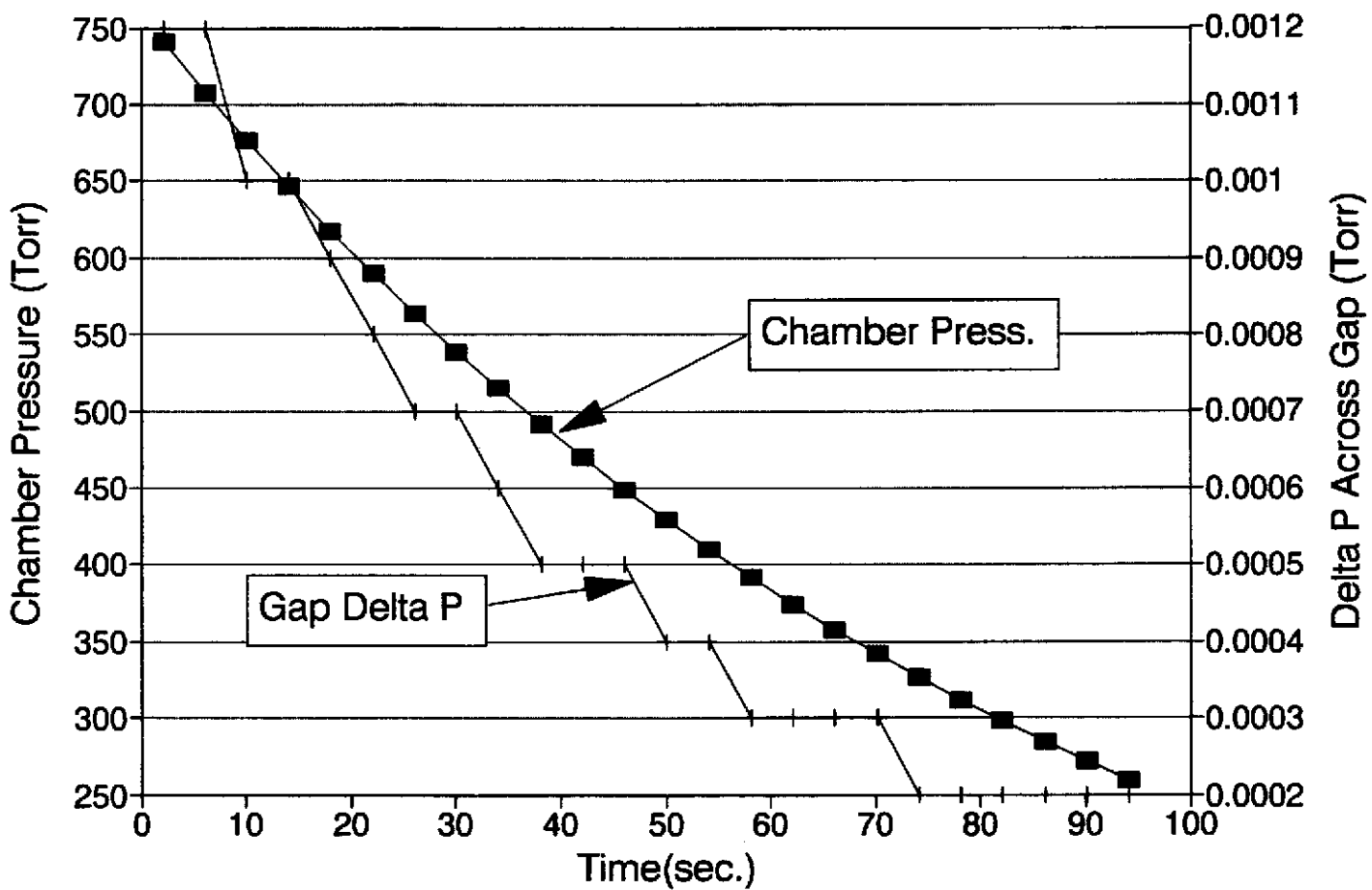

```

FLUID BCD 3GENERAL
BCD 9 PRESS. VS TIME IN 80K PUMP CHAMBER
BCD 9 ROUGHDOWN CHAMBER WITH TURBO BACKING PUMP
END
BCD 3PRESSURE DATA
REM NODE #, ELEVATION, INIT PRESS; ETC.
-1, 0., 760.$
5, 0., 760.$
10, 0., 760.$
9999, 0., 1.0 $ DUMMY PRESSURE NODE
END
BCD 3TUBE DATA
C ABS TUBE #, INIT NODE, TERM NODE, A(REF #, ARRAY DATA)
TUB 10, 1, 5, A1, 0.0$
TUB 30, 1, 5, A1, 0.0$
PMI -20, 5, 10, A5, 0.0$
END
BCD 3CONSTANTS DATA
GRAV=32.2 $
GC1=89.6606 $CONVERSION TO TORR
GC2=1.0 $
USRFLO=0.1 $
C SPARE6 = 0. (1.) CAUSES "DEBUG" TO BE .FALSE. (.TRUE.).
SPARE6 = 1. $
C SPARE7 = 0. (1.) CAUSES "NOFERR" TO BE .FALSE. (.TRUE.).
SPARE7 = 1. $
C THE FOLLOWING LINE CAUSES ORDER REDUCTION TO BE SUPRESSED.
ISOLVE = 2
C THE FOLLOWING PARAMETERS CONTROL CONVERGENCE FOR THE FLUID
C NETWORK SOLUTION AND OVERRIDE THE DEFAULT VALUES ...
KMAX=100 $
PRSABS=0.001 $
PRSREL=0.001 $
FLOABS=0.0001 $
FLOREL=0.0001 $
NDIM=10000$
NFLOOP= 10
PRLXCA= 0.001
EPS=0.01
PMPTOL=0.005
1=0.0 $ TOTAL MASS OUTFLOW, OUTER CHAM. VOLUME
5=0.0 $ TOTAL MASS OUTFLOW, INNER CHAM. VOLUME
10=760. $ PRESSURE IN OUTER CHAM. VOLUME (TORR)
50=760. $ PRESSURE IN INNER CHAM. VOLUME (TORR)
60=0. $ DELTA P
100= 0.0 $ ELAPSED TIME
200= .0662 $ PUMP FLOW
1000=2627. $ INITIAL AIR MASS, OUTER CHAM. VOLUME, GM.
2=16.0 $ TIME COUNTER
3=.075 $ INITIAL AIR DENSITY
6=.125 $ TIME STEP (SEC.)
END
BCD 3ARRAY DATA
REM L , D , K , E/D , FIVE EMPTY FIELDS
1, .125, .624, 1.50, .00018, 0.0, 0.0, 0.0, 0.0, 0.0, END$ANNULUS
C--- PUMP CHARACTERISTICS
C--- MASS FLOW RATE VS. (DOWNSTREAM - UPSTREAM PRESS.)
5, .0, 15., 1.0, 15., END
C--- PUMP DOWN CURVE
7, 4., .0004, 13., .0011, 22., .0019, 27., .0024, 34., .0030

```

43.,.0037,53.,.0047,67.,.0058,85.,.0073
135.,.0117,170.,.0149,220.,.0190,355.,.0310
460.,.0398,590.,.0512,760.,.0662,END

END

BCD 3EXECUTION

C---- OBTAIN PUMP MASS FLOW FROM CHAMBER PRESSURE

D1DEG1(XK10,A7,XK200)

F OPEN(UNIT=7,FILE='PRESS.OUT',ACCESS='SEQUENTIAL',

F + STATUS='OLD',FORM='FORMATTED')

F WRITE(7,50)

F 50 FORMAT(5X,'TIME(SEC)',5X,

F + 'DP(TORR)',1X,'P1(TORR)',/)

F 100 CONTINUE

C---- SET PUMP MASS FLOW

M W20=XK200

F CONTINUE

FLDSOL

F CALL PMPFLO

M IF(P1.GE.250.0)THEN

F CONTINUE

M IF(XK2.LE.0.)THEN

F CALL DATPRT

F 105 CONTINUE

F END IF

M XK2=XK2-1.0

F GO TO 100

F ELSE

F CONTINUE

F END IF

F CLOSE(UNIT=7)

END

BCD 3VARIABLES F

REM DYNAMIC VISCOSITY UNITS = LBM/FT-SEC

TUBE(10,.0000123,K3,80.)

C TUBE(20,.0000123,K3,80.)

TUBE(30,.0000123,K3,80.)

END

BCD 3VARIABLES 1

END

BCD 3VARIABLES 2

END

BCD 3OUTPUT CALLS

M IF(XK2.LE.0.)THEN

F CALL PPRINT

F CALL WPRINT

F ELSE

F CONTINUE

F END IF

CM IF(XK60.GE.2.0)THEN

CM WRITE(7,800)XK100,XK60,P1

CM ELSE

CM CONTINUE

CM END IF

F 800 FORMAT(5X,',',',',F9.2,',',',',F8.2,',',',',F8.2)

END

BCD 3SINROUTINE PMPFLO

C---- COMPUTE MASS OUTFLOW DURING SELECTED TIME STEP

M XK1=(W10+W30)*XK6*453.6

M XK5=W20*XK6*453.6

```

C---- COMPUTE DELTA P ACROSS GAP
M      XK60=ABS(P5-P1)
C---- COMPUTE NEW PRESSURE IN CHAMBER OUTER VOLUME
C
C---- OUTER VOLUME
M      XK10=.289*(XK1000-XK1)
M      P1=XK10
C
C---- COMPUTE ELAPSED TIME
M      XK100=XK100+XK6
C---- COMPUTE REMAINING AIR MASS
M      XK1000=XK1000-XK1
CM     XK5000=XK5000-XK5
C--- COMPUTE AIR DENSITY
M      XK3=XK1000/34926.
C----- UPDATE PUMP FLOW RATE
          D1DEG1(XK10,A7,XK200)
M      W20=XK200
C
          END
          BCD 3SINROUTINE DATPRT
M      IF(XK2.LE.0.)THEN
M      XK2=16.0
F      END IF
M      WRITE(6,200)XK1,XK5
M      WRITE(6,300)XK100
M      WRITE(6,400)XK1000
M      WRITE(6,700)XK10
M      WRITE(6,600)XK200
M      WRITE(6,980)XK3
M      WRITE(7,800)XK100,XK60,P1
M      CONTINUE
C
F 200   FORMAT(/,5X,'MASS OUTFLOW FROM OUTER VOL.= ',F10.4,' GRAMS',
F      +   /,5X,'MASS OUTFLOW FROM INNER VOL.= ',F10.4,' GRAMS',/)
F 300   FORMAT(5X,'ELAPSED TIME = ',F10.3,' SEC.')
F 400   FORMAT(5X,'REMAINING MASS, OUTER CHAM.= ', F10.2,' GRAMS')
F 500   FORMAT(5X,'REMAINING MASS, INNER CHAM.= ', F10.2,' GRAMS')
F 600   FORMAT(/,5X,'PUMPFLOW= ',F10.4,' LBM/SEC')
F 700   FORMAT(/,5X,'OUTER CHAMBER PRESS= ',F10.4)
F 800   FORMAT(5X,' ',F9.2,' ',F10.4,' ',F8.2)
F 980   FORMAT(5X,'AIR DENSITY= ',F6.4,1X,'LBM/FT^3')
          END
          BCD 3END OF DATA

```

22-141 50 SHEETS
22-142 100 SHEETS
22-144 200 SHEETS



Appendix
(Related Calculations)

Pumpdown of 80K Pump Chamber (Small Chamber)

22-141 50 SHEETS
22-142 100 SHEETS
22-144 200 SHEETS

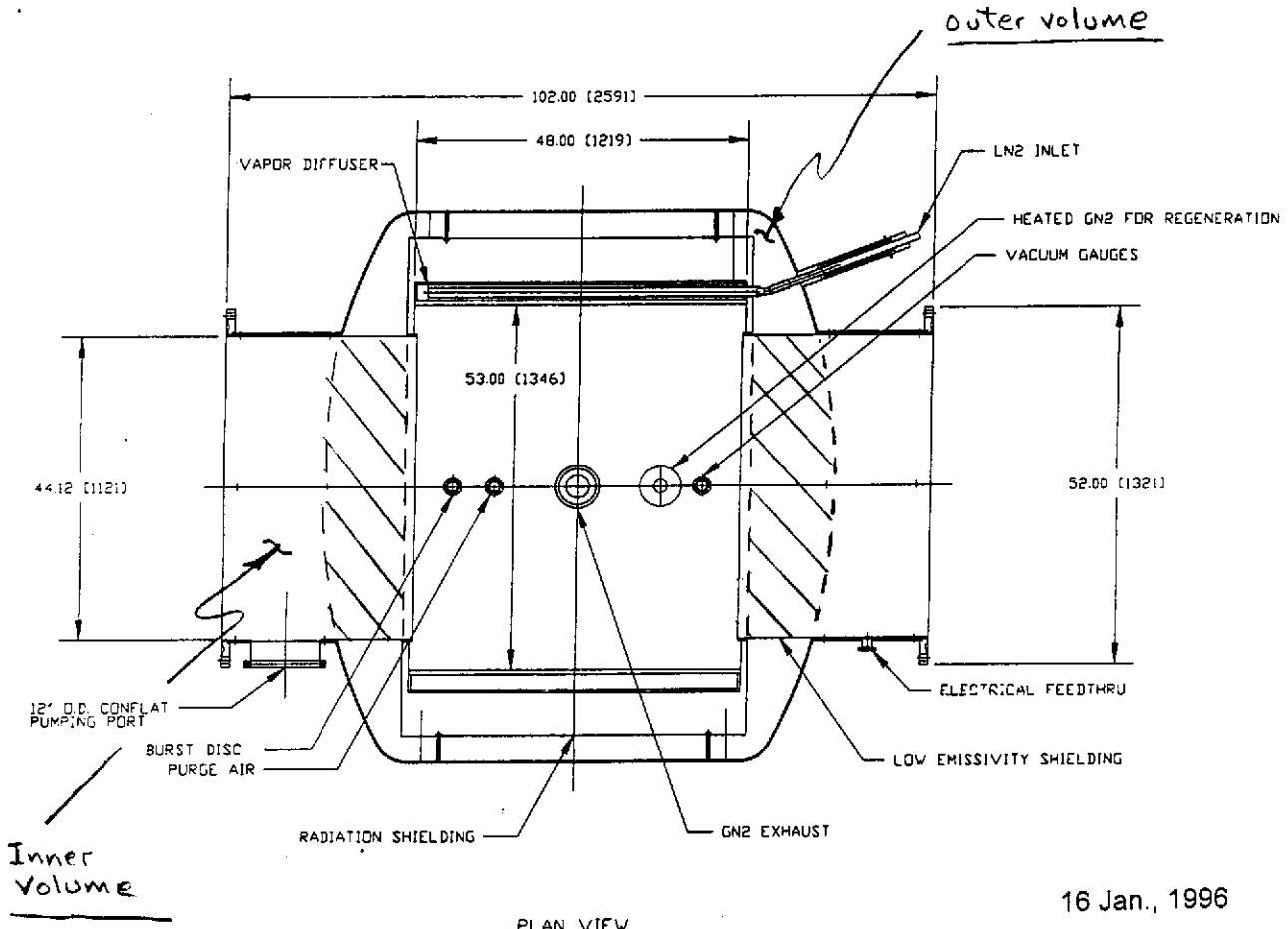

16 Jan., 1996

PLAN VIEW

Calculation of Volumes

Calculate the outer chamber volume (ref: sketch) by calculating the gross chamber volume bounded by the chamber shell & heads, & subtracting out the volume inside the thermal radiation shield & the cross-hatched volume in the sketch:

$$\begin{aligned}\text{Shell: } V &= \frac{\pi d^2}{4} \times \text{length} \\ &= \frac{\pi (79\frac{1}{2})^2}{4} (48) \\ &= 238,147 \text{ in}^3 (3.89 \text{ m}^3)\end{aligned}$$

Heads:

Volume of elliptically dished head is approximated by:

$$\begin{aligned}V &= 7.6 \times 10^{-5} d_i^3 && d_i: \text{in.} \\ \therefore V &= 7.6 \times 10^{-5} (79\frac{1}{2})^3 && V: \text{ft}^3 \\ &= 38.19 \text{ ft}^3\end{aligned}$$

For 2 heads, $76.37 \text{ ft}^3 (2.16 \text{ m}^3)$

\therefore Gross chamber volume (excluding the protruding beam ports) is:

$$\begin{array}{r} 2.16 \\ + 3.89 \\ \hline 6.05 \text{ m}^3 \end{array}$$



Volume inside the radiation shield:

$$\begin{aligned}
 V &= \frac{\pi}{4} d^2 \times \text{length} \\
 &= \frac{\pi}{4} (72)^2 \times (50) \\
 &= 203,472 \text{ in}^3 \quad (3.33 \text{ m}^3)
 \end{aligned}$$

Volume inside cross-hatched volume:

Approximate as cylinders $44\frac{1}{8}$ " dia. \times $10\frac{3}{4}$ " high

$$\begin{aligned}
 \therefore \text{Vol} &= 2 \times \frac{\pi}{4} d^2 \times \text{length} \\
 &= 2 \left(\frac{\pi}{4} \right) \left(44\frac{1}{8} \right)^2 \left(10\frac{3}{4} \right) \\
 &= 32877 \text{ in}^3 \quad (.54 \text{ m}^3)
 \end{aligned}$$

\therefore Outer chamber volume is

$$6.05 - (3.33 + .54) = 2.18 \text{ m}^3$$

#

The inner volume to be evacuated is the volume between closed gate valves. This includes the volume inside the radiation shield, the beam tube ports, and the spool piece on one end of the pump.

Beam tube ports:

$$\begin{aligned} V &= 2 \times \frac{\pi d_i^2}{4} \times \text{length} \\ &= 2 \left(\frac{\pi}{4} \right) \left(44 \frac{1}{8} \right)^2 \left(26 \frac{1}{4} \right) \\ &= 80282 \text{ in}^3 \quad (1.31 \text{ m}^3) \end{aligned}$$

Spool piece:

$$\begin{aligned} V &= \frac{\pi}{4} \left(44 \frac{5}{8} \right)^2 (36) \\ &= 56277 \text{ in}^3 \quad (.92 \text{ m}^3) \end{aligned}$$

∴ Total inner volume is:

$$3.33 + 1.31 + .92 = 5.56 \text{ m}^3$$



Mass of air in chamber :

Outer chamber volume initial air mass :

$$V = 2.18 \text{ m}^3$$

$$m = \rho V = 2.18 \text{ m}^3 \left(2.65 \frac{\text{lbm}}{\text{m}^3} \right) \\ = 5.79 \text{ lbm} \quad (2627 \text{ gm.})$$

Inner volume :

$$V = 5.56 \text{ m}^3$$

$$m = 5.56 (2.65) \\ = 14.73 \text{ lbm} \quad (6689 \text{ gm.})$$

//

Computations for computer simulation :

Density :

$$\rho = \frac{m}{V}$$

For the outer chamber volume

$$\rho = \frac{\text{XK1000}}{2180} \text{ gm./Liter}$$

$$\text{or } \rho = \left(\frac{\text{XK1000}}{2180} \frac{\text{gm}}{\text{Liter}} \right) \left(\frac{\text{Liter}}{.03532 \text{ ft}^3} \right) \left(\frac{\text{lbm}}{453.6 \text{ gm}} \right)$$

$$\rho = \left(\frac{\text{XK1000}}{34926} \right) \frac{\text{lbm}}{\text{ft}^3}$$



Pressure computation

$$P = \frac{mRT}{VM}$$

$$M = 28.97 \frac{\text{gm}}{\text{mole}}$$

$$R = 62.36 \frac{\text{torr} \cdot \text{l}}{\text{mole} \cdot \text{K}}$$

$$P = \frac{m(62.36)(293)}{V(28.97)}$$

$$P = 630.703 (m/V)$$

∴ Outer volume :

$$P = 630.703 (m/2180)$$

$$P = .289 m \text{ torr}$$

Inner volume :

$$P = 630.703 (m/5560)$$

$$= .113 m \text{ torr}$$



Turbo Backing Pump Curve

Pump has an approximately constant speed (90 m³/hr) for the pressures of interest.

<u>Pressure (Torr)</u>	<u>S (acfm)</u>	<u>ρ (lbm/ft³)</u>	<u>\dot{m} (lbm/sec)</u>
760	53.0 ↓	.0749	.0662
590		.0580	.0512
460		.0451	.0398
355		.0351	.0310
220		.0215	.0190
170		.0169	.0149
135		.0133	.0117
85		.0083	.0073
67		.0066	.0058
53		.0053	.0047
43		.0042	.0037
34		.0034	.0030
27		.0027	.0024
22		.0022	.0019
13		.0013	.0011
4		.0004	.0004

22-141 50 SHEETS
 22-142 100 SHEETS
 22-144 200 SHEETS



Pumpdown of 80K Pump Chamber

Fluid Flow Model:

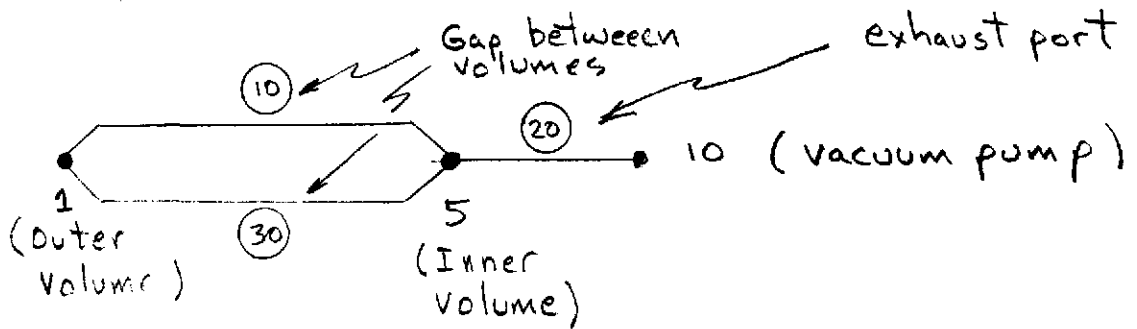

22-141 50 SHEETS
22-142 100 SHEETS
22-144 200 SHEETS



80 K Cryopump
Annular Gap

For performance considerations, the annular gap area should be as large as the turbo inlet port (10" i.d.)

For one gap:

$$\frac{A}{2} = \frac{\pi}{4} (D_o^2 - D_i^2) \quad (\text{Area of one gap} = \frac{1}{2} \text{ total})$$

D_i defined by low e shield (44.62")

$$\frac{1}{2} \times \frac{\pi}{4} (10^2) = \frac{\pi}{4} (D_o^2 - 44.62^2)$$

$$D_o = 45.18'' \text{ say } 45 \frac{1}{4}''$$

$$\begin{aligned} \therefore \text{Gap} &= (45 \frac{1}{4} - 44 \frac{5}{8}) / 2 \\ &= .3125 \text{ (} 5/16'' \text{)} \end{aligned}$$

The equivalent pipe diameter of a 5/16" gap is

$$\frac{\pi}{4} (45 \frac{1}{4}^2 - 44 \frac{5}{8}^2) = \frac{\pi}{4} d_{\text{equiv}}^2$$

$$d_{\text{equiv}} = 7.49''$$

CUSTOMER: LIGO

JOB NO:V59049

PAGE: 1

PRESSURE DROP ROUTE OR LINE ID:

PRESSURE: 100000.0 Pa 1.000 BAR
 TEMPERATURE: 293.000 K 293.000 K
 DENSITY : 1.150 KG/M³ 0.115E+01 KG/M³
 QUALITY : 1.000

ITEMNAME	FLOWRATE KG/S	I.D. METER	K / DO	CV	LENGTH M	PRESSURE Pa	Z1 METER	Z2 METER	DP-F Pa	DP-Z Pa	DP-T Pa	DP-SUM Pa	DENSITY KG/M ³	VELOCITY M/S	RE NO
EQ PIPE LENGTH	0.800E-03	0.0900			1.00	99999.99	0.00	0.00	0.01	0.00	0.01	0.01	0.115E+01	0.109	0.642E+03
EXPANSION LOSS	0.800E-03	0.0900	1.5000			99999.982	0.00	0.00	0.01	0.00	0.01	0.02	0.115E+01		
TOTAL									0.0179	0.0000		0.0179			

$0.018 \text{ Pa} = 0.0001 \text{ Torr} \checkmark$

$\frac{1}{2} \rho V^2 = \frac{1}{2} 11 \cdot 0.1^2 = 0.0055 \text{ Pa}$

No collapse problem due to pumpdown.

PROCESS SYSTEMS INTERNATIONAL, INC. WESTBOROUGH, MA					ENGINEERING CALCULATIONS	NO: V049-1-096 PAGE 1 OF 12
REV.	DEO #	DATE	BY:	CHECK	TITLE: Regen. System Process Calculations	
0	130	4/19/96	D Moore	J.W.W.		
					BY: D. Moore	DEPT.: 744
<u>PROJECT: LIGO</u>					<u>PROJECT NO: V59049</u>	

PURPOSE: Determine process requirements for the 80K pump regen. heaters, and to estimate the warmup time (time to reach 150 deg. C) for the pump under wintertime conditions in Washington.

METHOD: Standard heat transfer manual calculations and on spreadsheet format.

ASSUMPTIONS: Used weather conditions for Kennewick, Washington: 15 deg. F dry bulb (Above this temperature 97.5% of the time.)

INPUTS: Max. regen flowrate = 100 gm/sec for long pump; 50 gm/sec for short pump. N2 temperature from the vaporizer = -5 deg. F (20 deg. F approach temp. specified by mfg.)

REFERENCES:

CALCULATIONS: See attached.

CONCLUSIONS: Long pump heater size: 25 kw adequate. Short pump heater size: 12 kw adequate. Estimated warmup times, including liquid vaporization: long pump = 16.75 hrs., short pump = 8.0 hrs.

80K Pump Regeneration Process Calculations

Sizing of Regen Heaters:

Heaters must be sized to deliver hot N_2 gas to the 80K pumps. The 80K pumps are to be heated to $302^\circ F$ ($150^\circ C$). Assuming a $20^\circ F$ approach temperature, the gas temperature entering the cryopump should be about $325^\circ F$.

Wintertime Operation:

Using available design data, size the heater for $15^\circ F$ dry bulb wintertime conditions (see Attachment 1). Assume a 10 m.p.h. wind blowing across the line supplying the regen. gas to the cryopump. \therefore Calculate the temperature exiting the heater in order to overcome heat losses from the supply line.



Heat Loss thru 60 ft. of regen pipe:

Long pump:

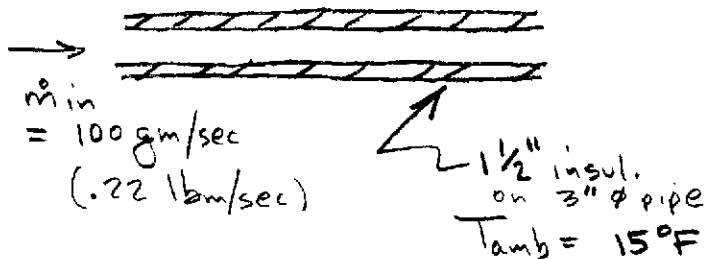

$$T_{out} = 325^\circ \text{F}$$

$$T_{in} = ?$$

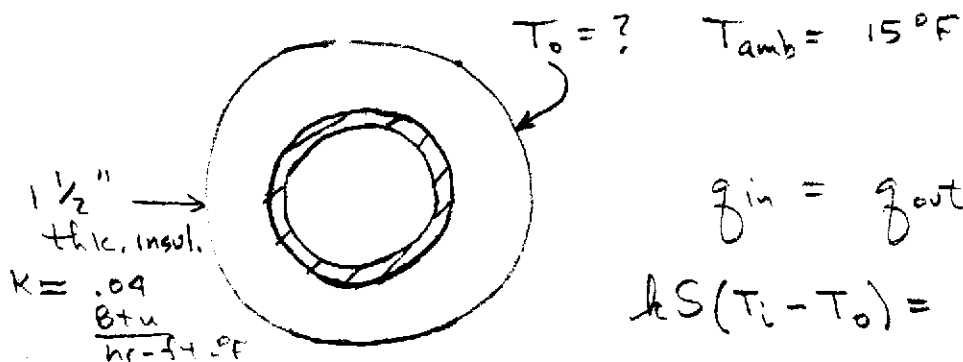

$$kS(T_i - T_o) = hA(T_o - T_{amb})$$

$$S = \frac{2\pi L}{\ln(r_o/r_i)}$$

$$= \frac{2\pi(1.0)}{\ln(6.5/3.5)} = 10.15 \text{ ft}$$

Assume 10 mph wind

$$A = 2\pi r_o L$$

$$= 2\pi \left(\frac{3.25}{12} \right) (1.0)$$

$$= 1.70 \text{ ft}^2/\text{ft}$$

$$Re = \frac{D_o u_{\infty}}{\nu_f} = \frac{\rho_f D_o u_{\infty}}{\mu_f}$$



$$10 \frac{\text{mile}}{\text{hr}} \left(\frac{5280 \text{ ft}}{\text{mile}} \right) = 52800 \frac{\text{ft}}{\text{hr}}$$

$$Re = \frac{\left(\frac{6.5}{12} \right) (52800) (.064)}{.04}$$

$$M_f = .04 \frac{\text{lb}_m}{\text{hr-ft}}$$

$$= 60000$$

$$\frac{hD_o}{k_f} = 170 \text{ (see pg 7)}$$

$$h = \frac{170 (.0135)}{(6.5/12)}$$

$$= 4.24 \text{ Btu/hr-ft}^2\text{-}^\circ\text{F}$$

To account for radiation, say $h = 4.5 \frac{\text{Btu}}{\text{hr-ft}^2\text{-}^\circ\text{F}}$

$$\therefore .04(10.15)(325 - T_0) = 4.5(1.70)(T_0 - 15)$$

$$131.95 - .406T_0 = 7.65T_0 - 114.75$$

$$8.06T_0 = 246.7$$

$$T_0 = 30.6 \text{ }^\circ\text{F}$$

$$\begin{aligned} \therefore q &= kS(T_i - T_0) \\ &= .04(10.15)(325 - 30.6) \\ &= 119.5 \frac{\text{Btu}}{\text{hr-ft}} \end{aligned}$$

for 60 ft of pipe

$$q = 119.5(60) = 7172 \text{ Btu/hr}$$



∴ Calculate the temp drop of the N₂ inside the pipe

$$q = \dot{m} c_p \Delta T$$

$$7172 = .22(3600)(.25) \Delta T$$

$$\Delta T = 36^\circ \text{F}$$

N₂ temp in needs to be

$$\begin{array}{r} 325 \\ + \quad 36 \\ \hline 361^\circ \text{F} \end{array} \quad \text{say } 360^\circ \text{F}$$

~~4~~

Short pump

1/2" ϕ pipe
(1.9" o.d.)

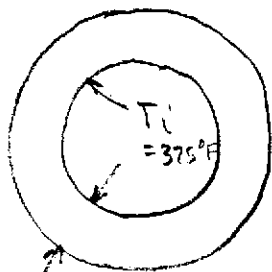

1/2" insul

50 gm/sec
(.11 km/sec)

$$S = \frac{2\pi(1.0)}{\ln(4.9/1.9)} = 6.63 \text{ ft}$$

$$A = 2\pi \left(\frac{4.9}{2(12)} \right) (1.0) = 1.28 \text{ ft}^2/\text{ft}$$

10 m.p.h. wind

$$Re = \frac{\left(\frac{4.9}{12} \right) (52800) (.084)}{.04} = 45300$$

$$\frac{h D_o}{k_f} = 150 \quad (\text{see pg 7})$$

$$h = \frac{150 (.0135)}{(4.9/12)}$$

$$= 4.96 \text{ Btu/hr-ft}^2\text{-}^\circ\text{F}$$

say $5.5 \text{ Btu/hr-ft}^2\text{-}^\circ\text{F}$

$$kS(T_i - T_o) = hA(T_o - T_{amb})$$

$$.04(6.63)(325 - T_o)$$

$$= 5.5(1.28)(T_o - 15)$$

$$86.19 - .265T_o = 7.04T_o - 105.6$$

$$191.8 = 7.305T_o$$

$$T_o = 26.3^\circ\text{F}$$

$$q = kS(T_i - T_o)$$

$$= .04(6.63)(325 - 26.3)$$

$$= 79.21 \text{ Btu/hr-ft}$$

for 60 ft of pipe

$$q = 60(79.21) = 4753 \text{ Btu/hr}$$

∴ Temp drop of N_2 :

$$q = \dot{m}c_p\Delta T$$

$$4753 = .11(3600)(.25)\Delta T$$

$$\Delta T = 48^\circ\text{F}$$

∴ T_{in} must be

$$\frac{325}{+ 48}$$

$$373 \text{ (say } 375^\circ\text{F)}$$





Fig. 6-9 Data for heating and cooling of air flowing normal to single cylinders, from McAdams [10].

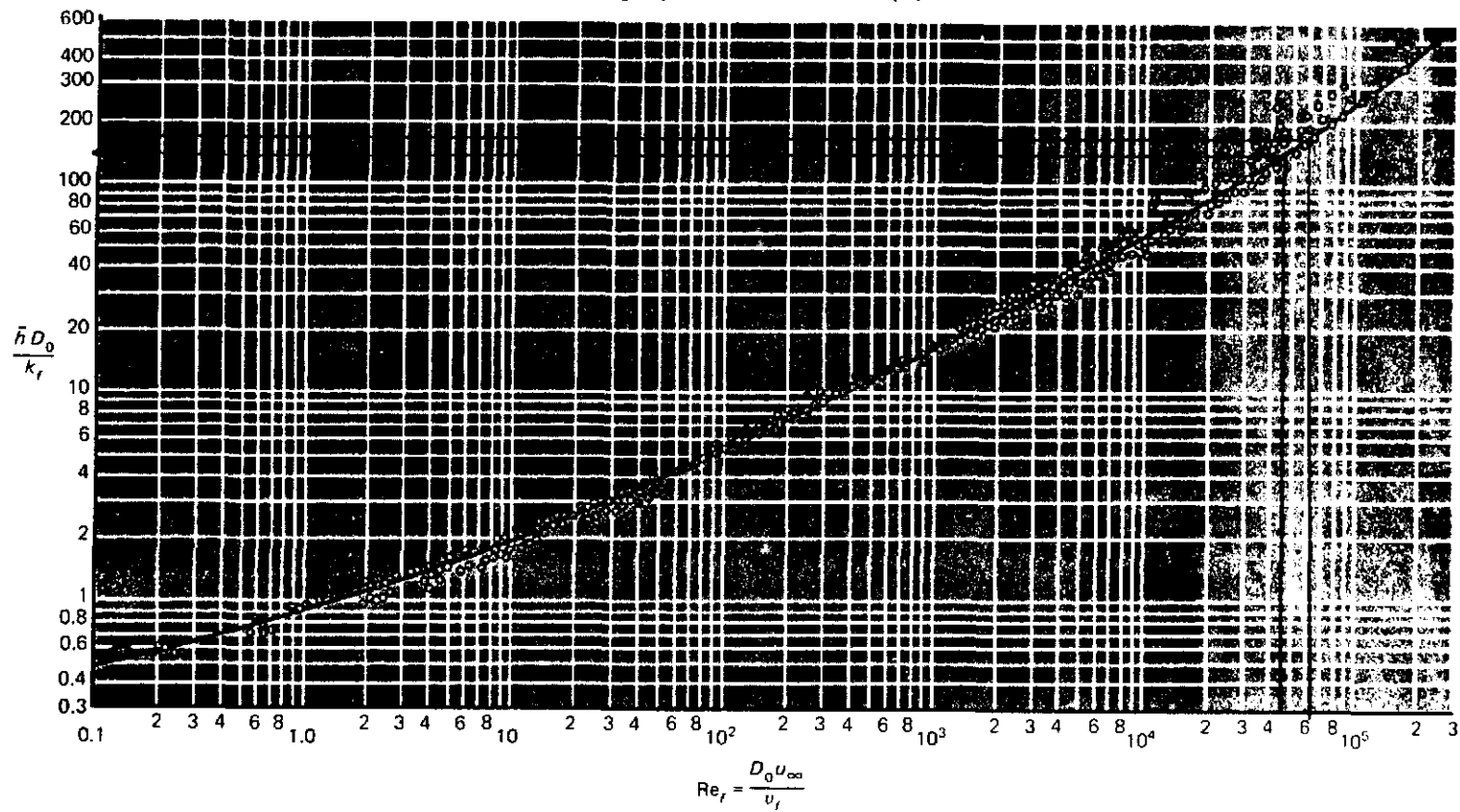

Pg 7 of 12
V049-1-096 REV C

Regen Heater Sizes:

Vaporizer design is based on 20°F approach temp. ∴ the N₂ gas out of the vaporizer will be 15°F - 20°F = -5°F (253 K)

Long pump:

100 gm/sec. flowrate at 253K
raised to 455K (360°F)

$$Q = \left(100 \frac{\text{gm}}{\text{sec}}\right) (472.8 - 262) \frac{\text{J}}{\text{gm}}$$
$$= 21080 \text{ watts}$$

(Heater size approx 25 kW)

100 gm/sec → 10572 SCFH (say 10600 SCFH)

Short pump:

50 gm/sec. flowrate at 253K raised to
464K (375°F)

$$Q = 50 \frac{\text{gm}}{\text{sec}} (482.3 - 262) \text{ J/gm}$$
$$= 11015 \text{ watts (Heater size approx 12 kW)}$$

50 gm/sec → say 5300 SCFH



Time to vaporize LN₂:

Long pump: ~ 1700 lbm of LN₂ (772,700 gm)
Purge gas flow = 100 gm/sec.
@ 253K

$$(\dot{m} \Delta h)_{N_2 \text{ gas}} = \dot{m} h_{fg}$$

$$\dot{m}_{\text{vaporized}} = \frac{(\dot{m} \Delta h)_{N_2 \text{ gas}}}{h_{fg}}$$

$$= \frac{(100 \text{ gm/sec})(262 - 79.6) \text{ J/gm}}{(78.4 + 118.1) \text{ J/gm}}$$

$$= 92.8 \text{ gm/sec. (.204 lbm/sec)}$$

∴ Time to vaporize is:

$$t = \frac{1702 \text{ lbm}}{.204 \text{ lbm/sec}}$$

$$= 8324 \text{ sec (2.3 hr.)}$$

Short pump: ~ 550 lbm of N₂

Purge gas flow = 50 gm/sec.

$$\dot{m}_{\text{vaporized}} = \frac{(50)(262 - 79.6)}{(78.4 + 118.1)}$$

$$= 46.4 \text{ gm/sec (.102 lbm/sec)}$$

∴ Time to vaporize is:

$$t = \frac{550}{.102} = 5392 \text{ sec (1.5 hr.)}$$



Long Pump Regen.
Warmup Time
Winter Conditions

N2 flow (gm/sec)	Cp of N2 (j/gm-K)	N2 in (K)	N2 out (K)	Cp alum. (j/gm-K)	Initial alum. temp (K)	Final alum. temp. (K)	Alum. mass (gm.)	Elapsed time (sec)
50	1.05	253	80	0.357	80	100	1341000	1054.2
50	1.05	253	100	0.481	100	120	1341000	2660.22
50	1.05	253	120	0.58	120	140	1341000	4888.02
50	1.05	253	140	0.654	140	160	1341000	7844.66
50	1.05	253	160	0.713	160	180	1341000	11761.2
50	1.05	253	180	0.76	180	200	1341000	17079.7
50	1.05	253	200	0.797	200	220	1341000	24761.9
100	1.05	436	220	0.826	220	240	1341000	25738.7
100	1.05	436	240	0.849	240	260	1341000	26845.1
100	1.05	436	260	0.869	260	280	1341000	28106.3
100	1.05	436	280	0.886	280	300	1341000	29557
100	1.05	436	300	0.902	300	320	1341000	31251.1
100	1.05	436	320	0.918	320	340	1341000	33272.5
100	1.05	436	340	0.934	340	360	1341000	35757.6
100	1.05	436	360	0.934	360	380	1341000	38896.7
100	1.05	436	380	0.934	380	400	1341000	43156.8
100	1.05	436	400	0.934	400	420	1341000	49783.8
100	1.05	436	420	0.934	420	423	1341000	52020.4

Time to vaporize LN2 = 2.3 hours
Total warmup time = 16.75 hours

Short Pump Regen.
Warmup Time
Winter Conditions

N2 flow (gm/sec)	Cp of N2 (j/gm-K)	N2 in (K)	N2 out (K)	Cp alum. (j/gm-K)	Initial alum. temp (K)	Final alum. temp. (K)	Alum. mass (gm.)	Elapsed time (sec)
50	1.05	253	80	0.357	80	100	398000	312.879
50	1.05	253	100	0.481	100	120	398000	789.537
50	1.05	253	120	0.58	120	140	398000	1450.73
50	1.05	253	140	0.654	140	160	398000	2328.25
50	1.05	253	160	0.713	160	180	398000	3490.66
50	1.05	253	180	0.76	180	200	398000	5069.16
50	1.05	253	200	0.797	200	220	398000	7349.16
50	1.05	436	220	0.826	220	240	398000	7928.97
50	1.05	436	240	0.849	240	260	398000	8585.73
50	1.05	436	260	0.869	260	280	398000	9334.34
50	1.05	436	280	0.886	280	300	398000	10195.5
50	1.05	436	300	0.902	300	320	398000	11201.1
50	1.05	436	320	0.918	320	340	398000	12400.9
50	1.05	436	340	0.934	340	360	398000	13876.1
50	1.05	436	360	0.934	360	380	398000	15739.4
50	1.05	436	380	0.934	380	400	398000	18268.2
50	1.05	436	400	0.934	400	420	398000	22201.8
50	1.05	436	420	0.934	420	423	398000	23529.5

Time to vaporize LN2 = 1.5 hours
Total warmup time = 8.036 hours

Attachment 1.

Table C-1 (Cont.)

STATE AND STATION	WINTER		SUMMER			STATE AND STATION	WINTER		SUMMER		
	Latitude	DB 97%	DB 2%	WB 2%	Outdoor Daily Range		Latitude	DB 97%	DB 2%	WB 2%	Outdoor Daily Range
Lubbock AP	33	15	97	72	26	Everett-Paine AFB	47	24	78	65	20
Lufkin AP	31	28	96	80	20	Kennewick	46	15	96	68	30
McAllen	26	38	100	79	21	Longview	46	24	86	66	30
Midland AP	32	23	98	73	26	Moses Lake, Larson AFB	47	-1	93	66	32
Mineral Wells AP	32	22	100	77	22	Olympia AP	47	25	83	65	32
Palestine CO	31	25	97	79	20	Port Angeles	48	29	73	58	18
Pampa	35	11	98	72	26	Seattle-Boeing Fld.	47	27	80	65	24
Pecos	31	19	100	71	27	Seattle CO	47	32	79	65	19
Plainview	34	14	98	72	26	Seattle-Tacoma AP	47	24	81	64	22
Port Arthur AP	30	33	92	80	19	Spokane AP	47	4	90	64	28
San Angelo, Goodfellow AFB	31	25	99	75	24	Tacoma-McChord AFB	47	24	81	66	22
San Antonio AP	29	30	97	77	19	Walla Walla AP	46	16	96	68	27
Sherman-Perrin AFB	33	23	99	78	22	Wenatchee	47	9	92	66	32
Snyder	32	19	100	74	26	Yakima AP	46	10	92	67	36
Tempe	31	27	99	78	22	WEST VIRGINIA					
Tyler AP	32	24	97	79	21	Beckley	37	6	88	73	22
Vernon	34	18	101	76	24	Bluefield AP	37	10	86	73	22
Victoria AP	28	32	96	79	18	Charleston AP	38	14	90	75	20
Waco AP	31	26	99	78	22	Clarksburg	39	7	90	75	21
Wichita Falls AP	34	19	100	76	24	Elkins AP	38	5	84	73	22
UTAH						Huntington CO	38	14	93	76	22
Cedar City AP	37	6	91	64	32	Martinsburg AP	39	10	94	77	21
Logan	41	7	91	65	33	Morgantown AP	39	7	88	74	22
Moab	38	16	98	65	30	Parkersburg CO	39	12	91	76	21
Ogden CO	41	11	92	65	33	Wheeling	40	9	89	75	21
Price	39	7	91	64	33	WISCONSIN					
Provo	40	6	93	66	32	Appleton	44	-6	87	74	23
Richfield	38	3	92	65	34	Ashland	46	-17	83	71	23
St. George CO	37	26	102	70	33	Beloit	42	-3	90	76	24
Salt Lake City AP	40	9	94	66	32	Eau Claire AP	44	-11	88	74	23
Vernal AP	40	-6	88	63	32	Fond du Lac	43	-7	87	74	23
VERMONT						Green Bay AP	44	-7	85	73	23
Barre	44	-13	84	72	23	La Crosse AP	43	-8	88	76	22
Burlington AP	44	-7	85	73	23	Madison AP	43	-5	88	75	22
Rutland	43	-8	85	73	23	Manitowoc	44	-1	86	74	21
VIRGINIA						Marinette	45	-4	86	72	20
Charlottesville	38	15	90	77	23	Milwaukee AP	43	-2	87	75	21
Danville AP	36	17	92	77	21	Racine	42	0	88	75	21
Fredericksburg	38	14	92	78	21	Sheboygan	43	0	87	74	20
Harrisonburg	38	9	90	77	23	Stevens Point	44	-12	87	73	23
Lynchburg AP	37	19	92	76	21	Waukesha	43	-2	89	75	22
Norfolk AP	36	23	91	78	18	Wausau AP	44	-14	86	72	23
Petersburg	37	18	94	79	20	WYOMING					
Richmond AP	37	18	93	78	21	Casper AP	42	-5	90	62	31
Roanoke AP	37	18	91	75	23	Cheyenne AP	41	-2	86	62	30
Staunton	38	12	90	77	23	Cody AP	44	-9	87	60	32
Winchester	39	10	92	76	21	Evanston	41	-8	82	57	32
WASHINGTON						Lander AP	42	-12	90	62	32
Aberdeen	47	27	80	61	16	Laramie AP	41	-2	80	59	28
Bellingham AP	48	18	74	65	19	Newcastle	43	-5	89	67	30
Bremerton	47	29	81	66	20	Rawlins	41	-11	84	61	40
Ellensburg AP	47	6	89	65	34	Rock Springs AP	41	-1	84	57	32
						Sheridan AP	44	-7	92	65	32
						Torrington	42	-7	92	67	30

EXPLANATION OF DESIGN CONDITIONS:

WINTER - 97% indicates that the temperature will be at or above the design temperature shown 97% of the time.

SUMMER - 2% indicates that the temperature will exceed the design temperature shown only 2% of the time.

OUTDOOR DAILY RANGE - The outdoor daily range of DB temperatures is the difference between the average maximum and average minimum temperatures during the warmest month at each location. Refer to page 39 when outdoor daily range is other than 20°.

22-141 50 SHEETS
 22-142 100 SHEETS
 22-144 200 SHEETS



PROCESS SYSTEMS INTERNATIONAL, INC. WESTBOROUGH, MA					ENGINEERING CALCULATIONS	NO: V049-1-092 PAGE 1 OF 4
REV.	DEO #	DATE	BY:	CHECK	TITLE: Pressure Drop Calculations for 80K Pump Lines	
0	0172	4/12/96	D. Moore	J. Than.		
					BY: D. Moore	DEPT.:744
<u>PROJECT: LIGO</u>					<u>PROJECT NO: V59049</u>	
<u>PURPOSE:</u> To determine if regeneration and GN2 vent lines are adequately sized for the intended service.						
<u>METHOD:</u> Use of in-house computer program for pressure drop analysis.						
<u>ASSUMPTIONS:</u> 1) The length of each of the lines are equivalent to 60 ft. of straight pipe. 2) Regen. flow rate is 100 gm./sec.						
<u>INPUTS:</u> Regen. heater delta p = .35 psid max. (vendor data) Vaporizer delta p = 2 psid (budget imposed on vendor) Estimated Cv for 1-1/2" globe valve in regen line = 31.66						
<u>REFERENCES:</u>						
<u>CALCULATIONS:</u> Calculations performed for : Case 1) 80K pump normal operation (long pump, frosted) Case 2) Long 80K pump cooldown from 150C (423K) Case 3) Regen of Long 80K pump.						
<u>CONCLUSIONS:</u> Case 1): Delta p = .0017 psid for 1-1/2 in. vent line. Case 2): Delta p = .1392 psid for 1-1/2 in. vent line. Case 3): Delta p = 9.413 psid from LN2 dewar to exit of vent line. (by inspection, the 80K short pump system is adequate for 50 gm/sec.) Conclusion: The lines are adequately sized for their intended service.						

PROCESS SYSTEMS INTERNATIONAL, INC 20 Walkup Drive, Westborough, MA 01581

CUSTOMER: LIGO

JOB NO:V59049

PAGE: 1

PRESSURE DROP ROUTE OR LINE ID:GN2 VENT, NORMAL OP.

PRESSURE: 101270.8 Pa 14.684 PSIA
TEMPERATURE: 77.778 K 140.000 R
DENSITY : 4.581 KG/M³ 0.29 LBS/FT³
QUALITY : 1.000

ITEMNAME	FLOWRATE LB/S	I.D. INCHES	K / DO	CV	LENGTH FT	PRESSURE PSIA	Z1 FEET	Z2 FEET	DP-F PSI	DP-Z PSI	DP-T PSI	DP-SUM PSI
1.5" PIPE	0.0096	1.6820			6.00	14.684	0.00	0.00	0.00017	0.0000	0.0002	0.0002
1.5" PIPE	0.0096	1.6820			6.00	14.684	0.00	0.00	0.00017	0.0000	0.0002	0.0003
1.5" PIPE	0.0096	1.6820			6.00	14.684	0.00	0.00	0.00017	0.0000	0.0002	0.0005
1.5" PIPE	0.0096	1.6820			6.00	14.684	0.00	0.00	0.00017	0.0000	0.0002	0.0007
1.5" PIPE	0.0096	1.6820			6.00	14.683	0.00	0.00	0.00017	0.0000	0.0002	0.0008
1.5" PIPE	0.0096	1.6820			6.00	14.683	0.00	0.00	0.00017	0.0000	0.0002	0.0010
1.5" PIPE	0.0096	1.6820			6.00	14.683	0.00	0.00	0.00017	0.0000	0.0002	0.0012
1.5" PIPE	0.0096	1.6820			6.00	14.683	0.00	0.00	0.00017	0.0000	0.0002	0.0014
1.5" PIPE	0.0096	1.6820			6.00	14.683	0.00	0.00	0.00017	0.0000	0.0002	0.0015
1.5" PIPE	0.0096	1.6820			6.00	14.683	0.00	0.00	0.00017	0.0000	0.0002	0.0017
								TOTAL	0.0017	0.0000		0.0017

BLOWER SUCTION DENSITY: 4.581 KG/M³ 0.286 LB/FT³

V049-1-092
PAZ of A

PROCESS SYSTEMS INTERNATIONAL, INC 20 Walkup Drive, Westborough, MA 01581

CUSTOMER: LIGO

JOB NO:V59049

PAGE: 1

PRESSURE DROP ROUTE OR LINE ID:GN2 VENT, COOLDOWN FROM 423K

PRESSURE: 101270.8 Pa 14.684 PSIA
 TEMPERATURE: 77.778 K 140.000 R
 DENSITY : 4.581 KG/M³ 0.29 LBS/FT³
 QUALITY : 1.000

ITEMNAME	FLOWRATE LB/S	I.D. INCHES	K / DO	CV	LENGTH FT	PRESSURE PSIA	Z1 FEET	Z2 FEET	DP-F PSI	DP-Z PSI	DP-T PSI	DP-SUM PSI
1.5" PIPE	0.0983	1.6820			6.00	14.670	0.00	0.00	0.01386	0.0000	0.0139	0.0139
1.5" PIPE	0.0983	1.6820			6.00	14.657	0.00	0.00	0.01387	0.0000	0.0139	0.0277
1.5" PIPE	0.0983	1.6820			6.00	14.643	0.00	0.00	0.01389	0.0000	0.0139	0.0416
1.5" PIPE	0.0983	1.6820			6.00	14.629	0.00	0.00	0.01390	0.0000	0.0139	0.0555
1.5" PIPE	0.0983	1.6820			6.00	14.615	0.00	0.00	0.01391	0.0000	0.0139	0.0694
1.5" PIPE	0.0983	1.6820			6.00	14.601	0.00	0.00	0.01393	0.0000	0.0139	0.0834
1.5" PIPE	0.0983	1.6820			6.00	14.587	0.00	0.00	0.01394	0.0000	0.0139	0.0973
1.5" PIPE	0.0983	1.6820			6.00	14.573	0.00	0.00	0.01396	0.0000	0.0140	0.1113
1.5" PIPE	0.0983	1.6820			6.00	14.559	0.00	0.00	0.01397	0.0000	0.0140	0.1252
1.5" PIPE	0.0983	1.6820			6.00	14.545	0.00	0.00	0.01398	0.0000	0.0140	0.1392
TOTAL									0.1392	0.0000		0.1392

BLOWER SUCTION DENSITY: 4.536 KG/M³ 0.283 LB/FT³

V049-1-092
Pg 2 of 4

PROCESS SYSTEMS INTERNATIONAL, INC 20 Walkup Drive, Westborough, MA 01581

CUSTOMER: LIGO

JOB NO:V59049

PAGE: 1

PRESSURE DROP ROUTE OR LINE ID:REGEN PUMP TO 423K(300F), VAPORIZER TO VENT 100 GM/SEC.

PRESSURE: 156520.5 Pa 22.695 PSIA
 TEMPERATURE: 423.000 K 761.400 R
 DENSITY : 1.246 KG/M^3 0.08 LBS/FT^3
 QUALITY : 1.000

ITEMNAME	FLOWRATE LB/S	I.D. INCHES	K / DO	CV	LENGTH FT	PRESSURE PSIA	Z1 FEET	Z2 FEET	DP-F PSI	DP-Z PSI	DP-T PSI	DP-SUM PSI
VAPORIZER	0.2203	1.6820				20.695	0.00	0.00	2.00000	0.0000	2.0000	2.0000
1.5" GLOBE	0.2203	1.6820				18.5	0.00	0.00	2.22355	0.0000	2.2236	4.2236
1.5" PIPE	0.2203	1.6820		31.660		17.926	0.00	0.00	0.54589	0.0000	0.5459	4.7694
HEATER	0.2203	6.0000			10.00	17.576	0.00	0.00	0.35000	0.0000	0.3500	5.1194
3.0" PIPE	0.2203	3.2600			6.00	17.564	0.00	0.00	0.01247	0.0000	0.0125	5.1319
3.0" PIPE	0.2203	3.2600			6.00	17.551	0.00	0.00	0.01247	0.0000	0.0125	5.1444
3.0" PIPE	0.2203	3.2600			6.00	17.539	0.00	0.00	0.01248	0.0000	0.0125	5.1569
3.0" PIPE	0.2203	3.2600			6.00	17.526	0.00	0.00	0.01249	0.0000	0.0125	5.1694
3.0" PIPE	0.2203	3.2600			6.00	17.514	0.00	0.00	0.01250	0.0000	0.0125	5.1819
3.0" PIPE	0.2203	3.2600			6.00	17.501	0.00	0.00	0.01251	0.0000	0.0125	5.1944
3.0" PIPE	0.2203	3.2600			6.00	17.489	0.00	0.00	0.01252	0.0000	0.0125	5.2069
3.0" PIPE	0.2203	3.2600			6.00	17.476	0.00	0.00	0.01253	0.0000	0.0125	5.2194
3.0" PIPE	0.2203	3.2600			6.00	17.464	0.00	0.00	0.01254	0.0000	0.0125	5.2320
80K PUMP	0.2203	0.0000			6.00	17.451	0.00	0.00	0.01255	0.0000	0.0125	5.2445
1.5" PIPE	0.2203	1.6820				17.201	0.00	0.00	0.25000	0.0000	0.2500	5.4945
1.5" PIPE	0.2203	1.6820			6.00	16.849	0.00	0.00	0.35172	0.0000	0.3517	5.8462
1.5" PIPE	0.2203	1.6820			6.00	16.490	0.00	0.00	0.35906	0.0000	0.3591	6.2053
1.5" PIPE	0.2203	1.6820			6.00	16.123	0.00	0.00	0.36688	0.0000	0.3669	6.5722
1.5" PIPE	0.2203	1.6820			6.00	15.748	0.00	0.00	0.37522	0.0000	0.3752	6.9474
1.5" PIPE	0.2203	1.6820			6.00	15.364	0.00	0.00	0.38416	0.0000	0.3842	7.3315
1.5" PIPE	0.2203	1.6820			6.00	14.970	0.00	0.00	0.39376	0.0000	0.3938	7.7253
1.5" PIPE	0.2203	1.6820			6.00	14.566	0.00	0.00	0.40411	0.0000	0.4041	8.1294
1.5" PIPE	0.2203	1.6820			6.00	14.151	0.00	0.00	0.41532	0.0000	0.4153	8.5447
1.5" PIPE	0.2203	1.6820			6.00	13.723	0.00	0.00	0.42750	0.0000	0.4275	8.9722
1.5" PIPE	0.2203	1.6820			6.00	13.282	0.00	0.00	0.44082	0.0000	0.4408	9.4130
TOTAL									9.4130	0.0000		9.4130

BLOWER SUCTION DENSITY: 0.730 KG/M^3 0.046 LB/FT^3

V049-1-092
Pg 4 of 4

PROCESS SYSTEMS INTERNATIONAL, INC. WESTBOROUGH, MA					ENGINEERING CALCULATIONS	NO: V049-1-094 PAGE 1 OF 12
REV.	DEO #	DATE	BY:	CHECK	TITLE: <u>Relieving requirements for 80K pump vacuum shell relief device.</u>	
0	0124	4/19/96	D Moore	D m (U)		
					BY: D.Moore	DEPT.: 744
<u>PROJECT: LIGO</u>					<u>PROJECT NO: V59049</u>	
<p><u>PURPOSE:</u> To determine the relieving requirements for the vacuum shell of the 80K pump so that in the event of a failure of the 80K pump reservoir, the vacuum shell and the large gate valves in the beam tube are protected from overpressure.</p>						
<p><u>METHOD:</u> Standard thermodynamic and heat transfer analyses, and the use of standard API formula for sizing relief valve orifice.</p>						
<p><u>ASSUMPTIONS:</u> See calculations</p>						
<p><u>INPUTS:</u> Maximum delta p allowed, 1.75 atm., is based on highest pressure differential the large gate valves were designed for.</p>						
<p><u>REFERENCES</u> API 520</p>						
<p><u>CALCULATIONS:</u> See attached.</p>						
<p><u>CONCLUSIONS:</u> Relieving device should be sized to handle a flow rate of 6524 lbm/hr for 110% of the set pressure. This requires an orifice size of 1.506 sq. in.</p>						

Cases to consider for sizing relief device:

1. Leak in the LN₂ reservoir cools the entire pump vacuum shell to 80K. Control valve is sized for approx. 9 lbm/hr., so it plays no significant role in this case.
2. Catastrophic rupture of LN₂ reservoir dumps entire liquid inventory at the bottom of the vacuum shell. Vent presumed blocked with ice.
3. LN₂ reservoir ruptures during cool-down. Manual cooldown valve is 100% open. GN₂ vent is open, since it will not have had sufficient time to ice up, and ∴ provides another relieving path. This case less severe than first two cases.
4. LN₂ reservoir ruptures during regen. cycle when pump is warming up. No liquid in reservoir. Max flow for regen is 10600 SCFH (~800 lbm/hr). This case is less severe than the first 2 cases





Case 1: A leak in the LN₂ reservoir cools the entire vacuum chamber shell to 80K (highly unlikely). Heat is then transferred from the environment to the shell. The relieving device must then pass the following flow rate (see analysis, Attachment 1):

$$\dot{m} = \frac{Q\beta}{c_p}$$

Q = heat transferred from environment to cold vacuum shell.

c_p = specific heat of N₂

β = volume coefficient of expansion



Approximate Surface Area:
 (Long Pump)

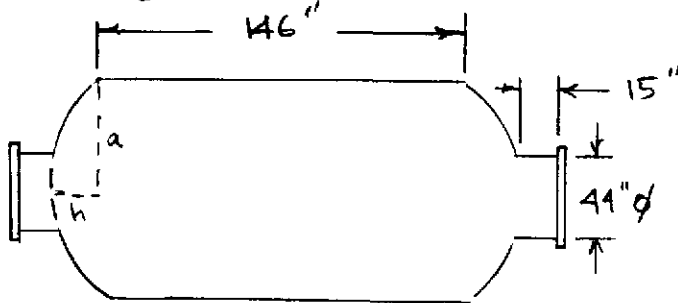

$a = 40''$

$h = 12\frac{1}{2}''$

Cylinder area = $\pi(80)(146) = 36,694 \text{ in}^2$

Ports: area = $2(\pi)(44)(15) = 4147 \text{ in}^2$

Dished heads:

$$A = 2 \times \pi(a^2 + h^2)$$

$$= 2\pi(40^2 + (12\frac{1}{2})^2)$$

$$= 11035 \text{ in}^2$$

Total:

36694
4147
<u>11035</u>
51876 in^2 ($3.346 \times 10^5 \text{ cm}^2$)

Heat transferred to cold shell (per unit area):

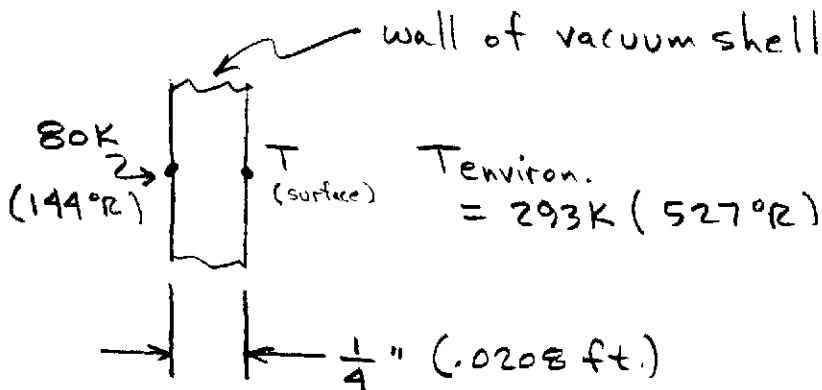

Energy balance:

$$\frac{kA}{t}(T-144) = hA(527-T) + \sigma A \epsilon (527^4 - T^4)$$

$$A = 1.0 \text{ ft}^2$$

$$\epsilon = 1.0$$

$$h = 0.27 \left(\frac{\Delta T}{d} \right)^{1/4}$$

d = dia of cylinder
(ft.)

$$= 6.667 \text{ ft}$$

$$\frac{k}{t}(T-144) = 0.27 \left(\frac{527-T}{d} \right)^{1/4} (527-T) + \sigma (527^4 - T^4)$$

$$k = 4.8 \frac{\text{Btu}}{\text{hr-ft}^2 \text{ } ^\circ\text{F}}$$

(near 80K)

$$\frac{4.8}{0.0208}(T-144) = .17(527-T)^{1/4}(527-T) + .1714 \times 10^{-8}(527^4 - T^4)$$

$$230.77(T-144) = .17(527-T)^{5/4} + .1714 \times 10^{-8}(527^4 - T^4)$$

Solution: $T = 146^\circ\text{F}$

$$Q = .17(527-146)^{5/4} + .1714 \times 10^{-8}(527^4 - 146^4)$$
$$= 418 \frac{\text{Btu}}{\text{hr-ft}^2}$$



$$\therefore Q_{\text{total}} = 418 \frac{\text{Btu}}{\text{hr-ft}^2} \times \left(\frac{51876}{144} \right) \text{ft}^2$$

$$= 150,585 \frac{\text{Btu}}{\text{hr}}$$

at 2 psig (16.7 psia) & 144 °R

$$\beta = \frac{1}{V} \left(\frac{dV}{dT} \right)_P$$

$$= .00789 \text{ } 1/^{\circ}\text{R}$$

$$\# C_p = .27 \text{ Btu/lbm-}^{\circ}\text{R}$$

$$\therefore \dot{m} = \frac{(150585)(.00789)}{.27}$$

$$= 4402 \frac{\text{lbm}}{\text{hr}} \left(1.22 \frac{\text{lbm}}{\text{sec}} \right)$$

—

Large gate valves at ends of pump are designed for $1\frac{3}{4}$ atm. differential pressure.

$$1.75 (14.7) = 25.73 \text{ psia (11 psig)}$$

Allowable overpressure = 110%

$$\therefore \text{relieving pressure} = 1.1 (25.73)$$

$$= 28.3 \text{ psia}$$



Case 2: Catastrophic rupture of LN₂ reservoir;
 LN₂ inventory collects at bottom of
 vacuum chamber; energy stored in 70°
 vacuum chamber vaporizes liquid.

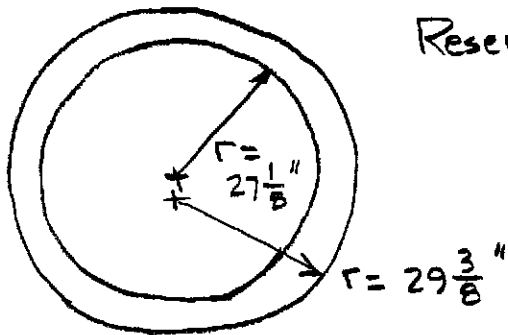

Reservoir (assume full)

$$A = \pi (29.375^2 - 27.125^2)$$

$$= 399.4 \text{ in}^2$$

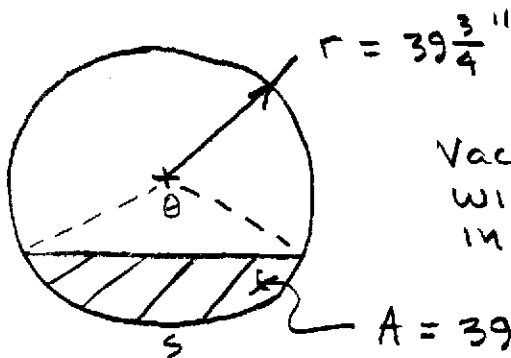

Vacuum chamber
 with reservoir liquid
 inventory at bottom.

$$A = 399.4 \text{ in}^2$$

$$A = \frac{1}{2} r^2 (\theta - \sin \theta)$$

$$399.4 = \frac{1}{2} (39.75)^2 (\theta - \sin \theta)$$

$$\text{Solution: } \theta = 1.503 \text{ rad.}$$

Arc length s: $s = r \theta$

$$= 39.75 (1.503)$$

$$= 59.74 \text{ ''}$$

∴ Total area at the liquid/vacuum shell interface is approximately

$$(14 \text{ ft}) \left(\frac{12 \text{ in.}}{\text{ft}} \right) (59.74 \text{ in.}) = 10,036 \text{ in}^2 \\ (69.69 \text{ ft}^2)$$

Due to the large temperature excess ($70^\circ\text{F} - (-320^\circ\text{F})$), the liquid will form a vapor blanket between it & the vacuum chamber, resulting in film boiling.

Referring to published boiling data for nitrogen, the heat flux at 390°F excess temperature is 8000 Btu/hr-ft^2

$$\text{or } Q_{\text{total}} = 8000 (69.69) \\ = 557,520 \text{ Btu/hr}$$

∴ vapor generation is :

$$\dot{m} = \frac{557,520 \text{ Btu/hr}}{85.46 \text{ Btu/lbm}} \\ = 6524 \text{ lbm/hr.}$$



Size relieving device for 6524 lb_m/hr:

Choking in the relieving device occurs when ratio of downstream to upstream pressure is:

$$\frac{P_{cf}}{P_1} = \left[\frac{2}{k+1} \right]^{k/(k-1)} = .53$$

∴ Choking will occur at 28.3 psia relieving pressure.

∴ area req'd for relief device is

$$A = \frac{\dot{m}}{C K_d P_1 K_b} \sqrt{\frac{T Z}{M}} \quad (\text{ref: API 520, sect. 4.3.2, eq. \# (2)})$$

$$\dot{m} = 6524 \text{ lb}_m/\text{hr}$$

$$C = 356 \text{ (Table 9, API 520)}$$

$$K_d = 0.975$$

$$P_1 = 28.3 \text{ psia}$$

$$K_b = 1.0$$

$$T = 144 \text{ }^\circ\text{R (gas temp.)}$$

$$Z = 1.0$$

$$M = 28.02 \text{ (molecular wt.)}$$





$$\therefore A = \frac{6524}{356(1.975)(28.73)} \sqrt{\frac{144(1.0)}{28.02}}$$

$$A = 1.506 \text{ in}^2$$

\therefore Orifice diameter is

$$d = \sqrt{\frac{4(1.506)}{\pi}}$$

$$= 1.385 \text{ in}$$

Attachment 1

mass cons: $\dot{m} = \frac{dm}{dt}$

1st law: $\frac{d(mu)}{dt} = \frac{dQ}{dt} - h\dot{m} = \frac{dQ}{dt} + h\frac{dm}{dt}$

$$u\frac{dm}{dt} + m\frac{du}{dt} = \frac{dQ}{dt} + h\frac{dm}{dt}$$

$$m\frac{du}{dt} = \frac{dQ}{dt} + (h-u)\frac{dm}{dt}$$

$$h = u + pv$$

$$m\frac{du}{dt} = \frac{dQ}{dt} + pv\frac{dm}{dt}$$

$$\frac{dQ}{dt} = m\frac{du}{dt} - pv\frac{dm}{dt}$$

Const. Volume (Control volume): $m = \frac{V}{v}$

Const pressure process: $h = u + pv$

$$dh = du + p dv$$

$$dm = -\frac{V dv}{v^2}$$

$$\frac{dQ}{dt} = m\frac{du}{dt} + \frac{Vp}{v}\frac{dv}{dt} = \frac{V}{v}\left(\frac{du}{dt} + p\frac{dv}{dt}\right) = \frac{V}{v}\frac{dh}{dt}$$

$$\dot{m} = \frac{dm}{dt} = -\frac{V}{v^2}\frac{dv}{dt}$$

$$\frac{Q}{\dot{m}} = +\frac{v dh}{dv}$$

at const pressure $\left(\frac{V}{v}\frac{dv}{dt}\right) = \alpha$ & $\frac{dh}{dt} = c_p$

$$dh = c_p dT \quad \& \quad dv = \frac{\alpha}{T} v dT$$

$$\frac{dh}{dv} = \frac{c_p T}{\alpha v}$$

$$\frac{Q}{\dot{m}} = \frac{c_p T}{\alpha}$$

\Rightarrow

$$\dot{m} = \frac{\alpha Q}{c_p T}$$

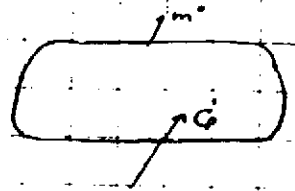

Attachment 1 (cont.)

But by definition,

$$\beta = \frac{1}{V} \left(\frac{\partial V}{\partial T} \right)_P$$

$$\therefore \frac{\dot{Q}}{T} = \frac{C_p T}{T} \left(\frac{\partial V}{\partial T} \right)_P$$

$$= \frac{C_p}{\beta}$$

or $\dot{m} = \frac{\dot{Q} \beta}{C_p}$

22-141 50 SHEETS
22-142 100 SHEETS
22-144 200 SHEETS



PROCESS SYSTEMS INTERNATIONAL, INC. WESTBOROUGH, MA					ENGINEERING CALCULATIONS	NO: V049-1-065 PAGE 1 OF 60
REV	DEO#	DATE	BY:	CHECK	TITLE: BAKEOUT BLANKETS HEAT TRANSFER ANALYSIS	
0		4/17/96	R.THAN	<i>D. Hill</i>		
					BY: R.THAN	DEPT: 744
PROJECT: LIGO					PROJECT NO: V59049	
<p><u>PURPOSE:</u> Determine power density, blanket thermal insulation requirements: For : general vacuum vessel shell section; support legs; end effects; blanket failure; thermocouple patch, warmup time, cooldown time.</p>						
<p><u>METHOD:</u> Finite difference models. Radiation network models.</p>						
<p><u>ASSUMPTIONS:</u></p>						
<p><u>INPUTS:</u></p>						
<p><u>REFERENCE:</u> -ASTM Annual Book of ASTM Standards, Section 4 Construction, Vol 0.406, Thermal Insulation; Environmental Acoustics. -J.P. Holman, Heat Transfer, 1981 McGraw-Hill. -M.N. Ozisik, Heat Conduction. 1980, John Wiley & Sons. -Siegel and Howell, Thermal Radiation Heat Transfer, McGraw-Hill.</p>						
<p><u>CALCULATIONS:</u> See attached</p>						
<p><u>CONCLUSIONS:</u> See section 3.0 page 8</p>						
<p><u>NOTES:</u></p>						

TABLE OF CONTENT

1. Bakeout requirements
 - 1.1 Bakeout system

2. Finite Difference models
 - 2.1 Blanket model
 - 2.2 Support leg model
 - 2.3 Gate valve end effect models

3. Results from the analyses
 - 3.1 Steady state profiles and parametric studies
 - 3.2 Warmup analysis
 - 3.3 CooldownnaAnalysis
 - 3.4 Blanke failure analysis
 - 3.5 Thermal couple patch
 - 3.6 BSC Support Leg analysis
 - 3.7 End effects 48" Gate valve analysis
 - 3.8 Pressure gauge pair bakeout

2. FINITE DIFFERENCE MODEL

Several finite difference models were setup to model the heat transfer of the blanket/vessel system. This was used to generate warmup, cooldown, steady state, blanket failure gradients, and thermal couple patch gradients and support leg gradients.

2.1 Blanket Model on Shell Section

A finite difference model was used to calculate temperature gradients for the failure of one blanket surrounded by other blankets. The model was also used to determine warmup and cooldown transients and steady state requirements. The blanket was modeled in cylindrical coordinates with the thickness of the blanket in the z-direction and the size of the blanket in the r-direction (circular blanket). The axisymmetry gives the effect in the third direction, thus a simulation of a failed blanket surrounded by operating blankets.

The boundary conditions on the surface of the blanket takes into account the convective and radiative losses. The boundary condition on the shell side is adiabatic (vacuum).

2.2 Support Leg Model

The support leg for the BSC was modeled with a blanket to determine the power density requirements for the blankets on the legs to maintain the appropriate bakeout temperature on the BSC. The support leg which is a square tube was modeled as a circular tube with the same material cross sectional area (length in z direction and thickness of blanket in the r direction). The legs on the BSC are 8 inch square tubes with 0.63 inch wall thickness. The internal boundary conditions was modeled as an adiabatic boundary condition. The radiation losses of the internal surface was ignored, but this is less than 20% of convective losses.

2.3 Gate Valves End Effect Model

Because of the end effects additional blankets beyond the isolatable section may be required to maintain a minimum temperature of the vacuum envelope wall or the gate. There are 4 cases that may be considered.

1. 48 inch valve closed. Maintain gate temperature to ensure bakeout of gate
2. 48 inch valve open. Maintain vacuum envelope wall temperature.
3. 44 inch valve open with cryopump cold. Maintain vacuum envelope wall temperature on the beam manifold side of the gatevalve.
4. 44 inch valve closed. Maintain gate temperature to ensure bakeout of gate

A finite difference model was used to model the heat transfer around the gatevalve for case 1. The model consist of 2 D cylindrical section finite difference grid similar to the previous model with a radiation network model to solve the radiation among the boundary surfaces of the finite difference elements and the endbores of the cylindrical vacuum envelope.

The model consist of a layer of steel, heater, and insulation. The R coordinates is in the direction of the steel and blanket thickness and the Z coordinate in the direction of the length of the cylindrical section. The radiation heat transfer model among each finite difference section of the steel (vacuum side) and the endbore areas is solved by a radiation network model. During each iteration of the finite difference grid (steel, heater and insulation), the radiation network is solved to determine heat transfer among the finite difference sections boundary surfaces(vacuum side of the steel). The iteration continues until the solution converges.

PROJECT: LIGO BY: R.THAN
 PROJECT NO: V59049 DATE:
 TITLE BAKEOUT BLANKETS HEAT TRANSFER ANALYSIS

BLANKET MODEL

$$\frac{Q}{A} = h_{air} \cdot [T_{surface} - T_{ambient}] + \sigma \cdot \epsilon \cdot [T_{surface}^4 - T_{ambient}^4]$$

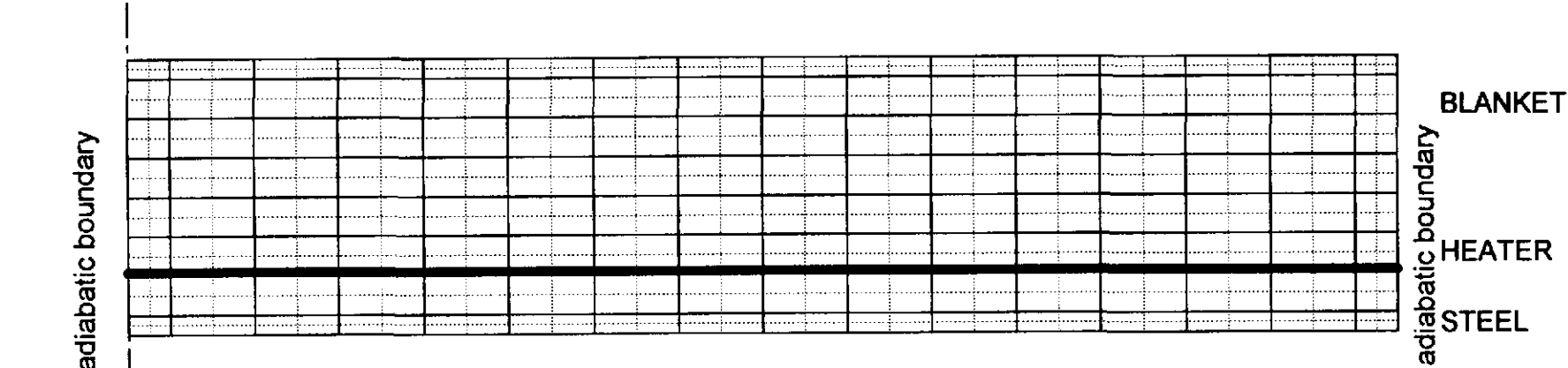

$$\rho \cdot C_p \cdot \frac{\partial T}{\partial t} = \frac{1}{r} \frac{\partial}{\partial r} \left(r \cdot k \frac{\partial T}{\partial r} \right) + \frac{\partial}{\partial z} \left(k \frac{\partial T}{\partial z} \right) + S$$

PROJECT: LIGO BY: R.THAN
 PROJECT NO: V59049 DATE:
 TITLE BAKEOUT BLANKETS HEAT TRANSFER ANALYSIS

END EFFECTS GATE VALVE CLOSED

$$\frac{Q}{A} = h_{air} \cdot [T_{surface} - T_{ambient}] + \sigma \cdot \epsilon \cdot [T_{surface}^4 - T_{ambient}^4]$$

$$\rho \cdot C_p \cdot \frac{\partial T}{\partial t} = \frac{1}{r} \frac{\partial}{\partial r} \left(r \cdot k \frac{\partial T}{\partial r} \right) + \frac{\partial}{\partial z} \left(k \frac{\partial T}{\partial z} \right) + S$$

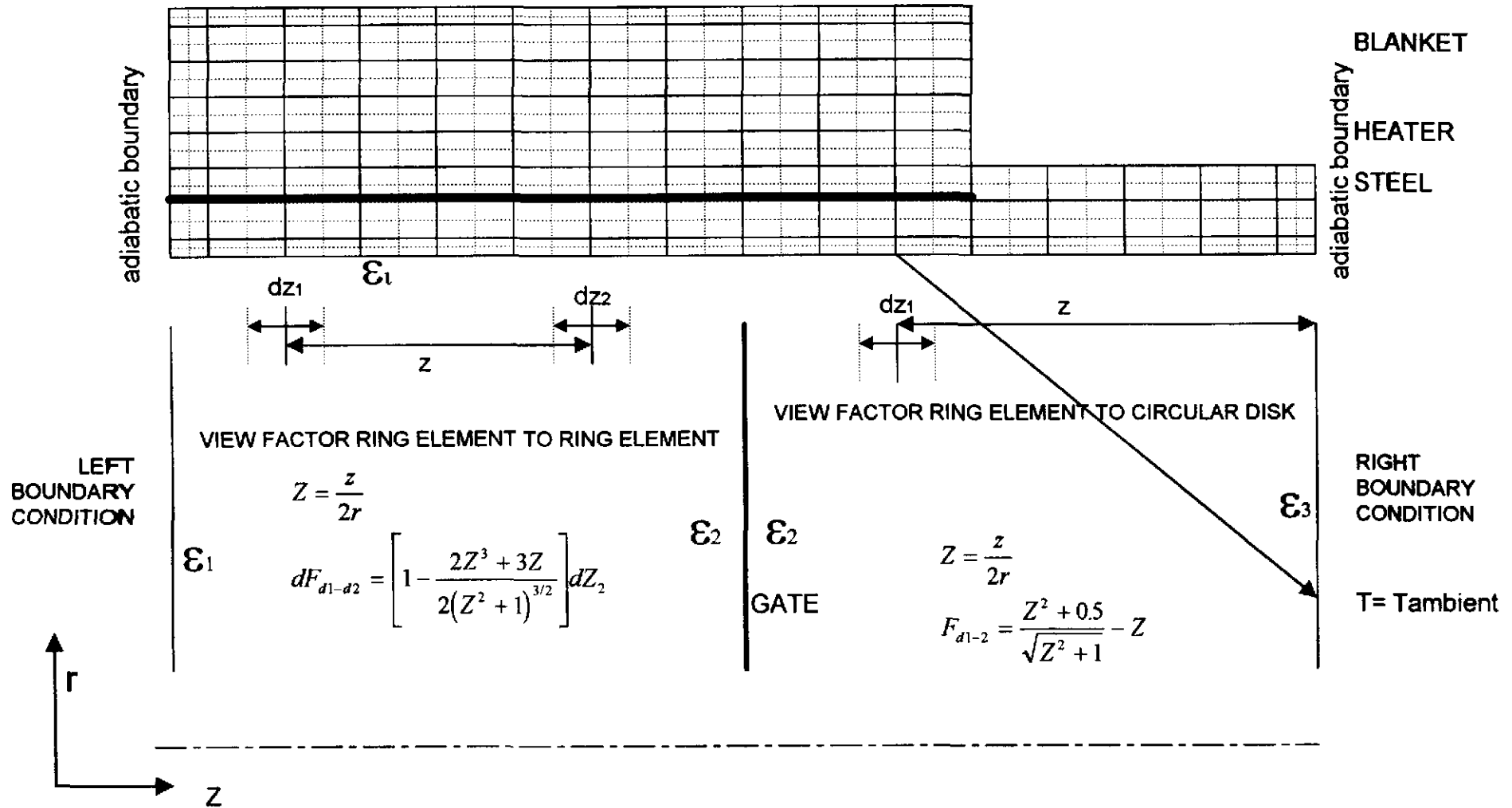

3. RESULTS OF THE ANALYSES

- a. With a design margin of 2 for the insulation performance (using fiberglass or calcium silicate) the required power density required to hold a temperature of 170C is 350W/m².
- b. Warmup of a 1.5 inch thick steel at a power density of 350W/m² takes about 48 hours. Since this is the thickest piece the entire system will follow the warmup of the thickest piece.
- c. Cooldown. With the insulation performing well, cooldown to 40C can take a full 72 hours.
- d. Blanket failure. The resulting temperature gradient is *dependent* on the thermal contact of the blanket with the vessel, the insulation performance and the thickness of the vessel wall. For a 0.25 inch thick vessel wall the temperature gradient is about 70C for a well performing insulation. For a poor performing insulation the gradient could be as high as 100C. With an additional insulation over the dead blanket the temperature gradient drops by 30C to 70C for poor insulation to 40C for a well performing insulation.
- e. Thermo couple patch unheated spots will cause approximately 2°C (gradient) lower temperature reading at the patch.
- f. Support legs. For the BSC support legs the required power density for the blankets on the support legs should be 600 W/m² or higher.
- g. Gate valve end effects.
48" valve: For case where the adjacent spoolpiece is the shortest.
Gate closed: To be able to maintain the gate sufficiently warm, a blanket system on the 0.3m spool piece adjacent to the gate valve is required which has a heater power density of about 1700 W/m².
Gate open: If a heating blanket is used on the 0.3 m spool piece adjacent to the gate valve (unbaked section) an additional power density of 75 W/m² is required for the blankets on the spoolpiece on the bakeout side of the gatevalve to maintain the *desired* temperature. If no heating blanket is used on the spoolpiece on other side of the gatevalve, an additional power density of 160 W/m² is required for the blankets on the spoolpiece on the bakeout side of the gatevalve to maintain the desired temperature

44" valve: The power density of the blanket system adjacent to the gate valve on the beam manifold side requires an additional 200W/m² to maintain a vessel temperature of 423K. Because of the low e liner in the cryopump side adjacent to the gatevalve, heating of the vacuum vessel wall next to the gatevalve does not have a significant effect on the requirements for the blanket system on the other beam manifold side of the gate valve. However, a heating blanket is required on the cryopump side to minimize conductive effects on the gatevalve body. A blanket system with a normal power density is sufficient to maintain a 423K temperature of the shell on the cryopump side.
- e. Pressure gauge pair bakeout jacket recommended power density to reach 250°C with 2 inch

e. Pressure gauge pair bakeout jacket recommended power density to reach 250°C with 2 inch fiberglass insulation or equivalent is about 600 W/m². To ensure that the temperature on the gauge is not exceeded each pressure gauge requires its own temperature control loop. If a thinner insulation thickness is used a higher power density is required.

f. Turbopump bakeout. The turbopump is allowed to be baked to 120°C. To ensure that this temperature is not exceeded the bakeout band on the turbopump should be independently controlled to a setpoint no higher than 120°C. The blanket system for baking the turbopump isolation bellows could be controlled at 150C without affecting the temperature on the turbopump.

3.1 Steady State

Insulation Thermal conductivity and Thickness

Insulation thermal conductivity of fiberglass or a similar material has a value of about 0.05 W/m-K at ambient conditions. The apparent thermal conductivity increases with increasing temperature. In order to have adequate margin for insulation performance and degradation a design margin of at least 2 is recommended.

Convective coefficient and radiant losses

In order to determine the sensitivity of the convective conditions a parametric study was carried out. The power density was determined to hold the vessel at 443K (170°C) for various insulation values while varying the convective conditions.

Figure 3.1-1 indicates that with forced convection over the blanket the required power density required for reaching 443K (170°C) is about 400 W/m² for a insulation thermal conductivity of 0.15 W/m-K and a blanket surface emissivity of 0.9. For an k value of 0.05 W/m-K the theoretical required power density for the blanket system is only about 150 W/m².

Figure 3.1-2 is a parametric study of the maximum operating temperature vs insulation thermal conductivity at three power densities.

Figure 3.1-3 is a graph of maximum operating temperature vs. power density with insulation k as a function of temperature and with a design margin of 2 for the k value. Two set of curves were generated, one with a low surface emissivity and low convective heat transfer, and one with a high emissivity and high convective values. In order to reach the operating temperature of 150 °C with a design margin of 2 the required power density is about 250W/m².

PROJECT: LIGO
 PROJECT NO: V59049

BY: R.THAN
 DATE: Apr. 3, 1996

Figure: V049-1-065-3.1-1, Convective Heat Transfer effect on power density

$$\frac{Q}{A} = h_{air} \cdot [T_{surface} - T_{ambient}] + \sigma \cdot \epsilon \cdot [T_{surface}^4 - T_{ambient}^4]$$

Vessel temperature = 443 K (170°C)

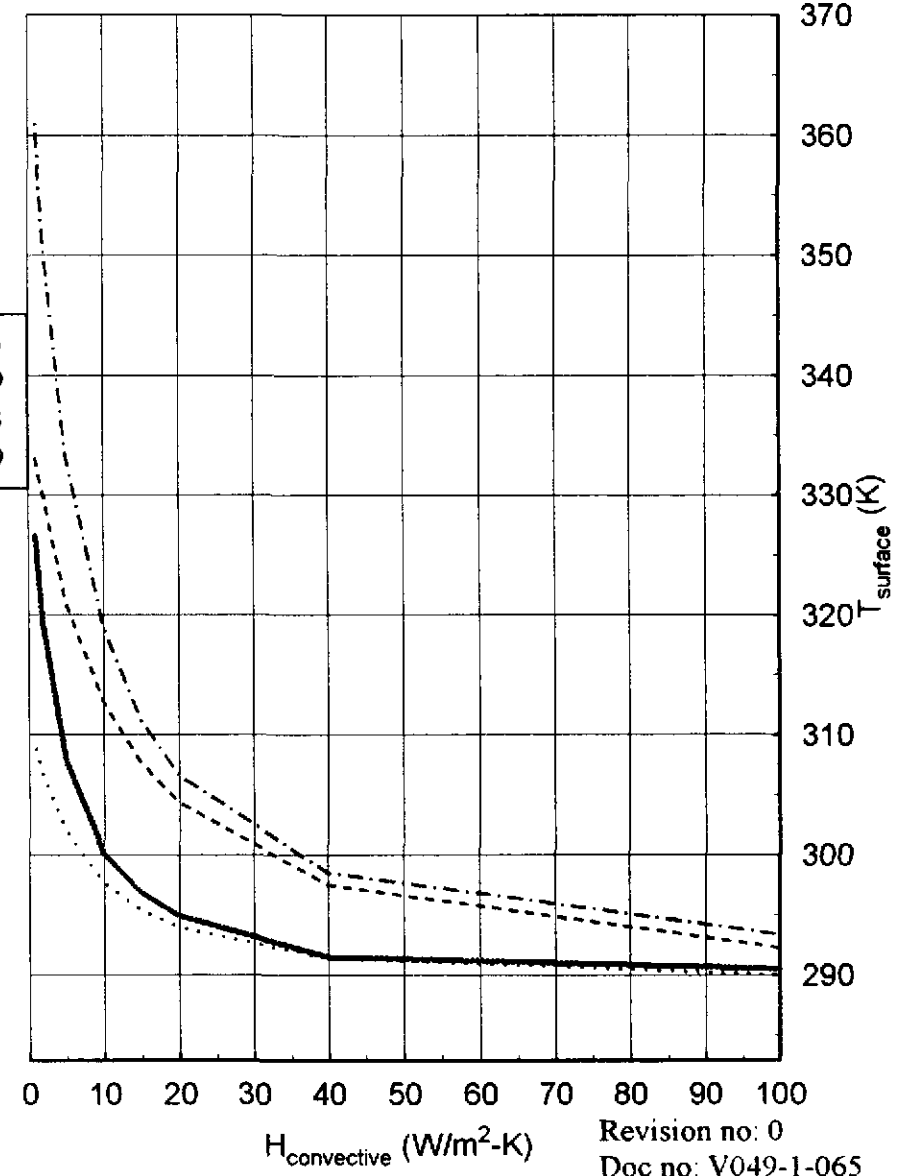
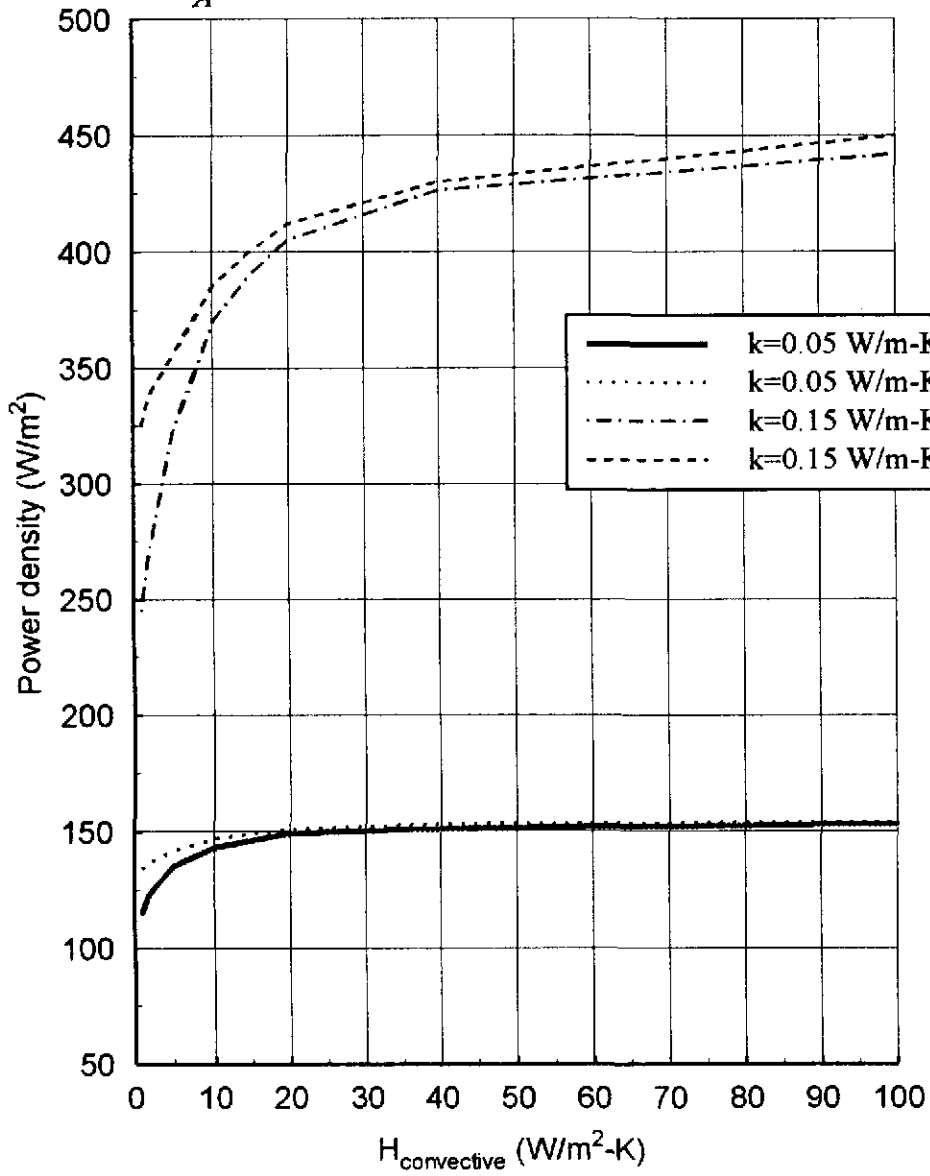

Power density = 450 W/m²

Power density = 250 W/m²

Power density = 150 W/m²

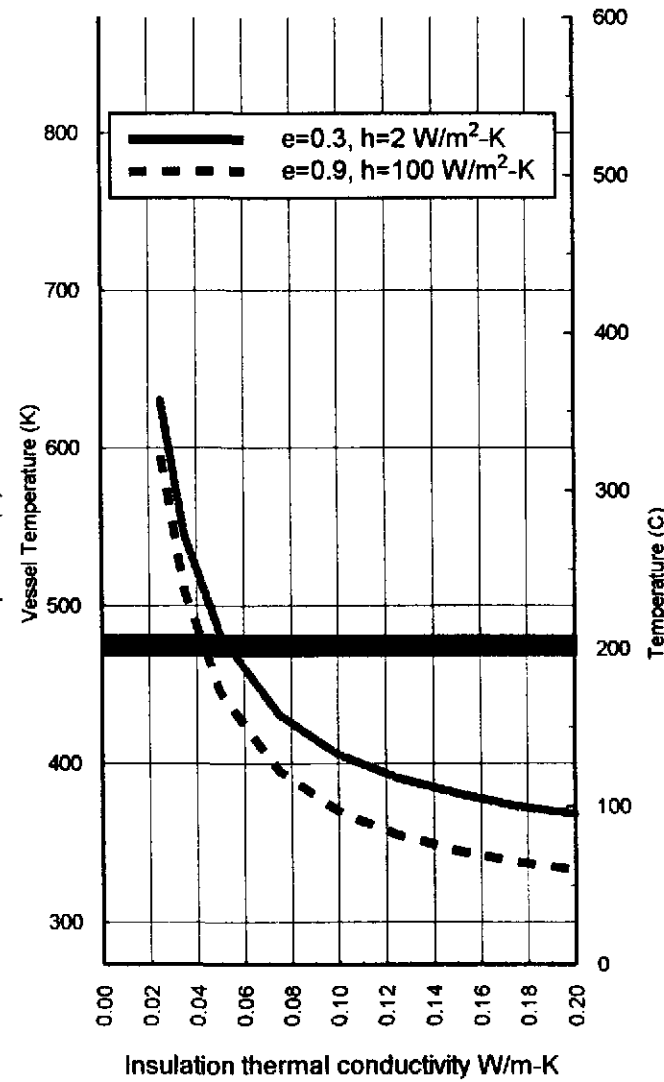
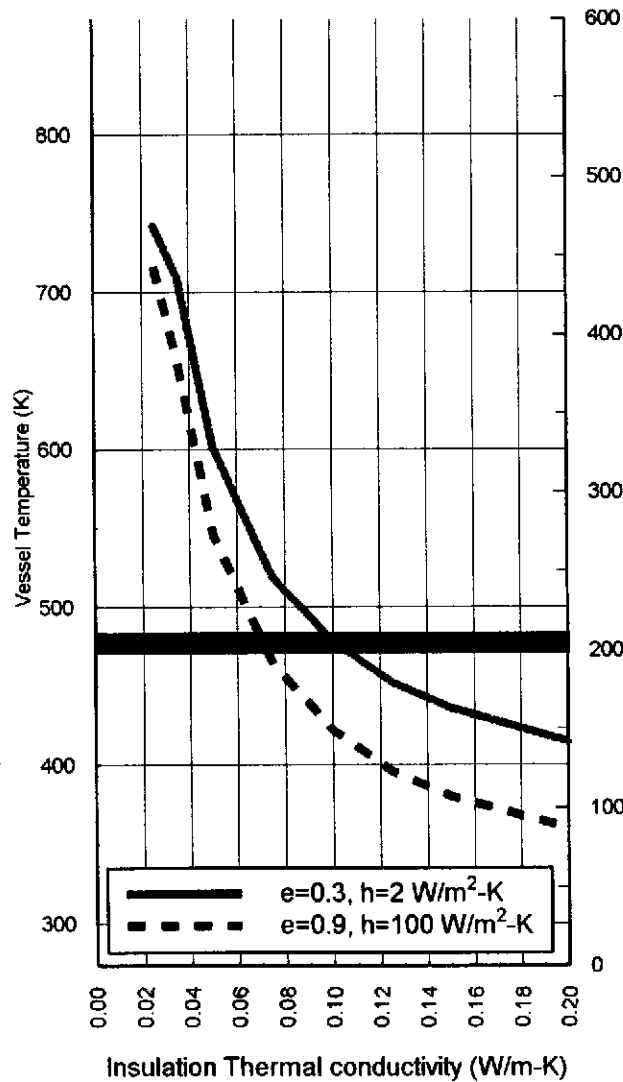
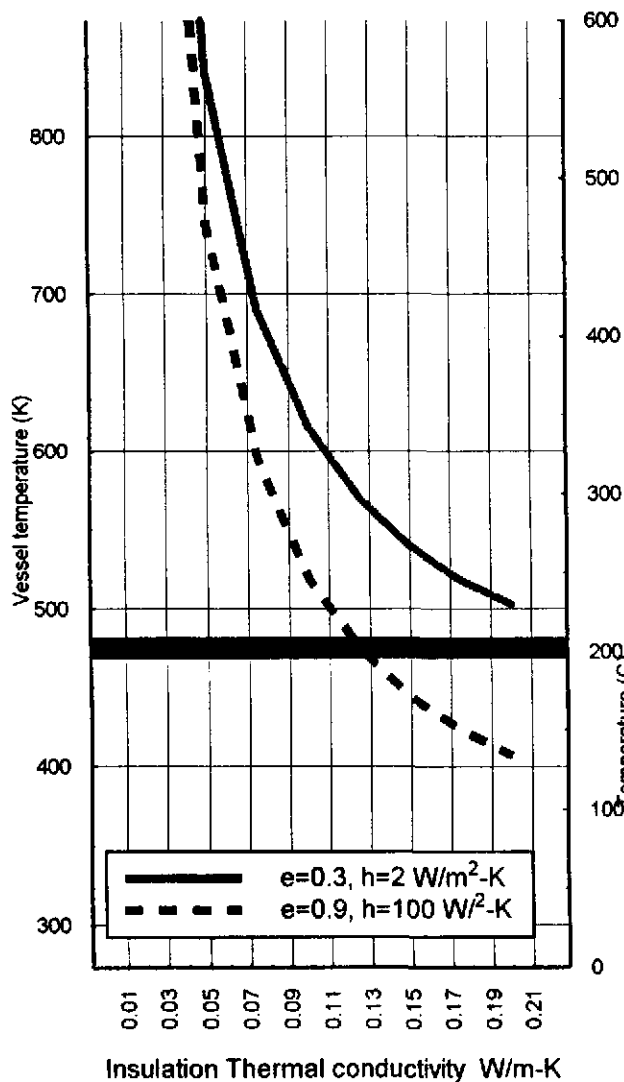

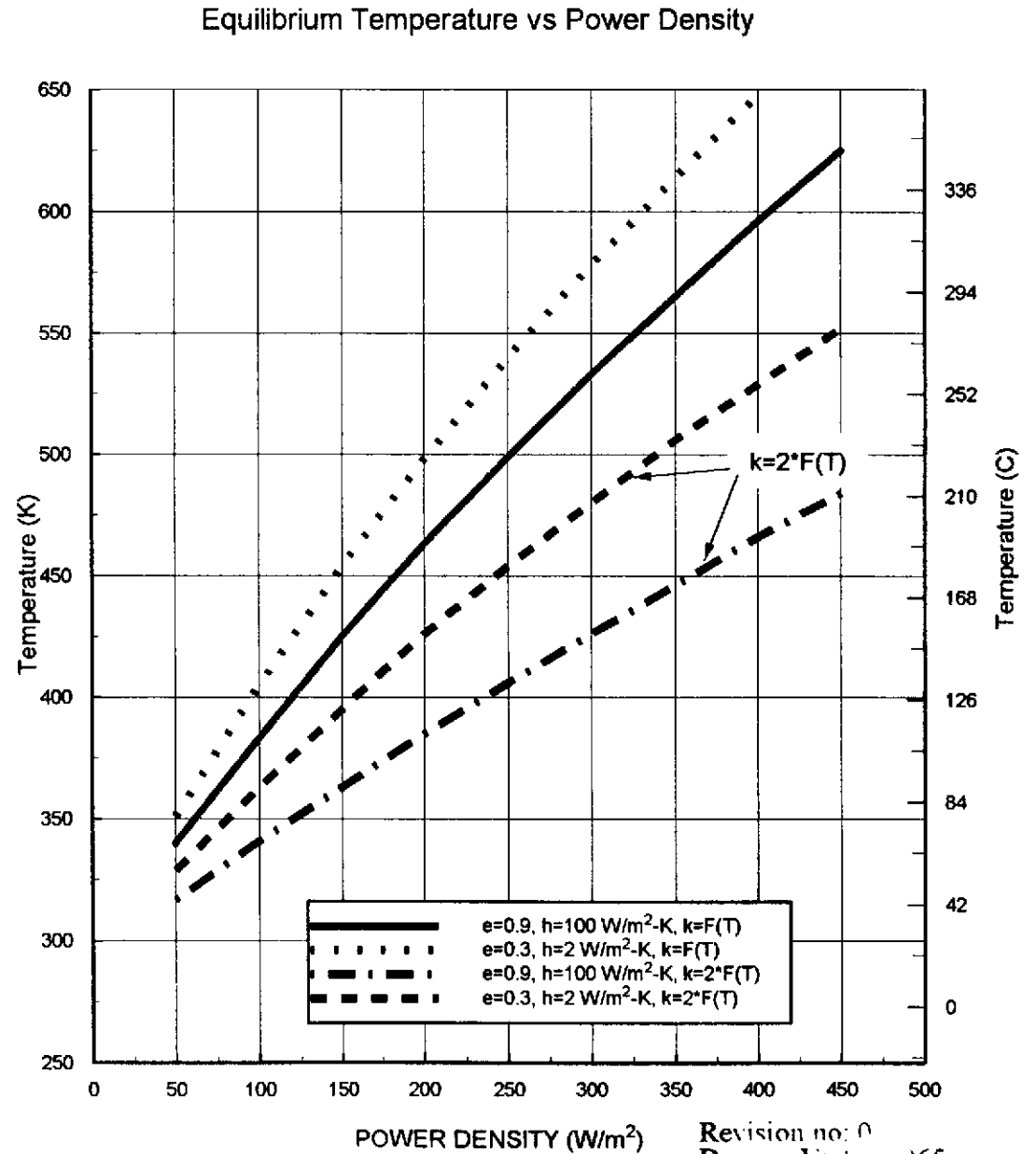
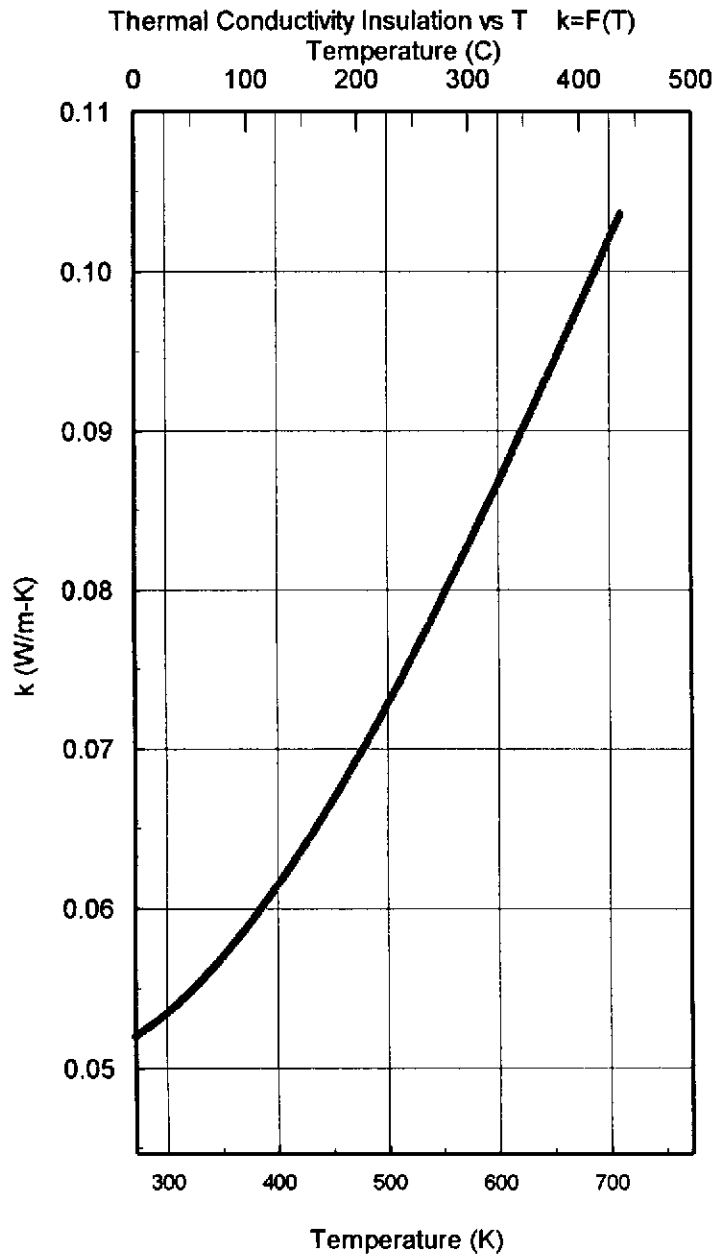

3.2 Warmup Analysis

Because of the temperature uniformity requirements warmup of the vessel will be dictated by the component that has the largest mass per unit surface area. The control system will control warmup to maintain uniformity. This means the entire system will track the warmup of the slowest heating component. This will most likely be the large flanges. Warmup will be dictated by the flanges, power density and insulation performance. In order to speedup the warmup, the power density for the flange heater blankets needs to be increased.

Figure 3.2-1

Warmup curves are plotted for three different steel thicknesses at two insulation/convective values. One set uses a design margin of 2 for the insulation's thermal conductivity along with a high convective coefficient. The other set uses a no margin for insulation's thermal conductivity along with a low convective coefficient.

Figure 3.2-2 and Figure 3.2-3

Warmup curves for 1.5 inch thick steel section, with heater and blanket surface temperature plotted for two insulation performance values.

Figure: V049-1-065-3.2-1 WARM-UP TIME

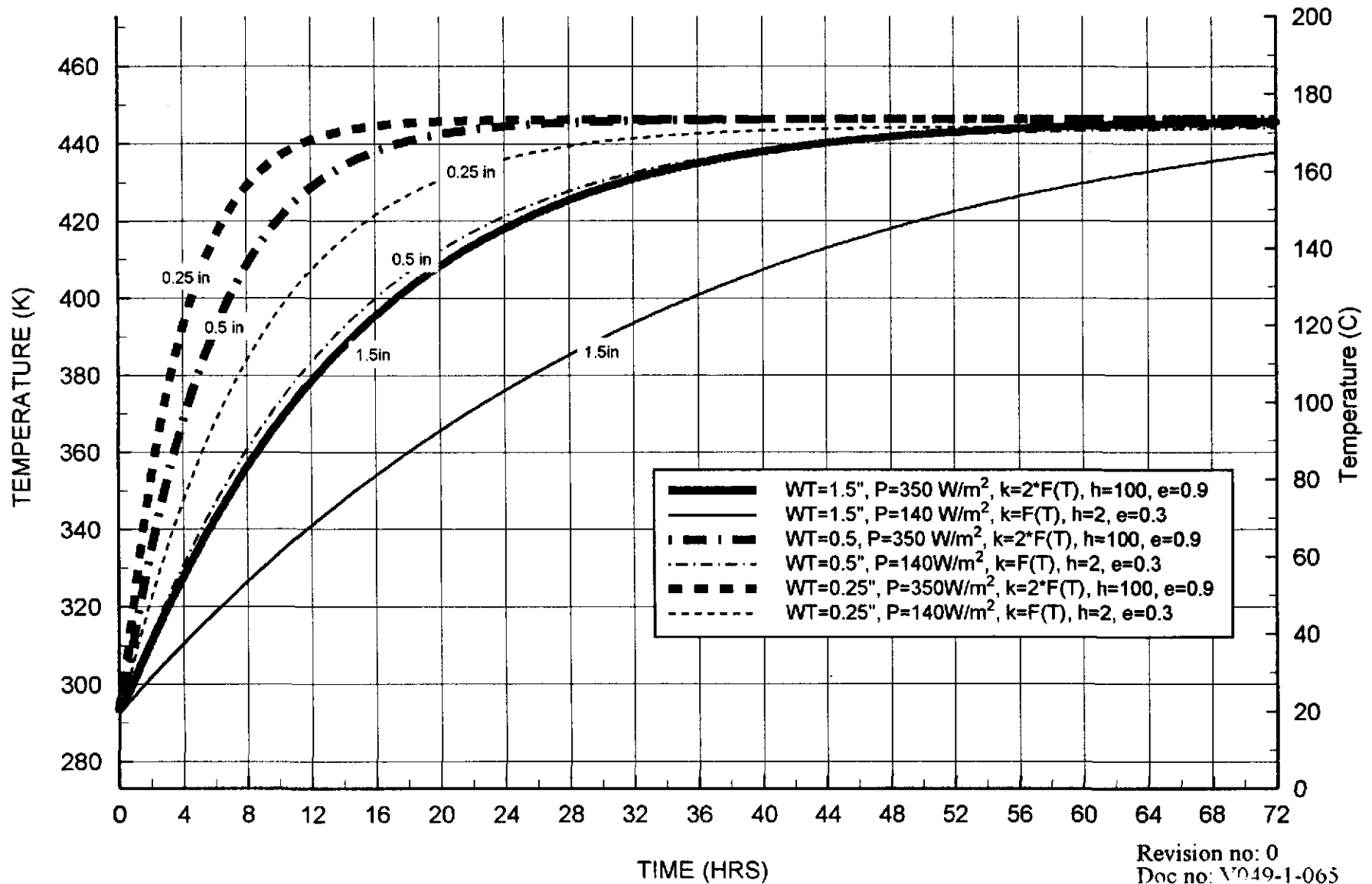

1.5 inch thick, $P=140\text{W/m}^2$, $k=F(T)$, $h=2\text{ W/m}^2\text{-K}$, $e=0.3$

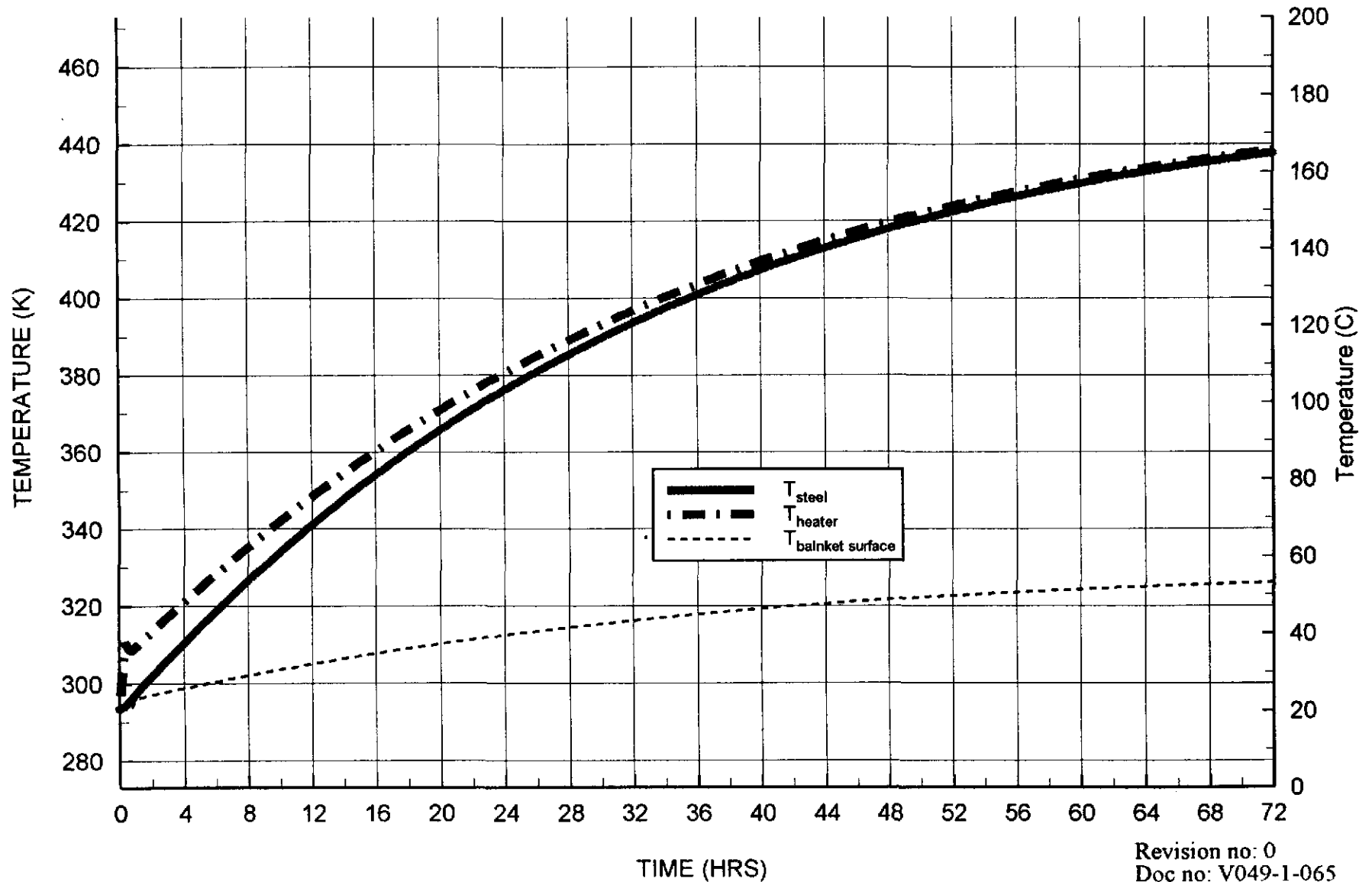
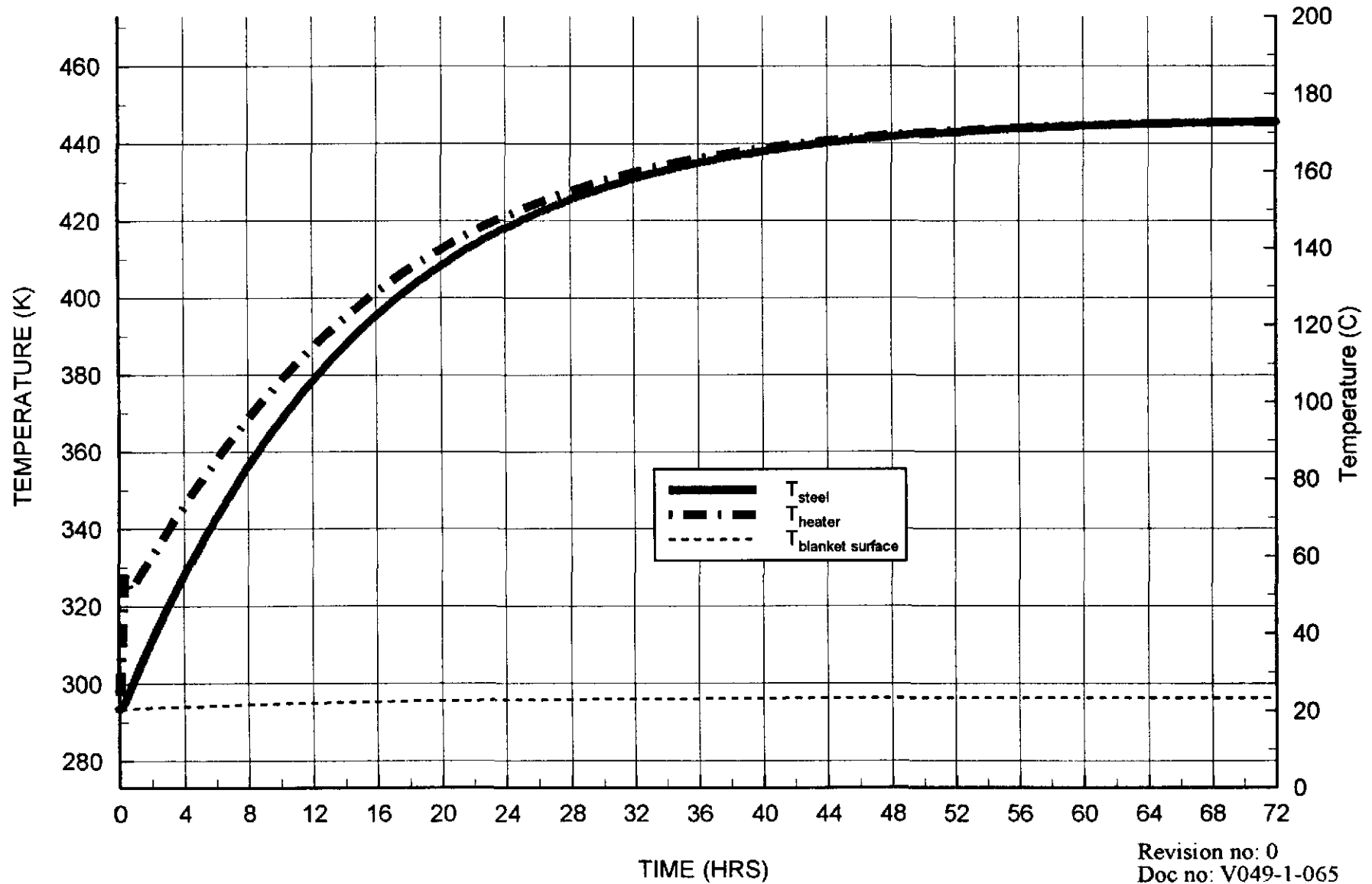

Figure: V049-1-065-3.2-3 WARM-UP TIME, FLANGE, HIGH POWER

1.5 inch thick, $P=350\text{W/m}^2$, $k=2 \cdot F(T)$, $h=100\text{ W/m}^2\text{-K}$, $e=0.9$



3.3 Cooldown

During cooldown, the control system is also operating to maintain temperature uniformity. Again this will result in the flanges dictating the cooldown of the entire system. With the insulation performing well cooldown will take 72 hours or more.

Figure 3.3-1
Cooldown of 0.25 inch thick steel section with good insulation values.

Figure 3.3-2
Cooldown of 0.50 inch thick steel section with good insulation values.

Figure 3.3-3
Cooldown of 1.50 inch thick steel section with good insulation values.

Figure: V049-1-065-3.3-1 COOL-DOWN TIME

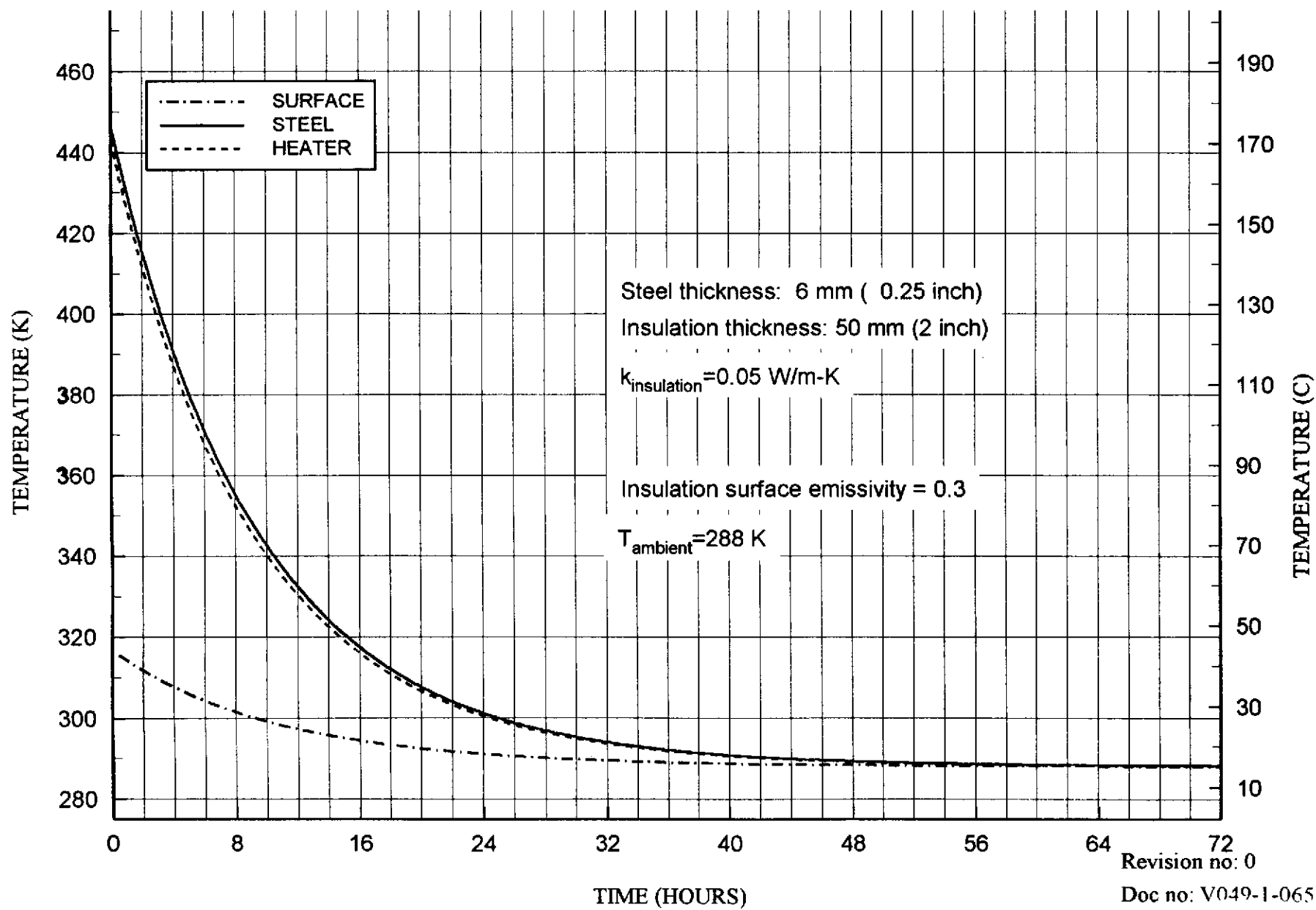

Figure: V049-1-065-3.3-2 COOL-DOWN TIME

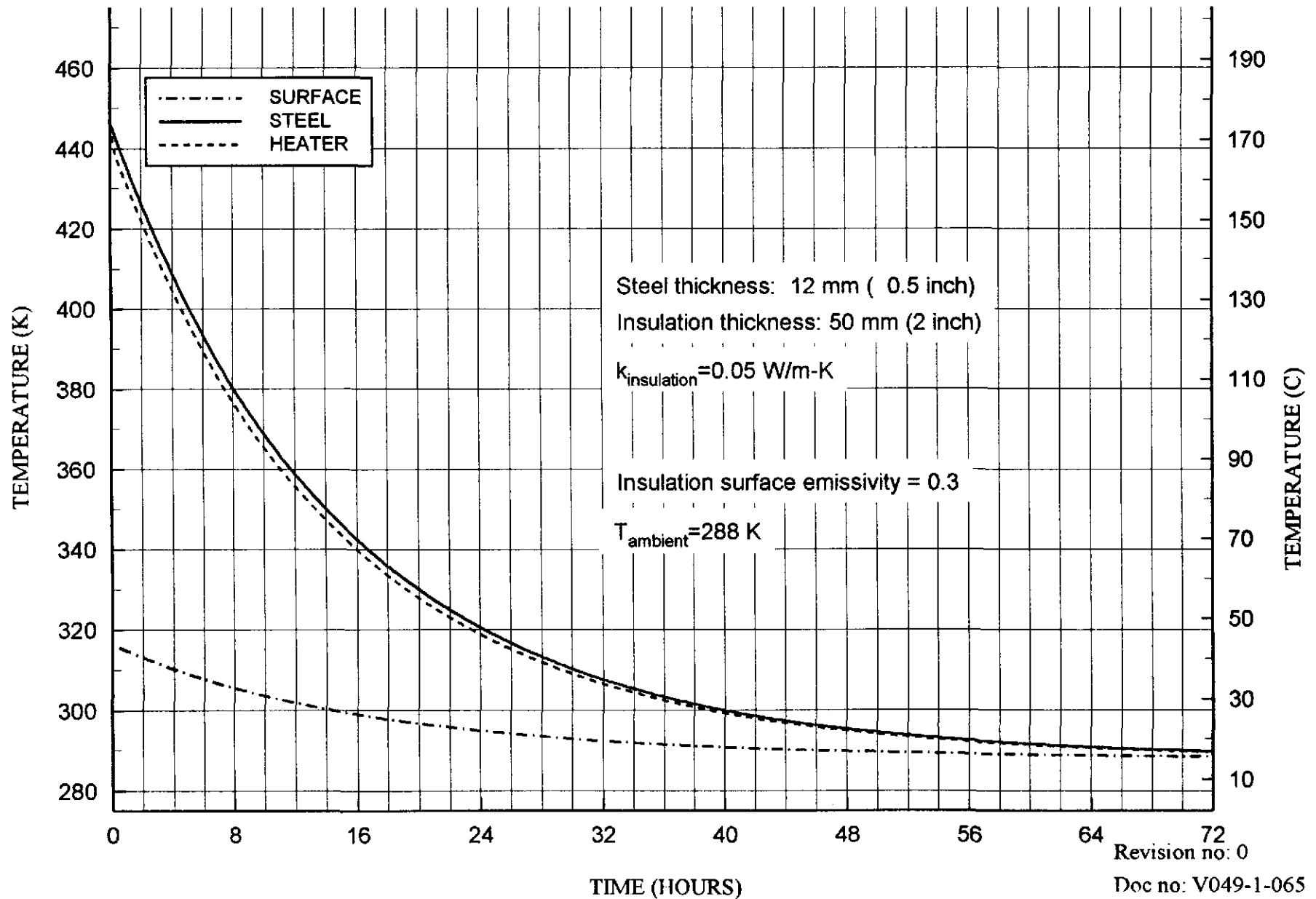
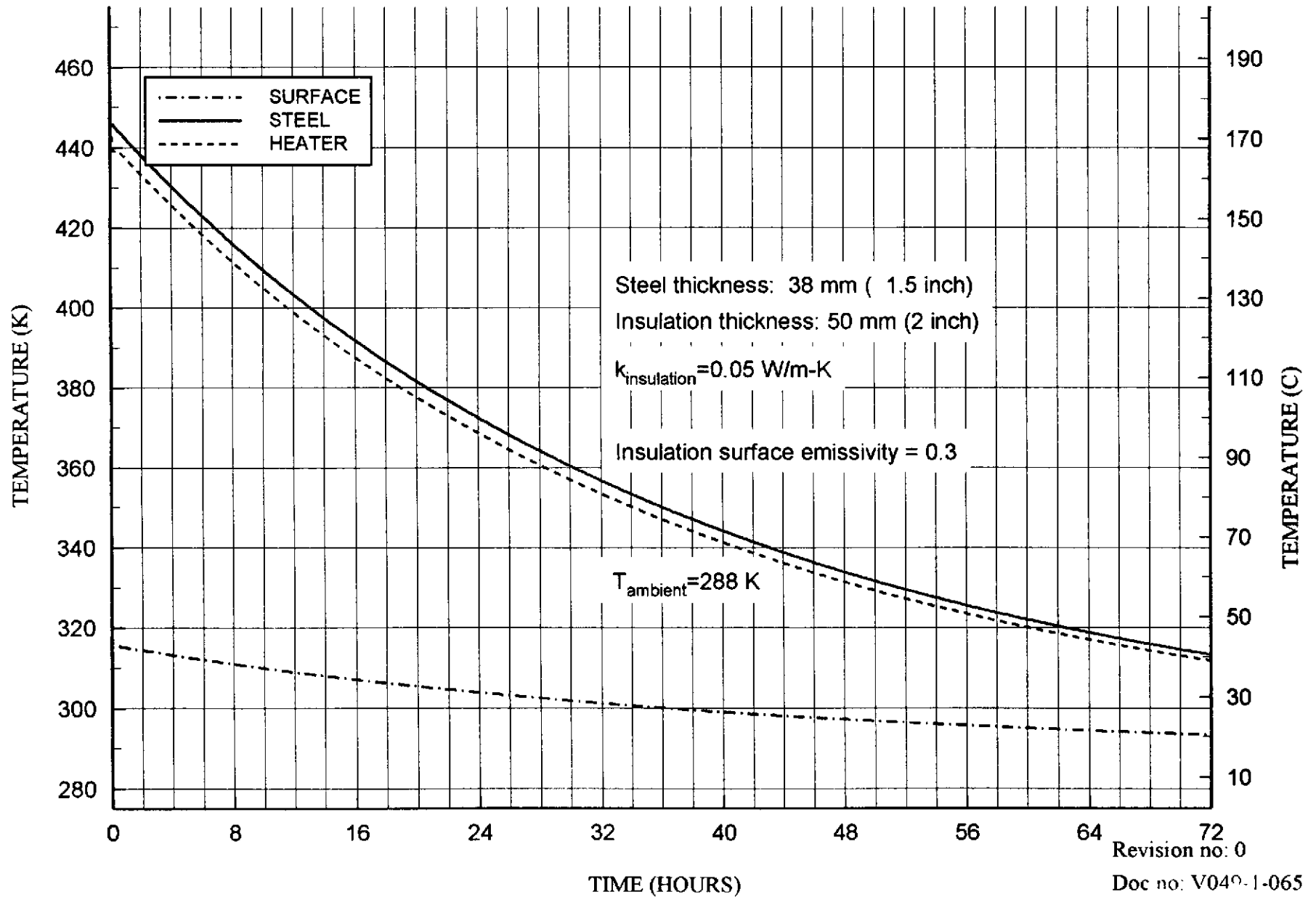

Figure: V049-1-065-3.3-3 COOL-DOWN TIME



3.4 Blanket Heater Failure

The blanket/heater/steel system was modeled, as described in section 2, to determine the temperature gradients developed under heater failure conditions. Calculations were done for two effective insulating values on 0.25 inch steel shell.

Figure 3.4-1 Blanket heater failure with poor performing insulation for 0.25 inch thick wall. The resulting gradient is about 100°C.

Figure 3.4-2 Blanket heater failure with well performing insulation for 0.25 inch thick wall. The resulting gradient is about 70°C.

Figure 3.4-3 Additional insulation above failed blanket with poor performing insulation for 0.25 inch thick wall. The resulting gradient is about 70°C.

Figure 3.4-4 Additional insulation above failed blanket with well performing insulation for 0.25 inch thick wall. The resulting gradient is about 40°C.

$k_{steel} = F(T)$

$k_{insulation} = 2 * F(T) \text{ W/m-K}$

$\epsilon = 0.9 \quad h_{air} = 100 \text{ W/m}^2\text{-K}$

Power density = 350 W/m²

Shell Wall Thickness = 6.4 mm (0.25 in)

$$\frac{Q}{A} = \frac{Q_{convective}}{A} + \frac{Q_{radiation}}{A} = h_{air} \cdot [T_{surface} - T_{ambient}] + \sigma \cdot \epsilon \cdot [T_{surface}^4 - T_{ambient}^4]$$

Q_{convection} ↗

T_{ambient} = 288 K

Q_{radiation} ↗

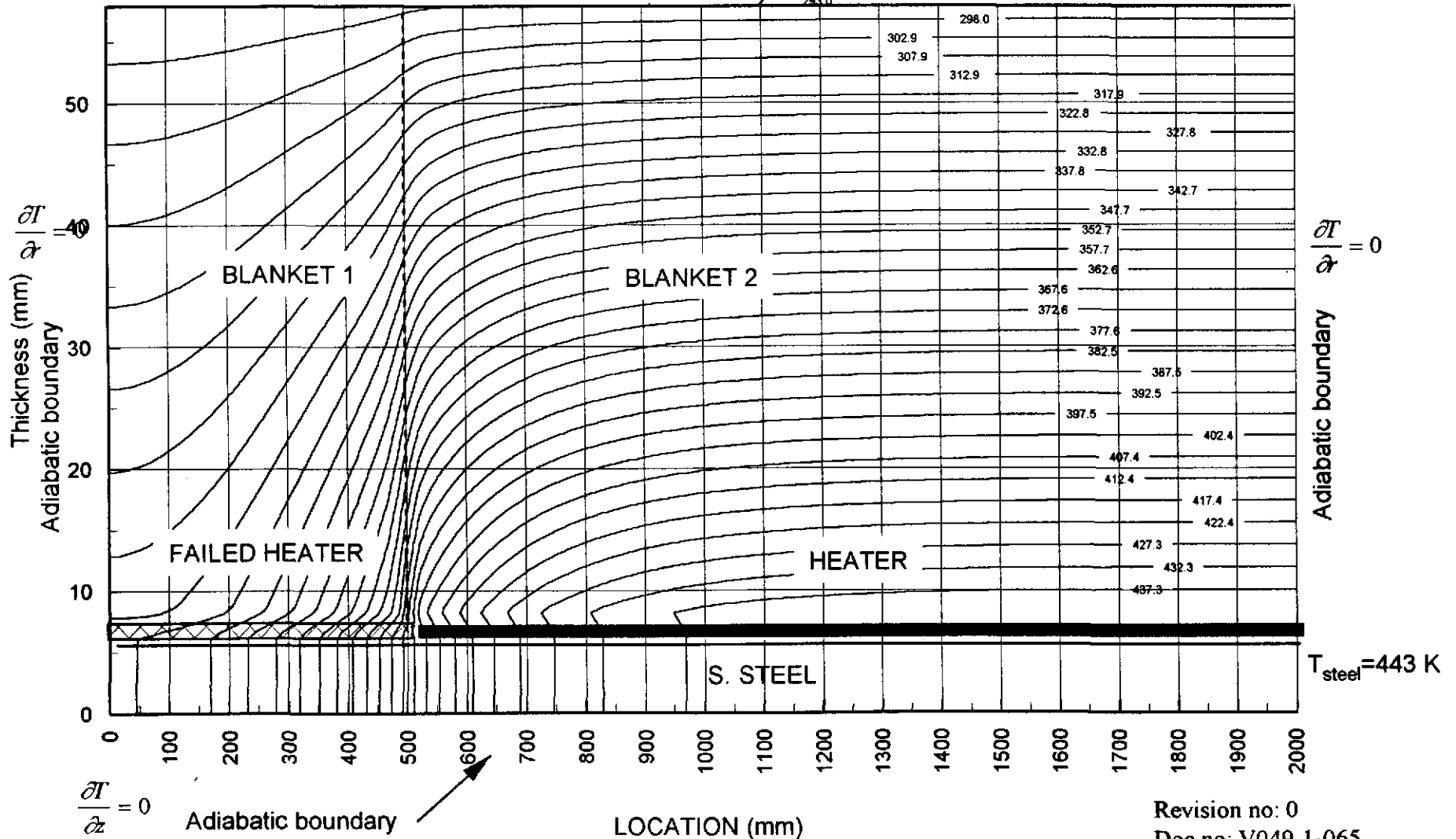

$$k_{\text{steel}} = F(T)$$

$$k_{\text{insulation}} = F(T) \text{ W/m-K}$$

$$\epsilon = 0.3 \quad h_{\text{air}} = 2 \text{ W/m}^2\text{-K}$$

$$\text{Power density} = 140 \text{ W/m}^2$$

$$\text{Shell Wall Thickness} = 6.4 \text{ mm (0.25 in)}$$

$$\frac{Q}{A} = \frac{Q_{\text{convective}}}{A} + \frac{Q_{\text{radiation}}}{A} = h_{\text{air}} \cdot [T_{\text{surface}} - T_{\text{ambient}}] + \sigma \cdot \epsilon \cdot [T_{\text{surface}}^4 - T_{\text{ambient}}^4]$$

$Q_{\text{convection}}$
297.8

$T_{\text{ambient}} = 288 \text{ K}$
302.7

$Q_{\text{radiation}}$
317.5

322.6

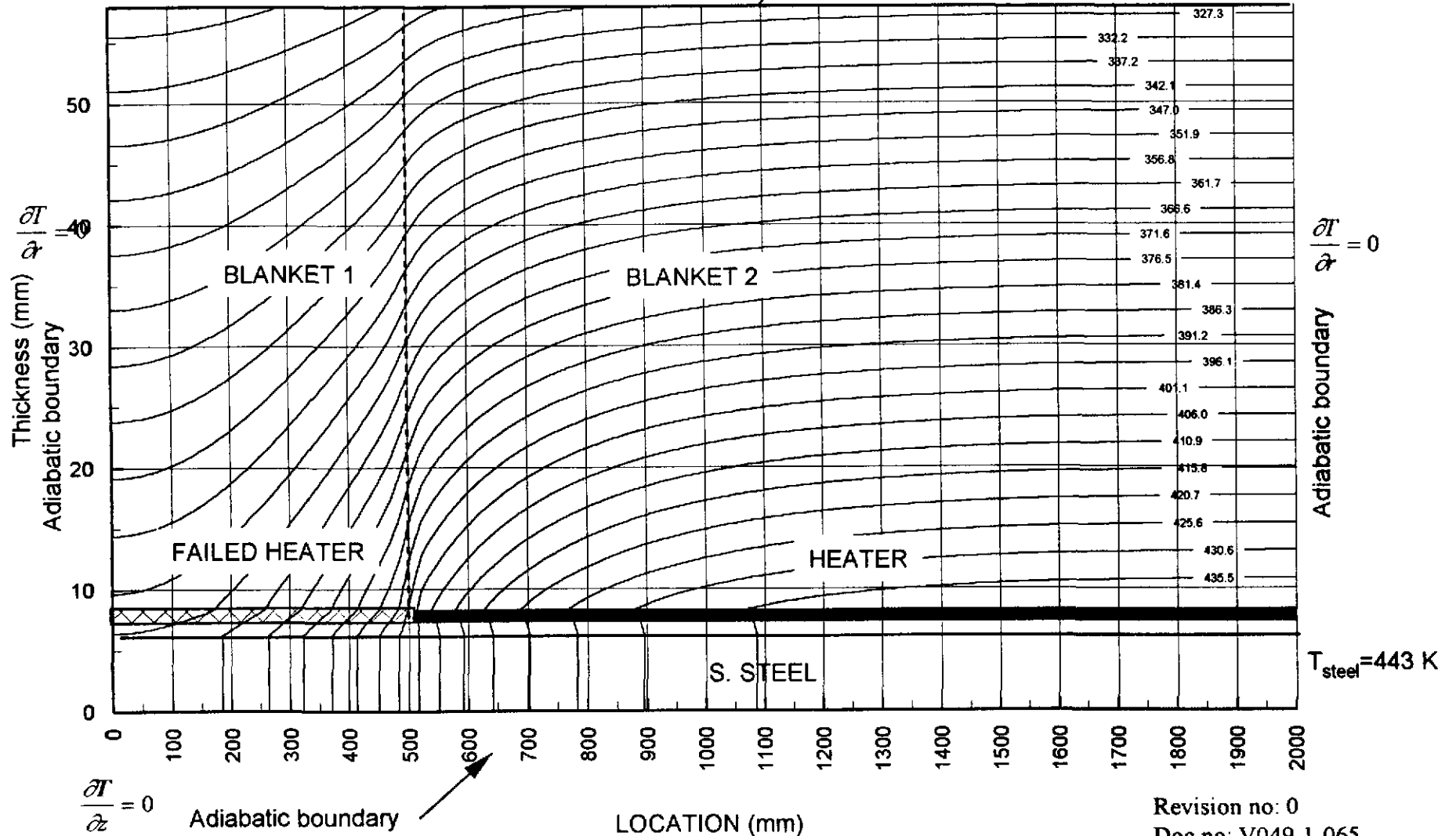

$k_{\text{steel}}=F(T)$
 $k_{\text{insulation}}=2 \cdot F(T)$ W/m-K
 $\epsilon=0.9$ $h_{\text{air}}=100$ W/m²-K
 Power density=350 W/m²
 Shell Wall Thickness=6.4 mm (0.25 in)

$$\frac{Q}{A} = \frac{Q_{\text{convective}}}{A} + \frac{Q_{\text{radiation}}}{A} = h_{\text{air}} \cdot [T_{\text{surface}} - T_{\text{ambient}}] + \sigma \cdot \epsilon \cdot [T_{\text{surface}}^4 - T_{\text{ambient}}^4]$$

$T_{\text{ambient}}=288$ K

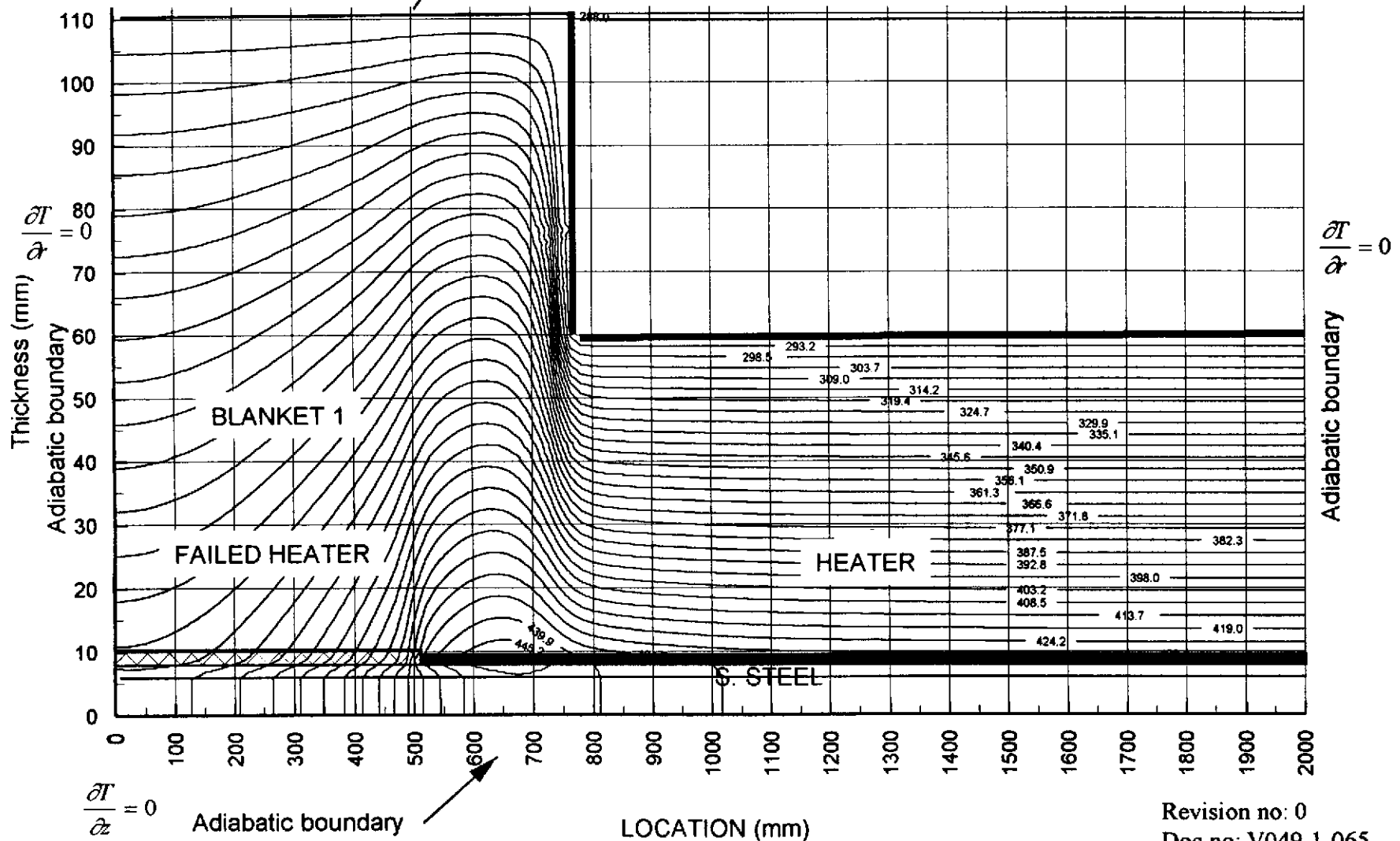

$$k_{\text{steel}} = F(T)$$

$$k_{\text{insulation}} = F(T) \text{ W/m-K}$$

$$\epsilon = 0.3 \quad h_{\text{air}} = 2 \text{ W/m}^2\text{-K}$$

$$\text{Power density} = 140 \text{ W/m}^2$$

$$\text{Shell Wall Thickness} = 6.4 \text{ mm (0.25 in)}$$

$$\frac{Q}{A} = \frac{Q_{\text{convective}}}{A} + \frac{Q_{\text{radiation}}}{A} = h_{\text{air}} \cdot [T_{\text{surface}} - T_{\text{ambient}}] + \sigma \cdot \epsilon \cdot [T_{\text{surface}}^4 - T_{\text{ambient}}^4]$$

$T_{\text{ambient}} = 288 \text{ K}$

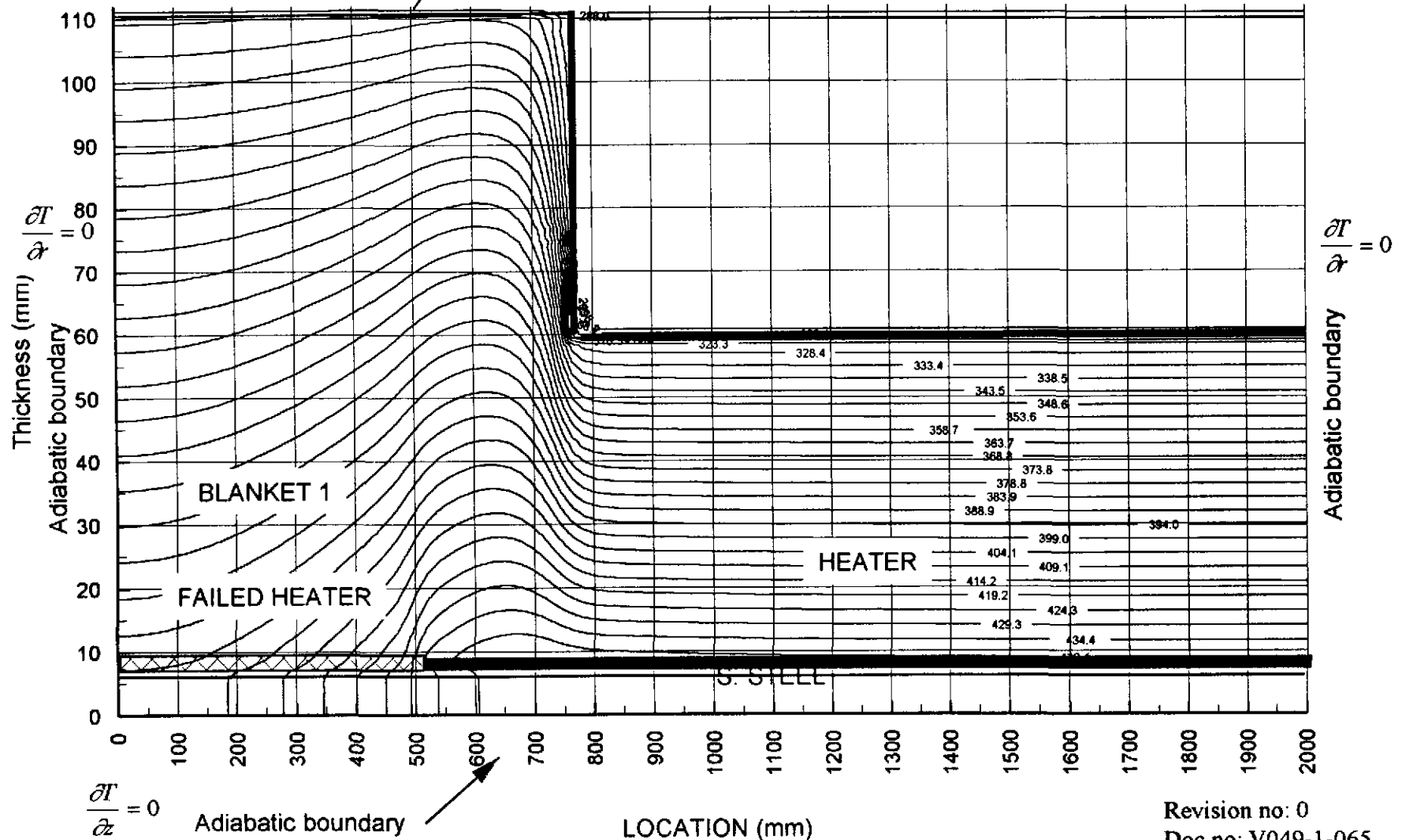

3.5 Thermal Couple Patch (3 inch X 3inch)

The unheated patch where the thermocouple is mounted will cause the thermocouple to read a lower local temperature. The case of a poor insulation performance was calculated to determine the gradient.

Figure 3.5-1 Temperature profile in steel/ blanket with unheated thermocouple patch. Poor performing insulation on 0.25 inch thick wall. The temperature in the patch is 1.3K lower than the other end of the blanket.

Figure 3.5-2 Temperature profile in steel/ blanket with unheated thermocouple patch. Poor performing insulation on 0.50 inch thick wall. The temperature in the patch is 1K lower than the other end of the blanket.

$k_{steel}=F(T)$

$k_{insulation}=0.15 \text{ W/m-K}$

$\epsilon=0.9$

Power density=350 W/m²

Shell Wall Thickness=6.4 mm (0.25 in)

$$\frac{Q}{A} = \frac{Q_{convective}}{A} + \frac{Q_{radiation}}{A} = h_{air} \cdot [T_{surface} - T_{ambient}] + \sigma \cdot \epsilon \cdot [T_{surface}^4 - T_{ambient}^4]$$

$Q_{convection}$

$T_{ambient}=288 \text{ K}$

$Q_{radiation}$

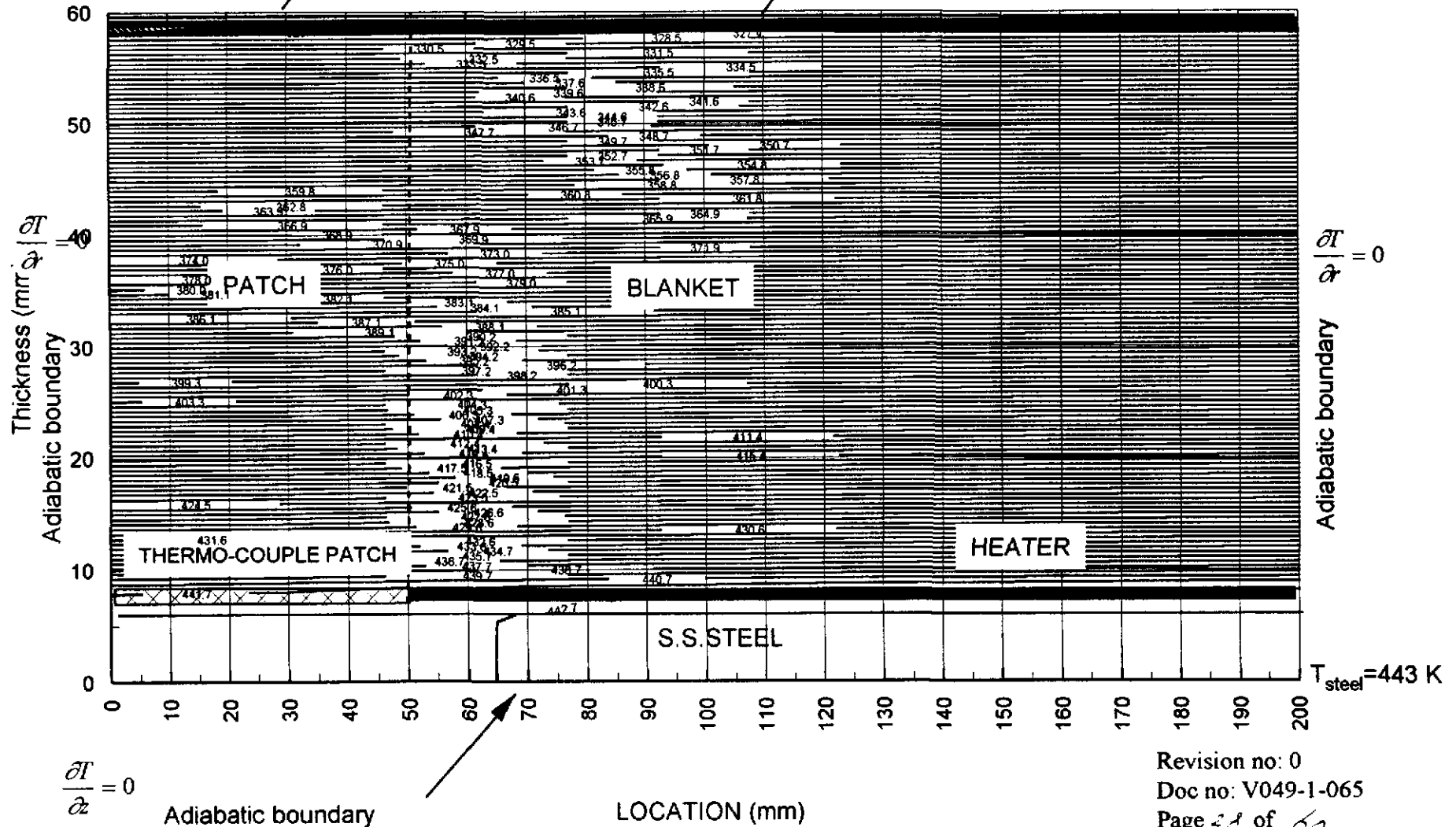

PROJECT: LIGO BY: R.THAN

Figure: V049-1-065-3.5-2 STEADY STATE PROFILE THERMO-COUPLE PATC

PROJECT NO: V59049 DATE: Apr. 8, 1996

$k_{\text{steel}}=F(T)$

$k_{\text{insulation}}=0.15 \text{ W/m-K}$

$\epsilon=0.9$

Power density=350 W/m²

Shell Wall Thickness=12.7 mm (0.50 in)

$$\frac{Q}{A} = \frac{Q_{\text{convective}}}{A} + \frac{Q_{\text{radiation}}}{A} = h_{\text{air}} \cdot [T_{\text{surface}} - T_{\text{ambient}}] + \sigma \cdot \epsilon \cdot [T_{\text{surface}}^4 - T_{\text{ambient}}^4]$$

$Q_{\text{convection}}$ (with arrow pointing up)

$T_{\text{ambient}}=288 \text{ K}$

$Q_{\text{radiation}}$ (with arrow pointing up)

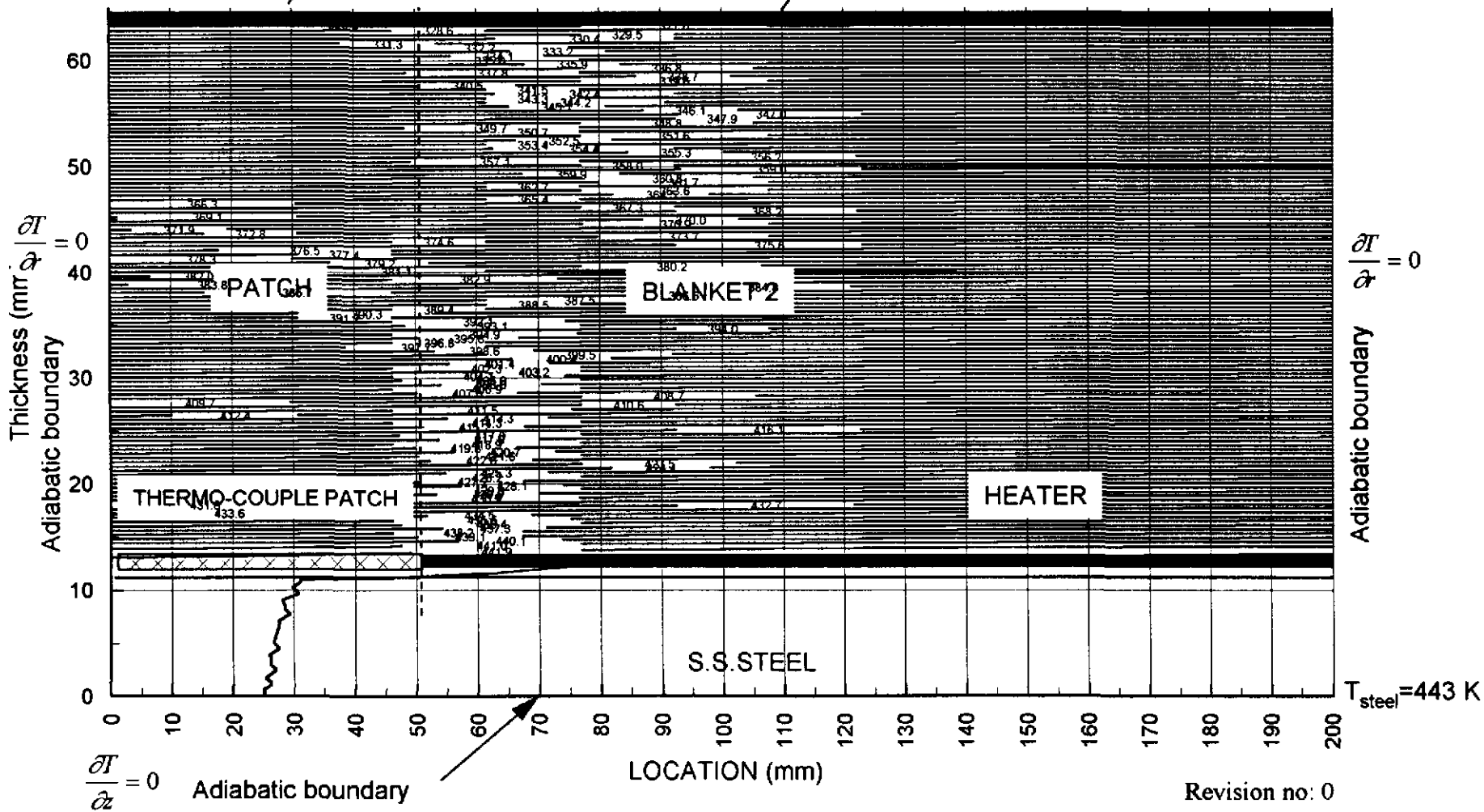

Revision no: 0

Doc no: V049-1-065

Page 29 of 60

3.6 Support Legs Analysis

BSC support leg

The legs are made of carbon steel, which have a much higher thermal conductivity than stainless steel. The support leg heating blanket system was modeled with a specified boundary temperature of 288K at the floor/leg interface and a power density sufficient to maintain a temperature of 423K at an insulation thermal conductivity of 0.15 W/m-K. A solution was sought that gave a zero heat flux at the vessel wall / leg interface. A minimum heater power density of 600W/m² is required to satisfy the above conditions.

Figure 3.6-1 Temperature profile at 600W/m².

Ham support leg

The supports for the HAM is much shorter than for the BSC. The shortest section is about 330mm. A minimum heater power density of approximately 3000 to 3500 W/m² is required for a zero heat flux solution and a vessel wall temperature of 423K (150C).

PROJECT: LIGO BY: R. THAN
 PROJECT NO: V59049 DATE: Apr.3, 1996

Figure: V049-1-065-3.6-01 STEADY STATE PROFILE BSC SUPPORT LEG

$$\frac{Q}{A} = \frac{Q_{convective}}{A} + \frac{Q_{radiation}}{A} = h_{air} \cdot [T_{surface} - T_{ambient}] + \sigma \cdot \epsilon \cdot [T_{surface}^4 - T_{ambient}^4]$$

$k_{steel} = F(T)$
 $k_{insulation} = 0.05 \text{ W/m-K}$
 $\epsilon = 0.9$
 Power density = 450 W/m^2
 Shell Wall Thickness = $16. \text{ mm (0.63 in)}$

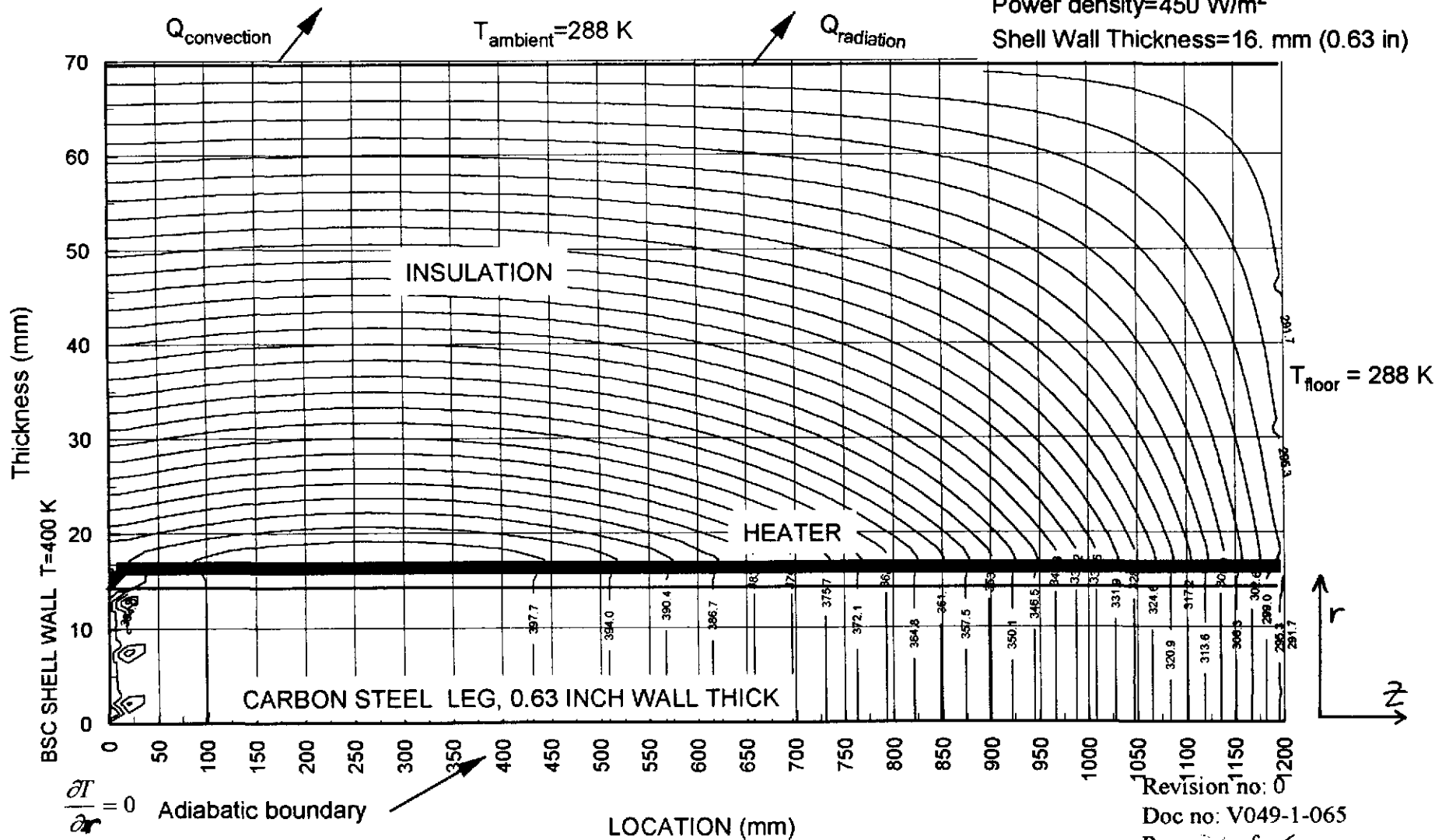

Revision no: 0
 Doc no: V049-1-065
 Page 1 of 60

3.7 End effects Gate Valve Analyses

48 inch gate valve.

For the 48 inch gate valve, which is located between two BSC's or 48" tube interconnect between the vertex and diagonal section, the spool piece on the other of the gate valve needs to be blanketed to keep the gate sufficiently hot when the gate is in the closed position.

The shortest spool piece (A-15) is about 0.3 m long

1. Gate valve closed

With the gate closed the blanket on the other side (0.3 m spoolpiece) of the gate requires a power density of 1700 W/m^2 to maintain the gate at 400K. A large portion of the energy is lost through conduction to the uninsulated section of the vessel. From the simple network model analysis (case I) only about 210 W/m^2 is lost to radiation.

2. Gate valve open.

From the simple network model analysis (case II): If a heating blanket is used on the 0.3 m spool piece adjacent to the gate valve (unbaked section) an additional power density of 75 W/m^2 is required for the blankets on the spoolpiece on the bakeout side of the gatevalve to maintain the desired temperature. If no heating blanket is used on the spoolpiece on other side of the gatevalve, an additional power density of 160 W/m^2 is required for the blankets on the spoolpiece on the bakeout side of the gatevalve to maintain the desired temperature.

44 inch gate valve

For the 44 inch gate valve at the cryopump, there are a few cases to be considered:

1. When the beam manifold isolatable section is being baked out the cryopumped may be used to cryopump the gasses. The gate is open and the shell near the gatevalve and the gate valve loses heat by radiation cooling to the 80K surface. To maintain the spoolpiece on the beammanifold side at 423K the additional power density required for the blankets on this spoolpiece is 200 W/m^2 .
2. When the beam manifold isolatable section is being baked out and the cryopump is not used to pump water vapo, the gate is closed. The gate loses heat by radiation cooling to the cryopump side. In this case however the cryopump could be left at ambient. It would make sense to bakeout the cryopump also.

Figure 3.7-1 Gate valve end effects. Gate at 393K with 1700 W/m^2 power density on the other side of gate and high convective coefficient. The convective coefficient is very conservative.

Figure 3.7-2 Gate valve end effects. Gate at 413K with 1500 W/m^2 power density on the other side of gate and low convective coefficient.

- I. Simple radiation network model case I 48" gate valve closed.
- II. Simple radiation network model case I 48" gate valve open.
- III. Simple radiation network model case I 44" gate valve open with low emissivity liner.

PROJECT: LIGO BY: R. THAN
PROJECT NO: V59049 DATE: Apr. 3, 1996

Figure: V049-1-065-3.7-1 GATE VALVE END EFFECT

$k_{\text{steel}} = F(T)$
 $k_{\text{insulation}} = 2 * F(T) \text{ W/m-K}$
 $\epsilon = 0.9 \quad h_{\text{air}} = 100 \text{ W/m}^2\text{-K}$
Shell Wall Thickness = 6.4 mm (0.25 in)

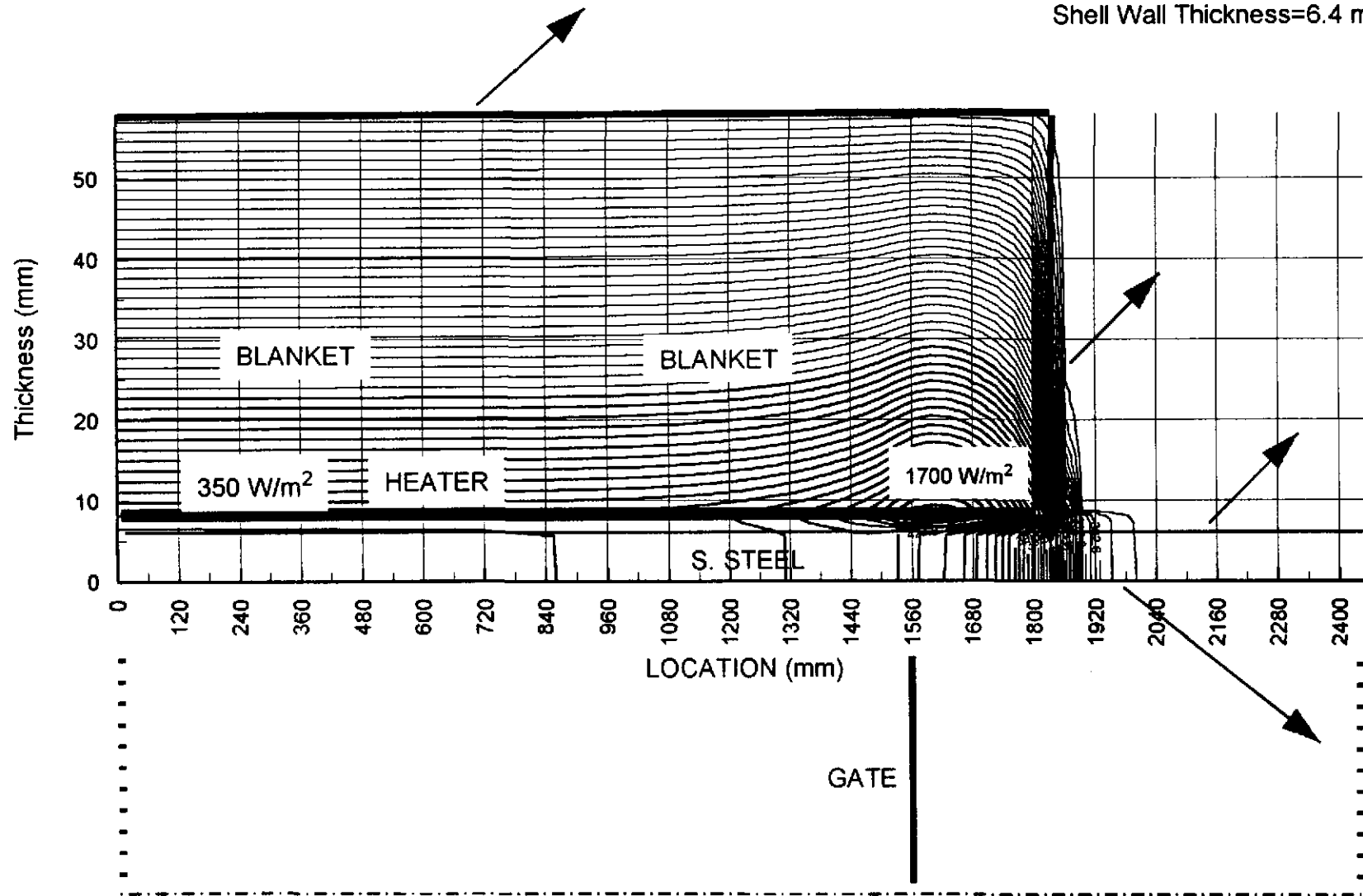

INSULATION THICKNESS 1 : 50.000 mm
 LENGTH 1 : 1500.000 mm
 LENGTH 2 : 30.000 mm
 LENGTH 3 : 900.000 mm
 BLANKET SURFACE EMMISIVITY : 0.900
 LEFT HEATER POWER DENSITY : 325.000 W/M^2
 RIGHT HEATER POWER DENSITY : 1700.000 W/M^2
 TEMPERATURE AMBIENT : 293.000 K
 DIAMETER VESSEL : 1.270 M
 QLEFT BORE : -4.435 W
 QGATE : -188.482 W
 QRIGHT BORE : -399.769 W
 TEMPERATURE LEFT BORE : 423.000 K E : 0.90
 TEMPERATURE GATE LEFT SURFACE : 393.102 K E : 0.30
 TEMPERATURE GATE RIGHT SURFACE : 393.102 K E : 0.30
 TEMPERATURE RIGHT BORE : 293.000 K E : 0.90
 EMISSIVITY SHELL : 0.70

Kinsulation=2*(T)
 Kair = 100 W/m^2
 Wall thickness 0.25 inch

LOCATION			TEMPERATURE			LOCATION			TEMPERATURE		
			K						K		
1	1	0.00	0.00	424.4506	43	1	1245.00	0.00	426.7801		
2	1	15.00	0.00	424.4506	44	1	1275.00	0.00	427.2161		
3	1	45.00	0.00	424.4525	45	1	1305.00	0.00	427.7137		
4	1	75.00	0.00	424.4556	46	1	1335.00	0.00	428.2713		
5	1	105.00	0.00	424.4591	47	1	1365.00	0.00	428.8776		
6	1	135.00	0.00	424.4626	48	1	1395.00	0.00	429.5040		
7	1	165.00	0.00	424.4661	49	1	1425.00	0.00	430.0883		
8	1	195.00	0.00	424.4693	50	1	1455.00	0.00	430.5089		
9	1	225.00	0.00	424.4721	51	1	1485.00	0.00	430.5350		
10	1	255.00	0.00	424.4745	52	1	1515.00	0.00	429.7526		
11	1	285.00	0.00	424.4765	53	1	1545.00	0.00	426.3849		
12	1	315.00	0.00	424.4780	54	1	1575.00	0.00	424.4080		
13	1	345.00	0.00	424.4790	55	1	1605.00	0.00	422.7239		
14	1	375.00	0.00	424.4797	56	1	1635.00	0.00	420.7158		
15	1	405.00	0.00	424.4801	57	1	1665.00	0.00	417.9706		
16	1	435.00	0.00	424.4802	58	1	1695.00	0.00	414.1466		
17	1	465.00	0.00	424.4803	59	1	1725.00	0.00	408.8718		
18	1	495.00	0.00	424.4804	60	1	1755.00	0.00	401.6407		
19	1	525.00	0.00	424.4808	61	1	1785.00	0.00	391.6745		
20	1	555.00	0.00	424.4818	62	1	1815.00	0.00	377.6942		
21	1	585.00	0.00	424.4835	63	1	1845.00	0.00	357.5135		
22	1	615.00	0.00	424.4863	64	1	1875.00	0.00	327.4201		
23	1	645.00	0.00	424.4907	65	1	1905.00	0.00	309.3670		
24	1	675.00	0.00	424.4971	66	1	1935.00	0.00	301.3976		
25	1	705.00	0.00	424.5060	67	1	1965.00	0.00	297.9092		
26	1	735.00	0.00	424.5182	68	1	1995.00	0.00	296.3607		
27	1	765.00	0.00	424.5343	69	1	2025.00	0.00	295.6476		
28	1	795.00	0.00	424.5553	70	1	2055.00	0.00	295.2939		
29	1	825.00	0.00	424.5822	71	1	2085.00	0.00	295.0957		
30	1	855.00	0.00	424.6162	72	1	2115.00	0.00	294.9656		
31	1	885.00	0.00	424.6587	73	1	2145.00	0.00	294.8662		
32	1	915.00	0.00	424.7113	74	1	2175.00	0.00	294.7812		
33	1	945.00	0.00	424.7761	75	1	2205.00	0.00	294.7035		
34	1	975.00	0.00	424.8551	76	1	2235.00	0.00	294.6294		
35	1	1005.00	0.00	424.9509	77	1	2265.00	0.00	294.5559		
36	1	1035.00	0.00	425.0666	78	1	2295.00	0.00	294.4780		
37	1	1065.00	0.00	425.2054	79	1	2325.00	0.00	294.3859		
38	1	1095.00	0.00	425.3714	80	1	2355.00	0.00	294.2564		
39	1	1125.00	0.00	425.5689	81	1	2385.00	0.00	294.0357		
40	1	1155.00	0.00	425.8029	82	1	2415.00	0.00	293.5955		
41	1	1185.00	0.00	426.0789	83	1	2430.00	0.00	293.0000		
42	1	1215.00	0.00	426.4027							

VD49-1-065
 33 of 60

PROJECT: LIGO BY: R. THAN

PROJECT NO: V59049 DATE: Apr. 3, 1996

Figure: V049-1-065-3.7-2 GATE VALVE END EFFECT

$$k_{\text{steel}} = F(T)$$

$$k_{\text{insulation}} = F(T) \text{ W/m-K}$$

$$\epsilon = 0.3 \quad h_{\text{air}} = 2 \text{ W/m}^2\text{-K}$$

Shell Wall Thickness = 6.4 mm (0.25 in)

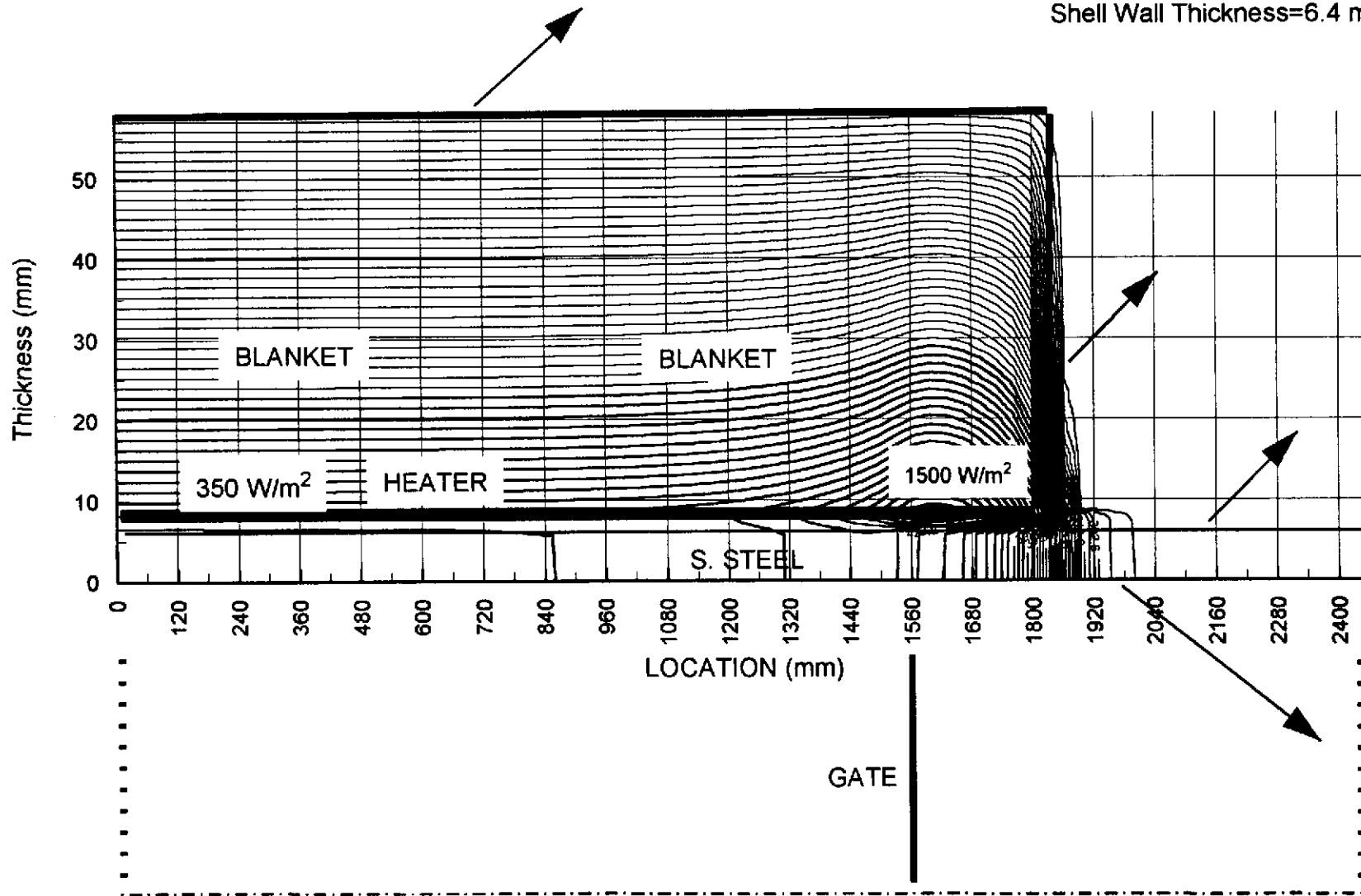

Revision no: 0

Doc no: V049-1-065

Page 34 of 60

INSULATION THICKNESS 1 : 50.000 mm
 LENGTH 1 : 1500.000 mm
 LENGTH 2 : 30.000 mm
 LENGTH 3 : 900.000 mm
 BLANKET SURFACE EMMISIVITY : 0.300
 LEFT HEATER POWER DENSITY : 140.000 W/M^2
 RIGHT HEATER POWER DENSITY : 1500.000 W/M^2
 TEMPERATURE AMBIENT : 293.000 K
 DIAMETER VESSEL : 1.270 M
 QLEFT BORE : -156.212 W
 QGATE : -148.772 W
 QRIGHT BORE : -827.104 W
 TEMPERATURE LEFT BORE : 423.000 K E : 0.90
 TEMPERATURE GATE LEFT SURFACE : 412.470 K E : 0.30
 TEMPERATURE GATE RIGHT SURFACE: 412.470 K E : 0.30
 TEMPERATURE RIGHT BORE : 293.000 K E : 0.90
 EMISSIVITY SHELL : 0.70

Kinsulation=1*(T)

Hair = 2 W/m^2

Wall thickness 0.25 inch

LOCATION			TEMPERATURE			LOCATION			TEMPERATURE		
			K						K		
1	1	0.00	0.00	429.0842	43	1	1245.00	0.00	440.0959		
2	1	15.00	0.00	429.0842	44	1	1275.00	0.00	441.1628		
3	1	45.00	0.00	429.1180	45	1	1305.00	0.00	442.3658		
4	1	75.00	0.00	429.1751	46	1	1335.00	0.00	443.7187		
5	1	105.00	0.00	429.2490	47	1	1365.00	0.00	445.2324		
6	1	135.00	0.00	429.3358	48	1	1395.00	0.00	446.9097		
7	1	165.00	0.00	429.4327	49	1	1425.00	0.00	448.7369		
8	1	195.00	0.00	429.5380	50	1	1455.00	0.00	450.6677		
9	1	225.00	0.00	429.6502	51	1	1485.00	0.00	452.5944		
10	1	255.00	0.00	429.7685	52	1	1515.00	0.00	454.3256		
11	1	285.00	0.00	429.8920	53	1	1545.00	0.00	452.8546		
12	1	315.00	0.00	430.0203	54	1	1575.00	0.00	452.7483		
13	1	345.00	0.00	430.1530	55	1	1605.00	0.00	453.0192		
14	1	375.00	0.00	430.2897	56	1	1635.00	0.00	453.1597		
15	1	405.00	0.00	430.4303	57	1	1665.00	0.00	452.8727		
16	1	435.00	0.00	430.5748	58	1	1695.00	0.00	451.9569		
17	1	465.00	0.00	430.7231	59	1	1725.00	0.00	450.2308		
18	1	495.00	0.00	430.8754	60	1	1755.00	0.00	447.4691		
19	1	525.00	0.00	431.0320	61	1	1785.00	0.00	443.3279		
20	1	555.00	0.00	431.1931	62	1	1815.00	0.00	437.2351		
21	1	585.00	0.00	431.3593	63	1	1845.00	0.00	428.2025		
22	1	615.00	0.00	431.5310	64	1	1875.00	0.00	414.5161		
23	1	645.00	0.00	431.7091	65	1	1905.00	0.00	397.0903		
24	1	675.00	0.00	431.8943	66	1	1935.00	0.00	383.6293		
25	1	705.00	0.00	432.0878	67	1	1965.00	0.00	373.1451		
26	1	735.00	0.00	432.2906	68	1	1995.00	0.00	364.8459		
27	1	765.00	0.00	432.5043	69	1	2025.00	0.00	358.1534		
28	1	795.00	0.00	432.7305	70	1	2055.00	0.00	352.6382		
29	1	825.00	0.00	432.9712	71	1	2085.00	0.00	347.9749		
30	1	855.00	0.00	433.2286	72	1	2115.00	0.00	343.9110		
31	1	885.00	0.00	433.5054	73	1	2145.00	0.00	340.2444		
32	1	915.00	0.00	433.8046	74	1	2175.00	0.00	336.8058		
33	1	945.00	0.00	434.1298	75	1	2205.00	0.00	333.4453		
34	1	975.00	0.00	434.4850	76	1	2235.00	0.00	330.0204		
35	1	1005.00	0.00	434.8749	77	1	2265.00	0.00	326.3860		
36	1	1035.00	0.00	435.3050	78	1	2295.00	0.00	322.3844		
37	1	1065.00	0.00	435.7815	79	1	2325.00	0.00	317.8344		
38	1	1095.00	0.00	436.3116	80	1	2355.00	0.00	312.5198		
39	1	1125.00	0.00	436.9036	81	1	2385.00	0.00	306.1762		
40	1	1155.00	0.00	437.5666	82	1	2415.00	0.00	298.4579		
41	1	1185.00	0.00	438.3116	83	1	2430.00	0.00	293.0000		
42	1	1215.00	0.00	439.1502							

V49-1-065
35 of 60

I. Simple Radiation Network Model 48" Gate Valve Closed

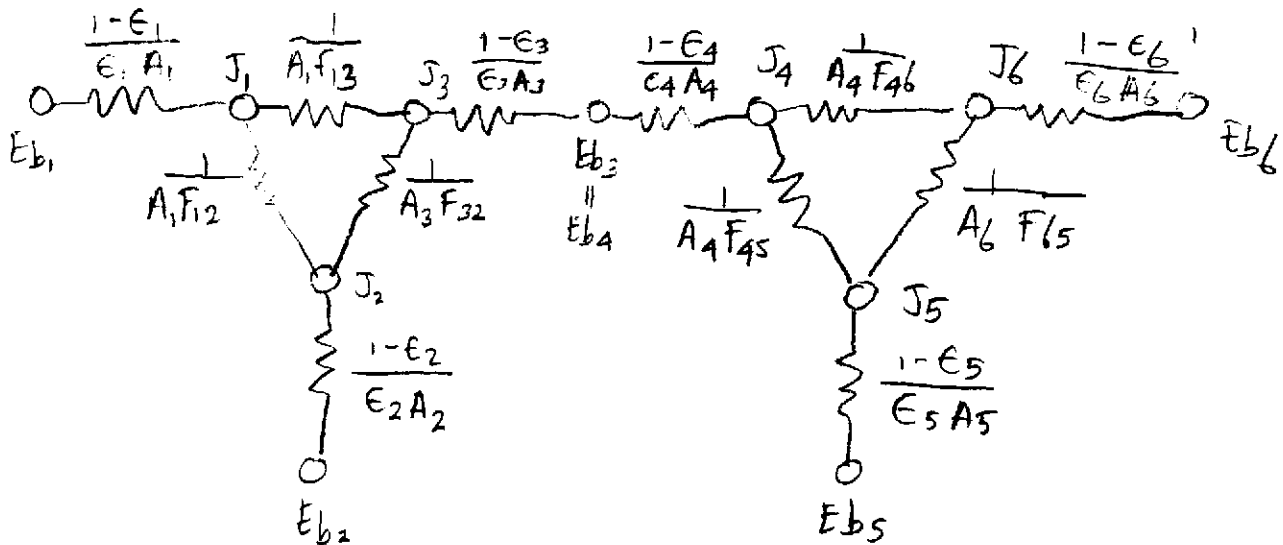
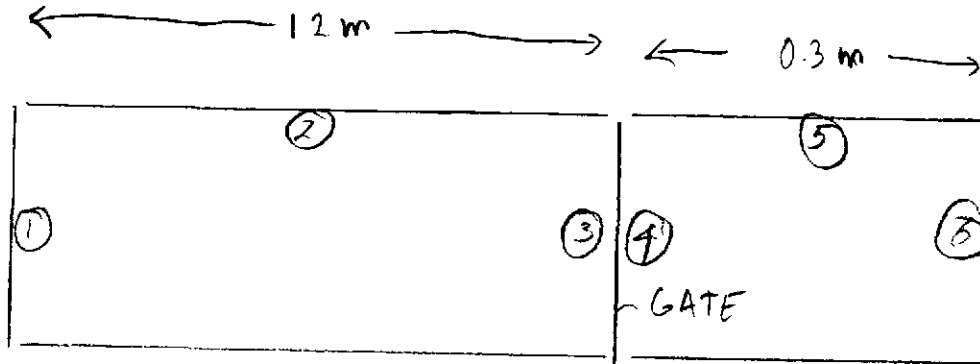

Areas

$$\begin{aligned} \text{rad}_1 &:= 0.64 \cdot \text{m} & \text{rad}_2 &:= 0.64 \cdot \text{m} & \text{rad}_3 &:= 0.64 \cdot \text{m} & \text{rad}_4 &:= 0.64 \cdot \text{m} & \text{rad}_5 &:= 0.64 \cdot \text{m} & \text{rad}_6 &:= 0.64 \cdot \text{m} \\ h_2 &:= 1.2 \cdot \text{m} & h_5 &:= 0.3 \cdot \text{m} & \sigma &:= 56.7 \cdot 10^{-9} \cdot \frac{\text{watt}}{\text{m}^2 \cdot \text{K}^4} \end{aligned}$$

$$\begin{aligned} A_1 &:= \pi \cdot \text{rad}_1^2 & A_1 &= 1.287 \cdot \text{m}^2 \\ A_2 &:= \pi \cdot 2 \cdot \text{rad}_2 \cdot h_2 & A_2 &= 4.825 \cdot \text{m}^2 \\ A_3 &:= \pi \cdot \text{rad}_3^2 & A_3 &= 1.287 \cdot \text{m}^2 \\ A_4 &:= A_3 & A_4 &= 1.287 \cdot \text{m}^2 \\ A_5 &:= \pi \cdot 2 \cdot \text{rad}_5 \cdot h_5 & A_5 &= 1.206 \cdot \text{m}^2 \\ A_6 &:= A_4 & A_6 &= 1.287 \cdot \text{m}^2 \end{aligned}$$

Emissivity

$$\varepsilon_1 := 0.9 \quad \varepsilon_2 := 0.7 \quad \varepsilon_3 := 0.3 \quad \varepsilon_4 := 0.3 \quad \varepsilon_5 := 0.7 \quad \varepsilon_6 := 0.9$$

Viewfactor parallel circular disks

$$RR_1 := \frac{\text{rad}_1}{h_2} \quad RR_1 = 0.533 \quad RR_2 := RR_1$$

$$X_1 := 1 + \frac{1 + RR_1^2}{RR_1^2}$$

$$F_{1,3} := 0.5 \cdot \left[X_1 - \sqrt{(X_1^2 - 4)} \right] \quad F_{1,3} = 0.188$$

$$F_{1,2} := 1 - F_{1,3} \quad F_{1,2} = 0.812$$

$$RR_4 := \frac{\text{rad}_4}{h_5} \quad RR_4 = 2.133 \quad RR_6 := RR_4$$

$$X_4 := 1 + \frac{1 + RR_4^2}{RR_4^2}$$

$$F_{4,6} := 0.5 \cdot \left[X_4 - \sqrt{(X_4^2 - 4)} \right] \quad F_{4,6} = 0.628$$

View factor algebra

$$F_{1,3} = 0.188$$

$$F_{1,2} = 0.812$$

$$F_{1,1} = 0$$

$$F_{3,1} = F_{1,3}$$

$$F_{2,1} = \frac{A_1}{A_2} F_{1,2} \quad F_{2,1} = 0.217$$

$$F_{2,3} = F_{2,1} \quad F_{2,3} = 0.217$$

$$F_{2,2} = 1 - F_{2,1} - F_{2,3} \quad F_{2,2} = 0.567$$

$$F_{3,3} = 0.0$$

$$F_{3,2} = F_{1,2}$$

$$i := 1..6 \quad j := 1..6$$

$$T_1 := 423 \cdot K$$

$$T_2 := 423.0 \cdot K$$

$$T_5 := 400 \cdot K$$

$$T_6 := 323.0 \cdot K$$

$$F_{4,5} = 1 - F_{4,6} \quad F_{4,5} = 0.372$$

$$F_{6,4} = F_{4,6} \quad F_{6,4} = 0.628$$

$$F_{5,4} = \frac{A_4}{A_5} F_{4,5} \quad F_{5,4} = 0.396$$

$$F_{6,5} = F_{4,5} \quad F_{6,5} = 0.372$$

$$F_{5,6} = F_{5,4} \quad F_{5,6} = 0.396$$

$$F_{5,5} = 1 - F_{5,4} - F_{5,6}$$

$$F = \begin{bmatrix} 0 & 0.812 & 0.188 & 0 & 0 & 0 \\ 0.217 & 0.567 & 0.217 & 0 & 0 & 0 \\ 0.188 & 0.812 & 0 & 0 & 0 & 0 \\ 0 & 0 & 0 & 0 & 0.372 & 0.628 \\ 0 & 0 & 0 & 0.396 & 0.207 & 0.396 \\ 0 & 0 & 0 & 0.628 & 0.372 & 0 \end{bmatrix}$$

$$A = \begin{bmatrix} 1.287 \\ 4.825 \\ 1.287 \\ 1.287 \\ 1.206 \\ 1.287 \end{bmatrix} \cdot m^2$$

$$i := 1..6 \quad j := 1..6$$

$$Eb_i := \sigma \cdot (T_i)^4$$

$$E_i := \epsilon_i \cdot Eb_i$$

Node 1

$$B_{1,j} := (1 - \epsilon_1) \cdot F_{1,j}$$

$$B_{1,1} := 1 - F_{1,1} \cdot (1 - \epsilon_1)$$

Node 2

$$B_{2,j} := (1 - \epsilon_2) \cdot F_{2,j}$$

$$B_{2,2} := 1 - F_{2,2} \cdot (1 - \epsilon_2)$$

Node 3 and Node 4 radiant balance

$$B_{3,j} := (1 - \epsilon_3) \cdot F_{3,j}$$

$$B_{4,j} := (1 - \epsilon_4) \cdot F_{4,j}$$

$$B_{3,3} := 1 - F_{3,3} \cdot (1 - \epsilon_3) - 0.5 \cdot \epsilon_3$$

$$B_{4,4} := 1 - F_{4,4} \cdot (1 - \epsilon_4) - 0.5 \cdot \epsilon_4$$

$$B_{3,4} := (1 - \epsilon_3) \cdot F_{3,4} - 0.5 \cdot \epsilon_3$$

$$B_{4,3} := (1 - \epsilon_4) \cdot F_{4,3} - 0.5 \cdot \epsilon_4$$

Node 5

$$B_{5,j} := (1 - \epsilon_5) \cdot F_{5,j}$$

$$B_{5,5} := 1 - F_{5,5} \cdot (1 - \epsilon_5)$$

$$B_{6,j} := (1 - \epsilon_6) \cdot F_{6,j}$$

$$B_{6,6} := 1 - F_{6,6} \cdot (1 - \epsilon_6)$$

$$B = \begin{bmatrix} 1 & -0.081 & -0.019 & 0 & 0 & 0 \\ -0.065 & 0.83 & -0.065 & 0 & 0 & 0 \\ -0.131 & -0.569 & 0.85 & -0.15 & 0 & 0 \\ 0 & 0 & -0.15 & 0.85 & -0.26 & -0.44 \\ 0 & 0 & 0 & -0.119 & 0.938 & -0.119 \\ 0 & 0 & 0 & -0.063 & -0.037 & 1 \end{bmatrix} \quad E = \begin{bmatrix} 1.634 \cdot 10^3 \\ 1.271 \cdot 10^3 \\ 0 \\ 0 \\ 1.016 \cdot 10^3 \\ 555.438 \end{bmatrix} \cdot \text{kg} \cdot \text{sec}^{-3}$$

$$J := B^{-1} \cdot E$$

$$J = \begin{bmatrix} 1.812 \cdot 10^3 \\ 1.804 \cdot 10^3 \\ 1.67 \cdot 10^3 \\ 1.039 \cdot 10^3 \\ 1.3 \cdot 10^3 \\ 669.017 \end{bmatrix} \cdot \frac{\text{watt}}{\text{m}^2}$$

$$Eb_3 := 0.5 \cdot (J_3 + J_4)$$

$$Eb_4 := Eb_3$$

$$T_i := \left(\frac{Eb_i}{\sigma} \right)^{0.25}$$

$$T = \begin{bmatrix} 423 \\ 423 \\ 393.126 \\ 393.126 \\ 400 \\ 323 \end{bmatrix} \cdot \text{K}$$

$$Q_i := \left[\frac{\epsilon_i}{(1 - \epsilon_i)} \right] \cdot A_i \cdot (Eb_i - J_i)$$

$$Q = \begin{bmatrix} 42.592 \\ 131.443 \\ -174.034 \\ 174.034 \\ 426.611 \\ -600.645 \end{bmatrix} \cdot \text{watt}$$

II. Simple Radiation Network Model 48" Gate Valve Open

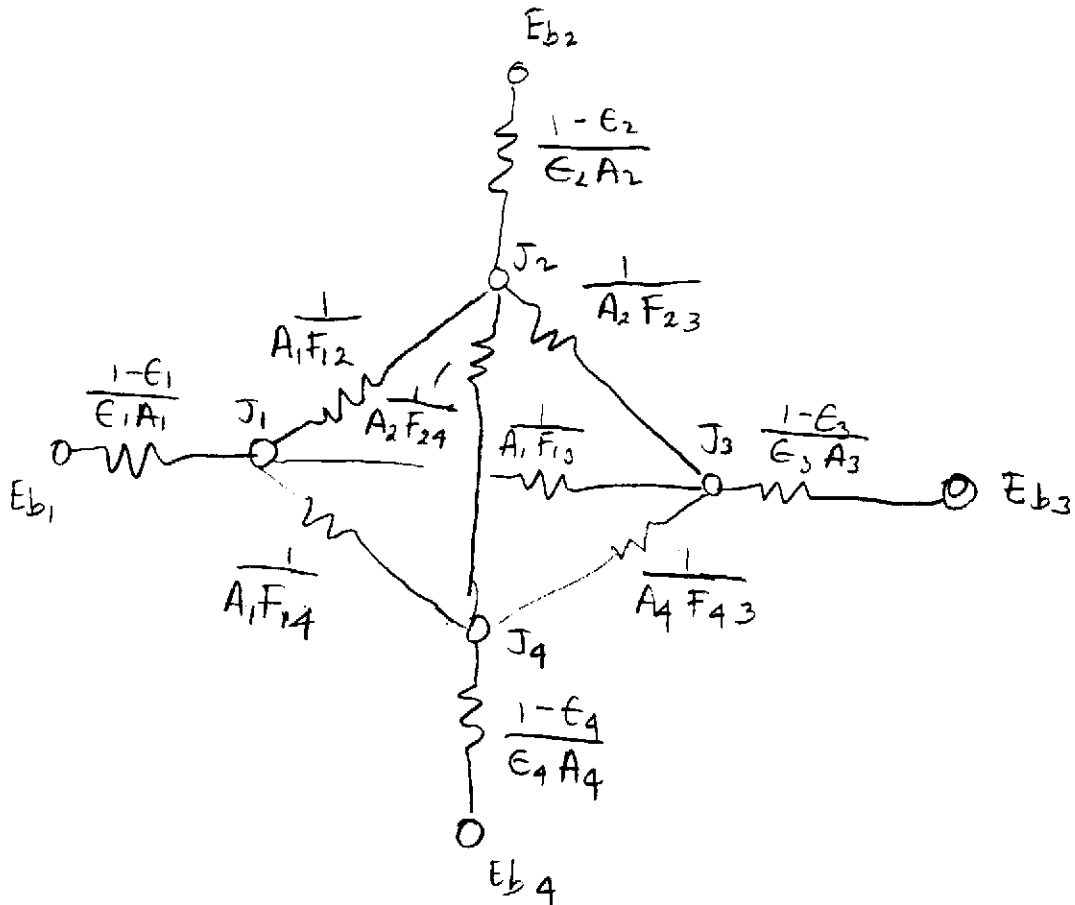
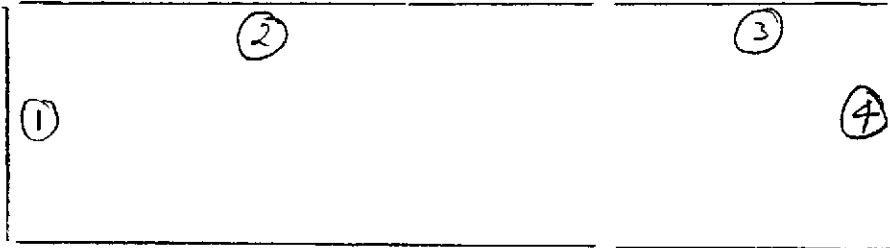

Areas

rad₁ := 0.64·m rad₂ := 0.64·m rad₃ := 0.64·m rad₄ := 0.64·m
 h₂ := 1.2·m h₃ := 0.3·m h₄ := h₂ + h₃

$$\sigma := 56.7 \cdot 10^{-9} \frac{\text{watt}}{\text{m}^2 \cdot \text{K}^4}$$

$$A_1 := \pi \cdot \text{rad}_1^2$$

$$A_2 := \pi \cdot 2 \cdot \text{rad}_2 \cdot h_2$$

$$A_3 := \pi \cdot 2 \cdot \text{rad}_3 \cdot h_3$$

$$A_4 := \pi \cdot \text{rad}_4^2$$

Emissivity

ε₁ := 0.9 ε₂ := 0.7 ε₃ := 0.7 ε₄ := 0.1

Viewfactor parallel circular disks

$$RR_1 := \frac{\text{rad}_1}{h_2} \quad RR_1 = 0.533 \quad RR_2 := RR_1$$

$$X_1 := 1 + \frac{1 + RR_1^2}{RR_1^2}$$

Calculate view factor to imaginary gate surface

$$F_{1\text{gate}} := 0.5 \cdot \left[X_1 - \sqrt{(X_1^2 - 4)} \right] \quad F_{1\text{gate}} = 0.188$$

$$F_{1,2} := 1 - F_{1\text{gate}} \quad F_{1,2} = 0.812$$

$$RR_4 := \frac{\text{rad}_4}{h_4} \quad RR_4 = 0.427$$

$$RR_3 := \frac{\text{rad}_4}{h_3} \quad RR_3 = 2.133$$

$$X_4 := 1 + \frac{1 + RR_4^2}{RR_4^2}$$

$$X_3 := 1 + \frac{1 + RR_3^2}{RR_3^2}$$

$$F_{1,4} := 0.5 \cdot \left[X_4 - \sqrt{(X_4^2 - 4)} \right] \quad F_{1,4} = 0.136$$

$$F_{4\text{gate}} := 0.5 \cdot \left[X_3 - \sqrt{(X_3^2 - 4)} \right] \quad F_{4\text{gate}} = 0.628$$

View factor algebra

$$F_{1,3} := 1 - F_{1,2} - F_{1,4}$$

$$F_{4,1} := \frac{A_1}{A_4} F_{1,4}$$

$$F_{1,1} := 0$$

$$F_{2,1} := \frac{A_1}{A_2} F_{1,2}$$

$$F_{2,2} := 1 - 2 \cdot F_{2,1}$$

$$F_{4,2} := F_{4gate} - F_{4,1}$$

$$F_{4,3} := 1 - F_{4gate} \quad F_{4,4} := 0.0 \quad F_{4,3} = 0.372$$

$$F_{2,4} := \frac{A_4}{A_2} F_{4,2}$$

$$F_{2,3} := 1 - F_{2,1} - F_{2,4} - F_{2,2}$$

$$F_{3,1} := \frac{A_1}{A_3} F_{1,3} \quad F_{3,2} := \frac{A_2}{A_3} F_{2,3}$$

$$F_{3,4} := \frac{A_4}{A_3} F_{4,3}$$

$$F_{3,3} := 1 - F_{3,1} - F_{3,2} - F_{3,4} \quad F_{3,4} = 0.396$$

$$T_1 := 423.K \quad T_2 := 423.0.K \quad T_3 := 300.K \quad T_4 := 293.0.K$$

$$F = \begin{bmatrix} 0 & 0.812 & 0.052 & 0.136 \\ 0.217 & 0.567 & 0.085 & 0.131 \\ 0.055 & 0.341 & 0.207 & 0.396 \\ 0.136 & 0.492 & 0.372 & 0 \end{bmatrix}$$

$$A = \begin{bmatrix} 1.287 \\ 4.825 \\ 1.206 \\ 1.287 \end{bmatrix} \cdot m^2$$

PROJECT: LIGO
PROJECT NO: V59049
TITLE: BAKEOUT BLANKETS HEAT TRANSFER ANALYSIS

BY: R.THAN
DATE:4/06/96

$i := 1..4$ $j := 1..4$

$$Eb_i := \sigma \cdot (T_i)^4$$

$$E_i := \epsilon_i \cdot Eb_i$$

Node 1

$$B_{1,j} := (1 - \epsilon_1) \cdot F_{1,j}$$

$$B_{1,1} := 1 - F_{1,1} \cdot (1 - \epsilon_1)$$

Node 2

$$B_{2,j} := (1 - \epsilon_2) \cdot F_{2,j}$$

$$B_{2,2} := 1 - F_{2,2} \cdot (1 - \epsilon_2)$$

Node 3 and Node 4

$$B_{3,j} := (1 - \epsilon_3) \cdot F_{3,j}$$

$$B_{3,3} := 1 - F_{3,3} \cdot (1 - \epsilon_3)$$

$$B_{4,j} := (1 - \epsilon_4) \cdot F_{4,j}$$

$$B_{4,4} := 1 - F_{4,4} \cdot (1 - \epsilon_4)$$

$$B = \begin{bmatrix} 1 & -0.081 & -0.005 & -0.014 \\ -0.065 & 0.83 & -0.026 & -0.039 \\ -0.017 & -0.102 & 0.938 & -0.119 \\ -0.122 & -0.443 & -0.334 & 1 \end{bmatrix}$$

$$E = \begin{bmatrix} 1.634 \cdot 10^3 \\ 1.271 \cdot 10^3 \\ 321.489 \\ 41.788 \end{bmatrix} \cdot \text{kg} \cdot \text{sec}^{-3}$$

$$J := B^{-1} \cdot E$$

$$J = \begin{bmatrix} 1.798 \cdot 10^3 \\ 1.755 \cdot 10^3 \\ 728.818 \\ 1.283 \cdot 10^3 \end{bmatrix} \cdot \frac{\text{watt}}{\text{m}^2}$$

$$T_i := \left(\frac{Eb_i}{\sigma} \right)^{0.25}$$

$$T = \begin{bmatrix} 423 \\ 423 \\ 300 \\ 293 \end{bmatrix} \cdot \text{K}$$

$$Q_i := \left[\frac{\epsilon_i}{(1 - \epsilon_i)} \right] \cdot A_i \cdot (Eb_i - J_i)$$

$$Q = \begin{bmatrix} 205.437 \\ 677.051 \\ -758.742 \\ -123.746 \end{bmatrix} \cdot \text{watt}$$

$$Qa_i := \frac{Q_i}{A_i}$$

$$Qa = \begin{bmatrix} 159.65 \\ 140.307 \\ -628.945 \\ -96.166 \end{bmatrix} \cdot \frac{\text{watt}}{\text{m}^2}$$

III. Simple Radiaton Network Model 44" Gate Valve Open with low ϵ liner

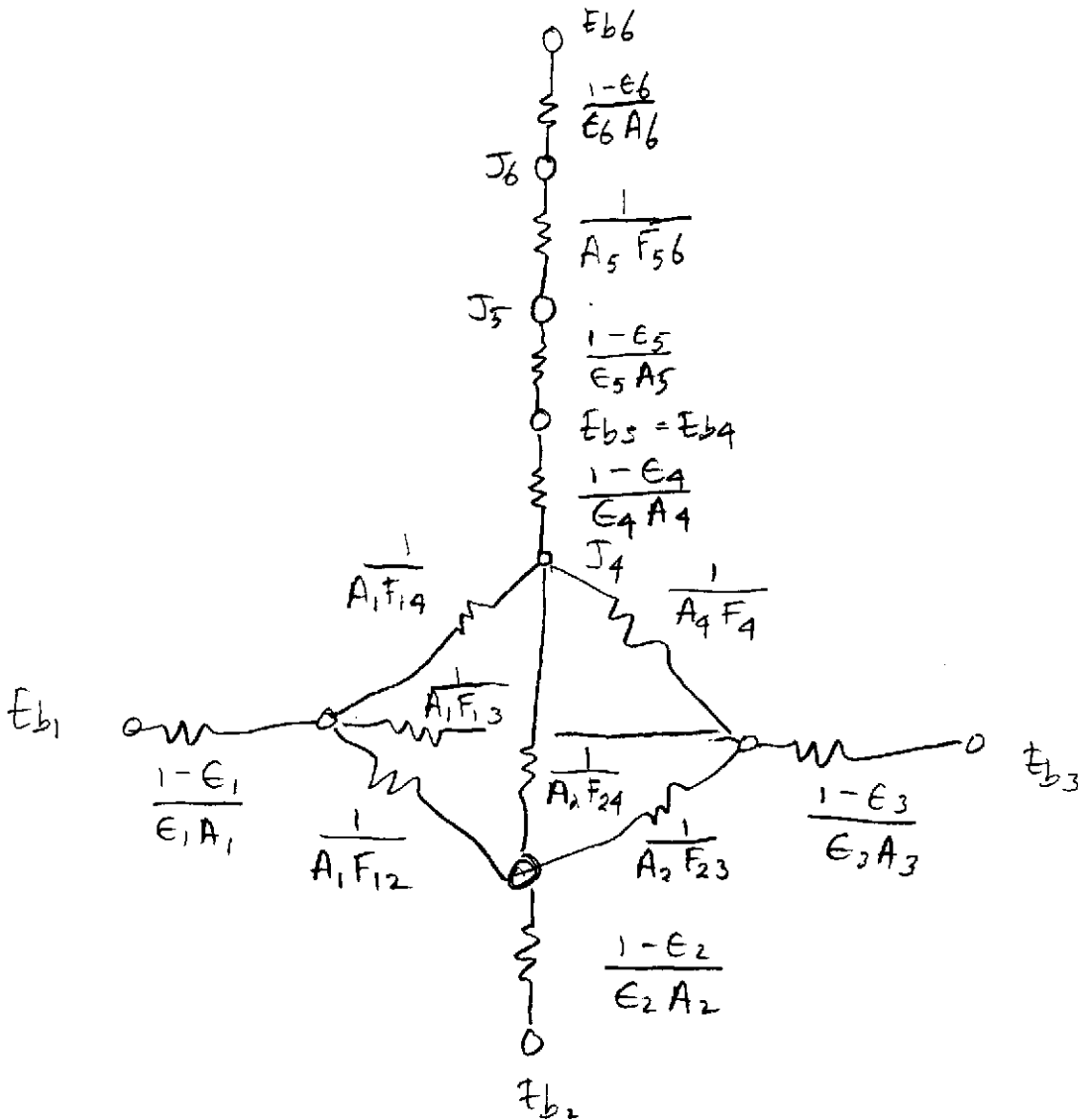
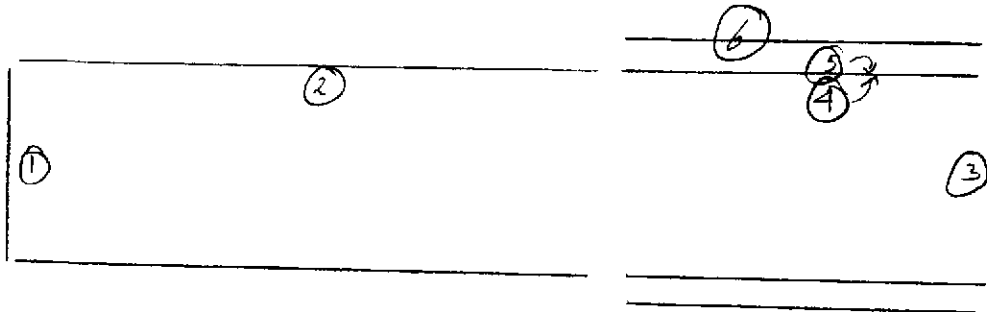

Areas

$$\text{rad}_1 := 0.60\text{-m} \quad \text{rad}_2 := 0.60\text{-m} \quad \text{rad}_3 := 0.60\text{-m} \quad \text{rad}_4 := 0.60\text{-m} \quad \text{rad}_5 := 0.60\text{-m} \quad \text{rad}_6 := 0.60\text{-m}$$

$$h_2 := 1.2\text{-m} \quad h_5 := 1.2\text{-m} \quad h_4 := 1.2\text{-m} \quad h_6 := 1.2\text{-m} \quad \sigma := 56.7 \cdot 10^{-9} \frac{\text{watt}}{\text{m}^2 \cdot \text{K}^4}$$

$$A_1 := \pi \cdot \text{rad}_1^2 \quad A_1 = 1.131 \cdot \text{m}^2$$

$$A_2 := \pi \cdot 2 \cdot \text{rad}_2 \cdot h_2 \quad A_2 = 4.524 \cdot \text{m}^2$$

$$A_3 := \pi \cdot \text{rad}_3^2 \quad A_3 = 1.131 \cdot \text{m}^2$$

$$A_4 := \pi \cdot 2 \cdot \text{rad}_4 \cdot h_4 \quad A_4 = 4.524 \cdot \text{m}^2$$

$$A_5 := \pi \cdot 2 \cdot \text{rad}_5 \cdot h_5 \quad A_5 = 4.524 \cdot \text{m}^2$$

$$A_6 := \pi \cdot 2 \cdot \text{rad}_6 \cdot h_6 \quad A_6 = 4.524 \cdot \text{m}^2$$

Emissivity

$$\epsilon_1 := 0.9 \quad \epsilon_2 := 0.7 \quad \epsilon_3 := 0.9 \quad \epsilon_4 := 0.1 \quad \epsilon_5 := 0.1 \quad \epsilon_6 := 0.7$$

Viewfactor parallel circular disks

$$L_2 := h_2 + h_4$$

$$RR_1 := \frac{\text{rad}_1}{L_2} \quad RR_1 = 0.25 \quad RR_2 := RR_1$$

$$RR_I := \frac{\text{rad}_2}{h_2} \quad RR_I = 0.5$$

$$X_1 := 1 + \frac{1 + RR_1^2}{RR_1^2}$$

$$X_I := 1 + \frac{1 + RR_I^2}{RR_I^2}$$

$$F_{1,3} := 0.5 \cdot \left[X_1 - \sqrt{(X_1^2 - 4)} \right] \quad F_{1,3} = 0.056$$

$$F_I := 0.5 \cdot \left[X_I - \sqrt{(X_I^2 - 4)} \right] \quad F_I = 0.172$$

$$RR_K := \frac{\text{rad}_4}{h_4} \quad RR_K = 0.5$$

$$X_K := 1 + \frac{1 + RR_K^2}{RR_K^2}$$

$$F_K := 0.5 \cdot \left[X_K - \sqrt{(X_K^2 - 4)} \right] \quad F_K = 0.172$$

View factor algebra

$$F_{1,3} = 0.056 \quad F_{1,2} = 1 - F_1$$

$$F_{1,2} = 0.828$$

$$F_{1,4} = 1 - F_{1,2} - F_{1,3} \quad F_{1,4} = 0.116$$

$$F_{1,1} = 0.0$$

$$F_{3,1} = F_{1,3}$$

$$F_{2,1} = \frac{A_1}{A_2} F_{1,2} \quad F_{4,1} = \frac{A_1}{A_4} F_{1,4}$$

$$F_{3,2} = F_K - F_{3,1}$$

$$F_{2,3} = \frac{A_3}{A_2} F_{3,2}$$

$$F_{3,4} = 1 - F_{3,2} - F_{3,1} \quad F_{3,3} = 0.0$$

$F_{1,5} = 0.0$	$F_{1,6} = 0.0$	$F_{4,5} = 0.0$	$F_{4,6} = 0.0$	$F_{5,1} = 0.0$	$F_{6,2} = 0.0$
$F_{2,5} = 0.0$	$F_{2,6} = 0.0$	$F_{5,5} = 0.0$	$F_{5,6} = 1.0$	$F_{6,1} = 0.0$	$F_{5,3} = 0.0$
$F_{3,5} = 0.0$	$F_{3,6} = 0.0$	$F_{6,5} = 1.0$	$F_{6,6} = 0.0$	$F_{5,2} = 0.0$	$F_{5,4} = 0.0$
		$F_{6,3} = 0.0$	$F_{5,4} = 0.0$	$F_{6,4} = 0.0$	

$$F_{2,4} = F_1 - F_{2,3}$$

$$F_{2,2} = 1 - F_{2,1} - F_{2,4} - F_{2,3} \quad F_{4,2} = \frac{A_2}{A_4} F_{2,4}$$

$$F_{4,3} = \frac{A_3}{A_4} F_{3,4} \quad F_{4,4} = 1 - F_{4,3} - F_{4,1} - F_{4,2}$$

$$T_1 = 423\text{-K} \quad T_2 = 423.0\text{-K} \quad T_3 = 80\text{-K} \quad T_6 = 293.0\text{-K} \quad T_4 = 0.0\text{-K} \quad T_5 = 0.0\text{-K}$$

$$F = \begin{bmatrix} 0 & 0.828 & 0.056 & 0.116 & 0 & 0 \\ 0.207 & 0.621 & 0.029 & 0.143 & 0 & 0 \\ 0.056 & 0.116 & 0 & 0.828 & 0 & 0 \\ 0.029 & 0.143 & 0.207 & 0.621 & 0 & 0 \\ 0 & 0 & 0 & 0 & 0 & 1 \\ 0 & 0 & 0 & 0 & 1 & 0 \end{bmatrix}$$

$$A = \begin{bmatrix} 1.131 \\ 4.524 \\ 1.131 \\ 4.524 \\ 4.524 \\ 4.524 \end{bmatrix} \cdot \text{m}^2$$

$$i := 1..6 \quad j := 1..6$$

$$Eb_i := \sigma \cdot (T_i)^4$$

$$E_i := \epsilon_i \cdot Eb_i$$

Node 1

$$B_{1,j} := -(1 - \epsilon_1) \cdot F_{1,j}$$

$$B_{1,1} := 1 - F_{1,1} \cdot (1 - \epsilon_1)$$

Node 2

$$B_{2,j} := -(1 - \epsilon_2) \cdot F_{2,j}$$

$$B_{2,2} := 1 - F_{2,2} \cdot (1 - \epsilon_2)$$

Node 3

$$B_{3,j} := -(1 - \epsilon_3) \cdot F_{3,j}$$

$$B_{3,3} := 1 - F_{3,3} \cdot (1 - \epsilon_3)$$

Node 4 and Node 5 radiant balance

$$B_{4,j} := -(1 - \epsilon_4) \cdot F_{4,j}$$

$$B_{4,4} := 1 - F_{4,4} \cdot (1 - \epsilon_4) - 0.5 \cdot \epsilon_4$$

$$B_{4,5} := -(1 - \epsilon_4) \cdot F_{4,5} - 0.5 \cdot \epsilon_4$$

$$B_{5,j} := -(1 - \epsilon_5) \cdot F_{5,j}$$

$$B_{5,5} := 1 - F_{5,5} \cdot (1 - \epsilon_5) - 0.5 \cdot \epsilon_5$$

$$B_{5,4} := -(1 - \epsilon_5) \cdot F_{5,4} - 0.5 \cdot \epsilon_5$$

Node 6

$$B_{6,j} := -(1 - \epsilon_6) \cdot F_{6,j}$$

$$B_{6,6} := 1 - F_{6,6} \cdot (1 - \epsilon_6)$$

$$B = \begin{bmatrix} 1 & -0.083 & -0.006 & -0.012 & 0 & 0 \\ -0.062 & 0.814 & -0.009 & -0.043 & 0 & 0 \\ -0.006 & -0.012 & 1 & -0.083 & 0 & 0 \\ -0.026 & -0.128 & -0.186 & 0.391 & -0.05 & 0 \\ 0 & 0 & 0 & -0.05 & 0.95 & -0.9 \\ 0 & 0 & 0 & 0 & -0.3 & 1 \end{bmatrix}$$

$$E = \begin{bmatrix} 1.634 \cdot 10^3 \\ 1.271 \cdot 10^3 \\ 2.09 \\ 0 \\ 0 \\ 292.517 \end{bmatrix} \frac{\text{watt}}{\text{m}^2}$$

$$J := B^{-1} \cdot E$$

$$J = \begin{bmatrix} 1.788 \cdot 10^3 \\ 1.741 \cdot 10^3 \\ 98.072 \\ 794.859 \\ 445.601 \\ 426.198 \end{bmatrix} \cdot \frac{\text{watt}}{\text{m}^2}$$

$$Eb_4 := 0.5 \cdot (J_4 + J_5)$$

$$Eb_5 := Eb_4$$

$$T_i := \left(\frac{Eb_i}{\sigma} \right)^{0.25}$$

$$T = \begin{bmatrix} 423 \\ 423 \\ 80 \\ 323.402 \\ 323.402 \\ 293 \end{bmatrix} \cdot K$$

$$Q_i := \left[\frac{\epsilon_i}{(1 - \epsilon_i)} \right] \cdot A_i \cdot (Eb_i - J_i)$$

$$Q = \begin{bmatrix} 280.215 \\ 782.175 \\ -974.612 \\ -87.778 \\ 87.778 \\ -87.778 \end{bmatrix} \cdot \text{watt}$$

$$Qa_i := \frac{Q_i}{A_i}$$

$$Qa = \begin{bmatrix} 247.764 \\ 172.899 \\ -861.746 \\ -19.403 \\ 19.403 \\ -19.403 \end{bmatrix} \cdot \frac{\text{watt}}{\text{m}^2}$$

3.8 Pressure Gauge Pair Bakeout

The pressure gauge pair will be baked out at 250°C. Since the gauge pair is mounted on a 1.5 inch conflat tee that is in turn mounted on a 14 inch nozzle conflat blank, the thermal path to the 150°C mass is reasonably long. To ensure that temperature is reached at the gauge the entire tee along with the gauge pair is heated to 250°C. With the temperature sensor mounted at the gauges, the gauges are insured to reach temperature. A temperature gradient will develop along the tee from 250°C to 150°C. The required power density required to reach 250°C with 2 inch thick fiberglass insulation is about 600 W/m².

CATALOG OF SELECTED CONFIGURATION FACTORS 789

25

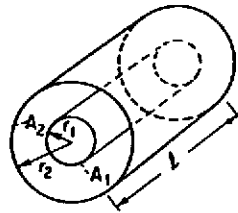

Two concentric cylinders of same finite length.

$$R = \frac{r_2}{r_1} \quad L = \frac{l}{r_1}$$

$$A = L^2 + R^2 - 1$$

$$B = L^2 - R^2 + 1$$

$$F_{2-1} = \frac{1}{R} - \frac{1}{\pi R} \left\{ \cos^{-1} \left(\frac{B}{A} \right) - \frac{1}{2L} \left[\sqrt{(A+2)^2 - (2R)^2} \cos^{-1} \left(\frac{B}{RA} \right) + B \sin^{-1} \left(\frac{1}{R} \right) - \frac{\pi A}{2} \right] \right\}$$

$$F_{2-2} = 1 - \frac{1}{R} + \frac{2}{\pi R} \tan^{-1} \left(\frac{2\sqrt{R^2-1}}{L} \right)$$

$$- \frac{L}{2\pi R} \left\{ \frac{\sqrt{4R^2+L^2}}{L} \sin^{-1} \left[\frac{4(R^2-1) + (L^2/R^2)(R^2-2)}{L^2 + 4(R^2-1)} \right] \right.$$

$$\left. - \sin^{-1} \left(\frac{R^2-2}{R^2} \right) + \frac{\pi}{2} \left(\frac{\sqrt{4R^2+L^2}}{L} - 1 \right) \right\}$$

where for any argument ξ :

$$-\frac{\pi}{2} \leq \sin^{-1} \xi \leq \frac{\pi}{2}$$

$$0 \leq \cos^{-1} \xi \leq \pi$$

26

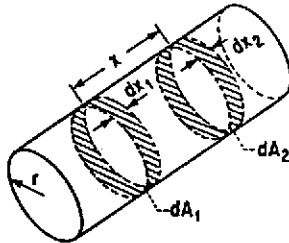

Two ring elements on the interior of a right circular cylinder.

$$X = \frac{x}{2r}$$

$$dF_{dA_1-dA_2} = \left[1 - \frac{2X^2 + 3X}{2(X^2 + 1)^{3/2}} \right] dX_2$$

27

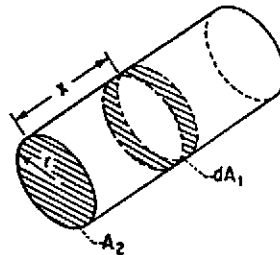

Ring element dA_1 on interior of right circular cylinder to circular disk A_2 at end of cylinder.

$$X = \frac{x}{2r}$$

$$F_{dA_1-A_2} = \frac{X^2 + \frac{1}{2}}{\sqrt{X^2 + 1}} - X$$

CATALOG OF SELECTED CONFIGURATION FACTORS 787

17

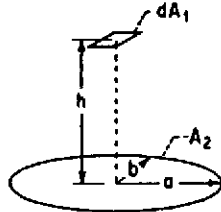

Plane element dA_1 to elliptical plate in plane parallel to element; normal to element passes through center of plate.

$$F_{d1-2} = \frac{ab}{\sqrt{(h^2 + a^2)(h^2 + b^2)}}$$

18

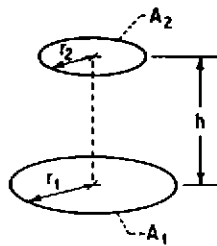

Parallel circular disks with centers along the same normal.

$$R_1 = \frac{r_1}{h} \quad R_2 = \frac{r_2}{h}$$

$$X = 1 + \frac{1 + R_2^2}{R_1^2}$$

$$F_{1-2} = \frac{1}{2} \left[X - \sqrt{X^2 - 4 \left(\frac{R_2}{R_1} \right)^2} \right]$$

19

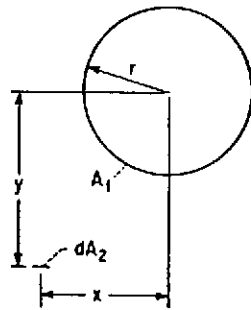

Strip element dA_2 of any length to infinitely long cylinder.

$$X = \frac{x}{r} \quad Y = \frac{y}{r}$$

$$F_{d2-1} = \frac{Y}{X^2 + Y^2}$$

20

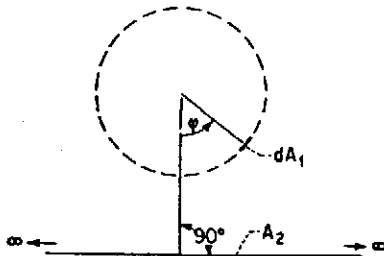

Element of any length on cylinder to plane of infinite length and width.

$$F_{d1-2} = \frac{1}{2}(1 + \cos \phi)$$

Specific heat of steels

Nearest AISI-SAE grade	Chemical composition, %						Treatment or condition	Mean apparent specific heat, J/Kg·K, Temperature ranges, °C											
	C	Mn	Cr	Ni	Mo	Other		60 to 100	150 to 200	200 to 250	250 to 300	300 to 350	350 to 400	450 to 500	550 to 600	650 to 700	700 to 750	750 to 800	850 to 900
1008	0.06	0.38	· · ·	· · ·	· · ·	· · ·	Annealed	481	519	536	553	574	595	662	754	867	1105	875	846
1008	0.08	0.31	· · ·	· · ·	· · ·	· · ·	Annealed	481	523	544	557	569	595	662	741	858	1139	960	· · ·
1010(a) . . .	0.10	0.42	· · ·	· · ·	· · ·	0.008 P; 0.028 S	Not known	450	500	520	535	565	590	650	730	825	(a)	(a)	(a)
1025	0.23	0.64	· · ·	· · ·	· · ·	· · ·	Annealed	486	519	532	557	574	599	662	749	846	1432	950	· · ·
1042	0.42	0.64	· · ·	· · ·	· · ·	· · ·	Annealed	486	515	528	548	569	586	649	708	770	1583	624	548
1078	0.80	0.32	· · ·	· · ·	· · ·	· · ·	Annealed	490	532	548	565	586	607	670	712	770	2081	615	· · ·
(b)	1.22	0.35	· · ·	· · ·	· · ·	· · ·	Annealed	486	540	544	557	578	599	636	699	816	2089	649	· · ·
1524	0.23	1.51	· · ·	· · ·	· · ·	0.11 Cu	Annealed	477	511	528	544	565	590	649	741	837	1449	821	536
4130(c) . . .	0.3	0.5	0.95	· · ·	0.2	· · ·	Hardened and tempered	477	515	· · ·	544	· · ·	595	657	737	825	· · ·	833	· · ·
4140	0.41	0.67	1.01	· · ·	0.23	· · ·	Hardened and tempered	· · ·	473(d)	· · ·	· · ·	· · ·	519(d)	· · ·	561(d)	· · ·	· · ·	· · ·	· · ·
5132	0.32	0.69	1.09	0.073	· · ·	· · ·	Annealed	494	523	536	553	574	595	657	741	837	1499	934	574
5140	0.39	0.79	1.03	· · ·	· · ·	· · ·	Hardened and tempered	452(d)	473(d)	· · ·	· · ·	· · ·	519(d)	· · ·	561(d)	· · ·	· · ·	· · ·	· · ·
(b)	0.35	0.59	0.88	0.26	0.20	· · ·	Annealed	477	515	528	544	569	595	657	737	825	1616	883	· · ·
(b)	0.33	0.55	0.17	3.47	· · ·	· · ·	Not known	481	523	536	548	569	590	662	749	1637	955	603	640
(b)	0.34	0.55	0.78	3.53	0.39	· · ·	Hardened and tempered	486	523	540	557	582	607	670	770	1051	1662	636	636
(b)	0.49	0.90	· · ·	· · ·	· · ·	1.98 Si; 0.64 Cu	Not known	498	523	540	557	578	603	666	749	829	904	1365	· · ·

(a) See graph of specific heat versus temperature. (b) No equivalent grade. (c) Nominal composition. (d) Value presented is mean value for range of temperatures between room temperature and the higher of the cited temperatures.

Specific heat of 1010 steel

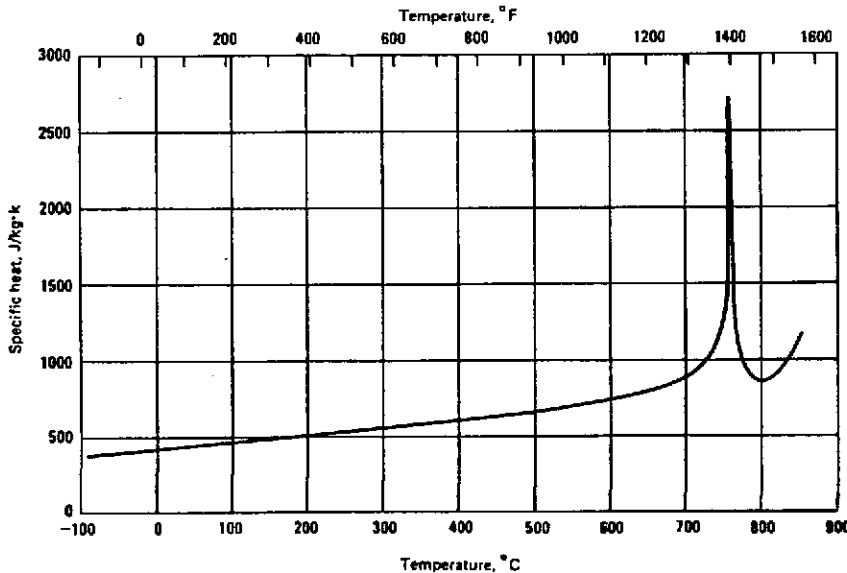

SPECIFIC HEAT ANSI 304

PROJECT: LIGO
PROJECT NO: V59049
TITLE: BAKEOUT BLANKETS HEAT TRANSFER ANALYSIS
BY: R. THAN
DATE:

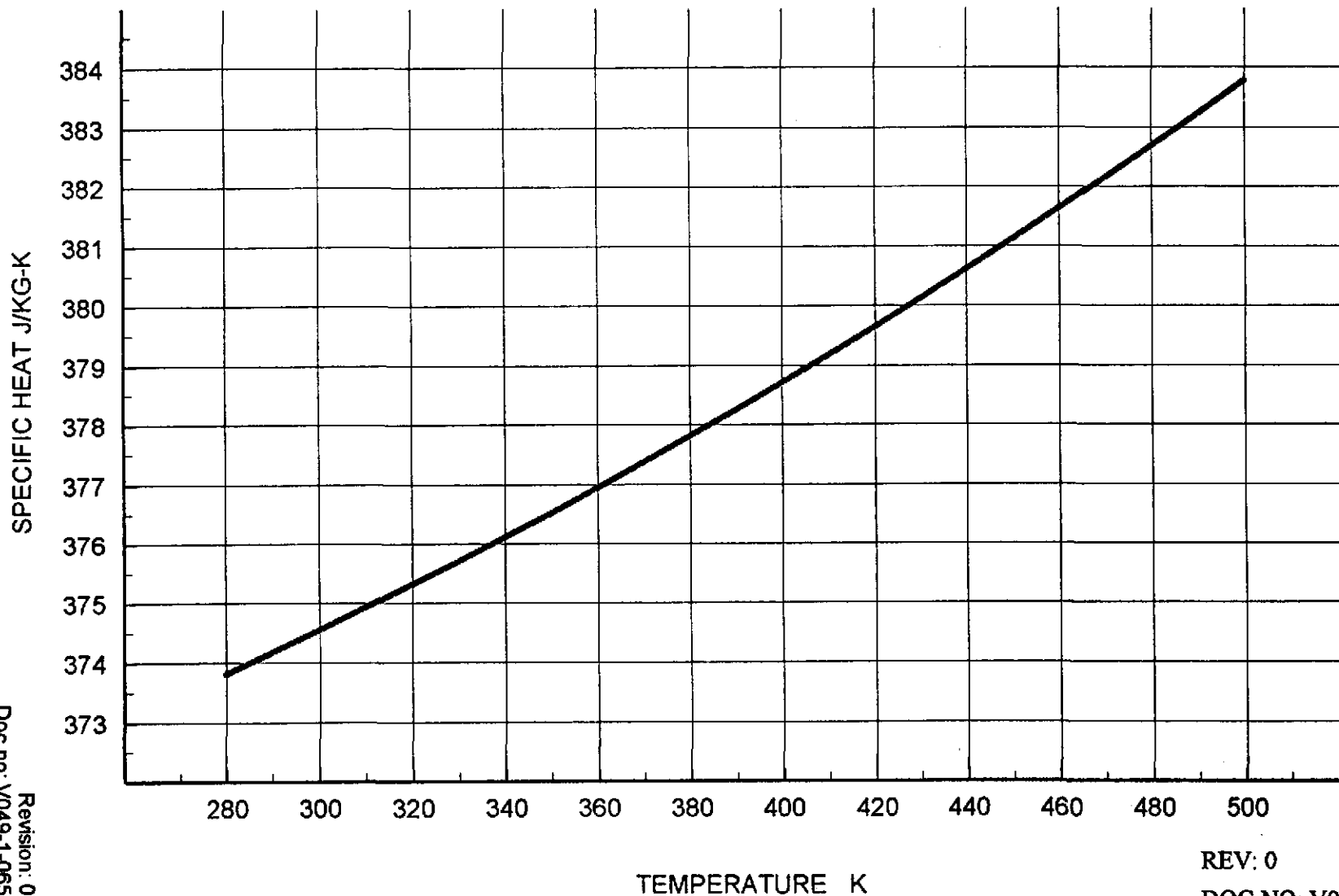

Revision: 0
Doc no: V049-1-065
Page 55 of 60

REV: 0
DOC NO: V049-1-065
Page of

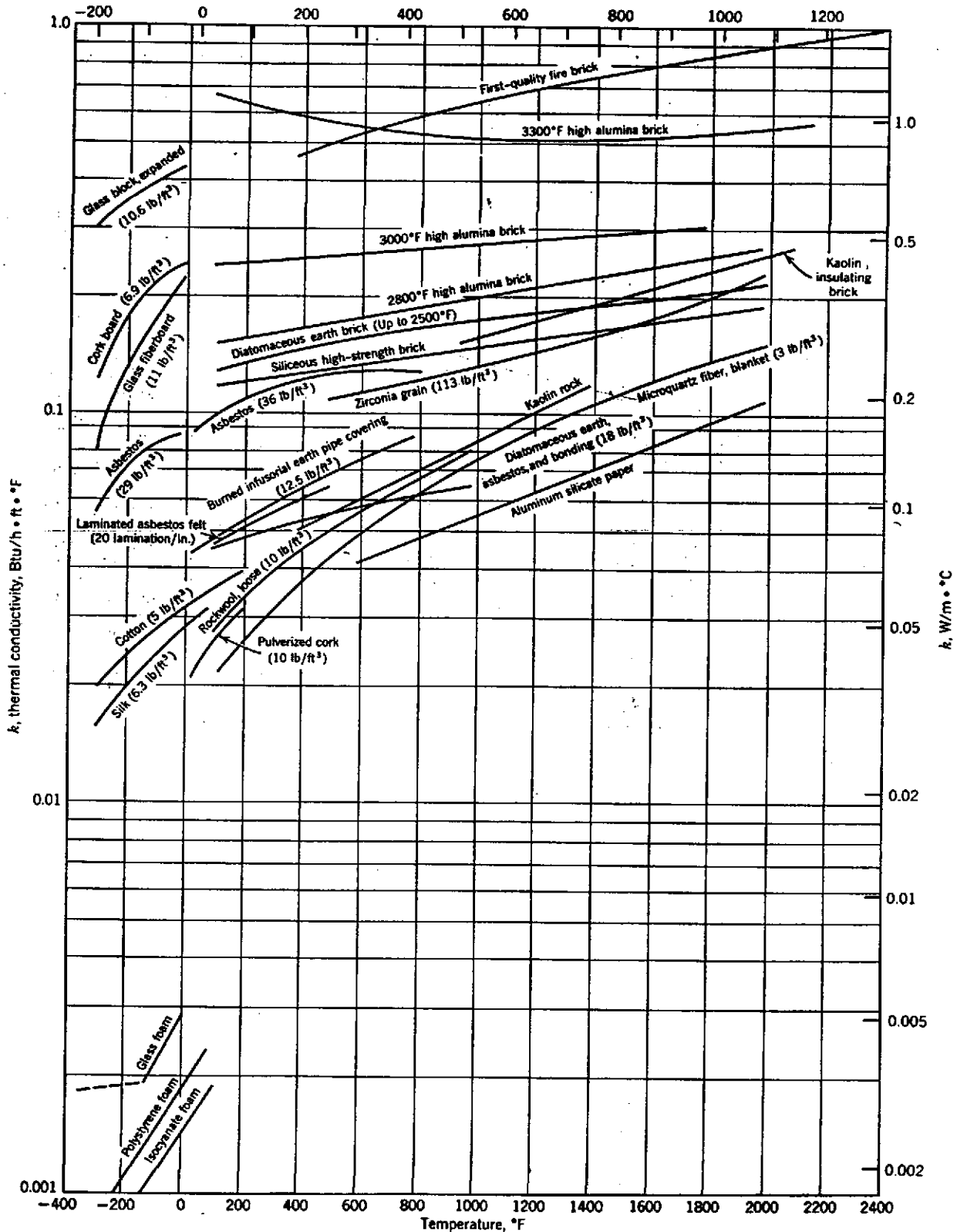

Figure H2.1 Effects of temperature on the thermal conductivities of thermal insulating materials. (Data from a number of sources—including Ref. 8, in Chapter 20 and Refs. 4, 14, and 19 of this handbook—were selected, plotted, and averaged to yield these curves.)

11-54 HEAT-TRANSFER EQUIPMENT

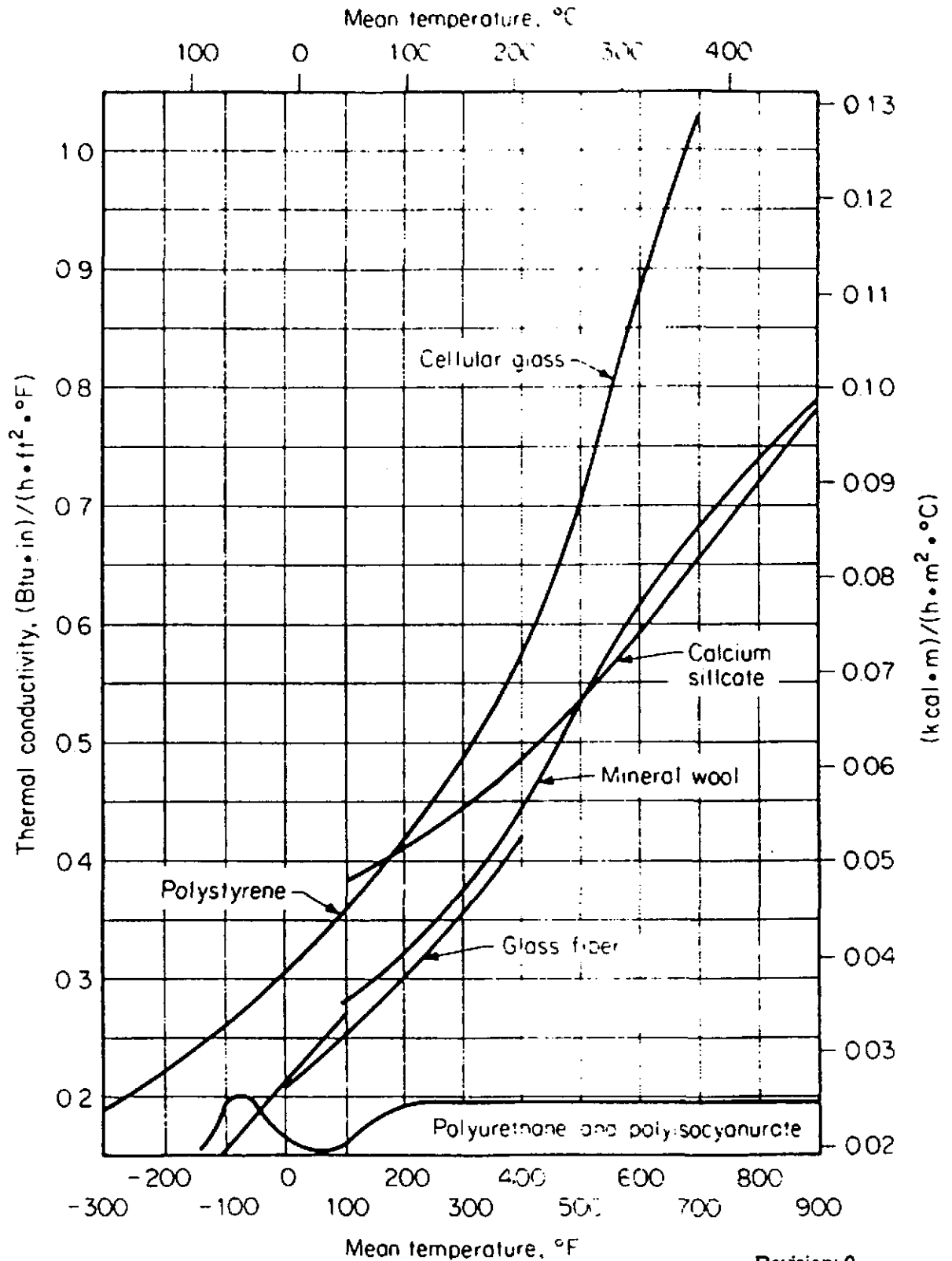

FIG. 11-42 Thermal conductivity of insulating materials.

Table 4 Typical Thermal Properties of Common Building and Insulating Materials--Design Values*

Description	Density, lb/ft ³	Conduc- tivity ^a (k), Btu-in. h-ft ² -°F	Conduc- tance (C), Btu h-ft ² -°F	Resistance (R)		Specific Heat, Btu lb.-°F
				Per inch thickness (1/k), ft ² -h Btu-in.	For thick- ness listed (1/C), ft ² -h Btu	
BUILDING BOARD						
Asbestos-cement board	120	4.0	—	0.25	—	0.24
Asbestos-cement board	0.125 in. 120	—	33.00	—	0.03	—
Asbestos-cement board	0.25 in. 120	—	16.50	—	0.06	—
Gypsum or plaster board	0.375 in. 50	—	3.10	—	0.32	0.26
Gypsum or plaster board	0.5 in. 50	—	2.22	—	0.45	—
Gypsum or plaster board	0.625 in. 50	—	1.78	—	0.56	—
Plywood (Douglas Fir) ^b	34	0.80	—	1.25	—	0.29
Plywood (Douglas Fir)	0.25 in. 34	—	3.20	—	0.31	—
Plywood (Douglas Fir)	0.375 in. 34	—	2.13	—	0.47	—
Plywood (Douglas Fir)	0.5 in. 34	—	1.60	—	0.62	—
Plywood (Douglas Fir)	0.625 in. 34	—	1.29	—	0.77	—
Plywood or wood panels	0.75 in. 34	—	1.07	—	0.93	0.29
Vegetable Fiber Board						
Sheathing, regular density ^c	0.5 in. 18	—	0.76	—	1.32	0.31
	0.78125 in. 18	—	0.49	—	2.06	—
Sheathing intermediate density ^c	0.5 in. 22	—	0.92	—	1.09	0.31
Nail-base sheathing ^c	0.5 in. 25	—	0.94	—	1.06	0.31
Shingle backer	0.375 in. 18	—	1.06	—	0.94	0.31
Shingle backer	0.3125 in. 18	—	1.28	—	0.78	—
Sound deadening board	0.5 in. 15	—	0.74	—	1.35	0.30
Tile and lay-in panels, plain or acoustic	0.5 in. 18	0.40	—	2.50	—	0.14
	0.5 in. 18	—	0.80	—	1.25	—
	0.75 in. 18	—	0.53	—	1.89	—
Laminated paperboard	30	0.50	—	2.00	—	0.33
Homogeneous board from recycled paper	30	0.50	—	2.00	—	0.28
Hardboard^d						
Medium density	50	0.73	—	1.37	—	0.31
High density, service temp. service underlay	55	0.82	—	1.22	—	0.32
High density, std. tempered	63	1.00	—	1.00	—	0.32
Particleboard^e						
Low density	37	0.71	—	1.41	—	0.31
Medium density	50	0.94	—	1.06	—	0.31
High density	62.5	1.18	—	0.85	—	0.31
Underlayment	0.625 in. 40	—	1.22	—	0.82	0.28
Waferboard	37	0.63	—	1.59	—	0.33
Wood subfloor	0.75 in. —	—	1.06	—	0.94	0.33
BUILDING MEMBRANE						
Vapor-permeable felt	—	—	16.70	—	0.06	—
Vapor-seal, 2 layers of mopped 15-lb felt	—	—	8.35	—	0.12	—
Vapor-seal, plastic film	—	—	—	—	Negl.	—
FINISH FLOORING MATERIALS						
Carpet and fibrous pad	—	—	0.48	—	2.08	—
Carpet and rubber pad	—	—	0.81	—	1.23	—
Cork tile	0.125 in. —	—	3.60	—	0.28	—
Terrazzo	1 in. —	—	12.50	—	0.08	—
Tile—asphalt, linoleum, vinyl, rubber vinyl asbestos ceramic	—	—	20.00	—	0.05	—
Wood, hardwood finish	0.75 in. —	—	1.47	—	0.68	—
INSULATING MATERIALS						
<i>Blanket and Batt^{1,2}</i>						
Mineral Fiber, fibrous form processed from rock, slag, or glass						
approx. 3-4 in.	0.3-2.0	—	0.091	—	11	—
approx. 3.5 in.	0.3-2.0	—	0.077	—	13	—
approx. 5.5-6.5 in.	0.3-2.0	—	0.053	—	19	—
approx. 6-7.5 in.	0.3-2.0	—	0.045	—	22	—
approx. 9-10 in.	0.3-2.0	—	0.033	—	30	—
approx. 12-13 in.	0.3-2.0	—	0.026	—	38	—
<i>Board and Slabs</i>						
Cellular glass	8.5	0.35	—	2.86	—	—
Glass fiber, organic bonded	4.0-9.0	0.25	—	4.00	—	—
Expanded perlite, organic bonded	1.0	0.36	—	2.78	—	—
Expanded rubber (rigid)	4.5	0.22	—	4.55	—	—

Heat Transfer
 Division

PROPERTIES OF SOLIDS
 THERMAL CONDUCTIVITY

G-E designation (1)	Material	Condition (2)		k _B		k _w		Range of 1/k _w values (4)	Rating (4)	Ref No. (5)	
		Density or pressure	Average temp	Conductivity (3)	Conductivity (3)	Resistivity (3)					
		lb/ft ³ except as noted	Deg F Deg C	(Btu)(ft) hr(ft ²) F	watt(in.) in.2 (C)	in.2 (C) watt(in.)					
NON-METALLIC MINERALS (Continued)											
	Fiberglas, white (glass wool blankets or bolts) All samples 1/2 inch thick and faced with aluminum foil	7.75 psia	86.0	30	.0287	.00126	794		A	130	
		4.66 psia	87.8	31	.0278	.00122	820		A	130	
		3.65 psia	84.2	29	.0276	.00121	826		A	130	
		1.73 psia	86.0	30	.0276	.00121	826		A	130	
		.266 psia	86.0	30	.0269	.00118	847		A	130	
		1.75									
		14.7 psia	95.0	35.0	.0257	.00113	885		A	130	
		11.0 psia	96.1	35.6	.0253	.00111	901		A	130	
		7.26 psia	88.9	31.6	.0234	.00103	971		A	130	
		4.42 psia	89.2	31.8	.0232	.00102	980		A	130	
		.398 psia	96.3	35.7	.0209	.00092	1087		A	130	
		2.45									
		14.6 psia	92.1	33.4	.0276	.00121	826		A	130	
		11.5 psia	93.2	34.0	.0273	.00120	833		A	130	
		8.31 psia	86.0	30	.0250	.00110	909		A	130	
		4.61 psia	86.0	30	.0246	.00108	926		A	130	
		.520 psia	92.5	33.6	.0237	.00104	962		A	130	
		2.8									
		14.6 psia	90.0	32.2	.0230	.00101	990		A	130	
		12.7 psia	91.4	33.0	.0234	.00103	971		A	130	
		10.3 psia	91.8	33.2	.0228	.00100	1000		A	130	
		82.5 psia	90.7	32.6	.0223	.000985	1020		A	130	
		6.00 psia	91.6	33.4	.0223	.000985	1020		A	130	
		2.94 psia	92.5	33.6	.0218	.000964	1042		A	130	
		3.5									
		14.6 psia	86.9	30.5	.0234	.00103	971		A	130	
		12.5 psia	86.5	30.3	.0230	.00101	990		A	130	
		10.0 psia	86.0	30.0	.0227	.000996	1005		A	130	
		7.37 psia	85.5	29.7	.0223	.000982	1020		A	130	
		5.48 psia	87.4	30.8	.0223	.000982	1020		A	130	
		3.43 psia	88.0	31.1	.0221	.000967	1031		A	130	
		2.79 psia	90.0	32.2	.0221	.000967	1031		A	130	
		1.53 psia	90.0	32.2	.0218	.000956	1042		A	130	
.202 psia	91.6	33.1	.0203	.000890	1124		A	130			
	Fiberglas batts (basic form) (TV-P)	3	68	20	.0207	.000912	1099		A	136	
			300	149	.0342	.00150	667		A	136	
			399	204	.0453	.00212	472		A	136	
		6	68.0	20	.0191	.000843	1190		A	136	
			300	149	.0271	.00119	840		A	136	
			399	204	.0351	.00154	649		A	136	
		9	68.0	20	.0184	.000806	1234		A	136	
			300	149	.0234	.00103	971		A	136	
			399	204	.0287	.00126	794		A	136	
A7AB	Fiberglas (for use up to 500 C) Preformed (PP) (some as TV-P with a small percentage of thermosetting plastic added to give rigidity of form)										
			75.2	24	.0276	.000957	1052		A	136	
		3.75	75.2	24	.0191	.000843	1190		A	136	
		2.0	50	10	.0207	.000908	1099		A	117	
			100	38	.0246	.00108	926		A	117	
		66	.0291	.00128	781		A	117			

(1) - (5) See bottom of page 8.

Title: SPECIFICATION FOR BAKEOUT CART SYSTEM CONTROL FUNCTIONALITY

**SPECIFICATION
FOR
BAKEOUT CART SYSTEM
CONTROL FUNCTIONALITY
LIGO VACUUM EQUIPMENT**

Hanford, Washington
and
Livingston, Louisiana

PREPARED BY *DAJ*
ELECTRICAL *F. Bank*
QUALITY ASSURANCE *N/A*
TECHNICAL DIRECTOR *D. A. Williams*
PROJECT MANAGER *Robert Bay*

Information contained in this specification and its attachments is proprietary in nature and shall be kept confidential. It shall be used only as required to respond to the specification requirements and shall not be disclosed to any other party.

REV	LTR	BY—DATE	APPD—DATE	DESCRIPTION OF ACTION
0		<i>PPS 4/8/96</i>	<i>REV 4/16/96</i>	<i>Issue for Design DEO# 0113</i>

PROCESS SYSTEMS INTERNATIONAL, INC				SPECIFICATION		
INITIAL APPROVALS	PREPARED BY	DATE	APPROVED BY	DATE	Number	Rev
	<i>PPS</i>	<i>4/8/96</i>	<i>D. A. Williams</i>	<i>4-11-96</i>	A V049-2-086	0

TABLE OF CONTENTS

1.	Bakeout Control System	Page
1.0	Scope	4
1.1	System Overview	4
1.2	Control System Hardware	4
1.3	Background Sub-Routines Running Continuously	5
1.4	Blankets 1-76 MODE-SEQUENCE Overview	6
1.5	Blankets 93-112 MODE-SEQUENCE Overview	18
1.6	System Alarming Overview	24
1.7	Emergency Shutdown System (ESD) Overview	25

SPECIFICATION

Number

A V049-2-086

Rev

0

**TABLE OF CONTENTS (Cont.)
(Appendix Index)**

Alarm Summary (3 pages) Appendix 1

Background Sub-Routines Running Continuously Appendix 2

A)	Background Subroutine Summary	V59049-0-029	Sheet 1 of 6
B)	System Duty Cycle Subroutine	V59049-0-029	Sheet 2 of 6
C)	Setpoint Deviation Subroutine (1-76)	V59049-0-029	Sheet 3 of 6
D)	Setpoint Deviation Subroutine (93-112)	V59049-0-029	Sheet 4 of 6
E)	Temp Range Alarm Filter Subroutine (1-112)	V59049-0-029	Sheet 5 of 6
F)	Individual Blanket PID Loop and Relay Control	V59049-0-029	Sheet 6 of 6

Blankets 1-76 Mode/Sequence Sub-Routines Appendix 3

A)	Control System MODE / SEQUENCE (1-76)	V59049-0-028	Sheet 1 of 9
B)	Ramp-Up (Initialize) (1-76)	V59049-0-028	Sheet 2 of 9
C)	Ramp-Down (Initialize) (1-76)	V59049-0-028	Sheet 3 of 9
D)	Ramp-Up and Ramp-Down Modes (1-76)	V59049-0-028	Sheet 4 of 9
E)	Cart High / Low T/C Subroutine (1-76)	V59049-0-028	Sheet 5 of 9
F)	Selection of Control T/C Subroutine (1-76)	V59049-0-028	Sheet 6 of 9
G)	Selection of Control T/C Subroutine (1-76) (Cont)	V59049-0-028	Sheet 7 of 9
H)	Descale Control T/C Subroutine (1-76)	V59049-0-028	Sheet 8 of 9
I)	Ramp-Up /Ramp-Down Setpoint Subroutines (1-76)	V59049-0-028	Sheet 9 of 9

Blankets 1-76 Mode/Sequence Permissives and Interlocks Appendix 4

Blanket 93-112 Mode/Sequence Sub-Routines Appendix 5

A)	Control System MODE / SEQUENCE (93-112)	V59049-0-030	Sheet 1 of 5
B)	Ramp-Up (Initialize)/ Ramp-Up Mode (93-112)	V59049-0-030	Sheet 2 of 5
C)	Selection of Control T/C Subroutine (93-112)	V59049-0-030	Sheet 3 of 5
D)	Descale Control T/C Subroutine (93-112)	V59049-0-030	Sheet 4 of 5
E)	Ramp-Up Setpoint Subroutines (93-112)	V59049-0-030	Sheet 5 of 5

Blankets 93-112 Mode/Sequence Permissives and Interlocks Appendix 6

SPECIFICATION

Number	Rev
A V049-2-086	0

1 BAKEOUT CONTROL SYSTEM

1.0 SCOPE

This functional specification covers the monitoring and control requirements of the LIGO Bakeout Cart System. The System includes up to (7) individual carts.

1.1 PROCESS SYSTEM OVERVIEW

Each Bakeout Cart has the following heater blankets available:

- A) (76) Chamber Blankets
- B) (16) Aux. Blankets
- C) (4) Gauge Blankets

The 76 Chamber blankets on each Cart can be networked together via the PLC Data Highway Plus network to form a "Configured System". The Configured System will communicate and control all chamber blankets to ramp at the same rate, and stay within the ± 20 Deg C temperature differential required. A master cart will be selected and this cart will control the Mode / Sequence for all the other carts on the Configured System.

The 16 Aux. Blankets and 4 Gauge Blankets on each cart will work independently.

1.2 CONTROL SYSTEM HARDWARE

The LIGO Bakeout Cart System consists of up to (7) seven Allen-Bradley PLC 5/30 controllers networked via Data Highway Plus cable spanning over any isolatable section of the Vacuum Vessel System. Each of the (7) seven carts contains a PC operator interface which is connected directly to the individual cart PLC. An individual Cart Control System layout is shown on the following drawings and specifications:

- | | | | |
|----|---|----------|---------------------|
| A) | PLC / PC / Data Acquisition Configuration | Drawing | V049-3-014 |
| B) | Cart Assembly | Drawings | V049-3-013 6 Sheets |
| C) | Electrical Schematic, Control System | Drawings | V049-3-011 8 Sheets |
| D) | Electrical Schematic, Heater Power | Drawing | V049-3-012 2 Sheets |
| E) | Fabrication of Bakeout Control Sys Cart | Spec | V049-2-068 |

SPECIFICATION	
Number	Rev
A V049-2-086	0

The following is a list of station numbers for the PLC network :

- A) Cart #1 PLC Station # 01
- B) Cart #2 PLC Station # 02
- C) Cart #3 PLC Station # 03
- D) Cart #4 PLC Station # 04
- E) Cart #5 PLC Station # 05
- F) Cart #6 PLC Station # 06
- G) Cart #7 PLC Station # 07

Each of the (7) seven carts contains a PC operator interface which is connected directly to the individual cart PLC via a Allen-Bradley Communication card (1771-KTX). The Operator interface system consists of Intellution FIX-DMACS for Windows NT software running on Pentium-120 PC's. Each Operator Interface is a FIX-DMACS stand alone SCADA node.

The following is a list of station numbers for the PC SCADA Nodes :

- A) Cart #1 SCADA Node Station # 11
- B) Cart #2 SCADA Node Station # 12
- C) Cart #3 SCADA Node Station # 13
- D) Cart #4 SCADA Node Station # 14
- E) Cart #5 SCADA Node Station # 15
- F) Cart #6 SCADA Node Station # 16
- G) Cart #7 SCADA Node Station # 17

1.3 BACKGROUND SUBROUTINES RUNNING CONTINUOUSLY

Reference drawing Dwg V59049-0-029 Sheet 1 in Appendix 2 for a flowchart describing how the Background tasks operate.

The following operations will run continuously in the background of the PLC program :

- a) The alarming system will be called every scan.
- b) The Cart to Cart System Inter-Communication routine will be called every 5 seconds.
- c) The Duty Cycle subroutine (1-112) will be called every 100 seconds. (Dwg V59049-0-029 Sheet 2 in Appendix 2)

SPECIFICATION

Number

A V049-2-086

Rev

0

- d) The Setpoint Deviation subroutine (1-76) will be called every 10 seconds.
(Dwg V59049-0-029 Sheet 3 in Appendix 2)
- e) The Setpoint Deviation subroutine (93-112) will be called every 10 seconds.
(Dwg V59049-0-029 Sheet 4 in Appendix 2)
- f) The T/C Range Check and Alarm Filter subroutine (1-112) will be called every time there is a T/C system heartbeat transition (off-on)
(Dwg V59049-0-029 Sheet 5 in Appendix 2)
- g) The Mode/Sequence operations of Blankets 1-76 will be called every scan.
(Dwg V59049-0-028 Sheet 1 in Appendix 3)
- h) The Mode/Sequence operations of Blankets 93-112 will be called every scan.
(Dwg V59049-0-030 Sheet 1 in Appendix 5)
- i) PID loop control (1-112) will be called every scan.
(Dwg V59049-0-029 Sheet 6 in Appendix 2)
- j) Relay control (1-112) will be called every scan.
(Dwg V59049-0-029 Sheet 6 in Appendix 2)

1.4 BLANKETS 1-76 MODE-SEQUENCE OVERVIEW

The Mode-Sequence overview for Blankets 1-76 will describe how the individual carts will operate Blankets 1-76 in various Mode-Sequences and how the operator will access these Modes-Sequences. Each individual cart will have series of Modes that will determine the operation required for blankets 1-76 and with-in each Mode are a series of Sequences which will control where blankets 1-76 are with-in a Mode. An example of a Mode would be RAMP-UP and with-in RAMP-UP there are (4) Sequences Initialize, Operating, Hold and Target.

Reference drawing Dwg V59049-0-028 Sheet 1 in Appendix 3 for a flowchart describing how the Mode-Sequence tie together.

SPECIFICATION	
Number	Rev
A V049-2-086	0

1.4.1 BLANKET 1-76 MODE-SEQUENCE SELECTION AND DISPLAY

The operator interface screens for Blanket 1-76 Mode Operations will contain the following Mode / Sequence indication and control access items:

- A) A display showing the "CURRENT MODE". This will indicate which Mode the Blankets 1-76 are currently in. (i.e. OFF, RAMP-UP, and RAMP-DOWN)
- B) A display showing the "CURRENT SEQUENCE". This will indicate in what sequence of the Mode the dock is currently in.

For OFF MODE no sequences exist:

For RAMP-UP MODE (4) sequence exists:

- i) Initialize
- ii) Operating
- iii) Hold
- iv) Target

For RAMP-DOWN MODE (4) sequence exists:

- i) Initialize
- ii) Operating
- iii) Hold
- iv) Target

- C) Software buttons providing the operator access to control which Mode-Sequence Blankets 1-76 can be in.

From OFF Mode the following Modes-Sequences can be initiated :

- i) RAMP-UP-Operating
- ii) RAMP-DOWN-Operating

From RAMP-UP-Operating the following Modes-Sequences can be initiated:

- i) RAMP-UP-Hold

SPECIFICATION

Number

A V049-2-086

Rev

0

From RAMP-UP-Hold the following Modes-Sequences can be initiated:

- i) OFF
- ii) RAMP-UP-Operating
- iii) RAMP-DOWN-Operating

From RAMP-UP-Target the following Modes-Sequences can be initiated:

- i) OFF
- ii) RAMP-DOWN-Operating

From RAMP-DOWN-Operating the following Modes-Sequences can be initiated:

- i) RAMP-DOWN-Hold

From RAMP-DOWN-Hold the following Modes-Sequences can be initiated:

- i) OFF
- ii) RAMP-DOWN-Operating
- iii) RAMP-UP-Operating

From RAMP-DOWN-Target the following Modes-Sequences can be initiated:

- i) OFF

- D) Displays showing all permissives and interlocks required for that Mode-Sequence, along with the status of each.
- E) Displays showing and allowing access to the following Blanket 1-76 information :
 - i) All alarming
 - ii) Set-Up Information
 - iii) Configured System information from other carts

SPECIFICATION

Number

A V049-2-086

Rev

0

1.4.2 BLANKET 1-76 MODE AND SEQUENCE DESCRIPTIONS

1.4.2.1 BLANKET 1-76 OFF MODE

This MODE will not allow any Blankets (1-76) to operate.

- a) All Blanket (1-76) PID controllers will be in manual with an output of CV(control variable) =0% open (Duty Cycle=0 Seconds).
- b) All necessary Blanket 1-76 alarming functions will be active. (See section 1.6 for alarming overview.)

This Mode waits for the operator to initiate another Mode-Sequence as described in section 1.4.1.

The operator will input the following cart set-up and system configuration information in OFF Mode :

- a) Ramp-Up Rate 1.0 Deg C / xxxx Seconds
- b) Ramp-Up Target Setpoint xxx Deg C
- c) Ramp-Down Rate 1.0 Deg C / xxxx Seconds
- d) Ramp-Down Target Setpoint xxx Deg C
- e) Which Blankets are Active
- f) Selection of all carts in the Configured System 1, 2, 3, 4, 5, 6, 7
- g) Selection of which cart is the Master

1.4.2.2 BLANKET 1-76 RAMP-UP MODE

This MODE initializes, operates and shuts down Blankets 1-76 and activates and de-activates SP Ramping .

SPECIFICATION

Number

A V049-2-086

Rev

0

1.4.2.2.1 BLANKET 1-76 RAMP-UP-Initialize

The Mode-Sequence is accessed from OFF or from RAMP-DOWN-Hold.

Reference drawing Dwg V59049-0-028 Sheet 2 in Appendix 3 for a flowchart describing how this Mode-Sequence operates.

The following occurs when RAMP-UP-Initialize is initiated:

- a) The Cart High/Low T/C Subroutine will be called. (Dwg V59049-0-028 Sheet 5 in Appendix 3)
- b) A 30 Second delay will occur to allow all carts on the Configured System to Communicate Cart High/Low values.
- c) The Configured System High/Low and Delta temperature will be determined.
- d) The Configured System starting Ramp Setpoint will be determined and loaded into Blankets 1-76.
- e) Advance to RAMP-UP-Operating

At any time during RAMP-UP-Initialize if any of the interlocks trip the associated alarm will activate and the Mode-Sequence will advance to OFF

See Appendix 4 for a listing of the Interlocks.

1.4.2.2.2 BLANKETS 1-76 RAMP-UP-Operating

The Mode-Sequence is accessed after a successful RAMP-UP-Initialize has occurred or from RAMP-UP-Hold.

Reference drawing Dwg V59049-0-028 Sheet 4 in Appendix 3 for a flowchart describing how this Mode-Sequence operates.

SPECIFICATION	
Number	Rev
A V049-2-086	0

The following operations will occur with-in RAMP-UP-Operating :

- a) All Blanket (1-76) PID controllers will be placed into auto and the CV will be determined by the Background Duty Cycle subroutine.
- b) After a heartbeat signal is received from the T/C system, the Cart High/Low T/C subroutine (1-76) will be called. (Dwg V59049-0-028 Sheet 5 in Appendix 3)
- c) Upon completion of item b, the Configured System High/Low and Delta temperature will be determined.
- d) Upon completion of item c, Selection of Control T/C subroutine (1-76) will be called. (Dwg V59049-0-028 Sheet 6/7 in Appendix 3)
- e) Upon completion of item d, Descaling of Control T/C subroutine (1-76) will be called. (Dwg V59049-0-028 Sheet 8 in Appendix 3)
- f) Upon completion of item e, the T/C system heartbeat signal will be reset and goto item b.
- g) If TDA_168 =0 Ramp-Up SP subroutine (1-76) will be called, if TDA_168=1 no ramping of Setpoint will occur (Dwg V59049-0-028 Sheet 9 in Appendix 3)

RAMP-UP-Operating will continue until either the operator selects and acknowledges the access button for RAMP-UP-Hold from the operator interface screen or all active blankets achieve their target SP or a interlock trip occurs putting Blankets 1-76 into OFF. When a interlock trips the associated alarm will activate.

See Appendix 4 for a listing of the Interlocks.

SPECIFICATION

Number

A V049-2-086

Rev

0

1.4.2..2.3 RAMP-UP -Hold

The Mode-Sequence is accessed from RAMP-UP-Operating.

Reference drawing Dwg V59049-0-028 Sheet 4 in Appendix 3 for a flowchart describing how this Mode-Sequence operates.

The following operations will occur with-in RAMP-UP-Hold :

- a) All Blanket (1-76) PID controllers will be placed into auto and the CV will be determined by the Background Duty Cycle subroutine.
- b) After a heartbeat signal is received from the T/C system, the Cart High/Low T/C subroutine (1-76) will be called. (Dwg V59049-0-028 Sheet 5 in Appendix 3)
- c) Upon completion of item b, the Configured System High/Low and Delta temperature will be determined.
- d) Upon completion of item c, Selection of Control T/C subroutine (1-76) will be called. (Dwg V59049-0-028 Sheet 6/7 in Appendix 3)
- e) Upon completion of item d, Descaling of Control T/C subroutine (1-76) will be called. (Dwg V59049-0-028 Sheet 8 in Appendix 3)
- f) Upon completion of item e, the T/C system heartbeat signal will be reset and goto item b.

RAMP-UP-Hold will continue until either the operator selects and acknowledges the access button for RAMP-UP-Operating from the operator interface screen or the operator selects and acknowledges the access button for OFF from the operator interface screen or a interlock trip occurs putting Blankets 1-76 into OFF. When a interlock trips the associated alarm will activate.

See Appendix 4 for a listing of the Interlocks.

SPECIFICATION	
Number	Rev
A V049-2-086	0

1.4.2..2.4 RAMP-UP -Target

The Mode-Sequence is accessed from RAMP-UP-Operating when all active blankets in the “Configured System” achieve their target setpoints.

Reference drawing Dwg V59049-0-028 Sheet 4 in Appendix 3 for a flowchart describing how this Mode-Sequence operates.

The following operations will occur with-in RAMP-UP-Target :

- a) All Blanket (1-76) PID controllers will be placed into auto and the CV will be determined by the Background Duty Cycle subroutine.
- b) After a heartbeat signal is received from the T/C system, the Cart High/Low T/C subroutine (1-76) will be called. (Dwg V59049-0-028 Sheet 5 in Appendix 3)
- c) Upon completion of item b, the Configured System High/Low and Delta temperature will be determined.
- d) Upon completion of item c, Selection of Control T/C subroutine (1-76) will be called. (Dwg V59049-0-028 Sheet 6/7 in Appendix 3)
- e) Upon completion of item d, Descaling of Control T/C subroutine (1-76) will be called. (Dwg V59049-0-028 Sheet 8 in Appendix 3)
- f) Upon completion of item e, the T/C system heartbeat signal will be reset and goto item b.

RAMP-UP-Target will continue until either the operator selects and acknowledges the access button for RAMP-DOWN-Operating from the operator interface screen or the operator selects and acknowledges the access button for OFF from the operator interface screen or a interlock trip occurs putting Blankets 1-76 into OFF. When a interlock trips the associated alarm will activate.

See Appendix 4 for a listing of the Interlocks.

SPECIFICATION	
Number	Rev
A V049-2-086	0

1.4.2.3 BLANKET 1-76 RAMP-DOWN MODE

This MODE initializes, operates and shuts down Blankets 1-76 and Activates and de-activates SP Ramping .

1.4.2.3.1 BLANKET 1-76 RAMP-DOWN-Initialize

The Mode-Sequence is accessed from OFF or from RAMP-UP-Hold.

Reference drawing Dwg V59049-0-028 Sheet 3 in Appendix 3 for a flowchart describing how this Mode-Sequence operates.

The following occurs when RAMP-DOWN-Initialize is initiated:

- a) The Cart High/Low T/C subroutine will be called.
(Dwg V59049-0-028 Sheet 5 in Appendix 3)
- b) A 30 Second delay will occur to allow all carts on the Configured System to Communicate Cart High/Low values.
- c) The Configured System High/Low and Delta temperature will be determined.
- d) The Configured System starting Ramp Setpoint will be determined and loaded into Blankets 1-76.
- e) Advance to RAMP-DOWN-Operating.

At any time during RAMP-DOWN-Initialize if any of the interlocks trip the associated alarm will activate and the Mode-Sequence will advance to OFF

See Appendix 4 for a listing of the Interlocks.

SPECIFICATION

Number

A V049-2-086

Rev

0

1.4.2.3.2 BLANKETS 1-76 RAMP-DOWN-Operating

The Mode-Sequence is accessed after a successful RAMP-DOWN-Initialize has occurred or from RAMP-DOWN-Hold.

Reference drawing Dwg V59049-0-028 Sheet 4 in Appendix 3 for a flowchart describing how this Mode-Sequence operates.

The following operations will occur with-in RAMP-DOWN-Operating:

- a) All Blanket (1-76) PID controllers will be placed into auto and the CV will be determined by the Background Duty Cycle subroutine.
- b) After a heartbeat signal is received from the T/C system, the Cart High/Low T/C subroutine (1-76) will be called. (Dwg V59049-0-028 Sheet 5 in Appendix 3)
- c) Upon completion of item b, the Configured System High/Low and Delta temperature will be determined.
- d) Upon completion of item c, Selection of Control T/C subroutine (1-76) will be called. (Dwg V59049-0-028 Sheet 6/7 in Appendix 3)
- e) Upon completion of item d, Descaling of Control T/C subroutine (1-76) will be called. (Dwg V59049-0-028 Sheet 8 in Appendix 3)
- f) Upon completion of item e, the T/C system heartbeat signal will be reset and goto item b.
- g) If TDA_168 =0 Ramp-Down SP subroutine (1-76) will be called, if TDA_168=1 no ramping of Setpoint will occur. (Dwg V59049-0-028 Sheet 9 in Appendix 3)

SPECIFICATION

Number	Rev
A V049-2-086	0

RAMP-DOWN-Operating will continue until either the operator selects and acknowledges the access button for RAMP-DOWN-Hold from the operator interface screen or a interlock trip occurs putting Blankets 1-76 into OFF. When a interlock trips the associated alarm will activate.

See Appendix 4 for a listing of the Interlocks.

1.4.2..3.3 RAMP-DOWN -Hold

The Mode-Sequence is accessed from RAMP-DOWN-Operating.

Reference drawing Dwg V59049-0-028 Sheet 4 in Appendix 3 for a flowchart describing how this Mode-Sequence operates.

The following operations will occur with-in RAMP-DOWN-Hold :

- a) All Blanket (1-76) PID controllers will be placed into auto and the CV will be determined by the Background Duty Cycle subroutine.
- b) After a heartbeat signal is received from the T/C system, the Cart High/Low T/C subroutine (1-76) will be called. (Dwg V59049-0-028 Sheet 5 in Appendix 3)
- c) Upon completion of item b, the Configured System High/Low and Delta temperature will be determined.
- d) Upon completion of item c, Selection of Control T/C subroutine (1-76) will be called. (Dwg V59049-0-028 Sheet 6/7 in Appendix 3)
- e) Upon completion of item d, Descaling of Control T/C subroutine (1-76) will be called. (Dwg V59049-0-028 Sheet 8 in Appendix 3)

SPECIFICATION	
Number	Rev
A V049-2-086	0

- f) Upon completion of item e,
the T/C system heartbeat signal will be reset and goto item b.

RAMP-DOWN-Hold will continue until either the operator selects and acknowledges the access button for RAMP-DOWN-Operating from the operator interface screen or the operator selects and acknowledges the access button for OFF from the operator interface screen or a interlock trip occurs putting Blankets 1-76 into OFF. When a interlock trips the associated alarm will activate.

See Appendix 4 for a listing of the Interlocks.

1.4.2..3.4 RAMP-DOWN -Target

The Mode-Sequence is accessed from RAMP-down-Operating when all active blankets in the "Configured System" achieve their target setpoints.

Reference drawing Dwg V59049-0-028 Sheet 4 in Appendix 3 for a flowchart describing how this Mode-Sequence operates.

The following operations will occur with-in RAMP-DOWN-Target :

- a) All Blanket (1-76) PID controllers will be placed into auto and the CV will be determined by the Background Duty Cycle subroutine.
- b) After a heartbeat signal is received from the T/C system, the Cart High/Low T/C subroutine (1-76) will be called. (Dwg V59049-0-028 Sheet 5 in Appendix 3)
- c) Upon completion of item b,
the Configured System High/Low and Delta temperature will be determined.
- d) Upon completion of item c,
Selection of Control T/C subroutine (1-76) will be called. (Dwg V59049-0-028 Sheet 6/7 in Appendix 3)

SPECIFICATION

Number

A V049-2-086

Rev

0

- e) Upon completion of item d,
Descaling of Control T/C subroutine (1-76) will be called.
(Dwg V59049-0-028 Sheet 8 in Appendix 3)
- f) Upon completion of item e,
the T/C system heartbeat signal will be reset and goto item b.

RAMP-DOWN-Target will continue until either the operator selects and acknowledges the access button for OFF from the operator interface screen or a interlock trip occurs putting Blankets 1-76 into OFF. When a interlock trips the associated alarm will activate.

See Appendix 4 for a listing of the Interlocks.

1.5 BLANKETS 93-112 MODE-SEQUENCE OVERVIEW

The Mode-Sequence overview for Blankets 93-112 will describe how the individual carts will operate blankets 93-112 in various Mode-Sequences and how the operator will access these Modes-Sequences. Each individual cart will have series of Modes that will determine the operation required for blankets 93-112 and with-in each Mode are a series of Sequences which will control where blankets 93-112 are with-in a Mode. An example of a Mode would be RAMP-UP and with-in RAMP-UP there are (4) Sequences Initialize, Operating, Hold and Target.

Reference drawing Dwg V59049-0-030 Sheet 1 in Appendix 5 for a flowchart describing how the Mode-Sequence tie together.

1.5.1 BLANKET 93-112 MODE-SEQUENCE SELECTION AND DISPLAY

The operator interface screens for Blanket 93-112 Mode Operations will contain the following Mode / Sequence indication and control access items:

- A) A display showing the "CURRENT MODE". This will indicate which Mode the Blankets 93-112 are currently in. (i.e. OFF and RAMP-UP)
- B) A display showing the "CURRENT SEQUENCE". This will indicate in what sequence of the Mode the dock is currently in.

For OFF MODE no sequences exist:

SPECIFICATION	
Number	Rev
A V049-2-086	0

For RAMP-UP MODE (4) sequence exists:

- i) Initialize
- ii) Operating
- iii) Hold
- iv) Target

- C) Software buttons providing the operator access to control which Mode-Sequence Blankets 93-112 can be in.

From OFF Mode the following Modes-Sequences can be initiated :

- i) RAMP-UP-Operating

From RAMP-UP-Operating the following Modes-Sequences can be initiated:

- i) RAMP-UP-Hold

From RAMP-UP-Hold the following Modes-Sequences can be initiated:

- i) OFF
- ii) RAMP-UP-Operating

From RAMP-UP-Target the following Modes-Sequences can be initiated:

- i) OFF

- D) Displays showing all permissives and interlocks required for that Mode-Sequence, along with the status of each.

- E) Displays showing and allowing access to the following Blanket 93-112 information :

- i) All alarming
- ii) Set-Up Information

SPECIFICATION

Number

A V049-2-086

Rev

0

1.5.2 BLANKET 93-112 MODE AND SEQUENCE DESCRIPTIONS

1.5.2.1 BLANKET 93-112 OFF MODE

This MODE will not allow any Blankets (93-112) to operate.

- a) All Blanket (93-112) PID controllers will be in manual with an output of CV(control variable) =0% open (Duty Cycle=0 Seconds).
- b) All necessary Blanket 93-112 alarming functions will be active. (See section 1.6 for alarming overview.)

This Mode waits for the operator to initiate another Mode-Sequence as described in section 1.5.1.

The operator will input the following cart set-up and system configuration information in OFF Mode :

- a) Ramp-Up Rate 1.0 Deg C / xxxx Seconds
- b) Gauge Ramp-Up Target Setpoint xxx Deg C
- c) Which blankets are Active
- d) Blanket xxx (xxx = 93 thru 108) target SP xxx Deg C
- d) Blanket xxx (xxx = 93 thru 108) TH setpoint xxx Deg C

1.5.2.2 BLANKET 93-112 RAMP-UP MODE

This MODE initializes, operates and shuts down Blankets 93-112 and Ramps Setpoints.

1.5.2.2.1 BLANKET 93-112 RAMP-UP-Initialize

The Mode-Sequence is accessed from OFF.

Reference drawing Dwg V59049-0-030 Sheet 2 in Appendix 5 for a flowchart describing how this Mode-Sequence operates.

SPECIFICATION	
Number	Rev
A V049-2-086	0

The following occurs when RAMP-UP-Initialize is initiated:

- d) The starting Ramp Setpoints will be determined and loaded into Blankets 93-112
- e) Advance to RAMP-UP-Operating

At any time during RAMP-UP-Initialize if any of the interlocks trip the associated alarm will activate and the Mode-Sequence will advance to OFF

See Appendix 6 for a listing of the Interlocks.

1.5.2.2.2 BLANKETS 93-112 RAMP-UP-Operating

The Mode-Sequence is accessed after a successful RAMP-UP-Initialize has occurred or from RAMP-UP-Hold.

Reference drawing Dwg V59049-0-030 Sheet 2 in Appendix 5 for a flowchart describing how this Mode-Sequence operates.

The following operations will occur with-in RAMP-UP-Operating :

- a) All Blanket (93-112) PID controllers will be placed into auto and the CV will be determined by the Background Duty Cycle subroutine.
- b) Selection of Control T/C subroutine (93-112) will be called. (Dwg V59049-0-030 Sheet 3 in Appendix 5)
- c) Upon completion of item b, Descaling of Control T/C subroutine (93-112) will be called. (Dwg V59049-0-030 Sheet 4 in Appendix 5)
- d) If TDA_168 =0 Ramp-Up SP subroutine (93-112) will be called, if TDA_168=1 no ramping of Setpoint will occur. (Dwg V59049-0-030 Sheet 5 in Appendix 5)

SPECIFICATION

Number	Rev
A V049-2-086	0

RAMP-UP-Operating will continue until either the operator selects and acknowledges the access button for RAMP-UP-Hold from the operator interface screen or all active blankets achieve their target SP or a interlock trip occurs putting Blankets 93-112 into OFF. When a interlock trips the associated alarm will activate.

See Appendix 6 for a listing of the Interlocks.

1.5.2..2.3 RAMP-UP -Hold

The Mode-Sequence is accessed from RAMP-UP-Operating.

Reference drawing Dwg V59049-0-030 Sheet 2 in Appendix 5 for a flowchart describing how this Mode-Sequence operates.

The following operations will occur with-in RAMP-UP-Hold :

- a) All Blanket (93-112) PID controllers will be placed into auto and the CV will be determined by the Background Duty Cycle subroutine.
- b) Selection of Control T/C subroutine (93-112) will be called. (Dwg V59049-0-030 Sheet 3 in Appendix 5)
- c) Upon completion of item b, Descaling of Control T/C subroutine (93-112) will be called. (Dwg V59049-0-030 Sheet 4 in Appendix 5)

RAMP-UP-Hold will continue until either the operator selects and acknowledges the access button for RAMP-UP-Operating from the operator interface screen or the operator selects and acknowledges the access button for OFF from the operator interface screen or a interlock trip occurs putting Blankets 93-112 into OFF. When a interlock trips the associated alarm will activate.

See Appendix 6 for a listing of the Interlocks.

SPECIFICATION	
Number	Rev
A V049-2-086	0

1.5.2..2.4 RAMP-UP -Target

The Mode-Sequence is accessed from RAMP-UP-Operating when all active blankets achieve their target setpoints.

Reference drawing Dwg V59049-0-030 Sheet 2 in Appendix 5 for a flowchart describing how this Mode-Sequence operates.

The following operations will occur with-in RAMP-UP-Target :

- a) All Blanket (93-112) PID controllers will be placed into auto and the CV will be determined by the Background Duty Cycle subroutine.
- b) Selection of Control T/C subroutine (93-112) will be called. (Dwg V59049-0-030 Sheet 3 in Appendix 5)
- c) Upon completion of item b, Descaling of Control T/C subroutine (93-112) will be called. (Dwg V59049-0-030 Sheet 4 in Appendix 5)

RAMP-UP-Target will continue until either the operator selects and acknowledges the access button for OFF from the operator interface screen or a interlock trip occurs putting Blankets 93-112 into OFF. When a interlock trips the associated alarm will activate.

See Appendix 6 for a listing of the Interlocks.

SPECIFICATION	
Number	Rev
A V049-2-086	0

1.6 SYSTEM ALARMING OVERVIEW

See Appendix 1 for a summary of cart alarms.

The Bakeout Cart alarming system will alert the operator through an alarm horn, alarm light and the cart PC of any abnormal conditions.

1.6.1 ALARM DISPLAYS

All alarms will be displayed on the operator interface screen where it is required. The alarms will be broken down into areas :

- a) Individual Blanket alarms 1-76
- b) System Blankets alarms 1-76 and Configured System alarms
- c) Individual Blanket 93-112
- d) System Blanket alarms 93-112
- e) Control System Hardware alarms

An alarm window showing the last 3 alarms with a time and date that the alarm occurred will be displayed on the bottom of each operator interface screen.

An alarm summary screen will be provided showing a listing of all the current alarms, with the time and date that the alarm occurred. A new alarm to the summary screen will be flashing on this screen until it is acknowledged by the operator. When acknowledged the alarm will stop flashing and remain on the summary screen until the alarm condition has cleared.

1.6.2 DOCK HORN AND LIGHT FUNCTIONS

Each cart has its own Alarm Horn and Light attached to the cart The Horn and light will activate each time an alarm occurs associated with the individual cart. The operator can silence the horn by either pushing the alarm acknowledge button on the front panel or through the operator interface screens.

The cart light will remain on until the alarm condition has cleared.

If the alarm occurs again after the horn has been silenced, the horn will re-activate.

SPECIFICATION

Number	Rev
A V049-2-086	0

1.6.3 ALARM HORN AND LIGHT TESTING

Each cart has a alarm Testing Button through the operator interface screen. When this button is activated the cart Horn and Light will activate for a period of xx seconds.

1.6.4 ALARM ACKNOWLEDGMENT

Each alarm will be detected by the FIX-DMACS operator interface system , trigger the beep function in the PC's where the alarm occurred and be displayed on the Alarm Summary Screen and other required screens.

Each alarm that is a process interlock will have a latching function in the PLC that will remain active until the operator acknowledges the alarm through the operator interface screens. The latching function is necessary to catch the alarms that occur and clear at a high rate of speed. See Appendix 1 for a listing of alarms that require the "PC-Button" to reset the alarm.

1.7 EMERGENCY SHUTDOWN SYSTEM (ESD) OVERVIEW

The Bakeout System emergency shutdown system (ESD), when activated will de-energize all heater related outputs for the entire "Configured System". A individual cart ESD system is a hard wired system that does not rely on any software to de-energize the outputs. Any other cart on the "Configured System" will rely on network communcations and software for the ESD to de-energize the outputs.

Any alarming functions that require outputs such as the alarm light and alarm hor are located on a separate circuit that is not effected by the ESD system. All alarming functions through-out the Bakeout System would remain operational in the event of an ESD activation. All discrete inputs would remain operational in the event of an ESD activation.

SPECIFICATION	
Number	Rev
A V049-2-086	0

APPENDIX 1
ALARM SUMMARY

SPECIFICATION

Number	Rev
A V049-2-086 A-1	0

Appendix 1 Rev 0

Bakeout System Alarm listing

Tag Name	Description	Min/Maj/Per	System Shutdown (1-76)	Local Shutdown (93-112)	Reset Active
----------	-------------	-------------	---------------------------	----------------------------	--------------

Thermocouple

TA xxxA	T/C-xxxA out of range when Blanket is active (xxx=1 thru 112)	Minor	--	--	Self-Reset
TA xxxB	T/C-xxxB out of range when Blanket is active (xxx=1 thru 112)	Minor	--	--	Self-Reset

Data Acquisition System

XA 134	PLC-Tempscan Heartbeat loss alarm	Major	Yes	Yes	PC-Button
XA 135	Tempscan-Copro Data Integrity Alarm	Major	Yes	Yes	PC-Button
XA 136	Tempscan-Copro Communication Alarm	Major	Yes	Yes	PC-Button

Chamber Blankets 1-76

SPDA10 xxx	Heater-xxx Set Point deviation of 10 Deg C when blanket active (xxx=1 thru 76)	Minor	--	--	Self-Reset
SPDA15 xxx	Heater-xxx Set Point deviation of 15 Deg C when blanket active (xxx=1 thru 76)	Minor	--	--	Self-Reset
SPDA20 xxx	Heater-xxx Set Point deviation of 20 Deg C when blanket active (xxx=1 thru 76)	Major	Yes	--	PC-Button

Chamber Blanket System 1-76

TDA 168	System Temp Delta of 20 Deg C or more in Ramp-Up/Down (1-76)	Minor	--	--	Self-Reset
TDA 169	System Temp Delta of 30 Deg C or more in Ramp-Up/Down (1-76)	Major	Yes	--	PC-Button
TH 165	Chamber Blanket System Hi Temp Alarm in Ramp-Up/Down (1-76)	Minor	--	--	PC-Button
THH 165	Chamber Blanket System HiHi Temp Alarm in Ramp-Up/Down (1-76)	Major	Yes	--	PC-Button

Aux. / Gauge Blankets 93-112

SPDA10 xxx	Heater-xxx Set Point Deviation of 10 Deg C when blanket Active (xxx=93 thru 112)	Minor	--	--	Self-Reset
TH xxx	Heater-xxx Hi Temp Alarm in Ramp-Up when Blanket active (xxx=93 thru 108)	Minor	--	--	Self-Reset
TDA 109	Heater-109 Differential Temp alarm between Blanket System Hi and Gauge Control Temp when blanket active	Minor	--	--	Self-Reset
TDA 110	Heater-110 Differential Temp alarm between Blanket System Hi and Gauge Control Temp when blanket active	Minor	--	--	Self-Reset
TDA 111	Heater-111 Differential Temp alarm between Blanket System Hi and Gauge Control Temp when blanket active	Minor	--	--	Self-Reset
TDA 112	Heater-112 Differential Temp alarm between Blanket System Hi and Gauge Control Temp when blanket active	Minor	--	--	Self-Reset

Aux. Blanket System 93-108

THH 166	Aux. Blanket System HiHi Temp Alarm in Ramp-Up (93-108)	Major	--	Yes	PC-Button
---------	---	-------	----	-----	-----------

Appendix 1 Rev 0

Bakeout System Alarm listing

Tag Name	Description	Min/Maj/Per	System Shutdown (1-76)	Local Shutdown (93-112)	Reset Active
----------	-------------	-------------	------------------------	-------------------------	--------------

Gauge Blanket System 109-112

TH 167	Gauge Blanket System Hi Temp Alarm in Ramp-Up (109-112)	Minor	---	---	Self-Reset
THH 167	Gauge Blanket System HiHi Temp Alarm in Ramp-Up (109-112)	Major	---	Yes	PC-Button

General

YA 160	Cart ESD alarm	Major	Yes	Yes	PC-Button
--------	----------------	-------	-----	-----	-----------

Communication

XA 153A	Communication loss to Cart #1 Alarm (when cart in System)	Major	Yes	Yes	PC-Button
XA 153B	Communication loss to Cart #2 Alarm (when cart in System)	Major	Yes	Yes	PC-Button
XA 153C	Communication loss to Cart #3 Alarm (when cart in System)	Major	Yes	Yes	PC-Button
XA 153D	Communication loss to Cart #4 Alarm (when cart in System)	Major	Yes	Yes	PC-Button
XA 153E	Communication loss to Cart #5 Alarm (when cart in System)	Major	Yes	Yes	PC-Button
XA 153F	Communication loss to Cart #6 Alarm (when cart in System)	Major	Yes	Yes	PC-Button
XA 153G	Communication loss to Cart #7 Alarm (when cart in System)	Major	Yes	Yes	PC-Button
XA 154	Cart System "Master-Slave" Configuration Mismatch	Permissive	---	---	Self-Reset
XA 155	Cart System "Cart Selection" Configuration Mismatch	Permissive	---	---	Self-Reset
XA 156A	Cart System (1-76) "Ramp-Up Rate Time" Config. Mismatch	Permissive	---	---	Self-Reset
XA 156B	Cart System (1-76) "Ramp-Down Rate Time" Config. Mismatch	Permissive	---	---	Self-Reset
XA 157A	Cart System (1-76) "Ramp-Up Target Set Point" Config. Mismatch	Permissive	---	---	Self-Reset
XA 157B	Cart System (1-76) "Ramp-Down Target Set Point" Config. Mismatch	Permissive	---	---	Self-Reset
XA 161A	Cart #1 has one or more Minor Alarms (1-76) (when cart in System)	Minor	---	---	Self-Reset
XA 161B	Cart #2 has one or more Minor Alarms (1-76) (when cart in System)	Minor	---	---	Self-Reset
XA 161C	Cart #3 has one or more Minor Alarms (1-76) (when cart in System)	Minor	---	---	Self-Reset
XA 161D	Cart #4 has one or more Minor Alarms (1-76) (when cart in System)	Minor	---	---	Self-Reset
XA 161E	Cart #5 has one or more Minor Alarms (1-76) (when cart in System)	Minor	---	---	Self-Reset
XA 161F	Cart #6 has one or more Minor Alarms (1-76) (when cart in System)	Minor	---	---	Self-Reset
XA 161G	Cart #7 has one or more Minor Alarms (1-76) (when cart in System)	Minor	---	---	Self-Reset
XA 162A	Cart #1 has one or more Major Alarms (1-76) (when cart in System)	Major	Yes	---	Self-Reset
XA 162B	Cart #2 has one or more Major Alarms (1-76) (when cart in System)	Major	Yes	---	Self-Reset

Appendix 1 Rev 0

Bakeout System Alarm listing

Tag Name	Description	Min/Maj/Per	System Shutdown (1-76)	Local Shutdown (93-112)	Reset Active
XA 162C	Cart #3 has one or more Major Alarms (1-76) (when cart in System)	Major	Yes	---	Self-Reset
XA 162D	Cart #4 has one or more Major Alarms (1-76) (when cart in System)	Major	Yes	---	Self-Reset
XA 162E	Cart #5 has one or more Major Alarms (1-76) (when cart in System)	Major	Yes	---	Self-Reset
XA 162F	Cart #6 has one or more Major Alarms (1-76) (when cart in System)	Major	Yes	---	Self-Reset
XA 162G	Cart #7 has one or more Major Alarms (1-76) (when cart in System)	Major	Yes	---	Self-Reset
XA 163A	Cart #1 has one or more Minor Alarms (93-112) (when cart in System)	Minor	---	---	Self-Reset
XA 163B	Cart #2 has one or more Minor Alarms (93-112) (when cart in System)	Minor	---	---	Self-Reset
XA 163C	Cart #3 has one or more Minor Alarms (93-112) (when cart in System)	Minor	---	---	Self-Reset
XA 163D	Cart #4 has one or more Minor Alarms (93-112) (when cart in System)	Minor	---	---	Self-Reset
XA 163E	Cart #5 has one or more Minor Alarms (93-112) (when cart in System)	Minor	---	---	Self-Reset
XA 163F	Cart #6 has one or more Minor Alarms (93-112) (when cart in System)	Minor	---	---	Self-Reset
XA 163G	Cart #7 has one or more Minor Alarms (93-112) (when cart in System)	Minor	---	---	Self-Reset
XA 164A	Cart #1 has one or more Major Alarms (93-112) (when cart in System)	Major	---	Yes	Self-Reset
XA 164B	Cart #2 has one or more Major Alarms (93-112) (when cart in System)	Major	---	Yes	Self-Reset
XA 164C	Cart #3 has one or more Major Alarms (93-112) (when cart in System)	Major	---	Yes	Self-Reset
XA 164D	Cart #4 has one or more Major Alarms (93-112) (when cart in System)	Major	---	Yes	Self-Reset
XA 164E	Cart #5 has one or more Major Alarms (93-112) (when cart in System)	Major	---	Yes	Self-Reset
XA 164F	Cart #6 has one or more Major Alarms (93-112) (when cart in System)	Major	---	Yes	Self-Reset
XA 164G	Cart #7 has one or more Major Alarms (93-112) (when cart in System)	Major	---	Yes	Self-Reset

PLC Hardware

XA 141	PLC-5 BAD BATTERY ALARM (MINOR)	Minor	---	---	Self-Reset
XA 142A	PLC-5 CHANNEL 1A QUEUE FULL ALARM (MINOR)	Minor	---	---	PC-Reset
XA 142B	PLC-5 CHANNEL 1B QUEUE FULL ALARM (MINOR)	Minor	---	---	PC-Reset
XA 143	PLC-5 BAD PROGRAM FILE ALARM (MAJOR)	Major	Yes	Yes	PLC-Reset
XA 144	PLC-5 BAD ADDRESS IN LADDER ALARM (MAJOR)	Major	Yes	Yes	PLC-Reset
XA 145	PLC-5 PROGRAMMER ERROR ALARM (MAJOR)	Major	Yes	Yes	PLC-Reset
XA 146	PLC-5 WATCHDOG TIMER FAULT ALARM (MAJOR)	Major	Yes	Yes	PLC-Reset
XA 147	PLC-5 BAD SYSTEM CONFIG. ALARM (MAJOR)	Major	Yes	Yes	PLC-Reset
XA 148	PLC-5 HARWARE ERROR ALARM (MAJOR)	Major	Yes	Yes	PLC-Reset
XI 149	PLC-5 IN RUN MODE	---	---	---	---
XA 150	PLC-5 IN PROGRAM MODE ALARM (MAJOR)	Major	Yes	Yes	PC-Reset
XA 151	PLC-5 FORCES PRESENT/ENABLED WARNING	Minor	---	---	Self-Reset
XA 152A	PLC-5 RACK 0 FAULT ALARM (MAJOR)	Major	Yes	Yes	Self-Reset
XA 152B	PLC-5 RACK 1 FAULT ALARM (MAJOR)	Major	Yes	Yes	Self-Reset

**APPENDIX 2
BACKGROUND SUB-ROUTINES
RUNNING CONTINUOUSLY**

A)	Background Subroutine Summary	V59049-0-029	Sheet 1 of 6
B)	System Duty Cycle Subroutine	V59049-0-029	Sheet 2 of 6
C)	Setpoint Deviation Subrouine (1-76)	V59049-0-029	Sheet 3 of 6
D)	Setpoint Deviation Subrouine (93-112)	V59049-0-029	Sheet 4 of 6
E)	Temp Range Alarm Filter Subroutine (1-112)	V59049-0-029	Sheet 5 of 6
F)	Individual Blanket PID Loop and Relay Control	V59049-0-029	Sheet 6 of 6

SPECIFICATION

Number

A V049-2-086 A-2

Rev

0

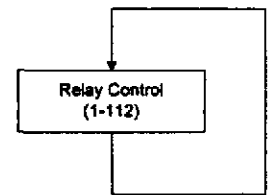
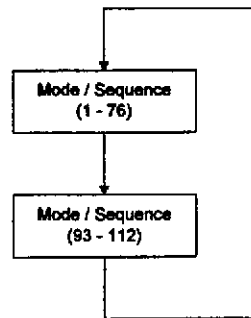
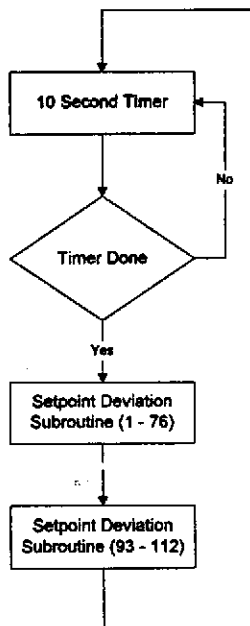
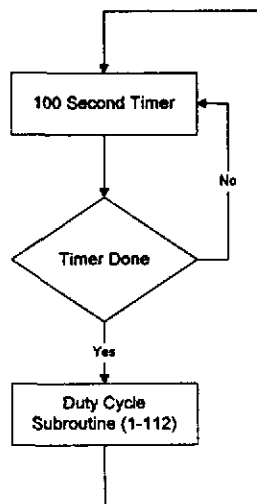
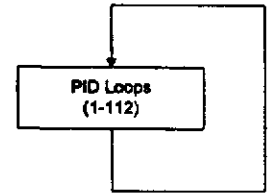
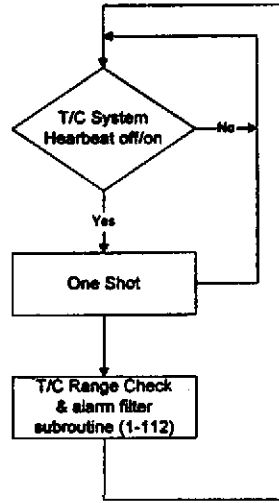
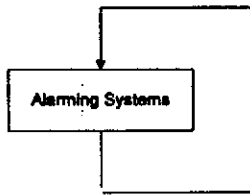
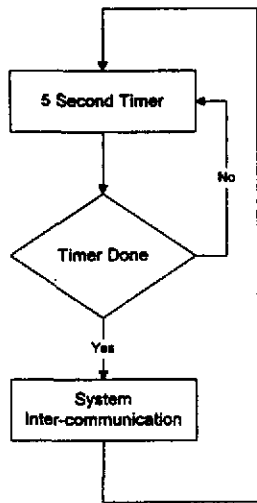

DUTY CYCLE SUBROUTINE
BLANKET 1-112

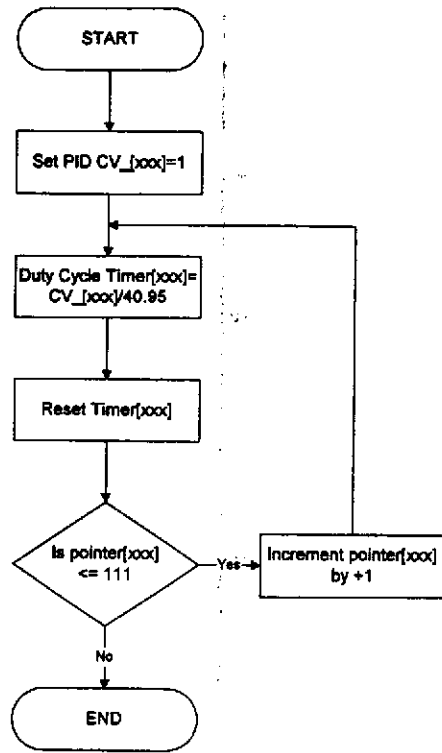

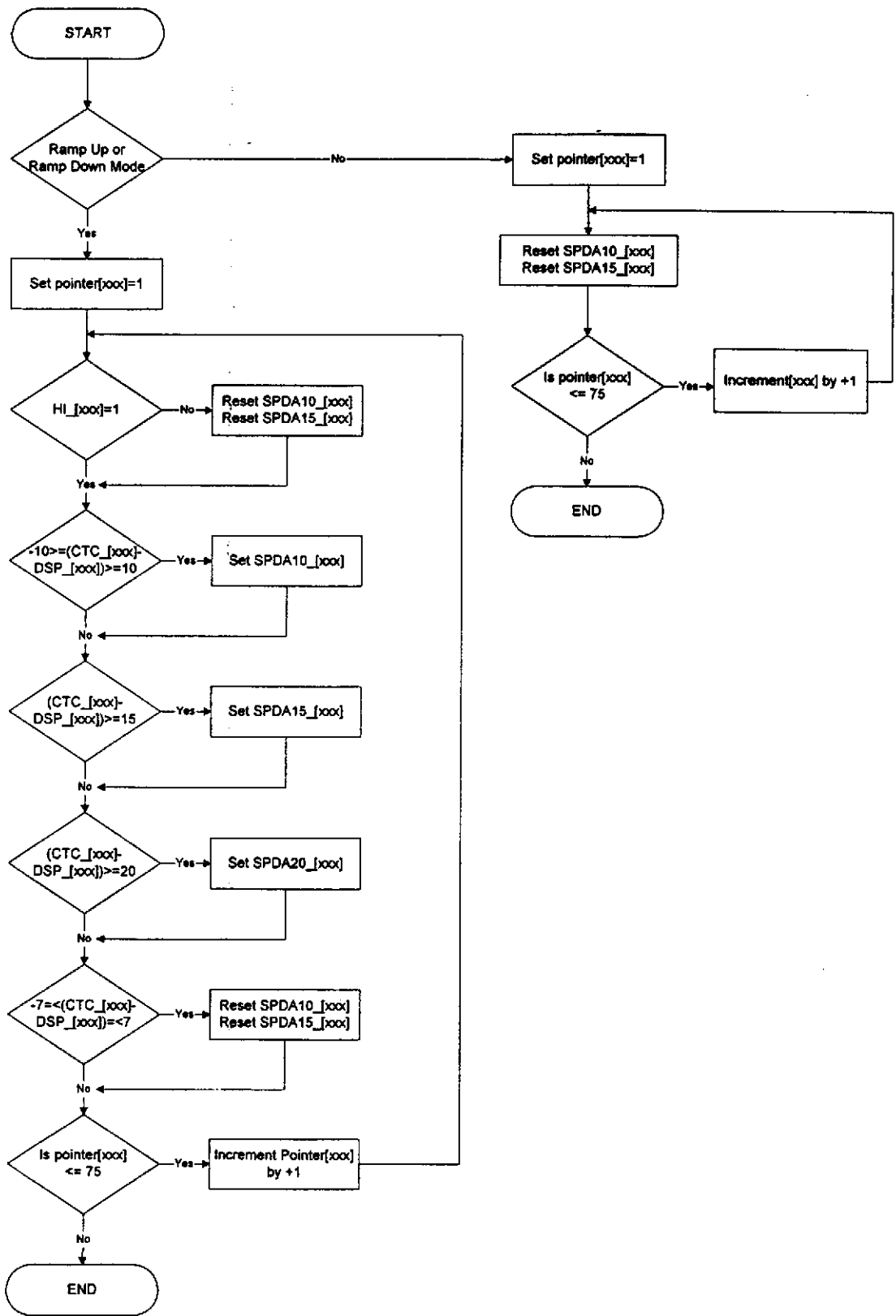

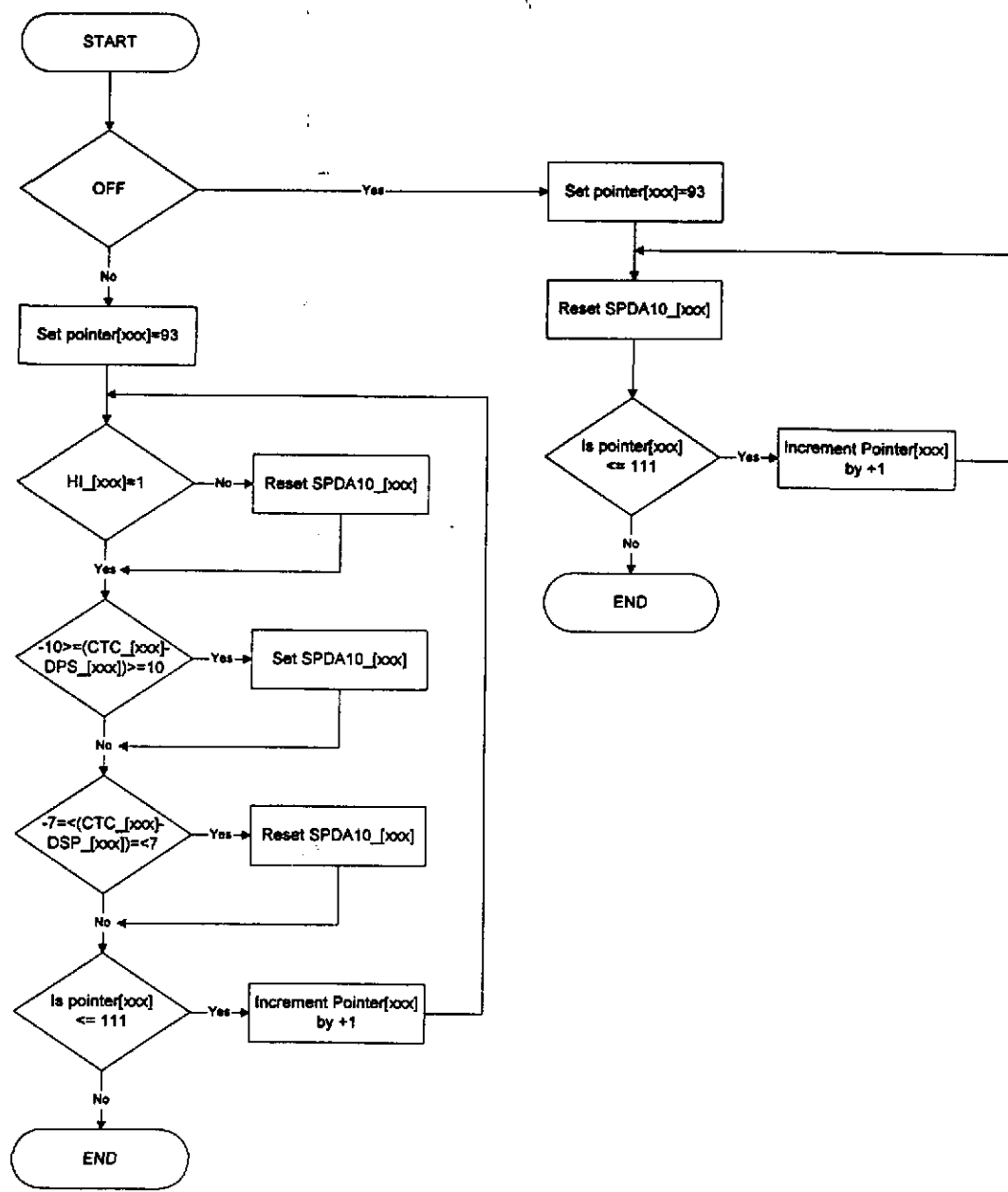

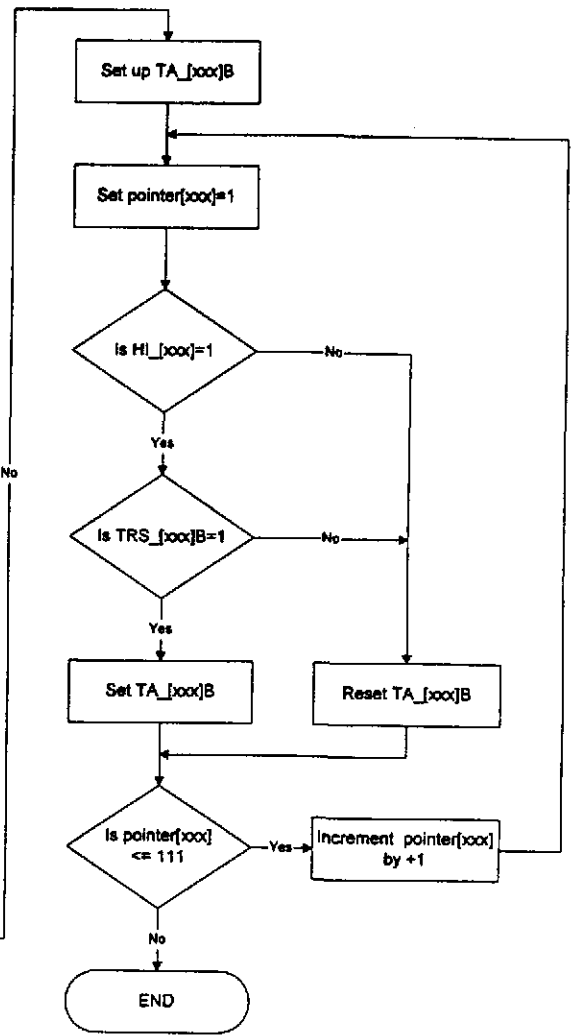
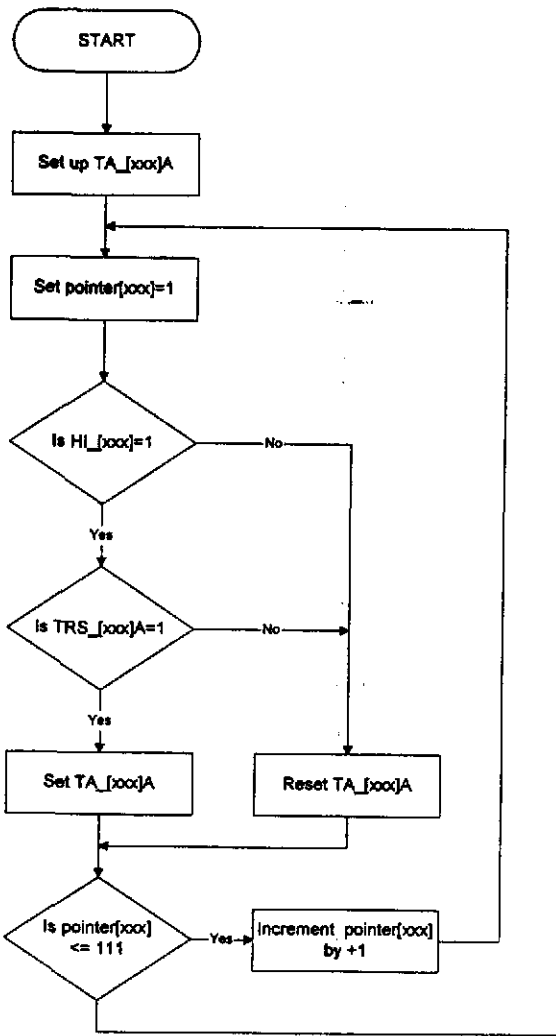

Individual Blanket PID Loop cycle

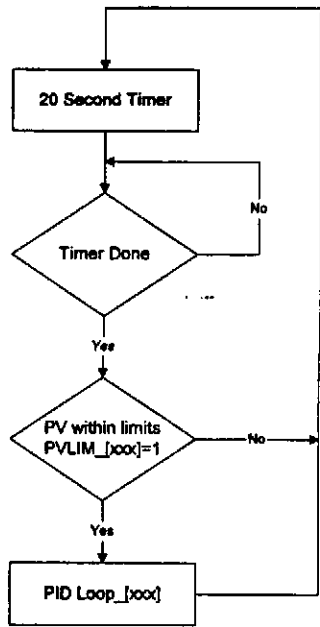

Individual Blanket PID Auto/Manual

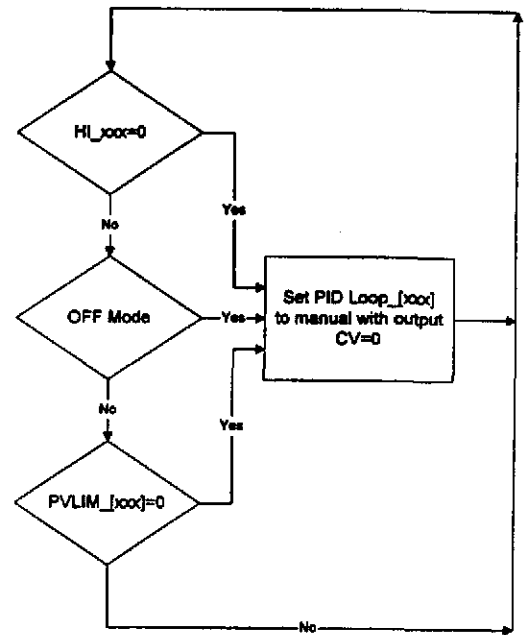

Individual Blanket Relay

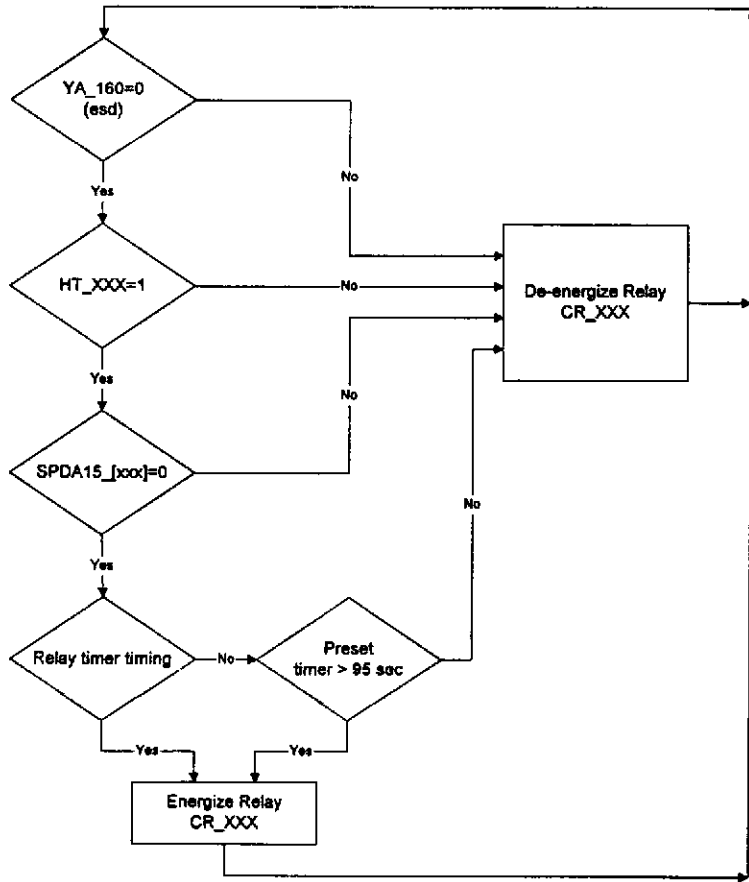

**APPENDIX 3
BLANKETS 1-76 MODE / SEQUENCE
SUB-ROUTINES**

A)	Control System MODE / SEQUENCE (1-76)	V59049-0-028	Sheet 1 of 9
B)	Ramp-Up (Initialize) (1-76)	V59049-0-028	Sheet 2 of 9
C)	Ramp-Down (Initialize) (1-76)	V59049-0-028	Sheet 3 of 9
D)	Ramp-Up and Ramp-Down Modes (1-76)	V59049-0-028	Sheet 4 of 9
E)	Cart High / Low T/C Subroutine (1-76)	V59049-0-028	Sheet 5 of 9
F)	Selection of Control T/C Subroutine (1-76)	V59049-0-028	Sheet 6 of 9
G)	Selection of Control T/C Subroutine (1-76) (Cont)	V59049-0-028	Sheet 7 of 9
H)	Descal Control T/C Subroutine (1-76)	V59049-0-028	Sheet 8 of 9
I)	Ramp-Up /Ramp-Down Setpoint Subroutines (1-76)	V59049-0-028	Sheet 9 of 9

SPECIFICATION

Number

A V049-2-086 A-3

Rev

0

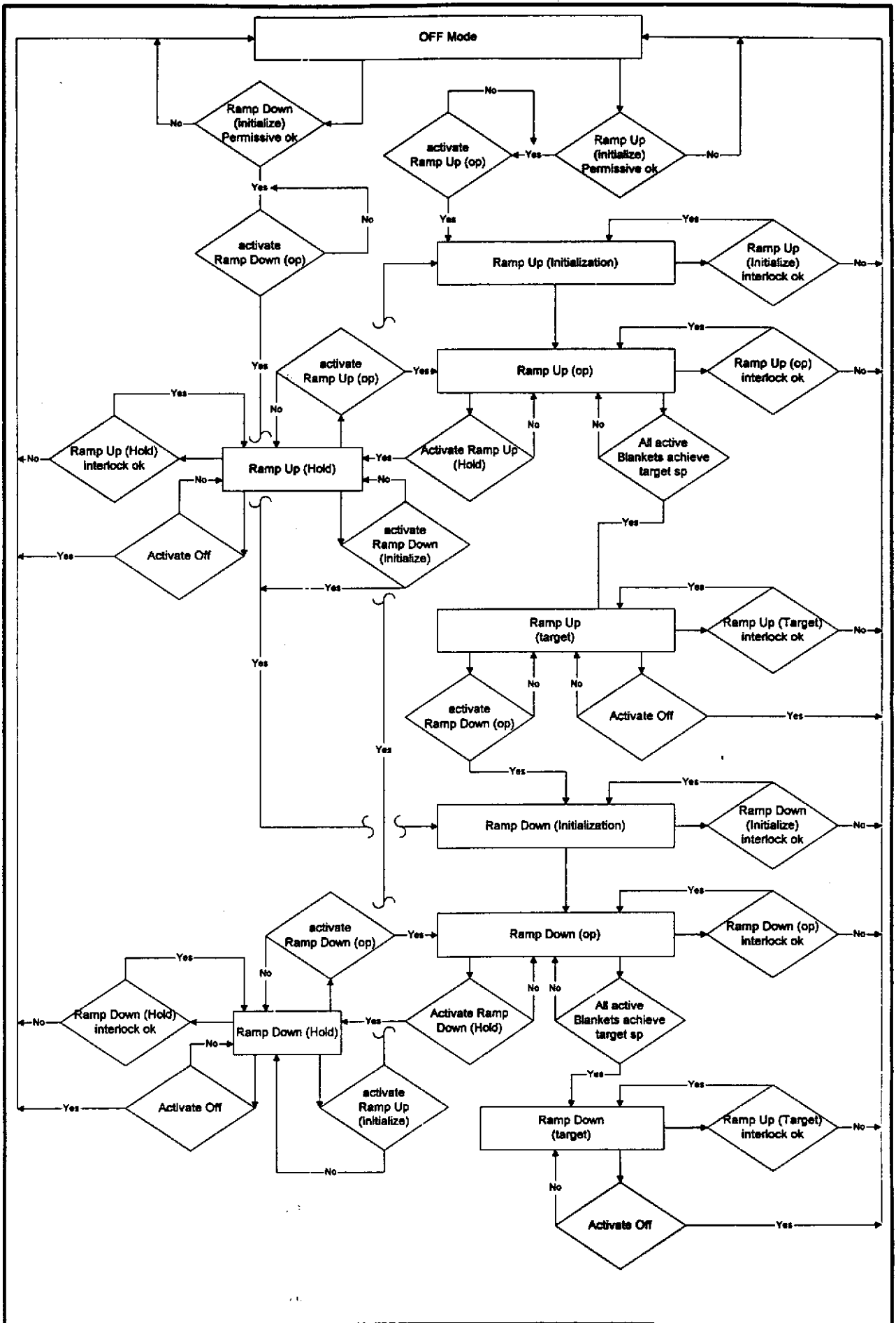

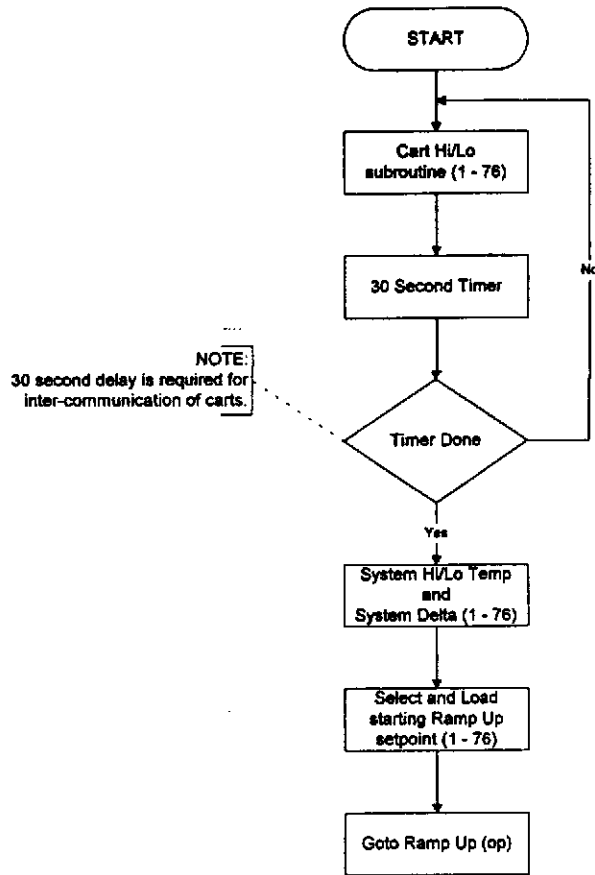

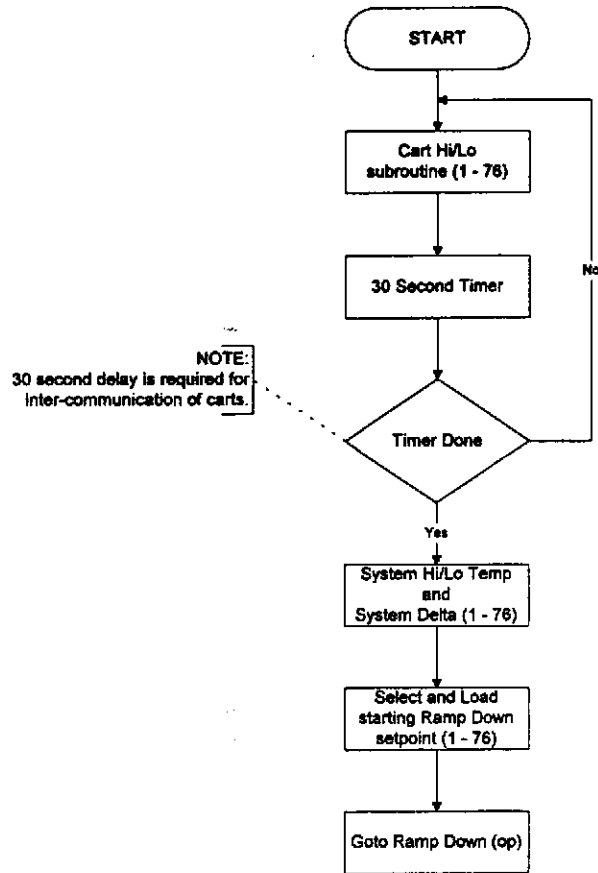

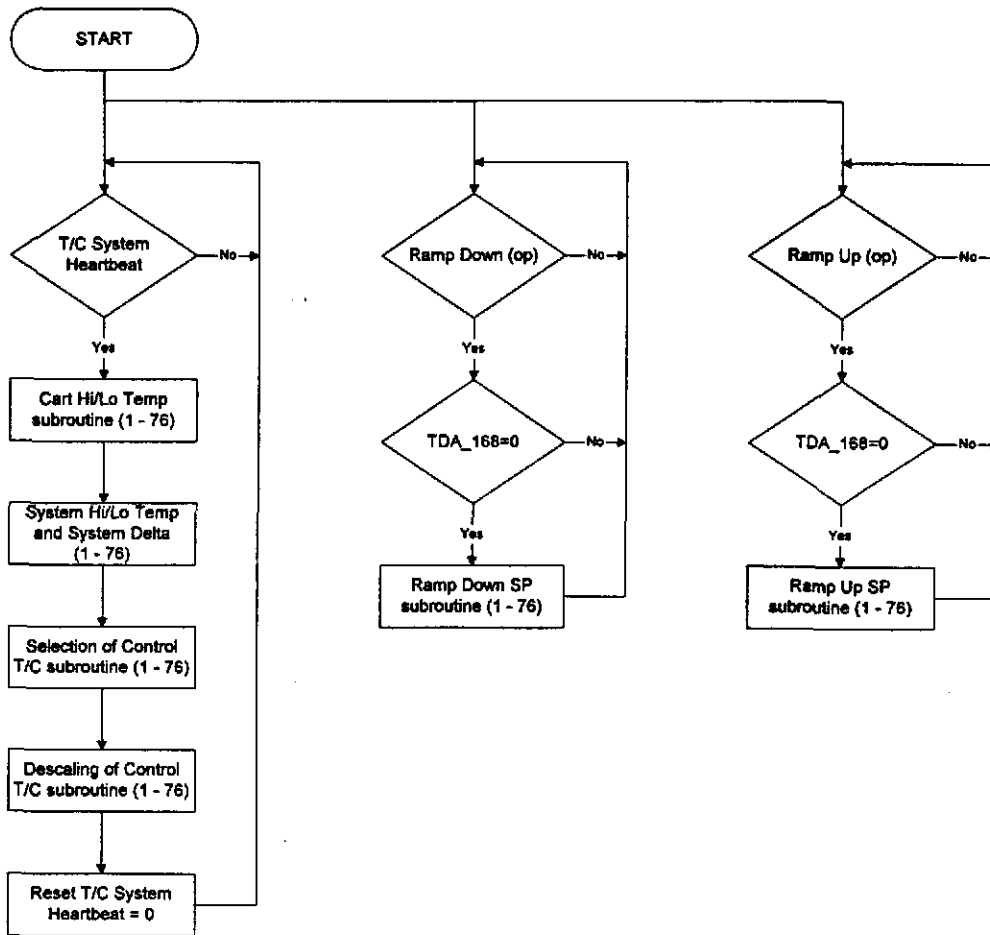

FOR [xxx] 1 THRU 076

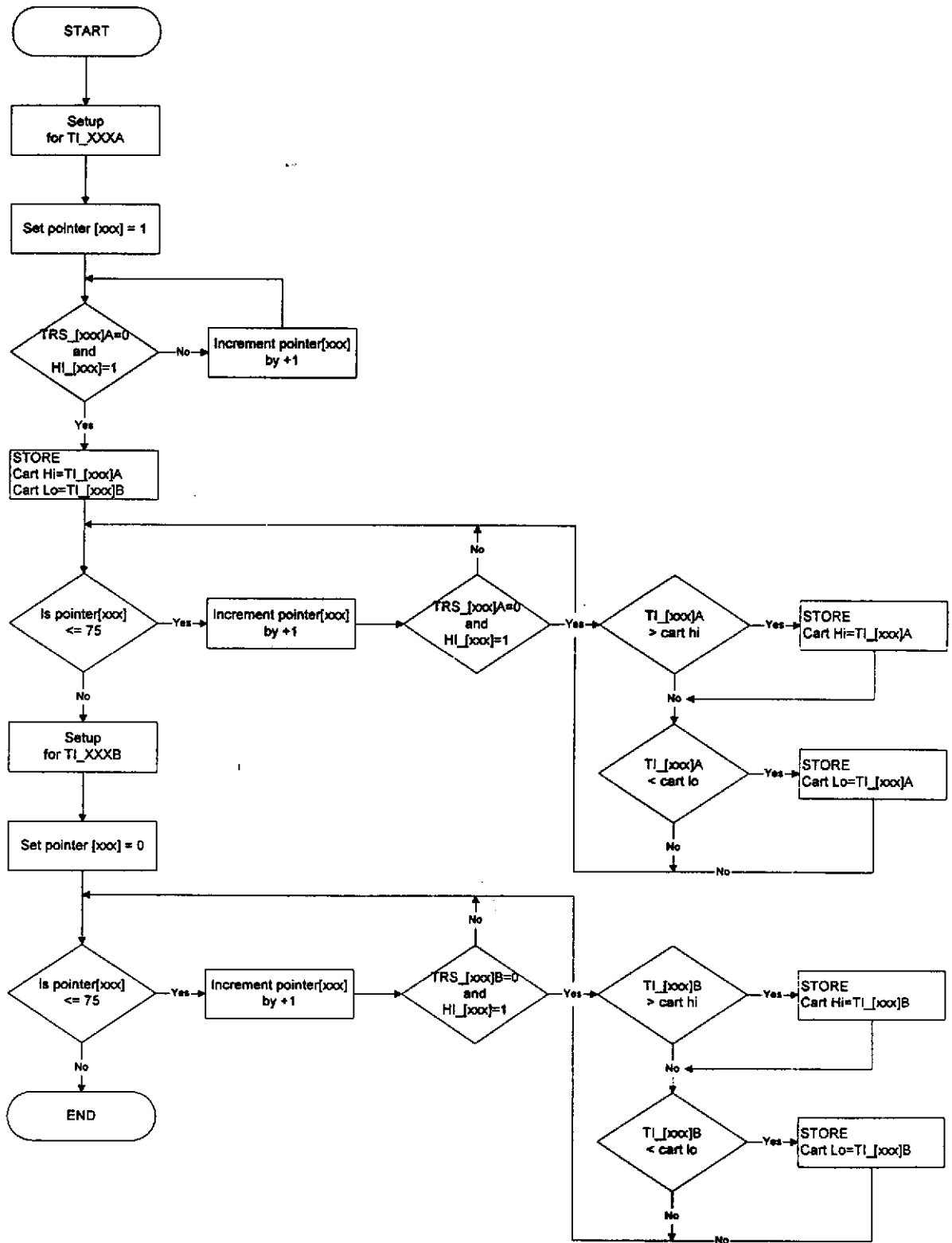

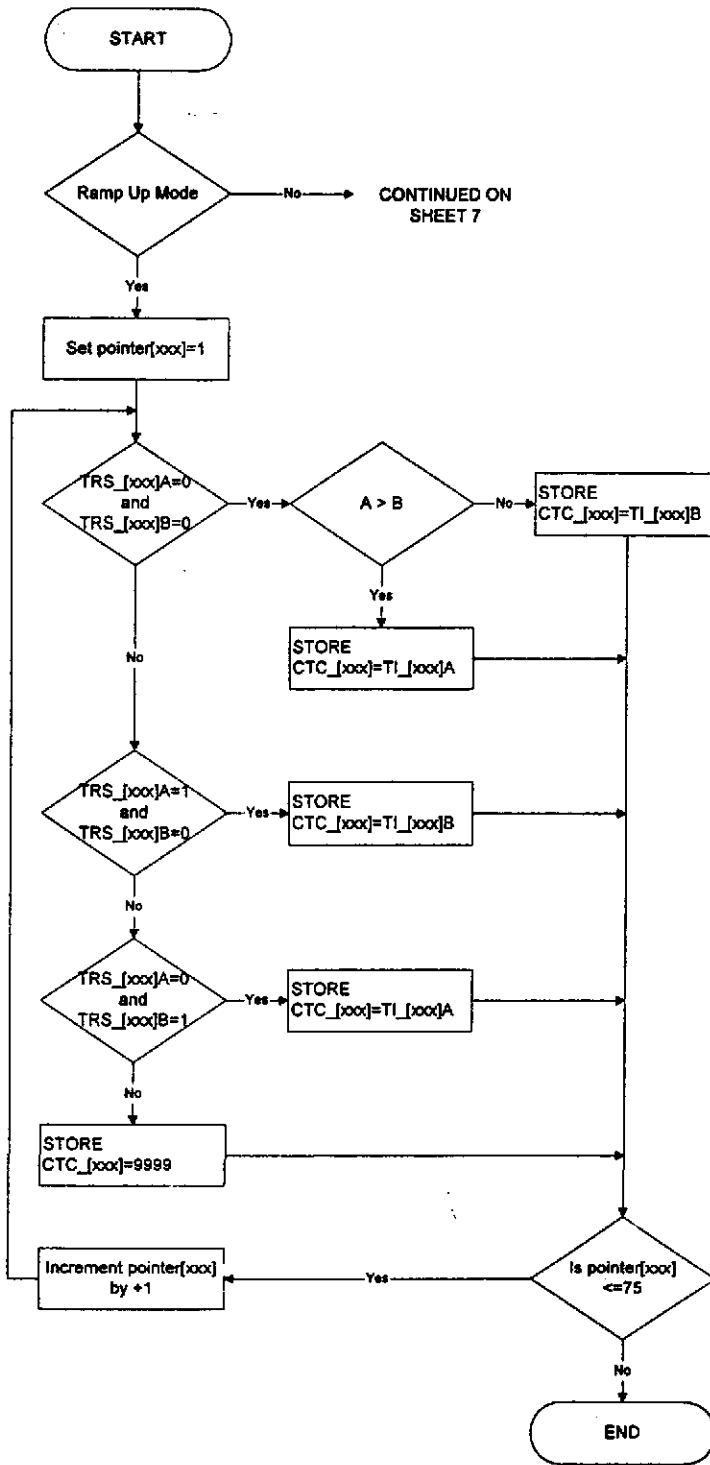

FROM SHEET 6

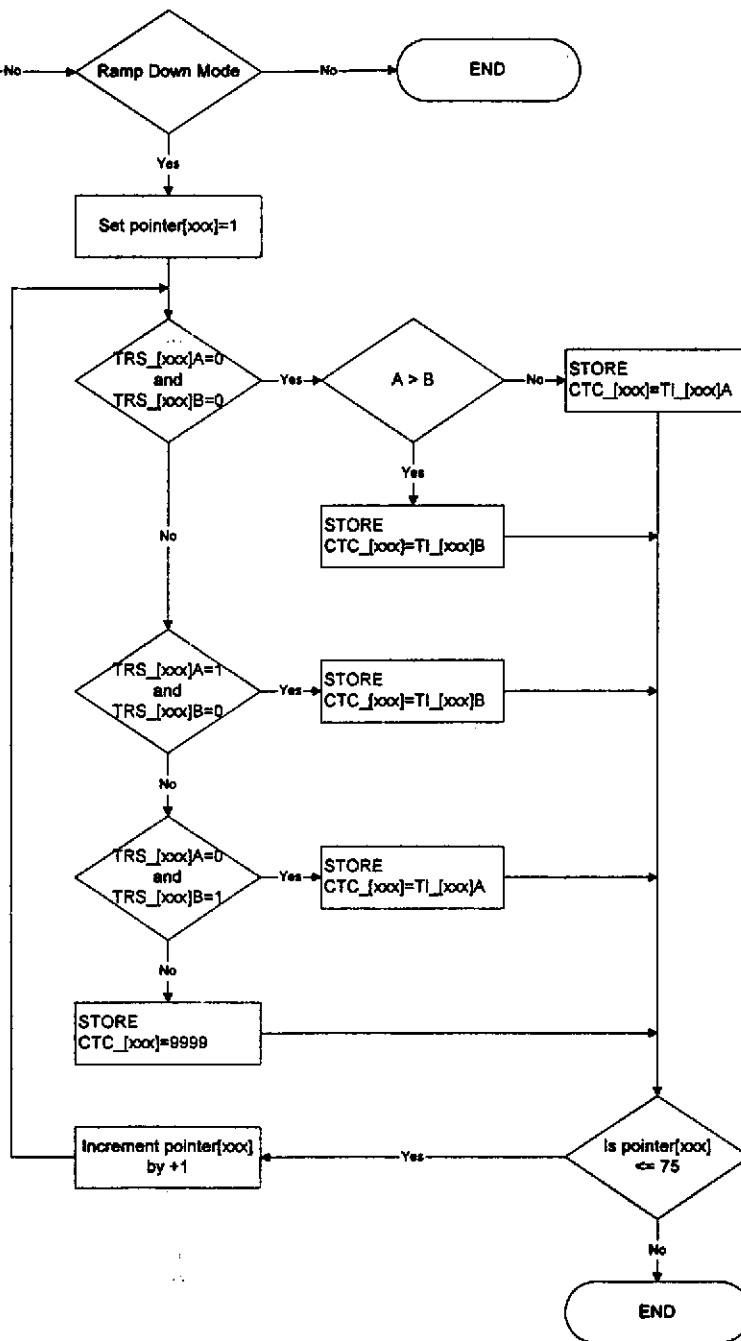

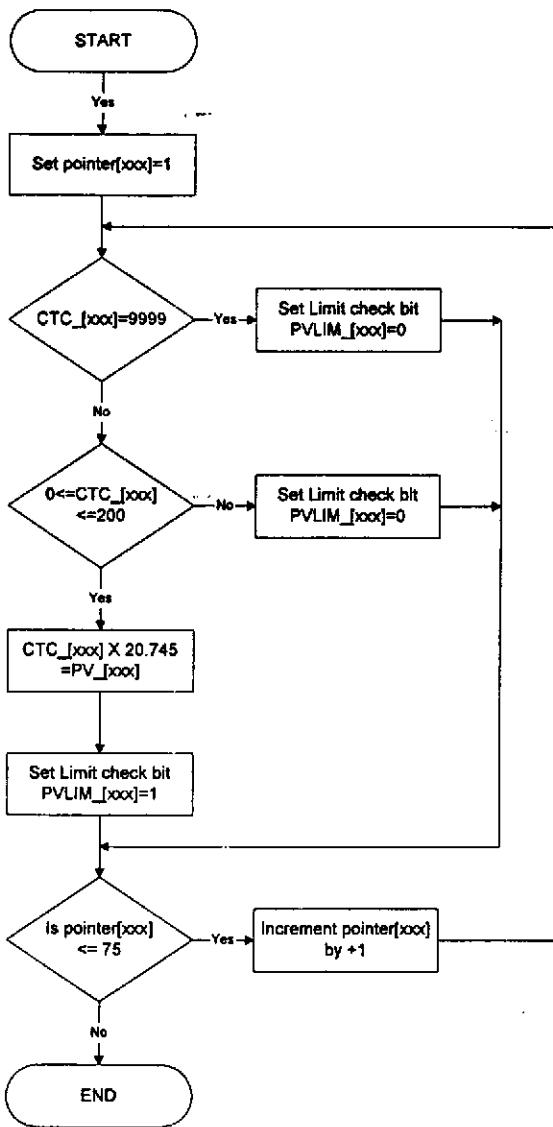

RAMP UP SETPOINT SUBROUTINE
BLANKET 1 - 76

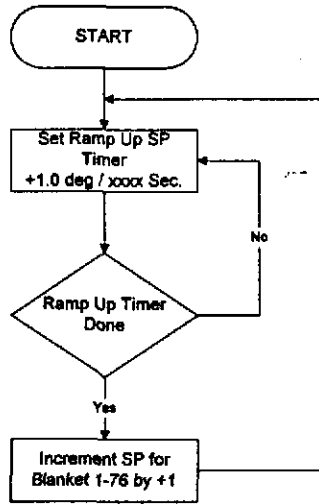

RAMP DOWN SETPOINT SUBROUTINE
BLANKET 1 - 76

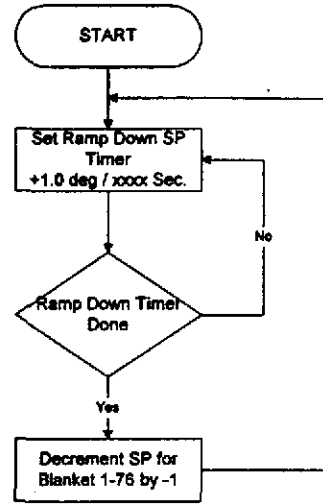

**APPENDIX 4
BLANKET 1-76 MODE / SEQUENCE
PERMISSIVES AND INTERLOCKS**

- A) RAMP-UP <Initialize> Permissives
- B) RAMP-UP <Initialize> Interlocks
- C) RAMP-DOWN <Initialize> Permissives
- D) RAMP-DOWN <Initialize> Interlocks
- E) RAMP-UP <Operating> Interlocks
- F) RAMP-DOWN < Operating> Interlocks
- G) RAMP-UP < Hold> Interlocks
- H) RAMP-DOWN <Hold> Interlocks
- I) RAMP-UP <Target> Interlocks
- J) RAMP-UP <Target> Interlocks

SPECIFICATION

Number	Rev
A V049-2-086 A-4	0

A) RAMP-UP <Initialize> Permissives

1) All Cart Configuration Permissives must be OK for all Carts in the "Configured System"

- XA_154 (Master-Slave) is OK
- XA_155 (Cart Selection) is OK
- XA_156A (RAMP-UP rate) is OK
- XA_157A (RAMP-UP target SP) is OK

2) No Active Minor Alarms for an individual Cart in the "Configured System" as follows :

i) No Thermocouple Range Alarms active

- TA_XXXA (where xxx = 1 thru 76) none active
- TA_XXXB (where xxx = 1 thru 76) none active

ii) No Chamber Blanket Alarms active

- SPDA10_XXX (where xxx = 1 thru 76) none active
- SPDA15_XXX (where xxx = 1 thru 76) none active

iii) No Blanket System Alarms active

- TDA_168 and TH_165 not active

iv) No PLC Hardware Alarms active

- XA_141 (Bad Battery) not active
- XA_142A (Chan 1A Queue Full) not active
- XA_142B (Chan 1B Queue Full) not active
- XA_151A (Forces present/enabled) not active

SPECIFICATION

Number	Rev
A V049-2-086 A-4	0

- v) No Minor Alarms from any other cart in the “Configured System”

- XA_161A (Cart #1 has one or more Minor Alarms) not active
- XA_161B (Cart #2 has one or more Minor Alarms) not active
- XA_161C (Cart #3 has one or more Minor Alarms) not active
- XA_161D (Cart #4 has one or more Minor Alarms) not active
- XA_161E (Cart #5 has one or more Minor Alarms) not active
- XA_161F (Cart #6 has one or more Minor Alarms) not active
- XA_161G (Cart #7 has one or more Minor Alarms) not active

- 3) No Active Major Alarms for an individual Cart in the “Configured System” as follows :

- i) No Data Acquisition Alarms active

- XA_134, XA_135, and XA_136 not active

- ii) No Chamber Blanket Alarms active

- SPDA20_xxx (Where xxx = 1 thru 76) none active

- iii) No Chamber Blankets System Alarms active

- TDA_169 and THH_165 not active

- iv) ESD Alarm YA_160 not active for an cart on the “Configured System”

- v) No PLC Hardware Alarms active

- XA_143 (Bad Program File) not active
- XA_144 (Bad Address) not active
- XA_145 (Program Error) not active
- XA_146 (Watchdog Timeout) not active
- XA_147 (Bad System Config) not active
- XA_148 (Hardware Error) not active
- XA_152A (Rack 0 Fault) not active
- XA_152B (Rack 1 Fault) not active

- vi) All Carts in “Configured System” must be in Run mode

- XI_149 (Run Mode) is active
- XA_150 (Program Mode) not active

SPECIFICATION	
Number	Rev
A V049-2-086 A-4	0

vii) No Major Alarms from any other cart in the "Configured System"

- XA_162A (Cart #1 has one or more Major Alarms) not active
- XA_162B (Cart #2 has one or more Major Alarms) not active
- XA_162C (Cart #3 has one or more Major Alarms) not active
- XA_162D (Cart #4 has one or more Major Alarms) not active
- XA_162E (Cart #5 has one or more Major Alarms) not active
- XA_162F (Cart #6 has one or more Major Alarms) not active
- XA_162G (Cart #7 has one or more Major Alarms) not active

B) RAMP-UP <Initialize> Interlocks

Any Active Major Alarms for an individual Cart in the "Configured System" as follows :

i) Any Data Acquisition Alarms active

XA_134, XA_135, or XA_136 active

ii) Any Chamber Blanket Alarms active

SPDA20_xxx (Where xxx = 1 thru 76) any active

iii) Any Chamber Blankets System Alarms active

TDA_169 or THH_165 active

iv) ESD Alarm YA_160 active for any Cart on the "Configured System"

v) Any PLC Hardware Alarms active

- XA_143 (Bad Program File) active
- XA_144 (Bad Address) active
- XA_145 (Program Error) active
- XA_146 (Watchdog Timeout) active
- XA_147 (Bad System Config) active
- XA_148 (Hardware Error) active
- XA_152A (Rack 0 Fault) active
- XA_152B (Rack 1 Fault) active

vi) Any Cart in "Configured System" not in RUN mode

- XI_149 (Run Mode) is not active
- XA_150 (Program Mode) active

SPECIFICATION	
Number	Rev
A V049-2-086 A-4	0

vii) Any Major Alarm from any other cart in the “Configured System”

- XA_162A (Cart #1 has one or more Major Alarms) active
- XA_162B (Cart #2 has one or more Major Alarms) active
- XA_162C (Cart #3 has one or more Major Alarms) active
- XA_162D (Cart #4 has one or more Major Alarms) active
- XA_162E (Cart #5 has one or more Major Alarms) active
- XA_162F (Cart #6 has one or more Major Alarms) active
- XA_162G (Cart #7 has one or more Major Alarms) active

C) RAMP-DOWN <Initialize> Permissives

1) All Cart Configuration Permissives must be OK for all Carts in the “Configured System”

- XA_154 (Master-Slave) is OK
- XA_155 (Cart Selection) is OK
- XA_156B (RAMP-DOWN rate) is OK
- XA_157B (RAMP-DOWN target SP) is OK

2) No Active Minor Alarms for an individual Cart in the “Configured System” as follows :

i) No Thermocouple Range Alarms active

- TA_xxxA (where xxx = 1 thru 76) none active
- TA_xxxB (where xxx = 1 thru 76) none active

ii) No Chamber Blanket Alarms active

- SPDA10_xxx (where xxx = 1 thru 76) none active
- SPDA15_xxx (where xxx = 1 thru 76) none active

iii) No Blanket System Alarms active

- TDA_168 and TH_165 not active

SPECIFICATION

Number

A V049-2-086 A-4

Rev

0

iv) No PLC Hardware Alarms active

- XA_141 (Bad Battery) not active
- XA_142A (Chan 1A Queue Full) not active
- XA_142B (Chan 1B Queue Full) not active
- XA_151A (Forces present/enabled) not active

v) No Minor Alarms from any other cart in the “Configured System”

- XA_161A (Cart #1 has one or more Minor Alarms) not active
- XA_161B (Cart #2 has one or more Minor Alarms) not active
- XA_161C (Cart #3 has one or more Minor Alarms) not active
- XA_161D (Cart #4 has one or more Minor Alarms) not active
- XA_161E (Cart #5 has one or more Minor Alarms) not active
- XA_161F (Cart #6 has one or more Minor Alarms) not active
- XA_161G (Cart #7 has one or more Minor Alarms) not active

3) No Active Major Alarms for an individual Cart in the “Configured System” as follows :

i) No Data Acquisition Alarms active

- XA_134, XA_135, and XA_136 not active

ii) No Chamber Blanket Alarms active

- SPDA20_xxx (Where xxx = 1 thru 76) none active

iii) No Chamber Blankets System Alarms active

- TDA_169 and THH_165 not active

iv) ESD Alarm YA_160 not active for any Cart on the “Configured System”

v) No PLC Hardware Alarms active

- XA_143 (Bad Program File) not active
- XA_144 (Bad Address) not active
- XA_145 (Program Error) not active
- XA_146 (Watchdog Timeout) not active
- XA_147 (Bad System Config) not active
- XA_148 (Hardware Error) not active
- XA_152A (Rack 0 Fault) not active
- XA_152B (Rack 1 Fault) not active

SPECIFICATION

Number

A V049-2-086 A-4

Rev

0

vi) All Carts in "Configured System" must be in Run mode

XI_149 (Run Mode) is active
XA_150 (Program Mode) not active

vii) No Major Alarms from any other cart in the "Configured System"

XA_162A (Cart #1 has one or more Major Alarms) not active
XA_162B (Cart #2 has one or more Major Alarms) not active
XA_162C (Cart #3 has one or more Major Alarms) not active
XA_162D (Cart #4 has one or more Major Alarms) not active
XA_162E (Cart #5 has one or more Major Alarms) not active
XA_162F (Cart #6 has one or more Major Alarms) not active
XA_162G (Cart #7 has one or more Major Alarms) not active

D) RAMP-DOWN <Initialize> Interlocks

Any Active Major Alarms for an individual Cart in the "Configured System" as follows :

i) Any Data Acquisition Alarms active

XA_134, XA_135, or XA_136 active

ii) Any Chamber Blanket Alarms active

SPDA20_xxx (Where xxx = 1 thru 76) any active

iii) Any Chamber Blankets System Alarms active

TDA_169 or THH_165 active

iv) ESD Alarm YA_160 active for any Cart on the "Configured System"

v) Any PLC Hardware Alarms active

XA_143 (Bad Program File) active
XA_144 (Bad Address) active
XA_145 (Program Error) active
XA_146 (Watchdog Timeout) active
XA_147 (Bad System Config) active
XA_148 (Hardware Error) active
XA_152A (Rack 0 Fault) active
XA_152B (Rack 1 Fault) active

SPECIFICATION

Number

A V049-2-086 A-4

Rev

0

vi) Any Cart in "Configured System" not in RUN mode

XI_149 (Run Mode) is not active
XA_150 (Program Mode) active

vii) Any Major Alarm from any other cart in the "Configured System"

XA_162A (Cart #1 has one or more Major Alarms) active
XA_162B (Cart #2 has one or more Major Alarms) active
XA_162C (Cart #3 has one or more Major Alarms) active
XA_162D (Cart #4 has one or more Major Alarms) active
XA_162E (Cart #5 has one or more Major Alarms) active
XA_162F (Cart #6 has one or more Major Alarms) active
XA_162G (Cart #7 has one or more Major Alarms) active

E) RAMP-UP <Operating> Interlocks

Any Active Major Alarms for an individual Cart in the "Configured System" as follows :

i) Any Data Acquisition Alarms active

XA_134, XA_135, or XA_136 active

ii) Any Chamber Blanket Alarms active

SPDA20_xxx (Where xxx = 1 thru 76) any active

iii) Any Chamber Blankets System Alarms active

TDA_169 or THH_165 active

iv) ESD Alarm YA_160 active for any Cart on the "Configured System"

v) Any PLC Hardware Alarms active

XA_143 (Bad Program File) active
XA_144 (Bad Address) active
XA_145 (Program Error) active
XA_146 (Watchdog Timeout) active
XA_147 (Bad System Config) active
XA_148 (Hardware Error) active
XA_152A (Rack 0 Fault) active
XA_152B (Rack 1 Fault) active

SPECIFICATION

Number

A V049-2-086 A-4

Rev

0

vi) Any Cart in "Configured System" not in RUN mode

XI_149 (Run Mode) is not active
XA_150 (Program Mode) active

vii) Any Major Alarm from any other cart in the "Configured System"

XA_162A (Cart #1 has one or more Major Alarms) active
XA_162B (Cart #2 has one or more Major Alarms) active
XA_162C (Cart #3 has one or more Major Alarms) active
XA_162D (Cart #4 has one or more Major Alarms) active
XA_162E (Cart #5 has one or more Major Alarms) active
XA_162F (Cart #6 has one or more Major Alarms) active
XA_162G (Cart #7 has one or more Major Alarms) active

E) RAMP-DOWN <Operating> Interlocks

Any Active Major Alarms for an individual Cart in the "Configured System" as follows :

i) Any Data Acquisition Alarms active

XA_134, XA_135, or XA_136 active

ii) Any Chamber Blanket Alarms active

SPDA20_xxx (Where xxx = 1 thru 76) any active

iii) Any Chamber Blankets System Alarms active

TDA_169 or THH_165 active

iv) ESD Alarm YA_160 active for any Cart on the "Configured System"

v) Any PLC Hardware Alarms active

XA_143 (Bad Program File) active
XA_144 (Bad Address) active
XA_145 (Program Error) active
XA_146 (Watchdog Timeout) active
XA_147 (Bad System Config) active
XA_148 (Hardware Error) active
XA_152A (Rack 0 Fault) active
XA_152B (Rack 1 Fault) active

SPECIFICATION

Number	Rev
A V049-2-086 A-4	0

vi) Any Cart in “Configured System” not in RUN mode

XI_149 (Run Mode) is not active
XA_150 (Program Mode) active

vii) Any Major Alarm from any other cart in the “Configured System”

XA_162A (Cart #1 has one or more Major Alarms) active
XA_162B (Cart #2 has one or more Major Alarms) active
XA_162C (Cart #3 has one or more Major Alarms) active
XA_162D (Cart #4 has one or more Major Alarms) active
XA_162E (Cart #5 has one or more Major Alarms) active
XA_162F (Cart #6 has one or more Major Alarms) active
XA_162G (Cart #7 has one or more Major Alarms) active

G) RAMP-UP <Hold> Interlocks

Any Active Major Alarms for an individual Cart in the “Configured System” as follows :

i) Any Data Acquisition Alarms active

XA_134, XA_135, or XA_136 active

ii) Any Chamber Blanket Alarms active

SPDA20_xxx (Where xxx = 1 thru 76) any active

iii) Any Chamber Blankets System Alarms active

TDA_169 or THH_165 active

iv) ESD Alarm YA_160 active for any Cart on the “Configured System”

v) Any PLC Hardware Alarms active

XA_143 (Bad Program File) active
XA_144 (Bad Address) active
XA_145 (Program Error) active
XA_146 (Watchdog Timeout) active
XA_147 (Bad System Config) active
XA_148 (Hardware Error) active
XA_152A (Rack 0 Fault) active
XA_152B (Rack 1 Fault) active

SPECIFICATION

Number

A V049-2-086 A-4

Rev

0

vi) Any Cart in “Configured System” not in RUN mode

XI_149 (Run Mode) is not active
XA_150 (Program Mode) active

vii) Any Major Alarm from any other cart in the “Configured System”

XA_162A (Cart #1 has one or more Major Alarms) active
XA_162B (Cart #2 has one or more Major Alarms) active
XA_162C (Cart #3 has one or more Major Alarms) active
XA_162D (Cart #4 has one or more Major Alarms) active
XA_162E (Cart #5 has one or more Major Alarms) active
XA_162F (Cart #6 has one or more Major Alarms) active
XA_162G (Cart #7 has one or more Major Alarms) active

H) RAMP-DOWN <Hold> Interlocks

Any Active Major Alarms for an individual Cart in the “Configured System” as follows :

i) Any Data Acquisition Alarms active

XA_134, XA_135, or XA_136 active

ii) Any Chamber Blanket Alarms active

SPDA20_xxx (Where xxx = 1 thru 76) any active

iii) Any Chamber Blankets System Alarms active

TDA_169 or THH_165 active

iv) ESD Alarm YA_160 active for any Cart on the “Configured System”

v) Any PLC Hardware Alarms active

XA_143 (Bad Program File) active
XA_144 (Bad Address) active
XA_145 (Program Error) active
XA_146 (Watchdog Timeout) active
XA_147 (Bad System Config) active
XA_148 (Hardware Error) active
XA_152A (Rack 0 Fault) active
XA_152B (Rack 1 Fault) active

SPECIFICATION

Number	Rev
A V049-2-086 A-4	0

vi) Any Cart in “Configured System” not in RUN mode

XI_149 (Run Mode) is not active

XA_150 (Program Mode) active

vii) Any Major Alarm from any other cart in the “Configured System”

XA_162A (Cart #1 has one or more Major Alarms) active

XA_162B (Cart #2 has one or more Major Alarms) active

XA_162C (Cart #3 has one or more Major Alarms) active

XA_162D (Cart #4 has one or more Major Alarms) active

XA_162E (Cart #5 has one or more Major Alarms) active

XA_162F (Cart #6 has one or more Major Alarms) active

XA_162G (Cart #7 has one or more Major Alarms) active

I) RAMP-UP <Target> Interlocks

Any Active Major Alarms for an individual Cart in the “Configured System” as follows :

i) Any Data Acquisition Alarms active

XA_134, XA_135, or XA_136 active

ii) Any Chamber Blanket Alarms active

SPDA20_xxx (Where xxx = 1 thru 76) any active

iii) Any Chamber Blankets System Alarms active

TDA_169 or THH_165 active

iv) ESD Alarm YA_160 active for any Cart on “Configured System”

v) Any PLC Hardware Alarms active

XA_143 (Bad Program File) active

XA_144 (Bad Address) active

XA_145 (Program Error) active

XA_146 (Watchdog Timeout) active

XA_147 (Bad System Config) active

XA_148 (Hardware Error) active

XA_152A (Rack 0 Fault) active

XA_152B (Rack 1 Fault) active

SPECIFICATION

Number

A V049-2-086 A-4

Rev

0

- vi) Any Cart in "Configured System" not in RUN mode
 XI_149 (Run Mode) is not active
 XA_150 (Program Mode) active

- vii) Any Major Alarm from any other cart in the "Configured System"
 XA_162A (Cart #1 has one or more Major Alarms) active
 XA_162B (Cart #2 has one or more Major Alarms) active
 XA_162C (Cart #3 has one or more Major Alarms) active
 XA_162D (Cart #4 has one or more Major Alarms) active
 XA_162E (Cart #5 has one or more Major Alarms) active
 XA_162F (Cart #6 has one or more Major Alarms) active
 XA_162G (Cart #7 has one or more Major Alarms) active

J) RAMP-DOWN <Target> Interlocks

Any Active Major Alarms for an individual Cart in the "Configured System" as follows :

- i) Any Data Acquisition Alarms active
 XA_134, XA_135, or XA_136 active

- ii) Any Chamber Blanket Alarms active
 SPDA20_xxx (Where xxx = 1 thru 76) any active

- iii) Any Chamber Blankets System Alarms active
 TDA_169 or THH_165 active

- iv) ESD Alarm YA_160 active for any Cart on the "Configured System"

- v) Any PLC Hardware Alarms active
 XA_143 (Bad Program File) active
 XA_144 (Bad Address) active
 XA_145 (Program Error) active
 XA_146 (Watchdog Timeout) active
 XA_147 (Bad System Config) active
 XA_148 (Hardware Error) active
 XA_152A (Rack 0 Fault) active
 XA_152B (Rack 1 Fault) active

SPECIFICATION	
Number	Rev
A V049-2-086 A-4	0

vi) Any Cart in "Configured System" not in RUN mode

XI_149 (Run Mode) is not active

XA_150 (Program Mode) active

vii) Any Major Alarm from any other cart in the "Configured System"

XA_162A (Cart #1 has one or more Major Alarms) active

XA_162B (Cart #2 has one or more Major Alarms) active

XA_162C (Cart #3 has one or more Major Alarms) active

XA_162D (Cart #4 has one or more Major Alarms) active

XA_162E (Cart #5 has one or more Major Alarms) active

XA_162F (Cart #6 has one or more Major Alarms) active

XA_162G (Cart #7 has one or more Major Alarms) active

SPECIFICATION

Number

A V049-2-086 A-4

Rev

0

**APPENDIX 5
BLANKETS 93-112 MODE/ SEQUENCE
SUB-ROUTINES**

- | | | |
|----|--|---------------------------|
| A) | Control System MODE / SEQUENCE (93-112) | V59049-0-030 Sheet 1 of 5 |
| B) | Ramp-Up (Initialize)/ Ramp-Up Mode (93-112) | V59049-0-030 Sheet 2 of 5 |
| C) | Selection of Control T/C Subroutine (93-112) | V59049-0-030 Sheet 3 of 5 |
| D) | Descale Control T/C Subroutine (93-112) | V59049-0-030 Sheet 4 of 5 |
| E) | Ramp-Up Setpoint Subroutines (93-112) | V59049-0-030 Sheet 5 of 5 |

SPECIFICATION	
Number	Rev
A V049-2-086 A-5	0

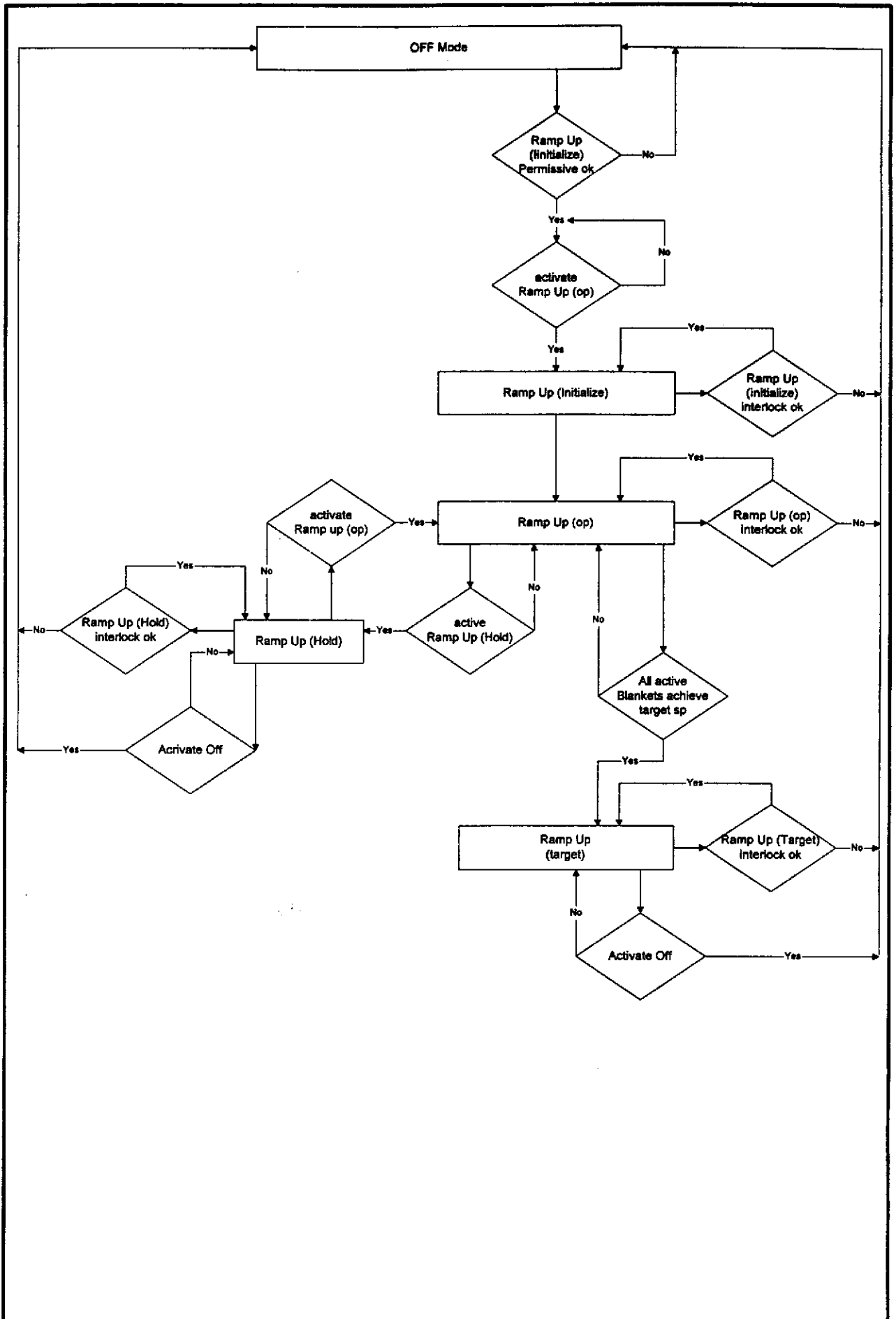

RAMP UP (INITIALIZE)

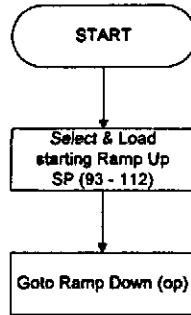

RAMP UP MODE

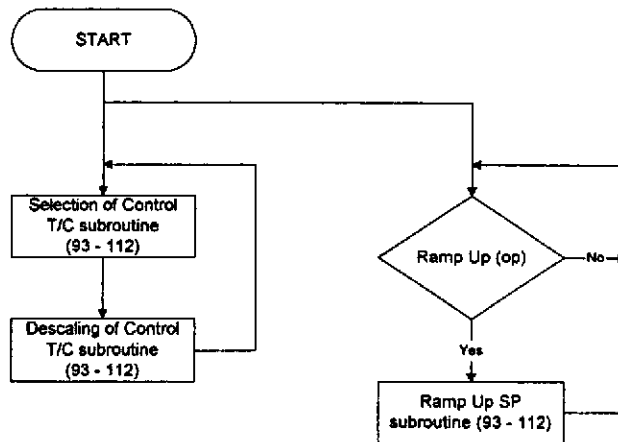

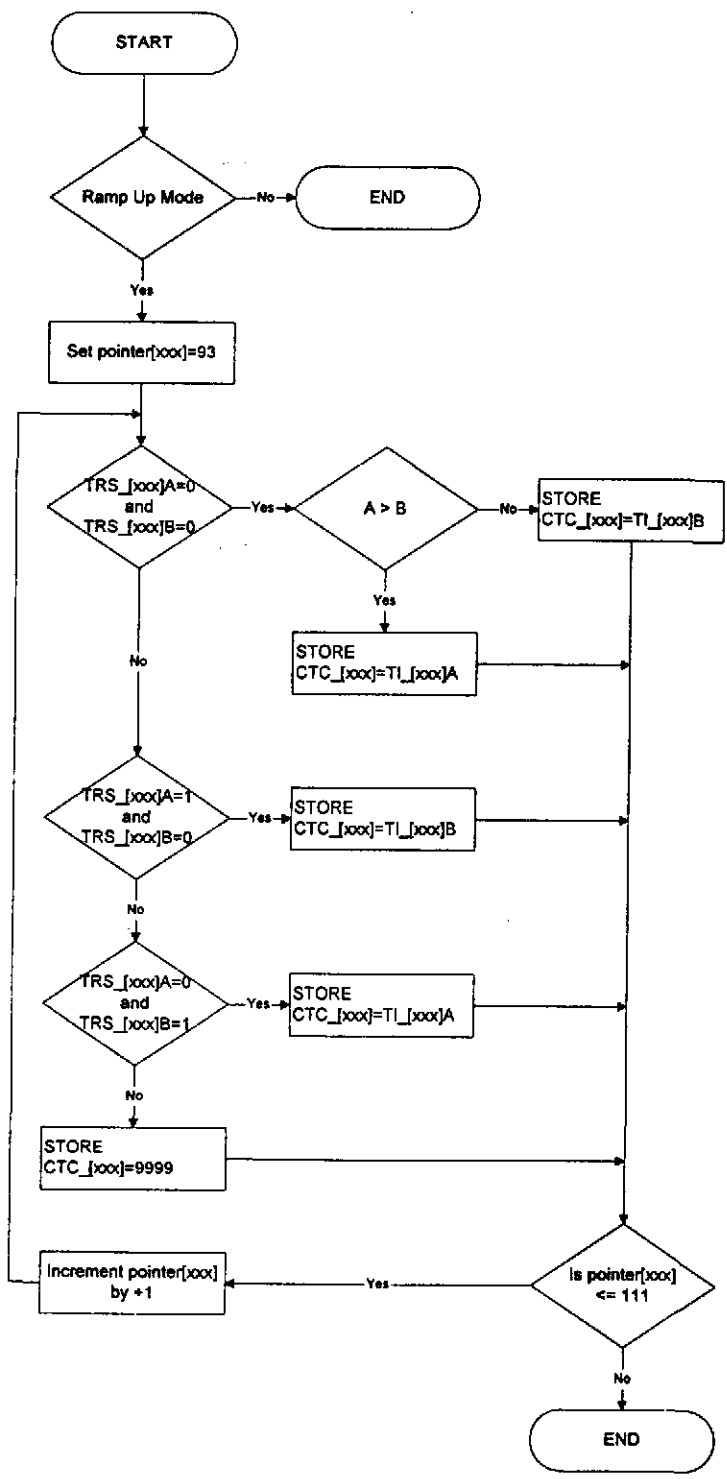

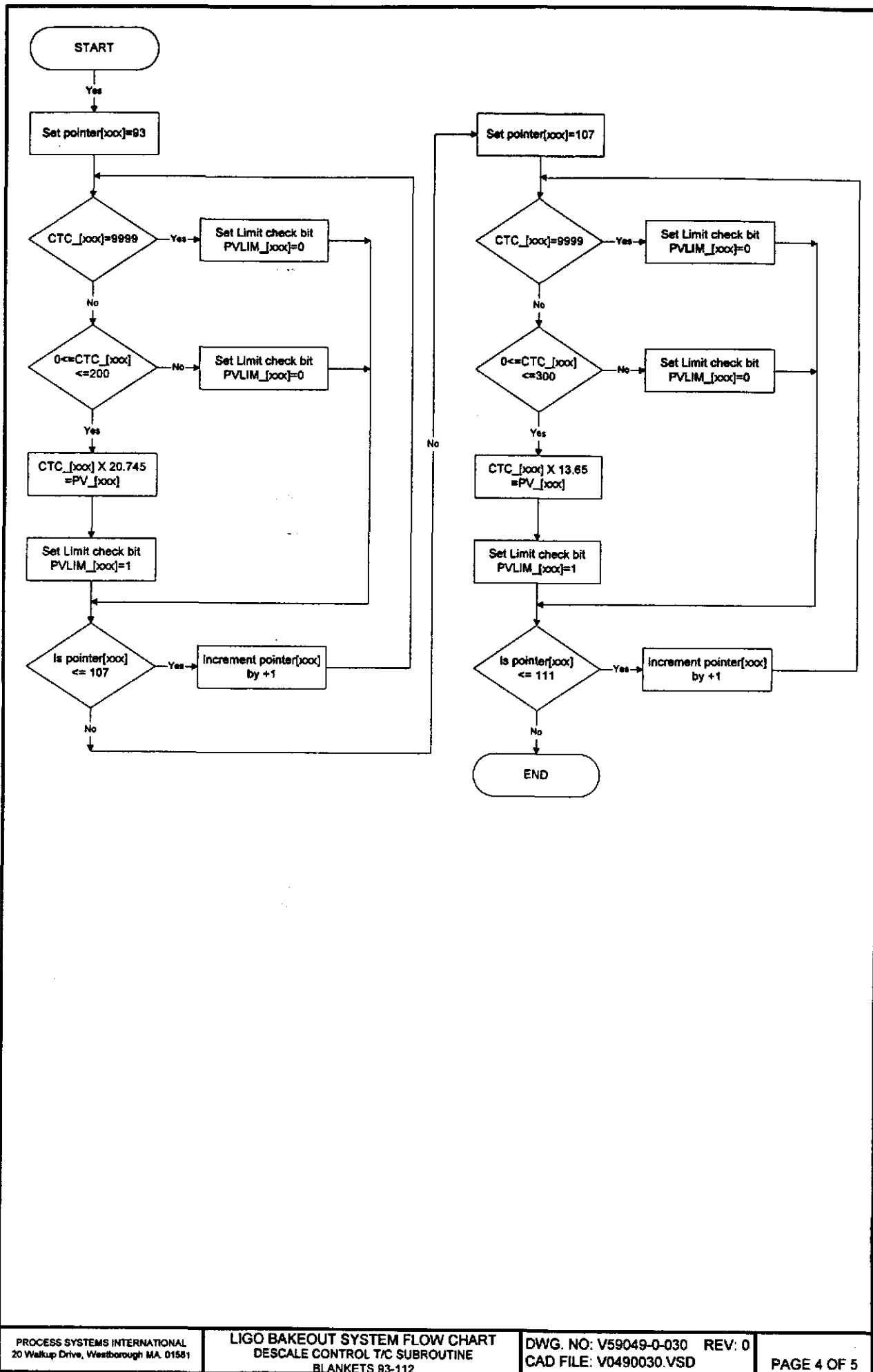

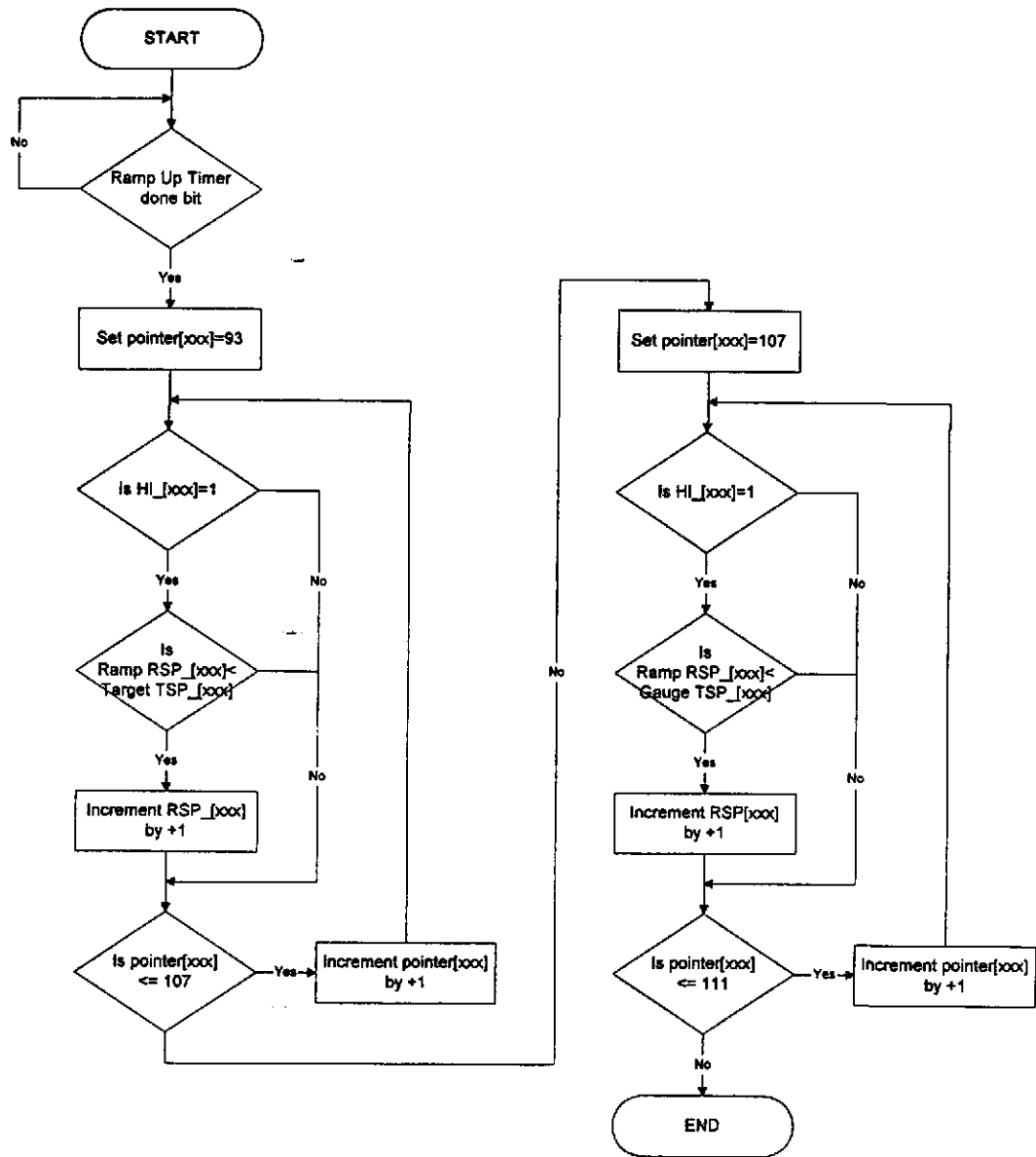

**APPENDIX 6
BLANKETS 93-112 MODE / SEQUENCE
INTERLOCKS AND PERMISSIVES**

- A) RAMP-UP <Initialize> Permissives
- B) RAMP-UP <Initialize> Interlocks
- C) RAMP-UP <Operating> Interlocks
- D) RAMP-UP <Hold> Interlocks
- E) RAMP-UP <Target> Interlocks

SPECIFICATION

Number	Rev
A V049-2-086 A-6	0

Title: SPECIFICATION FOR BAKEOUT CART SYSTEM CONTROL FUNCTIONALITY

A) RAMP-UP <Initialize> Permissives

1) No Active Minor Alarms for an individual Cart as follows :

i) No Thermocouple Range Alarms active

TA_xxxA (where xxx = 93 thru 112) none active

TA_xxxB (where xxx = 93 thru 112) none active

ii) No Aux. / Gauge Blanket Alarms active

SPDA10_xxx (where xxx = 93 thru 112) none active

TH_xxx (where xxx = 93 thru 108) none active

iii) No Aux. / Gauge System Alarms active

TH_167 not active

iv) No PLC Hardware Alarms active

XA_141 (Bad Battery) not active

XA_142A (Chan 1A Queue Full) not active

XA_142B (Chan 1B Queue Full) not active

XA_151A (Forces present/enabled) not active

2) No Active Major Alarms for an individual Cart as follows :

i) No Data Acquisition Alarms active

XA_134, XA_135, and XA_136 not active

ii) No Chamber Blankets System Alarms active

THH_166 and THH_167 not active

iii) ESD Alarm YA_160 not active

SPECIFICATION

Number

A V049-2-086 A-6

Rev

0

- iv) No PLC Hardware Alarms active
 - XA_143 (Bad Program File) not active
 - XA_144 (Bad Address) not active
 - XA_145 (Program Error) not active
 - XA_146 (Watchdog Timeout) not active
 - XA_147 (Bad System Config) not active
 - XA_148 (Hardware Error) not active
 - XA_152A (Rack 0 Fault) not active
 - XA_152B (Rack 1 Fault) not active

B) RAMP-UP <Initialize> Interlocks

Any Active Major Alarm for an individual Cart as follows :

- i) Any Data Acquisition Alarms active
 - XA_134, XA_135, or XA_136 active
- ii) Any Aux. / Gauge Blankets System Alarms active
 - THH_166 or THH_167 active
- iii) ESD Alarm YA_160 active
- iv) Any PLC Hardware Alarms active
 - XA_143 (Bad Program File) active
 - XA_144 (Bad Address) active
 - XA_145 (Program Error) active
 - XA_146 (Watchdog Timeout) active
 - XA_147 (Bad System Config) active
 - XA_148 (Hardware Error) active
 - XA_152A (Rack 0 Fault) active
 - XA_152B (Rack 1 Fault) active

SPECIFICATION

Number

A V049-2-086 A-6

Rev

0

C) RAMP-UP <Operating> Interlocks

Any Active Major Alarm for an individual Cart as follows :

- i) Any Data Acquisition Alarms active
XA_134, XA_135, or XA_136 active
- ii) Any Aux. / Gauge Blankets System Alarms active
THH_166 or THH_167 active
- iii) ESD Alarm YA_160 active
- iv) Any PLC Hardware Alarms active
XA_143 (Bad Program File) active
XA_144 (Bad Address) active
XA_145 (Program Error) active
XA_146 (Watchdog Timeout) active
XA_147 (Bad System Config) active
XA_148 (Hardware Error) active
XA_152A (Rack 0 Fault) active
XA_152B (Rack 1 Fault) active

D) RAMP-UP <Hold> Interlocks

Any Active Major Alarm for an individual Cart as follows :

- i) Any Data Acquisition Alarms active
XA_134, XA_135, or XA_136 active
- ii) Any Aux. / Gauge Blankets System Alarms active
THH_166 or THH_167 active
- iii) ESD Alarm YA_160 active

SPECIFICATION

Number	Rev
A V049-2-086 A-6	0

- iv) Any PLC Hardware Alarms active
 - XA_143 (Bad Program File) active
 - XA_144 (Bad Address) active
 - XA_145 (Program Error) active
 - XA_146 (Watchdog Timeout) active
 - XA_147 (Bad System Config) active
 - XA_148 (Hardware Error) active
 - XA_152A (Rack 0 Fault) active
 - XA_152B (Rack 1 Fault) active

E) RAMP-UP <Target> Interlocks

Any Active Major Alarm for an individual Cart as follows :

- i) Any Data Acquisition Alarms active
 - XA_134, XA_135, or XA_136 active
- ii) Any Aux. / Gauge Blankets System Alarms active
 - THH_166 or THH_167 active
- iii) ESD Alarm YA_160 active
- iv) Any PLC Hardware Alarms active
 - XA_143 (Bad Program File) active
 - XA_144 (Bad Address) active
 - XA_145 (Program Error) active
 - XA_146 (Watchdog Timeout) active
 - XA_147 (Bad System Config) active
 - XA_148 (Hardware Error) active
 - XA_152A (Rack 0 Fault) active
 - XA_152B (Rack 1 Fault) active

SPECIFICATION

Number

A V049-2-086 A-6

Rev

0

Table 3-1: VE Power Required^a at Load Centers
Corner StationPrepared By: RFW Date: 3/1/96
Approved By: FAB Date: 3-1-96

Voltage	208Y/120V, 3 ϕ							480Y/277V, 3 ϕ							
	Location b	# C ^c	ϕ	KVA d	CB (A)	# R ^e	Recepticle (NEMA)	nominal use	# C	ϕ	KVA	CB (A)	# R	Recepticle ^f (NEMA)	nominal use
VEAC-01	1	1	1.9	20			L5-20R	General/ION Pumps/ Aux Turbo	1	3	39.9	60		L22-60R	Bakeout/Clean Room
	1	1	2.9	30			L5-30R	Bakeout Control	1	3	39.9	60		L22-60R	Bakeout/Clean Room
VEAC-02	1	1	2.0	20			L21-50R	Turbo Control	1	3	39.9	60		L22-60R	Bakeout/Clean Room
	1	1	1.9	20			L5-20R	General/ION Pumps/ Aux. Turbo	1	3	39.9	60		L22-60R	Bakeout/Clean Room
	1	1	2.9	30			L5-30R	Bakeout Control	1					L22-60R	
VEAC-03	1	1	2.9	30			L5-30R	Bakeout Control	1	3	39.9	60		L22-60R	Bakeout/Clean Room
									1	3	39.9	60		L22-60R	
VEAC-04	1	1	2.9	30			L5-30R	Bakeout Control	1	3	39.9	60		L22-60R	Bakeout/Clean Room
									1	3	39.9	60		L22-60R	Bakeout/Clean Room
VEAC-05	1	1	1.9	20			L5-20R	General/ION Pumps/ Aux. Turbo	1	3	39.9	60		L22-60R	Bakeout/Clean Room
	1	1	2.9	30			L5-30R	Bakeout Control	1	3	39.9	60		L22-60R	Bakeout/Clean Room
	1	1	2.0	20			L21-50R	Turbo Control	1	3	20.0	30		Direct	Regen Heater
VEAC-06	1	1	1.9	20			L5-20R	General/ION Pumps/ Aux. Turbo	1	3	39.9	60		L22-60R	Bakeout/Clean Room
	1	1	2.9	30			L5-30R	Bakeout Control	1	3	39.9	60		L22-60R	Bakeout/Clean Room
	1	3	2.0	20			L21-50R	Turbo Pumps	1	3	20.0	30		Direct	Regen Heater
VEAC-07	1	1	2.9	30			L5-30R	Bakeout Control	1	3	39.9	60		L22-60R	Bakeout/Clean Room
	1	1	2.9	30			L5-30R	Bakeout Control	1	3	39.9	60		L22-60R	Bakeout/Clean Room
	1	1	1.9	20			L5-20R	General/ION Pumps/ Aux. Turbo	1	3	39.9	60		L22-60R	Bakeout/Clean Room

Table 3-1: VE Power Required^a at Load Centers
 Corner Station

Voltage	208Y/120V, 3φ							480Y/277V, 3φ							
	Location b	# C	φ	KVA d	CB (A)	# R ^e	Recepticle (NEMA)	nominal use	# C	φ	KVA	CB (A)	# R	Recepticle ^f (NEMA)	nominal use
VEAC-08	1	1	1.9	20			L5-20R	General/ION Pumps/ Aux Turbo	1	3	39.9	60		L22-60R	Bakeout/Clean Room
	1	1	2.9	30			L5-30R	Bakeout Control	1	3	39.9	60		L22-60R	Bakeout/Clean Room
									1	3	7.5	20		L22-20R	Roughing Pump
VEAC-09	1	3	2.0	20			L21-50R	Turbo Pump	1	3	7.5	20		L22-20R	Roughing Pump
	1	1	1.9	20			L5-20R	General/ION Pumps/ Aux. Turbo	1	3	39.9	60		L22-60R	Bakeout/Clean Room
			2.9	30			L5-30R	Bakeout Control	1	3	39.9	60		L22-60R	Bakeout/Clean Room
			2.9	30			L5-30R	Bakeout Control	1	3	13.3	20		Direct	Gate Valve
	1	3	2.0	20			L21-50R	Turbo Pump	1	3	13.3	20		Direct	Gate Valve
VEAC-10	1	1	2.9	30			L5-30R	Bakeout Control	1	3	39.9	60		L22-60R	Bakeout/Clean Room
VEAC-11	1	1	2.9	30			L5-30R	Bakeout Control	1	3	39.9	60		L22-60R	Bakeout/Clean Room
	1	1	2.9	30			L5-30R	Bakeout Control	1	3	39.9	60		L22-60R	Bakeout/Clean Room
									1	3	39.9	60		L22-60R	Bakeout/Clean Room
VEAC-12	1	1	2.9	30			L5-30R	Bakeout Control	1	3	39.9	60		L22-60R	Bakeout/Clean Room
	1	1	2.9	30			L5-30R	Bakeout Control	1	3	39.9	60		L22-60R	Bakeout/Clean Room
	1	3	2.0	20			L21-50R	Turbo Pumps	1	3	39.9	60		L22-60R	Bakeout/Clean Room
	1	1	1.9	20			L5-20R	General/ION Pumps/ Aux. Turbo	1	3	7.5	20		L22-20R	Roughing Pump
									1	3	13.3	20		Direct	Gate Valve
									1	3	7.5	20		L22-20R	Roughing Pump
VEAC-13	1	1	2.9	30			L5-30R	Bakeout Control	1	3	39.9	60		L22-60R	Bakeout/Clean Room

Table 3-1: VE Power Required^a at Load Centers
 Corner Station

Voltage	208Y/120V, 3φ							480Y/277V, 3φ							
	Location b	# C	φ	KVA d	CB (A)	# R ^e	Recepticle (NEMA)	nominal use	# C	φ	KVA	CB (A)	# R	Recepticle ^f (NEMA)	nominal use
VEAC-14	1	1	2.9	30			L5-30 R	Bakeout Control	1	3	39.9	60		L22-60R	Bakeout/Clean Room
	1	1	2.9	30			L5-30R	Bakeout Control	1	3	39.9	60		L22-60R	Bakeout/Clean Room
	1	1	2.9	30			L5-30R	Bakeout Control	1	3	13.3	20		Direct	Gate Valve
									1	3	39.9	60		L22-60R	Bakeout/Clean Room
VEAC-15	1	1	1.9	20			Direct	VE Control Xformer							
VEAC-16	1	1	1.9	20			Direct	VE Control Xformer							
VEAC-17	1	1	1.9	20			L5-20R	ION Pump	1	3	61.0	175		Direct	Air Compressor
	1	1	1.9	20			L5-20R	ION Pump	1	3	15.0	40		Direct	Rough Backing
	1	1	1.9	20			L5-20R	ION Pump	1	3	15.0	40		Direct	Rough Backing
	1	1	1.9	20			L5-20R	ION Pump							
	1	1	1.9	20			L5-20R	ION Pump							
	1	1	1.9	20			L5-20R	ION Pump							
	1	1	1.9	20			L5-20R	ION Pump							
	1	1	1.9	20			L5-20R	ION Pump							
	1	1	1.9	20			L5-20R	ION Pump							
	1	1	1.9	20			Direct	VE Control Xformer							
	1	3	4.0	30			L21-30R	Turbo Backing							
1	3	4.0	30			L21-30R	Turbo Backing								

Table 3-1: VE Power Required^a at Load Centers
 Mid Station

Voltage	208Y/120V, 3φ							480Y/277V, 3φ							
	Location b	# C	φ	KVA d	CB (A)	# R ^e	Recepticle (NEMA)	nominal use	# C	φ	KVA	CB (A)	# R	Recepticle ^f (NEMA)	nominal use
VEAC-01	1	1	1.9	20			L5-20R	General/ION Pumps/ Aux. Turbo	1	3	13.3	20		Direct	Gate Valve
	1	1	2.9	30			L5-30R	Bakeout Control	1	3	13.3	20		Direct	Gate Valve
	1	3	2.0	20			L21-50R	Turbo Pump	1	3	20.0	30		Direct	Regen Heater
	1	3	2.0	20			L21-50R	Turbo Pump	1	3	39.9	60		L22-60R	Bakeout/Clean Room
	1	1	2.9	30			L5-30R	Bakeout Control	1	3	39.9	60		L22-60R	Bakeout/Clean Room
VEAC-02	1	1	1.9	20			L5-20R	General/ION Pumps/ Aux. Turbo	1	3	13.3	20		Direct	Gate Valve
	1	1	2.9	30			L5-30R	Bakeout Control	1	3	13.3	20		Direct	Gate Valve
	1	3	2.0	20			L21-50R	Turbo Pump	1	3	20.0	30		Direct	Regen Heater
									1	3	39.9	60		L22-60R	Bakeout/Clean Room
VEAC-03	1	1	1.9	20			Direct	VE Control Xformer							
VEAC-04	1	1	1.9	20			L5-20R	ION Pump	1	3	25.0	80		Direct	Air Compressor
	1	1	1.9	20			Direct	VE Control Xformer							
	1	3	4.0	30			L21-30R	Turbo Backing							

End Station

Table 3-1: VE Power Required^a at Load Centers

Voltage	208Y/120V, 3φ							480Y/277V, 3φ						
	Location b	# C ^c	φ	KVA d	CB (A)	# R ^e	Recepticle (NEMA)	nominal use	# C	φ	KVA	CB (A)	# R	Recepticle ^f (NEMA)
VEAC-01	1	1	1.9	20		L5-20R	General/ION Pumps/ Aux. Turbo	1	3	13.3	20		Direct	Gate Valve
	1	1	2.9	30		L5-30R	Bakeout Control	1	3	13.3	20		Direct	Gate Valve
	1	3	2.0	20		L21-50R	Turbo Pump	1	3	20.0	30		Direct	Regen Heater
	1	3	2.0	20		L21-50R	Turbo Pump	1	3	39.9	60		L22-60R	Bakeout/Clean Room
	1	1	2.9	30		L5-30R	Bakeout Control	1	3	39.9	60		L22-60R	Bakeout/Clean Room
VEAC-03	1	1	1.9	20		Direct	VE Control Xformer							
VEAC-04	1	1	1.9	20		L5-20R	ION Pump	1	3	25	80		Direct	Air Compressor
	1	1	1.9	20		Direct	VE Control Xformer							
	1	3	4.0	30		L21-30R	Turbo Backing							

- a. All power to the VE is "facility power". Electronics racks used for CDS control of VE are provided with technical power and covered under the Detector-CC ICD.
- b. Locations are indicated in drawing PSI-V049-3-124, V049-3-305 and V049-3-505 where in this case, C= corner station, CC = Civil Construction, PD = Power Distribution, VEAC_n = n'th Vacuum Equipment AC location.
- c. Number of separate circuits and circuit breaker.
- d. Maximum continuous KVA per circuit.
- e. Number per receptacles (duplex receptacles for single phase locations).
- f. TBR Recepticles (TBD-VE)

PROCESS SYSTEMS INTERNATIONAL, INC. WESTBOROUGH, MA					ENGINEERING CALCULATIONS	NO: V049-1-010 PAGE 1 OF 2
REV.	DEO #	DATE	BY:	CHECK	TITLE: Cooling Water System Heat Loads	
1	0135	9/23/96	SM	D.h.W		
PROJECT: LIGO					BY: S.Motew	DEPT.:
PROJECT NO: V59049						
<u>PURPOSE: Summary of cooling water requirements for LIGO project.</u>						
<u>METHOD: Table</u>						
<u>ASSUMPTIONS: Cooling water available pressure= 65.psig (5.5bar), temperature = 68.F(20C)</u>						
<u>INPUTS: Vacuum pump and clean air compressor requirements.</u>						
<u>REFERENCES: Edwards High Vacuum Inc.</u>						
<u>CALCULATIONS: NA</u>						
<u>CONCLUSIONS: See table</u>						
<u>NOTES: Table will be updated with final clean air system cooling water requirements.</u>						

PROJECT:LIGO

LIGOV4.WB1
DATE:11/10/95 REV 1, 4/23/96

COOLING WATER SYSTEM HEAT LOADS

	INSTALLED		Q REJECTED		COOLING WATER		NO.	TOTAL C.WATER	
	KW	BTU/HR	KW	BTU/HR.	GPM	LPM		GPM	LPM
WA-CORNER:									
ROUGHING PUMP CART	22.5	76793	11.3	38396	3.8	14.5	2	7.7	29.1
MAIN TURBO CART	6.0	20478	3.6	12287	2.0	7.6	2	4.0	15.1
AUX.TURBO	0.8	2730	0.0	0	0.0	0.0	2	0.0	0.0
PURGE COMPRESSOR	44.8	152766	40.3	137489	13.7	52.0	1	13.7	52.0
	74.1	252767	55.1	188172	19.6	74.1		25.4	96.2
WA-MID									
MAIN TURBO CART	6.0	20478	3.6	12287	2.0	7.6	2	4.0	15.1
AUX.TURBO	0.8	2730	0.0	0	0.0	0.0	1	0.0	0.0
PURGE COMPRESSOR									
				12287	2.0	7.6		4.0	15.1
WA-END									
MAIN TURBO CART	6.0	20478	3.6	12287	2.0	7.6	2	4.0	15.1
AUX.TURBO	0.8	2730	0.0	0	0.0	0.0	1	0.0	0.0
PURGE COMPRESSOR									
				12287	2.0	7.6		4.0	15.1
LA-CORNER									
ROUGHING PUMP CART	22.5	76793	11.3	38396	3.8	14.5	2	7.7	29.1
MAIN TURBO CART	6.0	20478	3.6	12287	2.0	7.6	2	4.0	15.1
AUX.TURBO	0.8	2730	0.0	0	0.0	0.0	2	0.0	0.0
PURGE COMPRESSOR	44.8	152766	40.3	137489	13.7	52.0	1	13.7	52.0
	74.1	252767	55.1	188172	19.6	74.1		25.4	96.2
LA-END									
MAIN TURBO CART	6.0	20478	3.6	12287	2.0	7.6	2	4.0	15.1
AUX.TURBO	0.8	2730	0.0	0	0.0	0.0	1	0.0	0.0
PURGE COMPRESSOR									
				12287	2.0	7.6		4.0	15.1

LIGO Vacuum Equipment Instrument Air Requirements

Preliminary Instrument Air Requirements D. A. McWilliams
 Reference: P&ID V049-0-001 Rev 0 Feb 1, 1996

Supply Pressure: 80 to 120 psig
 Dewpoint - 60 C

Air Consumption (SCFM)
 Continuous Intermittent Peak
 (5 minute
 duration)

Corner Stations

WA	LA			
80 K Pumps				
WCP1	LCP1	1.5		
WCP2	LCP2	1.5		
Gate Valves				
WGV5	LGV3		0.6	
WGV6	LGV4		0.6	
WGV7	LGV5		0.6	
WGV8	LGV6		0.6	
Roughing Carts				
WRC1	LRC1	0.7	0.6	
WRC2	LRC2	0.7	0.6	
Turbo Carts				
WTC1	LTC1	0.7	0.6	
WTC2	LTC2	0.7	0.6	
Station Total		5.8	4.8	10.6

WA Midstations

80 K Pumps				
WCP3 or 5		1.5		
WCP4 or 6		1.5		
Turbo Carts				
WTC3 or 4		0.7	0.6	
Station Total		3.7	0.6	4.3

End Stations

WA	LA			
80 K Pumps				
WCP7 or 8	LCP3 or 4	1.5		
Turbo Carts		1.5		
WTC5 or 6	LTC3 or 4	0.7	0.6	
Station Total		3.7	0.6	4.3

PROCESS SYSTEMS INTERNATIONAL, INC.					ENGINEERING	NO: V049-1-034
WESTBOROUGH, MA					CALCULATIONS	PAGE 1 OF 15
REV	DEO#	DATE	BY:	CHECK	TITLE:	
0	0042	01/05/96	R. Than	DMW	COOLING WATER LINES SIZING	
1	0126	04/12/96	R.Than	DMW	CORNER STATION	
					END / MID STATION	
					BY: R. THAN	DEPT: 744
PROJECT: LIGO					PROJECT NO: V59049	

PURPOSE:

Determine cooling water lines / header sizes requirements

METHOD:

Turbulent flow: Cole brook formula, "Moody chart"

Laminar flow: Hagen-Poiseuille Flow

ASSUMPTIONS:

INPUTS: Budget 35 psi drop for equipment

Main flow from the cooling water system is provided in the mechanical room

Flow is distributed from the mechanical room to the interferometer room

REFERENCE:

CALCULATIONS:

see Attachments

CONCLUSIONS:

Corner stations: 3" Tube size Main supply into mechanical room, 1" or 1½" Tube header in Interferometer room. A 65 psid head is required from the cooling water system at the mechanical room battery limits

End / Mid stations: 1½" Tube size Main supply into mechanical room, 0.5" Tube header in Interferometer room.. A 65 psid head is required from the cooling water system at the mechanical room battery limits

NOTES:

CORNER STATION

TUBE SIZE	Flowrate GPM	Flowrate kg/s	ΔP Budget psid	ΔP Budget kPa	Header Velocity ft/s	Header Velocity m/s
3" Tube Mechanical Room Main Supply	50	3.12				
1" Tube Interferometer Room	8	0.50	17	117	3.2	0.98
Equipment Budget			35	69		
Margin			13	90		
Required from LIGO			65	276		

END/ MID STATIONS

TUBE SIZE	Flowrate GPM	Flowrate kg/s	ΔP Budget psi	ΔP Budget kPa	Header Velocity ft/s	Header Velocity m/s
1½" Tube Mechanical Room Main Supply	15	0.94				
½" Tube Interferometer Room	1.3	0.08	7	76	1.75	0.53
Equipment Budget			35	69		
Margin			23	158		
Required from LIGO			65	276		

COOLING WATER LINES					
CORNER STATION					
	Qty'	Each	Total		
<i>Mechanical Room</i>		L/min	L/min	GPM	kg/s
EDP200 Roughing cart	2	10	20	5.33	0.33
QDP80 Main Turbo backing Pump	2	6	12	3.20	0.20
Purge Compressor	1	70	70	18.67	1.17
			102	27.20	1.70
<i>Design</i>			128	34.00	2.13
<i>Interferometer Room</i>					
EH2600 Roughing Blower	2	6	12	3.20	0.20
STPH2000 Main Turbo	2	3	6	1.60	0.10
Aux Turbo cart	2	1	2	0.53	0.03
			20	5.33	0.33
<i>Design</i>			25	6.67	0.42
STATION TOTAL			153	40.67	2.54
END/MID STATION					
	Qty'	Each	Total		
<i>Mechanical Room</i>		L/min	L/min	GPM	kg/s
QDP80 Main Turbo backing Pump	1	6	6	1.60	0.10
Purge Compressor	1	35	35	9.33	0.58
			41	10.93	0.68
<i>Design</i>			51	13.67	0.85
<i>Interferometer Room</i>					
STPH2000 Main Turbo	1	3	3	0.80	0.05
Aux Turbo cart	1	1	1	0.27	0.02
			4	1.07	0.07
<i>Design</i>			5	1.33	0.08
STATION TOTAL			56	15.00	0.94

PROJECT: LIGO R.THAN
PROJECT NO: V59049 4/12/96
TITLE: COOLING WATER LINES SIZING

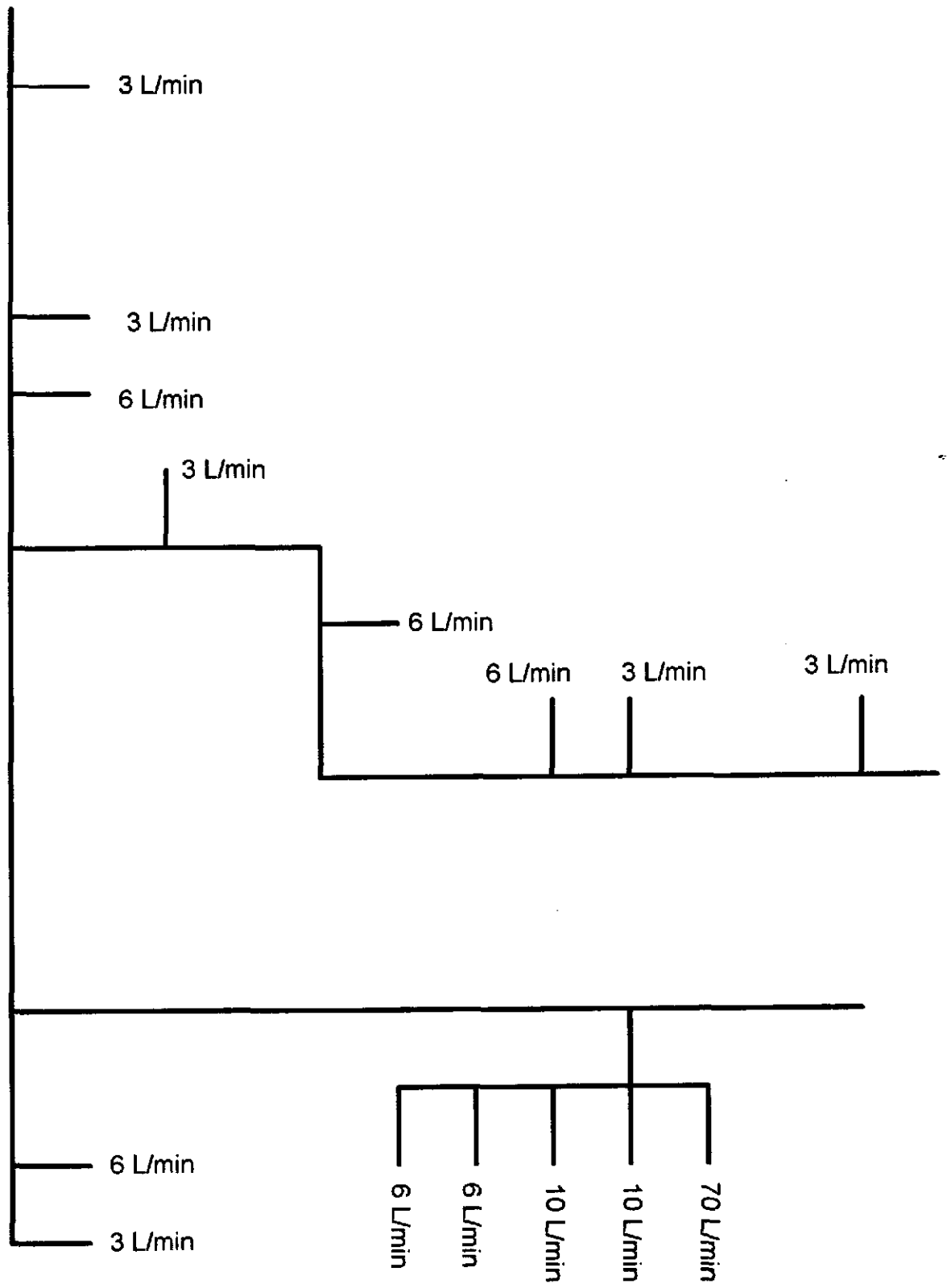

PROCESS SYSTEMS INTERNATIONAL, INC 20 Walkup Drive, Westborough, MA 01581

PROJECT: LIGO BY: R. THAN
 PROJECT NO:V59049 DATE: 4/12/**
 TITLE: COOLING WATER LINES SIZING COPPER TYPE L PAGE: 1 OF

PRESSURE DROP ROUTE OR LINE ID:COOLING WATER LINES CORNER STATION VACUUM EQUIPMENT ROOM

PRESSURE: 72.5 PSIA 57.810 PSIG
 TEMPERATURE: 518.400 R 58.400 F
 DENSITY : 62.390 LBS/FT³ 0.624E+02 LBS/FT³
 QUALITY : 1.000

ITEMNAME	FLOWRATE Lbs/S	I.D. in	K / DO	CV	LENGTH FT	PRESSURE PSI	Z1 FT	Z2 FT	DP-F PSI	DP-Z PSI	DP-T PSI	DP-SUM PSI	DENSITY Lbs/ft ³	VELOCITY ft/s	RE NO
1.5" TUBE LENGTH	0.110E+01	1.5000			262.40	71.64	0.00	0.00	0.86	0.00	0.86	0.86	0.624E+02	1.439	0.168E+05
1.5" ELBOW LR-90	0.110E+01	1.5000	1.0000			71.622	0.00	0.00	0.01	0.00	0.01	0.88	0.624E+02		
1.5" ELBOW LR-90	0.110E+01	1.5000	1.0000			71.608	0.00	0.00	0.01	0.00	0.01	0.89	0.624E+02		
1.5" ELBOW LR-90	0.110E+01	1.5000	1.0000			71.594	0.00	0.00	0.01	0.00	0.01	0.91	0.624E+02		
1.5" ELBOW LR-90	0.110E+01	1.5000	1.0000			71.580	0.00	0.00	0.01	0.00	0.01	0.92	0.624E+02		
1.5" ELBOW LR-90	0.110E+01	1.5000	1.0000			71.566	0.00	0.00	0.01	0.00	0.01	0.93	0.624E+02		
1/2" TUBE	0.275E+00	0.5450			32.80	70.30	0.00	0.00	1.27	0.00	1.27	2.20	0.624E+02	2.726	0.115E+05
1/2" ELBOW LR-90	0.275E+00	0.5450	3.0000			70.148	0.00	0.00	0.15	0.00	0.15	2.35	0.624E+02		
EQUIPMENT DP	0.275E+00	0.5450				35.145	0.00	0.00	35.00	0.00	35.00	37.35	0.624E+02		
1/2" ELBOW LR-90	0.275E+00	0.5450	3.0000			34.995	0.00	0.00	0.15	0.00	0.15	37.50	0.624E+02		
1/2" TUBE .035WT	0.275E+00	0.5450			32.80	33.73	0.00	0.00	1.27	0.00	1.27	38.77	0.624E+02	2.726	0.115E+05
1.5" ELBOW LR-90	0.110E+01	1.5000	1.0000			33.714	0.00	0.00	0.01	0.00	0.01	38.79	0.624E+02		
1.5" ELBOW LR-90	0.110E+01	1.5000	1.0000			33.700	0.00	0.00	0.01	0.00	0.01	38.80	0.624E+02		
1.5" ELBOW LR-90	0.110E+01	1.5000	1.0000			33.686	0.00	0.00	0.01	0.00	0.01	38.81	0.624E+02		
1.5" ELBOW LR-90	0.110E+01	1.5000	1.0000			33.672	0.00	0.00	0.01	0.00	0.01	38.83	0.624E+02		
1.5" ELBOW LR-90	0.110E+01	1.5000	1.0000			33.658	0.00	0.00	0.01	0.00	0.01	38.84	0.624E+02		
1.5" TUBE LENGTH	0.110E+01	1.5000			262.40	32.79	0.00	0.00	0.86	0.00	0.86	39.71	0.624E+02	1.439	0.168E+05
TOTAL									39.7061	0.0000		39.7061			

REVISION: 1
 DOC NO: V049-1-034
 PAGE: 5 OF 15

PROCESS SYSTEMS INTERNATIONAL, INC 20 Walkup Drive, Westborough, MA 01581

PROJECT: LIGO BY: R. THAN
 PROJECT NO:V59049 DATE: 4/12/**
 TITLE: COOLING WATER LINES SIZING COPPER TYPE L PAGE: 1 OF

PRESSURE DROP ROUTE OR LINE ID:COOLING WATER LINES CORNER STATION VACUUM EQUIPMENT ROOM

PRESSURE: 72.5 PSIA 57.810 PSIG
 TEMPERATURE: 518.400 R 58.400 F
 DENSITY : 62.390 LBS/FT^3 0.624E+02 LBS/FT^3
 QUALITY : 1.000

ITEMNAME	FLOWRATE Lbs/S	I.D. in	K / DO	CV	LENGTH FT	PRESSURE PSI	Z1 FT	Z2 FT	DP-F PSI	DP-Z PSI	DP-T PSI	DP-SUM PSI	DENSITY Lbs/ft^3	VELOCITY ft/S	RE NO
1" TUBE LENGTH	0.110E+01	1.0000			262.40	66.11	0.00	0.00	6.39	0.00	6.39	6.39	0.624E+02	3.239	0.252E+05
1" ELBOW LR-90	0.110E+01	1.0000	1.0000			66.041	0.00	0.00	0.07	0.00	0.07	6.46	0.624E+02		
1" ELBOW LR-90	0.110E+01	1.0000	1.0000			65.970	0.00	0.00	0.07	0.00	0.07	6.53	0.624E+02		
1" ELBOW LR-90	0.110E+01	1.0000	1.0000			65.899	0.00	0.00	0.07	0.00	0.07	6.60	0.624E+02		
1" ELBOW LR-90	0.110E+01	1.0000	1.0000			65.829	0.00	0.00	0.07	0.00	0.07	6.67	0.624E+02		
1" ELBOW LR-90	0.110E+01	1.0000	1.0000			65.758	0.00	0.00	0.07	0.00	0.07	6.74	0.624E+02		
1/2" TUBE .035WT	0.275E+00	0.5450			32.80	64.49	0.00	0.00	1.27	0.00	1.27	8.01	0.624E+02	2.726	0.115E+05
1/2" ELBOW LR-90	0.275E+00	0.5450	3.0000			64.340	0.00	0.00	0.15	0.00	0.15	8.16	0.624E+02		
EQUIPMENT DP	0.275E+00	0.5450				29.337	0.00	0.00	35.00	0.00	35.00	43.16	0.624E+02		
1/2" ELBOW LR-90	0.275E+00	0.5450	3.0000			29.187	0.00	0.00	0.15	0.00	0.15	43.31	0.624E+02		
1/2" TUBE .035WT	0.275E+00	0.5450			32.80	27.92	0.00	0.00	1.27	0.00	1.27	44.58	0.624E+02	2.726	0.115E+05
1" ELBOW LR-90	0.110E+01	1.0000	1.0000			27.849	0.00	0.00	0.07	0.00	0.07	44.65	0.624E+02		
1" ELBOW LR-90	0.110E+01	1.0000	1.0000			27.778	0.00	0.00	0.07	0.00	0.07	44.72	0.624E+02		
1" ELBOW LR-90	0.110E+01	1.0000	1.0000			27.708	0.00	0.00	0.07	0.00	0.07	44.79	0.624E+02		
1" ELBOW LR-90	0.110E+01	1.0000	1.0000			27.637	0.00	0.00	0.07	0.00	0.07	44.86	0.624E+02		
1" ELBOW LR-90	0.110E+01	1.0000	1.0000			27.566	0.00	0.00	0.07	0.00	0.07	44.93	0.624E+02		
1" TUBE LENGTH	0.110E+01	1.0000			262.40	21.18	0.00	0.00	6.39	0.00	6.39	51.32	0.624E+02	3.239	0.252E+05
TOTAL									51.3223	0.0000		51.3223			

REVISION: 1
 DOC NO: V049-1-034
 PAGE: 6 OF 15

PROCESS SYSTEMS INTERNATIONAL, INC 20 Walkup Drive, Westborough, MA 01581

PROJECT: LIGO
 PROJECT NO:V59049
 TITLE: COOLING WATER LINES SIZING

BY: R. THAN
 DATE: 4/12/**
 PAGE: 1 OF

PRESSURE DROP ROUTE OR LINE ID:COOLING WATER LINES CORNER STATION CLEAN AIR COMPRESSOR

PRESSURE: 72.5 PSIA 57.810 PSIG
 TEMPERATURE: 518.400 R 58.400 F
 DENSITY : 62.390 LBS/FT³ 0.624E+02 LBS/FT³
 QUALITY : 1.000

ITEMNAME	FLOWRATE Lbs/S	I.D. in	K / DO	CV	LENGTH FT	PRESSURE PSI	Z1 FT	Z2 FT	DP-F PSI	DP-Z PSI	DP-T PSI	DP-SUM PSI	DENSITY Lbs/ft ³	VELOCITY ft/S	RE NO
1.5" TUBE LENGTH	0.264E+01	1.5000			65.60	71.42	0.00	0.00	1.08	0.00	1.08	1.08	0.624E+02	3.454	0.402E+05
1.5" ELBOW LR-90	0.264E+01	1.5000	1.0000			71.342	0.00	0.00	0.08	0.00	0.08	1.16	0.624E+02		
1.5" ELBOW LR-90	0.264E+01	1.5000	1.0000			71.261	0.00	0.00	0.08	0.00	0.08	1.24	0.624E+02		
1.5" ELBOW LR-90	0.264E+01	1.5000	1.0000			71.181	0.00	0.00	0.08	0.00	0.08	1.32	0.624E+02		
1.5" ELBOW LR-90	0.264E+01	1.5000	1.0000			71.101	0.00	0.00	0.08	0.00	0.08	1.40	0.624E+02		
1.5" ELBOW LR-90	0.264E+01	1.5000	1.0000			71.020	0.00	0.00	0.08	0.00	0.08	1.48	0.624E+02		
1.5" ELBOW LR-90	0.264E+01	1.5000	1.0000			70.940	0.00	0.00	0.08	0.00	0.08	1.56	0.624E+02		
TOTAL									1.5601	0.0000		1.5601			

REVISION: #
 DOC NO: V049-1-034
 PAGE: 7 OF 15

PROCESS SYSTEMS INTERNATIONAL, INC 20 Walkup Drive, Westborough, MA 01581

PROJECT: LIGO
 PROJECT NO:V59049
 TITLE: COOLING WATER LINES SIZING

BY: R. THAN
 DATE: 4/12/**
 PAGE: 1 OF

PRESSURE DROP ROUTE OR LINE ID:COOLING WATER LINES CORNER STATION CLEAN AIR COMPRESSOR

PRESSURE: 72.5 PSIA 57.810 PSIG
 TEMPERATURE: 518.400 R 58.400 F
 DENSITY : 62.390 LBS/FT³ 0.624E+02 LBS/FT³
 QUALITY : 1.000

ITEMNAME	FLOWRATE Lbs/S	I.D. in	K / DO	CV	LENGTH FT	PRESSURE PSI	Z1 FT	Z2 FT	DP-F PSI	DP-Z PSI	DP-T PSI	DP-SUM PSI	DENSITY Lbs/ft ³	VELOCITY ft/S	RE NO
1" TUBE LENGTH	0.264E+01	1.0000			65.60	64.18	0.00	0.00	8.32	0.00	8.32	8.32	0.624E+02	7.773	0.604E+05
1" ELBOW LR-90	0.264E+01	1.0000	1.0000			63.772	0.00	0.00	0.41	0.00	0.41	8.73	0.624E+02		
1" ELBOW LR-90	0.264E+01	1.0000	1.0000			63.365	0.00	0.00	0.41	0.00	0.41	9.13	0.624E+02		
1" ELBOW LR-90	0.264E+01	1.0000	1.0000			62.958	0.00	0.00	0.41	0.00	0.41	9.54	0.624E+02		
1" ELBOW LR-90	0.264E+01	1.0000	1.0000			62.551	0.00	0.00	0.41	0.00	0.41	9.95	0.624E+02		
1" ELBOW LR-90	0.264E+01	1.0000	1.0000			62.145	0.00	0.00	0.41	0.00	0.41	10.36	0.624E+02		
1" ELBOW LR-90	0.264E+01	1.0000	1.0000			61.738	0.00	0.00	0.41	0.00	0.41	10.76	0.624E+02		
									TOTAL	10.7623	0.0000	10.7623			

REVISION: 1
 DOC NO: V049-1-034
 PAGE: 8 OF 15

PROCESS SYSTEMS INTERNATIONAL, INC 20 Walkup Drive, Westborough, MA 01581

PROJECT: LIGO BY: R. THAN
PROJECT NO:V59049 DATE: 4/12/**
TITLE: COOLING WATER LINES SIZING PAGE: 1 OF

PRESSURE DROP ROUTE OR LINE ID:COOLING WATER LINES CORNER STATION MECHANICAL ROOM MAIN

PRESSURE: 72.5 PSIA 57.810 PSIG
TEMPERATURE: 518.400 R 58.400 F
DENSITY : 62.390 LBS/FT³ 0.624E+02 LBS/FT³
QUALITY : 1.000

ITEMNAME	FLOWRATE Lbs/S	I.D. in	K / DO	CV	LENGTH FT	PRESSURE PSI	Z1 FT	Z2 FT	DP-F PSI	DP-Z PSI	DP-T PSI	DP-SUM PSI	DENSITY Lbs/ft ³	VELOCITY ft/S	RE NO
3" TUBE LENGTH	0.559E+01	3.0000			656.00	71.10	0.00	0.00	1.40	0.00	1.40	1.40	0.624E+02	1.828	0.426E+05
									TOTAL	1.3968	0.0000	1.3968			

REVISION: *A*
DOC NO: V049-1-034
PAGE: *9* OF *15*

PROJECT: LIGO R.THAN
PROJECT NO: V59049 4/12/96
TITLE: COOLING WATER LINES SIZING

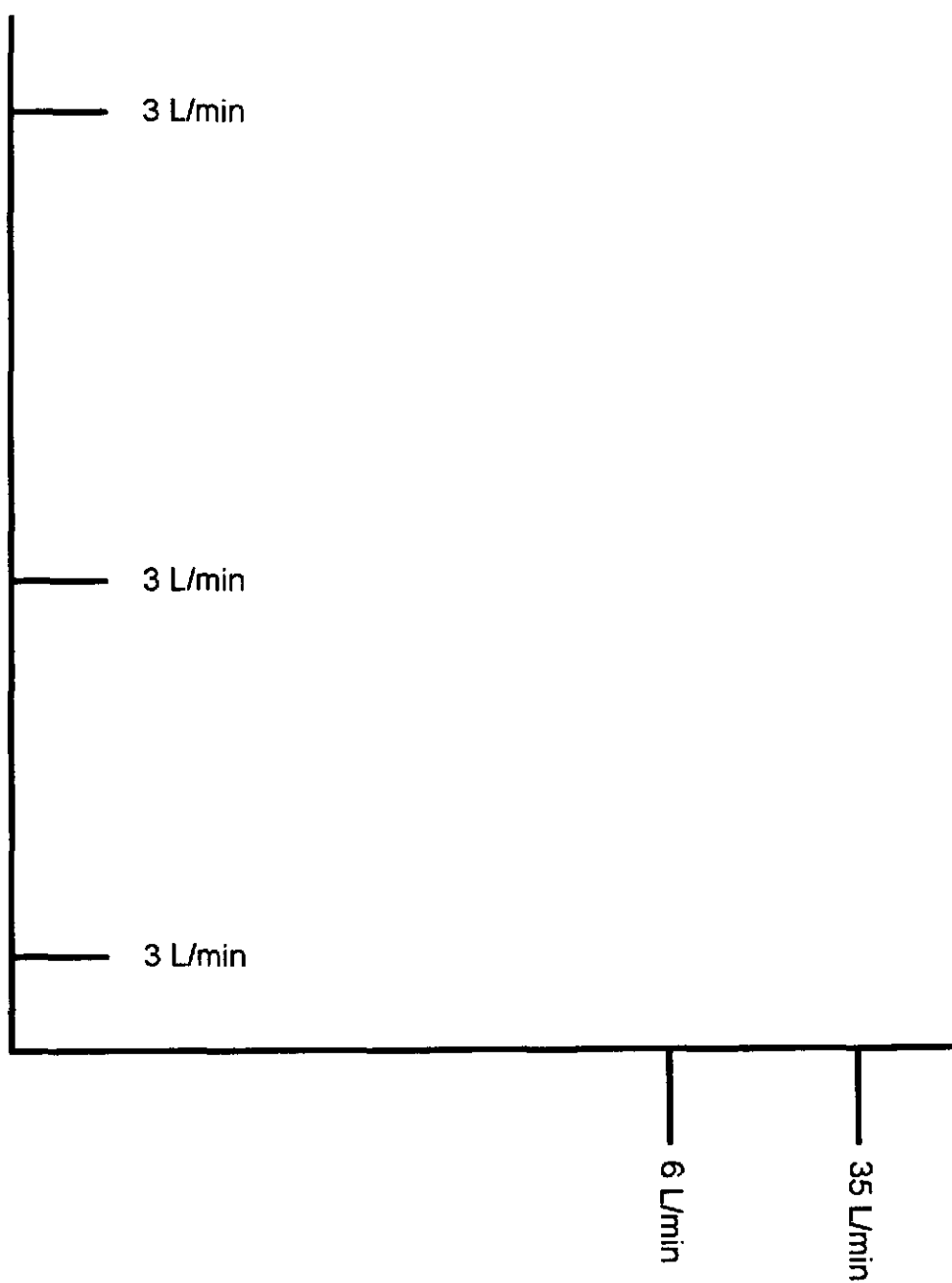

Revision: 1
Doc no: V049-1-034
Page 10 of 15

PROCESS SYSTEMS INTERNATIONAL, INC 20 Walkup Drive, Westborough, MA 01581

PROJECT: LIGO BY: R. THAN
 PROJECT NO:V59049 DATE: 4/12/**
 TITLE: COOLING WATER LINES SIZING COPPER TYPE L PAGE: 1 OF

PRESSURE DROP ROUTE OR LINE ID:COOLING WATER LINES END/MID STATION

PRESSURE: 72.5 PSIA 57.810 PSIG
 TEMPERATURE: 518.400 R 58.400 F
 DENSITY : 62.390 LBS/FT³ 0.624E+02 LBS/FT³
 QUALITY : 1.000

ITEMNAME	FLOWRATE Lbs/S	I.D. in	K / DO	CV	LENGTH FT	PRESSURE PSI	Z1 FT	Z2 FT	DP-F PSI	DP-Z PSI	DP-T PSI	DP-SUM PSI	DENSITY Lbs/ft ³	VELOCITY ft/S	RE NO
1/2" TUBE LENGTH	0.220E+00	0.5450			164.00	68.29	0.00	0.00	4.21	0.00	4.21	4.21	0.624E+02	2.181	0.923E+04
1/2" ELBOW LR-90	0.220E+00	0.5450	3.0000			68.190	0.00	0.00	0.10	0.00	0.10	4.31	0.624E+02		
1/2" ELBOW LR-90	0.220E+00	0.5450	3.0000			68.094	0.00	0.00	0.10	0.00	0.10	4.41	0.624E+02		
1/2" ELBOW LR-90	0.220E+00	0.5450	3.0000			67.998	0.00	0.00	0.10	0.00	0.10	4.50	0.624E+02		
1/2" ELBOW LR-90	0.220E+00	0.5450	3.0000			67.902	0.00	0.00	0.10	0.00	0.10	4.60	0.624E+02		
1/2" ELBOW LR-90	0.220E+00	0.5450	3.0000			67.806	0.00	0.00	0.10	0.00	0.10	4.69	0.624E+02		
1/2" TUBE .035WT	0.220E+00	0.5450			16.40	67.38	0.00	0.00	0.42	0.00	0.42	5.12	0.624E+02	2.181	0.923E+04
1/2" ELBOW LR-90	0.220E+00	0.5450	3.0000			67.288	0.00	0.00	0.10	0.00	0.10	5.21	0.624E+02		
EQUIPMENT DP	0.220E+00	0.5450				32.285	0.00	0.00	35.00	0.00	35.00	40.21	0.624E+02		
1/2" ELBOW LR-90	0.220E+00	0.5450	3.0000			32.189	0.00	0.00	0.10	0.00	0.10	40.31	0.624E+02		
1/2" TUBE .035WT	0.220E+00	0.5450			16.40	31.77	0.00	0.00	0.42	0.00	0.42	40.73	0.624E+02	2.181	0.923E+04
1/2" ELBOW LR-90	0.220E+00	0.5450	3.0000			31.672	0.00	0.00	0.10	0.00	0.10	40.83	0.624E+02		
1/2" ELBOW LR-90	0.220E+00	0.5450	3.0000			31.576	0.00	0.00	0.10	0.00	0.10	40.92	0.624E+02		
1/2" ELBOW LR-90	0.220E+00	0.5450	3.0000			31.480	0.00	0.00	0.10	0.00	0.10	41.02	0.624E+02		
1/2" ELBOW LR-90	0.220E+00	0.5450	3.0000			31.383	0.00	0.00	0.10	0.00	0.10	41.12	0.624E+02		
1/2" ELBOW LR-90	0.220E+00	0.5450	3.0000			31.287	0.00	0.00	0.10	0.00	0.10	41.21	0.624E+02		
1/2" TUBE LENGTH	0.220E+00	0.5450			164.00	27.07	0.00	0.00	4.21	0.00	4.21	45.43	0.624E+02	2.181	0.923E+04
TOTAL									45.4265	0.0000		45.4265			

Rev: 1
 Doc No: V049-1-034
 Page 11 of 15

PROCESS SYSTEMS INTERNATIONAL, INC 20 Walkup Drive, Westborough, MA 01581

PROJECT: LIGO BY: R. THAN
 PROJECT NO: V59049 DATE: 4/12/**
 TITLE: COOLING WATER LINES SIZING COPPER TYPE L PAGE: 1 OF

PRESSURE DROP ROUTE OR LINE ID: COOLING WATER LINES END/MID STATION

PRESSURE: 72.5 PSIA 57.810 PSIG
 TEMPERATURE: 518.400 R 58.400 F
 DENSITY : 62.390 LBS/FT³ 0.624E+02 LBS/FT³
 QUALITY : 1.000

ITEMNAME	FLOWRATE Lbs/S	I.D. in	K / DO	CV	LENGTH FT	PRESSURE PSI	Z1 FT	Z2 FT	DP-F PSI	DP-Z PSI	DP-T PSI	DP-SUM PSI	DENSITY Lbs/ft ³	VELOCITY ft/S	RE NO
1/2" TUBE LENGTH	0.176E+00	0.5450			164.00	69.69	0.00	0.00	2.81	0.00	2.81	2.81	0.624E+02	1.745	0.739E+04
1/2" ELBOW LR-90	0.176E+00	0.5450	3.0000			69.626	0.00	0.00	0.06	0.00	0.06	2.87	0.624E+02		
1/2" ELBOW LR-90	0.176E+00	0.5450	3.0000			69.565	0.00	0.00	0.06	0.00	0.06	2.94	0.624E+02		
1/2" ELBOW LR-90	0.176E+00	0.5450	3.0000			69.503	0.00	0.00	0.06	0.00	0.06	3.00	0.624E+02		
1/2" ELBOW LR-90	0.176E+00	0.5450	3.0000			69.442	0.00	0.00	0.06	0.00	0.06	3.06	0.624E+02		
1/2" ELBOW LR-90	0.176E+00	0.5450	3.0000			69.380	0.00	0.00	0.06	0.00	0.06	3.12	0.624E+02		
1/2" TUBE .035WT	0.110E+00	0.5450			16.40	69.26	0.00	0.00	0.12	0.00	0.12	3.24	0.624E+02	1.090	0.462E+04
1/2" ELBOW LR-90	0.110E+00	0.5450	3.0000			69.235	0.00	0.00	0.02	0.00	0.02	3.27	0.624E+02		
EQUIPMENT DP	0.110E+00	0.5450				34.232	0.00	0.00	35.00	0.00	35.00	38.27	0.624E+02		
1/2" ELBOW LR-90	0.110E+00	0.5450	3.0000			34.208	0.00	0.00	0.02	0.00	0.02	38.29	0.624E+02		
1/2" TUBE .035WT	0.110E+00	0.5450			16.40	34.09	0.00	0.00	0.12	0.00	0.12	38.41	0.624E+02	1.090	0.462E+04
1/2" ELBOW LR-90	0.176E+00	0.5450	3.0000			34.025	0.00	0.00	0.06	0.00	0.06	38.47	0.624E+02		
1/2" ELBOW LR-90	0.176E+00	0.5450	3.0000			33.964	0.00	0.00	0.06	0.00	0.06	38.54	0.624E+02		
1/2" ELBOW LR-90	0.176E+00	0.5450	3.0000			33.902	0.00	0.00	0.06	0.00	0.06	38.60	0.624E+02		
1/2" ELBOW LR-90	0.176E+00	0.5450	3.0000			33.841	0.00	0.00	0.06	0.00	0.06	38.66	0.624E+02		
1/2" ELBOW LR-90	0.176E+00	0.5450	3.0000			33.779	0.00	0.00	0.06	0.00	0.06	38.72	0.624E+02		
1/2" TUBE LENGTH	0.176E+00	0.5450			164.00	30.97	0.00	0.00	2.81	0.00	2.81	41.53	0.624E+02	1.745	0.739E+04
TOTAL									41.5330	0.0000					

Rev: 1
 Doc # V049-1-034
 Page 12 of 15

PROCESS SYSTEMS INTERNATIONAL, INC 20 Walkup Drive, Westborough, MA 01581

PROJECT: LIGO BY: R. THAN
 PROJECT NO: V59049 DATE: 4/12/**
 TITLE: COOLING WATER LINES SIZING COPPER TYPE L PAGE: 1 OF

PRESSURE DROP ROUTE OR LINE ID: COOLING WATER LINES END/MID STATION

PRESSURE: 72.5 PSIA 57.810 PSIG
 TEMPERATURE: 518.400 R 58.400 F
 DENSITY : 62.390 LBS/FT^3 0.624E+02 LBS/FT^3
 QUALITY : 1.000

ITEMNAME	FLOWRATE Lbs/S	I.D. in	K / DO	CV	LENGTH FT	PRESSURE PSI	Z1 FT	Z2 FT	DP-F PSI	DP-Z PSI	DP-T PSI	DP-SUM PSI	DENSITY Lbs/ft^3	VELOCITY ft/s	RE NO
3/4" TUBE LENGTH	0.176E+00	0.7800			164.00	72.01	0.00	0.00	0.49	0.00	0.49	0.49	0.624E+02	0.852	0.516E+04
3/4" ELBOW LR-90	0.176E+00	0.7800	3.0000			71.995	0.00	0.00	0.01	0.00	0.01	0.51	0.624E+02		
3/4" ELBOW LR-90	0.176E+00	0.7800	3.0000			71.980	0.00	0.00	0.01	0.00	0.01	0.52	0.624E+02		
3/4" ELBOW LR-90	0.176E+00	0.7800	3.0000			71.965	0.00	0.00	0.01	0.00	0.01	0.53	0.624E+02		
3/4" ELBOW LR-90	0.176E+00	0.7800	3.0000			71.951	0.00	0.00	0.01	0.00	0.01	0.55	0.624E+02		
3/4" ELBOW LR-90	0.176E+00	0.7800	3.0000			71.936	0.00	0.00	0.01	0.00	0.01	0.56	0.624E+02		
1/2" TUBE .035WT	0.110E+00	0.5450			16.40	71.81	0.00	0.00	0.12	0.00	0.12	0.69	0.624E+02	1.090	0.462E+04
1/2" ELBOW LR-90	0.110E+00	0.5450	3.0000			71.790	0.00	0.00	0.02	0.00	0.02	0.71	0.624E+02		
EQUIPMENT DP	0.110E+00	0.5450				36.787	0.00	0.00	35.00	0.00	35.00	35.71	0.624E+02		
1/2" ELBOW LR-90	0.110E+00	0.5450	3.0000			36.763	0.00	0.00	0.02	0.00	0.02	35.74	0.624E+02		
1/2" TUBE .035WT	0.110E+00	0.5450			16.40	36.64	0.00	0.00	0.12	0.00	0.12	35.86	0.624E+02	1.090	0.462E+04
3/4" ELBOW LR-90	0.176E+00	0.7800	3.0000			36.627	0.00	0.00	0.01	0.00	0.01	35.87	0.624E+02		
3/4" ELBOW LR-90	0.176E+00	0.7800	3.0000			36.613	0.00	0.00	0.01	0.00	0.01	35.89	0.624E+02		
3/4" ELBOW LR-90	0.176E+00	0.7800	3.0000			36.598	0.00	0.00	0.01	0.00	0.01	35.90	0.624E+02		
3/4" ELBOW LR-90	0.176E+00	0.7800	3.0000			36.583	0.00	0.00	0.01	0.00	0.01	35.92	0.624E+02		
3/4" ELBOW LR-90	0.176E+00	0.7800	3.0000			36.569	0.00	0.00	0.01	0.00	0.01	35.93	0.624E+02		
3/4" TUBE LENGTH	0.176E+00	0.7800			164.00	36.08	0.00	0.00	0.49	0.00	0.49	36.42	0.624E+02	0.852	0.516E+04
TOTAL									36.4221	0.0000		36.4221			

Rev: 1
 Doc V049-1-034
 Page 13 of 15

PROCESS SYSTEMS INTERNATIONAL, INC 20 Walkup Drive, Westborough, MA 01581

PROJECT: LIGO
PROJECT NO:V59049
TITLE: COOLING WATER LINES SIZING COPPER TYPE L

BY: R. THAN
DATE: 4/12/88
PAGE: 1 OF

PRESSURE DROP ROUTE OR LINE ID:COOLING WATER LINES END/MID STATION

CLEAN AIR.
COMPRESSOR

PRESSURE: 72.5 PSIA 57.810 PSIG
TEMPERATURE: 518.400 R 58.400 F
DENSITY : 62.390 LBS/FT³ 0.624E+02 LBS/FT³
QUALITY : 1.000

ITEMNAME	FLOWRATE Lbs/S	I.D. in	K / DO	CV	LENGTH FT	PRESSURE PSI	Z1 FT	Z2 FT	DP-F PSI	DP-Z PSI	DP-T PSI	DP-SUM PSI	DENSITY Lbs/ft ³	VELOCITY ft/S	RE NO
1" TUBE LENGTH	0.132E+01	1.0000			65.60	70.26	0.00	0.00	2.24	0.00	2.24	2.24	0.624E+02	3.886	0.302E+05
									TOTAL	2.2430	0.0000	2.2430			

Rev:1
Doc V049-1-034
Page 14 of 15



Copper Water Tube/engineering data

Nom- inal Tube Size in inches	Out- side Diam- eter in inches	TYPE "K"								TYPE "L"					
		Hard Drawn—20 Ft. Straight Lengths Soft Annealed—20 Ft. Straight Lengths or 40 Ft. and 60 Ft. Length Coils (to and including 1 1/4")								Hard Drawn—20 Ft. Straight Lengths Soft Annealed—20 Ft. Straight Lengths or 40 Ft. and 60 Ft. Length Coils (to and including 1 1/4")					
		Use: For Underground Service and General Plumbing and Heating Installations under Severe Conditions.								Use: For General Plumbing and Heating Installations.					
		TOLERANCE Tubing O. D. in inches		Nom. Wall Thick- ness in inches	Weight per Foot in Lbs.	HARD DRAWN		SOFT ANNEALED		Nom. Wall Thick- ness in inches	Weight per Foot in Lbs.	HARD DRAWN		SOFT ANNEALED	
Max.	Min.	Bursting Pressure in Lbs. *	Safe Working Stress in Lbs. Ⓢ			Bursting Pressure in Lbs. *	Safe Working Stress in Lbs. Ⓢ	Bursting Pressure in Lbs. *	Safe Working Stress in Lbs. Ⓢ			Bursting Pressure in Lbs. *	Safe Working Stress in Lbs. Ⓢ		
1/8"	.375	.376	.374	.035	.145	6720	1060	5600	930	.030	.126	5760	900	4800	800
1/4"	.500	.501	.499	.049	.288	7100	1170	5900	980	.035	.198	5000	800	4200	700
3/8"	.625	.628	.624	.048	.344	5800	920	4700	780	.040	.285	4800	740	3800	630
1/2"	.750	.751	.749	.048	.418	4700	760	3900	650	.042	.362	4000	650	3400	560
5/8"	.875	.878	.874	.065	.641	5300	880	4500	750	.045	.455	3700	590	3100	510
1"	1.125	1.1265	1.1235	.065	.838	4200	680	3500	580	.050	.655	3200	510	2700	450
1 1/8"	1.375	1.3765	1.3735	.065	1.04	3400	550	2800	465	.055	.884	2900	460	2400	400
1 1/4"	1.625	1.627	1.623	.072	1.36	3200	520	2700	450	.060	1.14	2700	430	2200	380
1 1/2"	1.875	1.877	1.873	.089	2.06	2800	450	2300	380	.070	1.75	2400	370	2000	330
2"	2.125	2.127	2.123	.095	2.92	2600	420	2200	360	.080	2.48	2220	350	1800	300
2 1/4"	2.625	2.627	2.623	.095	2.92	2600	420	2200	360	.080	2.48	2220	350	1800	300
3"	3.125	3.127	3.123	.109	4.00	2500	410	2100	350	.090	3.33	2100	330	1700	280
3 1/2"	3.625	3.627	3.623	.120	5.12	2400	380	2000	330	.100	4.29	2000	320	1700	280
4"	4.125	4.127	4.123	.134	6.51	2300	370	1900	320	.110	5.38	1900	300	1600	260
5"	5.125	5.127	5.123	.160	9.87	2200	360	1900	320	.125	7.61	1800	280	1500	250
6"	6.125	6.127	6.123	.192	13.87	2300	370	1900	320	.140	10.20	1600	260	1400	230
8"	8.125	8.127	8.121	.271	25.99	2400	390	2000	330	.200	19.29	1800	280	1500	250
10"	10.125	10.127	10.119	.338	40.3	2400	390	2000	330	.250	30.1	1800	290	1500	250
12"	12.125	12.127	12.119	.405	57.8	2400	400	2000	330	.280	40.4	1700	270	1400	230

Note: Information and data contained in these charts as taken from ASTM Specifications No. B-88, Federal Specification WW-T-799, and various Copper Tube Mill chart standards.

- Ⓢ From Cabra based on 150°F. with an allowable stress of 6000 P.S.I.
- * Bursting pressures are calculated from the following formula for thin, hollow cylinders under tension:

$$P = \frac{2tS}{D}$$

Where P = Bursting pressure, Lb. per Sq. In.
 t = Wall thickness, inches
 D = Outside tube diameter, inches
 S = Tensile strength (36,000 Lb. per Sq. In. for hard tubes and 30,000 for soft tubes)

- ☆ With safety factor of 8, maximum safe working pressure allowable by common usage up to 150°F. can be taken at 1/8 the above bursting pressure
- Rated internal pressure for copper water tube based on the strength of the tube alone and applicable to systems using suitable mechanical joints.

Rev. 1
 Doc # V049-1-03f
 Page 15 of 15

PROCESS SYSTEMS INTERNATIONAL, INC.					ENGINEERING	NO: V049-1-093
WESTBOROUGH, MA					CALCULATIONS	PAGE 1 OF 4
REV	DEO#	DATE	BY:	CHECK	TITLE:	
0	0126	04/12/96	R. Than	D. W. (u)	INSTRUMENT AIR LINES SIZING CORNER STATION	
					BY: R. THAN	DEPT: 744
PROJECT: LIGO					PROJECT NO: V59049	

PURPOSE:

Determine instrument air lines / header sizes requirements

METHOD:

Turbulent flow: Cole brook formula, "Moody chart"

Laminar flow: Hagen-Poiseuille Flow

ASSUMPTIONS: Line leng of 300 ft

INPUTS:

Corner station: Air 20 SCFM @ 70 psig

End/Mid station: Air 10 SCFM @ 70 psig

REFERENCE:

CALCULATIONS:

see Attachments

CONCLUSIONS:

0.5 inch ID copper lines gives for Corner station a pressure drop of 18 psi

0.5 inch ID copper lines gives for Mid/End station a pressure drop of 4 psi

NOTES:

PROJECT: LIGOBY: R.THAN DEPT: 744PROJECT NO: V59049DATE: 4/17/96**CORNER STATIONS**

	Qty'	SCFM	Total SCFM
Cryopump valve	2	1.5	3
Roughing cart purge	2	1.5	3
Turbocart purge	2	1.5	3
44/48 gatevalves	4	0.6	2.4
Total			11.4

END/MID STATION

	Qty'	SCFM	Total SCFM
Cryopump valve	2	1.5	3
Turbocart purge	1	1.5	1.5
Total			4.5

With a margin of 2 the pressure drop thru a 0.5 inch ID line are the following:

	I.D.	Flowrate	Flowrate	ΔP	ΔP
	inch	SCFM	kg/s	psi	bar
CORNER STATION	0.500	20	0.01	18	1.2
END/MID STATION	0.500	10	0.005	4	0.3

PROCESS SYSTEMS INTERNATIONAL, INC 20 Walkup Drive, Westborough, MA 01581

PROJECT: LIGO
 PROJECT NO: V59049
 TITLE: CORNER STATION INSTRUMENT AIR SYS.

BY: R. THAN
 DATE: 4/12/**
 PAGE: 1 OF

PRESSURE DROP ROUTE OR LINE ID: INSTRUMENT AIR HEADER 20 SCFM

PRESSURE: 600000.0 Pa 6.000 BAR
 TEMPERATURE: 293.000 K 293.000 K
 DENSITY: 6.910 KG/M³ 0.691E+01 KG/M³
 QUALITY: 1.000

ITEMNAME	FLOWRATE KG/S	I.D. METER	K / DO	CV	LENGTH M	PRESSURE Pa	Z1 METER	Z2 METER	DP-F Pa	DP-Z Pa	DP-T Pa	DP-SUM Pa	DENSITY KG/M ³	VELOCITY M/S	RE NO	Knunsen
1/2" TUBE	0.100E-01	0.013			25.0	573240.0	0.00	0.00	26760.00	0.00E+00	0.27E+05	0.27E+05	0.691E+01	11.42	0.57E+05	0.86E-0
1/2" TUBE	0.100E-01	0.013			25.0	545229.6	0.00	0.00	28010.42	0.00E+00	0.28E+05	0.55E+05	0.660E+01	11.96	0.57E+05	0.90E-0
1/2" TUBE	0.100E-01	0.013			25.0	515778.8	0.00	0.00	29450.76	0.00E+00	0.29E+05	0.84E+05	0.628E+01	12.57	0.57E+05	0.94E-0
1/2" TUBE	0.100E-01	0.013			25.0	484644.9	0.00	0.00	31133.89	0.00E+00	0.31E+05	0.12E+06	0.594E+01	13.29	0.57E+05	0.10E-0
1/2" ELBOW LR-90	0.100E-01	0.013	1.000			484086.5	0.00	0.00	558.40	0.00E+00	0.56E+03	0.12E+06	0.558E+01			
1/2" ELBOW LR-90	0.100E-01	0.013	1.000			483527.5	0.00	0.00	559.05	0.00E+00	0.56E+03	0.12E+06	0.557E+01			
1/2" ELBOW LR-90	0.100E-01	0.013	1.000			482967.8	0.00	0.00	559.69	0.00E+00	0.56E+03	0.12E+06	0.557E+01			
1/2" ELBOW LR-90	0.100E-01	0.013	1.000			482407.5	0.00	0.00	560.34	0.00E+00	0.56E+03	0.12E+06	0.556E+01			
1/2" ELBOW LR-90	0.100E-01	0.013	1.000			481846.5	0.00	0.00	560.99	0.00E+00	0.56E+03	0.12E+06	0.555E+01			
1/2" ELBOW LR-90	0.100E-01	0.013	1.000			481284.8	0.00	0.00	561.65	0.00E+00	0.56E+03	0.12E+06	0.555E+01			
1/2" ELBOW LR-90	0.100E-01	0.013	1.000			480722.5	0.00	0.00	562.30	0.00E+00	0.56E+03	0.12E+06	0.554E+01			
1/2" ELBOW LR-90	0.100E-01	0.013	1.000			480159.6	0.00	0.00	562.96	0.00E+00	0.56E+03	0.12E+06	0.553E+01			
1/2" ELBOW LR-90	0.100E-01	0.013	1.000			479595.9	0.00	0.00	563.62	0.00E+00	0.56E+03	0.12E+06	0.553E+01			
1/2" ELBOW LR-90	0.100E-01	0.013	1.000			479031.6	0.00	0.00	564.29	0.00E+00	0.56E+03	0.12E+06	0.552E+01			
							TOTAL		120968.35	0.00	120968.35	=	17.5404	PSI		

1
 1/2 I.D.
 5/8 O.D.

REVISION: 0
 DOC NO: V049-1-093
 PAGE 3 OF 4

PROCESS SYSTEMS INTERNATIONAL, INC 20 Walkup Drive, Westborough, MA 01581

PROJECT: LIGO BY: R. THAN
 PROJECT NO:V59049 DATE: 4/12/**
 TITLE: END/MID STATION INSTRUMENT AIR SYS. PAGE: 1 OF

PRESSURE DROP ROUTE OR LINE ID:INSTRUMENT AIR HEADER 10 SCFM

PRESSURE: 600000.0 Pa 6.000 BAR
 TEMPERATURE: 293.000 K 293.000 K
 DENSITY : 6.910 KG/M³ 0.691E+01 KG/M³
 QUALITY : 1.000

ITEMNAME	FLOWRATE KG/S	I.D. METER	K / DO	CV	LENGTH M	PRESSURE Pa	Z1 METER	Z2 METER	DP-F Pa	DP-Z Pa	DP-T Pa	DP-SUM Pa	DENSITY KG/M ³	VELOCITY M/S	RE NO	Knunsen
1/2" TUBE	0.500E-02	0.013			25.0	592955.9	0.00	0.00	7044.06	0.00E+00	0.70E+04	0.70E+04	0.691E+01	5.71	0.28E+05	0.86E-0
1/2" TUBE	0.500E-02	0.013			25.0	585828.1	0.00	0.00	7127.81	0.00E+00	0.71E+04	0.14E+05	0.683E+01	5.78	0.28E+05	0.87E-0
1/2" TUBE	0.500E-02	0.013			25.0	578613.5	0.00	0.00	7214.59	0.00E+00	0.72E+04	0.21E+05	0.675E+01	5.85	0.28E+05	0.88E-0
1/2" TUBE	0.500E-02	0.013			25.0	571308.9	0.00	0.00	7304.62	0.00E+00	0.73E+04	0.29E+05	0.666E+01	5.92	0.28E+05	0.89E-0
1/2" ELBOW LR-90	0.500E-02	0.013	1.000			571190.5	0.00	0.00	118.40	0.00E+00	0.12E+03	0.29E+05	0.658E+01			
1/2" ELBOW LR-90	0.500E-02	0.013	1.000			571072.1	0.00	0.00	118.43	0.00E+00	0.12E+03	0.29E+05	0.658E+01			
1/2" ELBOW LR-90	0.500E-02	0.013	1.000			570953.6	0.00	0.00	118.45	0.00E+00	0.12E+03	0.29E+05	0.658E+01			
1/2" ELBOW LR-90	0.500E-02	0.013	1.000			570835.2	0.00	0.00	118.48	0.00E+00	0.12E+03	0.29E+05	0.657E+01			
1/2" ELBOW LR-90	0.500E-02	0.013	1.000			570716.7	0.00	0.00	118.50	0.00E+00	0.12E+03	0.29E+05	0.657E+01			
1/2" ELBOW LR-90	0.500E-02	0.013	1.000			570598.1	0.00	0.00	118.52	0.00E+00	0.12E+03	0.29E+05	0.657E+01			
1/2" ELBOW LR-90	0.500E-02	0.013	1.000			570479.6	0.00	0.00	118.55	0.00E+00	0.12E+03	0.30E+05	0.657E+01			
1/2" ELBOW LR-90	0.500E-02	0.013	1.000			570361.0	0.00	0.00	118.57	0.00E+00	0.12E+03	0.30E+05	0.657E+01			
1/2" ELBOW LR-90	0.500E-02	0.013	1.000			570242.4	0.00	0.00	118.60	0.00E+00	0.12E+03	0.30E+05	0.657E+01			
1/2" ELBOW LR-90	0.500E-02	0.013	1.000			570123.8	0.00	0.00	118.62	0.00E+00	0.12E+03	0.30E+05	0.657E+01			
TOTAL									29876.20	0.00	29876.20	=	4.3320	PSI		

REVISION: 0
 DOC NO: V049-1-093
 PAGE 4 OF 4

Title:

HAZARDS ANALYSIS

HAZARDS ANALYSIS

FOR

LIGO VACUUM EQUIPMENT

Hanford, Washington
and
Livingston, Louisiana

PREPARED BY Stephen F. Toth

TECHNICAL DIRECTOR D. A. M. Williams

PROJECT MANAGER Robert Boyle

Information contained in this specification and its attachments is proprietary in nature and shall be kept confidential. It shall be used only as required to respond to the specification requirements and shall not be disclosed to any other party.

0	SFT 4/11/96	R 83 5/1/96	Issue for FDR per DEO # 0119			
REV LTR	BY—DATE	APPD—DATE	DESCRIPTION OF ACTION			
PROCESS SYSTEMS INTERNATIONAL, INC			SPECIFICATION			
INITIAL APPROVALS	PREPARED BY	DATE	APPROVED BY	DATE	Number	Rev
	SFT	4-11-96	R 83	5/1/96	A V049-2-093	0

LIGO Vacuum Equipment Hazards Analysis

Below is a release of the PHA sheets that constitute the Hazards Analysis required by the LIGO System Safety Plan. The major types of equipment and operations were analyzed with respect to hazards that result in damage to equipment or the environment or injury to personnel. The principal engineers were involved in the review of equipment and operations for which they are responsible. The analysis rates the hazards according to hazard probability and severity using the guides found in MIL-STD-882C section 4.5.1 and 4.5.2 which are also found in Tables 3.1, 3.2, and 3.3 of the LIGO Project System Safety Plan. The relevant definitions are referenced in the lower left hand corner of the PHA sheets. The Hazard Risk Index is given below for convenience. No hazards were found which fall in the Unacceptable or Undesirable categories.

Hazard Risk Index

<u>Hazard Risk Index</u>	<u>Risk Code Criteria</u>
1A, 1B, 1C, 2A, 2B, 3A	Unacceptable
1D, 2C, 2D, 3B, 3C	Undesirable (Project Manager Decision Required)
1E, 2E, 3D, 3E, 4A, 4B	Acceptable with review by Project Manager
4C, 4D, 4E	Acceptable without review

The PHA sheets completed are listed in the index below. This is a complete set of those sheets we anticipate being required. PSI will provide any other PHA sheets as needed.

Index of PHA sheets completed

Equipment:
1. An isolatable section
2. Beam Splitter Chamber
3. Horizontal Access Module
4. Roughing Pumps
5. Turbomolecular Pumps
6. Auxiliary Turbo Cart
7. Ion Pumps
8. Annulus Ion Pumps
9. 80 K Cryopumps
10. Large Gate Valves
11. Small Gate Valves
12. Blanket Bake Out System
13. Clean Rooms
14. Clean Air System
Operations:
1. Bake Out
2. Back to Air (Repressurization)
3. Cryopump Regeneration
4. Roughing
5. Turbo/Roughing
6. High Vacuum Operation

EQUIPMENT ITEM OR PROCESS: An Isolatable Section

Each isolatable section includes at least 1) a large gate valve for isolation and 2) a beam splitter. It may also contain a HAM or a cryopump.

A cryopump in itself is an isolatable section.

The individual hazards associated with each individual piece are considered on the individual equipment hazard sheets.

The one hazard that must be addressed for any isolatable section not containing a cryopump is overpressure.

There is no pressure relief for the vacuum shells except for the cryopumps. There also is no source of overpressure except for the following three causes:

HAZARD	CAUSE	CONSEQUENCES	SAFEGUARD	ACTION ITEM	HSC	HP	HRI
Overpressurization	Failure of back to air controller, failure of the pressure letdown valve to 1 psig, accidental change in setpoint	Loss of containment, flange leak.	RV on the back to air supply header	LIGO - Configure pressure alarm and shutdown of the back to air supply on the back to air pressure controller. *	1	E	1E
Overpressurization	Air Showers or purge air in use with the vessel closed and at atmospheric pressure	Loss of containment, flange leak.	RV on the back to air supply header. Procedures: Lockout on air shower supply until the chamber is opened and under purge.	Make part of operating procedures.	1	E	1E

Hazard Severity Categories (HSC): 1=Catastrophic, 2=Critical, 3=Marginal, 4=Negligible
 Hazard Probability (HP): A=Frequent, B=Probable, C=Occasional, D=Remote, E=Improbable
 Hazard Risk Index (HRI)

Rev. 0

Prepared by: SFT

Reviewed by: RDC

LIGO Vacuum Equipment
Hazards Analysis

Overpressure of section being baked out.	Initiation of bakeout with the system closed at atmospheric pressure.	Loss of containment: flange rupture, seam failure, etc.	Procedures: Heating an enclosed volume of gas from ambient to 200 C increases the pressure by 60 %. The operating procedures for bakeout must ensure that the section is at least rough pumped before heat is added.	Ensure this potential hazard is spelled out in the bakeout procedures.	2	E	2E

* This must be done on the back to air pressure controller because it is the only gauge accurate enough to be meaningful. The addition of a portable pressure control/transmitter for each site is an important feature to allow accurate gauging and control in the near atmospheric range.

EQUIPMENT ITEM OR PROCESS: Beam Splitter Chamber

HAZARD	CAUSE	CONSEQUENCES	SAFEGUARD	ACTION ITEM	HSC	HP	HRI
Overpressure	Failure to control pressure during back to ambient repressurization step	Loss of containment, Excess pressure on large flanged opening when the door is opened.	The purge air is controlled at 1 psig with a 2 psig relief valve setting limiting the source pressure.		3	E	3E
			Change to an accurate pressure gauge for control in the near atmospheric range.				
Loss of vacuum containment	Opening of a valve from an atmospheric pressure source.	Contamination, injury to personnel being sucked in, damage to equipment.	All valves larger than 2-1/2" have physical locking devices to prevent them being inadvertently being opened or closed. This is true of both manual and automatic valves. Personnel procedures governing their use and the breaking of vacuum.	None	1	E	1E
Loss of vacuum	"O"-Ring failure, flange leak, bellows leak, flex hose leak.	Operational upset, loss of on-stream time	Pressure gauges register leak, RGA identifies source as air. Clean Room can be put in place, the BSC isolated by the large gate valves, the leak found and repaired.	None	3	E	3E

Hazard Severity Categories (HSC): 1=Catastrophic, 2=Critical, 3=Marginal, 4=Negligible
 Hazard Probability (HP): A=Frequent, B=Probable, C=Occasional, D=Remote, E=Improbable
 Hazard Risk Index (HRI)

Rev. 0
 Prepared by: SFT
 Reviewed by: POC

LIGO Vacuum Equipment
 Hazards Analysis

EQUIPMENT ITEM OR PROCESS: Horizontal Access Modules

HAZARD	CAUSE	CONSEQUENCES	SAFEGUARD	ACTION ITEM	HSC	HP	HRI
Overpressure	Failure to control pressure during back to ambient repressurization step	Loss of containment, Excess pressure on large flanged opening when the door is opened.	The purge air is controlled at 1 psig with a 2 psig relief valve setting limiting the source pressure.		3	E	3E
			Change to an accurate pressure gauge for control in the near atmospheric range.				
Loss of vacuum containment	Opening of a valve from an atmospheric pressure source.	Contamination, injury to personnel being sucked in, damage to equipment.	All valves larger than 2-1/2" have physical locking devices to prevent them being inadvertently being opened or closed. This is true of both manual and automatic valves. Personnel procedures governing their use and the breaking of vacuum.	None	1	E	1E
Loss of vacuum	"O"-Ring failure, flange leak, bellows leak, flex hose leak.	Operational upset, loss of on-stream time	Pressure gauges register leak, RGA identifies source as air. Clean Room can be put in place, the BSC isolated by the large gate valves, the leak found and repaired.	None	3	E	3E

The HAM's are not isolatable from the BSC's. Repressureization is done through the BSC associated with that HAM.

Hazard Severity Categories (HSC): 1=Catastrophic, 2=Critical, 3=Marginal, 4=Negligible
 Hazard Probability (HP): A=Frequent, B=Probable, C=Occasional, D=Remote, E=Improbable
 Hazard Risk Analysis (HRI)

Rev. 0
 Prepared by: *SJT*
 Reviewed by: *DM*

LIGO Vacuum Equipment
 Hazards Analysis

EQUIPMENT ITEM OR PROCESS: **80 K Cryopumps**

HAZARD	CAUSE	CONSEQUENCES	SAFEGUARD	ACTION ITEM	HSC	HP	HRI
Overpressure of LN2 side	Blocked vent line	Rupture of LN2 annular section and N2 leak into chamber	RV-133 on the vent line. The RV will be sized for the maximum flow when the vent is iced up. One case would be maximum flow through the supply valve wide open.	PSI will develop and review both flows and pressure setting for RV-133.	2	E	2E
Overheating Aluminum LN2 Reservoir	1) Misoperation of heater, 2) Failure to monitor TE on warm vent gas	Rupture of LN2 annular section due to loss of aluminum strength	Procedures, TI-102 on vent gas	Ask Ligo to add alarm to TI-102 with shutdown of Electrical heater. Design temperature of LN2 reservoir set to 400 F to provide margin for regeneration at design pressure above maximum back pressure during regeneration.	3	D	3D
Rupture of LN2 Reservoir	Overpressure, over temperature, material defect.	Overpressure of cryopump due to vaporization of the LN2 reservoir in the hot (happens during regeneration) pump.	Pressure relief device - double "O" Ring sealed lift plate will be added to shell.	None	1	E	1E

Hazard Severity Categories (HSC): 1=Catastrophic, 2=Critical, 3=Marginal, 4=Negligible
 Hazard Probability (HP): A=Frequent, B=Probable, C=Occasional, D=Remote, E=Improbable
 Hazard Risk Index (HRI)

Rev. 3
 Prepared by: SET
 Reviewed by: PM

LIGO Vacuum Equipment
 Hazards Analysis

Overfilling cryopump	Failure of level control, failure to put level control back in operation on refill.	Spill LN2 out vent to atmosphere	Locate in safe location both in regard to liquid nitrogen and to build up of N2 vapor causing reduced O2 content.	None	4	D	4D
LN2 or GN2 leak into chamber	Defect or minor rupture of a weld or piping	Loss of vacuum, Pump would be valved off, repressurized, and the leak found and repaired	Pressure gauges, RGA will determine leak to be nitrogen	None	4	E	4E
Overpressure during back to air	Design pressure is close to clean air supply pressure	Vessel rupture or flange leak. The contained energy is too small to cause injury or damage beyond the vessel itself.	Three safety features are provided: 1) Relief valve on supply air set at 2 psig, 2) back to air valve will be controlled from a gauge accurate at atmospheric	None	4	E	4E
			3) a pressure relief device expected to be a specially designed rupture disk will be installed on the shell.				
Loss of liquid level in cryopump reservoir	Blocked supply line, empty dewar, failure of level control	Loss of effectiveness of cryopump, possible release of adsorbed water vapor.	None	Suggest LIGO add low level alarm to level control LIC-100.	4	E	4E

* The LN2 supply dewar, pressure building coil, and ambient vaporizer are all protected by the standard safety controls. The same is true for the electric heater which has overheat protection to avoid burning out the elements.

Hazard Severity Categories (HSC): 1=Catastrophic, 2=Critical, 3=Marginal, 4=Negligible
 Hazard Probability (HP): A=Frequent, B=Probable, C=Occasional, D=Remote, E=Improbable
 Hazard Risk Index (HRI)

Rev. 0
 Prepared by: S-T
 Reviewed by: FAB

LIGO Vacuum Equipment
 Hazards Analysis

EQUIPMENT ITEM OR PROCESS: Ion Pump

HAZARD	CAUSE	CONSEQUENCES	SAFEGUARD	ACTION ITEM	HSC	HP	HRI
Operation at too high pressure	1) Leak, 2) Turbomolecular pump failure, 3) Cryopump Failure, 4) Premature operation during pump down - operator error	Excessive current draw with pump damage or shortened pump life.	Large pumps have current trips built into the controllers. The gate valves separating the ion pump from the system are physically lockable. Procedures before valve is opened.	None	4	D	4D
	Pump restart after power failure	Excessive current draw with pump damage or shortened pump life.	The MultiVac controller will be set not to restart on return of power.	None	4	E	4E
Electrical Shock	Improper Contact with High Voltage Equipment	Injury or death	High voltage clearly marked, high voltage power cable run in cable tray marked high voltage. Design to applicable electrical codes.	None	1	E	1E
Ion Pump Failure	Defect, Electrical failure	Loss of pumping capacity.	Pump power controls and high amperage trip. Pump can be valved off and replaced without breaking the system vacuum. Short does not release materials into the chamber.	None	4	D	4D

Hazard Severity Categories (HSC): 1=Catastrophic, 2=Critical, 3=Marginal, 4=Negligible
 Hazard Probability (HP): A=Frequent, B=Probable, C=Occasional, D=Remote, E=Improbable
 Hazard Risk Analysis (HRI)

Rev. 0
 Prepared by: SFT
 Reviewed by: FAB

LIGO Vacuum Equipment
 Hazards Analysis

EQUIPMENT ITEM OR PROCESS: Annulus Ion Pumps

HAZARD	CAUSE	CONSEQUENCES	SAFEGUARD	ACTION ITEM	HSC	HP	HRI
Operation at too high pressure	1) "O" Ring Leak, 2) Turbomolecular pump failure, 3) Premature operation during pump down - operator error	Excessive current draw with pump damage or shortened pump life.	The 75 torr-liter/sec pumps and 25 torr-liter/sec pumps are fuse protected. The gate valves separating the ion pump from the system are physically lockable. Procedures before valve is opened.	None	4	D	4D
	Pump restart after power failure	Excessive current draw with pump damage or shortened pump life.	The MiniVac controllers return to their original state on power return so they will power up.	Make it part of procedure for extended power outage to shutoff ion pumps.	4	C	4C
Electrical Shock	Improper Contact with High Voltage Equipment	Injury or death	High voltage clearly marked. Care in locating controller and running power cables. Design to applicable electrical codes.	None	1	E	1E
Ion Pump Failure	Defect, Electrical failure	Loss of pumping capacity.	Pump power controls and high amperage trip. Pump can be valved off and replaced without breaking the system vacuum. Annulus space can be turbopumped to an acceptable vacuum.	None	4	D	4D

Hazard Severity Categories (HSC): 1=Catastrophic, 2=Critical, 3=Marginal, 4=Negligible
 Hazard Probability (HP): A=Frequent, B=Probable, C=Occasional, D=Remote, E=Improbable
 Hazard Risk Index (HRI)

Rev. 0
 Prepared by: SET
 Reviewed by: FAB

LIGO Vacuum Equipment
 Hazards Analysis

EQUIPMENT ITEM OR PROCESS: Blanket Bake Out System

HAZARD	CAUSE	CONSEQUENCES	SAFEGUARD	ACTION ITEM	HSC	HP	HRI
Electrical short circuit	Breakdown in insulation, moisture	damage to heating mantel, possible short to vessel, personnel injury	Blankets are designed specifically for each item of equipment. Construction of the blanket protects the heating elements. Each blanket is protected by a fuse. The power supply on the control cart has a circuit breaker.	None	3	E	3E
			Design to all applicable electrical standards. Blankets are not grounded, the equipment being baked and the control carts are grounded. Proper maintenance and storage of blankets and power cords.				
Accident	Assembly of blankets around the system is a manually intensive operation	Personnel injury, probably minor	Personnel training and written procedures.	Make part of training both for PSI manufacturing personnel and also LIGO operating personnel.	3	D	3D

Hazard Severity Categories (HSC): 1=Catastrophic, 2=Critical, 3=Marginal, 4=Negligible
 Hazard Probability (HP): A=Frequent, B=Probable, C=Occasional, D=Remote, E=Improbable
 Hazard Risk Index (HRI)

Rev. 0

Prepared by: *STP*

Reviewed by: *FAB*

LIGO Vacuum Equipment
Hazards Analysis

Non-uniform heating and cooling	Misoperation or set-up of the blanket system and controls	Excessive temperature differences in the equipment	Procedures for wiring the carts to the blankets must be rigorously followed. Incorrect setup will cause the control system to shutdown on temperature difference prematurely. The system is safe against excessive delta T's.	Make part of training both for PSI manufacturing personnel and also LIGO operating personnel.	4	C	4C
Loss of control	PC Failure	No hazard - Loss of ability to view system operations but the PLC's maintain control.	PLC's maintain control.	None	4	C	4C
	PLC Failure	No hazard	System shutdown - PLC failure trips the breaker on the cart	None	4	C	4C
	Thermal data acquisition system failure	No hazard	Erroneous signal shutdown the system on out of range temperature - similar to miswiring. No signal causes shutdown based on loss of timing signal.	None	4	C	4C
Overheat Equipment attached to the Main System	Auxiliary equipment such as Turbopumps which are close coupled to the system have lower acceptable temperatures than the design bakeout temperature of the main system.	Damage to auxiliary equipment components or electronics.	Bakeout procedure must address this problem.	Analyze the thermal conduction to the auxiliary equipment, whether it should be baked out separately so the insulation on the auxiliary section can be removed, etc.	4	C	4C

Hazard Severity Categories (HSC): 1=Catastrophic, 2=Critical, 3=Marginal, 4=Negligible
 Hazard Probability (HP): A=Frequent, B=Probable, C=Occasional, D=Remote, E=Improbable
 Hazard Risk Index (HRI)

Rev. C
 Prepared by: *ST*
 Reviewed by: *ST*

LIGO Vacuum Equipment
 Hazards Analysis

EQUIPMENT ITEM OR PROCESS: **Turbomolecular Pump Cart**

HAZARD	CAUSE	CONSEQUENCES	SAFEGUARD	ACTION ITEM	HSC	HP	HRI
Pump vents to vacuum chamber	1) backing pump failure, 2) magnetic bearing failure, 3) power failure	Contamination of chamber, possible damage to equipment in the chamber	Automatic shutoff valve on Turbo pump discharge interlocked to close on pump or power failure.	None	3	D	3D
Turbomolecular pump mechanical failure	Bearing failure, material failure of blades	Large amount of momentum to dissipate - possibly causing pump mounting failure.	The frame to which the Turbo Cart is bolted is designed for this load. The bolts for anchoring the cart are also designed for this load.	Make sure other users of the TurboCart, i.e., the Beam Tube Contractor is informed and correct bolts are always used - LIGO responsibility.			
Turbopump emergency shutdown	Power Failure	Damage to Turbopump.	The controller which controls the active magnetic bearings is supplied with battery backup. Procedures must ensure that the batteries are good and that they have sufficient charge.	Make sure information is passed to LIGO.	2	E	2E
			This is especially true if there is a series of power failures without enough up time to recharge.				

Hazard Severity Categories (HSC): 1=Catastrophic, 2=Critical, 3=Marginal, 4=Negligible
 Hazard Probability (HP): A=Frequent, B=Probable, C=Occasional, D=Remote, E=Improbable
 Hazard Risk Index (HRI)

	Controller failure, control cable failure	Damage to Turbopump.	Auxiliary bearings are provided to allow the pump to shutdown safely. They are only good for a limited number of "crash landing."	None	2	E	2E
Turbopump shutdown	Seal gas failure, seal failure. cooling water failure.	Pump damage, leakage into the vacuum system, contamination of the vacuum system	Seal gas is from the clean air system so there is no contamination.	None	3	E	3E
			Only the backing pump uses seal gas, loss of seal gas purge causes a pump shutdown. There is an automatic shutoff valve between the turbo and the backing pump actuated on pump shutdown..	None	3	E	3E
			Cooling water failure will trip the turbopump on high temperature, the backing pump also has TSH protection,	None	3	E	3E
Cart Mechanical Failure	Lifting the two parts of the cart together	Damage to equipment, injury to personnel	The carts will be clearly marked. Training and procedures. LIGO to enforce compliance by beam tube contractor.	None	2	E	2E

Rev. 0

Prepared by: JFT

Reviewed by:

LIGO Vacuum Equipment
Hazards Analysis

Overheating during bakeout	Too high temperature in the vacuum section to which the turbopump is coupled causing overheat by conduction.	Damage to electronics, components. Damage to turbopump (if running).	Temperature alarms and shutdowns on the blankets designed for heating the turbopump. This could terminate the bakeout if the condition cannot be alleviated. The turbopump is also TSH protected.	Investigate the bakeout scenario and determine whether this is a real problem. If so, it may be necessary to bakeout the pump first and then remove the pump blanket or bakeout everything to 120 C together and then remove the pump blanket and continue.	2	E	2E

Hazard Severity Categories (HSC): 1=Catastrophic, 2=Critical, 3=Marginal, 4=Negligible
Hazard Probability (HP): A=Frequent, B=Probable, C=Occasional, D=Remote, E=Improbable
Hazard Risk Index (HRI)

Rev. 0
 Prepared by: SFT
 Reviewed by: SM

LIGO Vacuum Equipment
 Hazards Analysis

EQUIPMENT ITEM OR PROCESS:

Auxiliary Turbo Cart

HAZARD	CAUSE	CONSEQUENCES	SAFEGUARD	ACTION ITEM	HSC	HP	HRI
Pump vents to vacuum chamber	1) backing pump failure, 2) magnetic bearing failure, 3) power failure	Contamination of chamber, possible damage to equipment in the chamber	Automatic shutoff valve on turbo inlet interlocked to close on pump or power failure. An automatic vent valve lets air into the turbo to keep flow in the direction of the backing pump under normal shutdown.	None	3	D	3D
Turbopump emergency shutdown	Power Failure, Controller failure, Control Cable Failure	Damage to Turbopump.	The system is designed for safe shutdown with all the required interlocks and safeties.	None	3	E	3E

Hazard Severity Categories (HSC): 1=Catastrophic, 2=Critical, 3=Marginal, 4=Negligible
 Hazard Probability (HP): A=Frequent, B=Probable, C=Occasional, D=Remote, E=Improbable
 Hazard Risk Index (HRI)

Rev. 0

LIGO Vacuum Equipment
Hazards Analysis

Prepared by: *SET*

Process Systems International, Inc.

Reviewed by: *AM*

Excessive Stress on Vacuum Equipment or Beam Tube	Improper Mounting and mate up to the roughing port.	Possible damage to equipment	The carts are designed to mate with the vacuum equipment. The carts must be bolted down. The beam tube contractor must provide suitable safe and stable means to attach to the beam tube.	LIGO to provide proper instructions and oversight to the beam tube contractor.	3	E	3E
---	---	------------------------------	---	--	---	---	----

Hazard Severity Categories (HSC): 1=Catastrophic, 2=Critical, 3=Marginal, 4=Negligible
Hazard Probability (HP): A=Frequent, B=Probable, C=Occasional, D=Remote, E=Improbable
Hazard Risk Index (HRI)

Rev. 0
 Prepared by: *BET*
 Reviewed by: *TS*

LIGO Vacuum Equipment
 Hazards Analysis

EQUIPMENT ITEM OR PROCESS: **Large Gate Valves**

HAZARD	CAUSE	CONSEQUENCES	SAFEGUARD	ACTION ITEM	HSC	HP	HRI
Valve closes with laser on	Operator initiated valve closure	Damage to gate valve and possibly other equipment.	Procedures and computer interlock (LIGO) to prevent large gate valve closure in the line of the beam with the laser powered.	Convey this requirement to LIGO.	1	D	1D
Valve not fully open or close	misoperation	system not isolated or valve impinges on beam path.	Positive indication of valve closure or valve opening is provided. Electric actuators have gear driven switches, pneumatic valves have limit switches on the actuators.	None	3	E	3E
Valves Fail to Close (Electrically operated valves)	Electrical system failure - motor or electrical supply	Failure to isolate section on demand.	All electrical components can be replaced or repaired without compromising vacuum system. These valves are not designed for emergency isolation.	None	4	D	4D
			Failure to close in combination with a system leak would be considered double jeopardy.				

Hazard Severity Categories (HSC): 1=Catastrophic, 2=Critical, 3=Marginal, 4=Negligible
 Hazard Probability (HP): A=Frequent, B=Probable, C=Occasional, D=Remote, E=Improbable
 Hazard Risk Index (HRI)

Rev. 0

Prepared by: SET
 Reviewed by: JS

LIGO Vacuum Equipment
 Hazards Analysis

Valves Fail to Close (Pneumatically operated valves)	Instrument Air Failure	Failure to isolate section on demand.	Failure to close in combination with a system leak would be considered double jeopardy.	None	4	D	4D
Valves Fail to Open	Electrical system failure - motor or electrical supply	Delay in bringing system back on-line	All electrical components can be replaced or repaired without compromising vacuum system.	None	4	D	4D
Valve Opens Unexpectedly	Operator or Control system failure	Section containing equipment or personnel exposed to rapid depressurization with damage to equipment and personnel injury or death.	Control system lockout procedure and physical lockout on valve to prevent opening. Personnel training and procedures	None	1	E	1E
Damage to "O" Ring Gaskets	Excessive temperature on bake out	Inability to reach vacuum, contamination by products of decomposition. The products generated by heating over 200 C are both toxic and dangerous (HF).	Blanket bake out system controls	None	2	E	2E

Hazard Severity Categories (HSC): 1=Catastrophic, 2=Critical, 3=Marginal, 4=Negligible
 Hazard Probability (HP): A=Frequent, B=Probable, C=Occasional, D=Remote, E=Improbable
 Hazard Risk Index (HRI)

Rev. 0

Prepared by: SFT
Reviewed by: TS

LIGO Vacuum Equipment
Hazards Analysis

22
Process Systems International, Inc.

EQUIPMENT ITEM OR PROCESS: Small Gate Valves

The small gate valves, 14 inches and smaller, are manually operated valves. The small valves use metal gasket conflat flanges rather than double "O" ring seals.

HAZARD	CAUSE	CONSEQUENCES	SAFEGUARD	ACTION ITEM	HSC	HP	HRI
Valve Opened Inadvertently.	Misoperation	Vacuum system opened to atmosphere with damage to equipment and contamination. Injury to personnel or damage to equipment sucked into the valve.	Physical lockout on valve to prevent opening. Personnel training and procedures.	LIGO to establish personnel training procedures in regard to opening system to atmosphere.	1	E	1E

There do not appear to be any hazards not addressed by the lockout devices and procedures.

Small valves in the 1-1/2" to 2-1/2" range have no lockout protection. These will have to be protected by personnel procedures.

Hazard Severity Categories (HSC): 1=Catastrophic, 2=Critical, 3=Marginal, 4=Negligible
Hazard Probability (HP): A=Frequent, B=Probable, C=Occasional, D=Remote, E=Improbable
Hazard Risk Index (HRI)

LIGOPHA.XLS
Small Gate Valves

Rev. 0
Prepared by: SFT
Reviewed by: TS

LIGO Vacuum Equipment
Hazards Analysis

EQUIPMENT ITEM OR PROCESS: Clean Room

HAZARD	CAUSE	CONSEQUENCES	SAFEGUARD	ACTION ITEM	HSC	HP	HRI

There do not appear to be any significant hazards inherent in clean room operation other than those normally associated with operating a small air compressor and physically setting up the pieces of the portable equipment. See attached HAZNOTES.

These would be handled by proper storage and maintenance of the clean rooms and training of the personnel who will set them up and operate in them.

Rev.
Prepared by: SET
Reviewed by: TS

LIGO Vacuum Equipment
Hazards Analysis
HAZNOTES

Subject Area: Clean Rooms
Date: 20-Mar-96
Meeting Attendance: Stephen Toth, Tom Starr

Notes:	Safety aspects of the clean rooms and their usage were discussed.
Description:	Each clean room consists of an enclosure made up of a frame covered by 40 mil sheets of polyethylene, a blower providing air, and an air filter. Each room will have electrical outlets and lighting. An anteroom will be provided for gowning prior to entry.
Usage	The clean rooms will be used to provide a clean (low particulate level) environment for the following operations: Final Assembly, Installation, and Opening of the Vacuum System to atmosphere. The air will be filtered but not dehumidified. No welding will take place in a clean room.
Hazards:	
Asphyxiation	The clean room is a partially enclosed space with a high air flow. At site there will be no welding (Argon Source) or use of nitrogen for drying so there can be no reduction in oxygen content. Purge air will be Class 100 clean air. Air for the air showers will be class 100 air but also dehumidified to -60 C dew point.
Flammability	The 40 mil sheets of polyethylene are considered to be flame retardant. With no ignition sources in the clean room and flame retardant walls there is no apparent fire hazard.
Other hazards	There are no other hazards inherent in clean room operation other than normally associated with operating a small air compressor and physically setting up the several pieces of the portable system.

Rev. 0
Prepared by: SFT
Reviewed by: TS

LIGO Vacuum Equipment
Hazards Analysis

EQUIPMENT ITEM OR PROCESS: Clean Air System - Vent and Purge

HAZARD	CAUSE	CONSEQUENCES	SAFEGUARD	ACTION ITEM	HSC	HP	HRI

There do not appear to be any hazards other than those involved in operating small air compressors.
See attached HAZNOTES.

Hazard Severity Categories (HSC): 1=Catastrophic, 2=Critical, 3=Marginal, 4=Negligible
Hazard Probability (HP): A=Frequent, B=Probable, C=Occasional, D=Remote, E=Improbable
Hazard Risk Index (HRI)

Rev. 8
Prepared by: SIF-7
Reviewed by: TS

LIGO Vacuum Equipment
Hazards Analysis
HAZNOTES

Subject Area: Clean Air Supply, Vent and Purge

Date: 20-Mar-96

Meeting Attendance: Tom Starr, Stephen Toth

Notes:	The vent and purge compressors and the clean air supply to the air showers was discussed from a safety viewpoint.
Description:	Vent and Purge clean air is provided as a manifolded utility to the various stations as required. The air is compressed either by two stage screw compressors or by parallel scroll compressors. Both types are oil free compressors. The air is compressed to around 90 psig, dried in a two-bed heatless mole sieve drier, filtered and then let down in two stages to 1 psig for supply to the vacuum equipment. The 1 psig supply header is protected by a relief valve set at approximately 2 psig.
Hazards:	There are no hazards other than those involved in operating small air compressors. Hazards or operational issues resulting from loss of instrument air or loss of purge air will be addressed in regard to the equipment being investigated or in the FMEA of the particular P&ID.

Rev. 0
 Prepared by: SFT
 Reviewed by: ROC

LIGO Vacuum Equipment
 Hazards Analysis

EQUIPMENT ITEM OR PROCESS: **Operation: Bake Out**

Most of the possible system hazards are covered in the Blanket Bake Out Equipment Hazard sheets.
 The additional hazards associated with the overall operation are covered below.

HAZARD	CAUSE	CONSEQUENCES	SAFEGUARD	ACTION ITEM	HSC	HP	HRI
Overpressure of section being baked out.	Initiation of bakeout with the system closed at atmospheric pressure.	Loss of containment: flange rupture, seam failure, etc.	Procedures: Heating an enclosed volume of gas from ambient to 200 C increases the pressure by 60 %. The operating procedures for bakeout must ensure that the section is at least rough pumped before heat is added.	Ensure this potential hazard is spelled out in the bakeout procedures.	2	E	2E
			The low ramp rate of the blanket system allows time to respond should the blankets be turned on before rough pumping is initiated.				
Failure of vessel walls or flanges	Stress induced by thermal expansion of large system.	Loss of containment	These stresses are addressed in the design of the equipment, expansion joints are incorporated in the design.	None	2	E	2E

Hazard Severity Categories (HSC): 1=Catastrophic, 2=Critical, 3=Marginal, 4=Negligible
 Hazard Probability (HP): A=Frequent, B=Probable, C=Occasional, D=Remote, E=Improbable
 Hazard Risk Index (HRI)

Rev. 0
 Prepared by: SFT
 Reviewed by: ROL

LIGO Vacuum Equipment
 Hazards Analysis

Overheating equipment	Some of the components of the system are more heat sensitive than others.	Damage to equipment, release of toxic gases or liquids, contamination.	The control system is available to monitor and protect the equipment.	Ensure this potential hazard is spelled out in the bakeout procedures.	2	E	2E
			Procedures are required to ensure that the limitations of the few heat sensitive components are understood and that the bakeout is done in a methodical manner.				
			That adequate time and oversight is provided.				

The remaining hazards of overheating and the like are covered on the blanket bakeout equipment section. There are sufficient controls, safeties, and interlocks to protect the system against overheating.

Hazard Severity Categories (HSC): 1=Catastrophic, 2=Critical, 3=Marginal, 4=Negligible
 Hazard Probability (HP): A=Frequent, B=Probable, C=Occasional, D=Remote, E=Improbable
 Hazard Risk Index (HRI)

Rev. 0
 Prepared by: SET
 Reviewed by: TS

LIGO Vacuum Equipment
 Hazards Analysis

Repressurization:

Once the section is isolated, the back to air connections are made.

The back to air process is initiated with the controller gradually pressurizing the system with the pressure signal from the Pirani gauge.

When the pressure is back to within two decades of atmospheric a portable pressure gauge/transmitter accurate in the near atmospheric range will be attached to one of the 1-1/2 inch conflat ports (the RGA port for example) and the control switched to this transmitter for the final stage of repressurization. The hazard associated with these actions are listed below

HAZARD	CAUSE	CONSEQUENCES	SAFEGUARD	ACTION ITEM	HSC	HP	HRI
Damage to equipment in the section being repressurized, i.e., optics0	Too rapid a flow of repressurization gas, gas flow into a sensitive section.	Repairs, realignment necessary.	Change to an accurate pressure gauge for control in the near atmospheric range.	PSI-None, all necessary equipment and instrumentation is provided.	2	E	2E
			Procedures, low ramp rate near atmospheric.	LIGO-Develop the philosophy and parameters necessary to prevent disruption of the interferometer.			
Overpressurization	Failure of back to air controller, failure of the pressure letdown valve to 1 psig, accidental change in setpoint	Loss of containment, flange leak.	RV on the back to air supply header	LIGO - Configure pressure alarm and shutdown of the back to air supply on the back to air pressure controller. *	1	E	1E

Hazard Severity Categories (HSC): 1=Catastrophic, 2=Critical, 3=Marginal, 4=Negligible
 Hazard Probability (HP): A=Frequent, B=Probable, C=Occasional, D=Remote, E=Improbable
 Hazard Risk Index (HRI)

Rev. 0
 Prepared by: B-F
 Reviewed by: TS

LIGO Vacuum Equipment
 Hazards Analysis

Vessel Entry:

Presumably the section was isolated and brought back to atmospheric pressure in order for work to be done in that section. Once it has been confirmed that the system is pressurized to near atmospheric, one or more clean rooms are put in place and preparations made to open the chamber. One or more small valves are opened to equalize to atmosphere, the purge air and air showers started, and the vessel opened up.

The hazard associated with these actions are listed below

HAZARD	CAUSE	CONSEQUENCES	SAFEGUARD	ACTION ITEM	HSC	HP	HRI
Moisture intrusion into chamber	Failure to start purge flow or insufficient purge flow	Might require a bakeout, or a longer pumpdown. Loss of onstream time.	Procedures	None	4	E	4E
Moisture on optics	Failure to start air shower flow or insufficient air shower flow	Need to redry optics	Procedures	None	4	E	4E
Vessel is opened to section under vacuum	Misoperation of large gate valve	Damage and loss of life	Procedures: See physical lockout of gate valves.	None	1	E	1E
Laser is energized	Misoperation	Probable destruction of gate valve opening section to the beam tube vacuum. Death and damage	Procedures	LIGO to provide both computer interlock and physical lockout of laser power when either the large gate valves are closed or vessel entry made.	1	E	1E

Hazard Severity Categories (HSC): 1=Catastrophic, 2=Critical, 3=Marginal, 4=Negligible
 Hazard Probability (HP): A=Frequent, B=Probable, C=Occasional, D=Remote, E=Improbable
 Hazard Risk Index (HRI)

Rev. 6
 Prepared by: SFT
 Reviewed by: TS

LIGO Vacuum Equipment
 Hazards Analysis

EQUIPMENT ITEM OR PROCESS: **Operation: Cryopump Regeneration**

Most of the possible hazards associated with regeneration of the cryopumps were covered in the cryopump hazard sheets. Listed below are mostly the same hazards but broken out into which portion of the process they are most likely to occur in.

Isolation:

Once it has been determined that the cryopump needs to be regenerated, the first step is to turn off the laser and isolate the cryopump with it's two large gate valves. The turbopump cart is attached to the 10" gate valve and the pump started to maintain vacuum and evacuate the water vapor during regeneration. The one immediate hazard is:

HAZARD	CAUSE	CONSEQUENCES	SAFEGUARD	ACTION ITEM	HSC	HP	HRI
Valve closes with laser on	Operator initiated valve closure	Damage to gate valve and possibly other equipment.	Procedures and computer interlock (LIGO) to prevent large gate valve closure in the line of the beam with the laser powered.	Convey this requirement to LIGO.	1	D	1D

Hazard Severity Categories (HSC): 1=Catastrophic, 2=Critical, 3=Marginal, 4=Negligible
 Hazard Probability (HP): A=Frequent, B=Probable, C=Occasional, D=Remote, E=Improbable
 Hazard Risk Index (HRI)

Rev. 0
 Prepared by: SET
 Reviewed by: PM

LIGO Vacuum Equipment
 Hazards Analysis

Initiate Regeneration:

The LN2 supply block valve is shut to the cryopump at the supply dewar and the level control valve LV-100 is closed and taken off automatic. The block valve to the ambient vaporizer opened. The operator opens the flow control valve slowly sending gas to the bottom of the reservoir in the cryopump while watching the vent line pressure gauge to make sure that the pressure did not get too high, and that liquid was not coming out of the vent line. The control room and the local operator will monitor the vent gas temperature until it warmed to within approximately 40 C of ambient.

HAZARD	CAUSE	CONSEQUENCES	SAFEGUARD	ACTION ITEM	HSC	HP	HRI
Too much regeneration nitrogen to the reservoir	Manually opening flow valve to quickly	Carryover of LN2 out the vent or if back pressure is too high lifting of relief valve with LN2 going out the relief valve.	Locate in safe location both in regard to liquid nitrogen and to build up of N2 vapor causing reduced O2 content.	None	4	D	4D
			Procedures: Operator to monitor nitrogen gas flow and vent pressure				
Break in regeneration feed line in Cryopump	Thermal Stress	Both vapor (from regen side) and liquid from reservoir into the shell side.	Vessel protected from over pressure by special rupture disk.	None	4	E	4E

Hazard Severity Categories (HSC): 1=Catastrophic, 2=Critical, 3=Marginal, 4=Negligible
 Hazard Probability (HP): A=Frequent, B=Probable, C=Occasional, D=Remote, E=Improbable
 Hazard Risk Index (HRI)

Rev. 0
 Prepared by: SET
 Reviewed by: DM

LIGO Vacuum Equipment
 Hazards Analysis

Finish Regeneration:

The heater blankets will be installed and the ramp up in temperature initiated. The control room will set the ramp rate on the electric heater and turn it on. Flow rate will be adjusted to both warm up at the desired rate and also to stay within the pressure limits of the reservoir. When the temperature of the vent gas reaches the desired 150 C, the controller will be set to hold temperature for some period of time.

HAZARD	CAUSE	CONSEQUENCES	SAFEGUARD	ACTION ITEM	HSC	HP	HRI
Overheating Aluminum LN2 Reservoir	1) Misoperation of heater, 2) Failure to monitor TE on warm vent gas	Rupture of LN2 annular section due to loss of aluminum strength	Procedures, TI-102 on vent gas. Design temperature of LN2 reservoir set to 400 F to provide margin for regeneration at design pressure above maximum back pressure during regeneration.	Ask Ligo to add alarm to TI-102 with interlock to shutdown of Electrical heater.	3	D	3D
Overpressure of Shell	Failure of Turbopump so there is no evacuation. Automatic valve closes protecting turbopump but blocking in shell side.	If there is sufficient water content still in the shell the vaporizing water will drive the pressure above design.	Special rupture disk on the shell.	LIGO - Configure pressure alarm on Pirani gauge at a pressure safely below relief pressure indicating loss of vacuum. Operator would then have time to shutdown electric nitrogen heater and have blankets turned off.	2	D	2D
Break in regeneration feed line in Cryopump	Thermal Stress	Both vapor (from regen side) and liquid from reservoir into the shell side.	Vessel protected from over pressure by special rupture disk.	None	4	E	4E

Hazard Severity Categories (HSC): 1=Catastrophic, 2=Critical, 3=Marginal, 4=Negligible
 Hazard Probability (HP): A=Frequent, B=Probable, C=Occasional, D=Remote, E=Improbable
 Hazard Risk Index (HRI)

Cool Down and Restart

The whole sequence of operations will be reversed.

The electric nitrogen gas heater turned off and the blankets turned off, allowed to cool down and removed. Nitrogen gas flow will be maintained but cut back to maintain a purge flow through the nitrogen vent line to prevent air and water vapor intrusion.

The LN2 block valve opened, the block valve to ambient vaporizer closed, and LV-100 opened slightly from the control room to cool down the reservoir.

When the reservoir is cooled down as evidenced by the vent gas temperature approaching 80 K, the flow rate can be increased and the reservoir filled.

When the level approaches the desired level, LV-100 can be put back in automatic. The turbopump can be turned off, valved off and disconnected.

The large gate valves opened, locked open, and the laser restarted.

HAZARD	CAUSE	CONSEQUENCES	SAFEGUARD	ACTION ITEM	HSC	HP	HRI
Overfilling cryopump	Failure of level control, failure to put level control back in operation on refill.	Spill LN2 out vent to atmosphere	Locate in safe location both in regard to liquid nitrogen and to build up of N2 vapor causing reduced O2 content.	None	4	D	4D

Rev. 0
 Prepared by: SFT
 Reviewed by: LHM

LIGO Vacuum Equipment
 Hazards Analysis

EQUIPMENT ITEM OR PROCESS: **Operation: Roughing**

The hazards associated with the roughing pumps are mostly covered on the roughing pump cart equipment hazard sheets. The additional hazards associated with the overall operation are covered below.

The volume to be roughed first must be closed. The open flanges are closed and bolted and valves are closed. The roughing pump cart is put in place, aligned with its port, and bolted down. The backing pump cart is permanently installed in the mechanical room. The flex hose is attached to the manifold connecting the two carts. The control cable linking the two is connected and power brought to the roughing pump. Cooling water and instrument air are attached and started. Once the overall setup is verified the suction gate valve on the chamber is opened and the automatic block valve on the cart is opened. The roughing pump and its backing pump can then be started. Pump down is monitored with the Pirani gauge sets on the volume to be roughed. When the desired pressure is reached the gate valve is closed and locked. The roughing pump can then be shutdown which automatically closes its suction valve. The roughing pump cart is disconnected from their utilities and removed.

HAZARD	CAUSE	CONSEQUENCES	SAFEGUARD	ACTION ITEM	HSC	HP	HRI
Failure to close gate valve before disconnecting roughing pump.	Operator error	Rapid repressurization, contamination, damage to interferometer optics, personal injury.	Procedures and training	Detailed check list of setup and disassembly is required.	1	E	1E
Failure to close gate valve before performing repairs or maintenance on the roughing/backing pumps.	Operator error	Rapid repressurization, contamination, damage to interferometer optics, personal injury.	Procedures and training	Sign off before working around an open gate valve is required.	1	E	1E

The roughing pump and backing pump are self protecting. The hazard involves working around a large vacuum volume until it is closed off and locked.

Hazard Severity Categories (HSC): 1=Catastrophic, 2=Critical, 3=Marginal, 4=Negligible
 Hazard Probability (HP): A=Frequent, B=Probable, C=Occasional, D=Remote, E=Improbable
 Hazard Risk Index (HRI)

Rev. 0
 Prepared by: ST-T
 Reviewed by: LM

LIGO Vacuum Equipment
 Hazards Analysis

EQUIPMENT ITEM OR PROCESS: **Operation: Turbo Roughing**

The hazards associated with turbo roughing are mostly covered on the turbomolecular pump cart equipment hazard sheets. The additional hazards associated with the overall operation are covered below.

The volume to be turbo roughed has been rough pumped. The turbo cart is put in place, aligned with its port, and bolted down. The flex hose connecting the turbo exhaust to the manifold connecting the turbo to its backing pump in the mechanical room is attached. Power is connected to the turbo cart and the control cable linking the two is connected. Cooling water, instrument air, and seal gas are attached and started. Once the overall setup is verified the suction gate valve on the chamber is opened. The turbo pump and its backing pump can then be started. Pump down is monitored with the gauge sets on the volume to be turbo pumped. When the desired pressure is reached the gate valve on the chamber is closed and locked. The turbo pump can then be shutdown. The turbo pump cart is disconnected from utilities and removed.

HAZARD	CAUSE	CONSEQUENCES	SAFEGUARD	ACTION ITEM	HSC	HP	HRI
Failure to close gate valve before disconnecting the turbo pump.	Operator error	Rapid repressurization, contamination, damage to interferometer optics, personal injury.	Procedures and training	Detailed check list of setup and disassembly is required.	1	E	1E
Failure to close gate valve before performing repairs or maintenance on the turbo pumps or the backing pump.	Operator error	Rapid repressurization, contamination, damage to interferometer optics, personal injury.	Procedures and training	Sign off before working around an open gate valve is required.	1	E	1E
Turbocart breaks free from chamber	Failure to properly bolt down the turbo cart and the turbo seizes up.	Rapid repressurization, contamination, damage to interferometer optics, personal injury.	Procedures, maintenance and house keeping.	Detailed assembly and setup procedures required. Keep bolts with the turbo pumps and mark them as special material.	1	E	1E

Once the turbo pump is up and running the turbo and its backing pump are self protecting. The hazards involved are those involved with working around a large vacuum volume until it is closed off and locked and properly mounting an elevated piece of high speed equipment.

Hazard Severity Categories (HSC): 1=Catastrophic, 2=Critical, 3=Marginal, 4=Negligible
 Hazard Probability (HP): A=Frequent, B=Probable, C=Occasional, D=Remote, E=Improbable
 Hazard Risk Index (HRI)

Rev. 0
 Prepared by: SFD
 Reviewed by: TS

LIGO Vacuum Equipment
 Hazards Analysis

EQUIPMENT ITEM OR PROCESS: **Operation: High Vacuum Operation**

Once the system is turbo pumped the next stage is to reach high vacuum and initialize operation of the interferometer. The pressure and setup of the system are verified as being ready for high vacuum operation. The pumped double "O" ring seals are pumped down with the auxiliary turbo pump and the annulus ion pumps started. The 80 K cryopump which has been kept purged with nitrogen vapor on the nitrogen side is cooled down and then filled with liquid nitrogen. The level control for liquid nitrogen makeup is put on automatic operation. The gate valves on the main ion pumps are opened and the ion pumps started. Pressure is monitored in the system with the cold cathode and RGA. The laser interferometer operation is initialized.

Most of the hazards associated with the 80 K cryopumps, ion pumps, large gate valves, and other equipment have been handled on the individual equipment hazard sheets. Additional hazards associated with overall operation are listed below:

HAZARD	CAUSE	CONSEQUENCES	SAFEGUARD	ACTION ITEM	HSC	HP	HRI
Opening the chamber to atmosphere	Misoperation	Rapid repressurization, damage to interferometer optics, contamination, personal injury	All valves over 2 1/2 inches are provided with lockable devices. Procedures:	Operations must establish the absolute prohibition against breaking vacuum without approval at the highest level.	1	E	1E
Gradual loss of vacuum	Flange leak, leak in any joint or weld	Reduction in accuracy of interferometer, contamination	Monitoring of RGA, vacuum gauges	None	3	D	3D

Hazard Severity Categories (HSC): 1=Catastrophic, 2=Critical, 3=Marginal, 4=Negligible
 Hazard Probability (HP): A=Frequent, B=Probable, C=Occasional, D=Remote, E=Improbable
 Hazard Risk Index (HRI)

Title:

FAILURE MODES, EFFECTS, AND CRITICALITY ANALYSIS

FAILURE MODES, EFFECTS, AND CRITICALITY ANALYSIS

FOR

LIGO VACUUM EQUIPMENT

Hanford, Washington
and
Livingston, Louisiana

PREPARED BY Stephen F. Tork

TECHNICAL DIRECTOR D. A. McWilliam

PROJECT MANAGER Barclay Boyington

Information contained in this specification and its attachments is proprietary in nature and shall be kept confidential. It shall be used only as required to respond to the specification requirements and shall not be disclosed to any other party.

0	SFT - 4/19/96	RSB 5/1/96	Issue for FDR per DEO # 0120
REV LTR	BY—DATE	APPD—DATE	DESCRIPTION OF ACTION

PROCESS SYSTEMS INTERNATIONAL, INC				SPECIFICATION		
INITIAL APPROVALS	PREPARED BY	DATE	APPROVED BY	DATE	Number	Rev
	SFT	4-19-96	D M W	5-1-98	A V049-2-094	0

LIGO Vacuum Equipment Failure Modes, Effects, and Criticality Analysis

Below is a release of the FMECA sheets that constitute the Failure Modes, Effects, and Criticality Analysis required by the LIGO System Safety Plan. The FMECA was performed following the procedures described in Section 4.7 of Guidelines for Hazard Evaluation Procedures, 1985 Edition published by The Center for Chemical Process Safety of the American Institute of Chemical Engineers. Issue # 1 of the P&ID's in conjunction with the PHA sheets was used to prepare the FMECA sheets. The analysis rates the hazards according to hazard probability and severity using the guides found in MIL-STD-882C section 4.5.1 and 4.5.2 which are also found in Tables 3.1, 3.2, and 3.3 of the LIGO Project System Safety Plan. The relevant definitions are referenced in the lower left hand corner of the FMECA sheets. The Hazard Risk Index is given below for convenience.

Hazard Risk Index

<u>Hazard Risk Index</u>	<u>Risk Code Criteria</u>
1A, 1B, 1C, 2A, 2B, 3A	Unacceptable
1D, 2C, 2D, 3B, 3C	Undesirable (Project Manager Decision Required)
1E, 2E, 3D, 3E, 4A, 4B	Acceptable with review by Project Manager
4C, 4D, 4E	Acceptable without review

Rev. 0
 Prepared by: SFT
 Reviewed by: FMB

LIGO Vacuum Equipment
 Failure Modes and Effects Analysis

P&I Number: V049-0-002 Rev. 1
 Node: 1
 System: Annulus Vacuum System
 Date: 4/3/96

Node 1 is the Annulus ion pump and the connections from the double "O" rings seals on the 104" and 4 - 60" flanges.
 This P&I represents 11 BSC's, Washington BSC 2,4,5,6,7,8,9, and Louisiana BSC 2,4,5. The numbers below reflect WBSC2.

ITEM:	IDENTIFICATION	DESCRIPTION	FAILURE MODES	EFFECTS	ACTION ITEM	HSC	HP	HRI
1		75 torr-liter/second ion pump	Ion pump shuts down on high current caused by high pressure	Loss of annulus pumping capacity, the MiniVac controller protects the pump with fuses. If the pump will not restart, the auxiliary turbo will be attached to the auxiliary turbo pumpout port and the annulus repumped.		4	D	4D
			High Pressure could be caused by premature operation during pumpdown or leakage through the "O" rings.	When the pressure is low enough the ion pump can be restarted.				
				If the pump cannot be restarted, the 2-1/2" AVHV can be closed and the ion pump replaced.				
				Current indication at the computer will indicate whether the pump is running. In addition, the local controller displays the pump condition. Periodic observation of the local controller condition should be made part of an operational checklist.	LIGO to include this in operating procedure.			

Hazard Severity Categories (HSC): 1=Catastrophic, 2=Critical, 3=Marginal, 4=Negligible
 Hazard Probability (HP): A=Frequent, B=Probable, C=Occasional, D=Remote, E=Improbable
 Hazard Risk Index (HRI)

Rev. 0
 Prepared by: SET
 Reviewed by: FAB

LIGO Vacuum Equipment
 Failure Modes and Effects Analysis

			ion pump shuts down on power failure	Loss of annulus pumping capacity. When the power returns the ion pump will restart. This probably is not a problem. After power returns the annulus ion pumps will have to be checked to see if they're running.	LIGO to include this in operating procedure.	4	D	4D
				If not they will need to be turbopumped and restarted as above.				
2		"O" Ring Seals on the 104" top section and the 4 - 60" ports and their connecting piping.	Seal Failure or Seal Leakage	Leakage on the BSC side would not be noticed with both the chamber and the annulus at high vacuum.	None	4	D	4D
				When the BSC is brought back to atmosphere a chamber side leak might be noticed if the annulus ion pump was kept on and the current monitored.				
				A small atmospheric side leak would show up as increased current draw on the ion pump. A larger leak would trip the ion pump.				
				Turbopumping the annulus in conjunction with the ion pump might allow continued operation until a convenient scheduled repair could be arranged.				

Hazard Severity Categories (HSC): 1=Catastrophic, 2=Critical, 3=Marginal, 4=Negligible
 Hazard Probability (HP): A=Frequent, B=Probable, C=Occasional, D=Remote, E=Improbable
 Hazard Risk Index (HRI)

Rev. 0
 Prepared by: SET
 Reviewed by: FAS

LIGO Vacuum Equipment
 Failure Modes and Effects Analysis

P&I Number: V049-0-002 Rev. 1
 Node: 2
 System: Beam Splitter Chamber
 Date: 4/3/96

ITEM:	IDENTIFICATION	DESCRIPTION	FAILURE MODES	EFFECTS	ACTION ITEM	HSC	HP	HRI
3	WBSC2	Beam Splitter Chamber	"O" Ring Seal Failure	Leakage into the BSC.- The section would have to be isolated, returned to atmospheric air pressure and the leak repaired. The failure would have to be major to both overwhelm the ion pump and be through both "O" rings. Very unlikely.	None	4	E	4E
			Any flange leak or leak in a feed through	The section would have to be isolated, returned to atmospheric air pressure and the leak repaired.	None	4	E	4E
			Overpressure caused by back to air system.	High enough pressure could cause flange leaks or rupture.	None	4	E	4E
				Protection is provided by 1) a highly accurate capacitance pressure gauge will be used to provide pressure measurement to the back to air controller. It will close the valve as the target pressure is reached.				
				2) the source pressure, the clean air supply is controlled at 1 psig and protected by a relief valve set at 2 psig.				

Hazard Severity Categories (HSC): 1=Catastrophic, 2=Critical, 3=Marginal, 4=Negligible
 Hazard Probability (HP): A=Frequent, B=Probable, C=Occasional, D=Remote, E=Improbable
 Hazard Risk Index (HRI)

			Opening of the RGA port valve, the Auxiliary pumpout valve, or the Air Shower Connection to the atmosphere with the BSC under vacuum.	Pressurize the BSC rapidly with damage to equipment. The opening of the vacuum system to atmosphere must be a highly controlled action in LIGO's operationing procedures. The air showers can only be connected when the BSC is at pressure.	None	4	E	4E
4	Gauge pair on WBSC2	A guage pair consists of a Pirani gauge and a Cold Cathode Gauge both reading locally and on the LIGO computer.	Either gauge can fail.	If the Pirani or Cold Cathode fails during pump down the section could be isolated and brought back to atmospheric and the gauge replaced or the gauges on the turbo could be used to monitor pumpdown.	None	4	E	4E
				At high vacuum the RGA can be used to monitor vacuum. The gauges could then be replaced at a time when the section was at atmospheric for other reasons.				
5	PCV120	Back to Air Control Valve	Is opened too rapidly	An inrush of too high a flow of clean airup to maximum supply rate of 200 SCFM pulling down supply header pressure. The receiver on the clean air supply header is protected by a Pressure switch which will close PCV120.	None	4	E	4E
				See above for overpressure of BSC.				

Rev. 0
 Prepared by: SFT
 Reviewed by: PAB

LIGO Vacuum Equipment
 Failure Modes and Effects Analysis

P&I Number: V049-0-003 Rev. 1
Node: 3
System: Annulus Vacuum System
Date: 4/4/96

Node 3 is the Annulus ion pump and the connections from the double "O" rings seals on the 104" and 4 - 60" flanges.
 This P&I represents 4 BSC's, Washington BSC 1 and 3, and Louisiana BSC 1 and 3. The numbers below reflect WBSC1.

ITEM:	IDENTIFICATION	DESCRIPTION	FAILURE MODES	EFFECTS	ACTION ITEM	HSC	HP	HRI
6		75 torr-liter/second ion pump	Ion pump shuts down on high current caused by high pressure	Loss of annulus pumping capacity, the MiniVac controller protects the pump with fuses. If the pump will not restart, the auxiliary turbo will be attached to the auxiliary turbo pumpout port and the annulus repumped.		4	D	4D
			High Pressure could be caused by premature operation during pumpdown or leakage through the "O" rings.	When the pressure is low enough the ion pump can be restarted.				
				If the pump cannot be restarted, the 2-1/2" AVHV can be closed and the ion pump replaced.				
				Current indication at the computer will indicate whether the pump is running. In addition, the local controller displays the pump condition. Periodic observation of the local controller condition should be made part of an operational checklist.	LIGO to include this in operating procedure.			

Hazard Severity Categories (HSC): 1=Catastrophic, 2=Critical, 3=Marginal, 4=Negligible
 Hazard Probability (HP): A=Frequent, B=Probable, C=Occasional, D=Remote, E=Improbable
 Hazard Risk Index (HRI)

Rev. 0
 Prepared by: SFT
 Reviewed by: FAB

LIGO Vacuum Equipment
 Failure Modes and Effects Analysis

			Ion pump shuts down on power failure	Loss of annulus pumping capacity. When the power returns the ion pump will restart. This probably is not a problem. After power returns the annulus ion pumps will have to be checked to see if they're running.	LIGO to include this in operating procedure.	4	D	4D
				If not they will need to be turbopumped and restarted as above.				
7		"O" Ring Seals on the 104" top section and the 4 - 60" ports and their connecting piping.	Seal Failure or Seal Leakage	Leakage on the BSC side would not be noticed with both the chamber and the annulus at high vacuum.	None	4	D	4D
				When the BSC is brought back to atmosphere a chamber side leak might be noticed if the annulus ion pump was kept on and the current monitored.				
				A small atmospheric side leak would show up as increased current draw on the ion pump. A larger leak would trip the ion pump.				
				Turbopumping the annulus in conjunction with the ion pump might allow continued operation until a convenient scheduled repair could be arranged.				

Hazard Severity Categories (HSC): 1=Catastrophic, 2=Critical, 3=Marginal, 4=Negligible
 Hazard Probability (HP): A=Frequent, B=Probable, C=Occasional, D=Remote, E=Improbable
 Hazard Risk Index (HRI)

Rev. 0
 Prepared by: SFT
 Reviewed by: FAB

LIGO Vacuum Equipment
 Failure Modes and Effects Analysis

P&I Number: V049-0-003 Rev. 1
 Node: 4
 System: Beam Splitter Chamber
 Date: 4/4/96

ITEM:	IDENTIFICATION	DESCRIPTION	FAILURE MODES	EFFECTS	ACTION ITEM	HSC	HP	HRI
8	WBSC1	Beam Splitter Chamber	"O" Ring Seal Failure	Leakage into the BSC.- The section would have to be isolated, returned to atmospheric air pressure and the leak repaired. The failure would have to be major to both overwhelm the ion pump and be through both "O" rings. Very unlikely.	None	4	E	4E
			Any flange leak or leak in a feed through	The section would have to be isolated, returned to atmospheric air pressure and the leak repaired.	None	4	E	4E
			Overpressure caused by back to air system. Back to air is done through another BSC in same isolatable section.	High enough pressure could cause flange leaks or rupture.	None	4	E	4E
				Protection is provided by 1) a highly accurate capacitance pressure gauge will be used to provide pressure measurement to the back to air controller. It will close the valve as the target pressure is reached.				

Hazard Severity Categories (HSC): 1=Catastrophic, 2=Critical, 3=Marginal, 4=Negligible
 Hazard Probability (HP): A=Frequent, B=Probable, C=Occasional, D=Remote, E=Improbable
 Hazard Risk Index (HRI)

Rev. 0
 Prepared by: SET
 Reviewed by: FRB

LIGO Vacuum Equipment
 Failure Modes and Effects Analysis

				2) the source pressure, the clean air supply is controlled at 1 psig and protected by a relief valve set at 2 psig.				
			Opening of the RGA port valve, the Auxiliary pumpout valve, or the Air Shower Connection to the atmosphere with the BSC under vacuum.	Pressurize the BSC rapidly with damage to equipment. The opening of the vacuum system to atmosphere must be a highly controlled action in LIGO's operationing procedures. The air showers can only be connected when the BSC is at pressure.	None	4	E	4E

Hazard Severity Categories (HSC): 1=Catastrophic, 2=Critical, 3=Marginal, 4=Negligible
 Hazard Probability (HP): A=Frequent, B=Probable, C=Occasional, D=Remote, E=Improbable
 Hazard Risk Index (HRI)

Rev. 0
 Prepared by: SET
 Reviewed by: FAB

LIGO Vacuum Equipment
 Failure Modes and Effects Analysis

P&I Number: V049-0-004 Rev. 1
 Node: 5
 System: Annulus Vacuum System
 Date: 4/4/96

Node 5 is the Annulus ion pump and the connections from the double "O" rings seals on the 2 - 84" and 2 - 60" flanges. This P&I represents all 19 HAM's, Washington 1-13, and Louisiana 1-6. The numbers below reflect WHAM1.

ITEM:	IDENTIFICATION	DESCRIPTION	FAILURE MODES	EFFECTS	ACTION ITEM	HSC	HP	HRI
9		75 torr-liter/second ion pump	Ion pump shuts down on high current caused by high pressure	Loss of annulus pumping capacity, the MiniVac controller protects the pump with fuses. If the pump will not restart, the auxiliary turbo will be attached to the auxiliary turbo pumpout port and the annulus repumped.		4	D	4D
			High Pressure could be caused by premature operation during pumpdown or leakage through the "O" rings.	When the pressure is low enough the ion pump can be restarted.				
				If the pump cannot be restarted, the 2-1/2" AVHV can be closed and the ion pump replaced.				
				Current indication at the computer will indicate whether the pump is running. In addition, the local controller displays the pump condition. Periodic observation of the local controller condition should be made part of an operational checklist.	LIGO to include this in operating procedure.			

Hazard Severity Categories (HSC): 1=Catastrophic, 2=Critical, 3=Marginal, 4=Negligible
 Hazard Probability (HP): A=Frequent, B=Probable, C=Occasional, D=Remote, E=Improbable
 Hazard Risk Index (HRI)

Rev. 0
 Prepared by: SET
 Reviewed by: FMS

LIGO Vacuum Equipment
 Failure Modes and Effects Analysis

			Ion pump shuts down on power failure	Loss of annulus pumping capacity. When the power returns the ion pump will restart. This probably is not a problem. After power returns the annulus ion pumps will have to be checked to see if they're running.	LIGO to include this in operating procedure.	4	D	4D
				If not they will need to be turbopumped and restarted as above.				
10		"O" Ring Seals on the 104" top section and the 4 - 60" ports and their connecting piping.	Seal Failure or Seal Leakage	Leakage on the HAM side would not be noticed with both the chamber and the annulus at high vacuum.	None	4	D	4D
				When the HAM is brought back to atmosphere a chamber side leak might be noticed if the annulus ion pump was kept on and the current monitored.				
				A small atmospheric side leak would show up as increased current draw on the ion pump. A larger leak would trip the ion pump.				
				Turbopumping the annulus in conjunction with the ion pump might allow continued operation until a convenient scheduled repair could be arranged.				

Hazard Severity Categories (HSC): 1=Catastrophic, 2=Critical, 3=Marginal, 4=Negligible
 Hazard Probability (HP): A=Frequent, B=Probable, C=Occasional, D=Remote, E=Improbable
 Hazard Risk Index (HRI)

Rev. 0
 Prepared by: SET
 Reviewed by: FAB

LIGO Vacuum Equipment
 Failure Modes and Effects Analysis

P&I Number: V049-0-004 Rev. 1
 Node: 6
 System: Horizontal Access Module
 Date: 4/4/96

ITEM:	IDENTIFICATION	DESCRIPTION	FAILURE MODES	EFFECTS	ACTION ITEM	HSC	HP	HRI
11	WHAM1	Horizontal Access Module	"O" Ring Seal Failure	Leakage into the HAM.- The section would have to be isolated, returned to atmospheric air pressure and the leak repaired. The failure would have to be major to both overwhelm the ion pump and be through both "O" rings. Very unlikely.	None	4	E	4E
			Any flange leak or leak in a feed through	The section would have to be isolated, returned to atmospheric air pressure and the leak repaired.	None	4	E	4E
			Overpressure caused by back to air system. Back to air is done through a BSC in same isolatable section.	High enough pressure could cause flange leaks or rupture.	None	4	E	4E
				Protection is provided by 1) a highly accurate capacitance pressure gauge will be used to provide pressure measurement to the back to air controller. It will close the valve as the target pressure is reached.				

Hazard Severity Categories (HSC): 1=Catastrophic, 2=Critical, 3=Marginal, 4=Negligible
 Hazard Probability (HP): A=Frequent, B=Probable, C=Occasional, D=Remote, E=Improbable
 Hazard Risk Index (HRI)

Rev. 0
 Prepared by: SFT
 Reviewed by: FMB

LIGO Vacuum Equipment
 Failure Modes and Effects Analysis

				2) the source pressure, the clean air supply is controlled at 1 psig and protected by a relief valve set at 2 psig.				
			Opening of the Air Shower Connection to the atmosphere with the HAM under vacuum.	Pressurize the HAM rapidly with damage to equipment. The opening of the vacuum system to atmosphere must be a highly controlled action in LIGO's operationing procedures. The air showers can only be connected when the HAM is at pressure.	None	4	E	4E

Hazard Severity Categories (HSC): 1=Catastrophic, 2=Critical, 3=Marginal, 4=Negligible
 Hazard Probability (HP): A=Frequent, B=Probable, C=Occasional, D=Remote, E=Improbable
 Hazard Risk Index (HRI)

Rev. 0
 Prepared by: SFT
 Reviewed by: TS

LIGO Vacuum Equipment
 Failure Modes and Effects Analysis

P&I Number: V049-0-005 Rev. 1
Node: 7
System: Large Gate Valves
Date: 4/5/96

This P&ID depicts the pneumatic and motor driven 44" and 48" gate valves.
 There are 8 - 44" pneumatic gate valves, Washington 5-8, and Louisiana 3-6.
 There are 8 - 48" and 16 - 44" electric gate valves, Washington 1-4, and 9-20. and Louisiana 1,2 and 7-12.
 The equipment and instrument numbers reflect WGV5 for pneumatic and WGV1 for electric.

ITEM:	IDENTIFICATION	DESCRIPTION	FAILURE MODES	EFFECTS	ACTION ITEM	HSC	HP	HRI
12		25 torr-liter/second ion pump	Ion pump shuts down on high current caused by high pressure	Loss of annulus pumping capacity, the MiniVac controller protects the pump with fuses. If the pump will not restart, the auxiliary turbo will be attached to the 1 1/2" auxiliary turbo pumpout port and the annulus repumped.		4	D	4D
			High Pressure could be caused by premature operation during pumpdown or leakage through the "O" rings.	When the pressure is low enough the ion pump can be restarted.				
				If the pump cannot be restarted, the 1-1/2" AVHV can be closed and the ion pump replaced.				

Hazard Severity Categories (HSC): 1=Catastrophic, 2=Critical, 3=Marginal, 4=Negligible
 Hazard Probability (HP): A=Frequent, B=Probable, C=Occasional, D=Remote, E=Improbable
 Hazard Risk Index (HRI)

Rev. 0
 Prepared by: SET
 Reviewed by: TS

LIGO Vacuum Equipment
 Failure Modes and Effects Analysis

				Current indication at the computer will indicate whether the ion pump is running. In addition, the local controller displays the pump condition. Periodic observation of the local controller condition should be made part of an operational checklist.	LIGO to include this in operating procedure.			
			Ion pump shuts down on power failure	Loss of annulus pumping capacity. When the power returns the ion pump will restart. This probably is not a problem. After power returns the annulus ion pumps will have to be checked to see if they're running.	LIGO to include this in operating procedure.	4	D	4D
				If not they will need to be turbopumped and restarted as above.				
13		Dual "O" Ring Seals and their connecting piping.	Seal Failure or Seal Leakage	Leakage on the chamber side would not be noticed with both the chamber and the annulus at high vacuum.	None	4	D	4D
				When the chamber is brought back to atmosphere a chamber side leak might be noticed if the annulus ion pump was kept on and the current monitored.				
				A small atmospheric side leak would show up as increased current draw on the ion pump. A larger leak would trip the ion pump.				

Hazard Severity Categories (HSC): 1=Catastrophic, 2=Critical, 3=Marginal, 4=Negligible
 Hazard Probability (HP): A=Frequent, B=Probable, C=Occasional, D=Remote, E=Improbable
 Hazard Risk Index (HRI)

Rev. 0

Prepared by: SET

Reviewed by: TS

LIGO Vacuum Equipment
Failure Modes and Effects Analysis

				Turbopumping the annulus in conjunction with the ion pump might allow continued operation until a convenient scheduled repair could be arranged.				
--	--	--	--	--	--	--	--	--

Rev. 0
 Prepared by: SFT
 Reviewed by: TS

LIGO Vacuum Equipment
 Failure Modes and Effects Analysis

P&I Number: V049-0-005 Rev. 1
 Node: 8
 System: Large Gate Valves
 Date: 4/5/96

The large gate valves, whether pneumatic or electric are driven from the computer. Since the opening of one of these valves exposes an atmospheric section to high vacuum and vice versa we recommend and plan to configure the controls such that they can only be operated from the control room. At the valve itself there is a lockout with a keyed padlock which prevents opening even if the computer initiates it. LIGO operating procedures will stress the critical nature of the lockout / tagout function. The lockout feature of the valves is also used in the open position.

ITEM:	IDENTIFICATION	DESCRIPTION	FAILURE MODES	EFFECTS	ACTION ITEM	HSC	HP	HRI
14	WGV5	44" Pneumatic Gate Valve	Valve Fails to Close, caused by instrument air failure, failure of drive mechanism, or failure to open lockout.	Failure to isolate a section when desired - causes a delay in isolating a section either for pumpdown to vacuum, repressurization, or cryopump regeneration.	None	4	D	4D
			Valve Fails to Open, caused by instrument air failure, failure of drive mechanism, failure to open lockout, or failure of the latching mechanism to release.	Failure to open a section when desired - causes a delay in open a section either for work to be performed at atmospheric pressure or return to operation of the interferometer and cryopump.	None	4	D	4D
			Valve is Closed with the Laser on	Damage to the valve and possibly other equipment	LIGO to prevent this happening both with procedures and also a computer interlock to prevent valve closure with the laser powered.	1	D	1D

Hazard Severity Categories (HSC): 1=Catastrophic, 2=Critical, 3=Marginal, 4=Negligible
 Hazard Probability (HP): A=Frequent, B=Probable, C=Occasional, D=Remote, E=Improbable
 Hazard Risk Index (HRI)

Rev. 0
 Prepared by: SFT
 Reviewed by: TS

LIGO Vacuum Equipment
 Failure Modes and Effects Analysis

			Valve fails to fully close or open	System not isolated or valve impinges on beam path	LIGO to program interlock to prevent laser operation until the beam path is clear.	3	E	3E
				The pneumatic valves have limit switches on the actuators which communicate with the computer.				
			Valve opens unexpectedly	Section containing equipment and personnel under atmospheric pressure is exposed to vacuum causing injury or death and damage to equipment on both sides of valve.	None	1	E	1E
				The safeguard to prevent this is a true "two key" operation - both the operator at the valve must open the lockout device and the computer must drive the valve for it to either open or close.				
			Valve drive damaged by attempted opening with excessive differential pressure	The section will have to be isolated with other valves and the valve repaired.	LIGO to include in the operating instructions allowable differential pressures before valve opening is allowed. Part of lockout procedure.	2	E	2E

Hazard Severity Categories (HSC): 1=Catastrophic, 2=Critical, 3=Marginal, 4=Negligible
 Hazard Probability (HP): A=Frequent, B=Probable, C=Occasional, D=Remote, E=Improbable
 Hazard Risk Index (HRI)

Rev. ↪
 Prepared by: ST-T
 Reviewed by: TS

LIGO Vacuum Equipment
 Failure Modes and Effects Analysis

P&I Number: V049-0-005 Rev. 1
Node: 9
System: Large Gate Valves
Date: 4/5/96

This P&ID depicts the pneumatic and motor driven 44" and 48" gate valves.
 There are 8 - 44" pneumatic gate valves, Washington 5-8, and Louisiana 3-6.
 There are 8 - 48" and 16 - 44" electric gate valves, Washington 1-4, and 9-20. and Louisiana 1,2 and 7-12.
 The equipment and instrument numbers reflect WGV5 for pneumatic and WGV1 for electric.

ITEM:	IDENTIFICATION	DESCRIPTION	FAILURE MODES	EFFECTS	ACTION ITEM	HSC	HP	HRI
15		25 torr-liter/second ion pump	Ion pump shuts down on high current caused by high pressure	Loss of annulus pumping capacity, the MiniVac controller protects the pump with fuses. If the pump will not restart, the auxiliary turbo will be attached to the 1 1/2" auxiliary turbo pumpout port and the annulus repumped.		4	D	4D
			High Pressure could be caused by premature operation during pumpdown or leakage through the "O" rings.	When the pressure is low enough the ion pump can be restarted.				
				If the pump cannot be restarted, the 1-1/2" AVHV can be closed and the ion pump replaced.				

Hazard Severity Categories (HSC): 1=Catastrophic, 2=Critical, 3=Marginal, 4=Negligible
 Hazard Probability (HP): A=Frequent, B=Probable, C=Occasional, D=Remote, E=Improbable
 Hazard Risk Index (HRI)

				Current indication at the computer will indicate whether the computer is running. In addition, the local controller displays the pump condition. Periodic observation of the local controller condition should be made part of an operational checklist.	LIGO to include this in operating procedure.			
			Ion pump shuts down on power failure	Loss of annulus pumping capacity. When the power returns the ion pump will restart. This probably is not a problem. After power returns the annulus ion pumps will have to be checked to see if they're running.	LIGO to include this in operating procedure.	4	D	4D
				If not they will need to be turbopumped and restarted as above.				
16		Dual "O" Ring Seals and their connecting piping.	Seal Failure or Seal Leakage	Leakage on the chamber side would not be noticed with both the chamber and the annulus at high vacuum.	None	4	D	4D
				When the chamber is brought back to atmosphere a chamber side leak might be noticed if the annulus ion pump was kept on and the current monitored.				
				A small atmospheric side leak would show up as increased current draw on the ion pump. A larger leak would trip the ion pump.				

Rev. 0
Prepared by: SFT
Reviewed by: TS

LIGO Vacuum Equipment
Failure Modes and Effects Analysis

				Turbopumping the annulus in conjunction with the ion pump might allow continued operation until a convenient scheduled repair could be arranged.				
--	--	--	--	--	--	--	--	--

Rev. 0
 Prepared by: SET
 Reviewed by: JS

LIGO Vacuum Equipment
 Failure Modes and Effects Analysis

P&I Number: V049-0-005 Rev. 1
 Node: 10
 System: Large Gate Valves
 Date: 4/5/96

The large gate valves, whether pneumatic or electric are driven from the computer. Since the opening of one of these valves exposes an atmospheric section to high vacuum and vice versa we recommend and plan to configure the controls such that they can only be operated from the control room. At the valve itself there is a lockout with a keyed padlock which prevents opening even if the computer initiates it. LIGO operating procedures will stress the critical nature of the lockout / tagout function. The lockout feature of the valves is also used in the open position.

ITEM:	IDENTIFICATION	DESCRIPTION	FAILURE MODES	EFFECTS	ACTION ITEM	HSC	HP	HRI
17	WGV1	48" Electric Gate Valve	Valve Fails to Close, caused by power failure, failure of drive mechanism, or failure to open lockout.	Failure to isolate a section when desired - causes a delay in isolating a section either for pumpdown to vacuum, repressurization, or cryopump regeneration.	None	4	D	4D
			Valve Fails to Open, caused by power failure, failure of drive mechanism, failure to open lockout, or failure of the latching mechanism to release.	Failure to open a section when desired - causes a delay in open a section either for work to be performed at atmospheric pressure or return to operation of the interferometer and cryopump.	None	4	D	4D
			Valve is Closed with the Laser on	Damage to the valve and possibly other equipment	LIGO to prevent this happening both with procedures and also a computer interlock to prevent valve closure with the laser powered.	1	D	1D

Hazard Severity Categories (HSC): 1=Catastrophic, 2=Critical, 3=Marginal, 4=Negligible
 Hazard Probability (HP): A=Frequent, B=Probable, C=Occasional, D=Remote, E=Improbable
 Hazard Risk Index (HRI)

Rev. 0
 Prepared by: *STP*
 Reviewed by: *TS*

LIGO Vacuum Equipment
 Failure Modes and Effects Analysis

			Valve fails to fully close or open	System not isolated or valve impinges on beam path	LIGO to program interlock to prevent laser operation until the beam path is clear.	3	E	3E
				The pneumatic valves have limit switches on the actuators which communicate with the computer.				
			Valve opens unexpectedly	Section containing equipment and personnel under atmospheric pressure is exposed to vacuum causing injury or death and damage to equipment on both sides of valve.	None	1	E	1E
				The safeguard to prevent this is a true "two key" operation - both the operator at the valve must open the lockout device and the computer must drive the valve for it to either open or close.				
			Valve drive damaged by attempted opening with excessive differential pressure	The section will have to be isolated with other valves and the valve repaired.	LIGO to include in the operating instructions allowable differential pressures before valve opening is allowed. Part of lockout procedure.	2	E	2E

Hazard Severity Categories (HSC): 1=Catastrophic, 2=Critical, 3=Marginal, 4=Negligible
 Hazard Probability (HP): A=Frequent, B=Probable, C=Occasional, D=Remote, E=Improbable
 Hazard Risk Index (HRI)

Rev. 0
 Prepared by: SET
 Reviewed by: JPM

LIGO Vacuum Equipment
 Failure Modes and Effects Analysis

P&I Number: V049-0-006 Rev. 1
Node: 11
System: 80K Cryopump LN2 and GN2 Supply
Date: 4/11/96

At each cryopump there is a dedicated LN2 supply dewar located outside the building. The cryopump regeneration system consists of an ambient vaporizer also located outside the building, a hand control valve, a flow indicator, and an electric heater to warm the gas.

The storage dewar includes a pressure building coil and all the normal pressure relief protection.

ITEM:	IDENTIFICATION	DESCRIPTION	FAILURE MODES	EFFECTS	ACTION ITEM	HSC	HP	HRI
18	LV-100	LN2 Level Control Valve	Valve fails closed	Failure to make up liquid to the cryopump with loss of effectiveness and eventual release of adsorbed water vapor.	LIGO to consider configuring low level alarm on LIC-100, LAL-100.	4	E	4E
				The protection against this is the level reading on the LIGO computer for LIC100.				
			Valve fails open	The cryopump reservoir overfills spilling LN2 out the vent.	LIGO to consider configuring high level alarm on LIC-100, LAH-100.	4	D	4D
				The protection against this is the level reading on the LIGO computer for LIC100.				

Hazard Severity Categories (HSC): 1=Catastrophic, 2=Critical, 3=Marginal, 4=Negligible
 Hazard Probability (HP): A=Frequent, B=Probable, C=Occasional, D=Remote, E=Improbable
 Hazard Risk Index (HRI)

Rev. 0
 Prepared by: SFT
 Reviewed by: DM

LIGO Vacuum Equipment
 Failure Modes and Effects Analysis

19		LN2 Dewar and associated vendor supplied valving and pressure building coil.	Dewar overpressures	Vessel rupture, protected by dual RV's 106 and 107 and rupture disks RD 106 and 107. Potentially blocked in liquid lines are protected by RV112, 132, and 136.	None	4	E	4E
20		Ambient Vaporizer	Outside surface covered with ice limiting effectiveness.	Inability to vaporize sufficient LN2 for regeneration. Regeneration can be stopped until the vaporizer can be derimed.	None	4	E	4E
21		Electric Heater	Heater burns out. Protection is by hard wired TSH-103.	Inability to heat the gas above ambient. This would slow regeneration.	LIGO to consider TAH on TSH-103.	4	E	4E
			JC-103 fails with low output.	Inability to heat the gas above ambient. This would slow regeneration.	None	4	E	4E
			TIC103 fails with high output;	Overheat the cryopump potentially above design temperature.	LIGO to configure high temperature alarms TAH-103A on TIC-103 and TAH-102 on TI-102.	4	E	4E

Hazard Severity Categories (HSC): 1=Catastrophic, 2=Critical, 3=Marginal, 4=Negligible
 Hazard Probability (HP): A=Frequent, B=Probable, C=Occasional, D=Remote, E=Improbable
 Hazard Risk Index (HRI)

Rev. 0

Prepared by: STT

Reviewed by: TOM

LIGO Vacuum Equipment
Failure Modes and Effects Analysis

P&I Number: V049-0-006 Rev. 1
Node: 12
System: 80K Cryopump
Date: 4/11/96

ITEM:	IDENTIFICATION	DESCRIPTION	FAILURE MODES	EFFECTS	ACTION ITEM	HSC	HP	HRI
22	WCP1	80 K Cryopump	Leakage from atmosphere	Failure to maintain vacuum, each cryopump has a gauge pair which will indicate loss of vacuum. The leak can either be repaired with the cryopump in service or the cryopump can be isolated and the leak repaired.	None	4	E	4E
			Rupture or leak from LN2 reservoir into the cryopump	Overpressure of the cryopump shell. Protection is provided by relief device on the cryopump shell.	None	4	E	4E
			Overpressure of LN2 reservoir, one cause would be vent blocked by ice.	Overpressure of the LN2 reservoir. Protected by RV-133 and PI-101.	LIGO to consider adding pressure alarm, PAH-101.	4	E	4E

Hazard Severity Categories (HSC): 1=Catastrophic, 2=Critical, 3=Marginal, 4=Negligible
Hazard Probability (HP): A=Frequent, B=Probable, C=Occasional, D=Remote, E=Improbable
Hazard Risk Index (HRI)

Rev. 0
 Prepared by: SET
 Reviewed by: FAB

LIGO Vacuum Equipment
 Failure Modes and Effects Analysis

P&I Number: V049-0-010 Rev. 1
 Node: 13
 System: Washington Site Left End Station
 Date: 4/11/96

Node 13 includes all the normally connected equipment. The BSC chamber covered on P&ID V049-0-002, WIP11, and WCP7.

ITEM:	IDENTIFICATION	DESCRIPTION	FAILURE MODES	EFFECTS	ACTION ITEM	HSC	HP	HRI
23	WIP11	2500 torr-liter/sec ion pump and its' associated 14" gate valve.	Ion pump shutdown. The ion pump controller protects it from damage due to high current draw.	Loss of ion pumping capacity. The ion pump can be restarted once the cause of the shutdown has been fixed (too high pressure due to leak, premature operation, etc.). If the ion pump is damaged and cannot be restarted, the 14" GVHV can be closed and the ion pump replaced.	None	4	D	4D
24	WCP7	80 K Cryopump (Short)	Leakage from atmosphere or LN2 side.	Loss of vacuum, possible contamination. PI-424 A or B will indicate leak. The cryopump can be isolated with WGV17 and 18 and repaired.	None	3	D	3D
25	PI 424 A or B	Gauge Pair on Cryopump	Either gauge fails electrically	Loss in the ability to read the vacuum level. Either an RGA can be attached to read the pressure or operation may continue without this information until it's convenient to isolate the cryopump and replace the	None	4	D	4D

Hazard Severity Categories (HSC): 1=Catastrophic, 2=Critical, 3=Marginal, 4=Negligible
 Hazard Probability (HP): A=Frequent, B=Probable, C=Occasional, D=Remote, E=Improbable
 Hazard Risk Index (HRI)

26	WGV18	Large Motor Operated Gate Valve	Valve fails to close	Inability to isolate cryopump for regeneration or back to air operation. Valve can be repaired and the valve closed.	None	4	D	4D
			Valve fails to open	Inability to return pump to operation. Valve can be repaired and the valve closed.	None	4	D	4D
			Valve closed with laser in operation	Damage to equipment and/or valve. Protection is by "two-key" lockout with both computer and physical lockout covered in operating procedures.	LIGO to consider adding interlock preventing closure of valve on beam line with the laser on.	2	E	2E
			Valve opened with pressure on one side or BSC open to clean room.	Damage to equipment, personnel injury or death. Protection is by "two-key" lockout with both computer and physical lockout covered in operating procedures.	None	2	E	2E
27	WGV17	Large Motor Operated Gate Valve	Valve fails to close	Inability to isolate cryopump for regeneration or back to air operation. Valve can be repaired and the valve closed.	None	4	D	4D
			Valve fails to open	Inability to return pump to operation. Valve can be repaired and the valve closed.	None	4	D	4D
			Valve closed with laser in operation	Damage to equipment and/or valve. Protection is by "two-key" lockout with both computer and physical lockout covered in operating procedures.	LIGO to consider adding interlock preventing closure of valve on beam line with the laser on.	2	E	2E

Hazard Severity Categories (HSC): 1=Catastrophic, 2=Critical, 3=Marginal, 4=Negligible
Hazard Probability (HP): A=Frequent, B=Probable, C=Occasional, D=Remote, E=Improbable
Hazard Risk Index (HRI)

Rev. ∞
 Prepared by: *STP*
 Reviewed by: *TS*

LIGO Vacuum Equipment
 Failure Modes and Effects Analysis

			Valve opened with pressure on one side or BSC open to clean room.	Damage to equipment, personnel injury or death. Protection is by "two-key" lockout with both computer and physical lockout covered in operating procedures.	None	2	E	2E
--	--	--	---	---	------	---	---	----

Hazard Severity Categories (HSC): 1=Catastrophic, 2=Critical, 3=Marginal, 4=Negligible
 Hazard Probability (HP): A=Frequent, B=Probable, C=Occasional, D=Remote, E=Improbable
 Hazard Risk Index (HRI)

Rev. 0

Prepared by: SET
Reviewed by: FIB

LIGO Vacuum Equipment
Failure Modes and Effects Analysis

P&I Number: V049-0-010 Rev. 1
Node: 14
System: Washington Site Left End Station
Date: 4/12/96

Node 14 includes the turbo pumping equipment and the clean air supply system equipment. The Turbo Cart and its' Turbo Backing Pump Cart are self-protected. See Hazards Analysis sheets for the Turbo Carts. The unit shuts down on loss of seal gas to the backing cart, loss of cooling water flow shuts it down on high temperature, power failure, etc.

An intrinsically safe wiring setup has been designed such that it is physically impossible to operate more than one turbo pump cart with a single backing pump.

Note: Added Safety and Interlock

It is suggested to add a pressure switch between PCV 426 and 427 for back to air operation. If the rate of flow is too high for the clean air supply to keep up with both PCV's will open to maintain pressure. Should the receiver pressure drop sufficiently it could be damaged and bed material sucked into the chamber being repressurized. The pressure switch would go to the LIGO computer and shutdown the back to air valve.

ITEM:	IDENTIFICATION	DESCRIPTION	FAILURE MODES	EFFECTS	ACTION ITEM	HSC	HP	HRI
28	WTC5	Turbopump cart and associated connections	Pump shuts down for any of a number of reasons; loss of utility, suction pressure above allowable due to leak or insufficient roughing.	Delay in pumping out the system. The cause of pump shutdown needs to be corrected and the process restarted.	None	4	E	4E

Hazard Severity Categories (HSC): 1=Catastrophic, 2=Critical, 3=Marginal, 4=Negligible
Hazard Probability (HP): A=Frequent, B=Probable, C=Occasional, D=Remote, E=Improbable
Hazard Risk Index (HRI)

29	HV 120 / 121	10" Pump out port valve	Valve opened to atmosphere with vacuum in the tube or cryopump. These are manual gate valves with a pad lock for both lock open and lock closed. LIGO procedures will regulate the opening or closing of these valves.	Loss of vacuum, damage to equipment in the tube, contamination, injury or loss of life to personnel near the valve.	LIGO to incorporate lockout procedures for locking gate valves in their operator training.	1	E	1E
30	WTC5B	Turbo pump backing cart	Pump shuts down for any of a number of reasons; loss of utility, signal from turbo cart controller.	Shutdown of turbo cart and delay in pumping out the system. The cause of pump shutdown needs to be corrected and the process restarted.	None	4	E	4E
31	WCA400	Class 100 Clean Air Supply System	System shutdown, either compressor out or drier beds won't switch. Three signals go to the LIGO computer for monitoring, Compressor running signal, Compressor Common Alarm, Drier Beds Common Alarm.	During turbo pumping this would cause shutdown of the Turbo Backing Pump on loss of seal air.	None	4	E	4E
				During back to air operation the receiver could be sucked down to vacuum damaging it.	LIGO to provide computer interlock between compressor running signal and back to air control valve, for example PCV 120.	3	D	3D

Rev. 6
 Prepared by: SFT
 Reviewed by: TS

LIGO Vacuum Equipment
 Failure Modes and Effects Analysis

				During purge operation through air showers loss of flow would allow contamination of optics with moisture.	None	4	E	4E
32	PCV-426	First stage letdown valve	Fail open	Increase downstream pressure	None	4	E	4E
			Fail closed	Loss of clean air flow tripping the turbo or cutting off air shower flow.	None	4	E	4E
33	PCV-427	Second stage letdown valve	Fail open	Increase downstream pressure might raise back to air pressure above vessel design pressure. Protection provided by accurate pressure control of back to air valve and PSV-425 on the clean air supply header.	None	4	E	4E
			Fail closed	Loss of clean air flow tripping the turbo or cutting off air shower flow.	None	4	E	4E

Hazard Severity Categories (HSC): 1=Catastrophic, 2=Critical, 3=Marginal, 4=Negligible
 Hazard Probability (HP): A=Frequent, B=Probable, C=Occasional, D=Remote, E=Improbable
 Hazard Risk Index (HRI)

Rev. 0
 Prepared by: ST
 Reviewed by: FRB

LIGO Vacuum Equipment
 Failure Modes and Effects Analysis

P&I Number: V049-0-011 Rev. 1
 Node: 15
 System: Washington Left Mid Station
 Date: 4/12/96

Node 15 includes all the normally connected equipment; WCP4, WBSC6, WIP9, WCP3, and WGV 9,10,11, and 12.

ITEM:	IDENTIFICATION	DESCRIPTION	FAILURE MODES	EFFECTS	ACTION ITEM	HSC	HP	HRI
34	WIP9	2500 torr-liter/sec ion pump and its' associated 14" gate valve.	Ion pump shutdown. The ion pump controller protects it from damage due to high current draw.	Loss of ion pumping capacity. The ion pump can be restarted once the cause of the shutdown has been fixed (too high pressure due to leak, premature operation, etc.). If the ion pump is damaged and cannot be restarted, the 14" GVHV can be closed and the ion pump replaced.	None	4	D	4D
35	WCP4	80 K Cryopump (Short)	Leakage from atmosphere or LN2 side.	Loss of vacuum, possible contamination. PI-245 A or B will indicate leak. The cryopump can be isolated with WGV11 and 12 and repaired.	None	3	D	3D
36	PI 245 A or B	Gauge Pair on Cryopump	Either gauge fails electrically	Loss in the ability to read the vacuum level. Either an RGA can be attached to read the pressure or operation may continue without this information until it's convenient to isolate the cryopump and replace the	None	4	D	4D

Hazard Severity Categories (HSC): 1=Catastrophic, 2=Critical, 3=Marginal, 4=Negligible
 Hazard Probability (HP): A=Frequent, B=Probable, C=Occasional, D=Remote, E=Improbable
 Hazard Risk Index (HRI)

Rev. 0
 Prepared by: STT
 Reviewed by: TS

LIGO Vacuum Equipment
 Failure Modes and Effects Analysis

37	WCP3	80 K Cryopump (Short)	Leakage from atmosphere or LN2 side.	Loss of vacuum, possible contamination. PI-244 A or B will indicate leak. The cryopump can be isolated with WGV9 and 10 and repaired.	None	3	D	3D
38	PI 244 A or B	Gauge Pair on Cryopump	Either gauge fails electrically	Loss in the ability to read the vacuum level. Either an RGA can be attached to read the pressure or operation may continue without this information until it's convenient to isolate the cryopump and replace the	None	4	D	4D
39	WGV12	Large Motor Operated Gate Valve	Valve fails to close	Inability to isolate cryopump for regeneration or back to air operation. Valve can be repaired and the valve closed.	None	4	D	4D
			Valve fails to open	Inability to return pump to operation. Valve can be repaired and the valve closed.	None	4	D	4D
			Valve closed with laser in operation	Damage to equipment and/or valve. Protection is by "two-key" lockout with both computer and physical lockout covered in operating procedures.	LIGO to consider adding interlock preventing closure of valve on beam line with the laser on.	2	E	2E
			Valve opened with pressure on one side or BSC open to clean room.	Damage to equipment, personnel injury or death. Protection is by "two-key" lockout with both computer and physical lockout covered in operating procedures.	None	2	E	2E

Hazard Severity Categories (HSC): 1=Catastrophic, 2=Critical, 3=Marginal, 4=Negligible
 Hazard Probability (HP): A=Frequent, B=Probable, C=Occasional, D=Remote, E=Improbable
 Hazard Risk Index (HRI)

Rev. 0
 Prepared by: *SPT*
 Reviewed by: *TS*

LIGO Vacuum Equipment
 Failure Modes and Effects Analysis

40	WGV11	Large Motor Operated Gate Valve	Valve fails to close	Inability to isolate cryopump for regeneration or back to air operation. Valve can be repaired and the valve closed.	None	4	D	4D
			Valve fails to open	Inability to return pump to operation. Valve can be repaired and the valve closed.	None	4	D	4D
			Valve closed with laser in operation	Damage to equipment and/or valve. Protection is by "two-key" lockout with both computer and physical lockout covered in operating procedures.	LIGO to consider adding interlock preventing closure of valve on beam line with the laser on.	2	E	2E
			Valve opened with pressure on one side or BSC open to clean room.	Damage to equipment, personnel injury or death. Protection is by "two-key" lockout with both computer and physical lockout covered in operating procedures.	None	2	E	2E
41	WGV10	Large Motor Operated Gate Valve	Valve fails to close	Inability to isolate cryopump for regeneration or back to air operation. Valve can be repaired and the valve closed.	None	4	D	4D
			Valve fails to open	Inability to return pump to operation. Valve can be repaired and the valve closed.	None	4	D	4D
			Valve closed with laser in operation	Damage to equipment and/or valve. Protection is by "two-key" lockout with both computer and physical lockout covered in operating procedures.	LIGO to consider adding interlock preventing closure of valve on beam line with the laser on.	2	E	2E

Hazard Severity Categories (HSC): 1=Catastrophic, 2=Critical, 3=Marginal, 4=Negligible
 Hazard Probability (HP): A=Frequent, B=Probable, C=Occasional, D=Remote, E=Improbable
 Hazard Risk Index (HRI)

			Valve opened with pressure on one side or BSC open to clean room.	Damage to equipment, personnel injury or death. Protection is by "two-key" lockout with both computer and physical lockout covered in operating procedures.	None	2	E	2E
42	WGV9	Large Motor Operated Gate Valve	Valve fails to close	Inability to isolate cryopump for regeneration or back to air operation. Valve can be repaired and the valve closed.	None	4	D	4D
			Valve fails to open	Inability to return pump to operation. Valve can be repaired and the valve closed.	None	4	D	4D
			Valve closed with laser in operation	Damage to equipment and/or valve. Protection is by "two-key" lockout with both computer and physical lockout covered in operating procedures.	LIGO to consider adding interlock preventing closure of valve on beam line with the laser on.	2	E	2E
			Valve opened with pressure on one side or BSC open to clean room.	Damage to equipment, personnel injury or death. Protection is by "two-key" lockout with both computer and physical lockout covered in operating procedures.	None	2	E	2E

Rev. 0
Prepared by: SPT
Reviewed by:

LIGO Vacuum Equipment
Failure Modes and Effects Analysis

P&I Number: V049-0-011 Rev. 1
Node: 16
System: Washington Left Mid Station
Date: 4/12/96

Node 16 includes the turbo pumping equipment and the clean air supply system equipment. The Turbo Cart and its' Turbo Backing Pump Cart are self-protected. See Hazards Analysis sheets for the Turbo Carts. The unit shuts down on loss of seal gas to the backing cart, loss of cooling water flow shuts it down on high temperature, power failure, etc.

Preliminary review of vendor information uncovered a need to prevent defeating the backing pump safeties with a local control switch. The preferred method is the use of a "jog" switch with spring return so local operation of the backing pump can only be done with the operator holding the switch.

An intrinsically safe wiring setup has been designed such that it is physically impossible to operate more than one turbo pump cart with a single backing pump.

Note: Added Safety and Interlock

It is suggested to add a pressure switch between PCV 261 and 284 for back to air operation. If the rate of flow is too high for the clean air supply to keep up with both PCV's will open to maintain pressure. Should the receiver pressure drop sufficiently it could be damaged and bed material sucked into the chamber being repressurized. The pressure switch would go to the LIGO computer and shutdown the back to air valve.

ITEM:	IDENTIFICATION	DESCRIPTION	FAILURE MODES	EFFECTS	ACTION ITEM	HSC	HP	HRI
42	WTC3	Turbopump cart and associated connections	Pump shuts down for any of a number of reasons; loss of utility, suction pressure above allowable due to leak or insufficient roughing.	Delay in pumping out the system. The cause of pump shutdown needs to be corrected and the process restarted.	None	4	E	4E

Hazard Severity Categories (HSC): 1=Catastrophic, 2=Critical, 3=Marginal, 4=Negligible
Hazard Probability (HP): A=Frequent, B=Probable, C=Occasional, D=Remote, E=Improbable
Hazard Risk Index (HRI)

Rev. 0
 Prepared by: SRT
 Reviewed by: TS

LIGO Vacuum Equipment
 Failure Modes and Effects Analysis

43	HV 240 / 241 / 242	10" Pump out port valves	Valve opened to atmosphere with vacuum in the tube or cryopump. These are manual gate valves with a pad lock for both lock open and lock closed. LIGO procedures will regulate the opening or closing of these valves.	Loss of vacuum, damage to equipment in the tube, contamination, injury or loss of life to personnel near the valve.	LIGO to incorporate lockout procedures for locking gate valves in their operator training.	1	E	1E
44	WTC3B	Turbo pump backing cart	Pump shuts down for any of a number of reasons; loss of utility, signal from turbo cart controller.	Shutdown of turbo cart and delay in pumping out the system. The cause of pump shutdown needs to be corrected and the process restarted.	None	4	E	4E
45	WCA200	Class 100 Clean Air Supply System	System shutdown, either compressor out or drier beds won't switch. Three signals go to the LIGO computer for monitoring, Compressor running signal, Compressor Common Alarm, Drier Beds Common Alarm.	During turbo pumping this would cause shutdown of the Turbo Backing Pump on loss of seal air.	None	4	E	4E
				During back to air operation the receiver could be sucked down to vacuum damaging it.	LIGO to provide computer interlock between compressor running signal and back to air control valve, for example PCV 120.	3	D	3D

Hazard Severity Categories (HSC): 1=Catastrophic, 2=Critical, 3=Marginal, 4=Negligible
 Hazard Probability (HP): A=Frequent, B=Probable, C=Occasional, D=Remote, E=Improbable
 Hazard Risk Index (HRI)

Rev. 0

Prepared by: *SET*

Reviewed by: *TS*

LIGO Vacuum Equipment
Failure Modes and Effects Analysis

				During purge operation through air showers loss of flow would allow contamination of optics with moisture.	None	4	E	4E
46	PCV-261	First stage letdown valve	Fail open	Increase downstream pressure	None	4	E	4E
			Fail closed	Loss of clean air flow tripping the turbo or cutting off air shower flow.	None	4	E	4E
47	PCV-284	Second stage letdown valve	Fail open	Increase downstream pressure might raise back to air pressure above vessel design pressure. Protection provided by accurate pressure control of back to air valve and PSV-260 on the clean air supply header.	None	4	E	4E
			Fail closed	Loss of clean air flow tripping the turbo or cutting off air shower flow.	None	4	E	4E

Hazard Severity Categories (HSC): 1=Catastrophic, 2=Critical, 3=Marginal, 4=Negligible
Hazard Probability (HP): A=Frequent, B=Probable, C=Occasional, D=Remote, E=Improbable
Hazard Risk Index (HRI)

Rev. 0
 Prepared by: SET
 Reviewed by: FMB

LIGO Vacuum Equipment
 Failure Modes and Effects Analysis

P&I Number: V049-0-012 Rev. 1
 Node: 17
 System: Washington Site Left Beam Manifold
 Date: 4/12/96

Node 17 includes all the normally connected equipment; WCP1, WBSC8, WIP5, and WGV 5 and 6.

ITEM:	IDENTIFICATION	DESCRIPTION	FAILURE MODES	EFFECTS	ACTION ITEM	HSC	HP	HRI
48	WIP5	2500 torr-liter/sec ion pump and its' associated 14" gate valve.	Ion pump shutdown. The ion pump controller protects it from damage due to high current draw.	Loss of ion pumping capacity. The ion pump can be restarted once the cause of the shutdown has been fixed (too high pressure due to leak, premature operation, etc.). If the ion pump is damaged and cannot be restarted, the 14" GVHV can be closed and the ion pump replaced.	None	4	D	4D
49	WCP1	80 K Cryopump (Long)	Leakage from atmosphere or LN2 side.	Loss of vacuum, possible contamination. PI-114 A or B will indicate leak. The cryopump can be isolated with WGV5 and 6 and repaired.	None	3	D	3D
50	PI 114 A or B	Gauge Pair on Cryopump	Either gauge fails electrically	Loss in the ability to read the vacuum level. Either an RGA can be attached to read the pressure or operation may continue without this information until it's convenient to isolate the cryopump and replace the	None	4	D	4D

Hazard Severity Categories (HSC): 1=Catastrophic, 2=Critical, 3=Marginal, 4=Negligible
 Hazard Probability (HP): A=Frequent, B=Probable, C=Occasional, D=Remote, E=Improbable
 Hazard Risk Index (HRI)

Rev. 0
 Prepared by: SFT
 Reviewed by: TS

LIGO Vacuum Equipment
 Failure Modes and Effects Analysis

51	WGV5	Large Pneumatic Gate Valve	Valve fails to close	Inability to isolate cryopump for regeneration or back to air operation. Valve can be repaired and the valve closed.	None	4	D	4D
			Valve fails to open	Inability to return pump to operation. Valve can be repaired and the valve closed.	None	4	D	4D
			Valve closed with laser in operation	Damage to equipment and/or valve. Protection is by "two-key" lockout with both computer and physical lockout covered in operating procedures.	LIGO to consider adding interlock preventing closure of valve on beam line with the laser on.	2	E	2E
			Valve opened with pressure on one side or BSC open to clean room.	Damage to equipment, personnel injury or death. Protection is by "two-key" lockout with both computer and physical lockout covered in operating procedures.	None	2	E	2E
52	WGV6	Large Pneumatic Gate Valve	Valve fails to close	Inability to isolate cryopump for regeneration or back to air operation. Valve can be repaired and the valve closed.	None	4	D	4D
			Valve fails to open	Inability to return pump to operation. Valve can be repaired and the valve closed.	None	4	D	4D
			Valve closed with laser in operation	Damage to equipment and/or valve. Protection is by "two-key" lockout with both computer and physical lockout covered in operating procedures.	LIGO to consider adding interlock preventing closure of valve on beam line with the laser on.	2	E	2E

Hazard Severity Categories (HSC): 1=Catastrophic, 2=Critical, 3=Marginal, 4=Negligible
 Hazard Probability (HP): A=Frequent, B=Probable, C=Occasional, D=Remote, E=Improbable
 Hazard Risk Index (HRI)

Rev. 0

Prepared by: SFT

Reviewed by: TS

LIGO Vacuum Equipment
Failure Modes and Effects Analysis

			Valve opened with pressure on one side or BSC open to clean room.	Damage to equipment, personnel injury or death. Protection is by "two-key" lockout with both computer and physical lockout covered in operating procedures.	None	2	E	2E
53	HV 146 / 147 / 148	10" Pump out port valves	Valve opened to atmosphere with vacuum in the tube or cryopump. These are manual gate valves with a pad lock for both lock open and lock closed. LIGO procedures will regulate the opening or closing of these valves.	Loss of vacuum, damage to equipment in the tube, contamination, injury or loss of life to personnel near the valve.	LIGO to incorporate lockout procedures for locking gate valves in their operator training.	1	E	1E

Hazard Severity Categories (HSC): 1=Catastrophic, 2=Critical, 3=Marginal, 4=Negligible
Hazard Probability (HP): A=Frequent, B=Probable, C=Occasional, D=Remote, E=Improbable
Hazard Risk Index (HRI)

Rev. ^o
 Prepared by: SFT
 Reviewed by: FRB

LIGO Vacuum Equipment
 Failure Modes and Effects Analysis

P&I Number: V049-0-013 Rev. 1
 Node: 18
 System: Washington Site Vertex Section
 Date: 4/16/96

Node 18 is the entire P&ID. The vertex section is one large isolatable section with only two large gate valves. There are no cryopumps in the vertex section. The FMEA information for the HAM's and BSC's is found on the FMEA sheets for P&ID's V049-0-002, 003 and 004.

ITEM:	IDENTIFICATION	DESCRIPTION	FAILURE MODES	EFFECTS	ACTION ITEM	HSC	HP	HRI
54	WIP1	2500 torr-liter/sec ion pump and its' associated 14" gate valve.	Ion pump shutdown. The ion pump controller protects it from damage due to high current draw.	Loss of ion pumping capacity. The ion pump can be restarted once the cause of the shutdown has been fixed (too high pressure due to leak, premature operation, etc.).	None	4	D	4D
				If the ion pump is damaged and cannot be restarted, the 14" GVHV can be closed and the ion pump replaced.				
55	WIP2	2500 torr-liter/sec ion pump and its' associated 14" gate valve.	Ion pump shutdown. The ion pump controller protects it from damage due to high current draw.	Loss of ion pumping capacity. The ion pump can be restarted once the cause of the shutdown has been fixed (too high pressure due to leak, premature operation, etc.).	None	4	D	4D
				If the ion pump is damaged and cannot be restarted, the 14" GVHV can be closed and the ion pump replaced.				

Hazard Severity Categories (HSC): 1=Catastrophic, 2=Critical, 3=Marginal, 4=Negligible
 Hazard Probability (HP): A=Frequent, B=Probable, C=Occasional, D=Remote, E=Improbable
 Hazard Risk Index (HRI)

Rev. 0
 Prepared by: *SET*
 Reviewed by: *FNB*

LIGO Vacuum Equipment
 Failure Modes and Effects Analysis

56	WIP3	2500 torr-liter/sec ion pump and its' associated 14" gate valve.	Ion pump shutdown. The ion pump controller protects it from damage due to high current draw.	Loss of ion pumping capacity. The ion pump can be restarted once the cause of the shutdown has been fixed (too high pressure due to leak, premature operation, etc.).	None	4	D	4D
				If the ion pump is damaged and cannot be restarted, the 14" GVHV can be closed and the ion pump replaced.				
57	WIP4	2500 torr-liter/sec ion pump and its' associated 14" gate valve.	Ion pump shutdown. The ion pump controller protects it from damage due to high current draw.	Loss of ion pumping capacity. The ion pump can be restarted once the cause of the shutdown has been fixed (too high pressure due to leak, premature operation, etc.).	None	4	D	4D
				If the ion pump is damaged and cannot be restarted, the 14" GVHV can be closed and the ion pump replaced.				
58	HV 109	10" Pump out port valve	Valve opened to atmosphere with vacuum in the tube. This is a manual gate valve with a pad lock for both lock open and lock closed. LIGO procedures will regulate the opening or closing of this valve.	Loss of vacuum, damage to equipment in the tube, contamination, injury or loss of life to personnel near the valve.	LIGO to incorporate lockout procedures for locking gate valves in their operator training.	1	E	1E
59	HV 145	6" Pump out port valve	Valve opened to atmosphere with vacuum in the tube. This is a manual gate valve with a pad lock for both lock open and lock closed. LIGO procedures will regulate the opening or closing of this valve.	Loss of vacuum, damage to equipment in the tube, contamination, injury or loss of life to personnel near the valve.	LIGO to incorporate lockout procedures for locking gate valves in their operator training.	1	E	1E



Hazard Severity Categories (HSC): 1=Catastrophic, 2=Critical, 3=Marginal, 4=Negligible
 Hazard Probability (HP): A=Frequent, B=Probable, C=Occasional, D=Remote, E=Improbable
 Hazard Risk Index (HRI)

Rev. 0
 Prepared by: SET
 Reviewed by: TS

LIGO Vacuum Equipment
 Failure Modes and Effects Analysis

60	WGV1	Large Motor Operated Gate Valve	Valve fails to close	Inability to isolate vertex section for pumpdown or back to air operation. Valve can be repaired and the valve closed.	None	4	D	4D
			Valve fails to open	Inability to return vertex section to operation. Valve can be repaired and the valve closed.	None	4	D	4D
			Valve closed with laser in operation	Damage to equipment and/or valve. Protection is by "two-key" lockout with both computer and physical lockout covered in operating procedures.	LIGO to consider adding interlock preventing closure of valve on beam line with the laser on.	2	E	2E
			Valve opened with pressure on one side or one of the BSC's or HAM's open to clean room.	Damage to equipment, personnel injury or death. Protection is by "two-key" lockout with both computer and physical lockout covered in operating procedures.	None	2	E	2E
61	WGV2	Large Motor Operated Gate Valve	Valve fails to close	Inability to isolate vertex section for pumpdown or back to air operation. Valve can be repaired and the valve closed.	None	4	D	4D
			Valve fails to open	Inability to return vertex section to operation. Valve can be repaired and the valve closed.	None	4	D	4D

Hazard Severity Categories (HSC): 1=Catastrophic, 2=Critical, 3=Marginal, 4=Negligible
 Hazard Probability (HP): A=Frequent, B=Probable, C=Occasional, D=Remote, E=Improbable
 Hazard Risk Index (HRI)

Rev. 
 Prepared by: 
 Reviewed by:

LIGO Vacuum Equipment
 Failure Modes and Effects Analysis

			Valve closed with laser in operation	Damage to equipment and/or valve. Protection is by "two-key" lockout with both computer and physical lockout covered in operating procedures.	LIGO to consider adding interlock preventing closure of valve on beam line with the laser on.	2	E	2E
			Valve opened with pressure on one side or one of the BSC's or HAM's open to clean room.	Damage to equipment, personnel injury or death. Protection is by "two-key" lockout with both computer and physical lockout covered in operating procedures.	None	2	E	2E
62	WTC2	Turbopump cart and associated connections	Pump shuts down for any of a number of reasons; loss of utility, suction pressure above allowable due to leak or insufficient roughing.	Delay in pumping out the system. The cause of pump shutdown needs to be corrected and the process restarted.	None	4	E	4E
63	WRC2	Roughing pump cart and associated connections	Pump shuts down for any of a number of reasons; loss of utility, suction pressure above allowable due to leak or insufficient roughing.	Delay in pumping out the system. The cause of pump shutdown needs to be corrected and the process restarted.	None	4	E	4E

Hazard Severity Categories (HSC): 1=Catastrophic, 2=Critical, 3=Marginal, 4=Negligible
 Hazard Probability (HP): A=Frequent, B=Probable, C=Occasional, D=Remote, E=Improbable
 Hazard Risk Index (HRI)

Rev. 0
 Prepared by: SET
 Reviewed by: FAB

LIGO Vacuum Equipment
 Failure Modes and Effects Analysis

P&I Number: V049-0-014 Rev. 1
Node: 19
System: Washington Site Diagonal Section
Date: 4/16/96

Node 19 is the entire P&ID. The diagonal section is one large isolatable section with only two large gate valves. There are no cryopumps in the diagonal section. The FMEA information for the HAM's and BSC's is found on the FMEA sheets for P&ID's V049-0-002 and 004.

ITEM:	IDENTIFICATION	DESCRIPTION	FAILURE MODES	EFFECTS	ACTION ITEM	HSC	HP	HRI
64	WIP7	2500 torr-liter/sec ion pump and its' associated 14" gate valve.	Ion pump shutdown. The ion pump controller protects it from damage due to high current draw.	Loss of ion pumping capacity. The ion pump can be restarted once the cause of the shutdown has been fixed (too high pressure due to leak, premature operation, etc.). If the ion pump is damaged and cannot be restarted, the 14" GVHV can be closed and the ion pump replaced.	None	4	D	4D
65	WIP8	2500 torr-liter/sec ion pump and its' associated 14" gate valve.	Ion pump shutdown. The ion pump controller protects it from damage due to high current draw.	Loss of ion pumping capacity. The ion pump can be restarted once the cause of the shutdown has been fixed (too high pressure due to leak, premature operation, etc.). If the ion pump is damaged and cannot be restarted, the 14" GVHV can be closed and the ion pump replaced.	None	4	D	4D

Hazard Severity Categories (HSC): 1=Catastrophic, 2=Critical, 3=Marginal, 4=Negligible
 Hazard Probability (HP): A=Frequent, B=Probable, C=Occasional, D=Remote, E=Improbable
 Hazard Risk Index (HRI)

Rev. 0
 Prepared by: SF7
 Reviewed by: TS

LIGO Vacuum Equipment
 Failure Modes and Effects Analysis

66	HV 174	10" Pump out port valves	Valve opened to atmosphere with vacuum in the tube. This is a manual gate valve with a pad lock for both lock open and lock closed. LIGO procedures will regulate the opening or closing of this valve.	Loss of vacuum, damage to equipment in the tube, contamination, injury or loss of life to personnel near the valve.	LIGO to incorporate lockout procedures for locking gate valves in their operator training.	1	E	1E
67	HV 160	6" Pump out port valves	Valve opened to atmosphere with vacuum in the tube. This is a manual gate valve with a pad lock for both lock open and lock closed. LIGO procedures will regulate the opening or closing of this valve.	Loss of vacuum, damage to equipment in the tube, contamination, injury or loss of life to personnel near the valve.	LIGO to incorporate lockout procedures for locking gate valves in their operator training.	1	E	1E
68	WGV3	Large Motor Operated Gate Valve	Valve fails to close	Inability to isolate diagonal section for pumpdown or back to air operation. Valve can be repaired and the valve closed.	None	4	D	4D
			Valve fails to open	Inability to return diagonal section to operation. Valve can be repaired and the valve closed.	None	4	D	4D
			Valve closed with laser in operation	Damage to equipment and/or valve. Protection is by "two-key" lockout with both computer and physical lockout covered in operating procedures.	LIGO to consider adding interlock preventing closure of valve on beam line with the laser on.	2	E	2E

Hazard Severity Categories (HSC): 1=Catastrophic, 2=Critical, 3=Marginal, 4=Negligible
 Hazard Probability (HP): A=Frequent, B=Probable, C=Occasional, D=Remote, E=Improbable
 Hazard Risk Index (HRI)

Rev. 0
 Prepared by: JET
 Reviewed by: TS

LIGO Vacuum Equipment
 Failure Modes and Effects Analysis

			Valve opened with pressure on one side or one of the BSC's or HAM's open to clean room.	Damage to equipment, personnel injury or death. Protection is by "two-key" lockout with both computer and physical lockout covered in operating procedures.	None	2	E	2E
69	WGV4	Large Motor Operated Gate Valve	Valve fails to close	Inability to isolate diagonal section for pumpdown or back to air operation. Valve can be repaired and the valve closed.	None	4	D	4D
			Valve fails to open	Inability to return diagonal section to operation. Valve can be repaired and the valve closed.	None	4	D	4D
			Valve closed with laser in operation	Damage to equipment and/or valve. Protection is by "two-key" lockout with both computer and physical lockout covered in operating procedures.	LIGO to consider adding interlock preventing closure of valve on beam line with the laser on.	2	E	2E
			Valve opened with pressure on one side or one of the BSC's or HAM's open to clean room.	Damage to equipment, personnel injury or death. Protection is by "two-key" lockout with both computer and physical lockout covered in operating procedures.	None	2	E	2E

Hazard Severity Categories (HSC): 1=Catastrophic, 2=Critical, 3=Marginal, 4=Negligible
 Hazard Probability (HP): A=Frequent, B=Probable, C=Occasional, D=Remote, E=Improbable
 Hazard Risk Index (HRI)

Rev. 0
 Prepared by: SF7
 Reviewed by:

LIGO Vacuum Equipment
 Failure Modes and Effects Analysis

70	WCT1	Turbopump cart and associated connections	Pump shuts down for any of a number of reasons; loss of utility, suction pressure above allowable due to leak or insufficient roughing.	Delay in pumping out the system. The cause of pump shutdown needs to be corrected and the process restarted.	None	4	E	4E
71	WRC1	Roughing pump cart and associated connections	Pump shuts down for any of a number of reasons; loss of utility, suction pressure above allowable due to leak or insufficient roughing.	Delay in pumping out the system. The cause of pump shutdown needs to be corrected and the process restarted.	None	4	E	4E

Hazard Severity Categories (HSC): 1=Catastrophic, 2=Critical, 3=Marginal, 4=Negligible
 Hazard Probability (HP): A=Frequent, B=Probable, C=Occasional, D=Remote, E=Improbable
 Hazard Risk Index (HRI)

Rev. 
 Prepared by: *SFT*
 Reviewed by: *FAB*

LIGO Vacuum Equipment
 Failure Modes and Effects Analysis

P&I Number: V049-0-015 Rev. 1
Node: 20
System: Washington Site Right Beam Manifold
Date: 4/16/96

Node 20 includes all the normally connected equipment; WCP2, WBSC7, WIP6, and WGV 7 and 8.

ITEM:	IDENTIFICATION	DESCRIPTION	FAILURE MODES	EFFECTS	ACTION ITEM	HSC	HP	HRI
72	WIP6	2500 torr-liter/sec ion pump and its' associated 14" gate valve.	Ion pump shutdown. The ion pump controller protects it from damage due to high current draw.	Loss of ion pumping capacity. The ion pump can be restarted once the cause of the shutdown has been fixed (too high pressure due to leak, premature operation, etc.).	None	4	D	4D
				If the ion pump is damaged and cannot be restarted, the 14" GVHV can be closed and the ion pump replaced.				
73	WCP2	80 K Cryopump (Long)	Leakage from atmosphere or LN2 side.	Loss of vacuum, possible contamination. PI-134 A or B will indicate leak. The cryopump can be isolated with WGV7 and 8 and repaired.	None	3	D	3D
74	PI 134 A or B	Gauge Pair on Cryopump	Either gauge fails electrically	Loss in the ability to read the vacuum level. Either an RGA can be attached to read the pressure or operation may continue without this information until it's convenient to isolate the cryopump and replace the	None	4	D	4D

Hazard Severity Categories (HSC): 1=Catastrophic, 2=Critical, 3=Marginal, 4=Negligible
 Hazard Probability (HP): A=Frequent, B=Probable, C=Occasional, D=Remote, E=Improbable
 Hazard Risk Index (HRI)

Rev. 0
 Prepared by: SE7
 Reviewed by: TS

LIGO Vacuum Equipment
 Failure Modes and Effects Analysis

75	WGV7	Large Pneumatic Gate Valve	Valve fails to close	Inability to isolate cryopump for regeneration or back to air operation. Valve can be repaired and the valve closed.	None	4	D	4D
			Valve fails to open	Inability to return pump to operation. Valve can be repaired and the valve closed.	None	4	D	4D
			Valve closed with laser in operation	Damage to equipment and/or valve. Protection is by "two-key" lockout with both computer and physical lockout covered in operating procedures.	LIGO to consider adding interlock preventing closure of valve on beam line with the laser on.	2	E	2E
			Valve opened with pressure on one side or BSC open to clean room.	Damage to equipment, personnel injury or death. Protection is by "two-key" lockout with both computer and physical lockout covered in operating procedures.	None	2	E	2E
76	WGV8	Large Pneumatic Gate Valve	Valve fails to close	Inability to isolate cryopump for regeneration or back to air operation. Valve can be repaired and the valve closed.	None	4	D	4D
			Valve fails to open	Inability to return pump to operation. Valve can be repaired and the valve closed.	None	4	D	4D
			Valve closed with laser in operation	Damage to equipment and/or valve. Protection is by "two-key" lockout with both computer and physical lockout covered in operating procedures.	LIGO to consider adding interlock preventing closure of valve on beam line with the laser on.	2	E	2E

Hazard Severity Categories (HSC): 1=Catastrophic, 2=Critical, 3=Marginal, 4=Negligible
 Hazard Probability (HP): A=Frequent, B=Probable, C=Occasional, D=Remote, E=Improbable
 Hazard Risk Index (HRI)

Rev. 0
 Prepared by: SET
 Reviewed by: TS

LIGO Vacuum Equipment
 Failure Modes and Effects Analysis

			Valve opened with pressure on one side or BSC open to clean room.	Damage to equipment, personnel injury or death. Protection is by "two-key" lockout with both computer and physical lockout covered in operating procedures.	None	2	E	2E
77	HV 176 / 177 / 178	10" Pump out port valves	Valve opened to atmosphere with vacuum in the tube or cryopump. These are manual gate valves with a pad lock for both lock open and lock closed. LIGO procedures will regulate the opening or closing of these valves.	Loss of vacuum, damage to equipment in the tube, contamination, injury or loss of life to personnel near the valve.	LIGO to incorporate lockout procedures for locking gate valves in their operator training.	1	E	1E

Hazard Severity Categories (HSC): 1=Catastrophic, 2=Critical, 3=Marginal, 4=Negligible
 Hazard Probability (HP): A=Frequent, B=Probable, C=Occasional, D=Remote, E=Improbable
 Hazard Risk Index (HRI)

Rev. 0
 Prepared by: JET
 Reviewed by: FAB

LIGO Vacuum Equipment
 Failure Modes and Effects Analysis

P&I Number: V049-0-016 Rev. 1
 Node: 21
 System: Washington Site Right Mid Station
 Date: 4/16/96

Node 21 includes all the normally connected equipment; WCP5, WBSC5, WIP10, WCP6, and WGV 13,14,15, and 16.

ITEM:	IDENTIFICATION	DESCRIPTION	FAILURE MODES	EFFECTS	ACTION ITEM	HSC	HP	HRI
78	WIP10	2500 torr-liter/sec ion pump and its' associated 14" gate valve.	Ion pump shutdown. The ion pump controller protects it from damage due to high current draw.	Loss of ion pumping capacity. The ion pump can be restarted once the cause of the shutdown has been fixed (too high pressure due to leak, premature operation, etc.). If the ion pump is damaged and cannot be restarted, the 14" GVHV can be closed and the ion pump replaced.	None	4	D	4D
79	WCP5	80 K Cryopump (Short)	Leakage from atmosphere or LN2 side.	Loss of vacuum, possible contamination. PI-344 A or B will indicate leak. The cryopump can be isolated with WGV13 and 14 and repaired.	None	3	D	3D
80	PI 344 A or B	Gauge Pair on Cryopump	Either gauge fails electrically	Loss in the ability to read the vacuum level. Either an RGA can be attached to read the pressure or operation may continue without this information until it's convenient to isolate the cryopump and replace the	None	4	D	4D

Hazard Severity Categories (HSC): 1=Catastrophic, 2=Critical, 3=Marginal, 4=Negligible
 Hazard Probability (HP): A=Frequent, B=Probable, C=Occasional, D=Remote, E=improbable
 Hazard Risk Index (HRI)

Rev. 0
 Prepared by: SET
 Reviewed by: D. M. W.

LIGO Vacuum Equipment
 Failure Modes and Effects Analysis

81	WCP6	80 K Cryopump (Short)	Leakage from atmosphere or LN2 side.	Loss of vacuum, possible contamination. PI-345 A or B will indicate leak. The cryopump can be isolated with WGV15 and 16 and repaired.	None	3	D	3D
82	PI 345 A or B	Gauge Pair on Cryopump	Either gauge fails electrically	Loss in the ability to read the vacuum level. Either an RGA can be attached to read the pressure or operation may continue without this information until it's convenient to isolate the cryopump and replace the	None	4	D	4D
83	WGV13	Large Motor Operated Gate Valve	Valve fails to close	Inability to isolate cryopump for regeneration or back to air operation. Valve can be repaired and the valve closed.	None	4	D	4D
			Valve fails to open	Inability to return pump to operation. Valve can be repaired and the valve closed.	None	4	D	4D
			Valve closed with laser in operation	Damage to equipment and/or valve. Protection is by "two-key" lockout with both computer and physical lockout covered in operating procedures.	LIGO to consider adding interlock preventing closure of valve on beam line with the laser on.	2	E	2E
			Valve opened with pressure on one side or BSC open to clean room.	Damage to equipment, personnel injury or death. Protection is by "two-key" lockout with both computer and physical lockout covered in operating procedures.	None	2	E	2E

Hazard Severity Categories (HSC): 1=Catastrophic, 2=Critical, 3=Marginal, 4=Negligible
 Hazard Probability (HP): A=Frequent, B=Probable, C=Occasional, D=Remote, E=Improbable
 Hazard Risk Index (HRI)

Rev. 0
 Prepared by: SET
 Reviewed by: TS

LIGO Vacuum Equipment
 Failure Modes and Effects Analysis

84	WGV14	Large Motor Operated Gate Valve	Valve fails to close	Inability to isolate cryopump for regeneration or back to air operation. Valve can be repaired and the valve closed.	None	4	D	4D
			Valve fails to open	Inability to return pump to operation. Valve can be repaired and the valve closed.	None	4	D	4D
			Valve closed with laser in operation	Damage to equipment and/or valve. Protection is by "two-key" lockout with both computer and physical lockout covered in operating procedures.	LIGO to consider adding interlock preventing closure of valve on beam line with the laser on.	2	E	2E
			Valve opened with pressure on one side or BSC open to clean room.	Damage to equipment, personnel injury or death. Protection is by "two-key" lockout with both computer and physical lockout covered in operating procedures.	None	2	E	2E
85	WGV15	Large Motor Operated Gate Valve	Valve fails to close	Inability to isolate cryopump for regeneration or back to air operation. Valve can be repaired and the valve closed.	None	4	D	4D
			Valve fails to open	Inability to return pump to operation. Valve can be repaired and the valve closed.	None	4	D	4D
			Valve closed with laser in operation	Damage to equipment and/or valve. Protection is by "two-key" lockout with both computer and physical lockout covered in operating procedures.	LIGO to consider adding interlock preventing closure of valve on beam line with the laser on.	2	E	2E

Hazard Severity Categories (HSC): 1=Catastrophic, 2=Critical, 3=Marginal, 4=Negligible
 Hazard Probability (HP): A=Frequent, B=Probable, C=Occasional, D=Remote, E=Improbable
 Hazard Risk Index (HRI)

Rev. 0
 Prepared by: SPT
 Reviewed by: TS

LIGO Vacuum Equipment
 Failure Modes and Effects Analysis

			Valve opened with pressure on one side or BSC open to clean room.	Damage to equipment, personnel injury or death. Protection is by "two-key" lockout with both computer and physical lockout covered in operating procedures.	None	2	E	2E
86	WGV16	Large Motor Operated Gate Valve	Valve fails to close	Inability to isolate cryopump for regeneration or back to air operation. Valve can be repaired and the valve closed.	None	4	D	4D
			Valve fails to open	Inability to return pump to operation. Valve can be repaired and the valve closed.	None	4	D	4D
			Valve closed with laser in operation	Damage to equipment and/or valve. Protection is by "two-key" lockout with both computer and physical lockout covered in operating procedures.	LIGO to consider adding interlock preventing closure of valve on beam line with the laser on.	2	E	2E
			Valve opened with pressure on one side or BSC open to clean room.	Damage to equipment, personnel injury or death. Protection is by "two-key" lockout with both computer and physical lockout covered in operating procedures.	None	2	E	2E

Hazard Severity Categories (HSC): 1=Catastrophic, 2=Critical, 3=Marginal, 4=Negligible
 Hazard Probability (HP): A=Frequent, B=Probable, C=Occasional, D=Remote, E=Improbable
 Hazard Risk Index (HRI)

Rev. 0
 Prepared by: SFT
 Reviewed by: JM

LIGO Vacuum Equipment
 Failure Modes and Effects Analysis

P&I Number: V049-0-016 Rev. 1
Node: 22
System: Washington Site Right Mid Station
Date: 4/16/96

Node 22 includes the turbo pumping equipment and the clean air supply system equipment. The Turbo Cart and its Turbo Backing Pump Cart are self-protected. See Hazards Analysis sheets for the Turbo Carts. The unit shuts down on loss of seal gas to the backing cart, loss of cooling water flow shuts it down on high temperature, power failure, etc.

An intrinsically safe wiring setup has been designed such that it is physically impossible to operate more than one turbo pump cart with a single backing pump.

Note: Added Safety and Interlock

It is suggested to add a pressure switch between PCV 361 and 384 for back to air operation. If the rate of flow is too high for the clean air supply to keep up with both PCV's will open to maintain pressure. Should the receiver pressure drop sufficiently it could be damaged and bed material sucked into the chamber being repressurized. The pressure switch would go to the LIGO computer and shutdown the back to air valve.

ITEM:	IDENTIFICATION	DESCRIPTION	FAILURE MODES	EFFECTS	ACTION ITEM	HSC	HP	HRI
87	WTC4	Turbopump cart and associated connections	Pump shuts down for any of a number of reasons; loss of utility, suction pressure above allowable due to leak or insufficient roughing.	Delay in pumping out the system. The cause of pump shutdown needs to be corrected and the process restarted.	None	4	E	4E

Hazard Severity Categories (HSC): 1=Catastrophic, 2=Critical, 3=Marginal, 4=Negligible
 Hazard Probability (HP): A=Frequent, B=Probable, C=Occasional, D=Remote, E=Improbable
 Hazard Risk Index (HRI)

Rev. 0
 Prepared by: SET
 Reviewed by: TS

LIGO Vacuum Equipment
 Failure Modes and Effects Analysis

88	HV 340 / 341 / 342	10" Pump out port valves	Valve opened to atmosphere with vacuum in the tube or cryopump. These are manual gate valves with a pad lock for both lock open and lock closed. LIGO procedures will regulate the opening or closing of these valves.	Loss of vacuum, damage to equipment in the tube, contamination, injury or loss of life to personnel near the valve.	LIGO to incorporate lockout procedures for locking gate valves in their operator training.	1	E	1E
87	WTC4B	Turbo pump backing cart	Pump shuts down for any of a number of reasons; loss of utility, signal from turbo cart controller.	Shutdown of turbo cart and delay in pumping out the system. The cause of pump shutdown needs to be corrected and the process restarted.	None	4	E	4E
88	WCA300	Class 100 Clean Air Supply System	System shutdown, either compressor out or drier beds won't switch. Three signals go to the LIGO computer for monitoring, Compressor running signal, Compressor Common Alarm, Drier Beds Common Alarm.	During turbo pumping this would cause shutdown of the Turbo Backing Pump on loss of seal air.	None	4	E	4E
				During back to air operation the receiver could be sucked down to vacuum damaging it.	LIGO to provide computer interlock between compressor running signal and back to air control valve, for example PCV 120.	3	D	3D

Hazard Severity Categories (HSC): 1=Catastrophic, 2=Critical, 3=Marginal, 4=Negligible
 Hazard Probability (HP): A=Frequent, B=Probable, C=Occasional, D=Remote, E=Improbable
 Hazard Risk Index (HRI)

Rev. 0
 Prepared by: SRT
 Reviewed by: TS

LIGO Vacuum Equipment
 Failure Modes and Effects Analysis

				During purge operation through air showers loss of flow would allow contamination of optics with moisture.	None	4	E	4E
89	PCV-361	First stage letdown valve	Fail open	Increase downstream pressure	None	4	E	4E
			Fail closed	Loss of clean air flow tripping the turbo or cutting off air shower flow.	None	4	E	4E
90	PCV-384	Second stage letdown valve	Fail open	Increase downstream pressure might raise back to air pressure above vessel design pressure. Protection provided by accurate pressure control of back to air valve and PSV-360 on the clean air supply header.	None	4	E	4E
			Fail closed	Loss of clean air flow tripping the turbo or cutting off air shower flow.	None	4	E	4E

Hazard Severity Categories (HSC): 1=Catastrophic, 2=Critical, 3=Marginal, 4=Negligible
 Hazard Probability (HP): A=Frequent, B=Probable, C=Occasional, D=Remote, E=Improbable
 Hazard Risk Index (HRI)

Rev. C
 Prepared by: *RET*
 Reviewed by: *FAB*

LIGO Vacuum Equipment
 Failure Modes and Effects Analysis

P&I Number: V049-0-017 Rev. 1
 Node: 23
 System: Washington Site Right End Station
 Date: 4/16/96

Node 23 includes all the normally connected equipment. The BSC chamber covered on P&ID V049-0-002, WIP12, WCP8, WGV19 and WGV20.

ITEM:	IDENTIFICATION	DESCRIPTION	FAILURE MODES	EFFECTS	ACTION ITEM	HSC	HP	HRI
91	WIP12	2500 torr-liter/sec ion pump and its' associated 14" gate valve.	Ion pump shutdown. The ion pump controller protects it from damage due to high current draw.	Loss of ion pumping capacity. The ion pump can be restarted once the cause of the shutdown has been fixed (too high pressure due to leak, premature operation, etc.). If the ion pump is damaged and cannot be restarted, the 14" GVHV can be closed and the ion pump replaced.	None	4	D	4D
92	WCP8	80 K Cryopump (Short)	Leakage from atmosphere or LN2 side.	Loss of vacuum, possible contamination. PI-524 A or B will indicate leak. The cryopump can be isolated with WGV19 and 20 and repaired.	None	3	D	3D
93	PI 524 A or B	Gauge Pair on Cryopump	Either gauge fails electrically	Loss in the ability to read the vacuum level. Either an RGA can be attached to read the pressure or operation may continue without this information until it's convenient to isolate the cryopump and replace the	None	4	D	4D

Hazard Severity Categories (HSC): 1=Catastrophic, 2=Critical, 3=Marginal, 4=Negligible
 Hazard Probability (HP): A=Frequent, B=Probable, C=Occasional, D=Remote, E=Improbable
 Hazard Risk Index (HRI)

Rev. 0
 Prepared by: SFT
 Reviewed by: TS

LIGO Vacuum Equipment
 Failure Modes and Effects Analysis

94	WGV19	Large Motor Operated Gate Valve	Valve fails to close	Inability to isolate cryopump for regeneration or back to air operation. Valve can be repaired and the valve closed.	None	4	D	4D
			Valve fails to open	Inability to return pump to operation. Valve can be repaired and the valve closed.	None	4	D	4D
			Valve closed with laser in operation	Damage to equipment and/or valve. Protection is by "two-key" lockout with both computer and physical lockout covered in operating procedures.	LIGO to consider adding interlock preventing closure of valve on beam line with the laser on.	2	E	2E
			Valve opened with pressure on one side or BSC open to clean room.	Damage to equipment, personnel injury or death. Protection is by "two-key" lockout with both computer and physical lockout covered in operating procedures.	None	2	E	2E
95	WGV20	Large Motor Operated Gate Valve	Valve fails to close	Inability to isolate cryopump for regeneration or back to air operation. Valve can be repaired and the valve closed.	None	4	D	4D
			Valve fails to open	Inability to return pump to operation. Valve can be repaired and the valve closed.	None	4	D	4D
			Valve closed with laser in operation	Damage to equipment and/or valve. Protection is by "two-key" lockout with both computer and physical lockout covered in operating procedures.	LIGO to consider adding interlock preventing closure of valve on beam line with the laser on.	2	E	2E

Hazard Severity Categories (HSC): 1=Catastrophic, 2=Critical, 3=Marginal, 4=Negligible
 Hazard Probability (HP): A=Frequent, B=Probable, C=Occasional, D=Remote, E=Improbable
 Hazard Risk Index (HRI)

Rev. 0
 Prepared by: SET
 Reviewed by: TS

LIGO Vacuum Equipment
 Failure Modes and Effects Analysis

			Valve opened with pressure on one side or BSC open to clean room.	Damage to equipment, personnel injury or death. Protection is by "two-key" lockout with both computer and physical lockout covered in operating procedures.	None	2	E	2E
--	--	--	---	---	------	---	---	----

Hazard Severity Categories (HSC): 1=Catastrophic, 2=Critical, 3=Marginal, 4=Negligible
 Hazard Probability (HP): A=Frequent, B=Probable, C=Occasional, D=Remote, E=Improbable
 Hazard Risk Index (HRI)

Rev. 0
 Prepared by: SFF
 Reviewed by: SM

LIGO Vacuum Equipment
 Failure Modes and Effects Analysis

P&I Number: V049-0-017 Rev. 1
Node: 24
System: Washington Site Right End Station
Date: 4/16/96

Node 24 includes the turbo pumping equipment and the clean air supply system equipment. The Turbo Cart and its' Turbo Backing Pump Cart are self-protected. See Hazards Analysis sheets for the Turbo Carts. The unit shuts down on loss of seal gas to the backing cart, loss of cooling water flow shuts it down on high temperature, power failure, etc.

An intrinsically safe wiring setup has been designed such that it is physically impossible to operate more than one turbo pump cart with a single backing pump.

Note: Added Safety and Interlock

It is suggested to add a pressure switch between PCV 526 and 527 for back to air operation. If the rate of flow is too high for the clean air supply to keep up with both PCV's will open to maintain pressure. Should the receiver pressure drop sufficiently it could be damaged and bed material sucked into the chamber being repressurized. The pressure switch would go to the LIGO computer and shutdown the back to air valve.

ITEM:	IDENTIFICATION	DESCRIPTION	FAILURE MODES	EFFECTS	ACTION ITEM	HSC	HP	HRI
96	WTC6	Turbopump cart and associated connections	Pump shuts down for any of a number of reasons; loss of utility, suction pressure above allowable due to leak or insufficient roughing.	Delay in pumping out the system. The cause of pump shutdown needs to be corrected and the process restarted.	None	4	E	4E

Hazard Severity Categories (HSC): 1=Catastrophic, 2=Critical, 3=Marginal, 4=Negligible
 Hazard Probability (HP): A=Frequent, B=Probable, C=Occasional, D=Remote, E=Improbable
 Hazard Risk Index (HRI)

97	HV 520 / 521	10" Pump out port valve	Valve opened to atmosphere with vacuum in the tube or cryopump. These are manual gate valves with a pad lock for both lock open and lock closed. LIGO procedures will regulate the opening or closing of these valves.	Loss of vacuum, damage to equipment in the tube, contamination, injury or loss of life to personnel near the valve.	LIGO to incorporate lockout procedures for locking gate valves in their operator training.	1	E	1E
98		Turbo pump backing cart	Pump shuts down for any of a number of reasons; loss of utility, signal from turbo cart controller.	Shutdown of turbo cart and delay in pumping out the system. The cause of pump shutdown needs to be corrected and the process restarted.	None	4	E	4E
99		Class 100 Clean Air Supply System	System shutdown, either compressor out or drier beds won't switch. Three signals go to the LIGO computer for monitoring, Compressor running signal, Compressor Common Alarm, Drier Beds Common Alarm.	During turbo pumping this would cause shutdown of the Turbo Backing Pump on loss of seal air.	None	4	E	4E
				During back to air operation the receiver could be sucked down to vacuum damaging it.	LIGO to provide computer interlock between compressor running signal and back to air control valve, for example PCV 120.	3	D	3D

Rev. 0
 Prepared by: JET
 Reviewed by: TS

LIGO Vacuum Equipment
 Failure Modes and Effects Analysis

				During purge operation through air showers loss of flow would allow contamination of optics with moisture.	None	4	E	4E
100	PCV-526	First stage letdown valve	Fail open	Increase downstream pressure	None	4	E	4E
			Fail closed	Loss of clean air flow tripping the turbo or cutting off air shower flow.	None	4	E	4E
101	PCV-527	Second stage letdown valve	Fail open	Increase downstream pressure might raise back to air pressure above vessel design pressure. Protection provided by accurate pressure control of back to air valve and PSV-525 on the clean air supply header.	None	4	E	4E
			Fail closed	Loss of clean air flow tripping the turbo or cutting off air shower flow.	None	4	E	4E

Hazard Severity Categories (HSC): 1=Catastrophic, 2=Critical, 3=Marginal, 4=Negligible
 Hazard Probability (HP): A=Frequent, B=Probable, C=Occasional, D=Remote, E=Improbable
 Hazard Risk Index (HRI)

Rev. 0
 Prepared by: SFT
 Reviewed by: *AM*

LIGO Vacuum Equipment
 Failure Modes and Effects Analysis

P&I Number: V049-0-018 Rev. 1
Node: 25
System: Washington Site Corner Station Mechanical Room
Date: 4/16/96

Node 25 includes the turbo and roughing backing pump carts and the clean air supply system equipment in the mechanical room. The Turbo Backing Pump Cart and Roughing Backing pump cart are self-protected. See Hazards Analysis sheets for the Turbo Carts and Roughing Pump Carts. The units shut down on loss of seal gas to the backing cart, loss of cooling water flow shuts them down on high temperature, power failure, etc.

An intrinsically safe wiring setup has been designed such that it is physically impossible to operate more than one turbo pump cart or roughing pump cart with a single backing pump.

Note: Added Safety and Interlock

It is suggested to add a pressure switch between PCV 184 and 198 for back to air operation. If the rate of flow is too high for the clean air supply to keep up with both PCV's will open to maintain pressure. Should the receiver pressure drop sufficiently it could be damaged and bed material sucked into the chamber being repressurized. The pressure switch would go to the LIGO computer and shutdown the back to air valve.

ITEM:	IDENTIFICATION	DESCRIPTION	FAILURE MODES	EFFECTS	ACTION ITEM	HSC	HP	HRI
102	WRC1B	Roughing pump backing cart	Pump shuts down for any of a number of reasons; loss of utility, signal from turbo cart controller.	Shutdown of roughing pump cart and delay in pumping out the system. The cause of pump shutdown needs to be corrected and the process restarted.	None	4	E	4E
103	WRC2B	Roughing pump backing cart	Pump shuts down for any of a number of reasons; loss of utility, signal from turbo cart controller.	Shutdown of roughing pump cart and delay in pumping out the system. The cause of pump shutdown needs to be corrected and the process restarted.	None	4	E	4E

Hazard Severity Categories (HSC): 1=Catastrophic, 2=Critical, 3=Marginal, 4=Negligible
 Hazard Probability (HP): A=Frequent, B=Probable, C=Occasional, D=Remote, E=Improbable
 Hazard Risk Index (HRI)

Rev. 0
 Prepared by: SET
 Reviewed by: TS

LIGO Vacuum Equipment
 Failure Modes and Effects Analysis

104	WTC1B	Turbo pump backing cart	Pump shuts down for any of a number of reasons; loss of utility, signal from turbo cart controller.	Shutdown of turbo pump cart and delay in pumping out the system. The cause of pump shutdown needs to be corrected and the process restarted.	None	4	E	4E
105	WTC2B	Turbo pump backing cart	Pump shuts down for any of a number of reasons; loss of utility, signal from turbo cart controller.	Shutdown of turbo pump cart and delay in pumping out the system. The cause of pump shutdown needs to be corrected and the process restarted.	None	4	E	4E
106	WCA100	Class 100 Clean Air Supply System	System shutdown, either compressor out or drier beds won't switch. Three signals go to the LIGO computer for monitoring, Compressor running signal, Compressor Common Alarm, Drier Beds Common Alarm.	During turbo pumping this would cause shutdown of the Turbo Backing Pump on loss of seal air.	None	4	E	4E
				During back to air operation the receiver could be sucked down to vacuum damaging it.	LIGO to provide computer interlock between compressor running signal and back to air control valve, for example PCV 120.	3	D	3D

Hazard Severity Categories (HSC): 1=Catastrophic, 2=Critical, 3=Marginal, 4=Negligible
 Hazard Probability (HP): A=Frequent, B=Probable, C=Occasional, D=Remote, E=Improbable
 Hazard Risk Index (HRI)

Rev. 0
 Prepared by: SET
 Reviewed by: TS

LIGO Vacuum Equipment
 Failure Modes and Effects Analysis

				During purge operation through air showers loss of flow would allow contamination of optics with moisture.	None	4	E	4E
107	PCV-184	First stage letdown valve	Fail open	Increase downstream pressure	None	4	E	4E
			Fail closed	Loss of clean air flow tripping the turbo or cutting off air shower flow.	None	4	E	4E
108	PCV-198	Second stage letdown valve	Fail open	Increase downstream pressure might raise back to air pressure above vessel design pressure. Protection provided by accurate pressure control of back to air valve and PSV-175 on the clean air supply header.	None	4	E	4E
			Fail closed	Loss of clean air flow tripping the turbo or cutting off air shower flow.	None	4	E	4E

Hazard Severity Categories (HSC): 1=Catastrophic, 2=Critical, 3=Marginal, 4=Negligible
 Hazard Probability (HP): A=Frequent, B=Probable, C=Occasional, D=Remote, E=Improbable
 Hazard Risk Index (HRI)

Rev. 0
 Prepared by: *SPT*
 Reviewed by: *TS*

LIGO Vacuum Equipment
 Failure Modes and Effects Analysis

P&I Number: V049-0-021 Rev. 1
Node: 26
System: Louisiana Site Left & Right Mid Joints
Date: 4/16/96

Node 26 is just the large gate valve at the mid joint connecting two beam tubes for both the left and right arms. The instrumentation (4 gauge pairs) and four pumpout ports are on the beam tube sections.

ITEM:	IDENTIFICATION	DESCRIPTION	FAILURE MODES	EFFECTS	ACTION ITEM	HSC	HP	HRI
109	LGV8	Large Motor Operated Gate Valve	Valve fails to close	Inability to isolate beam tube for pump down or back to air operation. Valve can be repaired and the valve closed.	None	4	D	4D
			Valve fails to open	Inability to return beam tube to operation. Valve can be repaired and the valve closed.	None	4	D	4D
			Valve closed with laser in operation	Damage to equipment and/or valve. Protection is by "two-key" lockout with both computer and physical lockout covered in operating procedures.	LIGO to consider adding interlock preventing closure of valve on beam line with the laser on.	2	E	2E
			Valve opened with pressure on one side.	Damage to equipment, personnel injury or death. Protection is by "two-key" lockout with both computer and physical lockout covered in operating procedures.	None	2	E	2E

Hazard Severity Categories (HSC): 1=Catastrophic, 2=Critical, 3=Marginal, 4=Negligible
 Hazard Probability (HP): A=Frequent, B=Probable, C=Occasional, D=Remote, E=Improbable
 Hazard Risk Index (HRI)

Rev. 0

Prepared by: SET

Reviewed by: TS

LIGO Vacuum Equipment
Failure Modes and Effects Analysis

110	LGV7	Large Motor Operated Gate Valve	Valve fails to close	Inability to isolate beam tube for pump down or back to air operation. Valve can be repaired and the valve closed.	None	4	D	4D
			Valve fails to open	Inability to return beam tube to operation. Valve can be repaired and the valve closed.	None	4	D	4D
			Valve closed with laser in operation	Damage to equipment and/or valve. Protection is by "two-key" lockout with both computer and physical lockout covered in operating procedures.	LIGO to consider adding interlock preventing closure of valve on beam line with the laser on.	2	E	2E
			Valve opened with pressure on one side.	Damage to equipment, personnel injury or death. Protection is by "two-key" lockout with both computer and physical lockout covered in operating procedures.	None	2	E	2E

Hazard Severity Categories (HSC): 1=Catastrophic, 2=Critical, 3=Marginal, 4=Negligible
 Hazard Probability (HP): A=Frequent, B=Probable, C=Occasional, D=Remote, E=Improbable
 Hazard Risk Index (HRI)

Rev. 0
 Prepared by: SET
 Reviewed by: FAB

LIGO Vacuum Equipment
 Failure Modes and Effects Analysis

P&I Number: V049-0-022 Rev. 1
Node: 27
System: Louisiana Site Left Beam Manifold
Date: 4/16/96

Node 27 includes all the normally connected equipment; LCP1, LGV 3 and 4. as well as the turbo cart (LTC1) and roughing pump cart (LRC1).

ITEM:	IDENTIFICATION	DESCRIPTION	FAILURE MODES	EFFECTS	ACTION ITEM	HSC	HP	HRI
111	LCP1	80 K Cryopump (Long)	Leakage from atmosphere or LN2 side.	Loss of vacuum, possible contamination. PI-614 A or B will indicate leak. The cryopump can be isolated with LGV3 and 4 and repaired.	None	3	D	3D
112	PI 614 A or B	Gauge Pair on Cryopump	Either gauge fails electrically	Loss in the ability to read the vacuum level. Either an RGA can be attached to read the pressure or operation may continue without this information until it's convenient to isolate the cryopump and replace the	None	4	D	4D
113	PI 680 A or B	Gauge Pair on 72" Beam Tube	Either gauge fails electrically	Loss in the ability to read the vacuum level when this section is isolated from the	None	4	D	4D
114	LGV3	Large Pneumatic Gate Valve	Valve fails to close	Inability to isolate cryopump for regeneration or back to air operation. Valve can be repaired and the valve closed.	None	4	D	4D
			Valve fails to open	Inability to return pump to operation. Valve can be repaired and the valve closed.	None	4	D	4D

Hazard Severity Categories (HSC): 1=Catastrophic, 2=Critical, 3=Marginal, 4=Negligible
 Hazard Probability (HP): A=Frequent, B=Probable, C=Occasional, D=Remote, E=Improbable
 Hazard Risk Index (HRI)

Rev. 6
 Prepared by: SET
 Reviewed by: TS

LIGO Vacuum Equipment
 Failure Modes and Effects Analysis

			Valve closed with laser in operation	Damage to equipment and/or valve. Protection is by "two-key" lockout with both computer and physical lockout covered in operating procedures.	LIGO to consider adding interlock preventing closure of valve on beam line with the laser on.	2	E	2E
			Valve opened with pressure on one side or BSC open to clean room (BSC in Vertex section).	Damage to equipment, personnel injury or death. Protection is by "two-key" lockout with both computer and physical lockout covered in operating procedures.	None	2	E	2E
115	LGV4	Large Pneumatic Gate Valve	Valve fails to close	Inability to isolate cryopump for regeneration or back to air operation. Valve can be repaired and the valve closed.	None	4	D	4D
			Valve fails to open	Inability to return pump to operation. Valve can be repaired and the valve closed.	None	4	D	4D
			Valve closed with laser in operation	Damage to equipment and/or valve. Protection is by "two-key" lockout with both computer and physical lockout covered in operating procedures.	LIGO to consider adding interlock preventing closure of valve on beam line with the laser on.	2	E	2E
			Valve opened with pressure on one side or BSC open to clean room (BSC in Vertex section).	Damage to equipment, personnel injury or death. Protection is by "two-key" lockout with both computer and physical lockout covered in operating procedures.	None	2	E	2E

Hazard Severity Categories (HSC): 1=Catastrophic, 2=Critical, 3=Marginal, 4=Negligible
 Hazard Probability (HP): A=Frequent, B=Probable, C=Occasional, D=Remote, E=Improbable
 Hazard Risk Index (HRI)

Rev. ∞
 Prepared by: *ST*
 Reviewed by: *TS*

LIGO Vacuum Equipment
 Failure Modes and Effects Analysis

116	HV 647 / 648	10" Pump out port valves	Valve opened to atmosphere with vacuum in the tube or cryopump. These are manual gate valves with a pad lock for both lock open and lock closed. LIGO procedures will regulate the opening or closing of these valves.	Loss of vacuum, damage to equipment in the tube, contamination, injury or loss of life to personnel near the valve.	LIGO to incorporate lockout procedures for locking gate valves in their operator training.	1	E	1E
117	HV 646	6" Pump out port valve	Valve opened to atmosphere with vacuum in the tube. These are manual gate valves with a pad lock for both lock open and lock closed. LIGO procedures will regulate the opening or closing of these valves.	Loss of vacuum, damage to equipment in the tube, contamination, injury or loss of life to personnel near the valve.	LIGO to incorporate lockout procedures for locking gate valves in their operator training.	1	E	1E
118	LTC1	Turbopump cart and associated connections	Pump shuts down for any of a number of reasons; loss of utility, suction pressure above allowable due to leak or insufficient roughing.	Delay in pumping out the system. The cause of pump shutdown needs to be corrected and the process restarted.	None	4	E	4E
119	LRC1	Roughing Pump cart and associated connections	Pump shuts down for any of a number of reasons; loss of utility, suction pressure above allowable due to leak or insufficient roughing.	Delay in pumping out the system. The cause of pump shutdown needs to be corrected and the process restarted.	None	4	E	4E

Hazard Severity Categories (HSC): 1=Catastrophic, 2=Critical, 3=Marginal, 4=Negligible
 Hazard Probability (HP): A=Frequent, B=Probable, C=Occasional, D=Remote, E=Improbable
 Hazard Risk Index (HRI)

Rev. 0
 Prepared by: JET
 Reviewed by: FAS

LIGO Vacuum Equipment
 Failure Modes and Effects Analysis

P&I Number: V049-0-023 Rev. 1
Node: 28
System: Louisiana Site Vertex Section
Date: 4/16/96

Node 28 is the entire P&ID. The vertex section is one large isolatable section with only two large gate valves. There are no cryopumps in the vertex section. The FMEA information for the HAM's and BSC's is found on the FMEA sheets for P&ID's V049-0-002, 003 and 004.

ITEM:	IDENTIFICATION	DESCRIPTION	FAILURE MODES	EFFECTS	ACTION ITEM	HSC	HP	HRI
120	LIP1	2500 torr-liter/sec ion pump and its' associated 14" gate valve.	Ion pump shutdown. The ion pump controller protects it from damage due to high current draw.	Loss of ion pumping capacity. The ion pump can be restarted once the cause of the shutdown has been fixed (too high pressure due to leak, premature operation, etc.). If the ion pump is damaged and cannot be restarted, the 14" GVHV can be closed and the ion pump replaced.	None	4	D	4D
121	LIP2	2500 torr-liter/sec ion pump and its' associated 14" gate valve.	Ion pump shutdown. The ion pump controller protects it from damage due to high current draw.	Loss of ion pumping capacity. The ion pump can be restarted once the cause of the shutdown has been fixed (too high pressure due to leak, premature operation, etc.). If the ion pump is damaged and cannot be restarted, the 14" GVHV can be closed and the ion pump replaced.	None	4	D	4D

Hazard Severity Categories (HSC): 1=Catastrophic, 2=Critical, 3=Marginal, 4=Negligible
 Hazard Probability (HP): A=Frequent, B=Probable, C=Occasional, D=Remote, E=Improbable
 Hazard Risk Index (HRI)

122	LIP3	2500 torr-liter/sec ion pump and its' associated 14" gate valve.	Ion pump shutdown. The ion pump controller protects it from damage due to high current draw.	Loss of ion pumping capacity. The ion pump can be restarted once the cause of the shutdown has been fixed (too high pressure due to leak, premature operation, etc.).	None	4	D	4D
				If the ion pump is damaged and cannot be restarted, the 14" GVHV can be closed and the ion pump replaced.				
123	LIP4	2500 torr-liter/sec ion pump and its' associated 14" gate valve.	Ion pump shutdown. The ion pump controller protects it from damage due to high current draw.	Loss of ion pumping capacity. The ion pump can be restarted once the cause of the shutdown has been fixed (too high pressure due to leak, premature operation, etc.).	None	4	D	4D
				If the ion pump is damaged and cannot be restarted, the 14" GVHV can be closed and the ion pump replaced.				
124	HV 609	10" Pump out port valve	Valve opened to atmosphere with vacuum in the tube. This is a manual gate valve with a pad lock for both lock open and lock closed. LIGO procedures will regulate the opening or closing of this valve.	Loss of vacuum, damage to equipment in the tube, contamination, injury or loss of life to personnel near the valve.	LIGO to incorporate lockout procedures for locking gate valves in their operator training.	1	E	1E
125	HV 645	6" Pump out port valve	Valve opened to atmosphere with vacuum in the tube. This is a manual gate valve with a pad lock for both lock open and lock closed. LIGO procedures will regulate the opening or closing of this valve.	Loss of vacuum, damage to equipment in the tube, contamination, injury or loss of life to personnel near the valve.	LIGO to incorporate lockout procedures for locking gate valves in their operator training.	1	E	1E

Hazard Severity Categories (HSC): 1=Catastrophic, 2=Critical, 3=Marginal, 4=Negligible
Hazard Probability (HP): A=Frequent, B=Probable, C=Occasional, D=Remote, E=Improbable
Hazard Risk Index (HRI)

Rev. 0
 Prepared by: *STH*
 Reviewed by: *TS*

LIGO Vacuum Equipment
 Failure Modes and Effects Analysis

126	LGV1	Large Motor Operated Gate Valve	Valve fails to close	Inability to isolate vertex section for pumpdown or back to air operation. Valve can be repaired and the valve closed.	None	4	D	4D
			Valve fails to open	Inability to return vertex section to operation. Valve can be repaired and the valve closed.	None	4	D	4D
			Valve closed with laser in operation	Damage to equipment and/or valve. Protection is by "two-key" lockout with both computer and physical lockout covered in operating procedures.	LIGO to consider adding interlock preventing closure of valve on beam line with the laser on.	2	E	2E
			Valve opened with pressure on one side or one of the BSC's or HAM's open to clean room.	Damage to equipment, personnel injury or death. Protection is by "two-key" lockout with both computer and physical lockout covered in operating procedures.	None	2	E	2E
127	LGV2	Large Motor Operated Gate Valve	Valve fails to close	Inability to isolate vertex section for pumpdown or back to air operation. Valve can be repaired and the valve closed.	None	4	D	4D
			Valve fails to open	Inability to return vertex section to operation. Valve can be repaired and the valve closed.	None	4	D	4D

Hazard Severity Categories (HSC): 1=Catastrophic, 2=Critical, 3=Marginal, 4=Negligible
 Hazard Probability (HP): A=Frequent, B=Probable, C=Occasional, D=Remote, E=Improbable
 Hazard Risk Index (HRI)

Rev. 0
 Prepared by: *SRT*
 Reviewed by: *D.M.W.*

LIGO Vacuum Equipment
 Failure Modes and Effects Analysis

			Valve closed with laser in operation	Damage to equipment and/or valve. Protection is by "two-key" lockout with both computer and physical lockout covered in operating procedures.	LIGO to consider adding interlock preventing closure of valve on beam line with the laser on.	2	E	2E
			Valve opened with pressure on one side or one of the BSC's or HAM's open to clean room.	Damage to equipment, personnel injury or death. Protection is by "two-key" lockout with both computer and physical lockout covered in operating procedures.	None	2	E	2E
128	LTC2	Turbopump cart and associated connections	Pump shuts down for any of a number of reasons; loss of utility, suction pressure above allowable due to leak or insufficient roughing.	Delay in pumping out the system. The cause of pump shutdown needs to be corrected and the process restarted.	None	4	E	4E
129	LRC2	Roughing pump cart and associated connections	Pump shuts down for any of a number of reasons; loss of utility, suction pressure above allowable due to leak or insufficient roughing.	Delay in pumping out the system. The cause of pump shutdown needs to be corrected and the process restarted.	None	4	E	4E

Hazard Severity Categories (HSC): 1=Catastrophic, 2=Critical, 3=Marginal, 4=Negligible
 Hazard Probability (HP): A=Frequent, B=Probable, C=Occasional, D=Remote, E=Improbable
 Hazard Risk Index (HRI)

Rev. 0

Prepared by: STT

Reviewed by: FAB

LIGO Vacuum Equipment
Failure Modes and Effects Analysis

P&I Number: V049-0-024 Rev. 1
Node: 29
System: Louisiana Site Right Beam Manifold
Date: 4/16/96

Node 29 includes all the normally connected equipment; LCP2, LGV 5 and 6.

ITEM:	IDENTIFICATION	DESCRIPTION	FAILURE MODES	EFFECTS	ACTION ITEM	HSC	HP	HRI
130	LCP2	80 K Cryopump (Long)	Leakage from atmosphere or LN2 side.	Loss of vacuum, possible contamination. PI-634 A or B will indicate leak. The cryopump can be isolated with LGV5 and 6 and repaired.	None	3	D	3D
131	PI 634 A or B	Gauge Pair on Cryopump	Either gauge fails electrically	Loss in the ability to read the vacuum level. Either an RGA can be attached to read the pressure or operation may continue without this information until it's convenient to isolate the cryopump and replace the	None	4	D	4D
132	PI 670 A or B	Gauge Pair on 72" Beam Tube	Either gauge fails electrically	Loss in the ability to read the vacuum level when this section is isolated from the	None	4	D	4D
133	LGV5	Large Pneumatic Gate Valve	Valve fails to close	Inability to isolate cryopump for regeneration or back to air operation. Valve can be repaired and the valve closed.	None	4	D	4D
			Valve fails to open	Inability to return pump to operation. Valve can be repaired and the valve closed.	None	4	D	4D

Hazard Severity Categories (HSC): 1=Catastrophic, 2=Critical, 3=Marginal, 4=Negligible
Hazard Probability (HP): A=Frequent, B=Probable, C=Occasional, D=Remote, E=Improbable
Hazard Risk Index (HRI)

Rev. 0
 Prepared by: *DET*
 Reviewed by: *TS*

LIGO Vacuum Equipment
 Failure Modes and Effects Analysis

			Valve closed with laser in operation	Damage to equipment and/or valve. Protection is by "two-key" lockout with both computer and physical lockout covered in operating procedures.	LIGO to consider adding interlock preventing closure of valve on beam line with the laser on.	2	E	2E
			Valve opened with pressure on one side or BSC open to clean room.	Damage to equipment, personnel injury or death. Protection is by "two-key" lockout with both computer and physical lockout covered in operating procedures.	None	2	E	2E
134	LGV6	Large Pneumatic Gate Valve	Valve fails to close	Inability to isolate cryopump for regeneration or back to air operation. Valve can be repaired and the valve closed.	None	4	D	4D
			Valve fails to open	Inability to return pump to operation. Valve can be repaired and the valve closed.	None	4	D	4D
			Valve closed with laser in operation	Damage to equipment and/or valve. Protection is by "two-key" lockout with both computer and physical lockout covered in operating procedures.	LIGO to consider adding interlock preventing closure of valve on beam line with the laser on.	2	E	2E
			Valve opened with pressure on one side or BSC open to clean room.	Damage to equipment, personnel injury or death. Protection is by "two-key" lockout with both computer and physical lockout covered in operating procedures.	None	2	E	2E

Hazard Severity Categories (HSC): 1=Catastrophic, 2=Critical, 3=Marginal, 4=Negligible
 Hazard Probability (HP): A=Frequent, B=Probable, C=Occasional, D=Remote, E=Improbable
 Hazard Risk Index (HRI)

Rev. 0
 Prepared by: SET
 Reviewed by: TS

LIGO Vacuum Equipment
 Failure Modes and Effects Analysis

135	HV 676 / 677 / 678	10" Pump out port valves	Valve opened to atmosphere with vacuum in the tube or cryopump. These are manual gate valves with a pad lock for both lock open and lock closed. LIGO procedures will regulate the opening or closing of these valves.	Loss of vacuum, damage to equipment in the tube, contamination, injury or loss of life to personnel near the valve.	LIGO to incorporate lockout procedures for locking gate valves in their operator training.	1	E	1E
-----	--------------------	--------------------------	--	---	--	---	---	----

Hazard Severity Categories (HSC): 1=Catastrophic, 2=Critical, 3=Marginal, 4=Negligible
 Hazard Probability (HP): A=Frequent, B=Probable, C=Occasional, D=Remote, E=Improbable
 Hazard Risk Index (HRI)

Rev. G
 Prepared by: SET
 Reviewed by: FAD

LIGO Vacuum Equipment
 Failure Modes and Effects Analysis

P&I Number: V049-0-025 Rev. 1
 Node: 30
 System: Louisiana Site Right End Station
 Date: 4/17/96

Node 30 includes all the normally connected equipment. The BSC chamber covered on P&ID V049-0-002, LIP6, and LCP4.

ITEM:	IDENTIFICATION	DESCRIPTION	FAILURE MODES	EFFECTS	ACTION ITEM	HSC	HP	HRI
136	LIP6	2500 torr-liter/sec ion pump and its' associated 14" gate valve.	Ion pump shutdown. The ion pump controller protects it from damage due to high current draw.	Loss of ion pumping capacity. The ion pump can be restarted once the cause of the shutdown has been fixed (too high pressure due to leak, premature operation, etc.).	None	4	D	4D
				If the ion pump is damaged and cannot be restarted, the 14" GVHV can be closed and the ion pump replaced.				
137	LCP4	80 K Cryopump (Short)	Leakage from atmosphere or LN2 side.	Loss of vacuum, possible contamination. PI-824 A or B will indicate leak. The cryopump can be isolated with LGV11 and 12 and repaired.	None	3	D	3D
138	PI 824 A or B	Gauge Pair on Cryopump	Either gauge fails electrically	Loss in the ability to read the vacuum level. Either an RGA can be attached to read the pressure or operation may continue without this information until it's convenient to isolate the cryopump and replace the	None	4	D	4D

Hazard Severity Categories (HSC): 1=Catastrophic, 2=Critical, 3=Marginal, 4=Negligible
 Hazard Probability (HP): A=Frequent, B=Probable, C=Occasional, D=Remote, E=Improbable
 Hazard Risk Index (HRI)

Rev. 0
 Prepared by: *JE*
 Reviewed by: *TS*

LIGO Vacuum Equipment
 Failure Modes and Effects Analysis

139	LGV11	Large Motor Operated Gate Valve	Valve fails to close	Inability to isolate cryopump for regeneration or back to air operation. Valve can be repaired and the valve closed.	None	4	D	4D
			Valve fails to open	Inability to return pump to operation. Valve can be repaired and the valve closed.	None	4	D	4D
			Valve closed with laser in operation	Damage to equipment and/or valve. Protection is by "two-key" lockout with both computer and physical lockout covered in operating procedures.	LIGO to consider adding interlock preventing closure of valve on beam line with the laser on.	2	E	2E
			Valve opened with pressure on one side or BSC open to clean room.	Damage to equipment, personnel injury or death. Protection is by "two-key" lockout with both computer and physical lockout covered in operating procedures.	None	2	E	2E
140	LGV12	Large Motor Operated Gate Valve	Valve fails to close	Inability to isolate cryopump for regeneration or back to air operation. Valve can be repaired and the valve closed.	None	4	D	4D
			Valve fails to open	Inability to return pump to operation. Valve can be repaired and the valve closed.	None	4	D	4D
			Valve closed with laser in operation	Damage to equipment and/or valve. Protection is by "two-key" lockout with both computer and physical lockout covered in operating procedures.	LIGO to consider adding interlock preventing closure of valve on beam line with the laser on.	2	E	2E

Hazard Severity Categories (HSC): 1=Catastrophic, 2=Critical, 3=Marginal, 4=Negligible
 Hazard Probability (HP): A=Frequent, B=Probable, C=Occasional, D=Remote, E=Improbable
 Hazard Risk Index (HRI)

Rev. 0
 Prepared by: SET
 Reviewed by: TS

LIGO Vacuum Equipment
 Failure Modes and Effects Analysis

			Valve opened with pressure on one side or BSC open to clean room.	Damage to equipment, personnel injury or death. Protection is by "two-key" lockout with both computer and physical lockout covered in operating procedures.	None	2	E	2E
--	--	--	---	---	------	---	---	----

Rev. 0
Prepared by: *SET*
Reviewed by: *AM*

LIGO Vacuum Equipment
Failure Modes and Effects Analysis

P&I Number: V049-0-025 Rev. 1
Node: 31
System: Louisiana Site Right End Station
Date: 4/17/96

Node 31 includes the turbo pumping equipment and the clean air supply system equipment.
The Turbo Cart and its' Turbo Backing Pump Cart are self-protected. See Hazards Analysis sheets for the Turbo Carts.
The unit shuts down on loss of seal gas to the backing cart, loss of cooling water flow shuts it down on high temperature, power failure, etc.

An intrinsically safe wiring setup has been designed such that it is physically impossible to operate more than one turbo pump cart with a single backing pump.

Note: Added Safety and Interlock

It is suggested to add a pressure switch between PCV 826 and 827 for back to air operation. If the rate of flow is too high for the clean air supply to keep up with both PCV's will open to maintain pressure. Should the receiver pressure drop sufficiently it could be damaged and bed material sucked into the chamber being repressurized. The pressure switch would go to the LIGO computer and shutdown the back to air valve.

ITEM:	IDENTIFICATION	DESCRIPTION	FAILURE MODES	EFFECTS	ACTION ITEM	HSC	HP	HRI
141	LTC4	Turbopump cart and associated connections	Pump shuts down for any of a number of reasons; loss of utility, suction pressure above allowable due to leak or insufficient roughing.	Delay in pumping out the system. The cause of pump shutdown needs to be corrected and the process restarted.	None	4	E	4E

Hazard Severity Categories (HSC): 1=Catastrophic, 2=Critical, 3=Marginal, 4=Negligible
Hazard Probability (HP): A=Frequent, B=Probable, C=Occasional, D=Remote, E=Improbable
Hazard Risk Index (HRI)

Rev. 0
 Prepared by: SET
 Reviewed by: TS

LIGO Vacuum Equipment
 Failure Modes and Effects Analysis

142	HV 820 / 821	10" Pump out port valve	Valve opened to atmosphere with vacuum in the tube or cryopump. These are manual gate valves with a pad lock for both lock open and lock closed. LIGO procedures will regulate the opening or closing of these valves.	Loss of vacuum, damage to equipment in the tube, contamination, injury or loss of life to personnel near the valve.	LIGO to incorporate lockout procedures for locking gate valves in their operator training.	1	E	1E
143	LTC4B	Turbo pump backing cart	Pump shuts down for any of a number of reasons; loss of utility, signal from turbo cart controller.	Shutdown of turbo cart and delay in pumping out the system. The cause of pump shutdown needs to be corrected and the process restarted.	None	4	E	4E
144	LCA800	Class 100 Clean Air Supply System	System shutdown, either compressor out or drier beds won't switch. Three signals go to the LIGO computer for monitoring, Compressor running signal, Compressor Common Alarm, Drier Beds Common Alarm.	During turbo pumping this would cause shutdown of the Turbo Backing Pump on loss of seal air.	None	4	E	4E
				During back to air operation the receiver could be sucked down to vacuum damageing it.	LIGO to provide computer interlock between compressor running signal and back to air control valve, for example PCV 120.	3	D	3D

Hazard Severity Categories (HSC): 1=Catastrophic, 2=Critical, 3=Marginal, 4=Negligible
 Hazard Probability (HP): A=Frequent, B=Probable, C=Occasional, D=Remote, E=Improbable
 Hazard Risk Index (HRI)

Rev. 0
 Prepared by: SE7
 Reviewed by: TS

LIGO Vacuum Equipment
 Failure Modes and Effects Analysis

				During purge operation through air showers loss of flow would allow contamination of optics with moisture.	None	4	E	4E
145	PCV-826	First stage letdown valve	Fail open	Increase downstream pressure	None	4	E	4E
			Fail closed	Loss of clean air flow tripping the turbo or cutting off air shower flow.	None	4	E	4E
146	PCV-827	Second stage letdown valve	Fail open	Increase downstream pressure might raise back to air pressure above vessel design pressure. Protection provided by accurate pressure control of back to air valve and PSV-825 on the clean air supply header.	None	4	E	4E
			Fail closed	Loss of clean air flow tripping the turbo or cutting off air shower flow.	None	4	E	4E

Hazard Severity Categories (HSC): 1=Catastrophic, 2=Critical, 3=Marginal, 4=Negligible
 Hazard Probability (HP): A=Frequent, B=Probable, C=Occasional, D=Remote, E=Improbable
 Hazard Risk Index (HRI)

Rev. 0
 Prepared by: SET
 Reviewed by: FAB

LIGO Vacuum Equipment
 Failure Modes and Effects Analysis

P&I Number: V049-0-020 Rev. 1
 Node: 32
 System: Louisiana Site Left End Station
 Date: 4/17/96

Node 32 includes all the normally connected equipment. The BSC chamber covered on P&ID V049-0-002, LIP5, and LCP3.

ITEM:	IDENTIFICATION	DESCRIPTION	FAILURE MODES	EFFECTS	ACTION ITEM	HSC	HP	HRI
147	LIP5	2500 torr-liter/sec ion pump and its' associated 14" gate valve.	Ion pump shutdown. The ion pump controller protects it from damage due to high current draw.	Loss of ion pumping capacity. The ion pump can be restarted once the cause of the shutdown has been fixed (too high pressure due to leak, premature operation, etc.). If the ion pump is damaged and cannot be restarted, the 14" GVHV can be closed and the ion pump replaced.	None	4	D	4D
148	LCP3	80 K Cryopump (Short)	Leakage from atmosphere or LN2 side.	Loss of vacuum, possible contamination. PI-724 A or B will indicate leak. The cryopump can be isolated with LGV9 and 10 and repaired.	None	3	D	3D
149	PI 724 A or B	Gauge Pair on Cryopump	Either gauge fails electrically	Loss in the ability to read the vacuum level. Either an RGA can be attached to read the pressure or operation may continue without this information until it's convenient to isolate the cryopump and replace the	None	4	D	4D

Hazard Severity Categories (HSC): 1=Catastrophic, 2=Critical, 3=Marginal, 4=Negligible
 Hazard Probability (HP): A=Frequent, B=Probable, C=Occasional, D=Remote, E=Improbable
 Hazard Risk Index (HRI)

Rev. 0
 Prepared by: *SE7*
 Reviewed by: *TS*

LIGO Vacuum Equipment
 Failure Modes and Effects Analysis

150	LGV9	Large Motor Operated Gate Valve	Valve fails to close	Inability to isolate cryopump for regeneration or back to air operation. Valve can be repaired and the valve closed.	None	4	D	4D
			Valve fails to open	Inability to return pump to operation. Valve can be repaired and the valve closed.	None	4	D	4D
			Valve closed with laser in operation	Damage to equipment and/or valve. Protection is by "two-key" lockout with both computer and physical lockout covered in operating procedures.	LIGO to consider adding interlock preventing closure of valve on beam line with the laser on.	2	E	2E
			Valve opened with pressure on one side or BSC open to clean room.	Damage to equipment, personnel injury or death. Protection is by "two-key" lockout with both computer and physical lockout covered in operating procedures.	None	2	E	2E
151	LGV10	Large Motor Operated Gate Valve	Valve fails to close	Inability to isolate cryopump for regeneration or back to air operation. Valve can be repaired and the valve closed.	None	4	D	4D
			Valve fails to open	Inability to return pump to operation. Valve can be repaired and the valve closed.	None	4	D	4D
			Valve closed with laser in operation	Damage to equipment and/or valve. Protection is by "two-key" lockout with both computer and physical lockout covered in operating procedures.	LIGO to consider adding interlock preventing closure of valve on beam line with the laser on.	2	E	2E

Hazard Severity Categories (HSC): 1=Catastrophic, 2=Critical, 3=Marginal, 4=Negligible
 Hazard Probability (HP): A=Frequent, B=Probable, C=Occasional, D=Remote, E=Improbable
 Hazard Risk Index (HRI)

Rev. 0
 Prepared by: SET
 Reviewed by: TS

LIGO Vacuum Equipment
 Failure Modes and Effects Analysis

			Valve opened with pressure on one side or BSC open to clean room.	Damage to equipment, personnel injury or death. Protection is by "two-key" lockout with both computer and physical lockout covered in operating procedures.	None	2	E	2E
--	--	--	---	---	------	---	---	----

Rev. 0
Prepared by: SPT
Reviewed by: AM

LIGO Vacuum Equipment
Failure Modes and Effects Analysis

P&I Number: V049-0-020 Rev. 1
Node: 33
System: Louisiana Site Left End Station
Date: 4/17/96

Node 33 includes the turbo pumping equipment and the clean air supply system equipment. The Turbo Cart and its Turbo Backing Pump Cart are self-protected. See Hazards Analysis sheets for the Turbo Carts. The unit shuts down on loss of seal gas to the backing cart, loss of cooling water flow shuts it down on high temperature, power failure, etc.

An intrinsically safe wiring setup has been designed such that it is physically impossible to operate more than one turbo pump cart with a single backing pump.

Note: Added Safety and Interlock

It is suggested to add a pressure switch between PCV 726 and 727 for back to air operation. If the rate of flow is too high for the clean air supply to keep up with both PCV's will open to maintain pressure. Should the receiver pressure drop sufficiently it could be damaged and bed material sucked into the chamber being repressurized. The pressure switch would go to the LIGO computer and shutdown the back to air valve.

ITEM:	IDENTIFICATION	DESCRIPTION	FAILURE MODES	EFFECTS	ACTION ITEM	HSC	HP	HRI
152	LTC3	Turbopump cart and associated connections	Pump shuts down for any of a number of reasons; loss of utility, suction pressure above allowable due to leak or insufficient roughing.	Delay in pumping out the system. The cause of pump shutdown needs to be corrected and the process restarted.	None	4	E	4E

Hazard Severity Categories (HSC): 1=Catastrophic, 2=Critical, 3=Marginal, 4=Negligible
Hazard Probability (HP): A=Frequent, B=Probable, C=Occasional, D=Remote, E=Improbable
Hazard Risk Index (HRI)

Rev. 0
 Prepared by: SET
 Reviewed by: TS

LIGO Vacuum Equipment
 Failure Modes and Effects Analysis

153	HV 720 / 721	10" Pump out port valve	Valve opened to atmosphere with vacuum in the tube or cryopump. These are manual gate valves with a pad lock for both lock open and lock closed. LIGO procedures will regulate the opening or closing of these valves.	Loss of vacuum, damage to equipment in the tube, contamination, injury or loss of life to personnel near the valve.	LIGO to incorporate lockout procedures for locking gate valves in their operator training.	1	E	1E
154	LTC3B	Turbo pump backing cart	Pump shuts down for any of a number of reasons; loss of utility, signal from turbo cart controller.	Shutdown of turbo cart and delay in pumping out the system. The cause of pump shutdown needs to be corrected and the process restarted.	None	4	E	4E
155	LCA700	Class 100 Clean Air Supply System	System shutdown, either compressor out or drier beds won't switch. Three signals go to the LIGO computer for monitoring, Compressor running signal, Compressor Common Alarm, Drier Beds Common Alarm.	During turbo pumping this would cause shutdown of the Turbo Backing Pump on loss of seal air.	None	4	E	4E
				During back to air operation the receiver could be sucked down to vacuum damaging it.	LIGO to provide computer interlock between compressor running signal and back to air control valve, for example PCV 120.	3	D	3D

Hazard Severity Categories (HSC): 1=Catastrophic, 2=Critical, 3=Marginal, 4=Negligible
 Hazard Probability (HP): A=Frequent, B=Probable, C=Occasional, D=Remote, E=Improbable
 Hazard Risk Index (HRI)

Rev. 0
 Prepared by: JFT
 Reviewed by: TS

LIGO Vacuum Equipment
 Failure Modes and Effects Analysis

				During purge operation through air showers loss of flow would allow contamination of optics with moisture.	None	4	E	4E
156	PCV-726	First stage letdown valve	Fail open	Increase downstream pressure	None	4	E	4E
			Fail closed	Loss of clean air flow tripping the turbo or cutting off air shower flow.	None	4	E	4E
157	PCV-727	Second stage letdown valve	Fail open	Increase downstream pressure might raise back to air pressure above vessel design pressure. Protection provided by accurate pressure control of back to air valve and PSV-725 on the clean air supply header.	None	4	E	4E
			Fail closed	Loss of clean air flow tripping the turbo or cutting off air shower flow.	None	4	E	4E

Hazard Severity Categories (HSC): 1=Catastrophic, 2=Critical, 3=Marginal, 4=Negligible
 Hazard Probability (HP): A=Frequent, B=Probable, C=Occasional, D=Remote, E=Improbable
 Hazard Risk Index (HRI)

Rev. 0
 Prepared by: STJ
 Reviewed by: AM

LIGO Vacuum Equipment
 Failure Modes and Effects Analysis

P&I Number: V049-0-026 Rev. 1
Node: 34
System: Louisiana Site Corner Station Mechanical Room
Date: 4/17/96

Node 34 includes the turbo and roughing backing pump carts and the clean air supply system equipment in the mechanical room. The Turbo Backing Pump Cart and Roughing Backing pump cart are self-protected. See Hazards Analysis sheets for the Turbo Carts and Roughing Pump Carts. The units shut down on loss of seal gas to the backing cart, loss of cooling water flow shuts them down on high temperature, power failure, etc.

An intrinsically safe wiring setup has been designed such that it is physically impossible to operate more than one turbo pump cart or roughing pump cart with a single backing pump.

Note: Added Safety and Interlock

It is suggested to add a pressure switch between PCV 684 and 698 for back to air operation. If the rate of flow is too high for the clean air supply to keep up with both PCV's will open to maintain pressure. Should the receiver pressure drop sufficiently it could be damaged and bed material sucked into the chamber being repressurized. The pressure switch would go to the LIGO computer and shutdown the back to air valve.

ITEM:	IDENTIFICATION	DESCRIPTION	FAILURE MODES	EFFECTS	ACTION ITEM	HSC	HP	HRI
158	LRC1B	Roughing pump backing cart	Pump shuts down for any of a number of reasons; loss of utility.	Shutdown of roughing pump cart and delay in pumping out the system. The cause of pump shutdown needs to be corrected and the process restarted.	None	4	E	4E
159	LRC2B	Roughing pump backing cart	Pump shuts down for any of a number of reasons; loss of utility.	Shutdown of roughing pump cart and delay in pumping out the system. The cause of pump shutdown needs to be corrected and the process restarted.	None	4	E	4E

Hazard Severity Categories (HSC): 1=Catastrophic, 2=Critical, 3=Marginal, 4=Negligible
 Hazard Probability (HP): A=Frequent, B=Probable, C=Occasional, D=Remote, E=Improbable
 Hazard Risk Index (HRI)

Rev. Δ
 Prepared by: SFT
 Reviewed by: SM

LIGO Vacuum Equipment
 Failure Modes and Effects Analysis

160	LTC1B	Turbo pump backing cart	Pump shuts down for any of a number of reasons; loss of utility.	Shutdown of turbo pump cart and delay in pumping out the system. The cause of pump shutdown needs to be corrected and the process restarted.	None	4	E	4E
161	LTC2B	Turbo pump backing cart	Pump shuts down for any of a number of reasons; loss of utility.	Shutdown of turbo pump cart and delay in pumping out the system. The cause of pump shutdown needs to be corrected and the process restarted.	None	4	E	4E
162	LCA600	Class 100 Clean Air Supply System	System shutdown, either compressor out or drier beds won't switch. Three signals go to the LIGO computer for monitoring, Compressor running signal, Compressor Common Alarm, Drier Beds Common Alarm.	During turbo pumping this would cause shutdown of the Turbo Backing Pump on loss of seal air.	None	4	E	4E
				During back to air operation the receiver could be sucked down to vacuum damaging it.	LIGO to provide computer interlock between compressor running signal and back to air control valve, for example PCV 120.	3	D	3D

Hazard Severity Categories (HSC): 1=Catastrophic, 2=Critical, 3=Marginal, 4=Negligible
 Hazard Probability (HP): A=Frequent, B=Probable, C=Occasional, D=Remote, E=Improbable
 Hazard Risk Index (HRI)

Rev. 0
 Prepared by: SRT
 Reviewed by: TS

LIGO Vacuum Equipment
 Failure Modes and Effects Analysis

				During purge operation through air showers loss of flow would allow contamination of optics with moisture.	None	4	E	4E
163	PCV-684	First stage letdown valve	Fail open	Increase downstream pressure	None	4	E	4E
			Fail closed	Loss of clean air flow tripping the turbo or cutting off air shower flow.	None	4	E	4E
164	PCV-698	Second stage letdown valve	Fail open	Increase downstream pressure might raise back to air pressure above vessel design pressure. Protection provided by accurate pressure control of back to air valve and PSV-675 on the clean air supply header.	None	4	E	4E
			Fail closed	Loss of clean air flow tripping the turbo or cutting off air shower flow.	None	4	E	4E

Hazard Severity Categories (HSC): 1=Catastrophic, 2=Critical, 3=Marginal, 4=Negligible
 Hazard Probability (HP): A=Frequent, B=Probable, C=Occasional, D=Remote, E=Improbable
 Hazard Risk Index (HRI)