

isc Silicon PNP Power Transistor

BD944/946/948

DESCRIPTION

- DC Current Gain-  
:  $h_{FE} = 85(\text{Min}) @ I_C = -500\text{mA}$
- Complement to Type BD943/945/947

APPLICATIONS

- Designed for use in audio output stages and general purpose amplifier applications.

ABSOLUTE MAXIMUM RATINGS( $T_a=25^\circ\text{C}$ )

SYMBOL	PARAMETER	VALUE	UNIT	
$V_{CBO}$	Collector-Base Voltage	BD944	-22	V
		BD946	-32	
		BD948	-45	
$V_{CEO}$	Collector-Emitter Voltage	BD944	-22	V
		BD946	-32	
		BD948	-45	
$V_{EBO}$	Emitter-Base Voltage	-5	V	
$I_C$	Collector Current-Continuous	-5	A	
$I_{CM}$	Collector Current-Peak	-8	A	
$I_B$	Base Current-Continuous	-1	A	
$P_C$	Collector Power Dissipation @ $T_C=25^\circ\text{C}$	40	W	
$T_J$	Junction Temperature	150	$^\circ\text{C}$	
$T_{stg}$	Storage Temperature Range	-65~150	$^\circ\text{C}$	

THERMAL CHARACTERISTICS

SYMBOL	PARAMETER	MAX	UNIT
$R_{th\ j-c}$	Thermal Resistance, Junction to Case	3.12	$^\circ\text{C/W}$
$R_{th\ j-a}$	Thermal Resistance, Junction to Ambient	70	$^\circ\text{C/W}$

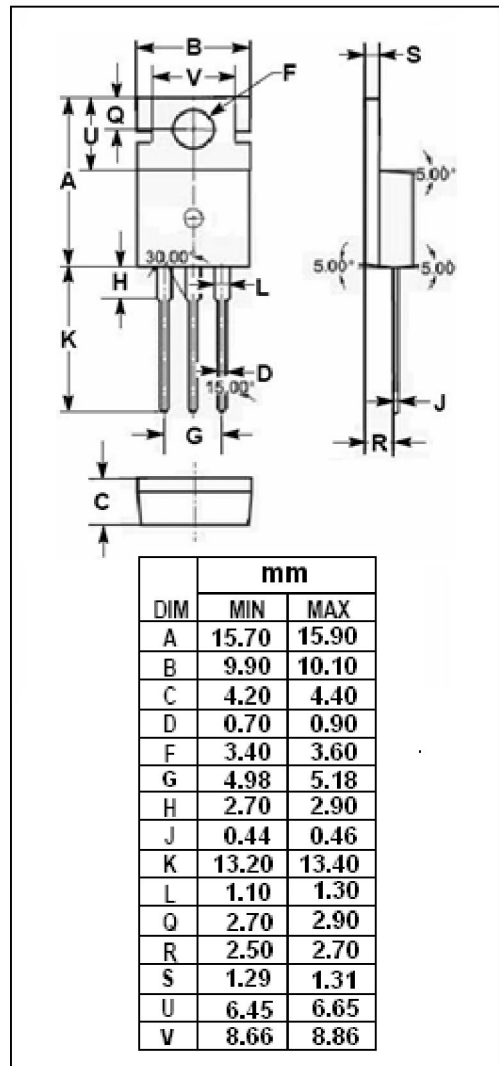
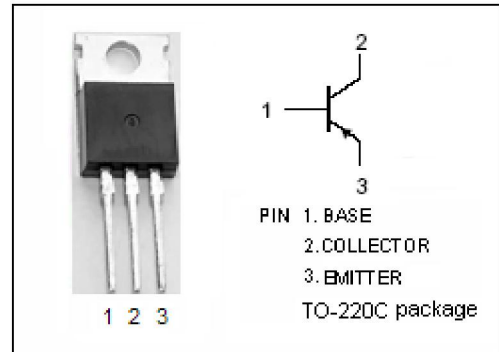

## isc Silicon PNP Power Transistor

## BD944/946/948

## ELECTRICAL CHARACTERISTICS

 $T_C=25^\circ\text{C}$  unless otherwise specified

SYMBOL	PARAMETER		CONDITIONS	MIN	TYP.	MAX	UNIT
$V_{CEO(SUS)}$	Collector-Emitter Sustaining Voltage	BD944	$I_C = -100\text{mA}; I_B = 0$	-22			V
		BD946		-32			
		BD948		-45			
$V_{CE(sat)}$	Collector-Emitter Saturation Voltage	BD944/946	$I_C = -2\text{A}; I_B = -0.2\text{A}$			-0.5	V
		BD948	$I_C = -3\text{A}; I_B = -0.3\text{A}$			-0.7	
$V_{BE(on)}$	Base-Emitter On Voltage	BD944/946	$I_C = -2\text{A}; V_{CE} = -1\text{V}$			-1.1	V
		BD948	$I_C = -3\text{A}; V_{CE} = -1\text{V}$			-1.3	
$I_{CBO}$	Collector Cutoff Current		$V_{CB} = V_{CB0max}; I_E = 0$ $V_{CB} = V_{CB0max}; I_E = 0, T_J = 150^\circ\text{C}$			-0.05 -1	mA
$I_{CEO}$	Collector Cutoff Current	BD944	$V_{CE} = -15\text{V}; I_B = 0$			-0.1	mA
		BD946	$V_{CE} = -20\text{V}; I_B = 0$				
		BD948	$V_{CE} = -25\text{V}; I_B = 0$				
$I_{EBO}$	Emitter Cutoff Current		$V_{EB} = -5\text{V}; I_C = 0$			-0.2	mA
$h_{FE-1}$	DC Current Gain		$I_C = -10\text{mA}; V_{CE} = -5\text{V}$	25			
$h_{FE-2}$	DC Current Gain		$I_C = -500\text{mA}; V_{CE} = -1\text{V}$	85		475	
$h_{FE-3}$	DC Current Gain	BD944/946	$I_C = -2\text{A}; V_{CE} = -1\text{V}$	50			
		BD948		40			
$h_{FE-4}$	DC Current Gain— <b>Only For BD948</b>		$I_C = -3\text{A}; V_{CE} = -1\text{V}$	30			
$f_T$	Current-Gain—Bandwidth Product		$I_C = -250\text{mA}; V_{CE} = -1\text{V}$	3			MHz