



Regular Governing Body Meeting
City of Rio Rancho
AGENDA
March 10, 2022
6:00 PM
Council Chambers

Governing Body Members

Greggory D. Hull, Mayor	Paul Wymer, Councilor District 4
Jim Owen, Councilor District 1	Karissa Culbreath, Councilor District 5
Jeremy Lenentine, Councilor District 2	Daniel Stoddard, Councilor District 6
Bob Tyler, Councilor District 3	

Meeting Information

This meeting will be conducted in-person and virtually, as well as streamed live on the City of Rio Rancho website at <https://rrnm.gov/2303/Watch-and-Download-City-Meetings>

Individuals wishing to present verbal public comment may do so in-person or remotely via Zoom meeting software with the below access information:

Join by Computer: <https://us06web.zoom.us/j/91804920905?pwd=ZIZ5NmduTUTF1RndxTVN2dHBTSnJ3Zz09>

Meeting ID: 918 0492 0905
Passcode: 903274

Join by Phone: 1 253 215 8782 US and enter ID and Passcode above

Call to Order and Pledge of Allegiance

Proclamations and Awards of Merit

Public Forum

Comments by Councilors

Consent Calendar

There will be no discussion of these items unless a Governing Body Member so requests, in which event the item will be moved to a discussion item on the regular agenda.

- [1. Minutes of February 24, 2022 Regular Meeting](#)
Minutes of February 24, 2022 Regular Meeting
- [2. D8, Appointment of Christopher H. Daniel to the Investment Advisory Group](#)
Daniels Resume_Redacted
- [3. R10, Resolution Accepting State Homeland Security Grant Program Funds and Authorizing a Budget Adjustment to the Federal Grants Fund \(259\)](#)
Resolution

- 4.** R11, Resolution Authorizing a Budget Adjustment to the Police Department Fleet Maintenance Budget for the Insured Repair of a Police Patrol Vehicle
Resolution
- 5.** R12, Resolution Accepting a New Mexico Department of Cultural Affairs, State Library Division American Rescue Plan Act (ARPA) Grant for the Library and Information Services Department
Resolution
- 6.** R13, Resolution Authorizing a Budget Adjustment to the Park Impact Fees Fund (353) to Fund the Construction of Sports Complex North Phase II
Resolution
- 7.** D9, Approval of a Permanent Change of Floor Plan to Expand Brew Lab 101 Beer and Cider Co. for Liquor License No. 67132 and 60062 located at 3301 Southern Blvd. Rio Rancho NM 87124
Brew Lab 101 - Permanent Change in Floor Plan Application

Boards and Commissions

Public Hearings

- 8.** O3, Ordinance of the City of Rio Rancho, New Mexico Amending the Zoning Classification and Official Zoning Map for the Property Legally Described as Hawksite, Tract 21 from C-1: Retail Commercial District to R-6: Multi-Family Residential District, Identifying Conditions of Development; Providing for Severability and an Effective Date
Ordinance
Application
NeighboringPropertyOwnerLetter_GB
UpdatedJustificationLetter
Location and Notification Map
Sign
Mountain Hawk Estates Master Plan Final
- 9.** D10, Site Plan Approval for Caliber Collision, 4705 Sundt Rd NE, Rio West Business Park, Block A, Lot 2A
Application
Zoning, Location
Site Plan
Authorization
Staff Comments
Reproduction of Notices
Public Comment

Second Reading of Ordinances

First Reading of Ordinances

Discussion and Deliberation

- 10.** R14, Resolution Authorizing the Write-Off and Removal of Uncollectible Ambulance, Utilities, Parks and Recreation, Alarm, and Library Accounts from the City's Accounts Receivable
Resolution
ATTACHMENT I - Financial Services Department Director Statement.pdf
ATTACHMENT II -Uncollectible Ambulance 12.31.2017 Redacted.pdf
ATTACHMENT III - Utilities Uncollectible 12.31.17.pdf

ATTACHMENT IV - PRCS Uncollectible 12.31.17.pdf
ATTACHMENT V - Alarms Uncollectible 12.31.2017.pdf
ATTACHMENT VI - Library Uncollectible 12.31.17.pdf

- 11.** D11, Advice and Consent of the Governing Body to Award Contract No. 22-PR-127: Construction of Sports Complex North Phase II Contract to T.A. Cole & Sons General Contractors, Inc.
Sports Complex North Ph2 Improvements Overview
Contract 22-PR-127 Revised

City Manager

Comments by Councilors

Adjournment

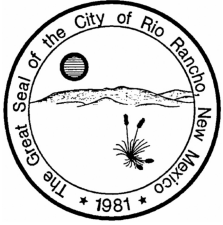

**CITY OF RIO RANCHO
COVER PAGE**

Legislation Item:

AGENDA DATE:
March 10, 2022

DEPARTMENT:
City Clerk

SUBJECT:
Minutes of February 24, 2022 Regular Meeting

BACKGROUND AND ANALYSIS:

IMPACT:

ALTERNATIVES:

DEPARTMENT RECOMMENDATION:

ATTACHMENT: [Minutes of February 24, 2022 Regular Meeting](#)



Governing Body
of the
City of Rio Rancho

MINUTES

FEBRUARY 24, 2022
6:00 PM
Council Chambers, City Hall

MEMBERS PRESENT:

Greggory D. Hull, Mayor
Jim Owen, Councilor Dist. 1
Jeremy Lenentine, Councilor Dist. 2(virtual)
Bob Tyler, Councilor Dist. 3(virtual)
Paul Wymer, Councilor Dist. 4
Karissa Culbreath, Councilor Dist. 5
Daniel Stoddard, Councilor Dist. 6

STAFF PRESENT:

Matt Geisel, City Manager
Peter Wells, Deputy City Manager
Greg Lauer, City Attorney
Carol Jaramillo, Dir. of Fin. Svcs. (virtual)
James Defillippo, Acting Fire Chief
Stewart Steele, Police Chief
Amy Rincon, Director of Development Svc.
Yolanda Lucero, Deputy City Clerk

CALL TO ORDER AND PLEDGE OF ALLEGIANCE

Mayor Hull called the meeting to order at 6:00 p.m.

Mayor Hull stated his Governing Body Meeting will convene under the virtual format prescribed by the Attorney General's Office guidance issued for public meetings subject to the Open Meetings Act. This includes virtual or telephonic access via Zoom meeting software by members of the public who choose to participate in this fashion.

PROCLAMATIONS AND AWARDS OF MERIT

PUBLIC FORUM

The following individual spoke under public forum:

Allison Poccia

COMMENTS BY COUNCILORS

Councilor Culbreath would like staff to look at all the options and opportunities available to help alleviate the traffic on 26th Street to find a resolution for the residents.

CONSENT CALENDAR

1.) Minutes of February 10, 2022 Regular Meeting

1 2.) R9, Resolution Accepting Funds from the Rocky Mountain Information Network to be
2 Paid to the New Mexico Association of Chiefs of Police

3
4 Daniel Stoddard moved to approve consent calendar. Seconded by Karissa
5 Culbreath.

6
7 The motion carried by a vote of 6 FOR and 0 AGAINST.

8 YES: Jim Owen, Jeremy Lenentine, Bob Tyler, Paul Wymer, Karissa Culbreath,
9 Daniel Stoddard

10 NO: None

11
12 **BOARDS AND COMMISSIONS**

13
14 **PUBLIC HEARINGS**

15
16 3.) D7, Site Plan Approval for Grande Development, 2340 Grande Blvd. SE, Gateway
17 South, Tract A14

18
19 Ms. Rincon presented this item. The subject property is located at 2340 Grande Blvd.
20 SE, legally described as Gateway South, Tract A14, and consists of approximately 1.49
21 acres. The subject property is zoned SU for C-1: Retail Commercial and select C-2 uses
22 require conditional use permits. Staff recommends the Governing Body approves the
23 applicant's request for Site Plan approval with findings and conditions.

24
25 Karissa Culbreath moved to approve D7. Seconded by Daniel Stoddard.

26
27 The motion carried by a vote of 6 FOR and 0 AGAINST.

28 YES: Jim Owen, Jeremy Lenentine, Bob Tyler, Paul Wymer, Karissa Culbreath,
29 Daniel Stoddard

30 NO: None

31
32 4.) O2, Ordinance of the City Of Rio Rancho, New Mexico Amending the Zoning
33 Classification and Official Zoning Map for Property Located at 2211 Golf Course Road
34 SE and 2215 Golf Course Road SE, and Described as Unit 16, Block 59, Lots 59a and
35 58a, from R-1: Single-Family Residential District to NC: Neighborhood Commercial
36 District, Identifying Conditions of Development; Providing for Severability and an
37 Effective Date

38
39 Ms. Rincon stated the applicant, through their agent, Steven M. Nakamura, requests
40 approval of a zone map amendment to change the zoning from R-1: Single-Family
41 Residential to NC: Neighborhood Commercial, for the property legally described as Unit
42 16, Block 59, Lots 58A and 59A. The subject property is approximately 0.84 acres,
43 located off of Golf Course Rd SE, a minor arterial road. The subject property is located
44 in the Golf Course Road Corridor Plan Area. This item was heard by the Planning and
45 Zoning Board at their meeting on January 25, 2022, and they recommended approval.

1 Daniel Stoddard moved to approve O2. Seconded by Karissa Culbreath.

2
3 The motion carried by a vote of 6 FOR and 0 AGAINST.

4 YES: Jim Owen, Jeremy Lenentine, Bob Tyler, Paul Wymer, Karissa Culbreath,
5 Daniel Stoddard

6 NO: None
7

8 **SECOND READING OF ORDINANCES**

9
10 **FIRST READING OF ORDINANCES**

11
12 **DISCUSSION AND DELIBERATION**

13
14 **CITY MANAGER**

15
16 **COMMENTS BY COUNCILORS**

17
18 **ADJOURNMENT**

19
20 6:16

21
22 **APPROVED THIS MARCH 10, 2022**

23
24
25
26 **ATTEST:**

Greggory D. Hull, Mayor

27
28
29 _____
Rebecca A. Martinez, City Clerk

30 **SEAL**



**CITY OF RIO RANCHO
COVER PAGE**

Legislation Item: D8

AGENDA DATE:

March 10, 2022

DEPARTMENT:

Administration

SUBJECT:

D8, Appointment of Christopher H. Daniel to the Investment Advisory Group

BACKGROUND AND ANALYSIS:

Pursuant to Municipal Code, Section 36.60, the Investment Advisory Group consists of the Mayor, Deputy Mayor, City Manager, Treasurer (Financial Services Department Director), another department director selected by the City Manager, and two residents of the City who have expert knowledge or professional experience in public finance or public funds investing. The City Manager is the chairperson of the group.

The Mayor, with the approval of the City Council, appoints the resident members of the group.

Mr. Daniel is a resident of the City of Rio Rancho. He is currently employed by the City of Albuquerque as their Chief Investment Officer. He has a Bachelor's degree from the University of North Carolina and Master of Business Administration from Georgia State University. He has experience in portfolio management, treasury, corporate finance, and accounting.

Mr. Daniel has previously served on the Investment Advisory Group as one of the two resident appointees.

If appointed, Mr. Daniel will serve another two-year term on the Investment Advisory Group with an expiration date of March 10, 2024.

IMPACT:

This appointment will fill a vacancy (resident) on the Investment Advisory Group caused by term expiration.

ALTERNATIVES:

Approve the appointment.

Do not approve the appointment.

DEPARTMENT RECOMMENDATION:

Mayor Hull recommends the reappointment of Christopher H. Daniel to the Investment Advisory Group.

ATTACHMENT: [Daniels Resume_Redacted](#)

Christopher H. Daniel

Objective

A challenging governmental investment portfolio manager position.

Summary of qualifications

I have extensive broad experience in portfolio management, treasury, corporate finance, accounting, strategic planning, team project management, public speaking & peer influence, employee supervision, and executive liason. My professional credentials include attainment of the Chartered Financial Analyst (CFA) designation, attainment of CPA licensure, and award of the Certified Treasury Professional (CTP) designation. My technology skills include strong knowledge of all Microsoft Office applications, portfolio management software, ERP applications, Sage (Peachtree) Accounting, and various other financial packages. I have very strong oral and written communication skills.

Work experience

City of Albuquerque

2006 -

Albuquerque, New Mexico

Chief Investment Officer 2014 – Present:

- Manage the City's \$600 million cash/investment portfolio
- Developed and implemented a pioneering strategic asset allocation approach to public funds management, resulting in over \$2 million incremental total return gain to date
- Oversee Treasury banking and cash management functions

ERP Program Manager 2010 – 2014:

- Direct 20-employee ERP Program which manages City core Financial & HR system
- Developed the Program from inception, and led it through several projects that reaped millions of dollars in operational efficiencies and business process improvements throughout the City
- Serve as Program liason to ERP Steering Committee and Executive Management

Assistant Treasurer 2006 – 2010:

- Co-manage entire Treasury Division 2007-2009
- Manage the City's Investment, Fiscal Agent Relations, and Cash Management Programs

New Mexico Student Loans

2002 - 2006

Albuquerque, New Mexico

Controller

- Direct general accounting functions of the state's primary student loan issuer
- Facilitate the Foundation's annual budget process
- Participate with leadership team on strategic decision-making

Rio Pecos Medical Associates, Ltd.

1995 - 2002

Roswell, New Mexico

Administrator

- Manage 14-doctor, 80+-employee medical practice
- Serve as corporate Treasurer and Controller
- Advise board of directors on company policy

Cathey, Hutton & Associates, Inc.

1993 - 1995

Dallas, Texas

Senior Financial Consultant

- Provide financial services to rural telecommunications firms
- Furnish business valuations & merger/acquisitions guidance
- Assist clients with tax & estate planning

GTE/Contel Corporation (now Verizon)

1986 - 1993

Dallas, Texas/Atlanta, Georgia

Administrator - Pricing & Earnings

- Supervise staff of five professional financial analysts & economists
- Develop cost and demand forecasts for regulated services
- Formulate pricing plans
- Monitor performance of access service offerings

Administrator - Financial Planning

- Assist in preparation of annual operating budget
- Monitor budget compliance

Turner Broadcasting, Inc. - Cable News Network

1981 - 1984

Atlanta, Georgia

Video Journalist

- Perform studio operations for live news broadcasts
- Participate in production of promotions and pre-recorded programming

Education

Georgia State University

1984 - 1986

Atlanta, Georgia

Master of Business Administration - Finance concentration

University of North Carolina

1976 - 1980

Chapel Hill, North Carolina

Bachelor of Arts - Radio, Television & Motion Pictures

Bachelor of Arts - History

Accreditations

- Chartered Financial Analyst (CFA)
- Certified Public Accountant (CPA) - licensed in New Mexico & Texas
- Certified Treasury Professional (CTP)

Professional memberships

- CFA Institute
- CFA Society New Mexico (Treasurer)
- Government Finance Officers Association (GFOA – Treasury & Investment Committee Member)
- Government Investment Officers Association (GIOA)
- American Institute of Certified Public Accountants (AICPA)
- New Mexico Society of Certified Public Accountants
- Association for Financial Professionals (AFP)
- City of Rio Rancho, NM Investment Committee
- Sandoval County, NM Treasurer Investment Committee
- Stonehenge/Estates Homeowners Association Boards of Directors (Treasurer)

References

Available upon request

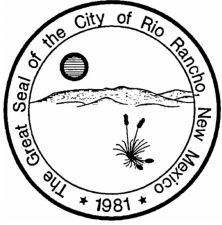

CITY OF RIO RANCHO COVER PAGE

Legislation Item: R10

AGENDA DATE:

March 10, 2022

DEPARTMENT:

Fire and Rescue

SUBJECT:

R10, Resolution Accepting State Homeland Security Grant Program Funds and Authorizing a Budget Adjustment to the Federal Grants Fund (259)

BACKGROUND AND ANALYSIS:

The New Mexico Department of Homeland Security & Emergency Management has awarded the Rio Rancho Fire & Rescue Department \$510,682 in grant funding. The Homeland Security Grant Program was established in 2003 and incorporates all projects that provide funding to local, state, and federal government agencies by the Department of Homeland Security. The purpose of the grant is to purchase equipment and pay for advanced training for law enforcement personnel in order to increase and/or sustain security.

The FY 2021 Homeland Security Grant Program plays an important role in the implementation of the National Preparedness System by supporting the building, sustainment, and delivery of core capabilities essential to achieving the National Preparedness Goal of a secure and resilient Nation. Delivering core capabilities requires the combined effort of the whole community, rather than the exclusive effort of any single organization or level of government. The FY 2021 Homeland Security Grant Program allowable costs support efforts to build and sustain core capabilities across the Prevention, Protection, Mitigation, Response, and Recovery mission areas, including the following priorities.

The funding is allotted as follows:

- \$10,000 for equipment and supplies for the SAR Bike Unit
- \$32,250 for Fire Station security (e.g., access entry systems)
- \$319,675 for protective measures (e.g., metal detectors, access entry systems) at the Rio Rancho Events Center
- \$32,000 for SWAT (e.g., equipment)
- \$60,996 for the Emergency Response Team (ERT) program (e.g., vehicle and equipment)
- \$55,761 for the Rio Rancho Office of Emergency Management's Community Emergency Response Team (CERT) program (e.g., training and equipment)

IMPACT:

This grant provides additional funding to municipal government.

ALTERNATIVES:

Approve the Resolution.

Do not approve the Resolution.

DEPARTMENT RECOMMENDATION:

Staff recommends approval of the Resolution.

ATTACHMENT: [Resolution](#)



**CITY OF RIO RANCHO
RESOLUTION**

RESOLUTION NO.

ENACTMENT NO.

**RESOLUTION ACCEPTING STATE HOMELAND SECURITY GRANT PROGRAM
FUNDS AND AUTHORIZING A BUDGET ADJUSTMENT TO THE FEDERAL
GRANTS FUND (FUND 259)**

WHEREAS: the New Mexico Department of Homeland Security & Emergency Management has awarded the Fire & Rescue Department \$510,682 in grant funding; and

WHEREAS: the Homeland Security Grant Program was established in 2003 and incorporates all projects that provide funding to local, state, and federal government agencies by the Department of Homeland Security; and

WHEREAS: the purpose of the grant is to purchase equipment and pay for advanced training for law enforcement personnel in order to increase and/or sustain security; and

WHEREAS: a budget adjustment is necessary to expend the grant funds as proposed.

NOW THEREFORE, BE IT RESOLVED BY THE GOVERNING BODY OF THE CITY OF RIO RANCHO:

That authorization is given for the following budget adjustment:

Federal Grants Fund (Fund 259)

Account	Project No.	Revised Budget	Increase	Decrease	Adjusted Budget
259-0000-331-2000 Federal Grants	FR2244	\$895,884	\$510,682		\$1,406,566
Total Revenue		\$895,884	\$510,682		\$1,406,566

Account	Project No.	Revised Budget	Increase	Decrease	Adjusted Budget
259-0000-424-4006 SWAT Program	FR2244	\$169,500	\$32,000		\$201,500
259-0000-424-4008 CERT Program	FR2244	\$27,359	\$15,362		\$42,721
259-0000-424-4009 ERT Program	FR2244	\$0	\$17,996		\$17,996
259-0000-424-5035 Repair & Maintenance Buildings	FR2244	\$0	\$32,250		\$32,250
259-0000-424-6020 Protective Clothing	FR2244	\$13,170	\$3,520		\$16,690
259-0000-424-6053					

Program Supplies	FR2244	\$0	\$400		\$400
259-0000-424-6070 Minor Equipment	FR2244	\$26,237	\$6,080		\$32,317
259-0000-424-7011 Building Improvement	FR2244	\$50,000	\$319,675		\$369,675
259-0000-424-7015 Vehicle and Heavy Equipment	FR2244	\$0	\$71,399		\$71,399
259-0000-424-7025 Major Equipment	FR2244	\$59,040	\$12,000		\$71,040
Total Expense		\$345,306	\$510,682		\$855,988

1
2
3
4
5
6
7
8
9
10
11
12
13
14
15

ADOPTED THIS _____ DAY OF _____, 2022.

Greggory D. Hull, Mayor

ATTEST:

Rebecca A. Martinez, City Clerk
(SEAL)

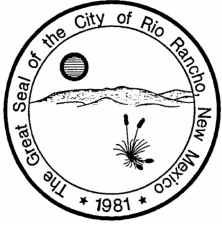

**CITY OF RIO RANCHO
COVER PAGE**

Legislation Item: R11

AGENDA DATE:

March 10, 2022

DEPARTMENT:

Police Department

SUBJECT:

R11, Resolution Authorizing a Budget Adjustment to the Police Department Fleet Maintenance Budget for the Insured Repair of a Police Patrol Vehicle

BACKGROUND AND ANALYSIS:

On April 16, 2021, a collision occurred between two police vehicles in the north lot of Police headquarters. An insurance recovery was received by the City for \$1,873, which was \$500 less than the repair cost. A subsequent check for the \$500 was received, completing the recovery. The total recovery amount is \$2,373.

IMPACT:

The vehicle has been repaired and returned to service. The impact of this Resolution will be to make the Police Department Fleet Management budget whole.

ALTERNATIVES:

Approve the Resolution.

Do not approve the Resolution.

DEPARTMENT RECOMMENDATION:

Staff recommends approval of the Resolution.

ATTACHMENT: [Resolution](#)



**CITY OF RIO RANCHO
RESOLUTION**

RESOLUTION NO.

ENACTMENT NO.

**RESOLUTION AUTHORIZING A BUDGET ADJUSTMENT TO THE POLICE
DEPARTMENT FLEET MAINTENANCE BUDGET FOR THE INSURED REPAIR OF A
POLICE PATROL VEHICLE**

WHEREAS: the City has received an insurance claim payment totaling \$2,373 for the purpose of repairing a police patrol car (Unit 1928) that was damaged in a motor vehicle accident; and

WHEREAS: a budget adjustment is necessary to expend the funds as intended.

**NOW THEREFORE, BE IT RESOLVED BY THE GOVERNING BODY OF THE CITY
OF RIO RANCHO:**

That authorization is given for the following budget adjustment:

Law Enforcement Fleet Maintenance (6025)

Account	Project No.	Revised Budget	Increase	Decrease	Adjusted Budget
101-0000-369.20-00 Insurance Recovery		\$19,070	\$2,373		\$21,443
Total Revenue		\$19,070	\$2,373		\$21,443

Account	Project No.	Revised Budget	Increase	Decrease	Adjusted Budget
101-6025-424.50-40 Fleet Maintenance		\$179,239	\$2,373		\$181,612
Total Expense		\$179,239	\$2,373		\$181,612

ADOPTED THIS _____ DAY OF _____, 2022.

Greggory D. Hull, Mayor

ATTEST:

Rebecca A. Martinez, City Clerk
(SEAL)

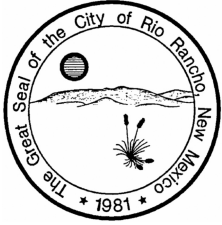

**CITY OF RIO RANCHO
COVER PAGE**

Legislation Item: R12

AGENDA DATE:

March 10, 2022

DEPARTMENT:

Library and Information Services

SUBJECT:

R12, Resolution Accepting a New Mexico Department of Cultural Affairs, State Library Division American Rescue Plan Act (ARPA) Grant for the Library and Information Services Department

BACKGROUND AND ANALYSIS:

The City has received a federal grant through ARPA from the New Mexico Department of Cultural Affairs, State Library Division in the amount of \$26,742 to cover certain costs related to impacts due to COVID-19. Specifically, the grant allows for costs such as personnel, technology, training, materials, supplies, equipment, and associated indirect costs.

The Library and Information Services Department will use this funding to buy needed books as well as miscellaneous minor furnishing and equipment that is up for replacement. The grant award must be spent by September 30, 2022.

IMPACT:

This grant will assist the Library and Information Services Department in providing quality services to the public.

ALTERNATIVES:

The Governing Body may choose to reject the grant award, in which case the City will not receive the funding.

DEPARTMENT RECOMMENDATION:

Staff recommends approval of the Resolution.

ATTACHMENT: [Resolution](#)



**CITY OF RIO RANCHO
RESOLUTION**

RESOLUTION NO.

ENACTMENT NO.

**RESOLUTION ACCEPTING A NEW MEXICO DEPARTMENT OF CULTURAL
AFFAIRS, STATE LIBRARY DIVISION AMERICAN RESCUE PLAN ACT (ARPA)
GRANT FOR THE LIBRARY AND INFORMATION SERVICES DEPARTMENT**

WHEREAS: the Library and Information Services Department has received a federal grant through ARPA from the New Mexico Department of Cultural Affairs, State Library Division in the amount of \$26,742 for costs such as personnel, technology, training, materials, supplies, equipment, and associated indirect costs; and

WHEREAS: the Library and Information Services Department is requesting approval from the Governing Body to accept the funds based on the State Grants-in-Aid to Public Library Statute/Administrative Code NMSA 1978 Section 18-2-4B, 4.5.2 NMAC and all funds must be spent by September 30, 2022.

NOW THEREFORE, BE IT RESOLVED BY THE GOVERNING BODY OF THE CITY OF RIO RANCHO:

That authorization is given the following budget adjustments:

Federal Grant (Fund 220)

Account	Project No.	Revised Budget	Increase	Decrease	Adjusted Budget
220-0000-331.20-00 State Grants	LB2227	\$0	\$26,742		\$26,742
Total Revenue		\$0	\$26,742		\$26,742

Account	Project No.	Revised Budget	Increase	Decrease	Adjusted Budget
220-0000-450.60-70 Minor Furn. & Equip.	LB2227	\$42,633	\$3,540		\$46,173
220-0000-450.60-74 Books	LB2227	\$53,154	\$23,202		\$76,356
Total Expense		\$95,787	\$26,742		\$122,529

ADOPTED THIS _____ DAY OF _____, 2022.

Greggory D. Hull, Mayor

ATTEST:

1
2
3
4

Rebecca A. Martinez, City Clerk
(SEAL)

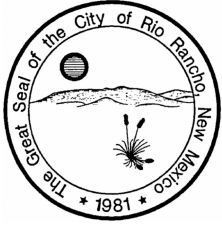

CITY OF RIO RANCHO COVER PAGE

Legislation Item: R13

AGENDA DATE:

March 10, 2022

DEPARTMENT:

Parks, Recreation & Community Services

SUBJECT:

R13, Resolution Authorizing a Budget Adjustment to the Park Impact Fees Fund (353) to Fund the Construction of Sports Complex North Phase II

BACKGROUND AND ANALYSIS:

Since 2009, the Parks, Recreation and Community Services Department has utilized City (predominantly Park Impact Fees), County, and State funds to bring power, water, and sewer utilities to the Rio Rancho Sports Complex North facility (located at 3616 Chayote Rd. NE), and to construct two Little League fields, a concrete plaza, a temporary parking lot, and drainage pond (Phase I).

The Design of Phases II-VI of the Sports Complex North facility were finalized in July 2020, and necessary energy code compliance changes to Phase II design were completed in late 2021. Phase II includes significant site grading and drainage, extending water and electrical utilities to the location, providing Fire/EMS vehicle access, landscaping, stabilizing disturbed earth, and constructing a concrete stairway and ramp from existing fields to a concrete pedestrian plaza, and concession and restroom building. Future phases will construct three additional ball fields and the facility main parking lot, each in individual funding phases as such funding becomes available.

The City has received multiple State Grants/Capital Outlay allocations (2018, \$50,000; 2019, \$625,000; 2020, \$850,000) totaling \$1,525,000 for design and construction of Phase II improvements and 1% for the Arts allocation. Grant funds available for construction, (\$1,474,881.52) and City Park Impact Fees (\$865,755) total \$2,340,636.52 to construct Phase II of the Complex. The low bid received for "IFB 22-PR-010 Construction of Sports Complex North Phase II" was \$2,198,213.13 excluding New Mexico Gross Receipts Tax. Including tax (\$168,987.63) the necessary construction budget of \$2,367,200.76 exceeds the current project budget by \$26,564.24 and does not include a contingency. The Parks, Recreation and Community Services Department is requesting a budget adjustment in the Park Impact Fees Fund (353) in the amount of \$125,000 from the Ending Fund Balance/Unreserved (353-0000-442.90-01) to PR1763, Park Construction/Park Projects (353-0000-442.76-10) line item to fully fund the contract (22-PR-127, T.A. Cole & Sons General Contractors, Inc.) amount and allow for a 4% contingency.

Sports Complex North Phase II construction work will begin in April 2022 and be completed by fall 2022.

IMPACT:

Approval of this Resolution will not impact the General Fund, and will allow the City to complete

construction of Phase II of Sports Complex North.

ALTERNATIVES:

Approve the Resolution.

Do not approve the Resolution.

DEPARTMENT RECOMMENDATION:

Staff recommends approval of the Resolution.

ATTACHMENT: [Resolution](#)



**CITY OF RIO RANCHO
RESOLUTION**

RESOLUTION NO.

ENACTMENT NO.

**RESOLUTION AUTHORIZING A BUDGET ADJUSTMENT TO THE PARK IMPACT
FEES FUND (353) TO FUND THE CONSTRUCTION OF SPORTS COMPLEX NORTH
PHASE II**

WHEREAS: the City has identified Phase II of the development of the Sports Complex North facility as the construction of a concession and restroom building with related improvements; and

WHEREAS: the construction of Sports Complex North Phase II has been bid and a low bid contractor identified; and

WHEREAS: a budget adjustment is necessary to move funds within the Park Impact Fees Fund unreserved ending fund balance to fully fund Phase II construction and award the contract.

NOW THEREFORE, BE IT RESOLVED BY THE GOVERNING BODY OF THE CITY OF RIO RANCHO:

That authorization is given for the following budget adjustment:

Park Impact Fees Fund (353)

Account	Project No.	Revised Budget	Increase	Decrease	Adjusted Budget
353-0000-442.76-10 Park Construction/Park Projects	PR1763	\$865,755	\$125,000		\$990,755
353-0000-442.90-01 Ending Fund Balance/ Unreserved	N/A	\$890,554		\$125,000	\$765,554
Total Sources		\$1,756,309	\$125,000	\$125,000	\$1,756,309

ADOPTED THIS _____ DAY OF _____, 2022.

Greggory D. Hull, Mayor

ATTEST:

Rebecca A. Martinez, City Clerk
(SEAL)

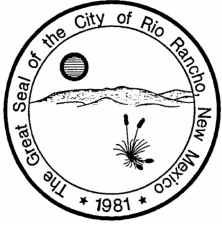

**CITY OF RIO RANCHO
COVER PAGE**

Legislation Item:

AGENDA DATE:
March 10, 2022

DEPARTMENT:
City Clerk

SUBJECT:
D9, Approval of a Permanent Change of Floor Plan to Expand Brew Lab 101 Beer and Cider Co. for Liquor License No. 67132 and 60062 located at 3301 Southern Blvd. Rio Rancho NM 87124

BACKGROUND AND ANALYSIS:

IMPACT:

ALTERNATIVES:

DEPARTMENT RECOMMENDATION:

On February 10, 2022 the Governing Body approved the Site Plan expansion and staff recommends approval of the permanent change in floor plan and expansion for Brew Lab 101 Beer and Cider Co.

ATTACHMENT: [Brew Lab 101 - Permanent Change in Floor Plan Application](#)



NMRLD

NEW MEXICO REGULATION & LICENSING DEPARTMENT

STATE OF NEW MEXICO
MICHELLE LUJAN GRISHAM, GOVERNOR
Linda M. Trujillo, Superintendent
Andrew Vallejos, Director

Permanent Change of Floor Plan or Expansion of a Liquor Licensed Premise Application
\$75.00 Fee: all fees non-refundable | NMAC 15.10.32.12 | NMAC 15.10.32.13

The licensee cannot make any changes or expand the premises until written approval has been granted for this request, as a site inspection may be required before approval is granted.

Application to Change or Expand the licensed premises shall be submitted with the following Required Documentation:

- 1. Application and \$75.00 fee
2. A copy of your existing Approved Floor Plan
3. A Proposed Detailed Floor Plan, on an 8 1/2 x 11" sheet, that includes the existing approved premises and any proposed change or expansion - Label all areas and include all entrances, exits, walls or enclosures as well as dimensions for any expansion.

For Expansions Only also include,

- 4. Proof of Tenancy for the expansion area and
5. Photos of expansion, showing all areas including the enclosure if a patio

Liquor License Number: 67132 & 60062 Licensee Email: scott@brewlab101.com

Owner Name: Brew Lab 101, LLC Lessee:

Business Name (DBA): Brew Lab 101 Beer & Cider Co. Phone No.: 505-263-7587

License Location: 3301 Southern Blvd., Rio Rancho, NM 87124

Mailing Address: P.O. Box 65505, Albuquerque, NM 87193

Square Footage: Current 4705 Adding/Changing: 5397 Total: (add both) 10,102

Reason for Request: Making temporary back patio permanent and adding indoor storage space

If the change or expansion of the licensed premises is twenty-five (25%) or more of the total existing square footage of the licensed premises, the Director may require the licensee to file an application for a Transfer of Location.

Will the Proposed Expansion bring the licensed premises within 300 feet of a church or school? Yes No

Has there been any change in the Ownership or Operation of the Licensee? Yes No If yes, please explain:

I (print name) Scott J. Salvas, Licensee for Liquor License No. 67132 & 60062 hereby attest that the requested change meets the definition of "licensed premises" in NMSA 1978 §60-3A-3 (O), which states in part "licensed premises means the contiguous areas or areas connected by indoor passageways of a structure and the outside dining, recreation and lounge areas of the structure... that are under the direct control of the licensee..."

Must sign in the presence of a Notary Public: Submitted by: (print name) Scott J. Salvas

Signature: [Signature] Title: President Date: 1/12/22

Notary Public Use Only: (State of New Mexico, County of Sandoval)

SUBSCRIBED AND SWORN TO before me this 12th day of January, 2022

By: Scott J. Salvas Notary Public: [Signature]

Date my Commission Expires: 01/14/2024

Required for Expansions only | Local Option District review

Local Governing Body of: Village, County, City Check one: Approved Disapproved

Signature and Title of Village/County/City Official: Date:

For Alcoholic Beverage Control Division Use Only: Application Fee \$ Received on: Receipt No.

Decision by Director, if required Approved Disapproved, Signed by Director: Date:

Processed by: Approved Disapproved, Date:

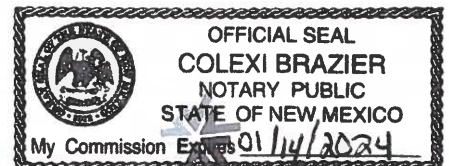



CITY OF RIO RANCHO COVER PAGE

Legislation Item: O3

AGENDA DATE:

March 10, 2022

DEPARTMENT:

Development Services

SUBJECT:

O3, Ordinance of the City of Rio Rancho, New Mexico Amending the Zoning Classification and Official Zoning Map for the Property Legally Described as Hawksite, Tract 21 from C-1: Retail Commercial District to R-6: Multi-Family Residential District, Identifying Conditions of Development; Providing for Severability and an Effective Date

BACKGROUND AND ANALYSIS:

The subject property is located southwest of the intersection of Unser Frontage Rd NE and Columbine Rd NE, is legally described as Hawksite, Tract 21, covers approximately 5.54 acres of land, and falls within the Mountain Hawk Subdivision Master Plan. The request is to change the zoning from C-1: Commercial Use to R-6: Multi-Family Residential. Adjacent properties to the north and west are zoned M-1: Industrial, TZ: Transitional Zoning, and C-1: Retail Commercial, and the properties to the east and south are zoned C-1: Commercial, SU: Special Use, TZ: Transitional Zoning, and R-3: Mixed Residential Zoning.

This item was heard by the Planning and Zoning Board at their meeting on February 8, 2022. The motion to recommend approval carried by a vote of six for and zero against.

REVIEW CRITERIA:

Rio Rancho Code of Ordinances (R.O. 2003) § 150.07(A) states, "Proposed amendments shall be submitted to the Governing Body through the Planning and Zoning Board."

The zone map amendment application was submitted to the Development Services Department and received for review by the Governing Body through the Planning and Zoning Board. Conforms.

R.O. 2003 § 150.07(B) states, "The Board shall study the proposals at a regular meeting or at a special meeting, if necessary, and shall submit its recommendations to the Governing Body. Notice of the application must be posted on the property at least one week prior to consideration of the application by the Board."

Proper notice was provided through a sign posted on the perimeter of the property on February 1, 2022. Conforms.

Pursuant to the criteria provided by R.O. 2003 Section 150.07 (D) (1) through (4), and (E) through (G), a request for change in zoning designation must address the following policies and criterion for a zone map change:

(1) A proposed zone change must be found to be consistent with the health, safety, morals, and general welfare of the city.

The applicant states, "The proposed ZMA provides the opportunity to further the health and welfare of the City by creating development conditions necessary to construct high quality mixed residential development that will meet the needs of future Mountain Hawk Subdivision and Rio Rancho Residents. Additionally, the zone change will allow the properties to be developed consistent with the approved Mountain Hawk Master Plan. The amendment will complement the existing and surrounding developed residential and commercial areas by allowing a variety of housing options in what the Rio Rancho Comprehensive Plan defines as a development node and future activity center (Page V-11). As described in Section 1.3 Development Nodes, 'The creation of development nodes where higher concentration of land uses exists in the form of commercial, multi-family and mixed-use developments helps to develop a sense of place.', the proposed ZMA will further the general welfare of the City by providing [a] variety of zones thus creating the sense of place for future and current residents."

The Planning and Zoning Board recommends the Governing Body finds the proposed R-6: Multi-Family Residential zoning would be consistent with the health, safety, morals, and general welfare of the City as it helps implement the Comprehensive Plan; particularly the notion of Development Nodes and a sense of place. The rezoning would also implement the Mountain Hawk Estates Master Plan which was amended in December of 2019.

(2) Stability of land use and zoning is desirable; therefore, the applicant must provide a sound justification for the change. The burden is on the applicant to show why the change should be made, not on the city to show why the change should not be made.

The applicant states, "This zone change request will allow for stability of land use and zoning as well as improve it. The zone map amendment will allow the property to be developed in a manner that is compatible with and viable for the surrounding Mountain Hawk Master Plan area and Rio Rancho neighborhoods. The requested amendment will allow for development that is consistent with the Rio Rancho Comprehensive plan goals to provide access to housing in underdeveloped areas and along U.S. Highway 550, due to an increasing population. Additionally, the Comprehensive Plan has identified goals under Section 6: Population and Housing ... to provide a variety of housing types that meet the needs of current and future populations within the city."

The Planning and Zoning Board recommends the Governing Body finds that the applicant has provided sound justification for the zoning change. Additionally, the zoning change would bring the tract in line with the Land Use Plan Map in the Mountain Hawk Estates Master Plan, where it is designated as R-6: Multi-Family Housing. Last, the R-6: Multi-Family Residential zone has a specific list of permissive uses and will lead to a stable understanding of what can be built on the subject area.

(3) A proposed change shall generally be consistent with adopted elements of the comprehensive plan or other city master plans and amendments thereto including privately developed area plans which have been adopted by the city. The applicant states, "The proposed ZMA does not change, but rather furthers the Rio Rancho Comprehensive Plan's intent. The Rio Rancho Comprehensive Plan outlines the Mountain Hawk Master Plan area and an activity center and development node. The Comprehensive Plan has a goal to provide housing near gateways and transportation corridors due to an increasing population." They go on to relate that "the Mountain Hawk Subdivision is along US Highway 550 and [the] Northwest loop, a highly utilized transportation corridor and designated gateway in the Comprehensive Plan."

The Planning and Zoning Board recommends the Governing Body finds that the zone map amendment would meet the intent of the Comprehensive Plan and the Mountain Hawk Estates Master Plan. As previously mentioned, the zone change would bring the tract in line with the Mountain Hawk Estates Master Plan, and it also realizes the Comprehensive Plan's goal of

providing housing near transportation corridors.

(4) The applicant must demonstrate that the existing zoning is inappropriate because: (a) There was an error, mistake or is necessary to correct an injustice that occurred when the existing zone map pattern was created, including the placement of an R-1 or transitional zone on an antiquated plat filed before the city's incorporation and adoption of its own zoning code or on land annexed by the City; or (b) Changed neighborhood or community conditions justify the change; or (c) A different use category is more advantageous to the community, as articulated in the comprehensive plan or other city master plan, even though (D)(1) or (2) does not apply. Applicant's reliance on this provision requires proof that (i) there is a public need for a change of the kind in question, and (ii) that need will be best served by changing the classification of the particular piece of property in question as compared with other available property.

The applicant calls out option c and maintains that "The proposed ZMA is more advantageous to the community, as demonstrated in [the previous sections] above." They also reiterate that they are "requesting the amendment to the zoning to match the recently approved Mountain Hawk Master plan," which designates this tract for Multi-Family Residential.

The Planning and Zoning Board recommends the Governing Body finds this criterion has been met as the zone change will align with the subject property's land uses as identified in the Mountain Hawk Master Plan.

(E) The cost of land or other economic considerations pertaining to the applicant shall not be the determining factor for a change of zone. The applicant states, "The cost of land or other economic considerations are not the determining factor for this request. The request is to bring the zoning in alignment with the approved Mountain Hawk Master Plan."

The Planning and Zoning Board recommends the Governing Body finds that the cost of the land or other economic considerations do not appear to be a justification for the proposed zone map amendment.

(F) Location on a collector or major street is not in itself sufficient justification of apartment, office, or commercial zoning. The applicant states that "Location on a major street is not the sole justification for this request. The request is to bring the zoning in alignment with the approved Mountain Hawk Master Plan."

The Planning and Zoning Board recommends the Governing Body finds that the sole justification for this request is not based on the site's location on a major street.

(G) A zone change request which would give a zone different from surrounding zoning to one small area, especially when only one premises is involved, is generally called a "spot zone." Such a change of zone may be approved only when: (1) The change will clearly facilitate realization of the comprehensive plan and any applicable adopted sector development plan or area development plan; or (2) The area of the proposed zone change is different from surrounding land because it could function as a transition between adjacent zones; because the site is not suitable for the uses allowed in any adjacent zone due to topography, traffic, or special adverse land uses nearby; or because the nature of structures already on the premises makes the site unsuitable for the uses allowed in any adjacent zone.

The applicant states, "The requested zone change will not create a spot zone. The request is to bring the zoning in alignment with the approved Mountain Hawk Master Plan. The requested change will also accomplish the Vision of Growth in Section 1 and the goals set forth in Section 6 of the Comprehensive Plan. The change will establish a transition from outside the Mountain Hawk Master Plan, currently zoned R-1, and through the plan from R-4 to R-6, C-1 and finally M-1 north of

the proposed change.”

The Planning and Zoning Board recommends the Governing Body finds that the request does not constitute a spot zoning, in that this zone change offers a transition between surrounding lower density residential and surrounding commercial and industrial uses.

The Planning and Zoning Board found that the proposed amendment conforms to the requirements promulgated within R.O. 2003 Section 150.07 (D) (1) through (4), and (E) through (G).

NOTIFICATIONS: In accordance with State Statute NMSA § 3-21-6, which stipulates notification procedures for this type of zoning action, all property owners within 100 feet of the subject property received a certified letter containing a notice of action and impending Governing Body hearing, with return service requested. A notice sign was erected on the subject property on February 1, 2022 by the applicant, as required by ordinance, and a legal notice was published in the Rio Rancho Observer on February 20, 2022.

INTERDEPARTMENTAL/INTERAGENCY REVIEW:

Reviewing Agency	Received Application for Review	Comments
DSD Planning and Zoning	X	Comments in document
DSD Engineering	X	No comments provided
Rio Rancho Public Schools	X	No comments provided
Fire and Rescue	X	No adverse comments
Police Department	X	No comments provided
SSCAFCA	X	No comments provided
MRCOG	X	No comments provided
Parks, Recreation, and Community Services	X	No adverse comments

IMPACT:

The Planning and Zoning Board recommended that the Governing Body approve the zone map amendment request subject to the findings set forth below:

GENERAL FINDINGS OF FACT:

1. The Planning and Zoning Board may make a recommendation to the Governing Body on the applicant’s request for a zone map amendment.
2. Following procedures for a zone map amendment, proper notice of hearing on this matter was given.
3. The applicant has the authority to make an application to request a zone map amendment.
4. The applicant and adjacent property owners received due process, as proper notice and an opportunity to present views was given.

SPECIFIC FINDINGS OF FACT:

The applicant has submitted an application and narrative which demonstrates that the change in zoning designation meets the requirements of the Rio Rancho Code of Ordinances (R.O. 2003) §150.07(D) Amendments, including:

1. The proposed zone change would be consistent with the health, safety, morals, and general welfare of the City by promoting implementation of the City’s Comprehensive Plan.
2. The applicant has provided sound justification, in a narrative dated January 3, 2022, for the proposed zone change and the zone map amendment would provide stability of zoning along with providing for adequate compatibility with surrounding zoning and future uses.

3. The proposed zone map amendment would be consistent with intent of the adopted elements of the Comprehensive Plan and Mountain Hawk Estates Master Plan.
4. The applicant has demonstrated that the R-6: Multi-Family zoning designation would be a more advantageous zoning for the site as opposed to the current C-1: Commercial zoning designation, as it offers more housing opportunities in an area that is projected to grow, given it's location next to a transportation corridor, and is currently lacking.
5. The cost of the land or other economic considerations does not appear to be a justification for the proposed zone map amendment.
6. The applicant has provided sufficient justification that the zone map amendment request is not based solely on the properties' location next to US 550.
7. The requested zone map amendment would not create a "spot zone" in that it offers a transition between surrounding zoning districts and is in alignment with the land use identified for the site in the Mountain Hawk Estates Master Plan.

ALTERNATIVES:

The Governing Body has four alternatives for the request for approval of a zone map amendment.

1. Approve the zone map amendment with the stated findings of fact and conditions of approval;
2. Deny the zone map amendment with findings that the applicant failed to address the criteria necessary for a change in zoning on the subject property;
3. Modify the zone map amendment conditions or provisions, and approve with the modifications;
4. Postpone its decision to allow for additional review and consideration.

DEPARTMENT RECOMMENDATION:

Staff and the Planning and Zoning Board recommend approval of the Ordinance to the Governing Body.

ATTACHMENT: [Ordinance](#)

ATTACHMENT: [Application](#)

ATTACHMENT: [NeighboringPropertyOwnerLetter_GB](#)

ATTACHMENT: [UpdatedJustificationLetter](#)

ATTACHMENT: [Location and Notification Map](#)

ATTACHMENT: [Sign](#)

ATTACHMENT: [Mountain Hawk Estates Master Plan Final](#)



**CITY OF RIO RANCHO
ORDINANCE**

ORDINANCE NO. 3

ENACTMENT NO.

**ORDINANCE OF THE CITY OF RIO RANCHO, NEW MEXICO AMENDING THE
ZONING CLASSIFICATION AND OFFICIAL ZONING MAP FOR THE PROPERTY
LEGALLY DESCRIBED AS HAWKSITE, TRACT 21 FROM C-1: RETAIL
COMMERCIAL DISTRICT TO R-6: MULTI-FAMILY RESIDENTIAL DISTRICT,
IDENTIFYING CONDITIONS OF DEVELOPMENT; PROVIDING FOR SEVERABILITY
AND AN EFFECTIVE DATE**

WHEREAS: the Governing Body of the City of Rio Rancho has adopted zoning regulations and an official zone map in accordance with New Mexico Statutes Annotated 1978 (NMSA 1978) Chapter 3, Article 21; and

WHEREAS: in accordance with Rio Rancho Code of Ordinances (R.O. 2003) Section 150.07, an application to amend the zoning ordinance on the subject property has been submitted by the City of Rio Rancho, and assigned City Case No. 22-100-00001; and

WHEREAS: the City of Rio Rancho Planning and Zoning Board held a duly noticed public hearing on February 8, 2022, regarding the proposed changes to the Official Zoning Map and, following study and consideration, has made findings (where applicable) whether or not the criteria in R.O. 2003 Section 150.07 are satisfied, and made these recommendations to the Governing Body regarding adoption of the changes; and

WHEREAS: the Governing Body received a report from the Planning and Zoning Board, and such report indicates the Planning and Zoning Board has studied and considered the proposed changes pursuant to R.O. 2003 Section 150.07, and said report includes specific findings related to the affected property; and

WHEREAS: a public hearing occurred, in accordance with procedures set forth in R.O. 2003 Section 150.07, and NMSA 1978 Section 3-21-6, on the proposed zoning district and Official Zone Map changes hereinafter described were duly advertised and held by the Governing Body of the City of Rio Rancho on March 10, 2022 and the Governing Body heard interested parties and citizens for and against the proposed amendments; and

WHEREAS: the proposed amendments to be adopted by this Ordinance comply with the statutory and regulatory requirements of the aforesaid Code of Ordinances and Statutes, and upon specific findings related to the subject property and determining the proposed amendment is consistent with the policies and criteria set forth in R.O. 2003 Section 150.07 (D) through (G), the Governing Body finds the amendments promote the health, safety, morals, and general welfare of the City.

1
2 **NOW THEREFORE, BE IT ORDAINED BY THE GOVERNING BODY OF THE CITY OF**
3 **RIO RANCHO:**

4
5 **Section 1. Rezoning of Property and Change in Land Use.** The Official Zone Map
6 is hereby amended by assigning a zoning designation on 5.54 acres from C-1: Retail
7 Commercial District to R-6: Multi-Family Residential District on the land legally described
8 as:

9 Hawksite, Tract 21, filed in the office of the County Clerk of Sandoval County New
10 Mexico in Book 17, Pages 16-19.

11
12 **Section 2. Land Use, Conditions, Development Standards/Regulations and use**
13 **of PROPERTY:** The property identified in Section 1, above, is subject to all requirements
14 of the R-6: Multi-Family Residential Zoning District set forth in R.O. 2003 Section 154.13
15 (as of the effective date of this ordinance or as subsequently amended).

16
17 **Section 3. Severability Clause.** If any section, paragraph, clause, or provision of
18 this Ordinance, or any section, paragraph, clause, or provision of any regulation
19 promulgated hereunder shall for any reason be held to be invalid, unlawful, or
20 enforceable, the invalidity, illegality, or unenforceability of such section, paragraph,
21 clause, or provision shall not affect the validity of the remaining portions of this
22 Ordinance or the regulation so challenged.

23
24 **Section 4. Effective Date.** This Ordinance shall become effective ten days after
25 adoption.

26
27 ADOPTED THIS _____ DAY OF _____, 2022.

28
29
30 _____
31 Gregory D. Hull, Mayor
32

33
34 ATTEST:

35
36 _____
37 Rebecca A. Martinez, City Clerk
38 (SEAL)

PLANNING & ZONING LAND USE APPLICATION

Please check appropriate box

(Fees are listed on the back)

Administrative Permit	Plan	Subdivision	Zoning
<input type="checkbox"/> Community Residential Care Facility	<input type="checkbox"/> Comprehensive Plan Amendment	<input type="checkbox"/> Final Plat	<input type="checkbox"/> Annexation
<input type="checkbox"/> Development Review Committee (DRC)	<input type="checkbox"/> Corridor Plan Amendment	<input type="checkbox"/> Preliminary Plat	<input type="checkbox"/> Appeal
<input type="checkbox"/> Home Occupation	<input type="checkbox"/> Master Plan	<input type="checkbox"/> Summary Plat	<input type="checkbox"/> Conditional Use Permit
<input type="checkbox"/> Model Home / Sales Office	<input type="checkbox"/> Master Plan Amendment	<input type="checkbox"/> Vacation of Plat	<input type="checkbox"/> Master Sign Plan
<input type="checkbox"/> Residential Child Care Facility 6 or <	<input type="checkbox"/> Specific Area Plan Amendment	<input type="checkbox"/> Street Name Change	<input type="checkbox"/> Site Plan
<input type="checkbox"/> Sign Permit	<input type="checkbox"/> Text Amendment	<input type="checkbox"/> Subdivision Interpretation	<input type="checkbox"/> Special Exception
<input type="checkbox"/> Other		<input type="checkbox"/> Subdivision Variance	<input type="checkbox"/> Variance
			<input checked="" type="checkbox"/> Zone Map Amendment
			<input type="checkbox"/> Zoning Certification
			<input type="checkbox"/> Zoning Interpretation

Please Print In Ink Only or Type

Application must be complete. Please attach the appropriate checklist for the action you are requesting, if applicable.

APPLICANT/AGENT INFORMATION

Applicant Name: AMREP SOUTHWEST, INC.		Phone: 505-896-9037	
Address: 409 NM HWY 52B		E-Mail: JARRODL@ASW/NC.COM	
City: RIO RANCHO	State: NM	Zip: 87124	
Proprietary Interest: 100	List Owners:		
Deed or Ownership Verification Provided: (Initials)		Letter of Authorization Provided: (Initials)	

Agent Name:		Phone:	
Address:		E-Mail:	
City:	State:	ZIP Code:	

DESCRIPTION OF REQUEST: (PLEASE ADD ADDITIONAL SHEET(S) IF NECESSARY)

SITE INFORMATION: (PLEASE PROVIDE ACCURATE LEGAL DESCRIPTION)

Subdivision/Unit: 25 / MOUNTAIN HAWK	Block(s): TRACT 21	Lot(s):
Existing Zoning: C-1	Proposed Zoning: R-6	
No. of existing lots: 1	No. of proposed lots: 1	Total area of site (acres)

ACKNOWLEDGEMENT

I hereby acknowledge that I have read this entire application and affirm that all information provided is correct. I agree to comply with the requirements of the City of Rio Rancho as outlined in all applicable laws, ordinances and regulations.

Print Name: JARROD LIKAR	Applicant: X	Agent:
Signature: 		Date: 1/3/22

FOR OFFICIAL USE ONLY

H.T.E. PROJECT #	FEE	RECEIPT #

APPLICATION ACCEPTED BY: _____ DATE: _____



January 3, 2022

Ms. Amy Rincon
Director of Development Services
City of Rio Rancho
3200 Civic Center Circle NE
Rio Rancho, NM 87144

Re: Request for a Zone Map Amendment

Dear Ms. Rincon:

AMREP Southwest, Inc. (the "Applicant") is the owner of all the real property (the "subject property") involved in this zone map amendment request. This is a request for a Zone Map Amendment ("ZMA") for approximately 5.54 acres within the Mountain Hawk Subdivision Master Plan more particularly identified as Tract 21, of the Rio Rancho Hawksite (the "Subject Property"). The Subject Property is located southwest of the intersection of Unser Frontage Road NE and Columbine Road NE (see below).



The applicant is requesting that Tract 21 be rezoned from C-1 to R-6. This zone change will place Tract 21 inline with the Mountain Hawk Estates Master Plan adopted on December 11, 2019 by the City's Governing Body.

SITE CONTEXT/ZONE MAP AMENDMENT

The subject property is situated within the existing Mountain Hawk Subdivision Master Plan. The surrounding area consists of residential neighborhoods and some commercial development along U.S. Highway 550. The Mountain Hawk Master Plan extends to the north of the requested ZMA property and is encompassed by a variety of zoning including R-4 (Single Family Residential), SU R-3 (Mixed Use Residential), C-1 (Retail Commercial), and M-1 (Industrial and Business). To the West of the subject property is the Rio Rancho Estates Subdivision, which is zoned T-Z (Transitional-Zone). On the Northern border of the property is Northwest Loop and New Mexico National Guard.

SECTION 150.07 JUSTIFICATION

This section of the request addresses the criteria for a zone map amendment. A justification per Section 150.07 (D-G), Policies for Deciding Zone Map Amendments, is provided below.

(D) The following policies for deciding zone map change applications pursuant to the City Zoning Code are:

1. A proposed zone change must be found to be consistent with the health, safety, morals, and general welfare of the City.

Applicant response: The proposed Zone Map Amendment is consistent with the health, safety, morals, and general welfare of the City. The proposed ZMA provides the opportunity to further the health and welfare of the City by creating the development conditions necessary to construct high quality mixed residential development that will meet the needs of future Mountain Hawk Subdivision and Rio Rancho residents. Additionally, the zone change will allow the properties to be developed consistent with the approved Mountain Hawk Master Plan. The amendment will complement the existing and surrounding developed residential and commercial areas by allowing a variety of housing options in what the Rio Rancho Comprehensive Plan defines as a growth node and future activity center. The proposed ZMA will further the general welfare of the City by providing the current and future residents with a variety of housing options in a developing neighborhood within Rio Rancho.

2. Stability of land use and zoning is desirable; therefore, the applicant must provide a sound justification for the change. The burden is on the applicant to show why the change should be made, not on the City to show why the change should not be made.

Applicant response: This zone change request will allow for stability of land use and zoning as well as improve it. The zone map amendment will allow the property to be developed in a manner that is compatible with and viable for the surrounding Mountain Hawk Master Plan area and Rio Rancho neighborhoods. The requested amendment will allow for development that is consistent with the Rio Rancho Comprehensive plan goals to provide access to housing in undeveloped areas and along U.S. Highway 550, due to an increasing population. Additionally, the Comprehensive Plan has a goal to provide a variety of housing types that meet the needs of current and future populations within the city. The proposed zoning will not destabilize the land use and zoning in the area, but will strengthen it with a mixture of residential uses that meet the needs of the surrounding community. The requested zone

change will allow the Property to be developed in a manner compatible with surrounding uses and consistent with current development possibilities. For this reason, there is sound justification for the requested zone change.

3. A proposed change shall generally be consistent with adopted elements of the Comprehensive Plan or other City master plans and amendments thereto including privately developed area plans which have been adopted by the City.

Applicant response: The proposed ZMA does not change, but rather furthers the Rio Rancho Comprehensive Plan's intent. The Rio Rancho Comprehensive Plan outlines the Mountain Hawk Master Plan area and an activity center and development node. The Comprehensive Plan has a goal to provide housing near gateways and transportation corridors due to an increasing population. The Mountain Hawk Subdivision is along U.S. Highway 550 and Northwest loop, a highly utilized transportation corridor and designated gateway in the Comprehensive Plan. In addition, the Comprehensive Plan provides a variety of housing types and mixed-used residential developments to meet the needs of all members of the community. The requested ZMA is consistent with the goals and policies outlined by the Rio Rancho Comprehensive plan and recently approved Mountain Hawk Master Plan.

4. The applicant must demonstrate the existing zoning is inappropriate because:

- a) The existing zoning is inappropriate because there was a judgment mistake in the original zoning.
- c) A different use category is more advantageous to the community, as articulated in the Comprehensive Plan.

Applicant response: The proposed ZMA is more advantageous to the community, as articulated in the Comprehensive Plan as demonstrated in section three above. The applicant is requesting an amendment to the zoning to match the recently approved Mountain Hawk Master Plan.

(E) The cost of land or other economic considerations pertaining to the applicant shall not be the determining factor for a change of zone.

Applicant response: The cost of land or other economic considerations are not the determining factor for this request. The request is to bring the zoning in alignment with the approved Mountain Hawk Master Plan.

(F) Location on a collector or major street is not in itself sufficient justification of apartment, office, or commercial zoning.

Applicant response: Location on a major street is not the sole justification for this request. The request is to bring the zoning in alignment with the approved Mountain Hawk Master Plan.

(G) A zone change request which would give a zone different from surrounding zoning to one small area, especially when only one premise is involved, is generally called a "spot zone." Such a change of zone may be approved when:

(1) The change will clearly facilitate realization of the Comprehensive Plan and any applicable adopted sector development plan or area development plan; or

(2) The area of the proposed zone change is different from surrounding land because it could function as a transition between adjacent zones; because the site is not suitable for the uses allowed in any adjacent zone due to topography, traffic, or special adverse land uses nearby; or because the nature of structures already on the premises makes the site unsuitable for the uses allowed in any adjacent zone.

Applicant response: The requested zone change will not create a spot zone. The request is to bring the zoning in alignment with the approved Mountain Hawk Master Plan.

We respectfully request that the Rio Rancho Planning and Zoning Board and Governing Body approve this request for a zone map amendment.

Sincerely,



Jarrod Likar, PE
AMREP Southwest, Inc.
Vice President-Land Development



The City of Rio Rancho

Development Services
Planning Division
3200 Civic Center Circle NE
Rio Rancho, NM 87144
Phone (505) 891-5005 • Fax (505) 896-8994

February 23, 2022

RE: Zone Map Amendment,
Case No. 21-100-00001
Mountain Hawk, Tract 21

Dear Property Owner:

You are receiving this certified notice because your property abuts a site where a land development decision is required by the Governing Body.

The applicant, AMREP Southwest, Inc., is requesting approval of a Zone Map Amendment for 5.54 acres within the Mountain Hawk Subdivision Master Plan, from C-1: Commercial Use to R-6: Multi-Family Residential. The subject property is legally described as MH, Tract 21, and is located southwest of the intersection of Unser Frontage Rd NE and Columbine Rd NE.

The Governing Body will consider the request and have the final approval on **Thursday, March 10, 2022** at 6:00 pm in the Council Chambers and Virtually as a hybrid meeting, through the Zoom link and number below.

On the back of this letter is a location map of the project, with the subject property identified with the black outline.

If you would like to comment on this application, you are encouraged to send in comments in writing, which will be presented to the Governing Body. This Governing Body meeting will be hybrid with options to participate virtually or in person. The City highly encourages citizens to watch the meeting live on the City's website www.rrnm.gov or on Sparklight cable channel 56.

For the Governing Body meeting, to participate virtually: Join via computer:
<https://zoom.us/j/91804920905?pwd=ZIZ5NmdTUTF1RndxTVN2dHBTSnJ3Zz09>
Meeting ID: 918-0492-0905 Passcode: 903274 Join via phone: 1-253-215-8782 US

Please do not hesitate to contact me via e-mail me at lruizcarlos@rrnm.gov or call me at 505-896-8785, if you have any questions concerning this matter. The agenda for this hearing and related staff reports will be posted on the City's website, www.rrnm.gov, the Friday before the hearing.

If you are an individual with a disability who is in need of a reader, amplifier, qualified sign language interpreter, or any form of auxiliary aid or service to attend or participate in the hearing or meeting, please contact the City Clerk, 505-891-5004, as soon as possible prior to the meeting. Please contact the City Clerk if a summary or other type of accessible format is needed.

Respectfully,

Liz Ruiz Carlos

Liz Ruiz Carlos
Municipal Planner I
Development Services Department
City of Rio Rancho

MOUNTAIN HAWK, TRACT 21 - ZONE MAP AMENDMENT

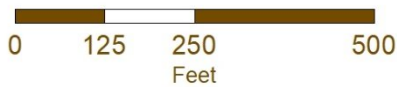

	Subject Property
	R-3
	C-1
	SU
	M-1
	TZ

DISCLAIMER: All information in this map is provided "as is" without warranty or any representation of accuracy, timeliness or completeness. This map is not a survey and should be used for graphical purposes only.



January 3, 2022

Ms. Amy Rincon
Director of Development Services
City of Rio Rancho
3200 Civic Center Circle NE
Rio Rancho, NM 87144

Re: Request for a Zone Map Amendment

Dear Ms. Rincon:

AMREP Southwest, Inc. (the "Applicant") is the owner of all the real property (the "subject property") involved in this zone map amendment request. This is a request for a Zone Map Amendment ("ZMA") for approximately 5.54 acres within the Mountain Hawk Subdivision Master Plan more particularly identified as Tract 21, of the Rio Rancho Hawksite (the "Subject Property"). The Subject Property is located southwest of the intersection of Unser Frontage Road NE and Columbine Road NE (see below).



The applicant is requesting that Tract 21 be rezoned from C-1 to R-6. This zone change will place Tract 21 in line with the Mountain Hawk Estates Master Plan adopted on December 11, 2019 by the City's Governing Body.

SITE CONTEXT/ZONE MAP AMENDMENT

The subject property is situated within the existing Mountain Hawk Subdivision Master Plan. The surrounding area consists of residential neighborhoods and some commercial development along U.S. Highway 550. The Mountain Hawk Master Plan extends to the north of the requested ZMA property and is encompassed by a variety of zoning including R-4 (Single Family Residential), SU R-3 (Mixed Use Residential), C-1 (Retail Commercial), and M-1 (industrial and Business). To the West of the subject property is the Rio Rancho Estates Subdivision, which is zoned T-Z (Transitional-Zone). On the Northern border of the property is Northwest Loop and New Mexico National Guard. Proposed zoning around Tract 21 from the approved Mountain Hawk Master Plan can be seen below and includes Commercial, Office and Mixed Use to the West, across the realignment of Northwest Loop, and East; Low/Medium Density Residential and Parks, Open Space and Drainage to the South and Light Industrial/Business Park to the North, across Northwest Loop.

LAND USE & ZONING

Figure 2. Future Land Use Plan

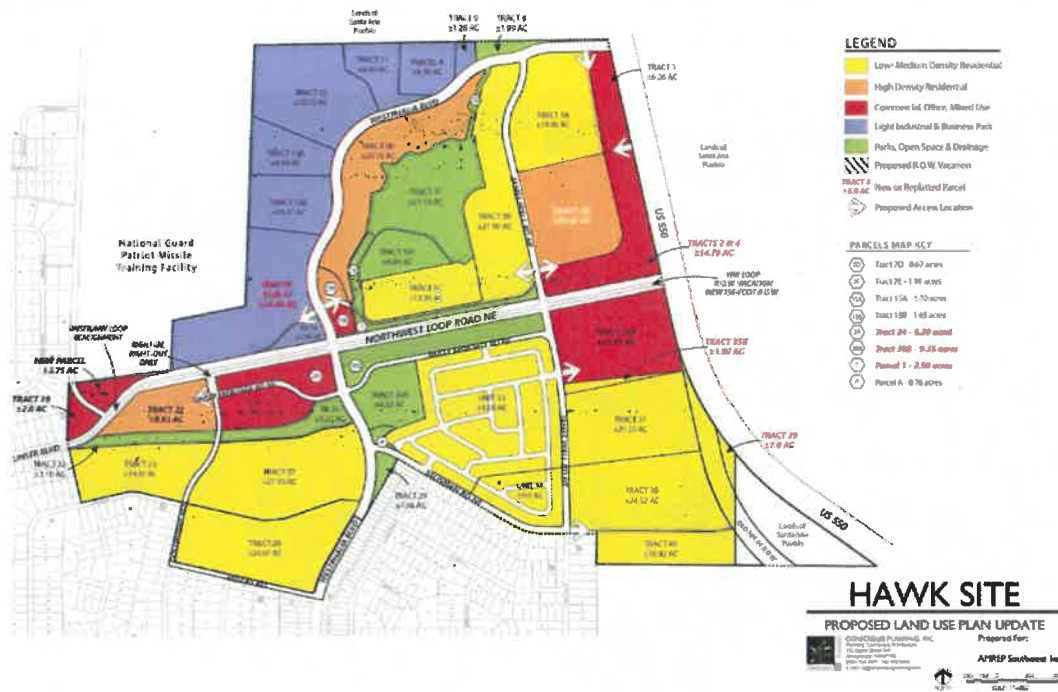

MOUNTAIN HAWK ESTATES MASTER PLAN

15

SECTION 150.07 JUSTIFICATION

This section of the request addresses the criteria for a zone map amendment. A justification per Section 150.07 (D-G), Policies for Deciding Zone Map Amendments, is provided below.

(D) The following policies for deciding zone map change applications pursuant to the City Zoning Code are:

1. A proposed zone change must be found to be consistent with the health, safety, morals, and general welfare of the City.

Applicant response: The proposed Zone Map Amendment is consistent with the health, safety, morals, and general welfare of the City. The proposed ZMA provides the opportunity to further the health and welfare of the City by creating the development conditions necessary to construct high quality mixed residential development that will meet the needs of future Mountain Hawk Subdivision and Rio Rancho residents. Additionally, the zone change will allow the properties to be developed consistent with the approved Mountain Hawk Master Plan. The amendment will complement the existing and surrounding developed residential and commercial areas by allowing a variety of housing options in what the Rio Rancho Comprehensive Plan defines as a development node and future activity center (Page V-11). As described in Section 1.3 Development Nodes, 'The creation of development nodes where higher concentration of land uses exist in the form of commercial, multi-family and mixed-use developments helps to develop a sense of place.', the proposed ZMA will further the general welfare of the City by providing this variety of zones thus creating the sense of place for current and future residents within a developing neighborhood within Rio Rancho.

2. Stability of land use and zoning is desirable; therefore, the applicant must provide a sound justification for the change. The burden is on the applicant to show why the change should be made, not on the City to show why the change should not be made.

Applicant response: This zone change request will allow for stability of land use and zoning as well as improve it. The zone map amendment will allow the property to be developed in a manner that is compatible with and viable for the surrounding Mountain Hawk Master Plan area and Rio Rancho neighborhoods. The requested amendment will allow for development that is consistent with the Rio Rancho Comprehensive plan goals to provide access to housing in undeveloped areas and along U.S. Highway 550, due to an increasing population. Additionally, the Comprehensive Plan has identified goals under Section 6: Population and Housing (depicted below) to provide a variety of housing types that meet the needs of current and future populations within the city.

6.4.2 GOALS

Goal PH-1: To ensure that regulations do not have an unreasonable negative impact on the cost or supply of housing.

Goal PH-2: Maintain the strength, vitality, and stability of all residential neighborhoods and types.

Goal PH-3: Promote a variety of housing types to meet the needs of all members of the community.

Goal PH-4: To ensure that single-family and multi-family residential neighborhoods provide an attractive living environment.

The proposed zoning will not destabilize the land use and zoning in the area, but will strengthen it with a mixture of residential uses that meet the needs of the surrounding community. The requested zone change will allow the Property to be developed in a manner compatible with surrounding uses and consistent with current development possibilities. For this reason, there is sound justification for the requested zone change.

3. A proposed change shall generally be consistent with adopted elements of the Comprehensive Plan or other City master plans and amendments thereto including privately developed area plans which have been adopted by the City.

Applicant response: The proposed ZMA does not change, but rather furthers the Rio Rancho Comprehensive Plan's intent. The Rio Rancho Comprehensive Plan outlines the Mountain Hawk Master Plan area and an activity center and development node. The Comprehensive Plan has a goal to provide housing near gateways and transportation corridors due to an increasing population. The Mountain Hawk Subdivision is along U.S. Highway 550 and Northwest loop, a highly utilized transportation corridor and designated gateway in the Comprehensive Plan. In addition, the Comprehensive Plan provides a variety of housing types and mixed-used residential developments to meet the needs of all members of the community. The requested ZMA is consistent with the goals and policies outlined by the Rio Rancho Comprehensive plan and recently approved Mountain Hawk Master Plan.

4. The applicant must demonstrate the existing zoning is inappropriate because:
 - a) The existing zoning is inappropriate because there was a judgment mistake in the original zoning.
 - c) A different use category is more advantageous to the community, as articulated in the Comprehensive Plan.

Applicant response: The proposed ZMA is more advantageous to the community, as articulated in the Comprehensive Plan as demonstrated in section one, two and three above. The applicant is requesting an amendment to the zoning to match the recently approved Mountain Hawk Master Plan.

(E) The cost of land or other economic considerations pertaining to the applicant shall not be the determining factor for a change of zone.

Applicant response: The cost of land or other economic considerations are not the determining factor for this request. The request is to bring the zoning in alignment with the approved Mountain Hawk Master Plan.

(F) Location on a collector or major street is not in itself sufficient justification of apartment, office, or commercial zoning.

Applicant response: Location on a major street is not the sole justification for this request. The request is to bring the zoning in alignment with the approved Mountain Hawk Master Plan.

(G) A zone change request which would give a zone different from surrounding zoning to one small area, especially when only one premise is involved, is generally called a "spot zone." Such a change of zone may be approved when:

- (1) The change will clearly facilitate realization of the Comprehensive Plan and any applicable adopted sector development plan or area development plan; or

(2) The area of the proposed zone change is different from surrounding land because it could function as a transition between adjacent zones; because the site is not suitable for the uses allowed in any adjacent zone due to topography, traffic, or special adverse land uses nearby; or because the nature of structures already on the premises makes the site unsuitable for the uses allowed in any adjacent zone.

Applicant response: The requested zone change will not create a spot zone. The request is to bring the zoning in alignment with the approved Mountain Hawk Master Plan. The requested change will also accomplish the Vision of Growth in Section 1 and the goals set forth in Section 6 of the Comprehensive Plan. The change will establish a transition form outside the Mountain Hawk Master Plan, currently zoned R-1, and through the plan from R-4 to R-6, C-1 and finally to M-1 north of the proposed change.

We respectfully request that the Rio Rancho Planning and Zoning Board and Governing Body approve this request for a zone map amendment.

Sincerely,



Jarrod Likar, PE
AMREP Southwest, Inc.
Vice President-Land Development

100ft Buffer Map: Mountain Hawk, Tract 21- ZMA







MOUNTAIN

HAWK

ESTATES

MASTER PLAN

CITY OF RIO RANCHO, NEW MEXICO

ADOPTED DECEMBER 11, 2019

**Prepared by:
CONSENSUS PLANNING, INC.**

**Prepared for:
AMREP SOUTHWEST, INC.**



MOUNTAIN HAWK ESTATES

MASTER PLAN

City of Rio Rancho, New Mexico

Adopted December 11, 2019

Original Plan* Adopted March 24, 2001

Prepared for:

AMREP Southwest, Inc.

333 Rio Rancho Blvd NE, Suite 202

Rio Rancho, NM 87124

Prepared by:

Consensus Planning, Inc.

302 8th Street NW

Albuquerque, NM 87102

**The Hawk Site Master Plan prepared by: Community Sciences Corporation*



**CITY OF RIO RANCHO
RESOLUTION**

RESOLUTION NO.128

ENACTMENT NO.19-126

**RESOLUTION AMENDING THE HAWSITE MASTER PLAN WITH SAID PLAN TO BE
NAMED MOUNTAIN HAWK ESTATES MASTER PLAN; AND
PROVIDING FOR AN EFFECTIVE DATE**

1
2
3
4
5 **WHEREAS:** the State of New Mexico has granted the City of Rio Rancho the power,
6 authority, jurisdiction and duty to enforce and carry out the provisions of
7 law relating to planning, platting, zoning, and the power to adopt, amend,
8 extend and carry out a general municipal or master plan which may be
9 referred to as the general or master plan, all pursuant to 3-19-1, NMSA,
10 1978; and

11
12 **WHEREAS:** the Governing Body of the City of Rio Rancho has adopted a
13 Comprehensive Plan that addresses and provides for specific goals,
14 policies, and actions; proposes land use throughout the City; provides for
15 adoption of specific area plans for specific area within the City; and also
16 provides for land use in master planned communities via master plans;
17 and

18
19 **WHEREAS:** the Governing Body of the City of Rio Rancho has adopted a
20 Comprehensive Plan that addresses land use in master planned
21 communities; and

22
23 **WHEREAS:** the Governing Body of the City of Rio Rancho approved the Hawksite
24 Master Plan on May 23, 2001 with Resolution No. 27 Enactment No. 01-
25 027; and

26
27 **WHEREAS:** the Planning and Zoning Board of the City of Rio Rancho reviewed the
28 amendments and modifications to the Hawksite Master Plan at their
29 meeting held on October 22, 2019, and following public hearing
30 recommends approval of those amendments and modifications; and

31
32 **WHEREAS:** the Governing Body of the City of Rio Rancho has reviewed the proposed
33 amendments (Case No. 19-410-06) to the Hawksite Master Plan at their
34 meeting held on December 11, 2019, and following public hearing and
35 receipt of the Planning and Zoning Board's report and recommendation,
36 has determined that the amended Plan is in conformance with the City of
37 Rio Rancho Comprehensive Plan.

38
39 **NOW THEREFORE, BE IT RESOLVED BY THE GOVERNING BODY OF THE CITY
40 OF RIO RANCHO:**

41
42 **Section 1.** The Governing Body hereby approves and adopts amendments to The
43 Hawksite Master Plan, now known as Mountain Hawk Estates Master Plan, comprised of
44 properties known legally as all lots, tracts, parcels, and rights of way within the plat of

1 Rio Rancho Hawksite, recorded in Plat Book 17, Pages 16-19. The Mountain Hawk
2 Estates Master Plan attached hereto as "Exhibit A" is hereby amended and adopted
3 with the following changes or conditions:

- 4 1. The City's Comprehensive plan, Generalized Land Use map (GLUM), Map L-2,
5 shall be modified to reflect the land uses in the updated "Mountain Hawk Master
6 Plan."
- 7 2. An amendment to the Hawksite Development Agreement may be required prior
8 to the approval of any preliminary or final plat or other action. Any development
9 or action proposed to implement this Mountain Hawk Estates Master Plan must
10 be consistent with and complementary to the Hawksite Development Agreement
11 and vice versa. Any necessary amendment to that development agreement to
12 implement this Master Plan must also be compliant with the City's Impact Fee
13 Subchapter as it may apply to the development agreement.
- 14 3. An update to the Drainage Implementation Plan and Drainage Master Plan are
15 required prior to the approval of any preliminary plat.
- 16 4. Vacation and dedication of right of way requires separate process and approval.
17 Land uses identified within any future vacated right-of-way are subject to and
18 contingent upon such vacation of right-of-way.
- 19 5. The "Utility" land use identified on Tract 9 on Figure 2. Future Land Use Plan, is
20 better identified as having a "Light Industrial & Business Park" land use
21 designation, and for purposes of implementation, said Tract 9 may be developed
22 for either Utility or Light Industrial & Business Park uses.

23
24 **Section 2.** Designs, layouts, and engineering requirements or details are subject to
25 compliance with City engineering and/or subdivision requirements prior to development.

26
27 **Section 3.** Effective Date:

28 This Resolution shall take effect immediately upon adoption.

29
30 ADOPTED THIS 11th DAY OF DECEMBER, 2019.

31
32 
33 _____
34 Gregory D. Hull, Mayor

35 ATTEST:

36 
37 _____
38 Rebecca A. Martinez, City Clerk
39 (SEAL)

TABLE OF CONTENTS

1. INTRODUCTION	1
2. EXISTING CONDITIONS	3
3. COMPREHENSIVE PLAN RESPONSE	5
4. LAND USE & ZONING	11
5. CONCEPTUAL DRAINAGE PLAN	19
6. CONCEPTUAL UTILITY PLAN	21
7. TRANSPORTATION	23
8. PUBLIC FACILITIES & SERVICES	27
9. APPENDICES	29

Page Intentionally Left Blank

1. INTRODUCTION

AMREP Southwest, Inc., the developer of the Master Plan Area, has prepared this document to provide a thorough reporting to the City of Rio Rancho regarding the privately held parcels of land formerly known as **The Hawk Site** – now known as **Mountain Hawk Estates**. The intention of this plan is to ensure development of a high quality, mixed-use, master-planned community. Because Mountain Hawk Estates is a large development, the sum of the land uses proposed are intended to reflect the long-range planning objectives of the City of Rio Rancho; offering a range of residential, shopping, employment, and public land uses.

This plan is a revision to the original Master Plan that was adopted on March 24, 2001. The following chapters detail updated land use patterns and proposed zoning changes, transportation and access including adjustments to the Northwest Loop Road within the boundaries of the plan area, housing opportunities, employment and economic development, and the preservation of natural features and open space for drainage and recreation purposes. As an updated plan, this document responds to the goals and policies of the City of Rio Rancho's updated 2010 Comprehensive Plan and will continue to support the development of Mountain Hawk Estates into a true asset for the City and its residents.

In 1988, Mountain Hawk Estates, which consists of approximately 574 acres, was annexed into the incorporated limits of the City of Rio Rancho. Of this total area, approximately 48 acres is subtracted for the Northwest Loop Road right-of-way and the wastewater treatment facility located at the northern edge of the site. The City originally designated the area as a transition zone until the owner received approval of the original Master Plan and subsequently established zoning.

Since the original master plan and zoning approvals in 2001, several zone map amendments have been approved to add additional commercial acreage and to reflect changes in platting and market demands for certain types of residential lots, but the plan was not updated over the years to reflect those zoning changes. As such, this updated plan will reflect the existing conditions and proposes further changes to successfully implement the City of Rio Rancho Comprehensive Plan vision.

The original Master Plan, as well as this update, creates an opportunity to appropriately plan for a concentration of residential neighborhoods, employment, business, and open space within a Comprehensive Plan-designated development node at Rio Rancho's northern edge. Mountain Hawk Estates can serve as an attractive entry to the City. Job creation for economic diversification is a principal development objective, and the updated plan maintains a high acreage of industrial land to achieve this purpose. A wide range of housing choices will provide an affordable community for employees and their families with easy access to Unser Boulevard and U.S. 550 that provide good connections to other employment areas, schools, shopping, and leisure activities.

Page Intentionally Left Blank

2. EXISTING CONDITIONS

The site is located adjacent to the western right-of-way of U.S. 550, approximately four miles west of New Mexico State Road 528 (NMSR 528). U.S. 550 allows access to the site from Interstate 25, the Town of Bernalillo, and is a major highway connecting to Farmington and the four-corners area. NMSR 528 is one of the main roads through the City of Rio Rancho. This site is located approximately 15 miles north of Albuquerque, approximately 45 miles south of Santa Fe and approximately 5 miles west of the Town of Bernalillo. There are views from the site to both the Sandia and Jemez Mountains.



The Sandia Mountains and existing homes from Westphalia Boulevard.

This site is bisected, east and west, by the Northwest Loop Road, currently a 300' wide right-of-way designated as a limited access regional principal arterial by the Long-Range Roadway System Map of the Mid-Region Metropolitan Planning Organization (MRMPO), which is part of the Mid-Region Council of Governments (MRCOG). The northern half of the Northwest Loop Road has been partially constructed to the southwestern corner of the National Guard facility adjacent to the property where it connects to Unser Boulevard. Plans for the Northwest Loop Road were originally to extend westerly, then southerly to Interstate 40, in the Rio Puerco area; however, no additional construction has occurred to date, and right-of-way within the Mariposa Master Plan area to the west of Mountain Hawk Estates has reverted back to the owner, so it is unlikely that further extension of the Northwest Loop will occur anytime soon.

There are two other major roads that have an impact on the planning of this site. Westphalia Boulevard is called out on the Long-Range Roadway Systems Map (LRRSM) as a minor arterial and bisects Mountain Hawk Estates from north to south. It is platted through the master plan area and continues south to the Paseo Gateway area around V. Sue Cleveland High School. The portion of Westphalia Boulevard within the master plan area south of the Northwest Loop Road has been constructed to support the development that has occurred since the master plan was originally adopted. Unser Boulevard also abuts the site and is called out on the LRRSM as a regional principal arterial. Unser Boulevard intersects the Northwest Loop Road at the west edge of the Mountain Hawk Estates plan area. More about this can be found in **CHAPTER 7: TRANSPORTATION**.

Mountain Hawk Estates is bounded by the New Mexico National Guard Patriot Missile training facility to the west, the Pueblo of Santa Ana reservation lands to the north and east, and Unit 25 of Rio Rancho Estates to the south and west.

The National Guard training site is an active facility. The access for National Guard lands is adjacent to the Northwest Loop Road, at the western edge of the site at a designated access point.

Rio Rancho Estates Unit 25 is located to the south and west of the site within the incorporated limits of the City of Rio Rancho. This area has been subdivided and sold to numerous private parties; however, to date, there has been little to no development in this area.

Since development of Mountain Hawk Estates has commenced, the multiple drainage ways that traverse the site have begun being channelized with ponding to account for runoff from the new development. According to the most recent FIRM (Flood Insurance Rate Map) map for Sandoval County, dated March 18, 2008 (Panel 35043C1900D), the site is within Zone X, an area of minimal flood hazard, and there are no floodplains or floodways running through the property. Further discussion of drainage measures tailored to this site are found in **CHAPTER 5** of this master plan.

The original plan proposed a variety of ways to sustain the anticipated development within Mountain Hawk Estates, while it was largely separated from the developed portions of the City of Rio Rancho. An example includes the use of the existing water treatment facility at the northern edge of the plan area that was primarily being used by the National Guard facility prior to development in the Mountain Hawk Estates plan area. Development of Mariposa to the west of Mountain Hawk Estates has added to the availability of water and sewer infrastructure to aid future development in the northern part of Rio Rancho. Further discussion of the existing and planned water and wastewater systems can be found in **CHAPTER 6** of this plan.

As proposed through the Vision 2020 Comprehensive Plan process and maintained by the City's updated 2010 Comprehensive Plan, Mountain Hawk Estates is a preferred "growth node." As employers, businesses, and homebuilders look for sites in Rio Rancho, Mountain Hawk Estates will provide parcels with a variety of land uses, zoning designations, and sizes. Discussion of this updated plan's conformance to the Rio Rancho Comprehensive Plan is found in **CHAPTER 3** with more specific Land Use and Zoning considerations in **CHAPTER 4**.

3. COMPREHENSIVE PLAN RESPONSE

AMREP Southwest, through this updated master plan, has coordinated with Rio Rancho's Comprehensive Plan vision as it pertains to growth, community appearance and character. This Master Plan also affords solutions for the practical aspects of planning by:

- Designing mixed-use convenience,
- Reducing vehicular trips,
- Balancing workspace opportunities with nearby housing matched to wage-earning potential,
- Creating public-accessible recreational / open space amenities, and
- Emphasizing economic development objectives that respond to community needs

The only immediate neighbors of occupation are the National Guard. Proposed positioning of land uses establishes a non-residential buffer that will, on the subject property, mitigate negative impacts from the activity at the National Guard facility. In addition, future retail and service establishments provided for in this Master Plan afford conveniences for National Guard employees and weekend in-training personnel, residents of Mountain Hawk Estates and Mariposa, as well as travelers along U.S. 550.

The original Master Plan was presented to representatives of the nearest residential neighbors, the *Enchanted Hills Homeowner's Association*. The land use mix proposed by this updated plan is in line with the mixed-use framework established by the original Master Plan. The requested updated land use categories are needed to ensure higher density, affordable housing for some of the tracts, and with the higher density, promote more public amenities such as open space, parks and trails.

There are numerous goals and policies from the City of Rio Rancho's Comprehensive Plan that affect the continued development of Mountain Hawk Estates. As described below, this updated plan furthers these goals and policies and the overall Comprehensive Plan vision for the City.

A. Natural Environment

As described elsewhere, the Master Plan includes multiple drainageways and incorporates those into open space areas and trail corridors, where possible. The Plan furthers the following Comprehensive Plan goals and policies:

- **GOAL CON-5:** Meet federal, state, regional and local water quality standards through coordinated, long-term strategies that address the many contributors to water pollution.
- **POLICY CON-12:** Develop and protect a public open space network.

The conceptual drainage plan (see **CHAPTER 5**) collects stormwater from the developed areas of the site and directs them to shared ponds and channels. These channels allow the stormwater to slow and reduce potential water pollution before leaving the site to the north via the primary arroyo that bisects the property. The ponds and channels are proposed to be retained as open space areas consistent with the original master plan with additional park space adjacent to them in two locations. Designated open space and drainage areas account for approximately 9% of the site, which meets a need to provide both recreation opportunities for future residents while preserving the natural environment.

B. Land Use

As described in **CHAPTER 4: LAND USE**, much of the planning area is proposed to support medium to high density single-family and multi-family residential uses. Significant land remains designated for industrial use, as well as commercial and mixed uses near major intersections. Open space corridors and two neighborhood park sites are also included. The proposed land uses further the following Comprehensive Plan goals and policies:

- **GOAL L-1:** Encourage mixed uses – retail, office, and residential centered on pedestrian-oriented developments along principal arterial roads.
- **GOAL L-2:** Encourage consolidation of lots to promote a variety of land uses in a planned manner.
- **GOAL L-3:** Maintain a balance of land uses throughout the City.
- **POLICY L-1:** Encourage the master planning of developments that establish a community character that considers circulation, landscaping, open space, storm drainage, utilities, and building location and design in the master plan.
- **POLICY L-2:** Promote and support neighborhood scale retail activities that are consistent with residential development.
- **POLICY L-3:** Promote and support development that incorporates walkability.
- **Action L-1:** Identify areas within the City where locating large-scale light industrial businesses such as light manufacturing, warehousing and research facilities are appropriate.

As stated above, the Plan promotes a mixed-use development pattern with commercial and high-density residential land uses centered around the U.S. 550 and Northwest Loop Road intersection. Additional commercial and medium- to high-density residential is found along the Northwest Loop Road and Westphalia Boulevard. The plan also maintains a large amount of industrial land that is appropriate for light manufacturing, warehousing, and research uses.

C. Population and Housing

Rio Rancho is continuing to be an area of growth and new housing development in the Albuquerque Metropolitan Area, and the Comprehensive Plan identifies areas along major roadways likely to experience this growth including Unser Boulevard and U.S. 550 that bookend this master plan area. This Plan supports several housing goals of the Comprehensive Plan including:

- **GOAL PH-2:** Maintain the strength, vitality, and stability of all residential neighborhoods and types.
- **GOAL PH-3:** Promote a variety of housing types to meet the needs of all members of the community.
- **GOAL PH-4:** To ensure that single-family and multifamily residential neighborhoods provide an attractive living environment.
- **Policy PH-1:** Promote quality, community-friendly multifamily development, through features such as enhanced open space and pedestrian connectivity

- **Policy PH-5:** Encourage mixed-use and mixed-income housing opportunities in designated growth nodes throughout the city.
- **POLICY PH-7:** Support residential developments with appropriate amenities for families with children.
- **POLICY PH-9:** Provide incentives to encourage residential development for a range of housing types and income levels throughout the city.

The Master Plan proposes a wide variety of housing densities within a designated growth node. The existing single-family development will be complemented by additional homes on a variety of lot sizes, as well as the inclusion of higher density options such as townhomes and apartments in other areas within the plan boundary.

D. Transportation

The transportation element of the Rio Rancho Comprehensive Plan seeks to develop a multi-modal transportation system that enables safe travel for all users, while also mitigating congestion and supporting mass transit. The proposed transportation plan described in **CHAPTER 7** supports many of the Comprehensive Plan's goals and policies including:

- **GOAL TR-1:** Encourage development that effectively mixes land uses to create an efficient transportation system that reduces congestion, improves air quality and creates opportunities to build Rio Rancho's economy.
- **GOAL TR-2:** Transportation facilities designed and constructed in a manner to facilitate Rio Rancho's economic goals, enhance livability and meet Federal, State, regional and local requirements.
- **POLICY TR-1:** Plan land uses to increase mode share and opportunities for multi-purpose trips (trip chaining) through proper location and design of transportation facilities.
- **POLICY TR-4:** Support complete street designs in the upgrade of existing and the development of future areas of Rio Rancho.
- **POLICY TR-9:** Plan rights-of-way prior to development review and, where appropriate, officially secure them by dedication or reservation of property.
- **POLICY TR-10:** Support the design of streets and highways to respect surrounding land uses, natural features and community amenities.

Roadways in the Planning Area will be constructed to respect surrounding land uses, natural features, and meet local and state requirements. The plan includes a request that the Northwest Loop Road right-of-way be narrowed and potentially be realigned with the terminus of Unser Boulevard. This request would enhance the livability of the area and support complete streets goals by following City of Rio Rancho standards for principal arterials and having shorter, more walkable crossings within the plan area. A more hospitable transportation system will encourage a shift in mode share to walking and biking between the mixed land uses presented in this updated plan.

E. Public Facilities

The Comprehensive Plan seeks to ensure that new development occurs in areas with existing public facilities and proximity to existing infrastructure (to minimize costs associated with infrastructure expansion). The Master Plan supports the following Comprehensive Plan goals and policies:

- **GOAL PF-1:** Provide a broad range of services and public facilities that meet the needs of current and future City residents, e.g. libraries, water supply, water and sewer lines, etc.
- **POLICY PF-3:** Make land use recommendations based on the availability of adequate public facilities necessary to support a proposed land use.

The Master Plan identifies existing and proposed public facilities and infrastructure development for Mountain Hawk Estates. Water and sewer infrastructure are already in place in much of the planning area, and new development will extend or install new facilities as needed for each individual project.

F. Parks and Recreation

The Comprehensive Plan identifies improving the City’s parks and recreation facilities as a clear need, especially in new master planned communities. Through the development of parks as part of residential communities within the plan area, this plan supports several Comprehensive Plan goals and policies to improve parks and recreation facilities including:

- **GOAL PR-1:** Establish new and maintain existing recreation and senior centers, parks, trails and open space that foster a quality community, support a strong economy, and meet the needs of current and future residents.
- **GOAL PR-3:** Develop, operate, and maintain parkland, recreation facilities and senior centers in a sustainable manner.
- **POLICY PR-1:** Develop pedestrian and bicycle linkages between neighborhoods and major natural areas, recreation facilities, and education, employment and retail centers.
- **POLICY PR-3:** Acquire land throughout the city to meet present and future parks, open space and recreation/senior center needs.

The Master Plan Area includes two locations for neighborhood parks that will be dedicated to the City of Rio Rancho. Open space and drainage corridors will include multi-use paths that connect between individual subdivisions, the major road network, and areas of commercial retail, services, employment, and other mixed-uses.

G. Urban Design

The urban design element of the Comprehensive Plan seeks to ensure that development follows basic design standards that support community identity and create a sense of place. The Master Plan furthers the following urban design goals of the Comprehensive Plan:

- **GOAL UD-1:** Create focused growth areas where existing public infrastructure can support higher density development.
- **GOAL UD 2:** Create traditional neighborhood patterns that support a sense of place.
- **GOAL UD 3:** Create street patterns with development that fosters human interaction.

- **GOAL UD-7:** Create subdivision linkages to open space recreational facilities.
- **POLICY UD-1:** Identify specific areas within the city where growth should be focused.

The updated master plan offers a variety of land uses centered around the two principal arterial roadways that bisect the plan area. A sense of place and human interaction will occur by narrowing the current Northwest Loop Road to a more manageable width and fostering the development of commercial and multi-family uses in proximity to one another. Individual subdivisions will connect to the adjacent street network, as well as to multi-use trail corridors in adjacent open space areas that offer recreational opportunities and linkages to areas of commercial development.

H. Economic Development

The City of Rio Rancho has sought to diversify its economy and attract additional employers. In addition, the City has sought to increase the amount of local retail opportunities within Rio Rancho, as well as expand the overall tax base.

- **GOAL EDP-1:** Create Jobs.
- **GOAL EDP-3:** Enhance the tax base.
- **GOAL EDP-4:** Improve the quality of life.
- **Goal EDR-1:** Expand the economic base of Rio Rancho.
- **Goal EDR-2:** Reduce retail sales leakage to other New Mexico cities.
- **Goal EDR-3:** Encourage large-scale manufacturing companies to relocate to Rio Rancho.

Development of the Master Plan Area will expand the City's tax base through both increased property taxes, and by supporting population growth and associated spending by new residents. Additionally, a large amount of industrial land is maintained that can be utilized for new companies to locate in Rio Rancho that would create jobs and expand the economic base of the city. Significant commercial uses designated by the plan will provide options for shopping, dining, and entertainment of residents of the residential areas and other nearby developments such as Mariposa, thus reducing leakage to other area cities.

Page Intentionally Left Blank

4. LAND USE & ZONING

A. Existing Land Use

The site is influenced by varying slopes, several ridgelines and frequent natural drainage ways. These facts led to the original Master Plan designation of fourteen distinct Planning Areas. Constraints imposed by the site's terrain were utilized as boundaries and buffers and served as a base for this updated plan in addition to the platting and installation of infrastructure that has occurred since the original plan was adopted.

The National Guard facilities located at the western edge of the plan area remain the dominant existing surrounding land use. Since adoption of the original plan, the Mariposa master planned community has begun developing to the southwest along Unser Boulevard and primarily consists of a variety of residential densities with a small, town center that includes some office and commercial space along with a park and community center.

Within the Mountain Hawk Estates plan area, the existing land uses are single-family residential with the remainder largely remaining vacant. Except for a city utility site, all the land north of the Northwest Loop Road is vacant. However, it has been bulk platted and utility infrastructure has been installed along the Westphalia Boulevard right-of-way.

The first subdivision within Mountain Hawk Estates has been completed on the south side of the Northwest Loop Road between James Wall Road and Westphalia Boulevard. Additional subdivisions that stalled during the economic downturn on the west side of Westphalia have been revived and are now seeing home construction.

B. Existing Zoning

Overall, existing zoning designations respond to the land uses and planning areas identified in the original master plan that were mapped to bulk land subdivision tracts. Much of the site is zoned Special Use for R-2 (SU/R-2), including the completed subdivision within Units 33 and 34. The SU/R-2 zone includes conditions stipulated in Ordinance No. 10, Enactment No. 01-10.

The SU/R-2 property located on the north side of the Northwest Loop Road was reconfigured in 2014 with revised platting around a central drainage parcel and neighborhood park. Originally, the drainageway paralleled Westphalia Boulevard, but modification was necessary because of requirements from the Office of the State Engineer. This modification also affected most of Reserve Area #1 and established Open Space (OS) and Parks and Recreation (PR) zoning in this area by replacing the Special Use for Multi-Use Facilities that existed prior.

The remaining portion of Reserve Area #1 (Tracts 8 & 9 and Parcel A) at the northern edge of the planning area, as well as Reserve Areas #2 and #3 from the 2001 Master Plan (generally defined by Tracts 22, 26, 30A and 30B) remain zoned Special Use for Multi-Use Facilities, which allows for drainage, transportation, sewage treatment, and/or open space uses subject to development per an approved Development Agreement or as determined via the platting process.

Tracts 27 and 28 located south of the Northwest Loop Road and west of Westphalia were rezoned in 2018 from SU/R-2 to SU/R-3 and are subject to the conditions established by Ordinance No. 31, Enactment No. 18-32 on November 14, 2018.

The last piece of Special Use zoning within the planning area is a sliver of land located between the U.S. 550 and Old State Highway 44 rights-of-way, which allows apartments. However, it should be noted that a significant portion of this tract is within the jurisdiction of the Pueblo of Santa Ana, and as such can no longer be privately developed.

R-1 single-family residential zoning exists near the southern and western edges of the plan area.

Regarding non-residential zoning, the original 2001 Master Plan designated C-1 commercial zoning along U.S. 550 and the Northwest Loop Road on what is now Tracts 1 thru 4, 19, 21, 24, and 25. In 2006, a portion of Tract 3 was rezoned from C-1 to the straight R-2 zone district in exchange for an equivalent change in acreage from SU/R-2 to C-1 for Tract 35, located at the southwest corner of U.S. 550 and the Northwest Loop.

Finally, the area to the north of the Northwest Loop Road and west of Westphalia is zoned M-1 Industrial and Business Park District along with the two smaller Tracts 15A1 and 15B at the northeast and southeast corners of Westphalia and Patriot Road.

Even though several zone changes and platting actions have occurred since adoption of the Master Plan in 2001, the plan has never been amended, so this updated plan serves an important purpose to accurately reflect the most current land use and zoning conditions, as well as proposing changes where needed to implement the City's Comprehensive Plan vision.

Figure 1. Existing Zoning

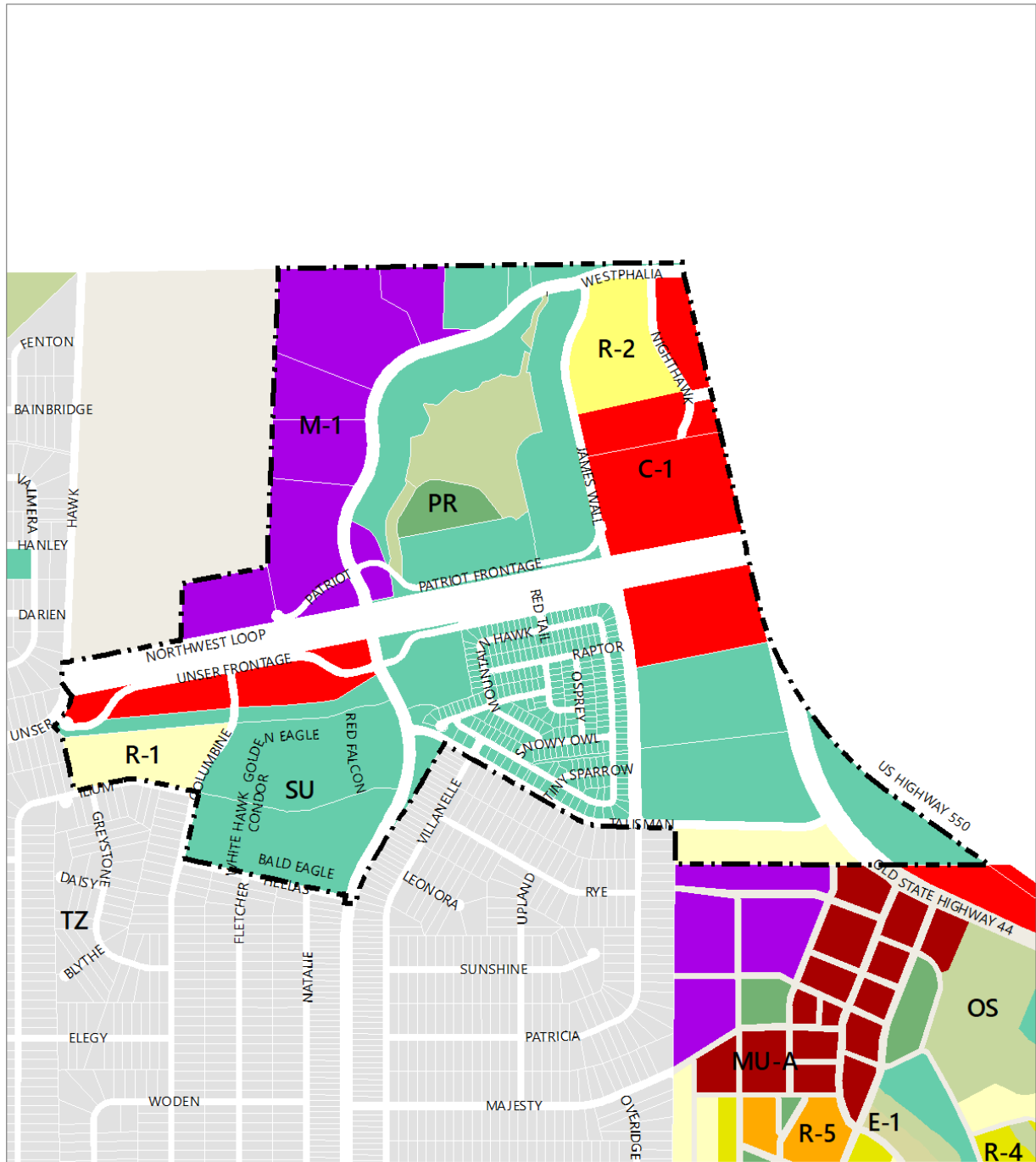

Zoning

- | | | |
|---|--|----------------------|
| ■ C-1 | ■ R-4 | Master Plan Boundary |
| ■ E-1 | ■ R-5 | |
| ■ M-1 | ■ MU-A | |
| ■ PR | ■ SU | |
| ■ R-1 | ■ OS | |
| ■ R-2 | ■ TZ | |

Prepared for:
AMREP Southwest, Inc.

Prepared by:
Consensus Planning, Inc.



C. Proposed Land Use

As a uniquely situated, master planned community, Mountain Hawk Estates can integrate commercial and manufacturing activities, a variety of housing types, dwelling densities, and recreational facilities in a cohesive manner.

In response to the City's updated Comprehensive Plan and changing market realities, this updated master plan proposes several modifications to the original land use plan and subsequent zoning. Additionally, proposed changes to the transportation system in this area warrant further review and changes to the land use patterns originally determined in 2001 and through subsequent zone changes over the years. This updated land use plan is presented in Figure 2.

Generally, the overall density of the residential areas will increase slightly in response to changing market conditions and to support the City of Rio Rancho's goals and policies to provide a variety of housing types available to families and individuals with a wide range of income levels. This increase in density is especially appropriate within a designated growth node, and additional residents in the northern part of the city will aid development of the proposed commercial and other land uses within the plan area.

The plan includes a net increase in the amount of acreage dedicated to industrial and manufacturing uses that will afford employment opportunities and continue to offer a transition between the National Guard site and the less intense uses to the east and south. Westphalia and the Northwest Loop Road then provide an additional buffer to higher density residential, commercial, and mixed-uses, which further step down to open space, parks, and more moderate density residential.

There is an overall decrease in the amount of commercial land with a focus of retaining commercial and mixed-uses adjacent to major intersections. The most significant reductions from existing conditions are within Tracts 3B and 21, which are proposed to accommodate higher-density residential uses such as townhouses and apartments. These new higher density residential uses are a critical component of creating a mixed-use activity node with a variety of housing types and densities as envisioned by the Comprehensive Plan. Some of these high-density residential uses are a relocation of the apartment uses first identified in the 2001 Master Plan that can no longer be built where originally planned due to a change in land ownership by the Pueblo of Santa Ana.

Other significant changes and modifications to the land use plan are the result of the vacation of a portion of the Northwest Loop Road and other smaller access and frontage road right-of-way in the plan area. More about the proposed roadway vacations is discussed in **CHAPTER 7: TRANSPORTATION**. If approved, the vacated right-of-way would add significant acreage to the adjacent parcels, which include medium density residential, commercial, and open space.

Figure 2. Future Land Use Plan

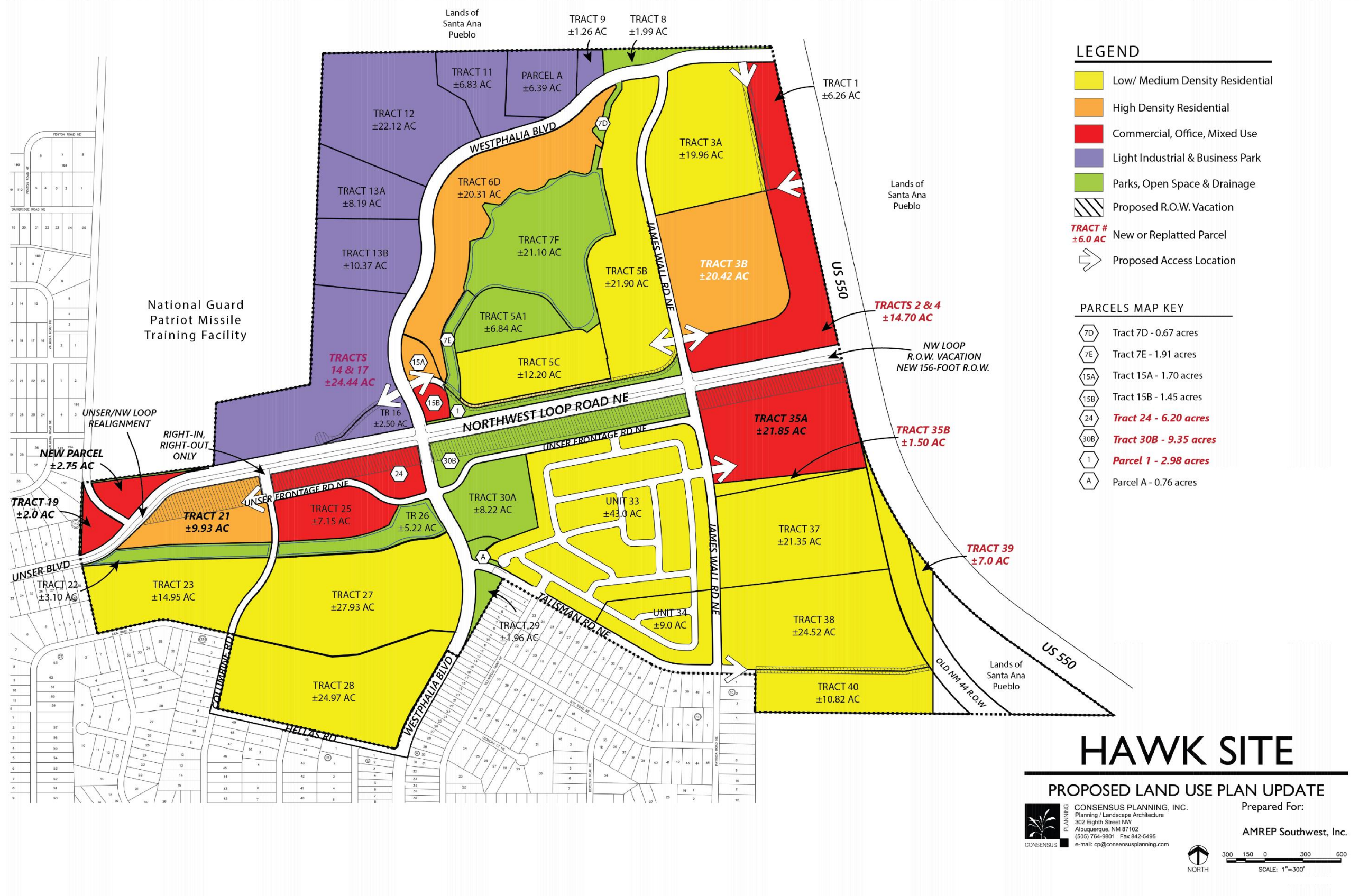

Page Intentionally Left Blank

A detailed description of the proposed changes are as follows:

- Designation of Parcel A as additional manufacturing. Parcel A was originally planned for sewer treatment facilities and is no longer needed for that purpose. A change to manufacturing is consistent with the other tracts of land north of the Northwest Loop Road and west of Westphalia Boulevard. This change is also a replacement acreage for Tracts 15A and 15B that are proposed to change from manufacturing to residential and commercial uses, as described further below. Residential and commercial for these two tracts are more appropriate on the east side of Westphalia as they abut other residential and open space tracts.
- Slight increase and generalization of the residential densities on Tracts 3A, 5B, 5C, 23, 37, 38, and 40. These properties are currently zoned R-1, R-2, and SU/R-2. A higher density land use consistent with the R-3 and R-4 zone districts is appropriate for these parcels and their proximity to major roadways within a designated growth node.
- Change from commercial to residential use for Tract 35B. This change adds to the overall total residential within the plan area and the lost commercial acreage will be replaced by the addition of acreage to Tract 35A from existing Northwest Loop Road right-of-way.
- Modify the remnant Tract 39 from multi-family to single-family. The remaining portion of Tract 39 originally identified by the 2001 Master Plan is now owned by the Pueblo of Santa Ana. While unlikely to develop soon, should the adjacent section of Old NM 44 right-of-way be vacated in the future, this tract could be combined with the vacated right-of-way and developed as an extension of the subdivisions proposed in Tracts 37 and 38. At this time a vacation is not being sought. If the adjacent right-of-way is never vacated, a commercial use may be appropriate next to U.S. 550.
- Add new higher density land use for Tracts 6D, 15A, and 21. These tracts are currently zoned SU/R-2, M-1, and C-1, respectively. This proposed land use adds a new development option that was not previously available in the plan. Such a land use could include townhouses or similar density single-family dwellings consistent with the uses found in the R-3, R-5, and R-6 zone districts.
- Convert Tract 3B from commercial to high-density residential. This change retains the intent of the original plan to include apartments but in a new location due to the limitation on development of the previously identified Tract 39 by Pueblo of Santa Ana ownership.
- Change Tract 15B from manufacturing to commercial and mixed uses. This small tract of land (1.45 acres), is more appropriate for general commercial uses near a major intersection rather than larger-scale manufacturing especially considering its adjacency to residential and open space uses as described above.
- Add additional commercial acreage to Tracts 19, 24, and 35A, plus create new commercial parcel through the vacation of the Northwest Loop Road right-of-way and realignment of Unser Boulevard at the western edge of the plan area. As described further in **CHAPTER 7: TRANSPORTATION**, this right-of-way is no longer necessary and would be more productively used for development that will add to Rio Rancho's tax base and provide goods and services to the residents of Mountain Hawk Estates and Mariposa, personnel at the National Guard facility, and travelers along U.S. 550.
- Add open space acreage to Parcel 1 and Tract 30B from proposed roadway vacation actions.

Tracts 33 and 34, which have already been developed will remain as low/medium-density residential and retain the SU/R-2 zone as established by the original 2001 Master Plan and zoning. Tracts 27 and 28 will likely develop under the existing SU/R-3 zone established in 2018 and related conditions of development. New zone districts responding to the changes identified in this proposed land use

plan will be requested through the City of Rio Rancho Zone Map Amendment process with straight zones utilized where possible. Table 1 breaks down the changes between the 2001 Master Plan to the existing conditions and the new proposed land uses in this updated Master Plan. Percentages are used because of varying acreages between the original, which did not use platted parcels, the existing platted lots, and the proposed tracts that are changing due to ownership and possible roadway vacations.

Table 1. Land Use Comparisons

Land Use/Zone District	2001 Master Plan	Existing Conditions	Updated Land Use Plan
Low/Medium Density Residential	55.0%	51.7%	48.7%
High Density Residential	2.7%	3.0%	10.5%
Commercial, Office, Mixed-Use	16.5%	15.9%	11.6%
Light Industrial & Business Park	14.2%	16.3%	16.2%
Parks, Open Space, and Drainage	11.6%	13.0%	13.1%
Total*	100.0%	99.9%	101.1%

*Totals may not equal 100% due to rounding.

This updated plan decreases the amount of low-density residential and replaces it with additional medium-density residential and an increase in the amount of higher density residential. There is a slight decrease in the amount of commercial, and the plan maintains the current amount of open space and industrial area.

The maximum number of dwelling units was set via a Development Agreement at 1,600. If that number is anticipated to change, the Development Agreement will need to be renegotiated to ensure the appropriate infrastructure and other requirements of the City of Rio Rancho are being provided.

5. CONCEPTUAL DRAINAGE PLAN

The primary philosophy for the drainage concept is the protection of life and property. Secondly, ensuring the stability of the arroyo system and providing for maintenance and perpetuation of that system for flood management, as necessary. Thirdly, the proper development of the site's drainage system is critical to providing an important aesthetic and recreational resource for future residents. A Master Drainage Plan was prepared and submitted as part of the original 2001 Hawk Site Master Plan approval.

As Mountain Hawk Estates develops, the natural drainage system of arroyos will be further enhanced to provide adequate storm water run-off and detention facilities and passive and recreational open space. Consequently, the subject of site drainage is a critical one to the master planned development of this area.

A well-developed, northward flowing central arroyo bisects Mountain Hawk Estates. In the southern half of the site, a series of finger-like extensions covered much of the original planning areas Seven through Fourteen, collecting water into a low area situated immediately to the east of Planning Area Seven. As a result, a storm water detention pond was constructed to the southeast of the Northwest Loop Road and Westphalia Boulevard intersection. This pond, located in the open space tract between the Northwest Loop and Frontage Road, releases through a culvert under the Northwest Loop Road, which is proposed to be upgraded during the development of Mountain Hawk Estates.



Central Drainage Arroyo Through Mountain Hawk Estates, Looking South.

The continuation of the central arroyo feature north of the Northwest Loop runs in a predominantly northern direction to the existing sewer treatment site. The original master plan kept this drainage tract parallel to the Westphalia Boulevard right-of-way, but it was replatted in 2014 to lead to a more centralized ponding area in the center of former Planning Area #2 (now known as Tract 7F) due to requirements from the Office of the State Engineer. Generally, no changes are proposed to this reconfigured overall drainage scheme. However, subsequent to approval of this revised Master Plan, the Drainage Management Plan will be updated to ensure proper stormwater function under amended development conditions.

Page Intentionally Left Blank

6. CONCEPTUAL UTILITY PLAN

A. Water

The original Mountain Hawk Estates development began with modest existing utilities. These existing utilities included Wastewater Treatment Plant #4, a lagoon/pond and sewage settling tank; Well Site #15 and Tank/Reservoir #15, a 1.0-million-gallon tank.

The 2001 Master Plan assumed the 1-million-gallon reservoir (located at City Well #15) had adequate storage for up to half of the proposed project and additional storage would be required thereafter.

Since the beginning of development in Mountain Hawk Estates, several water improvements have been completed including significant storage upgrades. Those improvements include the following:

- 2 Million Gallon Tank #12 West
- Hawk Site Booster Station and 16" Transmission Line
- 3 Million Gallon Second Tank #12 West
- 3 Million Gallon Second Tank #15

B. Wastewater

In addition to improvements to water infrastructure, several improvements to wastewater infrastructure have also been made, including:

- Lift Station #20 – Serving all of Mountain Hawk Estates and Southern Drainage Basin
- 12" Force Main to Mariposa Wastewater Treatment Plant
- 15" Wastewater Collection Main to LS #20

These improvements are consistent with the 2001 Master Plan, which stated that a permanent solution for disposal of wastewater from the Master Plan Area shall be a regional wastewater system designed to address the regional needs" of Mountain Hawk Estates, Mariposa and Loma Barbon. The Mariposa Wastewater Treatment Plant can be expanded as more development occurs within Mountain Hawk Estates and the surrounding area.

These utility improvements represent most of the major backbone infrastructure needed to service the Mountain Hawk Estates Master Plan Area. As the remaining units develop, additional collection (sewer) and distribution (water) lines will be constructed in accordance with the Development Agreement for the area.

Page Intentionally Left Blank

7. TRANSPORTATION

The original Mountain Hawk Estates development area included right-of-way for the future Northwest Loop (300') and the extension of Westphalia Boulevard (100'). All collectors and arterial roadways will remain with the amended Master Plan with some modifications to width or alignment proposed, specifically to Unser Boulevard and the Northwest Loop as described below. Smaller local roads will be eliminated in multiple areas subject to requests to vacate the right-of-way. The eliminated local roads will be replaced by new roads dedicated as part of future subdivisions or access roads included in commercial site plans. The reduction of these unnecessary local roads surrounding commercial, industrial or multi-family developments will reduce the City's maintenance burden and place the burden more directly on the future development.

A. Access and Transportation

Mountain Hawk Estates is bisected east-west by a limited access, divided, principal arterial; the Northwest Loop Road. This road forms the site's primary connection to nearby U.S. 550. Because it is a limited access corridor, the Northwest Loop Road is intended to connect to only a few major streets accessing areas to both the north and south within Mountain Hawk Estates. Roadway improvements within the Northwest Loop Road right-of-way currently afford restricted traffic across the site, linking the terminus of Unser Boulevard with U.S. 550. This Master Plan depicts two access points from U.S. 550 into the site north of the Northwest Loop Road. A third access into the site from U.S. 550 to the south of the Northwest Loop Road is located at the Old NM 44 right-of-way.

On the Northwest Loop Road, additional access points have been approved and offer entry to the Mountain Hawk Estates development in several key locations. These access points include the following:

- 1) Approximately a quarter mile west of U.S. 550, James Wall Road is anticipated to serve both the prospective commercial, multi-family, and mixed-use development of Tracts 2, 3B, and 4, as well as the large residential neighborhoods within Tracts 3A, 5B, and 5C. This extension of the existing street northward will serve as a major through-traffic opportunity for the existing neighborhood within Units 33 and 34, as well as future residents in Tracts 37, 38, and 40.
- 2) Providing access for Tracts 8 through 17, Westphalia Boulevard extends north from its current intersection with the Northwest Loop Road. If acceptable, this roadway will provide effective through-traffic circulation with an intersection on U.S. 550 at the very northeastern corner of Mountain Hawk Estates. This intersection is one of the proposed access points on U.S. 550 mentioned above. From the south, continuation of Westphalia Boulevard will create access and through-travel opportunities into the developed subdivisions in Units 33 and 34, as well as those under construction in Tracts 27 and 28 and onto the Northwest Loop Road.
- 3) Columbine Road provides internal access as well as potential through traffic connections onto existing streets in Unit 25 to the south (Ilium Road and Hellas Road), which provide additional connection to Westphalia Boulevard.

With the elimination of the Northwest Loop Road dedication in the Mariposa Master Planned Area to the west of Mountain Hawk Estates, the applicant would like to reclaim portions of the Northwest Loop that are unnecessary and excessive considering the unlikely expansion as originally envisioned and the only connection being to Unser Boulevard just west of the planning area. The Master Plan proposes to vacate the southern portions of the current right-of-way. These vacated

rights-of-way would then be absorbed into adjacent tracts and be zoned with the same zone designation as those adjacent tracts consistent with the proposed land uses in **CHAPTER 4**.

In addition to the excess portions of the Northwest Loop Road right-of-way, this Master Plan proposes the Patriot Road paralleling the north side of the Northwest Loop also be vacated. This roadway will be replaced by individual accesses to commercial tracts and new roads dedicated as part of the proposed residential subdivisions.

In the northeast part of the planning area, Hawk Way and Nighthawk Road are also proposed to be eliminated at this time, and future access and circulation will be determined by future development of the surrounding tracts.

Finally, a portion of the Unser Frontage Road paralleling the south side of the Northwest Loop is proposed to be vacated. This portion, located west of Columbine Road, does not connect through to Unser Boulevard and is unnecessary for the development of Tract 21. Individual access for Tract 21 will be determined when it is developed.

As a result of the eliminated right-of-way, Unser Boulevard would be realigned and extend to U.S. 550. The new right-of-way width will be 156 feet wide, which is the standard width for a regional principal arterial.

B. Multi-Modal System

It is recommended that other modes of transportation should be considered to lessen and reduce the impact of vehicular traffic within Mountain Hawk Estates. For example, the land use arrangement recognizes that significant amounts of trails, landscaping, and buffered areas with bikeways and pedestrian facilities will be incorporated within the plan. The proximity of jobs from the industrial and commercial land uses to the proposed residential neighborhoods will also reduce the number of internal-external trips by minimizing the distances driven by some residents and promoting the use of alternative transportation options for travel within the plan area. This will reduce the impact on the adjacent arterial roadways and the highway department system.

Figure 3 below shows the conceptual bicycle and pedestrian facilities within the Mountain Hawk Estates plan area. Major roadways within the planning area will be built to the City of Rio Rancho standards to include bike lanes and sidewalks, and other streets with lower speed limits will provide calmer traffic conditions for non-motorized travel between neighborhoods. In addition, several of the open space tracts may be enhanced with multi-use paths that will accommodate bikes and pedestrians with limited interaction with automobiles. Finally, all local roads within the Master Plan will include sidewalks, so residents and visitors may move about individual neighborhoods safely.

C. Traffic Impact Analysis

A traffic impact assessment (TIA) for the Hawk Site Development was completed in 2007. The study analyzed build and no-build scenarios in two timeframes and made recommendations for intersection improvements within the Mountain Hawk Estates plan area and outside of the plan area based on the anticipated trip generation and distribution. As Mountain Hawk Estates continues to develop, further study may be required by the City of Rio Rancho regarding changes to land use and requests to vacate right-of-way within the plan area.

Figure 3. Proposed Bicycle and Pedestrian Circulation.

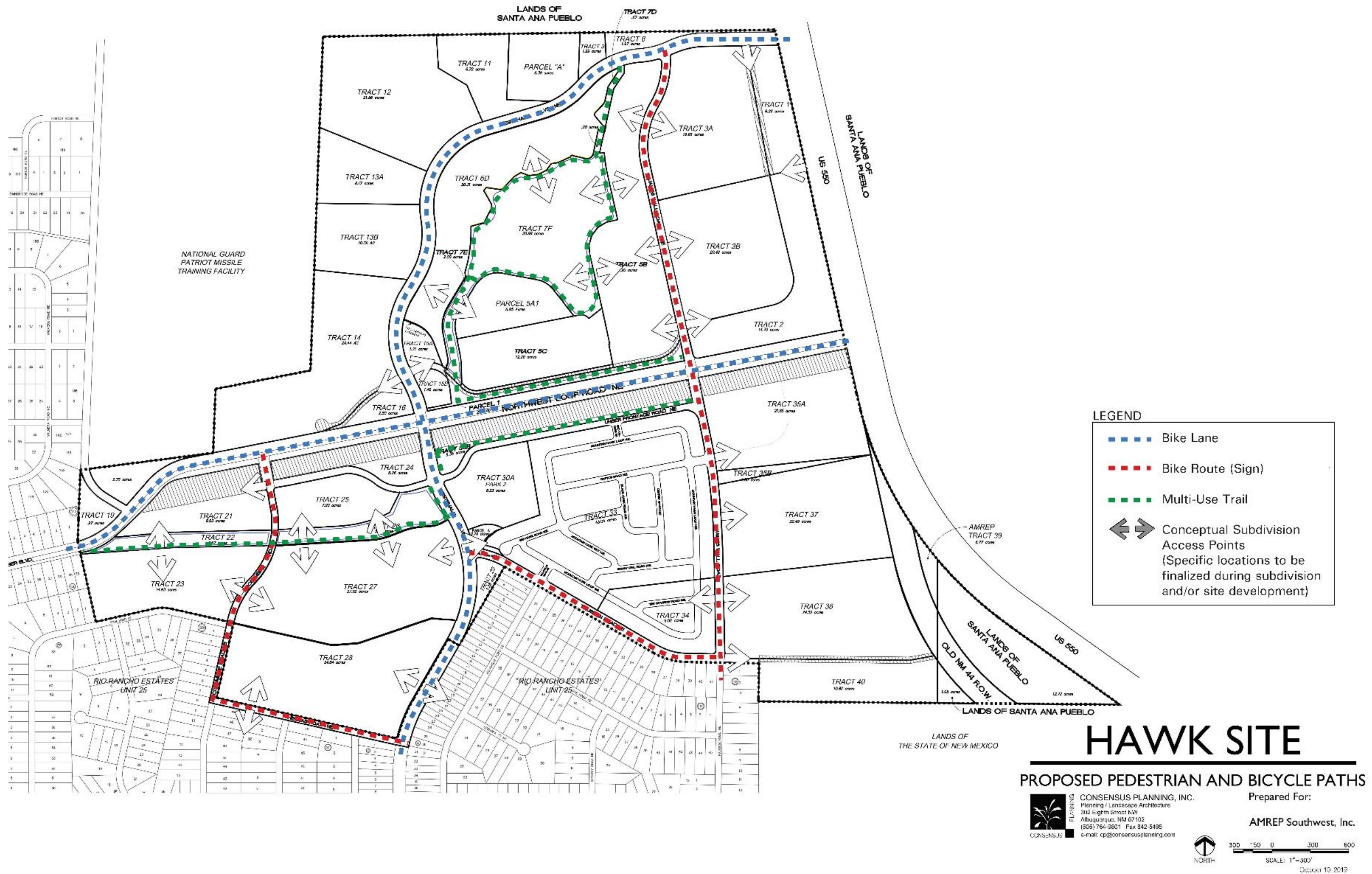

Page Intentionally Left Blank

8. PUBLIC FACILITIES & SERVICES

A. Public Safety

Because of its size, Mountain Hawk Estates will necessarily require that both Fire stations and Police substations be sited to serve the additional residential, commercial and industrial land users in the area. Because of its central location within the site and proximity to the Northwest Loop Road, a location at the eastern edge of Tracts 24 and 25 was considered for such public safety uses by the 2001 Master Plan. Alternatively, the Fire and Rescue and Police Departments may consider other locations. Since adoption of the original Master Plan, an additional Fire station was built within the Mariposa development to the southwest of Mountain Hawk Estates.

B. Schools

After meeting with Rio Rancho Public School officials and reviewing the Rio Rancho Public Schools Master Plan, the Rio Rancho Public School District (the “District”) determined that a school site was not desired in the Mountain Hawk Estates Master Plan Area. The District built Vista Grande Elementary School on Chayote Road to the south of Mountain Hawk Estates. In addition, since 2001, the District has built two more elementary schools (Sandia Vista and Cielo Azul) to the southeast and southwest of the planning area. To the extent that any new elementary school is necessary in the future, the desired location for this school would likely be west of Mountain Hawk Estates and serve students in Mariposa and other nearby developments in addition to Mountain Hawk Estates. Since 2001, V. Sue Cleveland High School and Rio Rancho Middle School were built to the south of the planning area. However, current planning does not preclude the District from acquiring a school site within the Master Plan Area through the District’s power of condemnation (See Superintendent of Schools letter in Attachments).

C. Open Space, Parks, & Trails

An important element of the master planned development of Mountain Hawk Estates is the establishment of open space areas that promote scenic recreational settings, afford lineal pedestrian access and provide areas that buffer potentially conflicting land uses from one another; particularly the residential areas developed in Units 33 and 34 and proposed for Tracts 5B and 5C adjacent to the Northwest Loop Road. Likewise, those homes closest to proposed non-residential sites and the National Guard training facility must be carefully buffered from potential negative impacts of commercial activity and traffic.

The original Master Plan provided for numerous greenbelt trails that connected with a central arroyo open space. In practice, these conceptual trail networks within individual subdivisions became narrow platted easements located between the backyards of homes. In response to resident and homebuilder concerns about these alley-like corridors doing little to enhance connectivity and instead becoming an attractive nuisance, this plan proposes elimination of those easements. This has already occurred in Units 33 and 34.

As an alternative to trails within each subdivision and the lack of functionality of the platted easements, local street networks and sidewalks established for each development will provide adequate bicycle and pedestrian circulation and ready access to a larger multi-use trail network that will be provided within the planned open space and drainage areas. Direct access to these trails will be provided from each development, as feasible and determined during the subdivision or site development process. Figure 3, in the Transportation Section of the plan, shows this conceptual network and possible access locations.

With ready access to streets with sidewalks and open space trail corridors, future residents will have ample opportunities for recreation as well as access to local shopping and employment areas. Approximately 45 acres, or 9 percent of the land within Mountain Hawk Estates, is reserved for open space and drainage uses with additional acreage set aside in neighborhood parks.

D. Neighborhood Amenities and Buffering

Much of what makes the master planned development of Mountain Hawk Estates viable is the careful attention to eliminating potentially undesirable conflicts between adjacent, differing, land uses. By providing a generous allocation of recreation open space through the center of the site and planning for the inclusion of ample lineal open space trails amenities between individual planning areas, there is not only the benefit of ameliorating noise and light disturbances but also attractive, recreational circulation.

As planning areas are successively outlined in greater detail for development, there is accommodation in the estimated allowance provided in the net developable acre calculations for such things as neighborhood parks, opportune open space locations and community centers. As a large, mixed-use master planned concept, Mountain Hawk Estates has the uncommon opportunity to foresee and eliminate potential land use conflicts before they occur. There is also the opportunity to create a pleasant environment for people who will live and work in this new Rio Rancho community.

9. APPENDICES

A. 2001 Letter from Rio Rancho Public Schools

B. 2001 Letter from NMDOT District Three

C. 1999 Letter from City of Rio Rancho regarding water availability

Page Intentionally Left Blank

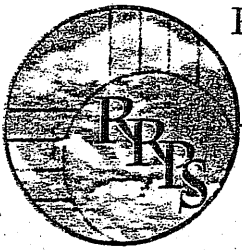

RIO RANCHO PUBLIC SCHOOLS

"Student Success is the Focus of Our Work"

Board of Education
500 Laser Road NE • Rio Rancho, New Mexico 87124

(505) 896-0667
Fax (505) 896-0662

Superintendent of Schools
V. Sue Cleveland, Ed.D.

School Board

Lisa C. Reid, *President*
Reinaldo A.Z. Garcia, *Vice President*
Joel A. Sherman, *Secretary*
Margaret M. Terry, *Member*
Don J. Schlichte, *Member*

May 22, 2001

Mr. James Jimenez
City Administrator
City of Rio Rancho
Rio Rancho, New Mexico, 87124

Dear Mr. Jimenez:

This letter is to confirm that the Rio Rancho Public School District's Five Year Plan does not foresee the need for construction of a school in the new AMREP development planned adjacent to the Hawk Missile Battalion site. The Rio Rancho Public School District has plans to complete an elementary school in the Enchanted Hills Subdivision. The district also hopes to construct another elementary school in the general area, provided funds become available in the next bond election. However, there are no plans to build a school inside the subdivision currently being proposed to the Rio Rancho Governing Body.

The Rio Rancho Public Schools appreciates your request for this information and your interest in cooperatively planning for future school construction.

Sincerely,

V. Sue Cleveland, Ed.D.
Superintendent of Schools

C/Board of Education





NEW MEXICO STATE HIGHWAY
AND TRANSPORTATION DEPARTMENT
AN EQUAL OPPORTUNITY EMPLOYER

DISTRICT THREE OFFICE

GARY E. JOHNSON
GOVERNOR

COMMISSION

Holm Bursum, III
Chairman, Socorro

Edward T. Begay
Vice-Chairman, Gallup

Peter T. Mocho, Sr.
Secretary, Albuquerque

Sherry Galloway
Member, Farmington

Albert N. Sanchez
Member, Santa Rosa

Sidney G. Strebeck
Member, Portales

DEPARTMENT

Secretary
Pete K. Rahn

General Office
P.O. Box 1149
Santa Fe, NM
87504-1149
505-827-5100

District One Office
P.O. Box 231
Deming, NM
88031-0231
505-546-2603

District Two Office
P.O. Box 1457
Roswell, NM
88202-1457
505-624-3300

District Three Office
P.O. Box 91750
Albuquerque, NM
87199-1750
505-841-2700

District Four Office
P.O. Box 30
Las Vegas, NM
87701-0030
505-454-3600

District Five Office
P.O. Box 4127
Coronado Station
Santa Fe, NM
87502-4127
505-827-9500

District Six Office
P.O. Box 2159
Milan, NM
87021
505-285-3200

January 9, 2001

James P. Merrill, Principal Planner
JMCS
Box 4881
Albuquerque, New Mexico 87196

Subject: **524-Acre Hawk Site Development, South Side of the NW Loop, West of Unser Boulevard**

Dear Mr. Merrill:

Based on our December 13, 2000 meeting, the District will approve of the following access points from the subject development onto the NW Loop with the following conditions:

- **Falcon Road (1500' west of NM550)** – Right-in/right-out access until such time as the NW Loop becomes a 4-lane facility. At that time the Developer will be required to eliminate this access and comply with the access policy as discussed in the UTPPB Resolution.
 - Prior to issuance of the interim driveway permit, The District will require the Developer to design the **interim and future** site access plans, and to submit them to the District for review and approval.
- **Hawk Boulevard (3500' west of NM550)** – Full Access intersection until such time as the NW Loop becomes a 4-lane facility. At that time the intersection may become a grade separated intersection with no access to the NW Loop.
- **Falcon Road and Hawk Boulevard**
 - The Developer will be responsible for informing all perspective buyers of the ultimate access plan prior to finalizing any purchase agreements.

NEW MEXICO STATE HIGHWAY
AND TRANSPORTATION DEPARTMENT
AN EQUAL OPPORTUNITY EMPLOYER

James Merrill
9 January 2001
Page 2

- The District respectfully requests that Sandoval County assist in informing all potential property owners that will be affected by the noted changes in access.
- The Department recommends that the Developer make provisions in the site plan for developing a future Frontage Road system along both sides of the NW Loop within the limits of their frontage. Along the south side of the NW Loop, the Frontage road should tie to the Unser Boulevard/NW Loop intersection.
- The Consultant shall provide construction plans, site grading and drainage plan approval, cultural resources approval, driveway permit applications, and traffic control plans for construction of the interim access intersections.

If you have any questions please contact this office at 841-2761.

Sincerely,

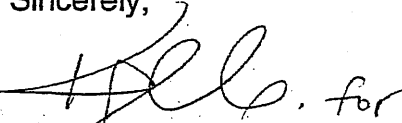
Steven P. Harris
District Three Engineer

cc: Katherine J. Trujillo
Mir Amiri
Julian Vigil
Eric Martinez
Ken Curtis, City of Rio Rancho
Frank Marquez, Sandoval County
Traffic File



GARY E. JOHNSON
GOVERNOR

COMMISSION

Holm Bursum, III
Chairman, Socorro

Edward T. Begay
Vice-Chairman, Gallup

Peter T. Mocho, Sr.
Secretary, Albuquerque

Sherry Galloway
Member, Farmington

Albert N. Sanchez
Member, Santa Rosa

Sidney G. Strebeck
Member, Portales

DEPARTMENT

Secretary
Pete K. Rahn

General Office
P.O. Box 1149
Santa Fe, NM
87504-1149
505-827-5100

District One Office
P.O. Box 231
Deming, NM
88031-0231
505-546-2603

District Two Office
P.O. Box 1457
Roswell, NM
88202-1457
505-624-3300

District Three Office
P.O. Box 91750
Albuquerque, NM
87199-1750
505-841-2700

District Four Office
P.O. Box 30
Las Vegas, NM
87701-0030
505-454-3600

District Five Office
P.O. Box 4127
Coronado Station
Santa Fe, NM
87502-4127
505-827-9500

District Six Office
P.O. Box 2159
Milan, NM
87021
505-285-3200



ADMINISTRATIVE
OFFICE

City of Rio Rancho

3900 Southern Blvd. SE • PO Box 15550
Rio Rancho, New Mexico 87174-0550
(505) 891-7201 • Fax (505) 891-7274

RECEIVED

OCT 14 1999

CAS

PAA
JTS
EWL

JOHN M. JENNINGS
Mayor

October 4, 1999

Cliff A. Spirock, CEO
Community Science Corporation
Post Office Box 1328
Corrales, New Mexico 87048

Reference: The Hawk Development Site, AMREP Southwest Owner, Request for Water Utility Availability, Dated September 22, 1999

Dear Mr. Spirock:

In response to your request for a non-binding letter of water and sewer expansion potential, I would have the following. As you are aware Wilson and Company recently conducted a study for Water and Wastewater Capacity Analysis for the City of Rio Rancho. In that capacity analysis, the Hawk Site area was not counted in their study due to lack of solid planning information by the major land owner in the area, AMREP Southwest. However, there was discussion of the potential for the Hawk Site Development, which had been discussed in the wastewater portion of the study. There was no discussion as to the capacity needs of the Hawk Site Development and accounting for the known water capacity needs of the City, again do to insufficient data. Whether or not the Hawk Site area was included in the capacity study, does not preclude a decision that the City does not plan to support such development activity in that area.

In June of 1993, United Water of New Mexico, previous water utilities company for the City of Rio Rancho, had applied for an additional 12,000 acre feet to support growth for the City of Rio Rancho. When the City took over the Utilities in June 1995, we continued to pursue the additional 12,000 acre feet for anticipated growth within the City of Rio Rancho. To date the City has expended a very large sum of funds to pursue the additional 12,000 acre feet, which should accommodate approximately 22,500 additional single family equivalent (SFE) water connections to the City's system. To date, the City has not been awarded a diversion of Water Rights Permit for the applied 12,000 acre feet.

You made note in your letter, dated September 22, 1999, that a hearing with the Office of the State Engineer was scheduled for November of 1999. However, due to circumstances beyond the control

of the City of Rio Rancho, that hearing date has been abandoned, and a new date has not been scheduled as of yet.

This letter is to inform you that it is the City of Rio Rancho's plans to support planned managed growth for the future of Rio Rancho and to provide water and wastewater utilities as that growth develops. We are aware of your general plans for development in the Hawk Site area, however, the exact numbers and types of development you planned for this area is unknown. We also understand that you must have some sort of indication from the City to move forward in your planning activities for the Hawk Site area.

It is with these facts that you and your client, AMREP Southwest, understand that it is the City's intent to support future growth within the City of Rio Rancho, as we are working diligently to secure the water rights for the anticipated growth. You should also understand that until such time as the City has a formal response on the request for the additional water rights for the City of Rio Rancho, we cannot obligate a specific quantity at this time. It is our greatest hopes that the Office of the State Engineer for the State of New Mexico, will act upon the permit request for the additional 12,000 acre feet of water sometime after the first of the year.

If you have any questions or comments, please contact me or my staff.

Sincerely,

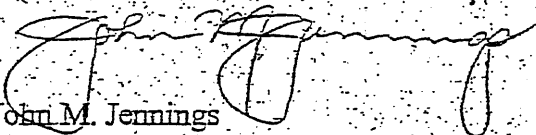
John M. Jennings
Mayor

c: James Jimenez, Acting City Administrator
Henry Pacelli, Chairman, Utilities Commission
Larry W. Webb, Director of Utilities
Art Corsie, Director of City Development

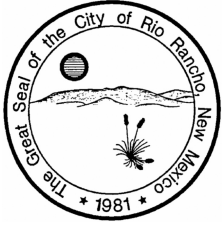

CITY OF RIO RANCHO COVER PAGE

Legislation Item: D10

AGENDA DATE:

March 10, 2022

DEPARTMENT:

Development Services

SUBJECT:

D10, Site Plan Approval for Caliber Collision, 4705 Sundt Rd NE, Rio West Business Park, Block A, Lot 2A

BACKGROUND AND ANALYSIS:

The subject property is located at 4705 Sundt Rd NE, legally described as Rio West Business Park, Block A, Lot 2A, and consists of approximately 1.90 acres. The subject property is zoned SU: Special Use per Ordinance No. 89-007. As stated in this Ordinance, "This development provides suitable sites for a wide range of industrial and commercial uses, provided such uses are conducted in a compatible and harmonious manner within industrial environments achieved through this development plan." All C-2 uses are permissive except (1) Lumber Yard (sawmill).

Per R.O. 2003 § 154.25 C-2: Wholesale and Warehousing Commercial District, (B)(27) Automotive dealers, motorcycle dealers and auto repair, major; are permissible provided, that (a) Repairs and associated activities are conducted within a completely enclosed building; or (b) A solid masonry wall at least six feet high is erected between the activity and any abutting or contiguous residential zone; (c) Applicants shall provide site plans which show lot dimensions, location and dimensions of proposed structures/facilities, parking, proposed signage, landscaping and buffers; if applicable, information with regard to the nature of the operation as well as hours of operation, for review and approval by the Planning and Zoning Board. The North American Industry Classification System or NAICS provides the classification of business establishments by type of economic activity. It is used by government and business in Canada, Mexico, and the United States of America. The NAICS classification of this business type would be 811: Repair and Maintenance, which would be consistent with the permissive use of auto repair in this zone.

CONFORMANCE WITH THE CITY ZONING ORDINANCE: The Rio Rancho Code of Ordinances (R.O. 2003) §154.43 (3) requires "All SU zoned property must have a site plan approved by the Governing Body. The site plan may accompany the application for a change in zoning designation or may be submitted for approval at a later date. Approval of the site plan must be obtained prior to any development of the property." Pursuant to the criteria provided by R.O. 2003 § 154.43 (3)(a) through (3)(j), the site plan at a minimum shall contain the following:

- a. Scale and north arrow; criteria is satisfied.
- b. Lot boundaries and easements; A 30-foot access easement is located along the west side of the property. A 15-foot access easement is located on the east side of the property along with a 7.5-foot waterline easement. A 10-foot Public Utility Easement will be granted to PNM to the south of the proposed building; Criteria is satisfied.
- c. Existing and proposed utilities; Criteria is satisfied.
- d. Existing and proposed rights-of-way; Criteria is satisfied.
- e. Proposed structure with uses, dimension, and setbacks; The Special Use ordinance requires a

25-foot setback from adjacent roadways and a 10-foot landscape strip between the road and any parking areas. The parking lot meets this minimum 10-foot setback, and the building is located over 57 feet from Sundt Road. No other side setbacks are required by the zoning, although large setbacks have been applied on all sides; Criteria is satisfied.

f. Proposed ingress, egress, parking and circulation; There will be one ingress and egress point for the property located off of Sundt Rd NE, a major collector street. Parking standards are per Chapter 154.76 for Industrial, Manufacturing, Wholesale Establishments of "1 space for each 2 employees on largest shift, or 1 space per 1,500 square feet of warehouse, whichever is greater." The proposed building is 11,500 square feet and therefore requires 8 spaces. Twenty-one spaces are proposed in the site plan, which also includes the two ADA standard spaces. Two bicycle spaces are also proposed as required in this section; Criteria is satisfied.

g. Landscaping and landscape buffers; The provided landscape plan shows compliance with the SU ordinance stipulating at least 10% of the site be landscaped, as well as the requirement in Chapter 154.61 that states at least 25% of the landscaping be located along the frontage of the property; Criteria is satisfied.

h. Elevations; Criteria is satisfied.

i. Adjacent property characteristics; Properties to the north, east, and west are zoned SU per the same Ordinance as the subject property. The properties to the south are zoned SU: Special Use for C-1: Retail Commercial District per Enactment No. 17-03. This property is not located within a Specific Area Plan; Criteria is satisfied.

j. Preliminary drainage plan; Water and Wastewater approval has not yet been granted from the Utilities Department. This will be required prior to any future development along with a grading and drainage plan and erosion plan; Criteria is satisfied.

NOTIFICATIONS: Adjacent property owners were notified of this hearing by mail. A notice sign was posted on the property as required by Ordinance. A legal notice was published in the February 20, 2022 edition of the Rio Rancho Observer for the March 10, 2022 Governing Body meeting. All legal notification requirements for this project have been met.

IMPACT:

The Development Services Department recommends the Governing Body approves the applicant's request for Site Plan Approval with the following conditions of approval and findings of fact:

General Findings:

1. R.O. 2003 154.43 (3) requires site plan approval by the Governing Body;
2. The property owner has the authority to apply for site plan approval;
3. The applicant and adjacent property owners received due process as proper notice and a full opportunity to present views were given.

Specific Findings and Conditions of Approval:

1. The subject property is zoned SU: Special Use District by Ordinance No. 89-007. The SU: Special Use zoning designation requires that a site plan be reviewed and approved by the Governing Body.
2. The site plan conforms to the Rio Rancho Code of Ordinances (R.O. 2003) Section 154.43.
3. Development of the site will conform to all City ordinances, standards, and specifications.
4. The review and subsequent building permit applications will ensure conformance to the approved site plan, and City ordinances, standards, and specifications.
5. The applicant shall address all of the Site Plan reviewers' comments.
6. The Director of the Development Services Department may approve minor changes to this site plan if the changes are consistent with the use and other written requirements and/or conditions of approval, if the buildings are the same general configuration, if the total square footage is not greater than 10% of the approved plan, the site circulation is similar in its effect on adjacent property or streets, and the approving official finds that neither the City nor any person will be

substantially aggrieved by the altered site plan.

7. This approval is valid for a period of two years from date of approval, in which time a building permit for the proposed structures must be applied for and issued, remain active, and the authorized construction shall be started and diligently pursued to completion without cessation of 30 days.

ALTERNATIVES:

Governing Body has three alternatives on the disposition of this request and may:

1. Approve the site plan;
2. Deny the site plan;
3. Postpone its decision to allow for further review and consideration.

DEPARTMENT RECOMMENDATION:

The Development Services Department recommends the Governing Body approves the applicant's request for Site Plan Approval with findings and conditions.

ATTACHMENT: [Application](#)

ATTACHMENT: [Zoning, Location](#)

ATTACHMENT: [Site Plan](#)

ATTACHMENT: [Authorization](#)

ATTACHMENT: [Staff Comments](#)

ATTACHMENT: [Reproduction of Notices](#)

ATTACHMENT: [Public Comment](#)

PLANNING & ZONING LAND USE APPLICATION

Please check appropriate box

(Fees are listed on the back)

Administrative Permit	Plan	Subdivision	Zoning
<input type="checkbox"/> Community Residential Care Facility	<input type="checkbox"/> Comprehensive Plan Amendment	<input type="checkbox"/> Final Plat	<input type="checkbox"/> Annexation
<input type="checkbox"/> Development Review Committee (DRC)	<input type="checkbox"/> Corridor Plan Amendment	<input type="checkbox"/> Preliminary Plat	<input type="checkbox"/> Appeal
<input type="checkbox"/> Home Occupation	<input type="checkbox"/> Master Plan	<input type="checkbox"/> Summary Plat	<input type="checkbox"/> Conditional Use Permit
<input type="checkbox"/> Model Home / Sales Office	<input type="checkbox"/> Master Plan Amendment	<input type="checkbox"/> Vacation of Plat	<input type="checkbox"/> Master Sign Plan
<input type="checkbox"/> Residential Child Care Facility 6 or <	<input type="checkbox"/> Specific Area Plan Amendment	<input type="checkbox"/> Street Name Change	<input checked="" type="checkbox"/> Site Plan
<input type="checkbox"/> Sign Permit	<input type="checkbox"/> Text Amendment	<input type="checkbox"/> Subdivision Interpretation	<input type="checkbox"/> Special Exception
<input type="checkbox"/> Other		<input type="checkbox"/> Subdivision Variance	<input type="checkbox"/> Variance
			<input type="checkbox"/> Zone Map Amendment
			<input type="checkbox"/> Zoning Certification
			<input type="checkbox"/> Zoning Interpretation

Please Print In Ink Only or Type

Application must be complete. Please attach the appropriate checklist for the action you are requesting, if applicable.

APPLICANT/AGENT INFORMATION

Applicant Name: Victory Development		Phone: (972) 707-9555
Address: 8201 Preston Road, Ste. 700		E-Mail:
City: Dallas	State: TX	Zip: 75225
Proprietary Interest: Contract Purchaser	List Owners: Rio West Business Park, LLC	
Deed or Ownership Verification Provided: (Initials) <i>MV</i>	Letter of Authorization Provided: (Initials) <i>MV</i>	
Agent Name: Consensus Planning, Inc.		Phone: (505) 764-9801
Address: 302 8th Street NW		E-Mail: vos@consensusplanning.com
City: Albuquerque	State: NM	ZIP Code: 87102

DESCRIPTION OF REQUEST: (PLEASE ADD ADDITIONAL SHEET(S) IF NECESSARY)

Site Development Plan approval for an 11,500 square foot automobile repair business.

SITE INFORMATION: (PLEASE PROVIDE ACCURATE LEGAL DESCRIPTION)

Subdivision/Unit : Rio West Business Park	Block(s): A	Lot(s): 2A-1
Existing Zoning: SU (Special Use) per Ord. No. 89-007	Proposed Zoning: No Change	
No. of existing lots: 1	No. of proposed lots: 1	Total area of site (acres) 1.90 acres

ACKNOWLEDGEMENT

I hereby acknowledge that I have read this entire application and affirm that all information provided is correct. I agree to comply with the requirements of the City of Rio Rancho as outlined in all applicable laws, ordinances and regulations.

Print Name: Michael J. Vos, AICP	Applicant:	Agent: Consensus Planning, Inc.
Signature: <i>Michael J. Vos</i>		Date: 1/28/2022

FOR OFFICIAL USE ONLY

H.T.E. PROJECT #	FEE	RECEIPT #

APPLICATION ACCEPTED BY: Michelle Costilla DATE: 1/31/2022

January 24, 2022

City of Rio Rancho

Attn: Development Services
3200 Civic Center Circle NE, 1st Floor
Rio Rancho, NM 87144

RE: Letter of Authorization - Victory Real Estate Development/Consensus
Planning/Isaacson & Arfman/Gallup Architects

To Whom It May Concern: -

As the Property Owner/Property Owner Representative of the property described in the Legal Description listed below, I hereby authorize Victory Real Estate Development/Consensus Planning/Isaacson & Arfman/Gallup Architects (potential Buyer and Buyer's professional consultants) to act as my agent in pursuit of all permitting and city feedback on their proposed project. I am aware of the request of land use.

Legal Description:

As contained the Title Commitment prepared for this property by Fidelity National Title Insurance Company, Commitment No. SP000114916, Commitment Date: July 26, 2021.

Lot numbered Two-A-One (2A-1) in Block lettered "A" of RIO WEST BUSEINSS PARK, as the same are shown and designated on the Summary Plat thereof filed in the office of the County Clerk of Sandoval County, New Mexico on December 14, 2016 in Volume 3, folio 4034.

Please feel free to contact me at jking@bradburystamm.com with any questions.

Sincerely,

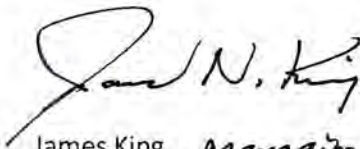



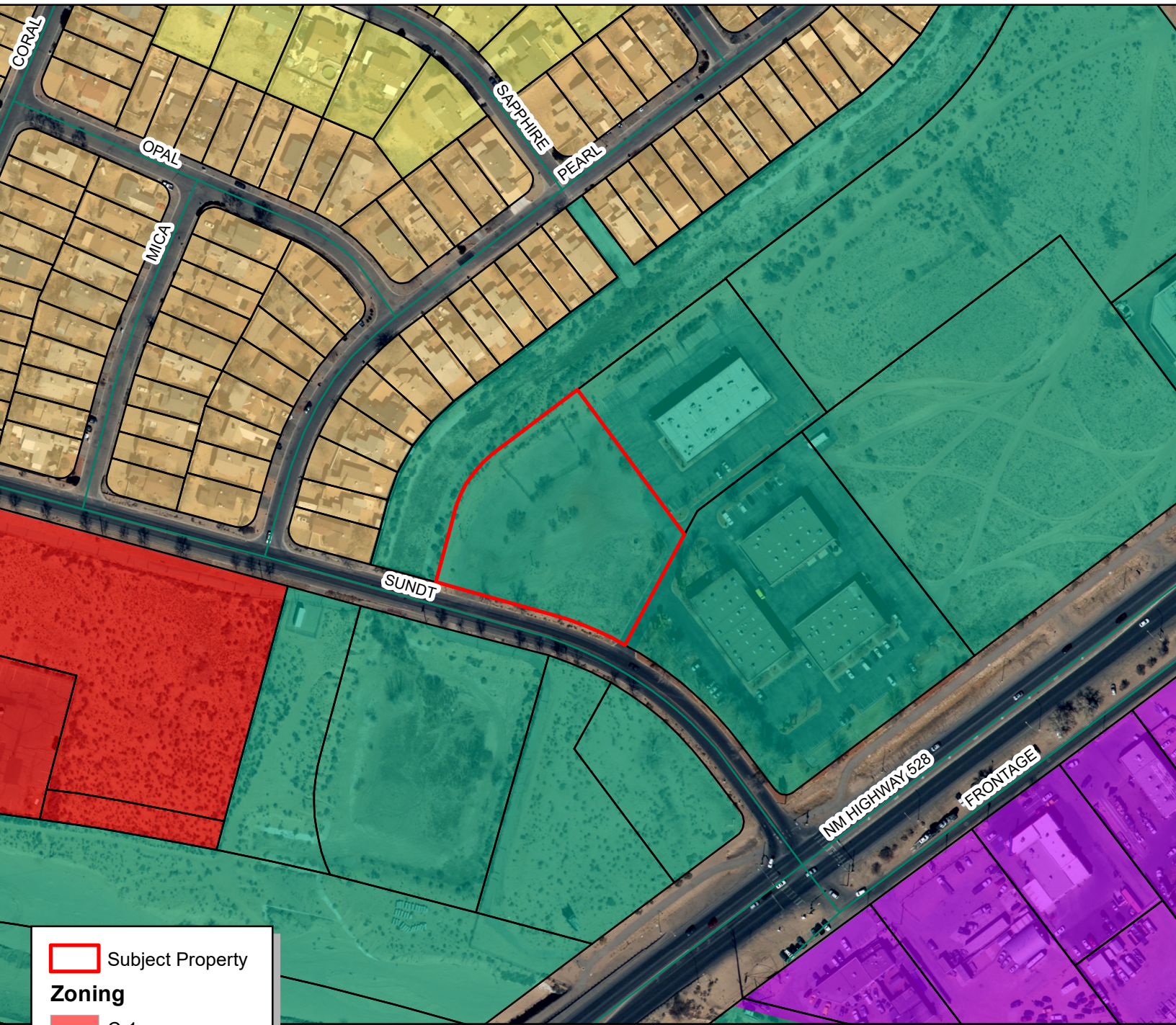

James King, *Managing Member*
Rio West Business Park, LLC
13731 Apache Plume Pl. NE
Albuquerque, NM 87111
Email: jking@bradburystamm.com

4705 SUNDT RD NE



 Subject Property

Zoning

-  C-1
-  M-1
-  R-1
-  R-3
-  SU

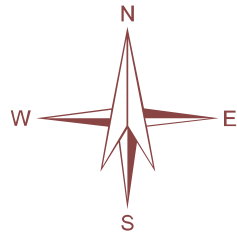

DISCLAIMER: All information in this map is provided "as is" without warranty or any representation of accuracy, timeliness or completeness. This map is not a survey and should be used for graphical purposes only.

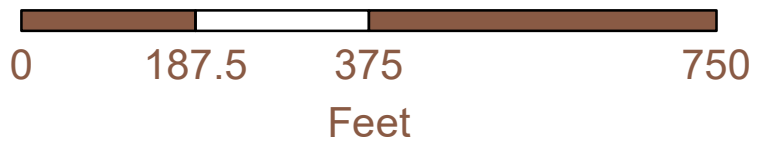

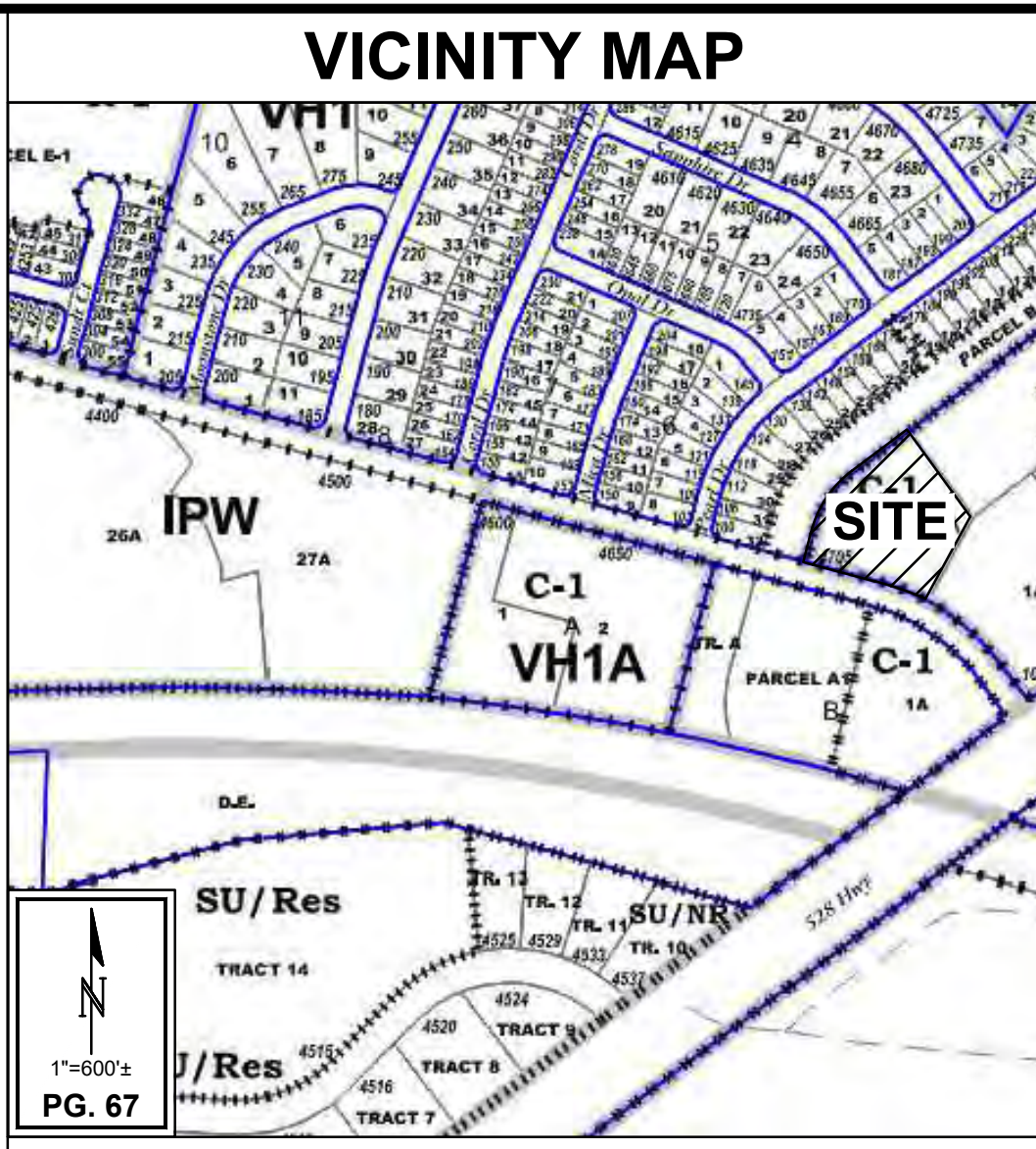

PROJECT INFORMATION

LEGAL: LOT 2A-1 IN BLOCK "A" OF RIO WEST BUSINESS PARK AS THE SAME IS SHOWN AND DESIGNATED ON THE SUMMARY PLAT THEREOF FILED IN THE OFFICE OF THE COUNTY CLERK OF SANDOVAL COUNTY, NEW MEXICO ON DECEMBER 14, 2016 IN VOLUME 3, FOLIO 4034.

ADDRESS: 4705 SUNDT ROAD N.E. RIO RANCHO, NEW MEXICO 87124

ZONING: SU (Special Use) per Ordinance No. 89-007

SITE AREA: 1.881 AC.

BUILDING AREA: 11,500 SF.

BUILDING HEIGHT:

ALLOWED: 32'
PROVIDED: 26'

BUILDING SETBACKS:

REQUIRED (ROAD): 25'
PROVIDED (ROAD): 57.94'
REQUIRED (SIDE): 10'
PROVIDED (EAST): 152.73'
PROVIDED (WEST): 48.86'
PROVIDED (NORTH): 60.00'

PARKING CALCULATIONS:

REQUIRED: 18 SPACES
PROVIDED: 21 SPACES (37 ADDITIONAL SPACES WITHIN GATES)

ADA REQUIRED: 1 SPACE
ADA PROVIDED: 2 SPACES (1 VAN ACCESSIBLE SPACE)

BICYCLE REQUIRED: 2 SPACES
BICYCLE PROVIDED: 2 SPACES

SITE LIGHTING NOTE:

ANY LIGHTING SHALL COMPLY WITH THE NIGHT SKY PROTECTION ACT AND BE PLACED SO AS TO REFLECT THE LIGHT AWAY FROM ADJACENT RESIDENTIAL DISTRICTS.

- KEYED NOTES**
1. LANDSCAPING.
 2. ASPHALT PAVING.
 3. REMOVE & DISPOSE EXISTING CURB & GUTTER.
 4. MEDIAN CURB & GUTTER.
 5. PCC APRON.
 6. PCC SIDEWALK.
 7. ADA PARKING SPACE W/ SIGNAGE.
 8. 24' SLIDING GATE W/ KNOCK BOX.
 9. 28' SWING GATE W/ KNOCK BOX.
 10. 4" STRIPING.
 11. DIRECTIONAL ARROWS.
 12. 6' TALL SECURITY FENCING.
 13. EXISTING SITE LIGHT POLE.
 14. GREASE INTERCEPTOR.
 15. PROPOSED FIRE HYDRANT.
 16. MONUMENT SIGN.
 17. GANGED UTILITY METERS/CONNECTIONS.
 18. TRANSFORMER.
 19. DUMPSTER ENCLOSURE.
 20. FIRE LANE MARKINGS.
 21. BIKE RACK.



timothy m. gallup
architect of record

601 S. Boulder Ave., Suite 808
Tulsa, Oklahoma 74119
918.499.9600

NO.	DATE	BY	DESCRIPTION

SITE PLAN

CALIBER COLLISION
RIO WEST BUSINESS PARK 2A-1
4705 SUNDT RD NE, RIO RANCHO, NM 87124
PROJECT NO. 212015

FILE NAME: .
DRAWN BY: BUBIDECUTS
DATE: xx/xx/2021
REVIEWED BY: FCA

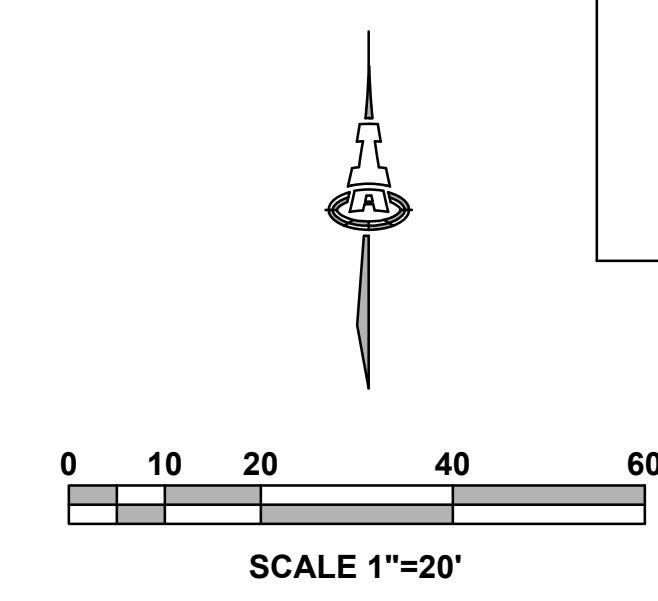

Isaacson & Arfman, Inc.
Civil Engineering Consultants

128 Monroe Street NE
Albuquerque, NM 87108
505-268-8828 | www.iacivil.com

CC-101

NO.	DATE	BY	DESCRIPTION

GENERAL LANDSCAPE NOTES

- PRIOR TO BEGINNING WORK ON THE PROJECT, THE LANDSCAPE CONTRACTOR SHALL REVIEW THE PROJECT IN THE FIELD WITH THE OWNER'S REPRESENTATIVE.
- IF DISCREPANCIES OCCUR BETWEEN THE DRAWINGS AND THE SITE, THE LANDSCAPE CONTRACTOR SHALL NOTIFY THE OWNER'S REPRESENTATIVE FOR CLARIFICATION PRIOR TO PROCEEDING ON THAT PORTION OF WORK.
- ALL PLANTING AREAS ARE TO HAVE WEEDS AND COMPETITIVE VEGETATION REMOVED PRIOR TO PREPARATION FOR PLANTING.
- ALL EXISTING PLANT MATERIALS TO REMAIN SHALL BE PROTECTED DURING CONSTRUCTION. DAMAGED MATERIALS SHALL BE REPLACED IN KIND AT THE CONTRACTOR'S EXPENSE.
- PLANT QUANTITIES ARE PROVIDED FOR CONTRACTOR'S CONVENIENCE ONLY, PLANS SHALL TAKE PRECEDENCE.
- THE OWNER'S REPRESENTATIVE SHALL APPROVE ALL PLANT MATERIAL PRIOR TO PLANTING. IN ADDITION, THE OWNER REPRESENTATIVE RESERVES THE RIGHT TO REFUSE ANY PLANT MATERIAL DEEMED UNACCEPTABLE. THE OWNER'S REPRESENTATIVE IS TO APPROVE ANY AND ALL SUBSTITUTIONS.
- IT IS THE LANDSCAPE CONTRACTOR'S RESPONSIBILITY TO LOCATE ALL UNDERGROUND UTILITIES PRIOR TO COMMENCEMENT OF PLANTING OPERATIONS.

LANDSCAPE CALCULATIONS

LOT SIZE:	(1.88 AC)	82,172 SF
BUILDING FOOTPRINT:		11,500 SF
REQUIRED LANDSCAPE 10%:		8,217 SF
PROVIDED (NOT INCLUDING RE-VEG AREA):		19,818 SF
REQUIRED FRONTAGE LANDSCAPE:		3,946 SF
PROVIDED:		6,090 SF

KEYED NOTES

- EXISTING TREE TO REMAIN
- EASEMENTS
- NEW SIGN
- PROPERTY LINE

PLANT LEGEND

QTY.	SYMBOL	SCIENTIFIC NAME COMMON NAME (WATER USE)	SIZE	MATURE SIZE
TREES				
7		ACER NEGUNDO 'SENSATION' SENSATION BOX ELDER (M)	2" CAL. B&B	40' HT. X 30' SPR.
10		CHILOPSIS LINEARIS DESERT WILLOW (L)	2" CAL. B&B	20' HT. X 25' SPR.
4		FORESTIERA NEOMEXICANA NEW MEXICO OLIVE (L+)	2" CAL. B&B	15' HT. X 15' SPR.
8		PINUS NIGRA AUSTRIAN PINE (M)	6" HT. B&B	30' HT. X 25' SPR.
1		VITEX AGNUS-CASTUS CHASTE TREE (M)	2" CAL. B&B	20' HT. X 20' SPR.
SHRUBS AND GROUNDCOVERS				
12		ACHILLEA TAYGETEA 'MOONSHINE' MOONSHINE YARROW (M)	2-GAL	2' HT. X 2' SPR.
7		CHRYSOTHAMNUS NAUSEOSA 'BLUE' CHAMISA (L)	5-GAL	5' HT. X 5' SPR.
14		ERICAMERIA LARICIFOLIA 'AQUIRRE' TURPENTINE BUSH (L)	5-GAL	3' HT. X 3' SPR.
18		FALLUGIA PARADOXA APACHE PLUME (L)	5-GAL	5' HT. X 5' SPR.
25		RHUS AROMATICA 'GRO-LOW' DWARF FRAGRANT SUMAC (M)	5-GAL	2' HT. X 6' SPR.
PERENNIALS				
9		ZAUSCHNERIA ARIZONICA HUMMINGBIRD TRUMPET (L)	1-GAL	3' HT. X 2' SPR.
DESERT ACCENTS				
40		HESPERALOE PARVIFOLIA BRAKELIGHTS RED YUCCA (L+)	3-GAL	3' HT. X 3' SPR.
9		DASYLIRON WHEELERI DESERT SPOON	5-GAL	5' HT. X 5' SPR.
ORNAMENTAL GRASSES				
47		MUHLENBERGIA C. 'REGAL MIST' MUHLY GRASS (L+)	5-GAL	2' HT. X 3' SPR.

MULCHES AND BOULDERS

15,862 sf		7/8" SANTA FE BROWN (3" DEPTH OVER FILTER FABRIC, DEWITT PRO-5 WEED CONTROL, OR EQUAL)
3,956 sf		2"-4" ROSE GOLD COBBLE (6" DEPTH OVER FILTER FABRIC, DEWITT PRO-5 WEED CONTROL, OR EQUAL)
38		LANDSCAPE BOULDERS - JUST GOLD BOULDER (27 C.F. TYP. SIZE), OR EQUAL

REVEGETATIVE SEEDING

16,362 sf

AREAS SHALL BE REVEGETATED BY HYDROMULCH APPLICATION. LIMITS OF REVEGETATED SEEDING SHOWN ON PLANS IS SCHEMATIC.

SANDY SOILS MIX (20 LBS. PLS PER ACRE TOTAL)
SCIENTIFIC NAME - COMMON NAME #PLS/AC

HILARIA JAMESII 'VIVA' - GALLETA	7.0
ORYZOPSIS HYMENOIDES 'NESPAR' - INDIAN RICE GRASS	5.0
BOUTELOUA GRACILIS 'HACHITA' - BLUE GRAMA	2.0
BOUTELOUA CURTIPENDULA 'VAUGHN' - SIDEOATS GRAMA	1.0
AGROPYRON SMITHII - WESTERN WHEAT	1.0
SPOROBOLUS CRYPTANDRUS - SAND DROPSEED	1.0
SPOROBOLUS AIROIDES 'SALADO' - ALKALI SACATON	1.0
EPHEDRA VIRIDIS - GREEN MORMON TEA	.25
ARTIPLEX CANESCENS - FOURWING SALTBRUSH	.25
ARTEMISIA FILIFOLIA - SAND SAGE	.5
SPHAERALCEA AMBIGUA - DESERT GLOBEMALLOW	.25
OENOTHERA PALLID - WHITE EVENING PRIMROSE	.25
BAILEYA MULTIRADIATA - DESERT MARGOLD	.25
PENSTEMON AMBIQIES - SAND PENSTEMON	.25

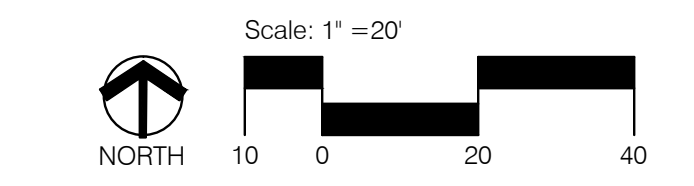
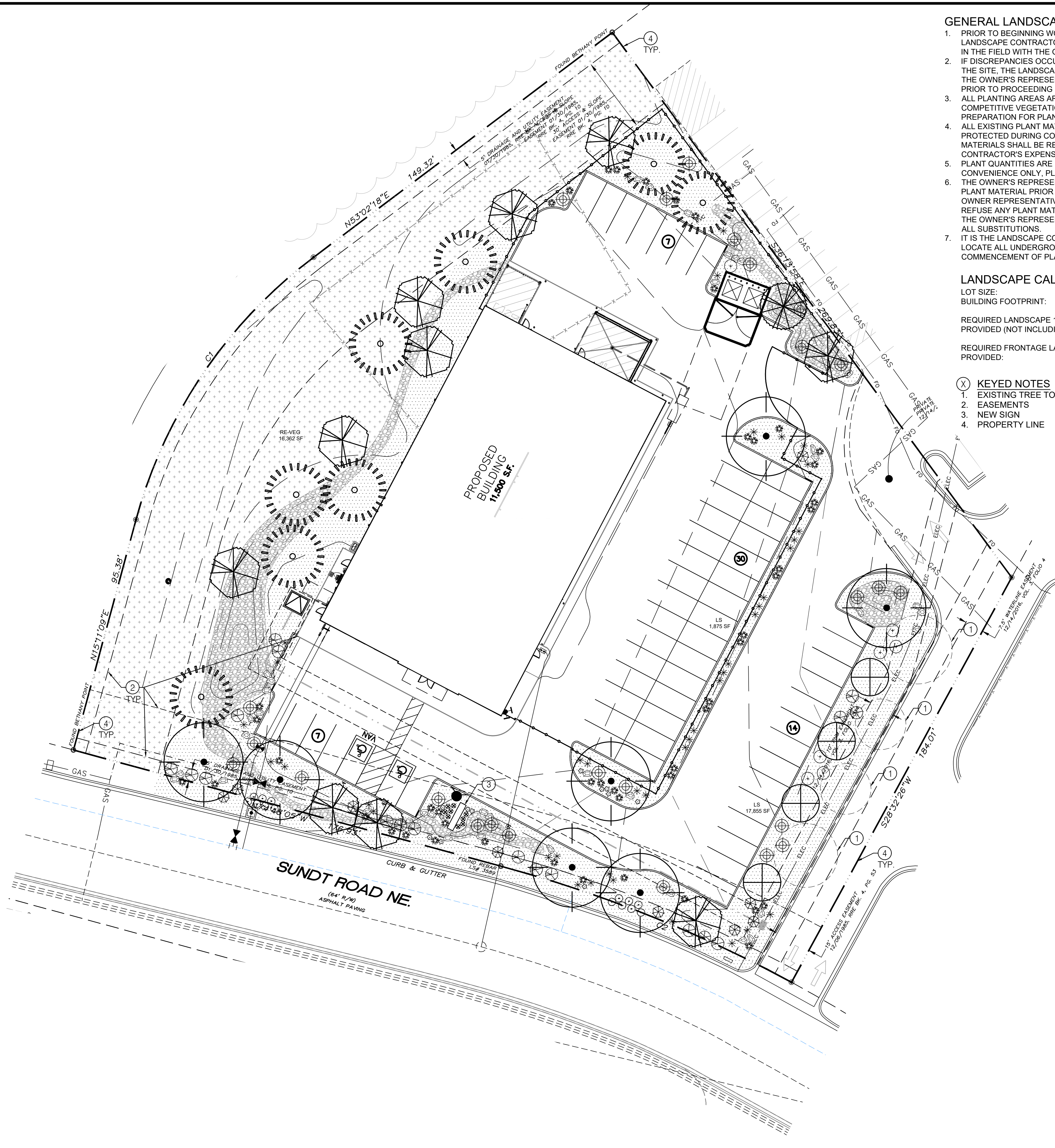

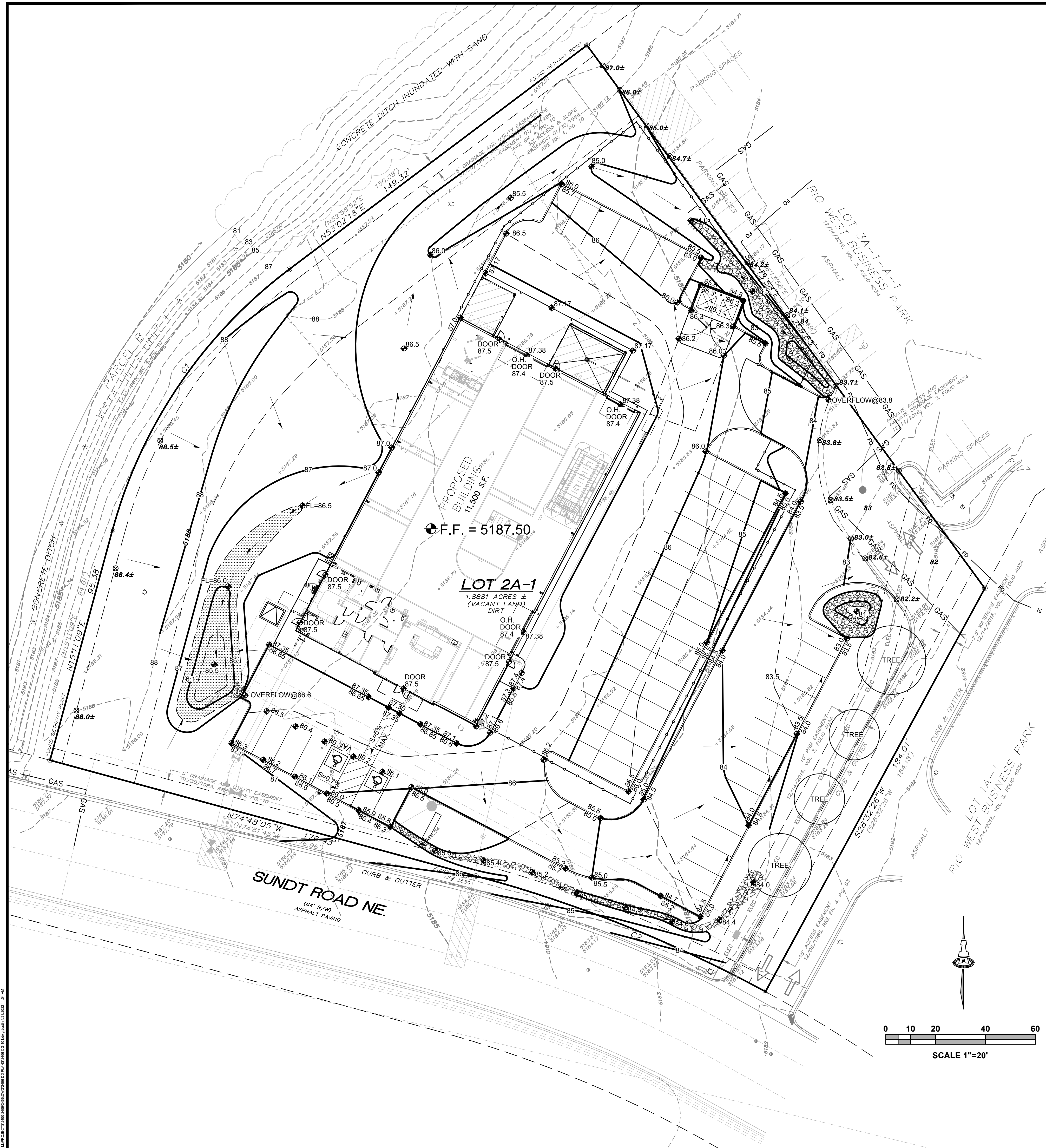

KEYED NOTES

- ADA COMPLIANT REQUIREMENTS:**
- SIDEWALK(S) AND RAMP(S): TARGET CROSS SLOPE = 1% TO 1.5%. CROSS SLOPE SHALL NOT EXCEED 2%
- ACCESSIBLE RAMP(S): TARGET LONGITUDINAL SLOPE = 7% LONGITUDINAL SLOPE SHALL NOT EXCEED 12:1 (8.3%).
- ACCESSIBLE PARKING: TARGET SLOPE = 1% TO 1.5%. SLOPE SHALL NOT EXCEED 2% SLOPE IN ANY DIRECTION
- CONSTRUCT NEW PAVING AT ELEVATIONS SHOWN. SEE PAVING PLAN FOR MATERIAL, EXTENTS, JOINTS, AND PAVING SECTIONS. NOTE: TO ENSURE READABILITY, NOT ALL PAVEMENT SPOT ELEVATIONS SHOW ADJACENT TOP OF CURB / TOP OF WALK. TEXT SHOWN WITHIN FLOWLINE INDICATES FLOWLINE ELEVATION. ADD 0.5' TYPICAL FOR TOP OF CURB / TOP OF ADJACENT WALK ELEVATIONS.
 - PROVIDE SMOOTH TRANSITION TO EXISTING PAVEMENT.
 - TOP OF ASPHALT TO BE FLUSH WITH TOP OF CONCRETE WALK THIS AREA FOR ADA ACCESS.
 - ADA COMPLIANT PARKING AREAS. MAX. SLOPE = 2% IN ANY DIRECTION.
 - ADA COMPLIANT 1:12 MAX. RAMP.
 - ADA COMPLIANT PEDESTRIAN WALK AT ELEVATIONS SHOWN.
 - HIGH POINT / GRADE BREAK LOCATION.
 - 0.5' AND DESIGN CONTOURS ARE SHOWN DASHED TO CLARIFY GRADING CONCEPT.
 - CONCENTRATED ROOF DISCHARGE TO SURFACE PAVEMENT.
 - ROOF DISCHARGE TO BE RELEASED AT GRADE. CONSTRUCT 3'X3'X12" DEEP GROUTED COBBLE PAD (SEE CG-501 FOR DETAIL) AT OUTLET WITHIN LANDSCAPED AREAS.
 - CONCENTRATED ROOF DISCHARGE TO UNPAVED AREA. INSTALL PRECAST SPLASHPAD.
 - CONCENTRATED ROOF DISCHARGE TO BE PIPED DIRECTLY TO STORM DRAIN.
 - PROVIDE 24" WIDE OPENING IN CURB TO PASS FLOW.
 - CONSTRUCT 1' DEEP WATER HARVESTING / DESILTATION BASIN THIS AREA.
 - CONCRETE DUMPSTER PAD SLOPED TO SAS DRAIN INLET. SEE UTILITY PLAN.
 - INSTALL ANGULAR ROCK EROSION PROTECTION TO LIMITS HATCHED.

VICINITY MAP

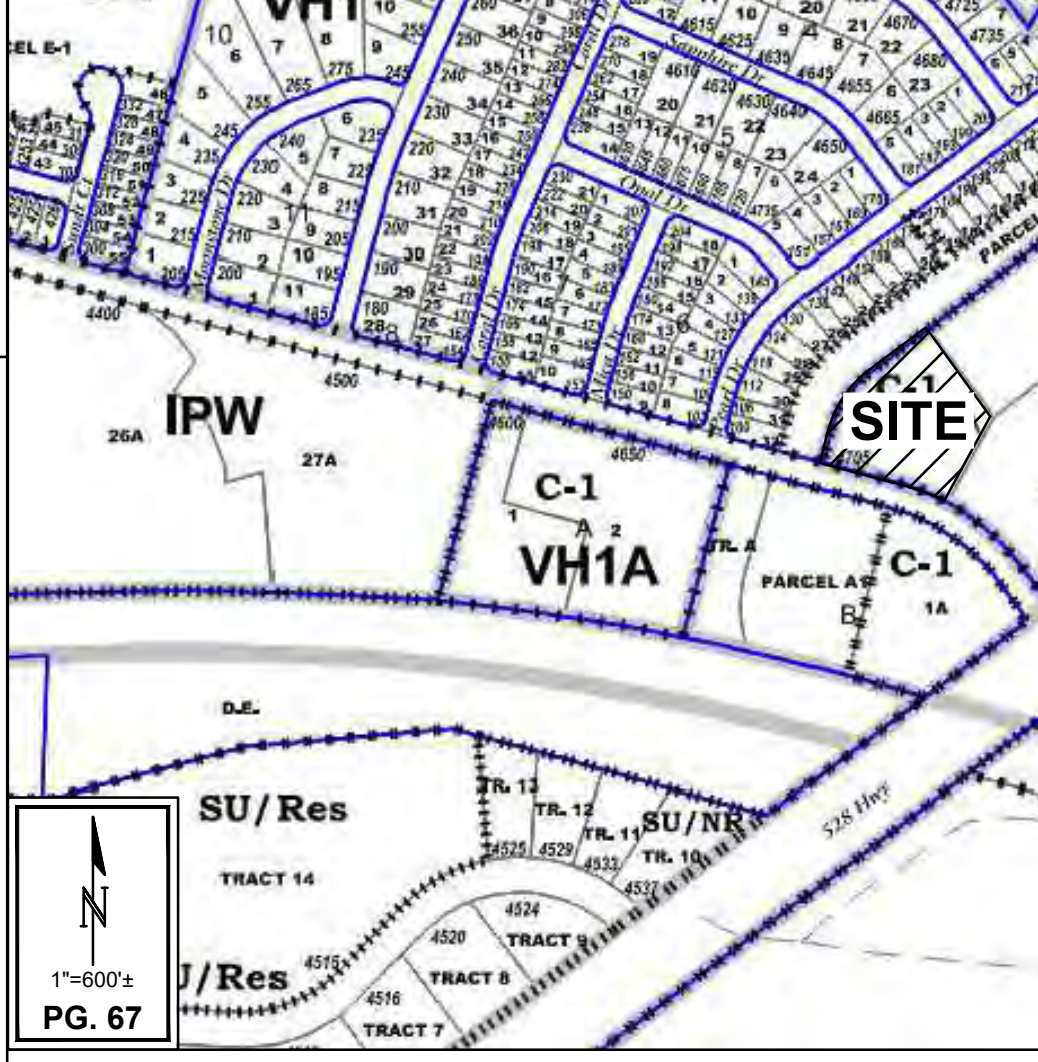

PROJECT INFORMATION

PROPERTY: THE SITE IS (AN UNDEVELOPED) (DEVELOPED) PROPERTY LOCATED WITHIN THE CITY OF RIO RANCHO. VICINITY MAP PAGE 67. THE SITE IS BOUNDED TO THE NORTHEAST AND SOUTHEAST BY DEVELOPED COMMERCIAL PROPERTIES, TO THE SOUTH BY A PAVED ROAD, AND TO THE WEST AND NORTHWEST BY AN ARROYO.

PROPOSED IMPROVEMENTS: THE PROPOSED IMPROVEMENTS INCLUDE A COMMERCIAL BUILDING WITH ASSOCIATED ASPHALT PAVED ACCESS, PARKING, AND LANDSCAPING.

LEGAL: LOT 2A-1 IN BLOCK 'A' OF RIO WEST BUSINESS PARK AS THE SAME IS SHOWN AND DESIGNATED ON THE SUMMARY PLAT THEREOF FILED IN THE OFFICE OF THE COUNTY CLERK OF SANDOVAL COUNTY, NEW MEXICO ON DECEMBER 14, 2016 IN VOLUME 3, FOLIO 4034.

ADDRESS: 4705 SUNDT ROAD N.E. RIO RANCHO, NEW MEXICO 87124

BENCHMARK: VERTICAL DATUM IS BASED UPON CONTROL MONUMENT 'E 227' ELEVATION = 5039.35 FEET (NAVD 1988).

OFF-SITE: NO OFF-SITE DRAINAGE AFFECTS THIS PROPERTY.

FLOOD HAZARD: PER SANDOVAL COUNTY FIRM MAP #35043C1894D, EFFECTIVE 3/18/2008, THE SITE IS LOCATED WITHIN FLOODZONE 'X' DESIGNATED AS AREAS DETERMINED TO BE OUTSIDE 500-YEAR FLOODPLAIN.

DRAINAGE PLAN CONCEPT: PER THE APPROVED MASTER DRAINAGE PLAN FOR RIO WEST BUSINESS PARK (JOE P. KELLEY, NMPE 9996, DATED 03/16/98), THIS BASIN (ID: LOTS 2A & 3A-1) IS PERMITTED TO FREE DISCHARGE TO DOWNSTREAM IMPROVEMENTS PREVIOUSLY CONSTRUCTED. ALLOWABLE DISCHARGE IS BASED ON LAND TREATMENT VALUES OF 0%A, 10%B, 13%C, 77%D (TOTAL DISCHARGE = 13.55 CFS = 4 CFS/ACRE).



timothy m. gallup
architect of record

601 S. Boulder Ave., Suite 808
Tulsa, Oklahoma 74119
918.349.9600

NO.	DATE	BY	DESCRIPTION

LEGEND

- 518.3 — EXISTING CONTOUR
- +5183.21 EXISTING SPOT ELEVATION
- 82 — PROPOSED 1.0' CONTOUR
- - - 82.5 - - - PROPOSED 0.5' CONTOUR
- ◆ 83.2 ◆ PROPOSED SPOT ELEVATION
- FLOW DIRECTION
- FF = 5187.50 FINISH FLOOR ELEVATION

Isaacson & Arfman, Inc.
Civil Engineering Consultants

128 Monroe Street NE
Albuquerque, NM 87108
505-268-8828 | www.isacivil.com

CONCEPTUAL GRADING & DRAINAGE PLAN

FILE NAME: BURDECUTS
DRAWN BY: xx/xx/2021
DATE: xx/xx/2021
REVIEWED BY: FCA

CALIBER COLLISION
RIO WEST BUSINESS PARK 2A-1
4705 SUNDT RD NE, RIO RANCHO, NM 87124
PROJECT NO. 212015

CG-101

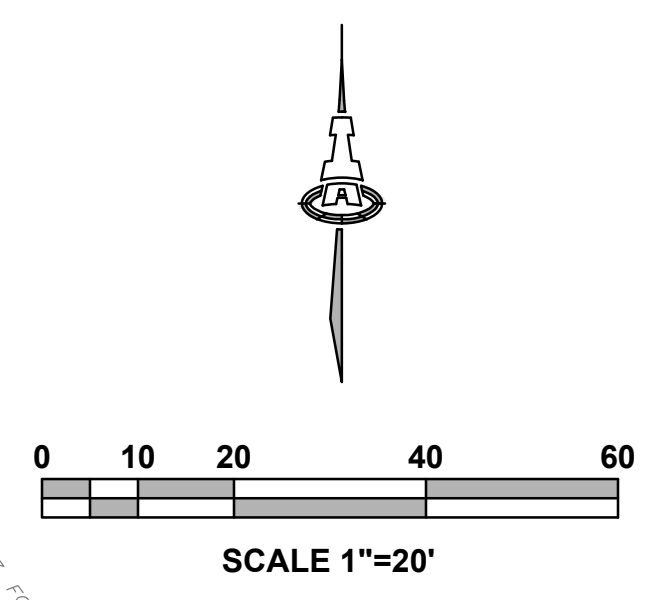
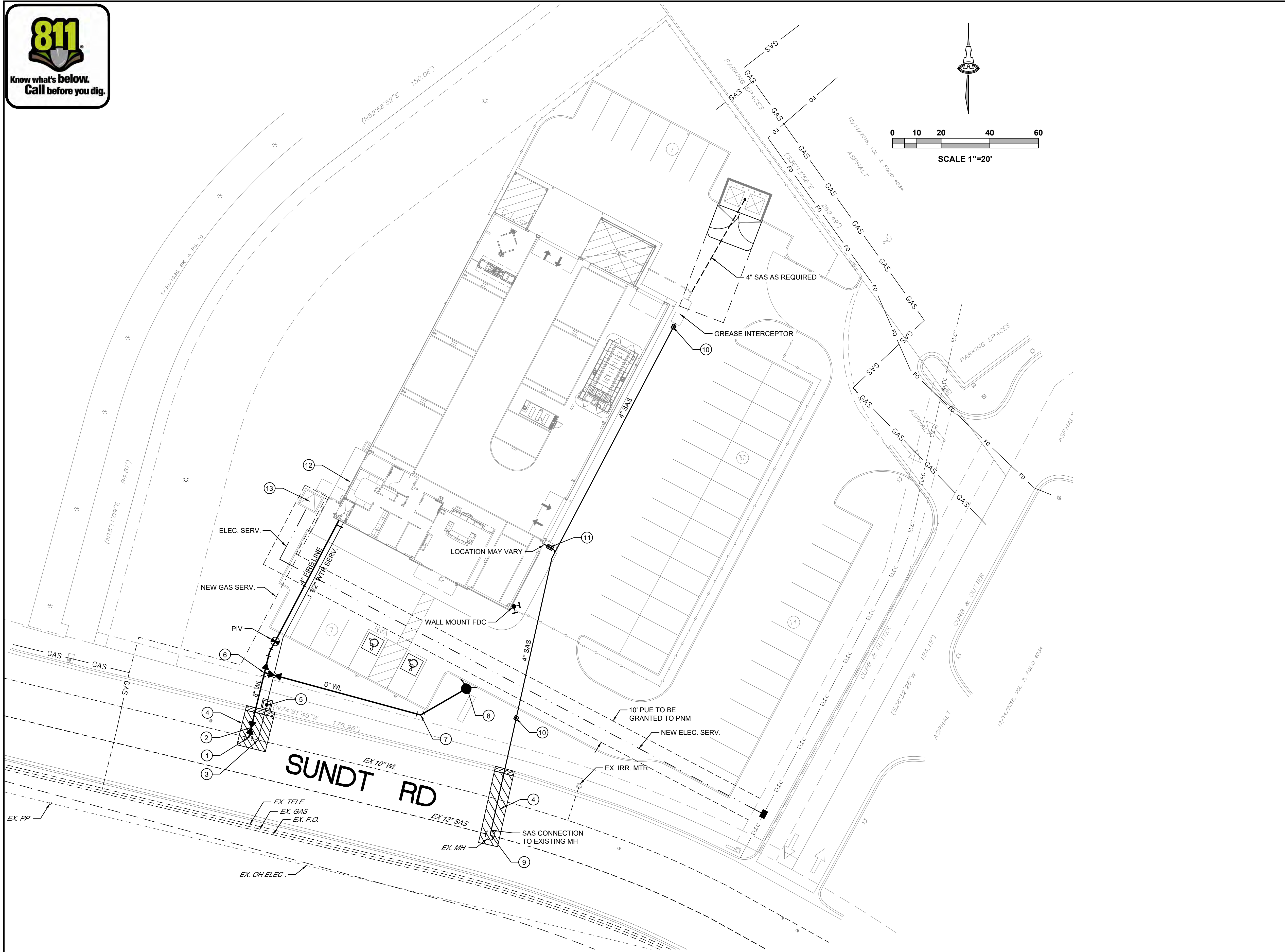

GENERAL NOTES

- SEE SHEET C-100 FOR ALL CIVIL GENERAL NOTES.
- EXISTING UTILITY LINES ARE SHOWN IN AN APPROXIMATE MANNER ONLY AND MAY BE INCOMPLETE OR OBSOLETE. SUCH LINES MAY OR MAY NOT EXIST WHERE SHOWN OR NOT SHOWN. ALL UTILITIES SHOULD BE FIELD VERIFIED AND LOCATED BY THE CONTRACTOR PRIOR TO COMMENCEMENT OF ANY CONSTRUCTION. THE CONTRACTOR IS FULLY RESPONSIBLE FOR ANY AND ALL DAMAGE CAUSED BY ITS FAILURE TO LOCATE, IDENTIFY AND PRESERVE ANY AND ALL EXISTING UTILITIES, PIPELINES, AND UNDERGROUND UTILITY LINES.
- CONTRACTOR SHALL NOT USE VIBRATORY COMPACTION EQUIPMENT OR HEAVY VEHICLES OVER EXISTING UTILITIES.
- SITE STORM DRAIN, ELECTRIC LINES & TRANSFORMERS AND GAS LINES ARE SHOWN FOR GENERAL INFORMATION ONLY TO PROVIDE AN OVERVIEW OF SITE UTILITIES AND POTENTIAL CONFLICTS. SEE MECHANICAL PLANS FOR GAS LINE SIZING. SEE CG-101 FOR STORM DRAIN DESIGN.
- ALL ABOVE GROUND UTILITY EQUIPMENT AND FITTINGS SHALL BE PAINTED IN COLORS TO MATCH BUILDING COLORS.

KEYED NOTES

- WATER KEYED NOTES**
- INSERT 10"x8" TEE WITH TRANSITION COUPLING
 - 8" GATE VALVE.
 - 10" x 1 1/2" TAPPING SADDLE
 - REMOVE & REPLACE ASPHALT PAVEMENT.
 - 1 1/2" WATER METER & BOX.
 - 8"x6" TEE & 6" GATE VALVE.
 - 6" - 45° BEND.
 - FIRE HYDRANT.
 - 4" SANITARY SEWER CONNECTION AT EXISTING MAIN.
 - SANITARY SINGLE CLEAN-OUT.
 - SANITARY DOUBLE CLEAN-OUT.
 - GANGED UTILITY METER CONNECTIONS.
 - ELECTRIC TRANSFORMER.

LEGEND

- - - EX 10" WTR	EXISTING WATERLINE
- - - EX 12" SAS	EXISTING SEWER LINE
⊙	EXISTING SEWER MANHOLE
— 8" WL	NEW WATER LINE
— 1 1/2" WTR SERV.	NEW WATER SERVICE
— 4" SAS	NEW SEWER SERVICE
⊕	SEWER SINGLE CLEAN OUT
⊕⊕	SEWER DOUBLE CLEAN OUT
▨	REMOVE & REPLACE ASPHALT
▩	REMOVE & REPLACE CURB & GUTTER



timothy m. gallup
architect of record
601 S. Boulder Ave., Suite 808
Tulsa, Oklahoma 74119
918.948.9600

NO.	DATE	BY	DESCRIPTION

CONCEPTUAL UTILITY PLAN
CALIBER COLLISION
RIO WEST BUSINESS PARK 2A-1
4705 SUNDT RD NE, RIO RANCHO, NM 87124
PROJECT NO. 212015

FILE NAME: BJB/DECJTS
DRAWN BY: BJB/DECJTS
DATE: xx/xx/2021
REVIEWED BY: FCA

Isaacson & Arfman, Inc.
Civil Engineering Consultants
128 Monroe Street NE
Albuquerque, NM 87108
505-268-8828 | www.iacivil.com

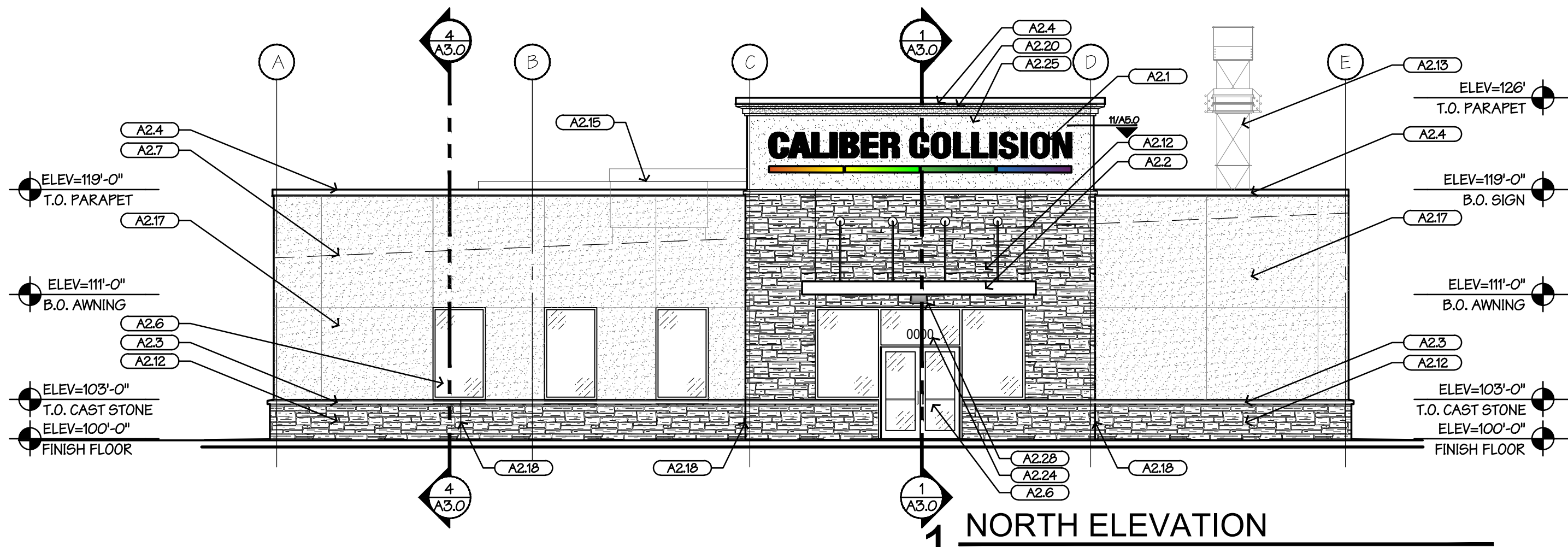

1 NORTH ELEVATION

SCALE: 1/8" = 1'-0"

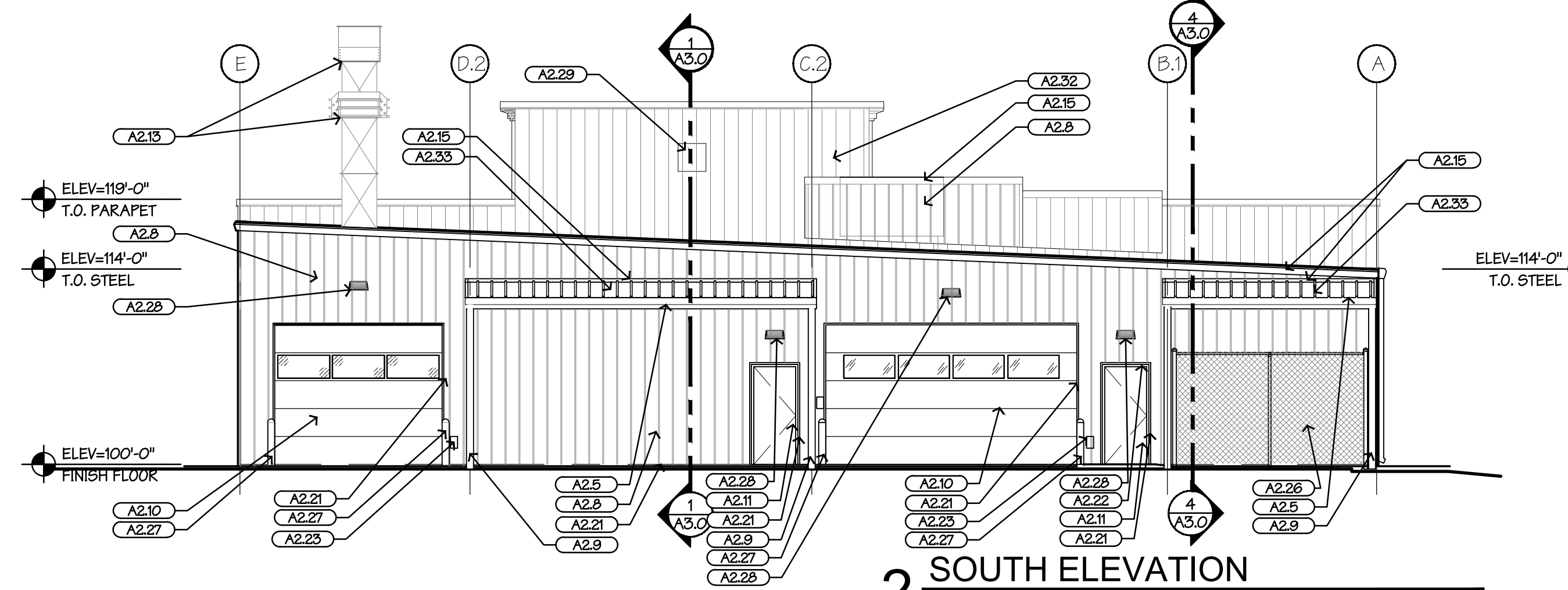

2 SOUTH ELEVATION

SCALE: 1/8" = 1'-0"

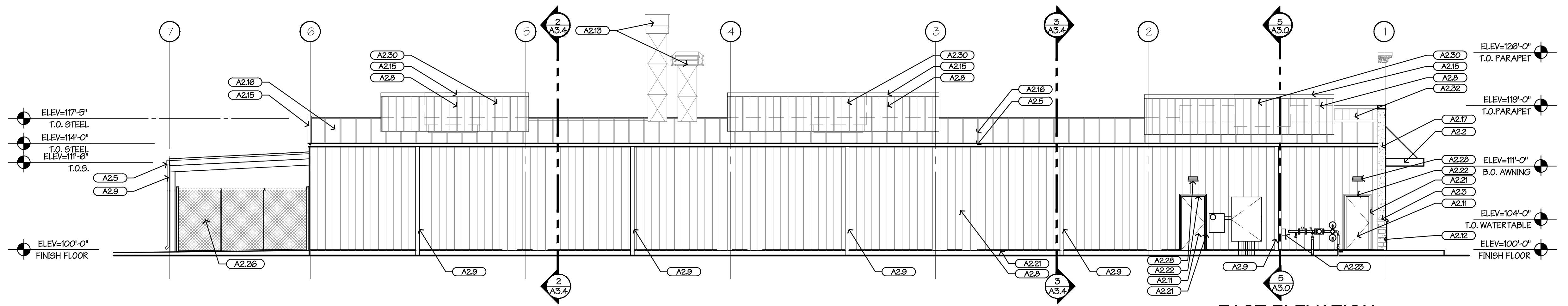

1 EAST ELEVATION

SCALE: 1/8" = 1'-0"

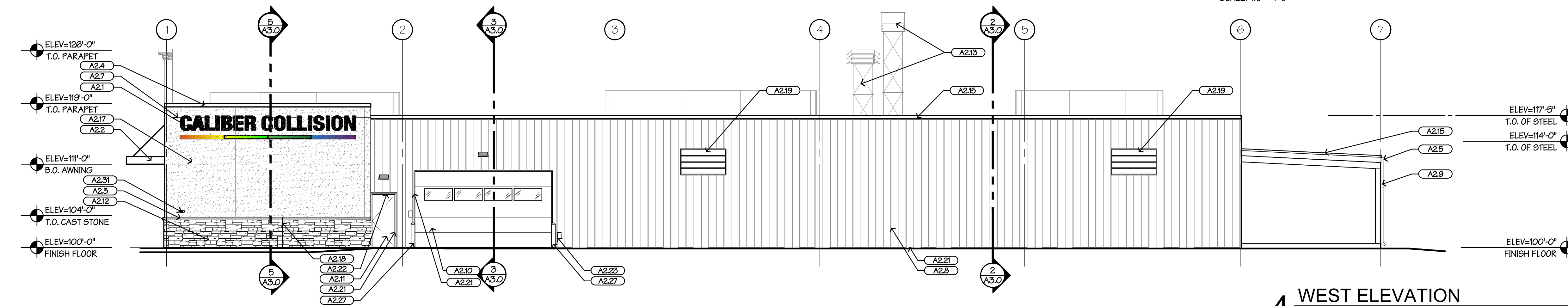

4 WEST ELEVATION

SCALE: 1/8" = 1'-0"

KEY NOTES

A2.1 SIGNAGE (BY OTHERS)-PROVIDE 3/4" FLYWD. BACKING (SEPARATE PERMIT)	A2.17 WATER MANAGED EIFS w/ V-GROOVE JOINTS & EXPANSION JOINTS @ 24'-0" O.C. MAX. (S11 - MATCH NOMADIC DESERT) CONTROL JOINT (IN MASONRY) @ 24'-0" MIN. O.C.
A2.2 PRE-MANUFACTURED MTL. AWNING W/ TIE RODS BY G.C. (CP1 - URBANE BRONZE)	A2.18 WALL LOUVER, (MML) REF. MEP
A2.3 CAST STONE SILL/WATER TABLE (CS-1)	A2.19 SHAPED EIFS CORNICE. (S11 - MATCH NOMADIC DESERT)
A2.4 PREFINISHED MTL. COPING (BURNISHED SLATE MTL-2) - PROVIDED BY MTL. BUILDING SUPPLIER AND BENT AND INSTALLED BY GC.	A2.20 PRE-FINISHED MTL "J" TRIM AT OPENINGS AND PANEL DRIP EDGES (MTL2 - BURNISHED SLATE)
A2.5 METAL GUTTER (BURNISHED SLATE)-PROVIDED BY MTL. BUILDING PROVIDER AND INSTALLED BY GC (MTL-2)	A2.21 DOOR DRIP EDGE
A2.6 STOREFRONT / GLAZING (AL-2)	A2.22 HOSE BIB, RE. MEP
A2.7 ROOF LINE BEYOND	A2.23 6" VINYL HOUSE NUMBER (WHITE)
A2.8 PRE-FINISHED MTL. BUILDING SIDING (MTL-3)	A2.24 WATER MANAGED EIFS ON 3/4" PLYWOOD (S12 - CUSTOM COLOR BLACK)
A2.9 PRE-FINISHED 6"x4" D (SQUARE) METAL DOWNSPOUT (BURNISHED SLATE MTL2) - PROVIDED BY MTL. BUILDING SUPPLIER AND INSTALLED BY G.C. (REFER TO H/SPL1 FOR CONNECTION TO UNDERGROUND DRAINAGE SYSTEM)	A2.25 CHAIN LINK FENCE COATED (BLACK) WITH BLACK VINYL PRIVACY SLATS
A2.10 FACTORY FINISHED SECTIONAL OH DOOR (OHD1)	A2.26 6" CONCRETE FILLED PIPE BOLLARD W/ YELLOW PLASTIC SLEEVE
A2.11 HOLLOW MTL. DOOR (PT-3) AND FRAME (NOMADIC DESERT)	A2.27 LIGHT FIXTURE OVER DOOR, RE. MPE
A2.12 MANUFACTURED STONE VENEER (M-1) w/ LIGHT BUFF MORTAR	A2.28 PROVIDE 24"x24" ACCESS PANEL FOR ACCESS TO POWER TO SIGN
A2.13 EXHAUST AND AIR INTAKE, REF. PAINT BOOTH	A2.29 RTU, RE. MPE
A2.14 WALL MOUNTED LIGHT FIXTURE, REF. MEP	A2.30 FIRE DEPARTMENT CONNECTION
A2.15 PREFINISHED MTL. COPING, HIGH EAVE FLASHING AND RAKE TRIM (BURNISHED SLATE MTL-2) BY PEMB SUPPLIER	A2.31 BACK OF PARAPET - PRE-FINISHED MTL. BUILDING SIDING (MTL-3)
A2.16 PRE-FINISH METAL BUILDING STANDING SEAM ROOFING (MTL-1)	A2.32 PRE-FINISHED PBR PANEL ON LEAN-TO ROOF (MTL5)

COLOR SCHEDULE - EXTERIOR REFER TO SHEET A6.4 FOR ADDITIONAL INFORMATION

FINISH KEY	DESCRIPTION	LOCATION	PRODUCT COLOR
AL2	STOREFRONT SYSTEM	OFFICE EXTERIOR	DARK ANODIZED BRONZE
CL1	CHAINLINK FENCE	PARTS AREA	BLACK PVC COATED
	PRIVACY SLATS	PARTS AREA	BLACK WINGED PVC SLATS
CP1	CUSTOM CANOPY	LOBBY ENTRANCE	REFINISHED DARK BRONZE
CS1	CAST STONE WATER TABLE/SILL (REF. ELEV)	OFFICE EXTERIOR	BUCKSKIN
	MASONRY MORTAR	---	10X LIGHT BUFF
EWL	EXTERIOR WALL LOUVER	EXTERIOR WALL LOUVER	FACTORY FINISHED
		IN LANDSCAPE AREAS	NATURAL GRAY CONCRETE
LPB	EXTERIOR LIGHT POLE BASE (24" HT)	EXPOSED DRIVE / PARKING AREAS	PAINT SAFETY YELLOW
M1	MANUFACTURED STONE VENEER	EXTERIOR FACADE ACCENT	EL DORADO - AUSTIN CREAM
	MASONRY MORTAR	---	10X LIGHT BUFF
M1	MANUFACTURED STONE VENEER	EXTERIOR FACADE ACCENT	EL DORADO - AUSTIN CREAM
	MASONRY MORTAR	---	10X LIGHT BUFF
MML	METAL WALL LOUVER	EXTERIOR WALL	COLOR TO MATCH BUFF CMU, SEE CMU ABOVE
MTL1	MTL. ROOFING	SHOP ROOF / OFFICE ROOF	SOLAR WHITE (SR.71 SR186)
MTL2	GUTTERS, DOWNSPOUTS, RAKES, CLOSURES, & PARAPET WALL CAPS	EXTERIOR	BURNISHED SLATE
MTL3	PBR - WALL PANEL AND TRIM	SHOP EXTERIOR SIDING, ROOF SCREENS, BACK SIDE OF PARAPETS	SADDLE TAN
MTL4	PBR PANELS AND TRIM	SHOP EXTERIOR SIDING, ROOF SCREENS, BACK SIDE OF PARAPETS	SADDLE TAN
MTL5	MTL. ROOFING	WASH/PARTS BAY ROOF	SOLAR WHITE (SR.71 SR186)
OHD1	SECTIONAL DOOR	SHOP	DESERT TAN (EXTERIOR) WHITE (INTERIOR)
PT3	EXTERIOR PAINT	EXTERIOR DOOR & FRAME PAINT	NOMADIC DESERT
PT5	EXTERIOR PAINT	EXTERIOR EXPOSED BUILDING STEEL	URBANE BRONZE
PT11	EXTERIOR PAINT	METAL DUMPSTER FENCE/GATE PARTS	TRICORN BLACK
PT12	EXTERIOR PAINT	DUMPSTER BOLLARDS & INTERIOR BOLLARDS	SAFETY YELLOW
SN1	EXTERIOR STAIN SEALER	DUMPSTER ENCLOSURE WOOD GATE SLATS	PECAN
S11	EXTERIOR FINISH	EXTERIOR CORNICE & WALL	CUSTOM COLOR - MATCH SW6107 NOMADIC DESERT
ST2	TEXTURED ACRYLIC COATING	SIGN PARAPET BACKDROP	CUSTOM COLOR - MATCH SW6250 TRICORN BLACK



timothy m. gallup
architect of record
601 S. Boulder Ave., Suite 808
Tulsa, Oklahoma 74119
918.949.9600

NO.	DATE	BY	DESCRIPTION

EXTERIOR ELEVATIONS
CALIBER COLLISION
601 WEST BUSINESS PARK DR. #4
4705 SUNDY FLD. W. BIRCH CANYON BLVD. #124
TULSA, OKLAHOMA 74119
PROJECT NO. 212015

FILE NAME: 212015
DRAWN BY: TRS
DATE: xx/xx/2021
REVIEWED BY: TMG

A2.0

EXTERIOR FINISH SCHEDULE WITH COLORS														
ITEM#	ITEMS:	COLOR:	KEY#	ITEMS:	COLOR:	KEY#	ITEMS:	COLOR:	KEY#	ITEMS:	COLOR:	KEY#	ITEMS:	COLOR:
1	METAL PANELS (FACADE), ROOF SCREENS, BACK OF PARAPETS	MATCH SADDLE TAN	4	EIFS (CORNICHE) AND (FACADE)	MATCH NOMADIC DESERT	7	PREFINISHED SECTIONAL DOOR	MATCH DESERT TAN	10	STORE FRONT GLAZING TUBES	ANODIZED DARK BRONZE	13		
2	CAST STONE	INTEGRAL COLOR BUFF	5	METAL COPING, TRIM, GUTTER AND DOWNSPOUTS, AWNINGS, AND EXPOSED STEEL STRUCTURE	MATCH BURNISHED SLATE	8	CHAINLINK FENCE WITH PRIVACY SLATS	BLACK VINYL	11	BOLLARDS	TRAFFIC YELLOW	14		
3	SINGLE SCORE CMU-SIGN BACKGROUND	DRYVIT SPECIAL MATCH BLACK	6	METAL DOORS AND FRAMES	MATCH NOMADIC DESERT	9	CAST STONE WATER TABLE	BUFF	12	EXPOSED STEEL STRUCTURE	MATCH URBANE BRONZE			



2 SOUTH ELEVATION
SCALE: 1/8" = 1'-0"



1 NORTH ELEVATION
SCALE: 1/8" = 1'-0"

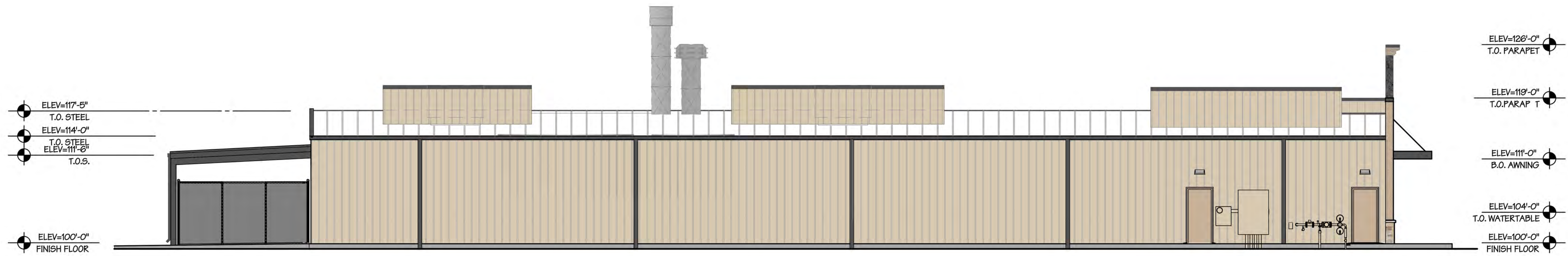

1 EAST ELEVATION
SCALE: 1/8" = 1'-0"

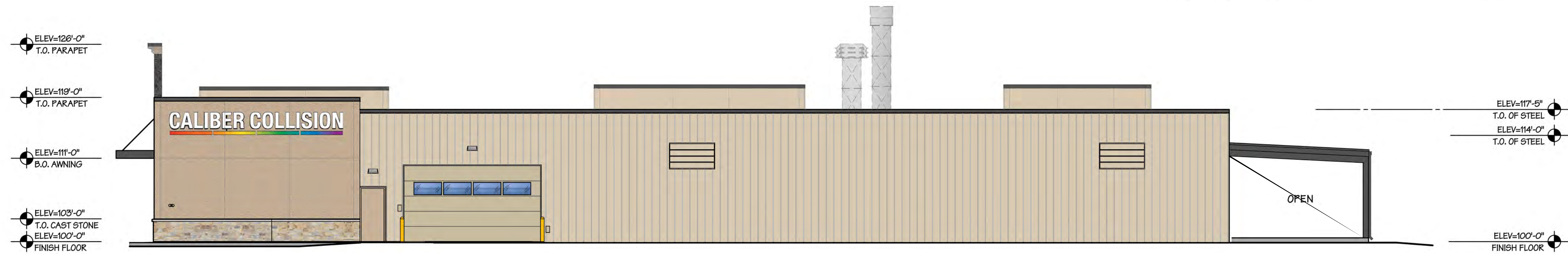

4 WEST ELEVATION
SCALE: 1/8" = 1'-0"

NO.	DATE	BY	DESCRIPTION

FILE NAME: 212015	EXTERIOR ELEVATIONS
DRAWN BY: TRS	CALIBER COLLISION
DATE: xx/xx/2021	RIO WEST BUSINESS PARK 2A-1
REVIEWED BY: TMG	4705 SUNDI TRD NE, RIO RANCHO, NM 87124
	PROJECT NO. 212015

January 24, 2022

City of Rio Rancho

Attn: Development Services
3200 Civic Center Circle NE, 1st Floor
Rio Rancho, NM 87144

RE: Letter of Authorization - Victory Real Estate Development/Consensus
Planning/Isaacson & Arfman/Gallup Architects

To Whom It May Concern: -

As the Property Owner/Property Owner Representative of the property described in the Legal Description listed below, I hereby authorize Victory Real Estate Development/Consensus Planning/Isaacson & Arfman/Gallup Architects (potential Buyer and Buyer's professional consultants) to act as my agent in pursuit of all permitting and city feedback on their proposed project. I am aware of the request of land use.

Legal Description:

As contained the Title Commitment prepared for this property by Fidelity National Title Insurance Company, Commitment No. SP000114916, Commitment Date: July 26, 2021.

Lot numbered Two-A-One (2A-1) in Block lettered "A" of RIO WEST BUSEINSS PARK, as the same are shown and designated on the Summary Plat thereof filed in the office of the County Clerk of Sandoval County, New Mexico on December 14, 2016 in Volume 3, folio 4034.

Please feel free to contact me at jking@bradburystamm.com with any questions.

Sincerely,

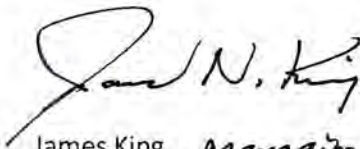

James King, *Managing Member*
Rio West Business Park, LLC
13731 Apache Plume Pl. NE
Albuquerque, NM 87111
Email: jking@bradburystamm.com

City of Rio Rancho

Development Services

3200 Civic Center Circle NE - Ste 130
Rio Rancho, NM 87144
(505) 891-5005 Fax: (505) 896-8994



February 18, 2022

Consensus Planning
302 8th St NW
Albuquerque, NM 87102

RE: Caliber Collision Site Plan (case 22-160-00005).

Please review the following staff comments for Grande Development Site Plan. Please make any necessary revisions and return to City staff via a PDF file to confirm changes have been made.

Planning:

1. Per Ordinance No. 89-007, C-2 uses are permissive except:
 - Auto dismantling yard
 - Tire recapping and retreading
 - Auto wrecking, auto salvage
2. Per R.O. 2003 Section 154.25 (B)(27), included in the C-2 permissive uses are "Automotive dealers, motorcycle dealers and auto repair, major; provided, that:
 - Repairs and associated activities are conducted within a completely enclosed building; or
 - A solid masonry wall at least six feet high is erected between the activity and any abutting or contiguous residential zone;
 - Applicants shall provide site plans which show lot dimensions, location and dimensions of proposed structures/facilities, parking, proposed signage, landscaping and buffers; if applicable, information with regard to the nature of the operation as well as hours of operation, for review and approval by the Planning and Zoning Board;
3. Verify dumpster access is acceptable with Waste Management

Engineering:

Response from Engineering on Site Plan:

1. No cutting of the asphalt on Sundt Road is allowed per City Code 96.03 I since is less than 5 years old.
2. Compliance with the Master Drainage Plan for Rio West Business Park is required.

Future Development:

1. A Trip Generation Report is required and an additional Traffic Study may be required for traffic if thresholds exceed those identified per the City of Rio Rancho, Design Process Manual (DPM) Vol II Chapter II.3.
2. 2.A Water / Waste Water Availability statement from the Utility Division is required. Contact Robert Lujan (891-5061) or Steve Gallegos (896-8715) for additional information. Waterline easements may be required for public waterlines.
3. A grading and drainage plan/ report and an erosion control plan are required with future development, and must conform to any currently approved master drainage plan for this area. Storm water drainage and water quality discharge will need to be addressed per the City of Rio Rancho, Design Process Manual (DPM) Vol II Chapter II.2.
4. Engineering drawings are required for development of public and private infrastructure. Work performed in the right-of-way will require a City of Rio Rancho, Right-of-Way Permit and a Traffic Control Plan. Contractors must be licensed and bonded to work in the City of Rio Rancho.

Fire and Rescue:

Per- International Fire Code 2015

1. Confirm fire hydrants are in approved distances and locations
2. Turning radius shall be 28 feet, IFC Appendix D
3. No crash gates shall be allowed. No dead ends shall be approved.
4. Fire Protections system may be required depending on Occupancy Use and Occupant load.
5. Access to the property widths shall be required to be 26 ft.

Further fire department comments may be required upon development.

Parks and Recreation:

1. Landscape requirements appear to be correct for the purpose of Site Plan approval.
2. Ensure final construction plans indicate where the irrigation meter (its size) the backflow preventer (its type) and the controller/master valve locations are.
3. Irrigation backflow preventer will need to be registered and tested per ordinance 54.0.
4. Plans shall also direct the contractor to comply at a minimum, with the Governor's Commission on Disability's Parking Lot Checklist: <http://gcd.state.nm.us/physical-accessibility/parking/> with respect to the type of Handicap Parking signage, 1' high by 2" thick lettering saying "No Parking" in the cross striped access aisles, and any other State statute requirements that show the additional requirement that there is no slope greater than 2.08% in ANY direction in the handicap parking spaces and the access aisle. As you have shown, the run of the route from parking to the building will not exceed 5%, but the cross slope of that route also cannot exceed 2.08%. Construction plans should call for the State-statute specific handicap parking signage as well.

If you have any additional questions or concerns please feel free to contact me at any time.

Respectfully,



Michelle Costilla
Municipal Planner I
Development Services Department
City of Rio Rancho
(505) 896-8362 mcostilla@rrnm.gov



The City of Rio Rancho

Development Services
Planning Division

3200 Civic Center Circle NE
Rio Rancho, NM 87144
Phone (505) 891-5005 • Fax (505) 896-8994

February 18, 2022

RE: Site Plan, Case No. 22-160-00005
4705 Sundt Rd NE (Rio West Business Park, Block A, Lot 2A)

Dear Property Owner:

You are receiving this certified notice because your property abuts a site where a land development decision is required by the Governing Body.

The applicant, Victory Development, through their agent Consensus Planning, Inc., requests approval of the Caliber Collision Site Plan in an SU: Special Use zoned property. The subject property is located at Rio West Business Park, Block A, Lot 2A.

The **Governing Body** will consider the request and have the final approval on **Thursday, March 10, 2022** at 6:00 pm in the **Council Chambers** and **Virtually** as a hybrid meeting, through the **Zoom link and number below**.

On the back of this letter is a location map of the project, with the subject property identified with a red outline.

If you would like to comment on this application, you are encouraged to send in comments in writing, which will be presented to the Governing Body. This Governing Body meeting will be hybrid with options to participate virtually or in person. The City highly encourages citizens to watch the meeting live on the City's website www.rnm.gov or on Sparklight cable channel 56.

For the **Governing Body meeting**, to participate virtually: Join via computer: <https://zoom.us/j/91804920905?pwd=ZlZ5NmRlTUTF1RndxTVN2dHBTSnJ3Zz09>. Meeting ID: 918-0492-0905 Passcode: **903274** Join via phone: 1-253-215-8782 US

Please do not hesitate to contact me via e-mail me at mcostilla@rnm.gov or call me at 505-896-8362, if you have any questions concerning this matter. The agenda for this hearing and related staff reports will be posted on the City's website, www.rnm.gov, the Friday before the hearing.

If you are an individual with a disability who is in need of a reader, amplifier, qualified sign language interpreter, or any form of auxiliary aid or service to attend or participate in the hearing or meeting, please contact the City Clerk, 505-891-5004, as soon as possible prior to the meeting. Please contact the City Clerk if a summary or other type of accessible format is needed.

Respectfully,

Michelle Costilla
Municipal Planner I
Development Services Department
City of Rio Rancho

4705 SUNDT RD NE

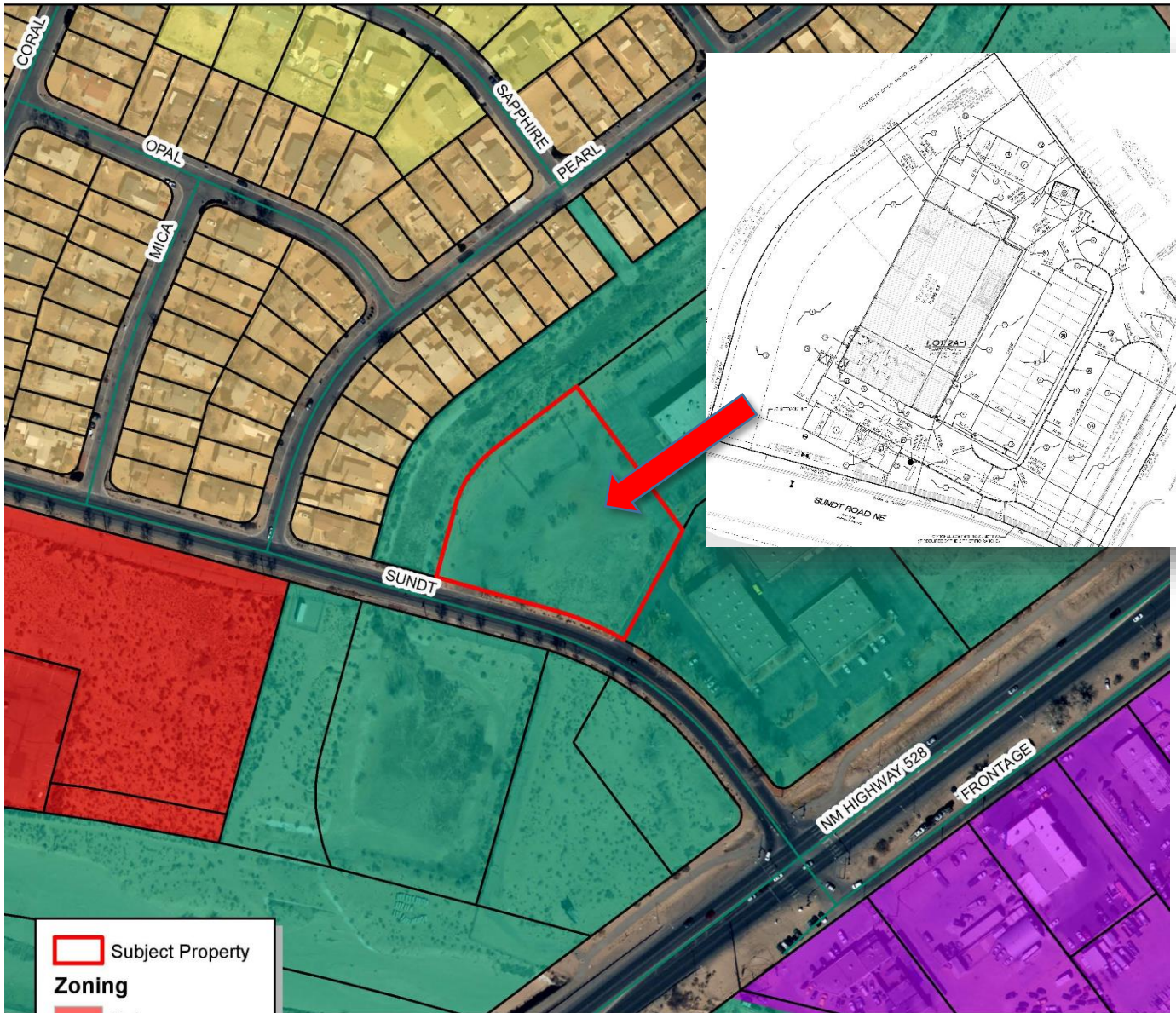

Subject Property

Zoning

- C-1
- M-1
- R-1
- R-3
- SU

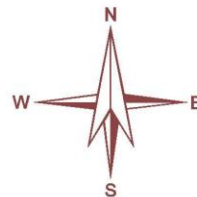

**CITY OF RIO RANCHO
PUBLIC HEARING NOTICE**

The Governing Body of the City of Rio Rancho will consider the following matter at its regularly scheduled meeting at 6:00 p.m. on Thursday, March 10, 2022:

Site Plan

Request #22-160-00003

The applicant, Victory Development, through their agent Consensus Planning, Inc., is requesting approval of a site plan for an auto repair business at the property located at 4705 Sundt Rd NE, legally described as Rio West Business Park, Block A, Lot 2A.



The meeting is scheduled for 6 p.m. in the Council Chambers at City Hall, 3200 Civic Center Cir. NE, Rio Rancho, NM. The public is invited to attend in-person or virtually. Materials related to these items are available for viewing in the Development Services Department at City Hall.

If you would like to comment on any of these applications, you are encouraged to submit a written comment to planning@rrnm.gov. Written comments will be read into the public record. To practice social distancing in order to slow the spread of COVID-19, you are encouraged to watch the meeting online at www.rrnm.gov.

**(Date of Publication:
Sunday February 20, 2022)**

PROPERTY NOTIFICATION MAP



-  Subject Property
-  Abutting Properties

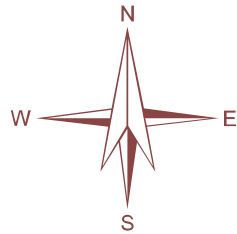

DISCLAIMER: All information in this map is provided "as is" without warranty or any representation of accuracy, timeliness or completeness. This map is not a survey and should be used for graphical purposes only.



MICHELLE COSTILLA

From: MICHELE ROST <speechshell@aol.com>
Sent: Monday, February 28, 2022 12:55 PM
To: MICHELLE COSTILLA
Subject: Site plan Case no. 22-160-00005

CAUTION: This email was received from an EXTERNAL source, use caution when clicking links or opening attachments.

Dear Ms. Costilla,
I live at 118 Pearl Drive, and I received the certified letter sent to concerning 4705 Sunday Rd. NE. I would like to express my concern about this business moving in. It sounds like they want to build yet another car repair place. We have CarCrafters and Quanz across 528 on the frontage road. If this collision repair shop is allowed to build there, we will be dealing with more traffic in this area. It would be better off of the Frontage Road. Currently we have a massive traffic problem due to the ASK Academy. At times I have been in line to turn left at 528 and Sundt up to 20 minutes due to that school traffic. Then I must wait again just to turn in at my street. The parents block the roads, park up and down our street, and all these cars idling are a tremendous amount of pollution. For a science academy they should have the students figuring out answers to global warming since the school is a big polluter here. With that much traffic in that particular area, we do not need another business adding to the traffic. The other businesses in the business park have a small amount of traffic. My other concern about this particular business is how much junk will be brought into this area. Are there going to be wrecked cars parked around there? I feel our area is trashy enough. Pearl Drive already looks like a trailer park. Rio Rancho allows people to park beat up campers that never move in their front yards. It is also permitted to park junk collecting carts/trailers in their front yards. I think we should have a beautification program for this area, not bring more trash and traffic to the area.

Sincerely,
Michele Rost
Speechshell@aol.com

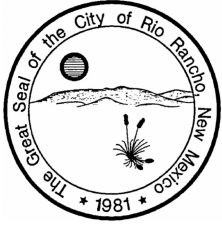

CITY OF RIO RANCHO COVER PAGE

Legislation Item: R14

AGENDA DATE:

March 10, 2022

DEPARTMENT:

Financial Services

SUBJECT:

R14, Resolution Authorizing the Write-Off and Removal of Uncollectible Ambulance, Utilities, Parks and Recreation, Alarm, and Library Accounts from the City's Accounts Receivable

BACKGROUND AND ANALYSIS:

The Resolution will allow for the write-off and removal of \$412,159.06 in uncollectible ambulance, utilities, parks and recreation, alarm, and library accounts from the City's books and records. Accounts proposed to be written off are four years old or, in some cases, older.

The City's Fire and Rescue Department provides emergency medical services to the public, and the costs of these services are billed to the patients.

The City's Utilities Department provides water and wastewater utility services and bills customers for the services provided.

The City's Parks, Recreation and Community Services Department provides recreational services, programs, and activities and bills customers/users for those services.

The City requires alarm registration with response services provided by the Police Department, and bills the customers/users for those services.

The City's Library and Information Services Department provides informational services and goods and bills those services and goods to the customer for whom such goods and services are provided and not returned/damaged.

Some of these accounts are not paid on time, and others are never paid (e.g., because of death, insolvency, the customer can't be located, etc.). After four years and multiple attempts to collect, these accounts are deemed uncollectible, as defined in the City's Uncollectible Accounts Receivable Policy (Section 2-4-1 through 2-4-7).

State Statute - Section 3-37-7 NMSA 1978 - provides a procedure by which a municipality may write-off certain uncollectible accounts by resolution, upon a statement of the nature and condition of those accounts by the municipality's finance officer. Carole Jaramillo, Director of the Financial Services Department, has provided such a statement, attached to the Resolution.

The aggregate amount of this write-off is \$412,159.06 and is broken down as follows:

- \$238,386.79 - Ambulance
- \$136,204.76 - Utilities

- \$1,527.00 - Parks and recreation programs and services
- \$8,075.00 - Alarms registration and response services
- \$27,965.51 - Libraries services

Per the City's Uncollectible Accounts Receivable Policy Section 2-4-4, a write-off of uncollectible accounts receivable from the City's accounting records does not constitute forgiveness of the debt, which is still payable by the debtor.

IMPACT:

The proposed Resolution will remove uncollectible accounts from the City's books and records, more accurately reflecting its financial position.

ALTERNATIVES:

Approve the Resolution.

Do not approve the Resolution.

DEPARTMENT RECOMMENDATION:

Staff recommends approving this Resolution.

ATTACHMENT: [Resolution](#)

ATTACHMENT: [ATTACHMENT I - Financial Services Department Director Statement.pdf](#)

ATTACHMENT: [ATTACHMENT II -Uncollectible Ambulance 12.31.2017 Redacted.pdf](#)

ATTACHMENT: [ATTACHMENT III - Utilities Uncollectible 12.31.17.pdf](#)

ATTACHMENT: [ATTACHMENT IV - PRCS Uncollectible 12.31.17.pdf](#)

ATTACHMENT: [ATTACHMENT V - Alarms Uncollectible 12.31.2017.pdf](#)

ATTACHMENT: [ATTACHMENT VI - Library Uncollectible 12.31.17.pdf](#)



**CITY OF RIO RANCHO
RESOLUTION**

RESOLUTION NO.

ENACTMENT NO.

**RESOLUTION AUTHORIZING THE WRITE-OFF AND REMOVAL OF
UNCOLLECTIBLE AMBULANCE, UTILITIES, PARKS AND RECREATION, ALARM,
AND LIBRARY ACCOUNTS FROM THE CITY'S ACCOUNTS RECEIVABLE**

WHEREAS: the City's Fire & Rescue Department provides emergency medical services to the public and bills those services to the patients to whom services are provided; and

WHEREAS: the City's Utilities Department provides water and wastewater utility services and bills those services to the customers to whom services are provided; and

WHEREAS: the City's Parks, Recreation and Community Services Department provides recreational services, programs, and activities to the public and bills those services to the customer for whom such services are provided; and

WHEREAS: the City requires alarm registration and the Police Department provides response services and bills those services to the customers for whom such services are provided; and

WHEREAS: the City's Library and Information Services Department provides informational services and goods, and bills those services and goods to the customer for whom such goods and services are provided; and

WHEREAS: in the course of providing such services, the City is occasionally left with uncollectible ambulance accounts, utilities accounts, parks and recreation accounts, alarm accounts and libraries; and

WHEREAS: the City has accrued \$238,386.79 in uncollectible ambulance accounts, \$136,204.76 in uncollectible utilities accounts, \$1,527.00 in uncollectible parks and recreation accounts, \$8,075.00 in uncollectible alarm accounts, and \$27,965.51 in uncollectible library accounts, which continue to be shown as current accounts receivable on the financial records of the City; and

WHEREAS: Section 3-37-7, NMSA 1978, provides a procedure by which a municipality may write-off certain uncollectible accounts upon a statement of the nature and condition of those accounts by the municipality's finance officer; and

WHEREAS: the City's Director of Financial Services, as the City's finance officer, has provided such a statement regarding the above-described uncollectible ambulance accounts, utilities accounts, parks and recreation accounts, alarm accounts, and library accounts which is attached hereto; and

1
2
3
4
5
6
7
8
9
10
11
12
13
14
15
16
17
18
19
20
21
22
23

WHEREAS: a write-off of uncollectible accounts receivable from the City's accounting records does not constitute forgiveness of the debt, which is still payable by the debtor.

NOW THEREFORE, BE IT RESOLVED BY THE GOVERNING BODY OF THE CITY OF RIO RANCHO:

That in accordance with NMSA 1978, § 3-37-7, and the attached statements of the City's Director of Financial Services, the accounts listed in said statement are hereby written off and removed from list of accounts receivable of the City.

ADOPTED THIS _____ DAY OF _____, 2022.

Greggory D. Hull, Mayor

ATTEST:

Rebecca A. Martinez, City Clerk
(SEAL)

Department of Financial Services

February 14, 2022

Pursuant to City's Uncollectible Accounts Receivable policy (Section 2-4-1 through 2-4-7), I am submitting the attached listings of uncollectible Ambulance, Utilities, Parks & Recreation (P&R), Alarm, and Library accounts. Each listing provides the basic account description as required in Section 2-4-7 (1.)(c)(1), which includes at a minimum: account holder name (unless protected by law), service provided, service date, call or account number, and other relevant information. Steve Perkins (Ambulance), Nita Gonzales (Utilities), Linda Mertens (PRCS), Celeste Soto (Alarms), and Rena Jackson (Libraries) prepared the listings.

The attached accounts meet the write-off criteria as outlined in Statute 3-37-7 NMSA 1978, and the City's Uncollectible Accounts Receivable policy, Section 2-4-5 and Section 2-4-7.

Each Ambulance account has been:

- Billed for a minimum of three (3) consecutive billing cycles
- Sent to a third-party collection
- Uncollectible for four (4) years or more

(Evidence of the collection activities provided upon request)

Each Utilities account is/has been:

- A closed utility account that was billed for a minimum of three (3) consecutive billing cycles before being sent to a third-party collection agency
- An active utility account that was reviewed on a monthly basis for possible discontinuance of service for non-payment, pursuant to § 51.09, R.O. 2003, before being sent to a third party collection agency
- Uncollectible for four (4) years or more

(Evidence of the collection activities provided upon request)

Each P&R account has been:

- Billed and subjected to internal collection efforts that may have included phone/email contact and preventing customer participation in other activities until past due amounts are paid.
- Uncollectible for four (4) years or more

(Evidence of the collection activities provided upon request)

Each Alarm account has been:

- Billed for a minimum of three (3) consecutive billing cycles
- Uncollectible for four (4) years or more

(Evidence of the collection activities provided upon request)

Each Library account has been:

- Billed for a minimum of three (3) consecutive billing cycles
- Sent to a third-party collection
- Uncollectible for four (4) years or more

(Evidence of the collection activities provided upon request)

The aggregate total write-off request is \$412,159.06 and can be broken-down as follows:

- \$238,386.79 for Ambulance
- \$136,204.76 for Utilities
- \$1,527.00 for PRCS
- \$8,075.00 for Alarms
- \$27,965.51 for Libraries



Department of Financial Services

It is my opinion that, pursuant to the City's Uncollectible Accounts Receivable policy, the accounts attached hereto meet the definition of an "Uncollectible Account," and that the criteria to write off these accounts has been satisfied. The write off request runs through 12/31/2017.

Respectfully submitted,

A handwritten signature in blue ink that reads 'Carole H. Jaramillo'.

Carole H. Jaramillo,
Director of Financial Services

Call No	Acct No	Call Date	Current Payor	Charges	Credits	Balance
17-00019	00019-17	1/1/2017	PRIVATE (SELF PAY)	\$537.68	\$430.15	\$107.53
16-00017	2407-13	1/1/2017	PRIVATE (SELF PAY)	\$539.76	\$439.76	\$100.00
17-00018	4541-11	1/1/2017	PRIVATE (SELF PAY)	\$521.04	\$256.04	\$265.00
17-00053	2448-15	1/2/2017	PRIVATE (SELF PAY)	\$551.20	\$0.00	\$551.20
17-00050	1009-06	1/2/2017	PRIVATE (SELF PAY)	\$856.44	\$826.44	\$30.00
17-00034	6435-07	1/2/2017	PRIVATE (SELF PAY)	\$427.40	\$349.75	\$77.65
17-00077	00077-16	1/3/2017	PRIVATE (SELF PAY)	\$531.44	\$437.69	\$93.75
17-00112-02	00112-17-02	1/4/2017	PRIVATE (SELF PAY)	\$548.08	\$0.00	\$548.08
17-00082	2977-12	1/4/2017	PRIVATE (SELF PAY)	\$111.00	\$0.00	\$111.00
17-00093	5968-16	1/4/2017	PRIVATE (SELF PAY)	\$510.64	\$460.64	\$50.00
17-00090	2150-07	1/4/2017	PRIVATE (SELF PAY)	\$531.44	\$444.86	\$86.58
17-00117	0081-08	1/5/2017	PRIVATE (SELF PAY)	\$111.00	\$0.00	\$111.00
17-00134	00134-17	1/5/2017	PRIVATE (SELF PAY)	\$111.00	\$0.00	\$111.00
17-00123	00123-17	1/5/2017	PRIVATE (SELF PAY)	\$569.92	\$344.92	\$225.00
17-00165	8714-16	1/6/2017	PRIVATE (SELF PAY)	\$444.04	\$219.04	\$225.00
17-00153	4868-08	1/6/2017	PRIVATE (SELF PAY)	\$466.92	\$0.00	\$466.92
17-00154	8588-16	1/6/2017	PRIVATE (SELF PAY)	\$531.44	\$253.29	\$278.15
17-00185	4541-11	1/7/2017	PRIVATE (SELF PAY)	\$484.60	\$219.60	\$265.00
17-00217	3087-04	1/8/2017	PRIVATE (SELF PAY)	\$524.16	\$274.16	\$250.00
17-00216	00216-17	1/8/2017	PRIVATE (SELF PAY)	\$111.00	\$0.00	\$111.00
17-00200	2150-07	1/8/2017	PRIVATE (SELF PAY)	\$530.40	\$443.97	\$86.43
17-00282	00282-17	1/10/2017	PRIVATE (SELF PAY)	\$558.48	\$308.48	\$250.00
17-00267	7237-07	1/10/2017	PRIVATE (SELF PAY)	\$551.58	\$336.58	\$215.00
17-00259	00259-17	1/10/2017	PRIVATE (SELF PAY)	\$530.40	\$0.00	\$530.40
17-00264	0982-03	1/10/2017	PRIVATE (SELF PAY)	\$484.60	\$142.14	\$342.46
17-00302	2265-05	1/11/2017	PRIVATE (SELF PAY)	\$498.16	\$0.00	\$498.16
17-00317	4868-08	1/11/2017	PRIVATE (SELF PAY)	\$111.00	\$0.00	\$111.00
17-00306	2578-16	1/11/2017	PRIVATE (SELF PAY)	\$550.16	\$250.16	\$300.00
17-00304	5387-15	1/11/2017	PRIVATE (SELF PAY)	\$434.68	\$334.68	\$100.00
17-00300	1128-13	1/11/2017	PRIVATE (SELF PAY)	\$512.72	\$0.00	\$512.72
17-00310-01	19858-16	1/11/2017	PRIVATE (SELF PAY)	\$111.00	\$0.00	\$111.00
17-00335	9858-16	1/12/2017	PRIVATE (SELF PAY)	\$454.44	\$379.44	\$75.00
17-00329	00077-16	1/12/2017	PRIVATE (SELF PAY)	\$535.60	\$441.85	\$93.75
17-00366	2150-07	1/13/2017	PRIVATE (SELF PAY)	\$521.04	\$435.92	\$85.12
17-00373	6435-07	1/14/2017	PRIVATE (SELF PAY)	\$427.40	\$340.63	\$86.77
17-00401	3205-07	1/15/2017	PRIVATE (SELF PAY)	\$502.28	\$402.28	\$100.00
17-00397	00397-17	1/15/2017	PRIVATE (SELF PAY)	\$111.00	\$0.00	\$111.00
17-00447	00447-17	1/16/2017	PRIVATE (SELF PAY)	\$111.00	\$0.00	\$111.00
17-00420	6478-13	1/16/2017	PRIVATE (SELF PAY)	\$629.16	\$0.00	\$629.16
17-00463	7654-12	1/17/2017	PRIVATE (SELF PAY)	\$632.32	\$367.32	\$265.00
17-00471	00397-17	1/17/2017	PRIVATE (SELF PAY)	\$748.80	\$648.80	\$100.00
17-00465	00465-17	1/17/2017	PRIVATE (SELF PAY)	\$481.48	\$0.00	\$481.48
17-00480	4765-16	1/17/2017	PRIVATE (SELF PAY)	\$530.40	\$430.40	\$100.00
17-00478	9984-16	1/17/2017	PRIVATE (SELF PAY)	\$511.68	\$246.68	\$265.00
17-00472	00472-17	1/17/2017	PRIVATE (SELF PAY)	\$111.00	\$0.00	\$111.00
17-00500	2276-06	1/18/2017	PRIVATE (SELF PAY)	\$424.28	\$354.77	\$69.51

17-00495	9472-10	1/18/2017	PRIVATE (SELF PAY)	\$514.80	\$227.38	\$287.42
17-00515	9858-16	1/18/2017	PRIVATE (SELF PAY)	\$111.00	\$0.00	\$111.00
17-00519	9858-16	1/18/2017	PRIVATE (SELF PAY)	\$533.52	\$451.34	\$82.18
17-00503	00077-16	1/18/2017	PRIVATE (SELF PAY)	\$536.64	\$442.89	\$93.75
17-00524	0081-08	1/19/2017	PRIVATE (SELF PAY)	\$111.00	\$0.00	\$111.00
17-00554	4844-12	1/20/2017	PRIVATE (SELF PAY)	\$573.04	\$308.04	\$265.00
17-00566	7890-11	1/20/2017	PRIVATE (SELF PAY)	\$634.40	\$533.39	\$101.01
17-00551	00551-17	1/20/2017	PRIVATE (SELF PAY)	\$445.08	\$0.00	\$445.08
17-00561-01	00561-17-02	1/20/2017	PRIVATE (SELF PAY)	\$437.80	\$0.00	\$437.80
17-00564	00564-17	1/20/2017	PRIVATE (SELF PAY)	\$521.04	\$0.00	\$521.04
17-00558	00558-17	1/20/2017	PRIVATE (SELF PAY)	\$608.36	\$0.00	\$608.36
17-00582	00582-17	1/21/2017	PRIVATE (SELF PAY)	\$501.24	\$0.99	\$500.25
17-00624	2448-15	1/23/2017	PRIVATE (SELF PAY)	\$732.16	\$0.00	\$732.16
17-00626	3413-04	1/23/2017	PRIVATE (SELF PAY)	\$566.44	\$416.44	\$150.00
17-00644	00644-17	1/24/2017	PRIVATE (SELF PAY)	\$561.60	\$442.33	\$119.27
17-00632	00632-17	1/24/2017	PRIVATE (SELF PAY)	\$111.00	\$0.00	\$111.00
17-00666	00665-17	1/25/2017	PRIVATE (SELF PAY)	\$556.40	\$0.00	\$556.40
17-00663	00663-17	1/25/2017	PRIVATE (SELF PAY)	\$456.52	\$406.52	\$50.00
17-00684	00019-17	1/26/2017	PRIVATE (SELF PAY)	\$533.52	\$426.82	\$106.70
17-00728-03	00728-17	1/27/2017	PRIVATE (SELF PAY)	\$432.60	\$0.00	\$432.60
17-00725	00725-17	1/27/2017	PRIVATE (SELF PAY)	\$111.00	\$0.00	\$111.00
17-00720	00720-17	1/27/2017	PRIVATE (SELF PAY)	\$111.00	\$0.00	\$111.00
17-00728-02	00728-17-01	1/27/2017	PRIVATE (SELF PAY)	\$432.60	\$0.00	\$432.60
17-00737	00737-17	1/27/2017	PRIVATE (SELF PAY)	\$417.00	\$0.00	\$417.00
17-00746	2276-06	1/28/2017	PRIVATE (SELF PAY)	\$427.40	\$357.45	\$69.95
17-00748	00750-17	1/28/2017	PRIVATE (SELF PAY)	\$485.64	\$0.00	\$485.64
17-00776	00776-17	1/29/2017	PRIVATE (SELF PAY)	\$111.00	\$0.00	\$111.00
17-00784	00784-17	1/29/2017	PRIVATE (SELF PAY)	\$111.00	\$0.00	\$111.00
17-00774	00774-17	1/29/2017	PRIVATE (SELF PAY)	\$111.00	\$0.00	\$111.00
17-00820	00820-17	1/30/2017	PRIVATE (SELF PAY)	\$523.12	\$85.25	\$437.87
17-00828	00828-17	1/30/2017	PRIVATE (SELF PAY)	\$111.00	\$0.00	\$111.00
17-00816-04	00816-17-04	1/30/2017	PRIVATE (SELF PAY)	\$653.08	\$0.00	\$653.08
17-00816	00816-17	1/30/2017	PRIVATE (SELF PAY)	\$653.08	\$0.00	\$653.08
17-00816-03	00816-17-03	1/30/2017	PRIVATE (SELF PAY)	\$653.08	\$0.00	\$653.08
17-00816-02	00816-17-02	1/30/2017	PRIVATE (SELF PAY)	\$653.08	\$0.00	\$653.08
17-00819	2087-11	1/30/2017	PRIVATE (SELF PAY)	\$471.08	\$0.00	\$471.08
17-00797	7261-14	1/30/2017	PRIVATE (SELF PAY)	\$111.00	\$0.00	\$111.00
17-00846	00846-17	1/31/2017	PRIVATE (SELF PAY)	\$452.36	\$109.90	\$342.46
17-00843	4635-13	1/31/2017	PRIVATE (SELF PAY)	\$451.32	\$0.00	\$451.32
17-00856	4794-13	2/1/2017	PRIVATE (SELF PAY)	\$136.00	\$0.00	\$136.00
17-00883	00883-17	2/1/2017	PRIVATE (SELF PAY)	\$536.23	\$0.00	\$536.23
17-00858	3575-08	2/1/2017	PRIVATE (SELF PAY)	\$631.23	\$0.00	\$631.23
17-00881	00881-17	2/1/2017	PRIVATE (SELF PAY)	\$578.30	\$0.00	\$578.30
17-00894	00894-17	2/2/2017	PRIVATE (SELF PAY)	\$638.88	\$0.00	\$638.88
17-00905	00905-17	2/2/2017	PRIVATE (SELF PAY)	\$933.40	\$633.40	\$300.00
17-00906	00906-17	2/2/2017	PRIVATE (SELF PAY)	\$615.28	\$480.00	\$135.28
17-00927	2660-12	2/3/2017	PRIVATE (SELF PAY)	\$699.43	\$609.51	\$89.92

17-00940	00077-16	2/3/2017	PRIVATE (SELF PAY)	\$555.35	\$455.35	\$100.00
17-00964	2276-06	2/4/2017	PRIVATE (SELF PAY)	\$555.35	\$481.90	\$73.45
17-00967	00967-17	2/4/2017	PRIVATE (SELF PAY)	\$556.63	\$0.00	\$556.63
17-00970	00970-17	2/4/2017	PRIVATE (SELF PAY)	\$541.33	\$469.49	\$71.84
17-00957	00957-17	2/4/2017	PRIVATE (SELF PAY)	\$136.00	\$56.00	\$80.00
17-01001	01001-17	2/6/2017	PRIVATE (SELF PAY)	\$705.18	\$612.62	\$92.56
17-01030	01030-17	2/6/2017	PRIVATE (SELF PAY)	\$136.00	\$0.00	\$136.00
17-01048	01048-17	2/7/2017	PRIVATE (SELF PAY)	\$136.00	\$36.00	\$100.00
17-01111	01111-17	2/9/2017	PRIVATE (SELF PAY)	\$905.35	\$0.00	\$905.35
17-01116	7890-11	2/9/2017	PRIVATE (SELF PAY)	\$795.70	\$692.79	\$102.91
17-01087	01087-17	2/9/2017	PRIVATE (SELF PAY)	\$666.93	\$416.93	\$250.00
17-01082	01082-17	2/9/2017	PRIVATE (SELF PAY)	\$635.05	\$550.51	\$84.54
17-01115	01115-17	2/9/2017	PRIVATE (SELF PAY)	\$701.35	\$0.00	\$701.35
17-01097	00077-16	2/9/2017	PRIVATE (SELF PAY)	\$654.18	\$554.18	\$100.00
17-01125	5060-16	2/10/2017	PRIVATE (SELF PAY)	\$136.00	\$0.00	\$136.00
17-01143	0795-12-02	2/10/2017	PRIVATE (SELF PAY)	\$136.00	\$0.00	\$136.00
17-01155	4811-07	2/11/2017	PRIVATE (SELF PAY)	\$548.98	\$482.32	\$66.66
17-01219	2239-02	2/13/2017	PRIVATE (SELF PAY)	\$689.88	\$386.80	\$303.08
17-01217	01217-17	2/13/2017	PRIVATE (SELF PAY)	\$813.55	\$548.55	\$265.00
17-01208	01208-17	2/13/2017	PRIVATE (SELF PAY)	\$913.00	\$813.00	\$100.00
17-01224	1413-91	2/14/2017	PRIVATE (SELF PAY)	\$628.68	\$544.87	\$83.81
17-01252	1541-11	2/14/2017	PRIVATE (SELF PAY)	\$640.15	\$540.15	\$100.00
17-01256	4811-07	2/15/2017	PRIVATE (SELF PAY)	\$541.33	\$474.66	\$66.67
17-01270	01270-17	2/15/2017	PRIVATE (SELF PAY)	\$638.88	\$0.00	\$638.88
17-01332	3791-13	2/16/2017	PRIVATE (SELF PAY)	\$542.60	\$442.60	\$100.00
17-01311	01311-17	2/16/2017	PRIVATE (SELF PAY)	\$868.85	\$634.92	\$233.93
17-01329	01329-17	2/16/2017	PRIVATE (SELF PAY)	\$638.88	\$507.58	\$131.30
17-01293	1844-09	2/16/2017	PRIVATE (SELF PAY)	\$554.08	\$454.08	\$100.00
17-01290	01290-17	2/16/2017	PRIVATE (SELF PAY)	\$696.25	\$0.00	\$696.25
17-01342	01342-17	2/17/2017	PRIVATE (SELF PAY)	\$512.00	\$0.00	\$512.00
17-01357	01357-17	2/18/2017	PRIVATE (SELF PAY)	\$136.00	\$0.00	\$136.00
17-01391-02	1880-14	2/19/2017	PRIVATE (SELF PAY)	\$621.03	\$0.00	\$621.03
17-01394	01394-17	2/19/2017	PRIVATE (SELF PAY)	\$862.00	\$0.00	\$862.00
17-01420	6779-16	2/20/2017	PRIVATE (SELF PAY)	\$666.93	\$0.00	\$666.93
17-01424	01424-17	2/21/2017	PRIVATE (SELF PAY)	\$664.38	\$0.00	\$664.38
17-01454	1011-04	2/22/2017	PRIVATE (SELF PAY)	\$136.00	\$0.00	\$136.00
17-01456	2276-06	2/22/2017	PRIVATE (SELF PAY)	\$752.98	\$656.93	\$96.05
17-01455	6290-11	2/22/2017	PRIVATE (SELF PAY)	\$923.20	\$617.50	\$305.70
17-01476	01476-17	2/22/2017	PRIVATE (SELF PAY)	\$729.40	\$0.00	\$729.40
17-01469	7261-14	2/22/2017	PRIVATE (SELF PAY)	\$556.63	\$506.63	\$50.00
17-01465	01465-17	2/22/2017	PRIVATE (SELF PAY)	\$550.25	\$450.25	\$100.00
17-01484	01484-17	2/23/2017	PRIVATE (SELF PAY)	\$583.40	\$0.00	\$583.40
17-01517	01517-17	2/24/2017	PRIVATE (SELF PAY)	\$698.80	\$374.25	\$324.55
17-01541	5936-11	2/24/2017	PRIVATE (SELF PAY)	\$136.00	\$0.00	\$136.00
17-01526	01526-17	2/24/2017	PRIVATE (SELF PAY)	\$569.38	\$0.00	\$569.38
17-01567	01567-17	2/25/2017	PRIVATE (SELF PAY)	\$652.90	\$597.90	\$55.00
17-01565	01565-17	2/25/2017	PRIVATE (SELF PAY)	\$641.43	\$0.00	\$641.43

17-01610	01610-17	2/27/2017	PRIVATE (SELF PAY)	\$700.08	\$680.08	\$20.00
17-01642	7595-15	2/28/2017	PRIVATE (SELF PAY)	\$136.00	\$0.00	\$136.00
17-01639	01639-17	2/28/2017	PRIVATE (SELF PAY)	\$136.00	\$0.00	\$136.00
17-01646	01646-17	2/28/2017	PRIVATE (SELF PAY)	\$635.05	\$360.05	\$275.00
17-01688	7237-07	3/1/2017	PRIVATE (SELF PAY)	\$582.13	\$367.13	\$215.00
17-01696	0716-02-04	3/1/2017	PRIVATE (SELF PAY)	\$594.88	\$494.88	\$100.00
17-01685	5351-12	3/1/2017	PRIVATE (SELF PAY)	\$1,011.88	\$961.88	\$50.00
17-01709	00725-17	3/2/2017	PRIVATE (SELF PAY)	\$701.35	\$0.00	\$701.35
17-01710	01710-17	3/2/2017	PRIVATE (SELF PAY)	\$742.15	\$713.11	\$29.04
17-01732	3326-09	3/3/2017	PRIVATE (SELF PAY)	\$688.60	\$613.60	\$75.00
17-01758	01758-17	3/4/2017	PRIVATE (SELF PAY)	\$618.48	\$334.52	\$283.96
17-01760	5548-16	3/4/2017	PRIVATE (SELF PAY)	\$515.83	\$415.83	\$100.00
17-01775	01775-17	3/4/2017	PRIVATE (SELF PAY)	\$710.28	\$0.00	\$710.28
17-01787	01787-17	3/4/2017	PRIVATE (SELF PAY)	\$650.35	\$0.00	\$650.35
17-01800	5286-12	3/5/2017	PRIVATE (SELF PAY)	\$642.70	\$377.70	\$265.00
17-01804	01804-17	3/5/2017	PRIVATE (SELF PAY)	\$136.00	\$0.00	\$136.00
17-01828	5548-16	3/6/2017	PRIVATE (SELF PAY)	\$515.83	\$415.83	\$100.00
17-01819	00737-17	3/6/2017	PRIVATE (SELF PAY)	\$607.00	\$0.00	\$607.00
17-01850	1850-17	3/7/2017	PRIVATE (SELF PAY)	\$649.38	\$643.75	\$5.63
17-01849	5548-16	3/7/2017	PRIVATE (SELF PAY)	\$514.55	\$414.55	\$100.00
17-01904	1904-17	3/8/2017	PRIVATE (SELF PAY)	\$677.13	\$0.00	\$677.13
17-01879	5548-16	3/8/2017	PRIVATE (SELF PAY)	\$531.13	\$431.13	\$100.00
17-01925	4490-07	3/9/2017	PRIVATE (SELF PAY)	\$619.10	\$354.10	\$265.00
17-01930	01930-17	3/10/2017	PRIVATE (SELF PAY)	\$136.00	\$0.00	\$136.00
17-01955	1955-17	3/10/2017	PRIVATE (SELF PAY)	\$611.45	\$462.00	\$149.45
17-01941	1941-17	3/10/2017	PRIVATE (SELF PAY)	\$660.55	\$459.50	\$201.05
17-01969	01969-17	3/11/2017	PRIVATE (SELF PAY)	\$546.43	\$0.00	\$546.43
17-01986	1986-17	3/11/2017	PRIVATE (SELF PAY)	\$564.28	\$0.00	\$564.28
17-01992	2024-07	3/12/2017	PRIVATE (SELF PAY)	\$621.03	\$371.03	\$250.00
17-02010	02010-17	3/13/2017	PRIVATE (SELF PAY)	\$596.15	\$0.00	\$596.15
17-02055	2276-06	3/14/2017	PRIVATE (SELF PAY)	\$674.58	\$585.52	\$89.06
17-02046	0300-05	3/14/2017	PRIVATE (SELF PAY)	\$706.45	\$565.16	\$141.29
17-02067	02067-17	3/14/2017	PRIVATE (SELF PAY)	\$136.00	\$0.00	\$136.00
17-02069	02069-17	3/15/2017	PRIVATE (SELF PAY)	\$668.20	\$579.87	\$88.33
17-02072	02072-17	3/15/2017	PRIVATE (SELF PAY)	\$136.00	\$19.86	\$116.14
17-02092	02092-17	3/16/2017	PRIVATE (SELF PAY)	\$876.03	\$763.94	\$112.09
17-02101	02101-17	3/16/2017	PRIVATE (SELF PAY)	\$647.80	\$561.80	\$86.00
17-02105	8498-16	3/16/2017	PRIVATE (SELF PAY)	\$619.75	\$519.75	\$100.00
17-02143	02143-17	3/17/2017	PRIVATE (SELF PAY)	\$136.00	\$0.00	\$136.00
17-02117	02117-17	3/17/2017	PRIVATE (SELF PAY)	\$665.65	\$0.00	\$665.65
17-02131	02131-17	3/17/2017	PRIVATE (SELF PAY)	\$602.53	\$0.00	\$602.53
17-02118	5955-08	3/17/2017	PRIVATE (SELF PAY)	\$136.00	\$0.00	\$136.00
17-02168	02168-17	3/18/2017	PRIVATE (SELF PAY)	\$799.53	\$0.00	\$799.53
17-02163	02163-17	3/18/2017	PRIVATE (SELF PAY)	\$569.38	\$0.00	\$569.38
17-02147	02147-17	3/18/2017	PRIVATE (SELF PAY)	\$136.00	\$25.00	\$111.00
17-02181	02181-17	3/19/2017	PRIVATE (SELF PAY)	\$591.05	\$0.00	\$591.05
17-02201	3120-07	3/20/2017	PRIVATE (SELF PAY)	\$556.63	\$0.00	\$556.63

17-02209	02209-17	3/20/2017	PRIVATE (SELF PAY)	\$570.65	\$0.00	\$570.65
17-02207	3131-12	3/20/2017	PRIVATE (SELF PAY)	\$637.60	\$532.50	\$105.10
17-02232	02232-17	3/20/2017	PRIVATE (SELF PAY)	\$717.93	\$0.00	\$717.93
17-02243	02243-17	3/21/2017	PRIVATE (SELF PAY)	\$136.00	\$0.00	\$136.00
17-02244	02244-17	3/21/2017	PRIVATE (SELF PAY)	\$649.08	\$0.00	\$649.08
17-02257	02257-17	3/21/2017	PRIVATE (SELF PAY)	\$641.43	\$0.00	\$641.43
17-02265	02265-17	3/22/2017	PRIVATE (SELF PAY)	\$646.53	\$560.68	\$85.85
17-02322	5088-16	3/23/2017	PRIVATE (SELF PAY)	\$691.15	\$0.00	\$691.15
17-02325	02325-17	3/23/2017	PRIVATE (SELF PAY)	\$660.55	\$360.55	\$300.00
17-02336	00981-17	3/24/2017	PRIVATE (SELF PAY)	\$623.58	\$0.00	\$623.58
17-02358	02358-17	3/25/2017	PRIVATE (SELF PAY)	\$635.05	\$453.89	\$181.16
17-02366	02366-17	3/26/2017	PRIVATE (SELF PAY)	\$719.20	\$0.00	\$719.20
17-02367	01710-17	3/26/2017	PRIVATE (SELF PAY)	\$726.85	\$698.34	\$28.51
17-02406	7890-11	3/27/2017	PRIVATE (SELF PAY)	\$793.15	\$690.53	\$102.62
17-02409	6889-11	3/27/2017	PRIVATE (SELF PAY)	\$136.00	\$108.78	\$27.22
17-02415	6889-11	3/27/2017	PRIVATE (SELF PAY)	\$781.68	\$681.68	\$100.00
17-02397	02397-17	3/27/2017	PRIVATE (SELF PAY)	\$777.85	\$677.85	\$100.00
17-02441	02441-17	3/28/2017	PRIVATE (SELF PAY)	\$593.60	\$474.88	\$118.72
17-02425	02425-17	3/28/2017	PRIVATE (SELF PAY)	\$944.88	\$824.91	\$119.97
17-02419	01465-17	3/28/2017	PRIVATE (SELF PAY)	\$646.53	\$546.53	\$100.00
17-02450	02450-17	3/29/2017	PRIVATE (SELF PAY)	\$551.53	\$0.00	\$551.53
17-02442	7237-07	3/29/2017	PRIVATE (SELF PAY)	\$578.30	\$363.30	\$215.00
17-02466	02466-17	3/29/2017	PRIVATE (SELF PAY)	\$879.85	\$0.00	\$879.85
17-02456	5742-12	3/29/2017	PRIVATE (SELF PAY)	\$900.95	\$0.00	\$900.95
17-02528	02528-17	4/1/2017	PRIVATE (SELF PAY)	\$673.30	\$0.00	\$673.30
17-02534	02534-17	4/1/2017	PRIVATE (SELF PAY)	\$136.00	\$0.00	\$136.00
17-02565	02565-17	4/2/2017	PRIVATE (SELF PAY)	\$643.98	\$502.19	\$141.79
17-02570	02570-17	4/2/2017	PRIVATE (SELF PAY)	\$811.00	\$0.00	\$811.00
17-02574-02	02574-17-02	4/3/2017	PRIVATE (SELF PAY)	\$136.00	\$0.00	\$136.00
17-02610-02	02610-17-02	4/4/2017	PRIVATE (SELF PAY)	\$577.03	\$80.06	\$496.97
17-02670-02	02670-17	4/6/2017	PRIVATE (SELF PAY)	\$531.13	\$0.00	\$531.13
17-02670	02670-17-02	4/6/2017	PRIVATE (SELF PAY)	\$531.13	\$0.00	\$531.13
17-02667	00750-17	4/6/2017	PRIVATE (SELF PAY)	\$673.30	\$0.00	\$673.30
17-02675	02675-17	4/6/2017	PRIVATE (SELF PAY)	\$651.63	\$0.00	\$651.63
17-02690	4221-05	4/7/2017	PRIVATE (SELF PAY)	\$136.00	\$0.00	\$136.00
17-02713	3051-15	4/7/2017	PRIVATE (SELF PAY)	\$705.18	\$0.00	\$705.18
17-02724	02724-17	4/8/2017	PRIVATE (SELF PAY)	\$136.00	\$0.00	\$136.00
17-02734	0766-12	4/9/2017	PRIVATE (SELF PAY)	\$659.28	\$559.28	\$100.00
17-02766	02766-17	4/10/2017	PRIVATE (SELF PAY)	\$660.55	\$0.00	\$660.55
17-02765	02765-17	4/10/2017	PRIVATE (SELF PAY)	\$664.38	\$634.38	\$30.00
17-02769	5388-15	4/10/2017	PRIVATE (SELF PAY)	\$702.63	\$610.36	\$92.27
17-02803	1706-07	4/11/2017	PRIVATE (SELF PAY)	\$136.00	\$0.00	\$136.00
17-02831	2024-07	4/12/2017	PRIVATE (SELF PAY)	\$638.88	\$388.88	\$250.00
17-02834	02834-17	4/12/2017	PRIVATE (SELF PAY)	\$701.35	\$601.35	\$100.00
17-02844	6842-14	4/12/2017	PRIVATE (SELF PAY)	\$851.80	\$751.80	\$100.00
17-02865	5286-12	4/13/2017	PRIVATE (SELF PAY)	\$560.45	\$295.45	\$265.00
17-02881	02881-17	4/13/2017	PRIVATE (SELF PAY)	\$663.10	\$413.10	\$250.00

17-02906	2371-16	4/14/2017	PRIVATE (SELF PAY)	\$136.00	\$0.00	\$136.00
17-02888	02888-17	4/14/2017	PRIVATE (SELF PAY)	\$543.88	\$471.74	\$72.14
17-02965	02965-17	4/16/2017	PRIVATE (SELF PAY)	\$607.63	\$0.00	\$607.63
17-02973	7533-12	4/16/2017	PRIVATE (SELF PAY)	\$136.00	\$0.00	\$136.00
17-02971	1491-14-02	4/16/2017	PRIVATE (SELF PAY)	\$658.00	\$640.00	\$18.00
17-03030	03030-17	4/17/2017	PRIVATE (SELF PAY)	\$651.63	\$565.20	\$86.43
17-03015	0315-17	4/17/2017	PRIVATE (SELF PAY)	\$737.05	\$0.00	\$737.05
17-03027	03027-17	4/17/2017	PRIVATE (SELF PAY)	\$570.65	\$0.00	\$570.65
17-03050	03050-17	4/18/2017	PRIVATE (SELF PAY)	\$747.25	\$0.00	\$747.25
17-03038	4970-14	4/18/2017	PRIVATE (SELF PAY)	\$689.88	\$551.91	\$137.97
17-03112	8568-11	4/20/2017	PRIVATE (SELF PAY)	\$537.50	\$437.50	\$100.00
17-03129	1540-08	4/20/2017	PRIVATE (SELF PAY)	\$641.43	\$341.43	\$300.00
17-03177	03177-17	4/22/2017	PRIVATE (SELF PAY)	\$570.65	\$398.12	\$172.53
17-03215	8568-11	4/23/2017	PRIVATE (SELF PAY)	\$608.90	\$501.25	\$107.65
17-03206	03206-17	4/23/2017	PRIVATE (SELF PAY)	\$624.85	\$541.48	\$83.37
17-03212	4/6/2786	4/23/2017	PRIVATE (SELF PAY)	\$529.85	\$429.85	\$100.00
17-03265	03265-17	4/25/2017	PRIVATE (SELF PAY)	\$136.00	\$0.00	\$136.00
17-03287	03287-17	4/26/2017	PRIVATE (SELF PAY)	\$668.20	\$0.00	\$668.20
17-03297	03297-17	4/26/2017	PRIVATE (SELF PAY)	\$622.30	\$0.00	\$622.30
17-03291	03291-17	4/26/2017	PRIVATE (SELF PAY)	\$702.63	\$0.00	\$702.63
17-03343	6889-11	4/28/2017	PRIVATE (SELF PAY)	\$766.38	\$666.38	\$100.00
17-03356	03356-17	4/28/2017	PRIVATE (SELF PAY)	\$136.00	\$0.00	\$136.00
17-03374	03374-17	4/29/2017	PRIVATE (SELF PAY)	\$638.88	\$479.16	\$159.72
17-03380	03380-17	4/29/2017	PRIVATE (SELF PAY)	\$136.00	\$0.00	\$136.00
17-03392	3871-15	4/30/2017	PRIVATE (SELF PAY)	\$552.80	\$452.80	\$100.00
17-03407	2457-99	4/30/2017	PRIVATE (SELF PAY)	\$670.75	\$467.52	\$203.23
17-03394	03394-17	4/30/2017	PRIVATE (SELF PAY)	\$136.00	\$0.00	\$136.00
17-03410	03410-17	4/30/2017	PRIVATE (SELF PAY)	\$624.85	\$524.85	\$100.00
17-03429	2427-04	5/1/2017	PRIVATE (SELF PAY)	\$557.90	\$484.16	\$73.74
17-03438	03438-17	5/1/2017	PRIVATE (SELF PAY)	\$697.53	\$605.85	\$91.68
17-03419	5931-15	5/1/2017	PRIVATE (SELF PAY)	\$814.18	\$0.00	\$814.18
17-03439	02191-17	5/1/2017	PRIVATE (SELF PAY)	\$762.55	\$730.00	\$32.55
17-03483	03483-17	5/3/2017	PRIVATE (SELF PAY)	\$573.20	\$523.20	\$50.00
17-03477	03477-17	5/3/2017	PRIVATE (SELF PAY)	\$763.83	\$0.00	\$763.83
17-03502	2211-07	5/3/2017	PRIVATE (SELF PAY)	\$136.00	\$0.00	\$136.00
17-03492	9080-11	5/3/2017	PRIVATE (SELF PAY)	\$799.53	\$762.86	\$36.67
17-03530	6889-11	5/4/2017	PRIVATE (SELF PAY)	\$684.13	\$584.13	\$100.00
17-03540	03540-17	5/4/2017	PRIVATE (SELF PAY)	\$136.00	\$0.00	\$136.00
17-03510	03510-17	5/4/2017	PRIVATE (SELF PAY)	\$555.35	\$0.00	\$555.35
17-03512	03512-17	5/4/2017	PRIVATE (SELF PAY)	\$642.70	\$0.00	\$642.70
17-03562	4592-12	5/5/2017	PRIVATE (SELF PAY)	\$741.50	\$378.16	\$363.34
17-03580	6592-15	5/6/2017	PRIVATE (SELF PAY)	\$686.05	\$656.05	\$30.00
17-03626	934-97	5/8/2017	PRIVATE (SELF PAY)	\$647.80	\$0.00	\$647.80
17-03627	03627-17	5/8/2017	PRIVATE (SELF PAY)	\$717.93	\$0.00	\$717.93
17-03640	03640-17	5/8/2017	PRIVATE (SELF PAY)	\$136.00	\$0.00	\$136.00
17-03699-01	03699-17	5/10/2017	PRIVATE (SELF PAY)	\$654.18	\$0.00	\$654.18
17-03721	4765-16	5/11/2017	PRIVATE (SELF PAY)	\$646.53	\$546.53	\$100.00

17-03727	3273-08	5/12/2017	PRIVATE (SELF PAY)	\$660.55	\$510.55	\$150.00
17-03739	03739-17	5/12/2017	PRIVATE (SELF PAY)	\$661.83	\$0.00	\$661.83
17-03744	03744-17	5/12/2017	PRIVATE (SELF PAY)	\$619.75	\$494.40	\$125.35
17-03737	03737-17	5/12/2017	PRIVATE (SELF PAY)	\$136.00	\$0.00	\$136.00
17-03772	03772-17	5/13/2017	PRIVATE (SELF PAY)	\$612.73	\$0.00	\$612.73
17-03756	03756-17	5/13/2017	PRIVATE (SELF PAY)	\$808.45	\$0.00	\$808.45
17-03762-01	2/12/5025	5/13/2017	PRIVATE (SELF PAY)	\$136.00	\$0.00	\$136.00
17-03762	5986-13	5/13/2017	PRIVATE (SELF PAY)	\$540.05	\$0.00	\$540.05
17-03759	03759-17	5/13/2017	PRIVATE (SELF PAY)	\$554.08	\$354.08	\$200.00
17-03803	6493-15	5/14/2017	PRIVATE (SELF PAY)	\$678.40	\$588.91	\$89.49
17-03795	03795-17	5/14/2017	PRIVATE (SELF PAY)	\$552.80	\$0.00	\$552.80
17-03778	934-97	5/14/2017	PRIVATE (SELF PAY)	\$136.00	\$0.00	\$136.00
17-03787	2326-13	5/14/2017	PRIVATE (SELF PAY)	\$136.00	\$0.00	\$136.00
17-03781	6842-14	5/14/2017	PRIVATE (SELF PAY)	\$552.80	\$452.80	\$100.00
17-03804	03804-17	5/15/2017	PRIVATE (SELF PAY)	\$136.00	\$0.00	\$136.00
17-03817	6478-13	5/15/2017	PRIVATE (SELF PAY)	\$655.45	\$0.00	\$655.45
17-03822	03822-17	5/16/2017	PRIVATE (SELF PAY)	\$536.23	\$486.23	\$50.00
17-03885	03885-17	5/18/2017	PRIVATE (SELF PAY)	\$548.98	\$329.86	\$219.12
17-03896	03896-17	5/18/2017	PRIVATE (SELF PAY)	\$528.58	\$0.00	\$528.58
17-03918	03918-17	5/19/2017	PRIVATE (SELF PAY)	\$601.25	\$522.55	\$78.70
17-03911	03911-17	5/19/2017	PRIVATE (SELF PAY)	\$658.00	\$628.00	\$30.00
17-03940	03940-17	5/20/2017	PRIVATE (SELF PAY)	\$686.05	\$0.00	\$686.05
17-03961	03961-17	5/21/2017	PRIVATE (SELF PAY)	\$680.95	\$430.95	\$250.00
17-03993	03993-17	5/22/2017	PRIVATE (SELF PAY)	\$711.55	\$0.00	\$711.55
17-04035	7023-15	5/23/2017	PRIVATE (SELF PAY)	\$668.20	\$618.20	\$50.00
17-04048	04048-17	5/24/2017	PRIVATE (SELF PAY)	\$651.63	\$565.20	\$86.43
17-04038	6478-13	5/24/2017	PRIVATE (SELF PAY)	\$554.08	\$0.00	\$554.08
17-04087	04087-17	5/25/2017	PRIVATE (SELF PAY)	\$575.75	\$0.00	\$575.75
17-04084	8254-14	5/25/2017	PRIVATE (SELF PAY)	\$689.88	\$424.88	\$265.00
17-04098	4765-16	5/25/2017	PRIVATE (SELF PAY)	\$552.80	\$452.80	\$100.00
17-04127	1350-08	5/26/2017	PRIVATE (SELF PAY)	\$698.80	\$696.25	\$2.55
17-04169	04169-17	5/28/2017	PRIVATE (SELF PAY)	\$703.90	\$0.00	\$703.90
17-04202	2150-07	5/29/2017	PRIVATE (SELF PAY)	\$649.08	\$562.94	\$86.14
17-04253	04253-17	5/30/2017	PRIVATE (SELF PAY)	\$136.00	\$0.00	\$136.00
17-04230	04230-17	5/30/2017	PRIVATE (SELF PAY)	\$136.00	\$0.00	\$136.00
17-04257	4566-16	5/30/2017	PRIVATE (SELF PAY)	\$136.00	\$0.00	\$136.00
17-04256	4478-16	5/30/2017	PRIVATE (SELF PAY)	\$536.23	\$464.97	\$71.26
17-04273	6475-16	5/31/2017	PRIVATE (SELF PAY)	\$136.00	\$0.00	\$136.00
17-04272	04272-17	5/31/2017	PRIVATE (SELF PAY)	\$557.90	\$0.00	\$557.90
17-04311	04311-17	6/1/2017	PRIVATE (SELF PAY)	\$552.80	\$0.00	\$552.80
17-04336	04336-17	6/2/2017	PRIVATE (SELF PAY)	\$136.00	\$0.00	\$136.00
17-04352	04352-17	6/2/2017	PRIVATE (SELF PAY)	\$136.00	\$0.00	\$136.00
17-04330	7474-14	6/2/2017	PRIVATE (SELF PAY)	\$580.85	\$320.02	\$260.83
17-04385	04385-17	6/4/2017	PRIVATE (SELF PAY)	\$136.00	\$0.00	\$136.00
17-04389	04389-17	6/4/2017	PRIVATE (SELF PAY)	\$864.55	\$0.00	\$864.55
17-04378	7261-14	6/4/2017	PRIVATE (SELF PAY)	\$554.08	\$504.08	\$50.00
17-04425	5088-16	6/5/2017	PRIVATE (SELF PAY)	\$693.70	\$0.00	\$693.70

17-04419	7143-12	6/5/2017	PRIVATE (SELF PAY)	\$754.90	\$654.90	\$100.00
17-04418	03206-17	6/5/2017	PRIVATE (SELF PAY)	\$520.93	\$451.42	\$69.51
17-04403	04403-17	6/5/2017	PRIVATE (SELF PAY)	\$635.05	\$404.11	\$230.94
17-04411	7474-14	6/5/2017	PRIVATE (SELF PAY)	\$696.25	\$386.84	\$309.41
17-04416	6180-07	6/5/2017	PRIVATE (SELF PAY)	\$641.43	\$0.00	\$641.43
17-04424	04424-17	6/5/2017	PRIVATE (SELF PAY)	\$734.50	\$634.50	\$100.00
17-04407	0965-09	6/5/2017	PRIVATE (SELF PAY)	\$632.50	\$0.00	\$632.50
17-04460	6063-07	6/6/2017	PRIVATE (SELF PAY)	\$560.45	\$486.42	\$74.03
17-04441	7320-12	6/6/2017	PRIVATE (SELF PAY)	\$632.50	\$548.25	\$84.25
17-04516	04516-17	6/8/2017	PRIVATE (SELF PAY)	\$532.40	\$267.40	\$265.00
17-04533	04533-17	6/8/2017	PRIVATE (SELF PAY)	\$813.55	\$569.48	\$244.07
17-04505	04505-17	6/8/2017	PRIVATE (SELF PAY)	\$512.00	\$0.00	\$512.00
17-04510	3792-15	6/8/2017	PRIVATE (SELF PAY)	\$673.30	\$573.30	\$100.00
17-04531	04531-17	6/8/2017	PRIVATE (SELF PAY)	\$680.95	\$0.00	\$680.95
17-04545-02	04545-17-02	6/9/2017	PRIVATE (SELF PAY)	\$541.33	\$0.00	\$541.33
17-04577	8381-16	6/10/2017	PRIVATE (SELF PAY)	\$618.48	\$0.00	\$618.48
17-04569	9984-16	6/10/2017	PRIVATE (SELF PAY)	\$632.50	\$367.50	\$265.00
17-04603	7890-11	6/11/2017	PRIVATE (SELF PAY)	\$779.13	\$678.12	\$101.01
17-04643	6464-12	6/12/2017	PRIVATE (SELF PAY)	\$579.58	\$0.00	\$579.58
17-04622	04622-17	6/12/2017	PRIVATE (SELF PAY)	\$698.80	\$0.00	\$698.80
17-04618	3284-11	6/12/2017	PRIVATE (SELF PAY)	\$656.73	\$356.73	\$300.00
17-04617	04617-17	6/12/2017	PRIVATE (SELF PAY)	\$594.88	\$0.00	\$594.88
17-04620	3792-15	6/12/2017	PRIVATE (SELF PAY)	\$652.90	\$552.90	\$100.00
17-04648	4156-15	6/13/2017	PRIVATE (SELF PAY)	\$547.70	\$0.00	\$547.70
17-04665	04665-17	6/13/2017	PRIVATE (SELF PAY)	\$623.58	\$0.00	\$623.58
17-04681	04681-17	6/14/2017	PRIVATE (SELF PAY)	\$564.28	\$494.28	\$70.00
17-04716	04716-17	6/15/2017	PRIVATE (SELF PAY)	\$686.05	\$0.00	\$686.05
17-04764	04764-17	6/16/2017	PRIVATE (SELF PAY)	\$632.50	\$0.00	\$632.50
17-04752	2776-15	6/16/2017	PRIVATE (SELF PAY)	\$621.03	\$538.10	\$82.93
17-04795	04795-17	6/18/2017	PRIVATE (SELF PAY)	\$930.85	\$0.00	\$930.85
17-04796	04796-17	6/18/2017	PRIVATE (SELF PAY)	\$887.50	\$806.55	\$80.95
17-04822	04822-17	6/18/2017	PRIVATE (SELF PAY)	\$869.65	\$839.65	\$30.00
17-04807	04807-17	6/18/2017	PRIVATE (SELF PAY)	\$136.00	\$0.00	\$136.00
17-04830	04830-17	6/19/2017	PRIVATE (SELF PAY)	\$664.38	\$576.49	\$87.89
17-04837	04837-17	6/19/2017	PRIVATE (SELF PAY)	\$556.63	\$83.70	\$472.93
17-04827	6842-14	6/19/2017	PRIVATE (SELF PAY)	\$551.53	\$451.53	\$100.00
17-04845	04845-17	6/19/2017	PRIVATE (SELF PAY)	\$642.70	\$0.00	\$642.70
17-04859	6842-14	6/20/2017	PRIVATE (SELF PAY)	\$550.25	\$450.25	\$100.00
17-04895	04895-17	6/21/2017	PRIVATE (SELF PAY)	\$654.18	\$0.00	\$654.18
17-04901-01	6943-07	6/21/2017	PRIVATE (SELF PAY)	\$638.88	\$0.00	\$638.88
17-04944	04944-17	6/22/2017	PRIVATE (SELF PAY)	\$649.08	\$0.00	\$649.08
17-04956	04956-17	6/23/2017	PRIVATE (SELF PAY)	\$668.20	\$579.87	\$88.33
17-04977	04977-17	6/23/2017	PRIVATE (SELF PAY)	\$556.63	\$410.33	\$146.30
17-04991	04991-17	6/24/2017	PRIVATE (SELF PAY)	\$136.00	\$0.00	\$136.00
17-05013	05013-17	6/25/2017	PRIVATE (SELF PAY)	\$853.08	\$0.00	\$853.08
17-05025	6509-15	6/26/2017	PRIVATE (SELF PAY)	\$679.68	\$414.68	\$265.00
17-05036	0716-02-04	6/26/2017	PRIVATE (SELF PAY)	\$665.65	\$565.65	\$100.00

17-05037	1313-00	6/26/2017	PRIVATE (SELF PAY)	\$677.13	\$302.13	\$375.00
17-05024	5912-16	6/26/2017	PRIVATE (SELF PAY)	\$589.78	\$569.78	\$20.00
17-05038	05038-17	6/26/2017	PRIVATE (SELF PAY)	\$624.85	\$594.85	\$30.00
17-05052	05052-17	6/27/2017	PRIVATE (SELF PAY)	\$555.35	\$0.00	\$555.35
17-05063	00563-17-02	6/27/2017	PRIVATE (SELF PAY)	\$559.18	\$259.18	\$300.00
17-05059	4765-16	6/27/2017	PRIVATE (SELF PAY)	\$550.25	\$450.25	\$100.00
17-05085	05085-17	6/28/2017	PRIVATE (SELF PAY)	\$704.53	\$629.53	\$75.00
17-05084	0090-00	6/28/2017	PRIVATE (SELF PAY)	\$552.82	\$252.82	\$300.00
17-05090	02881-17	6/28/2017	PRIVATE (SELF PAY)	\$540.05	\$290.05	\$250.00
17-05100	5592-14	6/28/2017	PRIVATE (SELF PAY)	\$632.50	\$532.50	\$100.00
17-05108	5286-12	6/29/2017	PRIVATE (SELF PAY)	\$547.70	\$282.70	\$265.00
17-05114	05114-17	6/29/2017	PRIVATE (SELF PAY)	\$632.50	\$548.25	\$84.25
17-05140	05140-17	6/30/2017	PRIVATE (SELF PAY)	\$670.75	\$595.75	\$75.00
17-05195	5379-11	7/1/2017	PRIVATE (SELF PAY)	\$632.50	\$0.00	\$632.50
17-05188	05188-17	7/1/2017	PRIVATE (SELF PAY)	\$855.63	\$745.87	\$109.76
17-05209	5076-12	7/2/2017	PRIVATE (SELF PAY)	\$519.65	\$419.65	\$100.00
17-05216	6889-11	7/2/2017	PRIVATE (SELF PAY)	\$684.13	\$584.13	\$100.00
17-05213	0982-03	7/2/2017	PRIVATE (SELF PAY)	\$136.00	\$0.00	\$136.00
17-05241	05241-17	7/3/2017	PRIVATE (SELF PAY)	\$645.25	\$512.00	\$133.25
17-05257	05257-17	7/3/2017	PRIVATE (SELF PAY)	\$714.10	\$0.00	\$714.10
17-05290	05290-17	7/4/2017	PRIVATE (SELF PAY)	\$664.38	\$576.49	\$87.89
17-05271	9956-16	7/4/2017	PRIVATE (SELF PAY)	\$136.00	\$0.00	\$136.00
17-05275	3702-02	7/4/2017	PRIVATE (SELF PAY)	\$692.43	\$0.00	\$692.43
17-05267	05267-17	7/4/2017	PRIVATE (SELF PAY)	\$688.60	\$0.00	\$688.60
17-05293	6215-16	7/4/2017	PRIVATE (SELF PAY)	\$641.43	\$376.43	\$265.00
17-05297	04764-17	7/5/2017	PRIVATE (SELF PAY)	\$636.33	\$0.00	\$636.33
17-05321	05321-17	7/5/2017	PRIVATE (SELF PAY)	\$655.45	\$0.00	\$655.45
17-05350	7680-15	7/6/2017	PRIVATE (SELF PAY)	\$136.00	\$0.00	\$136.00
17-05339	05339-17	7/6/2017	PRIVATE (SELF PAY)	\$569.38	\$0.00	\$569.38
17-05325	0041-15	7/6/2017	PRIVATE (SELF PAY)	\$551.53	\$0.00	\$551.53
17-05336	05336-17	7/6/2017	PRIVATE (SELF PAY)	\$512.00	\$0.00	\$512.00
17-05344	05344-17	7/6/2017	PRIVATE (SELF PAY)	\$136.00	\$44.97	\$91.03
17-05360	0875-10	7/7/2017	PRIVATE (SELF PAY)	\$779.13	\$704.13	\$75.00
17-05389	2179-07	7/8/2017	PRIVATE (SELF PAY)	\$670.75	\$582.13	\$88.62
17-05413	05413-17	7/8/2017	PRIVATE (SELF PAY)	\$136.00	\$0.00	\$136.00
17-05437	04830-17	7/9/2017	PRIVATE (SELF PAY)	\$682.23	\$592.30	\$89.93
17-05444	5379-11	7/9/2017	PRIVATE (SELF PAY)	\$647.80	\$0.00	\$647.80
17-05423	7376-08	7/9/2017	PRIVATE (SELF PAY)	\$709.00	\$334.00	\$375.00
17-05474	2457-96	7/11/2017	PRIVATE (SELF PAY)	\$550.25	\$250.25	\$300.00
17-05471	3440-13	7/11/2017	PRIVATE (SELF PAY)	\$637.60	\$0.00	\$637.60
17-05474-03	05474-17	7/11/2017	PRIVATE (SELF PAY)	\$559.18	\$259.18	\$300.00
17-05499	1994-16	7/12/2017	PRIVATE (SELF PAY)	\$136.00	\$0.00	\$136.00
17-05507	05507-17	7/12/2017	PRIVATE (SELF PAY)	\$559.18	\$0.00	\$559.18
17-05528	05528-17	7/13/2017	PRIVATE (SELF PAY)	\$136.00	\$0.00	\$136.00
17-05558	05507-17	7/14/2017	PRIVATE (SELF PAY)	\$561.73	\$0.00	\$561.73
17-05545	6889-11	7/14/2017	PRIVATE (SELF PAY)	\$686.68	\$586.68	\$100.00
17-05551	5658-12	7/14/2017	PRIVATE (SELF PAY)	\$543.88	\$443.88	\$100.00

17-05546	7261-14	7/14/2017	PRIVATE (SELF PAY)	\$552.80	\$502.80	\$50.00
17-05578-02	05578-17-02	7/15/2017	PRIVATE (SELF PAY)	\$136.00	\$0.00	\$136.00
17-05591	05591-17	7/15/2017	PRIVATE (SELF PAY)	\$652.90	\$545.25	\$107.65
17-05606	05606-17	7/16/2017	PRIVATE (SELF PAY)	\$517.10	\$270.78	\$246.32
17-05602	2024-07	7/16/2017	PRIVATE (SELF PAY)	\$632.50	\$382.50	\$250.00
17-05619	05619-17	7/16/2017	PRIVATE (SELF PAY)	\$679.68	\$579.68	\$100.00
17-05614	4811-07	7/16/2017	PRIVATE (SELF PAY)	\$541.33	\$474.66	\$66.67
17-05608	05608-17	7/16/2017	PRIVATE (SELF PAY)	\$649.08	\$0.00	\$649.08
17-05632	05632-17	7/17/2017	PRIVATE (SELF PAY)	\$136.00	\$0.00	\$136.00
17-05627	4592-12	7/17/2017	PRIVATE (SELF PAY)	\$136.00	\$69.36	\$66.64
17-05667	5379-11	7/18/2017	PRIVATE (SELF PAY)	\$647.80	\$0.00	\$647.80
17-05644	05644-17	7/18/2017	PRIVATE (SELF PAY)	\$700.08	\$0.00	\$700.08
17-05683	05683-17	7/19/2017	PRIVATE (SELF PAY)	\$526.03	\$0.00	\$526.03
17-05709	05709-17	7/20/2017	PRIVATE (SELF PAY)	\$136.00	\$0.00	\$136.00
17-05713	8446-15	7/20/2017	PRIVATE (SELF PAY)	\$672.03	\$0.00	\$672.03
17-05722	8446-15	7/20/2017	PRIVATE (SELF PAY)	\$930.85	\$925.75	\$5.10
17-05710	05710-17	7/20/2017	PRIVATE (SELF PAY)	\$668.20	\$0.00	\$668.20
17-05743	05743-17	7/21/2017	PRIVATE (SELF PAY)	\$603.80	\$0.00	\$603.80
17-05754	05754-17	7/21/2017	PRIVATE (SELF PAY)	\$675.85	\$0.00	\$675.85
17-05789	05789-17	7/22/2017	PRIVATE (SELF PAY)	\$717.93	\$467.93	\$250.00
17-05811	5658-12	7/23/2017	PRIVATE (SELF PAY)	\$809.73	\$709.73	\$100.00
17-05869	05869-17	7/25/2017	PRIVATE (SELF PAY)	\$646.53	\$0.00	\$646.53
17-05860	5286-12	7/25/2017	PRIVATE (SELF PAY)	\$643.98	\$378.98	\$265.00
17-05868	05868-17	7/25/2017	PRIVATE (SELF PAY)	\$136.00	\$130.00	\$6.00
17-05892	05892-17	7/26/2017	PRIVATE (SELF PAY)	\$533.68	\$518.93	\$14.75
17-05928	2317-16	7/27/2017	PRIVATE (SELF PAY)	\$700.08	\$621.25	\$78.83
17-05962	05962-17	7/28/2017	PRIVATE (SELF PAY)	\$654.18	\$554.18	\$100.00
17-05983-01	05983-17-01	7/29/2017	PRIVATE (SELF PAY)	\$136.00	\$0.00	\$136.00
17-06010	06010-17	7/30/2017	PRIVATE (SELF PAY)	\$636.33	\$0.00	\$636.33
17-06008	5379-11	7/30/2017	PRIVATE (SELF PAY)	\$607.63	\$0.00	\$607.63
17-06012	4059-15	7/30/2017	PRIVATE (SELF PAY)	\$973.63	\$823.63	\$150.00
17-06048	6842-14	7/31/2017	PRIVATE (SELF PAY)	\$816.10	\$716.10	\$100.00
17-06045	7278-10	7/31/2017	PRIVATE (SELF PAY)	\$537.50	\$0.00	\$537.50
17-06077	4040-08	8/1/2017	PRIVATE (SELF PAY)	\$654.18	\$580.92	\$73.26
17-06133	4101-06	8/3/2017	PRIVATE (SELF PAY)	\$527.30	\$0.00	\$527.30
17-06146	06146-17	8/4/2017	PRIVATE (SELF PAY)	\$728.13	\$0.00	\$728.13
17-06143	06143-17	8/4/2017	PRIVATE (SELF PAY)	\$575.75	\$0.00	\$575.75
17-06149	06149-17	8/4/2017	PRIVATE (SELF PAY)	\$791.88	\$741.88	\$50.00
17-06159	04830-17	8/5/2017	PRIVATE (SELF PAY)	\$587.23	\$510.14	\$77.09
17-06213	0236-16	8/7/2017	PRIVATE (SELF PAY)	\$651.63	\$551.63	\$100.00
17-06221	6221-17	8/7/2017	PRIVATE (SELF PAY)	\$545.15	\$0.00	\$545.15
17-06261	06261-17	8/9/2017	PRIVATE (SELF PAY)	\$681.43	\$101.75	\$579.68
17-06293	06293-17	8/9/2017	PRIVATE (SELF PAY)	\$675.85	\$0.00	\$675.85
17-06270	7614-14	8/9/2017	PRIVATE (SELF PAY)	\$876.03	\$763.94	\$112.09
17-06271	06271-17	8/9/2017	PRIVATE (SELF PAY)	\$136.00	\$0.00	\$136.00
17-06280	06280-17	8/9/2017	PRIVATE (SELF PAY)	\$697.53	\$0.00	\$697.53
17-06316	7890-11	8/10/2017	PRIVATE (SELF PAY)	\$136.00	\$0.00	\$136.00

17-06345-0106345-17-01	8/11/2017	PRIVATE (SELF PAY)	\$136.00	\$0.00	\$136.00
17-06368 06368-17	8/12/2017	PRIVATE (SELF PAY)	\$136.00	\$0.00	\$136.00
17-06364 06364-17	8/12/2017	PRIVATE (SELF PAY)	\$651.63	\$0.00	\$651.63
17-06372 06372-17	8/12/2017	PRIVATE (SELF PAY)	\$136.00	\$0.00	\$136.00
17-06351 06351-17	8/12/2017	PRIVATE (SELF PAY)	\$832.68	\$0.00	\$832.68
17-06396 3909-15	8/13/2017	PRIVATE (SELF PAY)	\$136.00	\$0.00	\$136.00
17-06403 06403-17	8/13/2017	PRIVATE (SELF PAY)	\$628.03	\$0.00	\$628.03
17-06408 06408-17	8/14/2017	PRIVATE (SELF PAY)	\$557.90	\$0.00	\$557.90
17-06459 0626-13	8/15/2017	PRIVATE (SELF PAY)	\$938.50	\$508.73	\$429.77
17-06460 06460-17	8/15/2017	PRIVATE (SELF PAY)	\$136.00	\$0.00	\$136.00
17-06466 06466-17	8/16/2017	PRIVATE (SELF PAY)	\$944.88	\$0.00	\$944.88
17-06474 0106-08	8/16/2017	PRIVATE (SELF PAY)	\$527.30	\$0.00	\$527.30
17-06498 06498-17	8/17/2017	PRIVATE (SELF PAY)	\$540.05	\$0.00	\$540.05
17-06486 4404-13	8/17/2017	PRIVATE (SELF PAY)	\$670.75	\$595.75	\$75.00
17-06492 3575-08	8/17/2017	PRIVATE (SELF PAY)	\$624.85	\$0.00	\$624.85
17-06493 06493-17	8/17/2017	PRIVATE (SELF PAY)	\$588.50	\$488.50	\$100.00
17-06487 06549-17	8/17/2017	PRIVATE (SELF PAY)	\$136.00	\$0.00	\$136.00
17-06533 06533-17	8/18/2017	PRIVATE (SELF PAY)	\$914.28	\$191.79	\$722.49
17-06541 6255-15	8/18/2017	PRIVATE (SELF PAY)	\$892.60	\$642.60	\$250.00
17-06574 04830-17	8/19/2017	PRIVATE (SELF PAY)	\$678.40	\$588.91	\$89.49
17-06549 06549-17	8/19/2017	PRIVATE (SELF PAY)	\$678.40	\$0.00	\$678.40
17-06590 06590-17-01	8/20/2017	PRIVATE (SELF PAY)	\$635.05	\$503.10	\$131.95
17-06587 3561-16	8/20/2017	PRIVATE (SELF PAY)	\$640.15	\$375.15	\$265.00
17-06600 7196-16	8/20/2017	PRIVATE (SELF PAY)	\$686.05	\$595.68	\$90.37
17-06603 8113-16	8/20/2017	PRIVATE (SELF PAY)	\$666.93	\$401.93	\$265.00
17-06604 06604-17	8/20/2017	PRIVATE (SELF PAY)	\$1,247.75	\$0.00	\$1,247.75
17-06638 6493-15	8/21/2017	PRIVATE (SELF PAY)	\$651.63	\$565.20	\$86.43
17-06625 00728-17	8/21/2017	PRIVATE (SELF PAY)	\$136.00	\$0.00	\$136.00
17-06615 3672-15	8/21/2017	PRIVATE (SELF PAY)	\$136.00	\$0.00	\$136.00
17-06642 06642-17	8/22/2017	PRIVATE (SELF PAY)	\$702.63	\$0.00	\$702.63
17-06655 06655-17	8/22/2017	PRIVATE (SELF PAY)	\$570.65	\$470.65	\$100.00
17-06681 06681-17	8/23/2017	PRIVATE (SELF PAY)	\$512.00	\$437.00	\$75.00
17-06697 06697-17-01	8/24/2017	PRIVATE (SELF PAY)	\$584.68	\$0.00	\$584.68
17-06710 5876-14	8/24/2017	PRIVATE (SELF PAY)	\$602.53	\$523.69	\$78.84
17-06724 1970-10	8/24/2017	PRIVATE (SELF PAY)	\$686.05	\$436.05	\$250.00
17-06703 6440-09	8/24/2017	PRIVATE (SELF PAY)	\$715.38	\$0.00	\$715.38
17-06720 06720-17	8/24/2017	PRIVATE (SELF PAY)	\$136.00	\$0.00	\$136.00
17-06749 0874-04	8/25/2017	PRIVATE (SELF PAY)	\$654.18	\$523.34	\$130.84
17-06739 3792-15	8/25/2017	PRIVATE (SELF PAY)	\$569.38	\$469.38	\$100.00
17-06791 06791-17	8/26/2017	PRIVATE (SELF PAY)	\$696.25	\$41.24	\$655.01
17-06796 06796-17	8/26/2017	PRIVATE (SELF PAY)	\$565.55	\$0.00	\$565.55
17-06808 06808-17	8/27/2017	PRIVATE (SELF PAY)	\$598.70	\$0.00	\$598.70
17-06821 3885-16	8/27/2017	PRIVATE (SELF PAY)	\$136.00	\$0.00	\$136.00
17-06813 06813-17	8/27/2017	PRIVATE (SELF PAY)	\$664.38	\$374.02	\$290.36
17-06860 06860-17	8/28/2017	PRIVATE (SELF PAY)	\$136.00	\$57.12	\$78.88
17-06846 06846-17	8/28/2017	PRIVATE (SELF PAY)	\$136.00	\$0.00	\$136.00
17-06847 06847-17	8/28/2017	PRIVATE (SELF PAY)	\$798.25	\$695.05	\$103.20

17-06890	06890-17	8/29/2017	PRIVATE (SELF PAY)	\$136.00	\$0.00	\$136.00
17-06906	3974-15	8/30/2017	PRIVATE (SELF PAY)	\$649.08	\$0.00	\$649.08
17-06923	06923-17	8/30/2017	PRIVATE (SELF PAY)	\$614.00	\$0.00	\$614.00
17-06934	06934-17	8/31/2017	PRIVATE (SELF PAY)	\$656.73	\$581.73	\$75.00
17-06950	06950-17	8/31/2017	PRIVATE (SELF PAY)	\$649.08	\$574.08	\$75.00
17-06943	6478-13	8/31/2017	PRIVATE (SELF PAY)	\$551.53	\$0.00	\$551.53
17-06962	06962-17	9/1/2017	PRIVATE (SELF PAY)	\$136.00	\$0.00	\$136.00
17-06987	6842-14	9/1/2017	PRIVATE (SELF PAY)	\$550.25	\$450.25	\$100.00
17-07026	8210-15	9/3/2017	PRIVATE (SELF PAY)	\$1,071.80	\$0.00	\$1,071.80
17-07022	2024-07	9/3/2017	PRIVATE (SELF PAY)	\$658.00	\$485.08	\$172.92
17-07032	5286-12	9/3/2017	PRIVATE (SELF PAY)	\$668.20	\$403.20	\$265.00
17-07044	07044-17	9/3/2017	PRIVATE (SELF PAY)	\$660.55	\$0.00	\$660.55
17-07090	7237-07	9/5/2017	PRIVATE (SELF PAY)	\$684.78	\$469.78	\$215.00
17-07100	2276-06	9/5/2017	PRIVATE (SELF PAY)	\$554.08	\$480.78	\$73.30
17-07099	07099-17	9/5/2017	PRIVATE (SELF PAY)	\$830.75	\$577.34	\$253.41
17-07083	5286-12	9/5/2017	PRIVATE (SELF PAY)	\$615.28	\$350.28	\$265.00
17-07095	00563-17-02	9/5/2017	PRIVATE (SELF PAY)	\$670.75	\$370.75	\$300.00
17-07121	0875-10	9/6/2017	PRIVATE (SELF PAY)	\$795.70	\$720.70	\$75.00
17-07124	5379-11	9/6/2017	PRIVATE (SELF PAY)	\$729.40	\$0.00	\$729.40
17-07130	03519-17	9/6/2017	PRIVATE (SELF PAY)	\$666.93	\$566.93	\$100.00
17-07139	2315-13	9/7/2017	PRIVATE (SELF PAY)	\$602.53	\$0.00	\$602.53
17-07149	0974-12	9/7/2017	PRIVATE (SELF PAY)	\$663.10	\$563.10	\$100.00
17-07138	07138-17	9/7/2017	PRIVATE (SELF PAY)	\$656.73	\$0.00	\$656.73
17-07171	5701-12	9/8/2017	PRIVATE (SELF PAY)	\$697.53	\$397.53	\$300.00
17-07160	07160-17	9/8/2017	PRIVATE (SELF PAY)	\$136.00	\$0.00	\$136.00
17-07174	07174-17	9/8/2017	PRIVATE (SELF PAY)	\$757.45	\$657.45	\$100.00
17-07187	07187-17	9/9/2017	PRIVATE (SELF PAY)	\$639.50	\$0.00	\$639.50
17-07199	07199-17	9/9/2017	PRIVATE (SELF PAY)	\$1,140.65	\$787.03	\$353.62
17-07201	07201-17	9/9/2017	PRIVATE (SELF PAY)	\$547.70	\$0.00	\$547.70
17-07245	4765-16	9/10/2017	PRIVATE (SELF PAY)	\$666.93	\$566.93	\$100.00
17-07280	2012-13	9/11/2017	PRIVATE (SELF PAY)	\$741.50	\$568.41	\$173.09
17-07304	07304-17	9/12/2017	PRIVATE (SELF PAY)	\$557.90	\$345.41	\$212.49
17-07323	2265-05	9/13/2017	PRIVATE (SELF PAY)	\$136.00	\$0.00	\$136.00
17-07306	5286-12	9/13/2017	PRIVATE (SELF PAY)	\$626.75	\$361.75	\$265.00
17-07339	4512-12	9/14/2017	PRIVATE (SELF PAY)	\$904.08	\$0.00	\$904.08
17-07328	1/7/5180	9/14/2017	PRIVATE (SELF PAY)	\$654.18	\$579.18	\$75.00
17-07348	6667-15	9/14/2017	PRIVATE (SELF PAY)	\$545.15	\$0.00	\$545.15
17-07357	07357-17	9/14/2017	PRIVATE (SELF PAY)	\$136.00	\$0.00	\$136.00
17-07369	1334-99	9/15/2017	PRIVATE (SELF PAY)	\$684.78	\$608.50	\$76.28
17-07361	03513-17	9/15/2017	PRIVATE (SELF PAY)	\$136.00	\$0.00	\$136.00
17-07394	3561-16	9/16/2017	PRIVATE (SELF PAY)	\$577.03	\$327.03	\$250.00
17-07442	7890-11	9/17/2017	PRIVATE (SELF PAY)	\$798.25	\$695.05	\$103.20
17-07443	07443-17	9/17/2017	PRIVATE (SELF PAY)	\$649.08	\$85.25	\$563.83
17-07451	07451-17	9/18/2017	PRIVATE (SELF PAY)	\$593.60	\$397.58	\$196.02
17-07486	8677-16	9/19/2017	PRIVATE (SELF PAY)	\$692.43	\$592.43	\$100.00
17-07488	04830-17	9/19/2017	PRIVATE (SELF PAY)	\$136.00	\$0.00	\$136.00
17-07485	07485-17	9/19/2017	PRIVATE (SELF PAY)	\$786.78	\$0.00	\$786.78

17-07478	7261-14	9/19/2017	PRIVATE (SELF PAY)	\$570.65	\$520.65	\$50.00
17-07504	07504-17	9/20/2017	PRIVATE (SELF PAY)	\$136.00	\$0.00	\$136.00
17-07496	07496-17	9/20/2017	PRIVATE (SELF PAY)	\$655.45	\$0.00	\$655.45
17-07543	07543-17	9/21/2017	PRIVATE (SELF PAY)	\$668.83	\$0.00	\$668.83
17-07606	07606-17	9/23/2017	PRIVATE (SELF PAY)	\$524.75	\$419.80	\$104.95
17-07613	2776-15	9/23/2017	PRIVATE (SELF PAY)	\$136.00	\$0.00	\$136.00
17-07612	07612-17	9/23/2017	PRIVATE (SELF PAY)	\$763.83	\$543.57	\$220.26
17-07611	07611-17	9/23/2017	PRIVATE (SELF PAY)	\$654.18	\$389.18	\$265.00
17-07623	07623-17	9/23/2017	PRIVATE (SELF PAY)	\$596.15	\$396.15	\$200.00
17-07633	07633-17	9/24/2017	PRIVATE (SELF PAY)	\$691.15	\$0.00	\$691.15
17-07635	0582-09	9/24/2017	PRIVATE (SELF PAY)	\$668.20	\$293.20	\$375.00
17-07640	07665-17	9/24/2017	PRIVATE (SELF PAY)	\$136.00	\$113.50	\$22.50
17-07646	07646-17	9/24/2017	PRIVATE (SELF PAY)	\$767.00	\$0.00	\$767.00
17-07686	07686-17	9/25/2017	PRIVATE (SELF PAY)	\$136.00	\$0.00	\$136.00
17-07673	07673-17	9/25/2017	PRIVATE (SELF PAY)	\$552.80	\$0.00	\$552.80
17-07665	07665-17	9/25/2017	PRIVATE (SELF PAY)	\$620.38	\$487.88	\$132.50
17-07679	07679-17	9/25/2017	PRIVATE (SELF PAY)	\$637.60	\$337.60	\$300.00
17-07701	07701-17	9/26/2017	PRIVATE (SELF PAY)	\$665.65	\$565.65	\$100.00
17-07715	07715-17	9/26/2017	PRIVATE (SELF PAY)	\$733.70	\$511.92	\$221.78
17-07708	07708-17	9/26/2017	PRIVATE (SELF PAY)	\$691.15	\$641.15	\$50.00
17-07705	07705-17	9/26/2017	PRIVATE (SELF PAY)	\$687.33	\$549.86	\$137.47
17-07728	6642-14-02	9/27/2017	PRIVATE (SELF PAY)	\$136.00	\$0.00	\$136.00
17-07747	2776-15	9/27/2017	PRIVATE (SELF PAY)	\$669.48	\$581.01	\$88.47
17-07723	07723-17	9/27/2017	PRIVATE (SELF PAY)	\$592.33	\$302.09	\$290.24
17-07746	6478-13	9/27/2017	PRIVATE (SELF PAY)	\$594.88	\$0.00	\$594.88
17-07774	07774-17	9/28/2017	PRIVATE (SELF PAY)	\$646.53	\$381.53	\$265.00
17-07788	04830-17	9/29/2017	PRIVATE (SELF PAY)	\$601.25	\$522.55	\$78.70
17-07815	1392-00	9/30/2017	PRIVATE (SELF PAY)	\$1,235.00	\$930.06	\$304.94
17-07820	2644-11	9/30/2017	PRIVATE (SELF PAY)	\$664.38	\$576.49	\$87.89
17-07860	07860-17	10/1/2017	PRIVATE (SELF PAY)	\$670.75	\$570.75	\$100.00
17-07866	5876-14	10/1/2017	PRIVATE (SELF PAY)	\$697.53	\$605.85	\$91.68
17-07857	3630-15	10/1/2017	PRIVATE (SELF PAY)	\$136.00	\$0.00	\$136.00
17-07908	07908-17	10/2/2017	PRIVATE (SELF PAY)	\$570.65	\$495.45	\$75.20
17-07872	07872-17	10/2/2017	PRIVATE (SELF PAY)	\$692.43	\$0.00	\$692.43
17-07893	07893-17	10/2/2017	PRIVATE (SELF PAY)	\$136.00	\$0.00	\$136.00
17-07900	07900-17	10/2/2017	PRIVATE (SELF PAY)	\$716.00	\$666.00	\$50.00
17-07923	6478-13	10/3/2017	PRIVATE (SELF PAY)	\$658.00	\$0.00	\$658.00
17-07948	8835-16	10/4/2017	PRIVATE (SELF PAY)	\$547.70	\$475.13	\$72.57
17-07973	07973-17	10/5/2017	PRIVATE (SELF PAY)	\$594.88	\$0.00	\$594.88
17-08013	2227-03	10/6/2017	PRIVATE (SELF PAY)	\$655.45	\$30.00	\$625.45
17-08032	05754-17	10/6/2017	PRIVATE (SELF PAY)	\$136.00	\$0.00	\$136.00
17-08027	08027-17	10/6/2017	PRIVATE (SELF PAY)	\$726.85	\$624.20	\$102.65
17-08049	08049-17	10/7/2017	PRIVATE (SELF PAY)	\$799.53	\$0.00	\$799.53
17-08051	08051-17	10/7/2017	PRIVATE (SELF PAY)	\$540.05	\$465.05	\$75.00
17-08053	08053-17	10/7/2017	PRIVATE (SELF PAY)	\$566.83	\$476.83	\$90.00
17-08090	7418-09	10/8/2017	PRIVATE (SELF PAY)	\$832.68	\$543.30	\$289.38
17-08136	08136-17	10/10/2017	PRIVATE (SELF PAY)	\$664.38	\$576.49	\$87.89

17-08141	0784-11	10/10/2017	PRIVATE (SELF PAY)	\$646.53	\$544.86	\$101.67
17-08130	08130-17	10/10/2017	PRIVATE (SELF PAY)	\$693.70	\$663.70	\$30.00
17-08157	08157-17	10/11/2017	PRIVATE (SELF PAY)	\$136.00	\$0.00	\$136.00
17-08153	6837-09	10/11/2017	PRIVATE (SELF PAY)	\$673.30	\$584.39	\$88.91
17-08149	08149-17	10/11/2017	PRIVATE (SELF PAY)	\$136.00	\$0.00	\$136.00
17-08172	08172-17	10/12/2017	PRIVATE (SELF PAY)	\$693.70	\$493.70	\$200.00
17-08184	5838-12	10/12/2017	PRIVATE (SELF PAY)	\$514.55	\$462.00	\$52.55
17-08199	08199-17	10/12/2017	PRIVATE (SELF PAY)	\$136.00	\$0.00	\$136.00
17-08227	0650-10	10/13/2017	PRIVATE (SELF PAY)	\$658.00	\$628.00	\$30.00
17-08204	1541-11	10/13/2017	PRIVATE (SELF PAY)	\$537.50	\$437.50	\$100.00
17-08241	08241-17	10/14/2017	PRIVATE (SELF PAY)	\$591.05	\$0.00	\$591.05
17-08311	08311-17	10/16/2017	PRIVATE (SELF PAY)	\$136.00	\$0.00	\$136.00
17-08302	08302-17	10/16/2017	PRIVATE (SELF PAY)	\$770.20	\$0.00	\$770.20
17-08318	0784-11	10/16/2017	PRIVATE (SELF PAY)	\$564.28	\$478.67	\$85.61
17-08307	2485-16	10/16/2017	PRIVATE (SELF PAY)	\$668.20	\$120.00	\$548.20
17-08357	08357-17	10/18/2017	PRIVATE (SELF PAY)	\$649.08	\$562.94	\$86.14
17-08380	08998-18	10/18/2017	PRIVATE (SELF PAY)	\$568.10	\$0.00	\$568.10
17-08393	6701-16	10/19/2017	PRIVATE (SELF PAY)	\$645.25	\$0.00	\$645.25
17-08419	08419-17	10/20/2017	PRIVATE (SELF PAY)	\$790.60	\$0.00	\$790.60
17-08443	08443-17	10/20/2017	PRIVATE (SELF PAY)	\$664.50	\$576.61	\$87.89
17-08454	7376-08	10/21/2017	PRIVATE (SELF PAY)	\$677.13	\$302.13	\$375.00
17-08460	08460-17	10/21/2017	PRIVATE (SELF PAY)	\$701.35	\$457.12	\$244.23
17-08487	8432-11	10/22/2017	PRIVATE (SELF PAY)	\$673.30	\$0.00	\$673.30
17-08527	08527-17	10/23/2017	PRIVATE (SELF PAY)	\$673.30	\$0.00	\$673.30
17-08569	08569-17	10/24/2017	PRIVATE (SELF PAY)	\$569.38	\$469.38	\$100.00
17-08563	08563-17	10/24/2017	PRIVATE (SELF PAY)	\$136.00	\$0.00	\$136.00
17-08597	7100-11	10/25/2017	PRIVATE (SELF PAY)	\$555.35	\$130.58	\$424.77
17-08611	08611-17	10/26/2017	PRIVATE (SELF PAY)	\$569.38	\$0.00	\$569.38
17-08608	6493-15	10/26/2017	PRIVATE (SELF PAY)	\$660.55	\$573.10	\$87.45
17-08604	8835-16	10/26/2017	PRIVATE (SELF PAY)	\$670.75	\$582.13	\$88.62
17-08612	08612-17	10/26/2017	PRIVATE (SELF PAY)	\$136.00	\$0.00	\$136.00
17-08613	08613-17	10/26/2017	PRIVATE (SELF PAY)	\$656.73	\$569.71	\$87.02
17-08603	3028-07	10/26/2017	PRIVATE (SELF PAY)	\$136.00	\$0.00	\$136.00
17-08653	08653-17	10/27/2017	PRIVATE (SELF PAY)	\$916.83	\$0.00	\$916.83
17-08630	5016-12	10/27/2017	PRIVATE (SELF PAY)	\$615.93	\$492.75	\$123.18
17-08650	08650-17	10/27/2017	PRIVATE (SELF PAY)	\$666.93	\$0.00	\$666.93
17-08642	08642-17	10/27/2017	PRIVATE (SELF PAY)	\$136.00	\$0.00	\$136.00
17-08684	08684-17	10/28/2017	PRIVATE (SELF PAY)	\$636.33	\$0.00	\$636.33
17-08667	08667-17	10/28/2017	PRIVATE (SELF PAY)	\$136.00	\$0.00	\$136.00
17-08725	08726-17	10/30/2017	PRIVATE (SELF PAY)	\$136.00	\$0.00	\$136.00
17-08723	1255-16	10/30/2017	PRIVATE (SELF PAY)	\$670.75	\$650.75	\$20.00
17-08742	6701-16	10/30/2017	PRIVATE (SELF PAY)	\$136.00	\$0.00	\$136.00
17-08784	08784-17	11/1/2017	PRIVATE (SELF PAY)	\$688.60	\$0.00	\$688.60
17-08779	08779-17	11/1/2017	PRIVATE (SELF PAY)	\$563.00	\$263.00	\$300.00
17-08785	4901-15	11/1/2017	PRIVATE (SELF PAY)	\$557.90	\$457.90	\$100.00
17-08809	9635-16	11/2/2017	PRIVATE (SELF PAY)	\$136.00	\$36.00	\$100.00
17-08828	4646-14-03	11/2/2017	PRIVATE (SELF PAY)	\$606.35	\$531.35	\$75.00

17-08808	05397-17	11/2/2017	PRIVATE (SELF PAY)	\$962.15	\$0.00	\$962.15
17-08855	08855-17	11/3/2017	PRIVATE (SELF PAY)	\$568.10	\$488.00	\$80.10
17-08861	4065-07	11/3/2017	PRIVATE (SELF PAY)	\$680.95	\$480.95	\$200.00
17-08840	08840-17	11/3/2017	PRIVATE (SELF PAY)	\$1,034.13	\$0.00	\$1,034.13
17-08900	08900-17	11/4/2017	PRIVATE (SELF PAY)	\$529.85	\$429.85	\$100.00
17-08876	8824-15	11/4/2017	PRIVATE (SELF PAY)	\$545.15	\$445.15	\$100.00
17-08918	0241-16	11/5/2017	PRIVATE (SELF PAY)	\$540.05	\$42.62	\$497.43
17-08912	7261-14	11/5/2017	PRIVATE (SELF PAY)	\$566.83	\$516.83	\$50.00
17-08940	08650-17	11/6/2017	PRIVATE (SELF PAY)	\$664.38	\$0.00	\$664.38
17-08930	0300-05	11/6/2017	PRIVATE (SELF PAY)	\$837.13	\$669.70	\$167.43
17-08958	08958-17	11/7/2017	PRIVATE (SELF PAY)	\$658.00	\$0.00	\$658.00
17-08978	08978-17	11/8/2017	PRIVATE (SELF PAY)	\$705.18	\$555.18	\$150.00
17-08980	2179-07	11/8/2017	PRIVATE (SELF PAY)	\$639.50	\$556.43	\$83.07
17-09002	09002-17	11/8/2017	PRIVATE (SELF PAY)	\$663.10	\$0.00	\$663.10
17-09021	4501-16	11/9/2017	PRIVATE (SELF PAY)	\$660.55	\$573.10	\$87.45
17-09036	09036-17	11/9/2017	PRIVATE (SELF PAY)	\$682.23	\$592.30	\$89.93
17-09041	09041-17	11/9/2017	PRIVATE (SELF PAY)	\$920.65	\$0.00	\$920.65
17-09096	09096-17	11/11/2017	PRIVATE (SELF PAY)	\$666.93	\$160.00	\$506.93
17-09101	09101-17	11/12/2017	PRIVATE (SELF PAY)	\$560.45	\$0.00	\$560.45
17-09189	09189-17	11/15/2017	PRIVATE (SELF PAY)	\$645.25	\$538.12	\$107.13
17-09205	09205-17	11/15/2017	PRIVATE (SELF PAY)	\$550.25	\$500.25	\$50.00
17-09233	09233-17	11/16/2017	PRIVATE (SELF PAY)	\$868.38	\$793.38	\$75.00
17-09213	09212-17	11/16/2017	PRIVATE (SELF PAY)	\$606.35	\$476.35	\$130.00
17-09263	00728-17	11/17/2017	PRIVATE (SELF PAY)	\$687.33	\$423.21	\$264.12
17-09284	09286-17	11/18/2017	PRIVATE (SELF PAY)	\$892.60	\$778.61	\$113.99
17-09273	0296-16	11/18/2017	PRIVATE (SELF PAY)	\$136.00	\$0.00	\$136.00
17-09318	5652-16	11/19/2017	PRIVATE (SELF PAY)	\$573.20	\$473.20	\$100.00
17-09309	9236-15	11/19/2017	PRIVATE (SELF PAY)	\$566.83	\$301.83	\$265.00
17-09304	09304-17	11/19/2017	PRIVATE (SELF PAY)	\$569.38	\$0.00	\$569.38
17-09305	7331-11	11/19/2017	PRIVATE (SELF PAY)	\$1,133.00	\$983.00	\$150.00
17-09323	09323-17	11/19/2017	PRIVATE (SELF PAY)	\$136.00	\$0.00	\$136.00
17-09350	5652-16	11/20/2017	PRIVATE (SELF PAY)	\$668.20	\$568.20	\$100.00
17-09383	6235-13	11/21/2017	PRIVATE (SELF PAY)	\$534.95	\$462.00	\$72.95
17-09373	09373-17	11/21/2017	PRIVATE (SELF PAY)	\$661.83	\$0.00	\$661.83
17-09427	09427-17	11/22/2017	PRIVATE (SELF PAY)	\$136.00	\$0.00	\$136.00
17-09422	09422-17	11/22/2017	PRIVATE (SELF PAY)	\$136.00	\$0.00	\$136.00
17-09459	09459-17	11/23/2017	PRIVATE (SELF PAY)	\$136.00	\$0.00	\$136.00
17-09446	09446-17	11/23/2017	PRIVATE (SELF PAY)	\$643.98	\$0.00	\$643.98
17-09475	09475-17	11/24/2017	PRIVATE (SELF PAY)	\$636.33	\$532.50	\$103.83
17-09488	09488-17	11/24/2017	PRIVATE (SELF PAY)	\$136.00	\$86.00	\$50.00
17-09470	4910-14-02	11/24/2017	PRIVATE (SELF PAY)	\$651.63	\$562.72	\$88.91
17-09509	09509-17	11/25/2017	PRIVATE (SELF PAY)	\$652.25	\$632.29	\$19.96
17-09511	3551-05	11/25/2017	PRIVATE (SELF PAY)	\$725.58	\$0.00	\$725.58
17-09507	4065-07	11/25/2017	PRIVATE (SELF PAY)	\$596.15	\$396.15	\$200.00
17-09491	09491-17	11/25/2017	PRIVATE (SELF PAY)	\$598.70	\$0.00	\$598.70
17-09506	2/9/5111	11/25/2017	PRIVATE (SELF PAY)	\$734.50	\$0.00	\$734.50
17-09520	9236-15	11/26/2017	PRIVATE (SELF PAY)	\$556.63	\$291.63	\$265.00

17-09526	09526-17	11/26/2017	PRIVATE (SELF PAY)	\$136.00	\$0.00	\$136.00
17-09537	9984-16	11/26/2017	PRIVATE (SELF PAY)	\$651.63	\$386.63	\$265.00
17-09608	09608-17	11/28/2017	PRIVATE (SELF PAY)	\$615.28	\$0.00	\$615.28
17-09601	08650-17	11/28/2017	PRIVATE (SELF PAY)	\$664.38	\$0.00	\$664.38
17-09599	05298-17	11/28/2017	PRIVATE (SELF PAY)	\$620.38	\$0.00	\$620.38
17-09630	09630-17	11/29/2017	PRIVATE (SELF PAY)	\$876.03	\$538.06	\$337.97
17-09627	09627-17	11/29/2017	PRIVATE (SELF PAY)	\$136.00	\$0.00	\$136.00
17-09617	09617-17	11/29/2017	PRIVATE (SELF PAY)	\$1,264.33	\$0.00	\$1,264.33
17-09623	7387-16	11/29/2017	PRIVATE (SELF PAY)	\$136.00	\$0.00	\$136.00
17-09639	09639-17	11/30/2017	PRIVATE (SELF PAY)	\$663.10	\$413.10	\$250.00
17-09671	1413-91	11/30/2017	PRIVATE (SELF PAY)	\$547.70	\$475.13	\$72.57
17-09642	09642-17	11/30/2017	PRIVATE (SELF PAY)	\$616.55	\$0.00	\$616.55
17-09704	6881-13	12/2/2017	PRIVATE (SELF PAY)	\$664.38	\$0.00	\$664.38
17-09731	09731-17	12/2/2017	PRIVATE (SELF PAY)	\$136.00	\$0.00	\$136.00
17-09720	3028-07	12/2/2017	PRIVATE (SELF PAY)	\$594.88	\$0.00	\$594.88
17-09715	2593-16	12/2/2017	PRIVATE (SELF PAY)	\$654.18	\$0.00	\$654.18
17-09743	7100-11	12/3/2017	PRIVATE (SELF PAY)	\$538.78	\$125.50	\$413.28
17-09790	09790-17	12/5/2017	PRIVATE (SELF PAY)	\$537.50	\$0.00	\$537.50
17-09839	0788-09	12/6/2017	PRIVATE (SELF PAY)	\$552.80	\$452.80	\$100.00
17-09832	1378-92	12/6/2017	PRIVATE (SELF PAY)	\$663.10	\$363.10	\$300.00
17-09822	8905-11	12/6/2017	PRIVATE (SELF PAY)	\$582.13	\$0.00	\$582.13
17-09875	7100-11	12/7/2017	PRIVATE (SELF PAY)	\$538.78	\$125.50	\$413.28
17-09879	4065-07	12/7/2017	PRIVATE (SELF PAY)	\$569.38	\$369.38	\$200.00
17-09872	9984-16	12/7/2017	PRIVATE (SELF PAY)	\$725.58	\$460.58	\$265.00
17-09908	08650-17	12/8/2017	PRIVATE (SELF PAY)	\$571.93	\$0.00	\$571.93
17-09934	7951-15	12/9/2017	PRIVATE (SELF PAY)	\$643.98	\$0.00	\$643.98
17-09964	09964-17	12/10/2017	PRIVATE (SELF PAY)	\$547.70	\$0.00	\$547.70
17-09981	09981-17	12/11/2017	PRIVATE (SELF PAY)	\$136.00	\$0.00	\$136.00
17-10009	1451-06	12/12/2017	PRIVATE (SELF PAY)	\$665.65	\$0.00	\$665.65
17-10040	10040-17	12/13/2017	PRIVATE (SELF PAY)	\$689.88	\$589.88	\$100.00
17-10085	10085-17	12/14/2017	PRIVATE (SELF PAY)	\$136.00	\$0.00	\$136.00
17-10071	10071-17	12/14/2017	PRIVATE (SELF PAY)	\$136.00	\$108.80	\$27.20
17-10105	1555-12	12/15/2017	PRIVATE (SELF PAY)	\$643.98	\$343.98	\$300.00
17-10090	5719-16	12/15/2017	PRIVATE (SELF PAY)	\$698.80	\$547.20	\$151.60
17-10091	10091-17	12/15/2017	PRIVATE (SELF PAY)	\$1,075.63	\$0.00	\$1,075.63
17-10093	09748-17	12/15/2017	PRIVATE (SELF PAY)	\$928.30	\$0.00	\$928.30
17-10141	10141-17	12/16/2017	PRIVATE (SELF PAY)	\$136.00	\$0.00	\$136.00
17-10142	10142-17	12/16/2017	PRIVATE (SELF PAY)	\$659.28	\$0.00	\$659.28
17-10135	10135-17	12/16/2017	PRIVATE (SELF PAY)	\$136.00	\$0.00	\$136.00
17-10176	1448-10	12/17/2017	PRIVATE (SELF PAY)	\$703.90	\$673.90	\$30.00
17-10161	10161-17	12/17/2017	PRIVATE (SELF PAY)	\$568.10	\$0.00	\$568.10
17-10195	09446-17	12/18/2017	PRIVATE (SELF PAY)	\$666.93	\$0.00	\$666.93
17-10205	10205-17	12/18/2017	PRIVATE (SELF PAY)	\$561.73	\$0.00	\$561.73
17-10222	10222-17-01	12/19/2017	PRIVATE (SELF PAY)	\$733.23	\$488.01	\$245.22
17-10225	1863-14	12/19/2017	PRIVATE (SELF PAY)	\$622.30	\$0.00	\$622.30
17-10234	821-91	12/20/2017	PRIVATE (SELF PAY)	\$136.00	\$0.00	\$136.00
17-10310	04632-17	12/22/2017	PRIVATE (SELF PAY)	\$565.55	\$465.55	\$100.00

17-10345	10345-17	12/23/2017	PRIVATE (SELF PAY)	\$571.93	\$371.93	\$200.00
17-10331	0716-02-04	12/23/2017	PRIVATE (SELF PAY)	\$136.00	\$0.00	\$136.00
17-10369	10369-17	12/24/2017	PRIVATE (SELF PAY)	\$693.70	\$0.00	\$693.70
17-10448	4512-12	12/26/2017	PRIVATE (SELF PAY)	\$136.00	\$0.00	\$136.00
17-10458	4501-16	12/27/2017	PRIVATE (SELF PAY)	\$569.38	\$494.33	\$75.05
17-10487	10487-17	12/27/2017	PRIVATE (SELF PAY)	\$680.95	\$591.16	\$89.79
17-10484	10484-17	12/27/2017	PRIVATE (SELF PAY)	\$637.60	\$0.00	\$637.60
17-10485	5379-11	12/27/2017	PRIVATE (SELF PAY)	\$633.13	\$0.00	\$633.13
17-10453	10453-17	12/27/2017	PRIVATE (SELF PAY)	\$570.65	\$0.00	\$570.65
17-10477	10477-17	12/27/2017	PRIVATE (SELF PAY)	\$666.93	\$661.68	\$5.25
17-10459	10459-17	12/27/2017	PRIVATE (SELF PAY)	\$636.95	\$0.00	\$636.95
17-10498	10498-17	12/28/2017	PRIVATE (SELF PAY)	\$136.00	\$0.00	\$136.00
17-10513	10513-17	12/29/2017	PRIVATE (SELF PAY)	\$580.85	\$0.00	\$580.85
17-10533	10533-17	12/29/2017	PRIVATE (SELF PAY)	\$543.88	\$471.74	\$72.14
17-10518	10518-17	12/29/2017	PRIVATE (SELF PAY)	\$737.68	\$0.00	\$737.68
17-10540	10540-17	12/29/2017	PRIVATE (SELF PAY)	\$560.45	\$486.42	\$74.03
17-10545	09748-17	12/30/2017	PRIVATE (SELF PAY)	\$871.55	\$0.00	\$871.55
17-10570	1373-92	12/31/2017	PRIVATE (SELF PAY)	\$589.78	\$324.78	\$265.00
				\$425,681.14	\$187,294.35	\$238,386.79

Uncollectible Ambulance Fees 2017 \$238,386.79

ID	Location	Customer		Month	Day	Year	Amount	Held	Credit
		Name							Agency
159589	21794	ABEYTA DAMIAN		6	19	17	155.71	N	MSB
136989	50556	ABEYTA LISA		9	19	17	332.94	N	MSB
162201	49338	ADAMS CURTIS		7	24	17	130.69	N	MSB
148413	26478	AGUIRRE JENNIFER		12	19	17	150.32	N	MSB
158891	211486	ALBERT JACOB T		6	19	17	254.76	N	MSB
155179	2916	ALBRIGHT CHELSEA OR		8	21	17	125.38	N	MSB
64367	39344	ALBRIGHT MARK OR MARISSA		7	27	17	96.51	N	MSB
108571	8326	ALIRE MARTINEZ DEBORAH		9	19	17	145.29	N	MSB
100155	159484	ALIVILLAR VANESSA		7	24	17	556.50	N	MSB
163083	10684	ANAYA SHANNA SHANTEL		6	19	17	0.01	N	MSB
151505	138232	ANDERSON KEVIN L & CHRISTIN A		10	24	17	138.40	N	MSB
81127	28710	ANDREWS DOUGLAS & MAURINE		12	19	17	58.64	N	MSB
83631	93631	ARAGON EUGENE		6	19	17	140.98	N	MSB
162375	35260	ARAGON PAULINE		12	19	17	331.26	N	MSB
157691	160072	ARAGON SHERI		8	21	17	463.72	N	MSB
137081	48156	ARANDA ALEXANDRIA		10	24	17	239.36	N	MSB
160819	159332	ARBOGAST ALEXANDRA E		10	24	17	296.77	N	MSB
150559	21808	ARCE CARMEN		6	19	17	123.16	N	MSB
161067	9970	ARCHULETA JOSEPH		11	27	17	212.39	N	MSB
160899	48640	ARMSTRON CLARISSA		11	27	17	279.50	N	MSB
64383	30292	ASHCRAFT BARBARA		11	27	17	79.21	N	MSB
159021	141176	ATENCIO AMANDA		8	21	17	576.31	N	MSB
95839	23944	ATENCIO RHIANN OR ANTHONY R		8	21	17	232.33	N	MSB
168491	49454	ATMA JORDAN		12	19	17	483.20	N	MSB
48301	27162	AUCLAIR MONEDA		10	24	17	349.41	N	MSB
136267	11628	AZPEITIA MELISSA		8	21	17	112.11	N	MSB
94533	139310	BACA CHARMAINE		9	19	17	810.37	N	MSB
141105	15604	BAEZA LINDA L		9	19	17	289.39	N	MSB
156221	15580	BAILEY CHRIS		7	24	17	915.68	N	MSB
134803	51152	BALDONADO NORBERT RAY		11	27	17	554.08	N	MSB
150185	44260	BALDWIN SETH OR CASSANDRA		9	19	17	164.79	N	MSB
158081	13672	BALZANO TARA		12	19	17	13.51	N	MSB
155929	38116	BAROS ANTIONETTE		7	24	17	266.02	N	MSB
140603	12668	BARRIOS JESUS		9	19	17	157.14	N	MSB
147471	34982	BENALLY OMAR		11	27	17	153.53	N	MSB
141621	49762	BERRYMAN MARK		11	27	17	172.05	N	MSB
117899	35298	BILLIE LEILED A		12	19	17	269.57	N	MSB
135897	33674	BIXLER II LOUS OR ELLY JO		8	21	17	241.05	N	MSB
149377	137808	BLAKELY JESSICA		10	24	17	113.22	N	MSB
98989	139524	BLASZKOWSKI JACQUELINE		6	19	17	214.67	N	MSB
128017	153320	BODEN TIERNEY L		5	15	17	372.36	N	MSB
66359	20710	BOLEY ANNE OR WILBUR		9	19	17	156.88	N	MSB
158291	24750	BOOTH JESHUA		8	21	17	107.57	N	MSB
157573	10440	BORDOW ADAM		8	21	17	227.38	N	MSB
147077	20560	BOWLIN JOHN		11	27	17	429.27	N	MSB
135839	47988	BOWMAN JENNIFER		6	19	17	231.77	N	MSB
31151	26474	BRADY ALLAN R		6	19	17	180.03	N	MSB
18235	11728	BREWER SANDRA		12	19	17	115.69	N	MSB
158885	5090	BRISTOW LINDA		6	19	17	233.38	N	MSB
159233	49676	BRONSON PATRICIA		11	27	17	284.48	N	MSB
165839	165839	BROOKHOUSER BOBBY		12	19	17	316.29	N	MSB
88643	714	BROOKS LINDA		9	19	17	99.80	N	MSB
140005	40868	BROOKS TINA OR WILLIAM		10	24	17	256.37	N	MSB
164713	25084	BROOKS WENDY		11	27	17	161.50	N	MSB
162477	24864	BROWN GREGORY		12	19	17	205.20	N	MSB

ID	Location	Customer		Month	Day	Year	Amount	Held	Credit
		Name							Agency
42835	23004	BUCKHANAN STEVEN & VEDA		11	27	17	395.96	N	MSB
164753	26684	BURCH ANTHONY		8	21	17	353.72	N	MSB
68039	23906	BURKHART LACEY		8	21	17	372.50	N	MSB
161977	14298	BUTLER CLAUDIA		11	27	17	176.00	N	MSB
140153	64294	C.N.A. AUTO		10	24	17	63.64	N	MSB
133111	150634	CADMAN ESTHER		12	19	17	127.39	N	MSB
89609	29886	CAMP BRENT OR CHRISTIEN		5	15	17	121.76	N	MSB
157371	9382	CAMPBELL EMMA		7	24	17	79.57	N	MSB
90875	149892	CANDELARIA SALLY		10	24	17	449.21	N	MSB
157291	8910	CANO KRISTINA		10	24	17	159.69	N	MSB
157517	32094	CANTRELL LINDSEY		12	19	17	272.68	N	MSB
150399	34376	CARLSON MIRANDA		8	21	17	601.30	N	MSB
138917	46004	CASTILLO PETER		5	15	17	192.99	N	MSB
163451	136612	CATES HELEN OR W SHAWN		11	27	17	212.86	N	MSB
99949	45568	CAWTHORN-BAXTER MICHAELA		10	24	17	268.84	N	MSB
134473	47506	CERVERA-PEREZ ROSA		10	24	17	154.68	N	MSB
98883	2484	CHACON ERICA		11	27	17	137.71	N	MSB
24821	82691	CHAPMAN MARK S		7	24	17	429.50	N	MSB
82691	19114	CHARLEY ISSAC		6	29	17	174.39	N	MSB
137409	50578	CHAAVEZ ANTHONY		9	19	17	195.36	N	MSB
152281	48646	CHAVEZ CANDI		6	19	17	981.92	N	MSB
158381	49954	CHAVEZ ZIGGY		6	19	17	14.15	N	MSB
28723	26964	CHENOWETH KATHLEEN		9	19	17	52.86	N	MSB
17529	11138	CHRISTOPHER DOMINGEZ		10	24	17	639.23	N	MSB
144343	138886	CLAY VANCE KEEGAN		10	24	17	431.57	N	MSB
130257	148796	COBB JARRED		12	19	17	382.79	N	MSB
153843	17470	COLLINS JESSICA		11	27	17	258.21	N	MSB
75309	14198	COLLINS KAREN		7	24	17	351.88	N	MSB
156335	10054	COLLOPY BRYAN A		12	19	17	168.57	N	MSB
158349	44632	COMBS CHRISTOPER OR YAJAIRA		7	24	17	361.53	N	MSB
100593	137460	CORLEY COLLEEN		7	24	17	235.48	N	MSB
161527	42184	COSBAN STEPHEN OR JENNIFER		11	27	17	438.75	N	MSB
148841	8488	COSTLEY HEATHER OR WILLIAM		11	27	17	303.90	N	MSB
164797	138290	COWAN KELLY		7	24	17	31.49	N	MSB
148941	22238	CRESPIN MARTINA		10	24	17	435.07	N	MSB
152283	24360	CRITES NICOLE		9	19	17	190.49	N	MSB
133587	42372	CRUZ DEYBY		10	24	17	417.94	N	MSB
148673	22402	CUMMINGS ARIANA		12	19	17	253.22	N	MSB
155971	18804	CUNY ISABELLA		7	24	17	90.81	N	MSB
158709	31026	CURRY GABRIEL		6	19	17	46.44	N	MSB
101131	48646	CUSHMAN CHRIS & VANISSA S		8	24	17	67.86	N	MSB
133569	142528	DAGNAN CRYSTAL		11	27	17	931.32	N	MSB
167555	3214	DALTON ERIC		12	19	17	67.64	N	MSB
151175	29318	DAMRON JESSICA		10	24	17	447.00	N	MSB
98195	14794	DARRAS GIN VIRGINIA		10	24	17	323.49	N	MSB
159813	44032	DAVIS DRAKE		12	19	17	636.33	N	MSB
150245	155100	DAVIS MACKIE L OR LOTTIE		10	24	17	29.47	N	MSB
162741	137994	DAWSON CANDICE		12	19	17	401.70	N	MSB
152083	26194	DAY JENNIFER L		12	19	17	1,069.66	N	MSB
155505	51730	DEAN JODIE		10	24	17	156.09	N	MSB
149071	35886	DEANDA CONRADO OR ELSA		6	19	17	265.71	N	MSB
163093	40056	DECKER SHAWN OR CHRISTY		6	19	17	234.86	N	MSB
44391	141450	DELIRA MARY		7	24	17	270.27	N	MSB
149399	34398	DENCH DEBRA M		11	27	17	107.66	N	MSB
15199	23102	DIAZ RALPH A		11	27	17	186.96	N	MSB

ID	Location	Customer		Month	Day	Year	Amount	Held	Credit
		Name							Agency
162917	142606	DIAZ-GARCIA	PAVEL	11	27	17	2,002.04	N	MSB
163861	160330	DILLARD	RICHARD W	6	19	17	342.37	N	MSB
139705	155072	DIXON	JEANETTE	11	27	17	173.26	N	MSB
161405	134816	DOMINGUEZ	TABITHA	9	19	17	348.79	N	MSB
32161	904	DONFRO SR	RICHARD D	8	21	17	295.31	N	MSB
13241	3786	DOTTIN	ALFRED R	10	24	17	0.01	N	MSB
166421	20838	DOYLE	REBECCA OR JERAMY	12	19	17	479.16	N	MSB
147143	10014	DRY	JENIFER	12	19	17	109.91	N	MSB
162521	143228	DUMAS	CATHALINA OR	7	24	17	149.88	N	MSB
160795	20838	DURAN	ALICIA OR ROCHA MATTHEW	8	21	17	449.06	N	MSB
98215	3094	DURAN	BRIAN	9	19	17	283.82	N	MSB
139283	7388	DURAN	MONICA	7	24	17	110.40	N	MSB
155035	3244	DUTCHER	PETER	10	24	17	113.35	N	MSB
156953	39206	DARLY	MEGAN	1	24	17	162.45	N	MSB
158199	13964	EBERT	ANTHONY	11	27	17	471.96	N	MSB
147505	44956	EBY	VICTORIA	7	24	17	281.24	N	MSB
156801	6890	EDWARDS	LEDELL OR LATASHA	12	19	17	556.05	N	MSB
142085	27608	ELAINE	P HERRERA	11	27	17	147.82	N	MSB
163015	24034	EMERSON	VERNIE OR	8	21	17	55.45	N	MSB
103123	12740	ENTWISLE	KIRK	12	19	17	112.81	N	MSB
156783	38070	ERIKSON	BLYTHE	8	21	17	17.84	N	MSB
160511	1515816	ESPINEZA-HERRERA	MELANIE	7	24	17	138.11	N	MSB
154095	38810	ESTRADA	NICOLAS	6	19	17	63.77	N	MSB
159417	21668	FABIANI	MICHAEL A	7	24	17	1,169.73	N	MSB
155079	24884	FANT	DAMIAN	9	19	17	1,114.98	N	MSB
74203	5374	FARMER	RAY	7	24	17	1,654.78	N	MSB
2429	15370	FARNSWORTH	GLENN	8	21	17	339.83	N	MSB
130893	138820	FARRELL	BRIAN	12	19	17	319.41	N	MSB
148749	6026	FERRELL	SAYDRA	10	24	17	0.01	N	MSB
135115	41632	FLYNN	SAM	8	21	17	70.97	N	MSB
12231	24106	FRAKES	ARIANA	12	19	17	201.70	N	MSB
163485	26942	FRASZ	BOHUMIL	8	21	17	1,404.84	N	MSB
109107	5244	GALLARDO	ENRIQUE	8	21	17	124.74	N	MSB
166657	154820	GARCIA	ALAINA	11	27	17	219.20	N	MSB
131731	214924	GARCIA	BRIANA	12	19	17	180.80	N	MSB
157209	43432	GARCIA	JOSEPH G	7	24	17	463.43	N	MSB
140071	50138	GARCIA	MATTHEW	6	19	17	811.75	N	MSB
149175	158938	GARNICA	DAVID OR ADRIANA	10	24	17	116.73	N	MSB
89865	49610	GAROFALO	LISA	7	24	17	112.49	N	MSB
140291	33258	GILMER	CARMAN	5	15	17	268.49	N	MSB
143765	214036	GILMORE	MARY ANN	6	19	17	430.50	N	MSB
107505	154404	GILSTRAP	JESSICA	12	19	17	183.25	N	MSB
164125	1764	GOMEZ	ANTHONY	10	24	17	323.80	N	MSB
161259	50074	GOMEZ	PERLA	7	24	17	236.00	N	MSB
90249	16578	GOODWIN-FORGEY	KRISTY	6	19	17	389.91	N	MSB
161099	4730	GRANILLO	MARIA	10	24	17	24.45	N	MSB
140649	6826	GRANT	CHRISTINE	11	27	17	279.67	N	MSB
167275	884	GRAY	JUSTIN	10	24	17	71.04	N	MSB
81639	6924	GREENE	BOBBY J	12	19	17	293.95	N	MSB
138125	150112	GREGORY-II	GEORGE	9	19	17	964.98	N	MSB
117325	26342	GRIFFITH	NICOLASA	7	24	17	815.86	N	MSB
14279	11538	GRIMES	GORDON	7	24	17	161.41	N	MSB
114835	22652	GUERRERO	EVELYN	7	24	17	205.25	N	MSB
115497	8326	GUILLORY	SHARON GAYLE	10	26	17	60.86	N	MSB
78951	35380	HACHFELD	ADAM	9	19	17	196.68	N	MSB

ID	Location	Customer		Month	Day	Year	Amount	Held	Credit
		Name							Agency
156425	137626	HALSTEAD	PATTI JO	12	19	17	665.03	N	MSB
162217	32378	HARRISON	MARISA	7	24	17	308.49	N	MSB
161491	11784	HARWOOD	ZACHARY	10	24	17	646.02	N	MSB
138899	14318	HAWTHORNE	MARCIA	7	24	17	43.05	N	MSB
68703	24400	HEAROD	GABRIELLE	12	19	17	279.64	N	MSB
149891	141448	HERNANDEZ	CRYSTAL	10	24	17	606.93	N	MSB
164963	42468	HERNANDEZ	JESUS OR LIBNI	11	27	17	524.17	N	MSB
156601	143576	HERNANDEZ	MANUEL OR ESTELLA	10	24	17	268.43	N	MSB
157585	50562	HERNANDEZ	SAL	5	15	17	786.22	N	MSB
164413	28390	HIGHTOWER	MIKE	5	15	17	107.29	N	MSB
164061	37938	HILL	DAVONTE OR LAVELLA	6	19	17	162.66	N	MSB
156303	20082	HINES	VENESA	5	15	17	328.03	N	MSB
114457	3730	HINSON	BRIAN OR LYNDA IBARRA	7	24	17	340.57	N	MSB
142843	44336	HOGGE	KIM	6	19	17	145.49	N	MSB
165511	142472	HOLDER	JESSICA	9	19	17	71.50	N	MSB
157277	46836	HOLLAND	DONELLA OR DAVID	11	27	17	316.68	N	MSB
163035	46378	HOLLIS	RAHDAYAH	12	19	17	679.86	N	MSB
12055	2342	HOLMES	ERIC T	6	19	17	27.76	N	MSB
149153	2314	HOPPE	JAMES	9	19	17	263.95	N	MSB
161445	14208	HOUSTON	STEVEN	12	19	17	780.25	N	MSB
126737	17540	HUDZIK	JAMES	7	24	17	575.65	N	MSB
152849	138546	HUFFMAN	MICHAEL	7	24	17	475.94	N	MSB
82509	41218	HUFFMON	TOMMY SHANE	6	19	17	188.17	N	MSB
90843	49092	HUNTER	JULIANNE	11	27	17	254.51	N	MSB
158823	36786	IRVIN	TAMEKA	11	27	17	917.67	N	MSB
159793	9234	JACKSON	MIRIAM	11	27	17	115.02	N	MSB
166445	15496	JANTZ	NICOLE	11	27	17	404.73	N	MSB
133841	8440	JARAMILLO	GEORGIA	11	27	17	213.56	N	MSB
157659	44442	JARDINE	DAVID OR CARROLE	5	15	17	209.74	N	MSB
161651	22494	JASON	BENNETT	11	27	17	406.64	N	MSB
152759	22138	JIMINEZ	ANNA	7	24	17	151.97	N	MSB
153909	9654	JOHNS	JASON	11	27	17	221.64	N	MSB
156343	47340	JOHNSON	JACOB OR LACHISHA	12	19	17	615.06	N	MSB
157649	30240	JOHNSON	LEAH	9	19	17	2,240.31	N	MSB
124091	140514	JOHNSON	TIM R	12	19	17	305.90	N	MSB
153331	20716	JONES	RONALD JR	11	27	17	80.67	N	MSB
101897	12914	JURTADO	ISELA	7	24	17	78.32	N	MSB
162575	11168	KALLESTEWA	TERRILL	5	15	17	480.76	N	MSB
143677	26230	KATCHER	CRYSTAL	11	27	17	498.47	N	MSB
18149	9232	KELLY	KAREN	11	27	17	0.01	N	MSB
145949	9014	KEYES	ASA	6	19	17	176.05	N	MSB
160183	36818	KIRBY	DAVID	11	27	17	91.56	N	MSB
163757	138690	KLEINMAN	CHRIS	12	19	17	201.14	N	MSB
158679	2958	KLOPP	JAMES	8	21	17	124.17	N	MSB
162379	213892	LAMOREAUX	DORISE	9	19	17	60.01	N	MSB
61559	44608	LANHAM	KELLIE	9	19	17	218.95	N	MSB
146247	18590	LAVALLE	KATHRYN	7	24	17	335.49	N	MSB
139355	20802	LEHMEIER	GUNTER OR DENEDIKT	11	27	17	221.39	N	MSB
142979	46546	LEOS	ADAM	5	15	17	129.38	N	MSB
135997	137632	LEWIS	NICOLE	12	19	17	434.31	N	MSB
153111	149828	LEWIS	SALLY	8	21	17	419.80	N	MSB
147071	144926	LEYVA	KARLA	5	15	17	143.34	N	MSB
100795	140972	LI	XING	11	27	17	647.51	N	MSB
164769	136530	LISTON	CALEB OR	10	24	17	51.50	N	MSB
82847	45744	LOBATO	DANIEL JR	7	24	17	99.35	N	MSB

ID	Location	Customer		Month	Day	Year	Amount	Held	Credit
		Name							Agency
131121	7986	LOPEZ	AMALIA	12	19	17	160.59	N	MSB
159753	22591	LOPEZ	GUSTAVO	8	21	17	91.05	N	MSB
82291	25644	LOPEZ	KAREN	12	19	17	678.83	N	MSB
152455	159408	LOPEZ	PETE	8	21	17	275.46	N	MSB
155301	31626	LOVATO-DORN	JACQUELINE	10	24	17	36.68	N	MSB
136629	156746	LOY	CARIJENE OR GARY	10	24	17	285.92	N	MSB
138103	45866	LUCERO	CHRISTINE M	7	24	17	113.65	N	MSB
160055	18452	LUCERO	FELISHA	7	24	17	654.63	N	MSB
164121	39368	LUJAN	MARY	7	24	17	434.90	N	MSB
155675	138070	LUNE	EDWARD OR KRISTA	10	24	17	175.67	N	MSB
149603	13294	MADRID	BRUNO	10	24	17	167.14	N	MSB
126293	5412	MAEO	MICHELLE	11	27	17	177.81	N	MSB
163885	48944	MALDONADO	ANGELIQUE	6	19	17	13.46	N	MSB
101323	29048	MANCINAS	LUZ MARIA	11	27	17	122.50	N	MSB
121267	35128	MARES	ANTHONY J	6	19	17	444.77	N	MSB
161539	9268	MARES	NICOLE	12	19	17	251.36	N	MSB
164321	136548	MARIA ISABEL	MENDOZA AVINA	7	24	17	210.61	N	MSB
111525	10124	MARKEY	DILIAH OR JAMES	11	27	17	1,204.67	N	MSB
132263	137478	MARQUEZ	IGANCIO E	11	27	17	593.71	N	MSB
116629	8276	MARQUEZ	ILEEN	11	27	17	159.14	N	MSB
155049	212314	MARSING	JEREMY OR AMY	12	19	17	363.38	N	MSB
45343	37826	MARTIN	RAY OR JOLEEN	12	19	17	233.77	N	MSB
146291	3844	MARTIN	RICHARD OR	10	24	17	176.85	N	MSB
132139	29124	MARTINEZ	GERALDINE	5	15	17	0.01	N	MSB
160139	148760	MARTINEZ	ISSAC	11	27	17	262.53	N	MSB
88659	34834	MARTINEZ	RACHEL OR ANDY	11	27	17	263.36	N	MSB
163373	25894	MARTINEZ	VIRGINIA	12	19	17	112.41	N	MSB
93047	137618	MASTERS	DARRELL	12	19	17	428.31	N	MSB
153341	227196	MATA	FRED OR GENEVA	10	24	17	410.45	N	MSB
155655	153042	MATHEWS	TWILA OR TRY	7	24	17	573.89	N	MSB
162037	32736	MCCANN	ROYLEE	10	24	17	366.90	N	MSB
166673	138678	MCCONNELL	WENDY	10	24	17	0.01	N	MSB
136429	29242	MCDONALD	JAMES OR DIXIE	6	19	17	174.58	N	MSB
144373	21546	MCNATT	MELANIE OR RICH	5	15	17	58.86	N	MSB
146105	51564	MCNEELY	TESSA	5	15	17	438.54	N	MSB
88389	48710	MCPHERSON	DEBBIE	11	27	17	137.64	N	MSB
122495	144002	MEDINA	ELISE & JERMEY	10	24	17	133.55	N	MSB
11319	6996	MEEKS	BETH	6	19	17	230.24	N	MSB
160263	12792	MELAD	ALEXANDER	9	19	17	641.06	N	MSB
156475	8574	MENDOZA	HECTOR	9	19	17	513.87	N	MSB
153603	8414	MENDOZA	JAVIER	8	21	17	339.63	N	MSB
35377	31876	METNIK	FRANK OR NANCY	11	27	17	425.90	N	MSB
97093	139020	MILLER	GRACE	12	19	17	60.42	N	MSB
163601	138194	MILLER	MADERA	10	24	17	173.47	N	MSB
122229	144032	MIRABEL	GENISE C	9	19	17	1,021.55	N	MSB
164693	154632	MITCHELL	LISA E	12	19	17	86.98	N	MSB
26197	1830	MITCHELL	SIBYL OR PAUL	6	19	17	52.08	N	MSB
162999	23564	MOLINA	CALTIN	7	24	17	234.37	N	MSB
80495	33000	MOLINA	STEPHANIE OR FRANKIE	11	27	17	117.61	N	MSB
160389	35988	MONTOYA	JERRAH	9	19	17	51.82	N	MSB
70707	46700	MONTOYA	JOSEPH V & FRANCES	7	24	17	501.47	N	MSB
112851	45810	MONTOYA	LESLIE	6	19	17	755.64	N	MSB
82419	38690	MONTOYA	LYNN	10	24	17	125.19	N	MSB
158511	40328	MONTOYA	RYAN	5	15	17	363.35	N	MSB
153141	36176	MONTOYA	VICTORIA	11	27	17	339.19	N	MSB

ID	Location	Customer		Month	Day	Year	Amount	Held	Credit
		Name							Agency
147987	136850	MORALES	ROBERT	5	15	17	474.33	N	MSB
36577	32018	MORROW	WADE & KEITH	8	21	17	320.34	N	MSB
119363	143972	MUNTZEL	GERALD R	5	15	17	83.31	N	MSB
158257	19016	MURPHY	BRANDON	7	24	17	193.07	N	MSB
29129	28520	NAFUS	GLENN AND MARY	12	19	17	196.96	N	MSB
105171	12558	MAJAR-JR	ANDREW G	9	19	17	56.05	N	MSB
144255	18470	NELSON	JULIA	6	19	17	141.70	N	MSB
79103	44728	NERU	JONATHAN OR DEBRA	12	19	17	245.96	N	MSB
124257	37080	NERU	RUBEN	8	21	17	401.76	N	MSB
134583	49454	NUNN	MONIQUE OR MARY LOPEZ	11	27	17	49.29	N	MSB
147113	6580	O'CONNOR	COLLEEN	9	19	17	126.32	N	MSB
163847	4360	OLIVAS	VERONICA OR	9	19	17	264.82	N	MSB
155619	212286	ONTIVEROS	EUGENIO	9	19	17	679.38	N	MSB
157705	23658	ORTIZ	BEATRIZ	12	19	17	59.93	N	MSB
164505	14276	OTERO	REESE	8	21	17	115.39	N	MSB
78459	51304	PACHITU	GHEORGHE	7	24	17	806.54	N	MSB
158517	151576	PADILLA	CHRISTINA	7	24	17	91.58	N	MSB
162641	1662	PAMELA	MONTOYA	6	19	17	387.95	N	MSB
30811	31474	PARHAM	ANN LYN	5	15	17	88.49	N	MSB
128269	24116	PATTERSON	HENRY	7	24	17	66.36	N	MSB
163413	44110	PAYNE	REANNA OR	11	27	17	363.66	N	MSB
164327	27732	PEARSON	HILARY	11	27	17	374.16	N	MSB
151807	30848	PECHIE	GLADYS M	10	24	17	113.70	N	MSB
142771	26500	PEREA	GEORGE D	11	27	17	74.78	N	MSB
86249	11464	PEREZ	DAVID	9	12	17	22.79	N	MSB
149695	1580	PEREZ	JOSEPH OR SHELBY CODERO	12	19	17	853.56	N	MSB
160735	13196	PEREZ	MONIKA	9	19	17	477.51	N	MSB
161293	44190	PEREZ	RUBEN D OR STEFANY	6	19	17	379.18	N	MSB
160669	137246	PHOUBON	THEVY	9	19	17	166.19	N	MSB
113385	136730	POLLARD	EVA JEAN DONEZ	7	24	17	649.44	N	MSB
109685	137558	PONCE	STEVEN OR DEBORAH	5	15	17	28.81	N	MSB
160077	34312	PRTOR	JACQUELINE	5	15	17	247.60	N	MSB
160633	19866	POSTON	JEFF	5	15	17	75.42	N	MSB
155229	36002	PORTER	MELISSIA	11	27	17	99.70	N	MSB
162935	11420	POTTER	DAVID	7	24	17	147.73	N	MSB
122409	143954	POTTS	DIANE	12	19	17	57.87	N	MSB
157321	4602	PREZIOSIO	KRYSTAL	8	21	17	1,348.28	N	MSB
143863	29898	PRICE	BEN	9	19	17	297.93	N	MSB
78453	19220	QUINONES	PAMELA	7	24	17	175.30	N	MSB
165397	30200	QUINTANA	THOMAS	10	24	17	187.97	N	MSB
156775	8248	RADEMAKER	MARK	5	15	17	102.43	N	MSB
149127	8498	RAEL	LAWRENCE	9	19	17	64.55	N	MSB
162791	32348	RAMIREZ	ASHLEY	6	19	17	110.10	N	MSB
157237	3400	RANDOLPH	VIRGIL	7	24	17	133.13	N	MSB
132679	48756	REDWINE	EARL	11	27	17	266.24	N	MSB
79011	44064	REED	BRIAN OR PEGGY	12	19	17	87.43	N	MSB
31009	23008	REICH	MARY C	11	27	17	67.04	N	MSB
160013	44768	ROACH	ARTHUR	10	24	17	6.95	N	MSB
154701	9522	ROACH	SANDRA V	6	17	17	29.25	N	MSB
163779	29964	ROBINSON	WESLEY OR PECIOUS	9	17	17	926.83	N	MSB
150877	38422	ROCHA	CLARISA	12	19	17	1,164.19	N	MSB
134527	24494	RODDY	KATHE	8	21	17	169.47	N	MSB
96117	136748	RODRIGUEZ	RAFAEL	10	24	17	1,043.69	N	MSB
138501	143584	RODRIGUEZ	STEVE OR JOHANA ESTRADA	10	24	17	266.26	N	MSB
116459	44454	ROMERO	DAVID	10	26	17	1,133.48	N	MSB

ID	Location	Customer		Month	Day	Year	Amount	Held	Credit
		Name							Agency
162297	19000	ROMERO	GABBY	9	19	17	1,065.11	N	MSB
90349	13038	ROSALLES	GUILLERMO	6	17	17	53.51	N	MSB
147895	24740	ROSAS JR	ALEJANDRO	11	27	17	288.76	N	MSB
161665	2920	ROSE SOLAEQUI	ARIANA	5	15	17	199.07	N	MSB
142033	30260	ROY	CYNTHIA	9	19	17	44.24	N	MSB
158829	156072	RUBALCABA	JOAQUIN	7	24	17	496.82	N	MSB
159403	1530	RUBIO	APRYLE	6	19	17	393.00	N	MSB
18217	42054	RUSILKO	DAVID	12	19	17	94.54	N	MSB
143651	219592	SAAVEDRA	ANNETTE	12	19	17	327.38	N	MSB
67089	148452	SALAS VENTURA JR	OR MELISSA	12	19	17	322.84	N	MSB
101789	141032	SALAZAR	JASON	8	21	17	220.18	N	MSB
152907	20988	SAMPLE	JASON	5	15	17	217.55	N	MSB
142839	50418	SANCHEZ AMBER	OR MARCOS	7	24	17	451.56	N	MSB
140041	34706	SANCHEZ	MARISSA E.	5	15	17	1,230.57	N	MSB
117445	18130	SCHALL	JENNIFER	12	19	17	302.67	N	MSB
122881	213268	SCHMIDT	LISA	10	24	17	138.60	N	MSB
138593	46992	SCHULTZE	JEREMY OR ARLENE	5	15	17	109.94	N	MSB
159957	19526	SELPH-JR	MARK T	6	19	17	287.69	N	MSB
164215	32254	SENA	DELFINA	7	24	17	292.81	N	MSB
124889	35886	SENA	GLORIA	10	24	17	95.64	N	MSB
166493	7158	SENA	PAUL	10	24	17	802.15	N	MSB
155627	139066	SHANE SOLOMON	OR MARIA	11	27	17	205.84	N	MSB
44147	19700	SHEETZ	STEPHEN	8	21	17	152.98	N	MSB
123589	137918	SHEPPARD	CATRINA	7	24	17	280.69	N	MSB
164565	22370	SILVA	CECILIA	9	19	17	95.89	N	MSB
115655	158016	SIMS	REGINA	10	24	17	202.31	N	MSB
142511	2596	SLAY CLIFTON	CARL	6	19	17	169.51	N	MSB
165659	19526	SMITH	JESSICA	8	21	17	331.98	N	MSB
163425	153260	SMITH TERRI	OR ARTIS	11	27	17	405.21	N	MSB
23653	20270	SNOW	GARY S	11	27	17	73.11	N	MSB
151283	34354	SOBIN	NADIA	9	19	17	113.62	N	MSB
159463	23190	SOTO	ARIDEL	10	24	17	786.27	N	MSB
132929	154358	STANSEN	KIERSTEN	9	19	17	264.62	N	MSB
73833	15136	STEIN	JOHN	7	24	17	137.57	N	MSB
159377	40834	STEVENSON	ROBERT	11	27	17	803.06	N	MSB
158629	30986	STEWART	MONTWELLA	9	19	17	180.51	N	MSB
165667	27222	STICHER	ADRIAN	12	19	17	738.95	N	MSB
158661	148614	STOKES	DAVID C	11	27	17	135.35	N	MSB
162967	48218	STRADER	CURTIS OR LESLIE	7	24	17	236.09	N	MSB
165565	9122	STUHLIK	BARBARA OR ERIC BERH	12	19	17	361.74	N	MSB
154733	137138	STULL	JOSEPH	10	24	17	882.72	N	MSB
143523	29838	STYRC	GRZEGORZ	6	19	17	170.88	N	MSB
140827	137770	SUAZO	ALEX	5	15	17	1,349.53	N	MSB
99983	20360	SULLIVAN	JENNIFER	8	21	17	128.42	N	MSB
161481	30626	SURRETTE	KATHLEEN	5	15	17	121.79	N	MSB
153061	160052	SUVAL	CHARLES	12	19	17	53.33	N	MSB
148793	51214	SWEENEY	JOHN BRANDON	7	24	17	401.15	N	MSB
141715	48314	TAPIA	STEVE	11	27	17	320.47	N	MSB
164353	39392	TAYLOR	JUSTINE	11	27	17	300.41	N	MSB
66259	38442	TAYLOR-BACA	TAMI	9	19	17	100.32	N	MSB
119135	140778	TENGBEH	ANDREW	12	19	17	183.89	N	MSB
147951	15512	TENNEY	DAWN	9	19	17	668.44	N	MSB
158553	26128	THOMPSON	KIRSTEN	6	19	17	354.94	N	MSB
161827	47352	THOMPSON	NIA	6	19	17	206.17	N	MSB
156203	49156	TORRES	LYNN	9	19	17	114.97	N	MSB

ID	Location	Customer		Month	Day	Year	Amount	Held	Credit
		Name							Agency
159111	143270	TORRES SALGADO	FRANSHESKA	7	24	17	181.05	N	MSB
163867	34704	TORSS	GODSEY	12	19	17	481.99	N	MSB
164051	29640	TORTORICI	BREANNA	6	19	17	479.02	N	MSB
165243	160330	TRUJILLO	ANTONIO	10	24	17	174.77	N	MSB
122909	34822	TRUJILLO	LAWRENCE D.	5	15	17	78.91	N	MSB
156025	151200	TRUJILLO	RON	9	19	17	322.10	N	MSB
54659	31516	TWOMEY	DENIS C.	9	19	17	346.66	N	MSB
163921	12746	VALDEZ	GENIVA	8	21	17	124.31	N	MSB
59319	9256	VALDEZ	JAMIE & CESAR	10	24	17	155.29	N	MSB
164329	44920	VALDEZ	VICTORIA	9	19	17	432.56	N	MSB
158957	10500	VALENCIA	ADAM	8	21	17	1,451.57	N	MSB
148563	3030	VALTIERRA	AARON OR JESSICA	12	19	17	635.25	N	MSB
164269	47684	VARGAS	ALISSA	11	27	17	304.37	N	MSB
126939	48626	VIGIL	EUNICE OR ERWIN	9	19	17	516.97	N	MSB
127531	153314	VIGIL	JOSHUA OR VIGIL CASEY	9	19	17	57.57	N	MSB
158751	142052	VIGIL	NICOLE	10	24	17	211.61	N	MSB
163721	24256	VIGIL	STEPHANIE	7	24	17	214.77	N	MSB
114429	159636	VIGIL	VANESSA	8	21	17	0.01	N	MSB
167477	151862	VILLAGRANA	MARIA	12	19	17	309.14	N	MSB
66951	143204	VILLAGRANA	ELIZABETH	7	24	17	546.70	N	MSB
148797	35000	VONBANK-BUOL	LANA	5	15	17	293.79	N	MSB
159771	140366	WAGNER-BRAVO	TIFFANY	9	19	17	328.00	N	MSB
126747	15746	WAKE	HEIDI	9	19	17	280.51	N	MSB
119119	15544	WALLACE	AMANDA	10	24	17	363.17	N	MSB
165729	136588	WALLACE	PRESTON	8	21	17	98.89	N	MSB
162565	7278	WARE	ANGELINA	11	27	17	566.00	N	MSB
156041	29470	WATTERS	SHANNON OR STEVE	11	27	17	271.17	N	MSB
149373	12214	WELCH	EVANGELINA	5	15	17	445.17	N	MSB
111793	33486	WELTER	KRISTY	12	19	17	361.26	N	MSB
127253	48186	WETZLAU	JOHN	11	27	17	511.14	N	MSB
161593	23706	WHAREPAPA	WITEARIKI R.	11	27	17	459.45	N	MSB
148057	137580	WHITAKER	OSCAR A.	7	24	17	171.66	N	MSB
153839	43872	WHITE	JESSICA OR ZACHARY LOVELETTE	7	24	17	76.45	N	MSB
86781	47142	WHITLOCK	LEIGH & CHARETTE MARG	11	27	17	439.03	N	MSB
70307	48846	WIEBER	TOM & JOHANNA	12	19	17	273.83	N	MSB
40705	16892	WILKINS	KAREN	12	19	17	431.41	N	MSB
111195	158740	WILLIAMS	GEORGE	12	20	17	92.67	N	MSB
167711	2958	WILLIAMS	NICHOLE	11	27	17	48.39	N	MSB
135807	44026	WILSON	LINDA	11	27	17	159.02	N	MSB
160653	26452	WILSON	RENEE M.	9	19	17	281.96	N	MSB
161755	14700	WILSON	SHERICE	5	15	17	126.24	N	MSB
163133	38742	WOESTENDIEK	ALEXANDER	8	21	17	423.98	N	MSB
163377	50188	WOLFORD	HEATHER	7	24	17	181.28	N	MSB
155289	20788	YAZZIE	JESSICA	11	27	17	218.34	N	MSB
156429	18654	YAZZIE	MICHELLE	8	21	17	543.96	N	MSB
115013	144130	YBARRA	TONY OR MELISSA	12	19	17	357.38	N	MSB
150603	47714	YUN RA	OR STEWARD ADAM	10	24	17	608.14	N	MSB
156835	48098	ZEYEN	MIKE	11	27	17	99.88	N	MSB
								N	MSB

Total

Utilities Uncollectible Accounts 2017 **136,204.76**

A/R Aging Report

PRCS Delinquent Fees 2017

ATTACHMENT IV
Jan 10, 2022

8:43 AM

A/R Transaction Date: From Jan 1, 2017 to Dec 31, 2017
Age Transactions as of: Dec 31, 2021

Name/Number	Receipt Number/Date	Original Balance	Credit On Account	Current	Days				Total
					1 to 30	31 to 60	61 to 90	Over 90	
Customers									
Alvarado, Todd #11507	1001034.015 Sep 12, 2017	\$540.00	\$200.00	\$0.00	\$0.00	\$0.00	\$0.00	\$340.00	\$340.00
Adult Flag Football Under the Lights: Thursday #9466									
Subtotal:		\$540.00	\$200.00	\$0.00	\$0.00	\$0.00	\$0.00	\$340.00	\$340.00
Campbell, Jason #16823	1001259.008 Nov 29, 2017	\$15.00	\$0.00	\$0.00	\$0.00	\$0.00	\$0.00	\$15.00	\$15.00
Winterfest Parade #9714									
Subtotal:		\$15.00	\$0.00	\$0.00	\$0.00	\$0.00	\$0.00	\$15.00	\$15.00
Kendrick, Sara #3143	1003833.001 Jun 19, 2017	\$65.00	\$20.00	\$0.00	\$0.00	\$0.00	\$0.00	\$45.00	\$45.00
Kidszone: July AM (Tuesday & Thursday) #8842									
Subtotal:		\$65.00	\$20.00	\$0.00	\$0.00	\$0.00	\$0.00	\$45.00	\$45.00
Lujan, Angelo #11501	1001033.015 Sep 12, 2017	\$540.00	\$500.00	\$0.00	\$0.00	\$0.00	\$0.00	\$40.00	\$40.00
Adult Flag Football Under the Lights: Thursday #9466									
Subtotal:		\$540.00	\$500.00	\$0.00	\$0.00	\$0.00	\$0.00	\$40.00	\$40.00
Masterson, Steve #6802	1001030.015 Sep 12, 2017	\$420.00	\$373.00	\$0.00	\$0.00	\$0.00	\$0.00	\$47.00	\$47.00
Adult Flag Football: Sunday #9467									
Subtotal:		\$420.00	\$373.00	\$0.00	\$0.00	\$0.00	\$0.00	\$47.00	\$47.00
Montoya, Lisamarie #4829	1003551.001 Jun 2, 2017	\$65.00	\$20.00	\$0.00	\$0.00	\$0.00	\$0.00	\$45.00	\$45.00
Kidszone: June PM (Tuesday & Thursday) #8839									
Subtotal:		\$65.00	\$20.00	\$0.00	\$0.00	\$0.00	\$0.00	\$45.00	\$45.00
Ramirez, Joey #9986	1001041.015 Sep 18, 2017	\$420.00	\$210.00	\$0.00	\$0.00	\$0.00	\$0.00	\$210.00	\$210.00
Adult Flag Football: Sunday #9467									
Subtotal:		\$420.00	\$210.00	\$0.00	\$0.00	\$0.00	\$0.00	\$210.00	\$210.00
Rivara, Jose #11215	1000743.015 Jun 8, 2017	\$500.00	\$240.00	\$0.00	\$0.00	\$0.00	\$0.00	\$260.00	\$260.00
Adult Flag Football: Sunday #9167									
Football & Basketball Sanction Fee									
Subtotal:		\$500.00	\$240.00	\$0.00	\$0.00	\$0.00	\$0.00	\$260.00	\$260.00
rodriguez, trish #15582	1001243.008 Nov 8, 2017	\$240.00	\$0.00	\$0.00	\$0.00	\$0.00	\$0.00	\$240.00	\$240.00
Payment reversal: Adult Softball Sunday Mixed 11:30 am #9358									
Debit for cancelled payment: Adult Softball Sunday Mixed 11:30 am #9358									
Subtotal:		\$35.00	\$0.00	\$0.00	\$0.00	\$0.00	\$0.00	\$35.00	\$35.00
Return check fee									
Staff Notes: Journal Entry - Check # 271 returned NSF									
Subtotal:		\$275.00	\$0.00	\$0.00	\$0.00	\$0.00	\$0.00	\$275.00	\$275.00
Sanchez, Philip #7043	1000581.015 Mar 14, 2017	\$500.00	\$250.00	\$0.00	\$0.00	\$0.00	\$0.00	\$250.00	\$250.00
Adult Flag Football Under the Lights: Thursday #8623									
Subtotal:		\$500.00	\$250.00	\$0.00	\$0.00	\$0.00	\$0.00	\$250.00	\$250.00
Grand Total:		\$3,340.00	\$1,813.00	\$0.00	\$0.00	\$0.00	\$0.00	\$1,527.00	\$1,527.00

Total Uncollectible PRCS Fees 2017

\$1,527.00

Summary By Account Report

Agency RIO RANCHO
 Action Dt From 1/1/2017
 Action Dt Thru 12/31/2017
 Status: All
 Location: All

Account Number	Account Name	0/29	30/59	60/89	GE90	Total
11238	MERCEDES BEN	\$0.00	\$0.00	\$0.00	\$350.00	\$350.00
873	MARIA VALDEZ	\$0.00	\$0.00	\$0.00	\$350.00	\$350.00
11128	MICHAEL OR J	\$0.00	\$0.00	\$0.00	\$300.00	\$300.00
11566	KELLY REYES	\$0.00	\$0.00	\$0.00	\$250.00	\$250.00
11581	ASHLEY SEGUR	\$0.00	\$0.00	\$0.00	\$250.00	\$250.00
12178	DEBORAH OR P	\$0.00	\$0.00	\$0.00	\$250.00	\$250.00
10341	KC TIRES	\$0.00	\$0.00	\$0.00	\$200.00	\$200.00
11597	MARY LOUISE	\$0.00	\$0.00	\$0.00	\$200.00	\$200.00
10532	SETH RAYMOND	\$0.00	\$0.00	\$0.00	\$150.00	\$150.00
11436	TRISTON BARR	\$0.00	\$0.00	\$0.00	\$150.00	\$150.00
11852	JONAS ALLALU	\$0.00	\$0.00	\$0.00	\$150.00	\$150.00
12191	JIM REIMER	\$0.00	\$0.00	\$0.00	\$150.00	\$150.00
7004	MELISSA OR D	\$0.00	\$0.00	\$0.00	\$150.00	\$150.00
7911	MICHAEL BREW	\$0.00	\$0.00	\$0.00	\$150.00	\$150.00
8663	TRAM ANH TRU	\$0.00	\$0.00	\$0.00	\$150.00	\$150.00
9107	CARL BAKER	\$0.00	\$0.00	\$0.00	\$150.00	\$150.00
9975	SCOTT CACERE	\$0.00	\$0.00	\$0.00	\$150.00	\$150.00
11098	ELIZABETH ST	\$0.00	\$0.00	\$0.00	\$100.00	\$100.00
11102	GERALD CASTA	\$0.00	\$0.00	\$0.00	\$100.00	\$100.00
11241	EDGAR CABRER	\$0.00	\$0.00	\$0.00	\$100.00	\$100.00
11312	JENNIFER OR	\$0.00	\$0.00	\$0.00	\$100.00	\$100.00
11368	GREGORY OR T	\$0.00	\$0.00	\$0.00	\$100.00	\$100.00
2826	BURGER KING	\$0.00	\$0.00	\$0.00	\$100.00	\$100.00
8835	REINALDO MCD	\$0.00	\$0.00	\$0.00	\$100.00	\$100.00
10324	BYRON TONEY	\$0.00	\$0.00	\$0.00	\$50.00	\$50.00
10485	JONATHAN PER	\$0.00	\$0.00	\$0.00	\$50.00	\$50.00
10562	FETTERS JASO	\$0.00	\$0.00	\$0.00	\$50.00	\$50.00
10852	VIVIANA GIL	\$0.00	\$0.00	\$0.00	\$50.00	\$50.00
10918	PREMIER PCS	\$0.00	\$0.00	\$0.00	\$50.00	\$50.00
11003	JEREMY STRIC	\$0.00	\$0.00	\$0.00	\$50.00	\$50.00
11134	TYLER OR MAR	\$0.00	\$0.00	\$0.00	\$50.00	\$50.00
11220	AARON THOMPS	\$0.00	\$0.00	\$0.00	\$50.00	\$50.00
11475	MARSHA OR JO	\$0.00	\$0.00	\$0.00	\$50.00	\$50.00
11512	MICHAEL HUST	\$0.00	\$0.00	\$0.00	\$50.00	\$50.00
11520	ANTHONY OR A	\$0.00	\$0.00	\$0.00	\$50.00	\$50.00
11527	TAMMY RAMOS	\$0.00	\$0.00	\$0.00	\$50.00	\$50.00
11551	JAUVER NEALE	\$0.00	\$0.00	\$0.00	\$50.00	\$50.00
11600	ALLYSIA ZARA	\$0.00	\$0.00	\$0.00	\$50.00	\$50.00
11603	ASHLEY STANL	\$0.00	\$0.00	\$0.00	\$50.00	\$50.00
11610	VICTORIA OR	\$0.00	\$0.00	\$0.00	\$50.00	\$50.00
11636	LANNY GOETZ	\$0.00	\$0.00	\$0.00	\$50.00	\$50.00
11660	GENEVIEVE SA	\$0.00	\$0.00	\$0.00	\$50.00	\$50.00
11679	NICOLE JANTZ	\$0.00	\$0.00	\$0.00	\$50.00	\$50.00
11730	ANABEL PARA	\$0.00	\$0.00	\$0.00	\$50.00	\$50.00
11734	WILLIAM ALCO	\$0.00	\$0.00	\$0.00	\$50.00	\$50.00
11741	GREG MONTOYA	\$0.00	\$0.00	\$0.00	\$50.00	\$50.00
11742	DAVE & MICHE	\$0.00	\$0.00	\$0.00	\$50.00	\$50.00
11743	PATRICIA OR	\$0.00	\$0.00	\$0.00	\$50.00	\$50.00
11762	ISSAC OR STE	\$0.00	\$0.00	\$0.00	\$50.00	\$50.00
11770	JESSICA VILL	\$0.00	\$0.00	\$0.00	\$50.00	\$50.00
11774	HOLIDAY CHAV	\$0.00	\$0.00	\$0.00	\$50.00	\$50.00
11777	ROBERT TRUJI	\$0.00	\$0.00	\$0.00	\$50.00	\$50.00
11783	JOSE OR MELI	\$0.00	\$0.00	\$0.00	\$50.00	\$50.00
11797	TATIANA FOST	\$0.00	\$0.00	\$0.00	\$50.00	\$50.00
11804	KEN STOPKA	\$0.00	\$0.00	\$0.00	\$50.00	\$50.00
11821	MARISSA SANC	\$0.00	\$0.00	\$0.00	\$50.00	\$50.00

Summary By Account Report

Account Number	Account Name	0/29	30/59	60/89	GE90	Total
11831	CANDICE OR J	\$0.00	\$0.00	\$0.00	\$50.00	\$50.00
11844	ANDREA CHAVE	\$0.00	\$0.00	\$0.00	\$50.00	\$50.00
11848	ALISSA KOEST	\$0.00	\$0.00	\$0.00	\$50.00	\$50.00
11854	RYAN KOON OR	\$0.00	\$0.00	\$0.00	\$50.00	\$50.00
11855	SCHLOTZSKY'S	\$0.00	\$0.00	\$0.00	\$50.00	\$50.00
11888	PAUL OR TERE	\$0.00	\$0.00	\$0.00	\$50.00	\$50.00
11891	ERIN MARTIN	\$0.00	\$0.00	\$0.00	\$50.00	\$50.00
12021	CHARLES IKO	\$0.00	\$0.00	\$0.00	\$50.00	\$50.00
12034	GLENN OR JEN	\$0.00	\$0.00	\$0.00	\$50.00	\$50.00
12045	AARON OR REB	\$0.00	\$0.00	\$0.00	\$50.00	\$50.00
12049	STEPHANIE BR	\$0.00	\$0.00	\$0.00	\$50.00	\$50.00
12071	RANADA OR AL	\$0.00	\$0.00	\$0.00	\$50.00	\$50.00
12090	JAYME ESPINO	\$0.00	\$0.00	\$0.00	\$50.00	\$50.00
12121	JOHN CRESPIN	\$0.00	\$0.00	\$0.00	\$50.00	\$50.00
12125	THOMAS CERVA	\$0.00	\$0.00	\$0.00	\$50.00	\$50.00
12126	TERRA ALASTI	\$0.00	\$0.00	\$0.00	\$50.00	\$50.00
12167	TAMMY RICHA	\$0.00	\$0.00	\$0.00	\$50.00	\$50.00
12184	MAGNUS FRAN	\$0.00	\$0.00	\$0.00	\$50.00	\$50.00
12223	PHIL REED	\$0.00	\$0.00	\$0.00	\$50.00	\$50.00
12283	MICHAEL GARC	\$0.00	\$0.00	\$0.00	\$50.00	\$50.00
12290	MICHAEL OR K	\$0.00	\$0.00	\$0.00	\$50.00	\$50.00
1437	DANNY OR ROS	\$0.00	\$0.00	\$0.00	\$50.00	\$50.00
282	PATRICK OR L	\$0.00	\$0.00	\$0.00	\$50.00	\$50.00
3073	ROSANNE HAYN	\$0.00	\$0.00	\$0.00	\$50.00	\$50.00
3217	PAUL LUJAN	\$0.00	\$0.00	\$0.00	\$50.00	\$50.00
3753	ROBERTA RATO	\$0.00	\$0.00	\$0.00	\$50.00	\$50.00
4069	FAT SQUIRREL	\$0.00	\$0.00	\$0.00	\$50.00	\$50.00
5296	ELZREE OR AR	\$0.00	\$0.00	\$0.00	\$50.00	\$50.00
5344	LEANN MARTIN	\$0.00	\$0.00	\$0.00	\$50.00	\$50.00
7080	STEPHANIE SA	\$0.00	\$0.00	\$0.00	\$50.00	\$50.00
7162	CLIFTON & KA	\$0.00	\$0.00	\$0.00	\$50.00	\$50.00
7684	KEVIN OR NAK	\$0.00	\$0.00	\$0.00	\$50.00	\$50.00
8071	GERARDO & EL	\$0.00	\$0.00	\$0.00	\$50.00	\$50.00
8187	SPORTS CLIPS	\$0.00	\$0.00	\$0.00	\$50.00	\$50.00
8262	DANIEL CARRI	\$0.00	\$0.00	\$0.00	\$50.00	\$50.00
8373	ADAN & GUADA	\$0.00	\$0.00	\$0.00	\$50.00	\$50.00
8399	NEAL PALMER	\$0.00	\$0.00	\$0.00	\$50.00	\$50.00
8575	JOE RUBALCAB	\$0.00	\$0.00	\$0.00	\$50.00	\$50.00
8777	BRYANT OR OP	\$0.00	\$0.00	\$0.00	\$50.00	\$50.00
8943	EVREN GONZAL	\$0.00	\$0.00	\$0.00	\$50.00	\$50.00
9092	VELMA BOYD	\$0.00	\$0.00	\$0.00	\$50.00	\$50.00
9161	WILSON BLACK	\$0.00	\$0.00	\$0.00	\$50.00	\$50.00
9186	DORIS HARVEY	\$0.00	\$0.00	\$0.00	\$50.00	\$50.00
9614	ANGELO OR AU	\$0.00	\$0.00	\$0.00	\$50.00	\$50.00
9791	GERALD TAPIA	\$0.00	\$0.00	\$0.00	\$50.00	\$50.00
10538	J. SANTIAGO	\$0.00	\$0.00	\$0.00	\$25.00	\$25.00
Totals		\$0.00	\$0.00	\$0.00	\$8,075.00	\$8,075.00
Total Accounts per Category		0	0	0	102	102
Percent of Accounts per Category		0.00%	0.00%	0.00%	100.00%	
Percent of Outstanding per Category		0.00%	0.00%	0.00%	100.00%	

Total Uncollectible Alarm Fees 2017 \$8,075.00

				Invoice			
Last name	First/middle name	Patron record	Barcode	number	Title	Cost	Date
HOSKINS	JULIA	.p1164612a	59125051026263	694859	Walking dad / writer, Fred Perry ; artist, David Hutchison.	10.99	2017-01-03
HOSKINS	JULIA	.p1164612a	59125051026263	694857	Playing dead / Fred Perry, David Hutchison.	10.99	2017-01-03
HOSKINS	JULIA	.p1164612a	59125051026263	694858	Grossery games / Fred Perry, Brian Denham.	10.99	2017-01-03
HOSKINS	JULIA	.p1164612a	59125051026263	694856	Captain Underpants and the perilous plot of Professor Poopypants : the fourth epic	16.99	2017-01-03
HOSKINS	JULIA	.p1164612a	59125051026263	694855	Getting to happy / Terry McMillan.	27.95	2017-01-03
HOSKINS	JULIA	.p1164612a	59125051026263	694860	The adventures of Captain Underpants / the first epic novel by Dav Pilkey ; with c	9.99	2017-01-03
HOSKINS	JULIA	.p1164612a	59125051026263	694862	Why? : over 1,111 answers to everything / Crispin Boyer.	19.99	2017-01-03
HOSKINS	JULIA	.p1164612a	59125051026263	694861	Guinness world records 2016.	28.95	2017-01-03
SHAW	BOBBY K	.p1179028a	59125050946990	694870	Friendship bracelets / Camilla Gryski.	5.95	2017-01-03
SHAW	BOBBY K	.p1179028a	59125050946990	694873	Macrame : 19 great weekend projects / [Jim Gentry].	9.95	2017-01-03
SHAW	BOBBY K	.p1179028a	59125050946990	694871	Chinese knotting : creative designs that are easy and fun! / Lydia Chen.	25.00	2017-01-03
SHAW	BOBBY K	.p1179028a	59125050946990	694874	Micro macramé : 25 superfine jewelry projects / Jenny Townley.	19.99	2017-01-03
SHAW	BOBBY K	.p1179028a	59125050946990	694872	Friendship bracelets / written by Liz Ungar, Clare Mayhew and Heather Hammonds ; e	12.95	2017-01-03
HOSKINS	JULIA	.p1164612a	59125051026263	694970	The last kids on Earth and the zombie parade / by Max Brallier ; illustrated by Do	13.99	2017-01-03
HUNTER	THOMAS DALE	.p1181245a	59125050969604	695030	Shrek 2 [videorecording] / DreamWorks Pictures presents a PDI/DreamWorks productio	25.00	2017-01-03
HUNTER	THOMAS DALE	.p1181245a	59125050969604	695033	Bob the builder. Building sky high! [videorecording] / director, Stuart Evans.	14.99	2017-01-03
HUNTER	THOMAS DALE	.p1181245a	59125050969604	695031	Looney tunes super stars. Bugs Bunny [videorecording] / Warner Bros.	19.99	2017-01-03
HUNTER	THOMAS DALE	.p1181245a	59125050969604	695034	Kung Fu Panda 3 [videorecording] / [presented by] Dreamworks Animation in associat	29.99	2017-01-03
HUNTER	THOMAS DALE	.p1181245a	59125050969604	695032	Happy feet [videorecording] / Warner Bros. Pictures presents ; in association with	5.99	2017-01-03
MCCANN	RYAN C	.p1183172a	59125050975734	695044	Me first / Helen Lester ; illustrated by Lynn Munsinger.	16.00	2017-01-03
MCCANN	RYAN C	.p1183172a	59125050975734	695046	Monkey and Elephant go gadding / Carole Lexa Schaefer ; illustrated by Galia Berns	13.55	2017-01-03
HENSON	AMY MARIE	.p1129164a	59125050748073	695641	Los gatos black on Halloween / Marisa Montes ; illustrated by Yuyi Morales.	16.95	2017-01-04
HENSON	AMY MARIE	.p1129164a	59125050748073	695640	The clue of the leaning chimney / by Carolyn Keene.	5.99	2017-01-04
KING	HANNAH DANIELLE	.p1174327a	59125050903686	695659	Middlesex / Jeffrey Eugenides.	15.00	2017-01-04
MARTINEZ	ISABELLA D	.p1179329a	59125050948285	695695	The Cloud Princess / written and illustrated by Khoa Le.	14.99	2017-01-04
BYRD	CALLI E	.p1183637a	59125051034622	695714	Tales from a not-so-glam TV star / Rachel Renée Russell with Nikki Russell a	13.99	2017-01-04
BYRD	CALLI E	.p1183637a	59125051034622	695713	My big fat zombie goldfish / Mo O'Hara ; illustrated by Marek Jagucki.	12.99	2017-01-04
BYRD	KASEY R	.p1183636a	59125051034614	695712	Into the woods : tales from the Hollows and beyond / Kim Harrison.	24.99	2017-01-04
BYRD	KASEY R	.p1183636a	59125051034614	695711	House rules : a novel / Jodi Picoult.	16.00	2017-01-04
VALENCIA	ELIZA	.p1157194a	59125050979777	697605	Tales from a not-so-happily ever after / Rachel Renée Russell with Nikki Rus	13.99	2017-01-10
VALENCIA	ELIZA	.p1157194a	59125050979777	697604	Old Yeller / by Fred Gipson ; drawings by Carl Burger.	23.00	2017-01-10
TORRES	EDUARDO J	.p1182184a	59125051030158	699085	Clever Jack takes the cake / written by Candace Fleming ; illustrated by G. Brian	25.00	2017-01-14
ROMO	MELANIE H	.p1183722a	59125051034812	699097	Move to lose : look and feel better in just 10 minutes a day / Chris Freytag.	24.95	2017-01-14
ROMO	MELANIE H	.p1183722a	59125051034812	699096	Care of the soul : a guide for cultivating depth and sacredness in everyday life /	14.00	2017-01-14
ROMO	MELANIE H	.p1183722a	59125051034812	699098	How did I get here? : finding your way to renewed hope and happiness when life and	13.95	2017-01-14
ROMO	MELANIE H	.p1183722a	59125051034812	699099	Breaking the habit of being yourself : how to lose your mind and create a new one	16.99	2017-01-14
SISNEROS	ABIGAIL NEVAEH	.p1183070a	59125050976526	699186	Lion & Tiger & Bear : Tag! You're it! / Ethan Long.	14.95	2017-01-14
LUJAN	VALERIE	.p1183313a	59125051034895	699740	Planet ark : preserving Earth's biodiversity / written by Adrienne Mason ; illustr	18.95	2017-01-17
LUJAN	VALERIE	.p1183313a	59125051034895	699739	Falling up : poems and drawings / by Shel Silverstein.	18.99	2017-01-17
MCGEORGE	JESSICA DIANN	.p1094636a	59125050985154	700235	Cat the cat, who is that? / by Mo Willems.	10.99	2017-01-18
YAZZIE	CARA	.p1183707a	59125050980700	700258	The best birthday ever / by Rico Green ; illustrated by the Disney Storybook Art T	4.99	2017-01-18
YAZZIE	CARA	.p1183707a	59125050980700	700257	Alan's big, scary teeth / by Jarvis.	16.99	2017-01-18
YAZZIE	CARA	.p1183707a	59125050980700	700256	My car / written and illustrated by Byron Barton.	16.99	2017-01-18
VEGA-DIAZ	NERISSA M	.p1169572a	59125051032881	701031	Cinder / written by Marissa Meyer.	9.99	2017-01-21
VALENCIA	ADAM GRANT	.p1178404a	59125050989107	701079	LEGO Star wars. The Yoda chronicles [videorecording] / produced by WIL FILM ApS ;	14.99	2017-01-21
VALENCIA	ADAM GRANT	.p1178404a	59125050989107	701077	Avatar, the last airbender. Book 1: water, Volume 4 [videorecording] / Nickelodeon	21.99	2017-01-21
VALENCIA	ADAM GRANT	.p1178404a	59125050989107	701076	Hell [sound recording] : the sequel / Bad Meets Evil.	13.99	2017-01-21
VALENCIA	ADAM GRANT	.p1178404a	59125050989107	701080	Freemaker adventures. Complete season one [videorecording].	39.99	2017-01-21

				Invoice			Cost	Date
Last name	First/middle name	Patron record	Barcode	number	Title			
VALENCIA	ADAM GRANT	.p1178404a	59125050989107	701078	Avatar, the last airbender. Book 1: water, Volume 5 [videorecording].		21.99	2017-01-21
MELLORS	CAITLYN J	.p1182741a	59125050979546	701907	LC Homeschool collection.		35.00	2017-01-24
PADILLA	NICHOLAS A	.p1183840a	59125050989545	701916	Before you judge me : the triumph and tragedy of Michael Jackson's last days / Tav		27.00	2017-01-24
MELLORS	CAITLYN J	.p1182741a	59125050979546	701912	LC Homeschool collection.		35.00	2017-01-24
MELLORS	CAITLYN J	.p1182741a	59125050979546	701911	LC Homeschool collection.		35.00	2017-01-24
MELLORS	CAITLYN J	.p1182741a	59125050979546	701910	LC Homeschool kit.		75.00	2017-01-24
MELLORS	CAITLYN J	.p1182741a	59125050979546	701909	LC Homeschool kit.		75.00	2017-01-24
MELLORS	CAITLYN J	.p1182741a	59125050979546	701908	LC Homeschool kit.		75.00	2017-01-24
CHAVEZ	TRISHELLE JENA	.p1124138a	59125050977391	702214	The unfairrest of them all / by Shannon Hale.		14.99	2017-01-25
GRAY	BIANCA MARIE	.p1169371a	59125050989750	702235	The complete idiot's guide to the ASVAB / by Laura Stradley and robin Kavanagh ; i		18.95	2017-01-25
SHOLAR	SUZU ANGEL	.p1141624a	59125050425821	702772	Tiny LEGO wonders : build 40 surprisingly realistic mini-models! / Mattia Zamboni.		24.95	2017-01-27
TOTSCHEK	NICOLETTE L	.p1183881a	59125050989248	702824	Fall leaves fall! / by Zoe Hall ; illustrated by Shari Halpern.		15.95	2017-01-27
TOTSCHEK	NICOLETTE L	.p1183881a	59125050989248	702825	Did I ever tell you how lucky you are? / by Dr. Seuss.		14.95	2017-01-27
RIOS	JUAN D	.p1183786a	59125050990105	702822	Ubuntu made easy : a project-based introduction to Linux / by Rickford Grant with		34.95	2017-01-27
RIOS	JUAN D	.p1183786a	59125050990105	702821	Cisco networking essentials / by Troy McMillan.		39.99	2017-01-27
RIOS	JUAN D	.p1183786a	59125050990105	702823	Sams teach yourself beginning programming in 24 hours / Greg Perry, Dean Miller.		29.99	2017-01-27
TOTSCHEK	NICOLETTE L	.p1183881a	59125050989248	702829	The virgin blue / Tracy Chevalier.		16.00	2017-01-27
TOTSCHEK	NICOLETTE L	.p1183881a	59125050989248	702827	Peanut Butter and Jellyfish / Jarrett J. Krosoczka.		16.99	2017-01-27
TOTSCHEK	NICOLETTE L	.p1183881a	59125050989248	702831	Crash & burn : a novel / Lisa Gardner.		27.95	2017-01-27
TOTSCHEK	NICOLETTE L	.p1183881a	59125050989248	702830	Dinosaurs in the winter / by Joyce Jeffries.		22.60	2017-01-27
TOTSCHEK	NICOLETTE L	.p1183881a	59125050989248	702828	Life drawing : a novel / Robin Black.		25.00	2017-01-27
TOTSCHEK	NICOLETTE L	.p1183881a	59125050989248	702826	Turkey Tot / by George Shannon ; illustrated by Jennifer K. Mann.		16.95	2017-01-27
PERRON	VIRGINIA A	.p1183274a	59125051035280	703191	The fix / K'wan.		6.99	2017-01-28
GAVILONDO	CESAR	.p1173456a	59125051034689	703879	Ice age. Continental drift [videorecording] / Twentieth Century Fox Animation pres		14.99	2017-01-31
GAVILONDO	CESAR	.p1173456a	59125051034689	703878	Pixels [videorecording] / Columbia Pictures presents in association with Lstar Cap		26.99	2017-01-31
GAVILONDO	CESAR	.p1173456a	59125051034689	703877	Alice in Wonderland [videorecording] / Walt Disney Productions ; directors, Clyde		29.99	2017-01-31
GAVILONDO	CESAR	.p1173456a	59125051034689	703876	Wreck-it Ralph [videorecording] / director, Rich Moore ; writers, Rich Moore ... [29.99	2017-01-31
GAVILONDO	CESAR	.p1173456a	59125051034689	703875	Angels in the outfield [videorecording] / Walt Disney Pictures ; produced by Irby		14.99	2017-01-31
OTERO	XAVIER ANTONIO	.p1182233a	59125050994933	703910	The zombie chasers / by John Kloepfer ; illustrated by Steve Wolfhard.		6.99	2017-01-31
OTERO	XAVIER ANTONIO	.p1182233a	59125050994933	703909	Adventure time / created by Pendleton Ward.		11.99	2017-01-31
OTERO	ALEXANDRA CHRISTIANA	.p1182234a	59125050994925	703913	Tortuga in trouble / by Ann Whitford Paul ; illustrated by Ethan Long.		29.95	2017-01-31
OTERO	ALEXANDRA CHRISTIANA	.p1182234a	59125050994925	703911	Happy Pig Day! / by Mo Willems.		8.99	2017-01-31
OTERO	ALEXANDRA CHRISTIANA	.p1182234a	59125050994925	703912	Snowy Valentine / written and illustrated by David Petersen.		14.99	2017-01-31
VILLASMIL	ANGELINA YVONNE	.p1166414a	59125051032626	704368	EB Boardbooks.		6.99	2017-02-01
VILLASMIL	ANGELINA YVONNE	.p1166414a	59125051032626	704369	The missing chums / by Franklin W. Dixon.		5.99	2017-02-01
REED	SANDRA LEE	.p1157656a	59125050981187	704409	Pedro Páramo / Juan Rulfo.		10.95	2017-02-01
WALTON	TONI LYNN	.p1175845a	59125050918007	705337	Hellstrip gardening : create a paradise between the sidewalk and the curb / Evelyn		24.95	2017-02-04
WALTON	TONI LYNN	.p1175845a	59125050918007	705331	Thea's tree / Alison Jackson ; illustrated by Janet Pedersen.		16.99	2017-02-04
FIELDS	JENNA M	.p1177717a	59125050942718	706016	The School for Good and Evil / Soman Chainani ; illustrations by Iacopo Bruno.		16.99	2017-02-07
MARES	DEBRA A	.p1148859a	59125051029549	707141	Esperanza rising / Pam Muñoz Ryan.		6.99	2017-02-10
MARES	DEBRA A	.p1148859a	59125051029549	707140	The miraculous journey of Edward Tulane / Kate DiCamillo ; illustrated by Bagram I		18.99	2017-02-10
PURCELLA	ANDREW	.p1183407a	59125050983746	707211	Brave story / Miyuki Miyabe ; translated by Alexander O. Smith.		23.99	2017-02-10
EMSWELLER	SADE	.p1130863a	59125050615363	708174	I know why the caged bird sings / Maya Angelou.		24.00	2017-02-14
CHRISTENSEN	BELINDA RAMIREZ	.p1159253a	59125050940522	708184	LC Homeschool collection.		35.00	2017-02-14
COPPLE	TALMAGE BRAD	.p1153849a	59125050646921	708182	Not-for-parents U.S.A. : everything you ever wanted to know / Lynette Evans.		14.99	2017-02-14
GAVILONDO	CESAR	.p1173456a	59125051034689	708187	Just my luck / Cammie McGovern.		16.99	2017-02-14
GAVILONDO	CESAR	.p1173456a	59125051034689	708186	Captain Underpants and the invasion of the incredibly naughty cafeteria ladies fro		5.99	2017-02-14
BACA	LEAH M	.p1132694a	59125050818041	709243	Post Office jobs : the ultimate 473 postal exam study guide and job finder / Denni		24.95	2017-02-17

Last name		First/middle name	Patron record	Barcode	Invoice number	Title	Cost	Date
EMSWELLER	SADE		.p1130863a	59125050615363	709608	Oh crap! potty training : everything modern parents need to know to do it once and	15.99	2017-02-18
EMSWELLER	SADE		.p1130863a	59125050615363	709609	Hungry girl clean & hungry : easy all-natural recipes for clean eating in the real	19.99	2017-02-18
EMSWELLER	SADE		.p1130863a	59125050615363	709607	Shades of hope : a program to stop dieting and start living / Tennie McCarty ; wit	25.95	2017-02-18
EMSWELLER	SADE		.p1130863a	59125050615363	709606	The bell jar / Sylvia Plath.	17.00	2017-02-18
EMSWELLER	SADE		.p1130863a	59125050615363	709610	The shadow effect : creative lighting, posing, and composition for photographers /	37.95	2017-02-18
DOOLEY	GABRIELLA JOY		.p1144505a	59125050987184	709616	Cinderella [videorecording] / a Walt Disney production ; story, William Peed [and	29.99	2017-02-18
MARTIN	JENNIFER		.p1130757a	59125051361462	710038	Amelia Bedelia road trip! / by Herman Parish ; pictures by Lynne Avril.	4.99	2017-02-20
MARTIN	JENNIFER		.p1130757a	59125051361462	710036	Mummies in the morning / by Mary Pope Osborne ; illustrated by Sal Murdocca.	4.99	2017-02-20
MARTIN	JENNIFER		.p1130757a	59125051361462	710040	Sophie the Awesome / by Lara Bergen ; illustrated by Laura Tallardy.	13.99	2017-02-20
SHAMBLEY	ERNEST DEON		.p1176527a	59125051027725	711044	100 bullshit jobs : -- and how to get them / Stanley Bing.	13.99	2017-02-22
PRESTON	STEPHEN D		.p1139047a	59125050827166	711715	Nurse Hitomi's Monster Infirmary / story by and art by Shake-O ; translation, Ambe	12.99	2017-02-24
SPENCER	BRANDON E		.p1163191a	59125050690440	712895	Office space [videorecording] / Twentieth Century Fox presents a Mike Judge film ;	25.00	2017-02-28
SPENCER	BRANDON E		.p1163191a	59125050690440	712899	Sin city [videorecording] : a dame to kill for / directors, Frank Miller, Robert R	29.99	2017-02-28
SPENCER	BRANDON E		.p1163191a	59125050690440	712897	3:10 to Yuma [videorecording] / Lionsgate presents ; in association with Relativit	14.99	2017-02-28
SPENCER	BRANDON E		.p1163191a	59125050690440	712896	The 40 year old virgin [videorecording] / Universal Pictures presents an Apatow Pr	14.99	2017-02-28
SPENCER	BRANDON E		.p1163191a	59125050690440	712900	Valkyrie [videorecording] / director, Bryan Singer.	29.99	2017-02-28
GIBBENS-WELCH	ELEXESS-NICHOLE		.p1180355a	59125050958953	712919	Babel [sound recording] / Mumford & Sons.	14.99	2017-02-28
ARAUJO	SUJEY A		.p1181529a	59125050966188	712920	Jumanji [videorecording] / TriStar Pictures presents an Interscope Communications/	14.99	2017-02-28
ARAUJO	SUJEY A		.p1181529a	59125050966188	712921	Marvel ultimate Spider-Man [videorecording] : avenging Spider-Man.	26.99	2017-02-28
ARAUJO	SUJEY A		.p1181529a	59125050966188	712922	Barbie and the Three Musketeers [videorecording] / Mattel Entertainment presents a	25.00	2017-02-28
ABEYTA	EMILY ANN		.p1183497a	59125050983043	712925	The sex lives of siamese twins : a novel / Irvine Welsh.	26.00	2017-02-28
LEE	TASHA T		.p1184304a	59125051045461	714151	New cottage style.	19.99	2017-03-03
LEE	TASHA T		.p1184304a	59125051045461	714150	The big book of weeknight dinners.	19.99	2017-03-03
LEE	TASHA T		.p1184304a	59125051045461	714149	Weeknights with Giada : quick and simple recipes to revamp dinner / Giada De Laure	35.00	2017-03-03
LEE	TASHA T		.p1184304a	59125051045461	714148	Start fresh : your child's jump start to lifelong healthy eating / Tyler Florence	19.99	2017-03-03
LEE	TASHA T		.p1184304a	59125051045461	714147	Ultimate crochet bible : a complete reference with step-by-step techniques / by Ja	29.95	2017-03-03
SULEIMAN	TALAYIA T		.p1184311a	59125050985808	714161	The history of music in fifty instruments / Philip Wilkinson.	29.95	2017-03-03
SULEIMAN	TALAYIA T		.p1184311a	59125050985808	714159	Horses : breeds, cultures, traditions / [text by Susanna Cottica and Luca Paparell	29.95	2017-03-03
SULEIMAN	TALAYIA T		.p1184311a	59125050985808	714160	The Titan's curse / Rick Riordan.	17.99	2017-03-03
SULEIMAN	TALAYIA T		.p1184311a	59125050985808	714158	Draw 50 dogs : the step-by-step way to draw beagles, German shepherds, collies, go	20.85	2017-03-03
LEE	TASHA T		.p1184304a	59125051045461	714156	Pokémon black and white / story by Hidenori Kusaka ; art by Satoshi Yamamoto	4.99	2017-03-03
LEE	TASHA T		.p1184304a	59125051045461	714153	Pokémon black and white / story by Hidenori Kusaka ; art by Satoshi Yamamoto	4.99	2017-03-03
LEE	TASHA T		.p1184304a	59125051045461	714155	New decorating book / [editor, Paula Marshall]	24.99	2017-03-03
LEE	TASHA T		.p1184304a	59125051045461	714157	Happy cooking : make every meal count...without stressing out / Giada De Laurentii	35.00	2017-03-03
LEE	TASHA T		.p1184304a	59125051045461	714154	A beautiful mess happy handmade home : a room-by-room guide to painting, crafting,	21.99	2017-03-03
LEE	TASHA T		.p1184304a	59125051045461	714152	A place called home / Jason Grant ; photography by James Geer.	39.95	2017-03-03
SULEIMAN	TALAYIA T		.p1184311a	59125050985808	714162	The complete illustrated encyclopedia of horses & ponies / Sarah Gorrie, Pippa Roo	39.99	2017-03-03
WOOD	LORETTA A		.p1156682a	59125051031149	714175	The complete guide to wood finishes / Derrick Crump.	18.00	2017-03-03
PURCELLA	ANDREW		.p1183407a	59125050983746	714189	The first four years / illustrated by Garth Williams.	15.00	2017-03-03
PURCELLA	ANDREW		.p1183407a	59125050983746	714190	Lirael ; daughter of the Clayr / Garth Nix.	16.89	2017-03-03
PURCELLA	ANDREW		.p1183407a	59125050983746	714196	City of bones / Cassandra Clare.	12.99	2017-03-03
PURCELLA	ANDREW		.p1183407a	59125050983746	714194	Craft of the wise : a practical guide to Paganism and witchcraft / Vikki Bramshaw.	29.95	2017-03-03
PURCELLA	ANDREW		.p1183407a	59125050983746	714197	The long winter / by Laura Ingalls Wilder ; illustrated by Garth Williams.	18.89	2017-03-03
PURCELLA	ANDREW		.p1183407a	59125050983746	714195	Daughters of the moon. Bks. 1-3 / Lynne Ewing.	9.99	2017-03-03
PURCELLA	ANDREW		.p1183407a	59125050983746	714193	The history of witchcraft / Lois Martin.	17.95	2017-03-03
PURCELLA	ANDREW		.p1183407a	59125050983746	714191	Little town on the prairie / Laura Ingalls Wilder ; illustrated by Garth Williams.	16.99	2017-03-03
PURCELLA	ANDREW		.p1183407a	59125050983746	714192	These happy golden years / by Laura Ingalls Wilder ; illustrated by Garth Williams	16.99	2017-03-03
SOLIS	JESSICA QUINTANA		.p1088515a	59125050686596	714926	This book just ate my dog! / Richard Byrne.	16.99	2017-03-06

				Invoice			Cost	Date
Last name	First/middle name	Patron record	Barcode	number	Title			
AVALLONE	AVERY ELIZABETH	.p1179711a	59125050951438	714941	Let's have a parade! / written by Erica Silverman ; illustrated by Jess Golden.		12.99	2017-03-06
ALLAN	BRENT ANTHONY	.p1184364a	59125051307135	714946	The Iceman : the true story of a cold-blooded killer / Anthony Bruno.		16.00	2017-03-06
SILVER	AVA L	.p1140110a	59125050406961	715305	The rule of thoughts / James Dashner.		18.99	2017-03-07
JONES	OLIVER MICHAEL	.p1163132a	59125050690887	715667	Build your own app for fun and profit / Scott La Counte.		15.95	2017-03-08
ESQUIBEL	MELISSA R	.p1184432a	59125051030950	716181	Head injury : a family nightmare / by Estelle Flynn.		11.24	2017-03-10
RIVERA	PANAHI M	.p1180405a	59125051013147	716199	Ratatouille [videorecording] / Walt Disney Pictures presents ; a Pixar Animation S		19.99	2017-03-10
THOMAS	ALEXANDER D	.p1184712a	59125051048945	716541	Hoodwinked [videorecording] / Blue Yonder Films ; Kanbar Entertainment ; produced		6.99	2017-03-11
THOMAS	ALEXANDER D	.p1184712a	59125051048945	716548	James and the giant peach [videorecording] / Walt Disney Pictures presents ; in as		14.99	2017-03-11
THOMAS	ALEXANDER D	.p1184712a	59125051048945	716544	Paddington [videorecording] / Heyday Films & Studio Canal ; directed by Paul King		29.99	2017-03-11
THOMAS	ALEXANDER D	.p1184712a	59125051048945	716546	DS2 [sound recording] / Future.		16.99	2017-03-11
THOMAS	ALEXANDER D	.p1184712a	59125051048945	716542	My crazy life / YG.		13.99	2017-03-11
THOMAS	ALEXANDER D	.p1184712a	59125051048945	716549	Islah [sound recording] / Kevin Gates.		13.99	2017-03-11
THOMAS	ALEXANDER D	.p1184712a	59125051048945	716547	Open season [videorecording] / Columbia Pictures presents a Sony Pictures Animatio		9.99	2017-03-11
THOMAS	ALEXANDER D	.p1184712a	59125051048945	716545	If you're reading this it's too late [sound recording] / Drake.		13.99	2017-03-11
THOMAS	ALEXANDER D	.p1184712a	59125051048945	716543	The pinkprint [sound recording] / Nicki Minaj.		13.99	2017-03-11
KANTZ	SUSAN JEAN	.p1125758a	59125050879597	716570	Stars, galaxies, and the Milky Way / Clive Gifford.		27.60	2017-03-11
JOHNSON	BOBBI DANIELLE	.p1171354a	59125050836977	716829	Bitten by a rattlesnake / Sue Hamilton.		27.07	2017-03-13
JOHNSON	BOBBI DANIELLE	.p1171354a	59125050836977	716828	The adventures of Captain Underpants : the first epic novel / by Dav Pilkey.		9.99	2017-03-13
JOHNSON	BOBBI DANIELLE	.p1171354a	59125050836977	716831	Are you Alice? / Ikumi Katagiri ; Ai Ninomiya.		11.99	2017-03-13
JOHNSON	BOBBI DANIELLE	.p1171354a	59125050836977	716832	Hedgehogs / by Josh Gregory.		28.00	2017-03-13
JOHNSON	BOBBI DANIELLE	.p1171354a	59125050836977	716830	Koalas / by Kari Schuetz.		22.95	2017-03-13
FAJARDO	AUDRINA GRACE	.p1184478a	59125051047236	716849	Oh dear, Geoffrey! / Gemma O'Neill.		15.99	2017-03-13
FAJARDO	AUDRINA GRACE	.p1184478a	59125051047236	716848	Has anyone seen Winnie and Jean? / E.B. McHenry.		16.95	2017-03-13
RODGERS	JULIETTE A	.p1183954a	59125051032576	717078	Vampire kisses / Ellen Schreiber.		16.99	2017-03-14
RODGERS	NICHOLAS EDWARD	.p1183923a	59125051032741	717076	Tarkin / James Luceno.		9.99	2017-03-14
RODGERS	NICHOLAS EDWARD	.p1183923a	59125051032741	717072	Star wars : Death Star / Michael Reaves and Steve Perry.		7.99	2017-03-14
RODGERS	NICHOLAS EDWARD	.p1183923a	59125051032741	717073	Kenobi / John Jackson Miller.		27.00	2017-03-14
RODGERS	NICHOLAS EDWARD	.p1183923a	59125051032741	717075	Star wars : Shatterpoint / Matthew Woodring Stover.		7.50	2017-03-14
RODGERS	NICHOLAS EDWARD	.p1183923a	59125051032741	717074	Bag of bones / Stephen King.		7.99	2017-03-14
GONZALEZ	DIEGO J	.p1183885a	59125050989206	717115	Animal farm / by George Orwell.		16.00	2017-03-14
ROBERSON	ALEX R	.p1145424a	59125050528863	717464	Simply unforgettable [sound recording] / by Mary Balogh.		99.00	2017-03-15
EVANS	ISAIAH CASH	.p1183936a	59125050988604	717475	The deepest water / Kate Wilhelm.		23.95	2017-03-15
BORDOW	SAMUEL D	.p1184319a	59125051030455	718206	Fullmetal alchemist / story and art by Hiromu Arakawa.		9.99	2017-03-17
GARCIA	AMARIE ANN	.p1180693a	59125050961304	718280	Save me [large print] / Lisa Scottoline.		34.99	2017-03-17
GARCIA	AMARIE ANN	.p1180693a	59125050961304	718279	Where my heart belongs [large print] / Tracie Peterson.		31.95	2017-03-17
MARTELL	MONICA MONIQUE	.p1181161a	59125050969950	718282	Wedding wings / written by Kiki Thorpe ; illustrated by Jana Christy.		5.99	2017-03-17
CURRIE	KORTNEE M	.p1120153a	59125051035355	718657	Thirteen reasons why : a novel / by Jay Asher.		10.99	2017-03-18
WOOLSEY	KARA L	.p1178494a	59125051006075	718687	Son of no one / Sherrilyn Kenyon.		27.99	2017-03-18
WOOLSEY	KARA L	.p1178494a	59125051006075	718690	Fullmetal alchemist / story and art by Hiromu Arakawa.		9.99	2017-03-18
SMITH	JESSICA ANNETTE	.p1183010a	59125050977557	718703	Fifty shades darker / E.L. James.		15.95	2017-03-18
ANDREWS	KERVIN M	.p1182117a	59125050972962	719029	Fear and loathing in Las Vegas [videorecording] / Universal Pictures presents a Rh		30.00	2017-03-20
GORSEGNER	TYLER	.p1183778a	59125051032998	719411	Trojan odyssey / Clive Cussler.		27.95	2017-03-21
MARTIN	JERRALEN B	.p1067467a	59125051033509	719863	Science fair flop / by Abby Klein ; illustrated by John McKinley.		5.99	2017-03-22
MATHEWS	GARY ALLEN	.p1134467a	59125050987630	719878	Sling blade [videorecording] / a Miramax Films release ; The Shooting Gallery ; pr		9.99	2017-03-22
LOZOYA	ANAYELY	.p1178877a	59125051048713	719903	Disney princess magazine.		5.00	2017-03-22
LOZOYA	ANAYELY	.p1178877a	59125051048713	719902	Big Dog and Little Dog / Dav Pilkey.		12.99	2017-03-22
LOZOYA	ANAYELY	.p1178877a	59125051048713	719901	Robot, go Bot! / by Dana Meachen Rau ; illustrated by Wook Jin Jung.		12.99	2017-03-22
LOZOYA	ANAYELY	.p1178877a	59125051048713	719899	The show must go on / by Jane O'Connor ; cover illustration by Robin Preiss Glas		16.99	2017-03-22

			Invoice				
Last name	First/middle name	Patron record	Barcode	number	Title	Cost	Date
LOZOYA	ANAYELY	.p1178877a	59125051048713	719898	The dazzling book report / by Jane O'Connor ; cover illustration by Robin Preiss G	16.99	2017-03-22
LOZOYA	ANAYELY	.p1178877a	59125051048713	719900	Counting ovejas / words by Sarah Weeks ; art by David Diaz.	17.99	2017-03-22
LOZOYA	ANAYELY	.p1178877a	59125051048713	719904	Disney princess magazine.	5.00	2017-03-22
RODRIGUEZ	CASANDRA	.p1184551a	59125051047715	719916	Justice : what's the right thing to do? / Michael J. Sandel.	25.00	2017-03-22
CONWAY	SEAN P	.p1184686a	59125051035884	720684	Welder's handbook : a complete guide to MIG, TIG, ARC & oxyacetylene welding / Ric	18.95	2017-03-24
HOOGERHUIS	LYNN P	.p1147604a	59125051028897	720722	Devil's advocate [videorecording] / Warner Bros. Pictures presents in association	5.99	2017-03-24
HOOGERHUIS	LYNN P	.p1147604a	59125051028897	720721	Carlito's way [videorecording] / Universal Pictures and Epic Productions present a	14.99	2017-03-24
HOOGERHUIS	LYNN P	.p1147604a	59125051028897	720720	The good, the bad and the ugly [videorecording] / United Artists presents a film p	19.99	2017-03-24
NIX	BETTY R	.p1184349a	59125051045693	720745	Great day for up! / by Dr. Seuss ; pictures by Quentin Blake.	8.99	2017-03-24
SILVER	DONNA S	.p1114551a	59125050406987	721080	The Golly sisters ride again / story by Betsy Byars ; pictures by Sue Truesdell.	12.47	2017-03-25
SILVER	DONNA S	.p1114551a	59125050406987	721081	Smurfs graphic novel / by Peyo [and Yvan Delporte ; translation, Joe Johnson ; let	5.99	2017-03-25
ANDRADE	ANNABEL	.p1184718a	59125051035678	721151	Perfect match / Jodi Picoult.	16.00	2017-03-25
LUJAN	MARIAH D	.p1170236a	59125050850150	721918	The Circle : a novel / Dave Eggers.	27.95	2017-03-28
LUJAN	MARIAH D	.p1170236a	59125050850150	721917	A thousand splendid suns / Khaled Hosseini.	25.95	2017-03-28
LUJAN	MARIAH D	.p1170236a	59125050850150	721919	Me before you [large print] / Jojo Moyes.	16.99	2017-03-28
DIAZ	LATISHA M	.p1181114a	59125051020688	721952	How to prepare for the GED test / Christopher M. Sharpe, Joseph S. Reddy, Kelly A.	18.99	2017-03-28
MEDINA	MARCOS D	.p1142082a	59125050982870	722431	Exploring South America / Rose Blue and Corinne J. Naden.	19.99	2017-03-29
ULMER	EMMALEA MAE	.p1183088a	59125050976336	722470	Dangerous personalities : an FBI profiler shows how to identify and protect yourse	25.99	2017-03-29
MITCHELL	MYRANDA L	.p1177929a	59125050940423	723279	A child called "it" : one child's courage to survive / Dave Pelzer.	11.95	2017-03-31
MITCHELL	MYRANDA L	.p1177929a	59125050940423	723325	Fifty shades of Grey / E.L. James.	26.95	2017-03-31
MITCHELL	MYRANDA L	.p1177929a	59125050940423	723326	Prince Lestat / Anne Rice.	28.95	2017-03-31
GRESZLER	NICHOLAS ANTHONY	.p1184115a	59125050987093	723607	Chainfire / Terry Goodkind.	17.99	2017-04-01
GRESZLER	NICHOLAS ANTHONY	.p1184115a	59125050987093	723606	Debt of bones / Terry Goodkind ; illustrations by Keith Parkinson.	5.99	2017-04-01
GARCIA	SAUL JR	.p1166377a	59125050797070	724053	A self-made man : the political life of Abraham Lincoln, 1809-1849 / Sidney Blumen	35.00	2017-04-03
BUSTOS	CRYSTAL STEPHANIE	.p1012442a	59125051046949	724853	F*ck feelings : one shrink's practical advice for managing all life's impossible p	19.99	2017-04-05
LINDSAY	GABRIELLE MARIE	.p1182971a	59125050977334	725477	Showing off / by Sarah Mlynowski, Lauren Myracle, and Emily Jenkins.	14.99	2017-04-07
SANTOS	MICHAEL A	.p1183155a	59125050975890	725478	Cats of the Clans / by Erin Hunter ; [illustrations by Wayne McLoughlin].	15.99	2017-04-07
TENA	CARLETTE SKY	.p1131306a	59125051036593	725850	Mirror mirror : a book of reversible verse / Marilyn Singer ; illustrated by Jos	17.00	2017-04-08
AGUINO	LEA R	.p1139371a	59125050391114	726296	The perfect resume : resumes that work in the new economy! / Dan Quillen.	12.95	2017-04-10
GIDEON	HAROLD C	.p1167849a	59125051035967	727158	Star wars. Dawn of the Jedi / story, John Ostrander & Jan Duursema, ... [et al.]	18.99	2017-04-12
GIDEON	HAROLD C	.p1167849a	59125051035967	727199	Spy vs. spy omnibus / Antonio Prohias.	49.99	2017-04-12
ZAMORA	ALEC BENJAMIN	.p1103179a	59125050453278	727917	Valhalla rising [videorecording] / IFC Films ; Nicolas Winding Refn presents a Nim	24.99	2017-04-14
ZAMORA	ALEC BENJAMIN	.p1103179a	59125050453278	727914	Scott Pilgrim vs. the world [videorecording].	29.99	2017-04-14
TORRES	ETHAN TYLER	.p1161114a	59125050765713	727946	Doc Martin. Series 4 [(DVD) videorecording] / Portman Film and Television ; Buffa	39.99	2017-04-14
SOUTHWOOD	NATALIE R	.p1185026a	59125051037567	728042	The hour I first believed : a novel / Wally Lamb.	29.95	2017-04-14
SOUTHWOOD	NATALIE R	.p1185026a	59125051037567	728043	Wishin' and hopin' : a Christmas story / Wally Lamb.	19.99	2017-04-14
TOUCHINE	SHAWN	.p1184403a	59125051046113	728878	The Lone Ranger and Tonto fistfight in heaven / Sherman Alexie.	16.00	2017-04-17
SOTO	DANIEL S	.p1161802a	59125050708903	729220	Aleph / Paulo Coelho ; translated from the Portuguese by Margaret Jull Costa.	24.95	2017-04-18
QUEZADA	MICHAEL	.p1177873a	59125050941199	729235	Around the way girl : a memoir / Taraji P. Henson with Denene Millner.	26.00	2017-04-18
QUEZADA	MICHAEL	.p1177873a	59125050941199	729234	Down the rabbit hole : curious adventures and cautionary tales of a former Playboy	25.99	2017-04-18
CORMAN	BRENDA DENISE	.p1166758a	59125050756910	730728	To kill a mockingbird / Harper Lee.	25.00	2017-04-21
BOULEY	KAYLA E	.p1185113a	59125051037419	730751	Stealing fire / Jo Graham.	14.99	2017-04-21
BOULEY	KAYLA E	.p1185113a	59125051037419	730749	Spirit gate / Kate Elliott.	25.95	2017-04-21
BOULEY	KAYLA E	.p1185113a	59125051037419	730750	Hand of Isis / Jo Graham.	14.99	2017-04-21
BOULEY	KAYLA E	.p1185113a	59125051037419	730748	Black ships : a novel / Jo Graham.	14.99	2017-04-21
WAHLL	MERIDEE PAIGE	.p1151394a	59125050861389	731560	How to build a dragon fort / adapted by Erica David.	16.99	2017-04-24
WAHLL	MERIDEE PAIGE	.p1151394a	59125050861389	731559	Rise of the Titans / by Kate O'Hearn.	17.99	2017-04-24
WAHLL	MERIDEE PAIGE	.p1151394a	59125050861389	731558	Surprises according to Humphrey / Betty G. Birney.	14.99	2017-04-24

				Invoice		
Last name	First/middle name	Patron record	Barcode	number	Title	Cost Date
MARIANO	DEWAYNE ARTHUR	.p1158413a	59125050900849	731562	The essential Michael Jackson [sound recording].	18.99 2017-04-24
SANDOVAL	FAITH C	.p1170536a	59125050853816	732048	Fortress Alcatraz : guardian of the Golden Gate / John Arturo Martini.	13.95 2017-04-25
JOHNSON	ANTWAN J	.p1184771a	59125051050024	732060	Double down / by Jeff Kinney.	13.95 2017-04-25
ROSAS	ANA RUTH	.p1173624a	59125050887251	732073	Now that's what I call music! 50 [sound recording].	18.99 2017-04-25
ALCANTAR	GABRIEL FR	.p1173853a	59125050898886	732074	Pokémon black & white. Set 4 [videorecording] / The Pokémon Company In	19.99 2017-04-25
MCCLENDON	AMY LYNN	.p1059683a	59125051034200	732563	Father Brown. [videorecording] Season 1.	39.99 2017-04-26
MCCLENDON	AMY LYNN	.p1059683a	59125051034200	732561	Little house on the prairie. Season 1 [videorecording] / NBC production in associa	34.99 2017-04-26
MCCLENDON	AMY LYNN	.p1059683a	59125051034200	732560	Tooth Fairy 2 [videorecording] / Twentieth Century Fox Home Entertainment and Wald	14.99 2017-04-26
MCCLENDON	AMY LYNN	.p1059683a	59125051034200	732562	Ender's game [videorecording] / producers, Roberto Orci, Alex Kurtzman, Gigi Pritz	29.99 2017-04-26
MCCLENDON	AMY LYNN	.p1059683a	59125051034200	732559	Doc Martin. Series 5 [videorecording] / Buffalo Pictures ; in association with Aub	39.99 2017-04-26
DAVIDSON	MAKAYLA	.p1124649a	59125050206056	732569	A love like ours / Becky Wade.	13.99 2017-04-26
DAVIDSON	MAKAYLA	.p1124649a	59125050206056	732571	Finale / Becca Fitzpatrick.	19.99 2017-04-26
DAVIDSON	MAKAYLA	.p1124649a	59125050206056	732570	Stars above : a Lunar Chronicles collection / written by Marissa Meyer.	17.99 2017-04-26
DAVIDSON	MAKAYLA	.p1124649a	59125050206056	732574	The fault in our stars / John Green.	17.99 2017-04-26
TORRES	ETHAN TYLER	.p1161114a	59125050765713	732588	Arthur Christmas [videorecording] / Columbia Pictures and Sony Pictures Animation	14.99 2017-04-26
BROWN	STEVEN F	.p1185394a	59125051057706	732594	Innerspeaker [sound recording] / Tame Impala.	12.99 2017-04-26
MCCLENDON	AMY LYNN	.p1059683a	59125051034200	733372	Visions [large print] : a Cainsville novel / Kelley Armstrong.	33.99 2017-04-28
MCCLENDON	AMY LYNN	.p1059683a	59125051034200	733371	Omens [large print] : a Cainsville novel / Kelley Armstrong.	33.99 2017-04-28
ROYBAL	JONI E	.p1179943a	59125050954093	733417	Peck, peck, peck / Lucy Cousins.	15.99 2017-04-28
ROYBAL	JONI E	.p1179943a	59125050954093	733416	Selling art without galleries : toward making a living from your art / Daniel Gran	19.95 2017-04-28
AUSTIN	JEROME MICHAEL	.p1184996a	59125051053002	733426	The amazing spider-man 2 [videorecording] / Columbia Pictures presents a Marvel En	30.99 2017-04-28
AUSTIN	JEROME MICHAEL	.p1184996a	59125051053002	733425	Bad grandpa [videorecording] / Paramount Pictures and MTV Films present ; a Dickho	30.99 2017-04-28
AUSTIN	JEROME MICHAEL	.p1184996a	59125051053002	733424	Dahmer vs. Gacy [videorecording] / Virgil Films and Walking Shadows present ; an A	24.99 2017-04-28
AUSTIN	JEROME MICHAEL	.p1184996a	59125051053002	733427	Caged animal [videorecording] / Phase 4 Films presents a PI Pipeline production w	29.99 2017-04-28
AUSTIN	JEROME MICHAEL	.p1184996a	59125051053002	733423	X-Men origins. Wolverine [videorecording] / Twentieth Century Fox and Marvel Enter	29.99 2017-04-28
ARANDA	ALEXANDRIA Z	.p1185219a	59125051050719	733428	LC Boardbooks.	6.95 2017-04-28
PEREA	CHARLES R JR	.p1179722a	59125051010697	734232	Darkness visible : a memoir of madness / William Styron.	25.00 2017-05-01
MONTEZ	PICASSO ELIJAH	.p1185235a	59125051051105	734237	Team America [videorecording] : world police / Paramount Pictures presents a Scott	5.99 2017-05-01
ANDERSON	COLTON M	.p1183701a	59125050980759	735076	The Battle of Gettysburg, 1863 / by Lauren Tarshis ; illustrated by Scott Dawson.	4.99 2017-05-03
ANDERSON	COLTON M	.p1183701a	59125050980759	735075	The Hindenburg disaster, 1937 / by Lauren Tarshis ; illustrated by Scott Dawson.	16.99 2017-05-03
CANTU	LIA MARIE	.p1185302a	59125051037765	735109	Underworld / by Jude Watson.	6.99 2017-05-03
CANTU	LIA MARIE	.p1185302a	59125051037765	735111	The girl games / Joan Holub & Suzanne Williams.	6.99 2017-05-03
CANTU	LIA MARIE	.p1185302a	59125051037765	735110	Dark warning / by Jude Watson.	6.99 2017-05-03
VALVERDE	JORDYN	.p1182627a	59125050980585	736065	Stink : the incredible shrinking kid / Megan McDonald ; illustrated by Peter H. Re	25.00 2017-05-06
VALVERDE	JORDYN	.p1182627a	59125050980585	736064	Bunnicula meets Edgar Allan Crow / by James Howe ; illustrated by Eric Fortune.	16.00 2017-05-06
VALVERDE	JORDYN	.p1182627a	59125050980585	736066	Junie B. Jones and the mushy gushy valentine [i.e. valentine] / by Barbara Park ;	4.99 2017-05-06
RAEL	DOREEN R	.p1155743a	59125051036411	736752	How the Grinch stole Christmas / by Dr. Seuss.	18.00 2017-05-09
RAEL	DOREEN R	.p1155743a	59125051036411	736751	A hatful of Seuss : five favorite Dr. Seuss stories.	25.00 2017-05-09
KELLOGG	KIMBERLY A	.p1185292a	59125051037799	736769	Cracking the ACT / by the staff of the Princeton Review.	19.99 2017-05-09
KELLOGG	KIMBERLY A	.p1185292a	59125051037799	736768	I'm a frog! / by Mo Willems.	8.99 2017-05-09
RUSSELL	SARAH N	.p1168521a	59125051058183	736805	My first book of Tagalog words : Filipino rhymes and verses / Liana Romulo ; illus	12.95 2017-05-09
HERNANDEZ	LUIS JR	.p1128539a	59125051056559	737292	I decided [sound recording] / Big Sean.	13.99 2017-05-10
FRENCH	DEVERON WILLIAN	.p1184839a	59125051054679	737344	Utterly otterly day / by Mary Casanova ; pictures by Ard Hoyt.	16.99 2017-05-10
AUSTIN	JEROME MICHAEL	.p1184996a	59125051053002	737987	All-new X-Men / Dennis Hopeless, writer ; Mark Bagley, penciler ; Andrew Hennessy,	15.99 2017-05-12
AUSTIN	JEROME MICHAEL	.p1184996a	59125051053002	737988	Luke Cage : Avenger / Adam Glass [and 4 others], writers ; Dalibor Talajčić [19.99 2017-05-12
AUSTIN	JEROME MICHAEL	.p1184996a	59125051053002	737986	Amazing fantastic incredible : a marvelous memoir / Stan Lee and Peter David and C	30.00 2017-05-12
BRENNER	EZRA M	.p1185446a	59125051038698	738017	The King's coat : a novel / by Dewey Lambdin.	6.99 2017-05-12
BARAY-MINNER	NORMA T	.p1185467a	59125051038185	738019	A lesson before dying / Ernest J. Gaines.	12.95 2017-05-12

				Invoice			
Last name	First/middle name	Patron record	Barcode	number	Title	Cost	Date
SAM	NADIA	.p1182247a	59125051029960	738376	A thousand words [videorecording] / Dreamworks Pictures presents a Work After Midn	30.99	2017-05-13
SAM	NADIA	.p1182247a	59125051029960	738378	American ultra [videorecording] / Lionsgate presents ; Palmstar Media Capital and	21.99	2017-05-13
SAM	NADIA	.p1182247a	59125051029960	738379	Daddy's home [videorecording] / Paramount Pictures and Red Granite Pictures presen	29.99	2017-05-13
SAM	NADIA	.p1182247a	59125051029960	738377	Paper towns [videorecording] / director, Jake Schreier.	29.99	2017-05-13
SAM	NADIA	.p1182247a	59125051029960	738375	Poltergeist [videorecording] / Metro-Goldwyn-Mayer presents a Steven Spielberg pro	14.99	2017-05-13
LUBER	JAKOB A	.p1185497a	59125051059272	739103	The great big especially beautiful Easter egg / James Stevenson.	15.00	2017-05-16
LUBER	JAKOB A	.p1185497a	59125051059272	739108	Too much ooze! / illustrated by Patric Spaziante.	14.75	2017-05-16
LUBER	JAKOB A	.p1185497a	59125051059272	739107	Slug needs a hug / Jeanne Willis ; [illustrated by] Tony Ross.	17.99	2017-05-16
LUBER	JAKOB A	.p1185497a	59125051059272	739106	The hiccupotamus / by Aaron Zenz.	12.99	2017-05-16
LUBER	JAKOB A	.p1185497a	59125051059272	739105	Morris goes to school / by B. Wiseman.	12.99	2017-05-16
LUBER	JAKOB A	.p1185497a	59125051059272	739104	A fine St. Patrick's day / by Susan Wojciechowski ; illustrated by Tom Curry.	15.95	2017-05-16
GUNN	ANDREW	.p1185050a	59125051052483	740122	Poor people / Fyodor Dostoevsky ; translated by Hugh Aplin ; [foreword by Charlott	12.00	2017-05-19
GUNN	ANDREW	.p1185050a	59125051052483	740121	The picture of Dorian Gray / Oscar Wilde.	25.00	2017-05-19
GALLEGOS	MELANIE S	.p1146920a	59125050933519	740151	LC Boardbooks.	5.99	2017-05-19
SANCHEZ	BRANDY RAY	.p1185519a	59125051059181	740177	Woman who glows in the dark : a curandera reveals traditional Aztec secrets of phy	15.95	2017-05-19
JAIMES	ALICE	.p1165724a	59125051038367	741074	EB Boardbooks.	4.95	2017-05-23
VILLACANA-ARMENTA	JOSE J	.p1185613a	59125051038334	741077	Star Wars. Scoundrels / Timothy Zahn.	27.00	2017-05-23
DeVORE	SAGELYN	.p1185726a	59125051055882	741610	Last ride [videorecording].	29.99	2017-05-24
DeVORE	SAGELYN	.p1185726a	59125051055882	741614	Teenage mutant ninja turtles [videorecording] : out of the shadows / Paramount Pic	29.99	2017-05-24
DeVORE	SAGELYN	.p1185726a	59125051055882	741613	Home [videorecording] / Dreamworks Animation SKG presents ; screenplay by Tom J. A	29.99	2017-05-24
DeVORE	SAGELYN	.p1185726a	59125051055882	741611	22 Jump Street [videorecording] / writers, Michael Bacall, Oren Uziel ; an Origina	30.99	2017-05-24
DeVORE	SAGELYN	.p1185726a	59125051055882	741612	Apocalypse now redux [videorecording] / directed and produced by Francis Ford Copp	25.00	2017-05-24
HOEDEBECK	DAWSON J	.p1179823a	59125051025018	742536	Batman begins [videorecording] / Warner Bros. Pictures presents in association wit	25.00	2017-05-26
HOEDEBECK	DAWSON J	.p1179823a	59125051025018	742535	Batman [videorecording] : the Dark Knight returns. part 1 / Warner Bros. Animation	19.99	2017-05-26
HOEDEBECK	DAWSON J	.p1179823a	59125051025018	742534	Green lantern [videorecording] / director Martin Campbell.	28.99	2017-05-26
BARKLEY	ANTONIE LYNN	.p1123081a	59125051055874	743850	The humongous book of basic math and pre-algebra problems : translated for people	19.95	2017-05-31
BARKLEY	ANTONIE LYNN	.p1123081a	59125051055874	743849	Geometry demystified / Stan Gibilisco.	19.95	2017-05-31
NEZ	DORIAN ROBIN	.p1166791a	59125050801773	743859	Escape from Darth Vader / written by Michael Siglain ; art by Stephane Roux.	12.99	2017-05-31
DeVORE	SAGELYN	.p1185726a	59125051055882	743889	Ripley's believe it or not! Unlock the weird! / text, Geoff Tibballs.	28.95	2017-05-31
MONTANO	GABBY	.p1181776a	59125051023484	744717	The Mutts diaries / Patrick McDonnell.	9.99	2017-06-02
ZENTZ	KAITLYN MARIE	.p1103441a	59125051057813	744742	The book of lost things / John Connolly.	23.00	2017-06-02
WALKER	JAMES H	.p1114472a	59125051051402	744745	Monster dinosaurs / adapted from an original text by Claire Llewellyn; illustratio	11.99	2017-06-02
WALKER	JAMES H	.p1114472a	59125051051402	744744	Cave of wonders / Matthew J. Kirby.	12.99	2017-06-02
GAPS	ROBERT W	.p1179735a	59125051010424	744797	Clawdeen Wolf and the freaky-fabulous fashion show / by Nessi Monstrata.	9.99	2017-06-02
RODRIGUEZ	GABRIEL FABIAN	.p1153048a	59125051062425	745096	New Mexico FamilyPass	25.00	2017-06-03
NOLAND	DAVID D	.p1145703a	59125051009780	745526	Acrylic decorative painting techniques : discover the secrets of successful decora	25.00	2017-06-05
NOLAND	DAVID D	.p1145703a	59125051009780	745527	Artist's handbook. Acrylics & gouache : materials, techniques, color and compositi	35.00	2017-06-05
PORTER	SAMANTHA DAWN	.p1162599a	59125050718829	745529	Tales from a not-so-perfect pet sitter / Rachel Renée Russell with Nikki Rus	13.99	2017-06-05
CANAFAX	CARLENE MARIE	.p1029046a	59125050920078	747042	Tales from a not-so-perfect pet sitter / Rachel Renée Russell with Nikki Rus	13.99	2017-06-09
CANAFAX	CARLENE MARIE	.p1029046a	59125050920078	747043	Oopsy saves the day! / written by Sonia Sander ; illustrations by Jeff Harter and	3.99	2017-06-09
CANAFAX	CARLENE MARIE	.p1029046a	59125050920078	747041	Battle of the Bulge : adapted from The guns at last light / Rick Atkinson, with Ka	19.99	2017-06-09
CANAFAX	CARLENE MARIE	.p1029046a	59125050920078	747040	D-Day / Rick Atkinson with Kate Waters.	18.99	2017-06-09
EDER	VENISE C	.p1114556a	59125050888689	747048	Why we get fat and what to do about it / Gary Taubes.	24.95	2017-06-09
PENA	ADAM EUGINE	.p1135528a	59125050980106	747051	Num8ers : the chaos / Rachel Ward.	17.99	2017-06-09
FALER	CHRISTOPHER	.p1182680a	59125051039472	747108	Insidious. Chapter 3 [videorecording] / Focus Features presents in association wit	30.99	2017-06-09
FALER	CHRISTOPHER	.p1182680a	59125051039472	747107	American hustle [videorecording] / Columbia Pictures and Annapurna Pictures presen	30.99	2017-06-09
ADAMS	DEAGLAN V	.p1185441a	59125051114457	747125	Minecraft construction handbook / written by Matthew Needler and Phil Southam [Fyr	8.99	2017-06-09
FALER	CHRISTOPHER	.p1182680a	59125051039472	747147	Snitch [videorecording] / producers, Nigel Sinclair ... [et. al.] ; writers, Justi	29.99	2017-06-09

				Invoice			Cost	Date
Last name	First/middle name	Patron record	Barcode	number	Title			
LYLES	KRYSTAL LEE	.p1183560a	59125050982300	747575	Fields where they lay : a Junior Bender mystery / Timothy Hallinan.		25.95	2017-06-10
LYLES	KRYSTAL LEE	.p1183560a	59125050982300	747574	Ice cold kill / Dana Haynes.		25.99	2017-06-10
LYLES	KRYSTAL LEE	.p1183560a	59125050982300	747570	Page one, hit and run : a Robin Hamilton mystery / Nancy Barr.		16.95	2017-06-10
ROSS	NATHANIEL MARCUS	.p1183561a	59125050981997	747579	Shadow wars : the secret struggle for the Middle East / Christopher Davidson.		30.00	2017-06-10
LYLES	BRANDEN MICHAEL	.p1184177a	59125050986376	747588	Bad Bears in the big city : an Irving & Muktuk story / Daniel Pinkwater ; illustra		16.00	2017-06-10
GUZMAN	ALYSSA REBECCA	.p1173855a	59125050898878	748203	Now that's what I call love songs [sound recording].		18.99	2017-06-13
GUZMAN	ALYSSA REBECCA	.p1173855a	59125050898878	748201	Mr. Popper's penguins [videorecording] / Twentieth Century Fox [and Dune Entertain		29.99	2017-06-13
GUZMAN	ALYSSA REBECCA	.p1173855a	59125050898878	748204	Paddington [videorecording] / Heyday Films & Studio Canal ; directed by Paul King		29.99	2017-06-13
GUZMAN	ALYSSA REBECCA	.p1173855a	59125050898878	748202	Now that's what I call music! 47 [sound recording].		18.99	2017-06-13
GALLEGOS	ASHLYN MALEAH	.p1184930a	59125051053838	748326	Asking about sex & growing up : a question-and-answer book for kids / Joanna Cole.		15.99	2017-06-13
SANDOVAL	CHRISTIAN	.p1185879a	59125051064827	748365	Nighttime Ninja / by Barbara DaCosta ; illustrated by Ed Young.		16.99	2017-06-13
WOBBE	EDY MARIE	.p1146537a	59125051029317	748767	Space / written and edited by Simon Holland.		10.99	2017-06-14
WOBBE	EDY MARIE	.p1146537a	59125051029317	748765	Dinosaurs before dark / by Mary Pope Osborne ; illustrated by Sal Murdocca.		3.99	2017-06-14
WOBBE	EDY MARIE	.p1146537a	59125051029317	748768	Space dictionary for kids : the everything guide for kids who love space / Amy And		13.95	2017-06-14
WOBBE	EDY MARIE	.p1146537a	59125051029317	748766	Everything space / Helaine Becker with National Geographic explorer Brendan Mullan		25.90	2017-06-14
WOBBE	EDY MARIE	.p1146537a	59125051029317	748764	Beowulf : a hero's tale retold / by James Rumford.		17.00	2017-06-14
JARVIS	PATRICIA A	.p1119778a	59125051058175	748779	Does a kangaroo have a mother, too? / Eric Carle.		16.99	2017-06-14
SANDOVAL	JEREMY DAVID	.p1133576a	59125050854574	748782	Judy Moody and the bucket list / Megan McDonald ; illustrated by Peter H. Reynolds		15.99	2017-06-14
SANDOVAL	JEREMY DAVID	.p1133576a	59125050854574	748781	Diary of a wimpy kid : Greg Heffley's journal / by Jeff Kinney.		13.95	2017-06-14
BUSTAMANTE	AYDEN JAMES	.p1180584a	59125050962500	748799	LC Boardbooks.		19.99	2017-06-14
BUSTAMANTE	AYDEN JAMES	.p1180584a	59125050962500	748798	Naptime with Theo & Beau / Jessica Shyba.		16.99	2017-06-14
LETHGO	CHRIS D	.p1181932a	59125050970842	750238	Wolven / by Di Toft.		16.99	2017-06-17
LETHGO	CHRIS D	.p1181932a	59125050970842	750239	Angry Birds playground : animals / by Jill Esbaum.		21.90	2017-06-17
MARSHALL	JONATHAN MICHAEL	.p1159226a	59125051064876	750270	Judy Moody and the not bummer summer / Megan McDonald ; [photographs by Suzanne Te		5.99	2017-06-17
MARSHALL	JONATHAN MICHAEL	.p1159226a	59125051064876	750272	Ralph S. Mouse / Beverly Cleary ; illustrated by Paul O. Zelinsky.		5.99	2017-06-17
MARSHALL	JONATHAN MICHAEL	.p1159226a	59125051064876	750267	Stink and the world's worst super-stinky sneakers / Megan McDonald ; illustrated b		22.78	2017-06-17
JACKSON	ANDRIANA A	.p1185290a	59125051037815	750284	Abduction [videorecording] / Lionsgate presents a Gotham Group, Vertigo Entertainm		29.99	2017-06-17
HINES	SANDRA	.p1110160a	59125000063516	751048	You are here : an owner's manual for dangerous minds / Jenny Lawson		15.99	2017-06-20
RONQUILLO- MARTINEZ	JACQUELINE	.p1079536a	59125050970776	751031	Despicable me [videorecording] / Illumination Entertainment ; Universal Pictures p		22.99	2017-06-20
SANDOVAL	VICTORIA B	.p1157249a	59125051050982	751045	Big magic : creative living beyond fear / Elizabeth Gilbert.		24.95	2017-06-20
SANDOVAL	CELINE M	.p1184627a	59125051048838	751094	Beautiful chaos / by Kami Garcia & Margaret Stohl.		18.99	2017-06-20
LIESTER	JENNIFER ANN	.p1186086a	59125051062458	751100	Tad [videorecording] : the lost explorer / Mediaset España and Intereconomia		14.99	2017-06-20
LIESTER	JENNIFER ANN	.p1186086a	59125051062458	751098	Wreck-it Ralph [videorecording] / director, Rich Moore ; writers, Rich Moore ... [29.99	2017-06-20
LIESTER	JENNIFER ANN	.p1186086a	59125051062458	751099	Tiny toon adventures. Volume 4 [videorecording] / Warner Bros. ; Steven Spielberg		19.99	2017-06-20
LIESTER	JENNIFER ANN	.p1186086a	59125051062458	751097	The Tigger movie [videorecording] / Walt Disney Pictures ; [produced by Cheryl Abo		29.99	2017-06-20
LIESTER	JENNIFER ANN	.p1186086a	59125051062458	751096	Cinderella [videorecording] / a Walt Disney production ; story, William Peed [and		29.99	2017-06-20
BLAHA	ZACHERY S	.p1154870a	59125050619860	751445	Chasing Vermeer / by Blue Balliett ; illustrated by Brett Helquist.		16.95	2017-06-21
HIGGINBOTHAM	JORY LEE	.p1184949a	59125051053366	752278	Find the good : unexpected life lessons from a small-town obituary writer / Heathe		16.95	2017-06-23
WOOD	CARLEY M	.p1186032a	59125051063001	752281	The medicinal gardening handbook : a complete guide to growing, harvesting, and us		14.95	2017-06-23
WOOD	CARLEY M	.p1186032a	59125051063001	752282	52 small changes for the mind / Brett Blumenthal.		16.95	2017-06-23
WOOD	CARLEY M	.p1186032a	59125051063001	752280	Complete guide to natural home remedies : 1,025 easy ways to live longer, feel bet		24.00	2017-06-23
WOOD	CARLEY M	.p1186032a	59125051063001	752279	The art of healing : uncovering your inner wisdom and potential for self-healing /		16.95	2017-06-23
HERNANDEZ	AZALEE	.p1173772a	59125051036429	752312	Star Wars. The phantom menace / story, George Lucas ; script, Henry Gilroy ; penc		24.99	2017-06-23
HERNANDEZ	AZALEE	.p1173772a	59125051036429	752311	The Batman strikes! Joker's wild! / Bill Matheny, writer ; Christopher Jones, penc		21.27	2017-06-23
HERNANDEZ	AZALEE	.p1173772a	59125051036429	752310	Daisy and the Beastie / by Jane Simmons.		12.95	2017-06-23
GRUFFITH	RANELDA	.p1185785a	59125051044266	752316	Thomas & friends. Thomas & the special letter [videorecording] / Gullane Entertain		25.00	2017-06-23
GUZMAN	ALYSSA REBECCA	.p1173855a	59125050898878	753389	Ravenpaw's path. Vol. 2, A clan in need / created by Erin Hunter ; written by Dan		6.99	2017-06-27
GUZMAN	ALYSSA REBECCA	.p1173855a	59125050898878	753388	The heart of a warrior / created by Erin Hunter ; written by Dan Jolley ; art by J		6.99	2017-06-27

				Invoice			Cost	Date
Last name	First/middle name	Patron record	Barcode	number	Title			
GUZMAN	ALYSSA REBECCA	.p1173855a	59125050898878	753390	Yo-kai watch / story and art by Noriyuki Konishi ; original story and supervision		9.99	2017-06-27
WALLS	CONSHATA N	.p1185682a	59125051056799	753914	Charcoal Joe : an Easy Rawlins mystery / by Walter Mosley.		26.95	2017-06-28
WALLS	NIGEL H	.p1185683a	59125051056781	753915	Big Nate : what's a little noogie between friends? / by Lincoln Peirce.		9.99	2017-06-28
LIESTER	JENNIFER ANN	.p1186086a	59125051062458	753917	Don't tell a soul / David Rosenfelt.		24.95	2017-06-28
SANDS-CRAIG	CHEYANNE S	.p1178370a	59125051005812	753940	Portrait of an addict as a young man : a memoir / Bill Clegg.		23.99	2017-06-28
FARLEY	STEVEN	.p1186091a	59125051043664	753946	The fall of the Roman Empire / Michael Grant.		25.00	2017-06-28
FARLEY	STEVEN	.p1186091a	59125051043664	753947	Beginning algebra / K. Elayn Martin-Gay.		50.00	2017-06-28
FARLEY	STEVEN	.p1186091a	59125051043664	753948	SPQR : a history of ancient Rome / Mary Beard.		35.00	2017-06-28
DELEON	DANIELLE L	.p1158225a	59125050998991	754851	Overcoming dyslexia : a new and complete science-based program for reading problem		15.95	2017-06-30
MONTES DE OCA	KRYSTA L	.p1185607a	59125051038870	754869	Beeswax alchemy : how to make your own candles, soap, balms, salves and home d		25.00	2017-06-30
CRUZ	A LANA JT	.p1186482a	59125051042229	754870	Dolphin tale [videorecording] / Alcon Entertainment ; written by Karen Janszen and		22.99	2017-06-30
ROURKE	JASON R	.p1185213a	59125051036627	755238	Private : #1 suspect / James Patterson and Maxine Paetro.		27.99	2017-07-01
LIESTER	JENNIFER ANN	.p1186086a	59125051062458	755645	LC Boardbooks.		4.99	2017-07-03
LIESTER	JENNIFER ANN	.p1186086a	59125051062458	755644	Nightschool : the weird books / Svetlana Chmakova ; toning artist, Dee DuPuy ; let		12.99	2017-07-03
LIESTER	JENNIFER ANN	.p1186086a	59125051062458	755654	LC Boardbooks.		7.99	2017-07-03
VALLE	PATRICIA DENISE	.p1096059a	59125051007032	755924	Rio Rancho / Gary Herron.		22.99	2017-07-05
TRUJILLO	MARTIN S	.p1175078a	59125051052442	755966	Florida / by Tamra B. Orr.		40.00	2017-07-05
WILSON	TOYA SJIRELLE	.p1185964a	59125051063787	756048	Dragonbreath / by Ursula Vernon.		12.99	2017-07-05
PIERSON	DOMINIQUE A	.p1165829a	59125050784219	757017	Wemberly worried / Kevin Henkes.		15.95	2017-07-07
SPIES	ERICA L	.p1178496a	59125051006109	757067	LC Boardbooks.		7.99	2017-07-07
MCCOLLUM	DIONE SHEREE	.p1178406a	59125051041981	757108	Alice in Wonderland [videorecording] / 2 Entertain ; directed and produced by Jona		14.99	2017-07-07
MCCOLLUM	DIONE SHEREE	.p1178406a	59125051041981	757109	Frankenweenie [videorecording] / Disney presents a film by Tim Burton ; directed b		29.99	2017-07-07
NONIES	ALABAMA	.p1185942a	59125051039621	757116	A book of sleep / Il Sung Na.		15.99	2017-07-07
GURLEY	JULIE K	.p1186272a	59125051043425	757132	Grace Hopper and the invention of the information age / Kurt W. Beyer.		27.95	2017-07-07
CHRISTENSEN	JENNIFER DEAN	.p1136485a	59125051069842	758447	Ice story : Shackleton's lost expedition / Elizabeth Cody Kimmel.		18.00	2017-07-11
SALAS	ANGEL RAMONA	.p1148626a	59125051058605	759073	Once upon a dream / Liz Braswell.		17.99	2017-07-12
MARSHALL	JONATHAN MICHAEL	.p1159226a	59125051064876	759076	Diary of a wimpy kid : the long haul / by Jeff Kinney.		9.99	2017-07-12
MARSHALL	JONATHAN MICHAEL	.p1159226a	59125051064876	759075	Diary of a wimpy kid : hard luck / by Jeff Kinney.		13.95	2017-07-12
NARVAIZ	JESSICA N	.p1178346a	59125050939060	759087	Atonement [sound recording] / by Ian McEwan.		29.99	2017-07-12
NARVAIZ	JESSICA N	.p1178346a	59125050939060	759091	The snow queen [sound recording] : a novel / Michael Cunningham.		29.99	2017-07-12
NARVAIZ	JESSICA N	.p1178346a	59125050939060	759090	Where we belong [sound recording] : a novel / Emily Giffin.		39.99	2017-07-12
NARVAIZ	JESSICA N	.p1178346a	59125050939060	759088	Happy ever after [sound recording] / Nora Roberts.		34.99	2017-07-12
NARVAIZ	JESSICA N	.p1178346a	59125050939060	759089	The Gilly salt sisters / Tiffany Baker.		24.99	2017-07-12
ROMERO	JONATHAN F	.p1186354a	59125051069727	759102	Jigs & fixtures for the table saw & router / from the editors of Woodworker's jour		17.95	2017-07-12
TOLEDO	CHEHREH M	.p1183021a	59125051026545	759910	Big Nate from the top / by Lincoln Peirce.		9.99	2017-07-14
CRUZ	A LANA JT	.p1186482a	59125051042229	759919	One Saturday evening / by Barbara Baker ; pictures by Kate Duke.		13.99	2017-07-14
CRUZ	A LANA JT	.p1186482a	59125051042229	759920	Henry and Mudge and the great grandpas : the twenty-sixth book of their adventures		14.95	2017-07-14
CRUZE	MATTHEW RODNEY	.p1186506a	59125051041601	760288	Unstable molecules / James Sturm, writer/designer/layouts ; Guy Davis, pencils/ink		13.99	2017-07-15
CRUZE	MATTHEW RODNEY	.p1186506a	59125051041601	760291	Superman : American alien / writer, Max Landis ; artists, Nick Dragotta, Tommy Lee		24.99	2017-07-15
CRUZE	MATTHEW RODNEY	.p1186506a	59125051041601	760290	Superman : the greatest stories ever told / Superman created by Jerry Siegel & Joe		19.99	2017-07-15
CRUZE	MATTHEW RODNEY	.p1186506a	59125051041601	760289	Beowulf : monster slayer : a British legend / story by Paul D. Storrie ; pencils a		26.60	2017-07-15
CRUZE	MATTHEW RODNEY	.p1186506a	59125051041601	760287	Where the sidewalk ends : the poems & drawings of Shel Silverstein.		25.00	2017-07-15
CRUZE	MATTHEW RODNEY	.p1186506a	59125051041601	760292	Wonder Woman and Justice League America / [written by Dan Vado, Chuck Dixon, and B		24.99	2017-07-15
CHAVEZ	SHANTEL M	.p1162018a	59125050847586	761552	Tales from a not-so-dorky drama queen / Rachel Renée Russell with Nikki Russ		13.99	2017-07-19
CHAVEZ	SHANTEL M	.p1162018a	59125050847586	761551	Eight keys / Suzanne LaFleur.		16.99	2017-07-19
CHAVEZ	VANESSA J	.p1163073a	59125050908727	761555	Ivy + Bean and the ghost that had to go / written by Annie Barrows ; illustrated b		14.95	2017-07-19
CHAVEZ	VANESSA J	.p1163073a	59125050908727	761554	When Charlie McButton lost power / Suzanne Collins ; illustrated by Mike Lester.		15.99	2017-07-19
CHAVEZ	VANESSA J	.p1163073a	59125050908727	761556	The Titan's curse / Rick Riordan.		17.99	2017-07-19

				Invoice			Cost	Date
Last name	First/middle name	Patron record	Barcode	number	Title			
THOMAS	DEVENCY J	.p1180019a	59125051011109	761616	Stop, train, stop! : a Thomas the Tank Engine story / illustrated by Owain Bell.		8.99	2017-07-19
THOMAS	DEVENCY J	.p1180019a	59125051011109	761615	May I pet your dog? : the how-to guide for kids meeting dogs (and dogs meeting kid		9.95	2017-07-19
EDWARDS	ILLYSSE C	.p1185743a	59125051055668	761627	My tattooed dad / Daniel Nesquens & Magicomora [illustrator] ; translated by Elisa		18.95	2017-07-19
EDWARDS	ANABELLE B	.p1185744a	59125051055650	761628	Zombie penpal / by Ken McMurtry ; [illustrated by Wes Louie].		6.99	2017-07-19
EDWARDS	ANABELLE B	.p1185744a	59125051055650	761629	Blood on the handle / by R.A. Montgomery ; cover artwork, Wes Lowe ; interior artw		6.99	2017-07-19
CHAVEZ	GABRIEL LYNN	.p1186462a	59125051320104	761632	Jurassic world : junior novelization / a novelization by David Lewman.		9.99	2017-07-19
CHAVEZ	GABRIEL LYNN	.p1186462a	59125051320104	761631	Loot : how to steal a fortune / Jude Watson.		16.99	2017-07-19
WILSON	RENEE MICHELLE	.p1113742a	59125051070352	762471	Lone survivor [videorecording] / Universal Pictures and Emmett/Furla Films present		19.99	2017-07-21
WILSON	RENEE MICHELLE	.p1113742a	59125051070352	762470	End of watch [videorecording] / Open Road Films and Exclusive Media present ; in a		29.99	2017-07-21
MCCOLLUM	DIONE SHEREE	.p1178406a	59125051041981	762484	The wild ones / C. Alexander London.		17.99	2017-07-21
JOE	ALEXANDRIA L	.p1186657a	59125051070238	762814	Mister Memory : a novel / Marcus Sedgwick.		25.95	2017-07-22
MARTINEZ	AARON M	.p1173707a	59125050886519	763228	America ascendant : a revolutionary nation's path to addressing its deepest proble		28.99	2017-07-24
MARTINEZ	AARON M	.p1173707a	59125050886519	763227	The World Book Encyclopedia.		50.00	2017-07-24
MARTINEZ	AARON M	.p1173707a	59125050886519	763229	Bandersnatch : C.S. Lewis, J.R.R. Tolkien, and the creative collaboration of the I		18.95	2017-07-24
SHOEMAKER	MATHEW O	.p1186104a	59125051062011	763276	The king : a novel of the Black Dagger Brotherhood / J.R. Ward.		27.95	2017-07-24
LINSON	PRESTON JOHN	.p1120308a	59125051015027	764168	Really spaced out! / adapted by Frank Berrios ; based on the teleplay "Beyond the		4.99	2017-07-26
CHAVEZ	VANESSA J	.p1163073a	59125050908727	764195	The sea of monsters : the graphic novel / by Rick Riordan ; adapted by Robert Vend		19.99	2017-07-26
WETZLAU	CARTER	.p1181398a	59125051055965	764222	Pokémon, Johto league champions [videorecording] : the complete collection.		49.99	2017-07-26
ROWE	ALYSSA M	.p1182367a	59125050990881	764226	The Berenstain bears blaze a trail / Stan & Jan Berenstain.		11.25	2017-07-26
HERRERA	ELLYAYNA MARY	.p1186731a	59125051070899	764234	Lulu Atlantis and the quest for true blue love / by Patricia Martin ; illustrated		15.99	2017-07-26
UNDERWOOD	KAYLA M	.p1186780a	59125051067937	764237	Uncles and antlers / Lisa Wheeler ; pictures by Brian Floca.		15.95	2017-07-26
VALDEZ	GLORIA A	.p1186787a	59125051067879	764239	Fox and the Hound II [videorecording] / Walt Disney Studios Home Entertainment.		29.99	2017-07-26
VALDEZ	GLORIA A	.p1186787a	59125051067879	764240	Elf [videorecording] / New Line Cinema presents Guy Walks Into a Bar production, a		25.00	2017-07-26
REYES	TABBITHA C	.p1184440a	59125051030570	765178	The hidden staircase [sound recording] / Carolyn Keene.		14.99	2017-07-28
TRUJILLO	FREDERICK J	.p1186998a	59125051040413	765184	Cinderella [videorecording] / a Walt Disney production ; story, William Peed [and		29.99	2017-07-28
TRUJILLO	FREDERICK J	.p1186998a	59125051040413	765185	Frozen [videorecording] / Walt Disney Animation Studios ; directed by Chris Buck,		29.99	2017-07-28
BLARE	KAITLYN M	.p1180200a	59125050957153	765259	Babymouse / by Jennifer Holm & Matthew Holm.		6.99	2017-07-28
WEARE	JACOB A	.p1185835a	59125051060486	765273	LC Boardbooks.		9.99	2017-07-28
DePEREA-DeROSEMAN	MICHAEL	.p1185656a	59125051039746	765272	Archer & Armstrong / Fred Van Lente; artists Clayton Henry with Pere Perez; colori		9.99	2017-07-28
MENDOZA-MUNOZ	GABRIELLE CHERI	.p1186937a	59125051065808	766378	Cell : a novel / Stephen King.		26.95	2017-08-01
BARNHART	MICHELLE M	.p1169806a	59125050841423	766979	Sesame Street. Elmo loves you [videorecording] / Children's Television Workshop ;		14.99	2017-08-02
QUINTANA	BIELLA M	.p1186387a	59125051069560	767010	Spanish for dental professionals : a step by step handbook / Deborah E. Bender, Ma		22.00	2017-08-02
DIXON	SPENCER CAGE	.p1122020a	59125051145089	767934	Animal farm ; 1984 / George Orwell.		24.00	2017-08-04
WILSON	RENEE MICHELLE	.p1113742a	59125051070352	767933	Only a witch can fly / by Alison McGhee ; illustrated by Taaeun Yoo.		16.99	2017-08-04
WILSON	RENEE MICHELLE	.p1113742a	59125051070352	767932	Bugs : poems about creeping things / David L. Harrison ; drawings by Rob Shepperso		16.95	2017-08-04
CORDOVA	JACOB LEE	.p1179846a	59125051074982	768298	Independence day. Resurgence [videorecording] / Twentieth Century Fox presents ; i		29.99	2017-08-05
TILSON	ETHAN NATHANIEL	.p1187039a	59125051074891	768314	Mission to Pluto : the first visit to an ice dwarf and the Kuiper belt / Mary Kay		18.99	2017-08-05
TILSON	LUKE MICHAEL	.p1187042a	59125051071640	768321	Five puptacular tales!		7.99	2017-08-05
TILSON	LUKE MICHAEL	.p1187042a	59125051071640	768319	Pete the cat. Pete at the beach / created by James Dean.		3.99	2017-08-05
TILSON	LUKE MICHAEL	.p1187042a	59125051071640	768320	Superman. A giant attack / by Donald Lemke ; pictures by Lee Ferguson.		13.55	2017-08-05
TILSON	LUKE MICHAEL	.p1187042a	59125051071640	768318	Pete the cat and his four groovy buttons / story by Eric Litwin ; created & illust		17.99	2017-08-05
TILSON	STELLA COCO	.p1187041a	59125051074883	768316	The peaches on the beaches : a book about inflectional endings / Brian P. Cleary ;		23.93	2017-08-05
TILSON	STELLA COCO	.p1187041a	59125051074883	768315	The nice mice in the rice : a long vowel sound book / Brian P. Cleary ; illustrat		23.93	2017-08-05
TILSON	STELLA COCO	.p1187041a	59125051074883	768317	Autumn leaves are falling / by Maria Fleming ; illustrated by Melissa Sweet.		3.99	2017-08-05
HAVILAND	CASSIDY RAE	.p1185482a	59125051057342	769134	The house of Dies Drear / Virginia Hamilton ; illustrations by Eros Keith.		18.95	2017-08-08
HENRY	SONIA M	.p1115096a	59125050086540	769713	The spider's war / Daniel Abraham.		16.99	2017-08-09
SANDERS	DELIA ANGELINA	.p1143675a	59125051073240	769735	The new health rules : simple changes to achieve whole-body wellness / Frank Lipma		19.95	2017-08-09
SANDERS	DELIA ANGELINA	.p1143675a	59125051073240	769733	The little black book of big red flags : relationship warning signs you totally sp		14.95	2017-08-09

Last name	First/middle name	Patron record	Barcode	Invoice number	Title	Cost	Date
SANDERS	DELIA ANGELINA	.p1143675a	59125051073240	769736	Smoke / Ellen Hopkins.	19.99	2017-08-09
SANDERS	DELIA ANGELINA	.p1143675a	59125051073240	769734	How to think more about sex / Alain de Botton.	16.00	2017-08-09
SANDERS	DELIA ANGELINA	.p1143675a	59125051073240	769732	Burned / Ellen Hopkins.	18.99	2017-08-09
SANDERS	DELIA ANGELINA	.p1143675a	59125051073240	769731	D.I.Y. beauty / by Karen W. Bressler & Susan Redstone.	5.99	2017-08-09
SANDERS	CAMILLE B	.p1152554a	59125051073232	769743	Only love today : reminders to breathe more, stress less, and choose love / Rachel	22.99	2017-08-09
SANDERS	CAMILLE B	.p1152554a	59125051073232	769741	Why therapy works : using our minds to change our brains / Louis Cozolino.	23.95	2017-08-09
SANDERS	CAMILLE B	.p1152554a	59125051073232	769739	The recovering heart : emotional sobriety for women / Beverly Conyers.	14.95	2017-08-09
SANDERS	CAMILLE B	.p1152554a	59125051073232	769742	Bold expressive painting : painting techniques for still lifes, florals and landsc	24.99	2017-08-09
SANDERS	CAMILLE B	.p1152554a	59125051073232	769740	Spirituality of gratitude : the unexpected blessings of thankfulness / Joshua Choo	16.00	2017-08-09
SANDERS	CAMILLE B	.p1152554a	59125051073232	769738	The Women's Health big book of yoga : the essential guide to complete mind/body fi	26.99	2017-08-09
SANDERS	CAMILLE B	.p1152554a	59125051073232	769737	The thrill of victory / Sandra Brown.	19.95	2017-08-09
WETZLAU	JOHN ALLEN	.p1155440a	59125050905681	769745	Picture cook : see. make. eat. / Katie Shelly.	18.95	2017-08-09
VALDEZ	GLORIA A	.p1186787a	59125051067879	769815	The terrible two get worse / Mac Barnett, Jory John ; illustrated by Kevin Cornell	13.95	2017-08-09
VALDEZ	GLORIA A	.p1186787a	59125051067879	769814	Storm of dogs / Erin Hunter.	16.99	2017-08-09
VALDEZ	GLORIA A	.p1186787a	59125051067879	769813	Say you're sorry / Michael Robotham.	24.99	2017-08-09
RODRIGUEZ	TRINITY MARIE	.p1187113a	59125051072317	769826	The hollow boy / Jonathan Stroud.	16.99	2017-08-09
ARGUELLO	DESTINY RAY	.p1178516a	59125050934509	769835	EB Boardbooks.	5.99	2017-08-09
ARGUELLO	DESTINY RAY	.p1178516a	59125050934509	769834	EB Boardbooks.	8.95	2017-08-09
ARGUELLO	DESTINY RAY	.p1178516a	59125050934509	769833	Potty training for dummies / Diane Stafford and Jennifer Shoquist.	14.99	2017-08-09
NAJERA	CHRISTIAN J	.p1177292a	59125051041221	769832	EB Boardbooks.	8.95	2017-08-09
BENAVIDEZ	ENRIQUE TOMAS	.p1153025a	59125051073018	770652	Sew me! sewing basics / Choly Knight.	19.99	2017-08-11
BENAVIDEZ	DOMINIC MICHAEL	.p1153026a	59125050594659	770654	Backyard : fun experiments for budding scientists / Lisa Burke.	12.99	2017-08-11
RAMIREZ	MARIA ELENA	.p1187173a	59125051145592	770741	Erec Rex. Book 2 : the monsters of Otherness / by Kaza Kingsley ; illustrations by	18.99	2017-08-11
RAMIREZ	MARIA ELENA	.p1187173a	59125051145592	770742	A cat named Swan / Holly Hobbie.	17.99	2017-08-11
LARA	ALEXIS	.p1165862a	59125051149636	771454	Pokemon, the movie. Volcanion and the mechanical marvel [videorecording].	19.99	2017-08-14
ZELEZNIK	JANE KAY	.p1178076a	59125050936264	771819	Kiss, bow, or shake hands, sales and marketing : the essential cultural guide--fro	20.00	2017-08-15
PAGANO	CRYSTAL MARIE	.p1116483a	59125050076830	771826	The queen of blood / Sarah Beth Durst.	19.99	2017-08-15
STRAHON	ERICA LETICIA	.p1110943a	59125050035505	772423	Talking to children about divorce : a parent's guide to healthy communication at e	13.99	2017-08-16
STRAHON	ERICA LETICIA	.p1110943a	59125050035505	772422	Coparenting after divorce : a GPS for healthy kids / Debra K. Carter.	21.95	2017-08-16
STRAHON	ERICA LETICIA	.p1110943a	59125050035505	772421	Divorce & money : how to make the best financial decisions during divorce / Violet	34.99	2017-08-16
ARGUELLO	DESTINY RAY	.p1178516a	59125050934509	772450	The wolfman [videorecording].	29.99	2017-08-16
NAJERA	CHRISTIAN J	.p1177292a	59125051041221	772449	The Lazarus effect [videorecording] / Relativity Media presents a Blumhouse/Mosaic	19.99	2017-08-16
NAJERA	CHRISTIAN J	.p1177292a	59125051041221	772448	Man of steel [videorecording] / director, Zack Snyder ; writer, David S.Goyer, Chr	22.99	2017-08-16
NAJERA	CHRISTIAN J	.p1177292a	59125051041221	772446	ParaNorman [videorecording] / Focus Features ; Laika ; directed by Sam Fell and Ch	29.99	2017-08-16
NAJERA	CHRISTIAN J	.p1177292a	59125051041221	772447	Spirit [videorecording] : stallion of the Cimarron / DreamWorks Pictures ; produce	14.99	2017-08-16
NAJERA	CHRISTIAN J	.p1177292a	59125051041221	772445	Winnie the Pooh [videorecording] : Frankenpooh and spookable Pooh / Disney.	25.00	2017-08-16
ARGUELLO	DESTINY RAY	.p1178516a	59125050934509	772454	Game of thrones. The complete first season [videorecording] / HBO Entertainment ;	49.99	2017-08-16
ARGUELLO	DESTINY RAY	.p1178516a	59125050934509	772452	Get hard [videorecording] / Warner Bros. Pictures ; directed by Etan Cohen ; writt	22.99	2017-08-16
ARGUELLO	DESTINY RAY	.p1178516a	59125050934509	772453	Star Wars. Episode VII, The Force awakens [videorecording] / a Lucasfilm Ltd. prod	29.99	2017-08-16
ARGUELLO	DESTINY RAY	.p1178516a	59125050934509	772451	Jonah Hex [videorecording] / Warner Bros. Pictures presents in association with Le	25.00	2017-08-16
DELGADO	JOSIAH O	.p1185097a	59125051040215	772458	Harley and Ivy, the deluxe edition / [Paul Dini, Bruce Timm, Shane Glines]	24.99	2017-08-16
PEREZ	SERGIO V	.p1187318a	59125051146061	773544	Sunset of the sabertooth / by Mary Pope Osborne ; illustrated by Sal Murdocca.	3.99	2017-08-19
PEREZ	SERGIO V	.p1187318a	59125051146061	773543	The knight at dawn / by Mary Pope Osborne ; illustrated by Sal Murdocca.	14.99	2017-08-19
RHODES	MADISON R	.p1187609a	59125051077613	773570	Camp Harlow [videorecording] / Pure Flix Entertainment & Grace Alone Films present	16.99	2017-08-19
RHODES	MADISON R	.p1187609a	59125051077613	773568	Ajami [videorecording] / Inosan Productions Ltd. and Twenty Twenty Vision Filmprod	29.99	2017-08-19
RHODES	MADISON R	.p1187609a	59125051077613	773569	Barefoot [videorecording] / production company, Roadside Attractions ; director, A	19.99	2017-08-19
RHODES	AMY R	.p1187608a	59125051077621	773566	The Smurfs. The legend of Smurfy Hollow [videorecording] / producer, Mary Bauder,	6.99	2017-08-19
RHODES	AMY R	.p1187608a	59125051077621	773565	Shrek 2 [videorecording] / DreamWorks Pictures presents a PDI/DreamWorks productio	7.99	2017-08-19

Last name		First/middle name		Patron record		Barcode		Invoice number		Title		Cost	Date
RHODES	AMY R	.p1187608a	59125051077621	773567	Open season, scared silly [videorecording] / written by Carlos Kotkin ; produced b	25.99	2017-08-19						
MARTIN	KIMBERLY F	.p1187612a	59125051078348	773574	Pinocchio [videorecording] / RKO Radio Pictures ; a Walt Disney production ; Walt	28.92	2017-08-19						
MARTIN	JOEL A	.p1187611a	59125051078355	773573	Ice age. Collision course [videorecording] / Twentieth Century Fox Animation prese	29.99	2017-08-19						
MARTIN	JOEL A	.p1187611a	59125051078355	773571	A turtle's tale [videorecording] : Sammy's adventures / An Wave Pictures Productio	19.99	2017-08-19						
MARTIN	JOEL A	.p1187611a	59125051078355	773572	The jungle book 2 [videorecording] / director, Steve Trenbirth ; writer, Karl Geur	29.99	2017-08-19						
NAJERA	ISABELLE RENEE	.p1146676a	59125050796320	774038	The mechanical / Ian Tregillis.	17.00	2017-08-21						
ADAMS	ZEYVIER A	.p1184202a	59125050986145	774091	Do not open! / Mark Parisi.	12.99	2017-08-21						
TOYA	STEVEN E	.p1185884a	59125051065006	774535	American sniper [videorecording] / writer, Jason Dean Hall ; producers, Clint East	22.99	2017-08-22						
BIGELOW	ETHAN M	.p1176707a	59125051014228	775006	The trouble with chickens : a J.J. Tully mystery / Doreen Cronin ; illustrated by	14.99	2017-08-23						
BIGELOW	ETHAN M	.p1176707a	59125051014228	775005	My name is Stilton, Geronimo Stilton / Geronimo Stilton ; [illustrations from idea	6.99	2017-08-23						
BIGELOW	ETHAN M	.p1176707a	59125051014228	775013	I'm a scaredy-mouse! / Geronimo Stilton ; illustrations by Giuseppe Facciotto (des	6.99	2017-08-23						
BIGELOW	ETHAN M	.p1176707a	59125051014228	775012	The third wheel / by Jeff Kinney.	10.46	2017-08-23						
BIGELOW	ETHAN M	.p1176707a	59125051014228	775011	Emperor Pickletine rides the bus / Tom Angleberger.	10.46	2017-08-23						
BIGELOW	ETHAN M	.p1176707a	59125051014228	775008	The Chicken Squad / Doreen Cronin ; illustrated by Kevin Cornell.	12.99	2017-08-23						
BIGELOW	ETHAN M	.p1176707a	59125051014228	775007	The shark attacks of 1916 / by Lauren Tarshis ; illustrated by Scott Dawson.	4.99	2017-08-23						
VALDIVIA	JOHN E	.p1183199a	59125050985535	775016	The Gospel according to Harry Potter : spirituality in the stories of the world's	12.95	2017-08-23						
ORTON	CHARLEE D	.p1187006a	59125051040397	775018	Short circuit / Jonny Zucker ; illustrated by Ned Woodman.	7.95	2017-08-23						
ORTON	CHARLEE D	.p1187006a	59125051040397	775017	If you take a mouse to the movies / by Laura Numeroff ; illustrated by Felicia Bon	15.95	2017-08-23						
DUKE	MONIQUE LANAE	.p1168303a	59125050865927	775803	Parachutes [sound recording] / Coldplay.	20.00	2017-08-25						
COWART	RUSSELL LEE 2ND	.p1186411a	59125051069354	775826	The ruins of Gorlan / John Flanagan.	7.99	2017-08-25						
NAJERA	ISABELLE RENEE	.p1146676a	59125050796320	776104	Z : a novel of Zelda Fitzgerald / Therese Anne Fowler.	25.99	2017-08-26						
ENGLISH	LASHUNDA D	.p1184233a	59125051045255	776117	Lunch Lady / Jarrett J. Krosoczka.	6.99	2017-08-26						
ENGLISH	LASHUNDA D	.p1184233a	59125051045255	776119	Decadence / Eric Jerome Dickey.	26.95	2017-08-26						
ENGLISH	LASHUNDA D	.p1184233a	59125051045255	776118	Lunch Lady / Jarrett J. Krosoczka.	6.99	2017-08-26						
HOLTZ	EMILY ANNE	.p1185079a	29075020962345	776167	Star wars, galactic crisis! / written by Ryder Windham.	4.00	2017-08-26						
ROYBAL	DOREEN A	.p1127665a	59125051078470	777374	Cory stories : a kid's book about living with ADHD / by Jeanne Kraus ; illustrated	14.95	2017-08-30						
ARRIOLA-ESPINOZA	ALEJANDRA	.p1182905a	59125050977995	777447	Shoe-la-la! / by Karen Beaumont ; illustrated by Leuyen Pham.	16.99	2017-08-30						
ARRIOLA-ESPINOZA	ALEJANDRA	.p1182905a	59125050977995	777445	The baker's dozen / Dan Andreasen.	16.95	2017-08-30						
ARRIOLA-ESPINOZA	ALEJANDRA	.p1182905a	59125050977995	777443	D.W.'s guide to preschool / Marc Brown.	15.95	2017-08-30						
ARRIOLA-ESPINOZA	ALEJANDRA	.p1182905a	59125050977995	777441	Sailing off to sleep / by Linda Ashman ; illustrated by Susan Winter.	12.95	2017-08-30						
ARRIOLA-ESPINOZA	ALEJANDRA	.p1182905a	59125050977995	777440	How my library grew, by Dinah : story and pictures / by Martha Alexander.	15.00	2017-08-30						
ARRIOLA-ESPINOZA	ALEJANDRA	.p1182905a	59125050977995	777446	LMNO peas / Keith Baker.	16.99	2017-08-30						
ARRIOLA-ESPINOZA	ALEJANDRA	.p1182905a	59125050977995	777444	Hickory dickory dock / Keith Baker.	16.00	2017-08-30						
ARRIOLA-ESPINOZA	ALEJANDRA	.p1182905a	59125050977995	777442	Good night, animals / Lena Arro, Catarina Kruusval ; translated by Joan Sandin.	15.00	2017-08-30						
ARRIOLA-ESPINOZA	ALEJANDRA	.p1182905a	59125050977995	777451	The best part of daddy's day / Claire Alexander.	16.99	2017-08-30						
ARRIOLA-ESPINOZA	ALEJANDRA	.p1182905a	59125050977995	777449	The very hungry caterpillar / by Eric Carle.	21.99	2017-08-30						
ARRIOLA-ESPINOZA	ALEJANDRA	.p1182905a	59125050977995	777450	100 bears / Magali Bardos.	19.95	2017-08-30						
ARRIOLA-ESPINOZA	ALEJANDRA	.p1182905a	59125050977995	777448	ABC kids / Basher.	17.99	2017-08-30						
LOPEZ	NICOLE A	.p1171665a	59125050838445	778219	Trouble at Trident Academy / Debbie Dadey ; illustrated by Tatevik Avakyan.	5.99	2017-09-01						
PAGANO	CRYSTAL MARIE	.p1116483a	59125050076830	778476	The iron traitor / Julie Kagawa.	9.99	2017-09-02						
GUTIERREZ	MATHIUS	.p1187136a	59125051072580	778496	Attack on Titan / [Hajime Isayama] ; translated and adapted by Sheldon Drzka ; let	10.99	2017-09-02						
HALL	MARIAH T	.p1187610a	59125051077605	778497	The queen of Versailles [videorecording] / Magnolia Pictures and Evergreen Picture	26.99	2017-09-02						
STRAHON	ERICA LETICIA	.p1110943a	59125050035505	778976	Family law in New Mexico : your guide to state law on living together, marriage, d	24.95	2017-09-05						
STRAHON	ERICA LETICIA	.p1110943a	59125050035505	778981	When parents part : how mothers and fathers can help their children deal with sepa	24.95	2017-09-05						
ESPARZA	MAURICIO	.p1178266a	59125050938385	779037	Chernobyl diaries [videorecording] / Alcon Entertainment, Filmation Entertainment	22.99	2017-09-05						
ESPARZA	MAURICIO	.p1178266a	59125050938385	779038	Kaboom!. Happy together collection [videorecording].	12.99	2017-09-05						
GALLEGOS	JONATHAN P	.p1186605a	59125051041452	779055	Prince Lestat / Anne Rice.	28.95	2017-09-05						
PAYNE	STEPHANIE D	.p1187652a	59125051077803	779609	True acting tips : a path to aliveness, freedom, passion, and vitality / Larry Sil	22.99	2017-09-06						

Last name		First/middle name		Patron record		Barcode		Invoice number	Title	Cost	Date
TALAMANTES	LYDIA	.p1180982a	59125050964688	779682	The Naturals / Jennifer Lynn Barnes.	17.99	2017-09-06				
MARTINEZ	PATRICIA ANN	.p1183119a	59125050976161	779696	And to think that I saw it on Mulberry Street / by Dr. Seuss.	8.99	2017-09-06				
MARTINEZ	PATRICIA ANN	.p1183119a	59125050976161	779693	Heather fell in the water / words by Doug MacLeod ; pictures by Craig Smith.	16.99	2017-09-06				
DUKE	MONIQUE LANAE	.p1168303a	59125050865927	780620	Deadpool : world's greatest / Gerry Duggan, writer ; Mike Hawthorne, penciler.	15.99	2017-09-08				
DUKE	MONIQUE LANAE	.p1168303a	59125050865927	780625	Spider-Man. Miles Morales / Brian Michael Bendis, writer ; Sarah Pichelli, artist	17.99	2017-09-08				
DUKE	MONIQUE LANAE	.p1168303a	59125050865927	780623	Star Wars, Poe Dameron / writer, Charles Soule ; artist, Phil Noto ; letterer, VC'	19.99	2017-09-08				
DUKE	MONIQUE LANAE	.p1168303a	59125050865927	780622	Ms. Marvel / writer, G. Willow Wilson ; artist, Adrian Alphona ; color artist, Ian	17.99	2017-09-08				
GRAVES	ARIANNA M	.p1182768a	59125051027246	780731	Green eggs and ham / by Dr. Seuss.	8.99	2017-09-08				
BAHR	CHENNILLE R	.p1187427a	59125051079304	780748	The frogs and toads all sang / Arnold Lobel ; color by Adrienne Lobel.	16.99	2017-09-08				
BAHR	CHENNILLE R	.p1187427a	59125051079304	780747	A place where sunflowers grow = Sabaku ni saita himawari / story, Amy Lee-Tai ; il	16.95	2017-09-08				
MONTANO	SHANIA	.p1187690a	59125051076813	780749	Cats behaving badly : why cats do the naughty things they do / Celia Haddon.	23.99	2017-09-08				
BOOT	BRENDON	.p1187008a	59125051145147	781071	The land before time II. The great valley adventure [videorecording] / [director,	9.99	2017-09-09				
BOOT	BRENDON	.p1187008a	59125051145147	781069	Ice age. The meltdown [videorecording] / Twentieth Century Fox Animation presents	14.99	2017-09-09				
BOOT	BRENDON	.p1187008a	59125051145147	781068	How to train your dragon 2 [videorecording] / Dreamworks Animation SKG ; written a	29.99	2017-09-09				
BOOT	BRENDON	.p1187008a	59125051145147	781070	The land before time [videorecording] / produced by Don Bluth, Gary Goldman, John	14.99	2017-09-09				
RIOS	LILLY VIVIAN	.p1161788a	59125051076110	781514	Secrets of Shakespeare's grave / by Deron R. Hicks ; illustrated by Mark Edward Ge	16.99	2017-09-11				
MENJUGA	ALIANA MARYLINDA	.p1187205a	59125051073778	781554	The Reece Malcolm list : a novel / Amy Spalding.	9.99	2017-09-11				
MENJUGA	ALIANA MARYLINDA	.p1187205a	59125051073778	781553	Ttyl / Lauren Myracle.	6.95	2017-09-11				
INESTROZA	WENDY T	.p1138535a	59125050822621	781904	How do we know about dinosaurs? : a fossil mystery / by Rebecca Olien ; illustrate	23.32	2017-09-12				
SOWDERS	DAVID A	.p1186327a	59125051042633	781931	Read & think Spanish / the editors of Think Spanish magazine.	20.00	2017-09-12				
SOWDERS	DAVID A	.p1186327a	59125051042633	781930	Advanced Spanish step-by-step : master accelerated grammar to take your Spanish to	16.00	2017-09-12				
MCCANTS	ISIS A	.p1187793a	59125051147671	781969	Black Beauty [sound recording] / by Anna Sewell.	22.99	2017-09-12				
VALDIVIA	AMANDA L	.p1183457a	59125051147598	781967	Drawing dragons and those who hunt them / Christopher Hart.	21.95	2017-09-12				
MCCANTS	ISIS A	.p1187793a	59125051147671	781974	Young rider.	5.00	2017-09-12				
MCLELLAN	ANTHONY PIO	.p1151935a	59125050873632	782482	Vietnam at war : the history, 1946-1975 / Phillip B. Davidson.	25.00	2017-09-13				
WADHAMS	AMY L	.p1187815a	59125051147796	782542	Castle waiting / by Linda Medley ; with an introduction by Jane Yolen.	29.99	2017-09-13				
QUINTANA	ALYANNA JEAN	.p1193720a	59125051301625	783259	Texas / written by Ann Heinrichs ; illustrated by Matt Kania.	27.07	2017-09-15				
VIGIL	CECILIA G	.p1187861a	59125051075492	783290	How not to die : discover the foods scientifically proven to prevent and reverse d	27.99	2017-09-15				
VIGIL	CECILIA G	.p1187861a	59125051075492	783289	What I know for sure / Oprah Winfrey.	24.99	2017-09-15				
ORTIZ	SONYA N	.p1187846a	59125051075526	783288	Red wagon / Renata Liwska.	16.99	2017-09-15				
ORTIZ	SONYA N	.p1187846a	59125051075526	783287	Marsupial Sue / by John Lithgow ; illustrated by Jack E. Davis.	17.95	2017-09-15				
THOMAS	TIFFANY N	.p1156488a	59125051148950	783292	New Mexico FamilyPass	25.00	2017-09-15				
ANGUS	KELLY R	.p1177627a	59125050998710	783297	ASVAB premier 2017-2018.	29.99	2017-09-15				
MCNERNEY	MELISSA MARTHA	.p1181277a	59125051071293	783577	The last Neanderthal : a novel / Claire Cameron.	26.00	2017-09-16				
MENJUGA	ALIANA MARYLINDA	.p1187205a	59125051073778	784609	The hypochondriac's handbook : syndromes, diseases, and ailments that probably sho	12.95	2017-09-19				
MENJUGA	ALIANA MARYLINDA	.p1187205a	59125051073778	784610	Find you in the dark / A. Meredith Walters.	15.00	2017-09-19				
WILLIAMS	LASHALLE	.p1187932a	59125051148075	784635	Pokémon X-Y / story Hidenori Kusaka ; art Satoshi Yamamoto ; [English adapta	4.99	2017-09-19				
ROCHA	ALEXIS ANN	.p1110236a	59125051084270	785065	The power of different : the link between disorder and genius / Gail Saltz, M.D.	25.99	2017-09-20				
MATT	ALBERTA	.p1175965a	59125051026644	785127	Premonition [videorecording] / TriStar Pictures, Metro-Goldwyn-Mayer Pictures, and	25.00	2017-09-20				
MATT	ALBERTA	.p1175965a	59125051026644	785126	Cabin in the woods [videorecording] / director, Drew Goddard ; writer, Joss Whedon	29.99	2017-09-20				
MATT	ALBERTA	.p1175965a	59125051026644	785125	Waiting to exhale [videorecording] / Twentieth Century Fox ; screenplay by Terry M	9.99	2017-09-20				
VALENZUELA	BANIA E	.p1185921a	59125051064488	786038	The DIY bride crafty countdown : 40 fabulous projects to make in the months, weeks	19.95	2017-09-23				
VILLICANA	GUADALUPE	.p1187770a	59125051075997	786043	Olivia / written and illustrated by Ian Falconer.	16.95	2017-09-23				
JAKE	ANGELA MIRIAM	.p1174661a	59125051004955	786073	Dolphins at daybreak / by Mary Pope Osborne ; illustrated by Sal Murdocca.	4.99	2017-09-23				
DIXON	CRYSTAL R	.p1187979a	59125051147929	786116	Bag of bones [videorecording] / producer, Michael Mahoney ; teleplay, Matt Venne ;	26.99	2017-09-23				
DIXON	CRYSTAL R	.p1187979a	59125051147929	786114	Scary movie 5 [videorecording] / producers, David Zucker, Phil Dornfield ; screenw	29.99	2017-09-23				
DIXON	CRYSTAL R	.p1187979a	59125051147929	786117	Sinister 2 [videorecording] / Gramercy Pictures presents ; in association with Ent	29.99	2017-09-23				
DIXON	CRYSTAL R	.p1187979a	59125051147929	786115	Dinosaur [videorecording] / Walt Disney Pictures presents ; directed by Ralph Zond	25.00	2017-09-23				

Last name	First/middle name	Patron record	Barcode	Invoice number	Title	Cost	Date
DIXON	CRYSTAL R	.p1187979a	59125051147929	786113	Lego Ninjago masters of Spinjitzu. Rise of the Green Ninja [videorecording].	14.99	2017-09-23
GOELDNER	PATRICIA C	.p1034004a	59125051077167	786814	The lord of the rings. The two towers [videorecording] / New Line Cinema presents	5.99	2017-09-26
GOELDNER	PATRICIA C	.p1034004a	59125051077167	786813	The Lord of the rings. The fellowship of the ring [videorecording] / New Line Cine	5.99	2017-09-26
GOELDNER	PATRICIA C	.p1034004a	59125051077167	786812	The Karate Kid [videorecording] / Columbia Pictures ; Robert Mark Kamen, writer ;	12.99	2017-09-26
HUST	LELAND AZUL	.p1145322a	59125051064124	786836	X-Men. Apocalypse [videorecording] / Twentieth Century Fox presents in association	29.99	2017-09-26
HUST	LELAND AZUL	.p1145322a	59125051064124	786834	Sex tape [videorecording] / Columbia Pictures presents ; an Escape Artists product	30.99	2017-09-26
HUST	LELAND AZUL	.p1145322a	59125051064124	786835	The night before [videorecording] / Columbia Pictures presents in association with	26.99	2017-09-26
HUST	LELAND AZUL	.p1145322a	59125051064124	786833	Into the blue [videorecording] / Columbia Pictures Corporation ; Mandalay Pictures	9.98	2017-09-26
HUST	LELAND AZUL	.p1145322a	59125051064124	786832	A thousand words [videorecording] / Dreamworks Pictures presents a Work After Midn	30.99	2017-09-26
HAYES	GARETT L	.p1160750a	59125051083454	786898	Residential building codes illustrated : a guide to understanding the 2009 Interna	49.95	2017-09-26
HAYES	GARETT L	.p1160750a	59125051083454	786899	Small business for dummies / by Eric Tyson and Jim Schell.	22.99	2017-09-26
HAYES	GARETT L	.p1160750a	59125051083454	786897	Nolo's quick LLC / Anthony Mancuso.	29.99	2017-09-26
COWAN	CHARLES GALLARDO JR	.p1166002a	59125051083637	786918	Dodge Durango & Dakota pick-ups automotive repair manual / by Jay Storer and John	24.95	2017-09-26
COWAN	CHARLES GALLARDO JR	.p1166002a	59125051083637	786916	Chilton's truck & van service manual, 2002 edition.	74.95	2017-09-26
COWAN	CHARLES GALLARDO JR	.p1166002a	59125051083637	786919	Chevrolet Impala & Monte Carlo automotive repair manual / by Mike Stubblefield and	24.95	2017-09-26
COWAN	CHARLES GALLARDO JR	.p1166002a	59125051083637	786917	Chilton's General Motors full-size trucks 1999-06 repair manual / by Jeff Kibler.	29.95	2017-09-26
GRAVES	ARIANNA M	.p1182768a	59125051027246	786958	Frog and toad are friends / by Arnold Lobel.	16.99	2017-09-26
PAULSON	KEVIN K	.p1187695a	59125051077027	786969	The forks over knives plan : how to transition to the life-saving, whole-food, pla	18.99	2017-09-26
SWEAT	LILLY E	.p1187631a	59125051077902	786968	Narwhal and Jelly / Ben Clanton.	12.99	2017-09-26
OBRIEN	SHAMUS P	.p1188006a	59125051146558	787011	Archangel [sound recording] / Soulfly.	15.99	2017-09-26
OBRIEN	SHAMUS P	.p1188006a	59125051146558	787009	Valleys of Neptune [sound recording] / Jimi Hendrix.	16.99	2017-09-26
OBRIEN	SHAMUS P	.p1188006a	59125051146558	787008	Animals [sound recording] / Pink Floyd.	20.00	2017-09-26
OBRIEN	SHAMUS P	.p1188006a	59125051146558	787010	Kinks [sound recording] / Kinks.	13.99	2017-09-26
OBRIEN	SHAMUS P	.p1188006a	59125051146558	787012	They bleed red [sound recording] / Devil You Know.	15.99	2017-09-26
DRUMMOND	CHRIS PAUL	.p1162106a	59125051083520	787501	Saving Private Ryan [videorecording] / Dreamworks Pictures and Paramount Pictures	19.99	2017-09-27
DRUMMOND	CHRIS PAUL	.p1162106a	59125051083520	787500	Death note [videorecording] / animation production, Madhouse ; production, Nippon	24.99	2017-09-27
DRUMMOND	CHRIS PAUL	.p1162106a	59125051083520	787499	Ill communication [sound recording] / Beastie Boys.	19.99	2017-09-27
DRUMMOND	CHRIS PAUL	.p1162106a	59125051083520	787506	Fear the walking dead. The complete first season [videorecording] / AMC presents ;	39.99	2017-09-27
DRUMMOND	CHRIS PAUL	.p1162106a	59125051083520	787505	Straight outta Compton [sound recording] / N.W.A.	9.99	2017-09-27
DRUMMOND	CHRIS PAUL	.p1162106a	59125051083520	787504	Compton [sound recording] : a soundtrack / by Dr. Dre.	13.99	2017-09-27
DRUMMOND	CHRIS PAUL	.p1162106a	59125051083520	787503	At.long.last.A\$AP [sound recording] / A\$ap Rocky.	18.99	2017-09-27
DRUMMOND	CHRIS PAUL	.p1162106a	59125051083520	787502	The Marshall Mathers LP. 2 / Eminem.	13.99	2017-09-27
JONES	RYAN CHANDLER	.p1188015a	59125051084080	787531	Blak and Blu [sound recording] / Gary Clark Jr.	13.99	2017-09-27
JONES	RYAN CHANDLER	.p1188015a	59125051084080	787530	Rearviewmirror [sound recording] / Pearl Jam.	13.99	2017-09-27
JONES	RYAN CHANDLER	.p1188015a	59125051084080	787529	Dizzy's world [sound recording] / Dizzy Gillespie Alumni All-Stars.	20.00	2017-09-27
SWIMMER	SONJA RENAE	.p1184430a	59125051046527	788187	Chinese Cinderella : the true story of an unwanted daughter / Adeline Yen Mah.	8.99	2017-09-29
CLICKNER	SUSAN M	.p1185273a	59125051050156	789386	The fallen man / Tony Hillerman.	24.00	2017-10-03
PADILLA	BETHANY A	.p1170535a	59125050832380	789404	The lacemaker and the princess / Kimberly Brubaker Bradley.	16.99	2017-10-03
GUTIERREZ-ORTEGA	KATARINA CONSUELO	.p1182228a	59125050994990	789907	The geek dad book for aspiring mad scientists : the coolest experiments and projec	18.00	2017-10-04
ASTORGA	CELEST VIDA	.p1188517a	59125051089626	789935	Aladdin [videorecording] / presented by Walt Disney Pictures ; co-produced by Dona	39.99	2017-10-04
ASTORGA	CELEST VIDA	.p1188517a	59125051089626	789934	Caillou. Fun and games with Caillou! [videorecording].	9.99	2017-10-04
ASTORGA	CELEST VIDA	.p1188517a	59125051089626	789933	The Super Mario Bros. super show!. Mario spellbound [videorecording] / producer, J	25.00	2017-10-04
ASTORGA	CELEST VIDA	.p1188517a	59125051089626	789932	Pocahontas II [videorecording] : journey to a new world / produced by Walt Disney	29.99	2017-10-04
THOMAS	TIFFANY N	.p1156488a	59125051148950	789941	Happy for no reason : 7 steps to being happy from the inside out / Marci Shimoff w	24.95	2017-10-04
THOMAS	TIFFANY N	.p1156488a	59125051148950	789938	Exploring mammals.	399.95	2017-10-04
THOMAS	TIFFANY N	.p1156488a	59125051148950	789942	Fox in socks / by Dr. Seuss.	11.99	2017-10-04
THOMAS	TIFFANY N	.p1156488a	59125051148950	789940	Exploring mammals.	399.95	2017-10-04
THOMAS	TIFFANY N	.p1156488a	59125051148950	789939	Exploring mammals.	399.95	2017-10-04

		Invoice					
Last name	First/middle name	Patron record	Barcode	number	Title	Cost	Date
THOMAS	TIFFANY N	.p1156488a	59125051148950	789951	How to be alive : a guide to the kind of happiness that helps the world / Colin Be	25.99	2017-10-04
THOMAS	TIFFANY N	.p1156488a	59125051148950	789949	Agnostic : a spirited manifesto / Lesley Hazleton.	26.00	2017-10-04
THOMAS	TIFFANY N	.p1156488a	59125051148950	789947	Fly high, fly guy! / Tedd Arnold.	6.99	2017-10-04
THOMAS	TIFFANY N	.p1156488a	59125051148950	789945	Today I will fly! / by Mo Willems.	8.99	2017-10-04
THOMAS	TIFFANY N	.p1156488a	59125051148950	789943	When everything changes, change everything : in a time of turmoil, a pathway to pe	19.95	2017-10-04
THOMAS	TIFFANY N	.p1156488a	59125051148950	789950	Morris goes to school / by B. Wiseman.	3.99	2017-10-04
THOMAS	TIFFANY N	.p1156488a	59125051148950	789948	Superman. I am Superman / by Michael Teitelbaum ; pictures by Rick Farley.	12.99	2017-10-04
THOMAS	TIFFANY N	.p1156488a	59125051148950	789946	Saving Leonardo : a call to resist the secular assault on mind, morals, & meaning	26.99	2017-10-04
THOMAS	TIFFANY N	.p1156488a	59125051148950	789944	The happiness project : or why I spent a year trying to sing in the morning, clean	25.99	2017-10-04
ARAGON	AALINA R	.p1169215a	59125051081862	790628	Twilight / Stephenie Meyer.	19.99	2017-10-06
MONTGOMERY	NEIL GORDON	.p1179961a	59125050954523	790636	Dorothy of Oz prequel / [written by Denton J. Tipton ; art by Blair Shedd ; colors	17.99	2017-10-06
MONTGOMERY	NEIL GORDON	.p1179961a	59125050954523	790635	Fangbone!, third-grade barbarian / Michael Rex.	5.99	2017-10-06
YEPA	AVA NOELLE	.p1188269a	59125051081896	790659	The Berenstain bears and the truth / Stan & Jan Berenstain.	12.00	2017-10-06
YEPA	AVA NOELLE	.p1188269a	59125051081896	790660	A pocket for Corduroy : story and pictures / by Don Freeman.	16.99	2017-10-06
DONATO	MARIA ELENA	.p1107783a	59125050599625	790662	Caring for your gerbil / Carol Koopmans.	15.00	2017-10-06
ADAMS	REBECCA J	.p1170342a	59125050847263	790937	Who says women can't be doctors? : the story of Elizabeth Blackwell / Tanya Lee St	16.99	2017-10-07
ADAMS	REBECCA J	.p1170342a	59125050847263	790936	Elizabeth Blackwell : physician and health educator / by Deborah Kent.	19.00	2017-10-07
ADAMS	REBECCA J	.p1170342a	59125050847263	790938	Elizabeth Blackwell, girl doctor / by Joanne Landers Henry ; illustrated by Robert	15.99	2017-10-07
OLGUIN	AUDRINA	.p1188502a	59125051088917	790942	Tangled [videorecording] / Walt Disney Pictures presents ; Walt Disney Animation S	29.99	2017-10-07
HOWLEY	TIA RENE	.p1125006a	59125051083876	791313	Covet / J.R. Ward.	7.99	2017-10-10
DeROUIN	KRISTI	.p1188377a	59125051150246	791405	Beach party surf monkey / Chris Grabenstein ; illustrated by Brooke Allen.	13.99	2017-10-10
DeROUIN	KRISTI	.p1188377a	59125051150246	791411	Stick Dog craves candy / by Tom Watson ; illustrations by Charles Grosvenor based	12.99	2017-10-10
DeROUIN	KRISTI	.p1188377a	59125051150246	791404	Do not open! / Mark Parisi.	12.99	2017-10-10
HOWLEY	TIA RENE	.p1125006a	59125051083876	792048	The angels' share : a Bourbon kings novel / J.R. Ward.	28.00	2017-10-11
PENA	SARA ELAINE	.p1143228a	59125050620603	792051	The year money grew on trees / written and illustrated by Aaron R. Hawkins.	16.00	2017-10-11
DRUMMOND	CHRIS PAUL	.p1162106a	59125051083520	792079	MLB 25 [videorecording] : greatest postseason home runs / Major League Baseball Pr	14.99	2017-10-11
DRUMMOND	CHRIS PAUL	.p1162106a	59125051083520	792078	Electrical banana : masters of psychedelic art / selects, texts, design, Norman Ha	39.95	2017-10-11
DRUMMOND	CHRIS PAUL	.p1162106a	59125051083520	792080	Best of ancient aliens [videorecording] / A&E Television Networks ; History.	19.99	2017-10-11
JONES	RYAN CHANDLER	.p1188015a	59125051084080	792099	The story of Kullervo / by J.R.R. Tolkien ; edited by Verlyn Flieger.	25.00	2017-10-11
ELLIS	CYNTHIA M	.p1117997a	59125051066491	792790	The amazing Maurice and his educated rodents / Terry Pratchett.	6.99	2017-10-13
FUSCO	SAMANTHA ANN	.p1188431a	59125051154743	792882	The PTSD workbook : simple, effective techniques for overcoming traumatic stress s	24.95	2017-10-13
BRYANT	ANGELA	.p1147755a	59125051051774	793989	Tangle journey : exploring the far reaches of tangle drawing, from simple strokes	22.99	2017-10-17
BRYANT	ANGELA	.p1147755a	59125051051774	793988	Drawing secrets revealed : basics / Sarah Parks.	22.99	2017-10-17
ARAGON	AALINA R	.p1169215a	59125051081862	794059	Bridge to Terabithia / Katherine Paterson ; illustrated by Donna Diamond.	16.89	2017-10-17
BENNETT	AMBER N	.p1181847a	59125051090038	794074	Uprooted / Naomi Novik.	25.00	2017-10-17
BENNETT	AMBER N	.p1181847a	59125051090038	794073	Going after Cacciato / Tim O'Brien.	15.00	2017-10-17
MOODY	GARY AARON	.p1188541a	59125051089105	794076	Hung. The complete first season [videorecording] / produced by Alexander Payne.	39.99	2017-10-17
MOODY	GARY AARON	.p1188541a	59125051089105	794077	Rome. First season [videorecording] / HBO Entertainment ; produced by Marco Valeri	29.99	2017-10-17
MOODY	GARY AARON	.p1188541a	59125051089105	794079	Rome. First season [videorecording] / HBO Entertainment ; produced by Marco Valeri	29.99	2017-10-17
MOODY	GARY AARON	.p1188541a	59125051089105	794078	Rome. First season [videorecording] / HBO Entertainment ; produced by Marco Valeri	29.99	2017-10-17
MERCADO	ANGELA D	.p1186241a	59125051042823	794562	Fifty shades freed / E.L. James.	15.95	2017-10-18
MERCADO	ANGELA D	.p1186241a	59125051042823	794561	A promise kept / Robin Lee Hatcher.	15.99	2017-10-18
CORTINAS	NICHOLAS D	.p1186243a	59125051042831	794563	Pirates don't take baths / John Segal.	16.99	2017-10-18
CORTINAS	NICHOLAS D	.p1186243a	59125051042831	794564	Secret Agent Splat! / Rob Scotton.	16.99	2017-10-18
OLGUIN	XAVIER	.p1188503a	59125051089477	794570	The bell bandit / by Jacqueline Davies.	15.99	2017-10-18
ASTORGA	CELEST VIDA	.p1188517a	59125051089626	794573	We : a manifesto for women everywhere / Gillian Anderson and Jennifer Nadel.	25.00	2017-10-18
ASTORGA	CELEST VIDA	.p1188517a	59125051089626	794571	Born for love : why empathy is essential-- and endangered / Maia Szalavitz and Bru	25.99	2017-10-18
ASTORGA	CELEST VIDA	.p1188517a	59125051089626	794572	Dreaming yourself awake : lucid dreaming and Tibetan dream yoga for insight and tr	17.95	2017-10-18

Last name	First/middle name	Patron record	Barcode	Invoice number	Title	Cost	Date
HERNANDEZ	MADALYNE M	.p1184603a	59125051048358	795360	Here's to the good times [sound recording] / Florida Georgia Line.	13.99	2017-10-20
CHAVEZ	BENNY J IV	.p1184613a	59125051048242	795362	Pokemon. BW rival destinies. Set 3 [videorecording] / The Pokémon Company In	26.99	2017-10-20
CHAVEZ	ARMANDO R	.p1184604a	59125051048341	795361	Spongebob, you're fired! [videorecording] / created by Stephen Hillenburg.	14.99	2017-10-20
PETTY	BRODY B	.p1188572a	59125051088891	795364	Mighty Morphin Power Rangers [videorecording] : the movie / Twentieth Century Fox	25.00	2017-10-20
PETTY	ISABELLA R	.p1188573a	59125051088883	795365	Finding Dory [videorecording] / [director, Andrew Stanton].	29.99	2017-10-20
GARDNER	KYLA RENEE	.p1163199a	59125050790059	795368	The twisted ones / by Scott Cawthon, Kira Breed-Wrisley.	9.99	2017-10-20
JONES	BRIAN T	.p1179220a	59125051146616	795375	Represent yourself in court : how to prepare & try a winning case / Paul Bergman,	39.99	2017-10-20
JONES	BRIAN T	.p1179220a	59125051146616	795373	The girl's guide to homelessness : a memoir / Brianna Karp.	16.95	2017-10-20
JONES	BRIAN T	.p1179220a	59125051146616	795374	Clean : overcoming addiction and ending America's greatest tragedy / David Sheff.	15.95	2017-10-20
JONES	BRIAN T	.p1179220a	59125051146616	795372	Contemplating divorce : a step-by-step guide to deciding whether to stay or go / S	16.95	2017-10-20
WHITE	RAVEN CHEYENNE	.p1188551a	59125051154495	795395	Addicted / Zane.	15.00	2017-10-20
FOSTER	SHARON MARIA	.p1163688a	59125050976393	795625	Exploring Mars / D. J. Ward.	27.93	2017-10-21
ARREDONDO	ANGEL ALEJANDRO	.p1152087a	59125050811905	795624	What game shall we play? / Pat Hutchins.	15.99	2017-10-21
OLGUIN	AUDRINA	.p1188502a	59125051088917	795642	When spring comes / by Kevin Henkes ; illustrated by Laura Dronzek.	17.99	2017-10-21
OLGUIN	AUDRINA	.p1188502a	59125051088917	795640	Little white rabbit / Kevin Henkes.	16.99	2017-10-21
OLGUIN	AUDRINA	.p1188502a	59125051088917	795641	All's fair in love and cupcakes [large print] / Betsy St. Amant.	30.99	2017-10-21
RAMIREZ	JULIE	.p1178944a	59125050934475	796341	Good morning, Digger / by Anne Rockwell ; illustrated by Melanie Hope Greenberg.	15.99	2017-10-24
RAMIREZ	JULIE	.p1178944a	59125050934475	796342	Bedtime for Mommy / Amy Krouse Rosenthal ; illustrated by LeUyen Pham.	16.99	2017-10-24
RAMIREZ	JULIE	.p1178944a	59125050934475	796346	Dr. Seuss's ABC.	8.99	2017-10-24
RAMIREZ	JULIE	.p1178944a	59125050934475	796347	The abyss surrounds us / Emily Skrutskie.	11.99	2017-10-24
RAMIREZ	JULIE	.p1178944a	59125050934475	796345	My many colored days / by Dr. Seuss ; illustrated by Steve Johnson with Lou Fanche	16.99	2017-10-24
RAMIREZ	JULIE	.p1178944a	59125050934475	796343	Thomas and the school trip / illustrated by Owain Bell.	25.00	2017-10-24
RAMIREZ	JULIE	.p1178944a	59125050934475	796344	Go! go! go! stop! / Charise Mericle Harper.	16.99	2017-10-24
JEAN-JACQUES	BRADLEY O	.p1188586a	59125051088776	796379	The God debate : a new look at history's oldest argument / Gerald Benedict.	19.95	2017-10-24
JEAN-JACQUES	BRADLEY O	.p1188586a	59125051088776	796377	Fallen angels / Harold Bloom ; illuminations by Mark Podwal.	16.00	2017-10-24
JEAN-JACQUES	BRADLEY O	.p1188586a	59125051088776	796380	Encyclopedia of angels / Richard Webster.	15.95	2017-10-24
JEAN-JACQUES	BRADLEY O	.p1188586a	59125051088776	796378	Two Messiahs : the Jesus of Christianity and the Jesus of Islam / Jeff Morton.	16.99	2017-10-24
FIGUEROA	MAYRA MICHELLE	.p1146971a	59125050886691	797129	LC Boardbooks.	6.95	2017-10-25
MADERA	LAYLA JAMILA	.p1188631a	59125051088131	797167	Eldest / Christopher Paolini.	21.00	2017-10-25
MADERA	LAYLA JAMILA	.p1188631a	59125051088131	797166	Fever, 1793 / by Laurie Halse Anderson.	16.95	2017-10-25
MADERA	LAYLA JAMILA	.p1188631a	59125051088131	797168	Brisingr, or, The seven promises of Eragon Shadeslayer and Saphira Bjartskular / C	27.50	2017-10-25
MADERA	LAYLA JAMILA	.p1188631a	59125051088131	797170	Eragon / Christopher Paolini.	18.95	2017-10-25
MADERA	LAYLA JAMILA	.p1188631a	59125051088131	797169	The speed of darkness / Catherine Fisher.	10.99	2017-10-25
SANDOVAL	KALEB AARON	.p1188844a	59125051085913	797171	City of evil [sound recording] / Avenged Sevenfold.	7.99	2017-10-25
FUSCO	SAMANTHA ANN	.p1188431a	59125051154743	797177	The casual vacancy / J.K. Rowling.	35.00	2017-10-25
DONATO	JOSEPH	.p1152230a	59125050546824	797922	The complete short stories of Ernest Hemingway / Ernest Hemingway.	22.00	2017-10-28
DONATO	JOSEPH	.p1152230a	59125050546824	797924	Boo, the world's cutest dog. Volume one, A walk in the park.	12.99	2017-10-28
DONATO	JOSEPH	.p1152230a	59125050546824	797923	I love that minifigure / [writers, Jen Anstruther, Jonathan Green, Kate Lloyd, Sim	18.99	2017-10-28
CEVERING	CASSANDRA MARIE	.p1158518a	59125051024045	797925	Currency trading for dummies / Kathleen Brooks and Brian Dolan.	26.99	2017-10-28
MILLER	ZACKARY T	.p1183804a	59125050990402	798016	Abraham Lincoln / Tanya Lee Stone.	14.99	2017-10-28
SELECIION	AURORA LYNN	.p1182055a	59125050970917	798014	Harmony / Carolyn Parkhurst.	26.00	2017-10-28
SELECIION	AURORA LYNN	.p1182055a	59125050970917	798013	Who will plant a tree? / written by Jerry Pallotta ; illustrated by Tom Leonard.	15.95	2017-10-28
MOODY	GARY AARON	.p1188541a	59125051089105	798018	Irish legends / Iain Zaczek.	25.00	2017-10-28
MOODY	GARY AARON	.p1188541a	59125051089105	798020	Mankind [videorecording] : the story of all of us / produced by Nutopia for Histor	29.99	2017-10-28
MOODY	GARY AARON	.p1188541a	59125051089105	798019	Through Indian eyes : the untold story of Native American peoples.	40.00	2017-10-28
GALLEGOS	DONALD A	.p1188904a	59125051086432	798027	The dark knight [videorecording] / Warner Bros. Pictures ; Legendary Pictures ; DC	26.99	2017-10-28
WAGAR	CHRISTAL R	.p1133529a	59125050984900	798034	Man the hunted : primates, predators, and human evolution / Donna Hart, Robert W.	29.95	2017-10-28
SOTO	AUBREE B	.p1143364a	59125051087521	798646	The wind through the keyhole / Stephen King.	27.00	2017-10-31

Last name	First/middle name	Patron record	Barcode	Invoice number	Title	Cost	Date
DUNN	MICHAEL A	.p1151342a	59125051072036	798647	Morgan [videorecording] / Twentieth Century Fox presents ; directed by Luke Scott	29.99	2017-10-31
CHAVEZ	MAXAMIS A	.p1176217a	59125050981161	798677	Powwow highway [videorecording] / Handmade Films ; executive producers, George Har	14.99	2017-10-31
CHAVEZ	MAXAMIS A	.p1176217a	59125050981161	798678	Dark skies [videorecording] / producer, Jason Blum ; screenwriter/director, Scott	29.99	2017-10-31
CHAVEZ	MAXAMIS A	.p1176217a	59125050981161	798681	Vacation [videorecording] / New Line Cinema presents in association with RatPac-Du	29.99	2017-10-31
CHAVEZ	MAXAMIS A	.p1176217a	59125050981161	798679	Predators [videorecording] / director, Robert Rodriguez.	29.99	2017-10-31
CHAVEZ	MAXAMIS A	.p1176217a	59125050981161	798680	Drag me to Hell [videorecording] / Universal Pictures and Ghost House Pictures pre	12.99	2017-10-31
FLORES	SANTANA JADE	.p1188396a	59125051080369	798699	Fallout / Ellen Hopkins.	18.99	2017-10-31
RODRIGUEZ	EMILY A	.p1175796a	59125050918825	798972	Sex and the city 2 [videorecording] / New Line Cinema presents ; a Darren Star pro	28.99	2017-11-01
GARUTI	BEVONNIE R	.p1187983a	59125051084437	798985	Mosquitoland / David Arnold.	17.99	2017-11-01
GARUTI	BEVONNIE R	.p1187983a	59125051084437	798986	The son of Neptune / Rick Riordan.	19.99	2017-11-01
OVITT	DANIEL JAMES	.p1188600a	59125051153554	798994	Find out about trees : with 18 projects and more than 250 pictures / Peter Mellett	9.99	2017-11-01
OVITT	DANIEL JAMES	.p1188600a	59125051153554	798995	Meet Chase the Police-Bot / adapted by Lisa Shea.	12.99	2017-11-01
OVITT	DANIEL JAMES	.p1188600a	59125051153554	798998	My little book of rocks, minerals, and gems / by Claudia Martin.	15.95	2017-11-01
OVITT	DANIEL JAMES	.p1188600a	59125051153554	798997	Say cheese-- and die screaming! [sound recording] / R.L. Stine.	39.99	2017-11-01
OVITT	DANIEL JAMES	.p1188600a	59125051153554	798996	Amazing animals / written by Margot Channing.	31.35	2017-11-01
CHAVEZ	ARMANDO R	.p1184604a	59125051048341	799583	Ready for anything / Keiko Kasza.	16.99	2017-11-03
CHAVEZ	BENNY J IV	.p1184613a	59125051048242	799585	The amazing dinosaur detectives : facts, myths and quirks of the dinosaur world /	13.99	2017-11-03
CHAVEZ	BENNY J IV	.p1184613a	59125051048242	799584	World's smallest dinosaurs / Rupert Matthews.	29.32	2017-11-03
CONJURSKIE	TREVOR THOMAS	.p1188153a	59125051082993	799586	The outsiders / S. E. Hinton.	10.00	2017-11-03
BURDG	SEAN R	.p1188539a	59125051089121	799592	Children's dinosaur encyclopedia / [original text by John Malam and Steve Parker ;	35.00	2017-11-03
BURDG	SEAN R	.p1188539a	59125051089121	799590	Dangerous dinosaurs / Tom Jackson.	26.60	2017-11-03
BURDG	SEAN R	.p1188539a	59125051089121	799589	Born to be giants : how baby dinosaurs grew to rule the world / Lita Judge.	17.99	2017-11-03
BURDG	SEAN R	.p1188539a	59125051089121	799591	Dinosaur / written by David Lambert.	19.99	2017-11-03
PETTY	ISABELLA R	.p1188573a	59125051088883	799593	Cupcake : a journey to special / Charise Mericle Harper.	14.99	2017-11-03
VAUGHN	ISABELLA	.p1188741a	59125051087257	799597	Extraordinary Jane / Hannah E. Harrison.	16.99	2017-11-03
VAUGHN	ISABELLA	.p1188741a	59125051087257	799595	Roawr! / Barbara Joosse ; illustrated by Jan Jutte.	16.99	2017-11-03
PETTY	ISABELLA R	.p1188573a	59125051088883	799594	Superlove / by Charise Mericle Harper ; illustrated by Mark Chambers.	16.99	2017-11-03
FUENTES	ARTURO	.p1187955a	59125051148026	799616	Meditation / Naomi Ozaniec.	25.00	2017-11-03
FUENTES	ARTURO	.p1187955a	59125051148026	799617	The complete idiot's guide to controlling anxiety / by Joni E. Johnston ; [edited	16.95	2017-11-03
PADILLA	THERESA J	.p1133521a	59125051086895	799909	Pete the Cat. Too cool for school / by Kimberly and James Dean.	3.99	2017-11-04
PADILLA	THERESA J	.p1133521a	59125051086895	799907	Biscuit visits the big city / story by Alyssa Satin Capucilli ; pictures by Pat Sc	16.99	2017-11-04
PADILLA	THERESA J	.p1133521a	59125051086895	799905	Biscuit and the baby / story by Alyssa Satin Capucilli ; pictures by Pat Schories.	16.99	2017-11-04
PADILLA	THERESA J	.p1133521a	59125051086895	799904	Bed, bats, & beyond / by Joan Holub ; illustrated by Mernie Gallagher-Cole.	14.95	2017-11-04
PADILLA	THERESA J	.p1133521a	59125051086895	799908	The Miss Nelson collection / Harry Allard, James Marshall.	12.99	2017-11-04
PADILLA	THERESA J	.p1133521a	59125051086895	799906	Amelia Bedelia's first library card / by Herman Parish ; pictures by Lynne Avril.	17.99	2017-11-04
PADILLA	THERESA J	.p1133521a	59125051086895	799911	I will love you forever / Tatsuya Miyanishi ; translation by Mariko Shii Gharbi ;	16.99	2017-11-04
PADILLA	THERESA J	.p1133521a	59125051086895	799912	Side tracked / by Diana Harmon Asher.	16.99	2017-11-04
PADILLA	THERESA J	.p1133521a	59125051086895	799910	The giant of Jum / Elli Woollard ; Benji Davies.	17.99	2017-11-04
CHAVEZ	ALICIA MARIE	.p1142577a	59125051055858	799913	Kubo and the two strings [videorecording] / Focus Features ; Laika ; directed and	29.99	2017-11-04
GARUTI	BEVONNIE R	.p1187983a	59125051084437	799951	The handy psychology answer book / Lisa J. Cohen, Ph. D.	21.95	2017-11-04
CHACON	CHRISTOPHER D	.p1188776a	59125051153216	799970	Diario de Greg : un renacuajo / Jeff Kinney.	13.99	2017-11-04
CHACON	MICHAEL AUSTIN	.p1188777a	59125051153224	799973	101 high-intensity workouts for fast results / [by the editors of Muscle & fitness	14.95	2017-11-04
CHACON	MICHAEL AUSTIN	.p1188777a	59125051153224	799971	101 diseases you don't want to get / Michael Powell with Oliver Fischer.	14.95	2017-11-04
CHACON	MICHAEL AUSTIN	.p1188777a	59125051153224	799977	Strength training bible for women : the complete guide to lifting weights for a le	21.95	2017-11-04
CHACON	MICHAEL AUSTIN	.p1188777a	59125051153224	799976	Core fitness solution : more than 5,000 customized workouts you can do anywhere /	24.99	2017-11-04
CHACON	MICHAEL AUSTIN	.p1188777a	59125051153224	799975	The strange case of Origami Yoda / Tom Angleberger.	9.71	2017-11-04
CHACON	MICHAEL AUSTIN	.p1188777a	59125051153224	799974	How to survive outdoors / Jason Polley.	18.00	2017-11-04
CHACON	MICHAEL AUSTIN	.p1188777a	59125051153224	799972	The male brain / Louann Brizendine.	24.99	2017-11-04

Last name	First/middle name	Patron record	Barcode	Invoice number	Title	Cost	Date
WOO	ISAIAH C	.p1187889a	59125051147135	800749	The tales of Beedle the Bard : [a wizarding classic from the world of Harry Potter	12.99	2017-11-07
FERNANDEZ	OLIVIA M	.p1179346a	59125050947915	800790	Nursing school entrance exams / by the staff of Kaplan Test Prep and Admissions.	22.99	2017-11-07
FERNANDEZ	OLIVIA M	.p1179346a	59125050947915	800789	Nursing school entrance exams / by the staff of Kaplan Test Prep and Admissions.	19.99	2017-11-07
PETTY	CAMERON J	.p1188477a	59125051094535	800799	Interstellar [videorecording] / directed by Christopher Nolan ; written by Jonatha	29.99	2017-11-07
PETTY	CAMERON J	.p1188477a	59125051094535	800796	Band of brothers [videorecording] / HBO presents in association with DreamWorks an	79.99	2017-11-07
PETTY	CAMERON J	.p1188477a	59125051094535	800798	Once upon a time. The complete third season [videorecording] / an ABC Studios prod	45.99	2017-11-07
PETTY	CAMERON J	.p1188477a	59125051094535	800797	Once upon a time. The complete third season [videorecording] / an ABC Studios prod	45.99	2017-11-07
PETTY	CAMERON J	.p1188477a	59125051094535	800795	Band of brothers [videorecording] / HBO presents in association with DreamWorks an	79.99	2017-11-07
ALLEN	RAJENE TAMIKA	.p1118320a	59125050808679	801223	The centurion's wife / Davis Bunn & Janette Oke.	19.99	2017-11-08
ALLEN	RAJENE TAMIKA	.p1118320a	59125050808679	801222	The Damascus way / Davis Bunn & Janette Oke.	19.99	2017-11-08
CUEVAS	AMILIA M	.p1187562a	59125051077746	801254	No, no, Gnome! / Ashlyn Anstee.	17.99	2017-11-08
CUEVAS	AMILIA M	.p1187562a	59125051077746	801253	I love my mommy / Giles Andreae ; & [illustrations by] Emma Dodd.	12.99	2017-11-08
JEAN-JACQUES	BRADLEY O	.p1188586a	59125051088776	801256	Skin game : a novel of the Dresden files / Jim Butcher.	27.95	2017-11-08
JEAN-JACQUES	BRADLEY O	.p1188586a	59125051088776	801255	The kills / Linda Fairstein.	25.00	2017-11-08
ARELLANO	SONIA M.	.p1188381a	59125051150311	801275	And if the moon could talk / Kate Banks ; pictures by Georg Hallensleben.	25.00	2017-11-08
DESIMONE	ETHAN JAMES	.p1167433a	59125050789044	801922	The old man and the sea / Ernest Hemingway.	20.00	2017-11-13
RODRIGUEZ	STEPHANY	.p1172823a	59125051026420	801924	The experiment [videorecording] / Stage 6 Films presents and Inferno, Magnet prese	24.99	2017-11-13
CORTEZ	ALICIA R	.p1187968a	59125051147978	801934	It's perfectly normal : a book about changing bodies, growing up, sex and sexual h	22.99	2017-11-13
GONZALES	SHAILYNN A	.p1184335a	59125051045743	802109	The Bane chronicles / Cassandra Clare, Sarah Rees Brennan, Maureen Johnson.	22.99	2017-11-13
ARIZMENDI	BREANNA D	.p1188003a	59125051147853	802126	The too-scary story / Bethanie Deeney Murguia.	16.99	2017-11-13
ARIZMENDI	BREANNA D	.p1188003a	59125051147853	802124	Waiting for wings / Lois Ehlert.	17.99	2017-11-13
ARIZMENDI	BREANNA D	.p1188003a	59125051147853	802122	Star Wars, the clone wars. Jedi in training / written by Heather Scott.	14.99	2017-11-13
ARIZMENDI	BREANNA D	.p1188003a	59125051147853	802120	Three little dinosaurs / [text and illustrations by] Charles Fuge.	14.95	2017-11-13
ARIZMENDI	BREANNA D	.p1188003a	59125051147853	802125	Little Plane learns to write / Stephen Savage.	16.99	2017-11-13
ARIZMENDI	BREANNA D	.p1188003a	59125051147853	802123	LEGO Star wars : Anakin to the rescue! / by Ace Landers ; illustrated by David Whi	12.99	2017-11-13
ARIZMENDI	BREANNA D	.p1188003a	59125051147853	802121	Who's in my family? : all about our families / Robie H. Harris ; illustrated by Na	15.99	2017-11-13
ARIZMENDI	BREANNA D	.p1188003a	59125051147853	802127	5 cherries / Vittoria Facchini ; translated from the Italian by Anna Celada.	18.95	2017-11-13
TATUM	PENELOPE	.p1188899a	59125051086440	802132	Brightest day / Geoff Johns & Peter J. Tomasi, writers ; Ivan Reis ... [et al.], a	29.99	2017-11-13
TATUM	PENELOPE	.p1188899a	59125051086440	802130	Adventure time. Banana guard academy / written by Kent Osborne & Dylan Haggerty ;	19.99	2017-11-13
TATUM	PENELOPE	.p1188899a	59125051086440	802131	Oddly Normal / written & illustrated by Otis Frampton.	9.99	2017-11-13
GALLEGOS	DONALD A	.p1188904a	59125051086432	802129	Rapunzel's revenge / Shannon Hale and Dean Hale ; illustrated by Nathan Hale.	19.99	2017-11-13
YOUNGREN	STACY RENEE	.p1147767a	59125051148224	802133	End of watch : a novel / by Stephen King.	30.00	2017-11-13
MARES	DESIREE ROSEMARY	.p1140388a	59125050491260	802692	Firefighters! : speeding! spraying! saving! / written by Patricia Hubbell ; illust	14.99	2017-11-14
RODRIGUEZ	KARIZMA R	.p1175798a	59125050918809	803312	6 steps to 7 figures : a real estate professional's guide to building wealth and c	16.95	2017-11-15
LARA	ALEXIS	.p1165862a	59125051149636	803337	Stolen / by Vivian Vande Velde.	16.99	2017-11-15
LARA	ALEXIS	.p1165862a	59125051149636	804110	Wild born / Brandon Mull.	12.99	2017-11-17
LARA	ALEXIS	.p1165862a	59125051149636	804111	The iron trial / Holly Black and Cassandra Clare ; with illustrations by Scott Fis	17.99	2017-11-17
LARA	ALEXIS	.p1165862a	59125051149636	804108	Division and multiplication / Rebecca Wingard-Nelson.	20.00	2017-11-17
LARA	ALEXIS	.p1165862a	59125051149636	804109	A mutiny in time / James Dashner.	12.99	2017-11-17
CORTEZ	JOAQUIN L	.p1187969a	59125051147986	804154	Amulet / Kazu Kibuishi.	24.99	2017-11-17
GUTIERREZ	MERCEDES A	.p1188956a	59125051085558	804156	Naruto / story and art by Masashi Kishimoto ; [English adaptation by Jo Duffy].	7.95	2017-11-17
GONZALEZ	AVENELLE L	.p1124946a	59125051054976	804458	Downfall / J. A. Jance.	26.99	2017-11-18
GONZALEZ	AVENELLE L	.p1124946a	59125051054976	804457	Her daughter's dream / Francine Rivers.	24.99	2017-11-18
GARCIA JAXON		.p1184799a	59125051054984	804493	Max and Jax in second grade / Jerdine Nolen ; illustrated by Karen Lee Schmidt.	14.32	2017-11-18
GARCIA JAXON		.p1184799a	59125051054984	804495	Bedtime monsters / Josh Schneider.	16.99	2017-11-18
GARCIA JAXON		.p1184799a	59125051054984	804494	The lamb who came for dinner / by Steve Smallman ; illustrated by Joelle Dreidemy.	15.95	2017-11-18
MACIAS	PETER JOHN	.p1150995a	59125051051220	805164	Entrepreneur magazine's ultimate guide to Google AdWords : how to access 100 milli	24.95	2017-11-21
MACIAS	PETER JOHN	.p1150995a	59125051051220	805167	The ADHD advantage : what you thought was a diagnosis may be your greatest strengt	25.95	2017-11-21

Last name		First/middle name		Patron record		Barcode		Invoice number	Title	Cost	Date
MACIAS	PETER JOHN	.p1150995a	59125051051220	805165	HeadTrash! : cleaning out the junk that stands between you and success / Tish Squi	21.95	2017-11-21				
MACIAS	PETER JOHN	.p1150995a	59125051051220	805168	100 deadly skills : survival edition : the SEAL operative's guide to surviving in	19.99	2017-11-21				
MACIAS	PETER JOHN	.p1150995a	59125051051220	805166	Schizophrenia : a brother finds answers in biological science / Ronald Chase.	19.95	2017-11-21				
RIEL	BRIDGET L	.p1167565a	59125051053630	805188	The encyclopedia of ancient Egypt / Margaret Bunson.	9.99	2017-11-21				
COOPER	MATTHEW E	.p1174607a	59125051091036	805191	Ray Donovan. The second season [videorecording].	29.99	2017-11-21				
RAMIREZ	DAMIAN J	.p1170729a	59125051093032	805190	Pokémon the movie. White : Victini and Zekrom [videorecording] / the Pok	19.99	2017-11-21				
HERNANDEZ	IDALY	.p1189038a	59125051094402	805214	Origami folding frenzy : boats, fish, cranes, and more! / by Christopher Harbo.	27.32	2017-11-21				
HERNANDEZ	IDALY	.p1189038a	59125051094402	805213	Beyond the solar system : exploring galaxies, black holes, alien planets, and more	27.95	2017-11-21				
HERNANDEZ	IDALY	.p1189038a	59125051094402	805212	United States of America / by Michael Burgan.	40.00	2017-11-21				
HERNANDEZ	IDALY	.p1189038a	59125051094402	805211	Shakira : star singer / Zella Williams.	25.00	2017-11-21				
HERNANDEZ	IDALY	.p1189038a	59125051094402	805210	A life in the wild : George Schaller's struggle to save the last great beasts / Pa	21.95	2017-11-21				
FOSTER	SHARON MARIA	.p1163688a	59125050976393	805216	The wump world / written and illustrated by Bill Peet.	17.95	2017-11-21				
MARTINEZ	KYRA	.p1174503a	59125050951081	805632	Cirque du Freak : the vampire's assistant / by Darren Shan.	15.95	2017-11-22				
MARTINEZ	KYRA	.p1174503a	59125050951081	805635	Cirque du freak : killers of the dawn / by Darren Shan.	8.99	2017-11-22				
MARTINEZ	KYRA	.p1174503a	59125050951081	805633	Lord of the shadows / by Darren Shan.	15.99	2017-11-22				
MARTINEZ	KYRA	.p1174503a	59125050951081	805634	The Lake of Souls / by Darren Shan.	7.99	2017-11-22				
MATTIA	TRESSA MARIE	.p1128383a	59125051044597	805654	Reunion [sound recording] / Karen Kingsbury with Gary Smalley.	19.99	2017-11-22				
CHACON	ANDREW A	.p1188778a	59125051153232	805673	Epidemic! : the world of infectious disease / Rob DeSalle, editor.	25.00	2017-11-22				
CHACON	ANDREW A	.p1188778a	59125051153232	805674	Physics in mind : a quantum view of the brain / Werner R. Loewenstein.	28.99	2017-11-22				
PARKER	TYANE	.p1167167a	59125051045941	806335	Alzheimer's and dementia for dummies.	26.99	2017-11-27				
POPE	CHRISTOPHER MICHAEL	.p1073656a	59125051089170	806376	Appropriate adult [videorecording] / ITV Studios presents in association with Sund	26.99	2017-11-27				
POPE	CHRISTOPHER MICHAEL	.p1073656a	59125051089170	806375	A most violent year [videorecording] / an A24 release ; in association with Partic	19.99	2017-11-27				
LOVATO	MARCUS ANTHONY	.p1144994a	59125051093529	806393	Essential psychology / edited by Philip Banyard, Gayle Dillon, Christine Norman an	150.00	2017-11-27				
FALLIN	EUGENIO	.p1177507a	59125050944912	806423	June / Gabrielle Lord.	10.99	2017-11-27				
FALLIN	EUGENIO	.p1177507a	59125050944912	806424	May / Gabrielle Lord.	10.99	2017-11-27				
CHRISTEN	GINA M	.p1187909a	59125051085012	806440	The world's religions / Huston Smith.	16.99	2017-11-27				
CHRISTEN	GINA M	.p1187909a	59125051085012	806439	Amish peace : simple wisdom for a complicated world / Suzanne Woods Fisher.	12.99	2017-11-27				
CHRISTEN	GINA M	.p1187909a	59125051085012	806442	Introducing world religions : a Christian engagement / Charles E. Farhadian.	49.99	2017-11-27				
CHRISTEN	GINA M	.p1187909a	59125051085012	806441	The Amish way : patient faith in a perilous world / Donald B. Kraybill, Steven M.	24.95	2017-11-27				
FIELDS	ELIZABETH MARIE	.p1189075a	59125051094063	806451	Innocence [sound recording] : a novel / Dean Koontz.	36.99	2017-11-27				
HILL	MELODY LOVE	.p1171430a	59125051152648	808020	Are you there God? It's me, Margaret / Judy Blume.	17.95	2017-12-01				
HILL	MELODY LOVE	.p1171430a	59125051152648	808019	Just in case : a trickster tale and Spanish alphabet book / Yuyi Morales.	17.95	2017-12-01				
HILL	MELODY LOVE	.p1171430a	59125051152648	808021	Chicken Lily / Lori Mortensen ; illustrated by Nina Victor Crittenden.	16.99	2017-12-01				
JENNINGS	DEBBIE DENISE	.p1116631a	59125050836936	808059	Pokémon black and white / story by Hidenori Kusaka ; art by Satoshi Yamamoto	4.99	2017-12-01				
BAHE	MARIAH L	.p1121164a	59125051056690	808065	Build your own gaming PC / Russell Barnes and Adam Barnes.	36.95	2017-12-01				
BAHE	MARIAH L	.p1121164a	59125051056690	808062	House of many ways / Diana Wynne Jones.	8.99	2017-12-01				
MONTANO	NICHELLE M	.p1187567a	59125051078132	808175	If you give a pig a pancake / by Laura Numeroff ; illustrated by Felicia Bond.	15.99	2017-12-01				
PROVEAUX ARMUJO	AUGUSTINE R	.p1187404a	59125051146350	808163	The fire within / Chris D'Lacey.	14.95	2017-12-01				
MONTANO	NICHELLE M	.p1187567a	59125051078132	808177	Home / Jeannie Baker.	15.99	2017-12-01				
MONTANO	NICHELLE M	.p1187567a	59125051078132	808176	Jeffry's Halloween / Mary Bryant Bailey ; pictures by Elizabeth Sayles.	16.00	2017-12-01				
MONTANO	NICHELLE M	.p1187567a	59125051078132	808182	The Shivers in the fridge / by Fran Manushkin ; illustrated by Paul O. Zelinsky.	16.99	2017-12-01				
MONTANO	NICHELLE M	.p1187567a	59125051078132	808181	Boo Cow / Patricia Baehr ; [illustrations by] Margot Apple.	14.95	2017-12-01				
MONTANO	NICHELLE M	.p1187567a	59125051078132	808184	Withering-by-Sea / Judith Rossell.	16.99	2017-12-01				
MONTANO	NICHELLE M	.p1187567a	59125051078132	808183	Bugs galore / Peter Stein ; illustrated by Bob Staake.	15.99	2017-12-01				
MONTANO	NICHELLE M	.p1187567a	59125051078132	808179	Gossamer / Lois Lowry.	16.00	2017-12-01				
MONTANO	NICHELLE M	.p1187567a	59125051078132	808186	Attack of the Zombie Rabbits / adapted by Maggie Testa ; based on the screenplay w	16.99	2017-12-01				
MONTANO	NICHELLE M	.p1187567a	59125051078132	808185	The girl in the well is me / Karen Rivers.	16.95	2017-12-01				
MONTANO	NICHELLE M	.p1187567a	59125051078132	808187	The bad beginning / by Lemony Snicket ; illustrations by Brett Helquist.	13.99	2017-12-01				

Last name		First/middle name		Patron record		Barcode		Invoice number	Title	Cost	Date
CARRIAGA	MOSES	.p1187985a	59125051084411	808192	The student Bible atlas / Tim Dowley.	20.99	2017-12-01				
CARRIAGA	MOSES	.p1187985a	59125051084411	808191	True or false? / written by Andrea Mills.	19.99	2017-12-01				
CARRIAGA	MOSES	.p1187985a	59125051084411	808194	The silence / Mark Alpert.	17.99	2017-12-01				
CARRIAGA	MOSES	.p1187985a	59125051084411	808193	Big book of why / by: Mark Shulman and K.C. Kelley.	19.95	2017-12-01				
CARRIAGA	MOSES	.p1187985a	59125051084411	808190	The rule of thre3 / Eric Walters.	17.99	2017-12-01				
CARRIAGA	MOSES	.p1187985a	59125051084411	808188	The subtle knife / Philip Pullman.	20.00	2017-12-01				
CARRIAGA	MOSES	.p1187985a	59125051084411	808189	Castle of shadows / by Ellen Renner ; illustrated by Wilson Swain.	15.99	2017-12-01				
GURLEY	BRADLEY COLE	.p1189141a	59125051093438	808205	Autobiography of a sadhu : a journey into mystic India / Rampuri.	18.95	2017-12-01				
GURLEY	BRADLEY COLE	.p1189141a	59125051093438	808206	Zen : the authentic gate / Kōun Yamada.	19.95	2017-12-01				
GALLEGOS	ISABELLA A	.p1189178a	59125051093099	808209	The bad beginning / by Lemony Snicket ; illustrations by Brett Helquist.	16.95	2017-12-01				
OLGUIN	KATERI R	.p1189346a	59125051091499	808212	Pocahontas [videorecording] / Walt Disney Pictures presents ; written by Carl Bind	29.99	2017-12-01				
MORALES	MERCADYZ	.p1186857a	59125051040678	808909	Spongebob comics / Stephen Hillenburg ; edited by Chris Duffy.	10.99	2017-12-04				
MORALES	MERCADYZ	.p1186857a	59125051040678	808910	Spongebob comics / Stephen Hillenburg ; edited by Chris Duffy.	10.95	2017-12-04				
MORALES	MERCADYZ	.p1186857a	59125051040678	808908	Spongebob comics / Stephen Hillenburg ; edited by Chris Duffy.	10.95	2017-12-04				
MORALES	ACALIA	.p1186856a	59125051040686	808907	Ninja Bunny : sister vs. brother / Jennifer Gray Olson.	19.99	2017-12-04				
MORALES	ACALIA	.p1186856a	59125051040686	808906	Douglas, you need glasses! / by Ged Adamson.	16.99	2017-12-04				
MORALES	ACALIA	.p1186856a	59125051040686	808905	How to dress a dragon / by Thelma Lynne Godin ; pictures by Eric Barclay.	16.99	2017-12-04				
MORALES	ACALIA	.p1186856a	59125051040686	808904	Ninja bunny / Jennifer Gray Olson.	16.99	2017-12-04				
MORALES	LORELAI	.p1186858a	59125051040660	808912	ODaniel / Wesley King.	16.99	2017-12-04				
MORALES	LORELAI	.p1186858a	59125051040660	808911	Peter Pan and Wendy / original text by J.M. Barrie ; illustrated by Robert Ingpen	17.95	2017-12-04				
CHAVEZ	RYDER JOHN	.p1188640a	59125051153687	809659	Spy kids [videorecording] / Dimension Films ; Troublemaker Studios ; written and d	25.00	2017-12-06				
CHAVEZ	RYDER JOHN	.p1188640a	59125051153687	809657	Astro Boy [videorecording] / Imagi Animation Studios ; Tezuka Production Company ;	19.99	2017-12-06				
CHAVEZ	RYDER JOHN	.p1188640a	59125051153687	809658	The interview [videorecording] / directed by Evan Goldberg & Seth Rogen ; writers,	14.99	2017-12-06				
CHAVEZ	RYDER JOHN	.p1188640a	59125051153687	809656	The great mouse detective [videorecording] / Walt Disney Pictures presents ; produ	19.99	2017-12-06				
POPE	CHRISTOPHER MICHAEL	.p1073656a	59125051089170	810411	Bill Nye's global meltdown [videorecording] : the five stages of climate change gr	19.99	2017-12-09				
POPE	CHRISTOPHER MICHAEL	.p1073656a	59125051089170	810410	The unknown known [videorecording] / RADiUS-TWC, History Films and Participant Med	14.99	2017-12-09				
ALDERETE	RICHARD S	.p1167013a	59125051092547	810424	Be a real estate millionaire : secret strategies for lifetime wealth today / Dean	24.95	2017-12-09				
ALDERETE	RICHARD S	.p1167013a	59125051092547	810426	The complete guide to locating, negotiating, and buying real estate foreclosures :	19.95	2017-12-09				
ALDERETE	RICHARD S	.p1167013a	59125051092547	810425	World War Z : an oral history of the zombie war / Max Brooks.	14.95	2017-12-09				
RODRIGUEZ	STEPHANY	.p1172823a	59125051026420	810533	EB Boardbooks.	10.99	2017-12-09				
RODRIGUEZ	STEPHANY	.p1172823a	59125051026420	810532	EB Boardbooks.	7.99	2017-12-09				
RODRIGUEZ	STEPHANY	.p1172823a	59125051026420	810531	EB Boardbooks.	5.95	2017-12-09				
RODRIGUEZ	STEPHANY	.p1172823a	59125051026420	810529	The bunny tales collection / written by Nicola Baxter ; illustrated by Cathie Shut	25.00	2017-12-09				
RODRIGUEZ	STEPHANY	.p1172823a	59125051026420	810530	EB Boardbooks.	7.99	2017-12-09				
RODRIGUEZ	STEPHANY	.p1172823a	59125051026420	810528	Push button / Aliki.	16.99	2017-12-09				
BACA	HALLIE	.p1189288a	59125051151384	810535	One hundred years of solitude / Gabriel García Márquez ; translated fr	14.00	2017-12-09				
DEWIG	JENNIFER J	.p1178432a	59125051043649	811562	One true bear / Ted Dewan.	14.99	2017-12-13				
RADIGAN	MARGARET J	.p1159772a	59125050671093	812947	Mickey & friends : 3 tales of fun.	7.99	2017-12-18				
LEE	VELINDA R	.p1174684a	59125050900369	812965	Doctor Sleep [large print] / Stephen King.	36.99	2017-12-18				
CHICO	DANIEL M	.p1187694a	59125051147531	813351	Trump revealed : an American journey of ambition, ego, money, and power / Michael	28.00	2017-12-19				
CHICO	DANIEL M	.p1187694a	59125051147531	813349	Music law : how to run your band's business / Richard Stim.	39.99	2017-12-19				
CHICO	DANIEL M	.p1187694a	59125051147531	813348	Conversations with Tom Petty / Paul Zollo.	24.95	2017-12-19				
CHICO	DANIEL M	.p1187694a	59125051147531	813350	The plant propagator's bible / Miranda Smith.	22.99	2017-12-19				
RASKIN	JONI M	.p1189191a	59125051092851	813352	What I know for sure [sound recording] / Oprah Winfrey.	24.99	2017-12-19				
SHAW	SELENE L	.p1189061a	59125051094147	813714	Yard sale / by James Stevenson.	15.00	2017-12-20				
SHAW	SELENE L	.p1189061a	59125051094147	813717	Toy fox terrier : America's dog / by Meish Goldish.	25.27	2017-12-20				
SHAW	SELENE L	.p1189061a	59125051094147	813715	Wait! I want to tell you a story / written and illustrated by Tom Willans.	15.95	2017-12-20				
SHAW	SELENE L	.p1189061a	59125051094147	813718	I won a what? / by Audrey Vernick ; illustrated by Robert Neubecker.	17.99	2017-12-20				

			Invoice				
Last name	First/middle name	Patron record	Barcode	number	Title	Cost	Date
SHAW	SELENE L	.p1189061a	59125051094147	813716	Everything dogs / by Becky Baines ; with Dr. Gary Weitzman.	21.90	2017-12-20
ZEMAN	NICHOLAS RYAN	.p1189470a	59125051090665	813724	Saga / Brian K. Vaughan, writer ; Fiona Staples, artist ; Fonografiks, lettering &	14.99	2017-12-20
ZEMAN	NICHOLAS RYAN	.p1189470a	59125051090665	813723	Saga / Brian K. Vaughan, writer ; Fiona Staples, artist ; Fonografiks, lettering &	14.99	2017-12-20
ZEMAN	NICHOLAS RYAN	.p1189470a	59125051090665	813722	Saga / Brian K. Vaughan, writer ; Fiona Staples, artist ; Fonografiks, lettering &	14.99	2017-12-20
ZEMAN	NICHOLAS RYAN	.p1189470a	59125051090665	813721	Saga / Brian K. Vaughan, writer ; Fiona Staples, artist ; Fonografiks, lettering &	14.99	2017-12-20
ZEMAN	NICHOLAS RYAN	.p1189470a	59125051090665	813727	Saga / Brian K. Vaughan, writer ; Fiona Staples, artist ; Fonografiks, lettering &	14.99	2017-12-20
ZEMAN	NICHOLAS RYAN	.p1189470a	59125051090665	813726	Saga / Brian K. Vaughan, writer ; Fiona Staples, artist ; Fonografiks, lettering &	9.99	2017-12-20
ZEMAN	NICHOLAS RYAN	.p1189470a	59125051090665	813725	Saga / Brian K. Vaughan, writer ; Fiona Staples, artist ; Fonografiks, lettering &	14.99	2017-12-20
MARION	KELLY M	.p1182362a	59125051028343	813736	The secrets of my life / Caitlyn Jenner, with Buzz Bissinger.	30.00	2017-12-20
CHAVEZ	RYDER JOHN	.p1188640a	59125051153687	813742	The widow / Fiona Barton.	26.00	2017-12-20
CHAVEZ	RYDER JOHN	.p1188640a	59125051153687	813740	It might have been what he said : a novel / Eden Collinworth.	23.95	2017-12-20
CHAVEZ	RYDER JOHN	.p1188640a	59125051153687	813741	Here comes the bribe : a bed-and-breakfast mystery / Mary Daheim.	23.99	2017-12-20
CHAVEZ	RYDER JOHN	.p1188640a	59125051153687	813739	Toxic bachelors / Danielle Steel.	27.00	2017-12-20
CHAVEZ	RYDER JOHN	.p1188640a	59125051153687	813738	It's my birthday / Helen Oxenbury.	15.00	2017-12-20
MILLER	AVERY ELIZABETH	.p1166196a	59125051100043	814459	An edible alphabet : 26 reasons to love the farm / by Carol Watterson ; illustrate	16.99	2017-12-26
MILLER	AVERY ELIZABETH	.p1166196a	59125051100043	814457	The great doughnut parade / written and illustrated by Rebecca Bond.	17.00	2017-12-26
MILLER	AVERY ELIZABETH	.p1166196a	59125051100043	814462	What's for lunch? / by Sarah L. Thomson ; illustrated by Nila Aye.	17.99	2017-12-26
MILLER	AVERY ELIZABETH	.p1166196a	59125051100043	814461	Let's cook! / Susan McQuillan, RD.	17.99	2017-12-26
MILLER	AVERY ELIZABETH	.p1166196a	59125051100043	814460	Fall harvests : bringing in food / Martha E.H. Rustad ; illustrated by Amanda Enri	23.93	2017-12-26
MILLER	AVERY ELIZABETH	.p1166196a	59125051100043	814458	Too pickley! / Jean Reidy ; illustrated by Geneviève Leloup.	11.99	2017-12-26
ARTEAGA-ZAPEDA	GABRIELA	.p1173244a	59125051036148	814590	EB Boardbooks.	6.95	2017-12-26
PACHECO	IZAIHA M	.p1167675a	59125050811046	815226	By the shores of Silver Lake / by Laura Ingalls Wilder ; illustrated by Garth Will	17.99	2017-12-27
ZEMAN	NICHOLAS RYAN	.p1189470a	59125051090665	815285	Sgt. Pepper's lonely hearts club band [sound recording] / Beatles.	18.98	2017-12-27
ZEMAN	NICHOLAS RYAN	.p1189470a	59125051090665	815286	Weeds. Season 7 [videorecording] / director, Jenji Kohan.	39.99	2017-12-27
ZEMAN	NICHOLAS RYAN	.p1189470a	59125051090665	815290	Everything now [sound recording] / Arcade Fire.	17.99	2017-12-27
ZEMAN	NICHOLAS RYAN	.p1189470a	59125051090665	815289	Rumours [sound recording] / Fleetwood Mac.	24.99	2017-12-27
ZEMAN	NICHOLAS RYAN	.p1189470a	59125051090665	815288	Weeds. Season 7 [videorecording] / director, Jenji Kohan.	39.99	2017-12-27
ZEMAN	NICHOLAS RYAN	.p1189470a	59125051090665	815287	Weeds. Season 7 [videorecording] / director, Jenji Kohan.	39.99	2017-12-27
BENSON	AJA KIMBERLY-GENE	.p1189541a	59125051155799	815302	The autistic brain : thinking across the spectrum / Temple Grandin and Richard Pan	28.00	2017-12-27
EAGLE-JOSEPH	JAYMI M	.p1189550a	59125051155187	815308	The report card / Andrew Clements.	16.99	2017-12-27
EAGLE-JOSEPH	JAYMI M	.p1189550a	59125051155187	815307	Scary stories 3 : more tales to chill your bones / collected from folklore and ret	16.99	2017-12-27
VALDEZ	DANTE RENO	.p1121298a	59125051099369	816277	Star wars. Aftermath / Chuck Wendig.	28.00	2017-12-29
VALDEZ	DANTE RENO	.p1121298a	59125051099369	816276	Blake's poetry and designs : authoritative texts, illuminations in color and monoc	20.60	2017-12-29
MENDOZA	ELGEN JOEL	.p1183552a	59125050982011	816345	Naruto. The Seventh Hokage and the scarlet spring, Uchiha Sarada / story and art b	9.99	2017-12-29
BARNHILL	LAUREN M	.p1189706a	59125051156185	816370	Alice through the looking glass [videorecording] / Walt Disney Pictures presents ;	29.99	2017-12-29
BARNHILL	LAUREN M	.p1189706a	59125051156185	816369	Alice in Wonderland [videorecording] / Walt Disney Pictures ; a Roth Films/Zanuck	29.99	2017-12-29
SALCIDA	LUCINDA PATRICIA	.p1058173a	59125051155856	816371	EB Boardbooks.	5.99	2017-12-29
SALCIDA	LUCINDA PATRICIA	.p1058173a	59125051155856	816377	EB Boardbooks.	8.99	2017-12-29
SALCIDA	LUCINDA PATRICIA	.p1058173a	59125051155856	816374	EB Boardbooks.	6.95	2017-12-29
DeROUIN	JACE J	.p1188378a	59125051150238	816417	Batman / Scott Snyder, writer ; Greg Capullo, penciller ; Jonathan Glapion, inker.	12.74	2017-12-29
DeROUIN	JACE J	.p1188378a	59125051150238	816416	Batman / Scott Snyder, writer ; Greg Capullo, penciller ; Jonathan Glapion, inker.	16.99	2017-12-29
GARCIA	GRACIE H	.p1189707a	59125051156177	816420	Happy feet two [videorecording] / Warner Bros. Pictures presents, in association w	22.99	2017-12-29
GARCIA	GRACIE H	.p1189707a	59125051156177	816423	Trolls [videorecording].	29.99	2017-12-29
GARCIA	GRACIE H	.p1189707a	59125051156177	816422	The angry birds movie [videorecording] / screenplay by Jon Vitti ; produced by Joh	30.99	2017-12-29
GARCIA	GRACIE H	.p1189707a	59125051156177	816421	Rio 2 [videorecording]	29.99	2017-12-29
GARCIA	GRACIE H	.p1189707a	59125051156177	816419	The wizard of Oz [videorecording] / a Metro-Goldwyn-Mayer picture ; screenplay by	20.99	2017-12-29
BARNHILL	LAUREN M	.p1189706a	59125051156185	816418	Daniel Tiger's neighborhood. Daniel visits the farm [videorecording] / author, Bec	6.99	2017-12-29

Last name	First/middle name	Patron record	Barcode	Invoice number	Title	Cost	Date
TOTAL 2017 OVERDUE WRITE OFF						21,305.51	

Last name	First/middle name	Patron record	Barcode	Amount owed	Invoice number	Date
FOUNTAIN	ERIC WILLIAM	.p1165113a	59125050753677	\$15.00	536311	2015-11-02
BOLANDER	DAVIE R	.p1136731a	59125050322507	\$15.00	536312	2015-11-02
MARQUEZ	LEANDRA PATRICE	.p1128404a	59125050709034	\$15.00	538946	2015-11-08
RIVERA	HAELEIGH	.p1158863a	59125050666309	\$15.00	694811	2017-01-01
MANYGOATS	MATOSKAH R	.p1176141a	59125051015266	\$15.00	694806	2017-01-01
ROJAS	CRISTELLA M	.p1161284a	59125050917173	\$15.00	694809	2017-01-01
LEACH	JESSE MICHAEL	.p1160381a	59125050977805	\$15.00	694810	2017-01-01
MANYGOATS	NOELANI	.p1176114a	59125051016538	\$15.00	694805	2017-01-01
RIVERA	ISIAH	.p1158861a	59125050666283	\$15.00	694812	2017-01-01
ANDERSON	MICHAEL ROBERT	.p1148926a	59125050683106	\$15.00	694816	2017-01-01
RAMIREZ-ROMERO	ROSA A	.p1154242a	59125050612709	\$15.00	694813	2017-01-01
HERRERA	LILY C	.p1182909a	59125051027584	\$15.00	697119	2017-01-08
MCATEE	JESSICA LYN	.p1175976a	59125050976955	\$15.00	697121	2017-01-08
CASTILLO	E FREIDA	.p1183116a	59125050976203	\$15.00	697124	2017-01-08
CARTER	SUZZANNE ELISE	.p1181800a	59125050974893	\$15.00	697125	2017-01-08
RODRIGUEZ	ERICA JUNE	.p1163835a	59125050979330	\$15.00	697132	2017-01-08
MENDES	MICHELLE D	.p1161756a	59125050985352	\$15.00	697136	2017-01-08
LONGMAN	LAKYN SAPPHIRE	.p1162148a	59125050717540	\$15.00	697135	2017-01-08
MONTAGUE	MONTGOMERY IV	.p1116561a	59125050949960	\$15.00	697142	2017-01-08
HALL	MEGHAN L	.p1175215a	59125050939417	\$15.00	699560	2017-01-15
PACHECO	MARILYN GRACE	.p1167792a	59125050814719	\$15.00	699559	2017-01-15
BRENNAN	ADRIANA	.p1179941a	59125050954119	\$15.00	699558	2017-01-15
LONGMAN	JOHN PHILIP	.p1052947a	59125050985725	\$15.00	699573	2017-01-15
BOWMAN	JOSEPH	.p1179473a	59125050981948	\$15.00	701535	2017-01-22
CHAVEZ	ARIYANNA	.p1179474a	59125050981955	\$15.00	701534	2017-01-22
ROSAS	ALEJANDRO JR	.p1173857a	59125050898894	\$15.00	701541	2017-01-22
ESPINO-VARGAS	BIANCA YURIDIA	.p1179109a	59125050949960	\$15.00	701538	2017-01-22
TRENT	ZACHARIAH ALEXANDER	.p1148324a	59125050965610	\$15.00	701545	2017-01-22
SANTIAGO	DANIEL L	.p1143755a	59125050504344	\$15.00	701548	2017-01-22
JONES	ALYSON C	.p1146628a	59125050534895	\$15.00	701547	2017-01-22
TORBAGHAN	JENNIFER G	.p1128621a	59125050853865	\$15.00	701549	2017-01-22
SPIES	LAURA J	.p1178508a	59125050995419	\$15.00	703526	2017-01-29
URIESTE	DANIEL	.p1181861a	59125050974539	\$15.00	703530	2017-01-29
PACHECO	ELYSIA S	.p1170111a	59125050848535	\$15.00	703528	2017-01-29
LUCERO	SAMANTHA B	.p1173383a	59125050890255	\$15.00	703531	2017-01-29
SHOLAR	SUZY ANGEL	.p1141624a	59125050425821	\$15.00	703544	2017-01-29
LEYDSMAN	SCOTT THOMAS	.p1114535a	59125050982748	\$15.00	703549	2017-01-29
MORGAN	CASIDY NICHOLE	.p1123410a	59125051035140	\$15.00	703546	2017-01-29
TENORIO	BRIAN	.p1183040a	59125050555320	\$15.00	705703	2017-02-05
MCCANN	RYAN C	.p1183172a	59125050975734	\$15.00	705704	2017-02-05
SCHAEFER	ELLA	.p1183587a	59125050981765	\$15.00	705699	2017-02-05
HUNTER	THOMAS DALE	.p1181245a	59125050969604	\$15.00	705708	2017-02-05
SANTIAGO	JOSE MIGUEL	.p1160546a	59125050680938	\$15.00	705710	2017-02-05
HOSKINS	JULIA	.p1164612a	59125051026263	\$15.00	705707	2017-02-05
LENTE	RAVEN G	.p1131226a	59125050375505	\$15.00	707928	2017-02-12
HANSEN	PRESTON SPENCER	.p1175876a	59125050919708	\$15.00	707933	2017-02-12
VALENCIA	ELIZA	.p1157194a	59125050979777	\$15.00	707931	2017-02-12
POHUMA	KAREN LOUISE	.p1174397a	59125050947816	\$15.00	707929	2017-02-12
BYRD	KASEY R	.p1183636a	59125051034614	\$15.00	707932	2017-02-12
SMITH	SANTIAGO JOSUE	.p1169369a	59125050829006	\$15.00	707935	2017-02-12
NUNEZ	MARISA INEZ	.p1164881a	59125051034523	\$15.00	707934	2017-02-12
GUTIERREZ	JOSIAH AMOS	.p1169875a	59125050842454	\$15.00	707941	2017-02-12
WOODS	JADEN ALYSE	.p1179152a	59125050949606	\$15.00	707937	2017-02-12
BYRD	CALLI E	.p1183637a	59125051034622	\$15.00	707938	2017-02-12
SHAW	BOBBY K	.p1179028a	59125050946990	\$15.00	707939	2017-02-12
TORRES	EDUARDO J	.p1182184a	59125051030158	\$15.00	710003	2017-02-19
VALENCIA	ADAM GRANT	.p1178404a	59125050989107	\$15.00	710005	2017-02-19
YAZZIE	CARA	.p1183707a	59125050980700	\$15.00	710011	2017-02-19
ROMO	MELANIE H	.p1183722a	59125051034812	\$15.00	710012	2017-02-19
WITT	TAMMY KRISTINE	.p1101731a	59125050559736	\$15.00	710013	2017-02-19
LUJAN	VALERIE	.p1183313a	59125051034895	\$15.00	712546	2017-02-26
MELLORS	CAITLYN J	.p1182741a	59125050979546	\$15.00	712547	2017-02-26
PADILLA	NICHOLAS A	.p1183840a	59125050989545	\$15.00	712551	2017-02-26
TOTSCHKE	NICOLETTE L	.p1183881a	59125050989248	\$15.00	712552	2017-02-26
RIOS	JUAN D	.p1183786a	59125050990105	\$15.00	712554	2017-02-26
GAVILONDO	CESAR	.p1173456a	59125051034689	\$15.00	714915	2017-03-05
LONG	ROZARIO	.p1182896a	59125050978290	\$15.00	714914	2017-03-05
AME	KIN'YAA'AANII	.p1182895a	59125050978308	\$15.00	714916	2017-03-05
GAMBILL	KERI M	.p1162689a	59125050972202	\$15.00	714918	2017-03-05

Last name	First/middle name	Patron record	Barcode	Amount owed	Invoice number	Date
WALTON	TONI LYNN	.p1175845a	59125050918007	\$15.00	714921	2017-03-05
OTERO	ALEXANDRA CHRISTIANA	.p1182234a	59125050994925	\$15.00	714919	2017-03-05
KUNY	ENRIQUE ANTONIO	.p1152078a	59125050963656	\$15.00	714922	2017-03-05
MARES	DEBRA A	.p1148859a	59125051029549	\$15.00	716805	2017-03-12
ROLAND	MARTIN CAREY	.p1142297a	59125050936843	\$15.00	716807	2017-03-12
PETERSON	RILEY E	.p1183977a	59125051032246	\$15.00	716810	2017-03-12
CHRISTENSEN	BELINDA RAMIREZ	.p1159253a	59125050940522	\$15.00	718990	2017-03-19
CEBALLOS	VENICE	.p1138653a	59125050956759	\$15.00	718987	2017-03-19
EMSWELLER	SADE	.p1130863a	59125050615363	\$15.00	718984	2017-03-19
DOOLEY	GABRIELLA JOY	.p1144505a	59125050987184	\$15.00	718988	2017-03-19
PAYTIAMO	JACQUELINE COLLETTE	.p1183894a	59125050989677	\$15.00	721501	2017-03-26
SANCHEZ	TERESITA	.p1184454a	59125051046824	\$15.00	721508	2017-03-26
SANCHEZ	NADIA MARIE	.p1184455a	59125051046808	\$15.00	721505	2017-03-26
DAVIS	DENISE FAY	.p1021533a	5912500061130	\$15.00	721515	2017-03-26
DEITZ	TASHA S	.p1168946a	59125050821292	\$15.00	721514	2017-03-26
YERBICH	LOUIE VINCENT	.p1158790a	59125050891501	\$15.00	721513	2017-03-26
CLARK	ANIYAH D	.p1184234a	59125051045248	\$15.00	721509	2017-03-26
PURCELLA	ANDREW	.p1183407a	59125050983746	\$15.00	721506	2017-03-26
BONNAFOUX	CARLOS J	.p1164297a	59125050977458	\$15.00	724021	2017-04-02
ABEYTA	EMILY ANN	.p1183497a	59125050983043	\$15.00	724023	2017-04-02
ARAUJO	SUJEY A	.p1181529a	59125050966188	\$15.00	724020	2017-04-02
SULEIMAN	TALAYIA T	.p1184311a	59125050985808	\$15.00	724024	2017-04-02
PENNINGTON	SEAN ANTHONY	.p1179917a	59125050954697	\$15.00	724028	2017-04-02
PAYNE	ELISSA M	.p1158071a	59125050645667	\$15.00	724029	2017-04-02
SPENCER	BRANDON E	.p1163191a	59125050690440	\$15.00	724026	2017-04-02
MCLELLAN	CONNOR AUGUSTINE	.p1175155a	59125051002777	\$15.00	724025	2017-04-02
LEE	TASHA T	.p1184304a	59125051045461	\$15.00	724027	2017-04-02
JOHNSTON	CHEYLA CARAY	.p1045939a	59125000100532	\$15.00	724034	2017-04-02
BAROS	ANTOINETTE L	.p1006378a	59125050787949	\$15.00	724035	2017-04-02
THOMAS	ALEXANDER D	.p1184712a	59125051048945	\$15.00	726230	2017-04-09
SANCHEZ	CAIA NICOLE	.p1129201a	59125051046261	\$15.00	726237	2017-04-09
SHROULOTE	RONALD J JR	.p1184285a	59125051031206	\$15.00	726234	2017-04-09
GONZALES	PAUL B JR	.p1184530a	59125051047426	\$15.00	728814	2017-04-16
FAJARDO	AUDRINA GRACE	.p1184478a	59125051047236	\$15.00	728811	2017-04-16
DOAMEKPOR	NUKU M	.p1167212a	59125050977540	\$15.00	728816	2017-04-16
EAST	JACEN LOGAN	.p1184591a	59125051048010	\$15.00	728819	2017-04-16
WASHINGTON	NAEVIA A	.p1184453a	59125051046816	\$15.00	728820	2017-04-16
GARCIA	AMARIE ANN	.p1180693a	59125050961304	\$15.00	728818	2017-04-16
RIMMER	MICHAEL ALLEN	.p1181615a	59125050965651	\$15.00	728821	2017-04-16
JOHNSON	BOBBI DANIELLE	.p1171354a	59125050836977	\$15.00	728824	2017-04-16
ROBERSON	ALEX R	.p1145424a	59125050528863	\$15.00	728826	2017-04-16
NIX	BETTY R	.p1184349a	59125051045693	\$15.00	731526	2017-04-23
RODGERS	NICHOLAS EDWARD	.p1183923a	59125051032741	\$15.00	731525	2017-04-23
LOZOYA	ANAYELY	.p1178877a	59125051048713	\$15.00	731524	2017-04-23
RODGERS	JULIETTE A	.p1183954a	59125051032576	\$15.00	731529	2017-04-23
MIERA	GABRIEL RUBEN	.p1177090a	59125051019649	\$15.00	731528	2017-04-23
COOPER	ASHLEY N	.p1184398a	59125051030679	\$15.00	731530	2017-04-23
HOGERHUIS	LYNN P	.p1147604a	59125051028897	\$15.00	731527	2017-04-23
RODRIGUEZ	CASANDRA	.p1184551a	59125051047715	\$15.00	731537	2017-04-23
ANDREWS	KERVIN M	.p1182117a	59125050972962	\$15.00	731535	2017-04-23
GORSEGNER	TYLER	.p1183778a	59125051032998	\$15.00	731538	2017-04-23
KANTZ	SUSAN JEAN	.p1125758a	59125050879597	\$15.00	731536	2017-04-23
WOOLSEY	KARA L	.p1178494a	59125051006075	\$15.00	734172	2017-04-30
SANTIAGO	J'MARIE A	.p1178021a	59125050996805	\$15.00	734169	2017-04-30
BURBANK	CHERYL	.p1181073a	59125050967640	\$15.00	734173	2017-04-30
SANTISTEVAN	LAUREN M	.p1182464a	59125050992077	\$15.00	734174	2017-04-30
ULMER	EMMALEA MAE	.p1183088a	59125050976336	\$15.00	734178	2017-04-30
MITCHELL	MYRANDA L	.p1177929a	59125050940423	\$15.00	734176	2017-04-30
CRAIG	CRESENCIA E	.p1176006a	59125050915441	\$15.00	734175	2017-04-30
JARAMILLO	MICHAEL ANTHONY	.p1132682a	59125050252704	\$15.00	734181	2017-04-30
LUJAN	MARIAH D	.p1170236a	59125050850150	\$15.00	734179	2017-04-30
DEDIOS	JEANETTE T	.p1179651a	59125051010622	\$15.00	736407	2017-05-07
HANEY	CHIARA LYNETTE	.p1180359a	59125051013287	\$15.00	736408	2017-05-07
CEREZO	DEVANEY	.p1184891a	59125051054141	\$15.00	736414	2017-05-07
OLMOS	JENNICA L	.p1178590a	59125050930564	\$15.00	736411	2017-05-07
GARCIA	SAUL JR	.p1166377a	59125050797070	\$15.00	736413	2017-05-07
DAWES	CHANTELLE M	.p1164790a	59125050760342	\$15.00	736416	2017-05-07
GUTIERREZ	CELIA MARIA	.p1129876a	59125050989131	\$15.00	736418	2017-05-07
RITCHIE	ALEX	.p1184786a	59125051036973	\$15.00	738739	2017-05-14

Last name	First/middle name	Patron record	Barcode	Amount owed	Invoice number	Date
GIDEON	HAROLD C	.p1167849a	59125051035967	\$15.00	738740	2017-05-14
RESENDIZ-SILIS SAI		.p1185025a	59125051052657	\$15.00	738738	2017-05-14
HUMPHRIES	BRIAN DUANE	.p1138093a	59125050317473	\$15.00	738736	2017-05-14
GIDEON	RONNY LEON	.p1141209a	59125051035561	\$15.00	738742	2017-05-14
WALL	SARA A	.p1132407a	59125050249783	\$15.00	738747	2017-05-14
SALAZAR	CHARLOTTE IVY	.p1184013a	59125050987945	\$15.00	738745	2017-05-14
KOPPEL	KYLE M	.p1128541a	59125050349054	\$15.00	738748	2017-05-14
BAIETT	WESLEY A	.p1144968a	59125050522981	\$15.00	738743	2017-05-14
TORRES	ETHAN TYLER	.p1161114a	59125050765713	\$15.00	738744	2017-05-14
ZAMORA	ALEC BENJAMIN	.p1103179a	59125050941199	\$15.00	738749	2017-05-14
KOPPEL	JESSICA M	.p1049208a	29075014136385	\$15.00	738751	2017-05-14
SALAZAR	ANGELIQUE A	.p1185280a	59125051059082	\$15.00	740502	2017-05-21
DRAUT	WILLIAM A	.p1179299a	59125051009103	\$15.00	740501	2017-05-21
QUEZADA	MICHAEL	.p1177873a	59125050941199	\$15.00	740505	2017-05-21
KINSNER	STEVEN K	.p1131696a	59125051051865	\$15.00	740511	2017-05-21
MARTELL	MONICA MONIQUE	.p1181161a	59125050969950	\$15.00	740513	2017-05-21
HARDY	CHRISTOPHER JOSEPH	.p1138543a	59125050965933	\$15.00	740510	2017-05-21
ROYBAL	JONI E	.p1179943a	59125050954093	\$15.00	743251	2017-05-28
WAHLL	MERIDEE PAIGE	.p1151394a	59125050861389	\$15.00	743254	2017-05-28
SOUTHWOOD	NATALIE R	.p1185026a	59125051037567	\$15.00	743253	2017-05-28
DAVIDSON	MAKAYLA	.p1124649a	59125050206056	\$15.00	743258	2017-05-28
CORMAN	BRENDA DENISE	.p1166758a	59125050756910	\$15.00	743257	2017-05-28
BOULEY	KAYLA E	.p1185113a	59125051037419	\$15.00	743261	2017-05-28
AUSTIN	JEROME MICHAEL	.p1184996a	59125051053002	\$15.00	743260	2017-05-28
MCCLENDON	AMY LYNN	.p1059683a	59125051034200	\$15.00	743262	2017-05-28
HERNANDEZ	JORGE IMMANUEL	.p1179110a	59125050949952	\$15.00	745387	2017-06-04
JAMES	MADISYN M	.p1181554a	59125051021876	\$15.00	745389	2017-06-04
PEREA	CHARLES R JR	.p1179722a	59125051010697	\$15.00	745391	2017-06-04
DANZER	TYLER EDWARD	.p1119044a	59125051049240	\$15.00	745388	2017-06-04
JAMES	MORGAN E	.p1181553a	59125051021884	\$15.00	745392	2017-06-04
ROSAS	ANA RUTH	.p1176224a	59125050887251	\$15.00	745397	2017-06-04
VALVERDE	JORDYN	.p1182627a	59125050980585	\$15.00	747876	2017-06-11
FRENCH	DEVERON WILLIAN	.p1184839a	59125051054679	\$15.00	747881	2017-06-11
TOMARDY	ELLCIA M	.p1137621a	59125050325336	\$15.00	747883	2017-06-11
SANCHEZ	JAZMIN L	.p1185215a	59125051037864	\$15.00	747888	2017-06-11
SCHNERCH	KYLIN CAPRI	.p1171859a	59125051057896	\$15.00	747887	2017-06-11
LUBER	JAKOB A	.p1185497a	59125051059272	\$15.00	750657	2017-06-18
SANCHEZ	SHIRLEY M	.p1184137a	59125051031560	\$15.00	750663	2017-06-18
KELLOGG	KIMBERLY A	.p1185292a	59125051037799	\$15.00	750661	2017-06-18
RAEL	DOREEN R	.p1155743a	59125051036411	\$15.00	750665	2017-06-18
GUNN	ANDREW	.p1185050a	59125051052483	\$15.00	753034	2017-06-25
SAM	NADIA	.p1182247a	59125051029960	\$15.00	753037	2017-06-25
RASMUSSEN	CRAIG M	.p1185711a	59125051039498	\$15.00	753042	2017-06-25
DeVORE	SAGELYN	.p1185726a	59125051055882	\$15.00	753045	2017-06-25
RANGEL	MICHAEL RILIE	.p1130439a	59125050904296	\$15.00	753040	2017-06-25
SANDOVAL	VICTORIA B	.p1157249a	59125051050982	\$15.00	755582	2017-07-02
BARKLEY	ANTONIE LYNN	.p1123081a	59125051055874	\$15.00	755581	2017-07-02
VILLACANA-ARMEI	JOSE J	.p1185613a	59125051038334	\$15.00	755580	2017-07-02
BURNS	HAILEY MARIE	.p1122398a	59125050798599	\$15.00	755587	2017-07-02
PADILLA	MELISSA ELIZABETH	.p1070214a	59125050979488	\$15.00	755592	2017-07-02
RODRIGUEZ	BRODY	.p1184755a	59125051049562	\$15.00	756393	2017-07-05
ABRAHAMSON	JOSHUA DANIEL	.p1184765a	59125051049513	\$15.00	756392	2017-07-05
ROSS	NATHANIEL MARCUS	.p1183561a	59125050981997	\$15.00	756394	2017-07-05
BUSTILLOS	ETHAN C	.p1180740a	59125050981542	\$15.00	756398	2017-07-05
HEWITT	NEVA J	.p1181816a	59125050972020	\$15.00	756397	2017-07-05
CHUDNOFF	KHADIJA	.p1182762a	59125050979439	\$15.00	756396	2017-07-05
ALLEN	NICHOLE LEE	.p1178849a	59125050932735	\$15.00	756399	2017-07-05
GRIEGO	KATHLEEN M	.p1036265a	59125050244719	\$15.00	756411	2017-07-05
BODMER	LILITH ANNE	.p1121890a	59125050968440	\$15.00	756410	2017-07-05
DELCURTO	DEVYN LEIGH	.p1161961a	59125050706196	\$15.00	756407	2017-07-05
AUGILAR	DYANNI R	.p1181872a	59125050971683	\$15.00	758025	2017-07-09
CHEE	LENEIL C	.p1181468a	59125051022064	\$15.00	758026	2017-07-09
HOEDEBECK	DAWSON J	.p1179823a	59125051025018	\$15.00	758028	2017-07-09
CANAFAX	CARLENE MARIE	.p1029046a	59125050920078	\$15.00	758033	2017-07-09
BREJCHA	TOM J	.p1171300a	59125050867253	\$15.00	758030	2017-07-09
FALER	CHRISTOPHER	.p1182680a	59125051039472	\$15.00	760590	2017-07-16
LYLES	KRYSTAL LEE	.p1183560a	59125050982300	\$15.00	760591	2017-07-16
SANCHEZ	JUSTIN DAVID	.p1180022a	59125050953426	\$15.00	760586	2017-07-16
MONTANO	GABBY	.p1181776a	59125051023484	\$15.00	760589	2017-07-16

Last name	First/middle name	Patron record	Barcode	Amount owed	Invoice number	Date
BUSTAMANTE	AYDEN JAMES	.p1180584a	59125050962500	\$15.00	760587	2017-07-16
RODRIGUEZ	GABRIEL FABIAN	.p1153048a	59125051062425	\$15.00	760598	2017-07-16
NOLAND	DAVID D	.p1145703a	59125051009780	\$15.00	760599	2017-07-16
STEWART	JACOB DEAN	.p1185412a	59125051058118	\$15.00	760593	2017-07-16
PRESTON	DAWN JANAE	.p1074103a	59125050094668	\$15.00	760602	2017-07-16
SANDOVAL	JEREMY DAVID	.p1133576a	59125050854574	\$15.00	760601	2017-07-16
SANDOVAL	CELINE M	.p1184627a	59125051048838	\$15.00	763180	2017-07-23
WOBBE	EDY MARIE	.p1146537a	59125051029317	\$15.00	763178	2017-07-23
LETHGO	CHRIS D	.p1181932a	59125050970842	\$15.00	763186	2017-07-23
WOOD	CARLEY M	.p1186032a	59125051043001	\$15.00	763188	2017-07-23
KING	EMMA C	.p1182860a	59125051027105	\$15.00	763187	2017-07-23
LIESTER	JENNIFER ANN	.p1186086a	59125051062458	\$15.00	763182	2017-07-23
GUZMAN	ALYSSA REBECCA	.p1173855a	59125050898878	\$15.00	763184	2017-07-23
PIERSON	DOMINIQUE A	.p1165829a	59125050784219	\$15.00	763183	2017-07-23
MCCLURG	TOMMIE C	.p1157645a	59125050636740	\$15.00	763185	2017-07-23
CHAVEZ	TERA L	.p1121474a	59125050132617	\$15.00	763190	2017-07-23
MACIAS-PRIETO	EBANI TERRY	.p1186092a	59125051062102	\$15.00	765949	2017-07-30
JACKSON	ANDRIANA A	.p1185290a	59125051037815	\$15.00	765957	2017-07-30
WITZKE	SARAH E	.p1185625a	59125051038409	\$15.00	765958	2017-07-30
MARSHALL	JONATHAN MICHAEL	.p1159226a	59125051064876	\$15.00	765954	2017-07-30
WALLS	CONSHATA N	.p1185682a	59125051056799	\$15.00	765960	2017-07-30
JAMES	ADRIAN T	.p1185938a	59125051064447	\$15.00	768687	2017-08-06
FARLEY	STEVEN	.p1186091a	59125051043664	\$15.00	768686	2017-08-06
TRUJILLO	MARTIN S	.p1175078a	59125051052442	\$15.00	768688	2017-08-06
HERNANDEZ	AZALEE	.p1173772a	59125051036429	\$15.00	768695	2017-08-06
GRIFFITH	RANELDA	.p1185785a	59125051044266	\$15.00	768691	2017-08-06
MARES	AKELA C	.p1167765a	59125050971667	\$15.00	768693	2017-08-06
WEARE	BRANDI ROSE	.p1185834a	59125051060494	\$15.00	771404	2017-08-13
WEARE	BRICE A	.p1185898a	59125051064686	\$15.00	771402	2017-08-13
ROURKE	JASON R	.p1185213a	59125051036627	\$15.00	771400	2017-08-13
CRUZ	A LANA JT	.p1186482a	59125051042229	\$15.00	771406	2017-08-13
NARVAIZ	JESSICA N	.p1178346a	59125050939060	\$15.00	771408	2017-08-13
MENDEZ	RACHEL	.p1155373a	59125050700777	\$15.00	771412	2017-08-13
MONTES DE OCA	KRYSTA L	.p1185607a	59125051038870	\$15.00	771407	2017-08-13
BONSAL	JEFFREY H	.p1173666a	59125050930861	\$15.00	771410	2017-08-13
GURLEY	JULIE K	.p1186272a	59125051043425	\$15.00	773982	2017-08-20
BENNETT	AMANDA MARIE	.p1180978a	59125050964720	\$15.00	773979	2017-08-20
JOE	ALEXANDRIA L	.p1186657a	59125051070238	\$15.00	773977	2017-08-20
NONIES	ALABAMA	.p1185942a	59125051039621	\$15.00	773978	2017-08-20
MCCOLLUM	DIONE SHEREE	.p1178406a	59125051041981	\$15.00	773988	2017-08-20
CHAVEZ	GABRIEL LYNN	.p1186462a	59125051320104	\$15.00	773985	2017-08-20
GONZALES	ERIN A	.p1166771a	59125051042682	\$15.00	773991	2017-08-20
CHAVEZ	VANESSA J	.p1163073a	59125050908727	\$15.00	773992	2017-08-20
CHAVEZ	SHANTEL M	.p1162018a	59125050847586	\$15.00	773994	2017-08-20
ANGEL	AZRIEL E	.p1185996a	59125051063647	\$15.00	776536	2017-08-27
CRUZE	MATTHEW RODNEY	.p1186506a	59125051041601	\$15.00	776530	2017-08-27
VALDEZ	GLORIA A	.p1186787a	59125051067879	\$15.00	776532	2017-08-27
DIXON	MIKAYLA N	.p1186804a	59125051067622	\$15.00	776535	2017-08-27
SHOEMAKER	MATHEW O	.p1186104a	59125051062011	\$15.00	776537	2017-08-27
DePEREA-DeROSE	REMMY	.p1185659a	59125051039712	\$15.00	776539	2017-08-27
DePEREA-DeROSE	MICHAEL	.p1185656a	59125051039746	\$15.00	776541	2017-08-27
DePEREA-DeROSE	JOHN	.p1185658a	59125051039720	\$15.00	776540	2017-08-27
WETZLAU	CARTER	.p1181398a	59125051055965	\$15.00	776544	2017-08-27
HOSTEEN	JOANN	.p1186481a	59125051042195	\$15.00	776538	2017-08-27
MARTINEZ	AARON M	.p1173707a	59125050886519	\$15.00	776547	2017-08-27
TRUJILLO	FREDERICK J	.p1186998a	59125051040413	\$15.00	778859	2017-09-03
TILSON	LUKE MICHAEL	.p1187042a	59125051071640	\$15.00	778858	2017-09-03
ALIRE	JAYLYNN A	.p1182465a	59125050992069	\$15.00	778866	2017-09-03
TILSON	STELLA COCO	.p1187041a	59125051074883	\$15.00	778868	2017-09-03
REYES	TABBITHA C	.p1184440a	59125051030570	\$15.00	778865	2017-09-03
MENDOZA-MUNO	GABRIELLE CHERI	.p1186937a	59125051065808	\$15.00	778863	2017-09-03
WILSON	RENEE MICHELLE	.p1113742a	59125051070352	\$15.00	778875	2017-09-03
CORDOVA	JACOB LEE	.p1179846a	59125051074982	\$15.00	778871	2017-09-03
ARNOLD	DANA M	.p1182063a	59125050973788	\$15.00	778869	2017-09-03
DePEREA-DeROSE	FRANCISCO	.p1185657a	59125051039738	\$15.00	781465	2017-09-10
SANDERS	CAMILLE B	.p1152554a	59125051073232	\$15.00	781475	2017-09-10
CHAVARRIA	LAURA D	.p1185899a	59125051044654	\$15.00	781471	2017-09-10
CADMAN	SOPHIA CLAUDETTE	.p1169065a	59125050828677	\$15.00	781474	2017-09-10
SANDERS	DELIA ANGELINA	.p1143675a	59125051073240	\$15.00	781476	2017-09-10

Last name	First/middle name	Patron record	Barcode	Amount owed	Invoice number	Date
NAJERA	CHRISTIAN J	.p1177292a	59125051041221	\$15.00	784090	2017-09-17
ARGUELLO	DESTINY RAY	.p1178516a	59125050934509	\$15.00	784096	2017-09-17
GONZALES	GLORIA E	.p1186664a	59125051041049	\$15.00	784097	2017-09-17
GAMBOA	ALYCIA ELENA	.p1187549a	59125051078819	\$15.00	784091	2017-09-17
WEAVER	TYRIQUE J	.p1181373a	59125050967392	\$15.00	784092	2017-09-17
PAGANO	CRYSTAL MARIE	.p1116483a	59125050076830	\$15.00	784098	2017-09-17
STRAHON	ERICA LETICIA	.p1110943a	59125050035505	\$15.00	784103	2017-09-17
MENDOZA	KALYNA J	.p1174749a	59125050904569	\$15.00	784101	2017-09-17
MARTIN	KIMBERLY F	.p1187612a	59125051078348	\$15.00	786510	2017-09-24
MOORE	CALEB W	.p1187437a	59125051079288	\$15.00	786514	2017-09-24
RHODES	MADISON R	.p1187609a	59125051077613	\$15.00	786521	2017-09-24
RAMIREZ	MARIA ELENA	.p1187173a	59125051145592	\$15.00	786515	2017-09-24
RHODES	AMY R	.p1187608a	59125051077621	\$15.00	786520	2017-09-24
SANCHEZ	MONICA ANN	.p1184431a	59125051046519	\$15.00	786522	2017-09-24
MOORE	MICHELLE P	.p1187436a	59125051079296	\$15.00	786519	2017-09-24
PADILLA	ADRIAN JAMES	.p1184599a	59125051047970	\$15.00	786525	2017-09-24
NAJERA	ISABELLE RENEE	.p1146676a	59125050796320	\$15.00	786524	2017-09-24
BARELA	TERESA M	.p1187093a	59125051072739	\$15.00	786529	2017-09-24
MARTIN	JOEL A	.p1187611a	59125051078355	\$15.00	786531	2017-09-24
BERK	LUCAS J	.p1187004a	59125051075047	\$15.00	786528	2017-09-24
BIGELOW	ETHAN M	.p1176707a	59125051014228	\$15.00	788960	2017-10-01
ENGLISH	LASHUNDA D	.p1184233a	59125051045255	\$15.00	788966	2017-10-01
CARR	EVAN THOMAS	.p1186476a	59125051068745	\$15.00	788961	2017-10-01
SHIVERS	ABIGAIL	.p1162551a	59125051058746	\$15.00	788965	2017-10-01
SCHIRMER	NELLIE THERESA	.p1180948a	59125050964928	\$15.00	788962	2017-10-01
ROYBAL	DOREEN A	.p1127665a	59125051078470	\$15.00	788964	2017-10-01
BINK	JOSH JAMES	.p1150788a	59125050557821	\$15.00	788972	2017-10-01
HURD	AYRUS MILES	.p1043571a	59125050826929	\$15.00	788975	2017-10-01
LAJEUNESSE	KASI AMALIA	.p1108747a	59125050015788	\$15.00	788973	2017-10-01
CLARK	KIMBERLY L	.p1187154a	59125051073174	\$15.00	788971	2017-10-01
BAHR	CHENNILLE R	.p1187427a	59125051079304	\$15.00	791280	2017-10-08
MARTINEZ	PATRICIA ANN	.p1183119a	59125050976161	\$15.00	791283	2017-10-08
DUKE	MONIQUE LANAE	.p1168303a	59125050865927	\$15.00	791278	2017-10-08
GALLEGOS	JONATHAN P	.p1186605a	59125051041452	\$15.00	791276	2017-10-08
HERNANDEZ	LILIANA MARIAH	.p1185082a	59125051052103	\$15.00	791277	2017-10-08
GRAVES	ARIANNA M	.p1182768a	59125051027246	\$15.00	791285	2017-10-08
ARRIOLA-ESPINOZA	ALEJANDRA	.p1182905a	59125050977995	\$15.00	791284	2017-10-08
ESPARZA	MAURICIO	.p1178266a	59125050938385	\$15.00	791288	2017-10-08
LONGMAN	MITCHELL M	.p1187526a	59125051146269	\$15.00	791291	2017-10-08
MCCOSKEY	MADISON R	.p1180896a	59125050963813	\$15.00	791287	2017-10-08
HALL	MARIAH T	.p1187610a	59125051077605	\$15.00	791292	2017-10-08
SERNA	SANTIAGO CARLOS	.p1149310a	59125050954267	\$15.00	791293	2017-10-08
MENJUGA	ALIANA MARYLINDA	.p1187205a	59125051073778	\$15.00	793629	2017-10-15
DOWNEY	KELLI R	.p1182611a	59125051029168	\$15.00	793631	2017-10-15
RUNNING BEAR	KAILEENA A	.p1182613a	59125051029176	\$15.00	793626	2017-10-15
NORRIS	THOMAS DELTON	.p1187064a	59125051071731	\$15.00	793634	2017-10-15
SOWDERS	DAVID A	.p1186327a	59125051042633	\$15.00	793636	2017-10-15
MCLELLAN	ANTHONY PIO	.p1151935a	59125050873632	\$15.00	793638	2017-10-15
AHLUWALIA	LIVLEEN K	.p1162751a	59125050964811	\$15.00	793637	2017-10-15
RUNNING BEAR	PAISLEY S	.p1182612a	59125051029184	\$15.00	793635	2017-10-15
McCANTS	ISIS A	.p1187793a	59125051147671	\$15.00	795908	2017-10-22
WADHAMS	AMY L	.p1187815a	59125051147796	\$15.00	795907	2017-10-22
VIGIL	CECILIA G	.p1187861a	59125051075492	\$15.00	795902	2017-10-22
ORTIZ	SONYA N	.p1187846a	59125051075526	\$15.00	795906	2017-10-22
ROCHA	ALEXIS ANN	.p1110236a	59125051084270	\$15.00	795903	2017-10-22
BOOT	BRENDON	.p1187008a	59125051145147	\$15.00	795909	2017-10-22
QUINTANA	ALYANNA JEAN	.p1193720a	59125051301625	\$15.00	795911	2017-10-22
ANGUS	KELLY R	.p1177627a	59125050998710	\$15.00	795912	2017-10-22
CASTLEBERRY	JOHN ROBERT	.p1154068a	59125050609507	\$15.00	795917	2017-10-22
WILSON	HOPE RUTH	.p1101309a	59125050423115	\$15.00	795922	2017-10-22
FELLOCK	MATTHEW	.p1182459a	59125050992226	\$15.00	798224	2017-10-29
MATT	ALBERTA	.p1175965a	59125051026644	\$15.00	798225	2017-10-29
OROZ	YAZMIN D	.p1185331a	59125051058829	\$15.00	798227	2017-10-29
SWIMMER	SONJA RENAE	.p1184430a	59125051046527	\$15.00	798226	2017-10-29
DIXON	CRYSTAL R	.p1187979a	59125051147929	\$15.00	798234	2017-10-29
SUSSMAN	MADISON	.p1182458a	59125050992234	\$15.00	798235	2017-10-29
MCNERNEY	MELISSA MARTHA	.p1181277a	59125051071293	\$15.00	798231	2017-10-29
KAMALA	KAI JOEL	.p1188134a	59125051083017	\$15.00	798232	2017-10-29
QUINTANA	MEGAN	.p1173921a	59125050899983	\$15.00	798238	2017-10-29

Last name	First/middle name	Patron record	Barcode	Amount owed	Invoice number	Date
LUCERO	ABIGAIL JOY	.p1173920a	59125050900005	\$15.00	798239	2017-10-29
JONES	RYAN CHANDLER	.p1188015a	59125051084080	\$15.00	798236	2017-10-29
DRUMMOND	CHRIS PAUL	.p1162106a	59125051083520	\$15.00	798245	2017-10-29
COWAN	CHARLES GALLARDO JR	.p1166002a	59125051083637	\$15.00	798242	2017-10-29
HARTMAN	SARA	.p1152704a	59125050918866	\$15.00	798248	2017-10-29
HAYES	GARETT L	.p1160750a	59125051083454	\$15.00	798246	2017-10-29
HUST	LELAND AZUL	.p1145322a	59125051064124	\$15.00	798251	2017-10-29
TYROLER	SIMON PATRICK	.p1132145a	59125050796197	\$15.00	798253	2017-10-29
CORDOVA	ANGEL B	.p1142931a	59125051083371	\$15.00	798252	2017-10-29
FLORES	JOHNAE L	.p1186479a	59125051069016	\$15.00	800382	2017-11-05
THOMAS	TIFFANY N	.p1156488a	59125051148950	\$15.00	800380	2017-11-05
BOULWARE	SONNIE D	.p1167619a	59125050788061	\$15.00	800384	2017-11-05
ASTORGA	CELEST VIDA	.p1188517a	59125051089626	\$15.00	800381	2017-11-05
ARAGON	AALINA R	.p1169215a	59125051081862	\$15.00	800387	2017-11-05
GARCIA	JUAN	.p1185988a	59125051064033	\$15.00	800393	2017-11-05
YEPA	AVA NOELLE	.p1188269a	59125051081896	\$15.00	800388	2017-11-05
ARIAS	BERENICE	.p1188513a	59125051089659	\$15.00	800390	2017-11-05
OBRIEN	SHAMUS P	.p1188006a	59125051146558	\$15.00	800394	2017-11-05
OLGUIN	AUDRINA	.p1188502a	59125051088917	\$15.00	801907	2017-11-12
AGUILAR	TIMAEUS ORION	.p1179903a	59125051080583	\$15.00	801904	2017-11-12
ADAMS	REBECCA J	.p1170342a	59125050847263	\$15.00	801906	2017-11-12
HOWLEY	TIA RENE	.p1125006a	59125051083876	\$15.00	801903	2017-11-12
DeROUIN	KRISTI	.p1188377a	59125051150246	\$15.00	804915	2017-11-19
CORTINAS	NICHOLAS D	.p1186243a	59125051042831	\$15.00	804918	2017-11-19
MERCADO	ANGELA D	.p1186241a	59125051042823	\$15.00	804917	2017-11-19
LARA	ALEXIS	.p1165862a	59125051149636	\$15.00	804914	2017-11-19
BRYANT	ANGELA	.p1147755a	59125051051774	\$15.00	804928	2017-11-19
BENNETT	AMBER N	.p1181847a	59125051090038	\$15.00	804921	2017-11-19
DONATO	JOSEPH	.p1152230a	59125050546824	\$15.00	804927	2017-11-19
ELLIS	CYNTHIA M	.p1117997a	59125051066491	\$15.00	804930	2017-11-19
MOODY	GARY AARON	.p1188541a	59125051089105	\$15.00	804932	2017-11-19
CHAVEZ	BENNY J IV	.p1184613a	59125051048242	\$15.00	806306	2017-11-26
FUSCO	SAMANTHA ANN	.p1188431a	59125051154743	\$15.00	806312	2017-11-26
FOSTER	SHARON MARIA	.p1163688a	59125050976393	\$15.00	806316	2017-11-26
CHAVEZ	ARMANDO R	.p1184604a	59125051048341	\$15.00	806309	2017-11-26
JEAN-JACQUES	BRADLEY O	.p1188586a	59125051088776	\$15.00	806313	2017-11-26
PETTY	BRODY B	.p1188572a	59125051088891	\$15.00	806311	2017-11-26
PETTY	ISABELLA R	.p1188573a	59125051088883	\$15.00	806314	2017-11-26
MADERA	LAYLA JAMILA	.p1188631a	59125051088131	\$15.00	808788	2017-12-03
GALLEGOS	DONALD A	.p1188904a	59125051086432	\$15.00	808791	2017-12-03
PEREA	ANGELETTE UILANI	.p1181822a	59125050971949	\$15.00	808794	2017-12-03
JONES	BRIAN T	.p1179220a	59125051146616	\$15.00	808796	2017-12-03
RAMIREZ	JULIE	.p1178944a	59125050934475	\$15.00	808797	2017-12-03
SELECION	AURORA LYNN	.p1182055a	59125050970917	\$15.00	808792	2017-12-03
CHEE	PRISCILLA MOLLY-KEALA	.p1181823a	59125050971931	\$15.00	808795	2017-12-03
PABLOFF	ISABELLE M	.p1177630a	59125050998868	\$15.00	808798	2017-12-03
CEVERING	CASSANDRA MARIE	.p1158518a	59125051024045	\$15.00	808805	2017-12-03
CHAVEZ	MAXAMIS A	.p1176217a	59125050981161	\$15.00	808800	2017-12-03
DUNN	MICHAEL A	.p1151342a	59125051072036	\$15.00	808808	2017-12-03
WAGAR	CHRISTAL R	.p1133529a	59125050984900	\$15.00	808812	2017-12-03
SOTO	AUBREE B	.p1143364a	59125051087521	\$15.00	808811	2017-12-03
BAHE	MARIAH L	.p1121164a	59125051056690	\$15.00	808813	2017-12-03
PETTY	CAMERON J	.p1188477a	59125051094535	\$15.00	810773	2017-12-10
GARUTI	BEVONNIE R	.p1187983a	59125051084437	\$15.00	810771	2017-12-10
FERNANDEZ	OLIVIA M	.p1179346a	59125050947915	\$15.00	810780	2017-12-10
OVITT	DANIEL JAMES	.p1188600a	59125051153554	\$15.00	810777	2017-12-10
WOO	ISAIAH C	.p1187889a	59125051147135	\$15.00	810776	2017-12-10
BURDG	SEAN R	.p1188539a	59125051089121	\$15.00	810778	2017-12-10
VAUGHN	ISABELLA	.p1188741a	59125051087257	\$15.00	810775	2017-12-10
GRIFFITH	ROBERT A	.p1172910a	59125050894927	\$15.00	810782	2017-12-10
CANDELARIA	JULIE ALEXANDRIA	.p1160486a	59125051146608	\$15.00	810785	2017-12-10
PADILLA	THERESA J	.p1133521a	59125051086895	\$15.00	810788	2017-12-10
RODRIGUEZ	EMILY A	.p1175796a	59125050918825	\$15.00	810781	2017-12-10
CHAVEZ	ALICIA MARIE	.p1142577a	59125051055858	\$15.00	810787	2017-12-10
MONTOYA	JADYN A	.p1122369a	59125051195407	\$15.00	810789	2017-12-10
GARCIA	PAUL R	.p1185618a	59125051056666	\$15.00	812917	2017-12-17
BROWN	DOHNAVIN ORION	.p1169018a	59125050828420	\$15.00	812913	2017-12-17
ARIZMENDI	BREANNA D	.p1188003a	59125051147853	\$15.00	812919	2017-12-17
ALLEN	RAJENE TAMIKA	.p1118320a	59125050808679	\$15.00	812918	2017-12-17

Last name	First/middle name	Patron record	Barcode	Amount owed	Invoice number	Date
FUENTES	ARTURO	.p1187955a	59125051148026	\$15.00	812920	2017-12-17
RIMMER	MIJA JOLI	.p1181372a	59125050967400	\$15.00	812924	2017-12-17
CUEVAS	AMILIA M	.p1187562a	59125051077746	\$15.00	812927	2017-12-17
TATUM	PENELOPE	.p1188899a	59125051086440	\$15.00	812923	2017-12-17
LAREDO	JAMIE LYNN	.p1168800a	59125050822456	\$15.00	812926	2017-12-17
GONZALEZ	AVENELLE L	.p1124946a	59125051054976	\$15.00	814418	2017-12-24
ROMERO	ANTONIO E	.p1119359a	59125050933089	\$15.00	814420	2017-12-24
MARES	DESIREE ROSEMARY	.p1140388a	59125050491260	\$15.00	814422	2017-12-24
CHACON	MICHAEL AUSTIN	.p1188777a	59125051153224	\$15.00	814423	2017-12-24
ARELLANO	SONIA M.	.p1188381a	59125051150311	\$15.00	814424	2017-12-24
GARCIA JAXON		.p1184799a	59125051054984	\$15.00	814421	2017-12-24
OTERO	KEITHA MICHELLE	.p1188442a	59125051090236	\$15.00	817256	2017-12-31
YAZZIE	MICHELLE	.p1188841a	59125051086564	\$15.00	817253	2017-12-31
HERNANDEZ	IDALY	.p1189038a	59125051094402	\$15.00	817254	2017-12-31
FIELDS	ELIZABETH MARIE	.p1189075a	59125051094063	\$15.00	817250	2017-12-31
CHRISTEN	GINA M	.p1187909a	59125051085012	\$15.00	817257	2017-12-31
GURLEY	BRADLEY COLE	.p1189141a	59125051093438	\$15.00	817251	2017-12-31
OLGUIN	KATERI R	.p1189346a	59125051091499	\$15.00	817252	2017-12-31
SALAZAR	RYAN ANTHONY	.p1187224a	59125051073612	\$15.00	817259	2017-12-31
QUIROZ	ALIYIAH DEANNA	.p1181803a	59125051093156	\$15.00	817261	2017-12-31
COOPER	MATTHEW E	.p1174607a	59125051091036	\$15.00	817264	2017-12-31
MARTINEZ	KYRA	.p1174503a	59125050951081	\$15.00	817265	2017-12-31
RODRIGUEZ	STEPHANY	.p1172823a	59125051026420	\$15.00	817267	2017-12-31
GARZA	CAROLINA MICHELLE	.p1173966a	59125051087034	\$15.00	817266	2017-12-31
ORTIZ	ANTOINETTE K	.p1179670a	59125051010309	\$15.00	817262	2017-12-31
MACIAS	PETER JOHN	.p1150995a	59125051051220	\$15.00	817273	2017-12-31
YOUNGREN	STACY RENEE	.p1147767a	59125051148224	\$15.00	817274	2017-12-31
LOVATO	MARCUS ANTHONY	.p1144994a	59125051093529	\$15.00	817275	2017-12-31
JENNINGS	DEBBIE DENISE	.p1116631a	59125050836936	\$15.00	817277	2017-12-31
POPE	CHRISTOPHER MICHAEL	.p1073656a	59125051089170	\$15.00	817279	2017-12-31

TOTAL 2017 COLLECTIONS WRITE OFF \$6,660.00

GRAND TOTAL 2017 LIBRARIES WRITE OFF \$27,965.51

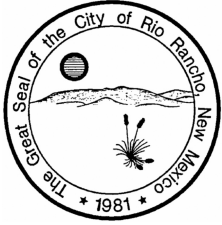

**CITY OF RIO RANCHO
COVER PAGE**

Legislation Item: D11

AGENDA DATE:

March 10, 2022

DEPARTMENT:

Parks, Recreation & Community Services

SUBJECT:

D11, Advice and Consent of the Governing Body to Award Contract No. 22-PR-127: Construction of Sports Complex North Phase II Contract to T.A. Cole & Sons General Contractors, Inc.

BACKGROUND AND ANALYSIS:

The City released IFB 22-PR-010 Construction of Sports Complex North Phase II on January 9, 2022. The bid closed on February 4, 2022 and the lowest bidder was T.A. Cole & Sons General Contractors, Inc. for the amount of \$2,198,213.13 excluding New Mexico Gross Receipts Tax.

The total contract budget including tax, \$2,367,200.76, is funded through multiple State Grants/Capital Outlay allocations and City Park Impact Fees.

Phase II will include extensive grading and drainage improvements, construction of a split concession and restroom building, emergency vehicle access, a pedestrian plaza, landscaping, utility extension and related improvements. Sports Complex North Phase II construction work will begin in April 2022 and be completed by fall 2022.

IMPACT:

Awarding the contract will allow the City to complete construction of Phase II of Sports Complex North and fully expend State grant funds.

ALTERNATIVES:

Approve the contract with T.A. Cole & Sons General Contractors, Inc. and construct Phase II of Sports Complex North.

Do not approve the contract.

DEPARTMENT RECOMMENDATION:

Staff recommends award of the construction contract to T.A. Cole & Sons General Contractors, Inc.

ATTACHMENT: [Sports Complex North Ph2 Improvements Overview](#)

ATTACHMENT: [Contract 22-PR-127 Revised](#)

VICINITY MAP

PROJECT AREA

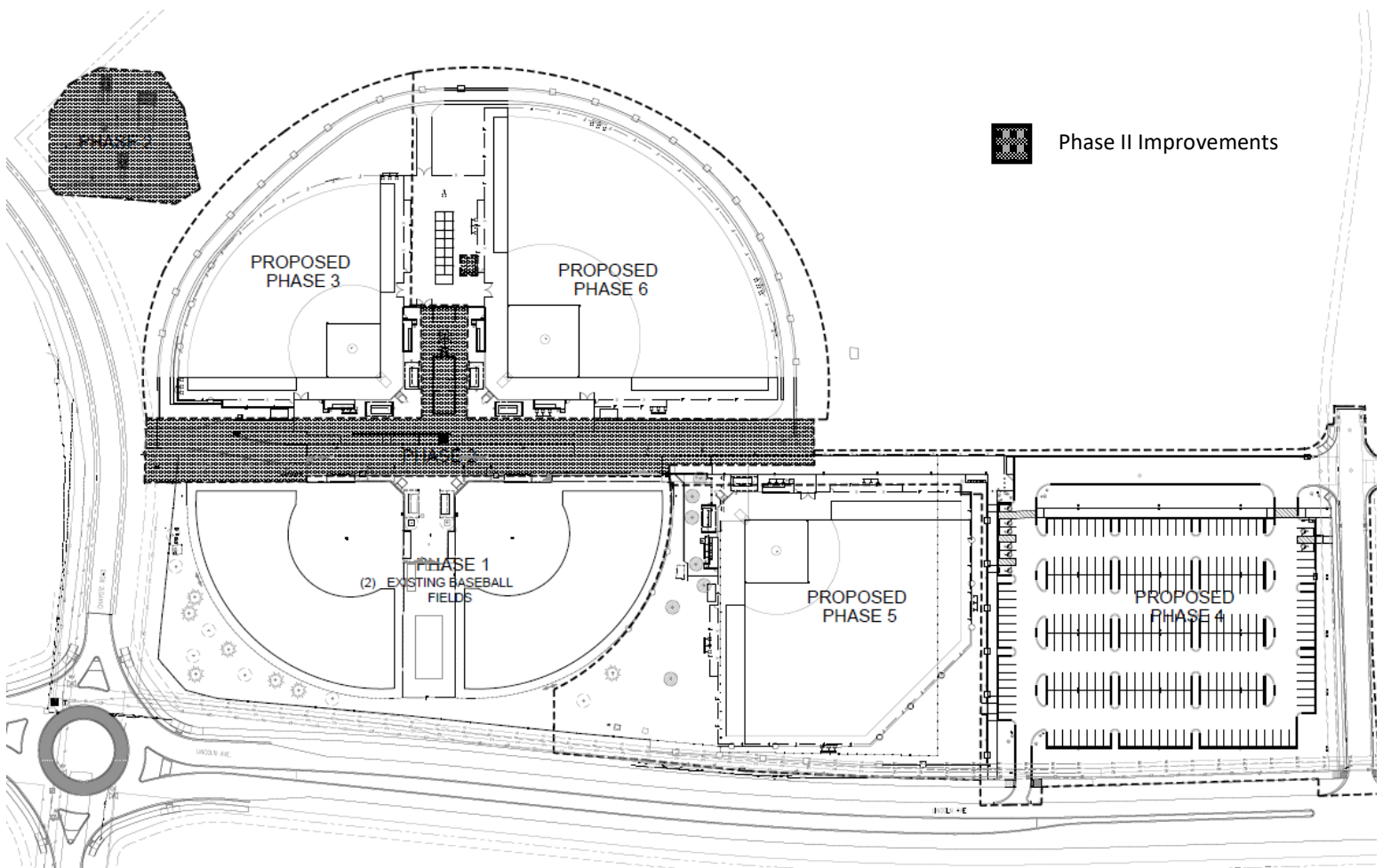
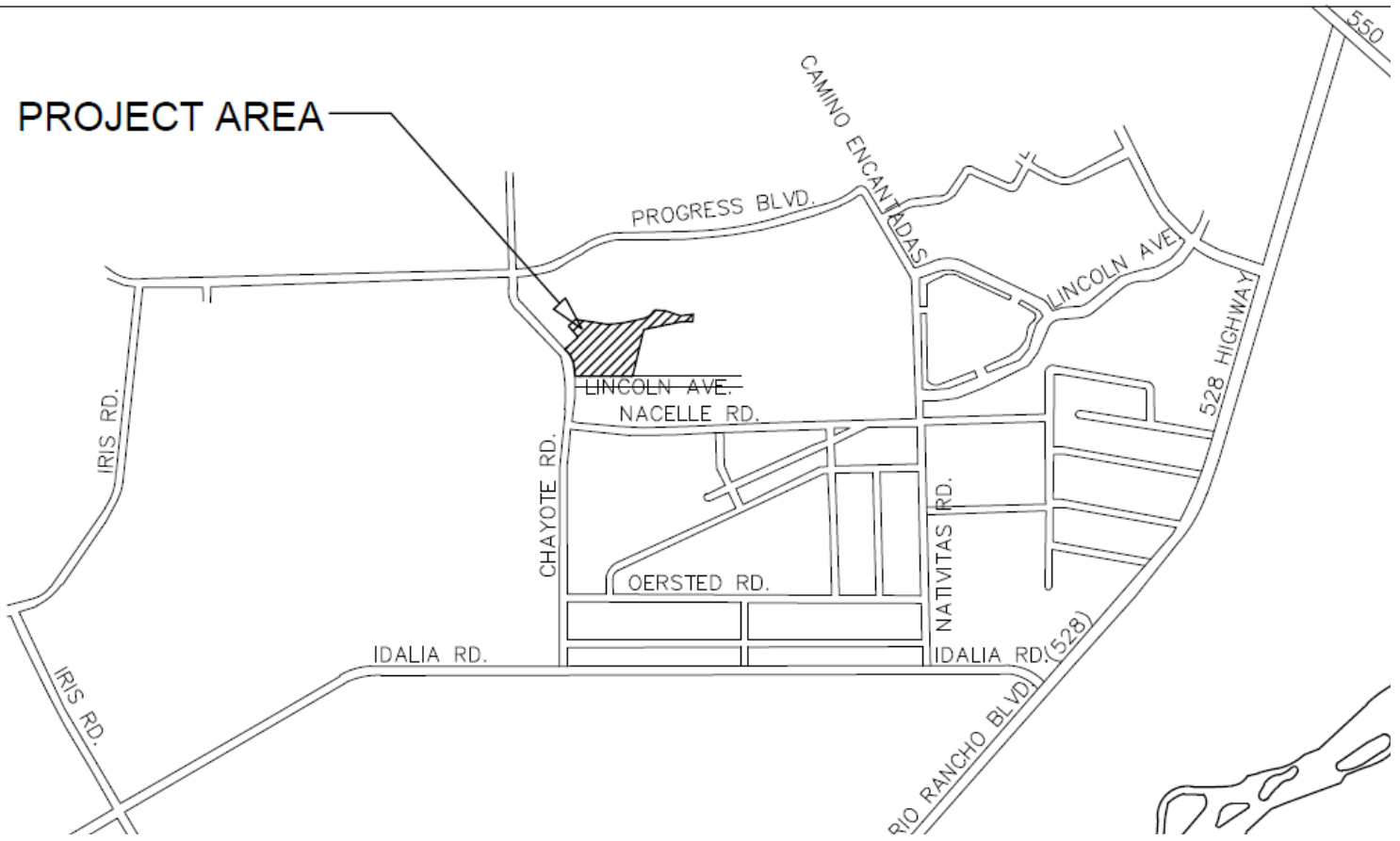

 Phase II Improvements

CONTRACT 22-PR-127
Construction Contract
Construction of the Sports Complex North - Phase II

THIS AGREEMENT is made and entered into by and between the City of Rio Rancho, hereinafter referred to as the “CITY,” and T.A.Cole & Sons, General Contractor, Inc., hereinafter referred to as the “CONTRACTOR.”

City and Contractor, in consideration of the mutual covenants hereinafter set forth, agree as follows:

1. WORK

CONTRACTOR shall complete all Work as specified or indicated here below. The Work and project are generally described in Invitation for Bid IFB 22-PR-010.

2. GENERAL CONDITIONS

The general conditions (“General Conditions”) of this Agreement shall be the Standard General Conditions of the Construction Contract prepared by the Engineers Joint Contract Documents Committee (EJCDC) Document C-700, 2007, and modifications thereto incorporated herein by reference.

3. ENGINEER

The ENGINEER of record for this project, as described in the General Conditions, is MRWM Landscape Architects.

4. CONTRACT TIMES

4.1 The Work will be substantially completed within **one hundred eighty (180)** consecutive calendar days after the date when the Contract Times commence to run as provided in Paragraph 2.03 of the General Conditions, and completed and ready for final payment in accordance with Paragraph 14.07 of the General Conditions.

4.2 Liquidated Damages. City and Contractor recognize that time is of the essence of this Agreement and that City will suffer financial loss if the Work is not completed within the times specified in Paragraph 4.1 above, plus any extensions thereof allowed in accordance with Article 12 of the General Conditions. The parties also recognize the delays, expense and difficulties involved in proving the actual loss suffered by City if the Work is not completed on time. Accordingly, instead of requiring any such proof, City and Contractor agree that as liquidated damages for delay (but not as a penalty) Contractor shall pay City **Five Hundred dollars (\$ 500.00)** for each day that expires after the substantial completion date established by the City’s written Notice to Proceed.

5. CONTRACT PRICE

The City shall pay the Contractor the Contract Sum in current funds for the Contractor's performance of the Contract. The Contract price comprises the Base Bid, Additive Alternate #1, and Additive Alternate #2 as described in IFB 22-PR-010 and all addenda thereto. The Contract price shall be **Two Million One Hundred Ninety-Eight Thousand, Two Hundred Thirteen Dollars and thirteen cents, (\$2,198,213.13)**, which excludes applicable gross receipts tax, subject to additions and deductions as provided in the Contract Documents.

6. NON-APPROPRIATIONS

The terms of this Agreement and all amounts payable hereunder are contingent upon sufficient appropriations therefore by the City's Governing Body. If sufficient appropriations are not made, the City shall notify the Contractor of the same, and this Agreement shall terminate forthwith.

7. PAYMENT PROCEDURES

Contractor shall submit Application for Payment in accordance with Article 14 of the General Conditions. Engineer will process applications for Payment as provided in the General Conditions. The City shall make progress payments on account of the Contract Price on the basis of Contractor's Applications for Payment as recommended by Engineer, twenty-one (21) days after receipt of the Engineer approved Application for Payment. All such payments will be measured by the schedule of values established in Paragraph 14.02 of the General Conditions (and in the case of Unit Price Work based on the number of units completed).

8. CONTRACTOR'S REPRESENTATIONS

In order to induce City to enter into this Agreement Contractor makes the following representations:

- 8.1 Contractor has examined and carefully studied the Contract Documents and other related data identified in the Bidding Documents including "technical data."
- 8.2 Contractor has visited the site and become familiar with and is satisfied as to the general, local and site conditions that may affect cost, progress, performance or furnishing of the Work.
- 8.3 Contractor is familiar with and is satisfied as to all federal, state and local laws and regulations that may affect cost, progress, performance and furnishing of the Work.
- 8.4 Contractor has examined all reports of explorations and tests of subsurface conditions at or contiguous to the site and all drawings of physical

conditions in or relating to existing surface or subsurface structures at or contiguous to the site (except underground facilities) which have been identified in Paragraph 4.02 A of the General Conditions. Contractor accepts the determination set forth in Paragraph 4.02 B of the General Conditions of the extent of the "technical data" contained in such reports and drawings upon which Contractor is entitled to rely as provided in Paragraph 4.02 B.1 of the General Conditions. Contractor acknowledges that such reports and drawings are not Contract Documents and may not be complete for Contractor's purposes. Contractor acknowledges that City and Engineer do not assume responsibility for the accuracy or completeness of information and data shown or indicated in the Contract Documents with respect to Underground Facilities at or contiguous to the site. Contractor has obtained and carefully studied (or assumes responsibility for having done so) all such additional supplementary examinations, investigations, explorations, tests, studies and data concerning conditions (surface, subsurface and underground facilities) at or contiguous to the site or otherwise which may affect cost, progress, performance or furnishing of the Work or which relate to any aspect of the means, methods, techniques, sequences and procedures of construction to be employed by Contractor and safety precautions and programs incident thereto. Contractor does not consider that any additional examinations, investigations, explorations, tests, studies or data are necessary for the performance and furnishing of the Work at the contract price, within the contract times and in accordance with the other terms and conditions of the contract documents.

- 8.5 Contractor is aware of the general nature of work to be performed by City and others at the site that relates to the Work as indicated in the Contract Documents.
- 8.6 Contractor has correlated the information known to Contractor, information and observations obtained from visits to the site, reports and drawings identified in the Contract Documents and all additional examinations, investigations, explorations, tests, studies and data with the Contract Documents.
- 8.7 Contractor has given City written notice of all conflicts, errors, ambiguities or discrepancies that Contractor has discovered in the Contract Documents. Contractor certifies that any written resolution thereof by City is acceptable and that the Contract Documents are generally sufficient to indicate and convey understanding of all terms and conditions for performance and furnishing of the Work.
- 8.8 Contractor shall make prompt payment to its subcontractors and suppliers for amounts owed for work performed on the construction project within seven days after receipt of payment from the City. If Contractor fails to pay Contractor's subcontractor and suppliers by first-class mail or hand delivery

within seven days of receipt of payment, Contractor shall pay interest to Contractor's subcontractors and suppliers beginning on the eight day after payment was due, computed at one and one-half percent of the undisputed amount per month or fraction of a month until payment is issued. These payment provisions apply to all tiers of contractors, subcontractors and suppliers.

9. CONTRACT DOCUMENTS

In addition to this Agreement, the Contract Documents, which comprise the entire agreement between City and Contractor concerning the Work, consist of the documents which are appended to this Contract as listed below in Subsection 9A and the documents which formed part of the IFB package upon which Contractor made its successful bid, as listed below in Subsection 9B.

A. Documents attached to hereto:

1. Contractor's Bid Form
2. The Bidder's Listing of Subcontractors for Compliance with Subcontractors Fair Practices Act
3. Bid Bond
4. Local/Area/Resident/Resident Veteran/Recycled Content Goods Preference Certification Form
5. Resident Veteran Preference Certification
6. Certification of Bidder Regarding Affirmative Action/Equal Employment Opportunity and Non-discrimination
7. Non-Collusion Affidavit
8. Construction Performance Bond
9. Labor and Materials Payment Bond
10. Certificates of Insurance

B. Documents which were part of the IFB package and not listed above:

1. Advertisement for Bids
2. Instructions to Bidders
3. Standard General Conditions of the Construction Contract, EJCDC Document No. C-700 (2007)
4. Supplemental Conditions
5. Notice to Contractor
6. Wage Rate Determination
7. Any Addenda issued for IFB 22-PR-010
8. Construction Plans as prepared by MRWM Landscape Architects

There are no Contract Documents other than those listed in Section 9 of this Agreement. The Contract Documents may only be amended, modified or supplemented as provided in Paragraphs 3.04 A & B, General Conditions. Any question regarding the documents which formed the IFB package shall be resolved by use of the documents maintained by City in its files on the Work. Contractor may obtain access to these documents at any time, upon reasonable notice.

10. MISCELLANEOUS

- 10.1 Terms used in this Agreement will have the same meaning as those defined in Article 1 of the General Conditions.
- 10.2 No assignment by a party hereto of any rights under or interests in the Contract Documents will be binding on another party hereto without the written consent of the party sought to be bound; and, specifically but without limitation, monies that may become due and monies that are due may not be assigned without such consent (except to the extent that the effect of this restriction may be limited by law), and unless specifically stated to the contrary in any written consent to an assignment, no assignment will release or discharge the assignor from any duty or responsibility under the Contract Documents.
- 10.3 The City and Contractor each binds themselves, their partners, successors, assigns and legal representatives to the other party hereto, in respect to all covenants, agreements and obligations contained in the Contract Documents.
- 10.4 Any provision or part of the Contract Documents held to be void or unenforceable under any Law or Regulation shall be deemed stricken, and all remaining provisions shall continue to be valid and binding upon the City and Contractor, who agree that the Contract Documents shall be reformed to replace such stricken provision or part thereof with a valid and enforceable provision that comes as close as possible to expressing the intention of the stricken provision.
- 10.5 If, through any cause, Contractor shall fail to fulfill in timely and proper manner Contractor's obligations under this Agreement, or if Contractor shall violate any of the covenants, agreements, or stipulations of this Agreement, the City shall thereupon have the right to terminate this Agreement by giving written notice to Contractor of such termination and specifying the effective date thereof, at least five (5) days prior to the effective date of such termination. In such event, all finished and/or unfinished documents, data, studies, surveys and reports prepared by Contractor under this Agreement shall, at the option of the City, become its property and Contractor shall be entitled to receive just and equitable compensation for any work satisfactorily completed hereunder.
- 10.6 Notwithstanding the above, Contractor shall not be relieved of liability to the City for damages sustained by the City by virtue of any breach of the contract by Contractor, and the City may withhold any payments to Contractor for the purpose of set-off until such time as the exact amount of damages due the City from Contractor is determined.

- 10.7 The City may terminate this Agreement at any time for the City's convenience, by giving at least thirty (30) days' notice in writing to Contractor. If the Agreement is terminated by the City as provided herein, Contractor will be paid for the time provided and expenses incurred up to the termination date. If this Agreement is terminated due to the fault of Contractor, paragraph 10.5 hereof relative to termination shall apply.
- 10.8 Notices: Any notice required or permitted to be given hereunder shall be sufficient if mailed to the address shown below or faxed to the number shown below for the party receiving notice, or to such other address or fax number of which such party has duly notified the other party in accordance with the provisions of this paragraph.

For notice to the City:
City of Rio Rancho
Dyane N. Sonier, Resource Development Manager
3200 Civic Center Circle
Rio Rancho, New Mexico 87144
Telephone: 505-896-8728
Fax: 505 264-1307
Email: dsonier@rrnm.gov

For notice to the Contractor:
T.A. Cole & Sons, General Contractors, Inc.
T. A. Cole III, President/CEO
PO Box 10660
2025 Calle Del Alondra NW
Albuquerque, NM 87184
Telephone: 505-898-2533
Fax: 505-898-2533
Email: scole@tacolesons.com

With copies to:
MRWM Landscape Architects
Aaron Zahm, Principal
1102 Mountain Rd. NW #201
Albuquerque, NM 87102
Telephone: 505 268-2266
Email: azahm@mrwmla.com

- 10.9 To the extent, if at all, that NMSA § 56-7-1 is applicable to any agreement to indemnify contained in this Contract, and any such agreement to indemnify contained in this Contract is interpreted to indemnify a party against liability, claims, damages, losses, or expenses, including attorney fees, arising out of bodily injury to persons or damage to property caused by, or resulting from, in whole or in part the negligence, act, or omission of the indemnitee, or the agents or employees of the indemnitee, or any legal entity for whose negligence, acts, or omissions any of them may be liable, any such agreement to indemnify contained this Contract shall not extend to liability, claims, damages, losses, or expenses, including attorney fees, arising out of:
- A. The preparation or approval of maps, drawings, opinions, reports, surveys, change orders, designs, or specifications by the indemnitee or the agents or employees of the indemnitee; or

- B. giving or failure to give directions or instructions by the indemnitee, or the agents or employees of the indemnitee, where such giving or failure to give directions or instructions is the primary cause of bodily injury to persons or damage to property.

10.10 Where documents listed in Section 9 contain terms that are different from City Ordinances, City Ordinances shall prevail. In that regard, any inconsistency between terms occurring among the following portions of this Agreement shall be resolved by giving precedence in the following order: (1) City Ordinances, (2) this Agreement (3) the Supplemental Conditions, and (4) the Standard General Conditions of the Construction Contract.

IN WITNESS WHEREOF, the parties have executed this Agreement to become effective as of the date of the last party's signature.

CITY OF RIO RANCHO

**T.A. COLE & SONS, GENERAL
CONTRACTORS, INC.**

By: _____
Matthew B. Geisel, City Manager

By: _____
T.A. Cole III, President/CEO

Date: _____

Date: _____

APPROVED AS TO FORM:

Gregory F. Lauer, City Attorney