

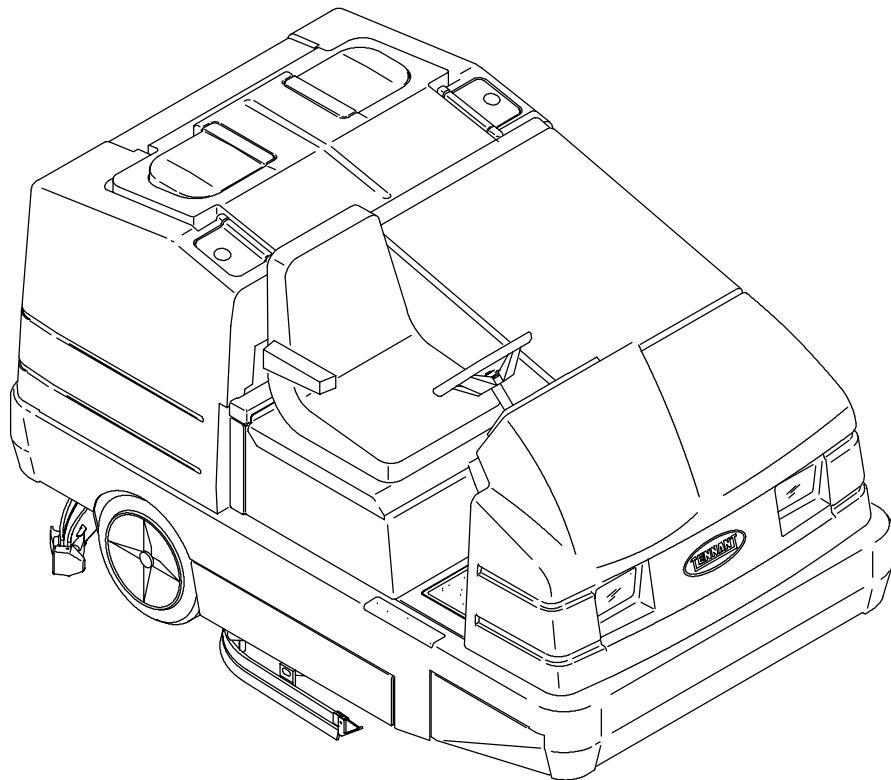

7400

Service Manual



MM428
Rev. 04 (3-02)



This service manual is intended to be an aid for the disassembly and reassembly of your TENNANT Model 7400.

This manual is organized into seven major groups: General Information, Chassis, Scrubbing, Electrical, Hydraulics, Engine-G/LPG and Engine-D.

General Information: Machine transport, machine jacking, machine storage, machine specifications, and machine maintenance chart.

Chassis: Tire/wheel replacement, brake adjustment and replacement, chassis lubrication, steering adjustment and replacement.

Scrubbing: Scrubber head repair/replacement, brush repair/replacement, squeegee repair/replacement, and scrubber troubleshooting.

Electrical: Battery maintenance and replacement, instrument panel replacement, and electrical troubleshooting.

Hydraulics: Valve replacement/repair, motor replacement/repair, cylinder replacement/repair, pump replacement/repair, filter replacement, and hydraulics troubleshooting.

Engine - G/LPG: Air filter replacement, oil changing, cooling system maintenance/repair, fuel system maintenance/repair, governor adjustment/repair, engine repair, engine troubleshooting, and engine repairs.

Engine - D: Air filter replacement, oil changing, cooling system maintenance/repair, fuel system maintenance/repair, governor adjustment/repair, engine repair, engine troubleshooting, and engine repairs.

Manual Number - MM428

Revision: 04

Published: 3-02



CALIFORNIA PROPOSITION 65 WARNING:

Engine exhaust from this product contains chemicals known to the State of California to cause cancer, birth defects, or other reproductive harm.

CONTENTS

	Page
SAFETY PRECAUTIONS	1-3
SPECIFICATIONS	1-6
GENERAL MACHINE	
DIMENSIONS/CAPACITIES	1-6
GENERAL MACHINE PERFORMANCE	1-6
POWER TYPE	1-7
STEERING	1-7
HYDRAULIC SYSTEM	1-8
BRAKING SYSTEM	1-8
TIRES	1-8
MACHINE DIMENSIONS	1-9
MAINTENANCE	1-10
MAINTENANCE CHART / G/LP	1-10
MAINTENANCE CHART / DIESEL ..	1-12
PUSHING, TOWING, AND	
TRANSPORTING THE MACHINE ...	1-14
PUSHING OR TOWING	
THE MACHINE	1-14
TRANSPORTING THE MACHINE ...	1-15
MACHINE JACKING	1-17
STORING MACHINE	1-18
HARDWARE INFORMATION	1-19
STANDARD BOLT TORQUE CHART	1-19
METRIC BOLT TORQUE CHART ...	1-19
BOLT IDENTIFICATION	1-19
THREAD SEALANT AND LOCKING	
COMPOUNDS	1-19
HYDRAULIC FITTING INFORMATION	1-20
HYDRAULIC TAPERED PIPE FITTING (NPT)	
TORQUE CHART	1-20
HYDRAULIC TAPERED SEAT FITTING (JIC)	
TORQUE CHART	1-20
HYDRAULIC O-RING FITTING TORQUE	
CHART	1-20

SAFETY PRECAUTIONS

The following precautions are used throughout this manual as indicated in their description:



WARNING: To warn of hazards or unsafe practices which could result in severe personal injury or death.

FOR SAFETY: To identify actions which must be followed for safe operation of equipment.

The machine is suited to sweep disposable debris. Do not use the machine other than described in this Operator Manual. The machine is not designed for use on public roads.

The following information signals potentially dangerous conditions to the operator or equipment:

FOR SAFETY:

1. **Do not operate machine:**
 - Unless trained and authorized.
 - Unless operator manual is read and understood.
 - If it is not in proper operating condition.
 - In flammable or explosive areas unless designed for use in those areas.
 - In areas with possible falling objects unless equipped with overhead guard.
2. **Before starting machine:**
 - Check for fuel, oil, and liquid leaks.
 - Keep sparks and open flame away from refueling area.
 - Make sure all safety devices are in place and operate properly.
 - Check brakes and steering for proper operation.
3. **When starting machine:**
 - Keep foot on brake and directional pedal in neutral.
4. **When using machine:**
 - Use brakes to stop machine.
 - Go slow on inclines and slippery surfaces.
 - Use care when reversing machine.
 - Do not carry passengers on machine.
 - Always follow safety and traffic rules.
 - Report machine damage or faulty operation immediately.

5. **Before leaving or servicing machine:**
 - Stop on level surface.
 - Set parking brake.
 - Turn off machine and remove key.
6. **When servicing machine:**
 - Avoid moving parts. Do not wear loose jackets, shirts, or sleeves.
 - Block machine tires before jacking machine up.
 - Jack machine up at designated locations only. Block machine up with jack stands.
 - Use hoist or jack of adequate capacity to lift machine.
 - Wear eye and ear protection when using pressurized air or water.
 - Disconnect battery connections before working on machine.
 - Avoid contact with battery acid.
 - Avoid contact with hot engine coolant.
 - Allow engine to cool.
 - Keep flames and sparks away from fuel system service area. Keep area well ventilated.
 - Use cardboard to locate leaking hydraulic fluid under pressure.
 - Use Tennant supplied or approved replacement parts.



WARNING: Engine emits toxic gases. Severe respiratory damage or asphyxiation can result. Provide adequate ventilation. Consult with your regulatory authorities for exposure limits. Keep engine properly tuned.



WARNING: Flammable materials can cause an explosion or fire. Do not use flammable materials in tank(s).



WARNING: Flammable materials or reactive metals can cause explosion or fire. Do not pick up.



WARNING: Moving belt and fan. Keep away.



WARNING: Strong Vacuum. Keep Away From Fan Inlet When Fan Is Running.

GENERAL INFORMATION

The following safety labels are mounted on the machine in the locations indicated. If these or any labels become damaged or illegible, install a new label in its place.

EMISSIONS LABEL - LOCATED ON THE SIDE OF THE OPERATOR COMPARTMENT.



FOR SAFETY LABEL - LOCATED ON THE SIDE OF THE OPERATOR COMPARTMENT.

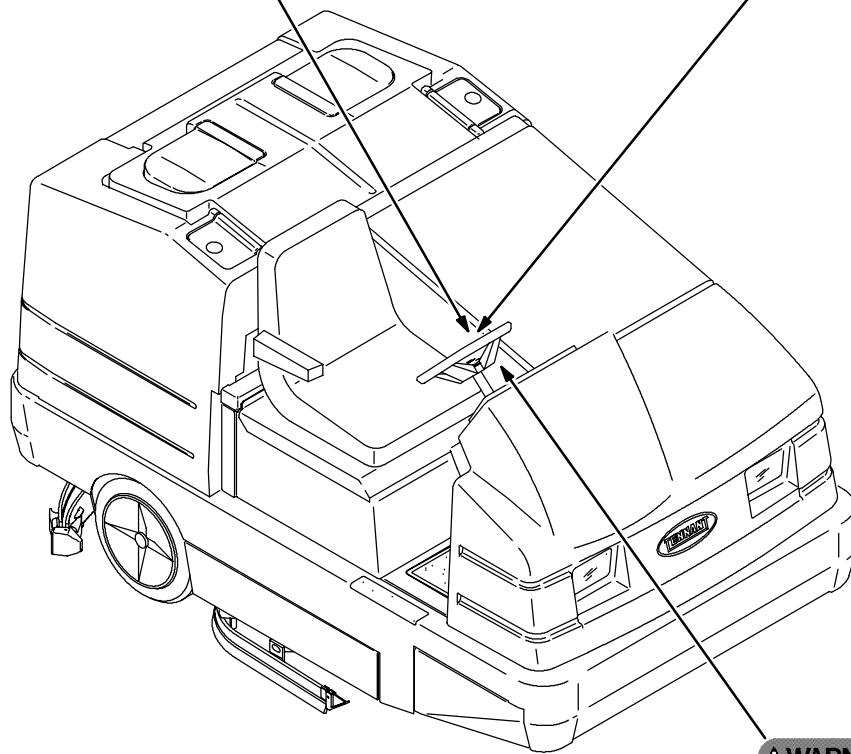
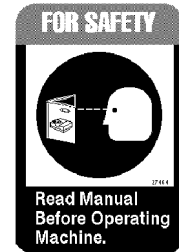

10783

FLAMMABLE SPILLS LABEL - LOCATED ON THE SIDE OF THE OPERATOR COMPARTMENT.

FAN AND BELT LABEL - LOCATED ON THE ENGINE COMPARTMENT LINTEL.

STRONG VACUUM LABEL - LOCATED ON THE VACUUM FAN HOUSING.

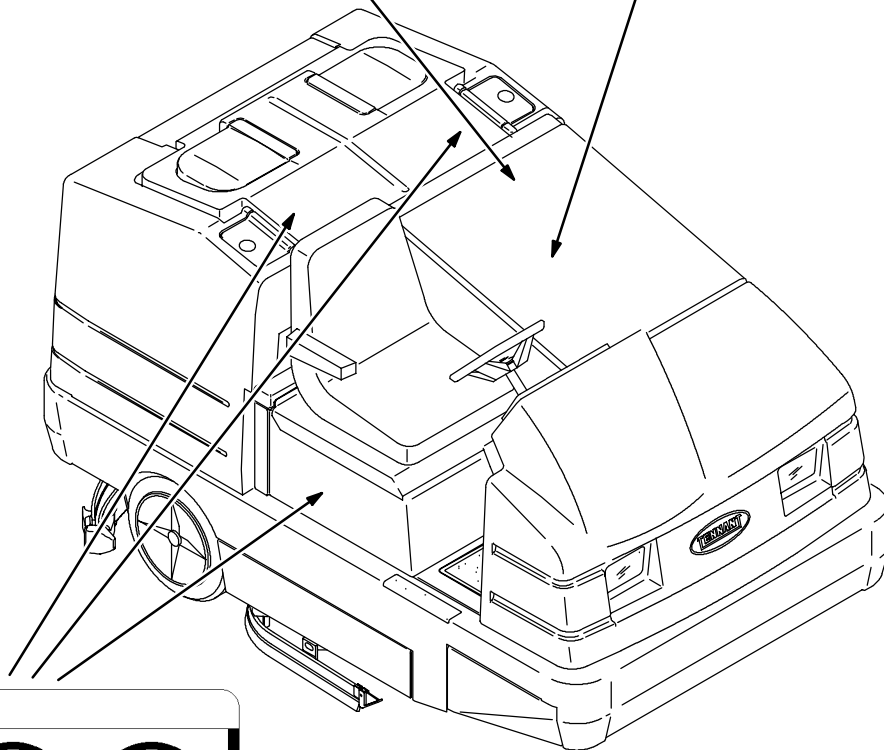

FLAMMABLE MATERIALS LABEL - LOCATED NEXT TO THE SOLUTION TANK COVERS AND ON THE DETERGENT TANK.

10783

GENERAL INFORMATION

SPECIFICATIONS

GENERAL MACHINE DIMENSIONS/CAPACITIES

Item	Dimension/capacity
Length	2460 mm (97 in)
Width	1525 mm (60 in)
Width with optional side brush	1590 mm (62.5 in)
Height	1475 mm (58 in)
Height with overhead guard	2045 mm (80.5 in)
Main scrub brush diameter	280 mm (11 in)
Main scrub brush length	1140 mm (45 in)
Side scrub brush diameter (option)	410 mm (16 in)
Squeegee width	1525 mm (60 in)
Scrubbing path width	1140 mm (45 in)
Scrubbing path width with optional side brush	1450 mm (57 in)
Debris tray volume capacity	42 L (1.5 ft ³)
Solution tank	265 L (70 gal)
Recovery tank	272 L (72 gal)
Detergent tank (option)	25 L (6.7 gal)
Total capacity with ES™ (option)	397 L (105 gal)
GVWR	2087 kg (4600 lb)

GENERAL MACHINE PERFORMANCE

Item	Measure
Maximum forward speed	12.9 kmh (8 mph)
Maximum reverse speed	6.4 kmh (4 mph)
Minimum aisle turn width	3190 mm (125.5 in)
Minimum turning radius, right	2660 mm (104.75 in)
Minimum turning radius, left	2030 mm (79.75 in)
Maximum rated incline for scrubbing	6°
Maximum rated incline for transport of machine	8°

POWER TYPE

Engine	Type	Ignition	Cycle	Aspiration	Cylinders	Bore	Stroke
Kubota V1505-B (E)	Piston	Diesel	4	Natural	4	78 mm (3.07 in)	78.4 mm (3.08 in)
	Displacement		Net power, governed			Net power, maximum	
	1500 cc (91.4 cu in)		24.6 kw (34 hp) @ 2400 rpm			27.2 kw (37.5 hp) @ 3000 rpm	
	Fuel		Cooling system			Electrical system	
	Diesel Fuel tank: 42 L (11.2 gal)		Water/ethylene glycol antifreeze			12 V nominal	
			Total: 7.5 L (2 gal)			37 A alternator	
			Radiator: 3.8 L (1 gal)				
	Idle speed, no load		(Fast) governed speed, under load			Engine lubricating oil without filter	
950 ± 50 rpm		2400 ± 50 rpm			6 L (6.35 qt) SAE-CC/CD rated engine oil		

Engine	Type	Ignition	Cycle	Aspiration	Cylinders	Bore	Stroke
Ford VSG 1.3	Piston	Distributorless- type spark	4	Natural	4	74 mm (2.91 in)	75 mm (2.97 in)
	Displacement		Net power, governed			Net power, maximum	
	1300 cc (79 cu in)		23.2 kw (32 hp) @ 2400 rpm			39.5 kw (53 hp) @ 4000 rpm	
	Fuel		Cooling system			Electrical system	
	Gasoline, 87 octane minimum, unleaded. Fuel tank: 42 L (11.2 gal)		Water/ethylene glycol antifreeze			12 V nominal	
			Total: 7.5 L (2 gal)			50 A alternator	
			Radiator: 3.8 L (1 gal)				
	Idle speed, no load		(Fast) governed speed, under load			Firing order	
	1350 ± 250 rpm		2400 ± 50 rpm			1-2-4-3, counterclockwise rotation	
	Spark plug gap		Valve clearance, cold			Engine lubricating oil with filter	
1 mm (0.04 in)		0.20 mm (0.008 in) intake 0.50 mm (0.002 in) exhaust			3.3 L (3.5 qt) 10W30 SAE-SG/SH		

GENERAL INFORMATION

STEERING

Type	Power source	Emergency steering
Front wheel, hydraulic cylinder and rotary valve controlled	Hydraulic accessory pump	Manual

HYDRAULIC SYSTEM

System	Capacity	Fluid Type
Hydraulic reservoir	38 L (10 gal)	TENNANT part no. 65869 - above 7° C (45° F)
Hydraulic total	74 L (19.5 gal)	TENNANT part no. 65870 - below 7° C (45° F)

BRAKING SYSTEM

Type	Operation
Service brakes	Mechanical drum brakes (2), one per rear wheel, cable actuated
Parking brake	Utilize service brakes, cable actuated

TIRES

Location	Type	Size	Pressure
Front (1)	Solid	460 x 130 mm (5 x 18 in)	-
Rear (2)	Solid	460 x 130 mm (5 x 18 in)	-

GENERAL INFORMATION

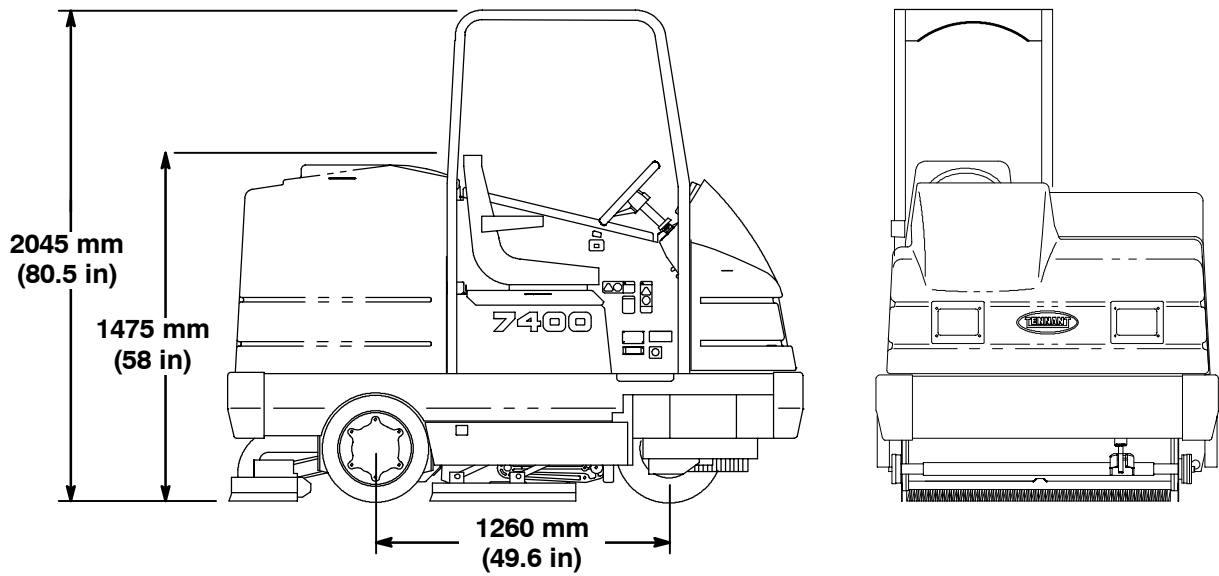
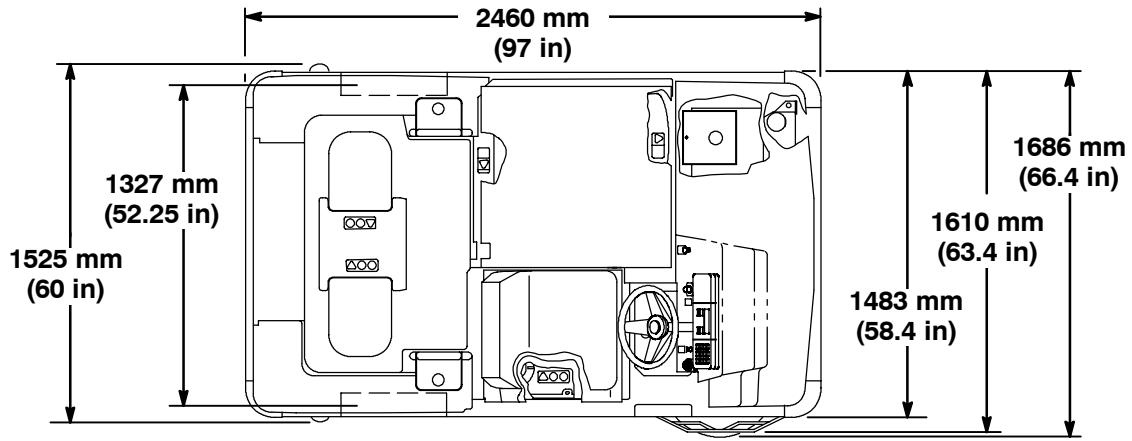

MACHINE DIMENSIONS

10919

MAINTENANCE

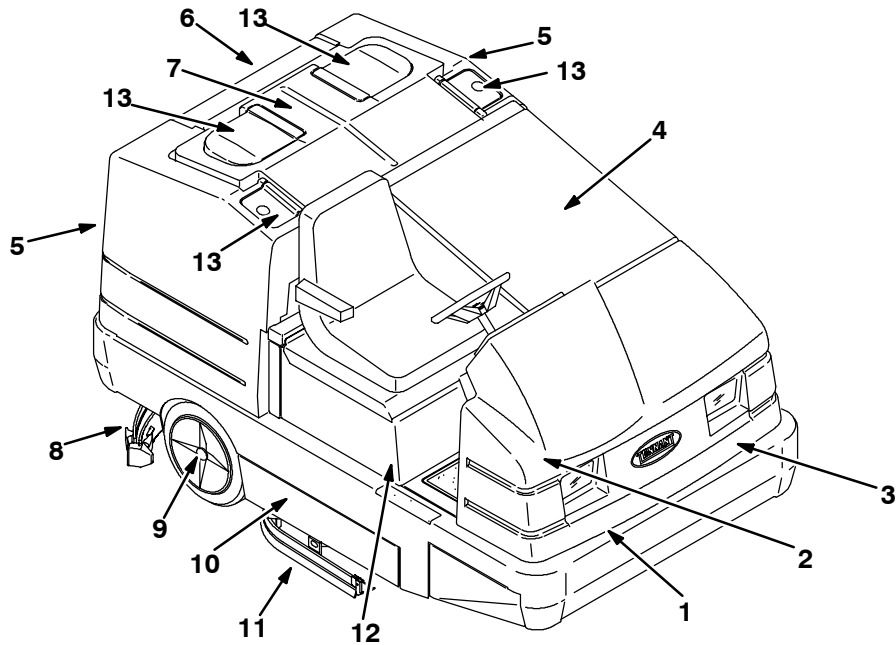

MAINTENANCE CHART / G/LP

Interval	Key	Description	Procedure	Lubricant/ Fluid	No. of Service Points
Daily	4	Engine air filter	Check indicator	-	1
			Empty dust cap	-	1
	4	Engine crankcase	Check oil level	EO	1
	8	Rear Squeegee	Check for damage and wear	-	1
			Check deflection	-	1
	11	Side Squeegees	Check for damage and wear	-	2
	10	Scrub brushes	Check for damage and wear	-	1
	7	Recovery tank	Clean	-	1
7	Recovery tank, ES™ mode	Clean ES™ filter	-	1	
5	Solution tank, ES™ mode	Clean	-	1	
50 Hours	10	Scrub brushes	Rotate end-for-end or front-to-rear	-	1
100 Hours	6	Radiator	Clean core exterior	-	1
			Check coolant level	WG	1
	4	Engine crankcase	Change oil and filter element	EO	1
	13	Cover seals	Check for damage and wear	-	4
	4	Engine	Check fan belt tension	-	1
			Check and adjust idle speed	-	1
			Check and adjust idle mixture	-	1
	3	Hydraulic fluid reservoir	Check fluid level	HYDO	1
	-	Tires	Check for damage	-	3
	8	Rear squeegee	Check leveling	-	1
8	Rear squeegee casters	Lubricate	SPL	2	

GENERAL INFORMATION

Interval	Key	Description	Procedure	Lubricant/ Fluid	No. of Service Points
100 Hours	10	Scrub brush idlers	Lubricate	SPL	2
	10	Scrub head skirts	Check for damage and wear	-	2
	-	Side brush skirt	Check for damage and wear	-	1
200 Hours	6	Radiator hoses and clamps	Check for tightness and wear	-	2
	4	Engine fan belt	Check tension	-	1
	2	Parking brake	Check adjustment	-	1
	2	Brake pedal	Check and adjust travel	-	1
	1	Front wheel support bearings	Lubricate	SPL	2
400 Hours	9	Rear wheel bearings	Check, lubricate, and adjust	SPL	2
	4	Engine	Clean or replace and adjust spark plugs	-	4
			■Check and adjust valve clearance	-	8
			Check and adjust idle speed	-	1
			Check and adjust carburetor idle mixture	-	1
			Replace PCV valve. Clean PCV hoses, tubes, and fittings	-	1
			Fuel filter, gasoline	-	1
800 Hours	3	Hydraulic reservoir	Replace filler cap	-	1
			Replace suction strainer	-	1
			Change hydraulic fluid	HYDO	1
	4	Hydraulic fluid filter	Change filter element	-	1
	-	Hydraulic hoses	Check for wear and damage	-	All
	6	Cooling system	Flush	WG	1
	1	Propelling motor	■Torque shaft nut	-	1
	1	Front wheel	■Torque wheel nuts	-	1
	12	Battery	■Clean and tighten battery cable connections	-	1

NOTE: Also check procedures indicated (■) after the first 50-hours of operation.

NOTE: More frequent intervals may be required in extremely dusty conditions.

LUBRICANT/FLUID

EO Engine oil, SAE-SG/SH rated

HYDO . . . Tennant or approved hydraulic fluid

WG Water and permanent-type ethylene glycol anti-freeze, -34° C (-30° F)

SPL Special lubricant, Lubriplate EMB grease (TENNANT part no. 01433-1)

DW Distilled water

GENERAL INFORMATION

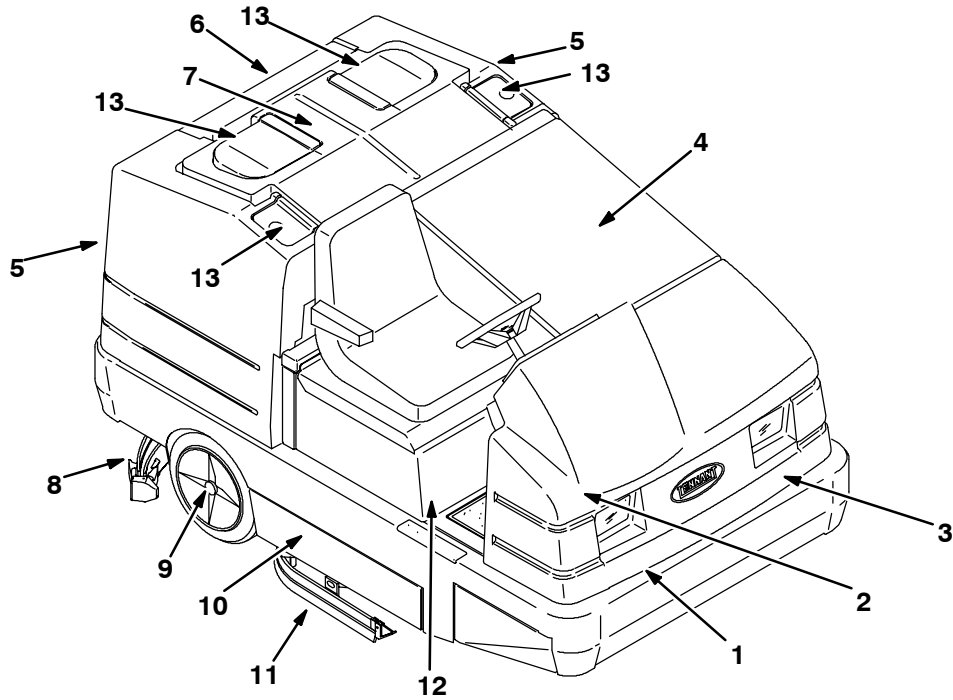

09076

MAINTENANCE CHART / DIESEL

Interval	Key	Description	Procedure	Lubricant/ Fluid	No. of Service Points
Daily	4	Engine air filter	Check indicator	-	1
			Empty dust cap	-	1
	4	Engine crankcase	Check oil level	EO	1
	8	Rear Squeegee	Check for damage and wear	-	1
			Check deflection	-	1
	11	Side Squeegees	Check for damage and wear	-	2
	10	Scrub brushes	Check for damage and wear	-	1
	7	Recovery tank	Clean	-	1
7	Recovery tank, ES™ mode	Clean ES™ filter	-	1	
5	Solution tank, ES™ mode	Clean	-	1	
50 Hours	10	Scrub brushes	Rotate end-for-end or front-to-rear	-	1
	4	Fuel pipes and clamps	Check for tightness and wear	-	1
100 Hours	6	Radiator	Clean core exterior	-	1
			Check coolant level	WG	1
	4	Engine crankcase	Change oil and filter	EO	1
	4	Engine fan belt	Check tension	-	1
	3	Hydraulic fluid reservoir	Check fluid level	HYDO	1
	-	Tires	Check for damage	-	3
	8	Rear squeegee	Check leveling	-	1
	8	Rear squeegee casters	Lubricate	SPL	2

GENERAL INFORMATION

Interval	Key	Description	Procedure	Lubricant/ Fluid	No. of Service Points
100 Hours	13	Cover seals	Check for damage and wear	-	4
	10	Scrub brush idlers	Lubricate	SPL	2
	10	Scrub head skirts	Check for damage and wear	-	2
	-	Side brush skirt	Check for damage and wear	-	1
200 Hours	6	Radiator hoses and clamps	Check for tightness and wear	-	2
	2	Parking brake	Check adjustment	-	1
	2	Brake pedal	Check and adjust travel	-	1
	1	Front wheel support bearings	Lubricate	SPL	2
400 Hours	9	Rear wheel bearings	Check, lubricate, and adjust	SPL	2
	4	Fuel filter	Replace cartridge	-	1
	6	Cooling system	Flush	WG	1
800 Hours	3	Hydraulic reservoir	Replace filler cap	-	1
			Replace suction strainer	-	1
			Change hydraulic fluid	HYDO	1
	4	Hydraulic fluid filter	Change filter element	-	1
	-	Hydraulic hoses	Check for wear and damage	-	All
	1	Propelling motor	■ Torque shaft nut	-	1
	1	Front wheel	■ Torque wheel nuts	-	1
	12	Battery	■ Clean and tighten battery cable connections	-	1

NOTE: Also check procedures indicated (■) after the first 50-hours of operation.

NOTE: More frequent intervals may be required in extremely dusty conditions.

LUBRICANT/FLUID

EO Engine oil, SAE-CC/CD rated

HYDO . . . Tennant Company or approved hydraulic fluid

WG Water and permanent-type ethylene glycol anti-freeze, -34° C (-30° F)

SPL Special lubricant, Lubriplate EMB grease (TENNANT part no. 01433-1)

DW Distilled water

GENERAL INFORMATION

PUSHING, TOWING, AND TRANSPORTING THE MACHINE

PUSHING OR TOWING THE MACHINE

If the machine becomes disabled, it can be pushed from the front or rear, but towed only from the rear.

The propelling pump has a bypass valve to prevent damage to the hydraulic system when the machine is being pushed or towed. This valve allows a disabled machine to be moved for a *very short distance* and at a speed to not exceed 1.6 kp/h (1 mph). The machine is NOT intended to be pushed or towed a long distance or at a high speed.

ATTENTION! Do not push or tow machine for a long distance and without using the bypass valve, or the machine hydraulic system may be damaged.

Turn the bypass valve 90° from the normal position before pushing or towing the machine. **The illustration shows the bypass valve in the pushing or towing position.**

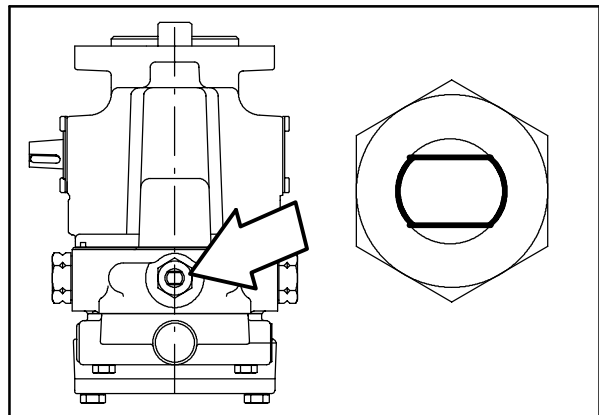
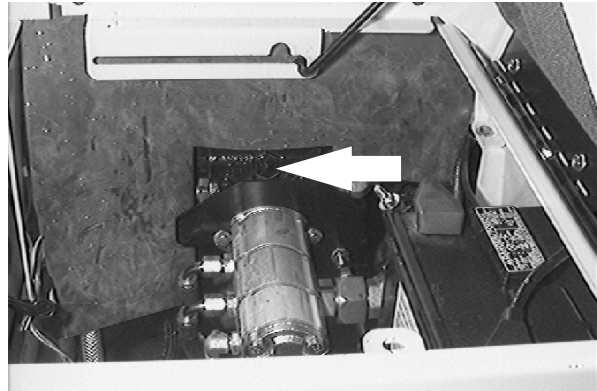

TRANSPORTING THE MACHINE

1. Position the rear of the machine at the loading edge of the truck or trailer.
2. If the loading surface is not horizontal or is higher than 380 mm (15 in) from the ground, use a winch to load machine.

If the loading surface is horizontal AND is 380 mm (15 in) or less from the ground, the machine may be driven onto the truck or trailer.

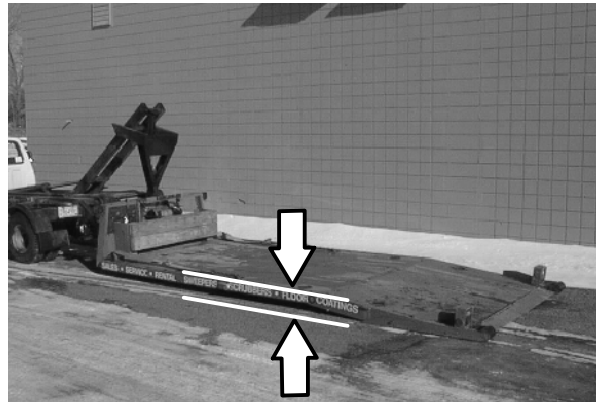

3. To winch the machine onto the truck or trailer, attach the winching chains in the holes at the bottom of the rear bumper.



If the machine has the optional rear tie down brackets, attach the winching chains to them.

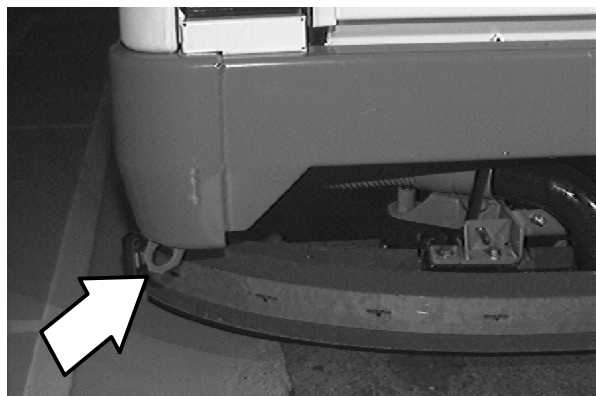

4. Turn the bypass valve 90° from the normal position before winching the machine onto the truck or trailer. See *PUSHING OR TOWING THE MACHINE* section of this manual. Make sure the machine is centered.

FOR SAFETY: When loading machine onto truck or trailer, use winch. Do not drive the machine onto the truck or trailer unless the loading surface is horizontal AND is 380 mm (15 in) or less from the ground.

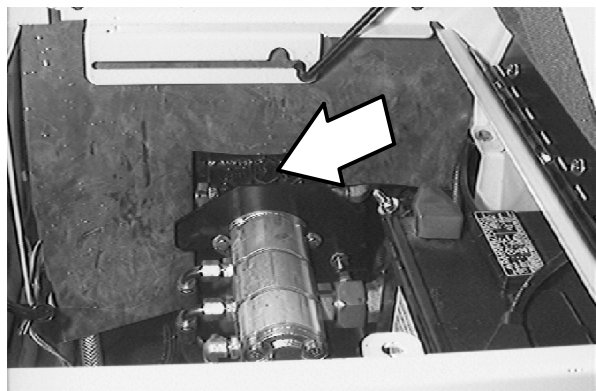

GENERAL INFORMATION

5. Position the machine onto the truck or trailer as far as possible. If the machine starts to veer off the centerline of the truck or trailer, stop and turn the steering wheel to center the machine.
6. Set the parking brake and block the machine tires. Tie down the machine to the truck or trailer before transporting.

The front tie down locations are in the holes at the bottom of the front bumper. If the machine has the optional tie down brackets, use them to tie down the machine.

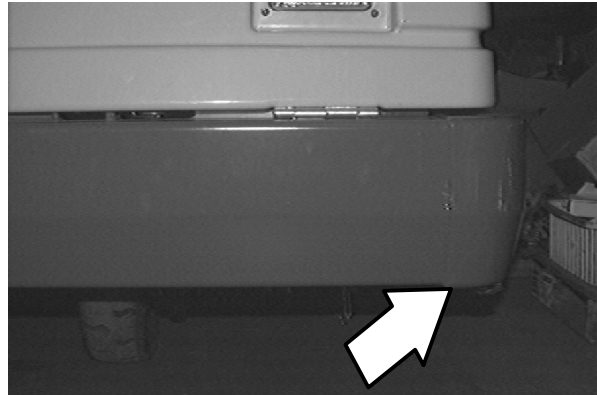

The rear tie down locations are in the holes at the bottom of the rear bumper. If the machine has the optional rear tie down brackets, use them to tie down the machine.

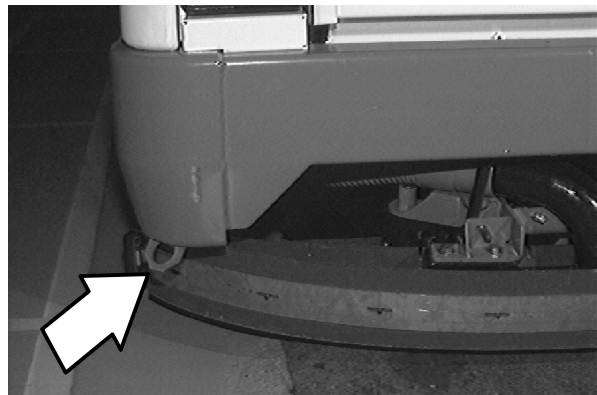

7. If the loading surface is not horizontal or is higher than 380 mm (15 in) from the ground, use a winch to unload machine.

If the loading surface is horizontal AND is 380 mm (15 in) or less from the ground, the machine may be driven off the truck or trailer.

FOR SAFETY: When unloading machine off truck or trailer, use winch. Do not drive the machine off the truck or trailer unless the loading surface is horizontal AND 380 mm (15 in) or less from the ground.

MACHINE JACKING

Empty the recovery and the solution tanks before jacking the machine. You can jack up the machine for service at the designated locations. Use a hoist or jack that will support the weight of the machine. Always stop the machine on a flat, level surface and block the tires before jacking the machine up.

FOR SAFETY: Before leaving or servicing machine; stop on level surface, set parking brake, turn off machine and remove key.

The front jacking location is the left front corner of the machine frame.

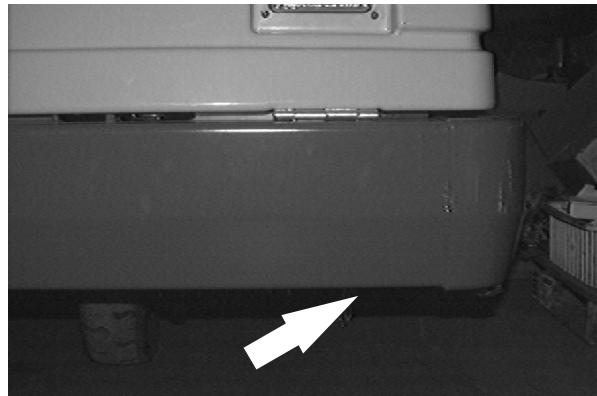

The rear jacking locations are the two rear corners of the machine frame.

FOR SAFETY: When servicing machine, block machine tires before jacking machine up.

FOR SAFETY: When servicing machine, jack machine up at designated locations only. Block machine up with jack stands.

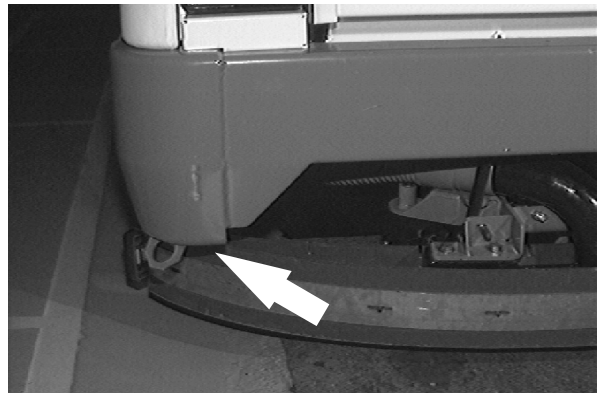

STORING MACHINE

When storing the machine for extended periods of time, the following procedures must be followed to lessen the chance of rust sludge, or other undesirable deposits from forming.

1. Drain and clean the solution and recovery tanks.
2. ES™ machines: Run clean water through the solution system and the ES™ solution pump.
3. Raise the rear squeegee and the scrub head.
4. Park the machine in a cool, dry area.
5. Remove or charge the battery every three months.

HARDWARE INFORMATION

The following charts state standard plated hardware tightening ranges for normal assembly applications. Decrease the specified torque by 20% when using a thread lubricant. Do not substitute lower grade hardware for higher grade hardware. If higher grade hardware than specified is substituted, tighten only to the specified hardware torque value to avoid damaging the threads of the part being threaded into, as when threading into speed nuts or weldments.

NOTE: Decrease torque by 20% when using a thread lubricant.





Exceptions to the above chart:

Check the machine for exceptions!

STANDARD BOLT TORQUE CHART

Thread Size	SAE Grade 5 Torque ft lb (Nm)	SAE Grade 8 Torque ft lb (Nm)
0.25 in	7-10 (9-14)	10-13 (14-38)
0.31 in	15-20 (20-27)	20-26 (27-35)
0.38 in	27-35 (37-47)	36-47 (49-64)
0.44 in	43-56 (58-76)	53-76 (72-103)
0.50 in	65-85 (88-115)	89-116 (121-157)
0.62 in	130-170 (176-231)	117-265 (159-359)
0.75 in	215-280 (291-380)	313-407 (424-552)
1.00 in	500-650 (678-881)	757-984 (1026-1334)

BOLT IDENTIFICATION

Identification Grade Marking	Specification and Grade
	SAE-Grade 5
	SAE-Grade 8
	ISO-Grade 8.8
	ISO-Grade 10.9

01395

THREAD SEALANT AND LOCKING COMPOUNDS

Thread sealants and locking compounds may be used on this machine. They include the following:

Loctite 515 sealant - gasket forming material. TENNANT Part No. 75567, 15 oz (440 ml) cartridge.

Loctite 242 blue - medium strength thread locking compound. TENNANT Part No. 32676, 0.5 ml tube.

Loctite 271 red - high strength thread locking compound. TENNANT Part No. 19857, 0.5 ml tube.

NOTE: Decrease torque by 20% when using a thread lubricant.

METRIC BOLT TORQUE CHART

Thread Size	Class 8.8 Torque ft lb (Nm)	Class 10.9 Torque ft lb (Nm)
M4	2 (3)	3 (4)
M5	4 (5)	6 (8)
M6	7 (9)	10 (14)
M8	18 (24)	25 (34)
M10	32 (43)	47 (64)
M12	58 (79)	83 (112)
M14	94 (127)	133 (180)
M16	144 (195)	196 (265)
M20	260 (352)	336 (455)
M24	470 (637)	664 (900)

GENERAL INFORMATION

HYDRAULIC FITTING INFORMATION

HYDRAULIC TAPERED PIPE FITTING (NPT) TORQUE CHART

NOTE: Ratings listed are when using teflon thread seal.

Size	Minimum Torque	Maximum Torque
1/4 NPT	10 ft lb (14 Nm)	30 ft lb (41 Nm)
1/2 NPT	25 ft lb (34 Nm)	50 ft lb (68 Nm)
3/4 NPT	50 ft lb (68 Nm)	100 ft lb (136 Nm)

HYDRAULIC TAPERED SEAT FITTING (JIC) TORQUE CHART

Tube O.D. (in)	Thread Size	Maximum Torque
0.25	0.44-20	9 ft lb (12 Nm)
0.38	0.56-18	20 ft lb (27 Nm)
0.50	0.75-16	30 ft lb (41 Nm)
0.62	0.88-14	40 ft lb (54 Nm)
0.75	1.12-12	70 ft lb (95 Nm)
1.0	1.31-12	90 ft lb (122 Nm)

HYDRAULIC O-RING FITTING TORQUE CHART

Tube O.D. (in)	Thread Size	Minimum Torque	Maximum Torque
0.25	0.44-20	6 ft lb (8 Nm)	9 ft lb (12 Nm)
0.38	0.56-18	13 ft lb (18 Nm)	20 ft lb (27 Nm)
		*10 ft lb (14 Nm)	12 ft lb (16 Nm)
0.50	0.75-16	20 ft lb (27 Nm)	30 ft lb (41 Nm)
		*21 ft lb (28 Nm)	24 ft lb (33 Nm)
0.62	0.88-14	25 ft lb (34 Nm)	40 ft lb (54 Nm)
0.75	1.12-12	45 ft lb (61 Nm)	70 ft lb (95 Nm)
1.0	1.31-12	60 ft lb (81 Nm)	90 ft lb (122 Nm)

NOTE: Do not use sealant on o-ring threads.

*Aluminum bodied components

CONTENTS

	Page
CHASSIS	2-3
SEAT	2-3
TO REMOVE SEAT ASSEMBLY	2-3
TO REPLACE SEAT ASSEMBLY	2-3
OPERATOR SEAT	2-4
STATIC DRAG CHAIN	2-4
BRAKES AND TIRES	2-5
SERVICE BRAKES	2-5
TO REPLACE BRAKE SHOES	2-5
REAR TIRES AND WHEELS	2-7
TO REPACK REAR WHEEL BEARINGS	2-7
FRONT TIRE AND WHEEL, AND WHEEL SUPPORT	2-9
TO REPLACE FRONT DRIVE MOTOR	2-9
TO REPLACE FRONT WHEEL HOUSING PIVOT BEARINGS ...	2-11

INTRODUCTION

This section includes information on the main chassis related components for example the seat, steering, brakes, and tires.

SEAT

The seat assembly is adjustable forward and backward on the 7400.

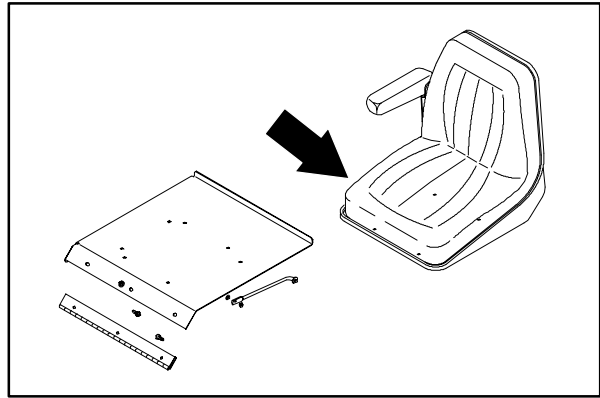

TO REMOVE SEAT ASSEMBLY

FOR SAFETY: Before Leaving Or Servicing Machine; Stop On Level Surface, Set Parking Brake, Turn Off Machine And Remove Key.

1. Tilt the seat assembly forward and engage the prop rod.
2. Remove the four hex screws and nuts holding the seat assembly hinge to the seat support.
3. Slide the prop rod to the opening in the slot and remove.
4. Remove the seat assembly from the machine.

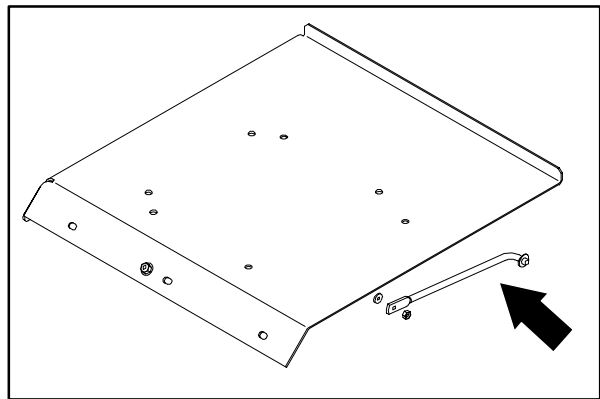

TO REPLACE SEAT ASSEMBLY

FOR SAFETY: Before Leaving Or Servicing Machine; Stop On Level Surface, Set Parking Brake, Turn Off Machine And Remove Key.

1. Position the seat assembly on the seat support.
2. Reinstall the four hex screws and nuts. Tighten to 18 - 24Nm (15 - 20 ft lb).
3. Slide the seat prop rod through large hole in slot.
4. Lower the seat.

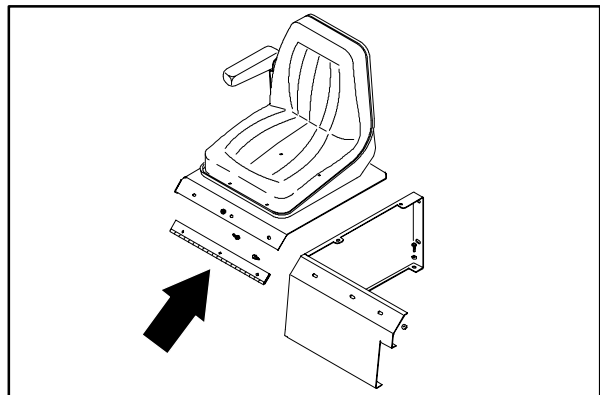

OPERATOR SEAT

The operator seat is a fixed back style with a forward-backward adjustment.

Adjust: Pull the lever out, slide the seat backward or forward to the desired position and release the lever.

Lift: Pull up on the seat mounting plate until the seat mount locks up.

Lower: Pull on the release lever and lower the seat mounting plate.

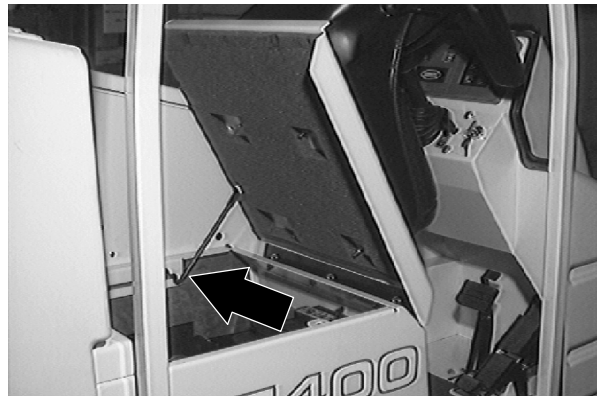
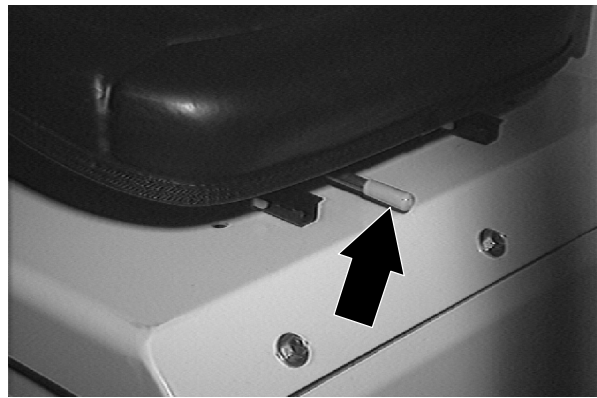

STATIC DRAG CHAIN

A static drag chain prevents the buildup of static electricity in the machine. The chain is attached to the machine with a hex screw by the scrub head torque tube mount bearing.

Make sure the chain is touching the floor at all times.

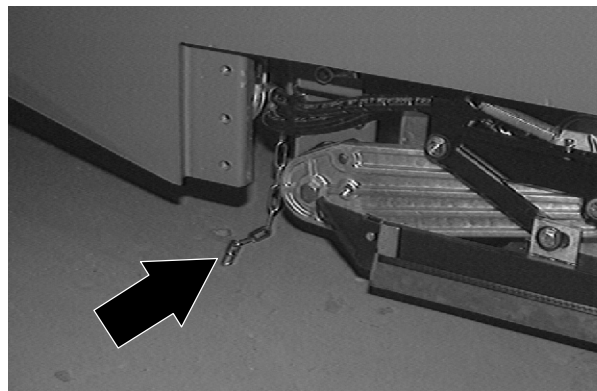

BRAKES AND TIRES

SERVICE BRAKES

The mechanical service brakes are located on the rear wheels. The brakes are operated by the foot brake pedal.

Check the brake adjustment every 200 hours of operation.

TO REPLACE BRAKE SHOES

FOR SAFETY: Before Leaving Or Servicing Machine; Stop On Level Surface, Set Parking Brake, Turn Off Machine And Remove Key.

1. Drain the solution and recovery tanks.
2. Make sure the parking brake is not engaged.
3. Remove floor plate from the operators compartment.
4. Loosen the jam nuts on the brake cable turn buckle. Rotate the turn buckle to loosen the tension on the brake cable.
5. Jack up one rear corner of the machine. Place jack stands under machine.

FOR SAFETY: Block machine tires before jacking machine up. Jack machine up at designated locations only. Block machine up with jack stands.

6. Remove the hub cap from the center of the tire and wheel assembly.
7. Remove the cotter pin, slotted nut, flat washer, and bearing cone.
8. Remove the tire and wheel assembly from the machine.
9. Remove the two springs holding the brake shoes together. Remove the old brake shoes.
10. Position the new brake shoes on the brake mounting plate.
11. Reattach the two brake springs to the new brake shoes.

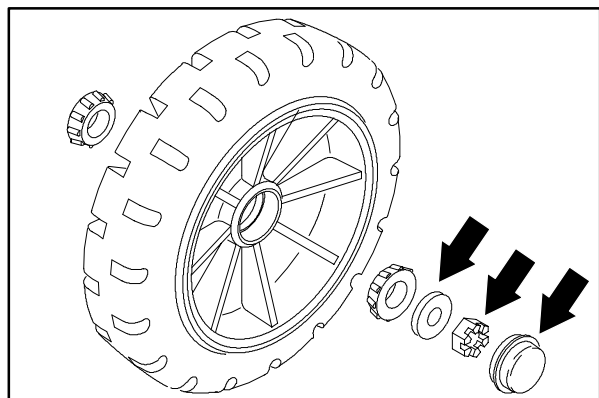
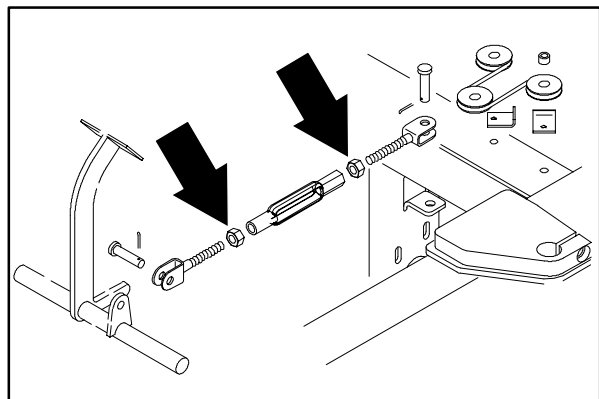
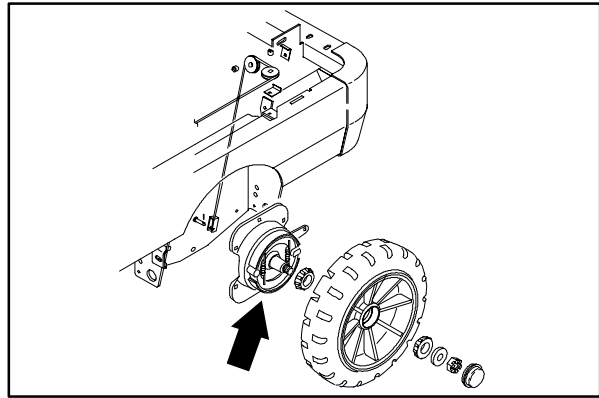

12. Pack the wheel bearings with Lubriplate EMB grease.
13. Slide the tire and wheel assembly on the axle.
14. Slide the outer bearing, flat washer and nut on the shaft.
15. Tighten nut with hand wrench until wheel binds, then back nut off to nearest hole.
16. Insert a new cotter pin through nut and hole.
17. Spin the tire and wheel assembly. The tire should spin freely.
18. Reinstall the hub cap in the center of the wheel.
19. Lower the machine.

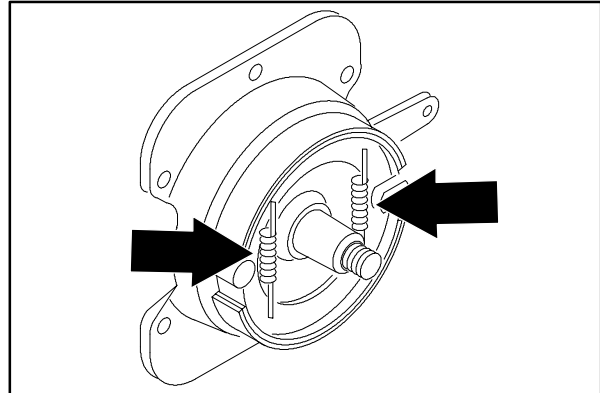

NOTE: Always replace brake shoes in sets.

20. Repeat the procedure on the other wheel.
21. Rotate the brake cable turn buckle until the brake cable is tight or until the brake pedal travels 25–50 mm (1–2 in) before engaging brakes.
22. Tighten the brake cable turn buckle jam nuts.
23. Reinstall the floor plate in the operators compartment.
24. Operate the machine and check the brakes for proper operation.

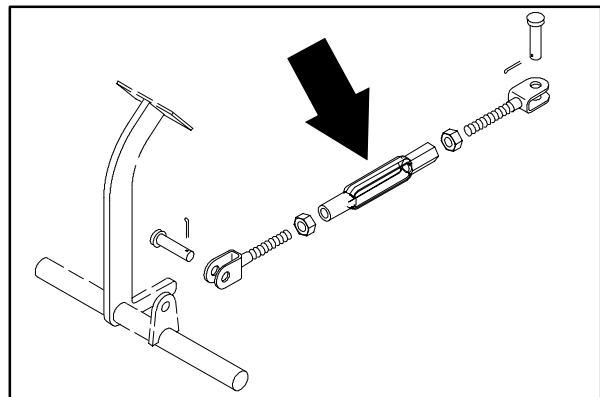

REAR TIRES AND WHEELS

The standard machine rear tires are semi-pneumatic.

Inspect the rear wheel bearings for seal damage, and repack and adjust every 1600 hours of operation. Use Lubriplate EMB grease (TENNANT part no. 01433-1).



TO REPACK REAR WHEEL BEARINGS

FOR SAFETY: Before Leaving Or Servicing Machine; Stop On Level Surface, Set Parking Brake, Turn Off Machine And Remove Key.

1. Drain the solution and recovery tanks.
2. Make sure the parking brake is not engaged.
3. Remove floor plate from the operators compartment.
4. Loosen the jam nuts on the brake cable turn buckle. Rotate the turn buckle to loosen the tension on the brake cable.
5. Jack up one rear corner of the machine. Place jack stands under machine.

FOR SAFETY: Block machine tires before jacking machine up. Jack machine up at designated locations only. Block machine up with jack stands.

6. Remove the hub cap from the center of the tire and wheel assembly.
7. Remove the cotter pin, slotted nut, flat washer, and bearing cone.
8. Remove the tire and wheel assembly from the machine.
9. Pack the wheel bearings with Lubriplate EMB grease.
10. Slide the tire and wheel assembly on the axle.
11. Slide the outer bearing, flat washer and nut on the shaft.

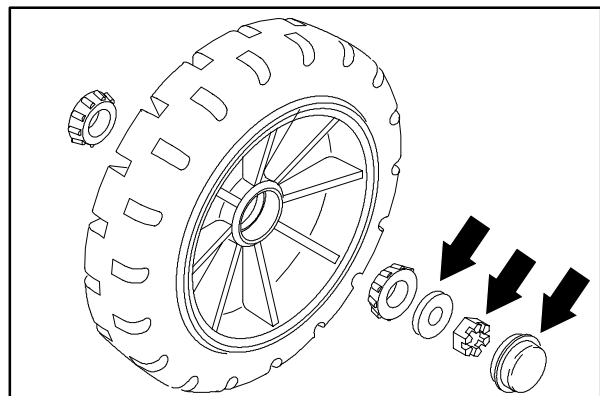
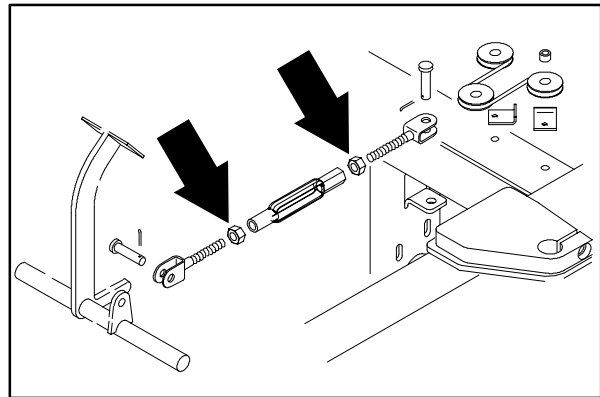

12. Tighten nut with hand wrench until wheel binds, then back nut off to nearest hole.
13. Insert a new cotter pin through nut and hole.
14. Spin the tire and wheel assembly. The tire should spin freely.
15. Reinstall the hub cap in the center of the wheel.
16. Lower the machine.
17. Repeat the procedure on the other wheel.
18. Rotate the brake cable turn buckle until the brake cable is tight or until the brake pedal travels 25–50 mm (1–2 in) before engaging brakes.
19. Tighten the brake cable turn buckle jam nuts.
20. Reinstall the floor plate in the operators compartment.
21. Operate the machine and check the rear wheels for proper operation.

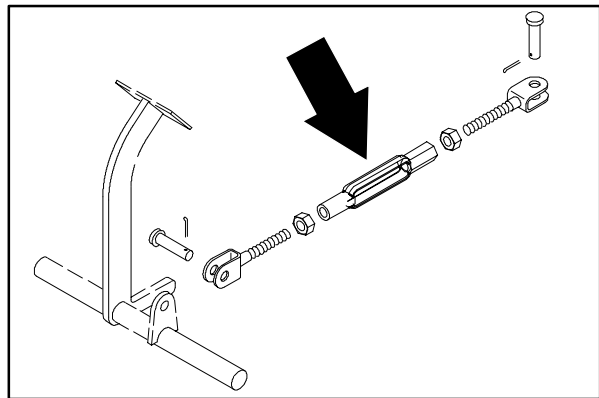
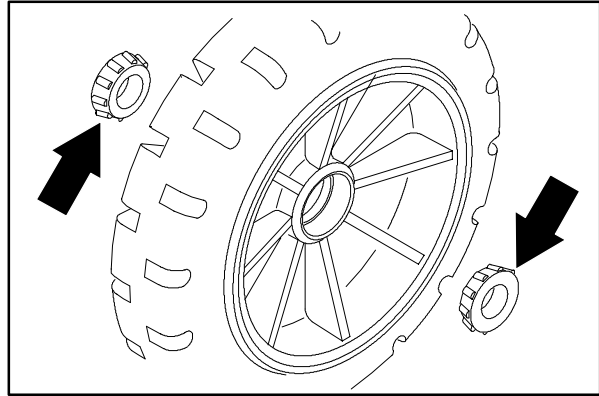

FRONT TIRE AND WHEEL SUPPORT

The front wheel support pivots the front wheel. The support has one grease fitting for the bearings. The front wheel support bearings must be lubricated every 200 hours of operation. Use Lubriplate EMB grease (TENNANT part no. 01433-1).

Torque the front wheel nuts to 142 - 156 Nm (105 - 115 ft lb) after the first 50-hours of operation, and every 800 hours thereafter.

Torque the front wheel hub nut to (375 ft lb)

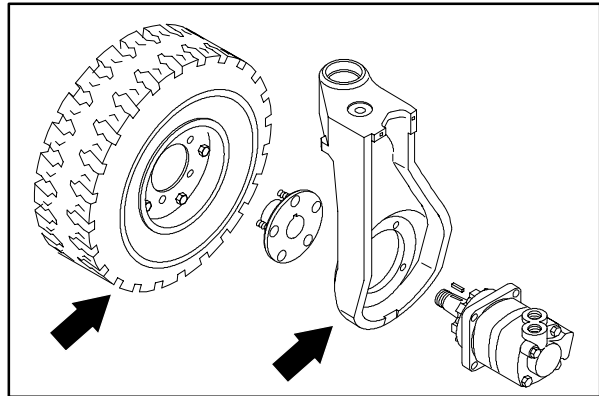

TO REPLACE FRONT DRIVE MOTOR

FOR SAFETY: Before Leaving Or Servicing Machine; Stop On Level Surface, Set Parking Brake, Turn Off Machine And Remove Key.

1. Engage parking brake, block rear tires.
2. Jack up front of machine. Use jack stands to support machine.

FOR SAFETY: Block machine tires before jacking machine up. Jack machine up at designated locations only. Block machine up with jack stands.

3. Remove the front tire and wheel assembly.
4. Remove the cotter pin and slotted nut from the front wheel drive motor shaft.
5. Use a puller to remove the drive hub from the tapered shaft of the drive motor.
6. Remove and plug the hydraulic hoses leading to the front wheel drive motor.

NOTE: Observe hydraulic cleanliness requirements when opening hydraulic lines.

7. Remove the four drive motor mounting bolts.
8. Slide the motor out of front wheel housing.

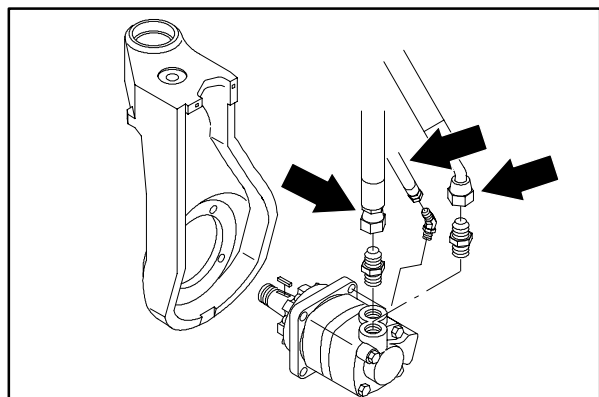
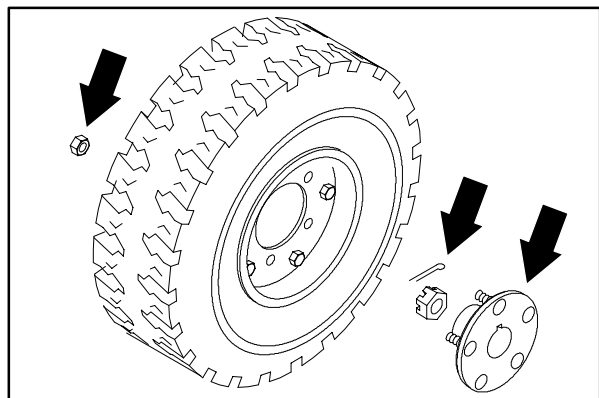
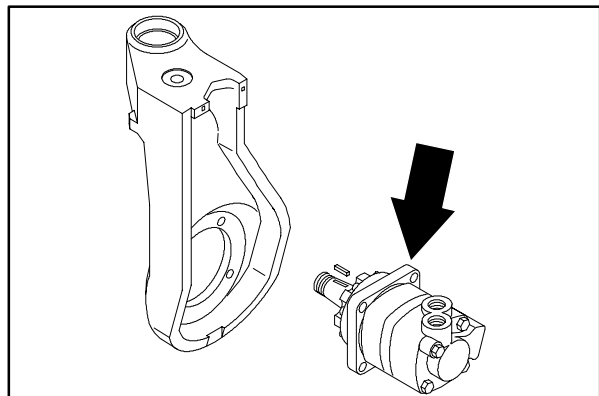

9. Remove the hydraulic fittings from the old motor and install in the new motor in the same orientation.
10. Slide the new motor in the front wheel housing. Note the orientation of the motor.
11. Reinstall the four socket-head screws. Torque to 90 - 117 Nm (70 - 85 ft lb).
12. Reconnect the hydraulic hoses to the drive motor.

NOTE: Make sure the square key is in place on the shaft of the new motor.

13. Mount the drive hub to tapered motor shaft. Tighten slotted nut to 500 Nm (375 ft lb). Install the cotter pin.
14. Install the front tire. Torque the front wheel nuts to 142 - 156 Nm (105 - 115 ft lb).
15. Remove jack stands and lower machine.
16. Operate the machine and check the front drive motor for any leaks.

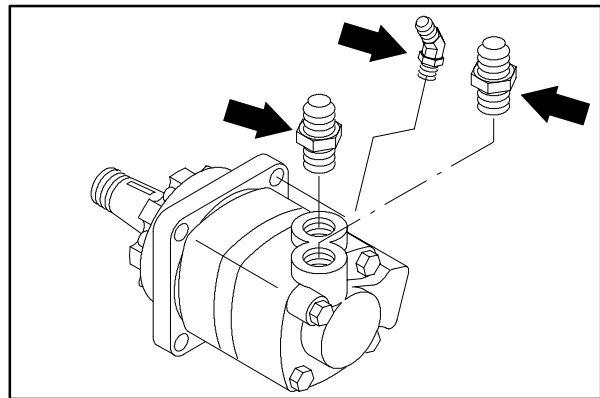
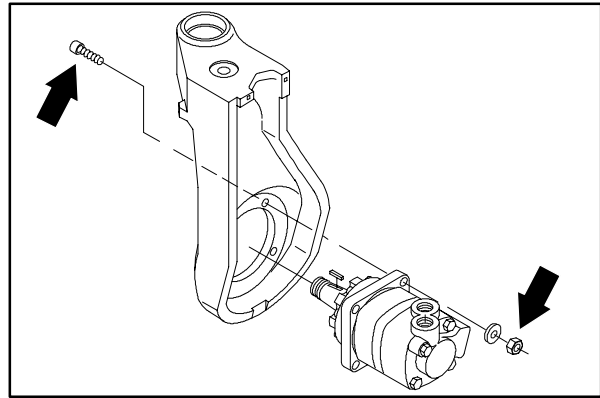

CHASSIS

TO REPLACE FRONT WHEEL HOUSING PIVOT BEARINGS

1. Engage parking brake, block rear tires.
2. Disconnect the battery cables from the battery.
3. Jack up front of machine. Use jack stands to support machine.

FOR SAFETY: Block machine tires before jacking machine up. Jack machine up at designated locations only. Block machine up with jack stands.

4. Remove the front tire and wheel assembly.
5. Remove and plug the hydraulic hoses leading to the front wheel drive motor.

NOTE: Observe hydraulic cleanliness requirements when opening hydraulic lines.

6. Remove the hydraulic hose clamp from the top of the wheel housing.
7. Remove the one 3/4 in. hex screw attaching the rod end of steering cylinder to the front wheel housing. Retain the spacer.
8. Remove the cotter pin and large slotted nut from the top of the pivot pin.
9. Loosen the two M10 socket head bolts holding the pivot pin to the machine frame.

NOTE: Use a floor jack to support the wheel housing before removing the pivot pin. The wheel housing and drive motor assembly is very heavy.

10. Remove the pivot pin from the bottom of the wheel support.

NOTE: Do not loose the thrust washer from on top of the wheel housing.

11. Remove the wheel housing and drive motor assembly out of the main frame.
12. Use a steel punch and hammer to drive the old bearing cups out of the wheel housing.

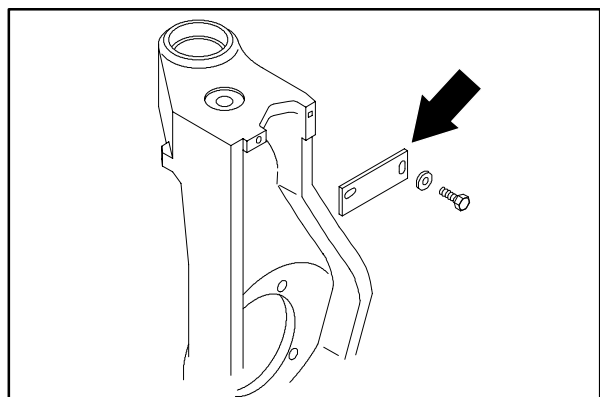
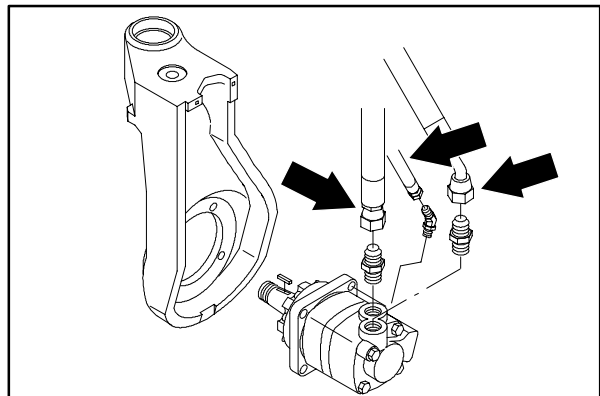
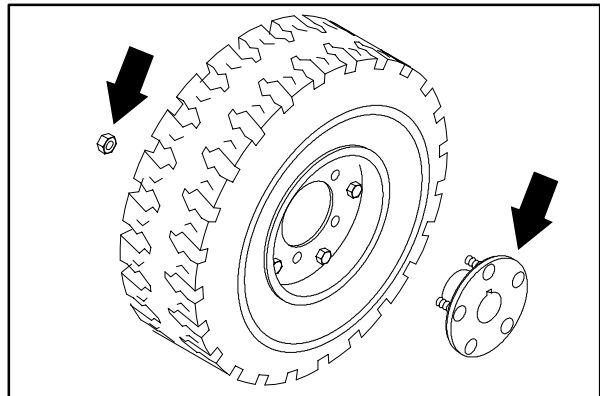
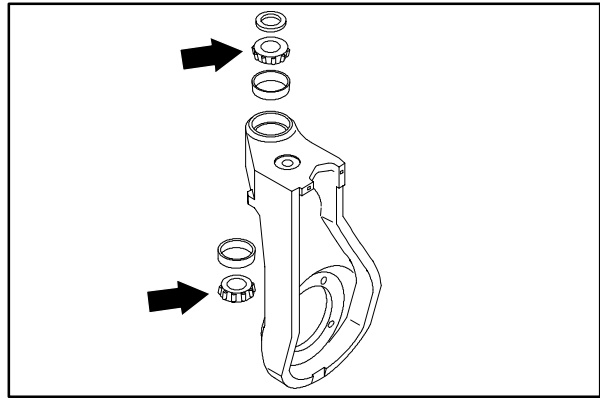

13. Install a new set of bearing cups in the wheel housing. Use a large press or a punch and hammer to install the cups.
14. Pack the new bearing cones with Lubriplate EMB grease. Coat the bearing cups with grease.
15. Position the new bearing cones in the wheel housing.
16. Position the thrust washer on top of the upper bearing cone.
17. Position the wheel housing back in the machine.
18. Slide the large pivot pin up through hole in the machine frame. Thread castle nut on the top of the pivot pin. Tighten to 34 - 40 Nm (25 - 30 ft lb). Check the wheel housing for play. If pin is not seated, tap with rubber mallet and re-torque castle nut.

NOTE: The wheel housing should rotate with a slight amount of drag.

19. Torque the top socket screw with a hand torque wrench to 100 - 115 Nm (73-85 ft lb).
20. Tighten the castle nut to the next slot and insert the cotter pin. Torque not to exceed 100 Nm (75 ft lb).
21. Check the casting to see if it rocks or binds. If it does, loosen top socket screw, move the casting to seat the bearings, and re-tighten the socket screw to 100 - 115 Nm (73-85 ft lb).
22. Tighten the lower socket screw to 100 - 115 Nm (73-85 ft lb).
23. Reinstall rod end of steering cylinder to the top of the wheel housing using the 3/4 in. x 3-1/4 in. hex screw, nyloc nut, and four flat washers. Tighten to 270 - 300 Nm (200 - 220 ft lb).

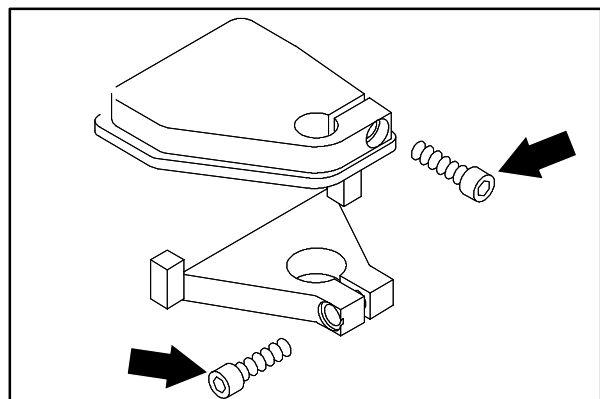
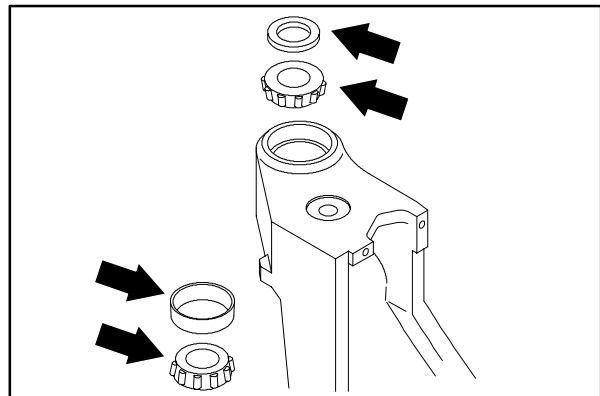
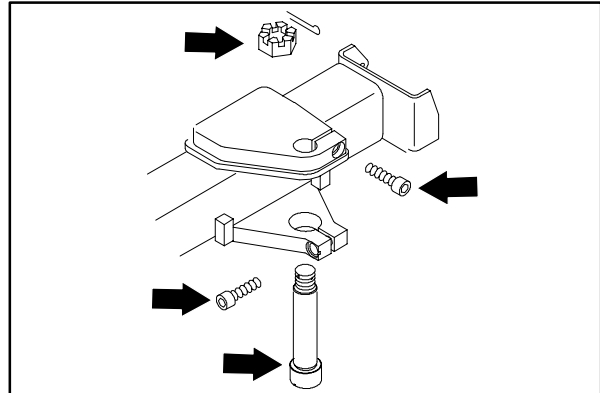
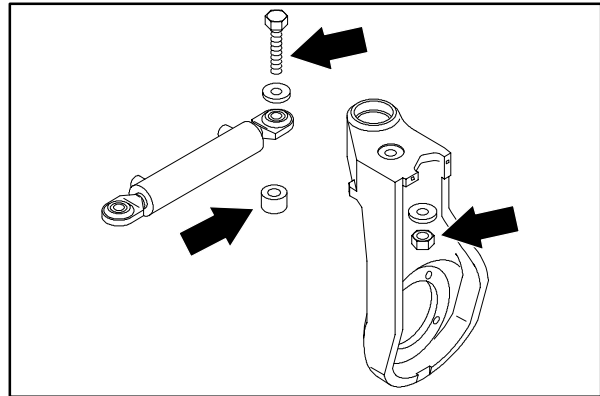

CHASSIS

24. Reconnect the hydraulic hoses to the drive motor.
25. Reinstall the hose clamp to the top of the wheel housing. Tighten M8 hex screws to 18.5 - 24Nm (15 - 20 ft lb).
26. Install the front tire. Torque the front wheel nuts to 142 - 156 Nm (105 - 115 ft lb)
27. Re-connect battery cables, start engine, run propelling in both directions, check for leaks.
28. Remove jack stands, lower machine to the ground.

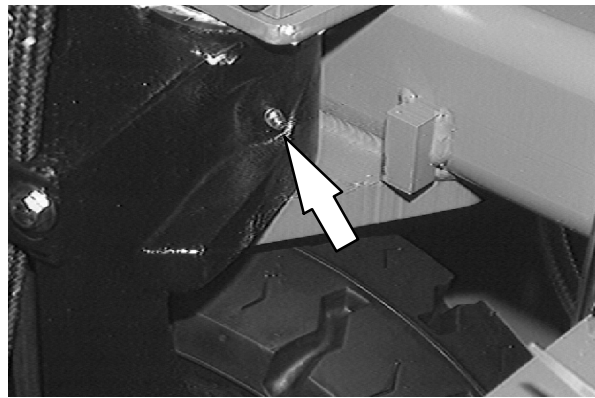

CONTENTS

	Page
INTRODUCTION	3-3
SOLUTION TANKS	3-4
TO REMOVE LH SOLUTION TANK ...	3-4
TO INSTALL LH SOLUTION TANK ...	3-5
TO REMOVE RH SOLUTION TANK ..	3-6
TO INSTALL RH SOLUTION TANK ...	3-7
RECOVERY TANK	3-8
TO REMOVE RECOVERY TANK	3-8
TO INSTALL RECOVERY TANK	3-11
SCRUB HEAD	3-13
TO REPLACE MAIN SCRUB BRUSHES	3-13
CHECKING AND ADJUSTING SCRUB BRUSH PATTERN	3-14
TO REPLACE MAIN BRUSH IDLER SHAFT BEARINGS	3-16
TO REMOVE MAIN BRUSH DRIVE MOTOR MOUNT PLATE	3-18
TO INSTALL MAIN BRUSH DRIVE MOTOR MOUNT PLATE	3-19
TO REPLACE OPTIONAL SIDE BRUSH	3-20
SQUEEGEES	3-21
TO REPLACE REAR SQUEEGEE LIFT CABLE	3-21
TO REPLACE REAR SQUEEGEE CENTERING SPRINGS	3-22
TO REMOVE REAR SQUEEGEE FRAME	3-23
TO INSTALL REAR SQUEEGEE FRAME	3-23
SQUEEGEE BLADES	3-24
REAR SQUEEGEE	3-24
TO REPLACE OR ROTATE REAR SQUEEGEE BLADES	3-24
TO ADJUST REAR SQUEEGEE BLADE DEFLECTION	3-25
TO LEVEL THE REAR SQUEEGEE .	3-26
SIDE SQUEEGEES	3-27
TO REPLACE SIDE SQUEEGEE BLADES	3-27
TO REPLACE SIDE BRUSH SQUEEGEE	3-28
SIDE BRUSH SKIRT	3-28
VACUUM FAN	3-29
TO REMOVE VACUUM FAN	3-29
TO INSTALL VACUUM FAN	3-30
TO REPLACE VACUUM IMPELLER .	3-31

INTRODUCTION

When the scrubbing mode is used, water flows from the solution tank through the solution valve to the two cylindrical scrub brushes. The brushes scrub the floor. As the machine is moved forward the squeegee wipes the dirty solution off the floor, which is then picked up and drawn into the recovery tank by the vacuum fan. There are three settings on the solution flow--high, low, and off.

SCRUBBING

SOLUTION TANKS

The two solution tanks hold the clean water and detergent mixture that will be applied to the floor for the scrubbing operation. There is a LH and a RH solution tank. They are connected by a large diameter solution line.

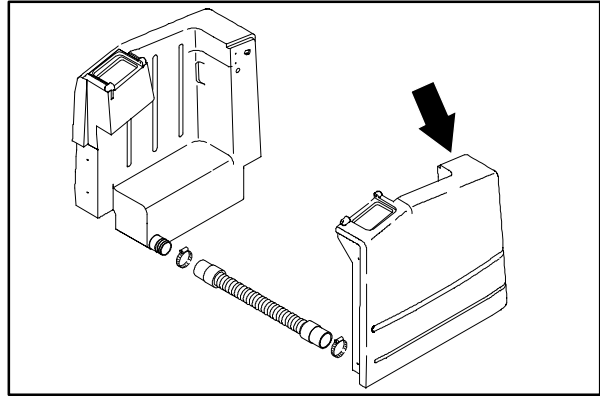

TO REMOVE LH SOLUTION TANK

FOR SAFETY: Before Leaving Or Servicing Machine; Stop On Level Surface, Set Parking Brake, Turn Off Machine And Remove Key.

1. Empty the solution and recovery tanks.
2. Open the engine side door and engine cover.
3. Unlatch the rear radiator cover panel and tilt it open.
4. Disconnect the wires going to the float switch at the back of the LH solution tank.
5. Remove the two hex screws from the rear tank bracket where it attaches to the LH solution tank.
6. Remove the one hex screw from the rear, lower corner of the LH tank. This hex screw is located near the left hand taillight.
7. Go to the front of the LH solution tank. Disconnect the solution cross-over line from the bottom, front of the LH solution tank.

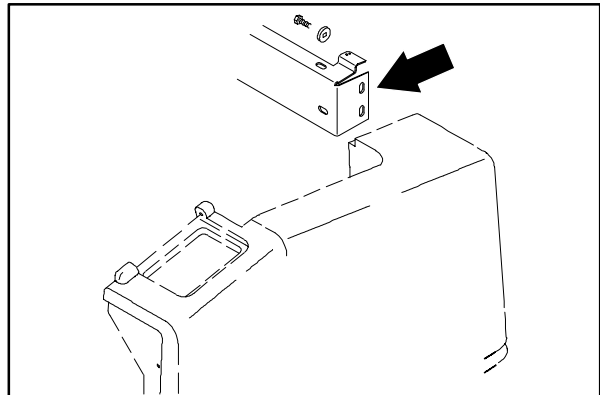
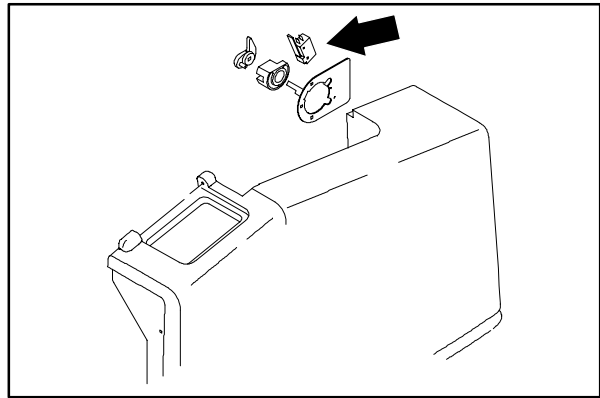

NOTE: Access the the clamp on the cross-over line is made easier by removing the two vacuum hoses leading to the recovery tank.

8. Remove the two M8 hex screws from the front of the LH solution tank near the engine alternator.
9. The LH solution tank can now be lifted up and out of the machine frame.

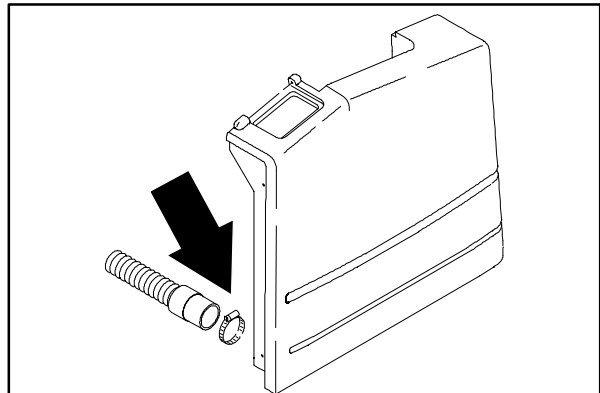

TO INSTALL LH SOLUTION TANK

FOR SAFETY: Before Leaving Or Servicing Machine; Stop On Level Surface, Set Parking Brake, Turn Off Machine And Remove Key.

1. Position the LH solution tank back in the machine frame.

NOTE: Be careful not to pinch hydraulic hoses or electrical wires during this procedure.

2. Reinstall the two M8 hex screws in the front of the LH solution tank near the engine alternator. Leave hardware loose for now.
3. Reinstall the two M8 hex screws in the top, rear of the LH solution tank in the rear tank bracket. Leave hardware loose for now.
4. Reinstall the one M8 hex screw in the rear, bottom of the LH solution tank near the LH taillight.
5. Tighten the five M8 hex screws to 18 - 24 Nm (15 - 20 ft lb).
6. Reconnect the solution cross-over line at the bottom of the tank.

NOTE: Reconnect the vacuum hoses if removed earlier.

7. Reconnect the wires to the float switch at the back of the LH solution tank.
8. Close the rear radiator cover panel and latch.
9. Close the engine side door and engine cover.
10. Fill the LH solution tank with water and check for leaks.

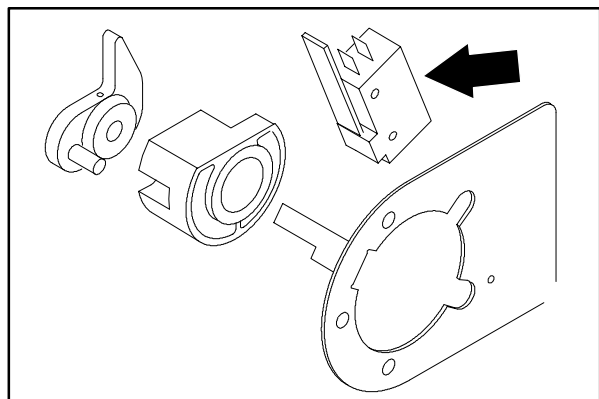
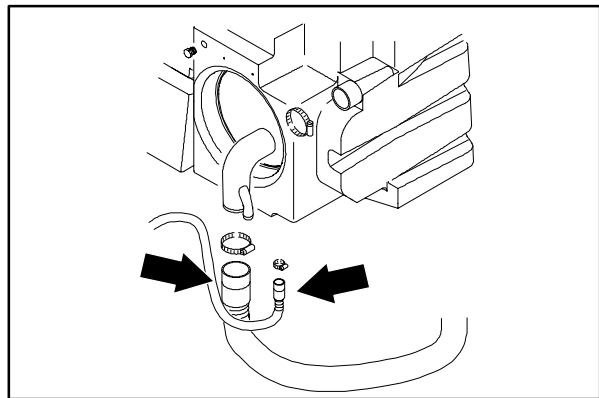
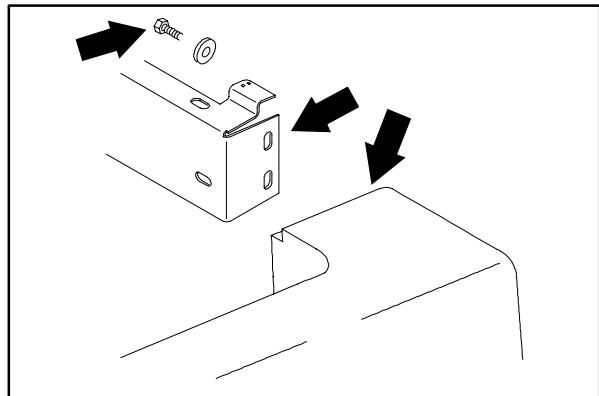
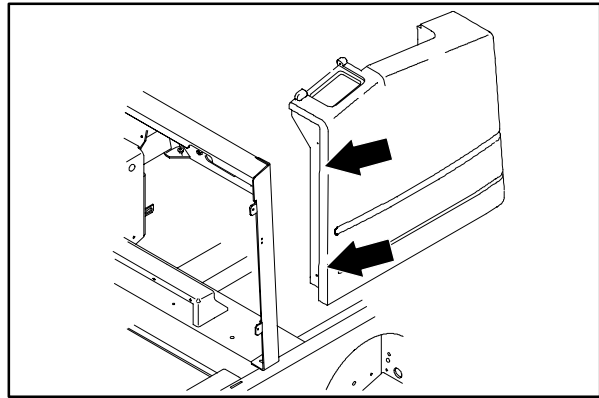

SCRUBBING

TO REMOVE RH SOLUTION TANK

FOR SAFETY: Before Leaving Or Servicing Machine; Stop On Level Surface, Set Parking Brake, Turn Off Machine And Remove Key.

1. The RH solution tank can only be removed after the LH solution and recovery tanks have been removed. See TO REMOVE LH SOLUTION TANK and TO REMOVE RECOVERY TANK instructions.
2. Remove the one hex screw from the rear, lower corner of the RH tank. This hex screw is located under the frame, above the drain cap.
3. Place the operators seat in the raised position and engage the prop rod.
4. Remove the two M8 hex screws from the front, right corner of the RH solution tank where it attaches to the seat support.
5. Disconnect any solution lines still attached to the RH solution tank.
6. The RH solution tank can now be lifted up and out of the machine frame.

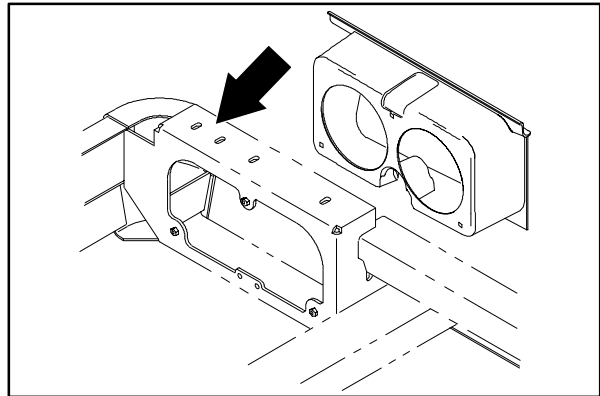
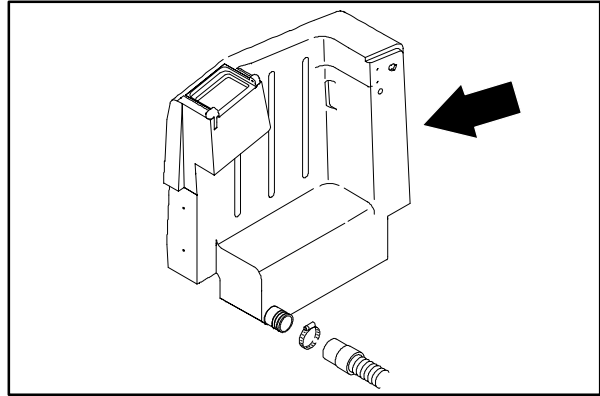

TO INSTALL RH SOLUTION TANK

FOR SAFETY: Before Leaving Or Servicing Machine; Stop On Level Surface, Set Parking Brake, Turn Off Machine And Remove Key.

1. Position the RH solution tank back in the machine frame.

NOTE: Be careful not to pinch hydraulic hoses or electrical wires during this procedure.

2. Reinstall the one M8 hex screw in the rear, bottom of the RH solution tank. This hex screw is located under the frame, above the drain cap. Leave hardware loose for now.
3. Reinstall the two M8 hex screws from the front, right corner of the RH solution tank where it attaches to the seat support. Leave hardware loose for now.
4. Reconnect any solution lines that were disconnected from the RH solution tank.
5. The remain RH solution tank hardware will be installed during the recovery tank installation. See TO INSTALL RECOVERY TANK and TO INSTALL LH SOLUTION TANK instructions.

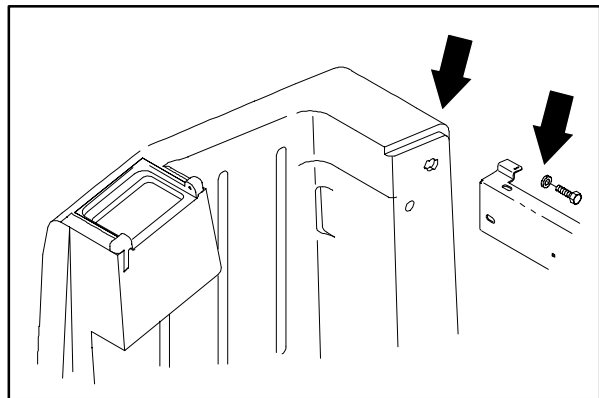
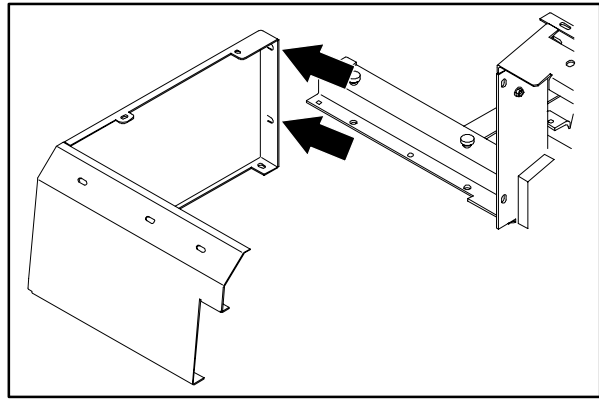

SCRUBBING

RECOVERY TANK

The recovery tank holds the used water and detergent solution pulled off the floor by the squeegee and scrubbing vacuum fan.

TO REMOVE RECOVERY TANK

FOR SAFETY: Before Leaving Or Servicing Machine; Stop On Level Surface, Set Parking Brake, Turn Off Machine And Remove Key.

1. Empty the solution and recovery tanks.
2. Place the operators seat in the raised position and engage the prop rod.
3. Remove the LH solution tank. See TO REMOVE LH SOLUTION TANK instructions.
4. Disconnect the vacuum and squeegee hoses from the front of the recovery tank.
5. Remove the two hex screws holding the demister cover on the recovery tank. Remove the demister cover.
6. If the machine is equipped with an overhead guard, it must be removed in order to remove the tank lintel.

NOTE: The engine hood must be supported in the open position before the next step can be completed.

7. Remove the clips on the bottom of the engine hood gas springs. Remove the gas springs from the ball studs on the support channel.
8. Remove the hex screws holding the support channel to the tank lintel and hood lintel. Remove the support channel from the machine.

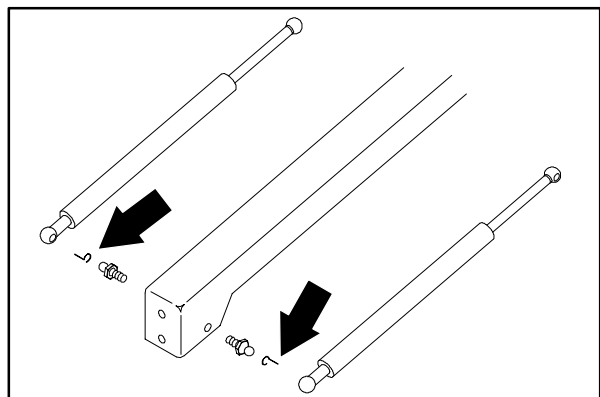
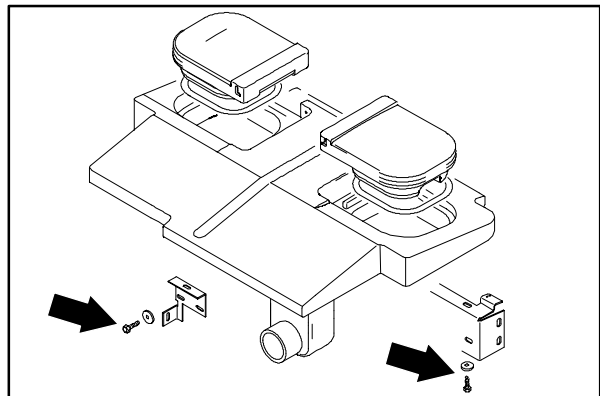
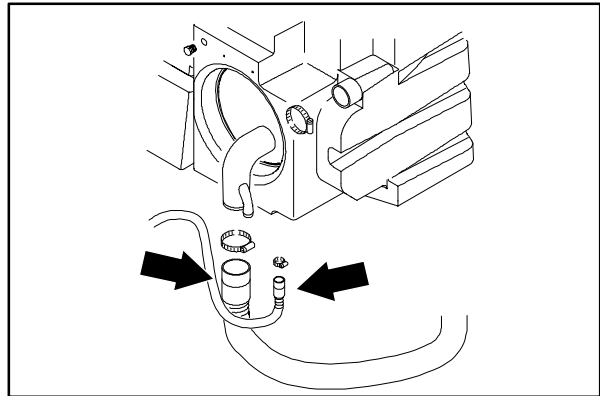
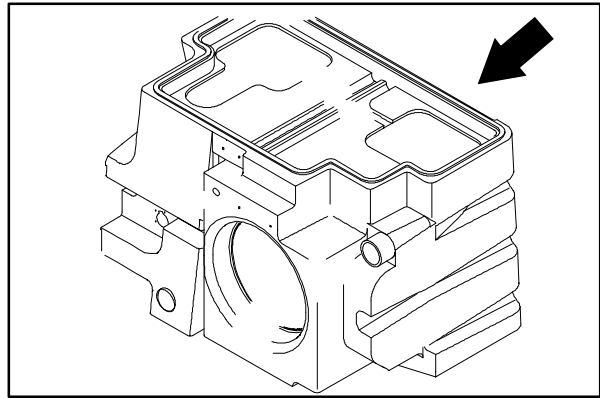

9. Remove the solution and recovery tank drain caps from the rear of the machine.
10. Remove the three hex screws holding the tank drain cover to the machine. Remove the cover.
11. Remove the hex screws holding the tank lintel to the frame, recovery tank, RH solution tank, and seat support. Remove the lintel from the machine.
12. Mark, disconnect, and plug the three hydraulic hoses leading to the engine fan hydraulic motor.

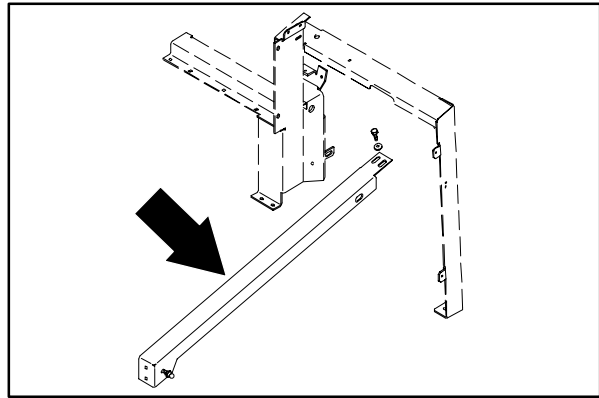

NOTE: Observe hydraulic cleanliness requirements when opening hydraulic lines.

13. Disconnect the solution line at the front of the recovery tank if the machine is equipped with the auto-fill option.
14. Disconnect the wires leading to the float switch that is located at the front, right corner of the recovery tank.

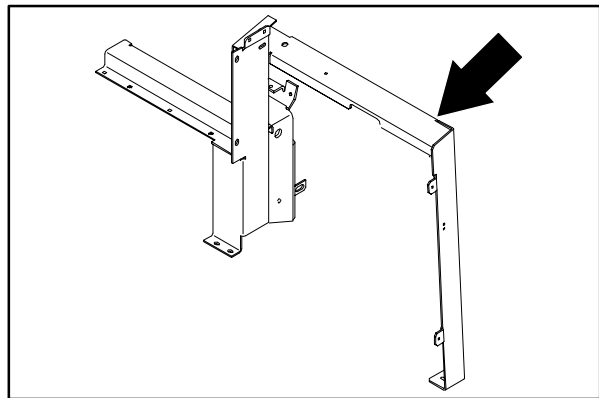

NOTE: Machines equipped with ES will have two switches on the float assembly.

15. Disconnect the solution hose at the back of the tank if the machine is equipped with the ES™ option.
16. Unplug the main electrical harness from the ES™ pump at the rear of the tank.
17. Remove the ES™ pump and cap assembly from the recovery tank.
18. Remove the one hex screw and two nyloc nuts holding the radiator assembly to the back of the recovery tank. Leave the black mount plate attached to the recovery tank. Do not disconnect the hoses from the radiator.

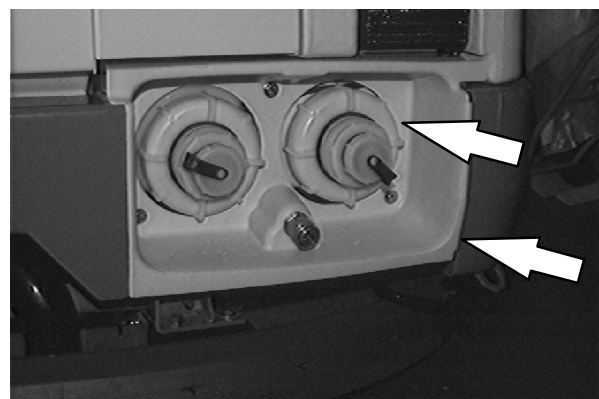
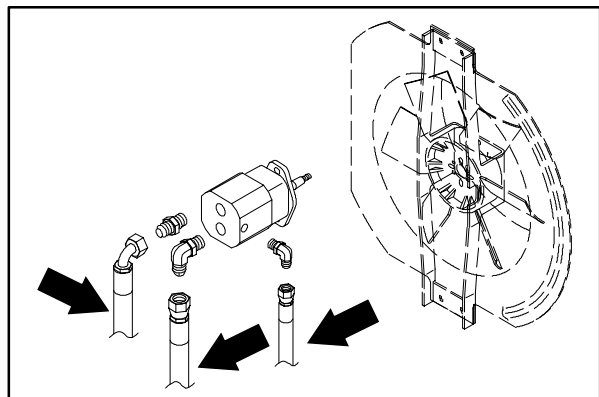

SCRUBBING

19. Carefully pull the radiator assembly back and out of the way of the recovery tank. Let the radiator assembly lean against the oil cooler.
20. Remove the two M8 hex screws attaching the rear tank bracket to the RH solution tank
21. Remove the one M8 hex screw under the rear of the tank, just above the drain cap.
22. Carefully push the recovery tank forward, lift it up, and remove it from the machine.

NOTE: An overhead hoist or two people must be used when lifting the recovery tank out of the machine frame.

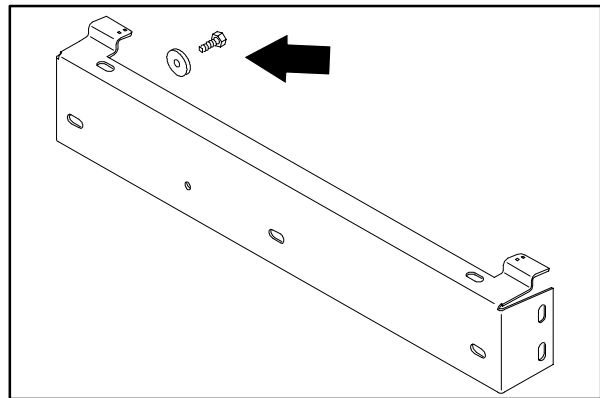

TO INSTALL RECOVERY TANK

FOR SAFETY: Before Leaving Or Servicing Machine; Stop On Level Surface, Set Parking Brake, Turn Off Machine And Remove Key.

NOTE: An overhead hoist or two people must be used when positioning the recovery tank back in the machine frame.

1. Position the recovery tank back in the machine frame.

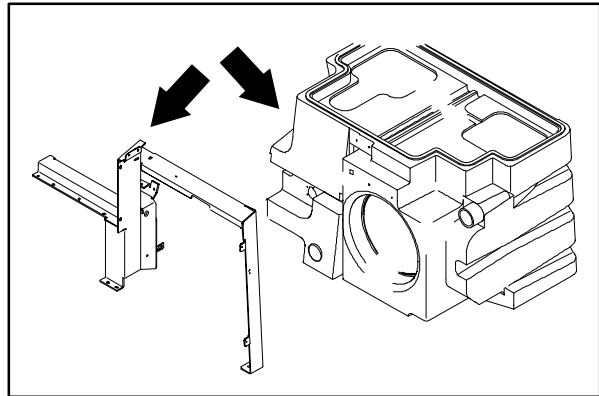

NOTE: Be careful not to pinch hydraulic hoses or electrical wires during this procedure.

2. Reinstall the tank lintel in the machine. Reinstall the six M8 hex screws. Leave the hardware loose for now.
3. Reconnect the solution line at the front of the recovery tank if machine is equipped with the auto fill option.
4. Reconnect the float switches at the front of the recovery tank to the main harness. See schematic in the ELECTRICAL section.
5. Carefully pivot the radiator assembly back in position on the rear of the recovery tank. Reinstall the hardware and tighten to 18 - 24 Nm (15 - 20 ft lb).
6. Plug the ES™ pump back in the main harness. See schematic in the ELECTRICAL section.
7. Reinstall the hardware in the rear tank bracket where it attaches to the RH solution tank.
8. Reinstall the one M8 hex screw under the rear of the tank, just above the drain cap.
9. Reinstall the support channel to the tank lintel and hood lintel. Reinstall the four M8 hex screws.
10. Tighten the all of the M8 hex screws to 18 - 24 Nm (15 - 20 ft lb).

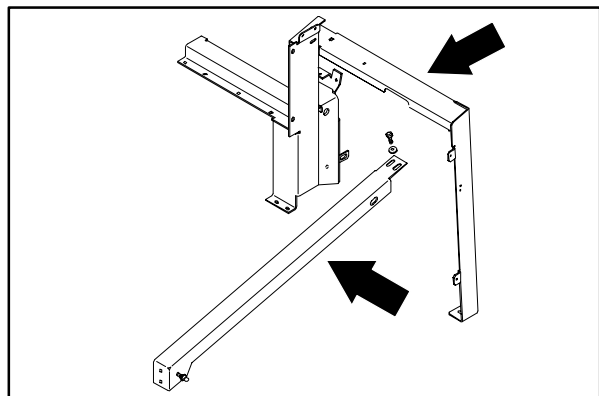
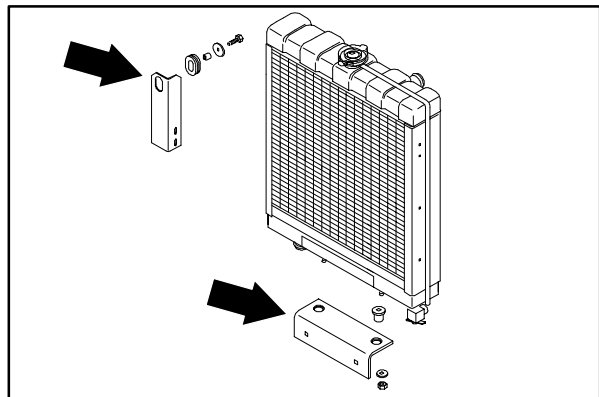
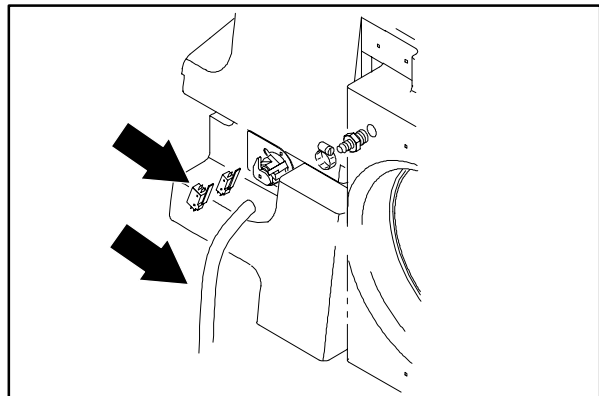

SCRUBBING

11. Reinstall the engine hood gas springs on the ball studs on the support channel. Reinstall the two clips.
12. Reconnect the hydraulic hoses to the engine fan motor. See schematic in the HYDRAULIC section.

NOTE: Observe hydraulic cleanliness requirements when opening hydraulic lines.

13. Reinstall the demister cover on the recovery tank. Reinstall the two M8 hex screws and tighten to 18 - 24 Nm (15 - 20 ft lb).
14. Reinstall the LH solution tank. See TO INSTALL LH SOLUTION TANK instructions.
15. Reconnect the two vacuum hoses to the front of the recovery tank.
16. Reinstall the overhead guard if it was removed earlier.
17. Reinstall the tank drain cover to the rear of the tanks. Reinstall the hardware and tighten to 18 - 24 Nm (15 - 20 ft lb).
18. Reinstall the solution and recovery tank drain covers.
19. Partially fill the recovery tank with water and check for any leaks and for proper operation of the float switches.

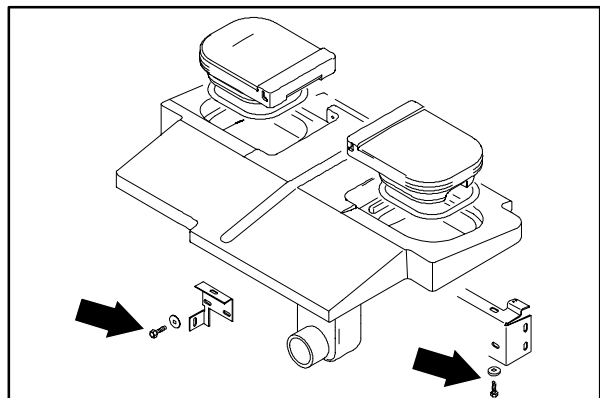
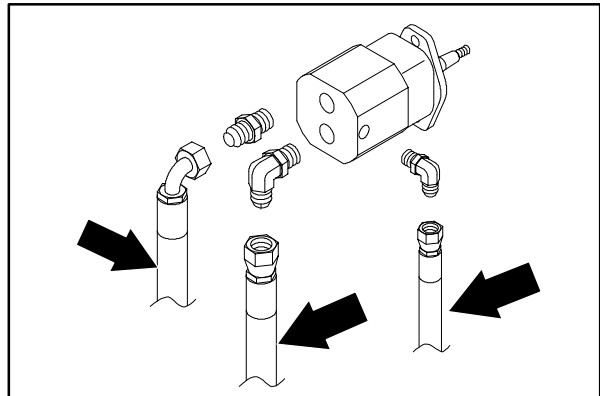
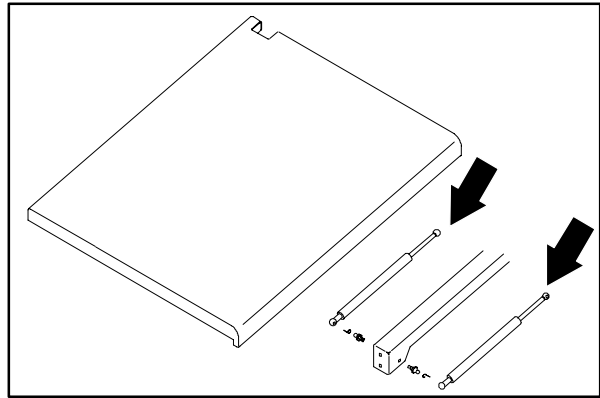

SCRUB HEAD

The scrub head contains the two cylindrical brushes, hydraulic motors, brush idler plate, brush wrap, and side squeegees. Water from the solution tank flows to the center of the scrub head brush wrap and is spread evenly in front of the scrub brushes.

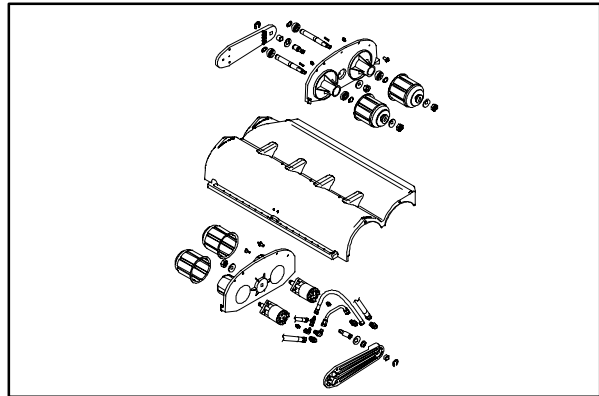

TO REPLACE MAIN SCRUB BRUSHES

1. Place the main scrub brushes in the raised position.

FOR SAFETY: Before Leaving Or Servicing Machine; Stop On Level Surface, Set Parking Brake, Turn Off Machine And Remove Key.

2. Open the RH brush door.
3. Pull back on the front ball joint locking collar on the leveling rod. Remove the leveling rod from the front ball stud.
4. Remove the two hair pins from the brush wrap attachment pins.
5. Remove the M12 hex screw holding the brush idler plate arm to the lift tube.
6. Remove the idler plate and side squeegee assembly from the machine.

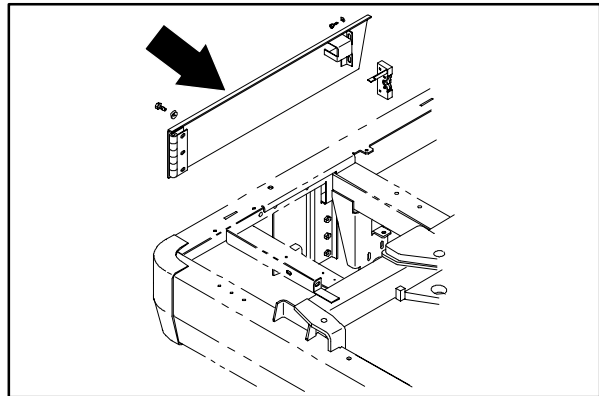

NOTE: Thread the mounting bolt into the idler arm removal hole if you are having trouble removing the idler arm.

7. Pull the two main brushes off the drive plugs.

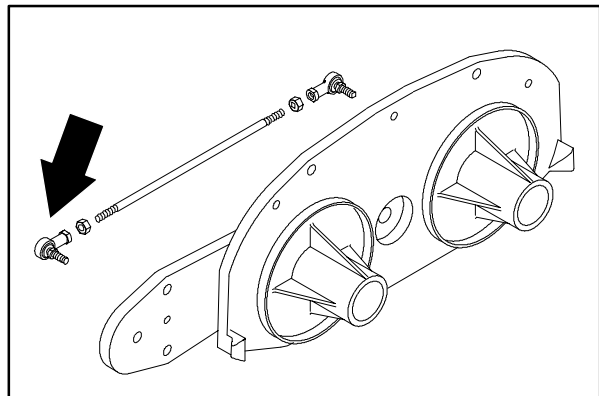

6. Line up the drive end of the new or rotated brushes with the brush drive plugs. The cylindrical scrub brushes must be installed with the V-patterns on the brushes pointing towards each other. Slide the brushes onto the brush drive plugs.

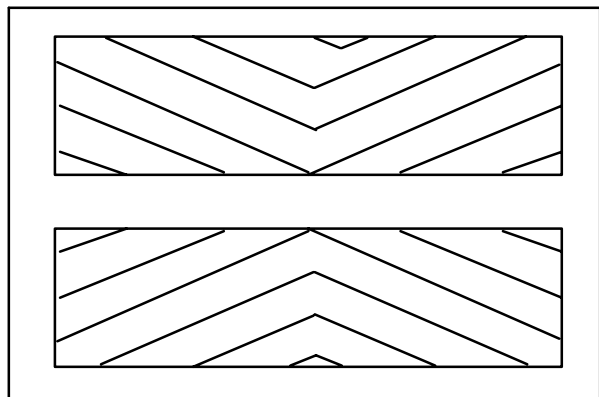

8. Reinstall the idler plate and side squeegee assembly in the machine.

NOTE: Lift up on the brush wrap slightly when installing the idler plate in the machine so the attachment pins line up with the holes in the plate.

SCRUBBING

- Align the two pins on the lift tube with the two holes in the brush idler plate arm.
- Reinstall the M12 hex screw in the brush idler plate arm. Tighten to 64 - 83 Nm (47 - 61 ft lb).

NOTE: Apply a small amount of grease to the threads on the bolt and in the tube.

- Reinstall the two hair pins in the brush wrap attachment pins.
- Reconnect the front of the leveling rod to the ball stud.
- Close the RH brush door and operate the machine. Check the main brushes for proper operation.

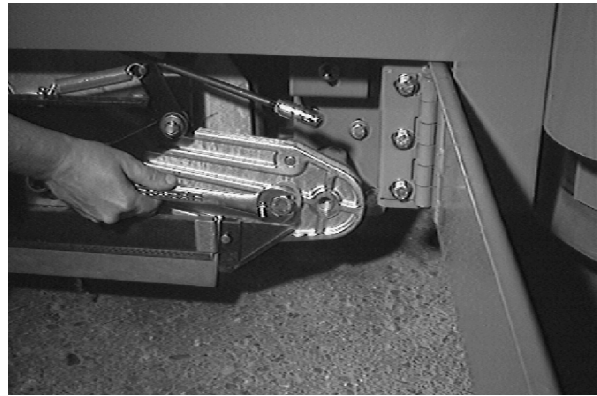

CHECKING AND ADJUSTING SCRUB BRUSH PATTERN

- Apply chalk, or some other material that will not easily blow away, to a smooth, level floor.
- Raise the scrub head. Position the scrub head over the chalked area.
- Set the parking brake.
- Lower the scrub head for 15 to 20 seconds while keeping the scrub head in one spot in the chalked area.

NOTE: If chalk or other material is not available, allow the brushes to spin on the floor for two minutes. A polish mark will remain on the floor.

- Raise the scrub head, release the parking brake, and drive the machine away from the chalked area.
- Observe the width of the brush pattern. If the brush patterns have parallel sides and are the same width, the brushes do not need taper adjustment.

If one or both of the brush patterns are tapered, the scrub head will have to be adjusted to straighten the brush pattern.

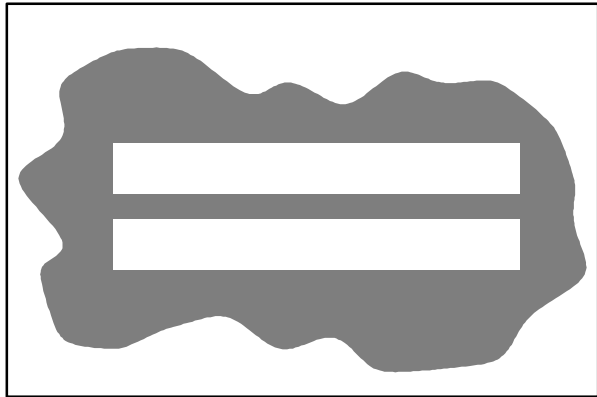

10355

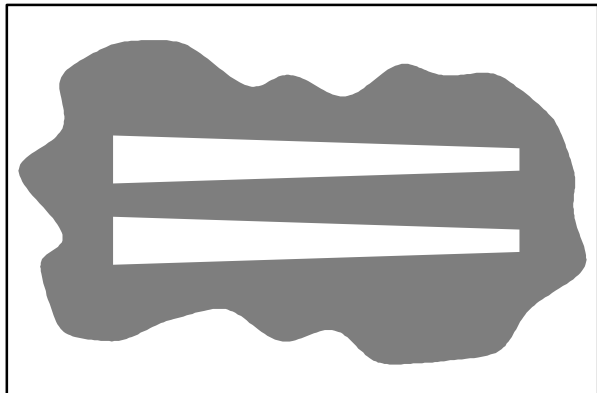

10652

- Loosen the three scrub head mounting bolts on the idler or drive side of the scrub head. Move the scrub head up to decrease the pattern width on that side of the scrub head. Move the scrub head down to increase the pattern width on that side of the scrub head. Tighten the mounting bolts and check the pattern again and readjust if necessary.

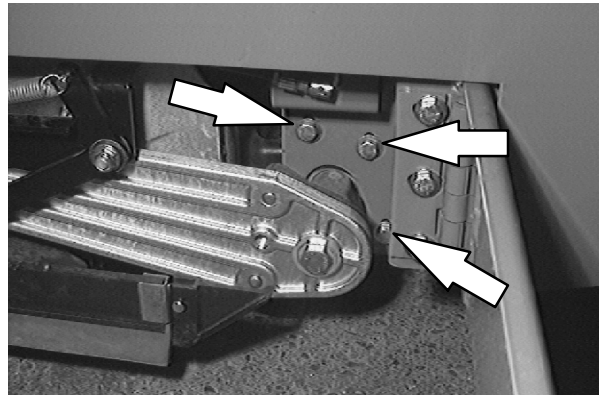

The brush patterns should be the same width. If one is narrower than the other, the scrub head needs to be leveled from front to rear.

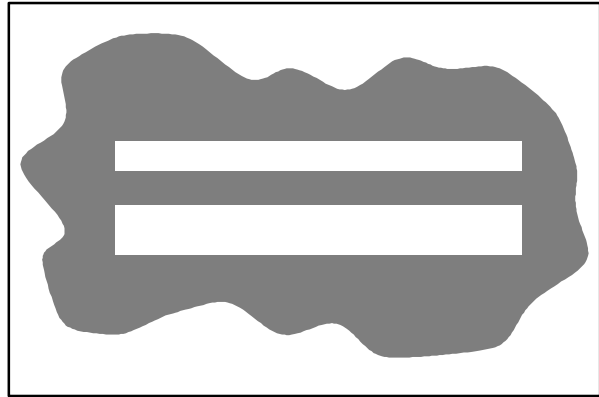

10653

- Lengthen or shorten the leveling rods on both sides of the scrub head. Lengthening the rods will increase the rear brush pattern width. Shortening the rods will increase the front brush pattern.

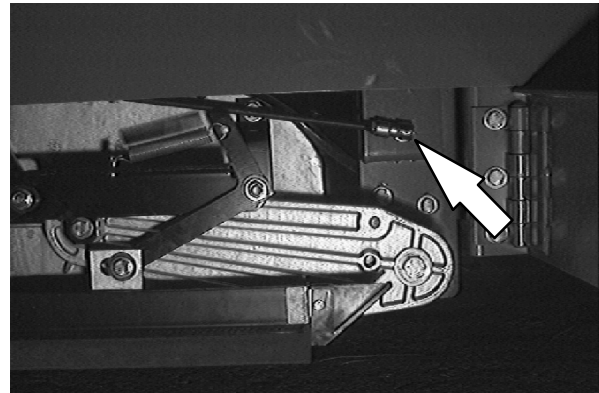

SCRUBBING

TO REPLACE MAIN BRUSH IDLER SHAFT BEARINGS

1. Place the main scrub brushes in the raised position.

FOR SAFETY: Before Leaving Or Servicing Machine; Stop On Level Surface, Set Parking Brake, Turn Off Machine And Remove Key.

2. Open the RH brush door.
3. Pull back on the front ball joint locking collar. Remove the leveling rod from the front ball stud.
4. Remove the two hair pins from the brush wrap attachment pins.
5. Remove the M12 hex screw holding the brush idler plate arm to the lift tube.
6. Remove the idler plate and side squeegee assembly from the machine.

NOTE: For better access to the shaft and bearings--remove the C-clip and brush arm from the idler plate.

7. Turn the idler plate and side squeegee assembly over. Remove the cotter pins, castle nuts, and washers from the idler plugs.
8. Use a puller to remove the idler plugs from the tapered shafts. Remove and retain the square key.
9. Remove the retaining rings from both ends of the idler shafts.
10. Use a press to remove the tapered shafts from the idler plate. Push the shafts out toward the direction of the idler plugs.

NOTE: Use a small amount of heat in the area of the bearings to help break the loctite loose.

11. Use a press to remove the bearing from the tapered end of the idler shaft.
12. Use a press to remove the bearing from the bearing housing in the idler plate. Discard the old bearings.
13. Use a press to install a new bearing in the bearing housing on the **outside** of the idler plate. The open face of the bearing points in. Use green loctite #680 on the outer diameter of the bearing before pressing in place.

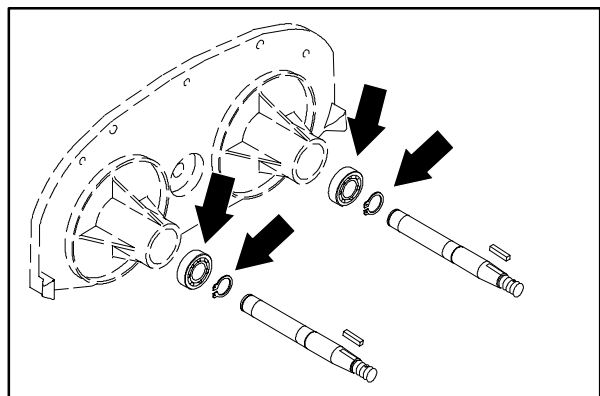
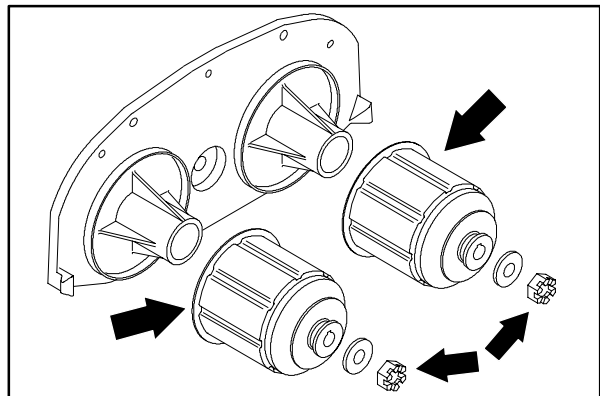
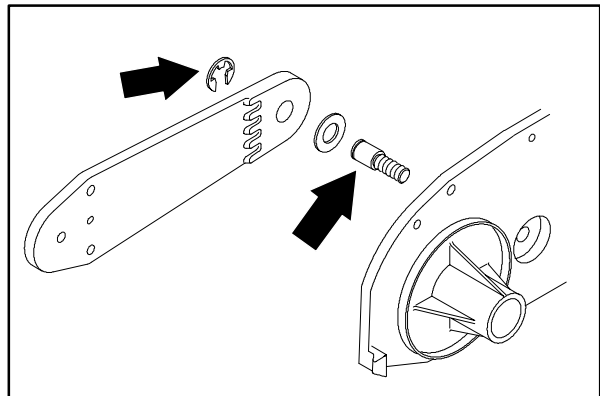
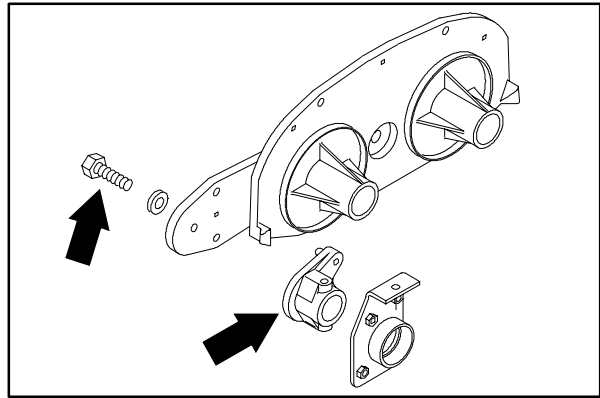

14. Use a press to install a new bearing on the tapered shaft. The open face of the bearing points in. Reinstall the retaining ring on the tapered shaft next to the bearing.
15. Reinstall the tapered shaft and bearing in the bearing housing on the **inside** of the idler plate. Use green loctite #680 on the outer diameter of the bearing before pressing in place.
16. Reinstall the retaining ring on the flat end of the tapered shaft on the outside of the idler plate.

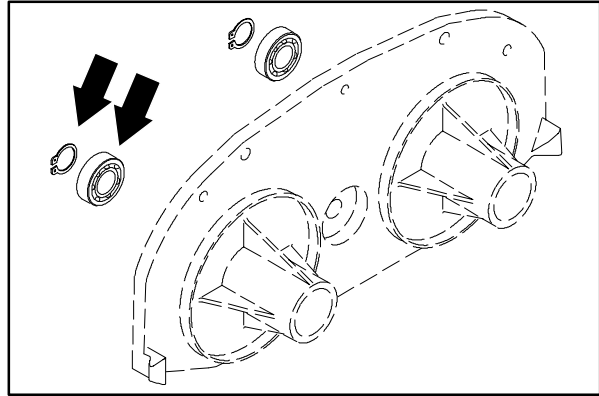

17. Reinstall the square key on the tapered shaft. Put a small amount of grease on the taper.
18. Reinstall the idler plugs, washers, and castle nuts. Hold the plug from turning and tighten the castle nut down hard until the slot in the nut lines up with the hole in the shaft. Install a new cotter pin.
19. Reinstall the brush arm and C clip if they were removed earlier.
20. Reinstall the idler plate and side squeegee assembly in the machine.

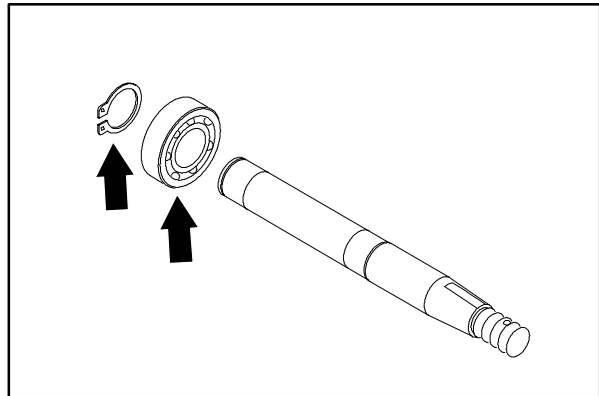

NOTE: Lift up on the brush wrap slightly when installing the idler plate in the machine so the attachment pins line up with the holes in the plate.

21. Align the two pins on the lift tube with the two holes in the brush idler plate arm.
22. Reinstall the M12 hex screw in the brush idler plate arm. Tighten to 64 - 83 Nm (47 - 61 ft lb).

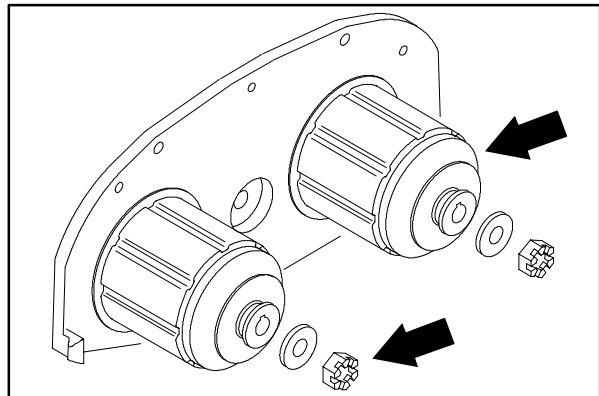

NOTE: Apply a small amount of grease to the threads on the bolt and in the tube.

23. Reinstall the two hair pins in the brush wrap attachment pins.
24. Reconnect the front of the leveling rod to the ball stud.
25. Close the RH brush door and operate the machine. Check the main brushes for proper operation.

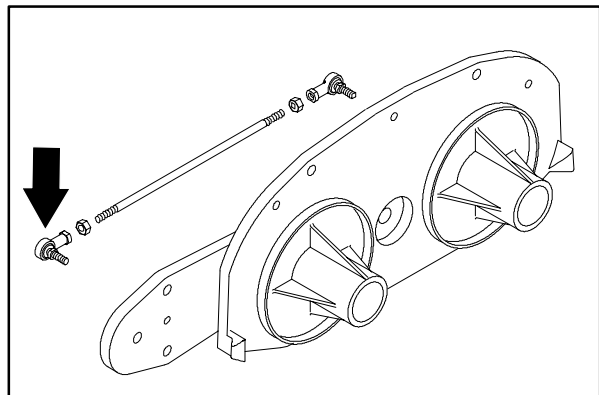

SCRUBBING

TO REMOVE MAIN BRUSH DRIVE MOTOR MOUNT PLATE

1. Place the main scrub brushes in the raised position.

FOR SAFETY: Before Leaving Or Servicing Machine; Stop On Level Surface, Set Parking Brake, Turn Off Machine And Remove Key.

2. Open the LH brush door.
3. Remove the front ball joint on the leveling rod from the machine frame.
4. Remove the two hair pins from the brush wrap attachment pins.
5. Remove the M12 hex screw holding the brush arm to the lift tube.
6. Remove the three hex screws holding the side squeegee assembly to the motor mount plate. Remove the side squeegee assembly.

NOTE: For better access to the hydraulic drive motors--remove the C-clip and brush arm from the motor plate.

7. Mark, disconnect, and plug the three hydraulic hoses leading to the main brush drive motors.

NOTE: Observe hydraulic cleanliness requirements when opening hydraulic lines.

8. Remove the motor mount plate assembly from the machine.

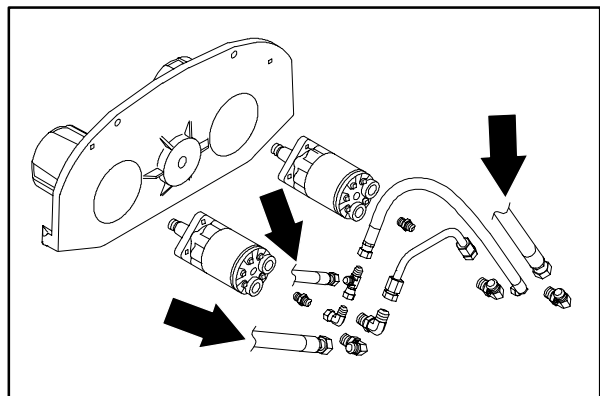
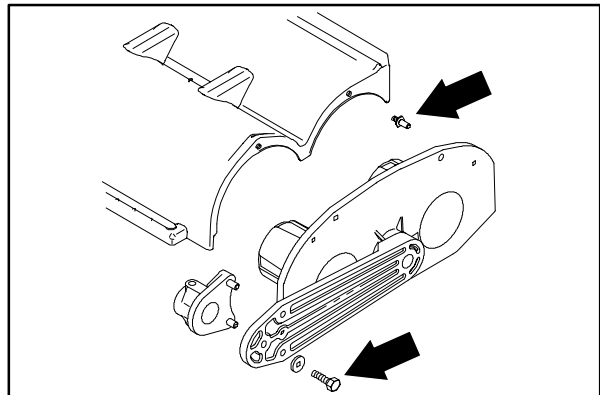
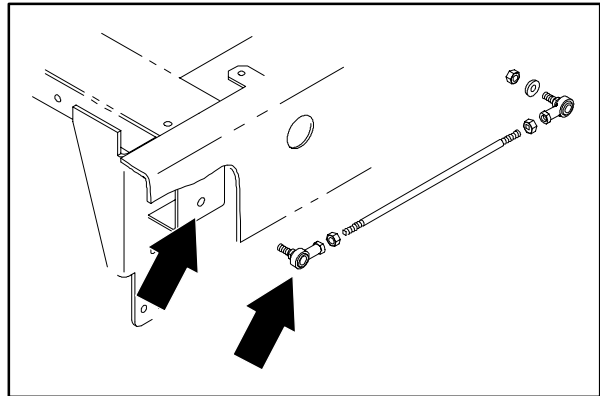
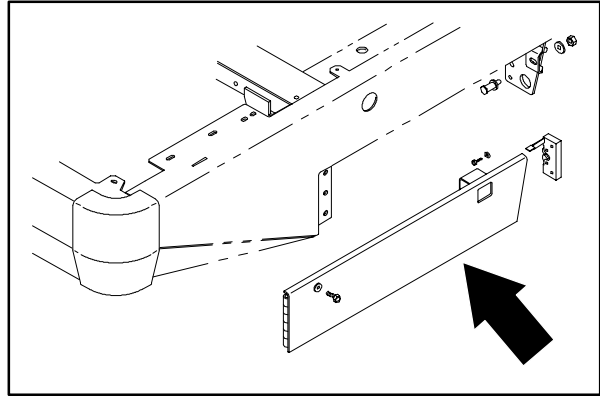

TO INSTALL MAIN BRUSH DRIVE MOTOR MOUNT PLATE

FOR SAFETY: Before Leaving Or Servicing Machine; Stop On Level Surface, Set Parking Brake, Turn Off Machine And Remove Key.

1. Position the motor plate assembly back in the machine.

NOTE: Lift up on the brush wrap slightly when installing the motor plate in the machine so the attachment pins line up with the holes in the plate.

2. Reinstall the two hair pins in the brush wrap attachment pins.
3. Reconnect the hydraulic hoses to the brush motors. See schematic in HYDRAULICS section.
4. Reinstall the brush arm and C clip if they were removed earlier.
5. Align the two pins on the lift tube with the two holes in the brush motor plate arm.
6. Reinstall the M12 hex screw in the brush motor plate arm. Tighten to 64 – 83 Nm (47 – 61 ft lb).

NOTE: Apply a small amount of grease to the threads on the bolt and in the tube.

7. Reinstall the front of the leveling rod ball joint to the machine frame.

NOTE: Observe hydraulic cleanliness requirements when opening hydraulic lines.

8. Reinstall the side squeegee assembly to the motor plate. Tighten the three hex screws to 37 – 48 Nm (26 – 34 ft lb).
9. Close the LH brush door and operate the machine. Check the main brush motors for proper operation.

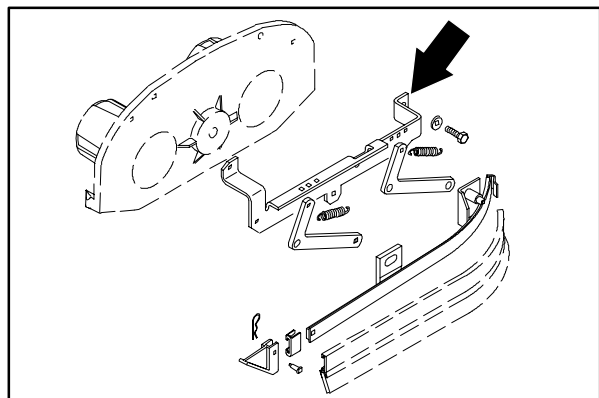
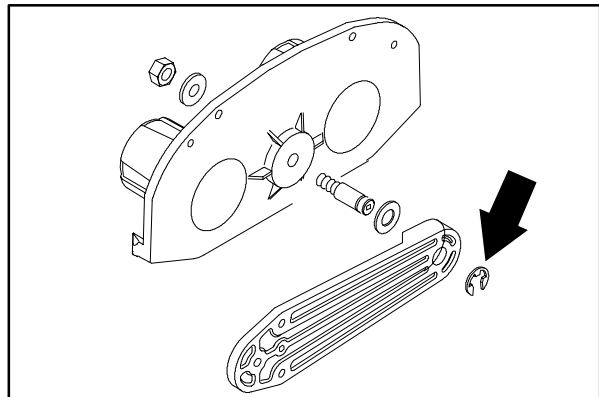
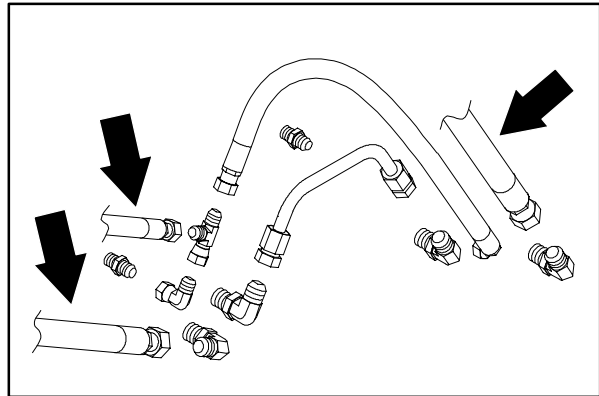
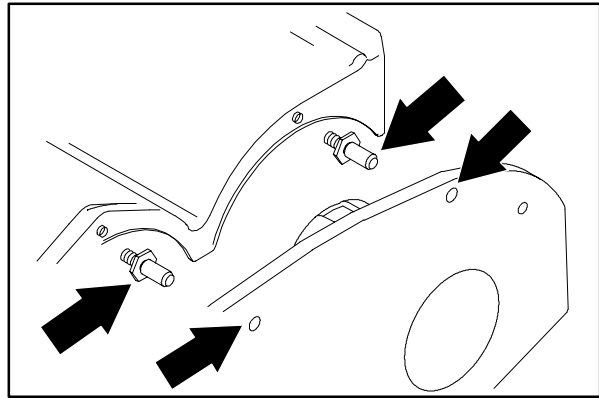

SCRUBBING

TO REPLACE OPTIONAL SIDE BRUSH

FOR SAFETY: Before Leaving Or Servicing Machine; Stop On Level Surface, Set Parking Brake, Turn Off Machine And Remove Key.

1. Rotate the side brush by hand until the spring clips are visible through the window in the side brush motor mount plate.
2. Reach in through the opening in the top of the side brush guard, through the mount plate window, and pinch the spring clips together.
3. Drop the brush off the drive hub. Remove the brush from the machine.
4. Position the new side brush under the machine.
5. Lift the side brush and line up the hub in the brush with the motor drive plug. Snap the brush up in place.
6. Operate the machine and check the side brush for proper operation.

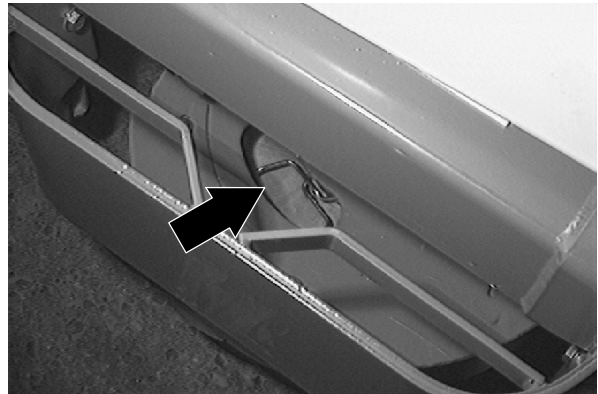
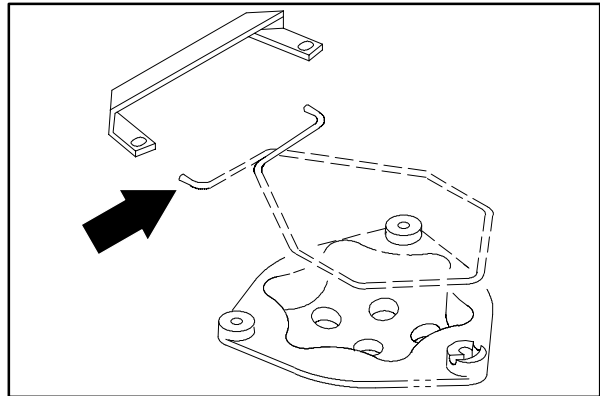
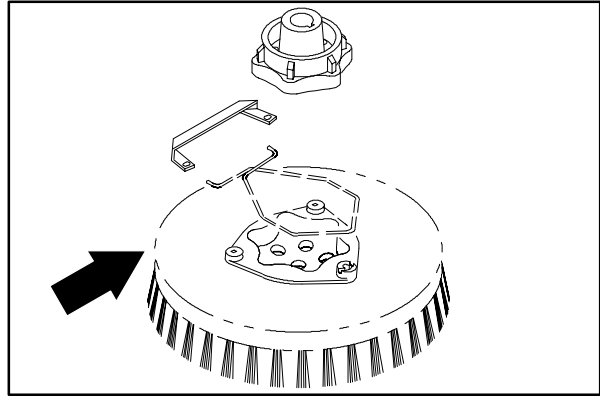

SQUEEGEES

The squeegee channels water into the vacuum fan suction. The front blade channels the water, and the rear blade wipes the floor.

There are two types of squeegee blades available; one for smooth surfaces is standard on the machine, and one for rough surfaces is an option.

The side squeegees control water spray and channel water into the path of the rear squeegee. Check the side squeegees for damage and wear daily.

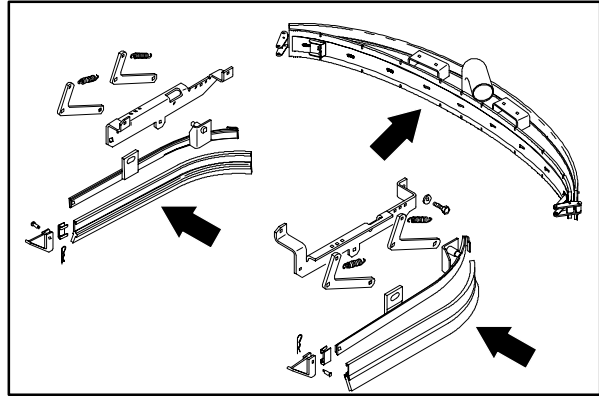

TO REPLACE REAR SQUEEGEE LIFT CABLE

1. Open the debris tray latch and swing the squeegee assembly out for better access.
2. Start engine, lower rear squeegee, shut off engine.

FOR SAFETY: Before Leaving Or Servicing Machine; Stop On Level Surface, Set Parking Brake, Turn Off Machine And Remove Key.

3. Remove the cotter pin and clevis pin from the squeegee lift cable where it attaches to the squeegee frame assembly.
4. Remove the cotter pin and clevis pin from the squeegee lift cable where it attaches to the squeegee lift bellcrank located near the lift cylinder.
5. Remove the clevis pin holding the cable roller to the frame. Remove the roller.
6. Remove and discard the old squeegee lift cable.
7. Position the new cable in the machine. Reinstall one end to the squeegee lift bellcrank located near the lift cylinder. Re-use the clevis and cotter pin.
8. Reinstall the other end to the squeegee pivot frame assembly. Re-use the clevis and cotter pin.
9. Reinstall the cable roller and clevis pin in the frame.
10. Start the machine and raise the squeegee. Swing the squeegee assembly back in. Check the lift cable for proper operation.

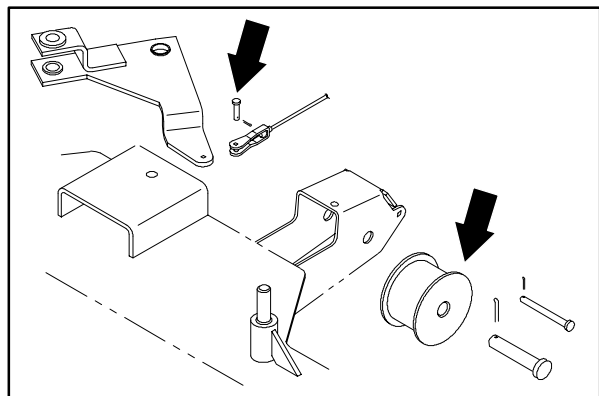
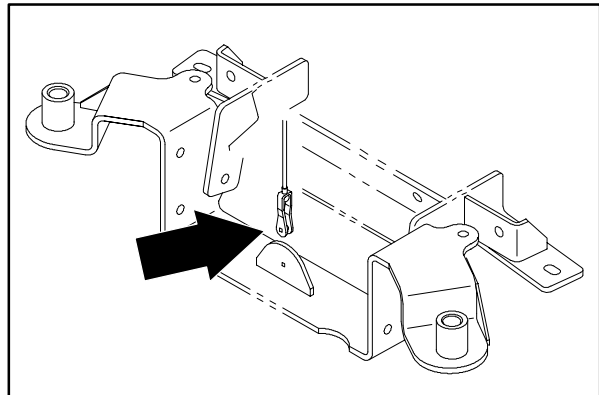
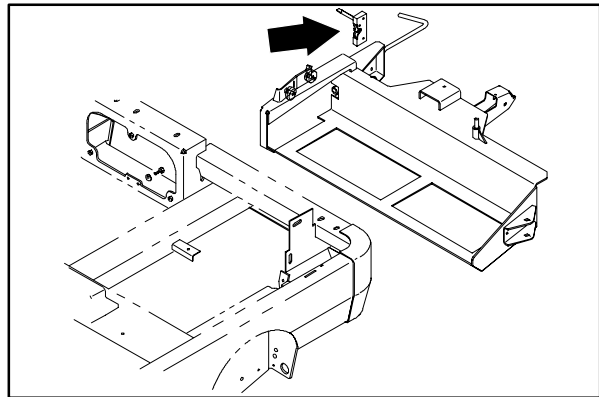

SCRUBBING

TO REPLACE REAR SQUEEGEE CENTERING SPRINGS

1. Open the debris tray latch and swing the squeegee assembly out for better access.
2. Start engine, lower rear squeegee, shut off engine.

FOR SAFETY: Before Leaving Or Servicing Machine; Stop On Level Surface, Set Parking Brake, Turn Off Machine And Remove Key.

3. Loosen the jam nuts on the squeegee down pressure spring rods. This will relax the tension on the springs.
4. Remove the nyloc nuts from the squeegee rod ball joints where they are connected to the debris tray.

NOTE: Remove both the upper and lower nuts on one side. Do one side at a time.

5. Remove and discard the old squeegee centering spring.
6. Position a new squeegee centering spring on the upper and lower ball joint studs.
7. Reinstall the two nyloc nuts and tighten to 37 - 48 Nm (26 - 34 ft lb).
8. Repeat this procedure on the other side if needed.
9. Start the machine and raise the squeegee. Swing the squeegee assembly back in. Check the centering springs for proper operation.

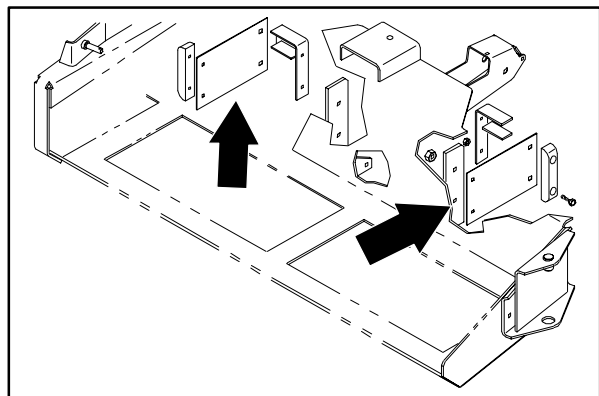
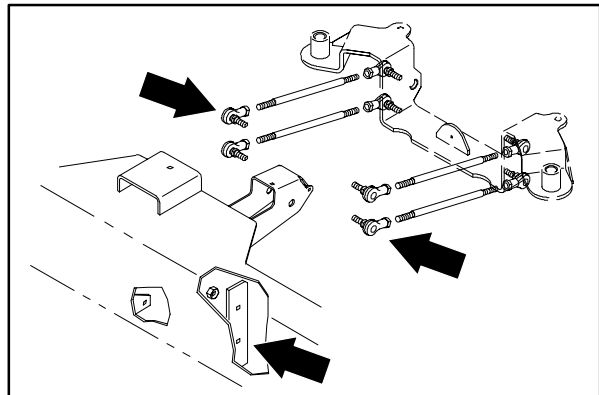
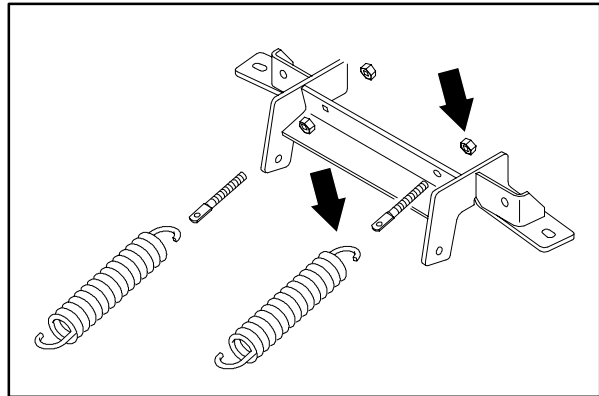
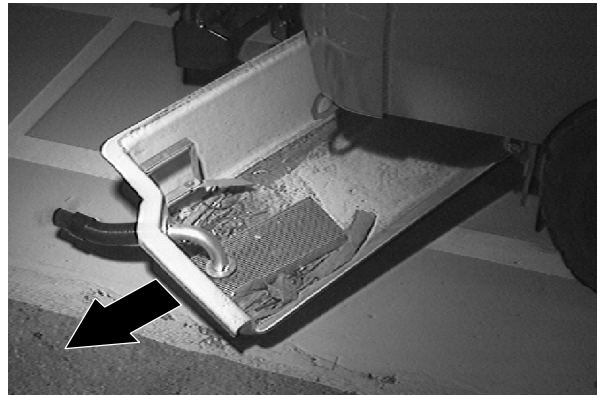

TO REMOVE REAR SQUEEGEE FRAME

1. Open the debris tray latch and swing the squeegee assembly out for better access.
2. Start engine, lower rear squeegee, shut off engine.

FOR SAFETY: Before Leaving Or Servicing Machine; Stop On Level Surface, Set Parking Brake, Turn Off Machine And Remove Key.

3. Remove vacuum hose from squeegee frame.
4. Remove the cotter pin and clevis pin from the squeegee lift cable where it attaches to the squeegee frame assembly.
5. Loosen the jam nuts on the squeegee down pressure spring threaded rods. This will relax the tension on the springs.
6. Remove the four hex screws and nuts holding the squeegee frame to the squeegee lift assembly.
7. Remove the squeegee frame from the machine.

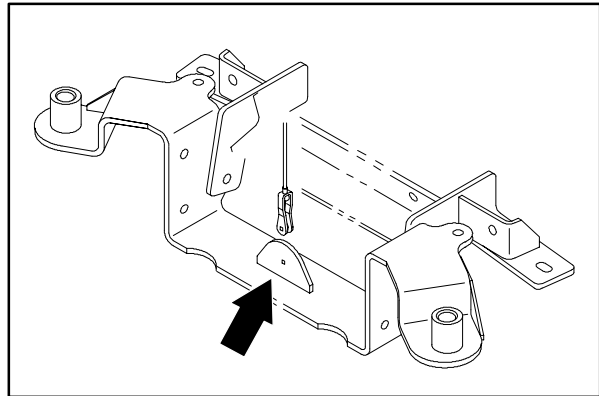
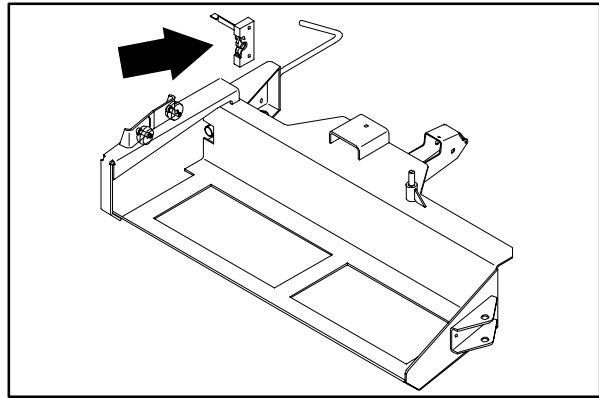

TO INSTALL REAR SQUEEGEE FRAME

FOR SAFETY: Before Leaving Or Servicing Machine; Stop On Level Surface, Set Parking Brake, Turn Off Machine And Remove Key.

1. Position the squeegee frame back under the lift assembly.
2. Reinstall the four hex screws and nuts. Tighten to 37 - 48 Nm (26 - 34 ft lb).
3. Re-connect the squeegee lift cable to the frame assembly. Re-use the clevis and cotter pin.
4. Re-apply tension on the down pressure springs using the threaded rods and jam nuts.
5. Reinstall the vacuum hose on the squeegee frame.
6. Start the machine and raise the squeegee. Swing the squeegee assembly back in.

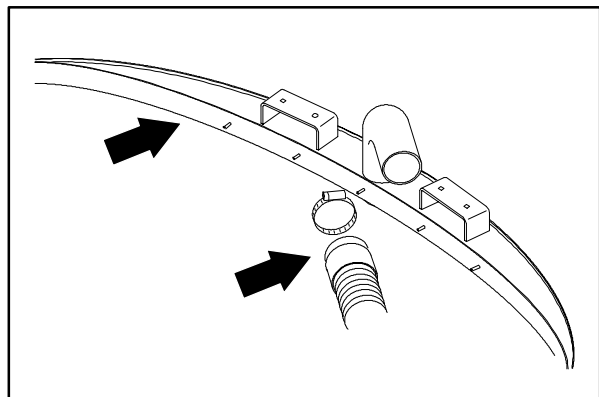
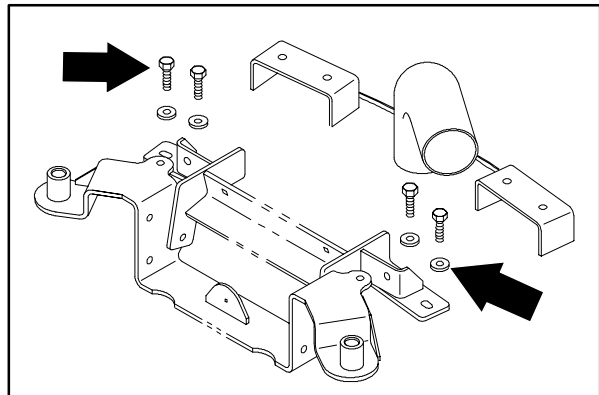

SQUEEGEE BLADES

REAR SQUEEGEE

Check the squeegee blades for damage and wear daily. Rotate or replace either of the squeegee blades if the leading edge is torn or worn half-way through the thickness of the blade.

The rear squeegee has two squeegee blades. Each blade has four wiping edges. To use them all, start with one wiping edge. To use the next wiping edge, rotate the blade end-for-end. To use the next wiping edge, rotate the top edges down, bottom edges up. To use the last edge, rotate the blade end-for-end.

Replace any worn or damaged squeegee blades.

TO REPLACE OR ROTATE REAR SQUEEGEE BLADES

1. Make sure the squeegee is raised off the floor.
2. Shut the engine off and set the parking brake.

FOR SAFETY: Before Leaving Or Servicing Machine; Stop On Level Surface, Set Parking Brake, Turn Off Machine And Remove Key.

3. Open the retaining band clamp and remove the squeegee blade.
4. Replace or rotate the squeegee blade to allow a new edge to face the front of the machine.
5. Place the squeegee blade over the pins of the squeegee frame.
6. Position the retaining band over the squeegee blade. Latch the retaining band clamp.
7. Adjust the squeegee blade leveling and deflection. See TO ADJUST REAR SQUEEGEE BLADE DEFLECTION or TO LEVEL THE REAR SQUEEGEE instructions.

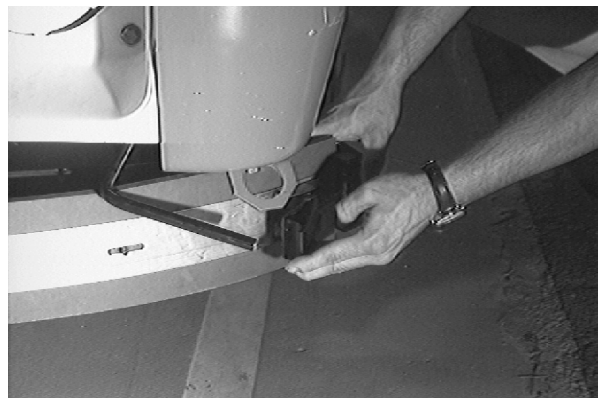

TO ADJUST REAR SQUEEGEE BLADE DEFLECTION

Deflection is the amount of curl the squeegee blade has when the machine travels forward with the squeegee lowered to the floor. The best deflection is when the squeegee wipes the floor just dry with a minimum amount of deflection.

1. Lower the squeegee and drive the machine forward.
2. Shut off the engine and set the machine parking brake.

FOR SAFETY: Before Leaving Or Servicing Machine; Stop On Level Surface, Set Parking Brake, Turn Off Machine And Remove Key.

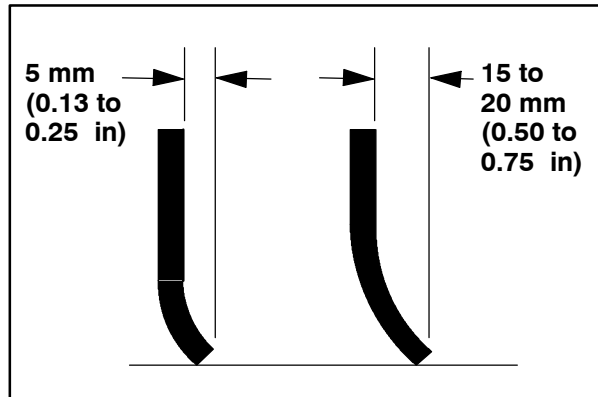

10918

3. Look at the deflection over the full length of the squeegee blade. The correct amount of deflection for the rear squeegee blade is 15 to 20 mm (0.50 to 0.75 in). The front slotted squeegee blade should contact the floor with a slight deflection, 5 mm (0.13 to 0.25 in).
4. To adjust the amount of deflection, unlock the height adjustment knobs on the two squeegee casters by sliding the locking bracket off to the side.

NOTE: If the locking brackets won't slide over, lift up the end of the squeegee to pick the caster up off the floor slightly. Then slide the locking bracket over.

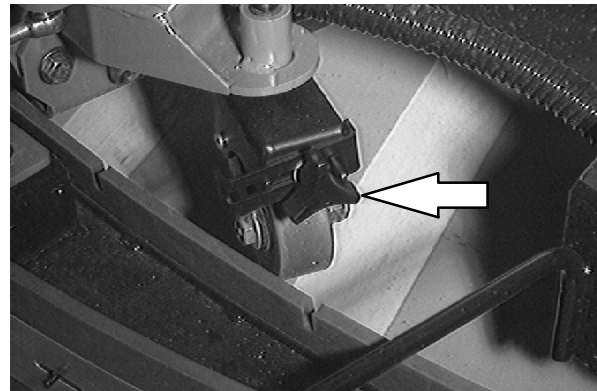

5. Turn the adjustment knob clockwise to decrease deflection, turn the adjustment knob counter-clockwise to increase the deflection. Be sure to turn the knobs the **same** number of turns.
6. Start the engine and drive the machine forward again to check the squeegee blade deflection. Readjust the squeegee blade deflection if necessary.
7. Slide the locking brackets back to lock the height adjustment knobs.
8. Raise the squeegee when finished.

SCRUBBING

TO LEVEL THE REAR SQUEEGEE

Leveling of the squeegee assures even contact over the length of the squeegee blade with the surface being scrubbed. Make sure this adjustment is done on an even, level floor.

1. Lower the squeegee and drive the machine forward.
2. Shut off the engine and set the machine parking brake.

FOR SAFETY: Before Leaving Or Servicing Machine; Stop On Level Surface, Set Parking Brake, Turn Off Machine And Remove Key.

3. Look at the deflection over the full length of the squeegee blade.
4. If the deflection is not the same over the full length of the blade, loosen the locking nut on the two rear squeegee balljoints.

NOTE: The rear squeegee links should be adjusted so there is 11 inches from the center lines of the two ball joints.

5. Turn the balljoint adjustment nut clockwise, from the rear of the machine, to increase the deflection at the ends of the squeegee. Turn the balljoint adjustment nut counter-clockwise, from the rear of the machine, to decrease the deflection at the ends of the squeegee blade.
6. Tighten the locking nuts.
7. Start the engine and drive the machine forward again to check the squeegee blade deflection.
8. Readjust the squeegee blade deflection if necessary.

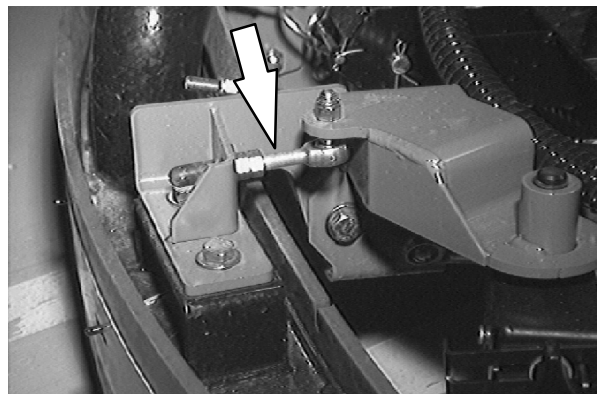
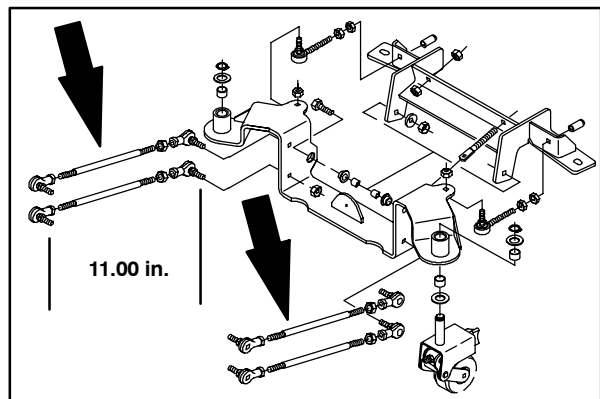
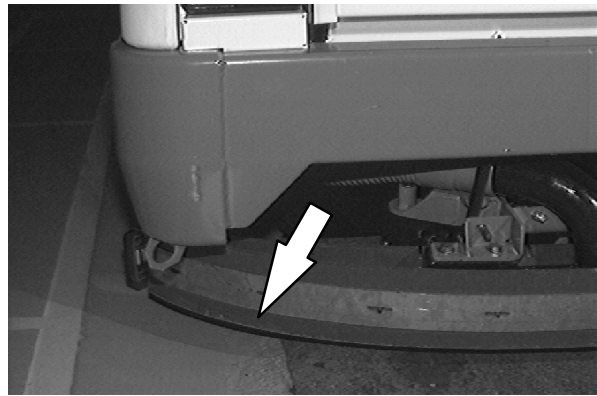

SIDE SQUEEGEES

The side squeegees control water spray and channel water into the path of the rear squeegee. Check the side squeegees for damage and wear daily. Replace the side squeegee blades whenever they become damaged or lose their shape or resilience. Replace the squeegee deflectors whenever they become worn.

TO REPLACE SIDE SQUEEGEE BLADES

1. Raise the scrub head.
2. Shut off the engine and set the machine parking brake.

FOR SAFETY: Before Leaving Or Servicing Machine; Stop On Level Surface, Set Parking Brake, Turn Off Machine And Remove Key.

3. Remove the cotter pin, clevis pin, deflector, and the retainer bracket from the front of the side squeegee.
4. Pull the squeegee blade out the front of the squeegee frame.
5. Slide the new squeegee blade onto the frame.

NOTE: Lubricating the squeegee frame where the squeegee makes contact will make it easier to install the squeegee blade.

6. Replace the retainer bracket, deflector, clevis pin, and cotter pin.
7. Repeat for the side squeegee on the other side of the scrub head.

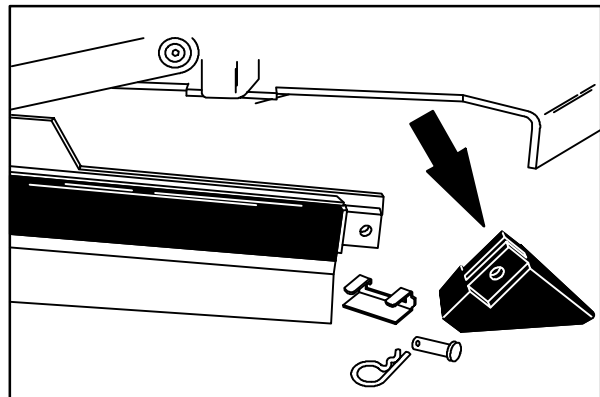
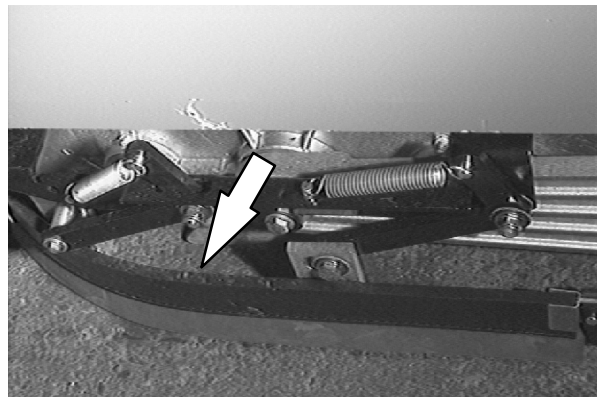

00000

SCRUBBING

TO REPLACE SIDE BRUSH SQUEEGEE

FOR SAFETY: Before Leaving Or Servicing Machine; Stop On Level Surface, Set Parking Brake, Turn Off Machine And Remove Key.

1. Raise the side brush.
2. Shut off the engine and set the parking brake.

FOR SAFETY: Before leaving or servicing machine; stop on level surface, set parking brake, turn off machine and remove key.

3. Remove the side brush guard.
4. Remove the retainer clip from the end of the squeegee.
5. Pull the squeegee blade out the front of the squeegee frame.
6. Slide the new squeegee blade onto the frame.

NOTE: Lubricating the squeegee frame where the squeegee makes contact will make it easier to install the squeegee blade.

7. Install the retainer clip on the end of the squeegee.
8. Install the side brush guard.



SIDE BRUSH SKIRT

The side brush skirt is located behind the squeegee blade. Check the skirt for wear and damage every 100 hours of operation.

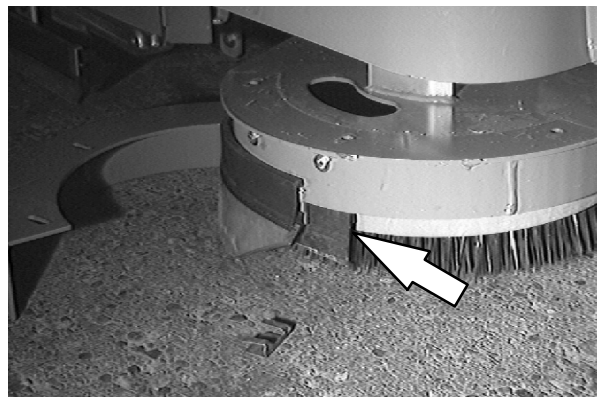

VACUUM FAN

The vacuum fan, when activated, creates a vacuum in the recovery tank. Water is pulled from the rear squeegee to the recovery tank through a vacuum hose. The vacuum fan's impeller is driven with a high speed hydraulic motor.

TO REMOVE VACUUM FAN

FOR SAFETY: Before Leaving Or Servicing Machine; Stop On Level Surface, Set Parking Brake, Turn Off Machine And Remove Key.

1. Open the engine cover, engine side door, and the front cover.
2. Loosen the hose clamp and remove the vacuum hose leading from recovery tank to the center of the vacuum fan housing.
3. Mark, disconnect, and plug the four hydraulic hoses going to the vacuum fan

NOTE: Observe hydraulic cleanliness requirements when opening hydraulic lines.

4. Remove three M10 hex screws, washers, and nyloc nuts holding vacuum fan to mounting brackets.
5. Remove the vacuum fan assembly from the machine.

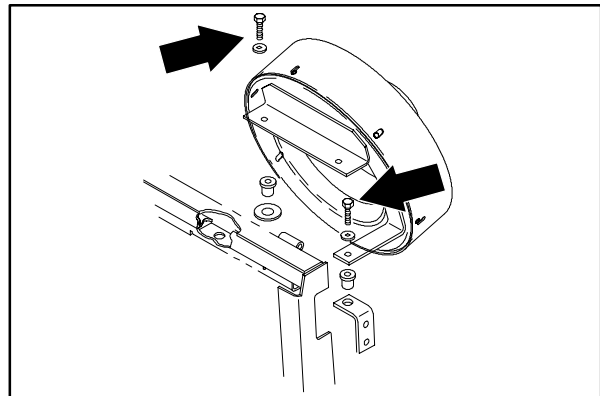
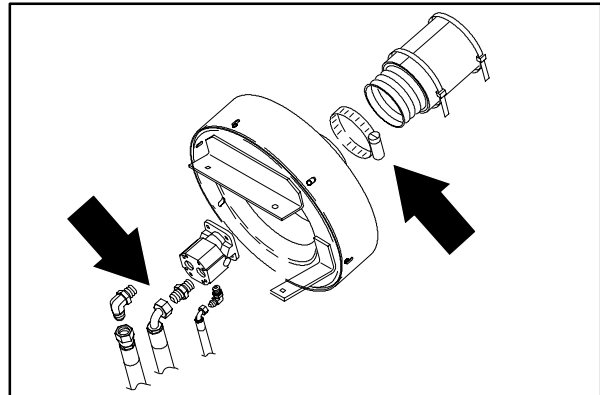
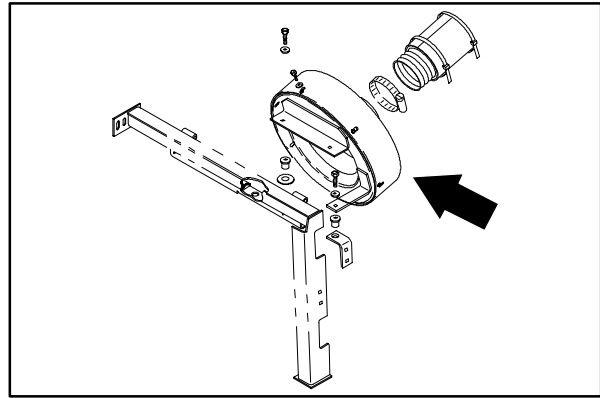

SCRUBBING

TO INSTALL VACUUM FAN

FOR SAFETY: Before Leaving Or Servicing Machine; Stop On Level Surface, Set Parking Brake, Turn Off Machine And Remove Key.

1. Position the vacuum fan assembly back in the machine
2. Align the three mounting holes in the vacuum fan housing with the three rubber isolators in the mounting brackets. Reinstall the three M10 hex screws, washers, and nyloc nuts. Tighten to 18 - 24 Nm (13 - 18 ft lb).
3. Reconnect the hydraulic hoses to the vacuum fan motor. See schematic in HYDRAULIC section.
4. Reinstall vacuum hose from recovery tank to vacuum fan housing. Hand tighten clamps.
5. Start the engine and turn on the vacuum fan. Check for leaks and proper operation.

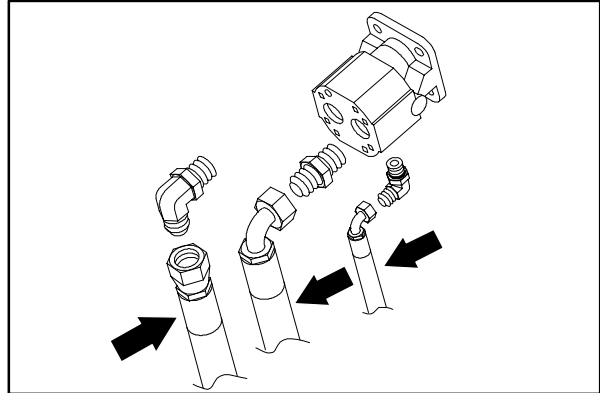

TO REPLACE VACUUM IMPELLER

FOR SAFETY: Before Leaving Or Servicing Machine; Stop On Level Surface, Set Parking Brake, Turn Off Machine And Remove Key.

1. Remove the vacuum fan from the machine. See TO REMOVE VACUUM FAN instructions.
2. Place the vacuum fan assembly in a vice or some other holding device.
3. Remove the six hex screws holding the front housing to rear housing. Remove the front housing.

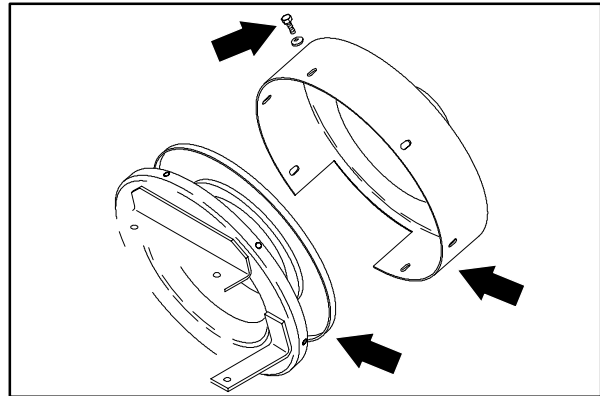

NOTE: Mark the front housing in relation to the rear housing so it is re-assembled correctly.

4. Remove crown nut on impeller shaft. Slide impeller off shaft.

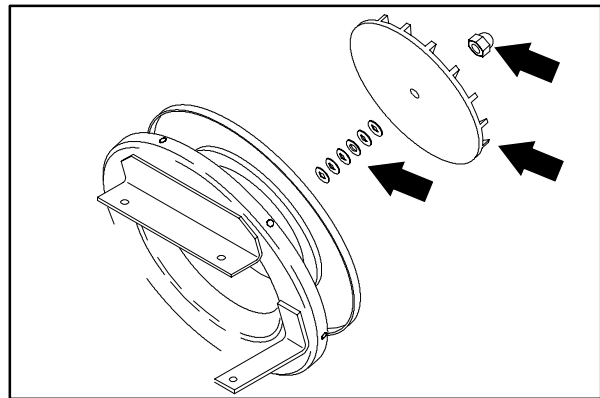

NOTE: Remove and save the key and any shims that are on the motor shaft, under the impeller.

5. Install the shims, key, new fan impeller, and crown nut. Tighten nut to 34 - 47 Nm (25 - 35 ft lb).

NOTE: Be sure the square key is on the motor shaft. Super gluing the key to the shaft helps keep it in place when installing the impeller.

NOTE: Use a small amount of blue loctite 242 on the motor shaft threads.

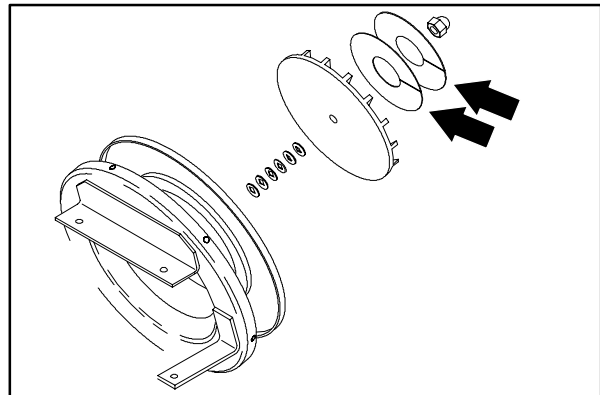

6. Reinstall the front housing on the rear housing. Reinstall the six hex screws and tighten to 22 - 27 Nm (16 - 20 ft lb).

NOTE: Tennant part no. 57543 plastic shims must be used for proper fan to housing clearance. Remove these shims after housing hardware has been tightened.

7. Reinstall the vacuum fan assembly in the machine. See TO INSTALL VACUUM FAN instructions.

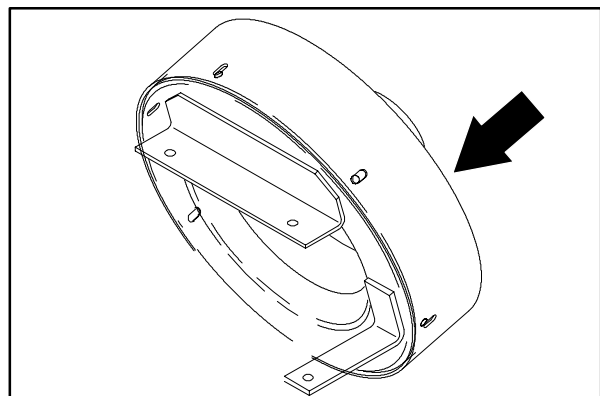

CONTENTS

	Page		Page
INTRODUCTION	4-3	SCRUB BRUSH WILL NOT TURN ON AND/OR DOWN (SCHEMATIC) .	4-38
BATTERY	4-4	SCRUB BRUSH WILL NOT TURN ON AND/OR DOWN (FLOW CHART)	4-39
TO REPLACE BATTERY	4-5	SQUEEGEE AND VACUUM FAN NOT TURNING ON AND GOING DOWN (SCHEMATIC)	4-41
INSTRUMENT PANEL	4-6	SQUEEGEE AND VACUUM FAN NOT TURNING ON AND GOING DOWN (FLOW CHART)	4-42
TO REPLACE INSTRUMENT PANEL .	4-6	SIDE BRUSH WILL NOT TURN ON AND GO DOWN (SCHEMATIC)	4-44
TO DISASSEMBLE INSTRUMENT PANEL	4-7	SIDE BRUSH WILL NOT TURN ON AND GO DOWN (FLOW CHART)	4-45
TO REASSEMBLE INSTRUMENT PANEL	4-8	WATER VALVES NOT OPERATING (SCHEMATIC)	4-47
TO REPLACE MACHINE RELAY	4-9	WATER VALVES NOT OPERATING (FLOW CHART)	4-48
TO REPLACE CIRCUIT BREAKER ..	4-10	HEAD LIGHTS WILL NOT TURN ON (SCHEMATIC)	4-49
GAS/LPG ELECTRICAL SCHEMATIC	4-11	HEAD LIGHTS WILL NOT TURN ON (FLOW CHART)	4-50
GAS/LPG ELECTRICAL SCHEMATIC	4-12	ES™ PUMP NOT WORKING (SCHEMATIC)	4-51
DIESEL ELECTRICAL SCHEMATIC .	4-13	ES™ PUMP NOT WORKING (FLOW CHART)	4-52
DIESEL ELECTRICAL SCHEMATIC .	4-14	REVERSE LIGHT OR ALARM NOT WORKING (SCHEMATIC)	4-54
GAS/LPG WIRE HARNESS GROUP .	4-15	REVERSE LIGHT OR ALARM NOT WORKING (FLOW CHART)	4-55
GAS/LPG WIRE HARNESS GROUP (OPTIONS)	4-18	DETERGENT METERING PUMP IS NOT OPERATING (SCHEMATIC)	4-57
DIESEL WIRE HARNESS GROUP ..	4-19	DETERGENT METERING PUMP IS NOT OPERATING (FLOW CHART) ...	4-58
DIESEL WIRE HARNESS GROUP (OPTIONS)	4-22	ALTERNATOR / BATTERY WARNING LIGHT STAYS ON WHEN ENGINE IS RUNNING (SCHEMATIC) .	4-59
ELECTRICAL	4-11	ALTERNATOR / BATTERY WARNING LIGHT STAYS ON WHEN ENGINE IS RUNNING (FLOW CHART)	4-60
DIAGNOSTICS	4-23	ALTERNATOR / BATTERY WARNING LIGHT WILL NOT TURN ON (SCHEMATIC)	4-61
OPERATING MODES	4-24	ALTERNATOR / BATTERY WARNING LIGHT WILL NOT TURN ON (FLOW CHART)	4-62
NORMAL MODE	4-25	ENGINE TEMPERATURE LIGHT WILL NOT TURN ON OR OFF (SCHEMATIC)	4-63
SCRUB BUTTON	4-25	ENGINE TEMPERATURE LIGHT WILL NOT TURN ON (FLOW CHART)	4-64
SQUEEGEE BUTTON	4-26	ENGINE TEMPERATURE LIGHT WILL NOT TURN OFF (FLOW CHART)	4-64
DETERGENT	4-27		
ES™ BUTTON	4-27		
OVERFLOW FLOAT	4-27		
MANUAL MODE	4-28		
ES™ BUTTON	4-28		
SIDE BRUSH BUTTON	4-28		
SQUEEGEE BUTTON	4-28		
ENGINE BUTTON	4-28		
SCRUB BUTTON	4-28		
DETERGENT BUTTON	4-28		
INPUT DISPLAY MODE	4-29		
ERROR DISPLAY MODE	4-30		
ES™ LED	4-30		
SIDE BRUSH LED	4-31		
SQUEEGEE LED	4-31		
SCRUB LED	4-32		
DETERGENT LED	4-32		
PRESSURE ADJUST MODE	4-33		
SCRUB BUTTON	4-33		
RESET SCRUB PRESSURES	4-34		
TROUBLESHOOTING	4-35		
INSTRUMENT PANEL DOES NOT POWER UP (SCHEMATIC)	4-36		
INSTRUMENT PANEL DOES NOT POWER UP (FLOW CHART) ...	4-37		

	Page
HYDRAULIC (HIGH) PRESSURE INDICATOR LIGHT WILL NOT TURN ON OR OFF (SCHEMATIC) ..	4-65
HYDRAULIC (HIGH) PRESSURE INDICATOR LIGHT WILL NOT TURN ON (FLOW CHART)	4-66
HYDRAULIC (HIGH) PRESSURE INDICATOR LIGHT WILL NOT TURN OFF (FLOW CHART)	4-66
ENGINE OIL PRESSURE WARNING LIGHT WILL NOT TURN ON OR OFF (SCHEMATIC)	4-67
ENGINE OIL PRESSURE WARNING LIGHT WILL NOT TURN ON (FLOW CHART)	4-68
ENGINE OIL PRESSURE WARNING LIGHT WILL NOT TURN OFF (FLOW CHART)	4-68
RECOVERY TANK FULL LIGHT WILL NOT TURN ON OR OFF (SCHEMATIC)	4-69
RECOVERY TANK FULL LIGHT WILL NOT TURN ON (FLOW CHART) .	4-70
RECOVERY TANK FULL LIGHT WILL NOT TURN OFF (FLOW CHART)	4-70
FUEL GAUGE (GAS AND DIESEL) (SCHEMATIC)	4-71
FUEL GAUGE (GAS AND DIESEL) (FLOW CHART)	4-72
FUEL GAUGE (LPG) (SCHEMATIC) .	4-73
FUEL GAUGE (LPG) (FLOW CHART)	4-74

INTRODUCTION

The machine electrical system consists of the battery, relays, instrument panels, and related components. This section includes information on these components and their troubleshooting.

BATTERY

The battery used in the machine is a low maintenance battery. It has been constructed with special materials and has extra electrolyte to reduce or eliminate maintenance. Its design reduces electrolyte loss and contamination. Do not add water, remove the battery vent plugs, or check the battery specific gravity. For specific instructions, see the battery label.

Do not allow the battery to remain in discharged condition for any time. Do not operate the machine if the battery is in poor condition or discharged beyond 80%, specific gravity below 1.120.

Periodically clean the top surface of the batteries and the terminals, and check for loose connections. Use a strong solution of baking soda and water. Brush the solution sparingly over the battery tops, terminals, and cable clamps. Do not allow any baking soda solution to enter the batteries. Use a wire brush to clean the terminal posts and the cable connectors. After cleaning, apply a coating of clear battery post protectant to the terminals and the cable connectors. Keep the tops of the batteries clean and dry.

Keep all metallic objects off the top of the batteries, which may cause a short circuit. Replace any worn or damaged wires.

The electrolyte level in regular non-sealed batteries can be checked. The level must always be above the battery plates. Never add acid to the batteries, only distilled water. Keep the battery caps on the batteries always except when adding water or taking hydrometer readings.

**FOR SAFETY: When Servicing Machine,
Avoid Contact With Battery Acid.**

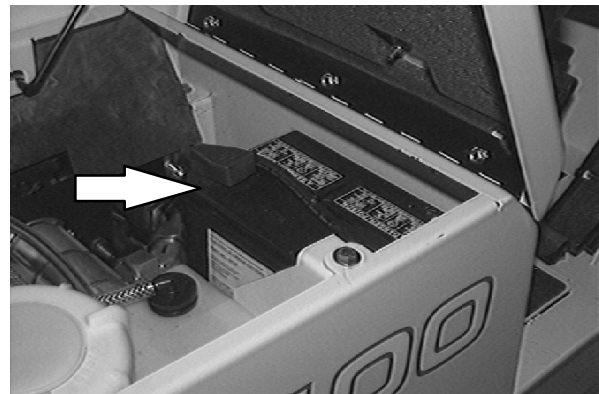
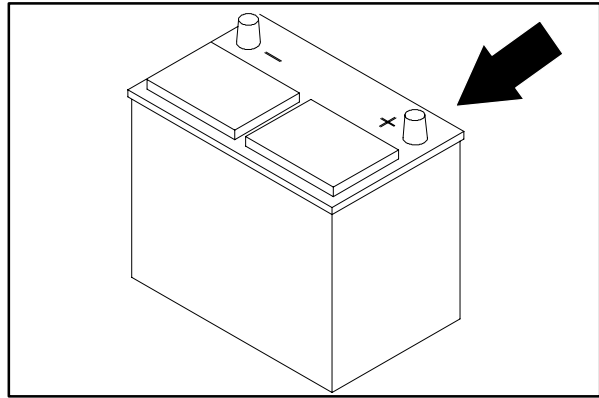

Using a hydrometer to measure the specific gravity is a way to determine the charge level and condition of the batteries. If one or more of the battery cells test lower than the other battery cells (0.050 or more), the cell is damaged, shorted, or is about to fail.

NOTE: Do not take readings immediately after adding distilled water. If the water and acid are not thoroughly mixed, the readings may not be accurate. Check the hydrometer readings against the following chart to determine the remaining battery charge level:

SPECIFIC GRAVITY at 27° C (80° F)	BATTERY CHARGE
1.260 - 1.280	100% Charged
1.230 - 1.250	75% Charged
1.200 - 1.220	50% Charged
1.170 - 1.190	25% Charged
1.110 - 1.160	Discharged

NOTE: If the readings are taken when the battery electrolyte is any temperature other than 27° C (80° F), the reading must be temperature corrected. Add or subtract to the specific gravity reading 0.004, 4 points, for each 6° C (10° F) above or below 27° C (80° F).

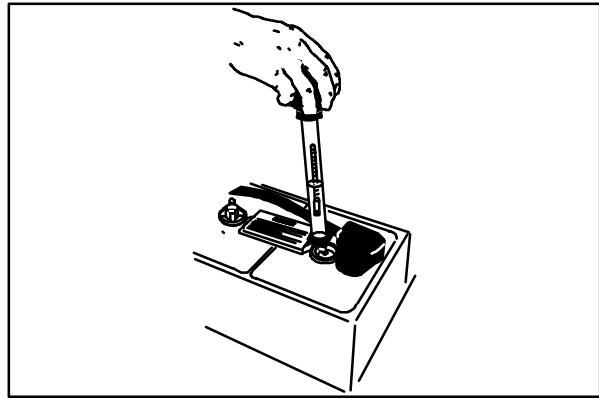

TO REPLACE BATTERY

FOR SAFETY: Before Leaving Or Servicing Machine; Stop On Level Surface, Set Parking Brake, Turn Off Machine And Remove Key.

1. Raise the seat support and engage the prop rod.
2. Disconnect the negative then the positive battery cables.
3. Remove the battery hold down bracket from the machine.
4. Tilt the battery and lift it out of the machine.
5. Clean the cables and the posts on the new battery and install back in the machine.
6. Reinstall the battery hold down bracket.
7. Reconnect the positive then the negative battery cables and close the seat support.

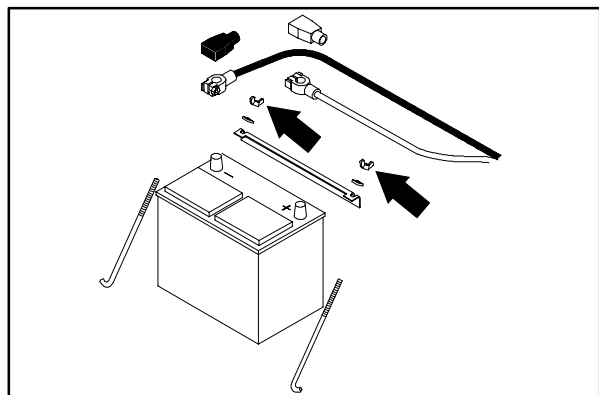
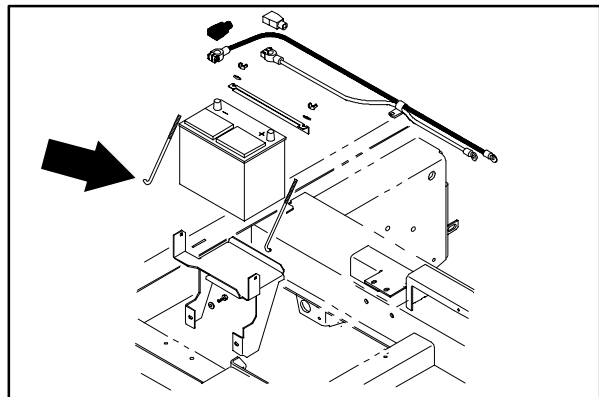

INSTRUMENT PANEL

The instrument panel consists of a circuit board, a touch panel, and a water/dust resistant plastic enclosure. Its touch panel controls various machine functions, while its indicator lights keep the operator informed on machine performance.

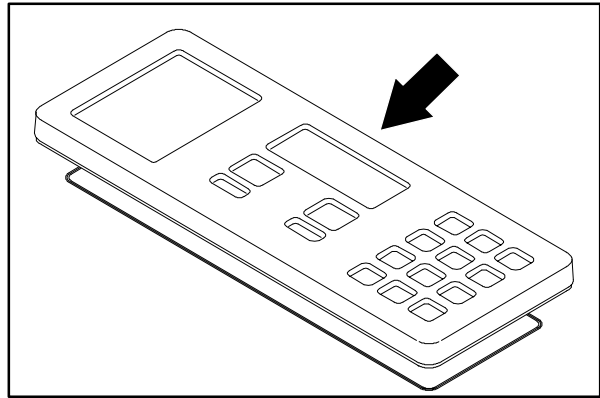

TO REPLACE INSTRUMENT PANEL

FOR SAFETY: Before Leaving Or Servicing Machine; Stop On Level Surface, Set Parking Brake, Turn Off Machine And Remove Key.

1. Raise the seat support and engage the prop rod.
 2. Remove the battery cables from the battery.
 3. Put the steering wheel in the lowest position.
 4. Open the front cover on the machine.
 5. Remove four M5 pan head screws holding the instrument panel to the dash panel.
 6. Pull the instrument panel back away from machine.
 7. Loosen the allen head screw in center of wire harness plug. Disconnect the harness.
 8. Remove instrument panel from machine.
 9. Install the new instrument panel back on the dash panel with the four M5 pan head screws and washers. Hand tighten snug.
 10. Push the main harness plug back in the instrument panel.
- NOTE: Slot in panel must line up with notch on plug. Hand tighten the allen head screw.*
11. Close the front cover.
 12. Reconnect the battery cables and lower the seat support.
 13. Start the machine and check for proper operation.

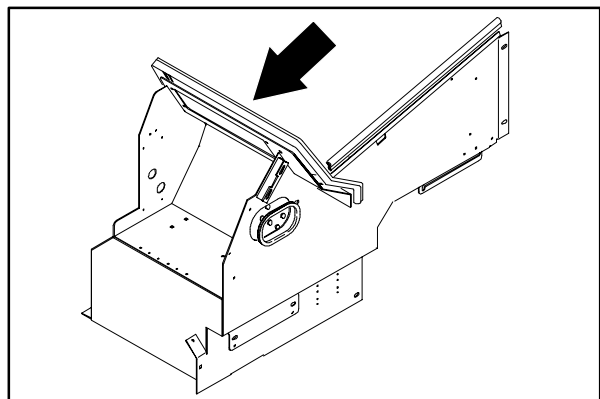
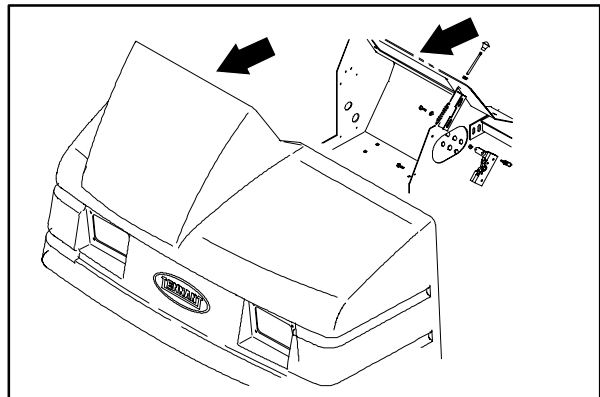

TO DISASSEMBLE INSTRUMENT PANEL

1. Remove panel from machine. See TO REPLACE INSTRUMENT PANEL instructions.
2. Place the instrument panel face down and remove the twelve larger pan head screws from the back.
3. The touch panel case can now be separated from the outer case and new O-ring gasket installed if necessary.
4. To disassemble the touch panel case further, remove the four smaller pan head screws from the center of case box.
5. Remove the case box from the circuit board / touch panel assembly.
6. The O-ring and connector gaskets can now be replaced in the case box if necessary.
7. Remove the eight pan head screws, unplug the flat connector and ground strap, remove the touch panel from the circuit board.
8. Any burned-out lamps can now be changed by turning them 1/4 turn counterclockwise and lifting out.
9. To replace the hour meter, unplug the two wires and remove the two pan head screws.

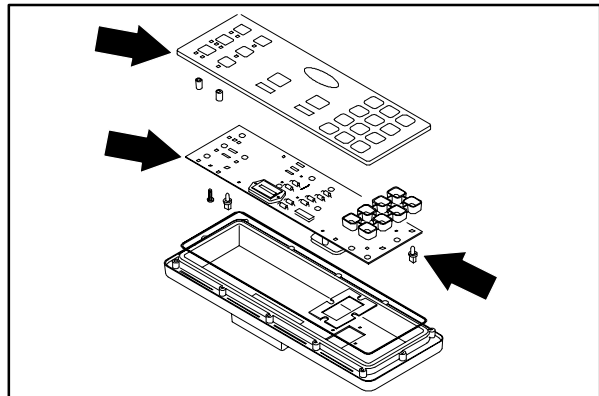
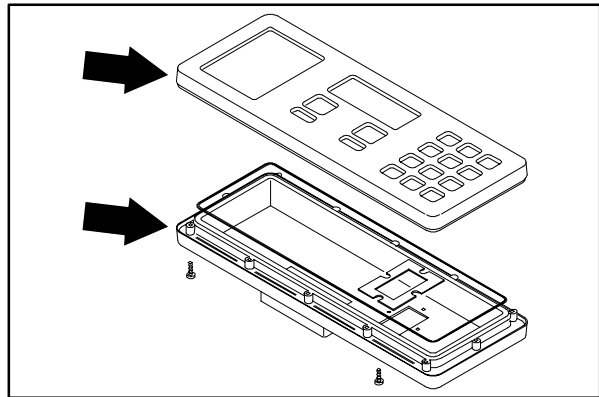
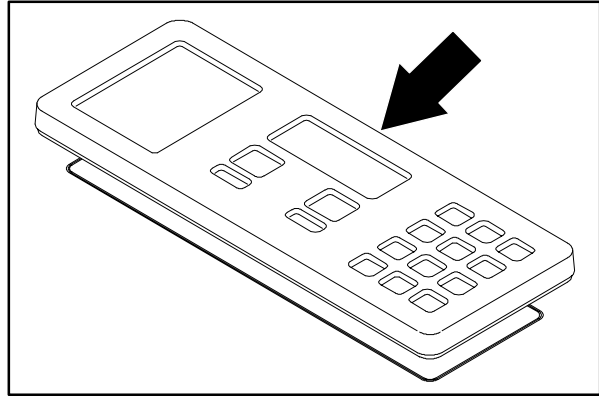

TO REASSEMBLE INSTRUMENT PANEL

1. Position the circuit board over the touch panel. Feed the flat connector from panel through the slot in board, plug it in and reconnect the ground strap.
2. Reinstall the eight pan head screws and lightly hand tighten.
3. Turn the circuit board assembly over and place it back in the case box.
4. Reinstall the four smaller pan head screws in center of case box. Lightly hand tighten.
5. Reinstall the touch panel case on the outer case.
6. Reinstall the twelve pan head screws and lightly hand tighten.
7. The instrument panel is now ready to be reinstalled in the machine. See TO REPLACE INSTRUMENT PANEL instructions.

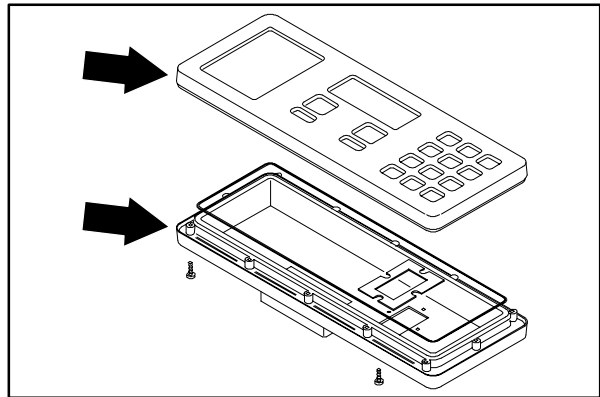
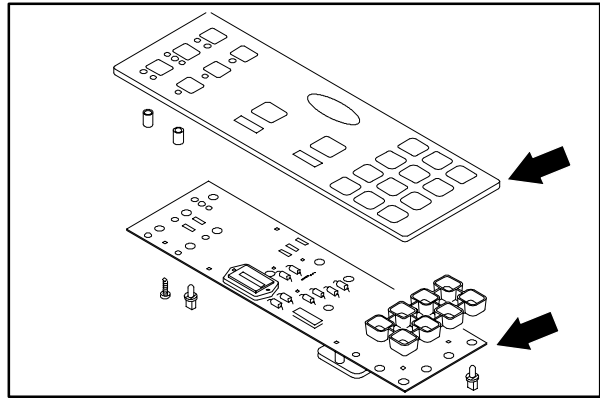

TO REPLACE MACHINE RELAY

FOR SAFETY: Before Leaving Or Servicing Machine; Stop On Level Surface, Set Parking Brake, Turn Off Machine And Remove Key.

1. Raise the seat support and engage the prop rod.
2. Remove the battery cables from the battery.
3. Open the front cover on the machine.
4. Locate the relays at the front of the operators compartment, near the hydraulic steering motor.
5. Lift up on the relay to harness locking tab.
6. Pull the harness plug out of the relay.
7. Remove the pan screw holding the relay to the operators compartment. Remove and discard the old relay.
8. Position the new relay on the operators compartment.
9. Reinstall the pan screw holding the relay to the operators compartment.
10. Reconnect the harness plug in the relay. See schematic in the ELECTRICAL section.
11. Reconnect the battery cables to the battery.
12. Lower the seat support.
13. Close the front cover on the machine.
14. Start and operate the machine, checking for proper operation.

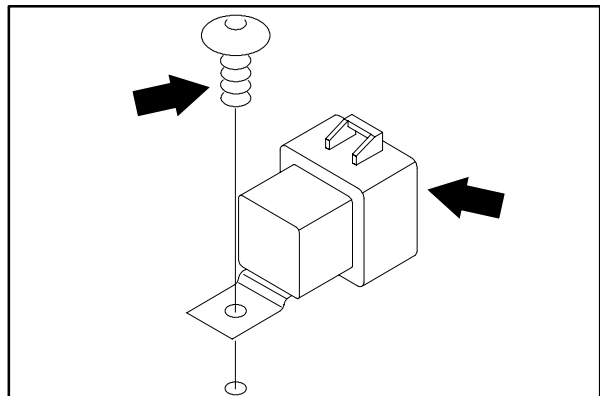
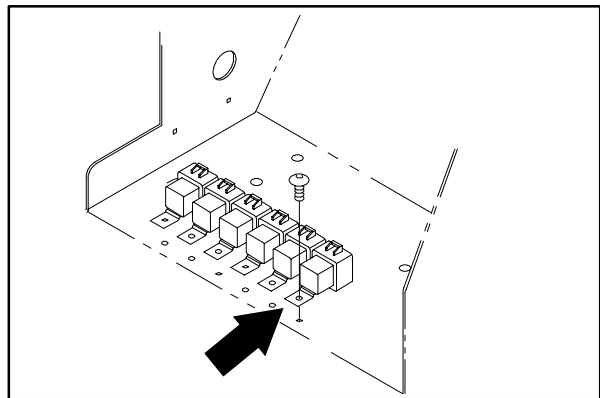
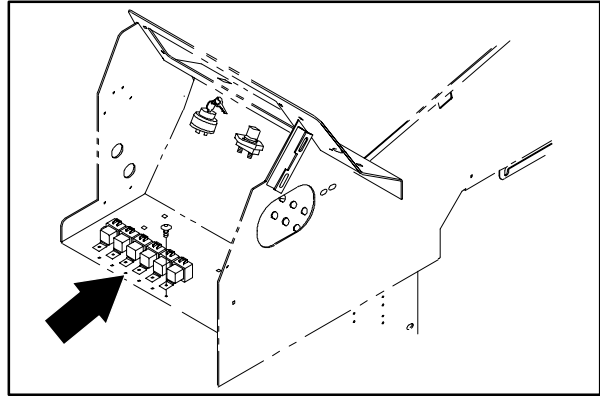

TO REPLACE CIRCUIT BREAKER

FOR SAFETY: Before Leaving Or Servicing Machine; Stop On Level Surface, Set Parking Brake, Turn Off Machine And Remove Key.

1. Raise the seat support and engage the prop rod.
2. Remove the battery cables from the battery.
3. Open the front cover on the machine.
4. Locate the circuit breakers at the front of the operators compartment, near the hydraulic steering motor.
5. Remove and retain the rubber boot on the front of the circuit breaker
6. Disconnect the electrical wires on the back of the circuit breaker.
7. Remove the steel retaining ring holding the circuit breaker to the dash panel. Remove the circuit breaker.
8. Position the new circuit breaker in the mounting hole on the dash panel.
9. Install the retaining ring on the new circuit breaker. Push the ring on all the way to the bottom of the circuit breaker.
10. Reconnect the wires to the back of the circuit breaker. See schematic in the ELECTRICAL section.
11. Reconnect the battery cables to the battery.
12. Lower the seat support.
13. Close the front cover on the machine.
14. Start and operate the machine, checking for proper operation.

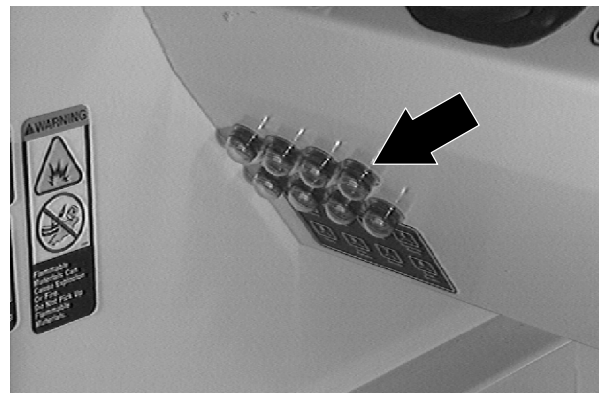
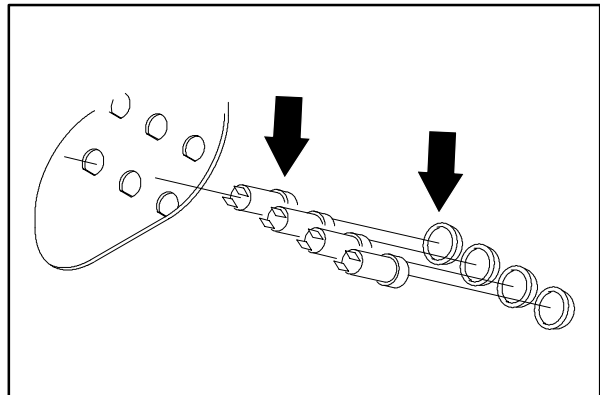
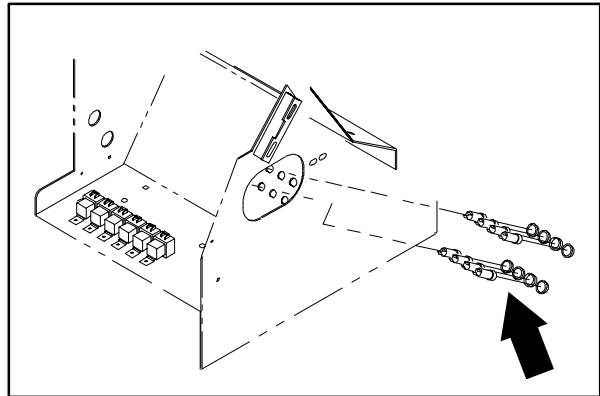
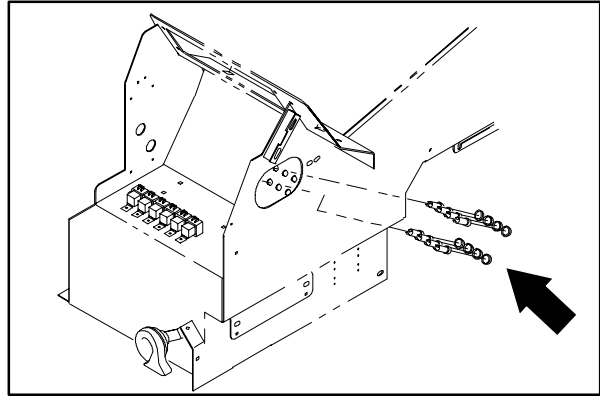

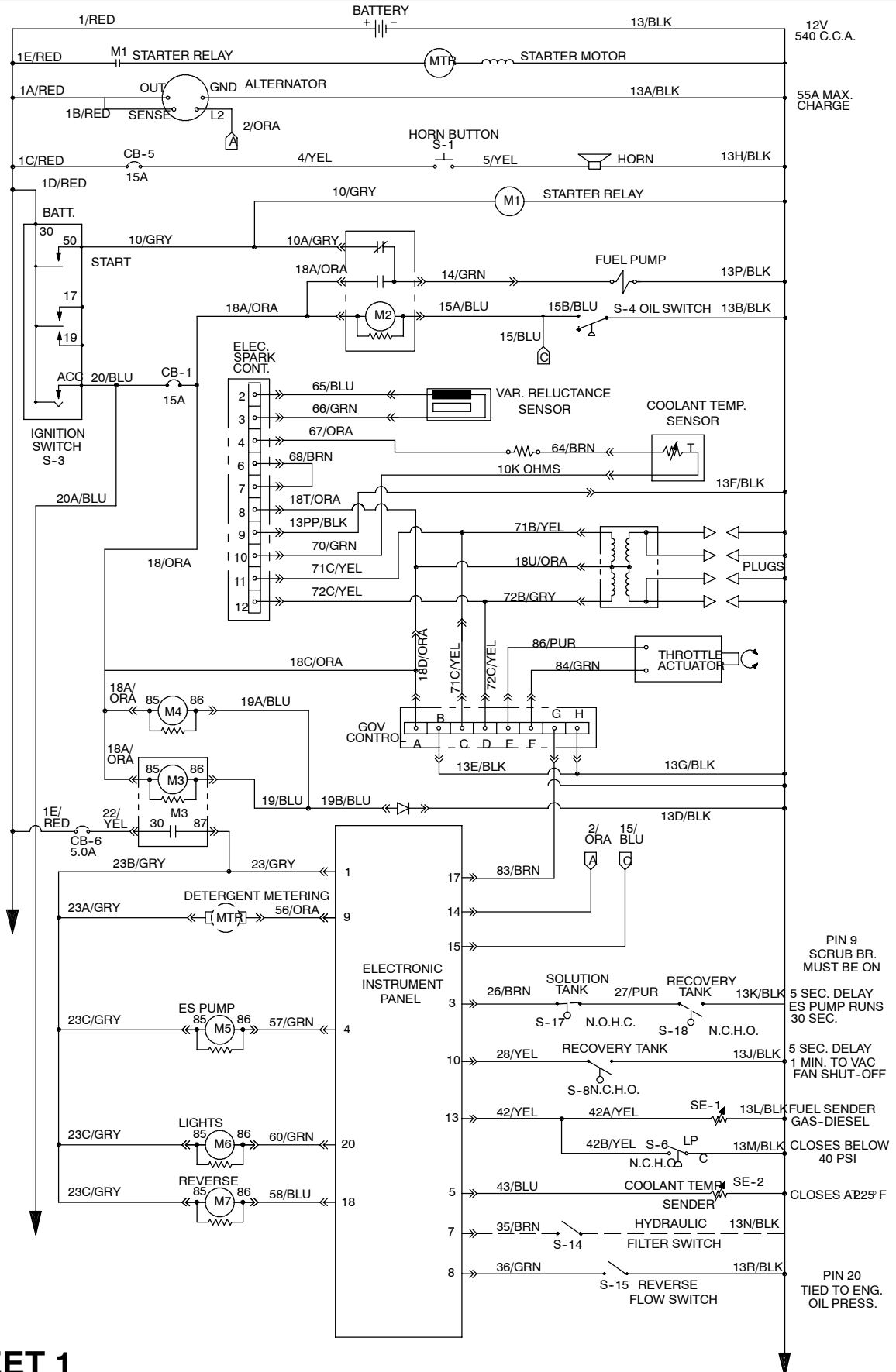

SHEET 1

GAS/LPG ELECTRICAL SCHEMATIC

ELECTRICAL

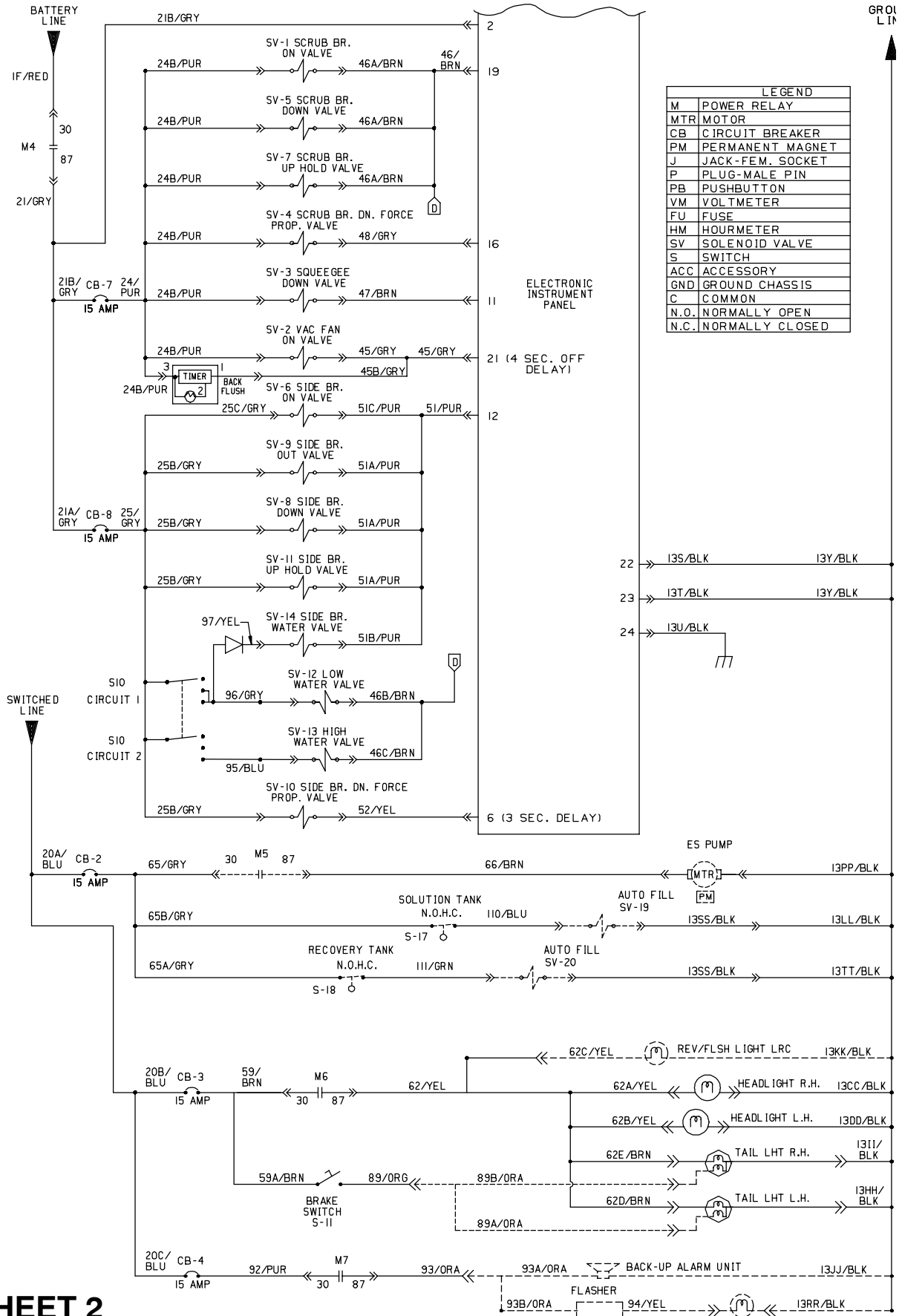

SHEET 2

GAS/LPG ELECTRICAL SCHEMATIC

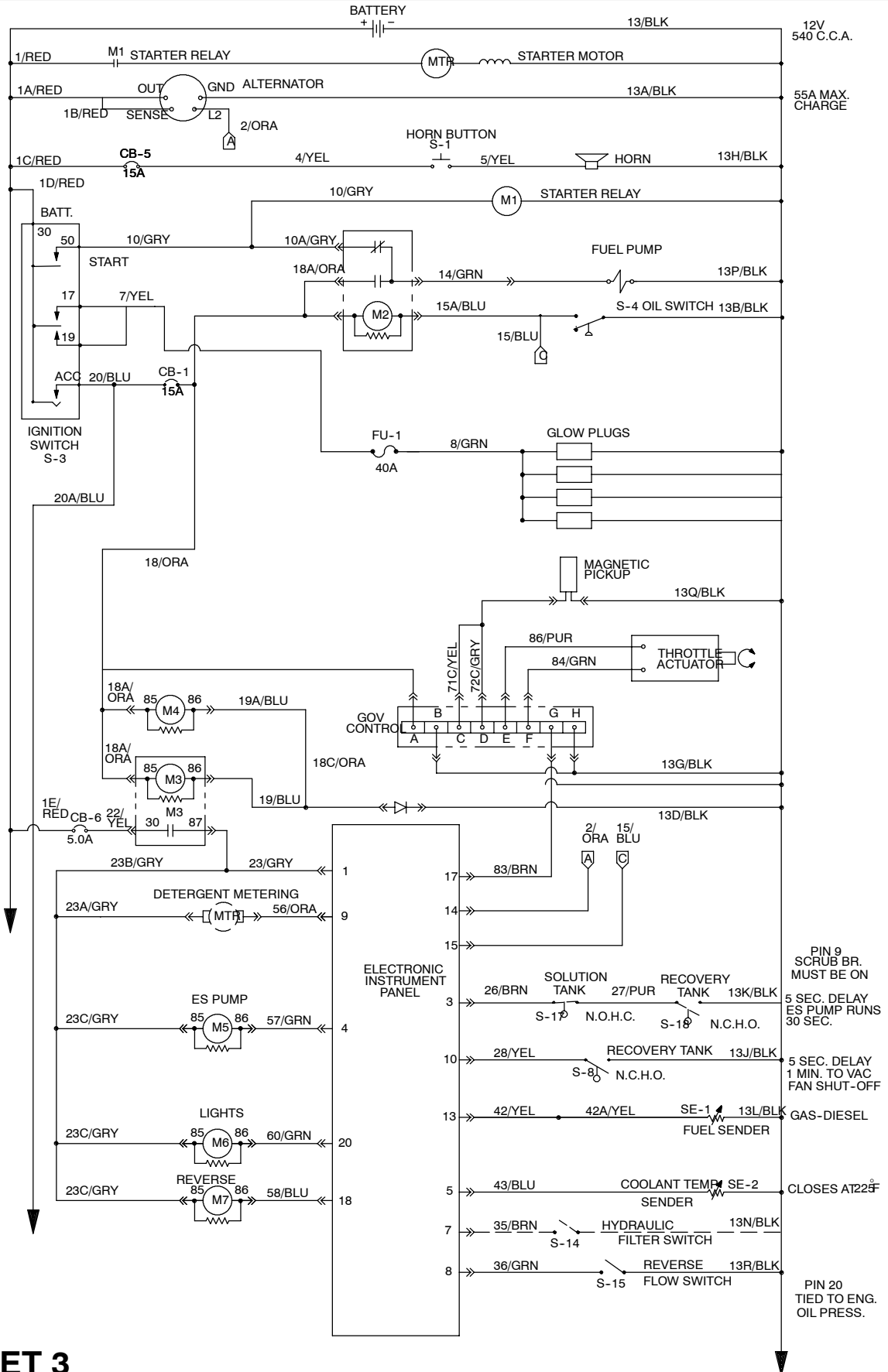

SHEET 3

DIESEL ELECTRICAL SCHEMATIC

ELECTRICAL

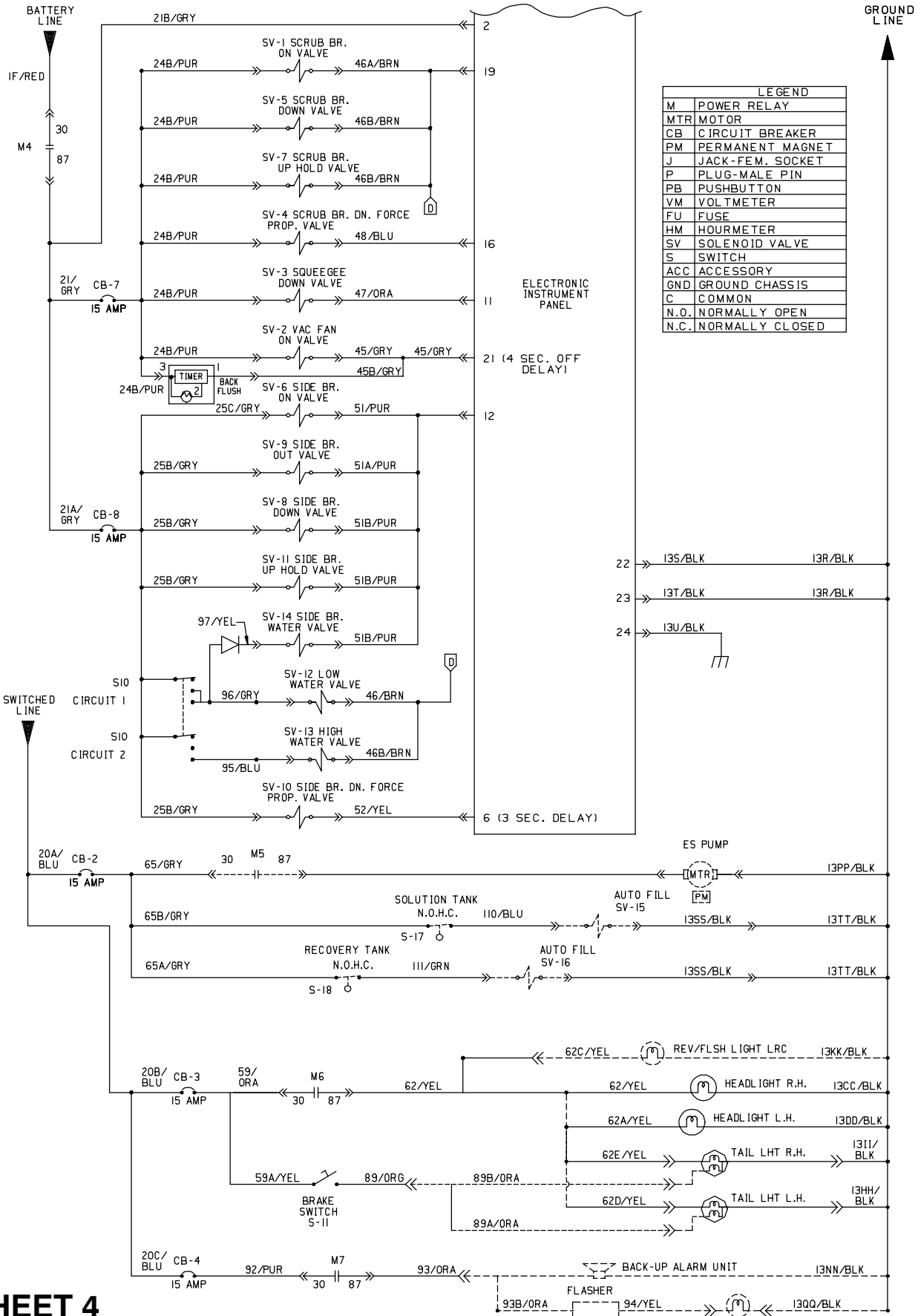

SHEET 4

DIESEL ELECTRICAL SCHEMATIC

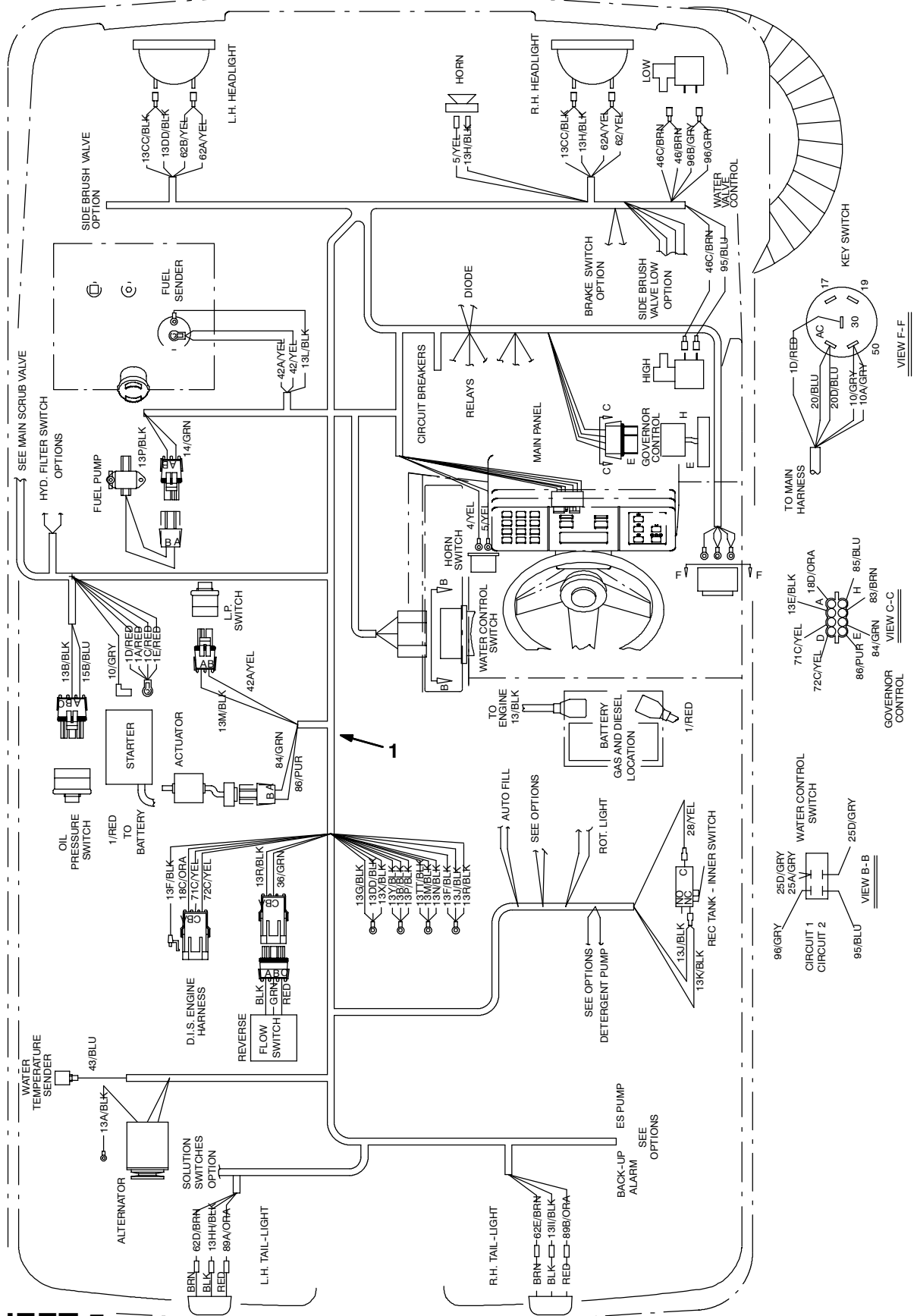

SHEET 5

GAS/LPG WIRE HARNESS GROUP

ELECTRICAL

SHEET 6

GAS/LPG WIRE HARNESS GROUP

RELAYS

- M2 FUEL PUMP
- M3 INSTRUMENT PANEL
- M4 HYD. SOLENOIDS
- M5 ES PUMP
- M6 HEADLIGHTS
- M7 REVERSE

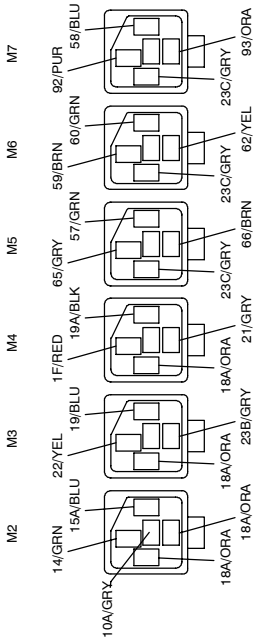

VIEW A-A

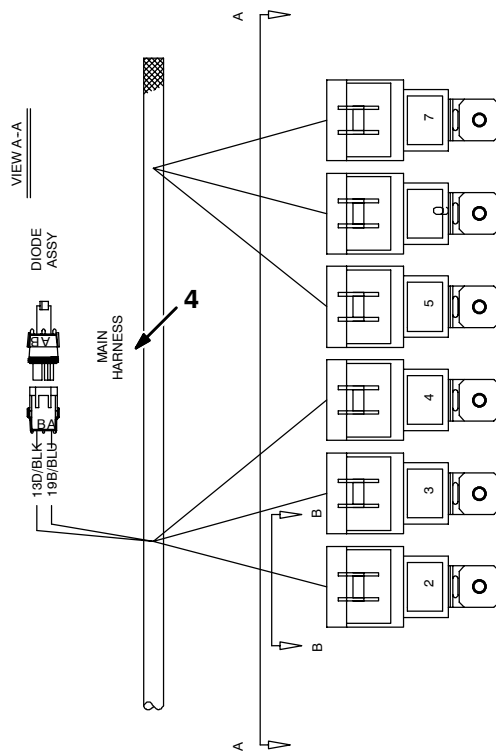

VIEW A-A

DIODE ASSY

MAIN HARNESS

TERMINALS

CIRCUIT BREAKERS

- CB-1 IGNITION
- CB-2 ES PUMP
- CB-3 HEADLIGHTS
- CB-4 BACK-UP ALARM
- CB-5 HORN
- CB-6 INSTRUMENT PANEL (5.0A)
- CB-7 SCRUB SOLENOIDS
- CB-8 SIDE BRUSH SOLENOIDS AND WATER VALVES

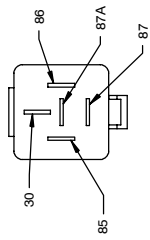
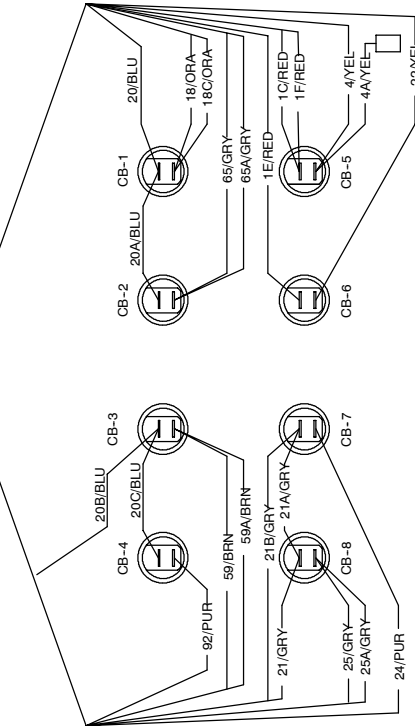

- 85 COIL +
- 86 COIL -
- 30 COMMON CONTACT
- 87 N.O. CONTACT
- 87A N.C. CONTACT

SECTION B-B

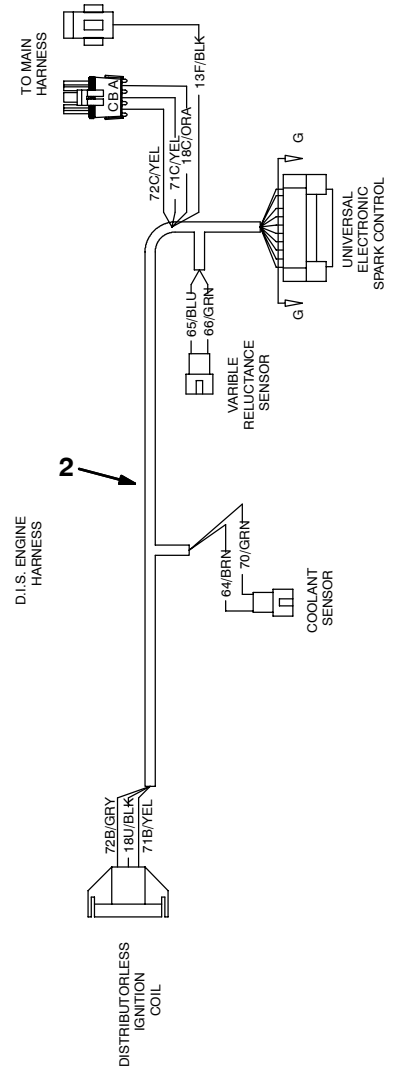

VIEW G-G

- UNIVERSAL ELECTRONIC SPARK CONTROL

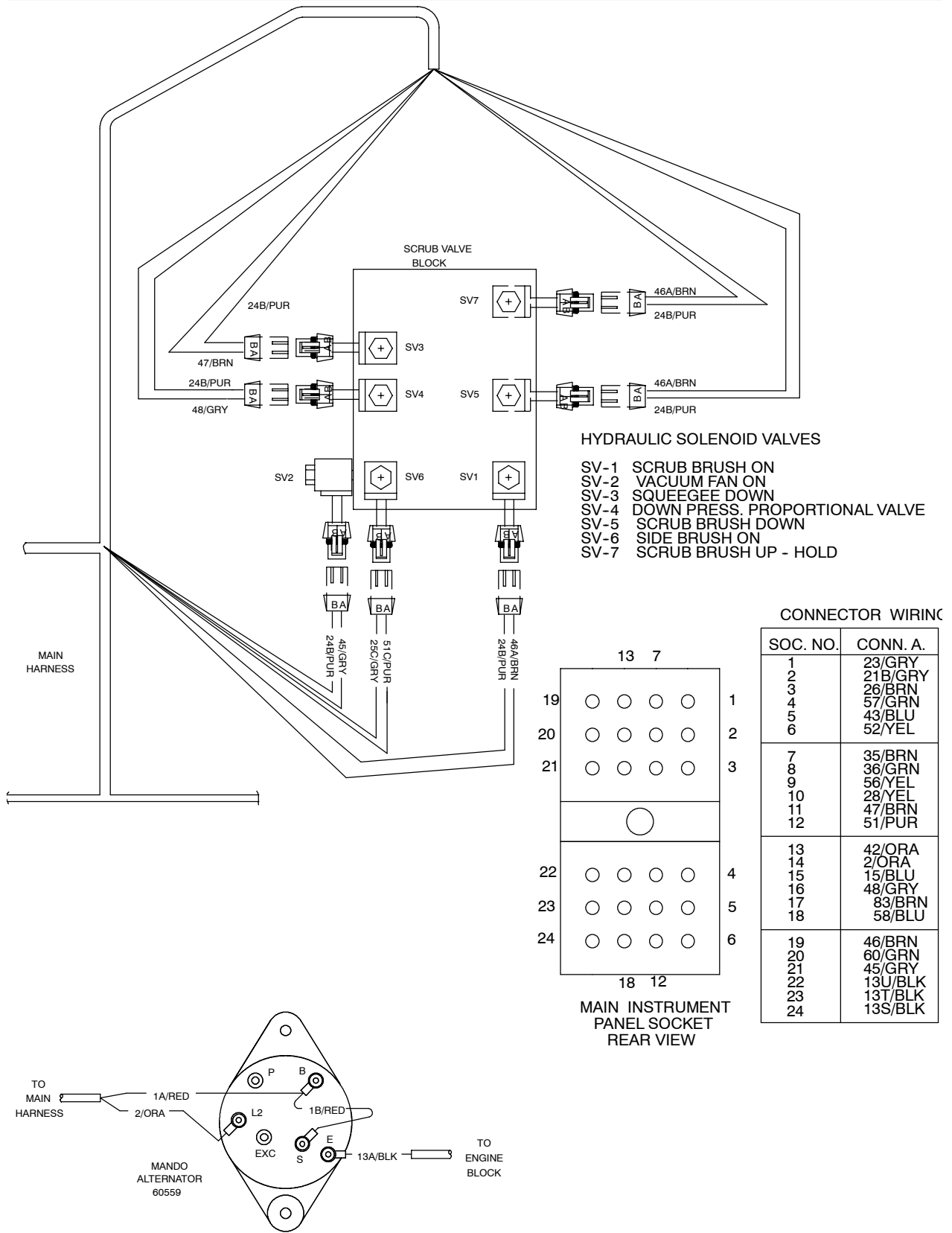

SHEET 7

GAS/LPG WIRE HARNESS GROUP

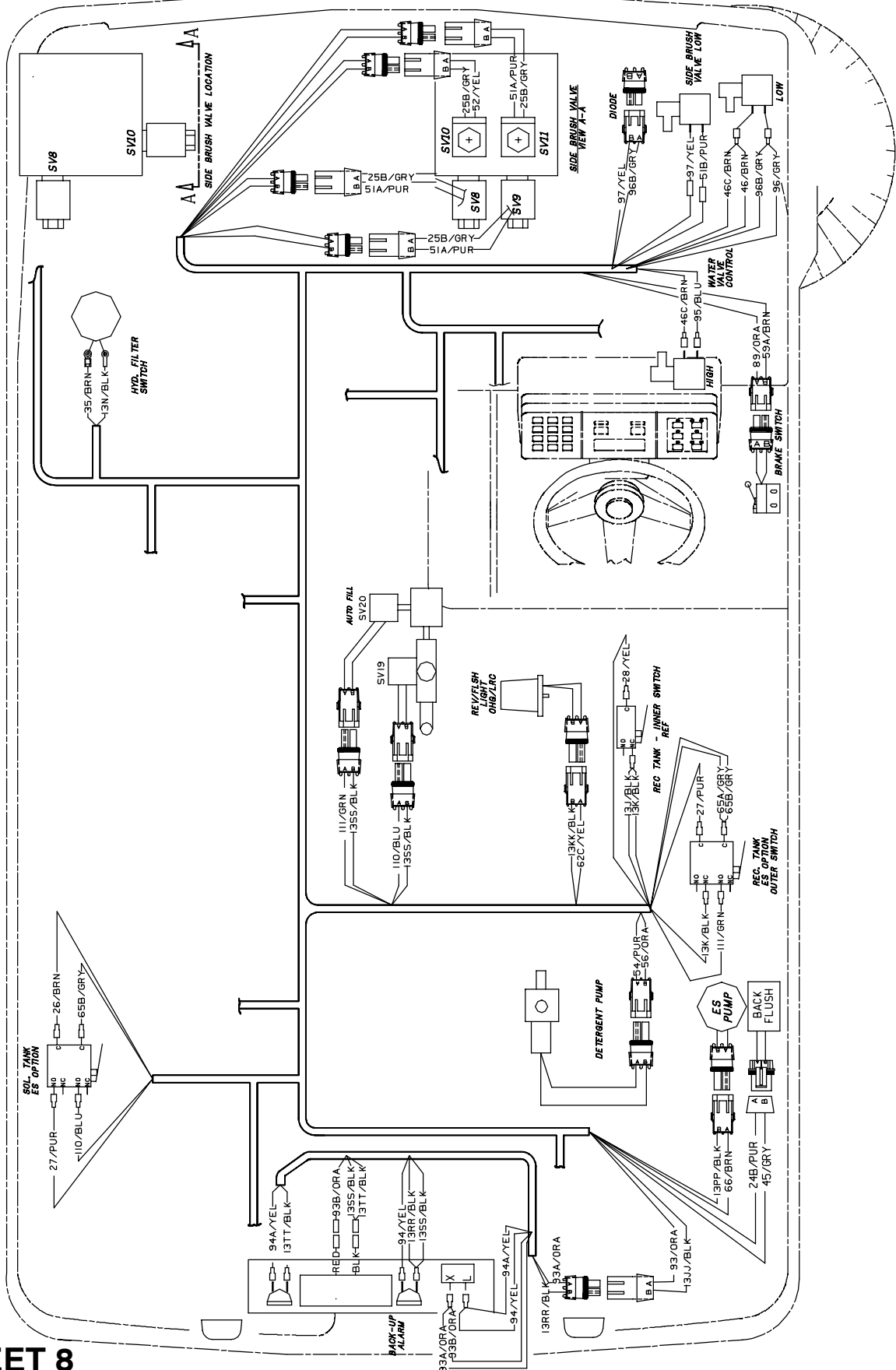

SHEET 8

GAS/LPG WIRE HARNESS GROUP (OPTIONS)

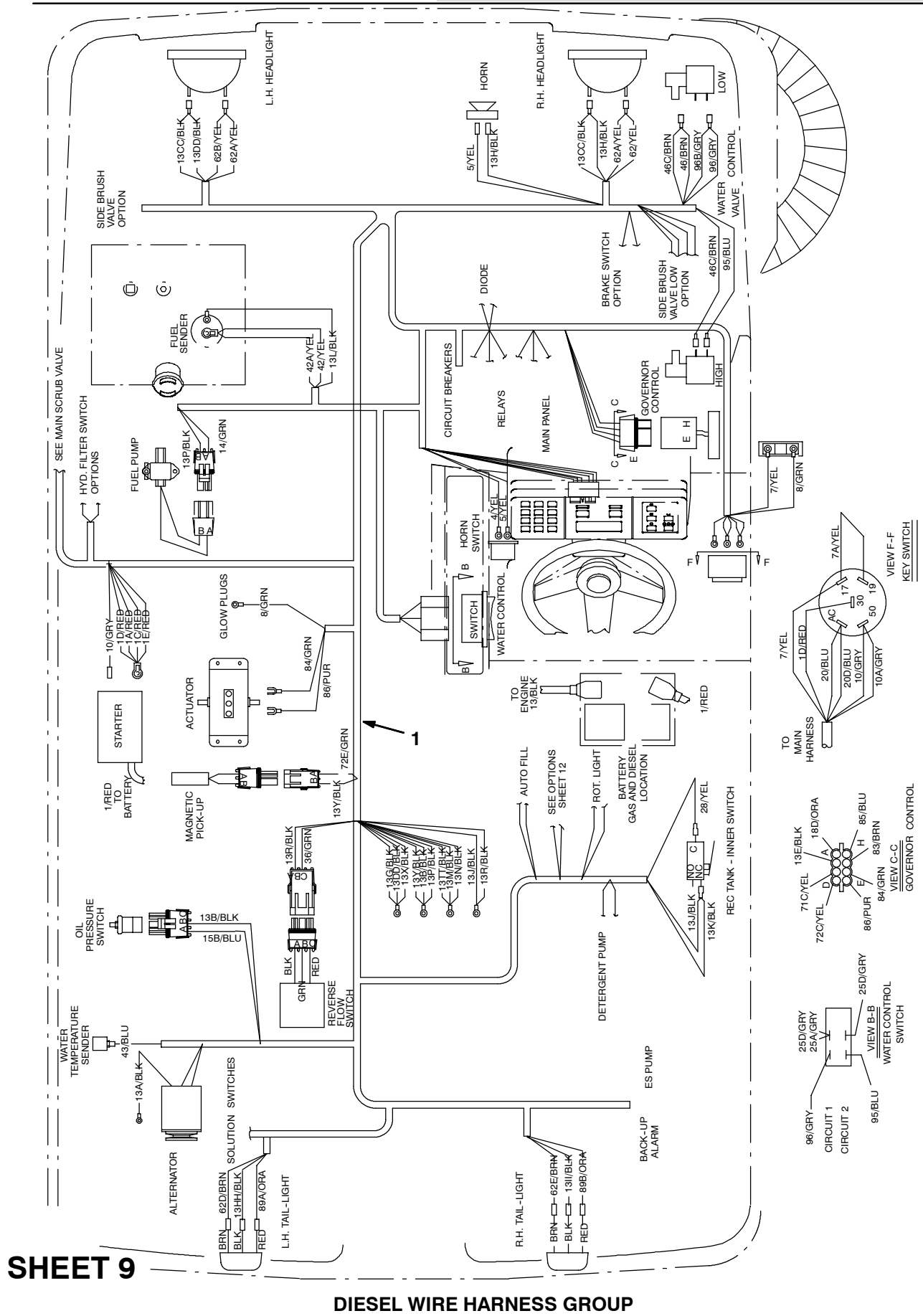

SHEET 9

DIESEL WIRE HARNESS GROUP

- CIRCUIT BREAKERS**
 CB-1 IGNITION
 CB-2 ES PUMP
 CB-3 HEADLIGHTS
 CB-4 BACK-UP ALARM
 CB-5 HORN
 CB-6 INSTRUMENT PANEL (5.0A)
 CB-7 SCRUB SOLENOIDS
 CB-8 SIDE BRUSH SOLENOIDS AND WATER VALVES

MAIN HARNESS

- RELAYS**
 M2 FUEL PUMP
 M3 INSTRUMENT PANEL
 M4 HYD. SOLENOIDS
 M5 ES PUMP
 M6 HEADLIGHTS
 M7 REVERSE

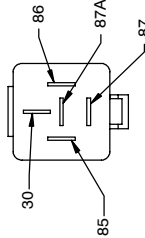
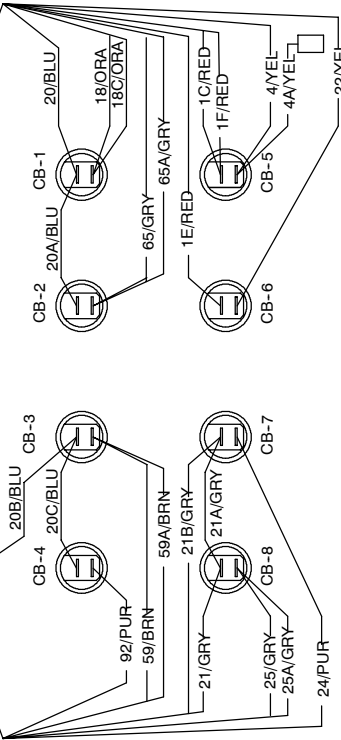
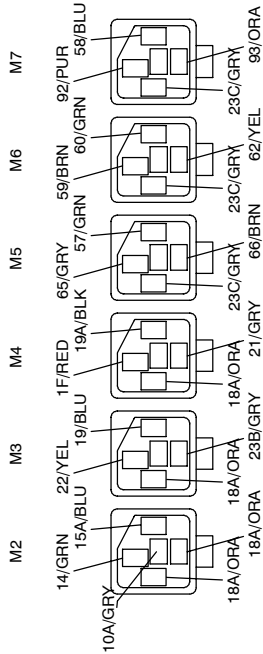

- 85 COIL+
 86 COIL -
 30 COMMON CONTACT
 87 N.O. CONTACT
 87A N.C. CONTACT

SECTION B-B

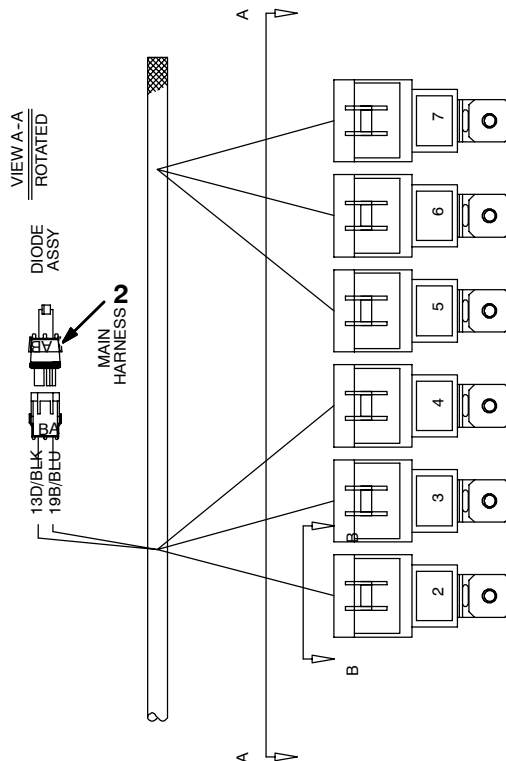

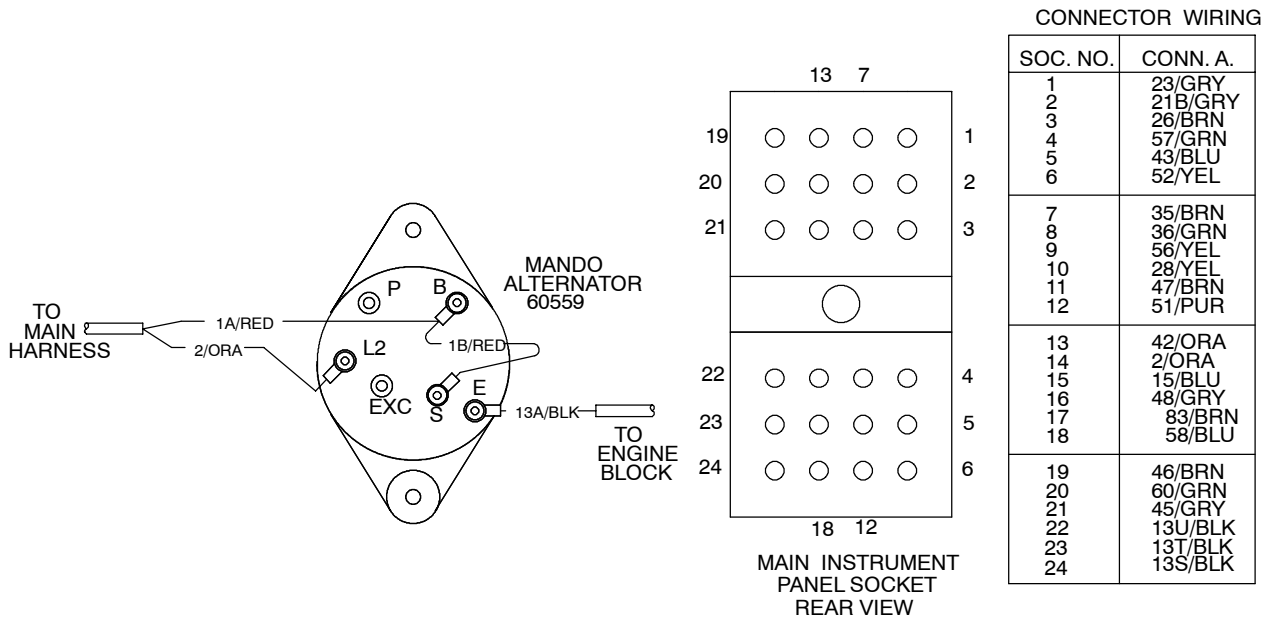
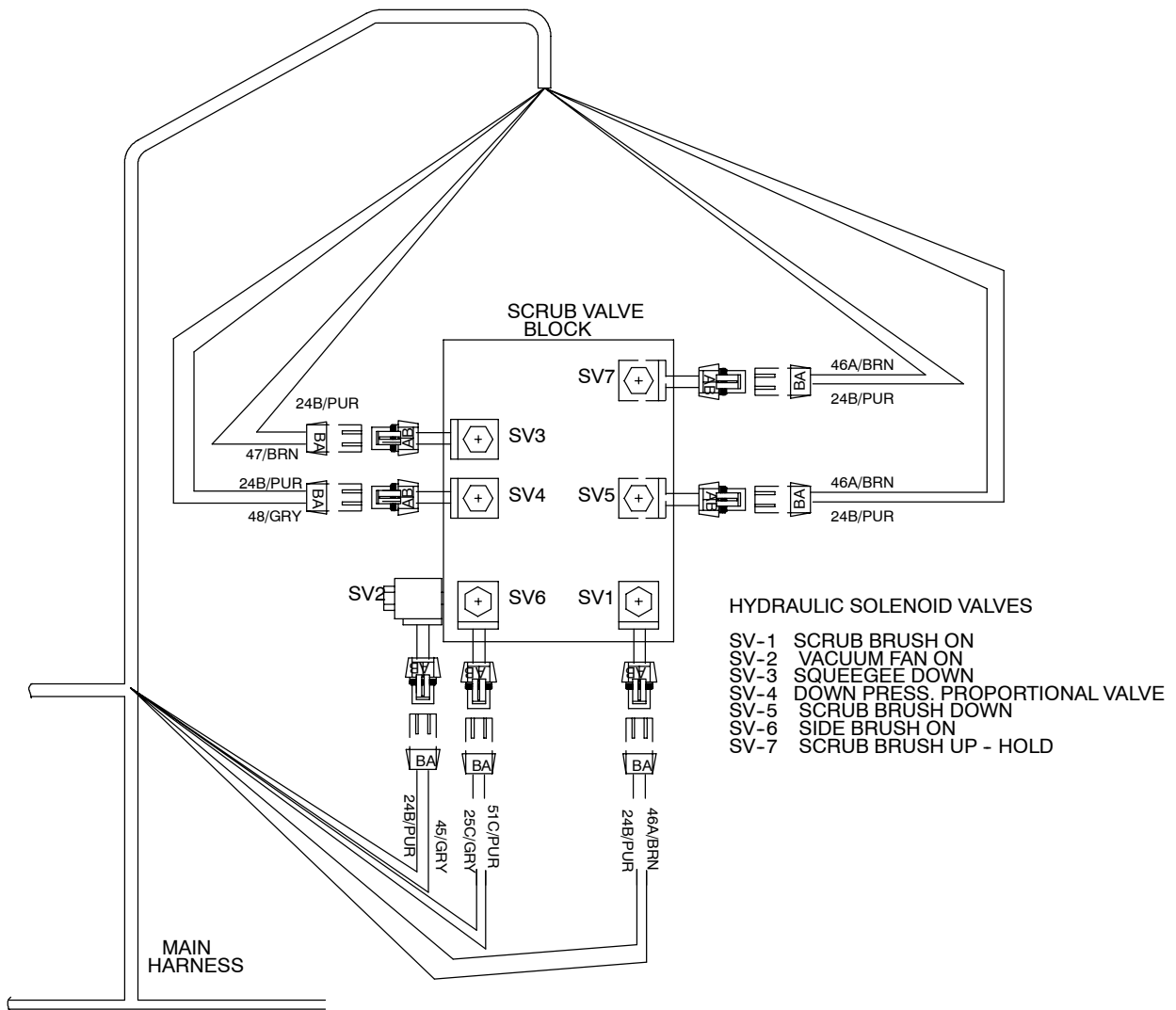

SHEET 11

DIESEL WIRE HARNESS GROUP

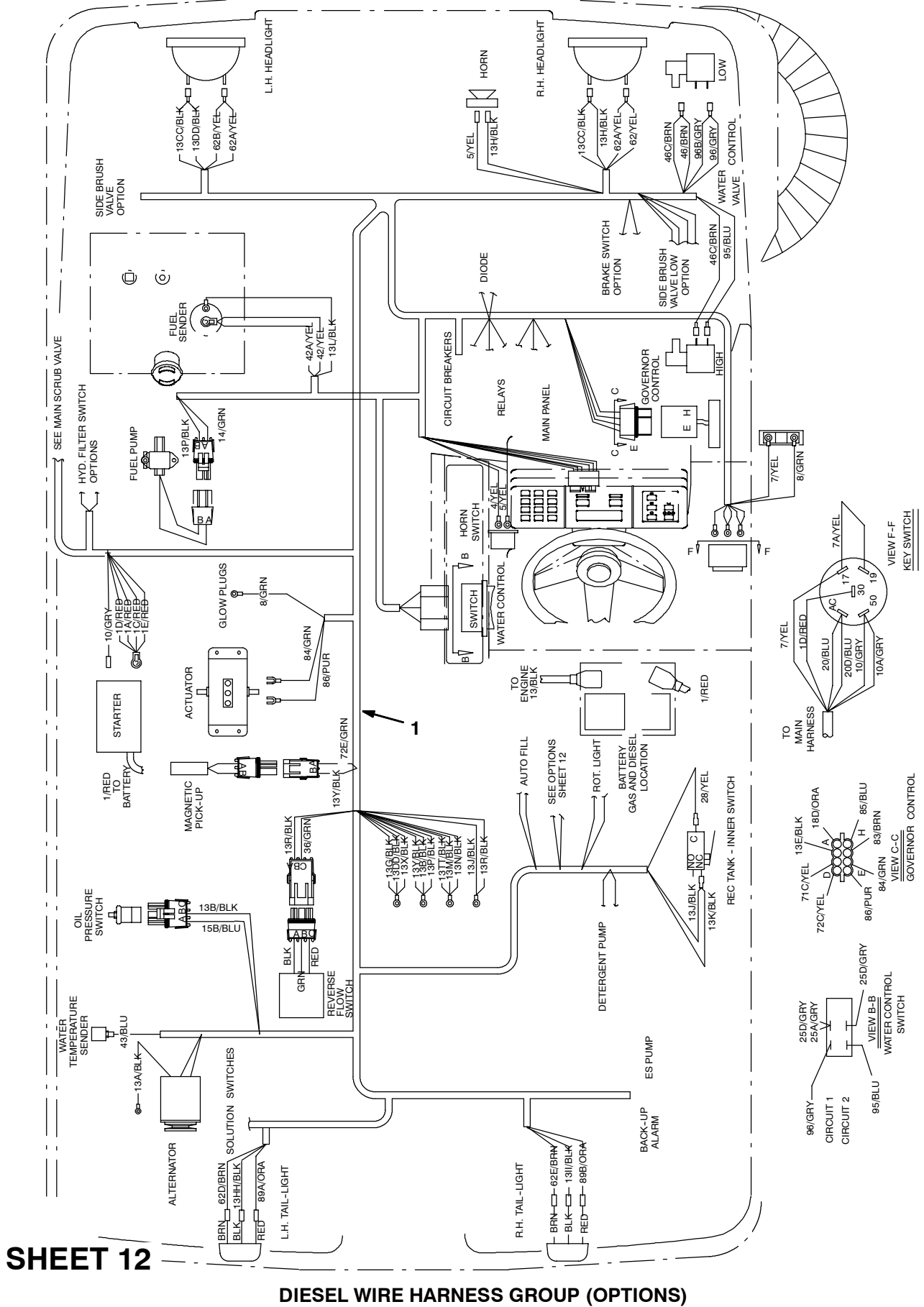

SHEET 12

DIESEL WIRE HARNESS GROUP (OPTIONS)

DIAGNOSTICS

The Model 7400 has an on-board diagnostic system. Each time the control board is powered up, it performs a self test. If the self test passes, the "OK" light is illuminated.

This trouble shooting section describes the different operating modes that are available, how to enter that mode, and a detail description of how that mode works.

OPERATING MODES

The Model 7400 has 6 different operating modes. The machine operator can access each mode by pressing various buttons on the control panel, holding them, and turning on the key. The common operating modes are detailed in the following charts.

Operating Modes	Entry Sequence (how to activate)
Normal Mode; <i>Normal operation.</i> More info pages 4-25 thru 4-27	Default (when key is turned on)
Manual Mode; <i>Manually operate discrete functions without interlocks.</i> More info page 4-28	<ol style="list-style-type: none"> 1. Push and hold the ES button 2. Turn on the key 3. Hold the ES button until the maintenance light comes on. 4. Release the ES button
Input Display Mode; <i>Display the state of floats, limit switches, and sensors.</i> More info page 4-29	<ol style="list-style-type: none"> 1. Push and hold the Squeegee button 2. Turn on the key 3. Hold the Squeegee button until the maintenance light comes on. 4. Release the Squeegee button
Error Display Mode; <i>Display the cause of a self-test failure.</i> More info pages 4-30 thru 4-32	<ol style="list-style-type: none"> 1. Push and hold the Detergent button 2. Turn on the key 3. Hold the Detergent button until the maintenance light comes on. 4. Release the Detergent button
Pressure Adjust Mode; <i>Adjust the pressure levels for the three down pressure settings.</i> More info page 4-33	<ol style="list-style-type: none"> 1. Push and hold the Side Brush button 2. Turn on the key 3. Hold the Side Brush button until the maintenance light comes on. 4. Release the Side Brush button
Reset Scrub Pressures; <i>Return the down pressure settings to the factory defaults.</i> More info page 4-34	<ol style="list-style-type: none"> 1. Push and hold the Scrub button 2. Turn on the key 3. Hold the scrub button 4. Wait for the maintenance light 5. While holding the Scrub button, press and hold the Side Brush button 6. Wait for the maintenance light to go out 7. Release the Scrub and Side Brush buttons 8. Turn the key off 9. Restart the machine

Operating Mode	Entry Sequence (how to activate)
Normal Mode; <i>Normal operation.</i>	Default (when key is turned on)

NORMAL MODE

The purpose of the normal mode is for the general operation of the machine. The machine will normally start in this mode. What follows is a brief description of each of the operations in the normal mode.

SCRUB BUTTON

The purpose of the scrub button is to turn the scrubbing operations on and off and adjust the scrubbing down pressure. Pressing the scrub button while the scrubbing operation is currently inactive will initiate the following actions:

1. The engine speed will be set to high.
2. If the machine is not in reverse, the main brushes will turn on and lower. The down pressure setting will be the same used during the last scrub cycle. The solution will flow at the high or low rate according to the water position switch.
3. If the machine is in reverse, the brushes will stay up until reverse is no longer sensed.
4. If the side brush LED is on, the side brush will turn on and lower. The down pressure setting will be the same used during the last scrub cycle.
5. The vacuum fan will turn on.
6. If the machine is not in reverse, the squeegee will lower.
7. If the machine is in reverse, the squeegee will stay up until reverse is no longer sensed.
8. If any of the detergent LED's are active, the water valves are turned on, and the machine is not in reverse, the detergent pump will run. The detergent pump will run at its slow rate if one LED is on. The detergent pump will run at its fast rate if two LED's are on.

SCRUB BUTTON (continued)

If the operator pushes and holds the scrub button, the pressure settings will begin to scroll. The pressure settings displayed after releasing the scrub button will become the new default down pressure setting.

If the scrub function was active and the operator pushes, then releases the scrub button, the following actions will take place:

1. The main brushes will turn off and rise.
2. The side brush will turn off and rise.
3. The solution flow will turn off.
4. The detergent pump will turn off.
5. A delay will pass, and then the squeegee will rise.
6. Another small delay will pass and the vacuum fan will turn off.

SQUEEGEE BUTTON

Pressing the squeegee button will start or stop the water pickup operation. If the operator presses the squeegee button while the squeegee LED is currently not illuminated will cause the following actions:

1. The squeegee LED will be illuminated.
2. The squeegee will drop and the vacuum fan will turn on, if the machine is not in reverse. If the machine goes into reverse while the squeegee is active, the squeegee will rise.

Pressing the squeegee button while the squeegee LED is on will cause the following actions:

1. The squeegee LED will turn off.
2. The squeegee will raise.
3. There will be a 30 second delay.
4. The vacuum fan will turn off.

DETERGENT

Pressing the detergent button will cause the detergent display to scroll through its three modes. The detergent pump will run only if the main scrub brushes are active and the solution switch is on.

- *Off (all LED's off)* – detergent pump off.
- *Low (left LED is on)* – detergent pump on low.
- *High (both LED's are on)* – detergent pump on high.

ES™ BUTTON

Pressing the ES™ button will enable or disable the ES™ system. The ES™ system will draw water from the recovery tank, through a filter and pump it into the solution tank. If the operator has turned on the ES™ system, and the recovery tank ES™ float reads a full tank, the ES™ pump will begin to run. The ES™ pump will continue to run for about 30 seconds after the ES™ float becomes uncovered.

OVERFLOW FLOAT

In order for the recovery tank float to become active, it must be consistently in the up position for at least 10 seconds. If the scrub or vacuum fan are active and the tank full float becomes active, the following actions will occur:

1. The overflow light will begin to blink.
2. A one minute delay will pass.
3. The overflow light will stop blinking and stay on.
4. The Scrub and Squeegee functions will be canceled.

Operating Mode	Entry Sequence (how to activate)
Manual Mode; <i>Manually operate discrete functions without interlocks.</i>	<ol style="list-style-type: none">1. Push and hold the ES™ button2. Turn on the key3. Hold the ES™ button until the maintenance light comes on.4. Release the ES™ button

MANUAL MODE

The purpose of the manual mode is to allow the operator to exercise individual functions on the machine.

NOTE: This mode disregards the effects of various interlocks. Do not scrub with the machine in this mode.

FOR SAFETY: When Servicing Machine, Avoid Moving Parts. Do Not Wear Loose Jackets, Shirts, Or Sleeves.

After entering the Manual Mode, the control buttons assume the following functions:

ES™ BUTTON

Pressing the ES™ button will toggle the ES™ pump on or off. In the on position, the ES™ pump will run regardless of the state of the floats.

SIDE BRUSH BUTTON

Pressing the Side Brush button will turn on and lower the side brush. If the main brush is off, the side brush will use the low pressure setting.

SQUEEGEE BUTTON

Pressing the Squeegee button will turn on the vacuum fan and lower the squeegee. Reverse is ignored.

ENGINE BUTTON

Pressing the Engine button will toggle the engine between high and low speed.

SCRUB BUTTON

Pressing the Scrub button will turn on and lower the main scrub head. Holding the Scrub button while scrub is active will cause the down pressure to scroll.

DETERGENT BUTTON

Pressing the Detergent button will cause the detergent LED's to scroll. If no LED's are on, the detergent pump will be off. If one LED is illuminated, the detergent pump will run in low speed. If both LED's are on, the detergent pump will run in high speed.

Operating Mode	Entry Sequence (how to activate)
Input Display Mode; <i>Display the state of floats, limit switches, and sensors.</i>	<ol style="list-style-type: none"> 1. Push and hold the Squeegee button 2. Turn on the key 3. Hold the Squeegee button until the maintenance light comes on. 4. Release the Squeegee button

INPUT DISPLAY MODE

In this mode, the operator can observe whether or not inputs to the panel are operating as intended. In the Input Display Mode, the segments of the gas gauge display the state of each input. If an input is open, the controller turns off the segment associated with that input. If an input is shorted to ground, the controller turns on the segment associated with that input.

The operation of the Input Display Mode is as follows:

- **SEGMENT 0** - Rightmost segment of the gas gauge. This segment displays the state of the ES float. This segment will illuminate when this input is shorted to ground.
- **SEGMENT 1** - Second segment from the right of the gas gauge. This segment displays the state of the recovery tank float. This segment will be illuminated when this input is shorted to ground.
- **SEGMENT 2** - Third segment from the right of the gas gauge. This segment displays the state of the reverse input. This segment will be illuminated when this input is shorted to ground.
- **SEGMENT 3** - Forth segment from the right of the gas gauge. This segment displays the state of the forward input. This segment will be illuminated when this input is shorted to ground.
- **ENGINE TEMPERATURE LIGHT** - In the Input Display Mode, the engine temperature light will blink until the engine reaches operating temperature.

Operating Mode	Entry Sequence (how to activate)
Error Display Mode; <i>Display the cause of a self-test failure.</i>	<ol style="list-style-type: none">1. Push and hold the Detergent button2. Turn on the key3. Hold the Detergent button until the maintenance light comes on.4. Release the Detergent button

ERROR DISPLAY MODE

Each time the operator starts the machine, the panel will run a self test on each output. If the panel passes the diagnostic, the “OK” indicator is illuminated. If the panel fails, a code is stored in a non volatile (preserved even after power down) memory. If the machine passes the diagnostic on the next startup cycle, the panel preserves the last failed code. In the Error Display Mode, the operator can obtain the error code stored after the last startup diagnostic failure. When the machine is in this mode, the LED’s on the operators panel will indicate which system experienced the failure. If the operator pushes the button associated with an illuminated LED, segments on the gas gauge will indicate which output failed and what type of failure occurred.

The operation of the Error Display Mode is as follows:

ES™ LED

Problem with the ES™ output. If the operator pushes the headlight button in this mode, the panel will display one of the following codes:

- **SEGMENT 0** - Rightmost segment of the gas gauge. This segment would indicate that the output was shorted to ground when the controller was expecting it to be open.
- **SEGMENT 0, 1** - First and second segments from the right of the gas gauge. These segments would indicate that the output was open when the controller was trying to short it to ground.

SIDE BRUSH LED

Problem with the side brush or side brush actuator outputs. If the operator pushes the side brush button in this mode, the panel would display one of the following codes:

- *SEGMENT 0* - Rightmost segment of the gas gauge. This segment would indicate that the side brush actuator output was shorted to ground when the controller was expecting it to be open.
- *SEGMENT 0, 1* - First and second segments from the right of the gas gauge. These segments would indicate that the side brush actuator output was open when the controller was trying to short it to ground.
- *SEGMENT 2* - Third segment from the right of the gas gauge. This segment would indicate that the side brush motor output was shorted to ground when the controller was expecting it to be open.
- *SEGMENT 2, 3* - Third and fourth segments from the right of the gas gauge. These segments would indicate that the side brush motor output was open when the controller was trying to short it to ground.

SQUEEGEE LED

Problem with the squeegee actuator or vacuum fan motor outputs. If the operator pushes the squeegee button in this mode, the panel would display one of the following codes:

- *SEGMENT 0* - Rightmost segment of the gas gauge. This segment would indicate that the squeegee actuator output was shorted to ground when the controller was expecting it to be open.
- *SEGMENT 0, 1* - First and second segments from the right of the gas gauge. These segments would indicate that the squeegee actuator output was open when the controller was trying to short it to ground.
- *SEGMENT 2* - Third segment from the right of the gas gauge. This segment would indicate that the vacuum fan motor output was shorted to ground when the controller was expecting it to be open.
- *SEGMENT 2, 3* - Third and fourth segments from the right of the gas gauge. These segments would indicate that the vacuum fan motor output was open when the controller was trying to short it to ground.

SCRUB LED

Problem with the main brush actuator or motor outputs. If the operator pushes the scrub button in this mode, the panel would display one of the following codes:

- *SEGMENT 0* - Rightmost segment of the gas gauge. This segment would indicate that the main brush actuator output was shorted to ground when the controller was expecting it to be open.
- *SEGMENT 0, 1* - First and second segments from the right of the gas gauge. These segments would indicate that the main brush actuator output was open when the controller was trying to short it to ground.
- *SEGMENT 2* - Third segment from the right of the gas gauge. This segment would indicate that the main brush motor output was shorted to ground when the controller was expecting it to be open.
- *SEGMENT 2, 3* - Third and fourth segments from the right of the gas gauge. These segments would indicate that the main brush motor output was open when the controller was trying to short it to ground.

DETERGENT LED

Problem with the headlight or detergent pump outputs. If the operator pushes the detergent button in this mode, the panel would display one of the following codes:

- *SEGMENT 0* - Rightmost segment of the gas gauge. This segment would indicate that the detergent pump output was shorted to ground when the controller was expecting it to be open.
- *SEGMENT 0, 1* - First and second segments from the right of the gas gauge. These segments would indicate that the detergent pump output was open when the controller was trying to short it to ground.
- *SEGMENT 2* - Third segment from the right of the gas gauge. This segment would indicate that the headlight output was shorted to ground when the controller was expecting it to be open.
- *SEGMENT 2, 3* - Third and fourth segments from the right of the gas gauge. These segments would indicate that the headlight pump output was open when the controller was trying to short it to ground.

Operating Mode	Entry Sequence (how to activate)
Pressure Adjust Mode; <i>Adjust the pressure levels for the three down pressure settings.</i>	<ol style="list-style-type: none"> 1. Push and hold the Side Brush button 2. Turn on the key 3. Hold the Side Brush button until the maintenance light comes on. 4. Release the Side Brush button

PRESSURE ADJUST MODE

When the machine is in this mode, the operator can adjust the down pressures for the main and side brushes. When the operator adjusts down pressure number 3, pressures 1 and 2 are automatically calculated and stored. The operator may make independent adjustments to pressures 1 and 2 after storing number 3. These adjustments will influence only the currently displayed setting.

The operator can change the pressure settings by pressing and holding the scrub button. When the *side brush* is **inactive** and the *main brush* is **active**, the operator can adjust the down pressure for the main brush. When the *side brush* and *main brush* are **active**, the operator can adjust the down pressure for the side brush.

To store the new down pressure settings, turn off the Side Brush and Scrub Panel LEDs on the touch panel. Then turn off the key switch.

The operation of the Pressure Adjust Mode is as follows:

SCRUB BUTTON

Pressing the Scrub button will start the normal scrub sequence. When scrub is active the following controls and displays take on alternate functions.

- **GAS GAUGE** - The gas gauge in the pressure adjust mode displays the relative down pressure of the main (when the side brush is inactive) or the side brush (when the side brush is active).
- **SQUEEGEE BUTTON** - Holding the squeegee button will **decrease** the down pressure.
- **DETERGENT BUTTON** - Holding the detergent button will **increase** the down pressure.

NOTE: *To return to the factory brush pressure settings, run RESET SCRUB PRESSURES from the Diagnostics menu.*

Operating Mode	Entry Sequence (how to activate)
Reset Scrub Pressures; <i>Return the down pressure settings to the factory defaults.</i>	<ol style="list-style-type: none">1. Push and hold the Scrub button2. Turn on the key3. Hold the Scrub button4. Wait for the maintenance light5. While holding the Scrub button, press and hold the Side Brush button6. Wait for the maintenance light to go out7. Release the Scrub and Side Brush buttons8. Turn the key off9. Restart the machine

RESET SCRUB PRESSURES

When the machine goes into this mode, the controller replaces the current brush down pressure settings with factory defaults. To initiate, follow the entry sequence (how to activate). The pressures will automatically reset.

TROUBLESHOOTING

The following troubleshooting section is organized with the section of the electrical schematic that pertains to that particular problem first, followed by the flow chart.

INSTRUMENT PANEL DOES NOT POWER UP (SCHEMATIC)

OPERATION:
 -KEY SWITCH ACTIVATES
 M3 AND M4
 -M3 CONTACT SUPPLIES
 14VDC TO INSTRUMENT
 PANEL (PIN 1)

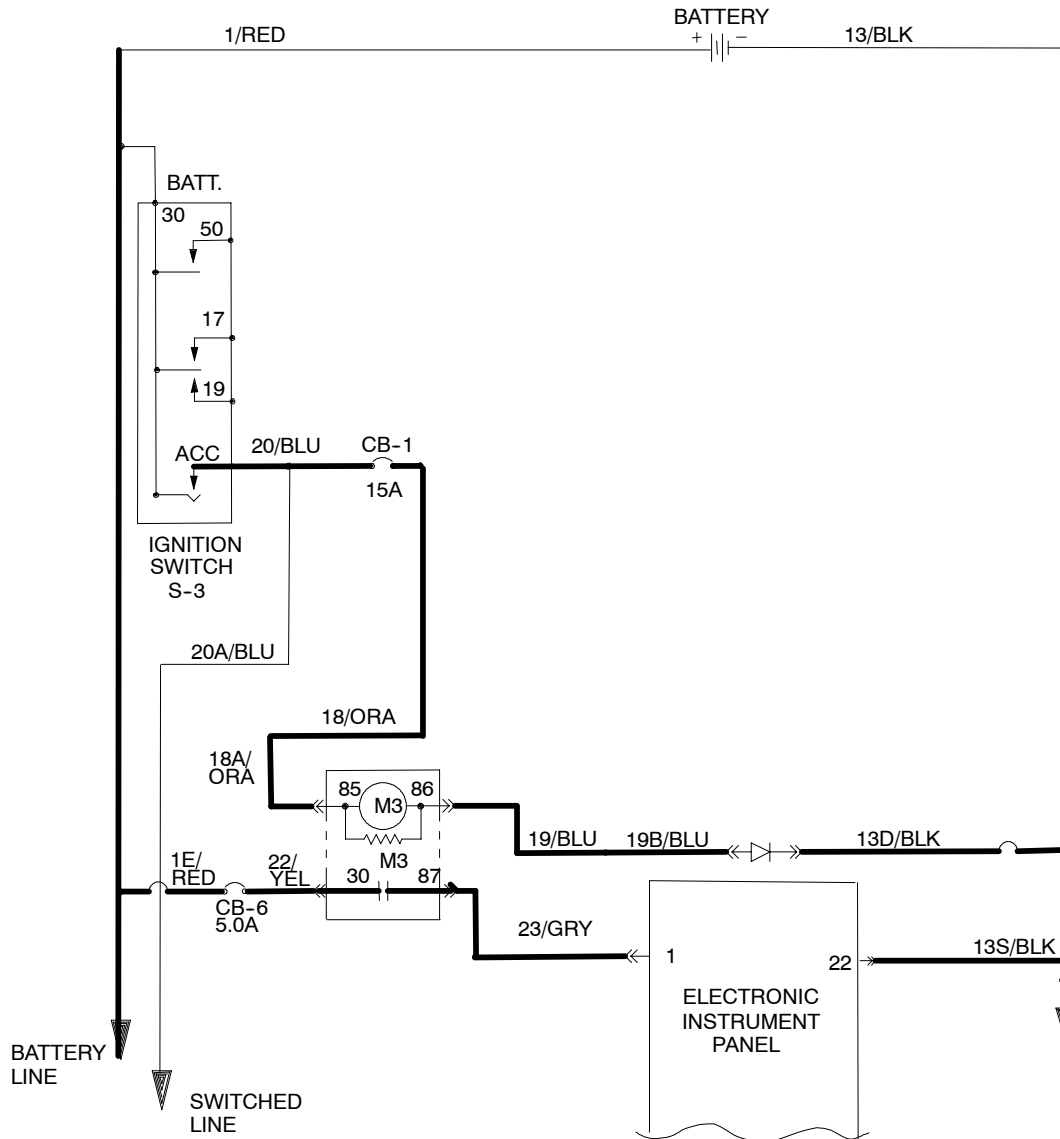

**INSTRUMENT PANEL
DOES NOT POWER UP
(FLOW CHART)**

OPERATION:
-KEY SWITCH ACTIVATES
M3 AND M4
-M3 CONTACT SUPPLIES
14VDC TO INSTRUMENT
PANEL (PIN 1)

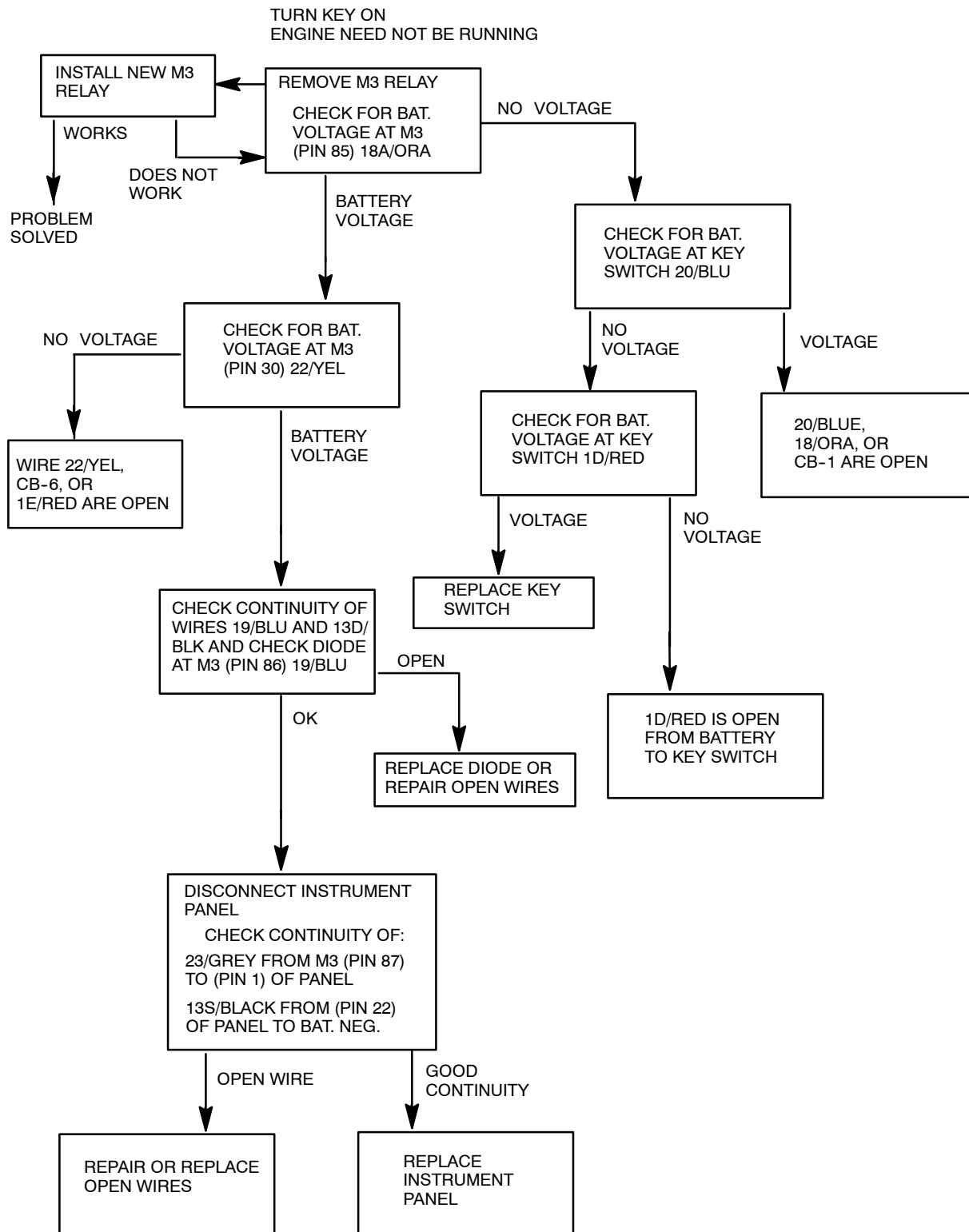

**SCRUB BRUSH WILL NOT
TURN ON AND/OR DOWN
(SCHEMATIC)**

OPERATION:
 -SCRUB IS SELECTED ON
 TOUCH PANEL
 -SCRUB SOLENOIDS ARE
 TURNED ON
 -HEAD WILL LOWER,
 BRUSHES WILL SPIN

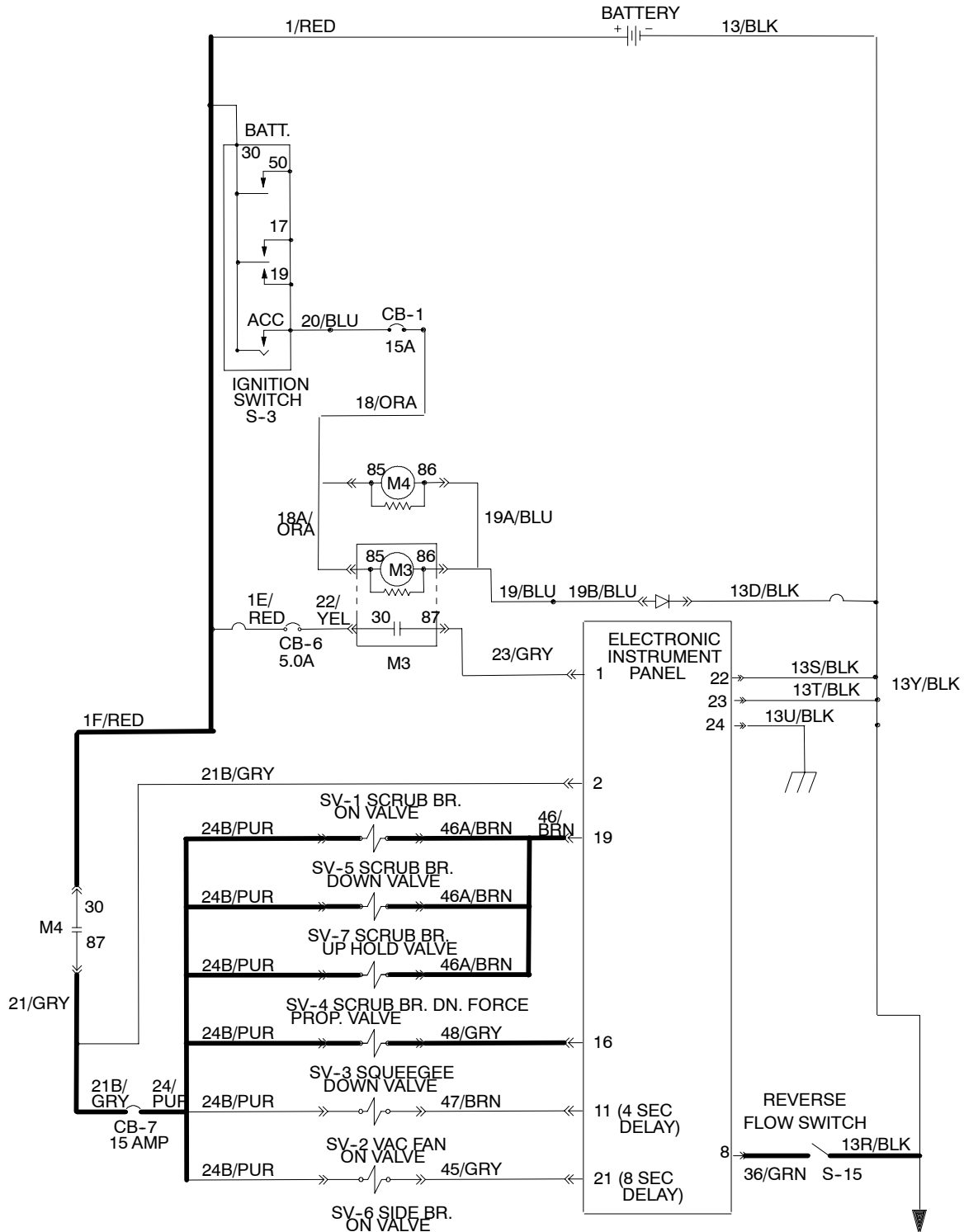

SCRUB BRUSH WILL NOT TURN ON AND/OR DOWN (FLOW CHART)

OPERATION:
 -SCRUB IS SELECTED ON TOUCH PANEL
 -SCRUB SOLENOIDS ARE TURNED ON
 -HEAD WILL LOWER, BRUSHES WILL SPIN

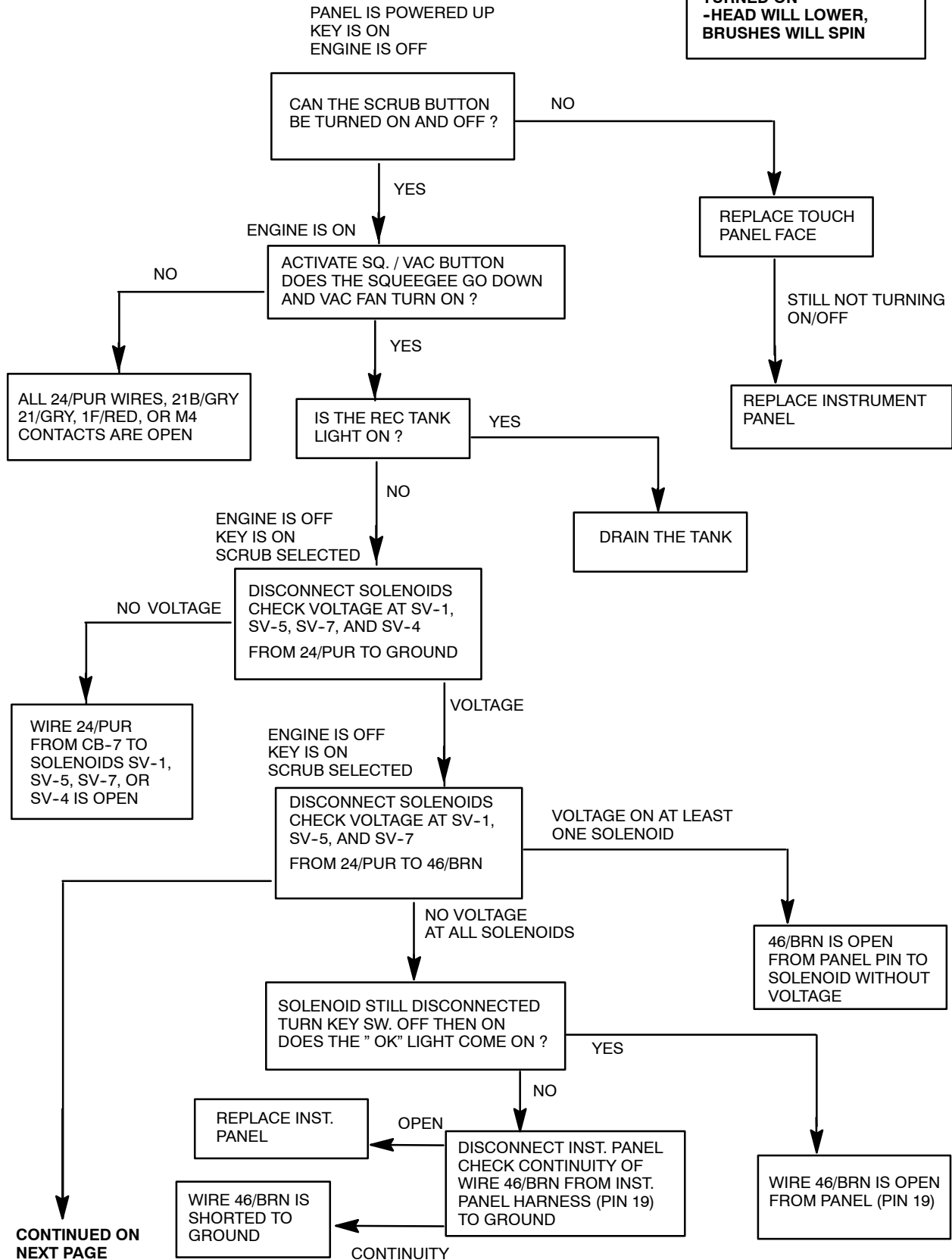

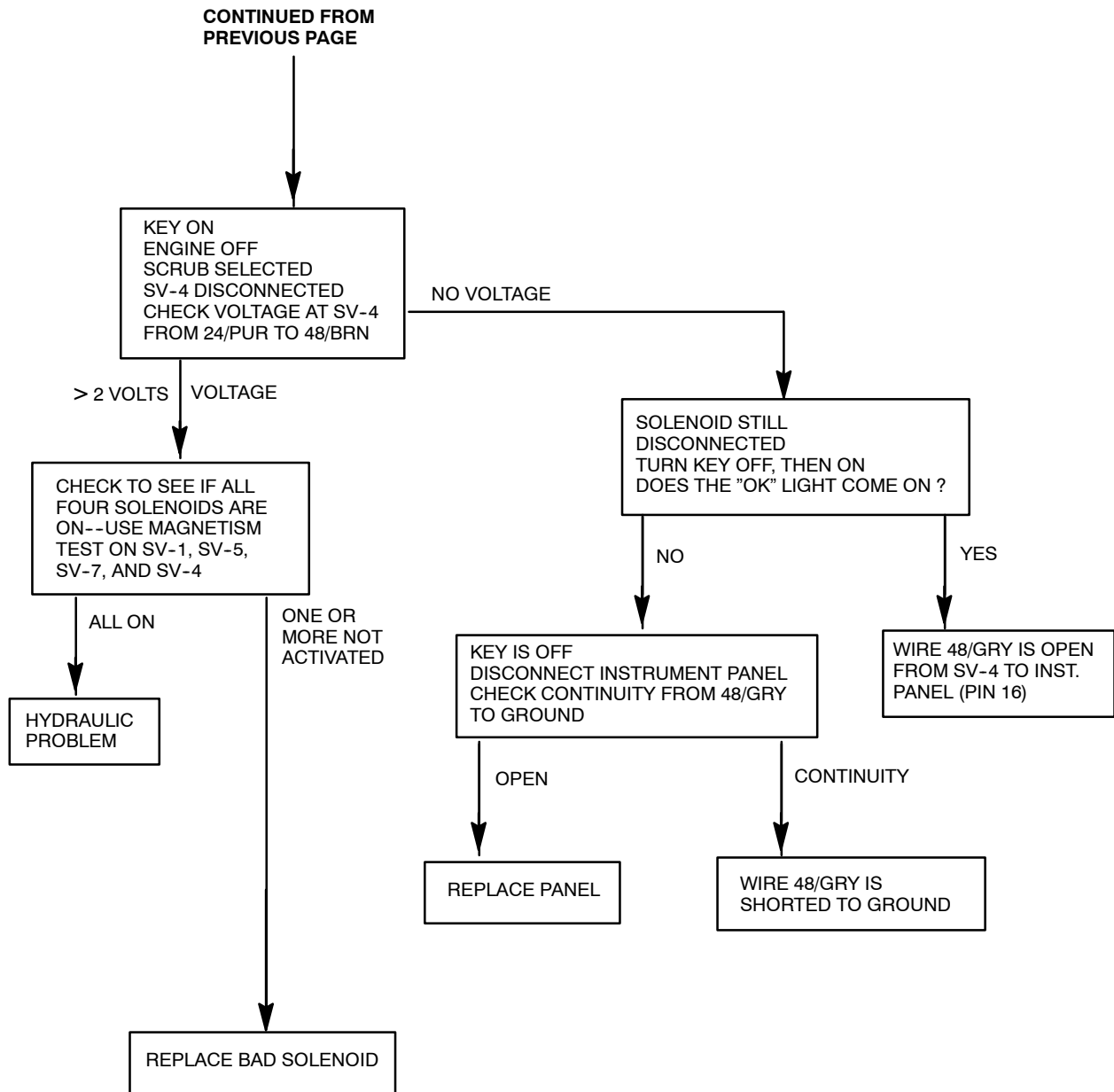

SQUEEGEE AND VACUUM FAN NOT TURNING ON AND GOING DOWN (SCHEMATIC)

OPERATION:
 -SQ/VAC IS SELECTED ON TOUCH PANEL
 -WITH MACHINE IN FWD OF NEUT., SV-3 AND SV-2 ARE TURNED ON
 -SQ. LOWERS AND VAC TURNS ON

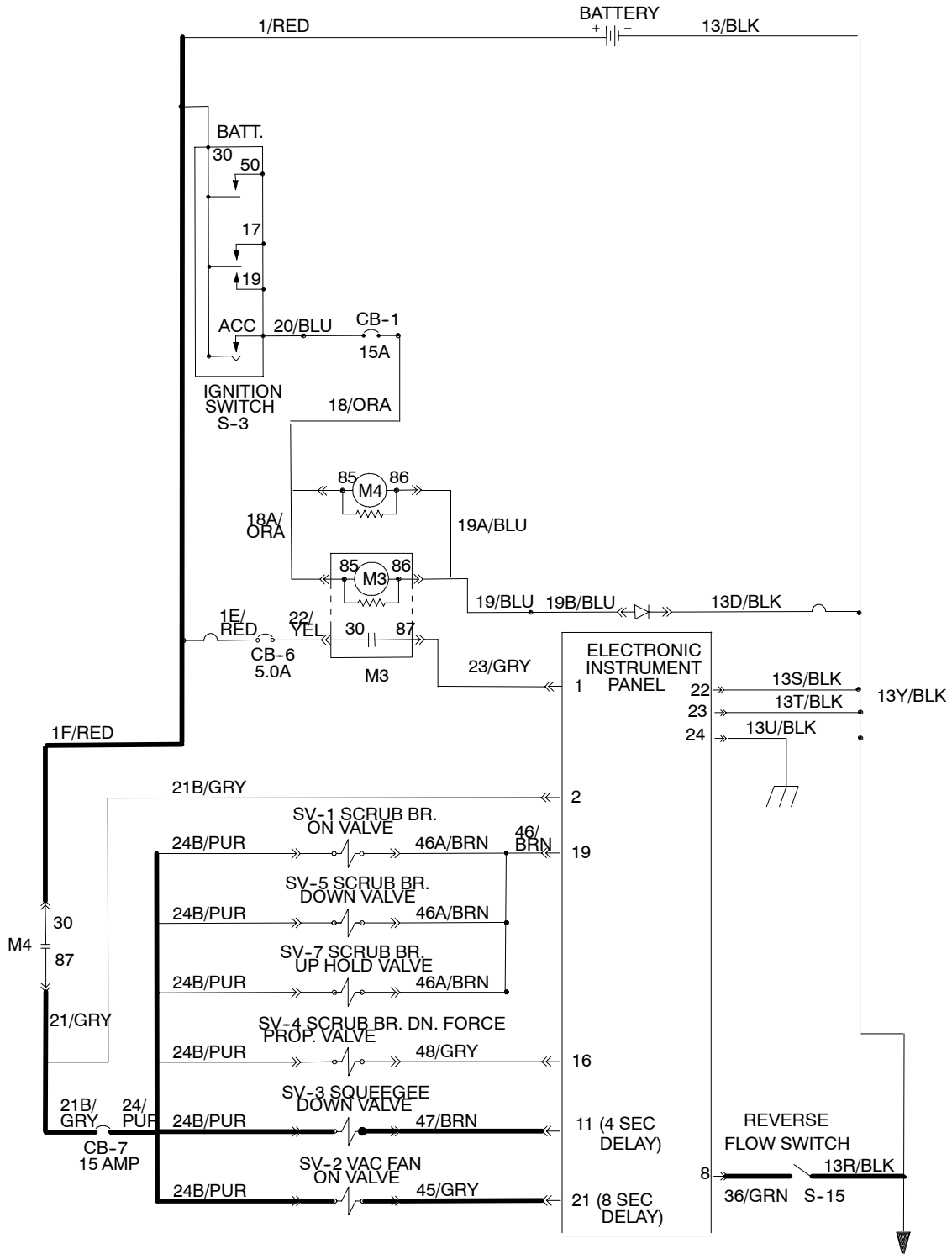

SQUEEGEE AND VACUUM FAN NOT TURNING ON AND GOING DOWN (FLOW CHART)

OPERATION:
 -SQ/VAC IS SELECTED ON TOUCH PANEL
 -WITH MACHINE IN FWD OF NEUT., SV-3 AND SV-2 ARE TURNED ON
 -SQ. LOWERS AND VAC TURNS ON

PANEL IS POWERED UP
 KEY IS ON
 ENGINE IS RUNNING

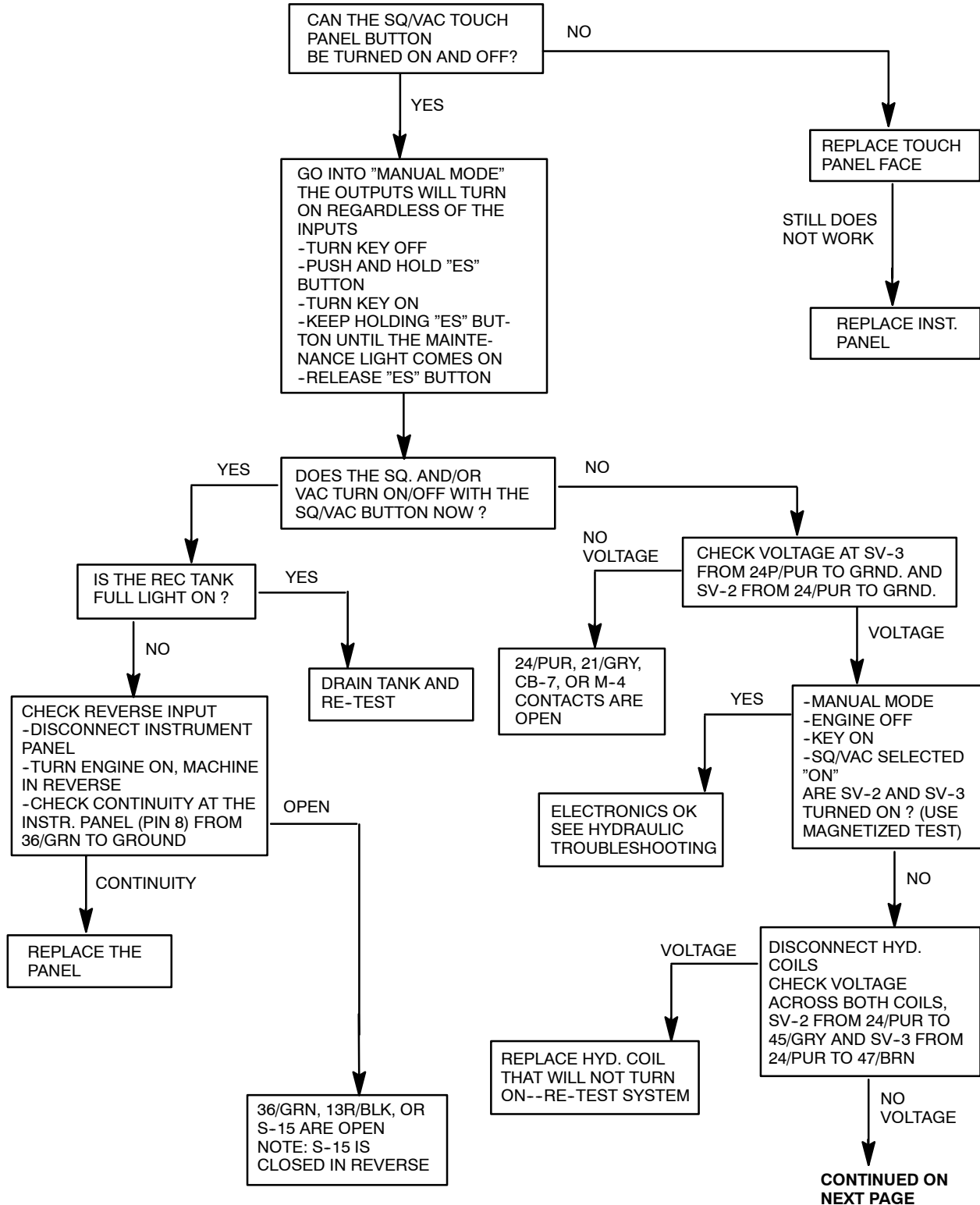

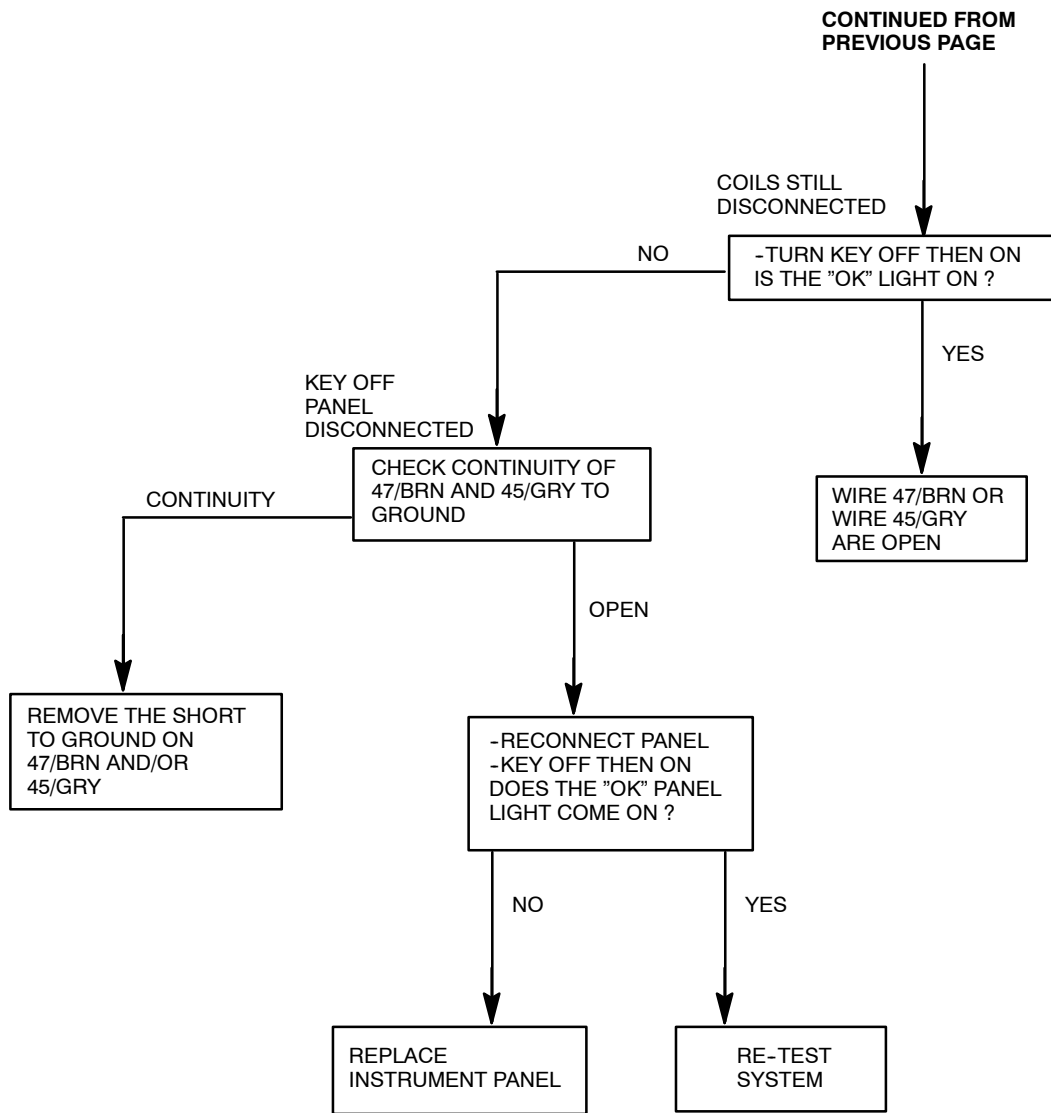

SIDE BRUSH WILL NOT TURN ON AND GO DOWN (SCHEMATIC)

OPERATION:
 -MACHINE MUST BE IN SCRUB MODE
 -SIDE BRUSH BUTTON IS ACTIVATED AND WILL TURN ON AND LOWER SIDE BRUSH
 -SV-6, SV-9, SV-8, SV-10, AND SV-11 WILL BE ON

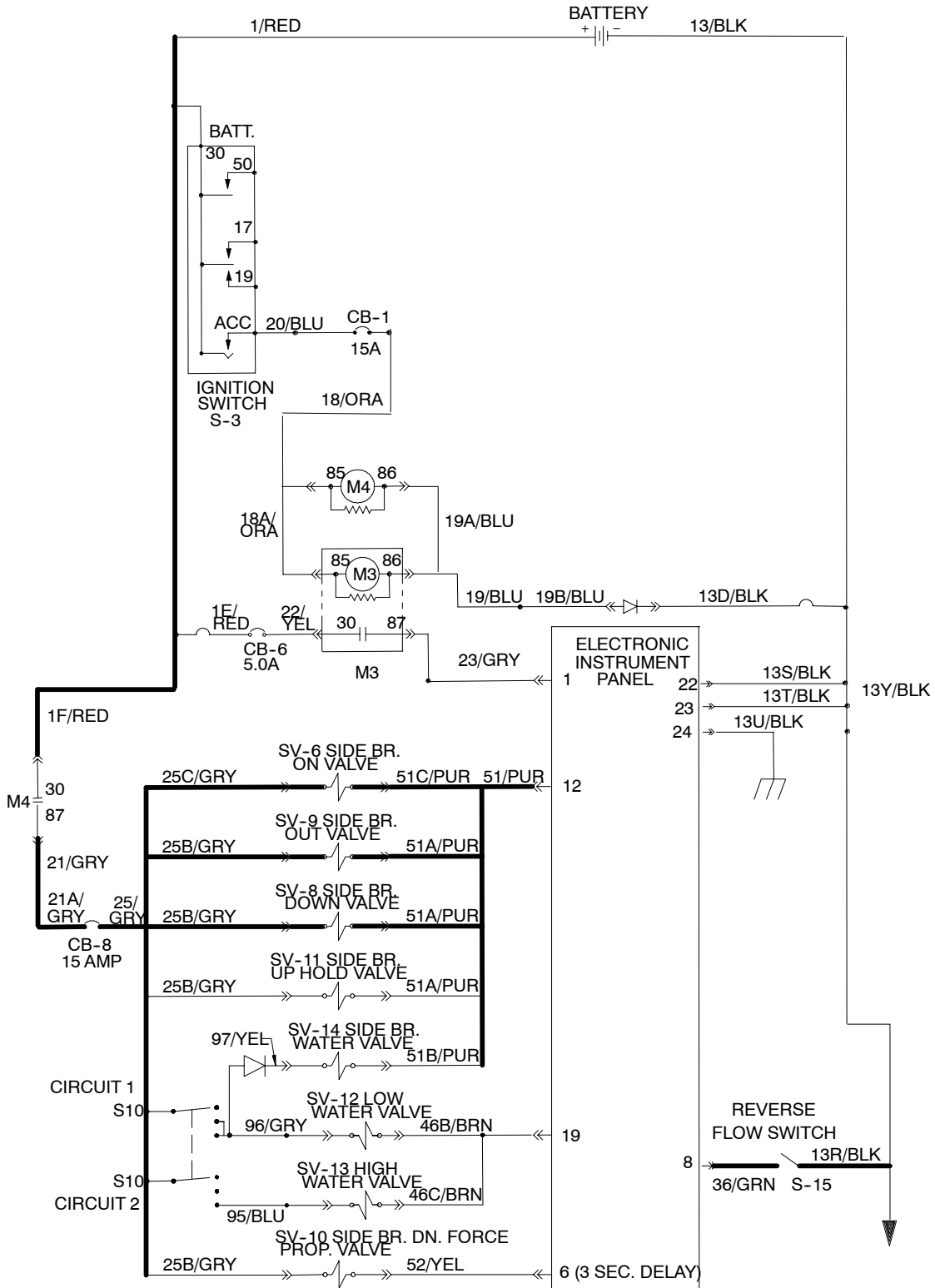

SIDE BRUSH WILL NOT TURN ON AND GO DOWN (FLOW CHART)

OPERATION:
 -MACHINE MUST BE IN SCRUB MODE
 -SIDE BRUSH BUTTON IS ACTIVATED AND WILL TURN ON AND LOWER SIDE BRUSH
 -SV-6, SV-9, SV-8, SV-10, AND SV-11 WILL BE ON

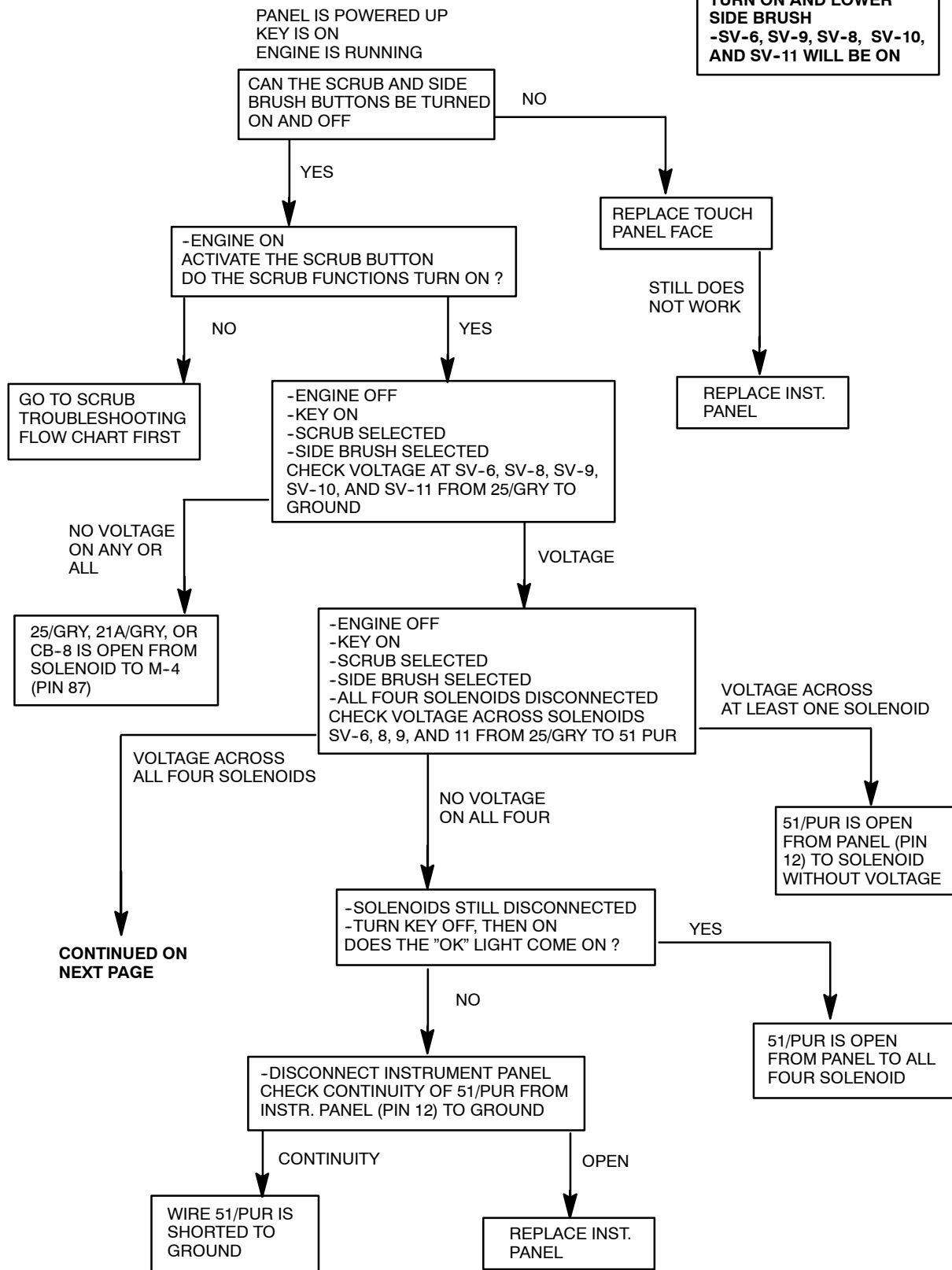

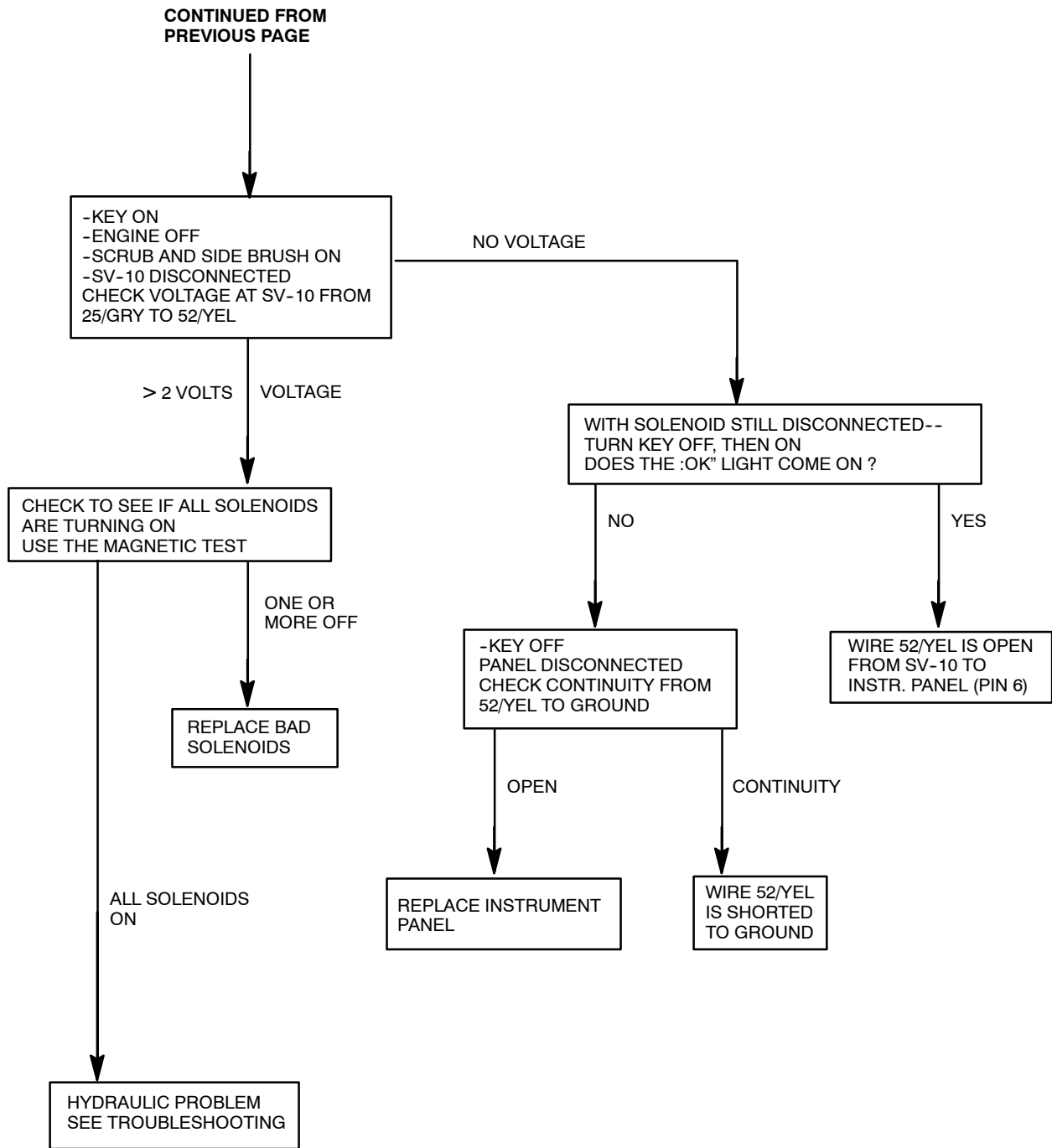

**WATER VALVES NOT OPERATING
(SCHEMATIC)**

OPERATION:
 -SCRUB FUNCTIONS MUST BE ON
 -WATER SWITCH IN POSITION #1 TURNS ON SV-12 LOW WATER VALVE AND SV-14 SIDE BRUSH VALVE
 -WATER SWITCH IN POSITION #2 TURNS ON SV-12, SV-14, AND SV-13 (HIGH WATER VALVE)

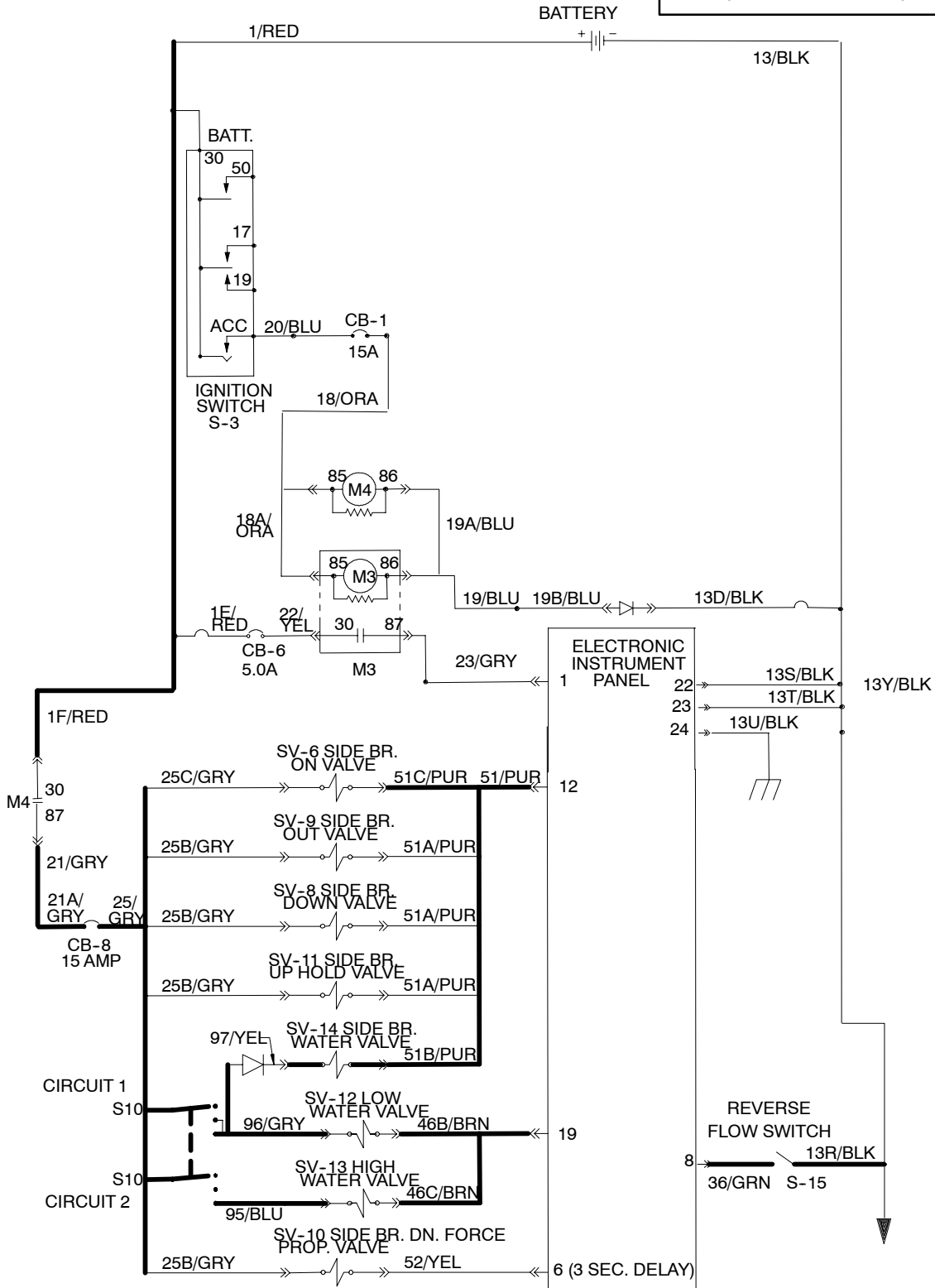

**WATER VALVES NOT OPERATING
(FLOW CHART)**

OPERATION:
 -SCRUB FUNCTIONS MUST BE ON
 -WATER SWITCH IN POSITION #1 TURNS ON SV-12 LOW WATER VALVE AND SV-14 SIDE BRUSH VALVE
 -WATER SWITCH IN POSITION #2 TURNS ON SV-12, SV-14, AND SV-13 (HIGH WATER VALVE)

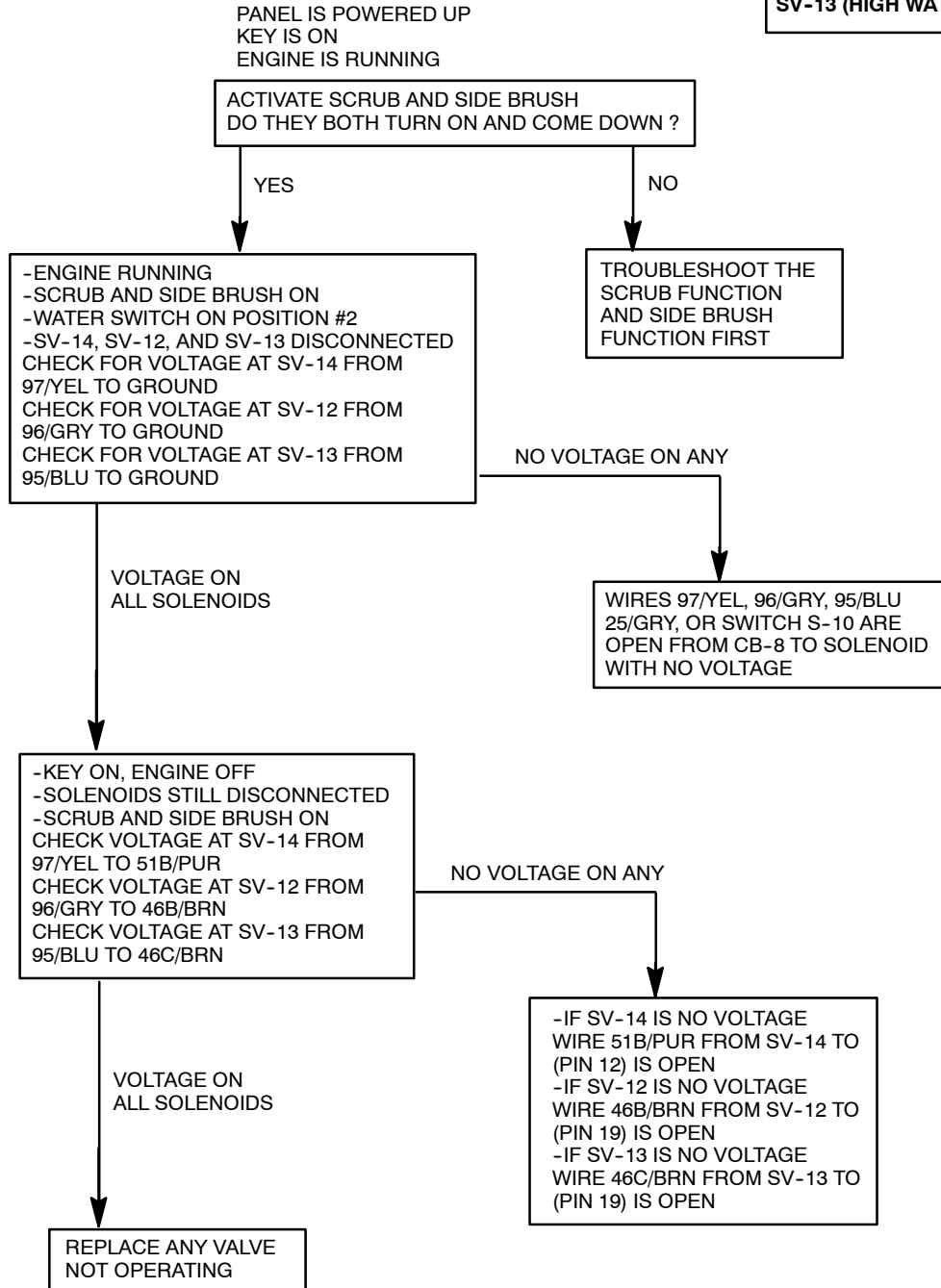

HEAD LIGHTS WILL NOT TURN ON (SCHEMATIC)

OPERATION:
-(PIN 15) TO GROUND BY OIL
PRESSURE SWITCH TURNS ON M6

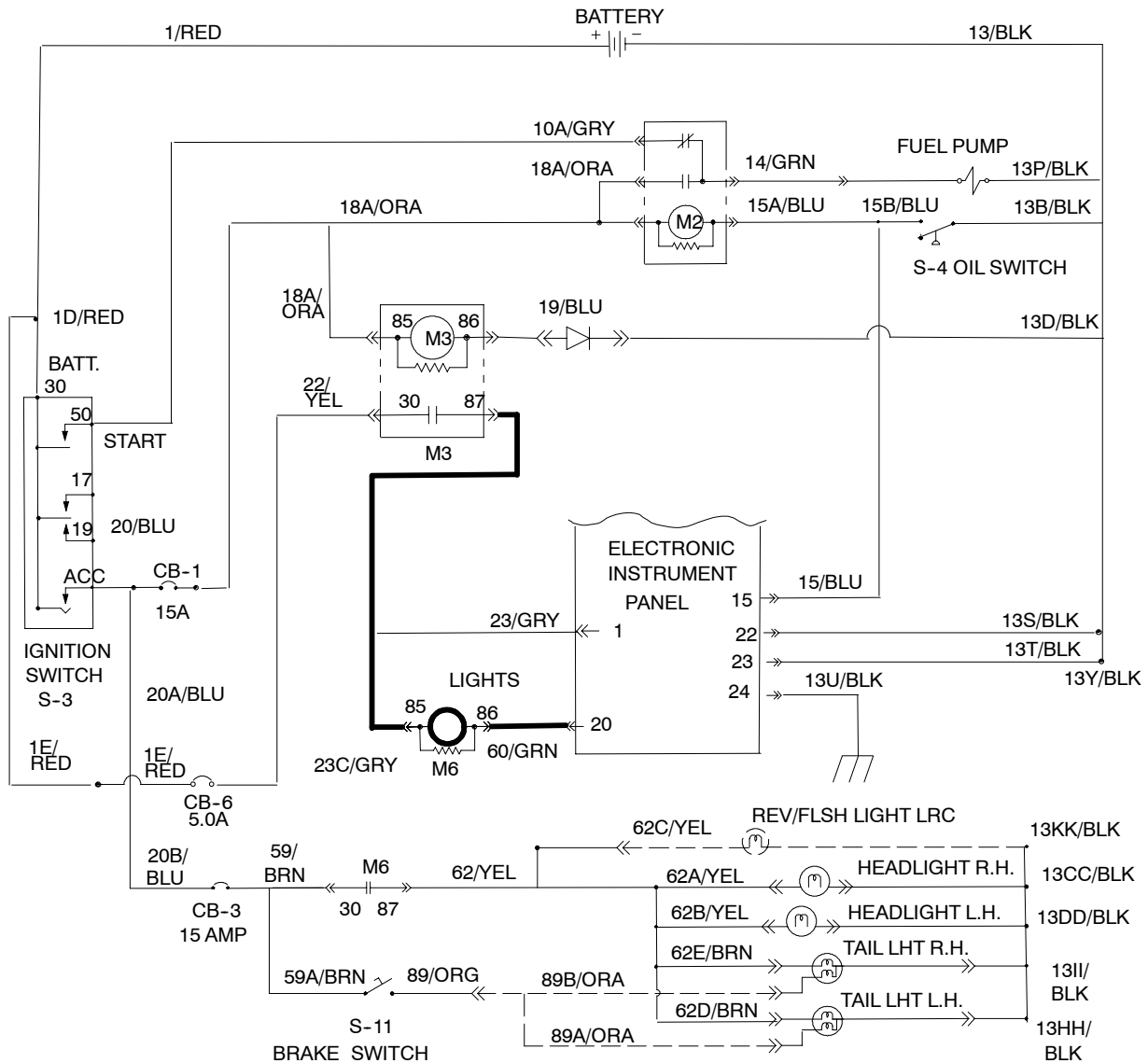

**HEAD LIGHTS WILL NOT TURN ON
(FLOW CHART)**

OPERATION:
 -(PIN 15) TO GROUND BY OIL
 PRESSURE SWITCH TURNS ON M6

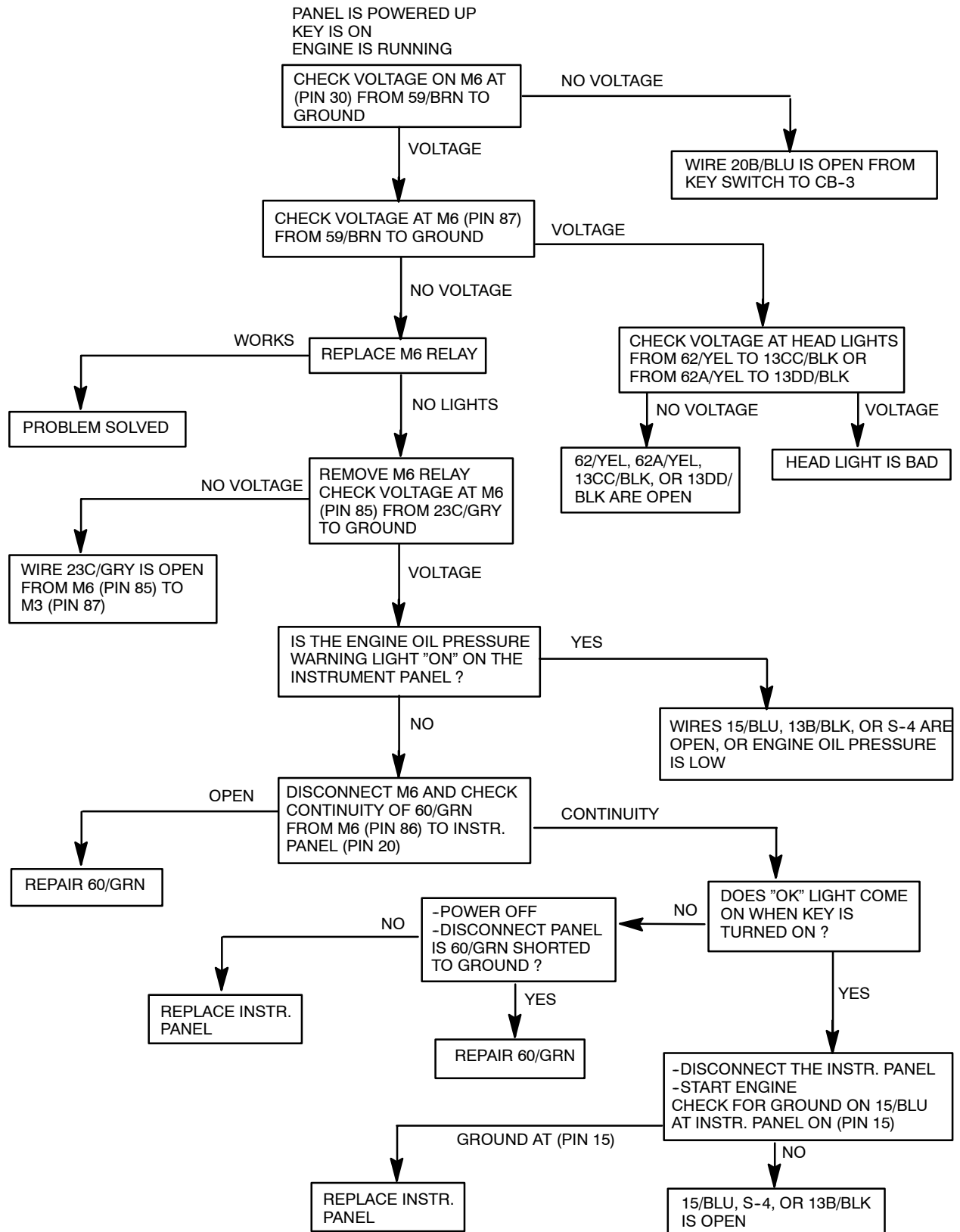

ES™ PUMP NOT WORKING (SCHEMATIC)

OPERATION:
 -IF ES™ IS SELECTED ON PANEL AND
 -S-17 AND S-18 CLOSE FOR 5 SECONDS
 -M5 RELAY WILL ACTIVATE, TURNING ON
 PUMP

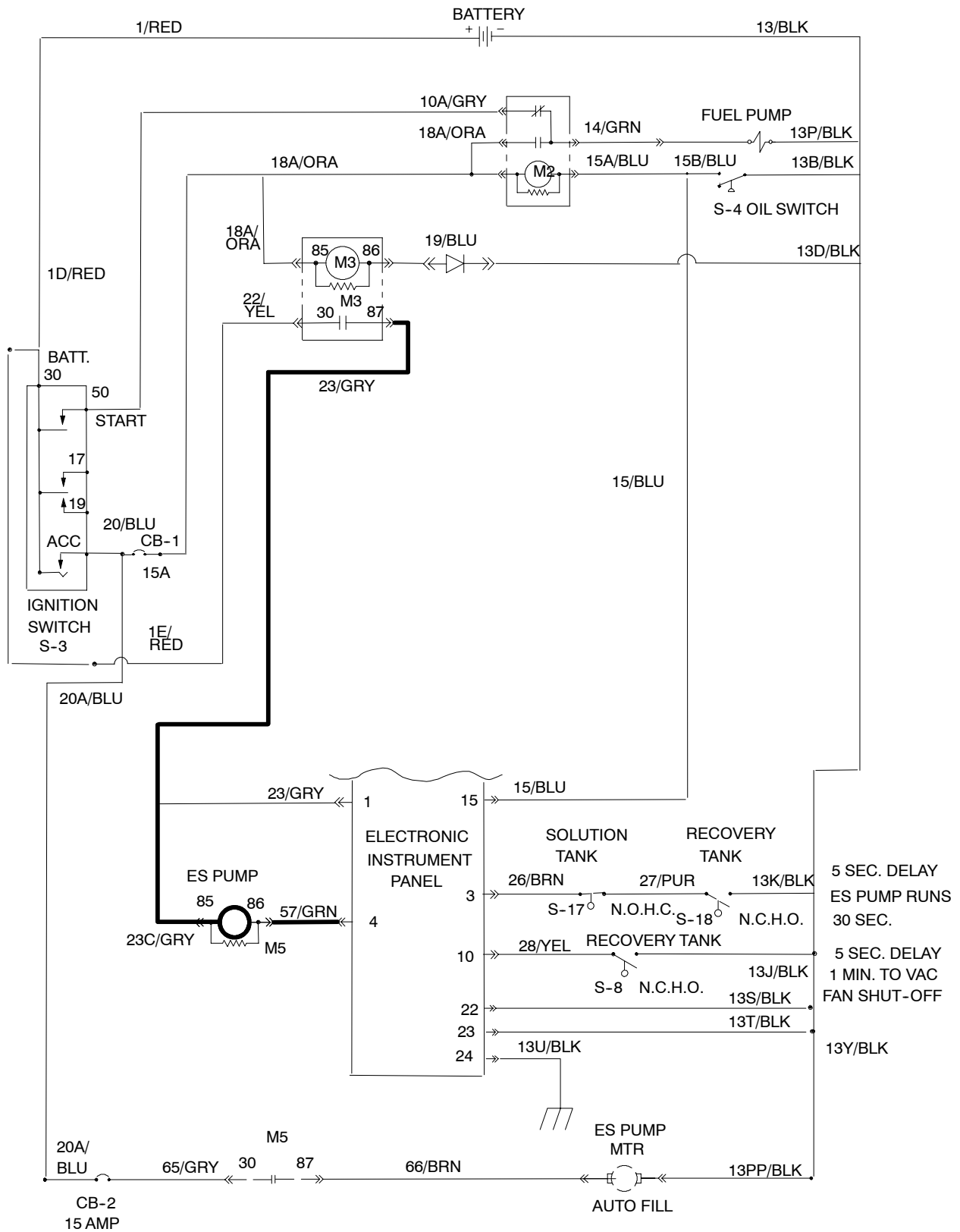

**ES™ PUMP NOT WORKING
(FLOW CHART)**

OPERATION:
 -IF ES™ IS SELECTED ON PANEL AND
 -S-17 AND S-18 CLOSE FOR 5 SECONDS
 -M5 RELAY WILL ACTIVATE, TURNING ON
 PUMP

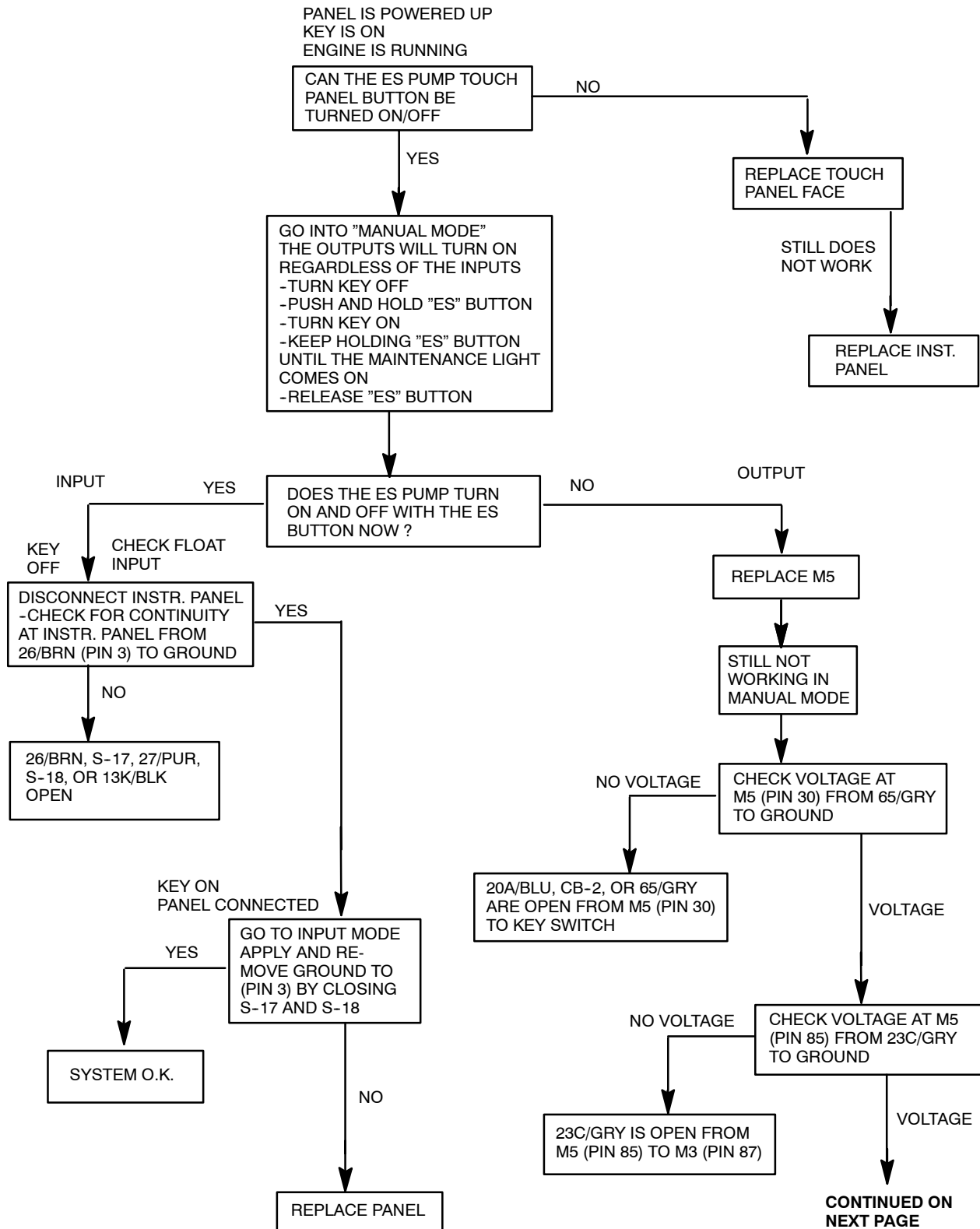

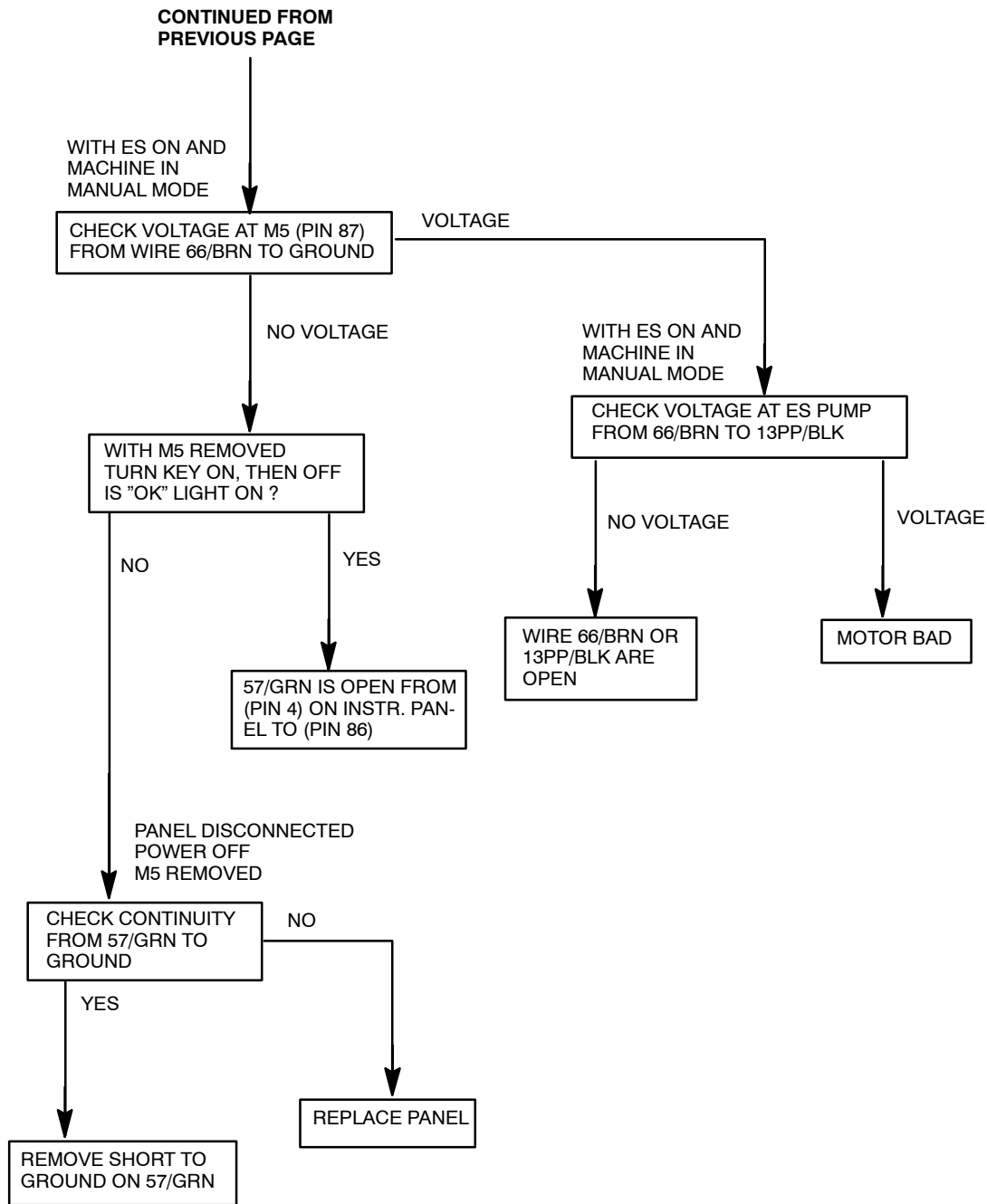

REVERSE LIGHT OR ALARM NOT WORKING (SCHEMATIC)

OPERATION:
 -GROUND AT (PIN 8) WHEN
 MACHINE IS IN REVERSE
 -TURNS ON M7
 -SUPPLIES POWER TO BACK-UP
 ALARM/LIGHT

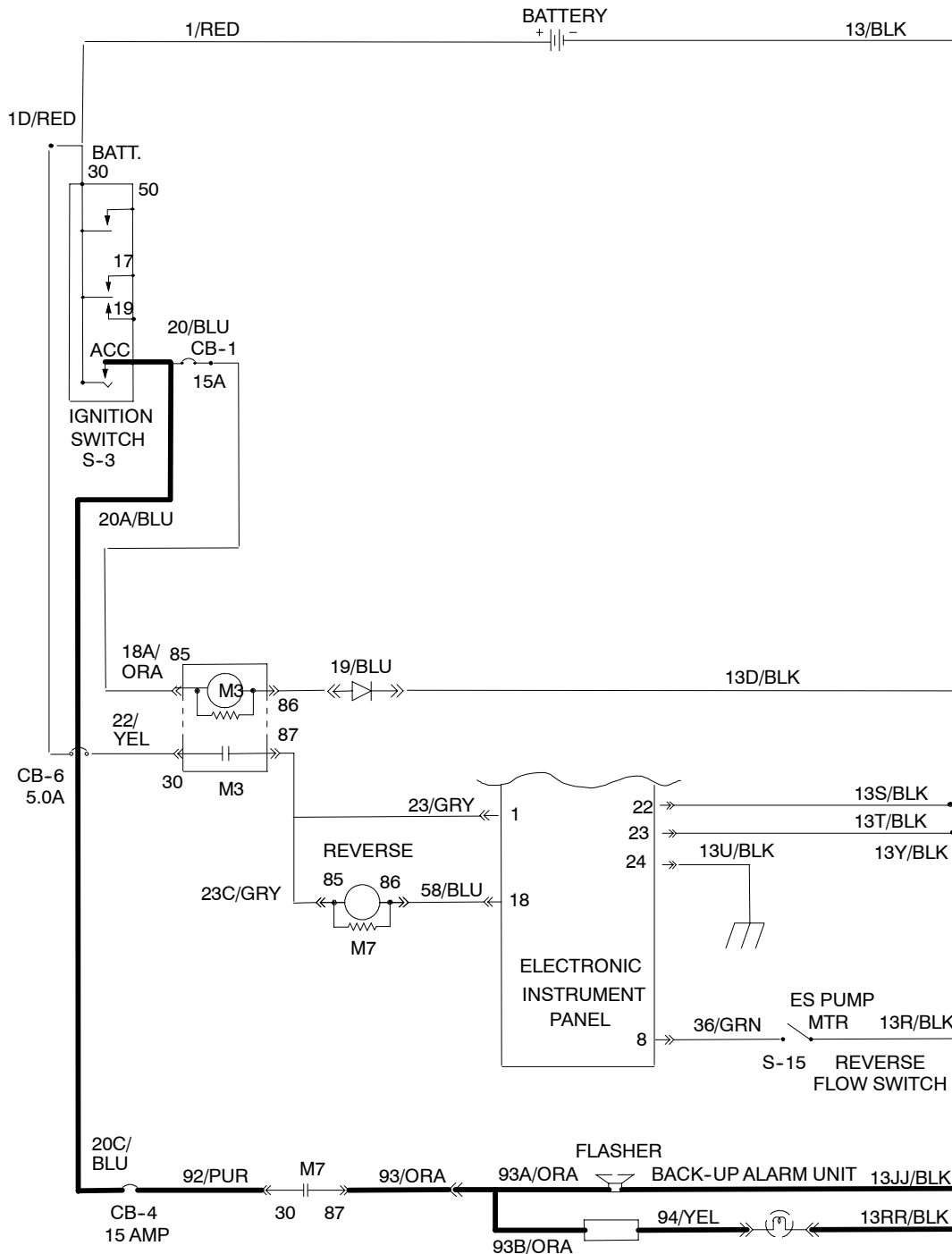

**REVERSE LIGHT OR ALARM
NOT WORKING
(FLOW CHART)**

OPERATION:
 -GROUND AT (PIN 8) WHEN
 MACHINE IS IN REVERSE
 -TURNS ON M7
 -SUPPLIES POWER TO BACK-UP
 ALARM/LIGHT

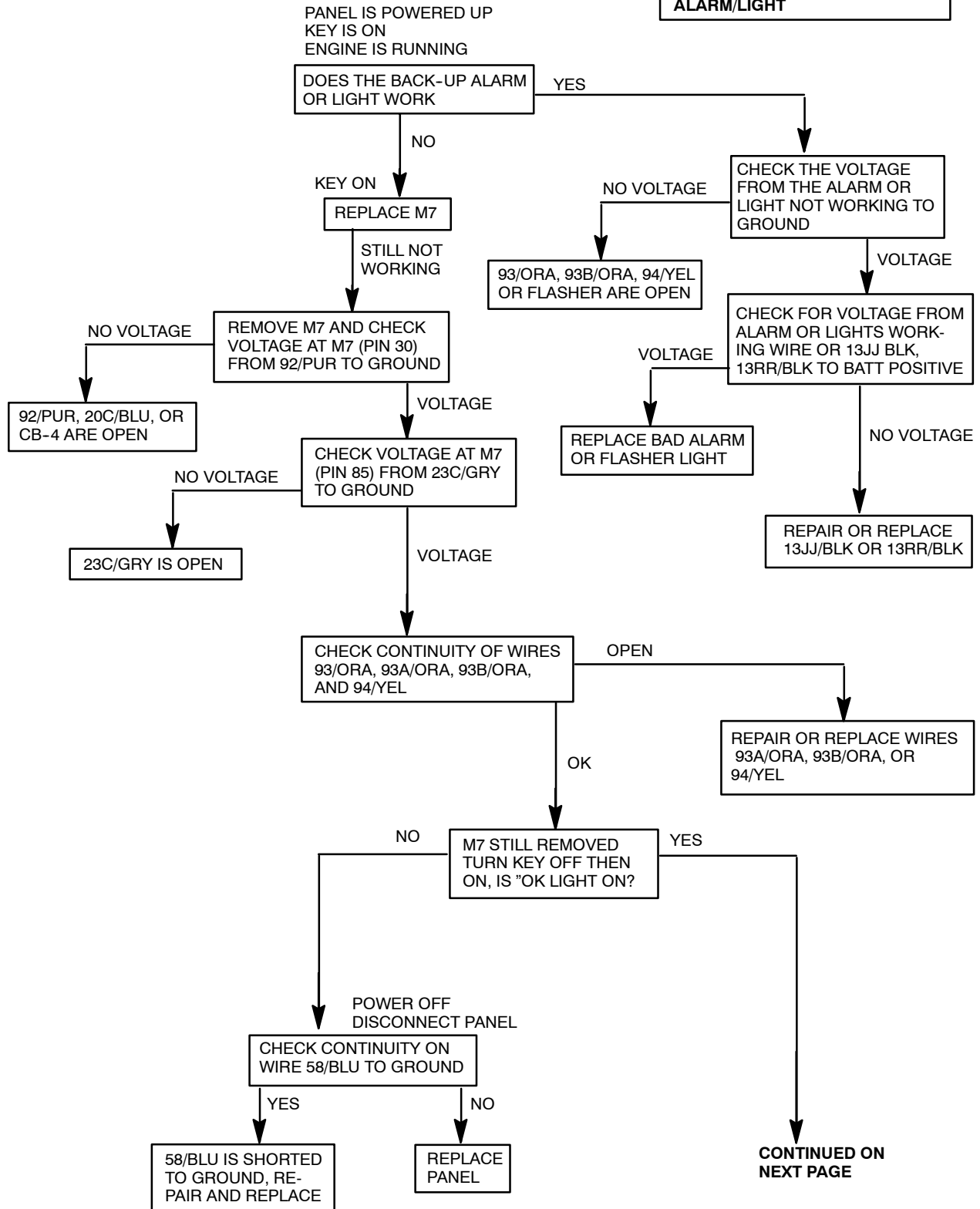

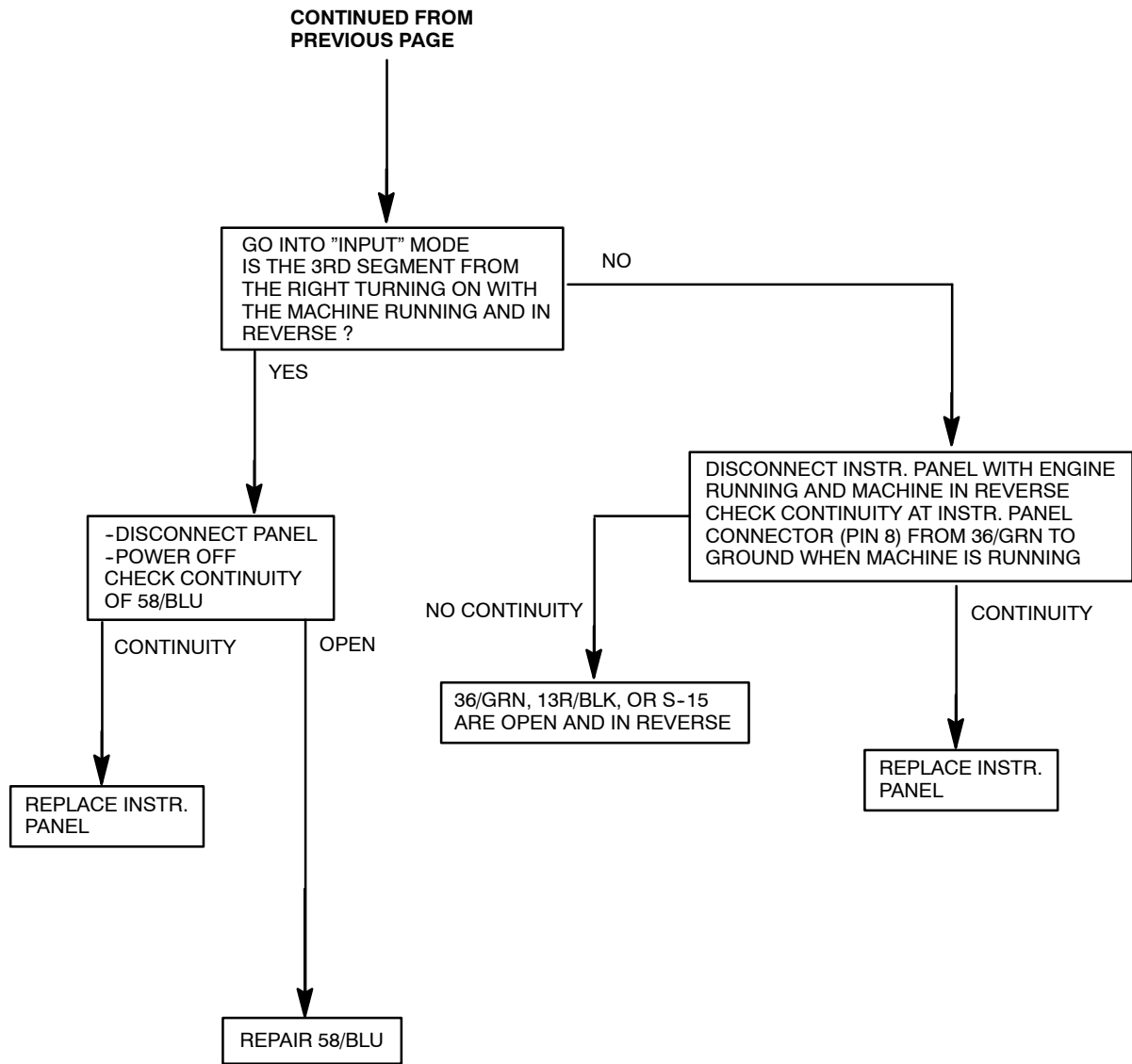

**DETERGENT METERING
PUMP IS NOT OPERATING
(SCHEMATIC)**

OPERATION:
 -PANEL DETERGENT BUTTON IS ACTIVE IN LOW OR HIGH POSITION
 -MACHINE IS IN SCRUB MODE
 -DETERGENT PUMP WILL BE TURNED ON WITH A PULSE WIDTH MODULATED SIGNAL

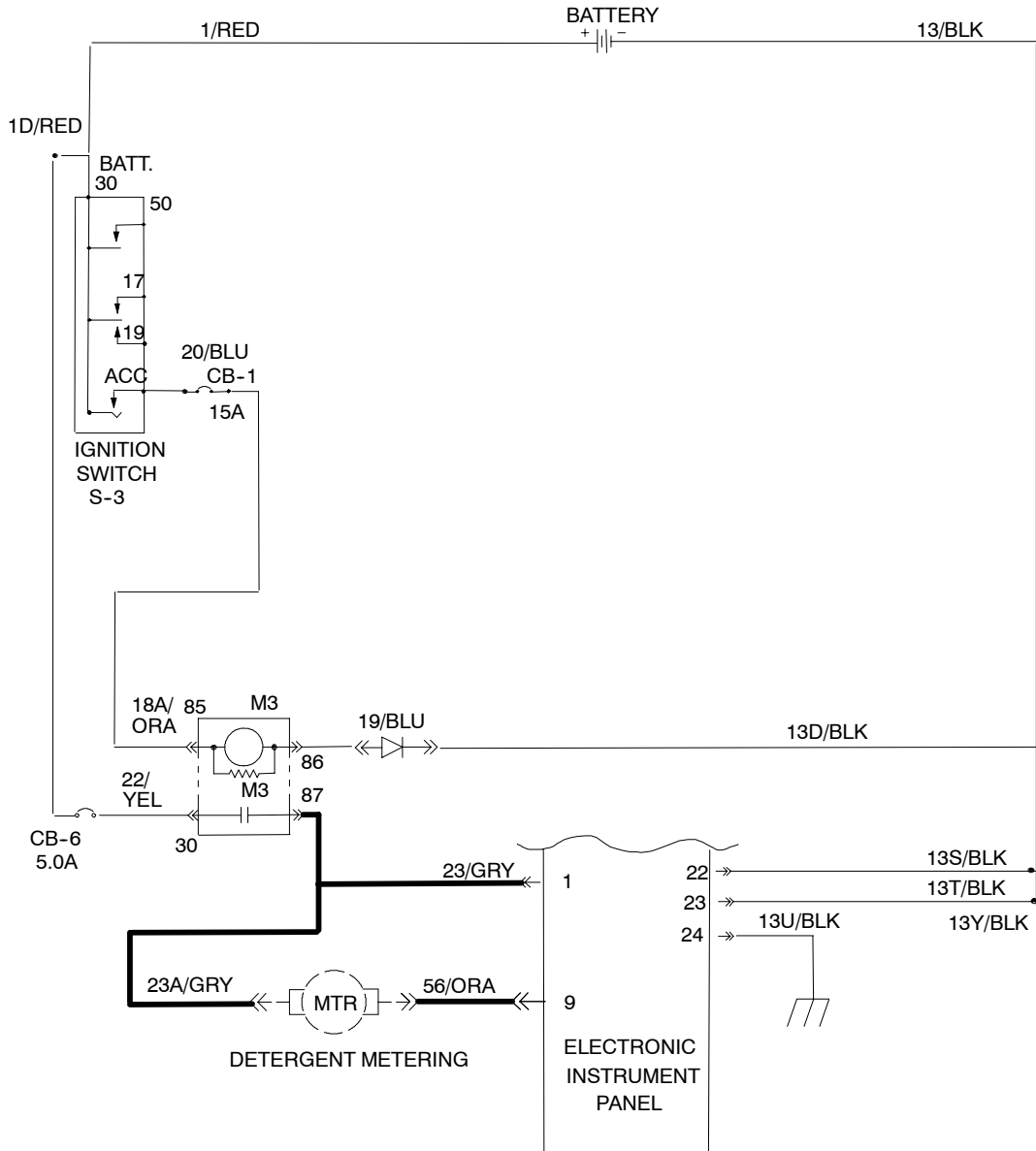

DETERGENT METERING PUMP IS NOT OPERATING (FLOW CHART)

OPERATION:
 -PANEL DETERGENT BUTTON IS ACTIVE IN LOW OR HIGH POSITION
 -MACHINE IS IN SCRUB MODE
 -DETERGENT PUMP WILL BE TURNED ON WITH A PULSE WIDTH MODULATED SIGNAL

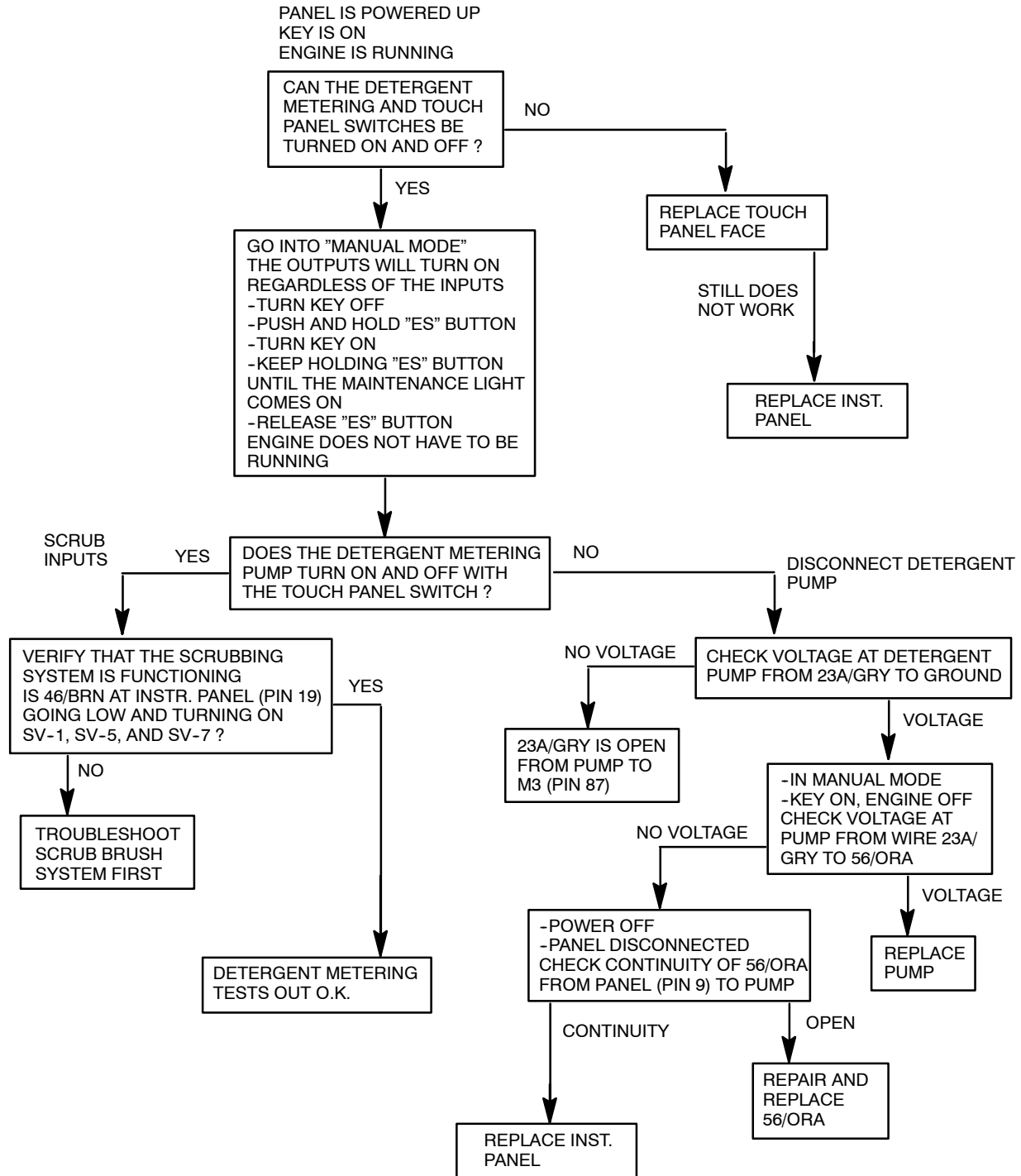

ALTERNATOR / BATTERY WARNING LIGHT STAYS ON WHEN ENGINE IS RUNNING (SCHEMATIC)

OPERATION:
 -CONNECTION L2 ON ALTERNATOR GOES TO BATTERY POSITIVE WHEN ALTERNATOR IS TURNED ON
 -BATTERY POSITIVE AT (PIN 14) TURNS OFF THE ALTERNATOR / BATTERY INDICATOR

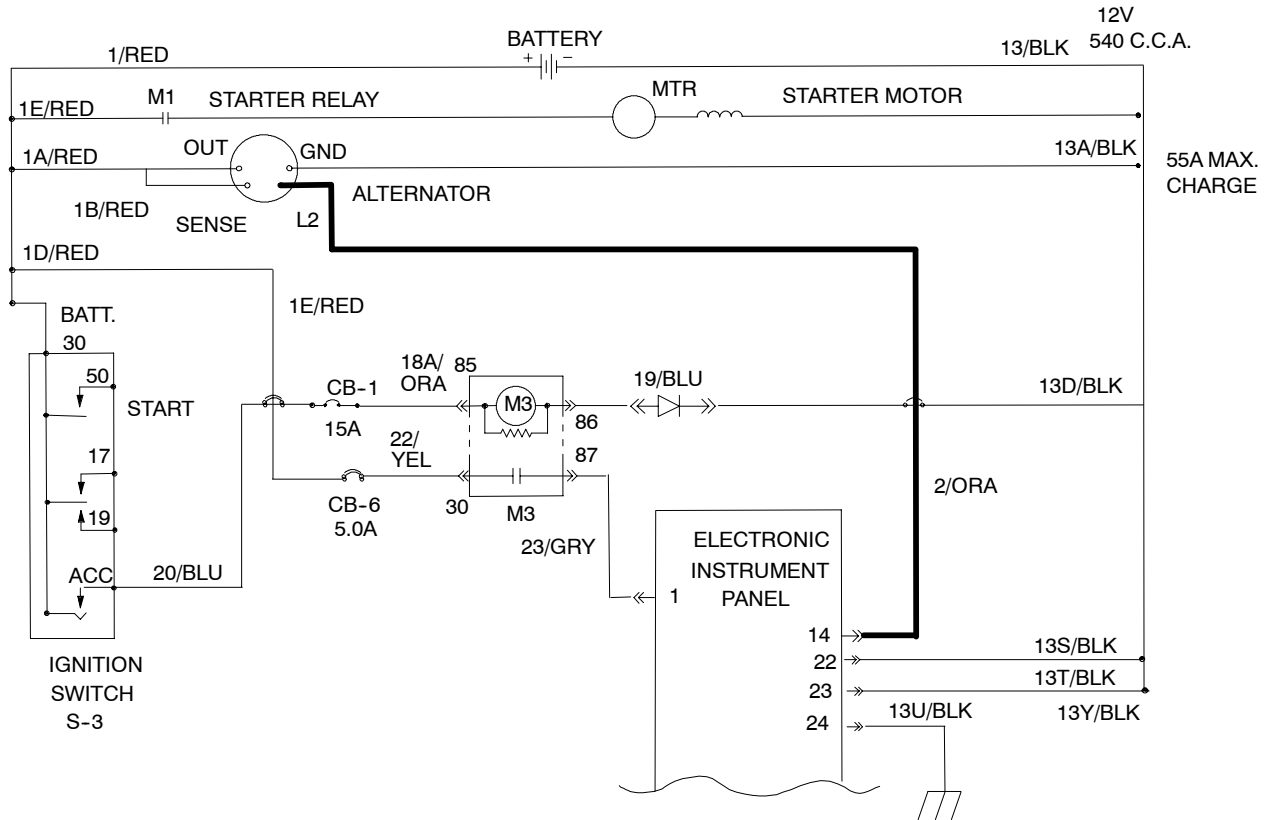

ALTERNATOR / BATTERY WARNING LIGHT STAYS ON WHEN ENGINE IS RUNNING (FLOW CHART)

OPERATION:
 -CONNECTION L2 ON ALTERNATOR GOES TO BATTERY POSITIVE WHEN ALTERNATOR IS TURNED ON
 -BATTERY POSITIVE AT (PIN 14) TURNS OFF THE ALTERNATOR / BATTERY INDICATOR

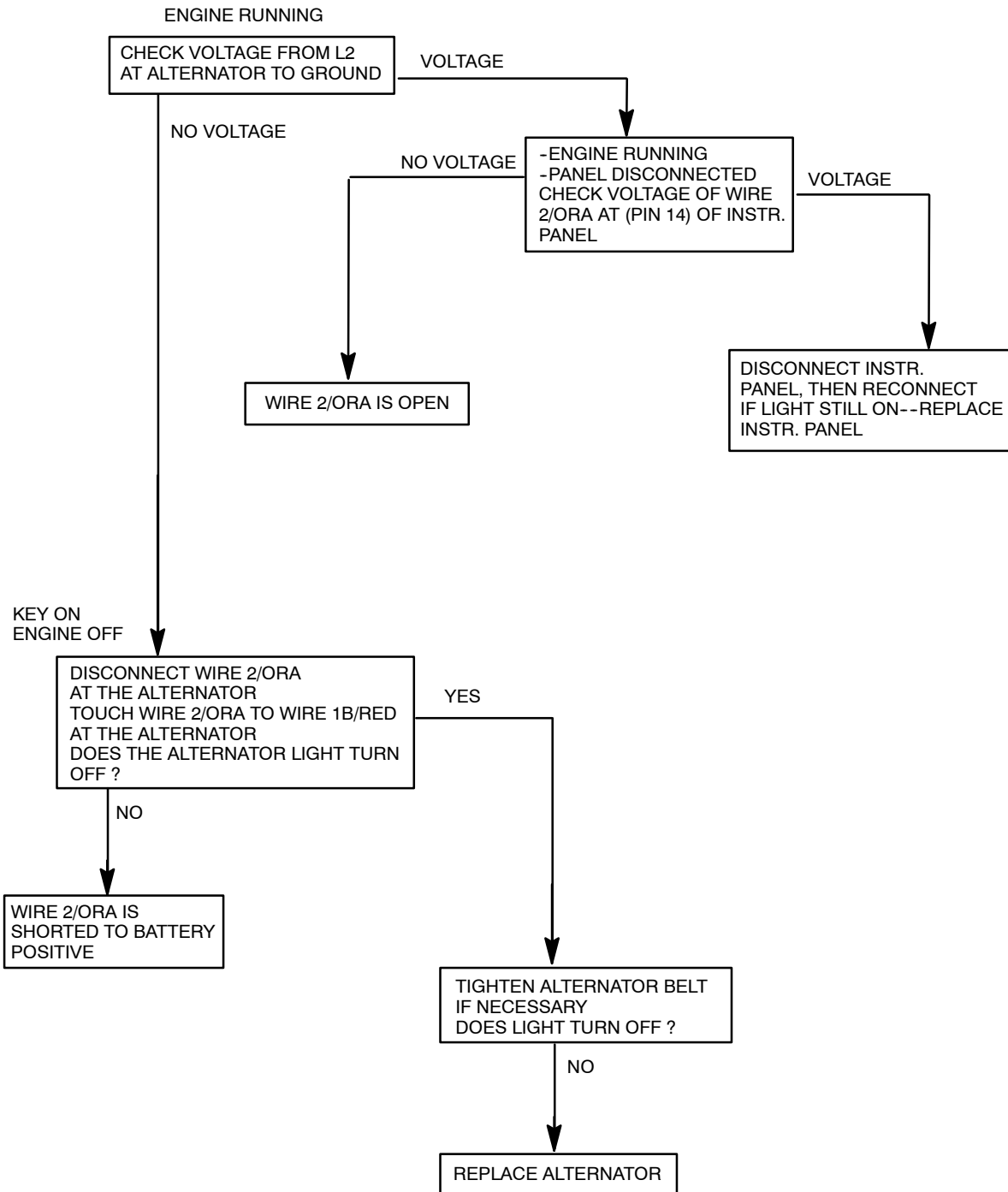

ALTERNATOR / BATTERY WARNING LIGHT WILL NOT TURN ON (SCHEMATIC)

OPERATION:
 -CONNECTION L2 ON ALTERNATOR GOES TO BATTERY POSITIVE WHEN ALTERNATOR IS TURNED ON
 -BATTERY POSITIVE AT (PIN 14) TURNS OFF THE ALTERNATOR / BATTERY INDICATOR

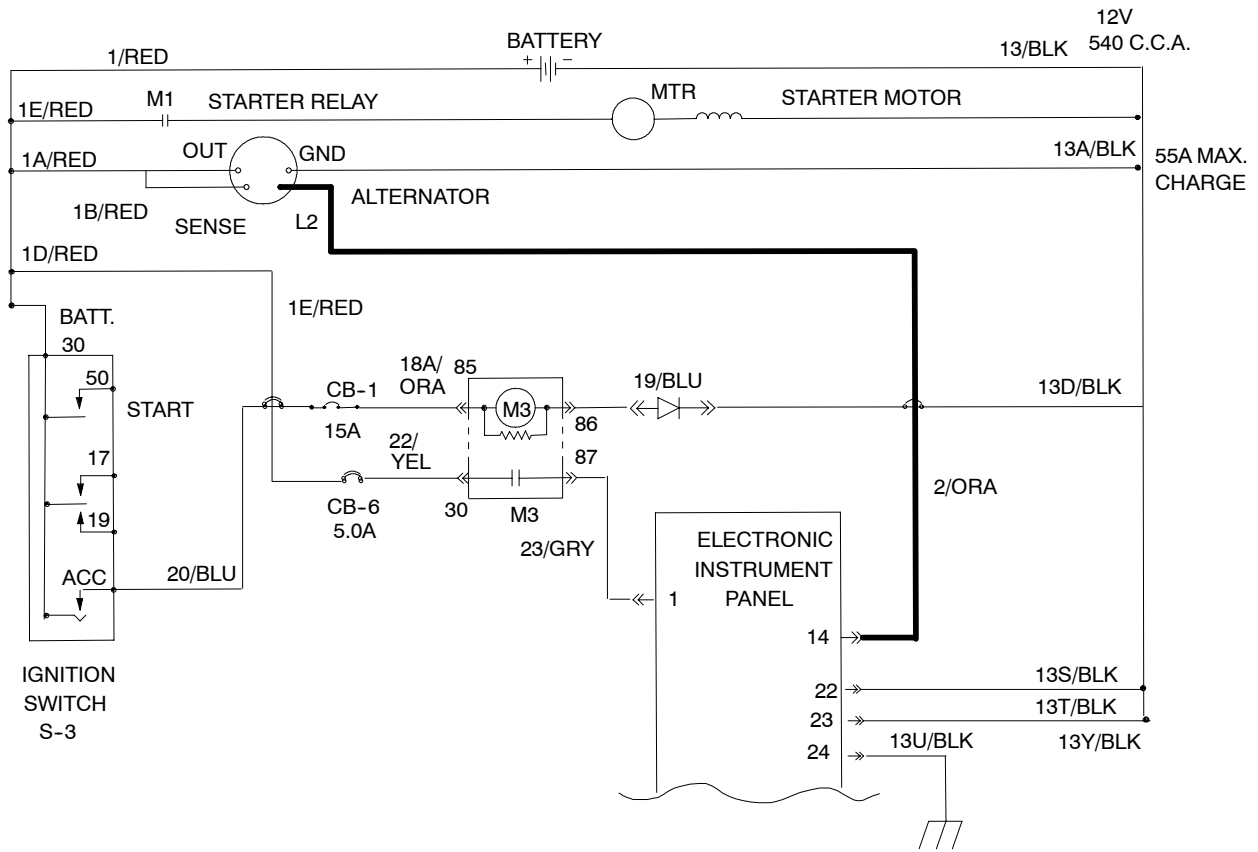

ALTERNATOR / BATTERY WARNING LIGHT WILL NOT TURN ON (FLOW CHART)

OPERATION:
-CONNECTION L2 ON ALTERNATOR GOES TO BATTERY POSITIVE WHEN ALTERNATOR IS TURNED ON
-BATTERY POSITIVE AT (PIN 14) TURNS OFF THE ALTERNATOR / BATTERY INDICATOR

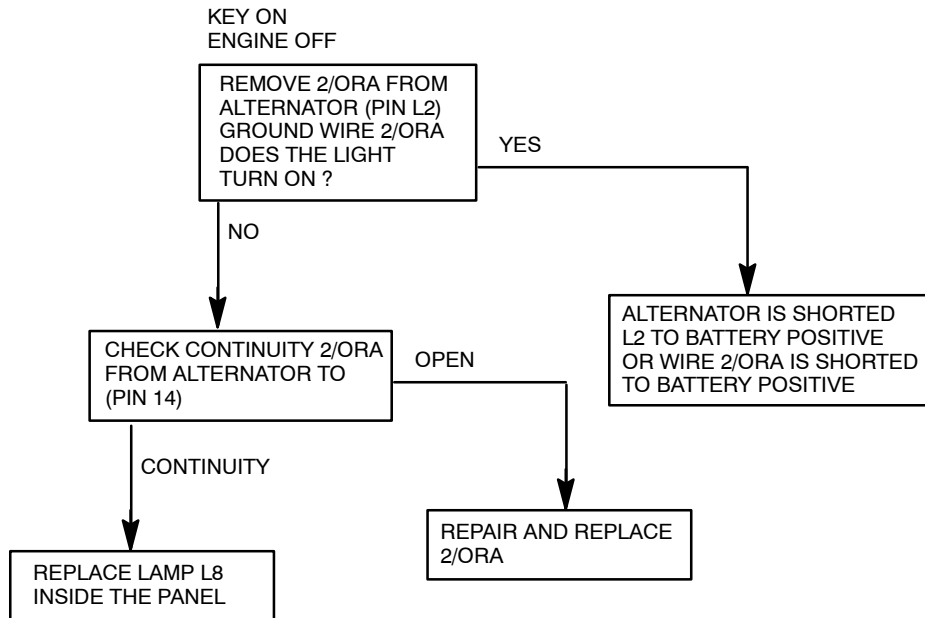

**ENGINE TEMPERATURE LIGHT
WILL NOT TURN ON OR OFF
(SCHEMATIC)**

OPERATION:
 -225 DEGREE F. SE-2 =-80 OHMS
 -COOLANT LIGHT TURNS ON

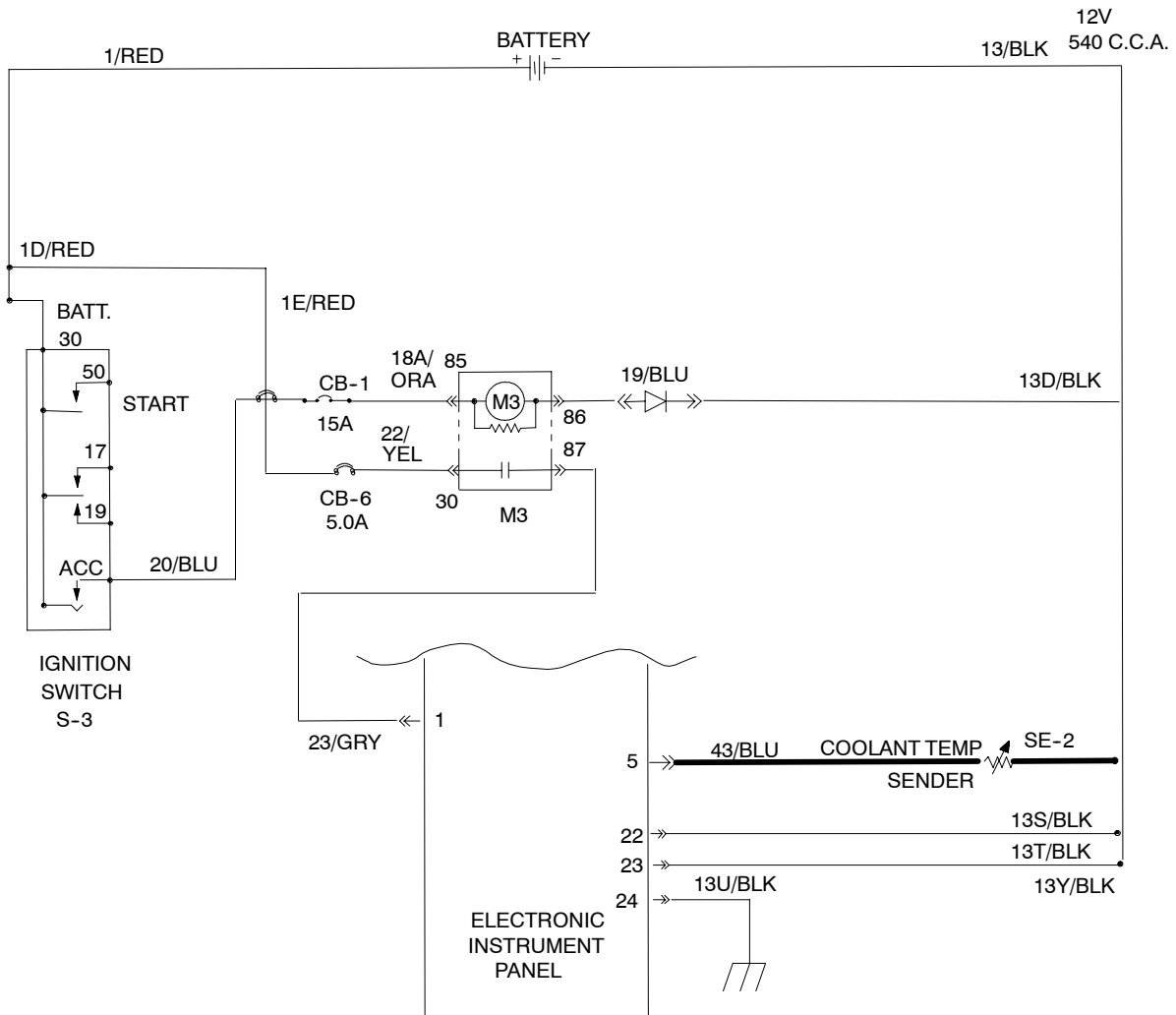

**ENGINE TEMPERATURE LIGHT
WILL NOT TURN ON
(FLOW CHART)**

OPERATION:
-225 DEGREE F. SE-2 =<80 OHMS
-COOLANT LIGHT TURNS ON

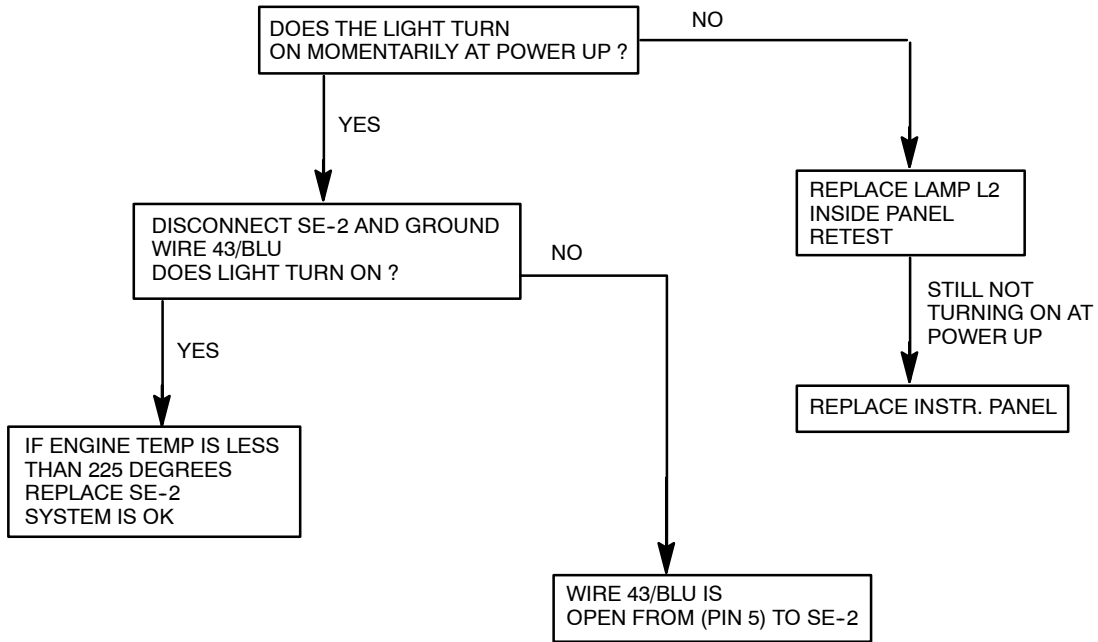

**ENGINE TEMPERATURE LIGHT
WILL NOT TURN OFF
(FLOW CHART)**

OPERATION:
-225 DEGREE F. SE-2 =<80 OHMS
-COOLANT LIGHT TURNS ON

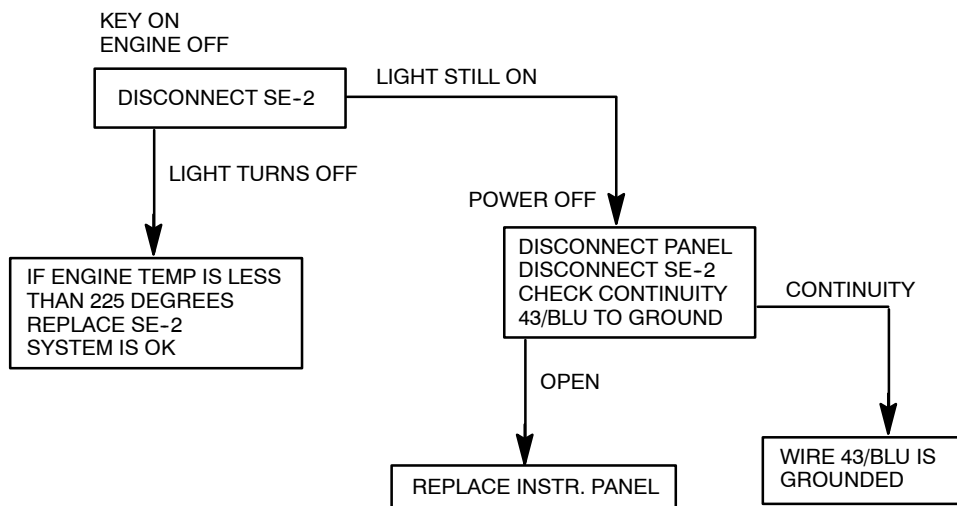

**HYDRAULIC (HIGH) PRESSURE INDICATOR
LIGHT WILL NOT TURN ON OR OFF
(SCHEMATIC)**

OPERATION:
-WHEN S-14 CLOSES, LIGHT
TURNS ON
-THIS LIGHT IS AN OPTION

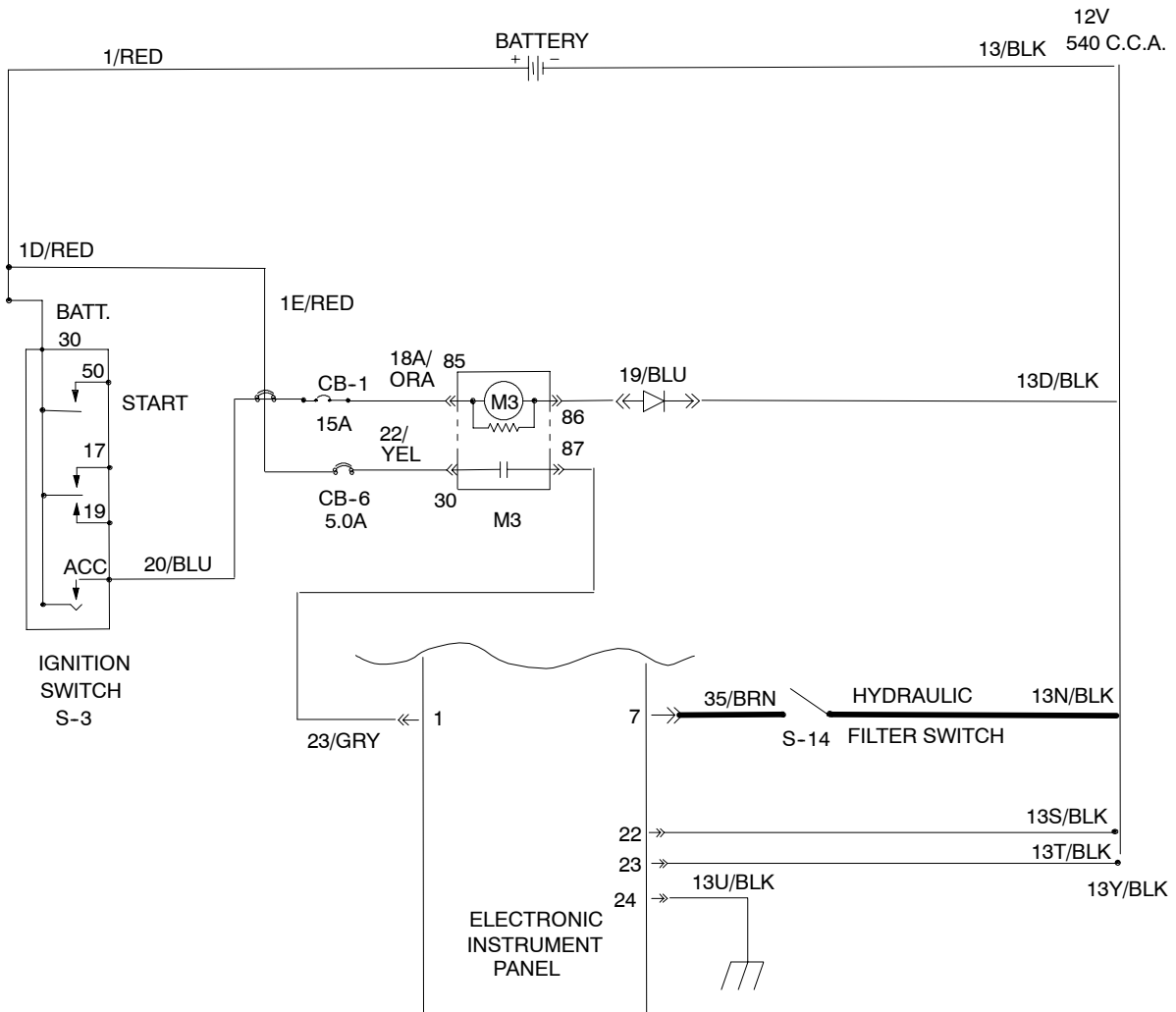

HYDRAULIC (HIGH) PRESSURE INDICATOR LIGHT WILL NOT TURN ON (FLOW CHART)

OPERATION:
 -WHEN S-14 CLOSES, LIGHT TURNS ON
 -THIS LIGHT IS AN OPTION

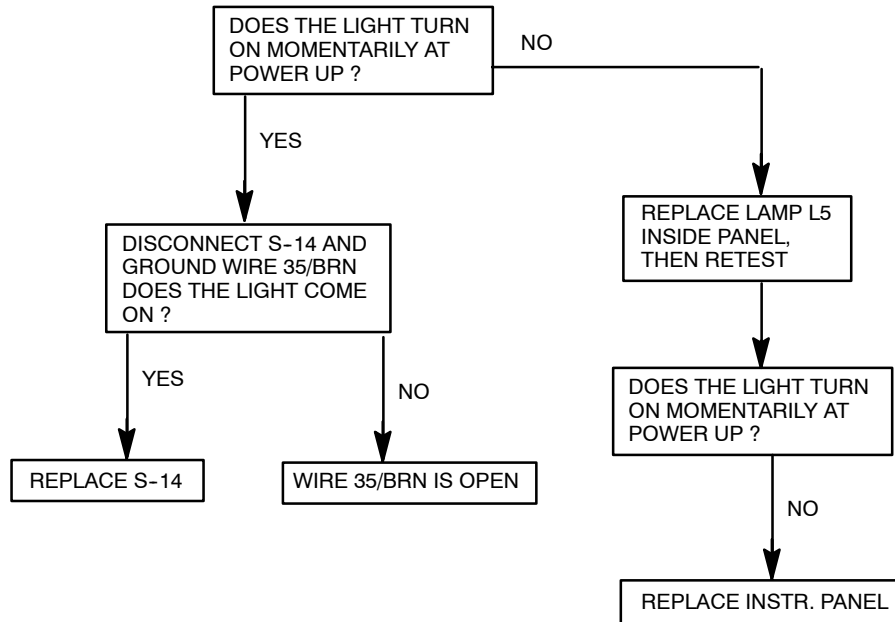

HYDRAULIC (HIGH) PRESSURE INDICATOR LIGHT WILL NOT TURN OFF (FLOW CHART)

OPERATION:
 -WHEN S-14 CLOSES, LIGHT TURNS ON
 -THIS LIGHT IS AN OPTION

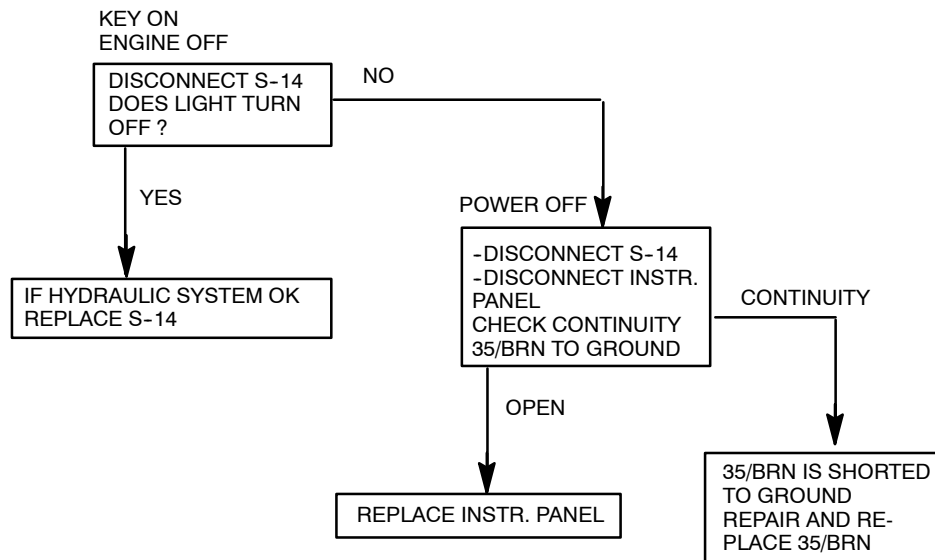

ENGINE OIL PRESSURE WARNING LIGHT WILL NOT TURN ON OR OFF (SCHEMATIC)

OPERATION:
 - (PIN 15) IS PULLED TO GROUND WHEN OIL PRESSURE IS HIGH ENOUGH
 - OIL LIGHT TURNS OFF

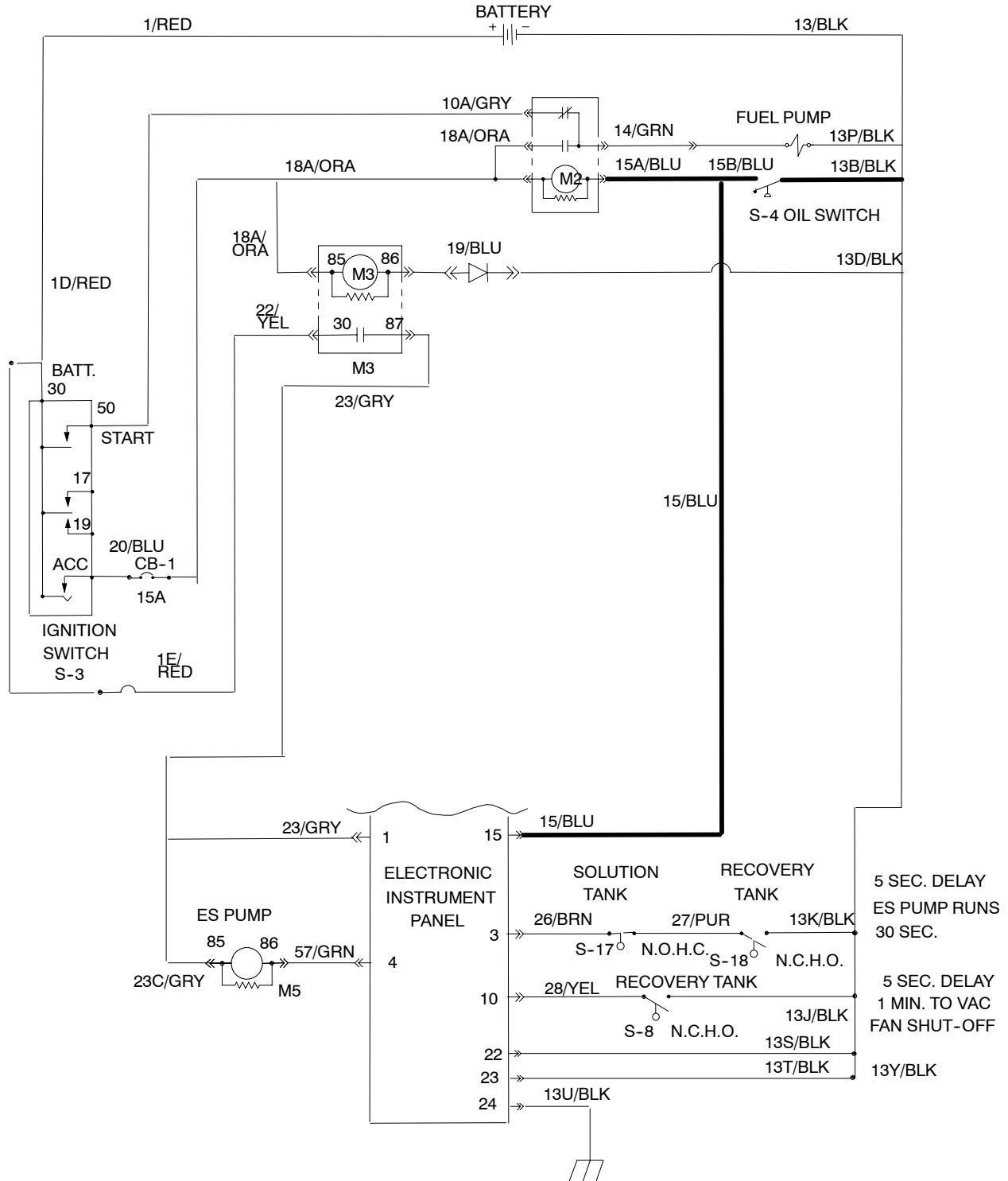

ENGINE OIL PRESSURE WARNING LIGHT WILL NOT TURN ON (FLOW CHART)

OPERATION:
-(PIN 15) IS PULLED TO GROUND WHEN OIL PRESSURE IS HIGH ENOUGH
-OIL LIGHT TURNS OFF

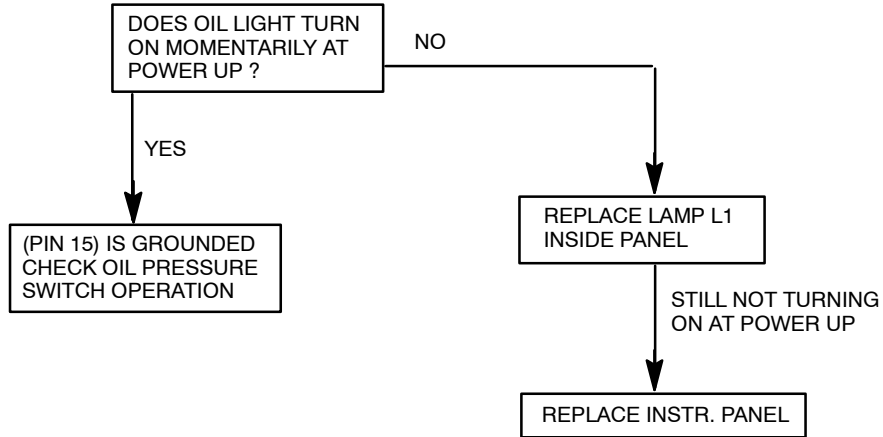

ENGINE OIL PRESSURE WARNING LIGHT WILL NOT TURN OFF (FLOW CHART)

OPERATION:
-(PIN 15) IS PULLED TO GROUND WHEN OIL PRESSURE IS HIGH ENOUGH
-OIL LIGHT TURNS OFF

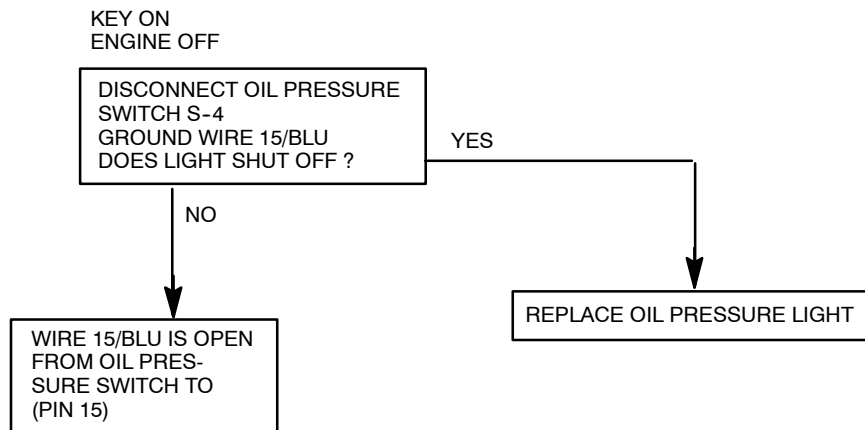

RECOVERY TANK FULL LIGHT WILL NOT TURN ON OR OFF (SCHEMATIC)

OPERATION:
 -IF S-8 CLOSES, THE RECOVERY TANK IS FULL
 -THE RECOVERY TANK LIGHT COMES ON
 -SCRUB , SQUEEGEE, AND VACUUM FAN TURNS OFF

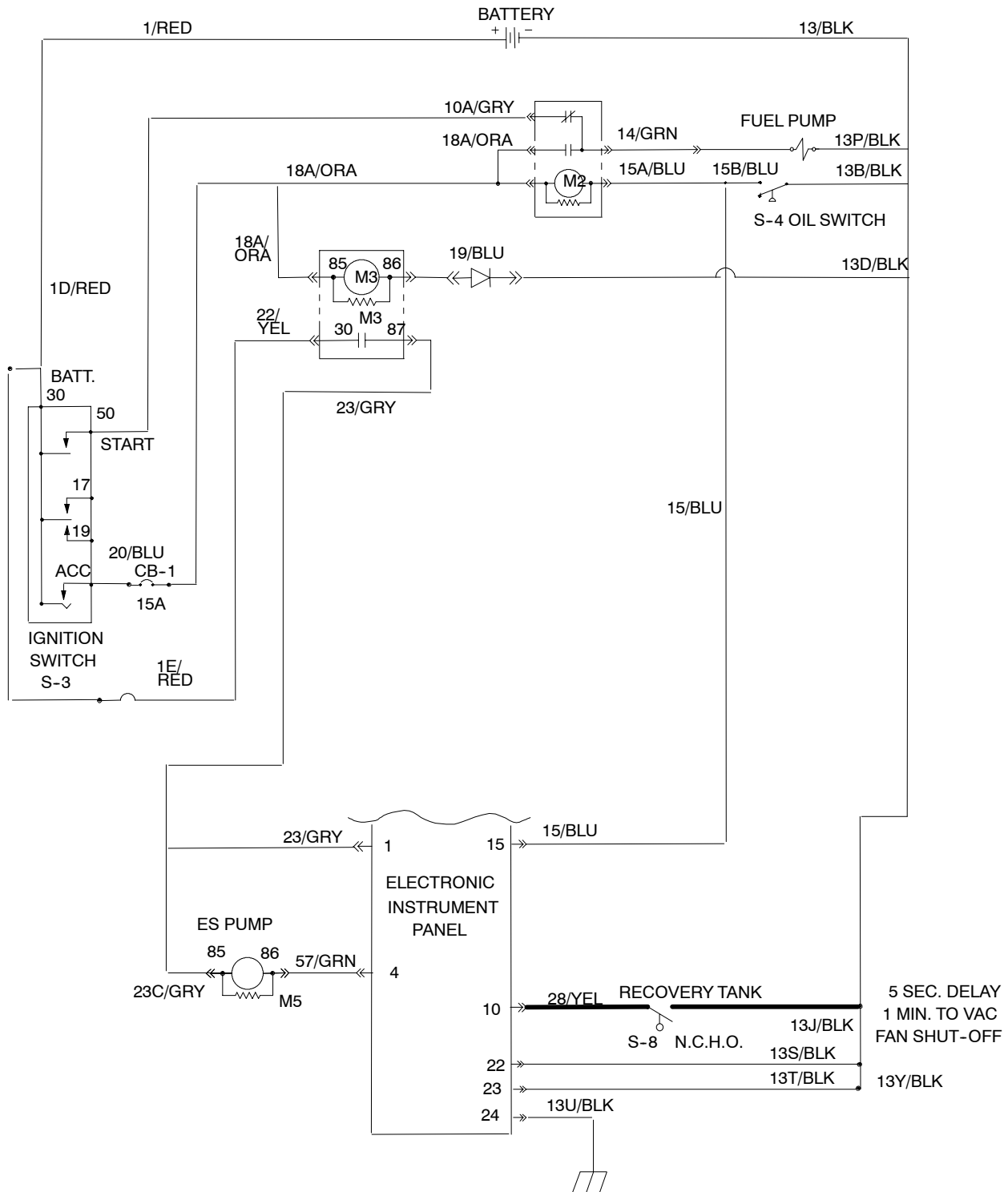

**RECOVERY TANK FULL LIGHT
WILL NOT TURN ON
(FLOW CHART)**

OPERATION:
 -IF S-8 CLOSES, THE RECOVERY TANK IS FULL
 -THE RECOVERY TANK LIGHT COMES ON
 -SCRUB , SQUEEGEE, AND VACUUM FAN TURNS OFF

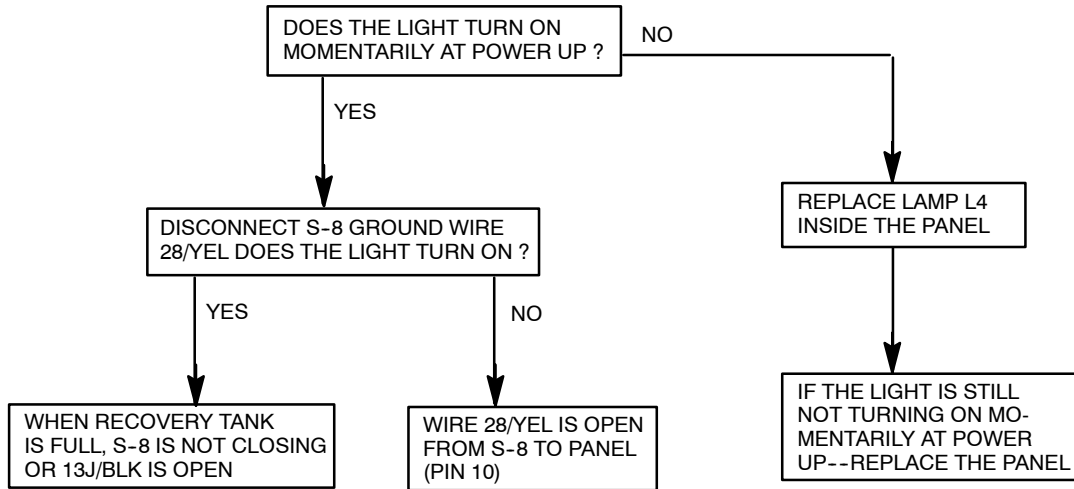

**RECOVERY TANK FULL LIGHT
WILL NOT TURN OFF
(FLOW CHART)**

OPERATION:
 -IF S-8 CLOSES, THE RECOVERY TANK IS FULL
 -THE RECOVERY TANK LIGHT COMES ON
 -SCRUB , SQUEEGEE, AND VACUUM FAN TURNS OFF

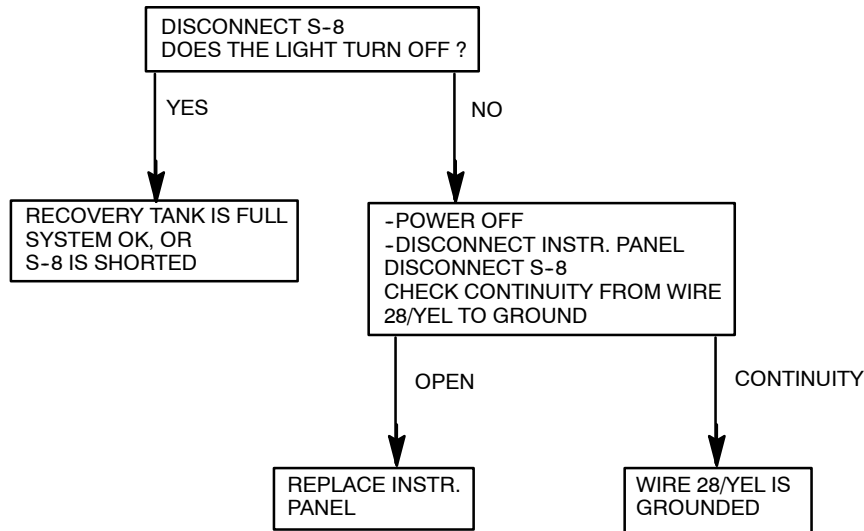

**FUEL GAUGE (GAS AND DIESEL)
(SCHEMATIC)**

OPERATION:
 -S-6 IS NOT ON MACHINE
 -SE-1 GREATER THE 90 OHMS=FULL TANK
 -SE-1 LESS THAN 10 OHMS=EMPTY TANK

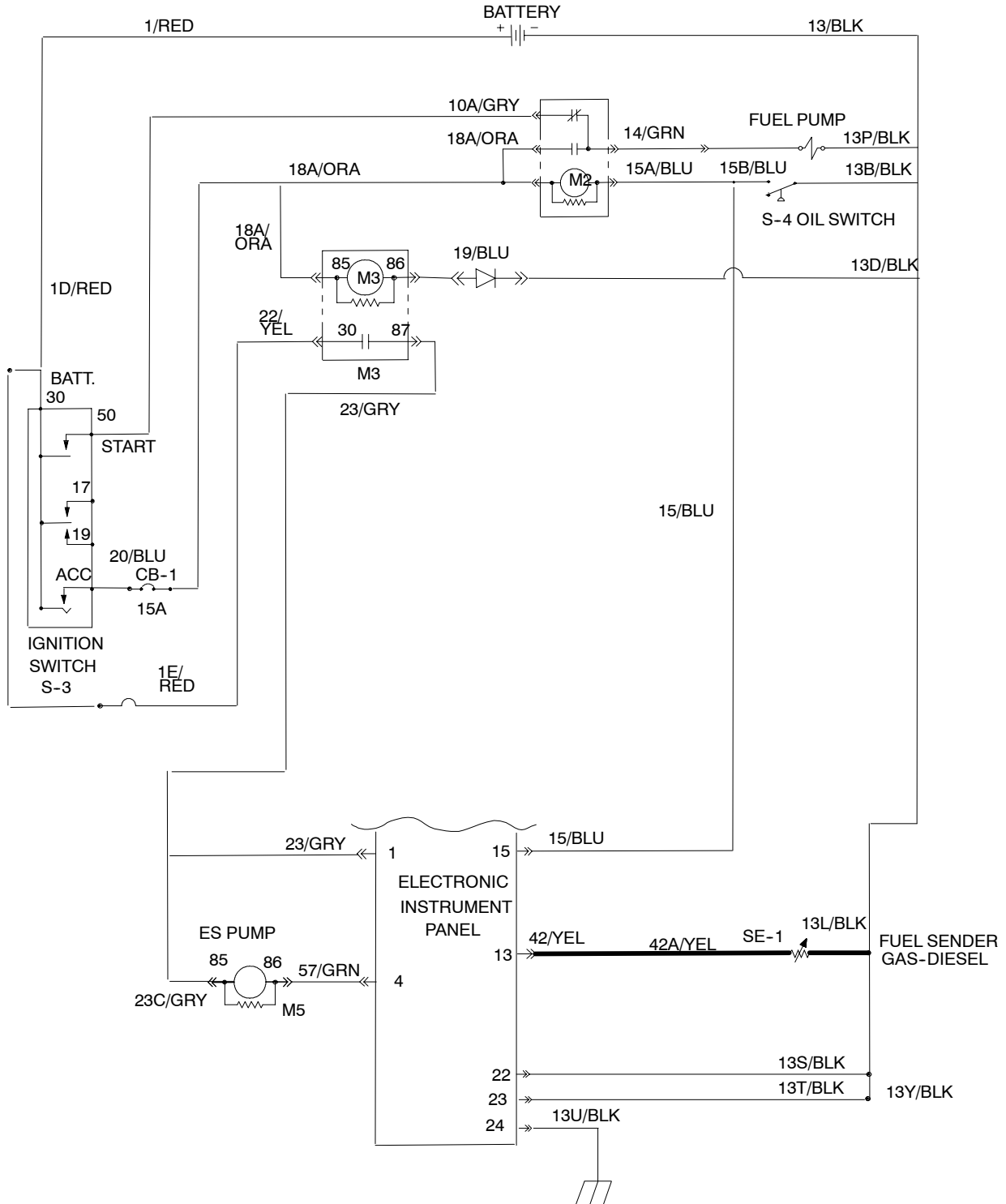

FUEL GAUGE (GAS AND DIESEL) (FLOW CHART)

OPERATION:
-S-6 IS NOT ON MACHINE
-SE-1 GREATER THE 90 OHMS=FULL TANK
-SE-1 LESS THAN 10 OHMS=EMPTY TANK

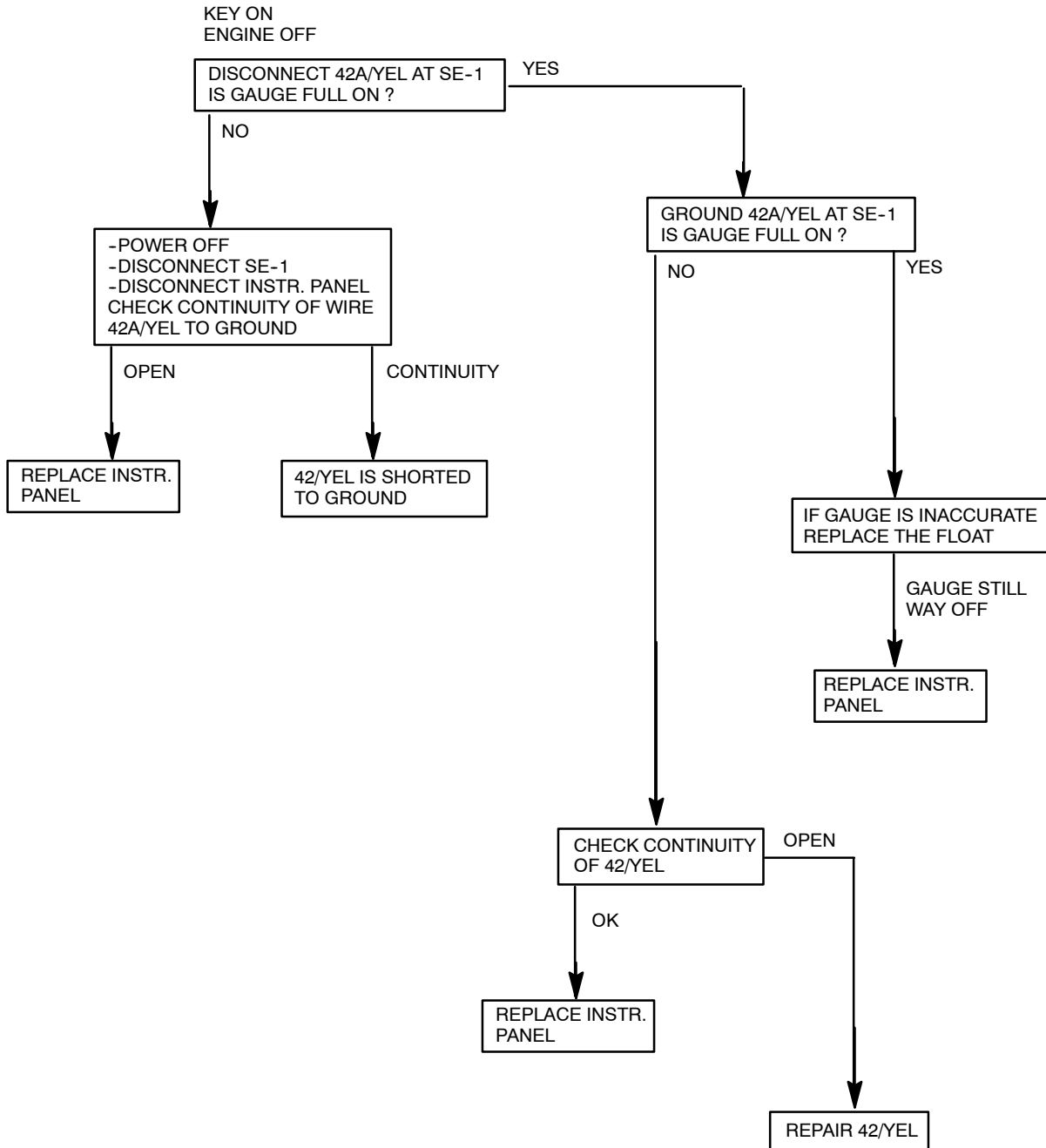

**FUEL GAUGE (LPG)
(SCHEMATIC)**

OPERATION:
 -S-6 IS OPEN = GAUGE IS OFF
 -S-6 IS CLOSED = LEFT 2 SEGMENTS OF GAUGE FLASH
 -SE-1 IS NOT ON MACHINE

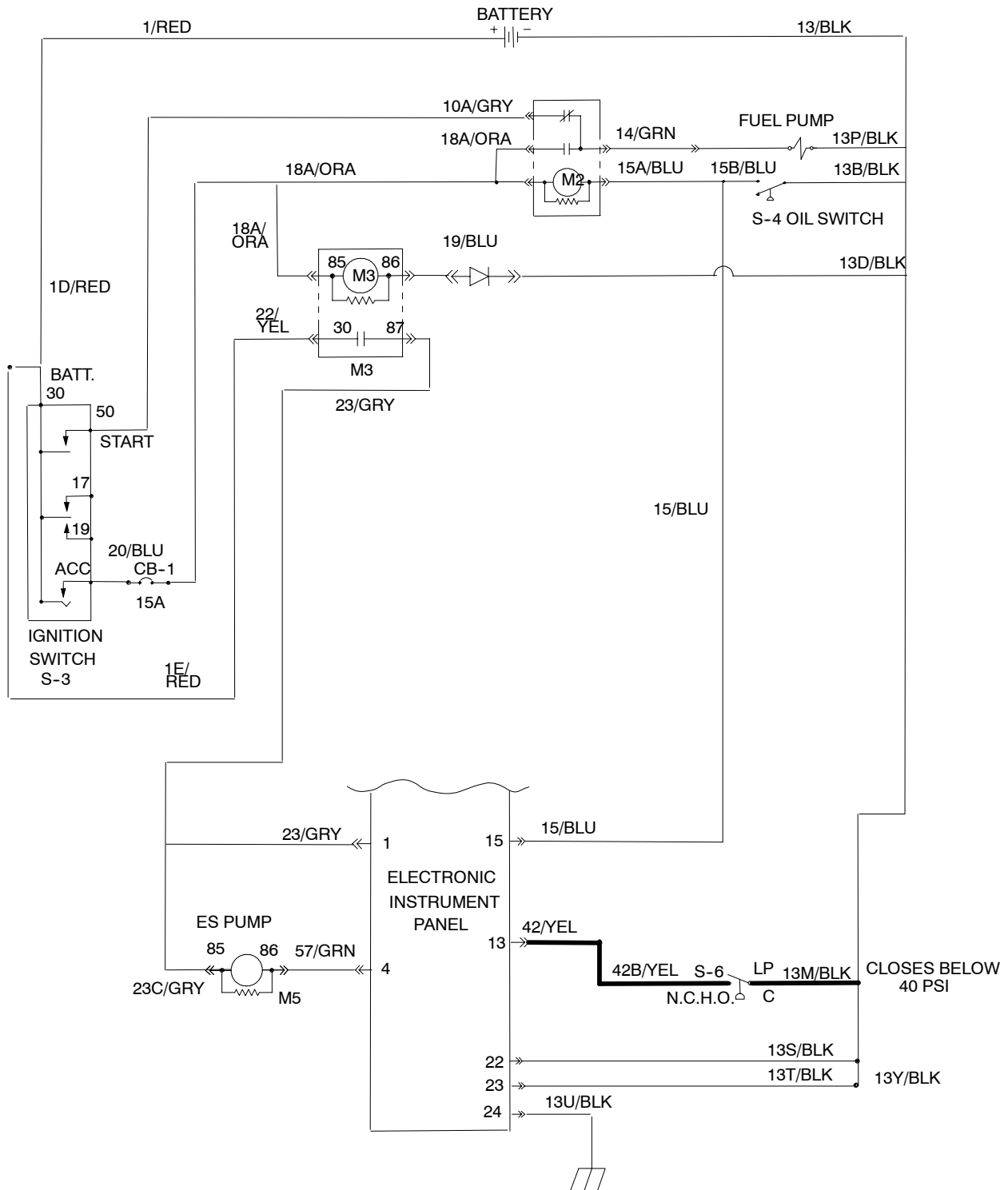

**FUEL GAUGE (LPG)
(FLOW CHART)**

OPERATION:
 -S-6 IS OPEN = GAUGE IS OFF
 -S-6 IS CLOSED = LEFT 2 SEGMENTS OF GAUGE FLASH
 -SE-1 IS NOT ON MACHINE

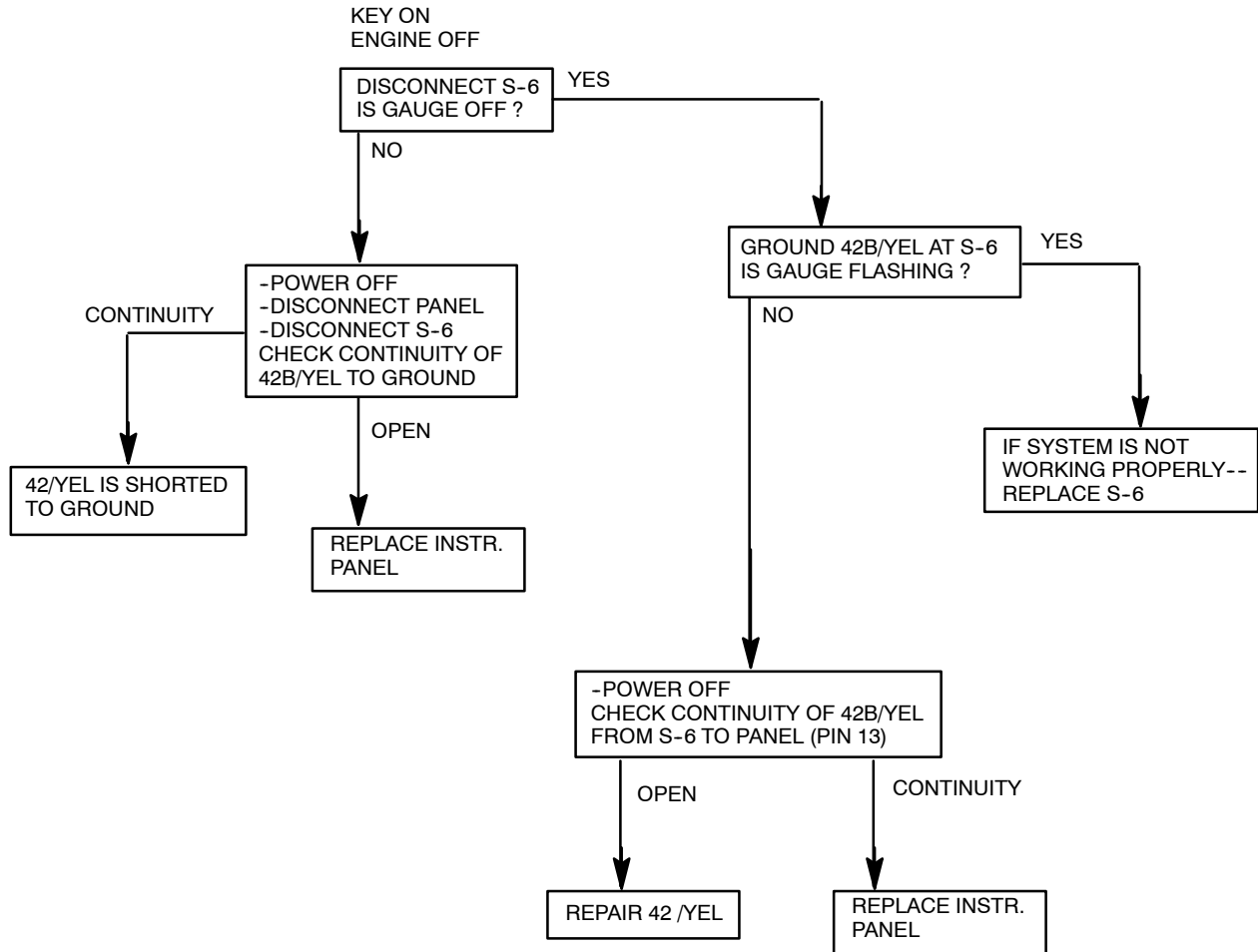

CONTENTS

	Page		Page
HYDRAULIC FLUID RESERVOIR	5-3	MAIN BRUSHES DO NOT LOWER	
HYDRAULIC FLUID	5-3	(FLOW CHART)	5-49
HYDRAULIC HOSES	5-4	MAIN BRUSH LIFT CIRCUIT	
TO REPLACE DIRECTIONAL PEDAL		(SCHEMATIC)	5-50
CENTERING SPRING	5-5	MAIN BRUSH LOWER CIRCUIT	
TO REPLACE DIRECTIONAL		(SCHEMATIC)	5-48
CONTROL CABLE	5-7	MAIN BRUSHES DO NOT RAISE	
TO ADJUST CENTERING SPRING	5-9	(FLOW CHART)	5-51
TO REPLACE PROPEL PUMP	5-10	MAIN BRUSHES DO NOT STAY UP	
TO REPLACE ACCESSORY PUMP	5-12	(FLOW CHART)	5-52
TO REPLACE STEERING CYLINDER	5-14	SCRUB FAN CIRCUIT	
TO REPLACE HYDRAULIC STEERING		(SCHEMATIC)	5-54
VALVE	5-15	SCRUB FAN DOES NOT TURN ON	
TO REPLACE MAIN HYDRAULIC VALVE ..	5-16	(FLOW CHART)	5-55
TO REPLACE SIDE BRUSH HYDRAULIC		SCRUB FAN DOES NOT TURN OFF	
VALVE	5-18	(FLOW CHART)	5-56
TO REPLACE SOLENOID VALVE		SCRUB FAN MOTOR SHAFT SEAL	
CARTRIDGE	5-20	LEAKS (FLOW CHART)	5-57
TO REPLACE ENGINE COOLING FAN		MAIN BRUSH ON CIRCUIT	
HYDRAULIC MOTOR	5-22	(SCHEMATIC)	5-58
TO REPLACE MAIN SCRUB BRUSH		SIDE BRUSH DOES NOT TURN ON	
HYDRAULIC MOTORS	5-24	(FLOW CHART)	5-59
TO REPLACE SCRUB HEAD ASSEMBLY		SIDE BRUSH DOES NOT TURN OFF	
LIFT CYLINDER	5-27	(FLOW CHART)	5-60
TO REPLACE OPTIONAL SIDE BRUSH		SIDE BRUSH EXTEND CIRCUIT	
HYDRAULIC MOTOR	5-28	(SCHEMATIC)	5-62
TO REPLACE OPTIONAL SIDE BRUSH		SIDE BRUSH DOES NOT GO OUT	
LIFT CYLINDER	5-29	(FLOW CHART)	5-63
TO REPLACE OPTIONAL SIDE BRUSH		SIDE BRUSH DOES NOT GO IN	
SWING CYLINDER	5-30	(FLOW CHART)	5-64
TO REPLACE SQUEEGEE LIFT		SIDE BRUSH LOWER CIRCUIT	
CYLINDER	5-31	(SCHEMATIC)	5-66
TO REPLACE VACUUM FAN HYDRAULIC		SIDE BRUSH DOES NOT STAY UP	
MOTOR	5-32	(FLOW CHART)	5-67
HYDRAULIC SCHEMATIC	5-35	SIDE BRUSH DOES NOT RAISE	
HYDRAULIC HOSE GROUP	5-37	(FLOW CHART)	5-68
HYDRAULIC HOSE GROUP/SIDE BRUSH		SIDE BRUSH DOES NOT LOWER	
OPTION	5-38	(FLOW CHART)	5-69
TROUBLESHOOTING	5-39	SQUEEGEE LIFT CIRCUIT	
ENGINE FAN CIRCUIT (SCHEMATIC) .	5-40	(SCHEMATIC)	5-70
ENGINE FAN SLOW OR DOESN'T RUN		SQUEEGEE DOES NOT LOWER	
(FLOW CHART)	5-41	(FLOW CHART)	5-71
ENGINE FAN MOTOR SHAFT SEAL		SQUEEGEE DOES NOT RAISE	
LEAKS (FLOW CHART)	5-42	(FLOW CHART)	5-72
MAIN BRUSH ON CIRCUIT		SQUEEGEE DOES NOT STAY UP	
(SCHEMATIC)	5-44	(FLOW CHART)	5-73
MAIN BRUSHES DO NOT TURN ON		STEERING CIRCUIT (SCHEMATIC) ...	5-74
(FLOW CHART)	5-45	EATON HYDRAULICS REPAIR	
MAIN BRUSHES DO NOT TURN OFF		MANUAL	5-75
(FLOW CHART)	5-46		

INTRODUCTION

The hydraulic system consists of the propel pump, accessory pump, control valve, drive motors, steering cylinder, and vacuum fan motor.

HYDRAULICS

HYDRAULIC FLUID RESERVOIR

The reservoir is located in the front left corner of the machine.

Mounted on top of the reservoir is a filler cap with a built-in breather and fluid level dipstick. Replace the cap every 800 hours of operation.

Check the hydraulic fluid level at operating temperature every 100 hours of operation. Make sure the hopper is down when checking hydraulic fluid level. The end of the dipstick is marked with FULL and ADD levels to indicate the level of hydraulic fluid in the reservoir.

Lubricate the filler cap gasket with a film of hydraulic fluid before putting the cap back on the reservoir.

ATTENTION! Do not overfill the hydraulic fluid reservoir or operate the machine with a low level of hydraulic fluid in the reservoir. Damage to the machine hydraulic system may result.

Drain and refill the hydraulic fluid reservoir with new hydraulic fluid every 800 hours of operation.

The hydraulic fluid filter is located at the bottom of the engine compartment. Replace the filter element every 800 hours of operation.

The reservoir has a built-in strainer outlet that filters hydraulic fluid before it enters the system. Replace the strainer every 800 hours of operation.

HYDRAULIC FLUID

The quality and condition of the hydraulic fluid play a very important role in how well the machine operates. Tennant's hydraulic fluid is specially selected to meet the needs of Tennant machines.

Tennant's hydraulic fluids provide a longer life for the hydraulic components. There are two fluids available for different temperature ranges:

Tennant part no.	Ambient Temperature
65869	above 7° C (45° F)
65870	below 7° C (45° F)

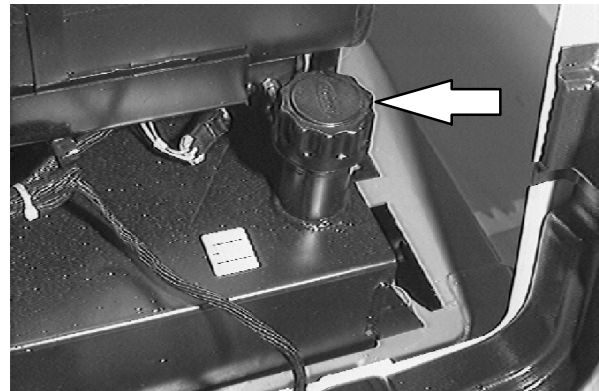
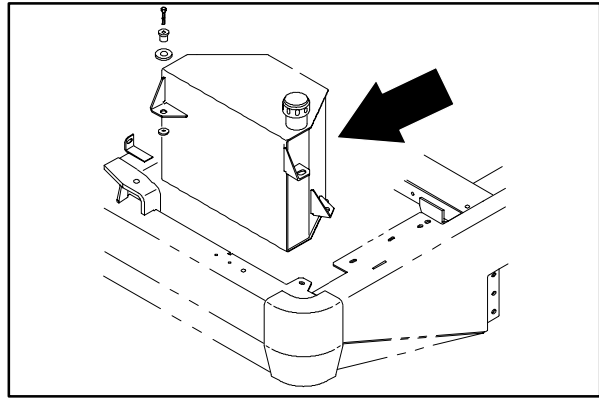

The higher temperature fluid has a higher viscosity and should not be used at the lower temperatures. Damage to the hydraulic pumps may occur because of improper lubrication.

The lower temperature fluid is a thinner fluid for colder temperatures.

If a locally-available hydraulic fluid is used, make sure the specifications match Tennant hydraulic fluid specifications. Using substitute fluids can cause premature failure of hydraulic components.

European manufactured machines are filled with locally available hydraulic fluids. Check the label on the hydraulic fluid reservoir.

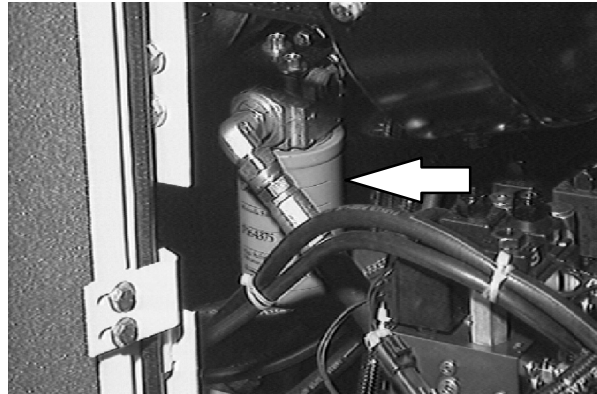

ATTENTION! Hydraulic components depend on system hydraulic fluid for internal lubrication. Malfunctions, accelerated wear, and damage will result if dirt or other contaminants enter the hydraulic system.

HYDRAULIC HOSES

Check the hydraulic hoses every 800 hours of operation for wear or damage.

Fluid escaping at high pressure from a very small hole can be almost invisible, and can cause serious injuries.

See a doctor at once if injury results from escaping hydraulic fluid. Serious infection or reaction can develop if proper medical treatment is not given immediately.

FOR SAFETY: When servicing machine, use cardboard to locate leaking hydraulic fluid under pressure.

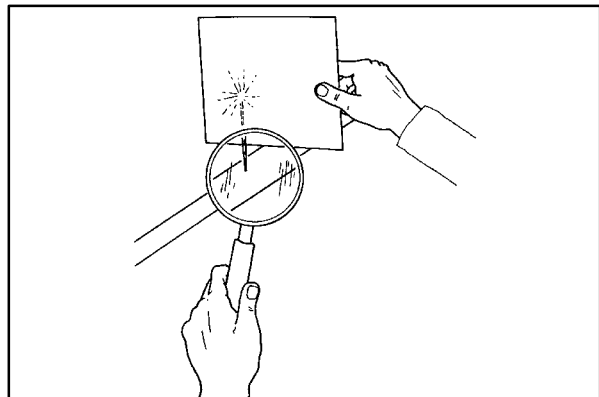

If you discover a fluid leak, contact your mechanic/supervisor.

HYDRAULICS

TO REPLACE DIRECTIONAL PEDAL CENTERING SPRING

FOR SAFETY: Before Leaving Or Servicing Machine; Stop On Level Surface, Set Parking Brake, Turn Off Machine And Remove Key.

1. Pivot the operators seat to the open position and engage the prop rod.
2. Disconnect the battery cables and remove the battery.
3. Locate the pedal centering spring on the right side of the accessory pump.
4. Remove the nyloc nut holding the centering spring balljoint to directional control arm on the propel pump.
5. Loosen the large jam nut holding the centering spring to the propel bracket.
6. Remove the spring assembly from bracket and position it up in the seat support area for disassembly access.
7. Remove the ball joint and jam nuts.
8. Unscrew the centering spring assembly from the directional control cable. Discard the old spring.

NOTE: The cable will have to be held to keep it from turning

9. Thread a new centering spring assembly all the way back on the directional control cable. Leave 1/4 in. of threads showing on the larger diameter threads on the cable.
10. Install two 1/4 in. jam nuts on the end of the cable. Tighten one to the centering spring housing and the other one to the balljoint. Leave 1/16 in. between the two jam nuts.
11. Use the large jam nut to lock the centering spring assembly in place.

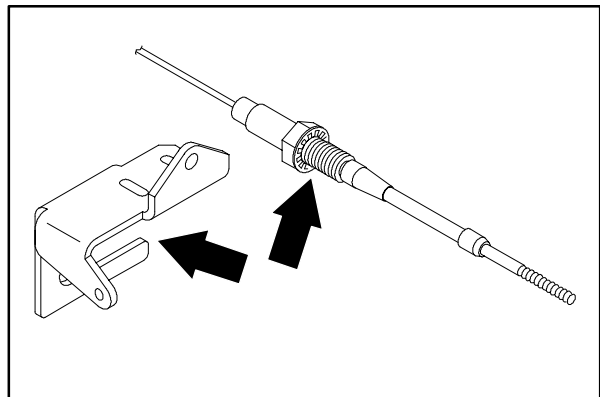
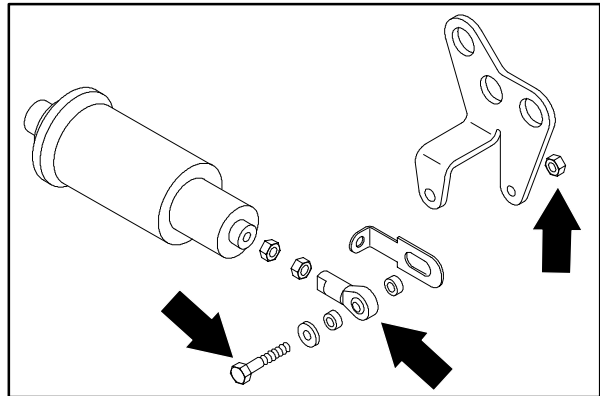
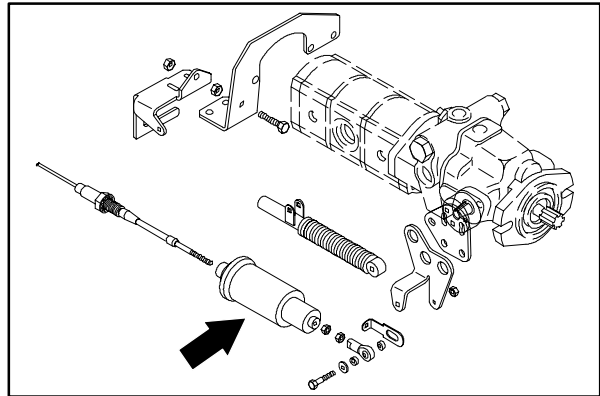
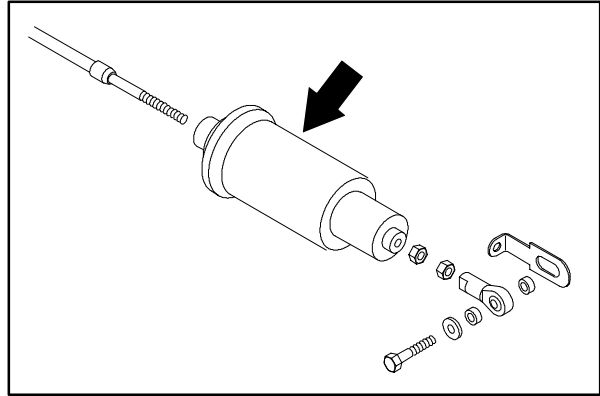

12. Reinstall the spring assembly balljoint back in the directional control arm. Tighten the nyloc nut to 11 - 14 Nm (7 - 10 ft lb).
13. Reinstall the battery and reconnect the battery cables.
14. Jack up the front of the machine.

FOR SAFETY: Block machine tires before jacking machine up. Jack machine up at designated locations only. Block machine up with jack stands

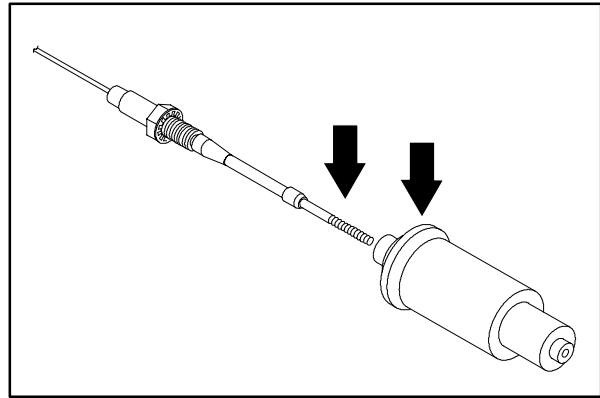

15. Check neutral centering of pump by starting machine and observing front tire for any rotation. If tire is rotating See TO ADJUST CENTERING SPRING instructions.
16. Once the neutral centering has been set, remove the jack stands, lower the machine, and close the operators seat.

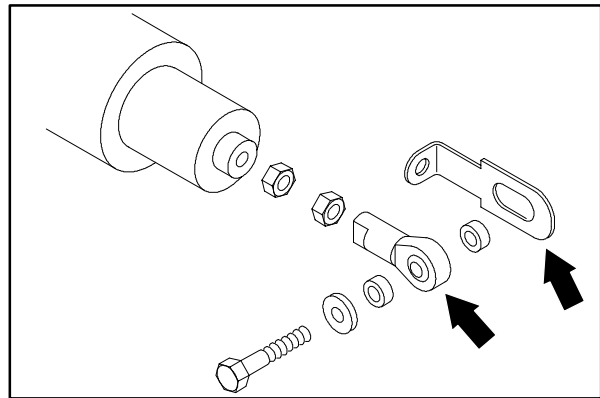

HYDRAULICS

TO REPLACE DIRECTIONAL CONTROL CABLE

FOR SAFETY: Before Leaving Or Servicing Machine; Stop On Level Surface, Set Parking Brake, Turn Off Machine And Remove Key.

1. Pivot the operators seat to the open position and engage the prop rod.
2. Disconnect the battery cables and remove the battery.
3. Locate the pedal centering spring on the right side of the accessory pump.
4. Remove the hex screw and nyloc nut holding the centering spring balljoint to directional control arm on the propel pump. Retain the two steel sleeves.
5. Loosen the large jam nut holding the centering spring to the propel bracket.
6. Remove the spring assembly from the mount bracket and position it up in the seat support area for disassembly access.
7. Remove the ball joint and jam nuts.
8. Unscrew the centering spring assembly from the directional control cable. Retain the old centering spring.

NOTE: The cable will have to be held to keep it from turning

9. Remove the two hex screw holding the floor plate in the operators compartment. Remove the floor plate.
10. Remove the clamp holding the directional cable to the operators compartment.
11. Reach in through the floor plate opening and remove the nyloc nut holding the directional control cable ball joint to the forward reverse pedal arm. Pull the directional control cable ball joint out of the pedal arm.
12. Loosen the large jam nut on the directional control cable. Drop the cable out of the slot. Remove the cable from the machine.

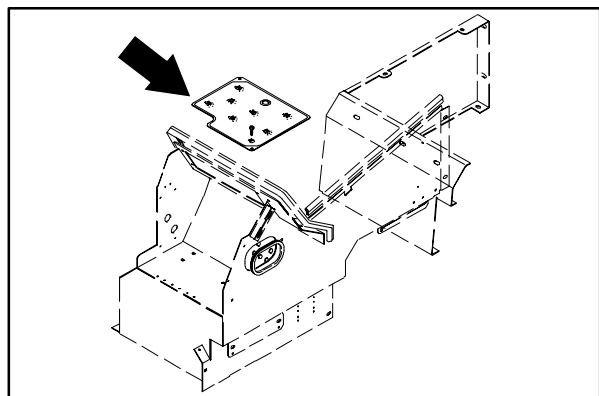
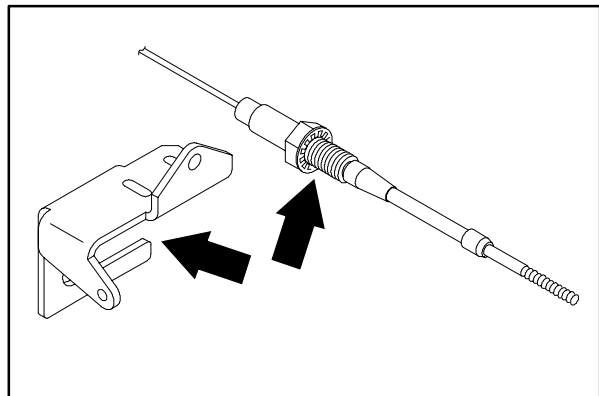
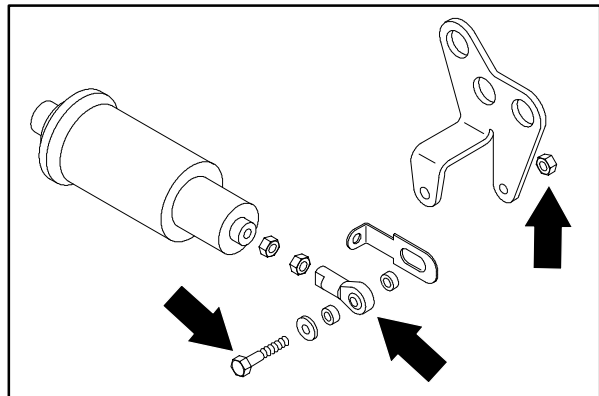
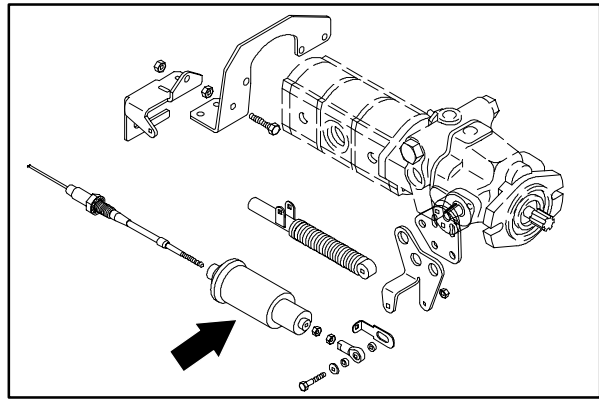

13. Install the old centering spring assembly all the way back on the new directional control cable. Leave 1/4 in. of threads showing on the larger diameter threads on the cable.
14. Install two 1/4 in. jam nuts on the end of the cable. Tighten one to the centering spring housing and the other one to the balljoint. Leave 1/16 in. between the two jam nuts.
15. Reinstall the centering spring/directional cable assembly back in the machine.
16. Use the large jam nut to lock the centering spring assembly in place on the mount bracket.
17. Reinstall the spring assembly balljoint back on the directional control arm. Reinstall the hex screw, two steel sleeves, and nyloc nut. Tighten to 11 - 14 Nm (7 - 10 ft lb).
18. Reach in through the floor plate opening and reinstall the cable ball joint in the forward reverse pedal arm. Reinstall the nyloc nut and tighten to 11 - 14 Nm (7 - 10 ft lb).
19. Use the large jam nut to lock the directional cable in place on the mount bracket.
20. Reinstall the cable clamp that holds the directional cable to the operators compartment.
21. Reinstall the battery and reconnect the battery cables.
22. Jack up the front of the machine.

FOR SAFETY: Block machine tires before jacking machine up. Jack machine up at designated locations only. Block machine up with jack stands.

23. Check neutral centering of pump by starting machine and observing front tire for any rotation. If tire is rotating See TO ADJUST CENTERING SPRING instructions.
24. Once the neutral centering has been set, remove the jack stands, lower the machine, and close the operators seat.

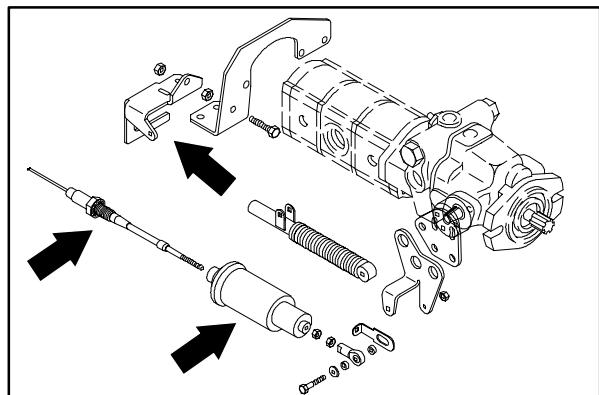
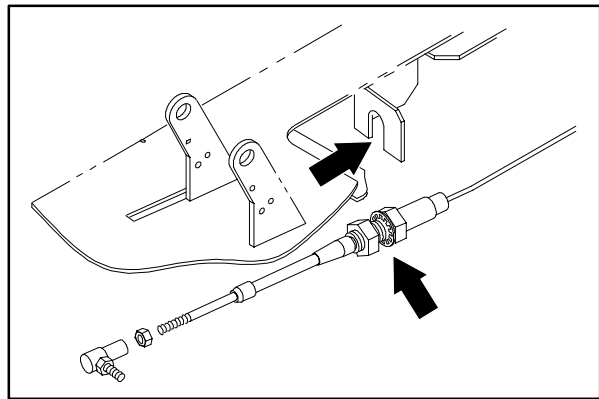
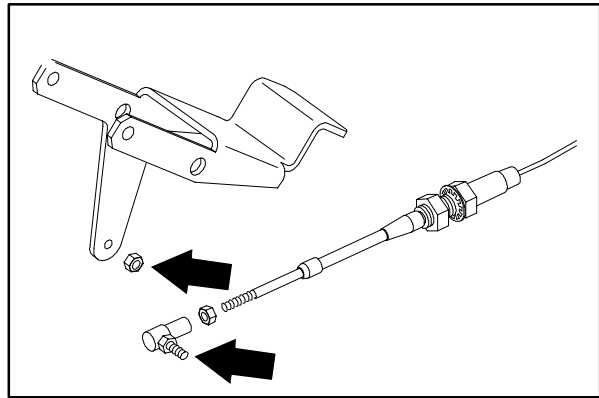
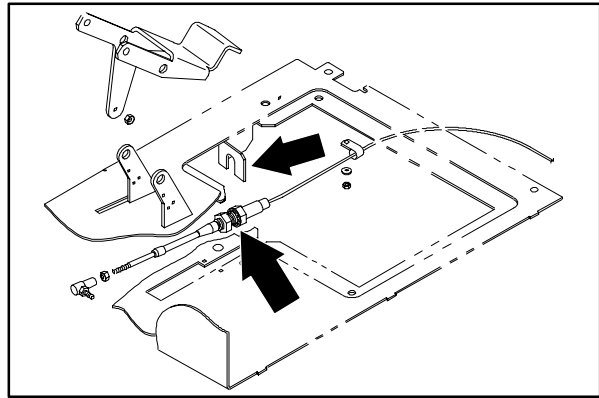

TO ADJUST CENTERING SPRING

FOR SAFETY: Before Leaving Or Servicing Machine; Stop On Level Surface, Set Parking Brake, Turn Off Machine.

1. Jack up the front of the machine.

FOR SAFETY: Block machine tires before jacking machine up. Jack machine up at designated locations only. Block machine up with jack stands

2. Check the neutral centering of the pump by starting the machine and observing the front tire for any rotation.
3. If tire is rotating, shut off the engine. Pivot the operators seat to the open position and engage the prop rod.
4. Locate the centering spring adjustment bracket on the right side of the accessory pump. Loosen the two M6 hex screws on top of the bracket.
5. Loosen the two jam nuts on the hex screw that is used to move the adjustment bracket back and forth.
6. Start the machine and observe the front tire for any rotation. If the tire is rotating in either direction, move the adjustment bracket backward or forward until rotation stops. Re-tighten the two jam nuts. Shut off the engine.
7. Once all the rotation has been eliminated, tighten the two M6 hex screws that hold the two brackets together. Tighten to 11 - 14 Nm (7 - 10 ft lb).
8. Lower the operators seat.
9. Remove the jack stands and lower the machine to the ground.

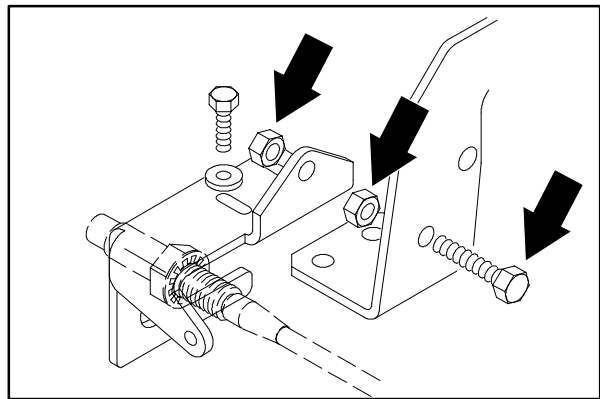
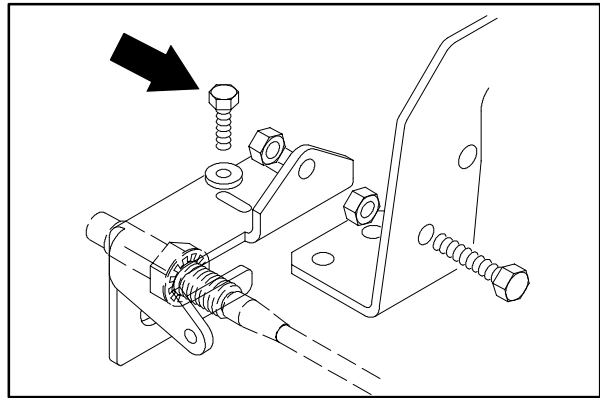
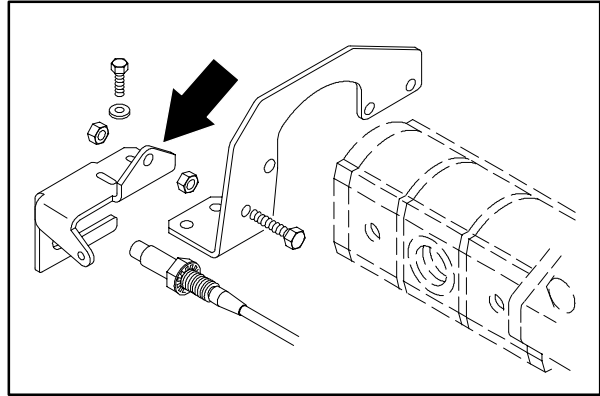

TO REPLACE PROPEL PUMP

FOR SAFETY: Before Leaving Or Servicing Machine; Stop On Level Surface, Set Parking Brake., Turn Off Machine And Remove Key.

1. Pivot the operators seat to the open position and engage the prop rod.
2. Disconnect the battery cables and remove the battery.

NOTE: The battery tray can also be removed for better access to the propel pump

3. Remove the detergent tank and the rubber sound flap from the machine.
4. Disconnect the tension spring leading from the directional spring bracket to the brush wrap.
5. Remove the two hex screws holding the accessory pump to the propel pump.
6. Lift the directional spring bracket up far enough to allow accessory pump removal.

NOTE: The main suction line to the accessory pump is held, by plastic ties, in a bundle of hoses near the main valve. Remove the plastic ties to gain slack in the suction line to ease pump removal.

7. The accessory pump can now be pulled out of the propel pump. Do not disconnect the hydraulic hoses leading to the accessory pump.
8. Mark, remove, and plug the hydraulic hoses leading to the propel pump.

NOTE: Observe hydraulic cleanliness requirements when opening hydraulic lines.

9. Remove the one socket screw holding the propel pump directional arm and hub to the pump shaft. Remove the hub and arm from the pump.

NOTE: The pump shaft is tapered so the hub may need to be removed with a puller.

10. Remove the two hex screws holding the propel pump to the engine bellhousing.

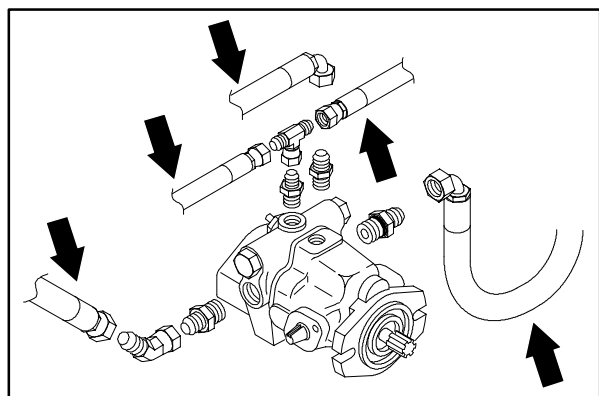
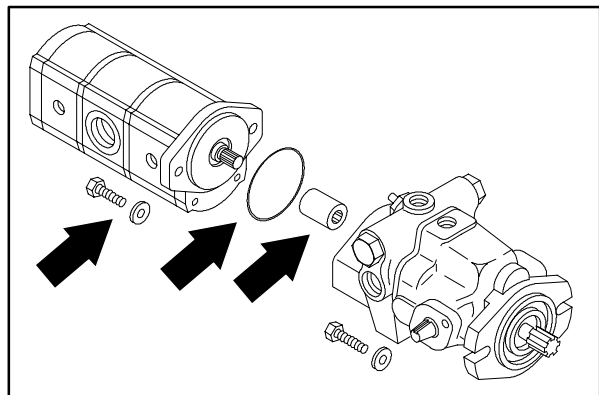
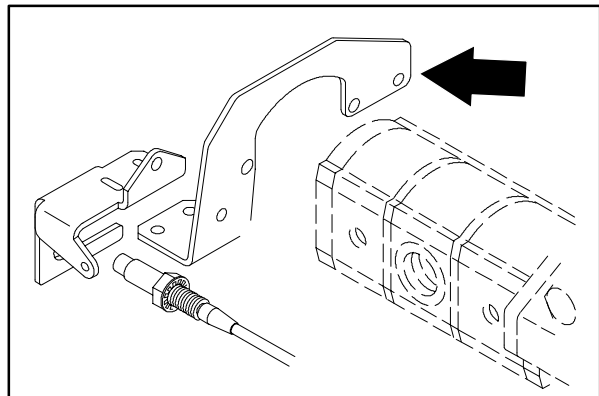
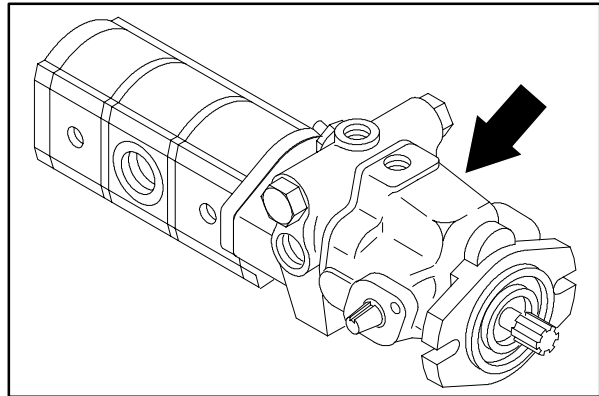

HYDRAULICS

11. Pull the propel pump out of the bellhousing and drive coupler. Remove the pump from the machine.
12. Remove the fittings from the old propel pump and install in the new pump in the same orientation.
13. Place grease on the splines of the new pump and install back in the machine.
14. Reinstall the two hex screws and washers. Use a small amount of blue loctite 242 on the threads. Tighten to 31 - 40 Nm (27 - 35 ft lb).
15. Reinstall the propel pump directional arm and hub to the pump shaft. Reinstall the socket screw. Tighten to 18 - 24 Nm (15 - 20 ft lb).
16. Reconnect the hydraulic hoses to the propel pump. See the schematic in this section.
17. Reinstall the accessory pump in the back of the propel pump. Make sure the O-ring is in place on the accessory pump.
18. Place the directional spring bracket back on the flange of the accessory pump.
19. Reinstall the two hex screws and washers. Use a small amount of blue loctite 242 on the threads. Tighten to 31 - 40 Nm (27 - 35 ft lb).
20. Reconnect the tension spring to the brush wrap and directional spring bracket.
21. Reinstall the detergent tank in the seat support area.
22. Reinstall the battery and reconnect the battery cables.
23. Start the machine. Check the propel pump for leaks and proper operation.

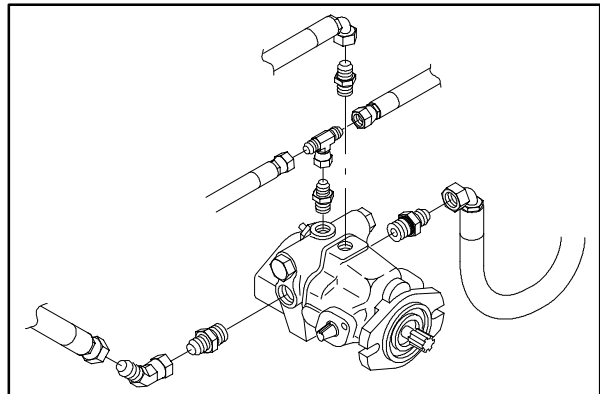
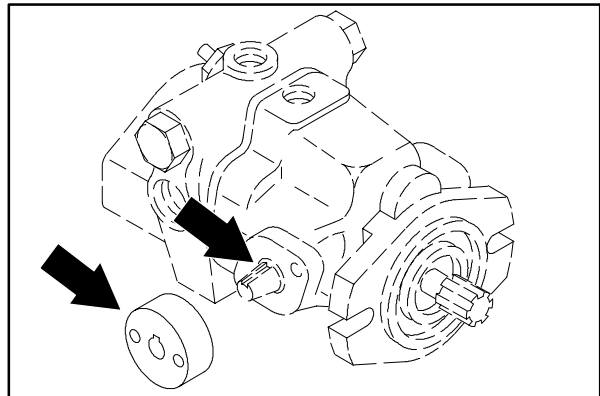
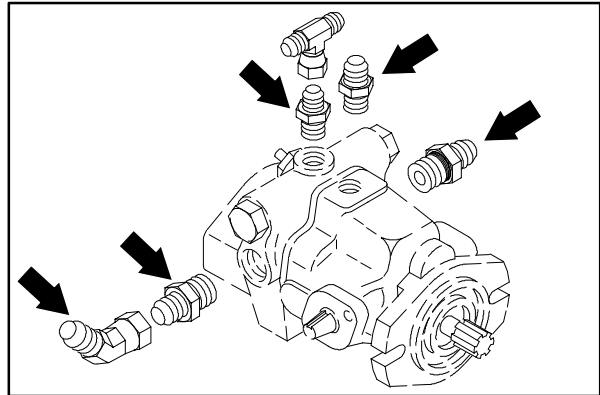
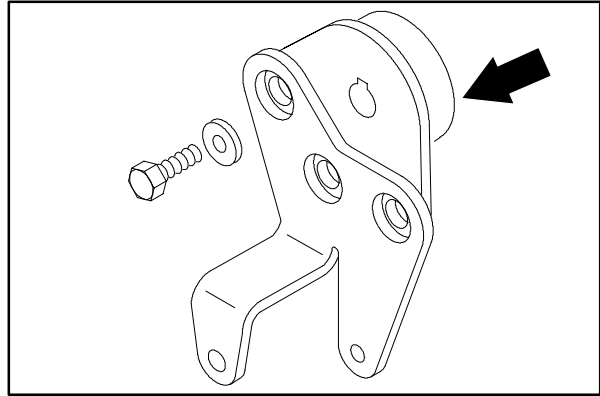

TO REPLACE ACCESSORY PUMP

FOR SAFETY: Before Leaving Or Servicing Machine; Stop On Level Surface, Set Parking Brake., Turn Off Machine And Remove Key.

1. Pivot the operators seat to the open position and engage the prop rod.
2. Disconnect the battery cables and remove the battery.
3. Remove the detergent tank from the machine.
4. Disconnect the tension spring leading from the directional spring bracket to the brush wrap.
5. Mark, remove, and plug the hydraulic hoses leading to the accessory pump.

NOTE: Observe hydraulic cleanliness requirements when opening hydraulic lines.

6. Remove the two hex screws holding the accessory pump to the propel pump.
7. Lift the directional spring bracket up far enough to allow accessory pump removal.
8. The accessory pump can now be pulled back out of the propel pump. Remove the accessory pump from the machine.
9. Remove the fittings from the old accessory pump and install in the new pump in the same orientation.
10. Place grease on the splines of the new pump and install back in the machine.
11. Position the accessory pump back in the propel pump. Make sure the O-ring is in place on the accessory pump.

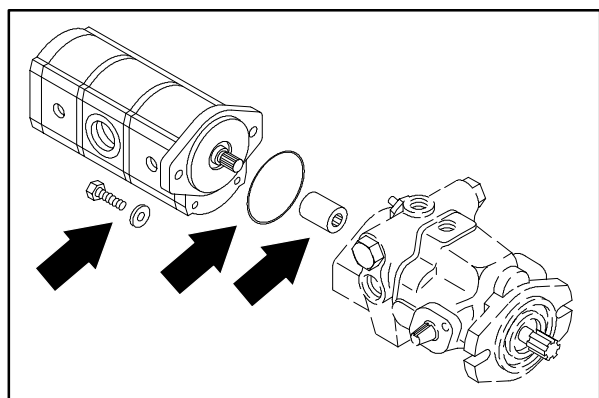
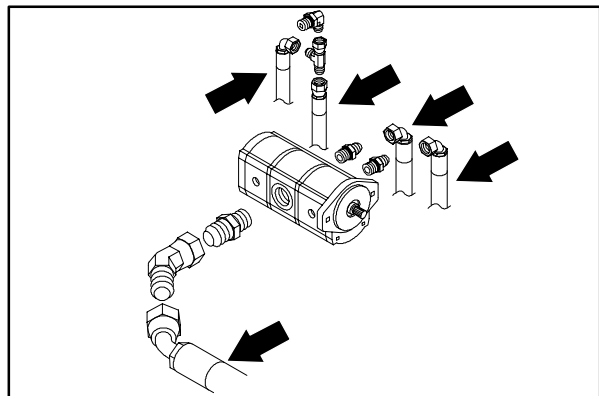
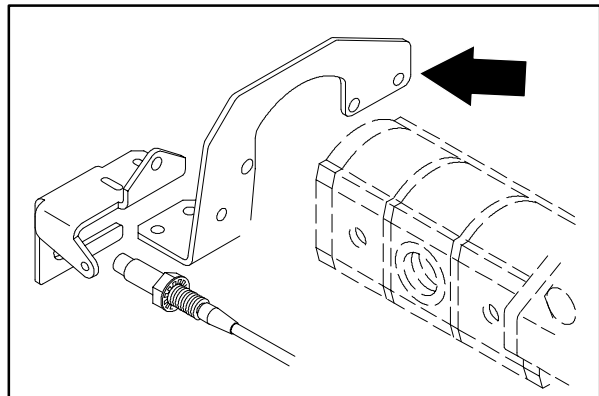
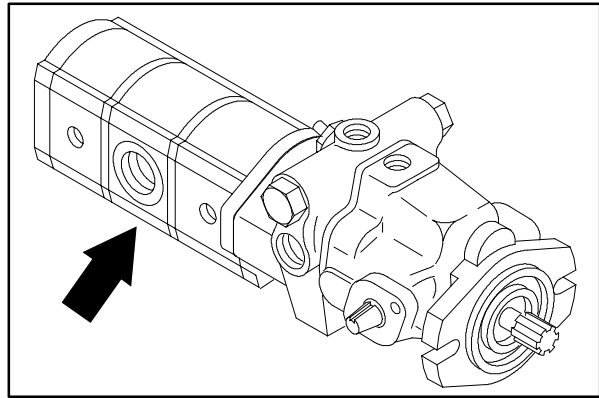

HYDRAULICS

12. Reinstall the two hex screws and washers. Use a small amount of blue loctite 242 on the threads. Place the directional spring bracket back under the bolt heads. Tighten to 31 - 40 Nm (27 - 35 ft lb).
13. Reconnect the hydraulic hoses to the accessory pump. See the schematic in this section.
14. Reconnect the tension spring to the brush wrap and directional spring bracket.
15. Reinstall the detergent tank in the seat support area.
16. Reinstall the battery and reconnect the battery cables.
17. Start the machine. Check the accessory pump for leaks and proper operation.

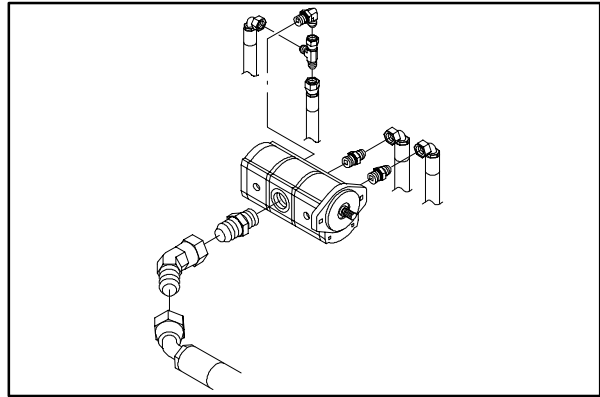
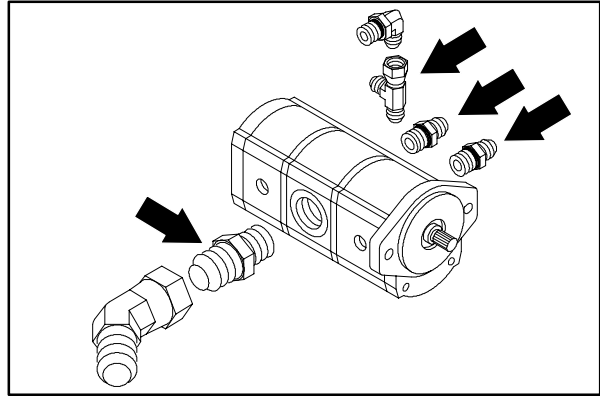

TO REPLACE STEERING CYLINDER

FOR SAFETY: Before Leaving Or Servicing Machine; Stop On Level Surface, Set Parking Brake., Turn Off Machine And Remove Key.

1. Turn the steering wheel to the left and open the machine front cover.
2. Mark, remove, and plug the two hydraulic hoses leading to the steering cylinder.

NOTE: Observe hydraulic cleanliness requirements when opening hydraulic lines.

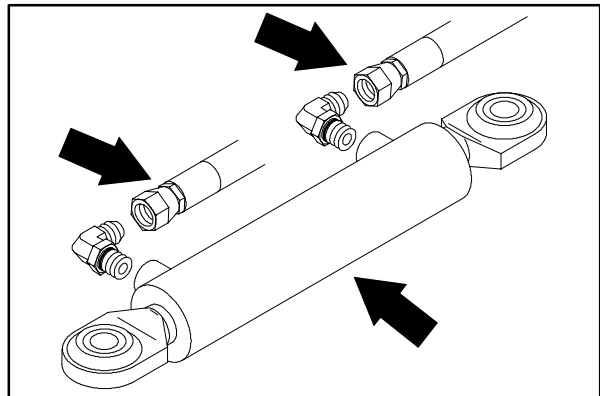

3. Remove the clamp holding the drive motor hoses to the drive motor casting. Move the hoses to gain access to steering cylinder attachment hardware.
4. Remove the large hex screw and nyloc nut holding the rod end of the steering cylinder to drive motor casting. Retain the spacer under the ball end.
5. Remove the large hex screw and nyloc nut holding the piston end of the steering cylinder to the machine frame.
6. Remove the steering cylinder from the machine.
7. Remove the fittings from the old cylinder and install in the new cylinder in the same orientation.
8. Position new cylinder and balljoint assembly back in the machine with rod end pointed toward the drive motor casting.
9. Reinstall the hex screw, spacer, and nyloc nut in the rod end of the steering cylinder and through the drive motor casting. Tighten to 271 Nm (200 ft lb).
10. Reinstall the hex screw and nyloc nut in the piston end of the steering cylinder and through the machine frame. Tighten to 271 Nm (200 ft lb).
11. Reconnect the hydraulic hoses to the steering cylinder. See schematic in this section.
12. Reinstall the clamp holding the drive motor hoses to the front casting. Tighten the hardware to 18 - 24 Nm (15 - 20 ft lb).
13. Start the machine and operate the steering. Check for any leaks and proper operation. Close the front cover.

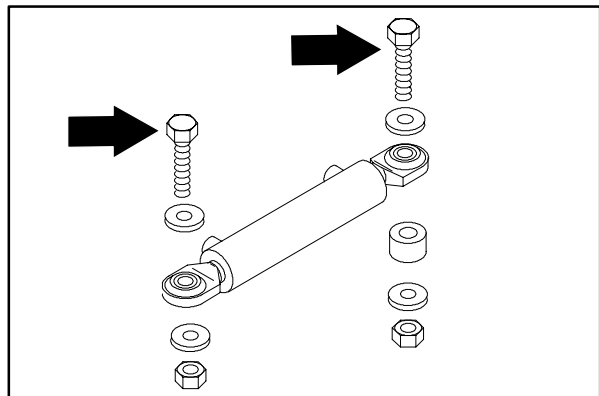
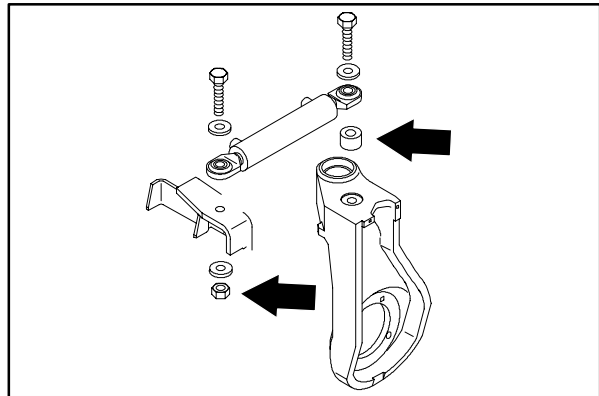
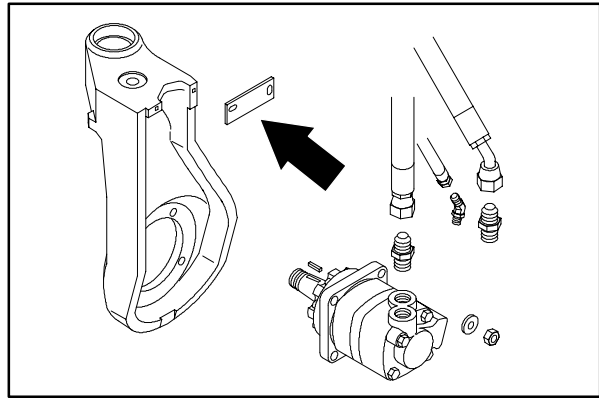

HYDRAULICS

TO REPLACE HYDRAULIC STEERING VALVE

FOR SAFETY: Before Leaving Or Servicing Machine; Stop On Level Surface, Set Parking Brake, Turn Off Machine And Remove Key.

1. Open the machine front cover.
2. Mark, remove, and plug the five hydraulic hoses leading to the steering control valve.

NOTE: Observe hydraulic cleanliness requirements when opening hydraulic lines.

3. Remove the four M6 hex screws holding the steering control valve to the steering column.
4. Pull the steering valve out of the steering column and remove it from the machine.
5. Remove the hydraulic fittings from old control valve and install in the new valve in the same orientation.
6. Install the new steering valve back in the machine. Position the ports in the same orientation as the old valve. Reinstall the four M6 hex screws and tighten to 8 - 10 Nm (5 - 7 ft lb).
7. Reconnect hydraulic hoses to steering valve. See schematic in this section.
8. Start the machine and operate the steering. Check for any leaks and proper operation.

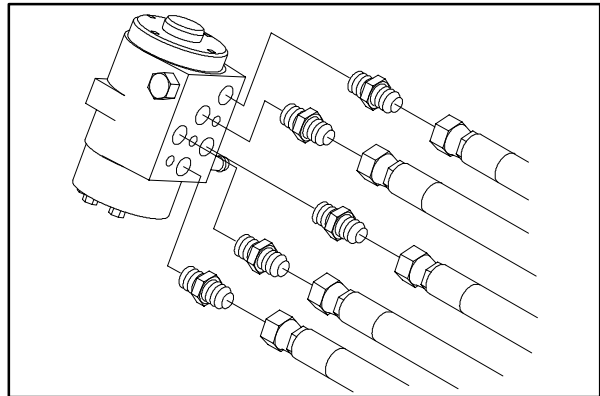
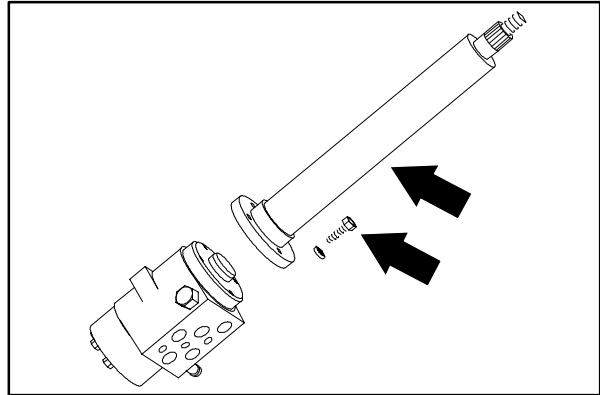
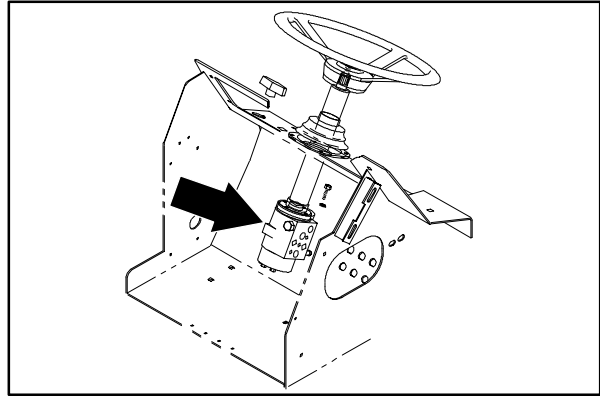

TO REPLACE MAIN HYDRAULIC VALVE

FOR SAFETY: Before Leaving Or Servicing Machine; Stop On Level Surface, Set Parking Brake., Turn Off Machine And Remove Key.

1. Raise the operators seat, engage the prop rod, and disconnect the battery cables from the battery.
2. Open the machine front cover, engine cover, and side door. Remove the side door from the machine.
3. If the machine is an LPG, remove the LP tank from the cradle.
4. Locate the main hydraulic valve under the vacuum fan. Disconnect the 7 electrical solenoids on the main valve from the main harness.
5. Mark, remove, and plug the hydraulic hoses leading to the main hydraulic valve.

NOTE: Observe hydraulic cleanliness requirements when opening hydraulic lines.

6. Remove the three M8 hex screws holding the main valve to the machine frame.
7. The main valve can now be removed from the machine.
8. Remove the hex screws holding the main valve to the mount bracket.
9. Remove hydraulic fittings from the old valve and install in the new valve in the same orientation.
10. Reinstall the mount bracket on the new valve. Reinstall the three M8 hex screws and washers. Tighten to 18 - 24 Nm (15 - 20 ft lb).

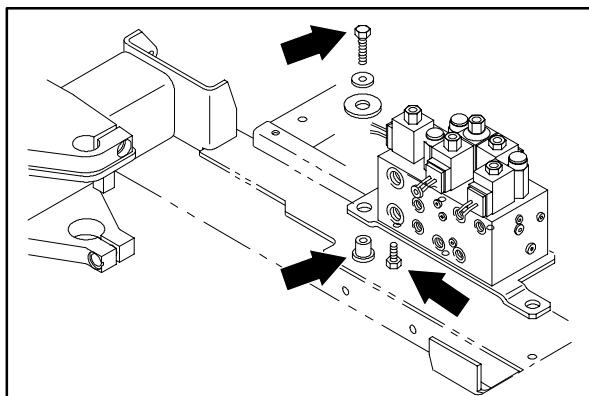
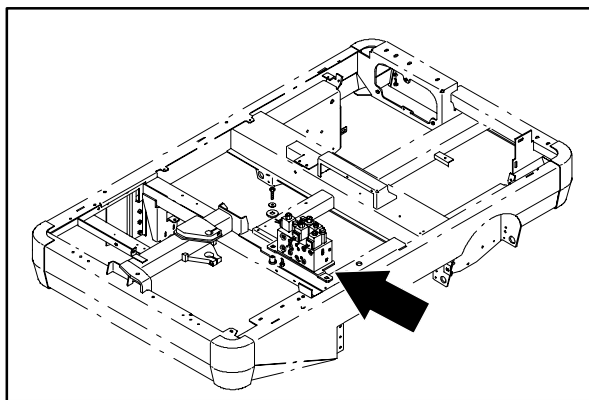
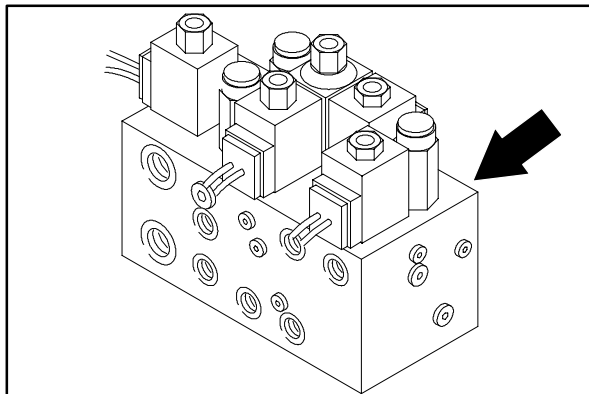

HYDRAULICS

11. Position the new valve back in the machine.
Reinstall the three M8 hex screws and washers. Tighten to 18 - 24 Nm (15 - 20 ft lb).
12. Reconnect the hydraulic hoses to the main valve. See schematic in this section.
13. Reconnect the 7 electric solenoids to the main harness. See ELECTRICAL section.
14. Reinstall the LP tank.
15. Reinstall the engine side door.
16. Reconnect the battery cables and close the operators seat.
17. Start the machine and check the main valve for any leaks.

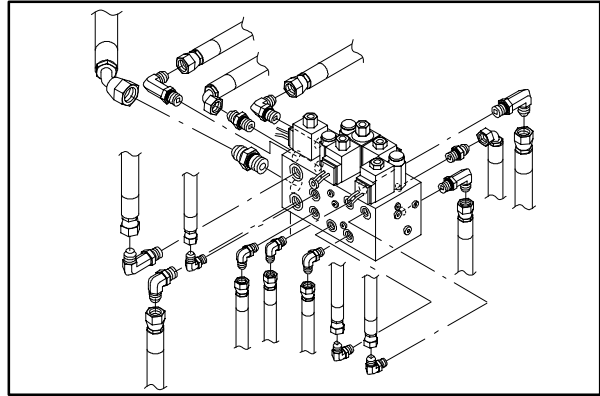

TO REPLACE SIDE BRUSH HYDRAULIC VALVE

FOR SAFETY: Before Leaving Or Servicing Machine; Stop On Level Surface, Set Parking Brake., Turn Off Machine And Remove Key.

1. Raise the operators seat, engage the prop rod, and disconnect the battery cables from the battery.
2. Open the machine front cover, engine cover, and side door. Remove the side door from the machine.
3. If the machine is an LPG, remove the LP tank from the cradle.
4. Locate the side brush hydraulic valve under the LP/gas tank cradle. Disconnect the 4 electrical solenoids from the main harness.
5. Mark, remove, and plug the hydraulic hoses leading to the side brush valve.

NOTE: Observe hydraulic cleanliness requirements when opening hydraulic lines.

6. Remove the three M8 hex screws holding the side brush valve to the LP tank cradle.
7. The side brush valve can now be removed from the machine.
8. Remove hydraulic fittings from the old valve and install in the new valve in the same orientation.

NOTE: Observe hydraulic cleanliness requirements when opening hydraulic lines.

9. Position the new valve back in the machine. Reinstall the three M8 hex screws and washers. Tighten to 18 - 24 Nm (15 - 20 ft lb).

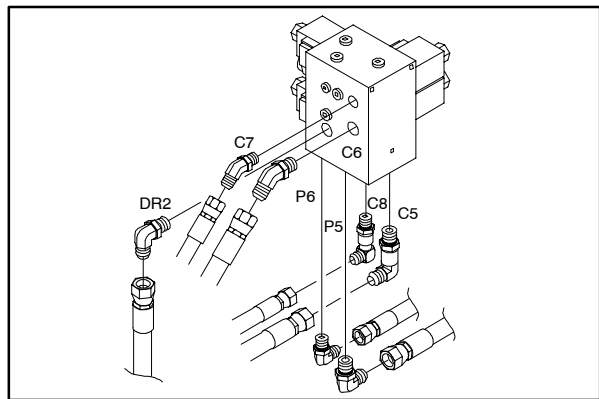
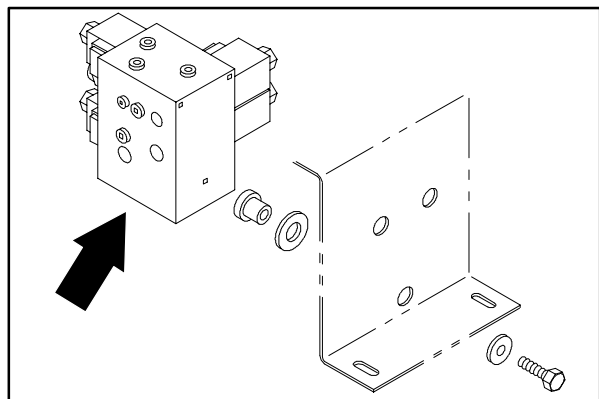
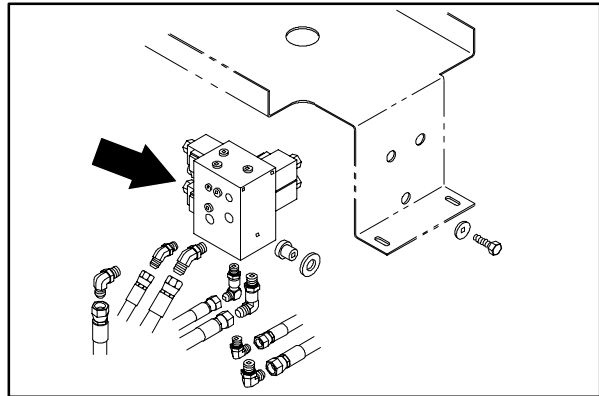

HYDRAULICS

10. Reconnect the hydraulic hoses to the side brush valve. See schematic in this section.

NOTE: Observe hydraulic cleanliness requirements when opening hydraulic lines.

11. Reconnect the 4 electric solenoids to the main harness. See ELECTRICAL section.
12. Reinstall the LP tank.
13. Reinstall the engine side door.
14. Reconnect the battery cables and close the operators seat.
15. Start the machine and check the side brush valve for any leaks.

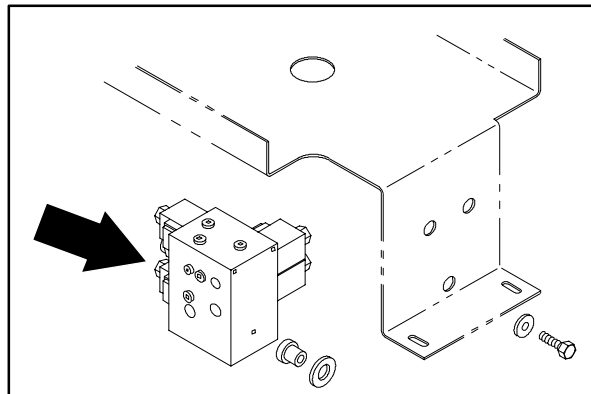

TO REPLACE SOLENOID VALVE CARTRIDGE

FOR SAFETY: Before Leaving Or Servicing Machine; Stop On Level Surface, Set Parking Brake, Turn Off Machine And Remove Key.

1. Raise the operators seat, engage the prop rod, and disconnect the battery cables from the battery.
2. Open the machine front cover, engine cover, and side door. Remove the side door from the machine.
3. If the machine is an LPG, remove the LP tank from the cradle.
4. Locate and identify the cartridge to be removed. Unplug the solenoid from the main harness.
5. Remove the hex nut and rubber O-ring from the cartridge stem.

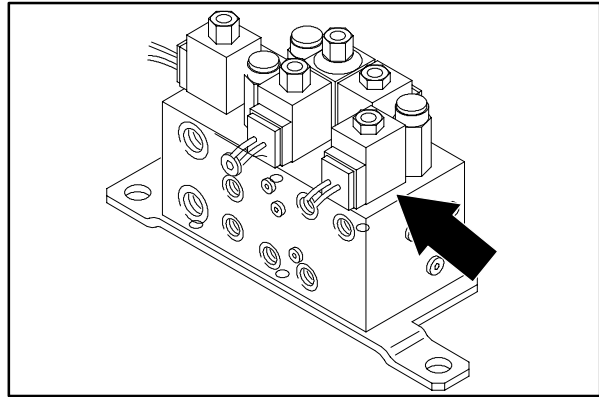

NOTE: The port marked SV-4 on the main valve and the port marked SV-10 on the side brush valve contain an extra washer on the cartridge stem between the top nut and O-ring.

6. Slide the electrical coil and rubber o-ring off the stem.

NOTE: Oil will run out of valve when the cartridge is removed.

7. Loosen and unscrew the cartridge stem out of the valve body.

NOTE: Observe hydraulic cleanliness requirements when opening hydraulic lines.

8. Install a new or rebuilt cartridge stem back in the port. Tighten to 47 Nm (35 ft lb).

NOTE: Make sure the new cartridge had an O-ring installed and oiled.

9. Slip the O-ring and coil back over the stem.

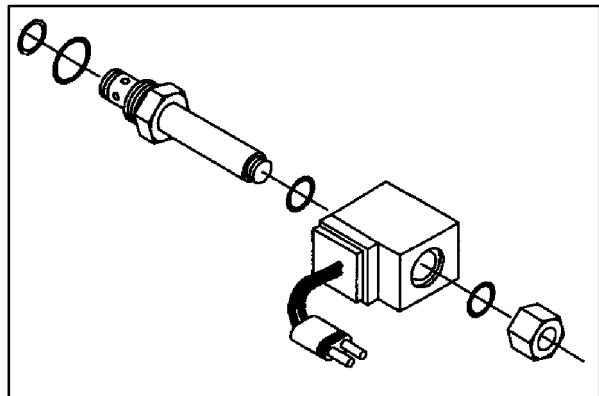

HYDRAULICS

10. Install the O-ring and hex nut on the stem and tighten to 170 Ncm (15 in lb).
11. Reconnect the coil to the main harness. See schematic in Electrical section.
12. Reinstall the LP tank.
13. Reinstall the engine side door.
14. Reconnect the battery cables and close the operators seat.
15. Start the machine and check the side brush valve for any leaks.

TO REPLACE ENGINE COOLING FAN HYDRAULIC MOTOR

FOR SAFETY: Before Leaving Or Servicing Machine; Stop On Level Surface, Set Parking Brake, Turn Off Machine And Remove Key.

1. Open the engine cover and side door.
2. Remove the hose from the vacuum fan and recovery tank.
3. Remove the air cleaner hose from the air cleaner and carburetor.
4. Mark, disconnect, and plug the three hydraulic hoses going to the fan motor.

NOTE: Observe hydraulic cleanliness requirements when opening hydraulic lines.

5. Remove the hydraulic fittings from the fan motor. Note the orientation of the fittings for proper reassembly in the new motor.
6. Reach in through the fan blades and remove the four M6 hex screws holding the fan blade to the motor hub. Set the fan blade down in the fan air chamber.
7. Remove the 5/16 in. nut and washer holding the fan blade hub to the motor shaft. Remove the hub from the shaft. Retain the square key from the motor shaft.

NOTE: The fan blade hub is on a tapered shaft and may need to be pried off the motor.

8. Remove the two M10 hex screws and nyloc nuts holding the fan motor to the mount bracket. Remove the fan motor from the machine.
9. Install the new fan motor on the mount bracket. Reinstall the M10 hex screws and nyloc nuts (nylocs positioned on the motor side). Tighten to 37 - 48 Nm (26 - 34 ft lb).

NOTE: The notch in the mount bracket is for the motor fitting.

10. Install the square key on the fan motor shaft.

NOTE: A small amount of super glue helps keep the key in place when installing the fan hub.

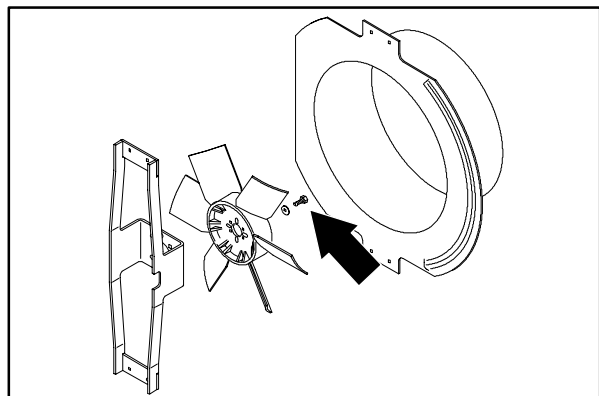
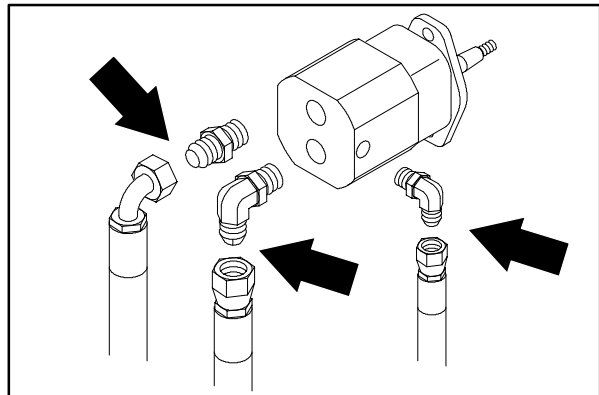
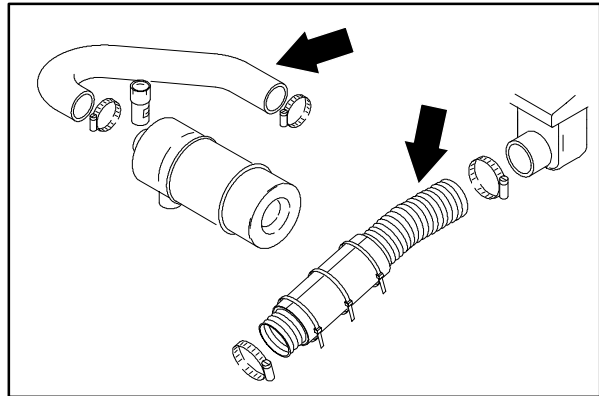
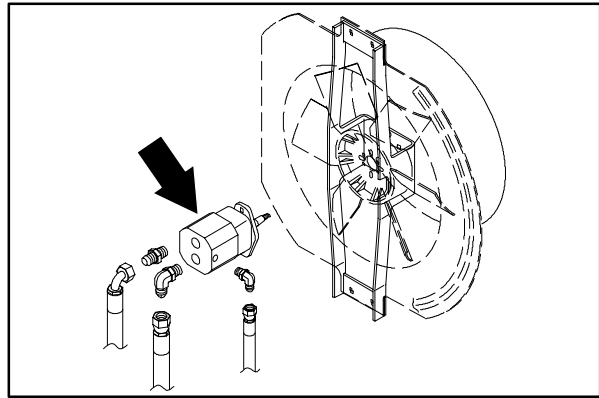

HYDRAULICS

11. Install the fan hub on the motor shaft.
Reinstall the 5/16 in. nut and tighten to 18 - 24 Nm (15 - 20 ft lb).

NOTE: Make sure key is in place on motor shaft.

12. Reinstall the fan blade back on the fan hub.
The deep side of the fan blade points to the back of the machine. Reinstall the four M6 hex screws and tighten to 7.9 - 9.9 Nm (6 - 7 ft lb).

13. Reinstall the hydraulic fittings in the fan motor in the same orientation as they were removed.

14. Reconnect the hydraulic hoses to the fan motor. See schematic in this section.

15. Reinstall the air cleaner hose and vacuum fan hose.

16. Reconnect the engine cover outer gas spring to lower ball.

17. Start machine and check for leaks. Check the engine fan for proper rotation. (air blows out the back of machine).

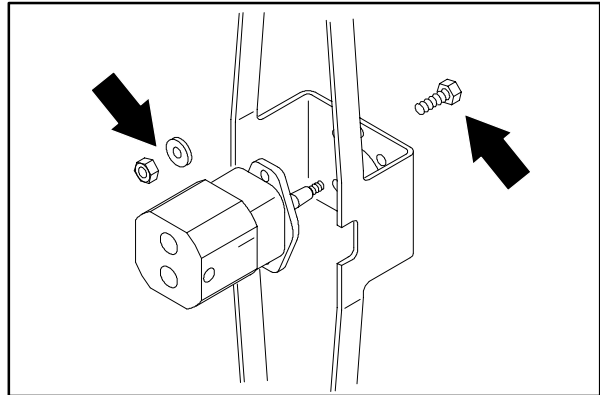
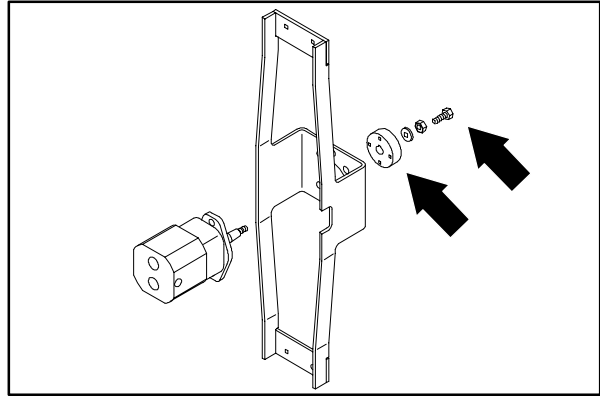

TO REPLACE MAIN SCRUB BRUSH HYDRAULIC MOTORS

1. Place the main scrub brushes in the raised position.

FOR SAFETY: Before Leaving Or Servicing Machine; Stop On Level Surface, Set Parking Brake, Turn Off Machine And Remove Key.

2. Open the LH brush door.
3. Remove the front ball joint on the leveling rod from the machine frame.
4. Remove the two hair pins from the brush wrap attachment pins.
5. Remove the three hex screws holding the side squeegee assembly to the motor mount plate. Remove the side squeegee.
6. Remove the M12 hex screw holding the brush idler plate arm to the lift tube.

NOTE: For better access to the hydraulic drive motors--remove the C-clip and brush arm from the motor plate.

7. Mark, disconnect, and plug the three hydraulic hoses leading to the main brush drive motors.

NOTE: Observe hydraulic cleanliness requirements when opening hydraulic lines.

8. Remove the motor mount plate assembly from the machine.
9. Turn the motor plate assembly over. Remove the cotter pins, castle nuts, and washers from the drive plugs.
10. Use a puller to remove the drive plug from the brush motors. Remove and retain the square key.
11. Remove the steel hydraulic tube running between the brush drive motors.

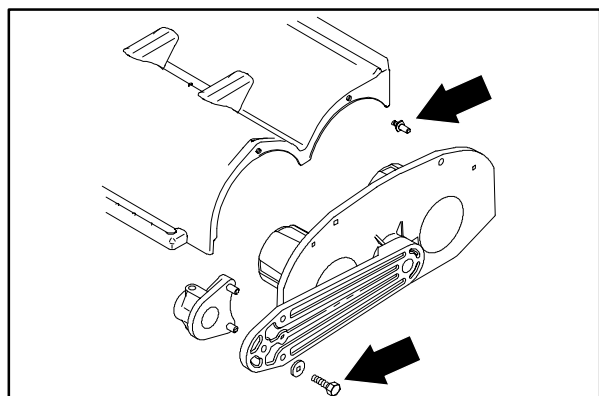
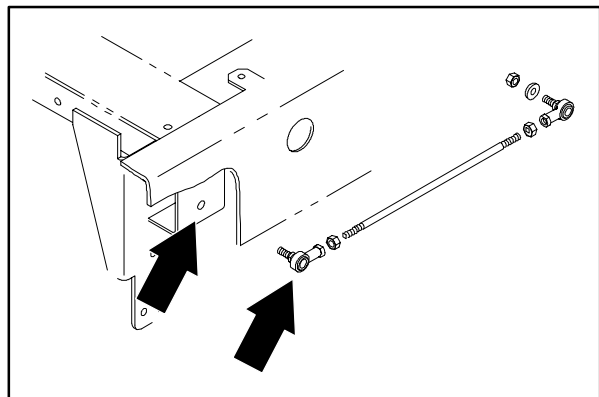
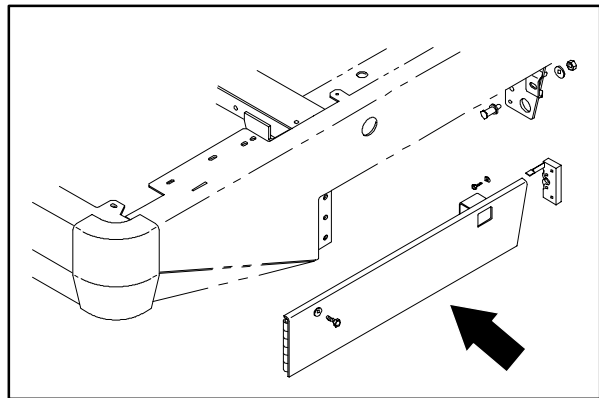
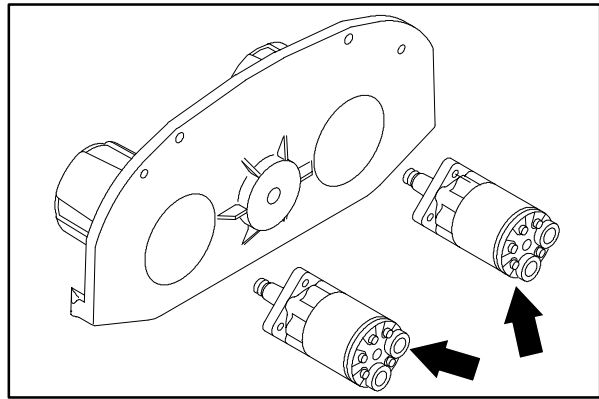

HYDRAULICS

12. Remove the four hex screws holding each brush motor to the motor plate.

NOTE: Make sure to note the orientation of the motor and fittings before removing the motors from the plate.

13. Remove the fittings from the old motor and install in the new motor in the same orientation.
14. Install the new brush motor and fittings in the motor plate in the same orientation as the old motor.

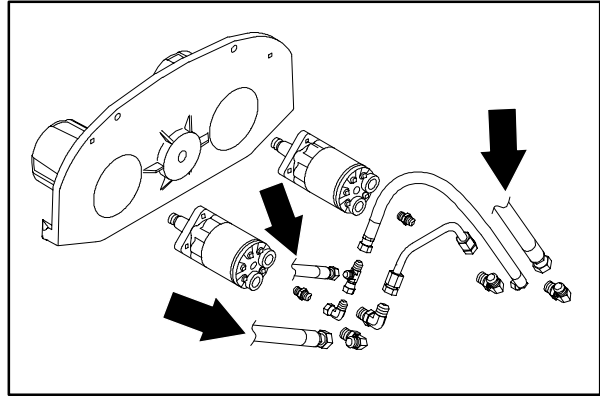

15. Reinstall the four hex screws and tighten to 37 - 48 Nm (26 - 34 ft lb).
16. Reinstall the steel hydraulic tube running between the brush drive motors.

NOTE: Observe hydraulic cleanliness requirements when opening hydraulic lines.

17. Reinstall the square key on the tapered motor shaft. Put a small amount of grease on the taper of the shaft.
18. Reinstall the drive plugs, washers, and castle nuts. Hold the plug from turning and tighten the castle nut down to 37 - 48 Nm (26 - 34 ft lb) and then until the slot in the nut lines up with the hole in the shaft. Install a new cotter pin.
19. Position the motor plate assembly back in the machine.

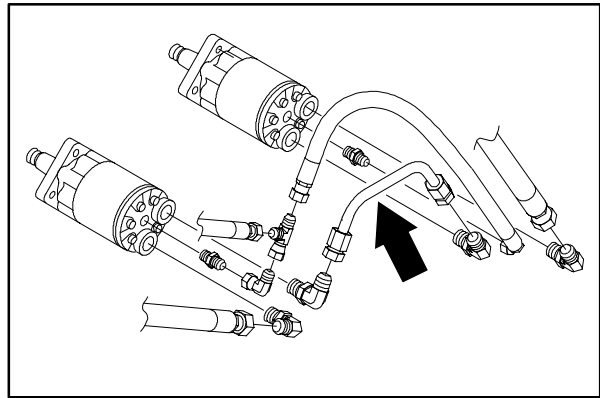

NOTE: Lift up on the brush wrap slightly when installing the motor plate in the machine so the attachment pins line up with the holes in the plate.

20. Reinstall the two hair pins in the brush wrap attachment pins.
21. Reconnect the hydraulic hoses to the brush motors. See schematic in this section.

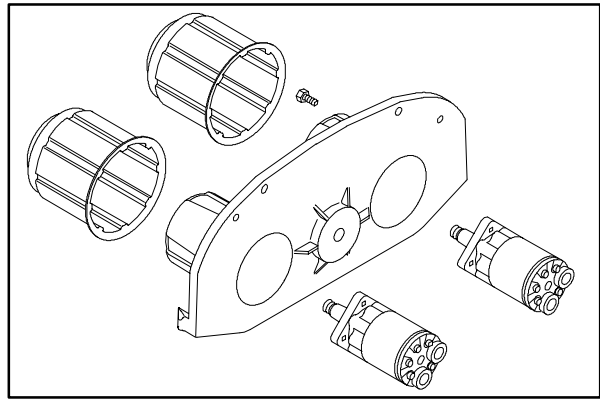

NOTE: Observe hydraulic cleanliness requirements when opening hydraulic lines.

22. Reinstall the brush arm and C-clip to the motor plate if they were removed earlier.
23. Align the two pins on the lift tube with the two holes in the brush arm.

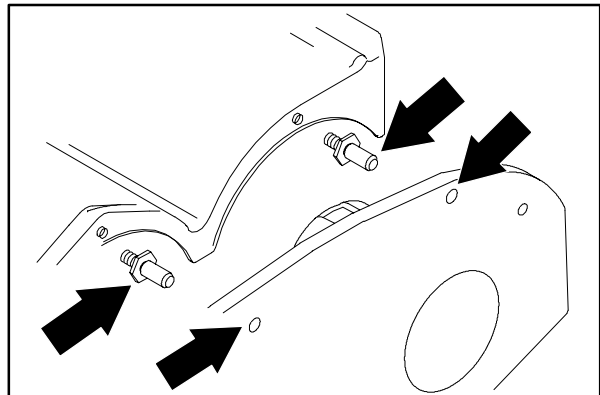

24. Reinstall the M12 hex screw in the brush arm. Tighten to 64 - 83 Nm (47 - 61 ft lb).

NOTE: Apply a small amount of grease to the threads on the bolt and in the tube.

25. Reinstall the front of the leveling rod ball joint to the machine frame.
26. Reinstall the side squeegee assembly to the motor plate. Tighten the three hex screws to 37 - 48 Nm (26 - 34 ft lb).
27. Close the LH brush door and operate the machine. Check the main brush motors for proper operation.

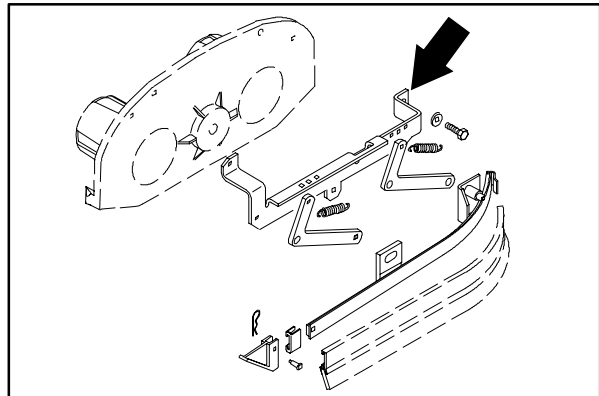
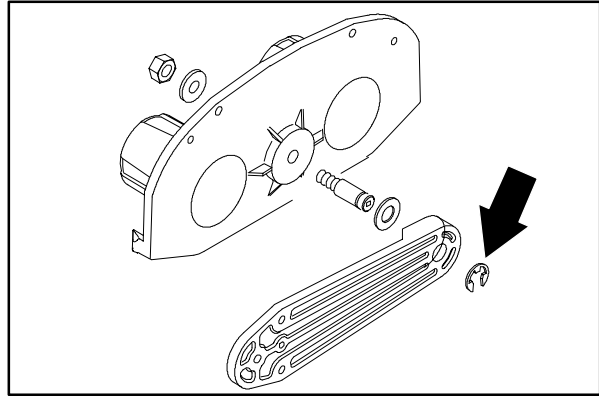

HYDRAULICS

TO REPLACE SCRUB HEAD ASSEMBLY LIFT CYLINDER

1. Start the engine and drop the main scrub brushes down until they just touch the floor.

FOR SAFETY: Before Leaving Or Servicing Machine; Stop On Level Surface, Set Parking Brake, Turn Off Machine And Remove Key.

2. Jack up the front of the machine and install jack stands under the frame.

FOR SAFETY: Block machine tires before jacking machine up. Jack machine up at designated locations only. Block machine up with jack stands.

3. Go under the machine on the LH side.
4. Locate the lift cylinder on the left side of the front scrub brush.
5. Mark, disconnect, and plug the two hydraulic hoses going to the lift cylinder.
6. Remove the two cotter pins and clevis pins.
7. Remove the lift cylinder from the machine.
8. Remove the hydraulic fittings from the lift cylinder and install in the new cylinder in the same orientation.
9. Install the new cylinder in the machine.

NOTE: The rod end of the cylinder points down.

10. Reinstall the upper and lower clevis and cotter pins.
11. Reconnect the hydraulic hoses to the new lift cylinder. See schematic in this section.
12. Remove the jack stands and lower the machine.
13. Start the machine and check the scrub head lift cylinder for proper operation.

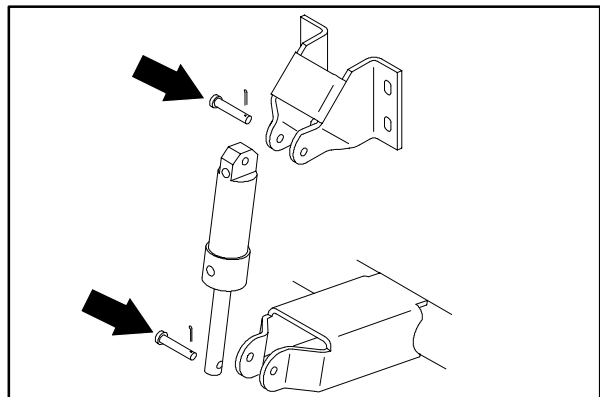
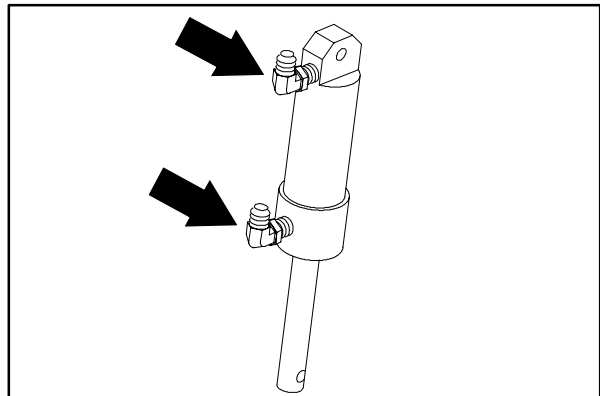
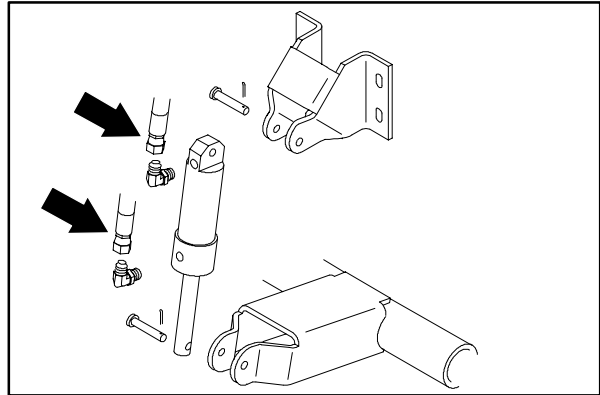
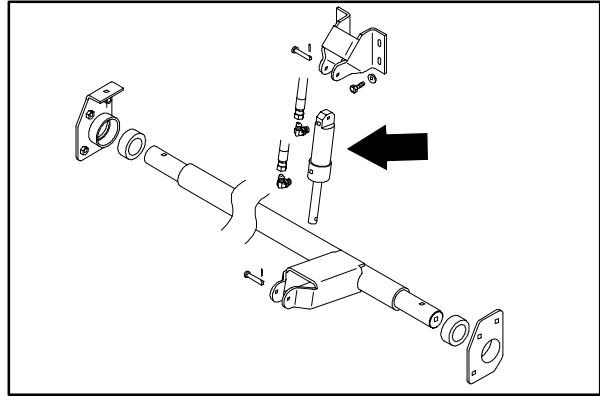

TO REPLACE OPTIONAL SIDE BRUSH HYDRAULIC MOTOR

1. Remove the side brush. See TO REPLACE OPTIONAL SIDE BRUSH instructions in the SCRUBBING section.

FOR SAFETY: Before Leaving Or Servicing Machine; Stop On Level Surface, Set Parking Brake, Turn Off Machine And Remove Key.

2. Remove the four hex screws holding the side brush guard to the machine frame.
3. Remove the hex screw holding the side brush drive hub to the side brush motor. Remove the drive hub from the motor.
4. Mark, disconnect, and plug the two hydraulic hoses going to the side brush motor.

NOTE: Observe hydraulic cleanliness requirements when opening hydraulic lines.

5. Remove the four hex screws holding the side brush motor to the mount plate.
6. Lift the motor straight up, tilt back, and remove it from the side brush assembly.

NOTE: Make sure to note the orientation of the motor to the mount plate.

7. Remove the hydraulic fittings from the old motor and install in the new motor in the same orientation.
8. Position the new motor back in the side brush assembly.
9. Reinstall the four hex screws and tighten to 37 - 48 Nm (26 - 34 ft lb).
10. Reconnect the hydraulic hoses to the motor. See schematic in this section.
11. Reinstall the drive hub, washers, and hex screw. Tighten to 18 - 24 Nm (15 - 20 ft lb).
12. Reinstall the side brush. See TO REPLACE OPTIONAL SIDE BRUSH instructions.
13. Reinstall the side brush guard to the machine frame. Tighten the four hex screws to 37 - 48 Nm (26 - 34 ft lb).
14. Operate the machine and check the side brush for proper operation.

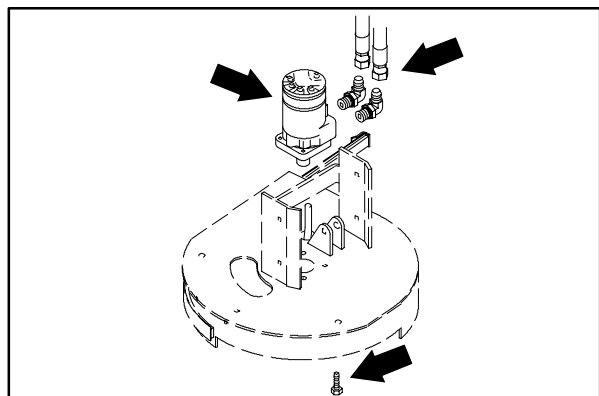
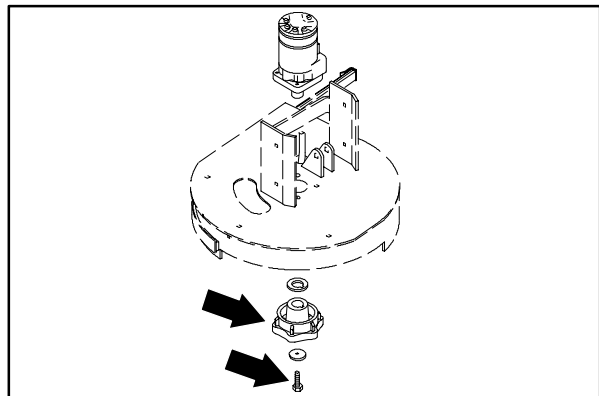
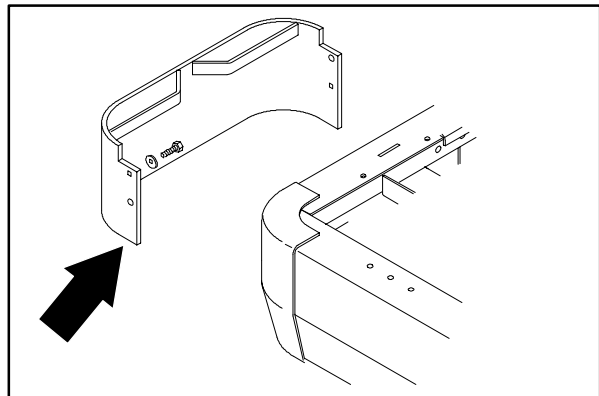
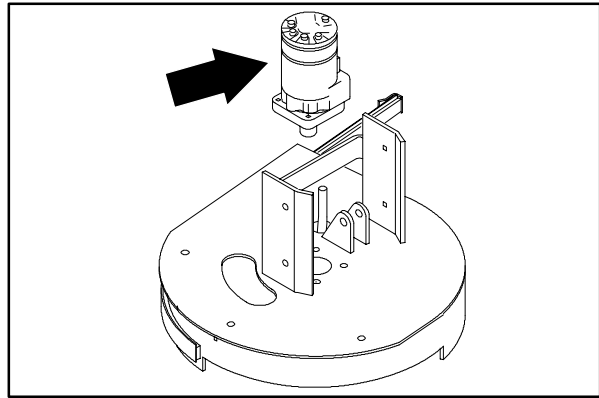

TO REPLACE OPTIONAL SIDE BRUSH LIFT CYLINDER

1. Remove the side brush. See TO REPLACE OPTIONAL SIDE BRUSH instructions.
2. Remove the four hex screws holding the side brush guard to the machine frame.
3. Remove the side brush hydraulic motor. See TO REPLACE OPTIONAL SIDE BRUSH HYDRAULIC MOTOR instructions.

FOR SAFETY: Before Leaving Or Servicing Machine; Stop On Level Surface, Set Parking Brake, Turn Off Machine And Remove Key.

4. Mark, disconnect, and plug the two hydraulic hoses going to the lift cylinder.

NOTE: Observe hydraulic cleanliness requirements when opening hydraulic lines.

5. Remove the two cotter pins and clevis pins holding the lift cylinder to the side brush assembly. Remove the lift cylinder from the machine.

NOTE: Make sure to note the orientation of the cylinder to the mount plate.

6. Remove the hydraulic fittings from the old cylinder and install in the new cylinder in the same orientation.
7. Position the new cylinder back in the side brush assembly.
8. Reconnect the hydraulic hoses to the cylinder. See schematic in this section.
9. Reinstall the side brush motor in the machine. See TO REPLACE OPTIONAL SIDE BRUSH HYDRAULIC MOTOR instructions.

10. Reinstall the side brush. See TO REPLACE OPTIONAL SIDE BRUSH instructions in the SCRUBBING section.
11. Reinstall the side brush guard to the machine frame. Tighten the four hex screws to 37 - 48 Nm (26 - 34 ft lb).
12. Operate the machine and check the side brush lift cylinder for proper operation.

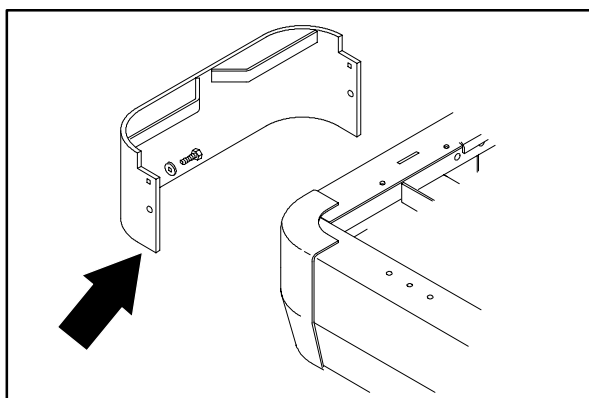
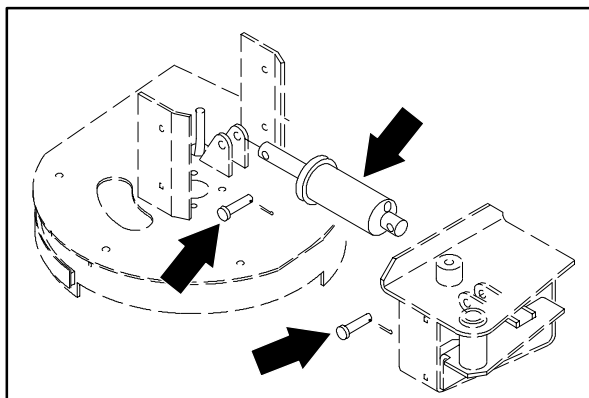
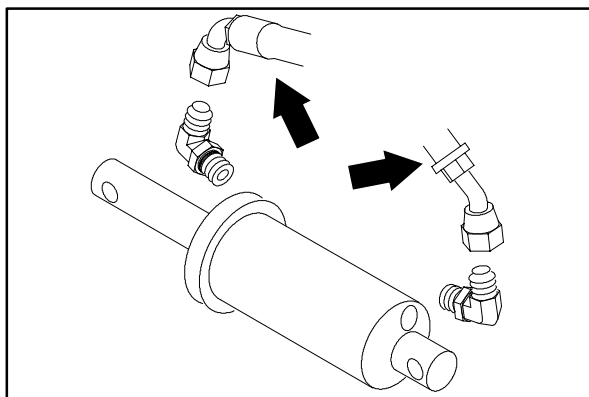
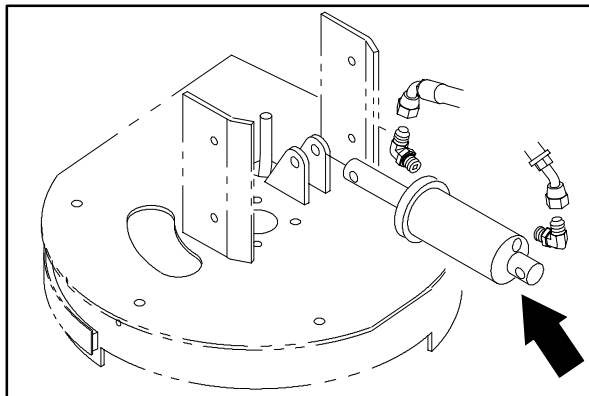

TO REPLACE OPTIONAL SIDE BRUSH SWING CYLINDER

FOR SAFETY: Before Leaving Or Servicing Machine; Stop On Level Surface, Set Parking Brake, Turn Off Machine And Remove Key.

1. Open the front cover on the machine.
2. Locate the swing cylinder down in front of the operators compartment.
3. Mark, disconnect, and plug the two hydraulic hoses going to the swing cylinder.

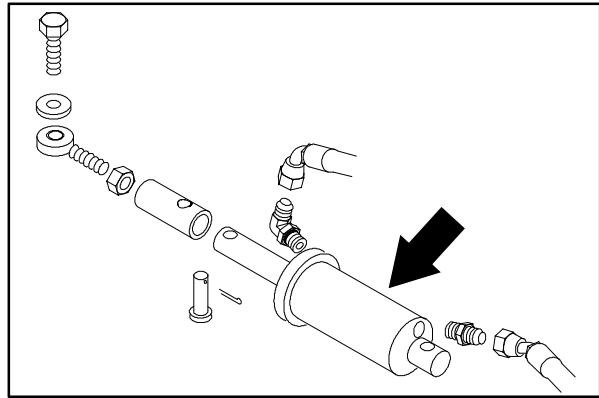

NOTE: Observe hydraulic cleanliness requirements when opening hydraulic lines.

4. Remove the cotter pin and clevis pin holding the rod end of the swing cylinder to the threaded sleeve and ball joint assembly.
5. Remove the cotter pin and clevis pin holding the other end of the swing cylinder to the machine frame.
6. Pull the swing cylinder back out of the threaded sleeve and remove it from the machine.
7. Remove the hydraulic fittings from the old cylinder and install in the new cylinder in the same orientation.
8. Position the new cylinder back in the side brush assembly. Position the rod end of the cylinder back in the threaded sleeve first, then install the clevis and cotter pin in the other end.
9. Reinstall the clevis and cotter pin in the rod end of the swing cylinder and through the hole in the threaded sleeve.
10. Reconnect the hydraulic hoses to the cylinder. See schematic in this section.
11. Operate the machine and check the side brush swing cylinder for proper operation.

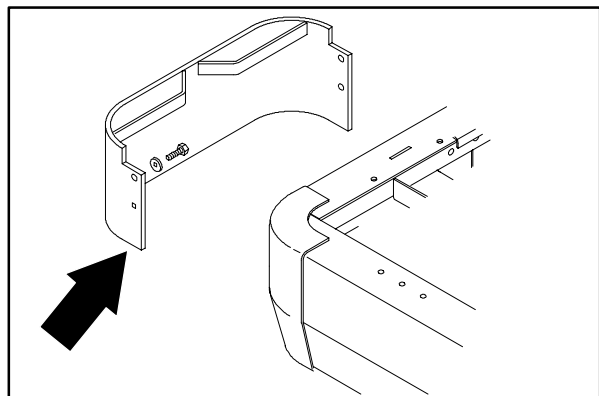
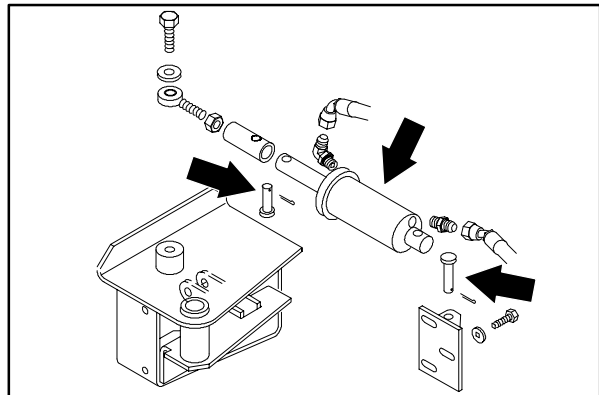
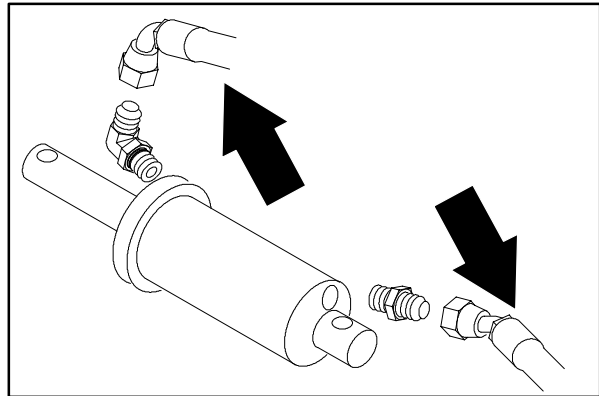

HYDRAULICS

TO REPLACE SQUEEGEE LIFT CYLINDER

1. Open the debris tray latch and swing the squeegee assembly out for better access.
2. Start engine, lower rear squeegee, shut off engine.

FOR SAFETY: Before Leaving Or Servicing Machine; Stop On Level Surface, Set Parking Brake, Turn Off Machine And Remove Key.

3. Mark, disconnect, and plug the two hydraulic hoses going to the squeegee lift cylinder.

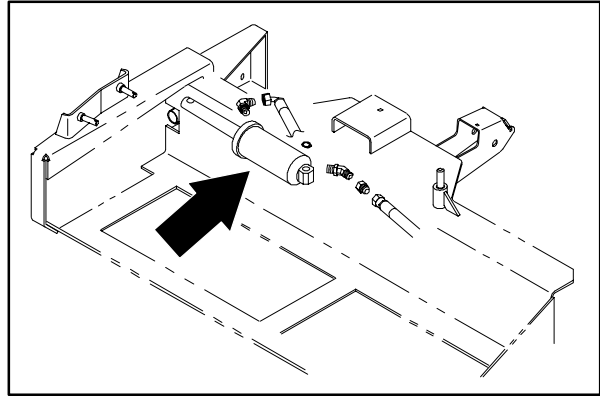

NOTE: Observe hydraulic cleanliness requirements when opening hydraulic lines.

4. Remove the snap retaining ring from the pin on the debris tray at piston end of the cylinder.

NOTE: The cylinder pin DOES NOT have a snap ring groove.

5. Remove the cotter pin and clevis pin from the rod end of lift cylinder and squeegee lift bellcrank.

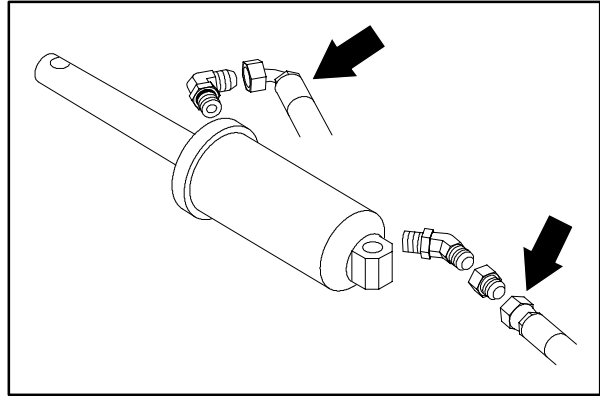

6. The cylinder can now be pulled up and off the pin and removed from the machine.
7. Remove the hydraulic fittings from the old cylinder and install in the new cylinder in the same orientation.
8. Position new cylinder back in the machine. Place the hole in the piston end of the cylinder on the pin on the debris tray. Reinstall the snap ring retainer on the pin.

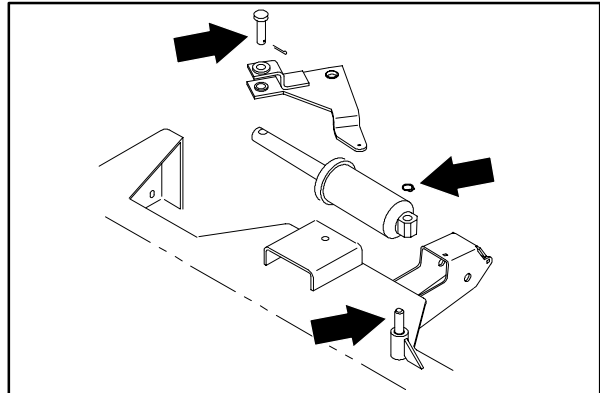

NOTE: The cylinder pin DOES NOT have a snap ring groove.

9. Align the hole in rod end of the cylinder with the hole in squeegee lift bellcrank. Reinstall the clevis and cotter pin.
10. Reconnect the hydraulic hoses to the squeegee lift cylinder. See schematic in this section.
11. Start the machine and raise the squeegee. Swing the squeegee assembly back in. Check the lift cylinder for proper operation.

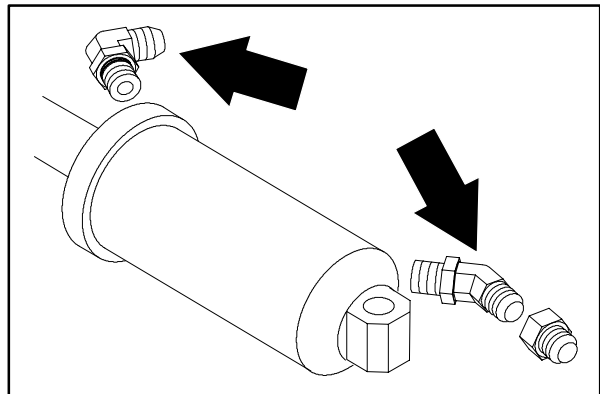

TO REPLACE VACUUM FAN HYDRAULIC MOTOR

FOR SAFETY: Before Leaving Or Servicing Machine; Stop On Level Surface, Set Parking Brake, Turn Off Machine And Remove Key.

1. Remove the vacuum fan from the machine. See TO REMOVE VACUUM FAN instructions in the SCRUBBING section.
2. Place the vacuum fan assembly in a vice or some other holding device.
3. Remove the six hex screws holding the front housing to the rear housing. Remove the the front housing.

NOTE: Mark the front housing in relation to the rear housing so it can be re-assembled correctly.

4. Remove the crown nut on the impeller shaft. Slide the impeller off the shaft.

NOTE: Remove and save the key and any shims that are on the motor shaft, under the impeller.

5. Turn the housing over and remove the four nyloc nuts and washers from the motor mount plate. Remove the motor mount plate from the housing.

NOTE: Note the orientation of hydraulic motor and fittings for proper re-assembly.

6. Remove the four flat head screws and nyloc nuts holding the hydraulic motor to the mount plate. Remove the old motor.
7. Install the new motor on the plate. Reinstall the flat head screws. Tighten to 9 - 13 Nm (7 - 10 ft lb).
8. Remove the hydraulic fittings from the old motor and install in the new motor in the same orientation.

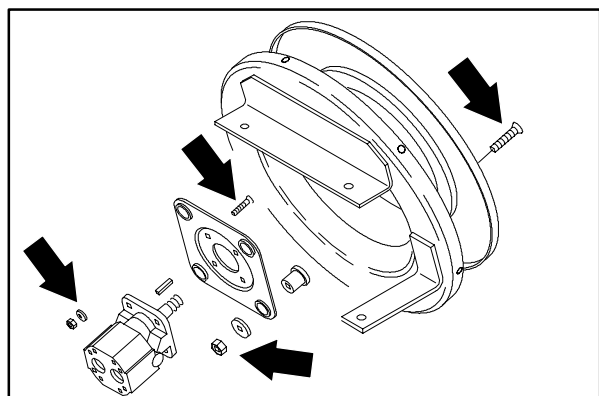
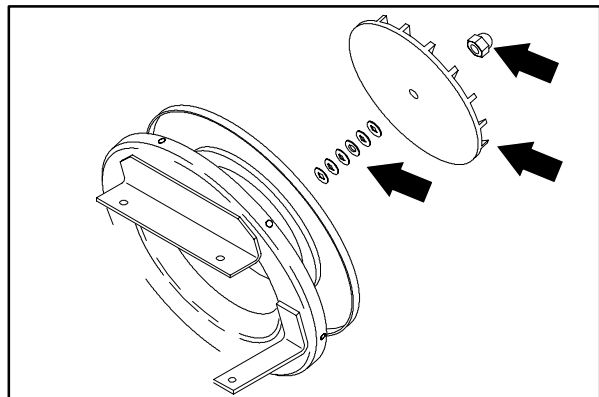
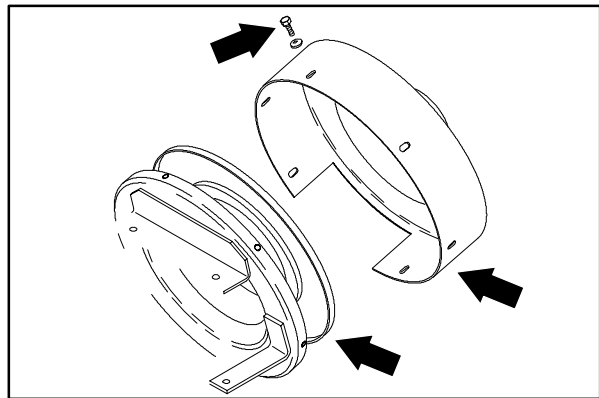
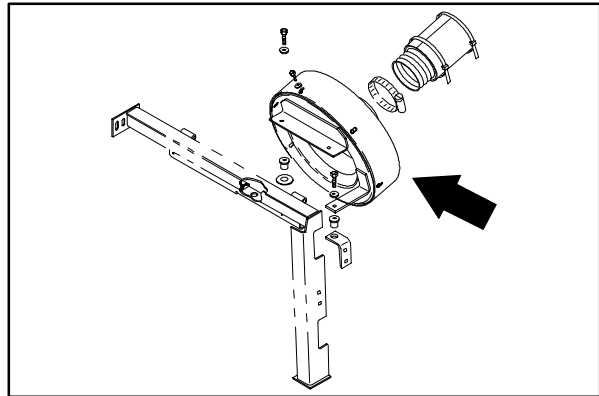

HYDRAULICS

9. Reinstall the motor and mounting plate on the rear housing. Reinstall the four nyloc nuts and tighten to 16 - 22 Nm (12 - 16 ft lb).

NOTE: Be sure the square key is on the motor shaft. Super gluing the key to the shaft helps keep it in place when installing the impeller.

10. Turn the housing over and reinstall shims, key, fan impeller, and crown nut. Tighten nut to 34 - 47 Nm (25 - 35 ft lb).

NOTE: Use a small amount of blue loctite 242 on the motor shaft threads.

11. Reinstall the front housing on the rear housing. Reinstall the six hex screws and tighten to 22 - 27 Nm (16 - 20 ft lb).

NOTE: Tennant part no. 57543 plastic shims must be used for proper fan to housing clearance. Remove these shims after housing hardware has been tightened.

12. Reinstall the vacuum fan assembly in the machine. See TO INSTALL VACUUM FAN instructions in the SCRUBBING section.

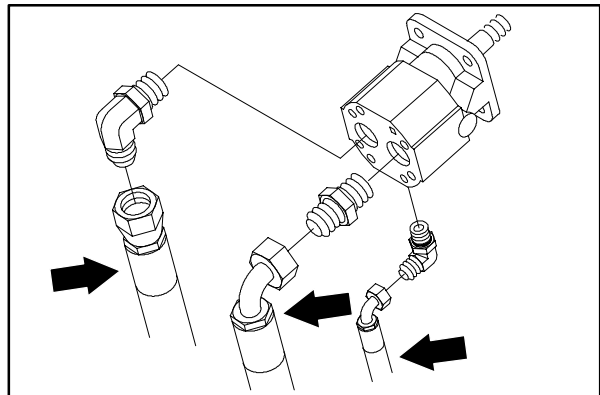
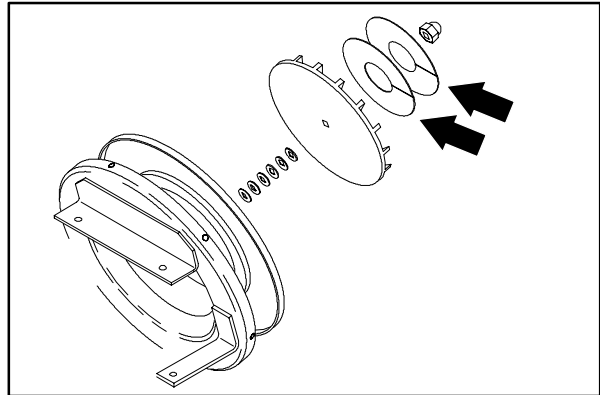
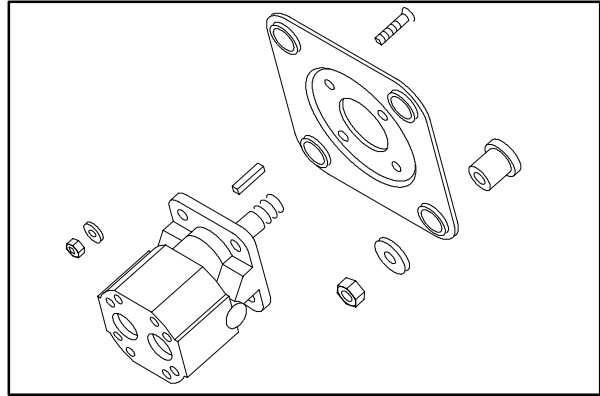

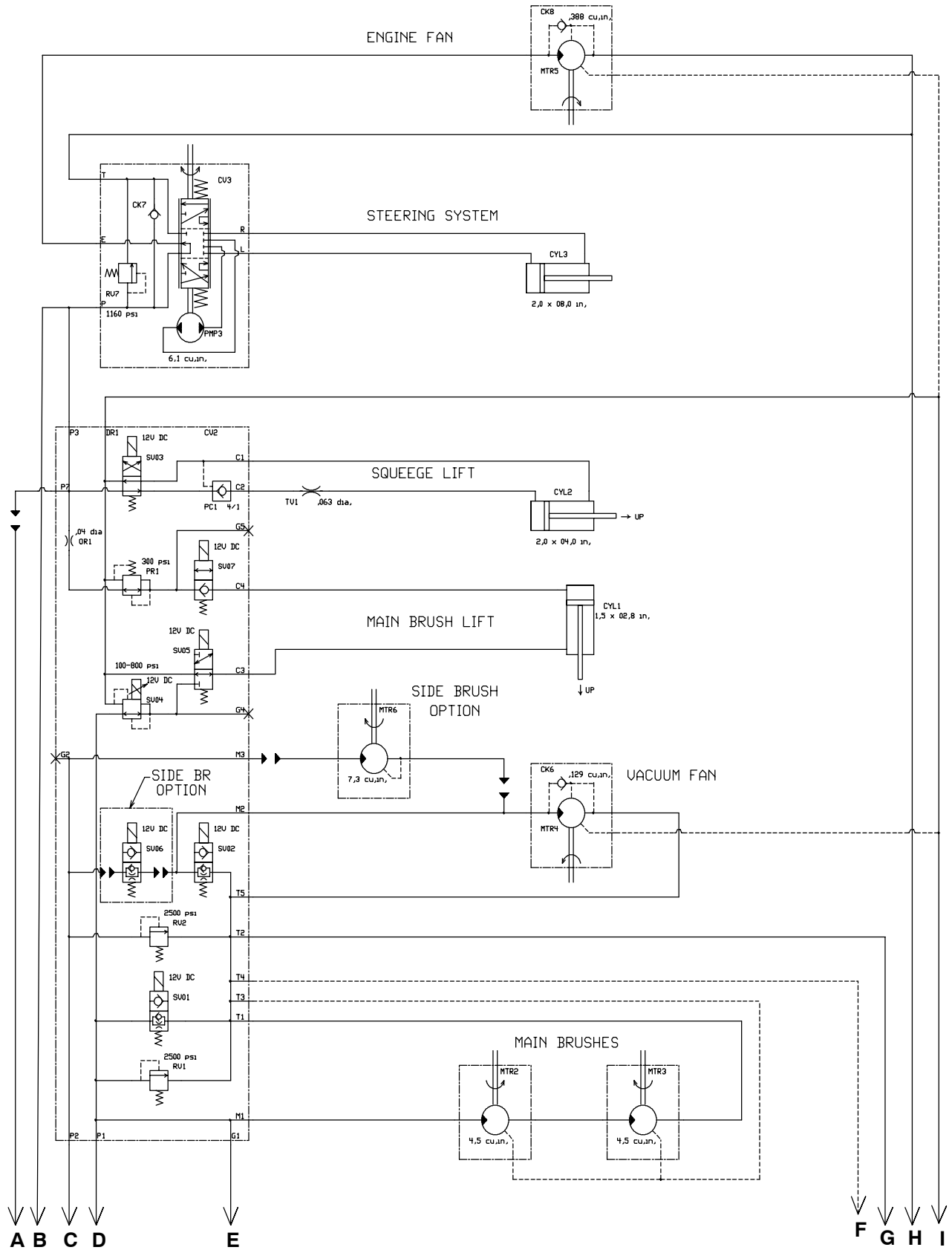

HYDRAULIC SCHEMATIC

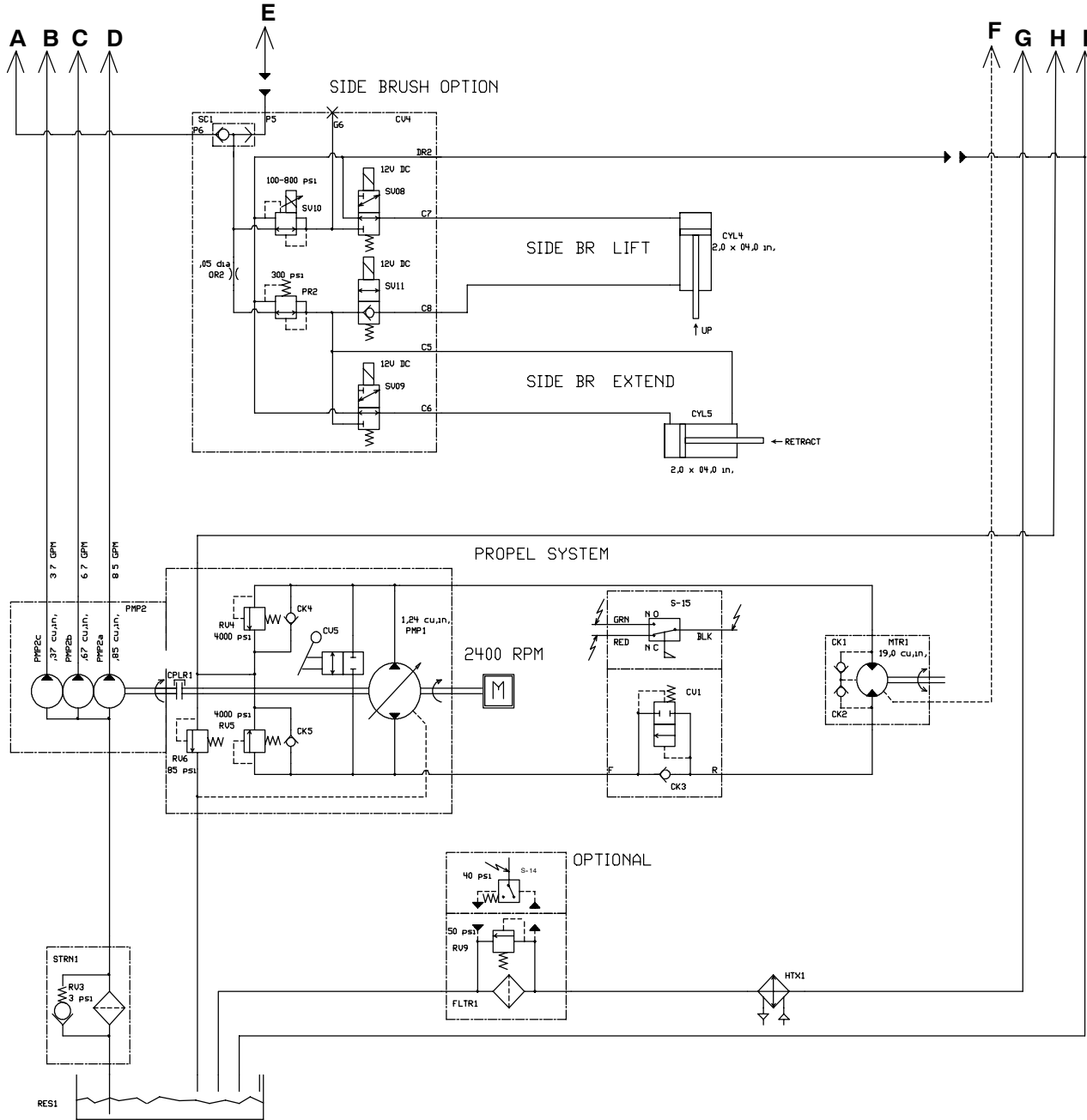

HYDRAULIC SCHEMATIC

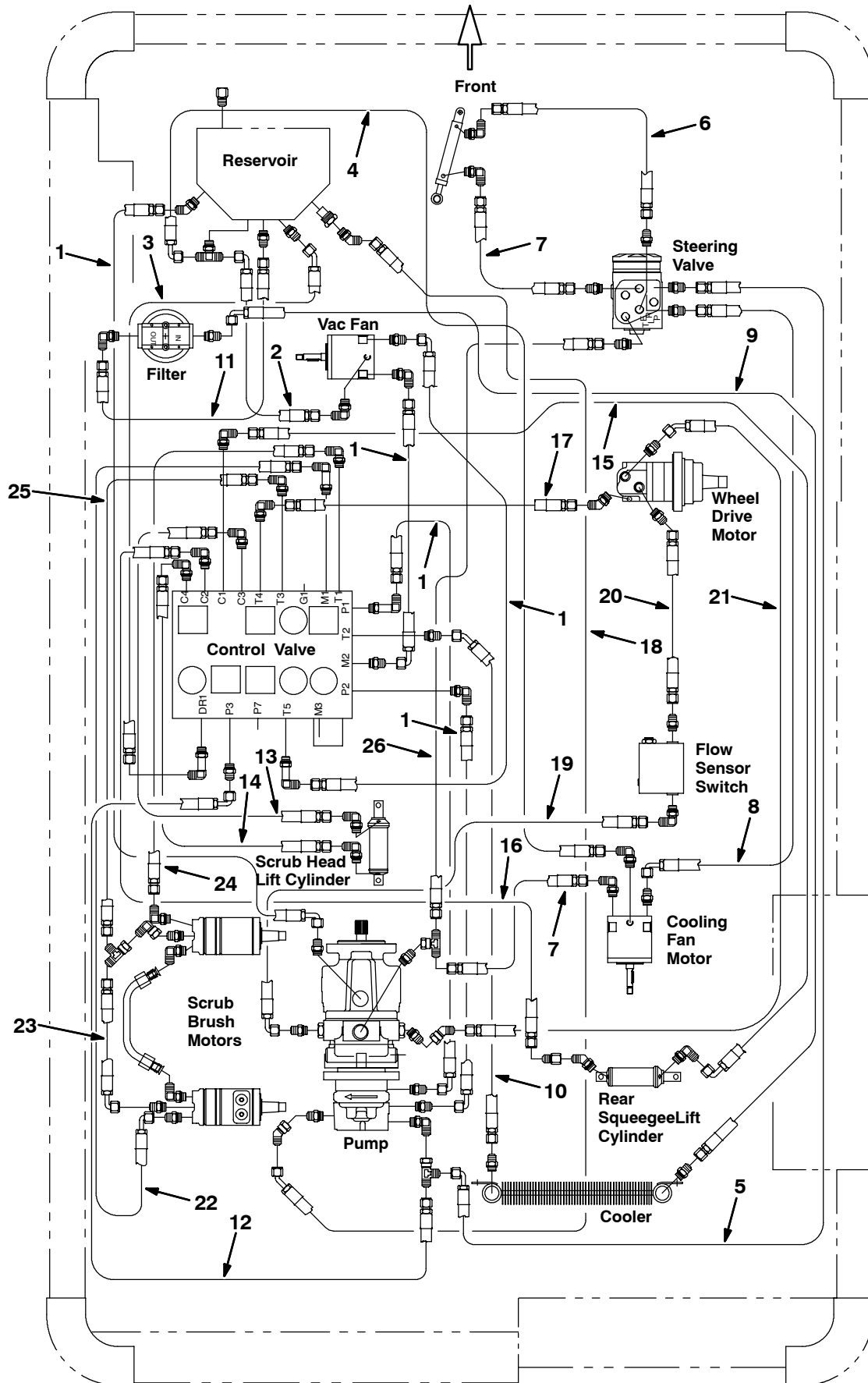

HYDRAULIC HOSE GROUP

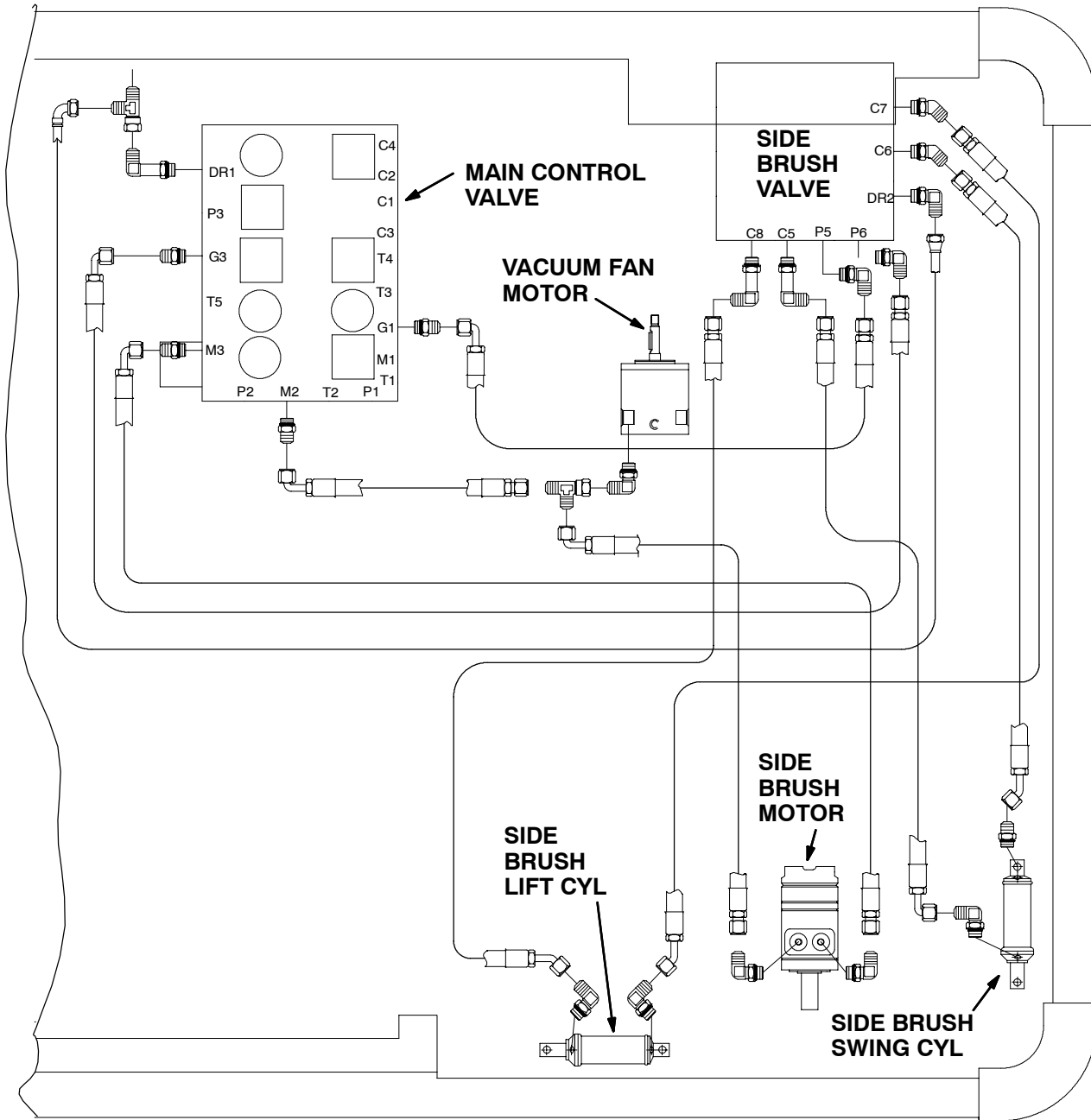

HYDRAULIC HOSE GROUP / SIDE BRUSH OPTION

TROUBLESHOOTING

The following troubleshooting section is organized with the section of the hydraulic schematic pertaining to that particular problem first, followed by the flow chart.

**ENGINE FAN CIRCUIT
(SCHEMATIC)**

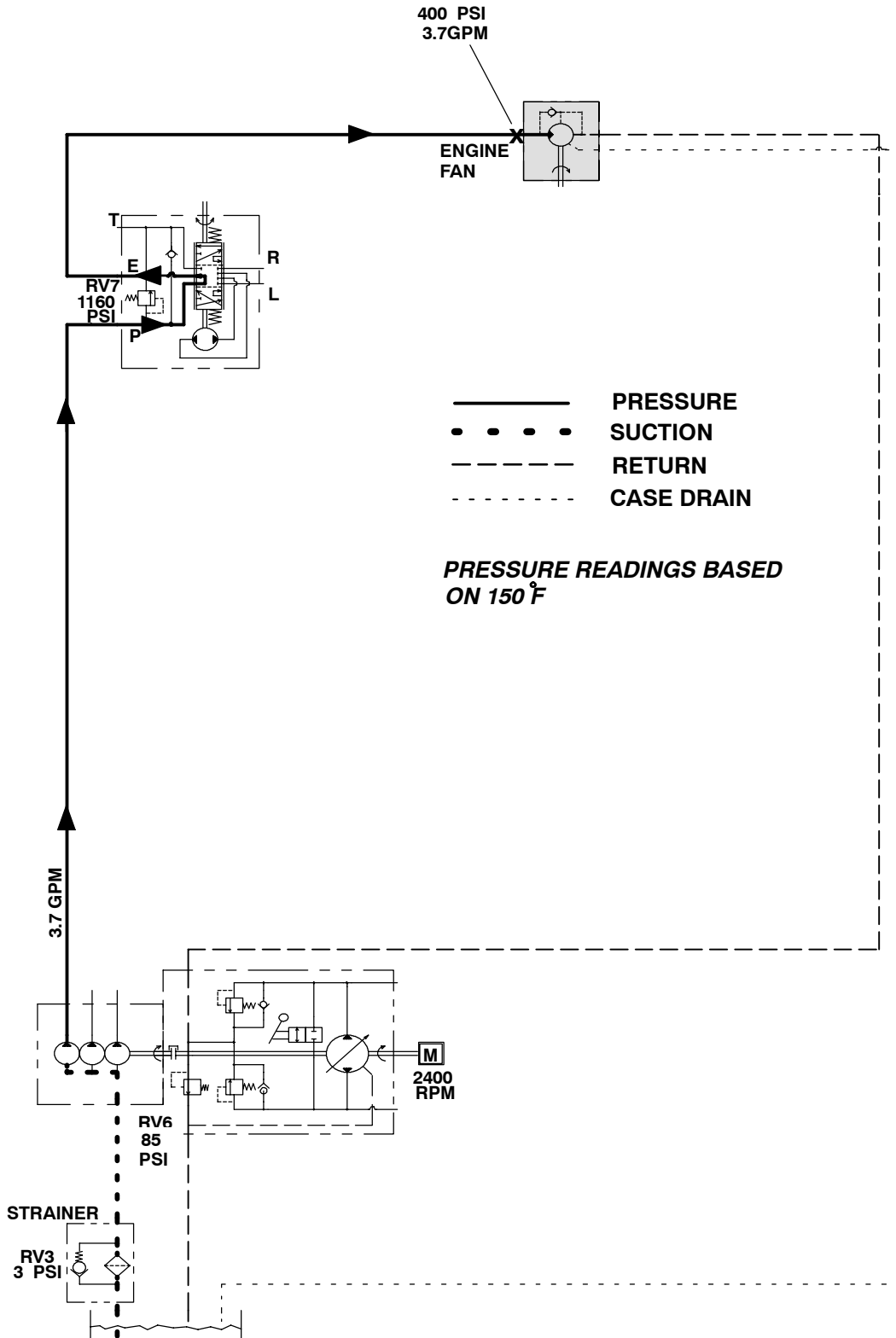

**ENGINE FAN SLOW OR DOESN'T RUN
(FLOW CHART)**

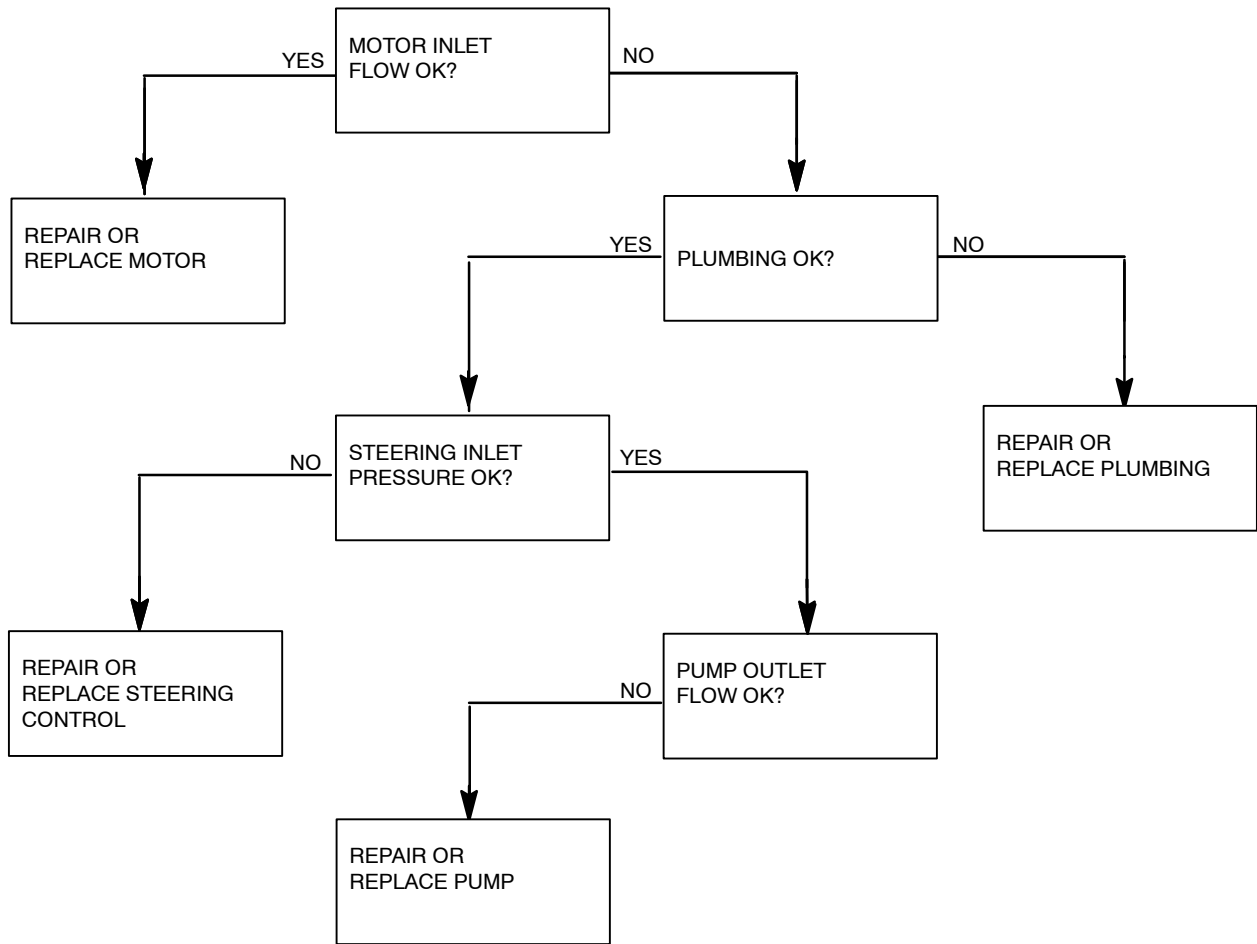

**ENGINE FAN MOTOR SHAFT SEAL LEAKS
(FLOW CHART)**

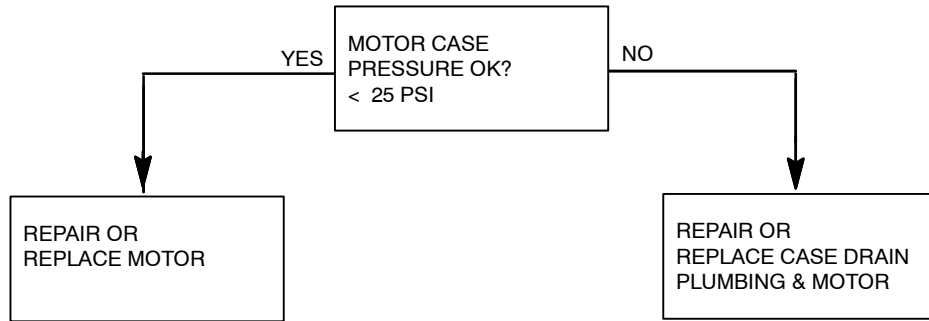

**MAIN BRUSH ON CIRCUIT
(SCHEMATIC)**

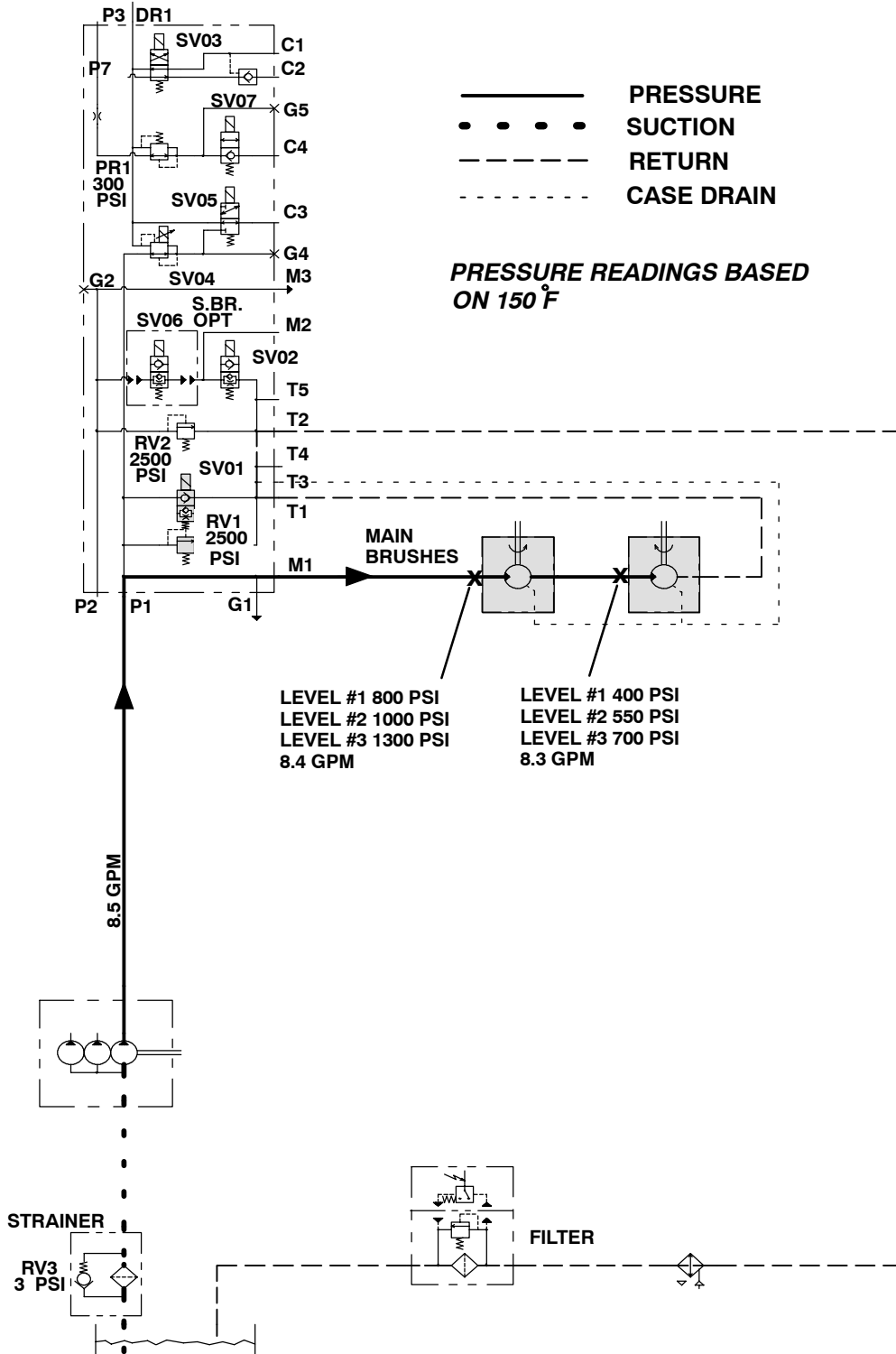

**MAIN BRUSHES DO NOT TURN ON
(FLOW CHART)**

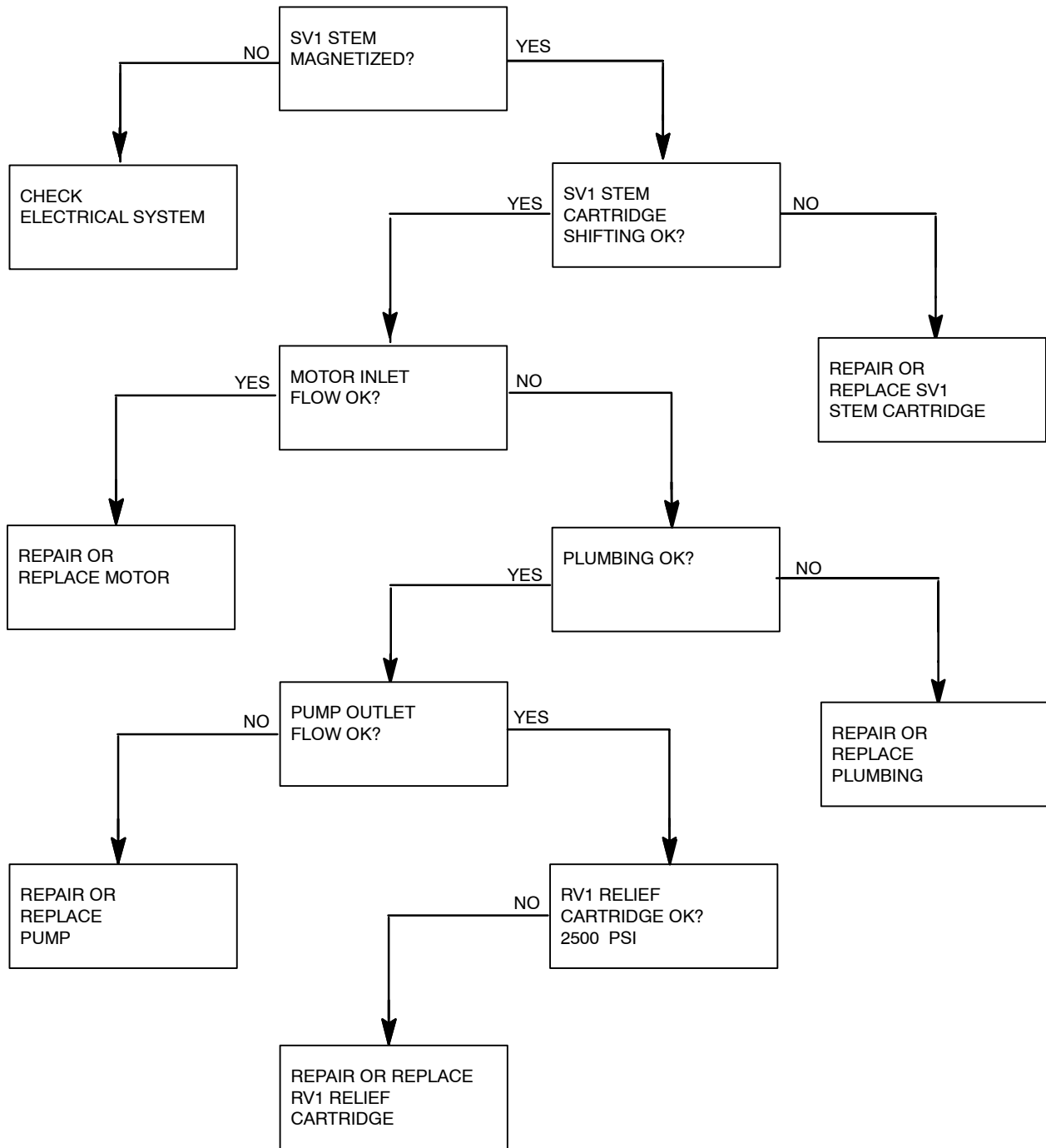

MAIN BRUSHES DO NOT TURN OFF
(FLOW CHART)

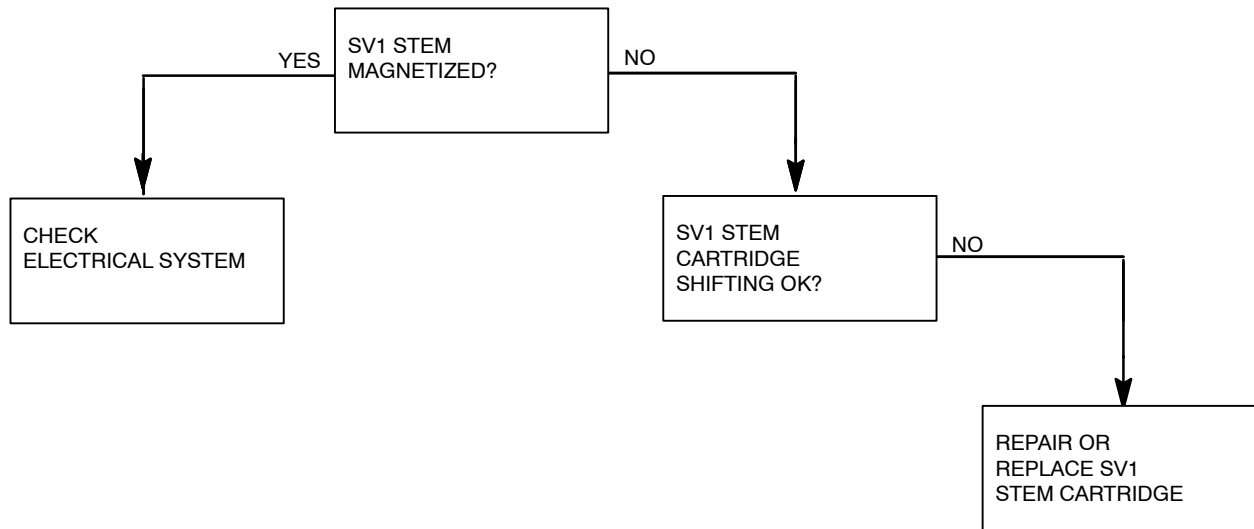

**MAIN BRUSH LOWER CIRCUIT
(SCHEMATIC)**

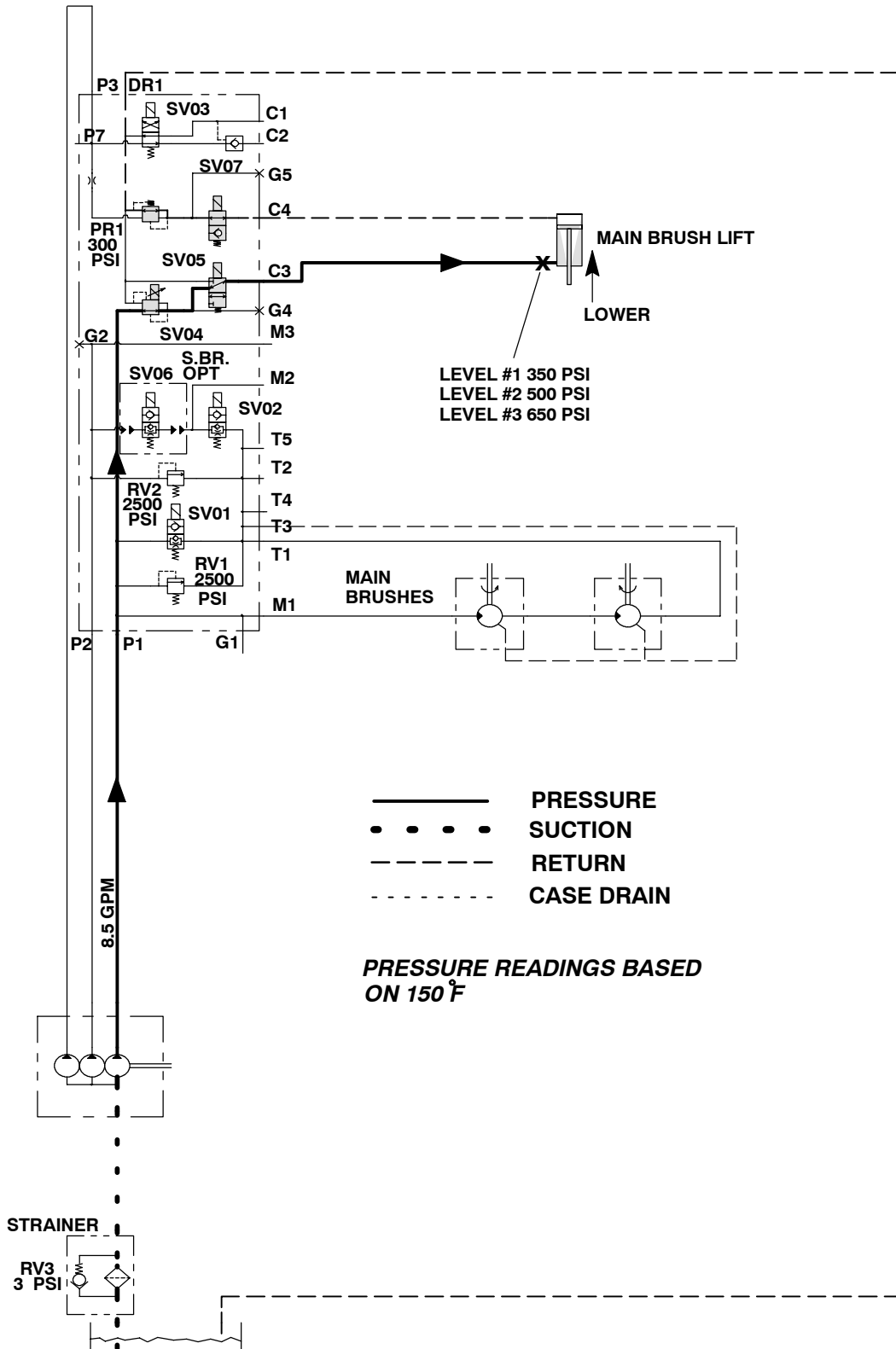

**MAIN BRUSHES DO NOT LOWER
(FLOW CHART)**

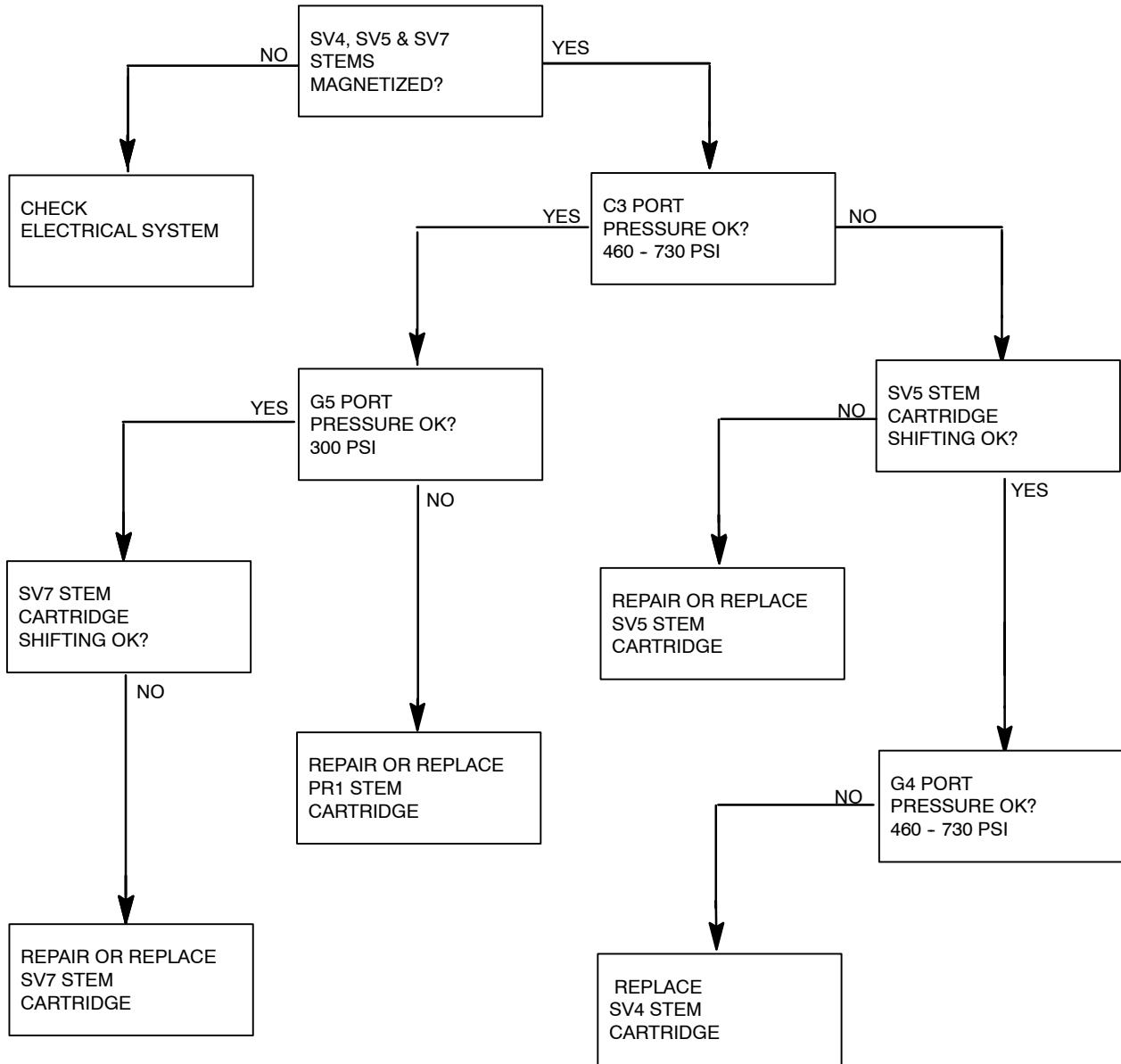

**MAIN BRUSH LIFT CIRCUIT
(SCHEMATIC)**

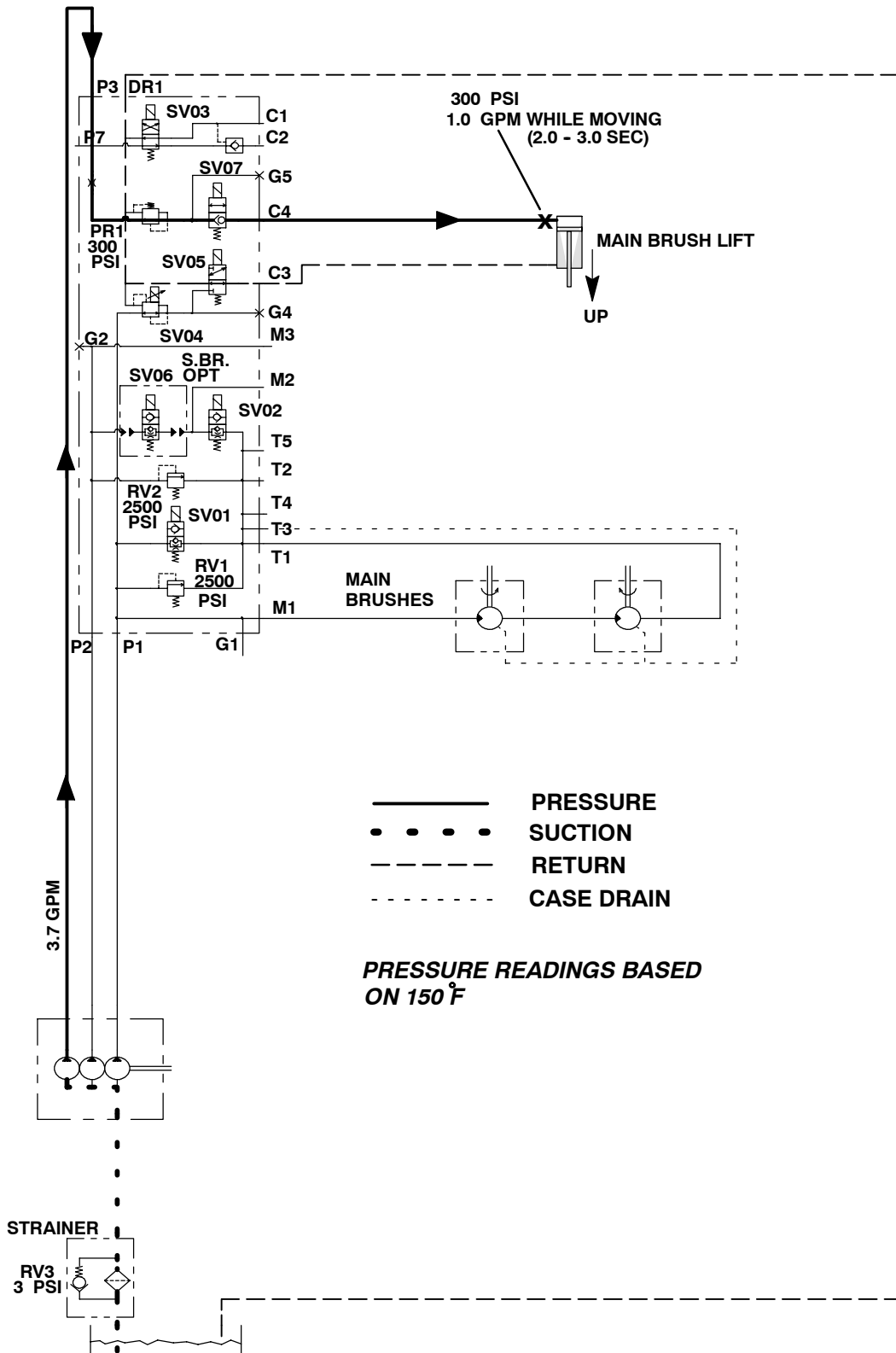

**MAIN BRUSHES DO NOT RAISE
(FLOW CHART)**

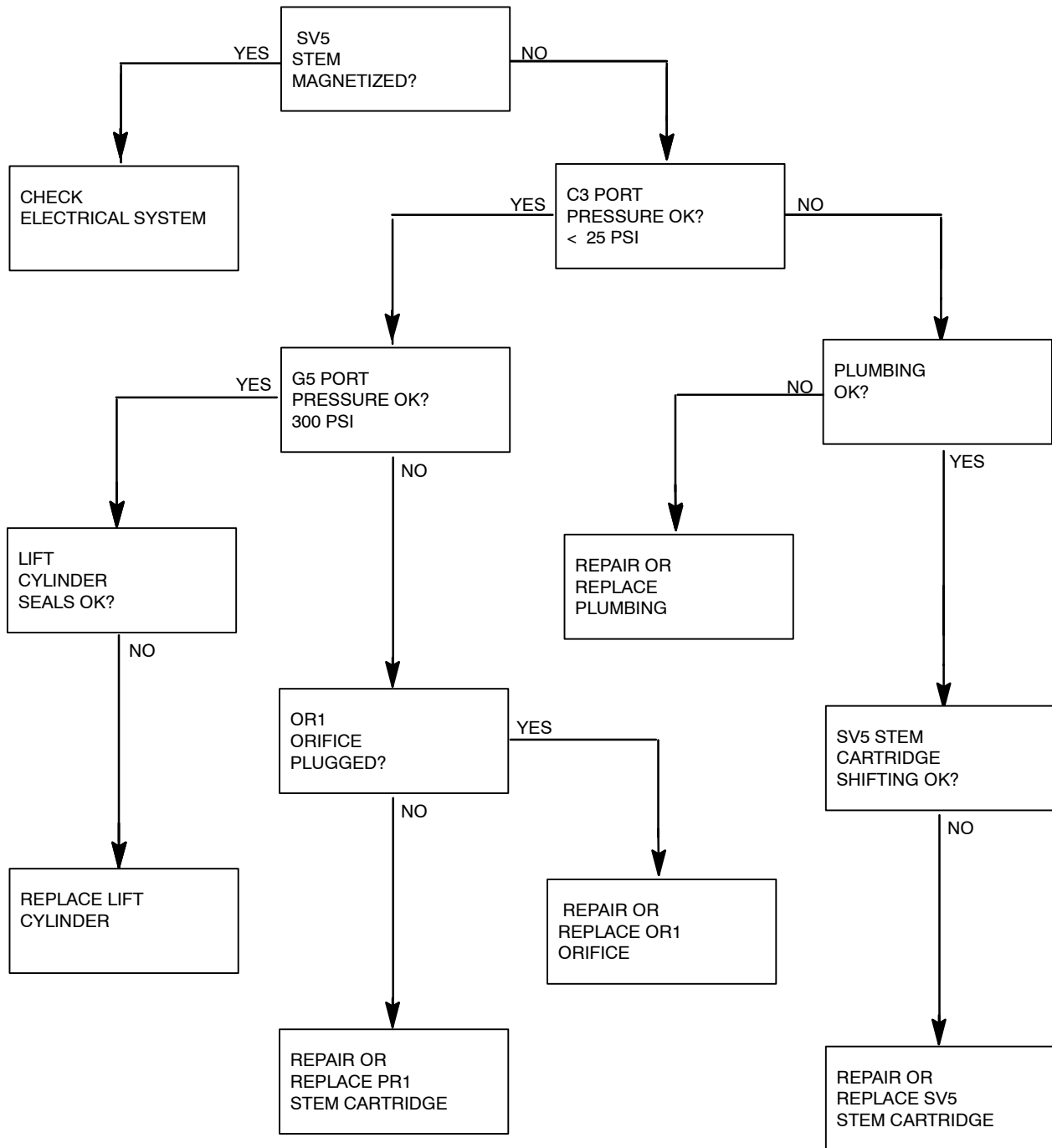

MAIN BRUSHES DO NOT STAY UP
(FLOW CHART)

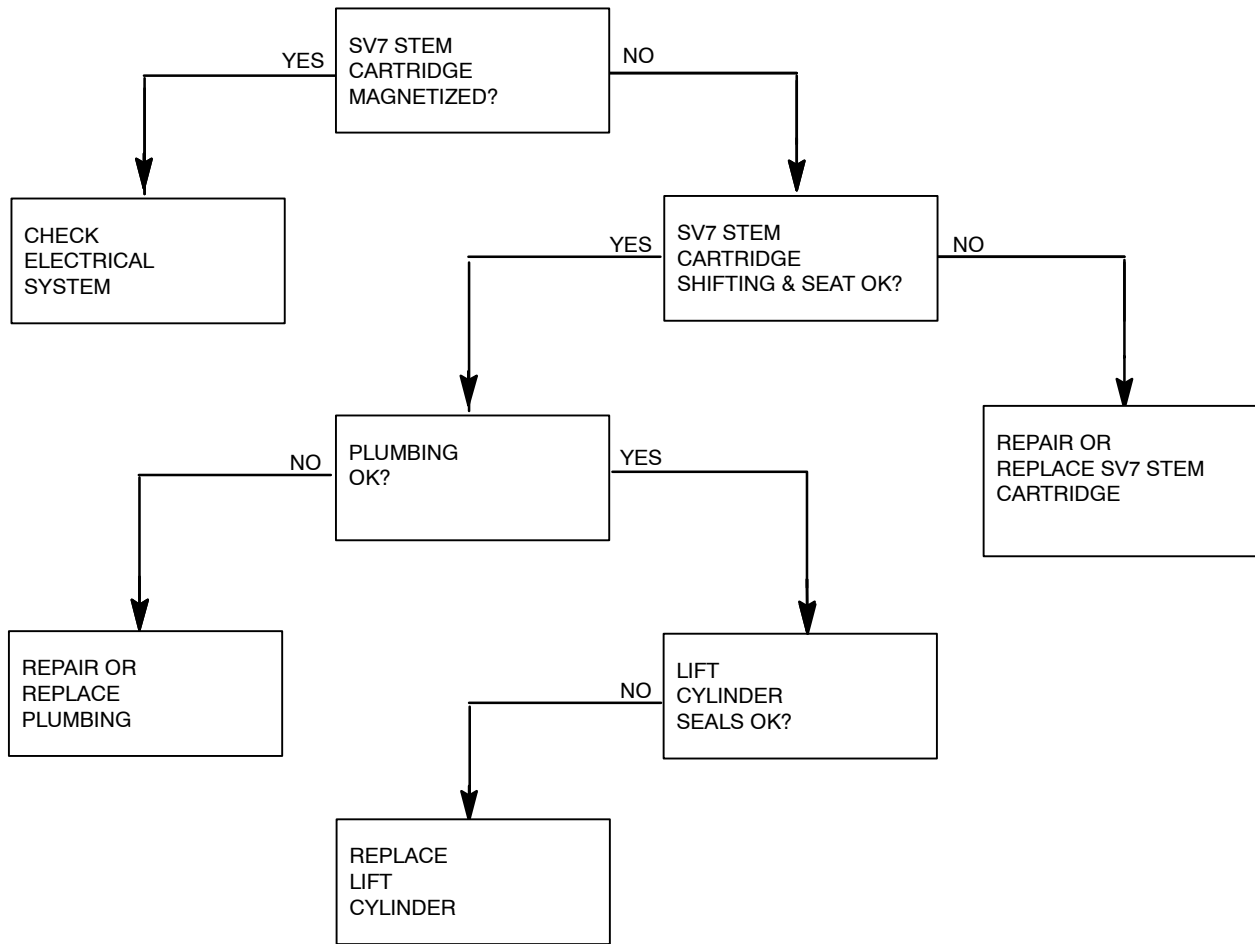

**SCRUB FAN CIRCUIT
(SCHEMATIC)**

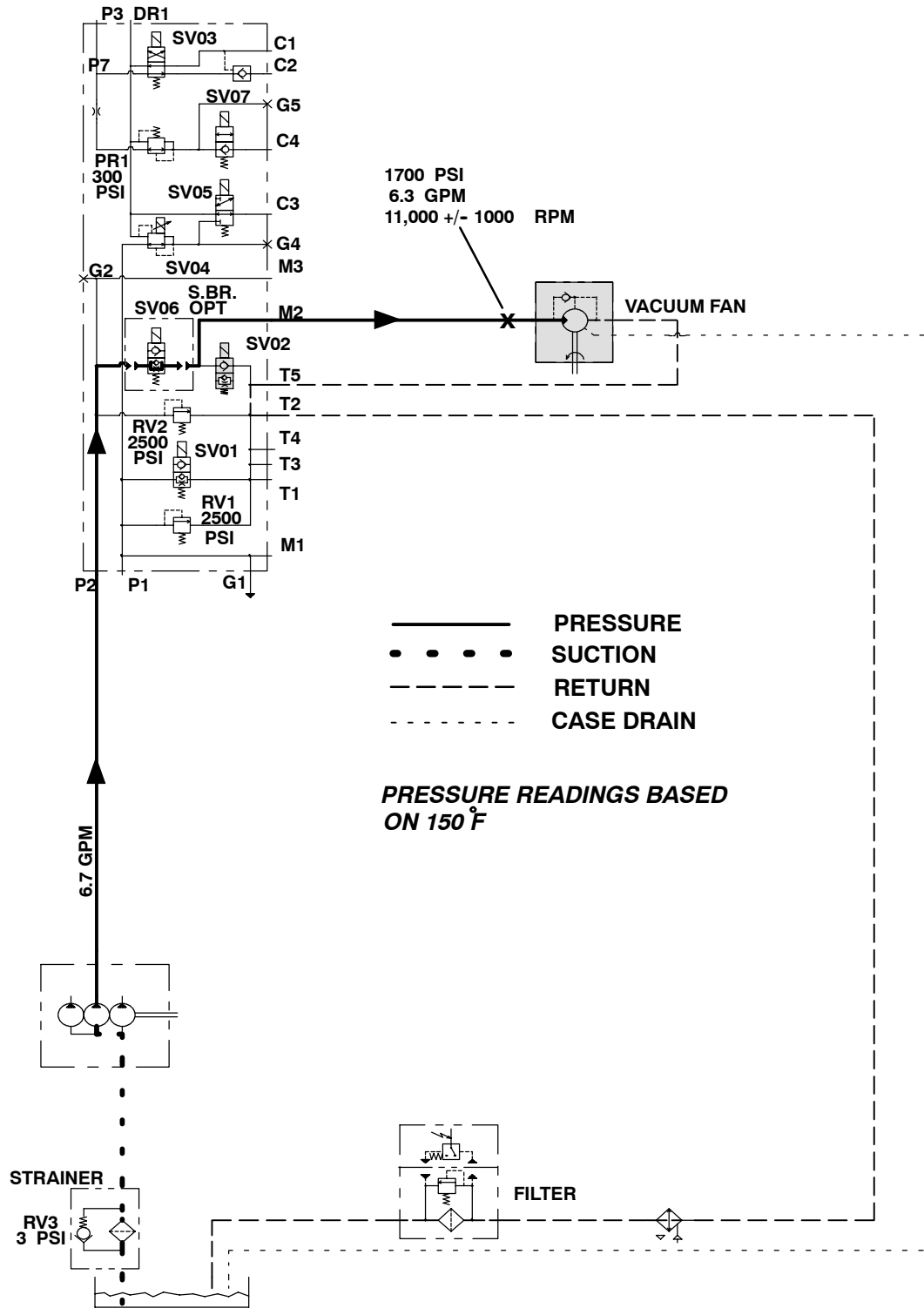

SCRUB FAN DOES NOT TURN ON
(FLOW CHART)

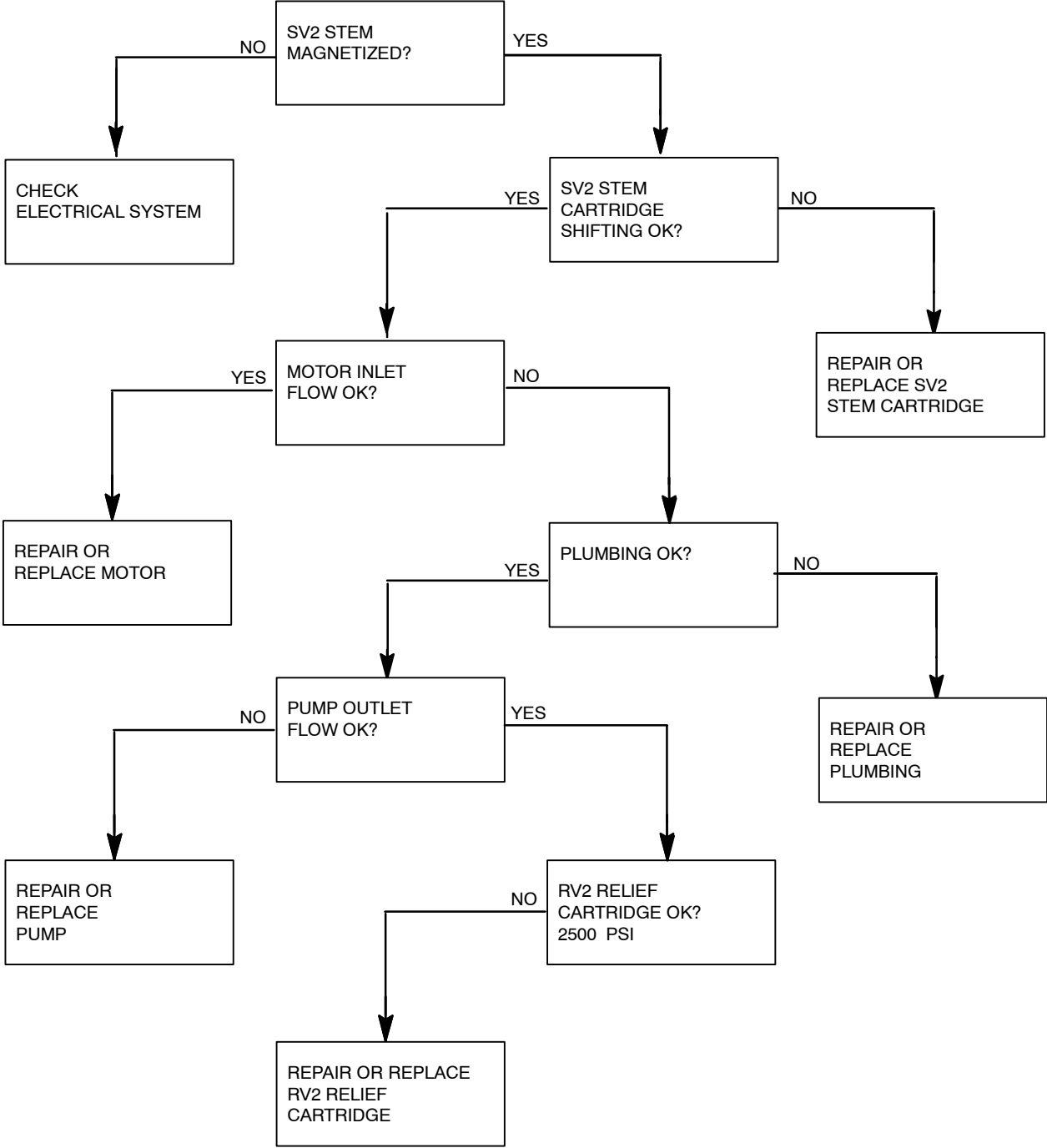

SCRUB FAN DOES NOT TURN OFF
(FLOW CHART)

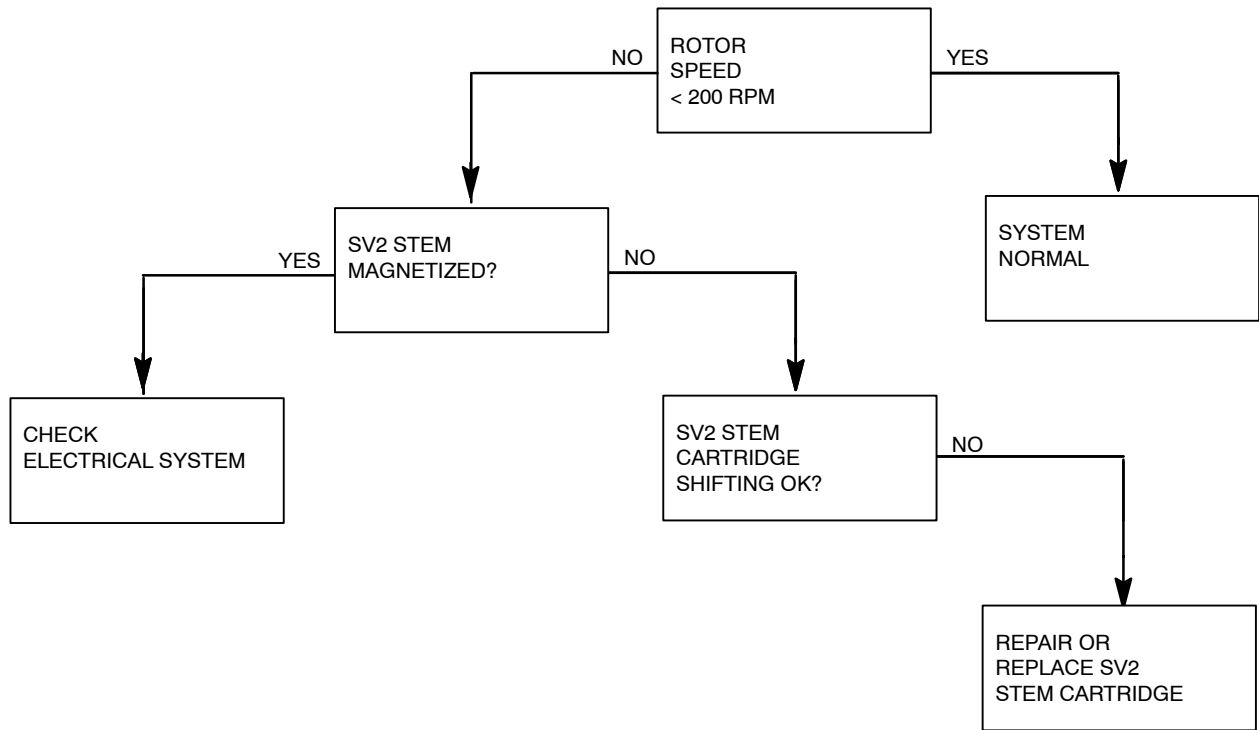

**SCRUB FAN MOTOR SHAFT SEAL LEAKS
(FLOW CHART)**

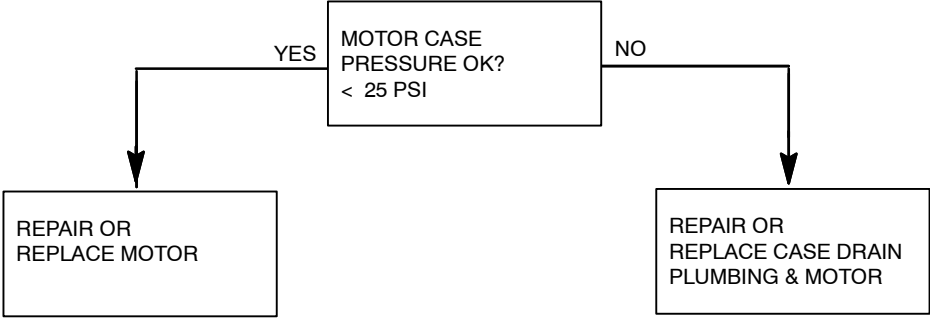

**MAIN BRUSH ON CIRCUIT
(SCHEMATIC)**

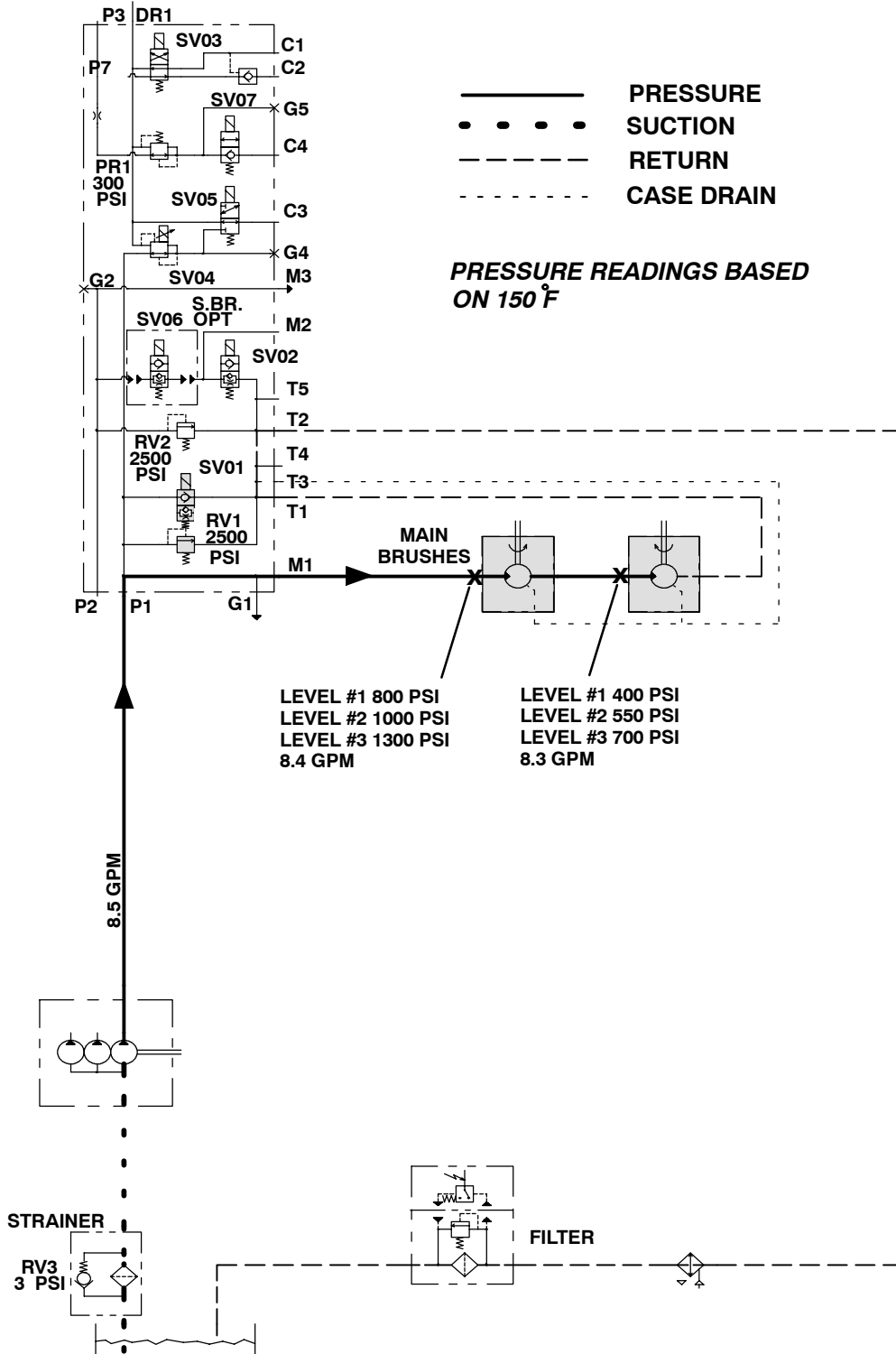

**SIDE BRUSH DOES NOT TURN ON
(FLOW CHART)**

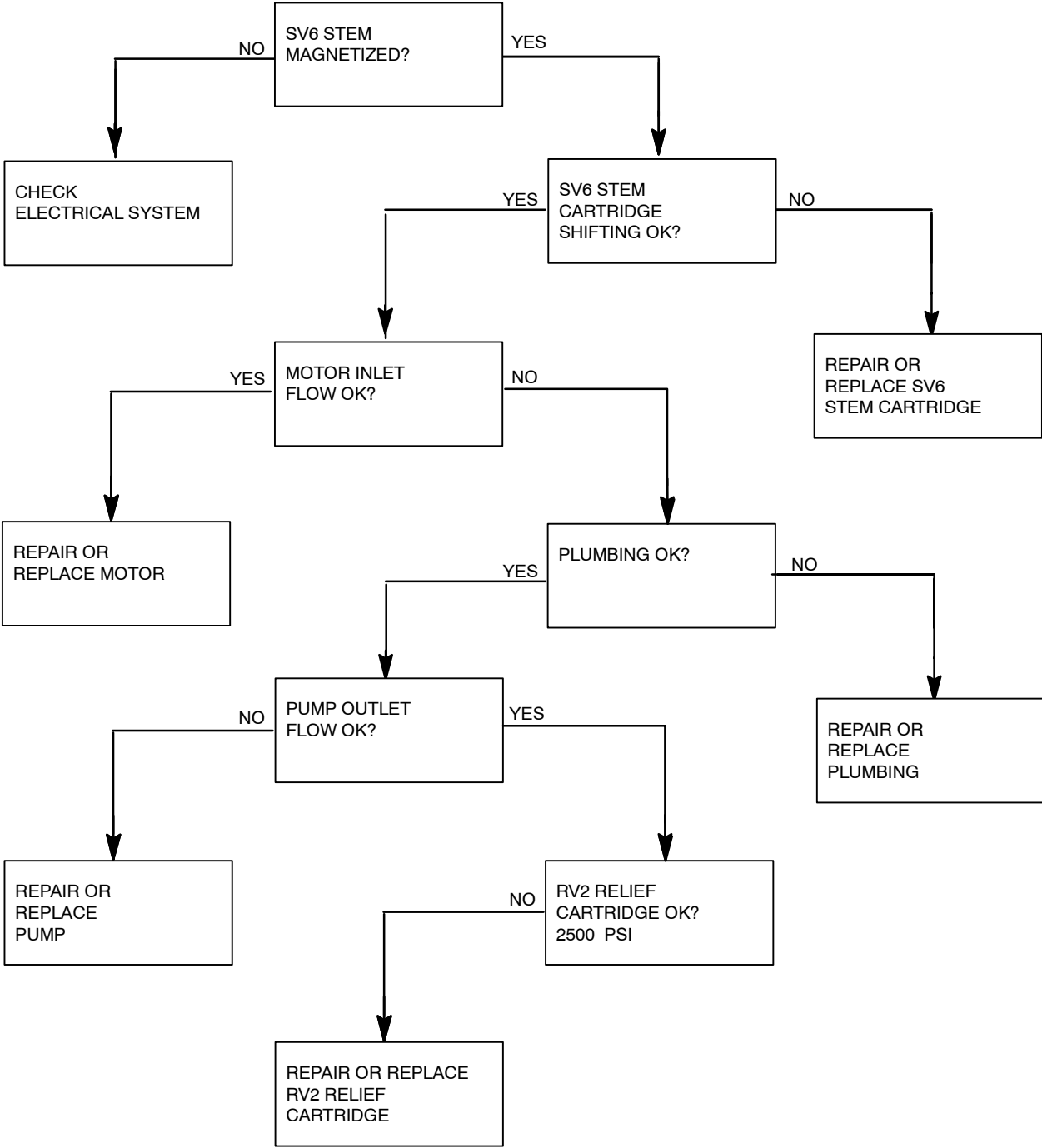

SIDE BRUSH DOES NOT TURN OFF
(FLOW CHART)

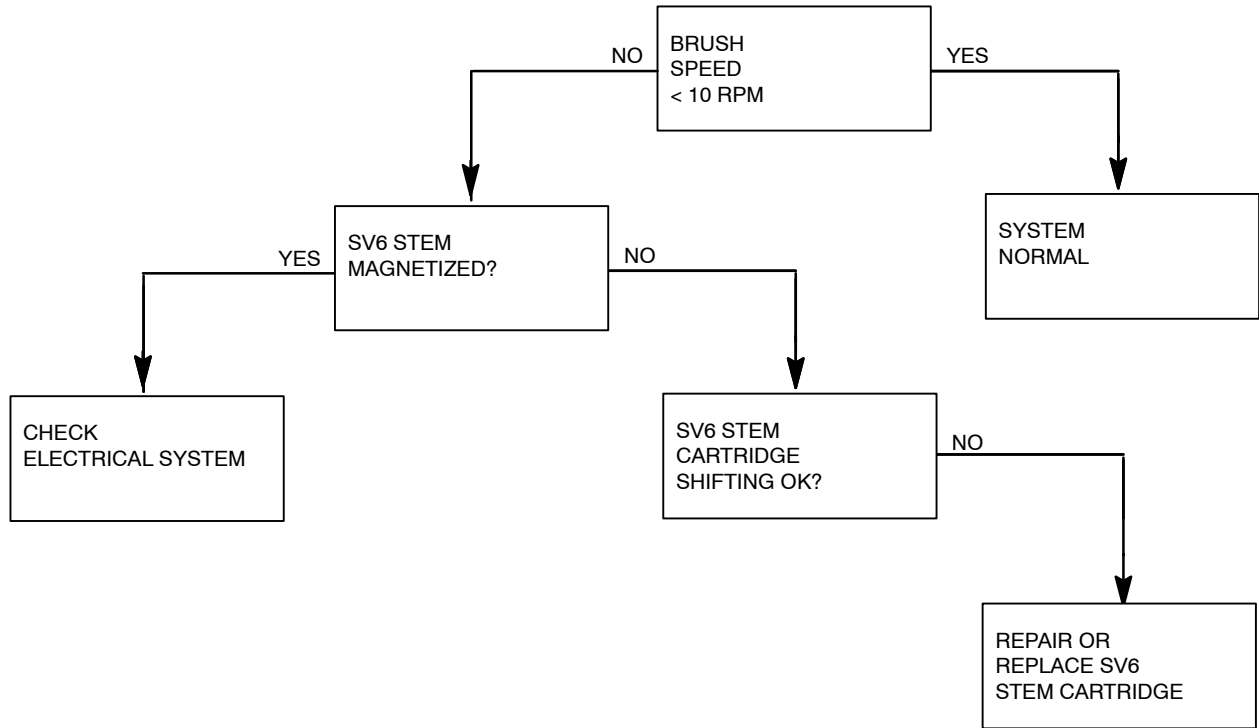

**SIDE BRUSH EXTEND CIRCUIT
(SCHEMATIC)**

(WITH MAIN BRUSHES ON)

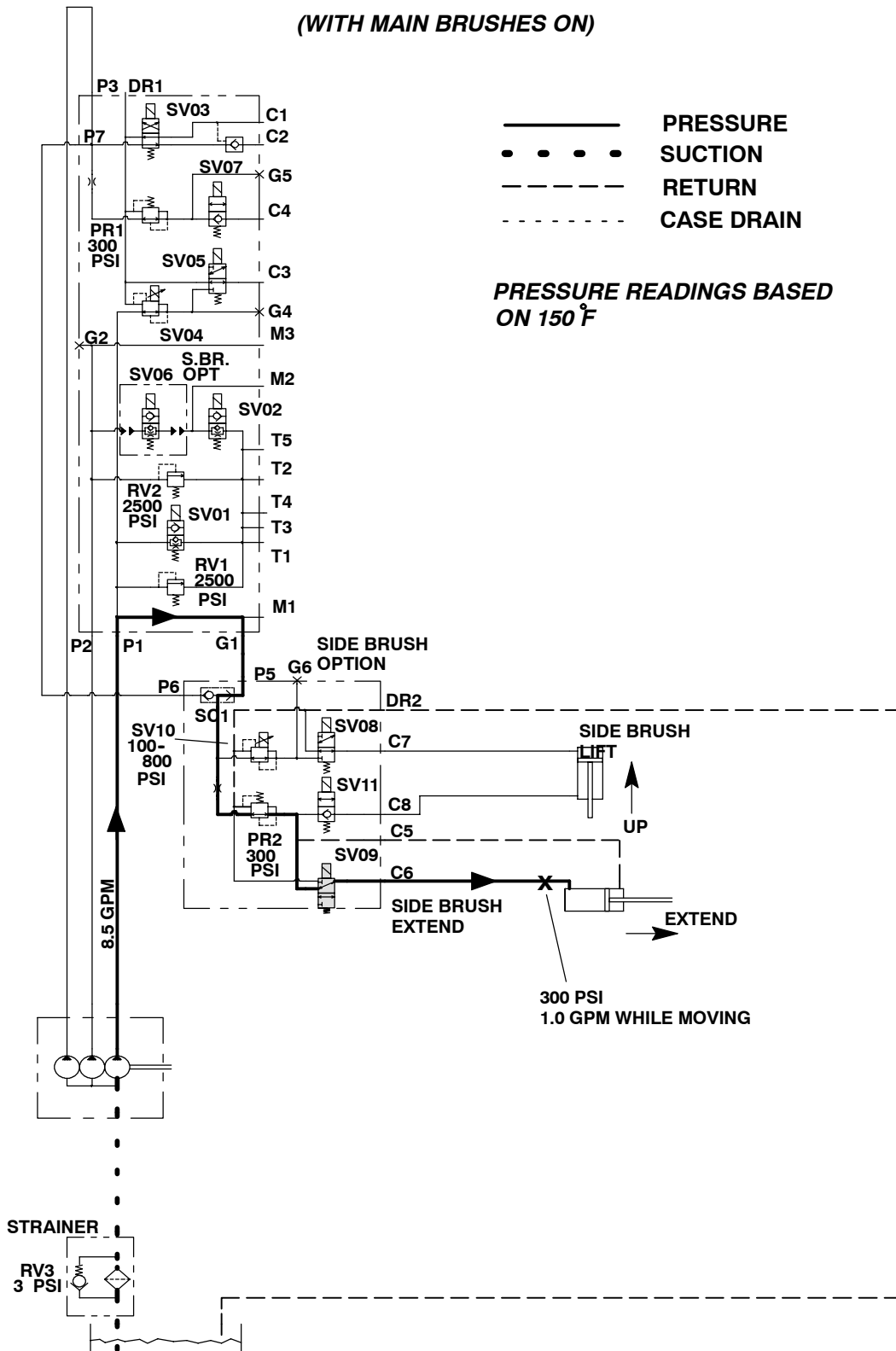

**SIDE BRUSH DOES NOT GO OUT
(FLOW CHART)**

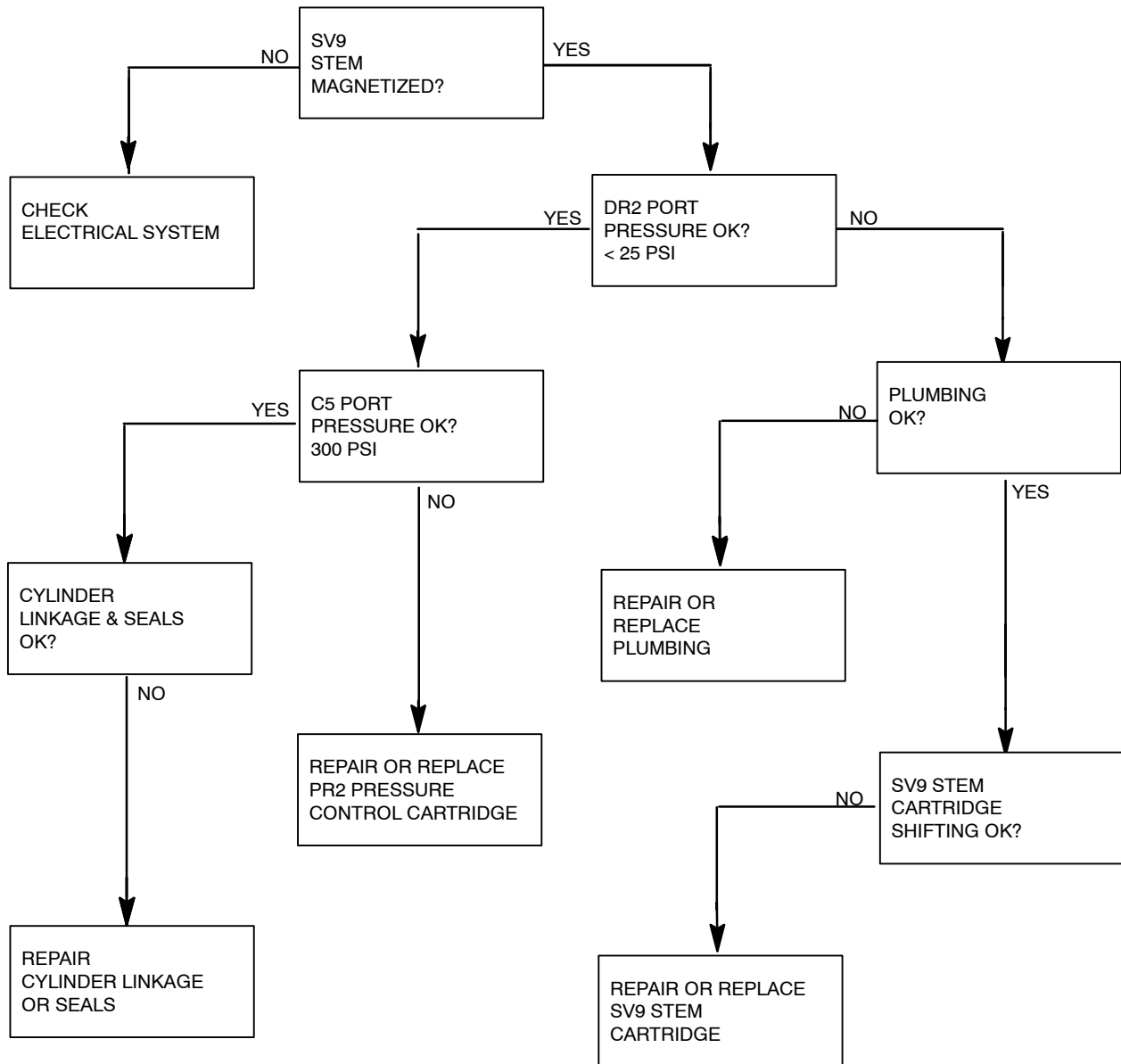

**SIDE BRUSH DOES NOT GO IN
(FLOW CHART)**

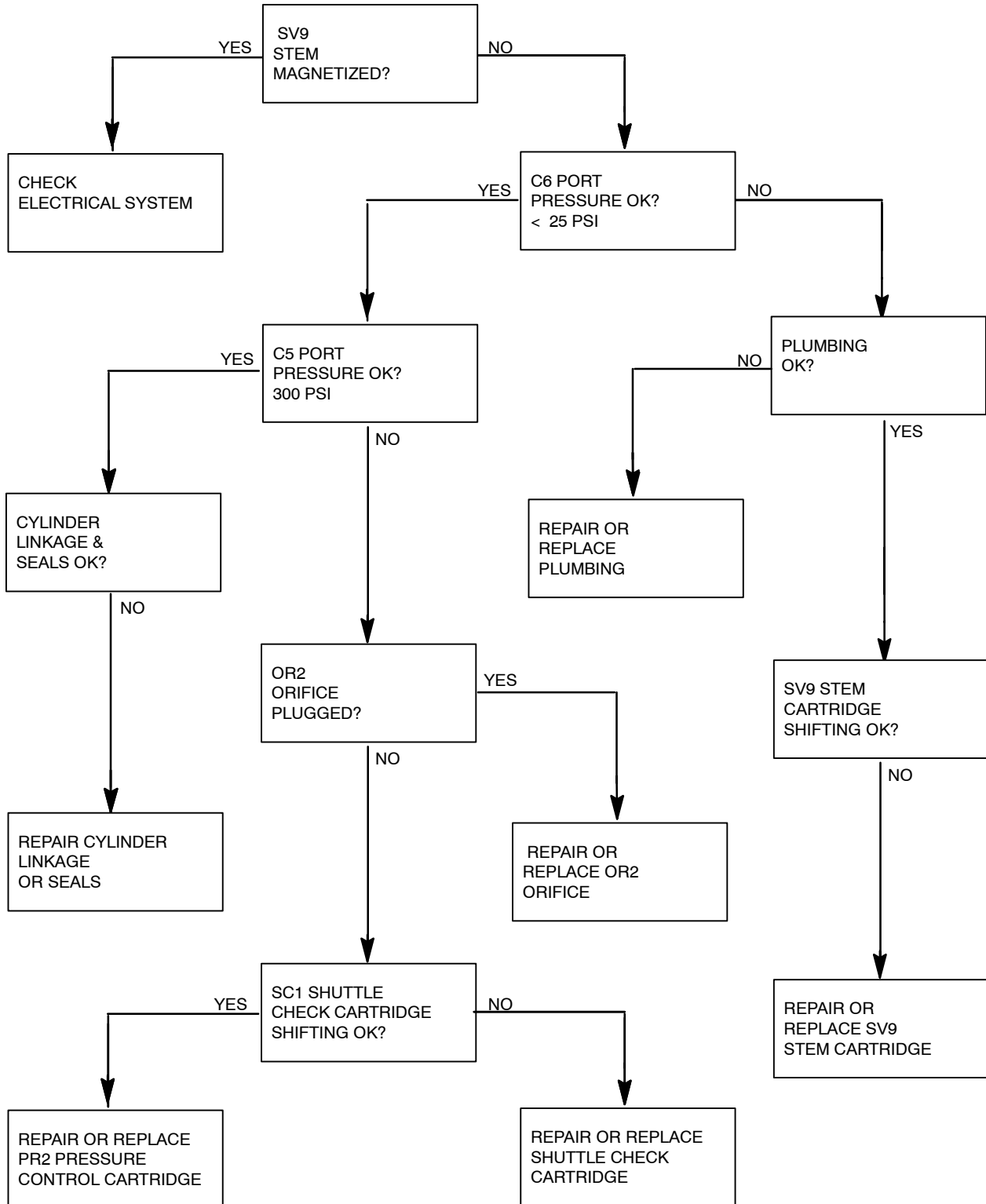

**SIDE BRUSH LOWER CIRCUIT
(SCHEMATIC)**

(WITH MAIN BRUSHES ON)

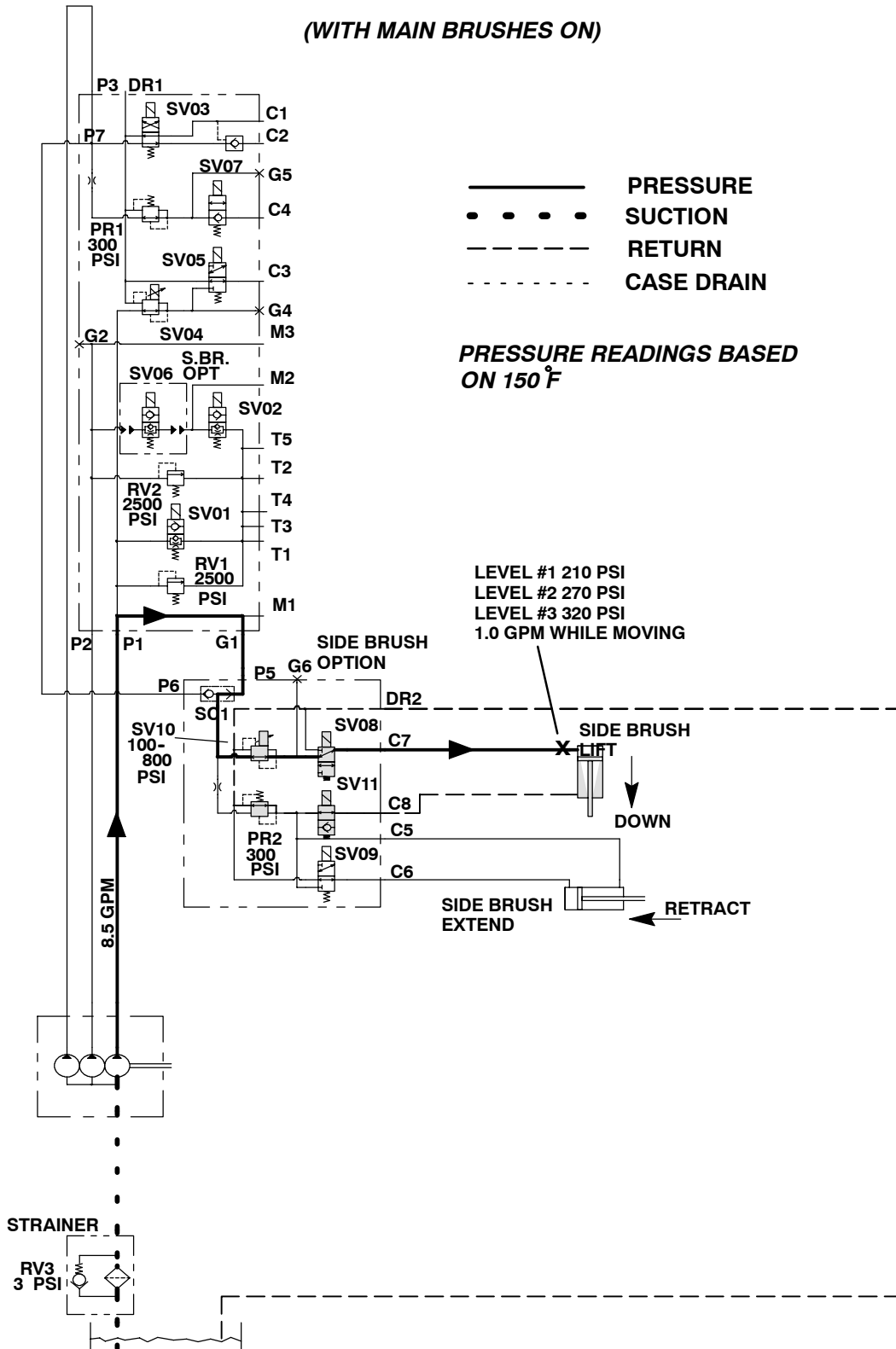

**SIDE BRUSH DOES NOT STAY UP
(FLOW CHART)**

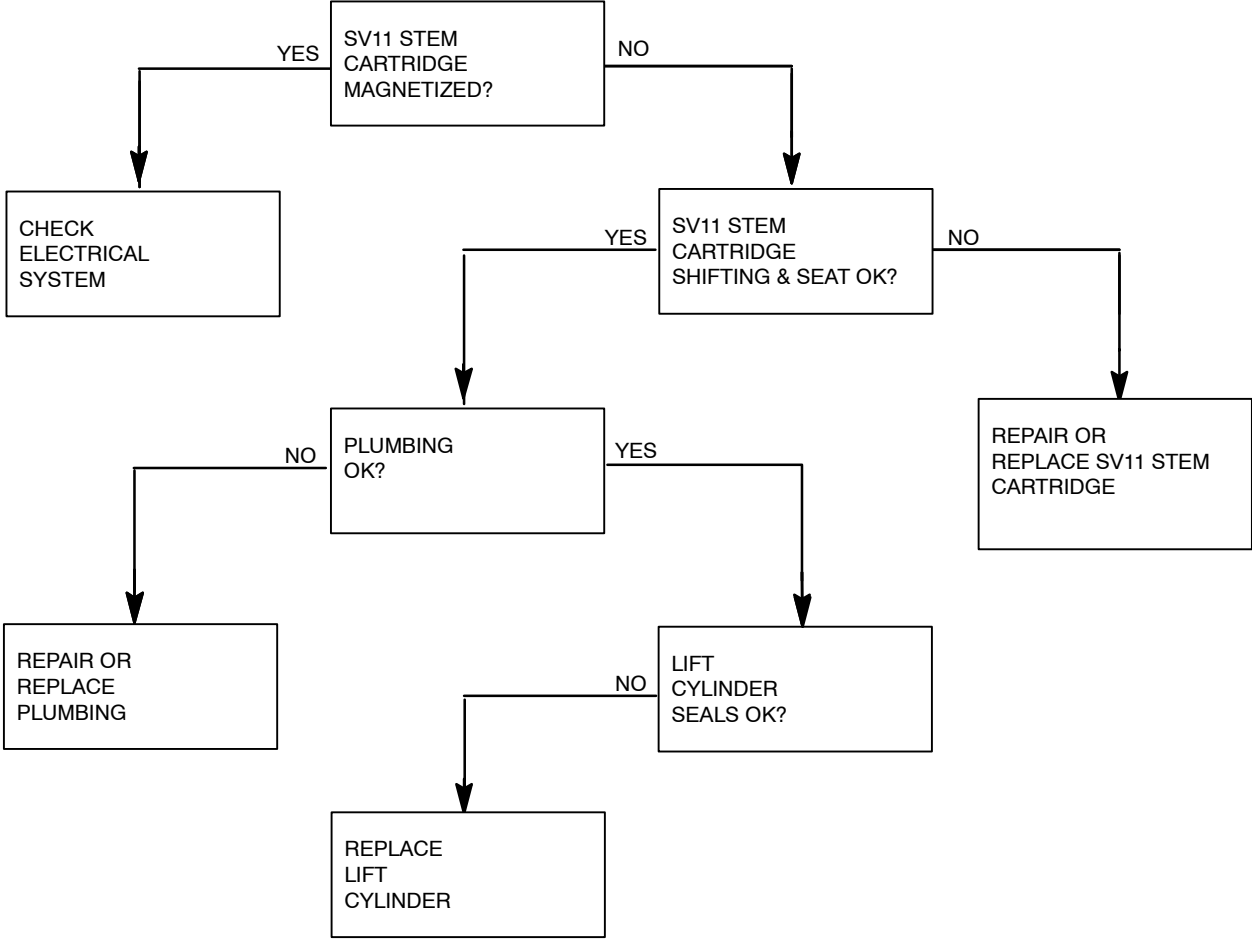

**SIDE BRUSH DOES NOT RAISE
(FLOW CHART)**

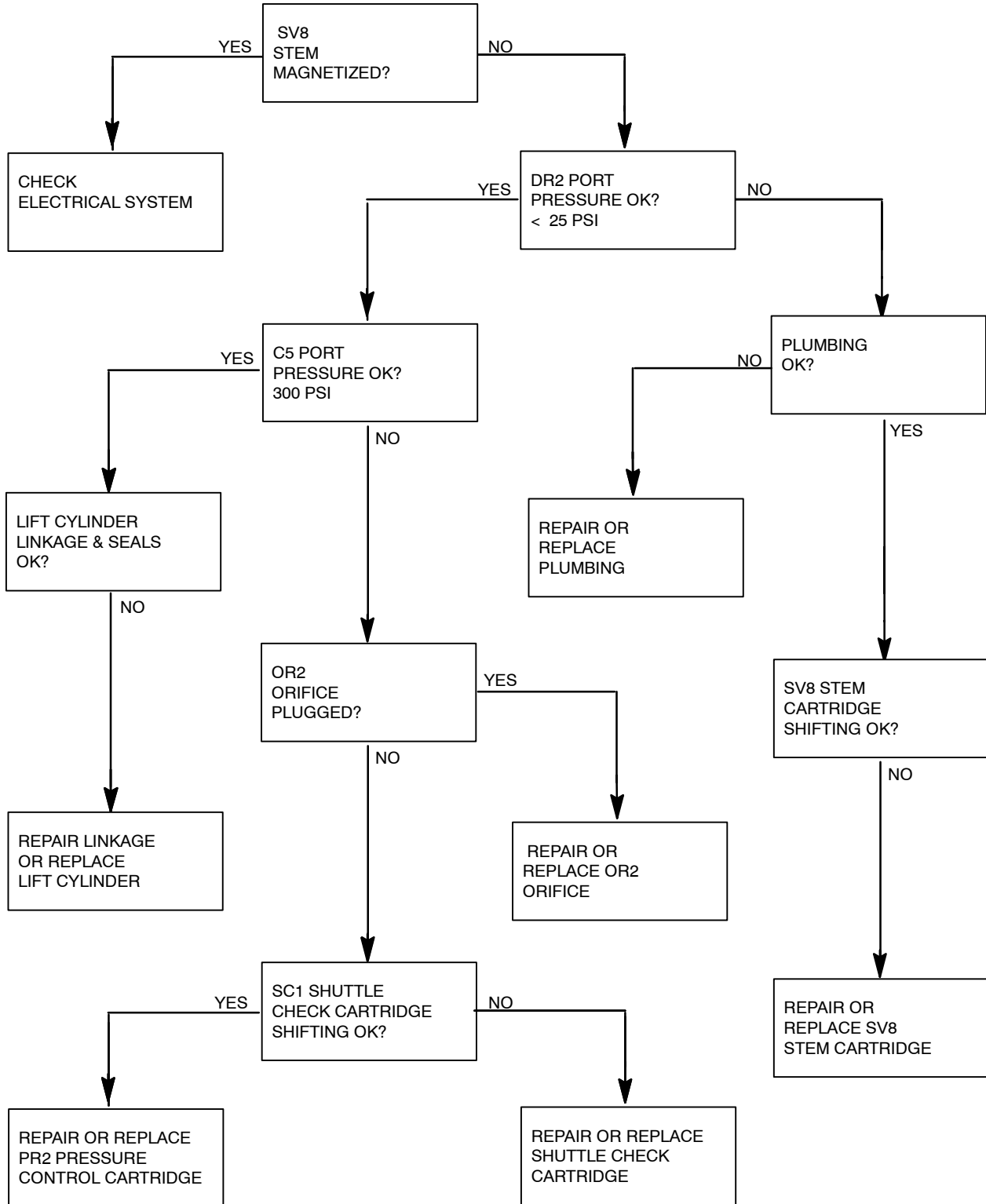

**SIDE BRUSH DOES NOT LOWER
(FLOW CHART)**

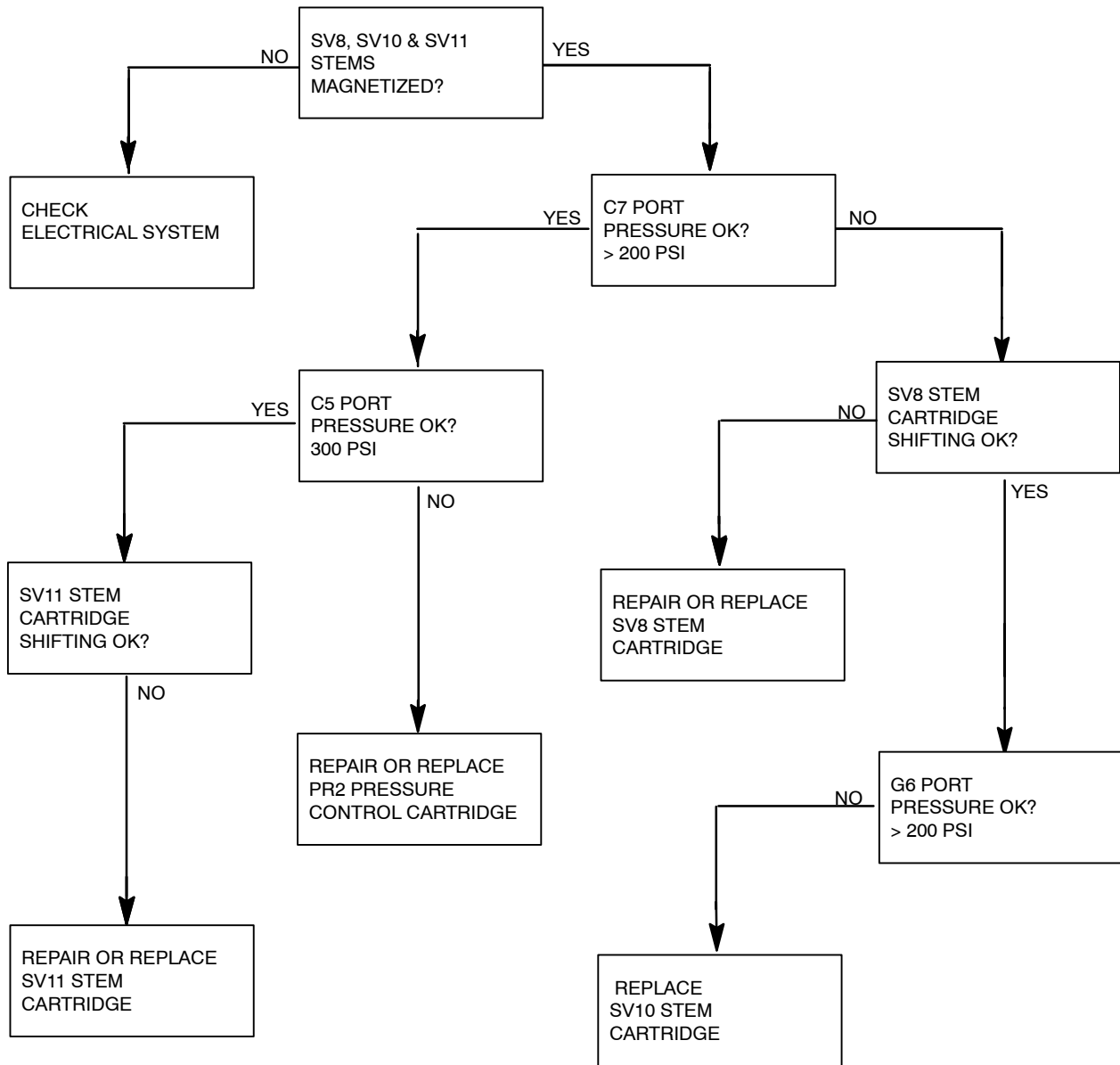

SQUEEGEE LIFT CIRCUIT
(SCHEMATIC)

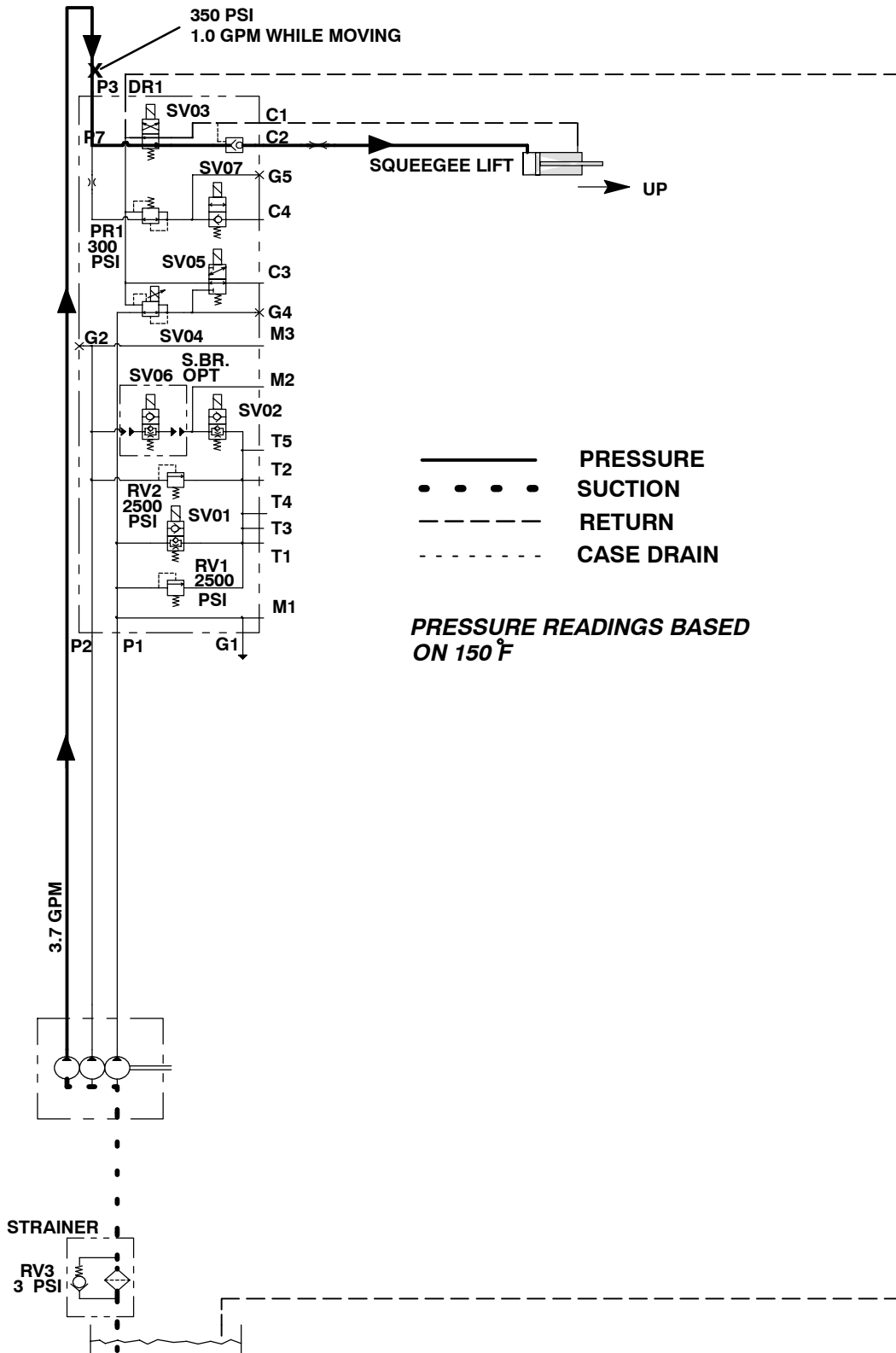

**SQUEEGEE DOES NOT LOWER
(FLOW CHART)**

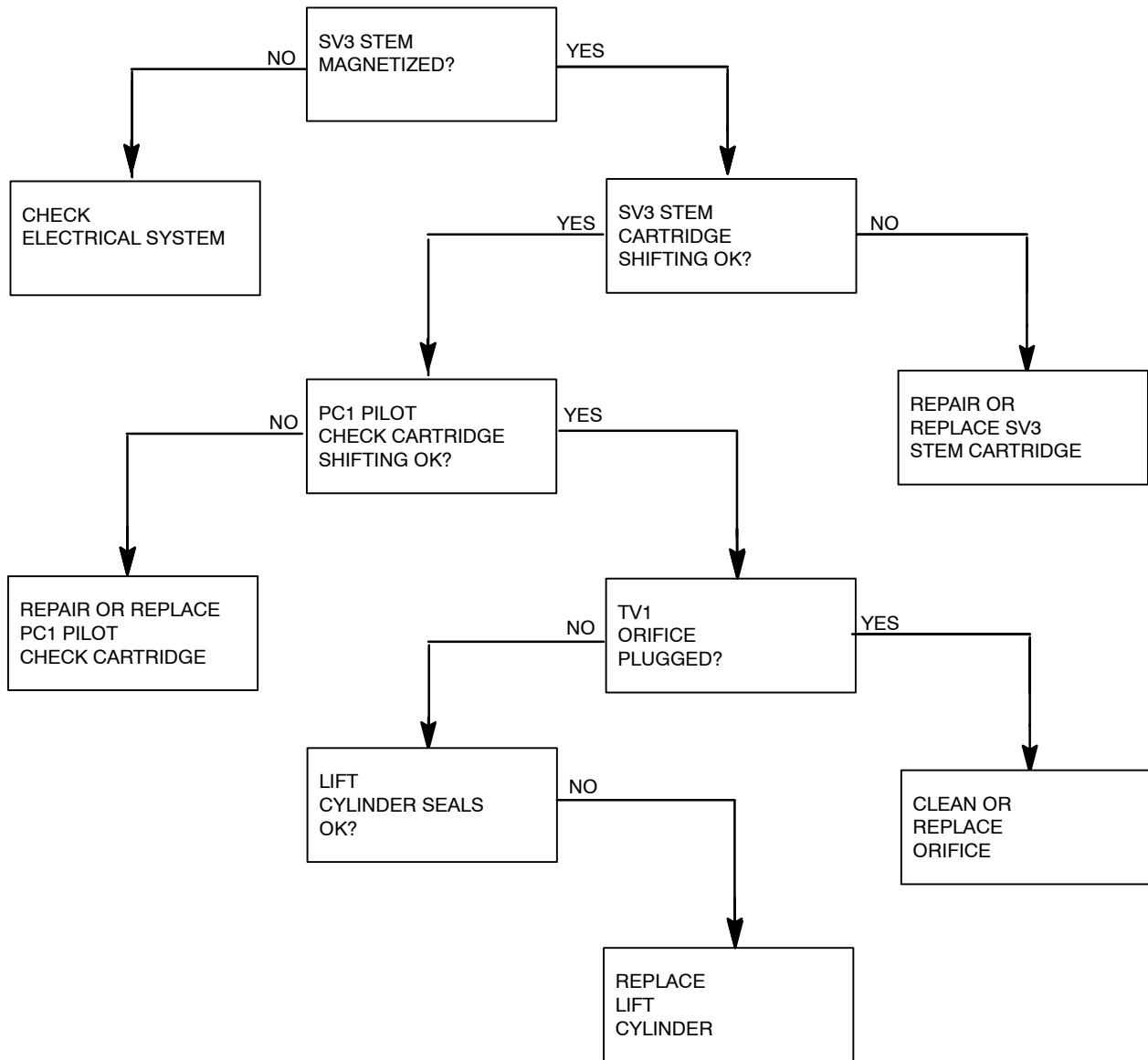

SQUEEGEE DOES NOT RAISE
(FLOW CHART)

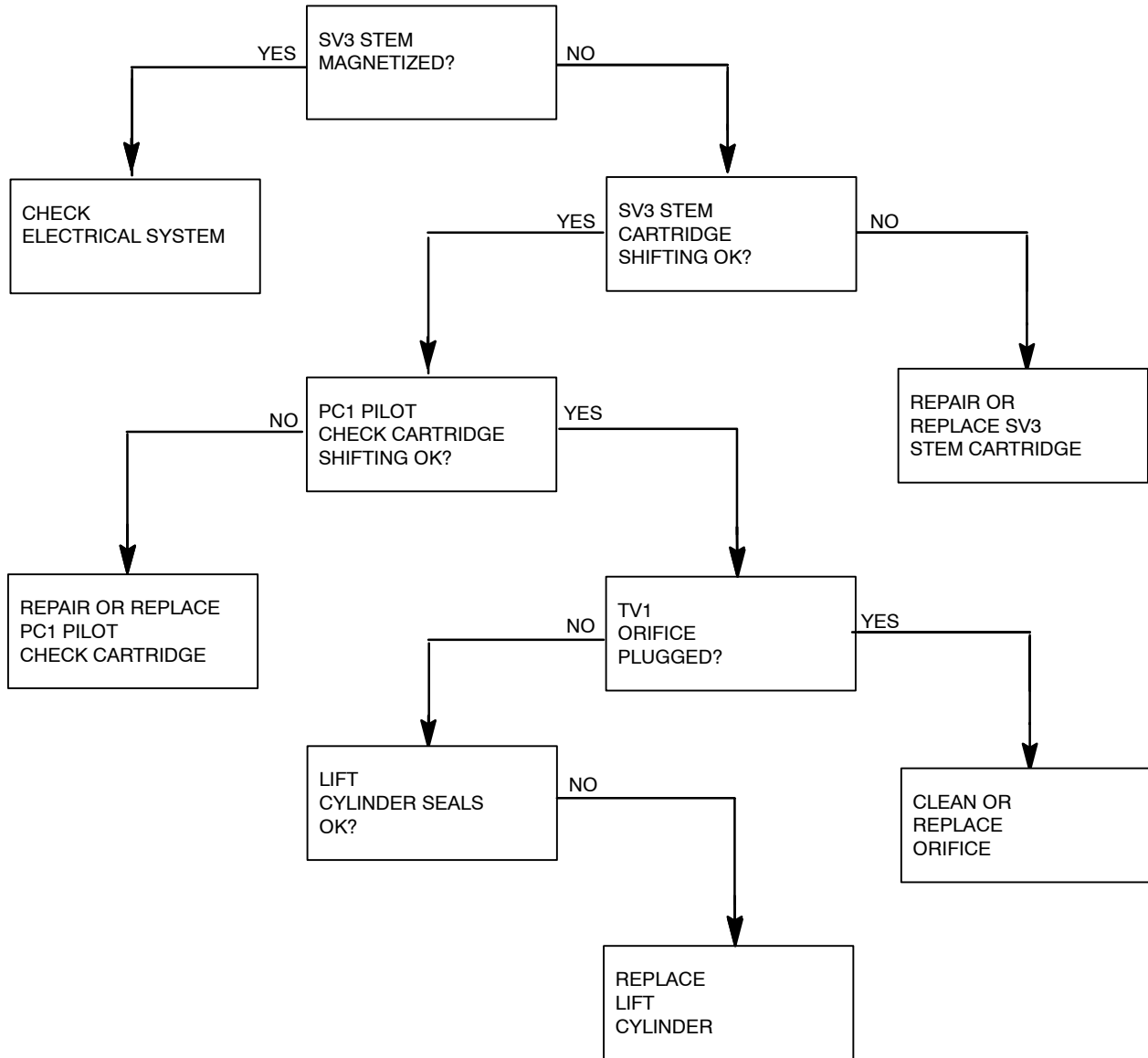

**SQUEEGEE DOES NOT STAY UP
(FLOW CHART)**

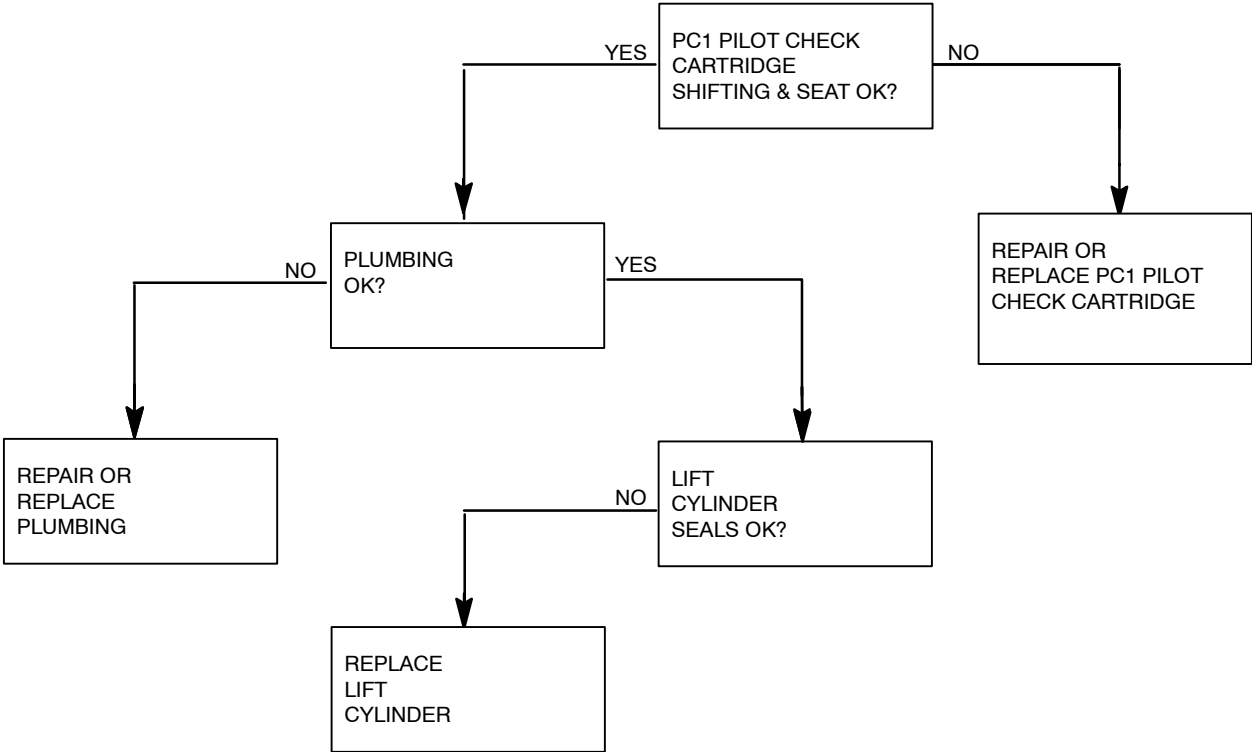

**STEERING CIRCUIT
(SCHEMATIC)**

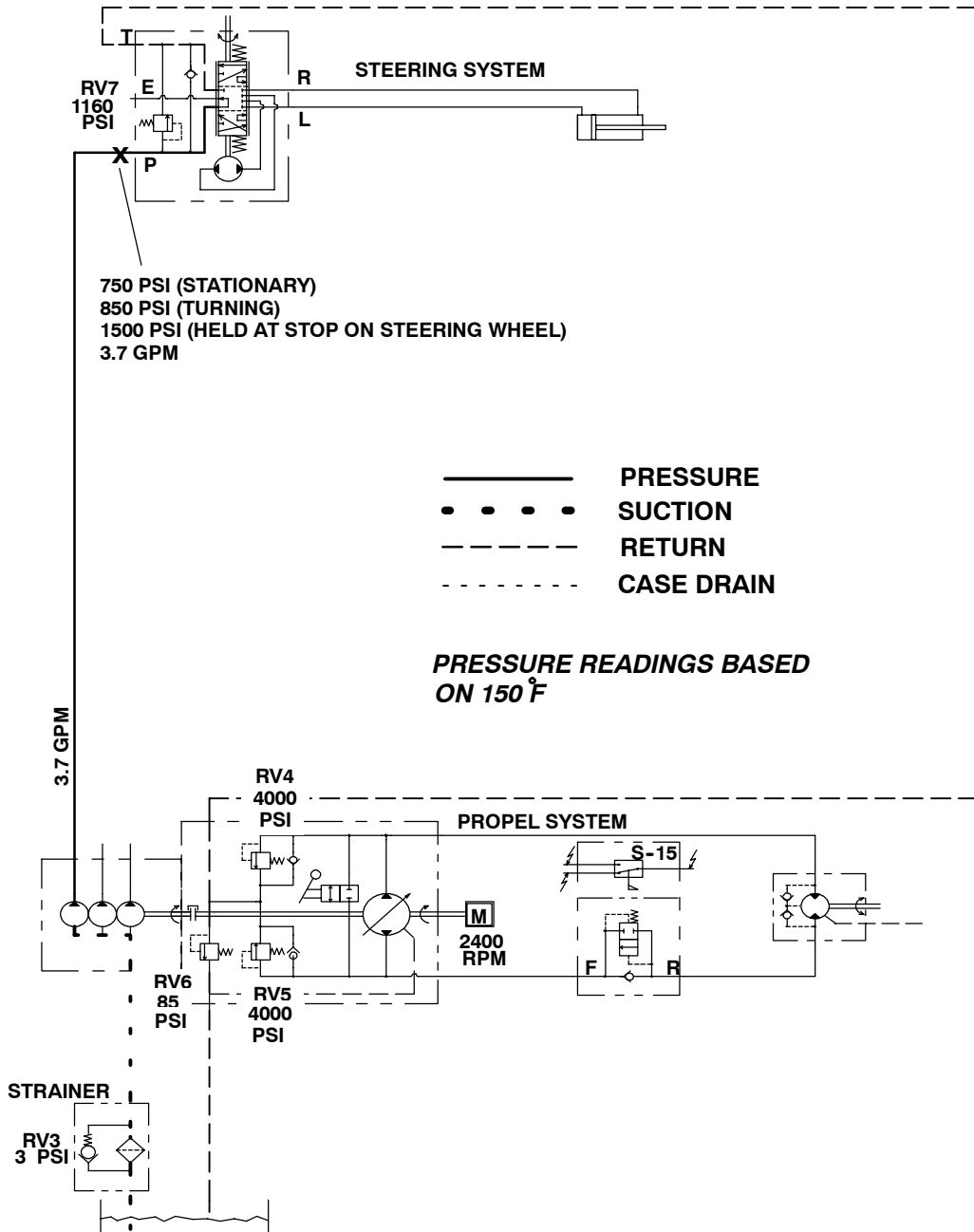



Repair Information

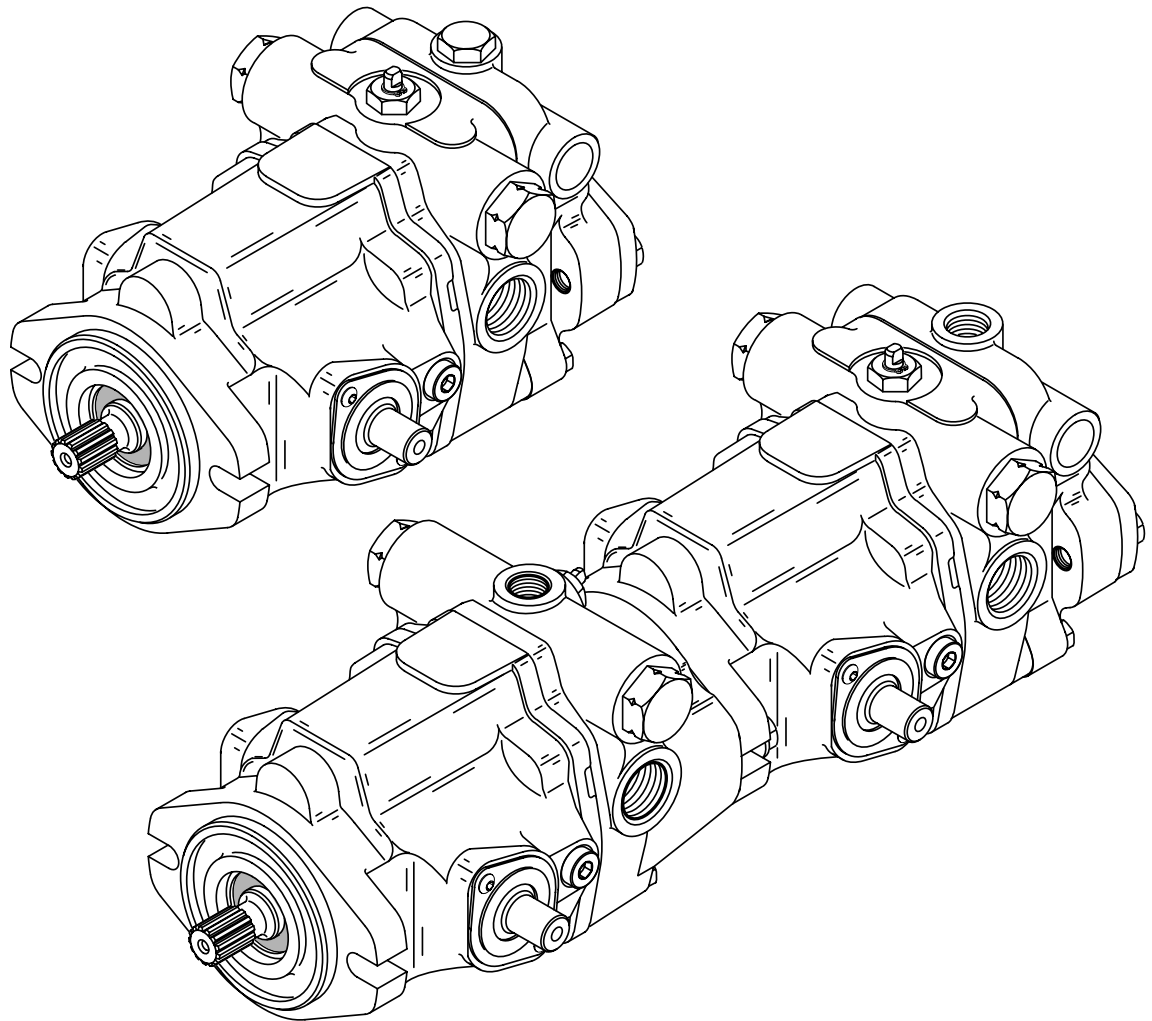

**Model 70142 / 70144, 20.3 cm³/r [1.24 in³/r] Displacement
and 70145, 23.6 cm³/r [1.44 in³/r] Displacement
Variable Displacement Piston Pump**

design code **01 02**

with **Valve Plate**

Introduction

Table of Contents

Introduction	2
Identification	3
Required Tools	3
Exploded View Drawing	4 & 5
Parts List	6 & 7
Disassembly and Inspection	8
Reassembly	9
Appendix A:	10
Appendix B:	11
Fault-Logic Trouble Shooting	12 - 16
Start-up Procedure	17

Introduction

This manual provides service information for the Eaton Models 70142 / 70144 and 70145 Variable Displacement Piston Pumps. Step by step instructions for the complete disassembly, inspection, and reassembly of the pump are given. The following recommendations should be followed to insure successful repairs.

- Remove the pump from the application.
- Cleanliness is extremely important.
- Clean the port areas thoroughly before disconnecting the hydraulic lines.
- Plug the pump ports and cover the open hydraulic lines immediately after they're disconnected.
- Drain the oil and clean the exterior of the pump before making repairs.
- Wash all metal parts in clean solvent.
- Use compressed air to dry the parts. Do not wipe them dry with paper towels or cloth.
- The compressed air should be filtered and moisture free.
- Always use new seals when reassembling hydraulic pumps.
- For replacement parts and ordering information refer to parts list 6-632.
- Lubricate the new rubber seals with a petroleum jelly (vaseline) before installation.
- Torque all bolts over gasketed joints, then repeat the torquing sequence to make-up for gasket compression.
- Verifying the accuracy of pump repairs on an authorized test stand is essential.

Identification and Tools Required

Identification Numbers

Stamped on each unit.

A - Product Number Description

- 70142 = Piston Pump (20.3 cm³/r [1.24 in³/r]) with Gerotor
- 70144 = Piston Pump (20.3 cm³/r [1.24 in³/r]) without Gerotor
- 70145 = Piston Pump (23.6 cm³/r [1.44 in³/r]) with or without Gerotor
- 78113 = Tandem Piston Pumps (20.3 cm³/r [1.24 in³/r]) **no Gear Pump**
- 78114 = Tandem Piston Pumps (20.3 cm³/r [1.24 in³/r]) with Gear Pump
- 78115 = Tandem Piston Pumps (23.6 cm³/r [1.44 in³/r]) **no Gear Pump**
- 78116 = Tandem Piston Pumps (23.6 cm³/r [1.44 in³/r]) with Gear Pump

B - Rotation,

- R = Righthand,
- L = Lefthand

C - Sequential Letters

D - Design Code Number

Single Pump - Product Number

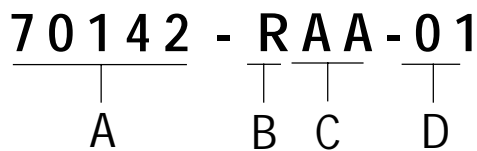

Tandem Pumps - Product Number

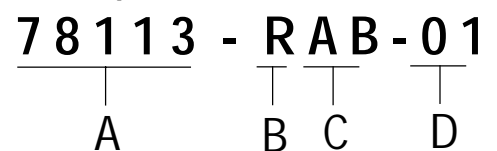

Serial Number Code:

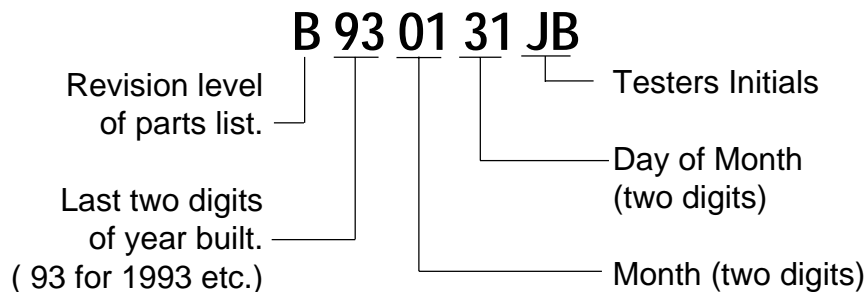

Required Tools

- 7/16 in. Hex Key (Allen)
- 9/16 in. End Wrench
- 1 in. End Wrench
- 9/16 in. Socket
- 1/2 in. Socket
- Internal Retaining Ring Pliers (straight .090 tip)
- External Retaining Ring Pliers (straight .070 tip)
- O-ring Pick
- Torque Wrench (135.6 N·m [100 lbf·ft] capacity)
- Hammer (soft face)
- Light Petroleum Jelly
- Seal Driver
- Arbor Press

Parts Drawing - Figure 1-1

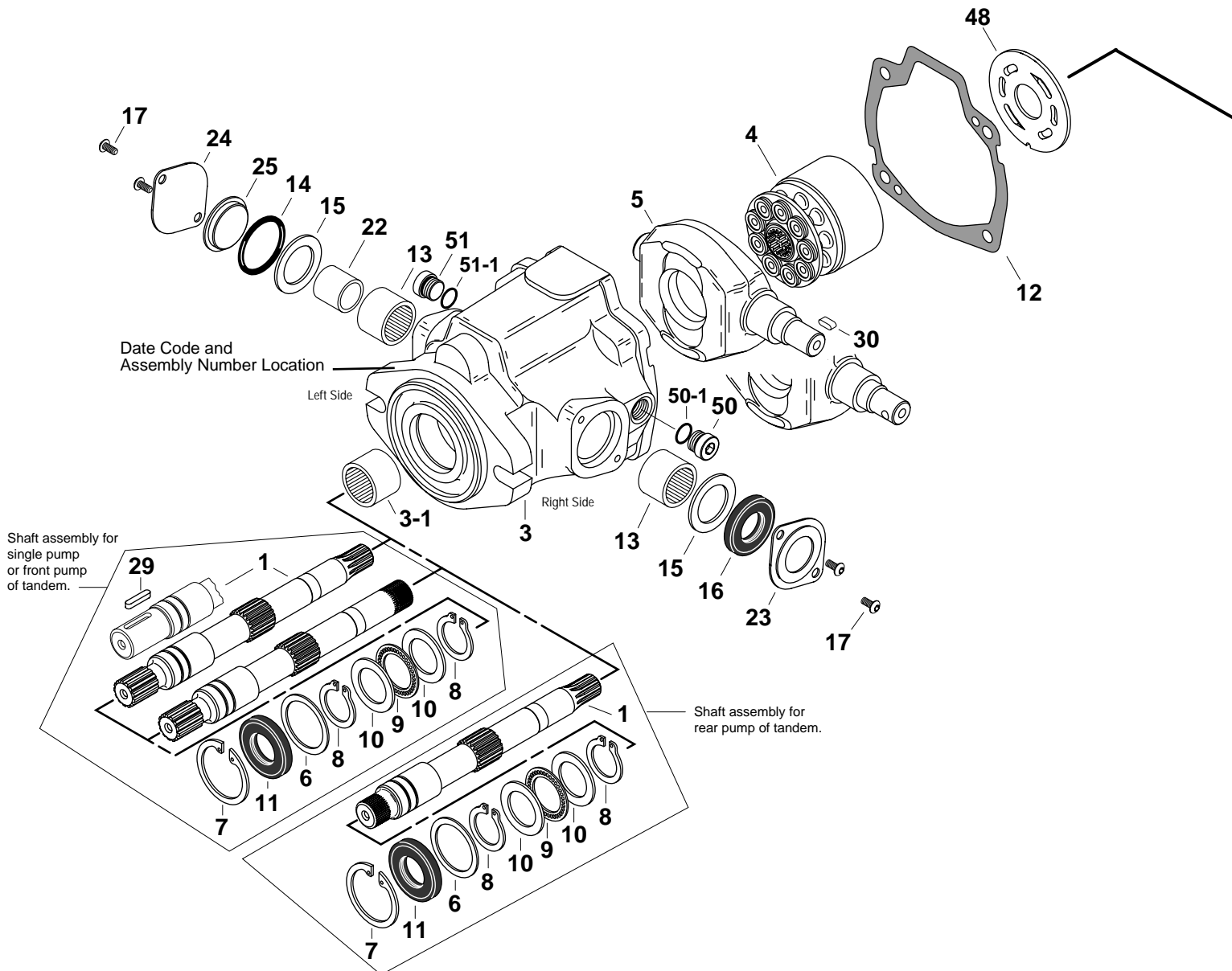

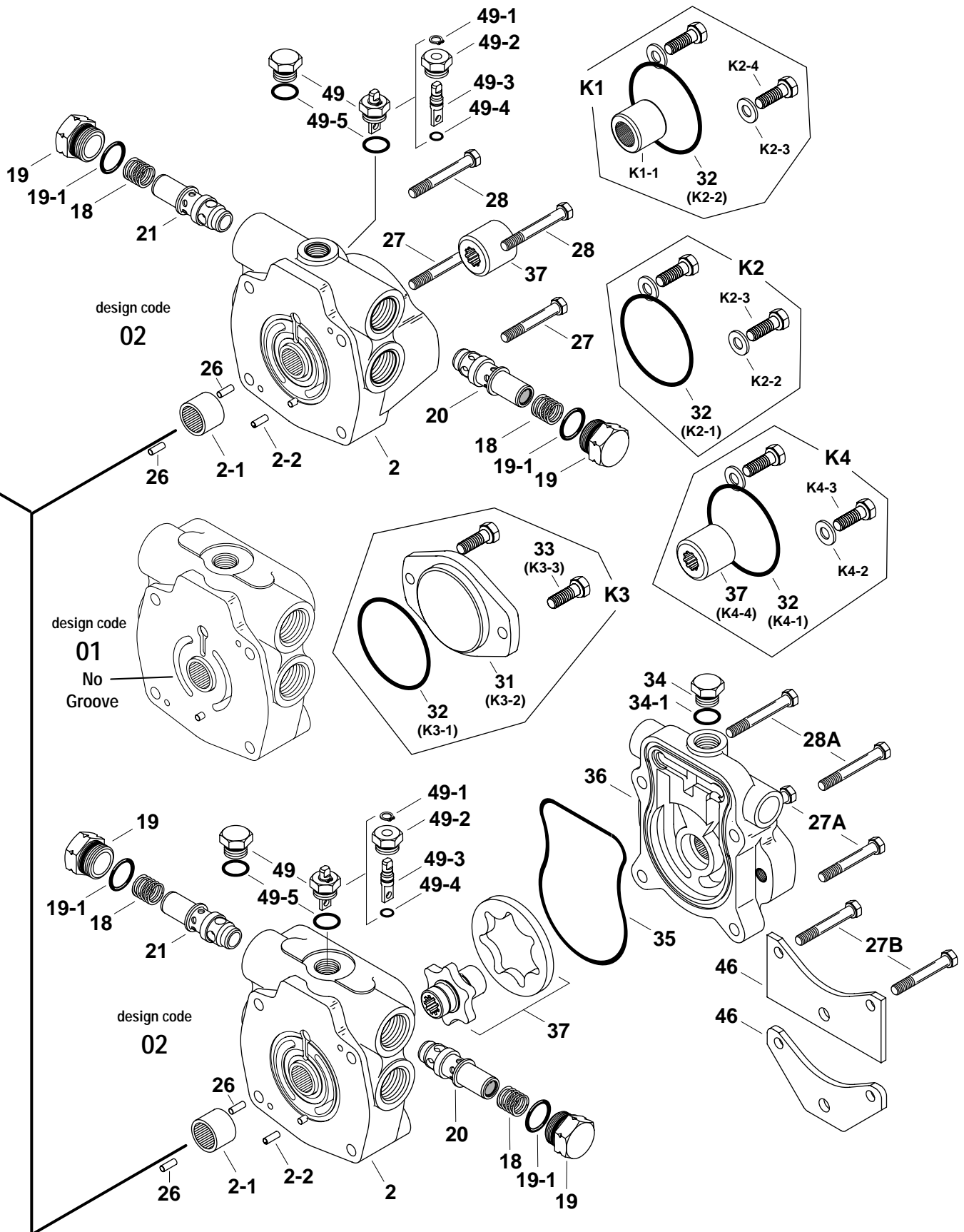

Parts List

Item	Qty.	Description
1	1	Drive Shaft
2	1	Backplate Assembly
3	1	Housing Assembly
4	1	Rotating Kit Assembly
5	1	Camplate
6	1	Washer
+ 7	1	Retaining Ring
+ 8	2	Retaining Ring
9	1	Thrust Bearing
10	2	Bearing Race
+ 11	1	Shaft Seal, Drive
+ 12	1	Housing Gasket
13	2	Needle Bearing
+ 14	1	O-ring, 3.175 mm Dia. x 31.75 mm ID. [.125 in. Dia. x 1.25 in. ID.]
15	2	Washer
+ 16	1	Shaft Seal, Trunnion
17	4	Screw, Pan Head
18	2	Spring
19	2	Plug Assembly
+ 19-1	2	O-ring, 2.38 mm Dia. x 22.23 mm ID. [.0937 in. Dia. x .875 in. ID.]
20	1	Relief Valve for Port "C"
21	1	Relief Valve for Port "D"
22	1	Inner Race
23	1	Seal Cover
24	1	Trunnion Cover
25	1	Cover, O-ring
26	2	Dowel Pin
27	2	Cap Screws, 5/16-18, 50.8 mm [2 in.] Long
28	2	Cap Screws, 5/16-18, 63.5 mm [2.5 in.] Long
29	1	Key, Drive Shaft
30	1	Key, Camplate Trunnion
31	1	Cover Plate (In K3 kit)
+ 32	1	O-ring (In K1, K2, K3 & K4 kit)
33	2	Cap Screws, Cover Plate (In K3 kit)
34	1	Plug Assembly
+ 34-1	1	O-ring, 2.21 mm Dia. x 16.36 mm ID. [.087 in. Dia. x .644 in. ID.]
+ 35	1	Molded O-ring
36	1	Charge Pump Adaptor
37	1	Gerotor set and coupler sub-assembly 6.9 cm ³ /r [.42 in ³ /r] displacement, 6.35 mm [.25 in.] width 13.8 cm ³ /r [.84 in ³ /r] displacement, 12.7 mm [.5 in.] width
37	1	9 tooth coupler (In K4 kit)
46	1	Mounting Bracket, Square shaped
46	1	Mounting Bracket, "V" shaped
48	1	Valve Plate

Parts List

Item	Qty.	Description
49	1	Dump Valve sub-assembly
+ 49-1	1	Retaining Ring
49-2	1	Separator Plug
49-3	1	Separator
+ 49-4	1	O-ring, 1.59 mm Dia. x 9.53 mm I.D. [.0625 in. Dia. x .375 in. I.D.]
+ 49-5	1	O-ring, 2.46 mm Dia. x 19.18 mm I.D. [.097 in. Dia. x .755 in. I.D.]
49	1	Plug Assembly
49-5	1	O-ring, 2.46 mm Dia. x 19.18 mm I.D. [.097 in. Dia. x .755 in. I.D.]
50	1	Plug Assembly
+ 50-1	1	O-ring, 1.98 mm Dia. x 11.89 mm ID. [.078 in. Dia. x .468 in. ID.]
51	1	Plug Assembly
+ 51-1	1	O-ring, 1.98 mm Dia. x 11.89 mm ID. [.078 in. Dia. x .468 in. ID.]

Mounting Kits

K1	1	Tandem Piston Pump Mounting Kit
K1-1	1	35T Coupler, 36.8 mm [1.45 in.] long
K1-2	1	O-ring, 1.59 mm Dia. x 101.6 mm ID. [.0625 in. Dia. x 4 in. ID.]
K1-3	2	Cap Screws
K1-4	2	Washer
K2	1	Gear Pump Mounting Kit
K2-1	1	O-ring, 1.59 mm Dia. x 82.55 mm ID. [.0625 in. Dia. x 3.25 in. ID.]
K2-2	2	Washer
K2-3	2	Cap Screws
K3	1	Cover Plate Kit
K3-1	1	O-ring, 1.59 mm Dia. x 82.55 mm ID. [.0625 in. Dia. x 3.25 in. ID.]
K3-2	1	Cover Plate
K3-3	2	Cap Screws
K4	1	Gear Pump Mounting Kit with Coupler
K4-1	1	9T Coupler
K4-2	1	O-ring, 1.59 mm Dia. x 101.6 mm ID. [.0625 in. Dia. x 4 in. ID.]
K4-3	2	Cap Screws
K4-4	2	Washer

Seal Repair Kit

70142-938	Seal Repair Kit for 70142, 70144 and 70145 piston pump.
-----------	---

Legend + Included in seal repair kit.

Disassembly

Disassembly

The following instructions apply to a variable displacement piston pump with or without a gerotor charge pump. A tandem pump assembly should be separated into individual pumps before disassembly.

1 Position the pump into a protected jaw vise, clamping onto the outer portion of the flange, with the input drive shaft down. Remove the four cap screws retaining charge pump adapter or backplate.

No gerotor charge pump skip to step 6.

2 Lift the charge pump adapter assembly straight up off backplate, shaft, and gerotor. Gerotor may stay in adapter or on backplate.

3 Remove o-ring from charge pump adapter.

4 Remove outer gerotor ring from either the charge pump adapter or the inner gerotor ring.

Refer to Appendix A for disassembly and inspection of charge pump adapter assembly.

5 Remove the inner gerotor ring and coupler assembly from shaft.

6 Lift backplate straight up off of shaft and housing. Remove valve plate from backplate or from rotating kit assembly, still in housing.

7 From backplate remove dump valve assembly or plug assembly, and relief valve assemblies. Note: Mark the relief valve in relationship to the cavity it was removed, for reassembly purposes.

Backplate Inspection:

- Check the bearing (press fit) in backplate. If needles remain in cage, move freely, and setting is at the dimension shown in figure 1-3, removal not required.

- Check roll pin in backplate. If tight and set to the dimension shown in figure 1-3, removal not required.

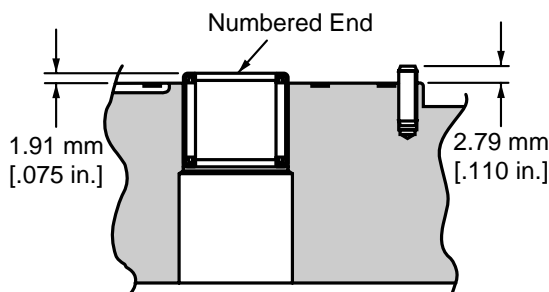

Figure 1-3

8 Remove housing gasket from housing or backplate.

9 To remove rotating kit assembly from housing, first remove pump from vise holding the rotating kit assembly in position. Lower pump so that the shaft end (flange end) is up. Set the rear of housing onto table with housing flat and rotating kit assembly at rest on table. Hole in table for protruding shaft is required. Remove by lifting the housing and shaft from rotating kit assembly.

Refer to Appendix B for disassembly and Inspection of rotating kit.

10 Remove retaining ring from the front of housing. Press the shaft, shaft seal or spacer, and washer from housing. Remove retaining ring, thrust washer, thrust bearing, second thrust washer, and second retaining ring from shaft.

11 To remove camplate from housing, remove the two screws from both sides of housing (four total) retaining seal cover and trunnion cover. Remove seal cover, shaft seal, washer, and bearing from housing. Remove trunnion cover, o-ring cover, o-ring, washer, inner race, and bearing from housing. Slide the camplate over to one side and remove thru the back side of housing.

Camplate Inspection:

- The finish on the piston shoe surfaces of the camplate should show no signs of scoring.

Housing Inspection:

- Check the bearing (press fit) in front of housing. If needles remain in cage, move freely, and setting at the dimension shown in figure 1-4, removal not required.

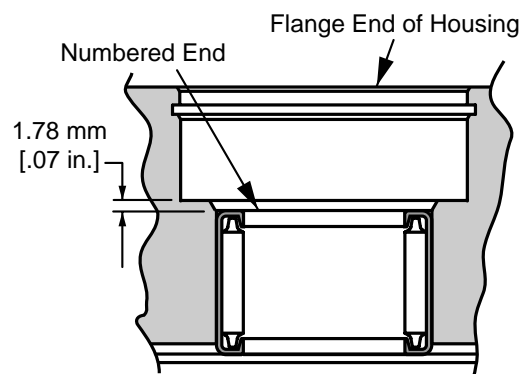

Figure 1-4

12 Discard the shaft seal, gaskets, and o-rings from all assemblies. Replace with new seals upon reassembly.

Reassembly

Reassembly

- 1 All parts should be cleaned and critical moving parts lubricated before reassembly.
- 2 If necessary, press new bearing in housing to dimension shown in figure 1-4 with the numbered end of bearing outward.
- 3 Starting with the camplate, insert camplate into the housing with the long trunnion side down and to the appropriate side of linkage on the machine.
- 4 On the short trunnion side of camplate install bearing (bearing with numbered side to the inside of pump), bearing race (race with chamfer toward inside of pump), washer, o-ring, o-ring cover, trunnion cover, and retain with two screws. Torque screws 4.1 to 5.4 N·m [36 to 48 lbf·in].
- 5 On the long trunnion side of camplate install bearing (bearing with numbered side to the inside of pump), washer, trunnion shaft seal, seal cover, and retain with two screws. Torque screws 4.1 to 5.4 N·m [36 to 48 lbf·in].
- 6 To install shaft, place exterior retaining ring, thrust race, thrust bearing, second thrust race, and second retaining ring onto shaft. Position washer and shaft seal or spacer onto shaft.
- 7 Install shaft assembly into front of housing: For units with spacer, retain with interior retaining ring and go on to step 8. For units with shaft seal, seat seal into position with seal driver and retain with interior retaining ring.

Refer to Appendix B for reassembly of rotating kit assembly.
- 8 With flange end of housing up, position rotating kit assembly onto shaft and into housing. Align the spline within the piston block with shaft internal spline. Make sure piston block is engaged fully to put piston shoes in contact with camplate. Check all parts for proper position before proceeding.
- 9 Clamp pump assembly in a protected jaw vise with the open end of the housing up. Install gasket and two dowel pins onto housing.
- 10 If necessary, press new bearing and roll pin in backplate to dimension shown in figure 1-3. Bearing installed with the numbered end outward. Roll pin installed with split oriented away from bearing.
- 11 Install new o-ring on relief valves. Install relief valve in its original cavity in backplate that it was removed. Torque 128 to 142 N·m [95 to 105 lbf·ft.]
- 12 Install new o-ring on dump valve or plug. Install dump valve or plug into backplate. Torque dump valve or plug to 36.6 to 40.7 N·m [27 to 30 lbf·ft]
- 13 Apply a small amount of petroleum jelly to the steel side of valve plate to hold in place for installation. Aligning the index pin, place the valve plate in position onto the backplate, with steel side against backplate.
- 14 Install backplate assembly onto housing assembly. Making sure valve plate and gasket stay in place.

No gerotor charge pump, skip to step 17.
- 15 Install inner gerotor and coupler assembly. The coupler has a "V" groove on one end and this end of coupler should enter backplate first. Lubricate inner gerotor.

Refer to Appendix A for reassembly of Charge relief valve in adapter plate.
- 16 Install o-ring and outer gerotor ring onto adapter plate. Lubricate both o-ring and outer gerotor ring to hold in position during assembly of adapter plate. Install adapter plate onto backplate. Make sure o-ring and gerotor ring stay in place.
- 17 Retain backplate and adapter plate (when used) with four cap screws, Torque 23 to 27 N·m [17 to 20 lbf·ft].
- 18 Install new o-rings on all plugs. Install plugs into housing. Torque 9/16 in. - 18 plug 28 to 32 N·m [21 to 24 lbf·ft].
- 19 Refer to start-up procedures on page 17.

Appendix A - Charge Pump Adapter Assembly

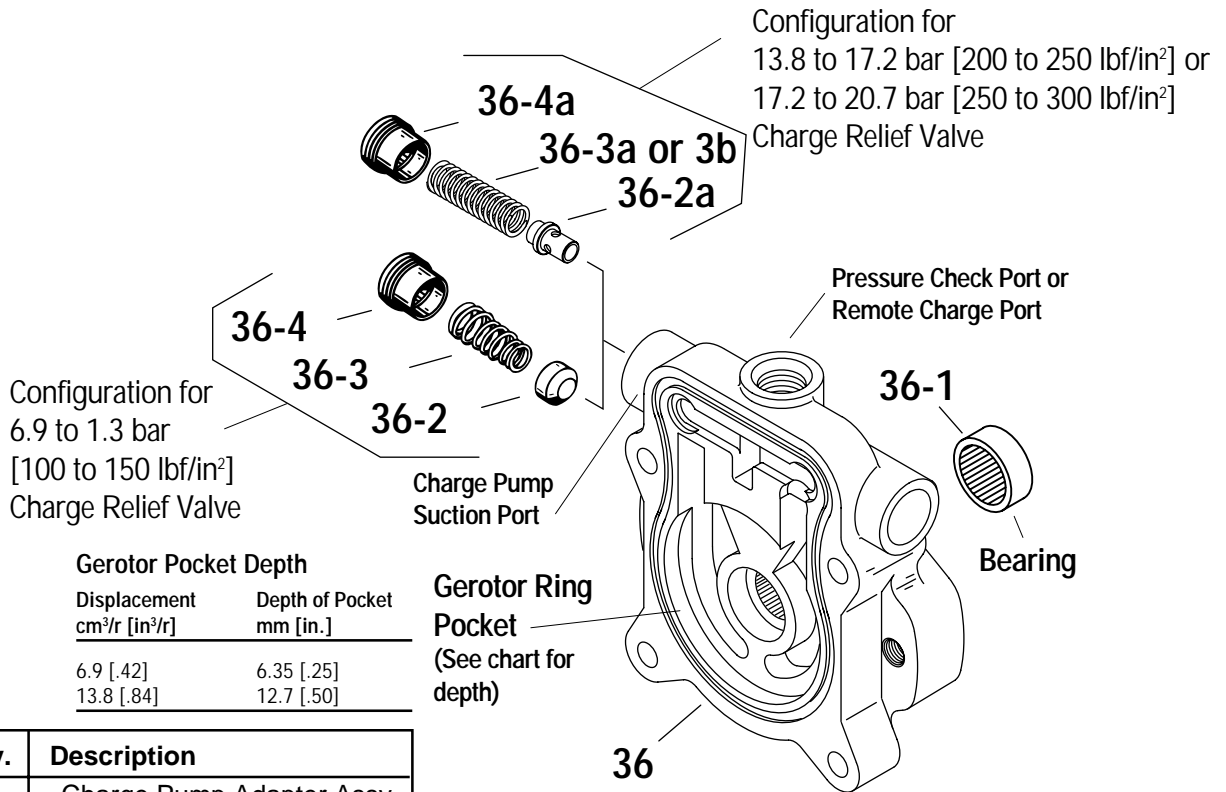

Gerotor Pocket Depth	
Displacement cm ³ /r [in ³ /r]	Depth of Pocket mm [in.]
6.9 [.42]	6.35 [.25]
13.8 [.84]	12.7 [.50]

Item	Qty.	Description
36	1	Charge Pump Adapter Assy.
36-1	1	Bearing (press fit)
36-2	1	Poppet, Cup
36-2a	1	Poppet, Pin
36-3	1	Spring, Tapered
36-3a	1	Spring, "Light Green" *
36-3b	1	Spring, "Pink" **
36-4	1	Spring Retainer
36-4a	1	Spring Retainer

*200 to 250 lbf/in²
 **250 to 300 lbf/in²

Reassembly - Charge Pump Adapter Assembly

- 1 If necessary, press new bearing in adapter assembly. The bearing to dimension shown in figure 1-2 with the numbered end of bearing outward and closest to mounting flange.
- 2 Install cup poppet or pin poppet, spring, and spring retainer into charge pump adapter. Torque retainer 6.8 to 9.5 N·m [5 to 7 lbf·ft.]

Disassembly - Charge Pump Adapter Assembly

1 Remove spring retainer, spring, and poppet from adapter assembly.

Inspection:

- Inspect the charge pump relief valve seat inside the charge pump adapter. Check to insure that seat is smooth and free of burrs or other defects.
- Inspect the charge pump relief valve spring.
- Inspect the bearing inside the charge pump adapter. The bearing needles must remain in the bearing cage and bearing at dimension shown in figure 1-2.
- Inspect the gerotor pocket inside the charge pump adapter assembly. It should not be scored excessively.

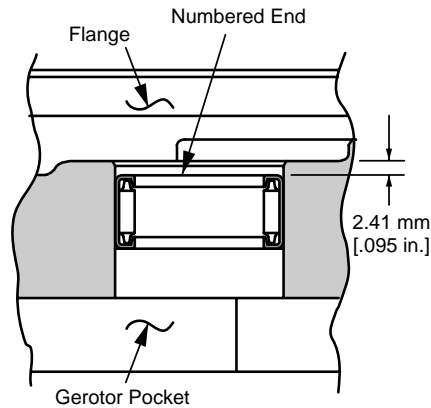
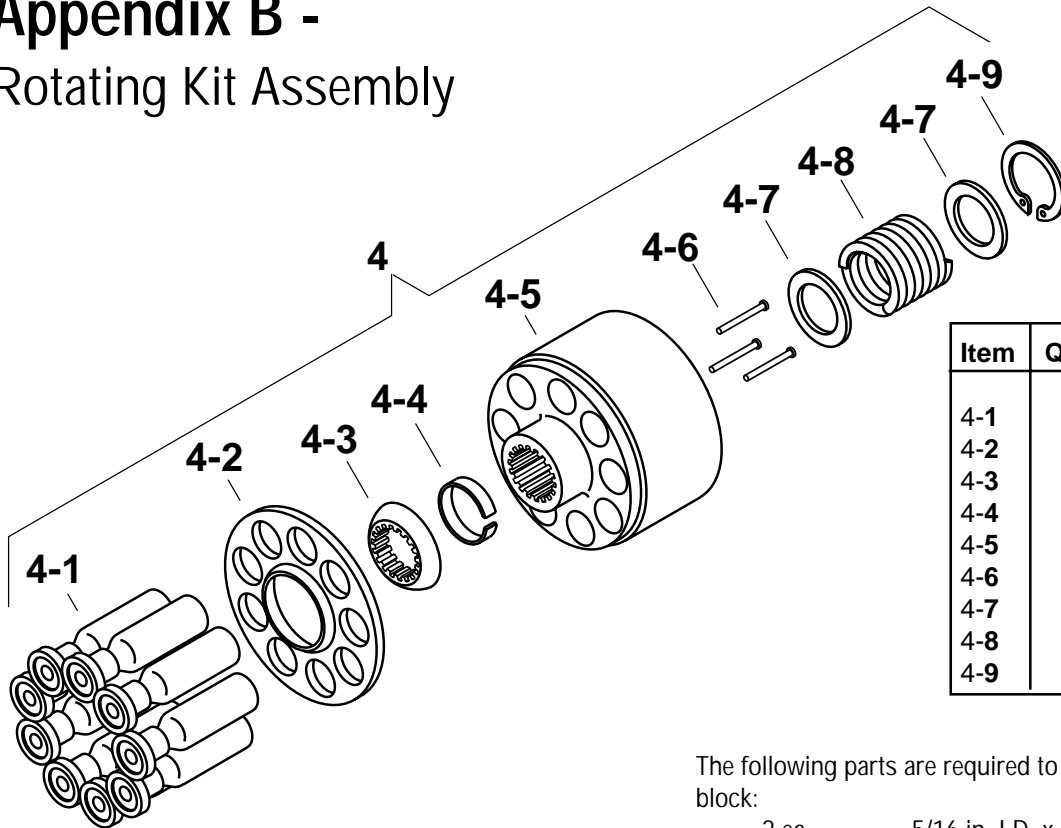

Figure 1-2

Appendix B - Rotating Kit Assembly



Item	Qty.	Description
4-1	9	Piston assemblies
4-2	1	Spider
4-3	1	Spider Pivot
4-4	1	Retainer
4-5	1	Piston Block
4-6	3	Pins
4-7	2	Washer
4-8	1	Spring
4-9	1	Retaining Ring

Disassembly - Rotating Kit Assembly

Disassembly of rotating assembly is required for inspection only.

- 1 Remove the nine piston assemblies, spider, and spider pivot from piston block.

Inspection:

- Examine the O.D. of the pistons for finish condition. They should not show wear or deep scratches. Inspect the shoes for a snug fit on the ball end of the pistons and a flat smooth surface that comes in contact with the camplate. **Do not lap piston shoes.**
- Examine the spider for wear in the pivot area.
- Examine the pivot to insure smoothness and no signs of wear.
- Inspect the piston block surface that makes contact with valve plate. This surface should be smooth and free of deep scratches. **Do not lap piston block.**
- The pistons should move freely in the piston block bore. If not free moving, examine the bore for scoring or contamination.

- 2 To inspect pins and spring **Caution** should be taken in removing spring. The **spring is highly compressed** and the retaining ring should not be removed without compressing the spring safely.

The following parts are required to disassemble the piston block:

- 2 ea. 5/16 in. I.D. x 15/16 in. O.D. flat washers
- 1 ea. 5/16 in. x 2-7/8 in. N.C. cap screw, and
- 1 ea. 5/16 in. N.C. nut

To remove spring, place one of the flat washers over the 5/16 in. x 2-7/8 in. cap screw. Put cap screw through the center of the piston block and apply the second washer. Let washer rest on the three pins and retain with nut. Turning nut and compressing spring inside the block. Use a pair of retaining ring pliers and remove the internal retaining ring. Remove nut, bolt, and the two washers from block. Removing the washer, spring, second washer, three pins, and pin keeper at the same time.

Reassembly - Rotating Kit Assembly

- 1 To reassemble the rotating kit assembly complete the following: Compress the pin keeper and install in the spline of the piston block. Install the three pins with head end to the inside of the block and position in the special grooves of the piston block spline.
- 2 Install the washer, spring, and second washer into the piston block. Use the two 5/16 in. I.D. washers, nut, and 5/16 in. x 2-7/8 in. cap screw to compress the spring and retain with retaining ring. Remove the nut, cap screw, and the two washers.
- 3 Install the pivot onto the three pins, spider on the pivot, and piston assemblies thru the spider and into piston block, resting on spider.

Fault - Logic Trouble Shooting

This fault - logic trouble shooting guide is a diagnostic aid in locating transmission problems.

Match the transmission symptoms with the problem statements and follow the action steps shown in the box diagrams. This will give expedient aid in correcting minor problems eliminating unnecessary machine down time.

Following the fault - logic diagrams are diagram action comments of the action steps shown in the diagrams. Where applicable, the comment number of the statement appears in the action block of the diagrams.

Explanatory Diagram

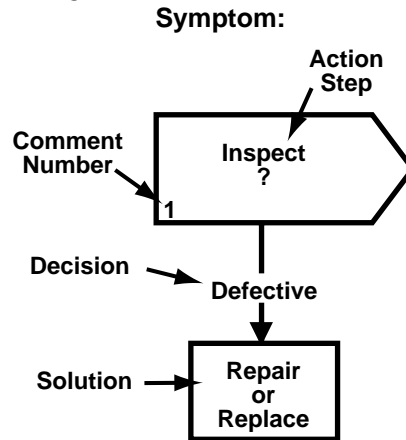

Recommended Gauge Locations

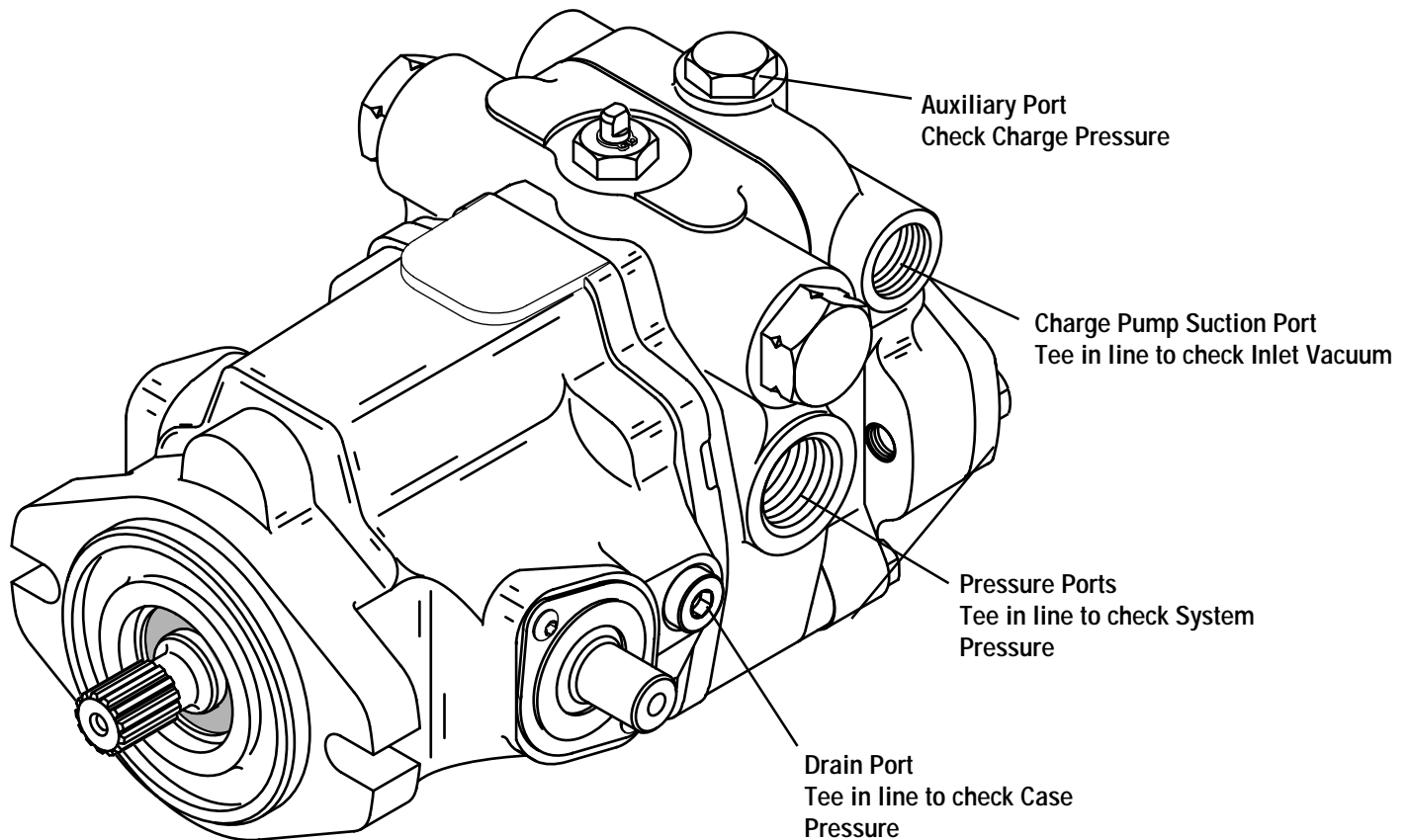

Figure 3-1

Gauges Recommended

Inlet vacuum gauge: 207 bar to 0 bar [30 lbf/in² to 30 inHg]

System pressure gauge: 700 bar [10,000 lbf/in²]

Charge pressure gauge: 0 to 50 bar [0 to 600 lbf/in²]

Case pressure gauge: 0 to 25 bar [0 to 300 lbf/in²]

Fault - Logic Trouble Shooting

Symptom: Neutral Difficult or Impossible to Find

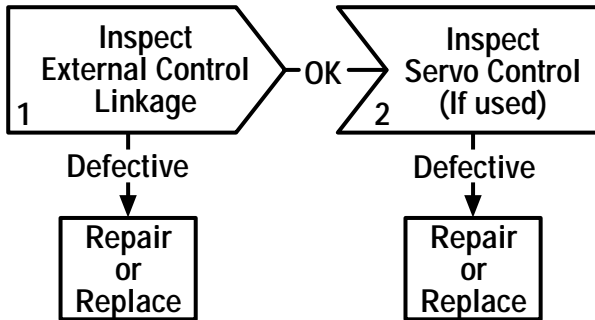

Symptom: System Operating Hot

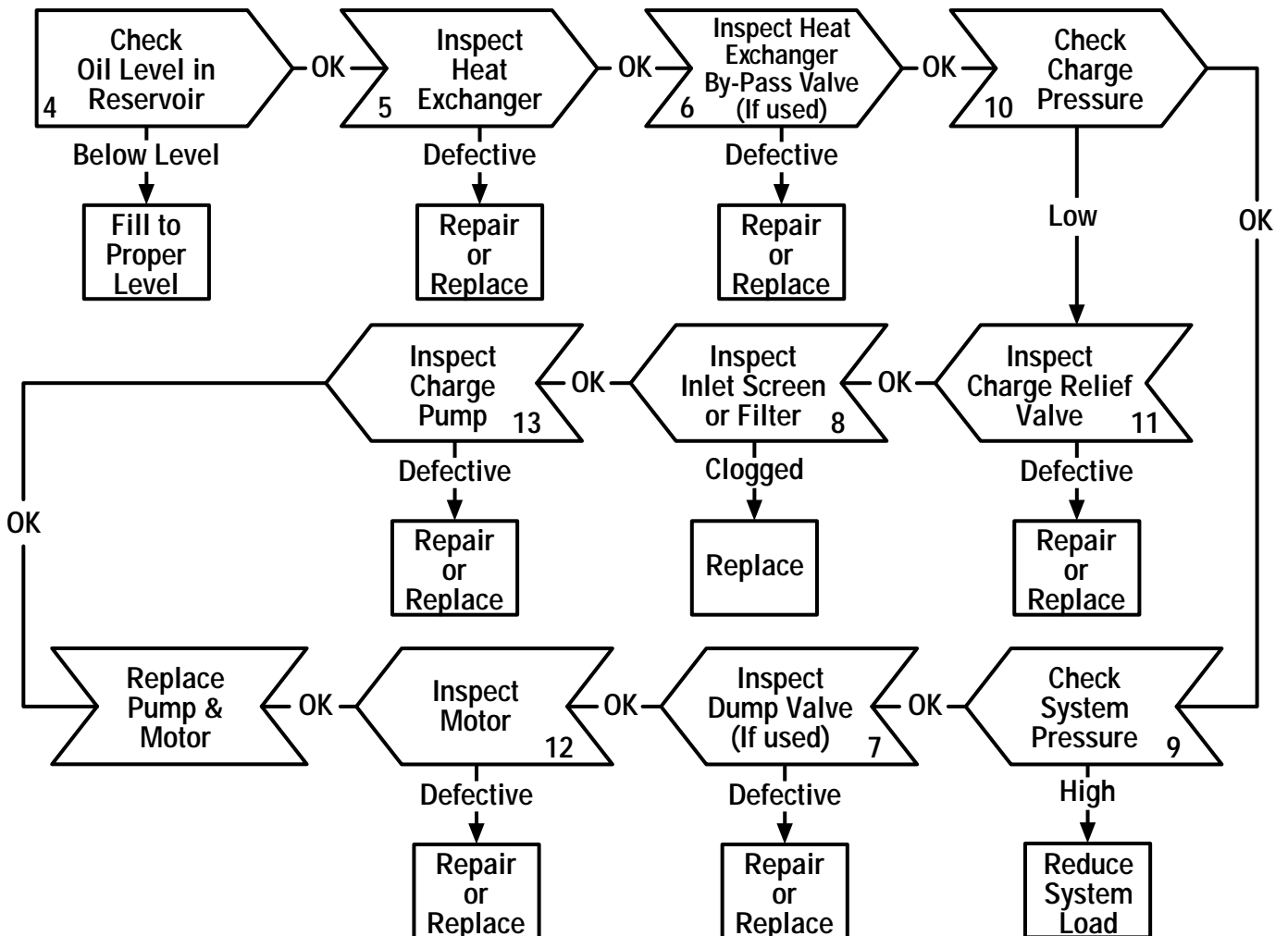

Fault - Logic Trouble Shooting

Symptom: Operates in One Direction Only

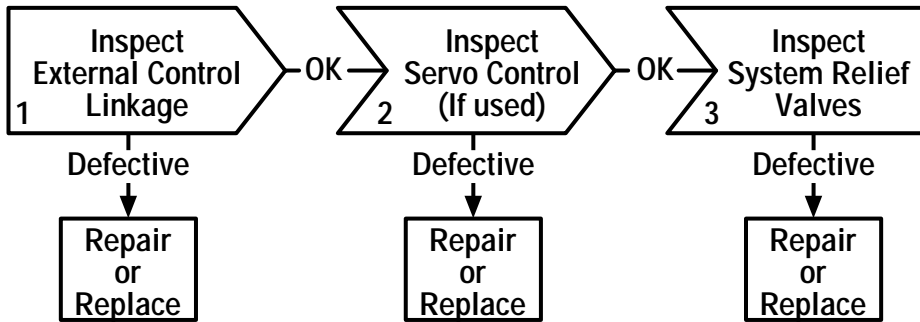

Symptom: System Response Sluggish

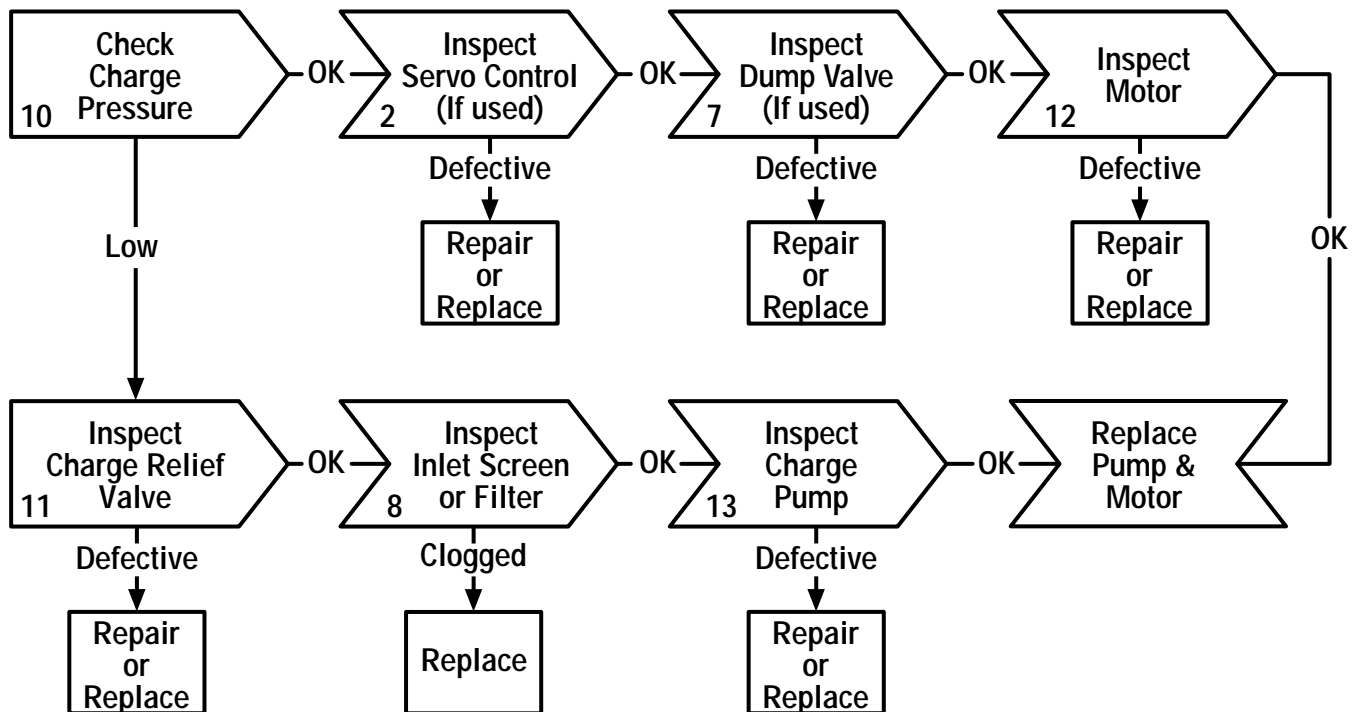

Fault - Logic Trouble Shooting

Symptom: System Will Not Operate In Either Direction

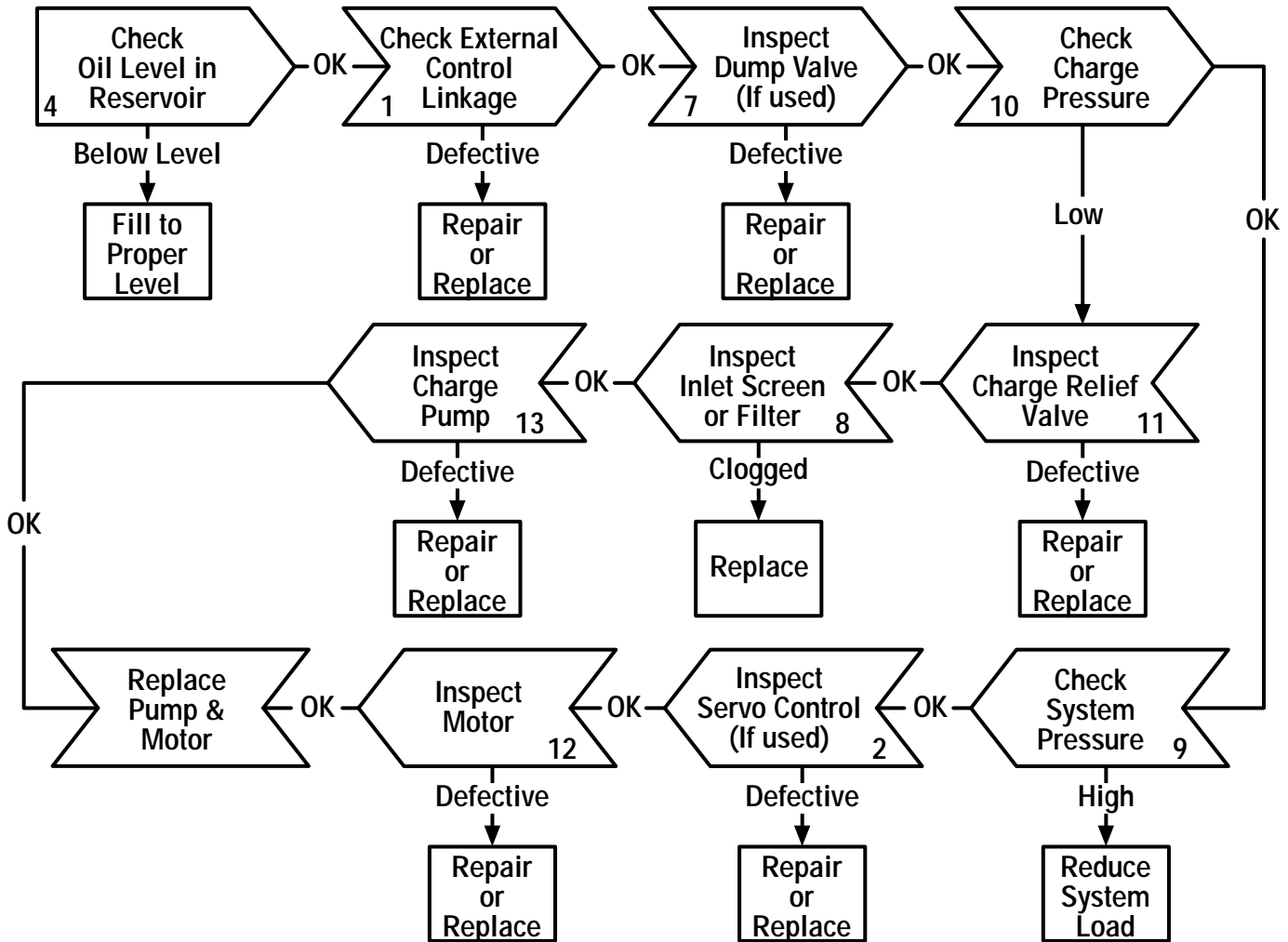

Fault - Logic Trouble Shooting

Diagram Action Step Comments

- 1 **Inspect External Control Linkage for:**
 - a. misadjusted or disconnected
 - b. binding, bent, or broken
 - c. misadjusted, damaged or broken neutral return spring
- 2 **Inspect Servo Control Valve for: (if used)**
 - a. proper inlet pressure
 - b. misadjusted, damaged or broken neutral return spring
 - c. galled or stuck control spool
 - d. galled or stuck servo piston
- 3 **Inspect System Relief Valves * for:**
 - a. improper pressure relief setting
 - b. damaged or broken spring
 - c. valve held off seat
 - d. damaged valve seat
- 4 **Check Oil Level in Reservoir:**
 - a. consult owner/operators manual for the proper type fluid and level
- 5 **Inspect Heat Exchanger for:**
 - a. obstructed air flow (air cooled)
 - b. obstructed water flow (water cooled)
 - c. improper plumbing (inlet to outlet)
 - d. obstructed fluid flow
- 6 **Inspect Heat Exchanger By-Pass Valve for: (if used)**
 - a. improper pressure adjustment
 - b. stuck or broken valve
- 7 **Inspect Dump Valve for: (if used)**
 - a. held in a partial or full open position
- 8 **Inspect Inlet Screen or Filter for:**
 - a. plugged or clogged screen or filter element
 - b. obstructed inlet or outlet
 - c. open inlet to charge pump
- 9 **Check System Pressure:**
 - a. See figure 3-1 for location of pressure gauge installation.
 - b. consult owner/operators manual for maximum system relief valve settings
- 10 **Check Charge Pressure:**
 - a. See figure 3-1 for location of pressure gauge installation.
 - b. consult owner/operators manual for maximum charge relief valve settings

- 11 **Inspect Charge Relief Valve for:**
 - a. improper charge relief pressure setting *
 - b. damaged or broken spring
 - c. poppet valve held off seat
- 12 **Inspect Motor for:**
 - a. disconnected coupling
- 13 **Inspect Charge Pump for:**
 - a. broken or missing drive key
 - b. damaged or missing o-ring
 - c. excessive gerotor clearance
 - d. galled or broken gerotor set

*** System/Charge Relief Valve
Pressure Settings for
Eaton's Variable Displacement
Controlled Piston Pumps**

Inlet Vacuum	6 inHg max.
Case Pressure	25 lbf/in ² maximum
Charge Pressure	100 to 150 lbf/in ² Standard 200 to 250 lbf/in ² Optional 250 to 300 lbf/in ² Optional
System Pressure	5000 lbf/in ² maximum 3000 lbf/in ² continuous

The high pressure relief valves are all factory preset and cannot be readjusted.

The pressure setting and assembly number is stamped on each high pressure relief valve cartridge.

Valve Identification Example:

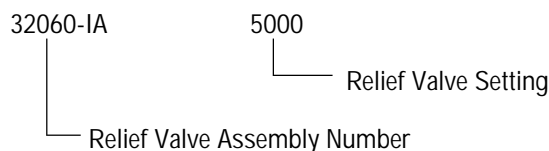

Start-up Procedure

When initially starting a new or a rebuilt transmission system, it is extremely important that the start-up procedure be followed. It prevents the chance of damaging the unit which might occur if the system was not properly purged of air before start-up.

- 1 After the transmission components have been properly installed, fill the pump housing at least half full with filtered system oil. Connect all hydraulic lines and check to be sure they are tight.
- 2 Install and adjust all control linkage.
- 3 Fill the reservoir with an approved oil that has been filtered through a 10 micron filter. Refer to Eaton Hydraulics Technical Data sheet number 3-401 titled Hydraulic Fluid Recommendations.
- 4 Gasoline or L.P. engines: remove the coil wire and turn the engine over for 15 seconds. Diesel engines: shut off the fuel flow to the injectors and turn the engine over for 15 seconds.
- 5 Replace the coil wire or return the fuel flow to the injectors. Place the transmission unit in the neutral position, start the engine and run it at a low idle. The charge pump should immediately pick up oil and fill the system. If there is no indication of fill in 30 seconds, stop engine and determine the cause.
- 6 After the system starts to show signs of fill, slowly move pump camplate to a slight cam angle. Continue to operate system slowly with no load on motors until system responds fully.
- 7 Check fluid level in the reservoir and refill if necessary to the proper level with an approved filtered oil.
- 8 Check all line connections for leaks and tighten if necessary.
- 9 The machine is now ready to be put into operation.
- 10 Frequent filter changes are recommended for the first two changes after placing the machine back into operation. Change the first filter in 3-5 hours and the second at approximately 50 hours approx. hours. Routinely scheduled filter changes are recommended for maximum life of the hydraulic system.

Notes

Notes

**Order parts from number 6-632 Parts Information booklet.
Each order must include the following information.**

1. Product and/or Part Number
2. Serial Code Number
3. Part Name
4. Quantity

Eaton Corporation
Hydraulics Division
15151 Hwy. 5
Eden Prairie, MN 55344
Telephone 612/937-9800
Fax 612/937-7130

Eaton Ltd.
Hydraulics Division
Glenrothes, Fife
Scotland, KY7 4NW
Telephone 44/592-771-771
Fax 44/592-773-184

Char-Lynn[®]

Disc Valve Motor

No. 7-118
May, 1999



Repair Information

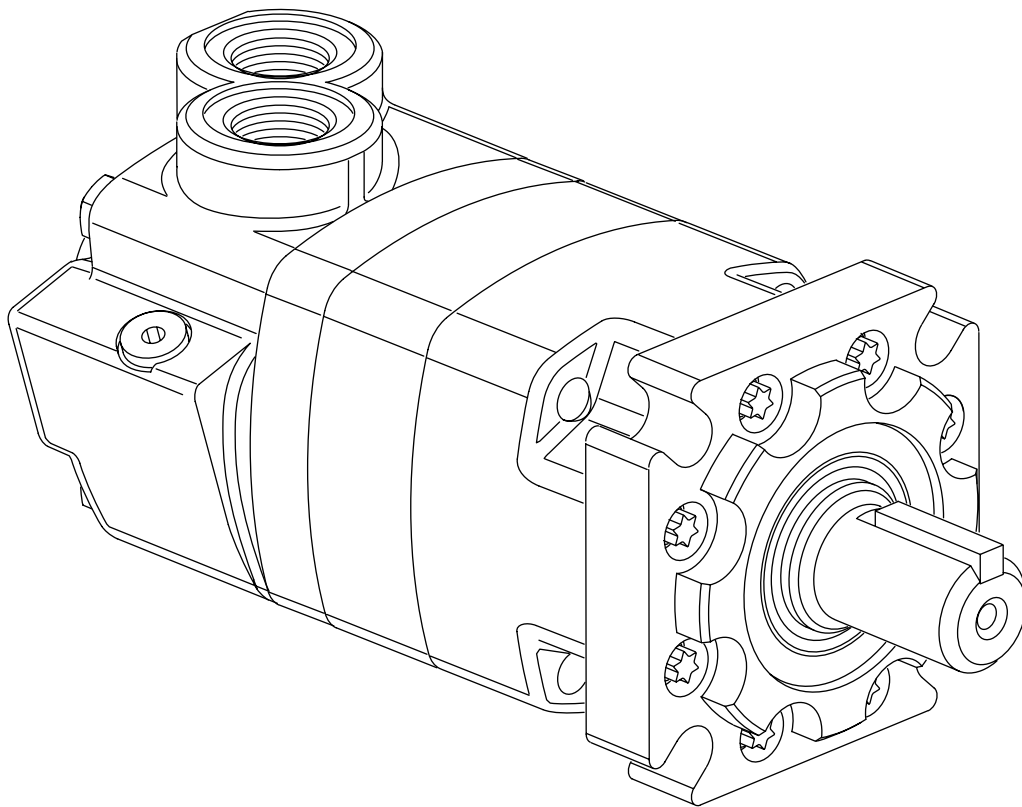

4000 Series
Geroler[®] Motors

Std., Whl. and Brgl. **-004** Std. and Whl. **-006**

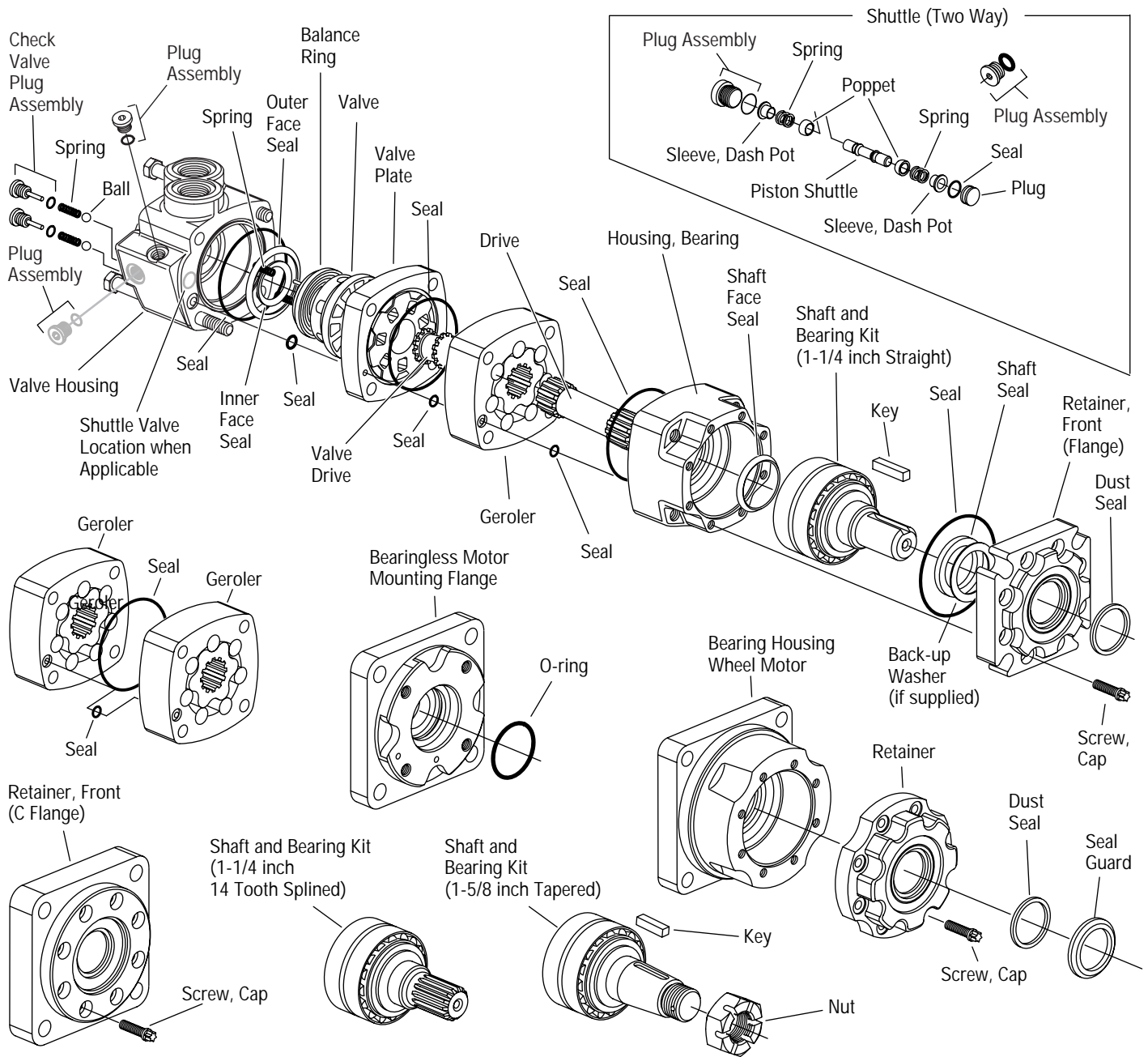

Tools

Wheel motor and bearingless motor repair information on page 9 and 10.
 Shuttle valve and seal guard repair information on page 10.
 Seal guard reference on page 10.

Tools required for disassembly and reassembly

- Torque wrench (68 Nm [600 lb-in] capacity)
- 300 to 400 mm [12 to 16 inch] breaker bar
- 3/4 inch and 1/2 inch sockets
- Small screwdriver (150 to 200 mm [6 to 8 inch] long, 6 mm [.25 inch] blade)
- 3/16 inch Hex Key
- Hydraulic press — 1335 N [300 lbf]
- Shaft face seal (-004) installation tool 600468
- Shaft face seal (-006) installation tool 600421-2
- * — Bullet (600463) for 1-1/4 inch diameter shafts
- Shaft seal installation tool (2 -1/4 inch socket)
- Torq wrench required for eight mounting flange screws (replacement screws or -006 design) No. E10

The following tools are not necessary for disassembly and reassembly but are extremely helpful

- Alignment studs (2), see dimensions below

* Available by special order, contact Eaton Corp., Hydraulics Division Service Dept.

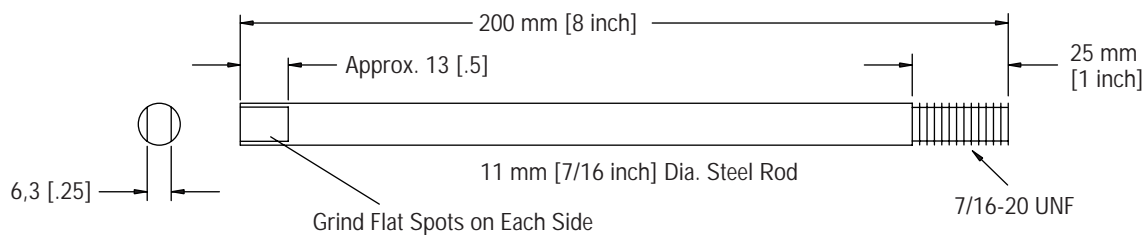

Disassembly

Cleanliness is extremely important when repairing a hydraulic motor. Work in a clean area. Before disconnecting the lines, clean port area of motor thoroughly. Use a wire brush to remove foreign material and debris from exterior joints of motor. Check shaft and keyway. Use 600 grit paper/cloth to remove all nicks, burrs, and sharp edges that might damage the shaft seals when installing retainer on shaft and bearing assembly. Before starting disassembly procedures, drain oil from inside of motor.

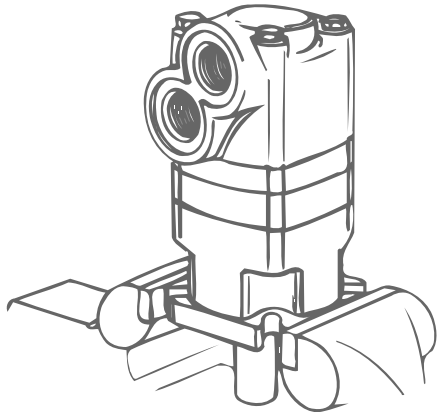

Figure 1

1 Place motor in a vise with output shaft down. Clamp across edge of mounting flange, not on housing (see Figure 1). Excessive clamping pressure will cause distortion. When clamping, use some protective device on vise, such as special soft jaws, pieces of hard rubber or board.

Although not all drawings show the motor in a vise, it is recommended that you keep the motor in the vise during disassembly. Follow the clamping procedures explained throughout the manual.

2 Remove 4 bolts from the valve housing.

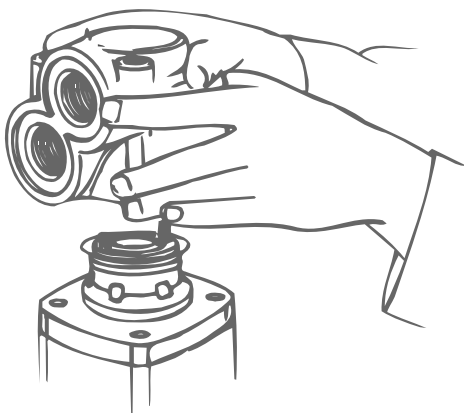

Figure 2

3 Lift valve housing straight up. If done carefully, the springs and balance ring subassembly will remain on valve for easy removal.

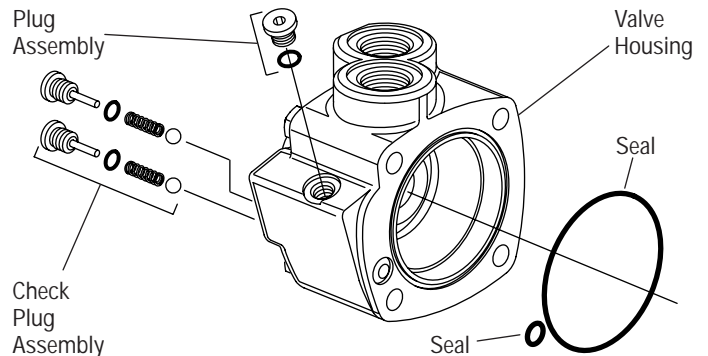

Figure 3

4 Carefully remove the following from the valve housing:

- 1 seal, 82,3 mm [3.24 inch] I.D.
- 1 seal, 8,9 mm [.35 inch] I.D.
- 2 check valve plug assemblies (plug, seal, spring, ball) 1 plug (case drain) with seal.

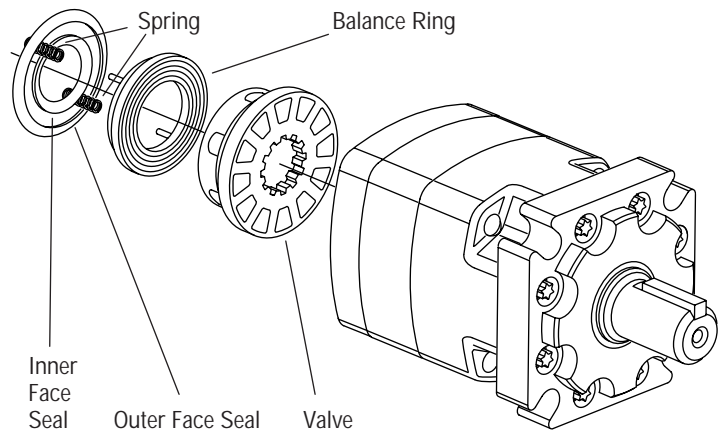

Figure 4

5 Remove 2 balance ring springs.

6 Remove balance ring subassembly.

7 Remove inner and outer face seals from the balance ring.

8 Lift off valve.

Disassembly

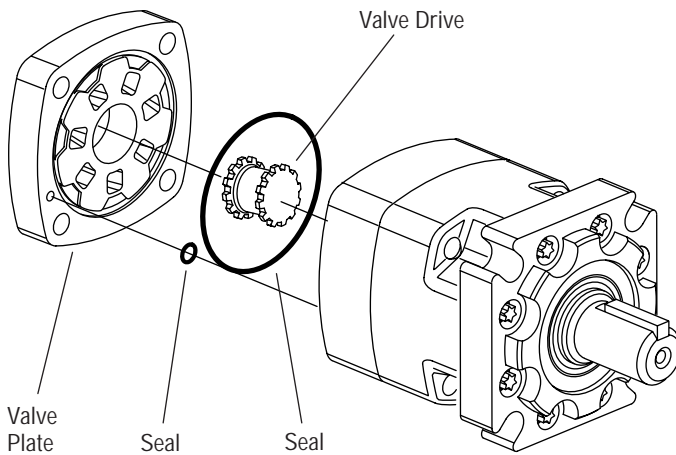

Figure 5

9 Remove valve plate.

10 Remove 88,6 mm [3.49 inch] I.D. seal from valve plate (see Figure 5).

11 Remove valve drive (see Figure 5).

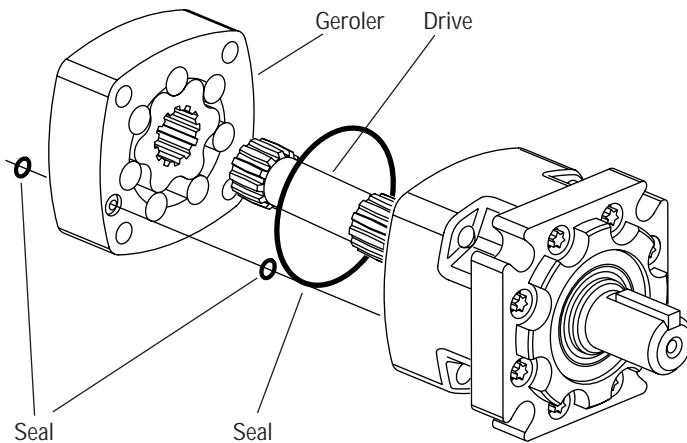

Figure 6

12 Remove Geroler. Retain rollers in outer Geroler ring if they are loose.

13 Remove 2 seals from Geroler, 1 seal on each side of Geroler.

14 Remove drive.

15 Remove 88,6 mm [3.49 inch] I.D. seal from bearing housing.

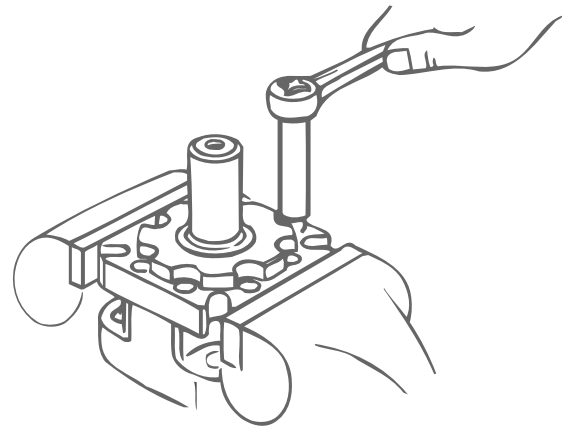

Figure 7

16 Use a stud remover or vise grips to remove studs (earlier models only). Clamp bearing housing in vise as shown in Figure 7. Loosen 8 screws. Remove screws, washers (discard washers, as they are not required for reassembly), and mounting flange (see Figure 8).

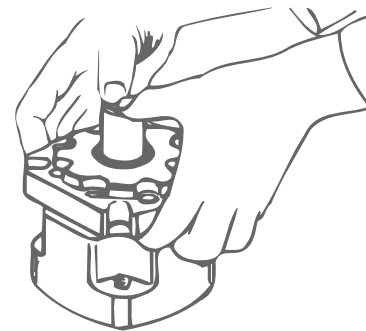

Figure 8

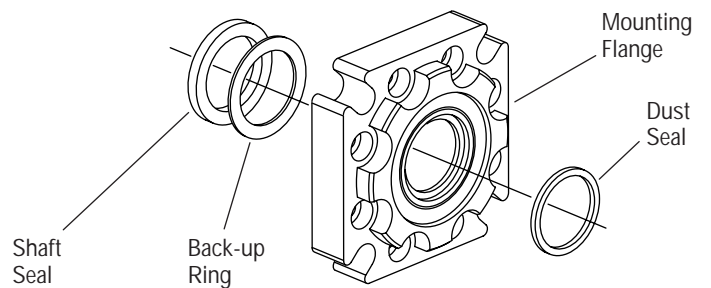

Figure 9

17 Remove shaft seal, back-up ring (if used) and dust seal from flange. Use a small screwdriver to remove dust seal. Do not damage bore of flange.

Disassembly

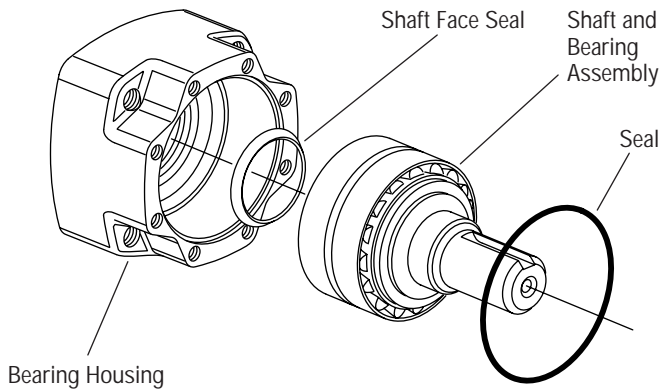

Figure 10

18 Remove shaft and bearing assembly. You may need a press to remove shaft and bearing assembly (see Figure 10).

19 Remove shaft face seal from bore of bearing housing (see Figure 10). Do not damage bore of bearing housing.

Note: Individual parts of the shaft and bearing assembly are not sold separately and must be replaced as a unit.

Reassembly

Check all mating surfaces. Replace any parts that have scratches or burrs that could cause leakage. Clean all metal parts in clean solvent. Blow dry with air. Do not wipe with cloth or paper towel because lint or other matter could get into the hydraulic system and cause damage. Do not use a coarse grit papers/cloth or try to file or grind motor parts. Check around the keyway and chamfered area of the shaft for burrs, nicks, or sharp edges that can damage the seals when reassembling the retainer.

Note: Lubricate all seals (prior to installation) with petroleum jelly such as Vaseline®. Use new seals when reassembling the motor.

Note: Shaft face seal installation tool is available by special order. Contact Eaton Corporation, Hydraulics Division (Service Department). 600468 (-004) 600421-2 (-006).

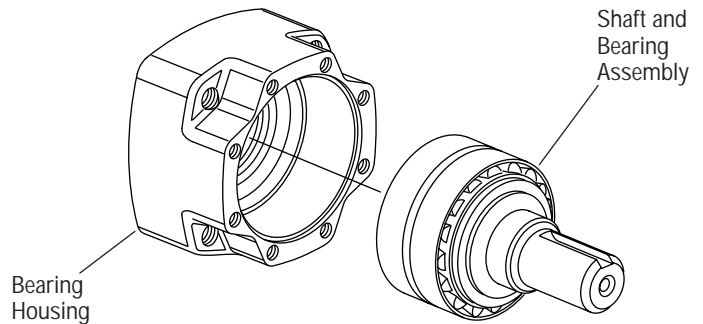

Figure 12

22 Install shaft and bearing assembly in bearing housing (see Figure 12). Do not damage seal in bore of housing. You may need a press to install shaft and bearing assembly.

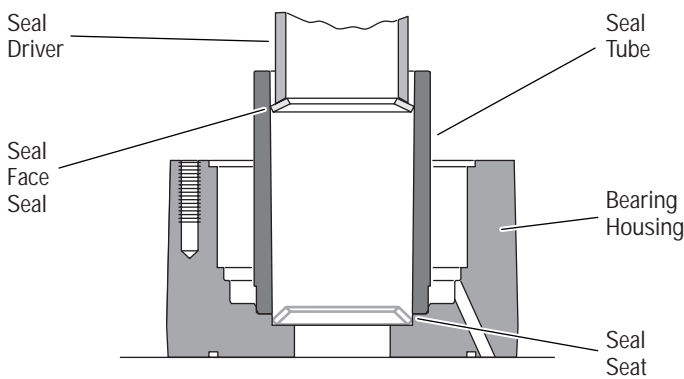

Figure 11

21 Place bearing housing on smooth flat surface with largest open end of housing up. Apply petroleum jelly to shaft face seal. Install seal in seal seat. Seat seal properly in groove (see Figure 11). A damaged or improperly installed shaft face seal could cause internal lubrication loss and subsequent parts wear.

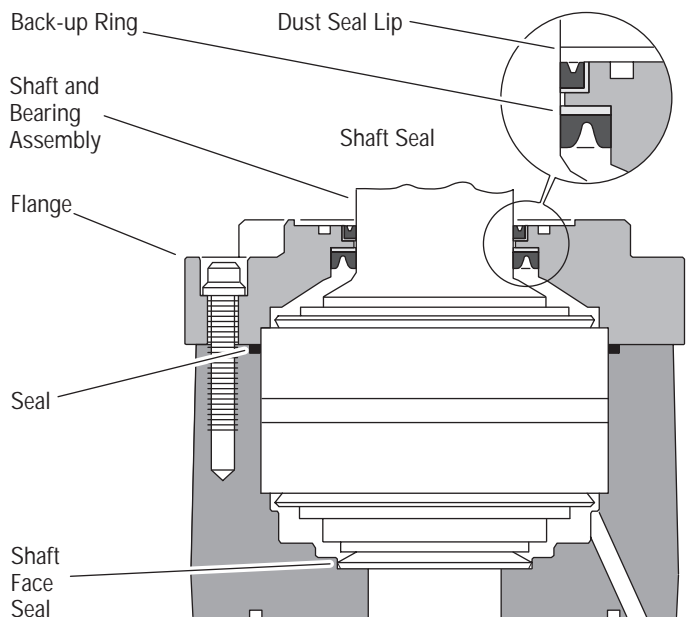

Figure 13

Reassembly

23 Apply petroleum jelly to 88,6 [3.49] ID seal. Install seal in seal groove of bearing housing (see Figure 13).

24 Use a small press, if available, to install dust seal in retainer. Metal side of dust seal must face toward flange, as shown in Figure 13. If a press is not available, use a plastic or rubber hammer to tap dust seal in place.

25 Install 92,1 [3.62] ID seal, back-up ring and shaft seal in retainer. Flat or smooth side of shaft seal must face toward retainer as shown in Figure 13. Apply petroleum jelly to inside diameter of shaft seal (after installing seal).

26 Before installing retainer, place a protective sleeve of bullet (see note below) over shaft. Grease inside diameter of dust and shaft seals. To prevent damage to seals, install retainer over shaft with a twisting motion. Do not cut or distort shaft seal. Damage to shaft seal will cause external leakage.

Note: Bullet 600463 for 1-1/4 inch diameter shafts available by special order through Eaton Hydraulics Division service department.

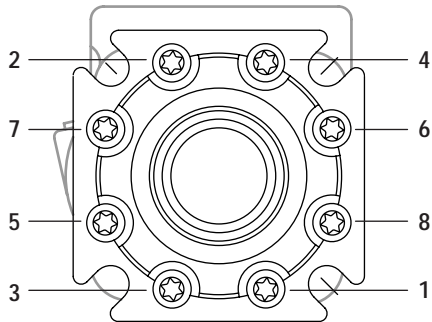

Figure 14

27 Lubricate threads of 8 screws with a film of light oil. Install and finger tighten screws. Clamp bearing housing in vise. Torque screws to 6 Nm [50 lb-in] in sequence (see Figure 14). Then final torque to 34 Nm [300 lb-in], in sequence. Install key (when used) in keyway of shaft.

Note: Full torque 34 Nm [300 lb-in] on one bolt at a time can damage bolt or retainer.

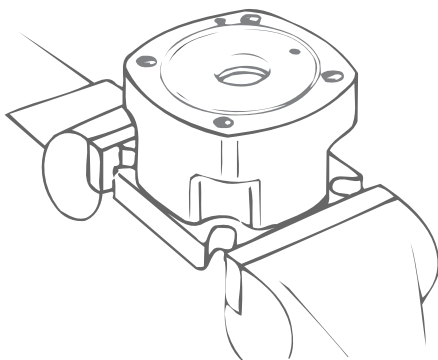

Figure 15

28 Reposition motor in vise with output shaft down. Clamp across edges of retainer as shown in Fig. 15.

29 Pour a small amount of light oil inside the output shaft.

30 Apply a light film of petroleum jelly on 88,6 mm [3.49 inch] I.D. seal. Install seal in bearing housing.

31 Install drive in output shaft (insert longer splined end of drive first), (see parts drawing on page 2).

32 To help in the reassembly procedure, it is recommended using two alignment studs (see special tools page 3) diagonally opposed in the four bolt holes of the bearing housing.

33 Apply petroleum jelly on 2 seals, 9,3 mm [.25 inch] I.D. Install seals (1 on each side of Geroler) in case drain grooves of Geroler.

Note: Installation at this point involves 3 steps in timing the motor. Timing determines the direction of rotation of the output shaft.

Timing parts include:

1. Geroler
2. Valve drive
3. Valve Plate
4. Valve

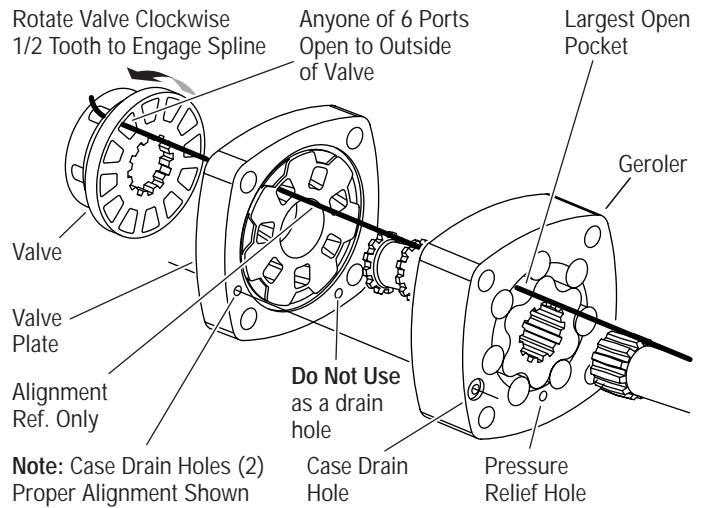

Figure 16 Timing Alignment

Timing Step No. 1 — Locate largest open pocket in Geroler. Then mark location of pocket on outside edge of Geroler (see Figure 16).

34 Align case drain hole and pressure relief hole in Geroler with case drain hole and pressure relief hole in bearing housing. Install Geroler on bearing housing (see Figure 16). Retain rollers in outer Geroler ring if they are loose.

35 Install valve drive in Geroler.

Reassembly

36 Apply a light film of petroleum jelly on 88,6 mm [3.49 inch] I.D. seal. Install seal in valve plate.

37 Align case drain hole in valve plate with case drain hole in Geroler. Install valve plate (seal side toward Geroler) on Geroler as shown in Figure 16.

Timing Step No. 2 — Locate slot opening in valve plate which is in line with largest open pocket of Geroler (see Figure 16).

38 Use the following procedure for installing the valve on the valve plate.

Timing Step No. 3 — Locate any one of the side openings of the valve that goes through to the face of the valve. **Line up this side opening in the valve with open slot of valve plate that is in line with largest open pocket of Geroler.** Rotate valve clockwise (1/2 spline tooth) to engage valve with the valve drive spline, alignment reference shown in Figure 17 (above). This procedure provides standard timing when pressurized as shown in Figure 17.

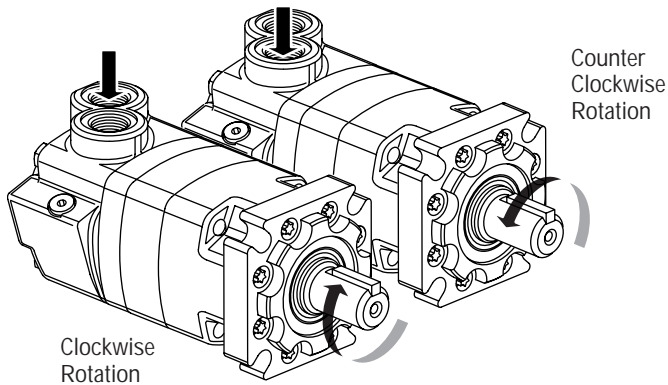

Figure 17

39 Apply clean grease on balance ring assembly springs. Install springs in 2 holes located inside bore face of valve housing (see Figure 18).

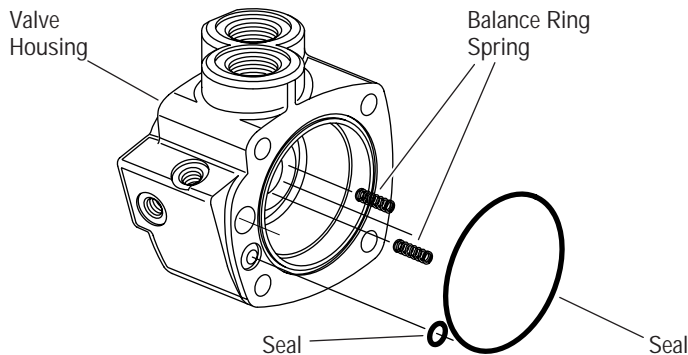

Figure 18

40 Apply a light film of petroleum jelly on 8,9 mm [.35 inch] I.D. seal. Install seal in case drain groove of valve housing.

41 Apply a light film of petroleum jelly on 82,3 mm [3.24 inch] I.D. seal. Install seal in outside seal groove of valve housing.

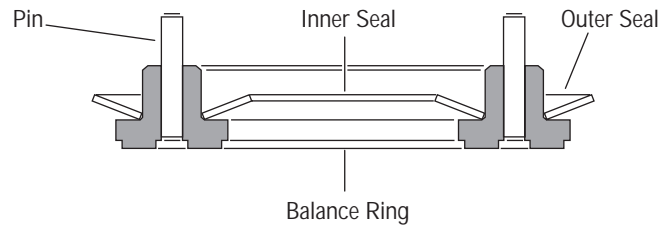

Figure 19

42 Apply petroleum jelly on inner and outer face seals. Install seals on balance ring as shown in Figure 19.

Important: Install face seals in the positions shown in Figure 19 or the motor will not operate properly. Do not force or bend these face seals. Any damage to these seals will affect the operation of the motor.

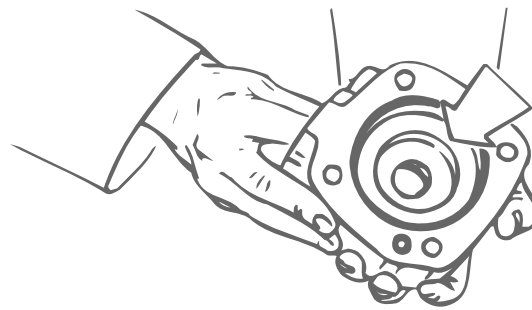

Figure 20

43 Align 2 pins of balance ring with 2 spring holes in valve housing as shown in Figure 20 . Install balance ring in valve housing.

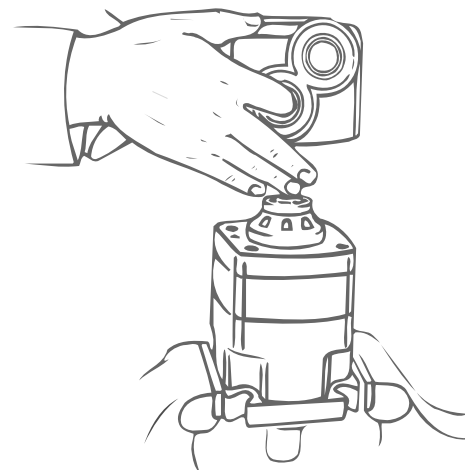

Figure 21

Reassembly

44 Insert your finger through port of housing. Apply pressure to side of balance ring assembly. Hold ring in position until valve housing is in place (see Figure 21). Align case drain hole in housing with case drain hole in valve plate. Install valve housing against valve plate (see Figure 22).

Note: After installing valve housing on valve plate, check between body parts of motor for unseated seals.

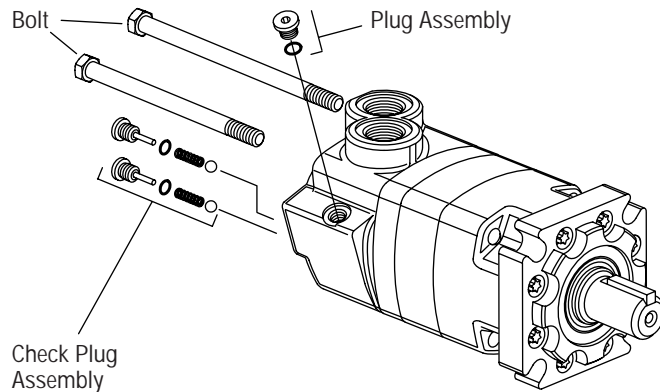

Figure 22

45 Install and finger tighten 2 bolts (or studs for earlier models) opposite alignment studs. Remove alignment studs and install remaining bolts (or studs and 4 nuts for earlier models). Torque bolts (or nuts) to 85 Nm [750 lb-in], in sequence (see Figure 23).

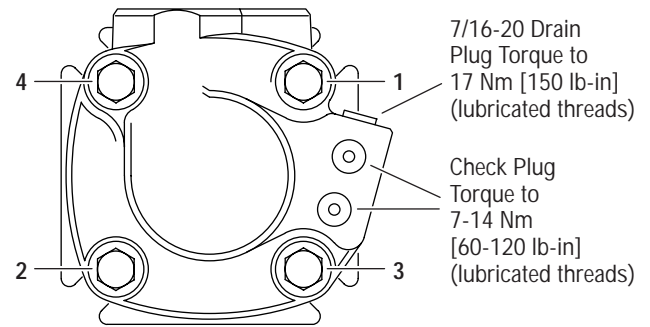

Figure 23

46 Install 2 check plug assemblies (ball, spring, plug with seal). Also install case drain plug with seal, parts shown in Figure 22 (plug torque shown in Figure 24).

Wheel Motors

A different bearing housing is used on wheel motors (see Figure 24). Other than this, the parts are the same as the standard motor and the same disassembly and reassembly procedures apply.

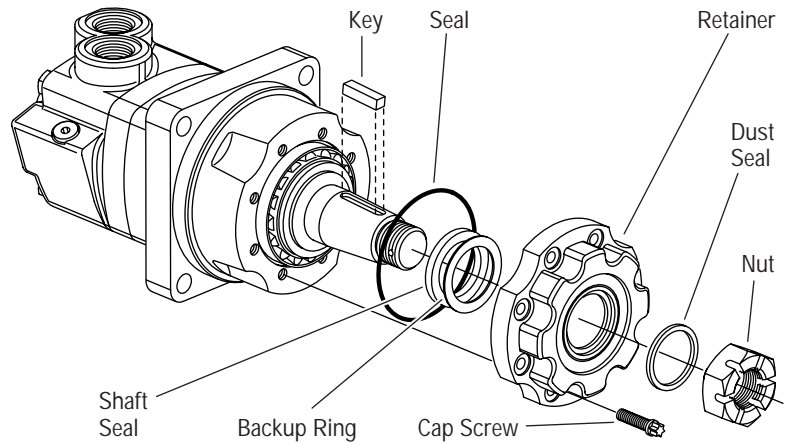

Figure 24

Bearingless Motors

This motor is the same as the standard without the shaft/bearing assembly, bearing housing and retainer. The mounting flange replaces the bearing housing (see Figure 25). Follow same disassembly and reassembly procedures as rear section of standard motor.

Important: Loctite® information for bearingless motor on page 10.

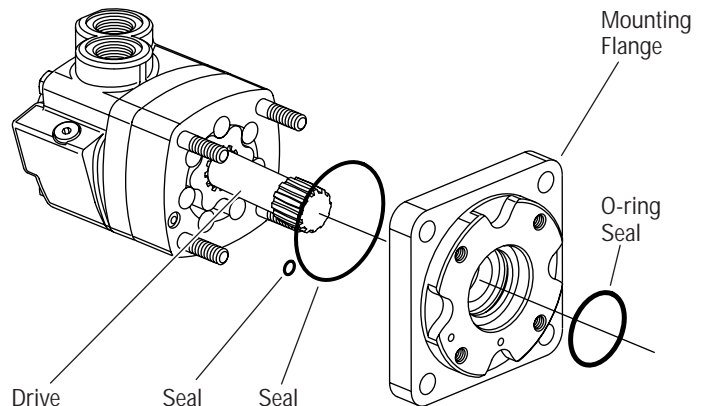

Figure 25

Reassembly

Important: This motor requires Loctite in threaded holes of mounting flange.

Follow these procedures:

Adequate Loctite penetration and sealing depend highly on cleanliness and dryness of threads. Use a non-petroleum base solvent to clean excess oil from threads of flange after disassembly. You may need to use a tap to clean threads of excess old Loctite. After you have fully reassembled the motor, apply 2 to 3 drops of Loctite no. 290 at top of threaded holes (see Figure 26).

Note: Allow Loctite 5 minutes for thread penetration before installing motor on gear case.

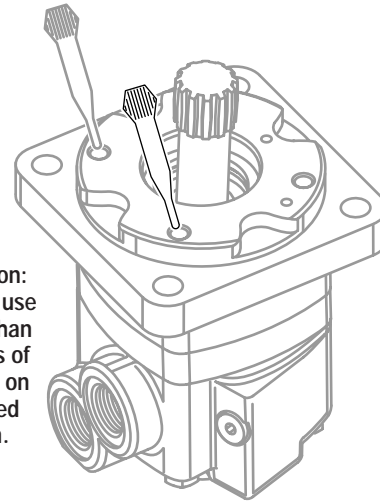

Attention:
Do not use more than 3 drops of Loctite on threaded portion.

Figure 26

Motors with Shuttle and, or Seal Guard

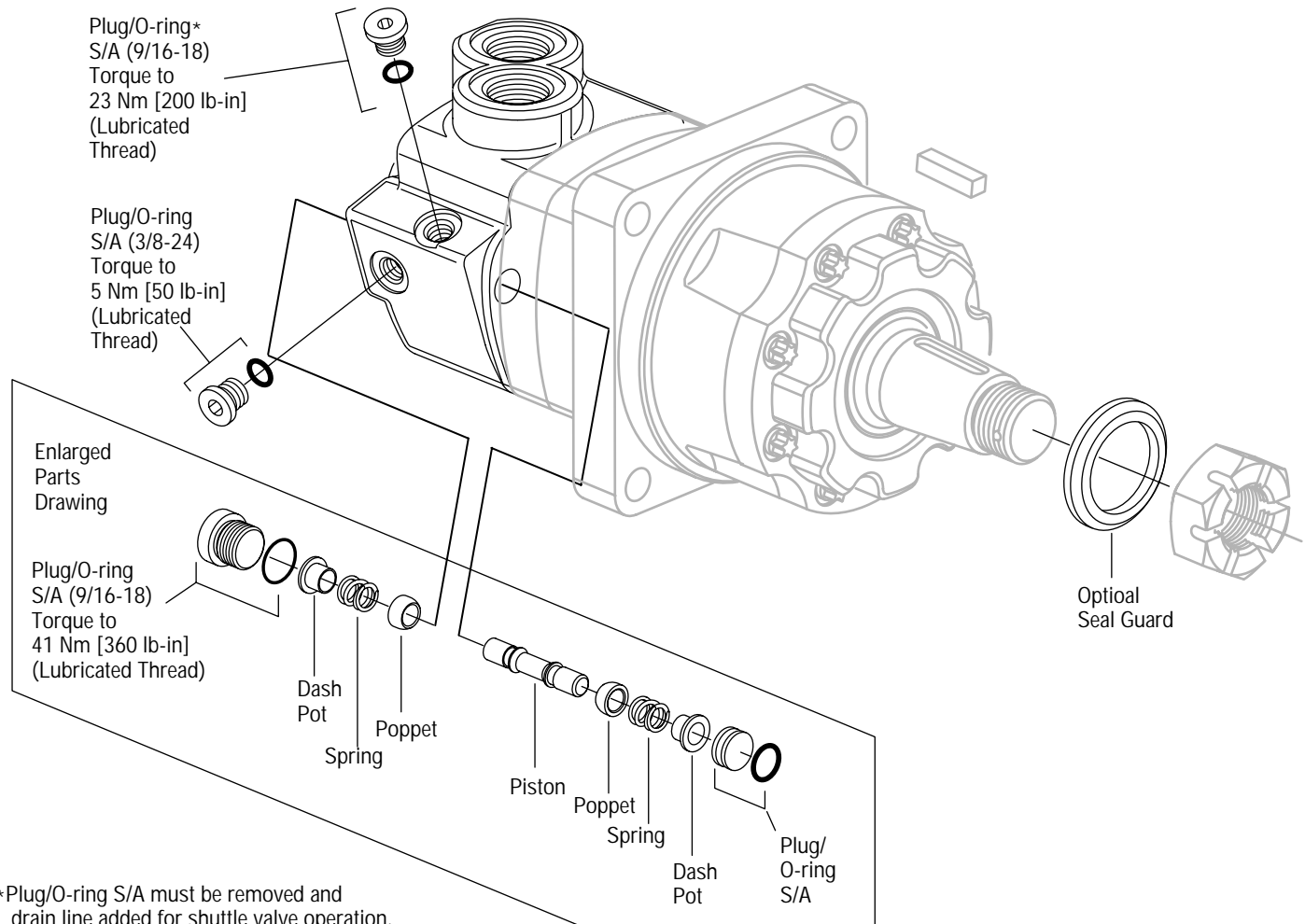

How to Order Replacement Parts

Each Order Must Include the Following:

- 1. Product Number
- 2. Date Code
- 3. Part Name
- 4. Part Number
- 5. Quantity of Parts

For more detailed information contact Eaton Corp. Hydraulics Division 15151 Highway 5 Eden Prairie, MN 55344.

- Specifications and performance data, Catalog No. 11-878.
- Replacement part numbers and kit information — Parts Information No. 6-126.

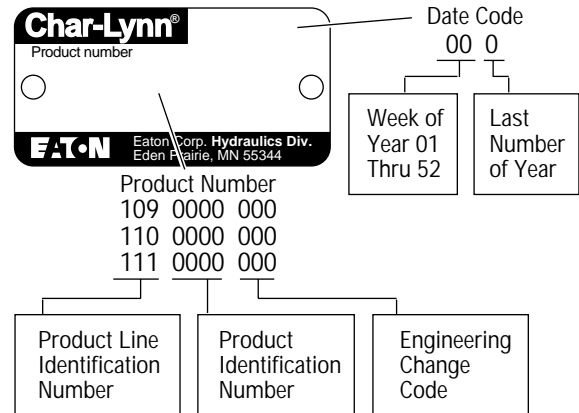

Product Numbers—4000 Series Motors

Use digit prefix —109-, 110-, or 111- plus four digit number from charts for complete product number—Example 111-1057.
Orders will not be accepted without three digit prefix.

Mounting	Shaft	Ports	Displ. cm ³ /r [in ³ /r] Product Number								
			110 [6.7]	130 [7.9]	160 [9.9]	205 [12.5]	245 [15.0]	310 [19.0]	395 [24.0]	495 [30.0]	625 [38.0]
Standard SAE B-Mount	1-1/4 inch Straight	1-1/16 O-ring	109-1100	-1101	-1102	-1103	-1104	-1105	-1106	-1212	-1215
		3/4 inch Split Flange	109-1001	-1054	-1002	-1003	-1055	-1056	-1057	—	—
	1-5/8 Inch Tapered	1-1/16 O-ring	109-1107	-1108	-1109	-1110	-1111	-1112	-1113	—	—
		3/4 inch Split Flange	109-1006	-1058	-1007	-1008	-1059	-1060	-1061	—	—
	1-1/4 Inch 14 T Splined	1-1/16 O-ring	109-1114	-1115	-1116	-1117	-1118	-1119	-1120	—	—
		3/4 inch Split Flange	109-1011	-1062	-1012	-1013	-1063	-1064	-1065	—	—
Standard SAE C-Mount	40 mm Straight	G 3/4 (BSP)	109-1184	-1185	-1227	-1224	-1225	-1189	-1190	—	—
	1-1/2 Inch 17 T Splined	G 3/4 (BSP)	109-1191	-1192	-1193	-1194	-1195	-1196	-1197	—	—
Wheel Motor	1-1/4 inch Straight	1-1/16 O-ring	110-1074	-1075	-1076	-1077	-1078	-1079	-1080	—	-1122
		3/4 inch Split Flange	110-1001	-1040	-1002	-1003	-1041	-1042	-1043	—	—
	40 mm Straight	G 3/4 (BSP)	110-1108	-1109	-1110	-1111	-1112	-1113	-1125	—	—
	1-5/8 Inch Tapered	1-1/16 O-ring	110-1081	-1082	-1083	-1084	-1085	-1086	-1087	1116	-1117
		3/4 inch Split Flange	110-1006	-1044	-1007	-1008	-1045	-1046	-1047	—	—
	1-1/4 Inch 14 T Splined	1-1/16 O-ring	110-1088	-1089	-1090	-1091	-1092	-1093	-1094	—	—
3/4 inch Split Flange		110-1011	-1048	-1012	-1013	-1049	-1050	-1051	—	—	
Bearingless		1-1/16 O-ring	111-1033	-1034	-1035	-1036	-1037	-1038	-1039	-1062	-1063
		3/4 inch Split Flange	111-1044	-1015	-1045	-1046	-1016	-1017	-1018	—	—
		G 3/4 (BSP)	111-1052	-1053	-1054	-1055	-1056	-1057	-1058	—	—

111-1057

4000 Series Motors

Eaton Corporation
Hydraulics Division
15151 Hwy. 5
Eden Prairie, MN 55344
Telephone: 612/937-7254
Fax: 612/937-7130

Sumitomo Eaton
Hydraulic Company Ltd.
Ooi-Cho Kameoka-Shi
621-0017 Kyoto
Japan
Telephone: [+81] 771-22-9601
Fax: [+81] 771-29-2020

Eaton Ltd.
Hydraulics Division
Glenrothes, Fife
Scotland, KY7 4NW
Telephone: [+44] (0)1592-771-771
Fax: [+44] (0)1592-773-184

Eaton Ltd.
7th Floor, Woo Duk Building
832-2 Yeoksam-Dong, Kangnam-Ku
Seoul 135-750
Korea
Telephone: [+82] 2-557-0595
Fax: [+82] 2-557-1634

Eaton B.V.
Boeing Avenue 11
1119 PC Schiphol-Rijk
The Netherlands
Telephone: [+31] (0)20-655 6776
Fax: [+31] (0)20-655 6800

Eaton Hydraulics (Shanghai) Co. Ltd.
388 Aidu Road, Waigaogiao FTZ
Pudong New Area
Shanghai 200137
Peoples Republic of China
Telephone: [+86] 21-5046 0758
Fax: [+86] 21-5046 0767

Sumitomo Eaton Hydraulic Co.
8 Temasek Blvd.
42-01 Suntec Tower Three
Singapore 03988
Telephone: [+65] 832-7727
Fax: [+65] 832-7733

Jining Eaton Hydraulic Co. Ltd.
6 Ji Da Road
Jining City
Shandong Province 272131
Peoples Republic of China
Telephone: [+86] 537-2221288
Fax: [+86] 537-2221557



Quality System Certified
Products in this catalog are manufactured
in an ISO-9001-certified site.

Char-Lynn® Hydraulic Motor

No. 7-125
January, 1995

EAT•N

Repair Information

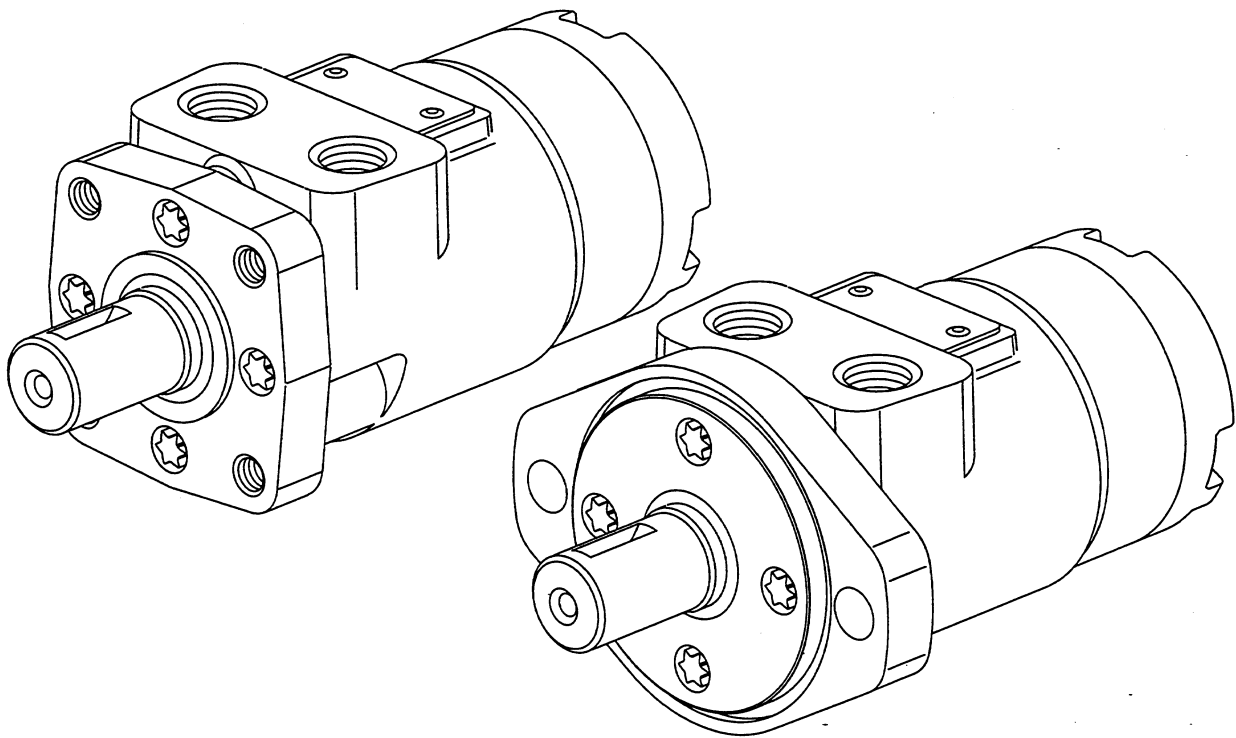

**A Series
General Purpose Geroler® Motor**

001 002 003

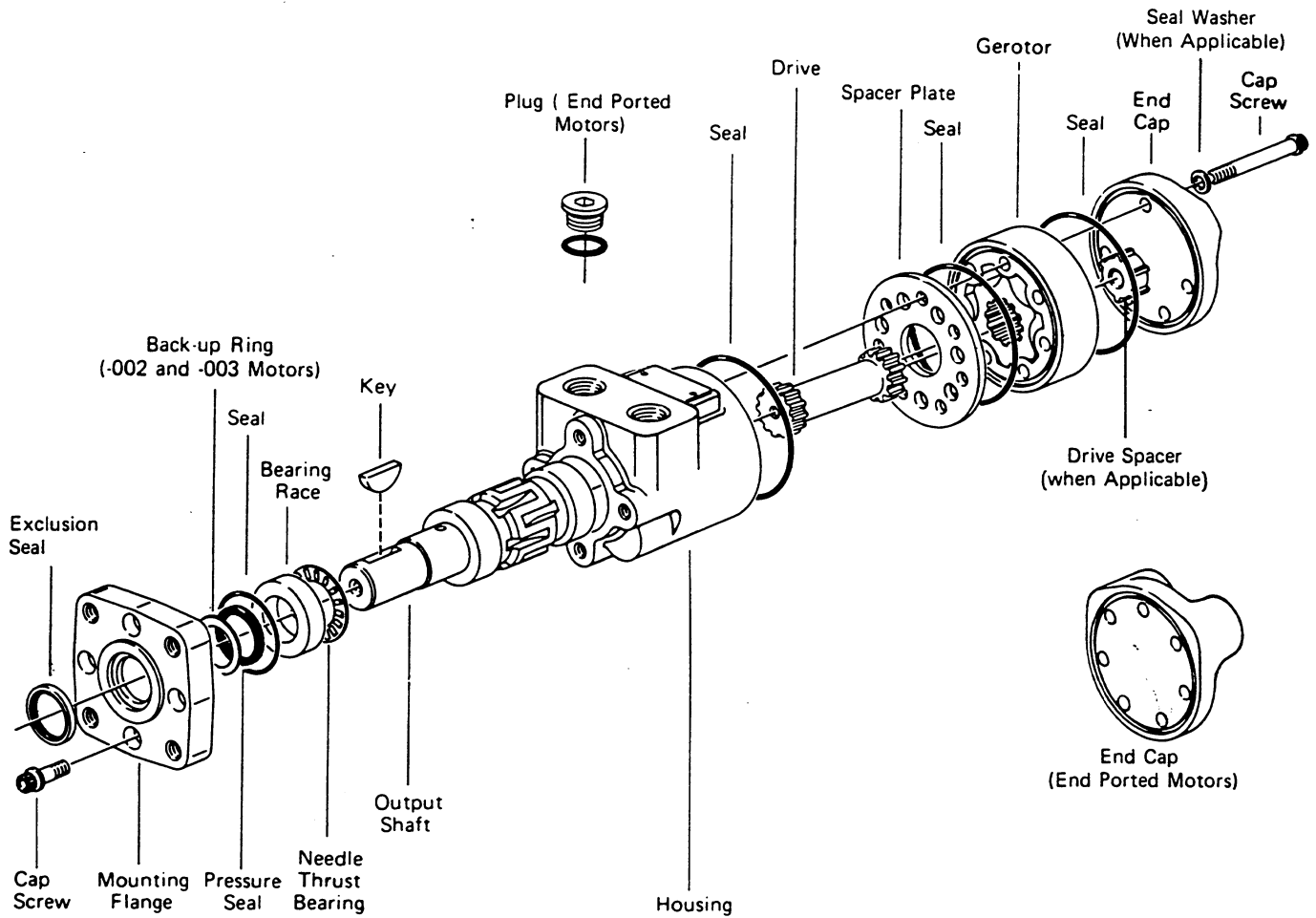

Tools required for disassembly and reassembly.

- Torque wrench (300 lb-in [34Nm] capacity)
- 12-16 in. [300-400mm] breaker bar
- * 5/16 –12 point socket no. 5422 (Heavy Duty 500 lb-in [56Nm] Capacity)
- Small screwdriver (6-8x1/4 in. [150-200x6mm] flat blade), see page 5 for tooling information.
- * Shaft pressure seal installation tool for 001 motor P/N 600470, for 002 and 003 motors P/N 600523
- * Seal sleeve or bullet P/N 600304 (1 in. dia. shaft), P/N 600466 (7/8 in. dia. shaft)

*Tools available—by special order—through our service department.

Repair Information

A Series Char-Lynn Motors Disassembly

Instructions in this manual are for standard A Series Motors (130-XXXX-001, 002 and 003).

Cleanliness is extremely important when repairing these motors. Work in a clean area. Before disconnecting lines, clean port area of motor. Remove key when used. Check shaft and key slot. Remove burrs, nicks and sharp edges. Before disassembly, drain oil from motor. Then plug ports and thoroughly clean exterior of motor.

Although not all drawings show the motor in a vise, we recommend that you keep the motor in a vise during disassembly. Follow the clamping procedures explained throughout the manual.

Gerotor End

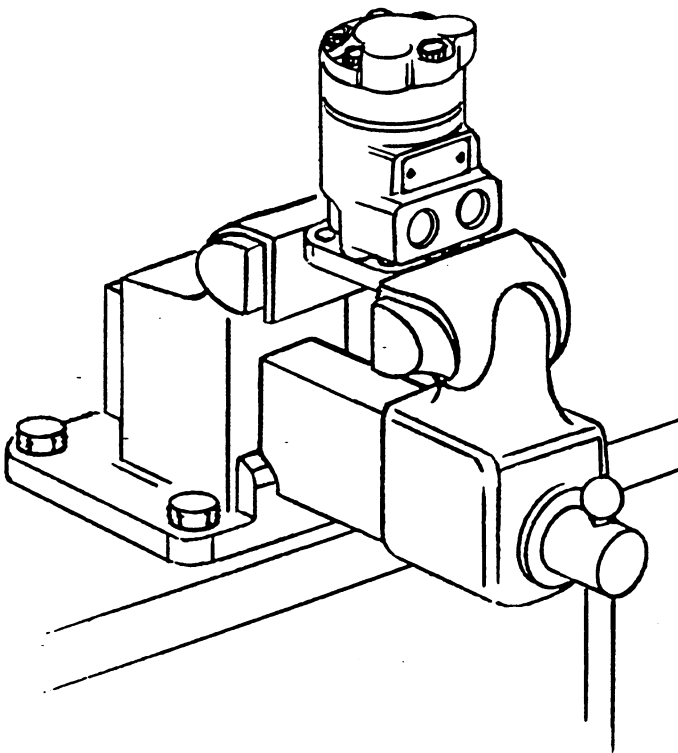

Figure 1

- 1 Place motor in vise and clamp across edge of flange with output shaft down. When clamping, use protective device on vise such as special soft jaws, pieces of hard rubber or board. See Figure 1.

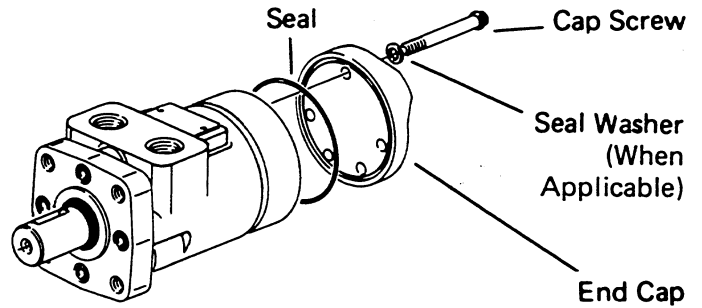

Figure 2

- 2 Remove cap screws and seal washers (when applicable). See Figure 2.
- 3 Remove end cap.
- 4 Remove seal from end cap.

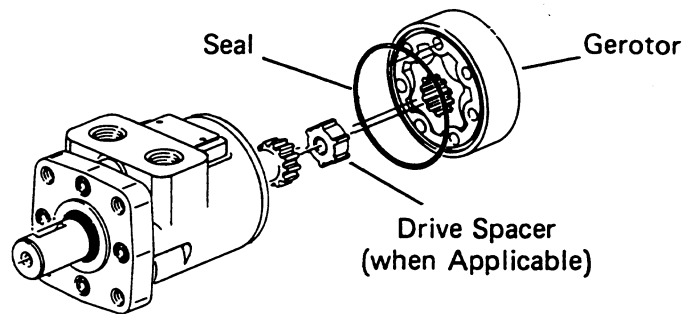

Figure 3

- 5 Remove gerotor.
- 6 Remove seal from gerotor (Figure 3).
- 7 Remove drive spacer if applicable.

3

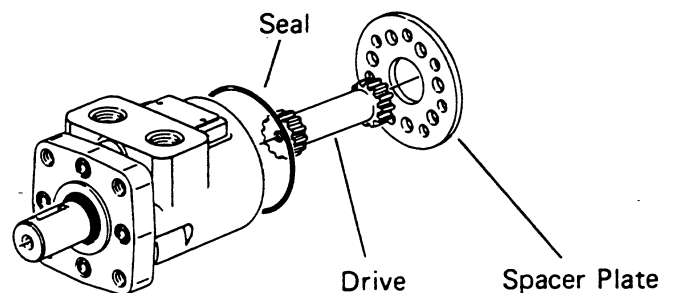

Figure 4

- 8 Remove drive. See Figure 4.
- 9 Remove spacer plate.
- 10 Remove seal from housing.
- 11 Remove output shaft from housing.
- 12 Remove needle thrust bearing from shaft or housing.

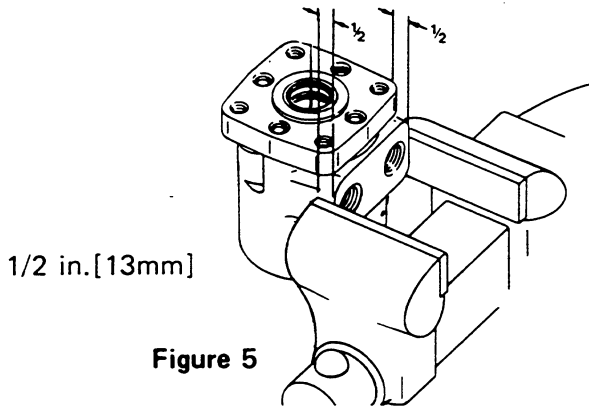

Figure 5

13 Reposition motor in vise. Clamp across ports as shown in Figure 5. Do not clamp on side of housing. Excessive clamping pressure on side of housing causes distortion.

14 Remove cap screws from mounting flange. These screws are assembled with Loctite to hold them in place.

The screws will require 300-400 lb-in [35-45 Nm] of torque to break loose and 100 lb-in [11 Nm] torque to remove. Do not use impact wrench on Loctited screws. This could result in rounded heads or broken sockets.

Note: If torque higher than given above is required to break screws loose, apply heat according to following instructions:

4

When heated, Loctite partially melts. This reduces torque required to remove screw. Use small flame propane torch to heat small area of housing where screw enters. See Figure 6. **Be careful not to overheat housing** and damage motor. Gradually apply torque to screw with **socket** wrench as heat is applied for 8 to 10 seconds. As soon as screw breaks loose, remove heat from housing. Continue turning screw until it is completely removed.

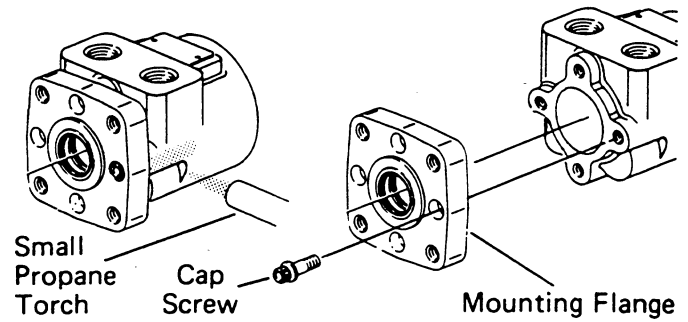

Figure 6

15 Remove motor from vise. Place motor on clean flat surface. Carefully remove flange from housing.

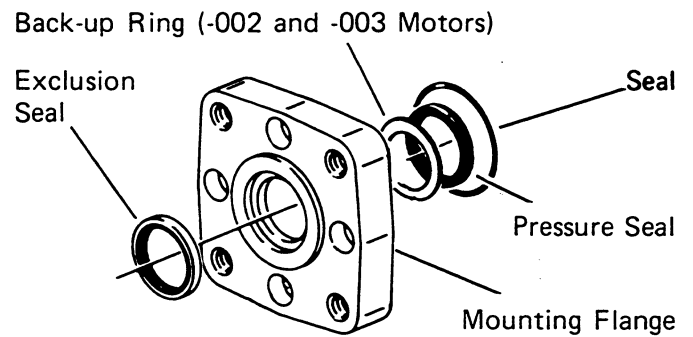

Figure 7

16 Exclusion seal, back-up ring, pressure seal and seal will come off with flange (Figure 7). Use seal removal tool, shown in Figures 8 and 9, to remove exclusion and pressure seals.

Important: Be careful not to scratch seal cavity O.D. This could create a leak path.

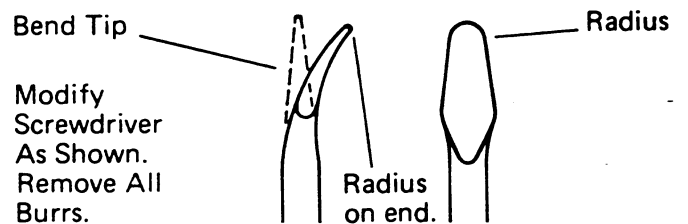
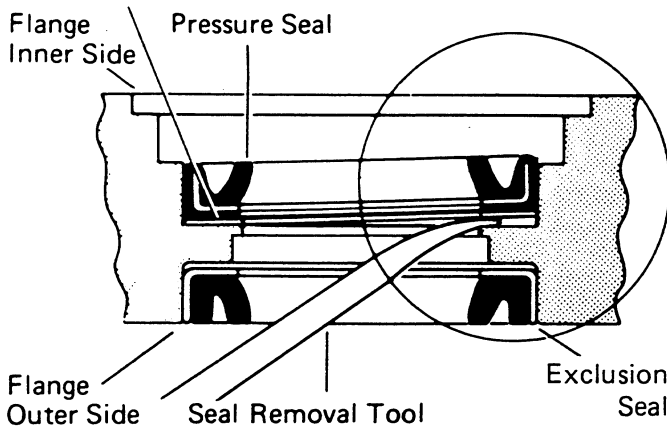

Figure 8

Back-up Ring (-002 and -003 Motors)



Work from outer side for both (either) seals.

Figure 9

Reassembly

Shaft End

Check all mating surfaces. Replace any parts with scratches or burrs that could cause leakage or damage. Clean all metal parts in clean solvent. Blow dry with air. Do not wipe parts with cloth or paper towel because lint or other matter could get into the hydraulic system and cause damage.

Check around key slot and chamfered area of shaft for burrs, nicks or sharp edges that could damage seals during reassembly. Remove nicks or burrs with a hard smooth stone (such as an Arkansas stone). Do not file or grind motor parts.

Note: Lubricate all seals with petroleum jelly. Use new seals when reassembling motor. Refer to parts list 6-130 for proper seal kit numbers.

Important: Do not stretch seals before installing them.

Cleanliness is extremely important in the successful application of Loctite. Before Loctite can be applied, the parts should be cleaned as follows:

Note: Fully cured Loctite resists most solvents, oils, gasoline and kerosene and is not affected by cleaning operations. It is not necessary to remove cured Loctite that is securely bonded in tapped holes; however, any loose particles of cured Loctite should be removed.

a. Wash the housing with solvent to remove oil, grease and debris. Pay particular attention to four tapped holes on flange end.

b. Blow dry with compressed air. Clean and dry tapped holes.

c. Wire brush screw threads to remove cured Loctite and other debris. Discard any screws that have damaged threads or rounded heads.

d. Wash screws with non-petroleum base solvent. Blow dry with compressed air.

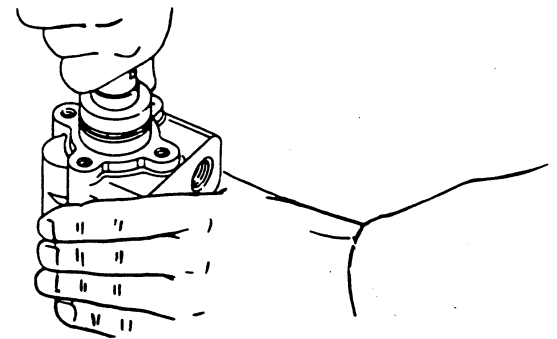
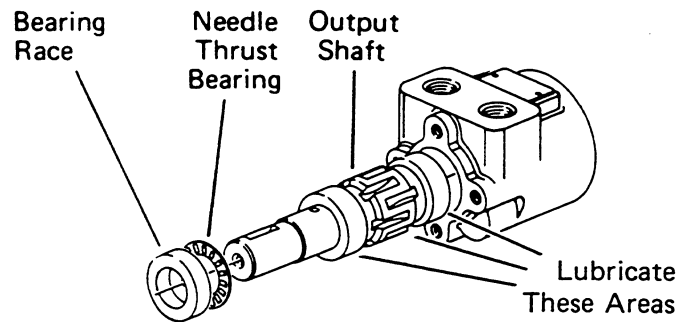
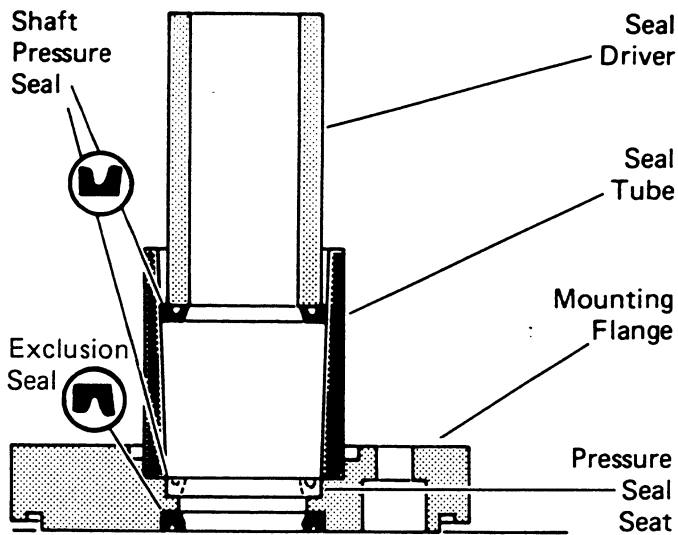

Figure 10

17 Lubricate output shaft with hydraulic oil, then install shaft in housing. See Figure 10.

Important: Do not permit oil to get into the four tapped holes.

18 Install needle thrust bearing, then bearing race on shaft. Pull shaft partially out of housing. Push all three parts in housing together. See Figure 10. The bearing race must rotate freely when in position.



Seal Installation Tool
 No. 600470 -001 Motors
 No. 600523 -002 and -003 Motors

Figure 11

19 Install exclusion seal in flange. See Figure 11. Carefully press exclusion seal into place.

20 Visually check seal seat in mounting flange for scratches or other marks that might damage the pressure seal. Check for cracks in flange that could cause leakage.

21 Lubricate I.D. of seal tube and O.D. of shaft pressure seal with light film of clean petroleum jelly. Align small I.D. end of seal tube with seal seat in mounting flange. Install back-up ring and pressure seal in tube with lips of seal face up. See Figure 11. Insert seal driver in tube and firmly push seal seat with a rotating action.

Important: After installing seal in flange, examine seal condition. If damaged or improperly installed, you must replace it before continuing with reassembly.

6

22 Install 1⁵/₁₆ in. [49 mm] I.D. seal in flange.

23 It is recommended to apply a light coat of Loctite Primer NF in tapped holes of housing. Allow primer to air dry for at least 1 minute. Do not force dry with air jet; the primer will blow away.

Use of primer is optional. With primer, Loctite curing time is approximately 15 minutes. Without primer, curing time is approximately 6 hours.

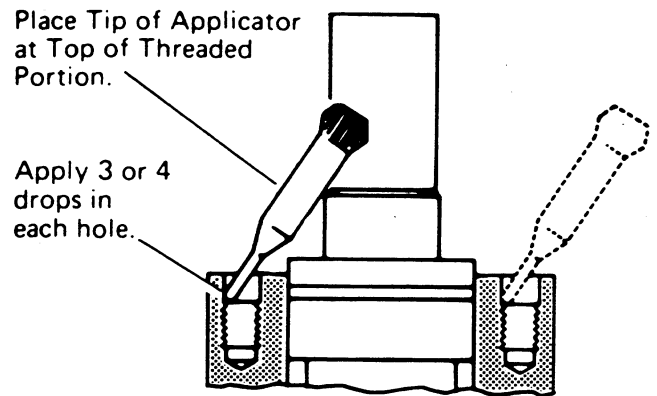

Figure 12

24 Apply 3 or 4 drops of Loctite sealant at top of thread for each of four holes in housing. See Figure 12. Do not allow parts with Loctite applied to come in contact with any metal parts other than those for assembly. Wipe off excess Loctite from housing face, using a non-petroleum base solvent.

Do not apply Loctite to threads more than 15 minutes before installing screws. If housing stands for more than 15 minutes, repeat application. No additional cleaning or removal of previously applied Loctite is necessary.

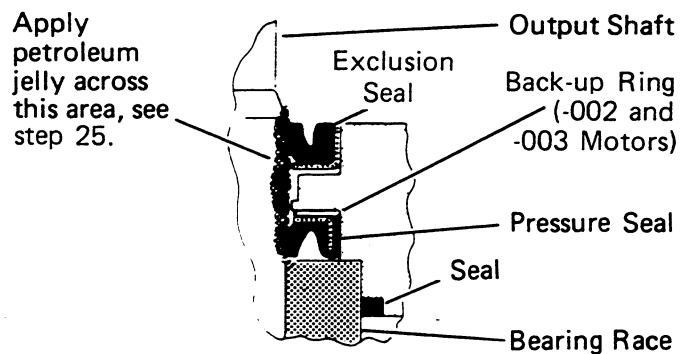

Figure 13

25 Before installing flange and seal assembly over shaft, place protective sleeve or bullet over shaft. Then lubricate space between exclusion seal and pressure seal, as well as lips of both seals. See Figure 13.

Install flange. Rotate flange slowly while pushing down over shaft. Be careful not to invert or damage seals.

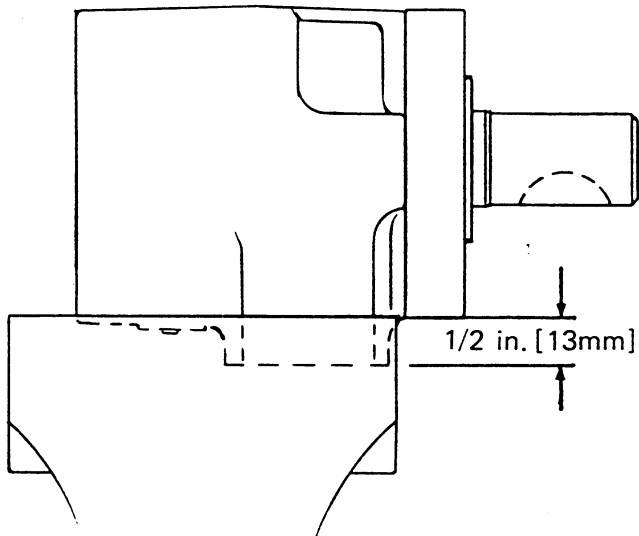

Figure 14

26 After removing bullet, clamp motor in vise as shown in Figure 14. Make sure shaft cannot fall out. Install **dry** screws and alternately torque them immediately to 250 lb-in [28 Nm]. If you use primer, allow to cure for **10 to 15 minutes**. Without primer, allow 6 hours curing time before subjecting motor to high torque reversals. On all other applications, you can run motor immediately.

If you use new screws, make sure they are the correct length: $\frac{7}{8}$ in. [22 mm] under head length. See parts list for correct part number.

Gerotor End

27 Reposition motor with gerotor end up, then clamp across ports. Do not clamp on side of housing.

Important: To aid installation of seals, apply light coat of clean petroleum jelly to seals. Do not stretch seals before installing them in groove.

28 Pour approximately 35 cc of clean hydraulic oil in output shaft cavity.

29 Install $2\frac{7}{8}$ in. [73 mm] I.D. seal in housing seal groove. Avoid twisting seal.

Timing Procedure

a. Install drive. Use felt tip marker to mark one drive tooth. Align this tooth with timing dot on shaft.

Note: If drive is not symmetrical, install larger splined end into shaft.

b. Install spacer plate.

c. Install $2\frac{7}{8}$ in. [73 mm] I.D. seal in gerotor seal groove. Carefully place gerotor on spacer plate, seal side toward spacer plate.

Standard Rotation Align any star point with tooth marked on drive. See Figure 15.

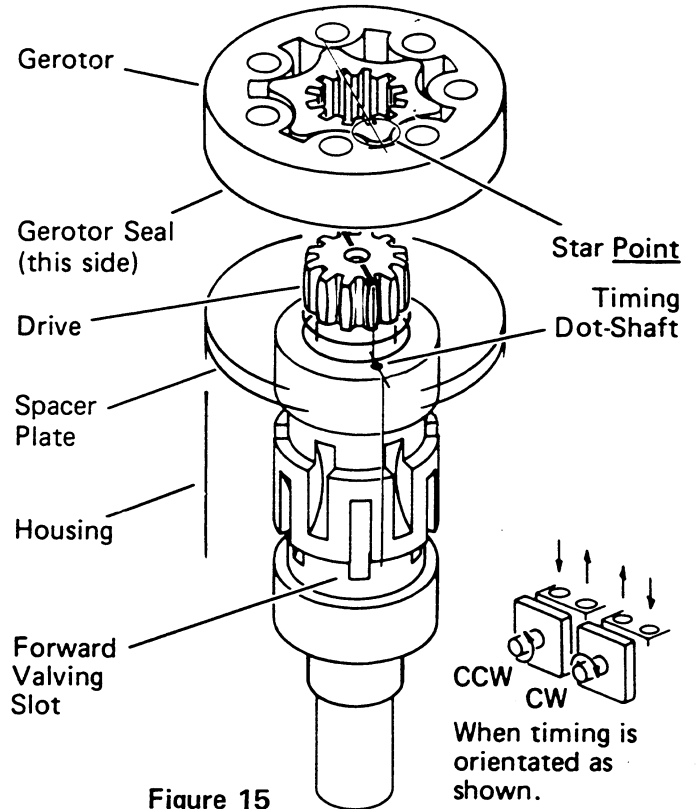

Figure 15

Reverse Rotation Align any star valley with marked tooth. See Figure 16.

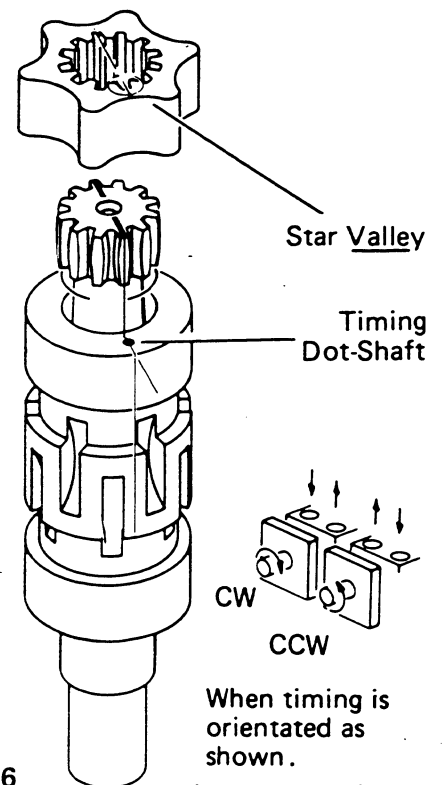

Figure 16

Reassembly Continued from Page 7

30 Rotate gerotor to line up with bolt holes. Be careful not to disengage star from drive or disturb gerotor seal.

31 Install drive spacer if applicable.

32 Install 2 7/8 in. [73 mm] seal in end cap. Carefully place end cap on gerotor.

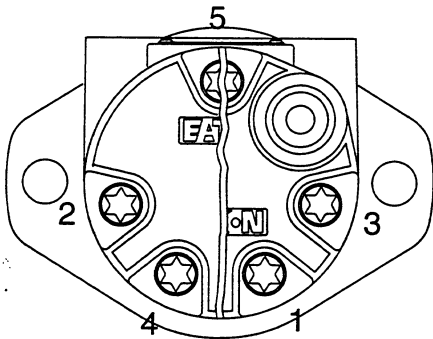

Bolt Torquing Sequence

Figure 17

33 Install cap screws and seal washers (if applicable) in end cap. Pretighten screws to 40 lb-in [7,4 Nm]. Make sure seal are properly seated. Then torque screws 275-300 lb-in [30-40 Nm] in sequence, as shown in figure 17.

How to Order Replacement Parts

Each Order Must Include the Following:

1. Product Number
2. Date Code
3. Part Name
4. Part Number
5. Quantity of Parts

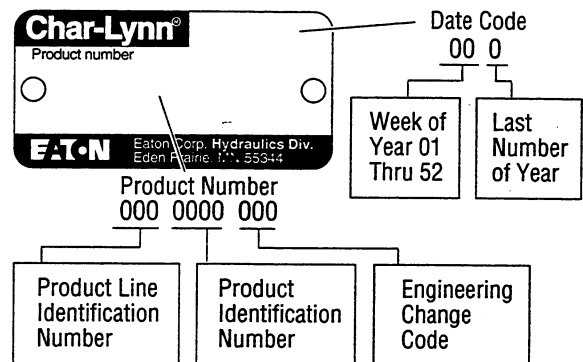

Eaton Corporation
Hydraulics Division
15151 Hwy. 5
Eden Prairie, MN 55344
Telephone 612/937-9800
Fax 612/937-7130

Eaton Ltd.
Hydraulics Division
Glenrothes, Fife
Scotland, KY7 4NW
Telephone 44/592-771-771
Fax 44/592-773-184



Repair Information

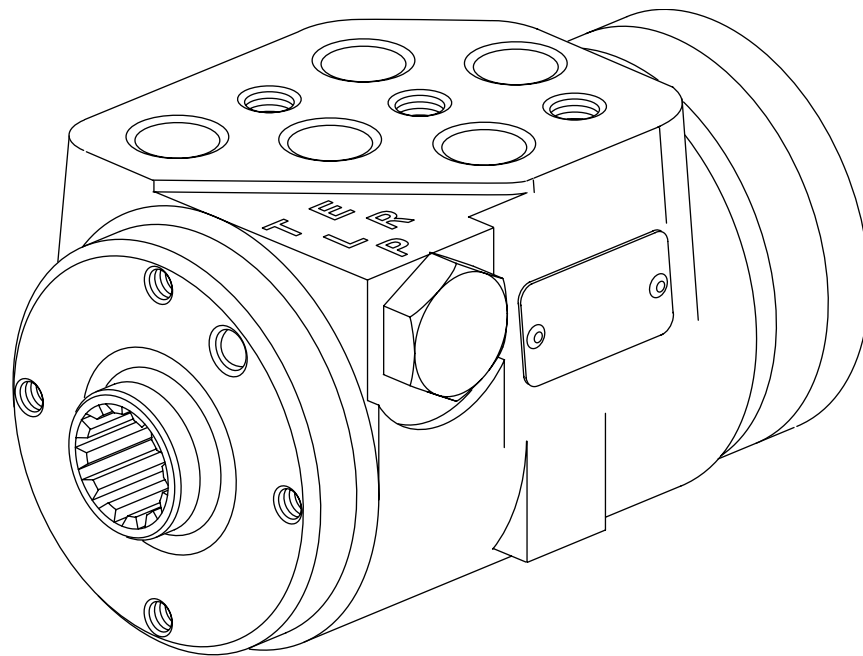

2 Series
Steering Control Unit

001

2 Series Steering Control Units

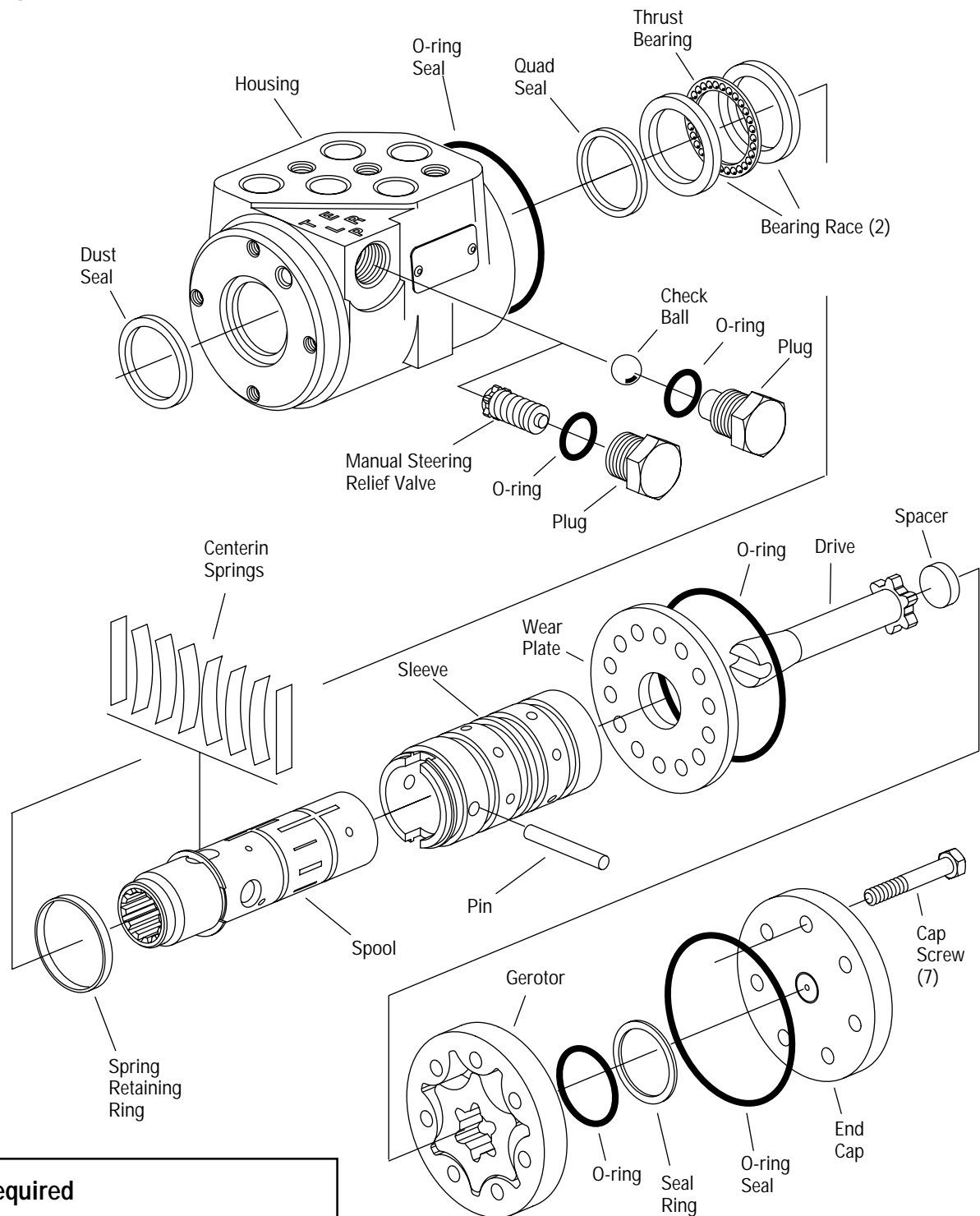

Tools Required

- 10 mm Socket
- 7/8 in. Socket
- Torque Wrench (18 Nm [160 lb-in] Capacity)
- Small Blade Screwdriver

2 Series Steering Control Units

Disassembly

Cleanliness is extremely important when repairing hydraulic Steering Control Units (SCU). Work in a clean area. Before disconnecting the hydraulic lines, clean the port area of the SCU. Before disassembly, drain the oil, then plug the ports and thoroughly clean the exterior of the SCU. During repairs, always protect machined surfaces.

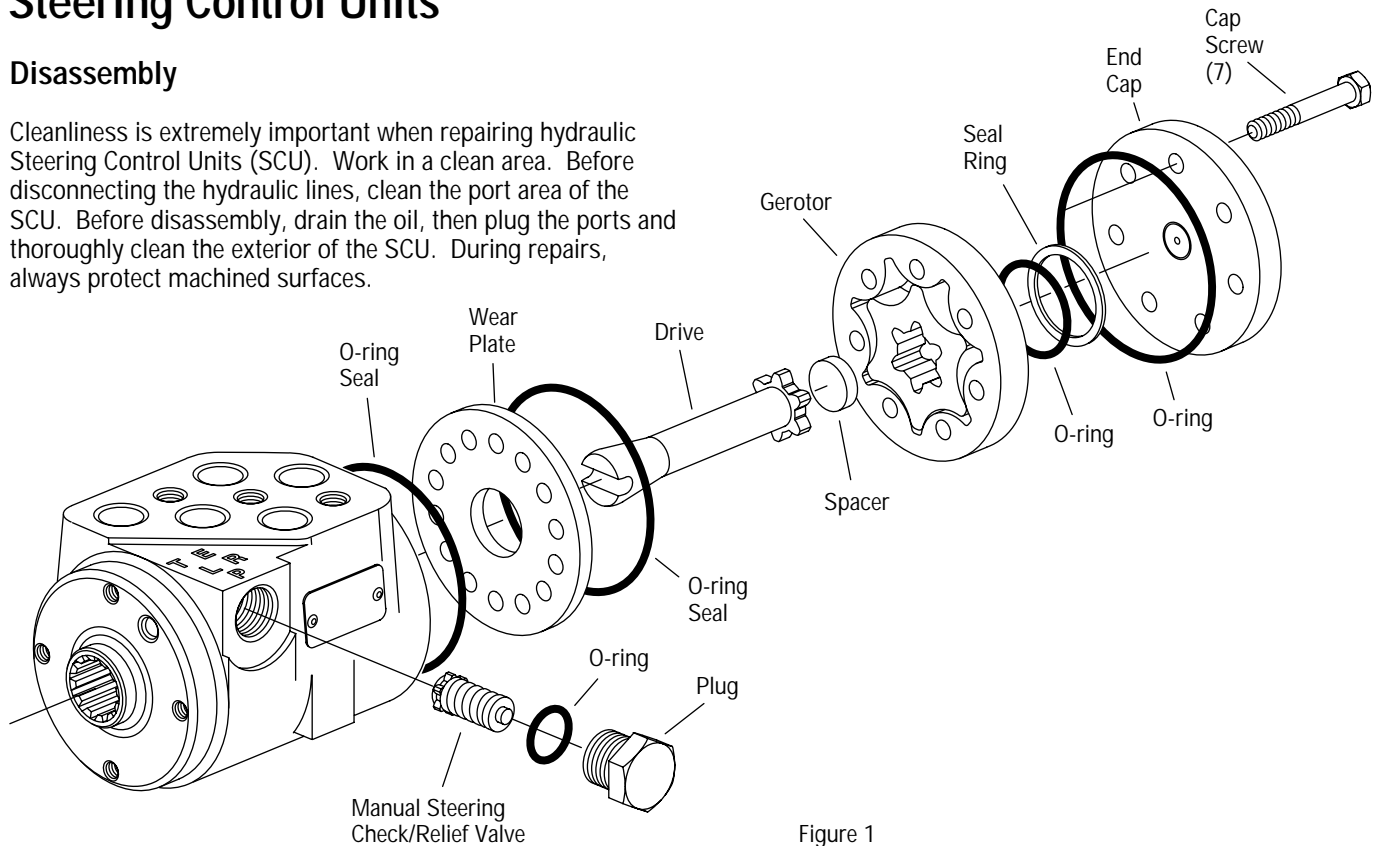

Figure 1

1 Remove the seven cap screws and disassemble the SCU as shown in Figure 1.

2 Remove the plug and manual steering check as shown in Figure 1.

Note: The manual steering check may be a check ball or a check/relief valve.

3 Slide the spool and sleeve from the housing (see Figure 2).

4 Remove the thrust bearing and bearing races.

5 Remove the quad seal.

6 Using a small blade screwdriver, carefully pry the dust seal from the housing.

Important: Do not damage the dust seal seat.

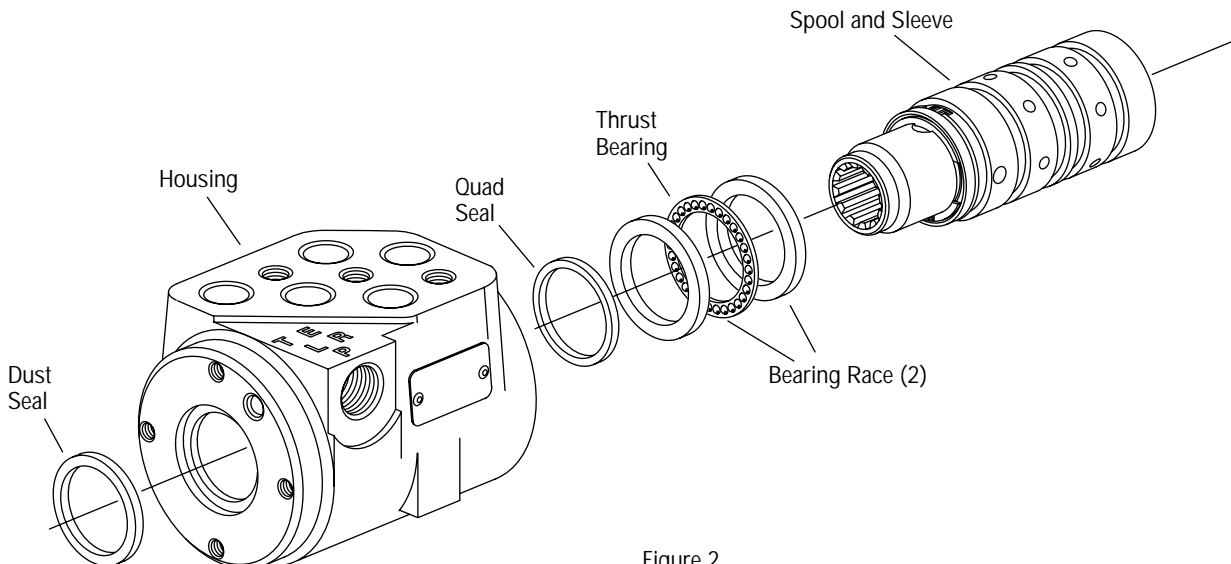

Figure 2

2 Series Steering Control Units

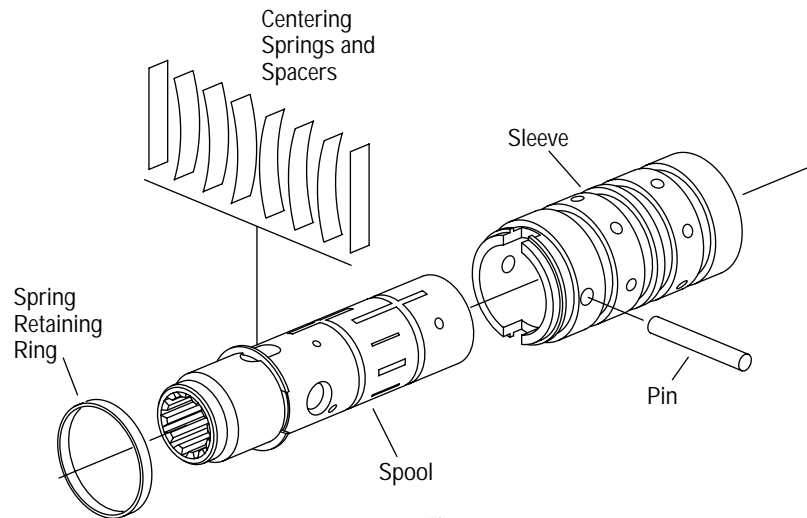

Figure 3

7 Remove the pin that holds the spool and sleeve together (see Figure 3).

8 Carefully slide the spool out of the sleeve. The springs and retaining ring will stay with the spool as it's removed.

9 Remove the retaining ring and springs.

Caution: The centering springs are under tension. Remove the retaining ring carefully.

Reassembly

Check all mating surfaces. Replace any parts with scratches or burrs that could cause leakage. Wash all metal parts in clean solvent. Blow them dry with pressurized air. **Do not** wipe parts dry with paper towels or cloth as lint in a hydraulic system will cause damage.

Note: Always use new seals when reassembling hydraulic steering control units. Refer to parts list 6-323 for seal kit part numbers, replacement parts, and ordering information.

Important: During reassembly lubricate the new seals with a petroleum jelly such as Vaseline®. Also lubricate machined surfaces and bearings with clean hydraulic fluid.

10 Install the quad seal:

- Put one of the bearing races and sleeve into the housing.
- Together, the housing and bearing race create a groove into which the quad seal will be installed.
- Hold the bearing race tightly against the input end of the housing by pushing on the gerotor end of the sleeve.
- Fit the quad seal into its seat through the input end of the housing. Be sure the seal is not twisted.
- Remove the sleeve and bearing race.

2 Series Steering Control Units

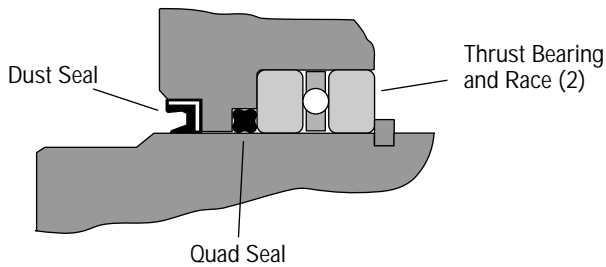

Figure 4

- 11 Lubricate and install the dust seal (see Figure 4 for correct seal orientation).
- 12 Install the centering springs in the spool. It is best to install the two flat pieces first. Next, install the curved pieces, three at a time.
- 13 Fit the retaining ring over the centering springs.
- 14 Apply a light coating of clean hydraulic fluid to the spool and slide it into the sleeve. Be sure the centering springs fit into the notches in the sleeve.
- 15 Install the pin (see Figure 3).
- 16 Apply a light coating of petroleum jelly to the inner edge of the dust and quad seals.
- 17 Put the thrust bearing and races into the housing. The thrust bearing goes between the two races (see Figure 2).
- 18 Apply a light coating of clean hydraulic fluid to the spool and sleeve assembly and slide it into the housing.

Important: Do not damage the dust or quad seals.

- 19 Clamp the housing in a vise as shown in Figure 5. Use just enough clamping force to hold the housing securely.

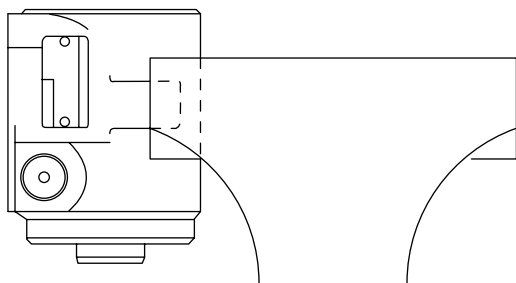

Figure 5

- 20 Lubricate and install a new o-ring seal in the groove in the housing.
 - 21 Install the wear plate and align the holes in the wear plate with threaded holes in the housing.
- Note: The holes in the wear plate are symmetrical.**
- 22 Install the drive, be sure the slot in the drive engages the pin.
 - 23 Lubricate and install a new o-ring seal in the groove in the wear plate.
 - 24 Install the gerotor and align the screw holes.
 - 25 Lubricate and install a new o-ring seal in the groove in the gerotor ring.
 - 26 Lubricate and install a new o-ring and seal ring in the groove in the gerotor star.
 - 27 Install the spacer.
 - 28 Install end cap and seven cap screws. Tighten cap screws, in a crisscross pattern, to 16 -18 Nm [140 -160 lb-in].
 - 29 Remove the SCU from the vise.
 - 30 Install the relief valve/check or check ball and plug. Use a new o-ring and tighten the plug to 17 Nm [150 lb-in].

2 Series Steering Control Units

Product Numbers 2 Series (Standard — 69 Bar [1000 PSI])

System	Ports	Relief Valve Setting Bar [PSI]	Displacement cm ³ /r [in ³ /r] and Product Number						
			31 [1.9]	39 [2.4]	51 [3.1]	63 [3.8]	74 [4.5]	100 [6.1]	
Open Center Non-Load Reaction	9/16 Inch Plug-O (4)	None	291-1001-001	291-1002-001	291-1003-001	291-1004-001	291-1005-001	291-1006-001	
		40 [580]	291-1001-041	291-1002-041	291-1003-041	291-1004-041	291-1005-041	291-1006-041	
		50 [725]	291-1001-051	291-1002-051	291-1003-051	291-1004-051	291-1005-051	291-1006-051	
		63 [914]	291-1001-061	291-1002-061	291-1003-061	291-1004-061	291-1005-061	291-1006-061	
		70 [1015]	291-1001-071	291-1002-071	291-1003-071	291-1004-071	291-1005-071	291-1006-071	
	9/16 -18 Inch SAE (4)	None	291-1007-001	291-1008-001	291-1009-001	291-1010-001	291-1011-001	291-1012-001	
		40 [580]	291-1007-041	291-1008-041	291-1009-041	291-1010-041	291-1011-041	291-1012-041	
		50 [725]	291-1007-051	291-1008-051	291-1009-051	291-1010-051	291-1011-051	291-1012-051	
		63 [914]	291-1007-061	291-1008-061	291-1009-061	291-1010-061	291-1011-061	291-1012-061	
		70 [1015]	291-1007-071	291-1008-071	291-1009-071	291-1010-071	291-1011-071	291-1012-071	
	Power Beyond Non-Load Reaction	9/16 Inch Plug-O (5)	None	291-5001-001	291-5002-001	291-5003-001	291-5004-001	291-5005-001	291-5006-001
			40 [580]	291-5001-041	291-5002-041	291-5003-041	291-5004-041	291-5005-041	291-5006-041
			50 [725]	291-5001-051	291-5002-051	291-5003-051	291-5004-051	291-5005-051	291-5006-051
			63 [914]	291-5001-061	291-5002-061	291-5003-061	291-5004-061	291-5005-061	291-5006-061
70 [1015]			291-5001-071	291-5002-071	291-5003-071	291-5004-071	291-5005-071	291-5006-071	
9/16 -18 Inch SAE (5)		None	291-5007-001	291-5008-001	291-5009-001	291-5010-001	291-5011-001	291-5012-001	
		40 [580]	291-5007-041	291-5008-041	291-5009-041	291-5010-041	291-5011-041	291-5012-041	
		50 [725]	291-5007-051	291-5008-051	291-5009-051	291-5010-051	291-5011-051	291-5012-051	
		63 [914]	291-5007-061	291-5008-061	291-5009-061	291-5010-061	291-5011-061	291-5012-061	
		70 [1015]	291-5007-071	291-5008-071	291-5009-071	291-5010-071	291-5011-071	291-5012-071	
Dynamic Signal Load Sensing	9/16 Inch Plug-O (5)	None	293-4001-001	293-4002-001	293-4003-001	293-4004-001	293-4005-001	293-4006-001	
	9/16 -18 Inch SAE (5)	None	293-4007-001	293-4008-001	293-4009-001	293-4010-001	293-4011-001	293-4012-001	

Product Numbers 2 Series (High Pressure — 103 Bar [1500 PSI])

Open Center Non-Load Reaction	9/16 Inch Plug-O (4)	None	291-1001-121	291-1002-121	291-1003-121	291-1004-121	291-1005-121	291-1006-121		
		80 [1160]	291-1001-081	291-1002-081	291-1003-081	291-1004-081	291-1005-081	291-1006-081		
		90 [1305]	291-1001-091	291-1002-091	291-1003-091	291-1004-091	291-1005-091	291-1006-091		
		100 [1450]	291-1001-101	291-1002-101	291-1003-101	291-1004-101	291-1005-101	291-1006-101		
	9/16 -18 Inch SAE (4)	None	291-1007-121	291-1008-121	291-1009-121	291-1010-121	291-1011-121	291-1012-121		
		80 [1160]	291-1007-081	291-1008-081	291-1009-081	291-1010-081	291-1011-081	291-1012-081		
		90 [1305]	291-1007-091	291-1008-091	291-1009-091	291-1010-091	291-1011-091	291-1012-091		
		100 [1450]	291-1007-101	291-1008-101	291-1009-101	291-1010-101	291-1011-101	291-1012-101		
		Power Beyond Non-Load Reaction	9/16 Inch Plug-O (5)	None	291-5001-121	291-5002-121	291-5003-121	291-5004-121	291-5005-121	291-5006-121
				80 [1160]	291-5001-081	291-5002-081	291-5003-081	291-5004-081	291-5005-081	291-5006-081
90 [1305]	291-5001-091	291-5002-091		291-5003-091	291-5004-091	291-5005-091	291-5006-091			
100 [1450]	291-5001-101	291-5002-101		291-5003-101	291-5004-101	291-5005-101	291-5006-101			
9/16 -18 Inch SAE (5)	None	291-5007-121	291-5008-121	291-5009-121	291-5010-121	291-5011-121	291-5012-121			
	80 [1160]	291-5007-081	291-5008-081	291-5009-081	291-5010-081	291-5011-081	291-5012-081			
	90 [1305]	291-5007-091	291-5008-091	291-5009-091	291-5010-091	291-5011-091	291-5012-091			
	100 [1450]	291-5007-101	291-5008-101	291-5009-101	291-5010-101	291-5011-101	291-5012-101			
Dynamic Signal Load Sensing	9/16 Inch Plug-O (5)	None	293-4001-121	293-4002-121	293-4003-121	293-4004-121	293-4005-121	293-4006-121		
	9/16 -18 Inch SAE (5)	None	293-4007-121	293-4008-121	293-4009-121	293-4010-121	293-4011-121	293-4012-121		

2 Series Steering Control Units

2 Series Steering Control Units

How to Order Replacement Parts

Each Order Must Include the Following:

1. Product Number
2. Date Code
3. Part Name
4. Part Number
5. Quantity of Parts

For More Detailed Information Contact Eaton Corp. Hydraulics Division 15151 Highway 5 Eden Prairie, MN 55344.

- Specifications and performance data, Catalog No. 11-872
- Replacement part numbers and kit information — Parts Information No. 7-310.

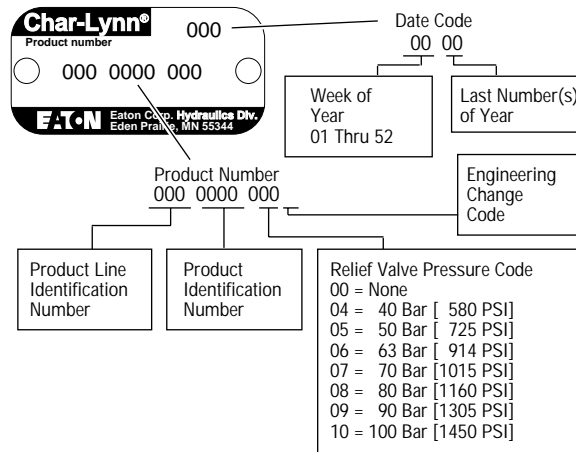

Eaton Corporation
Hydraulics Division
15151 Hwy. 5
Eden Prairie, MN 55344
Telephone 612/937-9800
Fax 612/937-7130

Eaton Ltd.
Hydraulics Division
Glenrothes, Fife
Scotland, KY7 4NW
Telephone 01-592-771-771
Fax 01-592-773-184

Eaton GmbH
Hydraulics Products
Am Schimmersfeld 7
40880 Ratingen, Germany
Telephone 02102-406-830
Fax 02102-406-800



Quality System Certified
Products in this catalog are manufactured
in an ISO-9001-certified site.

CONTENTS

	Page
INTRODUCTION	6-3
LUBRICATION	6-4
ENGINE OIL	6-4
COOLING SYSTEM	6-4
ENGINE FAN BELT	6-5
AIR INTAKE SYSTEM	6-5
AIR FILTER INDICATOR	6-5
AIR FILTER	6-5
TO REPLACE AIR FILTER ELEMENT	6-6
FUEL SYSTEM - GASOLINE	6-7
FUEL FILTER	6-7
CARBURETOR	6-7
FUEL SYSTEM - LPG	6-8
LP FUEL TANKS	6-10
TO CHANGE AN LPG FUEL TANK	6-12
FUEL FILTER LOCK	6-14
VAPORIZER-REGULATOR	6-14
CARBURETOR	6-14
OIL PRESSURE SWITCH	6-14
LPG FUEL TROUBLESHOOTING	6-15
CYLINDER HEAD	6-15
VALVE TAPPET CLEARANCE ...	6-15
CRANKCASE VENTILATION SYSTEM	6-15
GOVERNOR TROUBLESHOOTING	6-16
GOVERNOR	6-24
TO ADJUST GOVERNOR	6-24
DIGITAL CONTROLLER SET-UP	6-25
IGNITION SYSTEM	6-26
SPARK PLUGS	6-26
TO REPLACE SPARK PLUGS ...	6-26
FORD DISTRIBUTORLESS IGNITION SYSTEM	6-27
SYNOPSIS	6-27
ENGINE TEMPERATURE	6-27
RUN MODE	6-28
SERVICING AND TESTING	6-28
"FAILURE MODE OF DIS" IGNITION HARNESS	6-29
FORD DIS IGNITION	6-30
ENGINE COOLANT SENSOR	6-31
TO REPLACE ENGINE ALTERNATOR	6-32
TO REPLACE ENGINE STARTER ...	6-34
TO REMOVE ENGINE	6-35
TO INSTALL ENGINE	6-38
TO PURGE AIR FROM RADIATOR ..	6-40

GAS ENGINE SERVICE MANUAL

FORD VSG-411/413

TENNANT Part Number 38978

INTRODUCTION

This section includes repair information on the engine and related systems, such as fuel, electrical, and drive belts.

LUBRICATION

ENGINE OIL

Check the engine oil level daily. Change the engine oil and oil filter every 100 hours of machine operation. Use 10W30 SAE-SG/SH rated engine oil.

Fill the engine with oil to the level indicated on the oil dipstick. The engine oil capacity is 3.3 L (3.5 qt) including the oil filter.

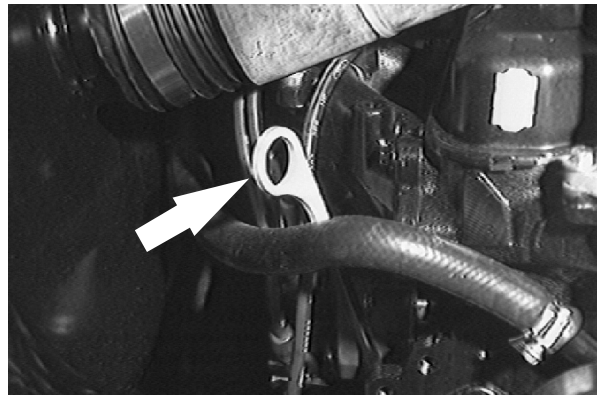

COOLING SYSTEM

Check the radiator coolant level every 100 hours of operation. Use clean water mixed with a permanent-type, ethylene glycol antifreeze to a -34°C (-30°F) rating.

FOR SAFETY: When Servicing Machine, Avoid Contact With Hot Engine Coolant.

ATTENTION! Never pour cold water or cold antifreeze into the radiator of an overheated engine. Allow the engine to cool down to avoid cracking the cylinder head or block. Keep the engine running while adding water.

Check the radiator hoses and clamps every 200 hours of operation. Tighten the clamps if they are loose. Replace the hoses and clamps if the hoses are cracked, harden, or swollen.

Check the radiator core exterior and hydraulic cooler fins for debris every 100 hours of operation. Blow or rinse all dust, which may have collected on the radiator, in through the grille and radiator fins, opposite the direction of normal air flow. The grille and hydraulic cooler open for easier cleaning. Be careful not to bend the cooling fins when cleaning. Clean thoroughly to prevent the fins becoming encrusted with dust. Clean the radiator and cooler only after the radiator has cooled to avoid cracking.

FOR SAFETY: When Servicing Machine, Wear Eye And Ear Protection When Using Pressurized Air Or Water.

Flush the radiator and the cooling system every 800 hours of operation, using a dependable cleaning compound.

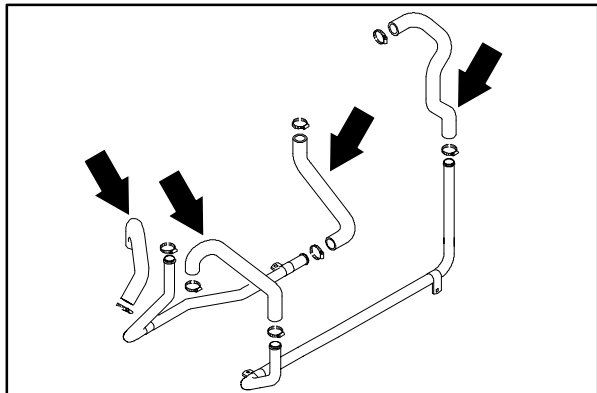
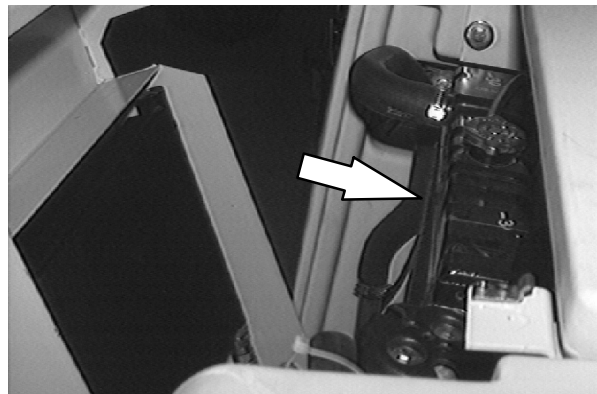
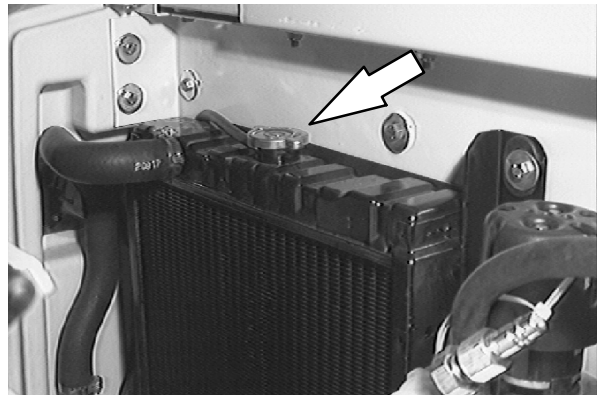

ENGINE FAN BELT

The engine fan belt is driven by the engine crankshaft pulley and drives the alternator pulley. Proper belt tension is 13 mm (0.50 in) from a force of 4 to 5 kg (8 to 10 lb) applied at the mid-point of the longest span.

Check and adjust the belt tension every 100 hours of operation.

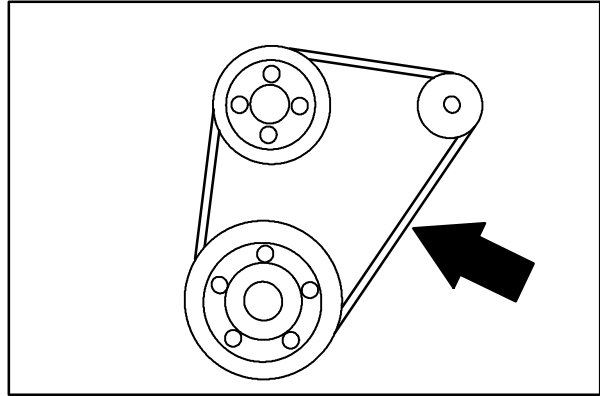

AIR INTAKE SYSTEM

AIR FILTER INDICATOR

The air filter indicator shows when to clean or replace the air filter element. Check the indicator daily. The indicator's red line will move as the air filter element fills with dirt. Do not clean or replace the air filter element until the red line reaches 5 kPa (20 in H₂O) and the "SERVICE WHEN RED" window is filled with red. The indicator's red line may return to a lower reading on the scale when the engine shuts off. The red line will return to a correct reading after the engine runs for a while.

Reset the air filter indicator by pushing the reset button on the end of the indicator after cleaning or replacing the air filter element.

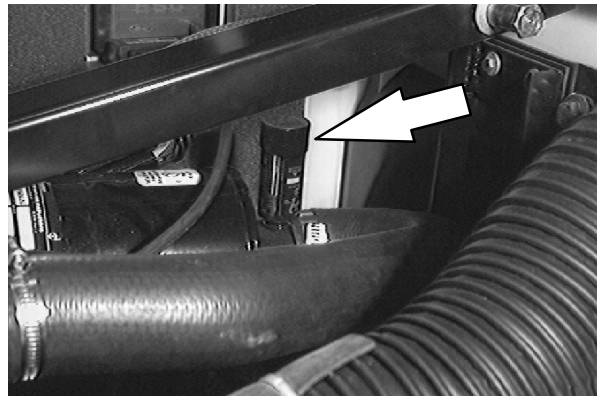

AIR FILTER

The engine air filter housing has a dust cap and a dry cartridge-type air filter element. Empty the dust cap daily. The air filter must be replaced whenever the filter element is damaged or has been cleaned three times.

Service the air filter element only when the air filter indicator shows restriction in the air intake system. Do not remove the air filter element from the housing unless it is restricting air flow.

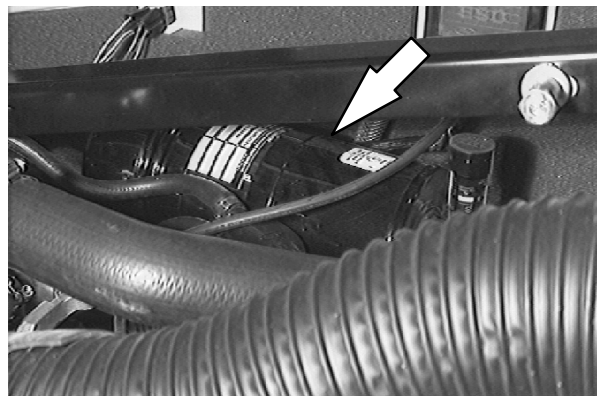

TO REPLACE AIR FILTER ELEMENT

FOR SAFETY: Before Leaving Or Servicing Machine: Stop On Level Surface, Set The Parking Brake, Turn Off Machine And Remove Key.

1. Open the engine cover and side door.
2. Unscrew the clamp ring on the filter.
3. Remove the dust cap.
4. Empty the dust cap.
5. Remove the filter wing nut.
6. Pull the filter element out of the filter housing.
7. Clean the interior of the air cleaner housing with a camp cloth. Clean the element housing sealing surfaces.
8. Using an air hose, direct dry, clean air maximum 205 kPa (30 psi) up and down pleats on the inside of the filter. Do not rap, tap, or pound dust out of the element.

FOR SAFETY: When Servicing Machine, Wear Eye And Ear Protection When Using Pressurized Air Or Water.

9. After cleaning the air filter element, inspect it for damage by placing a bright light inside. The slightest rupture requires replacement of the filter. Clean and inspect the seals on the ends of the element. They should be unbroken and flexible. Remember to replace the element after cleaning it three times.
10. Install the new or cleaned filter element so the fins on the element are at the intake end of the air cleaner. Be careful not to damage the fins. Make sure the element is seating evenly. Tighten the element wing nut.
11. Install the dust cap with the arrows pointing up. Tighten the clamp ring to hold it in place. Check all intake hose connections for leaks or abrasions.
12. Reset the air filter restriction indicator.
13. Close the access doors.

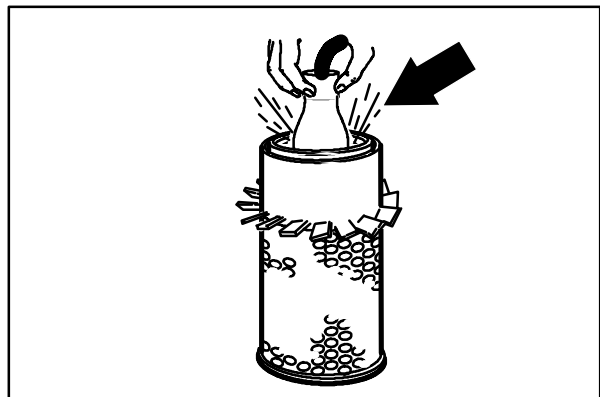
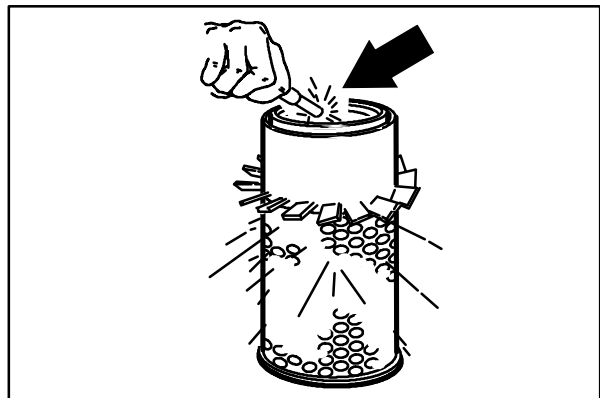
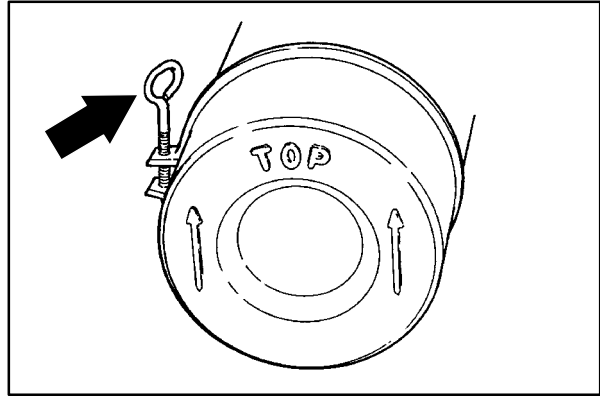

FUEL SYSTEM - GASOLINE

FUEL FILTER

The fuel filter trap fuel contaminants. The filter is located on the fuel line going into the carburetor.

Replace the filter elements every 400 hours of operation.

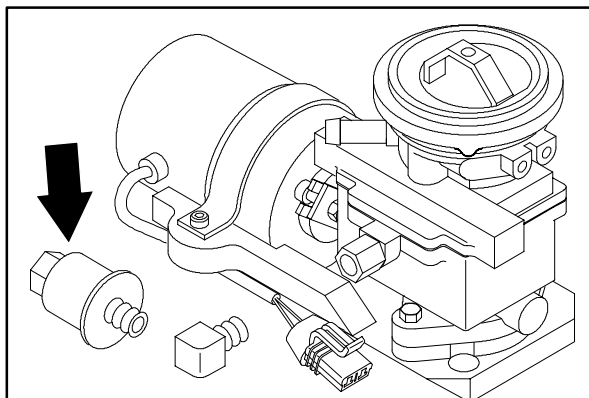
**CARBURETOR**

The carburetor has two basic adjustments. Those adjustments are idle fuel mixture and idle speed. Check and adjust idle fuel mixture and idle speed every 100 hours of operation.

FOR SAFETY: When Servicing Machine, Keep Flames And Sparks Away From Fuel System Service Area. Keep Area Well Ventilated.

The idle speed is controlled by a screw located on the side of the carburetor next to the throttle linkage. Increase the engine speed by turning the screw clockwise. Decrease the engine speed by turning the screw counter-clockwise. Idle speed is 800 to 900 rpm for gasoline, and 900 to 1000 for LPG, with no power to the electronic governor.

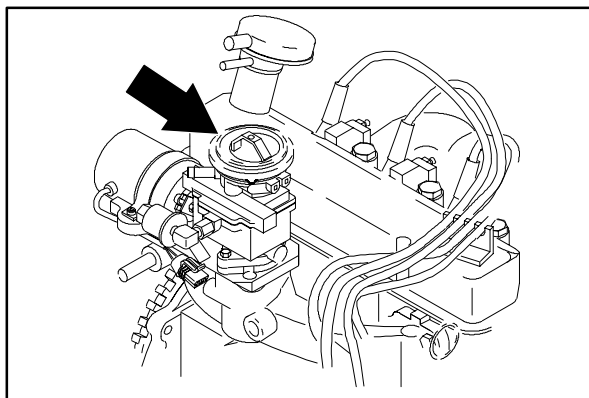

FUEL SYSTEM - LPG

The liquid withdrawal LPG fuel system has up of five components: the LPG fuel tank, pressure relief valve, fuel filter lock, vaporizer-regulator, and the carburetor.

Liquid LPG fuel flows from the LPG tank, under its own pressure, to the pressure relief valve. Usually this valve is closed, preventing LPG fuel from escaping into the atmosphere. The valve opens to relieve pressure if the fuel pressure exceeds system limits. From the pressure relief valve, the liquid LPG fuel flows to the fuel filter lock.

The fuel filter lock filters unwanted tank scale and deposits out of the LPG fuel. The fuel filter lock also stops the flow of LPG fuel when the engine is not operating. The oil pressure switch controls the fuel filter lock. When the engine oil pressure is 35 kPa (5 psi) or greater, the oil pressure switch permits an electrical current to open the fuel filter lock which allows LPG fuel to flow on to the vaporizer-regulator. The oil pressure switch is bypassed when the engine is being started, allowing LPG fuel to flow.

The vaporizer section of the vaporizer-regulator converts the liquid LPG fuel into a gaseous LPG fuel. From the vaporizer section, the gaseous LPG fuel is sent to the primary regulator section of the vaporizer-regulator. The primary regulator section reduces the pressure of the LPG fuel. The secondary regulator section reduces the LPG fuel pressure to the level required by the carburetor. From the vaporizer-regulator, the LPG fuel is sent to the carburetor where it is finally metered into the air flow sent to the engine combustion chamber.

Never operate an LPG powered machine if the LPG fuel system is leaking, or if any component in the fuel system is malfunctioning. Operating the machine under either of these conditions may cause a fire or explosion.

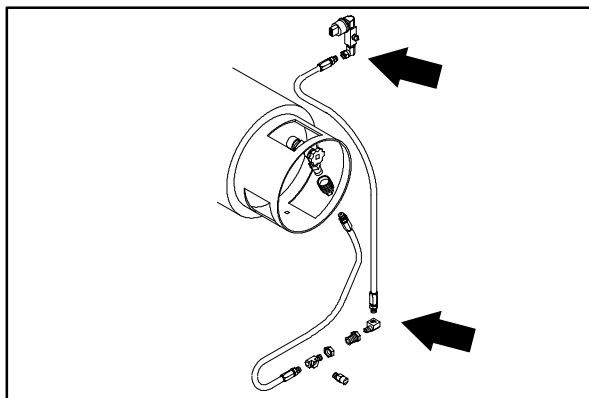
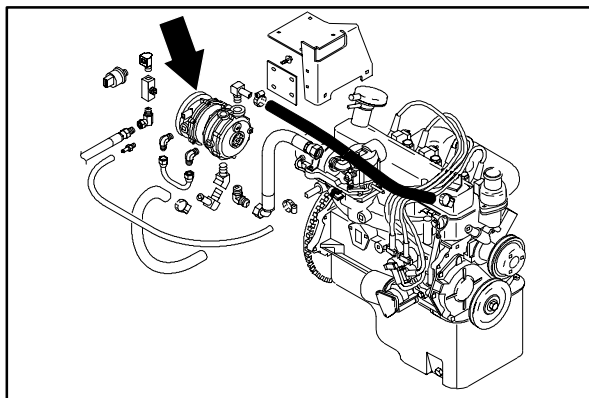

Check for frosting. If frosting occurs on or near any LPG component, there is a possible LPG fuel leak or malfunctioning component.

To locate the leak, apply a soapy water solution to the suspected area. Watch for bubbles forming in this suspected area. This area may have an LPG fuel leak. Repair or replace the part. Use Loctite brand Stainless Steel PST thread sealant when reassembling. Aging or high humidity does not affect this epoxy-type sealant. Be sure to follow application directions and apply proper torque when reconnecting fittings. Never bypass safety components except to test. If they are defective, replace them before operating the machine. Frosting does not occur before the engine reaches operating temperature. Check after engine reaches operating temperature.

Check routings of all LPG hoses. Keep them away from sharp edges, exhaust manifolds, or other hot surfaces. Check for signs of abrasion or deterioration. Replace worn or damaged hoses.

LP FUEL TANKS

The LPG fuel tanks should be inspected for sharp dents, gouges, leaks, and broken protecting rings whenever the tanks are refilled. All tank valves must be inspected for leaks using a soap solution. Valves must also be checked for dirt, paint, or other debris in the valve openings. The following specific checks must also be made:

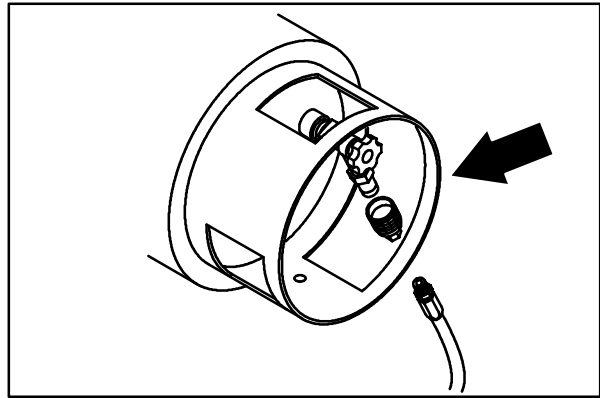

Filler Valve - Check the valve for proper functioning and the presence of the handwheel. Valve must be closed except during filling.

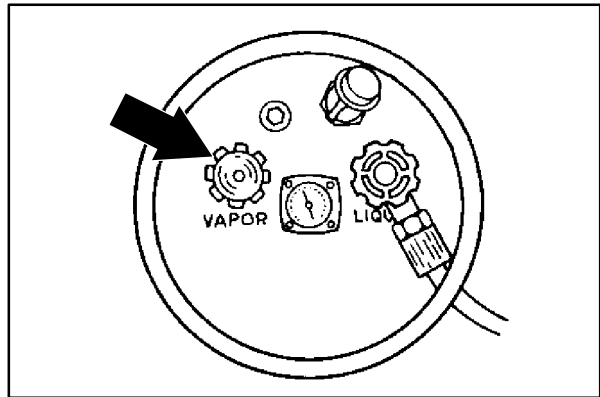

Liquid Service Valves - Check the valve for proper functioning and presence of the handwheel. The valve must be closed except when in service.

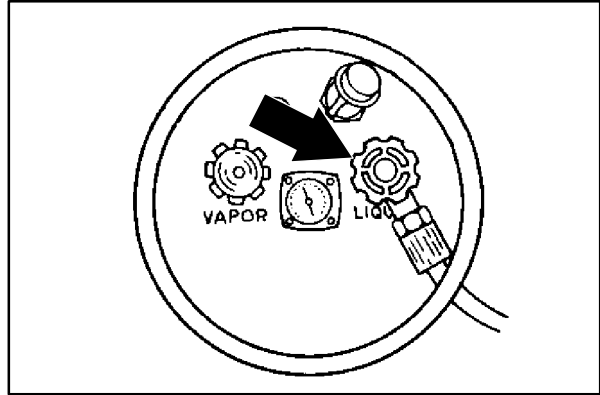

Tank Service Valve Coupling - Check for proper functioning, thread condition, and damaged or missing washers or o-rings.

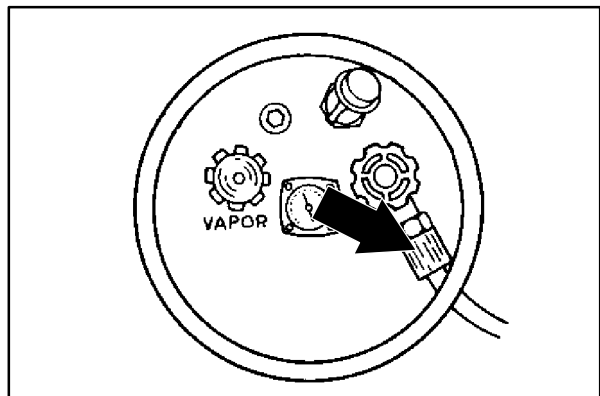

Safety Relief Valve – Check for damage. Check for the presence of the relief valve elbow and the proper direction of the elbow. If the rain cap is missing, check for foreign matter and replace the rain cap. Do not tamper with the relief valve setting.

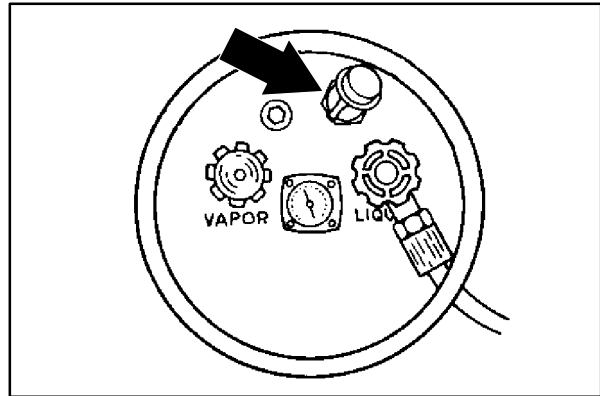

Magnetic Liquid Level Gauge – Check the operation against the maximum filling point as determined by weight.

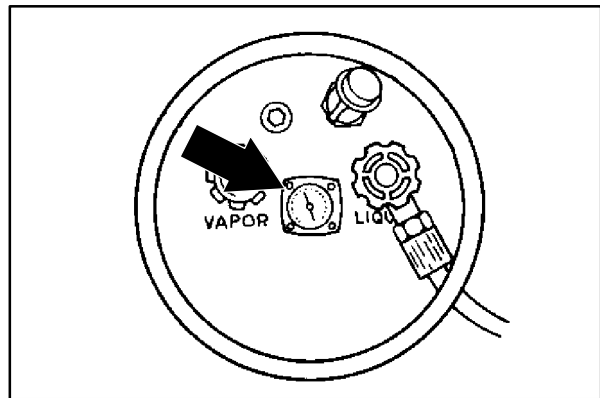

An LPG fuel tank with any of the stated defects must be removed from service and be repaired or destroyed accordingly.

If an LPG fuel tank is damaged or leaking, it should be removed to a designated safe area. Do not attempt to make repairs to the tank, regardless of condition. Qualified personnel must make repairs or disposal.

The care an LPG fuel tank receives has a direct bearing on how long that tank can be used safely. LPG fuel tanks must not be dropped or dragged across any surface. To move LPG fuel tanks, use a hand truck or roll the tank on its foot ring while it is being held in a position slightly off the vertical.

Whether the storage is inside or outside, fuel tanks should not be stored near combustible materials or high temperature sources such as ovens and furnaces, since the heat may raise the pressure of the fuel to a point where the safety relief valves would function. Store the tanks in a way that if the safety relief valves do function, they will relieve vapor and not liquid.

ENGINE-GAS/LP

Valves on empty tanks must be closed during storage and transportation.

Similar precautions should be taken in storing machines fitted with LPG fuel tanks. The machines may be stored or serviced inside buildings, provided there are no leaks in the fuel system and the tanks are not overfilled. While machines are being repaired inside a building, the shut-off valve on the tank must be closed, except when the engine has to be operated.

Changing the tank is a chance for the machine operator to carefully check over the tank, fittings, and the fuel lines and fittings. If abnormal wear is detected, report the findings to the appropriate personnel.

TO CHANGE AN LPG FUEL TANK

1. Park the machine in a designated safe area.
2. Close the tank service valve.
3. Operate the engine until it stops from lack of fuel, then set the machine parking brake.

FOR SAFETY: Before Leaving Or Servicing Machine: Stop On Level Surface, Set The Parking Brake, Turn Off Machine And Remove Key.

4. Put on gloves and remove the quick-disconnect tank coupling.
5. Inspect the LPG fuel lines for wear or damage.
6. Remove the empty LPG fuel tank from the machine.
7. Check the tank for damage or wear.
8. Store the tank in a designated, safe area.
9. Select a filled LPG fuel tank and inspect it for damage or leaks.

NOTE: Make sure the LPG fuel tank matches the fuel system (liquid tank with liquid system).

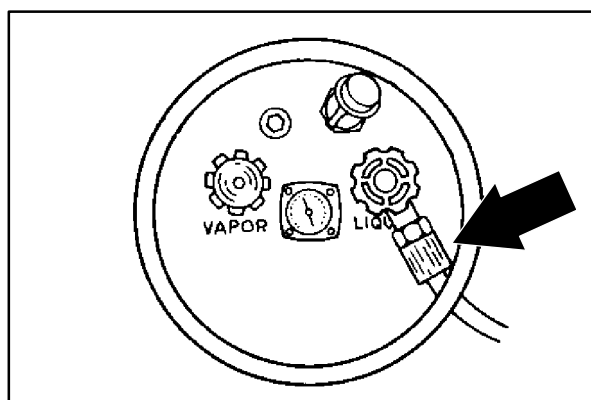
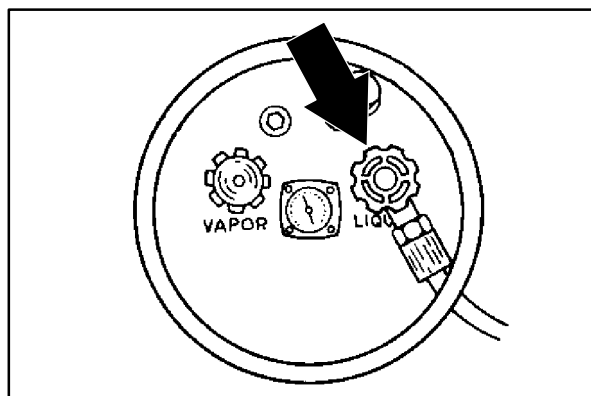

10. Carefully put the LPG tank in the machine so that the tank centering pin enters the aligning hole in the tank collar.

NOTE: If you cannot line up the centering pin, make sure you have the correct LPG fuel tank and then adjust the pin locator in or out.

11. Fasten the tank hold-down clamp to lock the tank in position.
12. Connect the LPG fuel line to the tank service coupling. Make sure the service coupling is clean and free of damage. Also make sure it matches the machine service coupling.
13. Open the tank service valve slowly and check for leaks. Close the service valve immediately if an LPG leak is found, and tell the appropriate personnel.
14. If no leaks are found, the engine is ready to start.

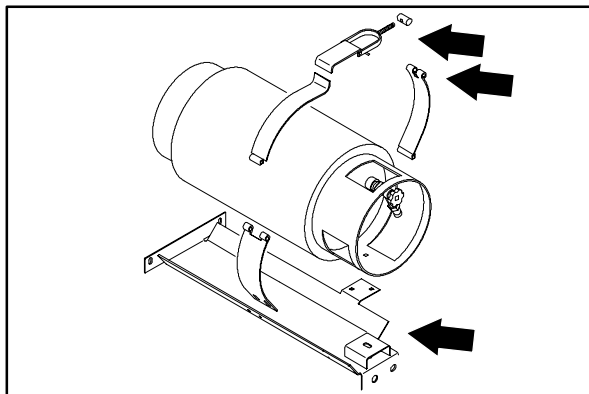

FUEL FILTER LOCK

The fuel filter lock filters the LPG fuel. It also stops the flow of LPG fuel to the engine when the engine is not operating or when the engine oil pressure is less than 35 kPa (5 psi).

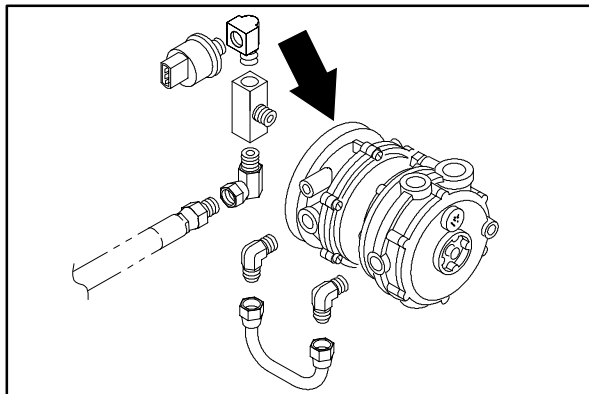

VAPORIZER-REGULATOR

If any malfunction is found, completely disassemble the vaporizer-regulator. Clean all the parts in alcohol.

Inspect all the parts and replace where needed. Carefully reassemble the vaporizer-regulator with the seal repair kit. Check for proper operation.

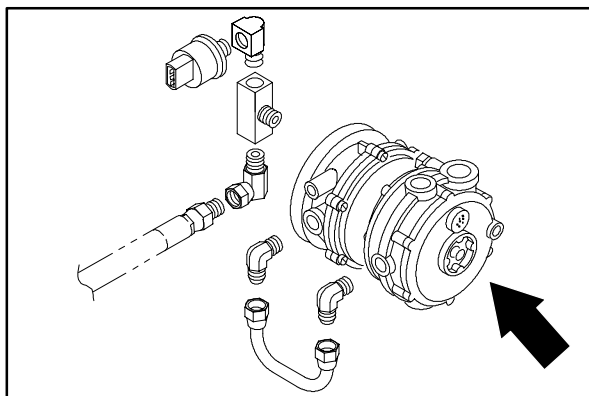

CARBURETOR

If any malfunction is found, completely disassemble the carburetor. Clean all the parts in alcohol.

Inspect all the parts and replace where needed. Carefully reassemble the carburetor with the seal repair kit.

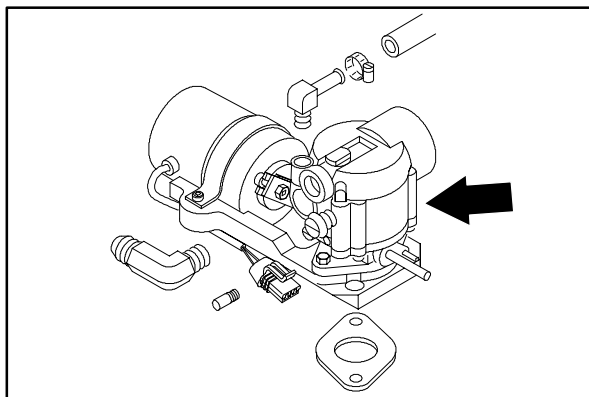

OIL PRESSURE SWITCH

The engine oil pressure switch requires no regular maintenance. Never bypass the oil pressure switch. The switch is a safety feature that prevents LPG fuel from flowing when the engine is not operating properly.

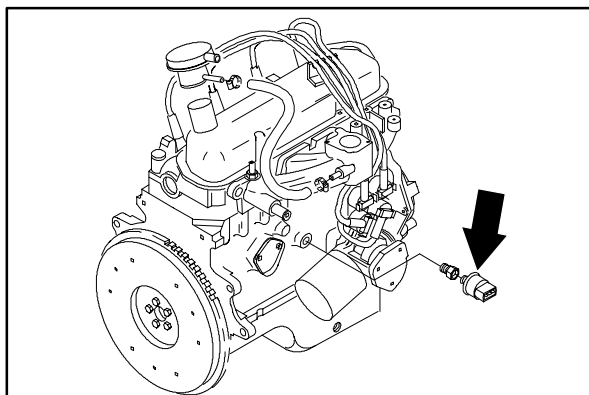

LPG FUEL TROUBLESHOOTING

Problem	Cause	Remedy
Engine will not start	Out of fuel	Replace fuel tank with full one
	Service valve opened too quickly - check valve stopped fuel flow	Close service valve and reopen slowly
	Plugged fuel filter	Replace filter
	Kinked or restricted fuel line	Straighten or replace fuel line
	Engine out of tune	Tune-up engine
	Oil pressure switch failure	Replace oil pressure switch
	Fuel lock valve failure	Repair or replace fuel filter lock
	Vaporizer-regulator failure	Repair or replace vaporizer-regulator
Engine runs unevenly or lacks power	Wrong type of fuel tank - vapor withdrawal tank	Replace vapor withdrawal tank with liquid withdrawal tank
	Plugged fuel filter	Replace filter
	Kinked or restricted fuel line	Straighten or replace fuel line
	Engine out of tune	Tune-up engine
	Restricted air filter	Clean or replace air filter element
	Vaporizer-regulator out of adjustment	Adjust vaporizer-regulator

CYLINDER HEAD

A three-stage torque procedure should be used when reassembling the cylinder head. Tighten the cylinder head bolts seasonally. See Ford VSG 411/413 Engine Service Manual.

VALVE TAPPET CLEARANCE

Check and adjust the intake valve clearance to 0.22 mm (0.009 in), and the exhaust valve clearance to 0.32 mm (0.013 in) while the engine is cold the first 50 hours of operation and every 400 hours there after. See Ford VSG 411/413 Engine Service Manual.

CRANKCASE VENTILATION SYSTEM

Clean the crankcase ventilation hoses, tubes, and fittings and replace the PCV valve every 400 hours of operation.

GOVERNOR TROUBLESHOOTING

1. The first step in this troubleshooting is to disconnect the throttle linkage at the carburetor and work the throttle at the carburetor by hand.

If you can run the engine by hand and it works with no problems, go to step four.

If the problem continues, it is not with the governor, it is with the ignition signal fuel systems or the engine itself.

2. Ignition Signal

The DIS engine has no distributor, but the timing signals that drive the governor originate from the Ignition Control input leads. They are the Yellow Wire #71 and the Yellow Wire #72. To test this, use the governor test harness (**TENNANT Part No. 66137**). Once the harness is in place, use a tach/dwell meter to test for the proper RPM's and a flat ignition signal. Test at the test plug at either Pin C, or Pin D.

NOTE: An inductive RPM pickup won't work for this test.

NOTE: When checking the RPM's at Pin C, and Pin D, the ignition signal will be half of the total RPM's the engine is running at because of the DIS system.

Your readings should be:

TOTAL READING-GAS

- a. Start/Idle - 800 RPM
- b. I - 1350 ± 50 RPM
- c. II - 2400 ± 50 RPM

TOTAL READING-LPG

- a. Start/Idle - 900 RPM
- b. I - 1350 ± 50 RPM
- c. II - 2400 ± 50 RPM

3. Fuel System

A common problem that has been encountered on LPG machines is a restricted fuel hose (a clogged fuel filter can have the same effect).

If the governor opens the carburetor wide open and the engine loses speed, the problem is not in the governor. The fuel system is at fault. The purpose of the governor is to open the carburetor and to bring the engine to set RPM's depending on where you have the speed control switch set at.

After you have verified that the ignition system and the fuel system are not at fault, go to the next step.

ENGINE-GAS/LP

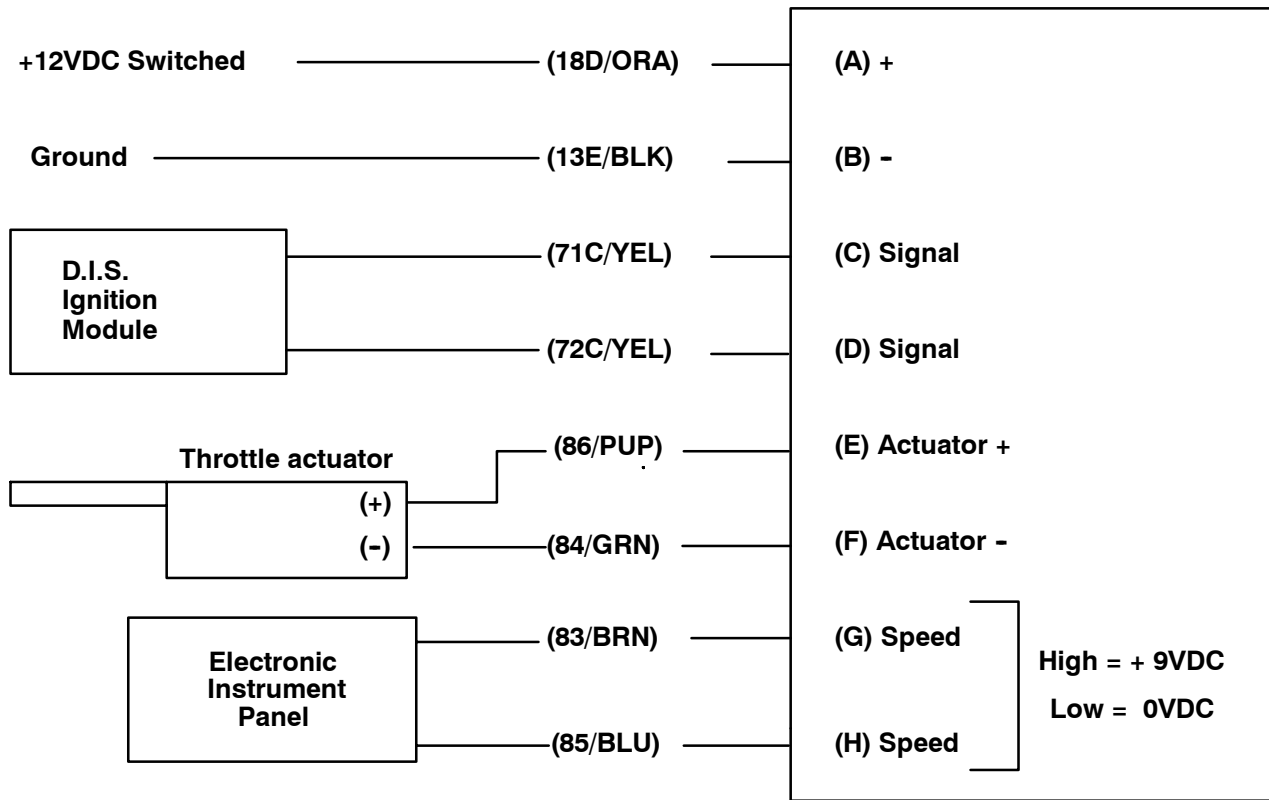

ELECTRONIC GOVERNOR WIRING PICTORIAL

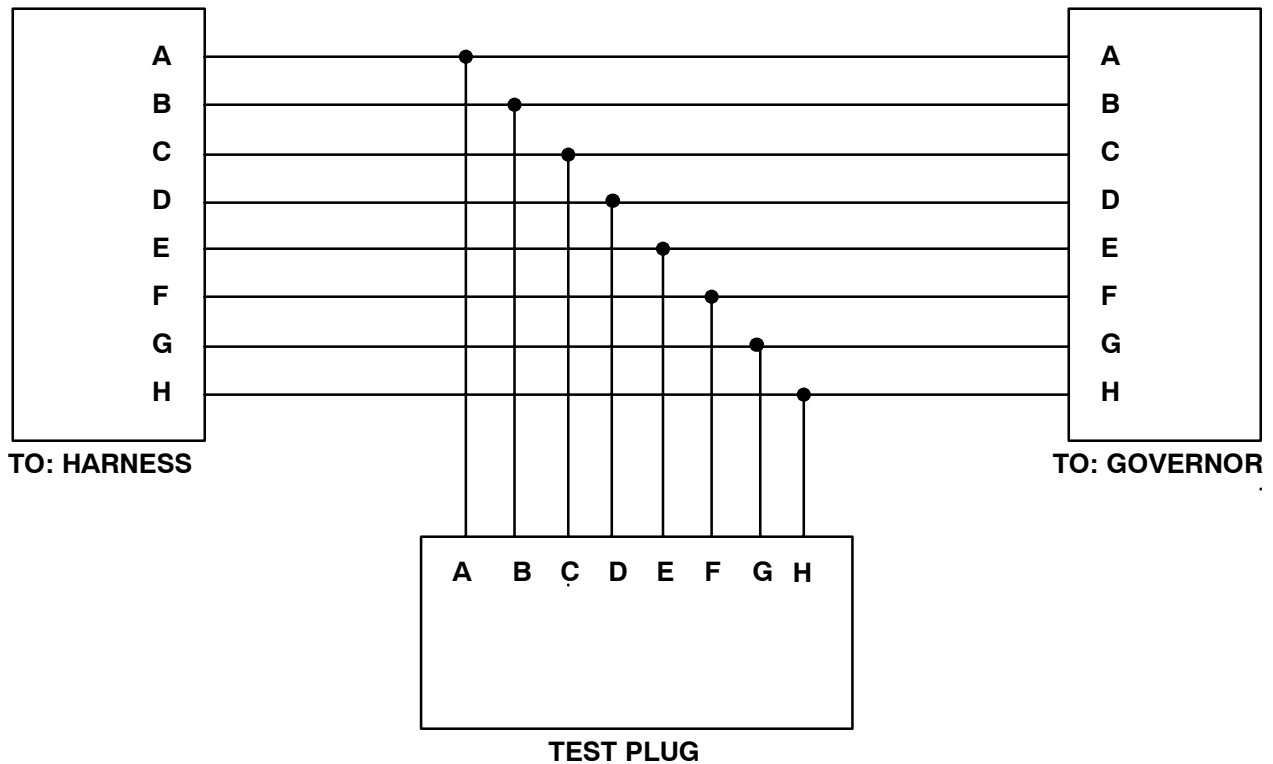

NOTE: The wire colors of the test harness do not necessarily match the machine harness.

5. System Grounds

The wire harness grounds on the machines with a DIS engine are routed to the stud on the alternator, and from there, a separate cable is routed to the bolt on the bell housing where the battery cable is attached.

If a bad ground is present, the engine will tend to run over speed.

The machine must have good grounds throughout from the battery cable to the control box.

The battery cable must be clean and tight.

There must not be a greater voltage drop than .2 volts between Pin B, on the test harness, the engine, the alternator, and the battery positive terminal and the battery negative terminal.

To do this, take your voltmeter and set it on the DC volts scale. Then with your positive probe, clamp it to battery positive. Then with the negative probe, move it to the above-stated places on the machine.

The actuator is internally isolated and does not require that the cable be grounded.

6. Start-Up Check

With the throttle switch in the engine start position, turn the ignition switch to the on position. The actuator should cycle the carburetor lever once.

NOTE: A cycle is to move from the off or idle position to the open position and then return to the off or idle position.

If this does not happen, the power wiring to the control box is probably at fault or the control box is faulty. IT IS RARE TO HAVE A FAULTY CONTROL BOX, so proceed with the following voltage checks BEFORE REPLACING IT.

7. Throttle Control Switch Check

If the engine doesn't respond to the throttle switch control:

- a. With the engine running, disconnect Wire 86, purple wire, at the actuator.

- b. Connect a jumper wire from the battery terminal on the starter to the terminal where you removed Wire 86, purple wire, from the actuator.

The engine should come up to operating speed. If the engine comes up to speed, replace the throttle control switch. If the engine doesn't respond, go to the next step.

8. Operating Voltage

The following voltage checks are done with the machine not running and using a Fluke or Beckman digital multimeter and the governor test harness.

Throttle control switch in start/idle position:

Pin A - Battery Voltage \pm .2

Pin B - 0 - this is a ground

Pin C - Battery Voltage \pm .2

Pin D - Battery Voltage \pm .2

Pin E - Battery Voltage \pm .2

Pin F - Battery Voltage \pm .2

Pin G - Battery Voltage \pm .2

Pin H - 3 to 3.5 VDC

Throttle control switch in the normal sweep position:

Pin G - < 1 VDC

Pin H - 7 to 9 VDC

Throttle control switch in the Litter sweep position:

Pin G - < 1 VDC

Pin H - < 1 VDC

The following voltage and RPM readings are at the electric control box using the test harness with the machine running.

NOTE: when you are testing if you should be in the DC or AC scale on your multimeter. You will also need your tach/dwell for the RPM checks.

The readings are taken with either a Fluke or Beckman digital multimeter:

Throttle control switch in the start/idle position:

Pin C - 675 ± 100 RPM

Pin D - 675 ± 100 RPM

Pin E - Battery Voltage $\pm .2$

Pin F - 6 to 6.5 VAC

Throttle control switch in the normal sweep position:

Pin C - 1100 ± 25 RPM

Pin D - 1100 ± 25 RPM

Pin E - Battery Voltage $\pm .2$

Pin F - 6.5 to 7 VAC

Throttle control switch in the litter sweep position:

Pin C - 1200 ± 25 RPM

Pin D - 1200 ± 25 RPM

Pin E - Battery Voltage $\pm .2$

Pin F - 7 to 7.5 VAC

If you do not get these values:

Pin A - Check battery, wiring/connections, and also the charging system.

Pin B - Check all grounds.

Pin C - Check ignition system and fuel systems.

Pin D - Check ignition system and fuel systems.

Pin E - Possible control board.

Pin F - Possible control board.

Pin G - Possible switch.

Pin F - Possible switch.

The volt readings at the actuator with the machine running and using a Fluke or Beckman digital multimeter:

At the terminal where Wire 84, green wire, is hooked to:

Start/Idle - 6 to 6.5 VAC \pm .2

Normal - 6.5 to 7 VAC \pm .2

Litter - 7 to 7.5 VAC \pm .2

At the terminal where Wire 86, purple wire, is hooked to:

Start/Idle - 12 to 14.5 VDC \pm .2

Normal - 12 to 14.5 VDC \pm .2

Litter - 12 to 14.5 VDC \pm .2

9. Control Box Adjustment

If all the above aspects, in particular the linkage, have been verified and the warmed up engine either:

- a. Hunts at running speed with the accessories off.
- b. Responds very sluggishly to switch changes, an adjustment change in the control box may be necessary.

FOR ANALOG CONTROLLERS:

Cut and remove the RTV seal on the back of the box.

A slight adjustment of the surge screw may be necessary to correct the conditions mentioned above. Turn the screw approximately 2° at a time and wait for 30 seconds to verify the change. Be careful. Only a slight change is necessary, and the "pot" can be broken if too much force is used.

After the control throttle response is achieved, verify that the operating speeds are correct and adjust, if necessary. After the speeds are reset, the surge screw may have to be readjusted.

In general, if a new box is being installed, a gasoline-equipped machine may require that the sensitivity be reduced slightly.

When the sensitivity is adjusted, the run speed should not be affected. If the adjustment is too great, the start speed will be affected. Verify that the start speed is correct.

If too much sensitivity is adjusted in, the engine will either hunt in a no load condition or over speed severely when the speed switch is actuated.

If too little sensitivity is adjusted in, the engine will seem sluggish. The engine speed will drop off when the load is increased and not recover promptly.

The engine speed should not drop off, but you can have the three hunts of the engine.

If, for some reason, the sensitivity adjustment became grossly maladjusted, a good starting point can be obtained by rotating the pot fully counterclockwise and then back clockwise 45°.

After the adjustments are made and verified, reassemble the back plate and reseal the plate with a bead of RTV to keep dust and moisture out of the box.

FOR DIGITAL CONTROLLERS:

See *TO ADJUST GOVERNOR* section of this manual.

GOVERNOR

The electronic governor controls engine speed. The governor consists of an ignition control assembly, a control box, and an actuator mounted on the engine. The ignition control assembly and control box regulate the actuator, which in turn controls the throttle.

The electronic governor is factory set and is not user serviceable.

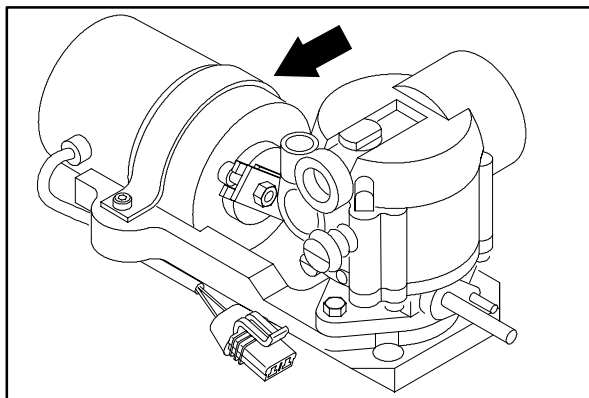

TO ADJUST GOVERNOR

1. Raise the front of the machine and place jack stands under the frame.

FOR SAFETY: Block machine tires before jacking machine up. Jack machine up at designated locations only. Block machine up with jack stands.

2. Start the engine and warm to operating temperature.
3. Move the speed switch to idle, all accessories off.
4. Move the speed switch to the fast position.
5. For ANALOG CONTROLLER: If engine speed surges occur, turn the surge adjustment screw (located on back of governor control box under hole plug) counterclockwise one-eighth of a turn.

Repeat until surges do not occur.

Replace hole plug if removed for adjustment.

6. For DIGITAL CONTROLLER: Follow the instructions on the *DIGITAL CONTROLLER SET-UP* diagram.
7. Remove the jack stands and lower the machine.

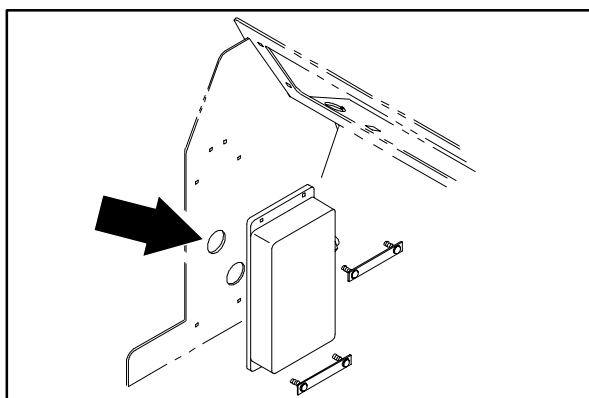
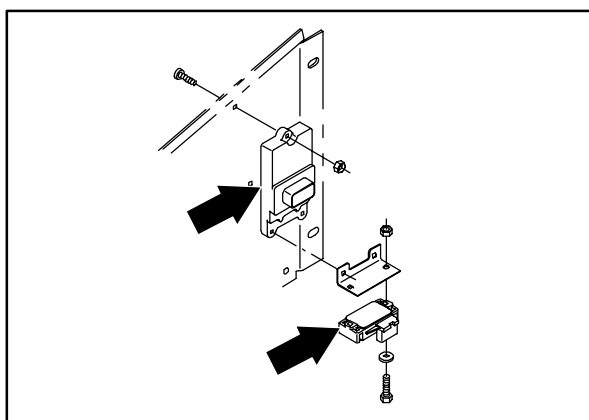

Set DIP switches according to controller label, before installing to controller.

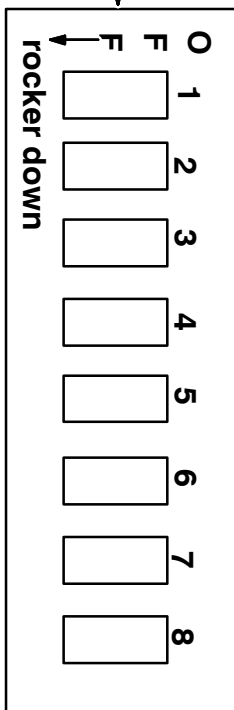

Digital Controller
p/n 374763

Controller Set-Up:		DIP Switch Settings:					
Program Number	Machine Model	Switch number starting from left					
		#1	#2	#3	#4	#5	#6
#1	355/6500/6550/8200/8210/7400 Gas/LP	ON	OFF	OFF	OFF	OFF	OFF
#2	6550/7400/8200/8210 Diesel w/ SJ actuator (linear)	OFF	ON	OFF	OFF	OFF	OFF
#3	355/6500/6550/7400 Diesel w/ SF (rotary) actuator	ON	ON	OFF	OFF	OFF	OFF
#4	800/810 Gas	OFF	OFF	ON	OFF	OFF	OFF
#5	800/810 LP	ON	OFF	ON	OFF	OFF	OFF
#6	800/810 550/1550 Diesel	OFF	ON	ON	OFF	OFF	OFF
#7	8400/8410 Gas	ON	ON	ON	OFF	OFF	OFF
#8	8400/8410 LP	OFF	OFF	OFF	ON	OFF	OFF
#9	8400/8410 Diesel	ON	OFF	OFF	ON	OFF	OFF
#10	6500II LP / Gas	ON	ON	OFF	ON	OFF	OFF
#11	6500II/6550II Diesel	OFF	OFF	ON	ON	OFF	OFF
#12	800/810 Diesel – 2 spd	ON	OFF	ON	ON	OFF	OFF
#13	800/810 Gas - 2 spd	OFF	ON	ON	ON	OFF	OFF
#14	800/810 LP – 2 spd	ON	ON	ON	ON	OFF	OFF
#15	355/6500/6550/8200/8210/7400 Gas/LP – special 2 spd	OFF	OFF	OFF	OFF	ON	OFF
#16	6550/7400/8200/8210 Diesel w/ SJ actuator (linear) sp. 2 spd	ON	OFF	OFF	OFF	ON	OFF
Special DIP Settings: ↓		Special DIP Settings: ↓					
Engines with Distributor		Altitude compensation					
#7	Distributor	#8 RPM added					
ON	Distributor	ON 200 rpm					
OFF	Non Distributor (DIS)	OFF 0 rpm					

Gain pot and Trouble shooting LED can be seen through here:
←

DIGITAL CONTROLLER SET-UP

IGNITION SYSTEM

SPARK PLUGS

Clean or replace, and set the gap of the spark plugs every 400 hours of operation. A wire gauge is best for checking the spark plug gap. A flat gauge should not be used unless the electrode surfaces have been dressed with a small file to get parallel surfaces between the center and side electrode. Set the spark plug gap by bending the side electrode. All spark plugs, new or used, should have the gaps checked and reset if necessary.

The proper spark plug gap is 1 mm (0.040 in).

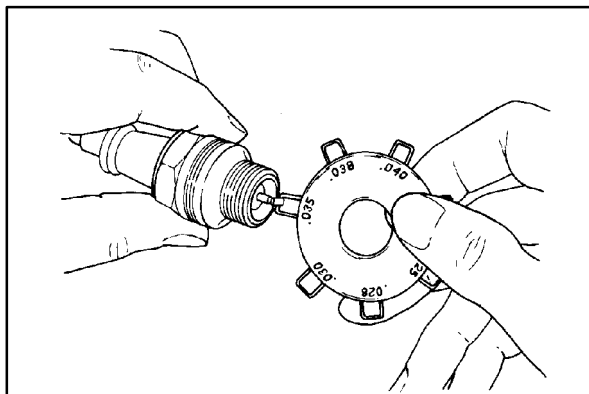

TO REPLACE SPARK PLUGS

FOR SAFETY: Before Leaving Or Servicing Machine: Stop On Level Surface, Set The Parking Brake, Turn Off Machine And Remove Key.

1. Open the engine cover and side door.
2. Remove the spark plug wires from the four spark plugs.

NOTE: Clean any dirt from the spark plug seat area before removing the spark plugs.

3. Remove the spark plugs from the engine
4. Clean the spark plug seat in the cylinder head.
5. Use a new seat gasket and screw the plug in by hand.
6. Tighten the spark plugs with a socket wrench of the correct size.

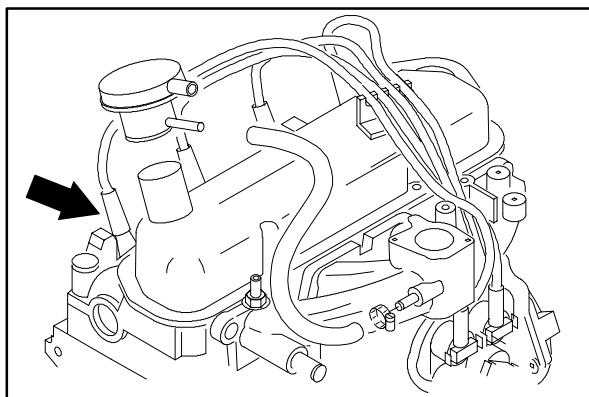

FORD DISTRIBUTORLESS IGNITION SYSTEM

SYNOPSIS

This is a troubleshooting guide for the Ford Distributorless Ignition System.

Unlike a conventional system, the Ford Distributorless Ignition System (DIS) uses two coils that each fire one pair of spark plugs. The spark plugs are also fired on both the power and exhaust stroke.

The DIS system also uses a Universal Electronic Spark Control (UESC) module which adjusts the timing of the engine. The degree of timing change needed is determined by electrical and vacuum input to the UESC, these are:

The engine harness has a separate wire for the gas and another for the LPG machines. Make sure you connect the correct wire for the type of fuel being used.

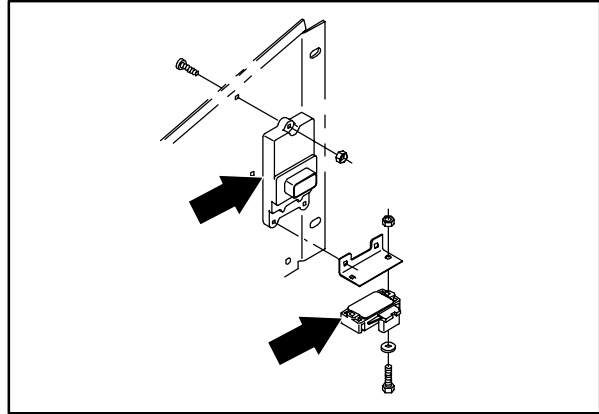
**ENGINE LOAD - FROM PRESSURE REDUCER:**

Located in the intake manifold.

Minimum 21 KPA (6.22" Hg)

Maximum 101 KPA (29.91" Hg)

ENGINE TEMPERATURE

The Engine Coolant Temperature Sensor (ECTS) located in the intake manifold water jacket sends engine temperature information to UESC.

Minimum -39° C 38° F

Maximum 112° C 232° F

When the engine is starting, at 250 RPM or less, the timing is set at 10° before top dead center (BTDC).

RUN MODE

In this mode the RPM is above 250 and the spark advance is calculated in three sections which are added together to maintain optimum running condition.

The Base Spark Advance (BSA) is calculated by the UESC module looking at speed and load inputs.

The Spark Advance Offset Temperature (SAOT) will change ignition timing. This is determined by the Engine Coolant Temperature (ECT). This allows the spark advance to be altered during cold engine conditions.

SERVICING AND TESTING

SERVICING:

1. Every 400 hours, remove the spark plugs and clean and adjust the electrode.
2. Clean and visually check spark plug high tension leads and test for resistance. The Ohm meter should read between 9,000 and 16,000 Ohms.

TESTING:

Secondary Coil Testing

Remove the four (4) spark plug wires and measure the secondary coil resistance by placing the meter into plug wire terminal.

1 - 4 at the coil

2 - 3 at the coil

On each test you should read $14,000 \pm 50$ Ohms.

Universal Spark Control Module Diaphragm Testing

Using a vacuum pump, apply 15" Hg to the UESC and vacuum inlet. The diaphragm should hold the pressure. If it fails, replace UESC unit.

To test the sensors and wiring harness, follow the direction on the next three pages.

“FAILURE MODE OF DIS” IGNITION HARNESS

The Ford DIS Universal Spark Control was checked for “poor connection”.

The results of open leads were:

Term 11 or 12 Ignition Coil Signal Leads - The governor received 1/2 of its intended signal and caused the actuator to hold the carb arm wide open. At the same time, the engine missed due to incorrect firing of plugs, but the speed still climbed to about 3,000-4,000 rpm. When either of these leads were opened at the start speed, the engine missed slightly and rose to double the start speed or about 3,000 rpm.

Term 9 Ground - Any failure here killed the engine instantly or caused the engine to slow down if it were cycled.

Term 6 & 7 Octane Selector - Opening these terminals retards the spark in varying degrees. Under light to moderate load conditions, no adverse effect will take place. However, run-on or pre-ignition may take place.

Term 4 & 10 Coolant Sensor - Contrary to previous thoughts, opening the lead doesn't noticeably affect the engine. The timing only changes a few degrees.

Term 2 & 3 Crank Position Sensor - Opening either of these leads kills the engine quickly and it will not start.

Term 8 Power Lead - Opening this lead kills the engine and it will not start.

In summary, no alarming effect happens except if the coil signal leads are interrupted. These are the end leads on the module and if the harness has too much tension on it, the signal will become intermittent and cause the engine to overspeed. The only obvious damage will probably occur to the propelling pump, as the fan is rated for operation to 10,000 rpm. If the acc. are on when the lead becomes intermittent, the engine will not develop enough power to overspeed excessively.

ENGINE-GAS/LP

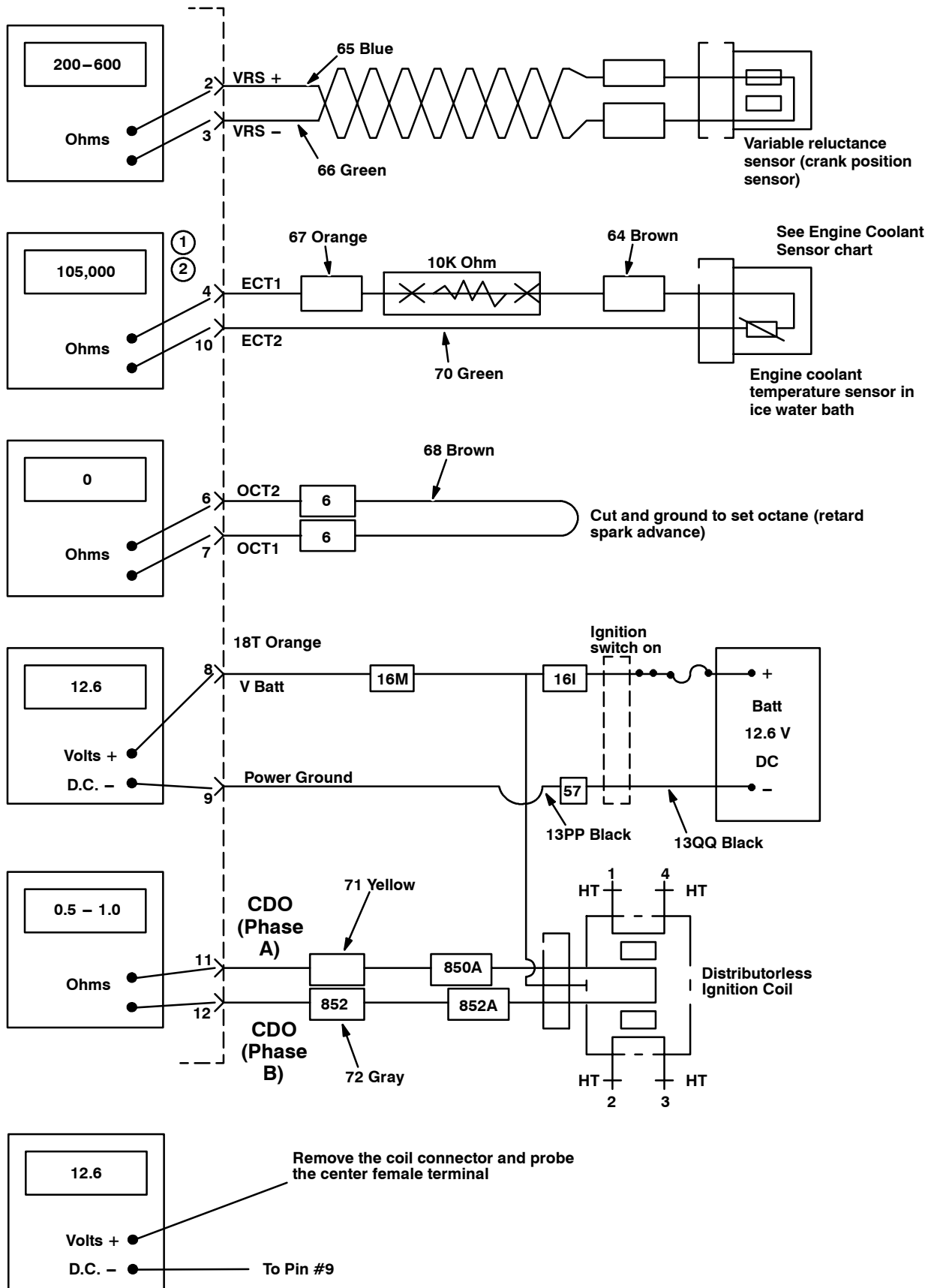

FORD DIS IGNITION

ENGINE COOLANT SENSOR

Temperature ° C ° F		Sensor (Ohms) ± .02°	Sensor & Harness (Ohms) ± .03°
-30	-22	481,000	491,000
-20	4	271,000	281,000
-10	14	158,000	168,000
0	32	95,000	105,000
10	50	58,750	68,750
20	68	37,300	47,300
30	86	24,270	34,270
40	104	16,150	26,150
50	122	10,970	20,970
60	140	7,600	17,600
70	158	5,360	15,360
80	176	3,840	13,840
90	194	2,800	12,800
100	212	2,070	12,070
110	230	1,550	11,550
120	248	1,180	11,180
130	266	930	10,930
140	284	701	10,701
150	302	550	10,550

TO REPLACE ENGINE ALTERNATOR

FOR SAFETY: Before Leaving Or Servicing Machine; Stop On Level Surface, Set Parking Brake, Turn Off Machine And Remove Key.

1. Raise the operators seat, engage the prop rod, and disconnect the battery cables from the battery.
2. Open the machine engine cover and side door. Remove the side door from the machine.
3. Remove the two hex screws holding the plastic fan belt cover to the front of the engine. Remove the cover.
4. Disconnect the wires from the back of the alternator.
5. Remove the hex screw from the top of the alternator.
6. Loosen the lower hex screw and nyloc nut and push the alternator in toward the engine. Remove the V-belt from the alternator drive pulley.
7. Remove the hex screw and nyloc nut from the bottom of the alternator. Remove the alternator.
8. If the new alternator does not have a drive pulley--remove the hex nut and washer holding the drive pulley to the old alternator. Install the drive pulley on the new alternator and tighten tight.
9. Install the new alternator back in the machine. Reinstall the lower hex screw and nyloc nut. Leave loose for now.
10. Reinstall the hex screw in the upper arm and the top of the alternator. Leave loose for now.

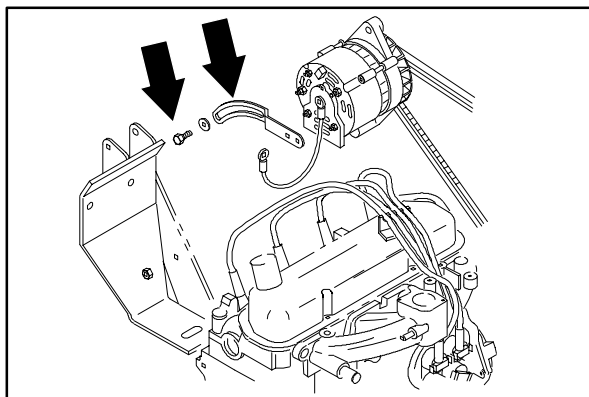
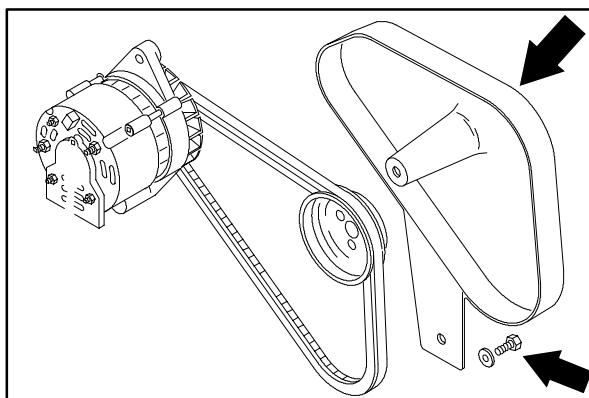
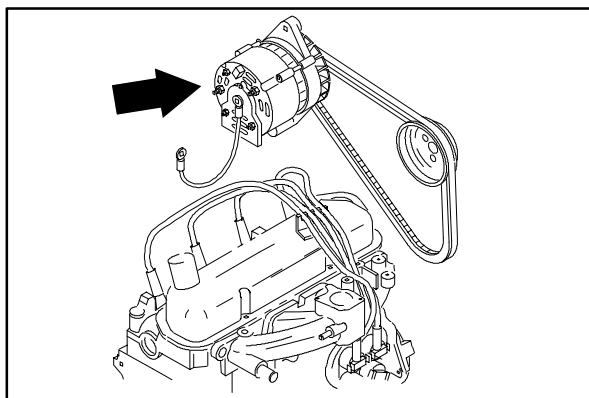

11. Reinstall the V-belt on the alternator drive pulley.
12. Pull the alternator away from the engine to tighten the V-belt. Tighten the upper hex screw tight.
13. Reconnect the wires to the back of the new alternator. See schematic in the ELECTRICAL section.
14. Reinstall the plastic belt cover to the front of the engine. Hand tighten the hex screws tight.
15. Reconnect the battery cables, close the operators seat and start the machine.
16. Check the new alternator for proper operation.

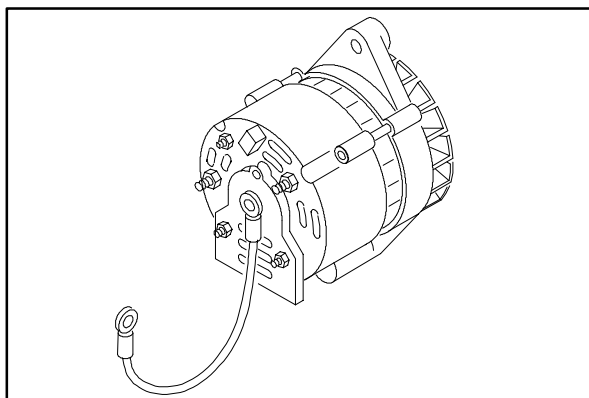

TO REPLACE ENGINE STARTER

FOR SAFETY: Before Leaving Or Servicing Machine; Stop On Level Surface, Set Parking Brake, Turn Off Machine And Remove Key.

1. Raise the operators seat, engage the prop rod, and disconnect the battery cables from the battery.
2. Open the machine front cover, engine cover, and side door. Remove the side door from the machine.
3. If the machine is an LPG, remove the LP tank from the cradle.
4. The vacuum fan assembly can be removed for better access to the starter. See TO REMOVE VACUUM FAN instructions in the SCRUBBING section.
5. Remove the air cleaner intake tube from the air cleaner and machine frame.
6. Reach in through the left side of the engine and disconnect the battery cable and electrical wires leading to the starter.
7. Reach in through the open seat support area and remove the three M10 hex screws holding the starter to the bellhousing.

NOTE: The bottom hex screw has a nyloc nut on the starter side.

8. Remove the starter out through the area of the vacuum fan and engine oil filter.
9. Position the new starter in the machine.
10. Reinstall the three M10 hex screws and one nyloc nut. The nyloc nut goes on the bottom hex screw. Tighten to 31 - 40 Nm (27 - 35 ft lb).
11. Reconnect the battery cable and electrical wires to the starter. See schematic in the ELECTRICAL section.

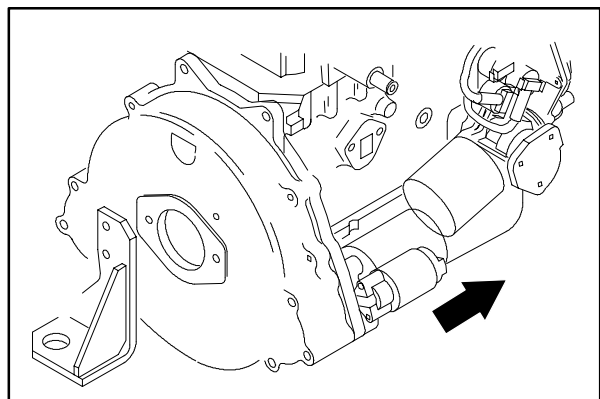
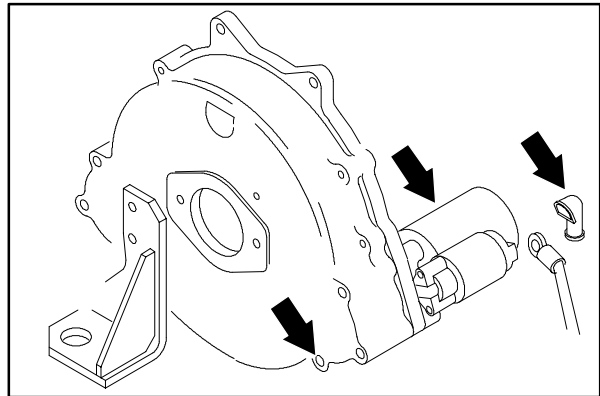
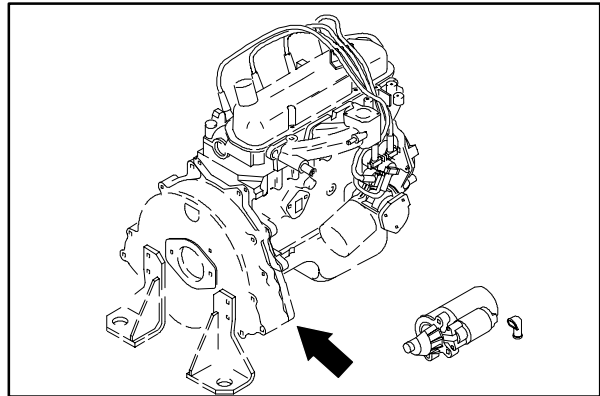
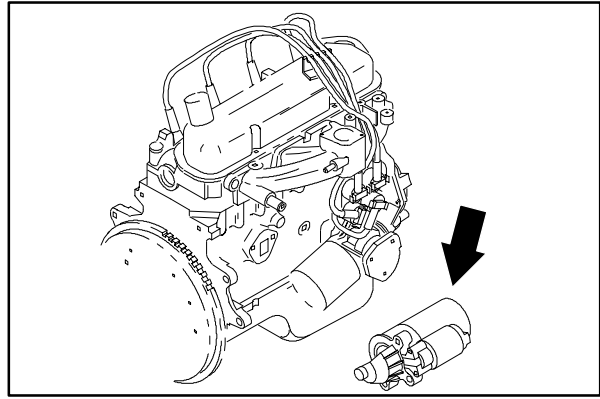

12. Reinstall the air cleaner intake tube to the air cleaner and machine frame.
13. If the vacuum fan was removed--reinstall. See TO INSTALL VACUUM FAN instructions in the SCRUBBING section.
14. Reconnect the battery cables to the battery and close the operators seat.
15. If the machine is an LPG--reinstall the LP tank.
16. Reinstall the engine side door and close the covers.
17. Start the machine.

TO REMOVE ENGINE

FOR SAFETY: Before Leaving Or Servicing Machine; Stop On Level Surface, Set Parking Brake., Turn Off Machine And Remove Key.

1. Pivot the operators seat to the open position and engage the prop rod.
2. Disconnect the battery cables and remove the battery.

NOTE: The battery tray can also be removed for better access to the propel pump.

3. Remove the detergent tank and the rubber sound flap from the machine.
4. Remove the two hex screws holding the propel pump to the engine bellhousing

NOTE: The main suction line to the accessory pump is held, by plastic ties, in a bundle of hoses near the main valve. Remove the plastic ties to gain slack in the suction line to ease pump removal.

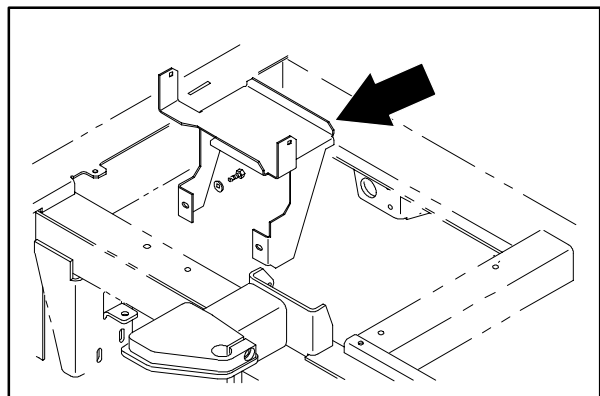
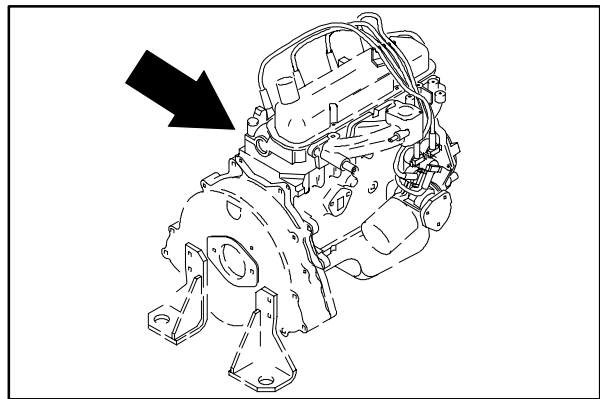

5. Remove the two hex screws holding the hydraulic flow valve to the back, left of the bellhousing. Do not disconnect any hydraulic hoses.
6. Pull the propel pump out of the bellhousing and drive coupler. Do not disconnect any hydraulic hoses.
7. If the machine is an LPG, remove the LP tank from the cradle.
8. Open the machine front cover, engine cover, and side door. Remove the side door from the machine.
9. Remove the vacuum hose from the vacuum fan and the recovery tank.
10. The vacuum fan assembly can be removed for better access to the engine. See TO REMOVE VACUUM FAN instructions in the SCRUBBING section.

NOTE: The engine hood must be supported in the open position before the next step can be completed.

11. Remove the clips on the bottom of the engine hood gas springs. Remove the gas springs from the ball studs on the support channel.
12. Remove the hex screws holding the support channel to the tank lintel and hood lintel. Remove the support channel from the machine.
13. Drain the radiator coolant.
14. Remove the radiator hoses where they connect to the engine.
15. Drain the engine oil.

NOTE: Disconnect the engine oil drain hose from the oil pan before lifting the engine completely out of the machine.

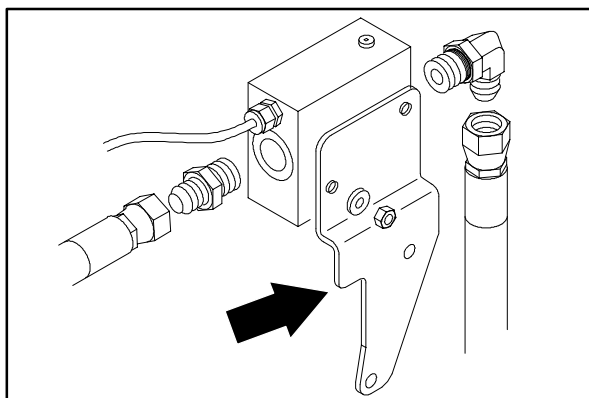
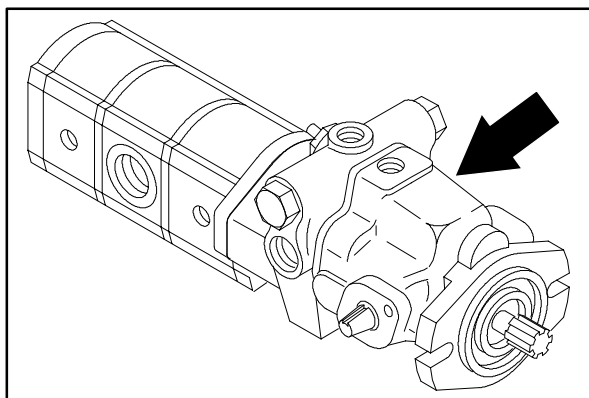
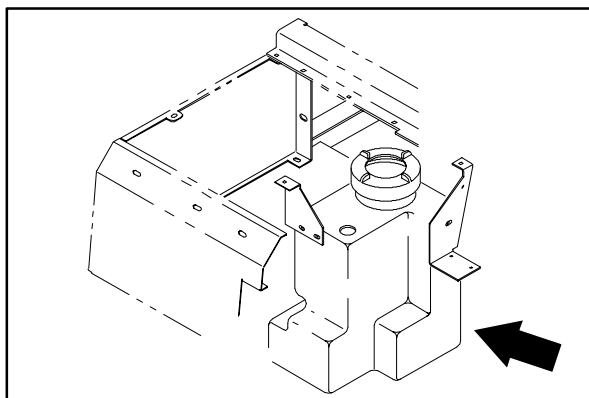

16. Disconnect the exhaust pipe at the engine manifold.
17. Disconnect the wire harness from all of the engine components and place it out of the way.
18. Disconnect the engine ground strap from frame.
19. Disconnect the battery cable and electric wires from the engine starter.
20. Disconnect the fuel line at the fuel pump on a gas machine.
21. Disconnect the fuel line from the LP tank at fuel lockoff / vaporizer on an LPG machine.
22. Using an overhead hoist, hook a chain or strap through two or three pick-up points on the engine. Put a slight amount of tension on the chain.
23. Remove the three M12 hex screws and nyloc nuts holding the motor mounts to the rubber isolators on the machine frame.
24. Engine can now be carefully lifted out.

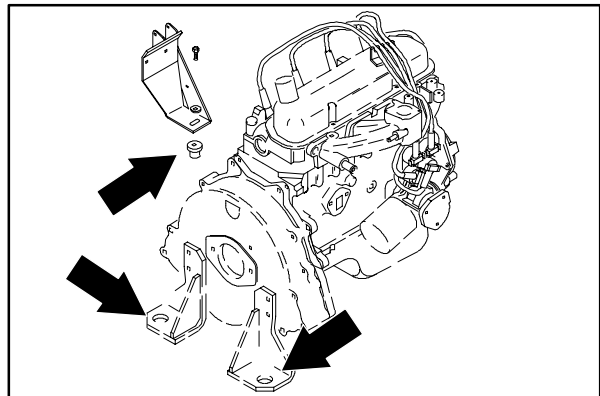
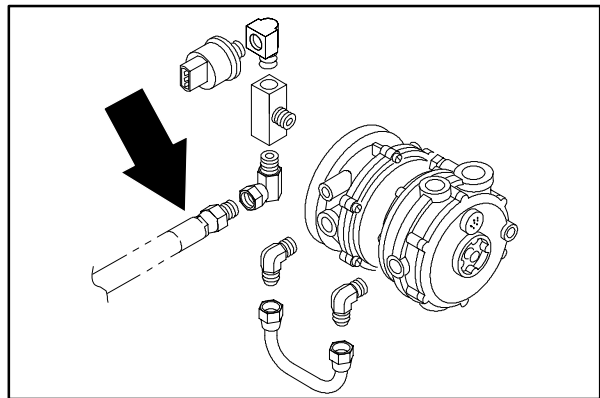
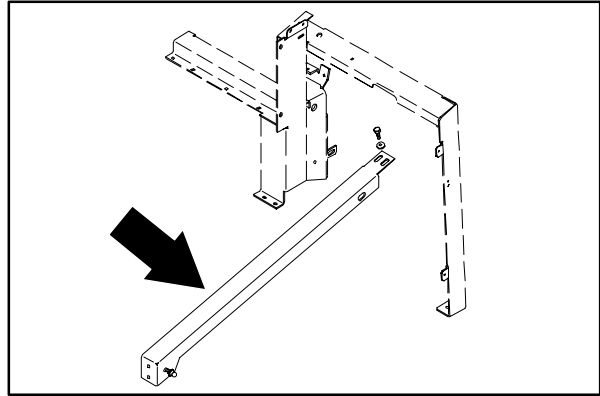

TO INSTALL ENGINE

FOR SAFETY: Before Leaving Or Servicing Machine; Stop On Level Surface, Set Parking Brake., Turn Off Machine And Remove Key.

1. Using a overhead hoist, hook a chain or strap through two or three pick-up points on top of the engine. Carefully position the engine back in the engine compartment.
2. Carefully Lower the engine assembly down on the the motor mounts.

NOTE: Make sure the hoses, wire harness, exhaust pipe, and propel pump are pulled back out of the way when lowering the engine assembly in place.

3. Reinstall the three M12 hex screws in the three motor mount isolators. Tighten to 64 - 83 Nm (50 - 60 ft lb)
4. Reconnect the ground cable from the bellhousing to the machine frame.
5. Reinstall the flow valve on the back, left of the bellhousing.
6. Reconnect the battery cable and electrical wires to the starter. See schematic in the ELECTRICAL section.
7. Reconnect the wire harness to engine components, alternator, governor actuator, oil switch, temperature sender, distributor, and ignition module. See schematic in the ELECTRICAL section.
8. Reinstall the propel pump back in the bellhousing. Use a small amount of blue loctite 242 on the threads. Reinstall the two hex screws. Tighten to 64 - 83 Nm (50 - 60 ft lb).

NOTE: Make sure the splines on pump line up with splines in coupler when installing pump.

9. Reinstall the detergent tank in the seat support area.
10. Reinstall the battery tray and battery.
11. Reinstall the exhaust pipe back on the manifold. Reinstall the muffler clamp and tighten tight.

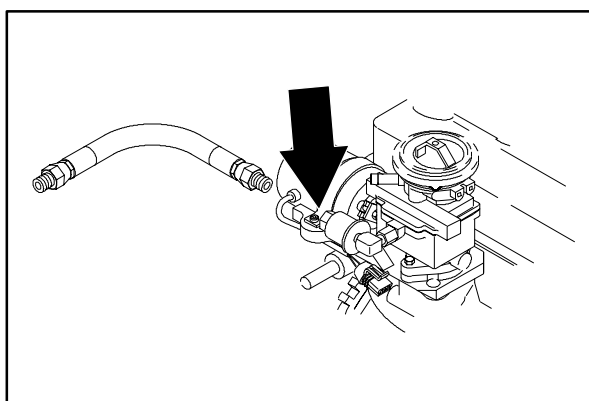
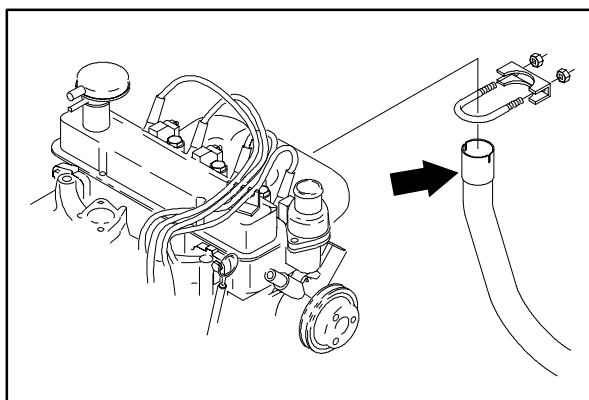
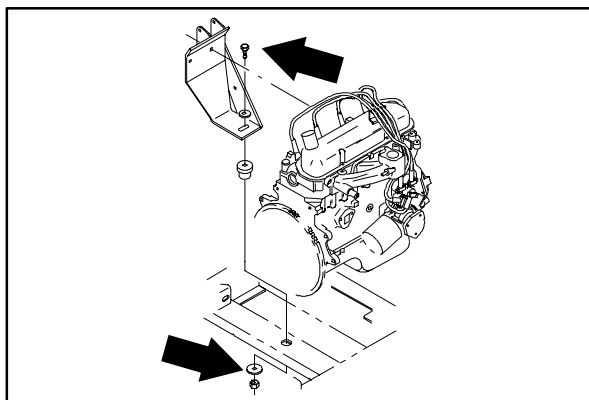
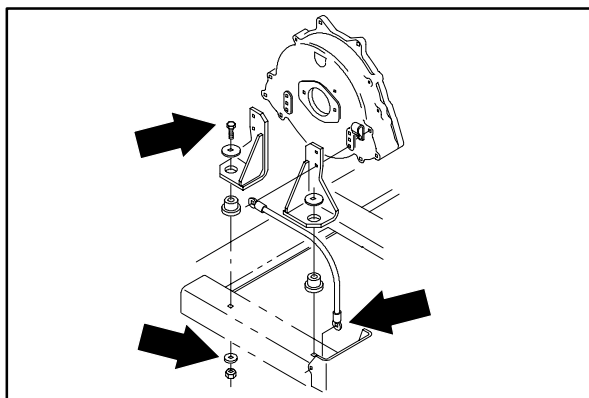

12. Reconnect the fuel line at the fuel pump on a gas machine.
13. Reconnect the fuel line from the LP tank at fuel lockoff / vaporizer on an LPG machine.
14. Fill the engine with the proper grade of oil.
15. Reinstall the radiator hoses to the engine and fill the radiator with coolant. See TO PURGE AIR FROM RADIATOR instructions.
16. If the vacuum fan was removed--reinstall. See TO INSTALL VACUUM FAN instructions in the SCRUBBING section.
17. Reinstall the vacuum hose on the recovery tank and vacuum housing.
18. Reinstall the support channel to the tank lintel and hood lintel. Reinstall the four hex screws and tighten to 18 - 24 Nm (15 - 20 ft lb).
19. Reinstall the engine hood gas springs on the ball studs on the support channel. Reinstall the two clips.
20. Reconnect the battery cables.
21. Disengage the prop rod and lower the seat.
22. Reinstall the LP tank on a LPG machine.
23. Jack up the front of the machine and place jack stands under the frame.

FOR SAFETY: Block machine tires before jacking machine up. Jack machine up at designated locations only. Block machine up with jack stands

24. Start the machine. Check the engine, hydraulic motors, and pumps for leaks.
25. Reinstall the engine side door and close the covers.

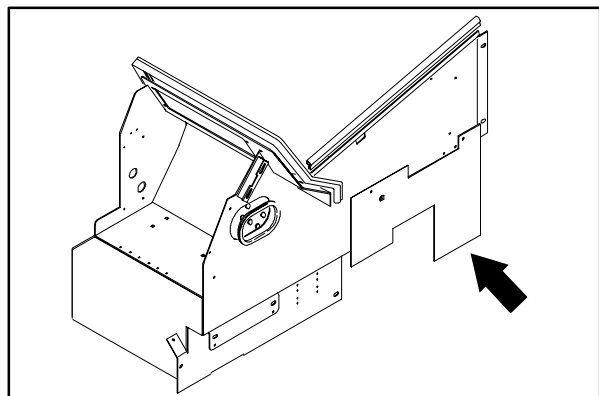
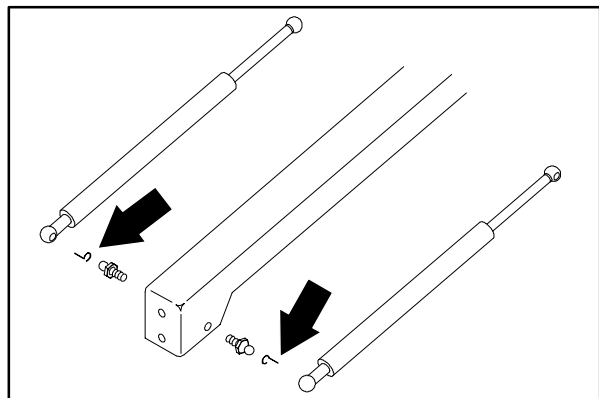
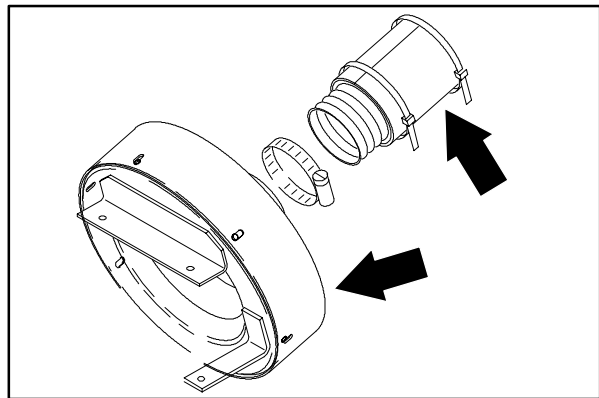
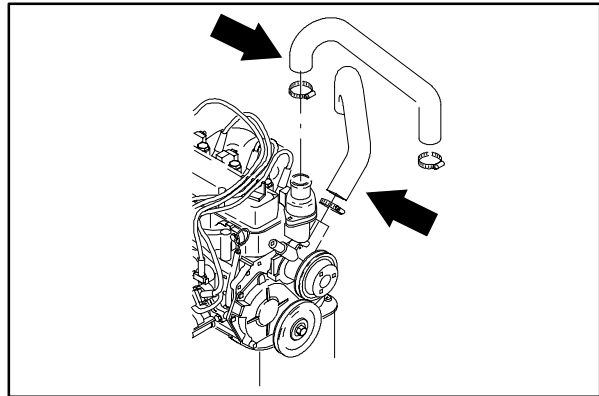

TO PURGE AIR FROM RADIATOR

FOR SAFETY: Before Leaving Or Servicing Machine; Stop On Level Surface, Set Parking Brake., Turn Off Machine And Remove Key.

1. Make sure that both radiator hoses are connected to the engine.
2. Remove the radiator cap and pour in approximately 1-1/2 gallons of coolant.
3. Open the engine cover and side door.
4. Loosen the hose clamp on the upper radiator hose. *This is the hose on the thermostat housing.*
5. Break the hose loose from the neck of the thermostat housing and **slowly** pull the hose off the neck.
6. Keep the hose off the neck until coolant starts to flow out of the hose.
7. Quickly place the hose back on the neck of the thermostat housing. Re-tighten the hose clamp.
8. Start the machine and run it to operating temperature. Shut off the engine.
9. Let the machine cool down for and carefully re-check the level of the radiator coolant. There should be enough room to pour another 1/2 gallon of coolant in. If not--repeat steps 4 thru 8.
10. If the machine overheats--repeat steps 4 thru 8.

NOTE: There may be air trapped in one of the radiator hoses. It might take one or two tries to completely purge all of the air from the cooling system.

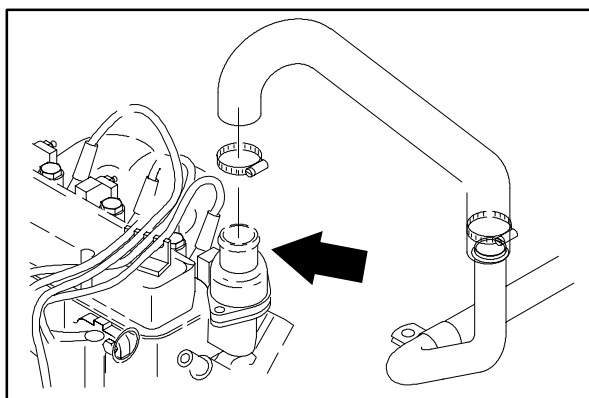
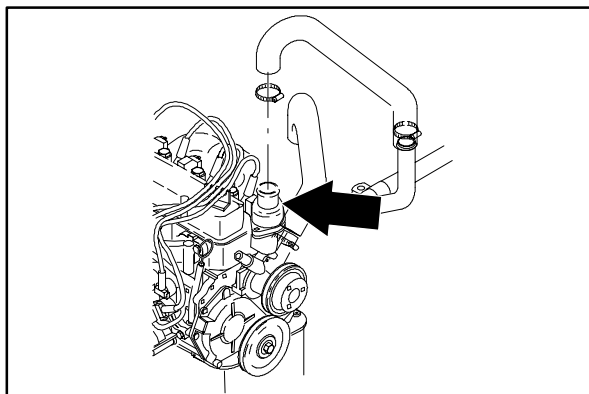
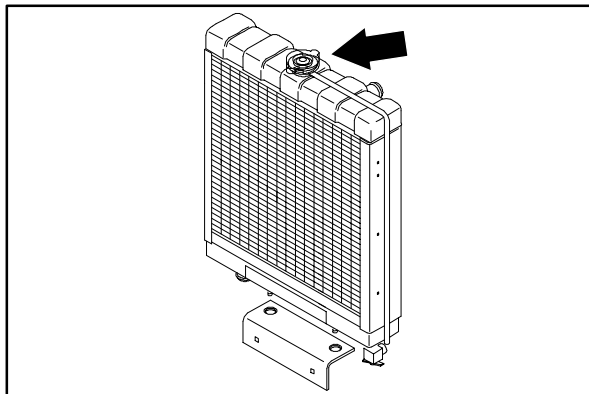

CONTENTS

	Page
LUBRICATION	7-3
ENGINE OIL	7-3
COOLING SYSTEM	7-3
ENGINE FAN BELT	7-4
AIR INTAKE SYSTEM	7-4
AIR FILTER INDICATOR	7-4
AIR FILTER	7-4
TO REPLACE AIR FILTER ELEMENT	7-5
FUEL SYSTEM	7-6
FUEL FILTER	7-6
TO REPLACE THE FUEL FILTER	
CARTRIDGE	7-6
FUEL LINES	7-7
TO PRIME FUEL SYSTEM	7-7
TO REPLACE ENGINE ALTERNATOR ..	7-8
TO REPLACE ENGINE STARTER	7-10
TO REMOVE ENGINE	7-12
TO INSTALL ENGINE	7-14
TO PURGE AIR FROM RADIATOR	7-16

DIESEL ENGINE SERVICE MANUAL**KUBOTA V1505 B (E)****TENNANT Part Number 84660**

INTRODUCTION

This section includes repair information on the engine and related systems, such as fuel, electrical, and drive belts.

ENGINE-DIESEL

LUBRICATION

ENGINE OIL

Check the engine oil level daily. Change the engine oil and oil filter every 100 hours of machine operation. Use 10W30 SAE-CC/CD rated engine oil.

Fill the engine with oil to the level indicated on the oil dipstick. The engine oil capacity is 6 L (6.3 qt) with out the oil filter.

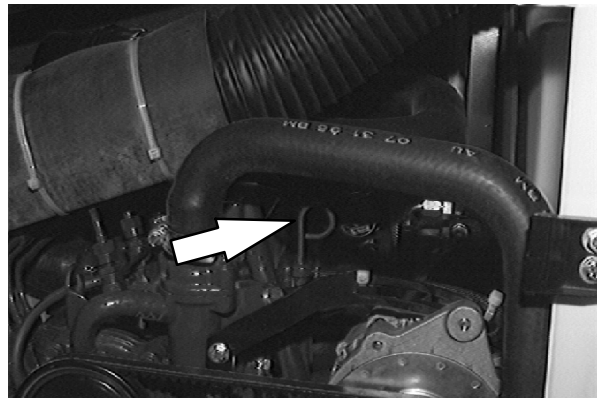

COOLING SYSTEM

Check the radiator coolant level every 100 hours of operation. Use clean water mixed with a permanent-type, ethylene glycol antifreeze to a -34°C (-30°F) rating.

FOR SAFETY: When Servicing Machine, Avoid Contact With Hot Engine Coolant.

ATTENTION! Never pour cold water or cold antifreeze into the radiator of an overheated engine. Allow the engine to cool down to avoid cracking the cylinder head or block. Keep the engine running while adding water.

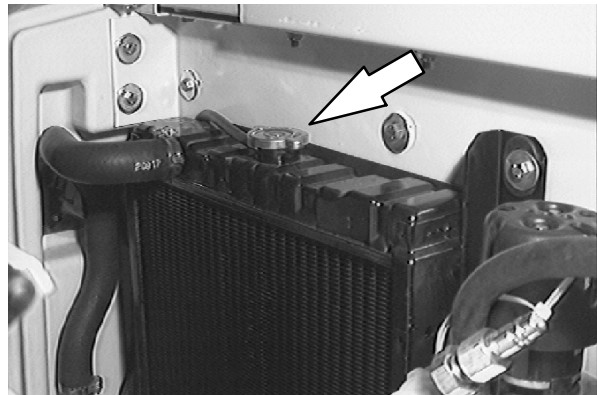

Check the radiator hoses and clamps every 200 hours of operation. Tighten the clamps if they are loose. Replace the hoses and clamps if the hoses are cracked, harden, or swollen.

Check the radiator core exterior and hydraulic cooler fins for debris every 100 hours of operation. Blow or rinse all dust, which may have collected on the radiator, in through the grille and radiator fins, opposite the direction of normal air flow. The grille and hydraulic cooler open for easier cleaning. Be careful not to bend the cooling fins when cleaning. Clean thoroughly to prevent the fins becoming encrusted with dust. Clean the radiator and cooler only after the radiator has cooled to avoid cracking.

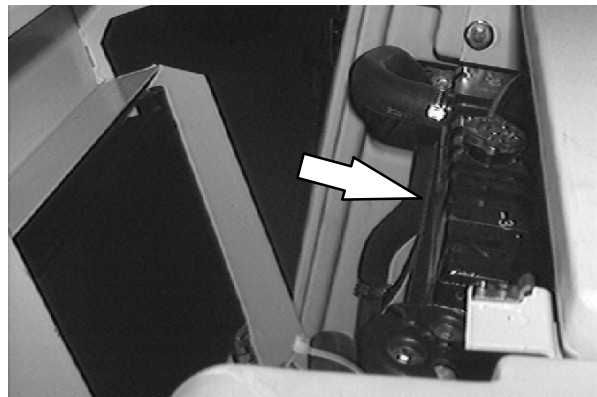

FOR SAFETY: When Servicing Machine, Wear Eye And Ear Protection When Using Pressurized Air Or Water.

Flush the radiator and the cooling system every 400 hours of operation, using a dependable cleaning compound.

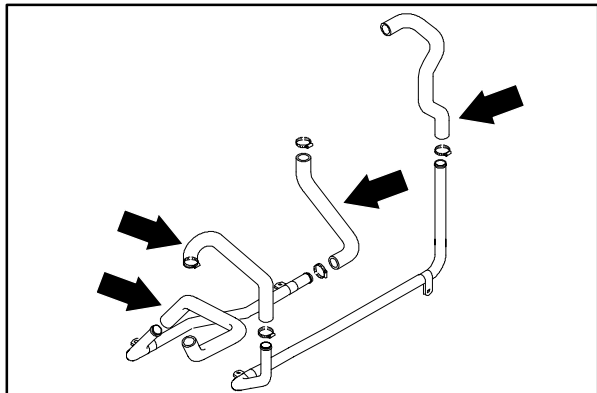

ENGINE FAN BELT

The engine fan belt is driven by the engine crankshaft pulley and drives the alternator pulley. Proper belt tension is obtained when the belt deflects 7 to 9 mm (0.28 to 0.35 in) from a force of 10 kg (22 lb) applied at the mid-point of the longest span.

Check and adjust the belt tension every 100 hours of operation.



WARNING: Moving belt and fan. Keep away.

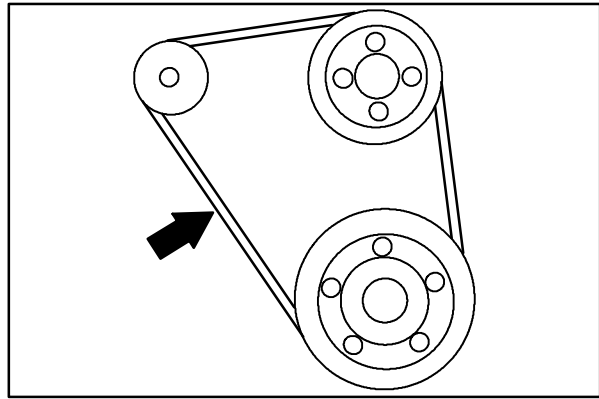

AIR INTAKE SYSTEM

AIR FILTER INDICATOR

The air filter indicator shows when to clean or replace the air filter element. Check the indicator daily. The indicator's red line will move as the air filter element fills with dirt. Do not clean or replace the air filter element until the red line reaches 5 kPa (20 in H₂O) and the "SERVICE WHEN RED" window is filled with red. The indicator's red line may return to a lower reading on the scale when the engine shuts off. The red line will return to a correct reading after the engine runs for a while.

Reset the air filter indicator by pushing the reset button on the end of the indicator after cleaning or replacing the air filter element.

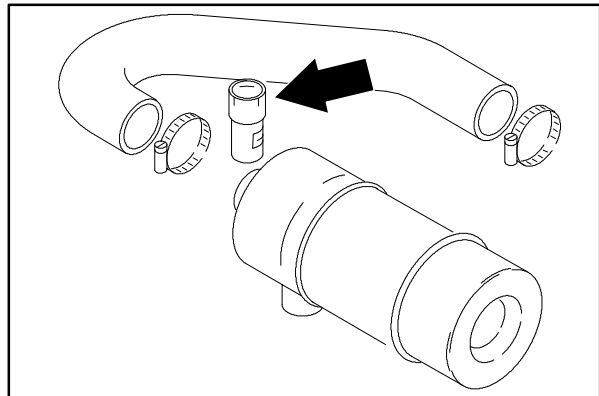

AIR FILTER

The engine air filter housing has a dust cap and a dry cartridge-type air filter element. Empty the dust cap daily. The air filter must be replaced whenever the filter element is damaged or has been cleaned three times.

Machines with the heavy duty air filter option have a safety element. It is inside the standard element. Replace, do not clean this element after the regular element has been damaged or cleaned three times.

Service the air filter element only when the air filter indicator shows restriction in the air intake system. Do not remove the air filter element unless it is restricting air flow.

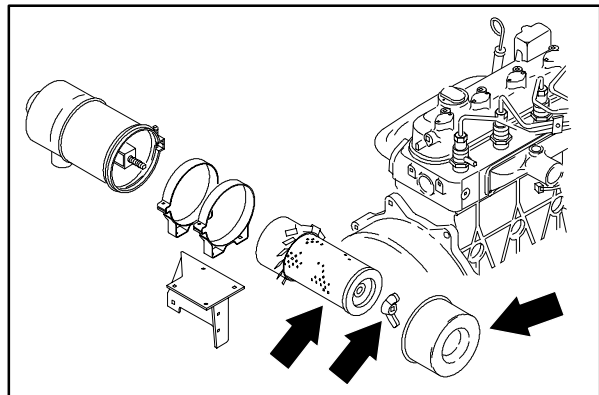

TO REPLACE AIR FILTER ELEMENT

FOR SAFETY: Before Leaving Or Servicing Machine: Stop On Level Surface, Set The Parking Brake, Turn Off Machine And Remove Key.

1. Open the engine cover and side door.
2. Unscrew the clamp ring on the filter.
3. Remove the dust cap.
4. Empty the dust cap.
5. Remove the filter wing nut.
6. Pull the filter element out of the filter housing.
7. Clean the interior of the air cleaner housing with a camp cloth. Clean the element housing sealing surfaces.
8. Using an air hose, direct dry, clean air maximum 205 kPa (30 psi) up and down pleats on the inside of the filter. Do not rap, tap, or pound dust out of the element.

FOR SAFETY: When Servicing Machine, Wear Eye And Ear Protection When Using Pressurized Air Or Water.

9. After cleaning the air filter element, inspect it for damage by placing a bright light inside. The slightest rupture requires replacement of the filter. Clean and inspect the seals on the ends of the element. They should be unbroken and flexible. Remember to replace the element after cleaning it three times.
10. Install the new or cleaned filter element so the fins on the element are at the intake end of the air cleaner. Be careful not to damage the fins. Make sure the element is seating evenly. Tighten the element wing nut.
11. Install the dust cap with the arrows pointing up. Tighten the clamp ring to hold it in place. Check all intake hose connections for leaks or abrasions.
12. Reset the air filter restriction indicator.
13. Close the access doors.

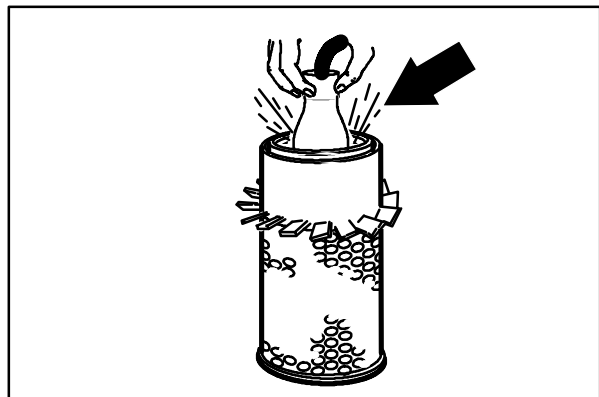
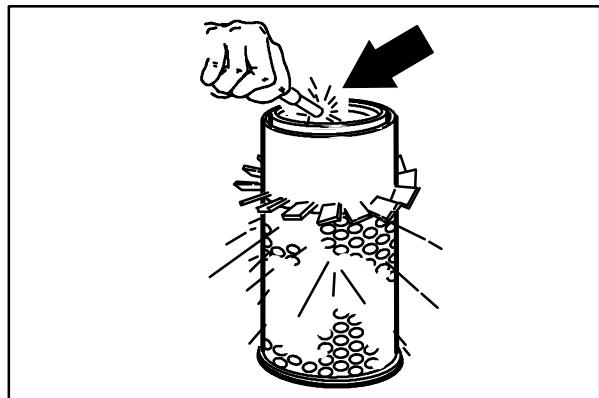
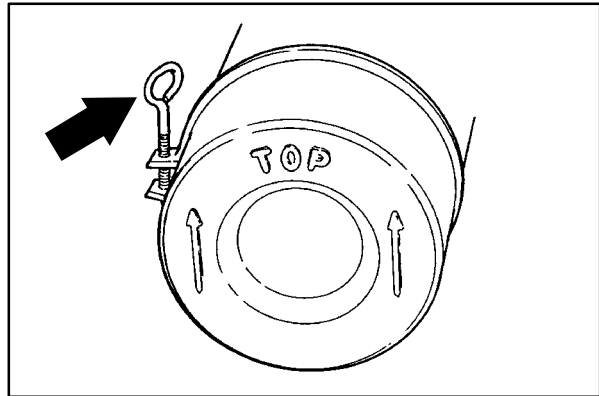

FUEL SYSTEM - DIESEL

The diesel fuel system is made up of five basic components which are: fuel tank, fuel filter/water trap, fuel pump, injection pump, and injectors.

Fuel flows from the fuel tank through the fuel filter/water trap. The water trap-filter separates water and impurities from the fuel. From the fuel water trap-filter, fuel is drawn through the electric fuel pump and pumped to the injection pump. The injection pump pressurizes and sends fuel to the injectors. The injectors atomize and inject proper amounts of fuel into the combustion chamber at the proper times. Excess fuel is returned to the fuel tank through an overflow pipe.

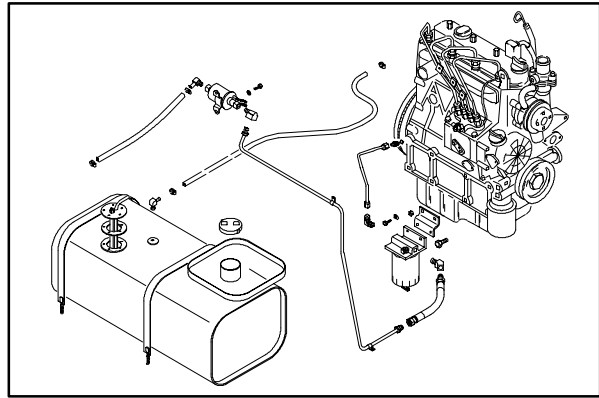

FUEL FILTER

The fuel filter cartridge filters impurities from the fuel. It is located low on the left side of the engine block.

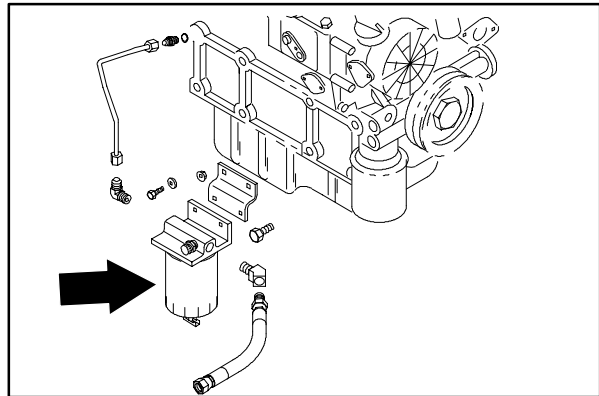

TO REPLACE THE FUEL FILTER CARTRIDGE

FOR SAFETY: Before Leaving Or Servicing Machine; Stop On Level Surface, Set Parking Brake, And Turn Off Machine.

1. Loosen the unit vent plug and open the water trap drain to drain diesel fuel.
2. Remove the filter cartridge from the filter head.
3. Lubricate the o-ring of the new filter cartridge and spin it onto the filter head.
4. Bleed the fuel lines of air as described in TO PRIME FUEL SYSTEM instructions.

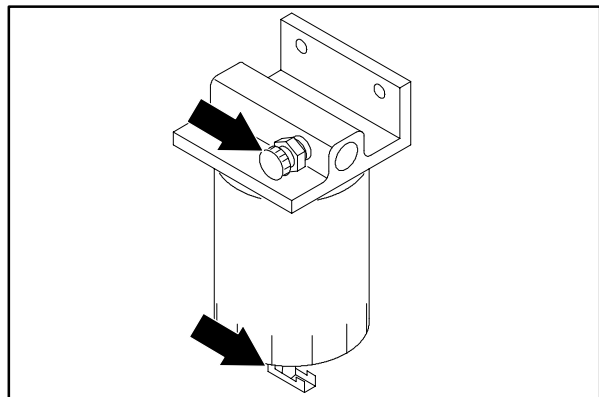

ENGINE-DIESEL

FUEL LINES

Check the fuel lines every 50 hours of operation. If the clamp band is loose, apply oil to the screw of the band, and securely tighten the band.

The rubber fuel lines can become worn-out whether the engine has been used much or not. Replace the fuel lines and clamp bands every two years.

If the fuel lines and clamp bands are found worn or damaged before two years' time, replace or repair them at once. Bleed the fuel system after replacement of any of the fuel lines, see TO PRIME THE FUEL SYSTEM. When the fuel lines are not installed, plug both ends with clean cloth or paper to prevent dirt from entering the lines. Dirt in the lines can cause fuel injection pump malfunction.

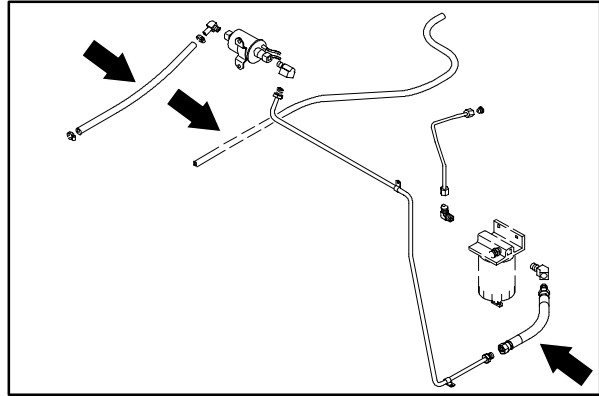

PRIMING FUEL SYSTEM

Typical diesel fuel systems require priming to remove pockets of air in the fuel lines and fuel components. This is usually required after running out of fuel, changing fuel filter elements or repairing a fuel system component. Air in the fuel system prevents smooth engine operation.

This fuel system however is self-priming. The return line comes from the top of the injector that causes all air to escape through the return line.

TO PRIME FUEL SYSTEM

FOR SAFETY: Before Leaving Or Servicing Machine; Stop On Level Surface, Set Parking Brake, And Turn Off Machine.

1. Make sure the fuel tank is full.
2. Open the air vent on top of the fuel filter.
3. Start the engine, operate it for one minute, then stop it; or operate the starter motor in ten-second intervals until a steady stream of fuel flows from the vent.
4. Close the air vent and shut off the engine.
5. Clean up any fuel that was spilled during the bleeding process.

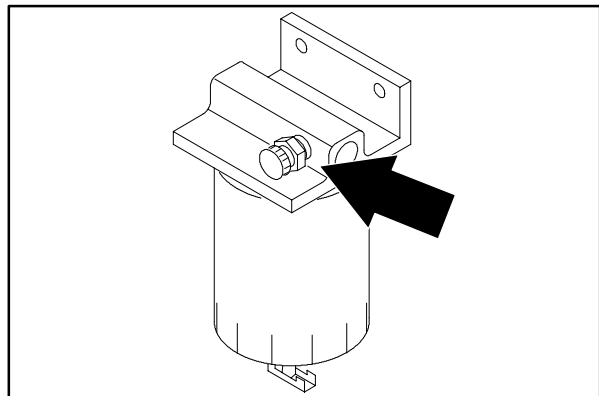

TO REPLACE ALTERNATOR ON DIESEL ENGINE

FOR SAFETY: Before Leaving Or Servicing Machine; Stop On Level Surface, Set Parking Brake, Turn Off Machine And Remove Key.

1. Raise the operators seat, engage the prop rod, and disconnect the battery cables from the battery.
2. Open the machine engine cover and side door. Remove the side door from the machine.
3. Remove the two hex screws holding the fan belt cover to the front of the engine. Remove the cover.
4. Disconnect the wires from the back of the alternator.
5. Remove the hex screw from the top of the alternator.
6. Loosen the lower hex screw and nyloc nut and push the alternator in toward the engine. Remove the V-belt from the alternator drive pulley.
7. Remove the hex screw and nyloc nut from the bottom of the alternator. Retain the spacer. Remove the alternator.
8. If the new alternator does not have a drive pulley--remove the hex nut and washer holding the drive pulley to the old alternator. Install the drive pulley on the new alternator and tighten tight.
9. Install the new alternator back in the machine. Reinstall the lower hex screw, spacer, and nyloc nut. Leave loose for now.
10. Reinstall the hex screw in the upper arm and the top of the alternator. Leave loose for now.

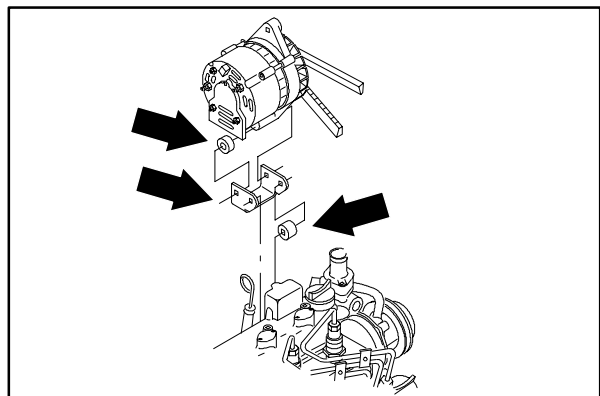
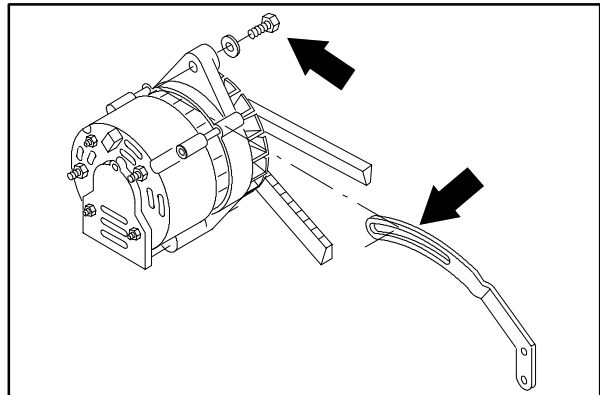
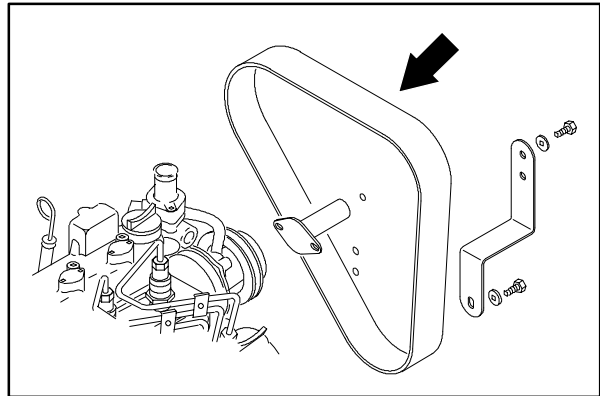
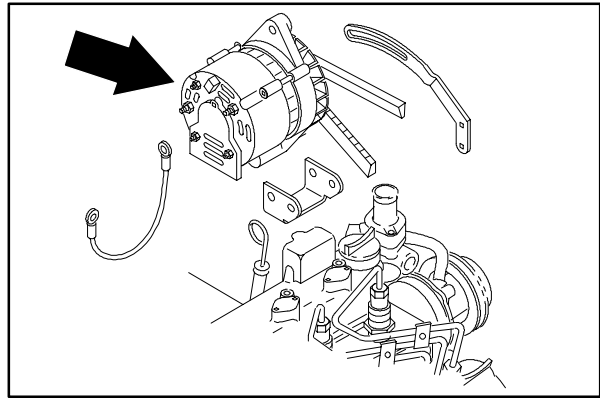

ENGINE-DIESEL

11. Reinstall the V-belt on the alternator drive pulley.
12. Pull the alternator away from the engine to tighten the V-belt. Tighten the upper hex screw tight.
13. Reconnect the wires to the back of the new alternator. See schematic in the ELECTRICAL section.
14. Reinstall the belt cover to the front of the engine. Hand tighten the hex screws tight.
15. Reconnect the battery cables, close the operators seat and start the machine.
16. Check the new alternator for proper operation.

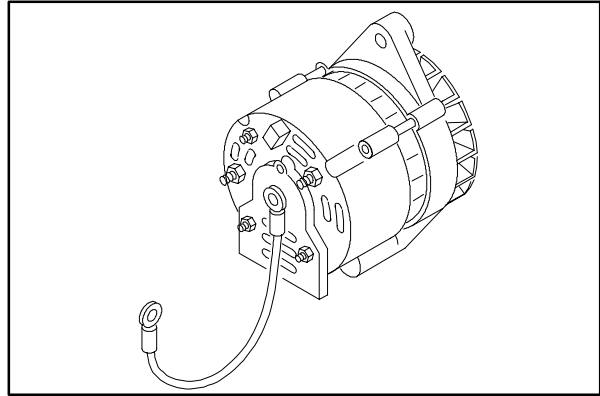

TO REPLACE STARTER ON DIESEL ENGINE

FOR SAFETY: Before Leaving Or Servicing Machine; Stop On Level Surface, Set Parking Brake, Turn Off Machine And Remove Key.

1. Raise the operators seat, engage the prop rod, and disconnect the battery cables from the battery.
2. Open the machine front cover, engine cover, and side door. Remove the side door from the machine.
3. The vacuum fan assembly can be removed for better access to the starter. See TO REMOVE VACUUM FAN instructions in the SCRUBBING section.
4. Remove the air cleaner intake tube from the air cleaner and machine frame.
5. Reach in through the left side of the engine and disconnect the battery cable and electrical wires leading to the starter.
6. Reach in through the left side of the engine and remove the two hex screws holding the starter to the bellhousing.
7. Remove the starter out through the area of the vacuum fan and engine oil filter.
8. Position the new starter in the machine.
9. Reinstall the two hex screws and tighten to 18 - 24 Nm (15 - 20 ft lb).
10. Reconnect the battery cable and electrical wires to the starter. See schematic in the ELECTRICAL section.

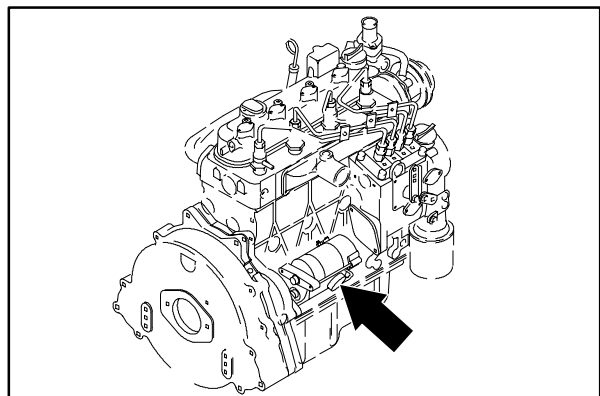
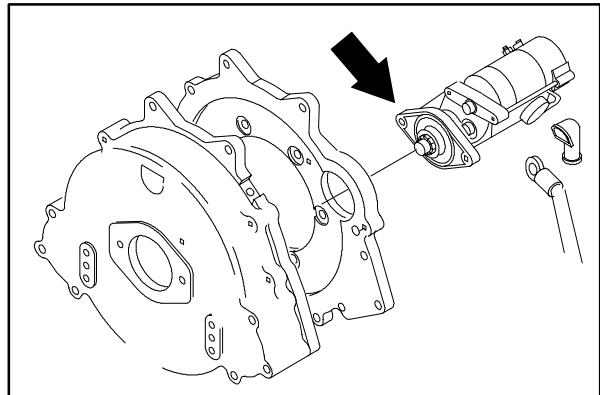
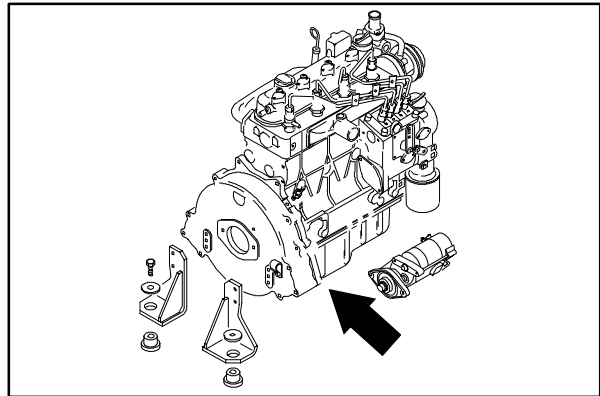
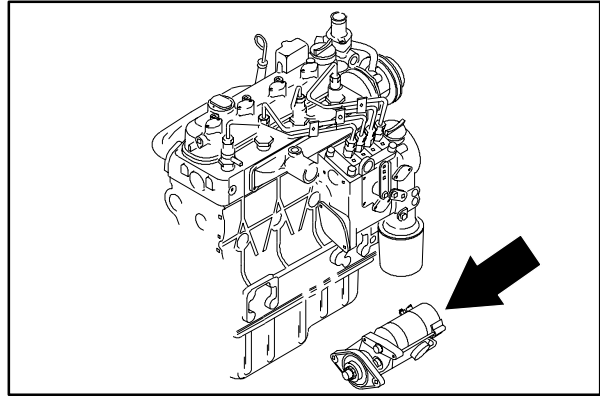

ENGINE-DIESEL

11. Reinstall the air cleaner intake tube to the air cleaner and machine frame.
12. If the vacuum fan was removed--reinstall. See TO INSTALL VACUUM FAN instructions in the SCRUBBING section.
13. Reconnect the battery cables to the battery and close the operators seat.
14. Reinstall the engine side door and close the covers.
15. Start the machine.

TO REMOVE DIESEL ENGINE

FOR SAFETY: Before Leaving Or Servicing Machine; Stop On Level Surface, Set Parking Brake., Turn Off Machine And Remove Key.

1. Pivot the operators seat to the open position and engage the prop rod.
2. Disconnect the battery cables and remove the battery.

NOTE: The battery tray can also be removed for better access to the propel pump

3. Remove the detergent tank and the rubber sound flap from the machine.
4. Remove the two hex screws holding the propel pump to the engine bellhousing

NOTE: The main suction line to the accessory pump is held, by plastic ties, in a bundle of hoses near the main valve. Remove the plastic ties to gain slack in the suction line to ease pump removal.

5. Remove the two hex screws holding the hydraulic flow valve to back, left of the engine mount. Do not disconnect any hydraulic hoses.
6. Pull the propel pump out of the bellhousing and drive coupler. Do not disconnect any hydraulic hoses.
7. Open the machine front cover, engine cover, and side door. Remove the side door from the machine.
8. Remove the vacuum hose from the vacuum fan and the recovery tank.
9. The vacuum fan assembly can be removed for better access to the engine. See TO REMOVE VACUUM FAN instructions in the SCRUBBING section.

NOTE: The engine hood must be supported in the open position before the next step can be completed.

10. Remove the clips on the bottom of the engine hood gas springs. Remove the gas springs from the ball studs on the support channel.

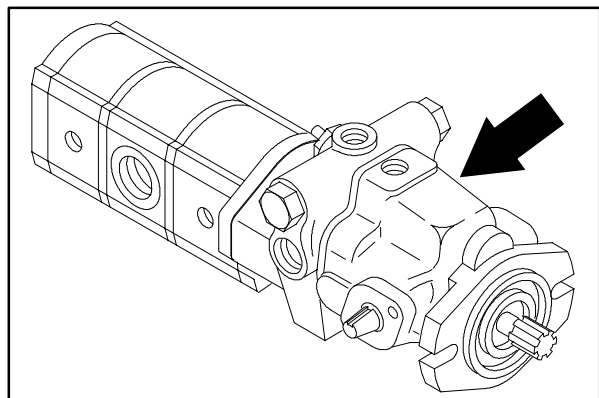
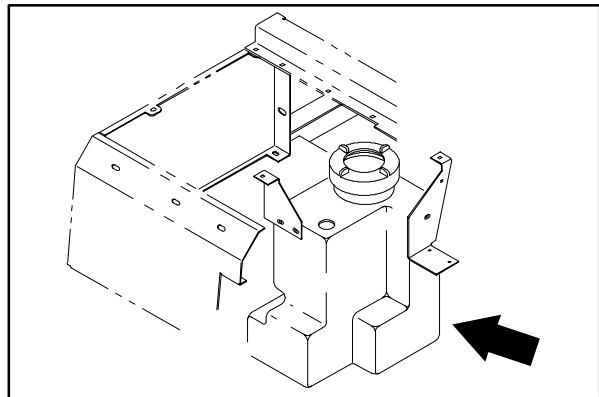
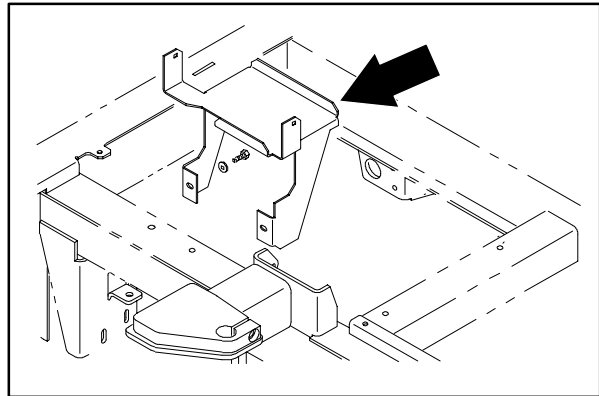
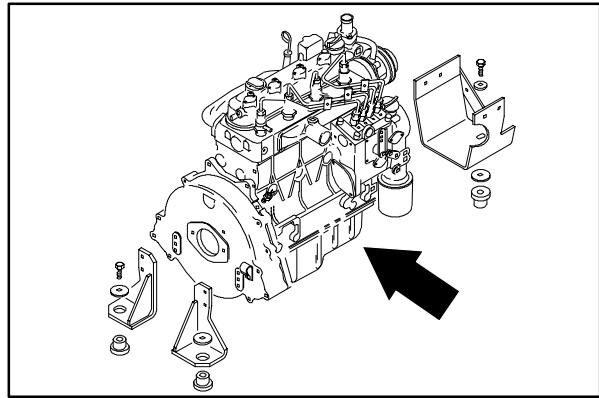

ENGINE-DIESEL

11. Remove the hex screws holding the support channel to the tank lintel and hood lintel. Remove the support channel from the machine.
12. Drain the radiator coolant.
13. Remove the radiator hoses where they connect to the engine.
14. Drain the engine oil.

NOTE: Disconnect the engine oil drain hose from the oil pan before lifting the engine completely out of the machine.

15. Disconnect the exhaust pipe at the engine manifold.
16. Disconnect the wire harness from all of the engine components and place it out of the way.
17. Disconnect the engine ground strap from frame.
18. Disconnect the battery cable and electric wires from the engine starter.
19. Disconnect the fuel line at the fuel filter/water separator on the left side of the engine. Disconnect the small fuel return line.
20. Using an overhead hoist, hook a chain through two pick-up points on the engine. Put a slight amount of tension on the chain.
21. Remove the three M12 hex screws and nyloc nuts holding the motor mounts to the rubber isolators on the machine frame.
22. Engine can now be carefully lifted out.

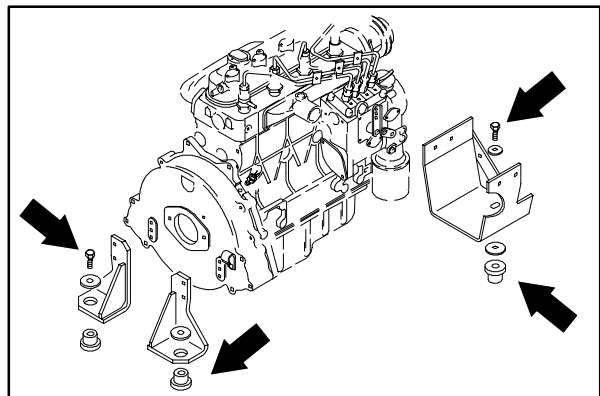
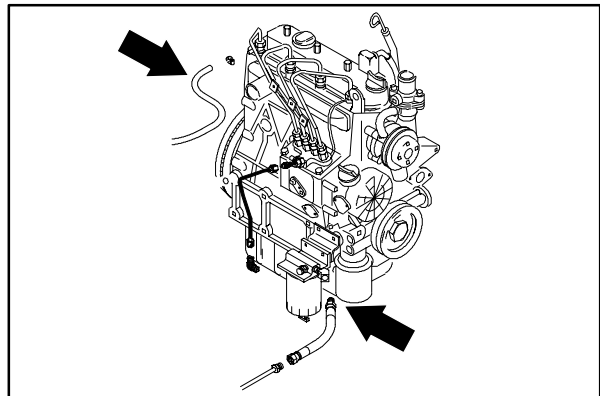
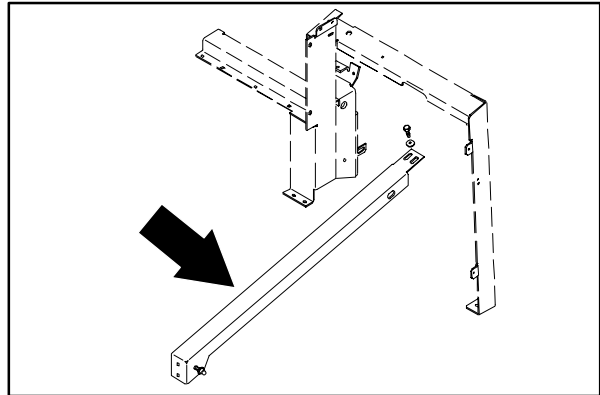
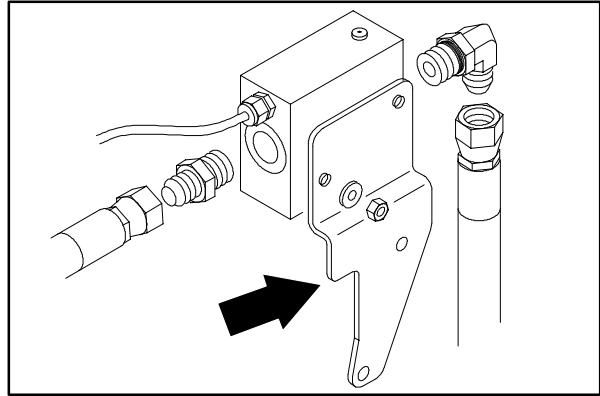

TO INSTALL DIESEL ENGINE

FOR SAFETY: Before Leaving Or Servicing Machine; Stop On Level Surface, Set Parking Brake., Turn Off Machine And Remove Key.

1. Using a overhead hoist, hook a chain through the two pick-up points on top of the engine. Carefully position the engine back in the engine compartment.
2. Carefully Lower the engine assembly down on the the motor mounts.

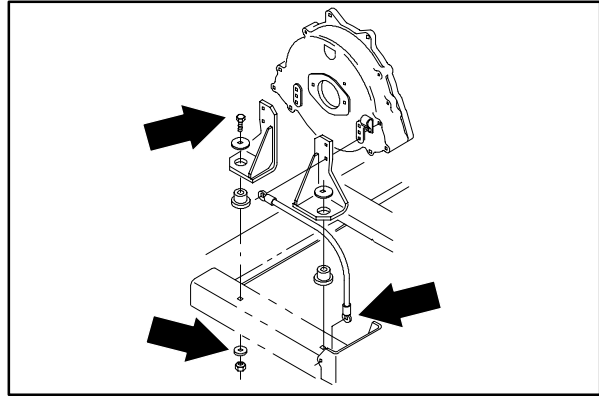

NOTE: Make sure the hoses, wire harness, exhaust pipe, and propel pump are pulled back out of the way when lowering the engine assembly in place.

3. Reinstall the three M12 hex screws in the three motor mount isolators. Tighten to 64 - 83 Nm (50 - 60 ft lb)
4. Reconnect the ground cable from the bellhousing to the machine frame.
5. Reinstall the flow valve on the back, left of the bellhousing.
6. Reconnect the battery cable and electrical wires to the starter. See schematic in the ELECTRICAL section.
7. Reconnect the wire harness to engine components, alternator, governor actuator, oil switch, and temperature sender. See schematic in the ELECTRICAL section.
8. Reinstall the propel pump back in the bellhousing. Use a small amount of blue loctite 242 on the threads. Reinstall the two hex screws. Tighten to 64 - 83 Nm (50 - 60 ft lb).

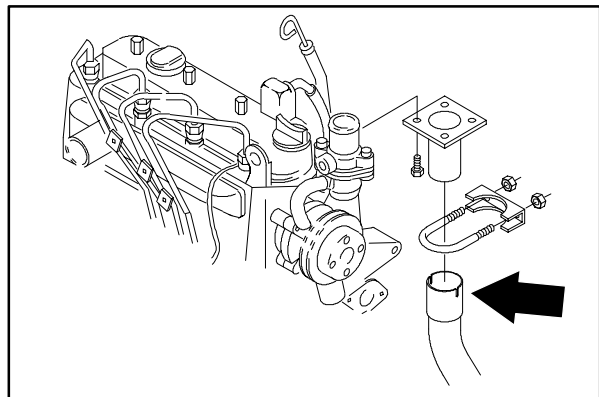
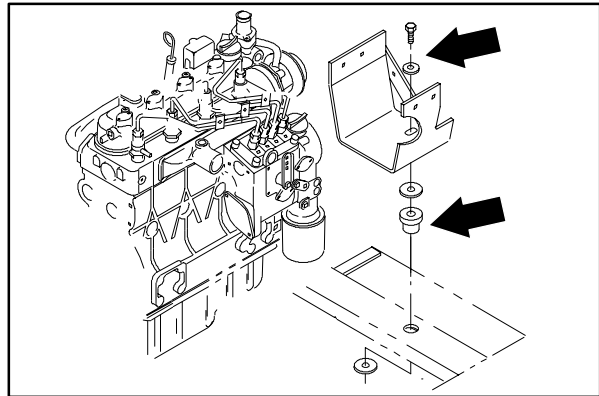

NOTE: Make sure the splines on pump line up with splines in coupler when installing pump.

9. Reinstall the detergent tank in the seat support area.
10. Reinstall the battery tray and battery.
11. Reinstall the exhaust pipe back on the manifold. Reinstall the muffler clamp and tighten tight.

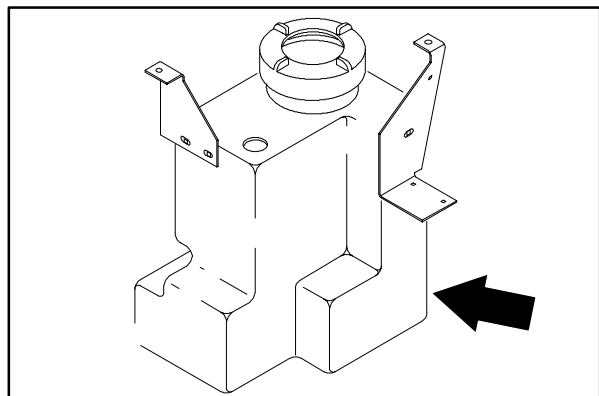

ENGINE-DIESEL

12. Reconnect the fuel line at the fuel filter/water separator on the left side of the engine.
13. Fill the engine with the proper grade of oil.
14. Reinstall the radiator hoses to the engine and fill the radiator with coolant. See TO PURGE AIR FROM RADIATOR instructions.
15. If the vacuum fan was removed--reinstall. See TO INSTALL VACUUM FAN instructions in the SCRUBBING section.
16. Reinstall the vacuum hose on the recovery tank and vacuum housing.
17. Reinstall the support channel to the tank lintel and hood lintel. Reinstall the four hex screws and tighten to 18 - 24 Nm (15 - 20 ft lb).
18. Reinstall the engine hood gas springs on the ball studs on the support channel. Reinstall the two clips.
19. Reconnect the battery cables.
20. Disengage the prop rod and lower the seat.
21. Jack up the front of the machine and place jack stands under the frame.

FOR SAFETY: Block machine tires before jacking machine up. Jack machine up at designated locations only. Block machine up with jack stands

22. Start the machine. Check the engine, hydraulic motors, and pumps for leaks.
23. Reinstall the engine side door and close the covers.

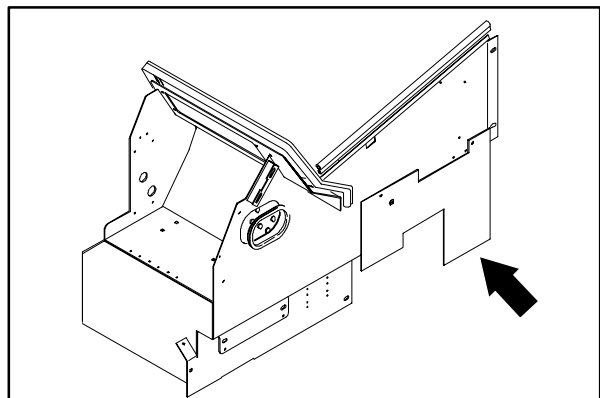
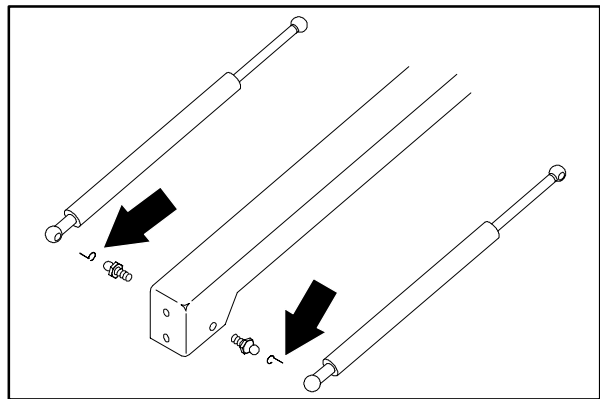
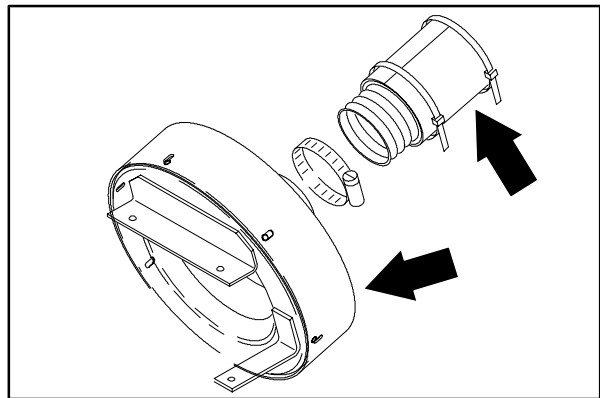
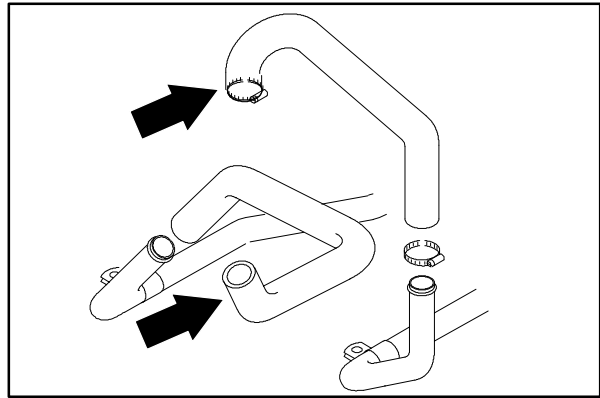

TO PURGE AIR FROM RADIATOR

FOR SAFETY: Before Leaving Or Servicing Machine; Stop On Level Surface, Set Parking Brake., Turn Off Machine And Remove Key.

1. Make sure that both radiator hoses are connected to the engine.
2. Remove the radiator cap and pour in approximately 1-1/2 gallons of coolant.
3. Open the engine cover and side door.
4. Loosen the hose clamp on the upper radiator hose. This is the hose on the thermostat housing.
5. Break the hose loose from the neck of the thermostat housing and **slowly** pull the hose off the neck.
6. Keep the hose off the neck until coolant starts to flow out of the hose.
7. Quickly place the hose back on the neck of the thermostat housing. Re-tighten the hose clamp.
8. Start the machine and run it to operating temperature. Shut off the engine.
9. Let the machine cool down for and carefully re-check the level of the radiator coolant. There should be enough room to pour another 1/2 gallon of coolant in. If not--repeat steps 4 thru 8.
10. If the machine over heats--repeat steps 4 thru 8.

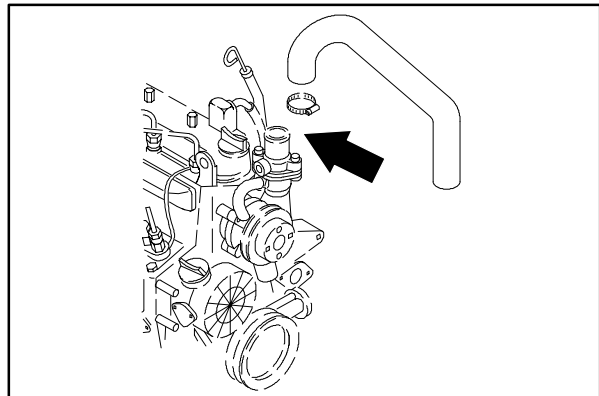
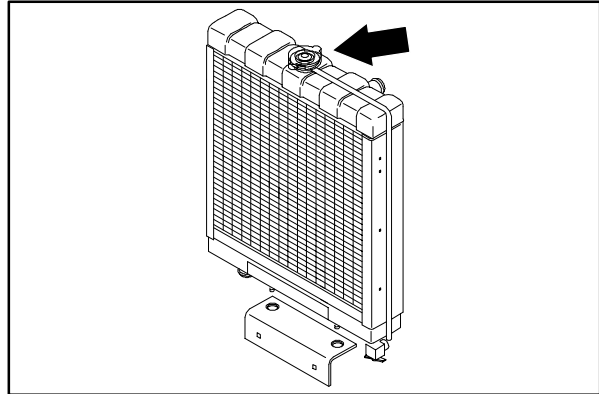

NOTE: There may be air trapped in one of the radiator hoses. It might take one or two tries to completely purge all of the air from the cooling system.

