



# High Voltage DC Relay



LSIS



# High Voltage DC Relay

Leading you toward a greater future  
than you imagine



## Leading Innovation, Creating Tomorrow

With over 30 years of experience in electric power and automation solutions, we provide quality products for industrial applications.

LSIS in cooperation with customers designs advanced DC solutions with innovative technology that enable them to bring next generation products to the market.

## What is LSIS High Voltage DC Relay?

The LSIS High Voltage DC Relay serves to supply and disconnect DC power, and contains hydrogen and nitrogen gas, which is optimized to withstand making and breaking. Therefore, it has excellent electrical durability, compact size, and low noise.



## Features

### Compact Design

Achieved compact size by filling with hydrogen and nitrogen gas to improve the breaking performance.

### Proven Safety

High value of short circuit current withstanding.

### Superior Reliability

Excellent performance with electrical and mechanical dururances.

# Sequence

## Operation sequence

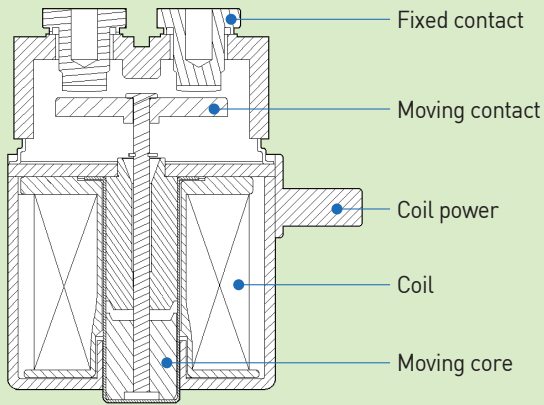

< Normal OPEN >

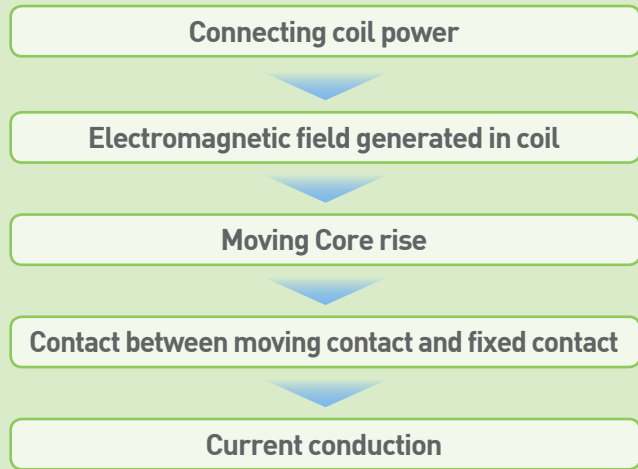

## Arc quenching

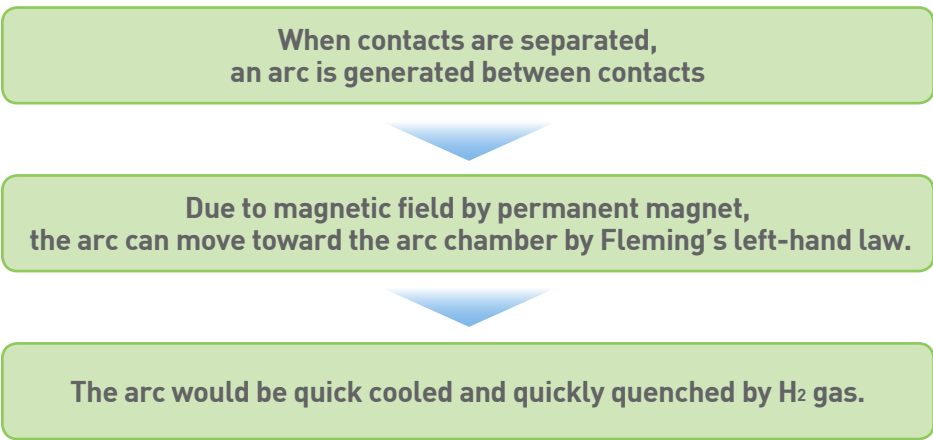
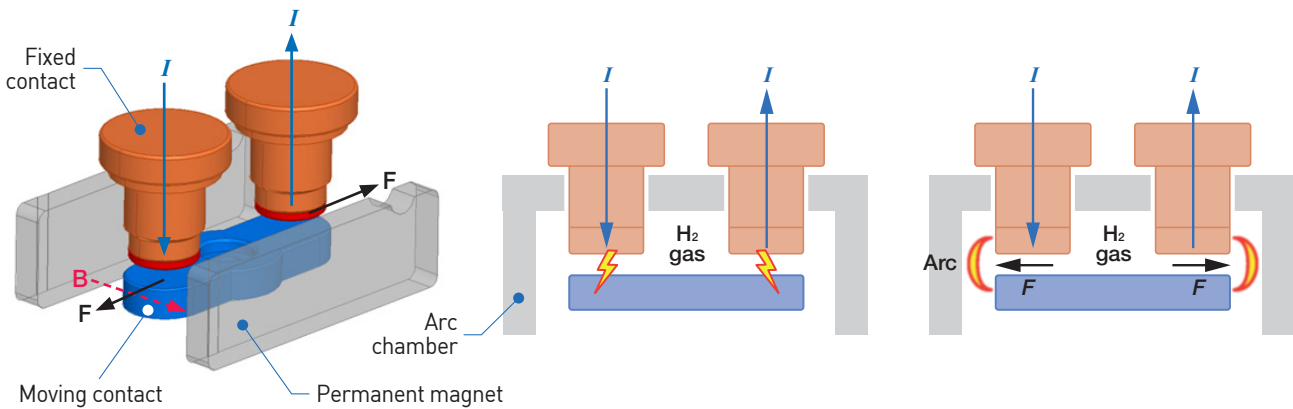

**Minimized contact damage  
by reducing arc quenching duration**

# Ordering Information & Option detail

## Ordering Information

**GPR-M 400 -A DC12V SM □**

①                      ②                      ③                      ④                      ⑤                      ⑥

**① Operating Voltage**

R | 450V  
R-M | 1,000V  
R-H | 1,500V~

**② Conventional thermal Current**

010 | 10A | 250 | 250A  
040 | 40A | 400 | 400A  
100 | 100A | 500 | 500A  
150 | 150A |

**③ Aux Type**

-A | Aux.  
blank | No Aux.

**④ Control Voltage**

DC12V  
DC24V  
DC48V

**⑤ Mounting Type**

blank | Bottom Mounting  
SM | Side Mounting

**⑥ Brand Name**

blank | General  
Brand name

## Option Detail

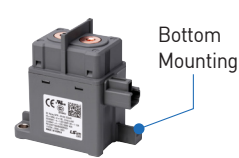
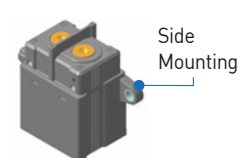
No	Item	Shape	Type	Remarks
③	Auxiliary contact		GPR-M400-A	ON / OFF detection of main contact
			GPR-H500-A	
④	Control voltage	-	See coil rating on page 10	Coil voltage 12/24/48V
⑤	Mounting type		ALL	Vertical mounting
			GPR150 / GPR-M150 GPR250 / GPR-M250	Horizontal mounting



# Application

LSIS High Voltage DC Relay can be utilized in various applications including commercial & industrial transportation systems, uninterruptible power systems(UPS), energy storage systems(ESS), and renewable energy systems such as photovoltaic systems(PV).

## Renewable Energy Application

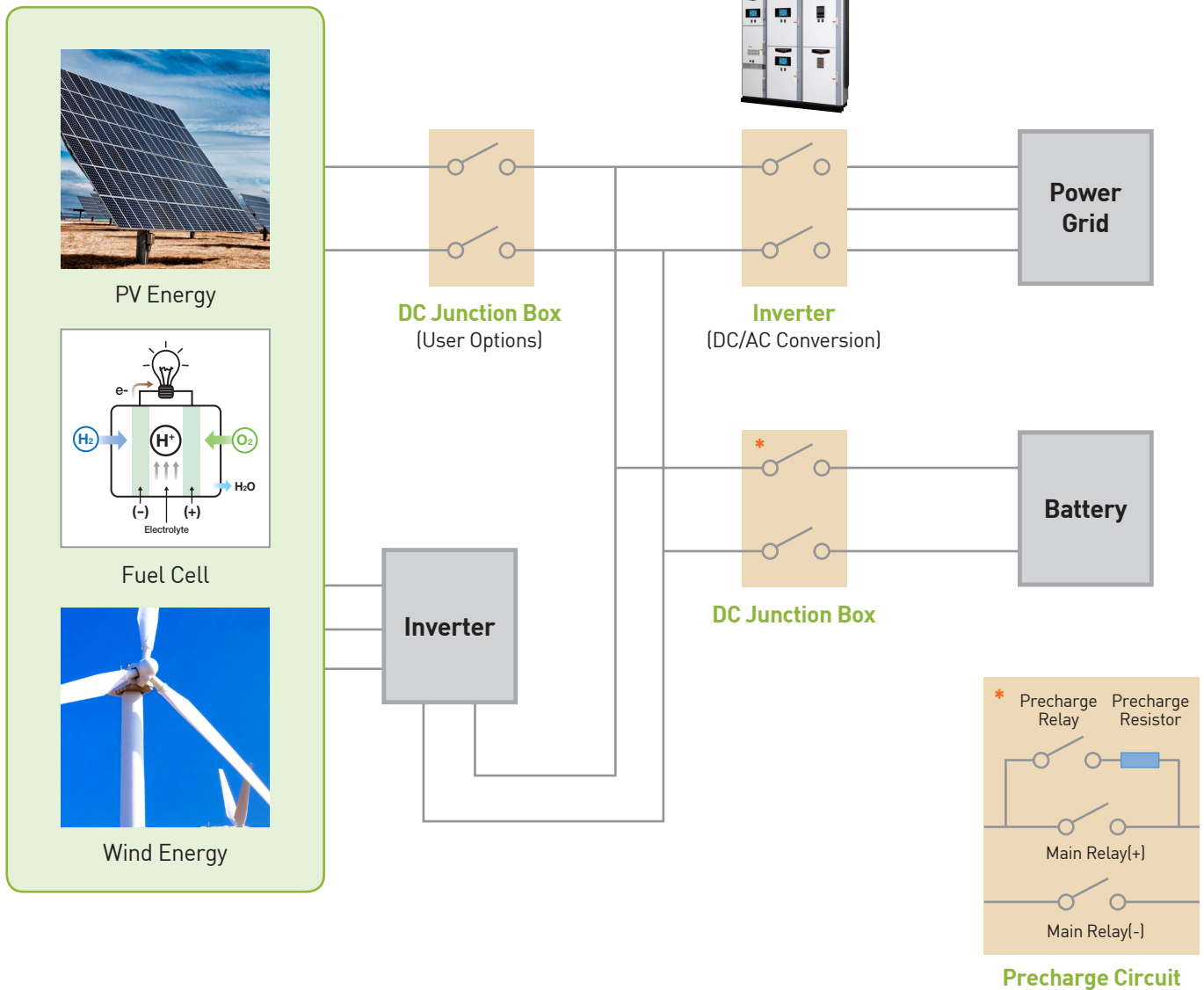

## Transportation Application

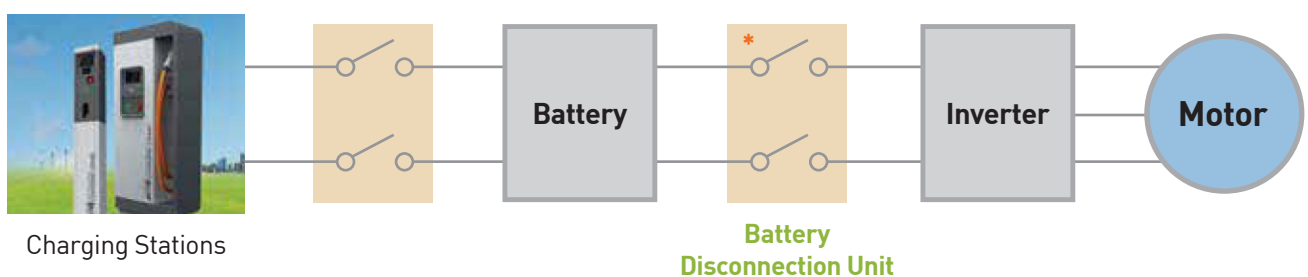

# Specifications (Standard Type)

## GPR Specifications



Model		GPR010	GPR040
Number of poles		1 Pole	1 Pole
Operating voltage, Ue		DC 450V	DC 450V
Rated impulse withstand voltage, Uimp		4kV	4kV
Conventional thermal current, Ith		10A	40A
Short time withstand current	2Min	15A	100A
	15Min	-	60A
Durability	Mechanical (*) (3,600 operations per hour)	200,000 cycles	200,000 cycles
	Electrical	10A, 450VDC, 150,000cycles (at 360cycles/Hr)(only Making)	40A, 450VDC, 1,000cycles (at 1,200cycles/Hr)
Voltage drop(Initial)		0.5V @ 10A	0.2V @ 20A
Operating time		Max. 50ms	Max. 50ms
Release time		Max. 30ms	Max. 30ms
Insulation strength(Initial)		Min. 100MΩ(@500VDC)	Min. 100MΩ(@500VDC)
Size, W × H × D( mm )		56 × 28 × 45	67 × 35 × 47
Temperature range		-40 ~ 85℃	-40 ~ 85℃
Humidity		5-95% R.H.	5-95% R.H.
Weight		85g	145g
Certification		CE CCC	CE CCC

\* The number of Mechanical times is the number that meets the basic performance after durability.





	GPR100	GPR150	GPR250	GPR400
	1 Pole	1 Pole	1 Pole	1 Pole
	DC 450V	DC 450V	DC 450V	DC 450V
	4kV	4kV	4kV	4kV
	100A	150A	250A	400A
	225A	320A	500A	800A
	150A	225A	350A	600A(7min)
	200,000 cycles	200,000 cycles	200,000 cycles	200,000 cycles
	100A, 450VDC, 1,000cycles (at 1,200cycles/Hr)	150A, 450VDC, 1,000cycles (at 1,200cycles/Hr)	250A, 450VDC, 1,000cycles (at 360cycles/Hr)	400A, 450VDC, 1,000cycles (at 360cycles/Hr)
	0.04V @ 20A	0.04V @ 20A	0.02V @ 20A	0.02V @ 20A
	Max. 50ms	Max. 50ms	Max. 30ms	Max. 30ms
	Max. 30ms	Max. 30ms	Max. 10ms	Max. 10ms
	Min. 100MΩ(@500VDC)	Min. 100MΩ(@500VDC)	Min. 100MΩ(@500VDC)	Min. 100MΩ(@500VDC)
	81 × 39 × 70	81 × 39 × 70	92 × 45 × 87	100 × 58 × 91
	-40 ~ 85°C	-40 ~ 85°C	-40 ~ 85°C	-40 ~ 85°C
	5-95% R.H.	5-95% R.H.	5-95% R.H.	5-95% R.H.
	330g	330g	500g	630g
	CE (CCC)	CE cRU <sup>us</sup> (CCC)	CE (CCC)	CE (CCC)

[ GPR ]

# Specifications (Standard Type)

## GPR-M/GPR-H Specifications



Model		GPR-M010	GPR-M040	GPR-M100
Number of poles		1 Pole	1 Pole	1 Pole
Operating voltage, Ue		DC 600V	DC 1000V	DC 1000V
Rated impulse withstand voltage, Uimp		4kV	4kV	6kV
Conventional thermal current, Ith		10A	40A	100A
Short time withstand current	2Min	-	100A	225A
	15Min	15A	60A	150A
Durability	Mechanical (*) (3,600 operations per hour)	200,000 cycles	200,000 cycles	200,000 cycles
	Electrical	5A, 600VDC, 10,000cycles (at 360cycles/Hr)(only Making)	20A, 1000VDC, 1,000cycles (at 360cycles/Hr)	50A, 1000VDC, 1,000cycles (at 360cycles/Hr)
Voltage drop(Initial)		0.5V @ 10A	0.2V @ 20A	0.04V @ 20A
Operating time		Max. 50ms	Max. 50ms	Max. 50ms
Release time		Max. 30ms	Max. 30ms	Max. 30ms
Insulation strength(Initial)		Min. 100MΩ(@1000VDC)	Min. 100MΩ(@1000VDC)	Min. 100MΩ(@1000VDC)
Size, W × H × D( mm )		56 × 28 × 45	67 × 35 × 47	81 × 39 × 70
Temperature range		-40 ~ 85℃	-40 ~ 85℃	-40 ~ 85℃
Humidity		5-95% R.H.	5-95% R.H.	5-95% R.H.
Weight		80g	145g	330g
Certification		CE cRUus CCC	CE cRUus CCC	CE cRUus CCC

\* The number of Mechanical times is the number that meets the basic performance after durability.





	GPR-M150	GPR-M250	GPR-M400	GPR-M400-A	GPR-H500-A
	1 Pole	1 Pole	1 Pole	1 Pole	1 Pole
	DC 1000V	DC 1000V	DC 1000V	DC 1000V	DC 1500V
	6kV	6kV	6kV	6kV	8kV
	150A	250A	400A	400A	500A
	320A	500A	750A	750A	900A
	225A	350A	500A	500A	750A
	200,000 cycles	200,000 cycles	200,000 cycles	200,000 cycles	200,000 cycles
	75A, 1000VDC, 1,000cycles (at 360cycles/Hr)	125A, 1000VDC, 1,000cycles (at 360cycles/Hr)	200A, 1000VDC, 1,000cycles (at 360cycles/Hr)	200A, 1000VDC, 3,000cycles (at 360cycles/Hr)	200A, 1500VDC, 1,000cycles (at 360cycles/Hr)
	0.04V @ 20A	0.02V @ 20A	0.02V @ 20A	0.02V @ 20A	0.04V @ 20A
	Max. 50ms	Max. 30ms	Max. 30ms	Max. 30ms	Max. 35ms
	Max. 30ms	Max. 10ms	Max. 10ms	Max. 10ms	Max. 15ms
	Min. 100MΩ(@1000VDC)	Min. 100MΩ(@1000VDC)	Min. 100MΩ(@1000VDC)	Min. 100MΩ(@1000VDC)	Min. 100MΩ(@1000VDC)
	81 × 39 × 70	92 × 45 × 87	100 × 58 × 91	100 × 58 × 99	118 × 70 × 108
	-40 ~ 85°C	-40 ~ 85°C	-40 ~ 85°C	-40 ~ 85°C	-40 ~ 85°C
	5-95% R.H.	5-95% R.H.	5-95% R.H.	5-95% R.H.	5-95% R.H.
	330g	500g	630g	750g	1.3kg
	CE cRUUS CCC	CE cRUUS CCC	CE cRUUS CCC	CE cRUUS	CE cRUUS

# [ GPR-M/GPR-H ]

## Coil Rating

Model	Rated Voltage	Pick-up Voltage (at 20°C)	Drop-out Voltage (at 20°C)	Power Consumption	Max. Allowable Voltage
GPR010 / GPR-M010	12VDC 24VDC	75%V or less of Rated Voltage (Initial)	10%V or more of Rated Voltage (Initial)	3W	125% of Rated
GPR040 / GPR-M040				3.5W	
GPR100 / GPR-M100				6.5W	
GPR150 / GPR-M150				6.5W	
GPR250 / GPR-M250				4.5W (inrush current : 2.9A(12V), 1.25A(24V))	
GPR400 / GPR-M400				4.5W (inrush current : 4.2A(12V), 2.1A(24V))	
GPR-M400-A				4.5W (inrush current : 4.2A(12V), 2.1A(24V))	
GPR-H500-A				5.0W (inrush current : 5.0A(12V), 2.5A(24V))	
GPR150				48VDC	
GPR250	7.5W				
GPR400	7.5W				

## Connection and Mounting

Model	Main Terminal Connection			Mounting	
	Screw	Allowed Torque	Wire for main Terminal (mm <sup>2</sup> )	Allowed SCREW	Allowed Torque
GPR010 / GPR-M010	187 P-Lock	Over 7 N-m	2	M4-10	1.8 ~2.7 N-m
GPR040 / GPR-M040	M4	1.5~2.0 N-m	10	M4-10	1.8 ~2.7 N-m
GPR100 / GPR-M100	M6	3.5~4.5 N-m	35	M5-12	3.0 ~4.0 N-m
GPR150 / GPR-M150	M6	3.5~4.5 N-m	50	M5-12	3.0 ~4.0 N-m
GPR250 / GPR-M250	M6	3.5~4.5 N-m	120	M6-14	6.0 ~8.0 N-m
GPR400 / GPR-M400	M6	3.5~4.5 N-m	120×2	M6-14	6.0 ~8.0 N-m
GPR-M400-A	M6	3.5~4.5 N-m	120×2	M6-14	6.0 ~8.0 N-m
GPR-H500-A	M8	6.0~9.0 N-m	150×2	M6-20	6.0 ~8.0 N-m



# Precautions

## Application Notes

### Specification range

- Please use it according to specification range such as coil rating, mounting information. Otherwise it may result in overheating or malfunction.

### Installation and maintenance

- If power is applied to the relay main contact, it may cause electric shock. Never touch it. During installation, maintenance and troubleshooting, the power to the relay must be disconnected.

### Connection

- Incorrect connection may cause malfunction, overheating or fire.

### Fail-safe

- It could be dangerous, when welding or sticking to contacts occurs. So, take double safety precautions and make sure that operation is foolproof.

### Polarity

- Relays have polarity. Check the polarity indicated on the housing and connect. If connected in the opposite polarity, the electric durability performance can not be guaranteed.
- Relay coils with PCBs are polarized. Check the indicated polarity and connect. If connected in the opposite polarity, the relay will not operate.

### Magnetism

- If the relays are in close contact to each other or installed close to strong magnetic parts such as a motor or a speaker, their operating characteristics may change or malfunction may occur. Therefore, check the magnetic effects of the actual installation and operating conditions.

### Vibration / shock

- To maintain initial performance, do not apply physical shock or drop the relay. Do not use dropped products. Use shock absorbers during transportation.
- The relay is designed not to be separated under normal use conditions. To maintain initial performance, do not disassemble the case. If the case is removed, relay performance can not be guaranteed.

### Temperature

- Condensation may also occur at contacts if the relay is used at temperatures below 0 ° C or in an environment where the ambient temperature changes rapidly below zero. This condensation can delay operation time or interfere in operation of the relay.
- If the relay is operated continuously, the coil temperature may rise and the operating voltage may rise.

### Coil voltage

- If you apply coil voltage very slowly, it may cause an operation error. Therefore, apply the coil voltage quickly.

### Mounting conditions

- When exposed to high temperature or high humidity or to an environment containing organic or sulphide gas for a long time (including shipping period), sulfide or oxide film may form on the surface of the contacts and cause poor contact, and malfunction. Please check the environment when you transport the product.
- Do not use the product in an environment where the main terminals may be exposed to foreign substances such as organic solvents (eg alcohol, benzene, thinner) or strong alkalis (eg ammonia, caustic soda). It may cause abnormal heat at the terminal part.
- This product is not waterproof. If you install it in a place where waterproofing is required, please find a way to meet your requirements.

### Additional information

- The reverse surge voltage generated by the coil of the relay may cause burnout of the load element. Therefore, take measures to prevent reverse surge voltage. Do not use DIODE because the operation time of relay is delayed and electrical performance is degraded.
- When using a capacitive load (C-load), we recommend applying a precharge circuit so that the inrush current does not exceed the rated current.
- Electrical performance has been verified without L load, and electrical life can be shortened if you use L load.
- When checking the conduction of the main contact, apply the minimum voltage (DC24V) and current (1A) to the main contact.
- To check the auxiliary contact conduction, apply DC5V 1mA ~ DC30V 100mA.

# Selection of Relay Type

For the proper use of a relay, you must not only be well informed of the characteristics of the relay and service conditions to determine whether the selected one fits for the conditions for application, but also fully understand the specifications of coil and contact, operate time, mechanical characteristics, and other conditions for the relay to be used. Please refer to the table below for details and considerations for selection.

Items		Details	Considerations for Selection
Coil	Pick-up Voltage (Current)	The value at which a relay should function when increasing the voltage to an unoperated relay.	<ul style="list-style-type: none"> <li>- Select a relay by considering a power supply ripple</li> <li>- Specifically take into account ambient temperature, coil temperature, and hot start</li> <li>- Be careful with the voltage drop when using the relay in conjunction with semiconductors</li> <li>- Be careful with the voltage drop when starting up</li> </ul>
	Drop-out Voltage (Current)	The value at which a relay should revert to the unoperated state when decreasing the voltage to an operated relay.	
	Maximum Continuous Voltage	The maximum allowable voltage to be continuously applied to the coil without causing damage. Short duration spikes of a higher voltage can be tolerated, but you must consult with the manufacturer above all.	
	Coil Resistance	The DC resistance of the coil of DC type relays.	
	Temperature Rise	If power is supplied to coil, the coil's temperature is increased and saturated. Temperature rise refers to the difference between the temperatures before and after the power application to the coil.	
Contact	Contact Rating	The allowable rated voltage and current.	<ul style="list-style-type: none"> <li>- Note that the life of relay is balanced with that of the device in which the relay is embedded.</li> <li>- If often exposed to high temperature, the rated life of the relay may be reduced. It is required to test the life in an actual environment.</li> <li>- Test and review need to be performed with actual load and application under an actual environment.</li> </ul>
	Contact Material	Material that forms contacts.	
	Life	The minimum number of times a relay can be operated under the normal condition while contacts are switching specific load.	
	Contact Resistance	The value combined together the resistance produced when contacts touch each other, that of terminals, and that of contact spring.	
Operate Time	Operating Time	The time elapsed since power is first supplied to the coil until the open contacts are normally closed, excluding bounce time.	<ul style="list-style-type: none"> <li>- Note that the operate time and bounce time may be changed according to the ambient temperature and applied voltage.</li> <li>- Note that bounce time is not excluded from both operate time and release time.</li> <li>- Note that switching life is affected by switching frequency.</li> </ul>
	Release Time	The time elapsed since power is cut off from the coil until the normally closed contacts are reclosed, excluding bounce time.	
	Bounce Time	The phenomenon that contacts intermittently switches on and off as movable parts and contacts collide.	
	Switching Frequency	The frequency of switching that repeats operations while satisfying the electrical life or mechanical life through the application of a pulse train to the operating coil at the rated voltage.	

Items		Details	Considerations for Selection
Mechanical Characteristics	Vibration Resistance	1) Functional : The vibration allowed to relay during operation, with contact not open for the specified time. 2) Destructive : The vibration the relay can endure in the process of shipment, installation or use without causing damage and change in the operating characteristics of the relay.	<ul style="list-style-type: none"> <li>- Consider the performance of a relay during the service with vibration and shock</li> <li>- Check the allowable ambient temperature of the relay.</li> </ul>
	Shock Resistance	1) Functional : The acceleration allowed to relay during operation, with contact not open for the specified time. 2) Destructive : The acceleration a relay can endure in the process of shipment or installation without causing damage and change in the operating characteristics of the relay.	
	Ambient Use Temperature	The allowable temperature of the environment in which the relay is mounted.	
	Life	The minimum number of times a relay can be operated under the normal condition without load on the contacts.	
Other Items	Breakdown Voltage (Dielectric Strength)	The maximum voltage tolerated by a relay without causing damage for a specific period, which is measured at the same points as insulation resistance.	- Select among plug-in type, soldering type, screwfastening type, and printed circuit board type to be used for connection
	Mounting, Connection	Mounting : Parallel type and vertical type Connection : Screw type and plug-in type used to connect to main circuit	- Select PCB mounting methods including soldering and cleaning to be used for protection
	Size	Size of relay (Width, Height, Depth)	- Select sealed construction type to be used in an adverse environment

## Warranty

LSIS warrants that the products shall be free from defects in material and workmanship for a period of twenty four (24) months from the manufacturing date of the products. If any defect due to LSIS' failure, the extent of LSIS' liability under this warranty shall be limited to, at LSIS' option, the repair, replacement. LSIS' obligation regarding to this warranty is conditioned upon the submission to LSIS of a written service request which specifies the defect and the relevant evidence within seven (7) days from the date recognizing the defect.

Notwithstanding the foregoing, the warranty above shall not apply, if the products have been subjected to misuse, abuse, negligence, improper installation, improper maintenance, improper transportation, accident, alteration or design change by anyone other than LSIS, or if the original name, serial number and/or identification marking have been defaced, altered or removed, or the products haven used in violation of instructions furnished by LSIS.

Under any circumstance, LSIS shall not have any other obligations, guaranties, conditions or liabilities, express or implied arising by law or otherwise (including, without limitation, any obligation of LSIS with respect to consequential damages) and whether or not occasioned by LSIS' negligence, than the above statement and shall not be extended, altered or varied.

## Coil Terminal Accessory



Main Terminal	Coil Terminal	Accessory(Not included)
<p><b>Pin Type Features:</b></p> <ul style="list-style-type: none"> <li>Terminal Type = Tab</li> <li>Mating Area Interface</li> <li>Dimensions (mm) 6.3×0.80</li> <li>Material = Brass</li> </ul> <p><b>Applicable Connector :</b></p> <ul style="list-style-type: none"> <li>Terminal Type = Receptacle</li> <li>Tyco 63445-2</li> </ul>	<p><b>Pin Type Features:</b></p> <ul style="list-style-type: none"> <li>Terminal Type = Tab</li> <li>Mating Area Interface</li> <li>Dimensions (mm) 4.8×0.80</li> <li>Material = Brass</li> </ul> <p><b>Applicable Connector :</b></p> <ul style="list-style-type: none"> <li>Terminal Type = Receptacle</li> <li>Tyco 5-160429-1</li> <li>61945-1</li> </ul>	<p><b>Components</b></p> <ul style="list-style-type: none"> <li>Main Terminal accessory : 2EA</li> <li>Coil Terminal accessory : 2EA</li> <li>Wire length : 300mm</li> </ul>

## Dimensions

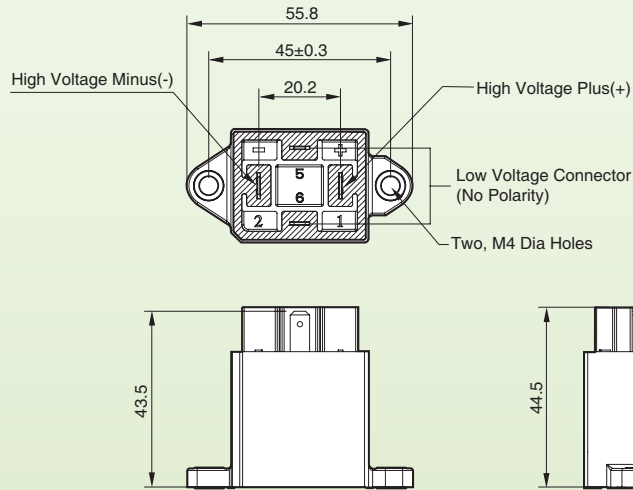

## General Tolerance

Less Than 10: ±0.25 / 10~50: ±0.5  
More Than 50: ±0.8

## Engineering Data

	Operating Voltage Characteristics	Current Distribution	Switching Life and Cutoff Curves
GPR010			
GPR-M010			

Note : I-T curve at ambient temperature of 23°C

※ The graph above is estimate, so please use it only for your reference.



# GPR040 / GPR-M040

## Coil Terminal Accessory

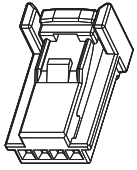
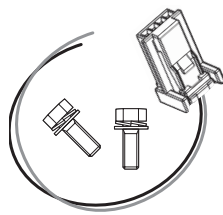

Housing : 1379658-1	Terminal : 1123343-1	Accessory(Not included)
 <ul style="list-style-type: none"> <li>• Connector Style = Receptacle</li> <li>• Contact Type = Tab</li> <li>• Receptacle Configuration =025</li> </ul>	 <ul style="list-style-type: none"> <li>• Contact Type = Receptacle</li> <li>• Applies To Wire/Cable</li> <li>• Wire/Cable Type = Discrete Wire</li> <li>• Wire Range = 0.20-0.602 [24-20] mm [AWG]</li> </ul>	 <p><b>Components</b>                      Coil Terminal Accessory : 1EA                      Flange Bolt M4-4 2EA                      Wire length : 300mm</p>

## Dimensions

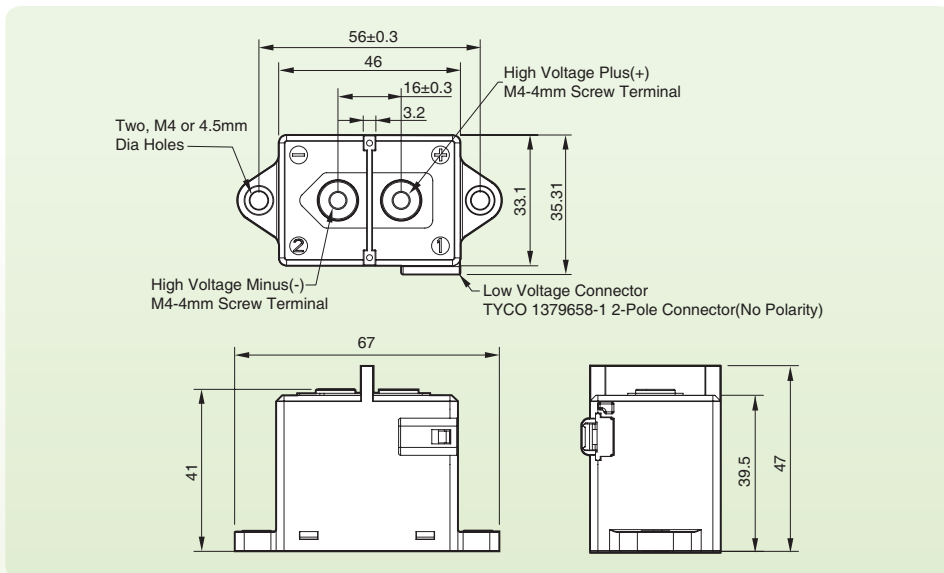

### General Tolerance

Less Than 10: ±0.25 / 10~50: ±0.5  
 More Than 50: ±0.8

## Engineering Data

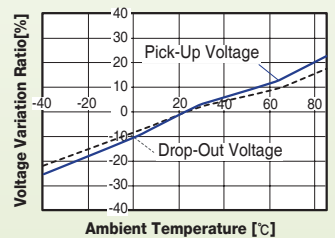
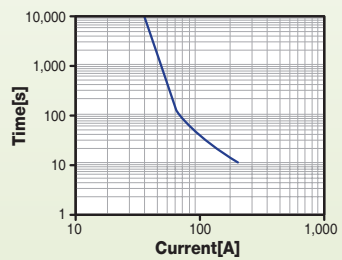
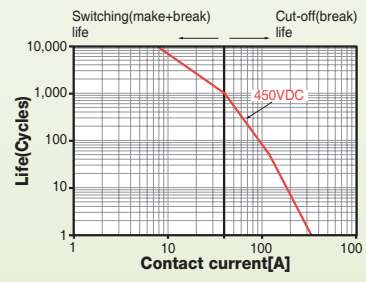
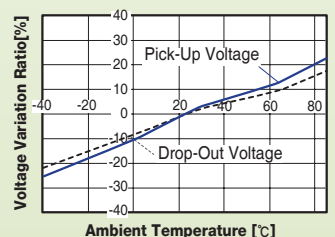
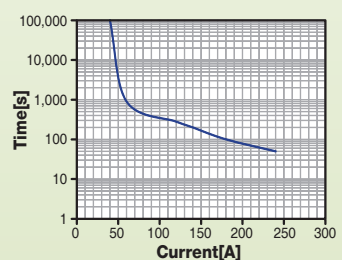
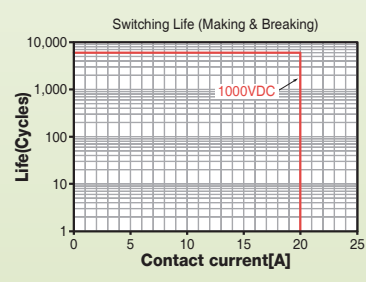
	Operating Voltage Characteristics	Current Distribution	Switching Life and Cutoff Curves
GPR040			
GPR-M040			

Note : I-T curve at ambient temperature of 23°C  
 ※ The graph above is estimate, so please use it only for your reference.

# GPR100 / GPR-M100



## Coil Terminal Accessory

Housing:MG651026(L)		Terminal:ST730676-3		Accessory(Not included)		
Part No.	Wire Range		Tab Thick	Material		<b>Components</b> Coil Terminal Accessory : 1EA Flange Bolt M6-7 2EA Wire length : 300mm
	AWG	mm <sup>2</sup>		Thick	Finish	
ST730676-3	18-16	AVSS(CAVS) 0.85-1.25	0.64	0.25	Copper Alloy Pre-Tin	

## Dimensions

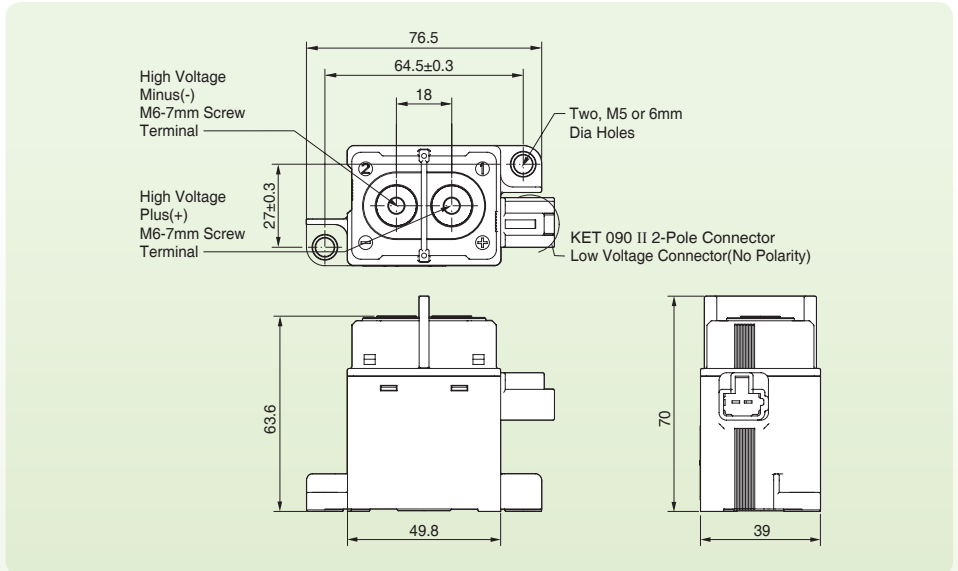

### General Tolerance

Less Than 10: ±0.25 / 10-50: ±0.5  
 More Than 50: ±0.8

## Engineering Data

	Operating Voltage Characteristics	Current Distribution	Switching Life and Cutoff Curves
GPR100			
GPR-M100			

Note : T curve at ambient temperature of 23°C

\* The graph above is estimate, so please use it only for your reference.

# GPR150 / GPR-M150



## Coil Terminal Accessory

Housing : MG651026(L)		Terminal : ST730676-3		Accessory(Not included)	
Part No.	Wire Range		Tab Thick	Material	
	AWG	mm <sup>2</sup>		Thick	Finish
ST730676-3	18-16	AVSS(CAVS) 0.85~1.25	0.64	0.25	Copper Alloy Pre-Tin

**Components**  
 Coil Terminal Accessory : 1EA  
 Flange Bolt M6-7 2EA  
 Wire length : 300mm

## Dimensions

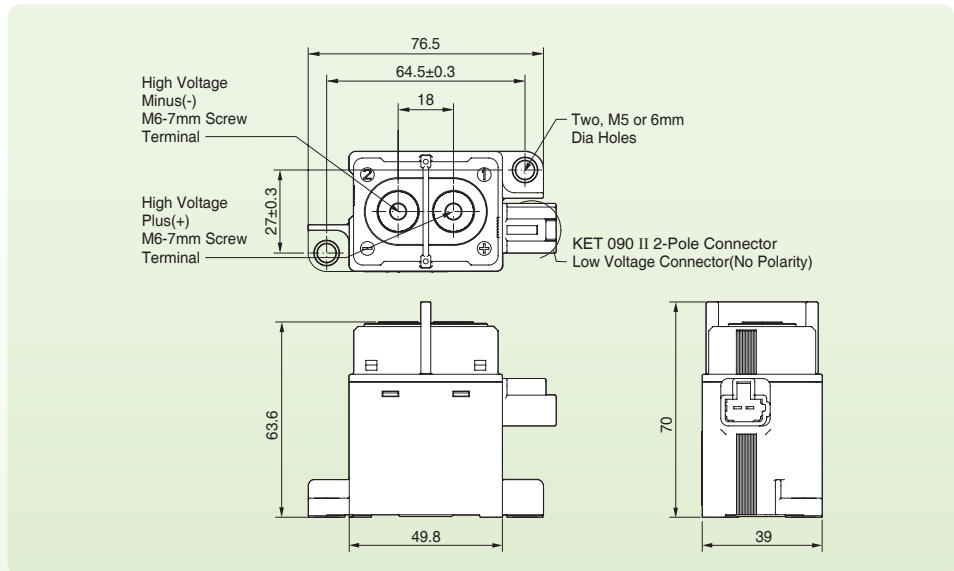

### General Tolerance

Less Than 10: ±0.3 / 10~50: ±0.5  
 More Than 50: ±0.8

## Engineering Data

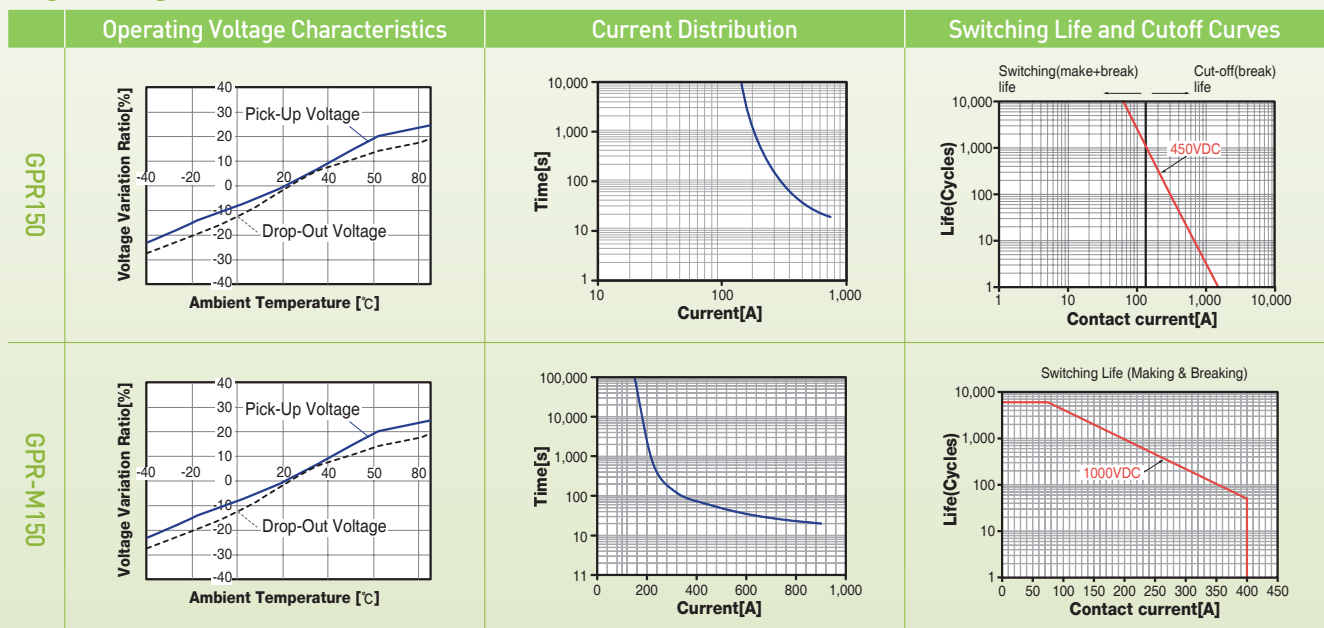

Note : I-T curve at ambient temperature of 23°C  
 ※ The graph above is estimate, so please use it only for your reference.

# GPR250 / GPR-M250



## Coil Terminal Accessory

Housing : MG651026(L)		Terminal : ST730676-3		Accessory(Not included)	
Part No.	Wire Range		Tab Thick	Material	
	AWG	mm <sup>2</sup>		Thick	Finish
ST730676-3	18-16	AVSS(CAVS) 0.85-1.25	0.64	0.25	Copper Alloy Pre-Tin

**Components**  
 Coil Terminal Accessory : 1EA  
 Flange Bolt M6-9 2EA  
 Wire length : 300mm

## Dimensions

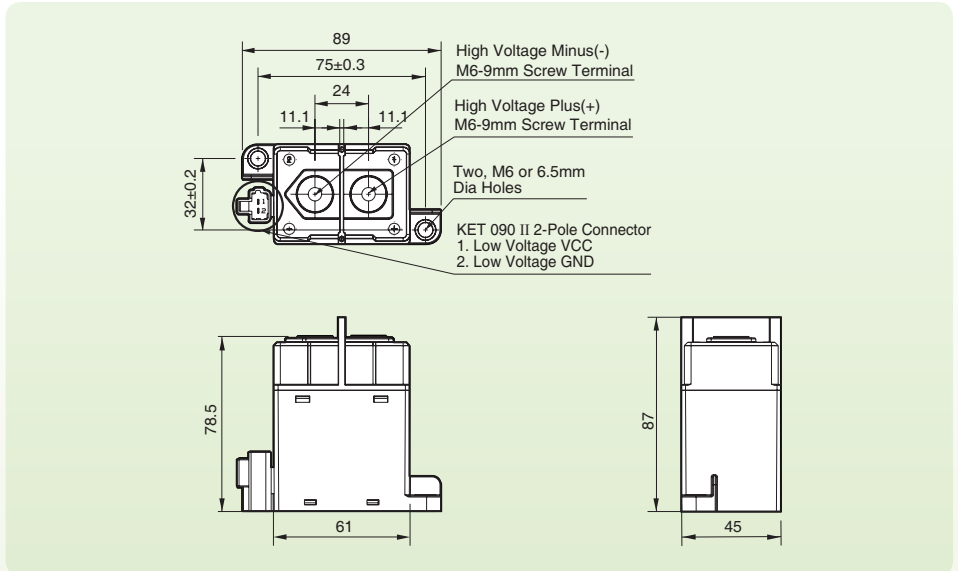

### General Tolerance

Less Than 10: ±0.3 / 10~50: ±0.5  
 More Than 50: ±0.8

## Engineering Data

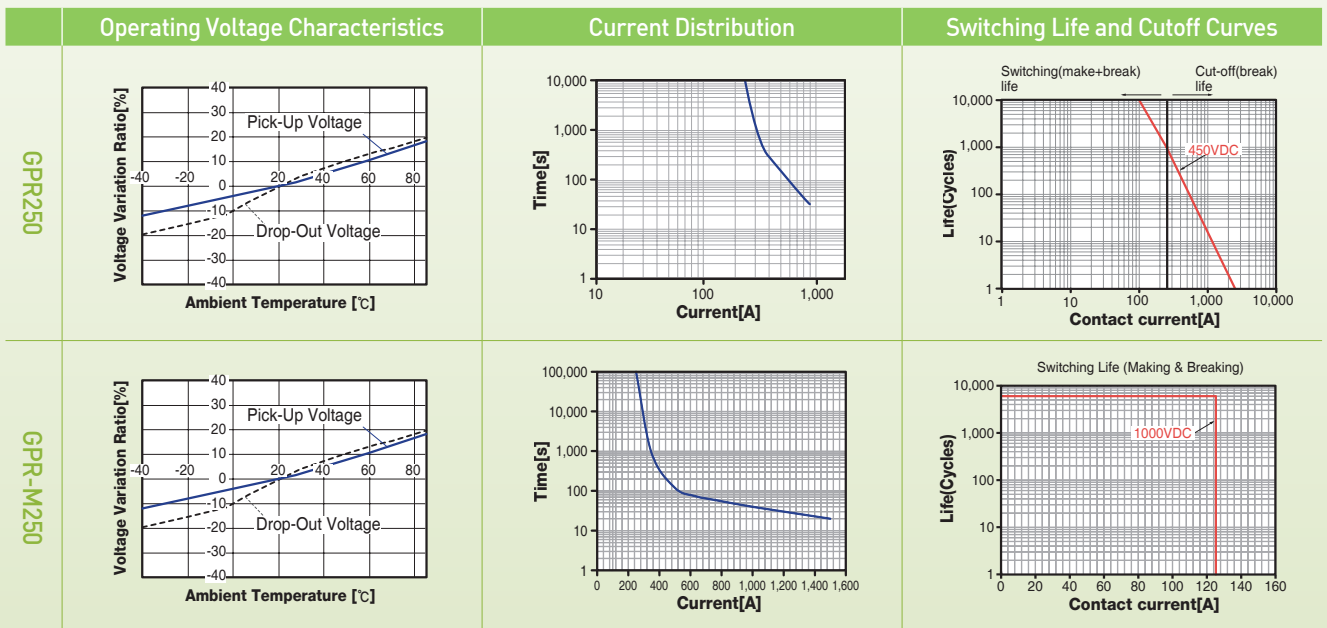

Note : I-T curve at ambient temperature of 23°C  
 ※ The graph above is estimate, so please use it only for your reference.



# GPR400 / GPR-M400

## Coil Terminal Accessory



Housing : MG651026(L)		Terminal : ST730676-3		Accessory(Not included)	
Part No.	Wire Range		Tab Thick	Material	
	AWG	mm <sup>2</sup>		Thick	Finish
ST730676-3	18-16	AVSS(CAVS) 0.85~1.25	0.64	0.25	Copper Alloy Pre-Tin

**Components**  
 Coil Terminal Accessory : 1EA  
 Flange Bolt M6-9 2EA  
 Wire length : 300mm

## Dimensions

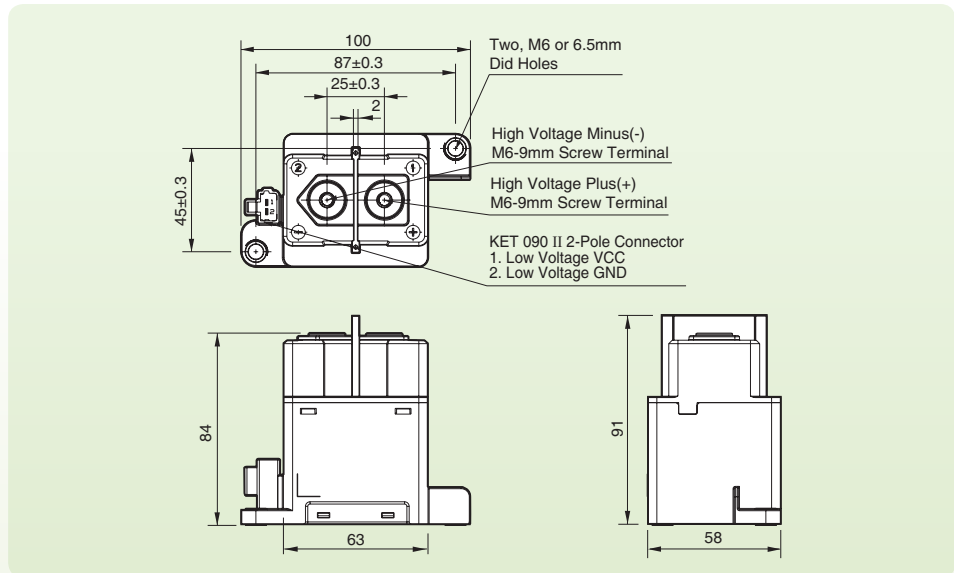

### General Tolerance

Less Than 10: ±0.25 / 10~50: ±0.5  
 More Than 50: ±0.8

## Engineering Data

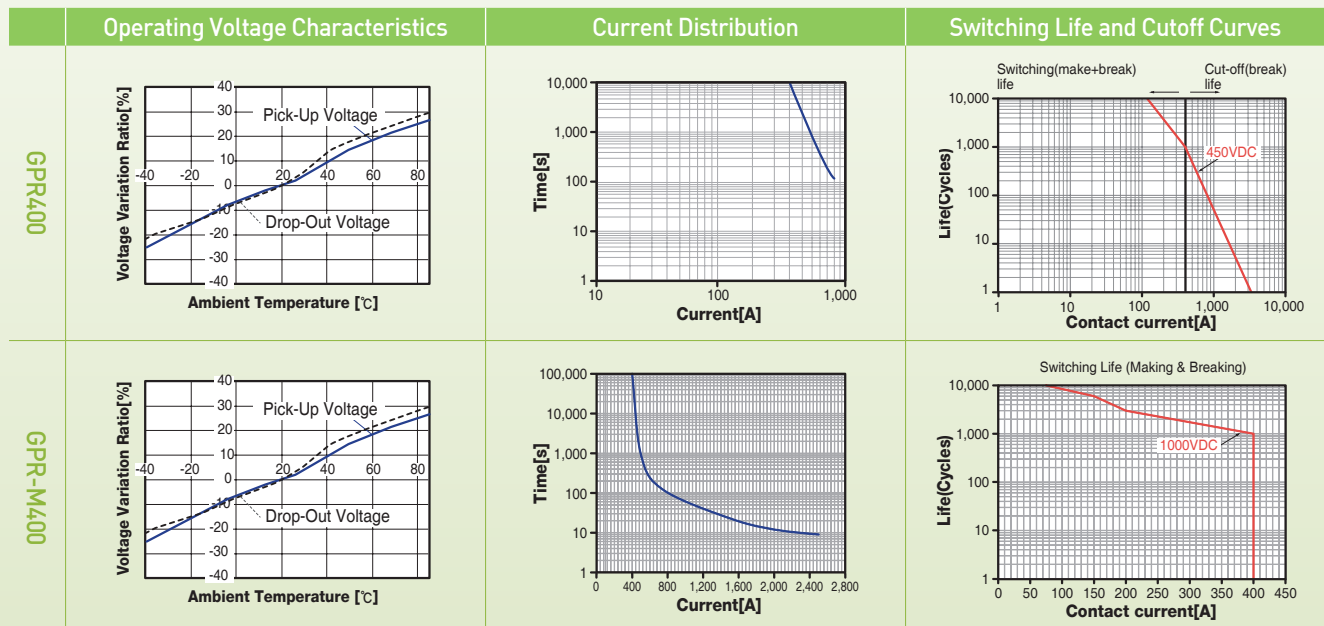

Note : I-T curve at ambient temperature of 23°C  
 ※ The graph above is estimate, so please use it only for your reference.

## Coil Terminal Accessory



Housing : MG651026(L)		Terminal : ST730676-3		Accessory(Not included)	
Part No.	Wire Range		Tab Thick	Material	
	AWG	mm <sup>2</sup>		Thick	Finish
ST730676-3	18-16	AVSS(CAVS) 0.85-1.25	0.64	0.25	Copper Alloy Pre-Tin

**Components**  
 Coil Terminal Accessory : 1EA  
 Flange Bolt M6-9 2EA  
 Wire length : 300mm

## Dimensions

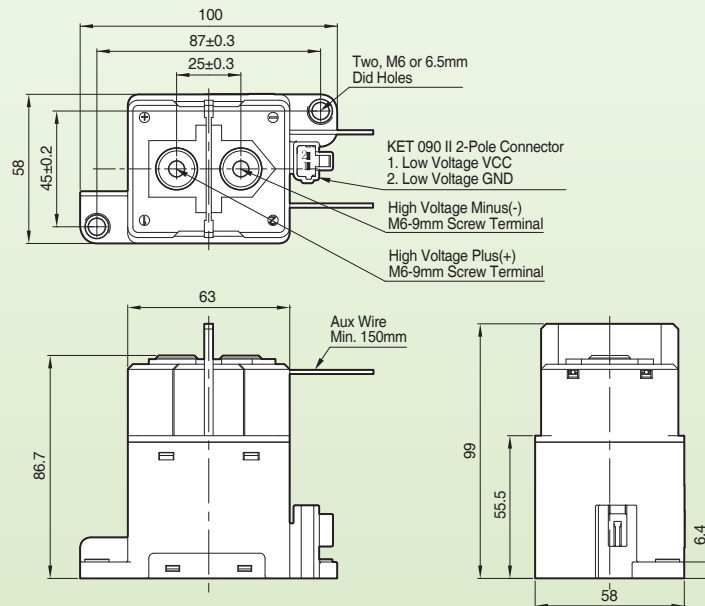

### General Tolerance

Less Than 10: ±0.25 / 10-50: ±0.5  
 More Than 50: ±0.8

## Engineering Data

Operating Voltage Characteristics	Current Distribution	Switching Life and Cutoff Curves

Note : I-T curve at ambient temperature of 23°C  
 ※ The graph above is estimate, so please use it only for your reference.

# GPR-H500-A



## Coil Terminal Accessory

Housing : MG651026(L)		Terminal : ST730676-3		Accessory(Not included)	
Part No.	Wire Range		Tab Thick	Material	
	AWG	mm <sup>2</sup>		Thick	Finish
ST730676-3	18-16	AVSS(CAVS) 0.85~1.25	0.64	0.25	Copper Alloy Pre-Tin

**Components**  
 Coil Terminal Accessory : 1EA  
 Wire length : 300mm  
 Nut M8 2EA  
 Spring-Washer 2EA  
 Plane-Washer 2EA

## Dimensions

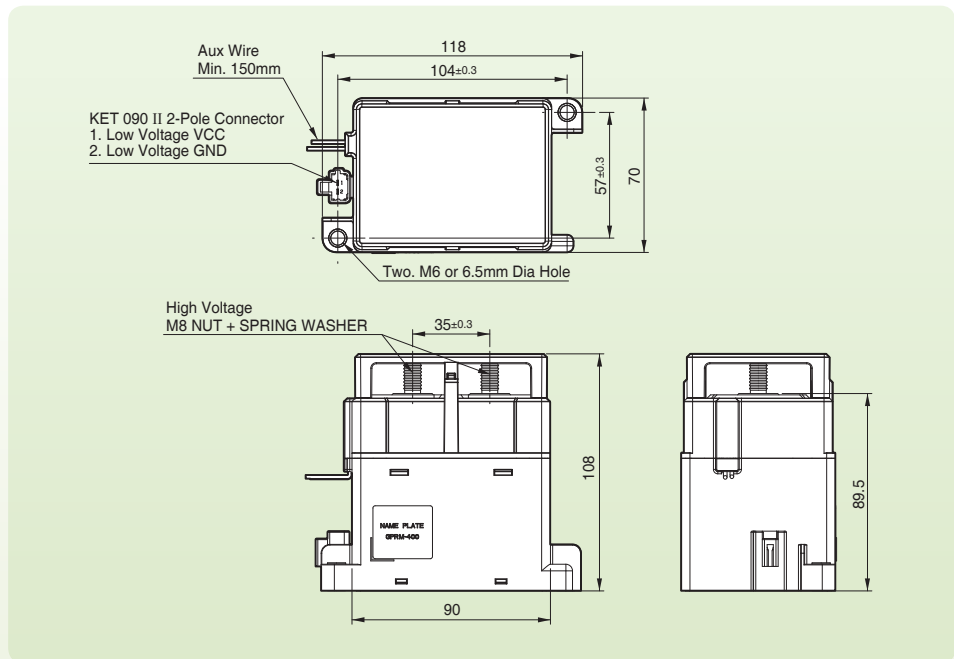

### General Tolerance

Less Than 10: ±0.25 / 10~50: ±0.5  
 More Than 50: ±0.8

## Engineering Data

Operating Voltage Characteristics	Current Distribution	Switching Life and Cutoff Curves

※ DC 1500V 300A: Breaking only

Note : I-T curve at ambient temperature of 23°C

※ The graph above is estimate, so please use it only for your reference.

# Reference

LSIS's High Voltage DC Relay is being applied to global automotive vehicles and has proven its quality with years of mass production experience

## GM (General Motors)



## Renault



## Daimler-Benz



## Porsche



## Volvo



## BMW



## Volkswagen



## Hyundai/KIA

