

## Exploded View

Sale Model:

AHU60-SG2

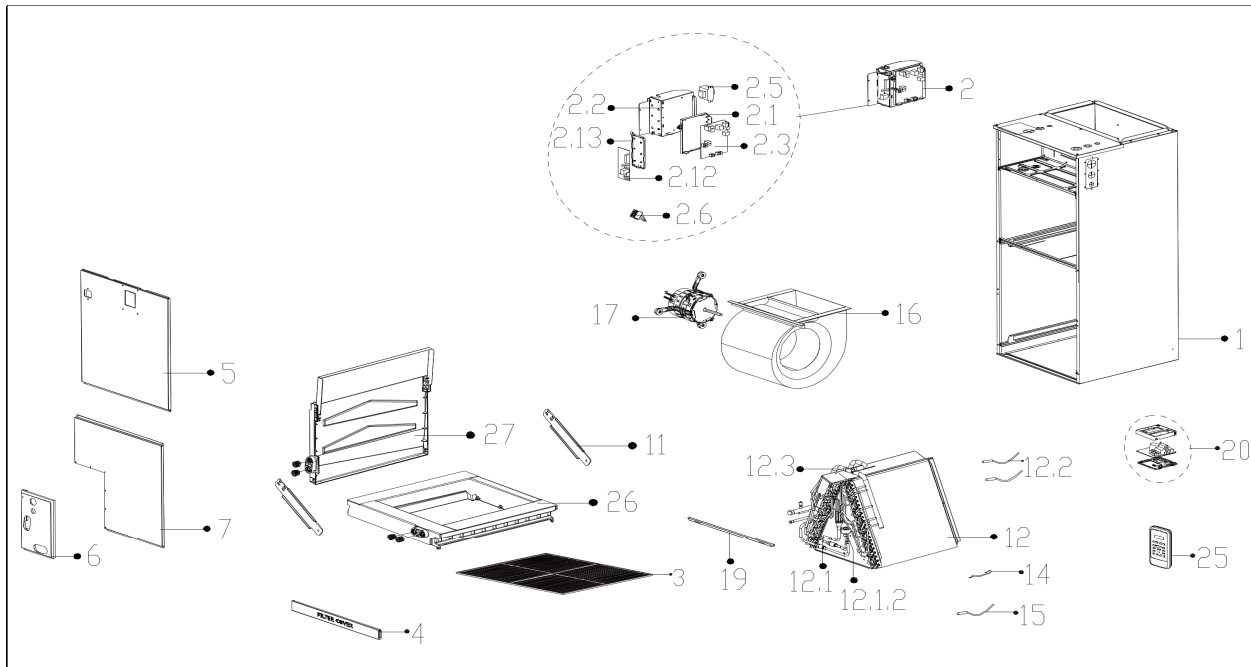

No.	Part Name	Quantity	BOM Code	Price	Remark1	Remark2
1	Chassis assembly	1	12223100000655			
2	Duct electronic control box subassembly	1	17223000007763			
2.1	Installation plate for main board	1	12123000000920			
2.2	E-part box Subassembly	1	12223100000631			
2.3	Duct main control board subassembly	1	17123000007980			
2.5	Linear Transformer	1	11203103000087			
2.6	Wire joint	1	17400401000085			
2.12	Data transfer module control board printed board s	1	17122000055387			
2.13	Bracket of main control board	1	12120300000522			
3	Air filter	1	12223000014172			
4	Dust mesh	1	12223100000660			
5	Upper Cover Plate assembly	1	12223100000670			
6	Clamp for connecting pipe assembly	1	12223100000711			
7	Under Cover Plate assembly	1	12223100000658			
11	Bracket for Water collector	1	12223100000663			
12	Evaporator assembly	1	15823100000603			
12.1	Evaporator inlet pipe subassembly	1	15123000012967			
12.1.2	Electronic expansion valve	1	15500213000245			
12.2	Pipe temperature sensor	1	11201007004863			
12.2	Pipe Temperature Sensor	1	11201007003437			
12.3	Evaporator outlet pipe subassembly	1	15123000012868			
15	Room Temperature Sensor	1	11201007004864			
16	Fan assembly	1	12200101000007			
17	Brushless DC Motor	1	11002015015863			
19	Clamp for Cover Plate assembly	1	12223100000668			
20	Wired controller	1	17317100006495			
25	Remote controller	1	17317000A63487			
26	Main Water collector assembly	1	12123100000027			
27	Deputy Water collector assembly	1	12123100000023			
28	Bracket for Water collector	1	12223100000632			