

Catalogue Building Services September 2017

OEM Asynchronous Circulation Pumps

Glandless Pumps





The international group WILO SE, which started as an historic family-run business with decades of experience, has grown over the last years into a modern and global operating company.

Within the WILO group the HVAC OEM Competence Centre is dedicated to the OEM market. With a wide range of products for each application and a comprehensive laboratory we serve our OEM customers. Our drivers are; our understanding of the market, our uncompromising commitment to the customer and the force of our innovations.

Our global strength, our problem-solving competence and the concrete benefits of using our products are the cornerstones of our success.

You will find in this catalogue some of our standard asynchronous products, but if you have any special request, please contact our team. We will be delighted to support you in finding the right solution to make your life easier.

Content

General information

- > OEM circulators page 4
- > Asynchronous motors page 9

Heating and cooling

- > Inline cast iron circulator : RS page 19
- > Inline cast iron circulator : TOP RL page 22
- > Inline cast iron circulator : TOP S page 24
- > Inline composite circulator : RS Ku page 25
- > Axial cast iron circulator : RSB page 28
- > Axial composite circulator : RSB Ku page 30
- > Hydraulic interface composite circulator : HU15 and HU25 page 32
- > Inline composite circulator with air venter : RSL Ku page 37
- > Multifunction integrated composite circulator : MSL12 page 40
- > Composite circulator with air venter : NFSL page 44
- > Composite circulator with air venter : KSL page 47

Sanitary hot water

- > Inline bronze circulator : Z15 page 51
- > Inline bronze circulator : Z25 page 53
- > Inline composite circulator : ZRS Ku page 54

Solar thermal energy systems

- > Inline solar circulator : ST/4.5 ECO, ST/6 ECO and ST/7 ECO page 57
- > Inline solar circulator : ST15/8 ECO page 59
- > Inline solar circulator : ST/8 High Flow page 60
- > Inline solar circulator : ST15/9 and ST15/11 page 61
- > Inline solar circulator : TOP-S25/13 page 62

Geothermal energy systems

- > Inline cast iron circulator : RSG/6 and RSG/7 page 64
- > Inline cast iron circulator : RSG/8 page 65

General information – OEM Circulators

Circulator designation

Wilo designation

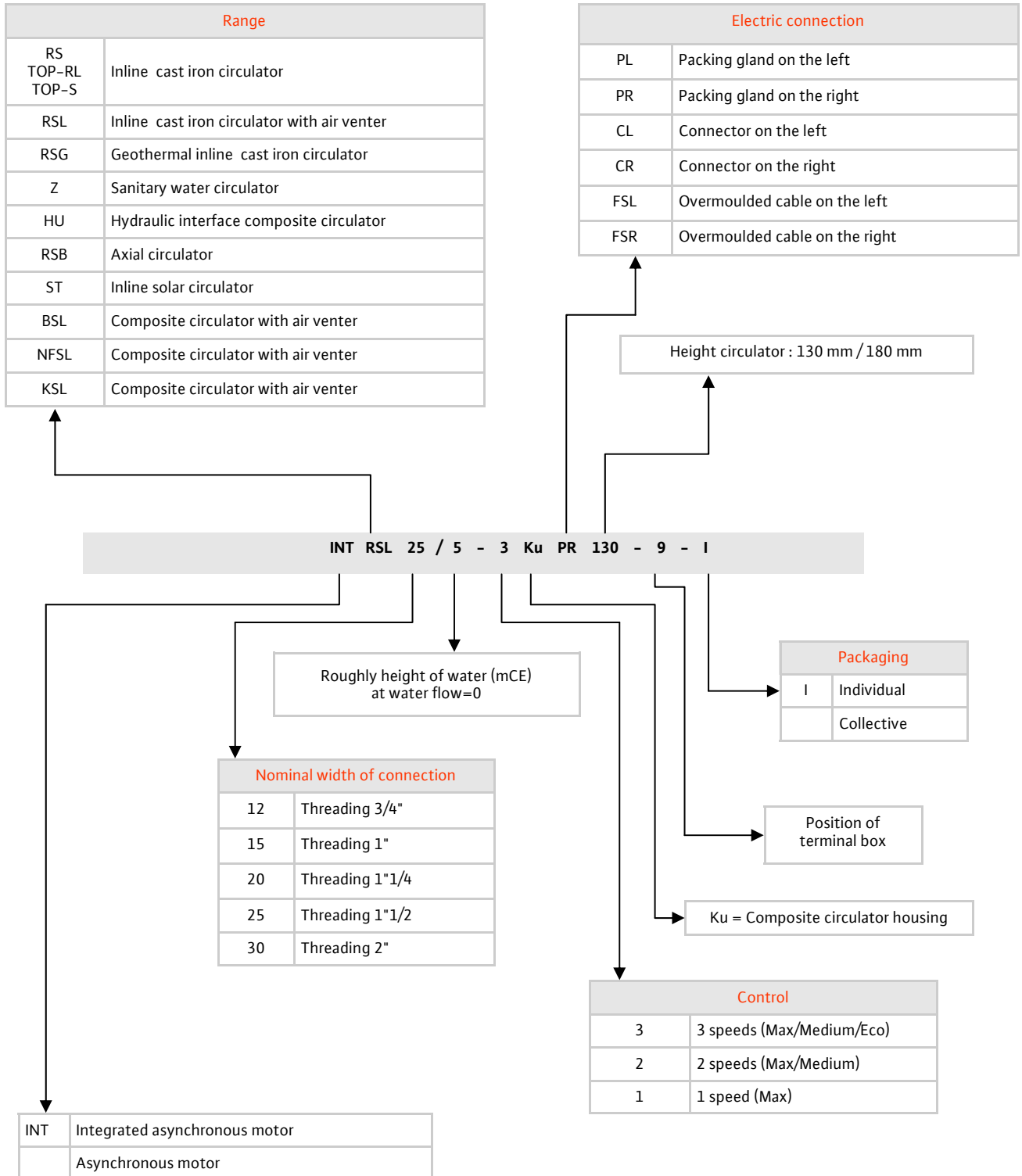

General information – OEM Circulators

Circulator designation

Circulator threaded connection

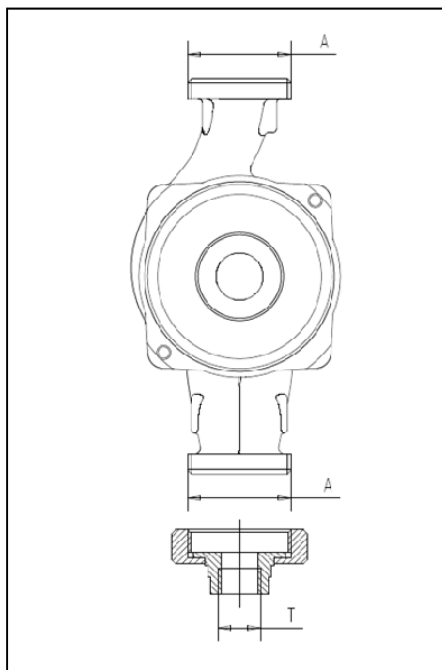

Désignation	WILO circulator's section designation	12	15	20	25	30
A	Circulator's thread diameter (inch) – G – classe B (cast iron pump housing)	3/4"	1"	1"1/4	1"1/2	2"
	Circulator's thread diameter (mm)	26,44	33,25	41,91	47,8	59,61
T	Pipe's diameter (inch) – Rp		1/2"	3/4"	3/4" or 1"	1"1/4
	Pipe's designation (mm)		15/21	20/27	20/27 or 26/34	33/42

Recommendations for hydraulic connections (cast iron or bronze or composite pump housing)

- > material for flat gasket type EPDM 70 shores
- > Especially for the cast iron and bronze pump housing size G1", the thread nut has to be chosen knowing that the length of usable threading is 8 mm max (see at right)

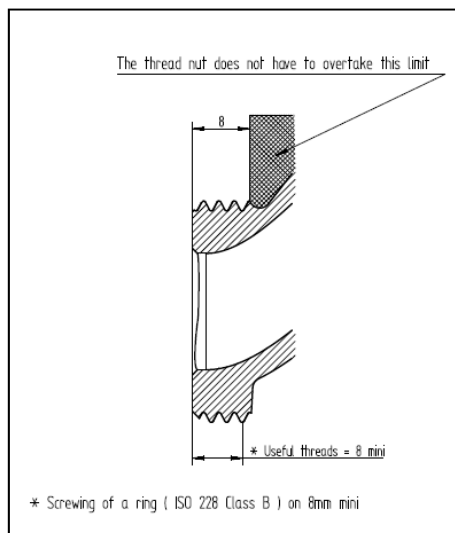

General information – OEM Circulators

Abbreviations and what they stand for

Abbreviation	Meaning
l/min	Revolutions per minute (rpm)
°dH	Degree of German water hardness, unit for assessing water hardness
H	Delivery head in m (1 m = 0.098 bar)
HVAC	Heating, Ventilation and Air Conditioning
PN	Nominal pressure. The pump has been validated at the defined pressure with security coefficient
Q	Volume flow in m ³ /h
Remote control	The speed selection of the pump can be defined by an external system
Stand alone or self controlled pump	Pump with integrated regulation (generally Δp -c and Δp -v)
TF	Nominative water temperature classification
VDI 2035	VDI guideline for the prevention of damage in hot water heating installations

General information – OEM Circulators

Approved circulator mounting arrangements :

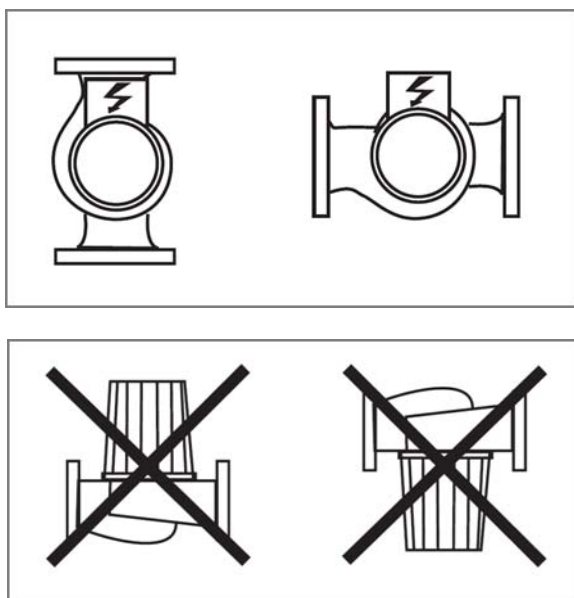

Viscous fluids / Hydraulic data

All hydraulic data contained in this catalogue are based on handling water having a kinematic viscosity = 1 mm² / s

Water / glycol mixtures allowed, mixing rate (max 1.1).

The hydraulic values of the pump and of the pipe system change when such liquids of different densities and/or viscosities are pumped.

Above 20% admixtures, the pumping data must be checked.

These data are measured after a minimum of 12 hours of running-in.

Minimum inlet pressure to prevent cavitation

To avoid cavitation (vapour forming within the circulator) it is necessary to maintain at the circulator suction port an adequately high positive pressure (static head) in relation to the vapor pressure of the fluid being handled.

For higher altitudes: add 0.1m head/100m height increase.

These minimum heads must be respectively increased when handling fluids of higher temperatures or lower densities, higher resistances at the circulator suction side and in regions of lower atmospheric pressures.

Minimum inlet pressure (m) at the circulator suction inlet to avoid cavitation noise at +40°C ambient and max. water temperatures	TOP-S TOP-RL		Other types
	50°C	0,5	0,5
	95°C	5	3
	110°C	11	10

Condensation

Circulators listed as being suitable of handling chilled water down to – 10°C are fully condensation–proof.

Working Pressure

Maximum working pressures to which circulators can be internally subjected to: PN3, PN6 or PN10 (see type plate)

Electrical Wiring

- > All Wilo circulators are suitable for wiring to the appropriate European standard voltage 230V (+10% / - 15%) to IEC 60038 standards
- > Frequency : 50Hz ±5%
- > All Wilo circulators with CE–mark according to EC Low Voltage Directive (P1≤300W) or EC machinery directive (P1<300W)

Automatic performance control

Heating circulators are, due to their high annual operating hours, among the largest power consuming appliances in buildings.

Their power consumption can however be considerably reduce when operating them in conjunction with an automatic performance control system; savings of up to 50% are thus attainable.

Automatic performance control will hydraulically optimise operations at all load conditions, particularly the problematic low-load periods so typical in central heating.

A further significant effect is the avoidance of flow noise generated at thermostatic radiator valves due to the prevention of undue head increases.

General information – OEM Circulators

Standard circulator*

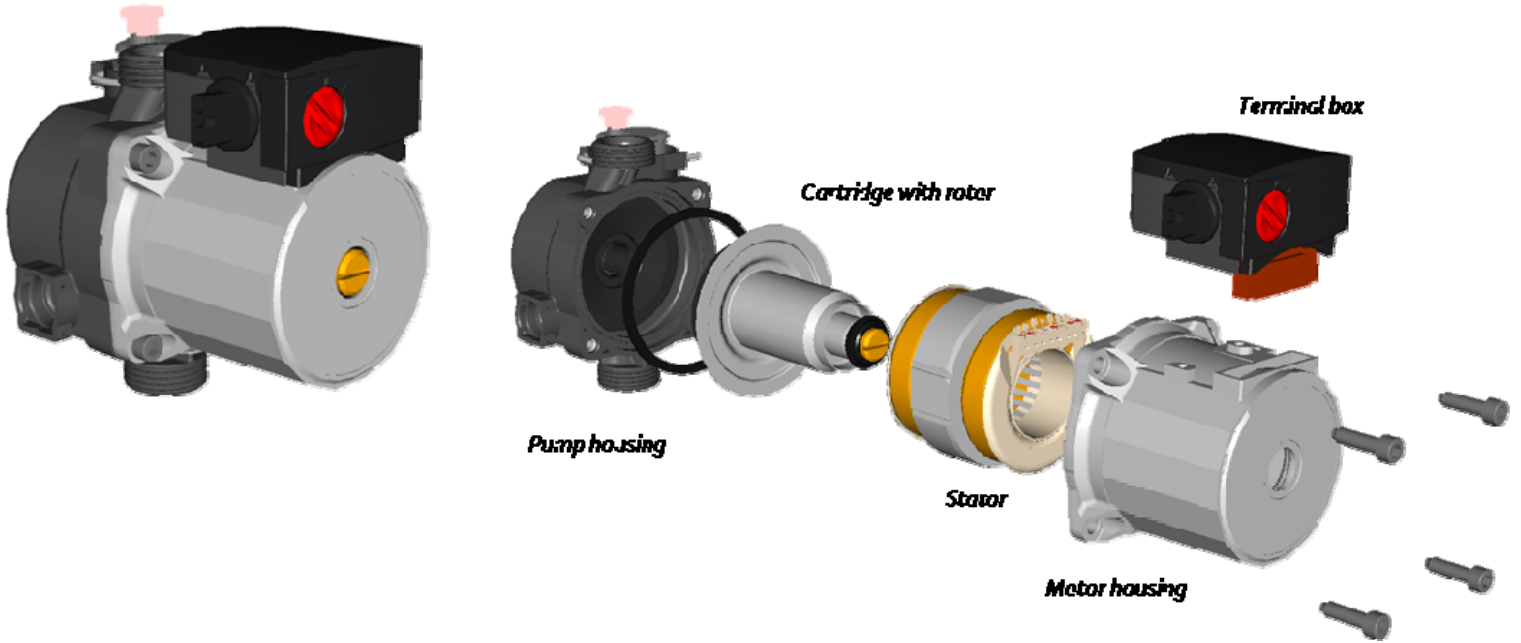

Integrated circulator *

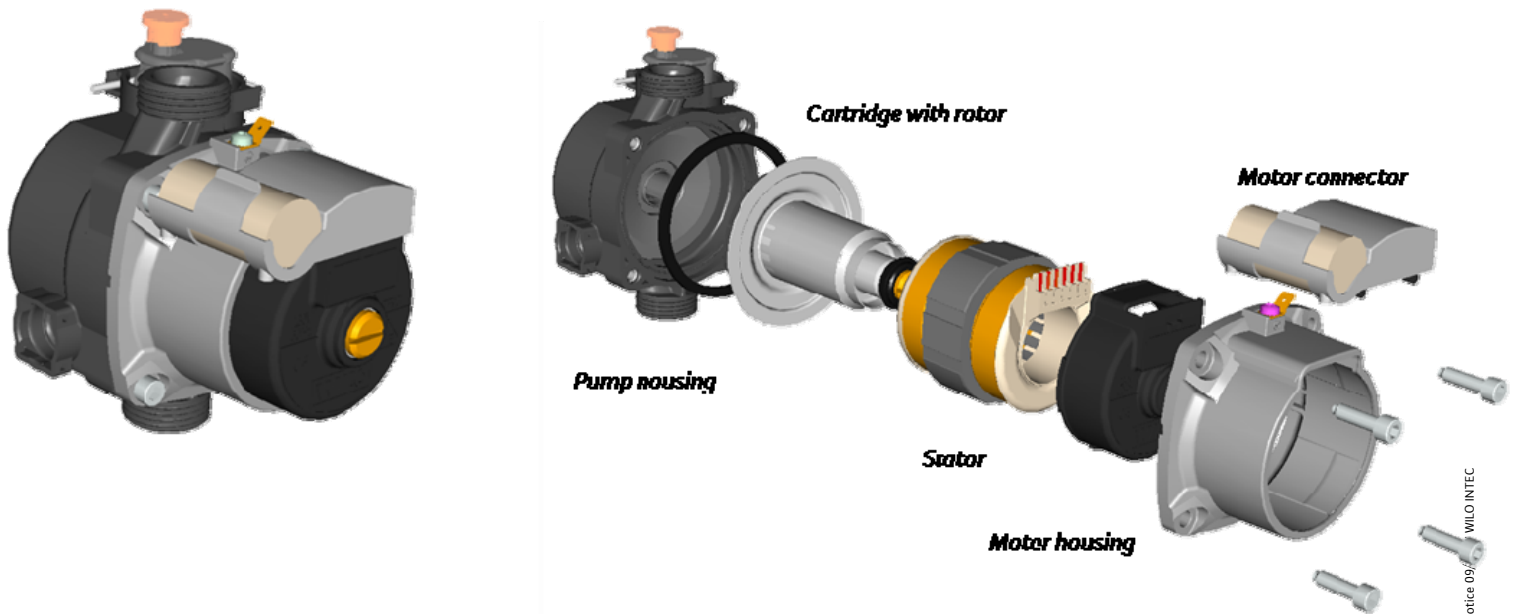

* Example of construction

General information – Asynchronous Motors

Integrated circulator : dedicated OEM motor design (White Good Approach)

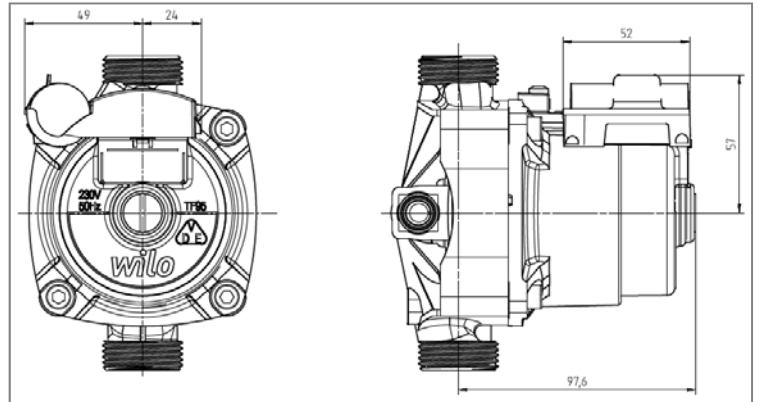

Product presentation

This product (WILO patent) is for use inside central heating boilers, offering less weight, reduced dimensions, optimised connection techniques for serviceability and an adapted industrial design. It's the result of a benchmark with White Good Products (e.g. dish washer).

This motor type fits in all standard and OEM pump housings. The hydraulic curves and the electrical data are according to the catalogue data for the standard pumps

The cable connection on the motor ("motor connector") is based on RAST 2.5 standards. It includes a water protected housing and the capacitor. The cable connection on the customer side ("customer connector") may be defined by the customer but shall be preferably in RAST type.

The earth is not provided but a standard separated earth pin is integrated.

The installer may dismount the motor connector from the circulator with a screw driver for service reasons ensuring that no water enters the open motor connection.

The product will be delivered with the cable / connector either mounted or separately.



Circulator



Cable / connector

Boiler integration

The earth connection is proposed as a standard 6.35 x 0.81 terminal. It must be linked to a cable from boiler or existing earth cable.

This new motor is certified VDE component (n° 40023360).

Product range

1 speed and 2 speeds remote control for boiler version are available.

There is no manual speed selector available.

Motor range head : 4m up to 6.7m (@ 0l/h)

Cable range – WILO standard (see drawing below)

Working length L : 250, 500, 750, 1000 ± 5 mm

Colour : black (for 1 speed and 2 speeds cable with connector end)

 brown, red, black, blue (for 2 speeds free ends)

Type : separate wires – class 2 – 0.5mm² – VDE approved

Ø outer Wire : 2.40 mm

Ends : RAST type connector or free wires

Option : cable customisation are possible with specific customer connector and with integrated earth terminal.

Working length
(L±15)

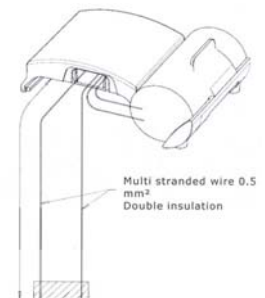

Ends

version

WG connector and

cable – 1 speed

2 speeds remote control description (4 wires)

1 – brown – blue : main supply (main + auxiliary)

2 – circulator speed selection from boiler :

- Blue (N) : neutral
- Shunt between blue – black : max speed
- Shunt between red – black : medium speed

General information – Asynchronous Motors

Positioning of motor connector

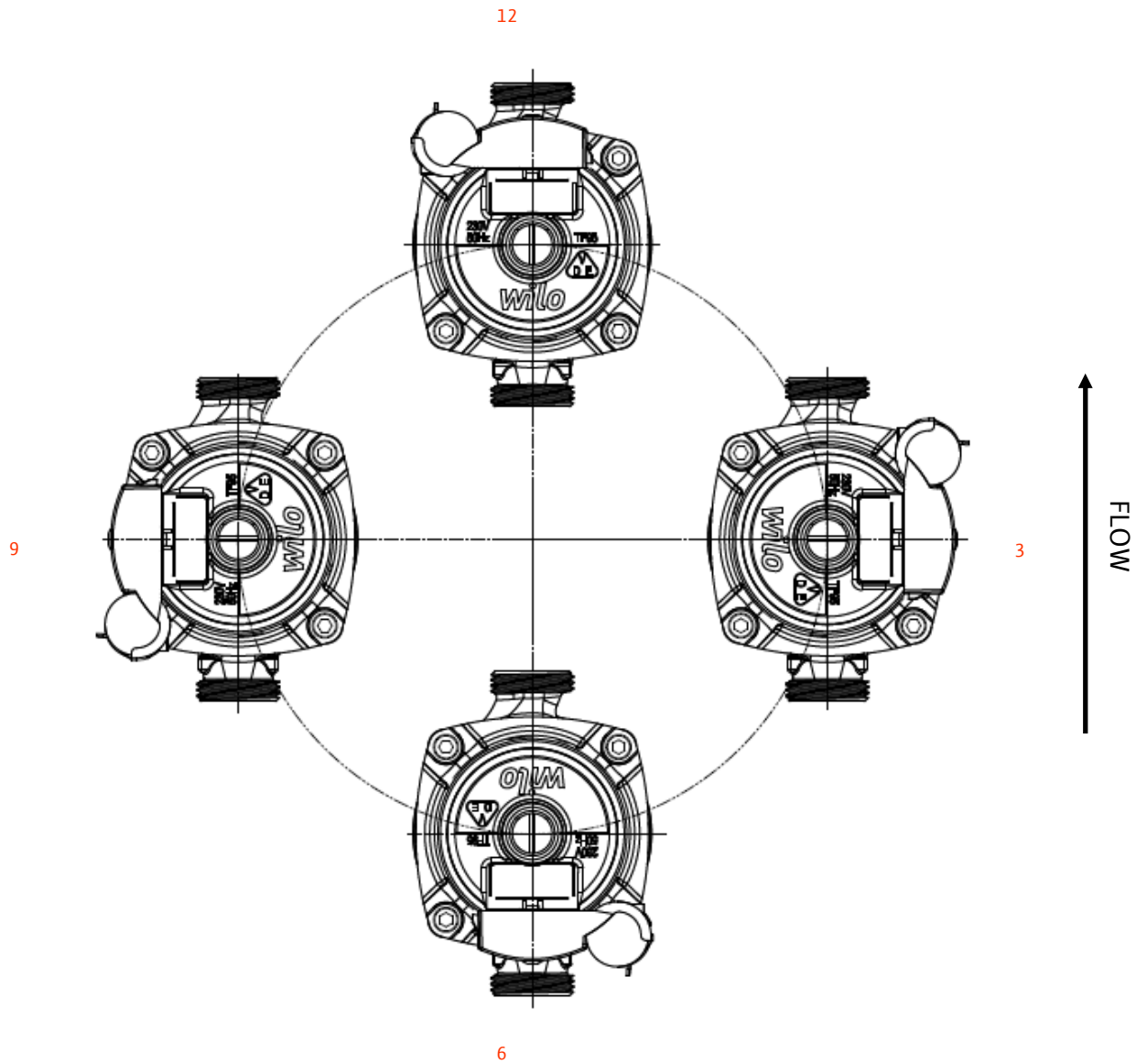

General information – Asynchronous Motors



Introduction

WILO INTEC has been producing circulating pumps with asynchronous motors for many years. This standard motor technology fits a large spectrum of pump housings for use in heating, solar, geothermal or sanitary applications. The motors can be customised with different types of speed control system:

- > 1 of 3 different speeds selected by installer
- > Remote control up to 3 speeds

General data on asynchronous motors

Motor

Canned rotor motors feature

- > Degree of protection : IP44 (except special terminal box – Please contact us)
- > Insulation class F (except for circulators */5 and INT*/6.7 which are class H)
- > Radio frequency interference : EN 50082-1

Normative water temperature classification

- > See type plates

Standard terminal box connections

3 mains solutions :

- > The connecting cable can be assembled by the customer through the packing cable gland (either right or left)
- > With a cable (mounted by Wilo Intec) according to the customer's specification (either right or left)
- > With a standard 3 ways connector integrated on the box (either right or left)

Permitted field of application

- > Heating water

Permissible ambient air temperatures

From 0°C to +60°C (with a fluid temperature not exceeding 95°C)

Temperature range for use in heating and A/C systems at max. ambient temperature +40°C : -10 to +110°C

Temperature profiles

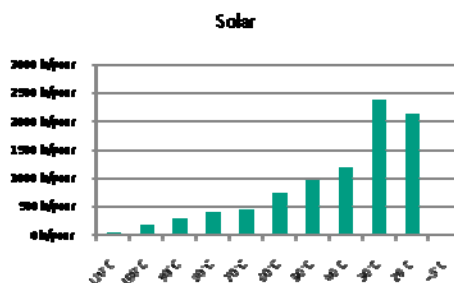
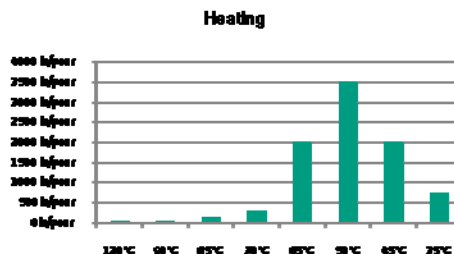

- > Drinking water
Temperature range for use in drinking-water circulation systems at max. ambient temperature +40°C : 0 to +65°C (short time duty 2h : +80°C)
Max. permitted total hardness in drinking-water circulation systems 18°Dh

General information – Asynchronous Motors

General points for pumps in heating systems

WILO pumps operate best with clean, good quality tap water.

The most frequently occurring factor which may have a negative effect on heating water can be oxygen, lime, sludge, acidity level and other substances (including chlorides and minerals).

In addition to the heating water quality, the installation also plays a significant part. The heating system shall be tight.

Materials shall be chosen which are not sensitive to oxygen diffusion (corrosion risks...).

New heating systems

In the case of new installations, it is first of all crucial to flush the entire installation thoroughly (without the pump mounted) before the central installation is commissioned. This will remove residue from the installation process (weld, slag, fitting products...) and preservatives (including mineral oil).

The system shall then be filled with clean, good quality tap water.

Existing heating systems

If a new boiler or heat pump is being installed in an existing heating system, the system must be flushed to avoid particles presence, sludge and other problems in the installation. Where applicable flushing shall be done before the new application is installed.

Loose dirt can only be removed where there is sufficient flow. Flushing will therefore take place section by section. Special attention must also be paid to "blind spots", where there is only a small amount of flow and where a lot of dirt can be accumulated.

The system shall then be filled with clean, good quality tap water.

If after the flushing the quality of the water in an existing installation proves still to be inadequate, certain measures must be taken to avoid pump problems. One option for removing pollution is to install a filter. Various kinds of filters are available for this. A screen filter is designed to trap large dirt particles. This filter is usually placed in the full flow part of the system. A fabric filter on the other hand, is designed to trap finer particles.

Very old heating systems or systems open to air

In heating systems which are open to air corrosion inhibitors shall be used. The product must be suitable for all materials used in the central heating installation. The supplier of the corrosion inhibitor must be consulted in this regards. Its usage regulations and instructions provided by the supplier of the water treatment product must be followed.

In old heating systems which remain very dirty after flushing, the usage of cleanser may help. The product must be suitable for all materials used in the central heating installation. The supplier of the cleanser must be consulted in this regards. Its usage regulations and instructions provided

by the supplier of the water treatment product must be followed. Particular attention must be paid on the full removal of the cleanser from the heating installation.

Given that a variety of water treatment products are available, it is not feasible for WILO to investigate all possible products. A number of well-known manufacturers and their products are :

Fernox :
 – Protector F1
 – Restorer F3

Sentinel :
 – X100
 – X400

Agent from the other manufacturers may also be used, provided the relevant manufacturer guarantees that it is suitable for all materials used and is corrosion resistant.

The system shall then be filled with clean, good quality tap water.

Forbidden materials

Some materials must not be used in installation because of too low PH value, composite attack, e.g. :

- Leak sealer
- Nutritive acid and deoxidant acid
- FERNOX DS40 system cleaner

General information – Asynchronous Motors

Positioning of control box

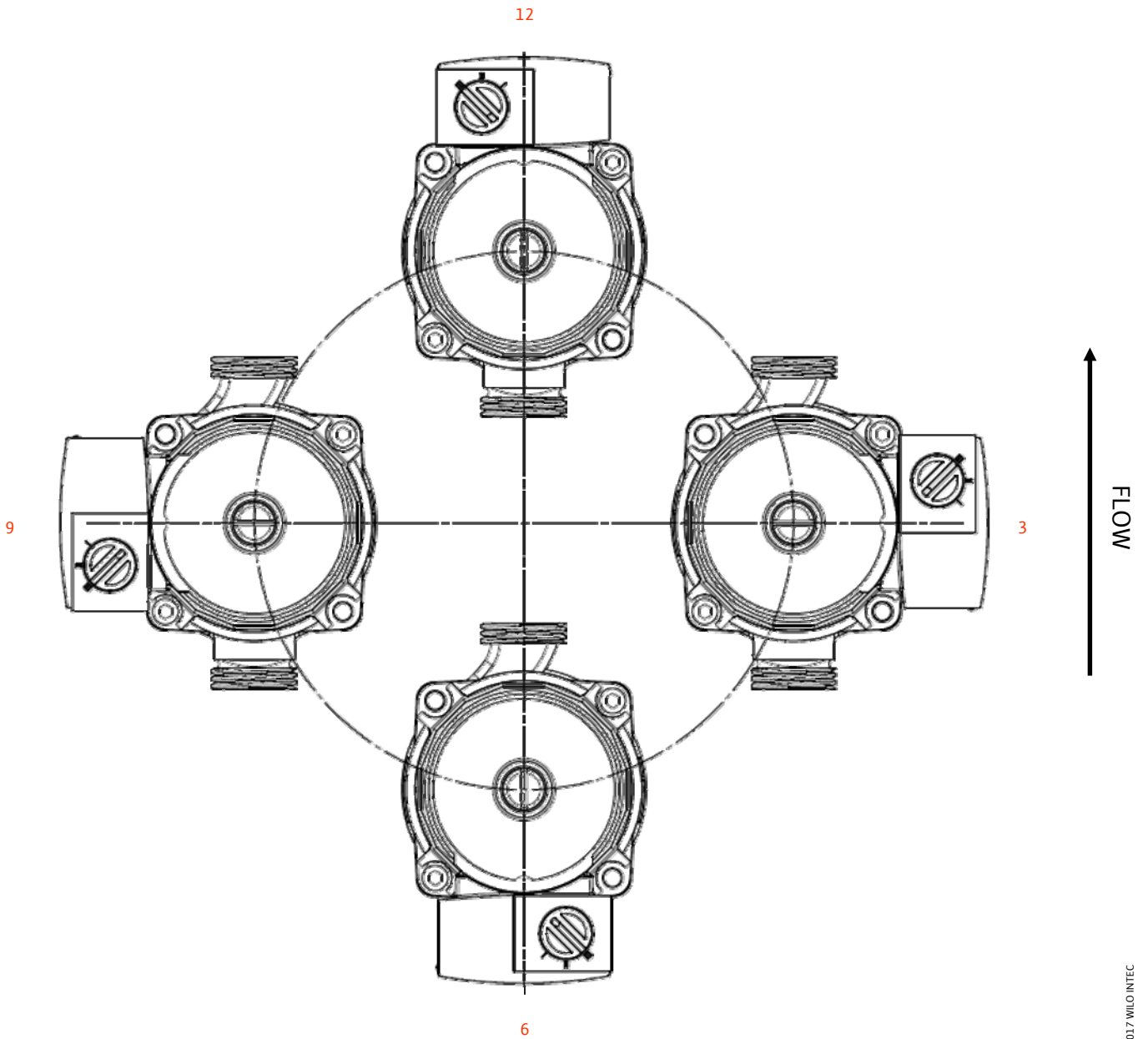

General information – Asynchronous Motors

OEM Standard Box

Positioning

The box WI2 can be supplied with the Packing Gland on the left side or the right side according to the customer's needs (excepted TOP range)

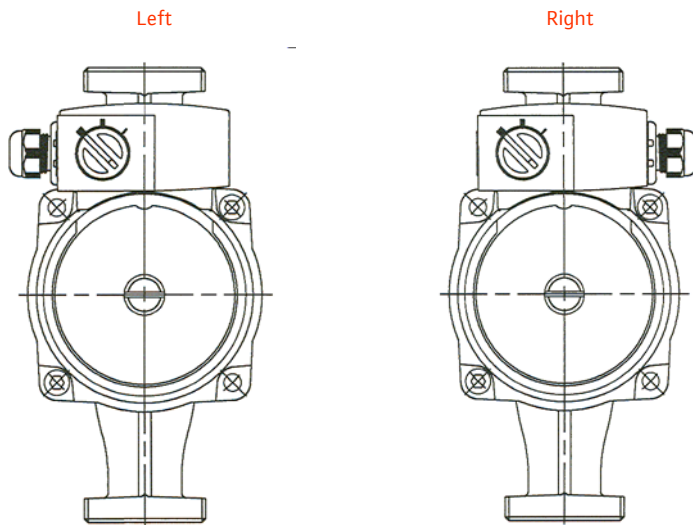

Cable gland

	Cable's diameter (mm)	
	min	max
PG9	5	8
PG11	6	9,5

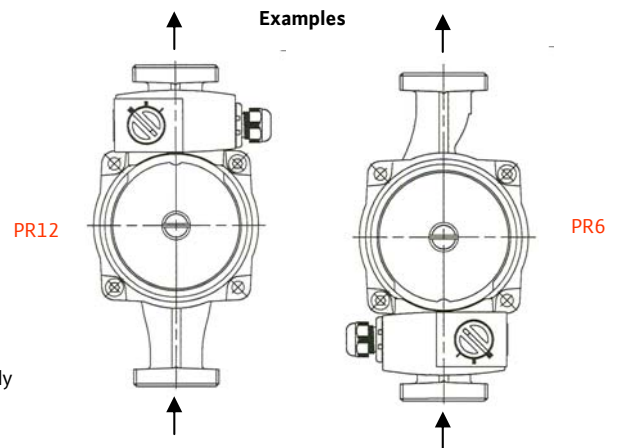

Data label position

The data label position has to be specified separately

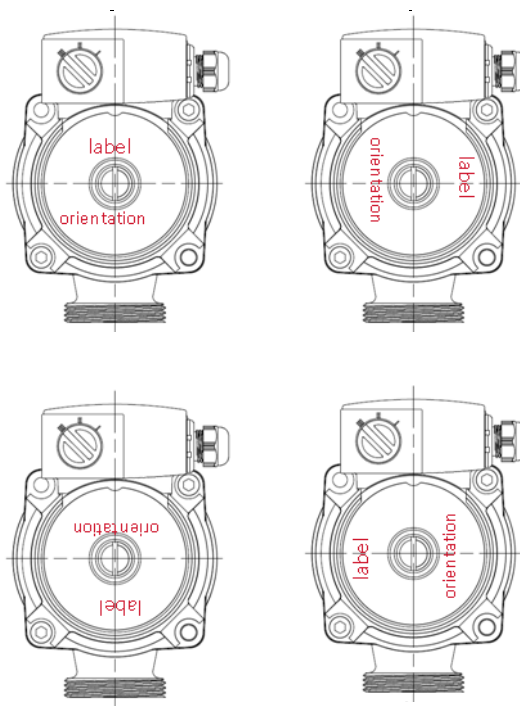

General information – Asynchronous Motors

Cables available as standard (excepted TOP range)

According to the customer's needs, the terminal box can be supplied :

- with the cable on the right side or on the left side
- with 1, 2 or 3 speeds

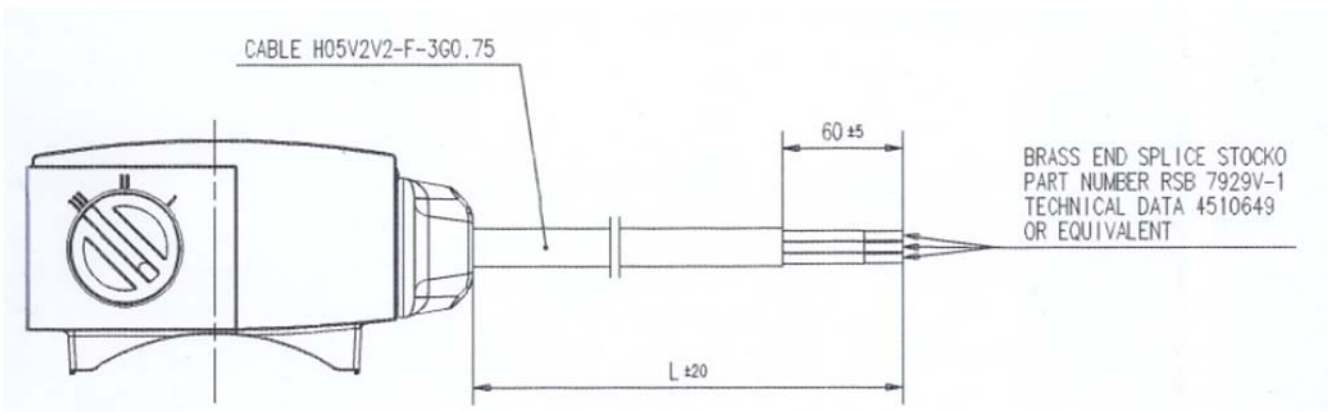

Standard length (mm)
500
1000
1500
2000
2500
3000

General information – Asynchronous Motors

Standard quick connection module V1 (Excepted TOP range)

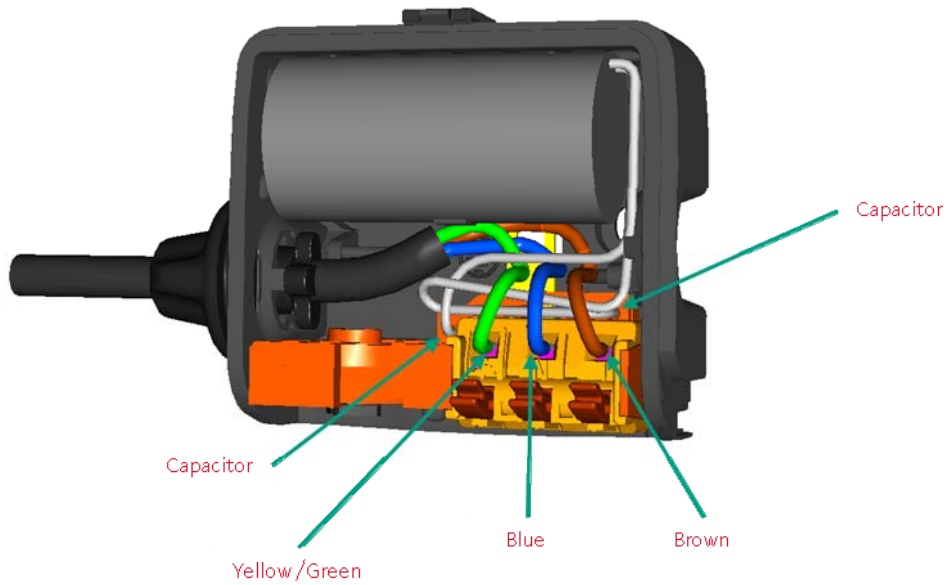

Quick connection module V2 (with remote control)

Short circuit (sanitary) = high speed
 Long circuit (heating) = selector speed chosen

Delivery status : cable for remote control will be mounted by Wilo Intec

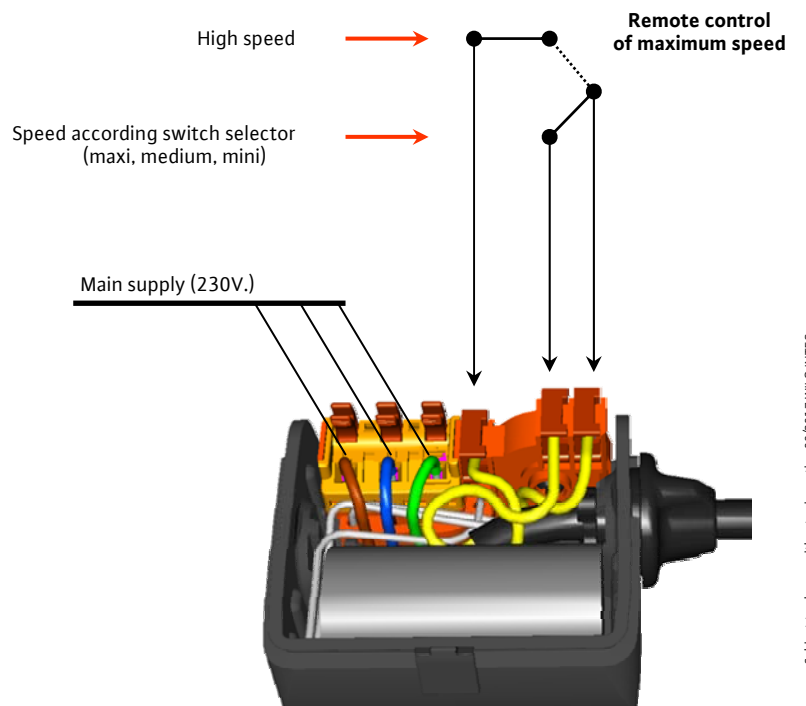
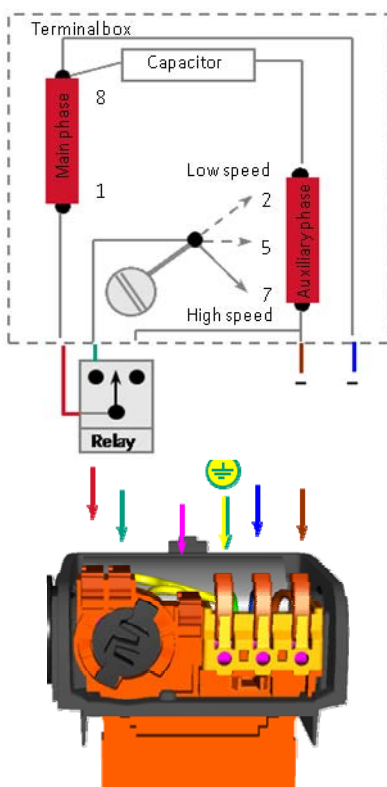

General information – Asynchronous Motors

Module with remote control (WS5)

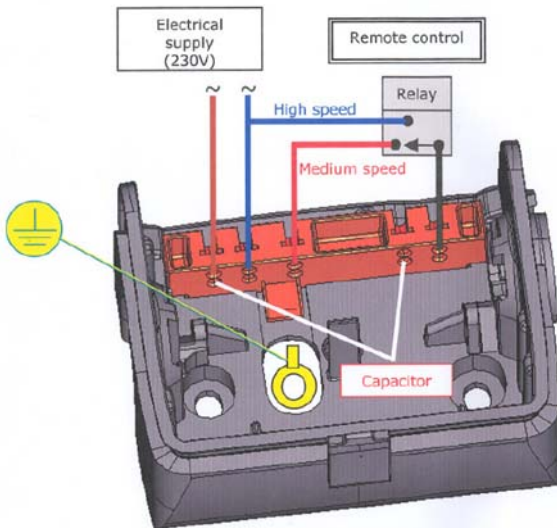

Index 4 (between high or medium speed)

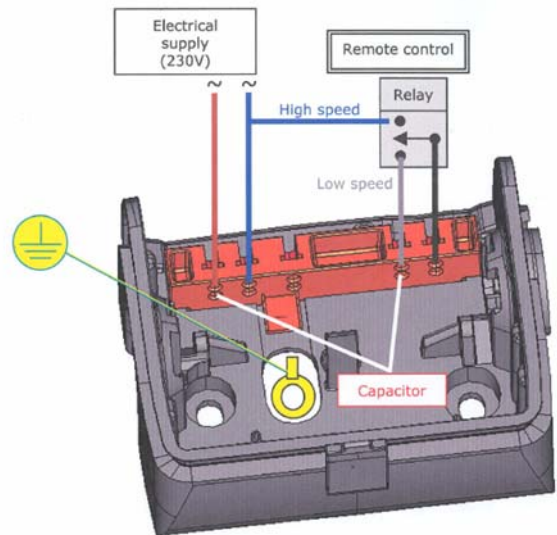

Index 5 (between high or low speed)

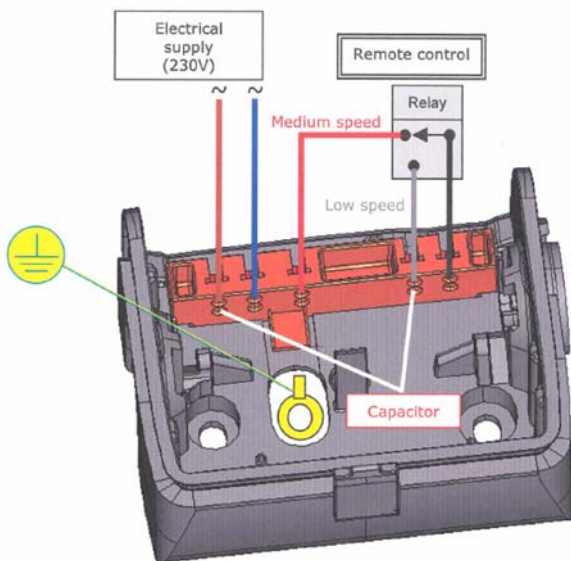

Index 6 (between medium or low speed)

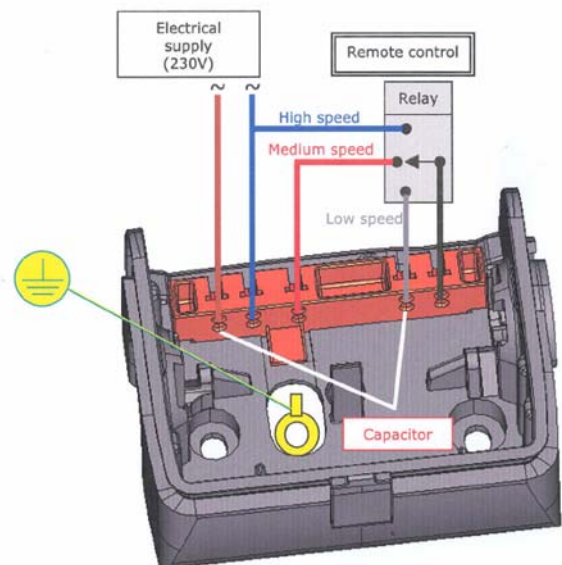

Index 7 (between high, medium or low speed)

Delivery status : cable for remote control will be mounted by Wilo Intec

Heating and cooling



Inline asynchronous circulators for heating application

Type : RS

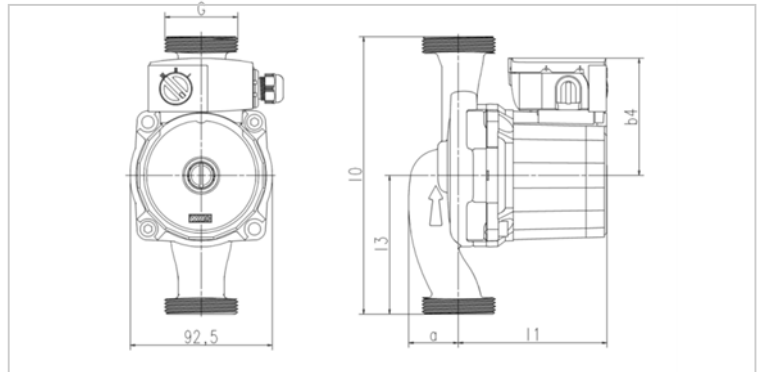

	Thread	Dimensions				
	G	I0	I3	I1	a	b4
RS15/4 /5 RS15/6 RS15/7	1"	130	65	96,6 96,6 109,6	28,5	72,5 76 76
RS20/4 /5 RS20/6 RS20/7	1"1/4	130	65	96,6 96,6 109,6	28,5	72,5 76 76
RS25/4 /5 RS25/6 RS25/7	1"1/2	130	65	96,6 96,6 109,6	33,9	72,5 76 76
RS25/4 /5 RS25/6 RS25/7	1"1/2	180	90	96,6 96,6 109,6	33	72,5 76 76
RS30/4 /5 RS30/6 RS30/7	2"	180	90	96,6 96,6 109,6	33	72,5 76 76

Inline asynchronous circulators for heating application

Type : RS

	n l/m	P1 W	I A	Capacitor µf/VDB
RS../4	max 2050	65	0,28	2 / 400
	1650	46	0,20	
	min 1300	30	0,13	
RS../5	max 2200	88	0,38	2 / 400
	2000	60	0,27	
	min 1600	40	0,18	

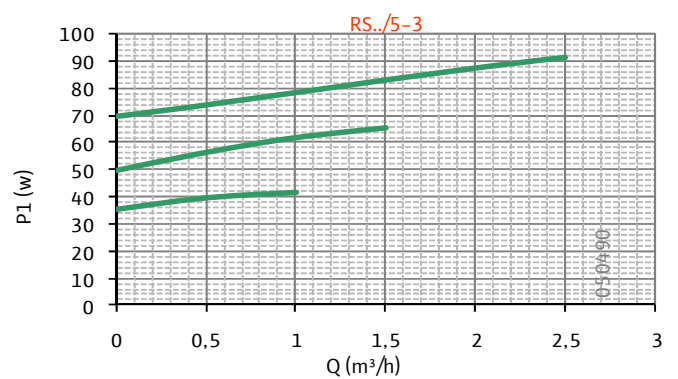
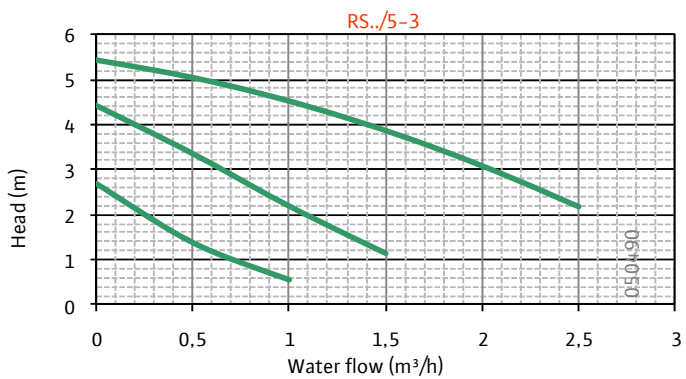
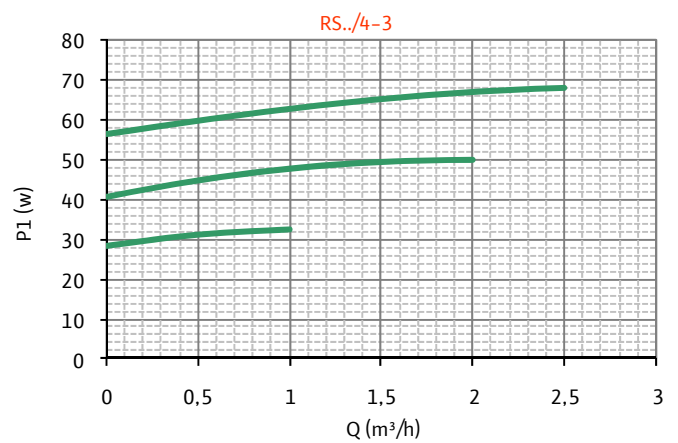
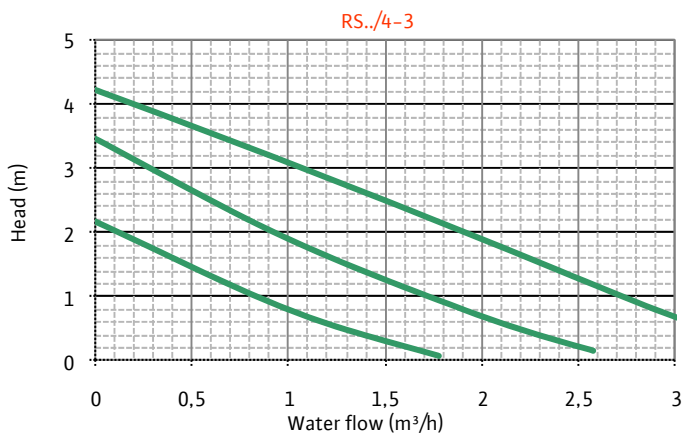

Inline asynchronous circulators for heating application

Type : RS

		n l/m	P1 W	I A	Capacitor µf/VDB
RS../6	max	2200	93	0,40	2,6 / 400
		1900	67	0,30	
	min	1450	46	0,20	
RS../7	max	2450	132	0,58	3,5 / 400
		2250	92	0,42	
	min	1850	62	0,30	

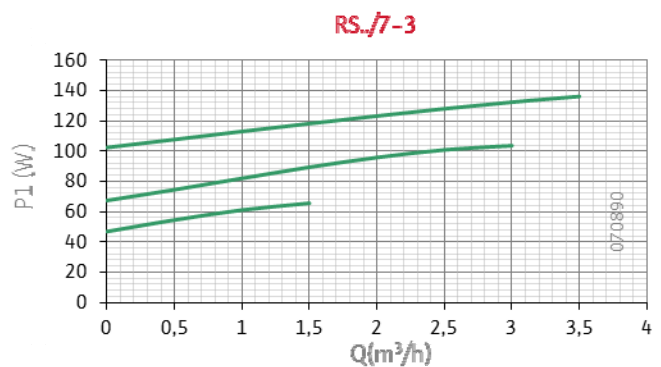
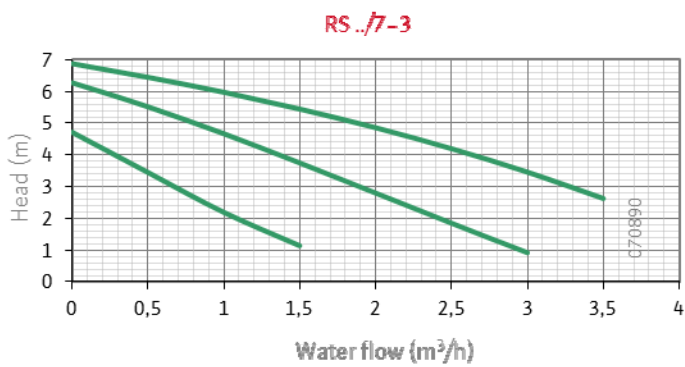
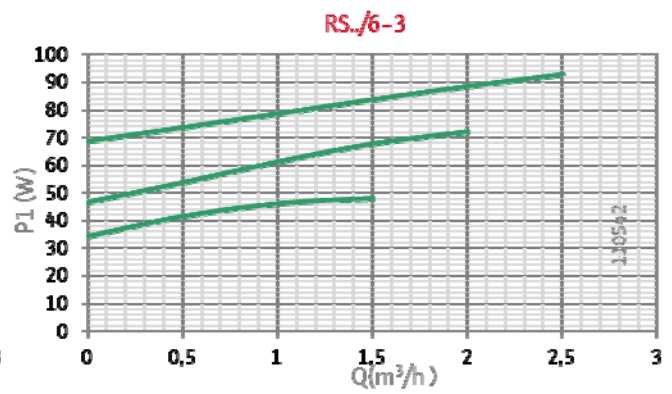
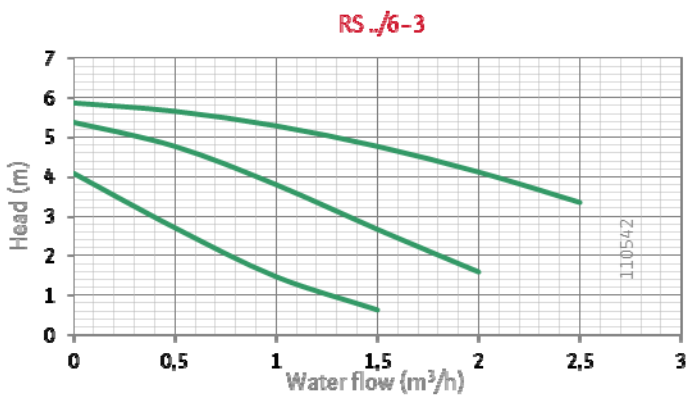

Inline asynchronous circulators for heating application

Type : TOP RL

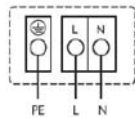
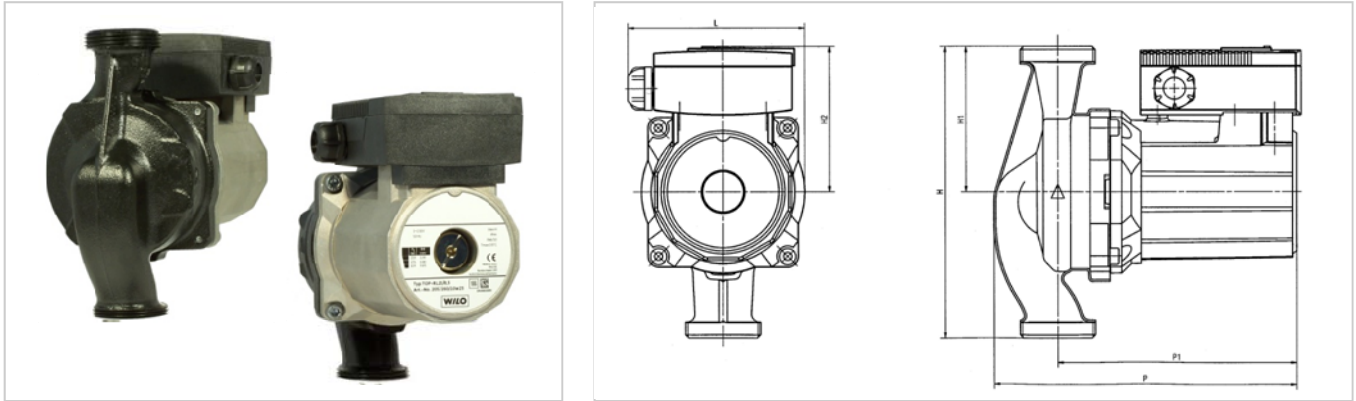

Wiring diagram

Internal protection against unacceptably high winding temperatures
 Tripping: Internal interruption of motor voltage
 Reset: Automatic after motor has cooled down

NB: supplied with PG on the left side

These pumps are also suitable for solar thermal and geothermal energy systems

	Steps	n 1/min	P1 W	I A	Capacitor µf/VDB
TOP-RL 30/4	1	2660	180	0,85	5 / 400
	2	2340	150	0,75	
	3	1710	110	0,55	
TOP-RL 25/7.5 TOP-RL 30/7.5	1	2420	205	1,00	5 / 400
	2	1950	165	0,80	
	3	1350	115	0,60	
TOP-RL 25/8.5 TOP-RL 30/8.5	1	2625	210	0,95	6 / 400
	2	2320	175	0,90	
	3	2000	120	0,65	

	Thread	Dimensions					
	G	I0	I3	P	I1	L	b4
TOP-RL 30/4	2"	180	90	196	156	104	92
TOP-RL 25/7.5	1"1/2	180	90	190	150	104	92
TOP-RL 30/7.5	2"	180	90	190	150	104	92
TOP-RL 25/8.5	1"1/2	180	90	189	150	110	90
TOP-RL 30/8.5	2"	180	90	189	150	110	90

Inline asynchronous circulators for heating application

Type : TOP RL

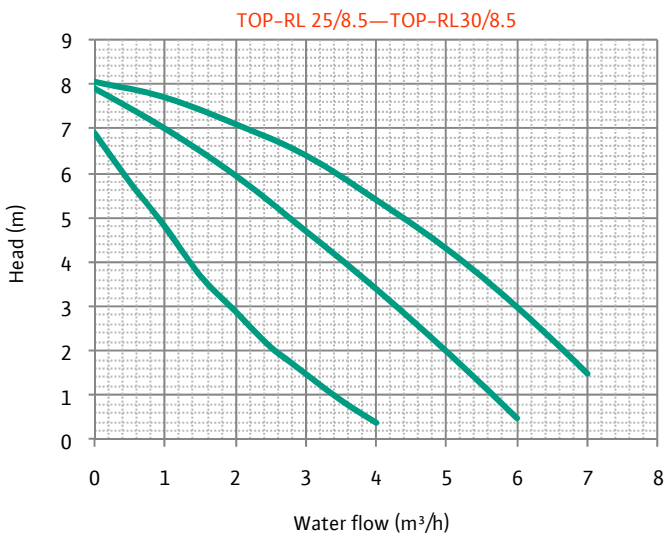
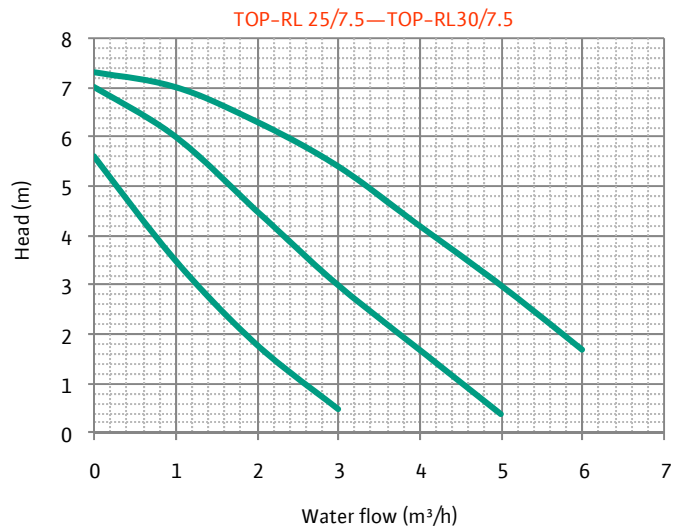
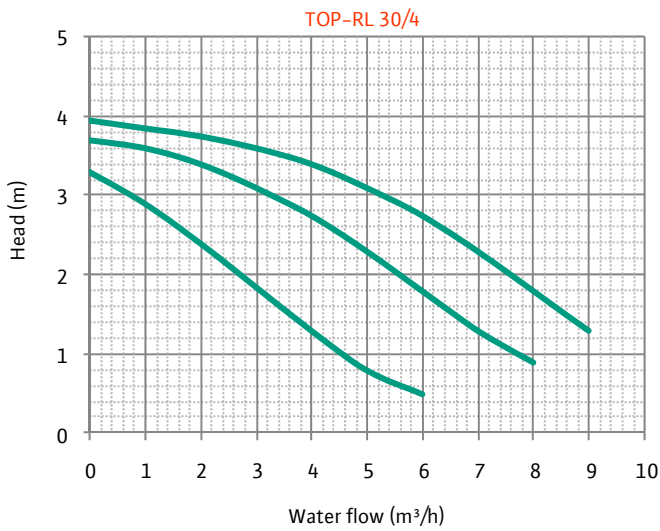

Inline asynchronous circulators for heating application

Type : TOP S

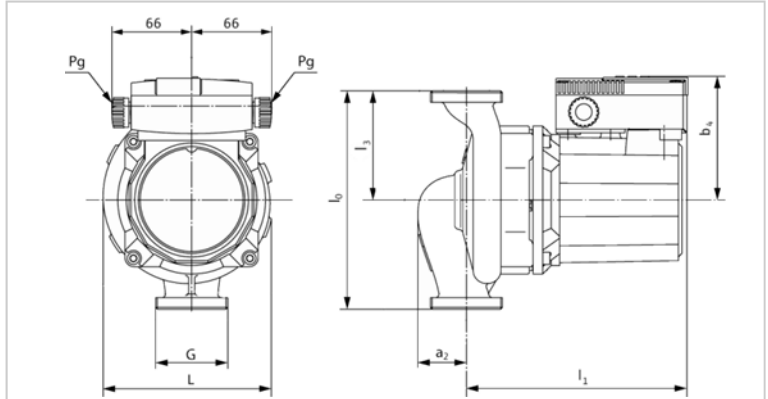

NB : supplied with PG on both sides

These pumps are also suitable for solar thermal and geothermal energy systems.

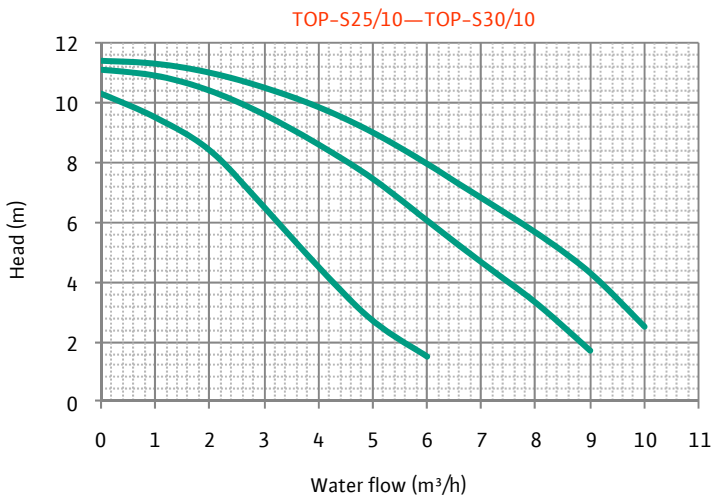

Wiring diagram

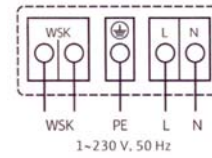

Internal protection against unacceptably high winding temperatures
 Tripping: Internal interruption of motor voltage
 Reset: Automatic after motor has cooled down

	Steps	n 1/min	P1 W	I A	Capacitor µf / VDB
TOP-S 25/10 TOP-S 30/10	1	2700	225 - 390	1,9	8 / 400
	2	2550	190 - 385	1,87	
	3	2400	165 - 335	1,72	

	Thread	Dimensions					
	G	l0	l3	a2	l1	L	b4
TOP-S 25/10	1"1/2	180	90	45	172	137	102
TOP-S 30/10	2"	180	90	45	172	137	102

Inline asynchronous circulators for heating application

Type : RS Ku

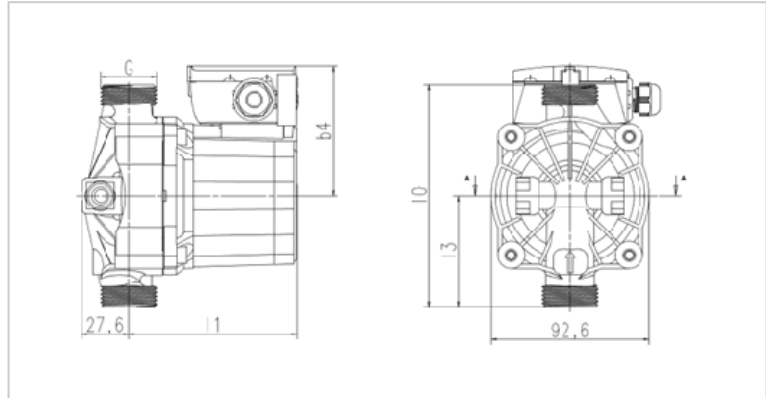

Connections G 1", 1"1/4, 1"1/2
 Suction and pressure side : screwed on minimum 3 threads
 Maximal torque on connections G 1", 1"1/4, 1"1/2 : 40 Nm
 Gasket : Ø30 x Ø21 x 2,1 (EPDM) G 1"
 Ø38 x Ø29 x 2,2 (EPDM) G 1" 1/4
 Ø44 x Ø32 x 2 (EPDM) G 1" 1/2

This circulator housing height can be supplied with 2 optional connections. They are defined to be connected to one manometer or one expansion vessel. Any other use has to be tested and validated by Wilo Intec.

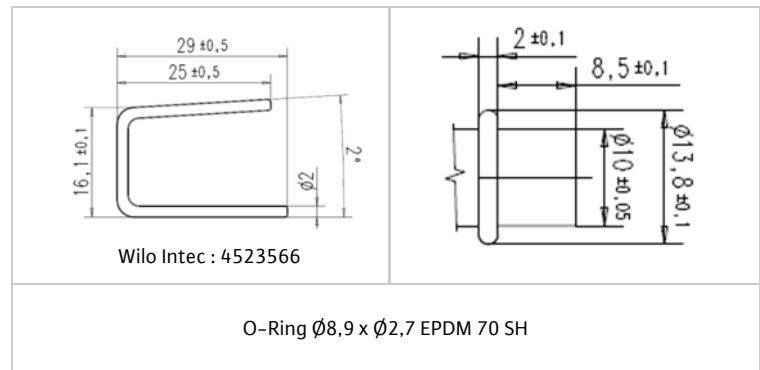

	Thread	Dimensions			
	G	l0	l1	a	b4
RS15/4 /5 Ku RS15/6 Ku RS15/7 Ku	1"	130	99 99 112	31,7	72,5 76 76
RS20/4 /5 Ku RS20/6 Ku RS20/7 Ku	1"1/4	130	99 99 112	31,7	72,5 76 76
RS25/4/5 Ku RS25/6 Ku RS25/7 Ku	1"1/2	130	99 99 112	31,7	72,5 76 76

Inline asynchronous circulators for heating application

Type : RS Ku

	n l/m	P1 W	I A	Capacitor µf / VDB
RS../4 Ku	max	2050	65	2 / 400
		1650	46	
	min	1300	30	
RS../5 Ku	max	2250	84	2 / 400
		1900	59	
	min	1300	39	

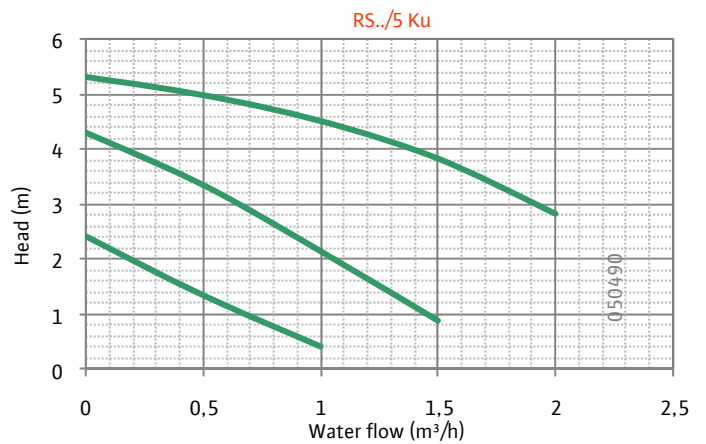
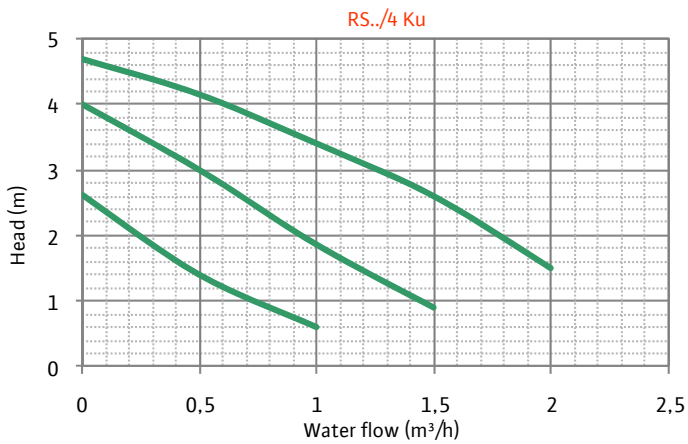

Inline asynchronous circulators for heating application

Type : RS Ku

	n l/m	P1 W	I A	Capacitor µf / VDB
RS../6 Ku	max	2200	93	2,6 / 400
		1900	67	
	min	1450	46	
RS../7 Ku	max	2450	125	3,5 / 400
		2250	91	
	min	1850	64	

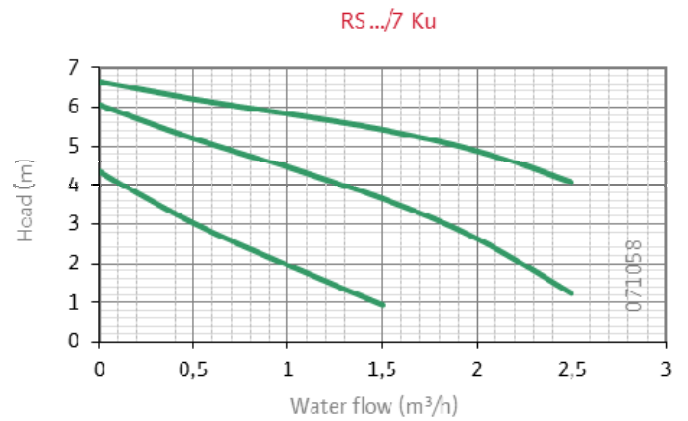
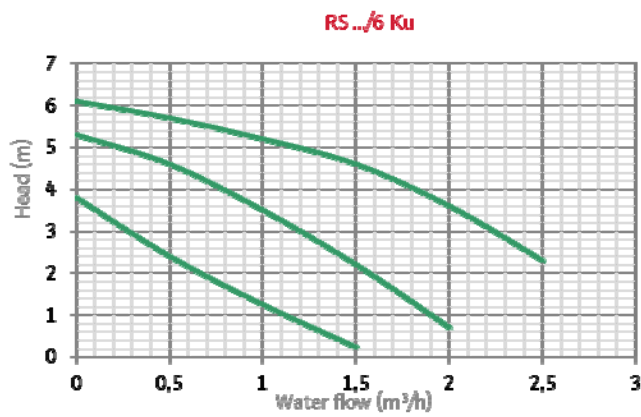

Specific asynchronous circulators for heating application

Type : RSB

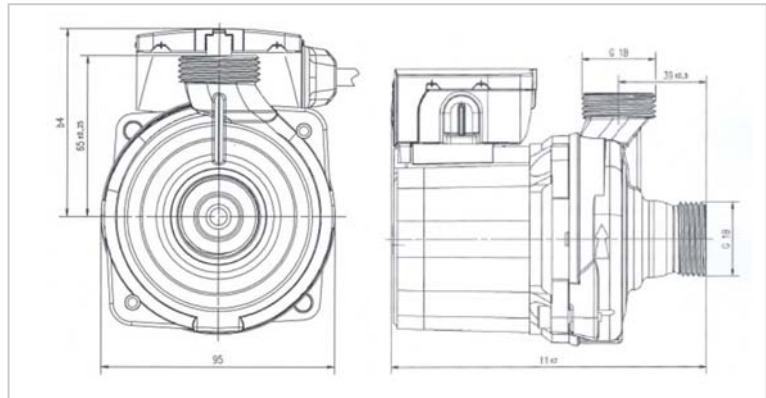

	n l/min	P1 W	I A	Capacitor µf / VDB
RSB15/5	max	2200	81	2 / 400
		1900	57	
	min	1400	38	
RSB15/6	max	2300	88	2,6 / 400
		2160	61	
	min	1560	44	
RSB15/7	max	2450	126	3,5 / 400
		2100	88	
	min	1800	57	

	Dimensions	
	l1	b4
RSB15/5	140	72,5
RSB15/6	140	76
RSB15/7	153	76

Specific asynchronous circulators for heating application

Type : RSB

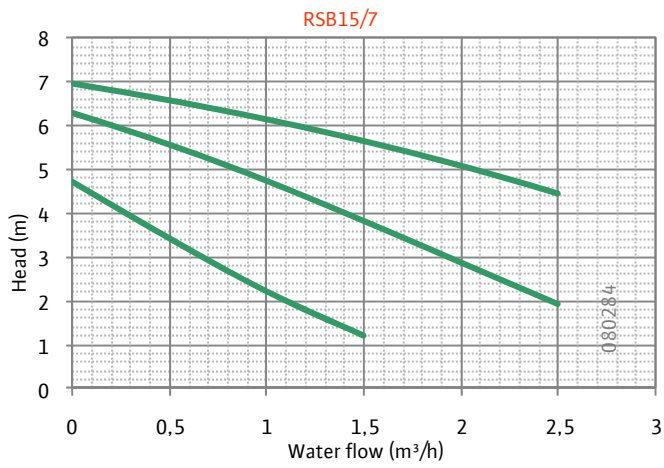
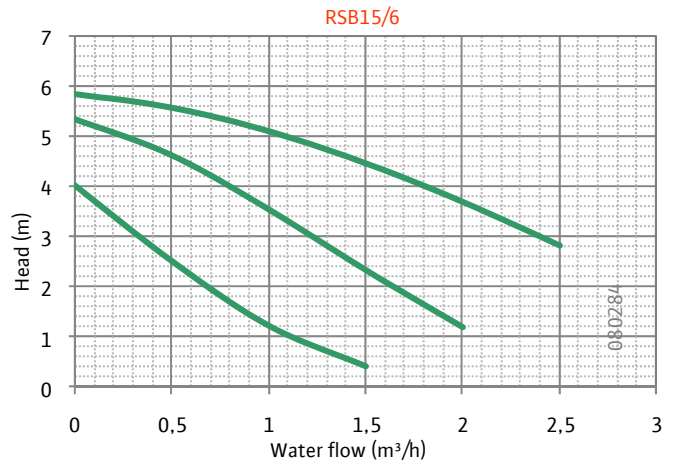
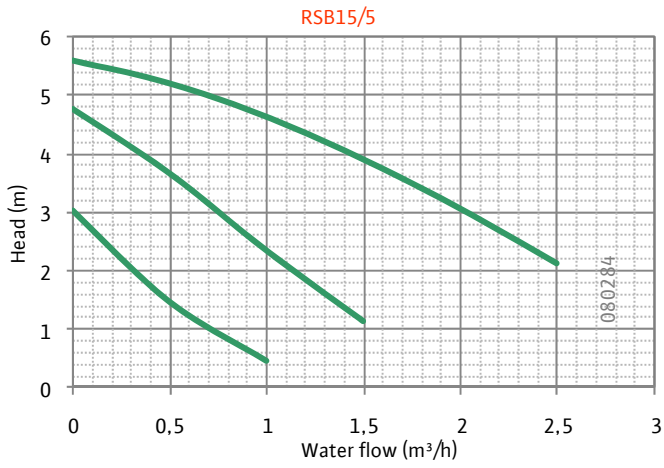

Specific asynchronous circulators for heating application

Type : RSB Ku

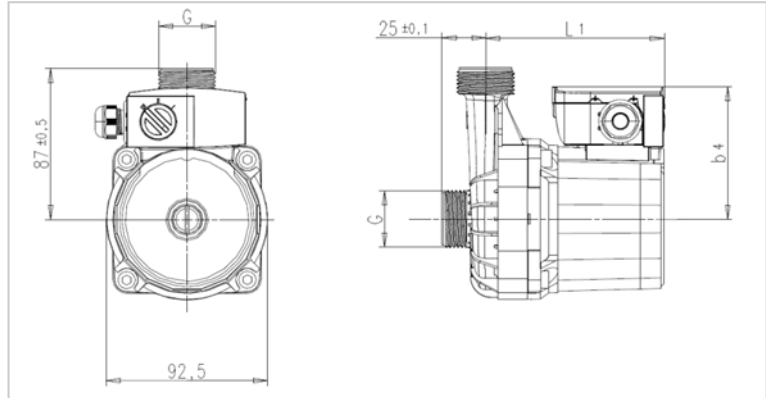

Connections G 1"

Suction and pressure side : screwed on minimum 3 threads

Maximal torque on connections G 1" : 40 Nm

Gasket : $\varnothing 30 \times \varnothing 21 \times 2,1$ (EPDM)

	n l/m	P1 W	I A	Capacitor $\mu\text{f}/\text{VDB}$
RSB15/5 Ku	max	2200	88	2 / 400
		2000	60	
	min	1600	40	
RSB15/6 Ku	max	2750	89	2,6 / 400
		2050	67	
	min	1350	44	
RSB15/7 Ku	max	2450	126	3,5 / 400
		2100	93	
	min	1550	63	

	Dimensions	
	l1	b4
RSB15/5 Ku	102,7	72,5
RSB15/6 Ku	102,7	76
RSB15/7 Ku	115,7	76

Specific asynchronous circulators for heating application

Type : RSB Ku

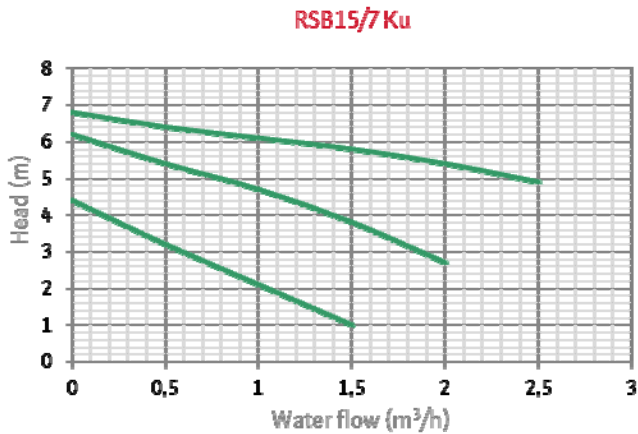
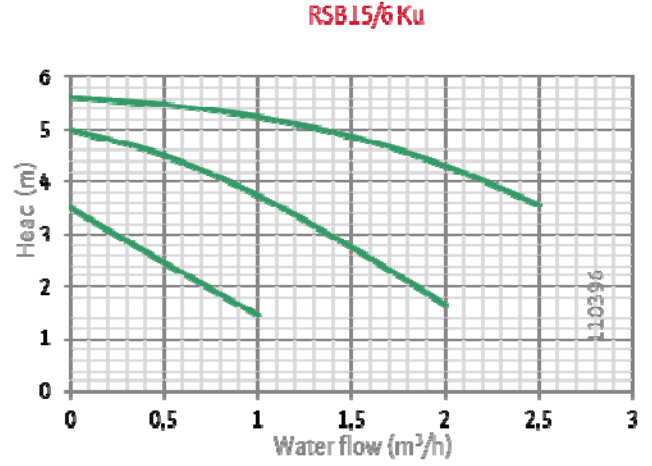
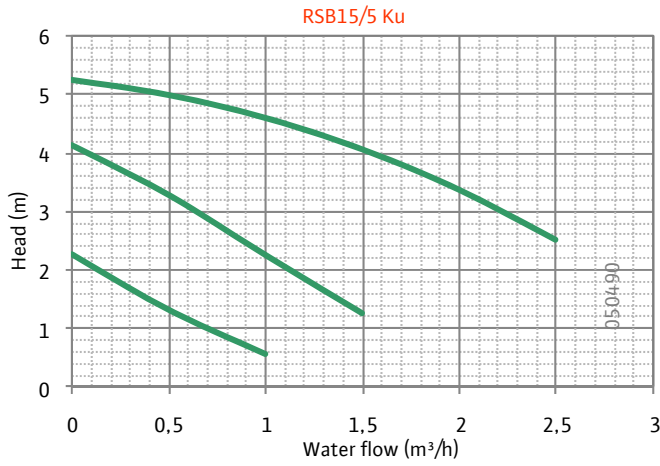

Specific asynchronous circulators for heating application

Type : HU15



Also available as Integrated Circulator

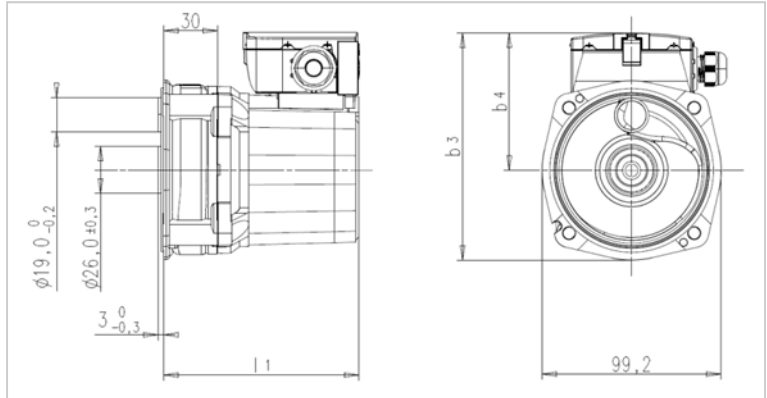

The arrow indicates the top side of the HU15. The HU15 should only be used in this orientation with the pressure outlet at 12 o'C.

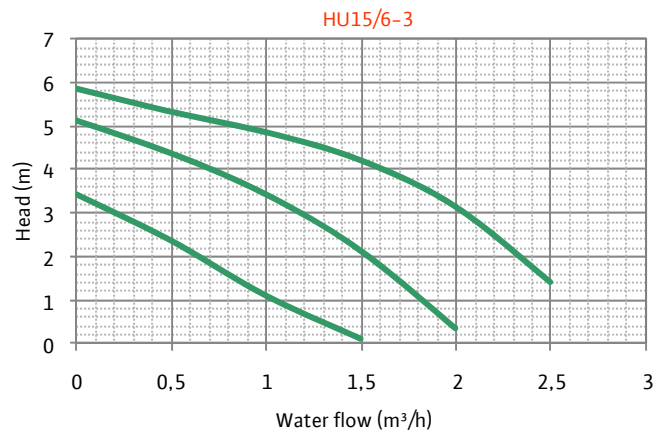
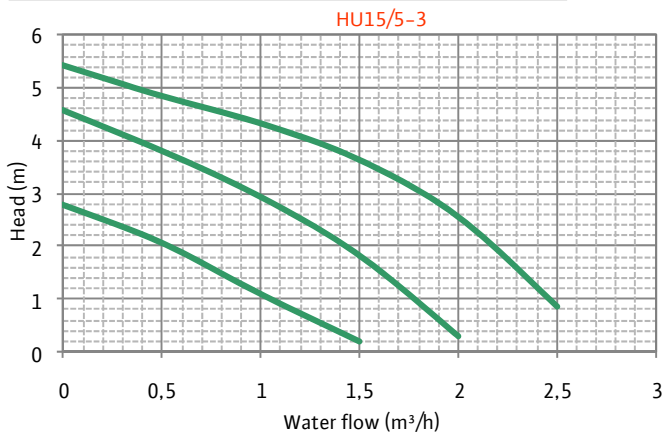

	n l/min	P1 W	I A	Capacitor µf / VDB
HU15/5	max 2200	83	0,36	2 / 400
	2000	62	0,27	
HU15/6	max 2200	86	0,38	2,6 / 400
	1900	64	0,30	
	min 1450	44	0,20	

	Dimensions		
	l1	b3	b4
HU15/5	108	125,6	72,5
HU15/6	108	125,6	76

Specific asynchronous circulators for heating application

Type : HU15 - screwing instructions

The guarantee of the water tightness on the circulator is linked to :

- > The way all its parts are correctly assembled
- > The way the 4 screws are screwed, according the following instruction

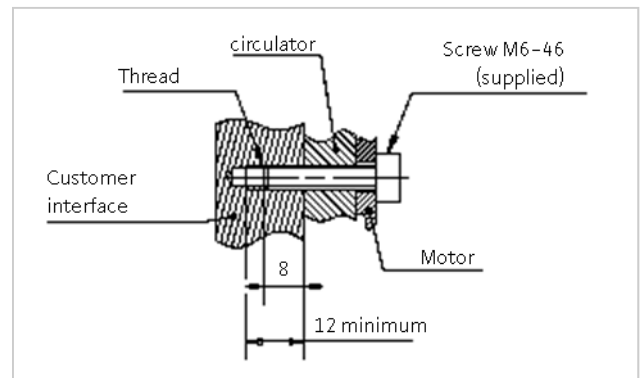
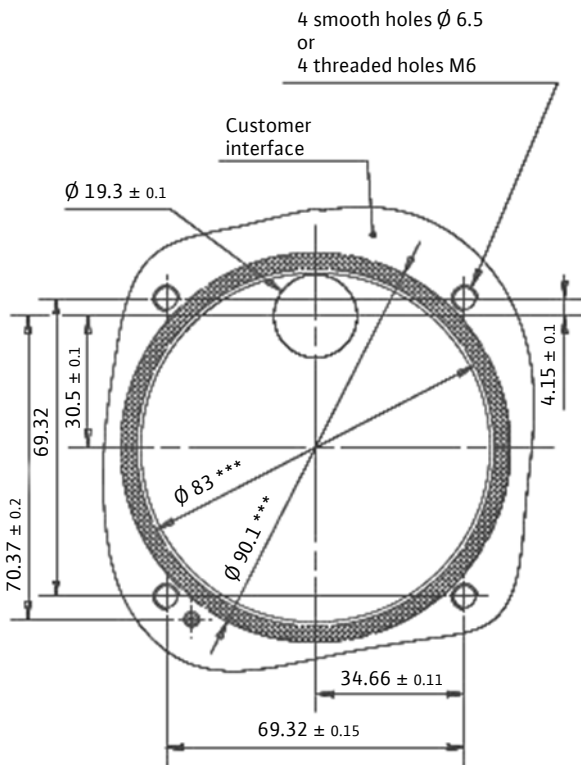
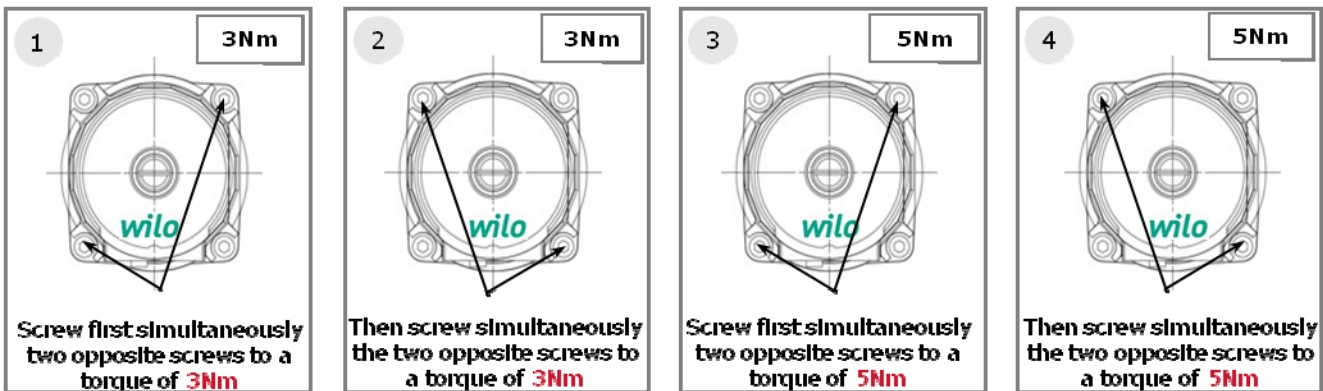

OR

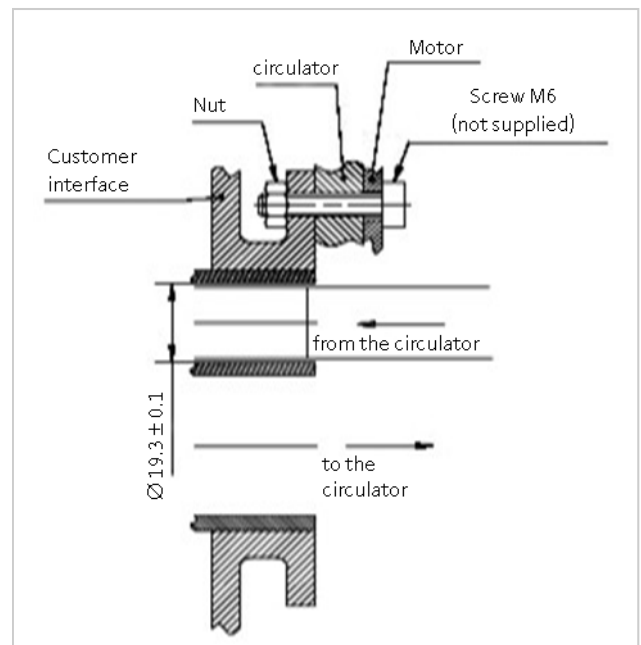

*** Zone with hatches
Referential B
Gasket compression surface

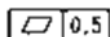
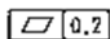

Zone without hatches
Beneath surface B

Specific asynchronous circulators for heating application

Type : HU25 Ku



Also available as *Integrated Circulator*

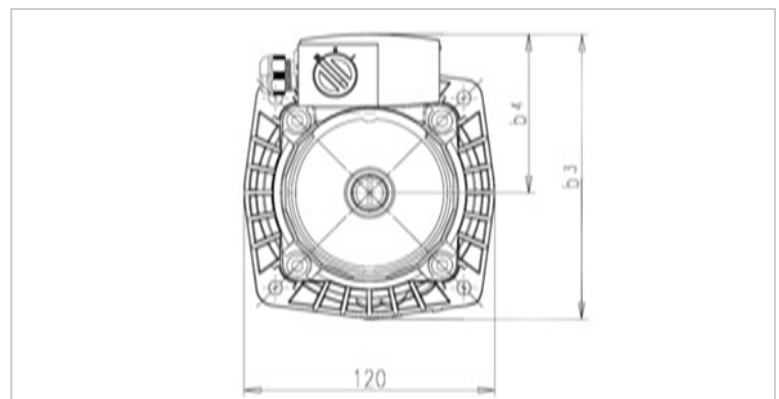
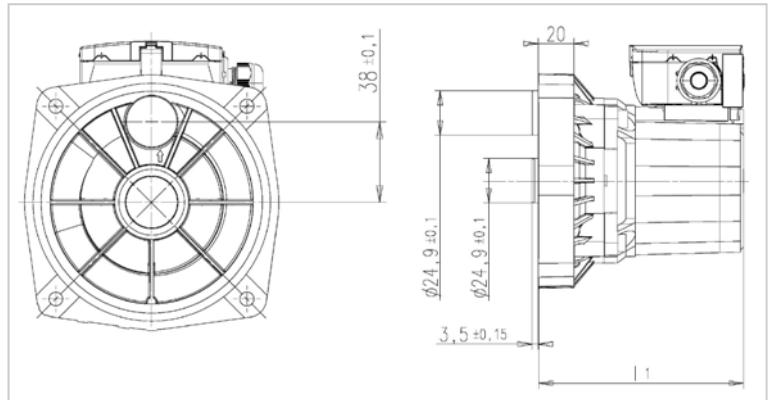

	Dimensions		
	l1	b3	b4
HU25/4 Ku	115	133	72,5
HU25/5 Ku	115	133	72,5
HU25/6 Ku	115	136,5	76
HU25/7 Ku	115	136,5	76

Specific asynchronous circulators for heating application

Type : HU25 Ku

	n l/min	P1 W	I A	Capacitor µf / VDB
HU25/4 Ku	max	2240	63	2 / 400
		1900	45	
	min	1350	30	
HU25/5 Ku	max	2300	83	2 / 400
		2000	58	
	min	1600	39	
HU25/6 Ku	max	2100	86	2,6 / 400
		1850	65	
	min	1320	45	
HU25/7 Ku	max	2700	110	3,5 / 400
		2200	85	
	min	1800	58	

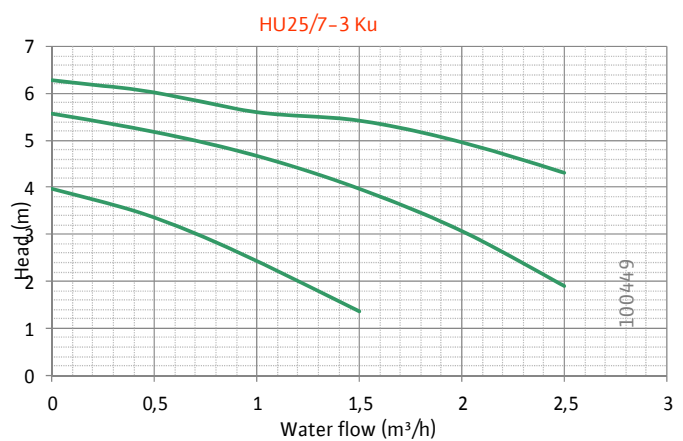
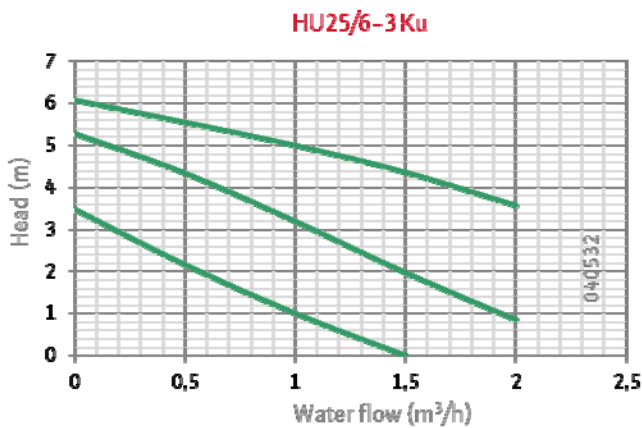
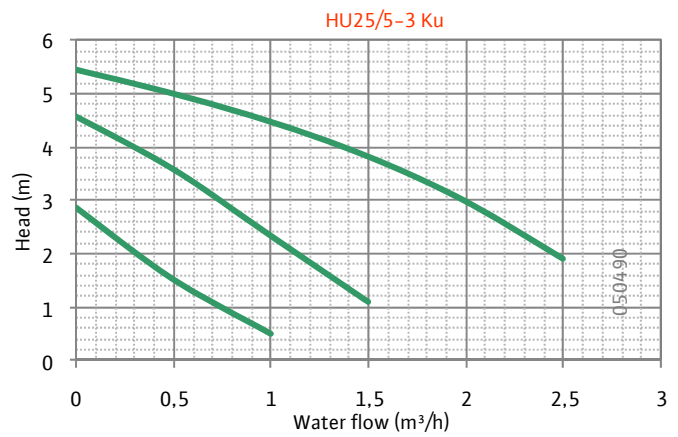
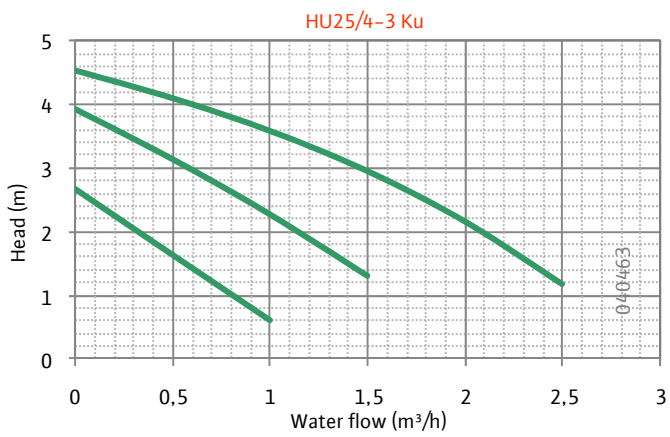

Subject to change without prior notice 09/2017 WIL0 INTEC

Specific asynchronous circulators for heating application

Type : HU25 Ku - screwing instructions

The guarantee of the water tightness on the circulator is linked to :

- > The way all its parts are correctly assembled
- > The way the 4 screws are screwed, according the following instruction

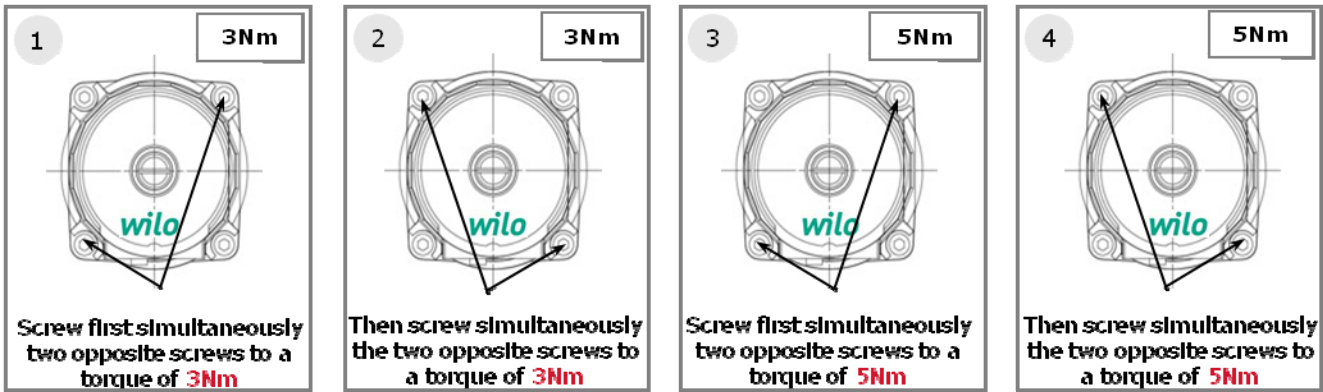

The HU25 Ku should only be used in this orientation with the pressure outlet at 12 o'clock

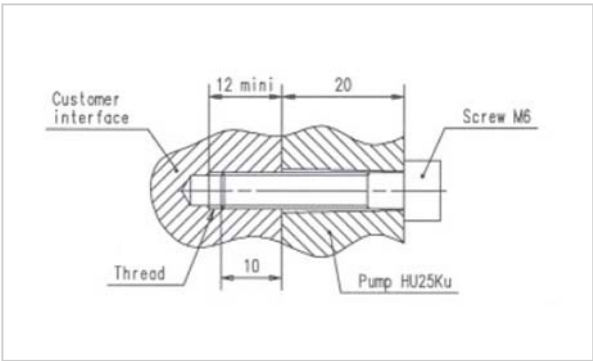
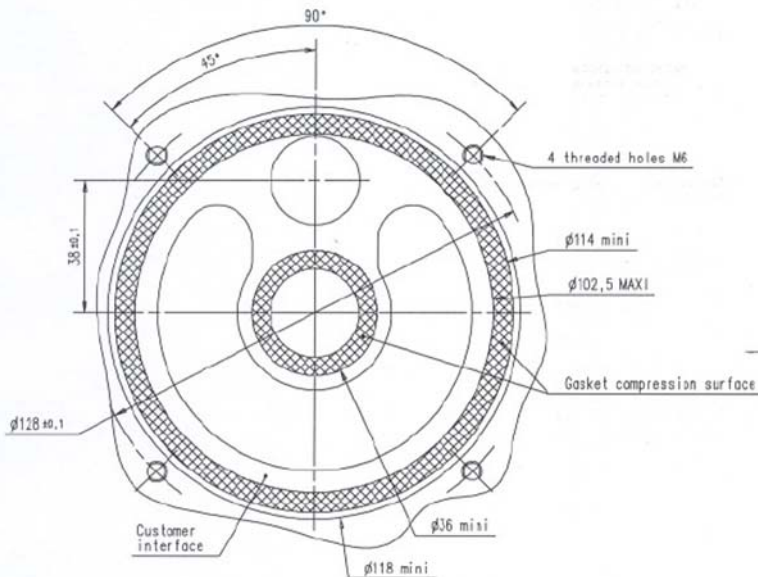

OR

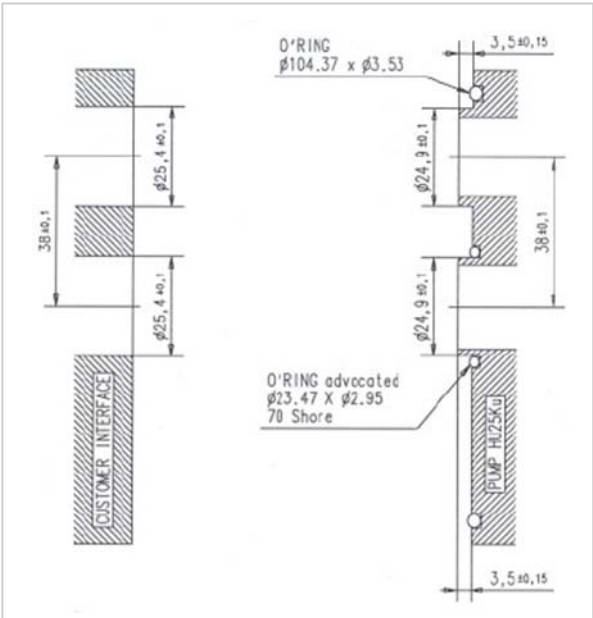

*** Zone with hatches
Referential B
Gasket compression surface



Zone without hatches
Beneath surface B



Inline asynchronous circulators for heating application

Type : RSL Ku

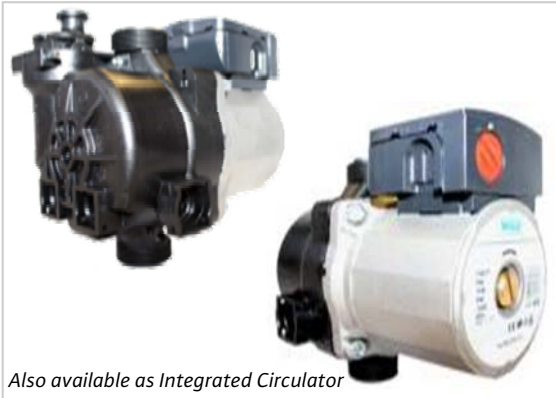

Also available as Integrated Circulator

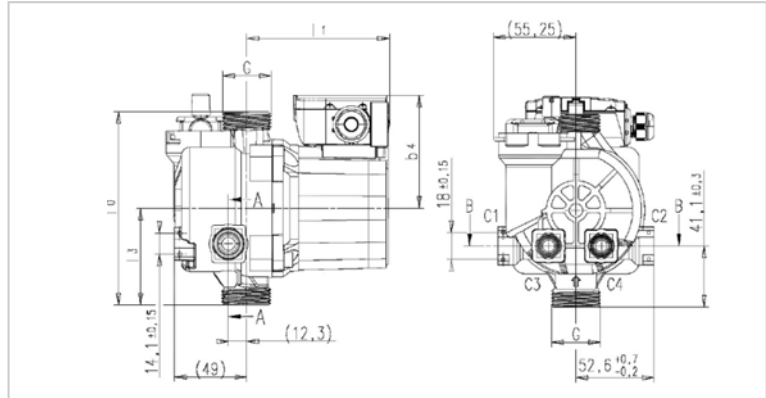

Connections G 1"

Suction and pressure side : screwed on minimum 3 threads

Maximal torque on connections G 1" : 40 Nm

Gasket : $\varnothing 30 \times \varnothing 21 \times 2,1$ (EPDM)

This circulator housing can be supplied with 4 optional connections. They are defined to be connected to one manometer or one expansion vessel. It's also possible to receive (by C1 or C2) the connection from the boiler short circuit but the maximum water flow allowed in this case is 1700l/h. Any other use has to be tested and validated by Wilo Intec.

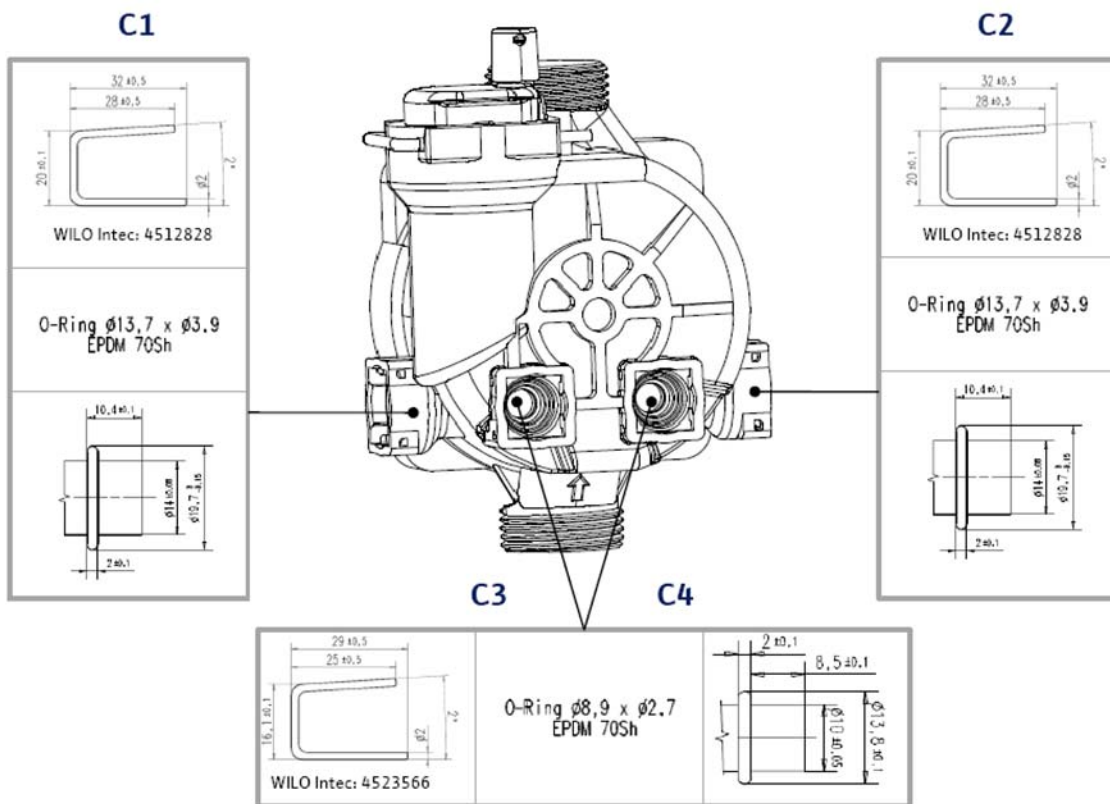

	Thread	Dimensions			
	G	l0	l3	l1	b4
RSL15/4 Ku	1"	130	65	95,6	72,5
RSL15/5 Ku				95,6	72,5
RSL15/6 Ku				95,6	72,5
RSL15/7 Ku				95,6	76
				108,6	76

Inline asynchronous circulators for heating application

Type : RSL Ku

	n l/min	P1 W	I A	Capacitor µf/VDB
RSL15/4 Ku	max	2150	62	2 / 400
		1650	45	
	min	1300	29	
RSL15/5 Ku	max	2200	84	2 / 400
		2000	58	
	min	1700	38	

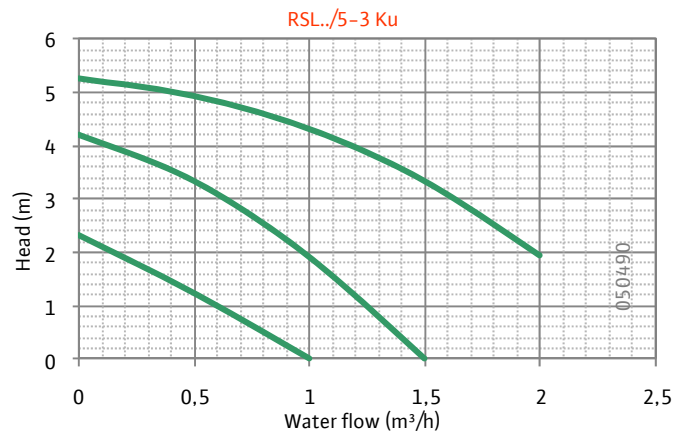
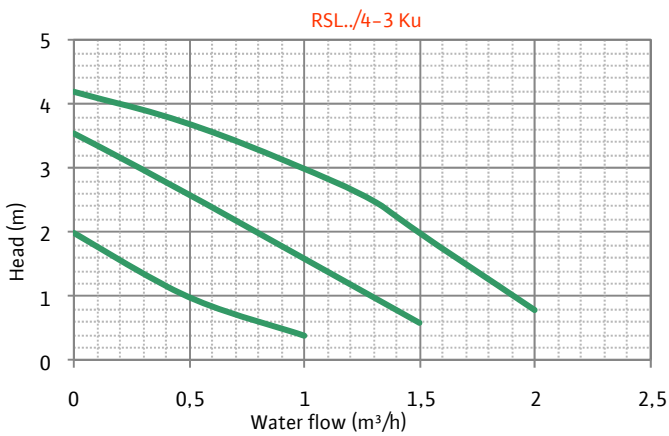

Inline asynchronous circulators for heating application

Type : RSL Ku

	n l/min	P1 W	I A	Capacitor µf/VDB
RSL15/6 Ku	max	2400	86	2,6/400
		2000	63	
	min	1700	42	
RSL15/7 Ku	max	2500	116	3,5/400
		2200	88	
	min	2100	53	

RSL .../6-3Ku

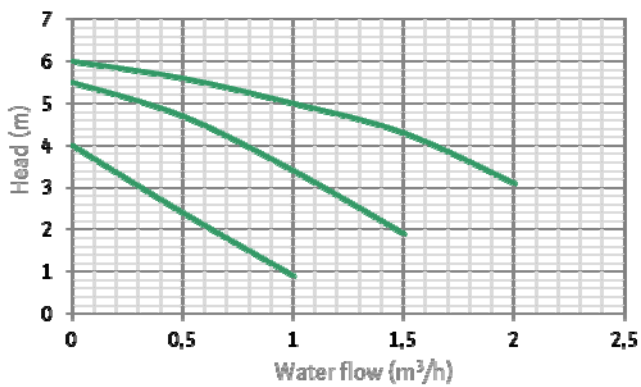

RSL .../7-3Ku

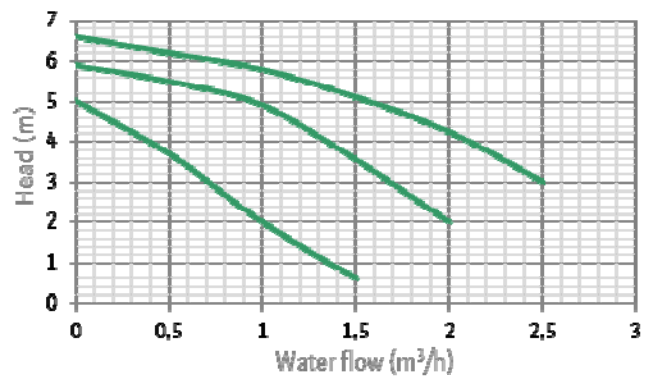

Specific asynchronous circulators for heating application

Magic circulator : Type : MSL12



Also available as Integrated Circulator

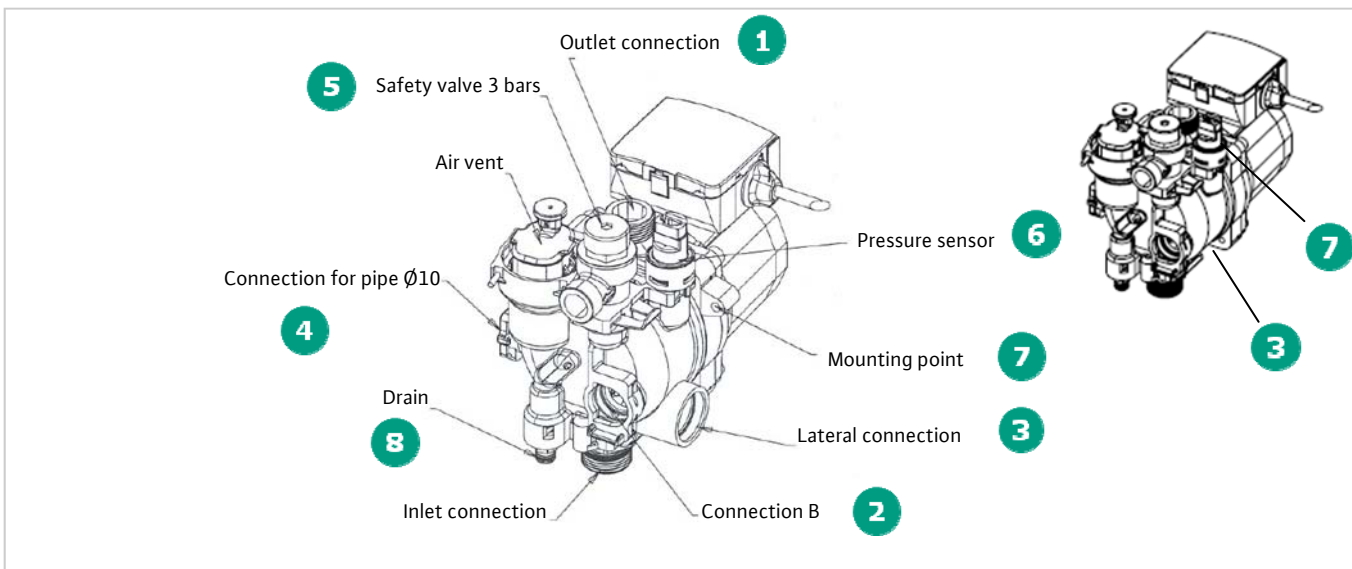
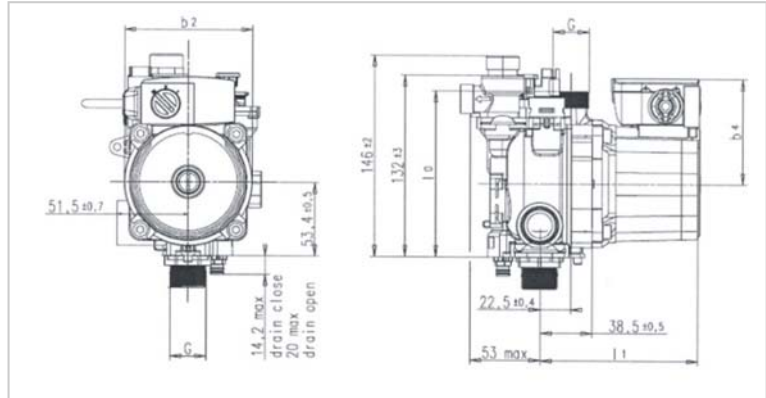

1	Outlet connection (pressure side)	Threaded 3/4" or clip pipe Ø18
2	Connection B	Opened or closed
3	Lateral connection	With or without
4	Connection for pipe Ø10	Opened or closed
5	Safety valve 3 bars	With or without
6	Pressure sensor	With or without
7	Mounting point	With or without
8	Drain	With or without

* Depending of the configuration of the connections, the delivery time can be 4 to 8 weeks

Specific asynchronous circulators for heating application

Magic circulator : Type : MSL12

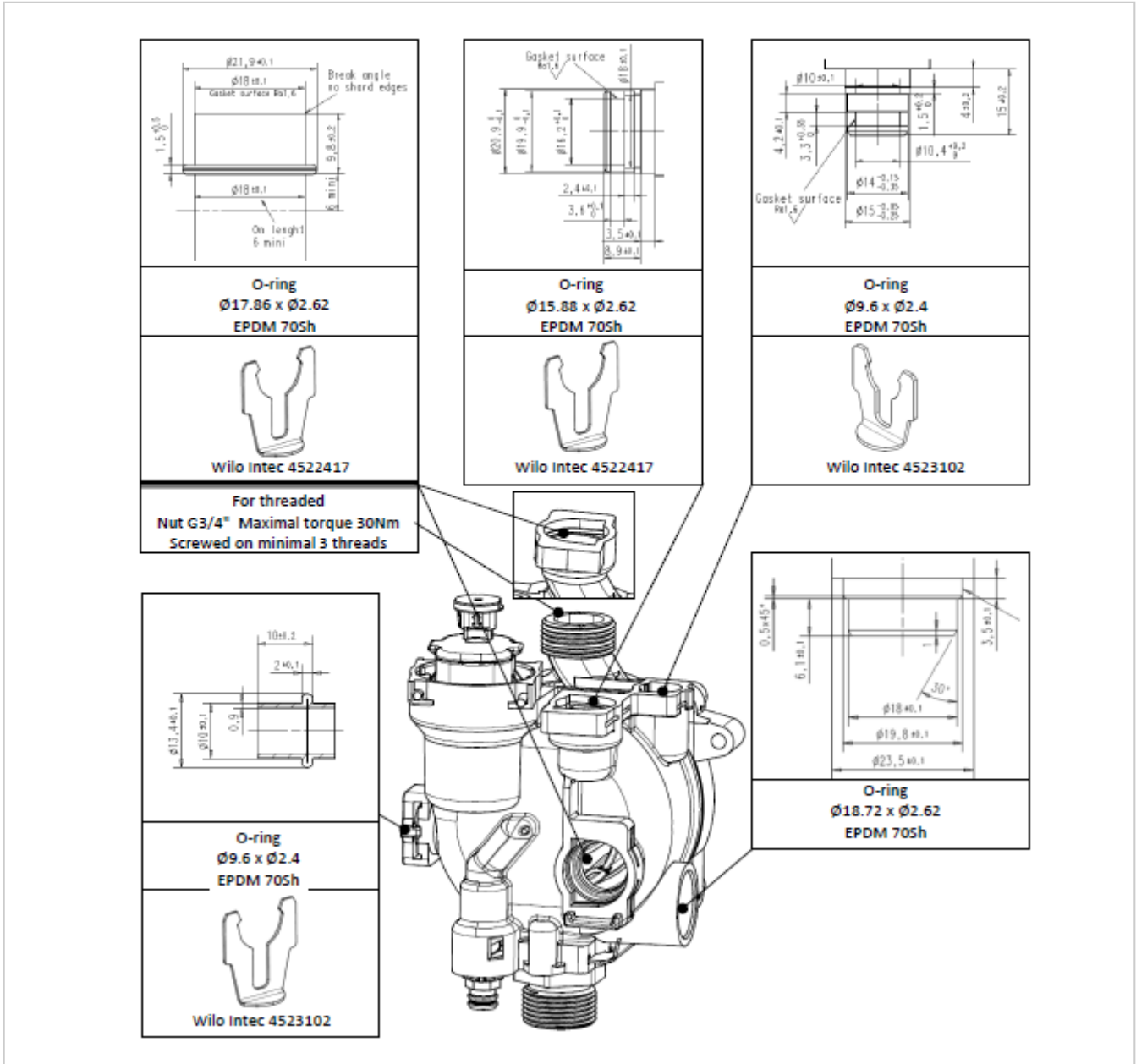

	Thread	Dimensions				
	G	l0	l1	b2	b4	
MSL12/5	3/4"	120	116,2	92,5	72,5	
MSL12/6	3/4"	120	116,2	92,5	76	
MSL12/7	3/4"	120	129,2	92,5	76	



Specific asynchronous circulators for heating application

Magic circulator : Type : MSL12

		n l/m	P1 W	I A	Capacitor µf / VDB
MSL12/5	max	2310	84	0,37	2 / 400
		2040	59	0,28	
	min	1560	40	0,18	
MSL12/6	max	2400	86	0,38	2,6 / 400
		2050	63	0,28	
	min	1730	42	0,19	
MSL12/7	max	2600	120	0,53	3,5 / 400
		2300	89	0,41	
	min	2040	59	0,27	

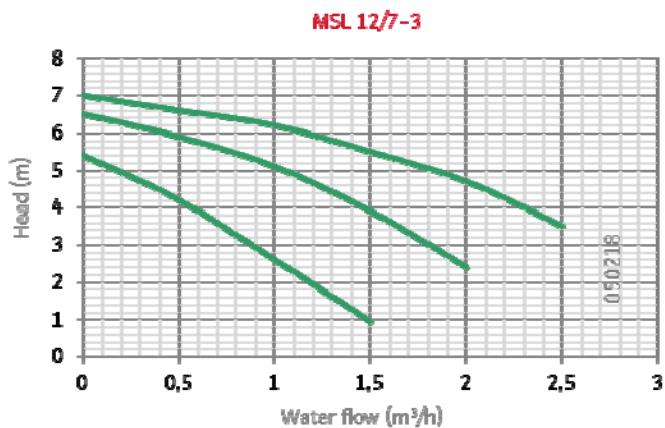
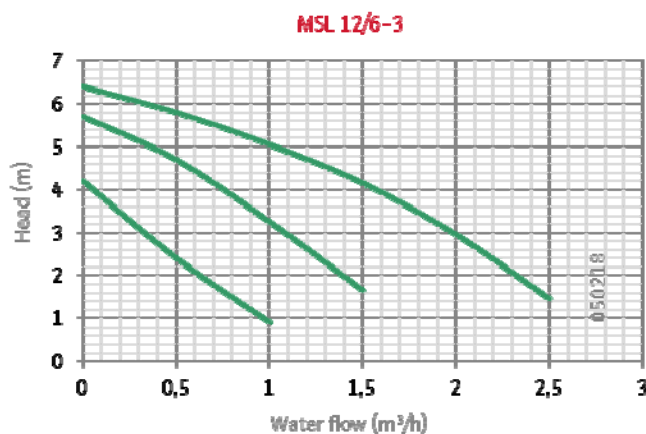
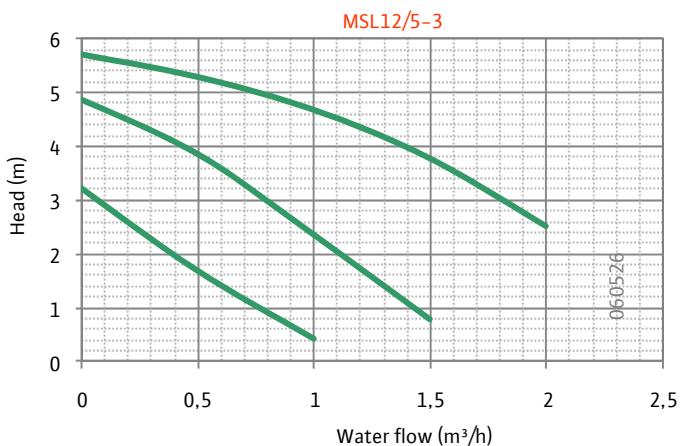

Specific asynchronous circulators for heating application

Magic circulator : Accessories

Pressure Sensor



Function :

Proportional pressure sensor

Connector :

Hedge connector Rast 2,5mm / 4 ways

Counter part :

STOCKO Rast 2.5 (ref : MFM7238 or MKF13474)
1 : GND - 2 : VCC - 3 /N/A - 4 : SIGNAL

Characteristics :

Input voltage : 5 Vdc \pm 0.2V / max. 10mA
Pressure range : 0 to 3,5 bars
0,5 bars : 1,40 Vdc \pm 0,110 Vdc
2,5 bars : 2,5 Vdc \pm 0,275 Vdc

Safety valve



3 bars outlet connection : 1/2"

Drain plug



Function :

Drain circulator

Specific asynchronous circulators for heating application

Type : NFSL

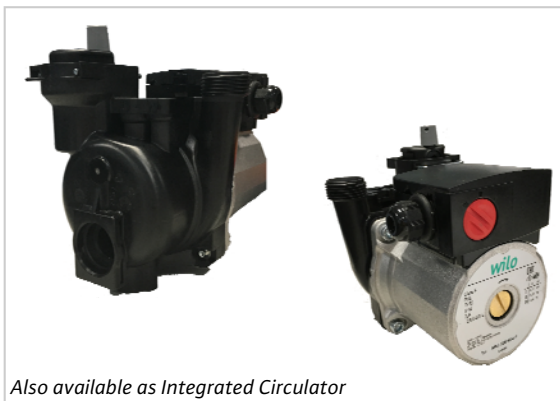

Also available as Integrated Circulator

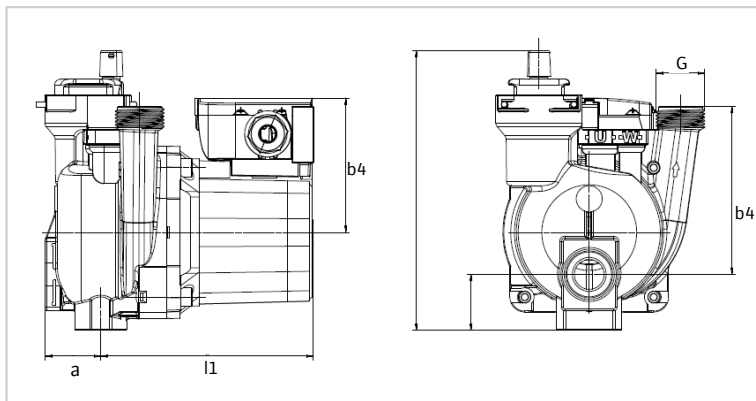

d	4,1
e	25
e1	31,5
e2	50,75
f	6
g	22
h	49

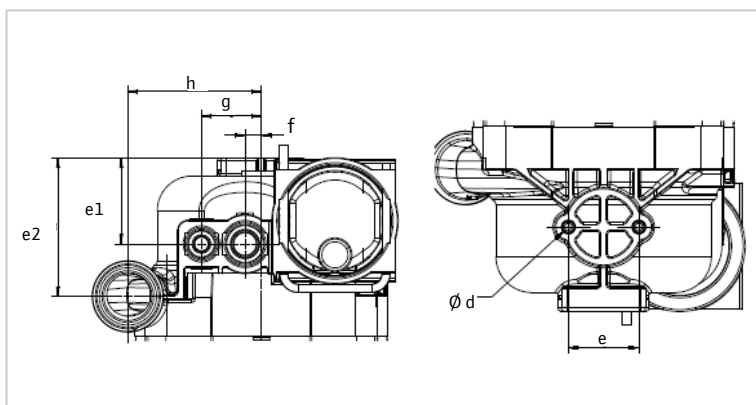

	Thread	Dimensions		
	G	l1	a	b4
NFSL12/6 HE	3/4"	114	29,8	72,5
NFSL12/6 HEP	3/4"	114	29,8	76
NFSL12/7 HE	3/4"	127	29,8	76

Specific asynchronous circulators for heating application

Type : NFSL

<p>O-Ring Ø8.9 x Ø2.7 EPDM 70 Sh</p>	<p>O-Ring Ø5.23 x Ø2.62 EPDM 70 Sh</p>	<p>O-Ring Ø16 x Ø1.9 EPDM 80 Sh</p>	<p>O-Ring Ø17 x Ø4 EPDM 70 Sh</p>
<p>WILO Intec: 4506548</p>	<p>WILO Intec: 4513187</p>	<p>NUT 63/4°: -Maximal torque : 30 Nm -Screwed on minimum 3 threads</p> <p>WILO Intec: 4517422</p>	

Screw for thermoplastic
Maximal torque : 3 Nm

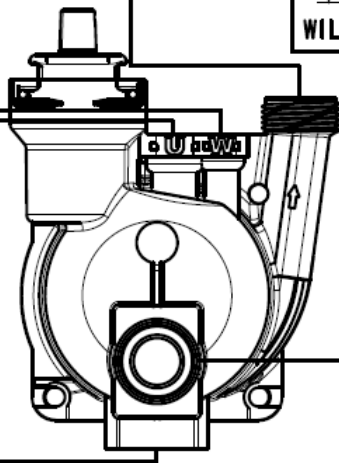

Please note that the connections U and W can be delivered open or closed

Specific asynchronous circulators for heating application

Type : NFSL

	n l/min	P1 W	I A	Capacitor µf/VDB
NFSL12/6 HE	max	2300	82	2 / 400
		2030	58	
	min	1720	39	
NFSL12/6 HEP	max	2400	83	2,6 / 400
		2130	58	
	min	1820	40	
NFSL12/7 HE	max	2570	118	3,5 / 400
		2450	78	
	min	1700	60	

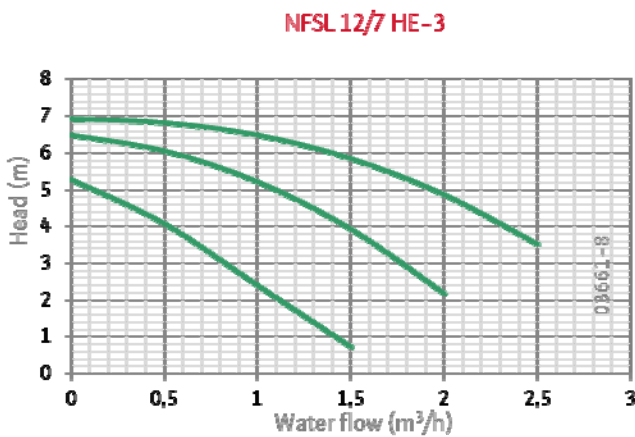
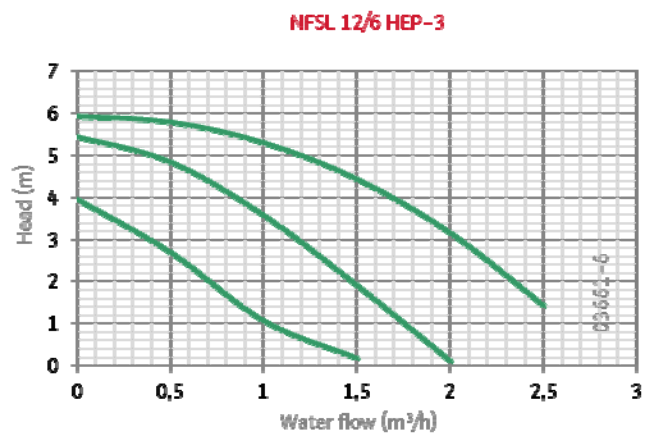
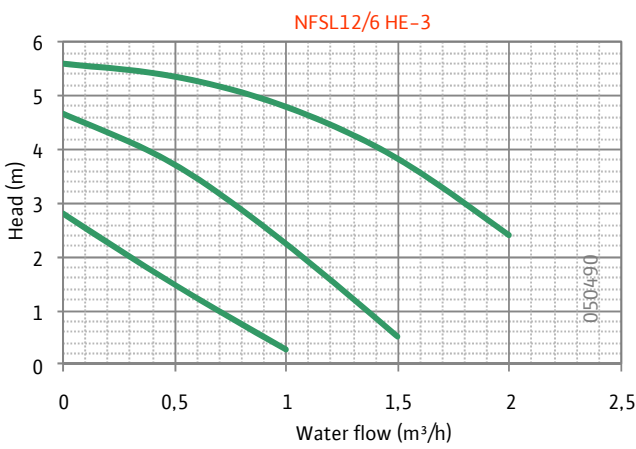

Specific asynchronous circulators for heating application

Type : KSL

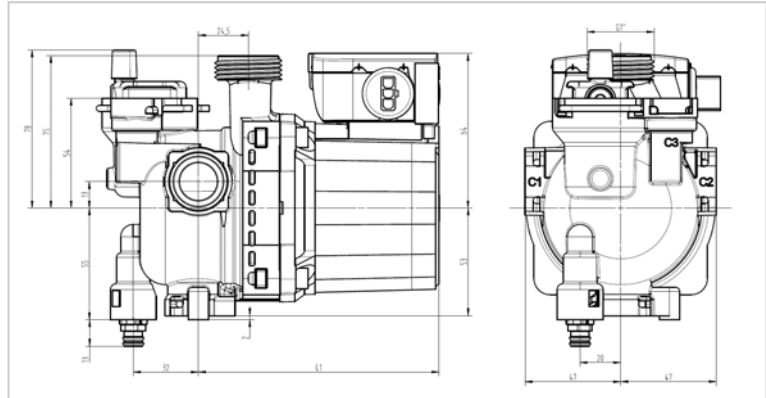

		n l/min	P1 W	I A	Capacitor µf/VDB
KSL15/5	max	2474	82	0,36	2 / 400
		1834	59	0,27	
	min	982	38	0,18	
KSL15/6	max	2634	82	0,35	2,6 / 400
		2255	59	0,26	
	min	1422	43	0,19	
KSL15/7	max	2724	117	0,51	3,5 / 400
		2470	84	0,40	
	min	1811	59	0,27	

	Thread	Dimensions	
	G	l1	b4
KSL15/5	1"	118	72
KSL15/6		118	76
KSL15/7		131	76

Specific asynchronous circulators for heating application

Type : KSL

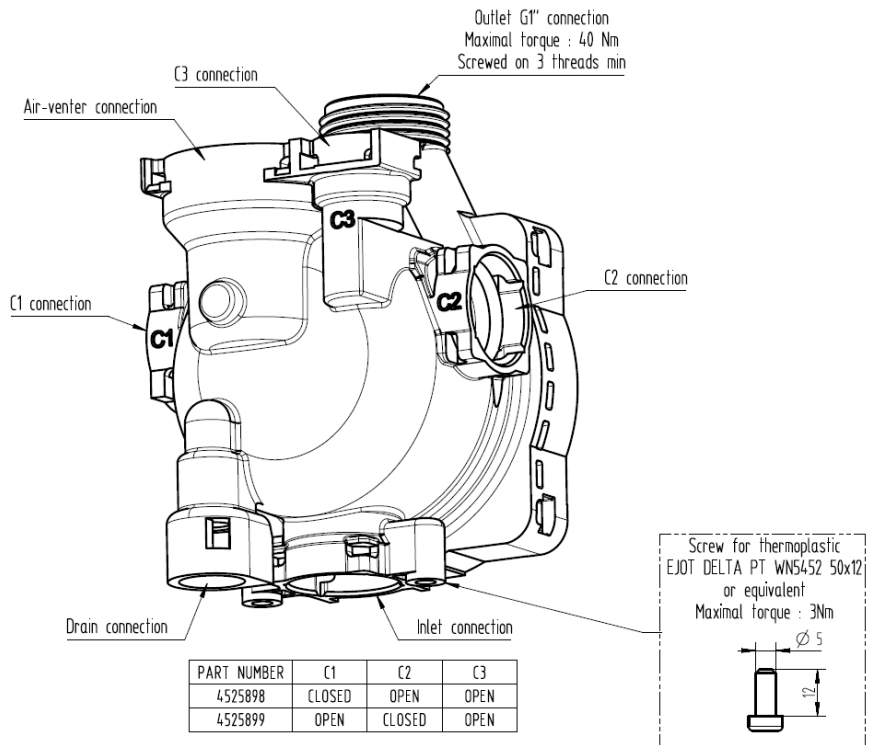

C3 connection

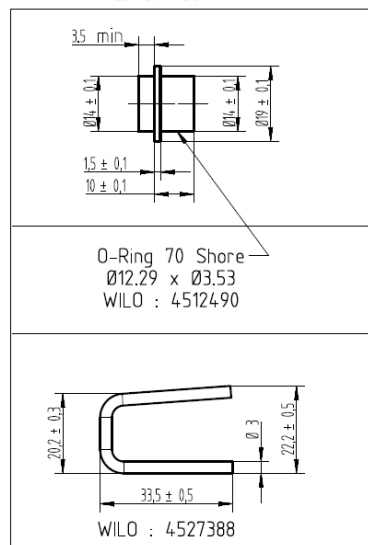

C1, C2, Inlet connection

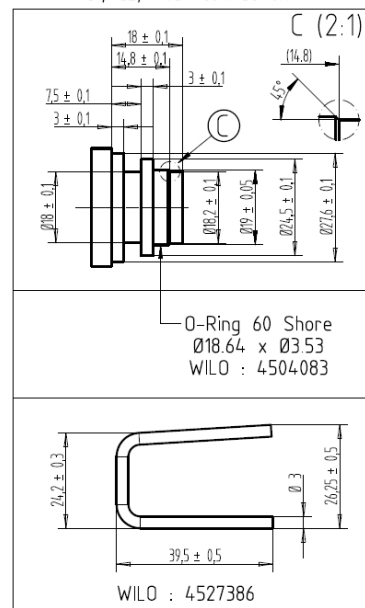

Specific asynchronous circulators for heating application

Type : KSL

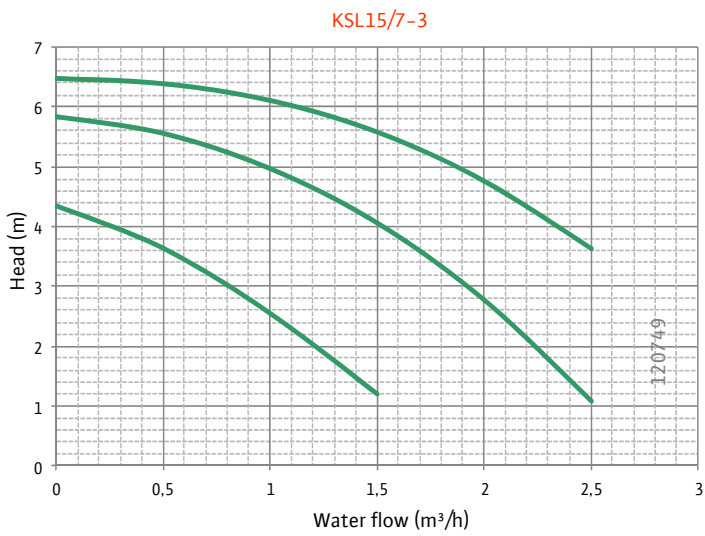
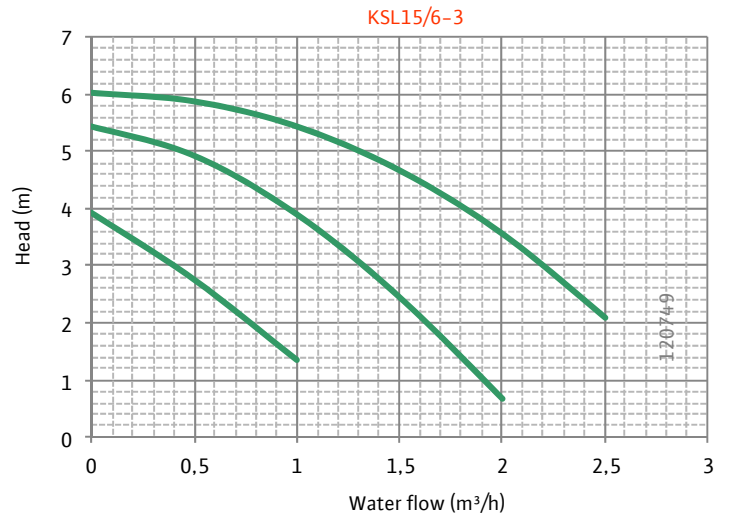
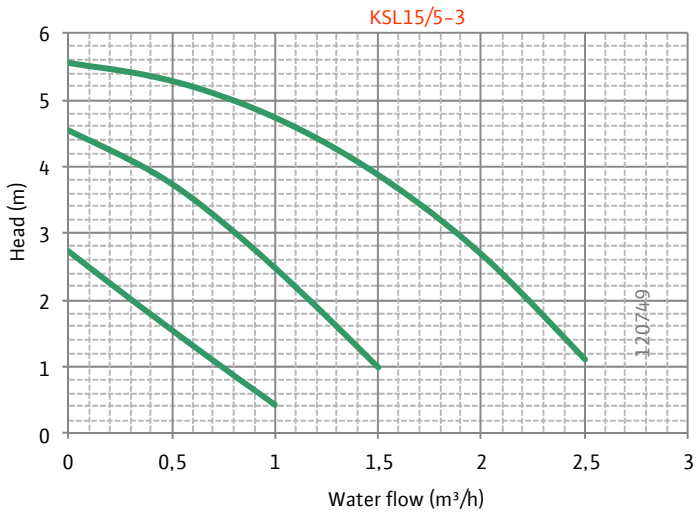

Sanitary hot water



Asynchronous circulators for sanitary application

Type : Z15

This circulator is suitable for drinking water only

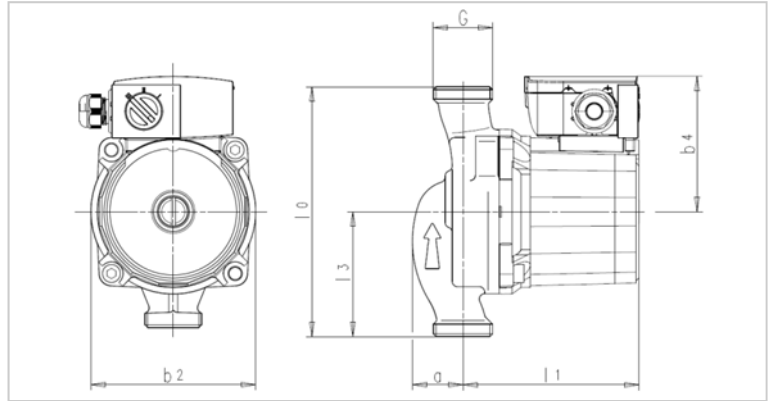

	n l/min	P1 W	I A	Capacitor µf / VDB
Z15/4	max	2500	58	2 / 400
		2300	41	
	min	2000	28	
Z15/6	max	2300	87	2,6 / 400
		1900	65	
	min	1500	44	
Z15/7	max	2500	122	3,5 / 400
		2300	88	
	min	1700	64	

	Thread	Dimensions					
	G	l0	l1	l3	a	b2	b4
Z15/4	1"	130	96,6	65	31,7	92,5	72,5
Z15/6			96,6				76
Z15/7			109,6				76

Asynchronous circulators for sanitary application

Type : Z15

This circulator is suitable for drinking water only

Z15/4-3

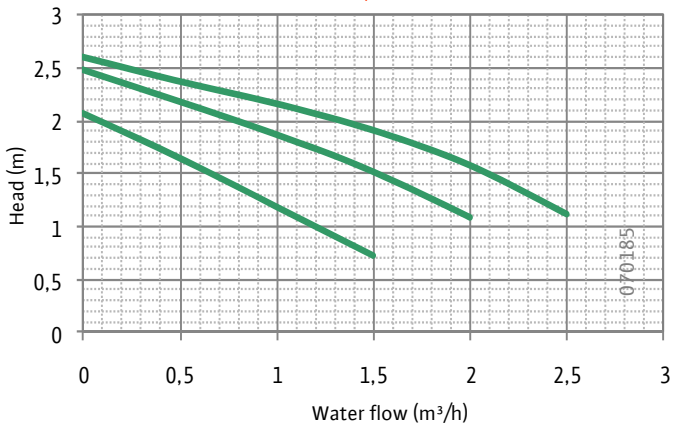

Z15/6-3

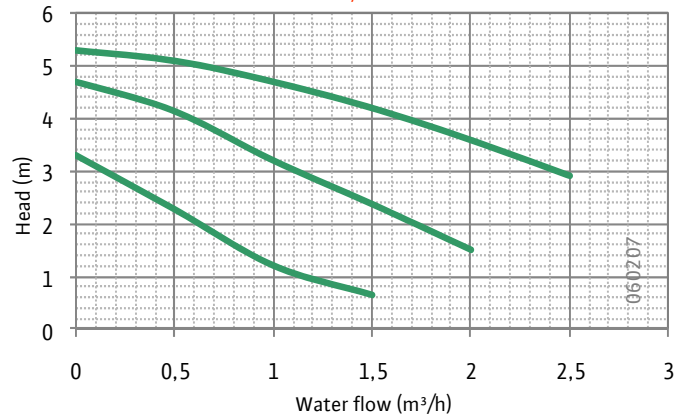

Z15/7-3

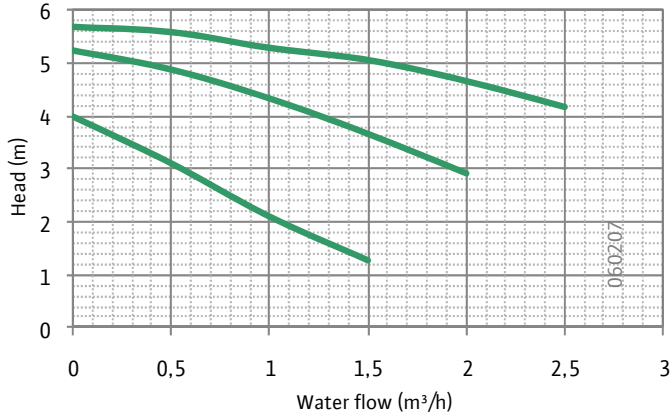

Asynchronous circulators for sanitary application

Type : Z25

This circulator is suitable for drinking water only

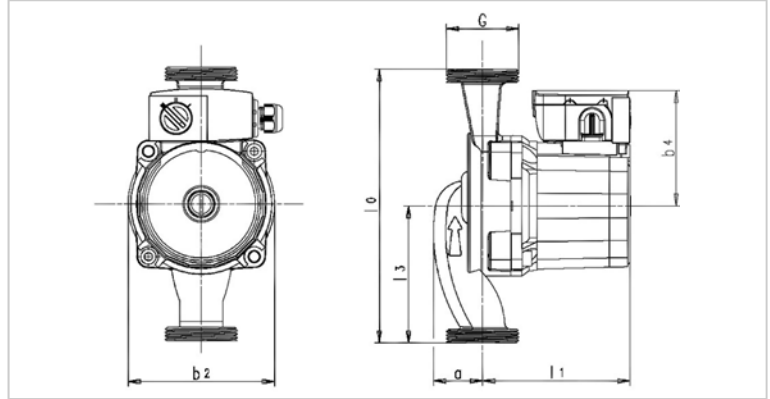

	n l/m	P1 W	I A	Capacitor μ f/VDB
Z25/4	max	2550	57	2 / 400
		2300	41	
	min	2000	27	
Z25/6	max	2200	99	2,6 / 400
		1900	74	
	min	1200	50	
Z25/7	max	2500	125	3,5 / 400
		2100	88	
	min	1800	57	

	Thread	Dimensions					
	G	l0	l3	l1	a	b2	b4
Z25/4	1"1/2	180	90	96,6	31,7	92,5	72,5
Z25/6							76
Z25/7							76

Type : Z25

This circulator is suitable for drinking water only

Z25/4-3

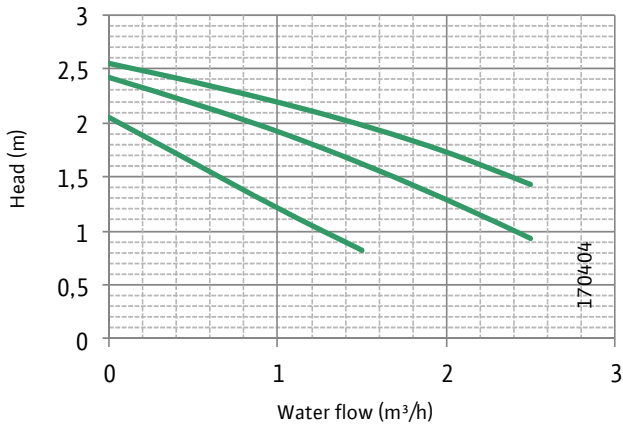

Z25/6-3

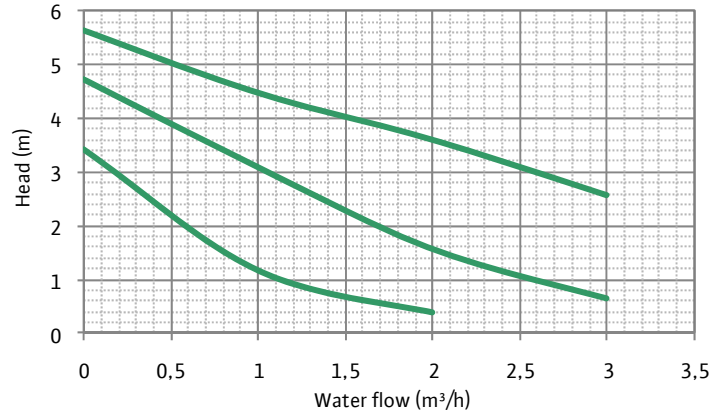

Z25/7-3

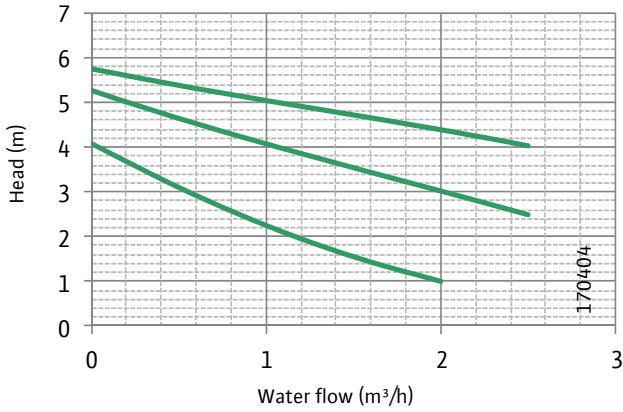

Asynchronous circulators for sanitary application

Type : ZRS Ku

This circulator is suitable for drinking water only

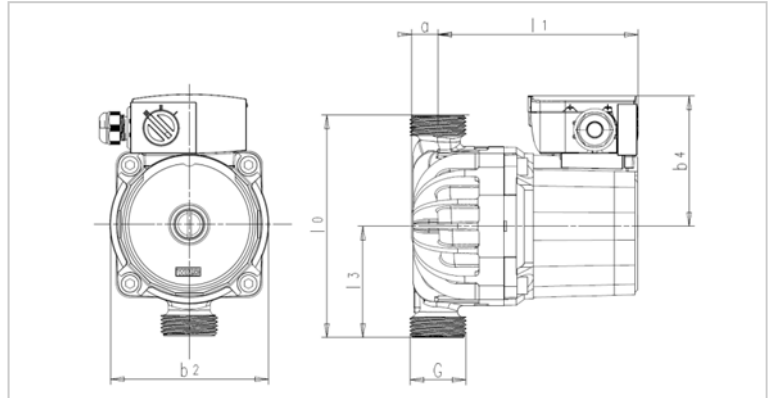

Connections G3/4" or G1" :

- > Maximal torque : 40Nm
- > Screwed on minimum 3 threads
- > Gasket (EP856, EP80/2 or equivalent)
- Ø24 x Ø16 x 2,1 (G3/4")
- Ø30 x Ø21 x 2,1 (G1")

	n l/min		P1 W	I A	Capacitor µf/VDB
ZRS../4 Ku	max	2600	55	0,24	2 / 400
		2500	39	0,18	
	min	2100	26	0,12	
ZRS../6 Ku	max	2450	85	0,38	2,6 / 400
		2000	63	0,29	
	min	1450	45	0,21	
ZRS../7 Ku	max	2650	115	0,51	3,5 / 400
		2400	86	0,40	
	min	1900	62	0,29	

	Thread	Dimensions					
	G	l0	l1	l3	a	b2	b4
ZRS12/4 Ku	3/4"	130	116,5	65	15,5	92,5	72,5
ZRS12/6 Ku			116,5				76
ZRS12/7 Ku			129,5				76
ZRS15/4 Ku	1"		116,5				72,5
ZRS15/6 Ku			116,5				76
ZRS15/7 Ku			129,5				76

Asynchronous circulators for sanitary application

Type : ZRS Ku

This circulator is suitable for drinking water only

ZRS../4-3 Ku

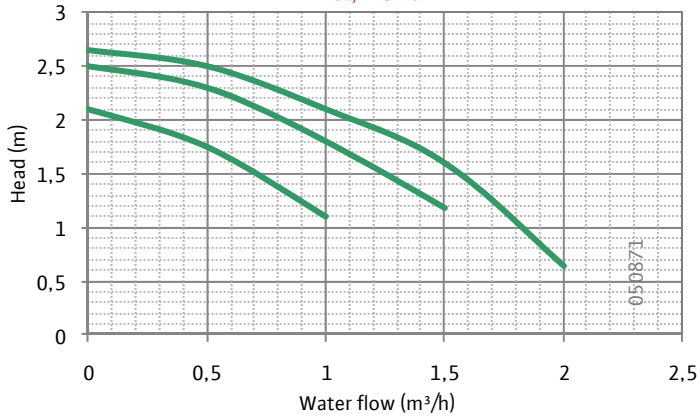

ZRS../6-3 Ku

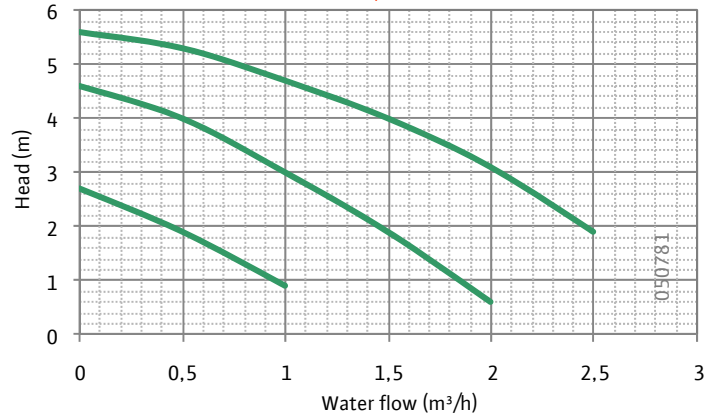

ZRS../7-3 Ku

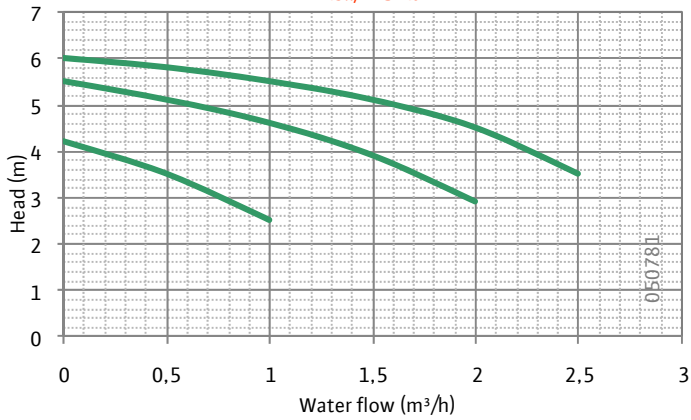

Solar thermal energy systems



Asynchronous circulators for solar application

Type : ST/6 ECO, ST/7 ECO

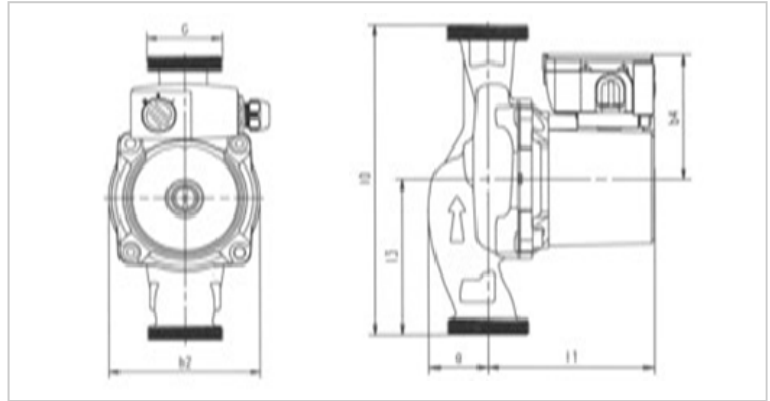

	Speed	P1 (500l/h) W	I (500l/h) A	Capacitor µf /VDB
ST../6 ECO	max	49	0,22	2/400
	med	43	0,19	
	min	36	0,16	
ST../7 ECO	max	51	0,23	2/400
	med	47	0,20	
	min	39	0,17	

	Thread	Dimensions					
	G	l0	l1	l3	a	b2	b4
ST15/6 ECO	1"	130	96,6	65	32,8	93	76
ST25/6 ECO	1"1/2	130		65	33,4	93	
ST25/6 ECO	1"1/2	180		90	34	95,5	
ST15/7 ECO	1"	130	96,6	65	28,1	92,5	76
ST25/7 ECO	1"1/2	130		65	33,8	92,5	
ST25/7 ECO	1"1/2	180		90	31,7	92,5	

Asynchronous circulators for solar application

Type : ST/6 ECO, ST/7 ECO

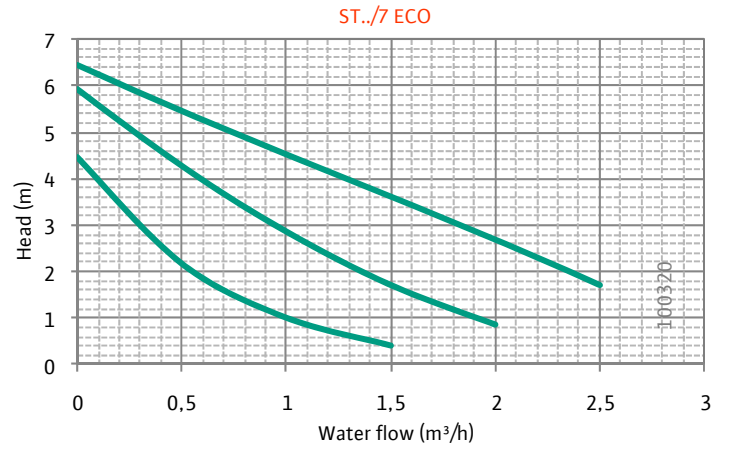
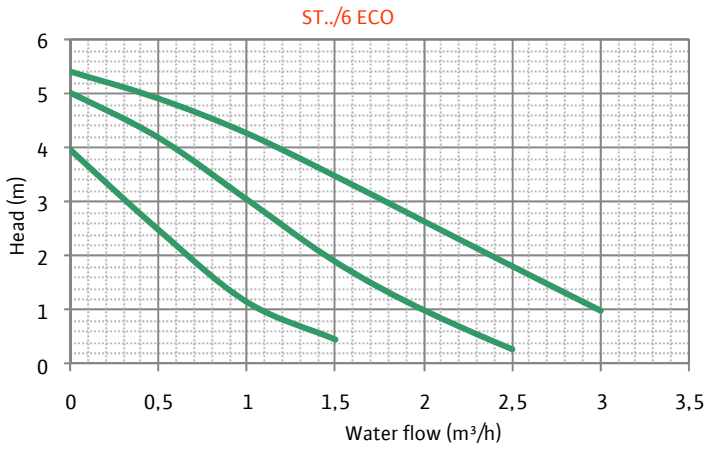

Asynchronous circulators for solar application

Type : ST15/8 ECO

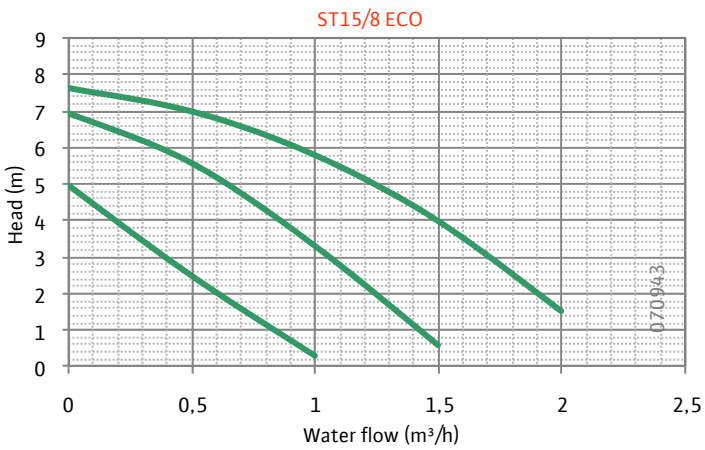
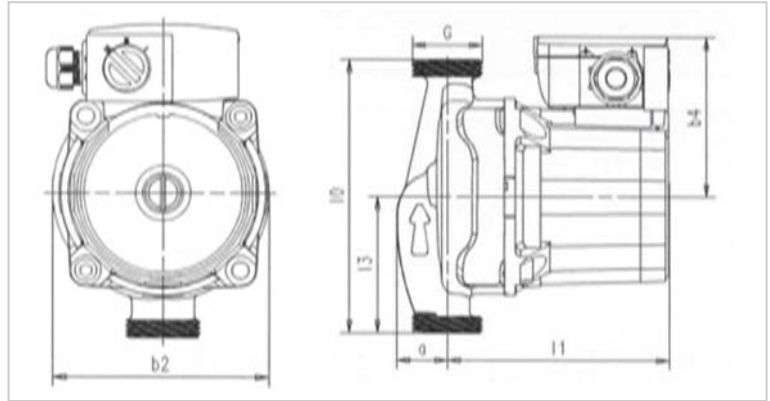

	Speed	P1 (500l/h) W	I (500l/h) A	Capacitor µf / VDB
ST15/8 ECO	max	86	0,37	3 / 400
	med	53	0,26	
	min	47	0,21	

	Thread	Dimensions					
	G	I0	I1	I3	a	b2	b4
ST15/8 ECO	1"	130	105,4	65	24	97	76

Asynchronous circulators for solar application

Type : ST/8 High Flow

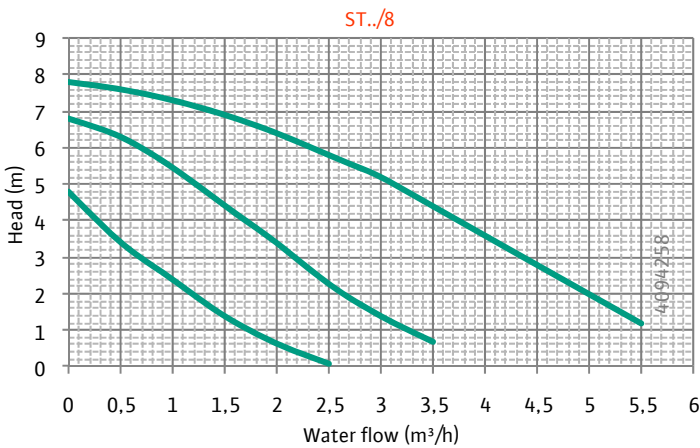
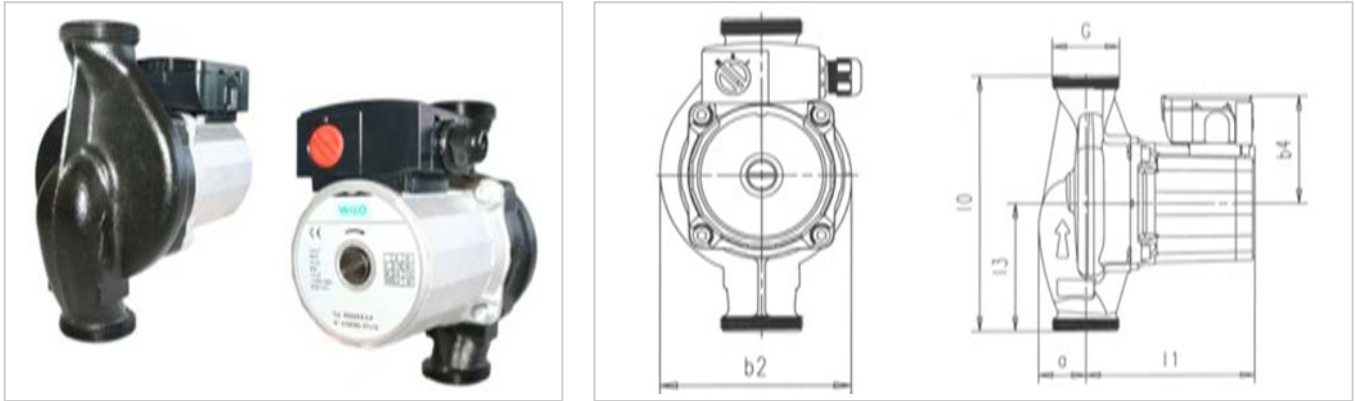

	Speed	P1 W	I A	Capacitor µf / VDB
ST25/8 ST30/8	max	2400	151	3,5 / 400
		2100	113	
	min	1800	81	

	Thread	Dimensions					
	G	l0	l1	l3	a	b2	b4
ST25/8	1"1/2	180	119	90	33,3	111	76
ST30/8	2"	180	119	90	33,3	111,5	76

Nota bene : Pump approved for TF95.
 Up to 50h/a at 110°C (max 2h/d) water temperature acceptable during pump operation
 Up to 50h/life time at 140°C water temperature acceptable without pump operation (stagnation)

Asynchronous circulators for solar application

Type : ST15/9 and ST15/11

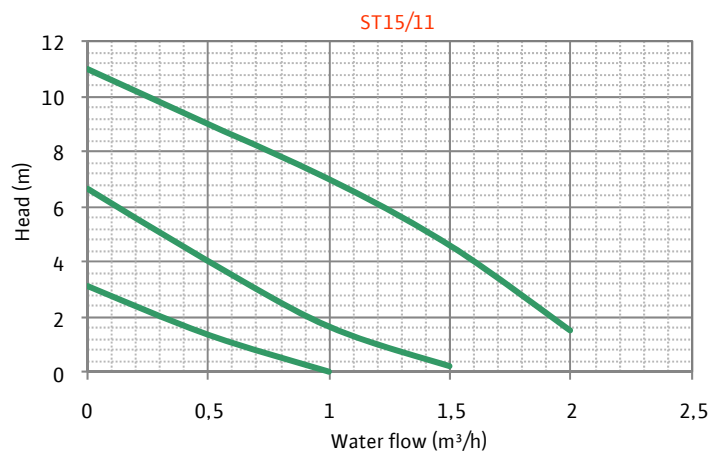
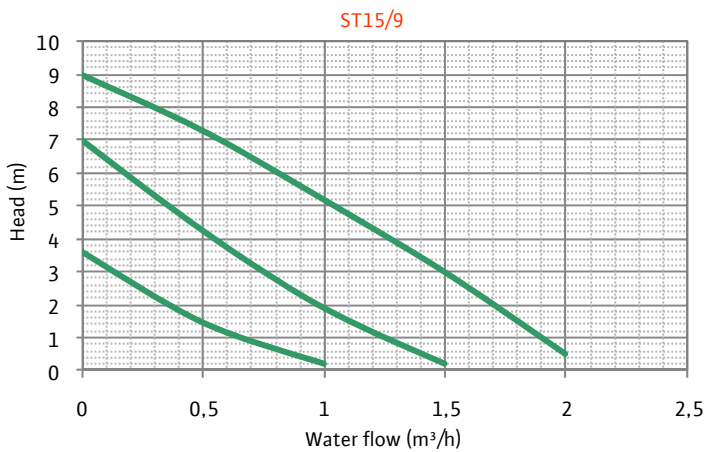
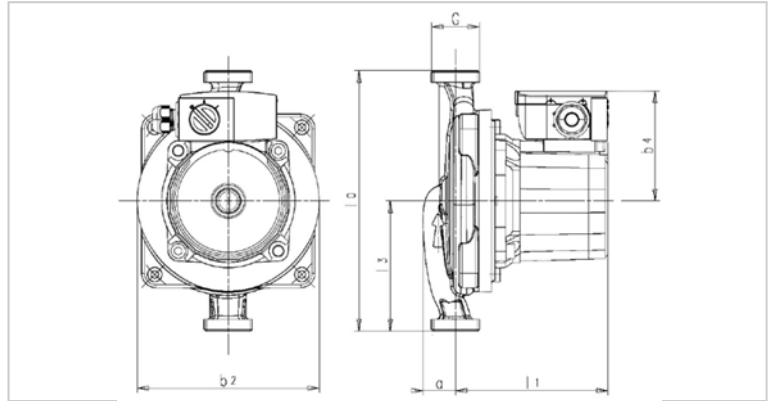

	Speed		P1 W	I A	Capacitor µf /VDB
ST15/9	max	2100	110	0,50	3 /400
		1600	78	0,35	
	min	1100	50	0,25	
ST15/11	max	2500	165	0,72	3,5 /400
		2100	115	0,55	
	min	1500	75	0,35	

	Thread	Dimensions					
	G	I0	I1	I3	a	b2	b4
ST15/9	1"	180	105,4	90	23,6	130,4	76
ST15/11	1"	180	118,4	90	23,6	130,4	76

Asynchronous circulators for solar application

Type : TOP S

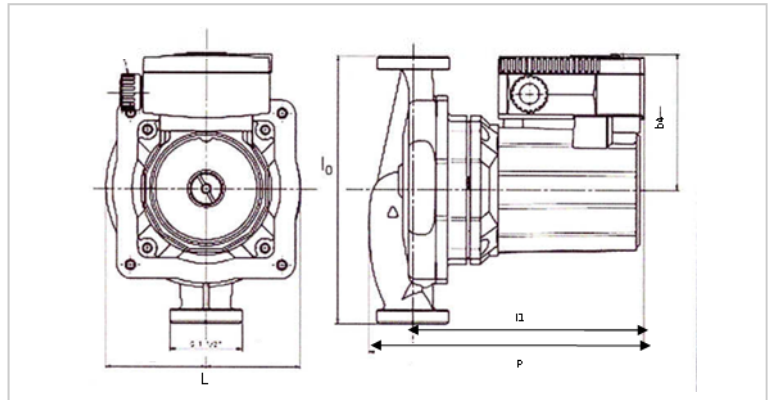

TOP-S25/13

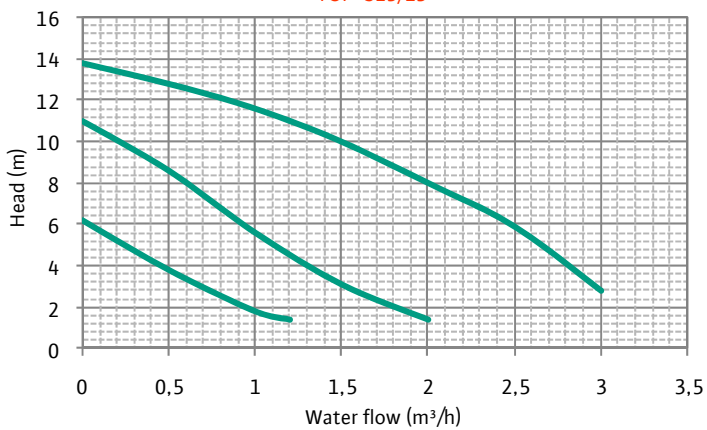

Wiring diagram

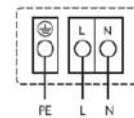

Internal protection against unacceptably high winding temperatures
 Tripping : Internal interruption of motor voltage
 Reset : Automatic after motor has cooled down

	Speed	P1 W	I A	Capacitor µf /VDB
TOP-S 25/13	max	2680	260	6 /400
		2380	200	
	min	1800	130	

	Thread	Dimensions					
	G	I0	I3	P	I3	L	b4
TOP-S 25/13	1"1/2	180	92	186	156	131	92

Geothermal energy systems



Asynchronous circulators for heat pump application

Type : RSG../6 and RSG../7

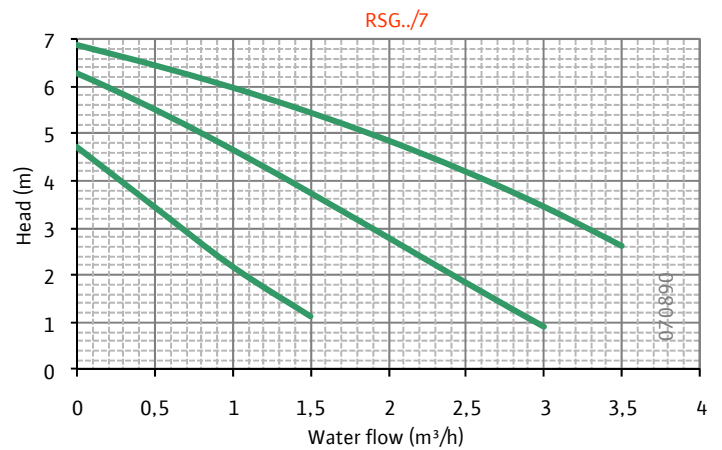
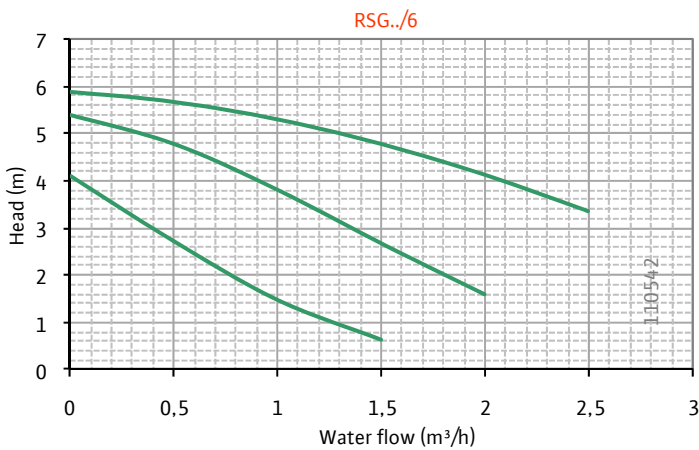
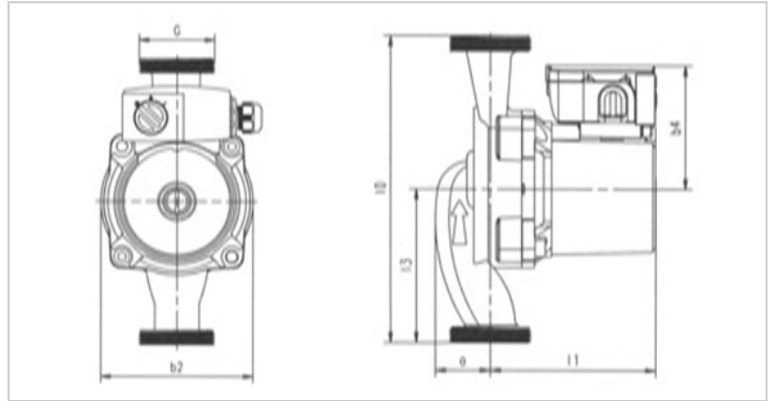

	Speed	P1 W	I A	Capacitor µf / VDB
RSG../6	max	93	0,40	2,6 / 400
	med	67	0,30	
	min	46	0,20	
RSG../7	max	132	0,58	3,5 / 400
	med	92	0,42	
	min	62	0,30	

	Thread	Dimensions					
	G	l0	l1	l3	a	b2	b4
RSG15/6	1"	130	96,6	65	28,1	92,5	76
RSG25/6	1"1/2	130		65			
RSG25/6	1"1/2	180		90			
RSG15/7	1"	130	109,6	65	28,1	92,5	76
RSG25/7	1"1/2	130		65			
RSG25/7	1"1/2	180		90			

Asynchronous circulators for heat pump application

Type : RSG../8

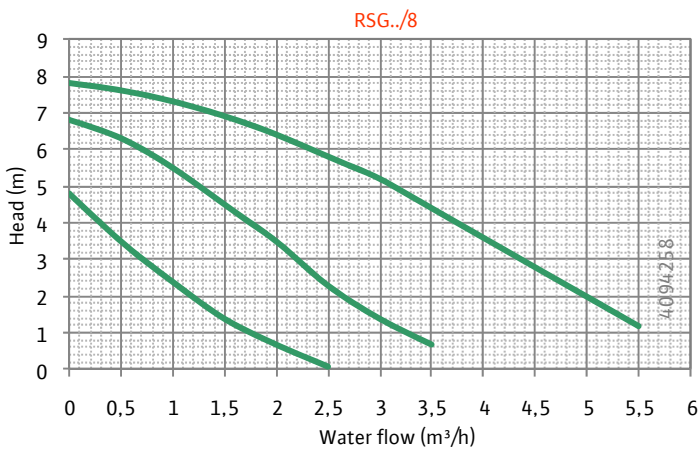
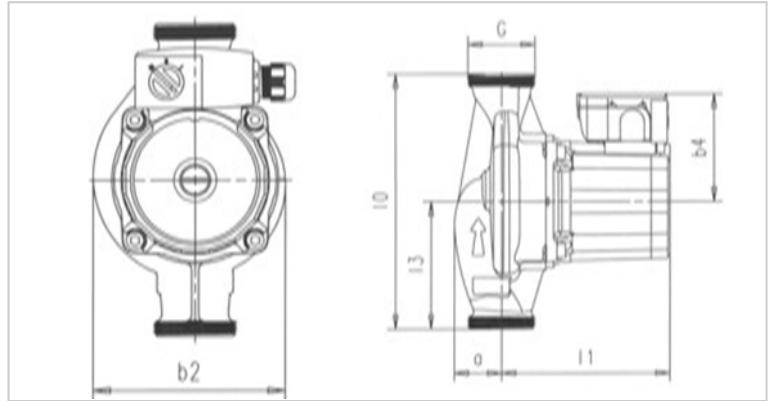

	n l/min	P1 W	I A	Capacitor µf /VDB
RSG../8	max	2400	151	3,5 /400
		2100	113	
	min	1800	81	

	Thread	Dimensions					
	G	l0	l1	l3	a	b2	b4
RSG25/8	1"1/2	180	119	90	33,3	111	76
RSG30/8	2"	180	119	90	33,3	111,5	76



Subject to change without prior notice.

Version September 2017 Wilo Intec / EN

WILO Group – OEM HVAC Competence Centre

WILO Intec
50, Avenue Eugène Casella
F-18700 Aubigny-sur-Nère
France
T +33 2 48 81 62 62
F +33 2 48 58 20 29
information@wilointec.com
www.wilo-oem.com