



2022
EDITION

PROJECTION SYSTEMS | SYSTEMES DE PROJECTION





QUALITY Know-how since 1947

The company ORAY, based south west of Paris in Dourdan, is dedicated to:

- The DESIGNING
- The MANUFACTURING
- The MARKETING

of projector screens and audiovisual accessories.

Keen to offer the best value for money on the whole range, ORAY takes special care of the choice of materials, the quality of the assembly and the innovative product designs.

All its services are certified ISO 9001: 2015.

SUSTAINABLE DEVELOPMENT Eco-socio-conception

Social and environmental issues are a priority for ORAY. These commitments led the company to engage several actions in order to improve its global performance:

- ECONOMICAL performance
- SOCIAL performance
- ENVIRONMENTAL performance

With its carbon footprint, improvement of insulation by infrared thermography, management system of environmental process, the company Oray establishes itself within an economical model looking towards the future.

TECHNOLOGY WATCH N°1 in France

The most exhaustive range

Through continuous search of new products and the wish to adapt as closely as possible to the technical developments of projection, the company managed by Eric Cantarel is the number 1 in France in the industry of projector screens and is one of the leaders worldwide.

CEDIA
MEMBER

Made in France



THE ORAY COMPANY IS ACTIVE ON ALL FRONTS

From cinema to education, from convention centers to home cinema, from the industry to simulators. All front or rear projection techniques are mastered and integrated in the most exhaustive range in the world.

Present in about 50 countries, **ORAY** supports its distributors in their most ambitious projects.



Chemin de Beaurepaire
91410 DOURDAN - FRANCE
Tel +33 (0)1 64 59 94 54 - www.oray.fr

TIPS FROM A SPECIALIST p 4

ELECTRIC SCREENS

Comfort range

Squar' p 7
HCM4 p 9

Premium range

Orion p 11
Orion Jumbo p 13
Inceling Orion p 15
Pantoscreen p 17

Monster range

GFO p 20
Polichinelle p 21
No limit p 22
Remote controls p 23

MANUAL SCREENS

Super Gear p 25
Oray 2000 p 26

MOBILE AND TRIPOD SCREENS

Mobiles

Butterfly p 28
Fly p 29
Dragonfly p 30
Cross Screen p 30
Miniscreen p 30

Tripods

Style, Byron 2, Screen p 31

FIXED SCREENS

Visible frames

Special video p 33
Cadre HC p 34
Cineframe p 35
Cineframe UST-ALR p 36
Cinevision 2 p 37
Le Mask p 38

Invisible frames

Cinevision 1 p 39
Special frame p 40

LARGE MOBILE SCREENS

Nomaddict 1 and 2 p 42
Cin'Air p 44

PROJECTION SURFACES p 45

MOUNTS, LIFTS & ACCESSORIES

For video projectors

Motorised mounts p 48
Fixed ceiling mounts p 50
Wall mounts p 50
Outdoor housing p 50

For flat screens

Fixed mounts p 51

PICTOGRAMS



ANY HEIGHT STOP
The screen can stop at several heights.



ADJUSTABLE HEIGHT
Adjusting the height of projection.



FIRE RESISTANT CLASSIFICATION
Classification of the projection surface.



ACOUSTICALLY TRANSPARENT
To place the speakers behind the screen.



MAXIMUM LOAD



CASING COLOR RAL
Other color maps on request, according to the references of RAL colour.



SPEED SOLO SYSTEM
Easier and faster mounting by only one person.



PRINTING ON FABRIC
Possibility to personalise the fabric.



CUSTOMIZABLE
You can choose another projection surface or ask for a product adapted to your measurements.



NOT-CUSTOMIZABLE
Available in **standard only**.



Technical datasheet download



ULTRA SHORT THROW
Model compatible with an Ultra Short Throw video projector

TIPS FROM A SPECIALIST



CHOOSE THE SIZE OF YOUR SCREEN

To choose the size of your screen, first check the available height under ceiling.

The selection of the projection format (4/3, 16/10 or 16/9) depends on the native resolution of the projector.

The best position of the spectator is considered to be at about 1,5 x the base of the screen, but it may vary depending on the headlamp resolution.

**PERFORATED SURFACE
(ACOUSTIC)**

Transonore or Microperf'Oray: These acoustically transparent surfaces allow to place the speakers behind the screen.

The microperf'Oray perforation, almost 2 times smaller than the Transonore perforation, is recommended when spectators are less than 6m from the screen.

**EMBEDDED SCREENS:
PROVIDE SAFETY TRAPS FOR
MAINTENANCE !**

For any recessed screen, maintenance traps must be provided in order to have access to the screen fasteners for its possible disassembly.

These traps are integrated as standard to all our false ceiling models.

EXTENSION BRACKETS

Several standard and made-to-measures options are possible to space a screen from a wall.

Be careful to always check that the wall resistance is adapted to the chosen bracket to avoid tearing.

**ULTRA-SHORT-THROW
=> FIXED OR TAB-
TENSIONED SCREEN**

Ultra Short Throw projection is made with a wide angle very close to the screen. The slightest ripple, even invisible to the naked eye, can generate an image distortion.

That is why we recommend the use of fixed frame screens. If your configuration requires a roll-up screen, the unique possible compromise will then be a tensioned screen.

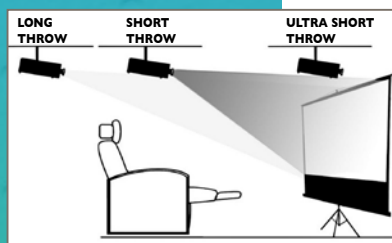

**TAB-TENSIONED SCREENS :
THINK ABOUT END-STOPS**

Attention, the end-stops of a tab-tensioned screen must be defined when manufacturing. The projection surface and the tensioner cable do not roll up on the same diameter.

Any further adjustment will prevent the proper functioning of the tensioning system, which may alter the flatness of the projection surface.



BLACKOUT SURFACES

In case the screen is placed in front a window that cannot be obscured by shutters or curtains, these black back surfaces prevent the outside light to cross the screen surface and alter the projection.

However, be careful not to leave the screen open in full sun, PVC could deform and spoil irretrievably.

ELECTRIC SCREENS

Actor for sustainable development, Oray offers 3 ranges of eco-designed motor screens reducing their environmental impact and improving their recyclability.



COMFORT RANGE



The best of standard screens: traditional formats up to 3m50 base.

- Squar' p 7
- HCM4 p 9



PREMIUM RANGE



The choice between standard and made-to-measure up to 5m base: customization of fabrics, casings, formats, etc.

- Orion p 11
- Orion Jumbo p 13
- In-ceiling Orion p 15



MONSTER RANGE



Over 5m base, large roll-up screens, 100 % made to measure.

- GFO p 20
- Polichinelle p 21
- No Limit p 22

The **SQUAR'** is a very functional screen, ultra compact and simple to recess with its white lacquered aluminium case. It is available in 2 versions: Pro or HC.



- The triangular weighing bar is perfectly integrated in the casing when the screen is rolled up.
- Wall or ceiling mounting
- Black borders only available for the HC screens.

Photo Squar' HC
Photo credit: «Cinelounge - HomeCine'Feel»



Triangular weighing bar



Squar' Pro



Squar' HC

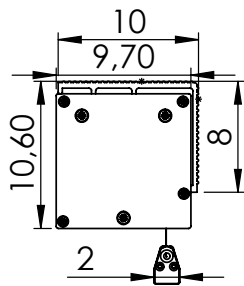

Casing profile
Power supply on the right

SQUAR' PRO



Image format
Ht x Base (cm)

Matt white
Reference

Casing
length (cm)

Image format Ht x Base (cm)	Matt white Reference	Casing length (cm)
16:10 format		
112 x 180	SQ1B1112180	192,1
125 x 200	SQ1B1125200	212,1
150 x 240	SQ1B1150240	252,1
169 x 270	SQ1B1169270	282,1
187 x 300	SQ1B1187300	312,1
219 x 350	SQ1B4219350	362,1
4:3 format		
135 x 180	SQ1B1135180	192,1
150 x 200	SQ1B1150200	212,1
180 x 240	SQ1B1180240	252,1
202 x 270	SQ1B1202270	282,1
225 x 300	SQ1B1225300	312,1
1:1 format		
150 x 150	SQ1B1150150	162,1
180 x 180	SQ1B1180180	192,1
200 x 200	SQ1B1200200	212,1
240 x 240	SQ1B1240240	252,1
300 x 300	SQ1B1300300	312,1

SQUAR' HC



Image format
Ht x Base (cm)

Blackout
matt white

Casing
length (cm)

Image format Ht x Base (cm)	Blackout matt white	Casing length (cm)
16:10 format 4 cm black borders + 20 cm drop		
120 x 192	SQ2B4120192	212,1
145 x 232	SQ2B4145232	252,1
164 x 262	SQ2B4164262	282,1
183 x 292	SQ2B4183292	312,1
214 x 342 no drop	SQ2B4214342	362,1
4:3 format 4 cm black borders		
144 x 192	SQ2B4144192	212,1
174 x 232	SQ2B4174232	252,1
196 x 262	SQ2B4196262	282,1
219 x 292	SQ2B4219292	312,1
Format 16:9 4 cm black borders + 30 cm drop		
108 x 192	SQ2B4108192	212,1
130 x 232	SQ2B4130232	252,1
147 x 262	SQ2B4147262	282,1
164 x 292	SQ2B4164292	312,1
192 x 342 no drop	SQ2B4192342	362,1



Remote controls
optional page 23



- FALSE-CEILING INTEGRATION
- ULTRA COMPACT

The **UNDERFACE +** for **SQUAR'** screens is easy to install and aesthetic:

It offers a 2 in 1 solution for the integration of your screen in a false ceiling.

Installation in two phases

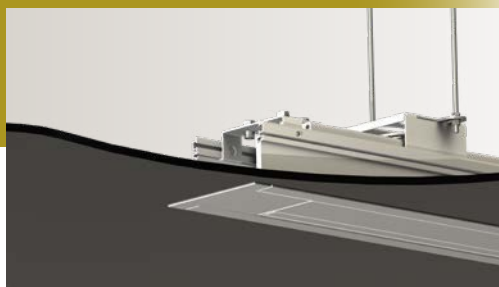

Closed system



Underface +

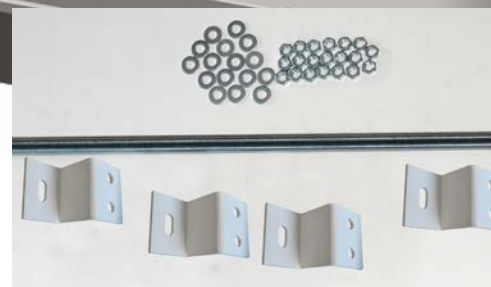

False-ceiling mounting set for underface +
1m threaded rods and fixing brackets

2 POSSIBILITIES FOR INSTALLATION:

- 1 - One shot installation:
 - Installation of the screen at the same time of the underface.
- 2 - Installation in two phases:
 - installation of the underface + during false ceiling construction.
 - installation of the screen in the underface+ when works are finished.

Underface +



Screen base (cm)	Reference
150	SQ4150
172 et 180	SQ4180
192 et 200	SQ4200
232 et 240	SQ4240
262 et 270	SQ4270
292 et 300	SQ4300
342 et 350	SQ4350

False-ceiling kit

1 kit for one underface	Reference
Up to 3m base	OPTKITFIX01
for SQ4350	OPTKITFIX02

The **STAND-OFF BRACKETS** can space the screen from the wall. Must be used without an underface.



Stand-off brackets, for wall offset.
One pair up to 300 cm base.
A trio for models 342 and 350 cm base.

Stand-off brackets



The pair	Reference
10 cm	OPTECAR10BSQ
20 cm	OPTECAR20BSQ
The trio	Reference
10 cm	OPTECAR10BSQ3
20 cm	OPTECAR20BSQ3



• **VERY SIMPLE
INTEGRATION**

The **HCM4** design screen offers a quick and easy installation thanks to the Speed solo system.

PLUG AND PLAY:
Ready to plug into your wall socket!

- Aluminum profile casing with white epoxy finish and black borders on the projection surface.
- Black out projection surface.
- Wall or ceiling mounting.

- Two models available:
- HCM4S with wired control (see options for this model - page 23)
 - HCM4R with infrared remote control and wired switch integrated on the receiver



Profile of the HCM4 casing.



Carter design



16:9 version



Stand-off bracket for a 10 or 20 cm wall distance

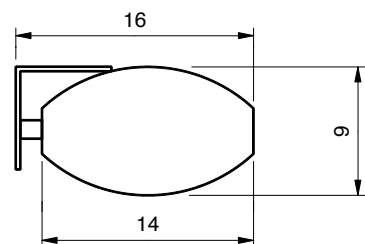

Casing profile
Power supply on the right

HCM4R et HCM4S

Image format Ht x Base (cm)	Ref. HCM4R Matt white + infrared remote control	Ref. HCM4S Matt white + Wired remote control	Casing length (cm)
4:3 formats			
4 cm black borders			
144 x 192	HCM4RB1150200	HCM4SB1150200	220
174 x 232	HCM4RB1180240	HCM4SB1180240	260
16:9 formats			
4 cm black borders + 30 cm drop			
97 x 172	HCM4RB1101180	HCM4SB1101180	200
108 x 192	HCM4RB1112200	HCM4SB1112200	220
130 x 232	HCM4RB1135240	HCM4SB1135240	260
16:10 formats			
4 cm black borders + 20 cm drop			
120 x 192	HCM4RB1125200	HCM4SB1125200	220
145 x 232	HCM4RB1150240	HCM4SB1150240	260



Stand-off brackets

The pair	Reference
10 cm	OPTECAR10
20 cm	OPTECAR20



Remote controls optional page 23

- SILENT
- DESIGN
- NO VISIBLE SCREW



PREMIUM RANGE



PREMIUM RANGE

Standard or made to measure up to 5m in length, with customised fabrics, casings, formats, etc.

- Orion p 11
- Orion Jumbo p 13
- Inceiling Orion p 15
- Pantoscreen p 17

A series of products that can be adapted to any project up to 5m fabric width.

Quiet motors, high standard of finishes, choice of projection surfaces, ...



The top of the range motorised screen, **ORION**, ensures its user reliability, aesthetics and uncompromising integration. This product has been designed for easy installation, whatever the constraints, thanks to the Speed Solo system. Available in 3 versions: Orion PRO, HC or Tensioned.



- **TENSIONED version**
The lateral cables allow the tensioned projection surface to remain flat regardless of the screen's environment. The tensioned version is the only possible compromise for ultra-short throw projection if a fixed frame screen is not possible.
- **HC and TENSIONED versions**
Black framed projection surface.

Photo credit: «Cinelounge - HomeCine'Feel»



Orion PRO Matt white



Image (cm)	Reference	Section	Casing length (cm)
16:10			
125 x 200	OR1B1125200	Small casing	216
150 x 240	OR1B1150240	Small casing	256
169 x 270	OR1B1169270	Small casing	286
187 x 300	OR1B1187300	Small casing	316
219 x 350	OR1B1219350	Large casing	366
250 x 400	OR1B1250400	Large casing	417
312 x 500	OR1B1312500	Large casing	517

Image (cm)	Reference	Section	Casing length (cm)
4:3			
135 x 180	OR1B1135180	Small casing	196
150 x 200	OR1B1150200	Small casing	216
180 x 240	OR1B1180240	Small casing	256
202 x 270	OR1B1202270	Small casing	286
225 x 300	OR1B1225300	Small casing	316
263 x 350	OR1B1263350	Large casing	366
300 x 400	OR1B1300400	Large casing	417
375 x 500	OR1B1375500	Large casing	517

Image (cm)	Reference	Section	Casing length (cm)
1:1			
180 x 180	OR1B1180180	Small casing	196
200 x 200	OR1B1200200	Small casing	216
240 x 240	OR1B1240240	Small casing	256
270 x 270	OR1B1270270	Small casing	286
300 x 300	OR1B1300300	Small casing	316
350 x 350	OR1B1350350	Large casing	366
400 x 400	OR1B1400400	Large casing	416



Orion HC Black out Matt white



Image (cm)	Reference	Section	Casing length (cm)
16:10			
4 cm black borders + 20 cm drop			
120 x 192	OR2B5120192	Small casing	216
145 x 232	OR2B5145232	Small casing	256
164 x 262	OR2B5164262	Small casing	286
182 x 292	OR2B5182292	Large casing	316
214 x 342	OR2B5214342	Large casing	366
245 x 392	OR2B5245392	Large casing	417
307 x 492	OR2B5307492	Large casing	517

Image (cm)	Reference	Section	Casing length (cm)
4:3			
4 cm black borders			
129 x 172	OR2B5129172	Small casing	196
144 x 192	OR2B5144192	Small casing	216
174 x 232	OR2B5174232	Small casing	256
196 x 262	OR2B5196262	Small casing	286
219 x 292	OR2B5219292	Large casing	316
257 x 342	OR2B5257342	Large casing	366
294 x 392	OR2B5294392	Large casing	417
369 x 492	OR2B5369492	Large casing	517

Image (cm)	Reference	Section	Casing length (cm)
16:9			
4 cm black borders + 30 cm drop			
108 x 192	OR2B5108192	Small casing	216
130 x 232	OR2B5130232	Small casing	256
147 x 262	OR2B5147262	Small casing	286
164 x 292	OR2B5164292	Large casing	316
192 x 342	OR2B5192342	Large casing	366
220 x 392	OR2B5220392	Large casing	417
277 x 492	OR2B5277492	Large casing	517

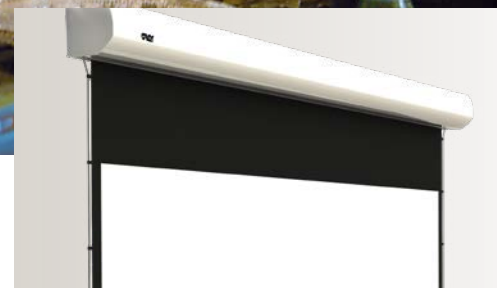

Orion tensioned Black out Matt white



Image (cm)	Reference	Section	Casing length (cm)
16:10			
4 cm black borders + 20 cm drop			
120 x 192	OR3B5120192	Small casing	244
145 x 232	OR3B5145232	Small casing	284
164 x 262	OR3B5164262	Large casing	314
182 x 292	OR3B5182292	Large casing	344
214 x 342	OR3B5214342	Large casing	394
245 x 392	OR3B5245392	Large casing	444
307 x 492	OR3B5307492	Large casing	544

Image (cm)	Reference	Section	Casing length (cm)
4:3			
4 cm black borders			
129 x 172	OR3B5129172	Small casing	224
144 x 192	OR3B5144192	Small casing	244
174 x 232	OR3B5174232	Small casing	284
196 x 262	OR3B5196262	Small casing	314
219 x 292	OR3B5219292	Large casing	344
257 x 342	OR3B5257342	Large casing	394
294 x 392	OR3B5294392	Large casing	444

Image (cm)	Reference	Section	Casing length (cm)
16:9			
4 cm black borders + 30 cm drop			
108 x 192	OR3B5108192	Small casing	244
130 x 232	OR3B5130232	Small casing	284
147 x 262	OR3B5147262	Small casing	314
164 x 292	OR3B5164292	Large casing	344
192 x 342	OR3B5192342	Large casing	394
220 x 392	OR3B5220392	Large casing	444
277 x 492	OR3B5277492	Large casing	544



Orion Pro, Orion HC and Orion Tensioned



Remote controls
optional page 23



- **MOTOR CUT-OFF SECURITY**
- **CASE WITHOUT VISIBLE SCREW**

- The ORION screen has a fully protective housing with no visible screws, including the screen brackets.
- The aluminium weighing bar closes the whole housing in raised position.
- White lacquered aluminium casing, other colours on request.
- Possibility of customising by printing all or part of the surface of the screen (logo, visual, texts...)



Standard sliding brackets for wall or ceiling mounting.

Photo credit: Préfecture de Limoges (Regards Design Audiovisuel)



Motor cut-off security device when closing



weighing bar



Stand-off bracket of 10 or 20 cm for a screen base < 4 m and up to 30 cm for a screen base < 3 m



30 cm offset for screens of 4 m and more, 10 to 40 cm for screens = 5 m 40 cm for all sizes

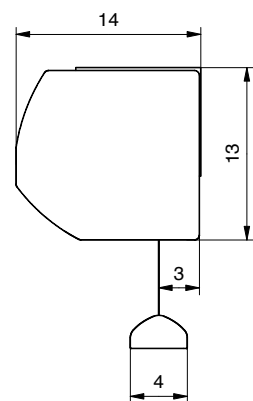

Small casing profile
Power supply on the right

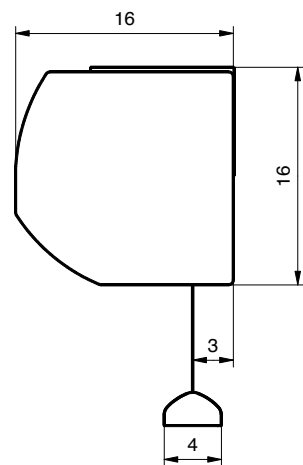

Large casing profile

Stand-off brackets- by pair or trio depending on the length of the casing

Screen base < 3 m		3m ≥ screen base < 5m		Screen base = 5 m	
Reference	the pair	Reference	the trio	Reference	the trio
OPTECAR10GOR2	10 cm	OPTECAR10GOR3	10 cm	OPTECAR10GOR5	10 cm
OPTECAR20GOR2	20 cm	OPTECAR20GOR3	20 cm	OPTECAR20GOR5	20 cm
OPTECAR30GOR2	30 cm	OPTECAR30GOR3	30 cm	OPTECAR30GOR5	30 cm
OPTECAR40GOR2	40 cm	OPTECAR40GOR3	40 cm	OPTECAR40GOR5	40 cm

The **ORION JUMBO** is a high-end motorised screen. It is available in 3 versions: Jumbo PRO, HC or Tensioned.

The **tensioned** version is the only possible compromise for **ultra-short-throw** projection if a fixed frame screen is not possible.



- **TENSIONED version**
The lateral cables allow the tensioned projection surface to remain flat regardless of the screen's environment.
- **HC and TENSIONED versions**
Black framed projection surface.



Jumbo PRO Matt white



Image (cm)	Reference	Casing length (cm)
16:10		
150 x 240	JU1B1150240	256
169 x 270	JU1B1169270	286
187 x 300	JU1B1187300	316
219 x 350	JU1B1219350	366
250 x 400	JU1B1250400	417
312 x 500	JU1B1312500	517
4:3		
180 x 240	JU1B1180240	256
202 x 270	JU1B1202270	286
225 x 300	JU1B1225300	316
263 x 350	JU1B1263350	366
300 x 400	JU1B1300400	417
375 x 500	JU1B1375500	517
1:1		
240 x 240	JU1B1240240	256
270 x 270	JU1B1270270	286
300 x 300	JU1B1300300	316
400 x 400	JU1B1400400	416



Jumbo HC Black out Matt white



Image (cm)	Reference	Casing length (cm)
16:10 4 cm black borders + 20 cm drop		
145 x 232	JU2B5145232	256
164 x 262	JU2B5164262	286
182 x 292	JU2B5182292	316
214 x 342	JU2B5214342	366
245 x 392	JU2B5245392	417
307 x 492	JU2B5307492	517
4:3 4 cm black borders		
174 x 232	JU2B5174232	256
196 x 262	JU2B5196262	286
219 x 292	JU2B5219292	316
257 x 342	JU2B5257342	366
294 x 392	JU2B5294392	417
369 x 492	JU2B5369492	517
16:9 4 cm black borders + 30 cm drop		
130 x 232	JU2B5130232	256
147 x 262	JU2B5147262	286
164 x 292	JU2B5164292	316
192 x 342	JU2B5192342	366
220 x 392	JU2B5220392	417
277 x 492	JU2B5277492	517



Jumbo Tensioned Black out Matt white



Image (cm)	Reference	Casing length (cm)
16:10 4 cm black borders + 20 cm drop		
145 x 232	JU3B5145232	256
164 x 262	JU3B5164262	286
182 x 292	JU3B5182292	316
214 x 342	JU3B5214342	366
245 x 392	JU3B5245392	417
307 x 492	JU3B5307492	517
4:3 4 cm black borders		
174 x 232	JU3B5174232	256
196 x 262	JU3B5196262	286
219 x 292	JU3B5219292	316
257 x 342	JU3B5257342	366
294 x 392	JU3B5294392	417
369 x 492	JU3B5369492	517
16:9 4 cm black borders + 30 cm drop		
130 x 232	JU3B5130232	256
147 x 262	JU3B5147262	286
164 x 292	JU3B5164292	316
192 x 342	JU3B5192342	366
220 x 392	JU3B5220392	417
277 x 492	JU3B5277492	517

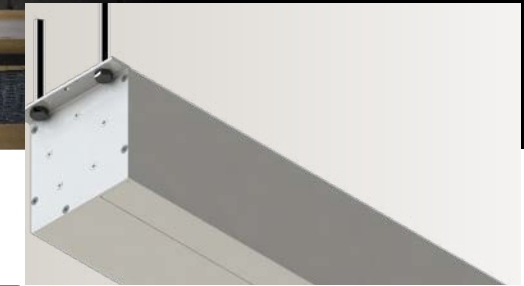

Easy to integrate square case



Remote controls optional page 23



- **MOTOR CUT-OFF SECURITY**
- **EASY TO INTEGRATE**

Caution before fixing to the wall: make sure that the wall will support the weight of the screen.

Standard ceiling mounting

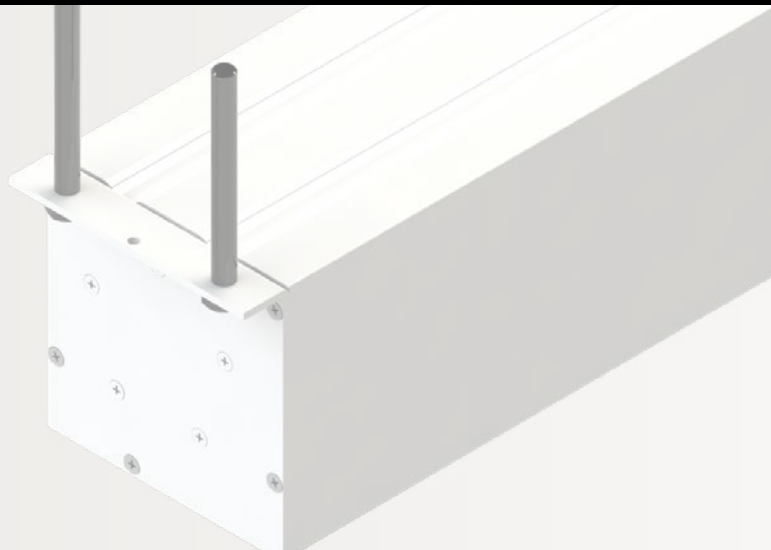

JUMBO accessories allow several fixing methods:

- Ceiling mounting
- Wall mounting (optional)
- Barrel mounting (optional)

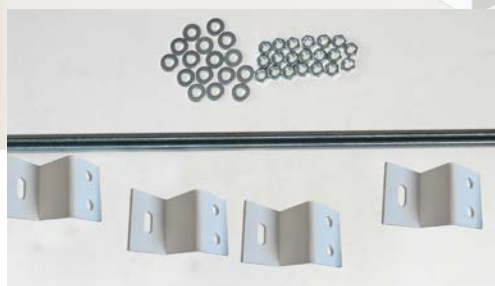

OPTION: Suspended mounting set
1m threaded rods and fixing brackets



OPTION: Barrel mounting

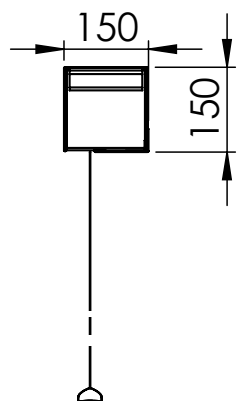

Casing profile
Power supply on the right

Suspended mounting

Reference	Unit
OPTKITOP2	1 kit

Barrel mounting

Reference	Unit
PATPERJUM01	The pair

Wall mounting

Reference	Unit
PATMURJUM15	The pair

Stand-off brackets

Reference	the pair
OPTECAR10JU	10 cm
OPTECAR20JU	20 cm
OPTECAR30JU	30 cm
OPTECAR40JU	40 cm

The **IN-CEILING ORION** is a all-in-one solution for an easy and aesthetic recessed installation. Easy installation, especially designed to fit any false ceiling.



- **TENSIONED version**
The lateral cables allow the tensioned projection surface to remain flat regardless of the screen's environment.
- **HC and TENSIONED versions**
Black framed projection surface.

Photo credit: «Cinelounge - HomeCine'Feel»

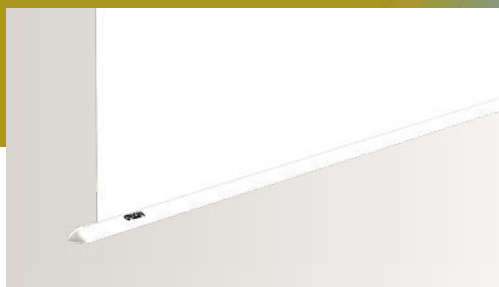

In-ceiling Orion PRO



Image (cm)	Matt white Ref.	Casing length (cm)
16:10		
150 x 240	OP1B1150240	256
169 x 270	OP1B1169270	286
187 x 300	OP1B1187300	316
219 x 350	OP1B1219350	366
250 x 400	OP1B1250400	417
312 x 500	OP1B1312500	517
4:3		
180 x 240	OP1B1180240	256
202 x 270	OP1B1202270	286
225 x 300	OP1B1225300	316
263 x 350	OP1B1263350	366
300 x 400	OP1B1300400	417
375 x 500	OP1B1375500	517
1:1		
240 x 240	OP1B1240240	256
270 x 270	OP1B1270270	286
300 x 300	OP1B1300300	316
400 x 400	OP1B1400400	416



In-ceiling Orion HC



Image (cm)	Black out Matt white	Casing Length (cm)
16:10 4 cm black borders + 20 cm drop		
145 x 232	OP2B5145232	256
164 x 262	OP2B5164262	286
182 x 292	OP2B5182292	316
214 x 342	OP2B5214342	366
245 x 392	OP2B5245392	417
307 x 492	OP2B5307492	517
4:3 4 cm black borders		
174 x 232	OP2B5174232	256
196 x 262	OP2B5196262	286
219 x 292	OP2B5219292	316
257 x 342	OP2B5257342	366
294 x 392	OP2B5294392	417
369 x 492	OP2B5369492	517
16:9 4 cm black borders + 30 cm drop		
130 x 232	OP2B5130232	256
147 x 262	OP2B5147262	286
164 x 292	OP2B5164292	316
192 x 342	OP2B5192342	366
220 x 392	OP2B5220392	417
277 x 492	OP2B5277492	517



In-ceiling Orion Tensioned



Image (cm)	Black out Matt white	Casing Length (cm)
16:10 4 cm black borders + 20 cm drop		
145 x 232	OP3B5145232	256
164 x 262	OP3B5164262	286
182 x 292	OP3B5182292	316
214 x 342	OP3B5214342	366
245 x 392	OP3B5245392	417
307 x 492	OP3B5307492	517
4:3 4 cm black borders		
174 x 232	OP3B5174232	256
196 x 262	OP3B5196262	286
219 x 292	OP3B5219292	316
257 x 342	OP3B5257342	366
294 x 392	OP3B5294392	417
369 x 492	OP3B5369492	517
16:9 4 cm black borders + 30 cm drop		
130 x 232	OP3B5130232	256
147 x 262	OP3B5147262	286
164 x 292	OP3B5164292	316
192 x 342	OP3B5192342	366
220 x 392	OP3B5220392	417
277 x 492	OP3B5277492	517



Weighing bar



Remote controls optional page 23



• **INVISIBLE WHEN ROLLED UP**

- The weighing bar closes the whole case in raised position
- Wired switch included
- Motor on the right
- The tensioned version is the only possible compromise for ultra-short throw projection if a fixed frame screen is not possible.

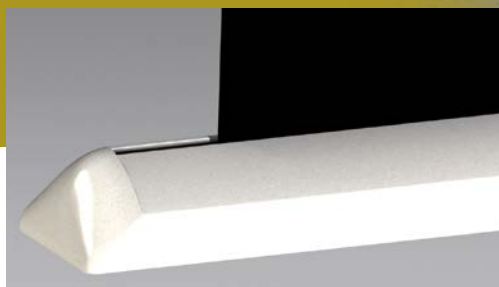
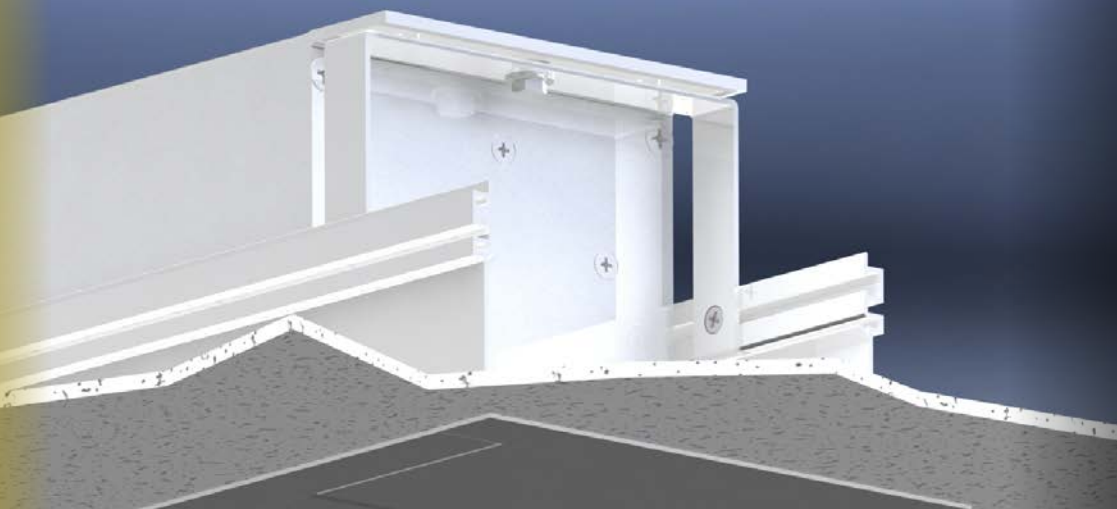

Weighing bar

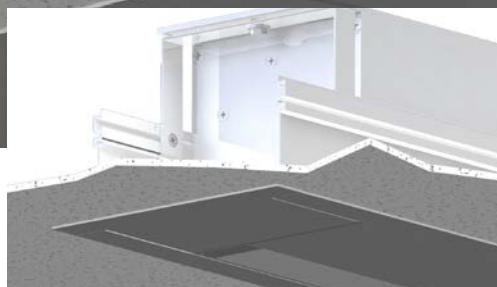

The weighing bar closes the whole case in raised position

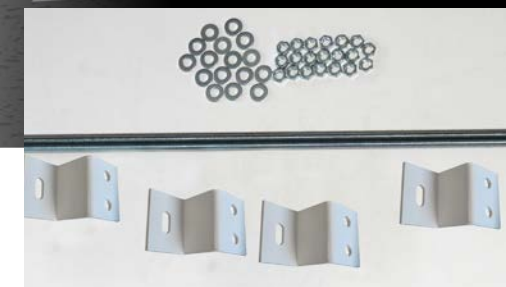

OPTION: mounting set
1m threaded rods and fixing brackets

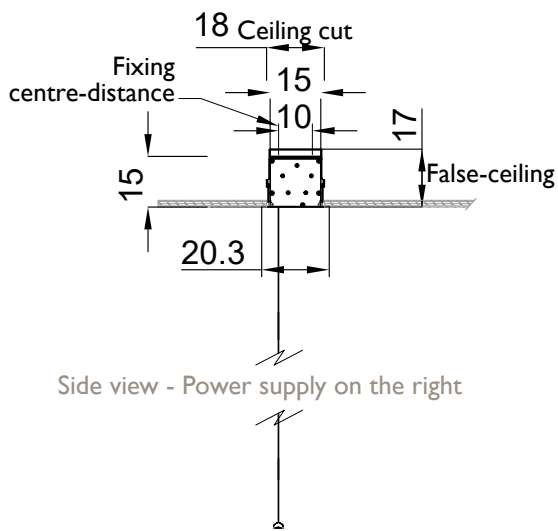

Wire switch included

Mounting kit

Base	Reference
screen < 300 cm	OPTKITOP2
screen ≥ 300 cm	OPTKITOP3

The **PANTOSCREEN WITHOUT CASING** is a recessable electric screen, equipped with a tensioning system at the back, invisible during the projection. It is the solution for a perfect integration in a media furniture, scene,...

- Motorised ascending screen
- The horizontal top bar of the screen can support an additional 500g per metre and is equipped with a mechanism for levelling the screen surface.
- Power supply on the right side.

Requires sturdy mounting to prevent tipping



Pantoscreen without casing



Upper bar



Tensioning system at the back

Pantoscreen without casing PRO 
Black out Matt white fabric.
Full width image.



Pantoscreen without casing HC 
Black out Matt white fabric.
4 cm black borders.



Pantoscreen without casing Tensioned 
Black out Matt white fabric.
4 cm black borders.



Remote controls optional page 23



- **WITHOUT CASING**
- **INVISIBLE TENSIONING SYSTEM AT THE BACK**

The **PANTOSCREEN WITH CASING** screen is equipped with a housing and a pantograph mechanism at the back. White aluminium casing as standard. Motorised ascending screen.

Pantoscreen with casing PRO with feet option



Casing



Option on feet

Screen that opens from the bottom to the top, with a supporting structure equipped with 4 wheels, for places where it is impossible to fix a screen.



Invisible tensioning system at the back

Pantoscreen with casing PRO 

Black out Matt white fabric. Full width image.

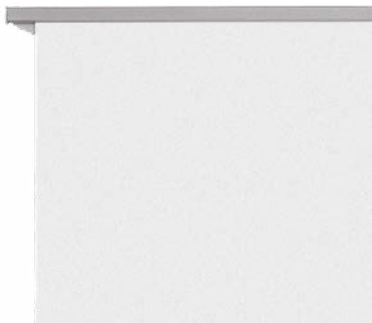

Pantoscreen with casing HC 

Black out Matt white fabric. 4 cm black borders.

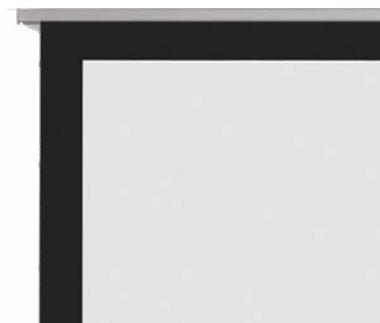

Pantoscreen with casing Tensioned 

Black out Matt white fabric. 4 cm black borders.



Remote controls optional page 23



- **INVISIBLE TENSIONING SYSTEM AT THE BACK**
- **NOMADIC: ON FEET**

MONSTER RANGE

Above 5m base, tailor-made for large images: giant formats, advanced technique, fast motorization, safety adapted to large rooms,...



MONSTER RANGE

Large screens for non-standard and 100% made-to-measure projects.

- GFO p 20
- Polichinelle p 21
- No Limit p 22

The **GFO** screens are the natural complement of Orion screens to equip high capacity conference rooms.

The **GFO** is easy to install and very compact.

The overall length of its housing is only 16,5 cm more than the image format.

Shanghai Tower



- Casing with white epoxy finish.
- Screen fitted with the patented roller counterbalance mechanism to prevent bending.
- Safety brake certified DIN-EN-13241
- Motor power: 350 W
- Diameter of the mechanism : 15 cm
- Weighing bar diameter: 3.4 cm
- Ceiling mount in standard
- Can be recessed in ceiling with underface option
- Up to 8 m base



OPTION Underface for embedding



OPTION Barrel mount.
Reference (The pair) PATPERGFO



OPTION Wall mount with or without offset



SUPPLIED AS STANDARD Ceiling mount

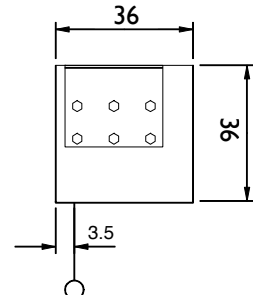
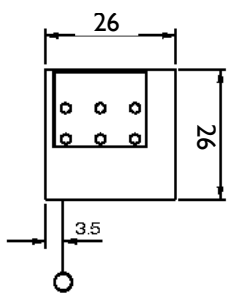

26x26 casing profile
up to 7m base
Power supply on the right

36x36 casing profile
between 7m and 8m base
Power supply on the right

Quote on request according to your specs.



Remote controls
optional page 23



- EASY INSTALLATION
- COMPACT
- ANTI-BENDING SYSTEM

The **POLICHINELLE** screens fits in the category of equipments for large auditoriums, conference centers and theatres. They are custom made for all formats with an image base from 7 meters up to 20 meters and more.



Carthage Festival, Tunisia - Photo credit: Cinelec

- The materials used ensures lightness and reliability to the whole system
- Aluminum structure covered with black fabric
- Roller tube in aluminium or carbon fiber for the largest sizes
- No arms in the lower part
- High rigidity
- Easy installation
- Voltage : 230V
- Power supply in the centre of the screen
- Security brake in case of power cut
- Can be mounted on a boom or suspended
- Stop-fall device in option



Winding tube



Barrel mount



2 possible motorisations:
Standard  or High speed 



Somfy transmitter and receiver included

The advantages of the HIGH SPEED version 

- The motor can work continuously without thermal cut-off
- Wattage : from 1 to 1.8 kW
- Rolling and unrolling speed : 0.5m/s
- Acceleration and deceleration are controlled to avoid coughs
- In case of power cut, end-stops are kept in memory
- Initial programming from a computer with saved data.
- End-stops are set at the installation site with a radio remote control.



Quote on request according to your specs.



- LIGHT
- VERY LARGE DIMENSIONS
- FLATNESS

The **NO LIMIT** screen is a modular rolling up screen of very large dimensions. An innovative concept which is a technical revolution for the large rolling up screens.

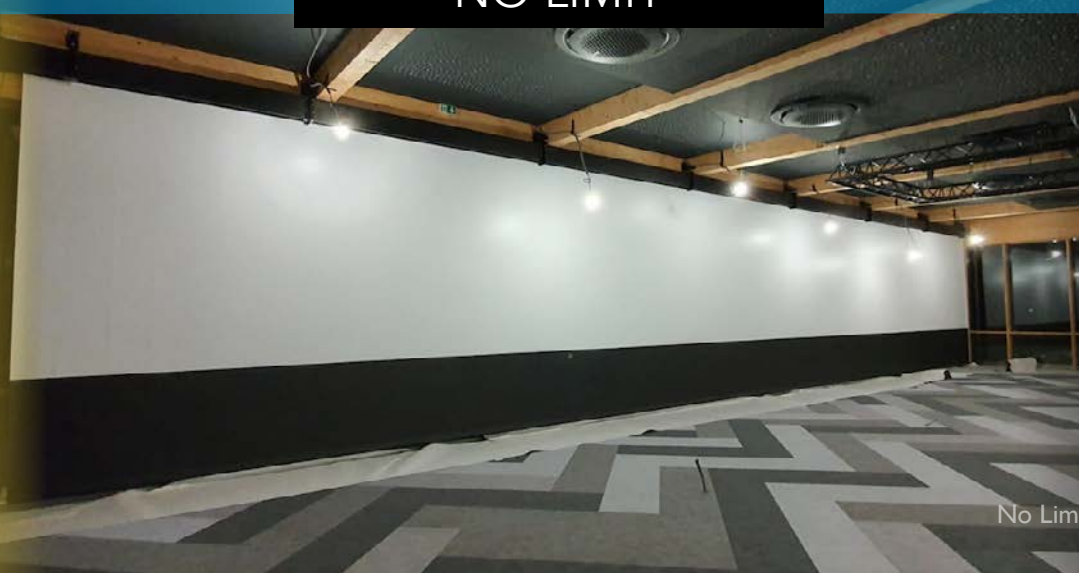

This system is adapted for the very large rolling up screens and ensures the perfect flatness of the fabric. Reliable, lightweight and easily carried. Up to 12 m, it can be fully assembled in our workshop. Above this dimension, it is assembled on site by qualified technicians. Maximal height of the projection surface: 10 meters

No Limit being installed - Videlio /Domaine La Résidence



Somfy transmitter and receiver included



Shanghai - New York University



Side view
Power supply on the left

The advantages of the NO LIMIT

The screen is equipped with a double tubular integrated 220V electric motor with 2 adjustable end stops. A large choice of fabrics are compatible with the system. Standard fastenings: suspension hooks for screens hung on a 50 mm scene pole. Other mounting options are available. Screen fitted with roller counterbalance mechanism to prevent bending.

Quote on request according to your specs.



- VERY LARGE ELECTRIC SCREEN
- FABRIC FLATNESS SYSTEM

INFRARED



Ref. OPTCOMIRHOME1

Infrared receiver + infrared remote control.

KEY SWITCH



Ref. OPTINTERCLE

Momentary position Key switch. Can be associated to a wired inverter.



Ref. : 6AMP0737

Fixed position key switch. Cannot be associated to another inverter.

RADIO TRIGGER



Ref. OPTCOMTRIG1

Radio TRIGGER. Open the screen when switching on the videoprojector. Compatible with videoprojector equipped with IEC C13 cable.

RADIO ORAY



Ref. OPTCOMMANDRAD7

Radio receiver + remote control (receiver only : 1MOT03080)



Ref. OPTCOMMANDRAD8

Radio receiver + remote control The receiver has a free terminal block for dry contacts.



Ref. 1MOT03083

1 channel remote



Ref. 1MOT03084

6 channels remote



Ref. OPTCOMMANDRAD9

Radio receiver + HF wall switch. Additional HF wall switch. 1MOT03085



Ref. 1MOT03086

Wired wall transmitter integrating a radio receiver function.

RADIO SOMFY



Ref. OPTCOMMANDRAD3

Radio receiver + remote control



Ref. OPTCOMMANDRAD4

Radio receiver + HF wall switch



Ref. 1MOT03012

Receiver only



Ref. 1MOT03016

Wall-mounted switch to be associated with a radio receiver.



Ref. 1MOT03011

Portable transmitter to be associated with a radio receiver.



Ref. : 1MOT03013

4-channel transmitter to control up to 4 devices to be associated with a radio receiver.

MANUAL SCREENS

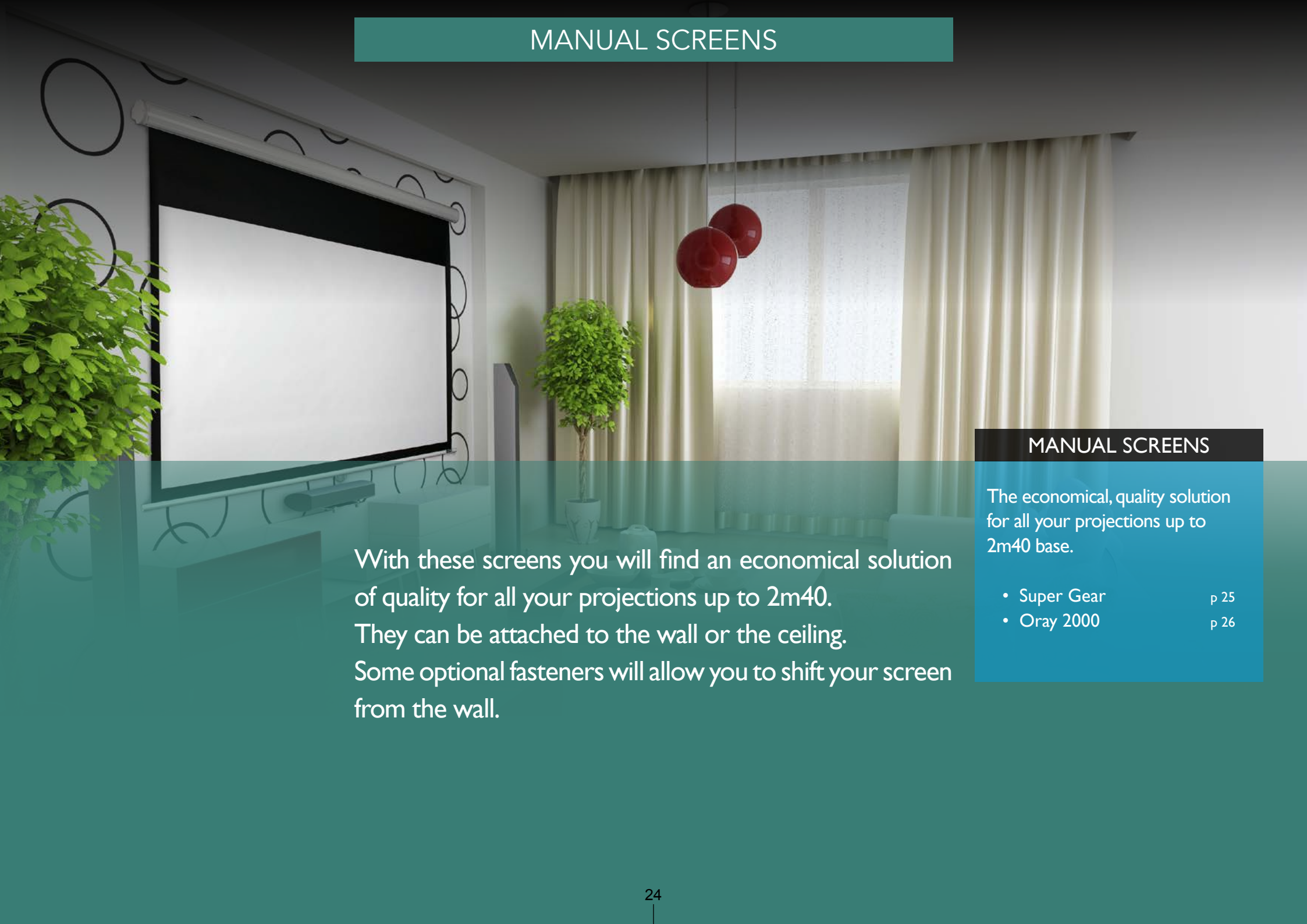

With these screens you will find an economical solution of quality for all your projections up to 2m40. They can be attached to the wall or the ceiling. Some optional fasteners will allow you to shift your screen from the wall.

MANUAL SCREENS

The economical, quality solution for all your projections up to 2m40 base.

- Super Gear p 25
- Oray 2000 p 26

The **SUPER GEAR** screen is equipped with an aluminum case which design is very modern.

Photo credit: Nicolas Plessis
Interview Production

- MI fire-resistant matt white projection surface for the PRO range.
- New SRS (Slow return system) stopping device which controls the progressive rising up of the weighing bar.



Case with white epoxy finish



Super Gear PRO



Super Gear HC

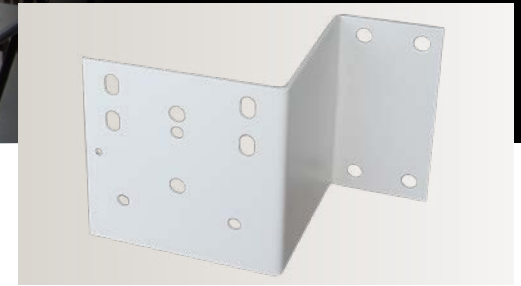

OPTION Stand-off brackets

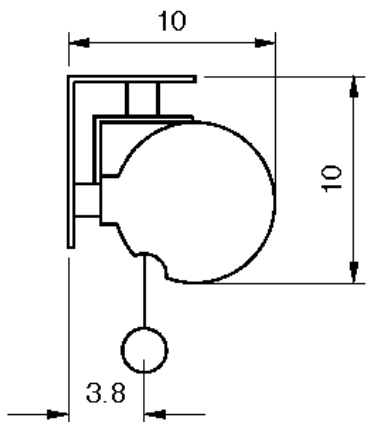

SUPERGEAR PRO

Image format Ht x Base (cm)	Matt white Ref.	Casing length (cm)
4:3 format		
135 x 180	MPP08B1135180	190
150 x 200	MPP08B1150200	210
180 x 240	MPP08B1180240	250
16:10 format		
112 x 180	MPP08B1112180	190
125 x 200	MPP08B1125200	210
150 x 240	MPP08B1150240	250
1:1 format		
150 x 150	MPP08B1150150	160
180 x 180	MPP08B1180180	190
200 x 200	MPP08B1200200	210
240 x 240	MPP08B1240240	250

SUPERGEAR HC

Image format Ht x Base (cm)	Matt white black out	Casing length (cm)
4:3 format 4 cm black borders		
174 x 232	MPP09B1180240	250
16:10 format 4 cm black borders + 20 cm drop		
108 x 172	MPP09B1112180	190
120 x 192	MPP09B1125200	210
145 x 232	MPP09B1150240	250
Format 16:9 4 cm black borders + 30 cm drop		
97 x 172	MPP09B1101180	190
108 x 192	MPP09B1112200	210
130 x 232	MPP09B1135240	250

Stand-off brackets

The pair	Reference
10 cm	OPTECAR10
20 cm	OPTECAR20
30 cm	OPTECAR30
40 cm	OPTECAR40

- ANY HEIGHT STOP
- SLOW RETURN SYSTEM
- SLIDING BRACKETS

The **ORAY 2000** is a manual screen with a white lacquered steel housing. It is equipped with a spring roller for silent operation.



- Wall or ceiling mounting brackets are integrated into the ends of the screen.
- It has a stop device on its whole height (approximately every 10 cm).

Photo credit: «Cinelounge - HomeCine'Feel»



White lacquered steel casing

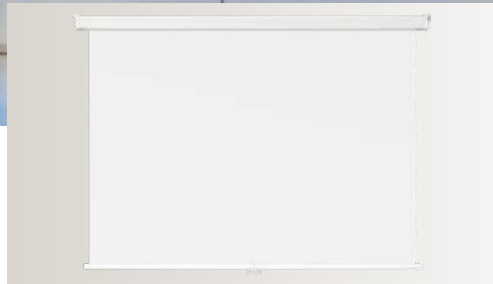

Oray 2000 PRO

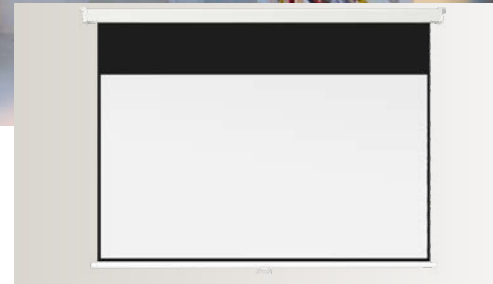

Oray 2000 HC

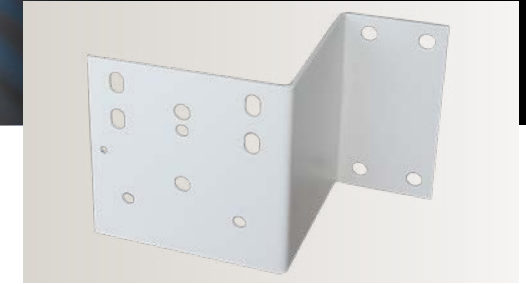

OPTION Stand-off brackets

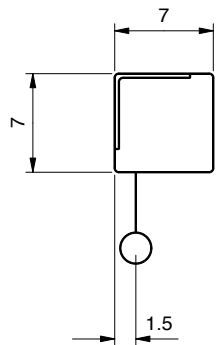

ORAY 2000 PRO 

Image format Ht x Base (cm)	Matt white Ref.	 Casing length (cm)
4:3 format		
135 x 180	MPP03B1135180	193
150 x 200	MPP03B1150200	213
16:10 format		
112 x 180	MPP03B1112180	193
125 x 200	MPP03B1125200	213
150 x 240	MPP03B1150240	253
1:1 format		
150 x 150	MPP03B1150150	163
180 x 180	MPP03B1180180	193
200 x 200	MPP03B1200200	213

ORAY 2000 HC 

Image format Ht x Base (cm)	Matt white blackout	 Casing length (cm)
4:3 format 4 cm black borders		
144 x 192	MPP02B1150200	213
16:9 format 4 cm black borders + 30 cm drop		
97 x 172	MPP02B1101180	193
108 x 192	MPP02B1112200	213
130 x 232	MPP02B1135240	253

Stand-off brackets

The pair	Reference
10 cm	OPTECAR10
20 cm	OPTECAR20
30 cm	OPTECAR30
40 cm	OPTECAR40



- **ECONOMIC**
- **ANY HEIGHT STOP**

MOBILE AND TRIPOD SCREENS



MOBILES and TRIPODS

The essential partners for your mobile projections.

- Butterfly mobile p 28
- Fly p 29
- Dragonfly, Crossscreen, Miniscreen p 30
- Tripods p 31

We present here a range both aesthetic and original, adapting to all your travelling constraints. Easy to set up, these screens are available in different formats

Ever more compact, the **BUTTERFLY MOBILE** is the fastest opening screen on the market. Ideal for rental or private use, up to 2m40 base.



- On both ends of the case of the screen, there is a handle and two large wheels that make it easy to carry around.
- The case design, fully made in aluminum, offers an efficient protection of the screen while carrying it around.
- Lift the top bar to open it instantly, thanks to the pantograph mechanism.



Wheels at the ends



Carrying handle



Pantograph mechanism

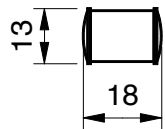

Side view
Large casing for
236cm base models

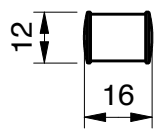

Side view
Small casing

BUTTERFLY MOBILE



Image format Ht x Base (cm)	Matt white blackout	Casing length (cm)
16:10 format 2 cm black borders		
117 x 156	BUT02B1120160	180
132 x 176	BUT02B1135180	200
147 x 196	BUT02B1150200	222
177 x 236	BUT02B1180240	262
Format 16:9 2 cm black borders + drop		
110 x 196	BUT02B1112200	222
133 x 236	BUT02B1135240	262
1:1 format 2 cm black borders		
196 x 196	BUT02B1200200	222



- QUICK RELEASE
- WHEELS AT THE ENDS

FLY is a generation of simple mobile screens, compacts and robusts.

Available in 3 versions:

- Fly Mono: Single front projection
- Fly Duo: double-sided surface, 2 formats
- Green Fly : Green background for inlay

- The height is adjustable thanks to a telescopic upright and a tilting device ensures parallax compensation.
- A tensioning device has been specially designed to hold the screen surface taut and wrinkle free.
- The opaque projection surface bears black borders.
- Matt white screen gain: 1.1



Fly Mono

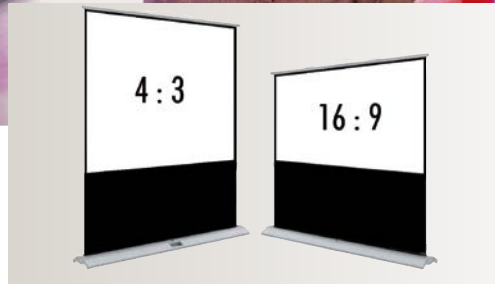

Fly Duo: Double-sided surface

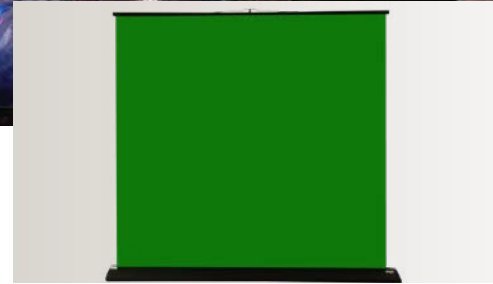

Green Fly



Telescopic upright

FLY MONO Single side front projection, black aluminum case.



Image format Ht x Base (cm)	Matt white blackout	 Casing length (cm)
4:3 format 2 cm black borders		
117 x 156	FLY01B1120160	170
132 x 176	FLY01B1135180	190
147 x 196	FLY01B1150200	210

FLY DUO Double-sided screen, Anodized aluminum case.



Image format Ht x Base (cm)	Matt white	 Casing length (cm)
117 / 88 x 156	FLY02B1120160	170
132 / 99 x 176	FLY02B1135180	190
147 / 110 x 196	FLY02B1150200	210

GREEN FLY
Green background for inlay,
black aluminum case.



Image format Ht x Base (cm)	green fabric	 Casing length (cm)
Special format		
220 x 180	FLY01VV220180	190
220 x 200	FLY01VV220200	210



- DESIGN
- MULTI-FORMAT
- LIGHTWEIGHT

The **DRAGONFLY** at the tip of innovation represents the entire know-how of ORAY in terms of mobile screens.



The **MINISCREEN** is a portable screen, ultra-light, very easy to use specially developed for Picoprojectors, to be placed on a table.

The **CROSS SCREEN** is an ultra-portable screen that gets easily and quickly assembled and disassembled while offering a wide projection surface.



DRAGONFLY: Horizontal pantograph system



CROSS SCREEN: lightweight



MINISCREEN Open feet

DRAGONFLY 

Multi-formats screen thanks to its pantograph system and horizontal opening.

- Easily carried around with its reinforced transport bag.
- Its 4-feet stand makes it very stable.
- The innovative horizontal opening offers a large screen that can fold back lengthwise, which reduces its bulkiness.

CROSS SCREEN 

With its transport bag, the CrossScreen is particularly adapted to nomadic presentations. Installed in a few minutes:

- Easy and very quick to set up
- Adjustable in height
- Can be fixed to the wall

MINISCREEN 

Ultra lightweight portable screen, very simple to set. It is dedicated to pico projectors and can be placed on a table.

- The black anodized aluminum housing combines lightness and quality.
- The fabric is tensioned thanks to an upright placed at the back of the casing.
- Easy to open in few seconds for your presentations to a wide audience in any circumstance.

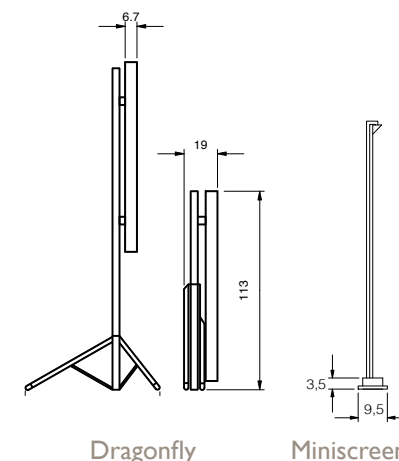

Image format Ht x Base (cm)	Black out Matt white Reference
3 Formats in 1: 4:3, 16:10 and 16:9	
101 x 134/ 162 /180	DRA01B1101180

Image format Ht x Base (cm)	Black out Matt white Reference
16:9 format	
75 x 133	CS1B1075133
87 x 155	CS1B1087155
100 x 177	CS1B1100177
112 x 200	CS1B1112200

Image format Ht x Base (cm)	Black out Matt white Reference
4:3 format 2cm side borders	
79 x 102	MIN01B1079102



- 
- **TRANSPORT BAG**
 - **COMPACT**
 - **LIGHTWEIGHT**

Tripods remain the must-have products in the institutional market and general public. From the Style, the most robust tripod of the market, to the Screen more intended to personal use, this range meets your needs for mobility and resistance.



Very robust and extremely easy to use. They are the ideal compromise for all projections that just need temporary installation.



SCREEN Telescopic upright

BYRON 2: White back
SCREEN: Black back

STYLE 5 wheels foot

STYLE tripod



OPTION Transport bag for tripods

SCREEN 

Small dimensions and easy to use, these screens are consumer-grade products. Black lacquered steel casing.

Image format Ht x Base (cm)	Black out Matt white Reference
1:1 format	
125 x 125	TRE03B1125125
150 x 150	TRE03B1150150
175 x 175	TRE03B1175175

STYLE 

White lacquered aluminium casing perfectly resistant to torsion.

- Supplied with a tiltable stem for parallax correction.
- Ultra robust handle.

Image format Ht x Base (cm)	Matt white tripod	Matt white wheels foot
4:3 format		
180 x 240	TRE06B1180240	
1:1 format		
150 x 150		PIE06B1150150
180 x 180		PIE06B1180180
200 x 200		PIE06B1200200
240 x 240	TRE06B1240240	

BYRON 2 

Black lacquered steel casing
Fire resistant matt white projection surface (M1)

Image format Ht x Base (cm)	Matt white Reference
1:1 format	
150 x 150	TRE02B1150150
180 x 180	TRE02B1180180
200 x 200	TRE02B1200200

Reference	Casing length (cm)
HOUSV2BYR150	150
HOUSV2BYR180	180
HOUSV2BYR200	200
HOUSV2BYR240	240



- CLASSIC
- POWERFUL



FIXED SCREENS

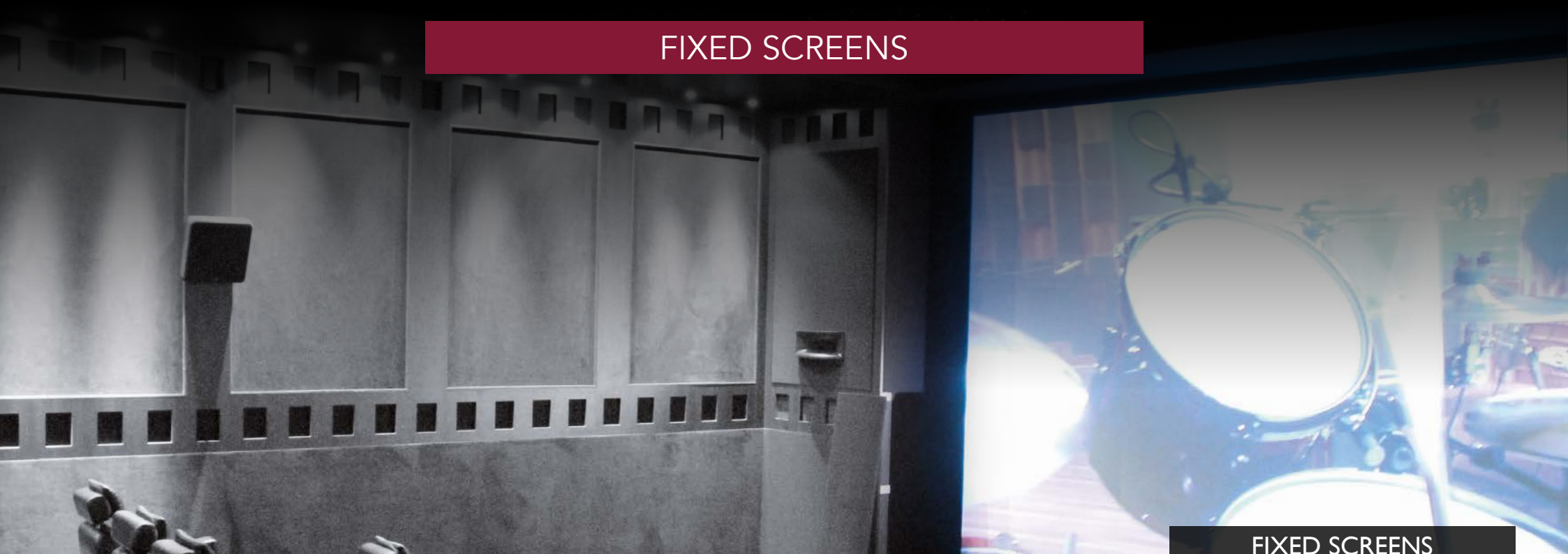

These screens meet all your requirements. Aesthetics and recessing features, flat surfaces and robustness, for all markets.

Easy to install, the aluminum frames come with a projection surface fixed with snap buttons or eyelets thus making mounting and dismounting easy.

No matter your architectural constraints, we are at your disposal for made to measure manufacturing of straight or arched frames and specific mounting devices.

FIXED SCREENS

- Special Video p 33
- Cadre HC p 34
- Cineframe p 35
- Cineframe UST-ALR p 36
- Cinevision II p 37
- Le Mask p 38

THE INVISIBLE FRAMES

- Cinevision I p 39
- Special frames p 40

The **SPECIAL VIDEO** is a "discreet" screen with a thin profile that leaves the focus to the projection. Easy to assemble, without tools!



- Rigid, design and easy to assemble,
- Avoids the projection of shadows on the image.
- The whole system can be assembled in a few minutes without any special tools. The frame is easily set up and locked automatically.
- The screen fabric is fixed at the back of the frame with snap buttons.



Black anodized



Profile of the frame



The screen fabric is fixed with snap buttons



OPTION removable legs: Black anodized feet with parallax compensation.

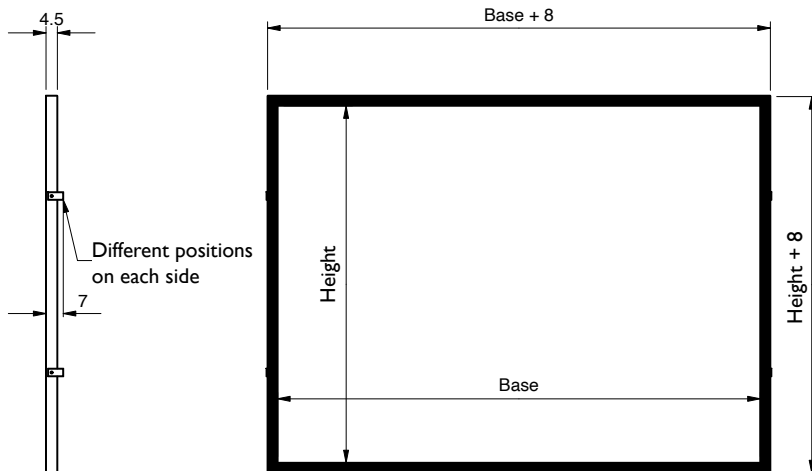

SPECIAL VIDEO



Image format
Ht x Base (cm) Matt white Ref.



4:3 format	
150 x 200	SP1B1150200
180 x 240	SP1B1180240
202 x 270	SP1B1202270
225 x 300	SP1B1225300
300 x 400	SP1B1300400
16:10 format	
125 x 200	SP1B1125200
150 x 240	SP1B1150240
169 x 270	SP1B1169270
187 x 300	SP1B1187300
250 x 400	SP1B1250400

Other sizes, fabrics, colours, ON REQUEST



- THICKNESS
- LIGHTWEIGHT
- EASY

Chic and elegance:
aluminum frame covered with
black velvet.



- The projection surface is fixed with snap buttons, totally invisible at the back of the frame.
- Easy to install and adapted to all configurations.
- Overall dimensions: image format + 16 cm



Great rigidity



Black velvet frame



The screen fabric is fixed with snap buttons



Bendable screen

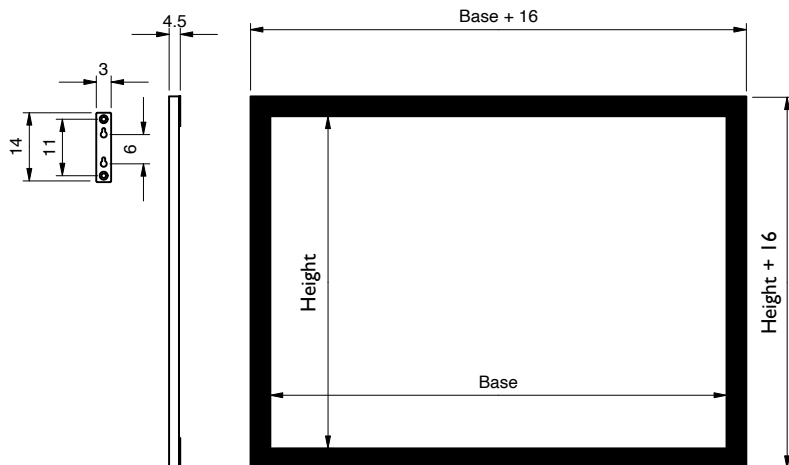

CADRE HC  

Image format Ht x Base (cm)	Matt white Ref.
4:3 format	
150 x 200	CH1B1150200
180 x 240	CH1B1180240
202 x 270	CH1B1202270
225 x 300	CH1B1225300
300 x 400	CH1B1300400
16:9 format	
112 x 200	CH1B1112200
135 x 240	CH1B1135240
152 x 270	CH1B1152270
169 x 300	CH1B1169300
225 x 400	CH1B1225400
16:10 format	
125 x 200	CH1B1125200
150 x 240	CH1B1150240
169 x 270	CH1B1169270
187 x 300	CH1B1187300
250 x 400	CH1B1250400

Other sizes, fabrics, colours, ON REQUEST



- FINISH
- REMOVABLE
- LIGHTWEIGHT

The **CINEFRAME** is a screen with a black velvet finish, which ensures it fits perfectly into your Home Cinema.



- Available from stock only in standard sizes.
- The Cineframe is delivered with wall fasteners.
- Easy to install, the frame is suspended, like a picture, with 2 screws located in the upper corners.



Black velvet finish



Fixing on the back



8 cm black velvet frame

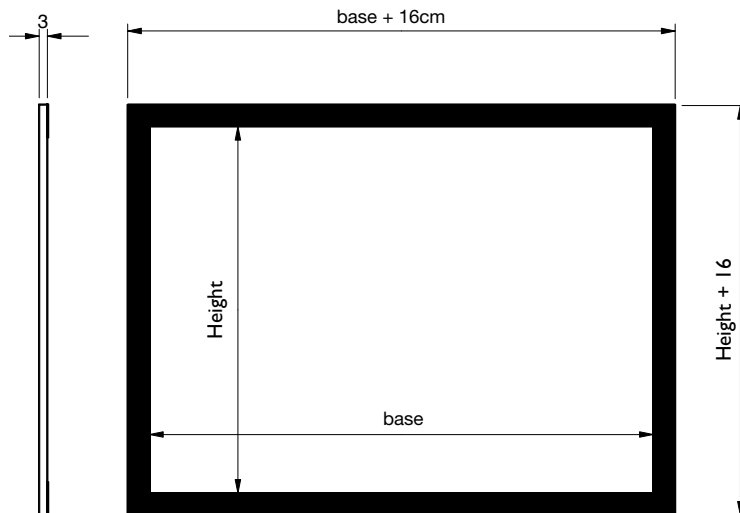

CINEFRAME

Image format Ht x Base (cm)	Matt white Ref.
16:10 format	
112 x 200	CIF01B1112200
135 x 240	CIF01B1135240
169 x 300	CIF01B1169300



- **FINISH**
- **EASY TO INSTALL**
- **ECONOMICAL**

The **CINEFRAME UST-ALR** is the essential screen for **ULTRA SHORT THROW** projection!



- Discreet 1cm black frame
- Perfect tension of the projection surface by means of springs
- Wall mounting
- The projection surface with directional structures directs the light of the video projector exclusively towards the viewer, rejecting all ambient light.

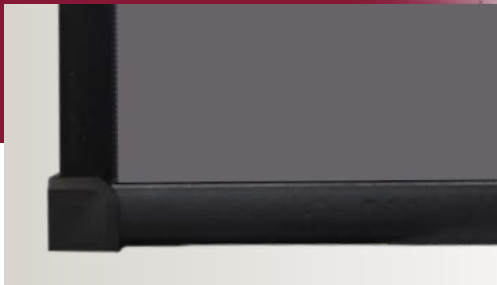

Frame detail

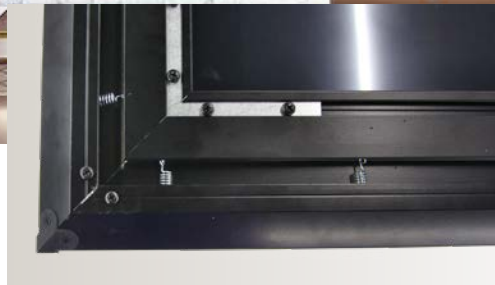

Fabric tensioning system with springs



Grey surface with ambient light rejection

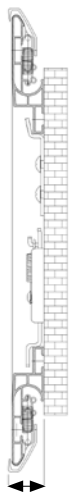

3,2

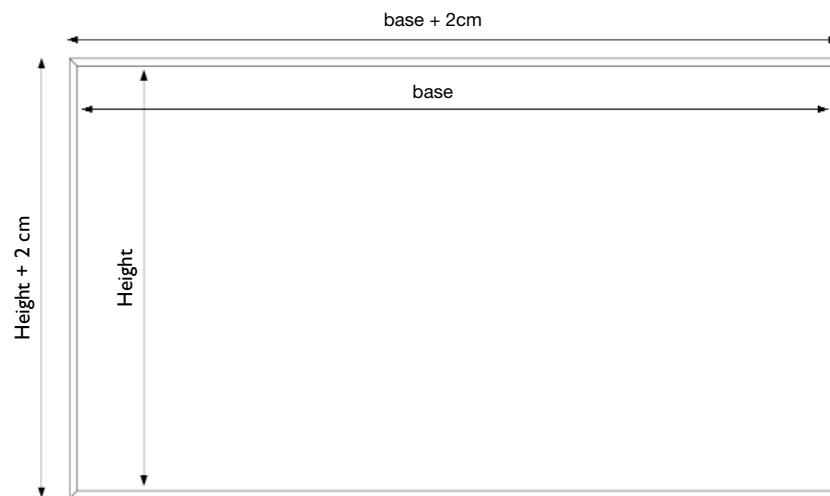

CINEFRAME UST-ALR 

Image format Ht x Base (cm)	ALR surface Ref.
16:9 format	
124 x 221	CIALR124221
149 x 265	CIALR149265



- **ULTRA SHORT THROW**
- **DISCREET**
- **AMBIENT LIGHT REJECTION**

CINEVISION II is a screen with a revolutionary lacing of the fabric and black velvet frame for your large sizes.

- Large aluminum profile for rigidity and masking of the fabric fixation.
- Tensioning device of the fabric easy to use.
- Wall mount or suspended,
- Custom made,
- Available in all dimensions,
- Black velvet frame width 21 cm.

Shangri-La Hotel Beijing - China

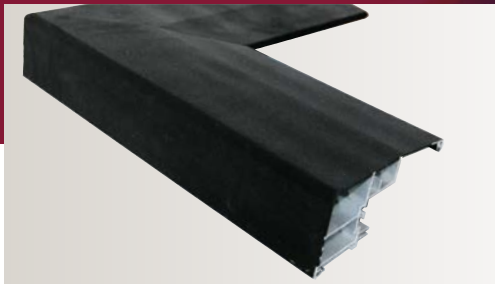

Aluminum frame covered with black velvet



Screen surface tensioning system.

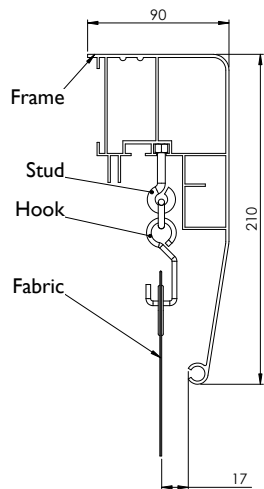

CINEVISION II 

Information required to perform a quotation:

- Type of projection surface
- Image format
- Mounting method
- Any installation details that may require modification of the standard product.

Quote on request according to your specs.



- RIGIDITY
- AESTHETICS

For a Home Cinema setting without compromise!
LE MASK is a framed screen with an electric masking system that allows you to adapt to the diffusion format of your movie.



- It is compatible for the following formats: 4:3, 16:9, 2,35:1 and 16:10.
- Perfect integration with its velvet finish.
- Acoustically transparent masking components within a Microperf Oray® fabric.
- The snap buttons fixation ensures a perfect flatness of the fabric.

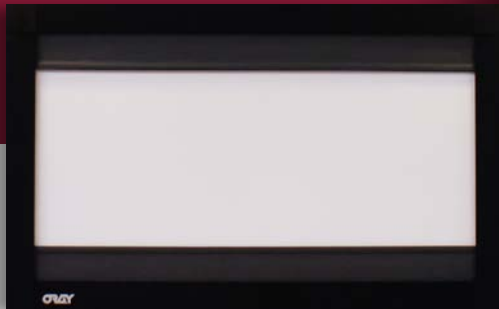

21 cm black velvet frame



With two horizontal masks: The image base is constant and allows the projection of 3 formats.

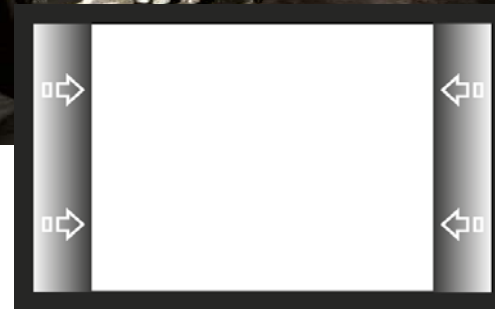

With two vertical masks: The image height is constant and allows the projection of 3 formats.



With two horizontal masks and two vertical masks: The mobile height and base allow the projection of 3 formats.

Your image is always perfectly framed, whatever the format.



LE MASK



Fully open, the screen format must match the native format of your projector.



Quote on request according to your specs.



- MULTI-FORMATS
- INTEGRATION

CINEVISION I is designed for large projection surfaces and adaptable to all movie theaters, it will also suit large conference rooms, communication rooms, show rooms and auditoriums.

- Wall mount on suspended,
- Custom made,
- Available in all dimensions,
- Can be mounted and dismantled as wished,
- Can be fixed at a distance from the wall with optional stand-off brackets.

Millau Museum



The projection surface is tensioned with eyelets at the back of the frame.

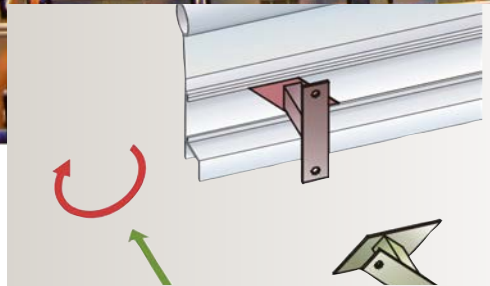

Quick suspension of the frame on its mounts and locking feature by 45° rotation of the junction part.



Millau Museum

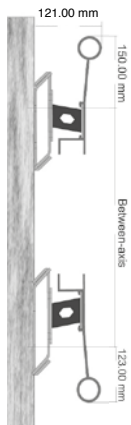

CINEVISION I 

Requested information to make a quote:

- Type of projection surface
- Image format
- Mount type
- All details related to the installation needing a modification of the standard product

Quote on request according to your specs.



- LIGHT WEIGHT
- LARGE SIZES

Simulators, event, we are at your disposal to study your wildest projects.

- Simulators,
- Amusement park,
- Event
- Museography.

We manufacture spherical, conical, circular (...), screens of any size.



Arched screen for simulator



“Carte postale” conical screen 54 meters.
World Expo Shanghai - China

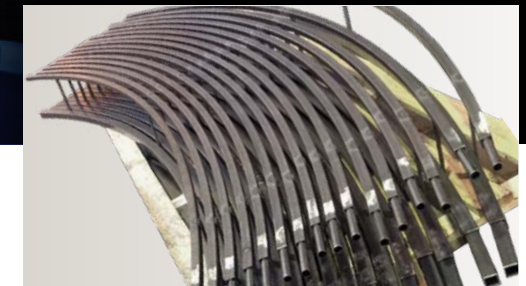

Curved raw bars

Requested information to make a quote:

- Type of projection surface
- Image format
- Mount type
- All details related to the installation needing a modification of the standard product

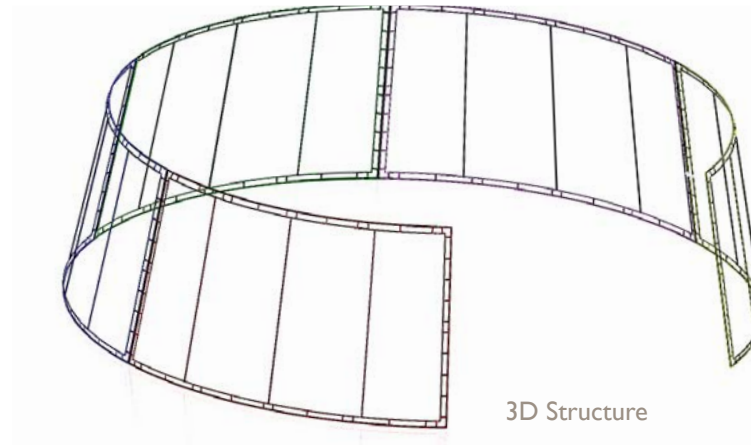

3D Structure

Quote on request according to your specs.



• **ENGINEERING DEPARTMENT**

LARGE MOBILE SCREENS



These large screens are indispensable for all your events and for rental purposes. They offer you large images, easy to install and to carry.

LARGE MOBILE SCREENS

These screens are ideal for rental and events.

FLIGHT-CASE SCREENS

- Nomaddict 1 and 2 p 42
- Spare fabrics p 43

INFLATABLE SCREENS

- Cin'Air p 44

The **NOMADDICT 1** is the ideal screen for temporary installations.

It comes with a very light and durable ABS carrying case with wheels.

The **NOMADDICT 2** is suitable for larger sizes.

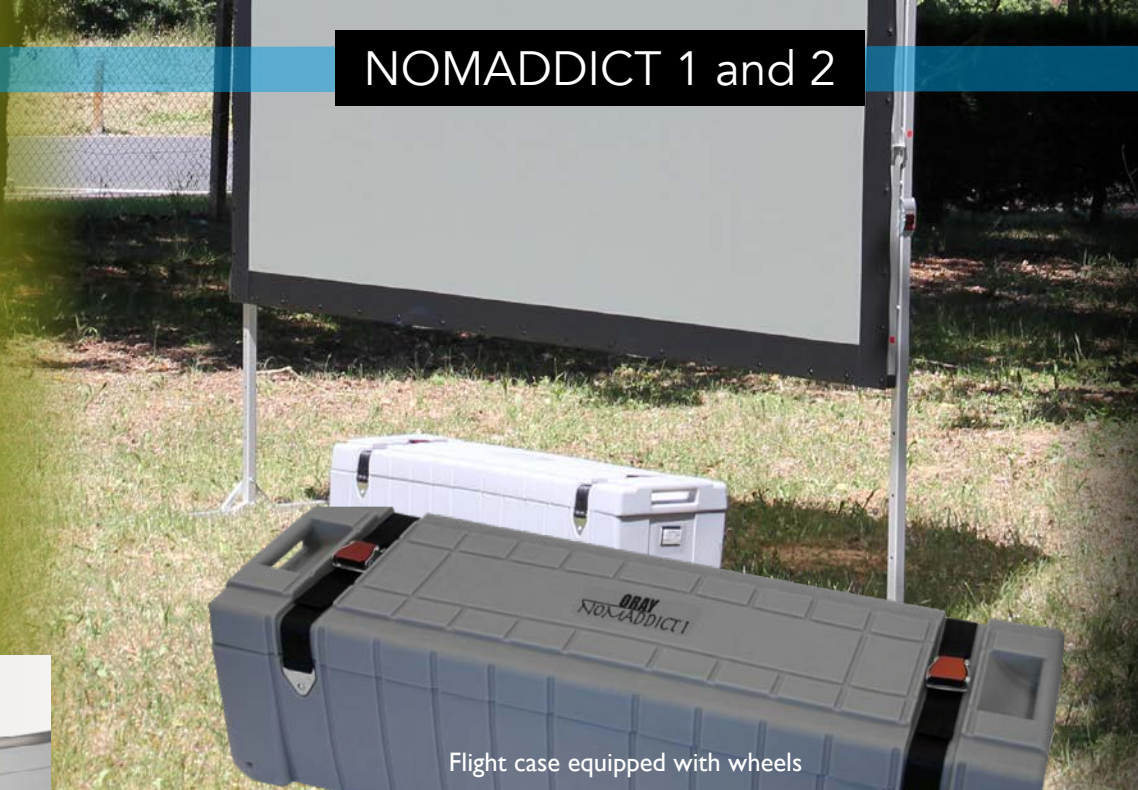

Flight case equipped with wheels

2 standard versions are available:

- **Matt white:** a matt white surface with white or black edges.
- **Duo** (delivered with 2 fabrics): a Matt white surface with white or black borders and a translucent surface with black borders.

For other surfaces, please contact us.



Suspension hook

NOMADDICT Suspension hook

for Nomaddict 1 the unit	Hook reference VLHOOK
--------------------------	---------------------------------

Frame < 5m : 2 hooks / Frame ≥ 5m : 3 hooks

for Nomaddict 2 the unit	Hook reference VXHOOK
--------------------------	---------------------------------

3 hooks are required

Hinge repair kit

Repair kit	Reference
for Nomaddict 1	VLREPAIRKIT
for Nomaddict 2	VXREPAIRKIT

NOMADDICT 1 **and NOMADDICT 2**

Model Nomaddict	Image (cm) Ht x Base	Matt white white borders	Matt white black borders	+ Matt white white borders	+ Matt white black borders	Flight-case (cm)
16:10 format						
Nomaddict 1	150 x 240	VL1B3150240	VL1B3150240N	VL1D1150240	VL1D1150240N	123 x 38 x 34
Nomaddict 1	183 x 293	VL1B3183293	VL1B3183293N	VL1D1183293	VL1D1183293N	123 x 38 x 34
Nomaddict 1	229 x 366	VL1B3229366	VL1B3229366N	VL1D1229366	VL1D1229366N	123 x 38 x 34
Nomaddict 1	244 x 390	VL1B3244390	VL1B3244390N	VL1D1244390	VL1D1244390N	123 x 38 x 34
Nomaddict 1	290 x 464	VL1B3290464	VL1B3290464N	VL1D1290464	VL1D1290464N	134 x 38 x 37
4:3 format						
Nomaddict 1	183 x 244	VL1B3183244	VL1B3183244N	VL1D1183244	VL1D1183244N	123 x 38 x 34
Nomaddict 1	229 x 305	VL1B3229305	VL1B3229305N	VL1D1229305	VL1D1229305N	123 x 38 x 34
Nomaddict 1	274 x 366	VL1B3274366	VL1B3274366N	VL1D1274366	VL1D1274366N	123 x 38 x 34
Nomaddict 1	320 x 427	VL1B3320427	VL1B3320427N	VL1D1320427	VL1D1320427N	123 x 38 x 34
Nomaddict 1	366 x 488	VL1B3366488	VL1B3366488N	VL1D1366488	VL1D1366488N	134 x 38 x 37
Nomaddict 2	457 x 610	VX1B3457610	VX1B3457610N	VX1D1457610	VX1D1457610N	134 x 38 x 37
Nomaddict 2	549 x 732	VX1B3549732	VX1B3549732N	VX1D1549732	VX1D1549732N	134 x 38 x 37
16:9 format						
Nomaddict 1	123 x 218	VL1B3123218	VL1B3123218N	VL1D1123218	VL1D1123218N	123 x 38 x 34
Nomaddict 1	150 x 266	VL1B3150266	VL1B3150266N	VL1D1150266	VL1D1150266N	123 x 38 x 34
Nomaddict 1	183 x 325	VL1B3183325	VL1B3183325N	VL1D1183325	VL1D1183325N	123 x 38 x 34
Nomaddict 1	206 x 366	VL1B3206366	VL1B3206366N	VL1D1206366	VL1D1206366N	123 x 38 x 34
Nomaddict 1	229 x 405	VL1B3229405	VL1B3229405N	VL1D1229405	VL1D1229405N	123 x 38 x 34
Nomaddict 1	274 x 488	VL1B3274488	VL1B3274488N	VL1D1274488	VL1D1274488N	123 x 38 x 34
Nomaddict 2	343 x 610	VX1B3343610	VX1B3343610N	VX1D1343610	VX1D1343610N	134 x 38 x 37
Nomaddict 2	411 x 732	VX1B3411732	VX1B3411732N	VX1D1411732	VX1D1411732N	134 x 38 x 37



Foot of a Nomaddict 2

NOMADDICT 1

Its clipped hinges make it very easy to assemble. Projection surface is tensioned with snap buttons.

NOMADDICT 2

For more rigidity, the frame section is 2 times larger than the one of Nomaddict 1. It is composed of 2 foldable and nestable parts delivered in 2 flight-cases.



- **TRANSPORTABLE**
- **LARGE DIMENSIONS**

FABRIC ONLY

Matt white fabric:
White borders or black borders

Translucent fabric:
Black borders



- The projection surface is attached to the back of the frame with completely invisible snap fasteners.
- Simple installation and adaptable to all configurations.



White borders

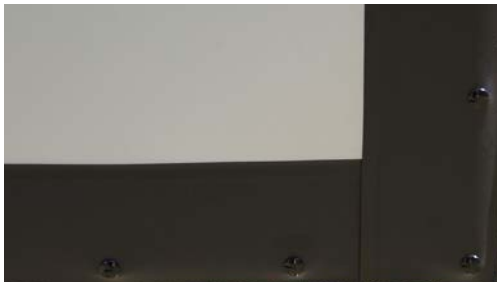

Black borders



Projection surface in its cover

Fabric only NOMADDICT 1 and 2

Model Nomaddict	Image format Ht x Base (cm)	Matt white white borders	Matt white black borders	Translucent HG black borders
16:10 format FABRIC ONLY				
Nomaddict 1	150x240	VL2B3150240	VL2B3150240N	VL2T1150240
Nomaddict 1	183x293	VL2B3183293	VL2B3183293N	VL2T1183293
Nomaddict 1	229x366	VL2B3229366	VL2B3229366N	VL2T1229366
Nomaddict 1	244x390	VL2B3244390	VL2B3244390N	VL2T1244390
Nomaddict 1	290x464	VL2B3290464	VL2B3290464N	VL2T1290464
4:3 format FABRIC ONLY				
Nomaddict 1	183x244	VL2B3183244	VL2B3183244N	VL2T1183244
Nomaddict 1	229x305	VL2B3229305	VL2B3229305N	VL2T1229305
Nomaddict 1	274x366	VL2B3274366	VL2B3274366N	VL2T1274366
Nomaddict 1	320x427	VL2B3320427	VL2B3320427N	VL2T1320427
Nomaddict 1	366x488	VL2B3366488	VL2B3366488N	VL2T1366488
Nomaddict 2	457x610	VX2B3457610	VX2B3457610N	VX2T1457610
Nomaddict 2	549x732	VX2B3549732	VX2B3549732N	VX2T1549732
16:9 format FABRIC ONLY				
Nomaddict 1	123x218	VL2B3123218	VL2B3123218N	VL2T1123218
Nomaddict 1	150x266	VL2B3150266	VL2B3150266N	VL2T1150266
Nomaddict 1	183x325	VL2B3183325	VL2B3183325N	VL2T1183325
Nomaddict 1	206x366	VL2B3206366	VL2B3206366N	VL2T1206366
Nomaddict 1	229x405	VL2B3229405	VL2B3229405N	VL2T1229405
Nomaddict 1	274x488	VL2B3274488	VL2B3274488N	VL2T1274488
Nomaddict 2	343x610	VX2B3343610	VX2B3343610N	VX2T1343610
Nomaddict 2	411x732	VX2B3411732	VX2B3411732N	VX2T1411732



- FINISH
- REMOVABLE
- LIGHTWEIGHT

The **CIN'AIR** is an inflatable, waterproof and environmentally friendly screen. It is ideal for events and all ephemeral installations.

- Made of 1100dtex nautical PVC fabric.
- High quality structure for durable use.
- Quick and easy to set up.
- Easy to store and transport.
- 100% airtight structure, without permanent wind tunnel for a total absence of noise.



Nomadic projection on the port of La Rochelle



4 screen sizes



CIN'AIR 

Image Ht x Base cm	Matt white Ref.	Bottom black part	Total dimensions cm
280 x 490	CAB1280490	90	410 x 570
390 x 700	CAB1390700	150	600 x 810
620 x 1100	CAB16201100	150	830 x 1200
790 x 1400	CAB17901400	220	1100 x 1500

INSTALLATION

The inflation/deflation time is very fast, about 10 to 25 minutes depending on the inflator.

OPTIONS

- additional or more powerful inflator,
- different projection surfaces available according to your needs.

STORAGE

Once deflated, the structure fits in a very small space: only 2m3 for the largest size!

Other projection surfaces, please contact us.



- **NOMAD**
- **LARGE DIMENSIONS**

PROJECTION SURFACES

Perforated fabric

With experience of more than 70 years, the ORAY company develops its own projection surfaces.

For flexible or rigid screens, each surface has been selected in order to optimize as much as possible your projector. You will find a large range of surfaces for front or rear projection, designed for all areas of the projection market.

PROJECTION SURFACES

- Front projection
- Rear projection
- Ad Window

More information on www.oray.fr

The FRONT PROJECTION surfaces are made of recyclable PVC.

They can be perforated (acoustic surfaces), or 3D for special applications.

Surfaces for REAR PROJECTION are translucent to allow projection from behind the screen. They are mainly used for screens on frame, as the Special Video or Flight-case screens.



Snap button



Snap buttons on white borders



Eyelet



Open hem

FRONT PROJECTION



- Matt white
- Black out Matt white
- Transonore
- Microper'Oray
- Microper'Oray HD 4K
- Special mother-of-pearl
- Metallic 3D
- Black contrast

REAR PROJECTION



- Translucent HC
- Translucent HG
- Translucent HD
- Translucent DF
- Translucent 3D

CONFECTION and KNOW-HOW

ORAY offers a wide range of confections, with made-to-measure dimensions: snap buttons, eyelets, open hems, round fabrics, etc.

AD WINDOW FILMS

For window displays, digital signage, permanent or repositionable adhesive projection films, holographic ... The widest and most specialised range of projection films on the market.

Contact us for any request.

RECOMMENDATIONS

Be careful not to forget ordering sandows. The fabrics must be mounted on their structures at a temperature of about 21°.

PRINTING ON FABRIC

ORAY customises your fabrics by printing them with a logo, text or image on part or all of the surface.



- CUSTOMIZED
- FINISHES

You can find all our surfaces in detail on www.oray.fr



Our range of motorised mounts for video projectors offers integration solutions for all your installations.

A wide range of fixed mounts for video projectors and flat screens allows to adapt to all your constraints.

MOUNTS & ACCESSORIES

- **MOTORISED MOUNTS**
for video projectors p 48
- **FIXED MOUNTS**
for video projectors p 50
- **FIXED MOUNTS**
for flat screens p 51

Our range of mounts is adapted to all kinds of integration to hide your video projector in the false ceiling.



Mini pantographe 15



Radio remote control supplied with Mini pantographe 10 and 20



Mini pantographe 10

10 kg max.

- Maximum run length: 80 cm
- Maximum load: 10 kg

Supplied with:

- Radio remote control (receiver equipped with up/ down buttons)
- Recessed installation frame.

Mini pantographe 10 

Reference	Run length
SVP0801	80 cm



Mini pantographe 15

15 kg max.

- Maximum run length: 100 cm
- Maximum load: 15 kg

Supplied with:

- Wired wall switch
- Mounting kit for projectors up to 407 x 420 mm.

Mini pantographe 15 

Reference	Run length
SVP0700	40 cm
SVP0701	100 cm

Reference	Options
OPTSVP07PLA	Recessed installation frame
OPTSVP07EXT	External mounting kit for video projector of 620 x 620 mm max.



Mini pantographe 20

25 kg max.

- Maximum run length: 195 cm
- Maximum load: 25 kg

Supplied with:

- Radio remote control (receiver equipped with up/ down buttons)

Mini pantographe 20 

Reference	Run length
SVP0601	97,5 cm
SVP0602	195,0 cm

Reference	Options
SVPMOPT01	Recessed installation frame.

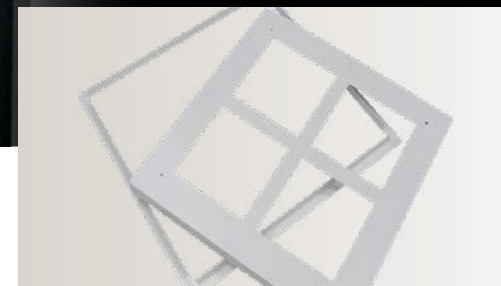

Recessed installation frame supplied with the mini pantographe 10



- INTEGRATION
- FINISHING

Pantographs and mirror mounts perfectly integrate the video projectors inside false ceilings.



Radio remote control for mirror mount

Mirror mount installed in false ceiling



Mini pantographe 30

30 kg max.

- Maximum run length: 400 cm
- Maximum load: 30 kg



Pantographe 100

100 kg max.

- Maximum run length: 400 cm
- Maximum load: 100 kg



Mirror mount

- Perfect integration
- Invisibility
- Small bulk

Supplied with:

- Radio remote control

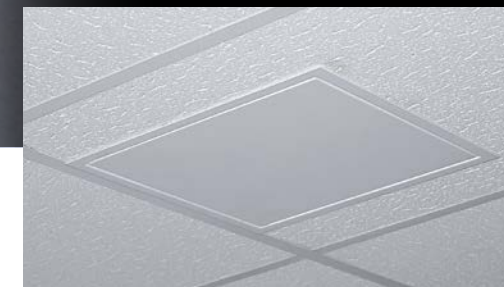

Invisibility of the mirror mount with the frame+cover kit

Mini pantographe 30



Reference	Run length
SVP0501	100 cm
SVP0502	200 cm
SVP0503	300 cm
SVP0504	400 cm

Reference	
SVP0PTPAT01	Recessed plate brackets
OPTCOMRAD3P	3 positions radio remote
OPTCOMIR3POS	3 positions infrared remote

Pantographe 100



Reference	Run length
SVP0401	100 cm
SVP0402	200 cm
SVP0403	300 cm
SVP0404	400 cm

Mirror mount



Reference	
SVPM001	
Reference	
SVPM0PT03	Package Frame+Cover



- INTEGRATION
- FINISHING

• For more products, please contact us

FIXED CEILING MOUNTS

- Independent adjustment of rotation, tilt and horizontal position
- Maximum load 15 kg
- Available in silver, black or white
- Suitable for most video projectors mounted in reverse position
- Possibility to align image axis to the fixing axis.



15 kg max.



15 kg max.

Kit 1 : Universal mount with short brackets.

Kits 2 to 5 : Fixed ceiling mount

FIXED CEILING MOUNTS (universal mount)

Kit 1 Short brackets

- Direct ceiling mounting

Kits 2 to 5 Adjustable brackets

- From 7 cm to 90 cm for kits 2 and 4 and from 7 cm to 150 cm for kits 3 and 5 with adjustable brackets.
- Cable inlay system for kits 4 and 5

Reference	Description Kits 1 to 5	Colours
SVP002A	Kit 1 Short brackets	Black
SVP002S	Kit 1 Short brackets	Silver
SVP002B	Kit 1 Short brackets	White
SVP003A	Kit 2 (7 to 90 cm)	Black
SVP003S	Kit 2 (7 to 90 cm)	Silver
SVP003B	Kit 2 (7 to 90 cm)	White
SVP004A	Kit 3 (7 to 150 cm)	Black
SVP004S	Kit 3 (7 to 150 cm)	Silver
SVP004B	Kit 3 (7 to 150 cm)	White
SVP005A	Kit 4 (7 to 90 cm)	Black
SVP005S	Kit 4 (7 to 90 cm)	Silver
SVP005B	Kit 4 (7 to 90 cm)	White
SVP006A	Kit 5 (7 to 150 cm)	Black
SVP006S	Kit 5 (7 to 150 cm)	Silver
SVP006B	Kit 5 (7 to 150 cm)	White



OUTDOOR HOUSING
Extreme protection for high power video projectors whatever the climate constraints are.

- 5 standard dimensions
- Custom-made on request



15 kg max.

Wall mount SVP0010

WALL MOUNTS FOR SHORT THROW PROJECTORS

To be fixed above the screen or the interactive board.

Mounting plate with independent tilting and horizontality adjustments

- Steel structure
- Maximum load 15 kg

Reference	Description
SVP0010	Short throw VP mount adjustable 75-135 cm



Outdoor housing

OUTDOOR HOUSING

- Tilting
- Made in fibreglass
- IP 54
- Patented product
- Antitheft with several locks
- Heating and ventilation system
- Swiveling when the mounting is made with a central screw on the base (standard)
- Control via a smartphone or PC thanks to an app with bluetooth
- Single-phase socket of 16Amp (3,5KWatt) except for the XXL reference 32 Amp (7KWatt)

• For more products, please contact us



WALL MOUNTS

VESA from 75 to 600 x 400



SPL031

30 kg max.

SPL037

30 kg max.

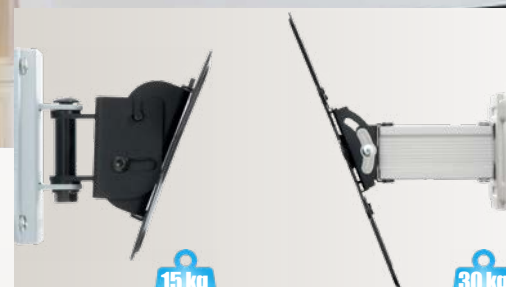

SPL038

15 kg max.

SPL040

30 kg max.



Ref.: SPL025, 26, 27

70 kg max.



Ref.: SPL028

30 kg max.

FIXED

- Ultra slim: 20mm from wall
- Level check for easy installation

Reference	Description	Max. load
SPL030	Vesa 100	15 kg
SPL031	Vesa 200	30 kg
SPL032	Vesa 400	30 kg
SPL033	Vesa 600	30 kg

TILTING

- Tilting: +5/-15°
- Level check for easy installation

Reference	Description	Max. load
SPL034	Vesa 100	15 kg
SPL035	Vesa 200	30 kg
SPL036	Vesa 400	30 kg
SPL037	Vesa 600	30 kg

TILTING AND PIVOTING

- Tilting: +5/-15°
- Twist: see board hereunder
- Level check for easy installation

Reference	Description	Off-Set	tilting pivoting	Max. load
SPL038	Vesa 100TW45	99mm	+25°/-25°	15 kg
SPL039	Vesa 200TW45	99mm	+20°/-20°	30 kg
SPL040	Vesa 400TW45	255mm	+40°/-40°	30 kg
SPL041	Vesa 100TW90	244mm	+65°/-65°	15 kg
SPL042	Vesa 200TW90	255mm	+60°/-60°	30 kg
SPL043	Vesa 400TW90	375mm	+65°/-65°	30 kg

UNIVERSAL MOUNTS FOR LARGE SIZE FLAT SCREENS: Ultra thin, for LED screens

SPL025, 26 et 27

- Extra-flat: the screen is as close to the wall as possible: 16 mm
- Steel wall plate and screen mount.
- Eccentric washer system to correct drilling errors
- Anti-tear system of the screen
- Built-in spirit level - Allows you to check the horizontality of the support when drilling

Reference	Fixation	Off-Set	Max. load
SPL025	Vesa 75-200	16mm	50kg
SPL026	Vesa 200-400	16mm	60kg
SPL027	Vesa 200-600	16mm	70kg

SPL028 and 29

- Steel wall plate and screen support
- Eccentric washer system to correct drilling errors
- Anti-tear system of the screen
- Tilttable 0°/-25°.

Reference	Fixation	Orientation	Max. load
SPL028	Vesa 200 - 400	non	30 kg
SPL029	Vesa 200 - 400	+ / - 90°	30 kg

2022
EDITION

PROJECTION SYSTEMS | SYSTEMES DE PROJECTION



Conception HPC communication.fr 01 64 59 13 28

ORAY
Chemin de Beaurepaire
91410 DOURDAN - FRANCE
Tel +33 (0)1 64 59 94 54
www.oray.fr



CEDIA
MEMBER

Made in France