

REPLACEMENT WHEELS

FOR EVERY PIPE & PIPE CUTTER



BEST EVER!

✓ **WHY REED? CUTTER WHEELS ARE BETTER...**

All Reed cutter wheels are made from high shock-resistant tool steel, while competitive wheels are made from carbon steel or still lower quality tool steel. By using this higher quality raw material, Reed cutter wheels can be made thinner and can therefore cut pipe more easily and leave less burr. Also, because of their higher quality, certified material, only Reed wheels can be heat-treated for the perfect balance between hardness and toughness to make the wheels resist breakage and last longer.

Reed pioneered the development of wheels for plastic pipe and today has the widest variety and highest quality wheels for various types and wall thicknesses of plastic pipe and tubing.

Reed offers the largest cutter wheel line for all types of pipe, tubing and conduit. Reed wheels are the best value for use in Reed cutters, or in the cutters of any other manufacturer.

CUTTER WHEEL INTERCHANGEABILITY CHARTS P. 7-9

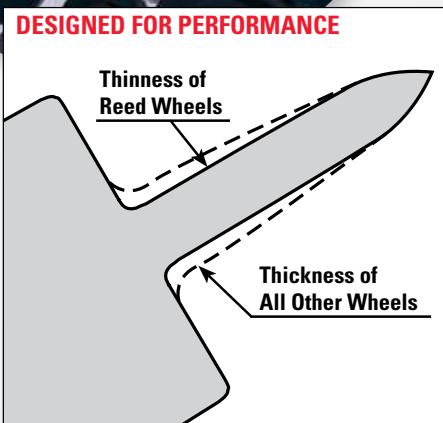

BE ON THE CUTTING EDGE WITH REED!



Back



Front

The most popular types of genuine Reed cutter wheels (P. 7) are also sold in convenient, two-pack display bags for quick and easy showroom purchases.

www.reedmfgco.com



PIPE TOOLS & VISES
SINCE 1896

Reed Replacement Cutter Wheels

Item Code	Reed Catalog No.	Std.* Pack	Reed Cutter	Blade Exposure**		Application
				inches	mm	
FOR HINGED CUTTERS						
03502	HS21/2	4	H21/2	0.312	7.9	Steel; Stainless Steel
03504	HS4	4	H4; LCRC4	0.316	8.1	Steel; Stainless Steel
03505	HS14	4	H4	0.275	7.0	Steel; Stainless Steel; Cast Iron; Ductile Iron
03506	HS6	4	H6	0.382	9.9	Steel; Stainless Steel; Copper
03507	HS16-8	4	H6; H8	0.350	8.9	Steel; Stainless Steel; Cast Iron; Ductile Iron
03508	HS8-12	4	H8; H12	0.450	11.4	Steel; Stainless Steel
03510	HX21/2	4	H21/2	0.383	9.7	Steel; Stainless Steel; Schd 80
03512	HX4	4	H4; LCRC4	0.383	9.7	Steel; Stainless Steel; Schd 80
03514	HX6	4	H6	0.476	12.1	Steel; Stainless Steel; Schd 80
03516	HX8	4	H8; H12	0.567	14.4	Steel; Stainless Steel; Schd 80
03518	HXX8	4	H8; H12	0.682	17.3	Steel; Stainless Steel; Schd 100
03522	HI4	4	H4; LCRC4	0.258	6.6	Cast Iron; Ductile Iron
03524	HI6	4	H6; H8; H12	0.410	10.4	Cast Iron; Ductile Iron
03525	H6PSE5	4	H6; H8; H12	0.400	10.2	Steel; Cast Iron; Ductile Iron
03624	2RBCI	4	H21/2	0.172	4.4	Cast Iron; Ductile Iron
FOR ROTARY™ CUTTERS						
03530	RCS8-36	4	LCRC8; LCRC12; LCRC16; RC20; RC24; RC30; RC36; RC42S	0.635	16.1	Steel; Stainless Steel
03535	RC18-30	4	LCRC8; LCRC12; LCRC16; RC20; RC24; RC30; RC36	0.500	12.7	Cast Iron; Ductile Iron (manual)
03550	RCX	4	LCRC8; LCRC12; LCRC16; RC20; RC24; RC30; RC36; RC42S	0.800	20.3	Heavy Wall Steel; Stainless Steel

REQUIRES: ONE SET (8) OF RC8-30XR ROLLERS (93222) WHEN USING RCX WHEELS

Reed Replacement Cutter Wheels, by Manufacturer

Manufacturer Cutter No.	Manufacturer Wheel	Reed Cat. No.	Item Code	Std. Pack*	Blade Exposure** inches	mm	Application
RIDGID®							
50	M-50	R2558	03670	12	0.188	4.8	Muffler Systems Tubing
10; 15; 20	E-1240	OSS	03655	12	0.160	4.1	Stainless Steel
10; 15; 20	E-1240	O	03660	12	0.180	4.6	Steel
10; 15; 20	F-158	O	03660	12	0.180	4.6	Copper; Aluminum
101; 103; 104; 105; 118; 150; 150L; 131; 132; 151; 152; 153; 205	E-3469	345T	03666	12	0.146	3.7	Copper; Aluminum; Brass
105; 150; 150L; 131; 132; 151; 152; 153; 205	E-4546	R4546	03668	6	0.161	4.1	Steel; Stainless Steel
131P; 132P; 151P; 152P; 153P; 205P	E-2155	R2155	04185	6	0.295	7.5	PE; PP-Standard & Heavy Wall
131P; 132P; 151P; 152P; 153P; 205P	E-5272	R5272	04186	6	0.295	7.5	PVC; ABS-Standard Wall
134P; 136P; 154P; 156P	E-702	680PVC	04192	4	0.575	14.6	PVC-Standard & Heavy Wall; CPVC
134P; 136P; 154P; 156P	E-2157	60P	04198	4	0.550	14.0	Thick Wall PE
136P; 156P	E-2880	80P	04199	4	0.750	19.1	ABS; PE; PP
1A; 2A; 42A; 202; 300; 360; 820; 364; 732; 300; 535	E-1032S	R1032/S	03532	6	0.450	11.4	Steel; Stainless Steel; Schd 80
1A; 2A; 42A; 202; 360; 820; 364; 732	F-514	2RBS	03612	12	0.300	7.6	Steel; Stainless Steel
1A; 2A; 42A; 202; 360; 820; 364; 732	F-3	2RBHD	03613	12	0.296	7.5	HD for Steel; Stainless Steel
1A; 2A; 42A; 202; 360; 820; 364; 733	F-3S	2RBHD	03613	12	0.296	7.5	HD for Steel; Stainless Steel
1A; 2A; 42A; 206; 360; 820; 364; 732	F-119	2RBCI	03624	4	0.172	4.4	Cast Iron
30; 40; 106; 108; 109; 133; 134; 136; 154; 156	E-2191	30-40	03665	12	0.250	6.4	Copper; Aluminum; Brass; Steel
30; 40; 106; 108; 109; 133; 134; 136; 154; 156	E-2558	30-40	03665	12	0.250	6.4	Copper; Aluminum; Brass; Steel
30; 40; 106; 108; 109; 133; 134; 154; 136; 156	E-2558	R2558	03670	12	0.188	4.8	Muffler Systems Tubing
30P; 40P; 106; 108; 109P; 133P; 134P; 136P; 154P; 156P	E-5299	3-6PVC	04194	12	0.377	9.6	3"-6" PVC; 4" Heavy Wall
30P; 40P; 106; 108; 109P; 133P; 134P; 136P; 154P; 156P	E-5299	30-40P	04190	12	0.343	8.7	ABS; PE; PP
30P; 40P; 133P; 134P; 136P; 154P; 156P	E-2156	30-40P	04190	12	0.343	8.7	ABS; PE; PP
3S; 4S; 44S; 466S; 466C; 466HWS; 468C; 468S; 468HWS; 472C; 472S; 472HWS; 764; 1224	F-229	3RG	03616	4	0.399	10.1	Steel; Stainless Steel
3S; 4S; 44S; 466S; 466C; 466HWS; 468C; 468S; 468HWS; 472C; 472S; 472HWS; 764	F-229S	3RG	03616	4	0.399	10.1	Steel; Stainless Steel
3S; 4S; 44S; 466S; 466C; 466HWS; 468C; 764	F-515	3RG	03616	4	0.399	10.1	Steel; Stainless Steel
468S; 468HWS; 472C; 472S; 472HWS							
42A; 202; 360; 820; 364; 732	E-1032	R1032/S	03532	6	0.450	11.4	Steel; Stainless Steel; Schd 80
466; 468; 472	E-1962	3RGC1	03617	4	0.285	7.2	Cast Iron; Ductile Iron
466C; 466S; 466HWS; 468C; 468S; 468HWS; 472C; 472S; 472HWS	E-3186	R3186	03526	4	0.680	17.3	Steel; Ductile Iron Heavy Wall