



Infrared  
and Laser  
Light Barriers

Inductive  
Proximity  
Switches

Sensors with  
Analogue Output

Laser Reflex  
Scanners

Accessories

# SENSORS

for Punching, Forming and Automation Systems



Company building

## Business Divisions of VESTER Elektronik GmbH

Trouble-free and safe production processes are essentially based on the functional safety of technical designs, devices and plants or else their monitoring. The prevention of failures by using control systems – in particular the safe, trouble-free punching and forming process – was the initial basic idea behind the foundation of our company.

And it has remained so ever since.

Today we develop and manufacture mechatronic systems which, by using sensors and IT components, become semi-intelligent products for a reliable controlling and monitoring of punching and forming processes to an unprecedented degree.

From this historical background **two business areas** have developed in our company.

Our classic business division consist of the product lines **“Sensor Technology and Process Monitoring”**. Here the focus lies on failure prevention by means of sensors, mainly light barriers and control systems and in particular the safe and trouble-free punching and forming process.

## Sensor Technology and Process Monitoring

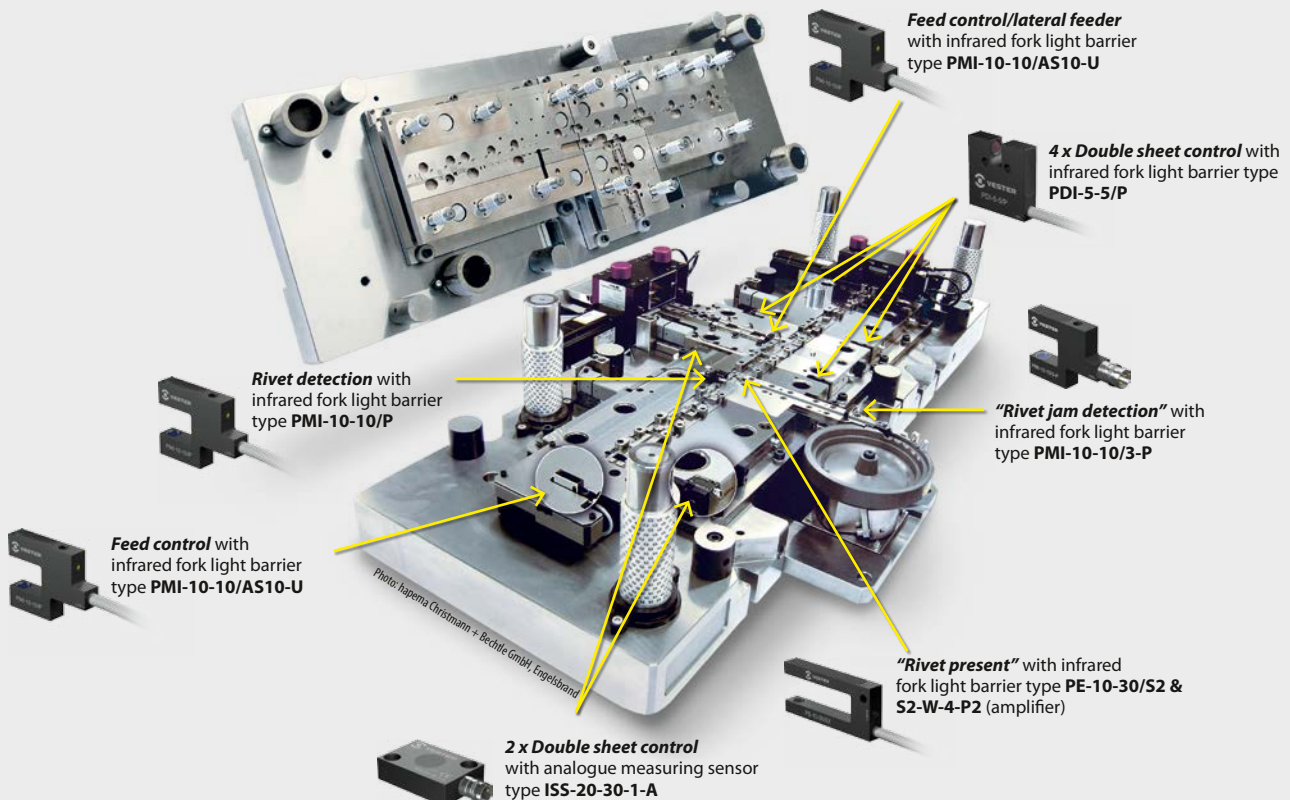

The sector of sensor technology is presented in this catalogue and subdivided into 11 chapters showing numerous IR and laser light barriers, complemented by proximity switches, fibre optics and various accessories.

The process monitoring with the SAS Advanced System enables to monitor and control all operations on the press.

Thus VESTER sensor technology and process monitoring systems help to detect malfunctions in the punching process in time to avoid tool breakage and expensive consequential damages.

Our new business division of **“test automation”** includes the product lines of our automated testing systems with image processing as well as laser marking systems.

Apart from the safe, trouble-free production with preventive error proofing, the 100% quality control for a faultless output and also the marking of parts for ensuring the traceability of the production sequence have become compulsory exercises for many industry branches.

Our VESTER VIDEOcheck testing systems control the manufactured products directly in process or in a process-oriented manner and thus ensure the output of faultless parts.

For the marking of continuously manufactured stampings and single parts the VESTER laser marking cells of the VLM product line are designed to meet the requirements of traceability.

For four decades our name has been a guarantor of innovative and well-engineered **systems for quality assurance and the monitoring of punching and forming processes.**

We offer a highly specialised know-how plus a broad product range in the fields of metrology and sensor technology for safe, transparent production processes and a consistent quality assurance.

## Test automation



Stamping line with **VIDEOcheck VVC 610** and **LASERmark VLM 600**: Laser marking of continuously manufactured stampings



Test cell **VIDEOcheck VVC 610** for stampings and **LASERmark VLM 600**



**VIDEOcheck VVC 120** with integrated feeder, bunker and lifting device



			Page
<b>Single-beam light barriers with integrated amplifier</b>			<b>K1</b>
Infrared fork light barriers			
PMI	6 mm series	3-pin M8	K1.1
		Cable output	K1.2
		4-pin M12	K1.3
		5-pin M16	K1.4
PDI	6 mm series	3-pin M8	K1.5
		Cable output	K1.6
PXI series		3-pin M8	K1.7
PSI	8 mm series	3-pin M8	K1.8 – 1.9
PKI	10 mm series	3-pin M8	K1.10 – 1.11
Red light fork light barriers			
PSV	8 mm series	3-pin M8	K1.12
Laser fork light barriers			
PSL	8 mm series	3-pin M8	K1.13
PKL	10 mm series	3-pin M8	K1.14
Split IR light barriers			
PGI series		3-pin M8	K1.15
Split laser light barriers			
PGI-L series		3-pin M8	K1.16
<b>Plug-in type single-beam light barriers - S2 with separate amplifier S2-....</b>			<b>K2</b>
Chopped light amplifiers			
S2-W-4-P2		4-pin M12	K2.1
S2-W-5-P2		5-pin M16	K2.2
Pulse amplifiers			
S2-D-4-P		4-pin M12	K2.3
S2-D-5-P		5-pin M16	K2.4
Infrared fork light barriers			
PM-S2	6 mm series	7-pin S2	K2.5
PE-S2	6 mm series	7-pin S2	K2.6
PS-S2	8 mm series	7-pin S2	K2.7 – 2.8
Split infrared light barriers			
PG-4-S2 / PG-M5-S2	Cylinder housing 4 mm / M5	4/7-pin S2	K2.9
PG-6-S2 / PG-M8-S2	Cylinder housing 6 mm / M8	4/7-pin S2	K2.10
PG-F1-S2 / PG-F2-S2	Flat housing	4/7-pin S2	K2.11 – 2.12
Split laser light barriers			
PGL-8-S2	Cylinder housing 8 mm	4/7-pin S2	K2.13
<b>Single-beam light barriers with separate chopped light or pulse amplifier</b>			<b>K3</b>
Chopped light amplifiers			
W-4-P2		4-pin M12	K3.1
W-5-P2		5-pin M16	
Pulse amplifiers			
D-4-P		4-pin M12	K3.2
D-5-P		5-pin M16	
Split infrared light barriers			
PG-4 / PG-M5	Cylinder housing 4 mm / M5		K3.3
PG-6 / PG-M8	Cylinder housing 6 mm / M8		K3.4
PG-F1	Flat housing		K3.5
PG-F2	Flat housing		K3.6
Split laser light barriers			
PGL	Cylinder housing 8 mm		K3.7
<b>Dual-beam light barriers</b>			<b>K4</b>
Infrared fork light barriers with separate amplifier			
PZ	8 mm series	4-pin M12	K4.1
Red light fork light barriers with integrated amplifier			
PZV	10 mm series	4-pin M8	K4.2

			Page
<b>Multi-beam light barriers with integrated amplifier</b>			<b>K5</b>
Infrared fork light barriers			
PBI	10 mm series	3-pin M8	K5.1
Infrared frame light barriers			
PRI	15 mm series	4-pin M12	K5.2
PRX	15 mm series	4-pin M12	K5.3
<b>Multi-beam light barriers with separate amplifier</b>			<b>K6</b>
Infrared fork light barriers			
PB	8 mm series	4-pin M12 5-pin M16	K6.1 – K6.2
Infrared frame light barriers			
PR	15 mm series	4-pin M12 5-pin M16	K6.3 – K6.4
Infrared bar light barriers as loop control			
DHS 801 / 1601 series		5-pin M12	K6.5 – 6.7
<b>Inductive proximity switches and ring sensors</b>			<b>K7</b>
Inductive proximity switches			
IS series		Cable output	K7.1
ISS plug-in type series		3-pin M8	K7.2
		4-pin M12	K7.3
Inductive ring sensors			
IRS series		4-pin M12	K7.4
<b>Contact sensors</b>			<b>K8</b>
IG/S2 plug-in type series		2-pin S2	K8.1
Amplifiers			
S2-B-4-P2		4-pin M12	K8.2
S2-B-5-P2		5-pin M16	K8.3
<b>Fibre optics, reflex scanners, amplifiers</b>			<b>K9</b>
Fibre optics			
RG / RW series			K9.1
Chopped light amplifiers			
W-R-4-P2		4-pin M12	K9.2
W-R-5-P2		5-pin M16	K9.3
Laser reflex scanners			
LRT 6K series		4-pin M8	K9.4
LRT 26K series		4-pin M12	K9.5
<b>Sensors with 0 – 10 V analogue output for metrological applications</b>			<b>K10</b>
Infrared fork light barriers with separate amplifier			
PSA	8 mm series	4-pin M12 5-pin M16	K10.1 K10.2
Inductive analogue sensors			
IS-A series		with open cable end with cable output	K10.3 K10.4
ISS-A plug-in type series		3-pin M8	K10.5
Analogue controller VCA 400			
VCA 400			K10.6
<b>Accessories</b>			<b>K11</b>
VK-...	Connection and extension cables		K11.1
WRA-8	Workshop adapters		K11.2
WS-8	Centre tool plug-in system		K11.3
SPG 10	Sensor testing device		K11.4

## Technical Terms

### Preliminary Note

While listing the technical terms we were deliberately exercising restraint so as not to create a technical reference book at this point. Rather, it is our main concern to give the end user a brief explanation of essential terms related to the application of our sensors. We raise no claims to completeness with regard to the representation of complex physical fundamentals.

### Operation Modes

We draw a distinction between static and dynamic operation. The compact single-beam light barriers with an integrated amplifier inherently function in static mode, i.e. the output will immediately follow the status of the light beam. Depending on the application, single-beam light barriers with a separate chopped light amplifier may also be operated in a purely dynamic mode. An interruption of the light beam causes an adjustable output pulse length. Multi-beam light barriers combine both principles and are therefore very versatile.

#### Static Operation :

The interruption of a light beam by an object causes a change of state on the amplifier output, which will continue until this interruption is undone by the object. The pulse length is roughly equivalent to the time of interruption.

#### Dynamic Operation :

Sensors with amplifiers which combine both operating principles can detect fast moving and small objects and create a defined output pulse. However, we can also detect those objects which, are still located inside the cross section of the sensor. This feature expands the range of applications, in particular of multi-beam stamping light barriers. Furthermore, the static operation mode also includes a continuous contamination control.

### Resolution

The smallest part size a sensor can reliably identify in its highest sensitivity setting.

### Output

#### PNP-switching :

The load is connected to the ground of the operating voltage source. The amplifier output will connect the load to the positive pole of the operating voltage source. PNP-switching sensors are state of the art and are required as standard by almost all industrial applications.

#### NPN-switching :

The load is connected to the positive pole of the operating voltage source. The amplifier output will connect the load to the ground of the operating voltage source.

### Operating Voltage

All sensors have an operating voltage range of 12 – 24 (30) VDC (-5 % / +20 %), inductive proximity switches of 10 – 30 VDC (-5 % / +10 %), depending on type. In industrial ambiance a 24 VDC supply has become established.

### Function Principle

VESTER single- and multi-beam light barriers mostly operate as infrared and red light one-way sensors. Laser light barriers run in the visible range (red light). The laser output power is below 1 mW (class 2). Nevertheless, with split-type versions you should never look directly into the laser beam! In a one-way sensor transmitter and receiver are arranged in a common optic axis, split-type models in separate housings, fork and frame light barriers in a common housing. Both the transmitter and receiver elements are classified for highest sensitivity to achieve the required accuracy and reliability.

### Housing

All fork and frame light barriers are made of high-quality anodised aluminium to ensure a high electro-mechanical stability for many years. The optical elements are protected by scratch-proof hardened glass. Each sensor has a sufficient number of mounting options either directly on the housing or, as is realised in most multi-beam light barriers, on special support rails and protective frames.

### Pulse Extension

Many SPS applications require an extension of short output signals from sensors into a defined time signal, which can be safely read within the SPS programme cycle time. This functionality is available as a pulse extension on a large number of sensors, particularly on multi-beam light barriers. The setting range is between 1 ms and 100 ms. The selected pulse length (default setting on delivery is 10 ms) also affects the sensor switching frequency, which must be taken into account with correspondingly fast counting operations.

### Function

With a digital switching operating mode the amplifier output can have only two states.

#### Bright function :

The amplifier output will be connected through if a sufficient quantity of light meets the receiver(s). There is no object between transmitter and receiver element.

#### Dark function :

The amplifier output will be connected through if the receiver is sufficiently darkened, with multi-beam light barriers at least one element. There is an object between transmitter and receiver. On many sensor types the "bright/dark switching" function is switchable, according to the case of application.

# Single-beam light barriers with integrated amplifier

# K1

Our compact models – with high resolution and repeating accuracy



Infrared fork light barrier



Laser fork light barrier



Red light fork light barrier



Split laser light barrier

- ▶ Single-beam light barriers with integrated amplifier
- ▶ Infrared fork light barriers

## PMI 6 mm series

with 3-pin connector M8

### Application

- Feed control
- Position control

### Specifications

Circuit	Constant light trigger
Operating voltage	12 – 30 VDC
Current consumption	max. 60 mA
Mode of operation	static
Output with LED	PNP
Function	dark function
Load current	200 mA short-circuit proof
Repeating accuracy	< 0.02 mm
Frequency	1 KHz
Temperature range	0 °C – 60 °C
EMC according to 2004/108/EG	EN 61000... C E
System of protection	IP 65

### Resolution

Fork width A [mm]:	5	10	20
Part diameter [mm]:	0.3	0.4	0.6

### Pin configuration

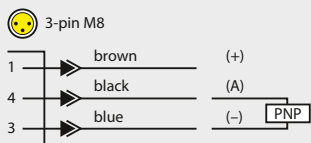

Article	Order No.
PMI- 5-10/3-P	6311-00000-3002
PMI-10-10/3-P	6312-00000-3002
PMI-10-20/3-P	6320-00000-3002
PMI-10-30/3-P	6317-00000-3002
PMI-20-10/3-P	6304-00000-3002
PMI-20-20/3-P	6324-00000-3002
PMI-20-30/3-P	6313-00000-3002

### Accessories (more accessories see chapter K11)

Article	Order No.
Connection cable 5 m:	
• VK-M8-g	2111-00005-0300
• VK-M8-w	2111-00005-1300

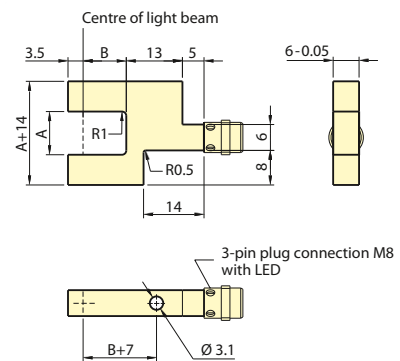

A [mm]:	5	10	10	10	20	20	20
B [mm]:	10	10	20	30	10	20	30



- ▶ Single-beam light barriers with integrated amplifier
- ▶ Infrared fork light barriers

## PMI 6 mm series

with free cable end 1.5 m

### Application

- Feed control
- Position control

### Specifications

Circuit	Constant light trigger
Operating voltage	12 – 30 VDC
Current consumption	max. 60 mA
Mode of operation	static
Output with LED	PNP
Function	dark function <sup>1)</sup>
Load current	200 mA short-circuit proof
Repeating accuracy	< 0.02 mm
Frequency	1 KHz
Temperature range	0 °C – 60 °C
EMC according to 2004/108/EG	EN 61000... CEE
System of protection	IP 65

<sup>1)</sup> with accessory AS10-U/4: external bright/dark function

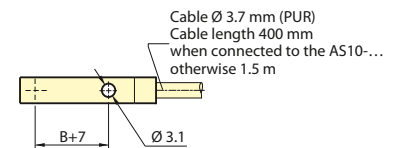
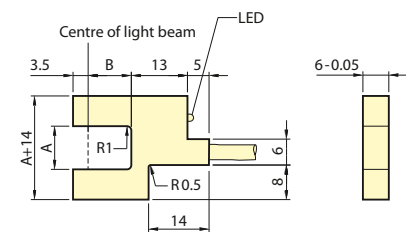

### Resolution

Fork width A [mm]:	5	10	20
Part diameter [mm]:	0.3	0.4	0.6

A [mm]:	5	10	10	10	20	20	20
B [mm]:	10	10	20	30	10	20	30

### Pin configuration

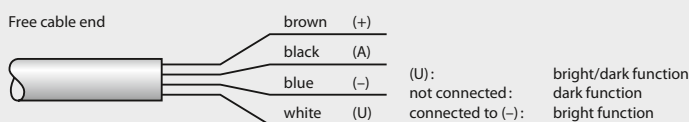

### Article

### Order No.

PMI- 5-10/P	6311-00000-0002
PMI-10-10/P	6312-00000-0002
PMI-10-20/P	6320-00000-0002
PMI-10-30/P	6317-00000-0002
PMI-20-10/P	6304-00000-0002
PMI-20-20/P	6324-00000-0002
PMI-20-30/P	6313-00000-0002

### Accessories (more accessories see chapter K11)

### Article

### Order No.

Mounting block for self-assembly!	
• AS10-U/4, 4-pin M12	2306-00000-1004
• AS10-U, 5-pin M16	2306-00000-1005

- ▶ Single-beam light barriers with integrated amplifier
- ▶ Infrared fork light barriers

## PMI 6 mm series

## with 4-pin connector M12

### Application

- Feed control
- Position control

### Specifications

Circuit	Constant light trigger
Operating voltage	12 – 30 VDC
Current consumption	max. 60 mA
Mode of operation	static
Output with LED	PNP
Function	bright / dark function
Load current	200 mA short-circuit proof
Repeating accuracy	< 0.02 mm
Frequency	1 KHz
Temperature range	0 °C – 60 °C
EMC according to 2004/108/EG	EN 61000... C E
System of protection	IP 65

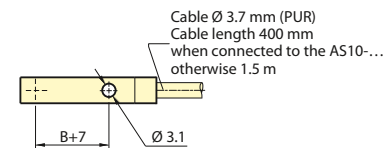
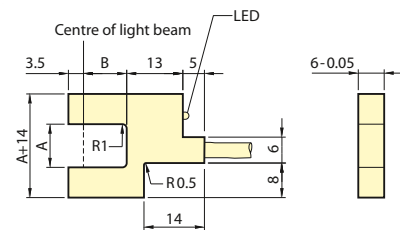

### Resolution

Fork width A [mm]:	5	10	20
Part diameter [mm]:	0.3	0.4	0.6

A [mm]:	5	10	10	10	20	20	20
B [mm]:	10	10	20	30	10	20	30

### Pin configuration

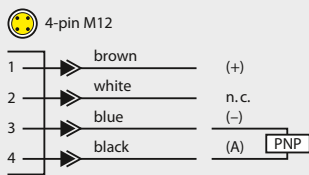

Article	Order No.
PMI- 5-10/AS10-U/4	6311-00000-1402
PMI-10-10/AS10-U/4	6312-00000-1402
PMI-10-20/AS10-U/4	6320-00000-1402
PMI-10-30/AS10-U/4	6317-00000-1402
PMI-20-10/AS10-U/4	6304-00000-1402
PMI-20-20/AS10-U/4	6324-00000-1402
PMI-20-30/AS10-U/4	6313-00000-1402

### Accessories (more accessories see chapter K11)

Article	Order No.
Connection cable 5 m:	
• VK-M12-5-g	2112-00005-0500
• VK-M12-5-w	2112-00005-1500
Extension cable 4-pin M12:	
• VK-M12-g/M12 (2 m)	2112-00002-0404
• VK-M12-g/M12 (5 m)	2112-00005-0404

### with mounting block AS10-U/4

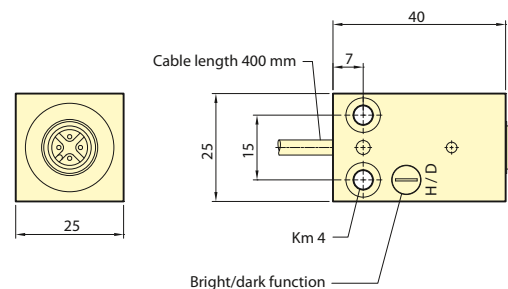

- ▶ Single-beam light barriers with integrated amplifier
- ▶ Infrared fork light barriers

## PMI 6 mm series

## with 5-pin connector M16

### Application

- Feed control
- Position control

### Specifications

Circuit	Constant light trigger
Operating voltage	12 – 30 VDC
Current consumption	max. 60 mA
Mode of operation	static
Output with LED	PNP
Function	bright / dark function
Load current	200 mA short-circuit proof
Repeating accuracy	< 0.02 mm
Frequency	1 KHz
Temperature range	0 °C – 60 °C
EMC according to 2004/108/EG	EN 61000... CEE
System of protection	IP 65

### Resolution

Fork width A [mm]:	5	10	20
Part diameter [mm]:	0.3	0.4	0.6

### Pin configuration

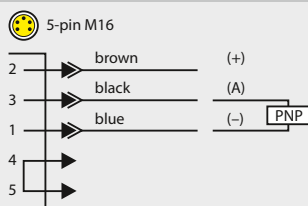

### Article

### Order No.

PMI- 5-10/AS10-U	6311-00000-1502
PMI-10-10/AS10-U	6312-00000-1502
PMI-10-20/AS10-U	6320-00000-1502
PMI-10-30/AS10-U	6317-00000-1502
PMI-20-10/AS10-U	6304-00000-1502
PMI-20-20/AS10-U	6324-00000-1502
PMI-20-30/AS10-U	6313-00000-1502

### Accessories (more accessories see chapter K11)

### Article

### Order No.

Connection cable (with free cable end):	
• VK-D/F-St-A (2 m)	2105-00002-0600
• VK-D/F-St-A (5 m)	2105-00005-0600
Extension cable 5/6-pin M16:	
• VK-D/D (2m)	2104-00002-0606
• VK-D/D (5m)	2104-00005-0606

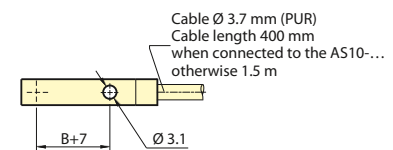
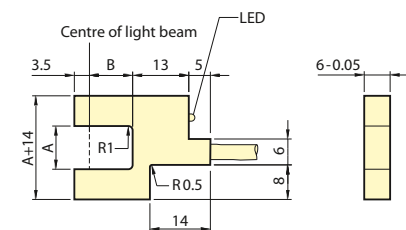
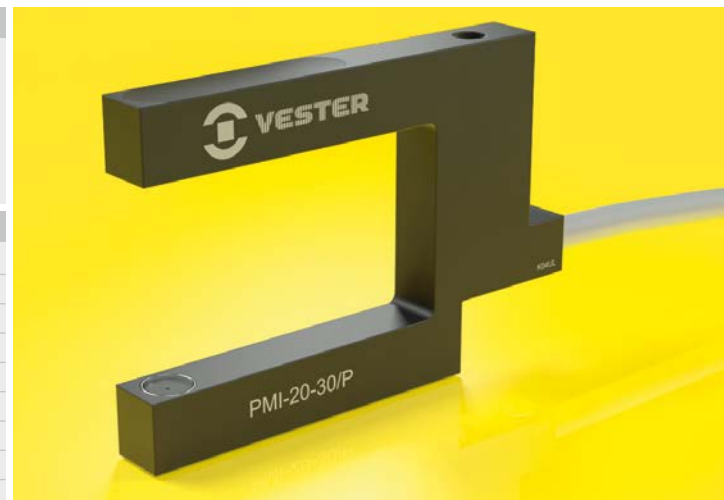

A [mm]:	5	10	10	10	20	20	20
B [mm]:	10	10	20	30	10	20	30

### with mounting block AS10-U

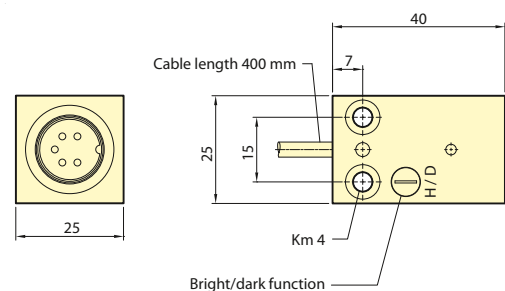

- ▶ Single-beam light barriers with integrated amplifier
- ▶ Infrared fork light barriers

## PDI 6 mm series

## with 3-pin connector M8

### Application

- Double sheet control

### Specifications

Circuit	Constant light trigger
Operating voltage	12 – 30 VDC
Current consumption	max. 60 mA
Mode of operation	static
Output with LED	PNP
Function	dark function
Load current	200 mA short-circuit proof
Repeating accuracy	< 0.02 mm
Frequency	1 KHz
Temperature range	0 °C – 60 °C
EMC according to 2004/108/EG	EN 61000... CE
System of protection	IP 65

### Resolution

Fork width A [mm]:	5
Part diameter [mm]:	0.3

### Pin configuration

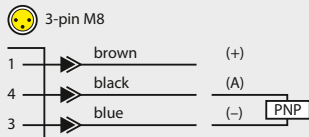

Article	Order No.
PDI-5-5/3-P	6327-00000-3002

### Accessories (more accessories see chapter K11)

Article	Order No.
Connection cable 5 m:	
• VK-M8-g	2111-00005-0300
• VK-M8-w	2111-00005-1300
Clamping plate:	
• KD-3	2203-00000-0000

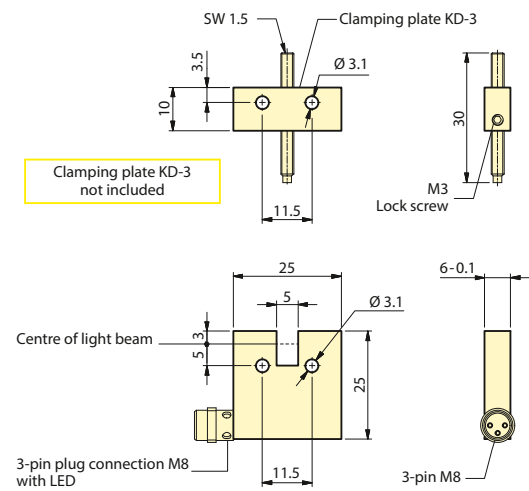



- ▶ Single-beam light barriers with integrated amplifier
- ▶ Infrared fork light barriers

## PDI 6 mm series

with free cable end 1.5 m

### Application

- Double sheet control

### Specifications

Circuit	Constant light trigger
Operating voltage	12 – 30 VDC
Current consumption	max. 60 mA
Mode of operation	static
Output with LED	PNP
Function	dark function <sup>1)</sup>
Load current	200 mA short-circuit proof
Repeating accuracy	< 0.02 mm
Frequency	1 KHz
Temperature range	0 °C – 60 °C
EMC according to 2004/108/EG	EN 61000... CEE
System of protection	IP 65

<sup>1)</sup> with accessory AS10-U/4 or AS10-U: external bright/dark function

### Resolution

Fork width A [mm]:	5
Part diameter [mm]:	0.3

### Pin configuration

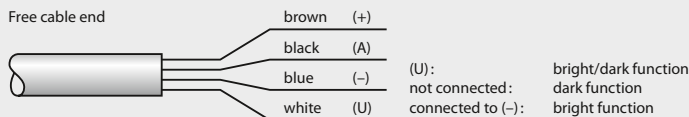

### Article

### Order No.

Fork light barrier with free cable end 1.5 m:	
• PDI-5-5/P	6327-00000-0002
Fork light barrier with mounting block:	
• PDI-5-5/AS10-U/4 (4-pin)	6327-00000-1402
• PDI-5-5/AS10-U (5-pin)	6327-00000-1502

### Accessories ( more accessories see chapter K11)

### Article

### Order No.

Mounting block for self-assembly!	
• AS10-U/4, 4-pin M12	2306-00000-1004
• AS10-U, 5-pin M16	2306-00000-1005
Clamping plate:	
• KD-3	2203-00000-0000

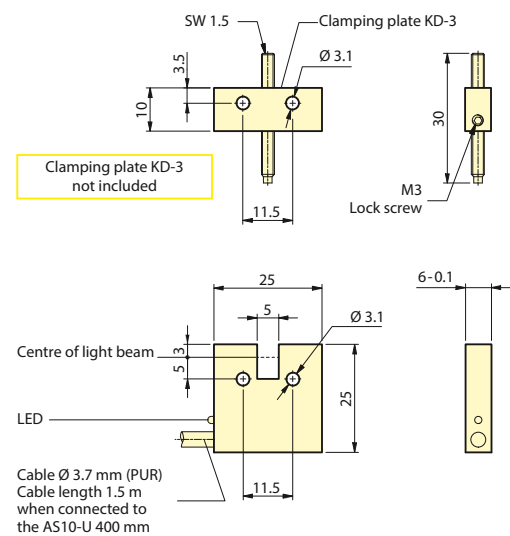

### Mounting block AS10-U/4

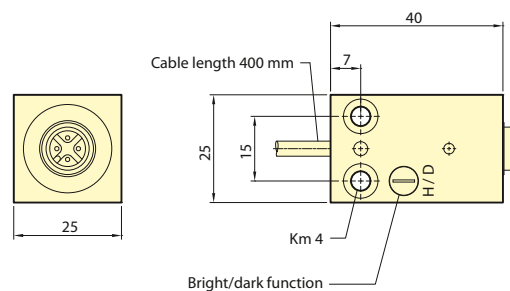

### Mounting block AS10-U

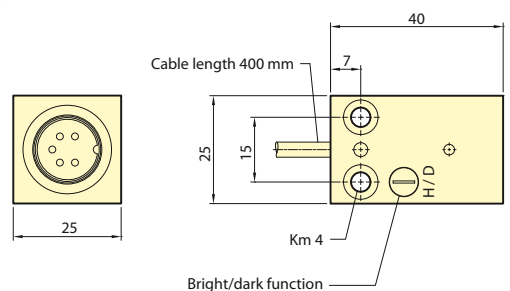

- ▶ Single-beam light barriers with integrated amplifier
- ▶ Infrared fork light barriers

## PXI series

## with 3-pin connector M8

### Application

- Double sheet control

### Specifications

Circuit	Constant light trigger
Operating voltage	12 – 30 VDC
Current consumption	max. 60 mA
Mode of operation	static
Output with LED	PNP
Function	bright / dark function
Load current	200 mA short-circuit proof
Repeating accuracy	< 0.02 mm
Frequency	1 KHz
Temperature range	0 °C – 60 °C
EMC according to 2004/108/EG	EN 61000... C E
System of protection	IP 65

### Resolution

Fork width A [mm]:	5
Part diameter [mm]:	0.3

### Pin configuration

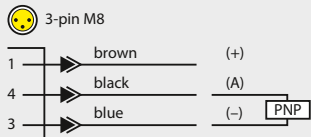

Article	Order No.
PXI-5-5/3-P	6327-00001-3002

### Accessories (more accessories see chapter K11)

Article	Order No.
Connection cable 5 m:	
• VK-M8-g	2111-00005-0300
• VK-M8-w	2111-00005-1300
Clamping plate:	
• KD-3	2203-00000-0000

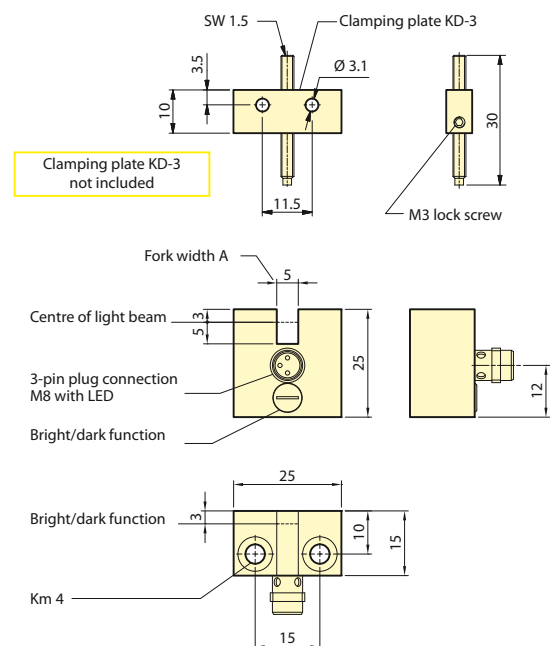

- ▶ Single-beam light barriers with integrated amplifier
- ▶ Infrared fork light barriers

## PSI 8 mm series

with 3-pin connector M8 | Constant light trigger

### Application

- Feed control
- Position control

### Specifications

Circuit	Constant light trigger
Operating voltage	12 – 30 VDC
Current consumption	max. 60 mA
Mode of operation	static
Output with LED	PNP
Function	bright / dark function
Load current	200 mA short-circuit proof
Repeating accuracy	< 0.02 mm
Frequency	1 KHz
Temperature range	0 °C – 60 °C
EMC according to 2004/108/EG	EN 61000... CEE
System of protection	IP 65

### Resolution

Fork width A [mm]:	10	20/25	30	40
Part diameter [mm]:	0.4	0.6	0.7	1.0

### Pin configuration

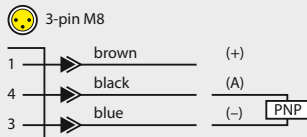

### Article

### Order No.

PSI-10-15/3-P	6331-00000-3002
PSI-10-30/3-P	6332-00000-3002
PSI-20-15/3-P	6333-00000-3002
PSI-20-30/3-P	6334-00000-3002
PSI-20-40/3-P	6351-00000-3002
PSI-20-60/3-P	6352-00000-3002
PSI-25-80/3-P	6360-00000-3002
PSI-30-15/3-P	6335-00000-3002
PSI-30-30/3-P	6336-00000-3002
PSI-30-40/3-P	6354-00000-3002
PSI-30-60/3-P	6355-00000-3002
PSI-40-40/3-P	6357-00000-3002
PSI-40-60/3-P	6358-00000-3002
PSI-40-80/3-P	6359-00000-3002

### Accessories (more accessories see chapter K11)

### Article

### Order No.

Connection cable 5 m:	
• VK-M8-g	2111-00005-0300
• VK-M8-w	2111-00005-1300

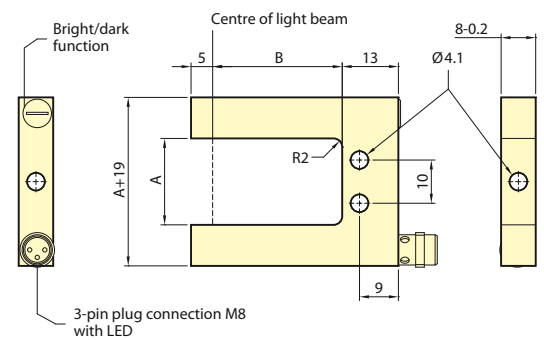

A [mm]:	10	10	20	20	20	20	25	30	30	30	30	30	40	40	40
B [mm]:	15	30	15	30	40	60	80	15	30	40	60	40	60	40	80

- ▶ Single-beam light barriers with integrated amplifier
- ▶ Infrared fork light barriers

## PSI 8 mm series

with 3-pin connector M8 | Chopped light trigger

### Application

- Feed control
- Position control

### Specifications

Circuit	Chopped light trigger
Operating voltage	12 – 30 VDC
Current consumption	max. 60 mA
Mode of operation	static
Output with LED	PNP
Function	bright / dark function
Load current	200 mA short-circuit proof
Repeating accuracy	< 0.02 mm
Frequency	4 KHz
Temperature range	0 °C – 60 °C
EMC according to 2004/108/EG	EN 61000... C E
System of protection	IP 65

### Resolution

Fork width A [mm]:	10	20 / 25	30 / 40
Part diameter [mm]:	0.2	0.3	0.4

### Pin configuration

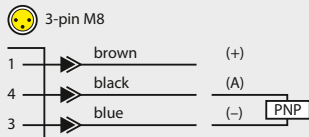

Article	Order No.
PSI-10-30/W-3-P	6332-00000-3022
PSI-20-30/W-3-P	6334-00000-3022
PSI-20-40/W-3-P	6351-00000-3022
PSI-20-60/W-3-P	6352-00000-3022
PSI-25-80/W-3-P	6360-00000-3022
PSI-30-30/W-3-P	6336-00000-3022
PSI-30-40/W-3-P	6354-00000-3022
PSI-30-60/W-3-P	6355-00000-3022
PSI-40-40/W-3-P	6357-00000-3022
PSI-40-60/W-3-P	6358-00000-3022
PSI-40-80/W-3-P	6359-00000-3022

### Accessories (more accessories see chapter K11)

Article	Order No.
Connection cable 5 m:	
• VK-M8-g	2111-00005-0300
• VK-M8-w	2111-00005-1300

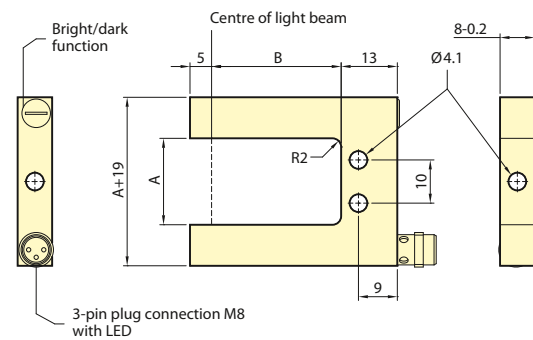

A [mm]:	10	20	20	20	25	30	30	30	40	40	40
B [mm]:	30	30	40	60	80	30	40	60	40	60	80



- ▶ Single-beam light barriers with integrated amplifier
- ▶ Infrared fork light barriers

## PKI 10 mm series

with 3-pin connector M8 | Fork width 10 to 20 mm

### Application

- Position control
- Parts counting in assembly lines

### Specifications

Circuit	Chopped light trigger
Operating voltage	12 – 30 VDC
Current consumption	max. 60 mA
Mode of operation	static
Sensitivity	2 levels : I / II
Output with LED	PNP
Function	bright / dark function
Load current	200 mA short-circuit proof
Repeating accuracy	< 0.02 mm
Frequency	4 KHz
Temperature range	0 °C – 60 °C
EMC according to 2004/108/EG	EN 61000... CE
System of protection	IP 65

### Resolution

Fork width A [mm]:	10 – 20
Part diameter [mm] with amplifier level I:	0.5
Part diameter [mm] with amplifier level II:	0.6

### Pin configuration

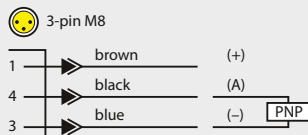

### Article

### Order No.

PKI-10/K/W-3-P2	6331-00000-3064
PKI-20/K/W-3-P2	6333-00001-3064

### Accessories (more accessories see chapter K11)

### Article

### Order No.

Connection cable 5 m:	
• VK-M8-g	2111-00005-0300
• VK-M8-w	2111-00005-1300

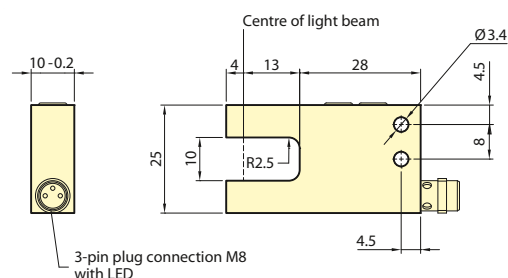

PKI-10/K/W-3-P2

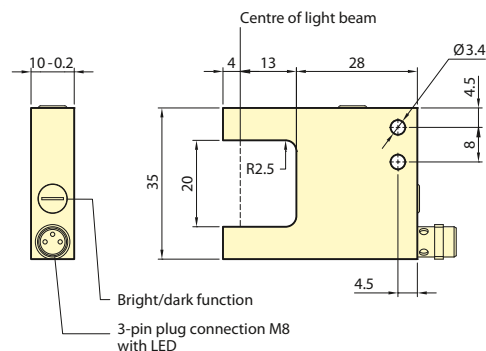
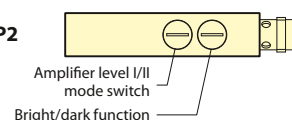

PKI-20/K/W-3-P2

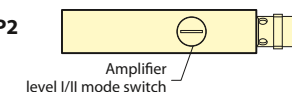

### Recommendations / instructions for the use of the dual-level chopped light amplifier:

- **Amplifier level I → High resolution:**  
Default setting for all fork light barriers
- **Amplifier level II → High operational reliability:**  
For fork light barriers when used in oil mist or dusty surroundings. The operational reliability is twice the level of amplifier level I.

- ▶ Single-beam light barriers with integrated amplifier
- ▶ Infrared fork light barriers

## PKI 10 mm series

with 3-pin connector M8 | Fork width 20 to 80 mm

### Application

- Position control
- Parts counting in assembly lines

### Specifications

Circuit	Chopped light trigger
Operating voltage	12 – 30 VDC
Current consumption	max. 60 mA
Mode of operation	static
Sensitivity	2 levels : I / II
Output with LED	PNP
Function	bright / dark function
Load current	200 mA short-circuit proof
Repeating accuracy	< 0.02 mm
Frequency	4 KHz
Temperature range	0 °C – 60 °C
EMC according to 2004/108/EG	EN 61000... C E
System of protection	IP 65

### Resolution

Fork width A [mm]:	20	30	50	80
Part diameter [mm] with amplifier level I:	0.5	0.6	0.8	0.9
Part diameter [mm] with amplifier level II:	0.6	0.8	0.9	1.1

### Pin configuration

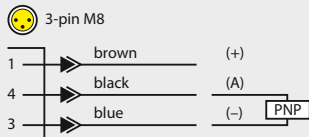

### Article

### Order No.

PKI-20/W-3-P2	6333-00000-3064
PKI-30/W-3-P2	6336-00000-3064
PKI-50/W-3-P2	6374-00000-3064
PKI-80/W-3-P2	6376-00000-3064

### Accessories (more accessories see chapter K11)

### Article

### Order No.

Connection cable 5 m:	
• VK-M8-g	2111-00005-0300
• VK-M8-w	2111-00005-1300



PKI-20/W-3-P2

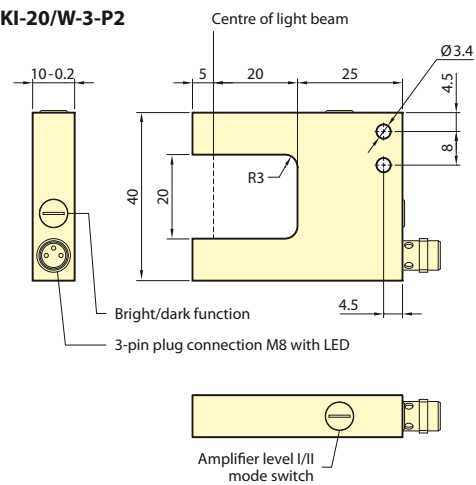

from PKI-30/W-3-P2

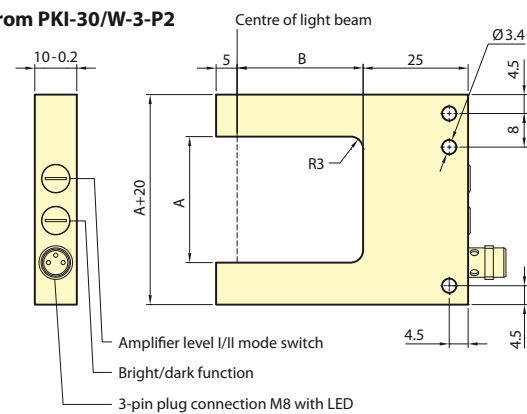

A [mm]: 30 50 80  
B [mm]: 30 50 50

### Recommendations / instructions for the use of the dual-level chopped light amplifier:

- **Amplifier level I → High resolution:**  
Default setting for all fork light barriers.
- **Amplifier level II → High operational reliability:**  
For fork light barriers when used in oil mist or dusty surroundings. The operational reliability is twice the level of amplifier level I.

- ▶ Single-beam light barriers with integrated amplifier
- ▶ Red light fork light barriers

## PSV 8 mm series

## with 3-pin connector M8

### Application

- Feed control
- Position control

### Specifications

Circuit	Chopped light trigger
Wavelength	650 nm, <b>red light</b>
Operating voltage	12 – 30 VDC
Current consumption	60 mA
Mode of operation	static
Output with LED	PNP
Function	bright / dark function
Load current	200 mA short-circuit proof
Repeating accuracy	< 0.02 mm
Frequency	4 KHz
Temperature range	0 °C – 60 °C
EMC according to 2004/108/EG	EN 61000... CEE
System of protection	IP 65

### Resolution

Fork width A [mm]:	10	20/25	30	40
Part diameter [mm]:	0.2	0.3	0.4	0.5

### Pin configuration

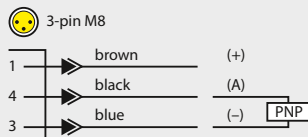

### Article

### Order No.

PSV-10-30/W-3-P	6332-00010-3022
PSV-20-30/W-3-P	6334-00010-3022
PSV-20-40/W-3-P	6351-00010-3022
PSV-20-60/W-3-P	6352-00010-3022
PSV-25-80/W-3-P	6360-00010-3022
PSV-30-30/W-3-P	6336-00010-3022
PSV-30-40/W-3-P	6354-00010-3022
PSV-30-60/W-3-P	6355-00010-3022
PSV-40-40/W-3-P	6357-00010-3022
PSV-40-60/W-3-P	6358-00010-3022
PSV-40-80/W-3-P	6359-00010-3022

### Accessories (more accessories see chapter K11)

### Article

### Order No.

Connection cable 5 m:	
• VK-M8-g	2111-00005-0300
• VK-M8-w	2111-00005-1300

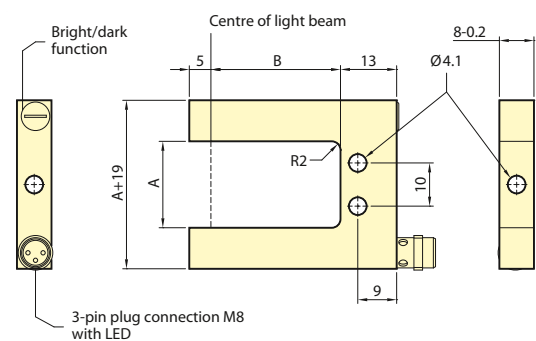

A [mm]:	10	20	20	20	25	30	30	30	40	40	40
B [mm]:	30	30	40	60	80	30	40	60	40	60	80

- ▶ Single-beam light barriers with integrated amplifier
- ▶ Laser fork light barriers

## PSL 8 mm series

with 3-pin connector M8

### Application

- Feed control
- Position control

### Specifications

Circuit	<b>Laser chopped light trigger</b>
Wavelength	650 nm, <b>red light</b>
Light beam diameter	0.2 mm
Laser output power	< 1 mW, laser class 2

#### Caution! Never look directly into laser beam!

Operating voltage	12 – 24 VDC
Current consumption	max. 30 mA
Mode of operation	static
Output with LED	PNP
Function	bright / dark function
Load current	200 mA short-circuit proof
Repeating accuracy	< 0.02 mm
Frequency	4 KHz
Temperature range	0 °C – 40 °C
EMC according to 2004/108/EG	EN 61000... CE
System of protection	IP 65



### Resolution

Fork width A [mm]:	10	20 / 30	40
Part diameter [mm]:	0.2	0.3	0.4

### Pin configuration

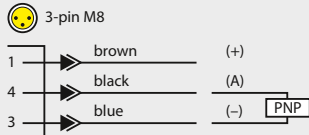

Article	Order No.
PSL-10-30/W-3-P	6532-00000-3022
PSL-20-30/W-3-P	6534-00000-3022
PSL-25-80/W-3-P	6560-00000-3022
PSL-30-30/W-3-P	6535-00000-3022
PSL-40-40/W-3-P	6557-00000-3022
PSL-40-80/W-3-P	6559-00000-3022

### Accessories (more accessories see chapter K11)

Article	Order No.
Connection cable shielded:	
• VK-M8-g-S (2 m)	2111-00902-0300
• VK-M8-g-S (5 m)	2111-00905-0300

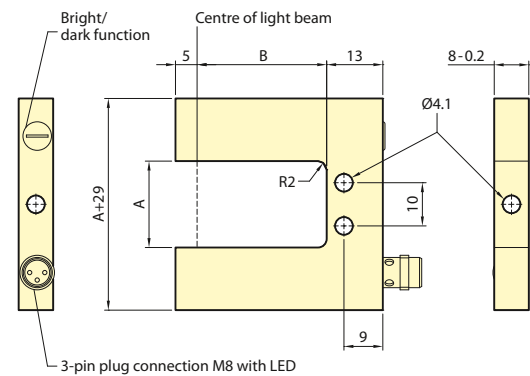

A [mm]:	10	20	25	30	40	40
B [mm]:	30	30	80	30	40	80



- ▶ Single-beam light barriers with integrated amplifier
- ▶ Laser fork light barriers

## PKL 10 mm series

with 3-pin connector M8

### Application

- Position control
- Parts counting in assembly lines

### Specifications

Circuit	Laser chopped light trigger
Wavelength	650 nm, <b>red light</b>
Light beam diameter	0.2 mm
Laser output power	< 1 mW, laser class 2

#### Caution! Never look directly into laser beam!

Operating voltage	12 – 24 VDC
Current consumption	max. 30 mA
Mode of operation	static
Output with LED	PNP
Function	bright / dark function
Load current	200 mA short-circuit proof
Repeating accuracy	< 0.02 mm
Frequency	4 KHz
Temperature range	0 °C – 40 °C
EMC according to 2004/108/EG	EN 61000... C€
System of protection	IP 65



### Resolution

Fork width A [mm]:	20	30	50	80	100
Part diameter [mm]:	0.3	0.3	0.4	0.5	0.7

### Pin configuration

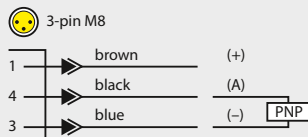

### Article

### Order No.

PKL-20/W-3-P	6533-00000-3064
PKL-30/W-3-P	6536-00000-3064
PKL-50/W-3-P	6574-00000-3064
PKL-80/W-3-P	6576-00000-3064
PKL-80-80/W-3-P	6549-00000-3064
PKL-100-100/W-3-P	6550-00000-3064

### Accessories (more accessories see chapter K11)

### Article

### Order No.

Connection cable shielded:	
• VK-M8-g-S (2 m)	2111-00902-0300
• VK-M8-g-S (5 m)	2111-00905-0300

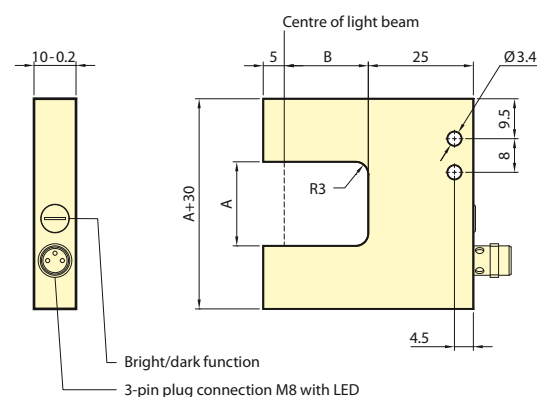

A [mm]:	20	30	50	80	80	100
B [mm]:	20	30	50	50	80	100

- ▶ Single-beam light barriers with integrated amplifier
- ▶ Split IR light barriers

## PGI series

## Flat housing, with 3-pin connector M8

### Application

- Feed control
- Position control
- Parts counting in assembly lines

### Specifications

Circuit	Chopped light trigger
Operating voltage	12 – 30 VDC
Current consumption	max. 60 mA
Mode of operation	static
Output with LED	PNP
Function	bright / dark function
Load current	200 mA short-circuit proof
Repeating accuracy	< 0.1 mm
Frequency	4 KHz
Temperature range	0 °C – 60 °C
EMC according to 2004/108/EG	EN 61000... CE
System of protection	IP 65

### Resolution

Max. distance A [mm]:	700
Part diameter [mm]:	> 1.4

### Pin configuration

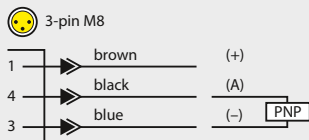

### Article

### Order No.

Split light barrier with separate transmitter and receiver:

- PGI/W-3-P 6450-00000-3022

### Accessories (more accessories see chapter K11)

### Article

### Order No.

Connection cable 5 m:

- VK-M8-g 2111-00005-0300
- VK-M8-w 2111-00005-1300

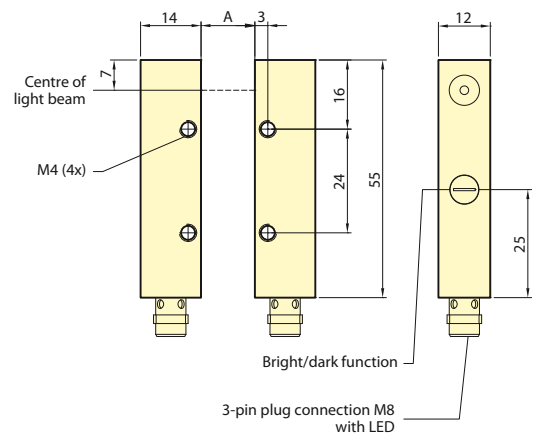

- ▶ Single-beam light barriers with integrated amplifier
- ▶▶ Split laser light barriers

## PGI-L series

## Flat housing, with 3-pin connector M8

### Application

- Feed control
- Position control
- Parts counting in assembly lines

### Specifications

Circuit	Laser constant light trigger
Wavelength	650 nm, red light
Light beam diameter	0.2 mm
Laser output power	< 1 mW, laser class 2

#### Caution! Never look directly into laser beam!

Operating voltage	12 – 24 VDC
Current consumption	max. 60 mA
Mode of operation	static
Output with LED	PNP
Function	bright / dark function
Load current	200 mA short-circuit proof
Repeating accuracy	< 0.02 mm
Frequency	1 KHz
Temperature range	0 °C – 40 °C
EMC according to 2004/108/EG	EN 61000... CEE
System of protection	IP 65



### Resolution

Max. distance A [mm]:	1000
Part diameter [mm]:	> 0.6

### Pin configuration

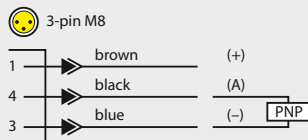

### Article

### Order No.

Split light barrier with separate transmitter and receiver:	
• PGI-L/3-P	6520-00000-3002

### Accessories ( more accessories see chapter K11)

### Article

### Order No.

Connection cable shielded:	
• VK-M8-g-S (2 m)	2111-00902-0300
• VK-M8-g-S (5 m)	2111-00905-0300

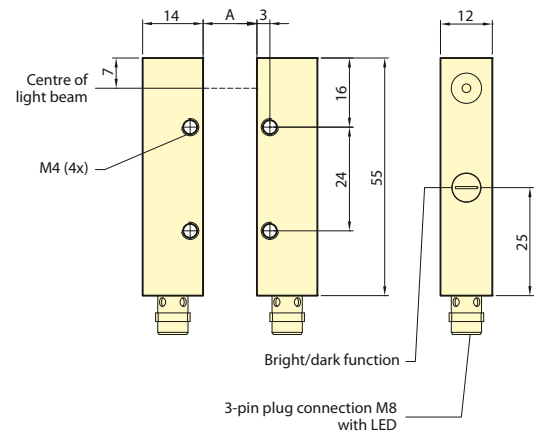





# Single-beam plug-in type light barriers – S2 with separate amplifier S2-...

The alternatives: amplifier and sensor types are interchangeable, high flexibility due to standardised miniature plug-in system S2.

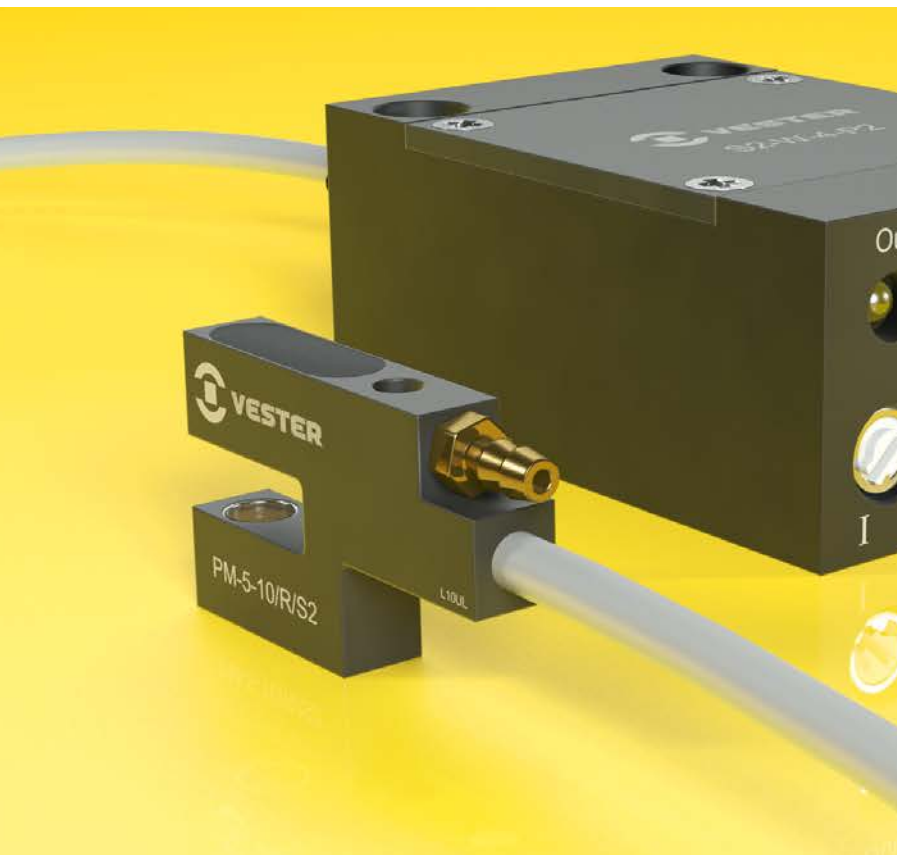

Infrared fork light barriers with cleaning nozzles



Dual-level chopped light amplifier



Split infrared light barriers



Split laser light barrier

- ▶ Single-beam plug-in type light barriers – S2 with separate amplifier S2-...
- ▶ Chopped light amplifier

## S2-W-4-P2

with 4-pin connector M12

### Application

- Amplifier for all plug-in type light barriers

### Specifications

Circuit	Chopped light trigger
Operating voltage	12 – 24 VDC
Current consumption	max. 60 mA
Mode of operation	static / dynamic <sup>1)</sup>
Pulse extension	max. 100 ms
Sensitivity	2 levels : I/II
Output with LED	PNP <sup>2)</sup>
Function	bright / dark function
Load current	200 mA short-circuit proof
Repeating accuracy	see sensor type
Frequency	4 KHz
Temperature range	0 °C – 60 °C
EMC according to 2004/108/EG	EN 61000... C E
System of protection	IP 64

<sup>1)</sup> switchable, default setting: static  
<sup>2)</sup> NPN amplifier on request

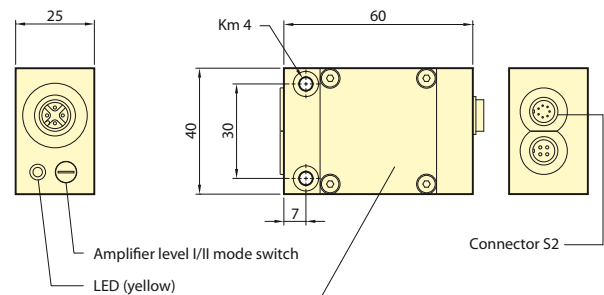

### Pin configuration

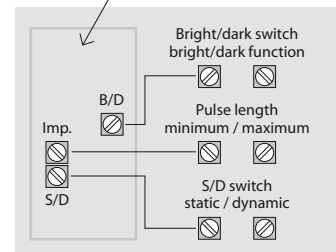
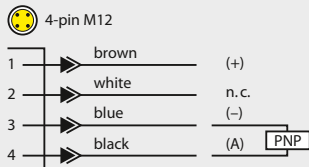

Article	Order No.
S2-W-4-P2	2000-00008-4064

### Accessories (more accessories see chapter K11)

Article	Order No.
Connection cable 5 m:	
• VK-M12-5-g	2112-00005-0500
• VK-M12-5-w	2112-00005-1500
Connection cable shielded (with free cable end) for split laser light barrier PGL-8-W-S2:	
• VK-M12-5-g-S (2 m)	2112-00902-0500
• VK-M12-5-g-S (5 m)	2112-00905-0500
Extension cable 4-pin M12:	
• VK-M12-g/M12 (2 m)	2112-00002-0404
• VK-M12-g/M12 (5 m)	2112-00005-0404

### Recommendations / instructions for the use of the dual-level chopped light amplifier:

- **Amplifier level I → High resolution:**  
Default setting for all fork light barriers as well as for split versions with small distances between transmitter and receiver.
- **Amplifier level II → High operational reliability:**  
Default setting for all split types in oil mist ambience or with large distances between transmitter and receiver ( $A_{max} > 50\%$ ).  
For PS-S2 series fork light barriers when used in oil mist ambience.  
The operational reliability is twice the level of amplifier level I.

- ▶ Single-beam plug-in type light barriers – S2 with separate amplifier S2-...
- ▶▶ Chopped light amplifier

## S2-W-5-P2

with 5-pin connector M16

### Application

- Amplifier for all plug-in type light barriers

### Specifications

Circuit	Chopped light trigger
Operating voltage	12 – 24 VDC
Current consumption	max. 60 mA
Mode of operation	static / dynamic <sup>1)</sup>
Pulse extension	max. 100 ms
Sensitivity	2 levels : I/II
Output with LED	PNP <sup>2)</sup>
Function	bright / dark function
Load current	200 mA short-circuit proof
Repeating accuracy	see sensor type
Frequency	4 KHz
Temperature range	0 °C – 60 °C
EMC according to 2004/108/EG	EN 61000... C E
System of protection	IP 64

<sup>1)</sup> switchable, default setting : static

<sup>2)</sup> NPN amplifier on request

### Pin configuration

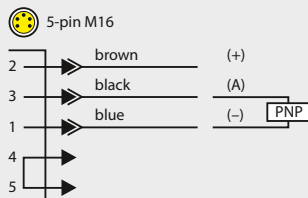

### Article

### Order No.

S2-W-5-P2                      2000-00008-0064

### Accessories ( more accessories see chapter K11)

### Article

### Order No.

Connection cable 5 m:	
• VK-D/F-St-A (2 m)	2105-00002-0600
• VK-D/F-St-A (5 m)	2105-00005-0600
Extension cable 5/6-pin M16:	
• VK-D/D (2 m)	2104-00002-0606
• VK-D/D (5 m)	2104-00005-0606

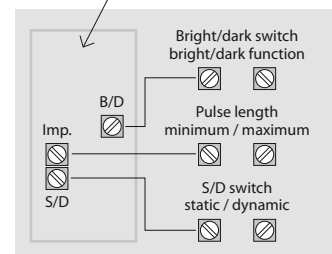
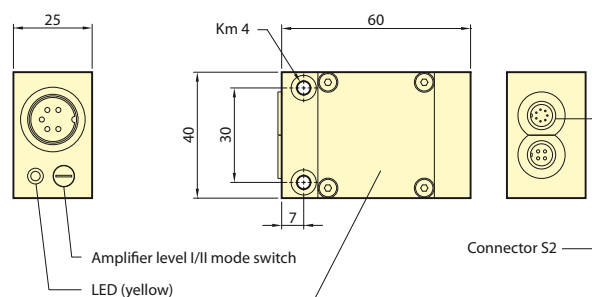

### Recommendations / instructions for the use of the dual-level chopped light amplifier:

- **Amplifier level I → High resolution:**  
Default setting for all fork light barriers as well as for split versions with small distances between transmitter and receiver.
- **Amplifier level II → High operational reliability:**  
Default setting for all split types in oil mist ambience or with large distances between transmitter and receiver ( $A_{max} > 50\%$ ).  
For PS-S2 series fork light barriers when used in oil mist ambience.  
The operational reliability is twice the level of amplifier level I.

- ▶ Single-beam plug-in type light barriers – S2 with separate amplifier S2-...
- ▶▶ Dynamic pulse amplifier

## S2-D-4-P

with 4-pin connector M12

### Application

- Amplifier for all plug-in type infrared light barriers

### Specifications

Circuit	Constant light pulse amplifier
Operating voltage	12 – 24 VDC
Current consumption	90 mA
Mode of operation	dynamic
Pulse extension	1 – 100 ms
Output with LED	PNP <sup>1)</sup>
Function	bright / dark function
Load current	200 mA short-circuit proof
Repeating accuracy	see sensor type
Frequency	max. 1 KHz
Temperature range	0 °C – 60 °C
EMC according to 2004/108/EG	EN 61000... C E
System of protection	IP 64

<sup>1)</sup> NPN amplifier on request

### Pin configuration

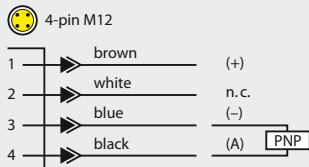

Article	Order No.
S2-D-4-P	2000-00008-4024

### Accessories (more accessories see chapter K11)

Article	Order No.
Connection cable 5 m:	
• VK-M12-5-g	2112-00005-0500
• VK-M12-5-w	2112-00005-1500
Extension cable 4-pin M12:	
• VK-M12-g/M12 (2 m)	2112-00002-0404
• VK-M12-g/M12 (5 m)	2112-00005-0404

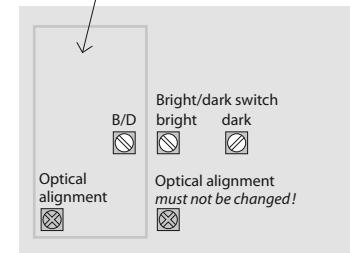
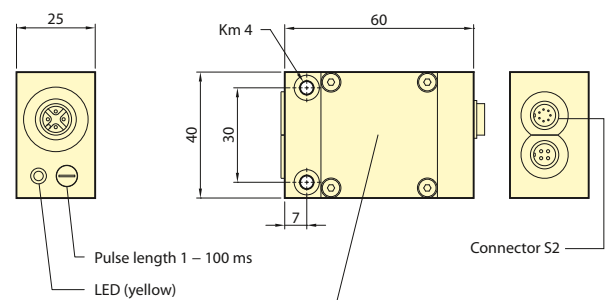

- ▶ Single-beam plug-in type light barriers – S2 with separate amplifier S2-...
- ▶▶ Dynamic pulse amplifier

## S2-D-5-P

with 5-pin connector M16

### Application

- Amplifier for all plug-in type infrared light barriers

### Specifications

Circuit	Constant light pulse amplifier
Operating voltage	12 – 24 VDC
Current consumption	90 mA
Mode of operation	dynamic
Pulse extension	1 – 100 ms
Output with LED	PNP <sup>1)</sup>
Function	bright / dark function
Load current	200 mA short-circuit proof
Repeating accuracy	see sensor type
Frequency	max. 1 KHz
Temperature range	0 °C – 60 °C
EMC according to 2004/108/EG	EN 61000... CEE
System of protection	IP 64

<sup>1)</sup> NPN amplifier on request

### Pin configuration

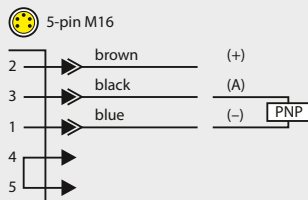

### Article

### Order No.

S2-D-5-P 2000-00008-0024

### Accessories (more accessories see chapter K11)

### Article

### Order No.

Connection cable 5 m:	
• VK-D/F-St-A (2 m)	2105-00002-0600
• VK-D/F-St-A (5 m)	2105-00005-0600
Extension cable 5/6-pin M16:	
• VK-D/D (2 m)	2104-00002-0606
• VK-D/D (5 m)	2104-00005-0606

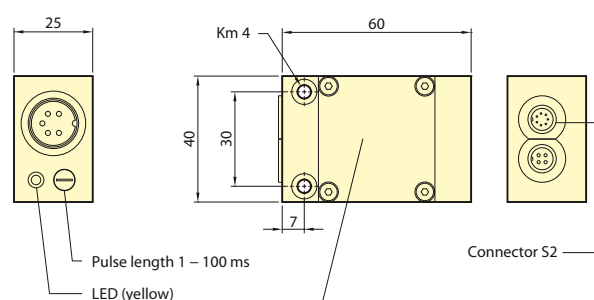

Pulse length 1 – 100 ms  
LED (yellow)

Connector S2

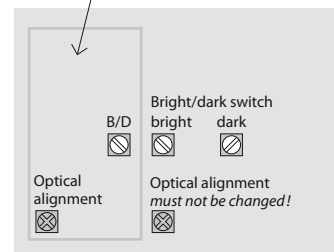

- ▶ Single-beam plug-in type light barriers – S2 with separate amplifier S2-...
- ▶ Infrared fork light barriers

## PM-S2 6 mm series

## with 7-pin connector S2

### Application

- Feed control
- Position control

### Specifications

Repeating accuracy	< 0.01 mm
Temperature range	0 °C – 60 °C
EMC according to 2004/108/EG	EN 61000... CE
System of protection (for plug-in amplifier types S2-...)	IP 64

### Resolution

Fork width A [mm] :	5	10	20
Part diameter [mm] :			
• with chopped light amplifier, amplifier level I	0.3	0.4	0.5
• with pulse amplifier	0.1	0.1	0.1

### Article Order No.

Fork light barrier (without amplifier) :	
• PM- 5-10/S2	6011-00006-0000
• PM-10-10/S2	6012-00006-0000
• PM-10-20/S2	6020-00006-0000
• PM-10-30/S2	6017-00006-0000
• PM-20-30/S2	6013-00006-0000
Fork light barrier with cleaning nozzles R :	
• PM- 5-10/R/S2	6011-40006-0000
• PM-10-10/R/S2	6012-40006-0000
• PM-10-20/R/S2	6020-40006-0000
• PM-10-30/R/S2	6017-40006-0000
• PM-20-30/R/S2	6013-40006-0000

### Accessories (more accessories see chapter K11)

Amplifier 4-pin M12 :	
• S2-W-4-P2	2000-00008-4064
• S2-D-4-P	2000-00008-4024
Amplifier 5-pin M16 :	
• S2-W-5-P2	2000-00008-0064
• S2-D-5-P	2000-00008-0024
Mounting block :	
• AS2	2300-00000-0002
Extension cable :	
• VK-S2/7 (1 m)	2115-00001-0707

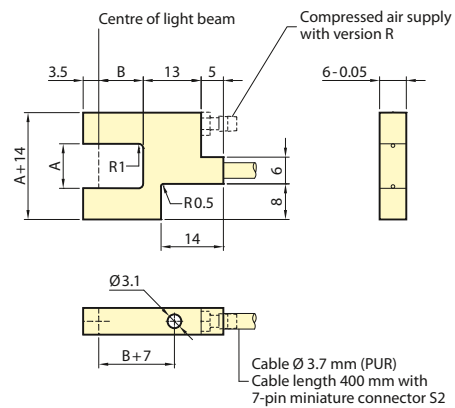

A [mm] :	5	10	10	10	20
B [mm] :	10	10	20	30	30



- ▶ Single-beam plug-in type light barriers – S2 with separate amplifier S2-...
- ▶ Infrared fork light barriers

## PE-S2 6 mm series

## with 7-pin connector S2

### Application

- Feed control
- Position control

### Specifications

Repeating accuracy	< 0.01 mm
Temperature range	0 °C – 60 °C
EMC according to 2004/108/EG	EN 61000... CE
System of protection (for plug-in amplifier types S2-...)	IP 64

### Resolution

Fork width A [mm] :	5	10	20	30
Part diameter [mm]:				
• with chopped light amplifier, amplifier level I	> 0.4	> 0.5	> 0.8	> 1.0
• with pulse amplifier	0.1	0.1	0.1	0.1

### Article

### Order No.

Fork light barrier (without amplifier) :

• PE-5-5/S2	6027-06006-0000
• PE-5-10/S2	6028-06006-0000
• PE-10-10/S2	6029-06006-0000
• PE-10-30/S2	6032-06006-0000
• PE-20-30/S2	6034-06006-0000
• PE-30-30/S2	6036-06006-0000

### Accessories (more accessories see chapter K11)

### Article

### Order No.

Amplifier 4-pin M12:

• S2-W-4-P2	2000-00008-4064
• S2-D-4-P	2000-00008-4024

Amplifier 5-pin M16:

• S2-W-5-P2	2000-00008-0064
• S2-D-5-P	2000-00008-0024

Mounting block:

• AS2	2300-00000-0002
-------	-----------------

Extension cable:

• VK-S2/7 (1 m)	2115-00001-0707
-----------------	-----------------



### Up to PE-10-30/S2:

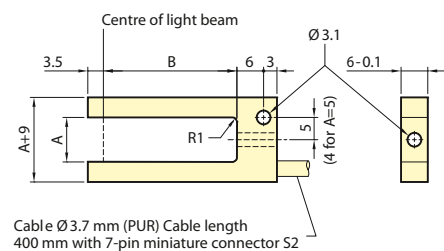

### PE-20-30/S2 and PE-30-30/S2:

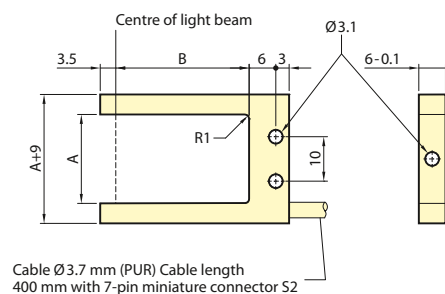

A [mm] :	5	5	10	10	20	30
B [mm] :	5	10	10	30	30	30

- ▶ Single-beam plug-in type light barriers – S2 with separate amplifier S2-...
- ▶ Infrared fork light barriers

## PS-S2 8 mm series

## with 7-pin connector S2

### Application

- Feed control
- Position control

### Specifications

Repeating accuracy	< 0.01 mm
Temperature range	0 °C – 60 °C
EMC according to 2004/108/EG	EN 61000... CE
System of protection (for plug-in amplifier types S2-...)	IP 64



### Resolution

Fork width A [mm] :	10	20	30	40
Part diameter [mm] :				
• with chopped light amplifier, amplifier level I	> 0.3	> 0.4	> 0.5	> 0.8
• with chopped light amplifier, amplifier level II	> 0.4	> 0.6	> 0.8	> 1.0
• with pulse amplifier	0.1	0.1	0.1	0.1

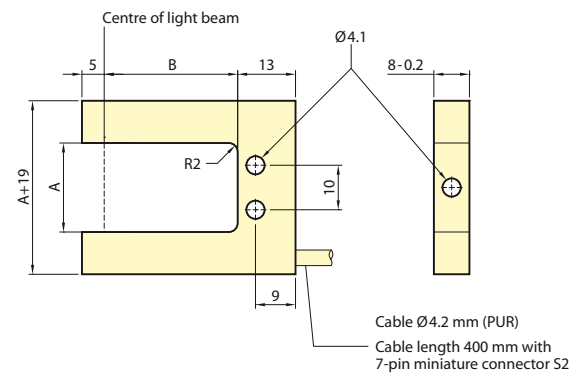

A [mm] :	10	10	20	20	20	20	30	30	30	30	40
B [mm] :	15	30	15	30	40	60	15	30	40	60	40

### Article

### Order No.

Fork light barrier (without amplifier) :

• PS-10-15/S2	6331-00006-0000
• PS-10-30/S2	6332-00006-0000
• PS-20-15/S2	6333-00006-0000
• PS-20-30/S2	6334-00006-0000
• PS-20-40/S2	6351-00006-0000
• PS-20-60/S2	6352-00006-0000
• PS-30-15/S2	6335-00006-0000
• PS-30-30/S2	6336-00006-0000
• PS-30-40/S2	6354-00006-0000
• PS-30-60/S2	6355-00006-0000
• PS-40-40/S2	6357-00006-0000

### Accessories (more accessories see chapter K11)

### Article

### Order No.

Amplifier 4-pin M12:

• S2-W-4-P2	2000-00008-4064
• S2-D-4-P	2000-00008-4024

Amplifier 5-pin M16:

• S2-W-5-P2	2000-00008-0064
• S2-D-5-P	2000-00008-0024

Mounting block:

• AS2	2300-00000-0002
-------	-----------------

Extension cable:

• VK-S2/7 (1 m)	2115-00001-0707
-----------------	-----------------

### Recommendations / instructions for the use of the dual-level chopped light amplifier:

- **Amplifier level I → High resolution:**  
Default setting for all fork light barriers!
- **Amplifier level II → High operational reliability:**  
For PS-S2 series fork light barriers when used in oil mist ambience.  
The operational reliability is twice the level of amplifier level I.

- ▶ Single-beam plug-in type light barriers – S2 with separate amplifier S2-...
- ▶ Infrared fork light barriers

## PS-S2 8 mm series

with cleaning nozzles | with 7-pin connector S2

### Application

- Feed control
- Position control

### Specifications

Repeating accuracy	< 0.01 mm
Temperature range	0 °C – 60 °C
EMC according to 2004/108/EG	EN 61000... CĒ
System of protection (for plug-in amplifier types S2-...)	IP 64

### Resolution

Fork width A [mm]:	10	20	30	40
Part diameter [mm]:				
• with chopped light amplifier, amplifier level I	> 0.3	> 0.4	> 0.5	> 0.8
• with chopped light amplifier, amplifier level II	> 0.4	> 0.6	> 0.8	> 1.0
• with pulse amplifier	0.1	0.1	0.1	0.1

### Article

### Order No.

Fork light barrier (without amplifier) **with cleaning nozzles**:

• PS-10-15/R/S2	6331-10006-0000
• PS-10-30/R/S2	6332-10006-0000
• PS-20-15/R/S2	6333-10006-0000
• PS-20-30/R/S2	6334-10006-0000
• PS-20-40/R/S2	6351-10006-0000
• PS-20-60/R/S2	6352-10006-0000
• PS-30-15/R/S2	6335-10006-0000
• PS-30-30/R/S2	6336-10006-0000
• PS-30-40/R/S2	6354-10006-0000
• PS-30-60/R/S2	6355-10006-0000
• PS-40-40/R/S2	6357-10006-0000

### Accessories (more accessories see chapter K11)

### Article

### Order No.

Amplifier 4-pin M12:	
• S2-W-4-P2	2000-00008-4064
• S2-D-4-P	2000-00008-4024
Amplifier 5-pin M16:	
• S2-W-5-P2	2000-00008-0064
• S2-D-5-P	2000-00008-0024
Mounting block:	
• AS2	2300-00000-0002
Extension cable:	
• VK-S2/7 (1 m)	2115-00001-0707

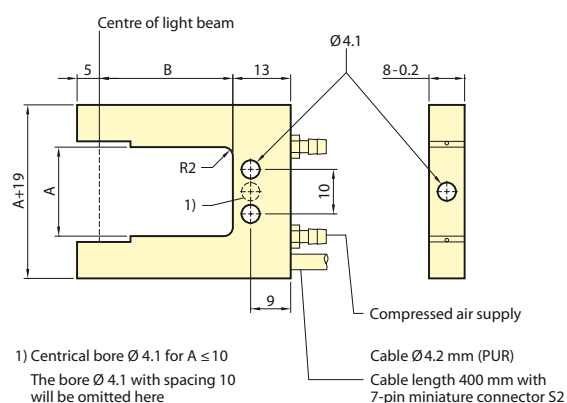

A [mm]:	10	10	20	20	20	20	30	30	30	30	40
B [mm]:	15	30	15	30	40	60	15	30	40	60	40

### Recommendations / instructions for the use of the dual-level chopped light amplifier:

- **Amplifier level I → High resolution:**  
Default setting for all fork light barriers!
- **Amplifier level II → High operational reliability:**  
For PS-S2 series fork light barriers when used in oil mist ambiance.  
The operational reliability is twice the level of amplifier level I.

- ▶ Single-beam plug-in type light barriers – S2 with separate amplifier S2-...
- ▶ Split infrared light barriers

## PG-S2 series

## Cylinder housing 4 mm / M5 | with 4/7-pin connector S2

### Application

- Feed control
- Position control
- Parts counting in assembly lines

### Specifications

Repeating accuracy	< 0.02 mm
Temperature range	0 °C – 60 °C
EMC according to 2004/108/EG	EN 61000... C E
System of protection (for plug-in amplifier types S2-...)	IP 64

### Resolution

Distance A [mm] :	25	125	250
Part diameter [mm] :			
• with chopped light amplifier, amplifier level I	> 0.9	> 0.4	–
• with chopped light amplifier, amplifier level II	> 1.2	> 0.8	> 0.5
• with pulse amplifier	0.1	0.1	0.5

### Article

### Order No.

Split light barrier (without amplifier):

• PG-4-S2	6404-00000-0000
• PG-M5-S2	6410-00000-0000

### Accessories (more accessories see chapter K11)

### Article

### Order No.

Amplifier 4-pin M12:

• S2-W-4-P2	2000-00008-4064
• S2-D-4-P	2000-00008-4024

Amplifier 5-pin M16:

• S2-W-5-P2	2000-00008-0064
• S2-D-5-P	2000-00008-0024

Mounting block:

• AS2	2300-00000-0002
-------	-----------------

Extension cable:

• VK-S2/7 (1 m)	2115-00001-0707
• VK-S2/4 (1 m)	2115-00001-0404

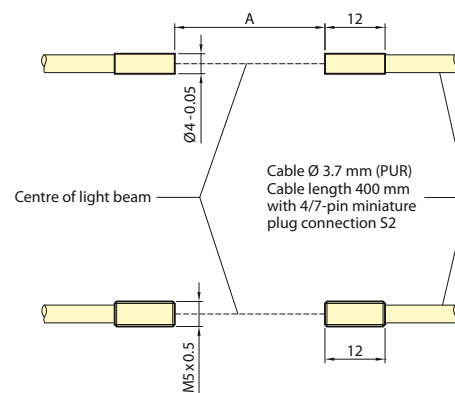

### Recommendations / instructions for the use of the dual-level chopped light amplifier:

- **Amplifier level I → High resolution:**  
Default setting for all split-type versions with small distances between transmitter and receiver, i.e. for  $A_{max} < 50\%$  !
- **Amplifier level II → High operational reliability:**  
Default setting for all split-type versions when used in oil mist surroundings or with large distances between transmitter and receiver ( $A_{max} > 50\%$ ).  
The operational reliability is twice the level of amplifier level I.

- ▶ Single-beam plug-in type light barriers – S2 with separate amplifier S2-...
- ▶▶ Split infrared light barriers

## PG-S2 series

## Cylinder housing 6 mm / M5 | with 4/7-pin connector S2

### Application

- Feed control
- Position control
- Parts counting in assembly lines

### Specifications

Repeating accuracy	< 0.02 mm
Temperature range	0 °C – 60 °C
EMC according to 2004/108/EG	EN 61000... CEE
System of protection (for plug-in amplifier types S2-...)	IP 64

### Resolution

Distance A [mm]:	100	500	1000
Part diameter [mm]:			
• with chopped light amplifier, amplifier level I	> 2.2	> 1.5	–
• with chopped light amplifier, amplifier level II	> 3.0	> 2.0	> 1.5
• with pulse amplifier	0.2	0.2	0.2

### Article

### Order No.

Split light barrier (without amplifier):	
• PG-6-S2	6414-00000-0000
• PG-M8-S2	6418-00000-0000

### Accessories (more accessories see chapter K11)

### Article

### Order No.

Amplifier 4-pin M12:	
• S2-W-4-P2	2000-00008-4064
• S2-D-4-P	2000-00008-4024
Amplifier 5-pin M16:	
• S2-W-5-P2	2000-00008-0064
• S2-D-5-P	2000-00008-0024
Mounting block:	
• AS2	2300-00000-0002
Extension cable:	
• VK-S2/7 (1 m)	2115-00001-0707
• VK-S2/4 (1 m)	2115-00001-0404

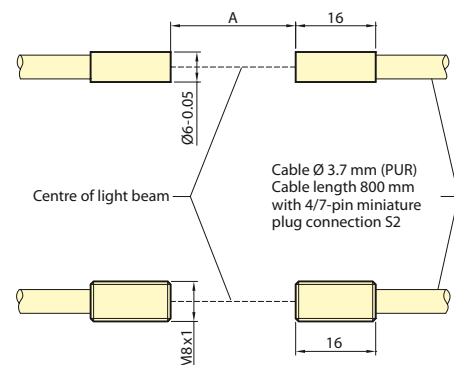

### Recommendations / instructions for the use of the dual-level chopped light amplifier:

- **Amplifier level I → High resolution:**  
Default setting for all split-type versions with small distances between transmitter and receiver, i.e. for  $A_{max} < 50\%$  !
- **Amplifier level II → High operational reliability:**  
Default setting for all split-type versions when used in oil mist surroundings or with large distances between transmitter and receiver ( $A_{max} > 50\%$ ).  
The operational reliability is twice the level of amplifier level I.

- ▶ Single-beam plug-in type light barriers – S2 with separate amplifier S2-...
- ▶ Split infrared light barriers

## PG-S2 series

## Flat housing F1 | with 4/7-pin connector S2

### Application

- Feed control
- Position control
- Parts counting in assembly lines

### Specifications

Repeating accuracy	< 0.02 mm
Temperature range	0 °C – 60 °C
EMC according to 2004/108/EG	EN 61000... CE
System of protection (for plug-in amplifier types S2-...)	IP 64

### Resolution

Distance A [mm] :	100	500	1000
Part diameter [mm] :			
• with chopped light amplifier, amplifier level I	> 2.2	> 1.5	–
• with chopped light amplifier, amplifier level II	> 3.0	> 2.0	> 1.5
• with pulse amplifier	0.2	0.2	0.2

### Article Order No.

Split light barrier (without amplifier):	
• PG-F1-S2	6424-00000-0000

### Accessories (more accessories see chapter K11)

Article	Order No.
Amplifier 4-pin M12:	
• S2-W-4-P2	2000-00008-4064
• S2-D-4-P	2000-00008-4024
Amplifier 5-pin M16:	
• S2-W-5-P2	2000-00008-0064
• S2-D-5-P	2000-00008-0024
Mounting block:	
• AS2	2300-00000-0002
Extension cable:	
• VK-S2/7 (1 m)	2115-00001-0707
• VK-S2/4 (1 m)	2115-00001-0404

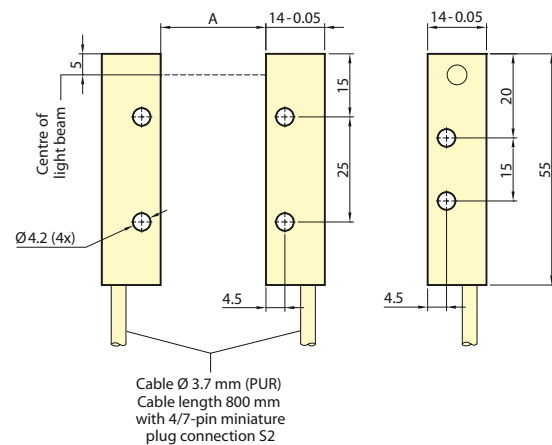
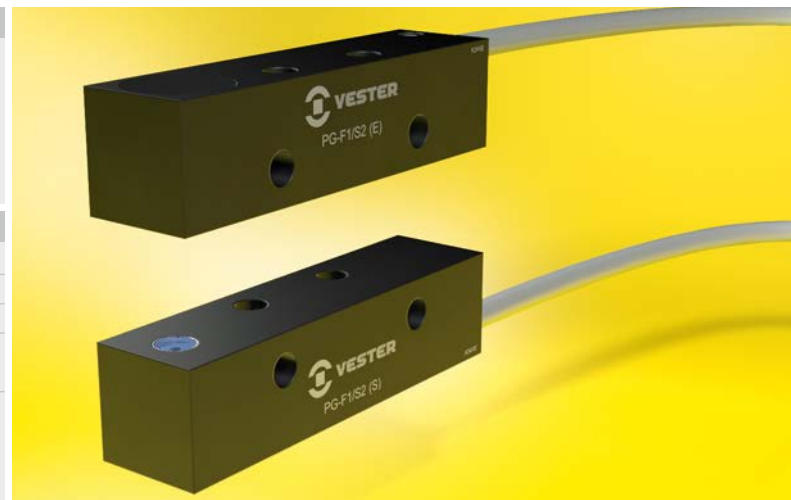

### Recommendations / instructions for the use of the dual-level chopped light amplifier :

- **Amplifier level I → High resolution:**  
Default setting for all split-type versions with small distances between transmitter and receiver, i.e. for  $A_{max} < 50\%$  !
- **Amplifier level II → High operational reliability:**  
Default setting for all split-type versions when used in oil mist surroundings or with large distances between transmitter and receiver ( $A_{max} > 50\%$  ).  
The operational reliability is twice the level of amplifier level I.



- ▶ Single-beam plug-in type light barriers – S2 with separate amplifier S2-...
- ▶▶ Split infrared light barriers

**PG-S2 series**
**Flat housing F2 | with 4/7-pin connector S2**
**Application**

- Feed control
- Position control
- Parts counting in assembly lines

**Specifications**

Repeating accuracy	< 0.02 mm
Temperature range	0 °C – 60 °C
EMC according to 2004/108/EG	EN 61000... C€
System of protection (for plug-in amplifier types S2-...)	IP 64

**Resolution**

Distance A [mm] :	25	125	250
Part diameter [mm] :			
• with chopped light amplifier, amplifier level I	> 0.9	> 0.4	–
• with chopped light amplifier, amplifier level II	> 1.2	> 0.8	> 0.5
• with pulse amplifier	0.1	0.1	0.5

**Article**
**Order No.**

Split light barrier (without amplifier) :	
• PG-F2-S2	6434-00000-0000

**Accessories** (more accessories see chapter K11)

**Article**
**Order No.**

Amplifier 4-pin M12:	
• S2-W-4-P2	2000-00008-4064
• S2-D-4-P	2000-00008-4024
Amplifier 5-pin M16:	
• S2-W-5-P2	2000-00008-0064
• S2-D-5-P	2000-00008-0024
Mounting block:	
• AS2	2300-00000-0002
Extension cable:	
• VK-S2/7 (1 m)	2115-00001-0707
• VK-S2/4 (1 m)	2115-00001-0404

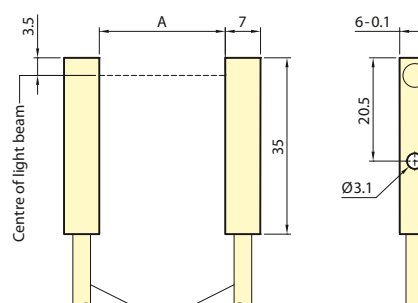

Cable Ø 3.7 mm (PUR)  
Cable length 400 mm  
with 4/7-pin miniature  
plug connection S2

**Recommendations / instructions for the use of the dual-level chopped light amplifier:**

- **Amplifier level I → High resolution:**  
Default setting for all split-type versions with small distances between transmitter and receiver, i.e. for  $A_{max} < 50\%$  !
- **Amplifier level II → High operational reliability:**  
Default setting for all split-type versions when used in oil mist surroundings or with large distances between transmitter and receiver ( $A_{max} > 50\%$ ). The operational reliability is twice the level of amplifier level I.

- ▶ Single-beam plug-in type light barriers – S2 with separate amplifier S2-...
- ▶ Split infrared light barriers

## PGL-S2 series

Cylinder housing 8 mm | laser | with 4/7-pin connector S2

### Application

- Feed control
- Position control
- Parts counting in assembly lines

### Specifications

Wavelength	650 nm, red light
Light beam diameter	0.2 mm
Laser output power	< 1 mW, laser class 2

### Caution! Never look directly into laser beam!

Repeating accuracy	< 0.02 mm
Temperature range	0 °C – 40 °C
EMC	EN 61000... C E
System of protection (for plug-in amplifier types S2-...)	IP 64

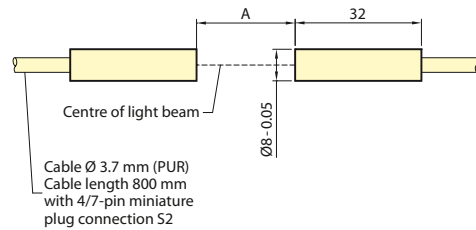

### Resolution

Distance A [mm]:	250	500	1000
Part diameter [mm]:			
• with chopped light amplifier, amplifier level I	> 0.8	> 0.8	> 0.8
• with chopped light amplifier, amplifier level II	> 1.0	> 1.2	> 1.4

### Adjustment device JEL-8

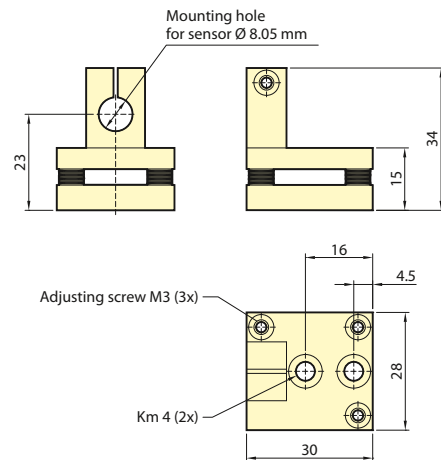

Article	Order No.
Split light barrier (without amplifier):	
• PGL-8-W-S2	6509-00006-0000

### Accessories (more accessories see chapter K11)

Article	Order No.
Amplifier 4-pin M12:	
• S2-W-4-P2	2000-00008-4064
Amplifier 5-pin M16:	
• S2-W-5-P2	2000-00008-0064
Mounting block:	
• AS2	2300-00000-0002
Extension cable:	
• VK-S2/7 (1 m)	2115-00001-0707
• VK-S2/4 (1 m)	2115-00001-0404
Adjustment device:	
• JEL-8	2300-00000-0008

### Recommendations / instructions for the use of the dual-level chopped light amplifier:

- **Amplifier level I → High resolution!**
- **Amplifier level II → High operational reliability:**  
The operational reliability is twice the level of amplifier level I.

## Single-beam light barriers with separate amplifier

Split single-beam infrared and laser light barriers:

Transmitter or receiver modules are permanently connected to the respective amplifier.

Split infrared light barriers ...

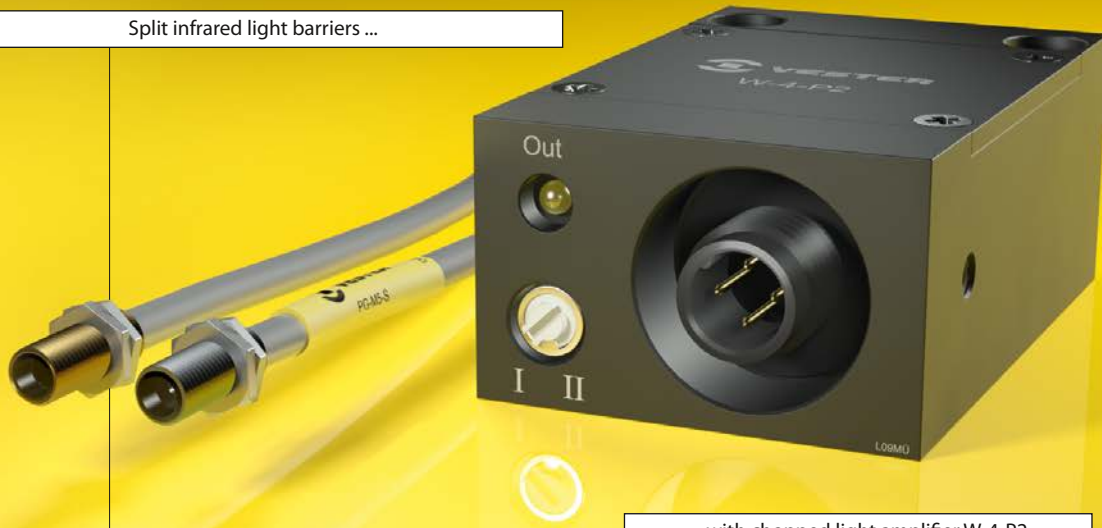

... with chopped light amplifier W-4-P2



... with pulse amplifier D-5-P

Split laser light barrier ...



... with chopped light amplifier W-5-P2

- ▶ Single-beam light barriers with separate amplifier
- ▶ Chopped light amplifiers

## W-4-P2 | W-5-P2

with 4-pin connector M12 or 5-pin connector M16

### Application

- For all split light barriers of the PG and PGL series with a separate amplifier

### Specifications

Circuit	Chopped light trigger
Operating voltage	12 – 24 VDC
Current consumption	max. 60 mA
Mode of operation	static / dynamic <sup>1)</sup>
Pulse extension	max. 100 ms
Sensitivity	2 levels: I/II
Output with LED	PNP <sup>2)</sup>
Function	bright / dark function
Load current	200 mA short-circuit proof
Repeating accuracy	see sensor type
Frequency	4 KHz
Temperature range	0 °C – 60 °C
EMC according to 2004/108/EG	EN 61000... C E
System of protection	IP 65

<sup>1)</sup> switchable, default setting: static  
<sup>2)</sup> NPN amplifier on request

### Pin configuration

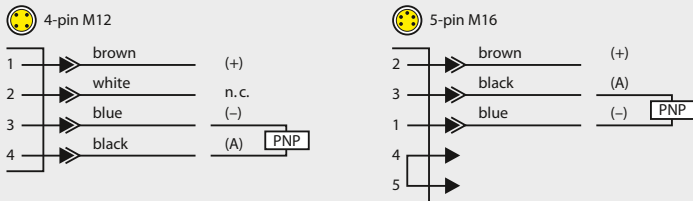

#### W-4-P2:

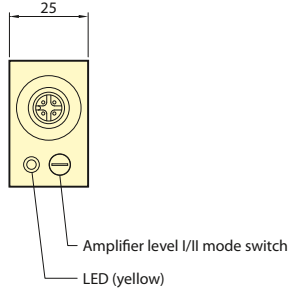

#### W-5-P2:

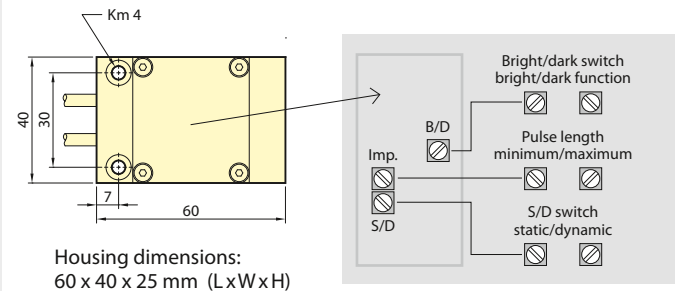
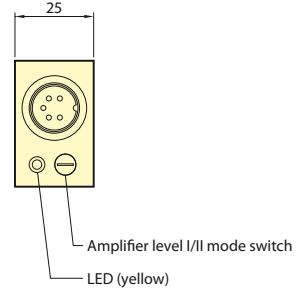

Housing dimensions:  
60 x 40 x 25 mm (L x W x H)

### Recommendations / instructions for the use of the dual-level chopped light amplifier:

- **Amplifier level I → High resolution:**  
Default setting for all split-type versions with small distances between transmitter and receiver, i.e. for  $A_{max} < 50\%$  !
- **Amplifier level II → High operational reliability:**  
Default setting for all split-type versions when used in oil mist surroundings or with large distances between transmitter and receiver ( $A_{max} > 50\%$ ).  
The operational reliability is twice the level of amplifier level I.



- ▶ Single-beam light barriers with separate amplifier
- ▶▶ Dynamic pulse amplifier

## D-4-P | D-5-P

with 4-pin connector M12 or 5-pin connector M16

### Application

- For all split light barriers of the PG series with a separate amplifier

### Specifications

Circuit	Constant light pulse amplifier
Operating voltage	12 – 24 VDC
Current consumption	90 mA
Mode of operation	dynamic
Pulse extension	1 – 100 ms
Output with LED	PNP <sup>1)</sup>
Function	bright / dark function
Load current	200 mA short-circuit proof
Repeating accuracy	see sensor type
Frequency	max. 1 KHz
Temperature range	0 °C – 60 °C
EMC according to 2004/108/EG	EN 61000... CEE
System of protection	IP 65

<sup>1)</sup> NPN amplifier on request

### Pin configuration

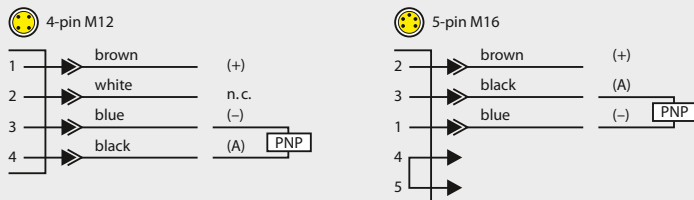

D-4-P:

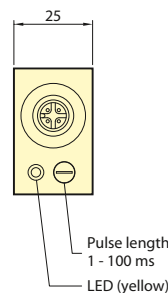

D-5-P:

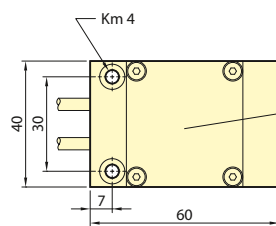
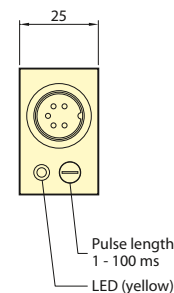

Housing dimensions:  
60 x 40 x 25 mm (LxWxH)

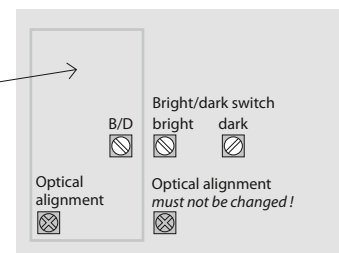

- ▶ Single-beam light barriers with separate amplifier
- ▶▶ Split infrared fork light barriers

## PG series

## Cylinder housing 4 mm / M5

### Application

- Feed control
- Position control
- Parts counting in assembly lines

### Specifications

Repeating accuracy	< 0.02 mm
Temperature range	0 °C – 60 °C
EMC according to 2004/108/EG	EN 61000... CE
System of protection	IP 65

### Resolution

Distance A [mm] :	25	125	250
Part diameter [mm] :			
• with chopped light amplifier, amplifier level I	>0.9	>0.4	–
• with chopped light amplifier, amplifier level II	>1.2	>0.8	>0.5
• with pulse amplifier	0.1	0.1	0.5

### Article

### Order No.

Split light barrier – with 4-pin connector:

• PG-4/W-4-P2	6401-00000-4064
• PG-M5/W-4-P2	6407-00000-4064
• PG-4/D-4-P	6401-00000-4024
• PG-M5/D-4-P	6407-00000-4024

Split light barrier – with 5-pin connector:

• PG-4/W-5-P2	6401-00000-0064
• PG-M5/W-5-P2	6407-00000-0064
• PG-4/D-5-P	6401-00000-0024
• PG-M5/D-5-P	6407-00000-0024

### Accessories 4-pin amplifier (more accessories see chapter K11)

### Article

### Order No.

Connection cable, length 5 m:

• VK-M12-5-g	2112-00005-0500
• VK-M12-5-w	2112-00005-1500

Extension cable 4-pin M12:

• VK-M12-g/M12 (2 m)	2112-00002-0404
• VK-M12-g/M12 (5 m)	2112-00005-0404

### Accessories 5-pin amplifier (more accessories see chapter K11)

### Article

### Order No.

Connection cable shielded (with free cable end):

• VK-D/F-St-A (2 m)	2105-00002-0600
• VK-D/F-St-A (5 m)	2105-00005-0600

Extension cable 5/6-pin M16:

• VK-D/D (2 m)	2104-00002-0606
• VK-D/D (5 m)	2104-00005-0606

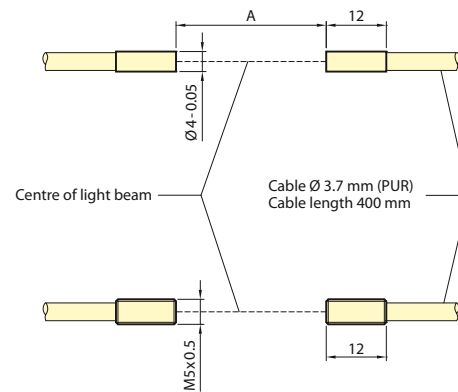

### Recommendations / instructions for the use of the dual-level chopped light amplifier:

#### • Amplifier level I → High resolution:

Default setting for all split-type versions with small distances between transmitter and receiver, i.e. for  $A_{\max} < 50\%$  !

#### • Amplifier level II → High operational reliability:

Default setting for all split-type versions when used in oil mist surroundings or with large distances between transmitter and receiver ( $A_{\max} > 50\%$  ).  
The operational reliability is twice the level of amplifier level I.



- ▶ Single-beam light barriers with separate amplifier
- ▶▶ Split infrared fork light barriers

## PG series

## Cylinder housing 6 mm / M8

### Application

- Feed control
- Position control
- Counting of ultra small parts

### Specifications

Repeating accuracy	< 0.02 mm
Temperature range	0 °C – 60 °C
EMC according to 2004/108/EG	EN 61000... C E
System of protection	IP 65

### Resolution

Distance A [mm] :	100	500	1000
Part diameter [mm]:			
• with chopped light amplifier, amplifier level I	> 2.2	> 1.5	–
• with chopped light amplifier, amplifier level II	> 3.0	> 2.0	> 1.5
• with pulse amplifier	0.2	0.2	0.2

### Article

### Order No.

Split light barrier – with 4-pin connector:

• PG-6/W-4-P2	6411-00000-4064
• PG-M8/W-4-P2	6415-00000-4064
• PG-6/D-4-P	6411-00000-4024
• PG-M8/D-4-P	6415-00000-4024

Split light barrier – with 5-pin connector:

• PG-6/W-5-P2	6411-00000-0064
• PG-M8/W-5-P2	6415-00000-0064
• PG-6/D-5-P	6411-00000-0024
• PG-M8/D-5-P	6415-00000-0024

### Accessories 4-pin amplifier (more accessories see chapter K11)

### Article

### Order No.

Connection cable, length 5 m:

• VK-M12-5-g	2112-00005-0500
• VK-M12-5-w	2112-00005-1500

Extension cable 4-pin M12:

• VK-M12-g/M12 (2 m)	2112-00002-0404
• VK-M12-g/M12 (5 m)	2112-00005-0404

### Accessories 5-pin amplifier (more accessories see chapter K11)

### Article

### Order No.

Connection cable shielded (with free cable end):

• VK-D/F-St-A (2 m)	2105-00002-0600
• VK-D/F-St-A (5 m)	2105-00005-0600

Extension cable 5/6-pin M16:

• VK-D/D (2 m)	2104-00002-0606
• VK-D/D (5 m)	2104-00005-0606

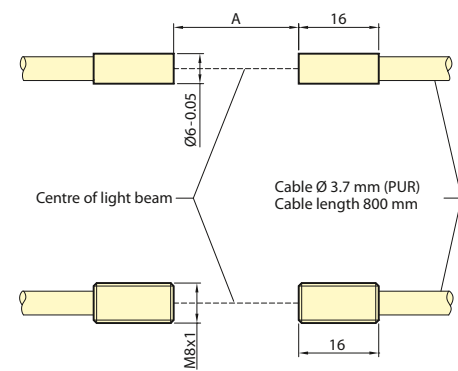

### Recommendations / instructions for the use of the dual-level chopped light amplifier:

- **Amplifier level I → High resolution:**  
Default setting for all split-type versions with small distances between transmitter and receiver, i.e. for  $A_{max} < 50\%$  !
- **Amplifier level II → High operational reliability:**  
Default setting for all split-type versions when used in oil mist surroundings or with large distances between transmitter and receiver ( $A_{max} > 50\%$ ).  
The operational reliability is twice the level of amplifier level I.

- ▶ Single-beam light barriers with separate amplifier
- ▶ Split infrared fork light barriers

## PG series

## Flat housing F1

### Application

- Feed control
- Position control
- Parts counting in assembly lines

### Specifications

Repeating accuracy	< 0.02 mm
Temperature range	0 °C – 60 °C
EMC according to 2004/108/EG	EN 61000... C E
System of protection	IP 65

### Resolution

Distance A [mm] :	100	500	1000
Part diameter [mm] :			
• with chopped light amplifier, amplifier level I	> 2.2	> 1.5	–
• with chopped light amplifier, amplifier level II	> 3.0	> 2.0	> 1.5
• with pulse amplifier	0.2	0.2	0.2

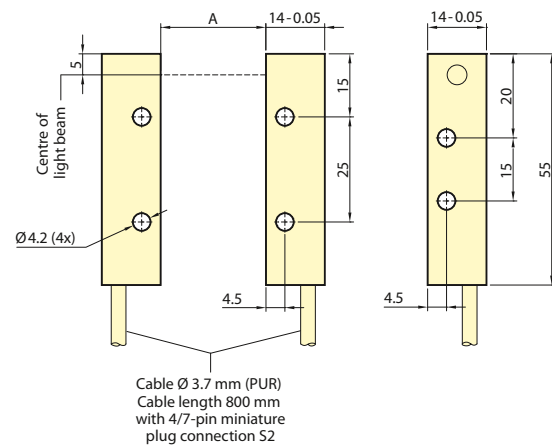

### Article Order No.

#### Split light barrier – with 4-pin connector:

• PG-F1/W-4-P2	6421-00000-4064
• PG-F1/D-4-P	6421-00000-4024

#### Split light barrier – with 5-pin connector:

• PG-F1/W-5-P2	6421-00000-0064
• PG-F1/D-5-P	6421-00000-0024

### Accessories 4-pin amplifier (more accessories see chapter K11)

#### Article Order No.

##### Connection cable, length 5 m:

• VK-M12-5-g	2112-00005-0500
• VK-M12-5-w	2112-00005-1500

##### Extension cable 4-pin M12:

• VK-M12-g/M12 (2 m)	2112-00002-0404
• VK-M12-g/M12 (5 m)	2112-00005-0404

### Accessories 5-pin amplifier (more accessories see chapter K11)

#### Article Order No.

##### Connection cable shielded (with free cable end):

• VK-D/F-St-A (2 m)	2105-00002-0600
• VK-D/F-St-A (5 m)	2105-00005-0600

##### Extension cable 5/6-pin M16:

• VK-D/D (2 m)	2104-00002-0606
• VK-D/D (5 m)	2104-00005-0606

### Recommendations / instructions for the use of the dual-level chopped light amplifier:

#### • Amplifier level I → High resolution:

Default setting for all split-type versions with small distances between transmitter and receiver, i.e. for  $A_{max} < 50\%$  !

#### • Amplifier level II → High operational reliability:

Default setting for all split-type versions when used in oil mist surroundings or with large distances between transmitter and receiver ( $A_{max} > 50\%$ ).

The operational reliability is twice the level of amplifier level I.

- ▶ Single-beam light barriers with separate amplifier
- ▶▶ Split infrared fork light barriers

## PG series

## Flat housing F2

### Application

- Feed control
- Position control
- Parts counting in assembly lines

### Specifications

Repeating accuracy	< 0.02 mm
Temperature range	0 °C – 60 °C
EMC according to 2004/108/EG	EN 61000... CĈ
System of protection	IP 65

### Resolution

Distance A [mm] :	25	125	250
Part diameter [mm]:			
• with chopped light amplifier, amplifier level I	> 0.9	> 0.4	–
• with chopped light amplifier, amplifier level II	> 1.2	> 0.8	> 0.5
• with pulse amplifier	0.1	0.1	0.5

### Article

### Order No.

Split light barrier – with 4-pin connector:

• PG-F2/W-4-P2	6431-00000-4064
• PG-F2/D-4-P	6431-00000-4024

Split light barrier – with 5-pin connector:

• PG-F2/W-5-P2	6431-00000-0064
• PG-F2/D-5-P	6431-00000-0024

### Accessories 4-pin amplifier (more accessories see chapter K11)

### Article

### Order No.

Connection cable, length 5 m:

• VK-M12-5-g	2112-00005-0500
• VK-M12-5-w	2112-00005-1500

Extension cable 4-pin M12:

• VK-M12-g/M12 (2 m)	2112-00002-0404
• VK-M12-g/M12 (5 m)	2112-00005-0404

### Accessories

### Article

### Order No.

Connection cable shielded (with free cable end):

• VK-D/F-St-A (2 m)	2105-00002-0600
• VK-D/F-St-A (5 m)	2105-00005-0600

Extension cable 5/6-pin M16:

• VK-D/D (2 m)	2104-00002-0606
• VK-D/D (5 m)	2104-00005-0606

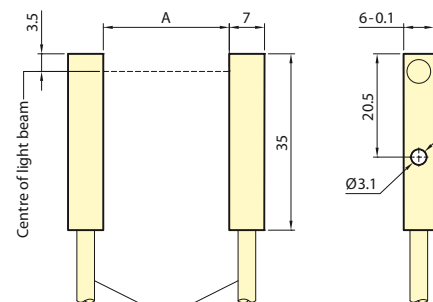

Cable Ø 3.7 mm (PUR)  
Cable length 400 mm  
with 4/7-pin miniature  
plug connection S2

### Recommendations / instructions for the use of the dual-level chopped light amplifier:

- **Amplifier level I → High resolution:**  
Default setting for all split-type versions with small distances between transmitter and receiver, i.e. for  $A_{max} < 50\%$  !
- **Amplifier level II → High operational reliability:**  
Default setting for all split-type versions when used in oil mist surroundings or with large distances between transmitter and receiver ( $A_{max} > 50\%$  ).  
The operational reliability is twice the level of amplifier level I.

- ▶ Single-beam light barriers with separate amplifier
- ▶ Split laser light barriers

## PGL series

## Cylinder housing 8 mm | laser

### Application

- Feed control
- Position control
- Parts counting in assembly lines



### Specifications

Wavelength	650 nm, red light
Light beam diameter	0.2 mm
Laser output power	< 1 mW, laser class 2

### Caution! Never look directly into laser beam!

Repeating accuracy	< 0.02 mm
Temperature range	0 °C – 40 °C
EMC	EN 61000... CEE
System of protection	IP 65

### Resolution

Distance A [mm]:	250	500	1000
Part diameter [mm]:			
• with chopped light amplifier, amplifier level I	> 0.8	> 0.8	> 0.8
• with chopped light amplifier, amplifier level II	> 1.0	> 1.2	> 1.4

### Article Order No.

Split light barrier – with 4-pin connector M12:

- PGL-8-W/W-4-P2 6509-00000-4064

Split light barrier – with 5-pin connector M16:

- PGL-8-W/W-5-P2 6509-00000-5064

### Accessories 4-pin amplifier (more accessories see chapter K11)

#### Article Order No.

Connection cable, length 5 m:

- VK-M12-g-5-S (2 m) 2112-00902-0500
- VK-M12-g-5-S (5 m) 2112-00905-0500

Extension cable 4-pin M12:

- VK-M12-g/M12 (2 m) 2112-00002-0404
- VK-M12-g/M12 (5 m) 2112-00005-0404

### Accessories 5-pin amplifier (more accessories see chapter K11)

#### Article Order No.

Connection cable shielded (with free cable end):

- VK-D/F-St-A (2 m) 2105-00002-0600
- VK-D/F-St-A (5 m) 2105-00005-0600

Extension cable 5/6-pin M16:

- VK-D/D (2 m) 2104-00002-0606
- VK-D/D (5 m) 2104-00005-0606

### Other accessories

#### Article Order No.

Adjustment device:

- JEL-8 2300-00000-0008

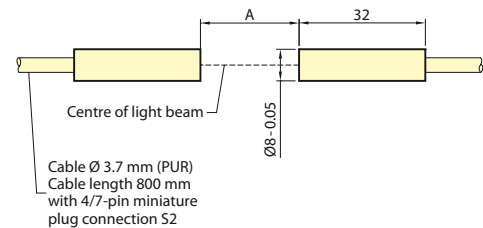

### Adjustment device JEL-8

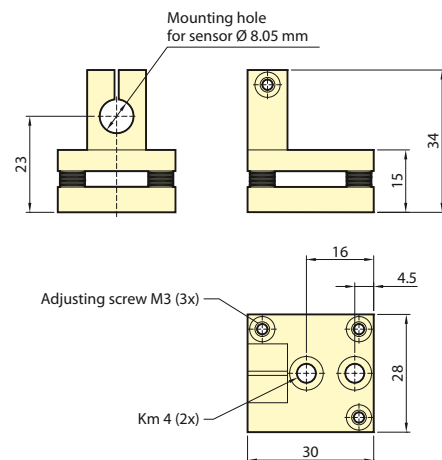

### Recommendations / instructions for the use of the dual-level chopped light amplifier:

- **Amplifier level I → High resolution!**
- **Amplifier level II → High operational reliability:**  
The operational reliability is twice the level of amplifier level I.

## Dual-beam light barriers

Our special models: for special applications – when more than just counting is required.  
Dual-beam light barriers with directional operation.



Infrared light barriers with optional cleaning nozzles

### Operating modes

- Bright function with direction recognition
- Dark function with direction recognition
- Bright function w/o direction recognition\*
- Dark function w/o direction recognition

Operating mode	1	2	3	4
Direction of movement			→ ←	→ ←
Receiver I				
Receiver II				
A1				
A2				

\*) Default value on delivery



Compact red light dual-beam light barriers with integrated amplifier



- ▶ Dual-beam light barriers
- ▶ Infrared fork light barriers with separate amplifier

## PZ 8 mm series

with 4-pin connector M12

### Application

- Forward/backward recognition (with counter)
- e.g. for applications in selective electroplating

### Specifications

Circuit	2 x constant light trigger
Operating voltage	12 – 24 VDC
Current consumption	< 40 mA
Mode of operation	static
Output 1 and 2 with LED	PNP
Function	bright / dark function with direction recognition
see <i>operating modes table</i>	
Load current	200 mA short-circuit proof
Repeating accuracy	< 0.01 mm
Frequency	3 KHz
Temperature range	0 °C – 50 °C
EMC according to 2004/108/EG	EN 61000... C E
System of protection	IP 65

### Resolution

Fork width A [mm] :	10	20 / 25	30 / 40
Part diameter [mm] :	0.4	0.8	1.2

### Pin configuration

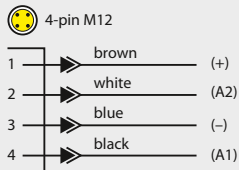

### Phase shift

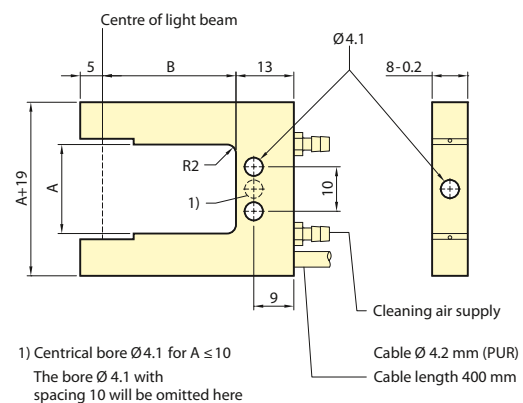
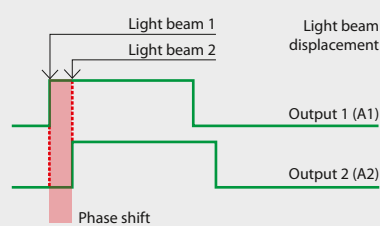

A [mm] :	10	10	20	20	20	20	25
B [mm] :	15	30	15	30	40	60	80

### Article

Fork light barrier:

• PZ-10-15/2-P2-M12	6231-00000-4182
• PZ-10-30/2-P2-M12	6232-00000-4182
• PZ-20-15/2-P2-M12	6233-00000-4182
• PZ-20-30/2-P2-M12	6234-00000-4182
• PZ-20-40/2-P2-M12	6251-00000-4182
• PZ-20-60/2-P2-M12	6252-00000-4182
• PZ-25-80/2-P2-M12	6260-00000-4182

Fork light barrier with cleaning nozzles R:

• PZ-10-15/R/2-P2-M12	6231-10000-4182
• PZ-10-30/R/2-P2-M12	6232-10000-4182
• PZ-20-15/R/2-P2-M12	6233-10000-4182
• PZ-20-30/R/2-P2-M12	6234-10000-4182
• PZ-20-40/R/2-P2-M12	6251-10000-4182
• PZ-20-60/R/2-P2-M12	6252-10000-4182
• PZ-25-80/R/2-P2-M12	6260-10000-4182

### Accessories (more accessories see chapter K11)

#### Article

#### Order No.

Connection cable 5 m (with free cable end):

• VK-M12-5-g	2112-00005-0500
• VK-M12-5-w	2112-00005-1500

### Constant light amplifier 2-P2

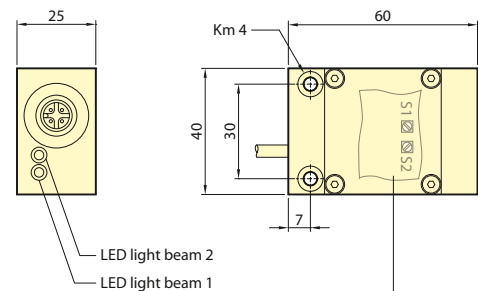

Housing dimensions (L x W x H):  
60 x 40 x 25 mm

### Operating modes

S1	S2	Modi	
⊗	⊗	1	Dark function w/o direction recognition
⊗	⊙	2*	Bright function w/o direction recognition
⊙	⊗	3	Dark function with direction recognition
⊙	⊙	4	Bright function with direction recognition

\*) Default value on delivery



- ▶ Dual-beam light barriers
- ▶ Red light fork light barriers with integrated amplifier

## PZV 10 mm series

with 4-pin connector M8

### Application

- Forward/backward recognition
- e.g. for applications on automatic winding machines and in selective electroplating

### Specifications

Circuit	2 x constant light trigger
Wavelength	650 nm, red light LED
Operating voltage	12 – 24 VDC
Current consumption	< 40 mA
Mode of operation	static
Output 1 and 2 with LED	PNP
Function	see operating modes table
Load current	200 mA short-circuit proof
Repeating accuracy	< 0.01 mm
Frequency	3 KHz
Temperature range	0 °C – 50 °C
EMC according to 2004/108/EG	EN 61000... C €
System of protection	IP 65

### Resolution

Fork width A [mm]:	25	30
Part diameter [mm]:	0.8	1.2

### Pin configuration

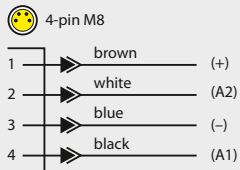

### Phase shift

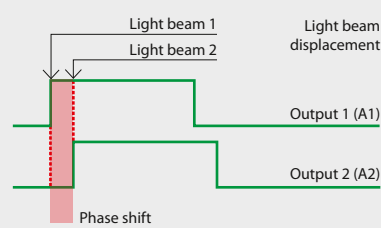

### Article

Fork light barrier:

• PZV-30-30/4-P	6210-00010-4182
• PZV-25-80/4-P	6220-00010-4182
• PZV-30-80/4-P	6230-00010-4182

### Order No.

### Accessories (more accessories see chapter K11)

#### Article

#### Order No.

Connection cable 5 m (with free cable end):

• VK-M8-4-w	2111-00005-1400
• VK-M8-4-g	2111-00005-0400

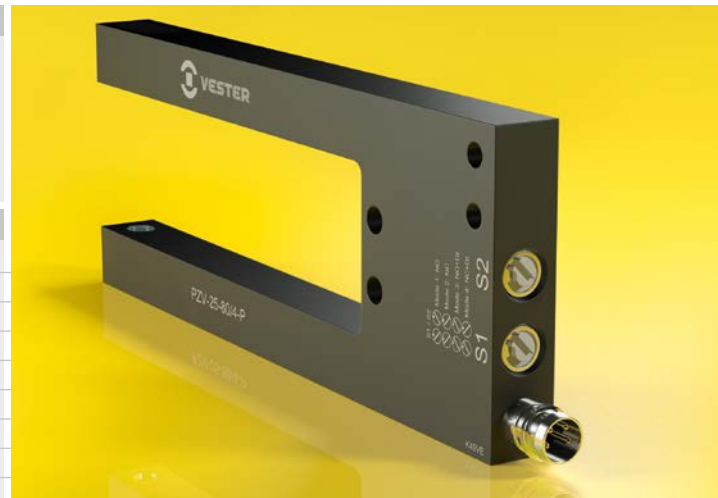

### PZV-30-30/4-P:

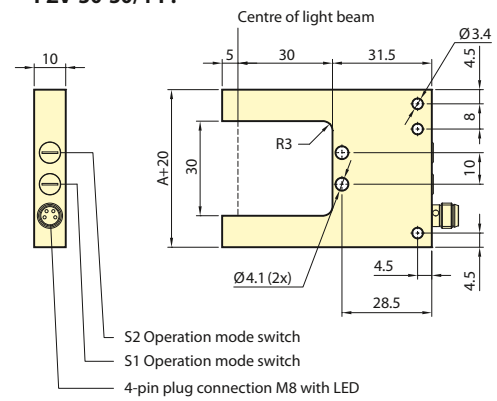

### PZV-25-80/4-P | PZV-30-80/4-P:

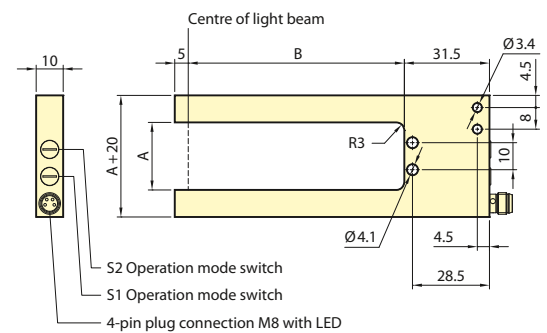

A [mm]:	25	30
B [mm]:	80	80

### Operating modes

S1	S2	Modi	
⊘	⊘	1	Dark function w/o direction recognition
⊘	⊘	2*	Bright function w/o direction recognition
⊘	⊘	3	Dark function with direction recognition
⊘	⊘	4	Bright function with direction recognition

\*) Default value on delivery

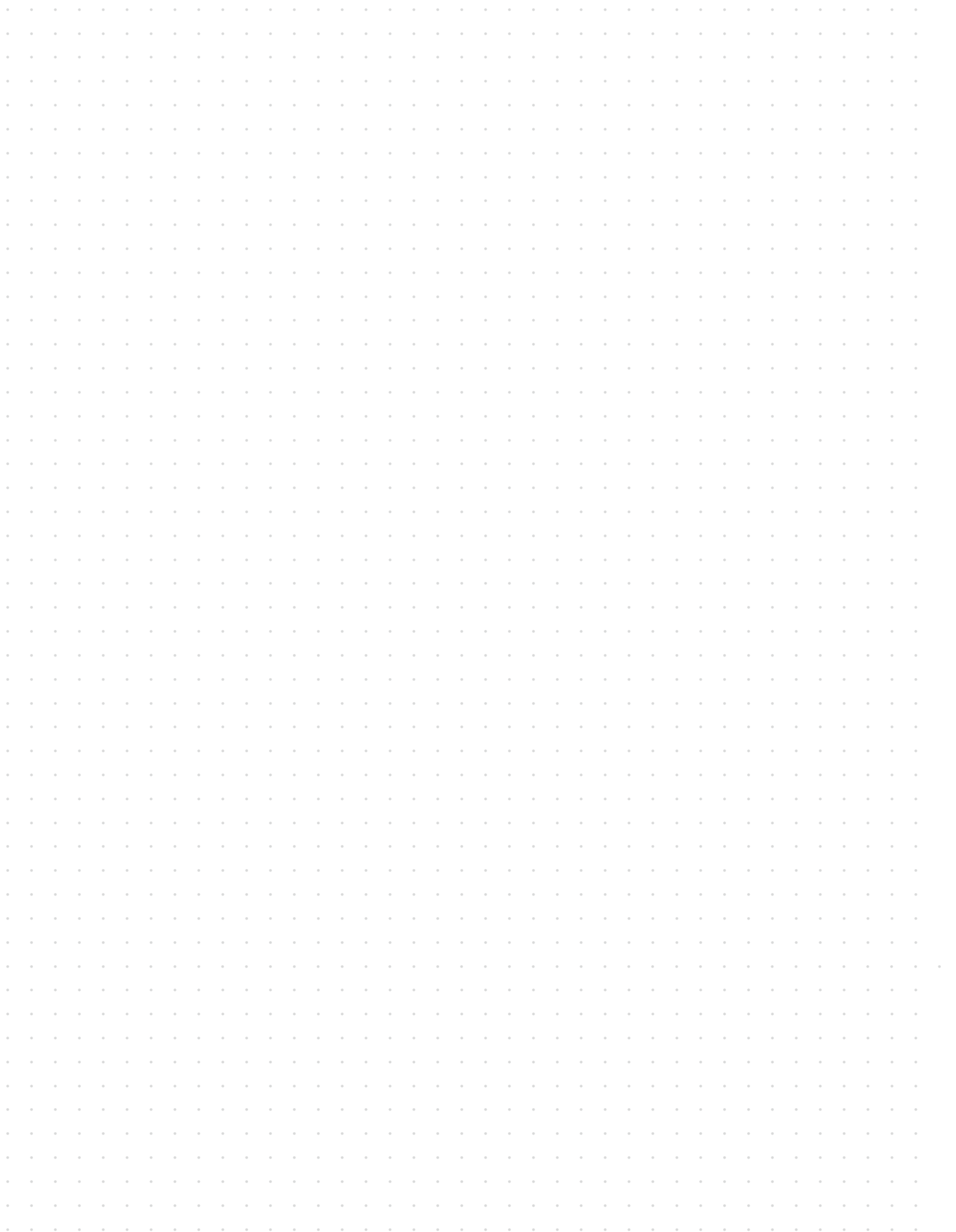

# Multi-beam light barriers with integrated amplifier

# K5

Compact fork and frame infrared multi-beam light barriers



Fork light barrier of the PBI series with protective frame\*



Frame light barrier of the PRI and PRX series

\*) Protective frame as optional accessory

- ▶ Multi-beam light barriers with integrated amplifier
- ▶ Infrared fork light barriers

## PBI 10 mm series

## with 3-pin connector M8

### Application

- Ejection control
- Counting of ultra small parts

### Specifications

Circuit	Constant light trigger
Operating voltage	12 – 24 VDC
Current consumption	50 – 200 mA, depending on type
Mode of operation	dynamic / static <sup>1)</sup>
Sensitivity static/dynamic	adjustable by 270° pot
Output with LED	PNP
Function	bright / dark function
Load current	200 mA short-circuit proof
Pulse length	10 ms, internally adjustable (1 – 100 ms)
Frequency	max. 1 KHz, depending on pulse length
Temperature range	0 °C – 60 °C
EMC according to 2004/108/EG	EN 61000... C €
System of protection	IP 65

<sup>1)</sup> internal switch for dynamic/static operating mode

### Resolution

Fork width A [mm] :	40	50	60
Part diameter [mm] :			
• dynamic	1.0	1.0	1.0
• static	2.0	2.0	2.5

### Pin configuration

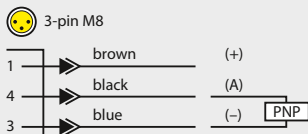

### Article

### Order No.

Fork light barrier:	
• PBI-40-40/3-P	8344-00000-3002
• PBI-50-75/3-P	8357-00000-3002
• PBI-60-75/3-P	8367-00000-3002

### Accessories ( more accessories see chapter K11)

### Article Order No.

Protective frame:	
• SRI 40-40	2300-00000-1180
• SRI 50-75	2300-00000-1182
• SRI 60-75	2300-00000-1183
Connection cable 5 m (with free cable end) :	
• VK-M8-g	2111-00005-0300
• VK-M8-w	2111-00005-1300



The protective frame is optionally available

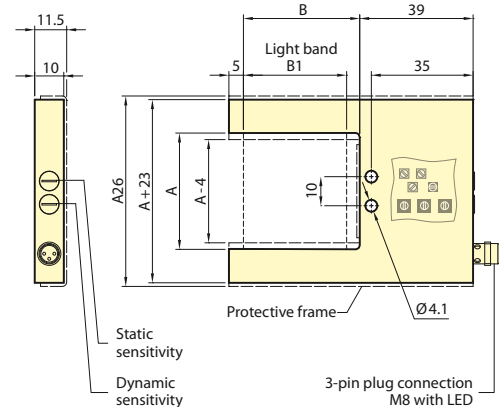

### Bright/dark switch

- ☑ bright function
- ☑ dark function <sup>1)</sup>

### Time control for pulse length <sup>2)</sup>

- ☑ min. (1 ms)
- ☑ max. (100 ms)

### SD/D switch

- ☑ statics + dynamics
- ☑ only dynamics

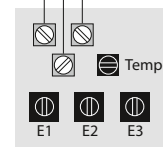

■ Must not be changed!

- 1) Default setting
- 2) Default setting: 10 ms

A [mm] :	40	50	60
B [mm] :	40	75	75
B1 [mm] :	35	69	69

- ▶ Multi-beam light barriers with integrated amplifier
- ▶ Infrared frame light barriers

## PRI 15 mm series

## with 4-pin connector M12

### Application

- Ejection control
- Counting of ultra small parts

### Specifications

Circuit	Constant light trigger
Operating voltage	12 – 24 VDC
Current consumption	50 – 200 mA, depending on type
Mode of operation	dynamic / static <sup>1)</sup>
Sensitivity static/dynamic	adjustable by 270° pot
Output with LED	PNP
Function	bright / dark function
Load current	200 mA short-circuit proof
Pulse length	10 ms, internally adjustable (1 – 100 ms)
Frequency	max. 1 KHz, depending on pulse length
Temperature range	0 °C – 60 °C
EMC according to 2004/108/EG	EN 61000... CEE
System of protection	IP 65

<sup>1)</sup> internal switch for dynamic/static operating mode

### Resolution

Light band B [mm] :	76	96	150
Part diameter [mm] :			
• dynamic	1.0	1.0	1.5
• static	1.0	1.5	2.0

### Pin configuration



### Article

### Order No.

Frame light barrier:	
• PRI-70-76/4-P	8300-00000-4002
• PRI-100-96/4-P	8301-00000-4002
• PRI-150-150/4-P	8302-00000-4002

Also available w/o tie-bar (7 mm)

### Accessories ( more accessories see chapter K11)

### Article

### Order No.

Protective frame:	
• SR 70-76	2300-00000-0230
• SR 100-96	2300-00000-0231
• SR 150-150	2300-00000-0232
Connection cable 5 m:	
• VK-M12-5-g	2112-00005-0500
• VK-M12-5-w	2112-00005-1500
Extension cable 4-pin M12:	
• VK-M12-g/M12 (2 m)	2112-00002-0404



The protective frame is optionally available

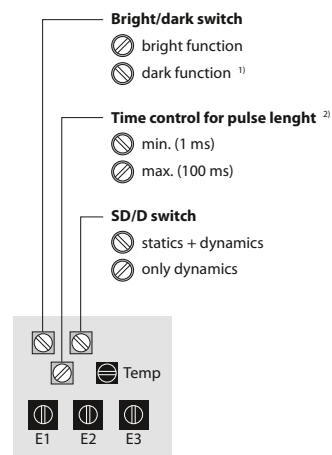
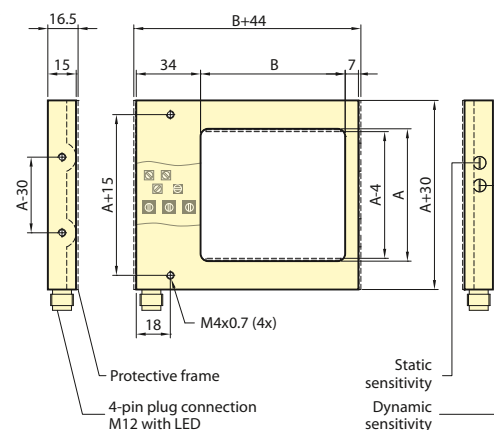

■ Must not be changed!

- 1) Default setting
- 2) Default setting: 10 ms

A [mm] :	70	100	150
B [mm] :	76	96	150

- ▶ Multi-beam light barriers with integrated amplifier
- ▶ Infrared frame light barriers

## PRX 15 mm series

with 4-pin connector M12

### Application

- Ejection control
- Counting of ultra small parts
- Very high-resolution frame light barrier with two light bands offset by 90° (dual light band)

### Specifications

Circuit	Constant light trigger
Operating voltage	12 – 24 VDC
Current consumption	150 – 200 mA
Mode of operation	dynamic / static <sup>1)</sup>
Sensitivity static/dynamic	adjustable by 270° pot
Output with LED	PNP
Function	bright / dark function
Load current	200 mA short-circuit proof
Pulse length	10 ms, internally adjustable (1 – 100 ms)
Frequency	max. 1 KHz, depending on pulse length
Temperature range	0 °C – 60 °C
EMC according to 2004/108/EG	EN 61000... C €
System of protection	IP 65

<sup>1)</sup> internal switch for dynamic/static operating mode

### Resolution

Frame cross section [mm] :	96 – 150
Part diameter [mm] :	
• dynamic	0,9
• static	0,9

### Pin configuration

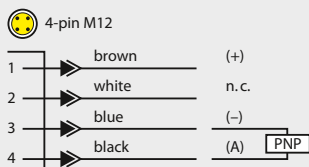

### Article Order No.

Frame light barrier:	
PRX-96-150/4-P	8320-00000-4002

### Accessories (more accessories see chapter K11)

Article	Order No.
Protective frame:	
• SRX-96-150	2300-00000-8230
Connection cable 5 m:	
• VK-M12-5-g	2112-00005-0500
• VK-M12-5-w	2112-00005-1500
Extension cable 4-pin M12:	
• VK-M12-g/M12 (2 m)	2112-00002-0404

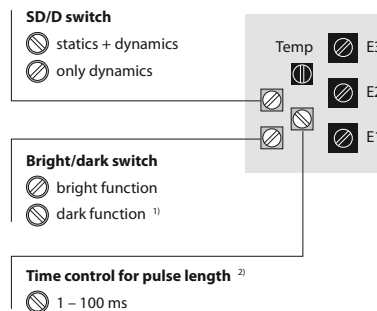
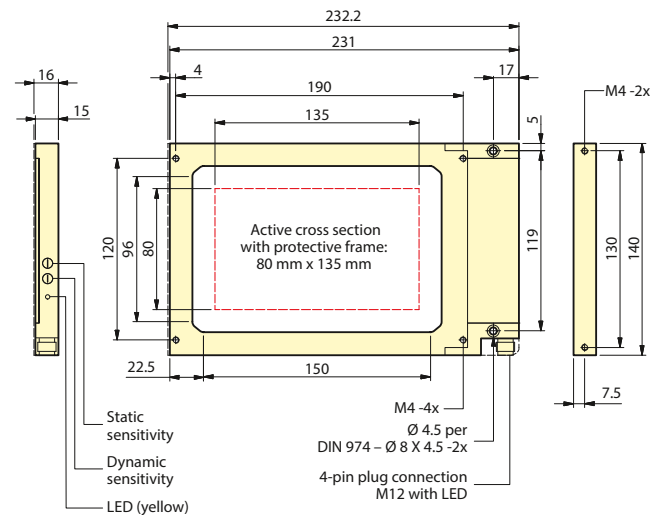
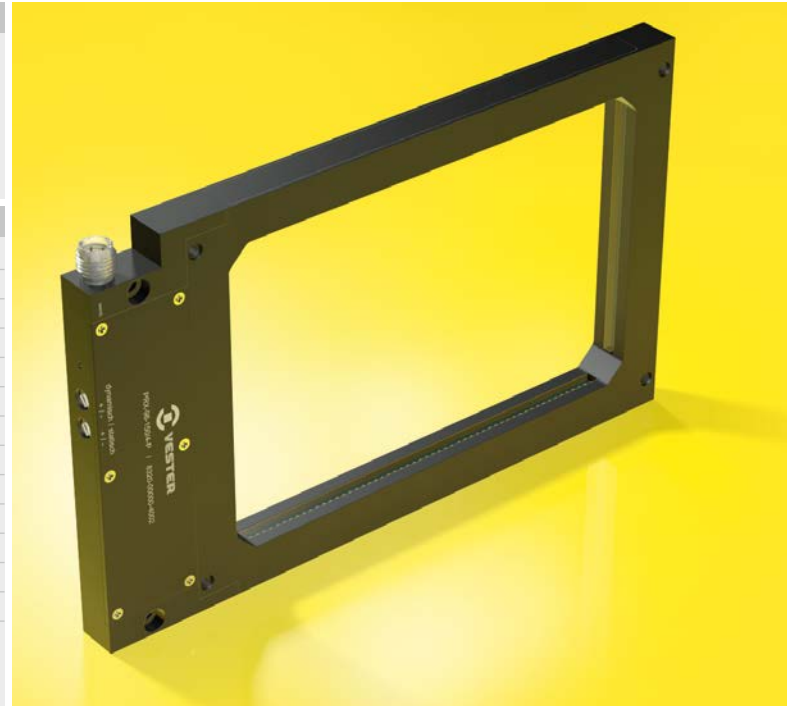

■ Must not be changed!

1) Default setting

2) Default setting: 10 ms



# Multi-beam light barriers with separate amplifier

Fork and frame infrared multi-beam light barriers



Fork light barrier of the PB series with protective frame\*

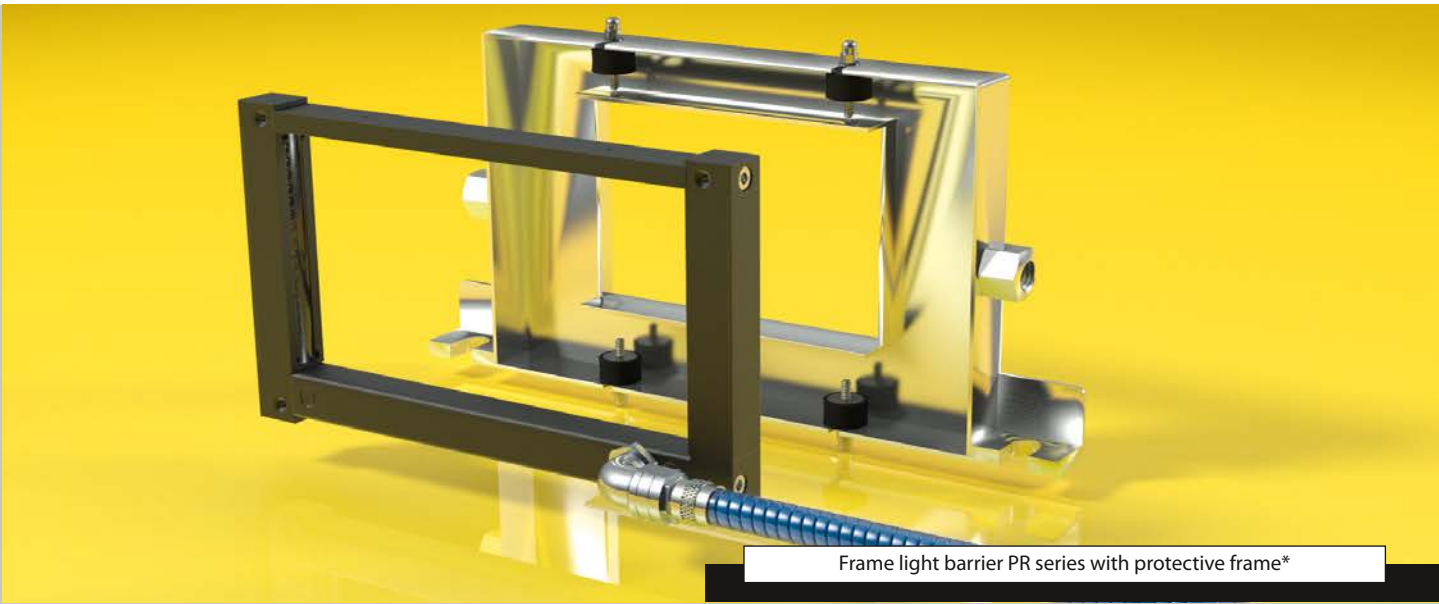

Frame light barrier PR series with protective frame\*

\*) Protective frame as optional accessory

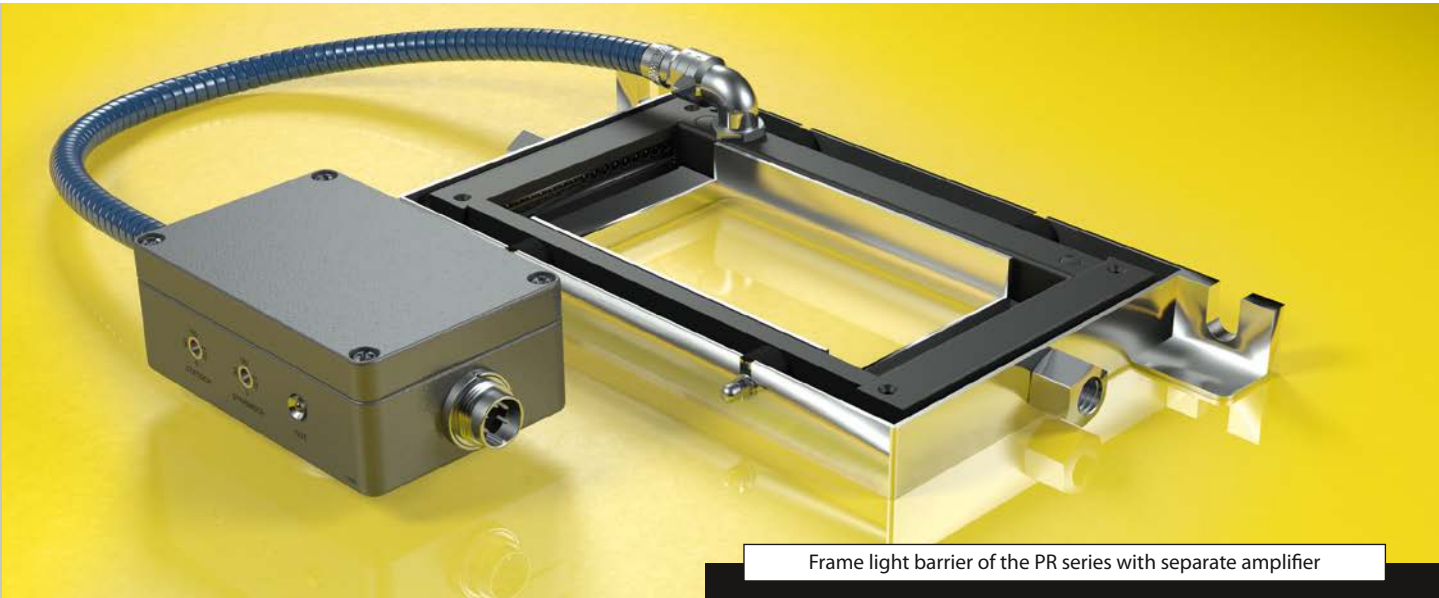

Frame light barrier of the PR series with separate amplifier

- ▶ Multi-beam light barriers with separate amplifier
- ▶ Infrared fork light barriers

## PB 8 mm series

with 4-pin connector M12 or 5-pin connector M16

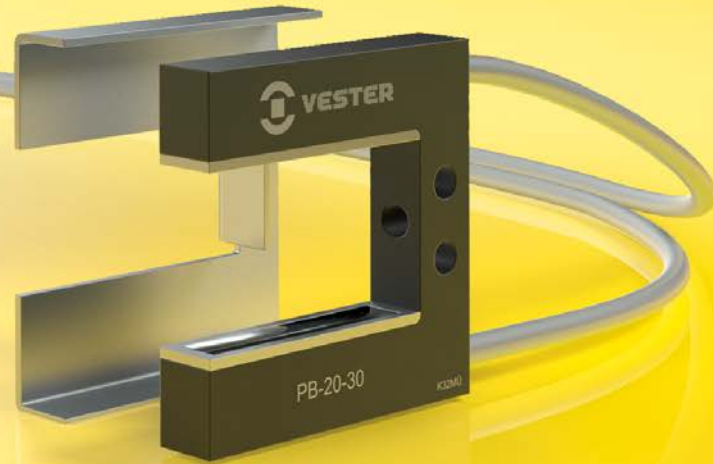

The protective frame is optionally available

### Application

- Ejection control
- Counting of ultra small parts

### Specifications

Circuit	Constant light trigger
Operating voltage	12 – 24 VDC
Current consumption	50 – 200 mA, depending on type
Mode of operation	dynamic / static <sup>1)</sup>
Sensitivity static/dynamic	adjustable by 270° pot
Output with LED	PNP, NPN on request
Function	bright / dark function
Load current	200 mA short-circuit proof
Pulse length	10 ms, internally adjustable (1 – 100 ms)
Frequency	max. 1 KHz, depending on pulse length
Temperature range	0 °C – 60 °C
EMC according to 2004/108/EG	EN 61000... C €
System of protection	IP 65

<sup>1)</sup> internal switch for dynamic/static operating mode

### Resolution

Fork width A [mm]:		10 – 30	40 – 60
Part diameter [mm]:	dynamic	0.8	1.0
Part diameter [mm]:	static	1.5	2.0

### Article Order No.

Fork light barrier with amplifier 4-pin plug:

• PB-10-15/4-P	8000-00000-4102
• PB-20-30/4-P	8001-00000-4102
• PB-30-30/4-P	8002-00000-4102
• PB-40-40/4-P	8003-00000-4102
• PB-50-75/4-P	8005-00000-4102
• PB-60-75/4-P	8006-00000-4102

Fork light barrier with amplifier 5-pin plug:

• PB-10-15/5-P	8000-00000-0102
• PB-20-30/5-P	8001-00000-0102
• PB-30-30/5-P	8002-00000-0102
• PB-40-40/5-P	8003-00000-0102
• PB-50-75/5-P	8005-00000-0102
• PB-60-75/5-P	8006-00000-0102

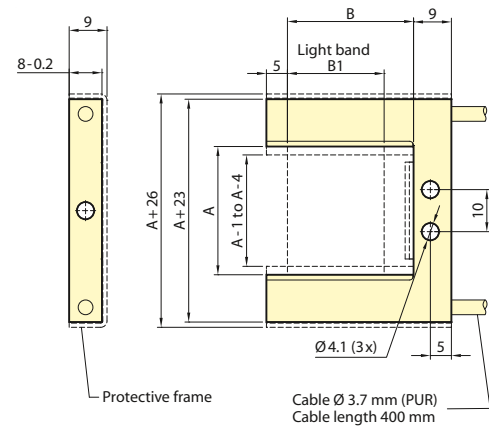

A [mm]:	10	20	30	40	50	60
B [mm]:	15	30	30	40	75	75
B1 [mm]:	10	23	23	35	69	69

### Constant light amplifier 4-P\*

#### Pin configuration

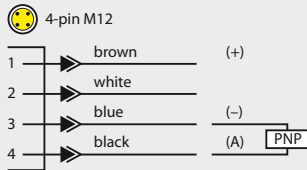

### Constant light amplifier 5-P\*

#### Pin configuration

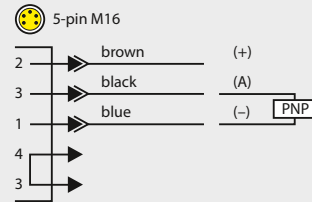

\*) With magnetic holder

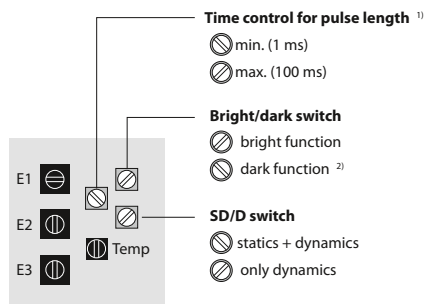
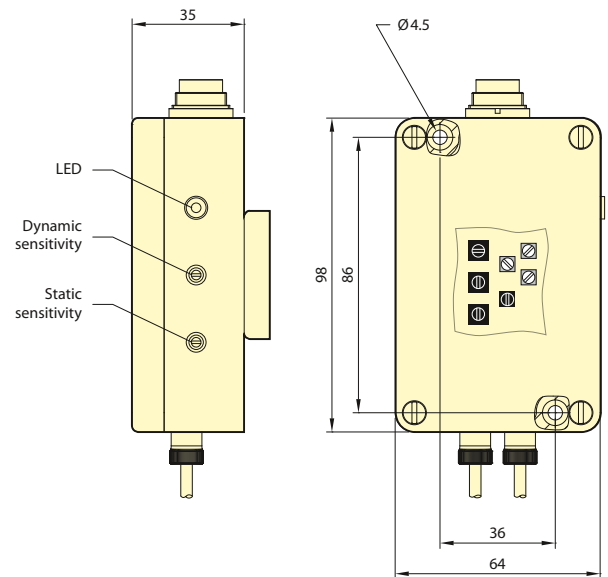
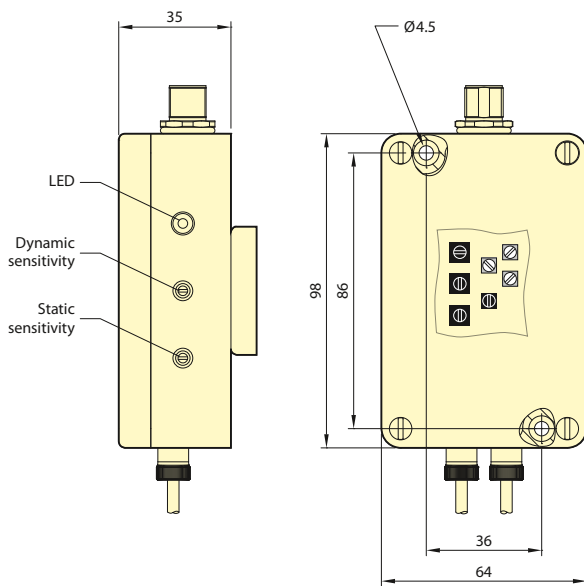

■ Must not be changed!

1) Default setting: 10 ms

2) Default setting

#### Accessories (more accessories see chapter K11)

Article	Order No.
<b>Connection cable M12 (5 m):</b>	
• VK-M12-5-g	2112-00005-0500
• VK-M12-5-w	2112-00005-1500
<b>Extension cable 4-pin M12:</b>	
• VK-M12-g/M12 (2 m)	2112-00002-0404
• VK-M12-g/M12 (5 m)	2112-00005-0404
<b>Connection cable 5/6-pin M16:</b>	
• VK-D/F-St-A (2 m)	2105-00002-0600
• VK-D/F-St-A (5 m)	2105-00005-0600
<b>Extension cable 5/6-pin M16:</b>	
• VK-D/D (2 m)	2104-00002-0606
• VK-D/D (5 m)	2104-00005-0606
<b>Protective frame:</b>	
• SR 10-15	2300-00000-0177
• SR 20-30	2300-00000-0178
• SR 30-30	2300-00000-0179
• SR 40-40	2300-00000-0180
• SR 50-75	2300-00000-0182
• SR 60-75	2300-00000-0183

- ▶ Multi-beam light barriers with separate amplifier
- ▶ Infrared frame light barriers

## PR 15 mm series

with 4-pin connector M12 or 5-pin connector M16



The protective frame is optionally available

### Application

- Ejection control
- Counting of ultra small parts

### Specifications

Circuit	Constant light trigger
Operating voltage	12 – 24 VDC
Current consumption	60 – 300 mA, depending on type
Mode of operation	dynamic / static <sup>1)</sup>
Sensitivity static/dynamic	adjustable by 270° pot
Output with LED	PNP, NPN on request
Function	bright / dark function
Load current	200 mA short-circuit proof
Pulse length	10 ms, internally adjustable (1 – 100 ms)
Frequency	max. 1 KHz, depending on pulse length
Temperature range	0 °C – 60 °C
EMC according to 2004/108/EG	EN 61000... C €
System of protection	IP 64

1) internal switch for dynamic/static operating mode

### Resolution

Light band B [mm]:		54–78	96–126	150–192	300
Part diameter [mm]:	dynamic	1	2	3	4
Part diameter [mm]:	static	2	4	6	8

### Article

### Order No.

Frame light barrier with amplifier 4-pin plug:

• PR-52-54/4-P	8200-00000-4102
• PR-100-66/4-P	8201-00000-4102
• PR-150-78/4-P	8202-00000-4102
• PR-200-96/4-P	8203-00000-4102
• PR-250-126/4-P	8204-00000-4102
• PR-300-150/4-P	8205-00000-4102
• PR-400-192/4-P	8206-00000-4102
• PR-500-300/4-P	8207-00000-4102

Frame light barrier with amplifier 5-pin plug:

• PR-52-54/5-P	8200-00000-0102
• PR-100-66/5-P	8201-00000-0102
• PR-150-78/5-P	8202-00000-0102
• PR-200-96/5-P	8203-00000-0102
• PR-250-126/5-P	8204-00000-0102
• PR-300-150/5-P	8205-00000-0102
• PR-400-192/5-P	8206-00000-0102
• PR-500-300/5-P	8207-00000-0102

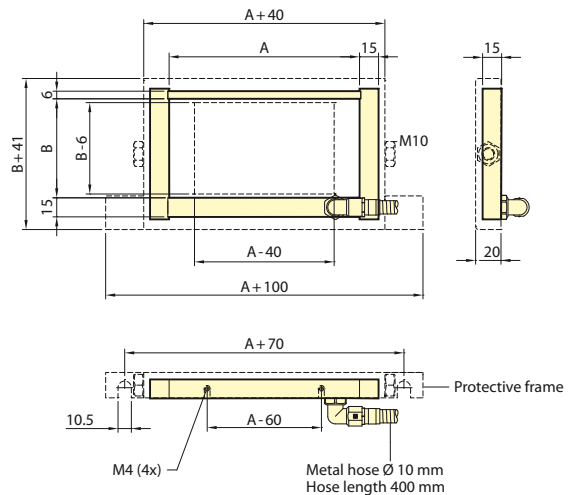

A [mm]:	52	100	150	200	250	300	400	500
B [mm]:	54	66	78	96	126	150	192	300

### Constant light amplifier 4-P\*

#### Pin configuration

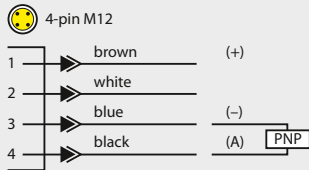

### Constant light amplifier 5-P\*

#### Pin configuration

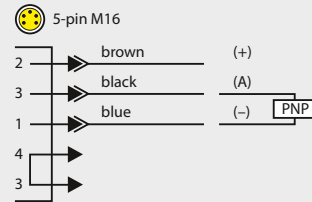

\*) With magnetic holder

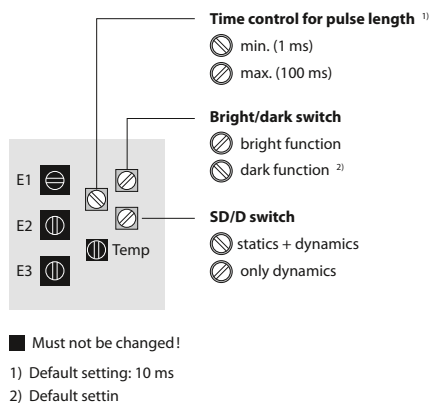
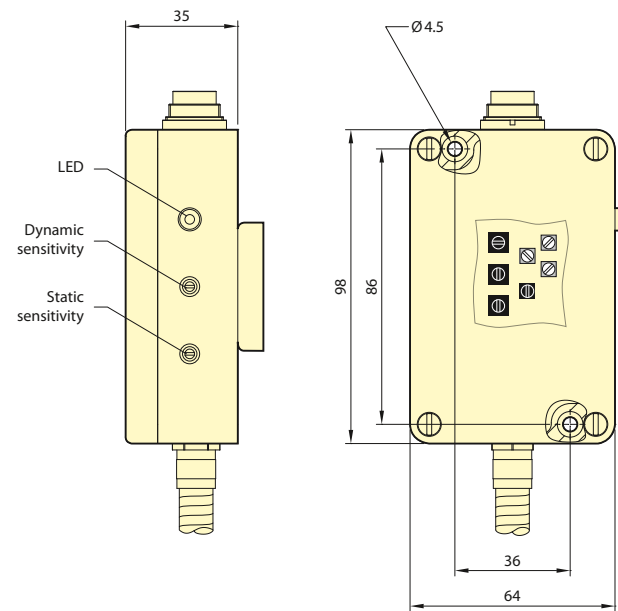
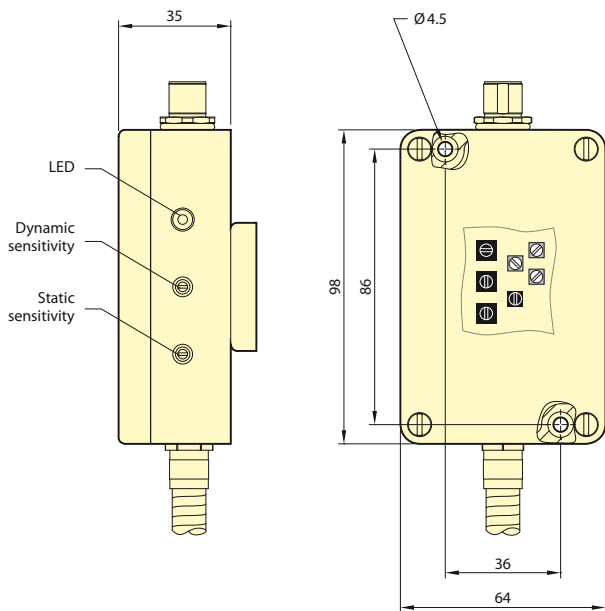

#### Accessories ( more accessories see chapter K11 )

Article	Order No.
<b>Connection cable M12 (5 m):</b>	
• VK-M12-5-g	2112-00005-0500
• VK-M12-5-w	2112-00005-1500
<b>Extension cable 4-pin M12:</b>	
• VK-M12-g/M12 (2 m)	2112-00002-0404
• VK-M12-g/M12 (5 m)	2112-00005-0404
<b>Connection cable 5/6-pin M16:</b>	
• VK-D/F-St-A (2 m)	2105-00002-0600
• VK-D/F-St-A (5 m)	2105-00005-0600
<b>Extension cable 5/6-pin M16:</b>	
• VK-D/D (2 m)	2104-00002-0606
• VK-D/D (5 m)	2104-00005-0606
<b>Protective frame:</b>	
• SR 150-78	2300-00000-0410
• SR 200-96	2300-00000-0411
• SR 250-126	2300-00000-0412
• SR 300-150	2300-00000-0413
• SR 400-192	2300-00000-0414
• SR 500-300	2300-00000-0415
<b>Magnetic holding device MS 80</b>	2300-00000-0036



## DHS series

### Multi-beam light barriers DHS 801 and DHS 1601 as loop control

The non-contacting, microprocessor-controlled infrared multi-beam light barriers DHS 801 and DHS 1601 are based on many years of experience in the field of optical sensor technology and automation engineering.

By the detection of thin and fast moving stamped strips these sensors are used primarily as loop control in coiling and uncoiling machines.

The requirement of winding or unwinding thin and perforated stamped strips from a coil in a smooth and jerk-free – and thus also thrust- and tension-free – manner is an essential element of the current winding technology.

A loop control has the purpose of regulating the coiling drive in such a way to ensure a continuous and vibration-free operation, depending on the growing or decreasing coil diameter.

Only that way it can be guaranteed that highly sensitive strip material can be wound or unwound without damages.

Furthermore, changing the strip shall require no additional adjustment on the sensor or the control: the system is designed to work independently from the material in use!



Rewinding station with DHS 801

The DHS series models are infrared multi-beam light barriers which self-align within an operating range between 50 mm and 400 mm, here the distance between transmitter and receiver components.

Depending on the model version, the DHS 801 has 8 IR light beams arranged horizontally as one-way light barriers over a range between 450 mm and 1250 mm in such a way that only one light beam will be crossed by the strip material loop. The DHS 1601 has 16 IR light beams.

Via programming adapter each light beam can be assigned exactly one output value between 0 and 10 VDC, which the amplifier module at the output will provide as a set value for the drive (frequency converter) until another light beam is crossed by the strip loop.

Strip flutter will not affect the function, for it doesn't matter if the concerning light beam is crossed only once or several times.

This ensures a continuous and vibration-free operation of the winder drive and will notably extend the service life of the drive components.

Both the first and last light beam can be programmed as digital "limit switches", e.g. if the strip is tightening or running out, which considerably enhances the functionality again by making extra limit switches redundant.

The two "wind" and "unwind" operating modes can be selected by switch, according to the current application.

### Performance features of the DHS multi-beam light barriers:

- Analogue control output: 0 – 10 VDC, set value for frequency converter
- 8 or 16 individually programmable one-way light barriers, default set value 0 – 10 VDC
- Programmable for individual default set values or fixed values (factory setting)
- Switchable winding / unwinding operation, optionally with PNP alarm signal for band tension and band end 'limit values'
- Resolution from 0.1 mm strip thickness
- Material-independent function; therefore no adjustment when changing the tool!
- Material-friendly winding procedure due to vibration-free, continuous drive operation; thus longer service life
- Easy retrofitting on automatic winding machines (frequency converter with set value input)



Strip accumulator with DHS 801

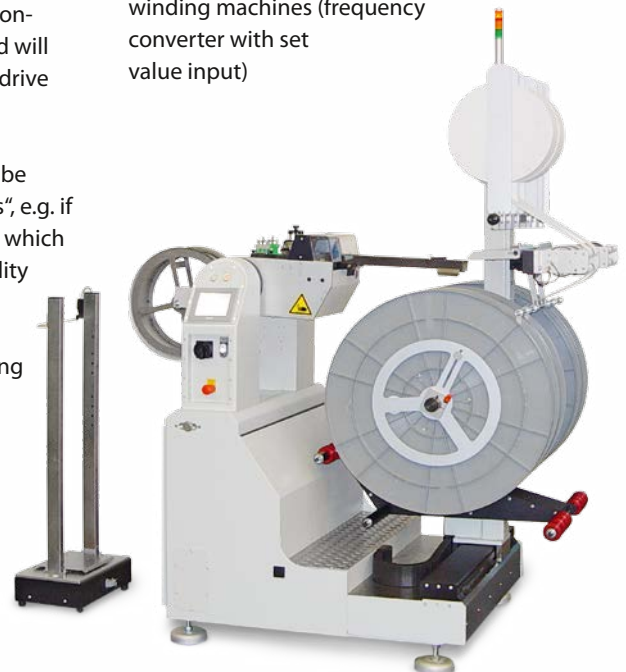

Quad winder with DHS 1601



- ▶ Multi-beam light barriers with separate amplifier
- ▶ Infrared bar light barriers

## DHS series

## Transmitter and receiver bar

### Application

- 8- or 16-channel loop control with variable operating range between 50 and 400 mm
- Switchable winding and unwinding operating modes stored in memory

### Specifications

Circuit	Constant light trigger, PIC controller
Operating voltage	24 VDC $\pm$ 10 %
Current consumption	< 200 mA
Mode of operation	dynamic
Sensitivity	> 0.1 mm, depending on distance A between transmitter and receiver bar
Output with LED	0 – 10 VDC, green LED lights up briefly when a light beam is crossed
Switch output SA	DHS 801: PNP, for channel 0 + 7 DHS 1601: PNP, for channel 0 + 15 dark function
Function	
Load current	max. 100 mA short-circuit proof
Frequency	>1 KHz
Temperature range	0 °C – 60 °C
EMC according to 2004/108/EG	EN 61000... CEE
System of protection	IP 65, for transmitter and receiver bar



### Transmitter and receiver bar with 8 or 16 light barriers

#### DHS 801/450:

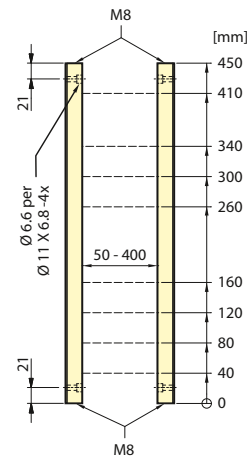

#### DHS 1601:

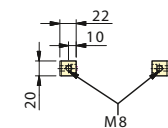
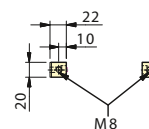
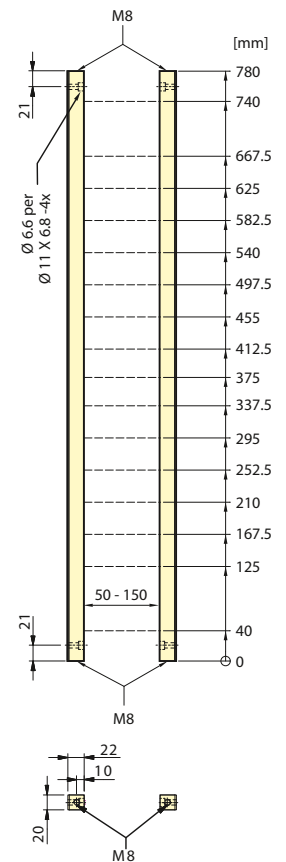

Drawing DHS 801/1250 on request

### Resolution DHS 801:

Distance A [mm]:	50 – 249	250 – 400
Material thickness [mm]:	0.2	0.1

### Resolution DHS 1601:

Distance A [mm]:	50 – 150
Material thickness [mm]:	0.1

### Article

### Order No.

DHS 801/450 complete system 450 mm	8701-45008-1000
DHS 801/2xSA-PNP, as above with switch output	8701-45008-3000
DHS 801/1250 complete system 1250 mm	8701-12508-1000
DHS 801/AE, 8-channel amplifier	8701-00008-1001
DHS 801/450/transmitter	8701-45008-1002
DHS 801/450/receiver	8701-45008-1003
DHS 801/1250/transmitter	8701-12508-1002
DHS 801/1250/receiver	8701-12508-1003

DHS 1601/780 complete system 780 mm	8701-78016-1000
DHS 1601/AE 16-channel amplifier	8701-00016-1001
DHS 1601/780/transmitter	8701-78016-1002
DHS 1601/780/receiver	8701-78016-1003

- ▶ Multi-beam light barriers with separate amplifier
- ▶ Infrared bar light barriers

## DHS series

## Amplifier

### Pin configuration

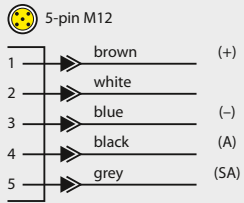

- Pin 1: +24 VDC
- Pin 2: Ext. range selection  
n.c. → memory range 1, yellow LED off  
5 VDC → memory range 2, yellow LED on
- Pin 3: 0 V
- Pin 4: Output 0 – 10 VDC
- Pin 5: switch output SA-PNP, with model version / 2xSA-PNP



Housing dimensions (LxWxH): 220 x 120 x 90 mm

### Accessories (more accessories see chapter K11)

Article	Order No.
Connection cable 5 m:	
• VK-M12-5-g	2112-00005-0500
• VK-M12-5-w	2112-00005-1500
DHS x /feet (pair)	8600-00110-0005
Stand A-1/100 for DHS compl.	0949-60140-0000
Protective plate DHS x / 450 transmitter compl.	8600-00110-0006
Protective plate DHS x / 450 receiver compl.	8600-00110-0007
Programming adapter:	
• PA16-DHS	8601-00100-0000

Freely programmable with programming adapter PA16-DHS!

**Note:**  
With the optional programming adapter output voltages between 0 and 10 V may be set for each channel!

Transmitter and receiver bar are both pluggable

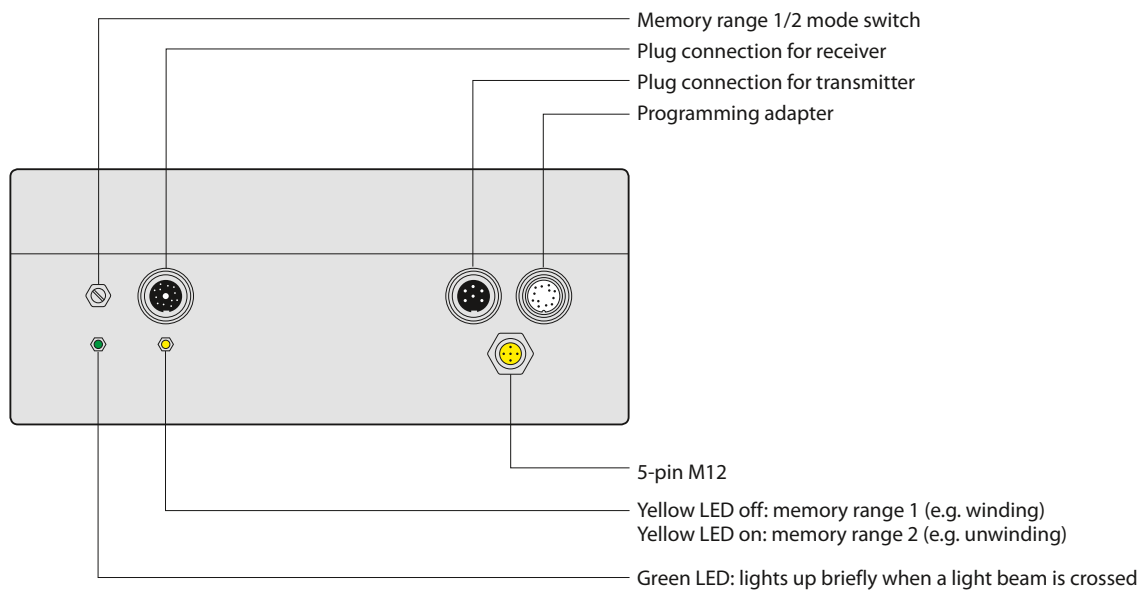

### Switch output SA:

Upon crossing the light beams of channels 0 + 7 (DHS 1601: channels 0 + 15), an additional output is activated, e.g. for band tension or band end (limit signals)

## Inductive switches and ring sensors

Inductive proximity switches are available in many sizes with plug connection and cable output. The universal sensor for nearly all applications.

Our ring sensors are available in three sizes and convince by a high resolution and reliability in a rough and oil mist ambience.

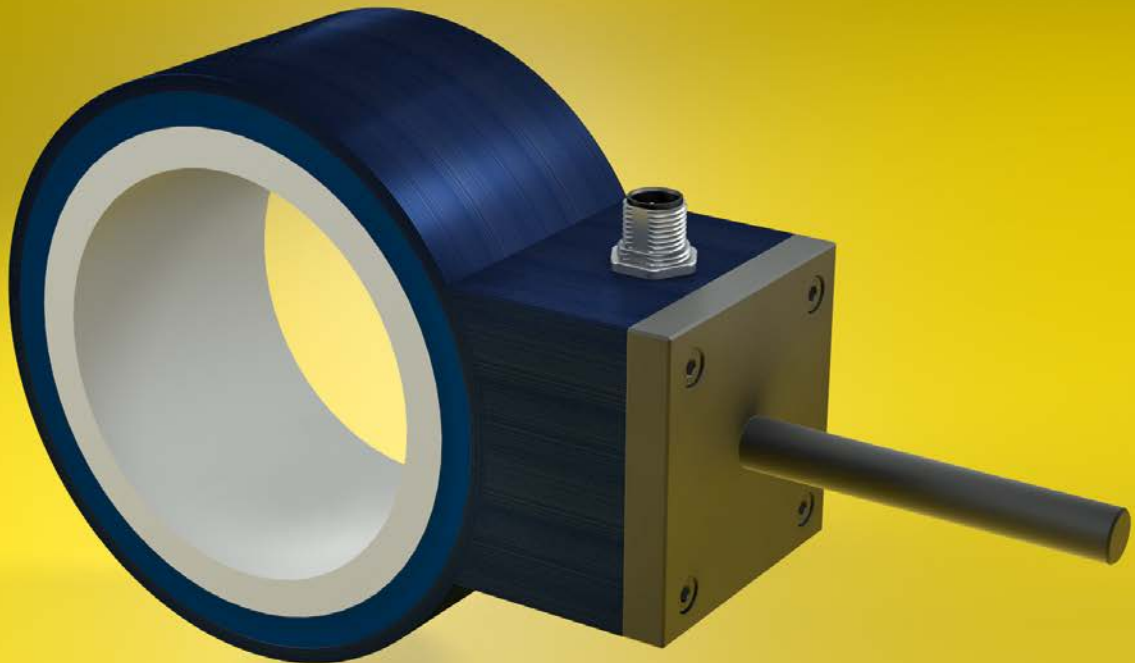

Ring sensor of the IRS series



Inductive proximity switch of the IS series



Inductive plug-in type proximity switch of the ISS series

- ▶ Inductive switches and ring sensors
- ▶ Inductive proximity switches

## IS series

## with cable output

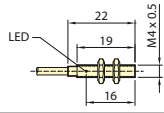
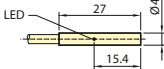
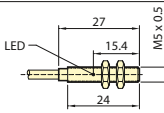
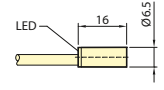
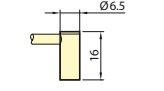
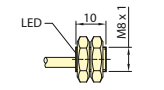
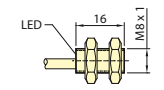
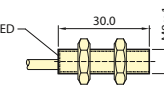
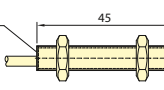
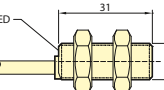
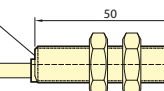
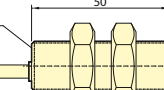
Sensor type	Sn ST 37	Order No.	Drawing
IS-M4-22-06	0.6 mm	6604-22060-0000	
IS-4-25-1,5	1.5 mm	6604-25150-0000	
IS-M5-25-1,5	1.5 mm	6605-25150-0000	
IS-6,5-16-1,5	1.5 mm	6606-16150-0000	
IS-6,5R-16-1,5	1.5 mm	6606-16159-0000	
IS-M8-10-1,5	1.5 mm	6608-10150-0000	
IS-M8-16-1,5	1.5 mm	6608-16150-0000	
IS-M8-32-1,5	1.5 mm	6608-32150-0000	
IS-M8-45-3	3 mm	6608-45300-0000	
IS-M12-31-4	4 mm	6612-31400-0000	
IS-M12-50-6	6 mm	6612-50600-0000	
IS-M18-50-12	12 mm	6618-50120-0000	

### Specifications

Operating voltage	10 – 30 VDC, polarity protected
Current consumption	max. 10 mA (Idle running)
Mode of operation	static
Output	cable output: PNP (S), – (BI), + (Br), length: 2.5 – 3 m
Function	make contact
Load current	200 mA short-circuit proof
Repeating accuracy	$R \leq 5\%$ of $S_r$ , with $S_r$ = real switching distance
Reduction factor for $S_n$ , with $S_n$ = nominal switching distance	V2A: appr. 0.85   AL: appr. 0.4   Cu: appr. 0.3
Frequency	max. 3 KHz, depending on type
Temperature range	0 °C – 70 °C
EMC according to 2004/108/EG	EN 61000... C E
System of protection	IP 65

### Accessories (more accessories see chapter K11)

Article	Order No.
Cylinder plug RS-5	1200-00006-0874
Mounting block AS 10-5	2306-00000-0005

- ▶ Inductive switches and ring sensors
- ▶ Inductive plug-in type proximity switches

## ISS series

## with 3-pin connector M8

Sensor type	Sn ST 37	Order No.	Drawing
ISS-6,5-58-4	4 mm	6606-58400-0000	
ISS-M8-45-1,5	1.5 mm	6608-45151-0000	
ISS-M8-60-3	3 mm	6608-60301-0000	
ISS-10-28-1 <sup>1)</sup>	2 mm	6610-28201-0000	
ISS-26-20-1,5/R <sup>2)</sup>	1.5 mm	6626-20151-0000	
ISS-26-20-1,5/L <sup>2)</sup>	1.5 mm	6626-20151-1000	

<sup>1)</sup> Alternative version with cable output on request

<sup>2)</sup> cable outlet with angled plug R = right-hand, L = left-hand

### Pin configuration

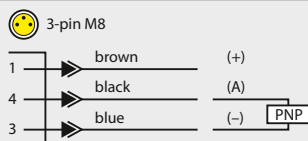

### Specifications

Operating voltage	10 – 30 VDC, polarity protected
Current consumption	max. 10 mA (Idle running)
Mode of operation	static
Output	PNP
Function	make contact
Load current	200 mA short-circuit proof
Repeating accuracy	$R \leq 5\%$ of $S_r$ , with $S_r$ = real switching distance
Reduction factor for $S_n$ , with $S_n$ = nominal switching distance	V2A: appr. 0.85   AL: appr. 0.4   Cu: appr. 0.3
Frequency	max. 1 KHz, depending on type
Temperature range	0 °C – 70 °C
EMC according to 2004/108/EG	EN 61000... C€
System of protection	IP 65 / 67

### Accessories (more accessories see chapter K11)

Article	Order No.
Connection cable (5 m):	
• VK-M8-g	2111-00005-0300
• VK-M8-w	2111-00005-1300

- ▶ Inductive switches and ring sensors
- ▶ Inductive plug-in type proximity switches

**ISS series**
**with 4-pin connector M12**

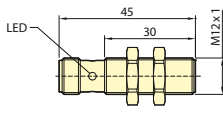
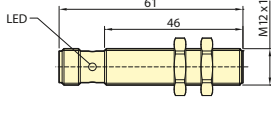
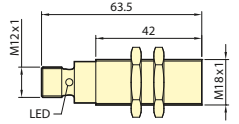
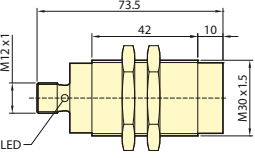
Sensor type	Sn ST 37	Order No.	Drawing
ISS-M12-45-4	4 mm	6612-45401-0000	
ISS-M12-61-6	6 mm	6612-61601-0000	
ISS-M18-66-12	12 mm	6618-66121-0000	
ISS-M30-84-40	40 mm	6630-84401-0000	

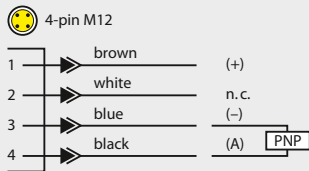
**Pin configuration**

**Specifications**

Operating voltage	10 – 30 VDC, polarity protected
Current consumption	max. 10 mA (Idle running)
Mode of operation	static
Output	PNP
Function	make contact
Load current	200 mA short-circuit proof
Repeating accuracy	$R \leq 5\%$ of $S_r$ , with $S_r$ = real switching distance
Reduction factor for $S_n$ , with $S_n$ = nominal switching distance	V2A: appr. 0.85   AL: appr. 0.4   Cu: appr. 0.3
Frequency	max. 1 KHz, depending on type
Temperature range	0 °C – 70 °C
EMC according to 2004/108/EG	EN 61000... C E
System of protection	IP 65 / 67

**Accessories** (more accessories see chapter K11)

Article	Order No.
Connection cable (5 m):	
• VK-M12-5-g	2112-00005-0500
• VK-M12-5-w	2112-00005-1500



- ▶ Inductive switches and ring sensors
- ▶▶ Inductive ring sensors

## IRS series

with 4-pin connector M12

### Application

- Ejection control in oil mist ambiance

### Specifications

Circuit	Trigger electronics
Operating voltage	12 – 24 VDC
Current consumption	appr. 50 mA
Mode of operation	dynamic
Sensitivity	adjustable by 270° pot
Output with LED	PNP
Load current	100 mA short-circuit proof
Frequency	max. 200 Hz
Temperature range	0 °C – 60 °C
EMC according to 2004/108/EG	EN 61000... C€
System of protection	IP 60

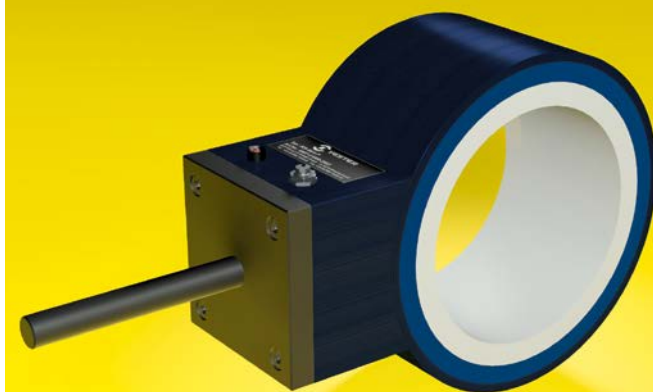

### Resolution

Diameter A* [mm]:	40	84	155
Part diameter [mm]:	1.5	3	6

\*) A = Test diameter without protective tube

### Pin configuration

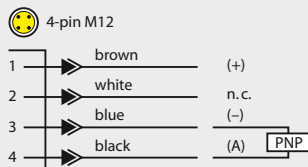

### Article

### Order No.

Ring sensor:	
• IRS-40/4-P	8907-41000-1003
• IRS-84/4-P	8907-41000-2003
• IRS-155/4-P	8907-41000-3003

### Accessories (more accessories see chapter K11)

### Article

### Order No.

Protective tube:	
• ST 40	2305-28174-0010
• ST 84	2305-28338-4010
• ST 155	2305-28379-9010
Connection cable:	
• VK-M12-5-g (5 m)	2112-00005-0500
• VK-M12-5-w (5 m)	2112-00005-1500
Extension cable 4-pin M12:	
• VK-M12-g/M12 (2 m)	2112-00002-0404
• VK-M12-g/M12 (5 m)	2112-00005-0404

### IRS-40:

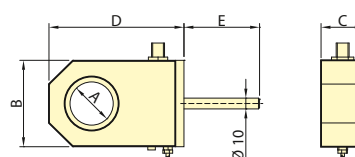

### IRS-84 | IRS-155:

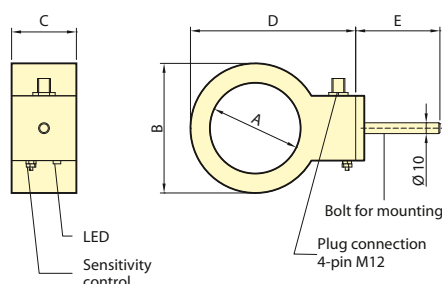

Dimensions [mm]	Ring sensor		
	IRS 40	IRS 84	IRS 155
A	40	84	155
B	80	120	200
C	40	60	60
D	125	157	237
E	70	70	90

### Protective tube

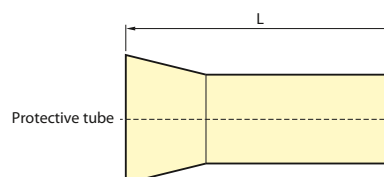

Dimension [mm]	Protective tube		
	ST 40	ST 84	ST 155
L	200	250	300

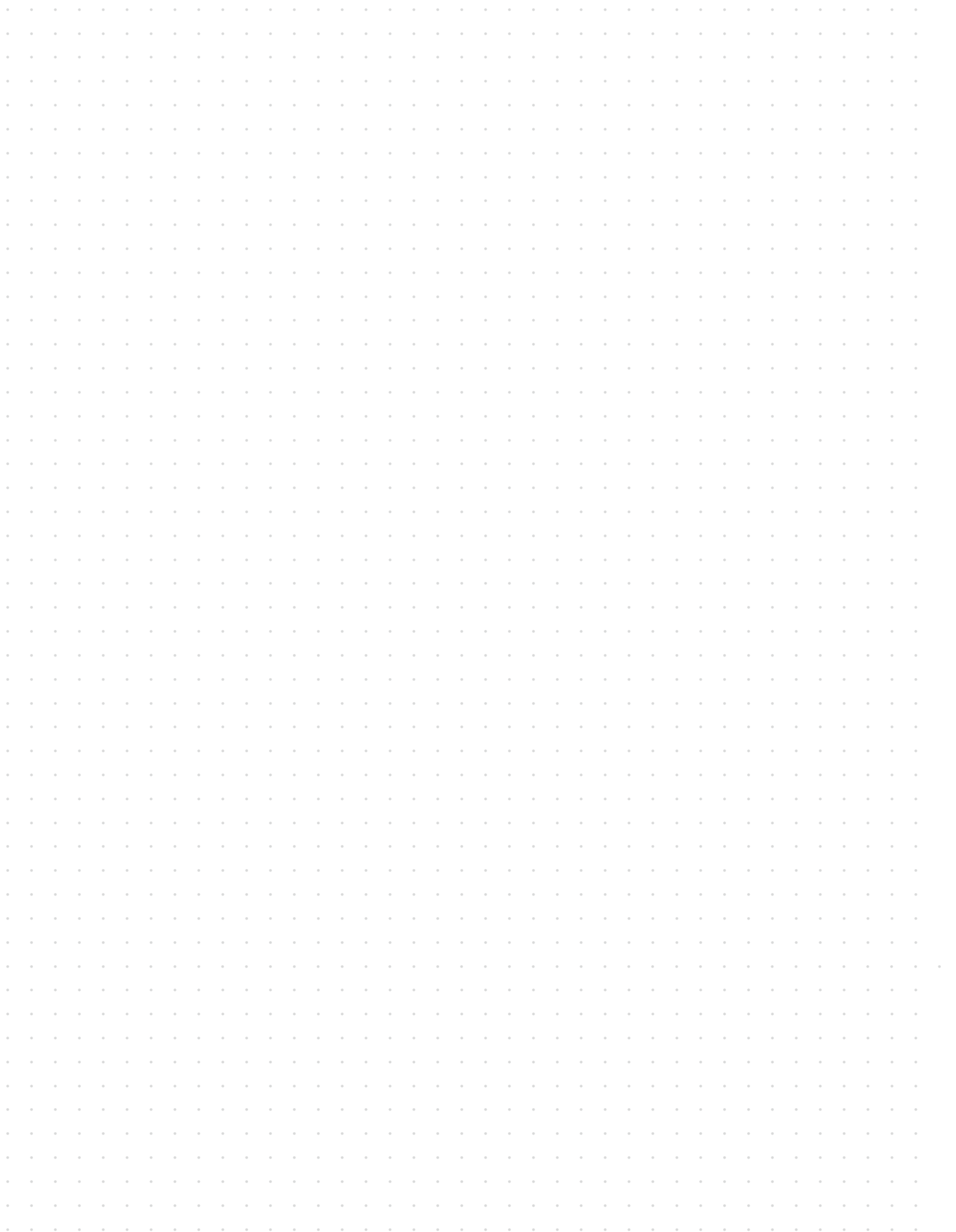

## Contact sensors

Contact sensors are robust mechanical sensors which supply a precise signal upon contact with metallically conductive objects and machine parts which can then be converted into an industrially useable PNP signal by the back-end trigger electronics.



Sensor of the IG/S2 series



Trigger electronics S2-B-4-P2

**IG-S2 series**

**with 2-pin miniature connector S2**

Sensor type	Ram identifier	Order No.	Drawing
IG-4-12/S2	/standard (ST 37)	6804-12000-2000	
IG-5-30/S2	/standard (ST 37)	6805-30000-2000	
IG-5-30/D/HSS/S2	/D/HSS	6805-30010-2000	
IG-6-30/S2	/standard (ST 37)	6806-30000-2000	
IG-6-30/D/HSS/S2	/D/HSS	6806-30010-2000	
IG-6-30/I/HSS/S2	/I/HSS	6806-30020-2000	
IG-M8-30/S2	/standard (ST 37)	6808-30000-2000	
IG-M8-30/D/HSS/S2	/D/HSS	6808-30010-2000	
IG-M8-30/I/HSS/S2	/I/HSS	6808-30020-2000	

Spring-loaded ram	IG-4-12	IG-5-30	IG-6-30	IG-M8-30
Spring force	0.5 N	2.5 N	2 N	2 N
Range of spring	0.5 mm	2 mm	2 mm	2 mm

- ▶ Contact sensors
- ▶ Amplifier

## S2-B-4-P2

with 4-pin connector M12

### Application

- Rivet control

### Specifications

Circuit	Trigger electronics
Operating voltage	12 – 24 VDC
Current consumption	< 15 mA
Mode of operation	static, upon contact with reference potential
Output with LED	PNP
Min. time of contact	0.3 ms
Contact resistance	< 3 KΩ at 24 VDC
Load current	200 mA short-circuit proof
Pulse length	10 ms or internally adjustable
Frequency	max. 1 KHz, depending on pulse length
Temperature range	0 °C – 60 °C (Amplifier), 0 °C – 150 °C (Sensor)
EMC according to 2004/108/EG	EN 61000... C€
System of protection	IP 60

### Pin configuration

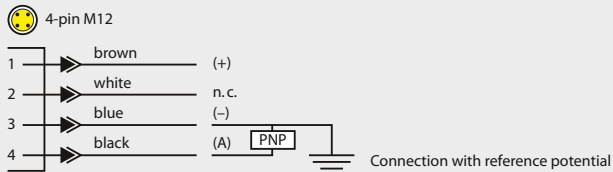

### Article

### Order No.

Trigger electronics:	
• S2-B-4-P2	2000-00008-4114

### Accessories (more accessories see chapter K11)

Article	Order No.
Connection cable 5 m:	
• VK-M12-5-g	2112-00005-0500
• VK-M12-5-w	2112-00005-1500
Extension cable 4-pin M12:	
• VK-M12-g/M12 (2 m)	2112-00002-0404
• VK-M12-g/M12 (5 m)	2112-00005-0404

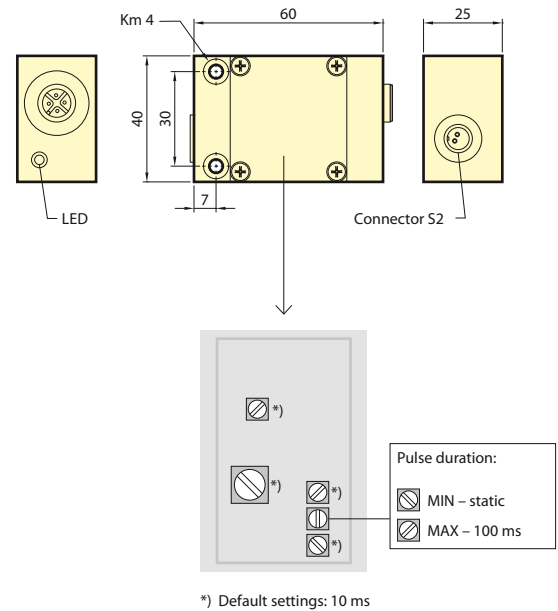

**S2-B-5-P2**

**with 5-pin connector M16**

**Application**

- Rivet control

**Specifications**

Circuit	Trigger electronics
Operating voltage	12 – 24 VDC
Current consumption	< 15 mA
Mode of operation	static, upon contact with reference potential
Output with LED	PNP
Min. time of contact	0.3 ms
Contact resistance	< 3 KΩ at 24 VDC
Load current	200 mA short-circuit proof
Pulse length	10 ms or internally adjustable
Frequency	max. 1 KHz, depending on pulse length
Temperature range	0 °C – 60 °C (Amplifier), 0 °C – 150 °C (Sensor)
EMC according to 2004/108/EG	EN 61000... C€
System of protection	IP 60



**Pin configuration**

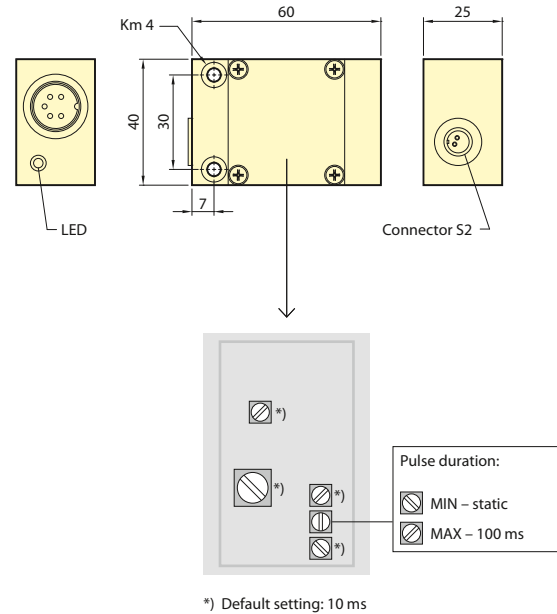
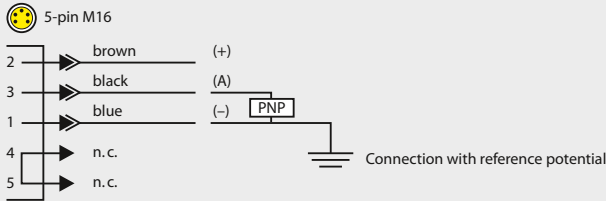

Article	Order No.
Amplifier 5-pin M16:	
• S2-B-5-P2	2000-00008-0114

**Accessories** (more accessories see chapter K11)

Article	Order No.
Connection cable:	
• VK-D/F-St-A (2 m)	2105-00002-0600
• VK-D/F-St-A (5 m)	2105-00005-0600
Extension cable 5/6-pin M16:	
• VK-D/D (2 m)	2104-00002-0606
• VK-D/D (5 m)	2104-00005-0606



## Fibre optics, reflex scanners, amplifiers

Fibre optics are available in many sizes with appropriate scanning ranges and cable lengths.

Due to their compact designs and dimensions they are particularly suitable where space is scarce or for applications with high ambient temperatures.

Laser reflex scanners of the LRT series with background suppression and large scanning range ensure safe and stable scans. Easy setup with visible laser light.

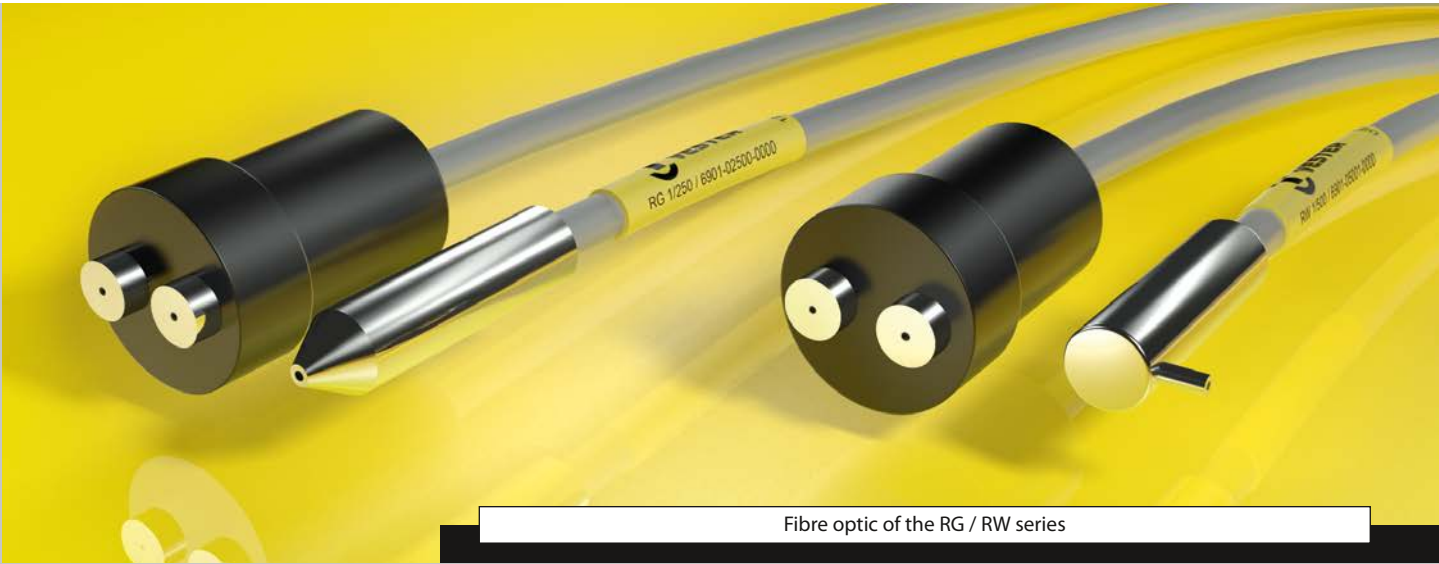

Fibre optic of the RG / RW series



Chopped light amplifier W-R-4-P2 with adapter for fibre optics support



Laser reflex scanner of the LRT series with red light laser for easy setup procedures

**RG / RW series**

Sensor type	Scanning range <sup>1)</sup>	Order No.	Drawing
RG 1/500	2 – 15 mm	6901-05000-0000	
RG 2/500	20 – 150 mm	6902-05000-0000	
RG 3/500	30 – 250 mm	6903-05000-0000	
RW 1/500	2 – 15 mm	6901-05001-0000	
RW 2/500	15 – 100 mm	6902-05001-0000	
RW 3/500	15 – 125 mm	6903-05001-0000	

1) Related to Kodak paper white mat, 200 g/sqm.  
 Other fibre lengths (250, 750, 1000 mm) on request.

**Specifications**

Reduction factor for scan range	metal glossy: 1, 2 – 3 / rusty: 0.2 – 0.6
Temperature range	-10 °C bis +250 °C

**Accessories** (more accessories see chapter K11)

Article	Order No.
Chopped light amplifier:	
• W-R-5-P2 5-pin	2000-00000-0064
• W-R-4-P2 4-pin	2000-00000-4064

- ▶ Fibre optics, reflex scanners
- ▶▶ Chopped light amplifier

## W-R-4-P2

with 4-pin connector M12

### Application

- Amplifier for all fibre optics of the RG/RW series

### Specifications

Circuit	Chopped light trigger
Operating voltage	12 – 24 VDC
Current consumption	70 mA
Mode of operation	static / dynamic
Pulse extension	max. 100 ms
Sensitivity	with 270° pot
Output with LED	PNP <sup>1)</sup>
Function	bright / dark function
Load current	200 mA short-circuit proof
Corrective factor for scan range	metal glossy: 1, 2 – 3 / rusty: 0.2 – 0.6
Frequency	4 KHz
Temperature range	0 °C – 60 °C
EMC according to 2004/108/EG	EN 61000... CEE
System of protection	IP 64

1) NPN amplifier on request

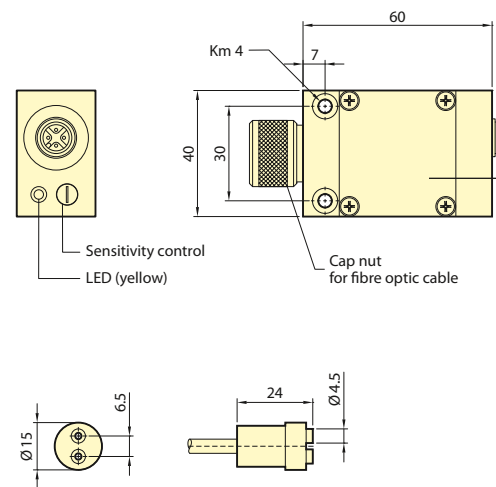

### Pin configuration

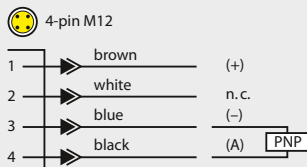

### Article

### Order No.

Amplifier 4-pin M12:	
• W-R-4-P2	2000-00000-4064

### Accessories (more accessories see chapter K11)

Article	Order No.
Connection cable 5 m:	
• VK-M12-5-g	2112-00005-0500
• VK-M12-5-w	2112-00005-1500
Extension cable 4-pin M12:	
• VK-M12-g/M12 (2 m)	2112-00002-0404
• VK-M12-g/M12 (5 m)	2112-00005-0404

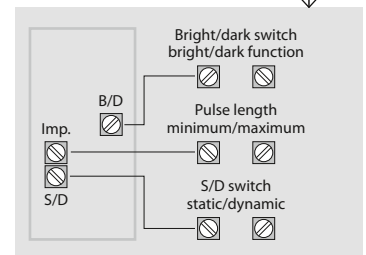

- ▶ Fibre optics, reflex scanners
- ▶ Chopped light amplifier

## W-R-5-P2

with 5-pin connector M16

### Application

- Amplifier for all fibre optics of the RG/RW series

### Specifications

Circuit	Chopped light trigger
Operating voltage	12 – 24 VDC
Current consumption	70 mA
Mode of operation	static / dynamic
Pulse extension	max. 100 ms
Sensitivity	with 270° pot
Output with LED	PNP <sup>1)</sup>
Function	bright / dark function
Load current	200 mA short-circuit proof
Corrective factor for scan range	metal glossy: 1, 2 – 3 / rusty: 0.2 – 0.6
Frequency	4 KHz
Temperature range	0 °C – 60 °C
EMC according to 2004/108/EG	EN 61000... C E
System of protection	IP 64

1) NPN amplifier on request

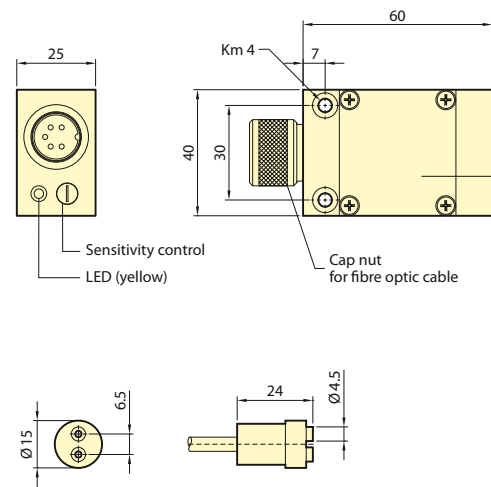

### Pin configuration

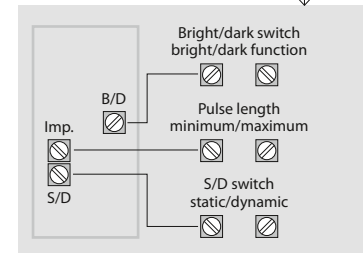
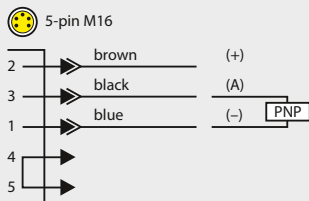

### Article Order No.

Amplifier 5-pin M16:	
• W-R-5-P2	2000-00000-0064

### Accessories (more accessories see chapter K11)

Article	Order No.
Connection cable 5/6-pin M16 :	
• VK-D/F-St-A (2 m)	2105-00002-0600
• VK-D/F-St-A (5 m)	2105-00005-0600
Extension cable 5/6-pin M16:	
• VK-D/D (2 m)	2104-00002-0606
• VK-D/D (5 m)	2104-00005-0606

- ▶ Fibre optics, reflex scanners
- ▶ Laser reflex scanners

## LRT series

with 4-pin connector M8

### Application

- Laser reflex scanners with background suppression



### Specifications

Circuit	Laser chopped light trigger
Wavelength	650 nm, red light
Light spot diameter	0.5 mm in focus (35 mm)
Laser output power	< 1 mW, laser class 2

#### Caution! Never look directly into laser beam!

Operating voltage	10 – 30 VDC
Current consumption	< 30 mA
Mode of operation	static
Sensitivity	Teach-in
Output yellow LED	PNP <sup>1)</sup>
Function	bright / dark function
Load current	100 mA short-circuit proof
Stability indicator	LED green
Frequency	1 KHz
Temperature range	0 °C – 60 °C
EMC according to 2004/108/EG	EN 61000... CEE
System of protection	IP 67

1) NPN amplifier on request

**Scanning range** 20 – 60 mm

Related to Kodak grey card 90 % reflection

Correction factor for:

- metal glossy 1.2 ... 1.6
- aluminium, black anodised 1.2 ... 1.8

### Pin configuration

4-pin M8

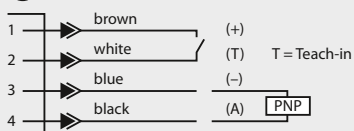

### Article

### Order No.

Laser reflex scanners:

- LRT 6K/150 6501-00000-0004

### Accessories (more accessories see chapter K11)

### Article

### Order No.

Connection cable 3 m:

- VK-M8-4-w 2111-00003-1400

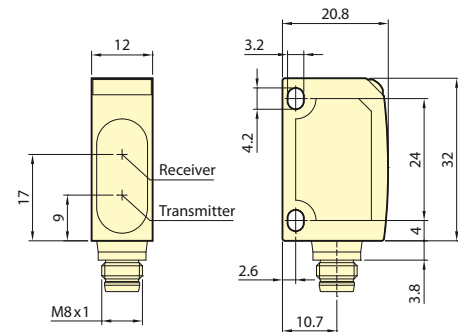

- ▶ Fibre optics, reflex scanners
- ▶ Laser reflex scanners

## LRT series

with 4-pin connector M12

### Application

- Laser reflex scanners with background suppression



### Specifications

Circuit	Laser chopped light trigger
Wavelength	660 nm, red light
Light spot diameter	see scanning range table
Laser output power	< 1 mW, laser class 2
<b>Caution! Never look directly into laser beam!</b>	
Operating voltage	10 – 30 VDC
Current consumption	< 50 mA
Mode of operation	static
Sensitivity	Potentiometer
Output yellow LED	PNP <sup>1)</sup>
Function	bright / dark function
Load current	200 mA short-circuit proof
Stability indicator	LED red
Frequency	2.5 KHz
Temperature range	0 °C – 45 °C
EMC according to 2004/108/EG	EN 61000... CE
System of protection	IP 67

1) NPN amplifier on request

Scanning range [mm]	30	50	60	80	100	150	200	300
Light spot [mm]	LRT 26K/150	1.8	0.7	0.1	1.1	2.5		
	LRT 26K/300	5x1.8			4x1.5	3.8x1.2	3x1	

### Correction factor for...

• metal glossy	1.2 ... 1.6
• aluminium, black anodised	1.2 ... 1.8

### Pin configuration

4-pin M12

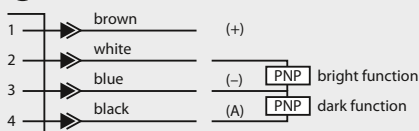

### Article Order No.

Laser reflex scanners:

• LRT 26K/150	6501-00000-0002
• LRT 26K/300	6501-00000-0003

### Accessories (more accessories see chapter K11)

#### Article Order No.

Connection cable 5 m:

• VK-M12-5-g	2112-00005-0500
• VK-M12-5-w	2112-00005-1500

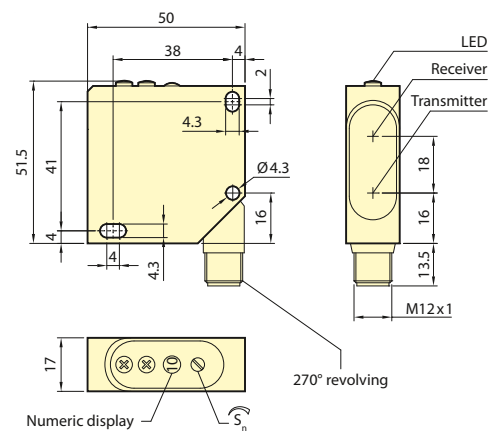



## Sensors with 0 – 10 V analogue output for metrological applications

# K10

Sensors with an analogue output are increasingly used for high-quality and at the same time manageable metrological applications, wherever space is limited or robust sensors in a difficult ambiance are required, e.g. for applications inside or close by the stamping tool.

For the precise feed control fork light barriers of the PSA series with cleaning nozzles are qualified well. For measuring the "BDC" and also for an analogue "double sheet control" inside the tool inductive analogue sensors are primarily used. Both sensor types can be combined with the VCA 400 analogue controller, an inexpensive subsystem for the analogue signal pre-processing in combination with already existing process monitoring systems.



- ▶ Sensors with 0 – 10 V analogue output for metrological applications
- ▶ Infrared fork light barriers with separate amplifier

## PSA 8 mm series

## with 4-pin connector M12

### Application

- Fork light barriers with cleaning nozzles and analogue amplifier: e.g. for metrological applications inside the stamping tool

### Specifications

Circuit	Amplifier with analogue output
Operating voltage	24 VDC $\pm 10\%$
Current consumption	< 80 mA
Mode of operation	static
Output $U_a$	0 – 10 V, Idle speed $U_a = 11.5$ V
Current output (optional)	0 – 20 mA
Load resistance $R_L$	> 1 K $\Omega$
Measuring range	see table
Repeatability	$\leq 4\%$ (from $U_a$ max.)
Linearity error	$\leq 3\%$ (from $U_a$ max.)
Temperature range	20 °C – 50 °C
EMC according to 2004/108/EG	EN 61000... C $\epsilon$
System of protection	IP 65

### Pin configuration

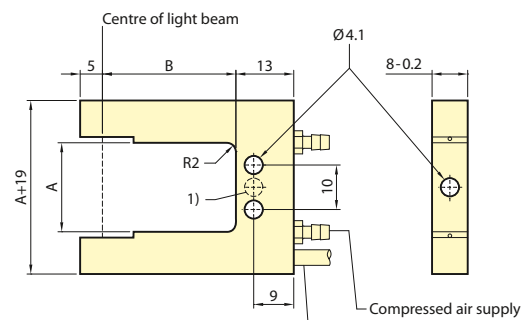
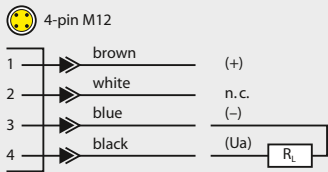

1) Central bore  $\varnothing 4.1$  for  $A \leq 10$   
The bore  $\varnothing 4.1$  with spacing 10 will be omitted here

A [mm]:	10	10	20	30
B [mm]:	15	30	30	30

### Output characteristic

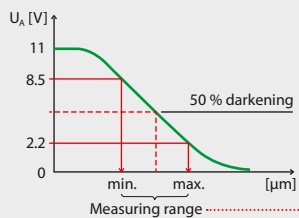

### Measuring range [µm]

Fork width A [mm]	Aperture [mm]		
	0.8	1.0	1.4
10	250	300	500
20	250	300	500
30	300	350	500

### Amplifier AV-4 with analogue output



### Article

### Order No.

#### Fork light barrier with cleaning nozzles:

• PSA-10-15-08/R/AV-4	6331-10008-4177
• PSA-10-15-10/R/AV-4	6331-10010-4177
• PSA-10-15-14/R/AV-4	6331-10014-4177
• PSA-10-30-08/R/AV-4	6332-10008-4177
• PSA-10-30-10/R/AV-4	6332-10010-4177
• PSA-10-30-14/R/AV-4	6332-10014-4177
• PSA-20-30-08/R/AV-4	6334-10008-4177
• PSA-20-30-10/R/AV-4	6334-10010-4177
• PSA-20-30-14/R/AV-4	6334-10014-4177
• PSA-30-30-08/R/AV-4	6336-10008-4177
• PSA-30-30-10/R/AV-4	6336-10010-4177
• PSA-30-30-14/R/AV-4	6336-10014-4177

### Accessories (more accessories see chapter K11)

### Article

### Order No.

#### Connection cable 5 m (with free cable end):

• VK-M12-5-g	2112-00005-0500
• VK-M12-5-w	2112-00005-1500

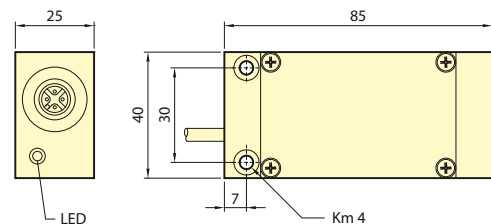

- ▶ Sensors with 0 – 10 V analogue output for metrological applications
- ▶ Infrared fork light barriers with separate amplifier

## PSA 8 mm series

## with 5-pin connector M16

### Application

- Fork light barriers with cleaning nozzles and analogue amplifier: e.g. for metrological applications inside the stamping tool

### Specifications

Circuit	Amplifier with analogue output
Operating voltage	24 VDC ± 10 %
Current consumption	< 80 mA
Mode of operation	static
Output U <sub>a</sub>	0 – 10 V, Idle speed U <sub>a</sub> = 11.5 V
Current output (optional)	0 – 20 mA
Load resistance R <sub>L</sub>	> 1 KΩ
Measuring range	see table
Repeatability	≤ 4 % (from U <sub>a</sub> max.)
Linearity error	≤ 3 % (from U <sub>a</sub> max.)
Temperature range	20 °C – 50 °C
EMC according to 2004/108/EG	EN 61000... CE
System of protection	IP 65

### Pin configuration

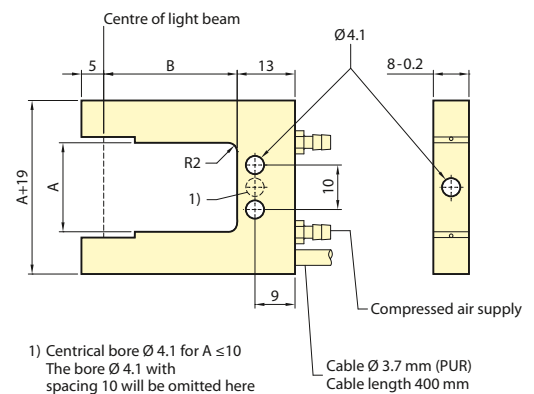
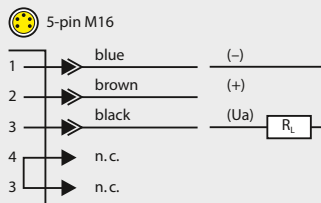

A [mm]:	10	10	20	30
B [mm]:	15	30	30	30

### Output characteristic

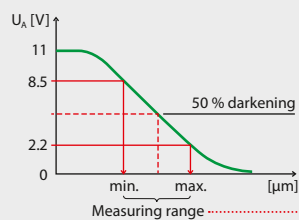

### Measuring range [µm]

Fork width A [mm]	Aperture [mm]		
	0.8	1.0	1.4
10	250	300	500
20	250	300	500
30	300	350	500

### Amplifier AV-5 with analogue output



### Article

### Order No.

#### Fork light barrier with cleaning nozzles:

• PSA-10-15-08/R/AV-5	6331-10008-0177
• PSA-10-15-10/R/AV-5	6331-10010-0177
• PSA-10-15-14/R/AV-5	6331-10014-0177
• PSA-10-30-08/R/AV-5	6332-10008-0177
• PSA-10-30-10/R/AV-5	6332-10010-0177
• PSA-10-30-14/R/AV-5	6332-10014-0177
• PSA-20-30-08/R/AV-5	6334-10008-0177
• PSA-20-30-10/R/AV-5	6334-10010-0177
• PSA-20-30-14/R/AV-5	6334-10014-0177
• PSA-30-30-08/R/AV-5	6336-10008-0177
• PSA-30-30-10/R/AV-5	6336-10010-0177
• PSA-30-30-14/R/AV-5	6336-10014-0177

### Accessories (more accessories see chapter K11)

### Article

### Order No.

#### Connection cable (with free cable end):

• VK-D/F-St-A (2 m)	2105-00002-0600
• VK-D/F-St-A (5 m)	2105-00005-0600

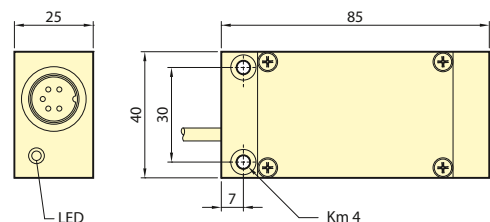

- ▶ Sensors with 0 – 10 V analogue output for metrological applications
- ▶ Inductive analogue sensors

**IS-A series**
**with free cable end**

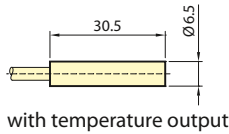
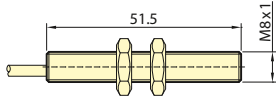
Sensor type	Linearity range $S_1$ flush	Order No.	Drawing
IS-6,5-30-1,5-A	0.5 – 2 mm Rated operating distance $S_e = 1.25$ mm (ST37)	6606-30120-0000	
IS-M8-51-1-A	0.5 – 1.5 mm Rated operating distance $S_e = 1$ mm (ST37)	6608-51100-0000	

**Specifications**

Operating voltage	24 VDC $\pm$ 10 %
Output voltage $U_a$	0 – 10 VDC
Load resistance $R_L$	> 5 k $\Omega$
Limit frequency	1 KHz
Max. temperature drift at $S_1$	$\pm$ 5 % (from $U_a$ max.)
Linearity error	$\pm$ 3 % (from $U_a$ max.)
Repeatability for IS-6,5-30-1,5-A	$\leq$ 3 % (from $U_a$ max.)
Temperature range	10 °C – 60 °C
EMC according to 2004/108/EG	EN 61000... C $\epsilon$
System of protection	IP 67

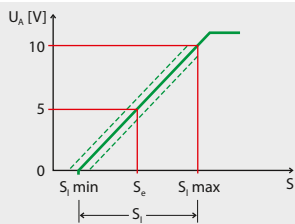
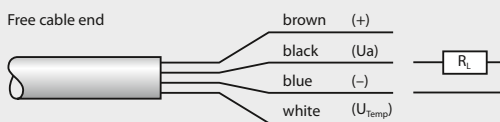
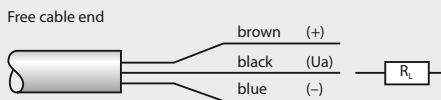
**Cable output (IS-6,5-30-1,5-A)**

**Cable output (IS-M8-51-1-A)**

**Accessories** (more accessories see chapter K11)

Article	Order No.
Analogue controller VCA 400 (Connection to VCA 400 with 3-pole M8 connector)	4440-00010-0000

- ▶ Sensors with 0 – 10 V analogue output for metrological applications
- ▶ Inductive analogue sensors

## IS-A series

## with cable output

### Application

- Double sheet control
- Measuring inside the stamping tool

### Specifications

Circuit	Analogue amplifier
Operating voltage	15 – 30 VDC, reverse polarity protected
Output voltage $U_a$	0 – 10 VDC
Load resistance $R_L$	1 k $\Omega$ min.
Limit frequency	500 Hz
Linearity range $S_i$	0 – 2 mm / quasi flush
Max. temperature drift at $S_i$	$\pm 5$ % (from $U_a$ max.)
Linearity error	$\pm 3$ % (from $U_a$ max.)
Repeatability	$\leq 3$ % (from $U_a$ max.)
Rated operating distance Se	1,00 mm, ST37
Temperature range	10 °C – 60 °C
Short circuit proof	yes
EMC according to 2004/108/EG	EN 61000... C $\epsilon$
System of protection	IP 67

**Note:** Effective distance  $S_e = 1,00$  mm by attenuation at BDC (reference: ST37).

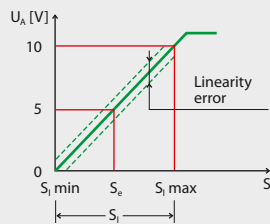

### Cable output

Free cable end

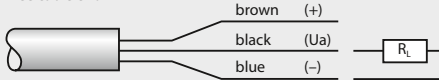

### Pin configuration

3-pin M8

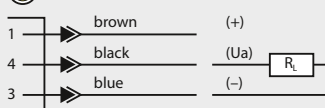

### Article

### Order No.

with cable output:

• IS-8-16-1-A 6608-16100-0000

with cable output and 3-pole M8 connector:

• IS-8-16-1-A/RS-M8 6608-16100-3000

### Accessories (more accessories see chapter K11)

### Article

### Order No.

Analogue controller VCA 400 4440-00010-0000  
(Connection to VCA 400 with 3-pole M8 connector)

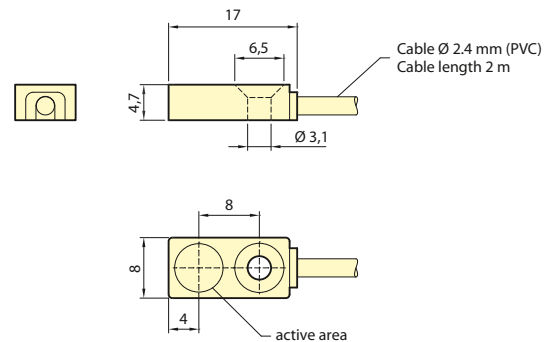

### 3-pole M8 connector

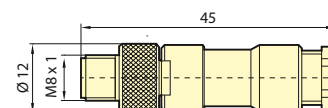

### Application example

see VCA 400 under K10.6



- ▶ Sensors with 0 – 10 V analogue output for metrological applications
- ▶ Inductive analogue sensors

## ISS-A series

with 3-in connector M8

### Application

- Double sheet control
- Measuring inside the stamping tool

### Specifications

Circuit	Analogue amplifier
Operating voltage	24 VDC $\pm 10\%$
Output voltage $U_a$	0 – 10 VDC
Load resistance $R_L$	5 k $\Omega$ min.
Limit frequency	1 KHz
Linearity range $S_i$	0.5 – 2 mm / flush mountable
Max. temperature drift at $S_i$	$\pm 5\%$ (from $U_a$ max.)
Linearity error	$\pm 3\%$ (from $U_a$ max.)
Repeatability	$\leq 3\%$ (from $U_a$ max.)
Rated operating distance $S_e$	1.25 mm, mit ST37
Max. operating range drift T at $S_e$	$\pm 0.125$ mm
Temperature range	10 °C – 60 °C
EMC according to 2004/108/EG	EN 61000... C $\epsilon$
System of protection	IP 67

**Instruction:** Rated operating distance  $S_e = 1.25$  mm with covering in BDC (Reference: ST37).

### Pin configuration

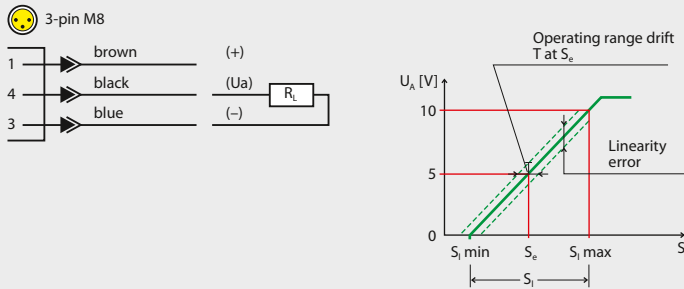

### Cable output

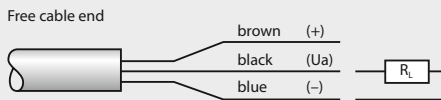

### Article Order No.

with 3-pin connector M8:  
 • ISS-20-30-1-A 6620-30151-0000

with cable output:  
 • IS-20-30-1-A 6620-30150-0000

### Accessories (more accessories see chapter K11)

Article Order No.  
 Analogue controller VCA 400 4440-00010-0000

Connection cable on VCA 400:  
 • VK-M8-g/M8-g (1 m) 2111-00001-0303  
 • VK-M8-g/M8-g (2 m) 2111-00002-0303  
 • VK-M8-w/M8-g (1 m) 2111-00001-1303  
 • VK-M8-w/M8-g (2 m) 2111-00002-1303

Connection cable 5 m:  
 • VK-M8-g 2111-00005-0300  
 • VK-M8-w 2111-00005-1300

Mounting bracket for tool:  
 • HD-IS-O (top) 2200-00011-0000  
 • HD-IS-U (bottom) 2200-00012-0000



ISS-20-30-1-A:

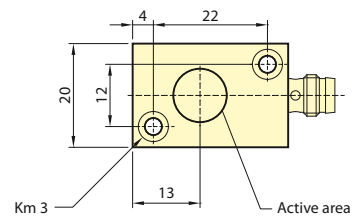
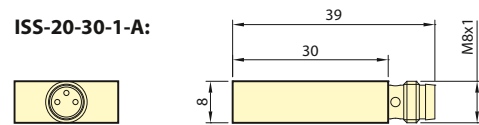

IS-20-30-1-A:

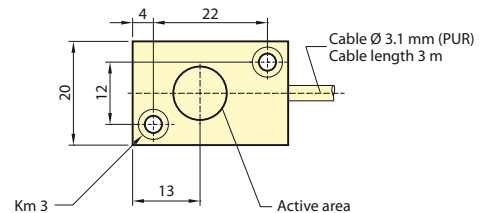
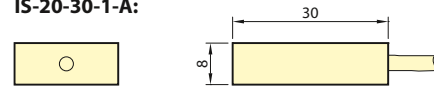

HD-IS-O

HD-IS-U

### Application example

see VCA 400 under K10.6



- ▶ Sensors with 0 – 10 V analogue output for metrological applications
- ▶ Analogue controller

## VCA 400



### Application

- Analogue controller VCA 400, Subsystem for controlling e.g. punch waste, double sheet and spring rupture

### Specifications

Operating voltage	24 VDC $\pm$ 10 %
Current consumption	max. 50 mA, without sensors
Input (IN1 - 4)	0 – 10 VDC
Measuring range	1.5 mm, linear
Output (A)	PNP, max. 500 mA, short-circuit proof
Temperature range	0 °C – 60° C
EMC according to 2004/108/EG	EN 61000... C E
System of protection	IP 67

### Pin configuration

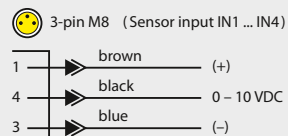
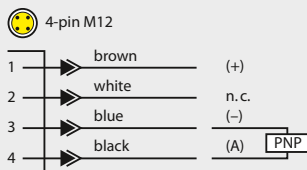

### Article

Analogue controller VCA 400

### Order No.

4440-00010-0000

### Accessories (more accessories see chapter K11)

Connection cable VCA 400:

• VK-M8-g/M8-g (1 m)	2111-00001-0303
• VK-M8-g/M8-g (2 m)	2111-00002-0303
• VK-M8-w/M8-g (1 m)	2111-00001-1303
• VK-M8-w/M8-g (2 m)	2111-00002-1303

Connection cable M12 (5 m):

• VK-M12-5-g	2112-00005-0500
• VK-M12-5-w	2112-00005-1500

- 4 analogue sensor inputs (0 – 10 VDC), 4 inputs control 1 output, i.e. only 1 input is needed by tool control.
- Analogue signal pre-processing by  $\mu$ -controller, PNP output for back-end tool control!
- Existing process controls can be upgraded with it.
- Easy distance setting by optical signal indicator and AUTOSET.
- Navigation with 4 keys and display.
- Cycle-to-cycle control (actual/set value autotracking with every cycle).
- The tolerance can be set / edited individually for each sensor.
- No start of the press in case of faulty sensor adjustment.
- High monitoring accuracy.
- Navigation in German, English, French and Italian.

Separate documentation on request.

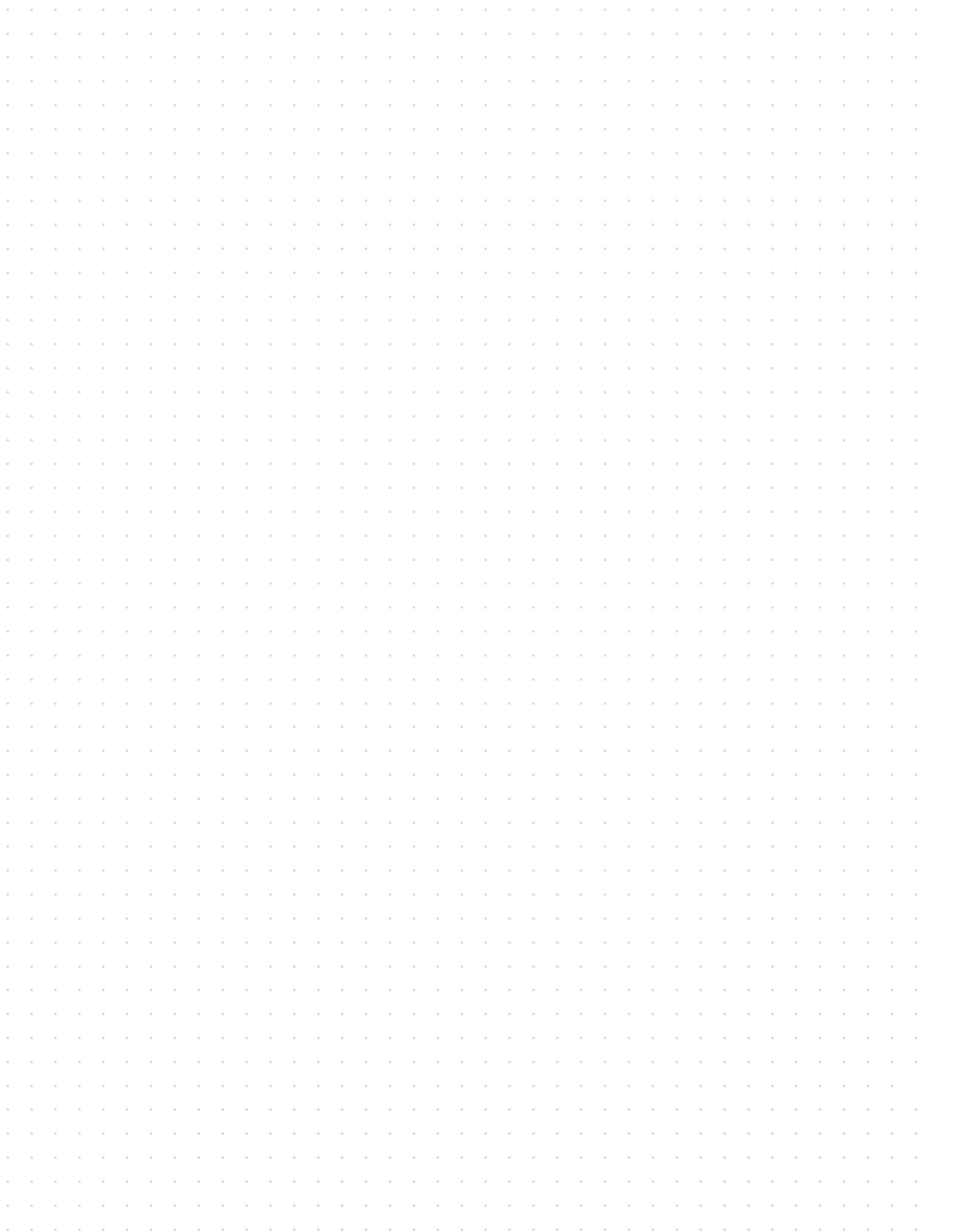

What you need besides cables!



Workshop adapter: 8-fold sensor / actuator adapter with integrated centre plug-in system WS-8



Sensor tester SPG 10

## VK series

Cable type	Sensor side	Drawing	Device side	Length	Order No.
VK-M8-g	3-pin M8 straight plug		free cable end	2 m 5 m	2111-00002-0300 2111-00005-0300
VK-M8-w	3-pin M8 angled plug		free cable end	2 m 5 m	2111-00002-1300 2111-00005-1300
VK-M8-g-S (shielded)	3-pin M8 straight plug		free cable end	2 m 5 m	2111-00902-0300 2111-00905-0300
VK-M8-w-S (shielded)	3-pin M8 angled plug		free cable end	2 m 5 m	2111-00902-1300 2111-00905-1300
VK-M8-g/M8-g	3-pin M8 straight plug		3-pin M8	1 m 2 m	2111-00001-0303 2111-00002-0303
VK-M8-w/M8-g	3-pin M8 angled plug		3-pin M8	1 m 2 m	2111-00001-1303 2111-00002-1303
VK-M8-g/M12	3-pin M8		4-pin M12	2 m 5 m	2111-00002-0304 2111-00005-0304
VK-M8-g/RS	3-pin M8		5-pin M16	2 m 5 m	2111-00002-0305 2111-00005-0305
VK-M8-g-2/M12	2x 3-pin M8		4-pin M12	2 m	2111-71002-0304
VK-M8-g-2/RS	2x 3-pin M8		5-pin M16	2 m	2111-00102-0305
VK-M12-5-g	5-pin M12 straight plug		free cable end	2 m 5 m	2112-00002-0500 2112-00005-0500
VK-M12-5-w	5-pin M12 angled plug		free cable end	2 m 5 m	2112-00002-1500 2112-00005-1500
VK-M12-g/M12	4-pin M12		4-pin M12	2 m 5 m	2112-00002-0404 2112-00005-0404
VK-M12-g/RS	4-pin M12		5-pin M16	2 m 5 m	2112-00002-0405 2112-00005-0405
VK-D/F-St-A (shielded)	5/6-pin M16		free cable end	2 m 5 m	2105-00002-0600 2105-00005-0600
VK-D/D (shielded)	5/6-pin M16		5/6-pin M16	2 m 5 m	2104-00002-0606 2104-00005-0606
VK-D/M12	5/6-pin M16		4-pin M12	2 m	2119-00002-0504
<b>Extension cables for single-beam light barriers (plug-in type) -S2</b>					
VK-S2/4	4-pin M9		4-pin M9	1 m	2115-00001-0404
VK-S2/7	7-pin M9		7-pin M9	1 m	2115-00001-0707

## WRA-8

### Specifications

Operating voltage with green LED display	12 – 24 VDC
Operating current (total current)	max. 4 A
Operating current per sensor / actuator channel	max. 2 A
LED status indicator yellow	for signal 1 and 2
System of protection	IP65
Temperature range	0 °C – 60 °C



### Pin configuration (8 x 5-pin M12)

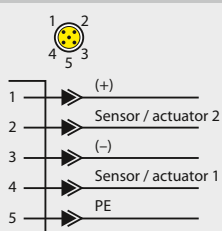

### Cable connection / internal terminal clamps

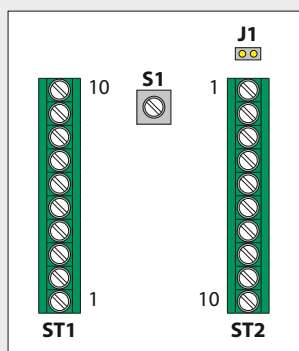

**J1** Jumper GND/PE (delivery condition: jumper inserted)

**S1** Mode switch for analogue applications  
 Digital applications (with LED) : default  
 Analogue applications (no LED)

ST1	Descript.	Colour	ST2	Descript.	Colour
1	+ Ub	BN	1	S/A 1/2	
2	+ Ub	GY-PK	2	S/A 2/2	
3	S/A 8/4	VT	3	S/A 3/2	
4	S/A 7/4	BK	4	S/A 4/2	
5	S/A 6/4	RT	5	S/A 5/2	
6	S/A 5/4	PK	6	S/A 6/2	
7	S/A 4/4	GY	7	S/A 7/2	
8	S/A 3/4	YE	8	S/A 8/2	
9	S/A 2/4	GN	9	GND	RT-BU/BU
10	S/A 1/4	WH	10	PE	

Article	Order No.
Workshop adapters WRA-8	4145-18600-0000

Accessories	
Connection cable	on request

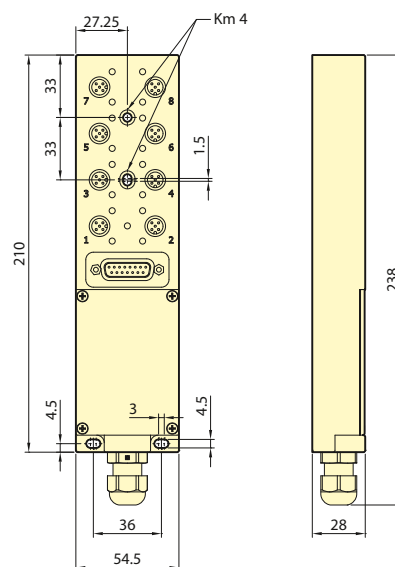

The workshop adapter of the WRA-8 series is an 8-fold sensor / actuator panel with an integrated central plug-in system.

Up to 8 individual sensors or actuators can be plugged in separately or combined centrally by means of an adapter and contacted via a common connection cable.

For joining them there is an adapter – the WS-8 central tool plug-in system – available under K11.3, which may be coupled directly to the WRA-8.

That way the wiring on a press can be reduced significantly and the connection to the tool is much more easy.

Both digital sensors (with LED display) and analogue sensors (without LED display) can be connected.

**WS-8**



**Cable connection / internal terminal clamps**

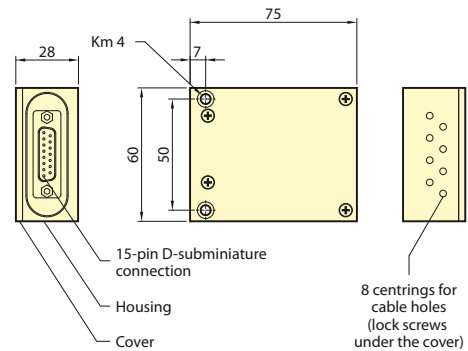
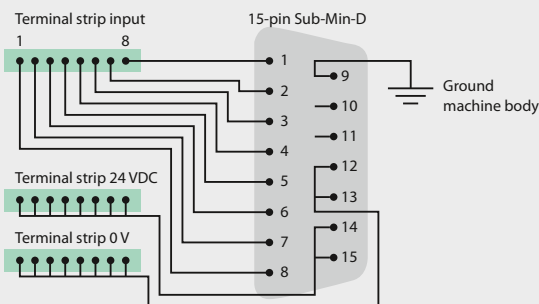

Adapter with 3 x 8-fold terminal for a permanent installation of the sensors used in the stamping tool; a maximum of 8 sensors (light barriers, inductive switches or contact sensors) can be connected.

Connection to the tool control system is made using a 15-pole D-subminiature multipin connection plus a link cable to the workshop adapter of the system.

Especially when using several sensors per tool, the WS-8 adapter can help to realise an elegant and clean solution that will bring huge time advantages with every tool change.

Article	Order No.
Adapter WS-8	2241-08000-1500

**Accessories**

Article	Order No.
Connection cable VK-WS-8 (1 m)	2141-00001-1515



## SPG 10



### Application

- Testing or adjusting PNP/NPN sensors

### Specifications

Operating voltage	230 VAC
Sensor voltage	24 VDC
Max. power consumption	appr. 400 mA
Temperature range	0 °C – 60 °C

Control panel:

- 1 Status LED
- 2 Plug socket for sensors with a 5- or 6-pin connector
- 3 Activation check (important only for Vester control unit)
- 4 Connecting terminal for sensors with free cable end
- 5 Volume control for piezo sound transducer
- 6 Piezo sound transducer

### Pin configuration

6-pin M16 (pin 6 not assigned)

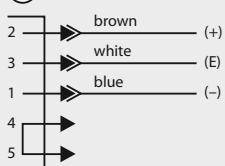

### Article

SPG 10

### Order No.

4410-00000-0000

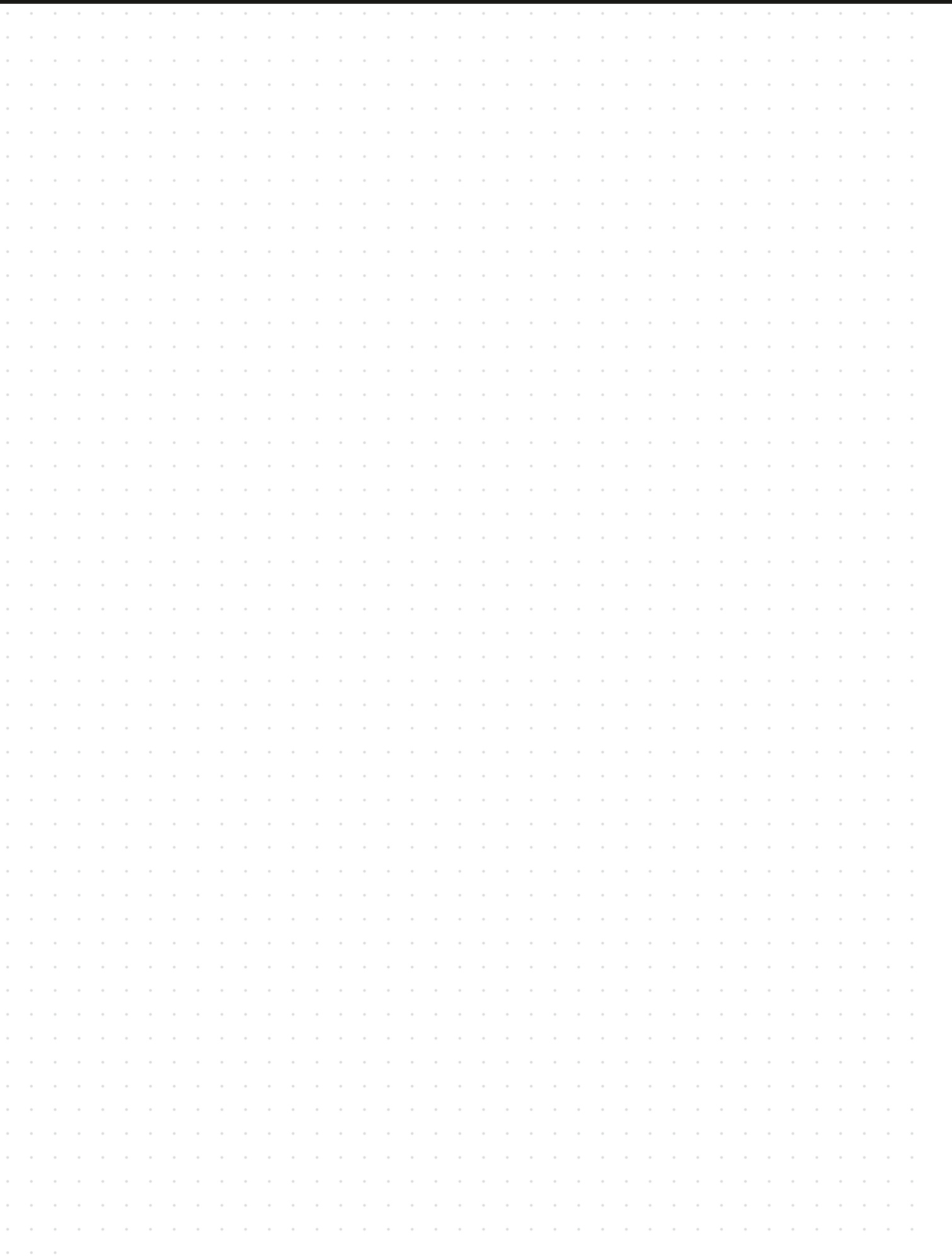







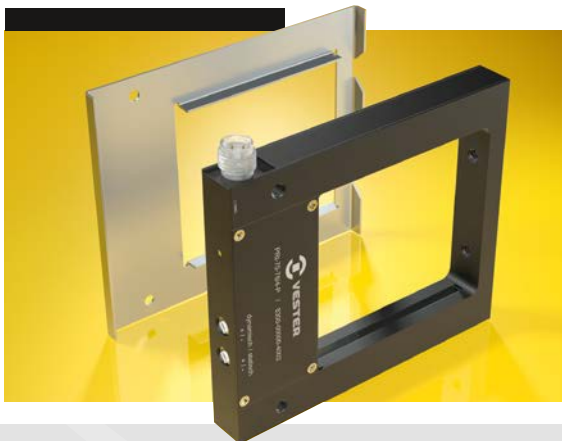

**Vester Elektronik GmbH**  
Otto-Hahn-Strasse 14  
75334 Straubenhardt  
Germany

Phone +49 (0) 70 82 / 94 93 - 0  
Fax +49 (0) 70 82 / 94 93 - 22

info@vester.de  
www.vester.de