

Special Products Catalog

Air, Vacuum, Electronic

MADE IN THE USA
REVISED 2011.04.15



MANUFACTURED BY BRAKE SYSTEMS INC. 2221 NE HOYT, PORTLAND, OR 97232
PH: 503-236-2116 FAX: 503-239-5005 TOLL FREE: 800-452-5734
EMAIL: brakesystems@brakesystemsinc.com

TABLE OF CONTENTS

ENGINE IDLE KITS	1-2
REMOTE THROTTLES	3-5
AIR SUPPLY KITS	6-7
BLUE OX TAIL GATE LOCK AIR CYLINDERS	8
REMOTE SENSOR ASSEMBLY (WM568)	9-10
DUAL CIRCUIT TREADLES	11-12
SYNCHRONIZING VALVE (WM571A)	13
VACUUM CONTROLS	14
TRAILER BRAKE TEST KIT (WM576)	15
AIR LINE ANTI FREEZE	16
THE SUPPLEMENTAL DRIVELINE BRAKE	17

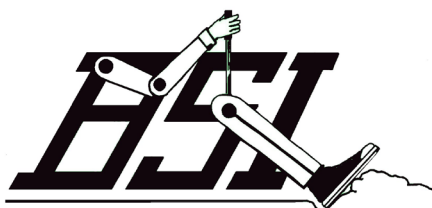

MADE IN THE USA

MANUFACTURED BY BRAKE SYSTEMS INC. 2221 NE HOYT, PORTLAND, OR 97232

PH: 503-236-2116 FAX: 503-239-5005 TOLL FREE: 800-452-5734

EMAIL: brakesystems@brakesystemsinc.com

REV. DATE: 04.08.11

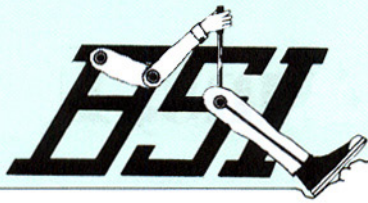

ENGINE IDLE KITS

The Engine Idle Kits energize auxiliary circuits when electronic engines are in idle mode. Typical uses for engine idle kits include exhaust brake/engine retarder interlock circuit, bus door interlock when used in conjunction with brake interlock, and bus deceleration lighting programs.

ENGINE IDLE KIT TYPES:

The 526B Idle Kit can be used with Williams floor mount pedals.

The 533A Idle Kit can be used with many Dodge pickup trucks with Cummins 5.9 electronic engines.

The 540A Idle Kit is used with Williams overhung (firewall) mount pedals.

The 544A Idle Kit is used with many International trucks, including some 2000 and later models, such as 4300, 4700, 4900 and models with DT466 and other engines.

Refer to the next page for part lists of each idle kit. . .



ENGINE IDLE KIT

526B:



540A:

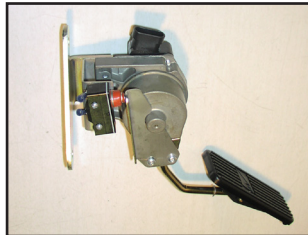

533A:

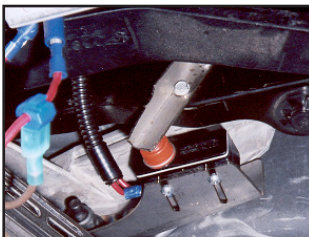

544A:

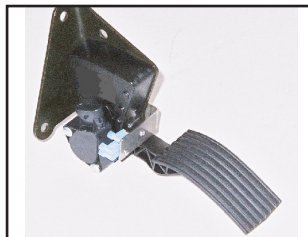

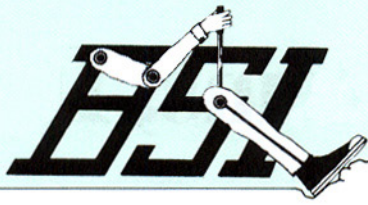

Brake Systems, Inc.

526B IDLE KIT:

Item	Qty	Part Number	Description
1	1	526-01	Bracket
2	1	526-02	Spacer
3	1	526-03	Switch
4	2	526-04	Cap Screw
5	2	526-05	Self Lock Nut
6	2	526-06	Cap Screw
7	2	526-07	Self Lock Nut
8	1	526-08	Cap Screw
9	1	526-09	Nut
10	1	526-10	Washer, Big
11	2	526-11	Washer, Small
12	1	11129	Catalog Page

533A IDLE KIT:

Item	Qty	Part Number	Description
1	1	533-01	Mounting Bracket
2	1	533-02	Striker Bracket
3	2	110388	Terminal
4	2	114778	Screw
5	2	115059	Washer
6	1	117784	Switch
7	1	117847	Tinnerman Nut
8	2	160048	Screw
9	1	11129	Catalog Page

540A IDLE KIT:

Item	Qty	Part Number	Description
1	1	540-01	Switch Bracket
2	1	540-02	Idle Bracket
3	2	104741	Blade Connector
4	2	114778	Screw
5	1	117785	Switch
6	1	117847	Tinnerman Nut
7	1	11129	Catalog Page

544A IDLE KIT:

Item	Qty	Part Number	Description
1	1	526-03	Switch
2	2	526-05	Lock Nut
3	1	544-01	Mounting Bracket
4	2	160045	Cap Screw
5	3	160046	Terminal, Elbow
6	1	160047	Terminal, Straight
7	1	11129	Catalog Page

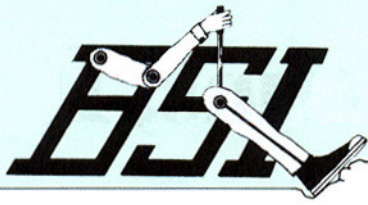

Brake Systems, Inc.

UNIVERSAL REMOTE THROTTLE 531

The 531A is a cable and bracket kit designed to mate with the Williams remote throttle control WM531 for Caterpillar, Cummins, Detroit, Mack and other electronic engines. Based on 2 inch maximum travel. In most cases, an electronic switch module (part number 134224) and an appropriate connector kit will be necessary to complete the wiring harness.

531A KIT			
1	1	531-01	Bracket
2	1	531-02	Lever Arm
3	1	531-03	Ball Joint
4	1	531-04	Cable Clamp
5	1	531-05	Mounting hardware

CABLE KIT			
6a	1	531024	Cable Assy -2'
6b	1	531036	Cable Assy -3'
6c	1	531048	Cable Assy -4'
6d	1	531060	Cable Assy -5'
6e	1	531072	Cable Assy -6'



REMOTE DRIVE AND SENSOR ASSEMBLY	
CUMMINS	131032
NAVISTAR	131032
CATERPILLAR	131520
DETROIT 2	131521
DETROIT 3	131522
** CUMMINS/BSI	160034

** ADJUSTABLE HIGH SPEED STOP

CONNECTOR KIT	
CATERPILLAR W ROUND CONN.	131771
CATERPILLAR W TRIANGLE CONN.	131772
CUMMINS & DDEC WITH IDLE V.	131773
DDEC II & III W/O IDLE V.	131774
NAVISTAR W 6 PIN CONN.	131775



UNIVERSAL REMOTE THROTTLE

KIT NO.:	COMES WITH:
531A1	531A and 531024
531A2	531A and 531036
531A3	531A and 531048
531A4	531A and 531060
531A5	531A and 531072

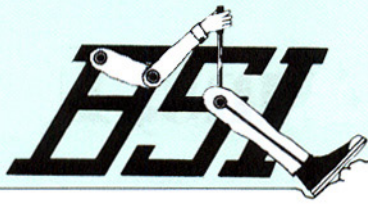

Brake Systems, Inc.

UNIVERSAL REMOTE THROTTLE 531B

The 531B (long stroke) is a cable and bracket kit designed to mate with the Williams remote throttle control WM531 for Caterpillar electronic engines. Based on 3 inch maximum travel. In most cases, an electronic switch module (part number 134224) and an appropriate connector kit will be necessary to complete the wiring harness.

531B KIT			
1	1	531-01	Bracket
2	1	531-02C	Lever Arm
3	1	531-03	Ball Joint
4	1	531-04	Cable Clamp
5	1	531-05	Mounting hardware

CABLE KIT			
6a	1	531024-3	Cable Assy -2'
6b	1	531036-3	Cable Assy -3'
6c	1	531048-3	Cable Assy -4'
6d	1	531060-3	Cable Assy -5'
6e	1	531072-3	Cable Assy -6'



OPTIONAL SENSOR DRIVE	
CATERPILLAR	132052
CATERPILLAR	132056*

*WITH H-HO STOP

CONNECTOR KIT	
CATERPILLAR w/ Triangle Conn.	131772
CATERPILLAR w/ Round Conn.	131771

OPTIONAL SENSOR	
CATERPILLAR w/ Triangle Plug	132484
CATERPILLAR w/ Round Plug	131138

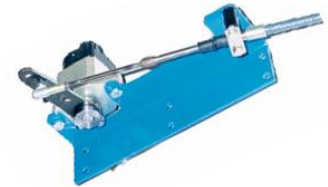

UNIVERSAL REMOTE THROTTLE LONG STROKE

KIT NO.:	COMES WITH:
531B1	531B and 531024-3
531B2	531B and 531036-3
531B3	531B and 531048-3
531B4	531B and 531060-3
531B5	531B and 531072-3

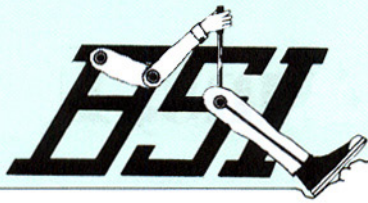

Brake Systems, Inc.

WM534

The WM534 remote switch module is an electrically actuated six pole, double throw switch that allows an operator to select between two independent stations. It can also be used to coordinate the operation of several functions from one station. It is designed for very low voltages and currents that are typically present in electronic engine throttle applications.

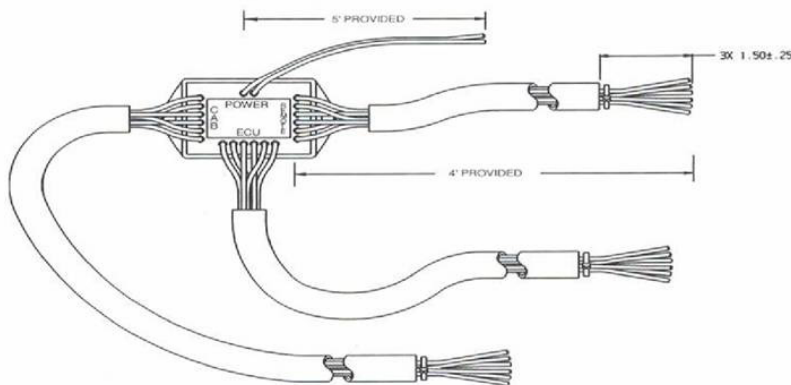
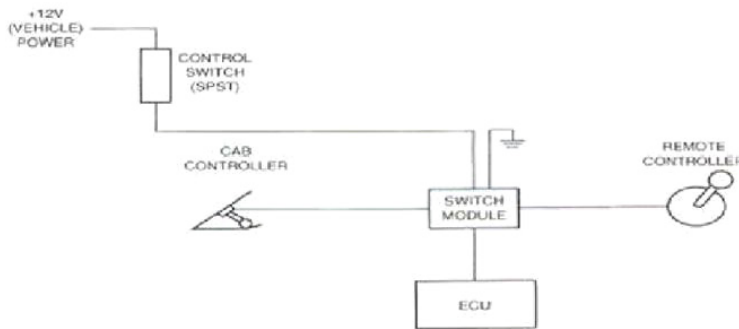

REMOTE THROTTLE SWITCH MODULE

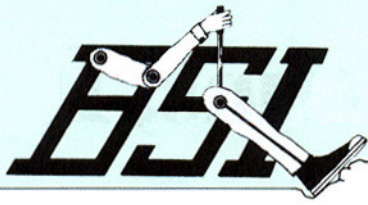

AIR SUPPLY KITS

The Air Supply Kits supply compressed air for engaging exhaust brakes.

AIR SUPPLY KIT TYPES:

The WM734A Air Supply Kit is used with butterfly brakes only.

The WM734B Air Supply Kit includes an air tank and may be used with the guillotine brake as well as the butterfly type brake.

The WM734C and WM734D Air Supply Kits are a complete supply and control kit for butterfly type exhaust brakes on vehicles without an air supply. Kit includes the (on demand) air compressor, mounting bracket and preassembled circuitry with two variations for idle validation. The WM734C kit includes pins to plug into the engine ECU. The WM734D kit includes a whisker switch with bracket to validate the pedal position.

The 160073 Air Control Assembly contains pre-plumbed wire and sealed control system, all ready to install. Add the compressor, dash switch and idle validation switch to make up the complete unit listed above as the WM734C or WM734D.

Refer to the following pages for part lists of each air supply kit. . .

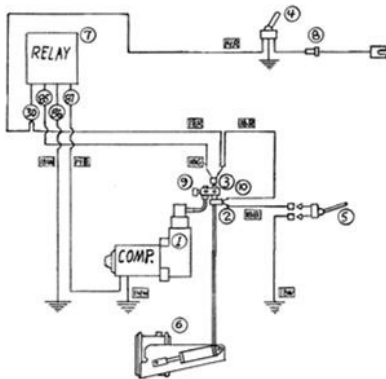

1. COMPRESSOR - 12V
2. SOLENOID
3. GOVERNOR
4. DASH SWITCH
5. IDLE VALIDATION SWITCH/SYSTEM
6. EXHAUST BRAKE
7. RELAY
8. FUSE
9. SAFETY POP-OFF
10. MANIFOLD BLOCK

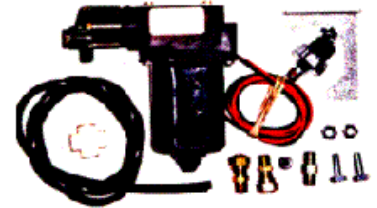

AIR SUPPLY KITS

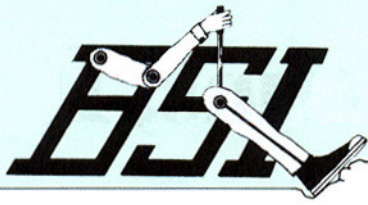

Brake Systems, Inc.

WM734A SUPPLY KIT:

Item	Qty	Part Number	Description
1	2	728-38	Cap Screw
2	2	728-39	Lock Nut
3	1	160015	Compressor
4	1	160016	Mounting Bracket
5	1	160018	Governor
6	1	160023	Pop Off
7	1	130917A	Roll Hose
8	1	3153X2	Plug
9	1	3325X2	Nipple
10	2	3950X2	Cross
11	2	10004B-102	Hose Barb
12	1	11124A	Catalog Page

WM734C,D SUPPLY KIT:

Item	Qty		Part Number	Description
	734C	734D		
1	1	1	728-12B	Switch, 12V
2	1	1	728-20B	Electrical Package
3	2	2	728-38	Cap Screw
4	2	2	728-39	Lock Nut
5	1	1	734-01A	DWG
6	2	2	10004B-102	Union, 1/2"
7	1	1	110345	Escutcheon Plate
8	1	1	160015	Compressor
9	1	1	160016	Bracket
10	2	-	160020	ECU Pin
11	1	1	160073	Control Assembly
12	1	1	3500X2	Elbow
13	-	1	WM779B	Whisker Kit

160073 CONTROL KIT:

Item	Qty	Part Number	Description
1	1	110390	Connector
2	1	114664	Cap Screw
3	1	117783	Connector
4	3	118872	Wire, Red, 14ga
5	1	118873	Wire, Green, 18ga
6	3	118874	Wire, Black, 18ga
7	4	118875	Wire, Red, 18ga
8	3	118876	Wire, White, 18ga
9	3	118881	Wire, Black, 14ga
10	1	130235	Connector
11	1	130238	Relay, 4 Pin
12	1	160066	Manifold Assembly
13	2	160069	Doubler Blade
14	1	160072	Enclosure Box
15	1	160078	Retainer
16	1	998108	Roll Loom, 1/2"
17	4	H10104	Roll Hose, 1/4"

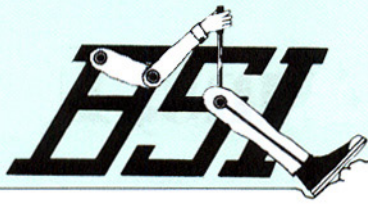

Brake Systems, Inc.

BLUE OX TAIL GATE LOCK AIR CYLINDERS

- Heavy Duty Assembly
- Cylinder Shell, Hard Anodized Aluminum
- Cylinder Rod, Stainless Steel, Heavy Duty
- End Cap, 2" Modular Cast Iron, Heavy Duty Mounting Boss
- 3 1/4" Die Cast, Heavy Duty Mounting Boss with Replaceable Bushings
- Piston, Proprietary Design with Buna-N Seals
- Trunion Pin: 1/2"
- Clevis Assy: 1/2" Pin
- Easily Rebuildable, All Components Available
- 40+ Years of Industrial/Automotive Service

Cylinder Assy	Retracted Length	Stroke	Cylinder Assembly with Installation Kit
WM-447D2	9.875	4	WM-447D2101
WM-447F2	11.875	6	WM-447F2101
WM-447H2	13.875	8	WM-447H2101

Bore Size: 2" Double Acting
 Rod Diameter: 1/2" x 20 U.N.F.
 Port Size: 1/8" NPT x 2
 Trunion Pin Dia. 1/2"
 Recommended Operating Pressure: 100 PSI
 Maximum Operating Pressure: 150 PSI

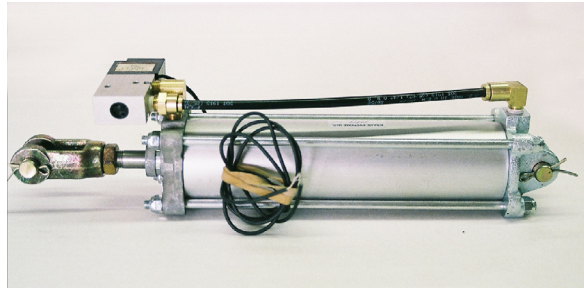

Cylinder Assy	Retracted Length	Stroke	Cylinder Assembly with Installation Kit
WM-463D	10.00	4	WM-463D101
WM-463F	12.00	6	WM-463F101
WM-463H	14.00	8	WM-463H101

Bore Size: 3 1/4" Double Acting
 Rod Diameter: 1/2" x 20 U.N.F.
 Port Size: 1/4" NPT x 2
 Trunion Pin Dia. 1/2"
 Recommended Operating Pressure: 100 PSI
 Maximum Operating Pressure: 150 PSI



WM447K1			
Installation Kit, Elec/Air			
Item No.	Qty.	Part No.	Description
1	1		Solenoid—4w
2	1		Breather
3	1		Fitting, Straight
4	1		Fitting, Elbow
5	1		Street Elbow
6	1		Nipple, Hex
7	1		Tubing, Nylon

WM463K1			
Installation Kit, Elec/Air			
Item No.	Qty.	Part No.	Description
1	1		Solenoid-4w
2	1		Breather
3	1		Fitting, Straight
4	1		Fitting, Elbow
5	1		Street Elbow
6	1		Nipple, Hex
7	1		Tubing, Nylon

REV. 2010.09.28

"Specializing in Manufacture and Distribution of  Air, Electronic Throttles and Exhaust Brakes"

BRAKE SYSTEMS, INC.

2221 N.E. Hoyt Street • Portland, Oregon 97232 • 503/236-2116 • FAX 503/239-5005 • E-Mail: brakesystems@brakesystemsinc.com

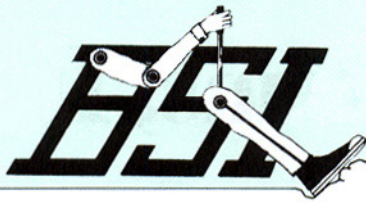

WM568

The WM568 hydraulic over electronic remote control assembly is composed of a hydraulic cylinder which positions an electronic sensor. It is used to control an electronic engine with a variable hydraulic pressure source, 0 to 80 PSI.

The WM568 unit can be used to dampen the response of an electronic engine to accelerator pedal position changes. Different sensors can be fit onto the unit to control different models of electronic engines.

SPECIFICATIONS:

Port Size	SAE 6 (9/16 to 18 UNF) straight thread w/ oring	
Maximum Operating Pressure	125 PSI (850 kPa)	
Operating Temperature	-20 F to 200 F (-29 C to 93C)	
Piston Area	3.14 inch (20 cm)	
Cylinder Stroke	0.5 inches (1.3 cm)	
Mounting	Bracket on main body	
Materials:	Body	Iridited die cast aluminum alloy
	Cover	Iridited die cast aluminum alloy
	Piston Assembly	Iridited die cast aluminum alloy
	Dynamic Seals	Viton
	Static Seals	Buna N

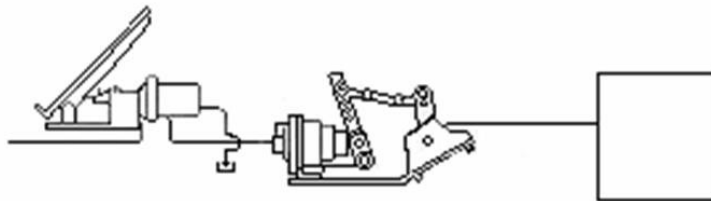

HYDRAULIC/ ELECTRONIC REMOTE SENSOR ASSEMBLY

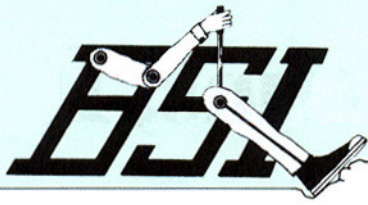

Brake Systems, Inc.

DIMENSIONAL DATA / CROSS SECTION & PARTS INFORMATION

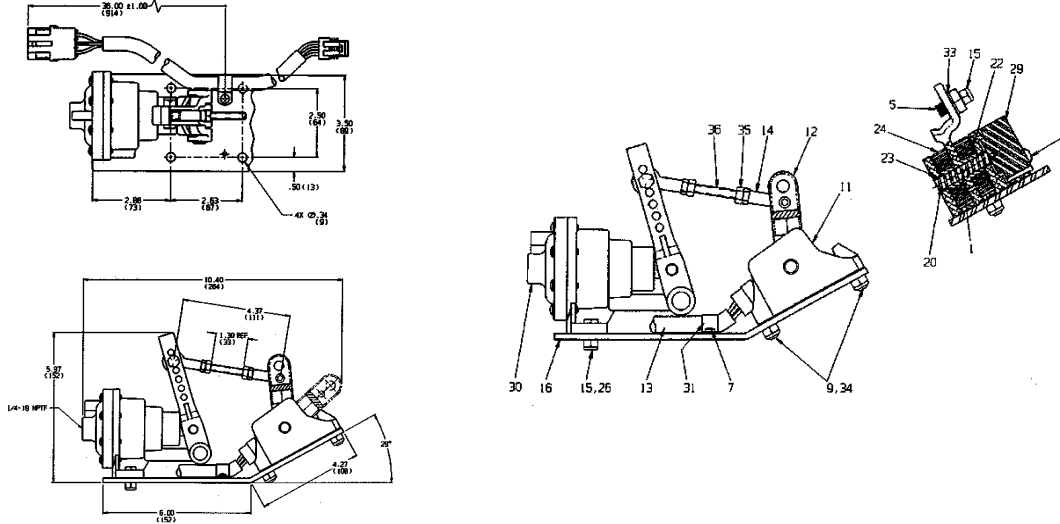

ORDERING INFORMATION

To order, specify WM568 _____ (part number). Select part number below.

Part Number	Applicable Engine
WM568E	DDEC II
WM568D	Caterpillar
WM568C	Navistar
WM568B	DDEC III without idle validation switch*
WM568A	Cummins, DDEC III with idle validation switch*

Service Kit	Service Kit Number	Kit Components
Cylinder repair kit	R512	119280 Repair kit, body lever assy. 119153
Part Number	Sensor Kit	130446 screw, 130996 clamp, 131165 harness, 131308 screw, 131856 sensor
WM568A	132034	
WM568B	132035	130446 screw, 130996 clamp, 131308 screw, 131856 sensor, 131970 harness
WM568C	340000	— — —
WM568D	131384	130446 screw, 130996 clamp, 131272 sensor, 131308 screw
WM568E	131140	130063 harness, 130446 screw, 130656 sensor, 130996 clamp, 131308 screw

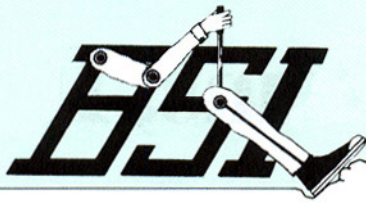

Brake Systems, Inc.

DUAL BRAKE VALVES TYPE E-4

The brake valve is a graduating directional control valve and is generally used to control all of the service brakes on a vehicle. The most popular configuration utilizes a pedal. However, other types of actuating means are available.

Dual brake valves, such as the E-4, are used in dual or split systems.

**TEREX SPECIAL
IN STOCK 101877**

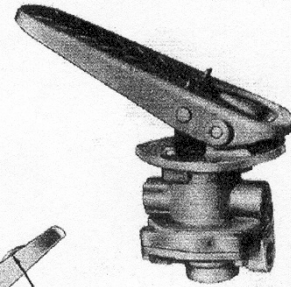
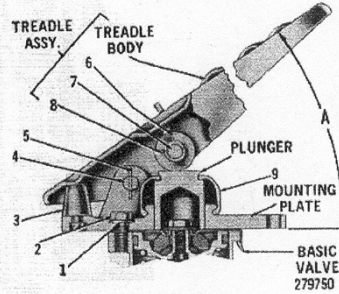

TYPE E-4 DUAL BRAKE VALVE O.E. PC. NO.	REMF. EXCH. (BASIC)* PC. NO.	REFERENCE DETAILS					
		TREADLE & MTG. PLATE ASSY. PC. NO.	TREADLE ASSY. PC. NO.	TREADLE BODY PC. NO.	PLUNGER PC. NO.	MTG. PLATE PC. NO.	A DEG.
A279757	279750	279751	228484	228281	236981	236979	27
280037	279750	280038	226834	226835	236981	236979	34
280246	279750	279751	228484	228281	236981	236979	27
281418	279750	281433	NONE	NONE	236981	236979	—
B282330	279750	—	226834	226835	236981	236979	34
B283846	279750	—	228484	228281	236981	236979	27
285569	279750	280038	226834	226835	236981	236979	34
C286208	279750	285825	283659	275460	235814	243807	17

A—Add Mounting Plate, 244433.
B—Add Mounting Plate, 246025.
C—Uses Stop Button, 239512 & Lock Nut, 230903.

E-4 BRAKE VALVE CONVERSION LIST

O.E. PC. NO.	REMF. EXCH. PC. NO.
279750	279750
279757	279750
280037	279750
280246	279750
280459	279750
280578	279750
280755	279750
280756	279750
281136	279750
281388	279750

O.E. PC. NO.	REMF. EXCH. PC. NO.
281418	279750
281423	279750
281424	279750
281445	281510
281510	281510
281571	279750
281752	279750
281574	281574
281575	281574
281856	279750

O.E. PC. NO.	REMF. EXCH. PC. NO.
281904	281904
282330	279750
282855	282855
282856	282855
283322	279750
283846	279750
284354	279750
285569	279750
286208	279750
286524	279750

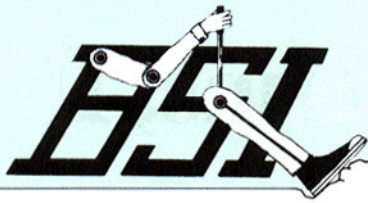

Brake Systems, Inc.

WM569A

The WM569A is a dual circuit brake application valve for air brake systems. A dual air brake system will provide many of the same safety considerations that passenger cars with hydraulic brakes have enjoyed since 1967. Many vehicles, including motor homes, utilize above floor mounted brake valves. Using such brake valves, it is unnecessary to drill holes through the floor board to mount and plumb the brake pedal.

Item	Qty	Part Number	Description	Item	Qty	Part Number	Description
1	1	101114	Mount Nut	11	3	114878	Screw
2	2	102371	Pin	12	3	115102	Lck. Washer
3	2	103113	Roller	13	1	116722	Base
4	1	103670	Cover	14	2	117216	Treadle Pin
5	1	103704	Spring	15	1	117259	Lever
6	1	104964	Flange	16	1	118775	Treadle
7	8	106857	Ret. Clip	17	1	160043	Spacer
8	1	110264	Spring	18	1	160044	Push Rod
9	1	114537	Jam Nut	19	1	286171	Valve—PBD
10	1	114780	Stp Screw				

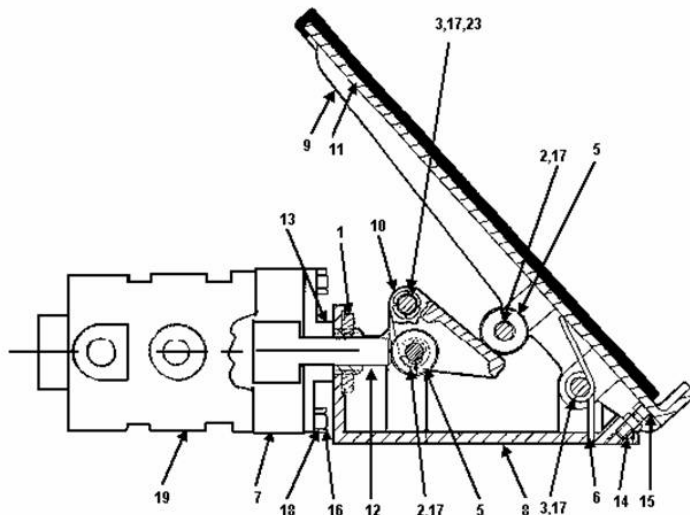

DUAL CIRCUIT TREADLE

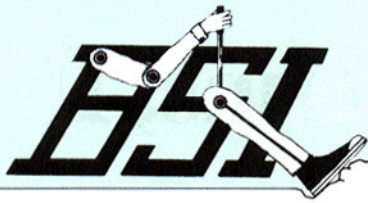

Brake Systems, Inc.

WM571A

The WM571A is usually part of the brake system of a truck with hydraulic brakes pulling a trailer with air brakes. The synchronizing valve provides the foot brake signal to the trailer. Selective trailer brake control is also available by using an air hand valve. Hydraulic/air ratio is approximately 13 to 1.

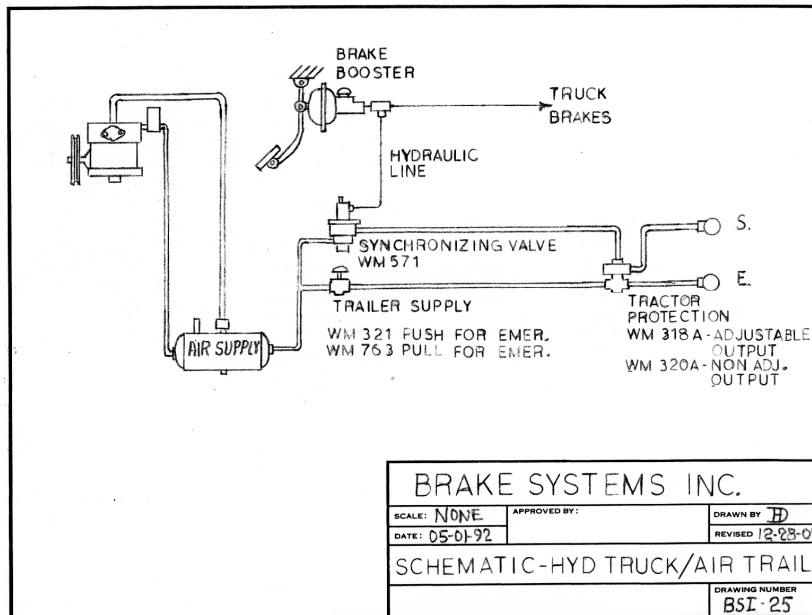
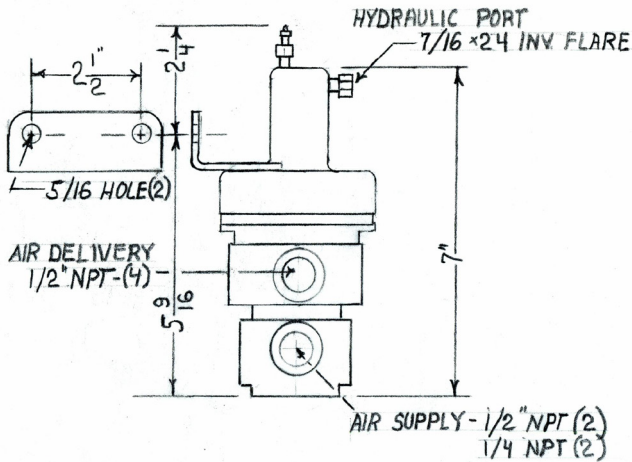

**SYNCHRONIZING VALVE
AIR/HYDRAULIC**

REV. 2010.12.13

"Specializing in Manufacture and Distribution of  Air, Electronic Throttles and Exhaust Brakes"

BRAKE SYSTEMS, INC.

2221 N.E. Hoyt Street • Portland, Oregon 97232 • 503/236-2116 • FAX 503/239-5005 • E-Mail: brakesystems@brakesystemsinc.com

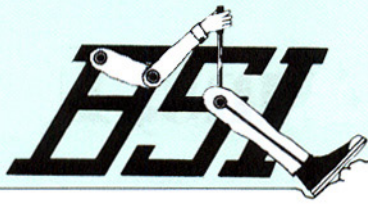

Brake Systems, Inc.

WM38 SERIES

A control valve (on-off) for trailers with vacuum suspended brake systems, (vacuum/hydraulic or straight vacuum). This is not a proportional brake application valve, it functions only to apply the trailer brakes (park), or release the brakes for normal operation.

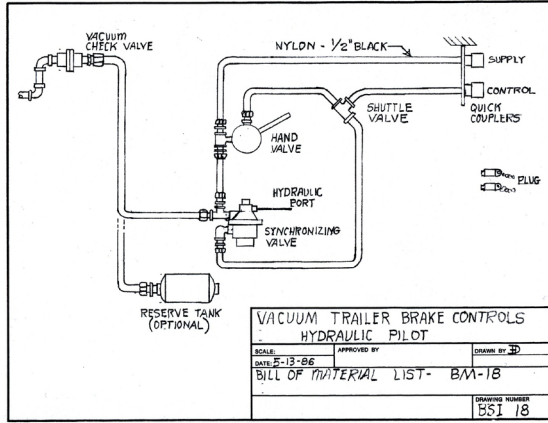

FOR VACUUM SYSTEMS



TRAILER CONTROL VALVE
WM38A

WM573 SERIES

The synchronizing valve provides trailer brakes with normal application of the foot brake on the towing vehicle. It is used in vacuum suspended brake systems such as vacuum/hydraulic trailer brakes. It will provide full trailer brake at 600psi (20in./Hg) or 700 psi (22 in./Hg).

In higher pressure hydraulic brake systems (1200 to 1500 psi), a hydraulic proportioning valve will hold off the trailer brake application until hydraulic pressures are attained. (see diagram BSI 18B)

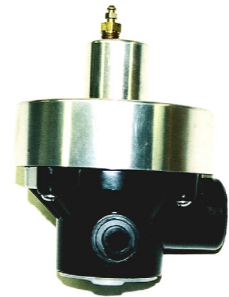
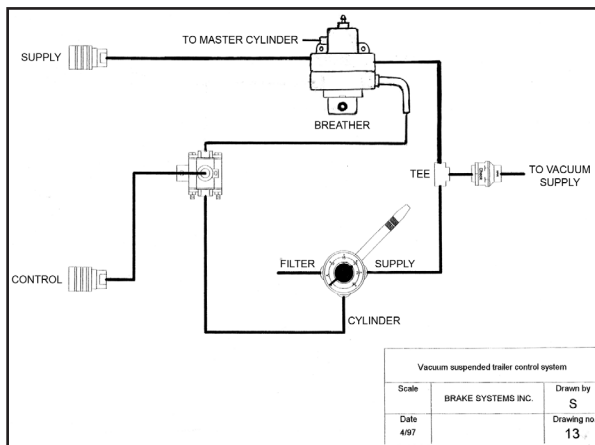

SYNCHRONIZING VALVE
WM573A

REV. 2011.04.15

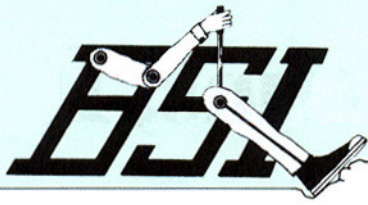

TRAILER BRAKE TEST KIT WM576

(ONE MAN) OPERATION

WM576, a slick quick way to test your trailer brakes in the yard (or anywhere else) with one man and an air supply (usually a tractor). Just insert the test kits glad hands between the air source and the trailer, block the tractor so it won't roll and test away. The control panel will go right with you under or next to the trailer and just turn the brakes on and off at your own speed and the following will happen:

1. Test for air leaks at the valves and tank connections with application.
2. Measure travel of push rods to verify adjustment is okay.
3. Check for air leaks when released.



**TRAILER BRAKE
TEST KIT**

Move on to the next trailer and repeat the above. After you've repositioned the tractor, the test time can be as little as 5 minutes.

Weight: 5 lbs

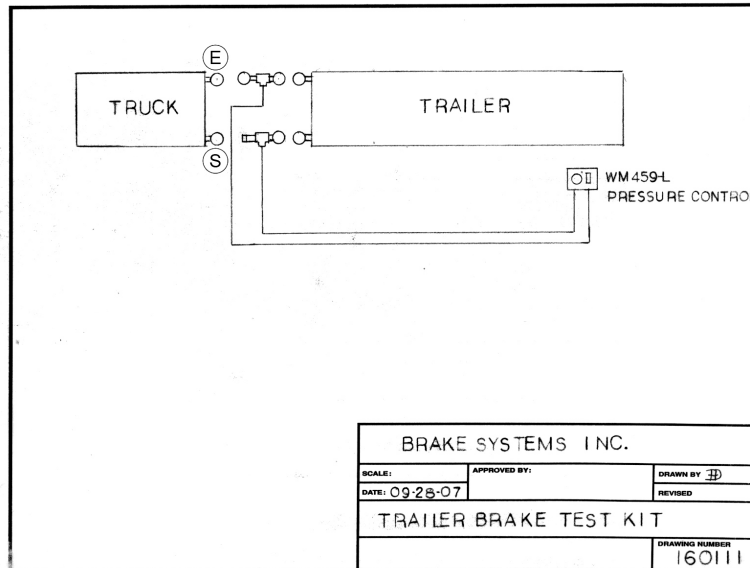

REV. 2011.04.15

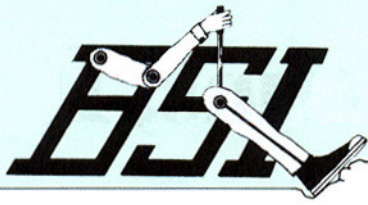

Brake Systems, Inc.

AIR LINE ANTI FREEZE



**Quart
99844**



**Gallon
99845**

When it's below freezing, air valves on trucks and industrial machinery often time cease to function or at least begin to leak as a result of water vapor freezing. In the valve assembly o-rings get hard and do not conform to metal parts easily (remember the space shuttle?).

BSI can supply alcohol injectors (downstream devices) or alcohol evaporators (compressor inlet) which will preclude most freezing problems. In certain high humidity ambient with temperatures at or near freezing, a highway truck may pump in a pint or so of water in a 400 mile run. Spitter valves will dump most of the water from the tank at intervals but the water vapor is always present and whenever the temperature drops below freezing, you're in for trouble. In some cases alcohol may be introduced to the air system by temporarily disconnecting the main air line from the compressor and pouring a few ounces directly into the air tank this way.

Containers of this product are stocked in Portland and may be picked up at the BSI warehouse or shipped by UPS with an additional hazmat charge. Call BSI for details.

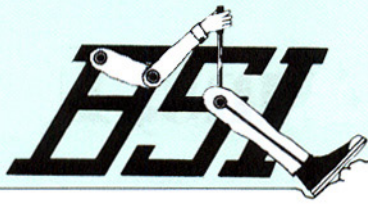

THE SUPPLEMENTAL DRIVELINE BRAKE

If you have a parking problem  has the solution.

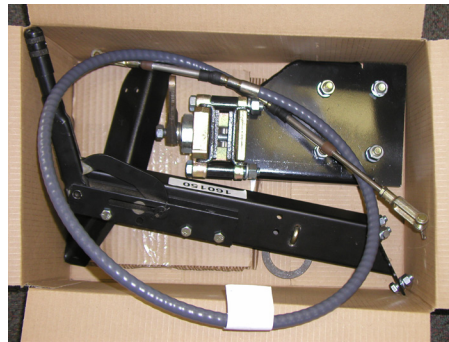

The Driveline Brake is a proven solution to provide a safe, reliable supplemental parking brake.

Everything you need is in the kit.

Rotor, caliper, brackets, cable plus easy to follow instructions.

Ask our sales professionals about the Driveline kit.

BSI Part Number 160158.

REV. 2011.01.27

17

"Specializing in Manufacture and Distribution of  Air, Electronic Throttles and Exhaust Brakes"

BRAKE SYSTEMS, INC.

2221 N.E. Hoyt Street • Portland, Oregon 97232 • 503/236-2116 • FAX 503/239-5005 • E-Mail: brakesystems@brakesystemsinc.com

BRAKE SYSTEMS, INC.
WARRANTY POLICY TERMS AND CONDITIONS
For New Pneumatic Systems

Brake Systems, Inc. warrants that products furnished by it will be free from defects in materials and workmanship until the first of the following occurs:

One (1) year after delivery of the product to the ultimate user;

50,000 miles of operation on highway vehicles;

1000 hours of operation on other types of equipment.

This warranty does not extend to 1.) any losses due to misuse, accident, abuse, neglect, normal wear and tear, or improper installation, maintenance or application; 2.) products that have been repaired or altered outside of Brake Systems, Inc. factory unless authorized in writing by Brake Systems, Inc.; or 3.) any labor charges for removal and/or replacement of the nonconforming or defective product or part thereof.

In the event that claims are made with regard to the defective product, the responsibility of Brake Systems, Inc. is limited to repairing or replacing any units which shall, within the provisions of the warranty specified above, be returned with transportation charges prepaid, and found to be defective. All warranty claims shall be presented within thirty (30) days after the defect is discovered. In no event shall Brake Systems, Inc. be liable for consequential damages related to misuse or misapplication of products.

The foregoing states Brake Systems Inc. sole responsibility for breach of this warranty. In no event shall Brake Systems be liable for consequential damages.

No other warranty, whether expressed or implied by operation of law or otherwise (including any warranty of merchantability, fitness or performance), shall exist in connection with the sale or use of any product sold by Brake Systems, Inc.

2221 N.E. Hoyt Street s Portland, Oregon 97232 s (503) 236-2116



BRAKE SYSTEMS, INC.



2221 N.E. HOYT PORTLAND, OR 97232

503-236-2116 FAX 503-239-5005

TOLL FREE 1-800-452-5734



PRODUCT LINES		WWW.BRAKESYSTEMSINC.COM email: brakesystems@brakesystemsinc.com
DISTRIBUTOR OF:		
AIR CYLINDERS	MIDLAND HALDEX BRAKE PRODUCTS	
BENDIX - POWER BRAKES HYDRAULICS & COMPRESSORS	PBD REPLACEMENT AIR VALVES	
BLUE OX EXHAUST BRAKES	REXROTH INDUSTRIAL CONTROLS WABCO	
C/R,SKF AIR DRYERS, BEARINGS	TSE SPRING BRAKES	
CARLISLE INDUSTRIAL BRAKE PRODUCTS	VELVAC BRAKE & ELECTRIC PRODUCTS	
CHICAGO RAWHIDE AIR DRYERS	WAGNER / FEDERAL MOGUL	
DELCO BOOSTERS & VACUUM PUMPS	WEATHERHEAD HOSE & FITTINGS	
DEL HYDRAULIC	WILLIAMS CONTROLS - AIR VALVES & ELECTRONIC THROTTLES	
ELECTRONIC THROTTLE CONTROLS	ZERO-RUST	
EUCLID / SEALCO/ARVIN-MERITOR	MANUFACTURER OF: SPECIALTY ELECTRONIC THROTTLE & BRAKE PRODUCTS	
FIRESTONE - RIDE RITE	EXHAUST BRAKES - BLUE OX	
GROVER AIR HORNS	AIR CYLINDERS - BSI & WILLIAMS	
HAYES LEMMERZ CONTROLLERS	AIR VALVES - BSI & WILLIAMS	
HORTON FAN CLUTCHES	REMANUFACTURER OF:	
 SUPER STORE	BRAKE BOOSTERS	
KIP SOLENOIDS	LUCAS/GIRLING BACKING PLATES	
LOCKTITE	AIR VALVES, FAN HUBS	
MAGNETEK / PATRIOT / GEMCO / WAGNER INDUSTRIAL BRAKE PRODUCTS	PRESSURE CONVERTERS	
MGM SPRING BRAKES	INDUSTRIAL CALIPERS	
 BRAKE PRODUCTS	AIR COMPRESSORS	

08/10

37

WWW.BRAKESYSTEMSINC.COM