

[Return to Table of Contents](#)

## GSX SERIES

**INTEGRATED SERVO MOTOR AND ACTUATOR**

**High quality screw for longer life**

**Ideal hydraulic replacement**

**Powerful and robust**

**Compact size**

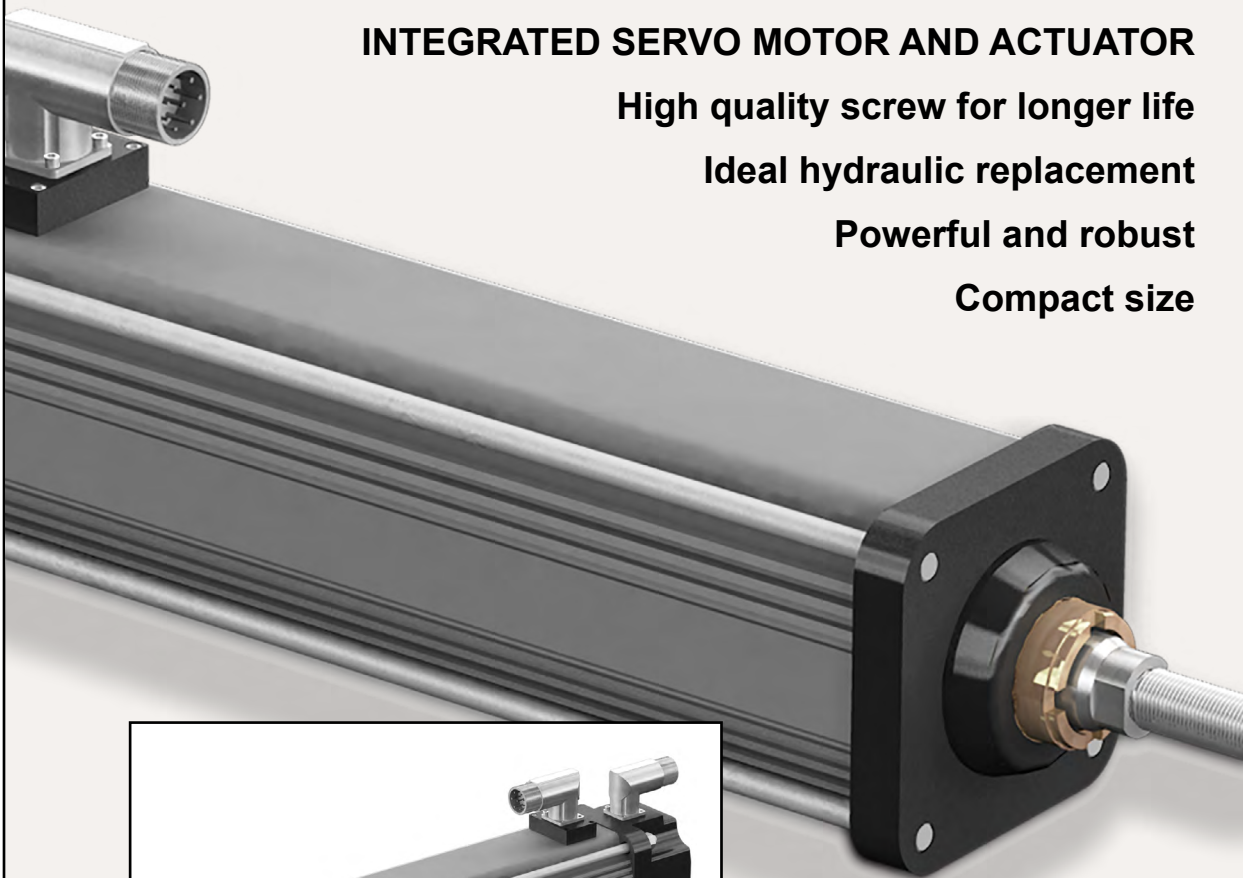

## The Advantages of Roller Screw Technology

Designers have five basic choices when it comes to achieving controlled linear motion. The table on page 3 gives you a quick overview of the general advantages that are associated with each. Because the roller screw technology common to all Exlar linear actuators might not be familiar to everyone using this catalog, allow us to present a general overview.

### Roller Screw Basics

A roller screw is a mechanism for converting rotary torque into linear motion in a similar manner to acme screws or ball screws. Unlike those devices, roller screws can carry heavy loads for thousands of hours in the most arduous conditions. This makes roller screws the ideal choice for demanding, continuous-duty applications.



The difference is in the way the roller screw is designed to transmit forces. Multiple threaded helical rollers are assembled in a planetary arrangement around a threaded shaft (shown below) which converts the motor's rotary motion into linear movement of the shaft or nut.

### Exlar Roller Screws vs Hydraulics & Pneumatics

In applications where high loads are anticipated or faster cycling is desired, Exlar's roller screw actuators provide an attractive alternative to the hydraulic or pneumatic options. With their vastly simplified controls, electro-mechanical units using roller screws have major advantages.

- Eliminates the need for a complex support system of valves, pumps, filters and sensors.
- Requires much less space.
- Extends working life.
- Minimizes maintenance.
- Eliminates hydraulic fluid leaks.
- Reduces noise levels.
- Allows the flexibility of computer programmed positioning.

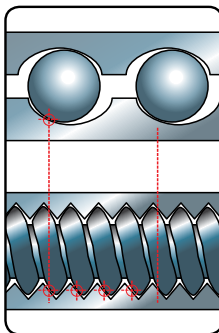

### Exlar Roller Screws vs Ball Screws Performance

**Loads and Stiffness:** Due to design factors, the number of contact points in a ball screw is limited by the ball size. Exlar's planetary roller screw designs provide many more contact points than possible on comparably sized ball screws. Since the number of contact points is greater, roller screws have greater load carrying capacities, plus improved stiffness. Plus an Exlar roller screw actuator takes up much less space to meet the designer's specified load rating.

**Travel Life:** As you would expect, with their higher load capacities, roller screws deliver major advantages in working life. Usually measured in "Inches of Travel," the relative travel lives for roller and ball screws are displayed on the graph on page 3. As shown, in a 2,000 lb. average load application applied to a 1.2 inch screw diameter with a 0.2 inch lead, the roller screw will have an expected service life that is 15 times greater than that of the ball screw.

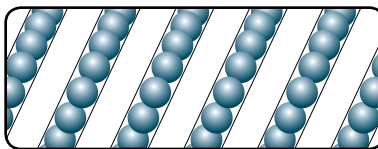

**Speeds:** Typical ball screw speeds are limited to 2000 rpm and less, due to the interaction of the balls colliding with each other as the race rotates. In contrast, the rollers in a roller screw are

fixed in planetary fashion by journals at the ends of the nut and therefore do not have this limitation. Hence, roller screws can work at 5000 rpm and higher, producing comparably higher linear travel rates.

# GSX Series Integrated Motor/Actuator

## GSX Series

### High Capacity Integrated Motor/Actuator

#### Description

For applications that require long life and continuous duty, even in harsh environments, the GSX Series actuator offers a robust solution. The life of these actuators can exceed that of a ball screw actuator by 15 times, all while delivering high speeds and high forces.

#### Sealed for Long Life with Minimum Maintenance

GSX Series actuators have strong advantages wherever outside contaminants are an issue. In most rotary-to-linear devices, critical mechanisms are exposed to the environment. Thus, these actuators must be frequently inspected, cleaned and lubricated.

In contrast, the converting components in all Exlar GSX units are mounted within sealed motor housing. With a simple bushing and seal on the smooth extending rod, abrasive particles or other contaminants are prevented from reaching the actuator's critical mechanisms. This assures trouble-free operation even in the most harsh environments.

Similarly, lubrication requirements are minimal. GSX actuators can be lubricated with either grease or recirculated oil. Recirculated oil systems eliminate this type of maintenance altogether. A GSX Series actuator with a properly operating recirculating oil system will operate indefinitely, without any other lubrication requirements.

Feature	Standard	Optional
External anti-rotate mechanism	No	Yes
Internal Anti-rotate Mechanism	No	Yes
Electric brake	No	Yes
External Limit Switches	No	Yes
Connectors	Right Angle, Rotatable	
Mounting Style	Extended Tie Rods, Side Tapped Mounting Holes, Trunnion, Rear Clevis, Front or Rear Flange	Specials available to meet OEM requirements
Rod End	Male or Female: U.S. Standard or Metric	
Lubrication	Greased, Oil Connection Ports are Built-in for Customer Supplied Recirculated Oil Lubrication	
Primary Feedback	Standard Encoders or Resolvers to Meet Most Amplifier Requirements	

Technical Characteristics	
Frame Sizes in (mm)	2 (60), 3 (80), 4 (100), 5.5 (140), 7 (180)
Screw Leads in (mm)	0.1 (2), 0.2 (5), 0.25 (6), 0.4 (10), 0.5 (13), 0.75 (19), 1 (25)
Standard Stroke Lengths	3 (75), 4 (100), 6 (150), 8 (200), 10 (250), 12 (300), 14 (350), 18 (450)
Force Range	103 to 11,528 lbf (458 to 51 kN)
Maximum Speed	up to 37.5 in/sec (952 mm/s)

Operating Conditions and Usage		
<b>Accuracy:</b>		
Screw Lead Error	in/ft (µm / 300 mm)	0.001 (25)
Screw Travel Variation	in/ft (µm / 300 mm)	0.0012 (30)
Screw Lead Backlash	in	0.004 maximum
<b>Ambient Conditions:</b>		
Standard Ambient Temperature	°C	0 to 65
Extended Ambient Temperature*	°C	-30 to 65
Storage Temperature	°C	-40 to 85
IP Rating		IP65S
Vibration**		3.5 grms; 5 to 520 hz

\* Consult Exlar for extended temperature operations

\*\* Resolver feedback

Ratings at 25°C, operation over 25°C requires de-rating.

## Product Features

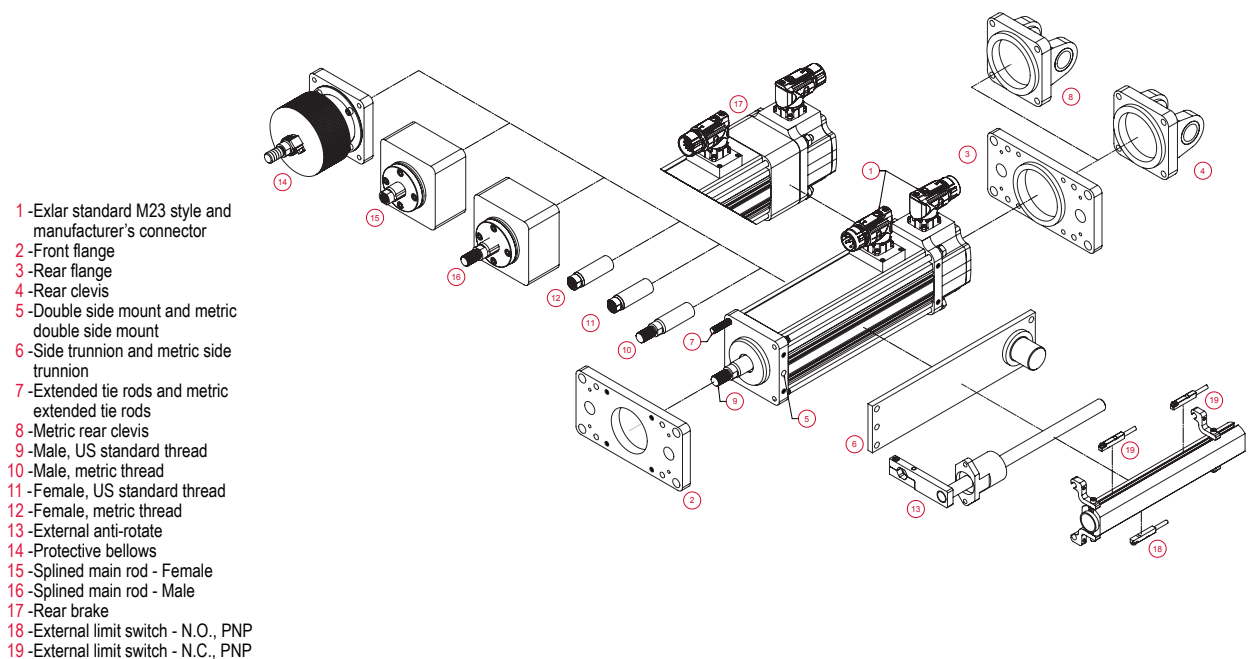
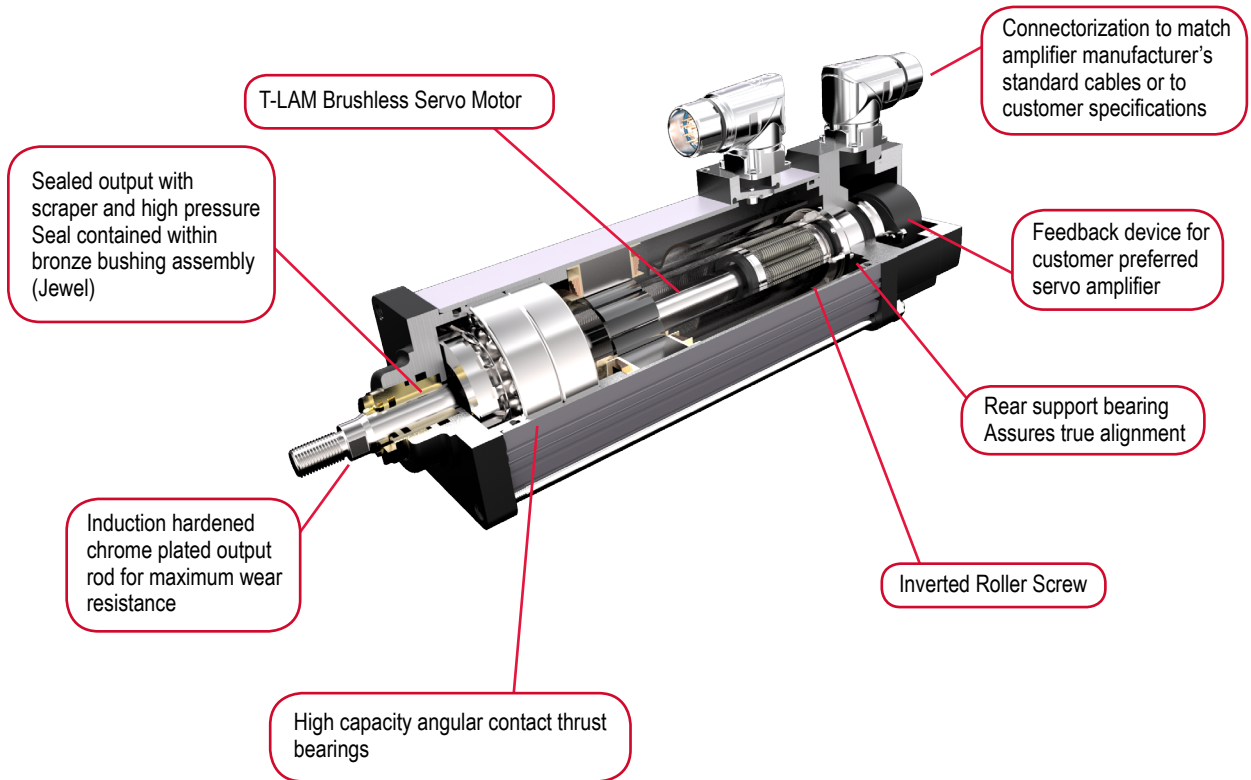

# GSX Series Integrated Motor/Actuator

## Industries and Applications:

Hydraulic cylinder replacement  
Ball screw replacement  
Pneumatic cylinder replacement

### Automotive

Dispensing  
Welding  
Pressing  
Riveting / Fastening / Joining

### Food Processing

Sealing  
Dispensing  
Forming  
Pick and Place Systems  
Fillers  
Cutting / Slicing / Cubing

### Sawmill/Forestry

Saw Positioning  
Fence Positioning  
Ventilation Control Systems

### Machining

Material Cutting  
Broaching  
Metal Forming  
Tube Bending  
Stamping

### Entertainment / Simulation

Animatronics  
Training Simulators  
Ride Automation

### Medical Equipment

Volumetric Pumps  
Patient Positioning

### Plastics

Die Cutters  
Part Eject  
Core Pull  
Formers

### Material Handling

Nip Roll Positioning  
Tension Control  
Web Guidance  
Wire Winding

### Test

Fatigue Testing  
Load Simulation Testing

Repeatable force, reliable positioning accuracy, and flexible control make GSX actuators a perfect fit for assembly presses or test stands.



Repeatable force control plus positioning accuracy extends the life of costly tools when Exlar linear actuators are used for precision applications.

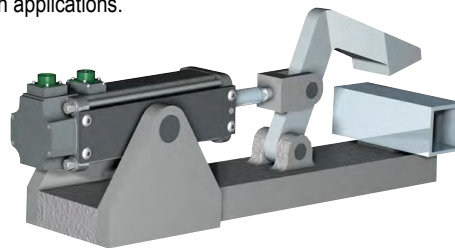

## Mechanical Specifications

### GSX20

Model No. (Motor Stacks)		1 Stack			2 Stack			3 Stack	
Screw Lead Designator		01	02	04	01	02	04	02	04
Screw Lead	in	0.1	0.2	0.4	0.1	0.2	0.4	0.2	0.4
	mm	2.54	5.08	10.16	2.54	5.08	10.16	5.08	10.16
Continuous Force (Motor Limited)	lbf	367	195	103	578	307	163	409	216
	N	1632	867	459	2571	1366	723	1817	962
Max Velocity	in/sec	8.3	16.8	33.3	8.3	16.8	33.3	16.8	33.3
	mm/sec	211.7	423.3	846.7	211.7	423.3	846.7	423.3	846.7
Friction Torque (standard screw)	in-lbf	1.0			1.1			1.1	
	N-m	0.11			0.12			0.12	
Friction Torque (preloaded screw)	in-lbf	2.3			2.3			2.3	
	N-m	0.25			0.26			0.26	
Min Stroke	in	3			3			6	
	mm	75			75			150	
Max Stroke	in	12			12			12	
	mm	300			300			300	
C <sub>a</sub> (Dynamic Load Rating)	lbf	2075	1540	1230	2075	1540	1230	1540	1230
	N	9230	6850	5471	9230	6850	5471	6850	5471
Inertia (zero stroke)	lb-in-s <sup>2</sup>	0.0007758			0.0008600			0.0009442	
	Kg-m <sup>2</sup>	0.00008766			0.00009717			0.0001067	
Inertia Adder (per inch of stroke)	lb-in-s <sup>2</sup> /in				0.00004667				
	Kg-m <sup>2</sup> /in				0.000005273				
Weight (zero stroke)	lb	4.5			5.0			5.5	
	Kg	2.04			2.27			2.49	
Weight Adder (per inch of stroke)	lb				0.5				
	Kg				0.23				

### GSX30

Model No. (Motor Stacks)		1 Stack			2 Stack			3 Stack	
Screw Lead Designator		01	02	05	01	02	05	02	05
Screw Lead	in	0.1	0.2	0.5	0.1	0.2	0.5	0.2	0.5
	mm	2.54	5.08	12.7	2.54	5.08	12.7	5.08	12.7
Continuous Force (Motor Limited)	lbf	792	449	190	1277	724	306	1020	432
	N	3521	1995	845	5680	3219	1363	4537	1922
Max Velocity	in/sec	5.0	10.0	25.0	5.0	10.0	25.0	10.0	25.0
	mm/sec	127.0	254.0	635.0	127.0	254.0	635.0	254.0	635.0
Friction Torque (standard screw)	in-lbf	1.5			1.7			1.9	
	N-m	0.17			0.19			0.21	
Friction Torque (preloaded screw)	in-lbf	3.3			3.5			3.7	
	N-m	0.37			0.39			0.41	
Min Stroke	in	3			3			5.9	
	mm	75			75			150	
Max Stroke	in	18			18			18	
	mm	450			450			450	
C <sub>a</sub> (Dynamic Load Rating)	lbf	5516	5800	4900	5516	5800	4900	5800	4900
	N	24536	25798	21795	24536	25798	21795	25798	21795
Inertia (zero stroke)	lb-in-s <sup>2</sup>	0.002655			0.002829			0.003003	
	Kg-m <sup>2</sup>	0.0003000			0.0003196			0.00033963	
Inertia Adder (per inch of stroke)	lb-in-s <sup>2</sup> /in				0.0001424				
	Kg-m <sup>2</sup> /in				0.00001609				
Weight (zero stroke)	lb	6.5			7.65			8.8	
	Kg	2.95			3.47			3.99	
Weight Adder (per inch of stroke)	lb				1.1				
	Kg				0.50				

\*See definitions on page 9

# GSX Series Integrated Motor/Actuator

## GSX40

Model No. (Motor Stacks)	1 Stack				2 Stack				3 Stack				
Screw Lead Designator	01	02	05	08	01	02	05	08	02	05	08		
Screw Lead	in	0.1	0.2	0.5	0.75	0.1	0.2	0.5	0.75	0.2	0.5	0.75	
	mm	2.54	5.08	12.7	19.05	2.54	5.08	12.7	19.05	5.08	12.7	19.05	
Continuous Force (Motor Limited)	lbf	2089	1194	537	358	3457	1975	889	593	2687	1209	806	
	N	9293	5310	2390	1593	15377	8787	3954	2636	11950	5378	3585	
Max Velocity	in/sec	5.0	10.0	25.0	37.5	5.0	10.0	25.0	37.5	10.0	25.0	37.5	
	mm/sec	127.0	254.0	635.0	953.0	127.0	254.0	635.0	953.0	254.0	635.0	953.0	
Friction Torque (standard screw)	in-lbf	2.7				3.0				3.5			
	N-m	0.31				0.34				0.40			
Friction Torque (preloaded screw)	in-lbf	7.2				7.5				8.0			
	N-m	0.82				0.85				0.91			
Min Stroke	in	4				6				8			
	mm	100				150				200			
Max Stroke	in	18		12		18		12		18		12	
	mm	450				450				450			
C <sub>s</sub> (Dynamic Load Rating)	lbf	7900	8300	7030	6335	7900	8300	7030	6335	8300	7030	6335	
	N	35141	36920	31271	28179	35141	36920	31271	28179	36920	31271	28179	
Inertia (zero stroke)	lb-in-s <sup>2</sup>	0.01132				0.01232				0.01332			
	Kg-m <sup>2</sup>	0.0012790				0.001392				0.001505			
Inertia Adder (per inch of stroke)	lb-in-s <sup>2</sup> /in					0.0005640							
	Kg-m <sup>2</sup> /in					0.00006372							
Weight (zero stroke)	lb	8.0				11.3				14.6			
	Kg	3.63				5.13				6.62			
Weight Adder (per inch of stroke)	lb					2.0							
	Kg					0.91							

## GSX50

Model No. (Motor Stacks)	1 Stack				2 Stack				3 Stack				
Screw Lead Designator	01	02	05	10	01	02	05	10	02	05	10		
Screw Lead	in	0.1	0.2	0.5	1.0	0.1	0.2	0.5	1.0	0.2	0.5	1.0	
	mm	2.54	5.08	12.7	25.4	2.54	5.08	12.7	25.4	5.08	12.7	25.4	
Continuous Force (Motor Limited)	lbf	4399	2578	1237	619	7150	4189	2011	1005	5598	2687	1344	
	N	19568	11466	5503	2752	31802	18634	8944	4472	24901	11953	5976	
Max Velocity	in/sec	4.0	8.0	20.0	40.0	4.0	8.0	20.0	40.0	8.0	20.0	40.0	
	mm/sec	101.6	203.0	508.0	1016.0	101.6	203.0	508.0	1016.0	203.0	508.0	1016.0	
Friction Torque (standard screw)	in-lbf	4.1				4.6				5.3			
	N-m	0.46				0.53				0.60			
Friction Torque (preloaded screw)	in-lbf	10.1				10.6				11.3			
	N-m	1.14				1.21				1.36			
Min Stroke	in	6				6				10			
	mm	152				152				254			
Max Stroke	in	10	14		10	10	14		10	14		10	
	mm	350				350				350			
C <sub>s</sub> (Dynamic Load Rating)	lbf	15693	13197	11656	6363	15693	13197	11656	6363	13197	11656	6363	
	N	69806	58703	51848	28304	69806	58703	51848	28304	58703	51848	28304	
Inertia (zero stroke)	lb-in-s <sup>2</sup>	0.02084				0.02300				0.02517			
	Kg-m <sup>2</sup>	0.002356				0.002599				0.002844			
Inertia Adder (per inch of stroke)	lb-in-s <sup>2</sup> /in					0.001208							
	Kg-m <sup>2</sup> /in					0.0001365							
Weight (zero stroke)	lb	46.0				53.0				60.0			
	Kg	20.87				24.04				27.2			
Weight Adder (per inch of stroke)	lb					3.0							
	Kg					1.36							

\*See definitions on page 9

## GSX60

Model No. (Motor Stacks)		1 Stack			2 Stack			3 Stack		
Screw Lead Designator		03	05	10	03	05	10	03	05	10
Screw Lead	in	0.25	0.5	1.0	0.25	0.5	1	0.25	0.5	1
	mm	6.35	12.7	25.4	6.35	12.7	25.4	6.35	12.7	25.4
Continuous Force (Motor Limited)	lbf	4937	2797	1481	8058	4566	2417	11528	6533	3459
	N	21958	12443	6588	35843	20311	10753	51278	29058	15383
Max Velocity	in/sec	10.0	20.0	40.0	10.0	20.0	40.0	10.0	20.0	40.0
	mm/sec	254.0	508.0	1016.0	254.0	508.0	1016.0	254.0	508.0	1016.0
Friction Torque (standard screw)	in-lbf		8.1			10.8			14.5	
	N-m		0.91			1.22			1.64	
Friction Torque (preloaded screw)	in-lbf		14.1			16.8			20.5	
	N-m		1.59			1.90			2.32	
Min Stroke	in		6			10			10	
	mm		150			250			250	
Max Stroke	in		10			10			10	
	mm		250			250			250	
C <sub>a</sub> (Dynamic Load Rating)	lbf	25300	22800	21200	25300	22800	21200	25300	22800	21200
	N	112540	101420	94302	112540	101420	94302	112540	101420	94302
Inertia (zero stroke)	lb-in-s <sup>2</sup>		0.0804			0.1114			0.1424	
	Kg-m <sup>2</sup>		0.009087			0.001259			0.01609	
Inertia Adder (per inch of stroke)	lb-in-s <sup>2</sup> /in					0.005190				
	Kg-m <sup>2</sup> /in					0.0005864				
Weight (zero stroke)	lb		48			62			76	
	Kg		21.77			28.12			34.47	
Weight Adder (per inch of stroke)	lb					8.0				
	Kg					3.63				

### DEFINITIONS:

**Continuous Force:** The linear force produced by the actuator at continuous motor torque.

**Max Velocity:** The linear velocity that the actuator will achieve at rated motor rpm.

**Friction Torque (standard screw):** Amount of torque required to move the actuator when not coupled to a load.

**Friction Torque (preloaded screw):** Amount of torque required to move the actuator when not coupled to a load.

**Min Stroke:** Shortest available stroke length.

**Max Stroke:** Longest available stroke length.

**C<sub>a</sub> (Dynamic Load Rating):** A design constant used when calculating the estimated travel life of the roller screw.

**Inertia (zero stroke):** Base inertia of an actuator with zero available stroke length.

**Inertia Adder (per inch of stroke):** Inertia per inch of stroke that must be added to the base (zero stroke) inertia to determine the total actuator inertia.

**Weight (zero stroke):** Base weight of an actuator with zero available stroke length.

**Weight Adder (per inch of stroke):** Weight adder per inch of stroke that must be added to the base (zero stroke) weight to determine the total actuator weight.



# GSX Series Integrated Motor/Actuator

## Weight Adders of GSX Accessories

Weight Adders of GSX Accessories	GSX20		GSX30		GSX40		GSX50		GSX60	
	lbs	kg	lbs	kg	lbs	kg	lbs	kg	lbs	kg
Front Flange Mount	0.7	0.3	1.7	0.8	4.0	1.8	10.8	4.9	15.2	6.9
Rear Flange Mount	1.0	0.5	1.8	0.8	5.0	2.3	12.8	5.8	30.4	13.7
Side Mount	0.0	0.0	0.0	0.0	0.0	0.0	0.0	0.0	0.0	0.0
Extended Tie Rod	0.0	0.0	0.1	0.0	0.2	0.1	0.3	0.2	0.5	0.2
Side Trunnion	0.8	0.3	0.8	0.3	1.8	0.8	4.6	2.1	9.3	4.2
3 inch Stroke	2.2	1.0	2.8	1.3	NA	NA	NA	NA	NA	NA
4 inch Stroke	NA	NA	NA	NA	5.1	2.3	NA	NA	NA	NA
6 inch Stroke	3.1	1.4	3.6	1.6	5.9	2.7	14.3	6.5	26.6	12.1
8 inch Stroke	NA	NA	NA	NA	6.7	3.0	NA	NA	NA	NA
10 inch Stroke	3.9	1.8	5.0	2.3	7.5	3.4	17.7	8.0	32.3	14.7
12 inch Stroke	4.4	2.0	5.7	2.6	8.2	3.8	NA	NA	NA	NA
14 inch Stroke	NA	NA	6.9	3.1	NA	NA	21.1	9.6	NA	NA
18 inch Stroke	NA	NA	7.6	3.5	10.6	4.8	NA	NA	NA	NA
Rear Clevis Mount w/ Pin	0.4	0.2	1.1	0.5	1.9	0.8	5.1	2.3	13.6	6.2
Anti-Rotation (incl. flange)	1.1	0.5	2.6	1.2	5.3	2.4	6.6	3.0	21.0	10.0
External Limit Switch (incl. AR)	1.2	0.5	2.8	1.2	5.6	2.5	6.9	3.1	21.4	9.7
3 inch Stroke	1.4	0.6	3.0	1.4	NA	NA	NA	NA	NA	NA
6 inch Stroke	1.5	0.7	3.2	1.5	6.0	2.7	7.8	3.5	22.2	10.1
8 inch Stroke	NA	NA	NA	NA	6.1	2.8	NA	NA	NA	NA
10 inch Stroke	1.6	0.7	3.5	1.6	6.3	2.8	8.1	3.7	22.4	10.2
12 inch Stroke	1.7	0.8	3.6	1.6	6.4	2.9	NA	NA	NA	NA
14 inch Stroke	NA	NA	3.7	1.7	NA	NA	8.5	3.9	NA	NA
18 inch Stroke	NA	NA	3.9	1.8	6.7	3.1	NA	NA	NA	NA
Splined Main Rod	0.3	0.1	1.0	0.5	2.2	1.0	4.8	2.2	14.8	6.7
Protective Bellows	0.2	0.1	0.3	0.1	0.3	0.2	0.4	0.2	0.9	0.4
Rod Clevis	0.2	0.1	0.5	0.2	1.4	0.6	3.5	1.6	8.2	3.7
Spherical Rod Eye	0.2	0.1	0.2	0.1	0.7	0.3	1.6	0.7	NA	NA
Rod Eye	0.2	0.1	0.3	0.2	1.2	0.5				

\*All weights are approximate

## Electrical Specifications

### GSX20

Motor Stator		118	138	158	168	218	238	258	268	318*	338*	358*	368*
Bus Voltage	Vrms	115	230	400	460	115	230	400	460	115	230	400	460
Speed @ Bus Voltage	rpm	5000											
RMS SINUSOIDAL COMMUTATION													
Continuous Motor Torque	lbf-in	7.6	7.3	7.0	7.0	11.9	11.5	11.0	11.3	15.0	15.3	14.6	14.9
	Nm	0.86	0.83	0.79	0.79	1.34	1.30	1.25	1.28	1.70	1.73	1.65	1.69
Torque Constant (Kt) (+/- 10% @ 25°C)	lbf-in/A	2.5	5.2	7.5	9.5	2.5	5.2	8.6	10.1	2.5	5.3	8.8	10.1
	Nm/A	0.28	0.59	0.85	1.07	0.28	0.59	0.97	1.15	0.29	0.59	0.99	1.15
Continuous Current Rating	(Greased) A	3.4	1.6	1.0	0.8	5.4	2.5	1.4	1.2	6.6	3.2	1.9	1.6
	(Oil Cooled) A	6.9	3.1	2.1	1.6	10.8	4.9	2.9	2.5	13.2	6.5	3.7	3.3
Peak Current Rating	A	6.9	3.1	2.1	1.6	10.8	4.9	2.9	2.5	13.2	6.5	3.7	3.3
O-PK SINUSOIDAL COMMUTATION													
Continuous Motor Torque	lbf-in	7.6	7.3	7.0	7.0	11.9	11.5	11.0	11.3	15.0	15.3	14.6	14.9
	Nm	0.86	0.83	0.79	0.79	1.34	1.30	1.25	1.28	1.70	1.73	1.65	1.69
Torque Constant (Kt) (+/- 10% @ 25°C)	lbf-in/A	1.7	3.7	5.3	6.7	1.7	3.7	6.1	7.2	1.8	3.7	6.2	7.2
	Nm/A	0.20	0.42	0.60	0.76	0.20	0.42	0.69	0.81	0.20	0.42	0.70	0.81
Continuous Current Rating	(Greased) A	4.9	2.2	1.5	1.2	7.6	3.5	2.0	1.8	9.4	4.6	2.6	2.3
	(Oil Cooled) A	9.7	4.5	2.9	2.3	15.2	7.0	4.1	3.5	18.7	9.2	5.3	4.7
Peak Current Rating	A	9.7	4.5	2.9	2.3	15.2	7.0	4.1	3.5	18.7	9.2	5.3	4.7
MOTOR STATOR DATA													
Voltage Constant (Ke) (+/- 10% @ 25°C)	Vrms/Krpm	16.9	35.5	51.5	64.8	16.9	35.5	58.6	69.3	17.3	36.0	59.9	69.3
	Vpk/Krpm	23.9	50.2	72.8	91.7	23.9	50.2	82.9	98.0	24.5	50.9	84.8	98.0
Pole Configuration		8	8	8	8	8	8	8	8	8	8	8	8
Resistance (L-L)(+/- 5% @ 25°C)	Ohms	2.6	12.5	28.8	45.8	1.1	5.3	15.5	20.7	0.76	3.1	9.6	12.2
Inductance (L-L)(+/- 15%)	mH	4.6	21.4	47.9	68.3	2.5	10.2	28.3	39.5	1.7	7.4	18.5	27.4
Brake Inertia	lbf-in-sec <sup>2</sup>	0.00012											
	Kg-cm <sup>2</sup>	0.135											
Brake Current @ 24 VDC	A	0.33											
Brake Holding Torque	lbf-in	19											
	Nm	2.2											
Brake Engage/Disengage Time	ms	14/28											
Mechanical Time Constant (tm), ms	min	4.7	5.1	5.5	5.6	2.0	2.1	2.3	2.2	1.3	1.2	1.4	1.3
	max	6.6	7.2	7.9	7.9	2.8	3.0	3.3	3.1	1.8	1.8	1.9	1.8
Electrical Time Constant (te)	ms	1.8	1.7	1.7	1.5	2.2	1.9	1.8	1.9	2.3	2.4	1.9	2.2
Insulation Class		180 (H)											

For amplifiers using peak sinusoidal ratings, multiply RMS sinusoidal Kt by 0.707 and current by 1.414.  
 \*Refer to performance specifications on page 7 for availability of 3 stack stator by stroke/lead combination.  
 Test data derived using NEMA recommended aluminum heatsink 10" x 10" x 1/4" at 25°C ambient.

Specifications subject to change without notice.

# GSX Series Integrated Motor/Actuator

## GSX30

Motor Stator		118	138	158	168	218	238	258	268	318*	338*	358*	368*
Bus Voltage	Vrms	115	230	400	460	115	230	400	460	115	230	400	460
Speed @ Bus Voltage	rpm	3000											
RMS SINUSOIDAL COMMUTATION													
Continuous Motor Torque	lbf-in	16.9	16.8	16.3	16.0	26.9	27.1	26.7	27.0	38.7	38.2	36.2	36.3
	Nm	1.91	1.90	1.84	1.81	3.04	3.06	3.01	3.05	4.37	4.32	4.09	4.10
Torque Constant (Kt) (+/- 10% @ 25°C)	lbf-in/A	4.4	8.7	15.5	17.5	4.4	8.7	15.5	17.5	4.4	8.7	15.6	17.5
	Nm/A	0.49	0.99	1.75	1.97	0.49	0.99	1.75	1.97	0.50	0.98	1.77	1.98
Continuous Current Rating	(Greased) A	4.3	2.2	1.2	1.0	6.9	3.5	1.9	1.7	9.7	4.9	2.6	2.3
	(Oil Cooled) A	8.6	4.3	2.4	2.0	13.8	6.9	3.8	3.4	19.5	9.9	5.2	4.6
Peak Current Rating	A	8.6	4.3	2.4	2.0	13.8	6.9	3.8	3.4	19.5	9.9	5.2	4.6
O-PK SINUSOIDAL COMMUTATION													
Continuous Motor Torque	lbf-in	16.9	16.8	16.3	16.0	26.9	27.1	26.7	27.0	38.7	38.2	36.2	36.3
	Nm	1.91	1.90	1.84	1.81	3.04	3.06	3.01	3.05	4.37	4.32	4.09	4.10
Torque Constant (Kt) (+/- 10% @ 25°C)	lbf-in/A	3.1	6.2	11.0	12.4	3.1	6.2	11.0	12.4	3.1	6.1	11.1	12.4
	Nm/A	0.35	0.70	1.24	1.40	0.35	0.70	1.24	1.40	0.35	0.69	1.25	1.40
Continuous Current Rating:	(Greased) A	6.1	3.0	1.7	1.4	9.7	4.9	2.7	2.4	13.8	7.0	3.7	3.3
	(Oil Cooled) A	12.2	6.1	3.3	2.9	19.5	9.8	5.4	4.9	27.6	13.9	7.3	6.5
Peak Current Rating	A	12.2	6.1	3.3	2.9	19.5	9.8	5.4	4.9	27.6	13.9	7.3	6.5
MOTOR STATOR DATA													
Voltage Constant (Ke) (+/- 10% @ 25°C)	Vrms/Krpm	29.8	59.7	105.8	119.3	29.8	59.7	105.8	119.3	30.3	59.2	106.8	119.8
	Vpk/Krpm	42.2	84.4	149.7	168.7	42.2	84.4	149.7	168.7	42.9	83.7	151.0	169.4
Pole Configuration		8	8	8	8	8	8	8	8	8	8	8	8
Resistance (L-L)(+/- 5% @ 25°C)	Ohms	2.7	10.8	36.3	47.9	1.1	4.4	14.1	17.6	0.65	2.6	9.3	11.6
Inductance (L-L)(+/- 15%)	mH	7.7	30.7	96.8	123.0	3.7	14.7	46.2	58.7	2.5	9.5	30.9	38.8
Brake Inertia	lbf-in-sec <sup>2</sup>	0.00033											
	Kg-cm <sup>2</sup>	0.38											
Brake Current @ 24 VDC	A	0.5											
Brake Holding Torque	lbf-in	70											
	Nm	8											
Brake Engage/Disengage Time	ms	19/29											
Mechanical Time Constant (tm), ms	min	4.9	4.9	5.2	5.4	2.0	2.0	2.0	2.0	1.1	1.2	1.3	1.3
	max	9.4	9.5	10.1	10.5	3.9	3.8	3.9	3.8	2.2	2.3	2.5	2.5
Electrical Time Constant (te)	ms	2.9	2.8	2.7	2.6	3.3	3.4	3.3	3.3	3.8	3.7	3.3	3.3
Insulation Class		180 (H)											

For amplifiers using peak sinusoidal ratings, multiply RMS sinusoidal Kt by 0.707 and current by 1.414.  
 \*Refer to performance specifications on page 7 for availability of 3 stack stator by stroke/lead combination.  
 Test data derived using NEMA recommended aluminum heatsink 10" x 10" x 3/8" at 25°C ambient.

Specifications subject to change without notice.

# GSX Series Integrated Motor/Actuator

## GSX40

Motor Stator		118	138	158	168	218	238	258	268	338*	358*	368*
Bus Voltage	Vrms	115	230	400	460	115	230	400	460	230	400	460
Speed @ Bus Voltage	rpm	3000										
RMS SINUSOIDAL COMMUTATION												
Continuous Motor Torque	lbf-in	47.5	47.5	45.9	45.4	75.1	78.6	78.7	79.5	106.9	105.3	106.9
	Nm	5.37	5.36	5.19	5.13	8.49	8.89	8.89	8.99	12.08	11.90	12.08
Torque Constant (Kt) (+/- 10% @ 25°C)	lbf-in/A	4.1	8.2	14.5	16.8	4.1	8.2	14.5	16.8	8.4	14.5	16.8
	Nm/A	0.46	0.93	1.64	1.90	0.46	0.93	1.64	1.90	0.95	1.64	1.90
Continuous Current Rating	(Greased) A	12.9	6.5	3.5	3.0	20.5	10.7	6.0	5.3	14.2	8.1	7.1
	(Oil Cooled) A	25.9	12.9	7.1	6.0	40.9	21.4	12.1	10.6	28.5	16.2	14.2
Peak Current Rating	A	25.9	12.9	7.1	6.0	40.9	21.4	12.1	10.6	28.5	16.2	14.2
O-PK SINUSOIDAL COMMUTATION												
Continuous Motor Torque	lbf-in	47.5	47.5	45.9	45.4	75.1	78.6	78.7	79.5	106.9	105.3	106.9
	Nm	5.37	5.36	5.19	5.13	8.49	8.89	8.89	8.99	12.08	11.90	12.08
Torque Constant (Kt) (+/- 10% @ 25°C)	lbf-in/A	2.9	5.8	10.3	11.9	2.9	5.8	10.3	11.9	5.9	10.3	11.9
	Nm/A	0.33	0.66	1.16	1.34	0.33	0.66	1.16	1.34	0.67	1.16	1.34
Continuous Current Rating	(Greased) A	18.3	9.1	5.0	4.3	28.9	15.1	8.5	7.5	20.1	11.4	10.1
	(Oil Cooled) A	36.6	18.3	10.0	8.6	57.9	30.3	17.1	15.0	40.3	22.9	20.1
Peak Current Rating	A	36.6	18.3	10.0	8.6	57.9	30.3	17.1	15.0	40.3	22.9	20.1
MOTOR STATOR DATA												
Voltage Constant (Ke) (+/- 10% @ 25°C)	Vrms/Krpm	28.0	56.0	99.3	114.6	28.0	56.0	99.3	114.6	57.3	99.3	114.6
	Vpk/Krpm	39.6	79.2	140.5	162.1	39.6	79.2	140.5	162.1	81.0	140.5	162.1
Pole Configuration		8	8	8	8	8	8	8	8	8	8	8
Resistance (L-L)(+/- 5% @ 25°C)	Ohms	0.42	1.7	5.7	7.8	0.2	0.72	2.26	3.0	0.5	1.52	2.0
Inductance (L-L)(+/- 15%)	mH	3.0	11.9	37.5	49.9	1.2	5.4	18.2	23.1	4.0	12.0	16.0
Brake Inertia	lbf-in-sec <sup>2</sup>	0.00096										
	Kg-cm <sup>2</sup>	1.08										
Brake Current @ 24 VDC	A	0.67										
Brake Holding Torque	lbf-in	97										
	Nm	11										
Brake Engage/Disengage Time	ms	20/29										
Mechanical Time Constant (tm), ms	min	4.5	4.5	4.8	4.9	2.1	1.9	1.9	1.9	1.2	1.3	1.2
	max	6.0	6.0	6.4	6.6	2.8	2.6	2.6	2.5	1.7	1.7	1.7
Electrical Time Constant (te)	ms	7.0	7.0	6.6	6.4	5.9	7.5	8.0	7.8	8.2	7.9	8.2
Insulation Class		180 (H)										

\*Refer to performance specifications on page 8 for availability of 3 stack stator by stroke/lead combination.  
Test data derived using NEMA recommended aluminum heatsink 12" x 12" x 1/2" at 25°C ambient.

Specifications subject to change without notice.

# GSX Series Integrated Motor/Actuator

## GSX50

Motor Stator		138	158	168	238	258	268	338	358	368
Bus Voltage	Vrms	230	400	460	230	400	460	230	400	460
Speed @ Bus Voltage	rpm	2400								
RMS SINUSOIDAL COMMUTATION										
Continuous Motor Torque	lbf-in	107.2	104.8	109.4	179.9	178.8	177.8	233.3	237.2	238.3
	Nm	12.12	11.84	12.36	20.32	20.20	20.09	26.36	26.80	26.93
Torque Constant (Kt) (+/- 10% @ 25°C)	lbf-in/A	11.8	20.2	23.6	11.8	20.2	23.6	12.0	20.2	24.0
	Nm/A	1.33	2.28	2.67	1.33	2.28	2.67	1.36	2.28	2.71
Continuous Current Rating	(Greased) A	10.2	5.8	5.2	17.0	9.9	8.4	21.7	13.1	11.1
	(Oil Cooled) A	20.3	11.6	10.4	34.1	19.8	16.8	43.4	26.2	22.2
Peak Current Rating	A	20.3	11.6	10.4	34.1	19.8	16.8	43.4	26.2	22.2
O-PK SINUSOIDAL COMMUTATION										
Continuous Motor Torque	lbf-in	107.2	104.8	109.4	179.9	178.8	177.8	233.3	237.2	238.3
	Nm	12.12	11.84	12.36	20.32	20.20	20.09	26.36	26.80	26.93
Torque Constant (Kt) (+/- 10% @ 25°C)	lbf-in/A	8.3	14.3	16.7	8.3	14.3	16.7	8.5	14.3	17.0
	Nm/A	0.94	1.62	1.88	0.94	1.62	1.88	0.96	1.62	1.92
Continuous Current Rating	(Greased) A	14.4	8.2	7.3	24.1	14.0	11.9	30.7	18.5	15.7
	(Oil Cooled) A	28.7	216.4	14.7	48.2	27.9	23.8	61.4	37.1	31.4
Peak Current Rating	A	28.7	16.4	14.7	48.2	27.9	23.8	61.4	37.1	31.4
MOTOR STATOR DATA										
Voltage Constant (Ke) (+/- 10% @ 25°C)	Vrms/Krpm	80.6	138.1	161.1	80.6	138.1	161.1	82.0	138.1	164.0
	Vpk/Krpm	113.9	195.3	227.9	113.9	195.3	227.9	116.0	195.3	232.0
Pole Configuration		8	8	8	8	8	8	8	8	8
Resistance (L-L)(+/- 5% @ 25°C)	Ohms	0.87	2.68	3.34	0.34	1.01	1.39	0.22	0.61	0.86
Inductance (L-L)(+/- 15%)	mH	21.7	63.9	78.3	8.9	27.6	41.5	6.3	17.8	28.2
Brake Inertia	lbf-in-sec <sup>2</sup>	0.0084								
	Kg-cm <sup>2</sup>	9.5								
Brake Current @ 24 VDC	A	1								
Brake Holding Torque	lbf-in	354								
	Nm	40								
Brake Engage/Disengage Time	ms	25/73								
Mechanical Time Constant (tm), ms	min	2.2	2.3	2.1	0.9	0.9	0.9	0.5	0.5	0.5
	max	2.8	3.0	2.7	1.1	1.1	1.1	0.7	0.7	0.7
Electrical Time Constant (te)	ms	25.0	23.9	23.4	26.1	27.3	29.9	28.0	29.0	32.9
Insulation Class		180 (H)								

Test data derived using NEMA recommended aluminum heatsink 12" x 12" x 1/2" at 25°C ambient

Specifications subject to change without notice.

# GSX Series Integrated Motor/Actuator

GSX Series

## GSX60

Motor Stator		138	158	168	238	258	268	358	368
Bus Voltage	Vrms	230	400	460	230	400	460	400	460
Speed @ Bus Voltage	rpm	2400							
<b>RMS SINUSOIDAL COMMUTATION</b>									
Continuous Motor Torque	lbf-in	254.2	249.9	261.9	424.8	423.0	427.5	595.6	615.0
	Nm	28.72	28.23	29.59	47.99	47.79	48.30	67.29	69.49
Torque Constant (Kt) (+/- 10% @ 25°C)	lbf-in/A	12.6	21.8	25.2	12.6	21.8	25.2	21.4	25.2
	Nm/A	1.42	2.46	2.84	1.42	2.46	2.84	2.42	2.84
Continuous Current Rating	(Greased) A	22.6	12.8	11.6	37.7	21.7	19.0	31.1	27.3
	(Oil Cooled) A	45.2	25.6	23.3	75.5	43.4	38.0	62.2	54.6
Peak Current Rating	A	45.2	25.6	23.3	75.5	43.4	38.0	62.2	54.6
<b>O-PK SINUSOIDAL COMMUTATION</b>									
Continuous Motor Torque	lbf-in	254.2	249.9	261.9	424.8	423.0	427.5	595.6	611.6
	(Nm)	28.72	28.23	29.59	47.99	47.79	48.30	67.29	69.10
Torque Constant (Kt) (+/- 10% @ 25°C)	lbf-in/A	8.9	15.4	17.8	8.9	15.4	17.8	15.1	17.8
	Nm/A	1.01	1.74	2.01	1.01	1.74	2.01	1.71	2.01
Continuous Current Rating	(Greased) A	31.9	18.1	16.4	53.4	30.7	26.8	44.0	38.4
	(Oil Cooled) A	63.9	36.2	32.9	106.7	61.3	53.7	88.0	76.8
Peak Current Rating	A	63.9	36.2	32.9	106.7	61.3	53.7	88.0	76.8
<b>MOTOR STATOR DATA</b>									
Voltage Constant (Ke) (+/- 10% @ 25°C)	Vrms/Krpm	85.9	148.9	171.8	85.9	148.9	171.8	146.1	171.8
	Vpk/Krpm	121.5	210.6	243.0	121.5	210.6	243.0	206.6	243.0
Pole Configuration		8	8	8	8	8	8	8	8
Resistance (L-L)(+/- 5% @ 25°C)	Ohms	0.3	1.0	1.2	0.13	0.41	0.5	0.23	0.3
Inductance (L-L)(+/- 15%)	mH	8.3	24.8	29.4	3.9	11.8	15.8	7.5	10.3
Brake Inertia	lbf-in-sec <sup>2</sup>	0.02815							
	Kg-cm <sup>2</sup>	31.8							
Brake Current @ 24 VDC	A	1.45							
Brake Holding Torque	lbf-in	708							
	Nm	80							
Brake Engage/Disengage Time	ms	53/97							
Mechanical Time Constant (tm), ms	min	3.9	4.0	3.6	1.6	1.6	1.6	1.0	0.9
	max	4.3	4.5	4.1	1.8	1.8	1.8	1.1	1.0
Electrical Time Constant (te)	ms	25.4	24.6	24.0	29.4	29.1	29.8	32.1	33.8
Insulation Class		180 (H)							

Test data derived using NEMA recommended aluminum heatsink 16" x 16" x 1" at 25°C ambient  
**The GSX60-06 can only accommodate a single stack stator.**

Specifications subject to change without notice.

# GSX Series Integrated Motor/Actuator

## Estimated Service Life

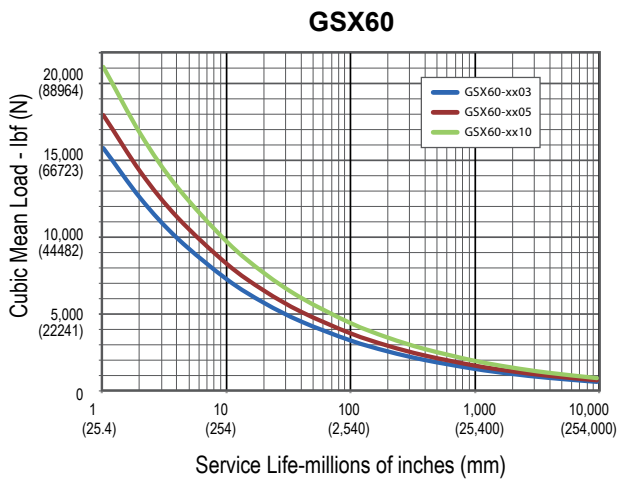
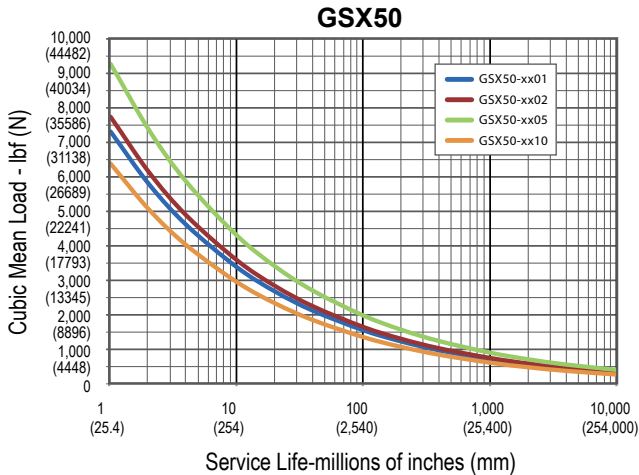
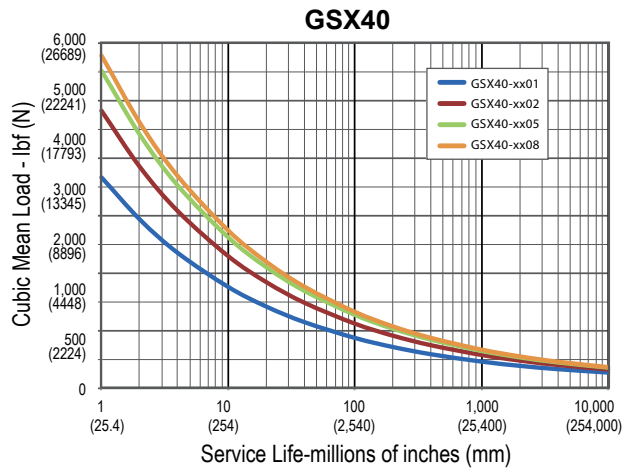
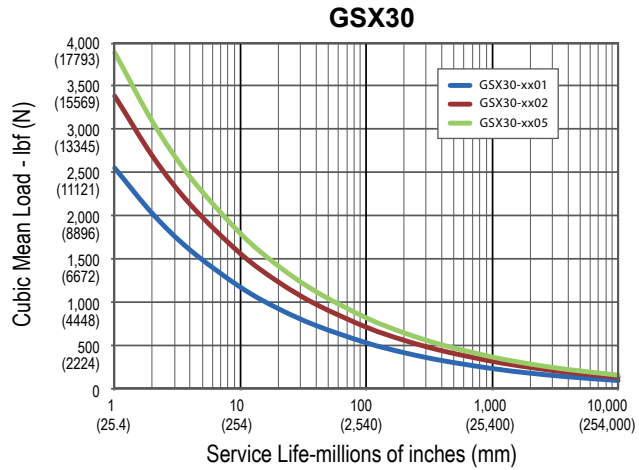
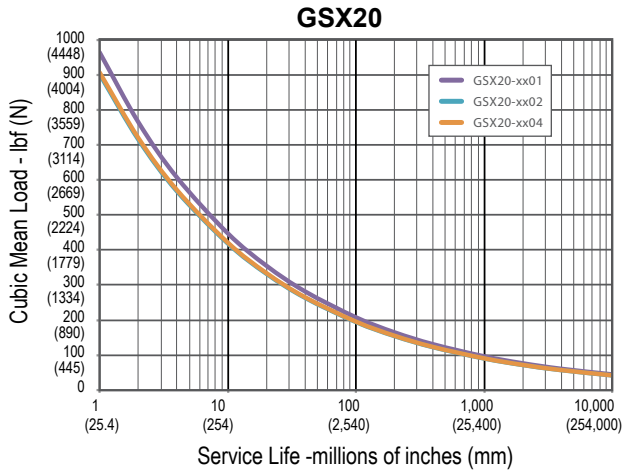

The  $L_{10}$  expected life of a roller screw linear actuator is expressed as the linear travel distance that 90% of properly maintained roller screws manufactured are expected to meet or exceed. This is not a guarantee and these charts should be used for estimation purposes only.

The underlying formula that defines this value is:  
Travel life in millions of inches, where:

$$L_{10} = \left( \frac{C_a}{F_{cml}} \right)^3 \times \ell$$

$C_a$  = Dynamic load rating (lbf)  
 $F_{cml}$  = Cubic mean applied load (lbf)  
 $\ell$  = Roller screw lead (inches)

For additional details on calculating estimated service life, please refer to the Engineering Reference, page 169.

### Service Life Estimate Assumptions:

- Sufficient quality and quantity of lubrication is maintained throughout service life (please refer to engineering reference on page 173 for lubrication interval estimates.)
- Bearing and screw temperature between 20° C and 40° C
- No mechanical hard stops (external or internal) or impact loads
- No external side loads
- Does not apply to short stroke, high frequency applications such as fatigue testing or short stroke, high force applications such as pressing. (For information on calculating estimating life for unique applications please refer to the engineering reference on page 169.)

## Speed vs. Force Curves

These charts represent typical linear speed versus linear force curves for the GSX actuators using common brushless motor amplifiers. The GSX Series are compatible with many different brushless motor amplifiers; any differences in the performance

ratings of these amplifiers can alter the actuator's performance. Thus, the curves below should be used for estimation only. (Further information is available by contacting your local sales representative.)

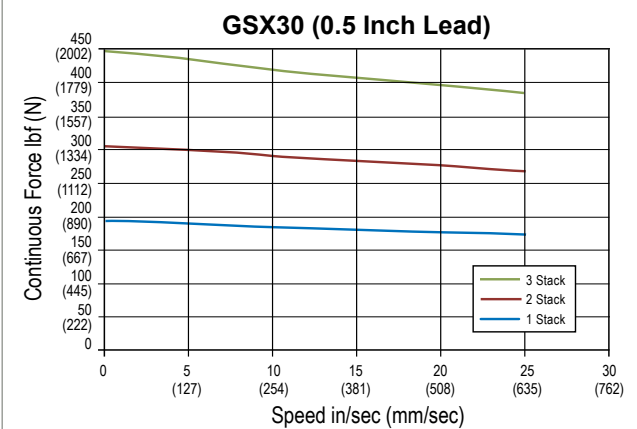
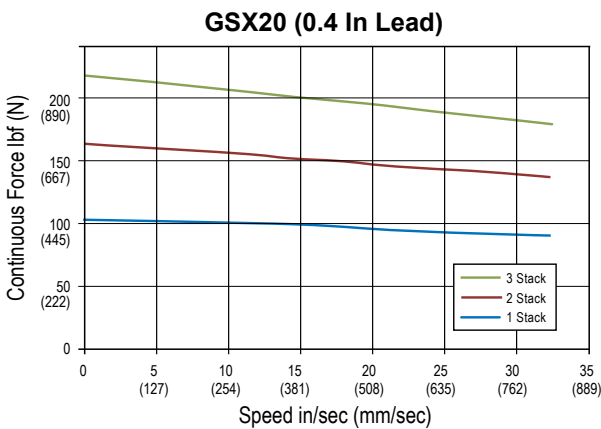
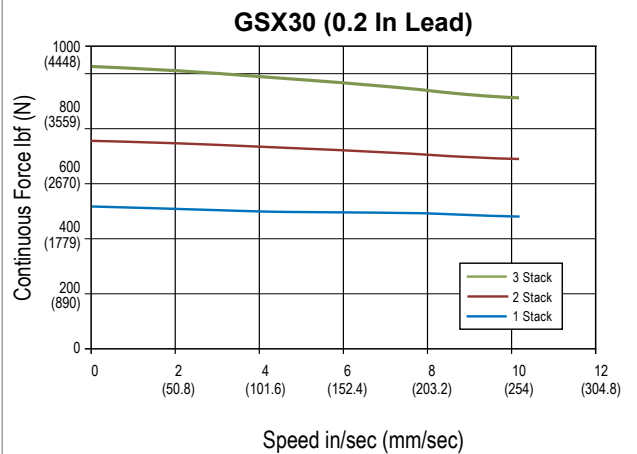
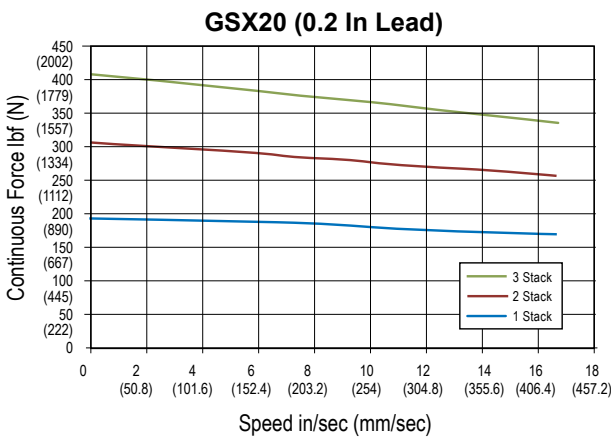
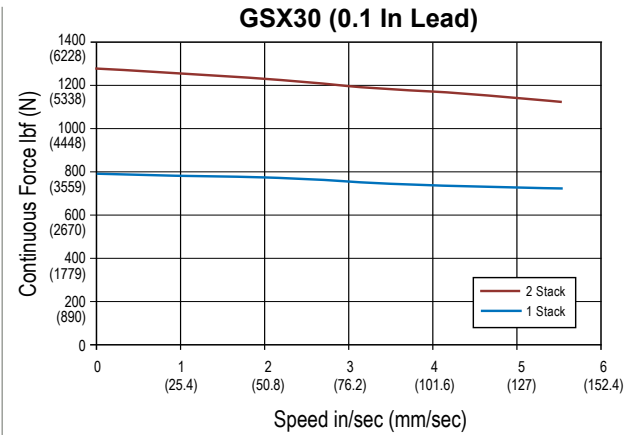
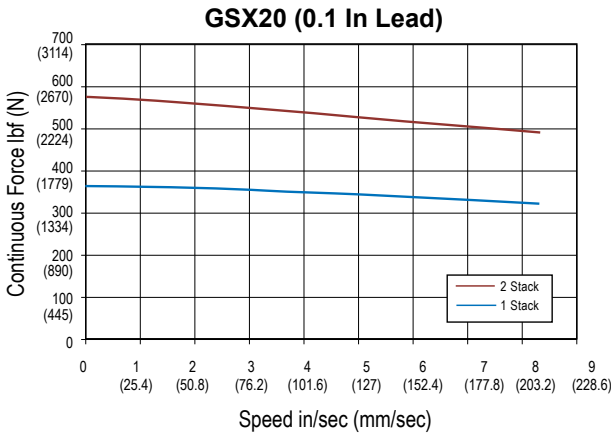

See page 22 for explanation of motor stator options (1x8, 2x8, 3x8)  
See page 7 for mechanical specifications

Test data derived using NEMA recommended aluminum heatsink 10" x 10" x 1/4" for GSX20 and 10" x 10" x 3/8" for GSX30. Testing ambient temperature 25°C.



# GSX Series Integrated Motor/Actuator

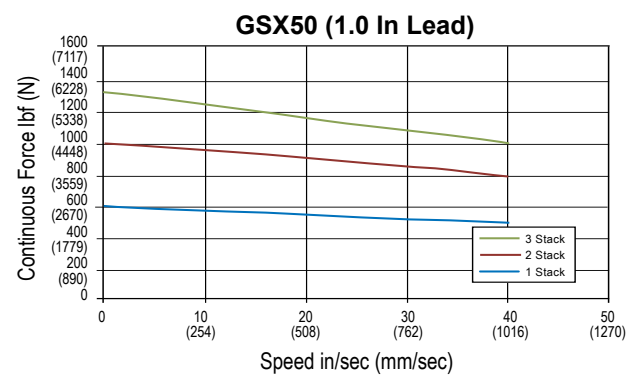
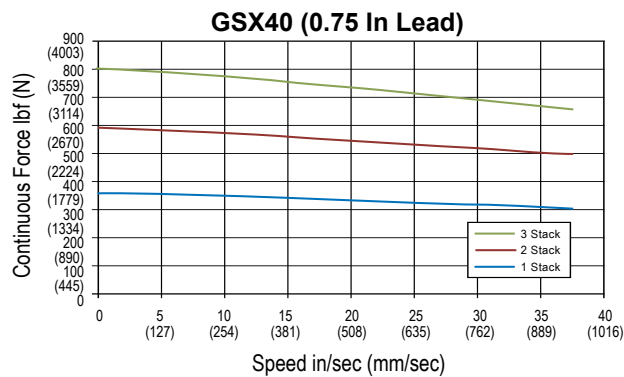
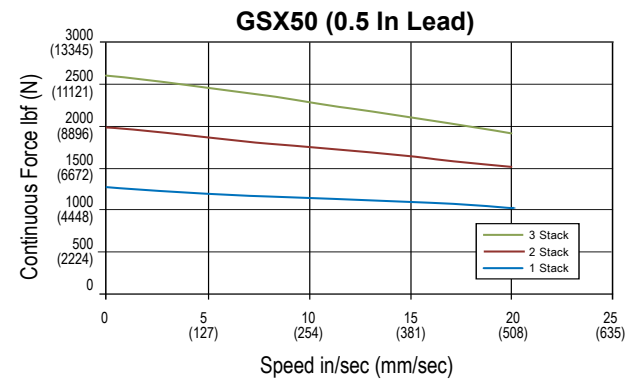
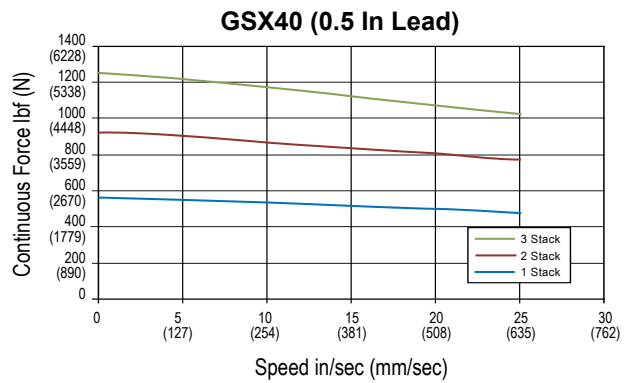
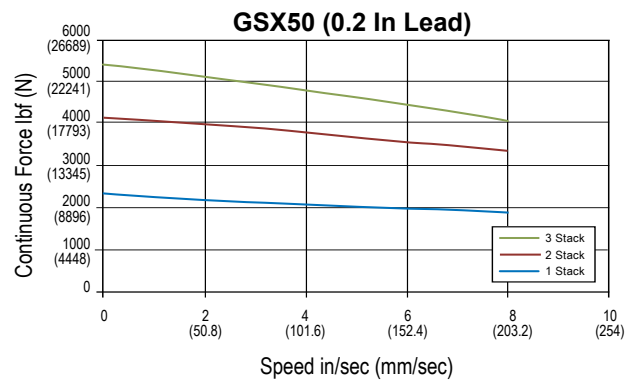
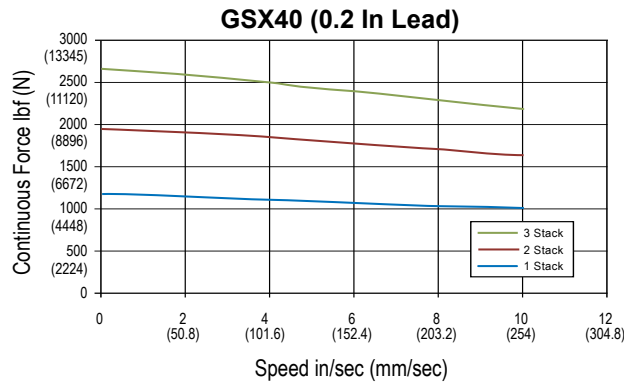
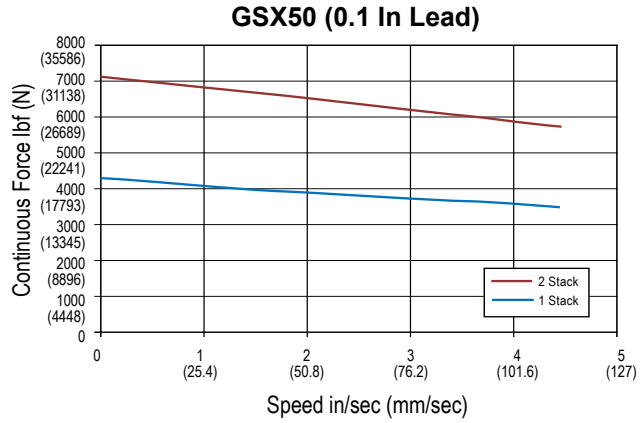
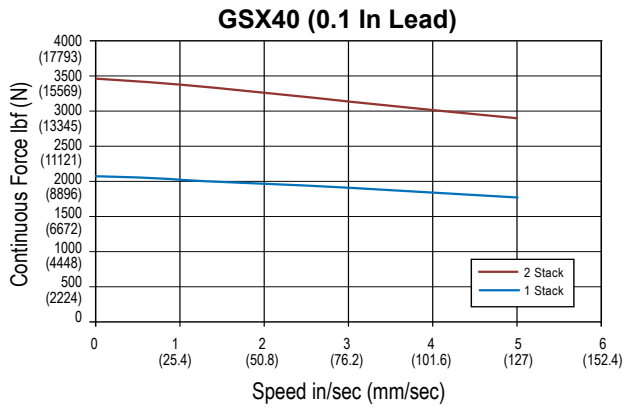

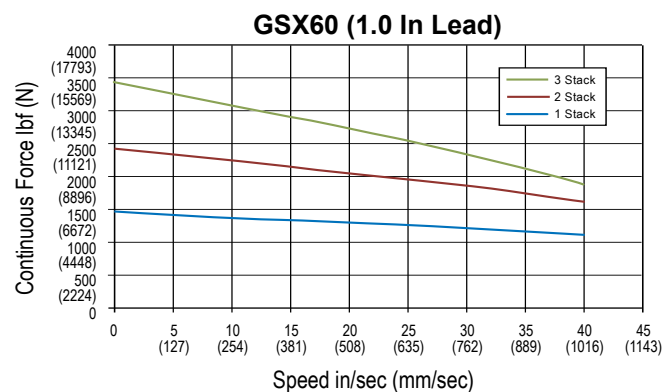
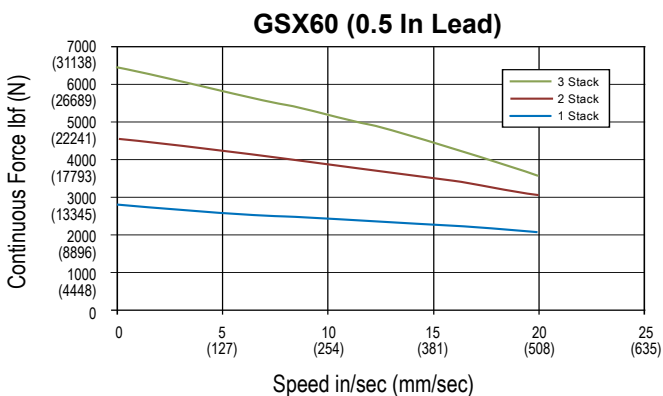
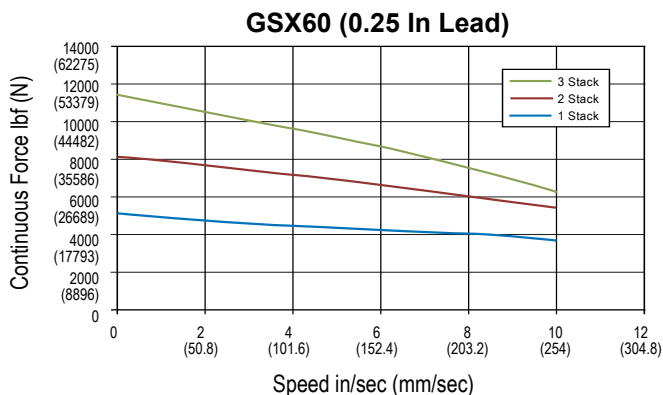

See page 22 for explanation of motor stator options (1x8, 2x8, 3x8)  
See page 7 for mechanical specifications

Test data derived using NEMA recommended aluminum heatsink 12" x 12" x 1/2" for GSX40, 12" x 12" x 1/2" for GSX50, and 16" x 16" x 1" for GSX60.  
Testing ambient temperature 25°C.

# GSX Series Integrated Motor/Actuator

## System Configuration

GSX Series actuators include an integrated brushless servo motor. The unique design gives users a variety of feedback configuration options so GSX units can be powered by almost any brushless motor amplifier on the market.

This flexibility means GSX actuators can be incorporated into today's high performance single and multi-axis motion control

systems. For food and beverage packaging, to multi-axis turning centers, to aircraft assembly, the GSX Series units offers incredible performance and durability.

The schematic below shows typical connections for a single axis system with actuator and servo amplifier.

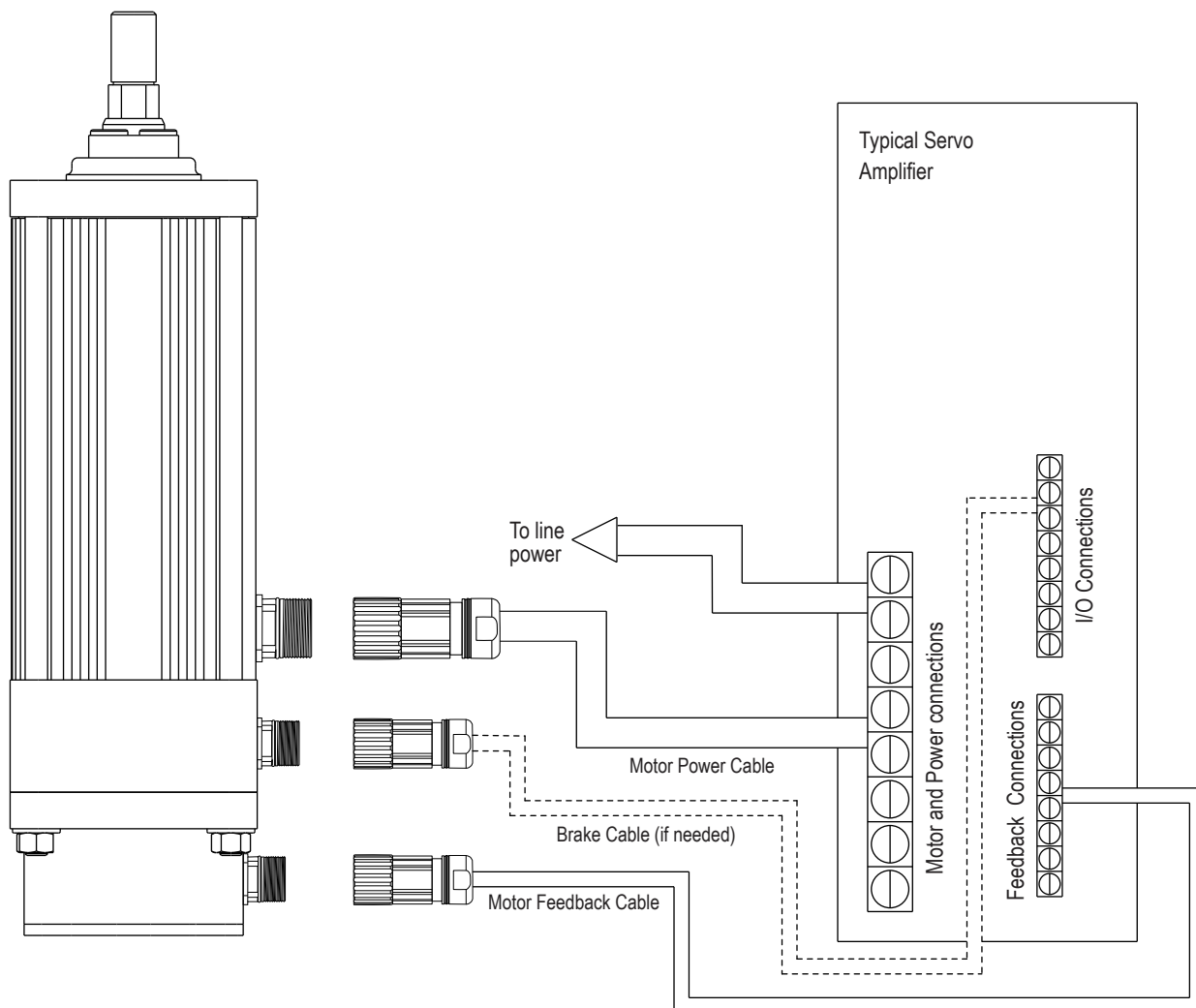

## Options

### AR = Anti-rotation Option

The unique design of the GSX Series of linear actuators permits the extending rod to rotate. This capability simplifies setup by allowing the user to rotate the rod in and out of the actuator for mechanical attachment or system testing.

However, this feature also requires that once setup and testing are completed, the rod be kept from rotating so proper linear motion will be maintained. In most applications the actuator's load is coupled to linear bearings, or some other support device. In these cases the load cannot rotate, so a separate anti-rotation system is not needed.

For applications in which the load is free to rotate, Exlar offers anti-rotation systems. Shorter GSX units use an anti-rotation arm on one side of the actuator. Longer strokes use arms on both sides.

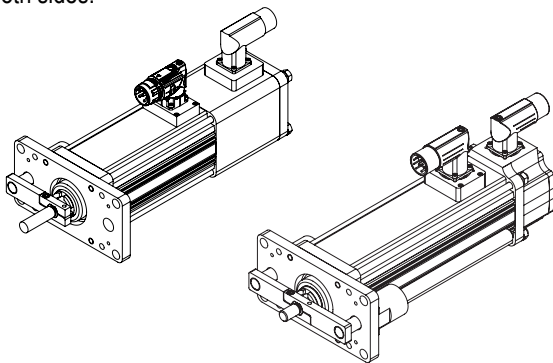

### PB = Protective Bellows

This option provides an accordion style protective bellows to protect the main actuator rod from damage due to abrasives or other contaminants in the operating environment. The standard material of this bellows is S2 Neoprene coated nylon with sewn construction. This standard bellows is rated for environmental temperatures of -40 to 250 degrees F. This option requires the main rod of the actuator to be extended beyond standard length. Not available with extended tie rod mounting option. Please contact your local sales representative for details.

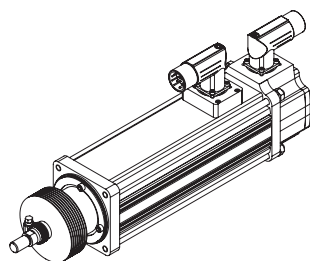

### RB = Rear Electric Brake

This option provides an internal holding brake for GSX Series actuators. The brake is spring activated and electrically released.

### SR = Splined Main Rod

This option provides a ball spline shafting main rod with a ball spline nut that replaces the standard front seal and bushing assembly. This rod restricts rotation without the need for an external mechanism. The rod diameter will be the closest metric equivalent to our standard rod sizes. Since this option is NOT sealed, it is not suitable for environments in which contaminants may enter the actuator.

*Note: This option affects overall length and mounting dimensions for GSX actuators. Consult your local sales representative if using splined main rod. Due to the reduced diameter of the splined main rod on the GSX50, the standard "A", "F", and "B" rod ends are not available and an "X" should be used in the model mask. Please see Actuator Rod Ends with Splined Main Rod Options on page 32 for dimensions.*

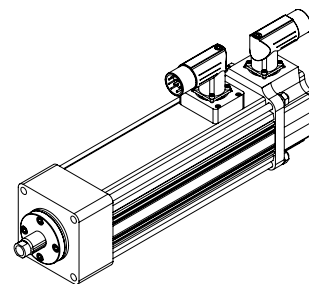

### L1, L2, L3 = Adjustable External Travel Switches

This option allows up to 3 external switches to be included with the GSX Series Actuator. These switches provide travel indication to the controller and are adjustable (must purchase external anti-rotate for this option). See page 29 for details.

# GSX Series Integrated Motor/Actuator

## Motor Speed

All Exlar T-LAM motors and actuators carry a standard motor speed designator (see chart). This is representative of the standard base speed of the motor for the selected bus voltage.

Designator	Base Speed	Actuator/Motor Series
-50	5000 rpm	GSX20
-30	3000 rpm	GSX30, GSX40
-24	2400 rpm	GSX50, GSX60

If the model number is created and the location for the motor speed designator is left blank, this is the base speed to which the motor will be manufactured. The model number can also be created including this standard speed designator.

## Feedback

### Absolute Feedback

Due to the variability in size of some feedback devices, especially absolute feedback devices which are often very large relative to the size of the actuator motor, the actual size of the actuator may differ in length and width from these drawings for feedback types other than standard resolvers and standard encoders. Please consult Exlar for details. In the event that you order an actuator that differs from these standard dimensions, you will be sent a drawing of the final configuration of your actuator.

## Motor Stators

GSX motor options are described with a 3 digit code. The first digit calls out the stack length, the second the rated bus voltage, and the third the number of poles of the motor. Refer to the mechanical/electrical specifications for motor torque and actuator rated force.

118	1 stack	115 Vrms	8 Pole	Class 180 H
138		230 Vrms		
158		400 Vrms		
168	2 stack	460 Vrms	8 Pole	Class 180 H
218		115 Vrms		
238		230 Vrms		
258		400 Vrms		
268	3 stack	460 Vrms	8 Pole	Class 180 H
318		115 Vrms		
338		230 Vrms		
358		400 Vrms		
368		460 Vrms		

\* Low voltage stators may be limited to less than catalog rated torque and/or speed. Please contact your local sales representative when ordering this option.

## Rod End Attachments

**Rear Clevis Pin  
Rod Eye**

**Spherical Rod Eye  
Rod Clevis**

See drawings on pages 30-32.

Attachments ordered separate from actuator.

## Oil Cooling and Lubrication Option

If you plan to use oil cooling with your GSX actuator, consult your local sales representative to discuss your application.

Exlar GSX actuators are normally delivered with high performance synthetic grease as a lubricant. The application of grease for the roller screw mechanism and bearings has proven adequate in thousands of applications over 25 years. However, in applications where the actuator is operated under high load, high speed and/or high duty cycle for extended periods of time, the grease will degrade prematurely and will eventually fail to provide the lubrication needed to maintain the operating efficiency and integrity of the roller screw and bearings. Continued operation of the actuator after the grease has broken down will cause premature failure of the device.

An ideal way to both lubricate and cool a GSX Series actuator in high performance applications is to flow a small amount of oil at low pressure through the actuator while it is in operation. A small amount of oil flow can, in many cases, allow operation of the actuator beyond normal continuous rated power levels. Oil flow lubrication has been used successfully and extensively in the field, allowing Exlar actuators to deliver thousands of hours of service between re-lubrication intervals even in the most arduous of applications.

Oil lubrication also significantly reduces actuator maintenance, saving valuable production time. With a recirculating oil system, lubricating oil is easily changed without having to access or

dismount the actuator. The ability to monitor oil condition can extend the usable life of the actuator by keeping the lubrication clean and fresh.

Some special application and actuator configuration considerations must be addressed prior to selecting and ordering a GSX actuator with oil lubrication. Please consult with Exlar Application Engineering prior to purchase.

A typical oil flow lubrication system involves use of a commercially available lubrication pump and plumbing to recirculate the oil. A schematic example of a possible oil system is shown below. Exlar Application Engineering can assist you in the development of an appropriate oil system, or recommend a pre-packaged oil circulation system.

**If you plan to use oil cooling with your GSX actuator, please consult Exlar to discuss your application.**

**Oil pressure within the actuator should never exceed 5 psi.**

**The Oil cooling option will limit maximum actuator acceleration.**

**Example Oil System Schematic**  
(Customer Supplied)

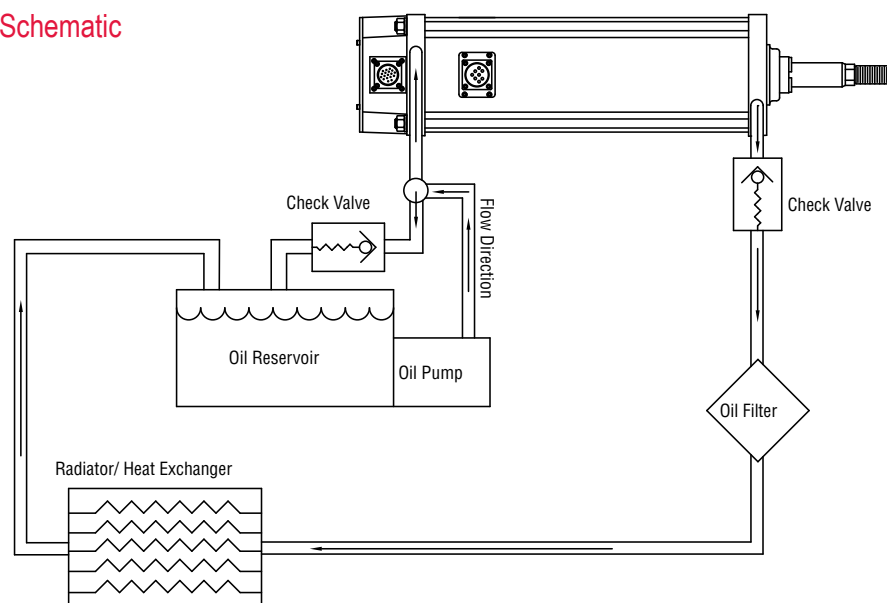

# GSX Series Integrated Motor/Actuator

[Return to Table of Contents](#)

## Dimensions Base Actuator

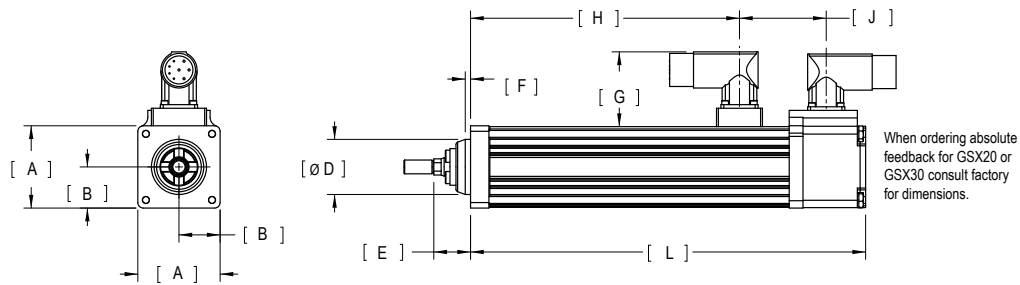

		GSX20	GSX30	GSX40	GSX50	GSX60
<b>A</b>	in	2.24	3.05	3.90	5.50	7.00
	mm	56.9	77.4	99.1	139.7	177.8
<b>B</b>	in	1.12	1.52	1.95	2.75	3.5
	mm	28.4	38.7	49.5	69.9	88.9
<b>Ø D</b>	in	1.500 +0.00/-0.03	2.000 +0.00/-0.03	2.500 +0.00/-0.03	3.000 +0.00/-0.03	3.375 +0.00/-0.03
	mm	38.10 +0.00/-0.08	50.80 +0.00/-0.08	63.50 +0.00/-0.08	76.20 +0.00/-0.08	85.73 +0.00/-0.08
<b>E<sup>5</sup></b>	in	1.00	1.32	1.65	2.13	1.94
	mm	25.4	33.5	41.9	54.0	49.4
<b>F</b>	in	0.14	0.09	0.10	0.13	0.13
	mm	3.7	2.3	2.5	3.2	3.2
<b>G</b>	in	2.04	2.04	2.04	2.04	2.04
	mm	51.7	51.7	51.7	51.7	51.7
<b>H (zero stroke)</b>	in	1.3	1.5	2.9	4.0	3.6
	mm	34	38	73	102	93
<b>J<sup>4</sup></b>	in	2.36	2.63	2.63	3.09	4.18
	mm	60.0	66.7	66.7	78.6	106.2
<b>L<sup>4</sup> (zero stroke)</b>	in	4.8	5.2	6.6	8.3	9.2
	mm	122	133	167	212	235

1. Dimensions shown are for referencing only and are subject to change
2. Dimensions reflect Exlar standard M23 style connectors (option I)
3. Dimensions may vary based on options selected. Consult Exlar for details or refer to drawings provided after receipt of order
4. If ordering a brake, add the following to dimensions J and L:  
 GSX20 add 1.78 in (45.2 mm)  
 GSX30 add 1.60 in (40.6 mm)  
 GSX40 add 2.33 in (59.2 mm)  
 GSX50 add 2.50 in (63.5 mm)  
 GSX60 add 3.58 in (90.9 mm)
5. If ordering bellows add 2 in (50.8 mm) to dimension E.

*Pre-sale drawings and models are representative and are subject to change. Certified drawings and models are available for a fee. Consult your local Exlar representative for details.*

## Front or Rear Flange Mount

GSX20, GSX50

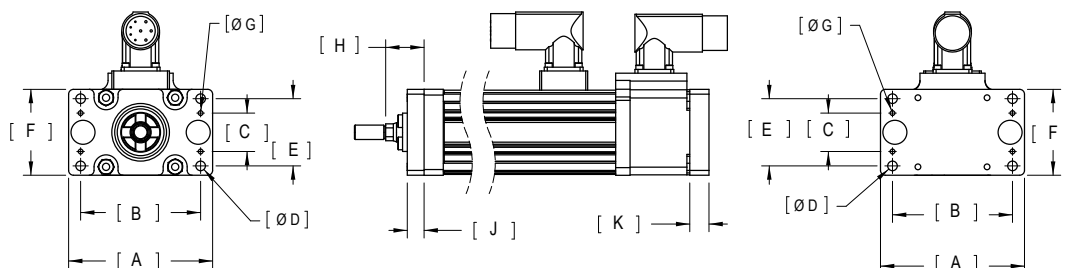

GSX30, GSX40, GSX60

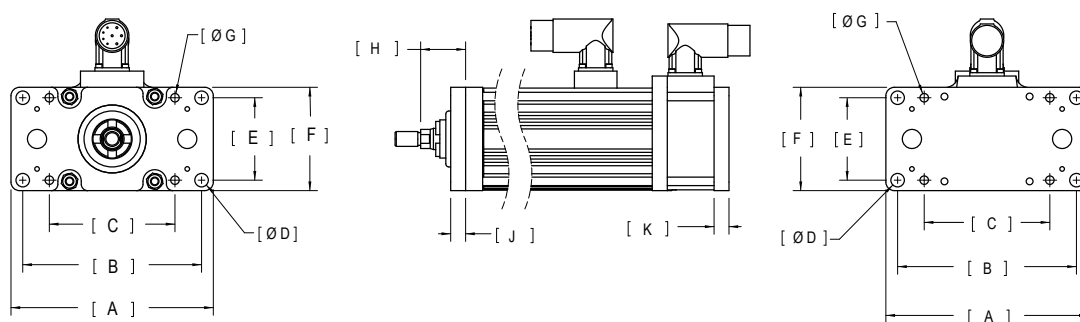

		GSX20	GSX30	GSX40	GSX50	GSX60
<b>A</b>	in	3.75	5.94	7.68	9.50	12.50
	mm	95.3	150.9	195.1	241.3	317.5
<b>B</b>	in	3.13	5.25	6.80	7.63	10.17
	mm	79.4	133.4	172.7	193.7	258.4
<b>C</b>	in	1.00	3.69	5.25	3.25	8.13
	mm	25.4	93.7	133.4	82.6	206.4
<b>Ø D</b>	in	0.250	0.397	0.516	0.563	0.781
	mm	6.35	10.08	13.10	14.29	19.84
<b>E</b>	in	1.75	2.43	2.92	4.88	5.38
	mm	44.5	61.7	74.2	123.8	136.5
<b>F</b>	in	2.24	3.05	3.80	6.50	6.80
	mm	56.8	77.4	96.5	165.1	172.7
<b>Ø G</b>	in	0.125 +0.001/-0.000	0.250 ±0.0005	0.250 ±0.001	0.250 +0.001/-0.000	0.250 +0.0005/-0.0000
	mm	3.18 +0.03/-0.00	6.35 ±0.013	6.35 ±0.025	6.35 +0.03/0.00	6.35 +0.013/0.000
<b>H<sup>1</sup></b>	in	1.00	1.32	1.65	2.13	1.94
	mm	25.4	33.5	41.9	54.0	49.4
<b>J<sup>1</sup></b>	in	0.44	0.44	0.63	0.75	0.75
	mm	11.1	11.1	15.9	19.1	19.1
<b>K</b>	in	0.50	0.44	0.63	0.75	1.31
	mm	12.7	11.1	15.9	19.1	33.3

- If ordering a splined main rod, add the following to dimensions H and J:  
 GSX20 add .50 in (12.7 mm), GSX30 add 1.20 in (30.5 mm), GSX40 add 1.77 in (45.0 mm)  
 GSX50 add 2.06 in (52.3 mm), GSX60 add 2.73 in (69.3 mm)

*Pre-sale drawings and models are representative and are subject to change. Certified drawings and models are available for a fee. Consult your local Exlar representative for details.*



# GSX Series Integrated Motor/Actuator

## Side Mount or Extended Tie Rod Mount

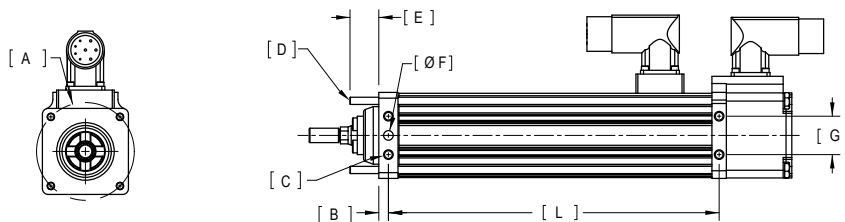

		GSX20	GSX30	GSX40	GSX50	GSX60
<b>Ø A</b>	in	2.546	3.536	4.243	6.125	7.778
	mm	64.66	89.80	107.76	155.58	197.57
<b>B<sup>2</sup></b>	in	0.25	0.25	0.31	0.41	0.44
	mm	6.4	6.4	7.9	10.3	11.1
<b>C<sup>1</sup></b>	in	1/4-20 UNC	1/4-20 UNC	3/8-16 UNC	1/2-13 UNC	5/8-11 UNC
	mm	M6 x 1.0	M6 x 1.0	M10 x 1.5	M12 x 1.75	M16 x 2
<b>D</b>	in	10-24 UNC	1/4-20 UNC	3/8-16 UNC	1/2-13 UNC	9/16-12 UNC
	mm	M5 x 0.8	M6 x 1.0	M8 x 1.25	M12 x 1.75	M14 x 2
<b>E</b>	in	0.75	0.96	1.38	1.50	1.65
	mm	19.1	24.4	35.1	38.1	41.9
<b>Ø F</b>	in	0.2500	0.2500	0.3750	0.5000	0.5000
	mm	+0/-0.0005 $\downarrow$ 0.25	+0/-0.0005 $\downarrow$ 0.25	+0/-0.0005 $\downarrow$ 0.44	+0/-0.0005 $\downarrow$ 0.50	+0/-0.0005 $\downarrow$ 0.62
<b>G</b>	in	1.00	1.75	1.75	3.00	3.00
	mm	25.4	44.5	44.5	76.2	76.2
<b>L</b> (zero stroke)	in	2.6	3.1	4.3	5.1	5.9
	mm	67	80	109	130	150

- Side mount options D and K = 8X for dimension C
- If ordering a splined main rod, add the following to dimension B:  
 GSX20 add .50 in (12.7 mm)  
 GSX30 add 1.20 in (30.5 mm)  
 GSX40 add 1.77 in (45.0 mm)  
 GSX50 add 2.06 in (52.3 mm)  
 GSX60 add 2.73 in (69.3 mm)

Pre-sale drawings and models are representative and are subject to change. Certified drawings and models are available for a fee. Consult your local Exlar representative for details.

## Side Trunnion Mount of Rear Clevis Mount

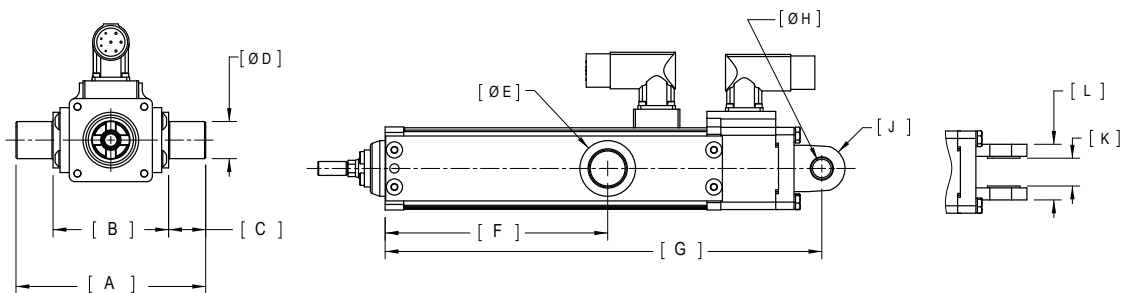

		GSX20	GSX30	GSX40	GSX50	GSX60
A	in	5.12	5.92	6.90	10.00	12.55
	mm	129.9	150.4	175.2	254.0	318.8
B	in	3.12	3.92	4.90	7.00	8.55
	mm	79.1	99.6	124.4	177.8	217.2
C	in	1.00	1.00	1.00	1.50	2.00
	mm	25.4	25.4	25.4	38.1	50.8
Ø D	in	1.000 +/-0.001	1.000 +/-0.001	1.500 +/-0.001	2.000 +/-0.001	2.500 +/-0.001
	mm	25 h7	25 h7	35 h7	50 h7	60 h9
Ø E	in	1.50	1.50	2.00	2.50	3.50
	mm	38.1	38.1	50.8	63.5	88.9
F (3" stroke)	in	3.0	5.4	NA	NA	NA
	mm	76	137	NA	NA	NA
F (4" stroke)	in	NA	NA	4.0	NA	NA
	mm	NA	NA	102	NA	NA
F (6" stroke)	in	6.0	6.0	6.0	6.0	6.0
	mm	152	152	152	152	152
F (8" stroke)	in	NA	NA	8.0	NA	NA
	mm	NA	NA	203	NA	NA
F (10" stroke)	in	10.0	10.0	10.0	10.0	10.0
	mm	254	254	254	254	254
F (12" stroke)	in	12.0	12.0	12.0	NA	NA
	mm	305	305	305	NA	NA
F (14" stroke)	in	NA	14.0	NA	14.0	NA
	mm	NA	356	NA	356	NA
F (18" stroke)	in	NA	18.0	18.0	NA	NA
	mm	NA	457	457	NA	NA
G <sup>1</sup> (zero stroke)	in	5.8	6.5	8.3	NA	NA
	mm	147	165	210	NA	NA
Ø H	in	0.500 +0.002/-0.001	0.750 +0.002/-0.001	0.750 +0.002/-0.001	1.000 +0.002/-0.001	1.750 +0.002/-0.001
	mm	12 H9	20 H9	20 H9	25 H9	45 H9
J	in	0.63	0.75	0.75	1.00	2.13
	mm	15.9	19.1	19.1	25.4	54.0
K	in	0.75	1.25	1.25	1.50	2.50
	mm	19.1	31.8	31.8	38.1	63.5
L	in	1.50	2.50	2.50	3.00	5.00
	mm	38.1	63.5	63.5	76.2	127.0

- If ordering a brake, add the following to dimension G:  
 GSX20 add 1.78 in (45.2 mm), GSX30 add 1.60 in (40.6 mm), GSX40 add 2.33 in (59.2 mm),  
 GSX50 add 2.5 in (63.5 mm), GSX60 add 3.58 in (90.9 mm)

Pre-sale drawings and models are representative and are subject to change. Certified drawings and models are available for a fee. Consult your local Exlar representative for details.

# GSX Series Integrated Motor/Actuator

## Rear Brake Extension Option

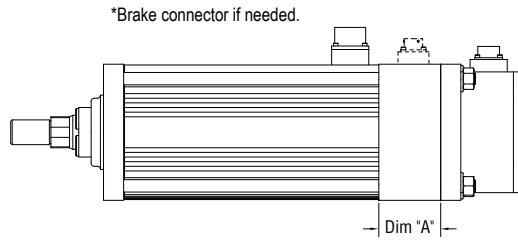

	GSX20	GSX30	GSX40	GSX50	GSX60
A in (mm)	1.78 (45.2)	1.60 (40.6)	2.33 (59.2)	2.50 (63.5)	3.58 (90.9)

\*Consult Exlar for connector and wiring information if ordering brake option.

## Anti-rotation Option GSX/M20, GSX/M30, GSX/M40 and GSX60

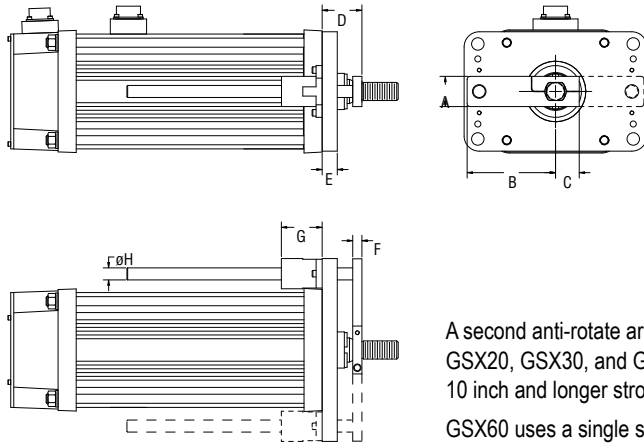

Dims in (mm)	GSX20	GSM30	GSM40	GSX60
A	0.60 (15.2)	0.79 (20.1)	1.25 (31.8)	1.75 (44.5)
B	1.81 (46.0)	2.54 (64.5)	3.78 (96.0)	5.79 (147)
C	0.54 (13.7)	0.71 (18.0)	0.98 (24.9)	1.55 (39.4)
D	1.00 (25.4)	1.30 (33.0)	1.64 (41.7)	1.94 (49.3)
E	0.44 (11.2)	0.44 (11.2)	0.63 (16.0)	0.75 (19.1)
F	0.28 (7.11)	0.32 (8.13)	0.38 (9.65)	0.50 (12.7)
G	0.31 (7.87)	1.69 (42.9)	1.69 (42.9)	2.81 (71.4)
øH	0.37 (9.40)	0.50 (12.7)	0.50 (12.7)	1.00 (25.4)

A second anti-rotate arm is used on GSX20, GSX30, and GSX40 models with 10 inch and longer stroke lengths.

GSX60 uses a single sided anti-rotate for all stroke lengths.

## Anti-rotation Option GSX50

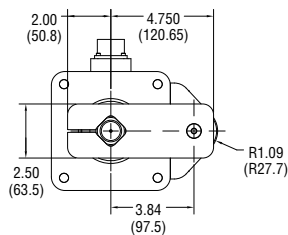

NOTE: GSX50 actuators use one arm for all stroke lengths.

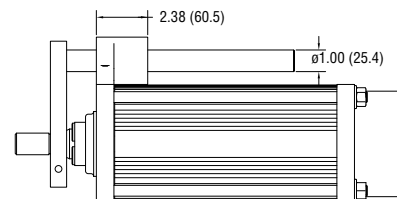
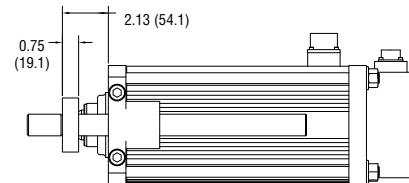

Pre-sale drawings and models are representative and are subject to change. Certified drawings and models are available for a fee. Consult your local Exlar representative for details.

## External Limit Switch Option

The external limit switch option (requires anti-rotate option) for the GSX Series of linear actuators provides the user with 1, 2, or 3 externally mounted adjustable switches for use as the end of travel limit switches or home position sensors.

The number of switches desired is selected by ordering the L1, L2, or L3 option, in which 1, 2 or 3 switches will be provided, respectively.

The switches are 9-30 VDC powered, PNP output, with either normally open or normally closed logic operation depending on the switch configuration ordered. Switches are supplied with 1 meter of 3-wire embedded cable. Below is a diagram indicating which logic operation will be provided for each switch, based on the option ordered.

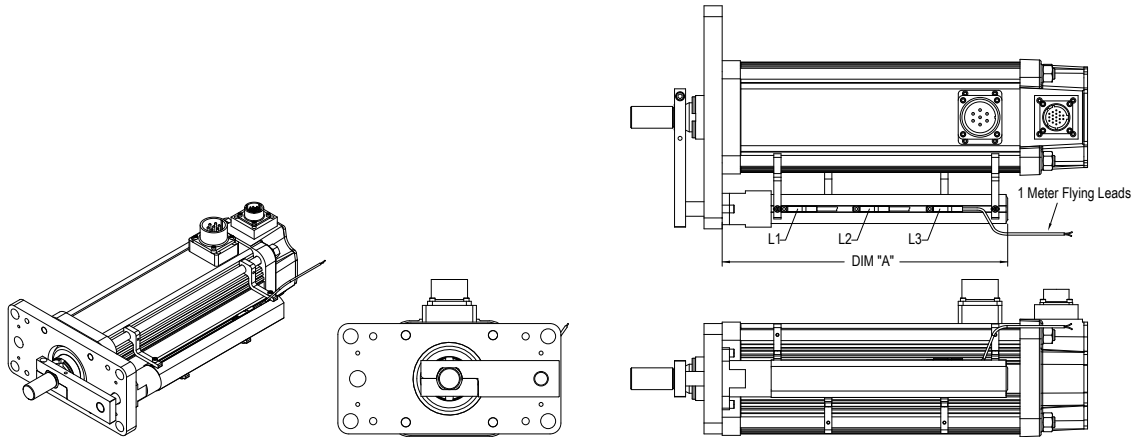

Dim A	3 inch (76 mm) stroke in (mm)	6 inch (152 mm) stroke in (mm)	8 inch (203 mm) stroke in (mm)	10 inch (254 mm) stroke in (mm)	12 inch (305 mm) stroke in (mm)	14 inch (355 mm) stroke in (mm)	18 inch (457 mm) stroke in (mm)
GSX20	5.515 (140.1)	8.515 (216.3)	NA	12.500 (317.5)	14.515 (368.7)	NA	NA
GSX30	6.932 (176.1)	9.832 (249.7)	NA	13.832 (351.3)	15.832 (402.1)	17.832 (452.9)	21.832 (554.5)
GSX40	NA	9.832 (249.7)	11.83 (300.5)	13.832 (351.3)	15.832 (402.1)	NA	21.832 (554.5)
GSX50	NA	11.667 (296.3)	NA	15.667 (397.9)	NA	19.667 (499.5)	NA
GSX60	NA	10.461 (265.7)	NA	14.461 (367.3)	NA	NA	NA

Option	SW1	SW2	SW3
L1	Not Supplied	Normally Open	Not Supplied
L2	Normally Closed	Not Supplied	Normally Closed
L3	Normally Closed	Normally Open	Normally Closed

Switch Type	Exlar Part Number	Turck Part Number
Normally Closed Switch	43404	BIM-UNT-RP6X
Normally Open Switch	43403	BIM-UNT-AP6X

*Pre-sale drawings and models are representative and are subject to change. Certified drawings and models are available for a fee. Consult your local Exlar representative for details.*

# GSX Series Integrated Motor/Actuator

## Actuator Rod End Options

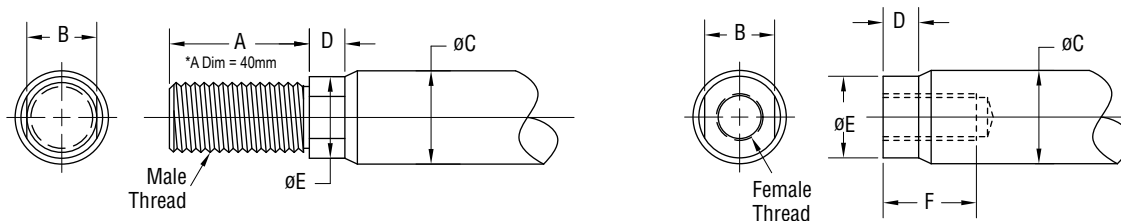

## Standard Rod End

	A	B	øC	D	øE	F	Male U.S.	Male Metric	Female U.S.	Female Metric
GSX20 in (mm)	0.813 (20.7)	0.375 (9.5)	0.500 (12.7)	0.200 (5.1)	0.440 (11.2)	0.750 (19.1)	3/8 – 24 UNF – 2A	M8 x 1 6g	5/16 – 24 UNF – 2B	M8 x 1 6H
GSX30 in (mm)	0.750* (19.1)	0.500 (12.7)	0.625 (15.9)	0.281 (7.1)	0.562 (14.3)	0.750 (19.1)	7/16 – 20 UNF – 2A	M12 x 1.75* 6g	7/16 – 20 UNF – 2B	M10 x 1.5 6H
GSX40 in (mm)	1.500 (38.1)	0.750 (19.1)	1.000 (25.4)	0.381 (9.7)	0.875 (22.2)	1.000 (25.4)	3/4 – 16 UNF – 2A	M16 x 1.5 6g	5/8 – 18 UNF – 2B	M16 x 1.5 6H
GSX50 in (mm)	1.625 (41.3)	1.125 (28.6)	1.375 (34.9)	0.750 (19.1)	1.250 (31.8)	1.750 (44.5)	1 – 14 UNS – 2A	M27 x 2 6g	1 – 14 UNS – 2B	M24 x 2 6H
GSX60 in (mm)	2.500 (63.5)	1.250 (31.8)	1.750 (44.5)	0.550 (14.0)	1.625 (41.3)	1.750 (44.5)	1 1/4 – 12 UNF – 2A	M30 x 2 6g	7/8 – 14 UNF – 2B	M25 x 1.5 6H

## Rod End with Splined Main Rod

	A	B	C	D	E	F	Male U.S.	Male Metric	Female U.S.	Female Metric
GSX20 in (mm)	0.813 (20.7)	0.375 (9.5)	0.512 (13.0)	0.200 (5.1)	0.440 (11.2)	0.750 (19.1)	3/8 – 24 UNF – 2A	M8 x 1 6g	5/16 – 24 UNF – 2B	M8 x 1 6H
GSX30 in (mm)	0.750* (19.1)	0.500 (12.7)	0.630 (16.0)	0.281 (7.1)	0.562 (14.3)	0.750 (19.1)	7/16 – 20 UNF – 2A	M12 x 1.75* 6g	7/16 – 20 UNF – 2B	M10 x 1.5 6H
GSX40 in (mm)	1.500 (38.1)	0.750 (19.1)	0.906 (23.0)	0.381 (9.7)	0.875 (22.2)	1.000 (25.4)	3/4 – 16 UNF – 2A	M16 x 1.5 6g	5/8 – 18 UNF – 2B	M16 x 1.5 6H
GSX50**** in (mm)	1.625 (41.3)	1.000** (25.4)	1.102 (28.0)	0.750*** (19.1)	1.102 (28.0)	1.500 (38.1)	1 – 14 UNS – 2A	M24 x 2 6g	3/4 – 16 UNF – 2B	M20 x 1.5 6H
GSX60 in (mm)	2.500 (63.5)	1.250 (31.8)	1.850 (47.0)	0.550 (14.0)	1.625 (41.3)	1.750 (44.5)	1 1/4 – 12 UNF – 2A	M30 x 2 6g	7/8 – 14 UNF – 2B	M25 x 1.5 6H

\* When Male, Metric (A), Dimension A = 1.575 (40 mm)

\*\* When Male, Metric (A), Dimension B = 0.945 (24 mm)

\*\*\*When Male (M or A) = 0.500 in (12.7 mm)

\*\*\*\*When GSX50 is ordered with a splined rod thread, dimensions are different in accordance with the table.

Part numbers for rod attachment options indicate the through hole size or pin diameter. Before selecting a spherical rod eye please consult the information on the anti-rotation option for the GSX actuators. Spherical rod eyes will allow the rod to rotate if the load is not held.

## Rod Clevis

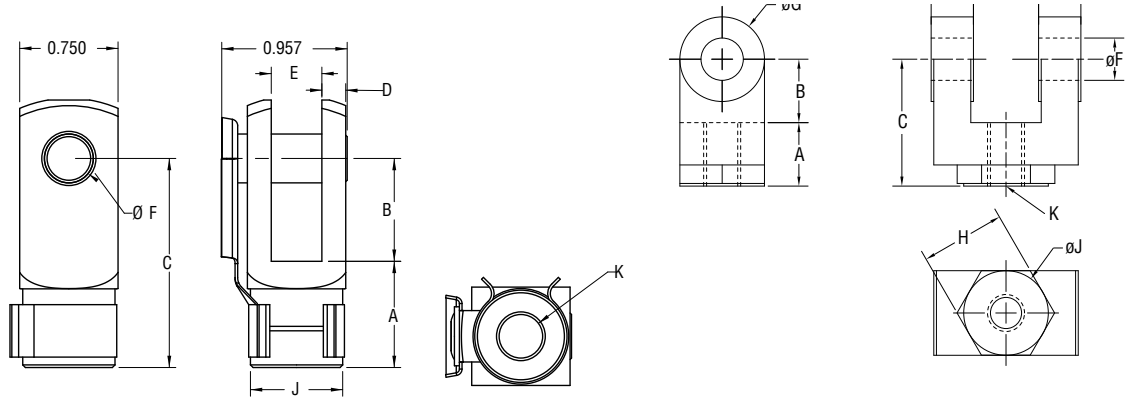

**Dimensions for RC038**

**Dimensions for RC050, RC075, RC100, RC138**

	A	B	C	D	E	ØF	ØG	H	ØJ	K
GSX20 RC038 in (mm)	0.810 (20.6)	0.785 (19.9)	1.595 (40.5)	0.182 (4.6)	0.386 (9.8)	0.373 (9.5)	0.951 (24.2)	NA	NA	3/8-24
GSX30 RC050 in (mm)	0.75 (19.1)	0.75 (19.1)	1.50 (38.1)	0.50 (12.7)	0.765 (19.43)	0.50 (12.7)	1.00 (25.4)	1.00 (25.4)	1.00 (25.4)	7/16-20
GSX40 RC075 in (mm)	1.125 (28.58)	1.25 (31.75)	2.375 (60.3)	0.625 (15.88)	1.265 (32.13)	0.75 (19.1)	1.50 (38.1)	1.25 (31.75)	1.25 (31.75)	3/4-16
GSX50 RC100 in (mm)	1.625 (41.2)	1.500 (38.1)	3.125 (79.4)	0.750 (19.1)	1.515 (38.5)	1.000 (25.4)	2.000 (50.8)	1.500 (38.1)	1.500 (38.1)	1-14
GSX60 RC138 in (mm)	2.00 (50.8)	2.125 (53.98)	4.125 (104.78)	1.00 (25.4)	2.032 (51.6)	1.375 (34.93)	2.75 (69.85)	2.00 (50.8)	2.00 (50.8)	1-1/4 - 12

## Spherical Rod Eye Dimensions

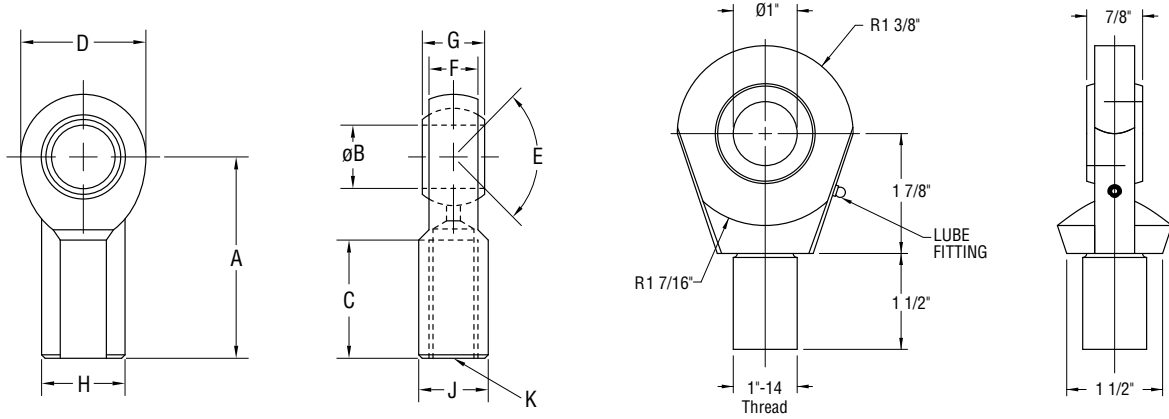

**Dimensions for SRM038, SRM044, SRM075**

**Dimensions for SRF100**

	A	ØB	C	D	E	F	G	H	J	K
GSX20 SRM038 in (mm)	1.625 (41.3)	.375 (9.525)	.906 (23.0)	1.0 (25.6)	12 deg	.406 (10.3)	.500 (12.7)	.688 (17.7)	.562 (14.3)	3/8-24
GSX30 SRM044 in (mm)	1.81 (46.0)	0.438 (11.13)	1.06 (26.9)	1.13 (28.7)	14 deg	0.44 (11.1)	0.56 (14.2)	0.75 (19.1)	0.63 (16.0)	7/16-20
GSX40 SRM075 in (mm)	2.88 (73.2)	0.75 (19.1)	1.72 (43.7)	1.75 (44.5)	14 deg	0.69 (17.5)	0.88 (22.3)	1.13 (28.7)	1.00 (25.4)	3/4-16
GSX50 SRF100 in (mm)	See GSX50 Special Rod Eye drawing to the right above. Requires female rod end.									

Pre-sale drawings and models are representative and are subject to change. Certified drawings and models are available for a fee. Consult your local Exlar representative for details.

# GSX Series Integrated Motor/Actuator

## Rod Eye

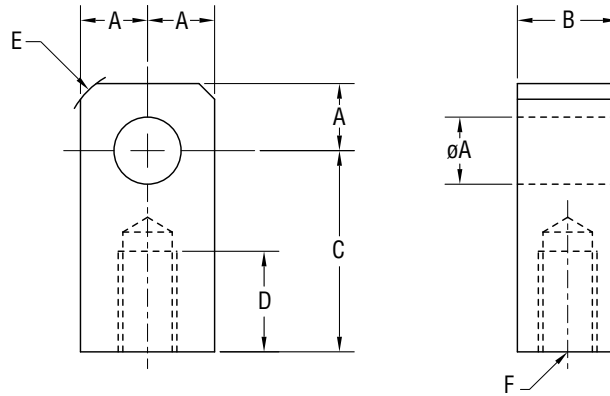

	$\phi A$	B	C	D	E	F
GSX20 RE038 in (mm)	0.50 (12.7)	0.560 (14.2)	1.000 (25.4)	0.500 (12.7)	0.25 x 45°	3/8 - 24
GSX30 RE050 in (mm)	0.50 (12.7)	0.75 (19.1)	1.50 (38.1)	0.75 (19.1)	0.63 (15.9)	7/16 - 20
GSX40 RE075 in (mm)	0.75 (19.1)	1.25 (31.8)	2.06 (52.3)	1.13 (28.7)	0.88 (22.3)	3/4 - 16
GSX50 RE100 in (mm)	1.00 (25.4)	1.50 (38.1)	2.81 (71.4)	1.63 (41.4)	1.19 (30.2)	1 - 14
GSX60 RE138 in (mm)	1.375 (34.93)	2.0 (50.8)	3.44 (87.3)	2.0 (50.8)	1.837 (46.67)	1 1/4 - 12

## Clevis Pin Dimensions

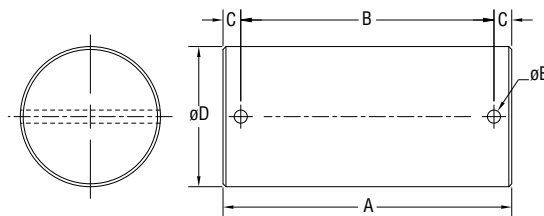

	A	B	C	$\phi D$	$\phi E$
CP050 <sup>1</sup> in (mm)	2.28 (57.9)	1.94 (49.28)	0.17 (4.32)	0.50 <sup>-0.001/-0.002</sup> (12.7 mm +0.00/-0.05)	0.106 (2.69)
CP075 <sup>2</sup> in (mm)	3.09 (78.5)	2.72 (69.1)	0.19 (4.82)	0.75 <sup>-0.001/-0.002</sup> (19.1 mm +0.00/-0.05)	0.14 (3.56)
CP100 <sup>3</sup> in (mm)	3.59 (91.2)	3.22 (81.8)	0.19 (4.82)	1.00 <sup>-0.001/-0.002</sup> (25.4 mm +0.00/-0.05)	0.14 (3.56)
CP138 <sup>4</sup> in (mm)	4.66 (118.3)	4.25 (108)	0.20 (5.08)	1.375 <sup>-0.001/-0.002</sup> (34.93 mm +0.00/-0.05)	0.173 (4.39)
CP175 <sup>5</sup> in (mm)	5.656 (143.6)	5.25 (133.3)	0.203 (5.15)	1.750 <sup>-0.001/-0.002</sup> (44.4 mm +0.00/-0.05)	0.173 (4.39)

<sup>1</sup> Fits GSX20 and GSX30 rear clevis, RC1050 and RE1050

<sup>2</sup> Fits GSX30, 40 and RC075, RE075 and SMR075

<sup>3</sup> Fits GSX50 rear clevis, RC100, RE100

<sup>4</sup> Fits RC138, RE138

<sup>5</sup> Fits GSX60 rear clevis

Pre-sale drawings and models are representative and are subject to change. Certified drawings and models are available for a fee. Consult your local Exlar representative for details.

[Return to Table of Contents](#)

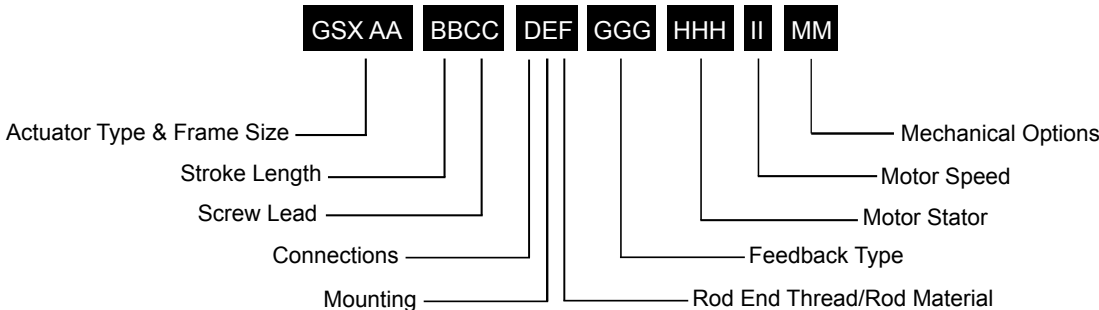

**AA = GSX Actuator Frame Size (Nominal)**

- 20 = 2 in (60 mm)
- 30 = 3 in (80 mm)
- 40 = 4 in (100 mm)
- 50 = 5.5 in (140 mm)
- 60 = 7 in (180 mm)

**BB = Stroke Length**

- 03 = 3 in (76 mm) GSX20, GSX30
- 04 = 4 in (102 mm) GSX40
- 06 = 5.9 in (150 mm) GSX30; 6 in (152 mm) GSX20, GSX40, GSX50, GSX60
- 08 = 8 in (203 mm) GSX40
- 10 = 10 in (254 mm) all models
- 12 = 12 in (305 mm) GSX20, GSX30, GSX40
- 14 = 14 in (356 mm) GSX30, GSX50
- 18 = 18 in (457 mm) GSX30, GSX40

**CC = Screw Lead**

- 01 = 0.1 in (2.54 mm) (GSX20, GSX30, GSX40, GSX50)<sup>9</sup>
- 02 = 0.2 in (5.08 mm) (GSX20, GSX30, GSX40, GSX50)
- 03 = 0.25 in (6.35 mm) (GSX60)
- 04 = 0.4 in (10.16 mm) (GSX20 only)
- 05 = 0.5 in (12.7 mm) (GSX30, GSX40, GSX50, GSX60)
- 08 = 0.75 in (19.05 mm) (GSX40)<sup>5</sup>
- 10 = 1.0 in (25.4 mm) (GSX50, GSX60)<sup>6</sup>

**D = Connections**

- I = Exlar standard M23 style<sup>7</sup>
- M = Manufacturer's connector<sup>3</sup>

**E = Mounting**

- C = Rear clevis
- F = Front flange
- R = Rear flange
- D = Double side mount<sup>13</sup>
- T = Side trunnion
- E = Extended tie rods
- K = Metric double side mount<sup>13</sup>
- Q = Metric side trunnion
- M = Metric extended tie rods
- G = Metric rear clevis

**F = Rod End Thread / Rod Material**

- M = Male, US standard thread
- A = Male, metric thread
- F = Female, US standard thread
- B = Female, metric thread

**GGG = Feedback Type**

See page 164 for detailed information.

**HHH = Motor Stator – 8 Pole<sup>1</sup> Class 180H<sup>12</sup>**

- 118 = 1 stack, 115 Vrms
- 138 = 1 stack, 230 Vrms
- 158 = 1 stack, 400 Vrms
- 168 = 1 stack, 460 Vrms
- 218 = 2 stack, 115 Vrms
- 238 = 2 stack, 230 Vrms
- 258 = 2 stack, 400 Vrms
- 268 = 2 stack, 460, Vrms
- 318 = 3 stack, 115 Vrms
- 338 = 3 stack, 230 Vrms
- 358 = 3 stack, 400 Vrms
- 368 = 3 stack, 460 Vrms

**II = Motor Speed**

- 24 = 2400 rpm, GSX50, GSX60
- 30 = 3000 rpm, GSX30, GSX40
- 50 = 5000 rpm, GSX20

**MM = Mechanical Options<sup>15</sup>**

- AR = External anti-rotate assembly<sup>11</sup>
- RB = Rear electric brake<sup>2</sup>
- PB = Protective bellows<sup>10</sup>
- SR = Splined main rod<sup>8, 12, 14</sup>
- L1/L2/L3 = External limit switches<sup>4</sup>

**NOTES:**

1. Stator voltage and pole options allow for catalog rated performance at varying amplifier bus voltages and pole configuration requirements. Refer to performance specification on pages 7-9 for availability of 3 stack stator.
2. The brake option may require a third cable, consult local sales representative.
3. Available as described in Feedback Types.
4. Requires AR option.
5. 0.75 lead not available above 12 inch.
6. 1.0 lead not available above 10 inch stroke.
7. GSX60 uses M40 size 1.5 power connector.
8. If not otherwise specified by the customer, an M24X2 male rod end will be used on the GSX50. See note on page 30.
9. 0.1 lead not available over 10" stroke on GSX50.
10. N/A with extended tie rod mounting option.
11. A second anti-rotate arm is used on GSX20, 30 and 40 for 10 inch and longer stroke.
12. See page 22 for optimized stator offerings.
13. Anti-rotate with D or K mount N/A on 10 inch or longer stroke except in GSX50.
14. Not available in Stainless Steel.
15. For extended temperature operation consult factory for model number.

For cables and accessories, see page 160.



For options or specials not listed above or for extended temperature operation, please contact Exlar



## Manufacturers Feedback Cable Selection Guide

Amplifier/Drive Selected	Feedback Selected	Manufacturers Part Number
Allen-Bradley/Rockwell: All Drives	RA1/RA2/RA3/RA4 AB8/AB9/ABB	2090-CFBM7DF-CDAXxy
AMKASYN: All Drives	AK1/AK2	DS Series Absolute Encoder Cable
Beckhoff: All Drives	BE1	ZK4000-26yy-2zzz
B&R Automation: All Drives	BR1 BR2	8CRxxx.12-1 8CExxx.12-1
Emerson/Control Techniques: Unidrive SP/Epsilon EP	CT1/CT3 CT2/EM2/EM5 CT4/CT7 CT5 CT5	SSBCABXXXX UFCSXXX SIBAAAXXXX SRBBBBXXXX SRBBABXXXX
Unidrive M	CT5	SRBBABXXXX
En/Epsilon/MDS	CT4/CT7 EM2/EM5	SIBAEAXXXX CFCSXXX
Elau: All Drives	EU1/EU4	SH Series Absolute Encoder Cable
G&L Motion Control/Danaher Motion: MMC Smart Drive/ Digital MMC Control	GL1 GL2 GL3 GL4	ENC-H&F ENC-L&M ENC-NSM ENDAT-AKM
Indramat/Bosch-Rexroth: DKC Series/DIAX	IN1 IN5 IN6 IN7	IKS4001 IKS4001 IKS4374 RKG4200
IndraDrive	IN7	RKG4200
Jetter Technologies: JetMove 2xx JetMove 6xx	JT1 JT1	JH/JL Series Resolver Cable Nr. 23 JH/JL Series Resolver Cable Nr. 423
Kollmorgen/Danaher: All Drives	KM4 KM5 KM6	VF-SB4474N-XX VF-RA2474N-XX CF-CB7374N-XX
Lenze/AC Tech: All Drives	LZ1 LZ5 LZ6	MCS Series Absolute Encoder Cable MCS Series Resolver Cable MCS Series Incremental Encoder Cable
Mitsubishi: MR-J3	MT1	MR-J3ENSCBLxxM-H
Momentum: All Drives	MN1 MN2 MN3 MN4	SC-AE1-xxx SC-AE2-xxx SC-IE1-xxx SC-RS1-xxx
Ormec: All Drives	OR2	Consult Exlar
Parker Compumotor: All Drives	PC6 PC7 PC8 PC9/ PCØ	SMH Series Incremental Encoder Cable SMH Series Resolver Cable COMPAX3 F-2C1-xx or Aries F-1A1-xx F-2B1-xx
Pacific Scientific: All Drives	PS3	CEF-RO-XXX-900X
Stober Drives: FDS/MDS 5000	SB3	Stober Absolute Encoder Cable
Siemens: 611U/Masterdrives/SMC20	SM2 SM3/SM4 SM5	6FX5002-2CF02-.... 6FX5002-2EQ10-.... 6FX5002-2CA31-....
SEW/Eurodrive: All Drives	SW1 SW3	CMP Series Resolver Cable CMP Series Absolute Encoder Cable
Yaskawa: Sigma II Series	YS2/YS3	JZSP-CMP02-XX(B)
Sigma V M	YS5	JZSP-CVP07-XX-(E)

# Manufacturers Power/Brake Cables

Models:		GSX20, GSX30, SLM/SLG060, SLM/SLG090			
Amplifier/Drive Selected	Feedback Selected	Power only 4 wire	Power + Brake/Therm	Brake Cable	
Allen-Bradley/Rockwell: All Drives	RA1/RA2/RA3/RA4 AB8/AB9/ABB	2090-CPWM7DF-16Axyy	2090-CPBM7DF-16Axyy	N/A	
AMKASYN: All Drives	AK1/AK2	N/A	DS Series Power Cable Size 1	N/A	
Beckhoff: All Drives	BE1	N/A	ZK4000-2xx1-2xxxx	N/A	
B&R Automation: All Drives	BR1/BR2	N/A	8CMxxx.12-1	N/A	
Emerson/Control Techniques: All Drives	CT1/CT3/CT4/CT5/CT7 CT2/EM2/EM5	PSBxA CMDS	PBBxA N/A	N/A CBMS	
Elau: All Drives	EU1/EU4	N/A	E-MO-111	N/A	
G&L Motion Control/ Danaher Motion: MMC Smart Drive/ Digital MMC Control	GL1 GL2 GL3 GL4	PWR-H&F...16AA N/A PWR-NSM...16AA N/A	N/A PWR-L&M...16-64 N/A PWR-AKM...16-64	Exlar CBL-ASSY1-xxA-xxx N/A Exlar CBL-ASSY1-xxA-xxx N/A	
Indramat/Bosch-Rexroth: DKC Series/DIAX IndraDrive	IN1/IN5/IN6 IN7	N/A N/A	MKD/MHD Power Cable Size 1 MSK Power Cable Size 1	N/A N/A	
Jetter Technologies: All Drives	JT1	N/A	JH/JL Power Cable Size 1 #24.1	N/A	
Kollmorgen/Danaher: All Drives	KM4/KM5/KM6	N/A	6 Amp - VP-508CFAN-XX 12 Amp - VP-508CFAN-XX 20 Amp - VP-508DFAN-XX	N/A	
Lenze/AC Tech: All Drives	LZ1/LZ5/LZ6	N/A	MCS Power Cable Size 1	N/A	
Mitsubishi: MR-J3	MT1	MR-J3P2-xM	N/A	MR-J3BRKS1-xM	
Momentum: All Drives	MN1/MN2/MN3/MN4	PCBL1.5-MNT-xxx	PCBL1.5-MNB-xxx	N/A	
Ormec: All Drives	OR2		Consult Exlar		
Parker Compumotor: All Drives	PC6/PC7 PC8/PC9/PC0	N/A N/A	SMH Power Cable Size 1 P-3B1-xx	N/A N/A	
Pacific Scientific: All Drives	PS3	N/A	PMA Power Cable Size 1	N/A	
Stober Drives: FDS/MDS 5000	SB3	N/A	Stober Power Cable Size 1	N/A	
Siemens: All Drives with flying leads	SM2/SM3/SM4/SM5		6FX5002-5DA01-....	N/A	
SEW/Eurodrive: All Drives	SW1/SW3	N/A	CMP Power Cable Size 1	N/A	
Yaskawa: Sigma II Series	YS2 YS3	N/A B1E-xxA	N/A B1BE-xxA	N/A N/A	
Yaskawa: Sigma V Series	Y55	B1EV-XXA-E	BABEV-XXA-E	BBEV-XXA-E	

# Manufacturers Power/Brake Cables

	GSX40, GSX50, SLM/SLG115, SLM142			GSX60 & SLM180		
	Power only 4 wire	Power + Brake/Therm	Brake Cable	Power only 4 wire	Power + Brake/Therm	Brake Cable
	2090-CPWM7DF-14Axyy	2090-CPBM7DF-14Axyy	N/A	2090-CPWM7DF-10Axyy	2090-CPBM7DF-10Axyy	N/A
	N/A	DS Series Power Cable Size 1	N/A	N/A	DS Series Power Cable Size 1.5	N/A
	N/A	ZK4000-2xx1-2xxxx	N/A	N/A	Exlar CBL-PWRB3-xxl-xxx	N/A
	N/A	8CMxxx.12-3	N/A	N/A	8CMxxx.12-5	N/A
	PSBxA CMMS	PBBxA N/A	N/A CBMS	PSBxB CMLS	PBBxB N/A	N/A CBMS
	N/A	E-MO-112	N/A	N/A	E-MO-114	N/A
	PWR-H&F...14-AA N/A N/A N/A	N/A PWR-L&M...14-6H N/A PWR-AKM...14-6H	Exlar CBL-ASSY1-xxA-xxx N/A N/A N/A	PWR-H&F...10-AA N/A N/A N/A	N/A PWR-L&M...12-6H N/A PWR-AKM...12-6H	Exlar CBL-ASSY1-xxA-xxx N/A N/A N/A
	N/A N/A	MKD/MHD Power Cable Size 1 MSK Power Cable Size 1	N/A N/A	N/A N/A	MKD/MHD Power Cable Size 1.5 MSK Power Cable Size 1.5	N/A N/A
	N/A	JH/JL Power Cable Size 1 #24.1	N/A	N/A	Exlar CBL-PWRB3-xxl-xxx	N/A
	N/A	6 Amp - VP-508CFAN-XX 12 Amp - VP-508CFAN-XX 20 Amp - VP-508DFAN-XX	N/A	N/A	Under 24 AMP use CP-508-ENBN-XXX Over 24 AMP Contact Kollmorgen Vendor	N/A
	N/A	MCS Power Cable Size 1	N/A	N/A	MCS Power Cable Size 1.5	N/A
	MR-J3P6-xM	N/A	MR-J3BRKS1-xM	MR-J3P7-xM	N/A	MR-J3BRKS1-xM
	PCBL2.5-MNT-xxx	PCBL2.5-MNB-xxx	N/A	PCBL4.0-MNT-xxx	PCBL4.0-MNB-xxx	N/A
		Consult Exlar			Consult Exlar	
	N/A N/A	SMH Power Cable Size 1 P-4B1-xx	N/A N/A	N/A N/A	SMH Power Cable Size 1.5 P-6B2-xx	N/A N/A
	N/A	PMA Power Cable Size 1	N/A	N/A	Exlar CBL-PWRB3-xxl-xxx	N/A
	N/A	Stober Power Cable Size 1	N/A	N/A	Stober Power Cable Size 1.5	N/A
		6FX5002-5DA11-....	N/A		6FX5002-5DA61-....	N/A
	N/A	CMP Power Cable Size 1	N/A	N/A	CM Power Cable Size 1.5	N/A
	B1E-xxA N/A	B1BE-xxA N/A	N/A N/A	B2E-xxA N/A	B2BE-xxA N/A	N/A N/A
	B1EV-XXA-E	BABEV-XXA-E	BBEV-XXA-E	B3EV-XXA-E	200V=BCBEV-XX(A)-E 400V=NA	BBEV-XX (A)-E

\*If stator current draw exceeds cable connector rating, a larger connector will be provided. Please note: Euro style connectors are size 1.5 M40 connectors. If the manufacturer does not offer a size 1.5 M40 power cable, an Exlar Power Cable must be purchased.

## Feedback Types for GSX, SLG, SLM

(Also specify the Amplifier/Drive Model being used when ordering)

- Standard Incremental Encoder – 2048 line (8192 cts) per rev. index pulse, Hall commutation, 5VDC
- Standard Resolver – Size 15, 1024 line (2048 cts) per rev. two pole resolver
- Motor files for use with select Emerson/CT, Rockwell /AB and Danaher/Kollmorgen Drives are available at [www.exlar.com](http://www.exlar.com)

**Allen-Bradley/Rockwell:** (Note: AB8, AB9 and ABB callouts are available only on spare/replacement actuators that have been previously ordered. For all new configurations using a Rockwell drive, please select from the options below. Consult Exlar for integration questions)<sup>3</sup>

Note: RA1, RA2, RA3, and RA4 callouts are not available for SLM/G motors.

- RA1 = Hiperface Stegmann SKM36 multi-turn absolute encoder. MPL Type V feedback (128 sin/cos) and Type 7 SpeedTec connectors and wiring when using the "M" connector option. 20 and 30 frame sizes only. (Formerly ABB)<sup>1,4</sup>
- RA2 = Hiperface Stegmann SRM50 multi-turn absolute encoder. MPL Type M feedback (1024 sin/cos) and Type 7 SpeedTec connectors and wiring when using the "M" connector option. 40, 50 and 60 frame sizes only. (Formerly AB9)<sup>1,4</sup>
- RA3 = Standard incremental encoder. MPL Type M feedback (2048 line) and Type 7 SpeedTec connector and wiring when using the "M" connector option. (Formerly AB8)<sup>4</sup>
- RA4 = Standard Resolver. MPL Type R feedback (4 pole) and Type 7 SpeedTec connectors and wiring when using the "M" connector option. (Formerly AB6)<sup>4</sup>

### Advanced Motion Control:

- AM1 = Standard Incremental Encoder
- AM2 = Encoder 1000 line, w/commutation, 5 VDC
- AM3 = Standard Resolver
- AM5 = Encoder 5000 line, w/commutation, 5 VDC

### Baldor:

- BD2 = Std Resolver – BSM motor wiring w/M23 connectors for 'M' option
- BD3 = Std Incremental Encoder – BSM motor wiring w/M23 connectors for 'M' option

### Beckhoff:

- BE2 = EnDat Heidenhain EQN1125 multi-turn absolute encoder – AM5XX motor wiring w/M23 euro connectors for 'M' option

### B&R Automation:

- BR1 = Standard Resolver
- BR2 = EnDat Heidenhain EQN1125/1325 multi-turn absolute encoder – 8LS/8LM motor wiring w/M23 euro connectors for 'M' option

### Copley Controls:

- CO1 = Standard Incremental Encoder
- CO2 = Standard Resolver

### Control Techniques/Emerson:

- CT1 = Hiperface Stegmann SRM050 multi-turn absolute encoder – 40-50-60 Frame Size. FM/UM/EZ motor wiring w/M23 euro connectors for 'M' option
- CT3 = Hiperface Stegmann SKM036 multi-turn absolute encoder – 20-30 Frame Size. FM/UM/EZ motor wiring w/M23 euro connectors for 'M' option
- CT4 = Standard Incremental Encoder – FM/UM/EZ motor wiring w/M23 euro connectors for 'M' option
- CT5 = Std Resolver – FM/UM/EZ motor wiring w/M23 euro connectors for 'M' option
- CT7 = Encoder 5000 line, with commutation, 5 VDC – FM/UM/EZ motor wiring w/M23 euro connectors for 'M' option
- CT9 = Unidrive SP with EnDat Heidenhain EQN1125 multi-turn absolute encoder w/M23 connectors

### Elmo Motion Control:

- EL1 = Standard Resolver
- EL2 = Standard Incremental Encoder
- EL3 = EnDat Heidenhain EQN1125 multi-turn absolute encoder

### Emerson/Control Techniques:

- EM2 = Std Incremental Encoder – NT motor wiring w/MS connectors for 'M' option
- EM5 = Encoder 5000 line, with commutation, 5 VDC – NT motor wiring w/MS connectors for 'M' option

### Elau:

- EU1 = Hiperface Stegmann SRM050 multi-turn absolute encoder – 40-50-60 Frame Size. SH motor wiring w/MS connectors for 'M' option
- EU4 = Hiperface Stegmann SKM036 multi-turn absolute encoder – 20-30 Frame Size. SH motor wiring w/MS connectors for 'M' option.

### Exlar:

- EX4 = Standard Resolver
- EX5 = Standard Resolver with KTY84 thermistor
- EX6 = EnDat Heidenhain EQN1125 multi-turn absolute encoder
- EX7 = Incremental encoder, 5000 line with commutation, 5Vdc
- EX8 = Hiperface Stegmann SRM50 multi-turn absolute encoder

### Indramat/Bosch-Rexroth:

- IN6 = Std Resolver – MKD/MHD motor wiring w/M23 euro connectors for 'M' option
- IN7 = Hiperface Stegmann SKM036 multi-turn absolute encoder – MSK motor wiring w/M23 euro connectors for 'M' option – plug & play option
- IN8 = Indradrive EnDat Heidenhain EQN1125 multi-turn absolute w/M23 connectors

Continued on next page

**Kollmorgen/Danaher:**

- KM4 = EnDat Heidenhain EQN1325 multi-turn absolute encoder (Sine Encoder)– AKM motor wiring w/M23 Intercontec euro connectors for 'M' option  
KM5 = Standard Resolver – AKM motor wiring w/M23 Intercontec euro connectors for 'M' option  
KM6 = Standard Incremental Encoder – AKM motor wiring w/ M23 Intercontec euro connectors for 'M' option

**Lenze/AC Tech:**

- LZ1 = Hiperface Stegmann SRM050 multi-turn absolute encoder – MCS motor wiring w/M23 euro connectors for 'M' option  
LZ5 = Standard Resolver – MCS motor wiring w/ M23 euro connectors for 'M' option  
LZ6 = Standard Incremental Encoder – MCS motor wiring w/ M23 euro connectors for 'M' option

**Parker Compumotor:**

- PC6 = Std Incremental Encoder – SMH motor wiring w/M23 connectors for 'M' option – European only  
PC7 = Std Resolver – SMH motor wiring w/M23 connectors for 'M' option – European only  
PC8 = Standard Incremental Encoder – MPP series motor wiring w/PS connectors for 'M' option – US Only  
PC9 = Hiperface Stegmann SRM050 multi-turn absolute encoder – MPP motor wiring w/PS connectors for 'M' option – US Only  
PC0 = Standard Resolver – MPP motor wiring w/PS connectors for 'M' option – US Only

**Schneider Electric:**

- SC2 = Hiperface Steamann SKM036 multi-turn absolute encoder – BSH motor wiring w/M23 euro connectors for 'M' option

**Stober Drives:**

- SB3 = EnDat Heidenhain EQN1125 multi-turn absolute encoder – ED/EK motor wiring w/M23 euro connectors for 'M' option  
SB4 = Standard Resolver ED/EK motor wiring W/23 connector for "M" option

**Siemens:**

- SM2 = Standard Resolver – 1FK7 motor wiring w/M23 connectors for 'M' option  
SM3 = EnDat Heidenhain EQN1325 multi-turn absolute encoder – 40-50-60 Frame Size. 1FK7 motor wiring w/M23 euro connectors for 'M' option  
SM4 = EnDat Heidenhain EQN1125 multi-turn absolute encoder – 20-30 Frame Size. 1FK7 motor wiring w/M23 euro connectors for 'M' option  
SM9 = Siemens Heidenhain EQN1325 4096 (12 bits) multi-turn absolute w/M23 connectors

**SEW/Eurodrive:**

- SW1 = Standard Resolver – CM motor wiring w/ M23 euro connectors for 'M' option  
SW2 = Standard Incremental Encoder  
SW3 = Hiperface Stegmann SRM050 multi-turn absolute encoder – CM motor wiring w/ M23 euro connectors for 'M' option

**Yaskawa:**

- YS5 = Yaskawa Sigma V absolute encoder<sup>4</sup>

**NOTES:**

1. Not compatible with Kinetix 300 Drives.
2. N/A with holding brake unless application details are discussed with your local sales representative.
3. All rotary motors to be used with Kinetix or Sercos based systems will require prior approval from Rockwell Automation.
4. Not available with rotary motors

## Sizing and Selection of Exlar Linear and Rotary Actuators

### Move Profiles

The first step in analyzing a motion control application and selecting an actuator is to determine the required move profile. This move profile is based on the distance to be traveled and the amount of time available in which to make that move. The calculations below can help you determine your move profile.

Each motion device will have a maximum speed that it can achieve for each specific load capacity. This maximum speed will determine which type of motion profile can be used to complete the move. Two common types of move profiles are trapezoidal and triangular. If the average velocity of the profile, is less than half the maximum velocity of the actuator, then triangular profiles can be used. Triangular Profiles result in the lowest possible acceleration and deceleration. Otherwise a trapezoidal profile can be used. The trapezoidal profile below with 3 equal divisions will result in 25% lower maximum speed and 12.5% higher acceleration and deceleration. This is commonly called a 1/3 trapezoidal profile.

The following pages give the required formulas that allow you to select the proper Exlar linear or rotary actuator for your application. The first calculation explanation is for determining the required thrust in a linear application.

The second provides the necessary equations for determining the torque required from a linear or rotary application. For rotary applications this includes the use of reductions through belts or gears, and for linear applications, through screws.

Pages are included to allow you to enter your data and easily perform the required calculations. You can also describe your application graphically and send to Exlar for sizing. Reference tables for common unit conversions and motion system constants are included at the end of the section.

### Linear Move Profile Calculations

- V**max = max. velocity-in/sec (m/sec)
- V**avg = avg. velocity-in/sec (m/sec)
- t**acc = acceleration time (sec)
- t**dec = deceleration time (sec)
- t**cv = constant velocity (sec)
- t**total = total move time (sec)
- acc** = accel-in/sec<sup>2</sup> (m/sec<sup>2</sup>)
- dec** = decel-in/sec<sup>2</sup> (m/sec<sup>2</sup>)
- cv** = constant vel.-in/sec (m/sec)
- D** = total move distance-in (m) or revolutions (rotary)

### Standard Equations

**V**avg = **D** / **t**total  
**If t**acc = **t**dec **Then: V**max =  
 (**t**total/(**t**total-**t**acc))(**V**avg)  
 and  
**D** = **Area under profile curve**  
**D** = (1/2(**t**acc+**t**dec)+**t**cv)(**V**max)

### Trapezoidal Move Profile

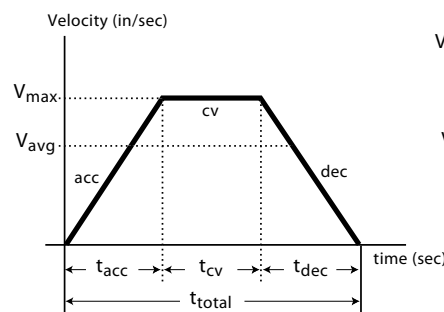

### Trapezoidal Equations

**If t**acc = **t**cv = **t**dec **Then:**  
**V**max = 1.5 (**V**avg)  
**D** = (2/3) (**t**total) (**V**max)  
**acc** = **dec** =  $\frac{\mathbf{V}_{\mathbf{max}}}{\mathbf{t}_{\mathbf{acc}}}$

### Triangular Move Profile

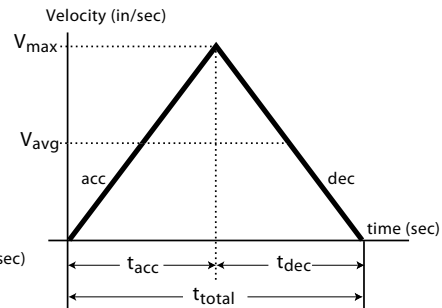

### Triangular Equations

**If t**acc = **t**total/2 **Then:**  
**V**max = 2.0 (**V**avg)  
**D** = (1/2) (**t**total) (**V**max)  
**acc** = **dec** =  $\frac{\mathbf{V}_{\mathbf{max}}}{\mathbf{t}_{\mathbf{acc}}}$

## Terms and (units)

- THRUST** = Total linear force-lbf (N)  
 $\theta$  = Angle of inclination (deg)  
**Ffriction** = Force from friction-lbf (N)  
**tacc** = Acceleration time (sec)  
**Facc** = Acceleration force-lbf (N)  
**v** = Change in velocity-in/sec (m/s)  
**Fgravity** = Force due to gravity-lbf (N)  
 $\mu$  = Coefficient of sliding friction  
**Fapplied** = Applied forces-lbf (N)  
 (refer to table on page 136 for different materials)  
**WL** = Weight of Load-lbf (N)  
 $g = 386.4$ : Acceleration of gravity - in/sec<sup>2</sup> (9.8 m/sec<sup>2</sup>)

## Thrust Calculation Equations

$$\text{THRUST} = \text{Ffriction} + [\text{Facceleration}] + \text{Fgravity} + \text{Fapplied}$$

$$\text{THRUST} = \text{WL}\mu\cos\theta + [(\text{WL}/386.4)(\text{v}/\text{tacc})] + \text{WL}\sin\theta + \text{Fapplied}$$

**Sample Calculations:** Calculate the thrust required to accelerate a 200 pound mass to 8 inches per second in an acceleration time of 0.2 seconds. Calculate this thrust at inclination angles( $\theta$ ) of 0°, 90° and 30°. Assume that there is a 25 pound spring force that is applied against the acceleration.

$$\text{WL} = 200 \text{ lbf}, \text{v} = 8.0 \text{ in/sec.}, \text{ta} = 0.2 \text{ sec.}, \text{Fapp.} = 25 \text{ lbf}, \mu = 0.15$$

$$\theta = 0^\circ$$

$$\begin{aligned} \text{THRUST} &= \text{WL}\mu\cos\theta + [(\text{WL}/386.4)(\text{v}/\text{tacc})] + \text{WL}\sin\theta + \text{Fapplied} \\ &= (200)(0.15)(1) + [(200/386.4)(8.0/0.2)] + (200)(0) + 25 \\ &= 30 \text{ lbs} + 20.73 \text{ lbs} + 0 \text{ lbs} + 25 \text{ lbs} = \mathbf{75.73 \text{ lbs force}} \end{aligned}$$

$$\theta = 90^\circ$$

$$\begin{aligned} \text{THRUST} &= \text{WL}\mu\cos\theta + [(\text{WL}/386.4)(\text{v}/\text{tacc})] + \text{WL}\sin\theta + \text{Fapplied} \\ &= (200)(0.15)(0) + [(200/386.4)(8.0/0.2)] + (200)(1) + 25 \\ &= 0 \text{ lbs} + 20.73 \text{ lbs} + 200 \text{ lbs} + 25 \text{ lbs} = \mathbf{245.73 \text{ lbs force}} \end{aligned}$$

$$\theta = 30^\circ$$

$$\begin{aligned} \text{THRUST} &= \text{WL}\mu\cos\theta + [(\text{WL}/386.4)(\text{v}/\text{tacc})] + \text{WL}\sin\theta + \text{Fapplied} \\ &= (200)(0.15)(0.866) + [(200/386.4)(8.0/0.2)] + (200)(0.5) + 25 \\ &= 26 \text{ lbs} + 20.73 \text{ lbs} + 100 + 25 = \mathbf{171.73 \text{ lbs force}} \end{aligned}$$

## Thrust Calculations

### Definition of thrust:

The thrust necessary to perform a specific move profile is equal to the sum of four components of force. These are the force due to acceleration of the mass, gravity, friction and applied forces such as cutting and pressing forces and overcoming spring forces.

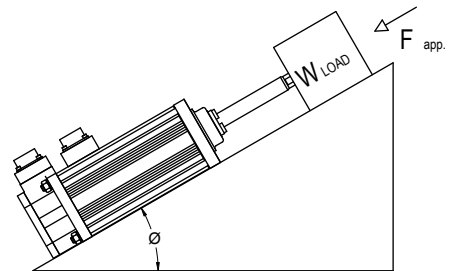

## Angle of Inclination

90°	Note: at $\theta = 0^\circ$ $\cos\theta = 1$ ; $\sin\theta = 0$ at $\theta = 90^\circ$ $\cos\theta = 0$ ; $\sin\theta = 1$
0°	
-90°	

It is necessary to calculate the required thrust for an application during each portion of the move profile, and determine the worst case criteria. The linear actuator should then be selected based on those values. The calculations at the right show calculations during acceleration which is often the most demanding segment of a profile.

## Motor Torque Calculations

When selecting an actuator system it is necessary to determine the required motor torque to perform the given application. These calculations can then be compared to the torque ratings of the given amplifier and motor combination that will be used to control the actuator's velocity and position.

When the system uses a separate motor and screw, like the FT actuator, the ratings for that motor and amplifier are consulted. In the case of the GSX Series actuators with their integral brushless motors, the required torque divided by the torque constant of the motor ( $K_t$ ) must be less than the current rating of the GSX or SLM motor.

Inertia values and torque ratings can be found in the GSX, FT, and SLM/SLG Series product specifications.

For the GSX Series the screw and motor inertia are combined.

### Motor with screw (GSX, FT, & EL)



### Motor & motor with reducer (SLM/SLG & ER)

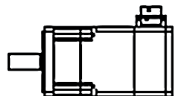

### Motor with belt and pulley

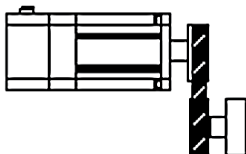

## Terms and (units)

- $\lambda$  = Required motor torque, lbf-in (N-m)
- $\lambda_a$  = Required motor acceleration torque, lbf-in (N-m)
- F** = Applied force load, non inertial, lbf (kN)
- S** = Screw lead, in (mm)
- R** = Belt or reducer ratio
- TL** = Torque at driven load lbf-in (N-m)
- vL** = Linear velocity of load in/sec (m/sec)
- $\omega_L$  = Angular velocity of load rad/sec
- $\omega_m$  = Angular velocity of motor rad/sec
- $\eta$  = Screw or ratio efficiency
- g** = Gravitational constant, 386.4 in/s<sup>2</sup> (9.75 m/s<sup>2</sup>)
- $\alpha$  = Angular acceleration of motor, rad/s<sup>2</sup>
- m** = Mass of the applied load, lb (N)
- JL** = Reflected Inertia due to load, lbf-in-s<sup>2</sup> (N-m-s<sup>2</sup>)
- Jr** = Reflected Inertia due to ratio, lbf-in-s<sup>2</sup> (N-m-s<sup>2</sup>)
- Js** = Reflected Inertia due to external screw, lbf-in-s<sup>2</sup> (N-m-s<sup>2</sup>)
- Jm** = Motor armature inertia, lbf-in-s<sup>2</sup> (N-m-s<sup>2</sup>)
- L** = Length of screw, in (m)
- $\rho$  = Density of screw material, lb/in<sup>3</sup> (kg/m<sup>3</sup>)
- r** = Radius of screw, in (m)
- $\pi$  = pi (3.14159)
- C** = Dynamic load rating, lbf (N)

## Velocity Equations

Screw drive:  $V_L = \omega_m \cdot S / 2\pi$  in/sec (m/sec)

Belt or gear drive:  $\omega_m = \omega_L \cdot R$  rad/sec

## Torque Equations

### Torque Under Load

Screw drive (GS, FT or separate screw):  $\lambda = \frac{S \cdot F}{2 \cdot \pi \cdot \eta}$  lbf-in (N-m)

Belt and Pulley drive:  $\lambda = T_L / R \eta$  lbf-in (N-m)

Gear or gear reducer drive:  $\lambda = T_L / R \eta$  lbf-in (N-m)

### Torque Under Acceleration

$\lambda_a = (J_m + J_r + (J_s + J_L)/R^2) \alpha$  lbf-in

$\alpha$  = angular acceleration = ((RPM / 60) x 2 $\pi$ ) /  $t_{acc}$ , rad/sec<sup>2</sup>.

$J_s = \frac{\pi \cdot L \cdot \rho \cdot r^4}{2 \cdot g}$  lb-in-s<sup>2</sup> (N-m-s<sup>2</sup>)

### Total Torque per move segment

$\lambda_T = \lambda_a + \lambda$  lbf-in (N-m)



# Calculating Estimated Travel Life of Exlar Linear Actuators

## Mean Load Calculations

For accurate lifetime calculations of a roller screw in a linear application, the cubic mean load should be used. Following is a graph showing the values for force and distance as well as the calculation for cubic mean load. Forces are shown for example purposes. Negative forces are shown as positive for calculation.

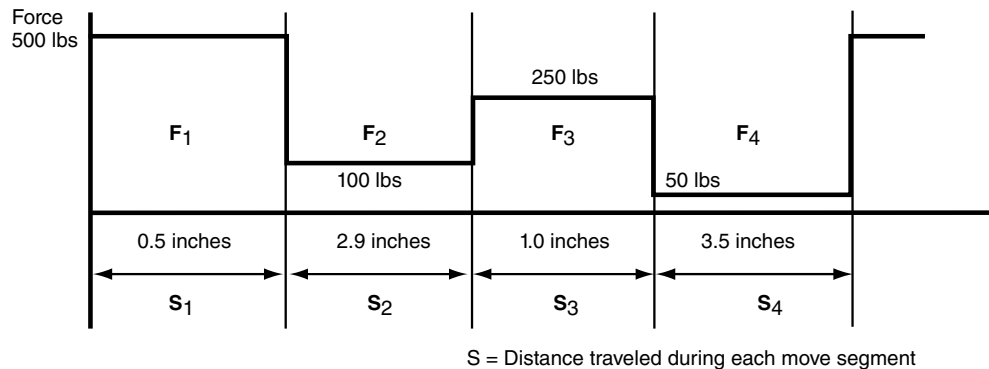

Cubic Mean Load Equation

$$F_{cml} = \sqrt[3]{\frac{F_1^3 S_1 + F_2^3 S_2 + F_3^3 S_3 + F_4^3 S_4}{S_1 + S_2 + S_3 + S_4}}$$

Value from example numbers is 217 lbs.

## Lifetime Calculations

The expected  $L_{10}$  life of a roller screw is expressed as the linear travel distance that 90% of the screws are expected to meet or exceed before experiencing metal fatigue. The mathematical formula that defines this value is below. The life is in millions of inches (mm). This standard  $L_{10}$  life calculation is what is expected of 90% of roller screws manufactured and is not a guarantee. Travel life estimate is based on a properly maintained screw that is free of contaminants and properly lubricated. Higher than 90% requires de-rating according to the following factors:

95% x 0.62      96% x 0.53

97% x 0.44      98% x 0.33

99% x 0.21

**Single (non-preloaded) nut:**

$$L_{10} = \left( \frac{C_a}{F_{cml}} \right)^3 \times \ell$$

## Short Stroke Lifetime Calculations

If your application requires high force over a stroke length shorter than the length of the rollers/nut, please contact Exlar for derated life calculations. You may also download the article "Calculating Life Expectency" at [www.exlar.com](http://www.exlar.com).

Note: The dynamic load rating of zero backlash, preloaded screws is 63% of the dynamic load rating of the standard non-preloaded screws. The calculated travel life of a preloaded screw will be 25% of the calculated travel life of the same size and lead of a non-preloaded screw for the same application.

# Thrust Calculations

## Total Thrust Calculations

Terms and (units)	Variables
<b>THRUST</b> = Total linear force-lbf (N)	$\emptyset$ = Angle of inclination - deg..... = _____
<b>F<sub>friction</sub></b> = Force from friction-lbf (N)	<b>t<sub>acc</sub></b> = Acceleration time - sec..... = _____
<b>F<sub>acc</sub></b> = Acceleration force-lbf (N)	<b>v</b> = Change in velocity - in/sec (m/s)..... = _____
<b>F<sub>gravity</sub></b> = Force due to gravity-lbf (N)	$\mu$ = Coefficient of sliding friction ..... = _____
<b>F<sub>applied</sub></b> = Applied forces-lbf (N)	<b>W<sub>L</sub></b> = Weight of Load-lbm (kg)..... = _____
386.4 = Acceleration of gravity - in/sec <sup>2</sup> (9.8 m/sec <sup>2</sup> )	<b>F<sub>applied</sub></b> = Applied forces-lbf (N) ..... = _____

## Thrust Calculation Equations

**THRUST** = [ **F<sub>friction</sub>** ] + [ **F<sub>acceleration</sub>** ] + **F<sub>gravity</sub>** + **F<sub>applied</sub>**  
**THRUST** = [ **W<sub>L</sub>** x  $\mu$  x cos $\emptyset$  ] + [ ( **W<sub>L</sub>** /386.4 ) x ( **v** / **t<sub>acc</sub>** ) ] + **W<sub>L</sub>**sin $\emptyset$  + **F<sub>applied</sub>**

**THRUST** = [ ( ) x ( ) x ( ) ] + [ ( /386.4 ) x ( / ) ] + [ ( ) ( ) ] + ( )  
**THRUST** = [ ( ) ] + [ ( ) x ( ) ] + [ ( ) ] + ( )  
 = \_\_\_\_\_ lbf.

Calculate the thrust for each segment of the move profile. Use those values in calculations below. Use the units from the above definitions.

## Cubic Mean Load Calculations

$$\sqrt[3]{\frac{F_1^3 S_1 + F_2^3 S_2 + F_3^3 S_3 + F_4^3 S_4}{S_1 + S_2 + S_3 + S_4}}$$

**F<sub>1</sub>**= \_\_\_\_\_      **S<sub>1</sub>**= \_\_\_\_\_      **F<sub>1</sub><sup>3</sup> S<sub>1</sub>**= \_\_\_\_\_  
**F<sub>2</sub>**= \_\_\_\_\_      **S<sub>2</sub>**= \_\_\_\_\_      **F<sub>2</sub><sup>3</sup> S<sub>2</sub>**= \_\_\_\_\_  
**F<sub>3</sub>**= \_\_\_\_\_      **S<sub>3</sub>**= \_\_\_\_\_      **F<sub>3</sub><sup>3</sup> S<sub>3</sub>**= \_\_\_\_\_  
**F<sub>4</sub>**= \_\_\_\_\_      **S<sub>4</sub>**= \_\_\_\_\_      **F<sub>4</sub><sup>3</sup> S<sub>4</sub>**= \_\_\_\_\_

Move Profiles may have more or less than four components. Adjust your calculations accordingly.

## Torque Calculations

### Terms and (units)

$\lambda$	= Torque, lb-in (N-m).....	= -----
<b>F</b>	= Applied Load, non inertial, lbf (N) .....	= -----
<b>S</b>	= Screw lead, in (m).....	= -----
$\eta$	= Screw or ratio efficiency (~85% for roller screws) .....	= -----
<b>g</b>	= Gravitational constant, 386 in/s <sup>2</sup> (9.8 m/s <sup>2</sup> ).....	= -----
$\alpha$	= Acceleration of motor, rad/s <sup>2</sup> .....	= -----
<b>R</b>	= Belt or reducer ratio .....	= -----
<b>T<sub>L</sub></b>	= Torque at driven load, lbf-in (N-m) .....	= -----
<b>V<sub>L</sub></b>	= Linear velocity of load, in/sec (m/sec) .....	= -----
$\omega_L$	= Angular velocity of load, rad/sec.....	= -----
$\omega_m$	= Angular velocity of motor, rad/sec.....	= -----
<b>m</b>	= Mass of the applied load, lbm (kg).....	= -----
<b>J<sub>R</sub></b>	= Reflected Inertia due to ratio, lb-in-s <sup>2</sup> (N-m-s <sup>2</sup> ) .....	= -----
<b>J<sub>S</sub></b>	= Reflected Inertia due to screw, lb-in-s <sup>2</sup> (N-m-s <sup>2</sup> ) .....	= -----
<b>J<sub>L</sub></b>	= Reflected Inertia due to load, lb-in-s <sup>2</sup> (N-m-s <sup>2</sup> ).....	= -----
<b>J<sub>M</sub></b>	= Motor armature inertia, lb-in-s <sup>2</sup> (N-m-s <sup>2</sup> ) .....	= -----
$\pi$	= pi .....	= 3.14159
<b>K<sub>t</sub></b>	= Motor Torque constant, lb-in/amp (N-m/amp).....	= -----

\* For the GS Series  $J_S$  and  $J_M$  are one value from the GS Specifications.

## Torque Equations

### Torque From Calculated Thrust.

$$\lambda = \frac{SF}{2 \cdot \pi \cdot \eta} \text{ lb-in (N-m)} = ( \quad ) \times ( \quad ) / 2\pi (0.85) = ( \quad ) \times ( \quad ) / 5.34 = \text{-----}$$

### Torque Due To Load, Rotary.

Belt and pulley drive:  $\lambda = T_L / R \eta$  lbf-in (N-m)

Gear or gear reducer drive:  $\lambda = T_L / R\eta$  lbf-in (N-m)

### Torque During Acceleration due to screw, motor, load and reduction, linear or rotary.

$$I = (J_m + (J_S + J_L) / R^2) \alpha \text{ lb-in (N-m)} = [ ( \quad ) + ( \quad + \quad ) / ( \quad ) ] ( \quad ) = \text{-----}$$

**Total Torque** = Torque from calculated Thrust + Torque due to motor, screw and load

$$( \quad ) + ( \quad ) + ( \quad ) = \text{-----}$$

$$\text{Motor Current} = \lambda / K_t = ( \quad ) / ( \quad ) = \text{-----}$$

# Exlar Application Worksheet

## Exlar Application Worksheet

Send to:  
**Exlar Automation**  
Email: [cha\\_applications@curtisswright.com](mailto:cha_applications@curtisswright.com)  
Fax: (952) 368-4877  
Attn: Applications Engineering

Date: \_\_\_\_\_ Company Name: \_\_\_\_\_

Address: \_\_\_\_\_

City: \_\_\_\_\_ State: \_\_\_\_\_ Zip Code: \_\_\_\_\_

Phone: \_\_\_\_\_ Fax: \_\_\_\_\_

Contact: \_\_\_\_\_ Title: \_\_\_\_\_

## Sketch/Describe Application

Velocity vs. Time

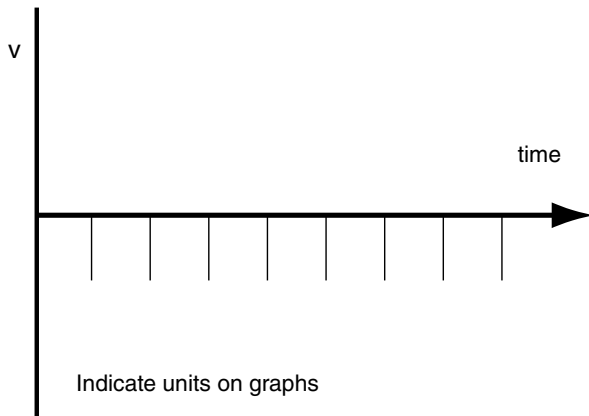

Force or Torque vs. Distance

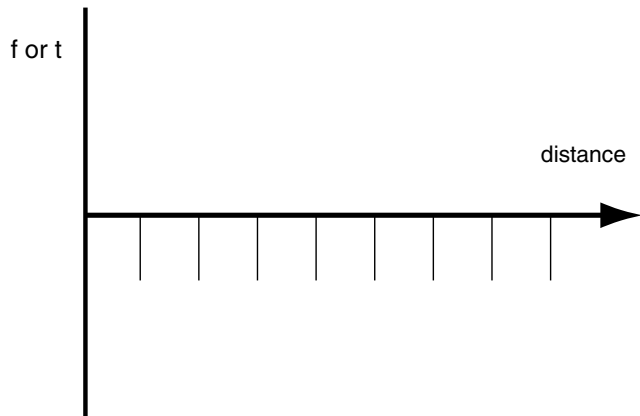

## Exlar Application Worksheet

Date: \_\_\_\_\_ Contact: \_\_\_\_\_ Company: \_\_\_\_\_

### Stroke & Speed Requirements

Maximum Stroke Needed ..... inches (mm), revs  
 Index Stroke Length ..... inches (mm), revs  
 Index Time ..... sec  
 Max Speed Requirements ..... in/sec (mm/sec), revs/sec  
 Min Speed Requirements ..... in/sec (mm/sec), revs/sec  
 Required Positional Accuracy ..... inches (mm), arc min

### Load & Life Requirements

Gravitational Load ..... lb (N)  
 External Applied Load ..... lbf (N)  
 Inertial Load ..... lbf (N)  
 Friction Load ..... lbf (N)  
 Rotary Inertial Load ..... lbf-in-sec<sup>2</sup> (Kg-m<sup>2</sup>)  
 or rotary mass, radius of gyr. .... lb (kg) ..... in (mm)  
 Side Load (rot. or lin. actuator) ..... lb (N)  
 Force Direction      \_\_\_ Extend                      \_\_\_ Retract                      \_\_\_ Both  
 Actuator Orientation      \_\_\_ Vertical Up                      \_\_\_ Vertical Down                      \_\_\_ Horizontal  
    \_\_\_ Fixed Angle                      \_\_\_ Degrees from Horizontal  
    \_\_\_ Changing Angle                      \_\_\_ to \_\_\_  
 Cycling Rate ..... Cycles/min/hr/day  
 Operating Hours per Day ..... Hours  
 Life Requirement ..... Cycles/hr/inches/mm

---

### Configuration

**Mounting:**    \_\_\_ Side      \_\_\_ Flange      \_\_\_ Ext Tie Rod      \_\_\_ Clevis      \_\_\_ Trunnion  
**Rod End:**    \_\_\_ Male      \_\_\_ Female      \_\_\_ Sph Rod Eye      \_\_\_ Rod Eye      \_\_\_ Clevis  
**Rod Rotation Limiting:**    \_\_\_ Appl Inherent      \_\_\_ External Required  
**Holding Brake Required:**                      \_\_\_ Yes                      \_\_\_ No  
**Cable Length:**    \_\_\_\_\_ ft (m)

# Reference Tables

## Rotary Inertia

To obtain a conversion from A to B, multiply by the value in the table.

B	Kg-m <sup>2</sup>	Kg-cm <sup>2</sup>	g-cm <sup>2</sup>	kgf-m-s <sup>2</sup>	kgf-cm-s <sup>2</sup>	gf-cm-s <sup>2</sup>	oz-in <sup>2</sup>	ozf-in-s <sup>2</sup>	lb-in <sup>2</sup>	lbf-in-s <sup>2</sup>	lb-ft <sup>2</sup>	lbf-ft-s <sup>2</sup>
A												
Kg-m <sup>2</sup>	1	10 <sup>4</sup>	10 <sup>7</sup>	0.10192	10.1972	1.01972x10 <sup>4</sup>	5.46745x10 <sup>4</sup>	1.41612x10 <sup>2</sup>	3.41716x10 <sup>3</sup>	8.850732	23.73025	0.73756
Kg-cm <sup>2</sup>	10 <sup>-4</sup>	1	10 <sup>3</sup>	1.01972x10 <sup>5</sup>	1.01972x10 <sup>3</sup>	1.01972	5.46745	1.41612x10 <sup>-2</sup>	0.341716	8.85073x10 <sup>-4</sup>	2.37303x10 <sup>-3</sup>	7.37561x10 <sup>-5</sup>
g-cm <sup>2</sup>	10 <sup>-7</sup>	10 <sup>-3</sup>	1	1.01972x10 <sup>-8</sup>	1.01972x10 <sup>-6</sup>	1.01972x10 <sup>-3</sup>	5.46745x10 <sup>-3</sup>	1.41612x10 <sup>-5</sup>	3.41716x10 <sup>-4</sup>	8.85073x10 <sup>-7</sup>	2.37303x10 <sup>-6</sup>	7.37561x10 <sup>-8</sup>
kgf-m-s <sup>2</sup>	9.80665	9.80665x10 <sup>4</sup>	9.80665x10 <sup>7</sup>	1	10 <sup>2</sup>	10 <sup>5</sup>	5.36174x10 <sup>5</sup>	1.388674x10 <sup>3</sup>	3.35109x10 <sup>4</sup>	86.79606	2.32714x10 <sup>2</sup>	7.23300
kgf-cm-s <sup>2</sup>	9.80665x10 <sup>-2</sup>	9.80665x10 <sup>2</sup>	9.80665x10 <sup>5</sup>	10 <sup>-2</sup>	1	10 <sup>5</sup>	5.36174 x10 <sup>3</sup>	13.8874	3.35109x10 <sup>-2</sup>	0.86796	2.32714	7.23300x10 <sup>-2</sup>
gf-cm-s <sup>2</sup>	9.80665x10 <sup>-5</sup>	0.980665	9.80665x10 <sup>2</sup>	10 <sup>-5</sup>	10 <sup>-3</sup>	1	5.36174	1.38874 x10 <sup>-2</sup>	0.335109	8.67961x10 <sup>-4</sup>	2.32714x10 <sup>-3</sup>	7.23300x10 <sup>-5</sup>
oz-in <sup>2</sup>	1.82901x10 <sup>-5</sup>	0.182901	1.82901x10 <sup>2</sup>	1.86505x10 <sup>-6</sup>	1.86505x10 <sup>-4</sup>	0.186506	1	2.59008 x10 <sup>-3</sup>	6.25 x10 <sup>-2</sup>	1.61880x10 <sup>-4</sup>	4.34028x10 <sup>-4</sup>	1.34900x10 <sup>-3</sup>
oz-in-s <sup>2</sup>	7.06154x10 <sup>-3</sup>	70.6154	7.06154x10 <sup>4</sup>	7.20077x10 <sup>4</sup>	7.20077x10 <sup>-2</sup>	72.0077	3.86089x10 <sup>2</sup>	1	24.13045	6.25 x10 <sup>-2</sup>	0.167573	5.20833x10 <sup>-4</sup>
lb-in <sup>2</sup>	2.92641x10 <sup>-4</sup>	2.92641	2.92641x10 <sup>3</sup>	2.98411x10 <sup>5</sup>	2.98411x10 <sup>3</sup>	2.98411	16	4.14414 x10 <sup>2</sup>	1	2.59008x10 <sup>-3</sup>	6.94444x10 <sup>-3</sup>	2.15840x10 <sup>-4</sup>
lbf-in-s <sup>2</sup>	0.112985	1.129x10 <sup>3</sup>	1.12985x10 <sup>6</sup>	1.15213x10 <sup>2</sup>	1.15213	1.51213 x10 <sup>3</sup>	6.1774 x10 <sup>3</sup>	16	3.86088x10 <sup>2</sup>	1	2681175	8.3333x10 <sup>-2</sup>
lbf-ft <sup>2</sup>	4.21403x10 <sup>-2</sup>	4.21403x10 <sup>2</sup>	4.21403x10 <sup>5</sup>	4.29711x10 <sup>3</sup>	0.429711	4.297114	2.304 x10 <sup>3</sup>	5.96755	144	0.372971	1	3.10809x10 <sup>-2</sup>
lbf-ft-s <sup>2</sup>	1.35583	1.35582x10 <sup>4</sup>	1.35582x10 <sup>7</sup>	0.138255	13.82551	1.38255x10 <sup>4</sup>	7.41289x10 <sup>4</sup>	192	4.63306x10 <sup>3</sup>	12	32.17400	1

## Torque

To obtain a conversion from A to B, multiply A by the value in the table.

B	N-m	N-cm	dyn-cm	Kg-m	Kg-cm	g-cm	oz-in	ft-lb	in-lb
A									
N-m	1	10 <sup>-2</sup>	10 <sup>7</sup>	0.109716	10.19716	1.019716 x10 <sup>4</sup>	141.6199	0.737562	8.85074
N-cm	102	1	10 <sup>5</sup>	1.019716 x10 <sup>3</sup>	0.1019716	1.019716 x10 <sup>2</sup>	1.41612	7.37562 x10 <sup>-3</sup>	8.85074 x10 <sup>-2</sup>
dyn-cm	10 <sup>-7</sup>	10 <sup>-5</sup>	1	1.019716 x10 <sup>-8</sup>	1.019716 x10 <sup>-6</sup>	1.019716 x10 <sup>-3</sup>	1.41612 x10 <sup>-5</sup>	7.2562 x10 <sup>-8</sup>	8.85074 x10 <sup>-7</sup>
Kg-m	9.80665	980665x10 <sup>2</sup>	9.80665 x10 <sup>7</sup>	1	10 <sup>2</sup>	10 <sup>5</sup>	1.38874 x10 <sup>3</sup>	7.23301	86.79624
Kg-cm	9.80665x10 <sup>-2</sup>	9.80665	9.80665 x10 <sup>5</sup>	10 <sup>-2</sup>	1	10 <sup>3</sup>	13.8874	7.23301 x10 <sup>-2</sup>	0.86792
g-cm	9.80665x10 <sup>-5</sup>	9.80665x10 <sup>-3</sup>	9.80665 x10 <sup>2</sup>	10 <sup>-5</sup>	10 <sup>-3</sup>	1	1.38874 x10 <sup>-2</sup>	7.23301 x10 <sup>-5</sup>	8.679624 x10 <sup>-4</sup>
oz-in	7.06155x10 <sup>-3</sup>	0.706155	7.06155 x10 <sup>4</sup>	7.20077 x10 <sup>-4</sup>	7.20077 x10 <sup>-2</sup>	72.077	1	5.20833 x10 <sup>-3</sup>	6.250 x10 <sup>-2</sup>
ft-lb	1.35582	1.35582x10 <sup>2</sup>	1.35582 x10 <sup>7</sup>	0.1382548	13.82548	1.382548 x10 <sup>4</sup>	192	1	12
in-lb	0.113	11.2985	1.12985 x10 <sup>6</sup>	1.15212 x10 <sup>-2</sup>	1.15212	1.15212 x10 <sup>3</sup>	16	8.33333 x10 <sup>-2</sup>	1

## Common Material Densities

Material	oz/in <sup>3</sup>	gm/cm <sup>3</sup>
Aluminum (cast or hard drawn)	1.54	2.66
Brass (cast or rolled)	4.80	8.30
Bronze (cast)	4.72	8.17
Copper (cast or hard drawn)	5.15	8.91
Plastic	0.64	1.11
Steel (hot or cold rolled)	4.48	7.75
Wood (hard)	0.46	0.80
Wood (soft)	0.28	0.58

## Coefficients of Sliding Friction

Materials in contact	μ
Steel on Steel (dry)	0.58
Steel on Steel (lubricated)	0.15
Aluminum on Steel	0.45
Copper on Steel	0.36
Brass on Steel	0.44
Plastic on Steel	0.20
Linear Bearings	0.001

